

# Durham E-Theses

---

## *Audiometry and hearing aids*

J. D. Hood

### How to cite:

---

Hood, J. D. (1947) Audiometry and hearing aids. Masters thesis, Durham University.

### Use policy

---

The full-text may be used and/or reproduced, and given to third parties in any format or medium, without prior permission or charge, for personal research or study, educational, or not-for-profit purposes provided that:

- a full bibliographic reference is made to the original source
- a <https://etheses.durham.ac.uk/id/eprint/9668/> is made to the metadata record in Durham E-Theses
- the full-text is not changed in any way

The full-text must not be sold in any format or medium without the formal permission of the copyright holders.

Please consult the [full Durham E-Theses policy](#) for further details.

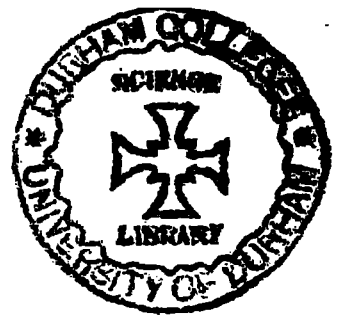

AUDIOMETRY and HEARING AIDS.

Thesis for Degree of Master of Science

in the

University of Durham

presented by

J. D. Hood, B.Sc.

April 22nd 1947.

-----

## I N T R O D U C T I O N .

---

In October 1944 I was appointed by the Medical Research Council to the staff of the Otological Research Unit at the National Hospital, Queen Square, London, W.C.1.

My work with this Unit has been concerned for the most part with the physical aspects of deafness and hearing aids, and has been carried out at the Deafness Clinic at the National Hospital as part of a programme of work designed to provide the Electro-Acoustics Committee of the Medical Research Council with experimental data required for the design of the standard types of valve aids recommended by the Committee for general use by the deaf. Details of the work and of the Committee's recommendations are to be found in its Report (in the press, H.M. Stationery Office).

Part of my own contribution to the above work forms the basis of this thesis which contains, in addition, some original observations directly related to the subject of Deafness and Hearing Aid design.

In Section I of the thesis are outlined some of the principal characteristics of hearing aids. Mention is made of aids other than valve aids, as these are still used in large numbers by some of the deaf population, but it is to be remarked at the outset that valve aids being far superior to any others, were the principal concern of the Electro-Acoustics Committee and were the only type used at the Deafness Clinic. The main features of the construction of modern valve aids are described with some remarks on decoupling, feedback and tone control.

It was necessary to have as many as ten or more different hearing aids in use at the Clinic, and means had to be devised to maintain them in constant working order and to make rapid check measurements of their performance. In addition, it was necessary to study the manner in which deterioration of the H.T. and L.T. batteries affected the performance of certain of these aids which were found to be of particular clinical value. Circuit diagrams of these aids are provided.

Before patients at the Clinic could be tested with various hearing aids, other tests had to be made in order to ascertain the degree of their hearing impairment. The principles and technique of these tests are discussed in

detail in Section II. This is devoted in particular to,

- A. Pure tone Audiometry, a common method of measuring the loss for pure tones, the limitations of which are explained, and
- B. Speech Audiometry, a more direct method of assessing a patient's inability to understand speech.

The latter method was developed at the Clinic in conjunction with the Electro-Acoustics Committee, and much of this section is devoted to the principles and practice of speech audiometry including the selection of test material.

In Section III is described the methods of evaluating by means of the speech audiometer the usefulness of the various hearing aids in meeting the individual requirements of deaf subjects.

Finally, in Section IV are contained some original observations and research carried out in connection with this work.

#### Acknowledgments.

During the early part of 1945 a good deal of my time was spent in the Acoustics Laboratory of the G.P.O. Research Station, Dollis Hill, where I was able to gain valuable experience in the methods and technique of Electro-acoustic measurements. This privilege of working at Dollis Hill was greatly appreciated and my grateful thanks are due to Dr W.G.Radley, Controller of Research, G.P.O.

My thanks are also due to Dr C.S.Hallpike, Director of the Otological Research Unit, for help in the general design of the work which forms the basis of this Thesis and for valuable discussion and criticism in the course of its preparation.

-----oOo-----

TABLE OF CONTENTS.

<u>SECTION I.</u> <u>Hearing Aids</u>	<u>Page</u>
1. Accoustic Aids	1
2. Electro-Acoustic Amplifiers	2 - 8
(a) Carbon Aids	
(b) Valve Aids	
(i) Design	
(ii) Decoupling	
(iii) Negative Feedback	
(iv) Tone Control	
3. Performance Tests	8 - 10
(a) Subjective Method	
(b) Objective Method	
4. Maintenance	10 - 12
(a) Power Supply	
(b) Routine Testing of Amplification	
5. Variation in amplification with Battery deterioration	12 - 16
 <u>SECTION II.</u> <u>Hearing Tests</u>	
1. Pure Tone Audiometry	17 - 23
Introduction	
(a) Threshold of Hearing	
(b) The audiogram	
(c) The limitations of the audiogram	
2. Speech Audiometry	24 - 38
(a) General principles	
(b) Test material	
(c) Correlation of Word Articulation and Sentence Intelligibility	
(d) Practical Procedure for Speech Audiometry as applied to Deaf Subjects	
(i) Test material	
(ii) The Speech Audiogram	

TABLE OF CONTENTS (Contd.)

	<u>Page</u>
<u>SECTION III. Evaluation of the Usefulness of Hearing Aids</u>	
1. Pure Tone Audiometer method.	40
2. Speech Audiometer method.	41 - 45
(a) Procedure	
(b) Overload of Hearing Aids	
(c) Difficulties arising in testing of patients suffering from Nerve Deafness.	
 <u>SECTION IV. Some original observations upon the correlation of the Speech and Pure Tone audiograms in a number of Deaf Subjects.</u>	

-----oO-----

## SECTION I.

### HEARING AIDS.

The various aids to hearing for the deaf may be grouped broadly under two main headings:

Acoustic Aids.

Electro-Acoustic Amplifiers.

#### 1. Acoustic Aids.

These appliances, the more common of which are the speaking tubes, ear trumpets and so-called auricles, are of a non-electrical nature. Their action depends upon the collection of sound at the expanded end of a tube, its passage along this tube with relatively little attenuation, and its delivery at the ear through the narrow end of the tube. The losses in the tube are mainly due to absorption, and affect the frequency above 3,000.c.p.s. The tube should be made of metal, hard rubber or vulcanite to avoid losses due to absorption. The benefit derived from the speaking tube depends upon the fact that the mouth of the speaker is brought effectively from a distance of 3 ft. directly to the meatus of the subject. The overall gain so obtained may amount to as much as 30 db. which may be very valuable in cases of slight deafness.

#### 2. Electro-Acoustic Amplifiers.

Electrical hearing aids are far superior to the non-electric type by virtue of their greater amplification and wider application. In this type the patient's ear is replaced by a microphone whereby the sound energy is changed to electrical energy, amplified and delivered to a receiver applied at the patient's ear. In some cases the receiver takes the form of a vibratory element, the so-called bone conduction receiver. This element is applied to the mastoid process or some bone of the head. In contrast to bone-conduction, conduction along the ear passage is known as air-conduction. With all electrical hearing aids there are concomitant parasitic noises which set a limit to the weakest sounds that can be made audible to a deaf subject. This background noise is particularly objectionable in cases of deafness due

to disease of the internal ear.

There are two main types in use, those using a very sensitive type of carbon microphone with or without an additional carbon amplifier, and those using a better quality microphone but necessitating an associated valve amplifier.

(a) Carbon Aids.

The carbon microphone consists essentially of a layer of carbon granules in contact with a carbon diaphragm. The system acts as a resistance to a current passing from a low tension battery of from three to four and a half volts, and this resistance varies as the diaphragm vibrates under sound pressures. In this way the current varies directly as the vibration of the impinging sound waves.

The voltage developed by the carbon microphone is considerably greater than that developed by any other microphone so that sufficient amplification is obtained to operate a low resistance telephone receiver in series with the microphone as in Fig. I showing a simple circuit of a non-valve aid.

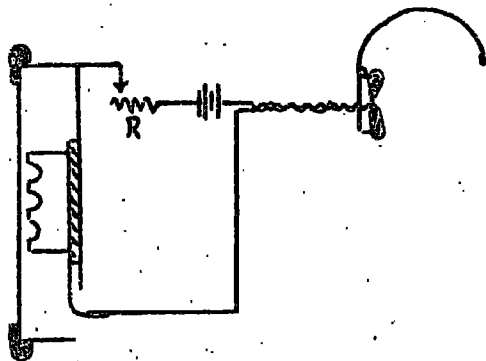

Fig. 1 Simple circuit of carbon microphone aid.

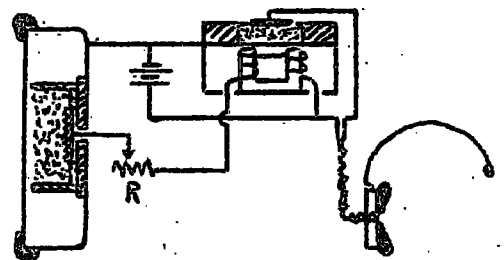

Fig. 2 Circuit employing carbon powder amplifier.

The resistance R in series with the batteries acts as a sensitivity control. The microphone has a diaphragm resonance usually between 500 and 1000 c.p.s. and this, in combination with the receiver resonant frequency, gives the system a sharp or 'peaked' response. Any attempt at damping the diaphragm results in serious loss of sensitivity and attempts have been made to broaden the characteristic by using two microphones with different resonant frequencies in parallel.

In most present day carbon microphone aids a carbon-powder amplifier is incorporated in the system as shown in Fig. 2 giving increased sensitivity. In this way a powder type microphone of a lower sensitivity but more uniform

characteristic can be used. With aids of this type the signal noise ratio is low, and this limits the permissible amplification. Furthermore, arcing between the contacts of the granules and the diaphragm necessitates renewal of the carbon shot after a period of use. On account of their extreme portability such aids are favoured by many despite the undoubted defects of reproduction. To this we should add that some American firms have now developed improved types with responses approaching those of valve amplifier aids.

(b) Valve Aids. (i) Design.

The employment of midget valves in electrical aids has made possible the use of high quality microphones such as the piezo electric crystal and electromagnetic, which give greater fidelity of reproduction. Furthermore, the increased amplification available in multi-valve instruments has permitted the use of filter circuits to give frequency response adjustment when desirable. In particular, the use of the crystal microphone, now almost universally adopted, greatly favours lightness and compactness.

The basic principle of hearing aid amplifiers generally follows the lines of resistance capacity coupled A/F amplifiers as shown in Fig.3, although it is not uncommon to find one stage of transformer coupling as in Fig.4. The size of the latter, however, limits its employment in very small aids. Very great stress is laid on the overall weight of the aid including batteries and in this respect the new layer-pack type of H.T. battery has found an admirable use in the hearing aid market.

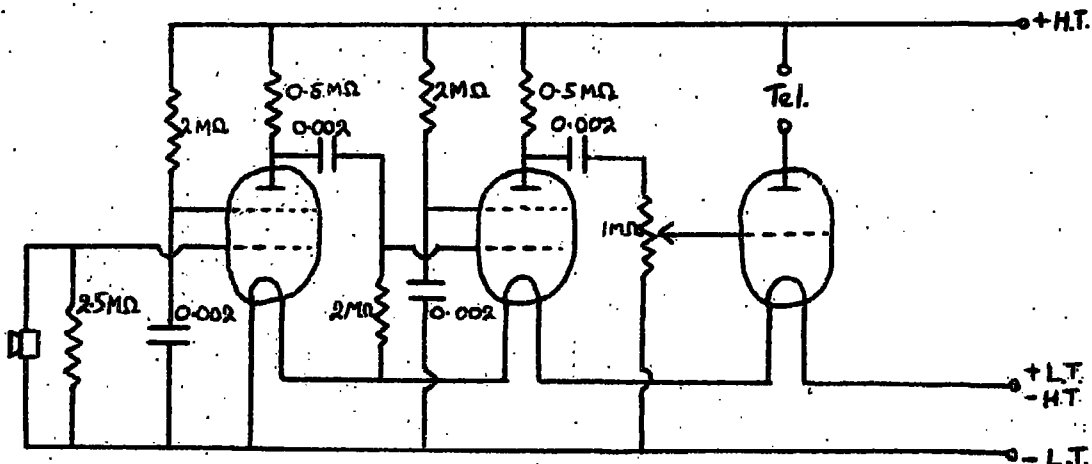

Fig.3 Typical circuit of three-valve aid.

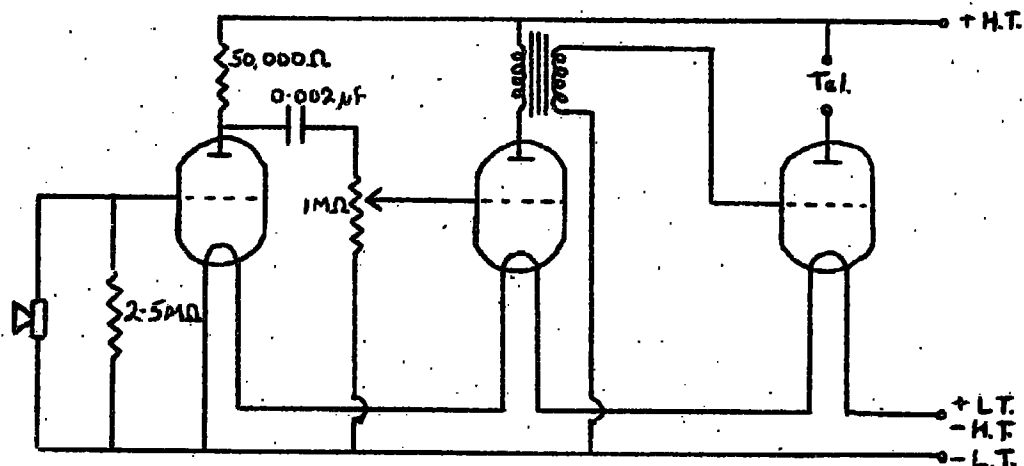

Fig.4 Circuit of valve aid using transformer coupling.

The high tension required by some recent aids is sometimes as little as  $22\frac{1}{2}$  volts and seldom above 45 volts while the low tension varies from 1.5 volts to 4.5 volts according to the mode of wiring of the filament circuit (miniature hearing aid valves normally require 1.4 filament voltage.)

Usually the filaments are wired in parallel so that only a single large 1.5 volt cell need be used, thus economising in weight and space. Triodes, tetrodes and pentode miniature valves are used.

Other miniature components such as resistors and condensers have been reduced to 'midget' dimensions. One-tenth watt resistors of the order of ten ohms to ten megohms are being made as small as  $\frac{3}{8}$ in. long and  $\frac{1}{8}$ in. in diameter.

The receivers used are usually of the moving-iron and piezo-electric crystal types. Moving coil receivers are considered too heavy and, furthermore, since they are of low impedance, they require an output matching transformer in the last valve circuit. The piezo-electric receiver is a capacitive impedance of the order of 10,000 ohms at 4,000 c/s and for maximum sensitivity the last valve of the amplifier can be of higher impedance than in the case of the moving iron type. Since the application of the D.C. anode voltage to the receiver must be prevented, the output load consists of a high resistance across which the telephone is connected in series with an isolating condenser.

(ii) Decoupling. Some trouble has been experienced with certain sensitive three-valve aids which have developed self-oscillation as the high tension battery has begun to age. The trouble arises in the increase of the internal resistance of the battery despite the fact that the voltage is at,

or only slightly below, the nominal value. Positive feed-back is then developed via the anode load of the first valve onto the grid of the second and the aid breaks into oscillation. This effect can be nullified by decoupling this valve in the manner shown in Fig. 5

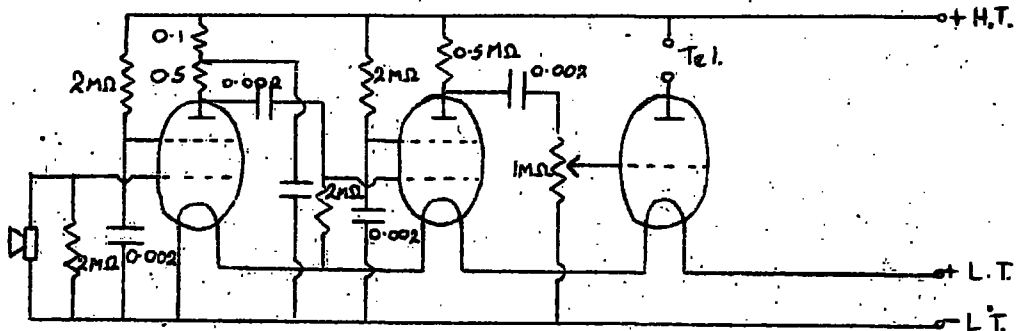

**Fig.5** Method of decoupling to prevent oscillation when H.T. Battery deteriorates.

As self-oscillation begins in an aid which has not been decoupled when the internal resistance reaches such low values as 150 to 200 ohms, this factor is of great importance, especially with the advent of the aforementioned layer-pack type batteries which have an initial internal resistance of from 90 to 110 ohms.

(iii) Negative Feedback in Hearing Aids. With the advent of miniature valves of relatively high amplification it has become possible to sacrifice part of the gain of an aid and take advantage of the improvement in quality offered by the use of negative feed-back.

Its effects upon performance are well-known including improved frequency response, reduction of distortion and noise introduced by the amplifying system as well as the increased stability with regard to the supply voltages and circuit elements.

A typical circuit of American design, shown in Fig.6, provides voltage feedback between anode and grid of the output stage. Here a fraction of the output voltage  $V$  is applied to the grid of valve 3.

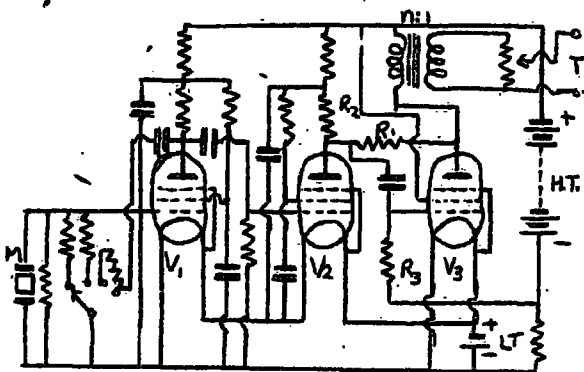

Fig.6 Valve aid incorporating negative feedback.

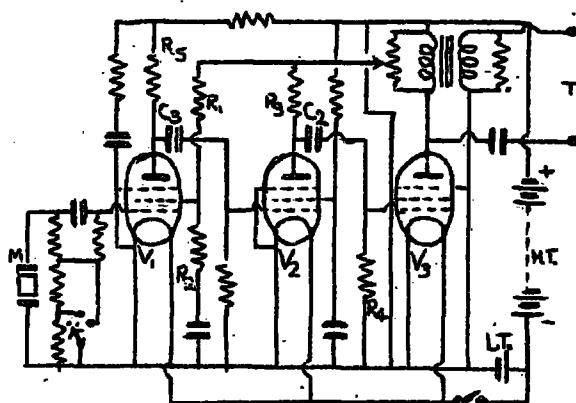

Fig.7 Western Electric Aid.

The Western Electric Co. have produced an aid the circuit diagram of which is given in Fig.7, in which negative feedback is used to improve fidelity of reproduction and a measure of positive feedback to counteract the effects of falling battery voltage. A fraction of the output voltage from the tapped resistor shunting the output transformer is applied to both the first and last valve. In the former case the feedback voltage is impressed upon the screen grid through the resistances  $R_1$ ,  $R_2$ , and condenser  $C_1$  in the latter case upon the grid through the resistance  $R_3$ , condenser  $C_2$  and resistance  $R_4$ . Positive feedback with increasing H.T. battery resistance is applied to the grid of valve 2.

(iv) Tone Control. The scientific basis for selective amplification in cases of deafness is by no means clear. In practice, however, many present day commercial hearing aids incorporate some form of tone control which gives the wearer a choice of two or more frequency responses which can be used at will to give (a) the most 'comfortable' response according to the individual's hearing loss or (b) the most suitable response for the conditions in which the aid is being used, such as restricted low frequency response to reduce disturbing street noises when the aid is being worn out of doors.

The crystal microphone is commonly used now in hearing aids and this makes possible a very easy means of introducing low frequency attenuation. The microphone is equivalent to a condenser of the order of 0.002 mfd. or an impedance of about half a megohm at 200 cycles across the input of the first valve. When this in turn is shunted by a resistance of less than this value (see Fig.8) the response at low frequencies can be reduced considerably.

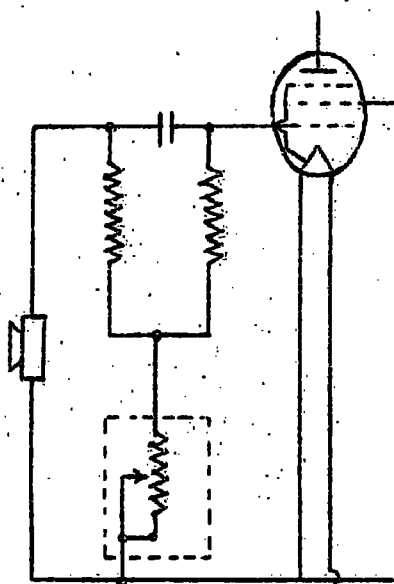

Fig.8 Low frequency attenuation.

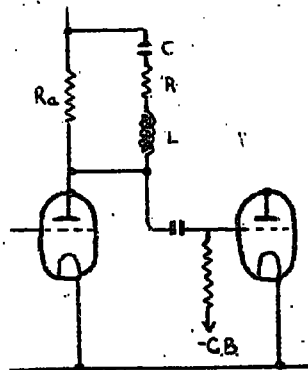

Fig.9 Filter circuit for reducing response at the middle of the speech range.

High frequency attenuation can be obtained by using a condenser in parallel with the anode resistance of a valve circuit. The condenser reduces the overall impedance of the anode load to high frequencies, and their amplification is consequently reduced while the low frequency response remains unchanged. On the other hand, a small inter-valve coupling condenser, together with a grid resistance, gives a response which decreases at low frequencies. If a response is required which rises gradually to each end of the frequency scale, it is necessary to incorporate a tuned circuit of the form shown in Fig.9 consisting of an inductance resistance and condenser. In this way, by choosing suitable values for the components, it is possible to attenuate those frequencies in the middle frequency range. This, of course, tends to reduce the effective amplification of the aid considerably, and provision will invariably have to be made to restore the overall gain by means of another stage of amplification.

An interesting circuit due to Planer and Marland Fig.10a [Bibliography (1)] utilises negative feedback in producing a selective response.

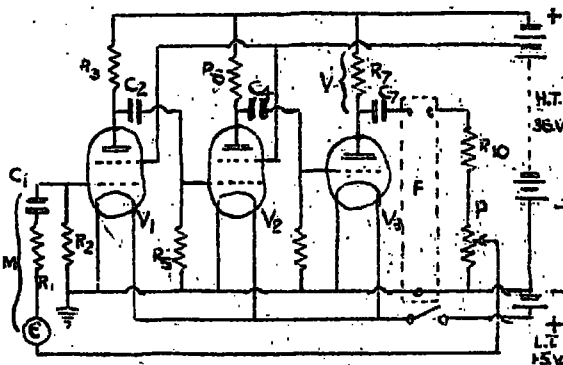

Fig.10a. Tone control by means of negative feedbacks.

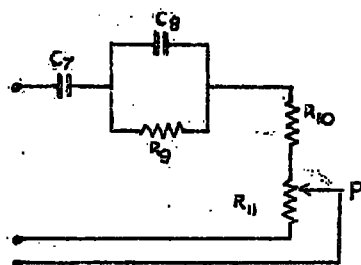

Fig.10b Correction network.

The amplifier proper possesses a substantially flat frequency characteristic, and incorporates a piezo-electric crystal microphone M of which the equivalent circuit is shown in the diagram. Degenerative feed-back is brought about by feeding back to the grid of the first valve a portion of the voltage across the output load by way of a correction network F of the form shown in Fig.10b and a potential divider P. In this way it is possible (a) to make use of the full gain of the aid with no frequency correction when listening to very faint sounds, or (b) to introduce the desired frequency response by means of the filter circuit and at the same time take advantage of the fidelity afforded by degeneration when listening to a source of adequate sound intensity.

### 3. Performance Tests.

The air to air amplification of a hearing aid is defined as 'the ratio in decibels of the free sound field required to produce a given loudness sensation in the unaided ear to the intensity of the field at the diaphragm of the hearing aid microphone that will produce the same sensation of loudness.' [Bibliography (2)]. Many methods have been devised to ascertain this ratio, both subjectively and objectively, and the above definition has been modified from time to time to conform to the various testing conditions. The basic principles remain the same, however, and the following methods are typical of those in current use.

#### (a) Subjective Method.

This method is dependant to a large extent upon the skill and judgment of an observer. The output from an oscillator is led through an attenuator calibrated in decibels to a loudspeaker. The hearing aid microphone is placed in front of the loudspeaker and a listener sits so that one ear faces the loudspeaker in a similar position to that occupied by the microphone. The listener listens to the sound from the hearing aid receiver and then quickly removes it to listen to the source in free air without moving his head. While so doing he quickly alters the reading of the attenuator to make the two sounds appear equally loud. After a number of alternate listenings a reading of the attenuator is obtained which gives a subjective value of the effective amplification of the aid at the frequency used. Care has to be taken in the choice of the level of the sound output from the loudspeaker lest the aid is overloaded, when its amplification will begin to fall off and distortion will be introduced.

(b) Objective Method.

Subjective methods although simple are not at all accurate, and are apt to vary by as much as 10 db. For more precise determinations, therefore, so-called artificial ears are used. These take the form of a coupling device between the hearing aid receiver and a microphone connected to an amplifier and meter calibrated in d.b. by means of which the sound pressure generated by the receiver is measured. The cavity enclosed by the artificial ear, the receiver and the microphone, must present to the receiver the same acoustical impedance as would a normal ear, otherwise the response of the receiver will differ from that which it will give in actual use.

It seems generally accepted in this country that a rigid walled cavity of volume, about 3c.c. combined with an acoustic resistance in the range 100 to 150 acoustic ohms, provides a sufficiently close representation of typical ears over the range of frequencies of most importance in telephone practise (say 150 to 3500 c/s). Fig. 11 gives a typical example.

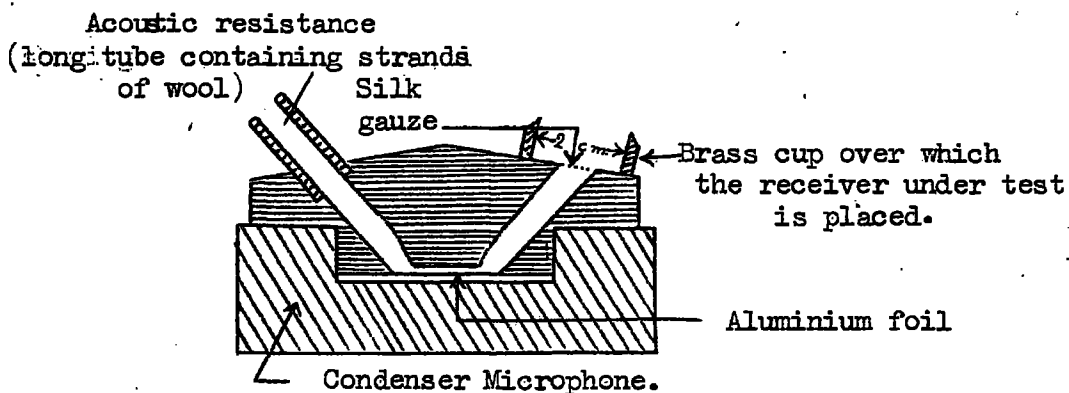

Fig. 11 Artificial Ear.

The hearing aid receiver is connected to the artificial ear and the microphone of the aid suspended in front of a loud speaker with the minimum of attachments so that it lies in the plane progressive sound field produced by the loudspeaker. The latter is situated in one side of a room lined with absorbent material in order to reduce reflection of sound to a minimum.

The sound pressure  $P_1$  (dynes /cm<sup>2</sup>) produced in the cavity of the artificial ear is then measured. Following this the aid microphone is removed and the sound pressure  $P_0$  at the point previously occupied by it is determined in the unobstructed sound field. This value is then corrected for the increase of pressure due to the obstruction caused by an average head and the sound

pressure  $P_2$  (dynes  $\text{cm}^2$ ) which would exist in the external ear in this position determined.

The overall acoustic amplification  $A$  of the hearing aid in db at each frequency is then given by the formula

$$A = 20 \log_{10} \frac{P_1}{P_2}$$

As before, care has to be taken to see that the sound level from the loudspeaker is not such as to exceed the power handling capacity of the aid, and preliminary tests to determine this are necessary.

#### 4. Maintenance.

##### (a) Power Supply.

In the Clinic it was necessary to have as many as twelve aids in commission at the same time. This would normally entail daily routine testing and changing of individual batteries if the aids were to be maintained at a constant performance level, and the time required would be considerable. In order to obviate this labour a battery unit was designed, the circuit diagram of which is shown in Fig.12 (see page 11), whereby the act of plugging of any aid into its particular socket not only connected the H.T. and L.T. to the correct supply, but also operated three meters installed in the front panel. In this way the H.T. and L.T. voltage working the aid together with the anode current could be read simultaneously and checked against calibration figures. The H.T. supply consisted of a number of nine volt batteries, so that it was possible to adjust the correct voltage to within 1.5 volts. The L.T. was made up with three large 1.5 Bell batteries and in one case a two-volt accumulator.

##### (b) Routine Testing of Amplification.

With constant use, hearing aids are liable to develop various faults which may result in a decrease of efficiency which is not immediately obvious. Normally a fall in gain is due to a running down of the battery supply, but when this is not so it may be due to a fault in one of the valves, the microphone, or, as is very often the case, as may be the result of the diaphragm of the receiver coming into contact with the magnet owing to a movement of the paper washer. It was of prime importance that all aids should maintain their efficiency, and any falling off in gain<sup>be</sup> detected at once. In order to do this a simple artificial ear was constructed which amounted to little more than a coupling device between the hearing aid receiver and the microphone of a

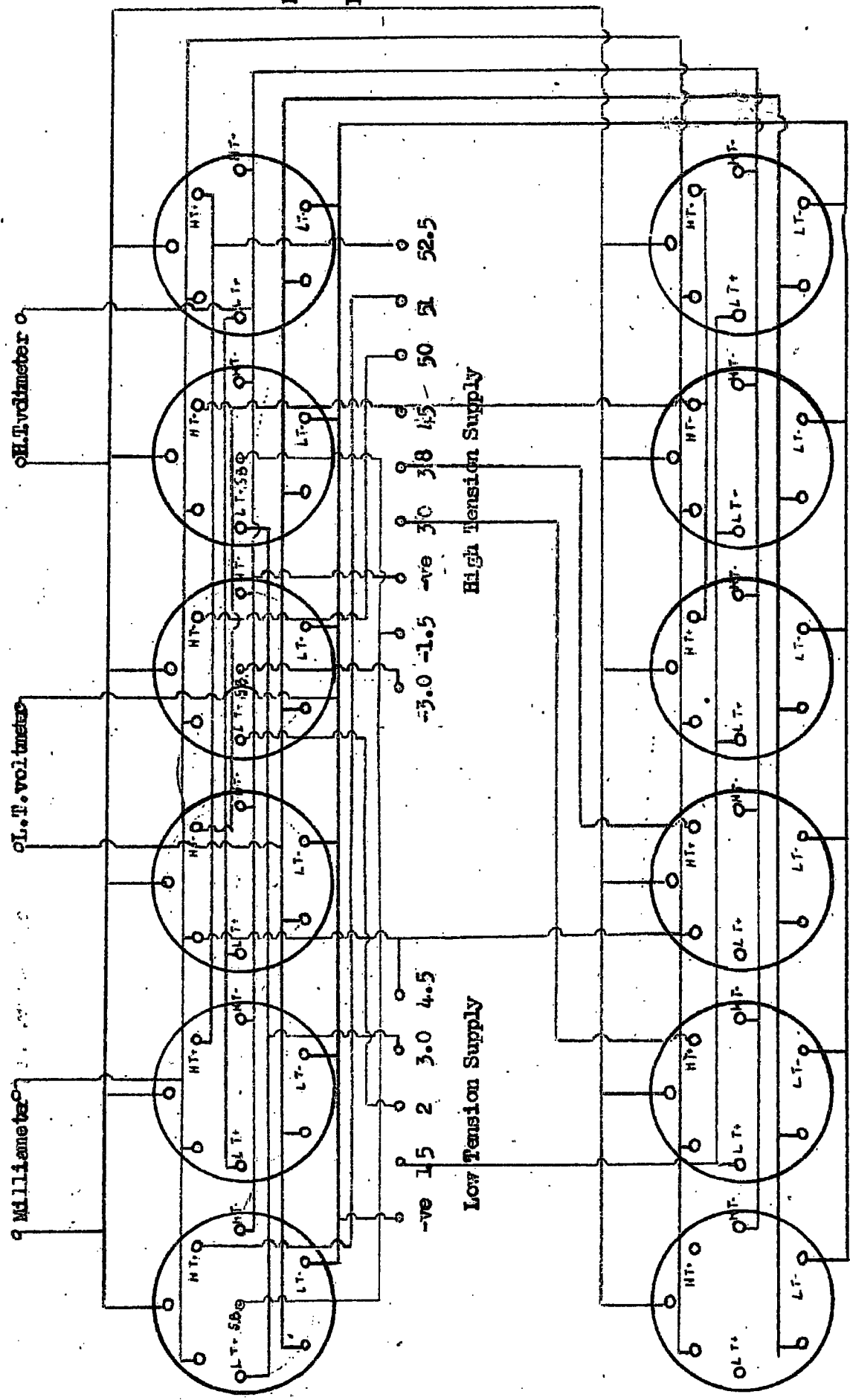

Fig. 12 Circuit diagram of wiring of sockets in panel of Battery Unit for hearing aids.

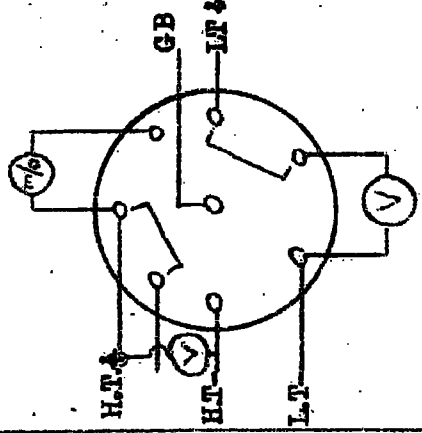

Diagram of plug showing connection leads and internal connections to the various meters.

noisemeter. The procedure was similar to that previously described and is shown in Fig.13.

Silence Room.

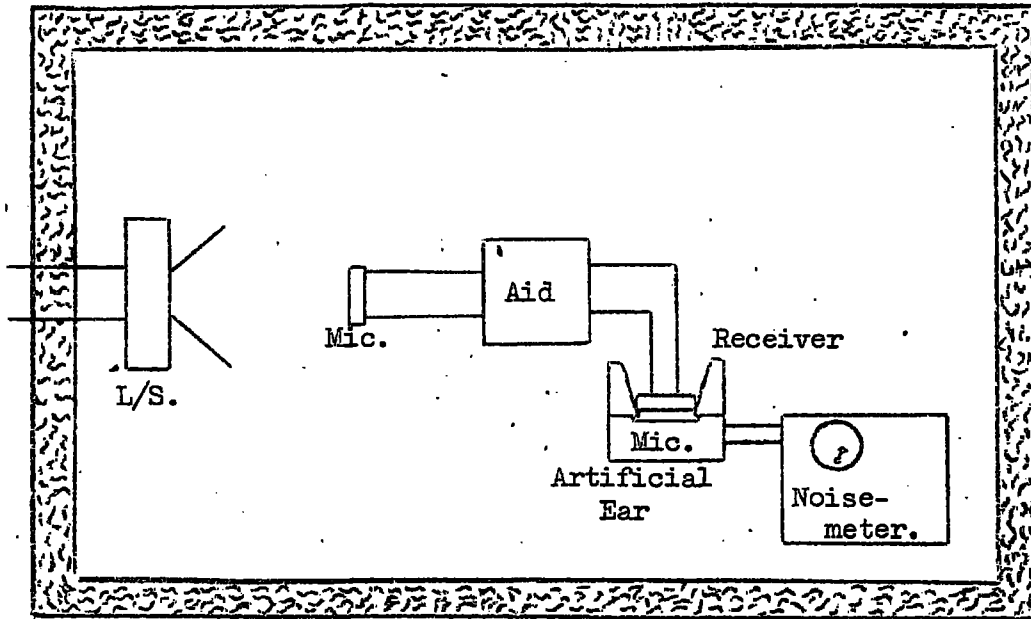

Fig.13 Diagram showing layout for routine testing of hearing aids.

The microphone of the aid was placed a fixed distance away from a loud-speaker and the volume control of the aid turned to the 'full gain' position. Pure tones of various frequencies were then relayed through the loudspeaker at chosen intensity levels, care having previously been taken to see that none of the aids overloaded at these levels. The noisemeter readings at each frequency were then taken and checked against readings that were taken when the aid was known to be in good working order. In this way it was possible to detect any falling off in gain and check all the aids accurately and quickly. It should be noted that the artificial ear used in this manner was not intended to provide absolute calibration data, and in consequence it was unnecessary to give detailed consideration to the design of the coupling chamber.

Amplification

5. Variation in Gain with Battery Deterioration.

The high tension voltage of hearing aid batteries varies from about 30 volts to 50, and the low tension from 1.5 to 4.5 volts. The manufacturers specify the voltages to be used with their particular aid and it was considered of interest, therefore, to investigate how the performance of these aids in

general varies with voltage.

The set-up used was the same as that described in the previous chapter with the exception that provision was made so that the voltage could be varied. The L.T. voltage was varied by introducing a resistance in series with the leads. This procedure could not be adopted in the case of the H.T. voltage since many of the aids were not decoupled and any appreciable resistance in the H.T. lead would have led to oscillation.

The voltage was varied by altering the tapping at the supply. A record of one syllable words was relayed over the loud speaker at a level corresponding to the normal conversational voice at three feet at the microphone of the hearing aid. The noisemeter reading was then found for five of the words. By comparing the average level of these words with that found by placing the noisemeter microphone in the same place previously occupied by the aid microphone, the apparent air to air amplification was found.

The H.T. and L.T. voltages were varied in the manner described above and the amplification found in each case. Figs.14 and 15 show the variation of gain with H.T. and L.T.voltage of the six typical hearing aids shown in Fig.16.

It must again be remarked that the artificial ear used probably varied in its response from one aid to another, and consequently it is not possible to compare with any great degree of accuracy the performance curves for any two different aids insofar as their respective gain is concerned. The information to be derived from the curves is therefore restricted to

- (a) comparison between the different curves for each individual aid
- (b) comparison between the curves for different aids of slope and critical 'cut-off' point for the L.T. voltage below which point the gain rapidly falls to zero.

Variation of gain of Hearing Aids with H.T.volts

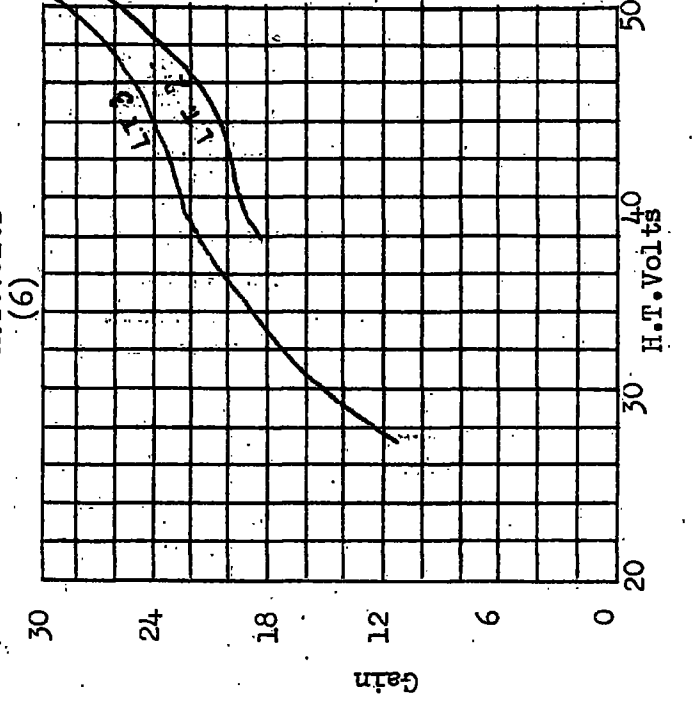
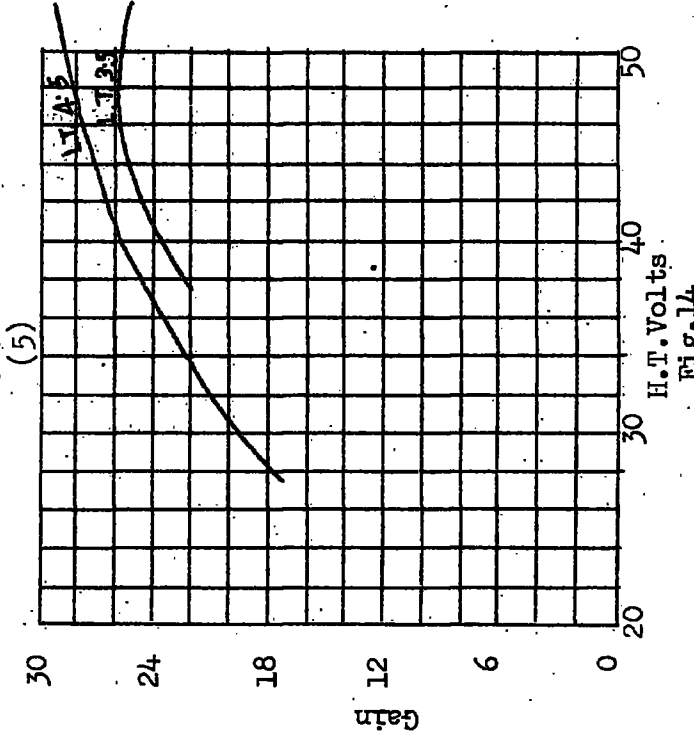
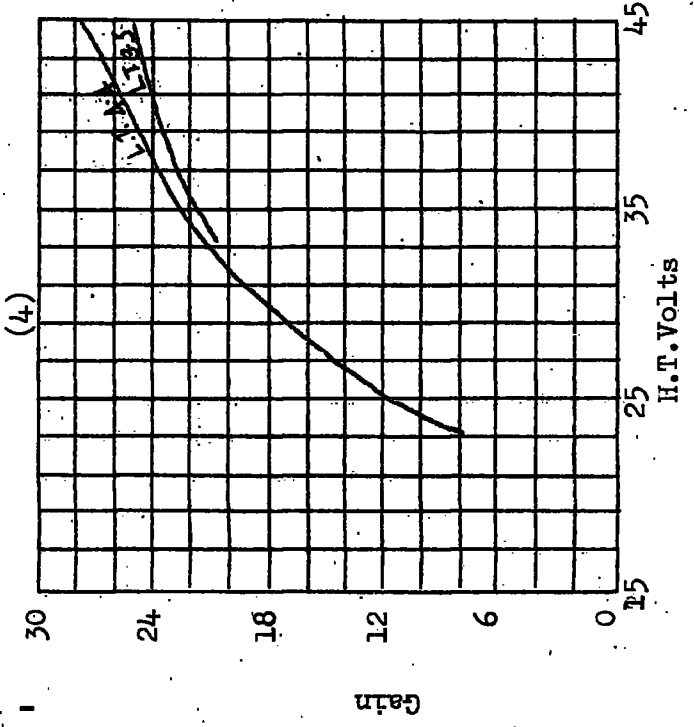
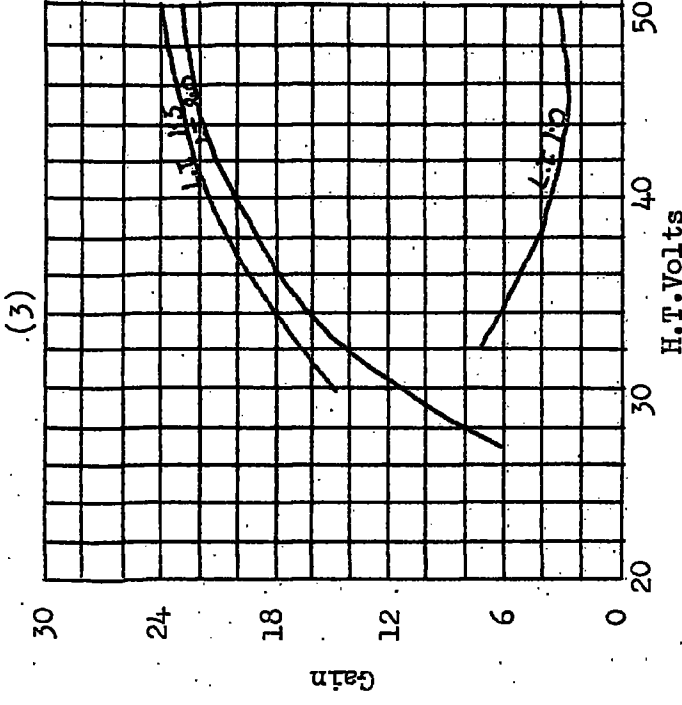
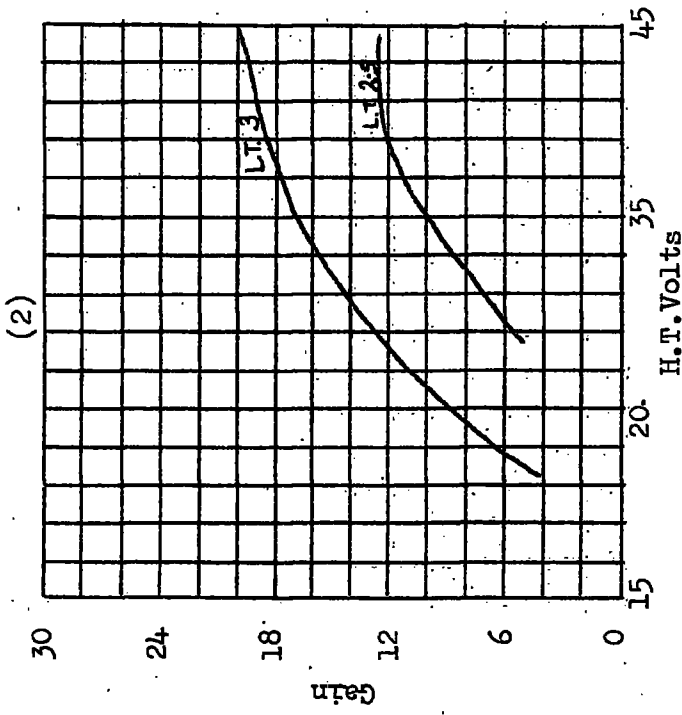
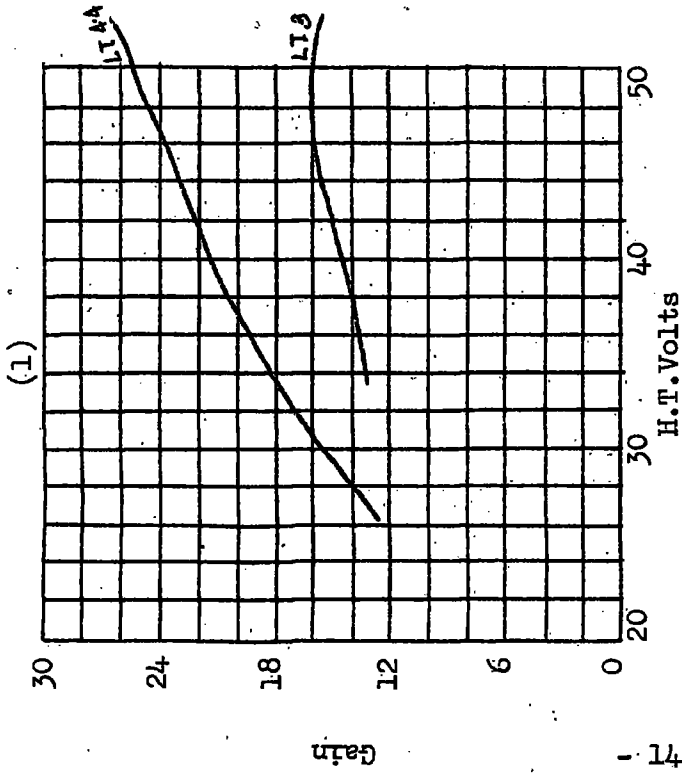
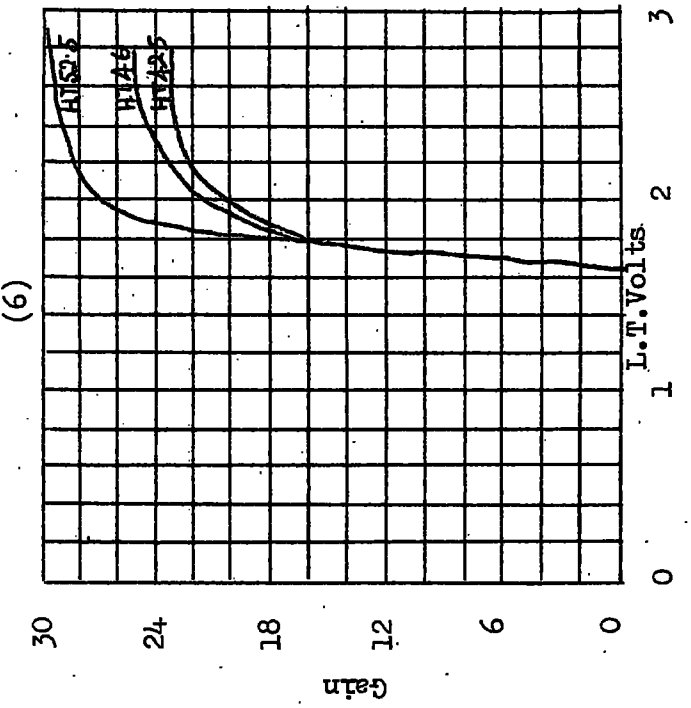
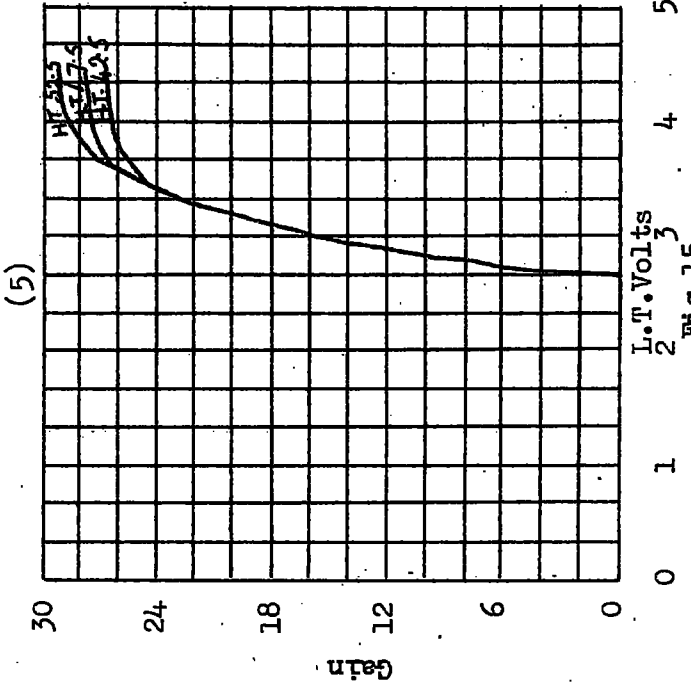
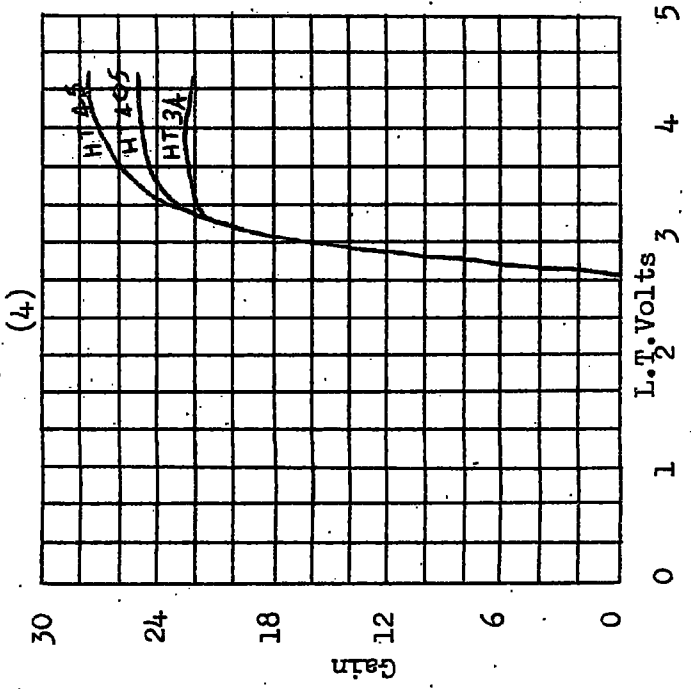
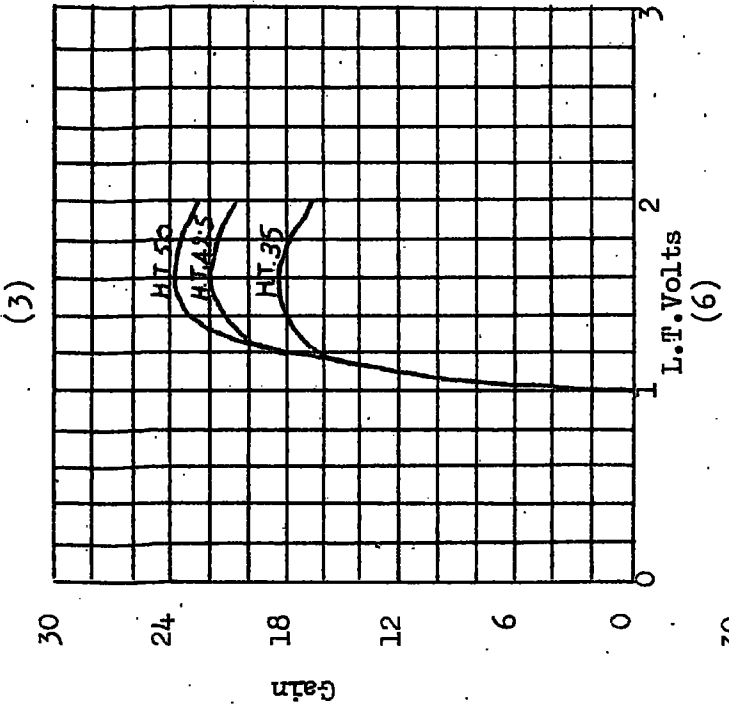
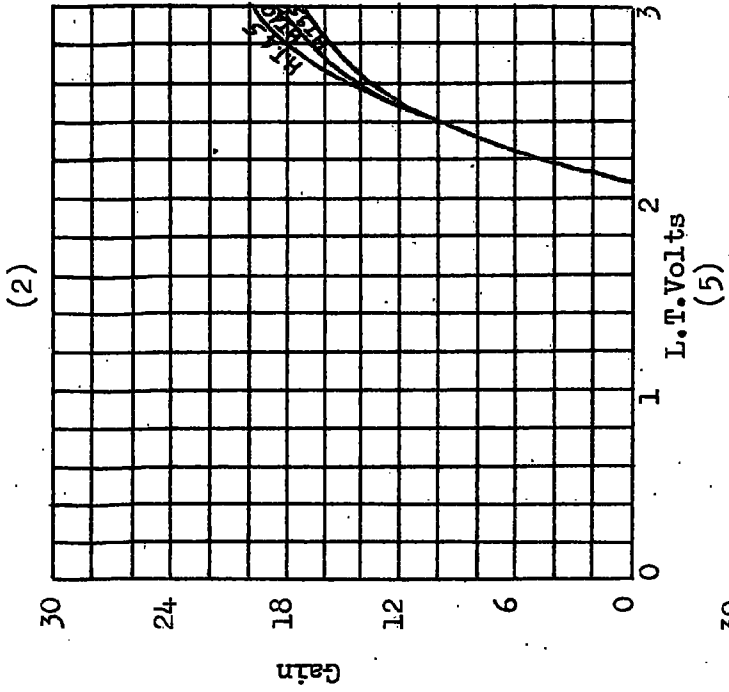
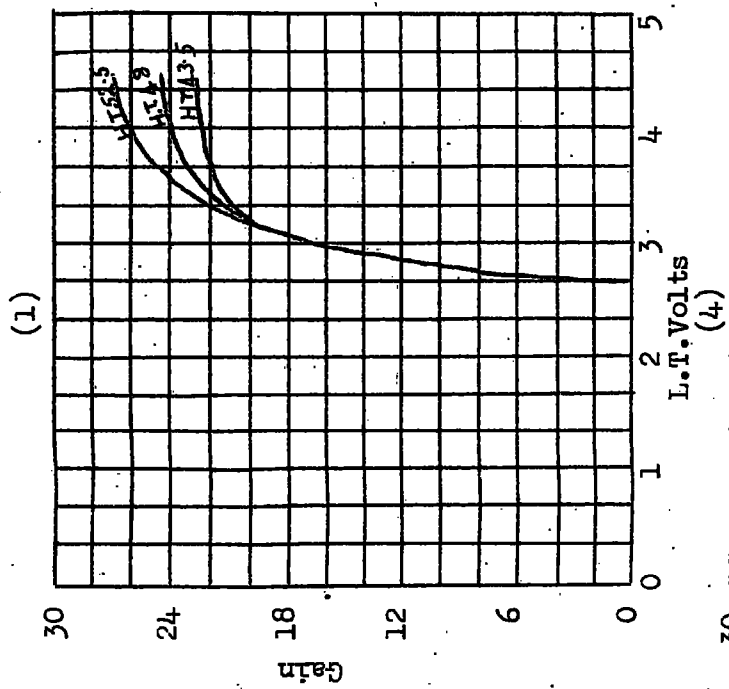

Fig. 14

Variation of gain of a hearing aid with L.T. volts



Circuit diagrams of Hearing Aids.

Fig. 16

(1)

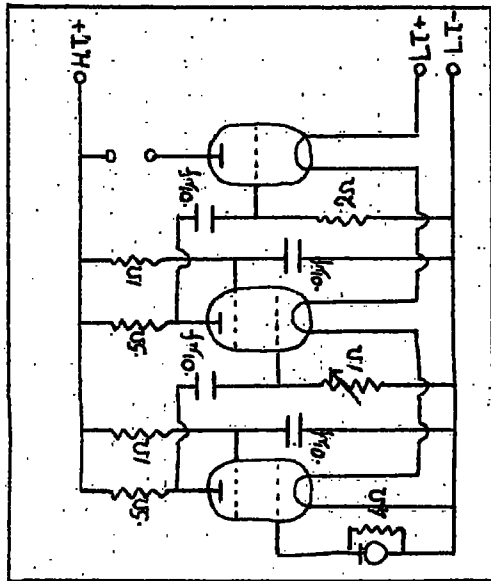

Belclere Model W

(4)

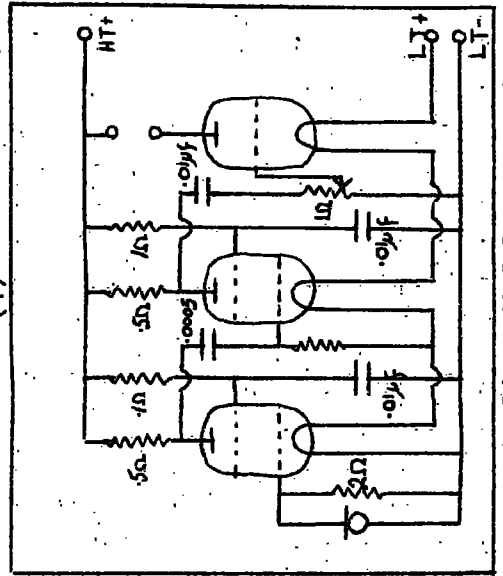

Amplivox Model V

(2)

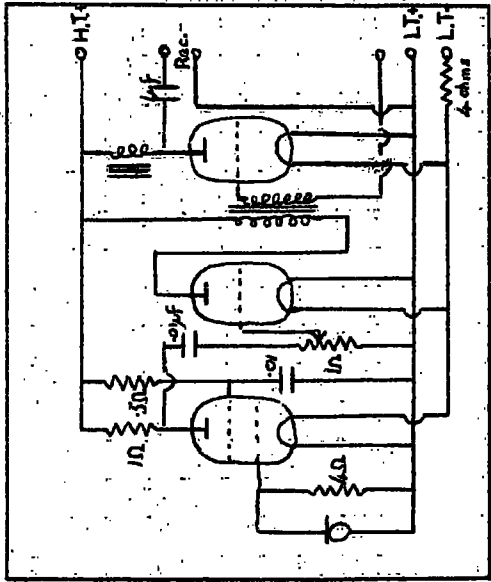

Belclere Model S

(5)

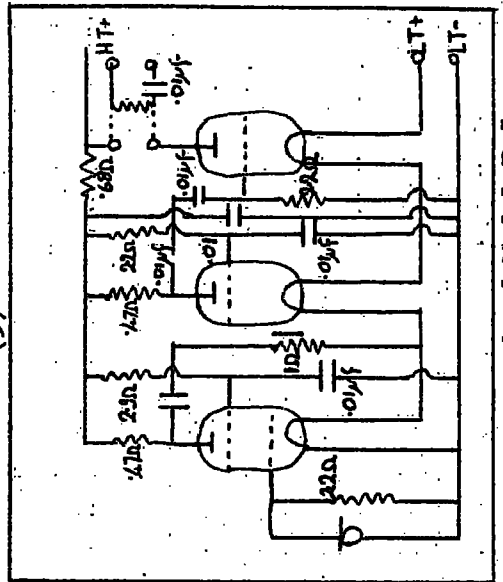

Bonochord Model P 3

(3)

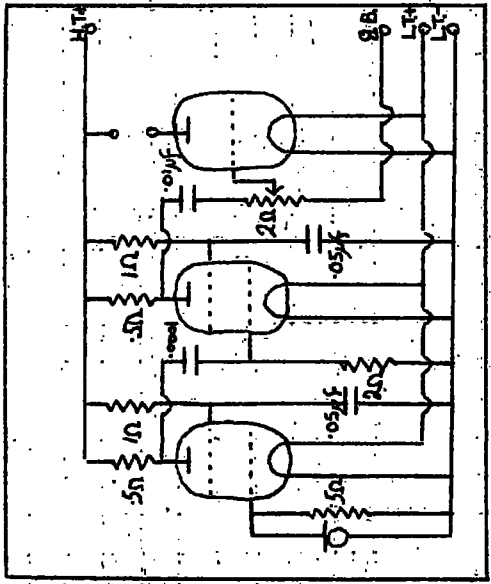

Amplivox Model D 8

(6)

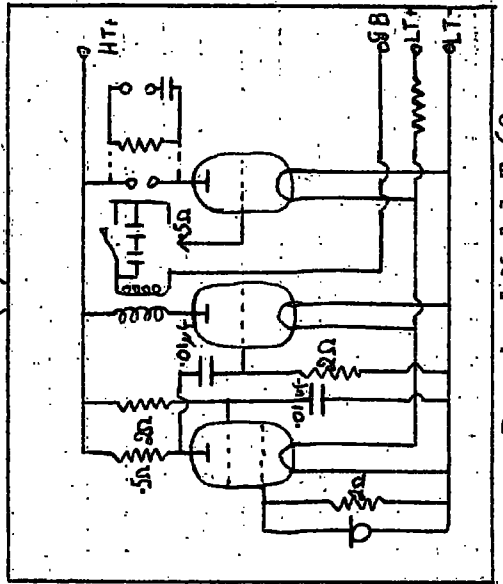

Bonochord Model T 60

## SECTION II.

### HEARING TESTS

#### 1. Pure Tone Audiometry.

##### Introduction

Before the development of the valve oscillator the otologist was dependant almost exclusively upon tuning forks for the measurement of hearing loss for pure tones. A tuning fork was struck and held close to the external auditory meatus of the patient who indicated when the tone was no longer heard. At this point the otologist transferred the fork to his own meatus and measured the time in seconds that elapsed before he too could no longer hear it. This gave a sensitivity comparison at the so-called threshold of hearing of patient and otologist, and by using the Bezold Edelman series of tuning forks with frequencies rising in octaves from 16 c.p.s. to 4096 it was possible to explore the hearing loss over a considerable part of the frequency range of the human ear. These tests were, of course, subject to errors in judgment and abnormalities of hearing of the tester. They were not, in consequence, very accurate and in the course of time various attempts were made to replace the tuning forks by a variety of electro-mechanical oscillators whereby it was possible to produce tones of variable frequency and intensity.

Many devices were constructed, all very unsatisfactory, and it was not until the advent of the valve oscillator in recent years that any great advance was made in the practical applications of audiometry which have since proved of such value to otologists in the diagnosis of deafness.

The modern audiometer, a typical circuit diagram of which is shown in Fig.17 usually consists of a reasonably stable audio-frequency valve oscillator covering the frequency range from 64 c.p.s. to 8192. The voltages so generated are applied by way of a system of attenuators calibrated in decibels \* to a good quality telephone receiver. The acoustic output of the receiver can usually be varied from 10 db below to 100 db above the normal threshold of hearing. This threshold value is obtained by taking the average of a large number of subjects between the ages of eighteen to twenty-five.

\* Decibel. The decibel is one-tenth of a bel. The number of decibels denoting the ratio of two amounts of power is 10 times the logarithm to the base 10 of this ratio.

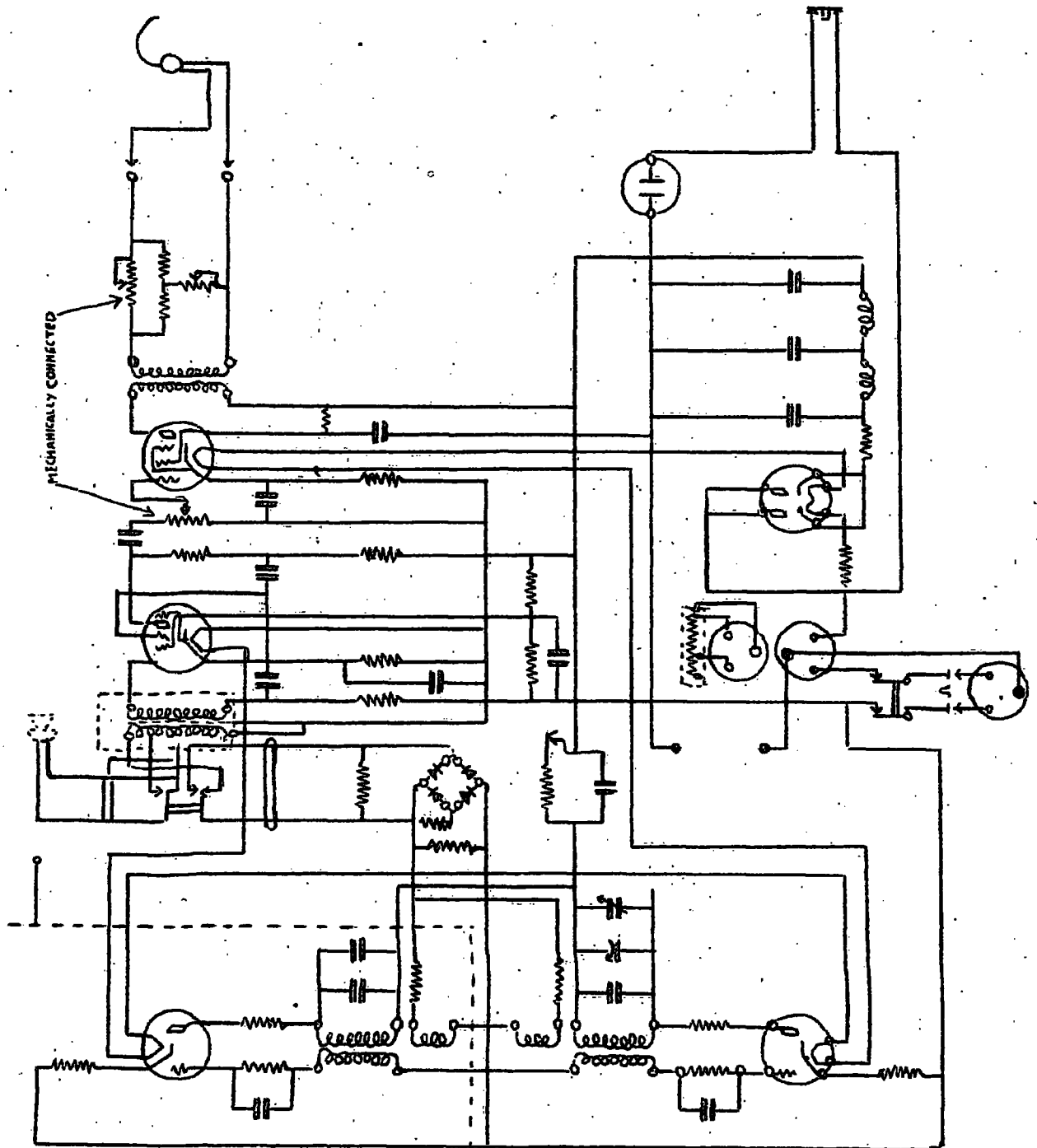

Circuit Diagram of Western Electric 6A Pure Tone Audiometer.

Fig.17

In general the audible frequency range of human hearing is taken as extending from 16 c.p.s. to 16000 c.p.s. Very few adults, especially those in later life or middle age, are able to hear a 16000 cycle tone, or much above 8000 or 10000 cycles; yet young children can frequently detect a note as high as 20,000 or even 25,000 cycles. Few sounds above 6,000 cycles however, are of importance in daily life.

The following diagram, Fig.18, shows <sup>more precisely</sup> the variation of the intensity of the pure tone at threshold with frequency for a normal hearing individual, and it can be seen that there is a minimum value of the intensity at about 2000 cycles at which the ear is most sensitive, while above and below this figure greater powers are required to excite the ear. The relation between apparent loudness of sound and its intensity is complex, and Knauss, making several assumptions, has shown that it can be expressed in the form of an equation as follows:

$$L = I (10^{-5/2} I + 1)^{-2/3} 10^{-3} \text{ sones}^{**}$$

where I represents the intensity in units of  $10^{-16}$  watts per sq.cm. The equation, however, breaks down at high and low intensities and between these limits is only an approximation.

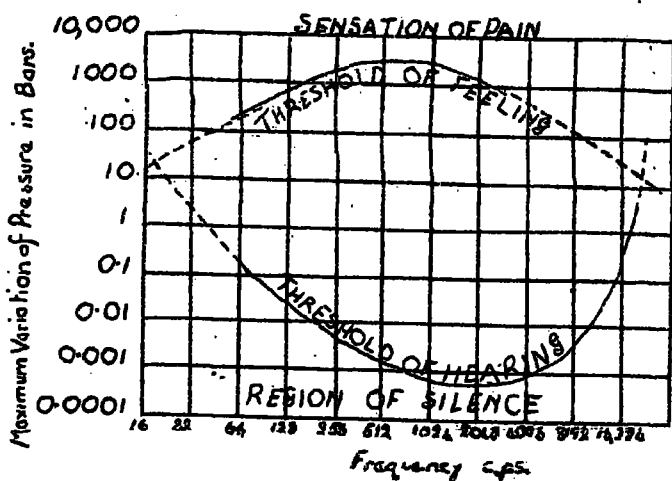

Fig.18

At 1000 cycles the threshold intensity is of the order of .0002 dynes per sq.cm. ( $10^{-16}$  watts per sq.cm.)

A sound when sufficiently loud, in addition to being heard in the ordinary way, produces a peculiar tickling or painful sensation at the ear. This is of some importance and reference will be made to it later. The upper curve of Fig.18 marks the onset of this kind of perception and is termed the threshold of pain or feeling.

\*\* Sone. The sone is a unit of loudness. It is defined as the loudness of a 1000 cycle tone 40 db above threshold. (The sone is a so-called 'subjective' unit.)

(a) Threshold of Hearing.

The technique of arriving at the threshold of hearing is a matter of some importance. If a continuous tone is used and gradually attenuated from a level well above threshold, this threshold is found to vary within fairly wide limits, since it is no easy matter to determine when the tone ceases to be heard in this way. More consistent readings can be obtained by approaching the 'just heard' point both from above and below and taking an average of the results. This is the procedure generally advised, and has been found to give fairly reliable results. Testing in this way with an interrupted signal of constant short duration, the threshold can usually be established within five decibels. Care, of course, needs to be devoted to the electrical technique of interrupting the signal since in certain circumstances serious difficulties may arise from transients which are particularly liable to occur when the tone interruption is accomplished by interrupting the output leads.

These transients may be well above the sensation level of the test tone and tend to give a false threshold value. Some audiometers in which a suitable type of valve with a bright emitter filament is incorporated, interrupt the signal by breaking the filament supply, thus eliminating the transients.

(b) The Audiogram.

Threshold readings are established in the manner described for the frequencies rising in octaves from 128c.p.s. to 8192c.p.s. and the chart on which they are recorded is known as an audiogram. In plotting an audiogram we are concerned not so much with the actual intensity of the tone at the threshold of hearing, but with the departure in decibels from the average normal threshold. In the audiogram this 'average normal' threshold level is taken as the reference level. It appears in the audiogram as a straight line marked 0 across the top of the chart shown below (Fig.19) and deafness at any point in the frequency range is expressed as a drop below this line.

Systematic audiometry has shown that there is a normal decline in hearing acuity with age. This particularly affects the high tones, and although exceptions are frequent where aged people exhibit keen hearing for the high tones, the average findings are shown in Fig.20.

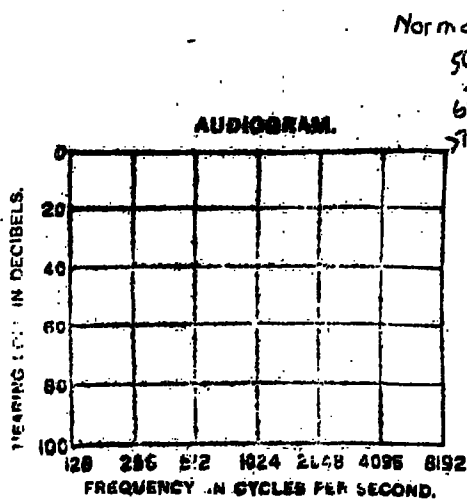

Fig.19

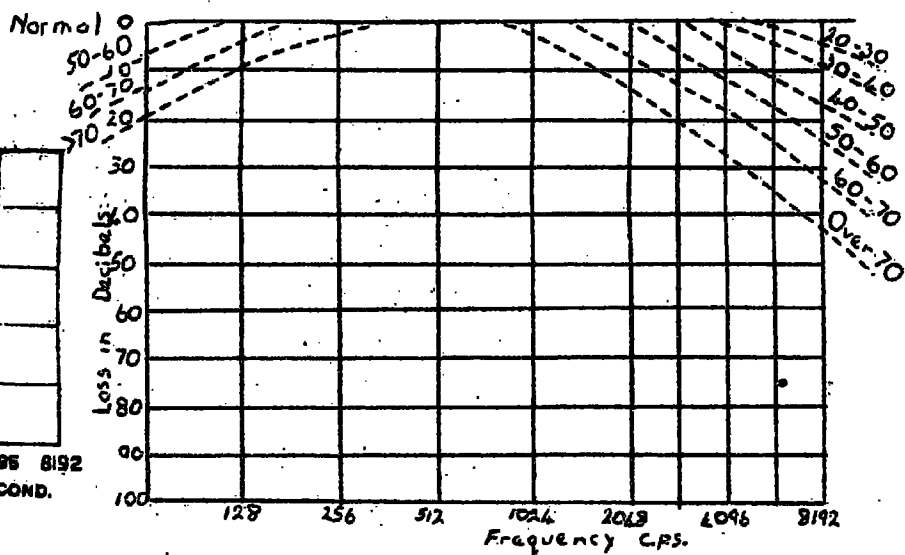
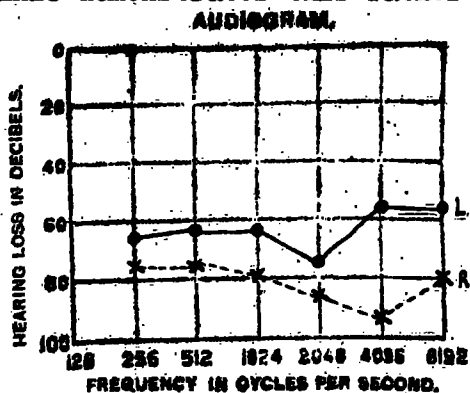

Fig.20

As can be seen from Fig.18 the frequency response of the human ear is by no means flat. The ear is, in fact, most sensitive in the middle frequency range (1,000 - 3,000c.p.s.) within which are included the important speech sounds as well as most of the common sounds of daily life.

(c) The Limitations of the Audiogram.

Although the audiogram gives an accurate description of reduction in sensitivity at threshold for pure tones, it is not always, as might appear, an adequate guide to the ability of the subject to hear and understand speech. Reference to the audiograms shown in Fig.21 of two patients who attended the Deafness Clinic demonstrates this rather well:



Subject A

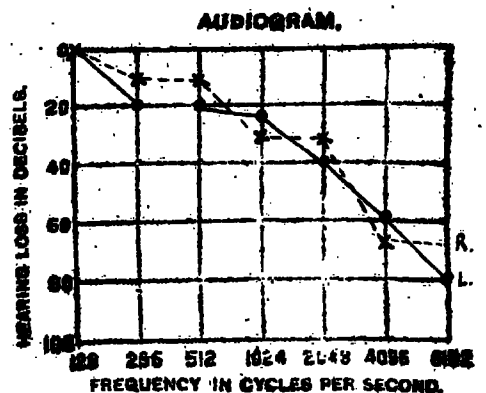

Subject B

Fig.21

Subject A, suffering from a very severe hearing loss was unable to hear loud conversation at one foot and could only with difficulty be made to understand shouted words. Subject B, on the other hand, although he could hear with ease ordinary conversation at one foot was unable to understand it, and the practical disability arising from his deafness was, therefore, very great, as great, in fact, as that of Subject A, in spite of the latter's much more advanced audiometric losses.

The difference between the hearing reactions of these two subjects is to be found in the causes of their deafness. Subject A was suffering from disease of the conducting mechanism of the middle ear, so-called 'conductive

deafness'. The effect of this type of deafness may be compared to that produced by stopping the ear with the finger. A certain reduction in intensity is achieved which applies equally for faint sounds and for loud sounds. This would mean that to a subject with a threshold loss of 40 db., sounds of 50, 60 and 70 db. above normal threshold would have loudnesses equivalent in a normal subject to those of sounds 10, 20 and 30 db., respectively above the latter's threshold. Subjects suffering from nerve deafness, as in the case of Subject B, present a very different picture to the otologist. In most cases the threshold for pure tones is very sharply defined and easily determined. Thereafter loudness increases disproportionately with intensity.

The cause of this audiometric peculiarity of nerve deafness, first described by E.P.Fowler of New York, is not known, although it has been the subject of extensive study by Steinberg and Gardner [see bibliography No.(3)] and others. These workers investigated the effect of deafness upon the sensation of loudness for pure tones at different intensities. They used experimental subjects with unilateral deafness of both conductive and nerve types, and made measurements of the intensities of the sounds falling on the two ears which were considered by the subjects to be equally loud.

The results of these loudness balancing tests are represented below, Fig.22. Chart A is characteristic of conductive deafness and Chart B is characteristic of nerve deafness. The intensities of the sounds are in decibels above the normal threshold:

Normal ear                      Ordinate  
Deaf ear                        Abscissa

In a normal subject points of equal loudness in the two ears would lie upon the interrupted line A, passing through the origin at O. In a subject with a conductive deafness of one ear, giving a thresholdal loss of 40 db., the points of equal loudness are found to lie upon curve B (Chart A). In a subject with a nerve deafness of one ear, giving the same threshold loss of 40 db., the points of equal loudness are found to lie upon Curve C (Chart B).

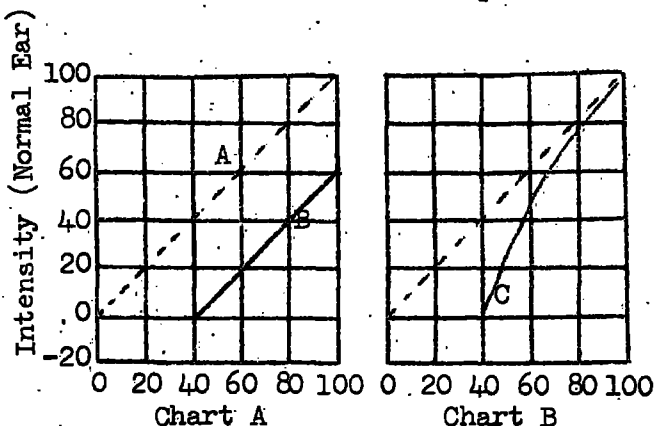

Fig.22 Intensity (Impaired Ear)

We see from the above that conductive deafness remains constant with intensity. Nerve deafness, however, decreases with intensity. These results explain the observation that when a patient with nerve deafness uses a hearing aid of which the amplification is sufficient to make the weaker sounds of speech audible, the louder sounds become disagreeably loud. Such phenomena do not occur with conductive deafness. It is clear that this variability of deafness with intensity observed in nerve deafness imposes strict limits on the amplification requirements of hearing aids suitable for such patients.

2. Speech Audiometry.

Introduction.

In devising the technique of speech audiometry the impairment of the normal capacity to understand spoken words has been accepted as the criterion of disability due to deafness which it is desired to measure. The measurement of this disability clearly lends itself to the conventional methods of articulation testing, using test lists of speech units, i.e., sentences, words, or nonsense syllables. Before proceeding to a detailed description of the method used, however, it is necessary for a full understanding to consider in some detail the various factors which are involved.

~~(1) Articulation Testing~~

(a) General Principles. The value of articulation testing methods has now been well established in the testing of

- i. transmission systems
- ii. evaluation of the effects of noise on communication
- iii. measurement of the basic audibility of words and commands
- iv. rating and training of communications personnel

A quantitative measure of the intelligibility of speech is obtained by counting the number of discrete speech units correctly recognised by the subject.

Typically an announcer reads lists of syllables, words, or sentences to the subject and the percentage number of items correctly recorded is called the articulation score. This percentage is taken as a measure of the intelligibility of the speech received.

The use of recorded speech obviates many variable factors, but unfortunately introduces inherent difficulties in recording. In general the word 'articulation' is confined to the recognition of words and syllables whereas the word 'intelligibility' is usually referred to sentences when the gist or thought conveyed is considered to be correctly interpreted.

(b) Test Material. If a proper assessment is to be made of the relative values of transmission systems, the testing material must be carefully selected lest the articulation scores obtained are a measure not only of the transmission systems but also of the intrinsic difficulty of the individual lists themselves. When lists of comparable difficulty are used, differences in articulation scores may then be interpreted as being due to the differences in the transmission systems, etc. the merits of which it is desired to investigate. In order that the lists be of equal difficulty and representative of con-

versational speech, consideration must be given to the following:

- (i) Representation of fundamental speech sounds.  
All, or nearly all, of the fundamental sounds into which speech can be analysed should be represented in each list of items. Furthermore, the relative frequency of occurrence of these fundamental speech sounds should reflect their distribution in normal speech.
- (ii) Types of test lists. These may consist of nonsense syllables, words or sentences. The psychological factors of meaning, context, rhythm, inflection, etc. are of great importance in determining the ease with which items of these lists are understood. Consequently, even though the lists are balanced with respect to phonetic composition, actual tests must be made in order to demonstrate that all lists are of equal difficulty.
- (iii) Difficulty and reliability of test lists. The range of difficulty provided by the lists should be such that there will be few items which are too difficult or too easy under the conditions chosen for testing. Items which are always or never correctly recorded by the listeners are useless in the testing of systems. If the lists are too long it is possible that the scores may be influenced by the subject becoming fatigued. The lists should, therefore, be kept as short as possible, compatible with complete representation of all of the foregoing factors. No list should be repeated twice, otherwise some of the items may be memorised and the resulting tests give a false comparison.

~~Test Lists in common use consist of Nonsense Syllable Lists, Word Lists or Sentence Lists.~~ These will be considered *seriatim*.

When it is desired to determine accurately the effectiveness of a device in transmitting particular speech sounds, nonsense syllables are superior to words or sentences as test items.

Reference to Fig.23 (page 26) which illustrates the distribution of consonants and vowels along the frequency scale with reference to their relative average power in speech, will show that a system with a limited response above <sup>say</sup> 3000 c.p.s. will not transmit such sounds as s, z, and th, as well as the others. Such selectivity can be efficiently investigated by the use of nonsense syllable lists. The lists are primarily a test of the efficiency of systems or parts of systems alone and not of the combined efficiency of system and user. For this reason the test/ <sup>results</sup> should be independent of the personal element and therefore entail taking the average of a number of listeners' scores.

Long practise is required in the use of these lists, and the most coherent results are obtained only with trained crews who are familiar with the technique of interpreting nonsense syllables. In this way the lists can be used to examine the articulation efficiency of microphones, receivers, etc. under normal conditions or in the presence of noise.

Table 1 shows the speech sounds, from which the syllables are formed.

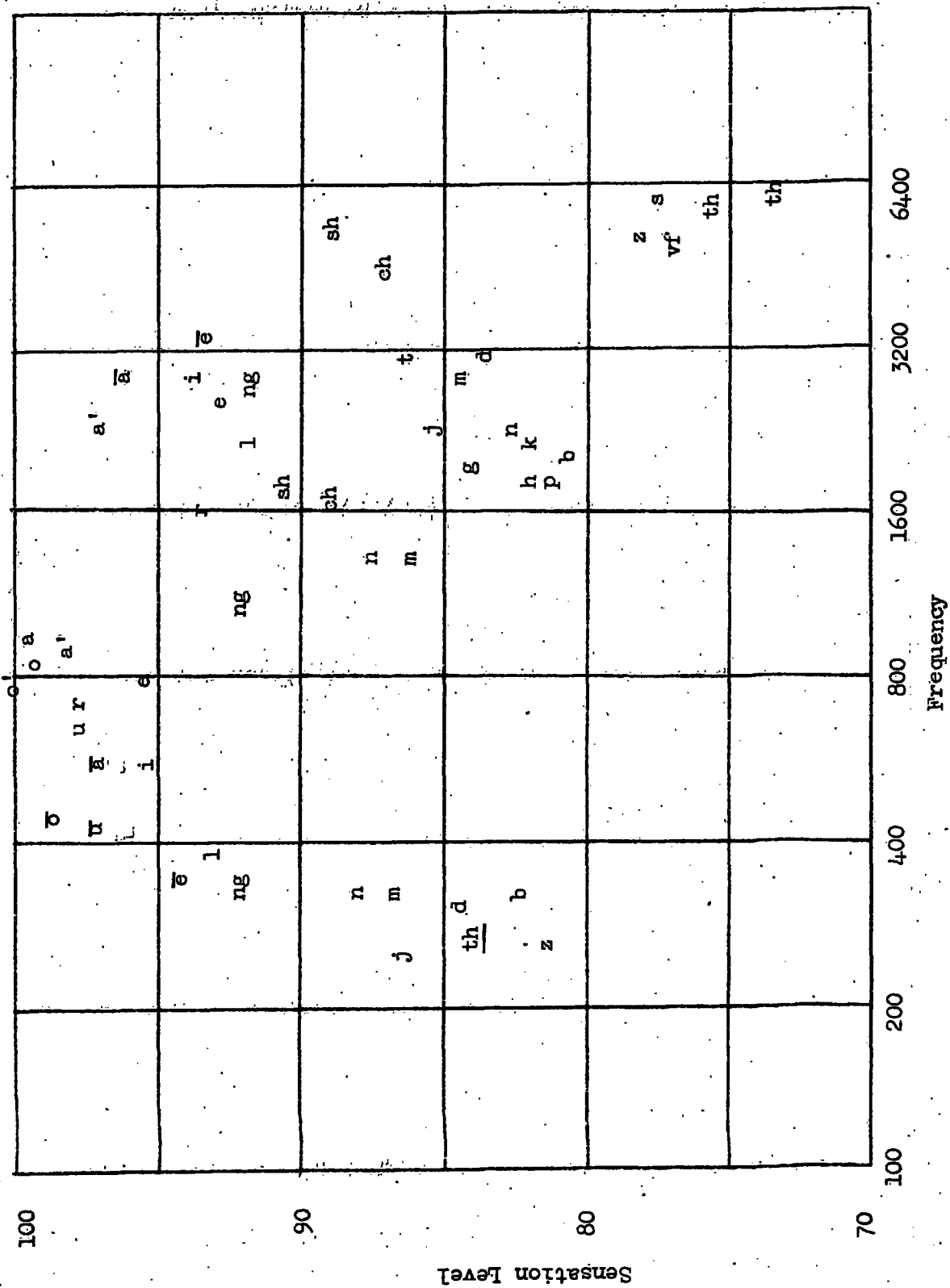

The relative distribution of power in speech sounds (p.76 Speech & Hearing, H. Fletcher)

Fig.23

The syllables can take the forms vowel-consonant (vow-con), consonant-vowel (con-vow), or consonant-vowel-consonant (con-vow-con) the last of which is the most usual. Random selections of the various letter formations are made but care must be taken in the preparation of the lists according to the conditions stated earlier and all syllables resembling English words should be rejected. Examples of these lists are shown in Table 2.

<u>Vowels</u>		<u>Consonants</u>	
<u>Long</u>		<u>Voiced Stops</u>	<u>Unvoiced Stops</u>
ā (as in take or face)		b (as in bold)	p (as in poor)
ā ( " " father or arm)		d ( " " dent)	t ( " " tent)
o ( " " orb or wall)		j (as " joke)	ch ( " " choke)
ō ( " " boat or low)		g ( " " gold)	k ( " " cold)
ē ( " " team or fleet)			
ū ( " " boot or glue)			
<u>Short</u>		<u>Voiced Fricatives</u>	<u>Unvoiced Fricatives</u>
a' (as in tack or cat)		v (as in vow)	f (as in face)
o ( " " let or fed)		z ( " " zone)	s ( " " soup)
i ( " " lit or sin)		zh ( " " azure)	sh ( " " shine)
u' ( " " run or sun)		th' ( " " then)	th ( " " thin)
u ( " " could or put)			
		<u>Transitional</u>	
		y (as in you)	
		w ( " " will)	
		h ( " " hot)	
		hw ( " " what)	
<u>Diphthongs</u>		<u>Semi-vowel</u>	
ī (as in bite or lime)		l (as in loaf)	
ow (as " cow or ouch)		r ( " " root)	
oi ( " " coil or boy)		m ( " " men)	
ew ( " " pew or cute)		n ( " " never)	
		ng ( " " wrong)	

Basic categories of the fundamental speech sounds.

Table I

<u>Speech sound. Key word.</u>		<u>Speech sound. Key word.</u>	
1	ha	1	gōb go-b
2	hā	2	shōl shoal
3	wa'	3	ros rus(t)
4	wi	4	jod ju(g)-d
5	vou	5	bok buck
6	a'r	6	zīk z-(d)ike
7	ez	7	bīch buy-ch
8	ūsh	8	kīth ki(te)-th
9	an	9	gīt gui(de)-t
10	id	10	yif y-if
11	jouv	11	sin sin
12	moush	12	te'rm term
13	rour	13	me-rl m-earl
14	zūth	14	pe'rv p-(n)erve
15	hūs	15	yēt y-eat
16	chush	16	bēl b-eel

17	jūm	j-(f)oo(t)-m	17	zēf	ze(al)-f
18	thup	th-(s)oo(t)-p	18	weng	whe(n)-ng
19	fuch	foo(t)-ch	19	kev	k-ev(er)
20	wo'ng	wa(ll)-ng	20	ha'ng	hang
21	chó-th	cha(lk)-th	21	pa'g	p-(r)ag
22	to'j	ta(ll)-j	22	yās	y-ace
23	ko'g	k-aug(er)	23	dap	d-ape
24	fōn	(tele)phone	24	yang	ya(cht)-ng
25	dōs	dose	25	lan	l-on

Syllable Lists

Table 2

Word Lists.

Despite the fact that nonsense syllable lists are the most accurate and economical material in articulation testing, they are useless with inexperienced personnel. When, therefore, it is required, for example, to assess the hearing of a deaf person, resort must be made to word lists. These are necessarily more clumsy to handle owing to the similarity of so many words, so that another factor is now introduced, viz., the 'intrinsic intelligibility' of the individual words. This latter factor will be dependant upon the listener's vocabulary and ability to build up the component speech sounds into words and aged people particularly find considerable difficulty in this. Whereas in syllable lists it is usual to mark upon the basis of consonant vowel and whole syllable scores, when word lists are used there is reason to believe that it is best to mark upon the basis of whole word scores, i.e., word articulation. This is because a consonant or vowel error is not necessarily due to the similarity between that called and the actual, but because the rest of the word understood leaves a choice of some several letters if a coherent word is to be repeated. Thirteen patients, for example, out of twentyfive called the word 'gate' instead of 'gape', and this cannot have been due to any likeness between the two final consonants. The word lists, besides fulfilling the conditions previously ascribed to test lists should be fairly representative of English speech, and rare and unfamiliar words rejected. The lists given on Table 3 are some of a set which have been used successfully in the testing of deaf people for hearing aids.

A	clamp	you	plow	add	lot	glow	}
B	live	quit	then	dog	nest	queer	
C	slum	shift	sum	gem	slap	caught	
D	blink	lost	date	pot	yet	dot	
E	kit	reel	mop	seek	gag	lamb	
1	choose	scare	gash	school	drop	salve	
2	high	wink	may	sense	check	puss	
3	black	base	time	tinge	take	clog	
4	rear	trade	fact	cheap	deck	ramp	
5	lend	love	mode	weave	sob	base	
6	gape	punt	teach	morn	fig	souse	
7	pipe	grudge	shrub	sir	shout	click	
8	find	solve	pup	that	please	walk	
9	shine	zone	dive	mitt	cast	job	
10	tug	inch	tack	bell	fame	pack	
11	curse	bed	kiss	time	ache	wash	
12	mast	roe	hedge	oath	sped	seed	
13	thick	cheat	so	naught	wharf	judge	
14	rode	yawn	flame	blind	who	ace	
15	sly	kid	shade	ninth	pulse	fast	
16	shove	feed	cost	boss	barred	pew	
17	true	hill	wide	quick	vow	web	
18	add	watch	dove	edge	trip	tilt	
19	good	thud	less	jade	stag	gang	
20	fowls	bronze	slash	wed	neck	cork	
21	nose	pass	fleet	own	path	fair	
22	flap	green	glove	wreck	cape	pick	
23	browse	puff	elf	mesh	gnaw	slush	
24	bathe	wrath	vile	hole	law	cart	
25	sick	odds	cuff	golf	class	roost	

Introductory words.

Word lists used in the testing of deaf people for hearing aids.

Table 3

Sentence Lists.

The recognition of sentences is influenced to a considerable degree by the psychological factors of meaning, context, rhythm, etc. so that the scores obtained with sentence lists are very high. Unless therefore, the systems under test differ greatly, little difference will be found in the sentence intelligibility scores and all will appear of equal merit. When the systems are so bad, however, that the recognition of single words is impossible, then resort must be made to sentence lists.

A case in point is the testing of extremely deaf individuals for hearing aids who are so deaf as to be unable to understand isolated words.

Two types of lists can be used:

- (a) those framed as questions so that a correct answer shows that the context has been grasped.
- (b) those which the listener is expected to repeat containing four or more key words on which the score is based.

Examples of the latter type are shown on page 32.

### Sentence Tests for Deaf People

1. The woman sat in the park.
2. The boy did his homework.
3. The player deals the cards.
4. The girl gets a prize.
5. Sailors part from their wives.
6. Carpenters use an axe.
7. The servant dropped a plate.
8. The artist draws a sketch.
9. The crowd looked at the queen.
10. The stranger asked the shortest way.
11. The furniture was moved in a van.
12. The fat child cut her thumb.
13. Schoolchildren learn lessons.
14. The baker had some more bread.
15. The labourer loads the lorry.
16. Darkness frightens little children.
17. The housekeeper bought the food.
18. Hens have chicks in the spring.
19. The shepherd found the lamb.
20. The younger son joined the air force.
21. The crowd jeered at the speaker.
22. The maid took care of the clothes.
23. The bright sun thawed the snow.
24. The shopkeeper shows his goods.
25. The infant screamed with rage.

- 
1. The man drank his beer.
  2. The boy took his grey coat off.
  3. The mother needed a lengthy rest.
  4. Cars skidded on the wet road.
  5. The agent let the old house.
  6. Twelve months make a year.
  7. The fat man mopped his brow.
  8. The teacher marks the exercises.
  9. The child was shown a picture.
  10. The clergyman preached a long sermon.
  11. The puppy chewed the ball of string.
  12. Visitors come to tea.
  13. The bus turned round the corner.
  14. Smokers strike matches.
  15. The gardener cuts the lawn.
  16. The gamblers tried their luck.
  17. A stitch in time saves nine.
  18. The magistrate bound her over.
  19. The woman burnt the cakes.
  20. The family enjoyed the play.
  21. The police feared a riot.
  22. Soldiers wear uniform.
  23. The thief took the watch.
  24. The black cat sharpened his claws.
  25. The procession passed the house.

Table 4.

(Ref: Fry & Kerridge, Lancet, Vol.1. 1939)

(c) The Correlation of Word Articulation  
and Sentence Intelligibility.

When words are used in an articulation test it is possible to derive three associated scores:

- (a) the consonant articulation.
- (b) the vowel articulation
- (c) the word articulation

The vowels are the easiest fundamental sounds in speech to recognise owing to the fact that:

- (a) their acoustic power is high, well above that of the consonants
  - (b) their location within the physiologically most effective portion of the frequency spectrum
  - (c) their limited number and dissimilarity.
- The vowel articulation score is, therefore, usually the highest.

The consonants are more difficult to recognise owing to:

- (a) the low sound power well below that of the vowels.
- (b) their wider distribution outside the physiologically most effective part of the frequency spectrum.
- (c) the greater similarity particularly of such sounds as s and z, p and b, etc.

The associated consonant articulation score is, except for high scores of vowel articulation, usually at least 10% below the latter.

These inherent difficulties, however, make the consonant articulation score a much more reliable indication of the efficiency of the system under test as their transmission is a test of so many more factors.

The word articulation score is naturally lower than the other two as the correct recognition of a word entails recognition of all of the fundamental sounds in the word. This latter statement is open to some criticism, as in certain three letter words the first two letters are sometimes sufficient clue to the third. The word 'should', for example, leaves few alternatives in the choice of the third letter. If this factor is taken into consideration, however, the word articulation score can be a very useful guide in the testing of transmitted speech.

In order to investigate the usefulness of a system in transmitting ideas it is necessary to use complete sentences of seven or eight words. There are certain important words in each sentence, and it is required that each one be

correctly recognised before the thought conveyed is considered to be understood. The percentage number of sentences correctly received is termed the 'sentence intelligibility'. It is not possible at times to make extensive use of sentences in the testing of transmission systems owing to the limited time available. A relation can be found, however, between the word articulation and the sentence intelligibility, so that for any individual score of the former obtained over a system the associated sentence intelligibility score can be ascertained. In order to investigate the above relation, the following tests were made:-

Five records of sentences were played to a crew of six. The output was varied by means of an attenuator from the zero position where approximately fifty percent of the sounds could just be heard to a setting of forty db. above. The attenuator was graduated in two db. steps and all of these were utilised in order to cover the range as fully as possible. In the same way records of word lists were played and the percentage consonant vowel and word scores found for all settings of the attenuator over the same range.

The curves of Figs.24 to 27 were obtained from these tests by plotting percentage scores against attenuator settings. It can be seen from Fig.27 that there is a very critical range of attenuator settings over which an increase of only four db. is sufficient to increase the sentence intelligibility by fifty per cent.

Fletcher [p266 Bibliography (4)] derived the curve of Fig.28 from the former curves by plotting the sentence intelligibility curve with reference to a curve for syllable articulation. He took the percentage recognition as the ordinate and an arbitrary value [100 - (syllable articulation)] termed distortion as the abscissa. The similarity between his curve and the one derived from the curves of Figs.26 and 27 is the more remarkable since Fletcher used nonsense syllables of three letters and not words.

Fig.29 shows the values of sentence intelligibility plotted against the corresponding values of word articulation. It can be seen that for comparatively low values of word articulation the sentence intelligibility is quite high. A person, therefore, having a score of 40% on word articulation would be able to understand more than 90% conversation. The relation between these two scores is quite independent of the manner of obtaining them, for example, if the word articulation score over one system introducing attenuation was x and the

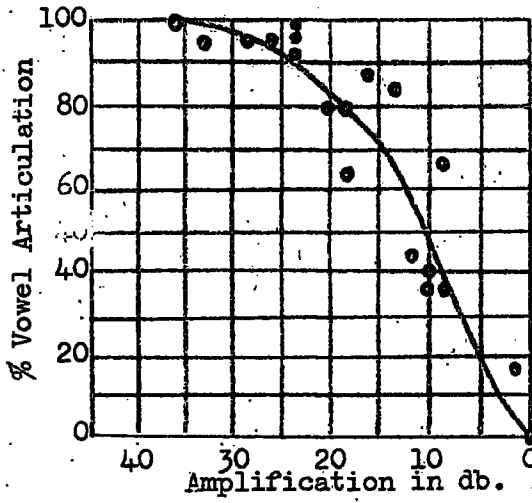

Fig. 24

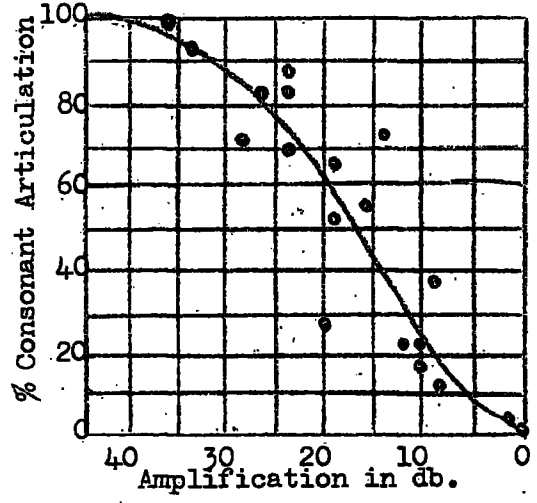

Fig. 25

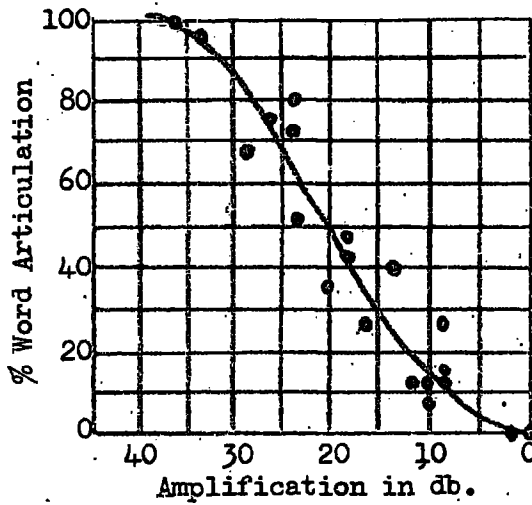

Fig. 26

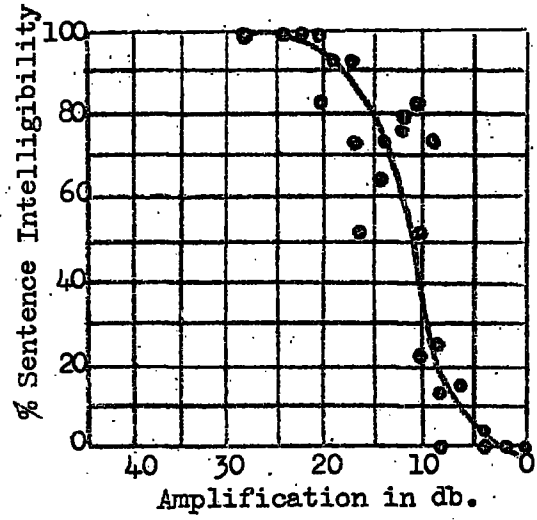

Fig. 27

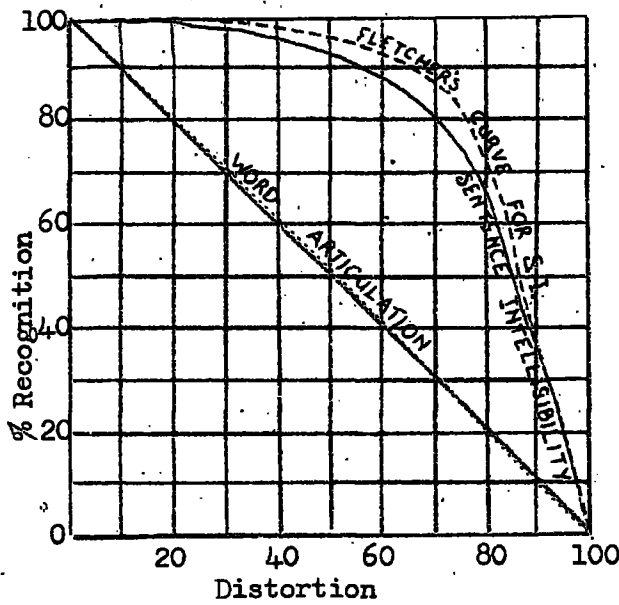

Fig. 28

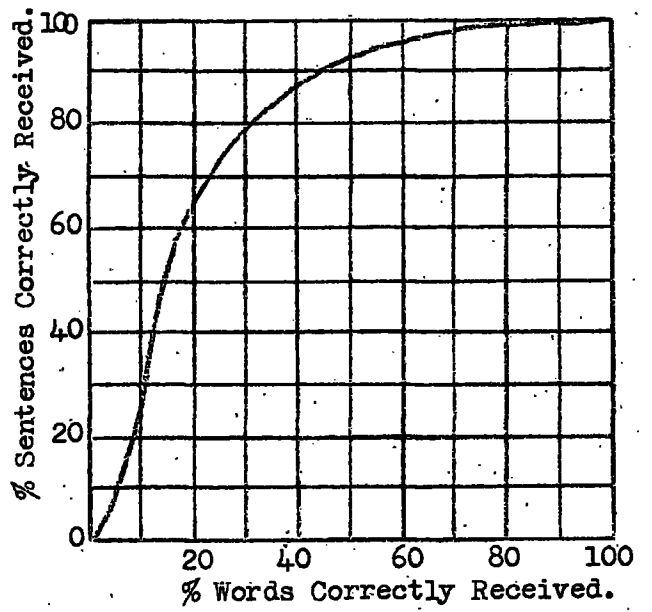

Fig. 29

corresponding sentence intelligibility score  $y$  then a word articulation score of  $x$  on a system introducing distortion and not attenuation would still have the associated score of  $y$  for the sentence intelligibility.

(d) Practical Procedure for Speech Audiometry as applied to Deaf Subjects.

(i) Test Material. The ability to understand connected phrases or sentences is, of course, the ultimate function of the hearing mechanism which we desire to assess, and this would be achieved most directly by the use of sentence tests. The procedure involved, however, would be too lengthy for use with deaf subjects, while tests with nonsense syllables are suited only for listeners trained in their use. Tests with lists of single words, therefore, remain as the only practical procedure at our disposal.

The words used in these lists were selected from those given in 'The Reports on Articulation Testing Methods' Psycho-Acoustic Laboratory, Harvard University [Bibliography (5)], particular attention being paid to all those factors previously described.

Disc recordings were made of the lists as spoken by a number of good but untrained speakers of both sexes. Arrangements were also made in the course of the recording process to balance the inequalities in loudness of the voices of the various speakers, and it was possible in this way to obtain from the records a reasonable uniformity of output. Thereafter the records were reproduced by means of a good quality amplifier loudspeaker system. The range of amplification extended from just below the normal threshold of hearing to 110 db. above it in 2 db. steps. Suitable means for maintaining the calibration of the amplifier and of the over-all acoustic output of the system were provided. The tests were carried out in a sound proof, well-damped room. The listener was seated with his ear resting against a padded ring at a fixed distance from the speaker, and was asked to repeat the words as reproduced through the loudspeaker. His responses were written down by a marker, and the percentage <sup>scores</sup> for vowels consonants and whole words then computed. It was found at the outset that the intrinsic intelligibility of the words in any one list covered a wide range; that is to say, the easier words in the list would be understood at an amplification of some 30 db or more below that required for the most difficult. It was recognised that a good test list should be made up of words having such a wide overall range of intrinsic intelligibility and being evenly graded within this range. All of the records made were systematically tested over the amplifier-loudspeaker system using a number of normal listeners and articulation curves similar to those in

Fig.26 obtained for each. The shape and slope of the articulation curve is a measure of the distribution of the order of difficulty of the words in the lists. For example, a very steep curve would indicate that all or most of the words in the lists were of the same order of difficulty, whereas a shallow curve would indicate a list composed of words of gradually increasing order of difficulty. In order that the records could be interchangeable it was important that their articulation curves should be identical; any records with articulation curves, therefore, which deviated from that of Fig.26 were rejected.

(ii) The Speech Audiogram.

The correlation previously made between word articulation and sentence intelligibility (Fig.28) is of great importance for by means of it we are able to ascertain a subject's ability to understand sentences from a study of that person's word articulation curve without having had to resort to the more laborious tests with sentences.

These two curves thus come to constitute the normal base line of these functions, and as such have been incorporated in the Speech Audiogram Chart which is shown in Fig.30. It will be noted that the 40% level for word articulation corresponds to 90% sentence intelligibility. Above the 40% level for word articulation, sentence intelligibility improves very little. Below the 40% level for word articulation, sentence intelligibility falls steeply. The 40% level for word articulation is, therefore, a critical one and is so marked upon the chart. Three levels of amplification are also marked upon the chart. These are based upon certain of the Beasley Gradings of social disability due to deafness ~~(see xxxxxx page xxx of appendix)~~. (See Bibliography No.6)

Grade No.1 In these subjects difficulty is experienced in hearing in the theatre or church. An amplification setting of 36.db. was selected as giving a speech intensity level at the ear of the listener corresponding to listening conditions in a theatre or church. It is marked 'Church level'.

Grade No.11 In these subjects difficulty is experienced in hearing in church and also with ordinary conversation. A second special level of amplification was selected to correspond with this Grade, and is marked upon the chart as 'Ordinary conversation'. This level was determined by sound level meter measurements. The actual words of one of the test records were spoken into the microphone of the sound level meter at a distance of three feet by a number of normal subjects using an ordinary conversational voice. The sound level meter readings for each word were recorded and the average values taken. The

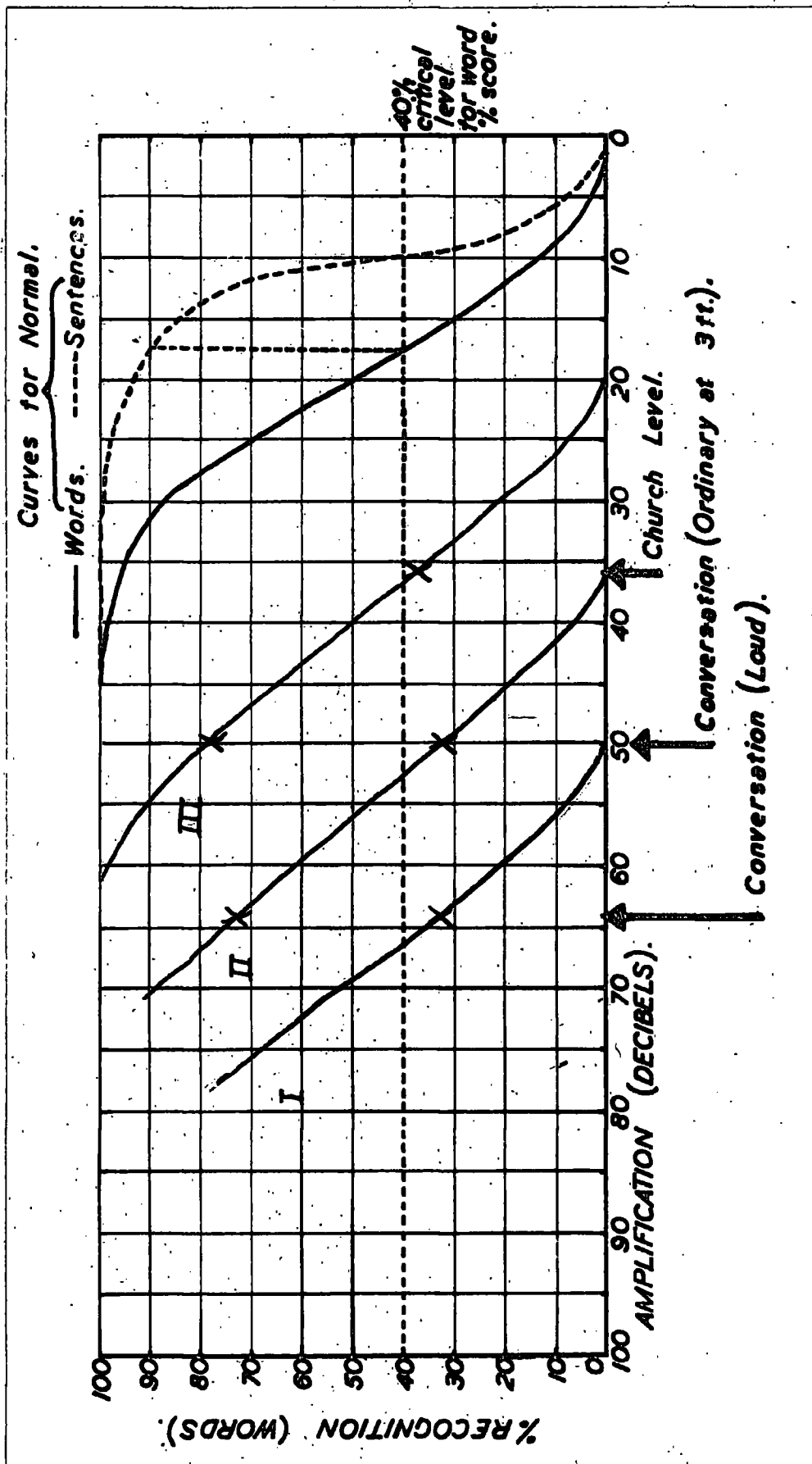

Fig. 30

words were then reproduced from the records using the amplifier-loudspeaker system with the microphone of the sound level meter placed at the listening point in front of the loudspeaker. The amplification setting of the amplifier was then adjusted to give the same sound level meter readings as obtained with the directly spoken voice. An amplification setting of 50 db. was found to give this result.

Grade No. III. In these subjects difficulty is experienced in hearing in church and with ordinary conversation. There is difficulty also in hearing loud conversation and in hearing over the telephone with a good line. A third special level of amplification at 64 db. was selected to correspond with this Grade, and is marked upon the chart as 'loud' conversation.

The tests are carried out at the three special levels and usually at some higher levels as well. With all but the slightly deaf subjects no score was obtained as a rule at either of the two lower of the three special levels. The score obtained with each test list provides one point upon a curve which is then inscribed upon the chart and is taken to constitute the unaided speech audiogram. Three such audiograms are shown in Fig. 30, each corresponding to one of the three Beasley gradings. The degree of the deafness, as expressed by the unaided speech audiogram, may be taken in general terms as the amount of displacement of its curve to the left of the normal. This displacement might be read at the speech threshold levels of the two curves, a course which is, however, open to a number of objections among which may be included the variable performance of the ear at or near to the threshold. For a variety of reasons it would seem preferable that this leftward displacement of the audiogram should be read at the so-called critical level of 40% word articulation. The displacement measured in this way has, therefore, been taken in all of our subjects as the measure in decibels of their unaided deafness for speech.

-----oO-----

### SECTION III

#### Evaluation of the Usefulness of Hearing Aids.

##### 1. Pure Tone Audiometer Method.

A technique sometimes adopted in America in assessing the merits of various hearing aids in meeting the requirements of the individual is based upon the assumption that ideally, the hearing aid should correct the subject's pure tone audiogram by selective amplification of those frequencies at which the hearing loss is greatest.

The unaided audiogram of the ear on which the aid receiver is to be worn is first plotted. The audiometer receiver is then placed over the microphone of the hearing aid under test and the procedure repeated with the subject wearing the hearing aid. By comparing the two curves thus obtained the measure of the amplification afforded the subject by the hearing aid at threshold intensities can be seen at a glance. Typical audiograms of a person taken in this way with and without a hearing aid are shown below, Fig. 31:

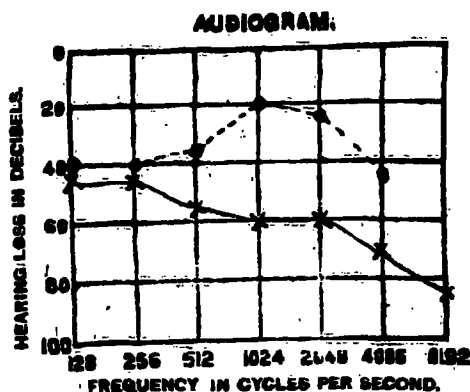

Fig. 31

Audiograms taken with and without a Hearing Aid.

This method is open to a number of objections. Unless elaborate precautions are taken to see that the coupling arrangements between the microphones of the aids tested and the audiometer receiver are such that the testing conditions are uniform throughout, the results obtained will not be reliable. Even so, this by itself would be an inadequate test of the aid since, as has been mentioned elsewhere, there is in general no very simple relation between a subject's audiogram, aided or otherwise, and his ability to interpret speech sounds.

## 2. Speech Audiometer Method.

### (a) Procedure.

It has been shown in Section II how use was made of selected word lists with an artificial voice in assessing a deaf subject's ability to understand speech. By an extension of this technique it has also been found possible to measure the practical value of hearing aids for patients. Before describing the details of this technique reference may be made to the speech audiometry chart described in Section II which is reproduced on the following page (Fig. 32). Following the tests required for the plotting of the unaided speech audiogram, the ear of the subject is replaced at the listening point in front of the loud speaker by the microphone of one or other of the hearing aids which it is desired to test. Further test lists are then listened to. In the course of a full examination tests are usually carried out at the lower two of the three special levels with each of the hearing aids tested. It has been found, however, in practice, that most of the information required can be obtained from tests at the 'ordinary' conversation level, and many of the tests with hearing aids have therefore been carried out at this level alone. In the final graphic record of the results the aids come to be arranged in order of merit from above downwards along this ordinate, the order depending, of course, upon the word articulation scores obtained. When, as is usually the case, the curve of the unaided audiogram pursues a course above the zero line parallel to the normal, it is possible to construct useful approximations to the full curves for each of the aids tested by drawing lines parallel to the normal curve and intersecting the 50 db ordinate at the respective articulation levels obtained with the aids in question. On the chart is shown the speech audiogram of a subject coming within the third of the Beasley Gradings. The chart also shows the results obtained with a number of hearing aids. Inspection of the chart in addition to revealing the absolute and relative values of the assistance provided by the various hearing aids, will also show whether or not the assistance provided by a particular aid will bring the patient's hearing capacity above the 40% or critical value for word articulation at any or all of the three fixed levels, i.e., church, ordinary conversation and loud conversation.

NAME	J. F. S.	AGE	35	SEX	M	EAR	L	DATE	3.3.46	SERIAL NO.	433
TEST NO.	1		2		3		4		5		
LIST NO.	1										
HEARING AID	Nil.		1		2		3		4		5
VOLUME SETTING	/		Full		Full		Full		Full		Full
tone control	/		/		/		/		/		/
SYMBOL	X		+		o		o		o		o

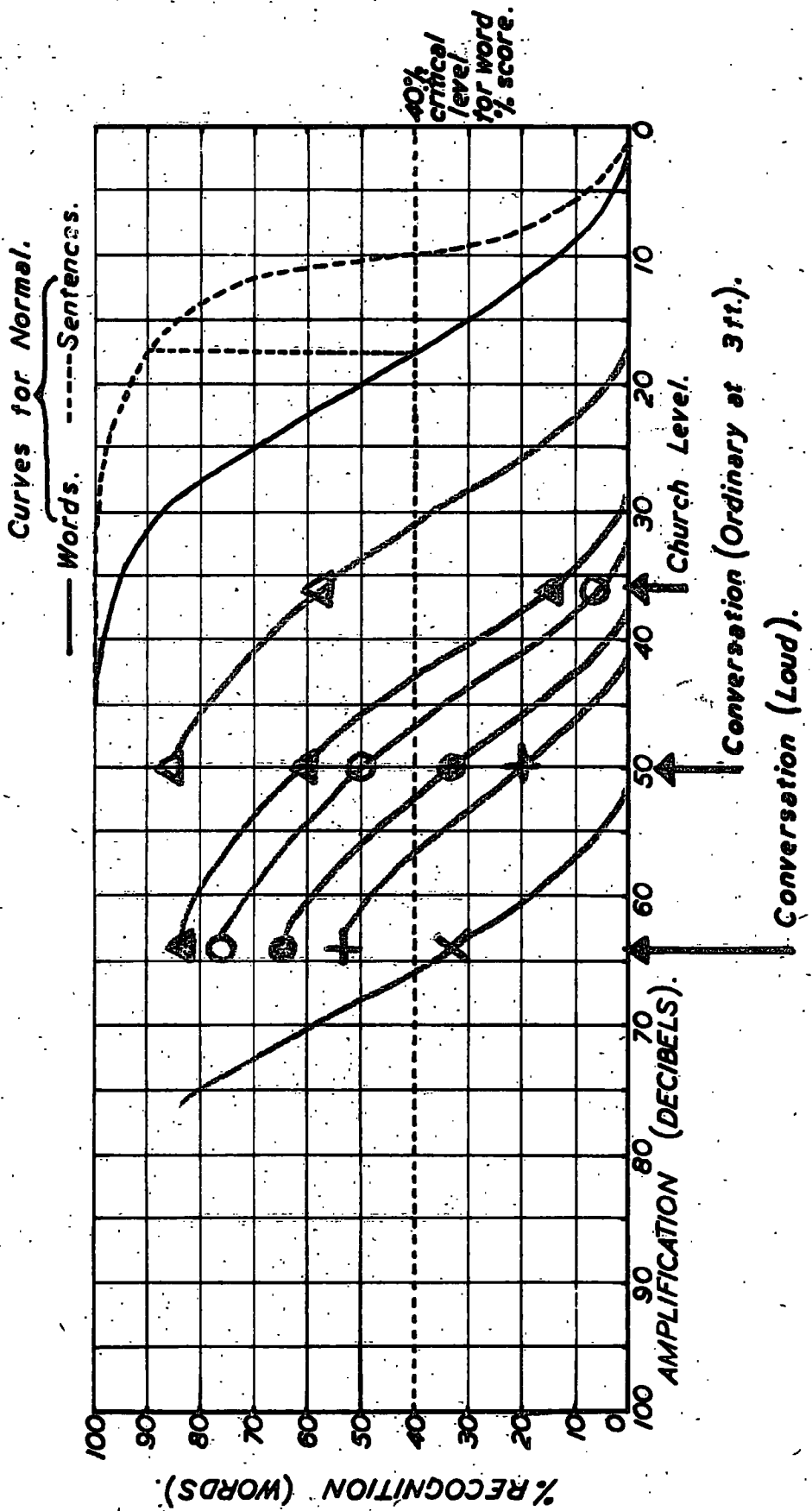

Fig. 32

Hearing Aid Test Results  
 Obtained with a Number of Commercial Aids.

(b) Overload of Hearing Aid.

It has been found in practise that all of the hearing aids used in the Clinic began to overload at an attenuator setting of the speech audiometer between 52 db and 60 db. In Fig.33 is shown this precise setting for a number of aids. This means that with increasing output from the speech audiometer above the overload point of each aid there was no corresponding increase from the hearing aids and instead they began to distort the speech sounds.

Hearing Aid.	Speech Audiometer Setting at which Aid began to Overload.
Beltone	52
Bonochord T60	52
Multitone	52
Belclere S.	54
Belclere W.	58
Amplivox V.	58
Bonochord P3	58

Fig.33

It would be thought, therefore, that the articulation scores taken with the speech audiometer set at 64 (loud conversation) would show a falling off in the articulation score. The articulation curves shown in Fig.34 taken with the subjects wearing the aids show that this is not so, and that in actual fact there is a gradual rise in the articulation curve up to this point, after which there is a rapid decline with further increase in output from the speech audiometer. It would appear, therefore, that the subjects do, in fact, derive additional benefit from the aid overloading despite the fact that there was no additional amplification.

(c) Testing of Patients suffering from Nerve Deafness.

In the testing of certain patients suffering from nerve deafness, a good deal of caution and patience was necessary when they were being tested with an aid. As described earlier (page 22) such patients, although their cochlear sensitivity may be much reduced as assessed by means of a pure tone audiometer, may hear sounds above their threshold at normal loudness level, and indeed their threshold of pain is sometimes reached at an intensity level below that of a

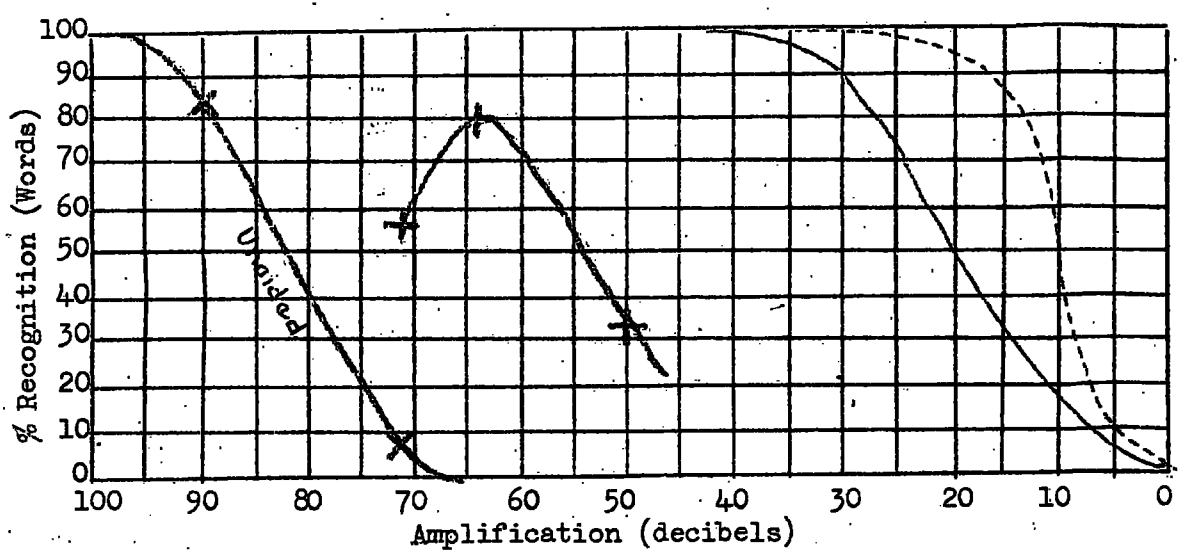
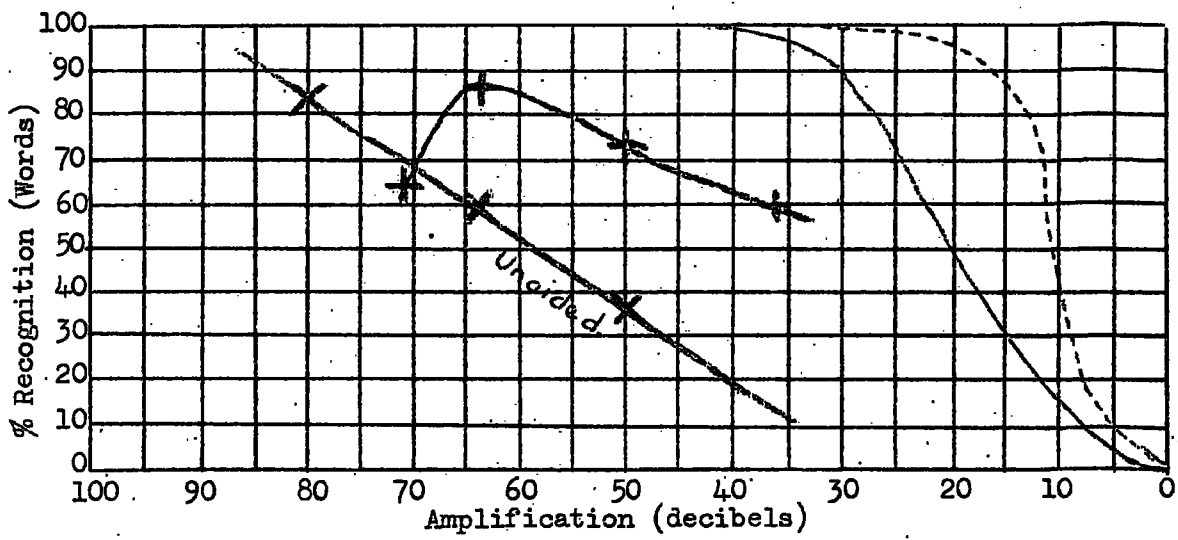
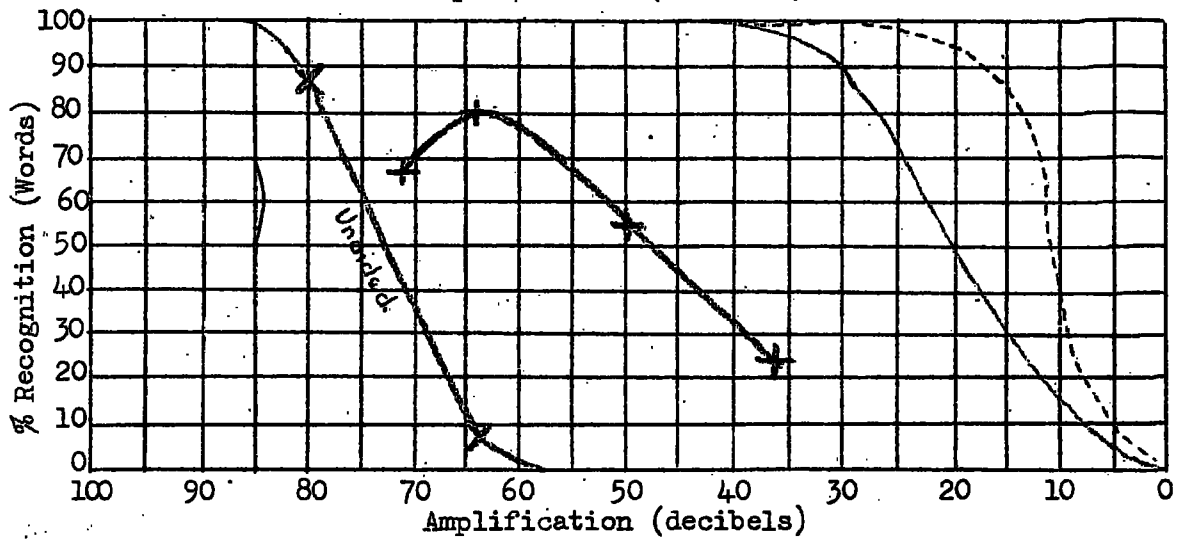
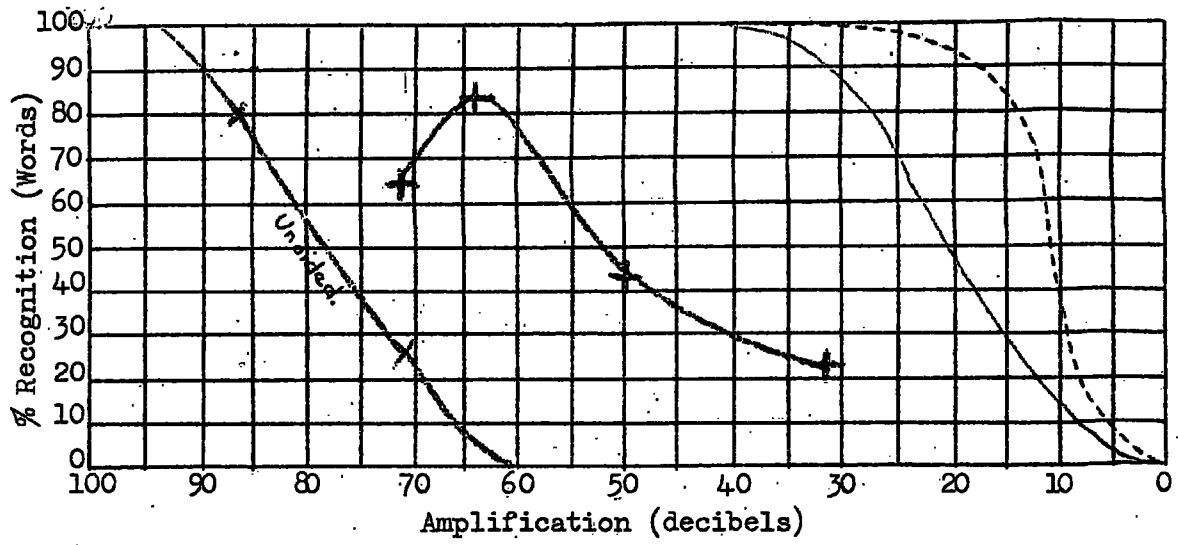

Speech audiometer charts showing four aided and unaided articulation curves.

Fig. 34

normal individual.

The audiogram of Fig. 35 shows the threshold of hearing (full line) and of pain (dotted line) of such a patient.

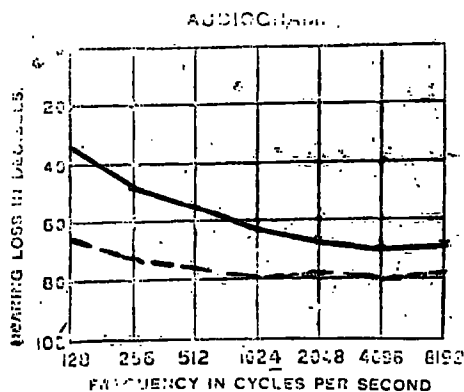

Fig. 35

For speech to be intelligible the intensity must lie between these limits and obviously the smaller the enclosed area the more difficult becomes the task of prescribing a suitable hearing aid. In these cases it is of paramount importance that the volume of the aid be adjusted to that most suited to the testing conditions. In certain cases the two curves lie so close together that a hearing aid is of no avail, although some of these patients at times find a speaking tube of some slight use.

#### S E C T I O N I V .

##### Some original observations upon the correlation of the Speech and Pure Tone audiograms in a number of Deaf Subjects.

The evaluation of the pure tone audiogram in terms of practical hearing disability has always presented a problem of interest and importance.

One of the best known of the earlier approaches to this problem is probably the percentage method of computing the hearing loss from a pure tone audiogram, a method based upon experimental work at the Bell Telephone Laboratories and referred to by Harvey Fletcher (Bibliography No. 4 p.201). According to this method the hearing loss in decibels for a pure tone is converted into a percentage hearing loss by multiplying the former by a factor  $k$ . The average value of  $k$  within the range of the principal speech frequencies, 512 to 2000 c.p.s., is 0.8. Users of the Western Electric Company's audiometer are given the following directions for arriving at the percentage hearing loss: 'The percent of hearing loss for speech is approximately equal to the average reading at 512, 1024 and 2048 multiplied by 0.8.' The imperfections of this method are now becoming well known, and these have been well stressed by Bunch (Bibliography No. 7 p.51). Bunch's work shows very clearly what has been known to otologists for a number of years, that patients with identical audiograms may show widely differing capacities for the hearing of speech. Conversely, patients with widely differing audiograms may be clinically indistinguishable in respect of deafness for speech.

In view of these observations it has been felt for some time that the information provided by the pure tone audiogram, i.e., a threshold test, is related in no very certain manner to the performance of the ear at the supra-liminal intensities involved in listening to speech.

More recently, however, the work of Sabine [Bibliography No. 8 ] upon the percentage evaluation of the pure tone audiogram has led to a reopening of the question upon what seems to be a much better considered basis. The following summary of his work and recommendations may be given:

The auditory field enclosed between the threshold and pain curves which

appear on the conventional audiogram is divided into a number of squares, forty-two in all, as shown in Fig.36 below.

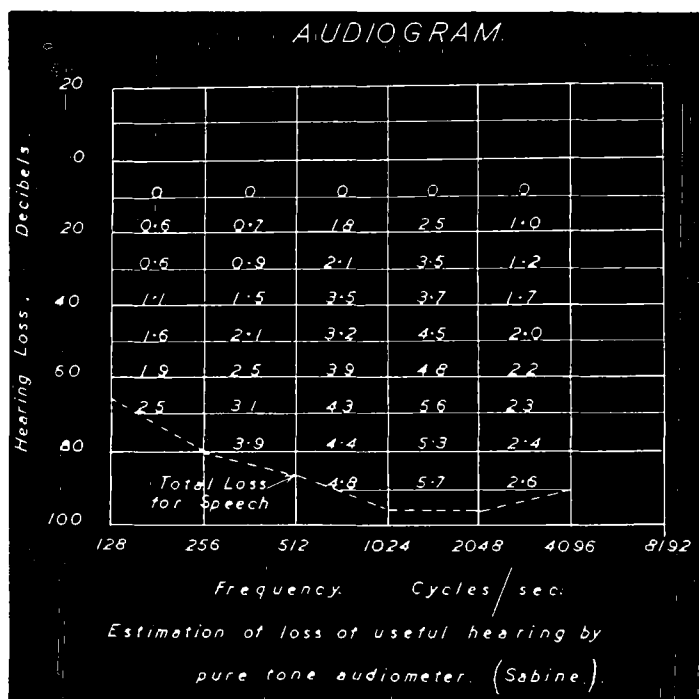

Fig. 36

To each square is assigned a value determined by its functional contribution to the hearing of speech. These values have been based in the main upon a consideration of the pitch and intensity discrimination functions in the different parts of the auditory field. (For the relevant data reference should be made to the work of Knudsen (Bibliography No. 9) and of Fletcher (Bibliography No.4 p.158). The total of the values so assigned to the various squares is equal to 100 and the total value of the squares above the threshold curve as inscribed upon such an audiogram chart gives the hearing loss directly as a percentage. This method of computing hearing loss as a percentage presents a number of advantages upon the Bell Telephone System, to which reference has already been made, and has now gained fairly wide acceptance as a standard procedure in the United States by the U.S.A. army and other authorities.

Fig.37 on the following page shows the type of chart, a development of that shown in Fig.36, which has been recommended by the American Medical Association for general use. Here the values inscribed in each column are cumulative from above downwards. Thus the value for the percentage of total hearing loss contributed by the hearing loss at any one of the four frequencies,

256, 512, 1024/or 4096 c.p.s. can be read directly from the chart, the figure in question being given in the square immediately above the level at which the hearing loss curve crosses the column concerned. Addition of the four cumulative values gives the total percentage loss.

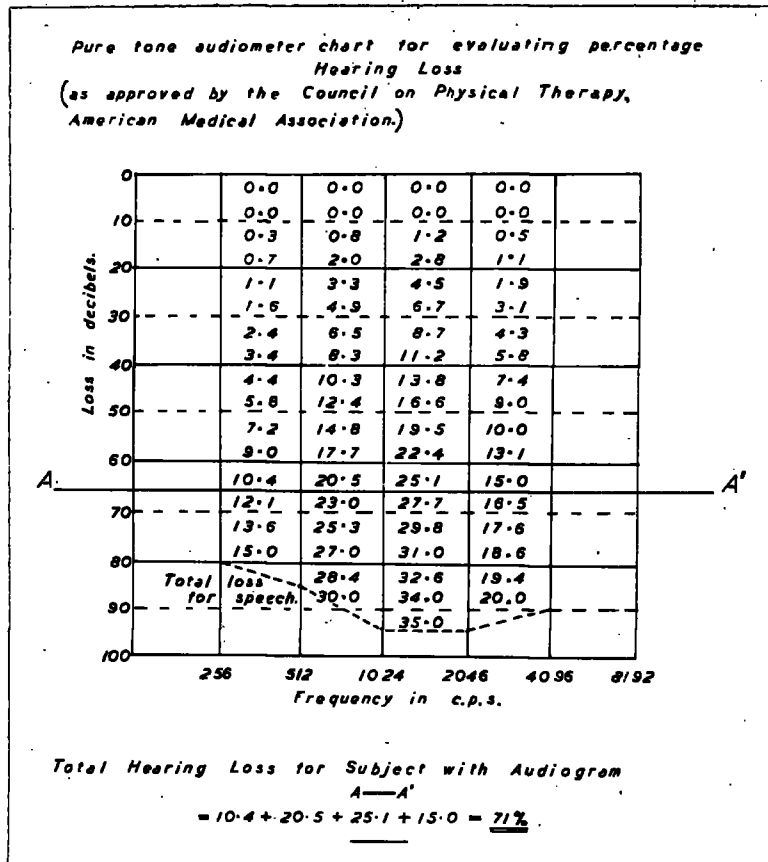
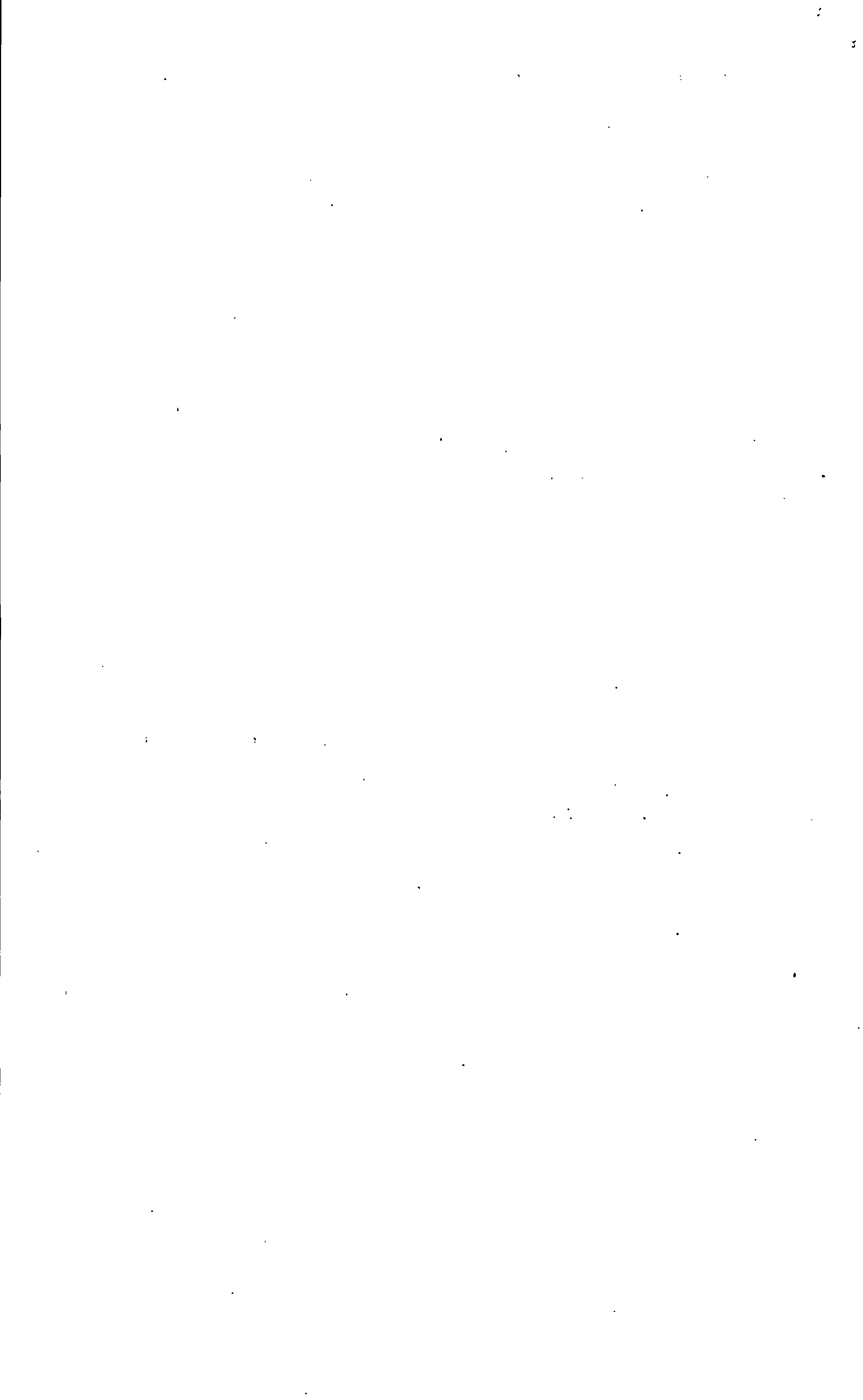

Fig. 37

Certain elements of doubt remain, however, particularly in view of the work of Fowler and of Steinberg & Gardiner on the so-called 'recruitment' phenomenon observed in cases of deafness due to disease of the nervous mechanism of the internal ear. Here, although deafness may be marked at threshold intensities of sound, there may be no apparent deafness at intensities well above threshold, as assessed by loudness balance tests. This emphasises again the probability that the relationship of the cochlear functions which are involved respectively in the hearing of pure tones at threshold and of speech sounds well above threshold, is by no means always a simple one. McFarlane [Bibliography No. 10] in particular has recently emphasised the limitations of the pure tone audiogram as a guide to hearing for speech.

In view of this conflict of views upon the value of the pure tone audiogram as a guide to the practical ability of the deaf person to hear speech, we have endeavoured to obtain further evidence by the comparative study of the pure tone audiograms and speech audiograms of a number of deaf subjects seen at the Deafness Clinic of the National Hospital, Queen Square. In all of the subjects investigated, a full clinical examination was carried out and a diagnosis of the



deafening disease made. The subjects were divided into two groups:

Group 'A' suffering from disease of the conducting apparatus of the middle ear.

Group 'B' suffering from disease of the nervous mechanism of the inner ear.

There were in all 27 cases in Group 'A' and 33 cases in Group 'B'. In all of the former and none of the latter paracusis Willisii was present. This is a symptom, characteristic of disease of the conducting apparatus, consisting of a subjective improvement of hearing for speech in noisy surroundings. The pure tone audiograms were taken with a Maico audiometer in the usual way and the percentage hearing losses were then derived from the audiograms by the Sabine-Fowler method. In addition, direct measurements of ability to hear speech were made in all cases by means of the speech audiometer, using the technique previously described, (page 36) the deafness for speech being defined as an increase in decibels above the normal intensity required by the deaf subject to give 40% word articulation. The results are presented in the form of a scattergram in the following Chart (Fig. 38) in which the ordinates are the percentage losses as derived from the pure tone audiogram by the Sabine-Fowler method, and the abscissae the speech deafness in decibels.

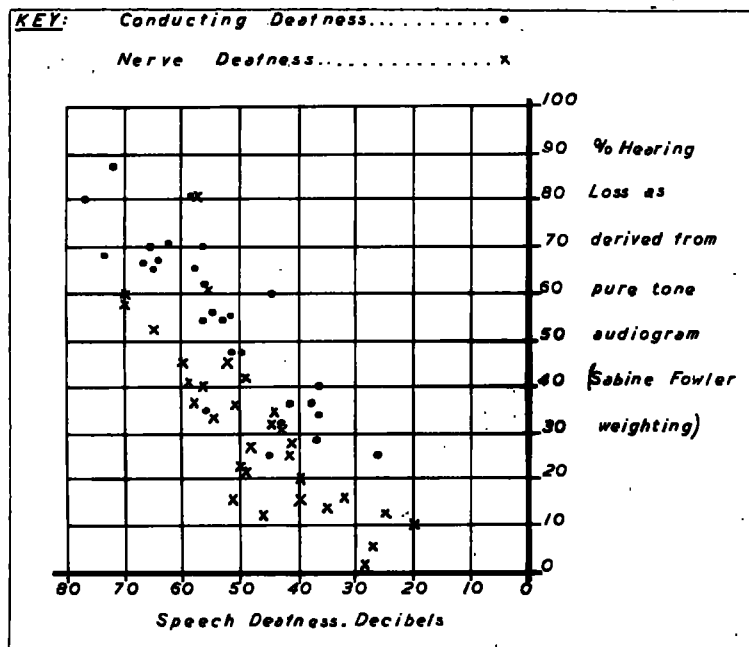

Fig. 38

## RESULTS.

Inspection of the scattergram shows that the distribution of the two groups of symbols, dots and crosses, shows a systematic differentiation. If each of the vertical columns bounded by successive ordinates be regarded as a particular grade of speech deafness, then in each grade the symbols are widely distributed, covering a range of percentage hearing loss of 50 db or more, with the conducting deafness symbols lying well above the nerve deafness symbols.

In other words, at any one level of deafness for speech the percentage hearing loss for pure tones is greater in cases of conducting deafness than in cases of nerve deafness. This difference may be considerable. Thus, in the speech deafness range, 40 to 50 db., there occurs a case of nerve deafness with a percentage loss of only 12%, together with a case of conducting deafness with a percentage loss of 60%.

Conversely, the chart may be divided horizontally into bands each representing a particular grading of deafness in terms of percentage loss. In each band conducting deafness symbols will be seen distributed well to the right of the nerve deafness symbols.

In other words, at any one level of percentage loss of hearing, the deafness for speech tends to be much less in cases of conducting deafness than in cases of nerve deafness.

Thus, in the percentage loss grading, 30% to 40%, there occur several cases of nerve deafness with a speech deafness of 50 to 60 db. together with several cases of conducting deafness with a speech deafness of only 30 - 40 db.

These results confirm, and to some extent systematise, the generally held belief that without reference to the character of the deafening disease pure tone audiometric findings cannot reliably be related to the hearing capacity for speech.

The investigation is being continued and it is hoped to analyse more closely certain aspects of cochlear function, such as pitch and intensity discrimination, which seem likely to be concerned in the hearing disability for speech found to occur in nerve deafness.

One feature of our findings seems worthy of particular note. As Steinberg & Gardiner have described, (Bibliography No. 11) loss of sensitivity at threshold occurring in cases of nerve deafness may be 'compensated' at higher intensities by reason of the so-called 'recruitment' phenomenon, thus, there may be in such a case a threshold loss for a particular tone of, say, 40 db.. Nevertheless,

the same tone at an intensity 80 db. above normal threshold will be heard by the same subject with the same loudness as by a normal person.

These observations not unnaturally suggest the possibility that this recruitment of loudness in cases of nerve deafness might be accompanied by a corresponding recruitment of hearing capacity for speech.

Our present findings certainly provide no confirmation of this possibility. They suggest, on the contrary, that the disability of subjects suffering from nerve deafness in respect of threshold sensitivity is increased in respect of hearing capacity for the supra-liminal sounds of speech.

-----oOo-----

## BIBLIOGRAPHY.

1. Planer, F.E. and Marland, E.A., (1945) Electronic Engineering 27, 450
2. Sabine, P.E. (1944) Journ. Acous. Soc. Amer. 16, 38.
3. Steinberg, H.C. & Gardner, M.B. (1937) Journ. Acous. Soc. Amer. 9, 11-23.
4. Fletcher, H. Speech & Hearing, New York, 1927 Van Nostrand Co. Inc.
5. Psycho-Acoustic Laboratory, Harvard University, Reports on Articulation Testing Methods. \*
6. Beasley, W.C. (1940) Larynscope (L) p.856-905.
7. Bunch, C.C. Clinical Audiometry, St. Louis, 1943 C.V. Mosby Co.
8. Sabine, P.E. (1942) Tr. Amer. Acad. Ophth. & Otolaryng.
9. Knudsen, V.O. (1923) Physical Rev. 19, 261.
10. Macfarlane, D. (1945) Laryngoscope 55, 105.
11. Steinberg, H.C. & Gardner, M.B. (1940) Journ. Acous. Soc. Amer. 11, 270.

\* These are restricted reports and are not yet generally available.

