

Durham E-Theses

*The mechanical deformation of single crystals of the
alkali halides and its effect on their electrical
properties*

T. L. Goodfellow

How to cite:

Goodfellow, T. L. (1955) The mechanical deformation of single crystals of the alkali halides and its effect on their electrical properties. Doctoral thesis, Durham University.

Use policy

The full-text may be used and/or reproduced, and given to third parties in any format or medium, without prior permission or charge, for personal research or study, educational, or not-for-profit purposes provided that:

- a full bibliographic reference is made to the original source
- a <https://etheses.durham.ac.uk/id/eprint/9585/> is made to the metadata record in Durham E-Theses
- the full-text is not changed in any way

The full-text must not be sold in any format or medium without the formal permission of the copyright holders.

Please consult the [full Durham E-Theses policy](#) for further details.

THE MECHANICAL DEFORMATION OF SINGLE CRYSTALS
OF THE ALKALI HALIDES AND ITS EFFECT ON THEIR
ELECTRICAL PROPERTIES

by

T. L. GOODFELLOW, B.Sc.

An account of work carried out at the Department of Physics, Science Laboratories, Durham Colleges in the University of Durham under the supervision of Mr. J.E. Caffyn, B.Sc. F. Inst. P. during the period 1952-55

Submitted in candidature for the degree of Ph.D.
of the University of Durham.



CONTENTS

Page

1. INTRODUCTION	
1.1 SUMMARY OF WORK	1.
1.2 THE EXPERIMENTS OF GYULAI AND HARTLY (1928)	1.
1.3 OTHER WORK	4.
1.4 THEORIES OF THE CONDUCTIVITY INCREASE	6.
1.5 THE PRESENT WORK	10.
2. THE GROWTH OF SINGLE CRYSTALS OF THE ALKALI HALIDES	
2.1 METHODS AVAILABLE	12.
2.2 THE FURNACES	14.
2.3 THE COOLERS	18.
2.4 THE TEMPERATURE CONTROLLER	19.
2.5 GENERAL ARRANGEMENT	23.
2.6 TECHNIQUE OF GROWTH	24.
2.7 CLEAVAGE OF CRYSTALS	28.
3. THE MEASUREMENT OF THE CONDUCTIVITY OF SINGLE CRYSTALS OF THE ALKALI HALIDES	
3.1 INTRODUCTION	31.
3.2 THE MEASUREMENT OF SMALL CURRENTS	32.
3.3 THE ELECTROMETER VALVES	37.
3.4 THE FEEDBACK AMPLIFIER	38.
3.5 VOLTAGE AMPLIFICATION	43.
3.6 TESTING OF THE RESPONSE TIME OF THE AMPLIFIER	44.

3.7 THE SWITCHING CIRCUIT	46.
3.8 THE CATHODE FOLLOWER	48.
3.9 PREPARATION OF CRYSTALS	51.
3.10 TESTING OF GRAPHITE ELECTRODES	55.
4. APPARATUS FOR THE PLASTIC DEFORMATION OF CRYSTALS	
4.1 BASIC DESIGN	56.
4.2 THE STRESS APPARATUS	57.
4.3 THE SECOND STRESS APPARATUS	62.
4.4 THE THIRD STRESS APPARATUS	69.
5. THE INVESTIGATION OF THE PROPERTIES OF SODIUM CHLORIDE CRYSTALS CONTAINING MANGANESE.	
5.1 INTRODUCTION	76.
5.2 GROWTH OF CRYSTALS	77.
5.3 CONDUCTIVITY MEASUREMENTS	79.
5.4 DISCUSSION OF THE CONDUCTIVITY RESULTS	83.
6. PRELIMINARY WORK ON THE MECHANICAL DEFORMATION OF SODIUM CHLORIDE CRYSTALS	
6.1 USING THE FIRST STRESS APPARATUS	85.
6.2 USING THE SECOND STRESS APPARATUS	88.

7. THE INCREASE IN CONDUCTIVITY OF SINGLE CRYSTALS OF THE ALKALI HALIDES UPON MECHANICAL DEFORMATION	
7.1 EXPERIMENTAL ARRANGEMENT	99.
7.2 CONDUCTIVITY MEASUREMENTS	103.
7.3 THE CONDUCTIVITY INCREASE	105.
7.4 THE TEMPERATURE DEPENDENCE OF THE CONDUCTIVITY CHANGE	108.
7.5 FURTHER EXPERIMENTS	110.
7.6 ETCHPITS	115.
8. THE POTENTIAL EFFECT IN SINGLE CRYSTALS OF ALKALI HALIDES UPON MECHANICAL DEFORMATION	
8.1 EXPERIMENTAL ARRANGEMENT	121.
8.2 INVESTIGATION OF THE NATURE OF THE POTENTIAL EFFECT	124.
8.3 THE TEMPERATURE DEPENDENCE OF THE POTENTIAL EFFECT	128.
8.4 THE VARIATION OF THE POTENTIAL EFFECT WITH INPUT RESISTANCE	130.
8.5 THE DEPENDENCE OF THE POTENTIAL EFFECT UPON THE NATURE OF THE CRYSTAL SURFACE	134.
8.6 THE VARIATION OF THE POTENTIAL EFFECT WITH STRESS	142.

9. DISCUSSION AND CONCLUSIONS

9.1 THE INCREASE IN CONDUCTIVITY UPON MECHANICAL
DEFORMATION

143.

9.2 THE POTENTIAL EFFECT UPON MECHANICAL DEFORMATION

150.

ACKNOWLEDGEMENTS

REFERENCES

1. INTRODUCTION

1.1 SUMMARY OF WORK

In the decade or so around 1930 there were carried out in Germany a number of experiments on the influence of plastic flow on the electrical conductivity of ionic crystals. This work, which centered in part around a controversy between Smekal (1929) and Joffe' (1930) on the importance of imperfections in determining the properties of ionic crystals, provides a close link between the properties of dislocations, positive and negative ion vacancies and colour centres. It has been suggested by various investigators in recent years (Cottrell; Haynes & Shockley 1948) that the behaviour of atomic or ionic imperfections in solids should be affected by the presence of dislocations. Seitz (1950) has suggested that the alkali halides offer a good example of this effect. The basic experimental facts and related interpretations seem to be as given in the following sections.

1.2 THE EXPERIMENTS OF GYULAI AND HARTLY (1928)

These workers compressed single crystals of rock-salt* in a lever press with the lever arm loaded with weights. The crystals were placed between measuring plates which served as electrodes and these were insu-

* Rocksalt will be used throughout to mean natural sodium chloride.



lated from the base plate and the pressure rod by amber blocks. The conduction current was measured by the rate of charge of a string electrometer with a potential of 100 - 300 V from a battery applied across the crystal and electrometer connected in series. The crystal was contained in an electrically heated, thick walled, iron box which was heavily insulated by asbestos and measurements were taken at a temperature of 38°C . The box was normally heated to a temperature of $60 - 70^{\circ}\text{C}$ to remove any water before being allowed to cool to the measuring temperature. The specimens were cleaved from large single crystal blocks of rock-salt from Wielicka and the electrode faces were dulled with emery paper and coated with graphite. Prof. Pohl and Dr. Pick (See Seitz 1950) have stated that the specimens of rocksalt may have been very pure, containing only of the order of one part in ten million of divalent impurity.

It was found on loading that the crystal showed an increased conductivity which decayed with time. Observations were made over various time intervals until the conduction current had reached a steady value and the magnitude of the conductivity increase was found to be negligible after about twenty minutes. The crystal was

then further loaded and the increase of conductivity was found on the application of stress increments, the total stress on the crystal being increased by each increment applied. Three values of stress increment were used when applying stress to the crystal, 20, 100 and 200 Kg/cm², and the total stress applied was as high as 700 Kg/cm² where the compressive strain in the rocksalt was about 30%. It was found that the value of the increased conductivity immediately after the application of the load was about 100 times the value of the permanent conductivity for a stress increment of 100 Kg/cm², the conductivity rising from about 10⁻¹⁶ to about 10⁻¹⁴ ohm⁻¹ cm⁻¹. If the crystal was loaded to a determined limit and then the stress removed it was found that the conductivity jump could not be observed on the reapplication of stress until the previous limit of stress had been reached, although a very much reduced conductivity increase took place at stresses just below the limit of stress previously applied. Many of the conductivity increases were observed to be proportional to the increments of stress applied.

The experiments of Gyulai and Hartly were confirmed by Stepanow (1933) who observed the effect in the tem-

perature range from 30 - 170°C using a similar method.

1.3 OTHER WORK

Quittner (1931) carried out some experiments on the compression of single crystals of rocksalt. His experiments were performed at a temperature of 200°C and only small stresses were applied (1.5 - 3.0 Kg/cm²). A conductivity increase was found on loading the crystal but the increase vanished on the removal of stress. It was pointed out, however, that unevenness of the crystal surface could have caused very considerable local stress concentrations.

Gyulai has observed very large effects when pellets of sodium chloride powder are pressed under hydrostatic load. Such pellets show a conductivity as high as $7.4 \times 10^{-7} \text{ ohm}^{-1} \text{ cm}^{-1}$ at 111°C after pressing. Seitz (1950) has suggested that it is likely that a large portion of this increase in conductivity must be attributed to migration on surfaces or along grain boundaries. The conductivity dropped with time and after a period of seventeen hours had reached a value of $1.6 \times 10^{-10} \text{ ohm}^{-1} \text{ cm}^{-1}$. The normal value of the conductivity of single crystals at this temperature is about $10^{-14} \text{ ohm}^{-1} \text{ cm}^{-1}$. The phenomenon of recrystallisation is also important, since when a

crystal is in a strain hardened condition (which does not represent a stable state of equilibrium) it can return to the stable state by this process. New unhardened crystal nuclei develop individually, and, by absorbing the hardened crystal mass, produce an entirely new grain texture. Gyulai used very high stresses in pressing the powdered sodium chloride and intensive recrystallisation took place since translucent pellets were produced showing no outward evidence of their powder origin. It is possible that this intensive process of recrystallisation has the effect of increasing the conductivity by a large factor.

Gyulai and Boros (1940) have also observed a conductivity increase upon deformation at a temperature of 40°C in synthetic potassium chloride and bromide crystals both pure, additively coloured and X-ray coloured. The total load applied to the crystal was only 45 Kg and hence the experiments were carried out at stresses much nearer to the threshold of plastic flow than the experiments of Gyulai and Hartly. The lever press was used as in this earlier work but in place of the string electrometer they used a tube electrometer and a Bay oscillograph. This gave increased sensitivity to the

measurement of conductivity and permitted closer observation of the time variation of the current jumps. Regular current jumps were not found in experiments on any one crystal and tests with different samples showed much scatter. The magnitude of the current jumps was also found not to be proportional to the load. To facilitate comparison between various samples the current jumps were expressed as increases in the specific conductance of the crystal for an applied stress of 1 Kg/cm^2 . The conductivity increases were found to be about twice as large for the coloured as for the uncoloured crystals. Also the effect appeared to be slightly larger for potassium chloride crystals than for potassium bromide crystals. The increased conduction current was found to decay much more rapidly than those observed by Gyulai and Hartly. The conduction currents reached their maxima in about 0.1 sec after the application of stress and after the elapse of 0.2 or 0.3 sec had already dropped to half their peak values.

1.4 THEORIES OF THE CONDUCTIVITY INCREASE

Most of the specimens of sodium chloride employed in the experiments described above probably had of the order

of one part per million of divalent impurity atoms which have positive ion vacancies associated with them. These vacancies are sufficiently mobile at the temperatures employed (Etzel and Maurer 1950) to be able to spend an appreciable fraction of their time free and thus contribute to the conductivity. Seitz (1950) has interpreted the increase in conductivity in terms of an electrolytic current associated with the generation of positive and negative ion vacancies during plastic flow, presumably as a result of the motion of the dislocations in the crystal. The positive ion vacancies should be able to migrate to the negative ion vacancies and produce uncharged pairs in the course of minutes, thereby removing the source of the extra carriers. The investigators do not quote the initial value of the electrical conductivity of their specimens, so it is only possible to infer that about 10^{18} pairs of vacancies per cm^3 are produced by a strain of the order of 10%.

Seitz (1950) has considered an edge-type dislocation which jogs from one slip plane to another. The last ion in the extra row on the extra plane introduced by the dislocation line may be either positive or negative and may be considered as an incipient negative ion or

positive ion vacancy respectively, since a normal vacancy could be produced by taking the appropriate ion from its normal site in the lattice and adding it to the edge of the plane at the jog. The extra row at the edge of the extra plane will now end with an ion of opposite sign and hence may be considered as an incipient ion vacancy of the appropriate sign. In this way jogs of this type represent excellent sources and sinks of positive and negative ion vacancies, which will be distributed throughout the volume of the crystal, assuming that it possesses the normal density and distribution of dislocation lines (about 10^9 lines/cm²). An incipient vacancy present at a jog may be evaporated if the dislocation is set in motion and if local heating occurs as the result of dissipation of energy by the dislocation. The energy expended during plastic flow may be expected to appear as local heating on the slip planes and should be able to evaporate vacancies from jogs of this type. It is also possible that vacancies are generated in large numbers as the result of collisions of dislocations.

The vacancies produced during plastic flow will eventually recombine with one another to form clusters

so that they will become immobile and cease contributing appreciably to the ionic conductivity. From a consideration of the jump frequency of a positive ion vacancy, Seitz (1950) considers that the recombination time appears to agree with the time of decay of the increased conduction current found by Gyulai and Hartly. Various coagulation groupings are possible, but it may be expected that the smaller groups will act as intermediate stages in the formation of large groups of vacancies.

Tyler (1952) has called attention to the work of Gyulai and Boros (1940) and has suggested that the conductivity increase may be due, at least in part, to the freeing of electrons by the motion of dislocations. Since free electrons are presumed to have a higher mobility than positive ion vacancies, under these circumstances, fewer will be needed to provide the observed enhancement of conductivity. The longer decay times of the conduction current observed by Gyulai and Hartly may be associated with a continued liberation of electrons during a plastic flow process which continues for some time after loading, rather than the diffusion of vacancies to clusters or boundaries. Gyulai and Hartly (1928) did in fact point out that work hardening and dimensional change induced in a specimen subsequent to

a stress increase, continued for a time comparable to the decay time of the increased conductivity produced. It is reasonable to expect the duration of flow to be much shorter at the lower stresses used by Gyulai and Boros.

Seitz (1954) has stated that he believes the effect obtained at low applied stresses to be fundamentally different in nature from that at high stresses, when the crystal is deformed as much as 10% but gives no reasons for this conclusion.

1.5 THE PRESENT WORK

The immediate aim of the present work was to repeat the experiments of Gyulai and Hartly and other workers on the increase in conductivity of alkali halides upon mechanical deformation. It was planned to carry out the experiments using modern electronic techniques for the measurement of the small conductivities of ionic crystals and also better recording methods. It was hoped too to extend the scope of the experiments in many ways, by increasing the range of temperature and by the use of synthetic crystals of various alkali halides with differing impurity contents. Apparatus was therefore designed capable of growing single crystals of alkali halides both

pure and with known amounts of impurity.

During the course of the work on the conductivity increase upon mechanical deformation a new phenomenon was discovered - the appearance of a potential between the electrodes of a crystal upon mechanical deformation - and considerable time was then devoted to investigating this effect.

Single crystals of sodium chloride containing manganese were grown and a joint programme of experiments was carried out both at Durham and Newcastle. Conductivity measurements were made on specimens from these crystals in both the annealed and quenched state. The general conclusions from the whole programme of experiments are presented elsewhere but the results and discussion of the conductivity measurements are given here.

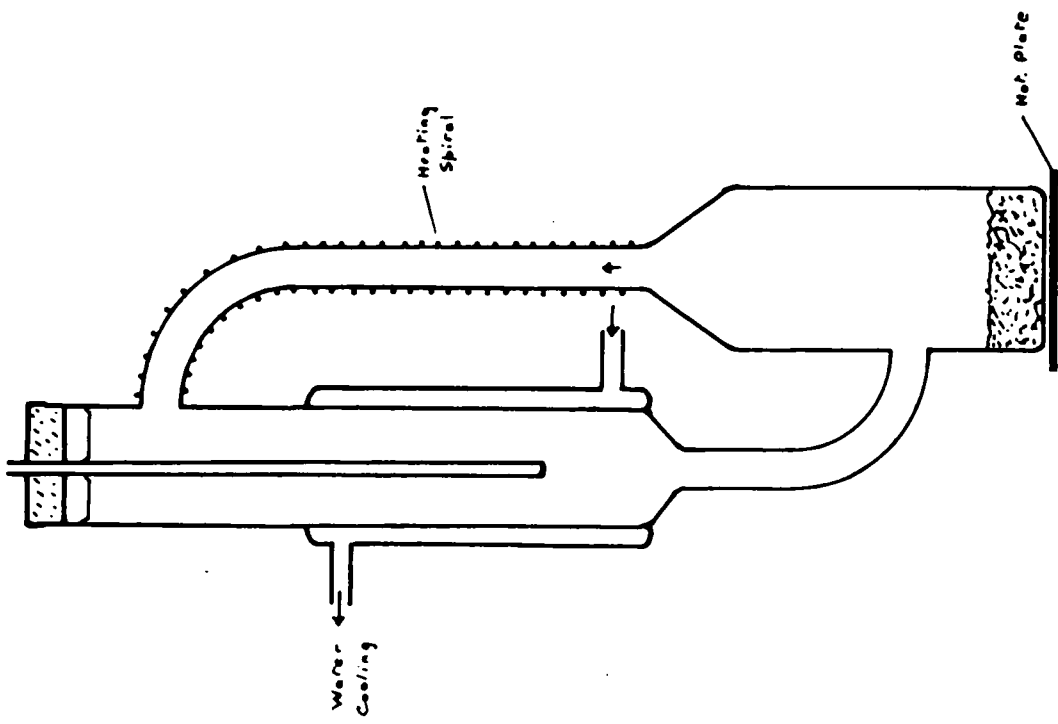

Figure 1 - The growth of single crystals from solution.

2. THE GROWTH OF SINGLE CRYSTALS OF THE ALKALI HALIDES

2.1 METHODS AVAILABLE

Three methods were available for the growth of single crystals of the alkali halides, growth from solution, by the Stöber (1925) process, and by the Kyropoulos (1926) process. (See also Menzies and Skinner 1949).

Some preliminary experiments were made to see if the growth of single crystals of sodium chloride from a solution in water was practicable. The apparatus used is shown in fig. 1. It was filled with a saturated solution of sodium chloride and excess salt was present in the vessel A, which was heated by a 60 W element under its flat base. The warm saturated liquid rose, its temperature being maintained by the heater B. On entering the vertical glass tube C, it cooled and in so doing deposited its excess salt on a seed crystal present at this point. The cool liquid fell into the vessel A where it was reheated and took up fresh salt, thus continuing the cycle.

The apparatus was run for periods of a week at a time and it was found possible to grow crystals up to a size of 3 mm cubes. Unfortunately it was not possible to obtain crystals of good quality, the major-

ity being "hoppers", in which the centres of the faces were indented in a step-wise manner. The method was therefore abandoned since it was too slow and produced crystals of poor size and quality.

It was decided to grow crystals from the melt, and the choice lay between the Kyropoulos process, in which the crystal is drawn from the melt, and the Stöber process. In this latter method, heating and cooling are applied to the material in such a way that isothermal planes move up through the material, which is at rest. The position of the isothermal corresponding to the temperature of solidification determines at any time the location of the solid-liquid boundary. Crystallisation begins when this isothermal surface reaches the lowest point of the vessel and then proceeds upwards through the melt.

In the Kyropoulos process a container holding the melt of the required material is maintained at a temperature some tens of degrees above the melting point. A seed crystal of the same material is allowed to dip into the melt. This seed is cooled by some means and crystallisation of the melt tends to take place on the seed following the same crystallographic orientation as the seed itself. The seed is then raised gradually,

keeping it at all times touching the melt, and a single crystal can be drawn out from the melt.

It was decided to try the Kyropoulos process since alkali halides had been extensively grown by this method in the past. It had the special advantage that, since it was desired to grow crystals of various alkali halides, with this process one could observe the growth, so that for a new substance one would quickly find the correct conditions for growth.

A description follows of the details of the apparatus that was constructed. Since no seed crystals were available in the first place they were grown by the original Kyropoulos method. Once seed crystals had been obtained by this method they were used to grow all further crystals, using the modification of the Kyropoulos technique devised by Korth (1933). Crystals, both pure and with added impurities, were grown from "Analar" sodium chloride. The description is given for this particular substance, but the method is quite general and the apparatus could be readily adapted for the growth of single crystals of other alkali halides.

2.2 THE FURNACES (See Walden 1939)

The furnace cores were made of "Thermal Alumina" and were cylindrical in shape, 5 in. internal diameter by 12 in. long. Cores of fireclay were also tried but proved to be rather unsatisfactory owing to the corrosive effect of sodium chloride vapour, which penetrated through the material and destroyed the heater windings.

The cores were wound with 60 ft. of 20 S.W.G. "Vacrom" (nickel-chromium alloy) wire. The windings were spaced so as to be slightly closer together near the ends of the core. This helped to give a uniform temperature within the core, and although full compensation was not achieved, the resulting temperature gradient was small enough to give satisfactory crystal growth. The ends of the winding were secured in the following way:- A short length (4 ft.) of resistance wire was wrapped round the end of the furnace core in a single loop. The two loose ends and the end of the furnace winding itself were then twisted into a triple strand which was used as the lead-out from the furnace. (See Walden 1939). This construction provided a firm anchoring point for the furnace winding at each end and, since the leads were now of triple thickness, they were prevented from being raised to red heat when the furnace

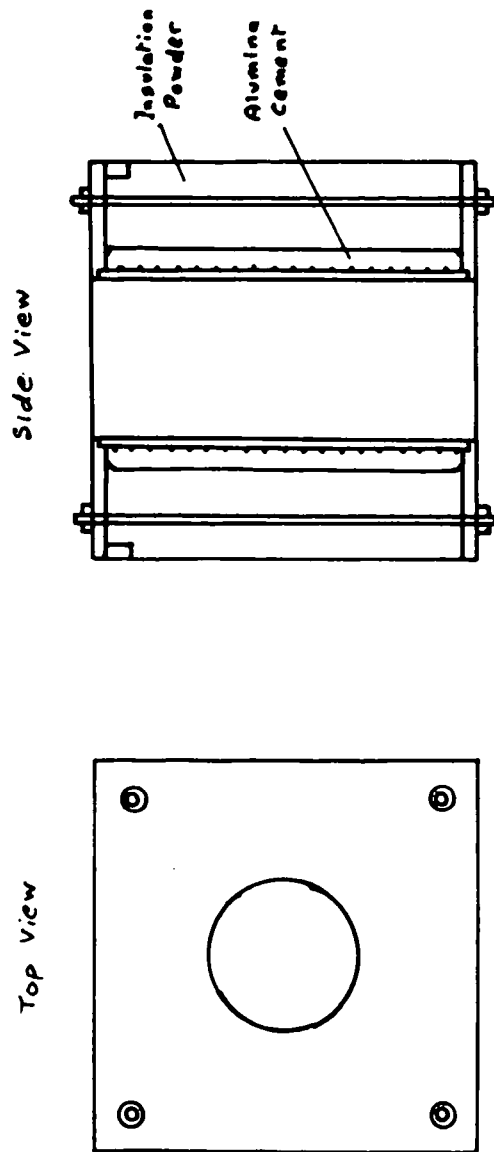

Figure 2 - The furnaces.

was in operation.

The furnace core was then soaked in water and the windings were plastered with a paste made by mixing C60 alumina cement with water. The cement was dried by leaving the core overnight with a low current (1 A) passing through the winding. The cement was then fired at high temperature, this being accomplished by a 24 h run of the completed furnace at a temperature of approximately 800°C .

The construction of the completed furnace is shown in fig. 2. It formed a cube with sides approx. 12 in. long. The top and bottom were made of "Sindanyo" asbestos compound sheet of $\frac{1}{2}$ in. thickness. Circular holes were cut in the centres and were rebated to $\frac{1}{4}$ in. to take the ends of the furnace cores. The sides of the furnaces were made of $\frac{3}{16}$ in. asbestos millboard and were bolted into the ends of the bottom sindanyo sheet, and also bolted to four sindanyo corner blocks at their upper ends. The space between the core and walls was filled with Newall's insulation powder (a form of diatomaceous earth). This very light earth required some time for insertion as it settled considerably on shaking the furnace. When full the top sheet was inserted

and was secured to the bottom sheet by four $\frac{1}{8}$ in. steel rods running vertically about $1\frac{1}{2}$ in. from the corners of the furnace.

The leads from the furnace were brought out through two small holes in one of the sides. It was found that the asbestos sides tended to buckle and crack in the course of time, especially at these holes, and it was later found necessary to use $3/16$ in. sindanyo sheets instead.

Covers of $\frac{1}{2}$ in. sindanyo sheet were used to close the upper end of the furnace. The lower end was closed by circular firebricks, $4\frac{3}{4}$ in. diameter and $1\frac{3}{4}$ in. thick. These bricks were constructed from Morgan Plastic Mouldable. This material was obtained in clay-like form and could be easily moulded when cold. It required drying above 100°C to remove the water content and then firing at red heat to consolidate the material.

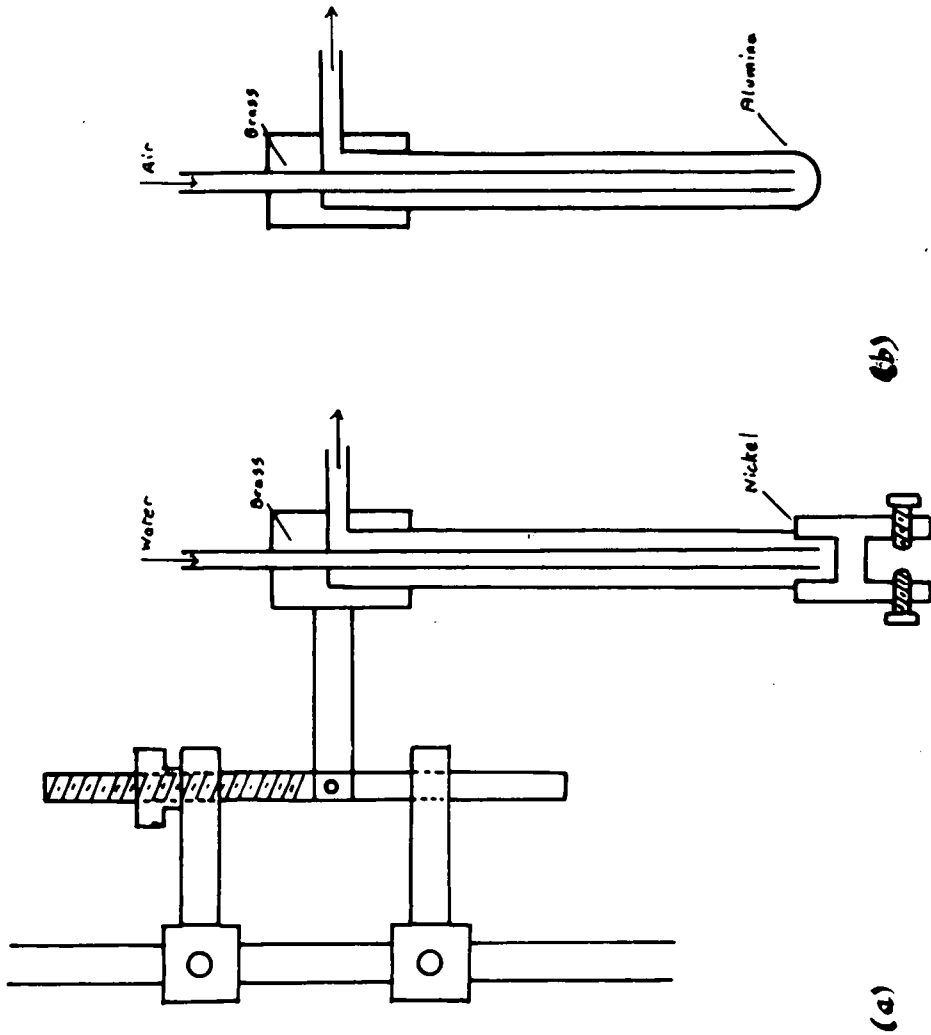

Figure 3 - The coolers.

2.3 THE COOLERS

The two types of cooler used are shown in fig. 3. The recrystallised alumina cooler used initially is shown in (a). It consisted of an alumina tube 12 in. long and 5 mm internal diameter with a wall thickness of $1\frac{1}{2}$ mm, and was rounded off at one end. It was mounted in a brass block by means of a grub screw and a narrow brass tube ran down it internally to within $\frac{1}{8}$ in. of the rounded end. Air could be blown down the central brass tube from a compressor, thus cooling the rounded tip and escaping to the atmosphere via the outer annular space.

The brass block was connected by copper strips to a steel rod of $\frac{3}{8}$ in. diameter, having a $\frac{3}{8}$ in. B.S.F. thread cut over 3 in. of its upper end. A heavy brass knurled nut ran on this thread and could be used to adjust the height of the cooler during the growing process. The whole assembly was mounted on a $\frac{1}{2}$ in. steel rod by two clamps and could be set at a convenient height at the start of the growing process.

Although the copper and brass parts of the cooling unit proved satisfactory, it was found that all the mild steel sections corroded badly under the action

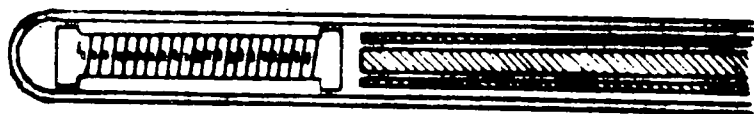

Figure 4 - The platinum resistance thermometer.

of the salt vapour and they were later replaced by sections in stainless steel.

The second cooling head is shown in fig. 3 (b). It consisted of a nickel tube (bore 8.5 mm and wall thickness 0.5 mm) and a nickel head which was brazed to this tube. The head had a cylindrical hole of diameter $\frac{3}{8}$ in. at its lower end and four nickel grub screws mounted at 90° to each other, so that a seed crystal of rectangular dimensions could be firmly held in it. This unit fitted into a brass block similar to that for the first unit and was brazed into the block. An inner brass tube was used as before but this time water cooling was employed. A stainless steel cooler was originally built, but it was found to corrode in the furnace, and was replaced by the nickel one described.

2.4 THE TEMPERATURE CONTROLLER

A platinum resistance thermometer was used to control the temperature of the "growing" furnace. It is shown in fig. 4. A piece of sindanyo sheet was turned down to a diameter of 4.5 mm and a thread $\frac{5}{1000}$ in. deep and 120 turns/in. was cut over a

length of about 5 cm. This was wound with 0.005 cm diameter platinum wire to give a resistance just over 100 ohms. The wire was then covered with a thin layer of a paste of alumina cement made by first sieving C60 alumina cement to a size of 60μ and then mixing with water. The cement was dried at 100°C in an oven and then fired at red heat in a furnace. The whole assembly was contained in a recrystallised alumina tube identical to that used for the air cooler. The leads were brought out by a twin bore tube of alumina of oval section which fitted inside the outer alumina sheath. The thermometer was suspended vertically inside the furnace so as to lie about $\frac{3}{4}$ in. from the furnace wall, with the element roughly mid-way down the core of the furnace.

The temperature controller (See Yates 1946) is shown in fig. 5. It consisted essentially of an a.c. bridge, two arms of which were formed by two windings of a transformer, and the others by a platinum resistance thermometer and a variable resistor, and a fixed resistor. Three sets of tapings of the transformer provided three sensitivity ranges. The out-of-balance signal was amplified by a high gain pentode using a small amount of negative feedback. The signal was

then limited by the double diode to a maximum of approx. 1.8 V; thus when the bridge was not near balance no damage occurred to the output valve or the thermal relay. The signal was applied to the control grid of an output pentode. A signal was fed to the screen grid of this valve from a 50 V winding on the bridge transformer. The output circuit of the pentode consisted of a 2.7:1 output transformer across the primary of which was connected a condenser of $0.25\mu\text{F}$ capacitance. This condenser, together with the primary of the transformer, formed a resonant circuit of low Q but with a resonant frequency close to 50c/s. The secondary of the transformer was connected to the hot-wire section of a Sunvic thermal relay. The a.c. potential on the screen grid was pre-set so that, when the control grid input was zero, the current through the relay was the triggering current (approx. 17 mA). In this way a small 50 c/s potential applied to the control grid of the pentode either increased or decreased the a.c. anode current, according to the phase of the applied potential. These changes were transferred to the secondary circuit of the transformer and made or broke the relay contacts. It was of course, necessary to obtain during the initial testing, the correct phase

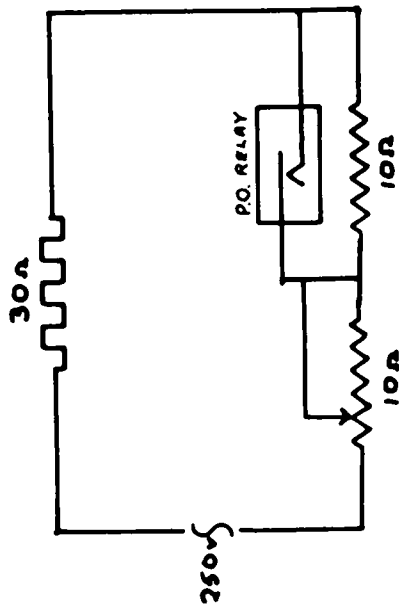

Figure 6 - The control circuit.

relationship between the output of the bridge and the auxiliary phasing 50 c/s potential. The power supplies were conventional and do not require further comment.

The current handling capacity of the thermal relay was rather too small (7 A) to control the furnace current directly, and so the thermal relay was used to control an auxiliary Post Office type relay with contacts suitable for making and breaking slightly larger currents. It was found that some "chattering" of the thermal relay tended to occur when the bridge was on the balance point. A $2\mu\text{F}$ condenser connected across the relay contacts helped to reduce the amount of this chatter passed to the P.O. type relay.

The control circuit is shown in fig. 6. Two 10 ohm rheostats with a maximum current capacity of 8.5 A were used in series with the furnace and the 250 V a.c. supply. One could be shorted out by the P.O. relay, and the other was pre-set so that the furnace temperature rose to just above the required operating temperature when the first rheostat was shorted out. When both rheostats were in circuit the temperature dropped to below the operating point.

The controller proved to be very reliable in practice and maintained the temperature to within 5°C about

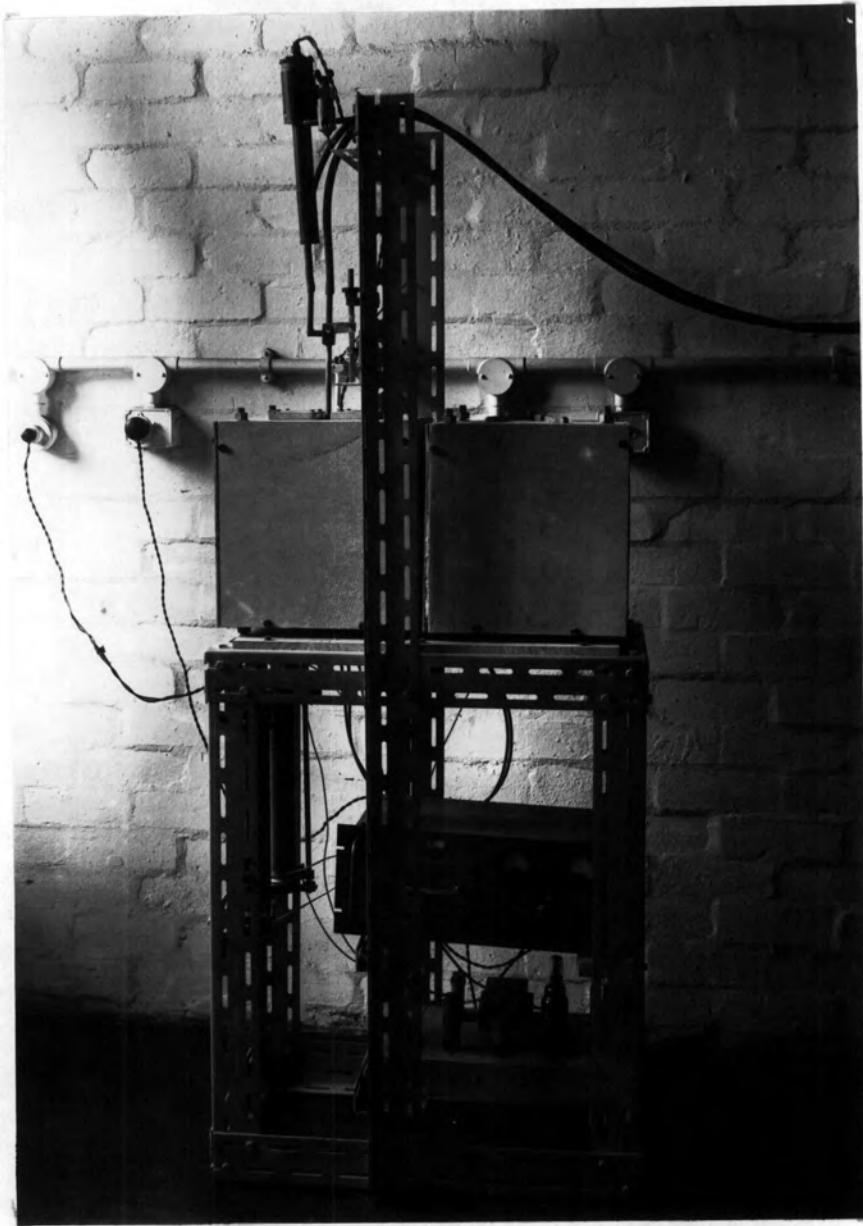

Figure 7 - The crystal growing unit.

any operating point when on the lowest sensitivity range. This proved to be quite acceptable for the growth of single crystals.

2.5 GENERAL ARRANGEMENT

Fig.7 is a photograph showing the general arrangement of the crystal growing unit. Two furnaces were mounted on a $\frac{1}{8}$ in. sindanyo sheet supported by "Dexion" (aluminium alloy) framework (27 x 15 x 33 in. - the latter measurement being the height). The framework extended over one furnace (the growing furnace) and carried the cooling mechanism. It also supported a galvanometer lamp, operating off the 12 V a.c. supply, and this served to illuminate the interior of the furnace so that the growing process could be easily observed. The second furnace was used to anneal crystals and was maintained at approx. 600°C by a fixed 10 ohm resistor in series with the furnace and mains supply.

The three controlling rheostats were mounted vertically at one side of the lowerhalf of the framework. The temperature controller was also mounted in the lower half of the framework so that the whole crystal growing unit was compact and readily portable.

Recrystallised alumina beakers were originally used

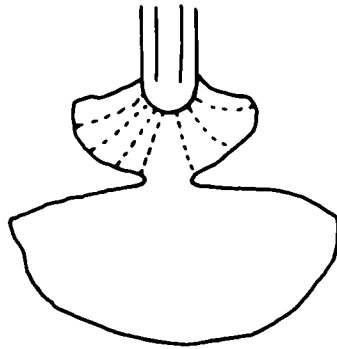

Figure 8 - Single crystal grown by the Kyropoulos process.

to hold the sodium chloride melt, since it was known that alumina was resistant to the corrosive effects of salt vapour. It was found however that these beakers had numerous tiny air holes in their walls as a result of the process of manufacture. These spherical cells filled with the melt and, if the wall was cooled, acted as centres from which cracks radiated to the surrounding part of the wall. Alumina beakers were expensive and were in no way superior to glazed porcelain beakers of 400 ml capacity which were subsequently used.

2.6 TECHNIQUE OF GROWTH

A beaker was filled with analar sodium chloride and was placed in the cold furnace. The furnace was brought up to a temperature about 50°C above the melting point. The alumina cooler was used and was lowered until it touched the surface of the melt. The air compressor was switched on and crystal deposition commenced on the tip of the cooler. The crystal growth was quite random, as shown in fig. 8, and in general, since there was no seeding, a mass of differently orientated crystals was formed. If the cooler

was now raised until only the lowest point of the crystal mass was in contact with the melt, there was a high probability that only a single crystal was in contact with the melt, and on further raising the cooler the single crystal which continued to grow at the solid/liquid interface was withdrawn. As the crystal increased in size it was necessary to lower the temperature of the furnace.

There was a limit to the size of crystal which could be grown by a given furnace and cooling system. A point was reached when the rate at which heat was being conducted away from the top of the crystal could not be made to exceed the rate at which heat was being supplied to it by the furnace, unless the melt temperature was allowed to fall too near to the freezing point. When this happened spontaneous crystallisation took place and the resulting growth was neither controllable nor did it produce a single crystal.

It was possible to produce single crystals of sodium chloride of hemispherical shape with a radius up to about 1.5 cm. These crystals were cleaved and used as seed crystals for the growth of further single crystals.

Sodium chloride crystals could now be grown using the water cooler. A single crystal was cut into a section approx. $2.0 \times 0.7 \times 0.7$ cm and was gripped in

the nickel chuck, the grub screws being tightened, taking care not to crack the crystal. With the melt temperature some 50°C above the melting point the seed was dipped into the melt, the rate of flow of the cooling water being adjusted so that the water just reached boiling point within the cooler. Under these conditions the crystal was "melted back", and this was allowed to continue until it was judged that a fresh crystal surface had been exposed to the melt. When this point was reached the rate of flow of the cooling water was increased, taking care to run it at such a rate that the temperature of the outer surface of the cooler was above the dew point of the atmosphere in order to avoid condensation of water which was liable to run down the surface of the cooler. The furnace temperature was also gradually reduced and the cooler raised as growth took place.

It was found that crystals some 4 cm in height by 3 cm diameter could be grown with lifting rates of the order of 1 cm per hour. As the crystal grew, the level of the melt surface fell, and thus in the latter stages of the growing process it was not necessary to raise the cooler as much as at the beginning of the growth.

If the temperature of the furnace was not symmetrical about the vertical axis, then the growing crystal tended to grow more rapidly on the side facing the coolest part of the furnace. This caused uneven growth and reduced the ultimate size of crystal which was obtained. Some trouble occurred in this respect and it was noticed that the firebricks forming the floor of the furnace were not concentric with the core, thus causing a greater cooling draught up one side.

Crystals were grown containing various impurities, namely lead, cadmium, copper and manganese. In the case of the first three, the appropriate chloride was mixed with sodium chloride in the cold. The mixture was then brought up to the melting point of sodium chloride in the furnace as usual. With manganese it was found that manganous chloride decomposed on heating before the sodium chloride melted and it was necessary to drop the required amount of cold powdered manganous chloride into the sodium chloride melt. Even so, some decomposition occurred and black manganese dioxide was formed.

When a crystal had been grown to the required size the cooler was raised and lifted out of the furnace.

The grub screws on the chuck were loosened and the crystal was transferred by means of tongs to the second furnace. The operation was performed fairly rapidly to prevent cooling and consequent cracking of the crystal. The second furnace had been switched on some time previously and was maintained at about 600°C .

Crystals were usually cooled down to room temperature overnight. The top of the annealing furnace was covered over completely, and the furnace was switched off and allowed to cool down on its own. This usually took about 12 h, and this rate of cooling was satisfactory in that it did not introduce appreciable strains into the crystals.

2.7 CLEAVAGE OF CRYSTALS

In order to prepare specimens for conductivity measurements and also for use as seed crystals it was necessary to cut the single crystals into sections with plane faces. This was most conveniently done by cleaving the crystals using an ordinary wood chisel and a wooden mallet. With some practice it was possible to split the crystals cleanly along the (100) planes, provided that they had been sufficiently

annealed and cooled slowly. For small specimens (say less than 1 cm square) it was more convenient to use a razor blade and the pressure of the hand to produce cleavage. In both methods it was absolutely necessary to have the cutting tool fairly accurately parallel to the cleavage plane before pressure was used, otherwise a shattered surface with many "steps" (i.e. discontinuities in planes of ions) was produced. With the razor blade method for small specimens steady pressure could be used for cleavage, but when using chisel and mallet it was important to employ a sharp tapping action if large crystals were to be cleaved cleanly.

It was found possible to polish crystal surfaces using a buffing wheel of cloth rotated at high speed and lubricated by a saturated solution of sodium chloride in water. The crystal was gripped on the bed of a milling machine and the buffing wheel mounted horizontally in the machine. By moving the bed of the mill in a horizontal direction it was possible to polish plane crystal surfaces normal to the axis of rotation of the buffing wheel. The method was not used extensively since clean flat surfaces were produced by cleavage. However the method would obviously be

valuable for polishing crystal surfaces other than the cleavage planes.

3. THE MEASUREMENT OF THE CONDUCTIVITY OF SINGLE CRYSTALS OF THE ALKALI HALIDES

3.1 INTRODUCTION

The problem was one of measuring small currents since a given voltage could be applied to the crystal and the resistance deduced by the application of Ohm's law. Unfortunately it was not possible to increase the sensitivity of measurement by the application of very large voltages, since it was known that the application of potentials over 300 V produces alkali metal dendrites within the crystal (See Joffé 1928). This is due to the deposition of the metallic element from the halide by electrolysis in the form of local deposits. At these points the field intensity is greater, resulting in further deposition at these places, and eventually dendritic bridges are formed from one electrode to the other. These bridges then carry the current and there is no further electrolysis.

The phenomenon of polarisation (Joffé 1928) has been observed in alkali halide crystals. If a potential E is applied to a crystal then instantaneously there flows a current I_0 . It is therefore possible to define an initial conductivity σ_0 given by $\sigma_0 = I_0 / E$. However

it is found that the current decreases from the initial value I_0 with time, ultimately reaching a steady value I .

It is now possible to define a permanent conductivity

$\sigma = I/E$. The decrease of conductivity is attributed to the build up of a polarisation potential P within the crystal.

Thus $\sigma_0 = I_0/E = I/(E - P)$. The quantity σ_0 has also been called the real conductivity.

For the measurement of the conductivity of the alkali halides at different temperatures it was desirable to construct a versatile apparatus capable of measuring conductivity currents having a very wide range of values. The specific resistance of a typical crystal could have values from 10^{15} to 10^8 ohm cm over the range of temperature from 0 - 400°C. Assuming that a potential of 100 V was to be applied to a specimen of 1 cm cube, the problem was one of measuring currents over a range from 10^{-13} - 10^{-6} A, and of measuring the conduction current over a period of time.

3.2 THE MEASUREMENT OF SMALL CURRENTS

The basic method of measurement (Manning and Bell 1940) is to place the specimen in the form of a plate or slab between two metal electrodes. One electrode,

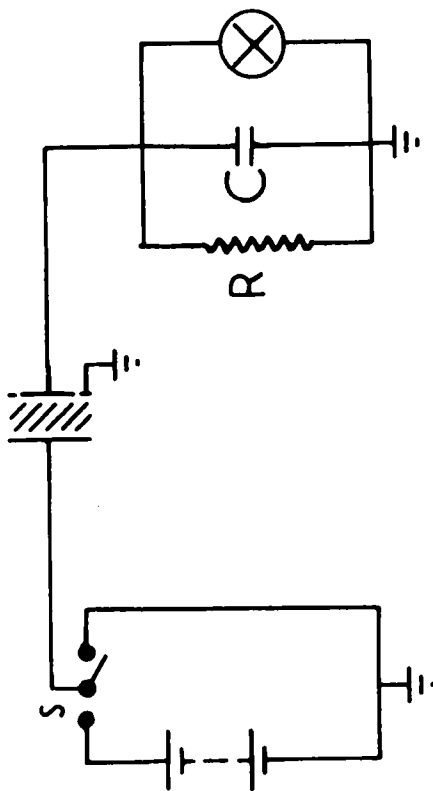

Figure 9 - Basic circuit for the measurement of small currents.

which is provided with a guard ring to eliminate surface conduction effects, is connected through an arrangement of shunts and capacitances to earth. The current through the specimen may be measured either by the potential drop through a standard resistance or by the time required to charge a condenser of known capacitance to a given potential. The potential drop can be measured by an electrometer or by an electrometer valve. The other electrode is connected to a source of constant potential of known value, the other pole of which is connected to earth. A switch is provided in order that the specimen may be discharge when desired. The circuit is shown in fig.9.

For measuring relatively high currents the resistance method is used. The current I produces a potential drop IR which is measured by the electrometer. If the current is very small, so that a measurable potential drop is not produced across available standard resistances (up to 10^{12} ohms), a small high quality condenser may be charged and the time rate of increase of this potential measured. The current is then equal to $C \cdot dV/dt$, where C includes the capacitance of the leads and electrometer as well as that

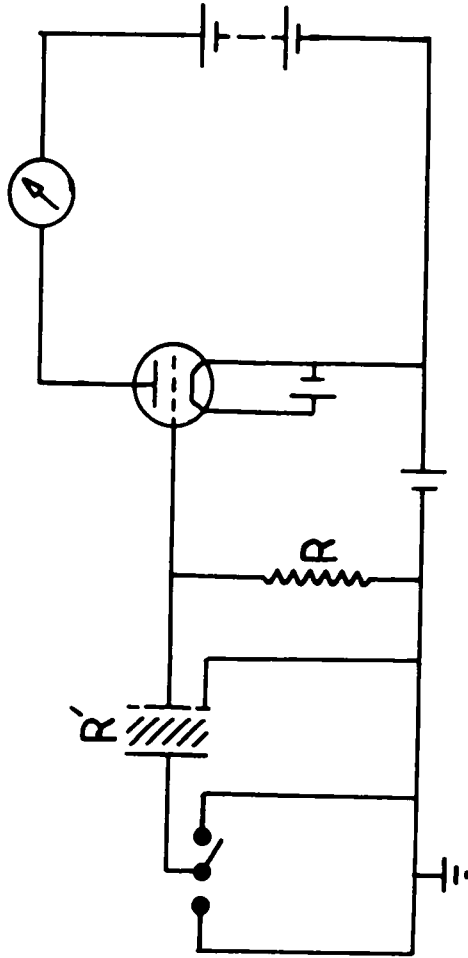

Figure 10 - Basic electrometer valve circuit.

of the condenser itself.

Various types of electrometer have been used in the past for this work. They suffer from two disadvantages however - the slow response of the instrument and also, since a null-balancing method is usually adopted, the manual effort required to apply the balancing e.m.f. Both objections are serious if it is desired to measure the conduction current at short time intervals after closing the circuit.

Electrometer valves have been developed by various manufacturers in which the grid current has been reduced to as low as 10^{-15} A. A simple circuit for such a valve is shown in fig.10. It may easily be shown that the application of a potential E at a time $t = 0$ causes the formation of a charge Q on the grid of the valve (assuming that the grid current of the valve is negligible) given by

$$Q = \frac{ER'C}{(R+R')} \left(1 - \exp\left(-\frac{(R+R')t}{RR'C}\right) \right)$$

where R is the grid leak resistor, R' is the resistance of the specimen to be measured and C is the capacitance of the valve (grid-cathode) together with stray capacitances.

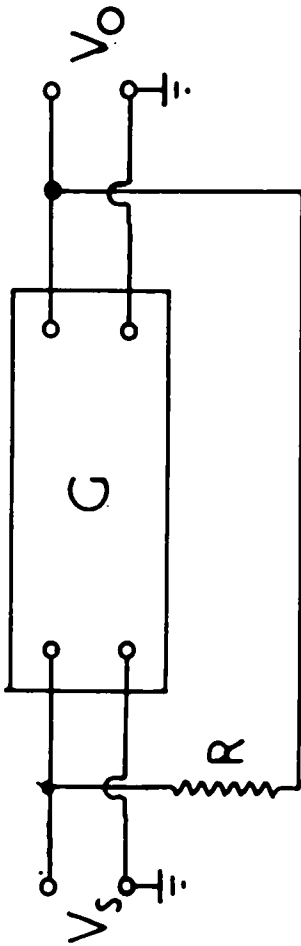

Figure 11 - The negative feedback amplifier.

The circuit thus has a time constant given by $RR'C/(R + R')$, and since in normal use $R' \gg R$, the time constant = RC . The maximum value of R likely to be used is 10^{11} ohm, and C may be 10 pF so that the time constant is a maximum of 1 sec compared to the 10 sec or more of the electrometer.

In the simplest circuit for an electrometer valve the change in anode current is used to indicate a change in grid voltage. Such an arrangement suffers from instability, nonlinearity and low amplification. Various circuits (see Peniek 1935) have been described using one valve and employing a resistance network to compensate for changes in battery voltage and valve characteristics, which are the most prominent causes of these defects. Such circuits are however tedious to balance and are not readily adapted to measuring rapidly varying currents.

The application of negative feedback to an amplifier has interesting consequences (Vance 1936), and the circuit for such an amplifier is given in fig. 11. The first stage of the amplifier can be formed by an electrometer valve. Let the total gain of the amplifier (including electrometer stage) be G . The current I to

be measured produces a potential drop V_1 across the resistor R , so that $V_1 = I.R$. If the potential appearing at the output terminals of the amplifier is V_0 , then owing to the negative feedback, the signal potential V_s at the input is given by

$$V_s = V_1 - V_0,$$

but $V_0 = G.V_s$,

therefore $V_0 = V_1 \cdot G / (G + 1)$.

By making G large V_0 can be made very nearly equal to V_1 .

The response of the circuit is linear if the input resistor R obeys Ohm's law. Furthermore changes of G due to non-linearity of the amplifier, or due to changes in the amplifier characteristics with time, will have a negligible effect on V_0 provided G remains large.

For the ordinary electrometer circuit the time constant is RC . In the feedback amplifier the potential of the input circuit only changes by V_s which is V_0/G . This is equivalent to decreasing the input resistance and hence the time constant is reduced by $1/G$. The time constant will therefore be RC/G , which is much smaller than for an ordinary electrometer or electrometer valve circuit (see sec. 3.6).

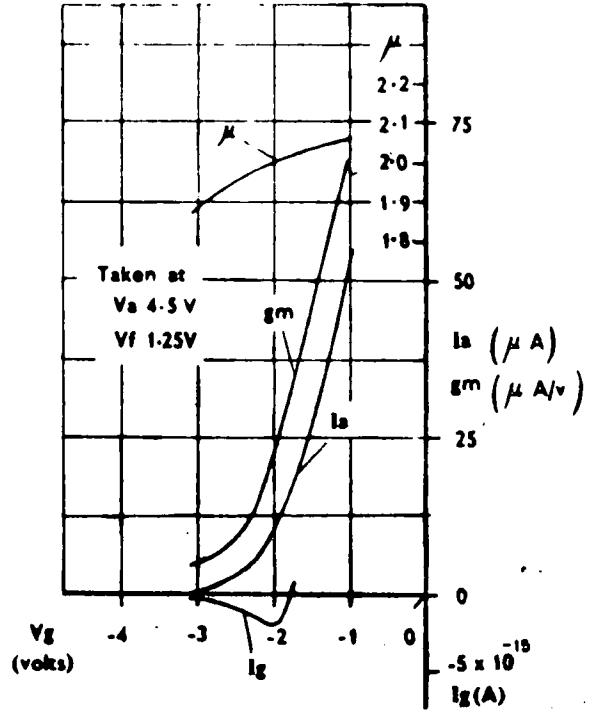
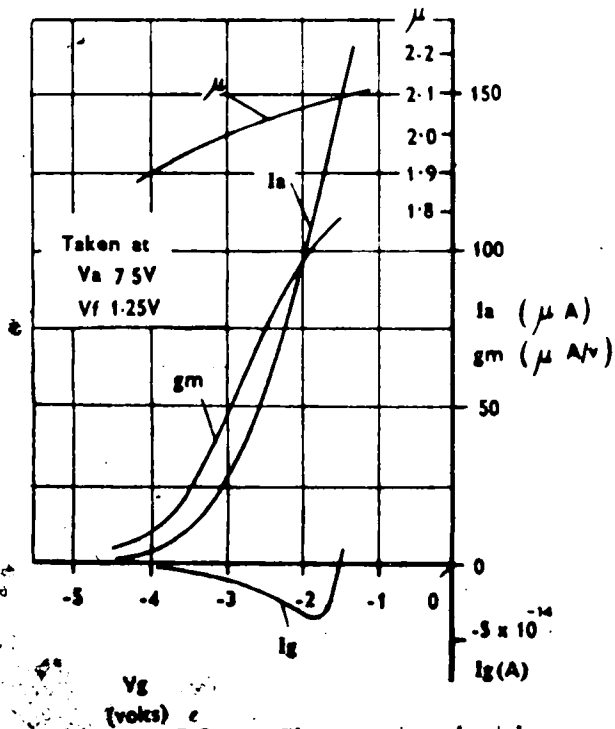
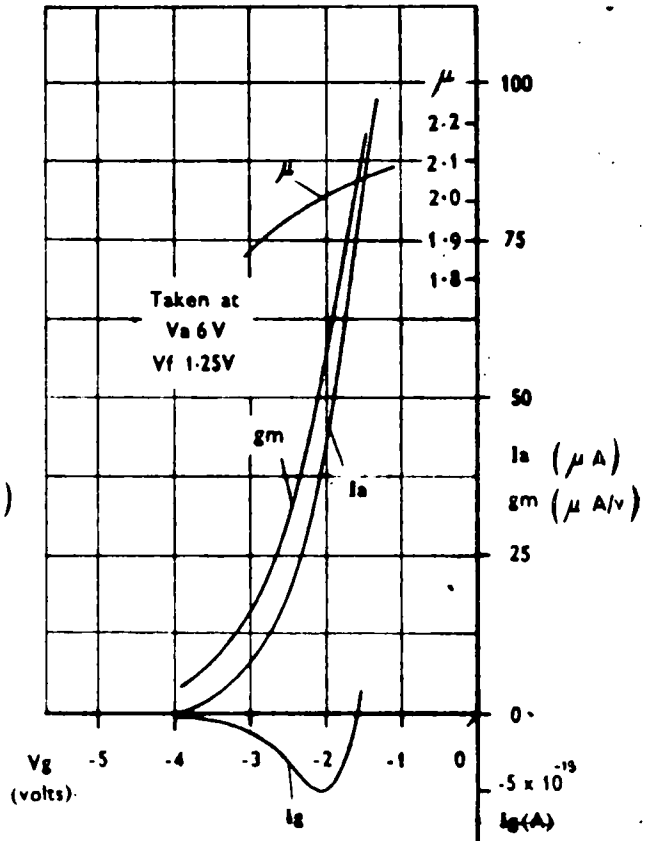
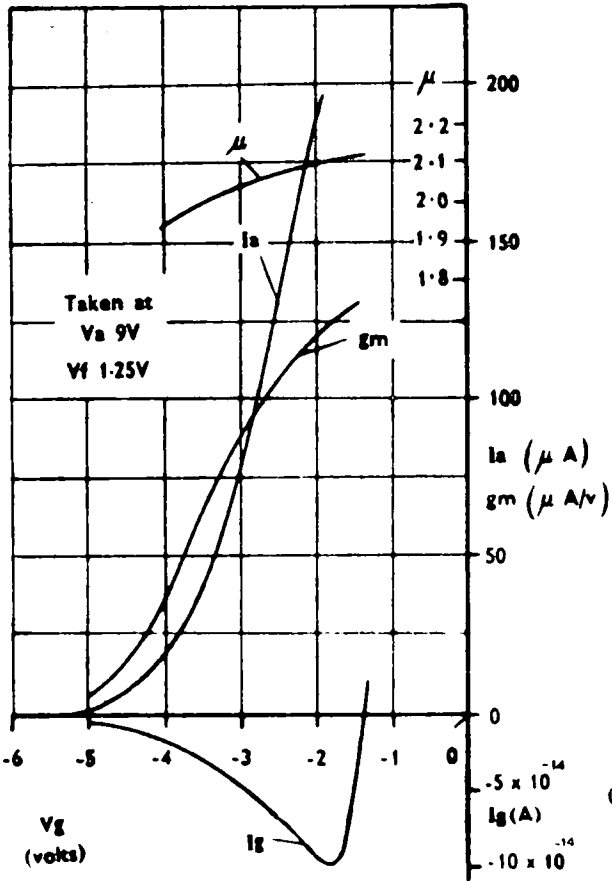

Figure 12 - Characteristic curves for Hivac XE2.

There are two other advantages of the negative feedback amplifier. The power output can be made large enough to operate a recorder, and it is possible to use a guard ring in the electrometer circuit effectively since the difference of potential from earth is only V_1/G .

3.3 THE ELECTROMETER VALVES

In choosing a suitable electrometer valve for the practical circuit it was decided to try to obtain one having a grid current not larger than 10^{-15} A. An Osram ETL electrometer triode was selected for use in preliminary work. It suffered however from various disadvantages:-

1. Its amplification factor was very low (2/7). 2.
- In the particular valve tested, the grid current was as much as 100 times greater than the makers average value. It appeared to vary considerably with time in a random manner, and suggested a certain amount of unreliability in the valve. 3. The valve was of large size.

A Hivac XE2 sub-miniature triode was then tested and subsequently it proved to be very satisfactory. The makers characteristic curves are shown in fig.12. It was decided to use the operating point $V_a = 6$ V and

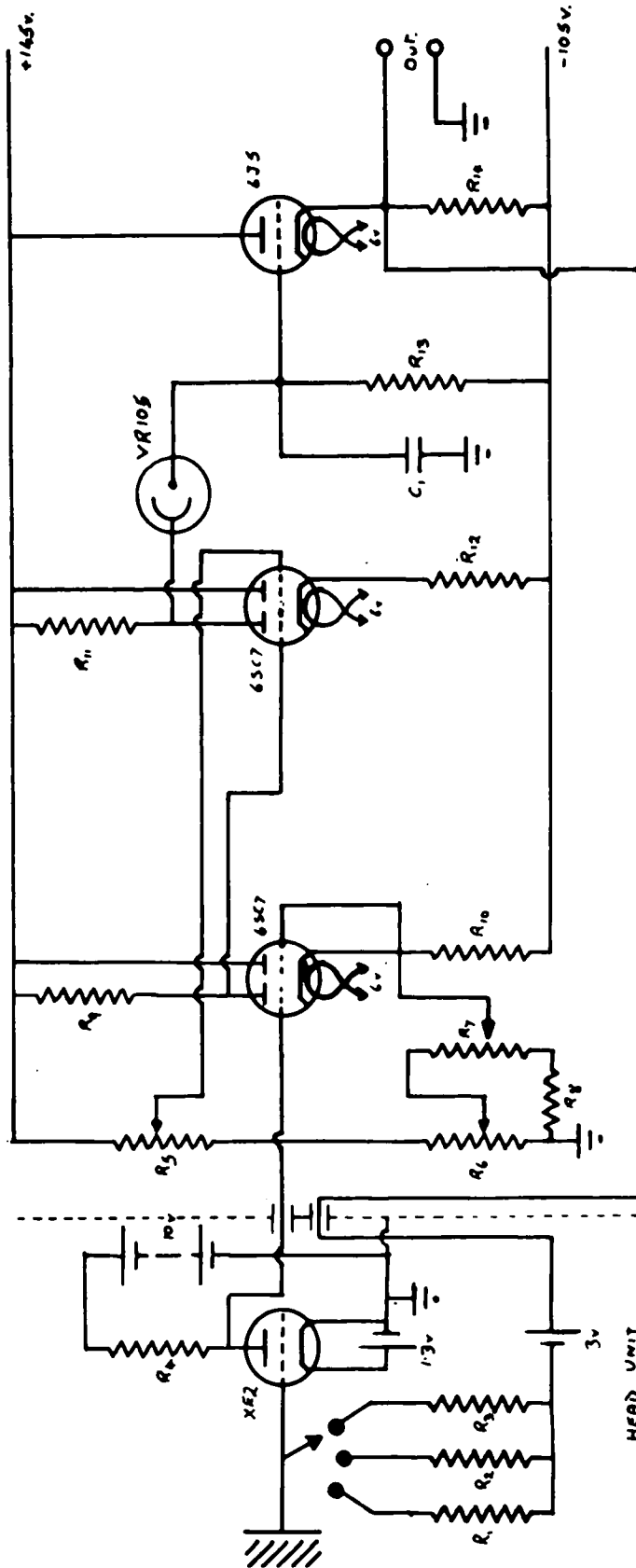

- R₁ 10⁶ Ω
- R₂ 10⁶ Ω
- R₃ 10⁶ Ω
- R₄ 500K Ω
- R₅ 25K Ω
- R₆ 5K Ω
- R₇ 10K Ω
- R₈ 20K Ω
- R₉ 500K Ω
- R₁₀ 300K Ω
- R₁₁ 250K Ω
- R₁₂ 200K Ω
- R₁₃ 2 MΩ
- R₁₄ 30K Ω
- C₁ .05 μF

Figure 13 - The d.c. amplifier.

$V_g = -3$ V, and the anode current under these conditions is 8μ A. An estimate of grid current was made by observing the rate of drift of grid potential about -3 V and was found to be about 5×10^{-15} A. The amplification factor is 1.9 under these operating conditions and is reduced to 1.7 by the use of an anode load resistor of 0.5 Megohm.

3.4 THE FEEDBACK AMPLIFIER

A diagram of the amplifier is shown in fig. 13. The description may conveniently be divided into three parts. (a) The head unit. This consisted of an aluminium box 7 x 5 x 3 in., containing an inner brass cylinder in which was suspended the electrometer valve by its four lead-in wires. The lead to the grid was brought into the aluminium box through the centre of a polished polystyrene insulator $1\frac{1}{2}$ in. in diameter and 1 in. thick, in order to maintain a leakage resistance greater than 10^{13} ohm. The box also contained a selection of grid leak resistances (Welwyn pyromatic type) from 10^9 - 10^{11} ohms, two dry cells (U2) to provide -3 V grid bias, and the anode load resistor R (wirewound).

The values of the grid leak resistances were

accurately determined by charging a small high quality condenser to a known potential and observing the rate at which its charge leaked away when a resistance was connected across it. A sensitive ballistic galvanometer was used to measure the charge on the condenser at any time. If Q_0 is the initial charge on the condenser C and Q the charge left at any time t , then $Q/Q_0 = \exp(-t/RC)$, where R is the value of the leakage resistance.

The anode potential was provided by a battery consisting of five lead acid cells of 3 ampere hours capacity. The heater current was supplied by a small "Nife" cell. This cell had an e.m.f. of just over 1.25 V and could be used to heat the filament of the valve directly. The heater and h.t. supplied were brought to the valve using a twin core screened cable - the screening being used as the earth line. (b) The amplifier (see Graham, Harkness & Thode 1947) The head unit was connected by a screened cable to the main body of the amplifier, which consisted of two stages of amplification provided by double triodes connected "cathode coupled". This arrangement gave maximum stability and freedom from drift. The amplification of each valve was just over 20, and since the electrometer valve had

a gain of nearly 2, the whole amplifier had a gain of roughly 800. The two stage amplifier was connected to the final stage through a VR 105 voltage regulator tube which functioned satisfactorily as a voltage dropping device with a current of a few μ A. The final stage was a cathode follower giving a low impedance output and restoring the signal to the correct phase for negative feedback via the grid leak resistor to the grid of the electrometer valve.

The heaters of the valves in the amplifier were supplied by three 2 V, 80 ampere hour accumulators in series, in order to avoid a.c. pickup from the heaters and also to ensure high stability. The high tension supply at 250 V was obtained from a stabilised power pack.

All the resistors in the amplifier, with the exception of R_{13} , were wirewound to give greater stability and freedom from drift. Those in the anode leads of the valves were Muirhead precision wirewound resistors. All the variable resistors were Colvern 4 watt wirewound types, with the exception of R_7 which was a Berco 7 watt wirewound potentiometer.

The lowest value of the capacitance of C_1 was rather critical. Obviously the size of this conden-

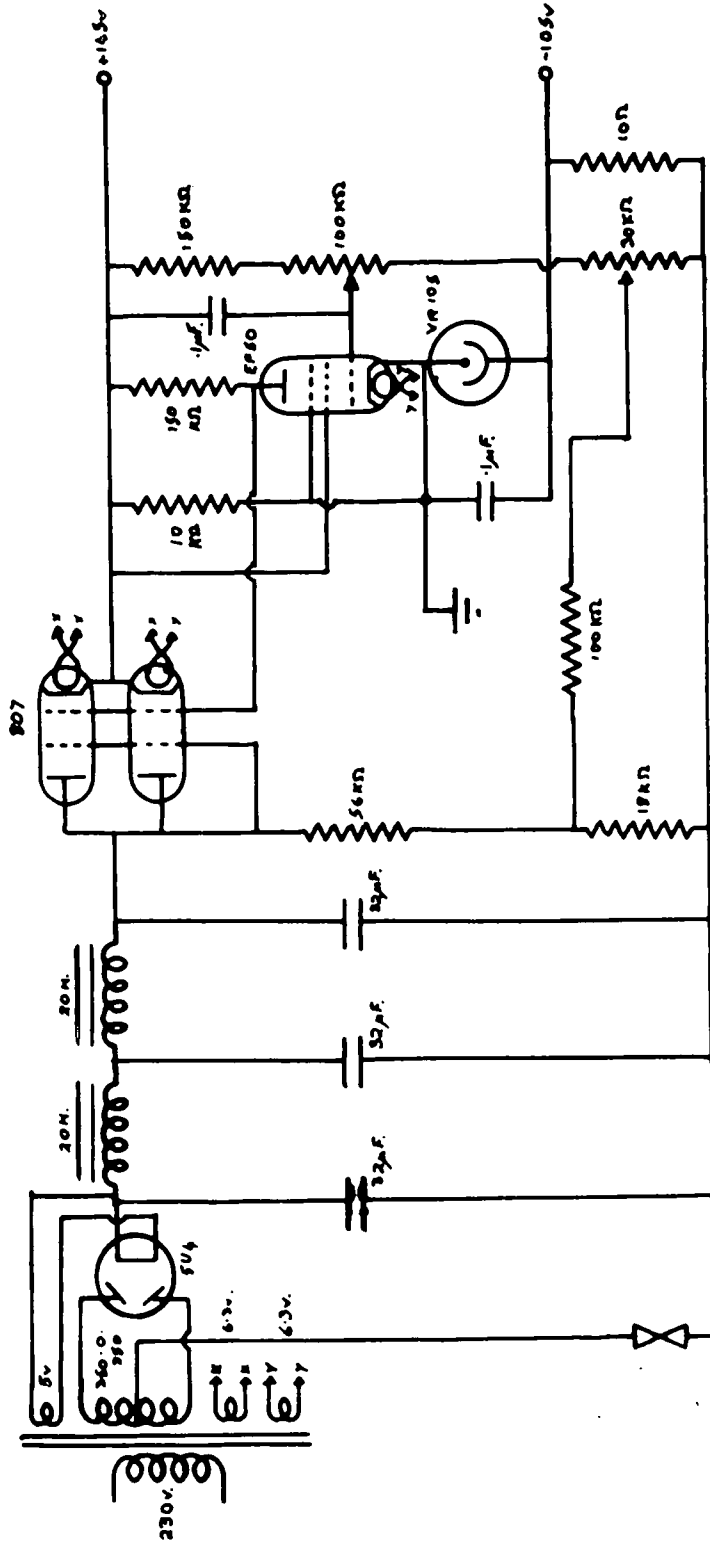

Figure 14 - The stabilised power supply.

ser limited the response of the amplifier to a.c. inputs since it shunted R_{13} . On the other hand the amplifier tended to oscillate if this condenser was below a certain value - this was found to be 0.05

μF , and meant that the amplification differed by 3% from one at 50 c/s. This was not serious since the frequency response of the amplifier was mainly limited by virtue of the fact that the grid leaks had impedances at quite low frequencies which were much smaller than their d.c. resistances.

R_7 and R_6 were the fine and coarse zero controls respectively, and were adjusted to give zero output from the cathode follower with zero input to the grid of the electrometer valve. The tapping on R_5 was adjusted to be about 40 V positive with respect to earth.

(c) The power pack. The stabilised h.t. supply is shown in fig. 14. It consisted of a conventional double diode rectifier giving about 500 V d.c. and a "series parallel" electronic stabiliser giving a supply of 30 mA at 250 V.

Any fluctuation in the voltage at the point A was fed by means of the resistance network to the grid of

the amplifier pentode EF 50. This altered the anode current of this valve and changed the potential drop across the anode load resistor. The grid potential applied to the 807 valves changed and altered the impedance of these valves in the appropriate sense so that the fluctuation in the potential at the point A was not passed into the output line. In a similar way, due to increase of potential across the 10 ohm resistor, changes in current drawn by the load were prevented from affecting the output voltage of the stabiliser. The voltage regulator tube VR 105 served to keep the cathode of the EF 50 at a constant reference potential with respect to the negative line. It tended to show jumps in operating voltage during use, but the effects on the stability of the amplifier were not serious. The output at 250 V had a ripple of 5 mV r.m.s. and was stable over a 10% change of input voltage.

The drift of the amplifier over short periods was quite low, usually better than 10 mV. It was necessary to wait about $\frac{1}{2}$ - 1 hour for the amplifier to warm up and for the drift to settle down. The noise level was quite reasonable - about 5 mV with a

10^{11} ohm resistor in the input (the greater proportion of this noise being accounted for by the shot noise of the grid leak resistor itself) and somewhat less with smaller grid leak resistors - this being low compared to the smallest signal that had to be handled in conductivity measurements.

3.5 VOLTAGE AMPLIFICATION

Since the output of the feedback amplifier was equal to the input (in fact it may very properly be called an impedance convertor, it was necessary to amplify the signal considerably in order to display the output on a cathode ray tube.

An amplifier was built following the circuit given by Goodwin (1941). It had three stages, the first two being push-pull stages incorporating a variable amount of negative feedback between them. The last stage was a push-pull output capable of giving a voltage swing up to 200 V. The power unit gave a 400 V stabilised d.c. supply for the h.t. of the second and third stages. The h.t. of the first stage was provided by two 90 V dry batteries. The heaters of the first two stages were supplied by high capacity accumulators, and the last stage by a winding on the mains transformer

of the power pack. Since this was operated from a constant voltage transformer, the heater voltage was fairly stable. The whole amplifier had a gain of over a million without feedback, but normally negative feedback was employed to reduce the gain to the required value.

It was intended to couple the amplifier to the impedance convertor and display the output on a cathode ray tube. However after the amplifier had been built a Furzehill 1684D*2 cathode ray oscilloscope became available. Since this incorporated a three stage d.c. amplifier with cathode coupled valves in each stage, giving a maximum sensitivity of 1.5 mm/mV at the screen, it could be used directly to display the output signal of the impedance convertor and the voltage amplifier that had already been built was not used in further work.

3.6 TESTING OF THE RESPONSE TIME OF THE AMPLIFIER.

A check on the response time of the amplifier was made in the following way. The grid of the electrometer valve was connected to the lower brass electrode and this was surrounded by the heating coil (see sec. 4.4). No crystal was, however, placed on the electrode. It was found on switching on the heating coil

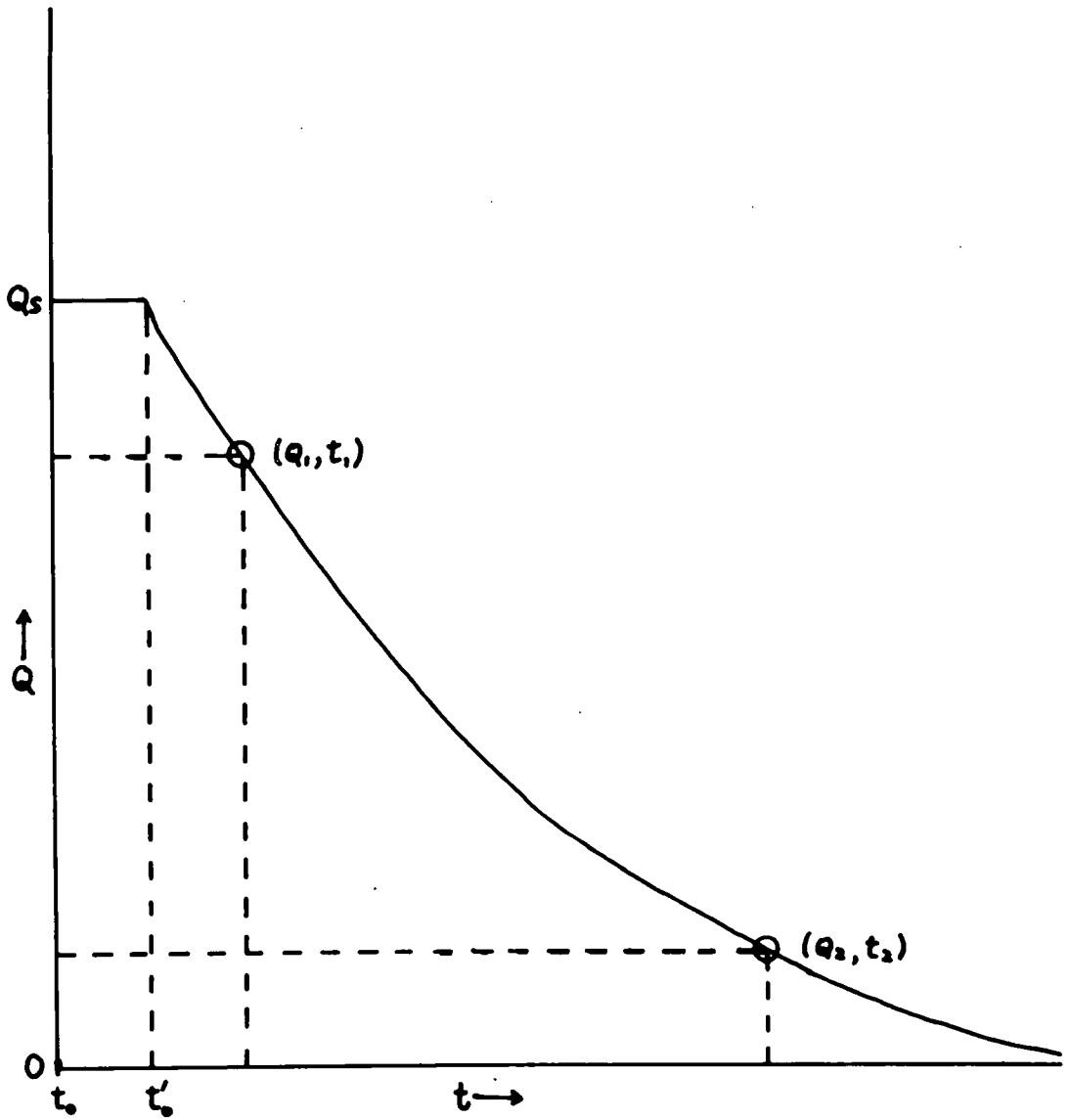

Figure 15 - Exponential decay curve.

that a large electric charge was picked up by the electrometer valve and this saturated the amplifier. On switching off the heating coil this charge decayed to zero and the rate of this decay was taken as a measure of the response time of the amplifier. A photograph was taken of the decay curve as shown on the screen of the oscilloscope.

Consider the decay curve shown in fig. 15. At the time t_0 the amplifier is saturated and the charge on the grid of the electrometer valve is represented by Q_0 . The heating coil is switched off at this point but the amplifier remains saturated until the time t'_0 is reached. The decay curve now become evident on the oscilloscope screen, ultimately reaching the point $Q = 0$ at the time $t = \infty$. We can measure a series of points (Q_1, t_1) , (Q_2, t_2) , etc. although it is necessary to take an arbitrary zero for t . The zero for Q is known since it is given by the zero trace on the screen, i.e. after a large time t has elapsed. Let us assume that the curve is given by the equation.

$$Q = Q_0 \exp(-t/T)$$

Then the points (Q_1, t_1) , (Q_2, t_2) etc are given by

$$Q_1 = Q_0 \exp(-t_1/T)$$

$$Q_2 = Q_0 \exp(-t_2/T)$$

Therefore $(t_2 - t_1)/T = \log_e (Q_1/Q_2)$

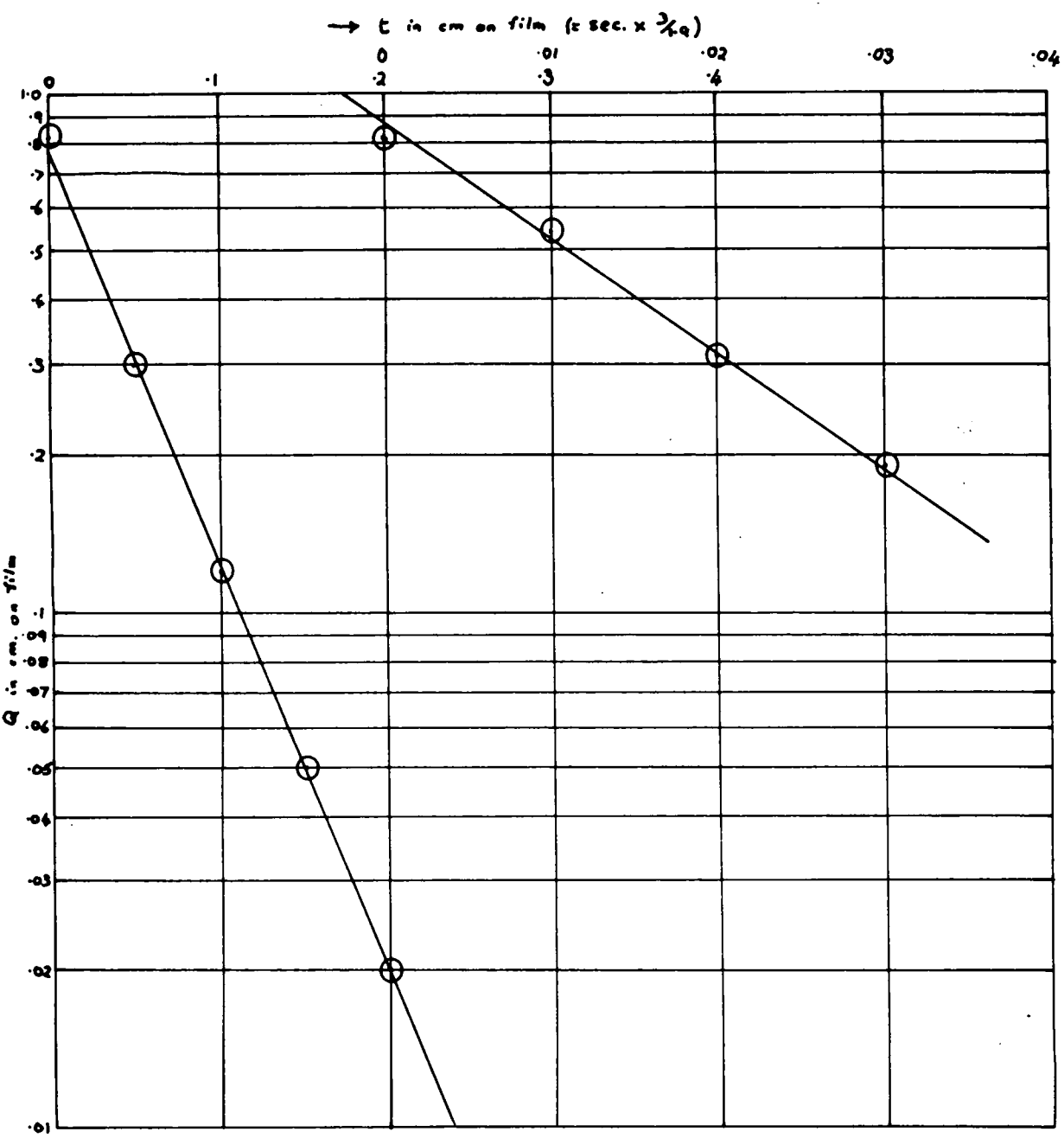

Figure 16 - $(\log Q, t)$ curves for the response time of the amplifier.

It will be noticed in this equation that the only values of t required are their differences ($t_2 - t_1$), although the absolute values of Q are needed. If a graph of Q against t is plotted on logarithmic graph paper the time constant T can be calculated from the slope of the graph (which should be a straight line).

A number of films of the decay curve were taken for various values of the grid leak in the electrometer valve circuit. The curves were measured up using a travelling microscope and (Q, t) curves were plotted and are shown in fig. 16. The points formed approximately a straight line and the time constants of the circuit were found to be 0.087 sec for the 10^{11} ohm grid leak, and 0.031 sec for the 10^{10} ohm grid leak. The decay curve for the 10^9 ohm grid leak was too steep to be measured up accurately on the travelling microscope.

3.7 THE SWITCHING CIRCUIT

The speed of the time base of the Furzehill C.R.O. could be reduced by the addition of external condensers and appeared to provide an excellent means of observing the form of the polarisation curve of alkali halide crystals.

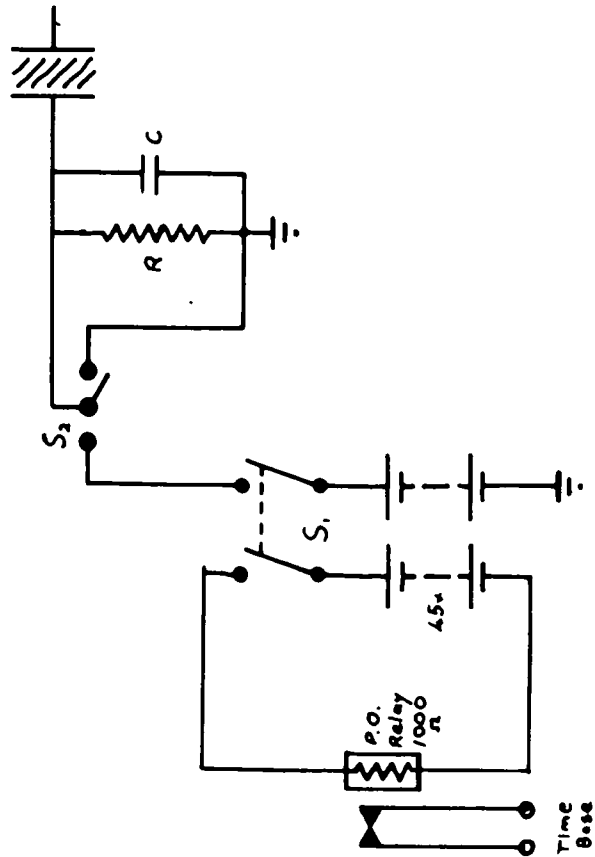

Figure 17 - The input switching circuit.

The input switching circuit is shown in fig. 17. The switch S_2 was spring loaded and normally connected the crystal to S_1 , but it could be used to earth the crystal if necessary. The crystal was always connected to earth via the 0.1 Megohm resistance, this resistance being chosen as the lowest that did not draw appreciable current from the h.t. battery. S_2 was a double pole switch and when used to apply a potential to the crystal also broke the contacts of the Post Office type relay. The C.R.O. was connected in the single sweep position and breaking these contacts started the sweep of the spot across the screen. The 0.001 μ F condenser was added since it was found that an inductive surge was shown on the C.R.O. when the potential was applied, and a condenser of this size appeared to reduce the transient surge considerably.

Provision was made to photograph the trace on the screen. An Avimo 35 mm oscilloscope camera was used together with Ilford 5B52 film. The screen was a blue photograph type with a 1 μ sec afterglow and the photography of transients with times down to 1/100 sec was quite easy. Unfortunately it was not possible to record polarisation curves lasting longer than 10 sec,

since this was the largest convenient sweep that could be used on the C.R.O.

3.8 THE CATHODE FOLLOWER

It has been mentioned that the impedance converter tended to oscillate without the presence of the condenser C_1 . When it had the value $0.05 \mu F$ it suppressed oscillation with grid leaks from 10^{11} - 10^9 ohms. However when using grid leaks below 10^9 ohms in value, it was found that a much higher value of C_1 had to be used to prevent oscillation, thus cutting very severely the response of the amplifier at low frequencies. It was decided therefore to build a separate unit to measure the conductivity of crystals requiring grid leaks of 10^8 ohms or less for the determination of their conductivity.

Some preliminary experiments were carried out with a view to using a Mullard EF 37A high gain pentode as an electrometer valve when operated with reduced potentials on its anode and heater. When the valve was operated as a triode with 90 V on the anode and 4.5 V instead of the usual 6.3 V on the heater, grid currents of as low as 10^{-12} A could be obtained at a grid voltage of -3 V.

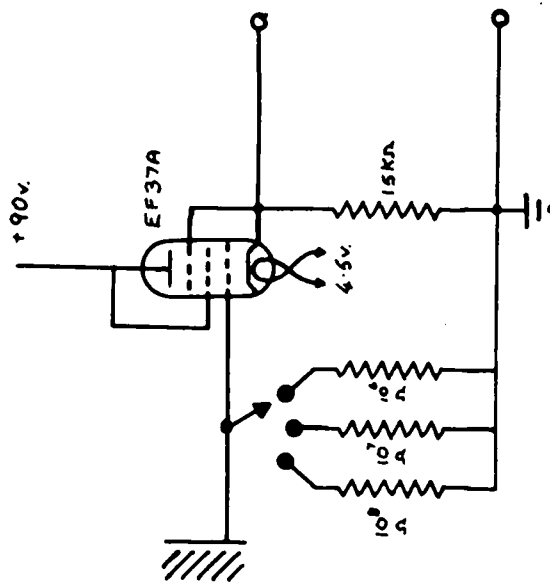

Figure 18 - The cathode follower.

A simple cathode follower circuit was constructed as shown in fig. 18. It was mounted in an aluminium box exactly similar to that used for the head unit of the impedance convertor. The h.t. was supplied by a 90 V battery, and the heater supply from three 80 ampere hour accumulators using a dropping resistor to give only 4.5 V across the valve. Three grid leaks, 10^8 , 10^7 and 10^6 ohms were used.

The time constant of the input circuit is again given by RC , where R is the value of the grid leak and C is the input capacitance of the electrometer valve. For a cathode follower it can be shown that the input capacitance C_{in} is given by $C_{in} = C_{gp} + (1 - A) \cdot C_{gk}$, where A is the amplification and the other symbols have their usual meaning. For the EF 37A, $C_{in} = 0.02 + 0.1 \times 6 = 0.62$ pF. If the stray capacitance of the grid lead is added to this it is evident that the time constant is less than 1/1000 sec even for the largest grid leak employed.

The gain was approximately 0.9, and was found to be linear over signal inputs of ± 2 V. The output signal was fed directly to the amplifier of the C.R.O. and the trace on the screen was brought back to zero,

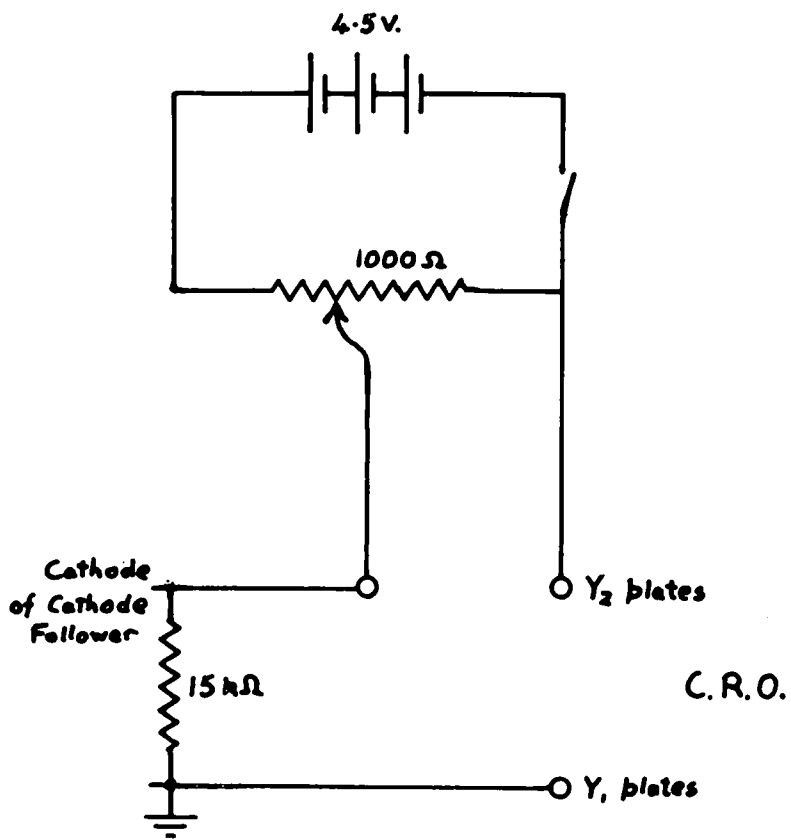

Figure 19 - The backing off circuit.

for zero input to the cathode follower, using the vertical deflection control on the oscilloscope. The unit was calibrated directly by applying known voltage inputs to the grid of the valve and observing the deflection of the trace on the C.R.O.

Although in general the vertical deflection control on the oscilloscope could be used to zero the trace on the screen, it was found that with the highest sensitivity range of the amplifier in the oscilloscope in use, the output from the amplifier was too great to allow the vertical deflection control to bring the trace back on to the screen again. It was therefore decided to build some form of "backing off" circuit to reduce the output from the cathode follower to zero for zero input. The circuit is shown in fig. 19. The battery consisted of three dry cells (U2) in series across a 1000 ohm wirewound variable resistance. Since there was a potential of 4.5 volts across the resistance it was possible to tap off any potential from zero to this value by suitable adjustment of the tapping point. This steady voltage tapped off was connected in series with one of the leads from the cathode follower to the input of the amplifier of the oscilloscope and, provided that it was connected in the right sense, it

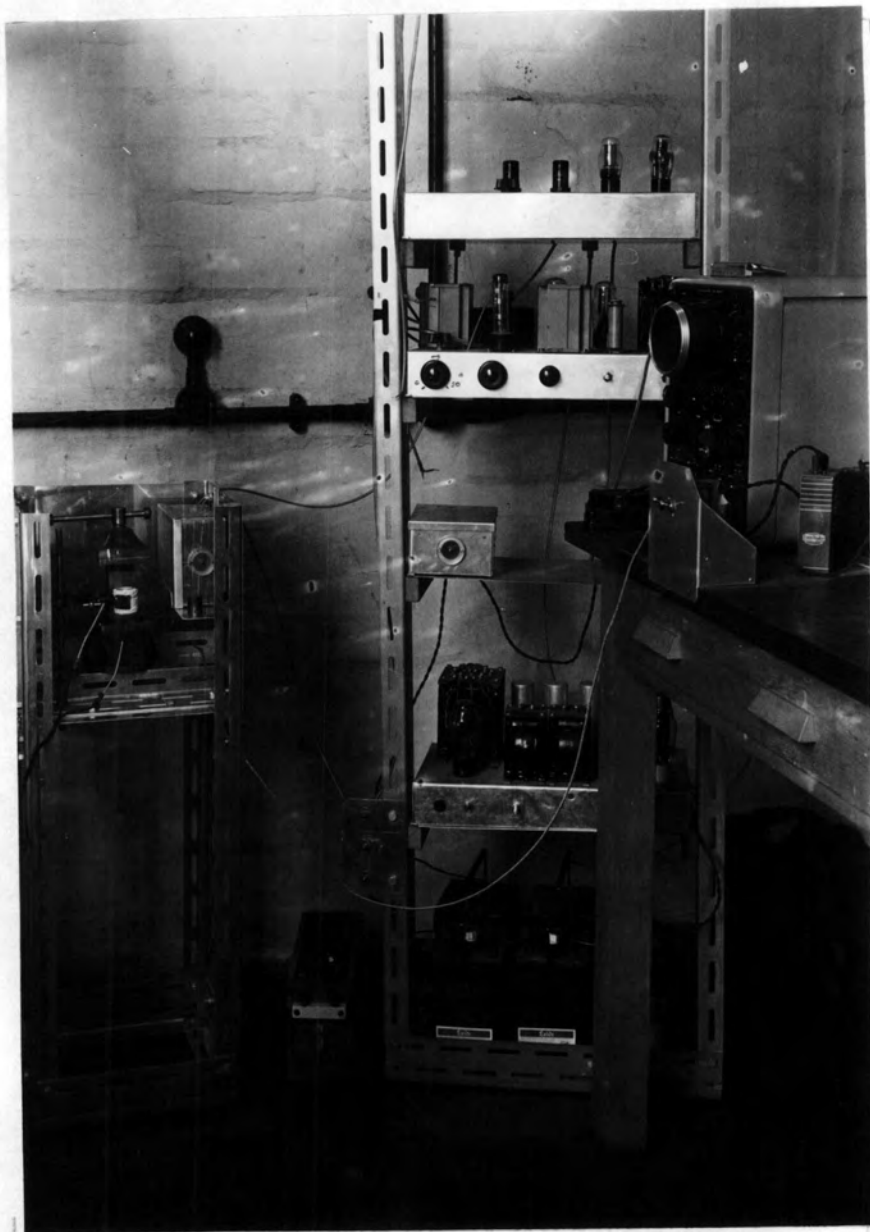

Figure 20 - General view of apparatus.

was possible to reduce the input to the amplifier to zero for zero input to the cathode follower.

A general view of the amplifiers, switching circuit, cathode ray oscilloscope, etc. is shown in fig. 20.

3.9 PREPARATION OF CRYSTALS

In order to measure the conductivity of crystals it was necessary to apply electrodes to two surfaces and various methods were used. In general the crystal was cleaved to give a specimen roughly 1 cm square and 0.5 cm thick.

A piece of platinum foil was connected to the negative end of a 1000 V line and sputtering was carried out in a portable vacuum apparatus using an atmosphere of air at a pressure of 0.1 mm of mercury. The method was abandoned after considerable experiment as it was found that the crystal became very hot during the discharge and cracking occasionally occurred. Furthermore it was difficult to control the direction and density of the sputtered metal. The method has apparently been used successfully elsewhere, but it was felt that with the apparatus available, neither the vacuum system nor the high tension supply, was suitable

in this case.

It was decided to try to evaporate an aluminium film onto the crystal surface and this proved very successful. Pieces of aluminium wire were attached to a filament made of a small coil of tungsten wire. The crystal was placed on a metal table on the base of a bell jar which could be evacuated by rotary and oil diffusion pumps to a pressure of 10^{-4} mm of mercury. A metal shield having an opening the size of the area to be covered by an aluminium film was placed over the crystal. A current of the order of 20 A was passed through the tungsten wire and the aluminium first melted, and was then boiled off the wire. At the low pressure the mean free path of the aluminium ions was large and they travelled in straight lines, thus depositing a reflecting film over the exposed crystal surface and also over the walls of the containing jar.

The aluminium surface proved to be very satisfactory as an electrode but it was necessary to keep the crystal dry, otherwise the aluminium was easily rubbed off, apparently due to the formation of a film of water on the crystal surface. All crystal specimens were kept in tubes containing a small quantity of silica gel

to absorb moisture. There was one disadvantage with aluminium electrodes - crystals could not be annealed, even at temperatures below the melting point of aluminium, without destroying the film, presumably due to the formation of the appropriate aluminium halide.

Experiments with electrodes of colloidal graphite were also carried out. The following "dag" dispersions of colloidal graphite were used:

Aquadag - colloidal graphite in water - this was quite useful though some dissolving of the surface layer of the crystal took place and the coating took some time to dry. Product 959 - colloidal graphite in isopropanol - this was very satisfactory. It was reasonably quick drying and had the advantage of being chemically inert to alkali halides. Also it did not introduce water to the crystal surface. Dispersion 56 - colloidal graphite in acetone - this preparation was far too quick drying and it produced a very uneven surface.

These dag compounds were applied directly to the crystal surface using a small sable hair brush. The crystal surface was generally roughened with fine emery paper, although the coating appeared to be quite firm even when the surface was not dulled.

As with the aluminium film, the graphite surfaces could not be used at high temperatures and annealing of crystals with dag films was impossible. The trouble in this case was the oxidation of the carbon in air at high temperatures.

The difficulty was not too serious since fresh electrodes could readily be applied after annealing. Furthermore the surface was left clean after the oxidation of the graphite and not contaminated as in the case of the aluminium film.

Melton "Liquid Silver" (Q50 grade) was also used. This was a black paint containing about 50% of silver in an oxidised form. It was painted on to the crystal surface as for the dag dispersions. The crystal was then placed in a furnace and taken up to a temperature of 600°C , thus reducing the paint to a film of metallic silver.

This preparation has many advantages. The film was not easily damaged and was in every way more durable than the other films tried. The crystal could readily be annealed without damage to the film and indeed the two operations of annealing and firing the paint could readily be combined.

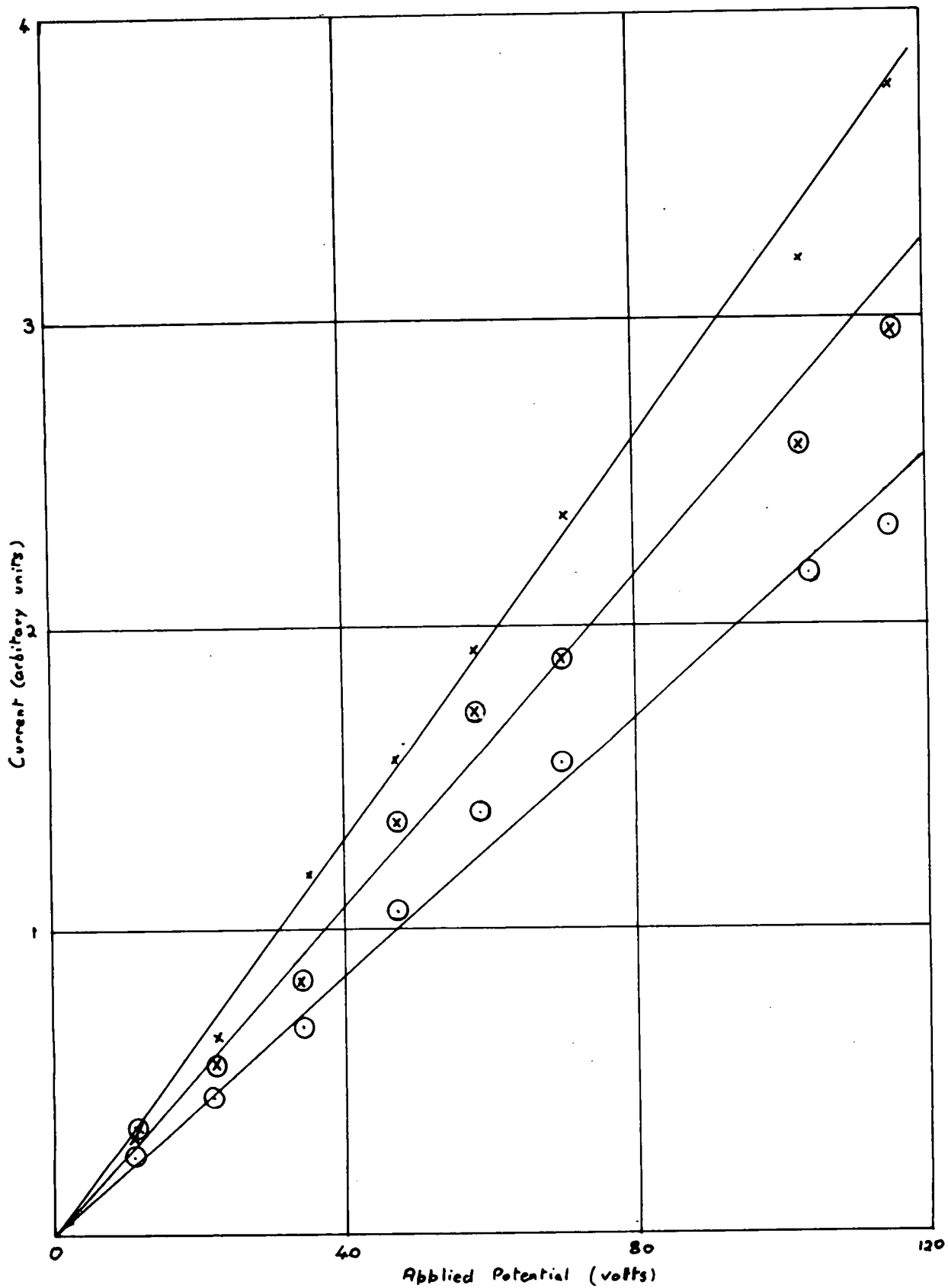

Figure 21 - Testing the ohmic response of the electrodes.

3.10 TESTING OF GRAPHITE ELECTRODES

It was desired to test electrically the efficiency of the graphite electrodes. In particular it was important to show that there was no rectifying layer present at the interface. Two samples of sodium chloride were taken and graphite was applied to their appropriate surfaces. The conductivity current (both initial and permanent) of both specimens was measured using a set of values of the applied potential over the range 11.2 to 116 volts.

The graphs of conductivity current against applied potential are shown in fig. 21. The x represents the permanent conductivity current of the first specimen and the \times and o the initial and permanent conductivity currents of the second specimen. It will be seen that the graphs of current against potential are straight lines as would be expected for an ohmic contact at the interface. If a rectifying layer were present it should give rise to a square law type of current v voltage graph.

4. APPARATUS FOR THE PLASTIC DEFORMATION OF CRYSTALS

4.1 BASIC DESIGN

It was desired to construct an apparatus which would hold an alkali halide sample and would enable the following measurements to be taken:- 1. the conductivity of the crystal, 2. the mechanical stress applied, 3. the strain, and 4. the temperature. In connection with this last requirement it was desired to mount the apparatus in a furnace and to perform experiments at different temperatures.

The basic difficulty in fulfilling these requirements was to maintain the electrical insulation of the relevant parts of the conductivity apparatus to as high as 10^{13} ohm. It was also necessary to measure the strain of the crystal at the same time and this requirement made the actual design of the apparatus very difficult.

An attempt was made to construct an apparatus on these lines using the apparatus already described to measure the electrical conductivity of the crystals. Stress could be applied directly by weights and strain measured by the use of an optical lever system. Specimens of sodium chloride could be cut about 1 cm square and 2 cm long, and as it was desired to measure a compression of 0.05% i.e. 0.001 cm, this meant a 1 mm throw

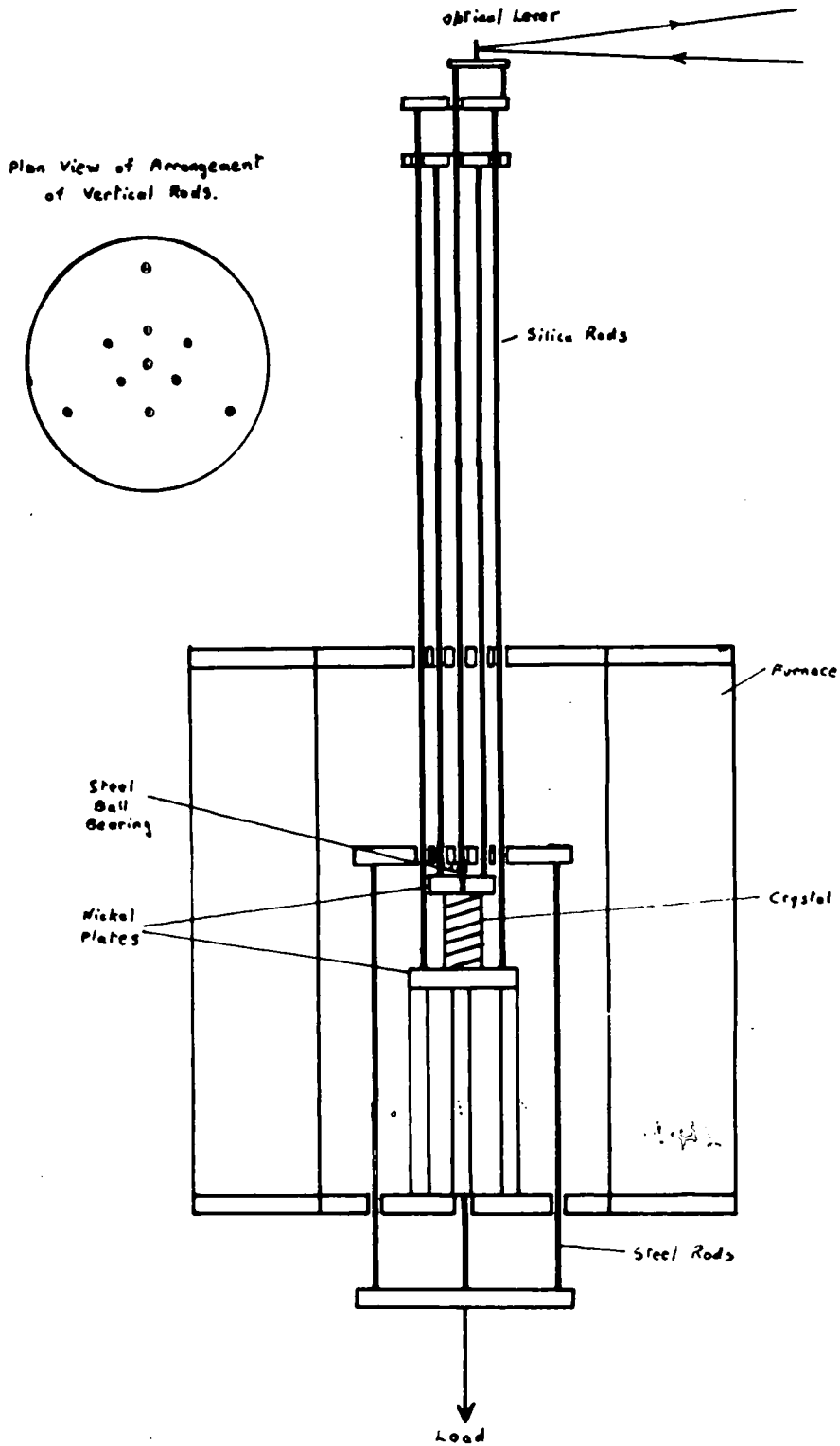

Figure 22 - The first stress apparatus.

on a scale if a magnification of 100 was to be used. The maximum throw of the optical lever in the room available, and without the use of mirrors, was 2.5 m so a lever arm of 2.5 mm was required to give this magnification.

4.2 THE STRESS APPARATUS

The apparatus is shown in fig. 22. It consisted of a furnace, similar to those used for growing crystals, supported on a steel framework having three levelling screws. The outer case of the furnace differed in that it had circular sheets of sindanyo at the top and bottom, with the sides formed by a sheet of 16 S.W.G. aluminium bolted at intervals of 2 in. into the edge of the bottom sheet of sindanyo. Two 5/16 in. diameter steel tie rods held the furnace together.

The furnace temperature was controlled by a platinum resistance thermometer mounted in an alumina tube and an electronic temperature controller, as described for the crystal growing furnace. There was a slight difference in the control circuit for since it was not required to run the furnace at temperatures

above 600°C , it was operated from a "Regavolt" giving a variable voltage a.c. supply up to a maximum current of 7 A. The relay in the temperature controller served to short out a 10 ohm resistor in series with the supply. In controlling the temperature about any given value the regavolt was first set so that with the series resistor shorted out the temperature of the furnace tended to rise slightly above the required value. With the control resistor in series the temperature tended to fall below the operating value and control was achieved in this way.

The crystal rested on a copper base plate which was supported by three $\frac{1}{2}$ in. diameter steel rods which in turn were anchored to the metal framework supporting the furnace. The copper plate carried three holes with grub screws at an angle of 45° to the plate (so that they could be tightened from the mouth of the furnace) and 3 mm diameter silica rods were supported in the holes. A second copper plate rested on the upper surface of the crystal and the plate also carried three holes for silica rods on its upper surface. This second copper plate had a v-shaped hole drilled in its

upper surface to hold a ball bearing which acted as a universal joint between the copper plate and a steel plate above carrying a corresponding v-shaped hole in its lower surface. This steel plate was connected by three 3/16 in. diameter steel rods, passing through holes in the base of the furnace, to a similar plate below the furnace base. Weights could be applied by a steel wire attached to this lower plate and the universal joint ensured that the compressive thrust was always directed along the vertical axis of the crystal. The loading weights were carried on a rising table and could be applied gradually to the specimen by slowly lowering this table. The silica rods passed through holes in the upper steel plate and the sindanyo cover to the furnace, and each set of three rods ended in a tufnol disc. The resistance of these rods was greater than 2×10^{14} ohm/cm at temperatures up to 150°C and they thus served to maintain the insulation between the two ends of the crystal. An optical lever 2.7 cm long carrying a small plane mirror and resting on gramophone needles as bearings, operated between these two tufnol discs. The lever threw a beam from a galvanometer lamp on to a

scale approx. 2.5 m from the mirror - the system having a magnification of about 93.

The whole apparatus was mounted on a dexion frame of very rigid construction. It was shielded from external electrostatic interference by aluminium sheeting and was earthed to a copper plate buried in the ground outside the room. This was necessary since the mains earth was not satisfactory. The earth lead to the room was rather long and was subject to pick-up from other electrical apparatus in the building. The head unit of the conductivity apparatus fitted into a slot of rectangular cross section cut in the screening at one side. The grid lead was made with fine wire from the lower steel plate of the hanging system to the insulated terminal on the head unit. The potential was applied to the crystal by a screened lead brought into the apparatus from the switching unit and was connected to the lower copper plate.

An early modification was made to the apparatus when it was discovered that the copper discs tended to scale at comparatively low temperatures, and they were replaced by similar discs made of nickel which were completely free from this defect.

The apparatus proved to be rather unsuccessful in

many ways:- 1. It was extremely difficult to set the crystal in position (this had to be carried out from the top of the furnace) and to adjust the optical lever system. 2. The silica rod system was very unstable and subject to external vibration. Furthermore it had a considerable drift, at times exceeding over a period of 5 minutes the value corresponding to the strain to be measured. Although this drift disappeared with time, it reappeared with loading and thus it was impossible to determine whether or not the specimen was deforming. 3. The apparatus suffered from an inherent disadvantage - that any changes in conductivity could not be observed until at least 10 sec after the loading had been carried out. This delay was due mainly to the necessity of replacing the screening round the apparatus. Furthermore when the weight was not applied but was held on the rising table, no conductivity measurements were possible owing to the insulation of the crystal being destroyed by the leakage via the rising table to earth.

The apparatus served to determine the conductivity of specimens using a nominal load of 1 Kg to keep the crystal in place. The apparatus also allowed the con-

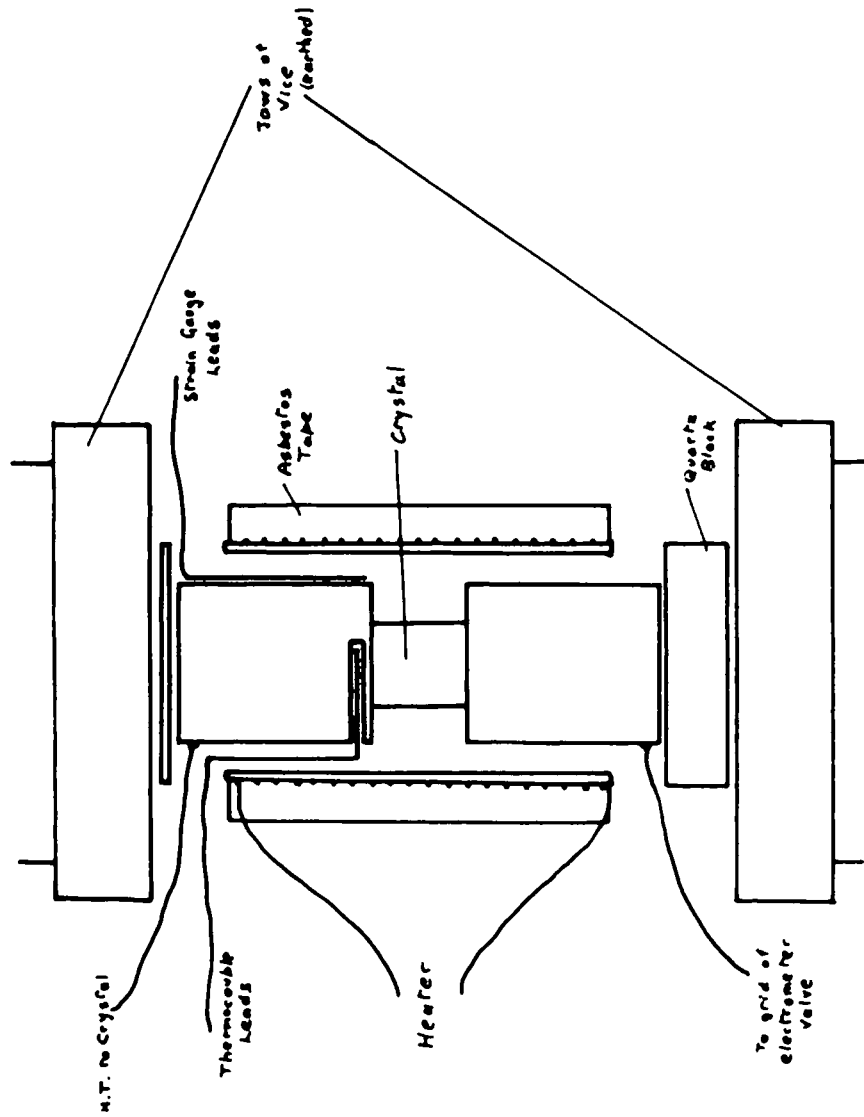

Figure 23 - The second stress apparatus.

ductivity measurement to be carried out over a wide range of temperatures from room temperature to near the melting point, although results near room temperature were not reliable owing to the difficulty of preventing water films which caused surface conduction. The apparatus could also be used to measure conductivity with the application of compressive loads up to about 50 Kg. The silica rod system was not assembled so that strain measurements were not possible. The apparatus was however subject to limitation 3. in this use.

4.3 THE SECOND STRESS APPARATUS

It was decided to build a second apparatus to measure the conductivity of crystals over a limited range of temperature and also to apply and measure stresses sufficient to cause plastic deformation of the crystal. It was also desired to improve upon limitation 3. above, so that measurements of the conductivity could be made simultaneously with the application of stresses to the crystal.

The apparatus is shown in fig.23. The crystal was held between the jaws of a small "Record" vice and stress was applied to it by rotation of the lead screw

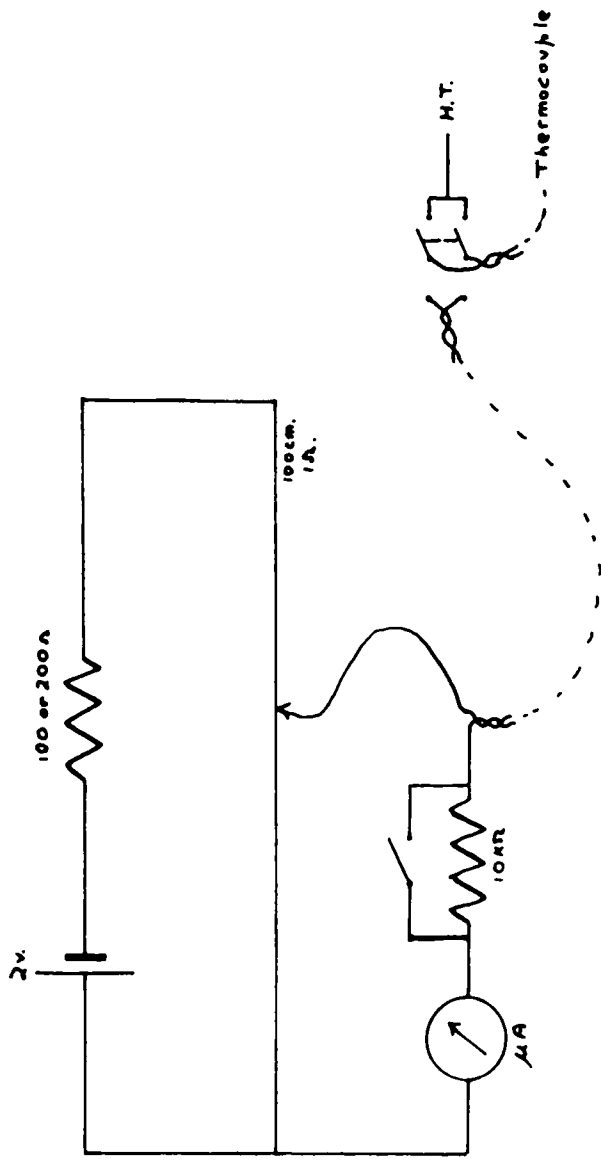

Figure 24 - The temperature measuring circuit.

of the vice. In order to insulate the crystal from the vice (which was earthed), a 1 in. diameter quartz disc 6.5 mm thick with a plate glass finish was used and it rested on the lower jaw of the vice. The crystal was held between an upper aluminium rod 2 in. long and $\frac{3}{4}$ in. diameter and a lower aluminium rod of the same diameter, and $\frac{3}{4}$ in. long. These rods served as connections to the electrodes on the surface of the crystal and were gripped between the jaws of the vice, the lower aluminium rod being connected to the grid of the electrometer valve. The upper rod was insulated from the upper jaw of the vice by a thin perspex sheet and a potential could be applied to it from the switching circuit (see sec. 3.7). It also carried a small hole drilled horizontally at its lower end, in which was inserted a copper/constantin thermojunction. This thermojunction was connected to a potentiometer circuit and was calibrated beforehand so that it could be used to indicate the temperature of the crystal.

The temperature measuring circuit is shown in fig. 24. The potentiometer circuit consisted of a slide wire 100 cm in length and having a resistance of 1 ohm. In series with the wire was a 2 V accumulator and a re-

sistance of 200 ohm. With this arrangement the current through the circuit was 10 mA and the potential drop across the slidewire was 10 mV. The balance point was obtained using a sensitive mirror galvanometer which was housed in a wooden box having an internal light system and a translucent scale mounted in the front wall of the box. A protection resistance was also incorporated in series with the galvanometer. The thermojunction consisted of two thin wires of copper and constantin which were brazed together at their ends, and the brazed portion was filed down until it fitted smoothly into the hole drilled in the side of the upper aluminium electrode. It was calibrated by immersing it in a beaker of silicone fluid which could be heated to various temperatures from room temperature to 360°C , the temperature being measured by a mercury-in-glass thermometer. The cold junction of the thermocouple was formed by the junction of the copper and the constantin wires with the measuring circuit, and was at room temperature. A calibration graph was drawn of the balance point in centimetres along the slide wire against the temperature difference between the hot junction of the thermocouple and room temperature, so

that it was necessary to add the room temperature to obtain the temperature of the hot junction from this graph. At high temperatures it was found that the e.m.f. of the thermocouple exceeded 10 mV and a series resistance of 100 ohms was used instead of 200 ohms in order to get the balance point on the wire again. With this temperature measuring system it was possible to determine the temperature of the thermojunction to an accuracy of $\pm 2^{\circ}\text{C}$ over most of the range, but with a somewhat greater error at the high temperature end.

The crystal and the aluminium cylinders were surrounded by a heater made of 26 S.W.G. nickel-chromium wire wound on a glass tube $1\frac{1}{2}$ in. long and 1 in. diameter covered by a layer of asbestos paper. The winding, which had a resistance of 20 ohms, was covered by a thick layer of asbestos tape to reduce heat loss to the outside and was operated from a regavolt variable transformer. It was not possible to regulate the temperature by means of a controller owing to the small dimensions of the apparatus, but it was found that an equilibrium temperature was reached for a given setting of the regavolt which was steady to a degree or two.

The apparatus was mounted on a dexion framework, the

vice being mounted vertically and surrounded by sheet aluminium in order to provide electrical screening. Provisions was made inside the screening to mount the head unit of the conductivity apparatus. Access to the screw of the vice was provided from the top of the casing, and stress was applied by hand while at the same time observing the deflection of the trace on the cathode ray tube. A view of the apparatus is shown on the left in fig. 20.

It was planned to attach a Saunders-Roe foil strain gauge to the upper aluminium cylinder by Araldite 103 cement (an epoxy resin). These strain gauges consist of a metal film on a plastic backing and show a change of resistance on deformation. The gauge can be calibrated for the measurement of stress, since if known loads are applied to the aluminium cylinder the gauge will respond to the strain of the cylinder, so that provided the elastic limit for aluminium is not exceeded a constant relationship will exist between the stress and the strain in the aluminium. The resistance of the strain gauge was measured by a simple Wheatstone network. The gauge (which had a resistance of approx.

65 ohms) formed one arm of the network and in the opposite arm was placed a decade resistance box reading down to 0.1 ohm. The final dial of the decade resistance box was a continuous slide wire reading to 0.001 ohm. The other two arms of the network were two 100 ohm fixed resistors of high stability. Power for the bridge was provided by a 2 V accumulator and the balance point was obtained using a sensitive mirror galvanometer.

Unfortunately it was found that the change of resistance of the strain gauge was only of the order of 0.005 ohm for an increase of stress of 20 Kg. The method was therefore far too insensitive for the measurement of stress. Moreover it was found that contact troubles occurred in the slide wire of the decade resistance box so that readings of resistance to 0.001 ohm were not always reproducible. Some method of increasing the change of resistance for a given stress had therefore to be found. This could be done if some material could be found which had a Young's modulus of elasticity smaller than that of aluminium, thus giving a greater strain to the strain gauge for a corresponding stress increment. If possible the material had to be useful at high temper-

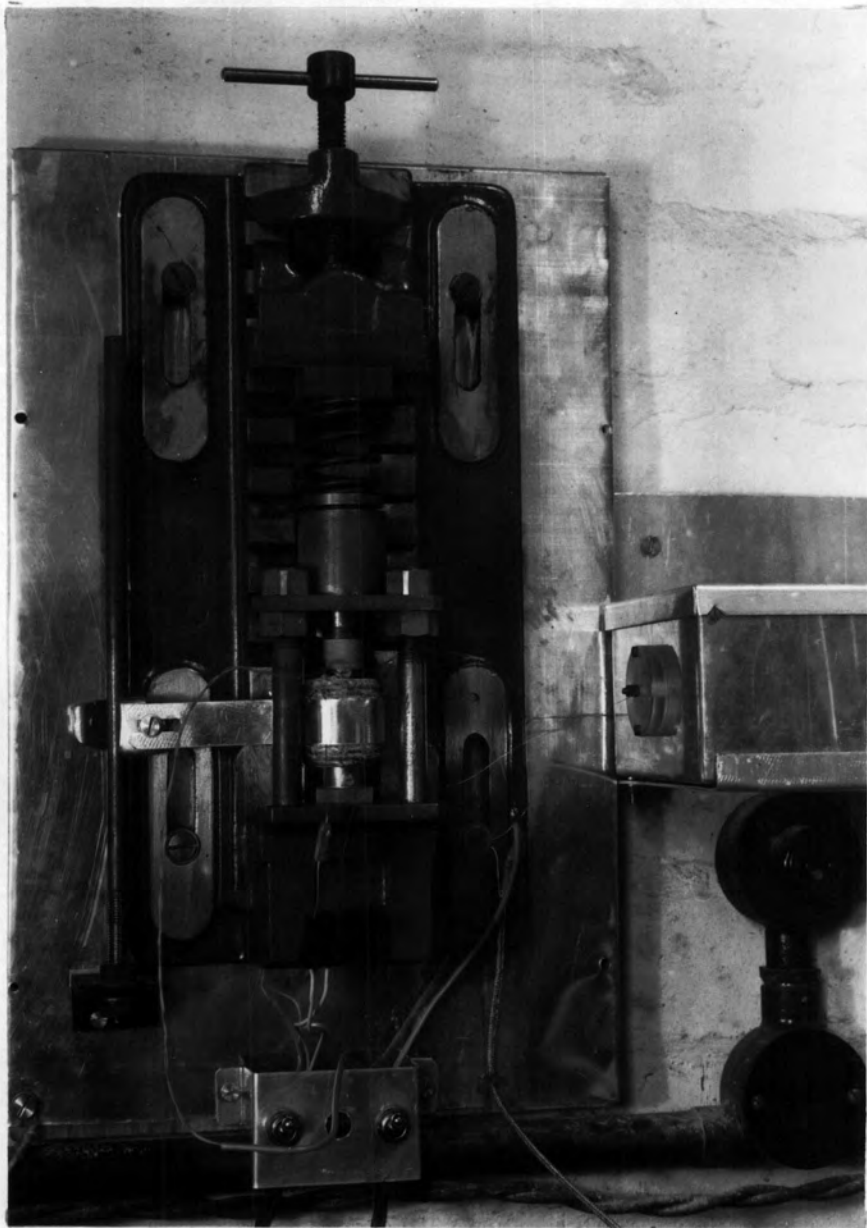

Figure 25 - The third stress apparatus.

atures, thus ruling out the possibility of using hard rubber, etc. It was decided to try Marco Resin which had a Young's modulus of elasticity of 1.93×10^{11} dyn/cm² compared to 7×10^{11} for aluminium. This polyester resin could be easily moulded when cold and when polymerised was machined into cylinders of $\frac{1}{8}$ in. diameter. Strain gauges were attached by means of Araldite cement and the system tested in the compression apparatus. Since the diameter of the cylinder had been reduced from $\frac{3}{4}$ in. to $\frac{1}{8}$ in. and the Young's modulus reduced by a factor of $2/7$, the resistance changes were now about eight times their original value for a given stress increment and were thus fairly easily measurable. A complication arose since it was found that the deformation of the resin was not purely elastic. At any stress, apart from the immediate elastic deformation, there was a slow plastic creep which appeared to relax slowly on removal of the stress.

There were further difficulties with this apparatus. Since the pressure produced by turning the lead screw of the vice was transmitted directly to the crystal and for any given instantaneous pressure above the yield point of the crystal, plastic flow took place, the value of

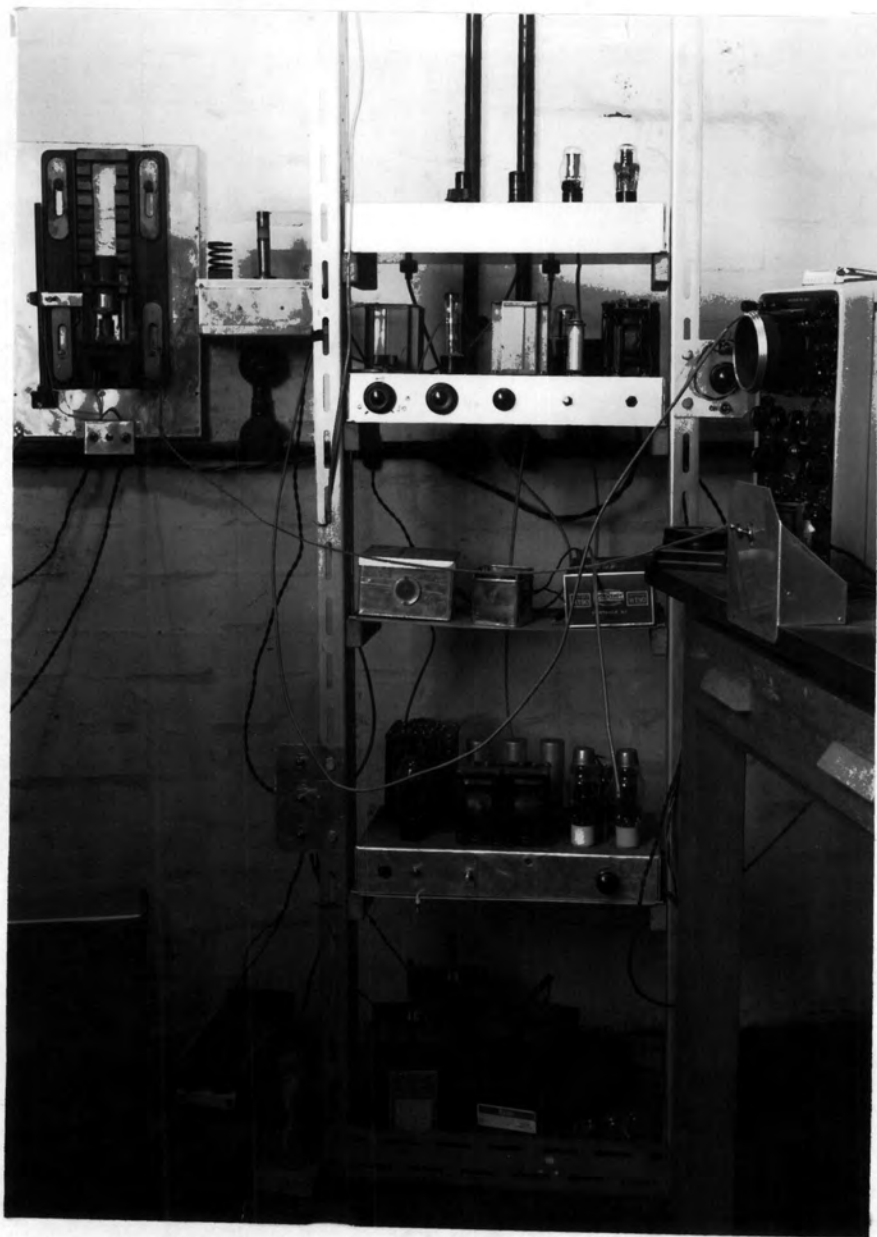

Figure 26 - General view of apparatus.

the stress on the crystal was reduced. Thus deformation was not taking place at constant stress and the value of the stress recorded was to some extent meaningless. It was considered desirable to construct an apparatus capable of use at high temperatures and although the strain gauges and the Marco Resin remained useful to 200°C they were clearly not suitable at temperatures much above that.

4.4 THE THIRD STRESS APPARATUS

For the reasons outlined above it was considered imperative to construct a third version of the stress apparatus. The final form is shown in fig. 25 and also on the left in fig. 26. A vice was again used to provide the stress but in this case a powerful spring was used "in series" with the jaws of the vice so that the stress was applied to the crystal via the spring. Since for any given stress the actual yield of the crystal was very small, the actual decrease of stress due to the increase in length of the spring by this amount was also very small, and the apparatus was almost a constant stress apparatus. The actual spring used had a length of 4.25 cm in the unstrained state and this was decreased to 3.7 cm under a load of 11.2

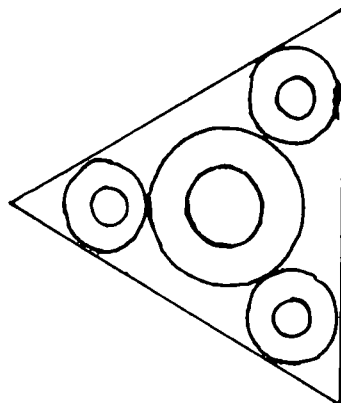
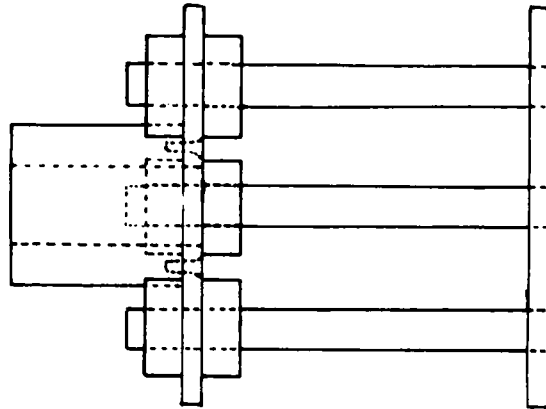
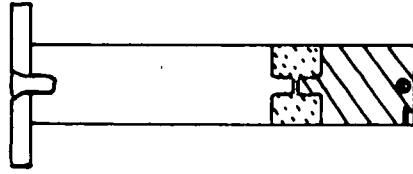

Figure 27 - The third stress apparatus.

Kg. When fully compressed the spring had a length of 2.2 cm and was thus capable of being loaded up to 41.5 Kg. Further loading was of course possible but the spring was then fully compressed and the stress transmitted directly to the crystal.

The small Record vice that had been used was no longer suitable owing to the increased number of components that had to be placed between the jaws, and a J & S machine table vice was purchased. This had jaws 3 in wide by $1 \frac{15}{16}$ in. deep and could take work $7 \frac{1}{2}$ in. long. However a further complication arose because the moving jaw of the vice was not rigidly guided so that it would move parallel to the fixed jaw. In order to ensure that the stress was applied so as to be always normal to the faces of the crystal some form of guide had to be constructed. This problem had not arisen with the previous apparatus because no spring was used between the jaws of the Record vice which had been of the normal bench type construction (with the moving jaw sliding in a guide).

The final form of the apparatus is shown in fig.

27. It consisted of two steel plates of $\frac{1}{4}$ in. thick-

ness, triangular in shape and separated by three steel rods at the apices of the triangles. Six nuts on the rods enabled the separation of the plates to be adjusted so that the upper plate could be aligned parallel to the lower. A massive steel cylinder was attached to the upper plate, and a $\frac{3}{4}$ in. hole was reamed out through the cylinder and the plate in a direction along the axis of the cylinder and normal to the plate. A steel rod was turned to a diameter of $\frac{3}{4}$ in. so as to be a smooth sliding fit through the cylinder. The electrode assembly consisted of a brass electrode screwed to a sindanyo disc $\frac{1}{8}$ in. thick (to provide both thermal and electrical insulation) and the disc was in turn screwed to the steel plunger previously described. A steel plate turned to a diameter equal to that of the spring was attached to the steel plunger and provided a bearing surface for the application of stress by the spring.

The dexion framework that had been used to support the second stress apparatus was not completely satisfactory. It was found that any chance mechanical vibration, e.g. a knock, door slamming, etc. caused a spurious microphonic response in the electrometer valve

circuit. It was decided therefore to make the mechanical mounting arrangement more rigid by attaching the vice to the wall of the room. A piece of timber 1 in. thick was attached by Rawlplugs to the brick wall of the room and a sheet of aluminium was placed over the surface of the board, and the vice screwed down on top of this. A heating coil similar to that described for the second stress apparatus was used but it was decided to replace the glass former by one turned out of gunmetal since temperatures near to the softening point of glass were to be used. The heating coil was attached to an aluminium strip which was in turn connected to a clamp running on a steel rod mounted in a vertical plane to the left of the stress apparatus. The heating coil could therefore be easily adjusted to any convenient position. The leads to the coil were connected to a two-pole two-way tumbler switch mounted at the base of the apparatus. This enabled the winding of the coil to be connected to earth or to the supply from the regavolt. The former position was used when electrical measurements were actually being taken.

In order to measure the temperature of the crystal a copper-constantin thermojunction was used as previously

described for the second stress apparatus, and was inserted in a small hole drilled in the side of the upper brass electrode so as to be as near as possible to the crystal. The thermocouple wires were brought out to a second two-pole two-way tumbler switch mounted at the base of the apparatus. This switch enabled the leads to be connected either to the potentiometer measuring circuit or to the upper electrode when electrical measurements were actually being taken - the circuit is shown in fig. 24. The precaution was not as important in this case but some electrical pick up did occur on the highest sensitivity ranges of the d.c. amplifier. In operation the apparatus was covered by a box of sheet aluminium in order to reduce electrical pick up from external sources. The screen is shown in the lower left hand corner of fig. 26. The vice and the whole of the screening were connected to an earth formed by a copper plate in the ground outside the room.

While the potential to be applied to the crystal was connected via the switching circuit to the upper brass electrode, the lower brass electrode was connected to the grid of the electrometer valve. A plat-

form was attached to the wall so that the head unit of the d.c. amplifier could be placed close to the stress apparatus. To do this a hole had to be cut in the side of the aluminium screening box and the insulated connection to the grid of the electrometer valve projected through this hole. The lower brass electrode was supported on a disc of fused quartz 1 in. in diam. and 6.5 mm thick. The resistance of the quartz at room temperature was greater than 10^{15} ohm cm so that it provided adequate electrical insulation. It was also fairly strong mechanically and no fractures were experienced although stresses up to 100 Kg/cm^2 on the crystal were applied.

The calibration of the spring has already been described. When inserting a crystal specimen between the electrodes it was found necessary to give a few half turns to the lead screw of the vice to hold the specimen in position. It was then possible to apply about 18 half turns of the screw before the spring became fully compressed. A half turn of the screw was adopted as the unit of incremental increase of stress and was found by calibration to correspond to a stress increment of 2.15 Kg. The initial load applied to

hold the crystal in place was therefore 2.15 Kg and then 18 half turns of the lead screw brought the total load to 41.5 Kg.

5. THE INVESTIGATION OF THE PROPERTIES OF SODIUM CHLORIDE CRYSTALS CONTAINING MANGANESE

5.1 INTRODUCTION

Experiments were carried out at King's College, Newcastle under the direction of Dr. E.E. Schneider on the measurement of the paramagnetic resonance absorption spectrum of sodium chloride crystals containing manganese. At the same time in Durham the conductivity and optical absorption of these crystals were studied. The author was responsible for the growth of the sodium chloride crystals containing manganese, for the analysis of their manganese content and its distribution, and for the measurements of their ionic conductivity.

It was hoped to use the paramagnetic resonance absorption of manganese to investigate the crystalline field in the neighbourhood of the manganese ion when it is added to ionic crystals as an impurity, and thus give direct information about the nature of the imperfections in the crystal. It was also proposed to use the measurements of conductivity and optical absorption on specimens taken from the same crystal to

give additional evidence of the internal structure of the specimens.

5.2 GROWTH OF CRYSTALS

Crystals were grown from Analar sodium chloride with the addition of various amounts of Analar manganese chloride (MnCl_2) as already described in sec. 2.6. The percentage of manganese present in the melt was found to be of the order of twenty times that present in the resulting crystal drawn from the melt. However it was found that the manganese present in the melt decomposed with time with the formation of black manganese dioxide. This precipitate adhered to the sides of the beaker and also gathered in a layer at the bottom of the beaker. From any one melt, therefore, it was found that the percentage of manganese present in successively drawn crystals fell steadily owing to this decomposition of the manganese in the melt. A series of crystals were grown having manganese contents up to a mole ratio Mn/NaCl of approx. 3×10^{-3} . Those having a mole ratio much above 1×10^{-3} were found to be cloudy and those at a ratio of 3×10^{-3} almost opaque. The manganese was clearly present as colloidal aggregates at these concen-

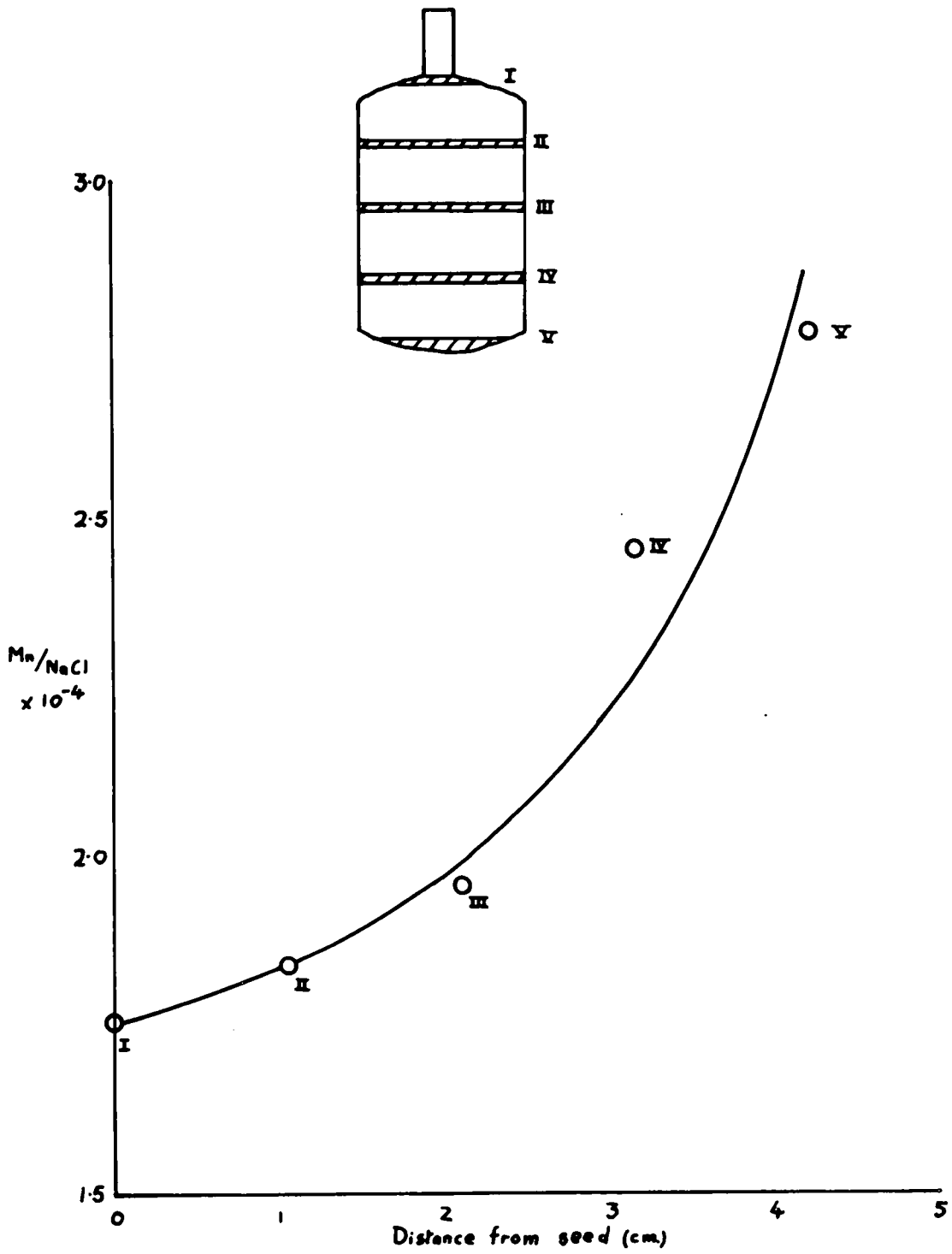

Figure 28 - Distribution of manganese down a crystal.

trations and not present only at the ionic lattice sites. The crystal with the greatest concentration of manganese used in these experiments was one with a mole ratio Mn/NaCl of 1.1×10^{-3} .

The distribution of manganese in the crystal was also determined and the results are shown in fig. 28. Five slices were cleaved at different levels in the single crystal and the manganese content analysed for each slice. The graph shows that the manganese content increases with distance from the seed in a manner comparable with the results found by Kelting and Witt (1949) for the distribution of calcium in sodium chloride.

The technique was developed for the determination of the amount of manganese present in crystals of sodium chloride. The method used was one given originally by Willard and Greathouse (1917), and consisted essentially in the conversion of all manganese to permanganate and estimation by colourimetric means.

A sample weighing approx. 1 g of sodium chloride containing manganese was boiled with 5 ml of concentrated sulphuric acid in a fume cupboard until all the chloride had been driven off as hydrogen chloride. 1 ml

of concentrated phosphoric acid was then added and the solution diluted to 10 ml with distilled water. While warm 0.2 g of potassium periodate was added and the solution was allowed to stand. The pink colour of the permanganate gradually appeared on standing and when cool the solution was made up to 25 ml in a graduated flask. The amount of manganese present was determined by measuring the absorption of this final solution at a wavelength of 5250 Å in a Unicam SP 600 spectrophotometer which read the optical density directly. A preliminary calibration experiment was first made - the optical densities of solutions of potassium permanganate of known concentrations were determined and a calibration graph was drawn relating optical density to manganese present in mg per 25 ml of solution. From this graph it was possible to read off directly the number of mg of manganese present in any solution. The method was found to be sensitive to 0.005 mg in 25 ml and since a 1 g sample of sodium chloride was generally used it gave manganese present to 5 parts/million.

5.3 CONDUCTIVITY MEASUREMENTS

Colloidal graphite electrodes were painted on to

specimens cleaved from the various crystals grown.

The usual size of specimen for the conductivity measurements was approx. 1.0 x 1.0 x 0.5 cm. The measurements were carried out in the original stress apparatus with nickel electrodes and the silica rod system dismantled. A nominal load of 1 Kg was used to keep the crystal in place. The conductivity was measured over a range of temperatures from 80 - 250°C using both the impedance converter and the cathode follower, the former at the low temperature end of the range and the latter for the higher conductivities at the high temperatures. A potential of 120 V was applied to the crystal in all cases and readings were taken also with the sign of the potential reversed. The temperature of the furnace was maintained by the electronic temperature controller already described and was measured by a mercury-in-glass thermometer. In taking measurements the current to the furnace winding had to be switched off and the winding connected to earth. This was necessary otherwise the a.c. pick-up became serious and masked the actual conduction current. This difficulty was not serious as the furnace temperature dropped only slowly with time and con-

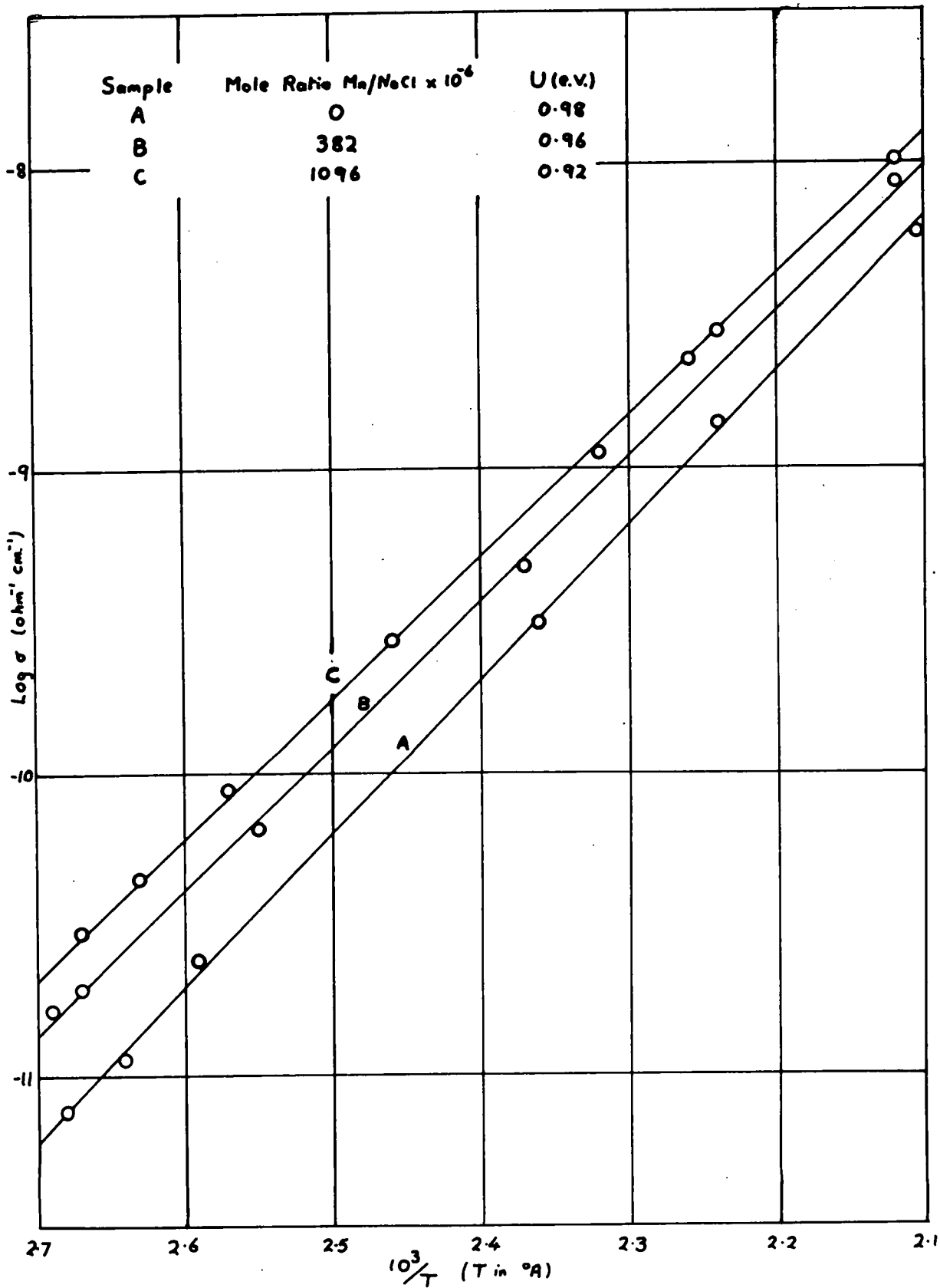

Figure 29 - Variation of conductivity with temperature for crystals of sodium chloride containing manganese.

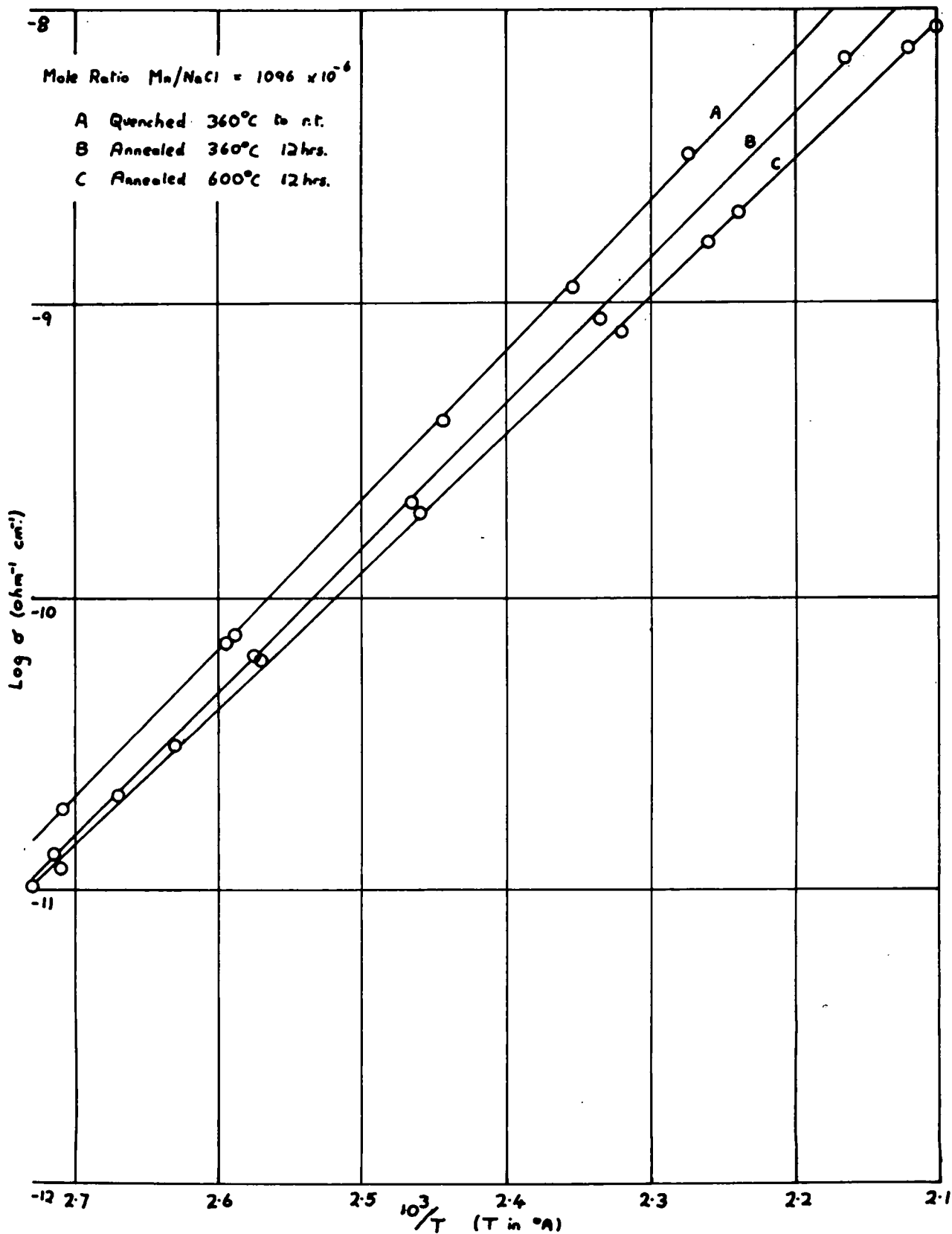

Figure 30 - Variation of conductivity with temperature for quenched and annealed NaCl/Mn crystals.

ductivity readings could be taken in less time than the furnace took to drop 1°C in temperature.

The initial conductivity immediately after applying the potential, and the terminal conductivity were obtained in each case. Fig. 29 shows the log of the initial conductivity plotted against the reciprocal of the temperature for the range $80 - 230^{\circ}\text{C}$ for three specimens containing 0, 382 and 1096×10^{-6} mole ratio Mn/NaCl. The line C has been raised slightly to give clarity. The specific conductivities of the three specimens A, B and C were 6.57×10^{-11} , 1.21×10^{-10} and 1.25×10^{-10} $\text{ohm}^{-1}\text{cm}^{-1}$ at 127°C . The activation energies calculated from the slopes of the curves were 0.98, 0.96 and 0.92 eV respectively. Fig. 30 shows the log of the initial conductivity plotted against temperature in the same way for two specimens, the line A refers to a specimen that had been quenched, line B (which has been raised for clarity) is the same specimen tested after annealing at 360°C for 12 hours. Finally the curve C is a different specimen from the same crystal which has therefore only been cooled from 600°C at the rate of one degree per minute. The activation energies obtained from these three lines were 1.01, 0.98 and 0.92 eV, and the

specific conductivities at a temperature of 127°C were 13.6, 9.4 and $12.5 \times 10^{-11} \text{ ohm}^{-1} \text{ cm}^{-1}$ respectively. These figures show that the specific conductivity at 127°C slightly increases on quenching and falls on annealing the quenched specimen. The activation energy is also greater in the quenched than in either the normally annealed specimen or the quenched and annealed specimen. Experiments on a second crystal containing 382×10^{-6} mole ratio Mn/NaCl, showed that on annealing crystals containing manganese at 600°C the manganese tended to come out of the crystal and form a layer (possibly of manganese dioxide) on the surface. This had a much higher conductivity and unless this surface layer was cleaved off the measured conductivity was too high. This phenomenon was detected for the first time with this crystal.

Quenching was carried out by heating the specimen in a furnace to a temperature of $300 - 360^{\circ}\text{C}$, and then removing it from the furnace and allowing it to cool to room temperature in the air supporting it by some insulator such as an asbestos mat. Since the specimens were quite small the cooling took place in a few minutes and the specimen often cracked owing to the

thermal strains set up. However it was possible to obtain some specimens which were free from cracks and suitable for further conductivity measurements.

5.4 DISCUSSION OF THE CONDUCTIVITY RESULTS

A complete discussion of the results of the programme of work carried out both at Durham and Newcastle on sodium chloride crystals containing manganese is given in the paper by Schneider and Caffyn (1955). The main conclusions directly applicable to the conductivity measurements are given below.

Two models were proposed to describe the distribution of the manganese in the quenched and slowly cooled state of the sodium chloride crystal. In the first case (model A) the manganese in the crystal that has been slowly cooled has formed aggregates or clusters together with some of the associated positive ion vacancies. The manganese in these clusters is still held in solid solution but in a much higher concentration of manganese. On heating the specimen to 300°C the clusters would be broken up by thermal activation and on quenching a more uniform distribution of the manganese would be frozen in. The positive ion vacancies would probably be similarly distributed around

the manganese ions, although if this were so the quenching process should not lead to an increased conductivity. On the other hand if more positive ions are trapped at the manganese clusters in the slowly cooled crystal then heating would free them, and this would account for the increased conductivity. The results show that the activation energy is greater in the quenched than in the unquenched crystals. The reverse would in fact be expected if the manganese and the positive ion vacancies were tied up in the cluster in the slowly cooled crystal.

Alternatively the manganese in the slowly cooled specimen can be considered as deposited close to or at internal boundaries (model B). The quenched state would be the same as for model A if the manganese ions were completely removed from the internal boundaries by heating. The higher activation energy in the quenched state could be explained by this model if the manganese ions which are distributed throughout the crystal were associated with positive ion vacancies freed from the internal boundaries by heating.

The increased conductivity with increased manganese impurity is explained by model B as due to the increased number of positive ion vacancies which, though associated

with a manganese ion at an internal boundary, may be freed to take part in the conduction. Etzel and Maurer (1950) have observed an increased conductivity on quenching sodium chloride crystals containing cadmium impurity and this could be explained in a similar way. Cunnell and Schneider (1954) have carried out experiments on the ionic conductivity of pure and mixed alkali halide crystals which indicated an aggregation of positive ion vacancies at internal boundaries.

6. PRELIMINARY WORK ON THE MECHANICAL DEFORMATION OF SODIUM CHLORIDE CRYSTALS

6.1 USING THE FIRST STRESS APPARATUS

Attempts were made to detect any conductivity change taking place on plastic deformation of sodium chloride crystals using the first stress apparatus. The crystal was in the form of a cube of side approx. 1 cm and was cleaved from single crystals of sodium chloride grown at Durham. Both graphite and aluminium electrodes were used. The upper surface of the crystal was connected to the grid of the electrometer valve in the head unit and a potential of 120 V was applied to the lower electrode of the crystal.

The general experimental procedure was to insert

the crystal between the nickel discs and to hold it in place by a load of 1 Kg on the hanging system, the silica rod arrangement to measure strain not being used. The temperature in the furnace was then brought up to the required value for the experiment using the temperature controller previously described. Most of the experiments were carried out at approx. 100°C since this was the lowest temperature at which it could be certain that water was not present on the surfaces of the crystal, causing a spuriously high surface conductivity to be measured. The potential was applied to the crystal and the conductivity measured by visual observation of the deflection of the spot on the screen of the cathode ray oscilloscope, using an appropriate value of grid leak resistance for the electrometer valve and also adjusting the gain of the d.c. amplifier in the oscilloscope. During the actual measurement of conductivity the furnace was switched off and the heater winding earthed. When the conductivity had been determined the sensitivities of the electrometer valve circuit and d.c. amplifier were adjusted until the conductivity was represented by a small deflection from zero on the

cathode ray tube. Under these conditions any large increases of conductivity should have been clearly visible. Weights were now added to the 1 kg already on the hanging system and the new stress was then applied gradually by means of the rising table. As the conductivity measurements could not be made while the new load was being applied there was some delay before any conductivity change could be detected after the application of stress. There was a further difficulty with the apparatus - the hanging system tended to sway somewhat when released from the rising table. This oscillation altered the capacitance of the grid circuit of the electrometer valve and was represented as an alternating signal on the screen of the C.R.O. It was necessary to steady the hanging parts and this further increased the time delay before being able to detect any conductivity change.

Experiments as described were repeated on various samples of sodium chloride grown at Durham and stresses up to about 25 Kg/cm^2 were used. Even when using stress increments as high as 10 Kg/cm^2 no significant conductivity change could be detected in any of the specimens. It was concluded that if any conductivity

change were taking place it was doing so in a time smaller than the time required for the measurement of conductivity after the application of stress. It was decided therefore to proceed with an apparatus capable of recording conductivity change within the shortest possible time of the application of stress to the crystal.

6.2 USING THE SECOND STRESS APPARATUS

A series of experiments were carried out on Durham sodium chloride crystals using the second stress apparatus. Visual observations were not relied upon but instead the trace on the screen of the cathode ray tube was photographed. For this reason the oscilloscope was adjusted to operate on single sweep with a transit time across the screen of 1 sec.

The experimental procedure was as follows. The crystal was usually about 1.0 x 1.0 x 0.5 cm in size and opposite faces were roughened with emery paper and coated with colloidal graphite. The crystal was placed between the metal electrodes and the screw of the vice tightened sufficiently to keep it in place. The heating coil was then switched on and the temperature of the crystal allowed to rise to over 100°C. The temperature was then allowed to fall to near room temperature

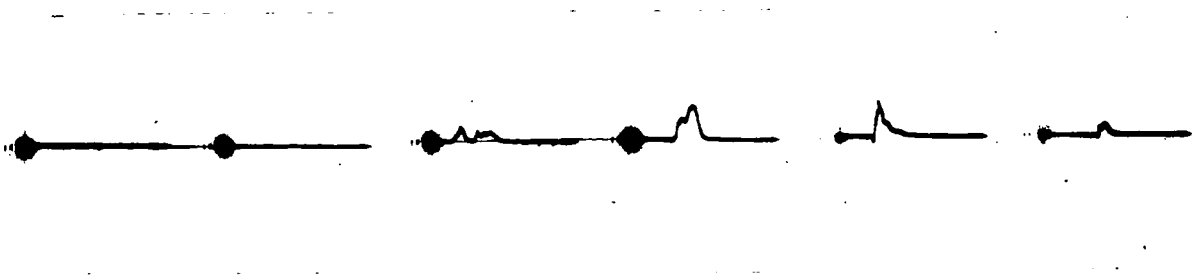

Figure 31 - Film taken on Durham sodium chloride.

(actually about 30°C) and measurements taken. In the first series of experiments no attempt was made to take the measurements at any precise value of temperature but only over a broad range around 30°C . Provided that the measurements were taken not too long after the temperature had fallen to this value no trouble was experienced from the deposition of water on the crystal surface, although ultimately this took place, giving rise to a high surface conductivity. A conductivity measurement consisted of the operations of opening the shutter of the camera, applying the potential to the crystal (this switch also started the sweep of the spot across the screen), applying stress to the crystal by giving the screw of the vice a given rotation, closing the camera shutter and then disconnecting the potential from the crystal (also at the same time re-setting the time base).

A series of typical exposures taken in this way is shown in fig. 31. It should be noted that the first of the exposures was taken without the application of stress to the crystal. The curve shows the distinction between the initial and the permanent con-

ductivity. On application of the potential the spot deflects instantaneously to a value (upwards in the figure) which represents the initial conductivity of the crystal. The current through the crystal then decays and the trace on the screen is seen to be approaching a final steady value - the permanent conductivity. On the photographs taken, since the sweep time was only 1 sec. this final conductivity value was never reached but it was quite easy to determine by visual observation of the spot on the screen after a sufficiently long time, say one minute, had elapsed after the application of potential to the crystal. The polarisation phenomena was also found on removing the potential from the crystal. The spot then deflected to a point above the zero trace line and slowly decayed with time to the zero position.

The third of the photographs shown in fig. 31 was taken using the same specimen as for the first photograph under identical conditions except that this time a stress was applied to the crystal. The actual time of application of stress was not accurately known but it was presumably applied at the time when the electrical effect (i.e. the deflections of the spot on the screen) first appeared. Visual observations confirmed

this to be so as far as could be judged by eye. As will be seen from the figure there was an irregular deflection of the spot. This could have been due to an increase in the conductivity of the crystal but it will be seen that at times the deflection of the spot was below the zero trace line. It was impossible to account for the whole of the deflection by a conductivity increase since a deflection below the zero line could only be attributed to a negative conductivity. It was thought that the effect might be due in part to a piezoelectric potential appearing at the surface of the quartz insulator under pressure and an experiment was carried out to test this hypothesis.

A piece of metal foil was attached to the grid of the electrometer valve and was placed between two quartz discs held between the jaws of the vice. The screw of the vice was rotated and an attempt was made to record any disturbance appearing at the grid of the electrometer valve while stress was being applied. No such potential could be detected and it was concluded that the previous potential effect originated within the sodium chloride crystal itself.

There was a very convenient method available for

distinguishing between a deflection due to a conductivity change and one due to the appearance of a potential at the surface of the crystal. If an experiment was carried out without the application of a potential to the crystal then any deflections must be due to the development of a potential at the crystal surface and changes in conductivity would not be indicated. The experimental procedure was adopted therefore of taking a series of photographs with a potential applied to the crystal only on successive exposures. By comparison of a pair of photographs, one with and one without the application of a high potential, it was possible to distinguish potential effects (common to both photographs) and changes in conductivity (only apparent on the photograph where a potential had been applied to the crystal).

In order to test whether the potential effect was due in some way to the graphite electrodes the experiment was repeated with Melton liquid silver electrodes. The crystal surfaces were roughened, the silver paint was applied and the crystal was heated in a furnace at 600°C . Precisely similar effects were observed as for crystals having graphite electrodes.

So far in all experiments on the potential effect, stress had been applied to the crystal normal to the electrode coatings on the crystal surface. An experiment was devised therefore to see if there was any change in the potential effect when there was no direct stress on the electrodes of the crystal. Liquid silver electrodes were applied to a crystal and when the electrodes had been formed by firing, thin copper wires were soldered to these electrodes. In painting on the electrodes care was taken to see that the edges of the silvered surface did not reach quite up to the edge of the crystal face. The crystal was then placed in the stress apparatus with the plane of the electrodes in the direction of the line of application of stress. The two aluminium cylinders of the stress apparatus were thus in contact with two unsilvered surfaces of the crystal. The two electrodes on the crystal were then connected by means of the attached copper wires, one to the grid of the electrometer valve and the other to the potential switching circuit. Stresses were then applied to the crystal and potential effects were found, thus showing that the potential effect did not depend on the direct application of stress through the electrodes of the crystal.

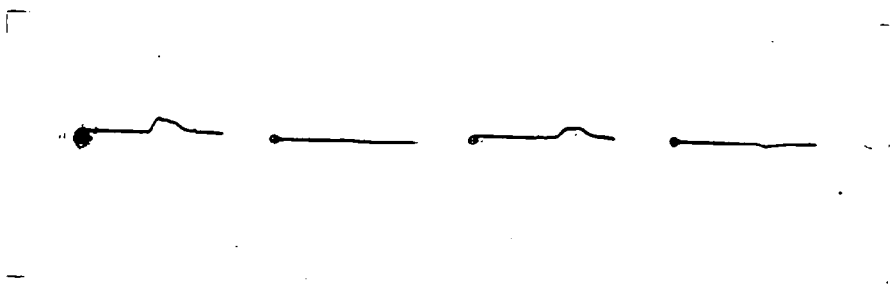

Figure 32 - Film taken on Harshaw sodium chloride.

In all the experiments described above the material used was sodium chloride grown as single crystals from the melt at Durham. By a comparison of photographs taken on a number of crystals using successive stress increments and alternate application of a potential it was found that most of the effects could be ascribed to the development of a potential, and that there was no evidence to confirm the change of conductivity found in sodium chloride by previous workers. This was somewhat surprising and it was decided to carry out experiments on single crystals of sodium chloride from other sources. A single crystal of sodium chloride grown by the Harshaw Chemical Co. of America became available at this time and some preliminary experiments were made using this material.

Experiments were performed in a similar way to those on Durham sodium chloride. Fig. 32 shows a typical experimental record using a Harshaw crystal. The specimen was maintained at a temperature of 140°C and the cathode follower head unit was used with an input resistance of 10^8 ohms. The first and third exposures on the film were taken with the application of a potential to the crystal, and the second and fourth

without the application of potential. All four exposures were taken with as far as possible equal increasing increments of stress. It was not easy to judge this with the existing apparatus, such equal stress increments being a matter of judgment of the degree of resistance encountered in rotating the screw of the vice. However a number of films of this type were taken and it was always possible to detect differences between those exposures where a potential had been applied to the crystal and those without. In all cases there was clear evidence of a conductivity change (the upward deflection of the spot was in the correct sense for a conductivity increase). The fourth exposure in fig. 32 shows the appearance of a potential effect though slight in magnitude in this case. The actual value of the conductivity of the crystal can be seen on the first and third photographs as the difference between the zero level trace (as indicated by the dark spot at the left before the sweep across the screen was started) and the actual trace before the conductivity increase on deformation appeared.

Experiments were also performed on Harshaw crys-

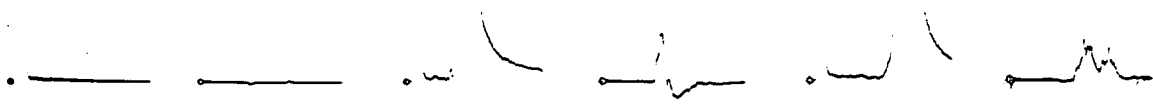

Figure 33 - Film taken on Harshaw sodium chloride.

tals using the electrometer valve and amplifier, and consequently with a much larger value of the input resistance. Fig. 33 is an experimental record with a grid lead of 10^{10} ohms and the crystal at a temperature of 85°C . There are six exposures on the film, numbers one, three and five were taken with a potential applied to the crystal and the others without. The first two exposures have been taken without the application of stress to the crystal but the remaining four exposures were taken with approximately equal increments of stress. The large conductivity increase can be seen in the third and fifth exposures. The maximum value of the increase is off scale but an estimate of its magnitude shows that there is about a fiftyfold increase in conductivity. On the fourth and sixth exposures on the film the effect ascribed to the development of a potential can be clearly seen. It is at times above and below the zero trace line, during the application of stress, thus indicating a change in sign of the potential during a stress application.

Liquid silver electrodes were formed on the sides of a Harshaw crystal and stress was applied to two other opposite faces of the crystal. The resulting experimental record differed very little from those obtained

with stress applied normal to the electrodes on the crystal. The conductivity increase was quite definite and there was also clear evidence of a potential effect.

At this stage experiments with the second stress apparatus were abandoned since it was decided that a more refined apparatus was necessary to investigate more precisely the phenomena that had been discovered. With the existing apparatus it was clear that for any given stress above the yield point of the crystal plastic flow would take place and the value of the effective applied stress would be reduced. In order to remove the ambiguity over the nature of the stress applied and in order to measure its value a third stress apparatus was constructed as described in sec. 4.4. With this apparatus it was possible to apply constant stresses to the crystal and it also enabled measurements to be taken over a wider range of temperature than had been possible before.

It will be convenient to describe the remainder of the work carried out under two headings. In chapter 7 the experiments dealing with the conductivity increase and in chapter 8 those dealing with the potential effect will be given. The experiments were

not in fact carried out in that order, indeed many experiments could give facts about the two phenomena at the same time.

7. THE INCREASE IN CONDUCTIVITY OF SINGLE CRYSTALS OF THE ALKALI HALIDES UPON MECHANICAL DEFORMATION

7.1 EXPERIMENTAL ARRANGEMENT

The size of crystal used was generally about 1.1 x 1.1 x 0.5 cm and opposite faces were roughened with emery paper and painted with colloidal graphite as previously described. The crystal under test was placed between the lower brass electrode and the upper brass plunger of the stress apparatus. It was later found advantageous to place discs of cardboard between the crystal and the brass cylinders as this reduced the magnitude of the potential effect. This will be described later in chapter 8. In order to make electrical contact the graphite electrodes on the crystal were connected to the brass cylinders by thin strips of aluminium foil. The stress was applied to the crystal through the helical steel spring which was fully compressed by a force of 41.5 Kg. It required 19 half-turns of the lead screw of the vice before the spring was under full compression and therefore each half-turn corresponded to a force increment of 2.15 Kg, or a stress increment of about 2 Kg/cm^2 on a normal specimen. Stress could still be applied to the

crystal once the spring had been fully compressed. However the actual value of the stress could only be very roughly guessed and the loading was subject to the same limitations as with the second stress apparatus, i.e. it was not taking place at constant stress.

The experiments were carried out at various temperatures and the procedure of bringing the crystal up to the correct temperature was rather tedious. The heater was switched on until the crystal had reached the required temperature as indicated by the thermojunction. At this point the heater was switched off and the furnace allowed to cool to the correct temperature (because of the thermal lag the temperature had risen slightly above the required value). If the furnace was now switched on there was found to be another thermal lag during which the temperature remained steady (or even tended to fall) and immediately it started to rise the heater was switched off. Measurements were then taken and could usually be completed during the period of some twenty seconds during which time the temperature of the crystal was steady to within 2°C of the required value. At high temperatures this procedure was not easy to carry out and conductivity

measurements had to be effected with some speed if there was not to be a considerable fall of temperature in the meantime.

It was usual to take a series of photographs on any one crystal with stress increments from the minimum to 40 Kg/cm^2 in half-turns of the screw of the vice, Alternate exposures were made with and without a potential applied to the crystal. In order to make possible photography of the trace over a longer time the single sweep time base of the cathode ray oscilloscope was lengthened to 3 sec by the addition of extra external condensers to the time base circuit. This procedure also had the advantage that it was not necessary to hasten unduly the application of stress to the crystal after the sweep of the time base had been started. This had in fact been rather inconvenient when the time base had been 1 sec or shorter.

The conductivity (both initial and permanent) of the specimen was first measured and the sensitivity of the amplifier etc. adjusted until the conductivity was shown as a deflection of a few mm on the screen when a potential of 120 V was applied to the crystal. This practice was adopted so that large increases in conductivity under stress were still shown on the screen and



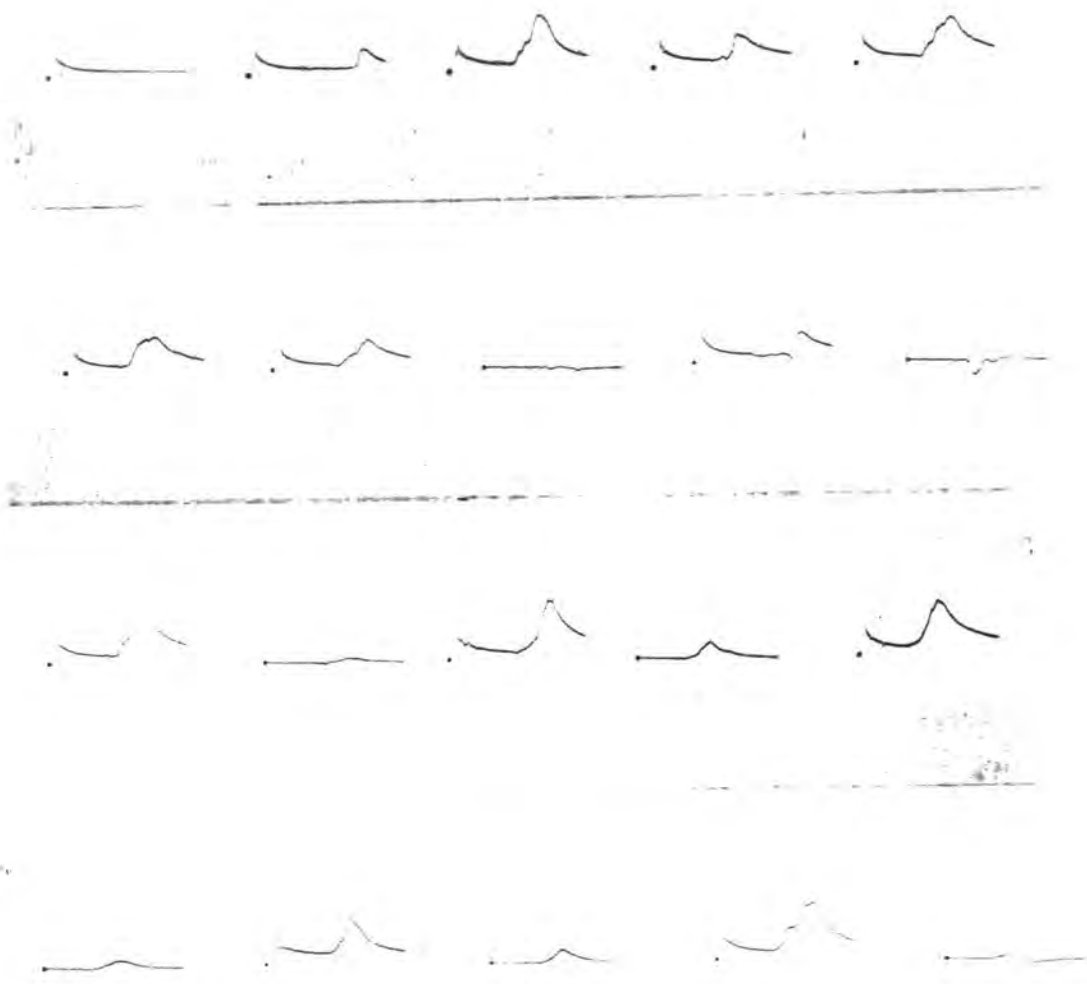

Figure 34 - Film taken on Harshaw potassium chloride.

did not go off scale.

A typical film record is shown in fig. 34 and was taken with a crystal of Harshaw potassium chloride at a temperature of 132°C . The first exposure shows only the ionic conductivity of the crystal in the absence of any applied stress and with a potential of 120 V applied. Stress increments were then applied to the crystal so that the total stress on the crystal was continually increased. Exposures two to seven shows the increased conductivity on application of stress to the crystal, each stress increment applied during the sweep being about 2 Kg/cm^2 . No potential was applied to the crystal for exposure number eight though the application of stress increments was still continued. Thereafter the exposures were taken alternately with and without the application of a potential to the crystal. The last exposure was taken with the spring at its limit of compression and the stress increment here was rather larger than normal. It will be seen that the potential developed was somewhat larger than the previous values. The increase of conductivity of the crystal shown in fig. 34 was not large being only some 5 - 10 times the value of the permanent conductivity for a stress increment of about 2 Kg/cm^2 . It was usual to

continue the application of stress to the crystals beyond the limit of compression of the spring. The stress increments were applied as a given small rotation of the screw of the vice and were roughly equal in magnitude although their actual value was not known. This was particularly necessary with some crystals where, as will be seen later, a conductivity increase did not appear at stresses below the limit of compression of the spring.

7.2 CONDUCTIVITY MEASUREMENTS

It was decided to make measurements of the conductivity (both initial and permanent) of all the crystals that were examined for conductivity changes under mechanical deformation. This was usually performed on a separate sample of a given crystal and was carried out at points over a range of temperature.

The crystal specimen (of similar size to those used for conductivity change measurements) with graphite electrodes applied was placed in the stress apparatus with only a small applied stress to hold it in place. The conductivity was determined at a series of temperatures over the range 100 - 320°C and in each case a graph was drawn of log conductivity against $10^3/T$, where

T was the temperature in degrees absolute. This graph was a straight line in all cases. A potential of 120 V was applied to the crystals in the conductivity determination, and an appropriate sensitivity range of the amplifier and suitable value of the input resistance of the electrometer valve were used. The observations were carried out visually and since there was a transparent ruled scale across the face of the cathode ray tube screen it was possible to note accurately the deflection of the spot on the application of the potential. Initial conductivity was obtained from the immediate deflection of the spot and the permanent conductivity was obtained from the deflection after allowing a period of about one minute to elapse after the application of potential.

From the log conductivity against $10^3/T$ graphs it was possible to obtain the activation energy from the slope. The conductivity may be represented by the equation

$$\sigma = A \exp(-E/kT),$$

where σ is the conductivity, A is a constant, T is the absolute temperature, k is Boltzmann's constant and E is the activation energy. The equation gives

$$\log_e \sigma - \log_e A = -E/10^3k \cdot 10^3/T,$$

	Specific conductivity at $10/T = 2.3$. $\text{Ohm}^{-1}\text{cm}^{-1}$.	Activation energy in eV.
<u>Samples of NaCl.</u>		
Harshaw	2.46×10^{-13}	1.12
Taylor, Taylor & Hobson	1.91×10^{-12}	1.10
Aberdeen	5.65×10^{-10}	0.96
Durham	2.38×10^{-10}	1.06
Hilger	4.94×10^{-12}	0.96
Korth	1.43×10^{-12}	1.08
<u>Samples of KCl</u>		
Harshaw	4.13×10^{-14}	0.88
Durham	6.56×10^{-12}	0.90
Hilger	3.01×10^{-13}	0.96
Hilger (with F-centres)	1.51×10^{-11}	0.62
KBr - Hilger	4.69×10^{-12}	0.79
NaI - Hilger	1.81×10^{-10}	0.43
KI - Harshaw	2.18×10^{-13}	0.82

Table 1 - Conductivities and activation energies of alkali halide crystals.

Crystal	Conductivity increase (times) for a stress incre- ment of 2 Kg/cm ² .	Specific conductivity before deformation	Specific conductivity after deformation
<u>KCl</u>			
Durham	6.2	1.1×10^{-13}	6.8×10^{-13}
Hilger	88	2.5×10^{-15}	2.2×10^{-15}
Hilger (coloured)	2.0	2.4×10^{-14}	4.8×10^{-14}
Harshaw	12	5.9×10^{-15}	7.4×10^{-15}
Harshaw KI	7.5	3.2×10^{-14}	2.4×10^{-14}
Hilger KBr	only found at high stresses.		
Hilger NaI	only found at high stresses.		
<u>NaCl</u>			
Aberdeen	None	Etchpits per cm ² . 5×10^3	
Durham	None	4×10^3	
Harshaw	only found at high stresses.	30×10^3	
Hilger	None	3×10^3	
Korth	None	3×10^3	
Taylor Hobson	None	15×10^3	

Table 2 - The conductivity increase for various samples of alkali halides.

and hence the slope of the graph should be

$$-E/10^3 k$$

with an appropriate correction since a graph of $\log_{10} \sigma$ was in fact plotted. The value of k can easily be converted to give E in eV.

Conductivity determination were carried out on a wide range of samples of alkali halides and the results of the conductivity measurements (including activation energies) are given in table 1.

7.3 THE CONDUCTIVITY INCREASE

A large number of samples of alkali halides were obtained from various sources and experiments were carried out to find if they showed an increase in the conductivity on mechanical deformation. The following crystals were examined: from Messrs. Hilger Ltd, KCl, NaCl, KBr, NaI, and KCl which had been coloured by the presence of F-centres introduced by heating with excess of the alkali metal; from the Harshaw Chemical Co., NaCl, KCl and KI; from Aberdeen University, NaCl; from Dr. Korth of Kiel, NaCl; from Messrs. Taylor, Taylor and Hobson, NaCl; NaCl and KCl grown at Durham.

The results of the measurements carried out on the above crystals are summarised in table 2. It will be

noticed that all the samples of potassium chloride examined showed clear evidence of a conductivity change for stresses above the yield point. Of the crystals examined Harshaw and Hilger potassium chloride showed this conductivity change to a striking degree, changes in conductivity of a hundredfold being easily obtainable.

The sample of Harshaw potassium iodide also showed the conductivity change quite clearly at low stresses but with the samples of Hilger potassium bromide and sodium iodide the position was not quite so clear. It was found with this crystal that the conductivity change could not be detected with the stress increments of 2 Kg/cm^2 applied up to the limit of about 40 Kg/cm^2 . The yield stress for sodium chloride is about 10 Kg/cm^2 and was probably not very different for this crystal. If the crystal was stressed above the limit of 40 Kg/cm^2 the conductivity change did appear although the stress increments were larger than had been applied during the compression of the spring in the stress apparatus. It seems that the difference between the phenomena in Hilger potassium bromide and sodium iodide and other crystals is one of magnitude and the increased con-

ductivity can only be detected when a much greater amount of plastic flow takes place in the crystal.

The results with samples of sodium chloride were very surprising since only with one crystal could a conductivity increase be detected. This occurred with Harshaw sodium chloride and then only at stresses greater than the compression limit of the spring. The crystal behaved in a very similar way to the crystal of potassium bromide just described. In all the other samples of sodium chloride no conductivity change could be observed. It was possible with the electrical apparatus to record a change of 10% in the conductivity but no such increase was found. When in fact increases of the order of 10,000% had been detected, this seemed to be a very reasonable limit of sensitivity for the detection of the phenomena. The application of stress to the crystal was carried out almost to the point of destruction. Many crystals developed a large number of internal cracks and they fell to a powder on removal from the apparatus. Considerable plastic flow had taken place as the crystal was found to be grossly distorted in shape on being removed and irregular markings found on the external faces indicated the extent of the slip process. At

these high stresses (greater than 40 Kg/cm^2) the phenomenon of recrystallisation was also found (see sec. 1.3) and the irregular orientation of the polycrystals could be seen by examining the surface of a cleaved face by reflected light. It seems therefore that the non-detection of the phenomena of a conductivity increase under mechanical deformation for many sodium chloride crystals can not be attributed to the failure to apply sufficient stress or to any lack of sensitivity of the electrical side of the apparatus used.

7.4 THE TEMPERATURE DEPENDENCE OF THE CONDUCTIVITY CHANGE

Ideally it was desirable to take a specimen of a given crystal, to place it in the stress apparatus and to determine the increase in its conductivity at various temperatures for constant increments of applied stress. This experiment was not completely possible since there were only a small number of stress increments available in the range from zero stress to the limit of 40 Kg/cm^2 and the whole of the temperature range desired could not be covered with one crystal specimen. Accordingly the experiments had to be carried out using a number of specimens cleaved from

	Temperature in °C.	Conductivity in- crease as a %.	Conductivity increase common scale.
Crystal I	166	67	67
	208	75	75
	208	293	75
	228	288	74
	290	45	12
	321	38	10
Crystal II	352	20	5
	373	10	2.5
	394	0	0
Crystal III	97	5000*	-
	120	800	755
	143	240	226
	166	71	67

* This value is very doubtful - the potential effect here is large and it is almost impossible to separate the conductivity increase from it.

All the readings on any one crystal were taken with a constant value of stress increment.

Table 3 - The variation of conductivity increase with temperature for Harshaw KCl crystals.

the same crystal. This would have been a perfectly satisfactory procedure if the results for different specimens under identical conditions had been reproducible. Although there was broad agreement in the conductivity increase for specimens from the same crystal, there could sometimes be a difference of as much as 300% in the increase at any one temperature. The process was therefore adopted of averaging out the results for a number of specimens. With any one specimen, readings were taken at a limited number of points over the temperature range from 100 - 400°C. This process was repeated with a number of specimens from the same crystal and although there were differences in the increases recorded at any one temperature, the general trend of the variation of the conductivity increase with temperature was substantially the same in all cases. Table 3 illustrates this process for a crystal of Harshaw potassium chloride.

Measurements were carried out on a crystal of Harshaw potassium chloride since in this particular crystal the value of the conductivity increase was large for any given stress and also because the magnitude of the potential effect was small. In actually carrying out the experiments alternate photographs were taken

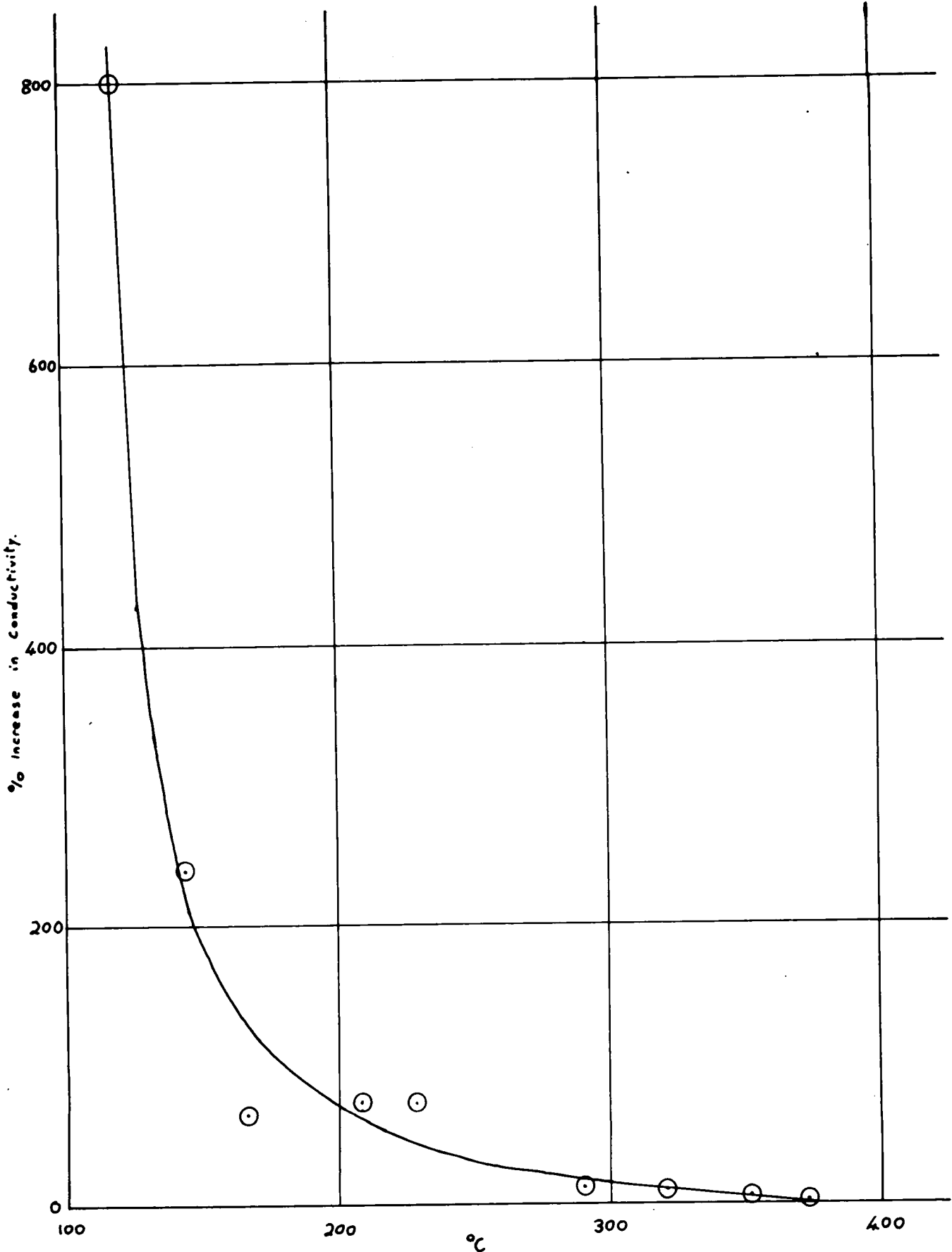

Figure 35 - Conductivity increase/temperature for Harshaw KCl.

as described with and without potential applied, and the conductivity change separated from the potential effect by a comparison of successive photographs. The results of the experiments are shown in fig. 35 where a graph of % conductivity increase against temperature in $^{\circ}\text{C}$ is plotted for the constant ($2\text{Kg}/\text{cm}^2$) stress increment applied. The highest value of the conductivity increase shown in the graph is at a temperature of 120°C . Higher values of the increase were recorded at lower temperatures but the measurements at this end of the range were somewhat uncertain since it was difficult to separate the contribution from the potential effect which was considerable here. Also there were wide variations in the magnitude of the increase from specimen to specimen so there was insufficient evidence to deduce the form of the graph below a temperature of 120°C .

7.5 FURTHER EXPERIMENTS

It was always found in examining the conductivity increase that once an increased conductivity had been obtained for a given value of stress, that if the stress was removed the conductivity increase could not be produced again on increasing the stress until the previous

value of the stress had been exceeded. However it should be noted here that there was found to be a slight conductivity increase at stresses just below the maximum value of the stress previously applied - this seems to agree with the findings of Gyulai and Hartly (1928). Apart from this very slight effect the conductivity increase does seem to be associated with the plastic flow in the crystal since alkali halide crystals are known to work harden after flowing at any given stress (see Schmidt and Boas 1936). Thus any stress below the new yield stress would not give rise to plastic flow and there would be no appearance of the conductivity change. If however the crystal were annealed it would be expected to revert to its strain free state and the yield stress would fall to the intrinsic minimum. In this condition low stresses should cause plastic flow and give rise to a conductivity increase.

This experiment was performed with a crystal of Harshaw potassium chloride. The crystal had graphite electrodes applied and its conductivity was measured at a temperature of 132°C . The usual stress increments were applied and the average value of the conductivity increase was determined. The crystal was then

Total applied stress in Kg/cm ² .	Conductivity increase (arbitrary units)	Conductivity in- crease after annealing at 600
6	-	2.3
8	1.5	-
10	-	2.0
12	2.5	-
14	-	1.5
16	2.8	-
18	-	1.5
20	3.3	-
22	-	2.0
24	2.8	-
26	-	1.7
28	3.3	-
30	-	2.0
32	2.7	-
34	-	2.0
36	-	-
38	-	3.0

The stress increments were 2 Kg/cm² and where a dash is shown in the table the stress increment was applied though a conductivity measurement was not made. Measurements were made at 132°C.

Table 4 - Effect of annealing on the conductivity increase in a Harshaw KCl crystal.

removed from the stress apparatus and was placed in a furnace which was slowly taken up to a temperature of 600°C and was maintained at this temperature for a few hours. The furnace was then allowed to cool down to room temperature over a period of 12 hours and the graphite electrodes which had been oxidised during the annealing were replaced. The crystal was then replaced in the stress apparatus and the conductivity change was redetermined under identical conditions to those before annealing. Although the crystal had been stressed to 34 Kg/cm^2 before annealing the conductivity increase now appeared at about 6 Kg/cm^2 . The actual value of the conductivity increase for a given stress increment was found to be about the same as before. The actual results of this experiment are given in table 4.

It was confirmed with various crystals that the magnitude of the conductivity increase was directly proportional to the value of the stress increment applied. The experiment was not easy to carry out with any degree of thoroughness with the stress apparatus available since it was not possible to apply the stress increment in a time small compared to the rate of decay of the conductivity increase. By applying different stress incre-

Harshaw potassium chloride at a temperature of 127°C. The specimen had graphite electrodes and cardboard discs were used to eliminate any potential effect.

<u>stress increment</u>	<u>Conductivity increase</u>
2 Kg/cm ²	20 times (average of six readings)
1 "	12 " (average of four readings)
0.5 "	4 " (average of two readings)

Table 5 - The variation of the conductivity increase with the applied stress increment.

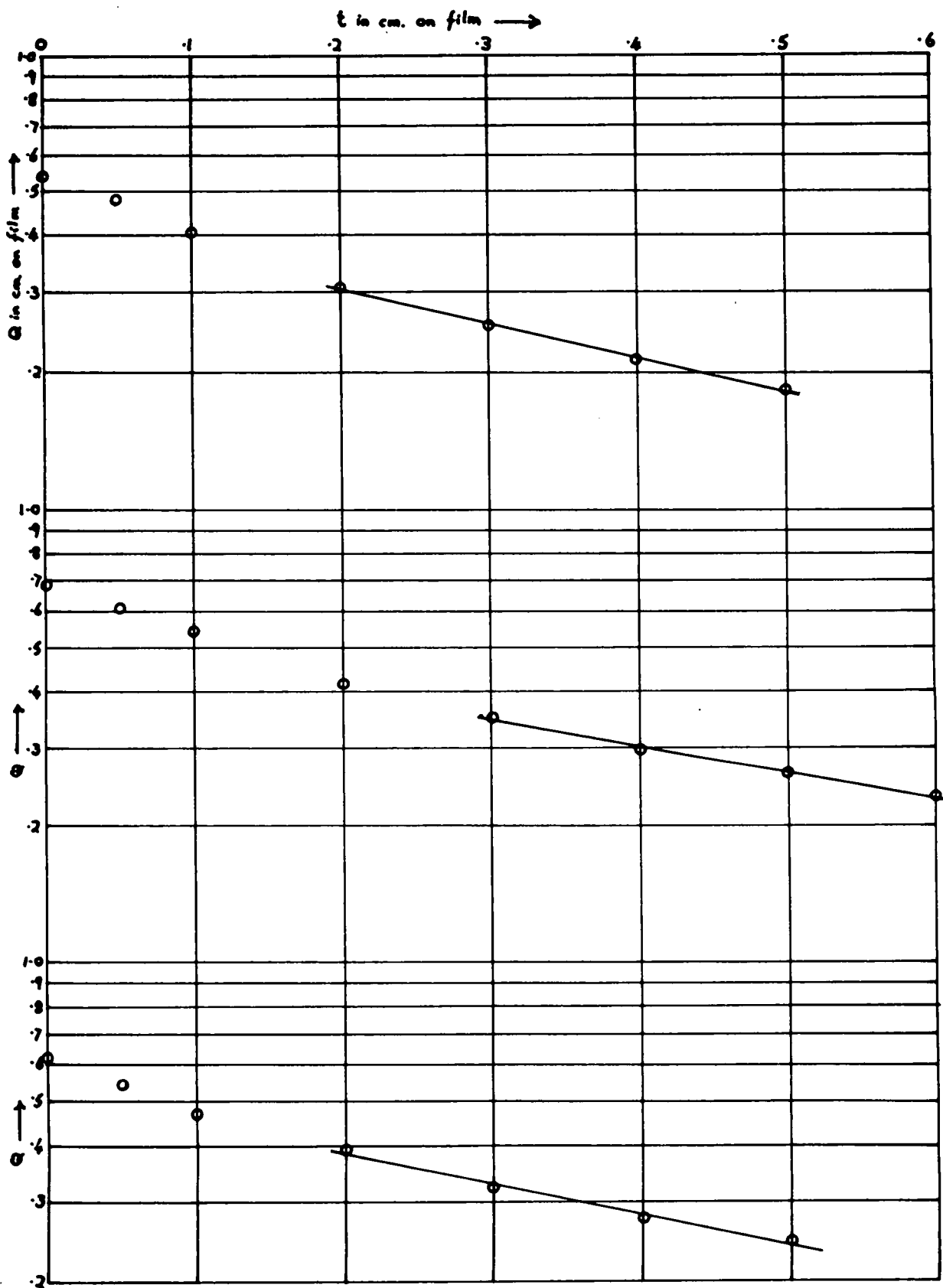

Figure 36 - The decay with time of the conductivity increase.

ments expressed as fractional rotations of the screw of the vice ($\frac{1}{8}$, $\frac{1}{4}$, $\frac{1}{2}$ etc), and by noting the corresponding conductivity increase for any one specimen at a given temperature, it could be shown (over a limited range of stress increments) that provided the stress increment was rapidly applied the conductivity increase was directly proportional to the magnitude of the stress increment. This is illustrated in table 5.

From the photographs of the conductivity increase on application of stress for various crystals an analysis was made of the shape of the decay curve of the conductivity. The films were measured up by means of a travelling microscope and a set of values of Q (the conductivity current) and t (the time) were obtained (see the analysis of an exponential curve given in sec. 3.6). The quantities Q and t were plotted on logarithmic graph paper and fig. 36 shows such graphs obtained from photographs of conductivity decay curves of a sample of Harshaw potassium chloride. It will be seen that the points lie very approximately on a straight line, showing that the decay is nearly exponential, especially for large values of t . The time constant of decay T has been calculated from the

formula of 3.6.

$$T = (t_2 - t_1) / (\log_e Q_1 - \log_e Q_2).$$

The average value of T for the three curves shown was T = 1.1 sec, the temperature at which the conductivity increases under stress were obtained being 132°C. Analysis of curves for crystals of Harshaw sodium chloride and Harshaw potassium iodide gave values of T of 0.3 and 0.8 seconds respectively, the temperature of the experiment being 109°C. These values of T seem to be in very good agreement with the values found by Gyulai and Boros (1940) since they found that the conductivity increases for potassium chloride and potassium bromide dropped to half their peak values after 0.2 - 0.3 sec. This would correspond to a time constant of decay of about 0.3 - 0.4 sec assuming that the decay curves were exponential. Detailed measurements were not made on the other crystals examined for the conductivity increase under stress but a rough qualitative assessment of the decay time constant was made by visual observation of the decay of the conductivity increase. The values of T in all cases were estimated to be of the same order of magnitude, i.e. in the range 0.3 - 1.1 seconds.

7.6 ETCHPITS

Amerlinckx (1954) has reported that when fresh cleavage faces of artificially grown single crystals of sodium chloride are etched in alcohol, well developed etchpits are obtained in a reproducible way, and results were obtained which led to the conclusion that there was a one-to-one correspondence between etchpits and dislocations. The cleavage faces of well-annealed specimens were found to consist of slightly disorientated grains and after etching the boundaries of these zones could be resolved into rows of well defined etchpits. That the substructure revealed in this way was a genuine structure of the material was proved by the fact that both halves of a cleaved specimen produced etch patterns which were mirror images.

In Amerlinckx's work two types of etchpits could be distinguished: (1) etchpits in low-angle grain boundaries, (2) etchpits distributed apparently at random and corresponding to a three dimensional network of dislocations. The observed density of etchpits belonging to the type (2) was of the order of $10^4/\text{cm}^2$. Taking into account the etchpits in grain boundaries, the total density became of the order of

$10^5/\text{cm}^2$. Experiments also showed that rows of etch-pits could be seen associated with slip traces in crystals that had been plastically deformed.

It was decided to attempt to take photographs of the etchpits on surfaces of specimens of the various sodium chloride crystals that had been used for experiments on the conductivity increase, in order to obtain some information on the numbers of dislocations present in these crystals. A microscope was available which could be adapted to throw the image of the object on to either a ground glass screen for visual observation or a photographic plate for recording. The specimens were cleaved from the crystals and were about 5 x 5 x 1 mm in size. It was found convenient to cement the lower surface of the specimen to the glass slide by a thin smear of rubber solution. This held the specimen in place on the slide and the rubber solution was sufficiently transparent not to interfere with the transmission of light through the crystal. The upper face of the specimen was always the freshly cleaved surface and as soon as the specimen had been attached to the slide it was etched by wiping lightly with a fine brush dipped in absolute methyl alcohol. The surface of the crystal was then dried rapidly in a stream of warm air

from a hair dryer. The stream of warm air was also allowed to play over the specimen whilst on the stage of the microscope. This prevented the deposition of water on the surface during observation of the etch-pits. The optimum time of etching appeared to vary from specimen to specimen but in many cases it was found preferable to make the etching time as short as possible. This amounted to one stroke of the brush dipped in alcohol across the face of the crystal and then immediate drying of the surface in the warm air stream.

Sub stage illumination was provided by a 24 watt bulb and it was found advantageous to stop down the iris in the condenser in order to increase the contrast in the final image. A 10X objective was used and this gave a magnification of about 50 when the image was focussed on the ground glass screen or photographic plate (the camera was conveniently constructed so that both the ground glass screen and the photographic plate lay at the same distance from the objective and it was easy to switch the light beam from one to the other). When the upper surface of the specimen was correctly focussed very little could be seen on the screen, but on slightly moving the image out of focus the etchpits



(a) Korth NaCl

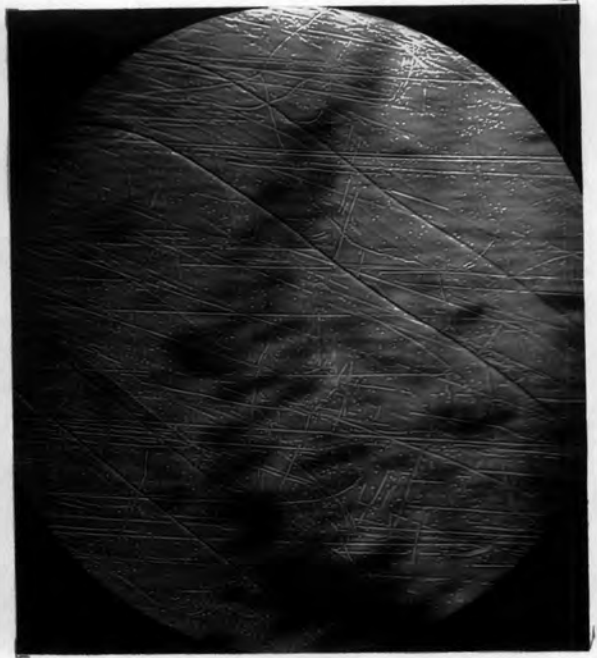

(b) Korth NaCl

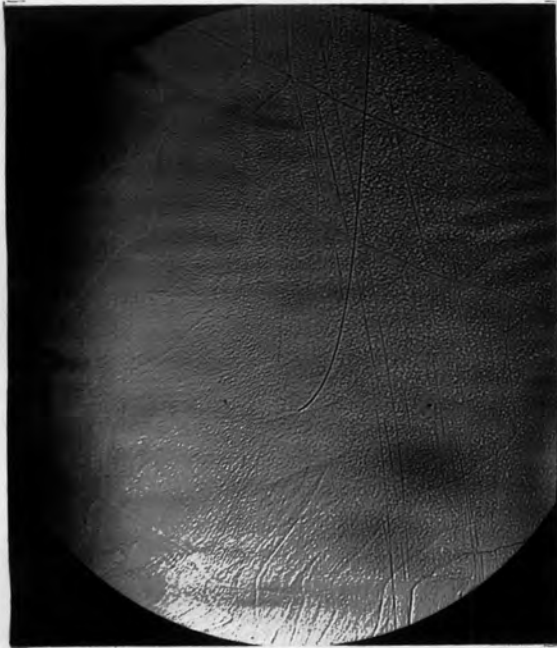

(c) Korth NaCl (deformed)



(d) Aberdeen NaCl.

Figure 37 - Etch pit photographs (X50)

showed clearly as light or dark coloured dots (depending on whether the objective was focussed slightly above or below the surface of the crystal). All photographs were in fact taken with the etchpits showing as light coloured spots. Cleavage steps could also be seen on many specimens but these could usually be easily distinguished from any lines due to rows of etchpits. The cleavage steps usually ran in roughly parallel bands across the face, and the larger steps showed as a light and a dark band running side by side on the photographic plate. The photographs were taken on Kodak B 20 high contrast process plates and exposure times were about 20 sec with the intensity of the sub-stage illumination reduced for photography by a variable resistance in series with the filament of the lamp.

Positives of some of the photographs of the various specimens of sodium chloride are shown in figs. 37 & 38. In all cases the magnification was 50X. The first photograph taken on Korth sodium chloride shows clearly some examples of rows of etchpits forming low-angle grain boundaries. The irregular veining of the grain boundaries can be easily distinguished from some cleavage steps running as parallel lines across



(a) Durham NaCl

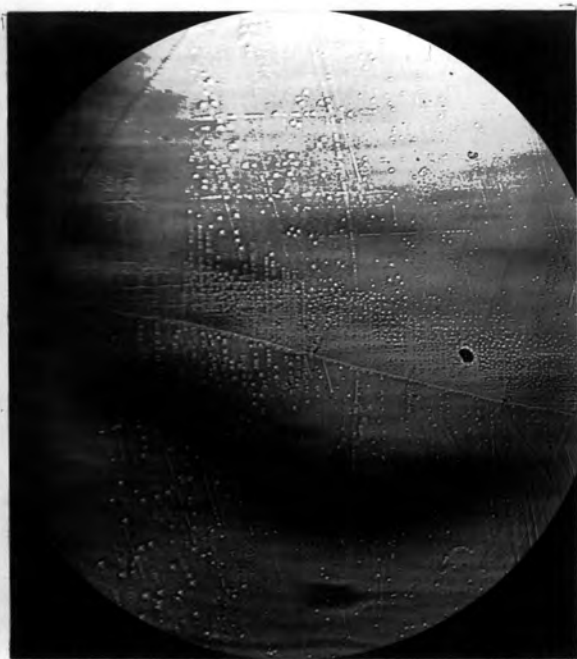

(b) Hilger NaCl.

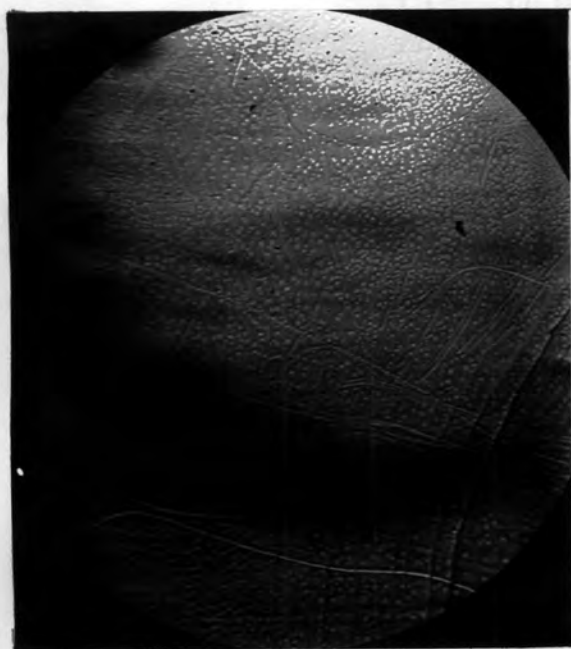

(c) Taylor Hobson NaCl

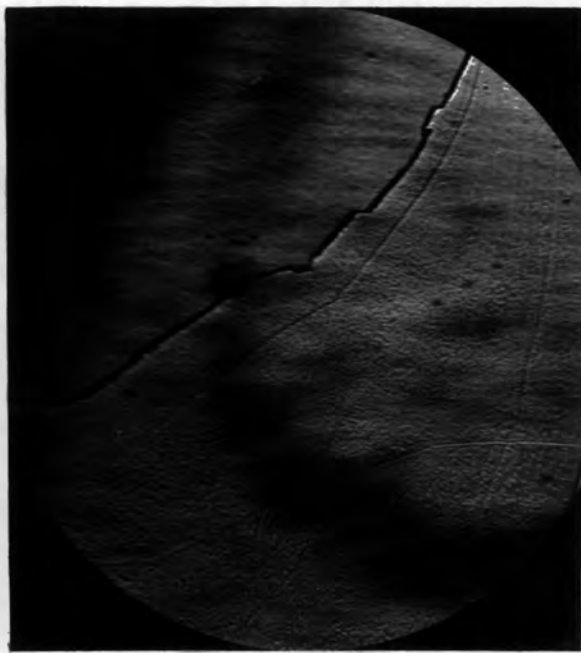

(d) Harshaw NaCl.

Figure 38 - Etchpits photographs (X50).

the photograph. The second photograph is also taken on Korth sodium chloride, but whereas the first photograph is typical, this photograph is remarkable for the large number of rows of etchpits running fairly regularly across the surface of the specimen. It may be that this specimen was slightly strained and it so happened that a large number of edge dislocations were running in the plane of the surface. Fig. 37(c) is a photograph taken on the same crystal but in this case the crystal was plastically deformed before being cleaved and etched. The large increase in the number of dislocations can be seen. Further plastic deformation increased considerably the number of etchpits but it was not possible to see them at this magnification. Fig. 38(b) is taken on Hilger sodium chloride and is interesting as it shows etchpits on slip lines just above the cleavage step running across the centre of the photograph. The specimen must have been slightly strained at this point since Amerlinckx shows photographs of this type for crystals that have been slightly deformed.

An estimate was made of the number of etchpits per square centimetre of crystal surface for all the samples of sodium chloride using these etchpit photographs and

the counts are recorded in table 2.

8. THE POTENTIAL EFFECT IN SINGLE CRYSTALS OF ALKALI HALIDES UPON MECHANICAL DEFORMATION

8.1 EXPERIMENTAL ARRANGEMENT

The experiments on the potential effect were carried out in the stress apparatus under similar conditions to the experiments on the conductivity change, the only difference being that the potential was not connected to the upper electrode of the crystal. The usual size of specimen was about 1.1 x 1.1 x 0.5 cm and colloidal graphite was applied to the electrode faces. The graphite coatings were in direct contact with the machined faces of the brass electrodes in the stress apparatus. Stress increments were applied to the specimens through the spring as described in sec. 7.1 for the conductivity change. The increments of stress were applied so that the total stress on the specimen was continually increased.

All the crystals mentioned in chapter 7 were examined for the presence of a potential effect and in all cases such an effect was found. A large part of the work was carried out on Aberdeen sodium chloride since some large single crystals of this material were available and also because the magnitude of the effect

Crystal	Potential effect (volts)
Durham KCl	0.06
Harshaw KCl	0.02
Hilger KCl	0.02
Hilger KCl (coloured)	< 0.01
Hilger KBr	- (only detected at high stresses)
Aberdeen NaCl	0.07
Durham NaCl	0.03
Harshaw NaCl	0.04
Hilger NaCl	0.07
Korth NaCl	0.04
Taylor Hobson NaCl	0.08
Hilger NaI	0.03

The potential effects were computed as averages for the various crystals irrespective of the sign of the effect. The stress increment was 2 Kg/cm^2 and the grid leak resistor 10^9 ohm . Cardboard discs were placed on the crystal electrodes.

Table 6 - The potential effect for various crystals.

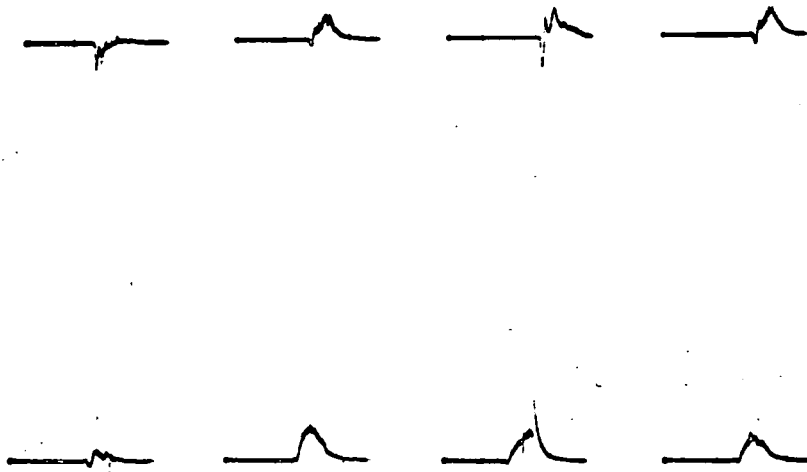

Figure 39 - Film taken on Aberdeen sodium chloride.

in this crystal was quite large for a given stress increment. Table 6 illustrates some of the values of the potential effect found with different crystals. It will be seen that there are no large differences in the magnitude of the potential effect from one crystal to another as has been found for the conductivity increase. A typical record taken on a crystal of Aberdeen sodium chloride is shown in fig. 39. The crystal was placed in the stress apparatus and stress was applied to the extent of three full turns of the screw of the vice. The eight exposures shown on the film are for successive stress increments of one half-turn of the screw. It will be seen that the first deflection was predominantly downwards with all further deflections mainly upwards. This phenomenon of the change of sign during an experiment i.e. with increasing total stress on the crystal was quite common. The sign of the potential effect frequently changed during the first few increments of stress applied to the specimen and further changes of sign at high stresses were also frequent. In some of the exposures on the film shown in fig. 39, especially on number five, a sharp "spike" or extremely fast deflec-

tion and return of the spot will be noticed. Visual observation of the screen confirmed that a spike was always associated with an audible noise generated by the production of a crack within the crystal.

Another feature of the photographs of the potential effect which is illustrated in fig. 39 is the particular type of deflection seen in exposures two to five - at first a deflection below the line changing to one above the line. This type of deflection (or the inverse i.e. deflection starting above the line etc.) was frequently seen in the experiments but no explanation was found.

Some of the photographs of the time variation of the potential effect with crystals of Aberdeen sodium chloride were analysed to determine the shape of the potential decay curve. In cases where the type of deflection was complex, this was always done on the later half of the trace i.e. on the final decay of the potential to zero. The traces on the recording film were measured up using a travelling microscope and an attempt was made to see if the curves were exponential. Using the formula given in sec. 3.6, the Q and t values (Q in this case being the

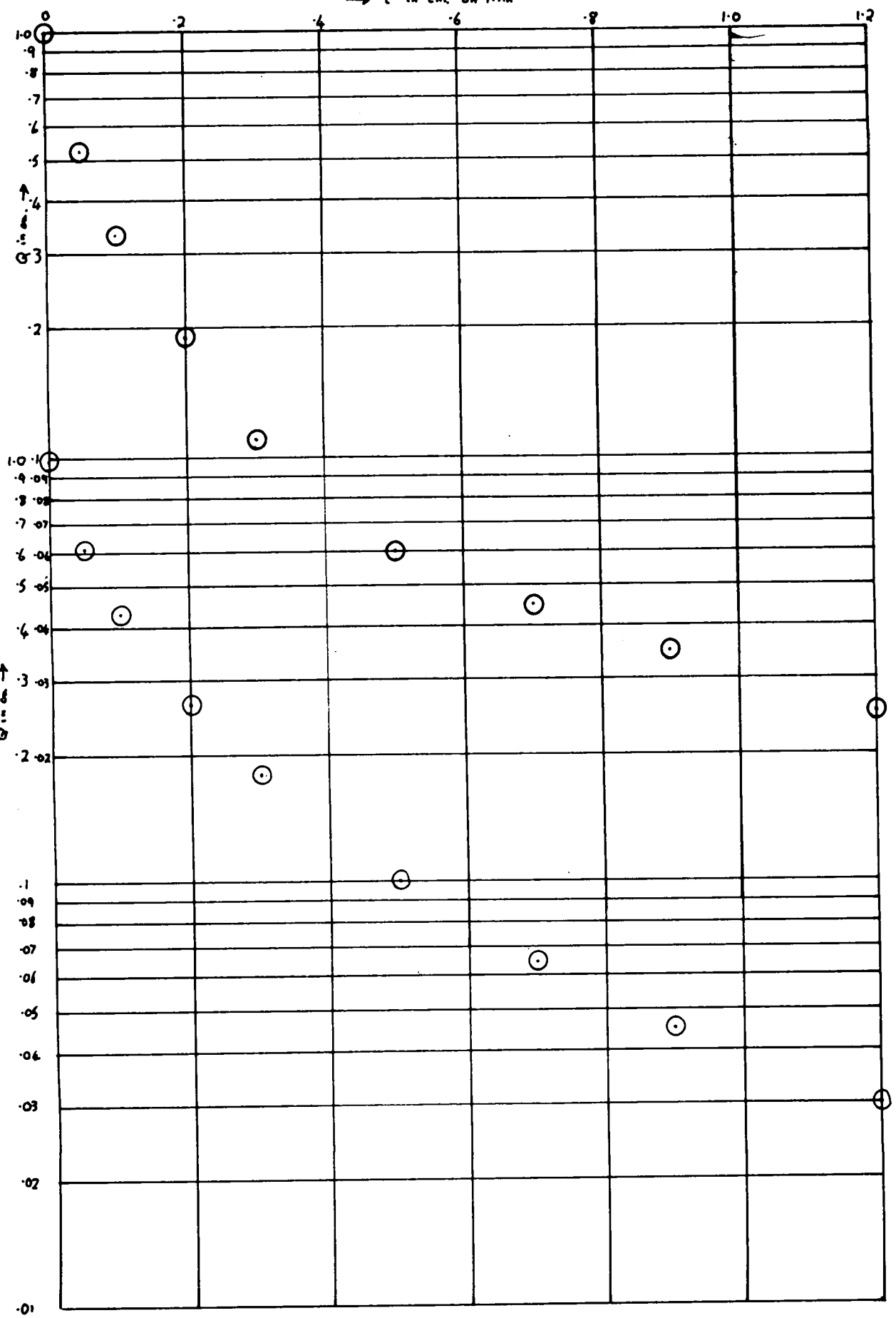

Figure 40ii- The decay with time of the potential effect.

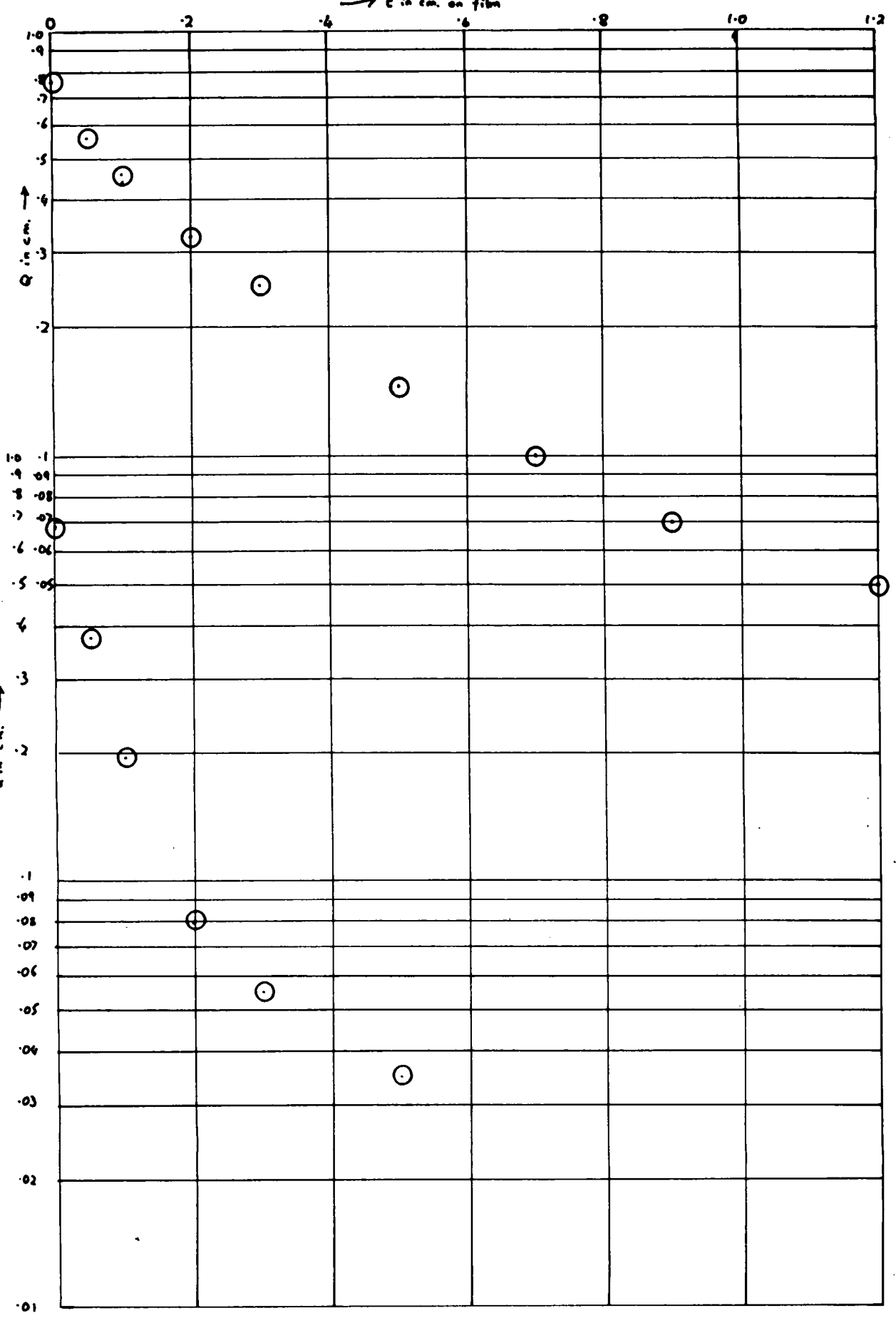

Figure 40(ii) - The decay with time of the potential effect.

magnitude of the potential developed and t the time) were plotted on logarithmic graph paper and are shown in fig. 40 for some curves taken on the same specimen at a temperature of 100°C . It will be seen that the curves are by no means exponential and the normal time constant of decay of an exponential curve can not be measured. However, defining the time constant as the time required for Q to drop to $1/e$ th of its initial value, it seemed to be in most cases of the order of 0.3 sec, thus being slightly smaller than the values found for the time constants of decay of the conductivity increases. The actual shape of the potential decay curve is best fitted by a hyperbola with axes formed by the zero trace line on the screen and by a vertical line drawn at the point where the time period of application of the stress increment has just ended.

8.2 INVESTIGATION OF THE NATURE OF THE POTENTIAL EFFECT

An important feature of the experiments on the potential effect was that it was not reproducible. Specimens of very similar shape and size were cleaved from a large single crystal of Aberdeen sodium chloride. The crystals were cut so that they were taken in success-

Potential Effect (arbitrary units)

Total Applied Stress. Kg/cm ² .	Crystal I	Crystal II	Crystal III	Crystal IV
2	- 0.8	+ 0.1	0	- 0.1
4	1.2	1.1	- 0.1	+ 0.4
6	0.9	1.0	0.2	0.4
8	1.0	1.2	0.2	0.4
10	0.4	0.1	0.1	0.1
12	1.0	1.2	0.3	0.4
14	0.9	1.0	0.3	0.4
16	- 1.2	+ 1.1	- 0.3	+ 0.3

The crystal I - IV were cleaved as four successive slices from a crystal of Aberdeen sodium chloride. Each specimen was placed in the apparatus the same way up as cut from the large crystal. Stress increments were 2 Kg/cm².

Table 7 - The variation of the potential effect for successive specimens of sodium chloride.

Potential effect (arbitrary units)

Total applied stress (Kg/cm²)

Crystal	2	4	6	8	10
Harshaw KCl	-	+ 0.4	-	+ 0.4	-
"	-	+ 0.1	-	+ 0.1	-
Harshaw KI	-	-	- 0.1	-	+ 0.1
Aberdeen NaCl	- 0.1	+ 0.1	+ 0.1	+ 0.2	+ 0.2
"	- 0.4	- 0.4	- 0.6	- 0.9	- 0.9
Harshaw NaCl	-	-	+ 0.2	+ 0.1	0
Durham NaCl	-	-	+ 0.3	-	+ 0.3
Taylor Hobson NaCl	-	-	+ 0.2	-	+ 0.1

Stress increments of 2 Kg/cm² were used. A dash in the table indicates that a measurement of the potential effect was not made at this stress value.

Table 8 - Values of applied stress at which the potential effect appeared for various crystals.

ive slices from the large crystal, the lower face of the first specimen having been in contact with the upper face of the next, and so on. The specimens were then tested for a potential effect at the same temperature (approx. 100°C) and under the same electrical conditions. Some results from this experiment are shown in table 7. Although a potential effect was found in all cases its magnitude and sign appeared to be quite random. In some cases the direction of the deflection was upwards when stress was first applied, in others the reverse. Furthermore the actual changes in sign of the potential effect during the further application of stress also appeared to be random.

A most important feature of the potential effect was revealed during these experiments - a potential frequently appeared before the applied stress had reached a value corresponding to the yield stress of the crystal (about 10 Kg/cm^2). Some typical experimental records showing this are given in table 8. The actual value of the applied stress at the onset of the potential appearance varied from specimen to specimen as well as from type of crystal in a quite random manner. In examining the conductivity change

no increases in conductivity were noted until the stress has reached the yield stress but in the case of the potential effect deflections were noticed on the screen from the first increment of stress (2 Kg/cm^2) in certain specimens. Since potential effects were present at stresses below the yield stress of the crystal it seemed highly doubtful that the potential effect was due to the process of plastic flow throughout the body of the crystal.

Experiments were carried out therefore to investigate whether the potential effect depended on the work hardening of the crystal. A crystal of Aberdeen sodium chloride with graphite electrodes was placed in the stress apparatus and four increments of stress were applied. During this stress application a potential effect was noted of a given sign. The stress on the crystal was reduced to zero and then reapplied, the crystal being left in the apparatus throughout and not touched in any way. During the reapplication of the first four increments of stress no potential effect was observed. On the application of the fifth increment the potential reappeared with the same sign and magnitude as before. The experiment could be repeated at a higher limit of

stress in the same way. It was always found that the potential effect could not be made to reappear at values of stress below the maximum value of stress that had been previously applied to the crystal, provided that the crystal was left untouched in the apparatus when the stress was removed after the first application. These experiments seemed therefore to indicate that the potential effect was associated with the process of plastic flow in the crystal since the effect was not found at stresses above which work hardening had taken place.

At this stage it was decided to investigate whether the potential effect could be made to reappear in a stressed crystal by annealing and the consequent reduction of the yield stress. A crystal was placed in the stress apparatus and stressed to a given limit. It was then removed and annealed at a temperature of 600°C for some hours. On removal from the furnace the graphite electrodes were renewed and the crystal replaced in the stress apparatus. It was then found that the potential effect could be made to appear at values of stress below the limit that had already been applied before

the annealing process. However the direction and magnitude of the potential that had been found previously for a specimen were not reproducible after the annealing process, although in some cases the results before and after annealing were fairly similar. The annealing process was extended to periods of a week at 550 - 600°C but the results on retesting the crystal were in no way different to those obtained with shorter periods of annealing. It should be mentioned here that these annealing experiments are by no means conclusive as changes in the potential effect were discovered when a specimen was merely removed and then replaced in the stress apparatus (see sec. 8.5).

8.3 THE TEMPERATURE DEPENDENCE OF THE POTENTIAL EFFECT

At this stage the experiments on the mechanical nature of the effect were discontinued in order to examine the way in which the effect depended on the temperature at which the experiments were carried out. A large number of experiments were performed on crystals of Aberdeen sodium chloride at various temperatures and an attempt was made to analyse the photographic records obtained. However the results were so random

in nature, both sign and magnitude, that it was not possible to obtain anything more than that the magnitude of the potential effect appeared to decrease with increasing temperature. A type of experiment was needed therefore where the potential effect was fairly reproducible for equal stress increments at a given temperature.

It was found that often in the course of an experiment on a crystal that apart from changes in the sign of the potential effect, there were periods during which the sign and magnitude of the potential were fairly constant for successive stress increments. During one of these period when the effect appeared to be reproducible the temperature of the crystal was changed and the next increment of stress was applied at a different temperature. In this way it was possible to cover a limited number of points in the temperature range to be investigated. The experiments were repeated on specimens of Aberdeen sodium chloride cleaved from the same single crystal. By combining the results on a number of specimens with fairly reproducible values of the potential effect at constant temperature, it was possible to plot the dependence of the potential effect on temperature,

	Temperature in °C.	Average potential (arbitrary units)	Potential on a common scale
Crystal I	97	1.3	1.3
	187	1.3	1.3
	282	0.05	0.05
	374	0.00	0.00
Crystal II	187	0.27	1.3
	208	0.12	0.58
	229	0.05	0.14
	238	0.00	0.

The potential was measured in all cases for a constant value of stress increment.

Table 9 - The variation of the potential effect with temperature in Aberdeen NaCl crystals.

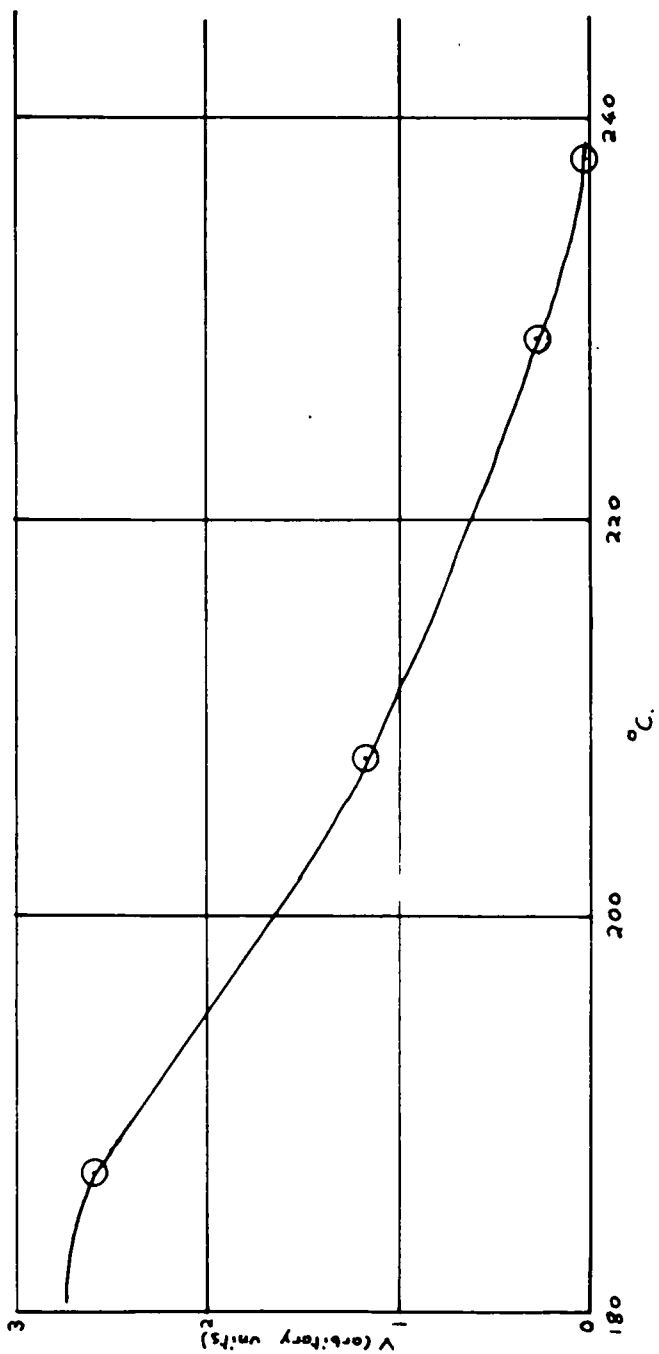

Figure 41 - Variation of the potential effect with temperature.

and this is shown in fig. 41. The values of the potential developed for different specimens were reduced to a common scale in arbitrary units of potential and each point on the graph represents an average for a number of crystals. This procedure was possible since the effect seemed to vary with temperature in a similar way for different specimens and the magnitude of the potential was equated to a common value at one particular temperature for a number of specimens. This is illustrated by some results shown in table 9. From fig. 41 it will be seen that the magnitude of the potential decreases with temperature becoming almost negligible at 250°C . The dependence of potential on temperature is not shown below 187°C since below this value there was too much variation in individual readings to be significant. It seems likely however that the rate of variation with temperature is smaller at temperatures below this particular value.

8.4 THE VARIATION OF THE POTENTIAL EFFECT WITH INPUT RESISTANCE

Particular care was taken with the measurements described under 8.3 to use the same value of the

input resistance of the potential measuring circuit (actually 10^8 ohms) when carrying out experiments at different temperatures. This was necessary since it was found that the value of the potential developed across the electrodes of a crystal under stress depended greatly on the value of the input resistance of the measuring circuit. This was in all practical cases the grid leak resistance of the electrometer valve or cathode follower and could vary from 10^6 - 10^{11} ohms. A few preliminary experiments showed that the magnitude of the potential decreased with a decreasing value of the input resistance of the measuring circuit.

A number of specimens of approximately similar size were cleaved from a crystal of Aberdeen sodium chloride and graphite electrodes were applied. The crystals were then placed in the stress apparatus and the potential effect measured at a temperature of 100°C . Four values of grid leak were used - 10^{11} , 10^{10} , 10^9 and 10^8 ohms. The value of the resistance of the specimens at this temperature was about 10^{12} ohms, this being considerably greater than all but the highest value of the grid leak. Readings of the potential effect were only taken when the sign and magnitude of

Crystal no.	Grid leak resistance (ohms)	Potential (volts)	Average potential (volts)
37	10^8	0.044	0.026
40	"	0.008	
35(13)	10^9	0.095	0.268
35(14)	"	0.127	
36(15)	"	0.316	
36(16)	"	0.372	
42	"	0.262	
43	"	0.284	
44	"	0.51	
41	"	0.175	
42	10^{10}	4.0	
43	"	2.51	
41	"	2.57	
42	10^{11}	9.1	8.83
43	"	8.51	
41	"	8.90	

Measurement at 100°C .

Table 10 - The variation of the potential effect with the input resistance for crystals of Aberdeen NaCl.

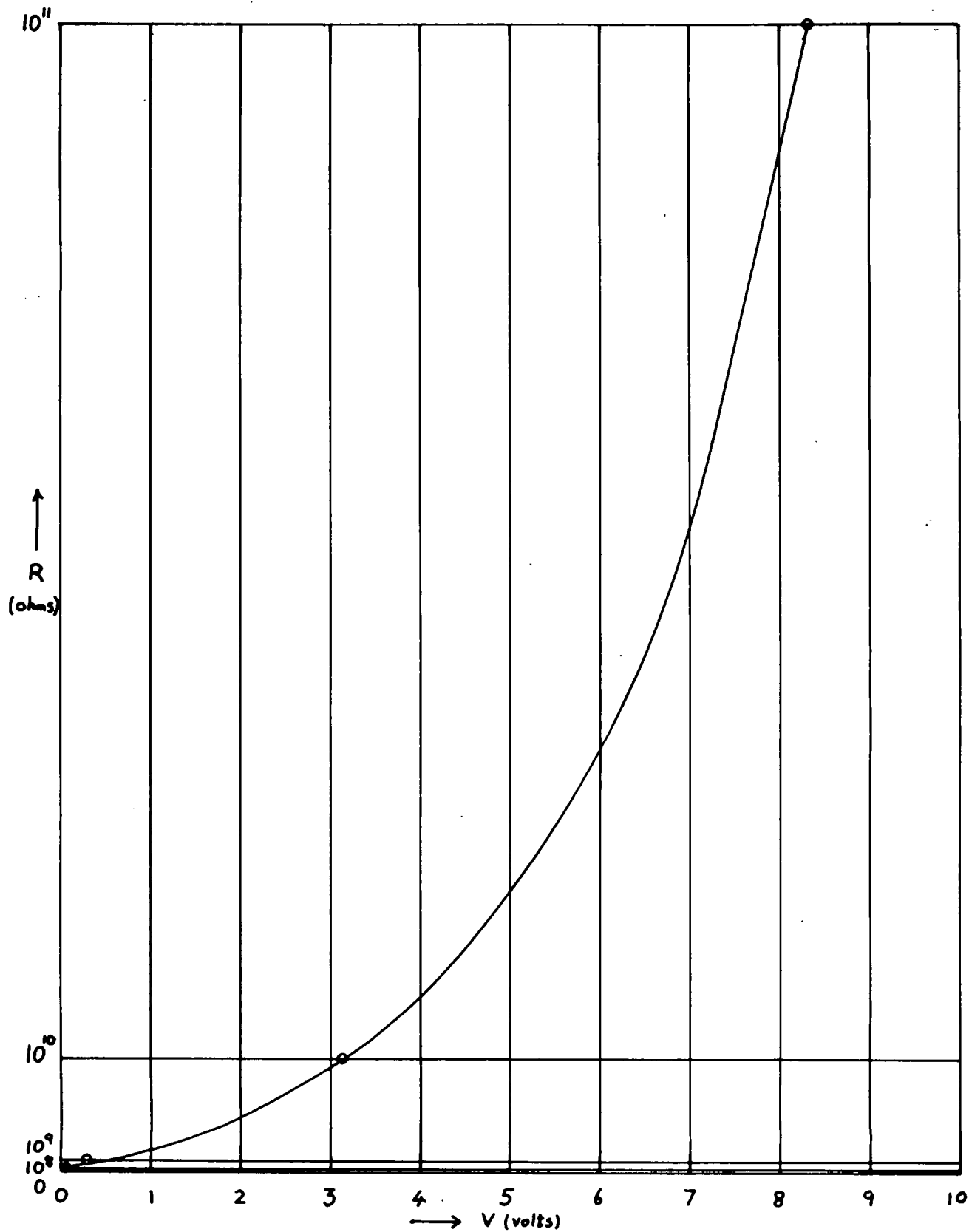

Figure 42 - Variation of the potential effect with input resistance.

the potential was steady for successive stress increments under identical conditions and then the potential was measured using all four values of grid leak resistance in turn. The actual magnitude of the potential at any value of grid resistance varied from specimen to specimen but the form of the variation of potential with resistance was similar in all cases and the potentials were averaged so that all the readings taken could be plotted on the same graph. Some of the readings are shown in table 10 and in fig. 42 the value of the grid leak resistance R is plotted against the magnitude of the potential V in volts.

An analogy may be drawn between the potential effect and the potential V in an external circuit supplied by a battery of e.m.f. E and internal resistance r . If this battery is connected to an external circuit of resistance R then the potential developed across the external load will be given by

$$V = E - Vr/R$$

or
$$1/V = 1/E + (r/E) \times (1/R).$$

If at any given temperature E and r are constant, which will normally be the case for a battery, then the graph of $1/V$ plotted against $1/R$ should be a

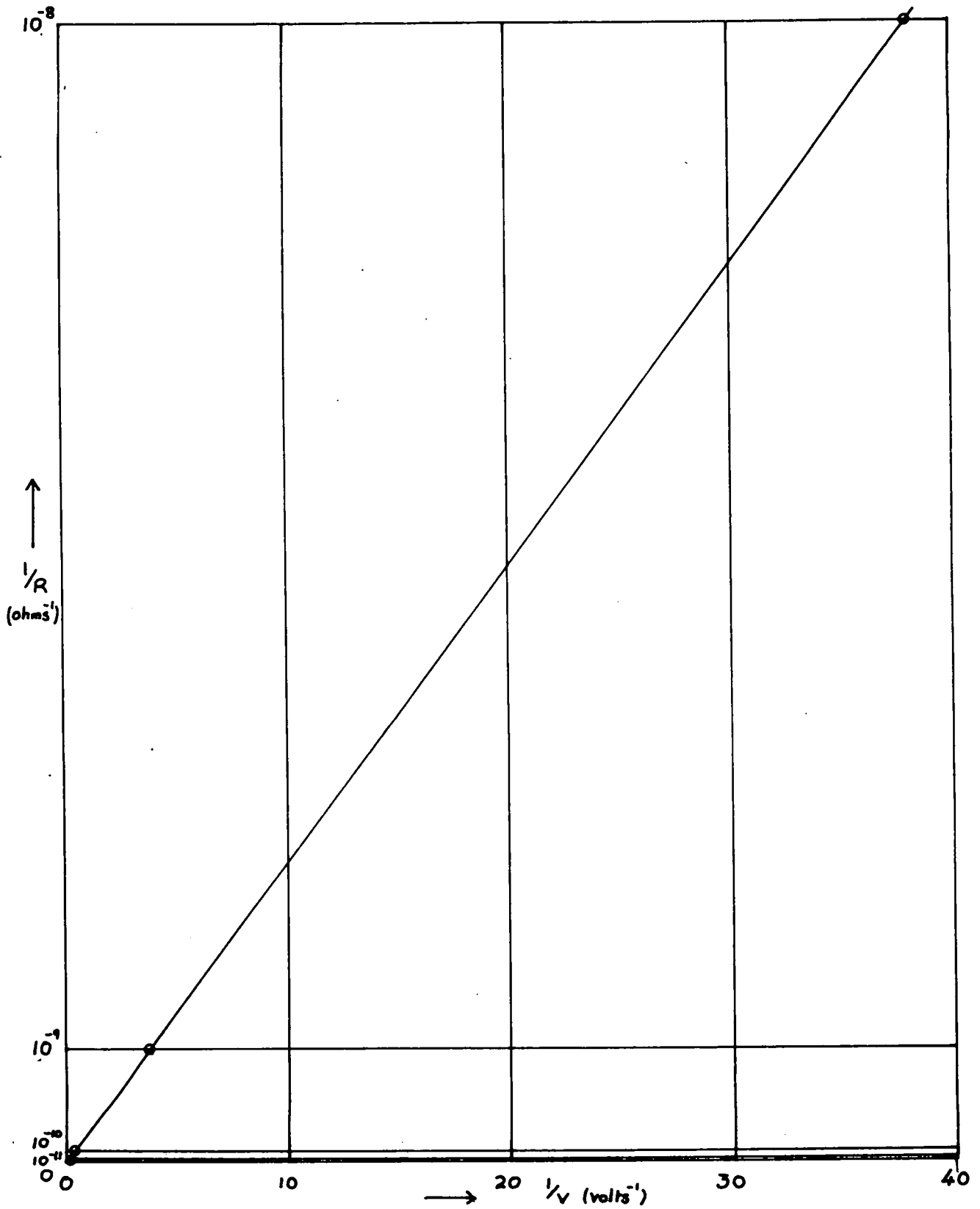

Figure 43. - Variation of the potential effect with input resistance.

straight line of slope r/E and with an intercept on the axis given by l/E .

It was decided therefore to see whether this analogy was applicable in the case of the potential effect. A graph was plotted of l/V against l/R where V in this case was the magnitude of the potential developed in volts and R was the resistance of the grid leak in ohms. The points are plotted in fig. 43 and the graph is fitted by a straight line which seems to indicate that this analogy is an empirical description of the nature of the process taking place in the production of a potential across the electrodes of the crystal. It is obviously not wise to carry this analogy too far since the process is probably one of the generation of a given quantity of charge by a given amount of mechanical deformation. The production and decay of this charge is manifest as the appearance and decay of an electrical potential across the electrodes of the crystal. On the other hand it should be noted that the assumption of the generation of a quantity of charge across a condenser of capacity C in parallel with a resistance R does not fit the observed results for the variation of the potential V with resistance R . The analogy to a

battery demonstrates that the crystal behaves as a low power energy source for a given amount of mechanical deformation.

8.5 THE DEPENDENCE OF THE POTENTIAL EFFECT UPON THE NATURE OF THE CRYSTAL SURFACE

It had been thought up to this stage that the potential effect was a phenomenon associated with the process of mechanical deformation throughout the body of the crystal. The random nature of the sign and magnitude of the potential for similar specimens was extremely puzzling and it seemed very difficult to give a satisfactory explanation. Some experiments were planned to see how the potential developed depended on the size and shape of the crystal. In carrying out these experiments an important fact concerning the potential effect was first noticed.

It has been mentioned before that if a crystal of the usual size with graphite electrodes was placed in the stress apparatus and loaded to a given limit and then the stress released, that the potential effect could only be made to reappear by exceeding the magnitude of the stress that had been previously

applied. It was now found that if a crystal was loaded to a given stress, then the stress released and the crystal removed from the apparatus, the potential could be made to reappear on replacing the crystal in the apparatus and loading to stresses below the value of the maximum stress that had been applied previously. In replacing the crystal in the stress apparatus it was unlikely that it would be positioned in exactly the same way between the brass electrodes. On the other hand if the crystal remained in the stress apparatus all the time the potential effect was not found on the reapplication of stress until the old limit of applied stress was exceeded. In this case the crystal would almost certainly be occupying exactly the same position between the brass electrodes. This seemed to indicate that the potential effect was in some way connected with the application of stress to the surface of the crystal and not associated with the process of plastic flow in the body of the crystal as was clearly the case with the conductivity increase.

At this stage another puzzling feature of the potential effect was noticed. A specimen was placed in the apparatus and stress increments were applied until it was found that the sign and magnitude of the potential

developed were constant over a number of stress increments. At this point the specimen was removed from the apparatus and was then immediately replaced but inverted, so that what had been the upper electrode of the specimen was now in contact with the lower brass electrode of the apparatus and vice versa. It was now found that the magnitude of the potential appearing was about the same as before the inversion but that the sign of the potential had altered. This meant that the sign of the potential with respect to the electrodes of the crystal was unaltered, e.g. if the upper electrode of the crystal had been developing a positive potential it still continued to give this potential when inverted so as to be the lower electrode, although the sign as observed at the output of the measuring apparatus appeared to be negative.

This phenomenon was not always found with every specimen that was tested in this way but it occurred in a sufficient proportion of the specimens tested to be significant. A possible explanation is that the crystal is deforming in a definite inhomogeneous way under the application of stress and although inverted still continues to deform in this way in many cases. It indicates that the effect is not solely a surface phenomenon

although it may be associated with the deformation of small parts of the specimen, perhaps especially at the edges of the electrodes.

It was decided to investigate whether the phenomenon was influenced in any way by the grinding of the crystal surfaces and application of graphite electrodes. Accordingly a specimen of the usual size was cleaved from a crystal of Aberdeen sodium chloride taking special care to get the cleavage across the larger faces (i.e. the electrodes) as perfect as possible. Surfaces were obtained with no cleavage step line visible to the naked eye. The crystal surfaces were not roughened with emery paper nor was colloidal graphite applied. Two pieces of thin aluminium foil were placed on the electrode surfaces and the crystal was placed between the brass electrodes in the stress apparatus. On application of stress increments to the crystal the potential effect was obtained. If the stress was now released and reapplied no potential was found until the stress exceeded the old limit. On the other hand if the position of the crystal was altered slightly before the reapplication of stress, the potential effect was found at low values of stress below the previous limit. With these experiments the

reapplication of stress to the crystal usually took place within a few minutes of the removal of the previous stress. Experiments were also performed where the crystal was left in the stress apparatus for periods up to 24 hours under zero load after stress had been previously applied. On reapplying stress at the end of this period the results did not differ in any way from those taken with only a short time period before the reapplication of stress. There seemed to be no relaxation process therefore in the crystal on or after the removal of stress.

Since the potential effect seemed to be associated with the crystal surface in some way it was thought that the surface irregularities might be the important factor and an attempt was made to reduce them. A crystal of the usual size was cleaved from a large crystal of sodium chloride and the electrode faces were ground by lapping them on a paper pad on which had been spread a small quantity of very fine carborundum powder. This produced a fine matt surface on the crystal free from all major surface irregularities. The carborundum was then removed from the crystal faces and they were polished on a pad on which some jeweller's rouge had been placed. The paper itself was attached

to a piece of plate glass to provide a reasonably flat backing. The crystal faces were polished on the rouge until a surface of optical finish was obtained. By holding the crystal surface against an optical flat it was possible to polish to some twenty wavelengths of light over the centre of the face in a comparatively short time. It was found better to start with a crystal of the correct thickness but of larger area. After the centres of the larger faces had been polished the extra material at the edges was cleaved away. The brass electrodes were given a fine finishing cut in the lathe and then polished with fine emery. The crystal was then placed in the stress apparatus with aluminium foil between the crystal and the brass electrodes and the potential effect on the application of stress examined. The values of the potential recorded were if anything larger than had been found with other surfaces. A possible explanation of this is that the polishing process had brought more points on the surfaces of the crystal into contact with the electrodes. It is possible too that a large proportion of the potential developed arose from stress applied at the edges of the electrode surfaces of the crystal and polishing could not eliminate this.

Stress in Kg/cm².

Potential effect.
(arbitrary units)

	polished and with Al foil	polished, sheet rubber and Al foil.	ground, card- board and Al foil.
2	+ 0.4	0	0
4	1.2	0	0
6	2.0	0	0
8	2.5	0	0
10	3.5	0	0
12	-	0	0
14	-	0	0
16	4.5	0	0
18	6.7	0	0
20	6.7	0	0
22	4.5	0	0
24	+ 4.5	0	0
26		0	- 0.1
28		0	0.1
30		0	0.2
32		0	0.2
34		- 0.1	- 0.3

Table 11 - The reduction of the potential effect in crystals of Aberdeen NaCl using rubber and cardboard on the electrodes.

It seemed that the polishing of the crystal could not be improved much further and it was decided to try to interpose some relatively soft material between the crystal and the metal electrodes. This interposed material would serve to transmit the applied stress as a whole to the specimen but would help to prevent the uneven distribution of stress over any irregularities on the electrode or the crystal face. The aluminium foil had been used for this purpose but was too thin to have any "cushioning" effect. Two materials were used between the crystal and the brass electrodes - pieces of thin sheet rubber, and discs of cardboard of about 1/16 in. thickness. The electrical connections were made by strips of aluminium foil on the surfaces of the crystals. It was found that the values of the potential effect recorded were very considerably reduced. This is illustrated in the results shown in table 11. In some experiments with the sheet rubber no potential effect was recorded for stresses up to 40 Kg/cm^2 . With this material it was found that the crystal tended to crack since there was an outward force along the electrode surfaces of the crystal caused by the pull from the rubber as it flowed outwards under compress-

ion. To some extent therefore a compromise was required between a very soft material which would even out stress irregularities completely (tending to crack the crystal) and one not quite so soft. Cardboard proved to be quite effective in reducing the potential without damage to the crystal and was used in experiments on the conductivity change for this purpose. The amount of reduction in the potential effect produced by using cardboard sheets is shown in table 11.

These experiments with various soft materials covering the electrodes of the specimens suggest that the potential effect is not due to the process of homogeneous plastic flow within the crystal. This must be so, since experiments were performed without observing a potential effect using stresses of 40 Kg/cm^2 at which stress plastic flow must be taking place. The signs of plastic flow (slip bands on the surface, some recrystallisation within the body of the crystal on cleaving, etc.) were always observed on removing the specimen from the apparatus. At the same time the experiments do not establish that the effect is a surface one. It is more probable that unless soft materials are used to cover the electrode surfaces small irregularities on the surfaces of the crystal receive a higher

The experiments were performed at a temperature of 100°C and with a grid leak resistor of 10⁹ ohms. Cardboard discs were used in both cases.

<u>Stress increment</u>	<u>Potential</u>	
	Taylor Hobson NaCl	Aberdeen NaCl
2 Kg/cm ²	0.37 V	0.17 V
1 "	0.17 V	0.078 V
0.5 "	0.095V	0.052 V

(all averages of 3-4 readings)

Table 12 - The variation of the potential effect with applied stress increment.

stress concentration and the regions of the crystal behind these irregularities deform plastically in some inhomogeneous way.

8.6 THE VARIATION OF THE POTENTIAL EFFECT WITH STRESS

Experiments were performed to investigate the variation of the potential effect with the magnitude of the stress increment applied. Crystals of sodium chloride were used with graphite electrodes and also discs of cardboard on the electrodes. The magnitude of the potential was reduced by this but it was possible to obtain fairly uniform values of the potential during the stressing of any one specimen. The magnitude of the potential was noted for various different stress increments and some of the results are shown in table 12. The potential seemed to be directly proportional to the value of the stress increment provided that the stress was applied fairly rapidly, i.e. in a short time compared to the decay time of the potential developed. This was a difficult condition to achieve in practice since the decay times were short (0.3 sec), so that the value of the potential was found to vary also with the rate of application of stress - a greater rate of application of stress giving a higher value of the potential.

9. DISCUSSION AND CONCLUSIONS

9.1 THE INCREASE IN CONDUCTIVITY UPON MECHANICAL DEFORMATION

It seems that the results given in chapter 7 confirm in many ways the work of Gyulai and Boros. In particular they show that the decay time constant of the increased conductivity is in the range 0.3 - 1.1 sec. Such small decay time constants would, as Tyler (1952) points out, be more consistent with the trapping of electrons released by the movement of dislocations during the process of plastic flow than with the trapping of vacancies. Seitz (1950) points out that this latter process is supported by the much longer time constants found by Gyulai and Hartly (1928). It does appear on the basis of both the work of Gyulai and Boros and the work here that there is no longer conclusive evidence for the vacancy generation theory proposed by Seitz. The long time constants recorded by Gyulai and Hartly were very probably a feature of the high stresses that they used. At these stresses plastic flow continues over an appreciable period of time after the application of stress and the decay of conductivity increase they obtained was associated with the diminishing generation of current carriers as the

process of flow took place.

It is possible to give some explanation of the variation of the increase of conductivity with temperature shown in fig. 35 using the theory of the generation of vacancies during plastic flow proposed by Seitz (1950). Etzel and Maurer (1950) have shown that if the ionic conductivity (σ) of sodium chloride is represented by the equation

$$\sigma = ne\mu$$

where n is the concentration of positive ion vacancies, e is the electronic charge and μ is the mobility of the positive ion vacancies, then for a "pure" crystal n is constant at temperatures below 550°C . The mobility varies with the absolute temperature T between 250 and 400°C according to the equation

$$\mu = (19600/T) \cdot \exp(-9860/T).$$

The mobility at 403°C is 1.4×10^{-5} and at 256°C is 3.0×10^{-7} $\text{cm}^2/\text{volt-sec}$.

In the experiments performed on the conductivity increase the value of the field strength was about 200 V/cm . With this field we should expect therefore the average velocity of the positive ion vacancies to be 2.8×10^{-3} and 6×10^{-5} cm/sec at 403 and 256°C

respectively. From X-ray measurements Darwin (1914) has proposed that there is a mosaic structure in crystals where the size of the mosaic blocks is about 10^{-4} cm. Cunnell (1951) has concluded from measurements on the conductivity of alkali halide crystals with added impurities that there is evidence for the existence of mosaic blocks of size about 2000 \AA within the crystal. If we assume that a moving positive ion vacancy is trapped on reaching a mosaic boundary then we should expect this trapping process to occur within $1/200$ sec after generation at 403°C and $1/6$ sec at 256°C . The vacancies liberated at 403°C would therefore only contribute to the increased conductivity for $1/200$ sec. This time is of the order of the response time of the electrical measuring apparatus and also small compared to the time of application of the stress increment (about $1/10$ sec), so that one would not expect to record any conductivity change. On the other hand at 256°C the average trapping time is $1/6$ sec and it should be possible to partially record the conductivity change. In fig. 35 the increased conductivity for a fixed value of the stress increment is plotted against temperature for the same

crystal. If we assume that a definite number of positive ion vacancies are generated by this fixed amount of plastic deformation independently of temperature we should expect therefore this graph to be a horizontal straight line were it not for the variation of the trapping time of the vacancies with temperature. The values of the conductivity increase at temperatures of 250 and 400°C from this graph are however in the same ratio as the calculated trapping times at these temperatures, thus showing that the theory of trapping of positive ion vacancies is well supported by the experimental evidence.

The extension of the theory to lower temperatures leads to certain difficulties. If the mobility of positive ion vacancies is calculated at 100°C by the extrapolation of the results of Etzel and Maurer (1950) (this may not be a valid process), then an average trapping time of 35 sec would be expected. This is clearly not so experimentally for the decay time constants of the conductivity increase at this temperature were in the range 0.3 - 1.1 sec. Furthermore extension down to a temperature of 40°C would lead to a trapping time of the order of twenty minutes. Seitz (1950) has also predicted this value from a considera-

tion of the jump frequency of the positive ion vacancy and has used it to explain the time constants of decay found by Gyulai and Hartly in their experiments.

It is possible that there are two mechanisms responsible for the conductivity change with plastic deformation - the generation of vacancies by moving dislocations as proposed by Seitz and the freeing of electrons by the motion of dislocations as proposed by Tyler. If the conductivity increase was predominantly due to the generation of vacancies at high temperatures, with the contribution due to the freeing of electrons being important at low temperatures results more in accord with the experimental facts would be expected. At high temperatures the decay time constants due to the trapping of positive ion vacancies would agree with those found experimentally, as has been seen. At low temperatures the time of removal of an electron from the conduction band should be shorter than for the trapping of a vacancy and hence should agree better with the values of the decay time constants found experimentally. It might be possible to obtain more information about the nature of the decay process of the increased conductivity by a study of the variation of the decay time constant over a

wide range of temperature for various crystals. Redfield (1953) has measured the electronic Hall effect in sodium chloride crystals and if this experiment could be performed on a crystal that was undergoing mechanical deformation at the same time it would be possible to determine whether the extra current carriers introduced by deformation were electrons or positive ion vacancies.

A most striking feature of the conductivity increase with plastic deformation that has been found in the present series of experiments is that the effect is not present in all crystals. All samples of sodium chloride with the exception of the Harshaw crystal did not show the effect. It seems that a study of the etchpits on the surfaces of the various crystals may help to explain this point.

It has been tacitly assumed up to now that the number of current carriers (whether they be vacancies or electrons) produced by a given amount of plastic deformation in any crystal would be a constant. It is more probable however that the generation of current carriers depends on the number of dislocations already present in the crystal. This would be so, no matter whether the current carriers

were generated by the collisions of dislocations or by collisions of dislocations with obstacles within the crystal. It will be seen from table 2 that the number of dislocations already present in the Harshaw crystal in the unstrained state is larger than in any of the other samples of sodium chloride. It would be expected therefore that the other samples of sodium chloride would have to be taken to a higher value of total stress than for the Harshaw crystal before the conductivity increase appeared. Since the effect in the Harshaw crystal only appeared at stresses above 40 Kg/cm^2 this would involve the use of quite high stresses and although the other specimens of sodium chloride were loaded to destruction no effect was found. However it was noticed that the Harshaw crystal was harder than the other crystals (Pratt 1955 has noted that hardening due to the interaction of clusters of vacancies with dislocations has been observed in alkali halide crystals) and therefore these other crystals crumbled into fragments at stresses lower than for the Harshaw crystal. Had this not been so it might have been possible to apply sufficiently high stresses to the other sodium chloride crystals to produce the conductivity increase.

Since all the crystals of potassium chloride showed the conductivity increase quite markedly, etchpits photographs on these crystals were attempted but no etchpits could be resolved at the magnification used. There may be two explanations of this - either the etching technique was not correct for this material, or that the number of etchpits was large enough not to be resolved at the magnification used. If the second explanation were true, it would be further support for the explanation given for the non-appearance of the conductivity effect in certain of the sodium chloride crystals.

9.2 THE POTENTIAL EFFECT UPON MECHANICAL DEFORMATION

It seems at first sight surprising that previous workers have not discovered the appearance of a potential on the application of stress to an alkali halide crystal. The explanation in the case of Gyulai and Hartly's experiments probably lies in the fact they used such large stresses that the potential effect was negligible compared to the magnitude of the conductivity increase. Their measuring apparatus was also crude and they did not attempt to distinguish between conductivity changes and any

potential effects there might have been. In the case of Gyulai and Boros it seems that a possible explanation of their non-discovery of a potential effect, despite using low stresses and a more refined electrical apparatus, is that they used crystals of potassium chloride and bromide where the conductivity increase is relatively large and the magnitude of the potential effect small compared to specimens of sodium chloride. Quittner mentions a small transient effect on the application of stresses below the yield stress to crystals of sodium chloride, which vanished on the removal of stress. It is possible that this was in fact a potential effect although Quittner did not distinguish it from a conductivity change.

Recently notice has come to hand of some experiments by Fischbach and Nowick (1955) in which they report the creation of a potential difference across sodium chloride crystals deformed in compression. It should be noted that information about their work was only received after the present programme of experiments had been completed. They report that on inhomogeneous deformation of a crystal a transient potential difference is developed such that the side of the crystal which has the higher stress concentra-

tion becomes negative. The potential decays to zero over a period of minutes in roughly hyperbolic fashion if the load is left on, although the removal of the load at any time causes the current flow to drop to zero almost instantaneously. Reapplication of the same load produces a new transient current in the same direction as the original flow, but smaller in magnitude. The direction of the initial current flow is unaffected by externally applied fields as large as ± 1000 V/cm.

The effect discovered independently by Fischbach and Nowick seems to be essentially the same as that described here. Some of the details are rather different - the time constant of decay being surprisingly large - although there is no information on the sodium chloride crystals used or the magnitudes of the stresses applied.

A reasonable conclusion from the experiments carried out here is that the potential effect is associated with plastic flow in small regions of the crystal, either close to surface irregularities or near to the edges of the crystal. In these regions the stress will be much greater than in the body of the crystal and is also likely to be inhom-

geneous in nature. Since plastic flow takes place it is probable that positive ion vacancies will be generated by the movement of dislocations during the period of slip. Nabarro (1948) has shown that in a body under uniform stress there is no force directing the motion of individual vacancies or interstitial ions (although the concentration gradient may be formally represented as producing a force). In a stress gradient the energies of neighbouring possible sites for a lattice defect are different, and each defect has a drift velocity superposed on its random diffusion. It is shown that the expression for the flux of lattice defects with non-uniform stress includes an extra term which varies as P^2 where P is the applied stress. Accordingly therefore in regions where inhomogeneous stress is applied to the crystal there will be a charge separation due to the movement of vacancies under this stress field. The magnitudes of the local stresses will be high and as the effect depends on the square of the stress the vacancies will be given a high drift velocity. The force on the vacancies due to the local inhomogeneous stress fields must be high so that the force on the vacancies due

to external applied electric fields up, to 1000 V/cm can be neglected. This would explain why the potential effect is unaffected by externally applied electric fields of this magnitude.

A difficulty that arises when considering this theory of the potential effect is that the time constant of decay appears to be smaller for the potential effect than for the conductivity change on the crystals examined here. However since many of the crystals did not show a conductivity change this may not be a valid objection. It would be expected that the decay process would be the same as for the conductivity change - the natural diffusion and trapping of the positive ion vacancies - and therefore the time constants ought to be similar. Fischbach and Nowick have apparently found large times of decay (of the order of minutes) so the difficulty over the value of the decay times may not be serious.

It also follows from this theory that the variation of the potential effect with temperature should be similar to that found for the conductivity change (assuming that the explanation for the latter is in terms of positive ion generation). There seems to be good agreement between the potential and conductivity

change variations with temperature as can be seen on comparison of the fig. 35 and 41. The steeper drop of the potential effect to zero with increasing temperature is probably accounted for by the relatively greater sensitivity of the conductivity change measurements so that the small increases at higher temperatures could be recorded.

The variation of the potential effect with the input resistance of the measuring circuit does indicate that the physical process in the effect is one of the separation of a definite quantity of charge for a given amount of plastic deformation. However the variation of the effect with input resistance does not give any information on the nature of the charge separation.

ACKNOWLEDGEMENTS

The author is deeply indebted to Mr. J.E. Caffyn who suggested the problem, and who continually gave invaluable advice and encouragement during the course of the work.

Grateful thanks are extended to Professor J.E.P. Wagstaff for the provision of laboratory facilities, and to various research students and to the laboratory staff of the Physics Department for their assistance, also to those members of staff of other Departments who were so helpful over certain problems.

Gifts of alkali halide crystals from Dr. J. J. Markham, Dr. K. Korth, the Physics Department, Aberdeen University, and Messrs. Hilger Ltd. were much appreciated.

The following awards are gratefully acknowledged:- a maintenance allowance from the Department of Scientific and Industrial Research (1952-1955), a Durham Colleges Pemberton Studentship (honorary), and a grant from the Durham Colleges Research Fund for apparatus.

REFERENCES

Cottrell; Haynes and Shockley - Strength of Solids (Bristol)

Proc. Phys. Soc. Suppl. (1948).

Cunnell - Ph.D. Thesis University of Durham (1951)

Cunnell and Schneider - Phys. Rev. 95 598A (1954).

Darwin - Phil. Mag. 27 315 (1914).

Etzel and Maurer - Jnl. Chem. Phys. 18 1003 (1950).

Fischbach and Nowick - Phys. Rev. to be published.

Goodwin - Yale Jnl. Biol. and Med. 14 101 (1941).

Graham, Harkness and Thode - J. Sci. Insts. 24 126 (1947).

Gyulai and Hartly - Zeits. f. Physik 51 378 (1928).

Gyulai - Zeits. f. Physik 78 630 (1932). See also Gyulai -

Zeits. f. Physik 96 210 (1935); Gyulai and Boros -

Zeits. f. Physik 96 355 (1935); Gyulai and Tomka -

Zeits. f. Physik 96 350 (1935).

Gyulai and Boros - Math. Natur. Anz. Ungar Akad. Wiss. 59

115 (1940).

Joffé - Zeits. f. Physik 62 730 (1930).

Joffé - The Physics of Crystals, McGraw Hill (1928).

Kelting and Witt - Zeits. f. Physik 126 697 (1949).

Korth - Zeits. f. Physik 84 677 (1933).

Kyropoulos - Z. Anorg. Chem. 154 308 (1926). See also Kyro-

poulos - Zeits. f. Physik 63 849 (1930).

Manning and Bell - Rev. Mod. Phys. 12 215 (1940).

Menzies and Skinner - Disc. Faraday Soc. 5 366 (1949).

- Nabarro - Strength of Solids (Bristol) Proc. Phys. Soc. Suppl.
75 (1948).
- Penick - Rev. Sci. Insts. 6 115 (1935).
- Pratt - Defects in Crystalline Solids (Bristol) Proc. Phys.
Soc. Suppl. 402 (1955).
- Quittner - Zeits. f. Physik 68 796 (1931). See also Quittner
- Zeits. f. Physik 56 597 (1929); 74 344 (1932); Beran
and Quittner - Zeits. f. Physik 64 760 (1930).
- Redfield - Phys. Rev. 91 753 (1953).
- Schmid and Boas - Plasticity of Crystals, F.A. Hughes Ltd.
(1950). Originally published in German 1936.
- Schneider and Caffyn - Defects in Crystalline Solids (Bristol)
Proc. Phys. Soc. Suppl. 74 (1955).
- Seitz - Phys. Rev. 80 239 (1950).
- Seitz - Rev. Mod. Phys. 26 7 (1954).
- Smekal - Zeits. f. Physik 55 289 (1929). See also Smekal -
Zeits. f. Physik 93 166 (1934); Physik. Zeits. 33 204
(1932).
- Stepanow - Zeits. f. Physik 81 560 (1933).
- Stöber - Z. Krist. 61 299 (1925).
- Tyler - Phys. Rev. 86 801 (1952).
- Vance - Rev. Sci. Insts. 7 489 (1936).
- Walden - J. Sci. Insts. 16 1 (1939).
- Willard and Greathouse - Jnl. Am. Chem. Soc. 39 2366 (1917).
- Yates - J. Sci. Insts. 23 229 (1946).

