

## Durham E-Theses

---

*Studies in the archaeology of the Valley of the Kings :  
with particular reference to tomb robbery and the  
caching of the royal mummies.*

Carl Nicholas Reeves

### How to cite:

---

Reeves, Carl Nicholas (1984) *Studies in the archaeology of the Valley of the Kings : with particular reference to tomb robbery and the caching of the royal mummies.* Doctoral thesis, Durham University.

### Use policy

---

The full-text may be used and/or reproduced, and given to third parties in any format or medium, without prior permission or charge, for personal research or study, educational, or not-for-profit purposes provided that:

- a full bibliographic reference is made to the original source
- a <https://etheses.durham.ac.uk/id/eprint/958/> is made to the metadata record in Durham E-Theses
- the full-text is not changed in any way

The full-text must not be sold in any format or medium without the formal permission of the copyright holders.

Please consult the [full Durham E-Theses policy](#) for further details.

## ABSTRACT

Carl Nicholas Reeves

STUDIES IN THE ARCHAEOLOGY OF THE VALLEY OF THE KINGS,  
with particular reference to tomb robbery  
and the caching of the royal mummies

This study considers the physical evidence for tomb robbery on the Theban west bank, and its resultant effects, during the New Kingdom and Third Intermediate Period. Each tomb and deposit known from the Valley of the Kings is examined in detail, with the aims of establishing the archaeological context of each find and, wherever possible, isolating and comparing the evidence for post-interment activity. The archaeological and documentary evidence pertaining to the royal caches from Deir el-Bahri, the tomb of Amenophis II and elsewhere is drawn together, and from an analysis of this material it is possible to suggest the routes by which the mummies arrived at their final destinations.

Large-scale tomb robbery is shown to have been a relatively uncommon phenomenon, confined to periods of political and economic instability. The caching of the royal mummies may be seen as a direct consequence of the tomb robberies of the late New Kingdom and the subsequent abandonment of the necropolis by Ramesses XI. Associated with the evacuation of the Valley tombs may be discerned an official dismantling of the burials and a re-absorption into the economy of the precious commodities there interred.

STUDIES IN THE ARCHAEOLOGY  
OF THE  
VALLEY OF THE KINGS,

with particular reference to  
tomb robbery and the caching of  
the royal mummies

(Volumes I-II)

Volume I: Text

by

Carl Nicholas Reeves

Thesis  
submitted for the degree of  
Doctor of Philosophy

School of Oriental Studies  
University of Durham

1984

The copyright of this thesis rests with the author.  
No quotation from it should be published without  
his prior written consent and information derived  
from it should be acknowledged.

## CONTENTS OF VOLUMES I-II

## VOLUME I

List of text figures	vi
List of tables	xii
List of abbreviations	xiii
Addenda	xlii
Preface	xliii

Introduction: the burial of Amenophis I	1
---	---

Part 1

Chapter 1: the burials of Tuthmosis I-II, Hatshepsut, Tuthmosis III and Hatshepsut- Meryetre	8
Chapter 2: the burials of Tuthmosis IV, Amenophis III, Tiye and Akhenaten	28
Chapter 3: the burials of Tutankhamun, Ay and Horemheb	54
Chapter 4: the burials of Ramesses I, Sethos I, Ramesses II and Merenptah	88
Chapter 5: the burials of Amenmesse, Sethos II, Siptah, Tawosret and Sethnakhte	100
Chapter 6: the burials of Ramesses III-XI	113
Chapter 7: burials of lesser royalty	127
Chapter 8: private burials	139
Chapter 9: miscellaneous tombs and pits	168

Contents	iv
----------	----

Part 2

Chapter 10: the royal caches	183
Chapter 11: the docketts	238
Chapter 12: the routes to the caches	264
Conclusions	292
Appendices A-C: excavations in the Valley of the Kings, 1898-1922	303
Appendix D: extracts from the Weigall MSS	379

VOLUME II

Notes to preface	1
Notes to introduction	2
Notes to chapter 1	7
Notes to chapter 2	21
Notes to chapter 3	43
Notes to chapter 4	65
Notes to chapter 5	72
Notes to chapter 6	77
Notes to chapter 7	85
Notes to chapter 8	90
Notes to chapter 9	108
Notes to chapter 10	114
Notes to chapter 11	131
Notes to chapter 12	138
Notes to conclusions	152
Notes to appendices	156



## LIST OF TEXT FIGURES

Fig. 1: AN B (after Thomas, <u>Necropoleis</u> , fig. 15)	2
Fig. 2: Dra Abu'l Naga and el-Taraf (based on P-M I <sup>2</sup> /ii, plan IV)	6
Fig. 3: the Valley of the Kings (based on BTMP, <u>Prelim. Report 1978</u> )	9
Fig. 4: KV20 (after Thomas, <u>Necropoleis</u> , fig. 10)	10
Fig. 5: KV38 ( <u>ibid.</u> , fig. 9)	13
Fig. 6: DB358 ( <u>ibid.</u> , fig. 15)	15
Fig. 7: Deir el-Bahri (based on P-M I <sup>2</sup> /ii, plan VIII)	16
Fig. 8: KV34 (after Thomas, <u>Necropoleis</u> , fig. 9)	18
Fig. 9: reconstructed burial-chamber grid (KV34)	20
Fig. 10: reconstructed burial-chamber grid (numbered) (KV34)	20
Fig. 11: KV42 (after Thomas, <u>Necropoleis</u> , fig. 9)	25
Fig. 12: KV43 ( <u>ibid.</u> )	29
Fig. 13: the West Valley (based on Lefébure, <u>Hypogées II</u> , pl. 1)	36
Fig. 14: WV22 (after Thomas, <u>Necropoleis</u> , fig. 9)	37
Fig. 15: WV A ( <u>ibid.</u> , fig. 14)	39
Fig. 16: WV25 ( <u>ibid.</u> , fig. 9, with corrections)	41
Fig. 17: KV55 ( <u>ibid.</u> , fig. 14)	43

Text figures	vii
Fig. 18: reconstructed layout (KV55) (after Reeves, <u>JEA</u> 67 (1981), fig. 1)	45
Fig. 19: small seal impressions (KV55) (Ayrton photograph, courtesy EES)	47
Fig. 20: relative positions of KV55 and KV6 (based on Carter, <u>MSS</u> , I.G.52)	51
Fig. 21: KV62 (after Thomas, <u>Necropoleis</u> , fig. 14)	54
Fig. 22: large seal impressions (KV62) (based on Carter, <u>MSS</u> , unnumbered)	60
Fig. 23: small seal impressions (KV62) ( <u>ibid.</u> )	60
Fig. 24: KV54 (after Thomas, <u>Necropoleis</u> , fig. 14)	68
Fig. 25: WV23 ( <u>ibid.</u> , fig. 11, with corrections)	69
Fig. 26: KV58 ( <u>ibid.</u> , fig. 15)	75
Fig. 27: distribution of finds (KV58) (after Reeves, <u>GM</u> 53 (1982), fig. 1)	79
Fig. 28: KV57 (after Thomas, <u>Necropoleis</u> , fig. 11)	81
Fig. 29: graffiti (KV57) (Gardiner, <u>Notebook</u> 70, 68 f., courtesy Griffith Institute)	84
Fig. 30: KV16 (after Thomas, <u>Necropoleis</u> , fig. 11)	88
Fig. 31: KV17 ( <u>ibid.</u> )	90
Fig. 32: KV7 ( <u>ibid.</u> , fig. 12)	94
Fig. 33: KV8 ( <u>ibid.</u> )	97
Fig. 34: KV10 ( <u>ibid.</u> )	100
Fig. 35: KV15 ( <u>ibid.</u> )	103
Fig. 36: KV47 ( <u>ibid.</u> , fig. 13, with corrections)	105
Fig. 37: section at entrance (KV47)	106
Fig. 38: KV14 (after Thomas, <u>Necropoleis</u> , fig. 12)	109

Fig. 39: KV11 (after Thomas, <u>Necropoleis</u> , fig. 13)	114
Fig. 40: KV2 ( <u>ibid.</u> )	115
Fig. 41: KV9 ( <u>ibid.</u> )	117
Fig. 42: KV1 ( <u>ibid.</u> )	119
Fig. 43: KV6 ( <u>ibid.</u> , with corrections)	120
Fig. 44: KV18 ( <u>ibid.</u> )	121
Fig. 45: KV4 ( <u>ibid.</u> , with corrections)	122
Fig. 46: KV5 ( <u>ibid.</u> , fig. 14)	127
Fig. 47: KV12 ( <u>ibid.</u> )	129
Fig. 48: KV56 ( <u>ibid.</u> , fig. 15)	130
Fig. 49: layout of deposit (KV56) (after Davis, <u>Siphtah</u> , 30)	132
Fig. 50: KV13 (after Thomas, <u>Necropoleis</u> , fig. 12)	134
Fig. 51: KV3 ( <u>ibid.</u> , fig. 14)	135
Fig. 52: KV19 ( <u>ibid.</u> )	137
Fig. 53: KV60 ( <u>ibid.</u> )	139
Fig. 54: KV48 ( <u>ibid.</u> , fig. 15)	140
Fig. 55: KV36 ( <u>ibid.</u> )	142
Fig. 56: reconstructed layout (KV36)	143
Fig. 57: mummy and coffins (KV36)	146
Fig. 58: KV45 (after Thomas, <u>Necropoleis</u> , fig. 15)	153
Fig. 59: KV46 ( <u>ibid.</u> , fig. 14)	153
Fig. 60: layout of burial (KV46) (after Quibell, <u>Yuaa &amp; Thuiu</u> , iv)	159
Fig. 61: section at entrance (KV46) (after Greene, <u>Century Magazine</u> (November 1905), 75)	161
Fig. 62: KV21 (after Thomas, <u>Necropoleis</u> , fig. 14)	163
Fig. 63: WV24 ( <u>ibid.</u> , fig. 15)	164
Fig. 64: KV27 ( <u>ibid.</u> , fig. 14)	165

Fig. 65: KV28 (after Thomas, <u>Necropoleis</u> , fig. 14)	165
Fig. 66: KV39 ( <u>ibid.</u> , fig. 9)	166
Fig. 67: KV44 ( <u>ibid.</u> , fig. 15)	167
Fig. 68: KV26 ( <u>ibid.</u> )	168
Fig. 69: KV29 ( <u>ibid.</u> )	168
Fig. 70: KV30 ( <u>ibid.</u> )	169
Fig. 71: KV31 ( <u>ibid.</u> )	171
Fig. 72: KV32 ( <u>ibid.</u> , fig. 9)	169
Fig. 73: KV37 ( <u>ibid.</u> , fig. 14)	170
Fig. 74: KV40 ( <u>ibid.</u> , fig. 15)	171
Fig. 75: KV41 ( <u>ibid.</u> )	171
Fig. 76: KV49 ( <u>ibid.</u> , fig. 14)	171
Fig. 77: KV50 ( <u>ibid.</u> , fig. 15, with corrections)	173
Fig. 78: KV51 ( <u>ibid.</u> , with corrections)	173
Fig. 79: KV52 ( <u>ibid.</u> )	173
Fig. 80: KV53 ( <u>ibid.</u> )	174
Fig. 81: KV59 ( <u>ibid.</u> , fig. 14)	174
Fig. 82: KV61 ( <u>ibid.</u> , fig. 15)	176
Fig. 83: unnumbered tombs and pits (main Valley)	178
Fig. 84: KV F (after Thomas, <u>Necropoleis</u> , fig. 14)	179
Fig. 85: unnumbered tombs and pits (West Valley)	180
Fig. 86: DB320 (after Thomas, <u>Necropoleis</u> , fig. 15)	184
Fig. 87: large seal impressions (DB320) (after Maspero, <u>Momies royales</u> , 521 f.)	186
Fig. 88: reconstructed layout (DB320)	186
Fig. 89: WN A (after Thomas, <u>Necropoleis</u> , fig. 16)	199
Fig. 90: relative positions of WN A and DB320 (based on P-M I <sup>2</sup> /ii, plan I)	199

Text figures	x
Fig. 91: KV35 (after Thomas, <u>Necropoleis</u> , fig. 9)	202
Fig. 92: reconstructed antechamber grid (KV35)	203
Fig. 93: reconstructed antechamber grid (numbered) (KV35)	203
Fig. 94: reconstructed burial-chamber grid (KV35)	205
Fig. 95: reconstructed burial-chamber grid (numbered) (KV35)	205
Fig. 96: reconstructed layout, (Jb) cache (KV35)	210
Fig. 97: the routes to the caches	290
Fig. 98: Antiquities Service excavations, 1898-1904	307
Fig. 99: Chassinat excavations, 1905/6 (West Valley)	308
Fig. 100: Antiquities Service excavations, 1898/9, the annotated Loret map (courtesy Wilbour Library)	309
Fig. 101: Davis excavations, 1902-1914	319
Fig. 102: Davis excavations, 1902-1914 (West Valley)	320
Fig. 103: Davis excavations, 1905/6, the Ayrton sketch map (after the original, courtesy John Romer)	327
Fig. 104: Davis excavations, 1905-1908, attested site designations	328
Fig. 105: Davis excavations, 1905/6, site 15 (after Ayrton, <u>PSBA</u> 28 (1906), pl. 1)	335
Fig. 106: Davis excavations, 1908/9, site 24 (after Jones & Burton, <u>Tombs</u> )	347
Fig. 107: Davis excavations, 1908/9, site 25 (after Jones & Burton, <u>Tombs</u> )	348

Text figures

xi

Fig. 108: Davis excavations, 1909/10, site 26 (after Jones & Burton, <u>Tombs</u> )	352
Fig. 109: Davis excavations, 1909/10, sites 26-27 (after Jones & Burton, <u>Tombs</u> )	353
Fig. 110: Davis excavations, 1909/10, site 28 (after Jones & Burton, <u>Tombs</u> )	355
Fig. 111: Carnarvon excavations, 1915-1922	363
Fig. 112: Carnarvon excavations, 1915-1922 (West Valley)	364

## LIST OF TABLES

Table 1: KV58, conspectus of main finds	76
Table 2: KV58, occurrence of names	78
Table 3: DB320, conspectus of main finds	216
Table 4: KV35, conspectus of main finds	222
Table 5: DB320, the mummies	224
Table 6: KV35, the mummies	229
Table 7: DB320, the coffins	232
Table 8: KV35, the coffins	236
Table 9: type A docketts (DB320, KV35)	252
Table 10: type B docketts, linen notations and graffiti	254
Table 11: post-interment activity in the Valley of the Kings	294

## LIST OF ABBREVIATIONS

Published sources

<u>AcOr</u>	<u>Acta Orientalia</u> (Lund/ Copenhagen)
<u>AE</u>	<u>Ancient Egypt</u> (London)
Aldred, <u>Akhenaten</u>	C. Aldred, <u>Akhenaten, Pharaoh of Egypt</u> (London 1972)
Aldred, <u>Jewels</u>	C. Aldred, <u>Jewels of the Pharaohs</u> (London 1971)
Aldred, <u>NK Art</u>	C. Aldred, <u>New Kingdom Art in Ancient Egypt</u> <sup>2</sup> (London 1961)
Amherst, <u>History</u>	Lady Amherst of Hackney, <u>A Sketch of Egyptian History</u> (London 1904)
<u>AMNH</u>	<u>Annals and Magazine of Natural History</u> (London)
<u>Antiquity</u>	<u>Antiquity</u> (Gloucester/Cambridge)
Arts Council, <u>5,000 Years</u>	Arts Council, <u>5,000 Years of Egyptian Art</u> (London 1962)
<u>ASAE</u>	<u>Annales du Service des Antiquités de l'Égypte</u> (Cairo)
d'Athanasī, <u>Researches</u>	G. d'Athanasī, <u>A Brief Account of the Researches and Discoveries in Upper Egypt made under the Direction of Henry Salt, Esq.</u> (London 1836)

- Aubert & Aubert, Statuettes J.-F. & L. Aubert, Statuettes égyptiennes chaouabtis, ouchebtis (Paris 1974)
- Ayrton & Loat, Mahasna E. R. Ayrton & W. L. S. Loat, Pre-Dynastic Cemetery at El Mahasna (London 1911)
- Bacon, Great Archaeologists E. Bacon (ed.), The Great Archaeologists (London 1976)
- Baedeker, Egypt (1902) K. Baedeker (ed.), Egypt and the Sudan<sup>5</sup> (Leipzig 1902)
- Baedeker, Egypt (1929) K. Baedeker (ed.), Egypt and the Sudan<sup>8</sup> (Leipzig 1929)
- Baillet, Inscriptions J. Baillet, Inscriptions grècques et latines de tombeaux des rois ou syringes à Thèbes (Cairo 1920-6)
- Bataille, Memnonia A Bataille, Les Memnonia (Cairo 1952)
- Bedell, Criminal Law E. D. Bedell, Criminal Law in the Egyptian Ramesside Period (Ann Arbor 1983)
- Belzoni, Narrative G. B. Belzoni, Narrative of the Operations and Recent Discoveries in Egypt and Nubia<sup>2</sup> (London 1822)
- Bénédite, Égypte G. Bénédite, Guide-Joanne - Égypte (Paris 1900)
- BFAC, Catalogue Burlington Fine Arts Club, Catalogue of an Exhibition of Ancient Egyptian Art (London 1921)

- Biblia  
BIE
- Bierbrier, LNK
- Bierbrier,  
Tomb-Builders
- BIFAO
- BiOr  
von Bissing,  
Fayencegefäße  
Blackman, MES
- BM, Guide 3rd-4th
- BM, Guide 4th-6th
- BM, Guide Egn. Colln.
- Biblia (Meriden, Conn.)  
Bulletin de l'Institut  
égyptien (Cairo)  
M. Bierbrier, The Late New  
Kingdom in Egypt  
(Warminster 1975)  
M. Bierbrier, The Tomb-Builders  
of the Pharaohs (London  
1982)  
Bulletin de l'Institut français  
d'archéologie orientale  
(Cairo)  
Bibliotheca Orientalis (Leiden)  
W. von Bissing, Fayence-  
gefäße (Cairo 1902)  
A. M. Blackman, Middle-  
Egyptian Stories (Brussels  
1972)  
British Museum, A Guide to  
the Third and Fourth  
Egyptian Rooms (London  
1904)  
British Museum, A Guide to  
the Fourth, Fifth and  
Sixth Egyptian Rooms, and  
the Coptic Room (London  
1922)  
British Museum, A General  
Introductory Guide to the  
Egyptian Collections  
(London 1930)

- BM, Guide Sculpture British Museum, A Guide to the Egyptian Galleries (Sculpture) (London 1909)
- BM, Mummies & Coffins British Museum, A Handbook to the Egyptian Mummies and Coffins (London 1938)
- BM, Tutankhamun British Museum, Treasures of Tutankhamun (London 1972)
- BMMA Bulletin of the Metropolitan Museum of Art (New York)
- Bonomi & Sharpe, Oimenepthah J. Bonomi & S. Sharpe, The Alabaster Sarcophagus of Oimenepthah I, King of Egypt (London 1864)
- Botti & Peet, Giornale G. Botti & T. E. Peet, Il giornale della necropoli di Tebe (Turin 1928)
- Bourriau, Umm el-Ga<sup>C</sup>ab J. Bourriau, Umm el-Ga<sup>C</sup>ab. Pottery from the Nile Valley before the Arab Conquest (Cambridge 1981)
- Breasted, Ancient Records J. H. Breasted, Ancient Records of Egypt (Chicago 1906)
- Breasted, Pioneer C. Breasted, Pioneer to the Past (London 1948)
- Brovarski, Golden Age E. Brovarski (ed.), Egypt's Golden Age (Boston 1982)
- Brugsch & Maspero, Trouvaille E. Brugsch & G. Maspero, La trouvaille de Deir-el-Bahari (Cairo 1881)

- Bruyère, Deir el Médineh (1931-2)
- B. Bruyère, Rapport préliminaire sur les fouilles de Deir el Médineh (1931-1932) (Cairo 1934)
- Bruyère, Mert Seger
- B. Bruyère, Mert Seger à Deir el Médineh (Cairo 1930)
- BSEG
- Bulletin de la Société d'Égyptologie, Genève (Geneva)
- BSFE
- Bulletin de la Société française d'Égyptologie (Paris)
- BTMP, Prelim. Report
- Berkeley Theban Mapping Project, Preliminary Reports (Berkeley 1978-)
- Bucher, Textes
- P. Bucher, Les textes des tombes de Thoutmosis III et d'Aménophis II (Cairo 1932)
- Budge, P. Greenfield
- E. A. W. Budge, The Greenfield Papyrus (London 1912)
- Budge, Lady Meux
- E. A. W. Budge, Some Account of the Collection of Egyptian Antiquities in the Possession of Lady Meux, of Theobald's Park, Waltham Cross<sup>2</sup> (London 1896)
- Budge, Nile & Tigris
- E. A. W. Budge, By Nile and Tigris (London 1920)
- Budge, Seti I
- E. A. W. Budge, An Account of the Sarcophagus of Seti I, King of Egypt, B.C. 1370 (London 1908)

- CAH I. E. S. Edwards, C. J. Gadd & N. G. L. Hammond (ed.), The Cambridge Ancient History<sup>2</sup> (Cambridge)
- Caminos, Ibrim R. A. Caminos, The Shrines and Rock Inscriptions of Ibrim (London 1968)
- Capart, Tout-Ankh-Amon J. Capart et al., Tout-Ankh-Amon (Brussels 1944)
- Capart, Tutankhamen J. Capart, The Tomb of Tutankhamen (London 1923)
- Carnarvon & Carter, Five Years The Earl of Carnarvon & H. Carter, Five Years' Explorations at Thebes (London 1912)
- Carter, Tut.ankh.Amen H. Carter (& A. C. Mace), The Tomb of Tut.ankh.Amen (London 1923-33)
- CdE Chronique d'Égypte (Brussels)
- Century Magazine The Century Illustrated Monthly Magazine (New York)
- Černý, Community J. Černý, A Community of Workmen at Thebes in the Ramesside Period (Cairo 1973)
- Černý, Graffiti J. Černý, Graffiti hiéroglyphiques et hiératiques de la nécropole thébaine (Cairo 1956)
- Černý, Hieratic Inscriptions J. Černý, Hieratic Inscriptions from the Tomb of Tut<sup>C</sup>ankhamūn (Oxford 1965)

- Černý, LRL
- Černý, Ostraca
- Černý, Valley
- Černý & Gardiner,  
Ostraca
- Černý & Sadek,  
Graffiti
- Chambers's Journal
- Champollion,  
Notices
- (Champollion), Textes  
et langages
- Charmes, L'Égypte
- Ciccarello,  
Graffito
- Ciccarello,  
Ushebties
- J. Černý, Late Ramesside  
Letters (Brussels 1939)
- J. Černý, Ostraca hiératiques  
(Cairo 1930-5)
- J. Černý, The Valley of the  
Kings (Cairo 1973)
- J. Černý & A. H. Gardiner,  
Hieratic Ostraca (Oxford  
1957-)
- J. Černý, A. A. Sadek et al.,  
Graffiti de la montagne  
thébaine (Cairo 1969-74)
- Chambers's Edinburgh Journal  
(Edinburgh)
- J.-F. Champollion, Monuments  
de l'Égypte et de la Nubie.  
Notices descriptives  
(Paris 1844-89)
- Textes et langages de l'Égypte  
pharaonique (Hommages à  
Jean-François Champollion)  
(Cairo 1973-4)
- G. Charmes, L'Égypte (Paris  
1891)
- M. Ciccarello, The Graffito  
of Pinutem I in the Tomb  
of Ramesses XI (San  
Francisco 1979)
- M. Ciccarello, Five Late-  
Ramesside Lost-Contour  
Alabaster Ushebties in  
the Tomb of Ramesses XI  
(San Francisco 1979)

- Ciccarello & Romer, Report M. Ciccarello & J. Romer, A Preliminary Report of the Recent Work in the Tombs of Ramesses X and XI in the Valley of the Kings (San Francisco 1979)
- Clarke & Engelbach, Masonry S. Clarke & R. Engelbach, Ancient Egyptian Masonry (Oxford 1930)
- Cone, Discovery P. Cone (ed.), The Discovery of Tutankhamun's Tomb (New York 1976)
- Currelly, Ages C. T. Currelly, I Brought the Ages Home (Toronto 1956)
- Daressy, Cercueils G. Daressy, Cercueils des cachettes royales (Cairo 1909)
- Daressy, Fouilles G. Daressy, Fouilles de la Vallée des rois (1898-1899) (Cairo 1902)
- Daressy, Ostraca G. Daressy, Ostraca (Cairo 1901)
- Daressy, Principal Monuments G. Daressy, A Brief Description of the Principal Monuments Exhibited in the Egyptian Museum Cairo<sup>3</sup> (Cairo 1925)
- Davies, RTA N. de G. Davies, The Rock Tombs of El Amarna (London 1903-8)

- Davies & Gardiner,  
Painted Box
- Davies & Macadam,  
Cones
- Davis, Harmhabi
- Davis, Hâtshopsîtû
- Davis, Iouiya & Touiyou
- Davis, Siphtah
- Davis, Thoutmôsis IV
- Davis, Tîyi
- Dawson & Uphill,  
Who Was Who
- Descr.
- N. M. Davies & A. H. Gardiner,  
Tutankhamun's Painted Box  
(Oxford 1962)
- N. de G. Davies & M. F. L. Macadam, A Corpus of Inscribed Egyptian Funerary Cones (Oxford 1957-)
- Th. M. Davis et al., The Tombs of Harmhabi and Touatânkhamanou (London 1912)
- Th. M. Davis et al., The Tomb of Hâtshopsîtû (London 1906)
- Th. M. Davis et al., The Tomb of Iouiya and Touiyou (London 1907)
- Th. M. Davis et al., The Tomb of Siphtah; the Monkey Tomb and the Gold Tomb (London 1908)
- Th. M. Davis et al., The Tomb of Thoutmôsis IV (London 1904)
- Th. M. Davis et al., The Tomb of Queen Tîyi (London 1910)
- W. R. Dawson & E. P. Uphill,  
Who Was Who in Egyptology<sup>2</sup>  
(London 1972)
- Commission des Monuments  
d'Égypte, Description de l'Égypte (Paris 1809-28)

- Donadoni, Fonti S. Donadoni (ed.), Le fonti indirette della storia egiziana (Rome 1963)
- Drenkhahn, Elephantine-Stele R. Drenkhahn, Die Elephantine-Stele des Sethnacht und ihr historischer Hintergrund (Wiesbaden 1980)
- Edgerton, Thutmosid Succession W. F. Edgerton, The Thutmosid Succession (Chicago 1933)
- Edwards, Decrees I. E. S. Edwards, Oracular Amuletic Decrees of the late New Kingdom (London 1960)
- Edwards, Pharaohs A. B. Edwards, Pharaohs, Fellahs and Explorers (New York 1891)
- Edwards, Thousand Miles A. B. Edwards, A Thousand Miles up the Nile<sup>2</sup> (London n.d.)
- Edwards, Tutankhamun I. E. S. Edwards, Tutankhamun: his Tomb and its Treasures (London 1979)
- EEFAR Egypt Exploration Fund Archaeological Report (London)
- Egn. Expedn. Bulletin of the Metropolitan Museum of Art, part 2, The Egyptian Expedition (New York)
- L'Égyptologie en 1979 Colloques internationaux du C.N.R.S., no. 595, L'Égyptologie en 1979 (Paris 1982)

- Engelbach, Archaeology R. Engelbach, Introduction to Egyptian Archaeology (Cairo 1946)
- Erman, Glossar A. Erman, Aegyptisches Glossar (Berlin 1904)
- EVO Egitto e Vicino Oriente (Pisa)
- (Fairman), J. Ruffle, G. A. Gaballa & K. A. Kitchen, Glimpses of Ancient Egypt. Studies in Honour of H. W. Fairman (Warminster 1979)
- Glimpses
- Faulkner, R. O. Faulkner, A Concise Dictionary of Middle Egyptian (Oxford 1972)
- Dictionary
- Fox, Schatz P. Fox, Der Schatz des Tut-ench-Amun (Wiesbaden 1960)
- Gaillard & Daressy, C. Gaillard & G. Daressy, La faune momifiée de l'antique Égypte (Cairo 1905)
- Faune momifiée
- Gardiner, Egypt A. H. Gardiner, Egypt of the Pharaohs (Oxford 1961)
- Gardiner, Grammar A. H. Gardiner, Egyptian Grammar<sup>3</sup> (London 1973)
- Gardiner, RAD A. H. Gardiner, Ramesside Administrative Documents (London 1948)
- Giles, Ikhnaton F. J. Giles, Ikhnaton, Legend and History (London 1970)
- Gitton, Épouse M. Gitton, L'épouse du dieu Ahmes Néfertary (Paris 1975)

- GM
- Goff, Symbols
- Grand Palais,  
Ramsès le grand
- Hammerton, Wonders
- Hanke,  
Amarna-Reliefs
- Hari, Horemheb
- Harper's Magazine
- Harris, Legacy
- Harris & Weeks,  
X-Raying
- Harris & Wente,  
Atlas
- Hayes,  
Sarcophagi
- Hayes, Scepter
- Göttinger Miszellen (Göttingen)
- B. L. Goff, Symbols of  
Ancient Egypt in the Late  
Period. The Twenty-first  
Dynasty (The Hague 1979)
- Grand Palais, Ramsès le grand  
(Paris 1976)
- J. A. Hammerton, Wonders of  
the Past (London n.d.)
- R. Hanke, Amarna-Reliefs aus  
Hermopolis (Hildesheim  
1978)
- R. Hari, Horemheb et la reine  
Moutnedjemet (Geneva 1964)
- Harper's New Monthly Magazine  
(New York)
- J. R. Harris (ed.), The Legacy  
of Egypt<sup>2</sup> (Oxford 1971)
- J. E. Harris & K. R. Weeks,  
X-Raying the Pharaohs  
(New York 1973)
- J. E. Harris & E. F. Wente (ed.),  
An X-Ray Atlas of the  
Royal Mummies (Chicago  
1980)
- W. C. Hayes, Royal Sarcophagi  
of the XVIII Dynasty  
(Princeton 1935)
- W. C. Hayes, The Scepter of  
Egypt (New York 1953-9)

- Helck, Materialien W. Helck, Materialien zur  
Wirtschaftsgeschichte  
des Neuen Reiches  
(Wiesbaden 1960-9)
- Helck, Militärführer H. W. Helck, Der Einfluss  
der Militärführer in der  
18. ägyptischen Dynastie  
(Leipzig 1939)
- Helck, Verwaltung W. Helck, Zur Verwaltung  
des Mittleren und Neuen  
Reiches (Leiden 1958)
- Hölscher,  
Excavation V U. Hölscher, The Excavation  
of Medinet Habu, V:  
Post-Ramessid Remains  
(Chicago 1954)
- Hornung, Haremhab E. Hornung, Das Grab des  
Haremhab im Tal der Könige  
(Bern 1971)
- Hornung, Tal E. Hornung, Tal der Könige<sup>2</sup>  
(Zurich/Munich 1983)
- Hornung, User E. Hornung, Die Grabkammer  
des Vezirs User (Göttingen  
1961)
- Hoving,  
Tutankhamun T. Hoving, Tutankhamun: the  
Untold Story (New York  
1978)
- ILN Illustrated London News  
(London)
- James & Davies,  
Sculpture T. G. H. James & W. V. Davies,  
Egyptian Sculpture (London  
1983)

- Janssen, Commodity Prices J. J. Janssen, Commodity Prices from the Ramessid Period (Leiden 1975)
- JARCE Journal of the American Research Center in Egypt (Boston)
- JEA Journal of Egyptian Archaeology (London)
- JEOL Jaarbericht van het Voor-aziatisch-Egyptisch Genootschap 'Ex Oriente Lux' (Leiden)
- JNES Journal of Near Eastern Studies (Chicago)
- Kees, Hohenpriester H. Kees, Die Hohenpriester des Amun von Karnak von Herihor bis zum Ende der Athiopenzeit (Leiden 1964)
- Keimer, Gartenpflanzen L. Keimer, Die Gartenpflanzen im alten Agypten (Berlin 1924-)
- Kitchen, TIP K. A. Kitchen, The Third Intermediate Period in Egypt (Warminster 1973)
- Krauss, Amarnazeit R. Krauss, Das Ende der Amarnazeit (Hildesheim 1978)
- LA W. Helck, E. Otto & W. Westendorf (ed.), Lexikon der Agyptologie (Wiesbaden 1972-)
- LD C. R. Lepsius, Denkmäler aus Agypten und Athiopien (Berlin/Leipzig 1849-56)

- LD Text C. R. Lepsius, Denkmäler aus Ägypten und Äthiopien. Text (ed. E. Naville, L. Borchardt & K. Sethe) (Leipzig 1897-1913)
- LdR H. Gauthier, Le livre des rois d'Égypte (Cairo 1907-17)
- Leek, Human Remains F. F. Leek, The Human Remains from the Tomb of Tut<sup>C</sup>ankhamun (Oxford 1972)
- Lefébure, Hypogées E. Lefébure, Les hypogées royales de Thèbes (Paris 1886-9)
- Legrain, Répertoire G. Legrain, Répertoire généalogique et onomastique du Musée du Caire. Monuments de la XVIIe et de la XVIIIe dynastie (Geneva 1908)
- Lepsius, Auswahl C. R. Lepsius, Auswahl der wichtigsten Urkunden ägyptischen Altertums (Leipzig 1842)
- L'Hôte, Lettres N. L'Hôte, Lettres écrites d'Égypte en 1838 et 1839 (Paris 1840)
- Lucas & Harris, Materials A. Lucas, Ancient Egyptian Materials and Industries<sup>4</sup> (revised and enlarged by J. R. Harris) (London 1964)

- Mariette,  
Mon. div.
- Martin,  
Royal Tomb
- Maspero,  
Causéries
- Maspero,  
Guide (1906)
- Maspero,  
Guide (1908)
- Maspero,  
Guide (1915)
- Maspero,  
Guide Boulaq
- Maspero, Histoire ancienne
- Maspero, Momies royales
- Maspero,  
New Light
- Maspero, Sites
- Maspero, Struggle
- A. Mariette, Monuments divers recueillis en Égypte et en Nubie (Paris 1872)
- G. T. Martin, The Royal Tomb at El-C<sup>c</sup>Amarna (London 1974-)
- G. Maspero, Causéries d'Égypte (Paris 1907)
- G. Maspero, Guide to the Cairo Museum<sup>3</sup> (Cairo 1906)
- G. Maspero, Guide to the Cairo Museum<sup>4</sup> (Cairo 1908)
- G. Maspero, Guide du visiteur au Musée du Caire (Cairo 1915)
- G. Maspero, Guide du visiteur au Musée de Boulaq (Boulaq 1883)
- G. Maspero, Histoire ancienne des peuples de l'Orient<sup>11</sup> (Paris 1912)
- G. Maspero, Les momies royales de Déir el-Baharî (Cairo 1889)
- G. Maspero, New Light on Ancient Egypt (London 1908)
- G. Maspero, Egypt: Ancient Sites and Modern Scenes (London 1910)
- G. Maspero, The Struggle of the Nations. Egypt, Syria and Assyria<sup>2</sup> (London 1910)

- Mayes, Belzoni S. Mayes, The Great Belzoni  
(London 1959)
- McLeod,  
Composite Bows W. McLeod, Composite Bows  
from the Tomb of Tut<sup>C</sup>ankh-  
amūn (Oxford 1970)
- McLeod, Self Bows W. McLeod, Self Bows and Other  
Archery Tackle from the  
Tomb of Tut<sup>C</sup>ankhamūn  
(Oxford 1982)
- MDAIK Mitteilungen des deutschen  
archäologischen Instituts,  
Abteilung Kairo (Berlin/  
Mainz)
- Montet, Osorkon II P. Montet, Les constructions  
et le tombeau d'Osorkon II  
à Tanis (Paris 1947)
- Montet, Psousennès P. Montet, Les constructions  
et le tombeau de Psousennès  
à Tanis (Paris 1951)
- Moursi,  
Hohenpriester M. I. Moursi, Die Hohenpriester  
des Sonnengottes von der  
Frühzeit bis zum Ende des  
Neuen Reiches (Munich 1972)
- Munich, Agyptischer  
Kunst Munich, Staatliche Sammlung  
Agyptischer Kunst<sup>2</sup> (Munich  
1976)
- Murnane,  
Coregencies W. J. Murnane, Ancient  
Egyptian Coregencies  
(Chicago 1977)
- Murray & Nuttall,  
Handlist H. Murray & M. Nuttall, A  
Handlist to Howard Carter's  
Catalogue of Objects in the  
Tomb of Tut<sup>C</sup>ankhamūn  
(Oxford 1963)

- Myśliwiec,  
Portrait royal
- NARCE
- Nature
- Naville,  
Deir el Bahari
- Naville, P. Iouiya
- Nims & Swaan, Thebes
- Nolte,  
Glasgefässe
- OB
- OIC, Handbook
- OLZ
- OMRO
- Orientalia
- K. Myśliwiec, Le portrait royal dans le bas-relief du Nouvel Empire (Warsaw 1976)
- Newsletter of the American Research Center in Egypt (Princeton/New York)
- Nature (London)
- E. Naville, The Temple of Deir el Bahari (London 1894-1908)
- E. Naville, The Funeral Papyrus of Iouiya (London 1908)
- C. F. Nims & W. Swaan, Thebes of the Pharaohs (London 1965)
- B. Nolte, Die Glasgefässe im alten Agypten (Berlin 1968)
- Orientalische Bibliographie (Berlin)
- Oriental Institute, Chicago, Handbook and Museum Guide (Chicago 1941)
- Orientalistische Literaturzeitung (Berlin)
- Oudheidkundige Mededelingen uit het Rijksmuseum van Oudheden te Leiden (Leiden)
- Orientalia (Rome)

- Palazzo Ducale, Tesori  
 Peet, Mayer Papyri
- Palazzo Ducale, Tesori dei Faraoni (Venice 1984)
- Peet, The Mayer Papyri A and B (London 1920)
- Peet, Tomb-Robberies of the Twentieth Egyptian Dynasty (Oxford 1930)
- Perepelkin, Gold Coffin
- G. Perepelkin, The Secret of the Gold Coffin (Moscow 1978)
- Perepelkin, Kéïe
- Yu. Ya. Perepelkin, Kéïe i Semnekhkeré (Moscow 1979)
- Perepelkin, Perevorot
- Yu. Ya. Perepelkin, Perevorot Amen-khotpa IV (Moscow 1967-)
- Petit Palais, Toutankhamon
- Petit Palais, Toutankhamon et son temps<sup>2</sup> (Paris 1967)
- Petrie, Buttons
- W. M. F. Petrie, Buttons and Design Scarabs (London 1925)
- Petrie, History
- W. M. F. Petrie, A History of Egypt during the XVIIth and XVIIIth Dynasties<sup>7</sup> (London 1924)
- P-M
- B. Porter & R. Moss, Topographical Bibliography of Ancient Egyptian Hieroglyphic Texts, Reliefs and Paintings (Oxford 1927-)

<u>PSBA</u>	<u>Proceedings of the Society of Biblical Archaeology</u> (London)
Pusch, <u>Brettspiel</u>	E. B. Pusch, <u>Das Senet-Brettspiel im alten Ägypten</u> (Munich 1979-)
Quibell, <u>Archaic Objects</u>	J. E. Quibell, <u>Archaic Objects</u> (Cairo 1904-5)
Quibell, <u>Yuaa &amp; Thuiu</u>	J. E. Quibell, <u>Tomb of Yuaa and Thuiu</u> (Cairo 1908)
<u>RA</u>	<u>Revue archéologique</u> (Paris)
<u>Rapports 1899-1910</u>	Gouvernement Égyptien, <u>Rapports sur la marche du Service des Antiquités de 1899 à 1910</u> (Cairo 1912)
<u>Rapport 1911</u>	Gouvernement Égyptien, <u>Rapport du Service des Antiquités pour l'année 1911</u> (Cairo 1912)
<u>Rapport 1912</u>	Gouvernement Égyptien, <u>Rapport du Service des Antiquités pour l'année 1912</u> (Cairo 1913)
<u>Rapport 1914-15</u>	Gouvernement Égyptien, <u>Rapport du Service des Antiquités pour 1914 et 1915</u> (Cairo 1916)
<u>RdC</u>	<u>Revue du Caire</u> (Cairo)
<u>RdE</u>	<u>Revue d'Égyptologie</u> (Paris)
<u>RdT</u>	<u>Recueil de Travaux relatifs à la philologie et à l'archéologie égyptiennes et assyriennes</u> (Paris)

- RE  
 Reisner, Ships & Boats  
 Reisner & Abd-ul-Rahman, Canopics  
 Rhind, Thebes  
 Romer, Floods  
 Romer, Project  
 Romer, Valley  
RSO  
 Ruffle, Heritage  
SA  
 Säve-Söderbergh, Ägypten u. Nubien  
SAK  
 Sandman, Texts
- Revue égyptologique (Paris)  
 G. A. Reisner, Models of Ships and Boats (Cairo 1913)  
 G. A. Reisner & M. H. Abd-ul-Rahman, Canopics (Cairo 1967)  
 A. H. Rhind, Thebes, its Tombs and their Tenants (London 1862)  
 J. Romer, A History of Floods in the Valley of the Kings (San Francisco 1979)  
 J. Romer, The Brooklyn Museum Theban Expedition. Theban Royal Tomb Project. Introduction (San Francisco 1979)  
 J. Romer, Valley of the Kings (London 1981)  
Rivista degli Studi Orientali (Rome)  
 J. Ruffle, Heritage of the Pharaohs (Oxford 1977)  
Studia Aegyptiaca (Budapest)  
 T. Säve-Söderbergh, Ägypten und Nubien (Lund 1941)  
Studien zur altägyptischen Kultur (Hamburg)  
 M. Sandman, Texts from the Time of Akhenaten (Brussels 1938)

- Sayce,  
Reminiscences
- Scamuzzi, Turin
- Schaden, Ay
- Schäfer & Andrae,  
Kunst
- Schiaparelli,  
Relazione
- Schmitz,  
Amenophis I  
Science  
Serapis
- Service des Antiquités,  
Principaux  
monuments
- Smith, Ancient Egypt
- Smith, Art &  
Architecture
- A. H. Sayce, Reminiscences  
(London 1923)
- E. Scamuzzi, Egyptian Art  
in the Egyptian Museum  
of Turin (Turin 1965)
- O. J. Schaden, The God's  
Father Ay (Ann Arbor 1977)
- H. Schäfer & W. Andrae, Die  
Kunst des alten Orients  
(Berlin 1925)
- E. Schiaparelli, Relazione  
sui lavori della Missione  
archaeologica italiana in  
Egitto, Anni 1903-20  
(Turin 1924-7)
- F. J. Schmitz, Amenophis I  
(Hildesheim 1978)  
Science (Washington DC)  
Serapis (Chicago)
- Service des Antiquités, Notice  
des principaux monuments  
exposées au Musée de Gizeh  
(Cairo 1892)
- W. S. Smith, Ancient Egypt  
as represented in the  
Museum of Fine Arts<sup>6</sup> (Boston  
1961)
- W. S. Smith, The Art and  
Architecture of Ancient  
Egypt (Harmondsworth 1958)

- Smith, Buhen  
Inscriptions
- Smith, Royal  
Mummies
- Smith, Tombs
- Smith,  
Tutankhamen
- Smith & Dawson,  
Mummies
- Sotheby & Co.,  
Burton Collection
- Spencer, Death
- Sphinx
- Spiegelberg,  
Graffiti
- Spiegelberg,  
Zwei Beiträge
- H. S. Smith, The Fortress  
of Buhen. The Inscriptions  
(London 1976)
- G. E. Smith, The Royal  
Mummies (Cairo 1912)
- J. L. Smith, Tombs, Temples  
and Ancient Art (Norman  
1956)
- G. E. Smith, Tutankhamen  
and the Discovery of his  
Tomb (London 1923)
- G. E. Smith & W. R. Dawson,  
Egyptian Mummies (London  
1924)
- Sotheby & Co., Catalogue of  
the very interesting Collection  
of Egyptian Antiquities,  
formed by James Burton  
(London 1836)
- A. J. Spencer, Death in  
Ancient Egypt (Harmondsworth  
1982)
- Sphinx (Uppsala)
- W. Spiegelberg, Agyptische und  
andere Graffiti (Inschriften  
und Zeichnungen) aus der  
thebanischen Nekropolis  
(Heidelberg 1921)
- W. Spiegelberg, Zwei Beiträge  
zur Geschichte und Topographie  
des thebanischen Necropolis  
im neuen Reich (Strassburg  
1898)

- Stuart,  
Funeral Tent
- Stuart,  
Nile Gleanings  
Studia Naster
- Studies Hughes
- Sunday Times  
Magazine
- Synopsis
- The Times
- Thomas,  
Necropoleis  
Trans. 5th ICO
- Trigger,  
Social History
- (Turner), Papyri
- Tyndale,  
Cataracts  
Urk. IV
- H. W. V. Stuart, The Funeral  
Tent of an Egyptian  
Queen (London 1882)
- H. W. V. Stuart, Nile  
Gleanings (London 1879)
- J. Quaegebeur (ed.), Studia  
Paulo Naster oblata, II:  
Orientalia antiqua (Leuven  
1982)
- Studies in Honor of George  
R. Hughes (Chicago 1976)
- Sunday Times Magazine (London)
- Synopsis of the Contents of  
the British Museum<sup>44</sup>  
(London 1842)
- The Times (London)
- E. Thomas, The Royal Necropoleis  
of Thebes (Princeton 1966)
- Transactions of the Fifth  
International Congress  
of Orientalists (Berlin  
1881)
- B. Trigger, B. J. Kemp,  
D. O'Connor & A. B. Lloyd,  
Ancient Egypt: a Social  
History (Cambridge 1983)
- (E. G. Turner), Papyri  
Greek and Egyptian (P. Turner)  
(London 1981)
- W. Tyndale, Below the  
Cataracts (London 1907)
- K. Sethe & W. Helck, Urkunden  
der 18. Dynastie (Urkunden  
des aegyptischen Altertums,  
IV) (Leipzig/Berlin 1906-58)

- |  |  |
|--|--|
| Waring & Gillow,<br><u>Theobald's Park</u> | Waring & Gillow Ltd.,<br><u>'Theobald's Park', Waltham<br/>Cross, Herts.</u> <sup>2</sup> (London<br>1911) |
| <u>Wb.</u>                                 | A. Erman & H. Grapow (ed.),<br><u>Wörterbuch der ägyptischen<br/>Sprache</u> (Leipzig/Berlin<br>1926-63)   |
| Wehr, <u>Dictionary</u>                    | H. Wehr, <u>A Dictionary of<br/>Modern Written Arabic</u> <sup>4</sup><br>(Wiesbaden 1979)                 |
| Weigall, <u>Glory</u>                      | A. Weigall, <u>The Glory of<br/>the Pharaohs</u> (London 1936)   |
| Weigall, <u>Guide</u>                      | A. Weigall, <u>A Guide to the<br/>Antiquities of Upper Egypt</u><br>(London 1910)                          |
| Weigall, <u>History</u>                    | A. Weigall, <u>A History of the<br/>Pharaohs</u> (London 1925-7)   |
| Weigall, <u>Life &amp;<br/>Times</u>       | A. Weigall, <u>The Life and Times<br/>of Akhnaton, Pharaoh of<br/>Egypt</u> (London 1923)                  |
| Weigall, <u>Treasury</u>                   | A. Weigall, <u>The Treasury of<br/>Ancient Egypt</u> (Edinburgh/<br>London 1911)                           |
| Weigall,<br><u>Tutankhamen</u>             | A. Weigall, <u>Tutankhamen and<br/>Other Essays</u> (New York<br>1924)                                     |
| Weigall,<br><u>Works of Art</u>            | A. Weigall, <u>Ancient Egyptian<br/>Works of Art</u> (London 1924)   |
| Weinstein,<br><u>Foundation Deposits</u>   | J. Weinstein, <u>Foundation<br/>Deposits in Ancient Egypt</u><br>(Ann Arbor 1973)                          |

- Wenig, Frau S. Wenig, Die Frau im alten Ägypten (Leipzig 1967)
- Wente, LRL E. F. Wente, Late Ramesside Letters (Chicago 1967)
- Wilcken,  
Chrestomathie L. Mitteis & U. Wilcken, Grundzüge und Chrestomathie der Papyruskunde, II (Leipzig 1912)
- Wilkinson,  
Topography J. G. Wilkinson, Topography of Thebes, and General View of Egypt (London 1835)
- Winlock, Materials H. E. Winlock, Materials Used at the Embalming of King Tūt-Cankh-Amūn (New York 1941)
- Winlock,  
Meryet-Amūn H. E. Winlock, The Tomb of Queen Meryet-Amūn at Thebes (New York 1932)
- Winlock, Three Princesses H. E. Winlock, The Treasure of Three Egyptian Princesses (New York 1948)
- Winlock & Crum,  
Epiphanius H. E. Winlock & W. E. Crum, The Monastery of Epiphanius at Thebes (New York 1926)
- ZAS Zeitschrift für ägyptische Sprache und Altertumskunde (Leipzig/Berlin)
- Zoëga, De origine G. Zoëga, De origine et usu obeliscorum (Rome 1797)

Manuscript sources

- Andrews, Journal E. B. Andrews (fl. 1899-1912),  
A Journal on the Bedawin, 1899-1912 (transcripts in  
the Egyptian Department,  
Metropolitan Museum of  
Art, New York, and the  
Library of the American  
Philosophical Society,  
Philadelphia)
- Ayrton photos. E. R. Ayrton (1882-1914)  
(Egypt Exploration Society  
archives, London)
- Burton, MSS J. Burton (1788-1862) (Department  
of Manuscripts, British  
Library)
- Carter, MSS, Notebooks  
and Cards H. Carter (1873-1939) (Griffith  
Institute, Oxford)
- Černý, MSS and  
Notebooks J. Černý (1898-1970) (Griffith  
Institute, Oxford)
- Gardiner, MSS and  
Notebooks A. H. Gardiner (1879-1963)  
(Griffith Institute, Oxford)
- Jones correspondence E. H. Jones (-1911) (National  
Library of Wales, Aberystwyth)
- Jones & Burton,  
Tombs E. H. Jones (-1911) & H. Burton  
(1879-1940), Tombs of the  
Kings (excavation journal,  
Egyptian Department,  
Metropolitan Museum of Art,  
New York)

- Lane, Notebooks E. W. Lane (1801-76) (Department of Manuscripts, British Library)
- Loret map V. Loret (1859-1946) (annotated copy of Loret, BIE (3 sér.) 9 (1898), pl. 1, Wilbour Library, Brooklyn Museum)
- Maspero correspondence G. Maspero (1846-1916) (correspondence with A. B. Edwards 1878-91, Somerville College, Oxford)
- Smith, Diary 1904/5 J. L. Smith (1863-1950) (Archives of American Art, Washington, DC)
- Weigall, MSS A. Weigall (1880-1934) (in the possession of Mrs P. Moore, London, and Mrs V. Hankey, Westerham)
- Wilkinson, Notebooks J. G. Wilkinson (1797-1875) (formerly on loan to the Griffith Institute, Oxford)

Other

- BM British Museum, London
- CG Catalogue général, Cairo Museum
- EES Egypt Exploration Society, London
- J Journal d'entrée, Cairo Museum

MFA	Museum of Fine Arts, Boston
MMA	Metropolitan Museum of Art, New York
ROM	Royal Ontario Museum, Toronto
UCL	University College London

## ADDENDA

Chapter 11, p.239. On the proposed misidentification of the royal mummies, cf. Wente, in Oriental Institute, Chicago, 1981-82 Annual Report, 86; also Harris, in University of Michigan News Release 37 (20 December 1971), 2.

Chapter 11, p. 242 ff. Doubts about the attribution of mummy CG 61065 to Tuthmosis I, based upon an estimate of the age at death and also upon the extended position of the arms - which perhaps suggests a date pre-Amenophis I (cf. Gray, JEA 58 (1970), 202 f.) - were noted in University of Michigan News Release 37 (20 December 1971), 1 ff.

Appendix A, p. 313. Add:

Site 12a

Between KV4 and KV28.

Finds/results.

Discovery of KV44 (26 January 1901). For the finds cf. Carter, ASAE 2 (1901), 144 f.

## PREFACE

As Maspero once remarked, 'Nothing is rarer now in the Theban necropolis than virgin tombs,<sup>1)</sup> - and indeed, to the one substantial intact burial he was then able to cite (the family vault of Sennudjem)<sup>2)</sup> there can be added only that of the architect Kha and his wife Meryt,<sup>3)</sup> discovered by Schiaparelli in 1906. Although this situation may, to some extent, be attributable to the awakened interest in and mad scramble for things Egyptian which followed in the wake of Napoleon's expedition,<sup>4)</sup> it is clear that the vast majority of Egypt's tombs had in fact been ransacked very much earlier. The salient national characteristic of the Egyptian people singled out for comment by Plato<sup>5)</sup> in the fourth century BC was a greed for wealth (τὸ φιλοχρήματον), and one of the ways in which this manifested itself was through robbery of the dead. Practised to our certain knowledge since predynastic times,<sup>6)</sup> robbery of this kind was to grow in attraction and extent in parallel with the development of funerary beliefs and the ever more lavish provisions made for the next life.

As a phenomenon, tomb robbery and its effects may be studied with most profit in the necropolis of New Kingdom Thebes. For the purposes of this thesis, research has been concentrated upon one specific area of the Theban west bank: Wadi Biban

el-Muluk, better known as the Valley of the Kings. Not only is post-interment activity better attested here in terms of both the archaeological and textual record than in any other part of Egypt, but the fact that the mortal remains of several of the tomb owners were later removed to be cached elsewhere provides a unique opportunity to study in some detail the changing responses to the apparent increase in tomb robbery during the late New Kingdom and early years of the Third Intermediate Period.

The thesis itself is divided into two main sections, preceded by an introduction. The first of these sections deals in turn with each tomb and deposit known from the Valley of the Kings. The aim has been not so much to draw up an exhaustive catalogue of the contents of every tomb, but to establish for later analysis the basic archaeological context of each find and, wherever possible, to isolate and compare the evidence for post-interment activity. The second part of the thesis draws together the archaeological and documentary evidence relating to the royal caches from Deir el-Bahri, the tomb of Amenophis II and elsewhere, from an analysis of which it has been possible to suggest the routes by which the royal mummies arrived at their final destinations. The overall conclusions are set out in a separate section at the end of the study, which is brought to a close with four appendices which chart the history of excavation in the Valley of the Kings between 1898 and 1922.

A number of the topics considered in this thesis have been treated previously by the writer in the following articles and reviews:

'The tomb of Tuthmosis IV: two questionable attributions', GM 44 (1981), 49 ff.

'A state chariot from the tomb of Ay?', GM 46 (1981), 11 ff.

'A reappraisal of Tomb 55 in the Valley of the Kings', JEA 67 (1981), 48 ff.

Review of Perepelkin, Gold Coffin, BiOr 38/3-4 (1981), 293 ff.

'The discovery and clearance of KV58', GM 53 (1982), 33 ff.

'Akhenaten after all?', GM 54 (1982), 61 ff.

Review of Harris & Wente, Atlas, BiOr 39/3-4 (1982), 264 ff.

'On the miniature mask from the Tut<sup>C</sup>ankhamūn embalming cache', BSEG 8 (1983), 81 ff.

'Excavations in the Valley of the Kings, 1905/6: a photographic record', MDAIK 40 (1984) (forthcoming)

'Two architectural drawings from the Valley of the Kings', CdE 60 (1985) (forthcoming)

In the preparation of this thesis many debts have been incurred. I am particularly grateful to my supervisor, Prof. J. R. Harris, who has generously given of his time and knowledge to the discussion and elucidation of several points arising from my research. I am further indebted to Miss Elizabeth Thomas, who has kindly answered numerous enquiries and made available to me revised extracts from her fundamental work, The Royal Necropoleis of Thebes; whilst John Romer has generously provided information on various points and allowed access to as yet unpublished material from his work in the tomb of Ramesses XI and elsewhere. To Dr Christine Lilyquist I am particularly grateful for knowledge of and permission to consult the unpublished day journal of E. Harold Jones and Harry Burton preserved in the Egyptian Department of the Metropolitan Museum of Art; to Mrs P. Moore and Mrs Vronwy Hankey for free access to the papers of Arthur Weigall; to Dr Patricia Spencer for knowledge of and access to the unpublished photographs of Edward R. Ayrton preserved in the archives of the Egypt Exploration Society, London; to Dr J. Málek and Miss Helen Murray for access to the papers of Carter, Černý, Gardiner and others preserved in the Griffith Institute, Oxford; and to the staff of the Oriental Library, Durham, and other institutions which have assisted me in my research. For information, comments and other kindnesses I should like to thank David Aston, Dr E. Brovarski, Rachel Campbell, Miss M. S. Drower, Prof. H. Goedicke, Prof. J.-C. Goyon, Mr T. G. H. James, Peter Lacovara, Christian Loeben, Dr N. Millet,

Dr G. T. Martin, Catharine Roehrig, Dr O. J. Schaden, Prof. A. F. Shore, Prof. W. K. Simpson, Prof. H. S. Smith, Miss F. Strachan, Dr A. J. Spencer, Dr W. J. Tait, Dr K. R. Weeks and Prof. E. F. Wentz. Last, but by no means least, I wish to thank my wife, my daughter and my parents, without whose forbearance this thesis would not have been written.

## INTRODUCTION

## INTRODUCTION

## THE BURIAL OF AMENOPHIS I

Amenophis I is the first king of the New Kingdom about whose funerary arrangements we know anything at all, and a consideration of his burial will be as appropriate a way as any to introduce this study.

The investigating commission of Year 16 of Ramesses IX<sup>1)</sup> records the location of the king's tomb in the following way:

The horizon of eternity of King Djeserka(re) l.p.h., Son of Re Amenophis l.p.h., nty ir mh-120 mdt m p3y.st <sup>c</sup>h<sup>c</sup>y p3 <sup>c</sup>k3, so called, north of the house (pr) of Amenophis l.p.h. of the garden (n p3 k3mw).<sup>2)</sup>

Owing to our as yet imperfect knowledge of Egyptian lexicography and of Theban topography during the New Kingdom, this text has been employed to support the claims of two quite different tombs.<sup>3)</sup>

An association with the first of these tombs, KV39 (fig. 66), was proposed by Weigall in 1911.<sup>4)</sup> He suggested that the immediate situation of the tomb might satisfactorily be reconciled with the P. Abbott description quoted above by identifying the <sup>c</sup>h<sup>c</sup>y (of) p3 <sup>c</sup>k3 or 'the high track'<sup>5)</sup> with

the remains of huts located upon the ridge above KV39.<sup>6)</sup> The candidates so far put forward for a 'house of Amenophis I.p.h. of the garden' in the southern part of the Theban necropolis remain unconvincing, however,<sup>7)</sup> whilst the available plan and section of the tomb (though admittedly in large part conjectural)<sup>8)</sup> are reminiscent more of a private tomb of the mid-18th dynasty - such as KV21<sup>9)</sup> - than of a royal sepulchre from the beginning of that epoch.<sup>10)</sup>

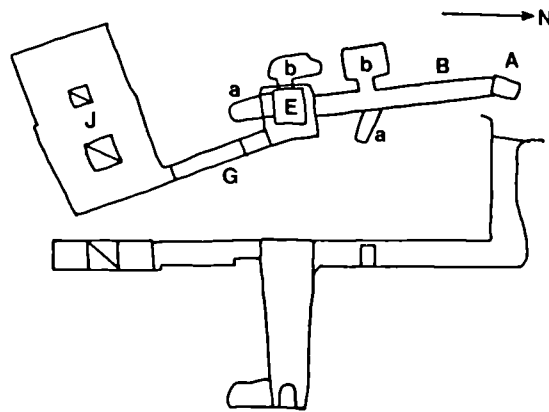

Fig. 1: AN B

More likely to be the tomb described in P. Abbott is AN B<sup>11)</sup> (fig. 1), worked by the Arabs as early as 1907<sup>12)</sup> and fully cleared by Carter in 1913/14.<sup>13)</sup> Carter describes it thus at the time of his first entry:

An immense boulder that had fallen from above blocked the greater part of the doorway opening into the first corridor (B),

at the bottom of the entrance shaft (A), 'leaving but a small space at the side to squeeze through'. Corridor (B) was 'partially filled with rubble, and half-way along it were two small chambers (Ba, Bb), one on each side, also filled with rubble'. At the end of the corridor had been excavated a well (E), 'choked almost to the brim with desert-silt', in the centre of which 'a deep hole bore evidence of the activities of' modern plunderers. Across from the well stretched another corridor (G), leading into 'a low spacious pillared hall (J) ... empty save for rubbish and shrivelled members of mummies buried in the rubbish strewn over the floor'.<sup>14)</sup> These were the remains of intrusive burials of the 22nd dynasty ('reign of Osorkon I',<sup>15)</sup> or later)<sup>16)</sup> which had clearly been burnt during some later plundering.<sup>17)</sup>

Beneath these layers Carter discovered traces of the original interment(s). Apart from some anonymous coffin debris,<sup>18)</sup> the most important pieces were a series of stone vessel fragments bearing inscriptions of the Hyksos king Apophis I and the king's daughter Heret (1),<sup>19)</sup> of Amosis I (3),<sup>20)</sup> of Ahmose-Nofretiri (8),<sup>21)</sup> and of Amenophis I (9).<sup>22)</sup> On the basis of name frequency, Carter inclined towards ascribing these fragments to a double burial of Amenophis I and Ahmose-

Nofretiri, the patron saints of the Theban necropolis.<sup>23)</sup>

Although scholarly opinion has tended to doubt the connection of Amenophis I with AN B and preferred to attribute the tomb to Ahmose-Nofretiri alone,<sup>24)</sup> the results of a recent study by Romer<sup>25)</sup> suggest that Carter's original interpretation was in fact substantially correct. Romer has recalled Carter's observation<sup>26)</sup> that AN B had been adapted during the 18th dynasty by the extension of the burial chamber (J) (as if to accommodate a second burial) and by the addition of a well (E).<sup>27)</sup> In the light of subsequent practice, the latter feature strongly suggests that the secondary working of the tomb had been carried out for a king.<sup>28)</sup> This king, to judge from the bulk of the inscriptions and what are perhaps to be recognised as ex voto offerings in the form of later private statuary,<sup>29)</sup> can have been none other than Amenophis I.<sup>30)</sup> Romer dates the adaptation of AN B to the reign of Tuthmosis III or thereabouts, on the grounds (a) that Hatshepsut's tomb in the Wadi Sikkat Taqa el-Zeide (WA D) was apparently influenced by the original plan of AN B,<sup>31)</sup> and (b) that the proportions of the enlarged burial chamber are very similar to those of KV34 (Tuthmosis III), KV35 (Amenophis II) and KV43 (Tuthmosis IV).<sup>32)</sup> It is not inconceivable, however, that AN B, the tomb of Ahmose-Nofretiri, was enlarged for the burial of Amenophis I during the latter's lifetime.<sup>33)</sup>

The weakness of Carter's identification has always been his explanation of the measurements cited in P. Abbott.<sup>34)</sup> The relevant section of this text, nty ir mh-120 mdt m p3y.st ch<sup>c</sup>y p3 c k3 hr.tw rf, Carter<sup>36)</sup> (following Breasted)<sup>37)</sup> translated: 'which is 120 cubits deep from its superstructure, which is called: "The-High-Ascent"'. This Carter takes to imply that the investigating commission had access to the interior of the tomb, and he manipulates his measurements accordingly.<sup>37)</sup> If, however, we connect the P. Abbott ch<sup>c</sup>y (the writing of which is otherwise unattested) with the word ch<sup>c</sup>, 'heap' or 'pile',<sup>38)</sup> a rather different translation becomes possible: 'which is 120 cubits down from its heap (of) the high track, so called'. This 'heap', I would suggest, is to be identified with the 'cairn' marked upon Carter's sketch map of the area some 60 m (= approx. 120 cu) to the (magnetic) north of AN B.<sup>39)</sup> Cf. fig. 2.

If AN B is indeed the tomb employed by both Ahmose-Nofretiri and Amenophis I, the 'house of Amenophis l.p.h. of the garden' is clearly to be recognised as the mortuary temple Meniset, to the (local) north of which the tomb is situated. This temple, dedicated (significantly enough) to the worship of both mother and son,<sup>40)</sup> is located on the very edge of the cultivation; the designation 'of the garden' will thus have been singularly appropriate.<sup>41)</sup>

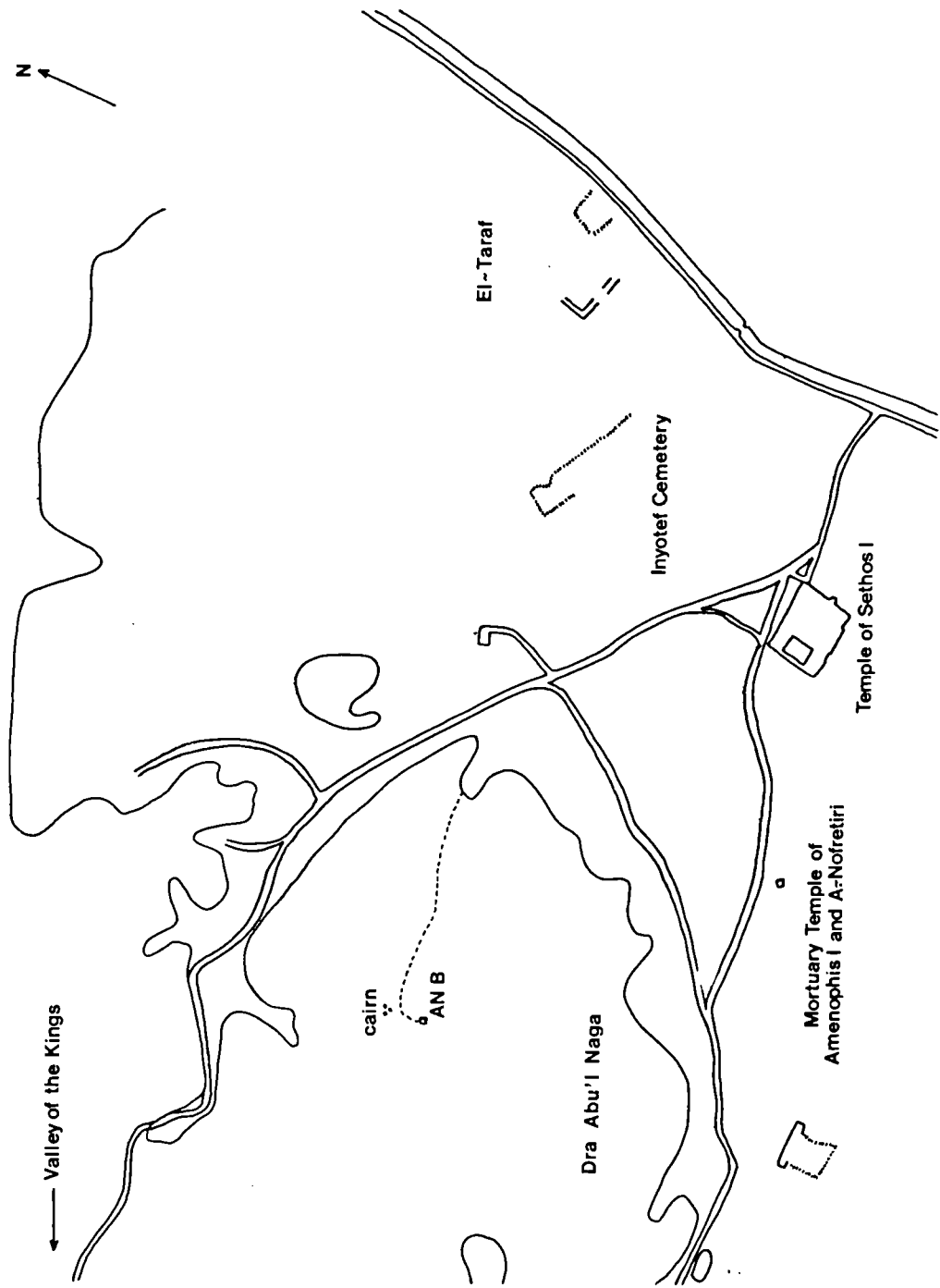

Fig. 2: Dra Abu'l Naga and el-Taraf

According to P. Abbott, the tomb of Amenophis I was found to be intact at the time of its inspection in Year 16 of Ramesses IX, 3 3ht 18.<sup>42)</sup> From a docket<sup>43)</sup> on the renewed coffin<sup>44)</sup> found containing the body<sup>45)</sup> within DB320, however, where Ahmose-Nofretiri was also cached,<sup>46)</sup> it is clear that within three decades the burial had required restoration. A second docket<sup>47)</sup> records a further restoration ten years later. The scribe Penamun, whom the docket records as having been involved in this restoration, had perhaps earlier been connected with an investigation into the burial of Ramesses IV within KV2.<sup>48)</sup>

PART 1

BURIALS IN THE VALLEY OF THE KINGS

It would be unjust to condemn the old archaeologists for not having conducted their excavations with the same exactness and method that we have the right to expect from our modern explorers. We must take into account the circumstances under which they had to work, and try to extract from their publications as much useful information as possible without wasting time in lamenting the lack of precision there displayed.

- Jean Capart, JEA 6 (1920), 225

## CHAPTER 1

THE BURIALS OF TUTHMOSIS I-II, HATSHEPSUT,  
TUTHMOSIS III AND HATSHEPSUT-MERYETRETuthmosis I; Hatshepsut (KV20)<sup>1)</sup>

The earliest recognisable royal tomb in the Valley of the Kings (fig. 3) is KV20 (fig. 4), the position of which was known both to Belzoni<sup>2)</sup> and to the French Expedition before him.<sup>3)</sup> The tomb was first made accessible as far as chamber (C) by James Burton in 1824.<sup>4)</sup> No progress, however, in clearing the tomb fully was made until the spring of 1903, when Carter began to excavate the rock-hard fill of the extremely long and winding corridor, work which was only completed the following year.<sup>5)</sup>

With the exception of a foundation deposit of Hatshepsut discovered at the entrance to the tomb,<sup>6)</sup> the first fragments of funerary furniture were found in the sloping passageway (G) which leads off from the north-west corner of chamber (F): 'broken fragments of stone vases bearing the cartouches of Aahmes Nofritari,<sup>7)</sup> Thoutmôsis I, and Hâtshopsîtû ... These showed clearly that the tomb had been robbed'.<sup>8)</sup>

The burial chamber itself (J) was choked with rubble, and the ceiling had collapsed. Clearance of this chamber revealed two yellow quartzite sarcophagi, inscribed respectively for Tuthmosis I<sup>9)</sup> and



Fig. 3: the Valley of the Kings

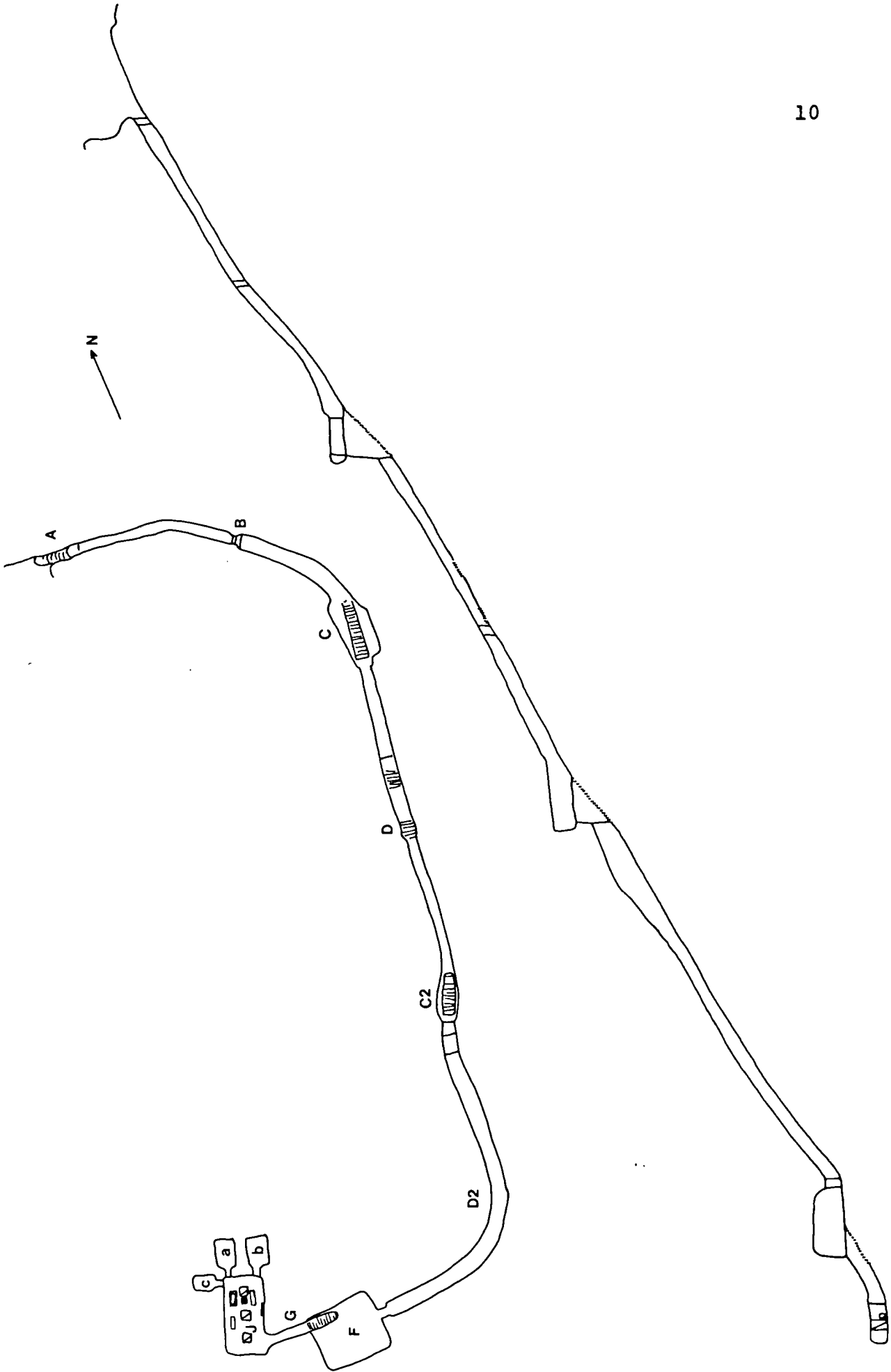

Fig. 4: KV20

for Hatshepsut as pharaoh,<sup>10)</sup> a canopic chest similarly inscribed for Hatshepsut,<sup>11)</sup> fifteen slabs inscribed in red and black ink with chapters from the Amduat (intended to line the burial chamber),<sup>12)</sup> and several fragments of the usual furnishings - stone vases, pottery, 'burnt pieces of wooden coffins and boxes' and 'a part of the face and foot of a large wooden statue covered with bitumen', fragments of faience, and 'some pieces of small inlay work'.<sup>13)</sup>

Carter's opinion, as that of most commentators after him, was that KV20 had been excavated by Hatshepsut regnant as a double tomb for herself and her father, Tuthmosis I, whom she had transferred from his original tomb, KV38.<sup>14)</sup> Romer's recent study of the Tuthmosid group of Valley tombs,<sup>15)</sup> however, though questioned by some,<sup>16)</sup> has shown that neither the surviving contents nor the design of KV38 permit it to have been excavated before the reign of Tuthmosis III. Moreover, the proportions of the ultimate chamber in KV20 differ from those employed in the rest of the tomb, and display a direct link with the architecture of Hatshepsut's temple at Deir el-Bahri. The possibility thus presents itself that KV20 rather than KV38 was the tomb excavated for Tuthmosis I by Ineni,<sup>17)</sup> and that this former tomb was only later adapted to accommodate Hatshepsut by the excavation of an additional chamber.<sup>18)</sup> The Hatshepsut foundation deposit recovered by Carter need not contradict this interpretation, since it might well have been placed at the time Hatshepsut began her adaptation of the tomb.<sup>19)</sup>

Assuming that Romer's reconstruction of the sequence of owners is correct, there can be no doubt that Tuthmosis I was at one stage buried within KV20 - first of all in chamber (F), and secondly, perhaps, in a new sarcophagus in Hatshepsut's pillared hall (J).<sup>20)</sup>

That Tuthmosis I did not remain long in KV20 is indicated by the new tomb prepared for him by Tuthmosis III, KV38.<sup>21)</sup> Hatshepsut's burial, however, seems to have been left to its fate: eventual sacking, evidenced by the roughly displaced sarcophagus lid<sup>22)</sup> and by the smashed and burnt condition of the material recovered by Carter.<sup>23)</sup> The mummy of Hatshepsut is not known,<sup>24)</sup> but a box inscribed with the queen regnant's cartouches and containing a mummified liver or spleen was recovered from DB320.<sup>25)</sup> This may well represent all that it had been possible to salvage of the queen's person, either from her destroyed tomb<sup>26)</sup> or, less likely, from a subsequent cache.<sup>27)</sup>

Other items belonging to the burial of Hatshepsut - including fragments from one or more of her coffins - were recovered from KV4 (Ramesses XI) by Romer; they are considered further below.<sup>28)</sup> The 'chair' or 'throne' (actually the legs and foot-board of a couch or bed) and draughtboard<sup>29)</sup> with associated pieces<sup>30)</sup> presented to the British Museum after 1887 by Jesse Haworth have often been connected with the burial of this queen, on the basis of a wooden cartouche said to have been found with them.<sup>31)</sup> The find-spot

of this group is usually stated to have been 'Deir el Bahari',<sup>32)</sup> and, according to Budge, the DB320 cache.<sup>33)</sup> Greville Chester, however, who procured the pieces for Haworth, had been informed by the local Egyptians that the objects 'were all found hidden away in one of the side chambers of the tomb of Ramessu IX., under the loose stones which encumber the place. The spot was pointed out to Mr. Chester by the Arab dealer who went with him'.<sup>34)</sup> Perhaps, as Petrie suggests,<sup>35)</sup> these were objects plundered from KV20 in antiquity and temporarily hidden; but the question as to precisely where they were hidden is probably better left open.<sup>36)</sup>

#### Tuthmosis I (KV38)<sup>37)</sup>

KV38 (fig. 5) was stumbled upon by Loret in March 1899;<sup>38)</sup> nothing is known of the circumstances surrounding the discovery, and the tomb yielded few finds.<sup>39)</sup> Amongst these, however, two classes of

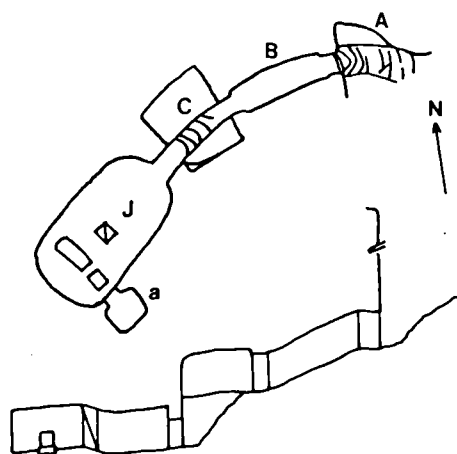

Fig. 5: KV38

object - the sarcophagus<sup>40)</sup> and the glassware fragments<sup>41)</sup> - clearly cannot be dated earlier than the reign of Tuthmosis III;<sup>42)</sup> and indeed Romer has pointed out how much the architecture of the tomb owes to the design of Tuthmosis III's own sepulchre, KV34.<sup>43)</sup> It would appear, therefore, that KV38 was not the original burial place of Tuthmosis I, as is usually maintained,<sup>44)</sup> but a tomb prepared and stocked with new items of funerary equipment for this long-dead monarch by Tuthmosis III. The tomb prepared for Tuthmosis I by Ineni is evidently to be sought elsewhere - presumably in the guise of the tomb traditionally ascribed to Hatshepsut, KV20.<sup>45)</sup>

At some indeterminate date, KV38 was plundered, as witness the paucity and smashed condition of the tomb's remaining funerary items (including the sarcophagus lid).<sup>46)</sup> An official re-opening of the tomb, perhaps prompted by (or connected with?) this destruction, is recorded in a recently discovered graffito:

l 3ht 13. Coming (?by) Meniunufer (?to) open  
(the tomb of) Aakheperkare. Userhet; Pa...;  
Amenhotpe; Iuef(...?) amun.<sup>47)</sup>

The year and the reign are unfortunately omitted, but, from the personnel involved, the inscription is clearly to be dated to the late 20th/early 21st dynasty.<sup>48)</sup>

The two outermost coffins<sup>49)</sup> prepared by Tuthmosis III for the reburial of Tuthmosis I<sup>50)</sup> eventually

found their way to the DB320 cache, having been usurped by and redecorated for 'King' Pinudjem I.<sup>51)</sup> It has not yet been demonstrated to my satisfaction, however, that the body found within this nest of coffins is that of Tuthmosis I himself.<sup>52)</sup>

Tuthmosis II (DB358?)<sup>53)</sup>

Neither of the two candidates to date put forward - KV42<sup>54)</sup> and WN A (Bab el-Muallaq)<sup>55)</sup> - can be considered particularly convincing in their claims to be the tomb of Tuthmosis II. The potential of a third tomb, however, DB358, seems hitherto to have escaped notice. Although strictly outside the scope of this thesis, the merits of this claim might briefly be considered.

DB358 (figs. 6-7) was discovered on 23 February 1929 by Winlock, by whom the circumstances of the find have been fully published.<sup>56)</sup> All of the material

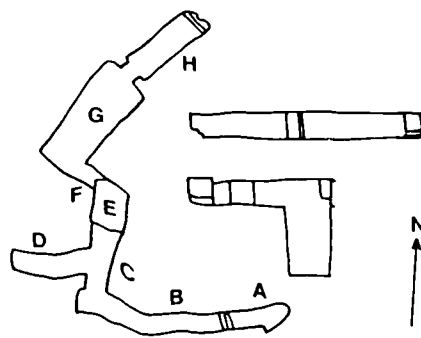

Fig. 6: DB358

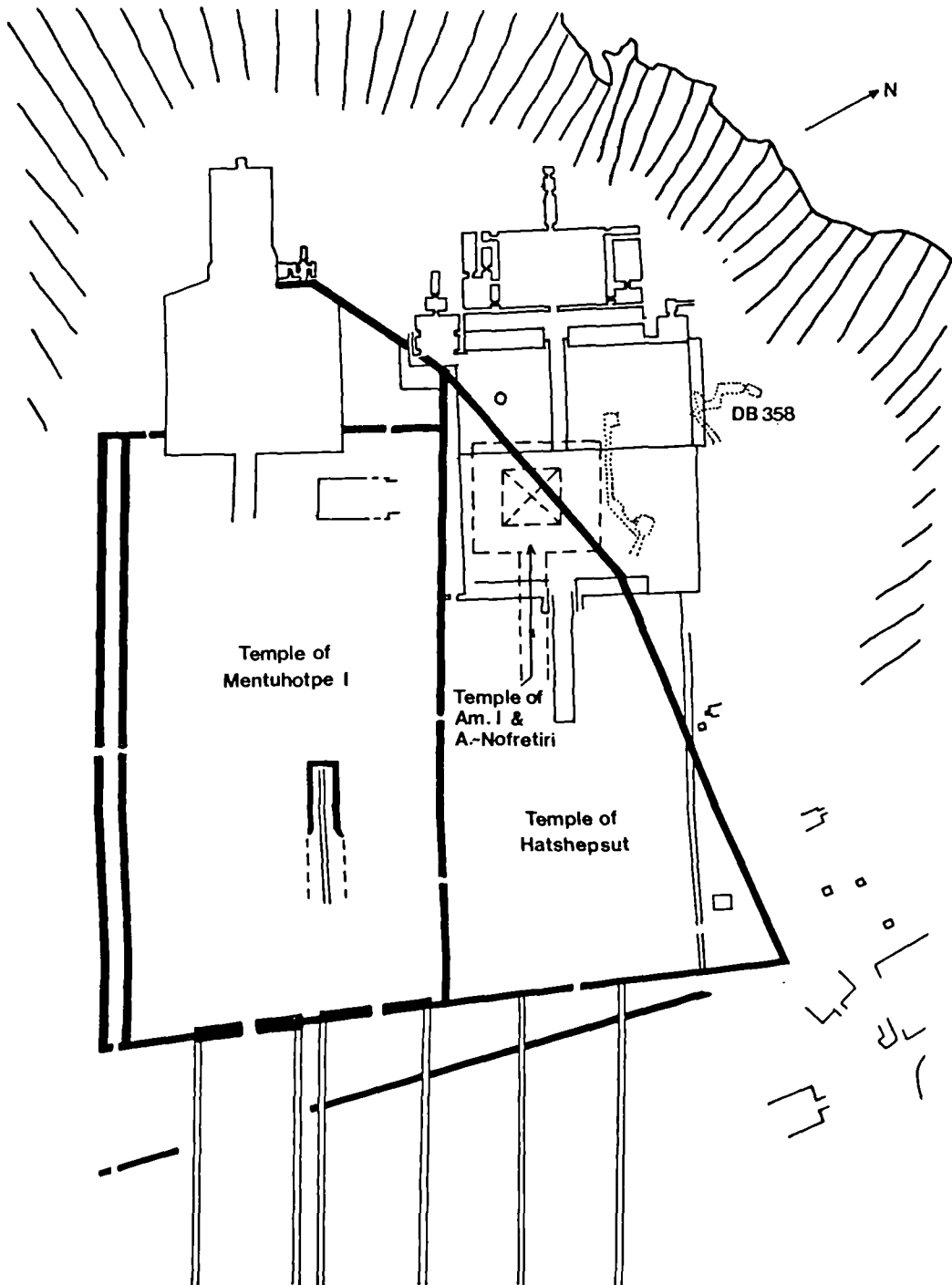

Fig. 7: Deir el-Bahri

could be attributed to a Queen Meryetamun of the early 18th dynasty,<sup>57)</sup> to whom Winlock wished to ascribe the tomb, or to a later, intrusive burial of the 21st dynasty, that of the king's daughter Nany.<sup>58)</sup> If, however, the presence of a well within AN B can be taken as good evidence that this tomb had been adapted for the burial of a king,<sup>59)</sup> then the assumption that DB358 had been excavated for Meryetamun is perhaps open to question. Despite Romer's dating of the excavation of this tomb to a period after the construction of the Hatshepsut colonnade which it underlies,<sup>60)</sup> the sum total of the evidence appears to favour the opposite sequence.<sup>61)</sup> Given Romer's comments on the similarity (apart from the well) of DB358 and WC A (the tomb of Hatshepsut's daughter, Nofrure),<sup>62)</sup> it is conceivable that the former constitutes the hitherto unrecognised tomb of Tuthmosis II, cleared out at the end of the New Kingdom following the transfer of his mummy, and re-used for the caching of Meryetamun and (latterly) for the burial of Nany.

The mummy of Tuthmosis II<sup>63)</sup> was discovered in DB320 contained in a replacement coffin of later date.<sup>64)</sup>

### Tuthmosis III (KV34)<sup>65)</sup>

KV34 (fig. 8) was discovered by Loret on 12 February 1898,<sup>66)</sup> and further work in the immediate vicinity of the tomb entrance was carried out by Carter in the spring of 1921.<sup>67)</sup> The tomb itself was cleared with care over a number of days. According to Loret:

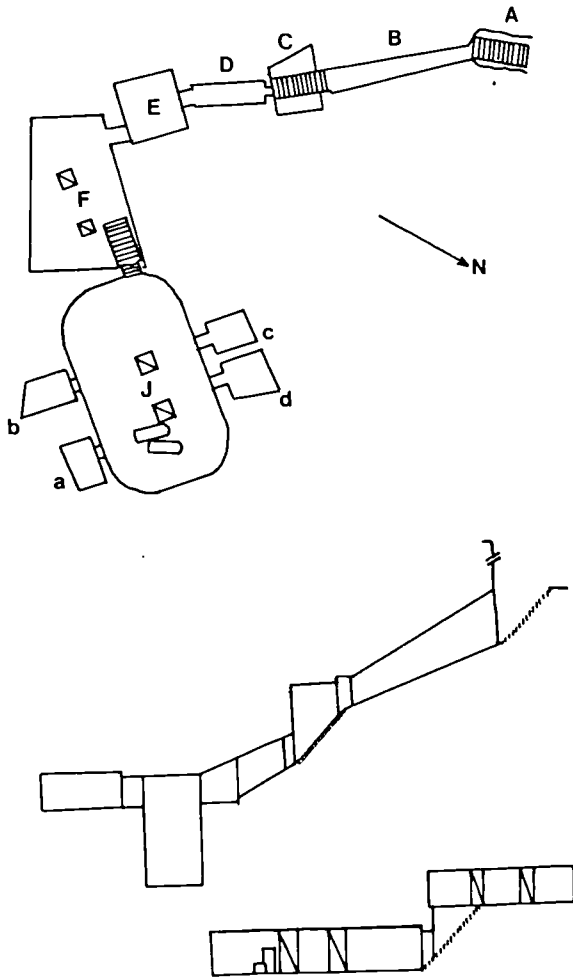

Fig. 8: KV34

J'en dressai le plan, je notai la place de tous les objets, même les plus minuscules, grâce à un quadrillage dessiné sur le plan et reproduit sur la poussière de la tombe.<sup>68)</sup>

Each object was marked with its find-spot and, for the objects from the burial chamber, the particular square in which it had been found; these latter were evidently referred to as 'tas' or 'heaps', owing to the numerous limestone chippings which covered the burial chamber floor.<sup>69)</sup> The majority of such markings have been published in Daressy's inventory of the tomb contents;<sup>70)</sup> and this, in the absence of Loret's full report, will serve as a convenient starting point for a consideration of the tomb's layout at the time of the discovery.<sup>71)</sup>

From the statement by Loret reproduced in the preceding paragraph, it would appear that the 'quadrillage' or grid was first established upon his sketch plan of the tomb, and only subsequently transferred to the burial chamber floor. It might be suspected, therefore, that this grid was rather abstract in its divisions, and not unduly influenced by, for example, the positions of the two pillars and the sarcophagus. The highest numbered 'tas' of which we possess any published record is 'tas 24';<sup>72)</sup> and 24 is, in fact, the number of sections into which the burial chamber can most evenly be divided. Cf. fig. 9.

The way in which these squares were numbered is less easy to discern. Within the burial chamber (J) of KV35,<sup>73)</sup> Loret evidently numbered the sections commencing from the entrance doorway and numbering across from right to left. This system, however, seems to have been adopted in KV35 in an attempt to maintain some sort of consistency with the method Loret had employed in the gridding of the antechamber (F) of that tomb, where the numbering had been influenced by the position of the entrance doorway at the right-hand side of the room. Loret ought, therefore, to have numbered the squares of the KV34 burial chamber (the antechamber of this tomb was apparently not gridded) from left to right, since the entrance doorway was located in the left-hand corner of the room. That this was, in fact, the system adopted would seem to be borne out by the 'tas' designation of the only numbered object which it is possible to recognise with any certainty from Loret's brief preliminary report: 'un cygne en bois bitumé', found 'près d'une colonne',<sup>74)</sup> its component parts having been published as CG 24914 from 'tas 5, 6 & 9'.<sup>75)</sup> Cf. fig. 10.

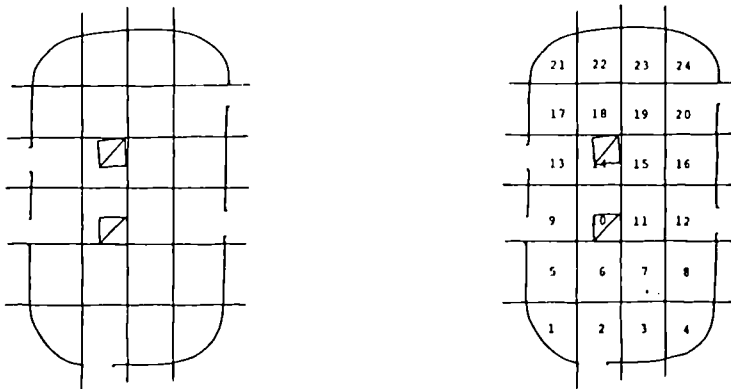

Figs. 9-10: the burial-chamber grids (KV34)

The distribution of material from the four side rooms off the burial chamber (J) was as follows. In 'la première pièce à droite' (Jb), Loret notes 'neuf statues entassées, en bois bitumé',<sup>76)</sup> and some bones of a baboon,<sup>77)</sup> none of which can be recognised among the attributable pieces published by Daressy. I suspect, however, that CG 24935, a fragmentary wooden mace from a statuette, perhaps originated in this room - Daressy assigns it to 'pièce 4';<sup>78)</sup> cf. further the wooden mummiform statue CG 24902 and the 'panthère' CG 24913 recovered from 'tas 7' and 'tas 8' respectively.<sup>79)</sup> 'Dans la seconde pièce à droite' (Ja), Loret found 'un grand nombre de jarres brisées, vidées, au col de quelques-unes desquelles adhèrent encore des bouchons de terre glaise, retenus par des cordes', as well as 'le squelette entier d'un taureau'.<sup>80)</sup> Amongst the former group are doubtless to be recognised CG 24957-8, various mud sealings, some mounted on string; these are to be attributed to 'pièce 3'.<sup>81)</sup> Several terracotta vessels recovered from 'tas 23' and 'tas 24' (CG 24946-7, 24951, 24953) are evidently to be located just outside the entrance to this side room.

As for the two side rooms to the left of the burial chamber, the first (Jc) was empty apart from a fragment of a brush and the remains of a rush torch.<sup>82)</sup> The second room (Jd) contained 'deux cercueils qui ont été ouverts autrefois, et refermés'.<sup>83)</sup> Assuming that Loret numbered these rooms in a clockwise manner - as in KV35 - it is reasonable to infer that the former was designated 'pièce 1' and the latter 'pièce 2'.

From his recent study of the tomb, Romer has been able to establish not only that Tuthmosis III had actually been interred within KV34, but also the sequence of events surrounding the burials.<sup>84)</sup> The operations may be summarised as follows:

1. Cutting of the tomb.
2. Plastering.
3. Painting of ceiling and friezes.
4. Enlargement of doorways (C-D), (D-E) and (E-F), presumably to allow the introduction of larger items of funerary furniture.
5. Sealing of the side rooms off the burial chamber.
6. Funeral.
7. Painting of the burial chamber texts.
8. Repainting of the well frieze (after 4).
9. Final closing of the tomb.<sup>85)</sup>

This latter operation clearly involved the erection of plastered blockings at both the entrance to and exit from the well, traces of which were noted though apparently without seal impressions.<sup>86)</sup> Romer further suggests the possibility that the entrance to the burial chamber (J) had been closed off with a dry stone wall.<sup>87)</sup>

The condition of the material recovered by Loret would suggest that KV34 had, at some stage, been heavily plundered: the sarcophagus had been damaged in an attempt (presumably successful) to remove the lid,<sup>88)</sup> whilst the extant wooden funerary furniture

had been smashed against the walls<sup>89)</sup> and had had its metal fittings and inlays ripped off or prised out.<sup>90)</sup> Moreover, the larger pieces of wood - including the hulls from the tomb's model boats,<sup>91)</sup> and the doors and lintels of the four side rooms off the burial chamber<sup>92)</sup> - had been bodily removed.

Official activity within the tomb, perhaps in connection with one or other phase of the tomb's plundering, is attested by a series of graffiti, two of which make mention of the late 20th dynasty scribe Amenhotpe.<sup>93)</sup> Apart from the evident date of these texts, they are singularly uninformative.

The disposition of the tomb's contents is perhaps rather more informative. We have already noted that Loret had found the two side rooms on the left of the burial chamber to be empty: their contents were presumably not carried off in toto by the tomb's plunderers, but merely swept out onto the floor of the burial chamber as in KV35. The reason for this action in the tomb of Amenophis II was to accommodate a number of mummies which had been removed from their original places of burial at the end of the New Kingdom or later. It is thus possible, if no more, that KV34 had served a similar purpose before the tomb was finally abandoned.<sup>94)</sup>

At some date subsequent to the removal of Tuthmosis III from KV34 the tomb was employed for two intrusive burials of the 'late dynastic or early Ptolemaic period'.<sup>95)</sup> As found by Loret, these coffined bodies had themselves been disturbed (see above), and their

covering of bat droppings<sup>96)</sup> presumably indicates that the tomb had remained open for some time after this. Without excluding the possibility that the disturbance of these intrusive burials occurred at some other, as yet unascertainable date, it is perhaps significant that the only late activity which can be discerned (albeit indirectly) within KV34 was during the 26th dynasty or later,<sup>97)</sup> when a duplicate of Tuthmosis III's sarcophagus was prepared for the high official Hapmen<sup>98)</sup> - who may well have been responsible for the removal of the king's canopic chest for his own use.<sup>99)</sup>

The mummy of Tuthmosis III<sup>100)</sup> - identified by remnants of its original wrappings<sup>101)</sup> and still contained in its original outer coffin from which most of the gilded gesso had been stripped<sup>102)</sup> - was recovered from the DB320 cache.

Hatshepsut-Meryetre; Sennufer (KV42)<sup>103)</sup>

KV42 (fig. 11) was first cleared by Carter in late November-early December 1900.<sup>104)</sup> The area in front of the tomb Carter excavated in January 1921, locating the tomb's foundation deposits and several pieces thrown out from the burial.<sup>105)</sup> The four deposits, all 'undisturbed excepting certain decay from torrential waters',<sup>106)</sup> were inscribed for Hatshepsut-Meryetre, principal wife of Tuthmosis III.<sup>107)</sup> Since such deposits were normally positioned at the time work on a tomb commenced,<sup>108)</sup> and certainly before any interment had been made (witness, in particular, the deposits of Tuthmosis IV from

## Chapter 1

WV22),<sup>109)</sup> it is clear that KV42 had not been excavated before the reign of Tuthmosis III. This dating, confirmed by Romer on the basis of the tomb's design,<sup>110)</sup> clearly renders impossible the still common attribution of KV42 to Tuthmosis II.<sup>111)</sup>

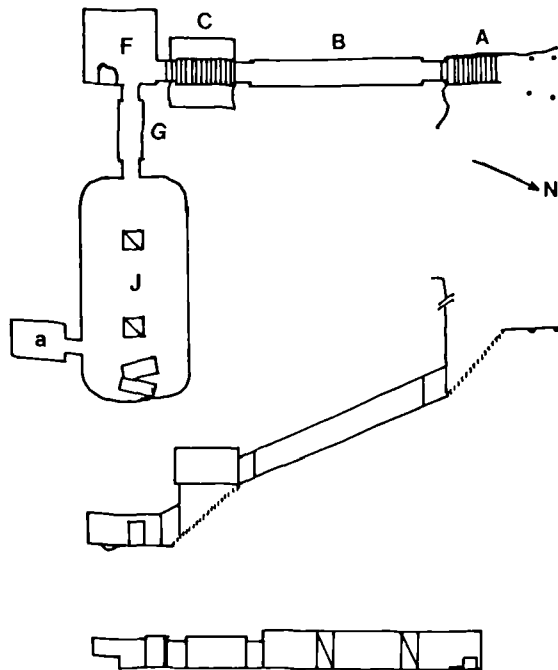

Fig. 11: KV42

That KV42 was not employed for the burial of Hatshepsut-Meryetre is, however, evident from the fact that the sarcophagus chamber had not been decorated with the intended scenes and texts from the Amduat<sup>112)</sup> - which, as Romer has shown from his

study of KV34, were at this period accomplished only after the funeral.<sup>113)</sup> Moreover, apart from the sarcophagus, which is unfinished and seems not to have been used,<sup>114)</sup> 'not a vestige of royal antiquities was found' in the tomb.<sup>115)</sup> Since Hatshepsut-Meryetre evidently lived on into the reign of her son, Amenophis II,<sup>116)</sup> it may well be that he wished to bury her elsewhere - perhaps in his own tomb (KV35), to judge from the remains recovered from there by Loret in 1898.<sup>117)</sup>

Be this as it may, there can be no doubt that KV42 had been employed for a burial of some sort in antiquity, and this burial appears to have been official rather than intrusive. Not only were there remains of 'the lower part of the original sealing of the door' at the tomb entrance,<sup>118)</sup> but Carter recovered several items of private funerary equipment belonging to the tomb's occupants. These included 'some gold leaf and an exquisite gold inlaid rosette, probably the bottom part of a menat', found 'a short distance along the passage (B) ..., under the rubbish',<sup>119)</sup> and 'some twenty or thirty, whole and broken, rough earthen jars, some with their sealings still intact', in the small room leading off from the burial chamber (Ja).<sup>120)</sup> Other pieces, unplaced but including canopic jars,<sup>121)</sup> several 'dummy vases' of painted limestone,<sup>122)</sup> an offering table<sup>123)</sup> and the remains of wooden 'sledges and coffins',<sup>124)</sup> reveal that the owners of these items were the mayor of Thebes, Sennufer,<sup>125)</sup> his wife, Sentnay, and a certain 'king's adornment' Baktre.<sup>126)</sup> That Sennufer was

permitted burial in this tomb is a clear indication of the esteem in which he, like his brother the vizier Amenemopet,<sup>127)</sup> was held by the king.<sup>128)</sup>

It was evident to Carter that the tomb had been plundered. 'The funereal furniture, vases and canopic jars were smashed and lying about on the ground of the passages and chambers, evidently just as the former robbers had thrown them ..., some being partly buried in the fine yellow mud ..., now dry, which was carried in by the water which had covered the floors of the lower chambers'.<sup>129)</sup> The tomb had been entered subsequent to this period of destruction and flooding, as Carter notes, since 'many vases were found on the steps outside, and ... some of the antiquities were actually lying on the surface of the dry mud'.<sup>130)</sup>

At what date the plundering of KV42 took place is not at all clear. No human remains were noted by Carter, and the subsequent fate of the Sennufer family is equally obscure.

#### Amenophis II (KV35)

See below, chapter 10.

## CHAPTER 2

THE BURIALS OF TUTHMOSIS IV, AMENOPHIS III,  
TIYE AND AKHENATENTuthmosis IV (KV43)<sup>1)</sup>

Its immediate position signalled by the discovery of two intact foundation deposits,<sup>2)</sup> the tomb of Tuthmosis IV (fig. 12) was first entered by Carter on 18 January 1903.<sup>3)</sup> The entrance (A-B) 'had been closed with roughly cut stones',<sup>4)</sup> still in position, and the corridor beyond (B) was 'filled with rubbish and strewn with broken antiquities'.<sup>5)</sup> At the far end of this corridor was the well (E), the doorway to which (D-E), according to Carter, 'shows evidence of having once been blocked and plastered over - for two consecutive times as there are remains of plaster and also mud. Part of an impression of the seal used - upon (the) plaster sealing - gives the common type of seal, i.e. the jackal over nine prisoners'.<sup>6)</sup> This blocking had been destroyed in antiquity, and the well negotiated by means of a palm-fibre rope, knotted at intervals, which Carter found tied to a column within the first chamber (F).<sup>7)</sup> This chamber, the doorway to which had been 'blocked, plastered over and painted',<sup>8)</sup> was 'practically clean and contained few antiquities, save some unimportant pieces and an inscribed paddle of a boat'.<sup>9)</sup> Through a further corridor (G), it gave access to a small antechamber (I), where, 'in the far corner of the left hand side we found a doorway, partially blocked

up with stones, which had been covered with plaster and sealed'.<sup>10)</sup> Immediately behind this was found

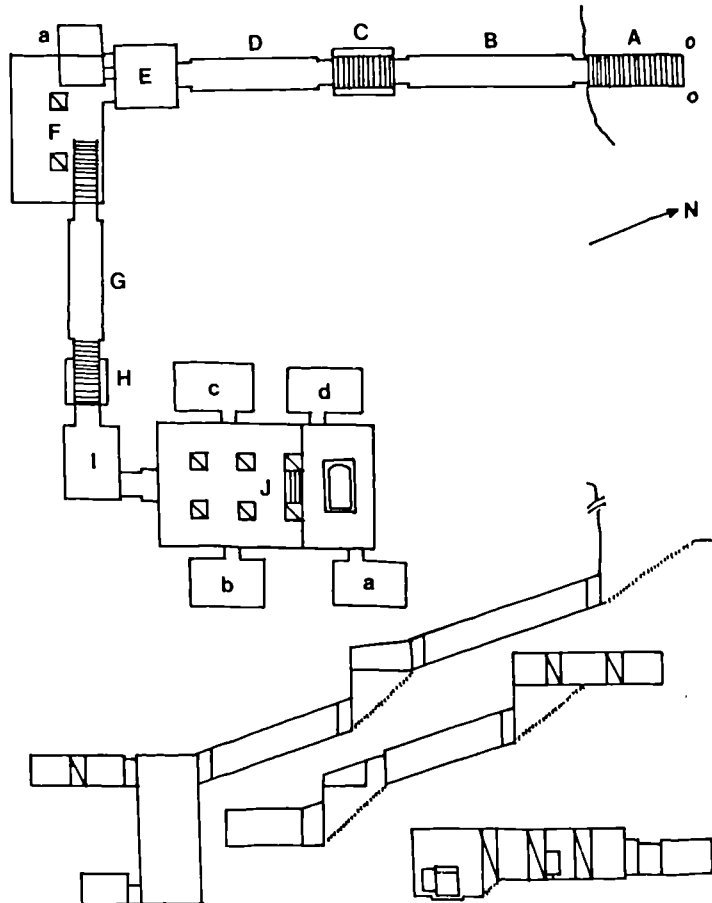

Fig. 12: KV43

evidence for the original presence of a wooden door, now missing.<sup>11)</sup> Carter's original description of the masonry blocking at this point (I-J) is as follows:

Here there were evidences of double sealing, there being two distinct seal impressions: one, the original, showing a jackal over nine prisoners, the other evidently later, because on a different plaster and giving the cartouches of the king Horemheb.<sup>12)</sup>

This quite specific testimony is undermined, however, (a) by Newberry, who describes the blocking as 'stamped all over (my italics) by a large stamp bearing the design of a jackal over nine prisoners, arranged in three rows',<sup>13)</sup> and (b) by Carter himself in a later publication, where he states: 'When the tomb of Tut.ankh.Amen was reclosed after the depredations of the tomb thieves, ... the seals then used were those of the royal necropolis which bore no royal names (i.e. the plain jackal and nine captives type);<sup>14)</sup> and this was the case when king Hor.em.heb ordered the tomb of Thothmes IV to be restored after its violation by robbers'<sup>15)</sup> (my italics again). It would appear, therefore, that Carter's original testimony is to be treated with caution: two builds there may possibly have been (as in the blocking to (D-E)), but only one type of seal - that of the jackal and nine captives - can be attested with certainty today, and that occurs upon the original build.<sup>16)</sup>

The burial chamber (J) was in chaos when discovered, the floor 'covered with rubbish and strewn with antiquities'.<sup>17)</sup> Some impression as to the original

distribution of the contents may, nevertheless, be discerned from the positions in which Carter found them. Thus, the south end of the burial chamber seems to have been intended for the king's chariot equipment<sup>18)</sup> - hence the term 'chariot hall' encountered in later documents;<sup>19)</sup> whilst the northern end of the burial chamber - the 'crypt' - appears to have held the mummy and embalmed viscera not only of Tuthmosis IV himself, but of other members of his family also, to judge from the three sets of canopic equipment recovered from this spot.<sup>20)</sup> The material in question consisted of two limestone jars and lids, with texts but no name;<sup>21)</sup> four limestone jars and lids, inscribed for the king's son Amenemhet;<sup>22)</sup> and fragments of an alabaster jar and more than one lid belonging to the king's daughter Tentamun.<sup>23)</sup> Doubtless the corpse recovered from side room (Jb) (below) represents the mummy of one of these individuals.

The king's sarcophagus lay in the usual position within the crypt, its lid prised off<sup>24)</sup> and upside down on the floor beside it.<sup>25)</sup> Three of its corners were supported by roughly stacked piles of limestone, the wooden head of the Mehytweret cow<sup>26)</sup> having been utilised for the fourth. The box itself was found empty, 'save for two wooden figures, cast in by the ancient plunderers'.<sup>27)</sup>

Adjoining either side of the burial chamber were two pairs of side rooms, much of the original contents of which appear to have been discharged into (J).<sup>28)</sup>

Of the rooms on the left hand side of the burial chamber, the first (Jc = Davis A) contained little more than a shabti<sup>29)</sup> and a mass of mummy bandages,<sup>30)</sup> the second (Jd = Davis B) a collection of mummified joints and geese.<sup>31)</sup> Of the rooms on the right, the first (Jb = Davis D) contained the unwrapped and rifled mummy of the child referred to above,<sup>32)</sup> propped up against the wall,<sup>33)</sup> and the debris of several hundred faience vessels and ritual objects;<sup>34)</sup> the second (Ja = Davis C) held the remains of more provisions in the form of broken jars, their sealings, and the wheat which had originally filled them.<sup>35)</sup> As in the earlier tombs of the dynasty, these chambers had originally been closed with wooden doors, the edges of which had then been plastered over.<sup>36)</sup> However, 'these (doors) have all been stolen by the ancient plunderers, and no evidence remains of them except their socket holes and a wooden lintel' to the doorway of (Jc).<sup>37)</sup>

It is thus apparent that the tomb of Tuthmosis IV had been subjected to intensive criminal activity in antiquity. The earliest phase which we are able to discern occurred before Year 8 of Horemheb, presumably during the troubled period following the Amarna interlude.<sup>38)</sup> Two graffiti inscribed upon the south wall of chamber (I) record the subsequent restoration of the tomb:<sup>39)</sup>

Year 8, 3 3ht 1, under the person (hm) of the dual king (nsw-bity) Djeserkheprure-setepenre, son of Re Horemheb-merenamun. His person l.p.h. commanded that the

fanbearer on the king's right hand, the royal scribe, overseer of the treasury, overseer of works in the Place of Eternity (st nḥḥ) and leader of the festival of Amun in Karnak, Maya, son of the noble Iawy, born of the lady of the house Weret, be charged to renew the burial (wḥm krs) of king (nsw) Menkheprure, true of voice, in the noble house (hwt špsst) upon the west of Thebes.<sup>40)</sup>

His assistant, the steward of the Southern City, Djehutymose, whose mother is Iniuhe of the City.<sup>41)</sup>

From the context, it is certain that the expression wḥm krs (lit.: to repeat the burial (of)) alludes to a restoration of the burial of Tuthmosis IV within KV43, and not to the removal of the king's body for reburial elsewhere.<sup>42)</sup> Evidence of the criminal activity which necessitated this restoration<sup>43)</sup> is naturally difficult to isolate. Indications of the wḥm krs within KV43 are, however, easier to discern. In the absence of any evidence for a subsequent restoration of the tomb on the scale evidently undertaken by Horemheb, it seems likely that the repairs - carried out with 'blue paste',<sup>44)</sup> or 'yellow plaster',<sup>45)</sup> - noted on several faience pieces from the burial<sup>46)</sup> are to be attributed to this period. A further reaction to the 18th dynasty robbery of the tomb might well be the erection of the plastered blocking in front of the burial chamber's

original wooden door: since private tombs of the period appear to have possessed either a wooden door or a stone blocking,<sup>47)</sup> a certain redundancy could be argued here, evidence of both methods of closure within this one doorway perhaps indicating that the door had been damaged by the robbers' intrusion and had had to be replaced.<sup>48)</sup> Certainly, on the analogy of Tutankhamun's burial, the possible presence of the jackal and nine captives seal upon this blocking might well be taken to suggest that it had been erected after the original closure of the tomb.<sup>49)</sup>

What appears to be more certain is that the masonry blocking at (D-E) is contemporaneous with that erected at (I-J): it too employs the jackal and nine captives motif on its original construction,<sup>50)</sup> whilst the fact that it had been breached and apparently reblocked with mud plaster recalls Carter's description of the (I-J) blocking discussed above.<sup>51)</sup> At least two intrusions within KV43 might, therefore, be postulated: the first evidently detected and the damage made good by closing off the doorways at (D-E) and (I-J) with mud-plastered blockings (the work of Maya?); the second intrusion resulting in the destruction of these secondary blockings, and perhaps prompting or associated with the transfer of the king's body elsewhere.

The results of this latter period of plundering were evident at the time of the tomb's discovery. The contents of the burial as found had been smashed<sup>52)</sup> and spread around the tomb, with a particular

concentration of objects in the burial chamber itself, where those involved had clearly sorted and divided their spoil by the light of the 'oil wicks' of which Carter found 'traces on stones'.<sup>53)</sup> Everything of conceivable value had been carried off, including every scrap of metal<sup>54)</sup> and large, re-usable pieces of wood such as doors, lintels, and the king's funerary barques.<sup>55)</sup> More than this: the lid of the king's sarcophagus had evidently been removed, and the body dragged out from within the coffins to be stripped of any remaining jewellery.<sup>56)</sup> This was apparently one of the first acts of the latest band of plunderers, since the sarcophagus was already open and empty when the systematic and thorough removal of the eye inlays of the king's wooden funerary statuettes began,<sup>57)</sup> two of which, after treatment, had been casually thrown into the sarcophagus box.<sup>58)</sup>

The state of the burial as found was clearly the state in which it had been finally abandoned by those removing the king's body for restoration and reburial elsewhere: the rough wall they erected on leaving was still intact in 1903.<sup>59)</sup>

The body of Tuthmosis IV<sup>60)</sup> was discovered in the KV35 cache in 1898, contained in a well preserved wooden coffin of later date.<sup>61)</sup> The fact that the mummy in the side room of KV43 had not been removed with that of the king is odd, and may suggest that those responsible for assembling the Valley caches

were practising a policy of deliberate selectivity in the bodies they restored and reburied;<sup>62)</sup> alternatively, and perhaps nearer the truth of the matter, the intention may have been to remove the child's body at some later date - an intention which, for some unknown reason, was never realised. Whatever the true explanation may be, the fate of the second and third occupants of the tomb remains a mystery: no trace of either individual was recovered from the KV35 cache, nor, apparently, from KV43 itself.<sup>63)</sup>

Finally, a number of fragments from the burial of Tuthmosis IV were recovered by Loret from the anonymous KV37.<sup>64)</sup>

Amenophis III (WV22)<sup>65)</sup>

WV22 (fig. 14), the tomb of Amenophis III, was officially discovered by Jollois and Devilliers in the West Valley (fig. 13) in 1799,<sup>66)</sup> though there

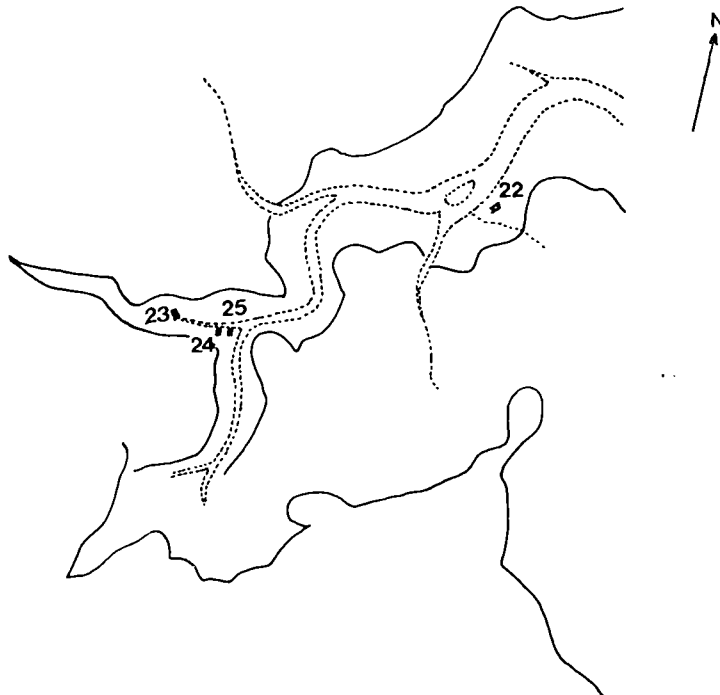

Fig. 13: the West Valley

is some evidence to suggest that the sepulchre may have been known to Browne some years earlier.<sup>67)</sup> Several items are known from the tomb;<sup>68)</sup> the only record of excavation we possess, however, relates to work carried out by Carter in 1915.<sup>69)</sup> This work, at 'the mouth of the water-course beneath (the) entrance of (the) tomb', and in the tomb's 'protective well' (E) and the chamber leading off it,<sup>70)</sup> uncovered a series of foundation deposits of Tuthmosis IV<sup>71)</sup> - for whom the tomb had evidently been begun<sup>72)</sup> - and a mass of funerary furniture belonging to Amenophis III, hopelessly smashed, as well as several items intended for the burial of

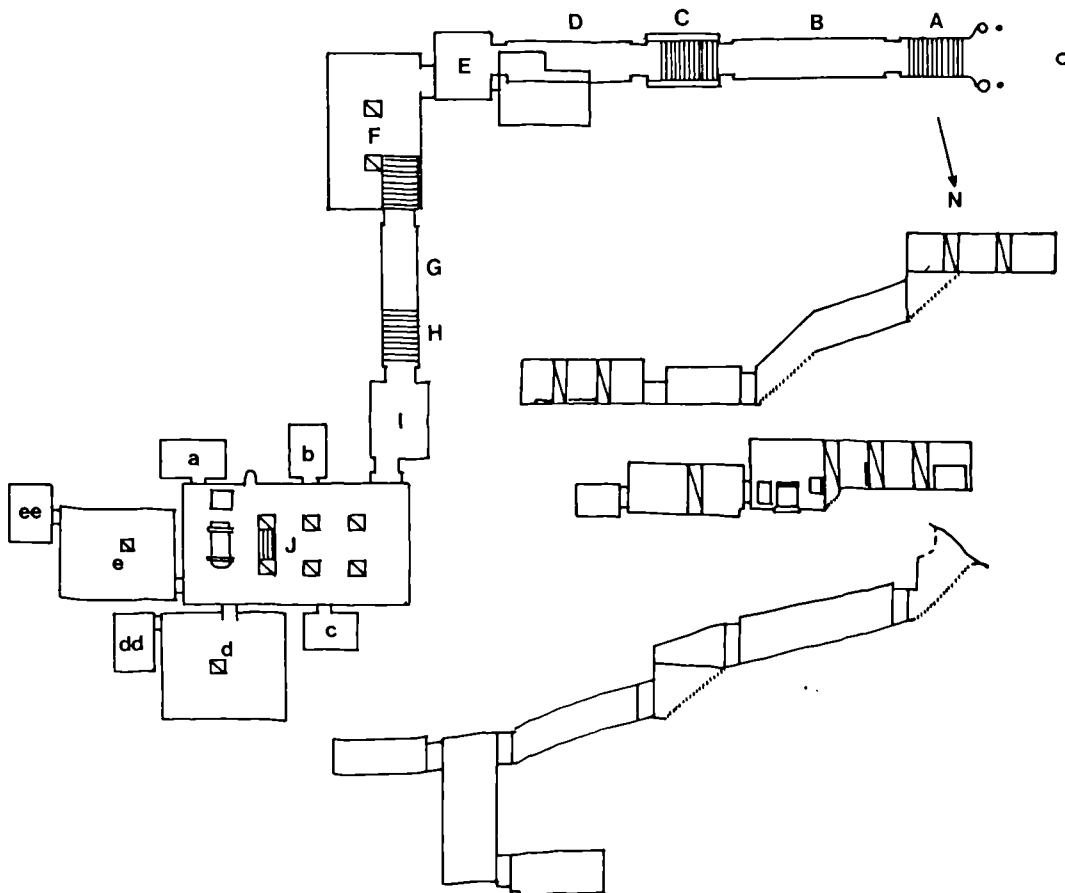

Fig. 14: WV22

Tiye.<sup>73)</sup> Taken in conjunction with the evidence of sealing at doorways (E-F) and (I-J),<sup>74)</sup> there can be no doubt that the burial of the king took place within the tomb. Whether Tiye and Sitamun were ever buried in WV22, however, as is sometimes suggested,<sup>75)</sup> must be considered doubtful.<sup>76)</sup>

Evidence of post-interment activity within the burial was extensive, from the damage caused in prising off the lid of the sarcophagus<sup>77)</sup> to the scattered and mutilated state of the tomb's contents. Carter's discovery (in the well) of a fragmentary faience ring-bezel bearing the prenomen of Ramesses II (wsr-m3<sup>C</sup>t-r<sup>C</sup>-stp-n-r<sup>C</sup>)<sup>78)</sup> is suggestive of interference of some sort during the Ramessid period, which may or may not be connected with the apparent Ramessid activity in the vicinity of WV23 (Ay).<sup>79)</sup> Remains of two intrusive burials were also found by Carter in the well.<sup>80)</sup> By the names on the coffins ('the ... of the house of Amun, Pedihor', and 'the lady of the house Ta(b)es, whose mother is Tabesheribet'),<sup>81)</sup> these interments were clearly of Third Intermediate Period date; their presence will presumably post-date the evacuation of the king's body sometime after Year 13 of Smendes<sup>82)</sup> - as indeed will the removal of the king's sarcophagus box.<sup>83)</sup> The body of Amenophis III was finally interred in the KV35 cache, where it was discovered by Loret in 1898.<sup>84)</sup>

(WV A)<sup>85)</sup>

WV A (fig. 15), situated at one end of the West Valley close to the tomb of Amenophis III (fig. 85)

and 'entièrement masqué par la masse des déblais' thrown out from WV22,<sup>86)</sup> was explored by Chassinat during the season 1905/6;<sup>87)</sup> it may, however, have been known to Lepsius some years earlier.<sup>88)</sup> The entrance to the tomb had been blocked by 'un mur construit en moellons lités à sec ..., ne laissant dans le haut qu'un étroit espace'.<sup>89)</sup> Within, Chassinat recovered 'des poteries brisées et six bouchons de jarres en argile séché au soleil ... de forme ronde ... ou allongée', carrying an inscription 'imprimée en relief'.<sup>90)</sup> As Thomas notes, a duplicate of this seal type was found at Malqata,<sup>91)</sup> and thus its attribution to the late 18th dynasty seems assured.

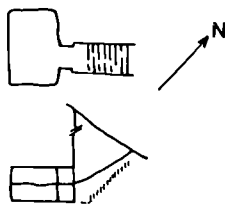

Fig. 15: WV A

No details are available as to the results of Harry Burton's clearance of the tomb.<sup>92)</sup> The 'fragments of harness and a portion of a large scarab' noted by Carter<sup>93)</sup> seem not to have been recovered from WV A but from the 'rubbish heaps covering the rocks to the south and the water course below' WV22.<sup>94)</sup> They are evidently to be connected with the leather fragments found by Chassinat amongst the 'éclats de calcaire provenant ... du creusement de l'hypogée d'Aménôthès III'.<sup>95)</sup>

It is tempting to see the identifiable contents of WV A as debris washed down from the heap of plunderers' spoil outside WV22.<sup>96)</sup> The presence and state of the blocking (apparently original)<sup>97)</sup> would nevertheless suggest that the tomb had been employed for some specific purpose in antiquity - perhaps as a storeroom for those commodities supplied for the burial of Amenophis III which the projected interments of Tiye and perhaps Sitamun(?) within (Jd) and (Je) had perforce displaced.<sup>98)</sup>

Akhenaten (WV25)<sup>99)</sup>

Amongst those objects inscribed for Akhenaten recovered by Carter during his clearance of the tomb of Tutankhamun (KV62)<sup>100)</sup> were several pieces with specific funerary connotations: e.g. the gilded wooden divinities wrapped in linen dated to Years 3-7 of Akhenaten.<sup>101)</sup> The most logical suggestion put forward to date is that objects of this class had originally been intended for Akhenaten's projected Theban tomb,<sup>102)</sup> plans for which - together with the objects which had thus far been prepared - were abandoned following the transfer to Amarna. If work on the tomb proper was ever initiated - which is not unlikely, given the advances which had evidently been made in the preparation of the burial equipment itself -, then it is tempting to identify this commencement as WV25 (fig. 16), a tomb of royal pretensions and of evident late-18th dynasty date,<sup>103)</sup> which had been abandoned before work had progressed beyond the second corridor.<sup>104)</sup>

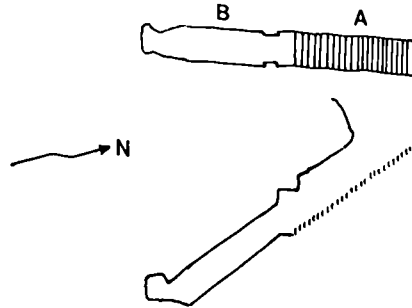

Fig. 16: WV25

WV25 was discovered by Belzoni in 1817,<sup>105)</sup> blocked off at the foot of the steps with 'a well-built wall of stones of various sizes'.<sup>106)</sup> The tomb was found to contain eight coffined mummies, arranged 'with their heads toward the outside' in two rows of four,<sup>107)</sup> 'imbedded four inches deep in mortar, which must have been soft when they were put into it; for when I had them removed, the impression of them remained perfect'.<sup>108)</sup> All the coffins were painted, one being covered with a painted pall,<sup>109)</sup> the design of which is said to have 'consisted of various devices and flowers',<sup>110)</sup> this, together with the fact that most of the coffins were varnished,<sup>111)</sup> suggests strongly a Third Intermediate Period date for the assemblage<sup>112)</sup> - a dating which the finds from Schaden's recent clearance (below) only serve to confirm.

Thomas appears to have been the first to note<sup>113)</sup> Belzoni's comment that one of the mummies 'had new

linen apparently, put over the old rags'.<sup>114)</sup> Thomas's view is that this mummy (which Belzoni does not specify further) had been rewrapped.<sup>115)</sup> However that may be, there is no justification for her suggestion<sup>116)</sup> that a second mummy - 'that which was distinguished from the rest' (by its linen pall?), and with 'bones which had assumed a yellow tint'<sup>117)</sup> - had also been rewrapped; nor for Schaden's erroneous view<sup>118)</sup> that Belzoni was here referring to a single mummy with rewrapped yellow bones.

Schaden's recent clearance of the unfinished passage of WV25 revealed fragments of mummy (including parts of the yellow skeleton), wrappings, sherds, a fragmentary faience shabti and some pieces of cartonnage.<sup>119)</sup> The presence of the latter would suggest that portions of the deposit, at least, did not pre-date the 22nd dynasty.<sup>120)</sup> Other items, 'of a distinctly royal nature',<sup>121)</sup> are 'several prongs from fayence uraeus serpents, part of a wooden flail ..., ... two left ears and parts of two right feet' from 'two lifesize wooden statues', and seemingly 'other wood fragments'.<sup>122)</sup> Schaden's report conveys but the barest impression as to which part of the corridor these pieces were found - merely in 'the pile of debris beyond the door'.<sup>123)</sup> It is, nevertheless, unlikely that these royal items are to be directly associated with the eight mummies found by Belzoni - or, for that matter, with WV25 itself.<sup>124)</sup> It is far more probable that this was material thrown out from

WV23 which had been deposited, presumably by floodwater, before the Third Intermediate Period mummies were interred.<sup>125)</sup>

(KV55)<sup>126)</sup>

This controversial deposit was discovered by Ayrton in early January 1907;<sup>127)</sup> further fragments relating to the tomb were recovered by Carter from a 'crack in (the) rock' above the entrance in the spring of 1921.<sup>128)</sup>

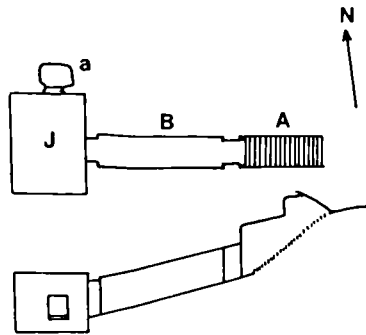

Fig. 17: KV55

The tomb itself (fig. 17) was unfinished.<sup>129)</sup> It had been sealed off at the top end of the corridor with 'rough blocks of limestone cemented together and coated on the outside with cement'.<sup>130)</sup> However, 'with the exception of a wall about three feet high, these had been pulled down',<sup>131)</sup> and the entrance had been 'closed by a loosely-built wall of limestone fragments, resting not on the rock beneath, but on the loose rubbish which had filled the stairway'.<sup>132)</sup> According to Weigall, this second wall had itself 'been partly pulled down, and had not been built up again'.<sup>133)</sup> No photographs were taken of this blocking,<sup>134)</sup> though

it is recorded that upon 'fragments of cement',<sup>135)</sup> from the original plastered surface was found 'the oval seal of ... a jackal crouching over nine captives'.<sup>136)</sup> The veracity of Weigall's statement that 'the entrance ... was sealed with the seal of Tutankhamon, a fragment of which was found',<sup>137)</sup> cannot now be checked.

The corridor beyond the successive blockings of the outer doorway (A-B) had been filled with rubble, to judge from the position of the blocking's secondary build, at the time of the original interment. This rubble had once filled the corridor to the roof, but by the time of the discovery had spread down the passage beyond any second blocking which may have existed at (B-J) and into the tomb's single chamber.<sup>138)</sup>

The relative positions of the contents of KV55 are set out in a schematic manner in fig. 18, based upon the photographic record and text published by Davis<sup>139)</sup> and upon descriptions given by Ayrton and others.<sup>140)</sup> This plan clearly illustrates the disturbed state in which the contents lay at the time of the discovery. Yet amidst this chaos can be discerned a definite division into (a) objects which, by their function and by the inscriptions which they carry, can be connected with the burial of Tiye - notably the shrine,<sup>141)</sup> but also other small items<sup>142)</sup> including seal impressions inscribed with the prenomen of Amenophis III,<sup>143)</sup> and (b) items similarly pertaining to the funerary equipment of Akhenaten - altered coffin,<sup>144)</sup> canopic jars<sup>145)</sup> and 'magical

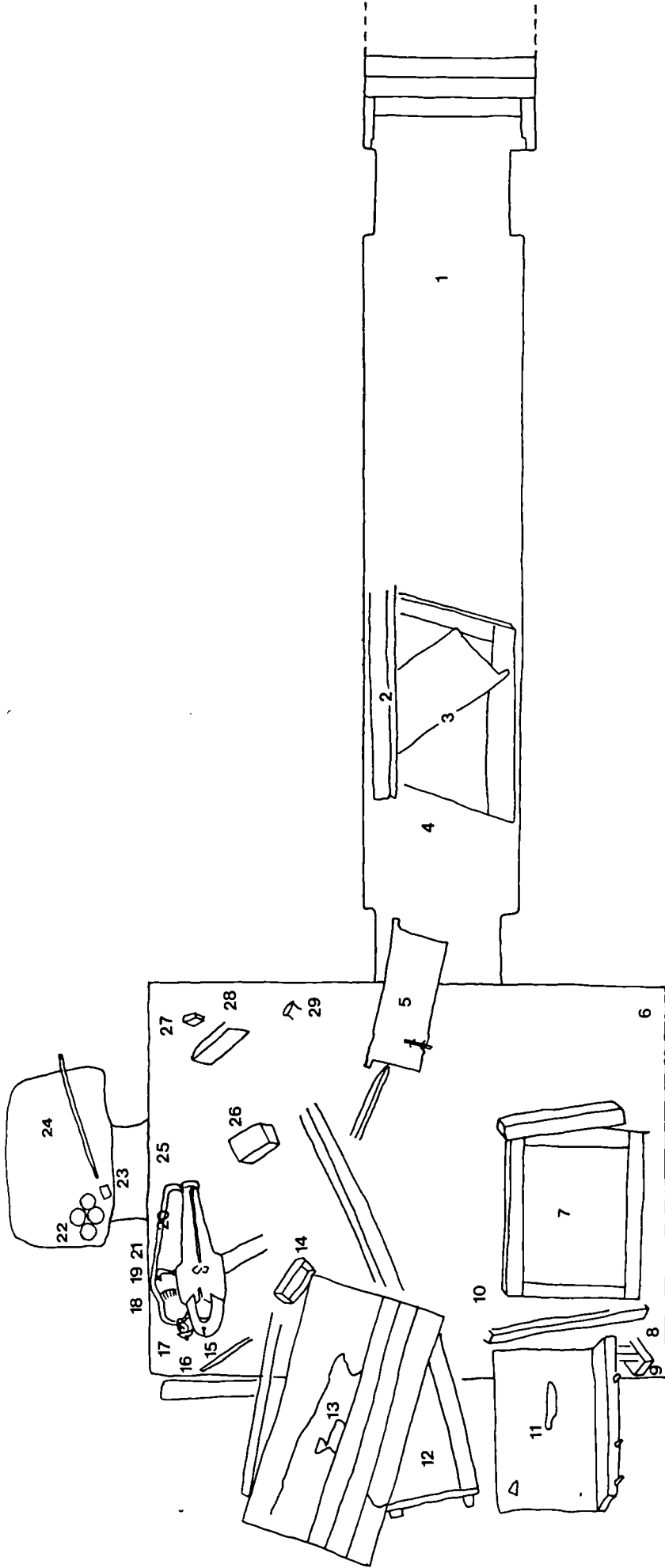

1, (this general area): blade of a small copper graving tool; mallet head; beads, Davis, 9; 2, modern planks, Davis, 2, 8, pl. xxiv; 3, panel and door from shrine, Davis, 1, 8, pl. xxiv; 4, (underneath): lid of large alabaster vase, Davis, 9; 5, second door from shrine, Davis, pl. xxv; 6, 'magic brick', Davis, 10; 7, panel from shrine with erased figure of Akhenaten, Davis, 14-15, pls. xxvii, xxix, xxxii-xxxiii; 8, (this general area): scattered blue beads, Davis, 10; 9, box, Davis, pl. xxix; 10, (underneath): 'magic brick', Davis, 10; 11, roof? of shrine, Davis, pl. xxvii; 12, panel from shrine, Davis, pl. xxvii; 13, side-panel? from shrine, Davis, pl. xxvii; 14, box, Davis, pl. xxvi; 15, vulture pectoral upon detached head of mummy, Lindon Smith, 64; Davis, pl. xxx; 16, broken remains of a wooden box containing 156 objects, including ointment vases, model papyrus rolls, wands, two figures of Bes, small figure of a girl carrying a vase, *wadjet*-eyes, and models of fruit, Ayrton, 280. See note to item 27; 17, (this general area): lion heads from bier; seal fragments; uraeus with late names of the Aten, Davis, 10; 18, gold collar, Davis, 9; cartouche amulet with early prenomen of the Aten, Davis, 22; 19, arm bent with three gold-foil bracelets, Davis, 9; 20, gold-foil sheets from interior of the coffin, Davis, 2, pl. xxx (one with cartouche of Akhenaten, Lindon Smith, 65); 21, right arm extended, three gold-foil

bracelets around wrist, Davis, 10; unplaced ornaments of the mummy: (i) inlaid gold flower, Davis, 22; cf. Ayrton, 281; (ii) beads, Davis, 22; (iii) gold foil with early names of the Aten, Davis, 22; (iv) ear-stud fasteners, Davis, 22; 22, canopic jars, Davis, pl. xxvi; 23, statue plinth?, Davis, 26? pl. xxvi; 24, 'magic brick', Davis, 10; 25, (underneath bier): 'magic brick'; seal fragments, Davis, 10; 26, box, Davis, pl. xxvi; 27, remains of a small box containing *psf-ky* amulets and other material 'for the ceremony of opening the mouth', including the handle of a chisel, four alabaster blocks, flint knives, and two red pebbles, Ayrton, 280. Elsewhere (Davis, 10) Ayrton describes the box as containing faience items, including small vases, wands, and figures of blue-glazed ware; this was probably due to confusion with the box recovered from the south-east corner of the chamber (item 16); 28, box, Davis, 10, pl. xxv (if not item 26); 29, alabaster 'vase stand', Davis, 8; unplaced objects include: (i) fragment of furniture with the cartouches of Tiye and Amenophis III, Davis, 32; (ii) hieratic label, Davis, 39; (iii) two gold shroud discs, Davis, 40; (iv) two gilt-bronze shroud discs, Davis, 40; (v) irregular bronze patches, Davis, 40; (vi) head of a goose in silver, Davis, 39.

KEY: the following abbreviations are employed: Davis = Th. N. Davis, *The Tomb of Queen Tiy* (1910), Ayrton = E. R. Ayrton, *The tomb of Thyi*, *PSBA* 29 (1907), 85 f., 277 ff., Lindon Smith = J. Lindon Smith, *Tombs, Temples and Ancient Art* (1957), 54 ff. The dimensions of the tomb are based upon Elizabeth Thomas, 'The plan of Tomb 55 in the Valley of the Kings', *JEA* 47 (1961), 24. The relative dimensions of the contents are to be regarded as *approximate* only.

Fig. 18: reconstructed layout (KV55)

bricks'.<sup>146)</sup> This dichotomy is, moreover, reflected in the positioning of the main items from each group, namely the shrine and the coffin, which, when found, bore no obvious relationship one to another. Indeed, the impression gained is that the shrine, though dismantled, had at one stage occupied the main area of the chamber, whilst the coffin and canopic jars had been consigned to the edge of the chamber, close to the entrance, as if having been introduced after the erection of the shrine. Taking into consideration both the implicitly personal nature of the objects involved (which would have been of little value in the funerary ritual of one - I here refer to Smenkhkare - for whom they were not inscribed), and the mixed nature of the material, it is thus evident that the deposit represents the remains of not one but two quite separate and distinct burials contained within the same tomb. This interpretation finds ready support in what we have already noted concerning the successive closings of the outer doorway, which suggest that the KV55 'cache' had been deposited on at least two separate occasions and partially cleared on a third.

It would appear, from certain items of funerary furniture recovered from WV22 by Carter,<sup>147)</sup> that Tiye had originally been intended for burial with her husband, Amenophis III.<sup>148)</sup> The fact that she outlived him by as much as 12 years,<sup>149)</sup> however, may have disrupted such plans, since it is perhaps unlikely that the burial of a pharaoh would have been re-opened, in the normal course of events, to allow secondary interments to be made.<sup>150)</sup> Alternatively, Akhenaten



Fig. 19: small seal impressions (KV55)

may have had his own plans for Tiye's burial<sup>151)</sup> \_ as Amenophis II evidently had for his mother, Hatshepsut-Meryetre.<sup>152)</sup> For whatever reason, the consort of Amenophis III was eventually laid to rest in the unfinished and previously unused KV55.

Akhenaten, on the other hand, was probably buried in the vast tomb he quarried for himself in the eastern mountain at el-Amarna.<sup>153)</sup> This tomb had clearly never been finished, as its attenuated plan shows.<sup>154)</sup> The fact that the king's sarcophagus chamber had been hastily fashioned from what, in a finished tomb, would have been the room beyond the well, can only imply that active preparations were made for the king's burial within following his death.<sup>155)</sup> Historical considerations, moreover, would seem to demand an Amarna burial for this king. Given (a) his stated wish to be buried at el-Amarna,<sup>156)</sup> and (b) the likelihood that Amarna remained the nominal capital of Egypt until the return to orthodoxy early in the reign of Tutankhamun,<sup>157)</sup> it would perhaps be perverse logic to postulate an original interment elsewhere. Akhenaten's presence within KV55 must, therefore, be the result of a reburial following the court's abandonment of Akhetaten and return to Thebes.

That there was activity of some sort within KV55 under Tutankhamun is shown by the presence of several small seal impressions carrying this king's prenomen (fig. 19).<sup>158)</sup> Since Tutankhamun is unlikely to have been involved with the preparation of Tiye's original burial (her

death having occurred, it would seem, several years before he ascended the throne), or, for that matter, the original burial of Akhenaten (whose obsequies will presumably have been carried out by his coregent and probable successor), these impressions must relate to the reburial of one or other of these individuals within KV55.<sup>159)</sup>

The situation within the tomb immediately following the introduction of the second burial must have been very different from that obtaining when the deposit was discovered in 1907. As found by Davis, the tomb was in a state of disarray: the shrine had been dismantled, as if to allow the removal of Tiye's coffined body from within, and one of the larger panels and a door had been dragged up the partially cleared rubble fill of the corridor and abandoned.<sup>160)</sup> This strongly suggests the planned removal from the tomb of Tiye's body and immediate effects, which, owing to the unwieldy nature of the component parts of the shrine, was never completed. Happily, the recent identification of Tiye's mummy as being amongst those recovered from side room (Jc) in the tomb of Amenophis II (KV35)<sup>161)</sup> indicates her ultimate destination, presumably via an intermediate resting-place.<sup>162)</sup> The date of this removal cannot be determined with any precision, but it undoubtedly took place before the end of the 20th dynasty, by which date accumulated debris from the excavations of KV16 (Ramesses I), KV17 (Sethos I), KV7 (Ramesses II), KV11 (Ramesses III) and KV6 (Ramesses IX) covered the tomb area.<sup>163)</sup> It is at least possible that the presence

of the tomb had been detected by those workmen employed upon the excavation of KV6, since the small side room (Bd) which lies immediately above the KV55 burial chamber has, unlike its fellows, been left unfinished;<sup>164)</sup> cf. fig. 20. Perhaps the workmen were anxious not to ruin the security of the tomb upon which they were working by colliding with this 'lost' tomb below.<sup>165)</sup>

Whether the remaining coffin was abandoned wilfully or of necessity owing to the shrine panel blocking the corridor is not clear. It seems likely, however, that the erasures and defacement of the coffin and the shrine also occurred at this time, and consequently that the abandonment of the second body - to all outward appearances that of Akhenaten himself - was a deliberate act.<sup>166)</sup>

The identity of the KV55 corpse has been hotly debated.<sup>167)</sup> At the time of its discovery, two doctors visiting the tomb (a Dr Pollock and 'a prominent American obstetrician')<sup>168)</sup> informed Davis that the badly preserved mummy was 'without doubt'<sup>169)</sup> that of a woman - an identification which would accord well with the manner in which the mummy had been laid out (right arm straight down by the side, the left arm bent with the hand on the breast<sup>170)</sup> - a typical woman's pose).<sup>171)</sup> Nevertheless, the results of more recent examinations<sup>172)</sup> are unanimous in seeing the skeletal remains as being those of a man, the estimated age of whom at death has been reduced over

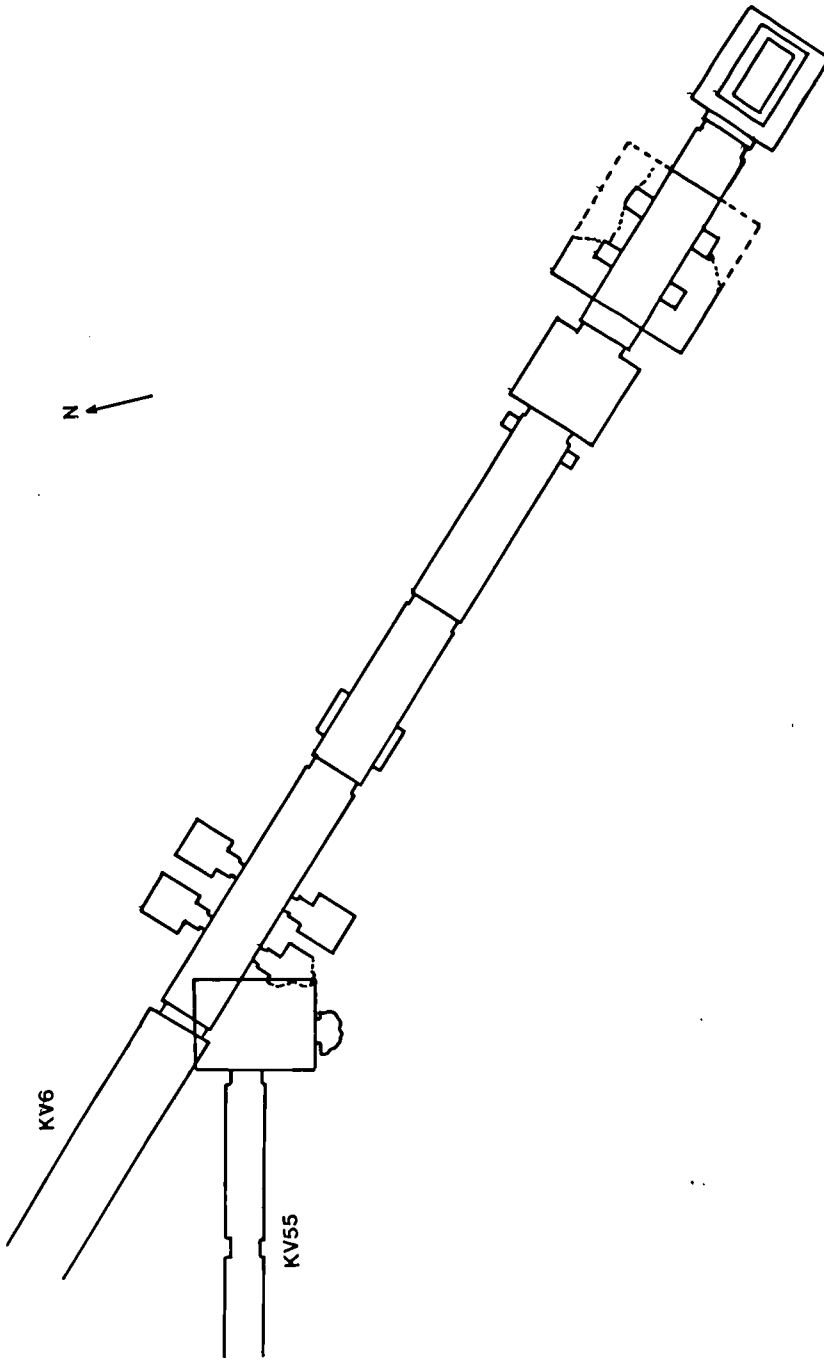

Fig. 20: relative positions of KV55 and KV6

the years from about 25/26+ to 20.<sup>173)</sup> A close physical resemblance to Tutankhamun was noted by Derry in 1927,<sup>174)</sup> restated in 1931<sup>175)</sup> and confirmed by the latest examination in 1963;<sup>176)</sup> whilst more recent work has suggested that both bodies possessed blood group A<sub>2</sub> with the serum antigen MN.<sup>177)</sup> As we have seen, the clear implication of the archaeological evidence is that the final owner and intended occupant of the KV55 coffin was Akhenaten; and since Akhenaten is the likely father of Tutankhamun,<sup>178)</sup> both the physical resemblance and common blood grouping are perfectly compatible with this conclusion - especially since it has recently been suggested that estimates of age at death based upon anatomical development are of quite doubtful reliability.<sup>179)</sup>

To conclude, the following sequence may fairly be deduced from the available evidence: (a) employment of the abandoned KV55 chamber for the (re)burial of Tiye; closing of the doorway with limestone blocks which were then plastered and impressed with the necropolis seal; (b) the partial destruction of this sealed doorway, and the introduction of the burial of Akhenaten; and finally (c) the destruction of this secondary blocking and the partial removal of the deposit before the end of the 20th dynasty; the deliberate defacement and abandonment of the Akhenaten coffin and its occupant.

#### 'Smenkhkare'

The tomb of this individual, whose identity is currently the subject of much scholarly debate,<sup>180)</sup>

has not yet been located, although certain items of surplus funerary equipment (all with variants of the nfr-nfrw-itn nomen) were recovered from the tomb of 'his' successor, Tutankhamun (KV62).<sup>181)</sup> It may be significant that the part of the Valley in which one might expect to find the burial of this king apparently has not yet been fully cleared.<sup>182)</sup>

## CHAPTER 3

## THE BURIALS OF TUTANKHAMUN, AY AND HOREMHEB

Tutankhamun (KV62)<sup>1)</sup>

The tomb of Tutankhamun (fig. 21) was discovered by Carter on 4 November 1922,<sup>2)</sup> and patiently cleared over the following decade. Thanks to Carter's painstaking and accurate record,<sup>3)</sup> it represents by far the best documented tomb in the Valley. The burial is, nevertheless, atypical in many respects,<sup>4)</sup> crammed uncomfortably as its contents were into an enlarged and adapted private sepulchre<sup>5)</sup> of the same general pattern as KV55.<sup>6)</sup> Tutankhamun's projected tomb, work on which had presumably proceeded but a little way at the time of his unexpected death, may well have been WV23,<sup>7)</sup> a tomb which was subsequently employed by his successor, Ay.<sup>8)</sup>

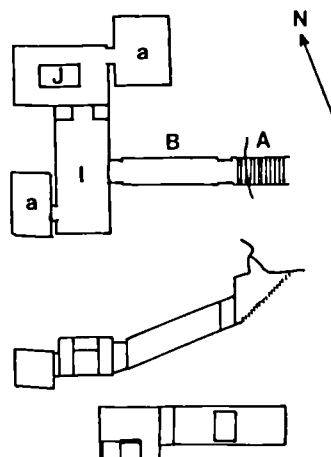

Fig. 21: KV62

The entrance to KV62 was situated 13 feet below the 20th dynasty ground level, beneath a series of huts employed by those working upon the excavation of KV9 during the reigns of Ramesses V and VI.<sup>9)</sup> The existence of the tomb below had clearly been forgotten by this date, and the erection of these structures effectively secured its protection for a further three millennia.

A rubble filled, debris strewn flight of steps at the entrance to the tomb<sup>10)</sup> led down from the ancient ground level to a plastered wall<sup>11)</sup> which showed 'trace(s) of two successive openings and reclosings',<sup>12)</sup> the former evidently of an illicit nature. Carter describes the blocking as follows:

Upon the plaster of the original unharmed part of the blocking fifty-seven seal impressions were visible at the time of the discovery. They proved to be 13 impressions of seal (A), 17 of seal (B), 8 of seal (C), 9 of seal (D), and 10 of seal (E). Upon the remaining portion of the second closing - originally a breach about one third in size of the doorway and occupying the whole of the upper southern corner - only seven seal impressions remained, and they were with fair certainty of type (H). Stamped upon the surface of the third closing - covering a hole similarly situated as the first breach, but not quite so large - were twenty-eight impressions of one kind and of type (H).<sup>13)</sup>

Beyond this wall lay a passage, filled to the ceiling with rubble<sup>14)</sup> interspersed with broken remnants of funerary furniture,<sup>15)</sup> which led to a second doorway:

My notes after examining ... both the original and subsequent closings at the time of the discovery record: 'No appreciable difference from the several sealings in the first doorway'. Since, from fragments preserved, I find no reason for changing that conclusion.<sup>16)</sup>

This second blocking gave access to the so-called 'Antechamber' (I), crammed full of funerary material.<sup>17)</sup> Opposite was a second chamber, the 'Annexe' (Ia), also full of objects, generally of a smaller scale and much less carefully arranged than in the first chamber.<sup>18)</sup> The blocking of the Annexe doorway Carter describes as follows:

Only the upper part of the blocking ... remained, the thieves having broken through the lower portion.<sup>19)</sup>

This breach had not been reblocked. The remains of the original blocking bore 33 seal impressions: eight of type (C); six of type (D); five of type (E); and 14 of type (G).<sup>20)</sup> Breasted<sup>21)</sup> apparently noted in addition seal type (H), to which Carter's response was: 'I have been unable to discover any trace of that seal among the thirty-three impressions, all of which can be identified'.<sup>22)</sup> The explanation for this

apparent contradiction, if not a simple misreading, may lie with the transposition at some stage of the reference letters for seal types (E) and (H).<sup>23)</sup> Alternatively, if less probably, the apparent (H) seal noted by Breasted may have come from a reblocking of the Annexe, the plaster of which will then have been broken up and pushed through into the Annexe at the time of the last period of robbery.<sup>24)</sup>

The wall at the northern end of the Antechamber was of limestone construction skimmed with gypsum plaster.<sup>25)</sup> The central portion of this partition consisted of a third plastered blocking. Carter's documentation of this blocking is rather vague. From notes appended to his drawings of the large seal impressions,<sup>26)</sup> however, it may be inferred that seal types (A), (E) and (F) were amongst those employed in the original closure; to which an annotated Burton photograph<sup>27)</sup> enables us to add types (B) and (C). Evidence for the state of the robbers' breach in the bottom right-hand corner of the blocking is rather more elusive. That Carter, Carnarvon and Lady Evelyn Herbert had access beyond this blocking<sup>28)</sup> is well documented,<sup>29)</sup> as is their clumsy method of concealing their means of access behind a basketwork tray and a handful of rushes.<sup>30)</sup> A photograph in the first volume of Carter's publication<sup>31)</sup> nevertheless depicts the hole closed and with the ovals of the seals clearly visible. This, in Lucas's view, was a sham, 'since the hole unlike that in the outermost doorway, had not been closed by the cemetery officials, but by Mr. Carter'.<sup>32)</sup> Some doubt is cast on Lucas'

conclusion, however, by reference to the relative positions of the 'Painted Box' in vol. I, pl. 42 and, for example, vol. I, pl. 16. In the former photograph, the knob end of this box faces towards the sealed doorway; whereas in pl. 16 - a photograph clearly taken after the illicit entry into the Burial Chamber (J), with Carter's 'camouflage' in position - the knob end of the box faces away from the blocking.<sup>33)</sup> Clearly the box had been dragged clear of the doorway after the first photograph had been taken, in order to allow Carter to remove the ancient reblocking of the robbers' hole and thereby gain access to the chambers beyond.<sup>34)</sup> Carter's doctoring of the evidence will thus have been minimal, and motivated, as Lucas suggests in his first article, by a desire not to be 'pestered constantly by people wanting to go in'.<sup>35)</sup> The type of the sealings employed on the (single?) reblocking are unfortunately not recorded. From the original print of the photograph in Tut.ankh.Amen I, pl. 42, however, they seem to have been of the jackal and nine captives variety - presumably (H).<sup>36)</sup>

Carter's penetration beyond this blocking revealed a further chamber<sup>37)</sup> containing four (of an intended five)<sup>38)</sup> huge gessoed and gilt shrines,<sup>39)</sup> the outermost of which had, in addition, been inlaid with blue faience. These shrines, nested one within another, enclosed a quartzite sarcophagus with mis-matched (granite) lid<sup>40)</sup> containing three anthropoid coffins, the two outermost of wood covered with gold foil and inlaid with glass and semi-precious stones, the innermost of solid gold, similarly adorned.<sup>41)</sup>

Within this latter coffin lay the mummy of the king, its head covered with a gold mask and the body encircled by inlaid 'shroud bands' of gold;<sup>42)</sup> the mummy itself had been freely decked with amulets, jewellery and royal regalia, as well as two fine daggers.<sup>43)</sup> The body of the king had not been touched since the day of the interment: to judge from the state of the seals, the thieves (see below) had penetrated no further than the outermost shrine.<sup>44)</sup>

Leading off from the Burial Chamber was the 'Treasury' (Ja), containing the king's canopic and other mortuary equipment.<sup>45)</sup> Two miniature coffins found in this room contained the mummies of two foetuses.<sup>46)</sup> The entrance to the Treasury had not been walled up, and thus those having access to the Burial Chamber had free range to plunder in this section of the tomb also. Such illicit activity was indeed to be detected - as elsewhere in the tomb - in the broken seals<sup>47)</sup> and in the jumbled contents (which frequently bore little relation to the contents specified in the hieratic labels)<sup>48)</sup> of hastily repacked boxes and caskets.

In attempting to establish the chronology and activities of the tomb robbers and the necropolis officials who followed them, the evidence of the tomb's seal impressions is of vital importance. The descriptions given above indicate, from the overall distribution of the seal types (A)-(G) (fig. 22), that none of the blockings post-dates the original closing of the tomb;<sup>49)</sup> whilst the varying combinations of seals employed to close the four doorways, as well as



(A) (B) (C) (E) (G)

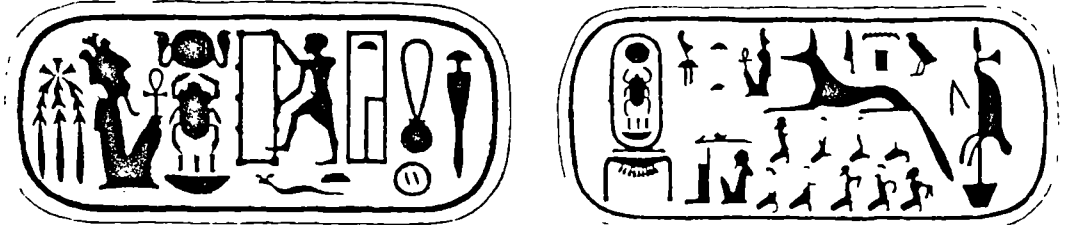

(D) (F)

Fig. 22: large seal impressions (KV62)

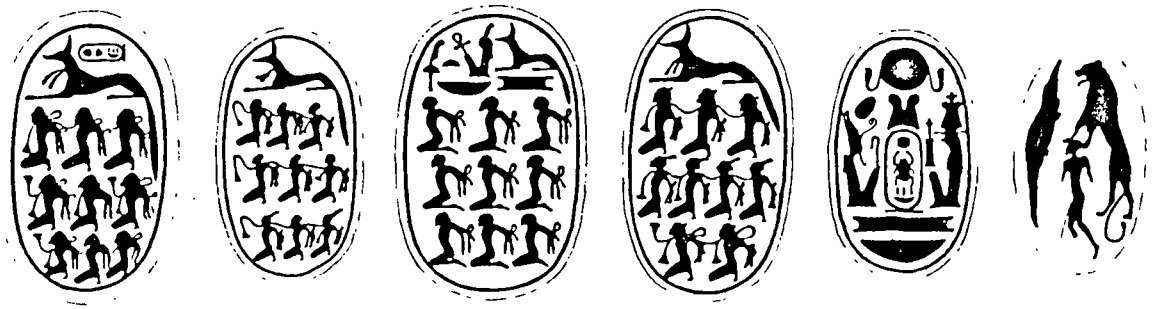

(I) (J) (K) (L) (M) (N)



(O) (P) (Q) (R) (S)

Fig. 23: small seal impressions (KV62)

logistic considerations, suggest that these blockings were erected on separate occasions over an indeterminate period of time,<sup>50)</sup> and perhaps in the presence of different officials.<sup>51)</sup> It is to be noted that the use of seal type (H) is restricted to those portions of the blockings which had been restored following the incursions by thieves, and that nowhere on the restored portions of the blockings does the name of the king under whom the restoration was carried out occur.<sup>52)</sup>

Closely associated with the large seals are the smaller impressions employed to seal individual items within the tomb. These are of 11 types, lettered (I)-(S) (fig. 23).

That seal type (I) was in use at the same time as type (J) is established with certainty by the fact that both were employed to close obj. nos. 237-8, the intact second and third (innermost) shrines surrounding the sarcophagus.<sup>53)</sup> The cartouched prenomen of Tutankhamun which type (I) incorporates would indicate that both impressions are contemporary with the original interment. By extension, all items sealed with types (I) or (J) are to be similarly construed - including the alabaster canopic chest (obj. no. 266**b**) and the two coffined fetuses (nos. 317**a-b**).

It is similarly to be assumed - for want of evidence to the contrary - that all the sealings which incorporate a version of the king's prenomen - types

(M), (O), (P) - pre-date the original closing of the tomb, since the seal rings so employed will have been superseded following the king's death.<sup>54)</sup> And since type (N) was used in conjunction with seal type (M) on obj. nos. 271-2, its date ought to be similar. The single example of Carter's type (R) I would likewise suggest is to be dated to a period before Tutankhamun's death, since it appears to contain a cryptogram of the prenomen of Akhenaten, nfr-hprw-r<sup>c</sup>.<sup>55)</sup>

A large variant of Carter's seal type (K) occurs on the original blocking of the Burial Chamber, where it is referred to as type (F); without much doubt, therefore, type (K) is contemporary with the original sealing of the tomb. The same conclusion might be reached for the series of resin-coated shrines from the Treasury, containing the figures of various deities, which were sealed with type (L). These sealings were, for the most part, found intact: once the thieves (who seem to have spent very little time in the Treasury in any case) had established the general nature of the shrines' contents, they evidently abandoned them for richer pickings elsewhere in the tomb.<sup>56)</sup>

One fragment of a large impression found upon the floor of the Antechamber (Carter's type (S)), when intact incorporated the cartouched prenomen and nomen of Ay; but since Ay was already king when the funeral ceremony took place, and since the form of the cartouche is not closely datable, its occurrence in the tomb is of equivocal significance.

Another impression, Carter's (Q), was found sealing the 'black shrine-like chest' no. 304.<sup>57)</sup> The impression is double struck and lacks the lower part; nevertheless, Carter's drawing suggested the possible restoration hr(-m-hb), 'Horemheb', in which case the sealing might well provide evidence of a restoration of the burial under that king.<sup>58)</sup> However, on what appears to be a second occurrence of the type (on obj. no. 193), Carter's original transcription of the bottom sign was n**w** and not m **h**b****.<sup>59)</sup> Further doubts arise when one considers the position within the tomb of the two pieces which bear this motif. Obj. no. 193 is a psš-kf mounted on a board and flanked by two miniature shrine-shaped pylons (of which only the door on the left-hand shrine had its seal present),<sup>60)</sup> and was found in the north-west corner of the Burial Chamber between the first outermost shrine and the chamber wall.<sup>61)</sup> Carter's obj. no. 304 was in an equally inaccessible position in the Treasury: 'the fourth of the fourth row of chests stacked in the south east corner'.<sup>62)</sup> If (Q) was the seal of Horemheb, we are faced with the problem as to why he should have chosen these two objects alone for resealing, when others were clearly left with their original seals broken. The conclusion must be that seal type (Q) is not inscribed with the nomen of Horemheb (one might, in any case, have expected the prenomen), and that at no time subsequent to the original stocking of the tomb were any of the contents resealed.

To judge from the double resealing to be seen in the outer and inner corridor blockings, at least two phases of robbery are to be distinguished within KV62. That the corridor beyond the outer doorway was not filled with rubble at the time of the first illicit entry is suggested by a number of features. First, the earlier breach in the blocking of the outer doorway is at a lower level than the later thieves' hole;<sup>63)</sup> no experienced tomb robber would attempt to burrow a hole through the middle of loose chip. Secondly, the plaster on the original blockings was not as damaged as that on the secondary resealings, clearly because the earlier impressions had hardened and the later were still soft when the rubble was introduced.<sup>64)</sup> Thirdly, several fragments were discovered by Carter beneath the fill, which seem to indicate<sup>65)</sup> that at the time of the original closure the corridor had been employed to store, amongst other items, the refuse embalming materials later reburied in KV54.<sup>66)</sup>

Other objects found within and below the rubble fill of the entrance corridor,<sup>67)</sup> rather than having been dropped at a time when the passage was only partially filled (i.e. at the time of the second robbery) (Carter's view),<sup>68)</sup> seem more likely to represent the remains of booty dropped outside the tomb at the time of the first robbery, debris which had subsequently been gathered up with the rubble employed to fill the corridor.<sup>69)</sup> None of this material can with confidence be associated with any of the rooms beyond the Burial Chamber blocking.<sup>70)</sup> Indeed, those pieces

which can be located with any confidence come exclusively from the Antechamber.<sup>71)</sup> This leads me to suspect, contrary to Carter's expressed opinion,<sup>72)</sup> that those involved in the first robbery did not penetrate beyond the Burial Chamber (or even the Annexe) blocking(s), and that the more extensive period of theft within the tomb occurred only later.

Precisely how much was lost from the tomb as a result of the robberies is impossible to assess.<sup>73)</sup> Certain classes of object, such as those of metal and glass,<sup>74)</sup> are lacking or only sparsely represented, to be sure, but it is usually only when we possess some indication such as a docket, scribbled at or before the funeral and specifying the contents of a particular box at that particular time that we can isolate specific pieces once present and now missing.<sup>75)</sup> The fragmentary box ll, for example, which Carter found upon the steps before the first doorway, had originally contained '1 silver chain with seal and 3 silver jugs for milk'<sup>76)</sup> - none of which was recovered by Carter; similarly the gold vessel mentioned in a docket on box 268 from the Treasury,<sup>77)</sup> and the gold vessels, 'grasshoppers' and other pieces once contained in box 575 + 594 from the Annexe.<sup>78)</sup> Note further the empty gold-plated shrine found in the Antechamber, which seems to have contained originally a gold(?) statuette of the king.<sup>79)</sup> Besides metal, linen too seems to have been sought after: cf. the docket on another fragmentary box, no. lk,<sup>80)</sup> found upon the steps of the tomb, and the general lack of such material in the burial. The robbers' predilection for

ointments and cosmetics is well attested by the empty, fingerprint-covered alabaster jars from the Annexe.<sup>81)</sup>

The material recovered from the fill of the entrance corridor<sup>82)</sup> certainly seems to support Carter's opinion that the first gang of robbers had as their prime objective the recovery of metal. This apparent selectivity, however, may merely be a reflection of the short time they were able to devote to their nefarious activities. The second period of theft was evidently more wide-ranging than the first, if equally brief,<sup>83)</sup> but it is not at all easy to distinguish between material stolen during the first robbery and items removed during the second. If, as I believe, access to the Annexe was restricted to the second phase of thefts, then clearly oils and unguents were among the commodities stolen at this time - though such commodities had clearly been robbed also during the first robbery, as the broken lids from vessels in the Antechamber, found in the corridor,<sup>84)</sup> clearly show.<sup>85)</sup>

As Carter notes, those who restored the burial following the thefts 'seem to have been in almost as great a hurry as the thieves, and their work of reparation was sadly scamped'.<sup>86)</sup> In fact, the officials seem to have been more anxious to restore a superficial order to the burial than to sort the disturbed material and replace it correctly in its original position;<sup>87)</sup> the Annexe appears to have been left much as it had been found by the later investigating party, with no attempt at sorting.<sup>88)</sup> As we have seen above, the restorers resealed none of the boxes.

The precise dates at which the robberies occurred remain unclear. The similarity in style between the type (H) restoration seals and the type (E) impressions employed at the time of the burial is noticeable,<sup>89)</sup> and would suggest that the robberies and subsequent restorations took place within a short time of the original closing of the tomb.<sup>90)</sup> Significant also is the fact that the thieves had been attracted by oils and unguents, the life-span of which was presumably limited.<sup>91)</sup> The possibility that the seal type (Q) is to be attributed to a restoration by Horemheb after the (first) robbery has, however, been considered above and dismissed.

To conclude: KV62 appears to have been subjected to two distinct periods of theft within a short time of the interment, perhaps under Ay though conceivably under Horemheb. The first robbers appear to have had access to the Antechamber only, and then for a comparatively short period of time; following the discovery of the thefts, the entrance corridor was filled with rubble and the robbers' breaches made up and sealed. The second phase of theft may perhaps have extended over a longer period than the first, and the robbers seem to have had access beyond the Burial Chamber and Annexe blockings. As Carter suggests, they were possibly caught in flagrante.<sup>92)</sup>

(KV54)<sup>93)</sup>

The shallow pit numbered KV54 (fig. 24) was first opened on 21 December 1907, and the contents examined on and before 17 January 1908.<sup>94)</sup> The excavators

themselves published few details of the find,<sup>95)</sup> and it was left to Winlock to assemble what evidence he could as to the context of those objects from the deposit which he had been able to secure for the Metropolitan Museum of Art.<sup>96)</sup> The nature of the material Winlock early recognised as a cache of refuse from the embalming of Tutankhamun, as well as remnants of the king's funerary meal.<sup>97)</sup> The association of such disparate groups of material seems not to have caused Winlock any great concern. In fact, as we saw in the previous section,<sup>98)</sup> there is reason to suspect that KV54 was not their original place of deposition. The facts (a) that fragments of the mud 'trays' and other pieces found by Winlock amongst the KV54 debris<sup>99)</sup> occur also amongst the material recovered by Carter from the corridor of KV62,<sup>100)</sup> and (b) that at least one of the KV54 seals may possibly be paralleled in the Tutankhamun burial,<sup>101)</sup> suggest a far close association of the two tombs' contents than has hitherto been suspected. The conclusion would seem to be that the embalming refuse and remains of the funerary meal were removed from the corridor of KV62 and reburied in KV54 following the former tomb's first period of theft, in order that the entrance passage might be completely filled with rubble.<sup>102)</sup>

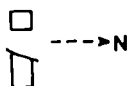

Fig. 24: KV54

Ay (WV23)<sup>103)</sup>

WV23 (fig. 25) was discovered in the winter of 1816 by Belzoni, who noted no finds with the exception of 'part of a sarcophagus remaining in the centre of a large chamber'.<sup>104)</sup> The tomb seems thereafter to have attracted little archaeological interest,<sup>105)</sup> until it was fully cleared by Schaden in the summer of 1972.<sup>106)</sup>

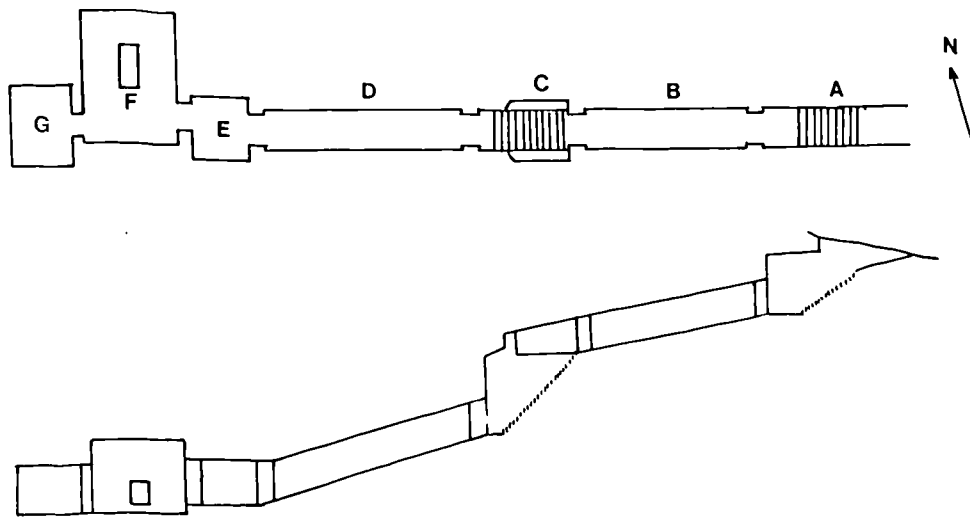

Fig. 25: WV23

Schaden's search for foundation deposits, in an attempt to settle the debate over the identity of WV23's original owner, was unsuccessful, although it should be noted that the area cleared did not include ground to the south of the tomb entrance owing to the danger of overhanging rocks.<sup>107)</sup>

Work within the tomb proved rather more productive. A 'test pit' sunk in corridor (B) revealed 'a uniform

layer of limestone chips and dust',<sup>108)</sup> with one or two intrusive items of recent date;<sup>109)</sup> this unstratified fill continued over the stairway (C) and ramp (D). 'Only in the bottom chambers were there any distinct levels recognisable.'<sup>110)</sup> Finds from (D) included 'a wooden hand (from a statuette) and an object of copper and gold foil', which 'turned out to be five discs with rosette and star patterns',<sup>111)</sup> presumably pail sequins.<sup>112)</sup>

The doorway at the end of corridor (D), through which access is gained to chamber (E), seems at one stage to have been blocked off and plastered: 'rocks, some with plaster still adhering to them, were found in the doorway and more rocks and plaster fragments were found in the debris in E chamber. Unfortunately, none of the plaster fragments bore any remains of a seal'.<sup>113)</sup> Since the floor of corridor (D) immediately before this doorway displayed a thin layer of what was later recognised to be the dark pharaonic level of the lower chambers, Schaden concluded that 'the tomb had been sealed and later opened during the New Kingdom'.<sup>114)</sup>

Several layers of stratification were visible in chamber (E), which was encumbered to a depth of 1.19 m immediately in front of the eastern doorway leading into (D).<sup>115)</sup> From the 'floor debris', Schaden recovered 'a wooden shawabty(?) beard and a leg fragment from a wooden statuette'; from 'the upper (mixed) fill', 'a thin gilt copper rosette'; and 'an interesting cluster of items ... found wedged between several

large rocks ... on top of the floor level fill':  
'half of a human pelvis', perhaps female; 'a small,  
poorly preserved cup (late Roman most probably) and  
the base of a jar (Roman)'.<sup>116)</sup>

Chamber (F) had been utilised as the sarcophagus  
hall. At the time of Schaden's clearance in 1972,  
'there was a depression in the center of the  
chamber resulting from the removal of the sarcophagus  
...', with 'debris thrown up against the east and  
west walls'.<sup>117)</sup> There was thus a distinct possibility  
'that these areas ... would be undisturbed'.<sup>118)</sup>  
Excavation, however, revealed that 'only the floor  
level was relatively free from Roman and post-Roman  
material'.<sup>119)</sup> Schaden's report thus distinguishes  
two main levels only: 'the pharaonic floor level  
and the mixed debris above it'.<sup>120)</sup>

The king's sarcophagus lid was found overturned,  
resting head north, upon the floor of (F), within  
Schaden's pharaonic layer 4.<sup>121)</sup> Several fragments  
of the box proper were found also, the largest 'a  
corner fragment bearing the name of Isis (from atop  
the head of the image of the goddess) ... Other  
fragments from the right side of the box were found  
on the floor (Schaden's italics) to the west of the  
original position of the box'.<sup>122)</sup> This tends to  
suggest not only that the sarcophagus had suffered  
extensive damage in the pharaonic period, but that  
the head of the sarcophagus had been orientated towards  
the south - contrary to the head-north orientation  
of the lid.<sup>123)</sup>

Chamber (G) was only lightly encumbered: 'the levels therein were the same as those in F chamber, only much thinner'.<sup>124)</sup> Finds included more pieces of the sarcophagus box and a fragment from a human skull.<sup>125)</sup>

It would, at this stage, perhaps be unwise to attempt anything but the most tentative reconstruction of the tomb's history, bearing in mind that Schaden's definitive report has yet to appear. Nevertheless, certain conclusions might be drawn here on the available evidence.

The most significant conclusion would seem to be that WV23 did contain a dynastic interment, presumably that of Ay himself:<sup>126)</sup> witness the presence of pail rosettes and the evidence of a blocked and plastered doorway at (D-E). The burial chamber, moreover, has been fashioned from what had originally been intended as the room beyond the (unexcavated) well (E)<sup>127)</sup> (as in the Amarna royal tomb),<sup>128)</sup> which in itself points to a hasty completion of the tomb brought on by Ay's death. Other items pertaining to this original interment probably include the sherds from two jars (one with a docket) recovered from 'the floor level of the lower chambers', and the numerous scraps of wooden funerary furniture.<sup>129)</sup>

At some later date the burial appears to have been the scene of intensive official activity, resulting in the destruction of Ay's names and figure in each tomb scene.<sup>130)</sup> My suspicion is that this activity

was prompted by one or more periods of theft within WV23, to which may be attributed the removal of the lid and damage to one of the four sides of the sarcophagus box 'afin d'en retirer la momie'.<sup>131)</sup> The evident damnatio memoriae was perhaps carried out only incidentally in the course of investigations into this illicit activity, in the same way that the Akhenaten coffin within KV55 appears to have been effaced only when Tiye came to be removed from the tomb.<sup>132)</sup> Otherwise, if the post mortem execration of the Amarna pharaohs was so thorough as to have included the opening of tombs and censoring of tomb scenes, one would be forced to ask why KV62, the tomb of Tutankhamun, had not been similarly treated.<sup>133)</sup> Perhaps significant in the case of WV23 is the lack of thoroughness with which the erasures have been carried out, which one would not expect had the official intruders had damnatio memoriae as their first priority. Witness (a) the intact state of the king's ka on the north-east wall of the burial chamber,<sup>134)</sup> and (b) several intact cartouches on the sarcophagus box<sup>135)</sup> and on the lid:<sup>136)</sup> being of rose granite, this would have taken more time and effort to efface than an investigating party would have been prepared to expend.<sup>137)</sup>

This suggested phase of activity presumably post-dates the reign of Horemheb, and indeed, what evidence we possess does tend to imply that the organised reaction to the Amarna pharaohs did not occur until later in the 19th dynasty.<sup>138)</sup> It is thus reasonable to infer that the effacements within WV23, and the thefts which prompted the action (not necessarily the first thefts

within the tomb), are to be similarly dated.<sup>139)</sup>

Ay's subsequent fate is not at all clear. Thomas has proposed that the nearby WV25 may have served as a cache for the occupant(s) of WV23;<sup>140)</sup> this, however, as considered above,<sup>141)</sup> is improbable. Nor is Schaden's suggestion, that the bone fragments recovered from chambers (E) and (G) of WV23 perhaps constitute all that remains of Ay's body<sup>142)</sup> (assuming, of course, that the sex of this skeletal material be male), susceptible of real proof. Perhaps more likely to shed light on the fate of Ay's mummy is the material recovered by Harold Jones from KV58, considered in the following section.

(KV58)<sup>143)</sup>

This small, single-chambered pit tomb<sup>144)</sup> (fig. 26) was discovered by E. Harold Jones in early January 1909.<sup>145)</sup> The circumstances of the discovery have been considered in detail elsewhere;<sup>146)</sup> here we need state only that the finds were recovered from both the fill of the shaft and the fill of the chamber, with a particular concentration occurring at a depth of just over six feet within the shaft (fig. 27).<sup>147)</sup> The likelihood is that this concentration represents the original point of deposition, from which smaller and predominantly lighter pieces washed down into the chamber and lower part of the shaft.<sup>148)</sup>

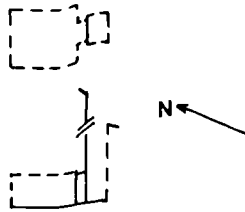

Fig. 26: KV58

The contents of the tomb are set out in table 1. The fragments of gold foil were described in some detail by Daressy, and sketches published of the more complete examples.<sup>149)</sup> Several of the pieces are inscribed,<sup>150)</sup> and from amongst these table 2 has been drawn up.

The terminus ante quem non furnished by the cartouches of Ay renders it highly improbable that the fragments of foil are to be connected with KV62 (Tutankhamun) alone.<sup>152)</sup> An ultimate provenance amongst Ay's funerary furnishings can, however, be demonstrated fairly convincingly in the case of at least one of the fragments<sup>153)</sup> - whilst this identification may, in its turn, be used to support a similar origin for the remaining fragments bearing Ay's name and/or titulary. On inscriptional evidence, therefore, the foil from KV58 might be attributed solely to WV23 (Ay's undoubted place of burial),<sup>154)</sup> or to both WV23 and KV62.<sup>155)</sup>

TABLE 1

KV58: CONSPECTUS OF MAIN FINDS

76

## Abbreviations employed:

D Daressy no. (in HT)  
 H Murray & Nuttall, Handlist  
 HT Davis, Harmhabi  
 S Fox, Schatz  
 T Carter, Tut.ankh.Amen

No.	Description	Proposed identification	Comparisons
D1		Shabti	
D2	Gold foil	From the chariot body?	T II, pl. 18
D3	Gold foil	Harness decoration	H 122hh
D4	Gold foil	Harness decoration	H 122aa for the shape
D5	Gold foil	From the chariot body?	T II, pls. 37-8
D6	Gold foil	Harness decoration?	
D7	Gold foil	Harness decoration	H 122ii
D8	Gold foil	Harness decoration	H 122ww
D9	Gold foil	Harness decoration	H 122aaaa*
D10	Gold foil	Axle decoration??	T II, pl. 39
D11	Gold foil	Axle decoration??	T II, pl. 39
D12	Gold foil	Harness decoration	H 122aaaa*
D13	Gold foil	Harness decoration	
D14	Gold foil	Harness decoration	T II, pl. 17, a for the design
D15/1	Gold foil	Harness decoration?	
D15/2	Gold foil	Uncertain	
D15/3	Gold foil	Uncertain	
D15/4	Gold foil	Uncertain	

TABLE 1/2

No.	Description	Proposed identification	Comparisons
D16	Uraei	From shabtis or similar?	S pl. 62
D17	Calcite knobs	Yoke saddle finials	T II, pl. 42
D18	Faience knobs	From a box	Cf. HT 3
D19	Faience knob	Finial from a goad or whip	T I, pl. 72

\*Note that two separate items appear to carry this number.

TABLE 2  
KV58: THE NAMES

Abbreviation employed:

HT Davis, Harmhabi

Daressy no. (HT):	3	4	5	8	9	15/1	15/2	15/3	15/4
Tutankhamun		x*		x*	x				
Ay (private)		x					x	x	x
Ay (royal)	x		x			x			

\*With Ankhesenamun<sup>151)</sup>

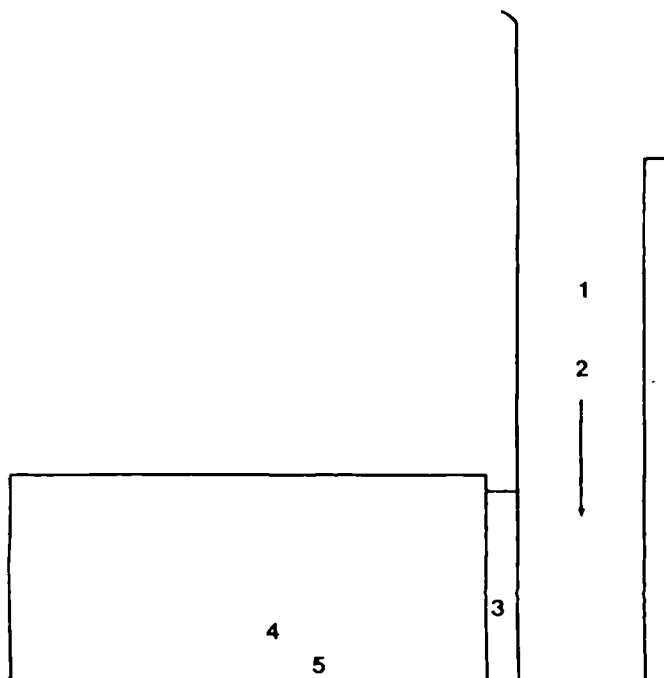

1. No finds (4 ft.) (Jones-Burton, Tombs, entry for 10 January 1909).
2. Three yoke-saddle finials, faience knob with cartouche of Ay, fragments of gold foil, faience inlays, uraei (6 ft.+) (11 January); faience inlays, fragments of copper, (fourth?) yoke-saddle finial, second faience knob with cartouche of Ay (12 January).
3. Fragments of gold foil (inc. Daressy nos. 3, 4, 8, 9, 13; cf. Davis, Harmhabi) (13 January).
4. Fragments of gold foil (unstratified within chamber) (15, 17, 22 January).
5. Alabaster shabti (on floor of chamber under 3 ft. of debris) (20 January).

Fig. 27: distribution of finds (KV58)

A consideration of the functional nature of the pieces suggests, however, that the deposit represents an assemblage from a single burial, despite the divergence of names.<sup>156)</sup> This view is based primarily upon the fact that the majority of the fragments can be shown to comprise elements from the equipment of one or more<sup>157)</sup> chariots:<sup>158)</sup> cf. table 1. The dating evidence furnished by the occurrence of Ay's royal titulary, together with the demonstrably funerary nature of at least one of the fragments, will indicate with whose burial they were associated originally.

The finds from KV58, together with the scraps recovered by Schaden from WV23 itself,<sup>159)</sup> indicate clearly that Ay's funerary arrangements were substantially in line with those of his royal predecessors. The presence of this material in a pit tomb so far from WV23 remains a mystery, however. Quite possibly KV58 represents the remains of a robbers' hoard, or workshop debris like that from KV4 (Ramesses XI)<sup>160)</sup> associated with a reburial of the king.<sup>161)</sup> The proximity to the tomb of Horemheb (KV57), wherein several unidentified skeletons were found,<sup>162)</sup> might, therefore, be significant. The possibility will be considered further in the following section.<sup>163)</sup>

#### Horemheb (KV57)<sup>164)</sup>

The tomb of Horemheb as king (fig. 28) was discovered by Ayrton for Davis on 22 February 1908.<sup>165)</sup> No details of any blocking of the outer doorways survive, though Weigall does state that corridor (B) beyond 'was quite

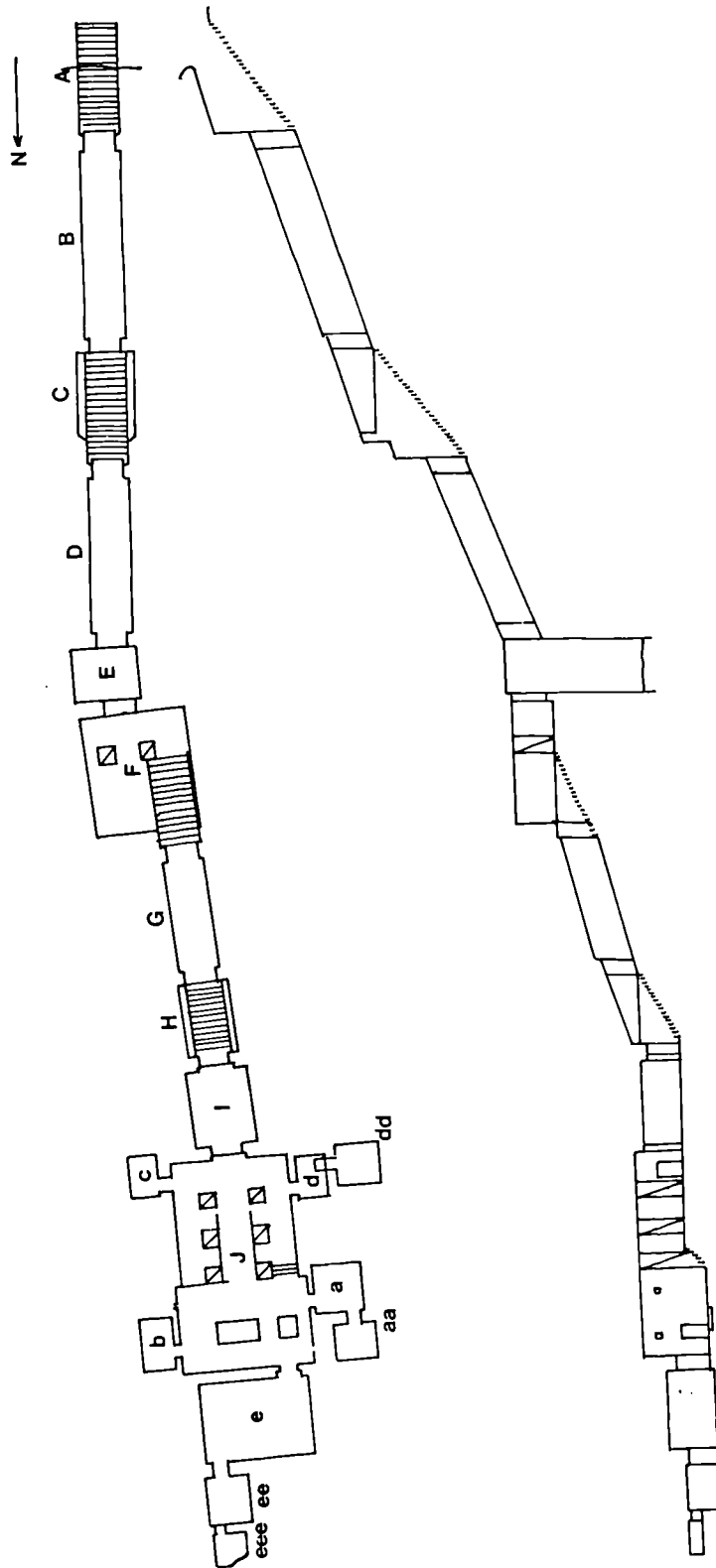

Fig. 28: KV57

choked with ... rubbish',<sup>166)</sup> according to Davis 'almost to the top'.<sup>167)</sup> This scree continued as far as the well (E), which was 'partly filled with rubbish'.<sup>168)</sup> The decorated north wall of the well<sup>169)</sup> had, as usual, been breached, plunderers having 'pulled away the blocks, and ... climbed through',<sup>170)</sup> into chamber (F). The staircase 'descending (down from (F)) to the third corridor (G) had once been concealed by being filled up with stone chippings and cemented over flush with the floor'.<sup>171)</sup> A further staircase (H) led to the antechamber (I), the entrance to which had originally been closed off with a wooden door.<sup>172)</sup>

The entrance to the burial chamber (J) had also been closed with a wooden door.<sup>173)</sup> The chamber itself was chaotic, strewn with builders' debris<sup>174)</sup> and funerary material.<sup>175)</sup> 'In all directions broken figures of the gods were lying, and two defaced statues of the king<sup>176)</sup> were overthrown beside the sarcophagus'.<sup>177)</sup> In the sarcophagus itself was 'a skull and a few bones of more than one person'.<sup>178)</sup> The lid, broken in antiquity and repaired by means of butterfly cramps,<sup>179)</sup> had been removed and lay on the ground.<sup>180)</sup> Beneath the sarcophagus were found 'six ... hollows in the rock',<sup>181)</sup> all but one containing wooden figures of deities.<sup>182)</sup>

In 'a little side chamber on the right' of the sarcophagus (Jb), Weigall noted 'two skulls and some broken bones lying in the corner. These appeared to be female ...'.<sup>183)</sup>

The north-west side chamber (Jaa) contained 'a fine painting of Osiris on the back wall; and, crouching at the foot of this, a statuette of a god with upraised hands had been placed ...'.<sup>184)</sup>  
 In the floor of side chamber (Jd), 'a square hole was cut, leading down to a small room' (Jdd) containing 'a skull and a few bones again of more than one person'.<sup>185)</sup>

Several graffiti are known from the tomb, all essentially unpublished. The following translations of the more pertinent of these are based upon transcriptions made by Gardiner and preserved in the Griffith Institute, Oxford (fig. 29).<sup>186)</sup>

- (a) (Presumably 'on one of the door posts' at the entrance):<sup>187)</sup>  
 Written (ir) in Year 4, 4 3ht 22, by the scribe of the army Butehamun, after he came to cause the command to be carried out in the House of Eternity of king Djeserkhepr(u)re-setepenre l.p.h.<sup>188)</sup>
- (b) ('Entrance door, on left thickness of wall'):<sup>189)</sup>  
 Written by the scribe of the general Kysen.
- (c) (Ibid., 'lower down'):<sup>190)</sup>  
 The scribe Butehamun; the king's scribe Djehutymose.

Correct

Griffiti in the back of the chamber

entrance door

On left thickness of wall

lower down

entrance  
not for  
surface

boundary

Out. by wall of first descending passage (to the left of the  
entrance)  
2.65 meters

In right thickness of entrance

Fig. 29: graffiti (KV57)

- (d) ('On right thickness of entrance'): <sup>191)</sup>  
 Year 6, 2? 3ht 12. Day of removing(?)/  
 investigating into(?) the burial(?) of king  
 Djoserkhepr(u)re-setepenre, by the vizier,  
 general and chief of the ... <sup>192)</sup>

The 'command' referred to in docket (a) (if indeed this is the correct transcription of the original hieratic group) <sup>193)</sup> is impossible to establish with any certainty from the available evidence. It clearly took place in the pr dt <sup>194)</sup> (in this instance 'burial chamber'?) of KV57, and probably at a time when the burials of Sethos I and Ramesses II were being restored; <sup>195)</sup> the obvious inference to make, therefore, is that we have here a circumspect record of burial restoration within the tomb of Horemheb. Another possibility, however, - and one for which only the most circumstantial evidence can be put forward - is that the generalised wording of the graffito conceals more than a simple record of burial restoration. We have already noted <sup>196)</sup> that the items recovered from KV58 seem to have originated in the West Valley tomb of Ay, and the possibility was there raised that this material might be associated with a reburial of Ay in the main Valley following the plundering of WV23. Since the remains of some four bodies were recovered from KV57, none of which seems to have been subjected to proper anatomical examination, it is perhaps the case that graffito (a) constitutes a record of transfer of Ay's body from his original tomb to that of Horemheb, the few funerary furnishings which it was possible to salvage from the

former tomb being temporarily stored, perhaps, in the nearby KV58 and for some reason not recovered.

Graffiti (b) and (c) were perhaps written during the same phase of activity as graffiti (a).

The correct interpretation of the fourth wall docket is difficult to establish with any certainty, owing to Gardiner's doubts as to the correct reading of the verb, whether f3i or šni.<sup>197)</sup> The reading f3i<sup>198)</sup> would perhaps imply that the burial of Horemheb had been removed from KV57 in antiquity, presumably for reburial elsewhere - in which case the bodies recovered by the Davis expedition will have comprised minor members of the king's family not removed at this time, remnants from the postulated Year 4 cache, or even the remains of intrusive burials of Third Intermediate Period date. Curiously enough, one of the few objects known to have been recovered from KV14 (Tawosret; Sethnakhte) was a 'bouton de meuble, ... avec cartouche d'Hor m heb';<sup>199)</sup> whilst the earlier of the two graffiti noted by Caminos in this latter tomb is dated to a Year 6, 2 3ht 18<sup>200)</sup> - conceivably a mere six days later than *graffito (d)* from KV57. Given the analogous delay of three days in the transfer of (Ramesses I), Sethos I and Ramesses II from KV17 to the tomb of Inhapi,<sup>201)</sup> it could be argued that docket (d) records the removal of Horemheb for repair and reburial in KV14. The greatest difficulty with this hypothesis, however, is that the body of Horemheb disappears from view

following the supposed transfer to KV14<sup>202)</sup> - whereas the remaining occupants of the KV14 cache, as we shall see, eventually surface in the tomb of Amenophis II (KV35).<sup>203)</sup>

Gardiner's alternative reading of the questionable sign in graffito (d) was šni - in which case the complete word is probably to be recognised as the Wb. 'fragen, sagen'.<sup>204)</sup> The implications of this rendering are rather less spectacular, but probably nearer the truth of the matter: that the docket records no more than an investigation into thefts, presumably, a matter of two years after the earlier phase of official activity within the tomb. Traces of this investigation and what I presume to have been a (further) restoration of the burial(s) within the tomb are perhaps to be recognised in the 'dead flowers ... found here and there amidst the débris'<sup>205)</sup> of the burial chamber, abundant floral remains being typical of interments and reinterments at this period.<sup>206)</sup>

The state in which Davis found the tomb contents is unlikely to have been the state in which the investigating party left the tomb. It had evidently been subjected to a further period of theft and wanton destruction, since the bodies of the occupants had been ripped to shreds. This phase of illicit activity seems not to have been detected by the necropolis administration (or else the damage done was not restored), as the state in which the tomb was discovered in 1908 clearly shows.

## CHAPTER 4

THE BURIALS OF RAMESSES I, SETHOS I,  
RAMESSES II AND MERENPTAHRameses I (KV16)<sup>1)</sup>

The discovery of KV16 (fig. 30) on 10/11 October 1817 was described by Belzoni,<sup>2)</sup> who noted 'a sarcophagus of granite'<sup>3)</sup> containing two intrusive mummies,<sup>4)</sup> and remnants of the burial's original funerary furnishings. These latter included two life-size guardian statues, one found 'in a corner' of the burial chamber (J), the other in side room (Ja),<sup>5)</sup> and 'a number of little images of wood, well carved, representing symbolical figures',<sup>6)</sup> probably also within the sarcophagus chamber. Burton<sup>7)</sup> and Lane,<sup>8)</sup> who visited the tomb independently some years later, note further the remains of a plastered blocking at (B-C) - though whether or not impressed with seals they do not state.

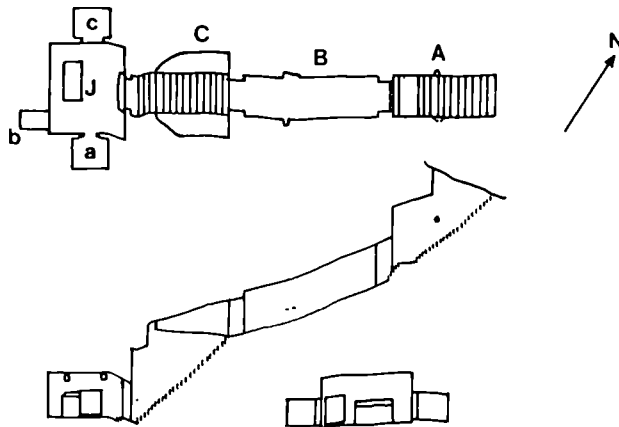

Fig. 30: KV16

The tomb clearly reflects the short interval (less than two full years) between Ramesses I's accession and his death: the proportions and form of the tomb are severely curtailed, the paintings hastily executed (but cf. above, chapter 1, s.v. Tuthmosis III), and the sarcophagus left unfinished.<sup>9)</sup> This latter displays the distinctive damage caused in levering off the lid and rolling it over onto the chamber floor.<sup>10)</sup>

Precisely when the plundering of the tomb, evidenced by the condition of the sarcophagus and the surviving funerary material, occurred is impossible to establish with any certainty. However, it may well have been this discernible activity which prompted the removal of the mummy of Ramesses I for reburial elsewhere several years prior to Year 10 of Siamun, 4 prt 17.<sup>11)</sup>

The body of Ramesses I has not been identified. A fragmentary, replacement coffin which had contained the mummy at the time of its transfer from KV17 to the tomb of Inhapi was recovered from DB320 in 1881,<sup>12)</sup> where, it is perhaps reasonable to assume, the royal mummy itself had once been interred.<sup>13)</sup>

#### Sethos I (KV17)<sup>14)</sup>

Belzoni made his most famous discovery in the Valley of the Kings on 16 October 1817: this was the tomb of Sethos I, now numbered KV17 (fig. 31).<sup>15)</sup>

No indications of any sort of blocking at the mouth of the tomb may be discerned from Belzoni's account,

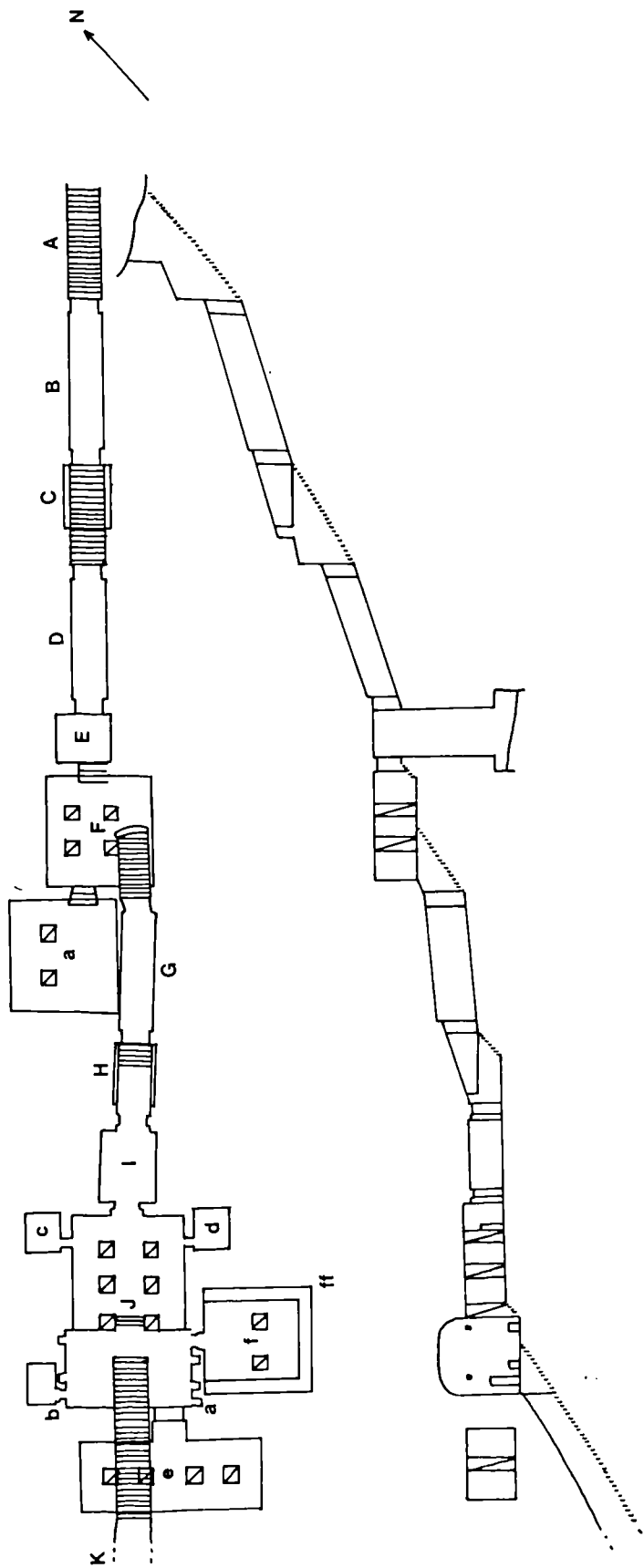

Fig. 31: KV17

though it is noted that the wall on the far side of the well (E-F) had been 'closely shut ... up, plastered ... over, and painted' in the usual fashion at the time of the interment.<sup>16)</sup> Through this blocking had been forced 'a little aperture', the sides of the well having been negotiated by means of two ropes which Belzoni found still in situ.<sup>17)</sup>

Belzoni noted the position of but few finds within KV17: 'the carcass of a bull ..., embalmed with asphaltum', in the four-columned 'Bull's, or Apis' Room' (Je);<sup>18)</sup> 'and also, scattered in various places (within (Je)?), an immense quantity of small wooden figures of mummies six or eight inches long, and covered with asphaltum to preserve them. There were some other figures of fine earth baked, coloured blue, and strongly varnished. On each side of the two little rooms ((Jc) and (Jd)?) were some wooden statues standing erect, four feet high, with a circular hollow inside, as if to contain a roll of papyrus,<sup>19)</sup> which I have no doubt they did. We found likewise fragments of other statues of wood and of composition'.<sup>20)</sup> Further miscellaneous pieces were recovered from the entrance to the tomb by James Burton,<sup>21)</sup> including 'a painting brush with a paint pot or jar'; 'a considerable number of broken jars ... thrown together in the midst of the shaly earth ... excavated from the lowest part of the tomb' may have represented the remains of the pharaoh's embalming refuse. Several other pieces relating to the burial have been found in the course of work in various parts of the necropolis.<sup>22)</sup>

The most important object recovered, however, was the fine outer coffin of calcite.<sup>23)</sup> This Belzoni discovered 'over a staircase in the centre of the saloon (i.e. the crypt of (J)), which communicated with a subterranean passage, leading downwards, three hundred feet in length'.<sup>24)</sup> 'The cover was not there: it had been taken out, and broken into several pieces, which we found in digging before the first entrance'.<sup>25)</sup> Despite Budge's assertion to the contrary,<sup>26)</sup> the lid does not appear to have been fastened onto the box:<sup>27)</sup> the copper-alloy traces still extant seem originally to have formed a sheathing designed to protect the rims of both box and lid. The weight of the lid, when in position, would perhaps have been considered sufficient to deter most would-be thieves, as it certainly was in the case of the later gigantic stone sarcophagi employed by the pharaohs of the 20th dynasty. It had, nevertheless, suffered 'some little violence . . . , because the edge of the chest is broken in several places, particularly near the left shoulder and left ankle and right foot. It would seem as if an iron tool had been applied to the left shoulder to wrench off the lid, and that the weight of the lid, when lifted from that spot by the lever, had broken the edge of the chest on the opposite side, near the right elbow, and also at the right foot'.<sup>28)</sup> The present shattered condition of the lid probably resulted from its fall to the ground below.

The mummy of Sethos I<sup>29)</sup> was discovered in DB320 in 1881, contained in a restored version of the original outer wooden coffin.<sup>30)</sup> From the hieratic texts on

both the coffin and bandages of the king, we may fair a form impression as to when the intrusions detectable in the archaeological record took place.<sup>31)</sup> According to a docket on the king's coffin - which had evidently but recently been restored to its present form - the high priest Herihor 'commanded r whm krs n king Menmaatre l.p.h., son of Re Setymer(en)ptah' in Year 6 of whm mswt, 2 3ht 7.<sup>32)</sup> A second restoration seems to have been required at an unspecified date subsequent to Year 10 of Smendes I, according to a notation on the mummy, when the king's body was rewrapped with dated linen of Pinudjem I;<sup>33)</sup> conceivably, this rewapping dates to Year 15 of Smendes, 3 3ht 6, when Ramesses II was introduced into KV17.<sup>34)</sup> Finally, in Year 7, 2 prt 16, Psusennes I, presumably by command of 'king' Pinudjem I, the mummy of Sethos I was rewrapped yet again<sup>35)</sup> employing linen of Year 6 made by the high priest of Amon-Re, Menkheperre.<sup>36)</sup>

A further docket on the coffin records that the removal of Sethos I from KV17 was effected in Year 10 of Siamun, 4 prt 17.<sup>37)</sup>

#### Ramesses II (KV7)<sup>38)</sup>

The tomb prepared for Ramesses II is that now numbered KV7 (fig. 32).<sup>39)</sup> Although it was accessible at least in part as early as the classical period,<sup>40)</sup> the only extensive clearance of which we possess any record is that undertaken by Burton during the season 1913/14.<sup>41)</sup> Burton describes the tomb as

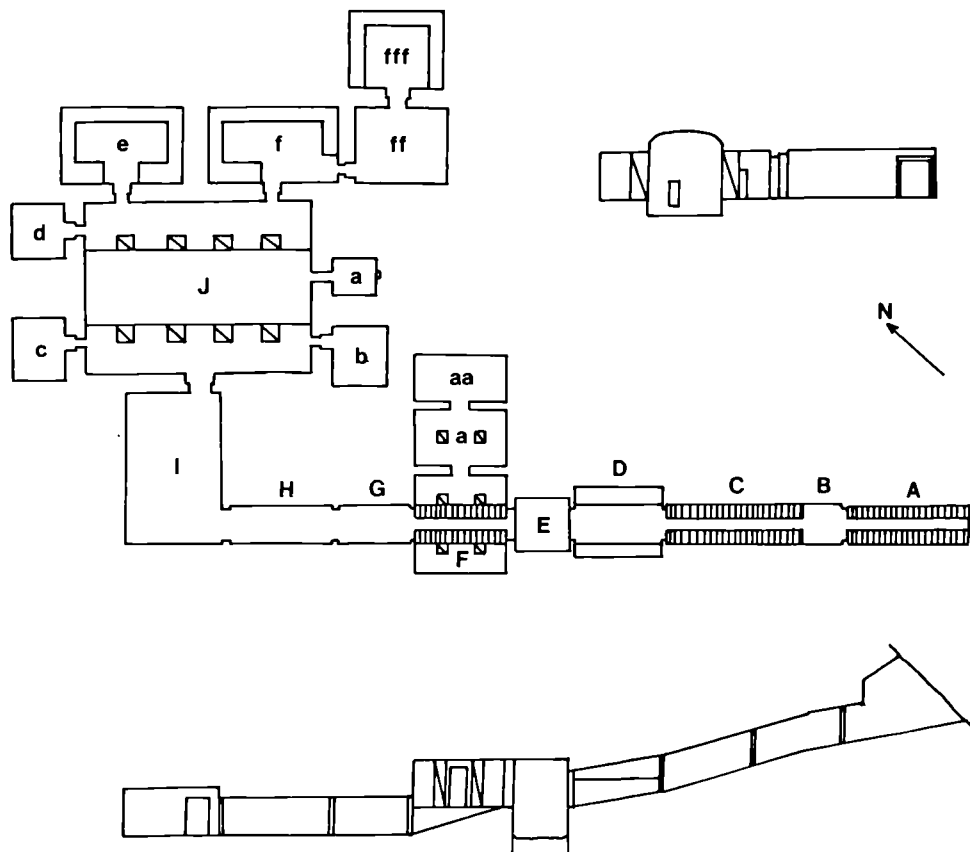

Fig. 32: KV7

'practically full of debris, stones etc. carried in by water';<sup>42)</sup> nevertheless, both he and his reis were able to penetrate 'on all fours about 200 ft. down, to (the) first chamber' (F).<sup>43)</sup> Although Burton's work in the burial chamber was not completed,<sup>44)</sup> and the sarcophagus not recovered, the fragments found are sufficient to indicate that the king had most probably been buried there.<sup>45)</sup>

According to the 'Strike Papyrus', an attempt had been made to enter the tomb of Ramesses II in Year 29 of Ramesses III by stripping stones from above the entrance.<sup>46)</sup> In the absence of further details, we may perhaps assume that the entry was foiled. An inspection of the tomb is probably recorded in P. Wien 30, II, dated to Year 6 of whm mswt,<sup>47)</sup> in which year (on 3 prt? 15) a docket was inscribed upon the king's coffin recording a 'renewal of the burial'.<sup>48)</sup>

A second docket on this coffin, dated to Year 15 of Smendes I, 3 3ht 6, records the removal of Ramesses II from his previous place of interment for reburial in the tomb of Sethos I (KV17).<sup>49)</sup> There is no evidence that the scribe Butehamun was involved in this work, as is sometimes implied: the two graffiti which mention this individual and which are attributed to KV7 by Spiegelberg<sup>50)</sup> are, in fact, to be found in the tomb of Ramesses III (KV11).<sup>51)</sup>

The king's body<sup>52)</sup> was recovered from the DB320 cache in 1881, contained in a restored royal coffin of New Kingdom date.<sup>53)</sup>

Merenptah (KV8)<sup>54)</sup>

Although accessible at least in part since antiquity,<sup>55)</sup> KV8 (fig. 33) was only cleared fully in 1903/4 by Carter,<sup>56)</sup> the debris yielding 'many fragments of the alabaster canopic box and shawabti figures ... Their technique is not good'.<sup>57)</sup> A limestone ostrakon from the tomb incorporates 'a sketch of the recumbent figure of the King on the Sarcophagus, with dimensions'.<sup>58)</sup>

Several stone sarcophagi have been attributed to KV8: (a) in chamber (H), 'the complete upper part of a large sarcophagus box ... beautifully hewn out of a solid block of rose granite ... The top is rounded and covered, as well as the sides, with incised religious inscriptions';<sup>59)</sup> (b) upside down in (J), 'the lid of the actual sarcophagus ... hewn and sculptured out of a block of rose granite in the form of a cartouche', displaying 'a recumbent figure of the king'.<sup>60)</sup> In addition, (c) a granite sarcophagus with a representation of Merenptah in relief on the lid was found at Tanis, where it had been re-used for Psusennes I;<sup>61)</sup> whilst (d) an unprovenanced fragment from a calcite 'coffin' of the king was acquired by the British Museum in 1911.<sup>62)</sup> The precise relationship of the elements from these sarcophagi is at present obscure; the confusion is indeed increased by the fact that other fragments with the cartouches of Merenptah, perhaps from the same anthropoid sarcophagus as (d), appear to have been recovered from KV47 - Siptah's tomb.<sup>63)</sup>

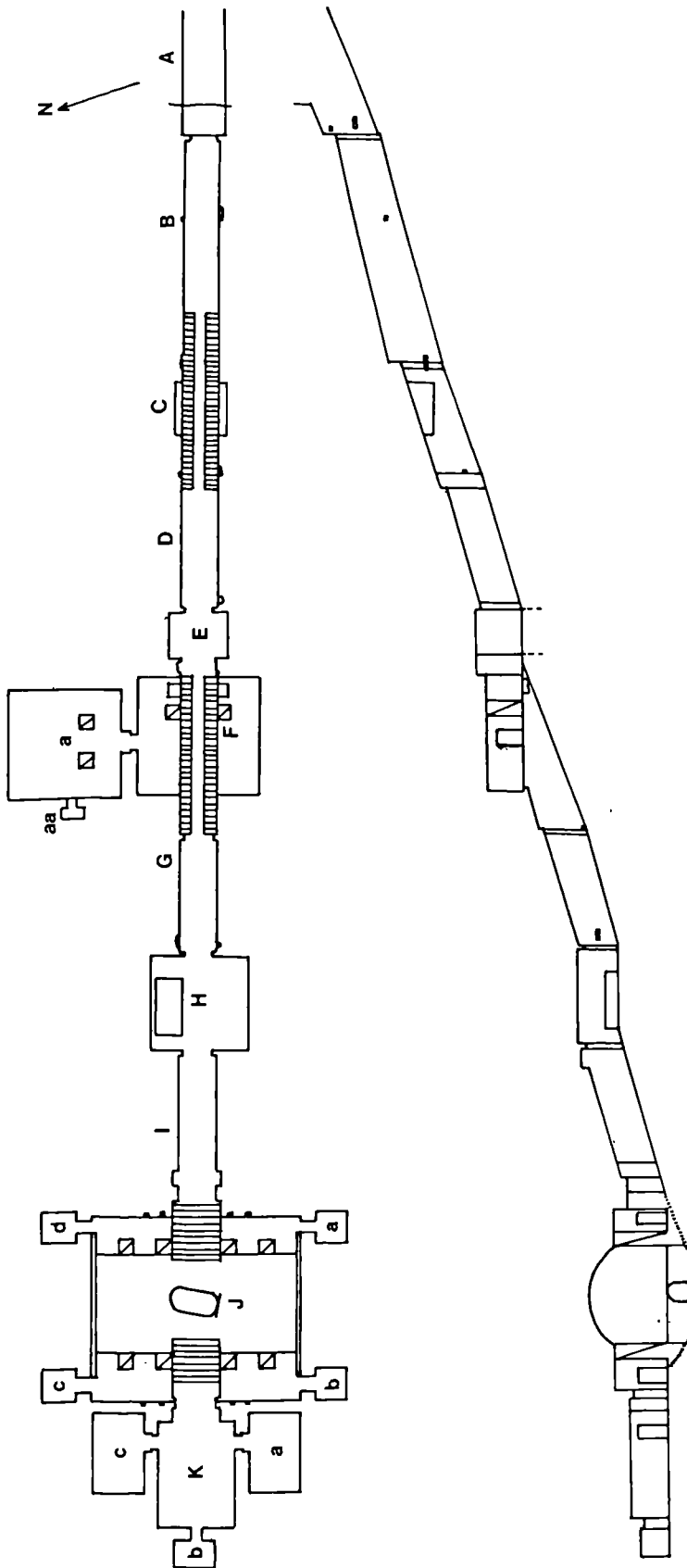

Fig. 33: KV8

Merenptah's employment of KV8 is suggested not merely by the tomb's archaeological finds, but by an important ostrakon recording the introduction of various items of funerary furniture, including the coffins (wtw).<sup>64)</sup> This text dates to Merenptah's Year 7, and appears to provide unequivocal proof (if such were needed) that tombs could be stocked several years in advance of the owner's death.

Other materials relating to a burial within KV8 were discovered by Carter on and after 21 February 1920 whilst digging 'on S. side of entrance of tomb ..., in centre of water course'.<sup>65)</sup> Amongst the finds was a cache of 13 calcite vessels,<sup>66)</sup> 'placed side by side in a group, a few stones laid on the top and covered with rubbish - as if carefully buried'.<sup>67)</sup> The docket on these jars,<sup>68)</sup> together with analyses of the contents,<sup>69)</sup> suggest that the cache was connected, if not with the actual embalming of Merenptah, at least with the anointing of the body with the 'seven sacred oils' in the pr nfr or funerary workshop.<sup>70)</sup> The fact that several of the vessels in the cache had been damaged or were incomplete when deposited<sup>71)</sup> is perhaps an indication that they were old and discarded, selected specifically for their funerary role. No precise parallel to the burial of such materials outside the royal tomb is known to me; the analogous ointment vessels of Tutankhamun were found in the passageway and in the Antechamber of KV62.<sup>72)</sup>

The King's Valley tomb of Isinofret, the probable wife of Merenptah,<sup>73)</sup> is alluded to in Cairo ostrakon J 72460, recently published by Thomas.<sup>74)</sup> The verso of this ostrakon reads as follows:

(From?) the work (p3 r-<sup>c</sup> b3k) of Isinofret to  
 (the tomb of?) my (p3y.i) greatest of seers,  
 Meryatum, 200 cubits. From the end (ph) of  
 the water of the sky (i.e. waterfall) to the  
 work (p3 b3k) of Isinofret, 445 cubits.

The obscurity of this text has been remedied somewhat by Miss Thomas's study; nevertheless, she fails to take her discussion to its logical conclusion. The location of the 'water of the sky' is not certain.<sup>75)</sup> Nevertheless, as we shall consider further below,<sup>76)</sup> the tomb of the 'greatest of seers, Meryatum' is almost certainly that now numbered KV5. An arc of 200 cubits described around the position of KV5 intersects the entrance of only one tomb: that of Merenptah. Given Isinofret's evident relationship to this king, there can be little doubt that she too was buried within KV8.

The body of Merenptah was discovered in KV35;<sup>77)</sup> that of Isinofret has not yet been positively identified.<sup>78)</sup>

## CHAPTER 5

THE BURIALS OF AMENMESSE, SETHOS II,  
SIPTAH, TAWOSRET AND SETHNAKHTEAmenmesse (KV10)<sup>1)</sup>

The tomb of the shadowy Amenmesse<sup>2)</sup> (fig. 34) is barely known from an archaeological point of view, since it has never been fully cleared. The only finds known to me originate from a minor excavation of the outer corridor (B?), undertaken by Ayrton in December 1907;<sup>3)</sup> these pieces, a calcite shabti fragment of Ramesses VI and a fragment from a calcite 'box?' of Sethos I, evidently owed their presence to flood deposition.<sup>4)</sup> Nothing related to the burial of Amenmesse himself has been found, except for what may be a fragment of a limestone sarcophagus(?) inscribed with his prenomen, which was recovered from the entrance of KV15 (Sethos II) by Lefébure.<sup>5)</sup>

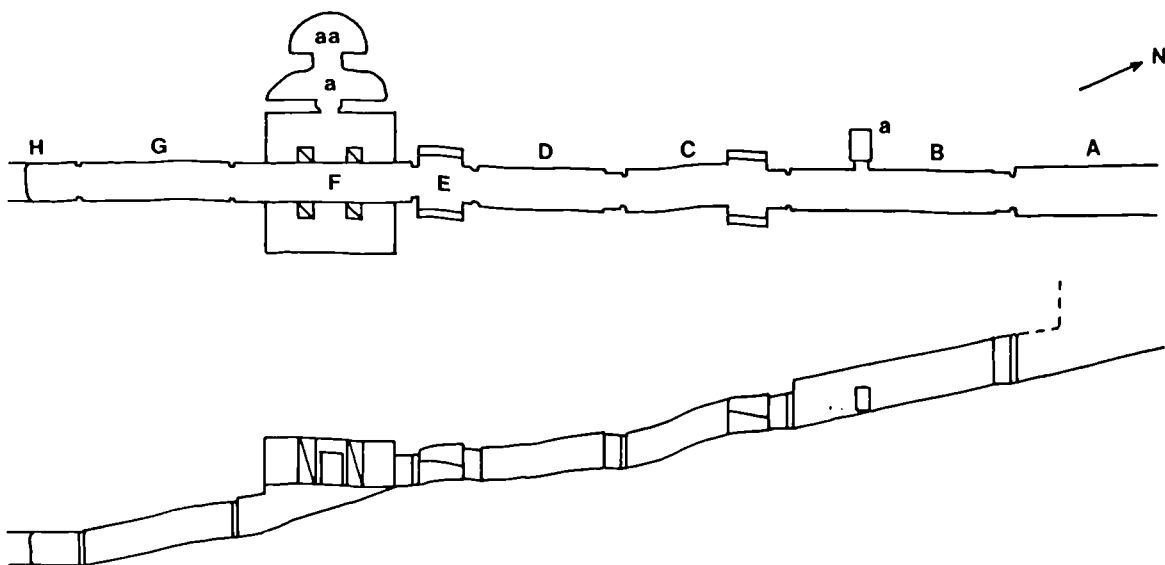

Fig. 34: KV10

KV10 appears to have been intended also as a place of burial for Takhat and Baktwerel, Amenmesse's mother and wife respectively.<sup>6)</sup> A fragment from the burial furniture of the former was found by Carter near KV55 in the spring of 1921.<sup>7)</sup>

It has been suggested that the erasures within KV10 constitute good evidence for damnatio memoriae.<sup>8)</sup> The subjects of the erasures within the tomb appear to have been rather arbitrarily chosen, however, and include the figures of deities; the erasure of Amenmesse's cartouches, in particular, has not been systematically carried out.<sup>9)</sup> At least some of the damage within KV10 might, therefore, be attributable to other agencies - such as flood damage (as in KV7)<sup>10)</sup> or Coptic habitation.<sup>11)</sup> A final decision on this point is hardly possible, however, until the tomb has been fully cleared and the scenes subjected to close study.

The whereabouts of Amenmesse's corpse is unknown; there is, in fact, no certainty that he was ever accorded burial within KV10.<sup>12)</sup> Takhat and Baktwerel are similarly unlocated - though, as implied above, the burial of the former within KV10 is at least a possibility.

### Sethos II (KV15)<sup>13)</sup>

The tomb commenced for Sethos II is that numbered KV15 (fig. 35), for which we possess several ostraca relating to the construction<sup>14)</sup> (including a preparatory

sketch, with dimensions, of the tomb's single chamber).<sup>15)</sup> As Thomas has observed,<sup>16)</sup> the tomb was never completed: no well had been excavated, and the corridor (G) beyond the four-columned chamber (F) had been adapted for use as the sarcophagus hall. It would appear, moreover, that the discernible change in decorative technique from relief carving to paint and line<sup>17)</sup> occurred only after an interval,<sup>18)</sup> during which the tomb was, to all intents and purposes, abandoned. It has been suggested (by Altenmüller)<sup>19)</sup> that this lapse was due to Tawosret's interment of the king within her own tomb, KV14 (see below). However, following the accession of Sethnakhte, who endeavoured to expunge all traces of the preceding reigns,<sup>20)</sup> the burial(s) within KV14 will have been dismantled, Sethos II himself reburied within KV15, and the decoration of this tomb hastily completed. According to Altenmüller's thesis, the excision and restoration of the king's cartouches in the earlier sections of the tomb was undertaken as part of the refurbishment carried out for Sethos II's reburial<sup>21)</sup> - against other scholars, such as Aldred,<sup>22)</sup> Krauss<sup>23)</sup> and Spalinger,<sup>24)</sup> who have seen these cartouche alterations as offering an accurate reflection of the contemporary political scene.

The only potential pieces of Sethos II's funerary equipment known to me are two faience shabti fragments now in the Metropolitan Museum of Art.<sup>25)</sup> That Sethos II was furnished with a reasonably full array of actual and not merely representational<sup>26)</sup> funerary

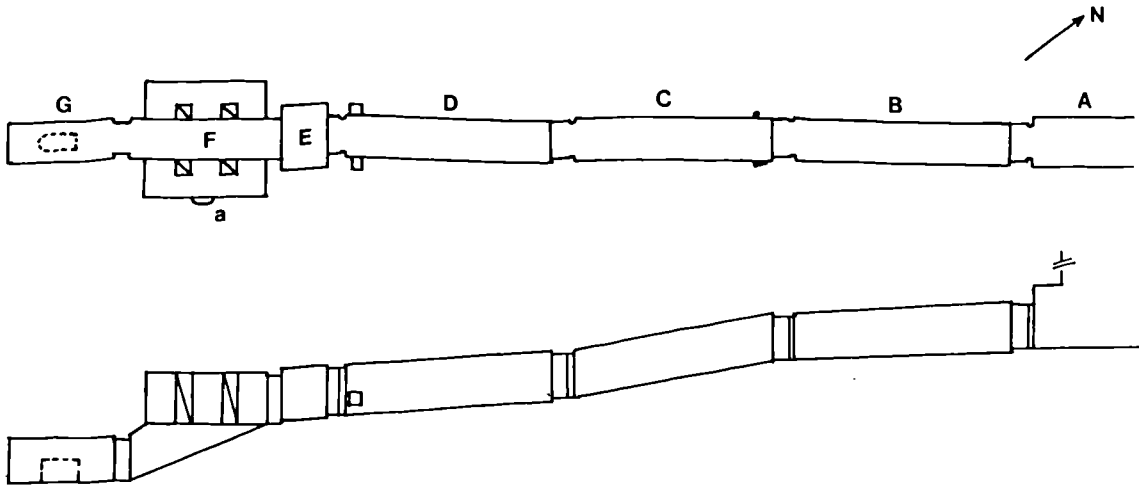

Fig. 35: KV15

material is evidenced nevertheless by P. Salt 124,<sup>27)</sup> which contains a reference to the theft of a number of such items at the time of the king's burial.<sup>28)</sup>

The body of Sethos II evidently survived the putative transfer from KV14 to KV15, only to be plundered at some later date. The king's tomb was inspected (presumably) in Year 6, probably of whm mswt, 2 3ht 7,<sup>29)</sup> evidently resulting in the transfer of the king's mummy. This eventually turns up in the KV35 cache, contained in a replacement coffin of later date.<sup>30)</sup> The mummy remains noted by Thomas<sup>31)</sup> within KV15 itself are presumably of Third Intermediate Period date.

Siptah (KV47)<sup>32)</sup>

KV47 (fig. 36) was discovered by Ayrton in November 1905, and penetrated at that time as far as chamber (I).<sup>33)</sup> Work was then abandoned owing to the precarious state of the ceiling and the general improbability of worthwhile finds.<sup>34)</sup> Davis later decided to complete his clearance of the tomb, however, and on 7 February 1912 Harry Burton commenced work in room (F), completing this final clearance the following spring.<sup>35)</sup> Finally, in the spring of 1922, Carter cleared the 'east side of (the) foothill' in which the tomb of Siptah was situated, turning up several items (mainly ostraca) of associated interest.<sup>36)</sup>

Ayrton published few clear details of the archaeological context. Nevertheless, it would appear that the entrance and outer corridors had been filled almost to the roof with mixed debris. This fill contained several late 19th/early 20th dynasty ostraca.<sup>37)</sup> Moreover, the rubbish covered and therefore post-dated the restored cartouches of Siptah<sup>38)</sup> (see below), and included a fragmentary faience shabti inscribed with 'the cartouche of Men-mat-Ra'.<sup>39)</sup>

Through this fill, along the east side of the corridor, had been cleared a passage (later silted up), the spoil from which had been heaped up against the west wall.<sup>40)</sup> On top of this rubbish, in corridor (B), Ayrton found fragments of 'an alabaster sarcophagus',<sup>41)</sup> and a shabti of Siptah,<sup>42)</sup> which had presumably been disturbed from the main fill when the later access

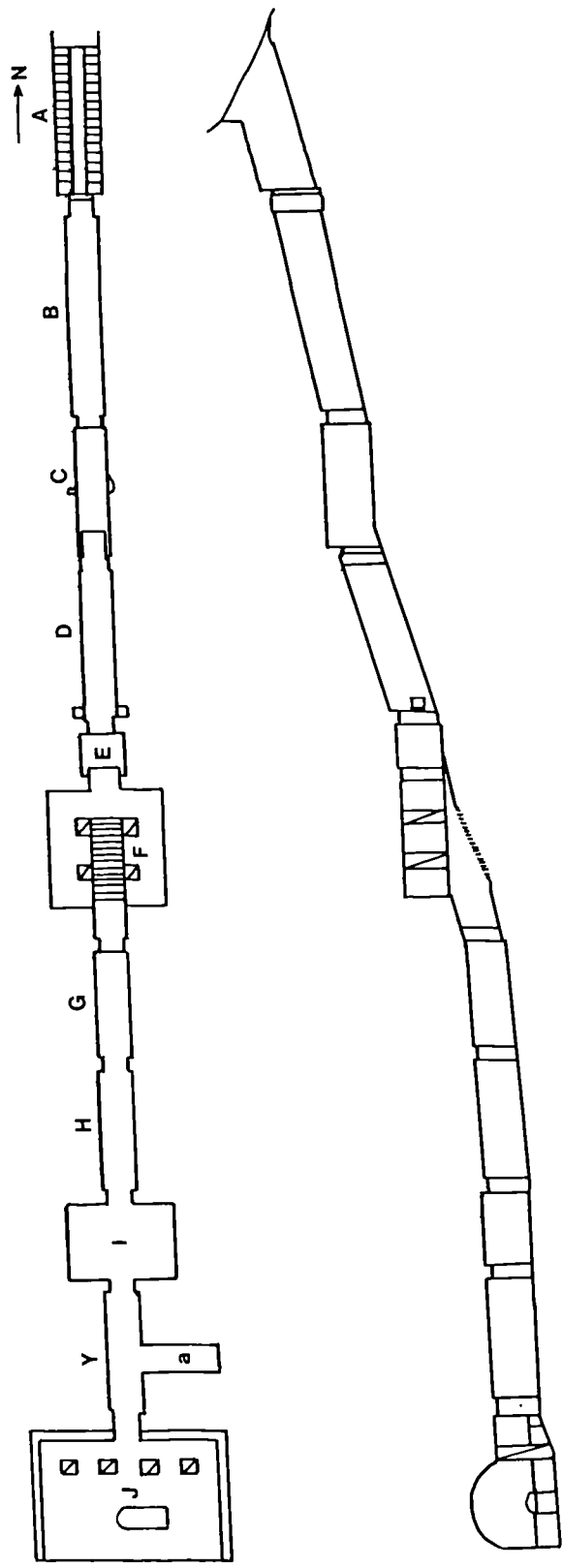
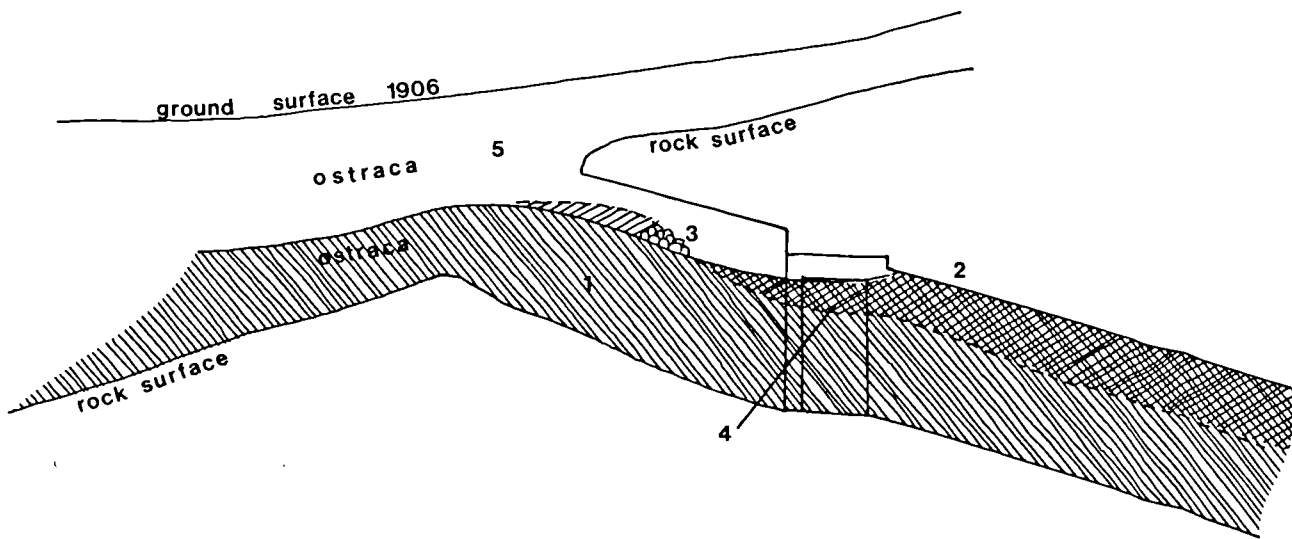

Fig. 36: KV47



1. Post-Siptah debris, including pottery and ostraca.
2. Passage cleared through debris and later silted-up.
3. Retaining wall associated with passage.
4. Ostrakon CG 25575, 'in door foot below entrance'.
5. Mound of debris from tombs of Sethos II, Tawosret and Siptah silted down to cover entrance.

Fig. 37: section at entrance (KV47)

passage was dug. The material excavated from this passage had evidently been held back by a 'rough chip-wall built on top of the mound' before the entrance doorway<sup>43)</sup> - a foot below which was found an ostrakon of the late 20th/early 21st dynasty.<sup>44)</sup> Cf. fig. 37.

From the finds recovered it seems reasonably clear that KV47 had been prepared and employed for the burials of Siptah and his mother, Tiaa.<sup>45)</sup> Furthermore, the tomb appears to have been disturbed within a short time of the king's death, since his cartouches have been erased and later restored in paint. According to Spalinger,<sup>46)</sup> this activity must have been contained within the 19th dynasty, since the 20th dynasty ruling line evidently questioned Siptah's legitimacy. Thus, he argues, the erasures are most likely to have been carried out by Tawosret, and the subsequent restorations by Bay.

Altenmüller, however, would prefer to see the excision and restoration of the cartouches within the late 19th dynasty royal tombs as having been motivated by religious rather than political considerations.<sup>47)</sup> He has suggested that the sarcophagus of Siptah had previously been usurped by Tawosret for her regal burial equipment, and that its return to KV47 was accomplished by Sethnakhte or his successor when the burial within KV14 (below) was dismantled. During this reburial of the king, the opportunity was taken to refurbish and up-date the tomb by replacing the old-style cartouches.

The ostrakon found 'in the door a foot below the entrance'<sup>48)</sup> may be translated as follows:

Year 7, 2 3ht 1. Going up to complete the work in this place by the gang: (list of 35 workmen).<sup>49)</sup>

According to Černý,<sup>50)</sup> the palaeography of this piece is suggestive of the late 20th/early 21st dynasty.<sup>51)</sup> Its apparent association with the passageway dug through the corridor fill suggests a connection with the evacuation of the king's mummy for reburial elsewhere, and provides us with a probable date for this activity.

The body of Siptah was discovered in the Amenophis II cache (KV35) in 1898;<sup>52)</sup> that of his mother has not been positively identified.<sup>53)</sup> The 'scattered' bones found in the KV47 sarcophagus<sup>54)</sup> are presumably intrusive and of Third Intermediate Period date.

Tawosret; Sethnakhte (KV14)<sup>55)</sup>

Work on the excavation of KV14 (fig. 38) seems to have begun when Tawosret was queen (a fact reflected in the princely width of the tomb's outer corridors),<sup>56)</sup> in Year 2 of Sethos II, 1 prr 8.<sup>57)</sup> It was continued, following the intervening reign of Siptah, by Tawosret regnant, and extended, according to Altenmüller, to receive the double burial of this queen and her dead husband Sethos II.<sup>58)</sup> This double

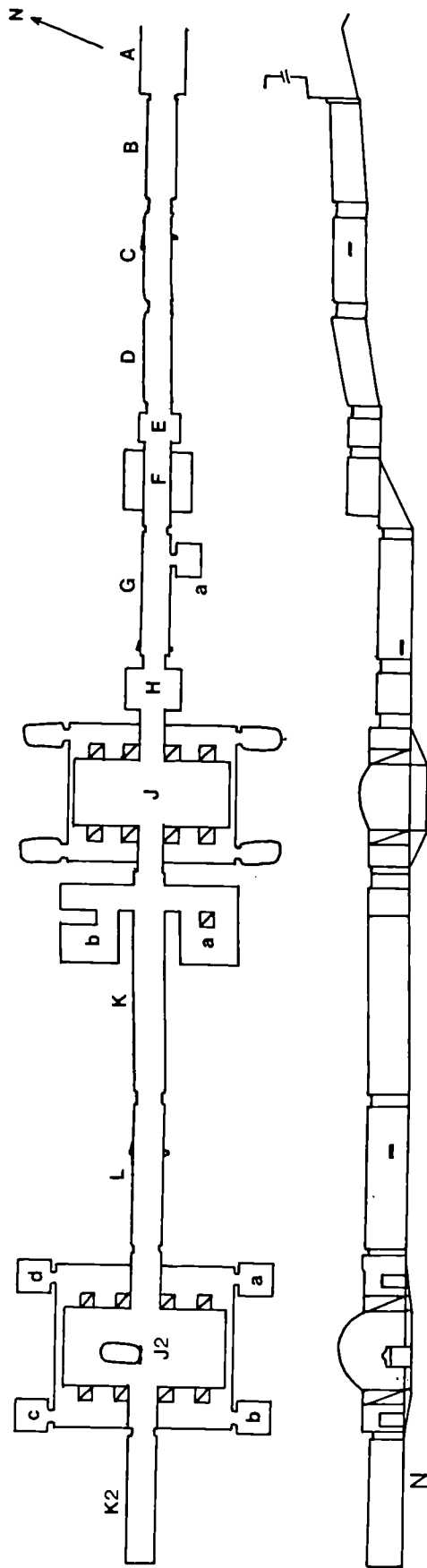

Fig. 38: KV14

burial was subsequently dismantled by Sethnakhte (or his successor), and the tomb prepared for this king's own interment. Each of these phases in the tomb's history was accompanied by major and minor alterations to the cartouches and to the tomb scenes, the ramifications of which are only now becoming apparent through close study.<sup>59)</sup>

The tomb has long been known, and probably for this reason has not attracted a great deal of archaeological (as opposed to epigraphic) interest. Nevertheless, explorations of some sort appear to have taken place in or before the year 1909, when the following object was registered in the Journal d'entrée:

J 41637. Bouton de meuble, forme papyrus évasé, avec cartouche d'Hor m heb. Terre émaillée bleue. Diam. (not stated). Biban el Molouk, décombres de Tausert.

This piece, which is perhaps unlikely to owe its presence to flood deposition, is the only object known to me from KV14.<sup>60)</sup>

Two graffiti noted by Caminos in the two side rooms (Ka) and (Kb) read as follows:

- (a) Year 6, 2 3ht 18.
- (b) Year 7, 2 ...<sup>61)</sup>

It is generally assumed that both dates refer to, and provide a chronological peg for, the second of the

tomb's three discernible building phases under Tawosret.<sup>62)</sup> This need not necessarily be so. Dockets on the coffins of Sethos I and Ramesses II<sup>63)</sup> attest to a spate of 'restoration' activity in the Valley of the Kings during Year 6 of whm mswt, whilst a graffito in the tomb of Horemheb records what is probably to be recognised as an official inspection of KV57 - perhaps more - in Year 6 of whm mswt (or Smendes), 2? 3ht 12.<sup>64)</sup> It is possible, therefore, that the first KV14 graffito is to be connected with the round of official activity which took in KV17, KV7 and KV57 - in which case the Horemheb box-knob (above) may well be a stray carried up at this time.

The possibility of some connection with the whm mswt restorations is strengthened by the date of the second graffito (b). As we saw in the previous section of this chapter, the mummy of Siptah seems to have been removed from KV47 in a late Year 7, 2 3ht 1; whilst the tomb of Sethos II (KV15) appears to have been inspected or otherwise investigated in a Year 7, 2 3ht 7<sup>65)</sup> - dates which are potentially so close to (b) above that they cannot fail to arouse suspicion. As we shall see below,<sup>66)</sup> the occupants of the side room (Jb) cache within KV35 appear to have been introduced en masse, at least a proportion of the mummies - including those of Siptah and Sethos II - having evidently been associated at an earlier stage in their travels. This association, I would suggest, began within KV14 - in which case the (Ka) and (Kb)

graffiti are to be recognised as recording the two main dates upon which the KV14 cache was perhaps established and enlarged.

Altenmüller suggests that the removal of Tawosret from KV14 by Sethnakhte occurred at the same time as the latter's reburial of Sethos II within KV15.<sup>67)</sup> If so, no trace of Tawosret's subsequent interment has as yet come to light - unless the improbable connection with KV56<sup>68)</sup> is to be maintained. Remains of Sethnakhte's burial - his cartonnage coffin<sup>69)</sup> and perhaps the king's body also<sup>70)</sup> - were recovered from KV35, where the occupants of the postulated KV14 cache were eventually transferred. The remains of a body in the sarcophagus of the KV14 burial chamber<sup>71)</sup> - if not a stray from the earlier occupation of the tomb - is probably intrusive and of Third Intermediate Period date.

## CHAPTER 6

## THE BURIALS OF RAMESSES III-XI

Rameses III (KV11)<sup>1)</sup>

KV11 (fig. 39) was commenced by Sethnakhte, but abandoned - perhaps owing to its unforeseen collision with KV10 (Amenmesse)<sup>2)</sup> - in favour of KV14.<sup>3)</sup> It was subsequently taken over by Rameses III, and continued on a re-aligned axis.<sup>4)</sup> To my knowledge, the tomb has never been fully cleared, and attributable finds are few.<sup>5)</sup> The documentary evidence (below) nevertheless leaves little doubt that Rameses III was interred here.

Champollion recorded three graffiti from the tomb,<sup>6)</sup> all undated, one of which seems to refer to an inspection by a party which included a 'god's father Hori'.<sup>7)</sup> This text, however, is only partially legible in Champollion's copies, and its value is consequently restricted. Two graffiti from the burial chamber of KV11<sup>8)</sup> list, among other names, those of the scribe Butehamun and his son Pakhyneter. The association of these individuals indicates a date in the reign of Smendes I,<sup>9)</sup> and it is conceivable that their presence in the tomb is to be seen in connection with the 'osirification',<sup>10)</sup> of Rameses III - a record of which, dated to Smendes' Year 13, 2 šmw 27, is preserved upon the mummy's wrappings.<sup>11)</sup>

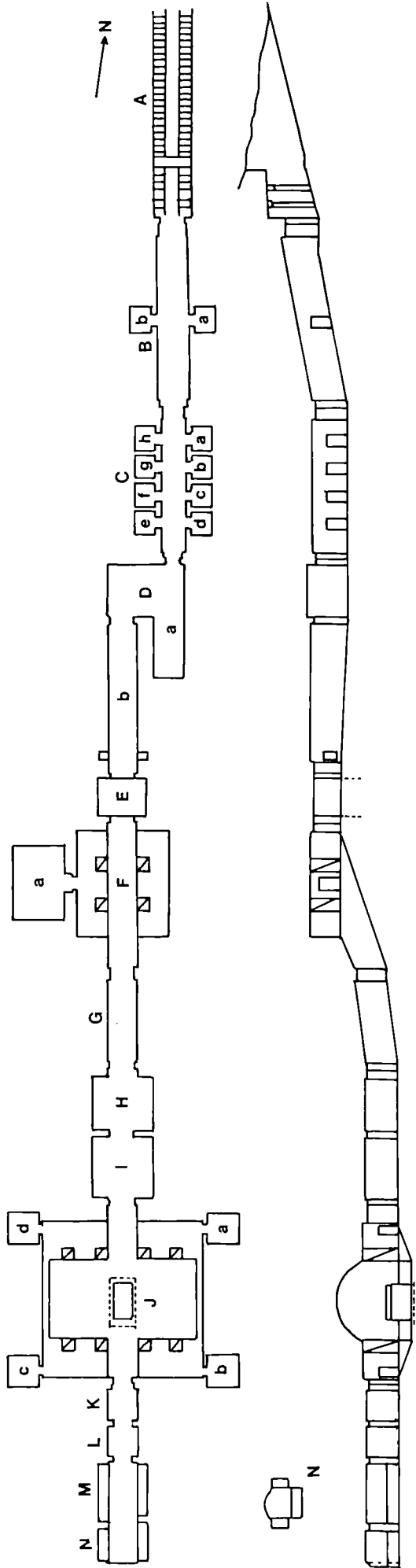

Fig. 39: KV11

The mummy of Ramesses III himself<sup>12)</sup> was discovered in DB320 in 1881, contained in a rough cartonnage case<sup>13)</sup> which had itself been deposited with the mummy of Ahmose-Nofretiri in the latter's large coffin.<sup>14)</sup> The king's badly effaced coffin box was recovered from KV35,<sup>15)</sup> covered with the lid from the coffin of Sethos II and containing the mummy of Amenophis III.<sup>16)</sup>

The human remains noted by the French Expedition within the 'storerooms' of KV11<sup>17)</sup> are presumably intrusive and of Third Intermediate Period date.

#### Ramesses IV (KV2)<sup>18)</sup>

KV2 (fig. 40) has never been systematically cleared, and the only discoveries known to me from within the tomb are 'bodies ... in the recesses behind' the burial chamber.<sup>19)</sup> Coptic activity within the tomb appears to have been restricted to the entrance corridor,<sup>20)</sup> and these bodies, therefore, may have been dynastic in date - presumably of the Third Intermediate Period.<sup>21)</sup>

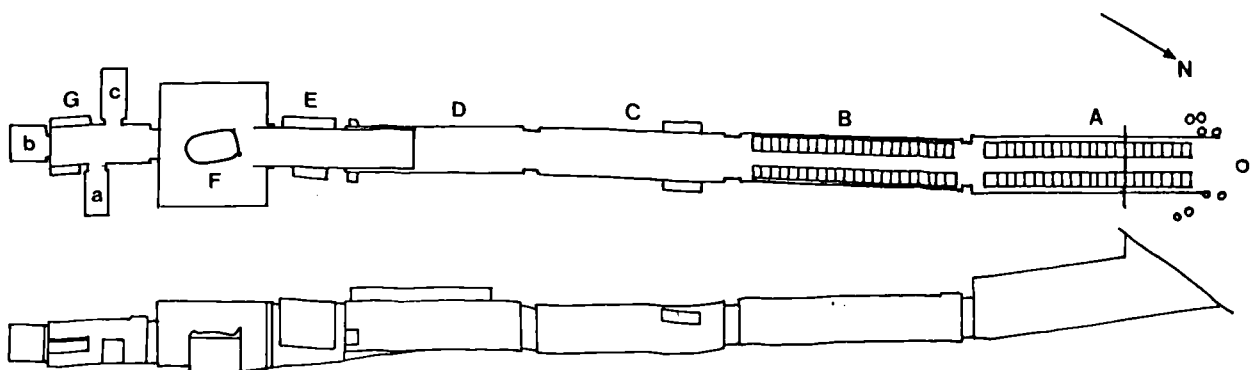

Fig. 40: KV2

Excavations in the immediate vicinity of the tomb entrance were carried out by Ayrton<sup>22)</sup> and Carter<sup>23)</sup> during the 1905/6 and 1920 seasons respectively. Both clearances yielded sufficient material to indicate that KV4 had been prepared for a royal burial.<sup>24)</sup> There can, moreover, be little doubt that the famous Turin papyrus<sup>25)</sup> represents KV2 completed and with Ramesses IV's burial in position, since the attenuated plan of the tomb as completed is evidently not as originally conceived.<sup>26)</sup> The tomb's bolted doors, depicted both on the Turin plan and upon a sketch of the entrance to KV2 preserved on an ostrakon in Cairo,<sup>27)</sup> may also be significant.

Robbery within the tomb is suggested by the damage sustained by the sarcophagus, the box having been broken through at one end and the lid displaced.<sup>28)</sup> The subsequent removal of the king's mummy - which, recoffined, eventually turns up in KV35<sup>29)</sup> - is perhaps attested by a graffito left by the scribe Penamun.<sup>30)</sup>

#### Ramesses V-VI (KV9)<sup>31)</sup>

KV9 (fig. 41) was fully cleared by Daressy in 1888,<sup>32)</sup> both this and later work yielding results sufficient to show that a burial within the tomb had been contemplated and doubtless carried out;<sup>33)</sup> cf. the check-lists, presumably of funerary material introduced into the tomb, recovered by Carter in 1917/18.<sup>34)</sup> With the exception of a wooden box fragment inscribed in ink for Ramesses V,<sup>35)</sup> everything that can with

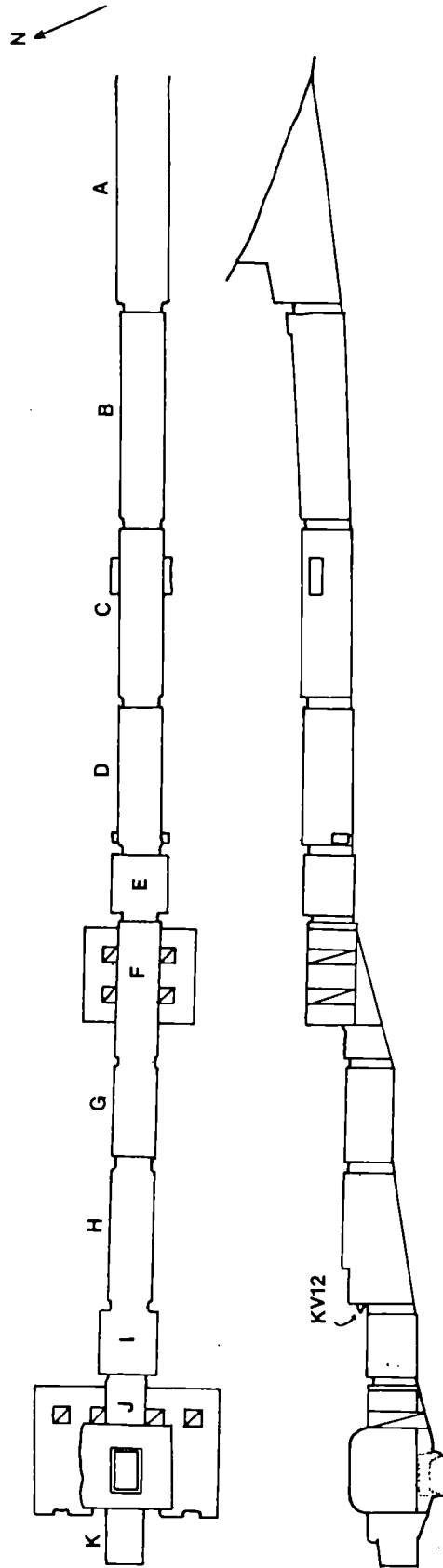

Fig. 41: KV9

certainly be attributed to this tomb appears to have been inscribed for Ramesses VI, as is the tomb decoration itself after room (E). The earlier parts of the corridor are inscribed, like the box, for Ramesses V, from whom Ramesses VI is thus held to have usurped the tomb. There is, however, no trace of cartouche usurpation or damnatio memoriae in these earlier texts, and it seems probable that KV9 was a double tomb shared by both kings.<sup>36)</sup> The date of Ramesses V's burial is recorded on an ostrakon (Year 2, 2 3ht 2, Ramesses VI), but without any intimation as to the place of interment.<sup>37)</sup>

Some account of an investigation into thefts from the tomb of Ramesses VI is preserved in the fragmentary P. Mayer B,<sup>38)</sup> the thieves perhaps having gained access to KV9 via KV12.<sup>39)</sup> The papyrus in question is undated, and cannot be directly tied in with the other tomb robbery documents.<sup>40)</sup> On the assumption that this is the robbery which prompted the visit recorded in the tomb's only published graffito,<sup>41)</sup> however, Aldred has suggested that this illicit activity is to be dated to before Year 9 of Ramesses IX.<sup>42)</sup>

The bodies of both Ramesses V<sup>43)</sup> and Ramesses VI<sup>44)</sup> were discovered in the KV35 cache in 1898.

#### Ramesses VII (KV1)<sup>45)</sup>

Although KV1 (fig. 42) has lain open since antiquity,<sup>46)</sup> no record of the tomb's clearance in more recent times has been published; the caption to one of Harry Burton's

photographs of this part of the Valley has, however, been thought to imply that work of some kind was done here during the season 1905/6.<sup>47)</sup> Several shabtis of Ramesses VII are attested,<sup>48)</sup> possibly from this clearance, whilst a fragmentary specimen was recently found in the modern floor fill of KV4 (Ramesses XI).<sup>49)</sup> Otherwise, no funerary material of this king is known to me.

The broken condition of the crudely finished sarcophagus lid<sup>50)</sup> is usually taken as good evidence that the tomb had at one stage contained a burial and was later plundered,<sup>51)</sup> whilst Hayes has suggested that four faience cups of Ramesses VII found in the vicinity of DB320<sup>52)</sup> might indicate the ultimate destination of the corpse.<sup>53)</sup> If so, the body of the king remains unidentified.

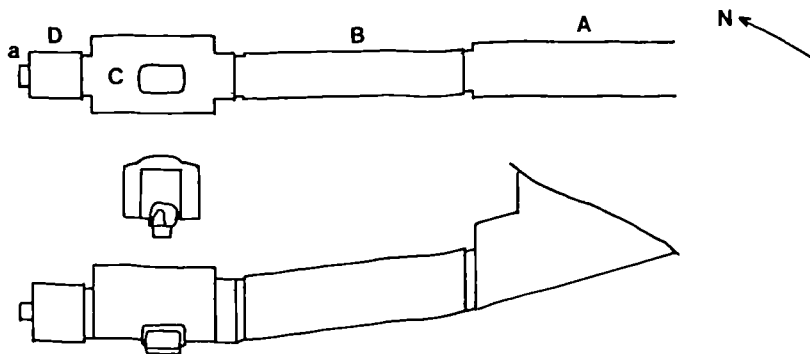

Fig. 42: KV1

### Ramesses VIII

No tomb or fragments of funerary material definitely associated with this king have yet been discovered in the Valley of the Kings,<sup>54)</sup> and neither

the DB320 nor KV35 caches have revealed any trace of the royal mummy.

Ramesses IX (KV6)<sup>55)</sup>

KV6 (fig. 43) was cleared by Daressy in 1888, revealing a large quantity of ostraca<sup>56)</sup> and some evidence to suggest that the king was interred there.<sup>57)</sup> No sarcophagus lid was found to cover the pit in the floor of the burial chamber,<sup>58)</sup> but the 'runners' of a large sledge<sup>59)</sup> may represent the base of a large wooden sarcophagus shrine.<sup>60)</sup>

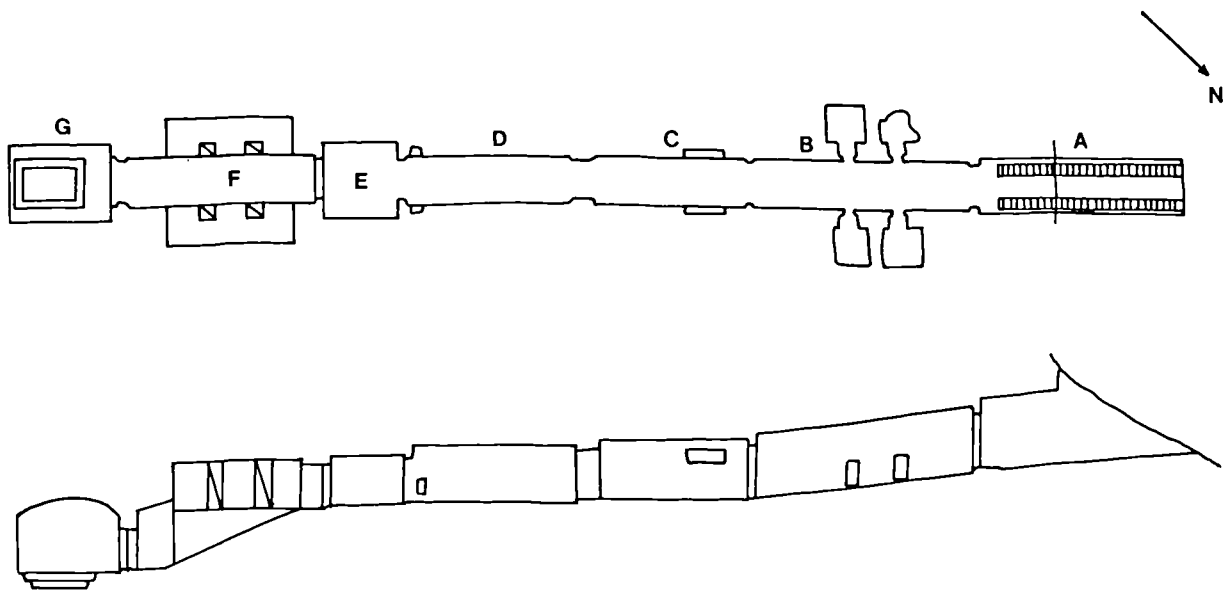

Fig. 43: KV6

The mummy of Ramesses IX was discovered in DB320 in a coffin belonging to Neskhons.<sup>61)</sup> DB320 also yielded a small wooden box, inlaid with ivory and inscribed with the cartouches of this king.<sup>62)</sup> A fragment from a similar (?the same) box was collected in Egypt in 1895/6 by Budge for Lady Meux;<sup>63)</sup>

unprovenanced, it may have originated in the DB320 cache, or possibly be a stray from Daressy's work within KV6.

#### Ramesses X (KV18)<sup>64)</sup>

The tomb of Ramesses X (fig. 44) has not, to my knowledge, been cleared beyond the first corridor, and it is consequently little known.<sup>65)</sup> No funerary objects relating to the tomb's (intended) occupant have been found. An alabaster shabti of this king, of 'lost contour' or 'peg' type, is mentioned by Aubert and Aubert, but dismissed as 'un faux manifeste'.<sup>66)</sup>

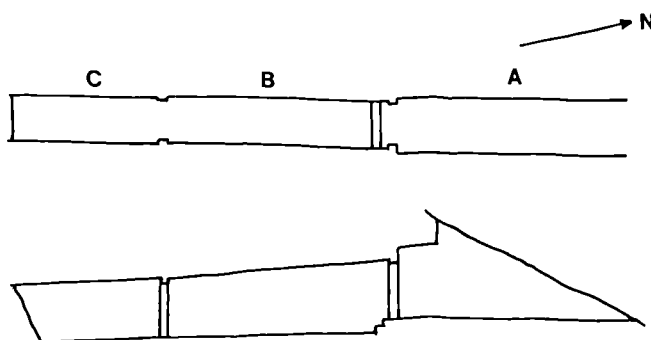

Fig. 44: KV18

#### Ramesses XI (KV4)<sup>67)</sup>

The tomb initiated for Ramesses XI, KV4 (fig. 45), has stood open since antiquity,<sup>68)</sup> and attracted little attention until its recent clearance between 1977-9 by Romer for the Brooklyn Museum.<sup>69)</sup>

As in a number of Valley tombs,<sup>70)</sup> the upper sections of the corridor yielded evidence of Coptic

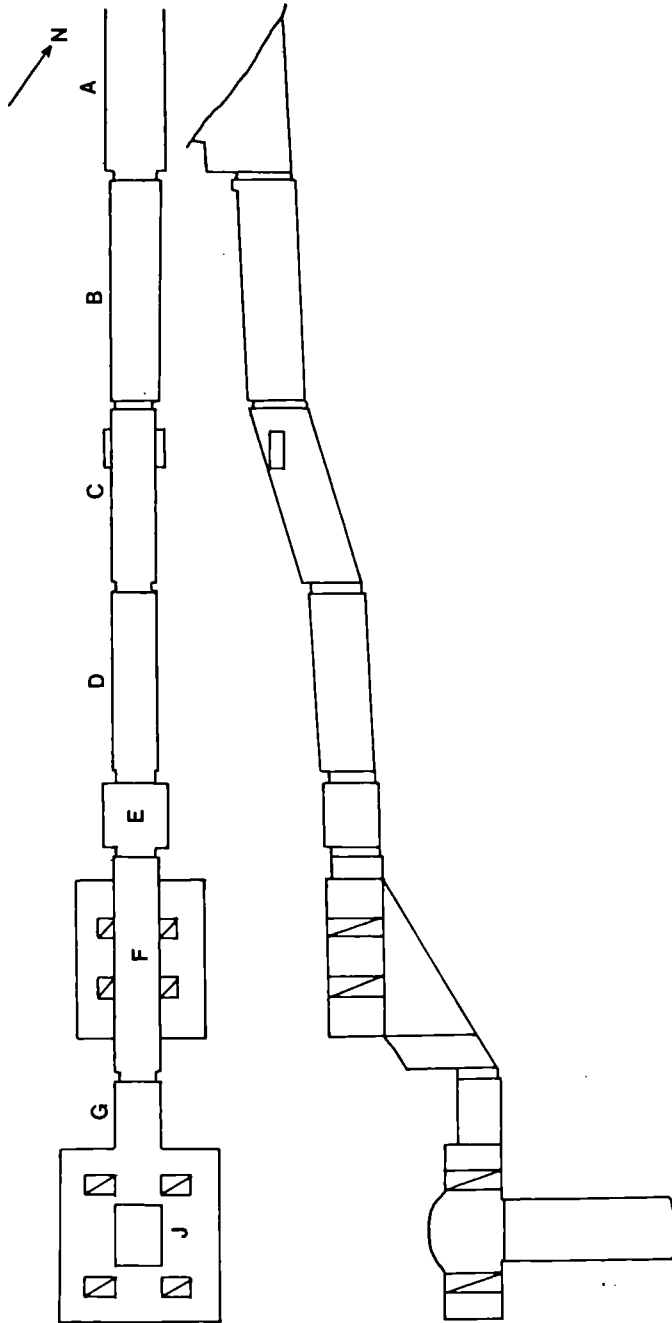

Fig. 45: KV4

activity, with remains of a beaten mud floor at (C-D), a rough stone wall at (E-F) (perhaps an animal byre) dated by 'a small heavily corroded Byzantine copper mite'<sup>71)</sup> (sic; presumably AE 4 module), and 'some decorated sherds'.<sup>72)</sup>

The lower sections of the corridor and the burial chamber itself were covered with a layer of chippings 20-25 cm in depth, amongst which 'small pieces of faience inlay,<sup>73)</sup> gold gesso<sup>74)</sup> and tiny fragments of cedar wood were found'.<sup>75)</sup> Three of an original four foundation deposits found at the mouth of the shaft in the burial chamber,<sup>76)</sup> inscribed for Ramesses XI, suggested that this shaft (unless a vertical extension of the original sarcophagus pit) was contemporary with the rest of the tomb architecture and was conceived of as the mythical 'Lake of Fire' from the Book of the Dead.<sup>77)</sup>

Clearance of the shaft resulted in a number of interesting finds. 'The uppermost level in the shaft consisted largely of limestone fragments that had fallen from the ceiling and quantities of animals that had also fallen into the pit'.<sup>78)</sup> Beneath were found the remains of a 22nd dynasty burial,<sup>79)</sup> consisting of bones, fragments of painted cartonnage,<sup>80)</sup> and the lower part of 'an uninscribed resin covered sarcophagus'<sup>81)</sup> (i.e. coffin). This material showed clear signs of burning; 'scanty Coptic material found in this level may indicate the date of this desecration'.<sup>82)</sup>

'Beneath this layer of burnt intrusive burials (sic) was another of clean limestone chippings and mud brick dust and fragments which were lying on the irregular floor of the shaft and which bore no signs of having been disturbed since late New Kingdom times ... Mixed in with this debris were broken pieces of burial equipment of several New Kingdom pharaohs':<sup>83)</sup> three calcite 'peg' shabtis of Ramesses IV;<sup>84)</sup> 'two fragments of an extremely large blue faience vessel that bore the Horus name shared by Tuthmosis I and Ramesses II';<sup>85)</sup> fragments of gilded gesso;<sup>86)</sup> and 'numerous pieces of wood from the funeral furniture of some of the kings of the Eighteenth Dynasty', most of which 'had been rendered into small slivers that resembled kindling'.<sup>87)</sup> These latter included fragmentary, resin-coated statue bases with yellow hieroglyphs which, in two cases,<sup>88)</sup> incorporated the prenomen of Tuthmosis III; fragments of a foot<sup>89)</sup> which joins a wooden goose from KV34;<sup>90)</sup> fragmentary wooden panels decorated with a distinctive running-spiral design<sup>91)</sup> found on similar pieces from KV20<sup>92)</sup> and KV35;<sup>93)</sup> and fragments from an anthropoid coffin<sup>94)</sup> which, from the feminine grammatical forms in the text<sup>95)</sup> and from the overall style, appears to have been prepared for a female ruler of the mid-18th dynasty - presumably Hatshepsut.<sup>96)</sup>

Until the material from this tomb has been studied fully, no definitive conclusions can be drawn. Nevertheless, the basic outline of KV4's history seems clear. It would appear that the tomb had been

abandoned by Ramesses XI unused;<sup>97)</sup> and that Pinudjem I had, at the beginning of his 'kingship',<sup>98)</sup> restored and re-inscribed a portion of the decoration, adding his own cartouche, possibly with a view to usurpation<sup>99)</sup> - an idea subsequently abandoned, perhaps, in favour of interment within the tomb of Inhapi.<sup>100)</sup>

The presence of royal funerary fragments within the burial chamber and the shaft<sup>101)</sup> seems to indicate that the role of KV4 changed once again following Pinudjem I's decision not to continue with his plans for usurpation. In fact, the tomb appears to have been employed as an ad hoc workshop for processing material from a number of royal burials, notably KV20 (Hatshepsut) and KV34 (Tuthmosis III).<sup>102)</sup> Amongst the fragments of gilded gesso recovered from KV4 are a number which clearly come from a royal coffin; and since the coffin of Tuthmosis III,<sup>103)</sup> found in the DB320 cache in 1881, had been carefully adzed over in antiquity to remove the major portions of its gilded-gesso surface, it is tempting to identify the site of this stripping with KV4.<sup>104)</sup> The important point would seem to be that those engaged upon this work went to great lengths to ensure that the coffin's basic role as a container for the king's body was not impaired.<sup>105)</sup> Scraping off the surface was a time-consuming procedure, which perhaps lessens the odds of this being the work of a common robber<sup>106)</sup> - who would, in any case, be unlikely to sort out his loot so close to the scene of the crime and in such an easily accessible tomb.<sup>107)</sup> In short, it would appear that the stripping was official in character, and that the material recovered from KV4 provides evidence

of a remarkable change of policy towards the royal mummies: that the work of stripping the dead of any negotiable commodities was part of a concerted effort to make the tombs less attractive to the robber, whilst at the same time refilling the dynasty's far-from-overflowing coffers - a change which, with hindsight, may perhaps be traced back to the final abandonment of the Valley of the Kings as a royal necropolis during whm mswt.<sup>108)</sup>

## CHAPTER 7

## BURIALS OF LESSER ROYALTY

Meryatum (KV5)<sup>1)</sup>

KV5 has lain inaccessible for several years, and has never been scientifically examined. James Burton, to whom we owe the only known plan of the tomb (fig. 46),<sup>2)</sup> discovered traces of the prenomen wsr-m3<sup>c</sup>t-r<sup>c</sup>-stp-n-r<sup>c</sup> both inside the tomb and on the doorway<sup>3)</sup> - hence its frequent (albeit mistaken) attribution to Ramesses II.<sup>4)</sup> A fragment 'of the breccia verd'antico' suggested to Burton the original presence of a sarcophagus;<sup>5)</sup> otherwise no finds are known to me from here.<sup>6)</sup>

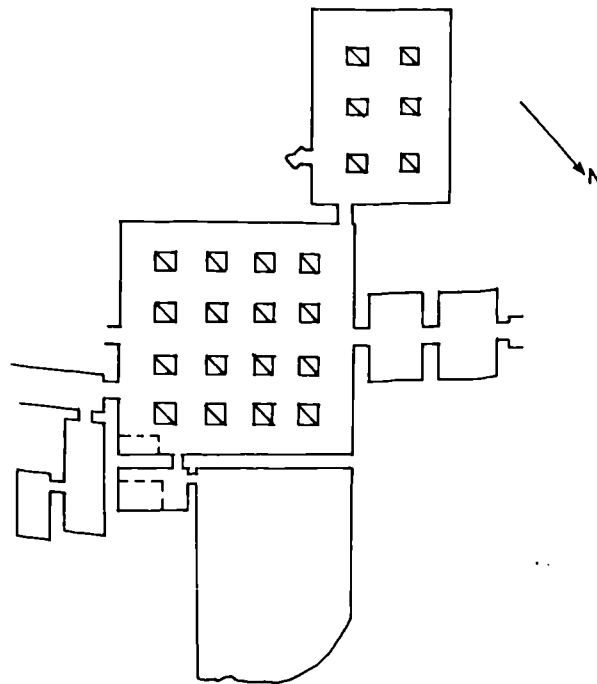

Fig. 46: KV5

An ostracon published by Thomas<sup>7)</sup> locates the tomb of the wr m33w Meryatum, a son of Ramesses II,<sup>8)</sup> as follows:

(1) From tr(t)yt<sup>9)</sup> to the general-in-chief (p3 imy-r mš<sup>c</sup> wr), (2) 30 cubits; (and to) the work (p3 r-<sup>c</sup> b3k) of the greatest of seers Meryatum, (3) 25 cubits. From tr(t)yt (and? to?) (4) the work(-place?) of the oils (p3 r-<sup>c</sup> b3k n n3 sgnn)<sup>10)</sup> to my (p3y.i) greatest of seers, 40 cubits. (5) Downstream on the northern path where the old work (p3 r-<sup>c</sup> b3k is) is, (6) 30 cubits to the general-in-chief.

None of the topographical features mentioned in this text can be identified with any certainty. Nevertheless, as Thomas suggests, p3 imy-r mš<sup>c</sup> wr is perhaps a euphemism for Ramesses II,<sup>11)</sup> in this instance concealing a reference to his tomb (KV7). If this latter identification is correct, it is apparent that the tomb of Meryatum cannot be far distant. Since the likelihood of another undiscovered tomb in the same area seems slight,<sup>12)</sup> it would seem probable that the tomb in question is KV5 itself - despite the apparent conflict between the measurements specified on the ostracon and those measured on the ground.<sup>13)</sup>

The subsequent fate of Meryatum, if he was ever buried here, is unknown.

(KV12)<sup>14)</sup>

This undecorated, multi-chambered tomb (fig. 47) was explored by James Burton, and to him we owe mention of 'remains of a body';<sup>15)</sup> his record of a graffito ('writing on wall')<sup>16)</sup> on the east wall of room (Ga) has not been verified.<sup>17)</sup> The Burton

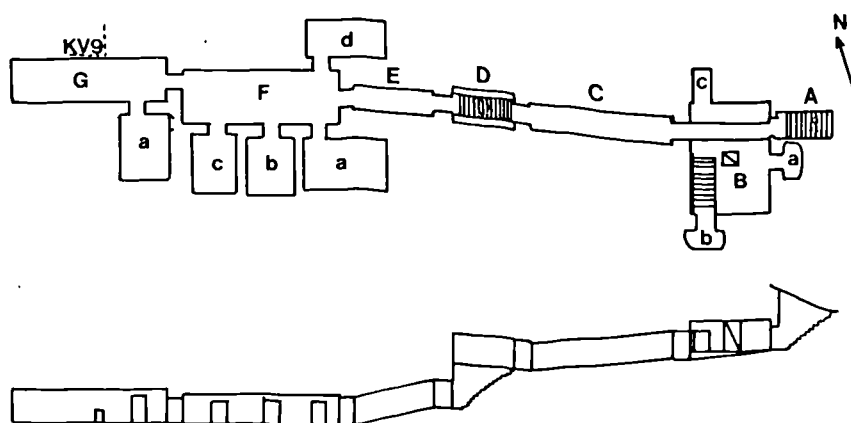

Fig. 47: KV12

corpse may represent the remains of the tomb's original occupant (or occupants, since KV12 appears to have been designed for a multiple burial). If so, it was probably interred in the end chamber (G), which Romer discovered to have been 'anciently sealed with mud plaster'.<sup>18)</sup>

The fact that KV12 had been broken into by the workmen excavating the later KV9 (Ramesses V/VI)<sup>19)</sup> suggests that the former burial may have been

disturbed at this time. Certainly KV12 must have been robbed at the time KV9 itself was despoiled - if, indeed, the robbers of KV9 did not find their way into the latter tomb via KV12, as the Ramesses VI shabtis recovered from the entrance by Jones might suggest.<sup>20)</sup>

The occupants of this tomb, intended or actual, are not known.<sup>21)</sup> It is not impossible, however, that KV12 is to be recognised as a tomb prepared for the children of Ramesses II, which documentary evidence would seem to suggest existed in the Valley proper.<sup>22)</sup>

(KV56)<sup>23)</sup>

KV56 (fig. 48), the 'Gold Tomb', was discovered by Ayrton on 5 January 1908.<sup>24)</sup> The shaft was 'entirely filled with washed-in debris, and we found on removing this that the chamber was more or less

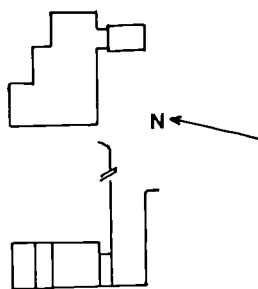

Fig. 48: KV56

filled with the same material to a depth of forty-one inches against the west wall'.<sup>25)</sup> Two distinct strata could be detected in the chamber's fill: 'the

upper rubbish', consisting 'of limestone chippings and mud, evidently washed in by water'; and 'the lower level on which the objects rested (six to twelve inches above floor level)', composed of 'lighter dust consolidated by water'.<sup>26)</sup>

The finds recovered from within KV56 included a circlet, earrings, several finger-rings, bracelets, a series of necklace ornaments and amulets, a pair of silver 'gloves' and a silver sandal. In addition, Ayrton was able to reconstruct from amongst a mass of fragments three vases of calcite and one of faience.<sup>27)</sup> The general layout of this material within the chamber is presented in fig. 49.<sup>28)</sup>

Since the names of both Sethos II and Tawosret occur on the objects from this tomb,<sup>29)</sup> Maspero was led to suggest that Davis had found a cache of material salvaged from the funerary equipment of Tawosret when her own tomb was usurped by Sethnakhte.<sup>30)</sup> The Tawosret connection, however, despite its recent revival,<sup>31)</sup> is far from convincing. Indeed, the results of a re-examination of the evidence by Aldred<sup>32)</sup> point strongly towards seeing the KV56 'cache' as the remains of an essentially intact burial. The 'stratum about a half inch thick of broken gold leaf and stucco covering an area of some four square feet, and the numerous scattered small curls in blue glazed composition and some large plaques of the same material with modelled undulating lines'<sup>33)</sup> Aldred interprets as 'most probably all that remained of a

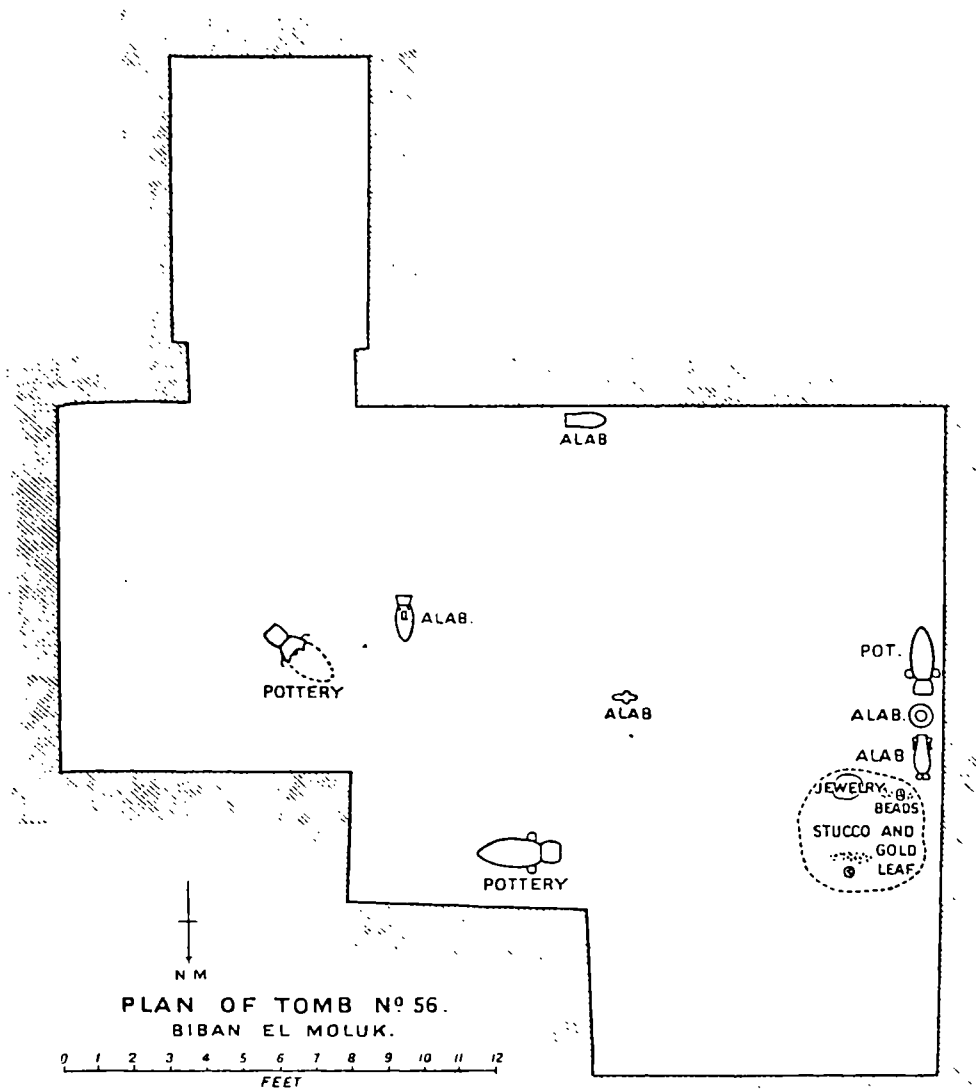

— THE UNNAMED GOLD TOMB —

Fig. 49: layout of deposit (KV56)

coffin rotted and flattened by the weight of mud and water washed into the tomb'.<sup>34)</sup> The pair of silver 'gloves' containing eight finger-rings, moreover, probably covered the hands of the mummy, perhaps originally having been wrapped into the bandages.<sup>35)</sup>

The area covered by the decayed coffin debris was a mere four square feet,<sup>36)</sup> and this, taken in conjunction with the tiny scale of several of the items recovered from the tomb (including finger-rings and the single surviving silver sandal) suggests that the occupant of the tomb was a child - to judge from the predominance of the cartouches of Sethos II and Tawosret, perhaps an offspring of the royal couple.<sup>37)</sup>

KV56 would thus appear to have been employed for the burial of a child of Sethos II and Tawosret, probably during the reign of the former. The tomb was evidently not watertight, since one or more flash floods in the Valley resulted in the deposition of a fine, water-borne silt which covered (and eventually decayed) the tomb's occupant and much of the funerary furniture. The location of the tomb was detected, perhaps as a result of subsidence in the shaft fill brought on by water movement, and the chamber entered and robbed of those pieces which were visible above the silt in-fill. The open tomb will then have been abandoned and subsequently filled with chippings and larger debris washed into the chamber in the course of further floods.<sup>38)</sup>

Bay (KV13)<sup>39)</sup>

The princely<sup>40)</sup> KV13 (fig. 50) has never been fully cleared, and is consequently little known. Its attribution to Bay (doubted by some)<sup>41)</sup> is based solely upon the presence of the title 'chancellor of the entire land' which precedes the obliterated name of the owner;<sup>42)</sup> whether the tomb was constructed specifically for Bay, or usurped by him, is unknown. No finds are known to me, but, as Thomas points out,<sup>43)</sup> the two sets of sarcophagus holds and the evident widening of the doorway to receive the sarcophagus suggest that preparations for burial had proceeded

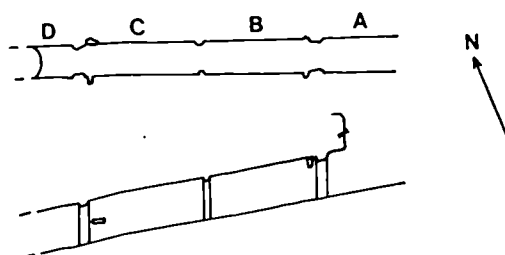

Fig. 50: KV13

to the stage whereby an interment could have been and most probably was made. The post mortem execration of Bay's memory implied by the mutilated state of his statue in Munich<sup>44)</sup> might, however, suggest that a similar fate befell his interment, the walls of the tomb being badly damaged. Bay's body has not been found.

(KV3)<sup>45)</sup>

KV3 (fig. 51) was entered by James Burton, who noted traces of Ramesses III's cartouches in the entrance passageway.<sup>46)</sup> The tomb was first cleared in 1912 by his namesake, Harry Burton,<sup>47)</sup> though both Quibell and Ayrton had made sundry clearances in the vicinity during the seasons 1904/5<sup>48)</sup> and 1905/6.<sup>49)</sup> Harry Burton's work yielded no dynastic finds, which may suggest that KV3 had never contained a burial; though it is conceivable that the later Coptic re-use of the tomb as a chapel<sup>50)</sup> had been exceedingly thorough in its disposal of any funerary material which may originally have been present.<sup>51)</sup>

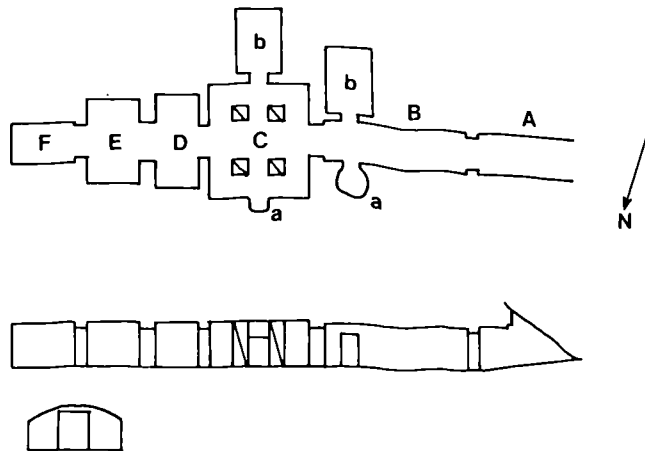

Fig. 51: KV3

The probable owner of this tomb is suggested by the recto of O. Berlin P 10063, which is inscribed with the following text:

(1) Year 28, l 3ht 17. On this day the gang went up (2) to the Great Place to found the (tomb) of a prince of his person, l.p.h.<sup>52)</sup>  
 (3) On this day the guardian of the tomb, Khaemwast, came, saying: (4) 'Hand over the three ..., so says the vizier To, your superior'. And they sought (5) the sculptor Iyerniutef and the sculptor Qenymin in order to hew ...<sup>53)</sup>

The precise find-spot of this ostrakon is not known. Nevertheless, the fact that the gang 'went up' (ts) to 'the Great Place' (t3 st C3t) makes it certain that the reference here is to activity in the Valley of the Kings.<sup>54)</sup> The date of the text is supplied by the mention of the vizier To, who is first attested in Year 16 of Ramesses III.<sup>55)</sup> The prince around whom all this activity was centred will thus have been a son of Ramesses III.

Although no tomb in the Valley can immediately be identified as having been intended for a son of this king, Wente points out<sup>56)</sup> that the dedicatory formula (dīw ...) discernible in Ramesses III's 'discarded'<sup>57)</sup> tomb KV3 is of the type which 'customarily heads the donation formula in tombs of other sons of Ramesses III'. This adds weight to Thomas's view that KV3 can never have been intended for a kingly burial,<sup>58)</sup> and suggests the possibility that this is the tomb alluded to in the Berlin ostrakon.

Mentuherkhepshef (KV19)<sup>59)</sup>

KV19 (fig. 52) was discovered by Belzoni,<sup>60)</sup> who is said to have found a number of mummies within.<sup>61)</sup> That these burials were intrusive is suggested (a) by the description of one of the coffins as a 'cercueil en carton peint',<sup>62)</sup> and (b) by the evidently late date of the 'fragments of bead work' which Ayrton recovered from the tomb during his clearance of 1905/6.<sup>63)</sup>

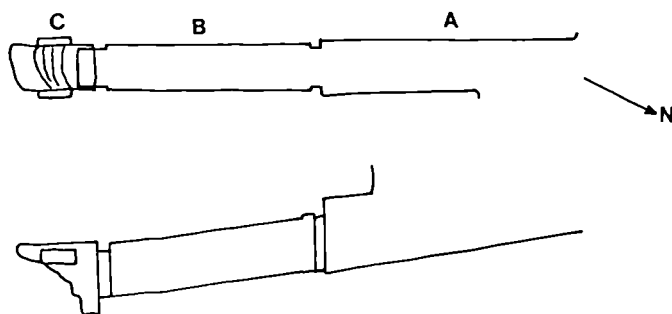

Fig. 52: KV19

That Mentuherkhepshef himself, a son of Ramesses IX,<sup>64)</sup> was interred within KV19, probably during the reign of Ramesses X,<sup>65)</sup> is indicated by the truncated form of the tomb: excavation had barely progressed into the first corridor before a pit was 'sunk in the floor in which the mummy was placed, and ... then covered with flat limestone slabs'.<sup>66)</sup> Fragments of the prince's coffin are perhaps to be recognised in the faience wig inlays(?) found by Ayrton.<sup>67)</sup>

No trace of Mentuherkhepshef's corpse has been discovered in either of the main caches. That the tomb was nevertheless accessible during the Third Intermediate Period is suggested by the decision to employ it for a series of secondary interments no earlier than the 22nd dynasty.<sup>68)</sup>

## CHAPTER 8

## PRIVATE BURIALS

In (KV60)<sup>1)</sup>

KV60 (fig. 53) was discovered by Carter for Davis in the spring of 1903, situated immediately in the entrance of the later KV19 (Mentuherkhepshef).<sup>2)</sup>

The contents were 'much destroyed and rifled': all that remained were 'two much denuded mummies of women', one of which lay in the lower half of an anthropoid coffin whilst the other was 'on the floor beside it'.<sup>3)</sup> The half coffin 'had been stripped of its

outer moulding, possibly on account of its being gilded, and the only inscription of value that could be made out was the following names and titles':

šdt nfrw nsw in m3<sup>c</sup>t hrw.<sup>4)</sup> Following Newberry, who was present at the tomb opening, Carter suggested

that the burial was that of two nurses of Tuthmosis IV.<sup>5)</sup>

Thomas, however, has suggested that In is to be recognised as the wetnurse of Hatshepsut, Sitre called In<sup>6)</sup> - which is possible, given the tomb's proximity to KV20.

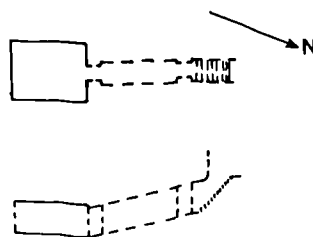

Fig. 53: KV60

Apart from the two mummies and the half coffin, the only pieces of burial furniture found appear to have been 'some mummified geese'<sup>7)</sup> - presumably embalmed provisions of the usual sort. As Carter suggests, 'the burial had probably been robbed by the workmen when making the tomb of Ment-hi-khopesh-ef'.<sup>8)</sup>

Sennufer (KV42)

See above, chapter 1.

Amenemopet (KV48)<sup>9)</sup>

The large, single-chambered pit tomb now numbered KV48 (fig. 54) was discovered by Ayrton for Davis in January 1906.<sup>10)</sup> Details of the layout of the deposit are unfortunately few. Ayrton does note, however, that 'a rough wall had been re-constructed to close' the doorway,<sup>11)</sup> which would imply that the original build of the blocking had been previously demolished, presumably by thieves, and rebuilt following the discovery of thefts within the tomb. Unfortunately, Ayrton does not specify the condition of the wall at the time of the discovery, and so it is not possible to establish with certainty whether the burial had been violated following this reblocking.

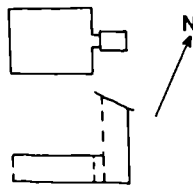

Fig. 54: KV48

The tomb had certainly been extensively plundered at some stage: 'the mummy ... had been unwrapped and thrown on one side', and the coffin, 'of wood coated with pitch and then painted with yellow hieroglyphs', was represented only by fragments, which 'lay scattered about the floor' together with 'fragments of a rough wooden chair and pieces of white pottery jars'.<sup>12)</sup> This material seems to have been found on top of a six-inch layer of 'rubbish', with only a few smaller items - four 'magical bricks',<sup>13)</sup> a clay seal<sup>14)</sup> and 'some wooden ushabtis'<sup>15)</sup> - subsequently being recovered from the rubble into which they had evidently strayed from above.

From the bricks and shabtis, the owner of the tomb furniture - presumably represented by the 'well-preserved body',<sup>16)</sup> - has been identified as Amenemopet called Pairy, brother to Sennufer and mayor of Thebes and vizier under Amenophis II.<sup>17)</sup> The fact that the contents of the chamber were deposited substantially above floor level suggests, perhaps, that the tomb had lain open for some time before the burial was introduced. Despite this, and the 'very poor' nature of the burial furniture, difficult to reconcile 'with the rank of the man',<sup>18)</sup> the probability must be that this is a primary burial, another mark of favour by Amenophis II towards the Sennufer family.<sup>19)</sup>

Maiherpri (KV36)<sup>20)</sup>

The burial of Maiherpri, 'child of the k3p' and 'fanbearer on the king's right hand',<sup>21)</sup> within KV36

(fig. 55) was discovered by Loret in March 1899.<sup>22)</sup> The relatively intact state of the assemblage places it amongst the more important of the Valley's tombs. Be this as it may, the circumstances of the find have never been properly published, and only one of the handful of unofficial accounts we possess<sup>23)</sup> would seem to be based upon an examination of the burial in situ. The account in question, by Schweinfurth, was originally prepared for popular consumption,<sup>24)</sup> and is thus rather general. Nevertheless, on the basis of Schweinfurth's description it has been possible to draw up a tentative reconstruction of the original layout of the major items within the chamber (fig. 56), which will serve as a convenient starting point for a consideration of the deposit.

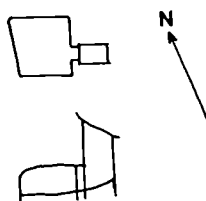
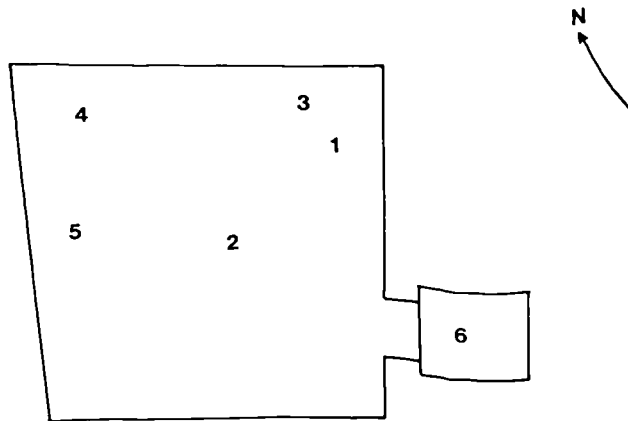

Fig. 55: KV36

From Schweinfurth's description, we learn nothing of the entrance blocking(s). For the layout, only the following details are certain: that the boxed provisions<sup>25)</sup> and the remains of garlands and other vegetable matter<sup>26)</sup> were located 'in der nördlichen Ecke' behind the gaming board and related pieces;<sup>27)</sup> and that one of the coffins<sup>28)</sup> was situated 'in der Mitte der Grabkammer', inverted, empty and without its lid.<sup>29)</sup> From these fixed points, and from the



1. The rectangular sarcophagus (CG 24001) containing two anthropoid coffins (CG 24002, 24004), the smaller holding the mummy of Maiherpri (CG 24100).
2. The unused coffin (CG 24003), inverted, empty and without its lid; on this rested 'ein prachtvoller Todtenpapyrus' (CG 24095).
3. 'Zwischen dem Sarkophag und der Wand der Grabkammer', the gaming board and related pieces (CG 24069-70).
4. 'In der nördlichen Ecke dahinter', the boxed provisions (CG 24047-56) and remains of garlands, etc. (inc. CG 24093-4).
5. 'An der dem Sarkophag gegenüberliegenden Wand', 13 large amphorae containing refuse embalming materials (inc. CG 24037-46).
6. 'Merkwürdige Waffen und verschiedenes Kunstgeräth sind aus dieser Grabkammer ans Tageslicht gebracht worden' (here?), inc. quivers (CG 24071-2), arrows (CG 24077-88) and wrist-guards (CG 24073-4).

Fig. 56: reconstructed layout (KV36)

given relative positions, it is possible to suggest the probable layout of the chamber. The wooden sarcophagus<sup>30)</sup> and related coffins<sup>31)</sup> were presumably orientated north-south in the regular manner (note that the wd3t-eye is present on what would technically be the sarcophagus' west side), and in consequence the original position is likely to have been lengthwise against either the east or the west wall of the chamber. Opposite the sarcophagus, lying against the wall of the chamber, Schweinfurth notes 13 large amphorae<sup>32)</sup> containing refuse embalming material.<sup>33)</sup> In the burial of Yuya and Tjuyu (KV46), both amphorae and boxed meat joints were piled together,<sup>34)</sup> and, despite the cramped nature of KV46 in comparison with the present tomb, it is possible that the arrangement here was similar. If so, the position of these jars against the west wall would imply that the body of Maiherpri lay against the east. As for the gaming box, Schweinfurth notes merely that it lay 'zwischen dem Sarkophag und der Wand der Grabkammer'.<sup>35)</sup> Since the meat joints and vegetable matter of the north corner are specified as being located 'dahinter', the box was perhaps at the head of the coffin. For the canopic box<sup>36)</sup> and contents<sup>37)</sup> and the Osiris bed,<sup>38)</sup> no positions are given; the former may have been situated at the foot of the coffin,<sup>39)</sup> whilst the latter perhaps lay against the south wall.

The body itself lay within two anthropoid coffins<sup>40)</sup> inside a rectangular wooden sarcophagus.<sup>41)</sup> Much speculation has surrounded the apparent fact that

Maiherpri possessed a 'spare' coffin,<sup>42)</sup> found unused in the centre of the chamber.<sup>43)</sup> According to Quibell, this coffin was the smallest of the three, 'though too large to go inside the second one'.<sup>44)</sup> Maspero's colourful explanation was that, 'fatigué de reposer dans l'une, il se transporterait dans une autre';<sup>45)</sup> this view is hardly credible. The size of the coffin suggests rather that it had originally been intended to fit within what was eventually employed as the innermost coffin.<sup>46)</sup> That it was found to be too large to be so employed suggests that the measurements made by the coffin designers were not as accurate as they might have been. Such errors were apparently not infrequent: similar problems faced the workmen employed at the burial of Tutankhamun.<sup>47)</sup> But whereas with the burial of the latter the discrepancies in size could be remedied by a little judicious shaving, this course of action seems not to have been practicable in the case of Maiherpri's inner coffin: the workmen were content to abandon it unused in the centre of the room.

Maiherpri's mummy was unwrapped on 22 March 1901,<sup>48)</sup> as a result of which we are comparatively well-informed as to the disposition of the body's several remaining ornaments (fig. 57); the position of those pieces which Loret had evidently removed at the time of the discovery<sup>49)</sup> is unfortunately not recorded. Within the outer anthropoid coffin,<sup>50)</sup> Daressy notes 'dix côtes de veau, enveloppées de bandelettes de toile'.<sup>51)</sup>

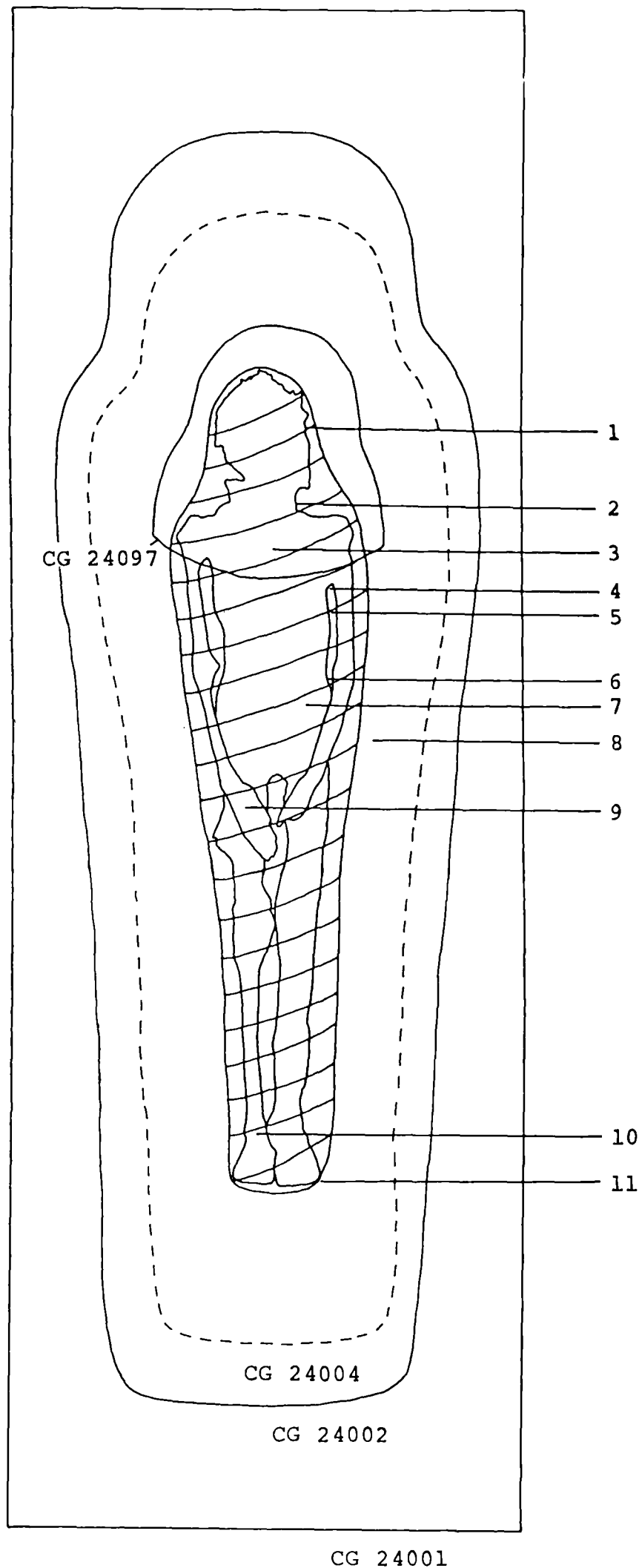

Fig. 57:  
mummy and  
coffins (KV36)

Key to fig. 57

1. 'Sous la tête ont été trouvés les bracelets nos. 24062 bis et ter et no. 24063 bis.'
2. 'Sous le cou était le collier no. 24065 bis.'
3. 'Deux perles longues en verre ... trouvées dans les linges sur la poitrine' (CG 25068 bis d).
4. 'Sous l'aisselle gauche était un paquet d'orge germé, semblable à celui qui dessine l'Osiris no. 24061.'
5. 'Entre ce bras (sc. gauche) et la poitrine, on à recueilli l'anneau d'or no. 24067 d.'
6. 'Une moitié de bracelet no. 24065 était sous les reins' (CG 24068 bis a).
7. 'La plaque no. 24067 c était entrée dans l'ouverture pratiquée dans la flanc gauche.'
8. (This general area) 'dans le fond du cercueil, le scarabée no. 24098'.
9. 'Au poignet droit des perles passées anciennement dans un fil de cuir formaient un bracelet incomplet no. 24068 bis c.'
10. 'L'objet no. 24067 b avait sa partie plate sur le cou de pied droit.'
11. 'Sous chaque pied, un petit chiffon contenait de la peau humaine avec de la resine et, semble-t-il, des débris végétaux'; 'le tube no. 24067 d ... entre les deux pieds'.

In addition, the coffin CG 24002 contained 'des linges enlevés à la momie', 'trois perles' (CG 24068 bis h) and 'des côtes de boeuf enveloppées de linge' (CG 24056 bis).

Unplaced on the mummy/in the (inner?) coffin:  
CG 24068 bis b, e, f, g, i.

Note that the broken line in this figure represents the approximate size of the coffin CG 24004 in relation to the other pieces, based upon Quibell's observation that it was only slightly larger than CG 24003. It is clear that a further, innermost coffin (i.e. CG 24003) had been allowed for in the original design.

The burial of Maiherpri had clearly been plundered in antiquity, though rather more selectively than most. According to Daressy, the innermost coffin<sup>52)</sup> containing Maiherpri's mummy 'avait déjà été ouvert, les chevilles étaient enlevées ou les tenons brisés et le couvercle n'adhérait plus'.<sup>53)</sup> The mummy lay within, 'la tête et le haut de la poitrine pris dans le masque n<sup>o</sup> 24097'.<sup>54)</sup> It had been extensively robbed, since 'ses bandes extérieures étaient déjà enlevées et de grandes sections pratiquées avec un instrument tranchant entame les bandelettes, surtout aux jambes'.<sup>55)</sup> This state of affairs was clearly reflected in both the range of goods still present within the tomb and in the condition of these items.<sup>56)</sup> As with all the robbed burials in the Valley of the Kings, no portable metalware was apparent, with the exception of a few scraps on the mummy (fig. 57) and elsewhere<sup>57)</sup> which appear to have been overlooked. Similarly absent were non-funerary linen and clothing;<sup>58)</sup> the canopic jars had also been disturbed.<sup>59)</sup> The ink docketts on several handled pottery jars from the tomb<sup>60)</sup> indicate that they had contained b3k-oil, the ben oil made from moringa nuts.<sup>61)</sup> Though two of the jars had been damaged, the contents seem not to have been touched - which, in view of Helck's assertion that the commodity was of some value,<sup>62)</sup> is surprising. It is perhaps the case that b3k-oil did not keep indefinitely, and had turned rancid by the time the tomb was plundered. This would explain the apparent lack of interest shown by the thieves, and might suggest that KV36 had not been despoiled until some years after Maiherpri's interment - and then, perhaps, only

incidentally in the course of other activity in the area, evidenced by the 'many ostraca and broken fragments some of the XIX-XXth dynasty' found by Carter in the vicinity in 1902.<sup>63)</sup>

Engelbach's opinion was that the burial had been subjected to 'an inspection during the XXIst Dynasty'.<sup>64)</sup> Whilst the principle of an official, or perhaps semi-official tidying-up within the burial is certain from the relatively organised state of the chamber when found, the proposed 21st dynasty date for this action is based rather more on tacit assumption than on hard fact. Since the tomb had been plundered only of its more portable valuables, the gold on the coffins being untouched and the mummy still preserving one or two pieces of its jewellery, this might argue that the burial had been accessible for a relatively short time only. If, therefore, the thefts that we are able to recognise took place in the Ramessid period, as Carter's ostraca might imply, then we should not expect any reorganisation of the burial to have occurred much after.

The date of Maiherpri's burial might here briefly be considered. Steindorff was probably widest of the mark when he suggested (though, in fairness, on topographical grounds alone) that Maiherpri 'was a special friend of Thutmosis I'.<sup>65)</sup> Since we possess a reasonably firm terminus ante quem non for the burial in the occurrence of the prenomen m3<sup>c</sup>t-k3-r<sup>c</sup> (Hatshepsut) on a linen winding-sheet from the tomb,<sup>66)</sup>

and since Maiherpri has been estimated as being about twenty years of age at the time of his death,<sup>67)</sup> a floruit spanning the reigns of Tuthmosis I and Hatshepsut is hardly probable. Quibell more reasonably suggested that Maiherpri was 'probably one of the companions of Thothmes III. in his childhood',<sup>68)</sup> basing himself, no doubt, upon the above-mentioned Hatshepsut linen mark and what he believed to be the 'typical Thothmes III. type' of the pottery.<sup>69)</sup> Daressy echoed this general dating ('contemporain de la reine Hatchepsu') two years later,<sup>70)</sup> and, although confessing some feelings of unease ('le style des divers objets, la forme des cercueils anthropoïdes aurait plutôt indiqué une époque plus rapprochée, celle des Aménophis II et III'), maintained the view in his CG description that Maiherpri had been interred 'vers le temps de Thoutmès III'.<sup>71)</sup>

Maspero, however, felt that Maiherpri 'must have lived during the reign of Amenôthes II, to judge from another discovery made in 1902, ... the son of ... perhaps Thutmôsis III, by a negro princess'.<sup>72)</sup> The nature of this 'other discovery' is difficult to establish with certainty, but was presumably connected with Carter's work in the KV36 area at this time, which resulted in the discovery of a box<sup>73)</sup> from the tomb of Maiherpri containing two leather loincloths,<sup>74)</sup> and other scraps including 'some fragments of a wooden box or coffin bearing the cartouches of Amenophis III'.<sup>75)</sup> That this latter was the evidence Maspero had in mind is strongly suggested by his revised dating of 1915,

when Maiherpri is identified as 'un prince ... qui vivait probablement encore sous Aménôthès III. Ce personnage ... était le fils d'une négresse et d'un Pharaon, peut-être Thoutmôsis IV'.<sup>76)</sup>

Despite Maspero, Daressy's dating, on the basis of the Hatshepsut linen mark, has remained the generally accepted view,<sup>77)</sup> with only sporadic instances of dissent.<sup>78)</sup> No argued criticism of the temp.-Hatshepsut dating appeared in print until 1968, when Nolte, basing herself primarily upon data supplied by Aldred and Harris, noted the following discrepancies:<sup>79)</sup>

- (a) the leather loincloths recovered by Carter, whilst they can occur as early as the reign of Hatshepsut (on the Deir el-Bahri Punt reliefs)<sup>80)</sup> and as late as Tutankhamun (cf. the 'Painted Box' of Tutankhamun<sup>81)</sup> and the Memphite tomb of Horemheb),<sup>82)</sup> date principally to the period Amenophis II-Tuthmosis IV;
- (b) the style of Maiherpri's funerary papyrus cannot pre-date Tuthmosis III, and is, in fact, very similar to that of Kha (temp. Amenophis III);<sup>83)</sup>
- (c) excluding Maiherpri, the first occurrence of the title 'fanbearer on the king's right hand' is in the reign of Amenophis II;<sup>84)</sup>
- (d) the piercing of ears is not attested in men before the reign of Amenophis II, and piercings

equal in size to those of Maiherpri first occur on the mummy of Tuthmosis IV.<sup>85)</sup>

From these features, it can be seen that Maiherpri's 20 or so years in life are unlikely to have pre-dated the reign of Amenophis II, and are in fact more likely to have fallen in (and perhaps just after) the reign of Tuthmosis IV.<sup>86)</sup>

To conclude: what evidence we possess seems to indicate (a) that Maiherpri was buried perhaps as late as the reign of Amenophis III, but more probably under Tuthmosis IV; (b) that the tomb was plundered of its more portable valuables as a result of its accidental discovery during the Ramessid period; and (c) that the burial was hastily tidied-up and the entrance reburied only a short time after these thefts.

#### Userhet (KV45)<sup>87)</sup>

KV45 (fig. 58) was opened by Carter on 25 February 1902.<sup>88)</sup> The single chamber proved to be 'a third full of rubbish', on top of which rested the remains of two 22nd dynasty<sup>89)</sup> mummies, each contained in a double coffin. 'Rain water' had decayed these to such an extent 'that it was impossible to remove anything excepting the face of the man's mummy case' and 'a small black limestone heart scarab' inscribed for the doorkeeper of the house Merenkhons.<sup>90)</sup> 'On the woman nothing was found.' Associated with the two mummies were two wooden shabti boxes and the 'scattered remains of wreaths'.<sup>91)</sup>

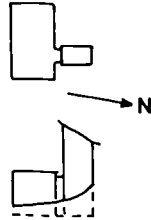

Fig. 58: KV45

In clearing out the floor debris of the chamber, Carter recovered fragments of canopic jars inscribed for the 18th dynasty overseer of the fields of Amun, Userhet, evidently the original owner of the tomb.<sup>92)</sup> No trace of Userhet's corpse was found; it had perhaps been destroyed by thieves, or thrown out at the time of the 22nd dynasty usurpation of the tomb.

Yuya and Tjuyu (KV46)<sup>93)</sup>

The tomb of Yuya and Tjuyu (fig. 59), the parents of Tiye, was discovered on 5 February 1905, situated between KV3 (temp. Ramesses III)<sup>94)</sup> and KV4 (Ramesses XI), the entrance concealed beneath a mass of chippings from the construction of these later tombs.<sup>95)</sup>

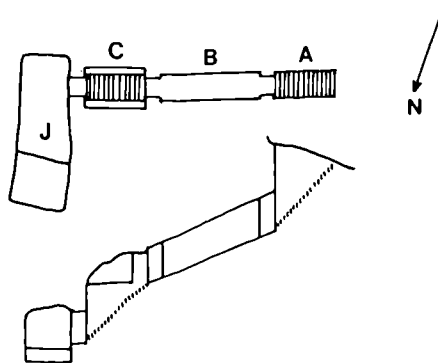

Fig. 59: KV46

The state of the blockings indicated from the start that the tomb had not survived unscathed. The accounts are in general agreement with Davis: the first doorway, at the bottom of the first flight of steps, 'was closed within eighteen inches of the top with flat stones, about twelve inches by four, laid in Nile mud plaster ... The opening was chin high'.<sup>96)</sup> Weigall adds that the wall had been 'plastered over with mud and stamped in many places with the seal of the priests of Amon'<sup>97)</sup> (i.e. the jackal and nine captives); he specifies that the blocking had been breached 'in the top right-hand corner'<sup>98)</sup> and, elsewhere, that it had been roughly reblocked.<sup>99)</sup> Behind this outer wall, within the corridor (which was empty save for a few stray pieces),<sup>100)</sup> 'a little pile of debris' was found,<sup>101)</sup> presumably rubble from the early resealing postulated below.

The doorway at the bottom of the second stairway was similarly 'closed with stones set in Nile mud plaster, with an opening at the top of about the same size as was found in the first doorway ... The face of the wall was plastered with mud and stamped from top to bottom with seals'<sup>102)</sup> - according to Quibell, of the jackal and nine captives variety.<sup>103)</sup> Several courses of the stones had been removed.<sup>104)</sup> At the foot of this wall, on either side of the corridor, were found two pottery bowls containing dried mud, and the sticks which had evidently been used to apply it to the wall.<sup>105)</sup>

When the inner doorway was breached on 13 February,<sup>106)</sup> the single, unfinished<sup>107)</sup> chamber was found to contain a burial of some quality.<sup>108)</sup> Closer inspection, however, showed it to have been disturbed in antiquity: cf. fig. 60.<sup>109)</sup> To the excavators, the evidence suggested that the burial had been plundered on one occasion only,<sup>110)</sup> 'within the lifetime of a person who had exact knowledge of the location of the tomb'.<sup>111)</sup> Furthermore, it was generally agreed that the thefts had been carried out 'with discretion',<sup>112)</sup> and that the contents remained substantially intact.<sup>113)</sup>

A re-examination of the available evidence (which, for this burial, is quite extensive) suggests, however, that the traditional interpretation of the KV46 burial might be challenged on a number of significant points. In particular, it is probable that the deposit had been plundered far more extensively than was originally recognised, and that more than one phase of activity can be isolated in the history of the tomb's violation.

To judge from the differing methods of embalming apparent in the mummies of Yuya and Tjuyu,<sup>114)</sup> they died at separate times and were not, for example, the victims of some virulent disease resulting in their simultaneous decease. This view is perhaps strengthened by the apparent differences in style between certain items of the couple's personal funerary equipment, in particular the canopic jars.<sup>115)</sup> As the evidence stands, it is not possible to determine

with any certainty which partner predeceased the other. Maspero's suggestion,<sup>116)</sup> based upon the disposition of the large wooden sarcophagus within the burial chamber,<sup>117)</sup> that Yuya was the first to be buried is a possibility, in view of the comparative longevity of women, but not susceptible of real proof.

The blockings of KV46 are evidently to be dated to the introduction of the last of the mummies to be interred within, since this entry will have involved the complete destruction of both closures. I personally doubt that these walls had been erected to replace blockings breached by thieves,<sup>118)</sup> since illicit entry did not normally involve the removal of the top few courses.<sup>119)</sup>

Both mummies had, nevertheless, been thoroughly ransacked at some stage,<sup>120)</sup> and the tomb is demonstrably lacking in many of the smaller items that one might expect to find in a substantially intact burial of a favoured noble and his wife. A comparison with the intact burial of the architect Kha,<sup>121)</sup> for example, indicates that there is a distinct lack of re-usable or recyclable commodities such as metal<sup>122)</sup> (to the extent that a sistrum lacks its loop and shakers)<sup>123)</sup> and glass.<sup>124)</sup> Noteworthy, too, is the almost total absence of garments and linen.<sup>125)</sup> There are, moreover, no ointment containers in the burial,<sup>126)</sup> only dummy examples,<sup>127)</sup> any originals presumably having been removed for the sake of their contents.<sup>128)</sup> Of the three calcite vessels that do remain - two jugs and a large jar<sup>129)</sup> - two have had

their sealed linen coverings ripped off in antiquity to establish what they held,<sup>130)</sup> whilst the removable lid of the third had presumably been thrown to the floor and broken.<sup>131)</sup> Lucas' analyses<sup>132)</sup> suggested that one of these vessels<sup>133)</sup> contained rancid castor oil,<sup>134)</sup> whilst for the contents of the other pitcher<sup>135)</sup> - 'a dark red substance' - no analysis is available; the jar<sup>136)</sup> was found to be filled with crude natron. To the thieves, these commodities were clearly of little value,<sup>137)</sup> and hence were rejected.

It is thus reasonable to assume that anything with any commercial value that was easily portable had been stolen in antiquity. As found in 1905, all that the tomb of Yuya and Tjuyu contained was of superficial value - literally so, since the only precious materials in evidence were gold and silver leaf. As the tomb robbery papyri suggest,<sup>138)</sup> the removal of such thin coatings was a difficult and time consuming process, often involving the burning of gilded items to separate the leaf from its base. This was evidently action to be resorted to only in the final count, when everything else of value that was to hand had been removed.

The early period of theft postulated by Quibell is supported by two features:

- (a) the negative evidence of the absence of perfumes and ointments, which, from their composition, must have had a limited life span;<sup>139)</sup>

- (b) the small-scale plastering work evidenced by the two bowls of mud plaster found at the entrance to the burial chamber<sup>140)</sup> - presumably indicating the presence of a plastered reblocking of the plunderers' hole not extant in 1905.

Since the tomb had not been plundered fully, this early phase of criminal activity cannot have been of very long duration.

Lindon Smith's plan of the deposit in situ (fig. 60), however, clearly indicates that the contents of the tomb had been ransacked after this restoration: the mummies had been disturbed within their coffins and robbed of those ornaments of value that remained, whilst promising looking boxes had had their sealings broken and their lids ripped off in the search for valuables.<sup>141)</sup> Several items found in the corridor in modern times<sup>142)</sup> were either in the process of being carried off when the thieves were apprehended, or else had been rejected by them when it was found that they were of little actual value. There seems to have been at least some attempt at putting the contents of the chamber in order after this sacking, since Tjuyu's mummy had been covered with a sheet,<sup>143)</sup> some boxes roughly refilled with a jumble of items,<sup>144)</sup> and the hole made by the robbers to gain access to the burial roughly blocked again with stones.<sup>145)</sup>

The date of this later ransacking can be narrowed down with some probability. Since the tomb had been

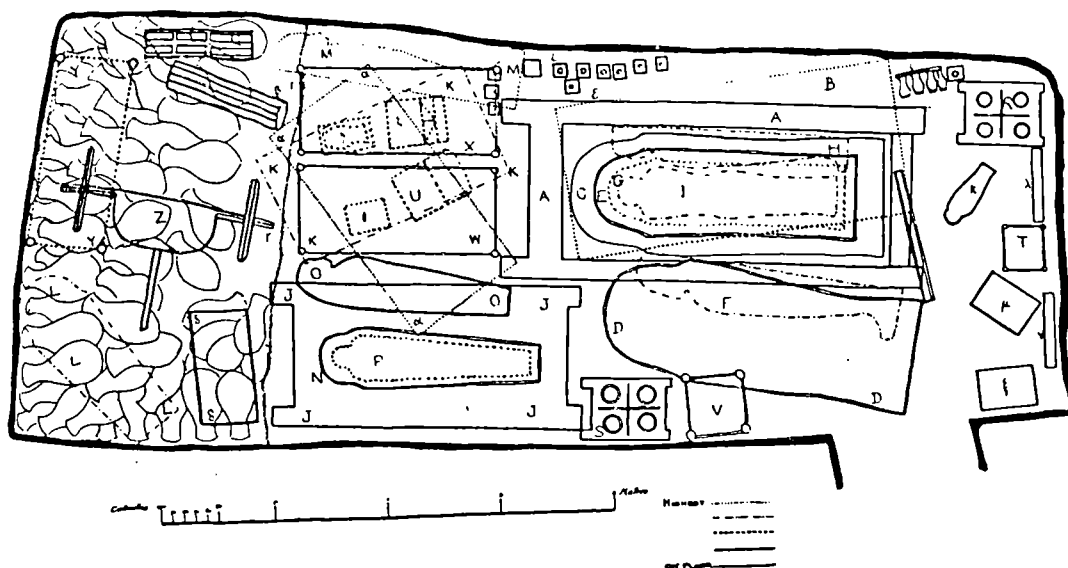

- |   |  |
|---|--|
| A. Canopy of Yuua, n° 51001.                | U. Gilt chair, n° 51112.               |
| B. Its lid, n° 51001.                       | V. Largest chair, n° 51113.            |
| C. Second coffin of Yuua, n° 51002.         | W. Gilt bedstead, n° 51110.            |
| D. Its lid.                                 | X. Painted bedstead, n° 51108.         |
| E. Third coffin of Yuua, n° 51003.          | Y. Silvered bedstead, n° 51109.        |
| F. Its lid.                                 | Z. Chariot, n° 51188.                  |
| G. Fourth coffin of Yuua, n° 51004.         | α. Side of coffin, n° 51005.           |
| H. Its lid.                                 | ε. Mat, n° 51187.                      |
| I. Mummy of Yuua, n° 51190.                 | γ. Here the 18 boxes of provisions.    |
| J. Outermost coffin of Thuiu, n° 51005.     | δ. Wig-basket, n° 51119.               |
| K. Its lid.                                 | ε. Ushabtis in their shrines.          |
| L. Second (gilt) coffin of Thuiu, n° 51006. | ζ. Jewel box of Yuua, n° 51117.        |
| M. Its lid.                                 | η. Alabaster vase, n° 51104.           |
| N. Third coffin of Thuiu, n° 51007.         | θ. Jewel-case of Thuiu, n° 51118.      |
| O. Its lid.                                 | ι. Limestone vases on stand, n° 51102. |
| P. Mummy of Thuiu, n° 51191.                | κ. Model coffin, n° 51054.             |
| Q. Cartonnage cage, n° 51011.               | λ. Osiris bed.                         |
| R. Canopic box of Yuua, n° 51012.           | μ. Box, n° 51115.                      |
| S. Canopic box of Thuiu, n° 51013.          | ν. Osiris bed.                         |
| T. Ibex chair, n° 51111.                    | ξ. Box, n° 51116.                      |

Fig. 60: layout of burial (KV46)

sealed by debris from KV3 and KV4, the period of theft cannot, logically, post-date Ramesses XI. The only 'section' we possess from Davis' excavations at this site (fig. 61)<sup>146)</sup> might lead one to infer, from the mixed Ramesses III/Ramesses XI nature of the stratum above the tomb entrance, that there was sufficient activity in the immediate vicinity of KV46 for the burial to have been discovered and looted at the time a site was being selected for KV4.<sup>147)</sup> Whilst definite proof is lacking, there is nevertheless a strong possibility that the latest disturbance of the Yuya-Tjuyu burial is to be attributed to the workmen of Ramesses XI.

The construction of KV3 some years earlier will have provided a similar opportunity for the discovery of KV46. Quibell does, in fact, publish two seal impressions of Ramesses III in his catalogue of objects from KV46,<sup>148)</sup> but these received no attention at the time and have more recently been discarded by Thomas as intrusive.<sup>149)</sup> Since KV3, evidently prepared for a son of Ramesses III,<sup>150)</sup> is in such close proximity to KV46, this treatment might appear to be justified.<sup>151)</sup> There are difficulties, however. Why, for instance, should Quibell, an archaeologist of wide experience, have included in a catalogue of the tomb's contents material which he knew to be unconnected with the burial?<sup>152)</sup> But equally, if he was satisfied that the sealings did come from the tomb of Yuya and Tjuyu, why does he totally ignore their significance in his reconstruction of the burial's history? The answer might be that Quibell was uncertain

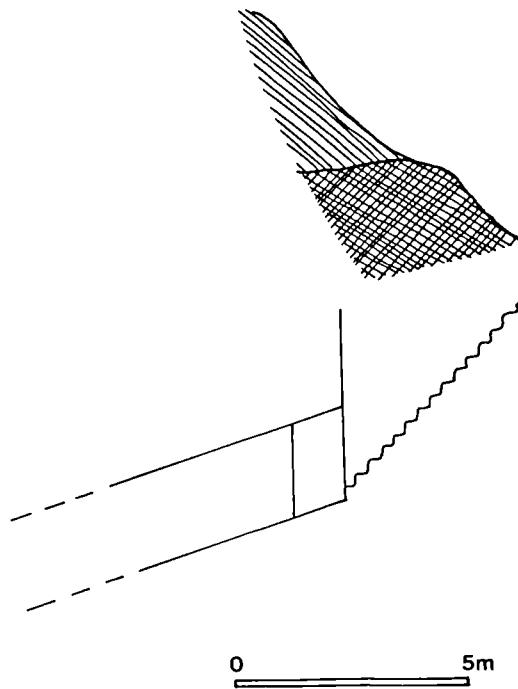

'Rubbish of Ramses III.'



'Rounded pebble and gravel deposit. Ramses III and Ramses XII' (sc. XI).

Fig. 61: section at entrance (KV46)

as to the origin of the Ramesses III sealings (he was not present when the tomb was first entered), and included them in the catalogue merely in the event that they should later prove meaningful. If these sealings are to be connected with the tomb, and there is some evidence to be mustered in favour of the attribution,<sup>153)</sup> they are obviously of importance in fixing the chronology of the tomb's robberies. Their presence would imply that, during the reign of Ramesses III - and before the final period of theft<sup>154)</sup> - KV46 had required official attention. However, neither the details of the discovery nor the items themselves are sufficiently well published to attribute any specific feature to a period of activity under this king.<sup>155)</sup>

In conclusion, the history of the burial might, on present evidence, be reconstructed as follows: (a) the respective interments of Yuya and Tjuyu, Yuya perhaps predeceasing his wife; (b) a possible robbery of the tomb's cosmetics and other items within a few years of the last interment, followed by an official reclosing of the tomb; (c) a probable further period of robbers' activity temp. Ramesses III, resulting in an official tidying-up and resealing within the tomb; and finally (d) a subsequent period of theft, possibly temp. Ramesses XI, followed by a rapid re-ordering of the burial and the rough reblocking of the robbers' hole in the outer doorway.

(KV21)<sup>156)</sup>

KV21 (fig. 62) was opened on 9 October 1817 by Belzoni,<sup>157)</sup> who found it blocked 'at the end of the first passage' by 'a brick wall, which ... had been forced through'. This breach led, via a further corridor, into 'a pretty large chamber, with a single pillar in the centre'. In one corner of this chamber 'we found two mummies on the ground quite naked, without cloth or case. They were females, and their hair pretty long and well preserved ...'. A room off the burial chamber contained 'fragments of several earthen vessels, and also pieces of vases of alabaster ...', the former perhaps having held the mummies' embalming refuse as in KV36 and KV46.<sup>158)</sup> What appears to have been a similar, intact vessel of this sort, 'with a few hieroglyphics on it, and large enough to contain two buckets of water', was found 'on the top of the staircase'.<sup>159)</sup>

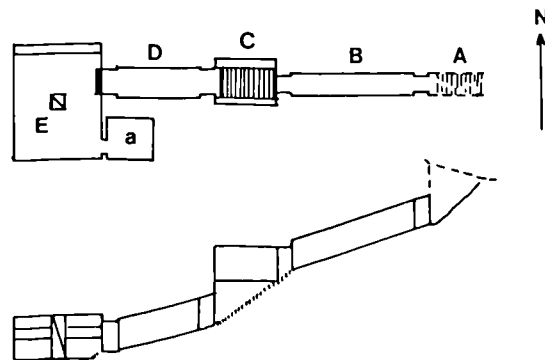

Fig. 62: KV21

What little evidence we possess seems to indicate that the burials within KV21 were of 18th dynasty

date. The tomb had evidently been despoiled in antiquity, and the gilded/silver-plated coffins and other items of furniture carried off bodily to be stripped of their metal coverings at leisure elsewhere. The mummies themselves had been completely divested of their bandages in the search for jewellery, and simply abandoned. The date of these thefts was perhaps late: note that the alabaster cosmetic pots had simply been smashed in situ, and not carried off for the sake of their contents.<sup>160)</sup> The activity seems, moreover, to have gone undetected by the necropolis administration, since the entrance blocking had not been made up.

(WV24)<sup>161)</sup>

This tomb (fig. 63) was first noted by Wilkinson.<sup>162)</sup> According to Thomas, 'the floor of the shaft and room, now covered with turab, yield on partial examination fragments of cloth, bones, wood, and pots', which may or may not be contemporaneous with the 18th dynasty jar sherd noted in the debris.<sup>163)</sup>

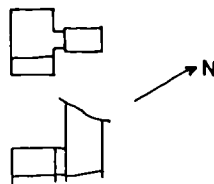

Fig. 63: WV24

(WV25)

See above, chapter 2.

(KV27)<sup>164)</sup>

Apparently known to Wilkinson and marked on his sketch map,<sup>165)</sup> KV27 (fig. 64) was examined by Lefébure, who noted 'quelques débris de momies' of uncertain date.<sup>166)</sup>

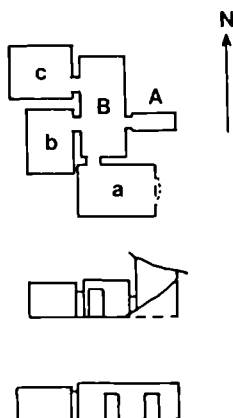

Fig. 64: KV27

(KV28)<sup>167)</sup>

KV28 (fig. 65) was evidently known to Wilkinson, and appears on his sketch map of the Valley.<sup>168)</sup> Lefébure describes the tomb as 'enfouie presque entièrement; il y a dedans des os et des linges de momies',<sup>169)</sup> again of uncertain date.

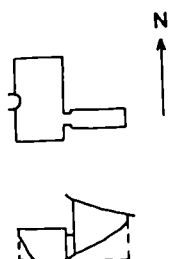

Fig. 65: KV28

(KV39)<sup>170)</sup>

This tomb (fig. 66) was briefly considered above.<sup>171)</sup> Weigall describes it as containing 'several fragments of pottery and alabaster',<sup>172)</sup> as well as 'some bones and other fragments of the burial' in a room off the burial chamber.<sup>173)</sup>

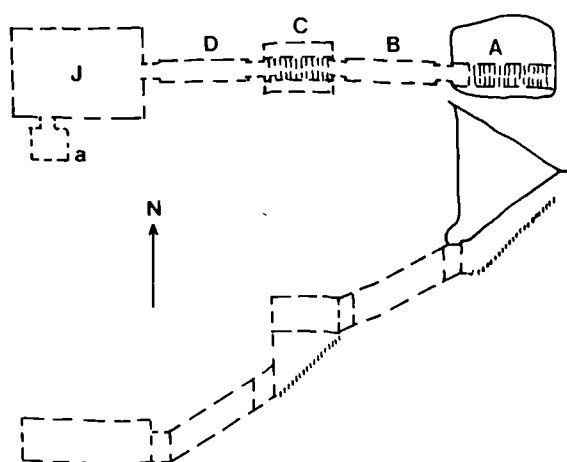

Fig. 66: KV39

(KV44)<sup>174)</sup>

This single-chambered pit tomb (fig. 67) was opened by Carter on 26 January 1901.<sup>175)</sup> The blocking of the chamber was intact, though 'very roughly done', and within Carter discovered 'three wooden coffins, placed beside one another at one side of the chamber, covered with wreaths of flowers'. These burials were clearly secondary, since 'there was rubbish in the tomb, occupying about one fifth of the space, amongst which were remains of earlier mummies without either coffins or funereal furniture'.<sup>176)</sup> These mummies

presumably represented all that remained of the original interment; certainly the fact that 'on the ceiling of the tomb were numerous bees' nests'<sup>177)</sup> suggests that the chamber had lain open for some time prior to the secondary interment. This would perhaps explain the well plundered state of the earlier burial.

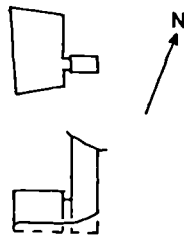

Fig. 67: KV44

Unfortunately, no trace was found to suggest either the date or the identities of the occupants of the earlier burial. For the secondary interments, a general date is provided by the red leather 'braces' from the third mummy, the lady of the house Tentkerersherit, which carry the cartouches of Osorkon II of the 22nd dynasty.<sup>178)</sup> The remaining two mummies of the secondary burial, Hesiufaa (no title)<sup>179)</sup> and a songstress of Amun whose name is lost,<sup>180)</sup> bore no specific indication of date, but are presumably of the same era.

(KV58)

See above, chapter 3.

## CHAPTER 9

## MISCELLANEOUS TOMBS AND PITS

(KV26)<sup>1)</sup>

No details of an interment within this tomb (fig. 68), which was noted by Loret in 1898,<sup>2)</sup> are known to me.

(KV29)<sup>3)</sup>

This tomb (fig. 69) is inaccessible, and no details of surviving contents (if any) are known to me.

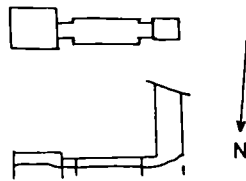

Fig. 68: KV26

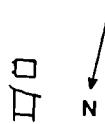

Fig. 69: KV29

(KV30)<sup>4)</sup>

KV30, a large, multi-chambered pit tomb (fig. 70), is little known. The only recorded find is a potsherd, which Thomas would date to the 18th dynasty.<sup>5)</sup> James Burton records a quarry mark(?), in 'red characters in chamber of pit'.<sup>6)</sup> The tomb was noted by Loret in 1898.<sup>7)</sup>

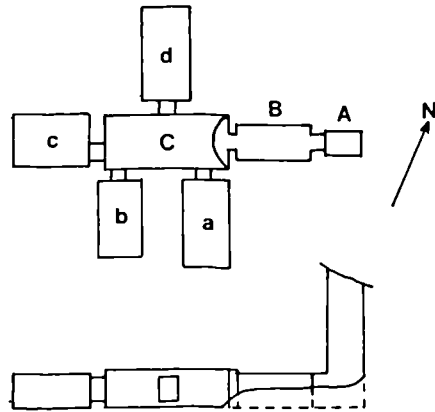

Fig. 70: KV30

(KV31)<sup>8)</sup>

No information is available as to this tomb's form (cf. fig. 71) or any surviving contents. It was noted by Loret in 1898.<sup>9)</sup>

(KV32)<sup>10)</sup>

This tomb (fig. 72), a Loret discovery in 1898,<sup>11)</sup> is apparently unfinished, and was perhaps never employed for a burial. No finds are known.

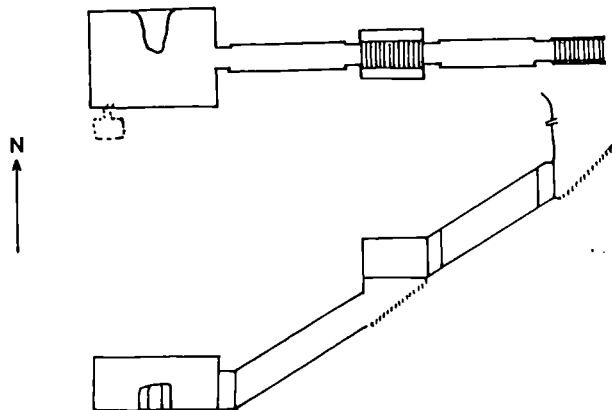

Fig. 72: KV32

(KV33)<sup>12)</sup>

KV33, discovered by Loret in 1898,<sup>13)</sup> is 'a small tomb with two empty rooms, reached by a flight of steps'.<sup>14)</sup> No evidence for an interment within is known to me.

(KV37)<sup>15)</sup>

KV37 (fig. 73) was cleared by Loret in 1899,<sup>16)</sup> his recorded finds consisting of a wooden mummiform statuette and fragmentary 'socle' of Tuthmosis IV,<sup>17)</sup> a fire-board,<sup>18)</sup> 33 ostraca<sup>19)</sup> and a 'vase fragment' of Sethos I.<sup>20)</sup> Thomas notes 'a number of pieces of large pots, B(ig) W(hitened) in part, ... as well as a few bones of undetermined origin' which she takes as evidence of an interment.<sup>21)</sup> Perhaps, however, this tomb served as a plunderers' 'workshop' for material looted from the royal tombs: cf. KV58 above.<sup>22)</sup>

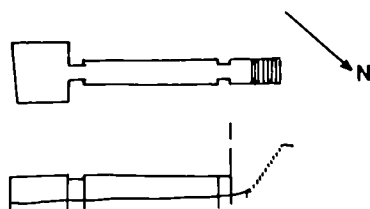

Fig. 73: KV37

(KV40)<sup>23)</sup>

KV40 (fig. 74) was evidently a Loret discovery (season 1899).<sup>24)</sup> No details are known of either its clearance or contents.

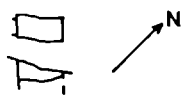

Fig. 71: KV31

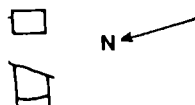

Fig. 74: KV40

(KV41)<sup>25)</sup>

This tomb (fig. 75), the last of several noted by Loret in 1899,<sup>26)</sup> is virtually unknown. Steindorff in 1902 described it as 'an open shaft, ... not yet ... examined'.<sup>27)</sup>

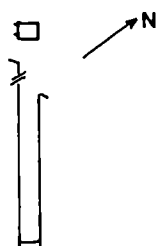

Fig. 75: KV41

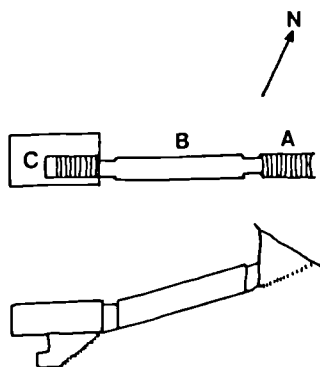

Fig. 76: KV49

(KV49)<sup>28)</sup>

KV49 (fig. 76) was discovered by Ayrton in January 1906.<sup>29)</sup> It had evidently been employed at some stage, since the doorway into the single chamber still preserves the remains of 'a dry stone wall covered with gritty white plaster'.<sup>30)</sup> That the tomb was accessible and in use during the late New Kingdom is shown not only by the presence of an ostrakon,<sup>31)</sup> mummy cloth, sherds and several gaming slabs with incised grids,<sup>32)</sup> but more particularly

by two graffiti written over the entrance doorway. These read as follows:

- (a) 1 prt 25. Coming and bringing the byssus, 20 (cloths?). Mixed hyrr, 5; shawls,<sup>33)</sup> 15: total, 20. The scribe Butehamun; Pakharu; Pennesttawy, son of Nessuimenopet; Hori; Takany; Amenhotpe; Kaka; Nakhtimenwast; Amennesttawy.
- (b) Completion on the second occasion: bringing clothing, 3 prt 5. The men who brought (it): Pait; the scribe Butehamun; Iyimennuef; Pakharu; Tjauemdi...; Hori, son of Kadjadja; Takairnayu; Nessuimenopet. Byssus, shawls, 45; long shawls,<sup>34)</sup> 5: total, 50.<sup>35)</sup>

These texts have been variously construed. Černý evidently took them as evidence for the provisioning of KV49 for a burial, and hence seems to have dated the excavation of the tomb to the late 20th dynasty.<sup>36)</sup> Thomas, on the other hand, has seen the graffiti as indicating that KV49 was in use in the later New Kingdom as a storeroom for rags for making into candles.<sup>37)</sup> A rather different interpretation is proposed below.<sup>38)</sup>

(KV50)<sup>39)</sup>

KV50 (fig. 77) was discovered by Ayrton in January 1906.<sup>40)</sup> The tomb 'had been almost completely plundered, only a few fragments of wood remaining from

the coffin. Propped up against the eastern wall was a large dog, quite perfect though stripped of its wrappings, and a monkey, still partially wrapped'.<sup>41)</sup>

The publication of this assemblage is rather vague, and it is impossible to decide whether KV50 had ever contained a human interment. The presence of 'a few fragments of wood remaining from the coffin'<sup>42)</sup> is indecisive, since these may have been fragments from the animals' coffins.

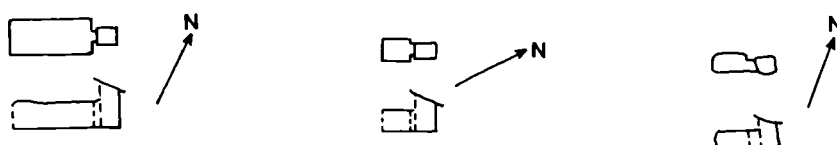

Figs. 77-79: KV50-52

(KV51)<sup>43)</sup>

Discovered slightly to the south-west of KV50, this single-chambered tomb (fig. 78) was 'completely filled with animals, all of which had been originally mummified and done up in cloth wrappings'.<sup>44)</sup> The animals included baboons, ducks and an ibis.<sup>45)</sup> A stucco mask, probably from a packet of intestines, is described as 'certainly of the XVIIIth Dynasty'.<sup>46)</sup>

The plundering and subsequent closure of this tomb are evidenced by the unwrapped state of the occupants and by the fact that the original entrance (Carter notes 'evidence of sealing')<sup>47)</sup> had been reblocked

'with bits of stone, and part of the disused lid of a mummy coffin'.<sup>48)</sup>

(KV52)<sup>49)</sup>

Another Ayrton discovery,<sup>50)</sup> KV52 (fig. 79) was found to contain two boxes: one serving as a coffin for the body and bandages of an unwrapped monkey, the other evidently a canopic chest, found empty.<sup>51)</sup> The remarks made in respect of KV50 (above) apply here also, and it is impossible to decide whether this despoiled tomb ever had a human occupant.

(KV53)<sup>52)</sup>

KV53 (fig. 80) was discovered by Ayrton during the season 1905/6, 'slightly to the north of Tomb 29'.<sup>53)</sup> The chamber's only find was 'an ostrakon of one "Hora, chief scribe in the Place of Truth";<sup>54)</sup> other ostraca/stelae/trial-pieces were found in the shaft.<sup>55)</sup> If the tomb had ever been employed for a burial, its robbery presumably coincided with the erection of the 'rough workmen's huts ... built over the mouth of the tomb'.<sup>56)</sup>

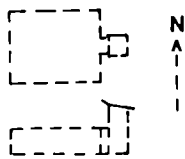

Fig. 80: KV53

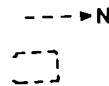

Fig. 81: KV59

(KV59)<sup>57)</sup>

This small pit (fig. 81) has been known for many

years, but no reference to its clearance or to its contents is known to me.

(KV61)<sup>58)</sup>

KV61 (fig. 82) was discovered by Jones in January 1910.<sup>59)</sup>

It showed every possibility of (being) a find, the filling of the pit appearing undisturbed and the door had been (sic) completely built up with stones to the top. However, after two days work we cleared to the top of (the) door of the chamber, and on peering inside saw that there was but a small, ill-hewn chamber half filled with debris. Hopeful of finding some evidence of the owner of the tomb in this water sodden debris, work was carefully proceeded with till every corner of the tomb was bare and bare were the results - for never even a potsherd was found. Ahmed<sup>60)</sup> thinks it isn't a 'robbed' tomb - but one which had been cleared of its contents thoroughly to hide them in some safe place. His argument proceeded that plundering usually left fragments of vases etc. broken ruthlessly in their (sic) vandalism whereas the contents appeared to be reverentially removed by some person or persons who cared for their preservation. But was the tomb ever occupied? Is it a finished tomb?<sup>61)</sup>

Since it is perhaps unlikely that those transferring a burial from the chamber would have cleared it so

thoroughly<sup>62)</sup> or have taken the trouble to reblock the entrance,<sup>63)</sup> logic would tend to support Jones's feeling that the tomb had never been used. If the chamber had been quarried in anticipation of a burial (which for some reason did not materialise), one could well imagine the quarrymen blocking the entrance so that it did not fill with sand and require clearing before it could be employed. The presence of a substantial layer of 'water sodden debris', however, is hardly conducive to this argument - unless it should prove to have been water-laid mud (rather than chippings), which might well have washed between the (dry stone?) walling of the entrance.<sup>64)</sup>

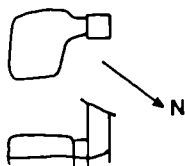

Fig. 82: KV61

(KV B)<sup>65)</sup>

KV B (cf. fig. 83) is 'the unfinished entrance to a tomb which had barely been begun'.<sup>66)</sup>

(KV C-E)<sup>67)</sup>

KV C-E were included in the sequence of unnumbered tombs by Thomas, on the basis of a vague statement by Davis to the effect that he had found 'two or three instances of commencements of tombs in the water courses which, after some progress had been

made, had been abandoned'.<sup>68)</sup> The location and even the precise number of these commencements is not known.

Thomas<sup>69)</sup> suggests that a reference to one of these tombs is contained in the Andrews Journal, entries for 4-5 January 1907. The 'tomb' in question is little more than a pit, and was discovered on the 'western face (of the mound) to the south of' KV9 in early January of that year. This 'recess in the rock' contained 'several large jars of the XXth dynasty type lying together. On digging deeper we came to a cut face with squared corners on either side, showing that a tomb had at least been begun at this spot'.<sup>70)</sup> This 'commencement', which I shall term KV C (cf. fig. 83), would seem to be analogous to the KV54 embalming cache discovered later that same year;<sup>71)</sup> whether this comparison is justified, however, is impossible to say, since the jars' contents are not recorded.<sup>72)</sup> Below this cutting, on 5 January 1907, Ayrton discovered the entrance to KV55.<sup>73)</sup>

(KV F)<sup>74)</sup>

KV F (fig. 84) is another 'commencement for a tomb',<sup>75)</sup> first noted by Carter in January 1921 and which he was inclined to see as having originally been intended for Tuthmosis III.<sup>76)</sup> However, the connection which Carter made between the four foundation deposits of Tuthmosis III<sup>77)</sup> and the excavation of KV F is far from proven; indeed, it is



Fig. 83: unnumbered tombs and pits (main Valley)

more likely that these are the deposits for KV34.<sup>78)</sup>

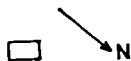

Fig. 84: KV F

(KV G)<sup>79)</sup>

The start of a 'potential corridor tomb', KV G (cf. fig. 83), is noted by Thomas. No other details are available.

(KV H)<sup>80)</sup>

KV H (cf. fig. 83) is a possible pit noted by Thomas.

(WV I-J)<sup>81)</sup>

The presence of two of three (the third being WV K) unnumbered pit tombs in the West Valley has been inferred by Thomas from a reference by L'Hôte to two excavations 'non achevés ou comblés' 'à côté de' WV23.<sup>82)</sup> The existence of at least one pit she thinks 'rather likely' from a personal inspection of the site. Cf. fig. 85.

(WV K)<sup>83)</sup>

'A filled pit' which 'may be a tomb'. Cf. fig. 85.

(KV L-M)

The existence of pits KV L-T was not known to Thomas at the time of her 1966 survey of the Valley tombs. The two here distinguished as KV L-M (cf. fig. 83) were noted by Jones as having been first

discovered in 1898.<sup>84)</sup> They appear to have contained intrusive fragments from the debris of the burials within KV35 (Amenophis II): 'broken large bl: gl: bead and fragment of decorated glass'.<sup>85)</sup>



Fig. 85: unnumbered tombs and pits (West Valley)

(KV N)

KV N (cf. fig. 83) is an 'unfinished pit 1 metre square which descended to 5 feet and then stopped'.<sup>86)</sup> Perhaps the unfinished entrance to a pit tomb, it was discovered by Jones on 21 December 1908, south of the path leading to KV35 (Amenophis II).<sup>87)</sup>

## (KV O)

KV O is an 'unfinished pit with (a) stone wall built around', possibly a 'workman's house';<sup>88)</sup> cf. fig. 83. A cone of Mentemhet,<sup>89)</sup> owner of TT34, was found in the immediate vicinity.

## (KV P)

KV P (cf. fig. 83) was discovered by Jones on 12 December 1909.<sup>90)</sup> Undisturbed, it was filled with 'ashes, broken fragments of pottery, flint flakes, fragments of broken wood (twigs), straw and burnt bones'.<sup>91)</sup> According to Jones' reis, similar pits were found outside KV55 (cf. KV C above), KV47 (cf. KV S) and KV36 (cf. KV T).<sup>92)</sup> Its true nature is not immediately apparent; 'Ahmed's'<sup>93)</sup> opinion ... is that after building a tomb the materials used in building by (the) workmen were swept up and burnt to clear (the) ground and disguise (the) fact of a tomb having been built'.<sup>94)</sup> It may, alternatively, represent the remains of an embalming cache similar to KV54.<sup>95)</sup> For a third possibility, cf. below, conclusions.

## (KV Q)

KV Q (cf. fig. 83) was discovered by Jones the day after KV P,<sup>96)</sup> and was filled with an undisturbed and essentially similar deposit of burnt fragments.

## (KV R)

KV R is little more than a pit filled with 'burnt rubbish'.<sup>97)</sup> Cf. fig. 83.

(KV S)

This is possibly one of the 'two or three' pits mentioned by Davis in 1908,<sup>98)</sup> stumbled upon before the discovery of KV47 (Siptah) and classified by Thomas<sup>99)</sup> as KV D or KV E; cf. fig. 83. For its fill, cf. KV P above.

(KV T)

No details are known of this pit, which was perhaps discovered by Loret (cf. KV L-M).<sup>100)</sup> Cf. fig. 83.

## PART 2

### THE ROYAL CACHES

À part quelques documents précieux pour l'histoire de la XXI<sup>e</sup> dynastie et quelques prières sur toile qu'on a chance de trouver avec les momies de la XVIII<sup>e</sup>, il n'y a peut-être là matière ni à de longues recherches ni à de grands résultats ...

- E. Lefébure, 'Le puits de Deir el Bahari', Annales du Musée Guimet 4 (1882), 17

## CHAPTER 10

## THE ROYAL CACHES

The 21st dynasty witnessed a dramatic change in the official attitude to the preservation of the royal dead. Instead of the interminable and for the most part ineffectual effort of guarding numerous individual tombs scattered over a wide area, the decision was taken to transfer the royal mummies and the bodies of other individuals with which these had become associated after death to a handful of easily guarded or little known tombs. A number of these so-called 'caches' have been considered in the first part of this study: KV57, the tomb of Horemheb; KV17, the tomb of Sethos I; and KV14, the tomb appropriated by Sethnakhte. The Theban necropolis's most famous mass reburials, however, are DB320 and KV35 (the tomb of Amenophis II), the former containing the corpses of at least 40 individuals and debris from a further 14 burials, the latter preserving the remains of 16 mummies and material from an additional three or four interments.<sup>1)</sup> The evidence from these two deposits is considered here in some detail, as a preliminary to establishing more precisely the history of the mummies following the evacuation of their original tombs.

(DB320)<sup>2)</sup>

DB320 (fig. 86), the larger of the two main caches, was discovered by a member of the Abd er-Rassul family in or about 1871,<sup>3)</sup> and over the next ten years

or so was entered illicitly on some three or more occasions - 'pour quelques heures seulement'<sup>4)</sup> - and plundered of its more portable grave goods: shabtis, papyri and other items.<sup>5)</sup> The appearance of such pieces on the Egyptian antiquities market soon led Maspero to suspect that a discovery of importance had been made on the Theban west bank. When, however, in July 1881, the source of the antiquities

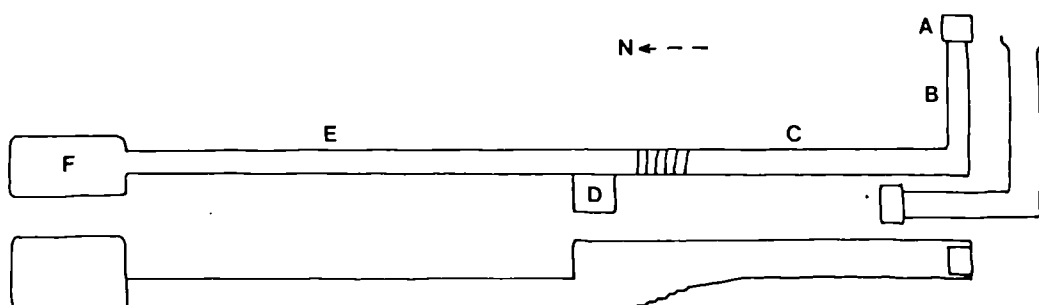

Fig. 86: DB320

was eventually revealed to Émile Brugsch,<sup>6)</sup> it came as a distinct shock to discover a single tomb which had served not only for the bodies of certain 21st dynasty persons of rank but also for members of the 17th, 18th, 19th and 20th dynasty royal lines.<sup>7)</sup> See table 3.

Brugsch's clearance of the tomb, carried out with the assistance of Kamal, Moutafian and 200 workmen, lasted a matter of two days. Needless to say, the clearance was far from 'scientific' in its

execution, and no full, first-hand account of the discovery was ever published. There is reason to suppose, however, that a report of some kind was prepared for the Museum, upon which Maspero (who had not seen the cache in situ) was to draw heavily in his discussions of the find:<sup>8)</sup> that Maspero employs the same phraseology in these published accounts might certainly be taken to suggest that he is quoting verbatim from some such ultimate source.<sup>9)</sup> It follows, therefore, that the main features of the cache at the time of Brugsch's entry in 1881 might be reconstructed from a critical analysis of Maspero's writings on the subject.<sup>10)</sup>

Unfortunately, we possess few details relating to the blocking of the cache.<sup>11)</sup> Maspero describes the situation at the bottom of the shaft as follows:

La baie était formé jadis par des battants en bois qui ont disparu: après chaque cérémonie on les assurait au moyen de grosses pastilles d'argile sur lesquelles les gardiens de la nécropole apposaient leur cachet d'office.<sup>12)</sup>

'Dans la salle et parmi les fragments qui encombraient le fond du puits', Maspero found 'une vingtaine environ de pains de terre sigillaire qui portaient des traces de caractères empreint sur une face'<sup>13)</sup> (fig. 87). These sealings are considered in more detail below, in connection with the burials of Neskhons and Pinudjem II.

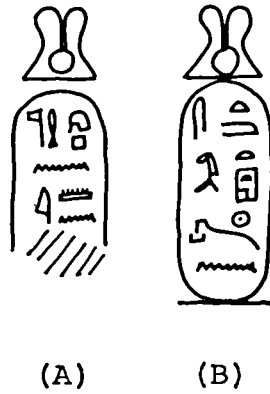

Fig. 87: the large sealings (DB320)

For the layout of the items within DB320 there is a good deal of evidence, albeit rather contradictory evidence. The results of a critical analysis of this material are set out on the plan in fig. 88, to which the numbered sections below refer. Further details of the tomb's contents will be found in tables 3, 5 and 7.



Fig. 88: reconstructed layout (DB320)

- (1) Coffin of Nebseni, containing a mummy.
- (2) 'Un cercueil dont la forme rappelait le style de la XVII<sup>e</sup> dynastie.'<sup>14)</sup> By 1889 Maspero has identified this with the coffin of Seqnenre-Taa II.<sup>15)</sup> Since, however, the Guides of 1906, 1908 and 1915<sup>16)</sup> return to the 1881 and 1883 accounts,<sup>17)</sup> which do not specify the owner of the second coffin and in fact place Seqnenre-Taa in the side chamber (D), the 1889 identification is likely to be erroneous. The second coffin can only have been that of Rai, containing the corpse of Inhapi, which to Maspero in 1881 'parait être contemporaine de Saqnounrî Tiouâqen par le style'<sup>18)</sup> (my italics); no other coffin remotely reminiscent of the 17th dynasty was found in the cache.<sup>19)</sup>
- (3) Inner and outer coffins of Duathathor-Henttawy, with her mummy.
- (4) Coffin of Sethos I, containing his mummy.
- (5) 'À côté des cercueils et jonchant le sol':<sup>20)</sup> shabti boxes, canopic jars, copper-alloy libation vessels. The shabti boxes may have included those of Duathathor-Henttawy; the canopic jars cannot be positively identified. Two sets of libation vessels were found in DB320, one set belonging to Isiemkheb, the other uninscribed; it is impossible to say which is alluded to here.
- (6) Leather canopy-shrine of Isiemkheb.

- (7) 'A cluster of mummy cases ... in such number as to stagger me.'<sup>21)</sup> No verifiable reconstruction of their precise order seems possible. Presumably this cluster included the coffin fragments of Ramesses I, which, from the evidence of the docket,<sup>22)</sup> will have been associated with that of Sethos I for some time prior to the introduction into DB320. Maspero notes that the 'débris des bois' of Ramesses I 'étaient placés à côté du cercueil de Thoutmos I<sup>er</sup>,<sup>23)</sup> (usurped by Pinudjem I and containing the body of 'Tuthmosis I'), which would suggest that this latter was also situated in the corridor. The coffined mummies of Amenophis I and Tuthmosis II Maspero similarly locates before the entrance to the side chamber (D).<sup>24)</sup>
- (8) 'Dans la niche (D), près de l'escalier':<sup>25)</sup> the coffined mummies of Amosis I, Siamun and Seqenenre-Taa II; the coffin of Ahhotpe II, containing the mummy of Pinudjem I; the coffin of Ahmose-Nofretiri, containing both her own(?) mummy and the cartonnaged mummy of Ramesses III; 'et d'autres', which may have included Tuthmosis III and Ramesses II.<sup>26)</sup> Maspero describes this chamber as 'filled up to the roof',<sup>27)</sup> whilst Wilson, paraphrasing Brugsch, describes the coffins as 'standing against the walls or ... lying on the floor'.<sup>28)</sup>
- (9) 'Dans la chambre du fond, le pêle-mêle était au comble, mais on reconnaissait à première vue la

prédominance du style propre à la XX<sup>e</sup> et à la XXI<sup>e</sup> dynastie.<sup>29)</sup>

As we shall consider in more detail below, there is little evidence to suggest that DB320 had been plundered in antiquity - at least under its 21st dynasty occupants. Nevertheless, Maspero's statement that 'le pêle-mêle était au comble' in the end chamber would seem to imply that the tomb had been ransacked at some stage. The finger of suspicion points directly at the Abd er-Rassuls. It might, therefore, be suspected that conclusions drawn from the layout of the cache possess only a limited value, since extensive Arab activity within DB320 could have significantly altered the ancient distribution of the contents.<sup>30)</sup> Whilst this is quite possible in the case of the smaller items, I doubt that it applies to the larger pieces within the tomb. If one considers (a) the weight of these coffins,<sup>31)</sup> and (b) the space available to manoeuvre them<sup>32)</sup> - plus the fact that the Abd er-Rassuls are said to have visited the cache on only three occasions, and then merely for a few hours (see above) - it would appear unlikely that any radical alteration could have been effected in the basic sequence. The positions in which Brugsch encountered the coffins in 1881 are, I would suggest, essentially the positions which they occupied in antiquity.

It is perhaps worth pointing out that there is no certainty that all the damage apparent in the cache

is to be attributed to the Abd er-Rassuls - though they were undoubtedly responsible for some of it.<sup>33)</sup> The docketts written upon those mummies which were at some stage restored pre-date their introduction into DB320 by about 40 years: the latest datable wrappings (on the mummy of Ramesses IX)<sup>34)</sup> date to Year 7 of Siamun, whilst the introduction of the royal mummies into DB320 cannot have taken place until at least Year 11 of Shoshenq I (the date of a linen docket on the mummy of Djedptahiufankh<sup>35)</sup> considered further below), and quite possibly Year 13 of this king (if the linen notation on the mummy of Nestanebtishru also refers to the reign of Shoshenq I).<sup>36)</sup> Since the transfer from the tomb of Inhapi to DB320 (see further below) was presumably undertaken to safeguard the royal dead, it is quite possible that the damage apparent in, for example, the mummy of Pinudjem I had occurred before arrival.<sup>37)</sup>

It was Winlock who, in an open letter published in 1931, first proposed to identify DB320 with the k3y of Inhapi mentioned in the coffin docketts as the resting-place of Amenophis I and destination of Ramesses I, Sethos I and Ramesses II.<sup>38)</sup> This conclusion was apparently confirmed by a fresh translation of the docketts on the Sethos I group of coffins<sup>39)</sup> published by Černý in 1948,<sup>40)</sup> which improved the logic of Winlock's argument by demonstrating that the docket relating to the transfer of Ramesses I, Sethos I and Ramesses II from KV17<sup>41)</sup> was only three days earlier than that recording their caching in t3 hwt nhh of Amenophis I.<sup>42)</sup> Winlock's

theory has, to my knowledge, been seriously challenged on only two occasions: once by Dewachter in 1975,<sup>43)</sup> who concluded that DB320 was the tomb of the Pinudjem I family; and more recently by Schmitz,<sup>44)</sup> who, on the basis of parallelism with t3 hwt nhh of the later docketts,<sup>45)</sup> has suggested that the tomb is to be recognised as t3 3ht nhh of Amenophis I referred to in P. Abbott.<sup>46)</sup> The most recent discussion, by Thomas,<sup>47)</sup> refutes both of these views, and comes down firmly in favour of Winlock's original conclusion that DB320 is the k3y of Inhapi. It is not proposed to go into the details of these earlier discussions here; in the case of Winlock (rather atypically), Černý and Schmitz, no allowances were made for the physical layout of the cache, whilst the discussions of Dewachter and Thomas, which do consider the archaeological context, are based, I believe, upon unsatisfactory source criticism and consequently upon false premises.

The basic layout of the cache was considered earlier in this chapter. Since, from the reconstructed layout, Ramesses I, Sethos I and Ramesses II had clearly been introduced before the body of Inhapi, and since it is perhaps likely that Ramesses II had been introduced before Amenophis I, DB320 cannot have been the k3y of Inhapi. In fact, the discovery of Inhapi's body close to the entrance of DB320 suggests that it was in her previous place of interment that she held a central position - and this arrangement can most satisfactorily be explained by assuming that the tomb in which the royal mummies had been stored

before their removal and final reburial in DB320 was the tomb of Inhapi. That Pinudjem II was interred in DB320<sup>48)</sup> on the very day that Ramesses I, Sethos I and Ramesses II were interred in the Inhapi tomb<sup>49)</sup> can be nothing more than fortuitous; there is, after all, no reason why two separate burials, probably in the same general area (see below), should not have been made by essentially the same officials on the same day.

Although DB320 cannot be the tomb of Inhapi, there are certain indications (notably Romer's observations on the method of quarrying)<sup>50)</sup> that DB320 does date from the late 17th/early 18th dynasty.<sup>51)</sup> Unfortunately, the tomb is no longer accessible, and from this distance and without further information it is impossible to comment objectively upon the suggestion that it was enlarged during the later New Kingdom.<sup>52)</sup> It would, in any case, be wrong to connect any such alteration with the decision to employ DB320 as a cache for the royal mummies:<sup>53)</sup> there is, as we shall see, little doubt that the original 21st dynasty occupants were already installed in the end chamber, and had been so for several years, by the time the cached mummies were introduced.

Evidence for the 21st dynasty usurpation of DB320 exists in the form of three docketts found 'au fond du puits, sur les jambages de la porte, ... tracées à l'encre noir, une à droite, deux à gauche'.<sup>54)</sup> That on the right jamb reads as follows:

Year 5 (of Siamun), 4 šmw 21. Day of burial of the chief of ladies, Neskhons, by the god's father of Amun, overseer of the treasury, Djedkhonsiufankh, son of ...; the prophet of Amon-Re, king of the gods, Ankhefenamun; the elder(?) of the hall, Nespay...; the god's father of Amun, chief of the army, Nespakashuty. The seals which are upon this place: the seal of the overseer of the treasury, Djedkhonsiufankh; the seal of the scribe of the treasury, Nes...<sup>55)</sup>

Two features suggest that this was Neskhons' original place of burial:

- (a) a strip of bandage from the mummy of Ramesses IX indicates that she was still alive in Year 5 of Siamun;<sup>56)</sup>
- (b) in spite of evidence to suggest petty plundering on the part of one or other burial party,<sup>57)</sup> the mummy and outer coffin of Neskhons are intact. Evidently, therefore, Neskhons had not been subjected to the concerted efforts of tomb robbers and thus had not, presumably, required reburial.<sup>58)</sup>

The later docket is preserved in two copies.<sup>59)</sup> The first of these consists of two lines only, having been abandoned by the scribe for want of space and the text rewritten in full a little lower down on the left jamb. The full text reads as follows:

Year 10 (of Siamun), 4 prt 20. Day of burial of the Osiris, the high priest of Amon-Re, king of the gods, great chief of the army, the leader Pinudjem, by the god's father of Amun, scribe of the army, chief inspector, Nespakashuty; the prophet of Amun, ...enamun; the god's father of Amun, Wennufer; by the king's scribe of the Place of Truth, Bakenmut; the chief workman, Pediamun; the chief workman, Amenmose; the god's father of Amun, chief of secrets, Pediamun, son of Ankhefenkhons.<sup>60)</sup>

As with Neskhons, there can be little doubt that this is the original burial place of Pinudjem II:

- (a) Pinudjem II's last attested year is Year 9, from linen on his mummy;<sup>61)</sup>
- (b) both Pinudjem II's mummy and coffins are intact.

The two types of seal impression found by Maspero (see above) are most probably to be connected with the burial of Neskhons, the title 'high priest of Amun' on type (A) reflecting the individual under whose tutelage the interment was made, rather than (as with Tutankhamun)<sup>62)</sup> the owner of the tomb. As for type (B), the text which this carries was rendered by Daressy as stm t3 hwt stp-n-r<sup>c. 63)</sup> We can now see that the individual with whom Daressy wished to connect this title is, in fact, Nespakashuty,<sup>64)</sup> who was present at both the burial of Neskhons and that of Pinudjem II.

Although no written records exist to throw light upon which of the remaining 21st dynasty corpses were original to DB320, this question might be at least partially resolved by examining the condition of the coffins and mummies (tables 5 and 7): since the Egyptians are perhaps unlikely to have transferred any mummy before its original burial had been disturbed (but see below, conclusions), except under the most exceptional circumstances (e.g. the transfer of Tuthmosis I from KV20 to KV38 by Tuthmosis III),<sup>65)</sup> it follows that those individuals represented in DB320 whose burials are intact are likely to be original to the tomb. One may conclude, therefore, that Djedptahiufankh and Nestanebtishru were buried in DB320 as and when they died. This is not altogether surprising, since Nestanebtishru appears to have been a daughter of Pinudjem II and Neskhons, as well as wife to Djedptahiufankh.<sup>66)</sup> Isiemkheb is thought to have been a lesser wife of Pinudjem II.<sup>67)</sup> From the amount of funerary material buried with her in DB320 - note the screwed-up leather canopy-shrine<sup>68)</sup> in the angle of the corridor,<sup>69)</sup> and what may have been her set of copper-alloy vessels next to the intrusive coffins in the first passage - it would seem probable that this was her original place of interment also. The fact that the gilded hands and face of her inner coffin and coffin board had been hacked off in antiquity is of no independent value: such damage is more likely to be evidence of petty pilfering by members of a burial party than evidence of tomb robbery proper,<sup>70)</sup> and is in fact attested on the inner coffin and coffin board of Neskhons.

The coffins of Masaharta, Maatkare-Mutemhet and Tayuheret have been abused in a similar manner - that of Tayuheret even having had its outer lid effaced. The relationship of these individuals is not as close, however,<sup>71)</sup> and it is possible that they had not originally been interred within DB320; though if, as seems likely, they were discovered in the end chamber of the tomb, they must have been introduced before the Inhapi group of coffins.

The remaining members of the 21st dynasty ruling line are Nodjmet, Pinudjem I and Duathathor-Henttawy; their coffins and corpses had been extensively pillaged in antiquity. These three individuals were evidently closely related,<sup>72)</sup> and appear to have shared a common place of burial which they abandoned for DB320 only after the former tomb - perhaps, as we shall consider, the k3y of Inhapi - had been robbed.

As was suggested earlier in this section, the cached coffins were introduced from a tomb in which the queen Inhapi appears to have held a central position, this tomb being, in all likelihood, the k3y of Inhapi. Three other individuals are known, from the evidence of the coffin docket, to have been intended for and doubtless buried in the Inhapi tomb: Ramesses I, Sethos I and Ramesses II.<sup>73)</sup> These same docket inform us that Amenophis I was already interred in the k3y with Inhapi when the Sethos I group of mummies was introduced.

If we examine the reconstructed layout of the cache, it will be seen that Inhapi is separated from Sethos I by Duathathor-Henttawy; that Sethos I lay close to Amenophis I; that between Amenophis I and Ramesses I lay Tuthmosis II; and that Ramesses I and Ramesses II were effectively separated by the coffins of Tuthmosis I/Pinudjem I and the side-chamber group of mummies. The side-chamber coffins, moreover - Amosis I, Siamun, Seqenenre-Taa II, Ahhotpe II and Ahmose-Nofretiri - are linked to those discovered in the corridor by the fact that the coffin of Ahhotpe II was found to contain the body of Pinudjem I. Clearly, therefore, both the coffins in the corridor and those in the side chamber are interrelated. The obvious conclusion to draw is that both sets of mummies were introduced into DB320 at the same time, and that both, presumably, shared the same immediate origin - the k3y of Inhapi.

The location of Inhapi's tomb may here conveniently be considered. If the royal mummies were transferred from this tomb to DB320 en masse, it is perhaps unlikely that the earlier place of interment will have been very far distant from the later. Furthermore, the fact that Inhapi's tomb is referred to as a k3y does yield some information as to the siting of the sepulchre. As its relationship to the adjective k3, 'high', clearly shows, the basic meaning of k3y is 'high place'<sup>74)</sup> - hence the Wb. rendering 'Hügel';<sup>75)</sup> and from the context it may be inferred that we have here a reference to a type of cliff tomb.

Situated a mere 750 metres to the south-west of the DB320 cache is the cliff tomb par excellence, WN A (Bab el-Muallaq)<sup>76)</sup> (fig. 89). This tomb, excavated in the sheer cliff face some 45 metres<sup>77)</sup> above ground level, is described by Bonomi as follows:

The highest tomb high up in the mountain, large and spacious; called el-Maaleg (= 'suspended', 'hanging')<sup>78)</sup> because it is so high up, being hung as it were in the air.<sup>79)</sup>

It was superficially explored by Robichon in 1931/2, and was found to have served 'comme cachette à cercueils ou comme catacombe de basse époque'<sup>80)</sup> - though the tomb itself is without doubt very much older.<sup>81)</sup>

Bataille records the following graffito, in Greek and dating to the Roman period, which clearly refers to an interment made within WN A:

En cet endroit le stolarque Hêraclas, fils de Renbouchis, a été placé dans le tombeau suspendu (ἐν τῷ κρεμαστηρίῳ τάφῳ) par les fils de Phthomônthes et ceux qui l'aimaient ... (?)<sup>82)</sup>

Clearly, therefore, this tomb had been noted since antiquity for its spectacular position, and the name given to it in classical as well as in modern times may be seen to reflect this siting. I am led to believe, therefore, given (a) its early date, (b) its proximity to DB320 (fig. 90), and (c) the evident

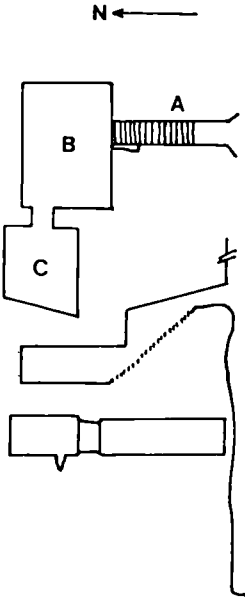

Fig. 89: WN A

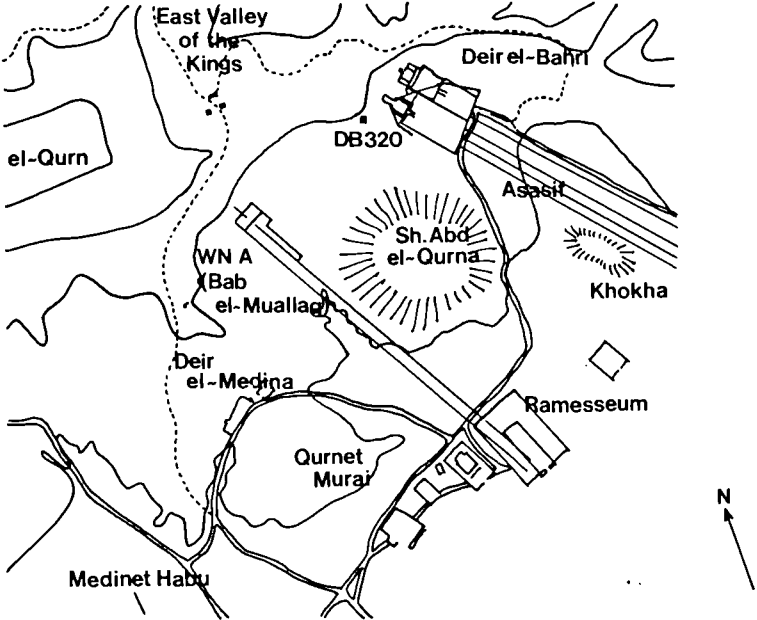

Fig. 90: relative positions of WN A and DB320

continuity in its name, that Bab el-Muallaq is none other than the k3y of Inhapi.

Although the date at which the royal mummies were cached in DB320 is nowhere explicitly stated, the transfer from the Inhapi k3y can only have taken place after Djedptahiufankh and Nestanebtishru had been buried. From the evidence of linen notations from his mummy,<sup>83)</sup> it appears that the former died in or soon after Year 11 of Shoshenq I;<sup>84)</sup> as for Nestanebtishru, she carried a docket dated to an unspecified Year 13,<sup>85)</sup> perhaps also of Shoshenq I but equally possibly relating to either Siamun or Psusennes II.<sup>86)</sup>

From the foregoing discussion one may conclude: (a) that DB320 was not the k3y of Inhapi; (b) that, originally excavated in the late 17th/early 18th dynasty, the tomb was re-employed during the 21st dynasty as a place for the burials of Neskhons and Pinudjem II; (c) that the tomb was employed as a family vault until at least Year 11 of Shoshenq I and the burial of Djedptahiufankh, and possibly until Year 13+ if the Nestanebtishru docket relates to this king; and finally (c) that the royal mummies, perhaps preceded by the bodies of Masaharta, Maatkare-Mutemhet and Tayuheret, and almost certainly including the mummies of Pinudjem I, Duathathor-Henttawy and Nodjmet, were introduced into DB320 from the tomb of Inhapi (WN A: Bab el-Muallaq) at some subsequent date.

Amenophis II (KV35)<sup>87)</sup>

KV35 (fig. 91) was first entered by Loret on 9 March 1898, and found to contain the remains not only of Amenophis II himself but of several other royal persons also.<sup>88)</sup> The tomb had been employed as a cache in antiquity, and as such was analogous to that discovered by Brugsch some 17 years previously within DB320.

Unlike DB320, KV35 was cleared with care, full attention being paid to the distribution of the many hundreds of objects and fragments found throughout the tomb. Loret's clearance of the two main chambers - the antechamber (F) and the burial chamber (J) - was particularly thorough:

Je me mis à l'oeuvre dans la première salle en la divisant en six sections et en notant sur le plan la place de tous les objets.<sup>89)</sup>

La grande salle fut divisée en dix-sept sections (et) chacune des chambres annexes fut l'objet d'un travail analogue ... En un mot, je m'arrangeai de façon à pouvoir publier un jour, non seulement l'inventaire complet de tous les fragments, mais encore un plan indiquant la place de chaque fragment.<sup>90)</sup>

An inventory of the tomb's contents was published by Daressy in 1902,<sup>91)</sup> which related each piece to a particular square, room, corridor or similar feature marked upon Loret's master plan. This plan, however,

was not published, and cannot now be traced.<sup>92)</sup> Nevertheless, a certain amount of progress in re-establishing the layout can be made: certain designations, such as 'puits' or 'couloir avant la 2e salle' are self-explanatory; whilst the 'pièces', numbered 1-4, are without doubt the four side rooms off the burial chamber. The 'sections' are evidently the grid squares into which Loret divided the tomb's two principal chambers; and since we know the number of such sections Loret established - six in the antechamber (F) and 17 in the burial chamber (J) -

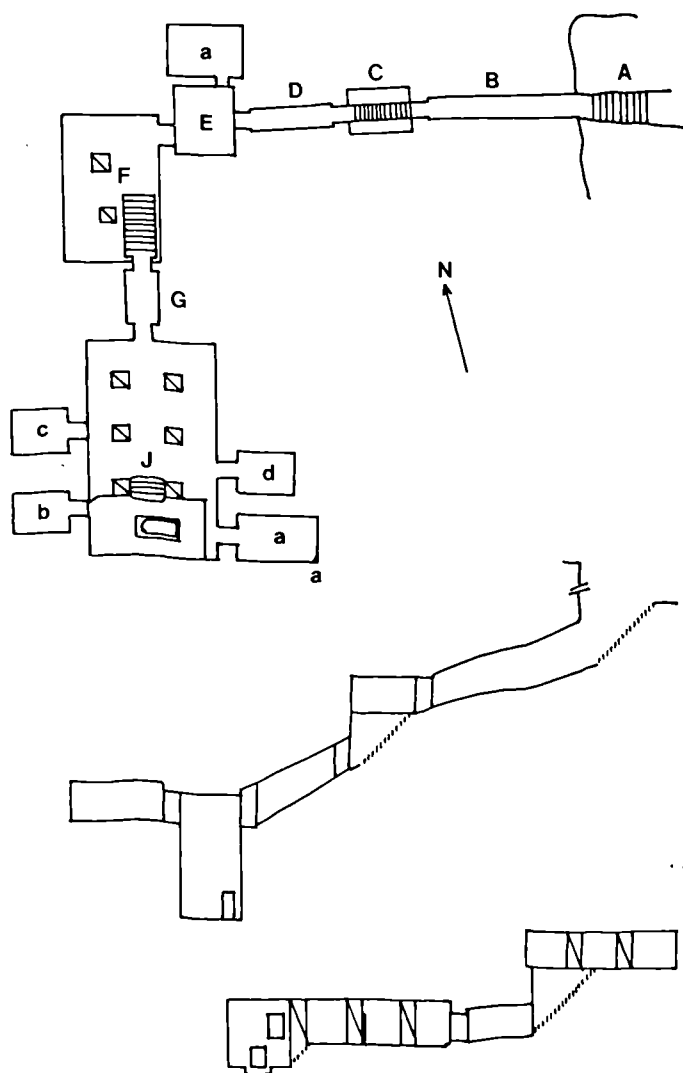
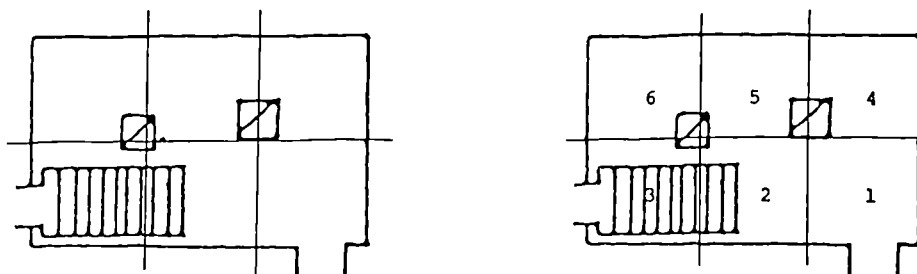

Fig. 91: KV35

it should, from a close scrutiny of the tomb's plan, be possible to suggest how and where he drew his divisions.

For the antechamber this is comparatively straightforward. Since the room contains two symmetrically-positioned pillars, it is fair to assume that they were employed to mark the intersections of the grid; cf. fig. 92. The numbering employed may be established by comparing Loret's brief description of the in situ layout of the more significant pieces with the designations attached to these same pieces (where they can be recognised) in Daressy's catalogue. Thus, Loret's 'grand serpent roulé sur lui-même',<sup>93)</sup> found near to the entrance doorway, can be identified as CG 24628 from section 1;<sup>94)</sup> 'deux grandes barques', found 'entre le pilier et le mur du droite',<sup>95)</sup> are CG 4944 and 4946 from section 4;<sup>96)</sup> whilst 'entre les deux colonnes',<sup>97)</sup> was another barque, CG 4945 from section 5.<sup>98)</sup> From these data, it is possible to reconstruct the numbered grid plan in fig. 93.



Figs. 92-93: the antechamber grid (KV35)

The system that was employed to divide the burial chamber into 17 sections is less easy to discern. If we assume that each column marks the corner of a grid square, as in (F), the upper part of the burial chamber (the chariot hall) may be divided into nine neat sections. It is then possible to see how Loret arrived at his odd total of 17 grid squares: for, if we continue the longitudinal divisions of the chariot hall into the crypt, <sup>and divide the crypt</sup> laterally through the sarcophagus, a logical if rather unequal division into eight further sections can be obtained - the two narrow divisions formed, of course, by the continuation of the chariot hall surface at the crypt's eastern end. Cf. fig. 94.

It is fair to assume that Loret numbered each sector in a fashion analogous to that employed in the antechamber, i.e. working from the entrance in, numbering across the chamber in parallel rows; and the correctness of this assumption can be demonstrated by the section numbers given to 'une grande Sekhet, en bois bitumé'<sup>99)</sup> (= CG 24620 from section 3)<sup>100)</sup> and a shabti inscribed with 'le nom du prince royal Oubkh-snou'<sup>101)</sup> (= CG 24272 presumably, from section 3):<sup>102)</sup> 'on a peine à les distinguer' from the entrance to the chamber.<sup>103)</sup> It is evident, moreover, that Loret numbered each horizontal row of squares (as one stands in the doorway) from right to left, as in the antechamber: for, 'dans l'angle gauche' of the crypt, 'au fond', Loret notes 'une grande tête de vache, en bois, de grandeur naturelle',<sup>104)</sup> which is clearly CG 24630 from section 15.<sup>105)</sup>

The only real uncertainty in this reconstruction relates to the ledge just outside the second room on the left hand side of the burial chamber. This, as already suggested, seems to have been divided into two sections. According to the present reconstruction, these were numbered only after the main sequence 1-15 had been established; it may well have been Loret's original intention to include objects found on this ledge with the material from sections 12 and 15. The relative paucity of pieces noted for squares 16 and 17, as compared with the mass of faience and wood attributed to the other squares at this end of the burial chamber, perhaps lends support to the numbering system adopted here: fig. 95.

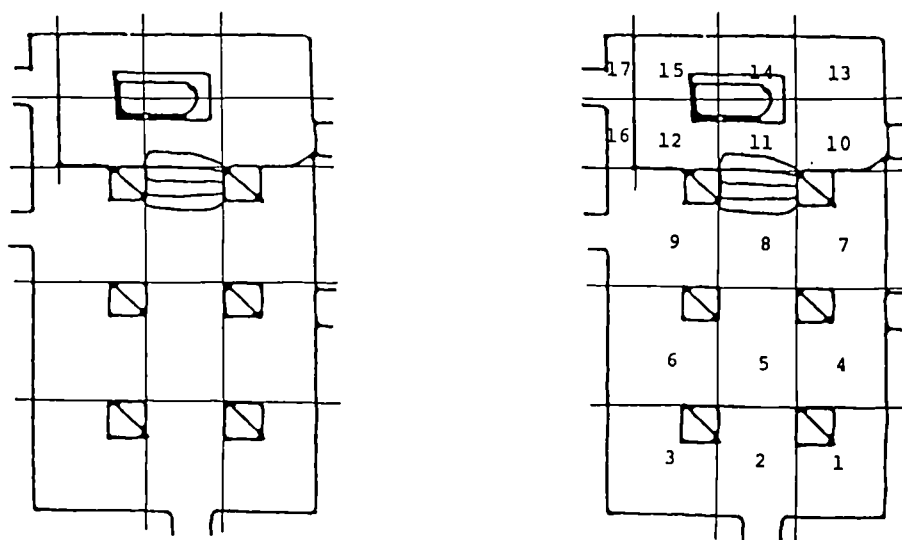

Figs. 94-95: the burial-chamber grid (KV35)

Although we have been able to suggest how Loret's grid was established and employed, in practical terms its value is severely restricted in that no distinction between finds from the antechamber and finds from the burial chamber may be detected in Daressy's listing of the tomb contents.<sup>106)</sup> Thus,

for the majority of the pieces<sup>107)</sup> recorded as having been recovered from sections 1-6, we cannot be certain whether these are grids 1-6 in the antechamber or grids 1-6 in the burial chamber. For pieces attributed to sections numbered 7 and above there is, of course, no ambiguity, since these numbers must relate to the burial chamber itself.

Loret's numbering of the four side rooms off the burial chamber may be established by reference to the descriptions given in his published report. The first chamber Loret entered was 'celle de gauche, au fond',<sup>108)</sup> i.e. (Ja). This was filled with the debris of 'une trentaine de grandes jarres, éventrées, ... des bouchons de terre glaise, des paquets d'étoffe, des viandes emmaillotées'.<sup>109)</sup> Amongst these are clearly to be recognised CG 24882-3 and 24889, attributed by Daressy to pièce 3.<sup>110)</sup> Next, Loret entered 'la première chambre à gauche',<sup>111)</sup> (Jd). Its contents consisted of 'des vases en porcelaine verte, la plupart en forme de vase hous, d'autres imitant le signe de la vie surmonté d'un goulet'.<sup>112)</sup> These are the series of vessels and amulets (CG 3860, 24351, etc.)<sup>113)</sup> originating in pièce 2; 'une panthère en bois bitumé',<sup>114)</sup> is evidently CG 24621, with the same attribution.<sup>115)</sup>

In the first chamber on the right of the burial chamber (Jc), Loret discovered 'trois cadavres ... côte à côte au fond, dans l'angle de gauche, les pieds tournés vers la porte. La partie droite de la chambre est emplie d'une quantité de petits cercueils

momiformes (CG 24283, etc.)<sup>116)</sup> et de statuettes funéraires (CG 24241, etc.),<sup>117)</sup> le tout en bois bitumé'.<sup>118)</sup> This, therefore, was Loret's pièce 1. Pièce 4, by process of elimination, was 'la seconde chambre à droite',<sup>119)</sup> walled-off and containing nine corpses, variously coffined. Finds here were relatively few, but included fragments of an alabaster representation of the 'baptism of pharaoh' (CG 24157)<sup>120)</sup> and three wooden funerary figures (CG 24610, 24628-9).<sup>121)</sup>

The contents of each of the burial chamber's four siderooms had thus been considerably confused since the original, 18th dynasty stocking of the tomb - though rooms (Ja), (Jc) and (Jd) appear to have preserved vestiges of their original contents in the form of provisions, objects of faience and shabtis respectively.<sup>122)</sup> Much of this material had been thrown out of the side rooms in antiquity, either wantonly in the search for valuables or deliberately when a re-use of one or other of the rooms was envisaged. The vast majority of the pieces thus thrown out appear subsequently to have found their way into the crypt.

To return to the occupants of the tomb. Amenophis II himself lay in what appears to have been a replacement coffin, 'specially inscribed',<sup>123)</sup> within the original stone sarcophagus, the lid of which lay nearby in fragments.<sup>124)</sup> It had clearly not been disturbed since antiquity, 'ayant vers la tête un bouquet de fleurs et sur les pieds une couronne de feuillage ...';<sup>125)</sup> the mummy itself 'était ... intacte, portant au cou une guirlande de feuilles et, sur la poitrine, un petit

bouquet de mimosa ...'.<sup>126)</sup> The cached mummies, as we have seen, were apparently confined to two of the burial chamber's four side rooms, (Jb) and (Jc): the former containing nine bodies, wrapped and in containers of one sort or another, the latter three anonymous bodies without coffins. A mummy found on the deck of a boat in the antechamber<sup>127)</sup> is probably to be connected with the corpses from (Jb) (see below), whilst the bones recovered from the well chamber (Ea) are perhaps to be connected with the original phase of the tomb's occupation under Amenophis II.<sup>128)</sup>

Loret's two descriptions of side room (Jb) are as follows:

J'y distingue ... neuf cercueils étendus sur le sol, six au fond, occupant toute la place, trois en avant, laissant à droite un petit espace libre. Il n'y a place, dans la longueur de la salle, que pour deux cercueils et, dans la largeur, que pour six, de sorte que les momies se touchent des coudes, des pieds, de la tête. Cinq des cercueils ont des couvercles. Quatre en sont dépourvus.<sup>129)</sup>

... Les cercueils et les momies étaient d'une teinte uniformément grise. Me penchant sur le cercueil le plus proche, j'y soufflai pour y lire un nom. La teinte grise était une couche de poussière qui s'envola et me laissa lire le nom et le prénom de Ramsès IV ... J'enlevai la

poussière du second cercueil: un cartouche s'y montra, illisible pour l'instant, peint en noir mat sur fond noir brillant. Partout des cartouches! Ici le prénom de Si-ptah; là, les noms de Séti II; plus loin, une longue inscription portant les titres complets de Thoutmès IV.<sup>130)</sup>

Thus, the first coffin which came to view was that of Ramesses IV; and since the only black coffin in the KV35 cache was that of Ramesses VI,<sup>131)</sup> his must have been the second. None of the other coffins can be placed with any degree of certainty from these vague descriptions alone. However, further on in the published report<sup>132)</sup> Loret appends a numbered list of what, it transpires, are the occupants of this chamber, arranged in a non-chronological order and concluding, significantly, with Ramesses VI and Ramesses IV:

- (1) Tuthmosis IV;
- (2) Amenophis III (coffin box of Ramesses III; lid of Sethos II);
- (3) Sethos II;
- (4) 'Akhenaten' (= Merenptah)<sup>133)</sup> (coffin box of Sethnakhte);
- (5) Siptah;
- (6) Ramesses V;
- (7) 'Sethnakhte' (= unknown woman 'D')<sup>134)</sup> (lid of Sethnakhte);
- (8) Ramesses VI;
- (9) Ramesses IV.

In short, it would appear that the ordering of this list reflects the positions in which Loret first encountered the mummies in (Jb), numbered in horizontal rows from top left to bottom right. Cf. fig. 96.

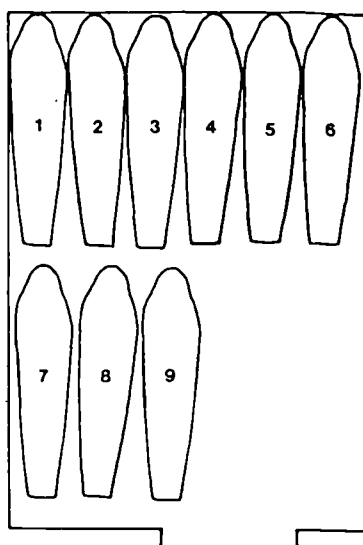

Fig. 96: reconstructed layout, (Jb) cache (KV35)

As found, the doorway into (Jb) had been sealed off by means of a wall of limestone blocks, which had been breached at the top right hand corner.<sup>135)</sup> Several of the blocks carry odd groups of hieratic signs<sup>136)</sup> which had evidently been inscribed when the blocks were arranged differently.<sup>137)</sup> When re-assembled into something approaching their original order, they appear to constitute a record of inspection in an indeterminate Year 13:

Year 13 ... This day ... inspection ...<sup>138)</sup>

The occupants of side room (Jc)<sup>139)</sup> differed from the (Jb) group of corpses in that they lacked coffins and had not been rewrapped.<sup>140)</sup> Only one of the three

bodies has been identified with any certainty: that of the 'Elder Woman',<sup>141)</sup> whom recent scientific study has shown to be Tiye, wife of Amenophis III.<sup>142)</sup> Her companions in room (Jc), a young boy<sup>143)</sup> and a youthful woman,<sup>144)</sup> remain unidentified. A toe belonging to the former was discovered in (Jd);<sup>145)</sup> this, combined with the fact that the left hand side of this room had been cleared in antiquity,<sup>146)</sup> suggests that the boy had at one stage been stored within.

The available archaeological evidence is not easily interpreted. The situation has been confused, moreover, by the assumptions (a) that the Year 13 inspection graffito referred to the contents of room (Jb),<sup>147)</sup> and thus had originally been inscribed when the blocks were employed to seal off this side room, and (b) that this closure had subsequently been completely dismantled and the component blocks re-erected in a different order. However, the introduction into or extraction from the cache of one or more mummies would demonstrably not have required the removal of more than the top few courses.<sup>148)</sup> An alternative hypothesis would be to see the extant blocking of (Jb) as the remains of an original build unconnected with the Year 13 graffito and in fact post-dating it by several years. Since the blocks in question had earlier been employed to close off the entrance to the burial chamber itself,<sup>149)</sup> I would suggest that the text had been written when the blocks were so associated. The inspection docket will, therefore, be a record of official activity within the tomb of Amenophis II before the (Jb) cache had been established.

The occupants of this room appear to have entered the tomb together, with a minimum of associated funerary furniture.<sup>150)</sup> The shrouds of Tuthmosis IV,<sup>151)</sup> Merenptah,<sup>152)</sup> Sethos II,<sup>153)</sup> Siptah,<sup>154)</sup> Ramesses IV<sup>155)</sup> and Ramesses V<sup>156)</sup> - even that of Amenophis II himself<sup>157)</sup> - each carry simple identifying docket, whilst the coffins of Sethos II,<sup>158)</sup> Siptah<sup>159)</sup> and Ramesses IV<sup>160)</sup> are of such similar design and workmanship that they can only have been supplied from the same workshop.<sup>161)</sup> There is a further indication of association. If, as I believe to be the case, the Year 13 inspection graffito is unconnected with the caching of the royal mummies, then we must presumably seek elsewhere an explanation for the potsherd containing black paint and inscribed with the prenomen and nomen of Siptah.<sup>162)</sup> It is tempting to connect this ad hoc palette with the hieratic docket written in black upon the coffin lid of Sethos II:<sup>163)</sup> this lid, together with a coffin box originally prepared for Ramesses III,<sup>164)</sup> had been employed to hold the mummy of Amenophis III, itself docketed with a restoration text dated to Year 12/13 of Smendes I<sup>165)</sup> (at which date the king's mummy was presumably still in its original tomb).<sup>166)</sup> The coffin lid docket is in a different hand, and is evidently later since it refers to the new owner as 'Nebmaatire-Amenophis l.p.h.' - in an attempt, presumably, to avoid confusion with Nebmaatiremerenamun Ramesses VI, with whom Amenophis III was now cached. Since the ad hoc palette probably entered KV35 with the mummy of Siptah himself, the latter's presence in the tomb at this time might also be postulated - and thus that of

the other royal dead whose association with this king has been noted above. In short, the cumulative evidence seems strongly to suggest that the occupants of the (Jb) cache had been gathered up from various tombs and earlier caches and walled into their chamber on a single occasion. The date of this transfer cannot be tied down with any precision, but presumably will not predate the apparent whm krs of Amenophis III within WV22 in Year 12/13 of Smendes I.

The difference in condition between the (Jc) group of corpses and those found in room (Jb) is striking, and would suggest, perhaps, that the former had been introduced into the tomb after the restoration of Amenophis II and the introduction of the coffined mummies in (Jb) - perhaps by the same officials, since their wrappings had been adzed off in an analogous fashion to those of the (Jb) corpses.<sup>167)</sup> The fact that a toe belonging to the naked prince was recovered from room (Jd) across the burial chamber<sup>168)</sup> seems to indicate that the partial clearance of this room had at some stage been carried out for the accommodation of him and his two companions. Their placement in room (Jc) will presumably have followed an unsettled period during which their remains were subjected to some violence - hence the detached toe - and, indeed, subsequent illicit activity can be detected elsewhere in the tomb. The renewed coffin of Amenophis II, for example, had been broken through at the foot end of the lid;<sup>169)</sup> whilst the blocking of the side room (Jb) cache had been partially dismantled<sup>170)</sup> and the two bodies closest to the entrance roughly searched for

objects of value.<sup>171)</sup> It is possible that the mummy of Sethnakhte was also removed from (Jb) at this time. His original presence in KV35 is suggested by the fact that his cartonnage coffin box had been employed to contain the mummy of Merenptah, whilst the lid held the body of the unknown woman 'D'. Sethnakhte himself had perhaps been dragged out of room (Jb) - hence the fragments of his cartonnage in the debris of the tomb<sup>172)</sup> - and stripped in the search for loot. The body itself is probably to be recognised as that found by Loret resting upon the deck of a model boat in the antechamber (F).<sup>173)</sup>

This plundering evidently did not go undetected, since there are clear indications that the tomb was subsequently re-organised. The three naked mummies, perhaps thrown out from their original storage place (Jd), were collected together within (Jc); the disturbed occupants of room (Jb) were re-arranged into some semblance of order; and Amenophis II was garlanded with wreaths and flowers.

To sum up, I would suggest the following sequence for the discernible post-interment activity within the tomb of Amenophis II: (a) robbery of the tomb at an undetermined date, resulting in a period of inspection/restoration perhaps in Year 8 of Ramesses VI(??) (n. 138 above), and certainly in Year 13 of a king whose name is not preserved; (b) the establishment of the cache in room (Jb), at the time the burial of Amenophis II himself was refurbished; (c) the introduction of the three unwrapped and uncoffined mummies, which were perhaps

placed within (Jd); (d) a further period of illicit activity, during which the mummy of Amenophis II and the cached mummies within (Jb) and (Jd) were disturbed; followed by (e) a final period of inspection, when the tomb was set in order and finally reclosed.

TABLE 3

## DB320: CONSPECTUS OF MAIN FINDS

## Abbreviations employed:

AE	Murray, <u>AE</u> (1934)
ASAE	Daressy, <u>ASAE</u> 9 (1908)
CCR	Daressy, <u>Cercueils</u>
MR	Maspero, <u>Momies royales</u>
RM	Smith, <u>Royal Mummies</u>

No.	Name	Coffin(s)	Body	Other items	References	Remarks
1.	Ahhotpe II	x			MR 544 f., 570, 581 CCR 8 f.	Coffin contained mummy of Pinudjem I (34)
2.	Ahmoose- Hentempet	x	x		CCR 24 ff. RM 20 f.	
3.	Ahmoose- Henttimehu	x	x		CCR 17 RM 19	Cf. MR 543 f. & (20) below
4.	Ahmoose- Inhapi		x		MR 530 ff. RM 8 ff.	Mummy contained in coffin of Rai (36)
5.	Ahmoose- Meryetamun		x		MR 539 f. RM 6 ff.	Mummy contained in coffin of Seniu (41)
6.	Ahmoose- Nofretiri	x	x?	4 calcite canopic jars	MR 535 f. CCR 3 f. RM 13 f.	Coffin also contained mummy of Ramesses III (39)
7.	Ahmoose- Sipair	x	x		CCR 9 f. RM 22 ff.	Cf. (19)
8.	Ahmoose- Sitkamose		x		MR 540 ff. RM 21 f.	Mummy contained in coffin of Pediamun (33)
9.	Amenophis I	x	x		MR 536 f. CCR 7 f. RM 18	
10.	Amosis I	x	x		MR 533 ff. CCR 3 RM 15 ff.	
11.	(anon.)	x	x		MR 548 ff. CCR 39 RM 114 ff.	The unknown man 'E'

TABLE 3/2

No.	Name	Coffin(s)	Body	Other items	References	Remarks
12.	(anon.)		x		MR 552, 582 (6) RM 14 f.	The unknown woman 'B' (= Maspero's 'Ramesses I'); Tetisheri? Orig. within (37)?
13.	(anon.?)		x		MR 574 ff. RM 31 f.	The unknown man 'C' found in coffin of Nebseni (28); Nebseni?
14.	(anon.)	x	x		MR 582 (2)	Female coffin
15.	(anon.)	x	x		MR 582 (3)	Male coffin without lid
16.	(anon.)	x	x		MR 582 (3)	Male coffin without lid
17.	(anon.)	x	x		MR 582 (3)	Male coffin without lid
18.	(anon.)	x	x		MR 582 (4)	Box coffin
19.	(anon.)	x			MR 582 (5)	Child's coffin; Ahmose-Sipair? (7)
20.	Bakt	x	x?		CCR 20 RM 56 f.	MR 544 attributes coffin & corpse to a fictitious 'Meshenuttimehu' in error; cf. CCR 17, n. 1 & (3) above
21.	Djedptah- iufankh	x	x	3 shabti boxes, Ptah-Seker-Osiris (with papyrus)	MR 572 ff., 590, 592 CCR 200 ff. RM 112 ff.	
22.	Duathathor- Henttawy	x	x	2 shabti boxes, Ptah-Seker-Osiris (with papyrus).	MR 576 f., 590, 592 CCR 63 ff. RM 101 ff.	Inner & outer coffins (outer lid missing)
23.	Hatshepsut			Wooden box containing a liver or spleen	MR 584 (6)	

TABLE 3/3

No.	Name	Coffin(s)	Body	Other items	References	Remarks
24.	Isiemkheb	x	x	Leather shrine, stand with 4 copper vases, provisions, broken shabti boxes, Ptah-Seker-Osiris (with papyrus)	MR 577, 584 ff. CCR 134 ff. RM 106 f.	
25.	Maatkare-Mutemhet	x	x	2 shabti boxes, Ptah-Seker-Osiris (with papyrus), pet baboon	MR 577, 590 ff. CCR 82 ff. RM 98 ff.	
26.	Masaharta	x	x	Remains of leather shrine?	MR 571, 589 CCR 66 ff. RM 106	
27.	Merymose			Calcite canopic jar with wooden lid	MR 583 (5)	
28.	Nebseni	x			MR 574 ff. CCR 20 ff.	Coffin contained body of the unknown man 'C' (13) (Nebseni?)
29.	Neskhons	x	x	Canopic jars, basket of glass/faience vessels, shabti box, Ptah-Seker-Osiris (with papyrus)	MR 566 ff., 578 f., 590 ff. CCR 110 ff. RM 107 ff.	One of Neskhons' coffins contained the mummy of Ramesses IX (40) when found
30.	Nestanebt-ishru	x	x	Broken shabti boxes	MR 579 ff. CCR 196 ff. RM 109 ff.	
31.	Nodjmet	x	x	Wooden canopic box, Ptah-Seker-Osiris (with papyrus)	MR 569 f., 592 f. CCR 40 ff. RM 94 ff.	

TABLE 3/4

No.	Name	Coffin(s)	Body	Other items	References	Remarks
32.	Paheripedjet	x			MR 582 CCR 34 ff. cf. RM 11	Coffin contained mummy of Rai (36)
33.	Pediamun	x			MR 540 CCR 12 ff.	Coffin contained mummy of Ahmose-Sitkamose (8)
34.	Pinudjem I	x	x	2 shabti boxes	MR 544 ff., 570, 581 CCR 50 ff.	Inner & outer coffins, originally prepared for Tuthmosis I; when found contained mummy (50). Mummy of Pinudjem I found in coffin of Ahhotpe (1)
35.	Pinudjem II	x	x	2(?) shabti boxes, Ptah-Seker-Osiris (with papyrus). Canopic jars?	MR 571 f., 592 ff. CCR 95 ff. RM 107	
36.	Rai	x	x		MR 530 CCR 4 ff. RM 11 ff.	Coffin contained mummy of Inhapi (4). Mummy of Rai found in coffin of Paheripedjet (32)
37.	Ramesses I	x			MR 551 f. CCR 26 ff. cf. RM 14	The mummy found near (originally within?) the fragmentary coffin was that of the unknown woman 'B' (12) (Tetisheri?)
38.	Ramesses II	x	x		MR 556 ff. CCR 32 ff. RM 59 ff.	
39.	Ramesses III	x	x		MR 535 f., 563 ff. CCR 34 RM 84 ff.	Cartonnaged mummy found in the coffin of Ahmose-Nofretiri (6)
40.	Ramesses IX		x	Ivory, wood & copper casket	MR 566 ff., 584 (7)	Mummy found in one of the coffins belonging to Neskhons (29)

TABLE 3/5

No.	Name	Coffin(s)	Body	Other items	References	Remarks
41.	Seniu	x			MR 539 CCR 11 f.	Coffin contained the mummy of Ahmose-Meryetamun (5)
42.	Seqenenre-Taa II	x	x		MR 526 ff. CCR 1 f. RM 1 ff.	
43.	Sethos I	x	x		MR 553 ff. CCR 30 f. RM 57 ff.	
44.	Siamun	x	x		MR 538 CCR 10 RM 18	
45.	Siese			Canopic jar	MR 583	
46.	Sitamun	x	x		MR 538 CCR 10 RM 19	
47.	Sutymose	x		Box	MR 584 (8-9)	The coffin is miniature, & contains bandages & an embalmed liver
48.	Tayuheret	x	x	Broken shabti boxes	MR 578, 590 CCR 171 ff. RM 105	
49.	Tetisheri			Mummy bandages	AE 69 ASAE 137	Cf. (12)
50.	'Tuthmosis I'		x		MR 581 f. RM 25 ff.	Mummy contained in coffins of Pinudjem I (34), which had originally been prepared for Tuthmosis I
51.	Tuthmosis II	x	x		MR 545 ff. CCR 18 RM 28 ff.	
52.	Tuthmosis III	x	x		MR 547 f. CCR 19 f. RM 32 ff.	

No.	Name	Coffin(s) Body	Other items	References	Remarks
53.	Wepnose		Calcite canopic jar	MR 583 (2)	
54.	Wepwawet- mose		Canopic jar	MR 583 (3)	

TABLE 4

## KV35: CONSPECTUS OF MAIN FINDS

## Abbreviations employed:

BIE Loret, BIE (3 sér.) 9 (1898)  
 CCR Daressy, Cercueils  
 FVR Daressy, Fouilles  
 RM Smith, Royal Mummies

No.	Name	Coffin	Body	Other items	References	Remarks
1.	Amenophis II	x	x	Cf. FVR 63 ff.	BIE 102, 108 RM 36 ff.	Coffin not in CCR
2.	Amenophis III	x	x	Cf. text	BIE 111 (2) CCR 217 f., cf. 221 f. RM 46 ff.	Body contained in coffin box of Ramesses III (11) covered with lid originally prepared for Sethos II (15) which had been docketed for Amenophis III
3.	(anon.)		x		BIE 103 f. RM 39 f.	'Webekhsenu'/ 'Webensenu'
4.	(anon.)		x		BIE 104 RM 40 ff.	The 'Younger Woman'
5.	(anon.)		x		BIE 111 f. RM 81 ff.	The unknown woman 'D'; formerly identified as Sethnakhte, in whose coffin lid (16) she was found
6.	(anon.)		x		BIE 100 f.	The body on the boat (Sethnakhte?)
7.	(anon.)		x		BIE 112	Skull only (Hatshepsut-Meryetre? Webensenu?)
8.	(anon.)		x		BIE 112	Skull only (Hatshepsut-Meryetre? Webensenu?)
9.	Hatshepsut-Meryetre			Cane	FVR no. CG 24112	Owner of (7)/(8)?

No.	Name	Coffin Body	Other items	References	Remarks
10.	Merenptah	x		BIE 111 (4) RM 65 ff.	Mummy contained in coffin box of Sethnakhte (16)
11.	Ramesses III	x		BIE 111 (2) CCR 221 f.	Coffin box only; contained mummy of Amenophis III (2), covered with lid of Sethos II (15) docketed for Amenophis III
12.	Ramesses IV	x	x	BIE 112 (9) CCR 222 ff. RM 87 ff.	
13.	Ramesses V	x	x	BIE 111 (6) CCR 224 RM 90 ff.	Mummy on the base of a coffin with no lid
14.	Ramesses VI	x	x	BIE 112 (8) CCR 224 ff. RM 92 ff.	
15.	Sethos II	x	x	BIE 111 (2-3) CCR 217 f. RM 73 ff.	The coffin box & lid covering (2) not originally associated
16.	Sethnakhte	x		BIE 111 (4) CCR 219 ff., 226(?)	Coffin box contained the mummy of Merenptah (10). The lid, turned upside down, held the anonymous woman 'D' (5). Cf. (6) above
17.	Siptah	x	x	'Palette' BIE 111 (5) CCR 218 f. RM 70 ff. FVR no. CG 24880	
18.	Tiye		x	BIE 103 RM 38 f.	The 'Elder Woman'
19.	Tuthmosis IV	x	x	BIE 111 (1) CCR 217 RM 42 ff.	
20.	Webensenu		Shabtis, canopic jar	FVR nos. CG 24269-73, 5031	Owner of (7)/(8)?

TABLE 5

## DB320: THE MUMMIES

## Abbreviations employed:

ASAE Derry, ASAE 34 (1934)  
 MR Maspero, Momies royales  
 RM Smith, Royal Mummies  
 XRA Harris & Wente, Atlas  
 XRP Harris & Weeks, X-Raying

No.	Name	CG no.	Description	References
1.	Ahmose- Henttempet	61062	Superficially intact, but hole in bandages over breast. Beneath the shroud, perhaps rewrapped with original wrappings. Both forearms broken off, with only fragments of right still remaining; detached left forearm replaced transversely across body, below wig	RM 20 f., pl. 15
2.	Ahmose- Henttimehu	61061	Superficially intact, with type A docket on breast. Original bandages apparently (a portion inscribed with extracts from the Book of the Dead), but those beneath chopped away. Body intact	MR 543 f. RM 19
3.	Ahmose- Inhapi	61053	Superficially intact, garlanded with flowers. Type A docket on breast. Wrappings powdery and dry to touch like (33). Body intact	MR 530 f. RM 8 ff.
4.	Ahmose- Meryetamun	61052	Superficially intact, type A docket on breast. Beneath, fragment of linen inscribed <u>pr mwt</u> , 'temple of Mut', and inner shroud with extracts from the Book of the Dead inscribed for a <u>h3ty-C</u> named Mentuhotpe. Body wall broken in, right arm pulled off and left forearm separated. X-rays reveal beads in pelvic area	MR 539 f. RM 6 ff. XRP 130 XRA 3C11- 3D6
5.	Ahmose- Nofretiri(?)	61055	Perhaps superficially intact, if 'd'assez mauvaise apparence'. Left hand broken off and lost; right hand and part of forearm broken off and lost. Impression of leaf-shaped embalming plate	MR 535 f. RM 13 f. XRP 127 f. XRA 3B5-12
6.	Ahmose- Sipair	61064	Superficially intact. Several inner bandages inscribed with ink notations (Book of the Dead?), unpublished. Body rewrapped on a stick, several bones missing	RM 22 ff., pl. 19, 2

No.	Name	CG no.	Description	References
7.	Ahmoose- Sitkamose	61063	Superficially intact, garlanded with flowers. Type A docket on breast, type B text on next innermost layer. Beneath, rewrapped with original wrappings. Major part of anterior wall of body chopped through. Left arm broken off at shoulder, and occipital region of skull smashed. Impressions of original jewellery in resin on body. X-rays reveal a pectoral in the oropharynx	MR 540 ff. RM 21 f. XRA 3C2-9
8.	Amenophis I	61058	Superficially intact, garlanded with flowers. Cartonnage casque. Orange shroud. Not unwrapped. X-rays reveal that body is intact, with bead girdle and small amulet on right arm	MR 536 f., pl. 4, b RM 18, pl. 13 ASAE 47 f. XRP 32 f., 129 f. XRA 1A13- 1B8
9.	Amosis I	61057	Superficially intact, garlanded with flowers. Type A docket on breast, type B text three layers beneath. With innermost wrappings, fragment of linen with name of Amenophis I. Head broken off trunk and nose smashed. Cranial cavity stuffed with linen (21st dynasty?). X-rays reveal beads sprinkled around knees	MR 533 ff., pl. 4, b RM 15 ff. XRP 125 ff. XRA 1A4-11
10.	(anon.)	61098	Unknown man 'E'. Apparently intact, covered with a sheepskin and accompanied by two sticks	MR 548 ff. RM 114 ff.
11.	(anon.)	61056	Unknown woman 'B' (Tetisheri?). Bandages for the most part removed, and mummy wrapped in matting. Head broken off trunk, right hand missing	MR 582 (6) RM 14 f. XRP 120 f. XRA 4A2-8
12.	(anon.?)	61067	Unknown man 'C' (probably Nebseni). Bandages disturbed. Body apparently intact	MR 574 ff. RM 31 f.
13.	(anon.)	-	Table 3, no. 14. Perhaps superficially intact. Apparently not examined	MR 582 (2)
14.	(anon.)	-	Table 3, no. 15. Perhaps superficially intact. Apparently not examined	MR 582 (3)
15.	(anon.)	-	Table 3, no. 16. Perhaps superficially intact. Apparently not examined	MR 582 (3)
16.	(anon.)	-	Table 3, no. 17. Perhaps superficially intact. Apparently not examined	MR 582 (3)

No.	Name	CG no.	Description	References
17.	(anon.)	-	Table 3, no. 18. Perhaps superficially intact. Apparently not examined	MR 582 (4)
18.	Bakt(?)	61076	Garlanded with flowers, but wrappings chopped through revealing a yellow-varnished coffin fragment, mirror handle, etc., and the bones of a young woman	MR 544 RM 56 f.
19.	Djedptah- iufankh	61097	Intact. Series of amulets and other items of jewellery. Copper-alloy embalming plate	MR 572 ff. RM 112 ff. XRA 4D11-4E6
20.	Duathathor- Henttawy	61090	Disturbed, with hole dug through bandages in front of thorax and abdomen. Osiris shroud. Several amulets etc. in wrappings (cf. x-rays). Body apparently intact	MR 576 f. RM 101 ff. XRP 172 f. XRA 3F3-11
21.	Isiemkheb	61093	Intact. Not unwrapped. Osiris shroud. X-rays reveal various items in wrappings. Body intact	MR 577, pl. 6, c RM 106 f., pl. 80 XRP 173 XRA 3F13-3G8
22.	Maatkare- Mutemhet	61088	Disturbed, wrappings of right arm slit in search for jewellery. Leather thong around head originally for amulet (missing). Three gold and silver rings on each thumb. X-rays reveal embalming plate (contra Smith). Left forearm broken	MR 577, pl. 19, b RM 98 ff. XRP 173 ff. XRA 3E5-3F1
23.	Masaharta	61092	Disturbed by Arabs and papyrus stolen. Impressions of 'braces' and pectoral ornament in skin on chest. One gold finger stall still in position on middle finger of right hand. Body apparently intact	MR 571 RM 106
24.	Neskhnos	61095	Intact. Osiris shroud. No objects of value noted. Body intact	MR 578 f. RM 107 ff.
25.	Nestanebt- ishru	61096	Intact. No objects of value noted, but distinct impression of embalming plate. Body intact	MR 579 ff. RM 109 ff.
26.	Nodjmet	61087	Disturbed by Arabs and papyrus stolen. Osiris shroud. Beneath, evidence of more ancient damage: gashes on both cheeks, bridge of nose, forehead and front of chest. Left humerus broken close to shoulder and both wrists broken; legs badly injured. Impressions of jewellery on right arm, some minor pieces still remaining elsewhere on body. X-rays reveal heart scarab and four sons of Horus	MR 569 f. RM 94 ff. XRP 171 XRA 3D3-3E3

No.	Name	CG no.	Descriptions	References
27.	Pinudjem I	-	Disturbed. Osiris shroud. Body perhaps intact	MR 570
28.	Pinudjem II	61094	Intact. Osiris shroud. The wrapping 'disposé exactement comme celui de Ramsès III' except that one of the layers of linen was there replaced by a halfa-grass mat. Series of amulets and other items of jewellery. Body intact	MR 571 f. RM 107
29.	Rai	61054	Presumably disturbed, surrounded in the coffin by a large quantity of linen. Impression of fusiform embalming plate, and barrel-shaped carnelian bead on right wrist. Body intact.	RM 11 ff.
30.	Ramesses II	61078	Superficially intact. Type B text beneath outer wrappings. Nut shroud. Body intact, except for genitals which are missing	MR 556 ff. RM 59 ff. XRP 155 XRA 2B3-11
31.	Ramesses III	61083	Superficially intact. Orange outer shroud, with 'figures mystiques' on retaining band around head. Beneath shroud, type B text and drawing of the winged ram of Amun. Several layers beneath this, various linen notations, etc., a number of which make mention of <u>imn-r<sup>c</sup>-hnm-nhh hry-ib t3 hwt</u> , 'Amon-Re-United-with-Eternity who is in the midst of the temple' (i.e. Medinet Habu), and two pectorals. Body intact. X-rays reveal three sons of Horus in left side of thoracic cage	MR 563 ff., pl. 17, a-b RM 84 ff. XRP 164 XRA 2E7- 2F2
32.	Ramesses IX	-	Superficially intact, garlanded with flowers. Beneath, type B text on breast. Not fully unwrapped. Head apparently detached from body, which is perhaps partly disarticulated	MR 566 ff. XRA 3A7- 3B3
33.	Seqenenre-Taa II	61051	Superficially intact. Beneath shroud, remains of original bandages. No objects noted. Body disarticulated owing to poor mummification	MR 526 ff. RM 1 ff. XRP 122 ff. XRA 1A2
34.	Sethos I	61007	Superficially intact. Yellowish shroud; beneath, original bandages put in order. Type B text and type A docketts. Head detached from body, anterior wall of abdomen broken in. X-rays reveal large <u>wd3t</u> -eye on left arm and other minor items	MR 553 ff. RM 57 ff. XRP 43, 152 f. XRA 2A5- 2B1

No.	Name	CG no.	Description	References
35.	Siamun	61059	Superficially intact, type A docket on breast. Several layers beneath, type B text. Body disarticulated: bones thrown pell-mell into an oblong bundle	MR 538 RM 18
36.	Sitamun	61060	Superficially intact, type A docket on breast. 'Body' consisted of a bundle of reeds surmounted by a skull	MR 538 RM 19
37.	Tayusheret	61091	Disturbed. Osiris shroud. No objects within wrappings other than a plain, fusiform embalming plate. Body intact	MR 578 RM 105
38.	'Tuthmosis I'	61065	Disturbed, wrappings in tatters. Body intact	MR 581 f. RM 25 ff. XRP 131 ff. XRA 1B10-1C5
39.	Tuthmosis II	61066	Superficially intact, garlanded with flowers. Beneath outer shroud, remains of original wrappings. Left arm broken off at shoulder joint and forearm separated at elbow. Right arm chopped off just above elbow. Whole of anterior abdominal wall broken away; ribs smashed. Right leg severed from body	MR 545 ff. RM 28 ff. XRA 1C7-1D3
40.	Tuthmosis III	61068	Superficially intact, apart from hole dug in chest. Body restored around four oars. Head broken from body and all four limbs detached. Feet broken off and each arm broken at elbow. Right arm and forearm tied to a piece of wood by a mass of fine linen. Remains of jewellery on shoulders beneath innermost bandages. X-rays reveal bracelet on right arm	MR 547 f., pl. 6, a RM 32 ff. XRP 38, 136 ff. XRA 1D5-1E2

TABLE 6

## KV35: THE MUMMIES

## Abbreviations employed:

BIE Loret, BIE (3 sér.) 9 (1898)  
 RM Smith, Royal Mummies  
 XRA Harris & Wente, Atlas  
 XRP Harris & Weeks, X-Raying

No.	Name	CG no.	Description	References
1.	Amenophis II	61069	Superficially intact, garlanded with flowers. Type A docket on breast. Beneath shroud, gashes in wrappings (especially on legs). Impressions of jewellery in resin, in particular of pectoral ornament in resin covering fifth dorsal spine. Body intact	BIE 108 RM 36 ff. XRP 138 f. XRA 1E3-1F1
2.	Amenophis III	61074	Superficially intact, fragments of garlands lying upon the mummy. Type B text on shroud. Several layers beneath, a sheet with red lines and hieroglyphs in black (Book of the Dead?); an inner bandage wound spirally around head and neck with a hieratic inscription in black ink (unpublished). Head broken off; front wall of body missing; back broken across loins. Right leg broken off trunk, and thigh separated from rest of leg. Left foot damaged. Bandaged in with mummy: leg bone of a fowl; another bird's limb bone; a human big toe; and a left ulna and radius. Skin packed with a resinous material	BIE 111 (2) RM 46 ff., pl. 32 XRA 1F11-1G9
3.	(anon.)	61071	Table 4, no. 3. Unwrapped. Large gash in left side of neck and thorax. Large oval hole in right side of frontal bone	BIE 103 f. RM 39 f.
4.	(anon.)	61072	Table 4, no. 4. Unwrapped. Exterior wall of chest smashed; left side of mouth broken away; right arm torn off just below shoulder	BIE 104 RM 40 ff.
5.	(anon.)	61082	Unknown woman 'D'. Disturbed. Bandages applied very carelessly. Hole in abdominal wall in epigastrium. Body otherwise intact	BIE 111 f. (7) RM 81 ff., pl. 67 XRA 4D2-9
6.	(anon.)	-	Table 4, no. 6 (the body on the boat). Unwrapped. Hole in sternum; skull pierced. Body otherwise intact	BIE 100 f.

No.	Name	CG no.	Description	References
7.	(anon.)	-	Table 4, no. 7. Skull only. Hatshepsut-Meryetre? Webensenu?	BIE 112
8.	(anon.)	-	Table 4, no. 8. Skull only. Hatshepsut-Meryetre? Webensenu?	BIE 112
9.	Merenptah	61079	Superficially intact, type A docket on breast. Beneath shroud, remains of original wrappings carelessly put in order. Impression of embalming plate. Penis end broken off and missing. Adze cuts all over body; right arm broken and anterior abdominal wall chopped away. Two toes missing (cf. (12) below). Hole in head	BIE 111 (4) RM 65 ff., pl. 45 XRP 157 XRA 2B12- 2C8
10.	Ramesses IV	61084	Superficially intact, type A docket on breast. Beneath shroud, mass of rags thrown around body. Foot broken off and finger nails displaced and lost. Hole in head	BIE 112 (9) RM 87 ff. XRP 165 f. XRA 2F3-12
11.	Ramesses V	61085	Superficially intact, type A docket on breast. Beneath, mass of torn bandages, a second sheet and more rags. Tips of fingers of left hand sliced off. Hole in head	BIE 111 (6) RM 90 ff. XRP 166 f. XRA 2G1-10
12.	Ramesses VI	61086	Disturbed, linen shroud pulled away from upper part. Below, mass of rags. Body rewrapped on board. Right forearm chopped off at elbow and wrist, with adze-cuts on right thigh (still in original wrappings). Hip bone and pelvis found at neck; elbow and humerus on right thigh, etc. Bandaged in with mummy; broken pieces of the head; the right hand of a woman; the distorted and mutilated right hand and forearm of a man (cf. (13) below)	BIE 112 (8) RM 92 ff., pl. 58 XRP 167 f. XRA 3A1-6
13.	Sethos II	61081	Superficially intact, type A docket on breast. Beneath shroud, original wrappings and several garments, one with the cartouche of Merenptah, and hieratic inscriptions in ink (unpublished). Sphinx amulets, blue faience <u>wdjt</u> -eyes and scarab around knee in resin. Head broken off body, and neck broken. Both arms separated from torso; right forearm and hand missing (cf. (12) above), as well as several fingers from left hand. Part of anterior wall of body broken away. Adze marks on skin	BIE 111 (3) RM 73 ff., pl. 64 XRP 158 f. XRA 2D9- 2E5

No.	Name	CG no.	Description	References
14.	Siptah	61080	Superficially intact, type A docket on breast. Beneath shroud, body rewrapped with original bandages. Inscribed piece of linen (Book of the Dead?). Right forearm broken and fixed by means of splints. Right cheek and front teeth smashed and lost. Ears broken off. Right arm broken at shoulder and right hand broken from forearm. Body wall broken through	BIE 111 (5) RM 70 ff., pl. 60 XRP 159 f. XRA 2C9- 2D8
15.	Tiye	61070	Unwrapped. Whole of front of abdomen and part of thorax broken away	BIE 103 RM 38 f. XRP 135 f. XRA 4C5- 4D1
16.	Tuthmosis IV	61073	Superficially intact, type A docket on breast. Stretched out on white-painted plank. Beneath shroud, body rewrapped with original bandages. Feet disarticulated, otherwise body intact	BIE 111(1) RM 42 ff. XRP 139 f. XRA 1F2-10

TABLE 7

DB320: THE COFFINS

232

## Abbreviations employed:

CCR      Daressy, Cercueils  
 JARCE    Niwiński, JARCE 16 (1979)  
 MR        Maspero, Mummies royales

No.	Name	CG no.	Descriptions	References
1.	Ahotpe II	61006	Original outermost coffin. Gold foil(?) covering removed and wood painted yellow	CCR 8 f.
2.	Ahmose-Hentempet	61017	Replacement 18th dynasty coffin. Painted black. Name of original owner erased and that of Ahmose-Hentempet substituted	CCR 24 ff.
3.	Ahmose-Hentimehu	61012	Original coffin, once gilded. Surface now adzed over and eye inlays removed	CCR 17
4.	Ahmose-Nofretiri	61003	Original outermost coffin. Gold foil(?) covering removed and wood painted yellow	CCR 3 f.
5.	Ahmose-Sipair	61007	Replacement(?) child's coffin, 18th dynasty type. All gilded surfaces adzed over and eye inlays removed. Type A docket on breast	CCR 9 f.
6.	Amenophis I	61005	Replacement coffin. Originally prepared for the w <sup>c</sup> b-priest Djehutymose, and redecorated and re-inscribed for Amenophis I. Type B texts on lid	CCR 7 f.
7.	Amosis I	61002	Original innermost coffin. Gold foil(?) covering removed and wood painted yellow	CCR 3
8.	(anon.)	61023	Table 3, no. 11. Replacement(?) coffin, the entire surface painted white. Uninscribed	CCR 39
9.	(anon.)	-	Table 3, no. 14. Female coffin. No details	MR 582 (2)
10.	(anon.)	-	Table 3, no. 15. Male coffin without lid. No details	MR 582 (3)
11.	(anon.)	-	Table 3, no. 16. Male coffin without lid. No details	MR 582 (3)

No.	Name	CG no.	Description	References
12.	(anon.)	-	Table 3, no. 17. Male coffin without lid. No details	MR 582 (3)
13.	(anon.)	-	Table 3, no. 18. Box coffin. No details	MR 582 (4)
14.	(anon.)	-	Table 3, no. 19. Child's coffin (Ahmose-Sipair (15)?)	MR 582 (5)
15.	Bakt	61015	Replacement coffin, 18th dynasty type. Surface adzed over(?) and eye inlays removed. Inscriptions in black ink	CCR 20
16.	Djedptah-iufankh	61034	(a) Original outer coffin, usurped from Nesshuenopet. Gilded left hand missing (b) Original inner coffin, usurped from Nesshuenopet. Intact (c) Original coffin board, usurped from (?). Intact	CCR 200 ff.
17.	Duathathor-Henttawy	61026	(a) Original outer coffin, lid missing. All gilded portions, with the exception of sacred images, adzed over (b) Original inner coffin. All gilded portions, with the exception of sacred images and main inscriptions, adzed over	CCR 63 ff.
18.	Isiemkheb	61031	(a) Original outer coffin. Intact (b) Original inner coffin. Gilded hands and face missing (c) Original coffin board. Gilded hands and face missing	CCR 134 ff.
19.	Maatkare-Mutemhet	61028	(a) Original outer coffin. Gilded left hand missing (b) Original inner coffin. Gilded hands and face missing (c) Original coffin board. Gilded hands and face missing	CCR 82 ff.
20.	Masaharta	61027	(a) Original outer coffin. Gilded right hand missing (b) Original inner coffin. Gilded hands and face missing (c) Original coffin board. Gilded hands and face missing	CCR 66 ff.
21.	Nebсени	61016	Original 18th dynasty coffin, gilded portions adzed over	CCR 20 ff.
22.	Neskhnos	61030	(a) Original outer coffin, usurped from a certain Isiemkheb. Intact (b) Original inner coffin, usurped from a certain Isiemkheb. Gilded hands and face missing. (c) Original coffin board, usurped from a certain Isiemkheb. Gilded hands and face missing	CCR 110 ff.

No.	Name	CG no.	Description	References
23.	Nestanebt- ishru	61033	(a) Original outer coffin. Intact (b) Original inner coffin. Intact (c) Original coffin board. Intact	CCR 196 ff.
24.	Nodjmet	61024	(a) Original outer coffin (originally made for a man). Gilded surfaces adzed over in their entirety, eye inlays removed (b) Original inner coffin (originally made for a man). Major portions of gilded surface adzed over; hands missing; eye inlays removed. Sacred images and main inscriptions preserved	CCR 40 ff. JARCE 62, n. 19
25.	Paheri- pedjet	61022	Original 20th dynasty coffin, employed for Ahmose-Inhapi. Intact	CCR 34 ff.
26.	Pediamun	61011	Original 21st dynasty coffin, employed for Ahmose-Sitkamose. Essentially intact	CCR 12 ff.
27.	Pinudjem I	61025	(a) 18th dynasty outer coffin, originally prepared for Tuthmosis I by Tuthmosis III, later appropriated and adapted by Pinudjem I. Major portions of 21st dynasty gilded surface adzed over. Sacred images and main inscriptions preserved (b) 18th dynasty second-innermost coffin, originally prepared for Tuthmosis I by Tuthmosis III(?), later appropriated and adapted by Pinudjem I. Major portions of 21st dynasty gilded surface adzed over. Sacred images preserved	CCR 50 ff.
28.	Pinudjem II	61029	(a) Original outer coffin. Intact (b) Original inner coffin. Intact (c) Original coffin board. Intact	CCR 95 ff.
29.	Rai	61004	Original outer coffin. Gilded surfaces adzed over and eye inlays removed. Isis and Nephthys at foot apparently preserved	CCR 4 ff.
30.	Ramesses I	61018	Replacement coffin, 21st dynasty type. Major portion of box missing. Type A docket on lid; type B text on head of box	CCR 26 ff.
31.	Ramesses II	61020	Original (or earlier) second-innermost(?) coffin. Original surface entirely removed, missing metal elements replaced in wood and the whole generally refurbished. Type B texts on lid	CCR 32 ff.

No.	Name	CG no.	Description	References
32.	Rameses III	61021	Replacement cartonnage. Traces of original gilding	CCR 34
33.	Seniu	61010	Original 18th dynasty coffin, employed for Ahmose-Meryetamun. Essentially intact	CCR 11 f.
34.	Seqenenre-Taa II	61001	Original coffin. Major portions of gilded surface, uraeus and eye inlays removed. Sacred symbols and main inscription preserved and restored	CCR 1 f.
35.	Sethos I	61019	Original outer(?)/second-innermost(?) coffin. Original surface entirely removed, face remodelled and coffin painted white overall with details in black. Type B texts on lid	CCR 30 f.
36.	Siamun	61008	Original inner(?) coffin, the gold foil(?) surface removed and the wood painted yellow	CCR 10
37.	Sitamun	61009	18th dynasty coffin, painted white, uninscribed. Type A docket on lid	CCR 10
38.	Sutymose	-	Miniature coffin, 20th(?) dynasty type, with bandages and embalmed liver	MR 584 (8), pl. 22, a
39.	Tayusheret	61032	(a) Original outer coffin, usurped from a songstress of Amun, Hatet. Gilded hands and face missing (b) Original inner coffin, usurped from a songstress of Amun, Hatet. Gilded hands and face missing (c) Original coffin board, gilded hands, face, etc. missing; some damage	CCR 171 ff.
40.	Tuthmosis II	61013	Replacement coffin, original owner unknown, redecorated and re-inscribed for Tuthmosis II	CCR 18
41.	Tuthmosis III	61014	Original second-innermost(?) coffin. All gilded surfaces adzed over and eye inlays removed	CCR 19 f.

## KV35: THE COFFINS

## Abbreviations employed:

BIE Loret, BIE (3 sér.) 9 (1898)  
 CCR Daressy, Cercueils  
 FVR Daressy, Fouilles

No.	Name	CG no.	Description	References
1.	Amenophis II	-	Replacement cartonnage coffin, inscribed for Amenophis II	BIE 108
2.	Amenophis III	61036	Replacement lid of Sethos II, any original decoration covered in yellow paint. Inscribed in same style as (4) and (9). Re-employed for Amenophis III by inscribing type A docket on breast	CCR 217 f.
3.	Ramesses III	61040	Original(?) coffin box of Ramesses III (re-employed to contain mummy of Amenophis III). All gilded surfaces adzed over. Too small to receive the cartonnage of Ramesses III from DB320	CCR 221
4.	Ramesses IV	61041	Replacement coffin, usurped from the w <sup>b</sup> -priest of Amenophis I, Ahaaa. Original decoration covered with a layer of plaster. Re-inscribed (in same style as (2) and (9)) in black ink for Ramesses IV	CCR 222 ff.
5.	Ramesses V	61042	Mummy of Ramesses V found upon the wooden base of a white-painted, rectangular wooden coffin	CCR 224
6.	Ramesses VI	61043	Replacement coffin, 18th dynasty type, usurped from the high priest of Menkheperre, Re. Name of original owner erased and replaced in ink with prenomen of Ramesses VI. Face missing	CCR 225 ff.
7.	Sethos II	61036-7	Replacement coffin box, uninscribed, the original decoration covered with a layer of plaster. Not originally associated with the lid in (2) above	CCR 218
8.	Sethnakhte	61039	Original cartonnage coffin, gilded surfaces adzed over	FVR no. 24737 CCR 219 ff.
9.	Siptah	61038	Replacement coffin, perhaps originally belonging to a woman. Original inscriptions adzed over and re-inscribed (in same style as (2) and (4)) in black ink for Siptah	CCR 218 f.

No.	Name	CG no.	Description	References
10.	Tuthmosis IV	61035	Replacement coffin, the remains of any original decoration covered with a layer of plaster. Re-inscribed for Tuthmosis IV with a column of neat hieroglyphs down the front	CCR 217

## CHAPTER 11

## THE DOCKETS

The most valuable body of evidence available to us from DB320 and KV35 is the series of docketts found upon the coffins and bandages of the cached mummies. Not only do these provide us with a valuable chronological framework for the history of the period, but, studied in conjunction with the more immediately relevant graffiti found upon the walls and in the vicinity of the royal tombs, they enable a good deal of headway to be made in reconstructing the movements of the mummies following the evacuation of their original tombs. Unfortunately, only a small proportion of the docketts (cf. tables 9-10) are accessible today. Of the remainder, a certain number are published in (often enhanced)<sup>1)</sup> photographs and in facsimiles of varying quality; others have never been published at all, casual mentions of their existence (sometimes with equally casual and frequently abbreviated translations) being all that is known of them today. Uncertainties abound, and the relocation and full publication of the relevant texts must be considered one of the priorities of future work in this area.<sup>2)</sup>

The veracity of the docketts

The consensus of modern scholarly opinion would seem to accept that the restoration parties involved in the rewrapping and reburial of the royal mummies were prone to confusing one body with another, and

that, consequently, the identifications which they attached to individual corpses are less than reliable.<sup>3)</sup> A re-examination of the history of the controversy suggests, however, that the unreliability of the docketts has been overstated.

Doubts seem to have first arisen when, in the summer of 1881, the mummies from DB320 arrived at Bulaq and it was found that several of the bodies had, in antiquity, become separated from their coffins and been replaced in containers to which they had no legitimate claim; cf. table 3. In 1898, Loret discovered that certain of the occupants of the second royal cache, KV35, had been subjected to a like confusion; cf. table 4. It was thus apparent to all that the identity of a corpse could not necessarily be assumed to be that specified by the formal inscriptions of the coffin.

Unfortunately, the validity of this conclusion was marred by Maspero's stated belief that one of the DB320 mummies, clearly labelled across the breast 'King's daughter, king's sister Meryetamun, may she live!',<sup>4)</sup> was in fact a corpse of the Middle Kingdom rewrapped as a replacement for the original 18th dynasty body which, he suggested, had been destroyed.<sup>5)</sup> The inference which seems then to have been drawn from this was that the identifications proclaimed by the docketts on the mummy need not, for whatever reason, indicate the true identity of the body;<sup>6)</sup> and although Maspero's doubts as to the ownership of the Meryetamun

body were effectively countered by Elliot Smith in 1912,<sup>7)</sup> the precedent had already been set that, where the anatomical data furnished by the corpse do not correspond with the expectations of the investigator, it is perfectly legitimate practice to dismiss the ancient attribution out of hand.<sup>8)</sup>

The subjectivity of this approach is exemplified by the treatment accorded mummies CG 61074 and 61073. As discovered by Loret in side room (Jc) of the KV35 cache,<sup>9)</sup> the former body was contained in a coffin box of Ramesses III and covered with a lid originally prepared as a replacement for Sethos II, later docketed in hieratic for 'Nebmaatre Amenophis l.p.h.'.<sup>10)</sup> The mummy itself had earlier been inscribed as follows (doubtful portions double underlined):

Year 12/13 3 prt 6. On this day renewing the  
burial of king Nebmaatre l.p.h. by the high  
 priest of Amon-Re king of the gods Pinudjem,  
son of the high priest of Amon-Re king of the  
 gods Piankh ...<sup>11)</sup>

The portions of the text which identify the mummy are clearly legible in the published photographs,<sup>12)</sup> and there can be no doubt that the 21st dynasty officials responsible for the execution of both the coffin and mummy dockets believed that CG 61074 was the body of Amenophis III. Nevertheless, Smith's observations that the method of 'stuffing under the skin of the legs, arms, neck, and perhaps other parts of the body, a resinous mass, which was moulded into

form' was 'analogous' to the 'process of packing that was revived three dynasties later',<sup>13)</sup> were subsequently taken by Derry to indicate that CG 61074 could not be the mummy of Amenophis III, despite the testimony of the texts.<sup>14)</sup> 'It is possible', suggested Derry, 'that this is an example of the mistakes which were apt to be made, when, owing to the frequent robberies of the tombs and desecration of the bodies, the priests undertook the removal and rewrapping of the mummies'.<sup>15)</sup> Despite the fact that the technique employed to pack this body 'is actually distinct from the method of the Twenty-first Dynasty in respect of the packing material',<sup>16)</sup> Derry's doubts have maintained their hold, and prompted at least one suggestion that CG 61074 is actually the mummy of Ramesses VI who bore a similar prenomen.<sup>17)</sup> Be this as it may - and it would not take us much further forward so far as the problem of embalming technique is concerned - there is no definite evidence that CG 61074 is the body of anyone other than Amenophis III, and the testimony of the docket cannot, in this case at least, be shown to be of dubious accuracy.

The reasons for doubting the identification of CG 61073, labelled as the corpse of Tuthmosis IV, are rather different, but equally tenuous. The coffin containing this body had clearly been prepared at some later date to accommodate Tuthmosis IV,<sup>18)</sup> and the docket on the breast of the mummy itself read 'Menkheprure',<sup>19)</sup> - the king's prenomen. The argument put forward by Giles,<sup>20)</sup> for one, is that Tuthmosis IV must have been older than the 28 years suggested by

an anatomical examination of this corpse<sup>21)</sup> - an observation which is especially pertinent in view of Baer's revival of a probable Year 20 of this king.<sup>22)</sup> It has in recent months been proposed, however, that the estimates of age at death so far put forward for the cached mummies are far less accurate than has hitherto been supposed,<sup>23)</sup> and on this basis alone much of the force of Giles' argument is lost.

As Winlock once argued, 'the docket written by the ancient officials must be accepted unless there is very strong evidence against it'.<sup>24)</sup> 'Very strong evidence' of the sort required apparently has yet to be produced, since there exists not one case where the identification of a docketed corpse can be shown to be false. Indeed, the fact that we possess several unidentified mummies from the DB320 cache in particular,<sup>25)</sup> which indicate that the restorers preferred to leave uninscribed any corpse concerning whose identity they had the slightest doubt, would seem indirectly to vouch for the reliability of those identifications they did feel confident enough to make.

#### Other problems of attribution

Before leaving the topic of mummy identification, a word should be said about those anonymous corpses identified by Maspero a short time after the discovery of DB320, often on very slender grounds.<sup>26)</sup> The improbability of several of Maspero's attributions was pointed out in 1912 by Smith.<sup>27)</sup> One attribution which seems to have gained general (if somewhat

grudging) acceptance, however, is that of CG 61065. Maspero's attribution of this mummy to Tuthmosis I<sup>28)</sup> was based upon its discovery in a pair of coffins which had been prepared for Tuthmosis I by Tuthmosis III (later usurped and adapted by Pinudjem I),<sup>29)</sup> and upon 'la ressemblance qu'il présente avec Thoutmos II'.<sup>30)</sup> Not only did Smith concur with Maspero in this identification, but he added fuel to the attribution by stating that the 'technique of mummification, ... as well as the position in which the arms are placed, indicates that the body was embalmed at a period earlier than that of Thoutmosis II and later than that of Ahmôsis I'.<sup>31)</sup> Harris, Kowalski and Walker have more recently restated the similarities between CG 61065 and Tuthmosis II, and they conclude that 'Smith and Maspero must be considered correct when they assume that these two mummies were closely related, but of course they could be brothers as well as father and son'.<sup>32)</sup> It should be noted that no archaeological evidence can be brought to bear to support either directly or indirectly the claims put forward for this corpse.

#### The types and terminology of the docket

Two basic types of docket are found associated with the cached mummies, written upon their linen wrappings, upon their coffins, and upon the walls of their tombs or on the surrounding cliffs. The two types are here distinguished as A and B, the location of the docket being indicated by the abbreviations LD (linen docket), CD (coffin docket) or WD (wall docket) as appropriate.

As stated above, only those WD of more immediate relevance are considered here; references to the more ephemeral jottings written within and around the tombs of Wadi Biban el-Muluk are noted in the earlier chapters of this study.

The standard type A docket preserves a record of the deceased's name, often with details of his or her status. The docket's purpose is clear: to facilitate identification. This is shown by the consistent location of the type in a prominent position on the shroud, on other bandages covering the breast of the mummy, or on the coffin lid.<sup>33)</sup> Cf. table 9. The majority of these texts are quite poorly published, and their archaeological yield is consequently restricted. Nevertheless, if Maspero's facsimiles are to be relied upon, certain correlations within the DB320 group may perhaps be ventured. From the handwriting of the type A docket attached to the mummy of Ahmose-Sitkamose,<sup>34)</sup> it seems that this text was written at the same time as the record of 'osirification' (see below) preserved on the next innermost layer of wrappings dated to Year 7 of Psusennes I, 4 3ht 8.<sup>35)</sup> This same hand appears to be evidenced both in the identifying dockets of Sitamun,<sup>36)</sup> Meryetamun<sup>37)</sup> and in the osirification text of Siamun which dates to Year 8 of Psusennes I, 3 prt 29<sup>38)</sup> - and, if so, thereby forms a link with Amosis I, who was osirified on the same day and presumably in the same place.<sup>39)</sup> Moreover, the hand of the Amosis I osirification text seems to occur again in the type A docket of Ahmose-Inhapi.<sup>40)</sup> The type A docketed mummies

from DB320, therefore, might well be seen as a homogeneous group, entered into the k3y of Inhapi and there restored and labelled at essentially the same time - between Years 7 and 8 of Psusennes I, some 60-odd years before the Sethos I group of corpses was interred there.<sup>41)</sup>

The evidence of the type A docketts from KV35 is less accessible than that from DB320. Although we know that Amenophis II, Tuthmosis IV, Merenptah, Sethos II, Siptah and Ramesses IV-V were docketed in an analogous manner,<sup>42)</sup> no facsimiles of these docketts were ever published,<sup>43)</sup> and for the majority we do not even possess hieroglyphic transcriptions. Nevertheless, external evidence<sup>44)</sup> would suggest that these mummies too form a homogeneous group, labelled individually following their restoration, perhaps in KV35 itself. At least one of the KV35 docketts was written in blue rather than in black ink.<sup>45)</sup>

The type B docketts are more directly instructive than the simple identification texts (which they often physically underlie), in that they contain records of specified activity carried out in connection with the corpse; cf. table 10. Five basic sorts of activity may be discerned in the type B docketts:

1. sipy, 'inspection'.<sup>46)</sup> The record of a visit, either routine or prompted by rumoured criminal activity, to ascertain the condition of the burial. Several records of tomb inspection have come down to us.<sup>47)</sup> Only one such text has been found upon the

wrappings of a corpse, however - that of the Meryetamun from DB358,<sup>48)</sup> where, indeed, it may well have to be construed as a record of inspection and subsequent restoration.<sup>49)</sup>

2. krs, 'burial'.<sup>50)</sup> As is clearly shown by its employment in both Sinuhe<sup>51)</sup> and the Shipwrecked Sailor,<sup>52)</sup> krs implies the provision of a proper Egyptian-style burial, from a coffin for the body<sup>53)</sup> to the appropriate amuletic protection. With both Neskhons and Pinudjem II,<sup>54)</sup> the expression is clearly used with reference to the original interment of the deceased. Its use of Sethos I in Year 7 of Psusennes I, 2 pꜣt 16,<sup>55)</sup> by which date the king had long been buried, suggests perhaps that the term could, on occasion, be employed as a contraction of whm krs (below).

3. whm krs, 'repetition of burial'.<sup>56)</sup> This expression ought, in theory, to indicate a repetition - i.e. a restoration - of the proper Egyptian burial alluded to above. Several instances of the term are known to me. Of the royal occurrences, the earliest clearly refer to activity within the original burial places of Tuthmosis IV<sup>57)</sup> and Sethos I<sup>58)</sup> respectively: the former text is actually inscribed upon a wall within KV43, whilst it seems reasonably clear from associated docketts that the mummy of Sethos I remained in KV17 for several years after the whm krs. The same conclusion might be reached for the docket (presumably a whm krs text also)<sup>59)</sup> written upon the coffin of Ramesses II in Year 6 of whm mswt, 3 pꜣt? 15:<sup>60)</sup> this mummy was not transferred to KV17 until Year 15 of Smendes, 3 3ꜣt 6,<sup>61)</sup>

before which date it had presumably remained within its own tomb, KV7. Further definite occurrences of the term relate to the burial of Amenophis I, and date respectively to Year 6, 4 prt 7,<sup>62)</sup> and Year 16, 4 prt 11, of Smendes I;<sup>63)</sup> they were presumably written within AN B.<sup>64)</sup> An apparent variant of the whm krs docket type is found upon the mummy of Ramesses II, dating to Year 15 of Smendes, 3 3ht .6.<sup>65)</sup> The relevant section of this text reads as follows:

... Day of bringing king Usermaatre-setepenre l.p.h. to whm.f r k3s.f (in) the tomb of king Menmaatre-Seti l.p.h. ...

whm.f r k3s.f, however, Wentz translates as '(to) renew him (and) to bury him',<sup>66)</sup> which might suggest that any similarity to the set expression whm krs is merely superficial; it may perhaps be relevant that Ramesses II had been removed from his own tomb and was about to be reinterred in that of Sethos I when he was subjected to these attentions.

The only non-royal occurrence of the term whm krs known to me is in a semi-hieratic restoration text written upon the reverse of an early 21st dynasty coffin board in the British Museum (BM 15659).<sup>67)</sup> This text may be translated as follows:

Year 3, 4 3ht 15. Day of renewing the burial (whm krs) of the Osiris Tameniut after it was found that the 'children of the tomb' (msw hr)<sup>68)</sup> had taken the coffins and obliterated their

names. They (the coffins) were replaced (swrd)<sup>69)</sup> again.

The purport of this docket is not entirely clear. Despite the claims of the restoration text, the names on the coffin board had not been obliterated, and they are, in fact, palimpsest over an original name (probably Nesmut).<sup>70)</sup> Furthermore, the restoration text was written by the same hand and with the same yellow paint as the main funerary text which runs down the centre of the reverse of the board (which had also had the owner's name changed to Tameniut). Two hypotheses might be put forward to explain these features: either the names on the coffin board, re-inscribed for Tameniut at the time of her original burial, had been neglected when the msw hr erased the names on the coffins proper - by a strange coincidence the scribe who had inscribed the board in the first place being employed to lay out the restoration text; or else the coffin board, and thus presumably its associated but now lost coffins also, was a replacement from the undertaker's surplus stock, provided after the originals had been stolen from the tomb. The latter hypothesis is clearly the more likely.

Finally, a study of the available evidence relating to the condition of the whm krs bodies<sup>71)</sup> is not particularly informative. Indeed, there would seem to be little discernible difference between those bodies subjected to whm krs and those which have been osirified (below).

4. whm sm3, 'repetition of interment'.<sup>72)</sup> This expression is found but once, upon the mummy of Tuthmosis II,<sup>73)</sup> perhaps inscribed at the time his body was reburied in the tomb of Amenophis I.<sup>74)</sup>

5. rdit wsir, 'osirification'.<sup>75)</sup> This term is restricted to four mummies from the DB320 cache: Ramesses III,<sup>76)</sup> Ahmose-Sitkamose,<sup>77)</sup> Amosis I<sup>78)</sup> and Siamun.<sup>79)</sup> The precise meaning of the expression, which may be translated 'to confer (the quality of) Osiris on' (Thomas),<sup>80)</sup> or more simply 'to osirify' (Kitchen),<sup>81)</sup> is quite uncertain. In theoretical terms it presumably contains an allusion to the Osiris myth, wherein Isis collected the dismembered portions of her husband's body which were then embalmed by Anubis and magically brought back to life.<sup>82)</sup> In practice, however, the condition of the osirified corpses could vary drastically. The osirified Ramesses III, for example, was free from post-mortem trauma,<sup>83)</sup> whereas the osirified body of Siamun consisted of little more than a collection of bones thrown pell-mell into an oblong bundle.<sup>84)</sup> Moreover, as stated above, there is little to distinguish those bodies which have been subjected to whm krs and those which have been osirified. It is perhaps the case, therefore, that the osirification texts reflect not so much a change in restoration technique as a change in the mummy's circumstances brought on by the abandonment of the original tomb.

Where the restorations took place

It is probable that the cached mummies were rewrapped and restored in a number of different places which varied according to circumstances. The docket found upon the wrappings of Ramesses IX,<sup>85)</sup> for example, seems to indicate that this particular corpse was removed from its tomb and rewrapped at Medinet Habu (t3 hwt),<sup>86)</sup> which served as the administrative centre of the Theban necropolis during the later New Kingdom.<sup>87)</sup> Several items of royal funerary furniture - shabtis of Amenophis III, Sethos I and Ramesses II/VI,<sup>88)</sup> and a pair(?) of 'wooden sandals which could have belonged only to a mummy of one of the kings of the Twentieth Dynasty',<sup>89)</sup> - are said to have been found there, but details are unfortunately lacking and the significance of the finds is uncertain; a shabti of Amenophis III, for example, was found in the Karnak cachette,<sup>90)</sup> and there is no evidence to suggest that any of the royal mummies were ever rewrapped at Karnak.<sup>91)</sup>

The mortuary temple at Medinet Habu was not, however, the only place where restorations of this sort were carried out. Winlock, for example, believed that the mummy of Meryetamun had been rewrapped in DB358,<sup>92)</sup> the restoration party bringing with them 'at least 82 square meters of linen',<sup>93)</sup> in the form of shawls and sheets; similar pieces of linen, the discarded clothing of the gods' images,<sup>94)</sup> have been found on most of the rewrapped corpses. Two enigmatic graffiti written above the entrance to KV49<sup>95)</sup> are perhaps to be connected with analogous restoration

work. These texts, which, by the presence of Butehamun, date to the period Ramesses XI-Smendes I, mention the deposition within the tomb of some 70 shawls and other items of linen on two separate occasions. It is thus perhaps the case that KV49 was in some way connected with the repair work known to have been carried out on the royal mummies at this time.<sup>96)</sup> If so, it is suggestive that Butehamun is mentioned only once in the restoration docket themselves, in connection with the osirification of Ramesses III,<sup>97)</sup> whose tomb is within reasonable striking distance of KV49.

The restoration of certain of the royal mummies within the Inhapi k3y and KV35 has been suggested above, p. 245.

TABLE 9  
TYPE A DOCKETS

Abbreviations employed:

ASAE	Daressy, ASAE 4 (1903)
BIE	Loret, BIE (3 sér.) 9 (1898)
CCR	Daressy, Cercueils
MR	Maspero, <u>Momies royales</u>
RdT	Groff, RdT 23 (1901)
RM	Smith, <u>Royal Mummies</u>
CD	coffin docket
LD	linen docket
+	denotes direction of hieratic
ns	direction not stated

No.	Name	Cache	Type	Details	References
1.	Ahmose-Henttimehu	DB320	LD/+	(s3t-nsw (snt-nsw (hnt-nsw hnwT-timhw The king's daughter, king's sister and king's wife Henttimehu	MR 544 (facs.)
2.	Ahmose-Inhapi	DB320	LD/+	(s3t-nsw hnt nsw (in-h pi) nh.ti The king's daughter and king's wife Inhapi, may she live!	MR 530 (facs.)
3.	Ahmose-Meryetamun	DB320	LD/+	(s3t-nsw (snt-nsw (mryt-1mn) nh.ti The king's daughter and king's sister Meryetamun, may she live!	MR 539 (facs.)
4.	Ahmose-Sipair	DB320	CD/ns	...)p3-i(... (Ahmose-Si) pai (r)	CCR 9 f. (transcr.)
5.	Ahmose-Sitkamose	DB320	LD/+	(s3t-nsw (snt-nsw (hnt-nsw wrt (s3t-k3-ms nh.ti The king's daughter, king's sister and great king's wife Sitkamose, may she live!	MR 541 (facs.)
6.	Amenophis II	KV35	LD/ns	('le prénom d'Aménophis II')	BIE 108
7.	Amenophis III	KV35	CD/+	(nb-m3 <sup>C</sup> t-r <sup>C</sup> }mn-htpw} .w.s. Nebmaat-re-Amenophis l.p.h.	BIE 111 (2) CCR 218, pl. 61 (transcr., photo) RM pl. 31 (photo)

No.	Name	Cache	Type	Details	References
8.	Amosis I	DB320	LD/ns	$\overline{ws}^c \overline{ir} \overline{nsw} (\overline{nb-phty-r}^c)$ $(\overline{i-h-ms})^c .w.s.$ The Osiris King Nebpentyre Amosis l.p.h.	MR 534 (transcr.)
9.	Merenptah	KV35	LD/+	$\overline{nsw} \overline{b3-n-r}^c$ King Baenre	RdT 32 (facs.)
10.	Rai	DB320	LD/ns	(No details)	RM 11
11.	Ramesses I	DB320	CD/+	$(\overline{mn-phty-r}^c)$ Menpentyre	MR 551 (facs.)
12.	Ramesses IV	KV35	LD/ns	('Un nom presque entièrement effacé et impossible à lire')	BIE 112 (9) cf. RM 87
13.	Ramesses V	KV35	LD/ns	('Prénom presque effacé')	BIE 111 (6)
14.	Sethos II	KV35	LD/ns	('Le nom de Sêti II')	BIE 111 (3) cf. RM 75
15.	Siamun	DB320	LD/ns	$\overline{s3-nsw} \overline{smsw} \overline{p3-s3-}^c \overline{imn}$ The king's eldest son Pa-Siamun	MR 538 (transcr.)
16.	Siptah	KV35	LD/ns	('Le nom du même roi')	BIE 111 (5) cf. RM 70, pl. 61
17.	Sitamun	DB320	CD/+	$\overline{s3t-nsw} \overline{s3t-imnt} (\text{sic})$ The king's daughter Sitamun	MR 538 (facs.) CCR 10 (transcr.)
18.	Tuthmosis IV	KV35	LD/ns	$\overline{mn-hprw-r}^c$ Menkheprure ('en grands signes hiératiques à l'encre bleu')	BIE 111 (1) ASAE 110 (transcr.)

## TYPE B DOCKETS, LINEN NOTATIONS AND GRAFFITI

## Abbreviations employed:

BIE	Loret, <u>BIE</u> (3 sér.) 9 (1898)
C	Wilson, <u>Century Magazine</u> (May 1887)
CCR	Daressy, <u>Cercueils</u>
G	Černý & Sadek, <u>Graffiti</u>
GHH	Černý, <u>Graffiti</u>
GMT	Spiegelberg, <u>Graffiti</u>
GPI	Ciccarello, <u>Graffito</u>
HA	Kees, <u>Hohenpriester</u>
HC	BM, <u>Mummies &amp; Coffins</u>
JARCE	Young, <u>JARCE</u> 2 (1963)
JEA 32	Černý, <u>JEA</u> 32 (1948)
JEA 40	Gardiner, <u>JEA</u> 40 (1954)
JEA 60	van Siclen, <u>JEA</u> 60 (1974)
MDAIK	Reeves, <u>MDAIK</u> 40 (1984) (forthcoming)
MR	Maspero, <u>Momies royales</u>
N	Gardiner, <u>Notebook</u> 70
NM	Champollion, <u>Notices</u> II
RM	Smith, <u>Royal Mummies</u>
RNT	Thomas, <u>Necropoleis</u>
TQM	Winlock, <u>Meryet-Amūn</u>
S	Bell, <u>Serapis</u> 6 (1980)
SAK	Altenmüller, <u>SAK</u> 10 (1983)
TIP	Kitchen, <u>TIP</u>
TTIV	Davis, <u>Thoutmōsis IV</u>
CD	coffin docket
G	graffito
LD	linen docket
LN	linen notation
WD	wall docket

Note: the chronological arrangement of the later docketts and graffiti is basically that suggested by Kitchen, TIP, 417 ff., with some emendations

No.	Date	Ruler	Type	Details	References
1.	Yr 8 3 <u>3ht</u> 1	Horemheb	WD/ KV43	Yr 8 3 <u>3ht</u> 1, under the person ( <u>hm</u> ) of the dual king ( <u>nsw-bity</u> ) Djoserkheprure-setepenre, son of Re Horemheb-merenamun. His person l.p.h. commanded that the fanbearer on the king's right hand, the royal scribe, overseer of the treasury, overseer of works in the Place of Eternity ( <u>st nhh</u> ) and leader of the festival of Amun in Karnak, Maya, son of the noble Iawy, born of the lady of the house Weret, be charged to renew the burial ( <u>wbm krs</u> ) of king ( <u>nsw</u> ) Menkheprure, true of voice, in the noble mansion ( <u>hwt špsst</u> ) upon the west of Thebes  His assistant, the steward of the Southern City, Djehutymose, whose mother is Iniuhe of the City	TTIV xxxiii f. (photos) RNT 249 (1)

No.	Date	Ruler	Type	Details	References
2.	Yr 8 3 <u>3ht</u> 6	Ramesses VI	G1860/ above KV35	Yr 8 3 <u>3ht</u> 6. On this day closing the tomb ( <u>hni p3 hr</u> ) by the high priest Ramessesnakhte, the king's butler Preherwenemef, the mayor of the City Amenmose, Pamose and the chief workman Amennakhte likewise	G no. 1860 (facs., transcr.) S 7
3.	Yr 9 2 <u>prt</u> 14	Ramesses IX	WD/ KV9	Yr 9 2 <u>prt</u> 14, under the person ( <u>hm</u> ) of the dual king ( <u>nsw-bity</u> ) Neferkaresetep..., son of Re Ramesses... On this day this visit was made by the scribe Amenhotpe and his son the scribe and deputy of draughtsmen of the tomb Amennakhte to see the Mansion of the Two Truths ( <u>hwt m3<sup>c</sup>ty</u> ) ... when they made writings in the tomb ( <u>m h<sup>c</sup>t</u> ) ... (the chief of scribes) of the mansion of the house of Amun Iymisba ... they went and they ... looked at the hills ...	NM 635 (facs.) GMT 92 II (transcr.)
4.	Yr 4 4 <u>3ht</u> 22	<u>w hm</u> <u>m swt</u> ?/ Herihor?	WD/ KV57	(Short hymn to Amon-Re, then) Written in Yr 4 4 <u>3ht</u> 22 by the scribe of the army Butehamun after he came to cause that the command(?) ( <u>sdm mdw</u> ?) be carried out in the House of Eternity ( <u>pr dt</u> ) in the tomb ( <u>p3 hr</u> ) of king ( <u>nsw</u> ) Djoserkhepr(u)re-setepenre l.p.h.  Written by the general's scribe, Kysen  The scribe Butehamun; the king's scribe Djehutymose	N 68 f. (transcr.) RNT 250 (9) TIP 418 (7)
5.	Yr 6 2 <u>3ht</u> 7	<u>w hm</u> <u>m swt</u> ?/ Herihor	CD/ S. I	Yr 6 2 <u>3ht</u> 7. The day the vizier ..., high priest of Amon-Re king of the gods Herihor commanded to renew the burial ( <u>w hm</u> ( <u>kr</u> )s) of king ( <u>nsw</u> ) Menmaatre l.p.h., son of Re Setymer(en)ptah, by the agent Herenamenpenaef and the youth Prepayit	MR 553 (transcr.) CCR 30, pl. 18 (transcr., photo) HA 11 RNT 249 (2a) TIP 417 (2) ( <u>prt</u> in error)
6.	Yr 6 2 <u>3ht</u> 7	<u>w hm</u> <u>m swt</u> ?/ Herihor?	G2056a/ above KV15	Yr 6 2 <u>3ht</u> 7. On this day approaching by the king's butler Sethherwenemef ... (king) Seti...	G no. 2056a (facs., transcr.) cf. 2056b-c

No.	Date	Ruler	Type	Details	References
7.	Yr 6 27 <u>3ht</u> 12	<u>whm</u> <u>mswt?/</u> Herihor?	WD/ KV57	Yr 6 27 <u>3ht</u> 12. Day of investigating into(?) ( <u>šn</u> ) the burial(?) ( <u>ks</u> ) of king ( <u>nsw</u> ) Djeserkhepr(u)re- setepenre, by the vizier, general and chief of the ...	N 69 (transcr.) RNT 250 (10) TIP 418 (7)
8.	Yr 6 2 <u>3ht</u> 18	<u>whm</u> <u>mswt?/</u> Herihor?	WD/ KV14	Yr 6 2 <u>3ht</u> 18	JEA 40, 43 (transcr.) SAK 4 (facs.)
9.	Yr 6 3 <u>prt?</u> 15	<u>whm</u> <u>mswt/</u> Herihor	CD/ R. II	Yr 6 3 <u>prt?</u> 15. Day the chief of ..., high priest of Amon-Re king of the gods Herihor commanded ...	MR 557 (facs., transcr.) CCR 32, pl. 22 (transcr., photo) HA 11 RNT 249 (2b) TIP 417 (3)
10.	Yr 7 2 ...	<u>whm</u> <u>mswt?/</u> Herihor?	WD/ KV14	Yr 7 2 ...	JEA 40, 43 (transcr.) SAK 4 (facs.)
11.	Yr 1	Smendes/ Pin. I	LN/ Nodj.	(Reference to 'the first year of Pinotmou')	RM 97 RNT 249 TIP 417 (6) GPI doc. 1
12.	Yr 3 3 <u>3ht</u> 15	Smendes?/ Pin. I?	CD/ Ta- meniut	Yr 3 3 <u>3ht</u> 15. Day of renewing the burial ( <u>whm</u> <u>krs</u> ) of the Osiris Tameniut after it was found that the 'children of the tomb' ( <u>msw hr</u> ) had taken the coffins and obliterated their names. They (the coffins) were replaced ( <u>swrd</u> ) again	HC 42 (transcr.)
13.	Yr 6 3 <u>prt</u> 7	Smendes/ Pin. I	LD/ T. II	Yr 6 3 <u>prt</u> 7. On this day the high priest of Amon-Re king of the gods Pinudjem son of the high priest of Amun Piankh commanded the overseer of the great double treasury Payneferher to repeat the burial ( <u>whm sm3</u> ) of (i.e. rebury?) king ( <u>nsw</u> ) Aaenre ( <u>sic</u> ) l.p.h.	MR 545 f. (facs., transcr.) RNT 249 (4a) TIP 418 (9) GPI doc. 2
14.	Yr 6 4 <u>prt</u> 7	Smendes/ Pin. I	CD/ Am. I	Yr 6 4 <u>prt</u> 7. On this day the high priest of Amon-Re king of the gods Pinudjem son of the high priest of Amun Pinudjem ( <u>sic</u> ) son of Piankh commanded to renew the burial ( <u>whm krs</u> ) of king ( <u>nsw</u> ) Djeserkare son of Re Amenophis l.p.h., by the overseer of the double treasury Pa...	MR 536 f. (facs., transcr.) CCR 8, pl. 7 (transcr., photo) RNT 249 (4b) TIP 418 (10) GPI doc. 3

No.	Date	Ruler	Type	Details	References
15.	Yr 9	Smendes/ Pin. I	LN/ R. III	The high priest of Amon-Re king of the gods Pinudjem son of Piankh, true of voice, for his father Amun in Yr 9	MR 564 (transcr.) RNT 250 (5a) TIP 418 (12) GPI doc. 4
16.	Yr 10	Smendes/ Pin. I	LN/ R. III	('La même formule, avec la date de l'an X')	MR 564 RNT 250 (5b) TIP 418 (13) GPI doc. 6
17.	Yr 10	Smendes/ Pin. I	LN/ S. I	Linen which the high priest of Amon-Re king of the gods Pinudjem son of Piankh made for his father Khons in Yr 10	MR 555 (transcr.) RNT 250 (6) TIP 418 (14) GPI doc. 7
18.	Yr 12/13 4? prt 6?	Smendes/ Pin. I	LD/ Am. III	Yr 12/13 4? prt 6? On this day renewing the burial(?) (whm krs?) of king (nsw) Nebmaatre l.p.h. by the high priest of Amon-Re king of the gods Pinudjem son of the high priest of Amon-Re king of the gods Piankh ... (by?) ... Wennufer(?)	BIE 109 RM pls. 32, 100-103 (photos) RNT 250 (13a) TIP 418 (22) GPI doc. 9
19.	Yr ? 1 prt 25; 3 prt 5	Smendes?/ Pin. I?	WD/ KV49	1 prt 25. Coming and bringing byssus, 20 (cloths?). Mixed byrr, 5; shawls, 15: total, 20. The scribe Butehamun; Pakharu; Pennesttawy son of Nessuimenopet; Hori; Takany; Amenhotpe; Kaka; Nakhtimenwast; Amennesttawy  Completion on the second occasion: bringing clothing, 3 prt 5. The men who brought it: Pait; the scribe Butehamun; Iyimennuef; Pakharu; Tjauendi...; Hori son of Kadjadja; Takairnayu; Nessuimenopet. Byssus, shawls, 45; long shawls, 5: total, 50	MDAIK (photo) GHH pl. 45-45a (facs., transcr.)
20.	Yr 13 2 smw 27?	Smendes/ Pin. I	LD/ R. III	Yr 13 2 smw 27? On this day the high priest of Amon-Re king of the gods Pinudjem son of the high priest of Amun Piankh commanded the scribe of the temple Djesersukhons and the scribe in the Place of Truth Butehamun to osirify (x rdit wsir) king (nsw) Usermaatre-meriamun, he being made firm and enduring forever (smn.ti w3h.ti dt)	MR 563 f. (facs., transcr.) RNT 250 (7) TIP 419 (25) GPI doc. 10

No.	Date	Ruler	Type	Details	References
21.	Yr 13 ...	Smendes?/ Pin. I?	WD/ KV35	Yr 13 ... This day ... inspection ( <u>sipty</u> ?) ...	BIE 109 JEA 60, 129 ff. (facs., transcr.)
22.	Yr 15 3 <u>3ht</u> 6	Smendes/ Pin. I	LD/ R. II	Yr 15 3 <u>3ht</u> 6. Day of bringing the Osiris king ( <u>nsw</u> ) Usermaatre- setepenre l.p.h. (to) renew him (and) to bury him ( <u>whm.f r k3s.f</u> ) (in) the tomb ( <u>p3 hr</u> ) of the Osiris king ( <u>nsw</u> ) Menmaatre-Sety l.p.h. by the high priest of Amun Pinudjem	MR 560 (facs., transcr.) JARCE 102, n. 15 RNT 250 (8), n. 22 TIP 419 (26) ( <u>prr</u> in error) GPI doc. 11
23.	Yr 16 4 <u>prr</u> 11	Smendes/ 'king' Pin. I/ Masaharta	CD/ Am. I	Yr 16 4 <u>prr</u> 11. The high priest of Amon-Re king of the gods Masaharta son of king ( <u>nsw</u> ) Pinudjem commanded to renew the burial ( <u>whm krs</u> ) of this god by the scribe of the treasury and scribe of the temple Penamun son of Sutymose(?)	MR 536 f. (facs., transcr.) CCR 8, pl. 7 (photo) RNT 251 (14) TIP 419 (27) GPI doc. 48
24 a-b	Yr 18	Smendes/ 'king' Pin. I/ Masaharta	LN/ Meryet. DB358	Linon which the high priest of Amun Masaharta, true of voice, made for his father Amun in Yr 18	TQM 87, 89, pl. 40 (transcr., photos) RNT 251 (15a-c) TIP 419 (29)
c.				Yr 18	
25.	Yr 19 3 <u>prr</u> 28	Smendes/ 'king' Pin. I/ Masaharta	LD/ Meryet. DB358	Yr 19 3 <u>prr</u> 28. On this day the inspection ( <u>sipty</u> ) of the king's wife Merye(t)amun	TQM 51, pl. 41 (transcr., photo) RNT 251 (16) TIP 419 (30)
26.	Yr 6	Psus. I/ 'king' Pin. I/ Men- kheperre	LN/ S. I	Linon which the high priest of Amon-Re Menkheperre made for his father Amun (in) Yr 6	MR 555 (transcr.) RNT 251 (17) TIP 420 (37)
27.	Yr 7 2 <u>prr</u> 16	Psus. I/ 'king' Pin. I/ Men- kheperre	LD/ S. I	Yr 7 2 <u>prr</u> 16. Day of burying ( <u>krs</u> ) king ( <u>nsw</u> ). Menmaatre l.p.h.	MR 554 f. (transcr.) RNT 251 (18) TIP 420 (38)
28.	Yr 7 4 <u>3ht</u> 8	Psus. I/ 'king' Pin. I/ Men- kheperre	LD/ Ahm.- Sit.	Yr 7 4 <u>3ht</u> 8. On this day osirifying ( <u>dit wsir n</u> ) the king's daughter and great king's wife Ahmose- Sitkamose, may she live!	MR 541 (facs., transcr.) RNT 250 (11) TIP 420 (39)

No.	Date	Ruler	Type	Details	References
29.	Yr 8 3 prt 29	Psus. I/ 'king' Pin. I/ Men- kheperre	LD/ Amosis I	Yr 8 3 prt 29. The person (hm) of the dual king (nsw-bity) and lord of the two lands Kheperkare-setepenamun l.p.h. Pinudjem-meryamun l.p.h. commanded to osirify (r rdit wsir) the Osiris king (nsw) Nebpehtyre l.p.h.	MR 534 (facs., transcr.) RNT 250 (12a) TIP 420 (40) GPI doc. 50
30.	Yr 8 3 prt 29	Psus. I/ 'king' Pin. I/ Men- kheperre	LD/ Siamun	Yr 8 3 prt 29. His person l.p.h. commanded to osirify (r rdit wsir n) the king's son Siamun	MR 538 (facs., transcr.) RNT 250 (12b) TIP 420 (41)
31.	Yr ? 1 3ht 13	Psus. I?/ 'king' Pin. I?/ Masaharta? Men- kheperre?	G2061/ near KV38	1 3ht 13. Coming (by) Meniunfer (to) open (wn) (the tomb of) Aakheperkare. Userhet; Pa...; Amenhotpe; Iufamun	G no. 2061 (facs., transcr.)
32.	Yr 1	Siamun (or Amenemope? Osochor?)/ Pin. II	LN/ Pin. II	... (Am)en in Yr 1	MR 572 (transcr.) RNT 251 (20) TIP 422 (57)
33.	Yr 3	Siamun (or Amenemope? Osochor?)/ Pin. II	LN/ Nes- khons	The high priest of Amun Pinudjem for his lord Amun (in) Yr 3	MR 579 (transcr.) RNT 251 (22) TIP 422 (61)
34.	Yr 3	Siamun (or Amenemope? Osochor?)/ Pin. II	LN/ Pin. II	... Amun (in) Yr 3	MR 572 (transcr.) RNT 251 (21) TIP 422 (62)
35.	Yr 5	Siamun (or Amenemope? Osochor?)/ Pin. II	LN/ R. IX	Gift (in) which the first great one of the harim of Amun, the priestess of Amonkhnemwast, Neskhons, made in Yr 5	MR 567 (transcr.) RNT 251 (23) TIP 422 (66)
36.	Yr 5 4 šmw 21	Siamun (or Amenemope? Osochor?)/ Pin. II	WD/ DB320	Yr 5 4 šmw 21. Day of burial (krs) of the chief of ladies Neskhons, by the god's father of Amun, overseer of the treasury Djedkhonsiufankh son of ...; the prophet of Amon-Re king of the gods Ankhefenamun; the elder(?) of the hall Nespay...; the god's father of Amun, chief of the army Nespakashuty. The seals which are upon this place: the seal of the overseer of the treasury Djedkhonsiufankh; the seal of the scribe of the treasury Nes...	MR 520 f. (facs., transcr.) JEA 32, 26 RNT 251 (24) TIP 422 (68)

No.	Date	Ruler	Type	Details	References
37.	Yr 7	Siamun (or Amenemope? Osochor?)/ Pin. II	LD/ R. IX	('Expedition faite au temple $\square \hat{c}$ , en l'an VII, pour emmailloter le roi RA-KHAMOIS ...')	MR 568 RNT 251 f. (25) TIP 422 (70)
38.	Yr 7	Siamun (or Amenemope? Osochor?)/ Pin. II	LN/ P. II	Linon which the high priest of Amun Pinudjem son of Menkheperre made for Amun (in) Yr 7	MR 572 (transcr.) RNT 252 (26) TIP 422 (71)
39.	Yr 9	Siamun (or Amenemope? Osochor?)/ Pin. II	LN/ Pin. II	Linon which the high priest of Amun Pinudjem (son of) Menkheperre made for Khons in Yr 9	MR 572 (transcr.) RNT 252 (27) TIP 422 (76)
40.	Yr 10 4 prt 17	Siamun/ Pin. II	CD/ R. I	(Yr 10 4 prt 17 of) king (nsw) Siamun. (Day of bringing king Menpeh)tyre out of the (tomb of king Menmaatire) Setymer(en)ptah (that he might be) taken into this high place ( $k3y$ ) of Inhapi which is a (great place ( $st \hat{c}3t$ ) (and in which Amen)ophis rests, by the prophet of Amon(-Re king) of the gods Ankhefenamun son of Baky, and the god's father of Amon(-Re king) of the gods, third prophet of Khonsemwast-Neferhotep, the scribe of offerings of the house of Amon-Re) king of the gods, sm-priest of the temple of (Usermaatire-setepenre) in the house of Amun, general of Tasetmerydjehuty, scribe and chief agent Nespakashuty son of Bak(en)khons. Afterwards Mut, the one having authority over the great place ( $st \hat{w}rt$ ), said: (That which was in good condition in my care ...)	MR 551 (transcr.) CCR 27, pl. 23 (transcr., photo) RNT 252 (28a) TIP 423 (77)
41.	Yr 10 4 prt 17	Siamun/ Pin. II	CD/ S. I	Yr 10 4 prt 17 of king (nsw) Siamun. Day of bringing king (nsw) Menmaatire-Setymery(en)-ptah l.p.h. out of his tomb that he might be taken into this high place ( $k3y$ ) of Inhapi which is a great place ( $st \hat{c}3t$ ), by the prophet of Amon-Re king of the gods Ankhefenamun son of Baky, and the god's father of Amon-Re king of the gods, third prophet of Khonsemwast-Neferhotep, (scribe) of offerings of the house of	MR 553 (transcr.) CCR 30 f., pl. 19 (transcr., photo) RNT 252 (28b) TIP 423 (77)

No.	Name	Ruler	Type	Details	References
41.	(cont'd)			Amon-Re king of the gods, sm-priest of the temple of Usermaatre-setepenre in the house of Amun, general of Tasetmerydjehuty, scribe and chief agent Nespakashuty son of Bakenkhons. Afterwards Mut, the one having authority over the great place ( <u>st wrt</u> ), said: That which was in good condition in my care, there has been no injury to it in the bringing out from the tomb in which they ( <u>sic</u> ) were in order to take them into this high place ( <u>k3y</u> ) of Inhapi which is a great place ( <u>st 3t</u> ) and in which Amenophis rests	
42.	Yr 10 4 prt 17	Siamun/ Pin. II	CD/ R. II	Yr 10 4 prt 17. Day of bringing king ( <u>nsw</u> ) Usermaatre-setepenre the great god out of this tomb of king ( <u>nsw</u> ) Menmaatre-Setymer(en)ptah that he might be taken into this high place ( <u>k3y</u> ) of Inhapi which is a great place ( <u>st 3t</u> ), by the prophet of Amon-Re king of the gods Ankhefenamun son of Baky, and the god's father of Amon-Re king of the gods, third prophet of Khonsemwast-Neferhotep, scribe of offerings of the house of Amon-Re king of the gods, sm-priest of the temple of king ( <u>nsw</u> ) Usermaatre-setepenre in the house of Amun, general of Tasetmerydjehuty, scribe and chief agent Nespakashuty son of Bakenkhons. Afterwards Mut, the one having authority over the great place ( <u>st wrt</u> ), said: That which was in good condition in my care, there has been no injury to it in the bringing out from the tomb in which they ( <u>sic</u> ) were in order to take them into this high place ( <u>k3y</u> ) of Inhapi which is a great place ( <u>st 3t</u> ) and in which Amenophis rests	MR 557 f. (fac., transcr.) CCR 33, pl. 22 (transcr., photo) RNT 252 (28c) TIP 423 (77)

No.	Date	Ruler	Type	Details	References
43.	Yr 10 4 prt 20	Siamun/ Pin. II	CD/ S. I	Yr 10 4 prt 20. Day of taking the god into his place in order to rest in the Mansion of Eternity ( <u>hwt nhh</u> ) (in which Amenophis ... is ... by the god's father of Amun, overseer of the treasury, Djedkhonsiufankh; the god's father of Amun ...; the god's father of Amun, third prophet of Khons ...	MR 554 (transcr.) CCR 31, pl. 19 (transcr., photo) RNT 252 (29b) TIP 423 (78)
44.	Yr 10 4 prt 20	Siamun/ Pin. II	CD/ R. II	Yr 10 4 prt 20. Day of taking the god into his place in order to rest in the Mansion of Eternity ( <u>hwt nhh</u> ) in which Amenophis-pahatyenamun is, in l.p.h., by the god's father of Amun, overseer of the treasury, Djedkhonsiufankh; the god's father of Amun, his third prophet, Iufenamun son of Nespakashuty; the god's father of Amun Wennufer son of Mentemwast; the god's father of Amun ...	MR 559 (facs., transcr.) CCR 33 f., pl. 23 (transcr., photo) RNT 252 (29c) TIP 423 (78)
45.	Yr 10 4 prt 20	Siamun/ Pin. II	WD/ DB320	Yr 10 4 prt 20. Day of burial ( <u>kr</u> ) of the Osiris, high priest of Amon-Re king of the gods, great chief of the army, the leader Pinudjem, by the god's father of Amun, overseer of the treasury, Djedkhonsiufankh; the god's father of Amun, scribe of the army, chief inspector Nespakashuty; the prophet of Amun, ...enamun; the god's father of Amun Wennufer; by the king's scribe of the Place of Truth Bakenmut; the chief workman Pediamun; the chief workman Amenmose; the god's father of Amun, chief of secrets, Pediamun son of Ankhefenkhons	MR 522 f. (facs., transcr.) C 5 (photo) (reversed) JEA 32, 25 ff. RNT 253 (30a-b) TIP 423 (79)
46.	Yr 5	Shosh. I/ Iuput	LN/ Djed- ptah.	Noble linen which the dual king ( <u>nsw-bity</u> ) lord of the two lands Hedjkheperre son of Re lord of appearances Shoshenq-meramun made for his father Amun in Yr 5; noble linen ...	MR 573 (transcr.) RNT 253 (31)

No.	Date	Ruler	Type	Details	References
47.	Yr 10	Shosh. I/ Iuput	LN/ Djed- ptah.	Noble linen which the dual king (nsw-bity) lord of the two lands Hedjkheperre son of Re lord of appearances Shoshenq-meramun made for his father Amun (in) Yr 10; noble line which the high priest of Amon-Re, great chief of the army Iuput true of voice, king's son of the lord of the two lands Shoshenq-meramun, made for his father Amun (in) Yr 10	MR 573 (transcr.) RNT 253 (32)
48.	Yr 11	Shosh. I/ Iuput	LN/ Djed- ptah.	('Identique sauf pour la date qui est $\beta_{in}^{\circ}$ (sic)')	MR 573 RNT 253 (33)
49.	Yr 13	Shosh. I? (or Siamun? Psus. I?)/ Iuput?	LN/ Nesta- nebt.	Linen for Min, Horus and Isis which the first great one of the harim Isiemkheb made in Yr 13	MR 579 (transcr.) RNT 251 (19) (in error)

## CHAPTER 12

## THE ROUTES TO THE CACHES

From the archaeological and documentary evidence mustered in the previous chapters, it is possible to venture a reconstruction - or rather a series of reconstructions - outlining the probable routes followed by the royal and non-royal mummies prior to their caching. Cf. fig. 97.

I. Occupants of burials in the Valley of the KingsTuthmosis I

As was noted in chapter 1,<sup>1)</sup> Tuthmosis I seems originally to have been interred within KV20 and only later transferred to KV38 by Tuthmosis III. A graffito in the vicinity of KV38<sup>2)</sup> records the opening of the tomb by Meniunufer, a son of Butehamun, on 1 3ht 13 of an unspecified year. In view of the appropriation by Pinudjem I of the two outermost coffins<sup>3)</sup> prepared for Tuthmosis I by Tuthmosis III,<sup>4)</sup> this opening will have occurred before the death of the high priest, perhaps during the reign of Psusennes I: cf. further below, s.v. Hatshepsut.

An unnamed and partially unwrapped mummy from the DB320 cache,<sup>5)</sup> discovered within the coffins usurped by Pinudjem I,<sup>6)</sup> is usually identified as that of this 18th dynasty king, if on somewhat tenuous grounds.

Whether or not the identification is to be believed, the corpse in question had probably been cached originally within the tomb of Ahmose-Inhapi (WN A),<sup>7)</sup> which was established and in use as early as Years 7-8 of Psusennes I, when the Amosis I group of mummies was interred there.<sup>8)</sup> The coffined bodies will subsequently have been transferred to the DB320 cache (probably corridor (C)),<sup>9)</sup> at a date after Year 11 of Shoshenq I.<sup>10)</sup>

### Hatshepsut

For her original place of burial, Hatshepsut extended the tomb of Tuthmosis I (KV20).<sup>11)</sup> From material recently recovered from within KV4 (Ramesses XI), it would appear that the queen's burial was subjected to official interference during the 'kingship' of Pinudjem I.<sup>12)</sup> A fragment of faience from KV4<sup>13)</sup> is inscribed with the Horus name shared by both Tuthmosis I and Ramesses II (q.v.); the disturbance of the burial might, therefore, have occurred at the time when one or other of these interments was investigated by Pinudjem I.<sup>14)</sup>

Hatshepsut's body has not been identified in either of the main caches, though a box which appears to have formed part of her original funerary equipment was recovered from DB320.<sup>15)</sup> This box was found to contain a mummified liver or spleen, and, unless it should transpire that hers is one of the unidentified female mummies from DB320, it may well be that this box contains all that it had been possible to recover of the queen from her ransacked burial within KV20.

It had presumably arrived in DB320 after Year 11 of Shoshenq I<sup>16)</sup> from the k3y of Inhapi (WN A),<sup>17)</sup> where perhaps it had first been cached by Pinudjem I.

### Tuthmosis III

The burial of Tuthmosis III within KV34 seems, from material recovered from KV4, to have been dismantled at the same time as that of Hatshepsut (q.v.) during the 'kingship' of Pinudjem I.<sup>18)</sup> The mummy, in its stripped coffin,<sup>19)</sup> presumably shared the same fate as the Hatshepsut box: reburial within the k3y of Inhapi (WN A)<sup>20)</sup> and caching with the rest of the Inhapi mummies in the Pinudjem II family vault (DB320), perhaps in side room (D),<sup>21)</sup> after Year 11 of Shoshenq I.<sup>22)</sup>

### Amenophis II

Amenophis II was discovered within his original sarcophagus in KV35, rewrapped,<sup>23)</sup> docketed<sup>24)</sup> and contained in a replacement cartonnage coffin.<sup>25)</sup> The history of his burial and the role of his tomb as a cache are considered fully in chapter 10.

### Tuthmosis IV

Tuthmosis IV was originally buried within KV43.<sup>26)</sup> His mummy was discovered in room (Jb) of the KV35 cache, docketed,<sup>27)</sup> rewrapped and stretched out on a white-painted plank<sup>28)</sup> similar to that employed for Ramesses V,<sup>29)</sup> and contained in a replacement coffin.<sup>30)</sup> No other connections with the occupants of the (Jb) cache suggest themselves, and it is perhaps the case that Tuthmosis IV had been restored (at the same time

as Ramesses V?) and introduced into KV35 directly from his original tomb after Year 13 of Smendes.<sup>31)</sup>

### Amenophis III

Amenophis III, at his death, was buried within WV22.<sup>32)</sup> According to a docket on the shroud of the mummy, this burial had required restoration (whm krs most probably) in Year 12/13 of Smendes, 4? prt 6?<sup>33)</sup> Sometime after this date, the mummy of Amenophis III, contained in the discarded coffin of Ramesses III<sup>34)</sup> (q.v.), was reburied in the KV35 (Jb) cache, where it was covered with the replacement coffin lid of Sethos II<sup>35)</sup> (q.v.), docketed within KV35 with the full name of Amenophis III<sup>36)</sup> to avoid confusion with Ramesses VI.<sup>37)</sup>

### Tiye

Despite evident preparations for burial within WV22, Tiye was not buried with her husband but may have opted instead for interment at el-Amarna, perhaps in one of the subsidiary tombs in the royal wadi.<sup>38)</sup> Following the abandonment of Akhetaten by Tutankhamun, she appears to have been reburied within KV55 in the Valley of the Kings, from where she was eventually removed during the reign of Ramesses IX.<sup>39)</sup> Her immediate destination at this time remains obscure.

The mummy of the 'Elder Woman' from the (Jc) cache within KV35<sup>40)</sup> has recently been identified as that of Tiye.<sup>41)</sup> As suggested above, her arrival in KV35 with her two anonymous companions is probably to be dated slightly later than that of the (Jb) mummies.<sup>42)</sup>

Ay

Originally buried within WV23,<sup>43)</sup> the mummy of Ay appears to have been removed to the main Valley for caching in the tomb of Horemheb (KV57), perhaps at some time during Years 4-6 of whm mswt.<sup>44)</sup> Subsequently, this cache was heavily plundered, and the mummy of Ay cannot now be recognised amongst the human debris discovered there.<sup>45)</sup>

Horemheb

Horemheb was evidently buried within KV57, which appears to have been subjected to official inspection and probably employed as a cache at the end of the New Kingdom.<sup>46)</sup> The king is perhaps represented by one of the fragmented skeletons recovered from the tomb by the Davis expedition.<sup>47)</sup>

Ramesses I

We possess only one type B docket for Ramesses I, on the head end of his fragmentary, replacement coffin.<sup>48)</sup> This docket<sup>49)</sup> records the removal of the king's mummy from the tomb of Sethos I (KV17) for reburial in the k3y of Inhapi (WN A)<sup>50)</sup> in Year 10 of Siamun, 4 prt 17. The precise date of the king's earlier interment within KV17 - when Ramesses I was evidently furnished with his new coffin<sup>51)</sup> - is not known, nor is the date of his removal from KV16, his original place of burial.<sup>52)</sup> Both dates, however, were presumably close to that of the analogous transfer of Ramesses II (q.v.) in Year 15 of Smendes, 3 3ht 6.<sup>53)</sup> The text relating to the introduction of Ramesses I into the Inhapi tomb in Year 10 of Siamun, 4 prt 20,<sup>54)</sup> is not preserved, though there is no reason to

believe that it was not originally present or that Ramesses I was never actually introduced into WN A.

The whereabouts of the king's corpse is a mystery, since the presence of his fragmentary coffin within DB320 (corridor (C)?<sup>55</sup>) possibly employed for the woman 'B'),<sup>56</sup> as well as his earlier association with Sethos I and Ramesses II, would seem to imply his interment there following transfer from the Inhapi k3y (WN A)<sup>57</sup> after Year 11 of Shoshenq I.<sup>58</sup> It may be, therefore, that his is to be recognised as one of the unidentified corpses found within DB320.<sup>59</sup>

### Sethos I

The burial of Sethos I, as has been seen,<sup>60</sup> was restored on several occasions before the occupants of the KV17 cache were removed for transfer to the k3y of Inhapi (WN A)<sup>61</sup> in Year 10 of Siamun, 4 prt 17.<sup>62</sup> The actual interment took place three days later, on 4 prt 20.<sup>63</sup> Sethos I remained in the Inhapi cache until at least Year 11 of Shoshenq I, after which date the occupants of this eyrie appear to have been reburied en masse within DB320.<sup>64</sup>

### Ramesses II

As already noted,<sup>65</sup> the earliest record of restoration activity in connection with Ramesses II occurs in a partially washed-out docket on the king's coffin, dated to Year 6 of whm mswt, 3 prt? 15.<sup>66</sup> Although the text is not fully legible, it evidently contained a record of burial restoration (whm krs)

similar to that found on the coffin of Sethos I, which had itself been restored in an analogous fashion a short time earlier (on 2 3ht 7).<sup>67)</sup>

The mummy of Ramesses II was transferred (via KV4?? cf. above, s.v. Hatshepsut) for reburial with Sethos I in KV17 in Year 15 of Smendes, 3 3ht 6.<sup>68)</sup> It remained in the KV17 cache until Year 10 of Siamun, 4 prt 17,<sup>69)</sup> when the large cartouches of the king seem to have been inscribed upon the lid and the corpse removed for reburial in the Inhapi k3y (WN A)<sup>70)</sup> on 4 prt 20.<sup>71)</sup>

The final transfer, perhaps to side room (D) of the Pinudjem II family vault (DB320), took place at a date after Year 11 of Shoshenq I.<sup>72)</sup>

### Merenptah

The mummy of Merenptah, originally buried within KV8,<sup>73)</sup> was discovered in the KV35 (Jb) cache, rewrapped,<sup>74)</sup> docketed<sup>75)</sup> and contained in the coffin box of Sethnakhte.<sup>76)</sup> Its presence in this coffin might conceivably indicate an earlier association with the KV14 cache, which was in use by Sethos II and Siptah (q.v.) as early as Years 6-7 of whm mswt,<sup>77)</sup> and was abandoned for KV35 only after Year 13 of Smendes.<sup>78)</sup> The mummy displays damage to the cranium<sup>79)</sup> analogous to that found in the skulls of CG 61071, Sethos II, the 'body on the boat' and Ramesses IV-VI,<sup>80)</sup> caused, presumably, at the time the original bandages were adzed off preparatory to rewrapping,<sup>81)</sup> perhaps within KV35.<sup>82)</sup>

Sethos II

Some years after his (re)burial within KV15,<sup>83)</sup> perhaps following a visit by the king's butler Sethherwenemef in Year 6 of whm mswt, 2 3ht 7,<sup>84)</sup> the mummy of Sethos II was removed to KV14.<sup>85)</sup> It was presumably at this time that the mummy of the king was furnished with its 'new' coffin (the lid and box not matching),<sup>86)</sup> clearly decorated in the same workshop as those of Siptah and Ramesses IV (q.v.).

Sethos II was removed from KV14 sometime after Year 13 of Smendes,<sup>87)</sup> and rewrapped,<sup>88)</sup> docketed<sup>89)</sup> and cached within room (Jb) in the tomb of Amenophis II (KV35). The king's coffin lid was at this time appropriated and inscribed with a hieratic docket<sup>90)</sup> identifying its new owner as Amenophis III (q.v.). For damage to the mummy's skull, cf. above, s.v. Merenptah.

Siptah

The mummy of Siptah was originally buried within KV47,<sup>91)</sup> from where it was removed - probably in Year 7 of whm mswt, 2 3ht 1<sup>92)</sup> - for reburial a short time after<sup>93)</sup> in a replacement coffin<sup>94)</sup> (cf. s.v. Sethos II, Ramesses IV) within the KV14 cache. Finally Siptah, like the other members of the KV14 cache, was removed, rewrapped<sup>95)</sup> and docketed<sup>96)</sup> and reburied within KV35 (Jb) at an as yet undetermined date after Year 13 of Smendes.<sup>97)</sup>

Unknown woman 'D'

The mummy of the unknown woman 'D' was discovered in room (Jb) of the KV35 cache, contained in a coffin

lid belonging to Sethnakhte.<sup>98)</sup> Her association with this lid might well indicate an earlier presence within KV14, which had been employed previously by Siptah and perhaps Merenptah (q.v.) amongst others. Both of these rulers seem to have shared their original tombs with their respective mothers<sup>99)</sup> - in which case it is possible that the unknown woman 'D' is to be recognised as either Tiaa or Isinofret. The body's itinerary will have followed that of the other mummies buried within KV14: transfer to KV35 at an as yet undetermined date after Year 13 of Smendes.<sup>100)</sup>

### Sethnakhte

He or his successor Ramesses III having apparently displaced the double burial of Tawosret and Sethos II within KV14, Sethnakhte took over the tomb for his own interment.<sup>101)</sup> Subsequently, in Years 6-7 of whm mswt,<sup>102)</sup> the sepulchre was employed as a cache for Sethos II, Siptah, probably Ramesses IV, and perhaps Merenptah, the woman 'D' and Ramesses V-VI (q.v.). At a date later than Year 13 of Smendes,<sup>103)</sup> the occupants of this tomb were transferred to KV35, in the burial chamber of which (J) fragments of Sethnakhte's cartonnage were found; the king's cartonnage coffin box and lid were discovered within room (Jb), having been employed for Merenptah and the unknown woman 'D' respectively.<sup>104)</sup> Sethnakhte's presence within KV35 thus seems assured, and an identification with the stripped 'body on the boat'<sup>105)</sup> is as likely as any. The skull of this corpse had been pierced in antiquity;<sup>106)</sup> cf. above, s.v. Merenptah.

Ramesses III

Ramesses III's continued presence within KV11 during the reign of Smendes is suggested by two graffiti in the burial chamber (J).<sup>107)</sup> Although we are not informed of the purpose of the official visit(s) which prompted these graffiti (they are little more than lists of the members of each party), it is conceivable that the presence of these individuals is to be seen as connected with the osirification of Ramesses III in Year 13 of Smendes, 2 šmw 27?,<sup>108)</sup> utilising linen from Medinet Habu which had perhaps been stored in KV49.<sup>109)</sup>

As discovered in DB320, the mummy of Ramesses III<sup>110)</sup> was contained in a replacement cartonnage case,<sup>111)</sup> which had itself been deposited in side room (D)<sup>112)</sup> with the mummy of Ahmose-Nofretiri in the latter's large coffin.<sup>113)</sup> Ramesses III and Nofretiri had evidently reached the DB320 cache together following the mass transfer from WN A (the Inhapi k3y)<sup>114)</sup> after Year 11 of Shoshenq I,<sup>115)</sup> where the king had presumably been interred following his restoration.

The original innermost coffin of Ramesses III,<sup>116)</sup> evidently discarded at the time of the king's restoration in Year 13 of Smendes, since it is too small to have contained the mummy's new cartonnage,<sup>117)</sup> was subsequently employed for Amenophis III (q.v.), perhaps at the time of his introduction into KV35.

### Ramesses IV

The removal of Ramesses IV from his original tomb, KV2,<sup>118)</sup> is not securely dated. Nevertheless, the fact that his replacement coffin<sup>119)</sup> shows signs of having been decorated in the same workshop as those of Sethos II and Siptah (q.v.), supplied at the time of their introduction into KV14 in Years 6-7 of whm mswt,<sup>120)</sup> suggests that Ramesses IV shared the same fate. As has been seen, the removal from KV14 to KV35, and the rewrapping<sup>121)</sup> and docketing<sup>122)</sup> of the mummies, took place at an as yet undetermined date subsequent to Year 13 of Smendes.<sup>123)</sup> The mummy displays a hole in the cranium; cf. above, s.v. Merenptah.

### Ramesses V

Ramesses V, whose mummy, rewrapped<sup>124)</sup> and docketed<sup>125)</sup> perhaps at the same time as that of Tuthmosis IV (q.v.), was discovered in side room (Jb) of the KV35 cache, seems originally to have been buried with his successor, Ramesses VI, within KV9.<sup>126)</sup> His movements will presumably have followed those of this king: see below.

### Ramesses VI

Ramesses VI's removal from KV9<sup>127)</sup> is not securely dated, and it is not clear whether or not he had been reburied within KV14 before his transfer to the KV35 cache (Jb) after Year 13 of Smendes.<sup>128)</sup> His mummy,<sup>129)</sup> the skull pierced (cf. s.v. Merenptah), was perhaps rewrapped at the same time as that of

Sethos II (q.v.): what is conceivably to be recognised as the latter king's right forearm and hand<sup>130)</sup> had been wrapped in with the badly damaged body of this later king.<sup>131)</sup>

### Ramesses IX

The mummy of Ramesses IX, originally buried in KV6,<sup>132)</sup> was found within one of the coffins of Neskhons in DB320,<sup>133)</sup> having been transferred there from the Inhapi k3y (WN A)<sup>134)</sup> after Year 11 of Shoshenq I.<sup>135)</sup> According to a docket on his wrappings,<sup>136)</sup> the mummy had been rewrapped at t3 hwt (i.e. Medinet Habu) in Year 7 of Siamun, employing linen<sup>137)</sup> made by the same Neskhons who perhaps supplied one of her own coffins to be used for the king at this time.

## II. Other individuals represented in the DB320 cache

### Tetisheri

Tetisheri, the commoner wife of Seqnenre-Taa II,<sup>138)</sup> was represented in DB320 by a series of her original mummy bandages<sup>139)</sup> and, conceivably, by the mummy CG 61056 - the unknown woman 'B'.<sup>140)</sup> No coffin has been ascribed to her.<sup>141)</sup> She presumably arrived in DB320 after Year 11 of Shoshenq I<sup>142)</sup> from the Inhapi k3y (WN A),<sup>143)</sup> where the majority of the latter tomb's occupants seem to have originated. The primary burial place of this queen, who evidently died in the reign of her grandson, Amosis I,<sup>144)</sup> has not yet been located.<sup>145)</sup>

Seqnenre-Taa II

According to P. Abbott, the burial of Seqnenre-Taa II was inspected in Year 16 of Ramesses IX, 3 3ht 18, and found to be intact.<sup>146)</sup> The king's body<sup>147)</sup> subsequently turns up in side room (D) of DB320, contained in its original coffin from which most of the gold leaf had been removed.<sup>148)</sup> It had presumably travelled via the Inhapi cache (WN A)<sup>149)</sup> after Year 11 of Shoshenq I.<sup>150)</sup>

Ahmose-Inhapi

Ahmose-Inhapi appears to have been a daughter of Seqnenre-Taa I and the third wife of Taa II.<sup>151)</sup> To judge from the Sethos I group of docketts,<sup>152)</sup> she was not buried with her husband but in a k3y or 'high place' which is probably to be recognised as the cliff tomb Bab el-Muallaq (WN A).<sup>153)</sup> The rewrapped mummy of Inhapi<sup>154)</sup> was discovered in corridor (B) of the DB320 cache contained in the coffin of the wetnurse Rai<sup>155)</sup> (q.v.). Apparent correlations in the handwriting of the identifying docket on the mummy's breast suggest that she had been restored within her original tomb in Years 7-8 of Psusennes I,<sup>156)</sup> a hundred years or more before the transfer to DB320 after Year 11 of Shoshenq I.<sup>157)</sup>

Ahmose-Hentempet

Ahmose-Hentempet was evidently a daughter of Seqnenre-Taa II and Ahhotpe I,<sup>158)</sup> the queen whose richly adorned and coffined mummy was found cached(?) in the Dra Abu'l Naga plain close to the entrance

to the Valley of the Kings in 1859.<sup>159)</sup> Hentempet's original burial place is unknown. Her rewrapped<sup>160)</sup> and recoffined<sup>161)</sup> mummy was found in the DB320 cache, having been transferred with the other occupants of the WN A k3y<sup>162)</sup> after Year 11 of Shoshenq I.<sup>163)</sup>

#### Ahmoose-Henttimehu

The rewrapped<sup>164)</sup> and docketed<sup>165)</sup> mummy of Ahmoose-Henttimehu, a daughter of Seqenenre-Taa II (presumably) and Ahmoose-Inhapi,<sup>166)</sup> was discovered in DB320. She had evidently been cached there following transfer from the tomb of her mother (WN A)<sup>167)</sup> - her original burial place? - at some time after Year 11 of Shoshenq I.<sup>168)</sup>

#### Ahhotpe II

Although it has been suggested that Ahhotpe II, the wife of Kamose (whose mummy was discovered in the Dra Abu'l Naga plain in 1857),<sup>169)</sup> had perhaps been buried originally within AN A,<sup>170)</sup> there is in fact no firm evidence to locate the tomb of this queen. Her large outer coffin<sup>171)</sup> was discovered in side chamber (D) of DB320,<sup>172)</sup> associated, it would appear, with the Amosis I group of mummies<sup>173)</sup> and containing the body of Pinudjem I<sup>174)</sup> (q.v.); the queen's own mummy has not been identified. The probability is that Pinudjem I and the entire group of cached mummies within DB320 had been introduced en masse from the Inhapi k3y (WN A).<sup>175)</sup> We may thus retrace Ahhotpe's steps to this earlier cache, where, it appears, her mummy was displaced from its coffin and is then lost site of.

Ahmoose-Sitkamose

The original tomb of this queen - as her name would imply, a daughter of Kamose<sup>176)</sup> - is unknown. We read from one of two<sup>177)</sup> docketts on her wrappings that she was osirified in Year 7 of Psusennes I, 4 3ht 18,<sup>178)</sup> at the same time, perhaps, that Inhapi was rewrapped.<sup>179)</sup> Sitkamose seems to have been removed from WN A at a date after Year 11 of Shosheng I,<sup>180)</sup> when, contained in the coffin of Pediamun<sup>181)</sup> (q.v.), she was introduced into DB320 with the other occupants of the Inhapi k3y.<sup>182)</sup>

Sitamun

The original burial place of Sitamun, probably another daughter of Kamose,<sup>183)</sup> is similarly unknown. Her 'mummy',<sup>184)</sup> docketed<sup>185)</sup> at a time chronologically close to the osirification of Siamun in Year 8 of Psusennes I, 3 prt 29,<sup>186)</sup> and contained in an anonymous white coffin,<sup>187)</sup> eventually turns up in the DB320 cache, having been transferred from the k3y of Inhapi (WN A)<sup>188)</sup> after Year 11 of Shosheng I.<sup>189)</sup>

Amosis I

The tomb of Amosis I is not yet located.<sup>190)</sup> As found in side chamber (D) of DB320, his mummy<sup>191)</sup> had been docketed twice: once with a simple identifying text<sup>192)</sup> and once with a record of osirification in Year 8 of Psusennes I, 3 prt 29.<sup>193)</sup> Both the date and purport of this latter docket were duplicated on the wrappings of Siamun,<sup>194)</sup> a probable son of Amosis,<sup>195)</sup> and this, coupled with the fact

that the original 18th dynasty coffins of both father<sup>196)</sup> and offspring<sup>197)</sup> are so similar, may well indicate that they shared the same original tomb.

The immediate origin of the mummies cached within DB320 was evidently the Inhapi k3y (WN A),<sup>198)</sup> which was finally evacuated after Year 11 of Shoshenq I.<sup>199)</sup> To judge from palaeographic similarities noted above,<sup>200)</sup> the interment within WN A took place at the time of osirification. This, it is to be noted, occurred in the same year as the probable burial of Pinudjem I (q.v.), whose original interment was perhaps also made in the Inhapi cliff tomb, like that of his wife Nodjmet (q.v.) before him.<sup>201)</sup>

#### Ahmose-Nofretiri

Ahmose-Nofretiri appears to have been interred originally within AN B, a tomb later enlarged and adapted to accommodate also the burial of Amenophis I (q.v.).<sup>202)</sup> The two patrons of the Theban necropolis will thus have shared the same subsequent fate. The mummies will have been rewrapped,<sup>203)</sup> the coffins refurbished<sup>204)</sup> and the pair reburied in the Inhapi k3y (WN A)<sup>205)</sup> before Year 10 of Siamun.<sup>206)</sup> Their eventual transfer to side room (D) of the DB320 cache will have occurred sometime after Year 11 of Shoshenq I.<sup>207)</sup> See further below, s.v. Amenophis I.

#### Ahmose-Meryetamun

The Meryetamun discovered within DB320 in the coffin of her steward, Seniu<sup>208)</sup> (q.v.), was probably a daughter of Amosis I and Ahmose-Nofretiri.<sup>209)</sup> Her

original tomb has not yet been located, but was presumably in the vicinity of Deir el-Bahri.<sup>210)</sup> The queen evidently arrived in DB320 after Year 11 of Sheshonq I,<sup>211)</sup> having been transferred from WN A<sup>212)</sup> where she appears to have been cached and rewrapped<sup>213)</sup> in Years 7-8 of Psusennes I.<sup>214)</sup>

### Siamun

The history of Siamun's mummy, found in side room (D) of DB320, is considered above, s.v. Amosis I.

### Rai

The mummy of Rai,<sup>215)</sup> wetnurse of Ahmose-Nofretiri,<sup>216)</sup> was discovered in DB320 in the coffin of a certain Paheripedjet<sup>217)</sup> (q.v.), her own coffin<sup>218)</sup> having been employed for Ahmose-Inhapi.<sup>219)</sup> The mummy of Rai was perhaps rewrapped and docketed<sup>220)</sup> within WN A at the same time as the Amosis I group of mummies,<sup>221)</sup> and transferred from there after Year 11 of Shoshenq I.<sup>222)</sup>

### Seniu

The scribe and chief steward of the god's wife, Seniu, was represented in the DB320 cache by his coffin,<sup>223)</sup> which had been employed to contain the mummy of Meryetamun<sup>224)</sup> (q.v.). His body may be amongst the anonymous corpses from the tomb.<sup>225)</sup> Seniu's original burial place was perhaps at Deir el-Bahri, where a shabti of his was found by Lansing in 1918/19.<sup>226)</sup>

### Amenophis I

The tomb which at present seems to have the strongest claim to be that of Amenophis I is AN B.<sup>227)</sup> According

to P. Abbott, the king's burial was inspected in Year 16 of Ramesses IX, 3 3ht 18, and found to be intact.<sup>228)</sup> A docket on the replacement coffin<sup>229)</sup> in which his corpse<sup>230)</sup> lay within DB320 records, however, that the burial later required restoration (whm krs) in Year 6 of Smendes, 4 prt 7.<sup>231)</sup> The coffin is very similar to that of Tuthmosis II<sup>232)</sup> (q.v.), who had perhaps been reburied with Amenophis I a month before this latter king's restoration took place. See further below, s.v. Tuthmosis II.

A second coffin docket records that the burial of Amenophis I had required further restoration (whm krs) within a matter of a decade, in Year 16 of Smendes, 4 prt 11.<sup>233)</sup>

According to a docket on the fragmentary coffin box of Ramesses I, the coffined body of Amenophis I had, by Year 10 of Siamun, 4 prt 17,<sup>234)</sup> been transferred to the tomb of Inhapi (WN A),<sup>235)</sup> where it remained until at least Year 11 of Shoshenq I, when the Inhapi mummies were introduced into DB320.<sup>236)</sup>

#### Ahmoose-Sipair

The attribution of a small (replacement?) coffin<sup>237)</sup> and 'roughly re clothed' mummy<sup>238)</sup> from the DB320 cache to the young prince Sipair, probably a son of Amenophis I,<sup>239)</sup> was made by Daressy on the basis of a poorly preserved docket written on the coffin lid.<sup>240)</sup> The Dra Abu'l Naga tomb of this individual<sup>241)</sup> is mentioned in P. Abbott as having been inspected in Year 16 of Ramesses IX, 3 3ht 18, and found to be

intact.<sup>242)</sup> At some later but as yet undetermined date, the child's mummy, perhaps with the other members of the early 18th dynasty royal line, was cached in the WN A k3y,<sup>243)</sup> from which it will have been removed for reburial in DB320 after Year 11 of Shoshenq I.<sup>244)</sup>

### Tuthmosis II

The original place of burial of Tuthmosis II is at present unknown; the possibility of his association with DB358, however, was noted in chapter 1. We know from a docket inscribed upon the wrappings of the mummy that the king was subjected to whm sm3, lit. 'repetition of burial', in Year 6 of Smendes, 3 prt 7,<sup>245)</sup> when a new coffin<sup>246)</sup> was evidently supplied and the body rewrapped.<sup>247)</sup> It is not altogether clear whether this 'reburial' was in his own tomb (on the assumption that whm sm3 is merely a variant of whm krs),<sup>248)</sup> or whether Tuthmosis II was removed from his own tomb for reburial elsewhere, perhaps in that of Amenophis I (q.y.). This latter alternative is perhaps the more attractive, but is possibly weakened by the fact that we do not possess for Tuthmosis II a restoration docket equivalent to that of Smendes I's Year 16, 4 prt 11, found upon the coffin of Amenophis I.<sup>249)</sup>

The proximity of Tuthmosis II to Amenophis I outside the entrance to room (D) in the corridor of DB320<sup>250)</sup> would seem to imply that the two bodies had reached this tomb together (after Year 11 of

Sheshonq I)<sup>251)</sup> and had earlier been associated in the k3y of Inhapi.<sup>252)</sup> See above, s.v. Amenophis I.

### Merymose

An alabaster canopic jar of the viceroy Merymose<sup>253)</sup> (a contemporary of Amenophis III who was originally buried at Qurnet Murai (TT383))<sup>254)</sup> was discovered in DB320; it is thus conceivable that his is one of the anonymous mummies from the cache.<sup>255)</sup> Alternatively, and perhaps nearer the truth of the matter, the canopic jar and its contents may represent all that it had been possible to salvage of the man from his heavily plundered tomb.<sup>256)</sup> The jar had presumably travelled via the Inhapi k3y (WN A)<sup>257)</sup> with the rest of the cached mummies after Year 11 of Shoshenq I.<sup>258)</sup>

### Bakt

The woman Bakt, otherwise unknown, is represented in the DB320 cache by an 18th dynasty coffin<sup>259)</sup> and (presumably) by its occupant.<sup>260)</sup> Coffin and corpse evidently arrived in DB320 with the rest of the cached mummies after transfer from the cliff tomb of Inhapi (WN A)<sup>261)</sup> after Year 11 of Shoshenq I.<sup>262)</sup>

### Nebseni

What is probably to be recognised as the body of the w<sup>c</sup>b-priest and scribe Nebseni<sup>263)</sup> was reburied in DB320 following transfer with the rest of the cached mummies from WN A<sup>264)</sup> after Year 11 of Shoshenq I.<sup>265)</sup> He is otherwise unknown to me.

Siese

The king's scribe Siese, otherwise unknown to me, is represented in DB320 by a single canopic jar<sup>266)</sup> and, perhaps, by one of the unidentified corpses from this cache.<sup>267)</sup> The itinerary of the jar presumably followed that of the other material cached within this tomb: previous burial within the Inhapi k3y (WN A)<sup>268)</sup> and transfer to DB320 after Year 11 of Shoshenq I.<sup>269)</sup>

Sutymose

This individual is represented in DB320 by a miniature wooden coffin (containing an embalmed liver) and a box.<sup>270)</sup> His may well be one of the unlabelled corpses from the cache,<sup>271)</sup> or alternatively, the body of Sutymose may have been destroyed, these few pieces representing all that it had been possible to salvage from his ransacked burial.<sup>272)</sup> Like the rest of the DB320 material, the miniature coffin and box had evidently been transferred from the Inhapi k3y (WN A)<sup>273)</sup> after Year 11 of Shoshenq I.<sup>274)</sup>

Wepmose

The king's scribe Wepmose is represented in DB320 by a calcite canopic jar,<sup>275)</sup> and conceivably by one of the cache's unlabelled mummies.<sup>276)</sup> His original place of burial is not known to me, but the jar had presumably arrived in DB320 from the tomb of Inhapi (WN A)<sup>277)</sup> with the rest of the cached mummies sometime after Year 11 of Shoshenq I.<sup>278)</sup>

Wepwawetmose

The deputy of the army Wepwawetmose is represented in the DB320 cache by a single canopic jar,<sup>279)</sup> which had presumably arrived with the other cached material from WN A<sup>280)</sup> after Year 11 of Shoshenq I.<sup>281)</sup> He is conceivably the owner of one of the unidentified mummies from the cache.<sup>282)</sup>

Paheripedjet

The 20th dynasty servant in the Place of Truth, Paheripedjet,<sup>283)</sup> is attested in DB320 by his coffin,<sup>284)</sup> which was employed to contain the mummy of Rai<sup>285)</sup> (q.v.) at the time of her transfer from the Inhapi k3y (WN A).<sup>286)</sup> It is possible (if no more) that his is one of the anonymous mummies from DB320.<sup>287)</sup>

Nodjmet

According to a linen docket discovered on her DB320 mummy,<sup>288)</sup> Nodjmet, wife of Herihor,<sup>289)</sup> was embalmed in or after Year 1 of Smendes.<sup>290)</sup> From her evident association with Pinudjem I (q.v.), who appears to have been transferred from the Inhapi k3y (WN A)<sup>291)</sup> with the rest of the cached mummies after Year 11 of Shoshenq I,<sup>292)</sup> her original place of burial may well have been WN A.

Pinudjem I

The body of Pinudjem I<sup>293)</sup> was discovered in side room (D) within DB320<sup>294)</sup> contained in the huge coffin of Ahhotpe II.<sup>295)</sup> His coffins,<sup>296)</sup> adapted from those originally prepared for Tuthmosis I by

Tuthmosis III,<sup>297)</sup> were found elsewhere in the cache containing the mummy of 'Tuthmosis I'.<sup>298)</sup> Pinudjem I had evidently been transferred to DB320 from the Inhapi tomb (WN A)<sup>299)</sup> in company with the rest of the cached mummies after Year 11 of Shoshenq I,<sup>300)</sup> and it may be that this tomb represents his original place of burial.<sup>301)</sup>

#### Duathathor-Henttawy

Duathathor-Henttawy was the wife of Pinudjem I.<sup>302)</sup> The discovery of her coffin together with other funerary equipment in the first corridor (B) of DB320<sup>303)</sup> indicates that this was not her original place of burial and that she had been transferred in the company of the other cached mummies. Both coffins<sup>304)</sup> and corpse<sup>305)</sup> had been plundered, and in this respect bear a close resemblance to the mummies and coffins of Pinudjem I and Nodjmet (q.v.). It is therefore not unreasonable to suppose these three individuals to have been transferred from the same original burial - presumably within the k3y of Inhapi (WN A)<sup>306)</sup> - after Year 11 of Shoshenq I.<sup>307)</sup>

#### Maatkare-Mutemhet

The inner coffin and coffin board<sup>308)</sup> of Mutemhet, a daughter of Pinudjem I and Henttawy, had been superficially despoiled in antiquity, and it is possible, therefore, that she had not originally been buried within DB320.<sup>309)</sup> If, however, as seems likely, she was discovered in the end chamber of the tomb (F),<sup>310)</sup> her burial must have been introduced before the Inhapi group of coffins.

Masaharta

The inner coffin and coffin board<sup>311)</sup> of Masaharta, high priest of Amun, had been abused in a similar way to those of Maatkare-Mutemhet and Tayuheret (below). It is likely, therefore, since the Pinudjem II group of corpses shows no signs of serious ancient plundering,<sup>312)</sup> that DB320 was not the man's original burial place. He had perhaps only later been restored<sup>313)</sup> and transferred to DB320 and reburied in the end chamber (F) of the tomb before the introduction of the Inhapi cache.

Tayuheret

The coffins and coffin board<sup>314)</sup> of Tayuheret, perhaps the wife of Masaharta,<sup>315)</sup> were recovered from DB320 in a similar, partially effaced state to those of Maatkare-Mutemhet and Masaharta himself (q.v.).<sup>316)</sup> The lady's post-interment history will thus, perhaps, have been similar to that of these two bodies: (re)burial in the end chamber (F) of DB320 before the introduction of the Inhapi corpses after Year 11 of Shoshenq I.<sup>317)</sup>

Pinudjem II

The original burial place of the high priest Pinudjem II in Year 10 of Siamun, 4 prt 20, is recorded in a docket<sup>318)</sup> at the bottom of the entrance shaft to DB320, the tomb in which his intact burial<sup>319)</sup> was found. Amongst the personnel involved may be noted the god's father Pediamun (q.v.).

Neskhons

Neskhons, wife of Pinudjem II,<sup>320)</sup> evidently predeceased her husband and was interred within the

burial chamber (F) of DB320 in Year 5 of Siamun, 4 šmw 21.<sup>321)</sup> The date of the burial is recorded in a docket<sup>322)</sup> at the bottom of the entrance shaft.

### Isiemkheb

Isiemkheb, daughter of the high priest Menkheperre and probably a lesser wife of Pinudjem II,<sup>323)</sup> seems, from the intact state of her coffined mummy<sup>324)</sup> and the substantial amount of her funerary furniture,<sup>325)</sup> to have been buried within DB320 as and when she died.<sup>326)</sup>

### Djedptahiufankh

Djedptahiufankh appears to have been buried within DB320 as and when he died.<sup>327)</sup> His mummy<sup>328)</sup> was wrapped in linen dating to Years 5, 10 and 11 of Shoshenq I,<sup>329)</sup> the last of which is perhaps the latest attested date from the Pinudjem II family vault (DB320).<sup>330)</sup> As was suggested above,<sup>331)</sup> the interment of Djedptahiufankh may have been seized upon as a suitable occasion for the transfer of the royal mummies from the k3y of Inhapi (WN A);<sup>332)</sup> certainly the layout of the later cache indicates that the latter were not transferred to DB320 before the man's death and interment.<sup>333)</sup>

### Nestanebtishru

This daughter of Pinudjem II and presumed wife of Djedptahiufankh<sup>334)</sup> carries a linen notation dated to Year 13 of an unspecified reign which is unlikely to be earlier than Siamun or Shoshenq I.<sup>335)</sup> Her

original place of burial was evidently DB320, where her intact, coffined mummy<sup>336)</sup> was found.

### Pediamun

The 21st dynasty coffin of Pediamun<sup>337)</sup> was employed to contain the body of Ahmose-Sitkamose<sup>338)</sup> (q.v.). He is perhaps to be identified with the god's father of Amun and chief of secrets Pediamun son of Ankhefenkhons who was involved in the burial of Pinudjem II within DB320 in Year 10 of Siamun, 4 prt 20.<sup>339)</sup> No trace of the man himself may be discerned in the tomb.

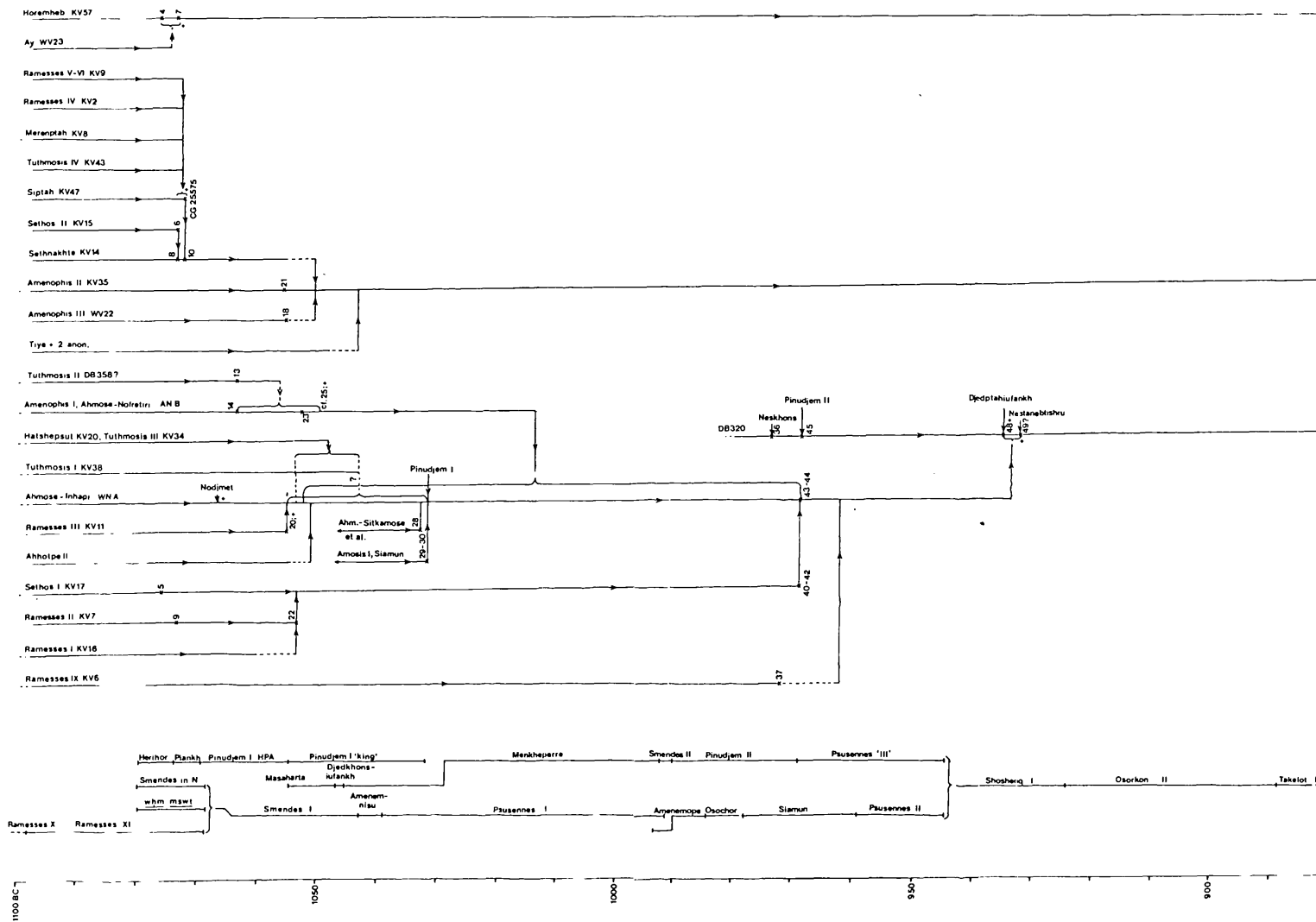

Fig. 97: the routes to the caches

Key to fig. 97

vertical broken line	uncertain time interval
horizontal broken line	probable route
bracket	upper and lower dates for transfer
+	or later
-	or earlier
X	docket or other inscriptional evidence (nos. refer to table 10)

## CONCLUSIONS

## CONCLUSIONS

Hitherto the main sources for the study of tomb robbery on the Theban west bank have been documentary, and the evidence of the tomb robbery papyri,<sup>1)</sup> the major portion of which are concerned with two spates of theft carried out during the reigns of Ramesses IX and Ramesses XI, is indeed of unique importance. Nevertheless, only three of the tomb robbery documents touch directly upon the plundering of the Valley of the Kings: P. Salt 124, which records the theft of objects from the tomb of Sethos II sometime after the king's burial;<sup>2)</sup> the Turin 'Strike Papyrus', which mentions in passing an attempted break-in to the tomb of Ramesses II in Year 29 of Ramesses III;<sup>3)</sup> and the sadly damaged P. Mayer B, which recounts in some detail a robbery carried out in the tomb of Ramesses VI, probably under Ramesses IX.<sup>4)</sup>

The archaeological evidence collected and analysed in the earlier sections of this study allow us not only to supplement the scant papyrological data, but also to place it in some sort of historical context. Most burials in the Valley of the Kings show clearly the results of the sort of activity conventionally identified as that of plunderers - widespread destruction and the absence of valuable grave goods -, and for a few tombs the archaeological record is sufficiently coherent to suggest when the disturbances so reflected actually took place. These instances, a number of

them frankly tentative, are set out in table 11.

Before the era of whm mswt, the only temporal grouping of note is that between the early robberies of KV62 (Tutankhamun), KV43 (Tuthmosis IV) and perhaps WV22 (Amenophis III).<sup>5)</sup> A second phase is presumably to be recognised in the attempted entry into KV7 (Ramesses II) in Year 29 of Ramesses III,<sup>6)</sup> whilst KV9 (Ramesses VI) - subsequent official interest in which is probably attested by the graffito of Year 9 of Ramesses IX, 2 prt 14?<sup>7)</sup> - perhaps constitutes a third grouping. Such peaks may, of course, be mere accidents of preservation so far as the archaeological and documentary record is concerned. On balance, however, it seems that the apparent increase in tomb robbery during the periods noted is significant, and reflects the political and economic situation of these times: at the end of the 18th dynasty the administration was disrupted through virtual civil war,<sup>8)</sup> whilst the administrative efficiency of the 20th dynasty was periodically undermined by corruption, inflation and famine.<sup>9)</sup>

The vast majority of robberies which took place in the royal wadi before whm mswt seem, nevertheless, to have been opportunistic in character and decidedly small-scale. The sort of petty and selective thieving to be detected in private tombs such as KV46 (Yuya and Tjuyu)<sup>10)</sup> (a burial accidentally stumbled upon at least twice, during the excavation of KV3 and conceivably during preparations for the

## POST-INTERMENT ACTIVITY IN THE VALLEY OF THE KINGS

No.	Tomb	Owner	Suggested date of disturbance	References
1.	KV46	Yuya & Tjuyu	<u>Temp.</u> Amenophis III	Chapter 8
2.	KV62	Tutankhamun	<u>Temp.</u> Ay/Horemheb	Chapter 3
3.	KV43	Tuthmosis IV	Yr 8 Horemheb	Table 10, no. 1
4.	WV22	Amenophis III	<u>Temp.</u> Horemheb or earlier	Chapter 2
5.	WV22	Amenophis III	Post-Ramesses II	Chapter 2
6.	KV36	Maiherpri	19th/20th dynasty	Chapter 8
7.	KV46	Yuya & Tjuyu	<u>Temp.</u> Ramesses III	Chapter 8
8.	KV7	Ramesses II	Yr 29 Ramesses III	Chapter 4
9.	KV12	Children of Ramesses II?	<u>Temp.</u> Ramesses V/VI	Chapter 7
10.	KV35	Amenophis II	Yr 8 Ramesses VI	Table 10, no. 2
11.	KV9	Ramesses VI	Yr 9 Ramesses IX	Table 10, no. 3
12.	KV55	Tiye & Akhenaten	<u>Temp.</u> Ramesses IX	Chapter 2
13.	WV23	Ay	<u>Temp.</u> Ramesses IX	Chapter 3
14.	KV60	In	<u>Temp.</u> Ramesses IX/X	Chapter 8
15.	KV46	Yuya & Tjuyu	<u>Temp.</u> Ramesses XI	Chapter 8
16.	KV57	Horemheb	Yr 4 <u>whm mswt?</u>	Table 10, no. 4
17.	KV17	Sethos I	Yr 6 <u>whm mswt</u>	Table 10, no. 5
18.	KV57	Horemheb	Yr 6 <u>whm mswt?</u>	Table 10, no. 7

No.	Tomb	Owner	Suggested date of disturbance	References
19.	KV15	Sethos II	Yr 6 <u>whm mswt?</u>	Table 10, no. 6
20.	KV7	Ramesses II	Yr 6 <u>whm mswt</u>	Table 10, no. 9
(21.	DB358?	Tuthmosis II	Yr 6 Smendes	Table 10, no. 13)
(22.	AN B	Amenophis I	Yr 6 Smendes	Table 10, no. 14)
23.	WV22	Amenophis III	Yr 12/13 Smendes	Table 10, no. 18
24.	KV11	Ramesses III	Yr 13 Smendes	Table 10, no. 20
25.	KV35	Amenophis II	Yr 13 Smendes?	Table 10, no. 21
26.	KV7	Ramesses II	Yr 15 Smendes	Table 10, no. 22
27.	KV17	Sethos I	Yr 15 Smendes	Cf. table 10, no. 22
28.	KV20	Hatshepsut	Ca. Yr 15 Smendes	Chapter 12
29.	KV34	Tuthmosis III	Ca. Yr 15 Smendes	Chapter 12
(30.	AN B	Amenophis I	Yr 16 Smendes	Table 10, no. 23)
31.	KV17	Sethos I	Yr 7 Psusennes I	Table 10, no. 27
(32.	?	Ahmo- Sitkamose	Yr 8 Psusennes I	Table 10, no. 28)
(33.	?	Amosis I; Siamun	Yr 8 Psusennes I	Table 10, nos. 29-30)
34.	KV38	Tuthmosis I	Pre-Yr 8 Psusennes I	Chapter 12
35.	KV6	Ramesses IX	Yr 7 Siamun?	Table 10, no. 37
36.	KV17	Sethos I	Yr 10 Siamun	Table 10, nos. 40-42

excavation of KV4 for Ramesses XI) was probably widespread. The initial plundering of KV10 (Amenmesse)<sup>11)</sup> - if this tomb had ever received a burial - and of KV12,<sup>12)</sup> both broken into as a result of accidental 'collisions' during the excavation respectively of KV14 and KV9, is evidently to be put in the same class.

The practicalities of tomb robbery are well illustrated in the papyri, but may be supplemented by archaeological evidence. Tombs such as KV62 (Tutankhamun),<sup>13)</sup> KV36 (Maiherpri) and KV46 (Yuya and Tjuyu),<sup>14)</sup> which had been robbed only superficially, allow us to discern which commodities the thieves had an interest in. These appear, basically, to be of two sorts: goods the origin of which would not have been immediately apparent, and which could have been disposed of with ease; and items made from materials which could be easily recycled (and therefore made anonymous) and employed for other purposes.

Amongst the first class may be noted linen, found in quantity in the intact tomb of Kha at Deir el-Medina<sup>15)</sup> but almost entirely lacking in the pilfered burials of Maiherpri and Yuya and Tjuyu.<sup>16)</sup> Fresh perfumes and cosmetics were also sought after, almost always stolen when a tomb was entered a short time after the interment (as, for example, within KV62),<sup>17)</sup> but frequently neglected by later thieves (as in KV36) when they had passed their prime.<sup>18)</sup>

Amongst the second class, that of materials which could be recycled, the most attractive was metal,<sup>19)</sup> which is rarely met with even in burials which have been subjected to the most cursory and selective plundering. Glass, at least in the 18th dynasty, was perhaps also a desirable commodity,<sup>20)</sup> though it was generally ignored by the intruders of the late New Kingdom.<sup>21)</sup> Other materials that may be mentioned are precious woods and ivory, the theft of which is attested by the tomb robbery papyri<sup>22)</sup> and, indirectly, by their comparative rarity in the archaeological record.

The discovery of thefts in the necropolis was perhaps the result of frequent 'inspections' during the cooler seasons,<sup>23)</sup> particularly in the later period.<sup>24)</sup> The restoration work carried out after a robbery had taken place is well illustrated in the tomb of Tuthmosis IV (KV43).<sup>25)</sup> In this burial broken faience vessels had been repaired, other damage and disorder presumably made good, breached blockings restored and resealed, and the wooden door to the burial chamber perhaps replaced by a masonry build as in WV22 (Amenophis III).<sup>26)</sup> With KV62, the tomb of Tutankhamun,<sup>27)</sup> the funerary equipment was hastily put back into some sort of order, the dismantled portions of the door blockings rebuilt and resealed, and the passage cleared of funerary material (which was then reburied) and filled with rubble to deter future plunderers. With Tutankhamun, and with Tuthmosis IV also, the responsibility for reburial and restoration devolved upon the necropolis administration, as, it appears, did the

initial interment of non-royal individuals such as Yuya and Tjuyu.<sup>28)</sup> This is indicated not only by the personnel involved in the KV43 restoration<sup>29)</sup> but also by the seals found associated with the door blockings, which are consistently of the jackal and nine captives variety.<sup>30)</sup> The numerous priestly officials attested by their seals<sup>31)</sup> as having been present at Tutankhamun's burial were evidently not involved in the subsequent resealings of the tomb.

When a tomb was stumbled upon only accidentally by the necropolis workforce, any breach made in the blockings to establish its content was either left or else closed with a dry stone build.<sup>32)</sup> In the case of KV46, two of the officials involved in reclosing the tomb appear to have resealed a number of the disturbed funerary items with their personal signets.<sup>33)</sup> This sort of resealing is not apparent in any other Valley tomb, and was certainly not undertaken by those officials involved in the re-ordering of KV62 after its two periods of theft.<sup>34)</sup>

The work of restoration in the royal necropolis was evidently but one aspect of the re-organisation of the west bank (and of the Egyptian administration generally) undertaken by Horemheb.<sup>35)</sup> Another aspect of these reforms was the re-establishment of the necropolis workforce based at Deir el-Medina.<sup>36)</sup> The pre-Horemheb settlement on the site appears to have been a quite different entity from that which was to evolve during the Ramessid period, one populated only sporadically by a

transient, perhaps even casual, workforce,<sup>37)</sup> in contrast to the specialised, tightly controlled and above all permanent community of later times.<sup>38)</sup> Whether or not this re-ordering of the workforce was a reaction to the thefts of previous years - in which those involved in excavating and stocking the tombs had almost certainly taken part<sup>39)</sup> - is perhaps debatable; but a permanent and extensive official presence on the west bank evidently did have the effect of drastically reducing the occurrence of major tomb robbery - if not lesser pilfering - throughout the greater part of the 19th and 20th dynasties. Indeed, the confidence of the later Ramessid rulers was such that they ceased to hide the tomb entrance from view as previously, and seem to have flanked it by a pair of large 'pylons' constructed from the excavated chip.<sup>40)</sup>

The spate of thefts that swept the west bank under Ramesses XI and are so well documented in the tomb-robbery papyri evidently shattered this confidence. These robberies - or rather the increasingly unsettled political situation which made such plundering possible - may well have prompted the king's final abandonment of plans for burial within the royal wadi. As at Amarna so many centuries previously,<sup>41)</sup> preparations were made for dismantling the more important tombs, not for transfer and reburial at another site, but with the aim of caching the occupants in safety in a smaller number of easily guarded hiding places. It is now clear that a good proportion of the evidence for 'plundering' so

conspicuous in the archaeological record is in fact to be attributed to this change in official policy towards the royal dead.<sup>42)</sup> Not only were the burials to be dismantled, but any grave goods of value buried with the dead were to be appropriated by the administration.<sup>43)</sup> It seems that this procedure was intended not only to lessen the attraction of the burials to would-be plunderers, and thus help towards the preservation of the mortal remains of the pharaohs themselves, but also to assist in propping up what was by this time an economy in decline. Foreign tribute and campaign booty were now things of the past, and Egypt's standing in matters of foreign trade had fallen to an all-time low, as the report of Wenamun shows only too clearly.<sup>44)</sup> Copper-mining expeditions had virtually ceased after Ramesses V-VI, and, following the revolt of Pinhasi in Year 19 of Ramesses XI or thereabouts, the Sudanese gold mines (in decline since the end of the 18th dynasty) were finally lost.<sup>45)</sup>

The first discernible stage in the realisation of this combined policy of salvage and restoration seems to date to Years 4-7 of whm mswt.<sup>46)</sup> This period saw not only the 'restoration' of the burials of Sethos I and Ramesses II within KV17 and KV7 respectively, but the establishment of the first caches within KV14 and probably within KV57 as well.<sup>47)</sup> By Year 10 of whm mswt, we read in the 'Late Ramessid Letters' of Piankh's order to 'uncover a tomb amongst the foremost tombs (or, the tombs of the ancestors) and preserve

its seal until I return'.<sup>48)</sup> This reference conveniently gives the lie to the docketers' claim that official interference in the tombs at this time was solely for the purposes of restoration and repair. It seems likely, in fact, that Piankh was employing the buried wealth of the necropolis to finance his campaign against Pinhasi in the south.<sup>49)</sup>

A second phase appears to have begun in Year 6 of Smendes, when the burial of Amenophis I was 'restored' and the mummy of Tuthmosis II perhaps cached with that of his predecessor within AN B.<sup>50)</sup> This particular round of official activity evidently continued throughout Pinudjem I's priesthood, and shows a noticeable increase just before and after his assumption of 'kingly' status - and, indeed, perhaps accounts for the strength of his position at this time. Amongst the work carried out during this period was the establishment of a cache within KV17 and the transfer of the KV14 mummies to the tomb of Amenophis II (KV35). The osirification and reburial of Ramesses III and the Amosis I<sup>51)</sup> group of corpses within WN A (the k3y of Inhapi)<sup>52)</sup> evidently followed, as did the analogous move of Amenophis I, Ahmose-Nofretiri and Tuthmosis II, and that of Hatshepsut (or what remained of her), Tuthmosis III and presumably Tuthmosis I. By the time Pinudjem I died, a certain degree of stability had evidently been achieved: the mummies had been relieved of their valuables (frequently, it would appear, in a very rough and ready manner),<sup>53)</sup> had for the most part been rewrapped and docketed,

and now lay safe within a handful of easily watched caches - KV17, WNA, KV35 and KV57. This stability was such that the status quo was maintained for a further 60 years until, in Year 10 of Siamun, for reasons which are not entirely clear, further rationalisation was necessary: the mummies from KV17 were transferred to the Inhapi k3y, whilst this cache itself was abandoned some 40 or more years later for the comparative safety of the Pinudjem II family vault (DB320).<sup>54)</sup>

Systematic and large-scale tomb robbery in the Valley of the Kings seems, therefore, to have been a comparatively rare phenomenon, confined to those periods of Egypt's history when the central and local administration was weak or occupied with more pressing matters. Petty pilfering during or shortly after the burial, or occasioned by the accidental discovery of old tombs during the course of work in the Valley, was on the other hand probably common at all periods. The thorough plundering to be seen in tombs such as those of Amenophis II, Tuthmosis IV, Amenophis III and Horemheb was not the result of tomb robbery as such, but of a concerted effort on the part of the Theban administration following the abandonment of the necropolis by Ramesses XI. The purpose of this organised dismantling of the royal burials was to safeguard the physical remains of the royal dead, but also to put the buried and frequently threatened wealth of their grave goods to better economic use.

## APPENDICES

## APPENDICES A-C

## EXCAVATIONS IN THE VALLEY OF THE KINGS 1898-1922

The archaeological exploration of the Valley of the kings reached its peak during the quarter century between 1898 and the discovery of the tomb of Tutankhamun in 1922, and the major portion of the usable archaeological data we possess originates from this period. The archaeological record is nevertheless confused and scattered, and much remains unpublished (and consequently inaccessible to all but a few scholars) in excavators' notebooks or in private letters. For these reasons it has seemed worthwhile to gather this material together, and to analyse and present it in a simplified and coherent form. In doing so, an attempt has been made to establish each excavator's scheme of work - where he excavated and when - and to collect and localise the codes and designations he attached to each site, and to identify the finds therefrom.

In utilising this survey, the following points should be borne in mind:

- (a) the division of each section into individual areas is frequently quite subjective, and has been undertaken solely to facilitate reference;

- (b) whilst every effort has been made to arrange areas chronologically, i.e. in the order in which they were cleared, the fact that on occasion several sites were being worked simultaneously has precluded absolute consistency in this matter.

It is hoped that future scholars will be able to elaborate upon the basic scheme presented here, for there remain a number of sources which I have been unable to trace<sup>1)</sup> or which it has not been practicable for me to consult.<sup>2)</sup>

## APPENDIX A

## ANTIQUITIES SERVICE EXCAVATIONS, 1898-1906

Introduction

Loret had succeeded de Morgan as Director General of the Service des Antiquités in 1897, a position which he held until 1899. Much of the archaeological work undertaken during his time in office was centred upon the royal wadis at Thebes: between 1898 and 1899 Loret numbered 16 tombs in the Valley of the Kings,<sup>3)</sup> of which five (KV26-28, 30-31) may have been known to earlier explorers<sup>4)</sup> and merely recleared. No substantial body of notes relating to Loret's work during these years appears to have survived,<sup>5)</sup> and our evidence for his scheme of work is meagre. According to the annotated map in the Wilbour Library,<sup>6)</sup> KV26-28 and KV30-35 represent the results of the 1898 season, KV29 and KV36-41 the fruits of the 1899 season. The discoveries were evidently not numbered consecutively,<sup>7)</sup> and it is not possible at present to establish any chronologically sound pattern of work - though some progress has been made in this direction by comparing the order in which the finds were entered in the Journal d'entrée.<sup>8)</sup> From the published lists of finds,<sup>9)</sup> it seems that Loret superficially explored several tombs already accessible, namely KV2 (Ramesses IV),<sup>10)</sup> (KV17) (Sethos I)<sup>11)</sup> and WV22 (Amenophis III);<sup>12)</sup> the fragment Loret recovered from the latter tomb is the only

indication we have of work having been carried out in the West Valley at this time.<sup>13)</sup> The Journal d'entrée numbering of the finds suggests that these open tombs were examined during the 1899 season.<sup>14)</sup>

Departmental work in the Valley of the Kings continued following Maspero's return to the Service in 1899. Much of this work was concerned with restoration,<sup>15)</sup> though at least one full-scale clearance - that of KV8 (Merenptah)<sup>16)</sup> - was carried out in 1903/4. The discovery and clearance of KV42, a tomb prepared originally for Hatshepsut-Meryetre,<sup>17)</sup> was undertaken by Carter at the behest and expense of Messrs Chinouda Macarios and Boutros Andraos in the winter of 1900.<sup>18)</sup> Other work was carried out through private funding, notably from Robert Mond who subsidised the work of repair in the tomb of Sethos I (KV17) in 1903/4,<sup>19)</sup> and a Mrs Goff who paid for the re-excavation of the tomb of Sethos II (KV15) between 1902 and 1904.<sup>20)</sup> The most important private benefactor was Theodore M. Davis, a wealthy American businessman. From 1905 onwards, however, Davis employed his own excavator and worked independently of the Antiquities Service.<sup>21)</sup> The work sponsored by Davis, whether carried out by the Inspectors of the Antiquities Service or by his own archaeologists, is considered as a whole in Appendix B.

Finally, in 1905, Chassinat undertook some minor clearance work in the West Valley which, for the sake of convenience, is considered here s.v. site 22.

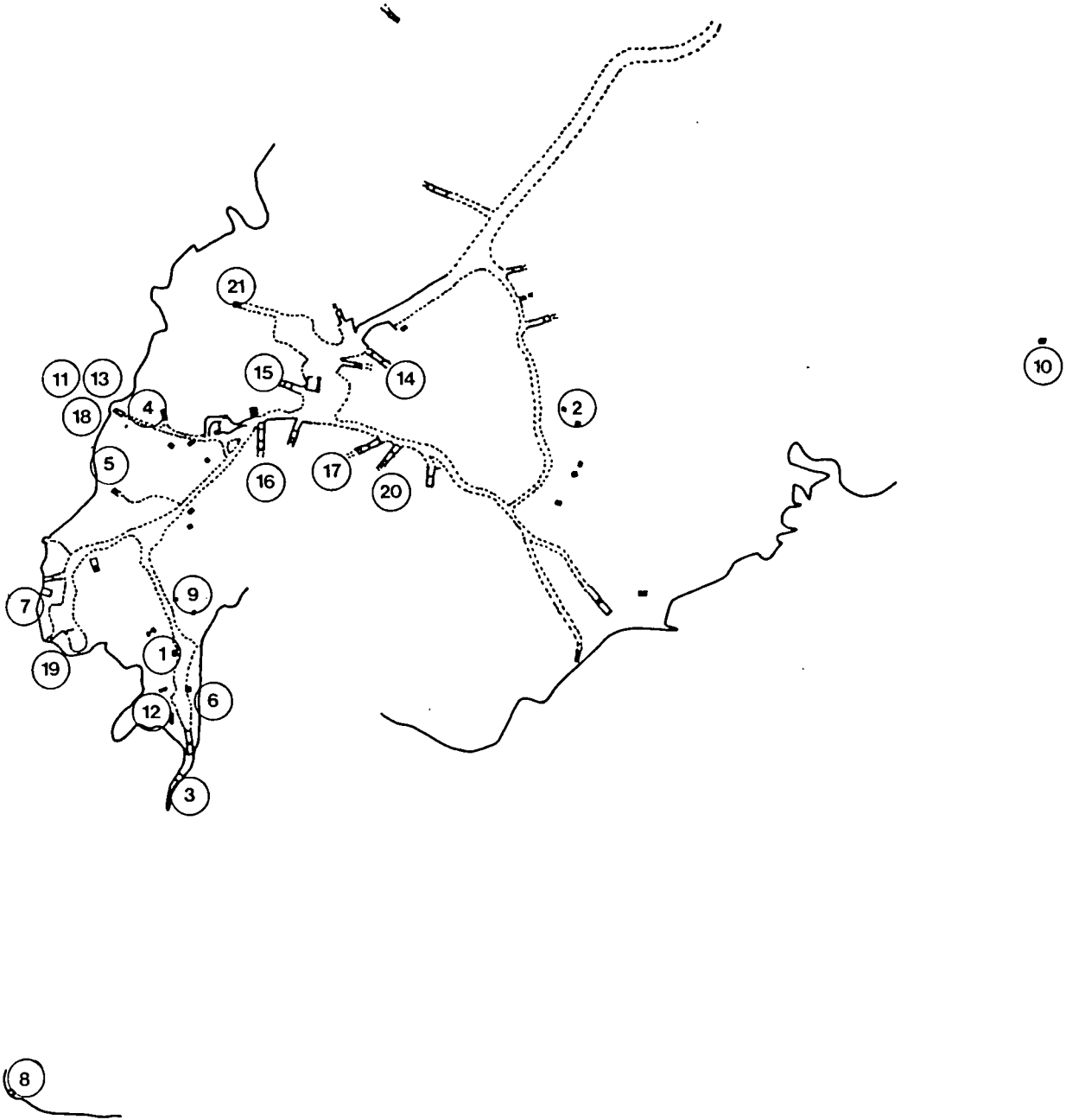

Fig. 98:  
Antiquities Service Excavations, 1898-1904

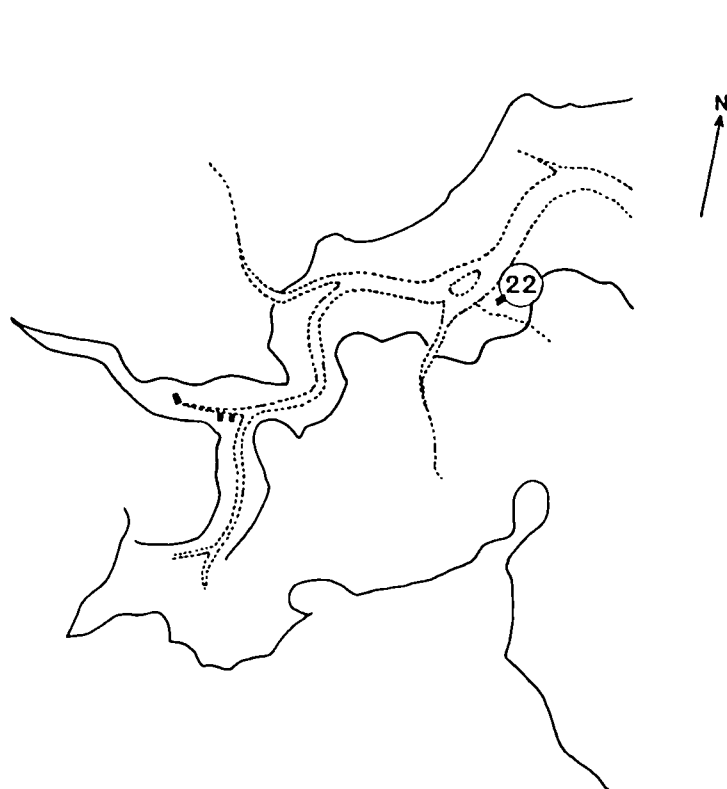
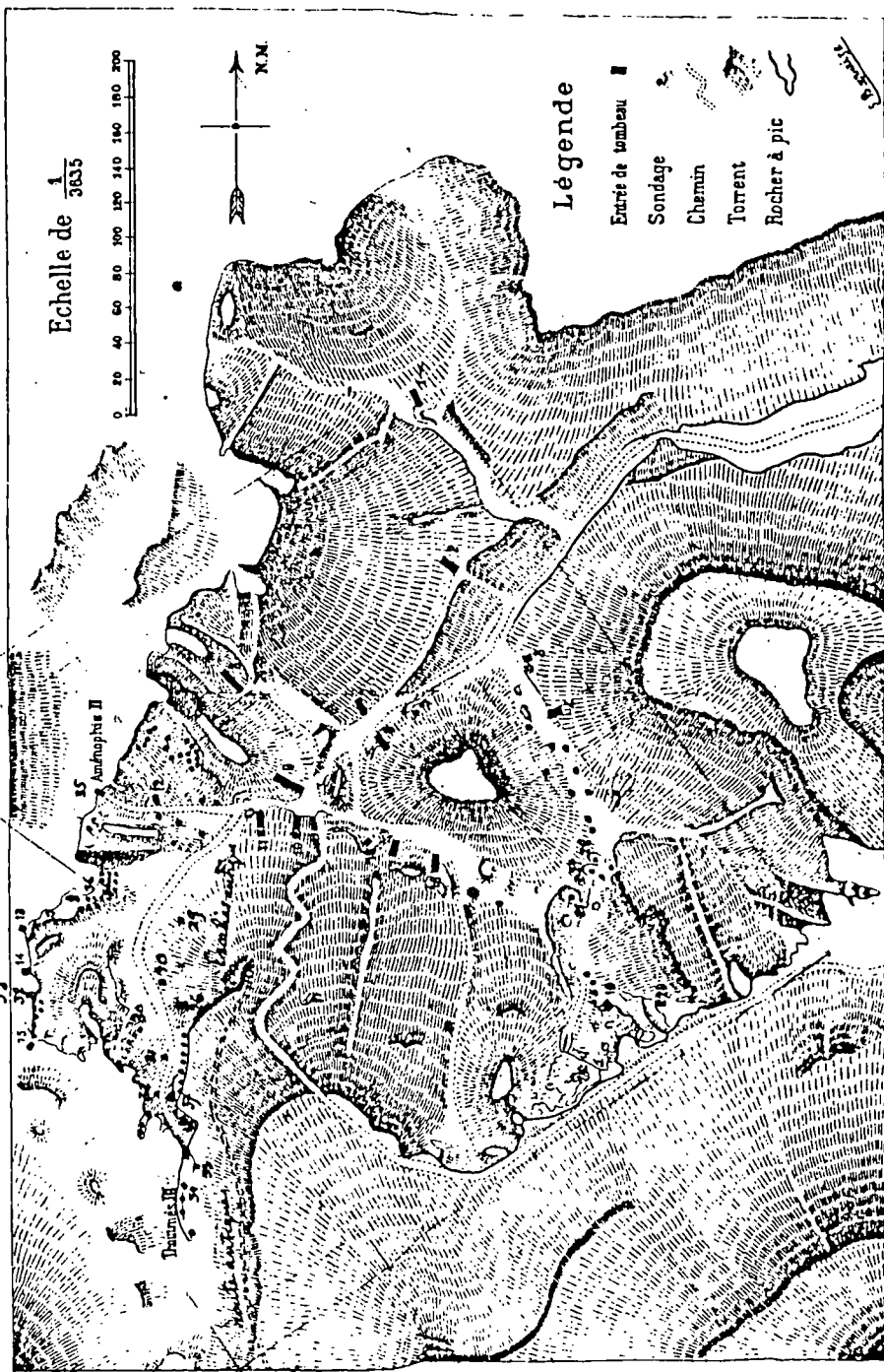

Fig. 99:  
Chassinat Excavations, 1905/6  
(West Valley)

Pl. I



VALLÉE DES ROIS A BIRAN-EL-MOLOUK

Carte revue et corrigée par V. Loret 18 Jan. 1901.

Les n° 26-41 sont les n° officiels publiés par l'Institut de France. Les n° 1-25 sont des n° provisoires.

41

Fig. 100:

Antiquities Service Excavations 1898/9, the annotated Loret map

Antiquities Service Excavations, 1898-1906

(figs. 98-99)

SPRING 1898 (4 February-early April)

Excavator.

Loret.

Basic sources.

Loret, BIE (3 sér.) 9 (1898), 91 ff., pl. 1 (Wilbour Library copy); Daressy, Fouilles, passim. Cf. further Schweinfurth, Sphinx 2 (1898), 145 ff.

Attested site designations.

None.

Site 1

Area KV26, KV30-32, with sondages in the bay to the immediate south of KV32.

Finds/results.

(Re)discovery of KV26 and KV30-32.

Site 2

Series of sondages along the wadi between KV3 and KV19.

Finds/results.

(Re)discovery of KV27-28.

Site 3

Series of sondages along the wadi leading to KV34.

Finds/results.

Discovery of KV33 and KV34 (Tuthmosis III). For finds from the latter cf. BIE (3 sér.) 9 (1898), 334 ff.; Daressy, Fouilles, 281 ff.

Site 4

Sondages in the area to the immediate north and south of KV12.

## Finds/results.

discovery of two shallow pits (KV L-M) later recleared by Jones: cf. below, appendix B, site 22.

Discovery of KV35 (Amenophis II) (9 March). For the finds cf. BIE (3 sér.) 9 (1898), 334 ff.; Daressy, Fouilles, 63 ff.

SPRING(?) 1899 (until 12 March+)

Excavator, basic sources, etc., as season 1898. Cf.

further Schweinfurth, Sphinx 3 (1900), 103 ff.;

Rapports 1899-1910, 6.

Site 5

Continuation of sondages along the base of the cliffs to the south of KV35.

## Finds/results.

Discovery of KV36 (Maiherpri) (March-April: BIE (3 sér.) 10 (1899), 245 ff.). For the finds cf. ibid.; Daressy, Fouilles, 1 ff. Cf. further appendix B, site 4.

Site 6

Continuation north along KV34 wadi.

## Finds/results.

Discovery of KV37, yielding funerary statuette fragments of Tuthmosis IV (Daressy, Fouilles, CG 24971, 24978 bis), a fire board (CG 24980) and 33 ostraca (cf. Daressy, Ostraca, 112).

Site 7

Continuation of sondages along base of cliffs to the north of KV15.

Finds/results.

Discovery of KV38 (Tuthmosis I) (March: Bénédite, Égypte, 537). For the finds cf. Romer, JEA 60 (1974), 120.

Site 8

Discovery of KV39.

Site 9

Discovery of KV40.

Site 10

Discovery of KV41.

For evidence of work in KV2 (Ramesses IV), (KV17) (Sethos I) and WV22 (Amenophis III), presumably this season, cf. above.

SPRING 1900 (January)

Excavator.

Carter.

Basic sources.

Rapports 1899-1910, 19; Maspero, Sites, 104 ff.

Attested site designation.

None.

Site 11

Re-arrangement and partial removal of the royal mummies from KV35 (Amenophis II).

WINTER 1900 (27 November-9 December+)

Excavator.

Carter.

Basic sources.

Carter, ASAE 2 (1901), 196 ff.; id., MSS, I.A.244 ff.

Cf. further Rapports 1899-1910, 40.

Attested site designations.

None.

Site 12

Clearance in the KV34 wadi.

Finds/results.

Discovery of KV42 (Hatshepsut-Meryetre). For the finds

cf. Carter, ASAE 2 (1901), 196 ff.; id., MSS, I.A.244 ff.

See addenda.

WINTER 1901-SPRING 1902 (24 November-22 March)

Excavator.

Carter.

Basic sources.

Carter, ASAE 2 (1901), 115 ff.; id., Notebook 17, 184 ff.;

id., ASAE 4 (1903), 43 ff. Cf. Rapports 1899-

1910, 32 f., 59 ff.

Attested site designations.

None.

Site 13

Investigation into robbery within KV35 (Amenophis II)  
(24 November+).

Site 14

Restoration work within KV6 (Ramesses IX).

Site 15

Restoration work within KV9 (Ramesses VI).

Site 16

Restoration work within KV11 (Ramesses III).

Site 17

Restoration work within KV16 (Ramesses I).

Site 18

Restoration work within KV35 (Amenophis II).

Finds/results.

'Small blue glaze pot' (Carter, ASAE 4 (1903), 45).

Site 19

Start of clearance of KV15 (Sethos II) (completed season  
1903/4).

Note also: 'In the valley, the pathways leading to each  
tomb have been widened, and a shelter for one hundred  
donkeys and boys made' (Carter, ASAE 4 (1903), 44).

Only one of the finds from this, the 1901/2 season, can  
be closely attributed (above, s.v. site 18). Other

## objects found were:

sandstone door lintel fragment inscribed for 'the scribe Ahmose called Pensekerty, true of voice' (Carter, ASAE 4 (1903), 45);

'sandstone fragment' inscribed with the prenomen of Hatshepsut (ibid.; J 36409);

'fragments of blue glaze ushabti-figures of Seti I' (ibid.; cf. J 36383);

'blue glaze models of tools (viz.: adze, hoe and yoke)' (ibid.);

11 ostraca and two 'artists' trial-pieces' (ibid.).

## WINTER 1903-SPRING 1904

## Excavator.

Carter.

## Basic sources.

Carter, ASAE 6 (1906), 112 ff.; Rapports 1899-1910, 120 .

## Attested site designations.

None.

Site 20

Restoration work within KV17 (Sethos I).

Site 21

Excavation of inner sections of KV8 (Merenptah) (G-K).

## Finds/results.

'The complete upper part of a large sarcophagus box' (H);  
sarcophagus lid of Merenptah (in (J));

'many fragments of the alabaster canopic box and shawabti figures (in the 'rubbish' of (J)); ostrakon, with 'a sketch of the recumbent figure of the King on the Sarcophagus, with dimensions' (Carter, ASAE 6 (1906), pl. 3) (unplaced).

Site 19 (cont'd)

Completion of clearance of KV15 (Sethos II).

WINTER 1905-SPRING 1906

Excavator.

Chassinat.

Basic sources.

Chassinat, EEFAR 1905-6, 82 f.; id., BIFAO 10 (1912), 165 ff.; Rapports 1899-1910, 210.

Attested site designations.

None.

Site 22

Exploration of WV A and other portions of the West Valley. 'M. Chassinat essayait d'arracher à la Vallée de l'Ouest le secret des tombeaux de Touatankhamânou et d'Harmhabi' (Rapports 1899-1910, 210).

## APPENDIX B

## DAVIS EXCAVATIONS, 1902-1914

Introduction

As was noted above, the early Theodore Davis seasons were conducted by the Antiquities Service Inspector based in Luxor<sup>22)</sup> - from 1902 until 1904 Howard Carter, and in 1904/5 J. E. Quibell. In 1905 Davis employed his own archaeologist, Edward R. Ayrton,<sup>23)</sup> thus relegating the new Inspector, Arthur Weigall, to a supervisory role. Ayrton was succeeded in 1908 by the artist E. Harold Jones. Jones died in 1911,<sup>24)</sup> and his place was taken by Harry Burton, who continued to dig for Davis until the latter's death in February 1915.<sup>25)</sup>

The excavations financed by Davis are, by virtue of their range and extent, among the most important ever undertaken in the Valley of the Kings. Over a period of 12 years, Davis was responsible for finding and/or clearing 30 or more tombs (KV45, 43, 60, 20, 46, D/E or S,<sup>26)</sup> 47, 49-52, 48, 53, 19, 55, 54, 10, 56, 57, L-M, 58, N-R, 61, 3, WV A and KV7), several of which were and still are of great archaeological importance. Unfortunately, Davis's published record of his work did not do justice to his discoveries, and the ambiguities, contradictions, errors and omissions with which his reports abound have been responsible for many subsequent misconceptions and wrong conclusions. Particular effort has therefore been made to locate and include here any unpublished material pertaining to the Davis seasons which might serve to restore some order to the excavations. Notable additions to the

published sources are the series of expedition photographs relating to the 1905/6, 1906/7 and 1907/8 seasons recently discovered in the archives of the EES,<sup>27)</sup> and the day journal kept by Jones between 1908-11 and thereafter continued by Burton which is now preserved in the Egyptian Department of the Metropolitan Museum of Art.<sup>28)</sup> A number of letters found amongst the Jones<sup>29)</sup> and Weigall<sup>30)</sup> papers also shed valuable light on the course of events, as does the Andrews Journal,<sup>31)</sup> whilst Weigall's copy of the Davis concession for the season 1905/6<sup>32)</sup> helps to clarify for us the terms under which Davis was permitted to work.

The most important document to have survived, however, is the sketch map noting areas cleared and site designations employed by Ayrton during the season 1905/6 (fig. 103 ).<sup>33)</sup> The evidence furnished by this map, together with the site codes written in ink or pencil upon those finds of ascertainable provenance, has enabled the meaning of several of the site designations employed during the Davis seasons to be established, and thus a mass of hitherto unprovenanced Davis material to be assigned to particular tombs or areas of the Valley. For the ostraca in particular, this will prove to be a development of some importance, since the context of the majority of these documents has previously been largely a matter for speculation.



Fig. 101:  
Davis Excavations, 1902-1914

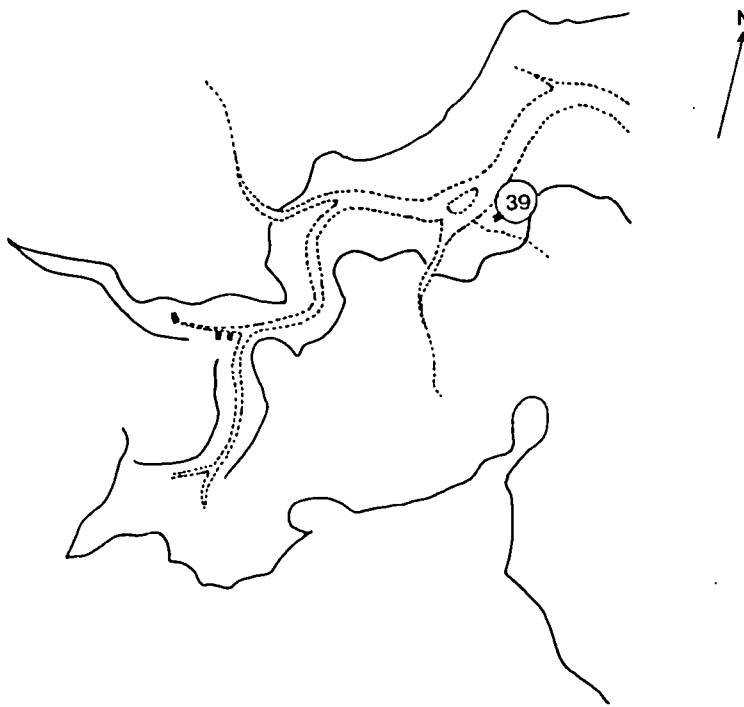

Fig. 102:  
Davis Excavations, 1902-1914  
(West Valley)

Davis Excavations, 1902-1914

(Figs. 101-102)

SPRING 1902 (18 January-late February)

Excavator.

Carter.

Basic sources.

Carter, ASAE 4 (1903), 45 ff.; Rapports 1899-1910, 75.

Attested site designations.

Davis 1902 ① (Černý, Ostraca, CG 25576);Davis 1902 B.N. ② (ibid., CG 25577);Davis 1902 ② (ibid., CG 25547);Davis 1902 ⑦ (ibid., CG 25744);Davis 1902 ⑩ (ibid., CG 25560);Davis 1902 ⑱ (ibid., CG 25553, 25636, 25672);Davis 1902 ⑳ (ibid., CG 25642).Site 1

'The site between tombs nos. 2 and 7' (three days); 'proved to be only the rubbish heap of tomb no. 2' (Carter, ASAE 4 (1903), 45).

Site 2

'Between the small valley on the east side and the un-inscribed tomb no. 5' (i.e. between KV5 and the area opposite KV3), working 'carefully along the edge of the foothill between the above two points, not leaving a part of the gebel uninvestigated' (until 25 January). 'The debris was probably from the tomb no. 5' (Carter, ASAE 4 (1903), 45).

## Finds/results.

Ostrakon 'with sketch of a king's head' (Carter, ASAE 4 (1903), pl. 1, 3).

Site 3

'The small valley ... running east from the main valley, beginning in front of the tomb no. 4' (Ramesses XI) (i.e. between KV4 and KV21 and beyond?), by means of 'a wide open trench across the valley, throwing the rubbish behind' (until 26 February, the intention being to 'finish the end of the valley next season' (Carter, ASAE 4 (1903), 45 f.); see below, site 5).

## Finds/results.

Discovery of KV45 (25 February);

'at the end of the valley near no. 28': 'fragment of an alabaster vase bearing the cartouche of Thotmes IV together with a few ostraca' (ibid., pl. 1, 1-2); 'a pottery vase sealed, and a rough wooden coffin of coptic times containing the skeleton and wrappings of a child ..., this latter ... found in the loose rubbish' and unconnected with the other objects;

beyond KV21(?) (cf. Carter, ASAE 4 (1903), 46): 'a few ostraca and the handle of a hoe'.

Site 4

'The site further up the main valley, where M. Loret had already begun to excavate and where he found the tomb of the prince Mai-her-pri no. 36 (cf. appendix A, site 5). This site was thoroughly dug out' (26 February+) (Carter, ASAE 4 (1903), 46 f.).

## Finds/results.

'In a small hollow in the rock over the tomb of Mai-her-pri': yellow-painted wooden box inscribed in

blue with the name and titles of Maiherpri (Carter, ASAE 4 (1903), 47, fig. 1; MFA 03.1036a-b), containing two network loincloths in leather (Carter, op. cit., pl. 2; MFA 03.1035, the other stolen from Chicago Natural History Museum);

'many ostraca and broken fragments of the XIX-XXth dynasty; pieces of glass and cornelian inlay (MFA; unnumbered. Gift of E. B. Andrews 19 September 1905), probably from an ornamental coat of mail; some fragments of a wooden box or coffin bearing the cartouches of Amenophis III' (Carter, ASAE 4 (1903), 46; cf. id., MSS, I.A.138(5)).

SPRING 1903 (early January-15 April)

Excavator.

Carter.

Basic sources.

Carter, ASAE 4 (1903), 176 f.; Davis, Thoutmôsis IV; id., Hâtshopsîtû; Rapports 1899-1910, 95;  
Carter, MSS, I.A.42 ff.

Attested site designations.

None.

#### Site 5

Between KV21 and the SE cliff face (cf. Davis, Thoutmôsis IV, vii).

Finds/results.

Discovery of KV43 (Tuthmosis IV); entered 18 January.  
For the finds with locations cf. Davis, Thoutmôsis IV, passim; for the foundation deposits, Carter, MSS, I.A.64 f.

Site 6

'The small valley, east of the Seti I tomb, containing the already known tombs nos. 19 and 20, ... resulting in the complete exploration of the valley' (Carter, ASAE 4 (1903), 176).

## Finds/results.

'Immediately in the entrance of no 19 (tomb of Ment-hi-khopeshef)' (Carter, loc. cit.: discovery of KV60, containing 'two much denuded mummies of women and some mummified geese' (ibid.); one of the women the 'royal governess In'. (Note that Carter, Notebook 16, 130, puts the discovery of this tomb before that of KV43; the date 1904/5 suggested in Davis, Siphtah, 23, is clearly in error);

'in the debris of the valley, many hieratic ostraca, two small ushabti figures of Seti I, and a small wooden cartouche of Thothmes I were found, these were forwarded (sic) to the Museum' (Carter, ASAE 4 (1903), 177);

start of clearance of KV20 (Tuthmosis I; Hatshepsut) (early February). (A)-(C) cleared 'by the end of February' (Davis, Hâtshopsîtû, 77); (C)-(C2) by '15th April' (ibid., 78). For the finds of this season cf. ibid., 78, 105 f.; Carter, MSS, I.A.255 ff.

WINTER 1903-SPRING 1904 (1 October-'the end of March')

## Excavator.

Carter.

## Basic sources.

Davis, Hâtshopsîtû, passim; Carter, ASAE 6 (1906), 119;  
Rapports 1899-1910, 120 f.

## Attested site designations.

None.

Site 6 (cont'd)

Continued clearance of KV20. (C2)-(F) cleared by 26 January; (F)-(J) by 11 February (Davis, Hâtshopsîtû, 78).  
Finds/results.

Cf. ibid., 79 (G); 80, 106 ff. (J); Carter, MSS, I.A.255 ff.

WINTER 1904-SPRING 1905 (20 December-late February+)

Excavator.

Quibell.

Basic sources.

Quibell, ASAE 7 (1906), 8 f.; Davis, Iouiya & Touiyou;  
Quibell, Yuaa & Thuiu; Rapports 1899-1910, 175.

Attested site designations.

None.

Site 7

Clearance of the 'upper part of the gully in which Thutmosis IV and Hatshepsuitu were found ... No success attended the search' (Quibell, ASAE 7 (1906), 8).

Site 8

'We gradually swept down the valley' (ibid.); clearance of the area between KV3 and KV4 (Ramesses XI) (January+).

Finds/results.

Discovery of KV46 (Yuya and Tjuyu) (6 February) by means of a 'trench we ran into the mound' (Quibell, ASAE 7 (1906), 8). For the finds cf. Davis, Iouiya & Touiyou, and Quibell, Yuaa & Thuiu (which do not always agree in detail).

WINTER 1905-SPRING 1906 (27 October+)

Excavator.

Ayrton.

Basic sources.

Ayrton sketch map (cf. fig. 100); Davis, Siphthah;  
Ayrton photos. 1-40 (cf. Reeves, MDAIK 40 (1984)  
(forthcoming)); Rapports 1899-1910, 208.

Attested site designations.

Davis 1905-6 (Černý, Ostraca, CG 25515,  
25516);  
Davis 1905-6 N (ibid., CG 25523);  
Davis 1905-6 P (ibid., CG 25578) (?between KV14 and  
KV13: cf. site 15 and fig. 103 );  
Davis 1905-6 W (ibid., CG 25736);  
Davis 1905-6 Z (ibid., CG 25570) (E of KV13: cf.  
site 15);  
Davis 1905-6 P.A. (ibid., CG 25653, 25659) (S side of  
KV35 gully: cf. site 16);  
Davis 1905-6 P.M. (ibid., CG 25535, 25564) (KV53: site 16);  
----- PM (ibid., CG 25647) (as P.M. above);  
Davis 1905-6 Ep (ibid., CG 25568) (80 m NE of KV29, on  
path and to either side: cf. site 15);  
----- Ep (ibid., CG 25532, 25644) (as Ep above);  
----- Ep 1 (ibid., CG 25506) (as Ep above);  
----- F2 (Ayrton photo. no. 2) (vicinity of KV2:  
cf. site 13);  
Davis 1905-6 Mp (Černý, Ostraca, CG 25595); CG 25595)  
Davis 1905-6 Mp 1 (ibid., CG 25574);  
Davis 1905-6 Np (ibid., CG 25534) (80 m ENE of KV47:  
cf. site 15);  
Davis 1905-6 Np ? (ibid., CG 25513) (as Np above);  
----- Np (ibid., CG 25506) (as Np above);  
Davis 1905-6 Np extreme pt. (ibid., CG 25573) (as Np  
above);



Fig. 103:  
Davis Excavations 1905/6, the Ayrton sketch map

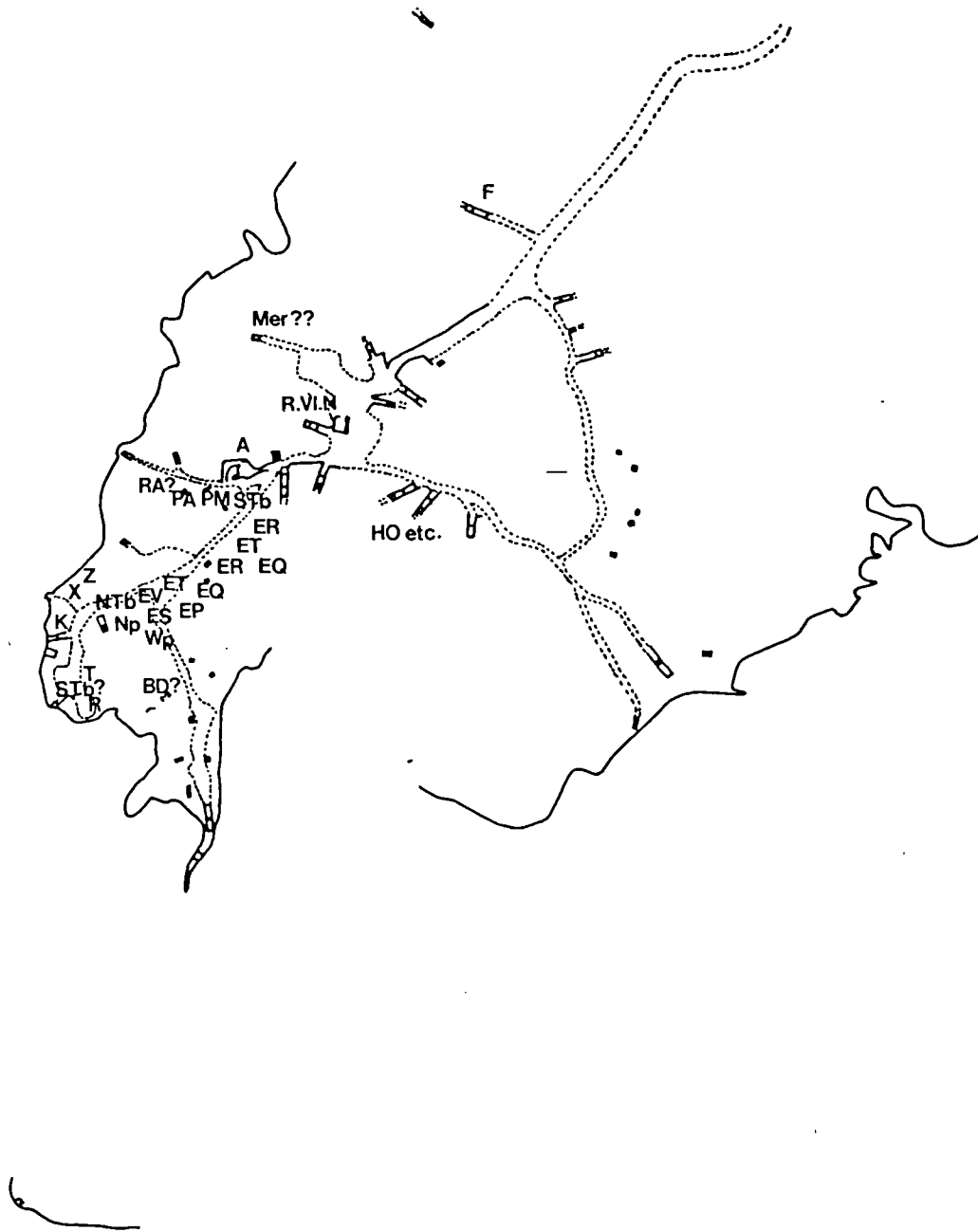

Fig. 104:  
Davis Excavations, attested site designations 1905-8

- Zam (Černý, Ostraca, CG 25644) (? cf. Z above);
- Davis 1905-6 G.4 (ibid., CG 25579);
- Davis 1905-6 G.8 (ibid., CG 25531);
- Davis 1905-6 No.38 (ibid., CG 25579);
- Davis 1905-6 st. N. of T. Tb. (ibid., CG 25653);
- 2 ft. N. of T. Tb. (ibid., CG 25653);
- Davis 1905-6 N. Tb. (ibid., CG 25740) (KV47: cf. site 15);
- N. Tb. 1 (ibid., CG 25522) (cf. N. Tb. above);
- Davis 1905-6 N. Tb. 4 (ibid., CG 25633) (cf. N. Tb. above);
- Davis 1905-6 N. Tb. 5 (ibid., CG 25593) (cf. N. Tb. above);
- Davis 1905-6 N. Tb. 6 (ibid., CG 25526) (cf. N. Tb. above);
- Davis 1905-6 N. Tb. 7 (ibid., CG 25503) (cf. N. Tb. above);
- Davis 1905-6 N. Tb. 8 (ibid., CG 25756) (cf. N. Tb. above);
- Davis 1905-6 N. Tb. 9 (ibid., CG 25610) (cf. N. Tb. above);
- Davis 1905-6 N. Tb. 12 (ibid., CG 25751) (cf. N. Tb. above);
- Davis 1905-6 N. Tb. 15 (ibid., CG 25756) (cf. N. Tb. above);
- Davis 1905-6 N. Tb. 17 (ibid., CG 25591) (cf. N. Tb. above);
- Davis 1905-6 N. Tb. 21 (ibid., CG 25502) (cf. N. Tb. above);
- Davis 1905-6 N. Tb. 24 (ibid., CG 25766) (cf. N. Tb. above);
- Davis 1905-6 N. Tb. 25 (ibid., CG 25739) (cf. N. Tb. above);
- Davis 1905-6 N. Tb. 28 (ibid., CG 25732) (cf. N. Tb. above);
- Davis 1905-6 N. Tb. 30 (ibid., CG 25731) (cf. N. Tb. above);
- Davis 1905-6 N. Tb. 31 (ibid., CG 25756) (cf. N. Tb. above);

- N. Tb. 35 (Černý, Ostraca, CG 25527)  
(cf. N. Tb. above);
- Davis 1905-6 N. Tb. 37 (ibid., CG 25605) (cf. N. Tb. above);
- Davis 1905-6 N. Tb. 38 (ibid., CG 25641) (cf. N. Tb. above);
- Davis 1905-6 N. Tb. 39 (ibid., CG 25719) (cf. N. Tb. above);
- N. Tb. 43 (ibid., CG 25639) (cf. N. Tb. above);
- Davis 1905-6 N. Tb. 44 (ibid., CG 25733) (cf. N. Tb. above);
- Davis 1905-6 N. Tb. 45 (ibid., CG 25730) (cf. N. Tb. above);
- Davis 1905-6 N. Tb. 46 (ibid., CG 25735) (cf. N. Tb. above);
- Davis 1905-6 N. Tb. 47 (ibid., CG 25614) (cf. N. Tb. above);
- Davis 1905-6 N. Tb. 49 (ibid., CG 25734) (cf. N. Tb. above);
- N. Tb. 50 (ibid., CG 25561) (cf. N. Tb. above);
- Davis 1905-6 N. Tb. 51 (ibid., CG 25572) (cf. N. Tb. above);
- Davis 1905-6 N. Tb. 52 (ibid., CG 25575) (cf. N. Tb. above);
- Davis 1905-6 N. Tb. 53 (ibid., CG 25632) (cf. N. Tb. above);
- Davis 1905-6 N. Tb. 60 (ibid., CG 25603) (cf. N. Tb. above);
- Davis 1905-6 N. Tb. 61 (ibid., CG 25638) (cf. N. Tb. above);

- Davis 1905-6 S. Tb. 4 (Černý, Ostraca, CG 25742)  
 (cf. site 16);
- Davis 1905-6 S. Tb. 12 (ibid., CG 25764) (as S. Tb. 4  
 above);
- Davis 1905-6 X (ibid., CG 25504, 25525, 25586) (NE of  
 KV13, at base of cliffs: cf. site 15);
- X (ibid., CG 25512, 25542, 25545) (as X  
 above);
- Davis 1905-6 X.1 (ibid., CG 25521) (as X above);
- X.5 (ibid., CG 25542) (as X above);
- X.6 (ibid., CG 25542) (as X above);
- Davis 1905-6 X.7 (ibid., CG 25509) (as X above);
- Davis 1905-6 X.9 (ibid., CG 25541) (as X above);
- Davis 1905-6 X.10 (ibid., CG 25521) (as X above);
- Davis 1905-6 X.11 (ibid., CG 25509) (as X above);
- X.13 (ibid., CG 25512) (as X above);
- Davis 1905-6 X.22 (ibid., CG 25521) (as X above);
- Davis 1905-6 X.23 (ibid., CG 25541) (as X above);
- Davis 1905-6 X.27 (ibid., CG 25537) (as X above);
- Davis 1905-6 X.34 (ibid., CG 25537) (as X above);
- Davis 1905-6 X.41 (ibid., CG 25521) (as X above);
- Davis 1905-6 X.43 (ibid., CG 25537) (as X above);
- X.55 (ibid., CG 25519) (as X above);
- X.59 (ibid., CG 25511) (as X above);
- X.64 (ibid., CG 25538) (as X above);
- Davis 1905-6 X.73 (ibid., CG 25509) (as X above).

See further fig. 103.

### Site 9

'Sundry excavations (sondages) in the rubbish heaps covering the rocks to the south and the water course below'  
 WV22 (Amenophis III) (Carter, MSS, I.A.124(6)).

Site 10

The 'promontory of rock in which Tomb No. 12 is situated'. This 'had been partially dug over on its southern face' the previous season (cf. Davis, Siphtah, 6). Three days spent 'excavating the upper layers of rubbish here' (ibid.). No results. The site temporarily abandoned with the intention of resuming work here later (below, site 21).

Site 11

'Slightly south of the tomb of Thothmes IV', digging 'up the slope to the face of the cliff' (ibid.).

Finds/results.

'The unfinished entrance to a tomb' (KV B).

Site 12

'In front of Uaa and Thuaa's tomb' (Davis, Siphtah, 6). Long trenches sunk 'from east to west across the front of Tomb No. 3. We then turned to north and south along the rock face, but with no results' (ibid.).

Site 13

'In front of the tomb of Rameses IV' (KV2) (Davis, Siphtah, 6 f. Davis Site F.

Finds/results.

'A series of ostraka' including: 'a king's head wearing the blue crown (Ayrton photo no. 4); 'sketch plan' of the entrance to KV2 (Ayrton photo. no. 3), with a lion holding a captive's head on the reverse; a hieratic ostrakon mentioning Amenophis I; another, mentioning Nebhepetre Mentuhotpe; sketch of the head of a Libyan (? = Ayrton photo. no. 18 left; described as 'from tomb of Siptah'); a horse and chariot (? = Ayrton photo.

no. 14; described as 'from tomb of Siptah'); also potsherds 'encrusted with plaster, and ... with colours', several with the name of Ramesses II.

Continuation 'up towards the mouth of the tomb of Rameses IV on the north' (Davis, Siptah, 7).

Finds/results.

'Debris of rough Coptic and Roman huts' (Ayrton photo. no. 1);

'dozens of fragments and about twenty specimens of alabaster ushabtis of Rameses IV' (cf. Ayrton photo. no. 5, inc. five wooden fragments and one fragmentary faience specimen); Coptic pottery (Winlock & Crum, Epiphanius I, pl. 33, B), ostraca fragments and an unopened letter on papyrus; portions of a foundation deposit(?) of Ramesses IV, consisting of 'wooden objects' found 'outside the tomb' (Davis, Siptah, 28). (Note that Carter discovered five further deposits some years later: appendix C, site 4).

#### Site 14

'The northern face of the promontory of rock which runs out from the perpendicular cliffs slightly south of the tomb of Amenhotep II' (Davis, Siptah, 7 f.), i.e. beyond KV48.

Finds/results.

'One or two ostraka of the XXth Dynasty' (ibid., 8); blue faience cup of Tutankhamun, 'at a depth of twelve feet from the surface', at the eastern end of the promontory (ibid.); 14 shabtis of Ramesses IV, 'at a higher level, somewhat to the east of this, and only three feet from the surface' (? = Gardiner photo. AHG/31.256, top left; cf. Ayrton photo. no. 5)

Site 15

November 1905: Davis introduces 'the policy of exhausting every mountain and foot-hill in the valley', commencing 'at the southern end of the "valley"' (Davis, Siptah, 1), i.e. north from KV34, to the junction with the western gully, and SW/S to KV15. Cf. fig. 105.

Finds/results.

(?This season?) Faience knob of Horemheb (J 41637), 'decombres de Tausert' (KV14); discovery and partial clearance of KV47 (Siptah). Davis N. Tb. Contents included: potsherds and ostraca, three with the names of Sethos II (one, Ayrton photo. no. 16 = CG 25766), others figured (Ayrton photos. 13-15, 17-18; though nos. 14 and 18 (left) perhaps from site 13 - see above); alabaster 'sarcophagus' fragments; canopic chest fragments of Tiaa (Aldred, JEA 49 (1963), fig. 1 and pl. 7, 2); shabtis and fragments of Siptah, another 'of a woman', and one with 'the cartouche of Men-mat-Ra' (cf. Ayrton photo. nos. 19-22); frag. dw3 wr adze of Tiaa (Aldred, JEA 49 (1963), 42, fig. 2). Cf. Ayrton, PSBA 28 (1906), pls. 1-2; Davis, Siptah, 11 ff. For Burton's completion of the clearance, cf. below, site 38.

Ostraca; cf. above, Attested site designations, Ep, Np, X, Z etc.

Site 16

The Amenophis II valley (see site 14 above), concentrating on the area immediately south of the KV11-KV12 promontory. Davis Site P.A. For views of the area before and after excavation cf. Ayrton photo. nos. 23-4.

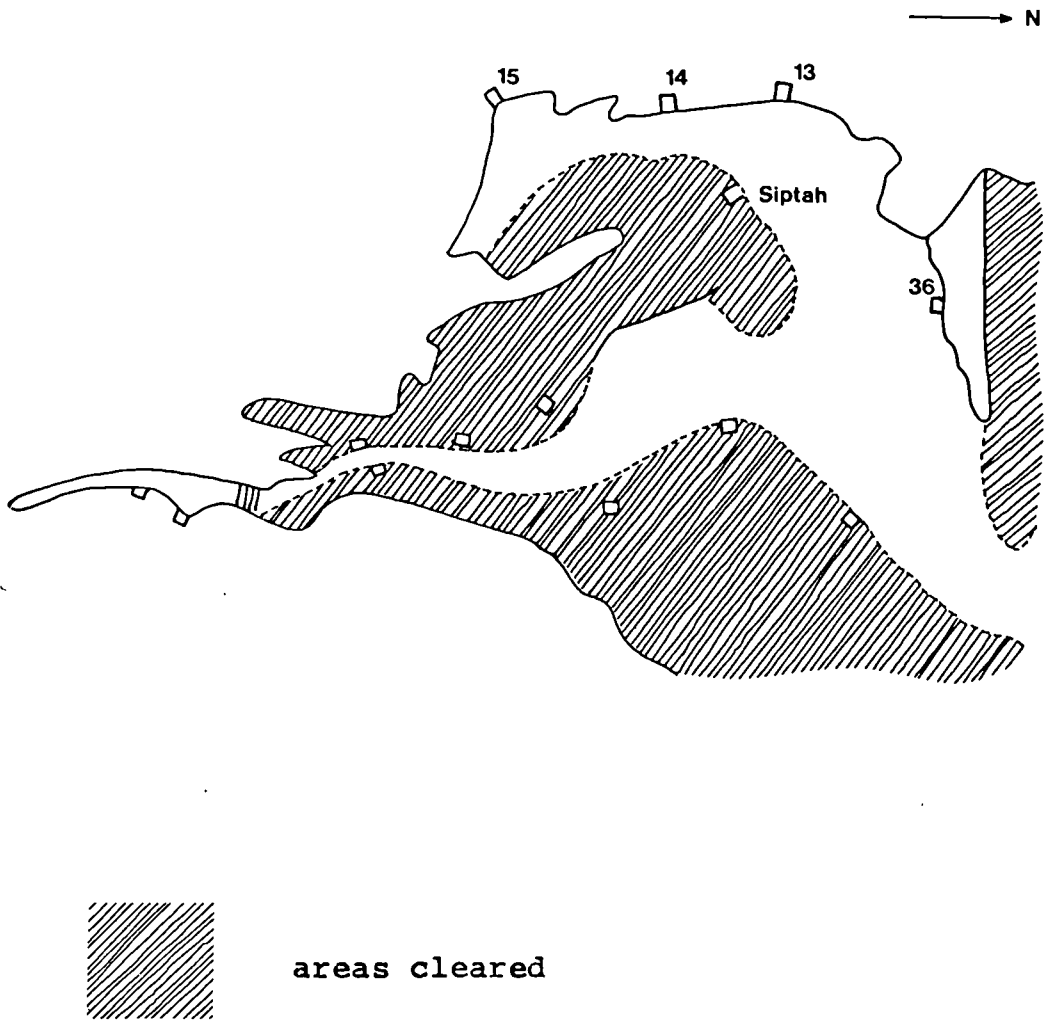

Fig. 105:  
Davis Excavations 1905/6, site 15

## Finds/results.

Discovery of KV49 (= S. Tb.). Hieratic graffito over entrance (Gardiner photo. AHG/31.261; Černý, Graffiti, no. 1282). In the entrance fill: two ostraca, one 'showing an official worshipping' (Gardiner photo. AHG/31.261, right), the other with 'a man offering to Queen Aahmes-Nefertari'. In the chamber: mummy cloth; sherds; ostrakon of 'Hay, the chief of workmen in the Place of Truth' (Daressy, ASAE 22 (1922), 75 f.); several gaming slabs with incised grids. Cf. Davis, Siphtah, 16 f.

Discovery of KV50. In the chamber: wood coffin fragments; a mummified dog; a mummified monkey. Cf. Davis, Siphtah, 17; and perhaps an unpublished letter from Davis to Weigall, dated 3 February, 1906.

Discovery of KV51. In the entrance: part of a coffin lid. In the chamber: several baboon mummies; an ibis mummy; mummified ducks; mummiform intestine packets; stucco intestine mask (cf. Reeves, BSEG 8 (1983), 81 ff.); a box coffin. Cf. Davis, Siphtah, 17 f.

Discovery of KV52. In the chamber: two wooden boxes, one with an unwrapped monkey mummy, the other partitioned into four compartments (a canopic chest?). Cf. Davis, Siphtah, 18.

Discovery of KV48. In the chamber: the unwrapped mummy of a man (cf. Weigall, Guide, 227); fragments of resin-coated coffin with yellow hieroglyphs; wooden 'shabtis' (cf. Ayrton photos. 26-7 = J 38755-7, 38759); a number of fragmentary blue faience shabtis (J 38773); four magical bricks (two: Ayrton photo. 28 = J 38758, 48849; the third, J 38755; the fourth ROM 906.6.1) inscribed, like the wooden 'shabtis', for 'the vizier

Amenemopet' (temp. Amenophis II); a clay sealing (J 38784); wooden chair fragments; sherds; a pair of rush sandals (ROM 906.6.13a-b). Cf. Davis, Siphtah, 18.

'On the other side of the path, and slightly to the north of Tomb 29, we discovered another burial place': KV53. In the entrance shaft: 'several ostraka'. In the chamber: stela (called an ostrakon) 'of Hora, chief scribe in the Place of Truth' (= Bruyère, Mert Seger, fig. 53, with no provenance; Ayrton photo. no. 42, 'from P.M.'). 'Nearby, and ... over the mouth of the tomb': 'remains of rough workmen's huts'; 'several ostraka and trial pieces' 'built into the walls of one of these' (cf. Ayrton photo. nos. 41, 43-4, 50 and perhaps 45, 47-9). Cf. Davis, Siphtah, 18 f.

### Site 17

'The end of February, 1906' (Davis, Siphtah, 23), clearance of KV19 (Mentuherkhepshef). For views of the entrance and presumably post-dynastic blocking, cf. Ayrton photos. 29-30.

#### Finds/results.

In the entrance: 'several ostraka ...', including 'a long religious inscription written in black ink, with the cartouches of Rameses Ra-hak-maat' (though 'there was nothing to prove its connection with the filling of the tomb'); displaced items from a foundation deposit of Ramesses IV (Ayrton photo. no. 54; J 38779). In the entrance fill: ostrakon 'with the cartouches of Rameses Ra-kheper-maat'. 'In and near the burial pit': potsherds; the 'upper part of a broken mummy'. Scattered:

'several fragments of a ... stela of a sedem ash in "The Place of Truth" ... named Hay ...; they all join together and fit another piece found in the Coptic midden outside the tomb of Rameses IV' (site 13 above). Unplaced: fire-stick and board (Ayrton photo. no. 51; ROM 906.6.10-11); resin-coated wooden shabtis (Ayrton photo. no. 52; J 38760); fragments of beadwork (Ayrton photo. no. 53; cf. J 38766); decorated faience fragments (Ayrton photos. 56-8; J 38755-6; ROM 906.6.12); faience shabtis (Ayrton photo. no. 55; ? = J 38773 from KV48). For a selection of the figured ostraca, cf. Ayrton photo. nos. 59-60. Cf. in general Davis, Siphtah, 28 f.

(For the possibility of work in KV11 (Ramesses III) this season cf. Gardiner photo. AHG/31.256, the bottom print of which = Dawson, AMNH (9 ser.) 16 (1925), 659, fig. 5.)

#### WINTER 1906-SPRING 1907

Excavator.

Ayrton.

Basic sources.

Davis, Tîyi; Rapports 1899-1910, 234.

Attested site designations.

Davis 1906-7 Mer. 19 (Černý, Ostraca, CG 25550);

Davis 1906-7 Mer. 34 (ibid., CG 25637);

Davis 1906-7 Mer. 37 (ibid., CG 25752);

Davis 1906-7 Mer. 65 (MMA 09.184.212);

Davis 1906-7 Mer. 68 (Černý, Ostraca, CG 25729);

Davis 1906-7 MEF.14 (ibid., CG 25728);

Davis 1906-7 NEF 1 (ibid., CG 25745);

Davis 1906-7 Nef 10 (ibid., CG 25743);

Site 18

1 January 1907: 'a space of about forty feet oblong' in the vicinity of KV55 (Davis, Tîyi, 1).

## Finds/results.

On the 'western face (of the mound) to the south of ... (KV9) ... in ... a recess in the rock' (KV C): 'several large jars of the XXth dynasty type' (Davis, Tîyi, 7). (Two jars formerly MMA 09.184.171-2).

Below this: discovery of KV55 with contents. For details cf. above, ch. 2. For the final clearance, cf. below, following site 21.

(Does the site designation Mer. refer to an otherwise unattested clearance in the vicinity of KV8 this season?)

## WINTER 1907-SPRING 1908

## Excavator.

Ayrton.

## Basic sources.

Davis, Siphtah; id., Harmhabi; Rapports 1899-1910, 262.

## Attested site designations.

Davis 1907-8 HO (Černý, Ostraca, CG 25566, 25594, 25645, 25759, 25773a, 25775) (presumably the workmen's houses between KV17 and KV21: cf. site 19);  
 Davis 1907-8 HO.13 (ibid., CG 25598) (as HO above);  
 Davis 1907-8 House 8.1 (ibid., CG 25563) (as HO above);  
 Davis 1907-8 House ζ7 (ibid., CG 25673) (as HO above);  
 Davis 1907-8 House ζ9 (ibid., CG 25673) (as HO above);  
 Davis 1907-8 House ζ9a (ibid., CG 25673) (as HO above);  
 Davis 1907-8 House ζ12 (ibid., CG 25656) (as HO above);  
 Davis 1907-8 HO.02.7 (ibid., CG 25661) (as HO above);

- Davis 1907-8 HO:θ(?)4 (Gardiner photo. AHG/31.258)  
 (as HO above);
- Davis 1907-8 House θ.5 (Černý, Ostraca,  
 CG 25716) (as HO above);
- Davis 1907-8 House θ.7 (ibid., CG 25658) (as HO above);
- Davis 1907-8 House κ.1 (ibid., CG 25606) (as HO above);
- Davis 1907-8 House κ.3 (ibid., CG 25726) (as HO above);
- Davis 1907-8 House λ.2 (ibid., CG 25621) (as HO above);
- Davis 1907-8 House λ.4 (ibid., CG 25609) (as HO above);
- Davis 1907-8 HO:λ.5 (ibid., CG 25559) (as HO above);
- Davis 1907-8 House λ6 (ibid., CG 25562) (as HO above);
- Davis 1907-8 House ν.1 (ibid., CG 25750) (as HO above);
- Davis 1907-8 House N (MMA 09.184.184E) (as HO above);
- Davis 1907-8 House ξ.11 (Černý, Ostraca,  
 CG 25554) (as HO above);
- Davis 1907-8 House π.4 (ibid., CG 25597) (as HO above);
- Davis 1907-8 House π.5 (ibid., CG 25643) (as HO above);
- Davis 1907-8 House π.13 (ibid., CG 25569) (as HO above);
- Davis 1907-8 House π.18 (ibid., CG 25651) (as HO above);
- Davis 1907-8 House φ.2 (ibid., CG 25585) (as HO above);
- Davis 1907-8 House φ.5 (ibid., CG 25625) (as HO above);
- Davis 1907-8 House φ.8 (ibid., CG 25773b) (as HO above);
- Davis 1907-8 House ψ.8 (ibid., CG 25580) (as HO above);
- Davis 1907-8 House ω.6 (ibid., CG 25652) (as HO above);
- Davis 1907-8 House ω.7 (ibid., CG 25528) (as HO above);
- Davis 1907-8 HO:ω.8 (ibid., CG 25747) (as HO above);
- Davis 1907-8 House ♀ mid (4) (ibid., CG 25655) (as HO  
 above);
- Davis 1907-8 (House) ♀ E.5 (Gardiner photo. AHG/31.259)  
 (as HO above);
- Davis 1907-8 HO ♀ E.7 (Gardiner photo. AHG/31.257) (as  
 HO above);

- Davis 1907-8 House ♀ E9 (Černý, Ostraca,  
CG 25707) (as HO above);
- Davis 1907-8 ER4 (ibid., CG 25630) (along the path in  
the vicinity of KV61: cf. site 21);
- Davis 1907-8 ER.5 (ibid., CG 25748) (as ER4 above);
- Davis 1907-8 ET (MMA 09.184.184B) (as ER4 above);
- ? Davis 1907-8 MB (MMA 09.184.188);
- Davis 1907-8 R.VI.N.3 (Černý, Ostraca,  
CG 25627a) (presumably KV9: cf. site 21);
- Davis 1907-8 R.VI.N.4 (ibid., CG 25617) (as R.VI.N.3  
above);
- Davis 1907-8 R.VI.N (ibid., CG 25615) (as R.VI.N.3  
above).

### Site 19

Between KV16 and KV21.

Finds/results.

Workmen's houses between KV17 (cf. appendix D, doc. 8),  
KV18 and KV21 (MMA Accession cards), finds including  
ostraca (cf. above, Attested site designations); jew-  
ellery mould (MMA 09.184.181 = Hayes, Scepter II, 217,  
fig. 129).

'In chip near' KV17: shabtis of Sethos I (cf. MMA  
09.184.213).

Discovery of KV54. For the contents and further details  
cf. Davis, Tîyi, 4 f.; Winlock, Materials; Reeves,  
BSEG 8 (1983), 81 ff.

### Site 20

Partial clearance of KV10 (Amenmesse) (cf. appendix D,  
doc. 3).

## Finds/results.

Base of alabaster shabti of Ramesses VI; alabaster 'box(?)' fragment of Sethos I (apparently in upper layers). Cf. loc. cit.; Weigall, Guide, 206.

Site 21

3 January 1908: 'the small side valley which leads to the tomb of Amenhotep II ... beginning ... at the western extremity ... along the north side of the mound ... occupied by the ... tomb of Rameses VI (No. 9)' (Davis, Siphtah, 31).

## Finds/results.

Ostraca from the vicinity of KV9 (cf. above, Attested site designations).

5 January 1908 (appendix D, docs. 4-5): discovery of KV56. Cf. Ayrton, PSBA 30 (1908), 116; Davis, Siphtah, 35 ff.; id., Tîyi, 41 ff.

22 February 1908 (appendix D, doc. 7): discovery of KV57 (Horemheb). Cf. Davis, Harmhabi, passim.

Continuation of work southwards along the path near KV61 (cf. fig. 103).

## Finds/results.

Ostraca (cf. above, Attested site designations, ER, ET etc.).

30 January+ 1908: final clearance of KV55; removal of shrine panels 'to copy' (appendix D, doc. 6).

WINTER 1908-SPRING 1909 (18 November-7 March)

Excavator.

Jones.

Basic sources.

Jones & Burton, Tombs; Rappports 1899-1910, 292.

Attested site designation.

Davis 1908-9 House J.2 (Černý, Ostraca, CG 25565);  
attribution of finds otherwise probably by date.

### Site 22

Between KV57 and KV35.

Finds/results.

From area W of KV57, below path: several fragments of glass (26-30 November); fragmentary faience shabti with prenomen of Amenophis II(?) (27 November); 'circular alabaster ?vase cover' (26 November); 'fragment of dark green stone with parallel edges worked' (28 November); faience fragments (27-29 November); 'fragment of alabaster or marble' (28 November); carnelian bead (29 November); 'small piece of gold foil' (29 November); 'fragment of coloured glass (light blue and green)' (2 December).

'On N side of Amenophis II': 'two shallow pit tombs (KV L-M) discovered and emptied by Reis Mohammed in 1898 when Amenophis II was discovered (cf. above, appendix A, site 4) ... Broken large bl: gl: bead and fragment of decorated glass found in rubbish' (4 December).

'2 alabaster ushabtis in debris in front of steps (of KV12) and 1 metre below surface ..., painted green';

one with the prenomen of Ramesses VI. They 'appear in undisturbed debris at mouth of No. 12 and appear to have been thrown therefrom' (7 December).

'Ostrakon with drawing of a prince grotesque, fragment of blue glass and 2 broken beads', from N of KV35 (9 December).

'Ostrakon with crude grotesque drawing of a dog and portion of an eye in black (charcoal) ... in front and to S of Amen. II' (11 December).

Ostrakon, '?name lost'; 'at foot of camera on mound above monkey tombs' (cf. above, site 16) (11 December).

'Bl: gl: palette ... and several small pots (similar to those generally found in foundation deposits)'; 'found 1 ft. above rock level ... (in) ... solid water sodden debris' to S of KV35 (12 December).

'Two fragments of mud sealings - the impress being coloured blue'; jackal and nine captives type (MMA 09.184.258-9); 'bl: gl: fragment of face with black spots'. From '1 ft. above rock level' in wadi leading to KV35 (16 December).

'Fragment of decorated glass vase' in debris opposite W end of KV12 (18 December).

'Unfinished pit (KV N) 1 metre square which descended to 5 feet and then stopped'; on S side of path? (21 December).

'Unfinished limestone seated statuette with face roughly put in in red paint', from in front of KV12 (25 December).

Site 23

Continuation along wadi in general area of KV57 (which Davis began to copy this season - see Rapports 1899-1910, 292) and KV56 (30 December-14 January).

## Finds/results.

Fragment of inscribed alabaster; 'lower part of bl: gl: ankh' (?MMA 14.6.37a-b). From SW or E of KV57 (30 December).

Two ostraca and two inscribed potsherds (one, MMA 14.6.219), 'in debris opposite and in front of Horemheb's tomb about 4 metres from steps' (31 December).

'4 broken pieces of inscribed pottery, 3 inscribed limestone fragments and one with the part of a figure roughly sketched in (one, MMA 14.6.218). Also 2 blue glazed fragments of vases and portion of inlay in faience blue-glazed with circular pattern (probably king's helmet)'; 'found in rubbish in front of Horemheb' (2 January).

Ostrakon; presumably from E of KV57 (3/4 January).

'Large broken ostrakon with drawing of Hawk (head broken)'; from between KV57 and KV56 (7 January).

'Fragment of blue glass vase and pottery with portion of hieratic inscription'; from S or W of KV57 (8 January).

'Fragment of wooden sarcophagus', 20+ feet deep above KV58 (9 January).

Discovery of KV58 (10 January; clearance until 22 January). For the contents cf. Davis, Harmhabi, 3, 125 ff.; Reeves, GM 46 (1981), 11 ff.

'Fragments of blue glazed vase decorated in black',  
'in trench (near Tausert's tomb)' (14 January).

#### Site 24

Alongside and beneath the donkey shed. Cf. fig. 106  
(14-28 January).

#### Finds/results.

Three limestone canopic jar fragments, one with blue-filled inscription (prob. MMA 14.6.49), at depth of 5 feet; also, alabaster shabti, 'colour washed off' (15 January).

Decorated fragment of limestone with lower part of god's figure, under donkey shed at depth of about 8 feet; 'blue glaze fragment of large vase with lower part of kneeling figure painted in black' (MMA 14.6.35); 'fragment of blue faience decorated with incised lines' (prob. MMA 14.6.30) (16 January).

Head from rough limestone statue, at depth of 12 feet (17 January; body found 22 January).

Six large and six small pall rosettes, copper-alloy, with other fragments 'in trench near (?) stones (possibly workman's house ...)' (18 January).

Fragment of inscribed alabaster sarcophagus(?), from E of donkey shed door(?) (21 January).

Body of limestone statuette (to join head found 17 January); alabaster fragment (22 January).

Ostrakon fragment: '?workmen's list with red checking spots'; 'fragment of limestone chipping with crude chalk drawing of a face and outline of figure' (27 January).

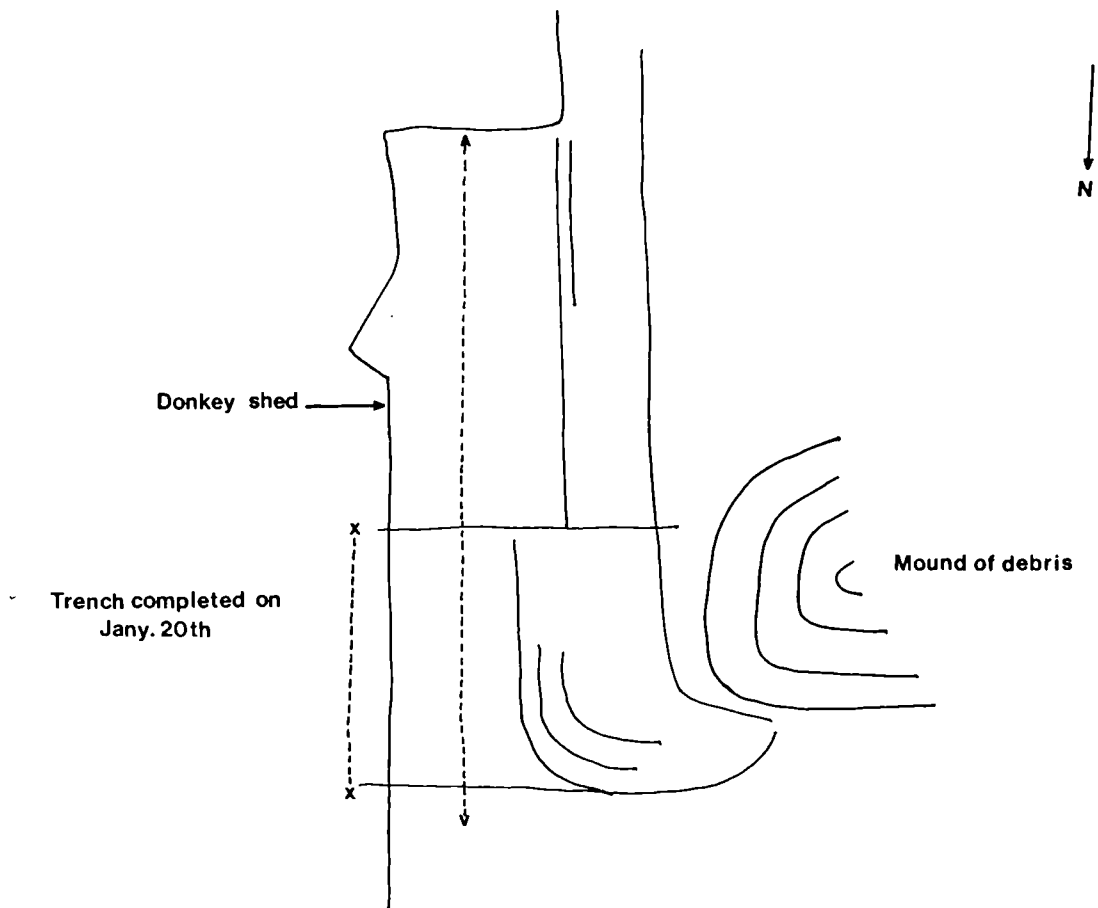

Fig. 106:  
Davis Excavations 1908/9, site 24

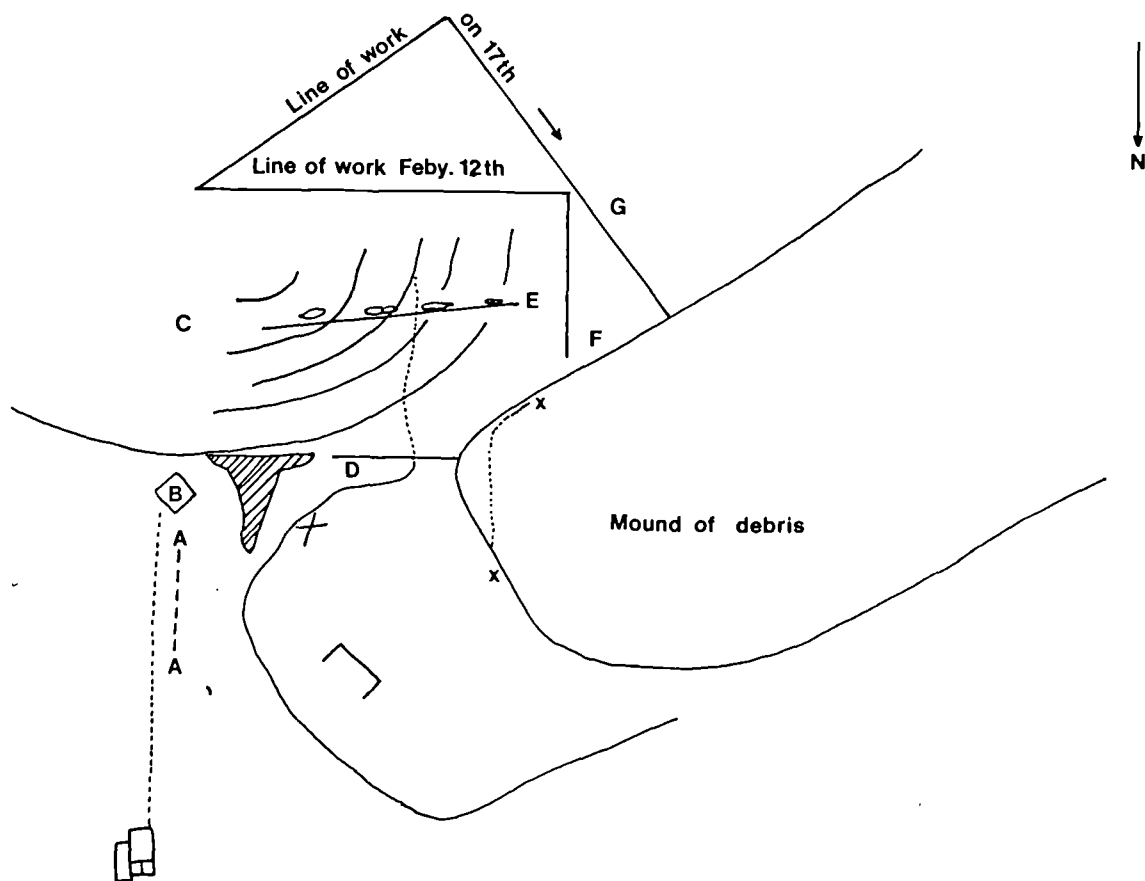

Fig. 107:  
Davis Excavations 1908/9, site 25

Site 25

'Trench 1 metre deep all along the wady going through the path and under shed' (fig. 107, A-A) (29 Jan.-4 Feb.).

## Finds/results.

Broken base of limestone canopic(?) jar; neck fragment of alabaster vase; 'left top corner of slab blue glaze (broken) with  $\llcorner$  only inscript. possibly  $\text{P}$ ' (29/30 January).

Small canopic jar 'at level 10 ft.'; lower part of steatite shabti, incised hieroglyphs; two fragments of an inscribed stela (31 January).

Middle portion of blue glazed shabti inscribed in black, '?cartouches' (1 February).

fragments of alabaster, 'at 15 ft.' (3 February).

Continuation of work (fig. 107, B-C) (4 February).

## Finds/results.

'Unfinished pit (KV 0) with stone wall built around - ?workman's house'; funerary cone of Mentemhet (TT34) (4 February).

Continuation of work (fig. 107, C-D), 'descending with gradual slope to W' (5-12 February).

## Finds/results.

'Large quantity of tomb "dressings"' (6-8 February);  
'fine head carved in limestone in profile (8 February);  
'fragments of limestone with rough charcoal drawings' (10 February).

(??) Continuation of work (fig. 107, D-x-x) (12-13 February).

## Finds/results.

'Limestone fragment with drawing coloured of woman nursing child'; also 'other unimportant fragments' (12 February).

(Here?) 'wig ornaments in blue glaze wedge shaped also fragments of blue glaze ?tiles or inlay and several fragments of limestone with sketch and inscriptions' (13 February).

Continuation of work (fig. 107, x-x) (13-18 February).

## Finds/results.

Several ostraca 'over the whole field' (14/15 February).

'Descending towards mound at F-G' (17-18 February).

## Finds/results.

'Fragments of blue glaze broken beads small bits of gold foil and fragment of ushabti ... also limestone ostraka' (17 February); 'two fragments of small offering table or stela' (18 February).

Continuation of work (fig. 107, F-G) (19 February-7 March).

'This ... mound of debris occupied the remainder of the season, the work being stopped on March 7th'. No finds recorded.

WINTER 1909-SPRING 1910 (24 November-26 January)

Excavator.

Jones.

## Basic sources.

Jones & Burton, Tombs; Davis, Harmhabi, pls. 10-13.

## Attested site designations.

None; attribution of finds probably by date.

Site 26

Some 20-30 m S of KV50-52, 'removing debris thrown over cliff from small (monkey) tombs' (24 November-15 December). Cf. figs. 108-9.

## Finds/results.

Remains of workmen's huts 'built on rock level' at base of cliff (about 25/26 November).

'Fragments of carved small stela' S of northernmost huts (26 November).

'Square sunk pit (KV P) 12 feet below surface level and 1 metre deep. 1½ x 2 metres. In the pit found ashes, broken fragments of pottery, flint flakes, fragments of broken wood (twigs), straw and burnt bones' (12 December).

'Further out on the flat another pit (KV Q) similar to above found a little deeper but with same filling of undisturbed ashes, pottery fragments - ball shaped flints, a piece of pumice stone, pottery fragments with mark  $\Delta$ , many ashes and fine grey ash dust' (13 December).

Continuation W towards KV36 (15-20 December).

## Finds/results.

Pit (KV R) containing 'burnt rubbish' slightly to the N of KV36.

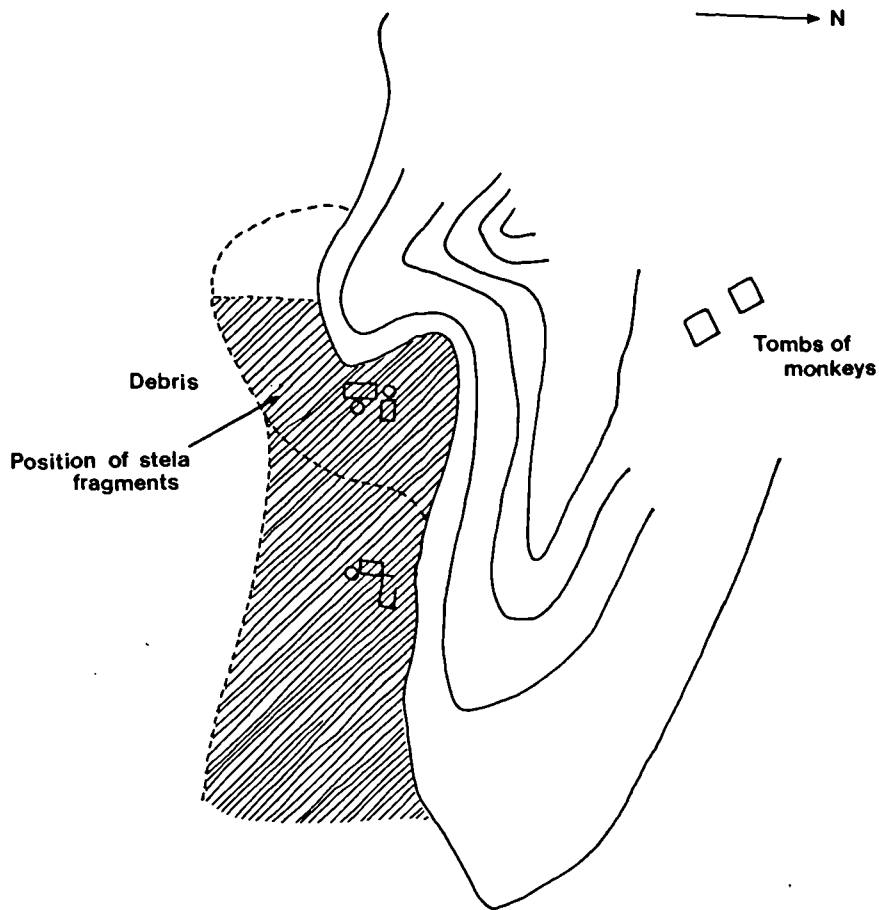

work completed by 29 November 1909

Fig. 108:  
Davis Excavations 1909/10, site 26

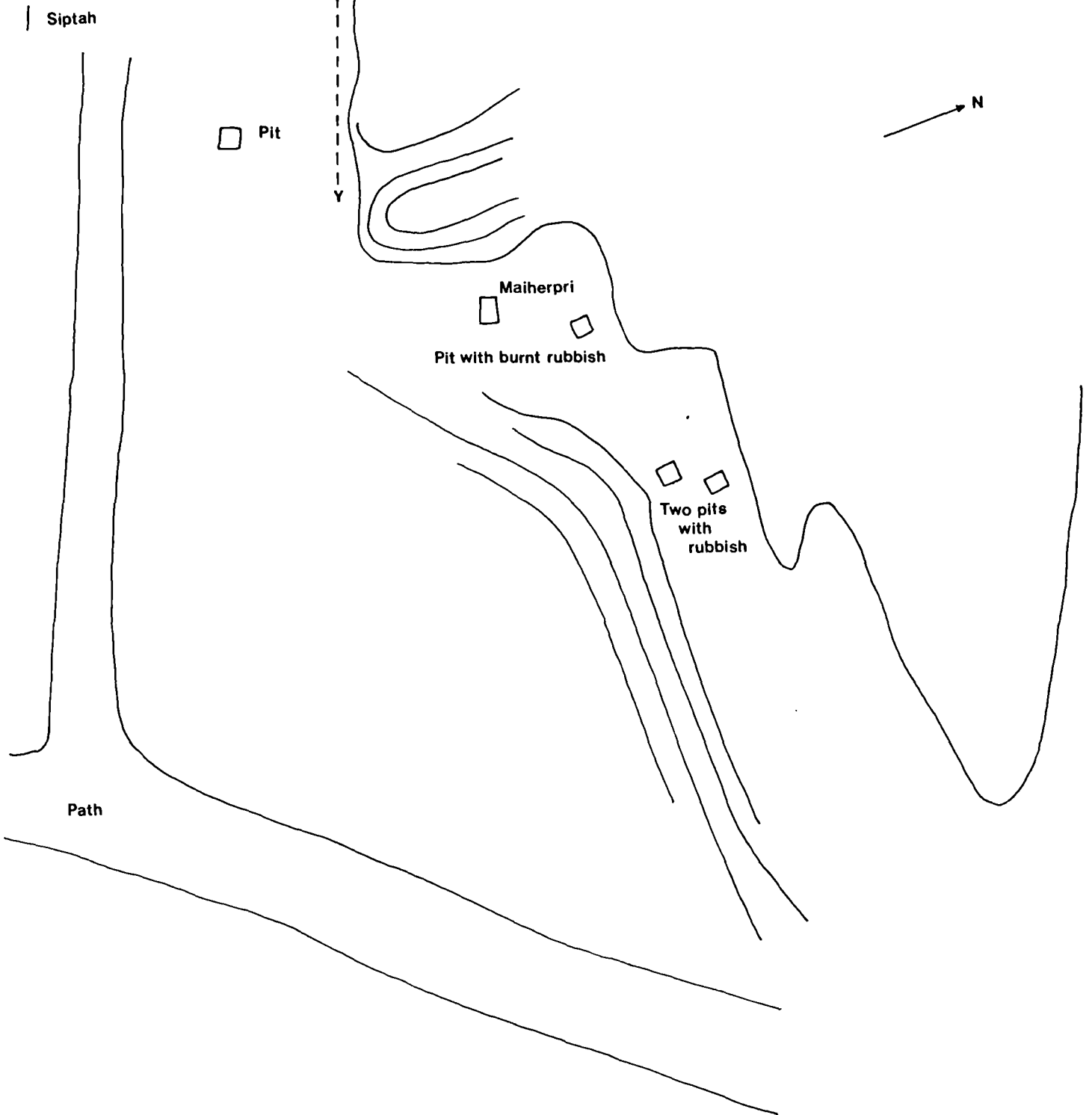

Fig. 109:  
Davis Excavations 1909/10, sites 26-7

Site 27

A trench NNE of KV13 (19-20, 27 December). Cf. fig. 109.

Finds/results.

None recorded.

Site 28

To N and S along the footpath due E of KV47 (27-29 December). Cf. fig. 110.

Finds/results.

'Several ostraka' (27-28 December); 'carved stone fragment with upper part of cartouche probably Merneptah' (prenomen) (27 December).

'Unfinished stela at corner A with broken pot ostraka with cartouches of Rameses II and several other fragments. Stela ... with cartouche of Amenhetep (prenomen) and well cut figure of King sandalled feet etc. before Osiris. Before two figures kneeling and adoring complete while third figure contemplated but unfinished - on left in front of third figure' the name Penamun (MMA 14.6.182; cf. Hayes, Scepter II, 384) (29 December).

Site 29

'Near Seti II tomb No. 15' (29 December).

Finds/results.

'Without result.'

Site 30

'Left of the path leading to Thothmes III tomb' (?25 December-6 January+?).

Finds/results.

Discovery of KV61 (6 January+).

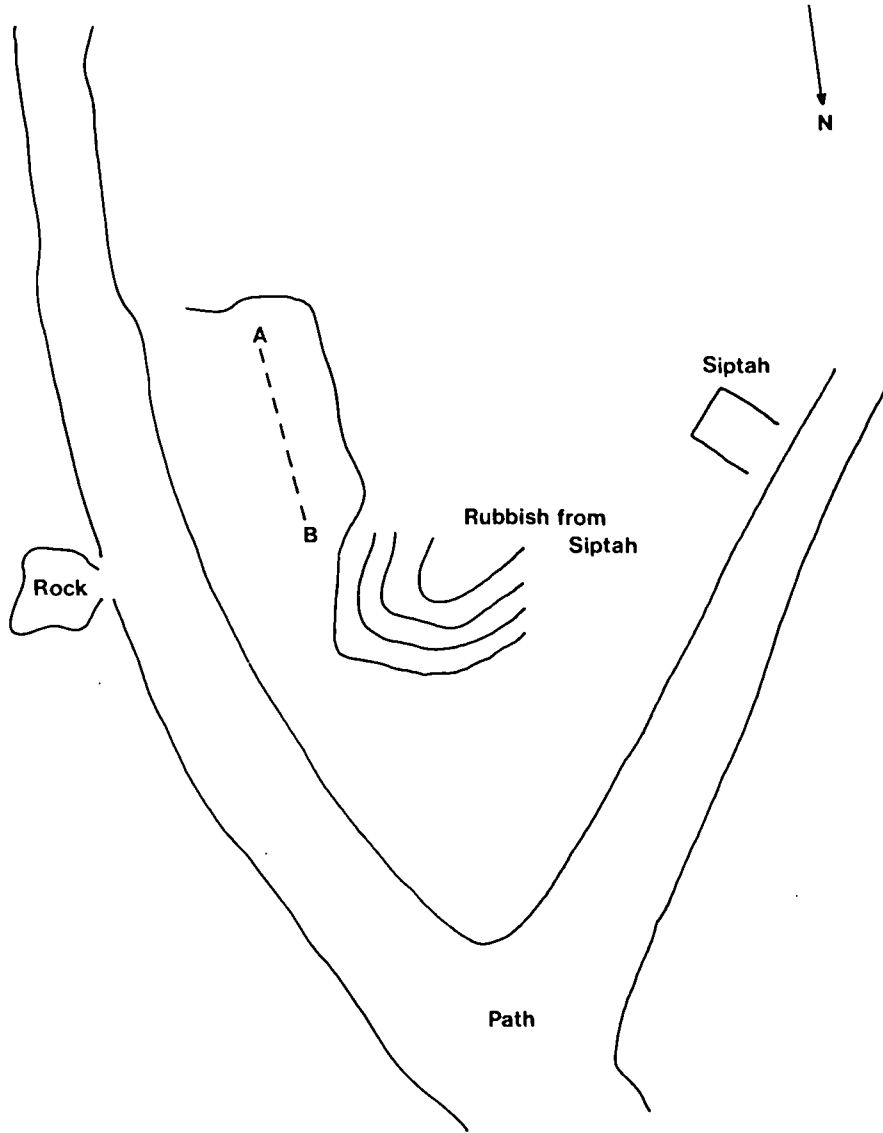

Fig. 110:  
Davis Excavations 1909/10, site 28

Site 31

Presumably the area between and below KV43 and KV20 (no dates, but probably after 6 January). Cf. Davis, Harmhabi, pl. 11.

Finds/results.

'A few blue glass long beads'; 'a wedge of wood with the cartouche of Hatasoo.'

Site 32

'Clearance of sloping desert on all sides' (presumably of KV43 and KV20) (before 26 January). Cf. Davis, Harmhabi, pl. 8(?) .

Finds/results.

'Several ostraka ... near the group of workmen's houses to the SE of the engine room' (sc. KV18); 'a splinter of sundried wood with traces of incut hieroglyphs.'

Site 33

'The valley (in which Tomb No. 4 is). On the north side a trench was cut some 10 feet deep through undisturbed debris to the bed rock' (before 26 January). Cf. Davis, Harmhabi, pls. 7, 10, 12-13.

Finds/results.

'A fragment of the handle of perhaps a fan in wood ...', inscribed for the god's father Userhetet; 'limestone chip with inscription in red paint.'

Site 34

'Reconnaissance de la Vallée de l'Ouest' (Rapports 1899-1910, 323). No further details, but cf. Carter, Notebook 17, 203, and s.v. site 36, below.

## WINTER 1910-SPRING 1911

## Excavator.

Jones.

## Basic sources.

Rapport 1911, 15; Andrews, Journal.

## Attested site designations.

None.

Site 35

'Dans la grande vallée' (Rapport 1911, 15). No further details.

## Finds/results.

'... rien ... qui vaille d'être mentionné auprès des découvertes des années précédentes: du moins M. Crane a-t-il poussé fort loin la copie des peintures qui décorent l'hypogée d'Harmhabi ...' (ibid.). Cf. above, site 23.

Site 36

The 'Priest King's' valley (Andrews, Journal, entry for 11 December 1910) = 'le vallon nouveau' (Rapport 1911, 15). Cf. Carter, Notebook 17, 203.

## Finds/results.

No further details.

## SPRING 1912 (7-23 February)

## Excavator.

Burton.

## Basic sources.

Jones & Burton, Tombs; Burton, BMMA 11 (1916), 13 ff.; Rapport 1912, 26.

Attested site designations.

None; attribution of finds probably by date.

Site 37

Clearance of KV3 (temp. Ramesses III), commencing 'just outside the entrance which was filled with rubble up to 3 ft. from the top' (7-15 February). Cf. Winlock & Crum, Epiphanius I, 19.

Finds/results.

'An earthenware jar ... about 20 ft. from the entrance' (9 February); '2 Coptic lamps' (10 February); '4 earthenware Coptic jars ... found in the chamber with four supports' (i.e. (C)) (11 February); 'two capitals and two bases and part of a column ... found in the last chamber but one' (E) (12 February). (For the column capitals cf. the photograph reproduced by Romer, Valley, 204).

Site 38

Continued clearance of KV47 (Siptah) (cf. site 15 above), commencing 'in the main chamber' (F) (7-23 February).

Finds/results.

Broken shabti (in passage (G)-(H)) (16 February); and another, 'carrying Siptah's cartouches', in (I) (18 February).

Site 39

West Valley, precise dates uncertain. Davis 'envoyait une partie de ses chantiers dans la vallée de l'ouest, (et) il s'attaquait à plusieurs points de l'Ouadièn' (Rapport 1912, 26). Cf. Carter, MSS, I.A.124(6): 'during the years 1905 and 1914 (sc. 1912), the late Messrs. Ayrton,

Jones (sic) and Mr. Burton, on behalf of Theo. M. Davis, made sundry excavations (sondages) in the rubbish heaps covering the rocks to the south and the water course below this tomb' (sc. WV22). The work 'amounted to test trenches in search of another tomb, (and) the clearance of a small tomb chamber (WV A) under the vertical cliff, known before him.'

Finds/results.

'Fragments of harness (Carter, MSS, I.A.138(10)) and a portion of a large scarab' (ibid., I.A.138(11)).

WINTER 1912-SPRING 1913 (16 December-8 March)

Excavator.

Burton.

Basic sources.

Jones & Burton, Tombs; Burton, BMMA 11 (1916), 13 ff..

Attested site designations.

None; probably by date.

Site 38 (cont'd)

Continued clearance of KV47 (Siptah).

Finds/results.

'Two fragments of alabaster, prob. part of the sarcophagus' (L) (4 January); red granite sarcophagus and lid (in L) (8 February); fragments of canopic chest (from (L) and (J)) (13 and 19-20 January; 5-6 March); four lids 'with lotus flowers painted on them' (L) (22 January). Cf. Burton, BMMA 11 (1916), 13 ff.

WINTER 1913-SPRING 1914 (11 December-11 February+?)

Excavator.

Burton.

Basic source.

Jones & Burton, Tombs.

Attested site designations.

None; attribution of finds probably by date.

Site 40

Clearance of KV7 (Ramesses II), commencing 'to the right ... (and) to the left' of the entrance (11 December-14 January). Cf. Baillet, Inscriptions, 193; Romer, Valley, 236; and further appendix C, site 2.

Finds/results.

'Frag. of a statue with hieroglyphics (sic) on one side. Limestone' (D) (18 December); 'fragment of alabaster with part of a figure engraved on it' (F) (23 December); green and blue faience shabti fragments ((F) and (H)) (23 December; 3 January); 'limestone lid 7 cm in diameter with lotus flower painted on top' (G) (31 December); fragment of blue faenze (sic) with black hieroglyphics (sic) and part of cartouche ... of Ramses II' (prenomen) (I) (31 December); 'small alabaster lid, round 6 cm. diameter' (G) (1 January); 'small pieces of glass' (G) (1 January); corner 'fragment ... blue glaze ... Part of cartouche of Ramses II on one side' (prenomen) (I) (MMA 14.6.221; cf. Hayes, Scepter II, 346) (4 January); 'one or two odd pieces of blue glaze' (5 January); 'pieces of alabaster belonging either to canopic box or sarcophagus' (J) (12-13 January); ostrakon (J 44892: Keimer, ASAE 33 (1933), 197 f., figs. 89a-b).

Site 41

'to the north and above No. 8' (25-28 January).

Finds/results.

'Sketch of a monkey' (28 January).

Continuation 'to the south of the tomb' (29-31 January).

Finds/results.

'Square seal with hieroglyphics (sic) on either side (30 January).

Continuation 'clearing downwards towards No. 6' (31 January-11 February).

Finds/results.

'Limestone ring (plain)' (2 February); otherwise  
'nothing of importance'.

Clearance at 'corner of path up to No. 8' (11 February+; here the record stops).

No finds recorded.

## APPENDIX C

## CARNARVON EXCAVATIONS, 1915-1922

Introduction

Following Davis's death, the concession to excavate in the Valley of the Kings passed to the Fifth Earl of Carnarvon, whose work was directed by Howard Carter. With the obvious exception of KV62 (Tutankhamun), the results of their efforts disappointed the excavators.<sup>34)</sup> Nevertheless, relatively full records were kept, and of these the major portion is preserved in the Griffith Institute, Oxford.<sup>35)</sup> It has thus been a relatively simple matter to reconstruct the scheme of work during the Carnarvon seasons and to identify and assign to specific sites the individually numbered finds (including ostraca) made during these years.

Carnarvon died on 6 April 1923, a short time after the discovery of KV62. The concession to excavate in the Valley was then allowed to lapse, although Carter continued his work of clearance in the tomb of Tutankhamun until February 1932.

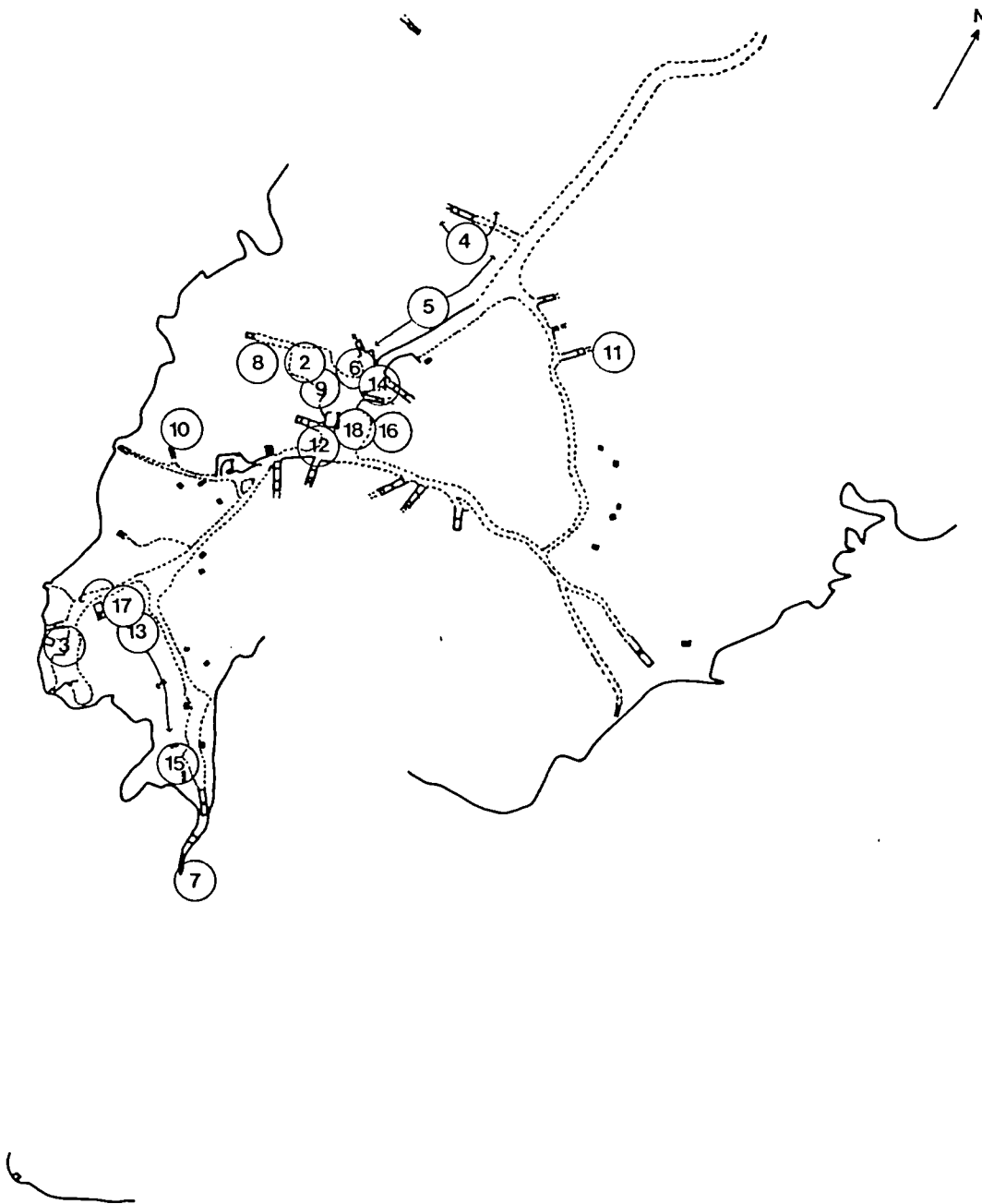

Fig. 111:  
Carnarvon Excavations, 1915-1922

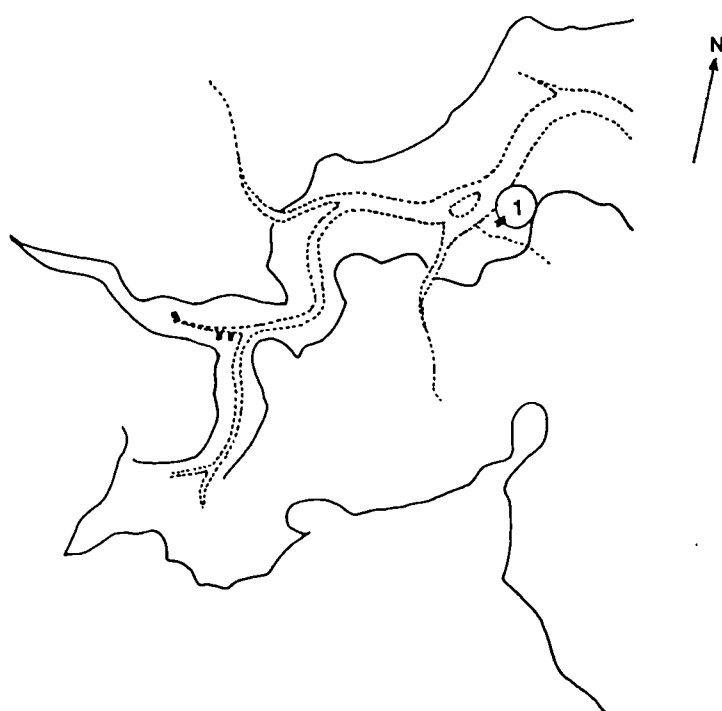

Fig. 112:  
Carnarvon Excavations, 1915-1922  
(West Valley)

Carnarvon Excavations, 1915-1922

(Figs. 111-112)

SPRING 1915 (8 February-8 March)

Excavator.

Carter.

Basic sources.

Carter, MSS, I.A.123 ff.; I.J.386-7, nos. 1-105. Cf.Carter, Tut.ankh.Amen I, 79.

Attested site designation.

None; attribution of finds by number.

Site 1

WV22 (Amenophis III). 'Commenced by clearing the mouth of the water course beneath entrance of tomb.'

Finds/results.

1 frag. alabaster shabti, Tiye ('Carnarvon colln. 1920' = I.A.138(19));

2-4 frags. faience, glass (4 = I.A.138(13)).

'Before entrance of tomb.'

Finds/results.

5-58 five (of six) foundation deposits of Tuthmosis IV, intact (I.A.139(1 ff.); I.A.139a).

'Rubbish of protective well.'

Finds/results.

59 frag. alabaster shabti, Tiye ('Highclere coll. 1920' = I.A.138(19));

60 'bitumenised' wooden box(?) fragments, Tiye (I.A.138(19));

- 61-2, 65-6, 74 serpentine, alabaster, wood shabti fragments, Amenophis III (61 = I.A.138(27); 62 = I.A.138(16); 65 = I.A.138(27); 66 = I.A.138 (16); 74, 'Highclere coll. 1920' = I.A.138(14) & (17));
- 63-4 intrusive coffin fragments (I.A.138(28));
- 67, 73, 77, 81 faience, glass, ivory inlays (73, uraeus head = I.A.138(22), 'Highclere coll. 1920'; 77 = I.A.138(15));
- 69-70, 75, 80, 87-8 frags. alabaster, glass, faience (87 = I.A.138(13); 88 = I.A.138(24));
- 71 'bitumenised' wooden figure of Tiye, fragmentary, three-quarter life-size;
- 72 'bitumenised' Sekhmet figure;
- 76 ebony veneer frags. ('Cairo Museum, 1916' = I.A.138(15));
- 78 faience pectoral frag. ('Highclere coll. 1920' = I.A.138(23));
- 79 faience ring bezel, wsr-m3<sup>c</sup>t-r<sup>c</sup> stp-n-r<sup>c</sup> (Ramesses II) (I.A.138(28));
- 82 halfa grass;
- 83 human skull and hand;
- 84-5 beads, amulets (85 = I A.138(12));
- 86 frag. inscribed wood (I.A.134 (3));
- 89 fragmentary wooden labels, hieratic;
- 90 various splinters of wood.

'Protective well chamber.'

Finds/results.

- 91 stone vessel fragments;
- 92 wood fragments;
- 93 frag. polychrome faience shabti (I.A.138(20));
- 94 hand of wooden statue of Tiye (I.A.138(25));

- 95-6, 101-2 fragments of polychrome glass, faience  
 (96, frag. faience bracelet = I.A.138(13));  
 97 fragmentary wooden labels, hieratic ('9 labels in  
 all');  
 98-9 alabaster, limestone, schist shabti fragments  
 (99, 'Highclere coll. 1920' = I.A.138(18));  
 100 faience bowl frag. (I.A.138(21));  
 103 ivory-inlaid ebony veneer ('Cairo Museum');  
 104 gold strip;  
 105 parts of chariot and wheel (I.A.140 ff.; Western,  
JEA 59 (1973), 91 ff.).

Burial chamber (J).

Finds/results.

(no number) alabaster canopic chest frag. (I.A.131(2)).

WINTER 1917-SPRING 1918 (1 December-2 February)

Excavator.

Carter.

Basic sources.

Carter, MSS, I.J.319 ff. (photos.); I.J.386-7, nos.  
 106-215.

Attested site designation.

A; attribution of finds by number.

### Site 2

'Commenced operations in the E. valley. Beginning in the  
 small lateral valley situated between the tomb of Ramses II  
 and Ramses VI, and running approximately N.W.-S.E.'

## Finds/results.

('From same site but from Burton's excavations on behalf of Theo. M. Davis - 1914'; cf. appendix B, site 40.)

106-8 ostraca (I.F.80-2).

('Mostly from top loose stuff and probably from former excavations'.)

109-10 frags. inscr. alabaster canopic chest/sarcophagus;

111 potsherds with traces of colour and mortar, human skull and animal bone;

112-5 frags. faience, polychrome glass, inlay, amulets, bronze;

116-7, 119-29, 132-40 ostraca ('upper stratum') (125 = CG 25620, 25755; 138 = CG 25649);

118 arm and foot of statuette;

130 'frag. of arragonite finial' (yoke harness boss?);

131 sandstone hones and wooden mallet ('lower stratum');

141 'frag. alab. (?)bull's head from a vase' ('upper stratum');

142 frag. clay model of a lotus flower ('upper stratum').

('Middle and lower stratum'.

143-88, 191-6, 200, 203-15 ostraca (143 = I.F.83; 147 =

I.F.84-7; 148 = I.F.88; 149 ('floor level of workmen's huts') = CG 25760; 151 = CG 25524; 152 = CG 25677;

153 = CG 25679; 154 = CG 25678; 155 = CG 25680; 156 =

CG 25622; 157 = CG 25552; 158 = CG 25631; 159 = CG 25616;

161 = CG 25551; 163 = CG 25727; 165 = I.F.106; 167 =

CG 25552; 171 = I.F.107; 172 = CG 25706; 175 = CG 25753;

176 ('prob. dates the level of the huts of this part of

the valley') = CG 25671; 177 = CG 25646; 178 = CG 25540; 180 = CG 25627b; 183 = I.F.115; 184 = CG 25618; 186 = CG 25539; 193 = I.F.121; 204 = I.F.122; 206 = CG 25754; 211 = I.F.123-4 (cf. Carter, Tut.ankh.Amen II, pl. 2, a); 212 = CG 25581; 214 = CG 25623);

189 red pottery jar containing skeleton of a snake (I.B.201);

190 large polychrome glass bead ('period ?Ramses II') (I.A.279; BFAC, Catalogue, 40, no. 4). (An additional note reads: 'Below these (?huts) a filling of boulders, flint and sand');

197, 202 copper-alloy model knives (197 = I.A.276);

198 fragment of 'very fine jasper bead' (I.A.279);

199 gold foil.

(Cf. Carter, MSS, I.G.52, for precise find-spots.)

SPRING 1919 (19-24 February)

Excavator.

Carter.

Basic sources.

Carter, MSS, I.A.233-4; I.J.386-7, nos. 216-26

Attested site designation.

B; attribution of finds by number.

### Site 3

'Before tomb of Thothmes I' (KV38).

Finds/results.

216-26 uninscribed foundation deposit material (pottery and copper-alloy model tools).

SPRING 1920 (5 January+)

Excavator.

Carter.

Basic sources.

Carter, MSS, I.J.386-7, nos. 227-75.

Attested site designations.

C, D, E, F; attribution of finds by number.

Site 4

'In front of and on the S.W. side of the mouth of the tomb of Ramses IV' (KV2) (5-?10 January) (site C).

Finds/results.

227-8, 231-2 frags. faience, polychrome glass, wood (232, wood frag.: Ramesses IV);

229-30 fragmentary alabaster, faience shabtis, Ramesses IV;

234-6, 239 intact foundation deposits, Ramesses IV;

238 ostrakon.

Site 5

'Depression in foot hill between tombs Ramses II-IV (i.e. KV7-KV21), wherein debris from excavations of tombs had been anciently thrown' (10-?15 January) (site D).

Finds/results.

243 ostrakon.

Site 6

'South of the entrance of the tomb of Ramses II' (KV7)  
(15 January-?17 February).

## Finds/results.

- 244, 246-7 ostraca;
- 245 painted wood, Ramesses II;
- 248 two plumb-bobs, stone rubber, stock of brush;
- 249 mud jar sealing (I.E.2).

(Cf. Carter, MSS, I.G.52, for precise find-spots.)

Site 7

'Investigated canyon above tomb of Thothmes III, wherein there were many boulders artificially placed there' (sic). (In a note Carter adds: 'These boulders and debris, (?) from an excavation of a tomb of early date, are very puzzling. Possibly they may comprise the debris from the tomb No. 39 at the head of the upper valley - hidden like that of the tomb of Amenhotep I (i.e. AN B). (The ground above around the edges of the canyon still requires exploration)'.)  
(17-?21 February) (site E).

## Finds/results.

further details.

Site 8

'Before entrance of the tomb of Merenptah' (KV8). (In a note Carter adds: 'Barring a certain depth of top stuff this ground was undisturbed since dynastic times'.) (21 February-?5 March) (site F).

## Finds/results.

- 250-1, 253-6, 270-1 ostraca;

252 'frag. of arragonite - ?portion of furniture';  
 257-69 cache of alabaster vessels, Ramesses II and  
 Merenptah (I.C.168 ff.).

'Lower stratum below entrance of Merenptah tomb' (5-?10  
 March).

Finds/results.

272-5 copper chisels and fragments.

'Water-course south side of the tomb of Merenptah and  
 debris above on that side' (10-16 March).

Finds/results.

'only further remains of workmen's huts.'

(Cf. Carter, MSS, I.G.52, for precise find-spots.)

WINTER 1920-SPRING 1921 (1 December-3/13 March)

Excavator.

Carter.

Basic sources.

Carter, MSS, I.J.386-7, nos. 276-350.

Attested site designations.

H, I, L; attribution of finds by number.

### Site 9

'Recommenced excavations. Lateral valley between tombs  
 Ramses II and VI' (KV7-9) (1-?22 December).

Finds/results.

276-85 ostraca (278 = CG 25788; 279 = CG 25789; 280 =  
 CG 25823).

(Cf. Carter, MSS, I.G.52, for precise find-spots.)

Site 10

'Investigated in front of tomb No. 12 for deposits' (1 December) (site L).

Finds/results.

further details.

Site 11

'Prepared tomb No. 4 as Magazine.'

Finds/results.

specified, but a note by Carter reads: 'See pottery found at entrance'.

Site 12

'Continued beside entrance of tomb of Ramses VI' (KV9) (23 December-?3 January) (site H).

Finds/results.

286-98, 300-2 ostraca (289 = CG 25803; 290 = CG 25798; 293 ('level of floor of huts'); 296 = CG 25807; 300c = CG 25815a; 300f = CG 25809; 300g = CG 25809; 300i = CG 25832c; 300k = CG 25809; 300l = CG 25813; 300p = CG 25805; 300q = CG 25815b; 300r = CG 25815a; 300s = CG 25809; 300y = CG 25832a; 300z = CG 25832b; 300cc = CG 25816; 300dd = CG 25821; 300ee = CG 25829; 300jj = CG 25817; 300oo = CG 25802; 300rr = CG 25828; 300qq = CG 25808; 300ss = CG 25812; 302 = CG 25819);

299 'place for making and mixing mortar or plaster' (among huts). ('(?)a hut re-used for mixing plaster for Ramses VI tomb'. A further note by Carter reads: 'The huts here ... were built partly upon ground made up with numbers of boulders'.)

(Cf. Carter, MSS, I.G.52, for precise find-spots.)

Site 13

'The portion (of the Valley) leading to the tomb of Thothmes III' (3 January+). ('Though there were immense heaps of rubbish from former excavations accumulated on the upper stratum and rock slopes, the ground below had not been attacked since ancient times') (site I).

## Finds/results.

- 303 fire-stick and matrix;
- 304 model obelisk in limestone;
- 305-9 ostraca (305 = CG 25822);
- 310-3 frag. limestone vessels 'from burial of Sennefer' (i.e. KV42);
- 314-7 four foundation deposits of Hatshepsut-Meryetre (I.A.240);
- 318-9 loose foundation deposit objects, Tuthmosis III.

(Cf. Carter, MSS, I.G.51, for precise find-spots.)

Site 14

'Between opening of tomb Ramses IX and cache of Akhenaten' (KV6-KV55).

## Finds/results.

- 320 limestone stela of Inumose ('top stratum');
- 321-3 ostraca (322 = CG 25830);
- 324 frag. ?canopic jar, Takhat ('lower stratum');
- 325 fragmentary faience amulet.

(Cf. Carter, MSS, I.G.50-51, for precise find-spots.)

Site 15

'End of Thothmes III valley' (site I).

## Finds/results.

- 326 frag. polychrome faience 'funerary figure' ('loose rubbish');
- 327 frags. faience, glass, beads;
- 328 frag. faience shabti, Sethos I;
- 329, 331 ostraca (331, 'lower stratum');
- 330 frag. limestone 'tablet';
- 332 'shoulder of a basalt statuette of a king'.

(Cf. Carter, MSS, I.G.51, for precise find-spots.)

'Extreme end of Thothmes III valley, below rift containing king's tomb' (site I).

## Finds/results.

- 333-6 four foundation deposits, Tuthmosis III, one intact ('in bed rock');
- 'commencement for a tomb' (KV F).

(Cf. Carter, MSS, I.G.50-51, for precise find-spots.)

Site 16

'South of opening of cache Akhenaten' (KV55) (before 3/13 March).

## Finds/results.

- 337-41, 343-6 ostraca (337-41, 'top stratum'; 343-4, 'Davis rubbish'; 344 = CG 25824; 345-6, 'lower stratum');
- 342 five frag. alabaster shabtis 'of a (?) Ramses';
- 347-8 frags. of wood with hieroglyphic text (348, 'yellow incised in ebony'; 'middle stratum');
- 349 jasper burnisher and frags. copper-alloy ('such as rosettes, etc. ?from Akhenaten cache left by ancients'; 'in crack in rock');

350 'misc. frags. faience, glass, bronze and statuette in wood' ('loose rubbish').

(Cf. Carter, MSS, I.G.52, for precise find-spots.)

SPRING 1922 (8 February-'March')

Excavator.

Carter.

Basic sources.

Carter, MSS, I.J.387, nos. 351-432.

Attested site designation.

K; attribution of finds by number.

#### Site 17

'Recommended excavations on the east side of foot hill containing the tomb of Siptah' (KV47). (Carter adds in a note: 'The greater part of this spot was covered with large mounds of rubbish thrown out during the excavations of Siptah's tomb by Theo. M. Davis') (8 February+) (site K).

Finds/results.

( 'Toploose rubbish from former excavations')

351 two frags. faience model coffin, of Tiaa (I.A.277);

352 frag. faience vase, Sethos I (I.A.278);

353-5, 357-63, 365 ostraca (359 = CG 25806; 361 = CG 25800; 361a = CG 25781);

356 limestone plumb-bob;

364 limestone drill top;

366 ebony veneer from box.

('"Sondaged", but mostly undisturbed.')

367-78 ostraca;

379 plaster model of a dog;

380 copper spike.

('Undisturbed stratum (man's height above rock bed).

(Rough walls ... were uncovered in this stratum).')

381-92 ostraca (381 = CG 25801; 381a = CG 25794; 384 =

CG 25787; 390 = CG 25790; 391 = CG 25786);

393 zeer (in situ);

394 frags. glass, faience, beads etc.

('Lower stratum - on bed rock.')

395-7 terracotta pots (397: see further below);

398 limestone statuette (see below);

399 'two limestone desks for (?)use';

400-20 ostraca (400 = CG 25780; 401 = CG 25783; 402 =

CG 25782; 403 = CG 25784; 404 = CG 25779; 405 =

CG 25785 ('397-405. This group in small shelf in

rock over hut ... Wrapped in mat'); 409 = CG 25796;

411 = CG 25831; 412 = CG 25814; 415 = CG 25792;

416 = CG 25793; 417 = CG 25791; 418 = CG 25804).

'Loose rubbish before and on both sides of the tomb of Siptah.'

Finds/results.

421-31 ostraca (422 = CG 25825; 429 = CG 25797; 430 =

CG 25810; 431 = CG 25799);

432 'debris (misc.) from tomb of Siptah (glass, shawabtis, leather, etc.)'.

WINTER 1922-SPRING 1923 (1 November+)

Excavator.

Carter.

Basic sources.

Carter, MSS, I.J.387, nos. 433-5.

Attested site designation.

?H; attribution of finds by number.

Site 18

'Excavation before tomb of Ramses VI' (KV9) (1 November+)  
(site H?).

Finds/results.

433 entrance to KV62 (Tutankhamun);

434 ostracon;

435 '(?)mortar trough for Ramses VI (?)tomb'.

(Cf. Carter, MSS, I.G.52, for precise locations.)

## APPENDIX D

EXTRACTS FROM THE WEIGALL MSS<sup>36)</sup>Document 1

## Copie

Direction Générale du  
Service des Antiquités  
Autorisation de Fouilles

Je soussigné, Directeur Général du Service des Antiquités, agissant en vertu des Pouvoirs qui me sont délégués, autorise par la présente M. Théodore M. Davis, sujet Américain, résidant à (sic) à exécuter des fouilles scientifiques dans la vallée des Rois, dans les terrains appartenant à l'Etat, libres, non bâtis, non cultivés non compris dans la zone militaire, cimetières, carrières, etc. etc. en général, non affectés à un service public, et aux conditions suivantes:

1<sup>o</sup> Les travaux de fouilles seront exécutés aux frais, risques et périls de M. Davis par les soins de M. Eduard N. Ayrton (sic): celui-ci ne devra avoir aucune autre occupation, et devra se tenir constamment sur le champ de fouilles;

2<sup>o</sup> Les travaux seront exécutés sous le contrôle du Service des Antiquités qui aura le droit non seulement de surveiller les travaux, mais encore d'en rectifier la marche s'il juge utile au succès de l'entreprise.

3<sup>o</sup> Si un tombeau, ou tout autre monument quelconque, vient à être découvert, M. Ayrton est tenu d'en aviser immédiatement l'Inspecteur en Chef du Service des Antiquités de la Haute Egypte à Louxor;

4<sup>o</sup> M. Davis aura le privilege d'ouvrir lui même le tombeau ou le monument découvert, et d'y pénétrer le premier.

5<sup>o</sup> Dès l'instant de l'ouverture, l'Inspecteur en Chef du Service des Antiquités placera sur le lieux le nombre de gardiens qu'il jugera nécessaire.

6<sup>o</sup> M. Davis, après avoir examiné le dit tombeau, ou monument et pris les notes qu'il jugera nécessaires, le consignera à l'Inspecteur du Service des Antiquités ou à tout autre agent que le Service lui aura désigné.

7<sup>o</sup> M. Davis est tenu de rediger aussitôt un procès verbal indiquant les particularités observées au moment de l'ouverture et la place occupée par chaque objet, en y joignant des photographies et des dessins autant que possible.

8<sup>o</sup> M. Davis n'aura droit à aucun des objets renfermés dans le tombeau ou le monument découvert; ces objets, ainsi que le monument ou le tombeau restant la propriété du Service des Antiquités; M. Davis se reserve seulement de publier la trouvail et il sera indiqué dans les catalogues du Musée comme ayant été l'auteur de la découverte.

9<sup>o</sup> M. Davis, une fois des fouilles terminées, est tenu de remettre à ses frais dans un état satisfaisant de nivellement, tous les terrains sur lesquelles il aura opéré.

10<sup>o</sup> M. Davis s'engage en outre:

- A à ne pas prendre d'estampage au papier humide sur les monuments coloriés;
- B à déposer au Musée, et, si possible, à la Bibliothèque Khediviale, un exemplaire des ouvrages, mémoires, tirages à part, recueils de gravures publiés par ses soins sur les objets découverts au cours de ses fouilles;
- C à livrer le Service des Antiquités, dans le délai d'un an à partir de la date où ses travaux auront pris fin: 1<sup>o</sup> un croquis, ou s'il y a lieu, au jugement du Service, un plan du champ des fouilles qui puisse être publié dans les annales du Musée; 2<sup>o</sup> une liste sommaire se référant à ce plan et indiquant la position des objets formant un ensemble, tels que sarcophages, barques, statues funéraires, verres, amulettes appartenant à un même sarcophage.

11<sup>o</sup> Toute infraction de la part de M. Davis ou de ses agents, aux conditions ci-dessus énoncées, entraînera de plein droit sans mise en demeure ou formalité quelconque l'annulation de la présente autorisation. Le Service des Antiquités procédant par voie administrative fera cesser immédiatement tout travail et prendra toutes les mesures qu'il jugera nécessaire pour ses intérêts et pour la sauvegarde des monuments ou objets qui auraient été déjà découverts au moment de la cessation des fouilles, et ce, sans que M. Davis, ou quelconque de ses agents, ait droit à une indemnité ou à une compensation quelconque de quelque nature que ce soit.

La présente autorisation est valable pour un an à partir du 1<sup>er</sup> Novembre 1905.

Fait double au Caire le (sic)

Le Directeur Général  
du Service des Antiquités  
signé: G. Maspero

Vu et accepté  
la présente autorisation  
signé: Theo. M. Davis

Document 2

Dahabya Beduin  
Egypt

Sunday. Jan. 13. 1907

My dear Weigall

I am just back from the Valley, spent most of the afternoon in the tomb (KV55) and have decided that it is too dangerous for me or any other man to attempt to move the coffin. Personally I would not think of touching it, and think you will be of the same opinion when you carefully examine it.

The photographer<sup>37)</sup> has worked all day, Smith has finished the Queen. The photographer will monopolize the tomb Monday and Tuesday. Smith will commence to paint

the coffin early tomorrow morning and finish Tuesday afternoon.

Ayrton will take the measures of everything connected with the tomb and locate by sketch the situ of everything in the tomb: none of the workmen will be there on Tuesday - from all of which you will see that there will be nothing for you to do before Wednesday. I merely make this as a suggestion, fearing that you will be disappointed if you go over tomorrow - I shall not go over until Wednesday morning. Jo Smith's father, a most ingenious man, goes over tomorrow morning to examine and report a possible scheme to lift the coffin & mummy - his conclusion will be submitted to you on Wednesday when you can consider its feasibility.

Kind regards

Theo. M. Davis

Document 3

Biban el Moluk

Dec. 30. 1907

Dear Weigall

Just a line to, perhaps, catch you before you leave for Cairo, to say that we have dug out a portion of the rubbish from the tomb of Amenmeses (KV10) leaving a level floor for a further space of five metres and rebuilt the ras(?) at that point. This will give the Company room

for another table of equal length to their other two and should do nicely.<sup>38)</sup> The only objects found were the bottom piece of an alabaster ushabti of Rameses VI and a fragment from an alabaster box(?) with the cartouches of Sety I. Shewing that at least the upper layers of the tomb rubbish must be due to comparatively recent entry of water which has washed in these things.

\*

Yrs.

Edward R. Ayrton

Document 4

Biban el Moluk

Jan. 5. 1907 (sc. 1908)<sup>39)</sup>

Dear Weigall

Just a line to let you know that we have discovered a tomb (KV56) running under the tomb of Rameses VI at a depth of some 20 ft. below the path level and immediately before the tomb of Rameses III.

I have asked your Reyz to put guards over it and understand from Mr. Davis that he is writing to you. I understand from him that he will not open it until some date near the 17th Jan. 1907 (sic).

I shall probably want to move the tourist path back across the entrance of Rameses III Tomb (sic). But we can settle that later or when I see you.

Hope you enjoyed your visit to Cairo.

Yrs. in haste

Edward R. Ayrton

Document 5

Dahabya Beduin  
Egypt

Luxor  
January 5/1908

Arthur Weigall Esq  
Inspector etc.

Dear Sir

I beg to advise you that I have this day discovered what I suppose to be a large tomb (KV56). Owing to the request of Sir Eldon Gorst I shall not open or enter the tomb until the 17th inst.<sup>40)</sup>

Will you kindly exercise your rights and duties under your Inspectorship in the matter of guarding the site of the tomb and oblige.

Yrs. truly

Theo. M. Davis

P.S. Your Rais was informed this morning of the find and asked to set the guards at once.

T. M. Davis

Document 6

Dahabya Beduin  
Egypt

January 29/1908

Dear M. Maspero

I would like to take out of the tomb of Queen "Thyi" (KV55), the doors which now rest on a pile of rock at the mouth of the corridor, also the boards in the last chamber. This for the reason that I may have copied such inscriptions as already have not been done. It seems a pity to allow the doors etc. to remain in the tomb uncopied, and liable to decay beyond preservation.

I would also like to transfer the doors etc. to the tomb next to Thyi's, there to stay until copies are made.

It is possible that useful inscriptions may be found and therefore it would seem worthy of transportation (sic?).

If you agree with my application I shall be glad if you will at once issue the necessary order to Mr. Weigall.

Very truly

Theo. M. Davis

I would like to have the key to Thyi's tomb tomorrow morning not later than 9 am as I am going to Valley at 10.

T. M. Davis

(Superscription:)

M. Weigall

Allow M. Davis to take the panels out of the tomb, or generally to do what is necessary to copy them. When he has copied them, pray, take them all and send them to Cairo, that the bier may be built up again in the Museum.<sup>41)</sup>

Louxor 30/1 1908

G. Maspero

Document 7

Biban el Moluk

Feb. 22nd 1908

Dear Weigall

We have just found another tomb (KV57),<sup>42)</sup> this time

of Bab-type, in the continuation of the digging which led to the discovery of the jewellery of Tausert.

I will be glad if you will keep this information private until Davis' arrival.

I am writing to you first since I should like you to endorse my request that one of your guards should stay on it at night. We shall not need police for at least three days.

Yrs.

Edward R. Ayrton

\*

Document 8

Dahabya Beduin  
Egypt

Dec. 31. 1908. Copy

Dear Mr Davis

It was at the beginning of the season that I unpacked the ostraka at the Museum. Mr. Jones and Mr. George saw them on the tables and floor of the room which Maspero himself gave me leave to use.

Last year's ostraka are all packed in the boxes in the tomb of Horemheb. These I formally handed over to Mr. Weigall by letter at the close of last season, telling him that I had packed the ostraka in separate boxes, so that Mr. Alan Gardiner could work on them at Mr. Weigall's house during last summer.<sup>43)</sup> You said that you had no objection to Mr. Gardiner's working them over, when I asked you last season. The so-called "Mediterranean" ostraka are with these, and you saw one or two of them dug out yourself in those workmen's huts by the tomb of Seti I.<sup>44)</sup> They are ostraka with curious marks on them, and I only had a theory that they might lead to some new ideas, but as this was a private theory of my own, I naturally did not mention it to you, since you did not receive my theories at all kindly.

Petrie may quite possibly have some of these ostraka. I did all I could to prevent stealing, and this is not on my conscience. I think if you gave a small sum of baksheesh, as I suggested to you before, you would lessen this evil tho' I doubt if it could be stamped out of the native of Gurna.

Yrs truly

Edward R. Ayrton