

## Durham E-Theses

---

### *The expression of pea (pisum sativum) vicilin in the yeast, Saccharomyces cerevisiae*

Gregor James Stewart

#### How to cite:

---

Stewart, Gregor James (1989) The expression of pea (pisum sativum) vicilin in the yeast, Saccharomyces cerevisiae. Doctoral thesis, Durham University.

#### Use policy

---

The full-text may be used and/or reproduced, and given to third parties in any format or medium, without prior permission or charge, for personal research or study, educational, or not-for-profit purposes provided that:

- a full bibliographic reference is made to the original source
- a <https://etheses.durham.ac.uk/id/eprint/9350/> is made to the metadata record in Durham E-Theses
- the full-text is not changed in any way

The full-text must not be sold in any format or medium without the formal permission of the copyright holders.

Please consult the [full Durham E-Theses policy](#) for further details.

**The expression of Pea (*Pisum sativum*)  
vicilin in the yeast, *Saccharomyces cerevisiae***

**Gregor James Stewart**

**Thesis for the degree of  
Doctor of Philosophy**

**Department of Biological Sciences  
University of Durham**

**1989**

The copyright of this thesis rests with the author.  
No quotation from it should be published without  
his prior written consent and information derived  
from it should be acknowledged.



**25 JUN 1990**

## **DEDICATION**

**This thesis is dedicated to my Mum and Dad. Without whom none of this would have been possible.**

## DECLARATION

No part of this thesis has been previously submitted for any other degree in this or any other university. All work was performed by the author except where otherwise stated.

*G. S.*

## STATEMENT OF COPYRIGHT

The copyright of this thesis rests with the author. No quotation from it should be published without his prior written consent and information derived from it should be acknowledged.

### ERRATA

For Eschericia read Escherichia

For GFR167 read GRF167

For innoculate/innoculum/etc. read inoculate/inoculum

## ABSTRACT

This study has demonstrated and investigated the expression of a cDNA, coding for the pea seed storage protein vicilin, in the yeast, *Saccharomyces cerevisiae*. The cDNA was contained in the plasmid pLG1.63 and has been characterised and sequenced. The sequence showed that the cDNA coded for a 47KDa type of vicilin with a putative 24 amino-acid signal peptide, a proteolytic cleavage site and one glycosylation signal. The cDNA was cloned into two yeast expression vectors. The first utilised the GAL10 promoter rendering expression of the cDNA inducible by galactose, the construct was called pDUB2300. The second construct, pDUB2302, placed the cDNA under the control of the PGK promoter, rendering the cDNA constitutively expressed. When transformed into yeast, both constructs produced an immunoreactive vicilin species of  $M_r = 49\text{KDa}$ . In the case of pDUB2302 the protein was produced at upto 5.5% of total cell protein. The protein was shown to be associated with a particulate fraction and displayed altered precipitation characteristics when compared with pea vicilin. By using tunicamycin and N-glycosidase, the protein was shown to be unglycosylated. Partial purification and  $^{35}\text{S}$ -methionine labelling demonstrated that the signal peptide remained uncleaved. Cell fractionation studies indicated that vicilin was enriched in the yeast microsomal fraction, suggesting that vicilin was located in the ER. This was confirmed by electron microscopy of immuno-gold labelled yeast which showed vicilin associated with the ER. The electron micrographs also suggested that a small proportion of the protein might be reaching the Golgi apparatus and the vacuole membrane. The presence of specific cleavage products on some western blots suggested that vicilin possessed a cleavage site for a yeast protease, though whether this was the same site as the pea proteolytic cleavage site was not determined. The pattern and nature of the expression of vicilin from this cDNA was discussed in the context of heterologous protein expression in yeast in general and plant storage protein expression in yeast in particular.

## ACKNOWLEDGMENTS

I would like to thank my supervisors Dr Martin Watson and Dr John Gatehouse for their support, criticisms and encouragements during the duration of my work in Durham. I would also like to thank Dave Bown and Paul Preston for their help and expertise in the sequencing experiments. Thanks must also go to my friends and colleagues in the Department of Biological Sciences at Durham, in particular:- Nick Harris, Helen Graham, Ali Ashby, Andy Ryan, Mustapha, Khalid, Charlie Shaw, Denis Murhpy, Alan Duffel and the rest of the Playgroup.

I would also like to acknowledge the financial support of the SERC and, at times, my parents.

## **CONTENTS**

<b>TITLE PAGE</b>	<b>i</b>
<b>DEDICATION</b>	<b>ii</b>
<b>DECLARATION</b>	<b>iii</b>
<b>STATEMENT OF COPYRIGHT</b>	<b>iii</b>
<b>ABSTRACT</b>	<b>iv</b>
<b>ACKNOWLEDGMENTS</b>	<b>v</b>
<b>CONTENTS</b>	<b>vi</b>
<b>LIST OF FIGURES</b>	<b>xi</b>
<b>ABBREVIATIONS</b>	<b>xv</b>
<b>CHAPTER 1. INTRODUCTION</b>	
<b>1.1 GENERAL INTRODUCTION</b>	<b>1</b>
<b>1.2 THE PEA SEED STORAGE PROTEIN VICILIN</b>	<b>2</b>
1.2.1 Introduction	2
1.2.2 Structure and Genetics of Vicilin	2
<b>1.3 BIOLOGY AND GENETIC ENGINEERING OF YEAST</b>	<b>3</b>
1.3.1 <i>Saccharomyces cerevisiae</i> –General Description and Biology	3
1.3.2 Genetic Engineering in Yeast	11

1.3.3 Applications of Yeast Vectors	17
1.3.4 The Expression of Heterologous Genes in Yeast	20
1.4 AIMS AND OBJECTIVES	26
<b>CHAPTER 2. MATERIALS AND METHODS</b>	
2.1 CHEMICALS AND ENZYMES	29
2.2 YEAST AND BACTERIAL STRAINS	30
2.3 PLASMIDS	30
2.4 GROWTH CONDITIONS AND MEDIA	31
2.5 DNA PREPARATION	32
2.5.1 Large Scale Preparation of Plasmid DNA	33
2.5.2 Mini-prep. Method 1.	35
2.5.3 Mini-prep. Method 2.	36
2.5.4 Preparation of M13 Single-stranded DNA	37
2.5.5 Yeast DNA Preparation	38
2.6 TRANSFORMATION TECHNIQUES	38
2.6.1 Bacterial Transformation	38
2.6.2 Transformation with M13 Derivatives	39
2.6.3 Transformation of <i>Saccharomyces cerevisiae</i>	40
2.6.4 LiAc Transformation of <i>Saccharomyces cerevisiae</i>	41
2.7 DNA MANIPULATIONS	41
2.7.1 Restriction Digests	41
2.7.2 Ligation of DNA	42
2.7.3 Phosphatase Treatment	43
2.7.4 Addition of Linkers to DNA	44
2.7.5 Nick Translating DNA	46

2.7.6 Random Priming of DNA	4 7
2.7.7 Southern Blotting	4 8
2.8 AGAROSE GEL ELECTROPHORESIS	4 9
2.8.1 Isolation of DNA from Agarose Gels	5 1
2.9 DNA SEQUENCING	5 4
2.9.1 Annealing the Template to the Primer	5 4
2.9.2 The Sequencing Reaction	5 5
2.9.3 The Sequencing Gel	5 6
2.10 PROTEIN PREPARATION	5 8
2.10.1 Extraction of Protein from Yeast 1.	5 8
2.10.2 Extraction of Protein from Yeast 2.	5 8
2.11 POLYACRYLAMIDE GEL ELECTROPHORESIS	5 9
2.11.1 Standard Laemmli Gel	5 9
2.11.2 Schagger Gel	6 1
2.12 WESTERN BLOTTING	6 3
2.13 ELECTRON MICROSCOPY OF IMMUNO-GOLD LABELLED YEAST	6 5
2.13.1 Cryosectioning	6 5
2.13.2 Embedded Sections	6 5
2.13.3 Immuno-labelling of Cut Sections	6 6
2.14 SUBCELULAR FRACTIONATION	6 7
2.14.1 Preparation of Vacuoles	6 7
2.14.2 Microsome Preparation	6 9
2.14.3 Carboxypeptidase Y Assay	7 0
2.14.4 NADPH Cytochrome C Reductase Assay	7 1
2.15 IMMUNOFLUORESCENCE OF YEAST CELLS	7 1
2.16 OTHER BIOCHEMICAL TECHNIQUES	7 2

2.16.1 Ammonium sulphate Precipitation	7 2
2.16.2 Cyanogen bromide Treatment	7 3
2.16.3 Immunoprecipitation	7 4
2.16.4 Protein Estimation	7 5
2.16.5 Colony Western Blot	7 6
2.16.6 TCA Precipitation	7 6
2.16.7 N-glycosidase Digestion	7 7

### **CHAPTER 3. RESULTS**

3.1 RESTRICTION MAPPING OF pLG1.63	7 8
3.2 SEQUENCING OF pLG1.63 cDNA INSERT	7 9
3.3 CONSTRUCTION OF pDUB2300	8 1
3.4 EXPRESSION OF VICILIN FROM pDUB2300 IN YEAST	8 2
3.4.1 Transformation and Initial Screening of Transformants	8 2
3.4.2 Molecular Weight of Heterologous Vicilin	8 4
3.4.3 Induction Kinetics of Vicilin Expression	8 5
3.4.4 Yeast expressed Vicilin is Found in a Particulate Fraction	8 6
3.4.5 Subcellular Location of Vicilin	8 7
3.4.6 Effect of Tunicamycin on Heterologous Vicilin	8 9
3.5 CONVERTING THE EcoRI cDNA TO A BamHI FRAGMENT	8 9
3.5.1 Adding BamHI Linkers to the cDNA	9 0
3.5.2 Construction of pDUB2301	9 0
3.6 CONSTRUCTION OF pDUB2302/3	9 0
3.7 EXPRESSION OF VICILIN FROM pDUB2302	9 1
3.7.1 Transformation of <i>Saccharomyces cerevisiae</i> and Confirmation of Expression	9 1
3.7.2 Level of Expression of Heterologous Vicilin	9 3

<b>3.7.3 Investigation of the Form of the Heterologous Vicilin</b>	<b>9 4</b>
<b>3.7.4 Radio-labelling of Heterologous Vicilin</b>	<b>9 5</b>
<b>3.7.5 Partial Purification of the Heterologous Vicilin</b>	<b>9 9</b>
<b>3.7.6 Glycosylation State of the MC16 Produced Vicilin</b>	<b>1 0 0</b>
<b>3.7.7 Subcellular Location of Vicilin in MC16</b>	<b>1 0 1</b>
<b>3.8 ELECTRON MICROSCOPY OF IMMUNO-GOLD LABELLED YEAST</b>	<b>1 0 4</b>
<b>CHAPTER 4. DISCUSSION</b>	<b>1 0 9</b>
<b>REFERENCES</b>	<b>1 2 1</b>

## **LIST OF FIGURES**

Pages containing figures are not numbered. The page number appearing after each figure refers to the page in the main text after which the figure appears.

1.1	Hydrophilicity Profile of Vicilin.	4
1.2.1	Evolutionary Tree for Vicilin Genes.	6
1.3.1	Yeast Cell Division.	7
2.1	Southern Blotting Apparatus.	4 8
2.16.1	Standard Curve for Protein 1.	7 5
2.16.2	Standard Curve for Protein 2.	7 5
3.1.1	Restriction maps of pLG1.63, pDUB4 and pDUB7.	7 8
3.1.2	Restriction Digests of pLG1.63.	7 8
3.2.1	Sequencing Strategy for pLG1.63.	7 9
3.2.2	DNA Sequence of the Vicilin cDNA.	7 9
3.2.3	Definitive Restriction Map of pLG1.63.	8 0
3.3.1	Construction of pDUB2300.	8 1
3.3.2	Restriction Digests Confirming the Correct Construction of pDUB2300.	8 1
3.4.1	Demonstration of the Expression of Vicilin from pDUB2300.	8 3
3.4.2	Comparison of Heterologous Vicilin with that from Developing Pea Seeds.	8 3
3.4.3	Demonstration of Induction of Vicilin Expression by Galactose.	8 4
3.4.4	Growth Curve for Transformed GFR167 1.	8 4
3.4.5	Time Course for the Induction of Vicilin Expression 1.	8 5
3.4.6	Growth Curve for Transformed GFR167 2.	8 5
3.4.7	Time course for the Induction of Vicilin Expression 2.	8 5
3.4.8	Vicilin is Associated with a Particulate Fraction.	8 6
3.4.9	Standard Curve for CPY Activity.	8 7

3.4.10 Location of Vicilin within a Vacuole Preparation.	8	7
3.4.11 Effect of Tunicamycin on Heterologous Vicilin.	8	8
3.5.1 Construction of pDUB2301.	8	9
3.5.2 Restriction Digests Confirming the Correct Construction of pDUB2301.	8	9
3.6.1 Restriction Digests Demonstrating the cloning of the cDNA into pMA91.	9	0
3.6.2 Orientation of the cDNA within the Vector.	9	0
3.6.3 Summary of the Construction of pDUB2302/3.	9	0
3.7.1 DNA Extracted from LEU <sup>+</sup> Yeast Colonies.	9	1
3.7.2 Southern Blot of Extracted Yeast DNA.	9	1
3.7.3 Colony Western Blot of Transformed MC16.	9	1
3.7.4 Demonstration of Vicilin Expression from pDUB2302.	9	1
3.7.5 Initial Demonstration of the form of Vicilin Expressed from pDUB2302.	9	1
3.7.6 Level of Expression of Heterologous Vicilin 1.- Western Blot.	9	2
3.7.7 Level of Expression of Heterologous Vicilin 2.- Calibration Curve.	9	2
3.7.8 Ammonium sulphate Precipitation of Yeast Proteins.	9	3
3.7.9 Labelling of Yeast Proteins with <sup>35</sup> S methionine.	9	5
3.7.10 Identification of <sup>35</sup> S methionine Labelled Vicilin.	9	5
3.7.11 Identification of <sup>35</sup> S methionine Labelled Vicilin?	9	6
3.7.12 Immunoprecipitation of Yeast Proteins and Cyanogen bromide Cleavage.	9	6
3.7.13 Apparent Immunoprecipitation of Vicilin.	9	6
3.7.14 Demonstration of Shortcomings in Immunoprecipitation Technique.	9	7
3.7.15 Partial Purification of Vicilin	9	8
3.7.16 Partial Purification of <sup>35</sup> S methionine Labelled Vicilin.	9	9
3.7.17 Western Blot and Autoradiogram of Labelled, Partially Purified Vicilin.	9	9
3.7.18 1st Demonstration of the Effect of N-glycosidase on Vicilin.	1	0 0
3.7.19 2nd Demonstration of the Effect of N-glycosidase on Vicilin.	1	0 0

3.7.20 Occurrence of Vicilin in Three cell Compartements.	1	0	1
3.7.21 Vicilin is Present in the Microsome Fraction.	1	0	2
3.7.22 Further Demonstration of Vicilin in the Microsome Fraction.	1	0	2
3.8.1 Electron Micrographs of Cryosectioned Yeast Cells (GFR167/pDUB2300)	1	0	3
3.8.2 As 3.8.1.	1	0	3
3.8.3 Electron Micrographs of Resin Embedded Sections (MC16/pDUB2302).	1	0	4
3.8.4 As 3.8.3.	1	0	5
3.8.5 As 3.8.3.	1	0	5
3.8.6 Electron Micrographs of Resin Embedded Sections (GFR167/pDUB2300).	1	0	5
3.8.7 As 3.8.6.	1	0	5
3.8.8 Electron Micrographs of MC16/pDUB2302 cells prepared by the Method of Brada and Schekman (1988).	1	0	6
3.8.9 As 3.8.8.	1	0	6
3.8.10 As 3.8.8.	1	0	6
3.8.11 As 3.8.8.	1	0	7
4.1 Hydrophilicity Profile of the First 60 Residues of the Predicted Sequence of the Vicilin cDNA	1	1	5

## ABBREVIATIONS

rDNA	Ribosomal RNA gene cluster
cDNA	Complementary DNA
ssDNA	Single-stranded DNA
bp	Base-pair
Kbp/Kb	Kilobase-pair/Kilobase
PEG	Polyethyleneglycol
Tc <sup>r</sup>	Tetracycline resistant
Amp <sup>r</sup>	Ampicillin resistant
EM	Electron Microscope
RFLP	Restriction frag ment length polymorphism
PGK	Phosphoglycerate kinase
X-Gal	5-bromo-4-chloro-3-indolyl- $\beta$ -D-galactoside
IPTG	Isopropylthio- $\beta$ -galactoside
EtBr	Ethidium Bromide
UV	Ultraviolet
RE	Restriction endonuclease
DTT	Dithiothreitol
(d)(dd)ATP	(deoxy)(dideoxy) Adenosine triphosphate
(d)(dd)CTP	(deoxy)(dideoxy) Cytidine triphosphate
(d)(dd)GTP	(deoxy)(dideoxy) Guanosine triphosphate
(d)(dd)TTP	(deoxy)(dideoxy) Thymidine triphosphate
dNTP	deoxynucleotide triphosphate
PVP	Polyvinylpyrrolidone
BSA	Bovine serum albumin

<b>TEMED</b>	<b>N,N,N',N'-tetramethylethylenediamine</b>
<b>SDW</b>	<b>Sterile distilled water</b>
<b>PAGE</b>	<b>Polyacrylamide gel electrophoresis</b>
<b>kD</b>	<b>Kilodalton</b>
<b>PBS</b>	<b>Phosphate buffered saline</b>
<b>CPY</b>	<b>Carboxypeptidase Y</b>
<b>PMSF</b>	<b>Phenylmethylsulfonylfluoride</b>
<b>FITC</b>	<b>Fluorescein isothiocyanate</b>
<b>TCA</b>	<b>Trichloroacetic acid</b>
<b>ER</b>	<b>Endoplasmic reticulum</b>

## 1.1 GENERAL INTRODUCTION

The seeds of the plant *Pisum sativum*, the pea, have long been used as a highly proteinaceous foodstuff and can provide most of the essential amino-acids (except for cysteine and methionine in which they are deficient). The principal proteins which provide the nourishing qualities of the pea are the seed storage proteins, there to provide a nitrogen source for the developing embryo after germination of the seed. These proteins (described in more detail in section 1.2) are not only used as a direct foodstuff but are also used in the food industry as additives since their physical properties make them useful as foaming, emulsifying and gelating agents. An investigation into the genetics, synthesis, storage and physical/biological properties of the storage proteins of pea forms a major part of the research currently underway at Durham.

Advances in the field of molecular biology over the last 20 or so years has meant that questions about the fundamental processes underpinning biological existence can be asked and in many cases answered. Great steps have already been taken in filling in the blanks of how the genetic code on DNA is turned into the proteins and enzymes of the cell, ie transcription and translation and the controls thereof. It has emerged that prokaryotes and eukaryotes have certain basic similarities at the molecular level but that between prokaryotes and eukaryotes there are major differences. Even between eukaryotes there are many differences in transcription and translation. One question that can be asked is just how different two widely disparate eukaryotes are in dealing with the same DNA or gene. In this thesis, the expression of DNA coding for a pea seed storage protein will be expressed in the yeast *Saccharomyces cerevisiae* in order to at least partially answer this question. The molecular biology of *Saccharomyces cerevisiae* is fairly well understood and is very tractable to the techniques of molecular



biology and has been used to express many foreign genes over the last 8 years (see section 1.3.3). In order to understand the objectives of this project it necessary to fill-in some of the background information on the structure and genetics of the pea storage protein vicilin, the biology of yeast and the history of genetic engineering in yeast.

## **1.2 THE PEA SEED STORAGE PROTEIN VICILIN**

### **1.2.1 Introduction**

Storage proteins in pea occur as two immunologically distinct groups:- 11S, legumin (Casey 1979b) and 7S vicilin (Gatehouse *et al.* 1981). A third storage protein, convicilin occurs which is immunologically related to vicilin (Casey and Sanger 1980; Croy *et al.* 1980c). From the comparison of DNA sequences convicilin has been shown to be a member of the vicilin family of storage proteins (Bown *et al.* 1988) The ratio of vicilin to legumin varies between cultivars from 0.5 to 4.0 (Casey *et al.* 1982, Gatehouse *et al.* 1984b, Muller 1983). Convicilin is usually a minor component but sometimes occurs as the major storage protein (Casey and Domoney 1984). All three proteins are globulin type seed proteins as defined by Osborne (1924) "Soluble in dilute salt solutions at neutral pH" and are located in the protein bodies of the pea cotyledon. Vicilin and legumin can account for 60-70% of the total seed protein.

### **1.2.2 Structure and Genetics of Vicilin**

When analysed by gel filtration and ultracentrifugation, vicilin gives a  $M_r$  of 145000 to 170000 (Gatehouse *et al.* 1981). However when analysed by SDS-PAGE a more complex polypeptide pattern emerges. Major polypeptides of  $M_r$  50000, 33000, 19000, 16000, 13500 and 12500 are seen along with minor polypeptides of 35000 and 31000 (Gatehouse *et al.* 1981, 1984b; Thompson *et al.* 1978). Most vicilin preparations

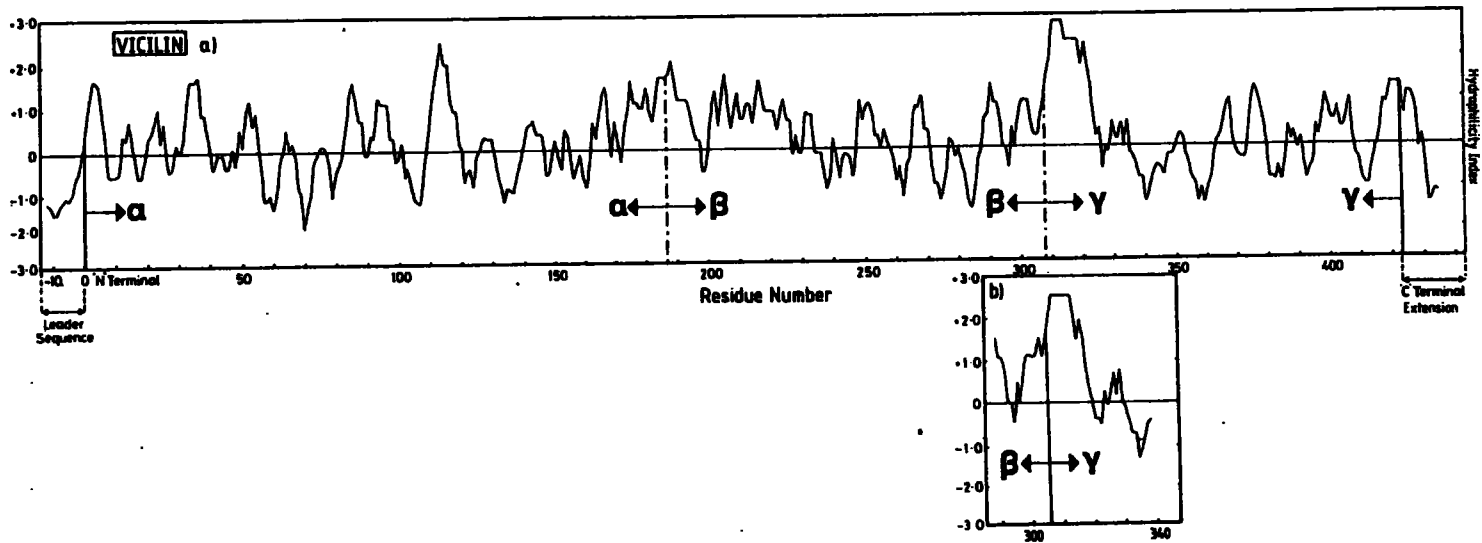
were seen to contain varying amounts of convicilin (depending on the method of purification) which has subunits of 70000 and a  $M_r$  of 210000-280000 (ie. trimeric or tetrameric) (Croy *et al.* 1980c). When vicilin was synthesised *in vitro* only the 50000 forms were seen (Croy *et al.* 1980b) and similarly when vicilin was isolated from seed early in development, only the 50000 forms were found with very small amounts of the smaller polypeptides (Croy *et al.* 1980b, Gatehouse *et al.* 1981). The situation was clarified by Chrispeels *et al.* (1982a,b) who showed, in a pulse-chase experiment, that the radioactivity incorporated into the 50000 forms could be chased into the smaller polypeptides as development proceeded. One of the 50000 forms, actually 47000, was seen to disappear altogether. This led Gatehouse *et al.* (1981) to propose a model for the structure of vicilin. The molecule is a trimer of 50000 subunits, some of which may be proteolytically cleaved at defined sites. This gives rise to a heterogeneous population of molecules containing different mixtures of cleaved and uncleaved 50000 subunits. It explains the heterogeneity of observed vicilin molecules. The cleaved subunits would be held in the structure by non-covalent interactions (Gatehouse *et al.* 1981, 1984b). This model has since been confirmed and further experiments have shown that the vicilin trimers are assembled in the E.R. and then transported to the protein bodies where proteolytic cleavage occurs within 6-12 hours. It has been suggested that the immunological similarity and co-purification of convicilin indicates the possibility of hybrid molecules (Croy *et al.* 1980c, Gatehouse *et al.* 1981). Two-dimensional gel analysis has revealed charge heterogeneity between vicilin species and suggests six different 50000 forms.

Vicilin polypeptides are synthesised on the R.E.R. and the signal peptide is removed cotranslationally (Gatehouse *et al.* 1981, Higgins and Spencer 1981). Some of the 50000 type vicilins and the 16000 type polypeptides have been shown to be core

glycosylated in the E.R. but outer chain modification in the Golgi was not investigated (Chrispeels *et al.* 1982a; Badenoch-Jones *et al.* 1981; Davey and Dudman 1979). The 16000 and 12500 polypeptides have been shown to be immunologically cross-reactive and to be homologous by peptide mapping. It has been suggested that they differ only in that the 16000 form is glycosylated and the 12500 is not (Davey *et al.* 1981).

Studies on the accumulation of proteins during pea seed development have shown that storage proteins are differentially synthesised. Vicilin appears early in development and legumin and convicilin 2-3 days later (Croy *et al.* 1980c; Gatehouse *et al.* 1981, 1982a, 1984b). During early embryogenesis, transcriptional activity rapidly increases to a maximum before eventually tailing off. This is accompanied by a decrease in the sequence complexity of mRNA species, with a small population of mRNAs becoming very abundant (Cullis 1976; Gatehouse *et al.* 1982a; Millerd and Spencer 1974; Morton *et al.* 1983). It has been shown that these mRNAs code for the storage proteins (Gatehouse *et al.* 1981, 1982a). Complementary DNAs have been cloned and isolated and used in Northern and Dot-blot hybridisations to show that the storage protein mRNAs show a relatively long half-life of more than 10 hours and that the levels of mRNA rose and fell in agreement with the estimates for the synthesis and accumulation of the storage proteins (Gatehouse *et al.* 1982a, 1984b). It has been postulated by Croy and Gatehouse (1985) that the evidence presented above together with changes in the expression of specific storage protein genes during seed development (Evans *et al.* 1984) that the control of expression of storage protein genes is at the level of transcription, though control at a translational level cannot be ruled out.

Purified vicilin polypeptides and cDNAs have been sequenced and their sequences compared (Gatehouse *et al.* 1982b; Hirano *et al.* 1982; Lycett *et al.* 1983a,b). The amino-acid and DNA sequences of the  $M_r$ 50000 types show strong homology and



**Figure 1.1 Hydrophilicity Profiles for Vicilin Molecules**

a) 50000M<sub>r</sub> type vicilin.

b) 47000M<sub>r</sub> type vicilin.

The sites of potential proteolytic cleavage are marked. Solid lines indicate cleaved sites, broken lines indicating uncleaved sites.

support the model for vicilin structure proposed by Gatehouse *et al.* (1981). The precursor form  $\alpha\beta\gamma$  has two potential proteolytic cleavage sites, between the  $\alpha$  and  $\beta$  subunits and between the  $\beta$  and  $\gamma$  subunits. Vicilin genes and cDNAs can be classified into three groups according to the degree of proteolytic cleavage of their respective protein products:-

Type A, No cleavage, 50000 type vicilin.

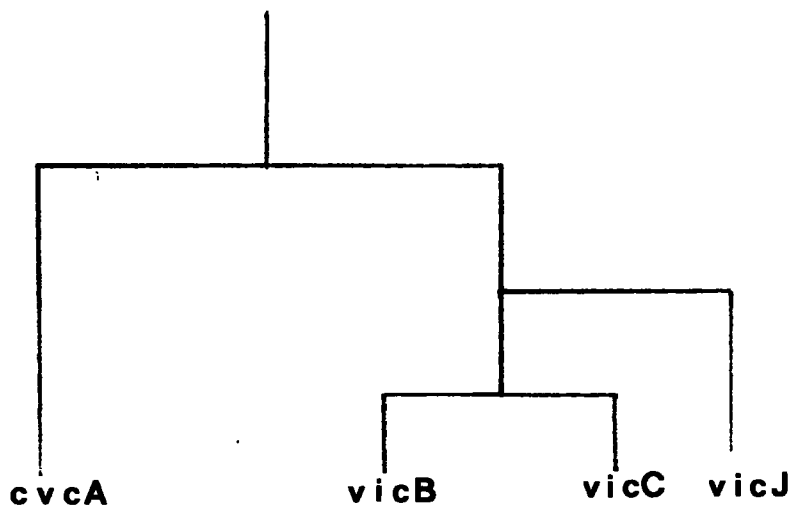
Type B, cleavage at the  $\beta$ - $\gamma$  site only leading to 33000 and 12500 (16000 if glycosylated) subunits.

Type C, cleavage at both sites giving 19000 ( $\alpha$ ), 13000 ( $\beta$ ) and 12500 (16000) ( $\gamma$ ) subunits.

Cleavage at the  $\alpha$ - $\beta$  site is thought to occur only very infrequently since a 31000M<sub>r</sub> species is seen on SDS-PAGE at a very low level. Gatehouse *et al.* (1983) proposed that the amino acid sequence around the cleavage site was important in both the sequence itself and in its position in the protein structure. Hence the sequence Gly-Lys-Glu-Asn immediately before the cleavage site is thought to be on the surface of the protein whereas the corresponding Glu-Gly-Leu-Arg in the noncleaved form of vicilin is more hydrophobic and lacks the Asn residue. A hydrophilicity profile of vicilin from the predicted amino-acid sequence (figure 1.1) shows the cleavage site in an area of irregular structure flanked by an  $\alpha$  helix and a  $\beta$  sheet. This area might be expected to be on the surface of the protein (Croy and Gatehouse 1985). Lycett *et al.* (1983b) sequenced two cDNA clones, pDUB7 and pDUB4 (47000 type) which together covered most of the proposed preprovicilin message. That is, the signal <sup>sequences encoding</sup> sequence, coding region with or without cleavage sites, stop codons and polyadenylation site. The 5' end of pDUB7 yielded a sequence coding

for a methionine followed by 14 amino-acids before the sequence corresponding to the N-terminus of the mature protein was reached. This putative signal peptide was hydrophobic enough to function as such and the methionine was proposed as the start of translation. The cDNA also showed the proteolytic cleavage site ( $\beta$ - $\gamma$ ) and a glycosylation signal Asn-Ala-Ser. A third cDNA, pDUB2, corresponded to the 3' end of a 50000 type vicilin and showed the C-terminus, two stop codons and a single poly adenylation signal (ATAAA) which is unusual in plants. The two classes of cDNA showed 86% homology and differed mostly around the cleavage site. The sequences of vicilin cDNAs have been compared to phaseolin (french bean) and  $\beta$ -conglycinin (soybean). The sequences show considerable homology and again differ mostly around the cleavage sites (Croy *et al.* 1984a). Casey *et al.* (1984) compared the sequence of a cDNA for convicilin to those published for vicilin, phaseolin and  $\beta$ -conglycinin. Convicilin showed a high degree of homology to vicilin but less to that of phaseolin and  $\beta$ -conglycinin. The major differences between vicilin and convicilin were an insertion at the N-terminus of convicilin of 121 amino-acids, together with changes in the signal peptide extending it by 4 amino-acids. The other differences were regions of low homology around the  $\alpha$ - $\beta$  processing site, convicilin not being processed (Bown *et al.* 1988). From their comparative sequence data Casey *et al.* (1984) suggested that the evolutionary divergence of phaseolin,  $\beta$ -conglycinin and the pea 7S storage proteins (vicilin and convicilin) occurred before the divergence of vicilin and convicilin.

Domoney and Casey (1985) used cDNAs for convicilin, two classes of vicilin and three classes of legumin in hybridisation studies to digested pea genomic DNA, in an effort to deduce the gene copy number of the storage proteins. Their results suggested that there were 11 vicilin genes, 8 legumin genes and one convicilin gene (per haploid



**Figure 1.2.1 Evolutionary Tree for Vicilin Genes**

genome) and that between pea variants no difference in gene number for the storage proteins existed. These figures have since been updated by J. Gatehouse (personal communication) giving rise to the evolutionary tree shown in figure 1.2.1. The tree shows the putative evolutionary split between convicilin and vicilin due to the N-terminal insertion in convicilin and that there are now thought to be two convicilin genes. The number of vicilin genes thought to occur has also increased with 5 genes in the vicJ family coding for 47000 type proteins and 10 genes in two groups, the type B proteins in the vicB group and the type A proteins in the vicC group.

In this study a previously uncharacterised cDNA is used. It was cloned by Lawrence Gatehouse as part of his M.Sc. thesis and is contained in the plasmid pLG1.63. The cDNA is thought to be a full length cDNA for a 47000 type vicilin ie. it is thought to code for the signal peptide and go on through to the 3' untranslated region.

### **1.3 BIOLOGY AND GENETIC ENGINEERING OF YEAST**

#### **1.3.1 *Saccharomyces cerevisiae*—General Description and Biology**

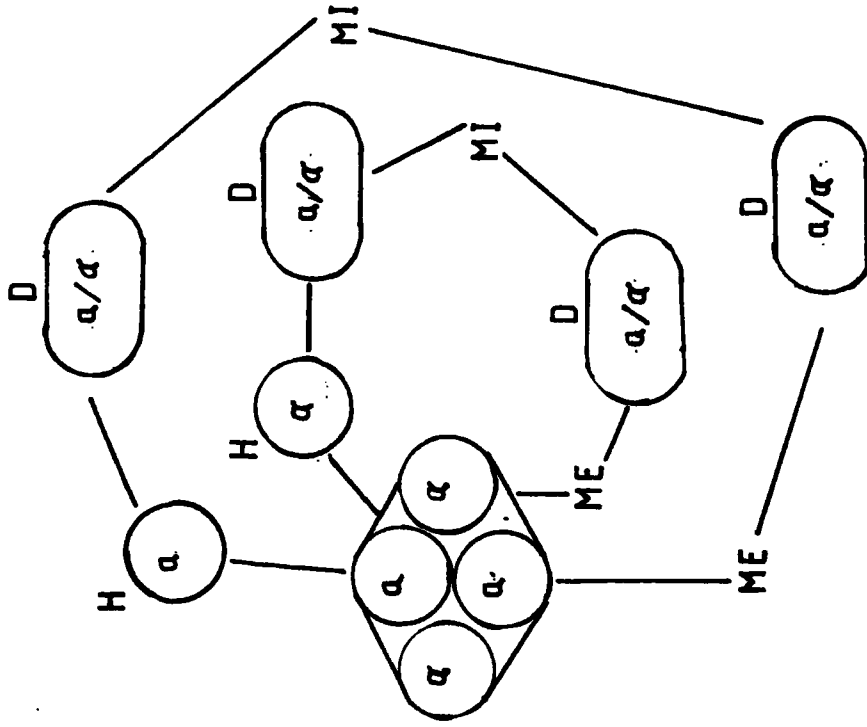
The yeast *Saccharomyces cerevisiae* has been an economically important fungus for thousands of years due to its ability to undergo fermentation to produce ethanol and its use in baking as a bread leavener via CO<sub>2</sub> production. The genus *Saccharomyces* is of the class Ascomyceteae (order Gymnascales, family Saccharomycetaceae) (Clements F.E., 1909 after Saccardo P.A. 1889) and according to Bessey (1950) the Saccharomycetaceae represent the ultimate degree of simplification of the Ascomycetes. The common feature of the Saccharomycetaceae is the production of a single ascus instead of a cluster of asci from branched hyphae. They also lack the protective perithecium or apothecium (Bessey 1950). In the case of *Saccharomyces cerevisiae* the mycelial form is unicellular rather than filamentous.

ME - meiosis

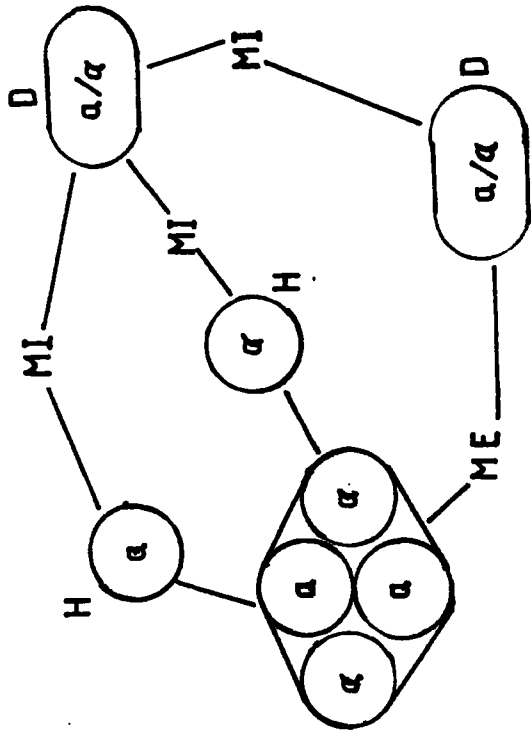
MI - mitosis

H - haploid

D - diploid



HOMOTHALLIC



HETEROTHALLIC

**Figure 1.3.1 Yeast Cell Division**  
 Diagram summarising the differences between Homo- and Heterothallic yeast division.

Cell division in yeast occurs by the process of budding. After the initiation of DNA replication a portion of the cell wall becomes more curved until eventually a protuberance is formed called the bud. The bud then grows to a size less than that of the original cell, meanwhile the nucleus has been stretched along the length of the bud and cell, attached to the mitotic spindle and fibres. When the bud has reached a certain size, the nucleus splits in two at the join of the bud and the cell to sequester one copy of the chromosomes in the bud and one in the cell. The join between the bud and the cell then narrows until the two cells separate. Unlike higher eukaryotes the nuclear membrane persists during mitosis (reviewed by Byers, 1981).

The discovery of mating types in yeast (Lindegrens and Lindegrens 1943) represented an important step in the study of yeast genetics. Lindegrens used vegetative cells derived from spores in mating experiments and found that yeast had two mating types, then named *a* and  $\alpha$ . Type *a* cells would only mate with type  $\alpha$  cells and *vice versa*. It then became apparent that yeast strains were of two classes, heterothallic and homothallic. Heterothallic yeast displayed the classic mating type behaviour whereas homothallic cells appeared to undergo fusions of cells derived from spores of the same mating type, independent of mating type. Mating a heterothallic spore with a homothallic spore resulted in asci with two hetero- and two homothallic spores (Winge and Roberts 1949). It was later found that a single pair of alleles was responsible (now called the *HO* locus) and that the homothallic allele was dominant masking the *a* and  $\alpha$  genes (Oeser 1962, Hopper and Hall 1975). Spores of one mating type germinate to give cells of the same mating type until a switch to the opposite mating type occurs, then cell fusion takes place making an *a*/ $\alpha$  diploid. The diagram fig(1.3.1) summarises the differences between hetero- and homothallic yeast division. In heterothallic yeast both the haploid and diploid forms are stable and can persist indefinitely. However,

in the homothallic yeast, the haploid cells are not stable and almost immediately fuse to form stable diploids.

The yeast cell cycle is typical of most eukaryotes ie a  $G_1$  phase followed by the initiation<sup>of</sup> chromosomal DNA replication, the S phase, during which chromosomal replication is completed, a  $G_2$  phase during which nuclear migration occurs and the M phase during which nuclear division occurs and the mother cell and bud separate (Pringle and Hartwell, 1981).

During conditions of nitrogen deprivation or general starvation in the presence of a non-fermentable carbon source such as acetate, diploid  $a/\alpha$  yeast can undergo meiosis and sporulation. Meiosis is entered into following  $G_1$  and thereafter the chromosomes undergo DNA synthesis, pairing, recombination and segregation. Spore wall nucleation is mediated by the spindle pole body which duplicates and separates and undergoes modification during metaphase of meiosis II. The spore walls then close around the four haploid nuclei and spore maturation continues. In addition to the many genes involved in the control of mitosis (CDC genes), as many as 50-100 genes have been found to be essential for sporulation (though not necessarily for meiosis) (Esposito and Klapholz, 1981).

The haploid *Saccharomyces cerevisiae* genome consists of 17 chromosomes ranging in size from 150kbp to 2500kbp giving a total genome size of 14000kbp of which 95% is thought to be single copy sequences. Telomeres and centromeres are found in higher concentrations in yeast than in other eukaryotes and the small genome size coupled with the low percentage of repetitive sequences has meant that yeast has been widely used as a model system for structure and replication studies of the eukaryote chromosome (Fangman and Zakian, 1981).

The regulation of gene expression has been shown to operate in both positive and negative manners. This has been reviewed by Guarente (1984) who states that all yeast genes show the eukaryotic TATA box which is present in many promoters thought to be recognised by RNA polymerase II. Positive control of gene expression has been shown to be mediated by upstream activation sites (UASs) which act similarly to mammalian enhancers. These UASs lie hundreds of nucleotides upstream of the start of transcription and mediate the control of transcription in response to physiological signals. For instance, the UAS of the GAL10 gene, situated more than 100bp upstream of the TATA box, mediates the induction of transcription of GAL10 in response to galactose, only in the presence of a functional GAL4 gene (the GAL4 gene product has been shown to bind to the GAL10 UAS, Giniger *et al.* 1985). UASs have been found for the CYC1, HIS3, HIS4, GAL1, GAL7 and TRP5 genes. The UASs of HIS3, HIS4 and TRP5 all share an activator gene AAS3 which seems to modulate transcription in conditions of general amino-acid starvation.

The study of negative control has not yielded any examples of a repressor or operator (c.f. the *lac* operon of *Escherichia coli*) system, however negatively acting sequence elements have been shown to exist. In the case of the glucose repressed *ADR II* an upstream region appears to mediate the glucose repressed condition. The CYC1 gene has such an element between its UAS and the TATA box the removal of which increases transcription 2-3 fold. A long range negative control region is found upto 1 kbp from the HMR and HML loci. These loci code for copies of the a and  $\alpha$  mating factors, the transcription of which is prevented by the SIR1-SIR4 loci, mediated by the negative control sequences. These sites do not occur near the MAT loci. Guarente (1984) hypothesises that the UASs are the primary mode of gene regulation in yeast, with certain genes containing arrays of UASs each one independently functioning to

yield a variety of responses. The effect of the UASs on cloned foreign genes will depend on the proximity of a UAS to the promoter used. If the promoter is a yeast promoter normally regulated by a UAS then the regulation will occur, on the other hand a cloned foreign promoter may well not be regulated by the yeast UAS.

### 1.3.2 Genetic Engineering in Yeast

Transformation of *S. cerevisiae* was first reported by Hinnen *et al.* (1978), who fused yeast spheroplasts (made by digesting off the cell wall with a mixture of enzymes) in PEG.CaCl<sub>2</sub> in the presence of plasmid pYeleu10. This DNA was the ColE1 plasmid from *E. coli* into which had been cloned yeast DNA containing the LEU2 gene. Stable leu<sup>-</sup> auxotrophs were restored to prototrophy at a frequency of 1x10<sup>-7</sup> per viable cell. In this case all the transformants were shown to have integrated part or all of the hybrid plasmid into their genome and provided, for the first time, a demonstration of the integration of cloned heterologous DNA into the genome of a eukaryote. The plasmid pYeleu10 was called a YIp- Yeast Integrating plasmid.

The construction of a shuttle vector for yeast was first reported by Beggs (1978) and was based on the *E. coli* plasmid pMB9 joined with the yeast 2 $\mu$  plasmid. This is a naturally occurring yeast plasmid present in most *S. cerevisiae* strains at 60-100 copies (Clark-Walker and Miklos 1974). It is a 6.3kb double-stranded, circular DNA molecule which is present in the nucleus of the cell (Broach 1981). The plasmid is inherited in a non-Mendelian, cytoplasmic fashion (Livingston 1977) and is stably maintained in all strains that do not already possess an endogenous 2 $\mu$ , once they are introduced (Broach 1981). The 2 $\mu$  circle does not integrate into the genome and there are no sequences homologous to 2 $\mu$  in the genome (Cameron *et al.* 1977). The 2 $\mu$  plasmid has been sequenced (Hartley and Donelson 1980) and this confirmed the presence of

two 599bp inverted repeats which separate two unique sequence regions of 2774bp and 2346bp first observed by Hollenberg *et al.* (1976). In yeast, recombination occurs between the repeats resulting in the plasmid being isolated as a mixed population of equal amounts of two forms of the plasmid which differ in the orientation of the unique regions to each other (Beggs 1978). Multimers ( $4\mu$ ,  $6\mu$  etc.) have been seen to constitute 20% of the isolated population (Petes and Williamson 1975, Guerineau *et al.* 1976). The  $2\mu$  plasmid contains four open reading frames, each of which codes for a poly-adenylated RNA (Broach *et al.* 1979, Sutton and Broach 1985). The first of these is FLP (Broach and Hicks 1980, Broach *et al.* 1982a) which is the largest coding region and codes for a site-specific recombinase, which catalyses recombination between the inverted repeats, recognising a site near the centre of the repeats. REP1 and REP2 encode trans-acting factors which promote equipartitioning during cell division, ensuring that each progeny cell has at least one copy of  $2\mu$  (Kikuchi 1983, Jayaram *et al.* 1983, Cashmore *et al.* 1986). The fourth open reading frame, D, has not yet been characterised. The origin of replication has been shown to be located at the junction of one of the repeats and the large unique region. The plasmid appears to confer no selective advantage to cells harbouring it and has not been shown to have any function other than its own replication and maintenance (Broach *et al.* 1981). The origin of the plasmid is likely to be chromosomal rather than viral since its replication follows cell cycle control, it is located in the nucleoplasm associated with nucleosomes and encodes no virion like proteins (Broach 1981). It has been suggested that the replication of  $2\mu$  is a good model for chromosomal replication (Huberman *et al.* 1987).

The shuttle vectors developed by Beggs (1978), as well as having pMB9 and  $2\mu$ , had cloned into them randomly sheared yeast chromosomal DNA. By selecting for Tc<sup>r</sup>

(from pMB9) and  $leu^+$  prototrophy in *E. coli* two constructs were found to be positive, pJDB248 and pJDB219. These transformed  $leu^-$  yeast to prototrophy at a frequency of  $5 \times 10^{-4}$ – $3 \times 10^{-3}$  per viable cell. In contrast to Hinnen (1978), these plasmids could be recovered from the yeast as free plasmid and were inherited in a non-Mendelian fashion. This type of plasmid is called a YEp, Yeast Episomal plasmid. They are characterised by a high frequency of transformation and by high copy number (25-100 per cell) (Gerbaud *et al.* 1979). One of their drawbacks is that novel rearrangements of recombinant plasmids can occur in both *E. coli* and yeast.

The next development in yeast vectors was the discovery of the ARS element:- Autonomous Replicating Sequence. The observation of an autonomously replicating yeast chromosomal element, which also allowed expression of yeast structural genes linked to it, had been made by Struhl *et al.* (1979) when they cloned a 1.4kb yeast DNA fragment containing the TRP1 gene and inserted this into pBR322. The resultant recombinant plasmid was observed to restore TRP<sup>+</sup> prototrophy and be recoverable as covalently closed, circular DNA from transformed yeast. It had previously been noted that pBR322 was unable to replicate in yeast (Beggs 1978). The yeast DNA must contain a chromosomal replicator. At first the presence of a centromere on the 1.4kb fragment was thought to be important, however, Stinchcomb *et al.* (1979) showed that it was the ARS1 element that was vital. ARS elements have since been genetically characterised and all ARS elements have been shown to contain an 11bp core consensus:-

5'(A/T)TTTAT(A/G)TTT(A/T)3' (Broach *et al.* 1983)

ARS elements have also been discovered in *Xenopus laevis* (Kearsey 1983) and have been shown to function in yeast as an ARS (Kearsey 1983,1984). The 11bp core consensus is not, in itself, sufficient for ARS function. The smallest fragment reported

to have ARS function is a 19bp fragment containing the ARS1 core consensus. It is not however an efficient ARS and transformants grow only very slowly (Srienc *et al.* 1985). Kearsey (1984) used the HO ARS and *Xenopus* ARS to identify a 14bp core consensus critical for ARS function as well as a 20bp region 3' to the core which was important in the efficiency of the ARS function. The importance of sequences 3' to the core region have been variously reported and elements upto 100bp from the core have been shown to have an effect (Srienc *et al.* 1985, Snyder *et al.* 1986). Sequences 5' to the core have been shown to have a minor effect on ARS efficiency, though to a lesser extent than the 3' sequences (Celniker *et al.* 1984, Srienc *et al.* 1985, Strich *et al.* 1986). Palzkill *et al.* (1986) showed that the 3' sequences were conserved between ARS elements and that all ARS elements contain multiple near matches to the core consensus. It has since been shown that ARS function is dependant on an exact match to the core consensus plus multiple near matches 3' to the core (Palzkill and Newlon 1988). Huberman *et al.* (1987) demonstrated that the replication of  $2\mu$  proceeds bi-directionally from a single origin coincident with the ARS element and that all detectable initiation events occurred within the ARS element. It was then hypothesised that ARS elements were the origins of chromosomal DNA replication. Palzkill and Newlon (1988) suggested that the structure of ARS elements show analogy to other systems such as *E. coli* and SV40 virus, where the first step in DNA replication is the binding of the initiator protein to multiple sites in the origin of replication (Tjian 1978, Tegtmeyer *et al.* 1983, Fuller *et al.* 1984). The binding of the initiator triggers localised unwinding of the duplex at the origin rendering the DNA competent for initiation of DNA replication (Baker *et al.* 1986, Dodson *et al.* 1987). Palzkill and Newlon (1988) hypothesise that multiple copies of the core consensus may act as binding sites for the initiator. The presence of multiple copies of the core consensus leads to the ARS element being A+T-rich which could facilitate duplex unwinding.

However, to date, no proteins have been identified that bind to the core consensus or copies thereof (Palzkill and Newlon 1988). Yeast vectors based on ARS elements are called YRp's, Yeast Replicating plasmids. They are characterised by a greater than 1% loss on non-selective media, ie the transformants are unstable, only those that integrate into the genome are stably maintained (Stinchcolmb *et al.* 1979). Their copy number is less than that of YEp's but this may be an advantage when cloning a deleterious gene. They are readily recovered from yeast and transform at high frequency,  $10^2$ - $10^3$  transformants per  $\mu\text{g}$  of DNA (Old and Primrose, in 'Principles of Genetic Manipulation', 1985).

The next class of vectors to be developed were those containing a yeast centromere. Centromeres had first been cloned into vectors by Struhl *et al.* (1979) and Kingsman *et al.* (1979). In both cases the centromere was cloned along with an ARS element and a linked gene. Clarke and Carbon (1983) then cloned a centromere from chromosome III and cloned this into a YRp. They then isolated recombinants which were stably maintained through mitosis and meiosis and identified the stabilising region as lying between the LEU2 and CDC10 loci from chromosome III, on a 1.6kb fragment. The presence of this with either of 2 ARS elements tested resulted in the plasmids behaving as mini-chromosomes. Linked markers on the mini-chromosomes segregated in the first meiotic division as centromere linked genes and were demonstrated to be unlinked to genes on other chromosomes (Clarke and Carbon 1983, Hsiao and Carbon 1981). Other centromeres (CEN4, CEN6, CEN11) have been isolated and shown to convey similar properties to YRp's, i.e. increased stability on non-selective media and segregation at mitosis and meiosis (Stinchcomb *et al.* 1982, Fitzgerald-Hayes *et al.* 1982a).

The sequence of yeast centromeres has been determined and reveals four regions of

sequence homology (Fitzgerald-Hayes *et al.* 1982b)

Element I, 14bp ATAAGTCACATGAT

Element II, 87/89bp 93% (CEN3) or 94% (CEN11) A+T rich

Element III, 11bp TGATTTCCGAA

Element IV, 10bp TTTAGAGCAA

Arranged in the order I, II, III, 248-252bp, IV. The region from element II to 20bp beyond element III shows 71% sequence homology and has been suggested as the functional unit of the centromere (Bloom and Carbon 1982). Plasmids containing centromeres are called YCp's, Yeast Centromere plasmids and differ from YRp's in their enhanced stability and Mendelian segregation. They display the lowest copy number of all yeast vectors and as such are useful in the study of deleterious genes. It does however make them difficult to recover from yeast cells.

Orr-Weaver *et al.* (1981) observed that cut duplex DNA does not have a stable end in yeast and most cut vectors integrate into the genome. Szostak and Blackburn (1982) linearised a YRp and cloned telomeres from the protozoan, *Tetrahymena*, onto the ends. The telomeres came from the rDNA of *Tetrahymena* and had been shown to contain variable (20-70) numbers of copies of the 6bp repeat 5'-CCCCAA-3', called C<sub>4</sub>A<sub>2</sub>. The C<sub>4</sub>A<sub>2</sub> strand has several nicks, one every 2-4 repeats as well as a hairpin end (Blackburn and Gall 1978). When the linear plasmid was transformed into yeast, the construct was found to be maintained as a linear molecule with the original structure intact, i.e. the yeast could recognise the *Tetrahymena* telomeres and use them. By removing one telomere and cloning on random yeast fragments, yeast telomeres were cloned and they proved to be structurally and functionally very

similar to *Tetrahymena* telomeres (Szostak and Blackburn 1982). Dani and Zakian (1983) found that linear CEN/TELOMERE plasmids were less mitotically stable than circular CEN plasmids and postulated that the centromere and telomere need to remain a certain distance apart to ensure stable mitotic segregation. However, Murray and Szostak (1983b) compared short linear plasmids, less than 20kb, to longer linear plasmids, 55kb. They found that the longer plasmids were much more stable than the short ones and approached the stability of YCp's. The length of yeast chromosomes has been estimated at 150-1,000 kb (Strathern *et al.* 1979) so the small linear plasmids were an order of magnitude smaller than the chromosomes whereas the larger linear plasmid behaved more like a chromosome because of its size. These mini-chromosomes will prove useful in the study of DNA replication in yeast and in the study of chromosome behaviour during mitosis and meiosis.

### **1.3.3 Applications of Yeast Vectors**

The primary purpose of recombinant DNA research is to work towards a full understanding of the molecular biology of the system under study. In the case of yeast the main thrust of research has been to identify yeast genes, associate the genes with their functions and find out how the genes are regulated. A first step in this process would be the shotgun cloning of restriction digested or randomly sheared yeast genomic DNA into a suitable shuttle vector and then transforming a mutant yeast and looking for complementation. Thereafter, analysis of the complementing plasmid can reveal the size of the gene and perhaps ascertain the extent of the areas involved in regulation of the gene e.g. the promoter. DNA sequencing can also be used to elucidate the control elements of the gene. Such an approach allowed the discovery of introns in the yeast actin gene (Gallwitz and Sures 1980, Ng and Abelson 1980) and in the tRNA genes (Abelson 1979, and Olson 1981). The direction of transcription

of a gene can be determined by DNA sequencing or by DNA strand separation in  $\lambda$  vectors and R-looping methods using the EM (Thomas *et al.* 1976). Such methods revealed the divergent transcription of the MAT (Klar *et al.* 1981, Nasmyth *et al.* 1981) and GAL (St. John and Davis 1981) loci, the histone genes (Hereford *et al.* 1979) and the rDNA (Philippesen *et al.* 1978). The direction of transcription can also be determined by cloning the DNA into  $\lambda$  with bacterial promoters and observing which orientation allows transcription. The direction of reading the HIS3 gene was first determined this way (Struhl and Davis 1980, Struhl *et al.* 1980). Other examples of the use of cloned genes in genetic analysis include:-

- 1) The mapping of the 8 tyrosine tRNA genes by linked RFLP's (Olson *et al.* 1979a).
- 2) The discovery of the TY1 element (Cameron *et al.* 1979) and the observation that if TY1 is inserted in front of the coding region, it can alter the regulation of the gene (Chaleff and Fink 1980, Errede *et al.* 1980, Roeder *et al.* 1980, Scherer and Davis 1981, Ciriacy and Williamson 1981, Williamson *et al.* 1981).
- 3) The correlation of the genetic and physical map of the HIS4 gene (Roeder and Fink 1980).
- 4) The general method of cloning mutant genes by transforming with the wild-type gene cloned into a YIp vector and then rescuing the genetic marker. In some cases this resulted in the cloning of the mutant gene where the plasmid had integrated and a heteroallelic duplication of the gene had been produced round the vector.

The identification of genes and their function by complementing mutant alleles is complicated in yeast by the presence of more than one copy of a gene or by another gene whose product is functionally homologous. Rine *et al.* (1983) observed that by increasing the gene dosage of an inhibited gene, the effects of the inhibitor can

be overcome. A concentration of inhibitor was determined that just prevented wild-type growth and then the yeast was transformed with vectors containing yeast DNA and transformants were picked which were resistant at that concentration. Rine *et al.* (1983) used this method to clone genes conferring resistance to tunicamycin, compactin and ethoinine.

Recombinant DNA technology has also been used to alter cloned yeast genes and then replace the wild-type gene with the altered gene or look for restoration of function in a mutant strain. Struhl and Davis (1980) and Struhl *et al.* (1980) cloned the HIS3 gene into a  $\lambda$  vector and partially deleted the yeast DNA using chelating agents (Parkinson and Huskey 1971). It was found that the gene was transcribed in *E. coli* and yeast if 100bp or greater, 5' to the start of the protein coding region remained intact.

Deletions in the HIS3 gene were also made by removing internal restriction fragments (Scherer and Davis 1979) and replacing the normal gene in the genome by using a YIp vector. Frameshift mutations were used to demonstrate that the histone gene was not essential for yeast viability (Rykowski *et al.* 1981). Another experiment used DNA internal to a gene of interest cloned into a YIp, which integrated into the genome such that the indigenous gene was disrupted and its function abolished. This method was used to demonstrate that the actin gene is essential for viability (Shortle *et al.* 1982). Point mutations can be introduced by chemical mutagens or by synthesis of altered DNA (Hutchinson *et al.* 1978, Muller *et al.* 1978, Itakura and Riggs 1980, Shortle *et al.* 1980). Mutations such as these can be returned to the genome by the method of Scherer and Davis (1979) or by using a YCp whose low copy no. may be of advantage if the mutation is deleterious. Wallace *et al.* (1980) removed the intervening sequence from the yeast tRNA<sub>tyr</sub> gene in its ochre suppressing SUP6 form by a method involving chemical DNA synthesis and found that the intervening sequence was not essential

for the expression of the tRNA.

The above examples show what progress is being made in the field of yeast genetic analysis, however this thesis is concerned with the expression of heterologous genes in yeast and it would be appropriate to turn our attention to the subject at this point.

#### 1.3.4 The Expression of Heterologous Genes in Yeast

Early attempts at the expression of foreign genes in yeast involved the use of cloned bacterial genes. Cohen *et al.* (1980) cloned the gene encoding chloramphenicol resistance from *Escherichia coli* into a YEp vector and found that some of the transformed yeast were  $\text{cam}^r$ . However it was not demonstrated whether the bacterial or yeast transcription and translation signals were being utilised. Similarly, gentamycin resistance was conferred on yeast (Jiminez and Davies, 1980) but due to recombination between the yeast and bacterial DNA it was unclear which transcriptional controls were being used. Breunig *et al.* (1982) demonstrated transcription of the  $\beta$ -lactamase gene in yeast and showed that the bacterial promoter was used. Struhl *et al.* (1976) had shown that a cloned yeast gene conferring histidine prototrophy on an auxotrophic *Escherichia coli* had used the yeast promoter. This raised the possibility that promoters of yeast and *Escherichia coli* would work in either organism. However, it soon became apparent that Breunig *et al.* had found the exception rather than the rule. Rose *et al.* (1981) showed that though the yeast URA3 promoter functioned in both yeast and *Escherichia coli* (driving expression of the  $\beta$ -galactosidase gene) the *Escherichia coli*  $\text{Tc}^r$  promoter linked to the same gene functioned only in *Escherichia coli*. The first attempt at expressing a mammalian gene in yeast (Beggs *et al.* 1980) showed that although rabbit  $\beta$ -globin specific transcripts were detectable, initiation occurred downstream from the normal start of transcription. Thus it became clear

that in order to express foreign genes in yeast, yeast promoters would have to be used.

Using the *Escherichia coli*  $\beta$ -galactosidase gene, expression in yeast was reported using the URA3, CYC1 and ARG3 promoters (Guariente and Ptashne 1989, Rose *et al.* 1981, Crabeel *et al.* 1983). The first expression of a human gene was reported by Tuite *et al.* (1982) who expressed human interferon  $\alpha$  using the yeast PGK promoter. These experiments produced fusion proteins with some of the protein being derived from yeast DNA sequences. Hitzeman *et al.* (1981) produced a promoter fragment by Bal31 digestion of the ADH1 gene which added no extra yeast amino-acids to the expressed genes. The interest in yeast as a producer of foreign proteins is twofold. As a major industrial organism with no known pathological interactions with humans, yeast could prove the organism of choice for the production of pharmaceutically useful proteins. Since yeast is a eukaryote its ability to glycosylate and process higher eukaryote proteins would give it an advantage over *Escherichia coli*. Secondly, as has been previously mentioned, yeast could prove a useful tool in answering some of the basic questions of eukaryote biology. An example of a pharmaceutically useful protein expressed in yeast is the human hormone insulin. Previously, two methods had been used to express insulin in *Escherichia coli*, the first by Goeddel *et al.* (1979b) expressed the A and B chains separately as  $\beta$  galactosidase fusion proteins which were cleaved apart with cyanogen bromide and then chemically linked. The second method by Wetzel *et al.* (1981) expressed DNA coding for the proinsulin form with the C peptide replaced by a 6 amino-acid "mini-C" peptide. The peptide produced was then subjected to proteolysis to yield the active form. Thim *et al.* (1986) expressed proinsulin and proinsulin-like cDNAs in yeast, in which the C peptide had been replaced by a spacer peptide or was absent. The promoter used in this case was the triose

phosphate isomerase promoter from the fission yeast *Schizosaccharomyces pombe*' and the cDNA was linked to the  $\alpha$  mating factor  $\text{p}^{\alpha}$  peptide. They found that insulin was secreted into the culture medium and that the presence of the C peptide or spacer peptide was essential for the cleavage of the B-C-A unit. Most of the insulin was found in the form B-Lys-Arg-A which could be converted to the form B-s-s-A (mature human insulin) by enzymatic digestion with trypsin and carboxypeptidase B (Kemmler *et al.* 1971). This demonstrated that yeast could be of use in expressing hormones such as insulin. In an attempt to boost the yield of heterologous yeast insulin, Cousens *et al.* (1987) reported the expression of a proinsulin/human superoxide dismutase fusion protein from an ADH2-GAPDH fusion promoter. In this case the fusion protein formed large aggregates in the cells which when purified and subjected to cyanogen bromide digestion, yielded 100mg/litre proinsulin. The proinsulin was not cleaved in this case because the protein had not been directed through the yeast secretory pathway. Other hormones that have been successfully expressed in yeast are glucagon (Moody *et al.* 1987), murine granulocyte-macrophage colony-stimulating factor and bovine interleukin 2 (Price *et al.* 1987). Two features which these constructs had in common were the use of  $\alpha$  mating type  $\text{p}^{\alpha}$  peptides and the use of cDNAs for the foreign genes. The reason cDNAs were used and not complete genes reflects the difference in yeast and higher eukaryote mRNA processing. When Beggs *et al.* (1980) analysed the products of transcription of the rabbit  $\beta$  globin gene in yeast, they found that the mRNA still contained one intron and only extended as far as half way through the second. The inability of *Saccharomyces cerevisiae* to correctly splice higher eukaryote introns was further demonstrated by Langford *et al.* (1983) who cloned an intron containing fragment from duck or *Acanthamoeba* into the intron containing yeast actin gene. In both cases only the yeast introns were removed by yeast. It was noted that the DNA surrounding the intron was not responsible for

the differences in splicing between yeast and higher eukaryotes but that sequences internal to the intron were responsible. All yeast introns have been shown to contain an octanucleotide

5' TACTAACA 3'

20-55 nucleotides upstream of the 3' splice site. A single change from A to C at position eight prevents splicing from occurring. The sequence is not found in higher eukaryote introns (Langford and Gallwitz 1983, Langford *et al.* 1984).

The observation that yeast could recognise and process a higher eukaryote signal peptide was first made by Hitzeman *et al.* (1983). Expression of human preinterferon using the PGK promoter caused interferon to be secreted into the culture medium in a form which had the same N-terminus as mature interferon ie. the signal peptide had been removed. Other signal peptides that have been seen to work in yeast are those for human pancreatic secretory trypsin inhibitor (Izumoto *et al.* 1987), calf chymosin (Mellor *et al.* 1983), rhaumatin (Edens *et al.* 1984) wheat  $\alpha$  amylase (Rothstein *et al.* 1987), wheat  $\alpha$  gliadin (Neill *et al.* 1987), human salivary  $\alpha$  amylase (Sato *et al.* 1986), *Bacillus amyloliquifaciens*  $\alpha$  amylase (Ruhonen *et al.* 1987) human lysozyme (chicken/human hybrid signal) (Jigami *et al.* 1986) and *Kluveromyces lactis* killer toxin (Baldari *et al.* 1987). The structural constraints on what constitutes a functional yeast signal peptide will be discussed in chapter 4.

The efficiency of transcription and translation of foreign genes in yeast depends on many factors fundamental to the control of gene expression in yeast. For instance, the distance between the promoter and the start codon might affect mRNA secondary structure (Old and Primrose, 1985) since it has been noted (Derynck *et al.* 1983) that the level of mRNA of interferon  $\gamma$  and of yeast PGK mRNA was less despite being driven from the same promoter. Another factor affecting foreign gene expression is

codon bias. Bennetzen and Hall (1982) found that for the yeast genes ADH1 and GAPDH (glyceraldehyde-3-phosphate dehydrogenase), 96% of the 1004 amino-acids were coded for by 25 out of the possible 61 triplets. They also found that genes which were strongly expressed were more biased than weakly expressed genes. A similar pattern of codon bias has been demonstrated in *Eschericia coli* (Post *et al.* 1979) with some of the preferred triplets being incompatible between the two organisms. Having the correct transcription termination signals is also important. A sequence homologous to the yeast transcription termination consensus sequence

5'TAG..TATGT...(AT rich)..TTT3' (Zaret and Sherman 1982, 1984)

was found in the 3' noncoding region of wheat  $\alpha$  gliadin and transcription termination was seen to occur there (Neill *et al.* 1987)

It has been variously reported that yeast can glycosylate foreign proteins. In the case of human interleukin 1 $\beta$  (Baldari *et al.* 1987) and *Bacillus amyloliquifaciens*  $\alpha$ amylase (Ruohonen *et al.* 1987) yeast glycosylated the two proteins, neither of which was glycosylated in the original organism. Whereas in the case of human salivary  $\alpha$  amylase (Sato *et al.* 1986) an intermediate form of the protein was detected which was glycosylated to a lesser extent than the mature protein, yeast made both forms of the protein. Price *et al.* (1987) reported that of the two proteins they expressed in yeast (both of which had the Asn-X-Ser glycosylation signal) only murine granulocyte-macrophage colony-stimulating factor was glycosylated. The reason why bovine interleukin 2 was not glycosylated was possibly due to the accessibility of the glycosylation site which may have been buried if the conformation of the protein was not the same as in the homologous system. Glycosylation was also reported in the case of phaseolin (Cramer *et al.* 1985) (see below). It appears, therefore, that given the right glycosylation signal yeast can glycosylate heterologous proteins, depending on the accessibility of the

glycosylation site.

Most of the foreign genes expressed in yeast have been mammalian genes with only a few examples of plant genes being used. The first reported plant gene to be expressed was that for the sweet tasting protein thaumatin from *Thaumatococcus danielli* (Edens *et al.* 1984) reported efficient signal peptide cleavage but no cleavage of the C-terminal extension which is cleaved off in the plant. Wheat  $\alpha$  amylase has been expressed in yeast and its own signal peptide was sufficient to cause the protein to be secreted into the culture medium (Rothstein *et al.* 1987). To date 4 reports of the expression of seed storage proteins exist. The first of these was phaseolin which was expressed from its own promoter and had its signal peptide cleaved and was glycosylated (Cramer *et al.* 1985). In a later report Cramer *et al.* (1987) showed that hybrid signal peptides of the yeast *PHO5* gene and phaseolin were not efficiently cleaved, possibly due to the amino-acid environment surrounding the signal peptide (see chapter 4 for a fuller discussion). Wheat  $\alpha$  gliadin was expressed in yeast and appeared to localise in the ER (Neill *et al.* 1987). A cDNA coding for the 50000  $M_r$  form of vicilin has been expressed in yeast (Watson *et al.* 1988). The cDNA lacked all but 3 amino-acids of the signal peptide and the form of polypeptide coded for had no proteolytic cleavage point and no glycosylation signal. The yeast expressed protein was found in the soluble extract which meant it was very likely cytoplasmically located. Some assembly of the 50000 forms into larger molecular weight aggregates was seen but the majority of the protein was in the monomeric form. A hybrid cDNA coding for preprolegumin has been expressed in yeast by Yarwood *et al.* (1987). They reported that the protein was localised in the Golgi apparatus but the cleavage of the signal peptide has not yet been determined, the protein was not proteolytically cleaved.

## 1.4 AIMS AND OBJECTIVES

As demonstrated in the previous section, there exists evidence to suggest that yeast can recognise higher eukaryote protein processing signals ie. it can cleave signal peptides and glycosylate the proteins. It may also be the case that yeast can assemble oligomeric proteins too. To test whether this is the case with the seed storage protein vicilin, it is proposed that a complete cDNA for preprovicilin be expressed in yeast and the resultant polypeptide analysed. The first step in this process is to prove that the cDNA contained in the plasmid pLG1.63 does indeed code for preprovicilin of the 47000 M<sub>r</sub> type. This will be done by restriction mapping and size determination in comparison to other known cDNAs for the 47000 type and by DNA sequencing. The sequence data should reveal the presence of the signal peptide coding region,  $\beta$ - $\gamma$  processing site and the glycosylation site. The cDNA will then be cloned into a suitable expression vector, one using the PGK promoter to gain high levels of expression and another using the GAL10 promoter which is an inducible promoter which only expresses a gene adjacent to it when galactose is added to the growth medium. The resultant recombinant plasmids will be transformed into yeast and expression looked for. Thereafter, the project will attempt to answer the following questions:-

- 1) Can yeast produce an immunoreactive vicilin species?
- 2) Can it recognise the signal peptide and direct the protein into the E.R.?
- 3) Can yeast cleave the signal peptide accurately?
- 4) Can yeast glycosylate vicilin?
- 5) Does yeast possess a protease capable of cleaving vicilin at the  $\beta$ - $\gamma$  site?

6) What is the subcellular location of the vicilin?

7) Does the yeast assemble the polypeptides into trimers?

The subcellular location of the expressed vicilin will be of particular interest . The yeast vacuole is the major site of proteases (Cooper, 1982) and resembles the lysosome of higher eukaryotes. If vicilin is directed into the vacuole then this will be the most likely site of proteolytic processing. If it is demonstrated that yeast cannot process vicilin but can remove the signal peptide, then the major product will be provicilin, which is the substrate for the pea processing enzyme in the protein bodies. Thus the yeast expressed vicilin will provide a means of assaying for the enzyme and could lead to its isolation and characterisation. One area of research in seed storage proteins is relating the sequence of the amino-acids to the three dimensional structure and the physical properties of the protein. In order to determine what the effects of mutations in the DNA coding for the proteins are, the protein will have to be made in an organism which fulfills two criteria. Firstly, the organism must be biologically tractable ie the ability to transform the organism with plasmids bearing mutated copies of the genes of interest and the rapid determination of the effects of the mutations on the final protein product. Secondly, the organism must have been demonstrated to produce the non-mutated form of the protein with the same conformation and physical properties as the protein derived from the homologous organism. This study sets out to ascertain whether yeast fulfills the second of these criteria with respect to pea vicilin and if not just how different the heterologous protein is.

## **Chapter 2. MATERIALS AND METHODS**

- 2.1) Chemicals And Enzymes**
- 2.2) Yeast And Bacterial Strains**
- 2.3) Plasmids**
- 2.4) Growth Conditions And Media**
- 2.5) DNA Preparation**
- 2.6) Transformation Techniques**
- 2.7) DNA Manipulations**
- 2.8) Agarose Gel Electrophoresis**
- 2.9) DNA Sequencing**
- 2.10) Protein Preparation**
- 2.11) Polyacrylamide Gel Electrophoresis**
- 2.12) Western Blotting**
- 2.13) Immune-Electron Microscopy of Yeast**
- 2.14) Subcellular Fractionation**
- 2.15) Immunofluorescence**
- 2.16) Protein Manipulations**

## **2.1 Chemicals and Enzymes**

All chemicals and enzymes were bought from Sigma chemical company or BDH limited except:-

Restriction enzymes and other DNA modifying enzymes were bought from either Northumbrian Biologicals Limited (NBL) or Boehringer Mannheim (FGR)

Radioactively labelled chemicals and the nick translation kit were from Amersham Ltd. (UK).

Yeast nitrogen base, bactopectone and agar were from Difco laboratories (USA)

Yeast extract was bought from Biolife (Italy) and tryptone from BBL Microbiology Systems (USA)

Gold conjugated antibodies were from Bioclin, L.R. white from the London Resin Co Ltd. and Osmium tetroxide from Agar Aids Ltd.

Goat anti-rabbit conjugated antibodies and Hydroxyl-Apatite were bought from Bio-rad Labs. (USA)

Sephadex G50, X-gal, IPTG and Ficoll were from Pharmacia Fine Chemicals (Sweden)

Nitrocellulose was from Schleicher and Schuell (FGR)

Non-Fat Dried Milk was from Cadbury-S<sup>c</sup>hweppes Ltd.

Caesium chloride was from Boehringer Mannheim (FGR) and DAB (3,3'-Diamino benzidine tetrahydrochloride dihydrate) was from Aldrich Chemical Co.ltd.

## 2.2. Yeast And Bacterial Strains.

### *Escherichia coli*

JM83

*ara, lac-proAB, rpsL, strA, φ80, lacZ, M15*

JM101

*(lac-pro)thi, F' traD36, supE, proAB, lac<sup>F</sup>Z, M15*

### *Saccharomyces cerevisiae*

MD404C $\alpha$

*His<sup>-</sup>, Trp<sup>-</sup>, Ura<sup>-</sup>, Leu<sup>-</sup>.*

MC16 $\alpha$

*Ade<sup>-</sup>, His<sup>-</sup>, Lys<sup>-</sup>, Leu<sup>-</sup>.*

DBY746 $\alpha$

*His<sup>-</sup>, Trp<sup>-</sup>, Ura<sup>-</sup>, Leu<sup>-</sup>.*

GF $\alpha$ 167 $\alpha$

*His<sup>-</sup>, Ura<sup>-</sup>.*

## 2.3 Plasmids

The following plasmids were used in this study:-

Plasmid	Comments	Reference
pLG1.63	pUC8 with vicilin cDNA	L.Gatehouse, M.Sc.Thesis
pUC8	pBR322 based vector with multiple cloning site	Vierra and Messing 1982
M13mp9	M13 based vector for sequencing	BRL
pUC1813	Hybrid pUC vector	Kay and McPherson, 1987
pBM150	YCp vector with GAL1/10 promoter	Johnston and Davies, 1984
pMA91	YE <sub>p</sub> vector with PGK promoter	Mellor <i>et al.</i> 1983

## 2.4. Growth Conditions And Media

*Escherichia coli* strains were grown in Luria broth and on Luria agar:-

Tryptone	10g.litre <sup>-1</sup>
Yeast Extract	5g.litre <sup>-1</sup>
NaCl	5g.litre <sup>-1</sup>
(Agar	15g.litre <sup>-1</sup> )
	or 6.5g.litre <sup>-1</sup> for top/soft agar
d.H <sub>2</sub> O	upto 1 litre

### Autoclaved

Antibiotics were made up in 20% ethanol at 5mg.ml<sup>-1</sup> and filter sterilised. 10ml of this was added to 1 litre of L-broth. Growth took place at 37°C with shaking.

X-gal was made up as a 10% solution in Dimethylformamide and added to agar to give 10µl per plate.

IPTG was made up as a 100mM solution in sterile distilled water and added to agar to give a final concentration of 40nM.

For the growth of bacteria harbouring M13 derived plasmids (see next section) 2xYT media was used:-

Tryptone	16g.litre <sup>-1</sup>
Yeast Extract	10g.litre <sup>-1</sup>
NaCl	5g.litre <sup>-1</sup>
H <sub>2</sub> O	upto 1 litre

### Autoclaved.

Antibiotics were added as before.

*S. cerevisiae* was grown on Yeast Pepto-Dextrose medium (YPD) as a complete medium and on supplemented Yeast Minimal Medium. Growth took place at 30°C with shaking.

#### **YPD**

Yeast Extract	10g.litre <sup>-1</sup>
Glucose	20g.litre <sup>-1</sup>
Bactopeptone	20g.litre <sup>-1</sup>
(Agar	15g.litre <sup>-1</sup> )
H <sub>2</sub> O	upto 1 litre

Autoclaved.

#### **YMM**

YNB w/o Amino acids	6.7g.litre <sup>-1</sup>
Glucose	20g.litre <sup>-1</sup>
Amino Acids	20mg.litre <sup>-1</sup>
(Agar	15g.litre <sup>-1</sup> )
H <sub>2</sub> O	upto 1 litre

Autoclaved.

Amino acids were dissolved in distilled water at 10mg.ml<sup>-1</sup> and then autoclaved.

N.B.- all solutions, growth media and equipment were sterilised by autoclaving at 15p.s.i. for 15 minutes. Antibiotics were filter sterilised.

### **2.5 DNA Preparation**

All the above plasmids (except M13mp9) were purified from their *E.coli* hosts in large

quantities by the following method:-

### **2.5.1 Large Scale Preparation Of Plasmid DNA (after Birnboim and Doly, 1979)**

From an agar plate or glycerol culture, 5ml of L-broth was inoculated and grown overnight with the appropriate selection. This was then used as an inoculum for 1 litre of L-broth which was grown at 37° with vigorous shaking until the O.D. reached 0.4-0.6 at 600nm. At this stage 2.5ml of chloramphenicol solution was added (34mg.ml<sup>-1</sup> in ethanol) and the incubation continued overnight, (20hrs approx.)

The bacteria were harvested at 9000rpm for 1 minute in 250ml tubes in the MSE 18 centrifuge. The supernatant was discarded and the pellets resuspended in a total of 10ml of solution 1. :-

20% Glucose	0.5ml
0.25M EDTA pH 8.0	0.4ml
1M Tris.HCl pH 8.0	0.25ml
H <sub>2</sub> O	8.85ml

10mg of Lysozyme was added and the solution mixed and left at room temperature for 30 minutes. Thereafter, 20ml of solution 2 was added, the contents mixed and left on ice for 10 minutes.

#### **Solution 2:-**

Distilled water	17.6ml
10N NaOH	0.4ml
10% SDS	2ml

Then 15ml of 3M NaAc pH 4.8 was added, the contents mixed and left on ice for

10 minutes. The solution was then poured into 2x50ml MSE tubes, balanced and centrifuged at 15000rpm for 45 minutes at 5°C. All the supernatant was poured into a 100ml polyallomer tube and an equal volume of isopropanol added. The contents were mixed thoroughly and then left on ice for 30 minutes. The solution was then split between two 100ml tubes, the tubes were balanced and centrifuged at 12000rpm for 30 minutes at 5°C. The supernatant was then discarded and the excess drained off onto tissue paper. Both pellets were then resuspended in a total of 22ml TES pH 8.0:-

1M Tris.HCl pH 8.0	10ml.litre <sup>-1</sup>
0.25M EDTA pH 8.0	4ml.litre <sup>-1</sup>
5M NaCl	2ml.litre <sup>-1</sup>

Distilled water to 1 litre

Autoclaved.

Exactly 29.8g of CsCl was added and dissolved before the addition of 0.41ml ethidium bromide (10mg.ml<sup>-1</sup>). The volume was made up to 39ml with TE pH 8.0 (10mM Tris.HCl pH 8.0, 1mM EDTA pH 8.0) and the solution poured into a large Beckmann quickseal tube. This was balanced against another tube containing Top-up Solution:-

CsCl 59.6g

EtBr 0.82ml (10mg.ml<sup>-1</sup> solution).

TE upto 78ml.

The tubes were balanced to within 0.1g and any airgaps filled with Bretoil. The tubes were then heat sealed and centrifuged at 44000rpm at 15°C for 20hrs in a VTi 50 rotor. After this the tubes were carefully removed from the rotor and observed

under U.V. illumination. Usually two bands would be seen, the lower of which was the plasmid DNA band. This was removed into a sterile 15ml corex tube using a syringe. The plasmid solution was made upto 22ml with TES and the CsCl gradient centrifugation step repeated.

This time there was usually only one band visible under UV or a small amount of chromosomal DNA contamination was present, in either case only the lower plasmid band was removed. The DNA solution was extracted four times with CsCl saturated isopropanol to remove the EtBr. The solution was then dialysed against TE pH 8.0 for 24hrs with 2 changes. The DNA was then stored at  $-20^{\circ}\text{C}$  in  $500\mu\text{l}$  aliquots.

All plasmids except M13mp9 and its derivatives were prepared from time to time in small quantities by the minilystate method or mini-prep.

### **2.5.2 Mini-prep Method 1 (Birnboim and Doly, 1979. Modified by Ish-Horowitz 1982)**

In this method, solution 1 and solution 2 are the same as for the large scale preparation of DNA except that solution 1 has lysozyme added at  $2\text{mg.ml}^{-1}$ , after autoclaving.

Bacteria were grown up overnight in 5ml of L-broth with selection, innoculated from an agar plate or stored glycerol. From this, 0.5ml was removed and pelleted, the supernatant discarded and the pellet resuspended in  $100\mu\text{l}$  of solution 1. The tube was left on ice for 30 minutes and then  $200\mu\text{l}$  of solution 2 was added, the tube vortexed and then left on ice for 5 minutes. After this  $150\mu\text{l}$  of 3M NaAc pH4.8 was added, the tube vortexed and left on ice for 30 minutes to precipitate proteins and cell debris. The tube was then centrifuged for 4 minutes in a microfuge, the supernatant removed to a fresh tube to which 1ml of ethanol was added and the tube placed at  $-80^{\circ}\text{C}$  for 30 minutes.

After this period the solution was centrifuged for 10 minutes, the supernatant discarded and the pellet resuspended in 100 $\mu$ l 0.1M NaAc. 0.05M Tris.HCl pH8.0. Then 0.4ml of ethanol was added, the tube mixed and placed at -80°C for 20 minutes. The tube was then centrifuged and the pellet vacuum dried before being resuspended in 50 $\mu$ l sterile distilled water.

### 2.5.3 Mini-prep Method 2 (Crouse *et al.*, 1983)

The bacteria were grown up as in method 1 and all 5ml was centrifuged at top speed in a benchtop centrifuge for 10 minutes. The supernatant was discarded and the pellet resuspended in 180 $\mu$ l of solution1 (without lysozyme). The bacteria were then transferred to an eppendorf tube, 8 $\mu$ l of 50mg.ml<sup>-1</sup> lysozyme was added and the tube left at room temperature for 5 minutes. The tube was then chilled on ice for two minutes before 400 $\mu$ l of solution 2 was added, the contents mixed and placed on ice for 5 minutes. Next, 300 $\mu$ l of 3M NaAc pH 4.8 was added, the tube mixed and then left on ice for 10 minutes. The tube was then centrifuged for 10 minutes in a microfuge. The bulk (750 $\mu$ l) of the supernatant was removed to a fresh tube and 500 $\mu$ l of isopropanol was added, the tube mixed thoroughly and then centrifuged for 5 minutes. The supernatant was discarded and the pellet washed in 1ml of cold 70% ethanol. The tube was then centrifuged for 5 minutes and all the ethanol removed. The pellet was resuspended in 200 $\mu$ l TES and an equal volume of phenol was added. The tube was vortexed and 200 $\mu$ l of chloroform was added, the tube was again vortexed and then centrifuged for 3 minutes. The upper, aqueous layer was removed to a clean tube, to which was added 20 $\mu$ l of 3M NaAc pH 4.8 and 500 $\mu$ l of ethanol. This was placed at -80°C for 20 minutes before being centrifuged for 10 minutes in a microfuge. The pellet was dried under vacuum before being resuspended in 50 $\mu$ l of TE. The DNA was stored at -20°C.

#### 2.5.4 Preparation Of M13 Single-stranded DNA (BRL sequencing handbook)

This technique was performed on M13mp9 and derivatives thereof containing DNA cloned into the universal cloning site in preparation for dideoxy sequencing (see section 2.9).

JM101 was inoculated into 10ml of L-broth and grown overnight at 37°C. 1ml of this was added to 100ml of 2xYT which was then dispensed into sterile universals in 2ml aliquots. Clear plaques from a lawn of bacteria (see M13 transformation) were picked off with a sterile cocktail stick and inoculated into the 2xYT. The universals were incubated at 37°C overnight. The cultures were then transferred to Eppendorf tubes and centrifuged for 5 minutes. The supernatant was carefully removed to a fresh tube and 200µl of 20% PEG6000. 2.5M NaCl was added. The tube was vortexed and left at room temperature for 45 minutes. The tube was then centrifuged for 5 minutes and the supernatant removed. The pellet was resuspended in 200µl of TE and 200µl of phenol was added, the tube was vortexed and then left at room temperature for 20 minutes. The tube was then centrifuged for 3 minutes and the aqueous phase removed to a fresh tube. To this was added 9µl of 3M NaAc pH 4.8 and 0.3 ml of ethanol. The tube was then placed at -80°C for 20 minutes. The tube was then centrifuged for 10 minutes, the pellet vacuum dried and finally resuspended in 20µl of TE. The DNA was stored at -80°C.

### 2.5.5 Yeast DNA-prep (J.Yarwood, personal communication)

Single colonies were inoculated into 5ml of YPD or YMM and grown up to late log phase. The cells were harvested on a bench-top centrifuge and then resuspended in 0.5ml of 1M sorbitol, 0.1ml 25mM EDTA pH 7.5 and then transferred to Eppendorf tubes. Then either 20 $\mu$ l of 2.5mg.ml<sup>-1</sup> zymolase/ glucylase or 30 $\mu$ l of 100mg.ml<sup>-1</sup> Novozyme sp 234<sub>was added</sub> and the cells incubated at 37°C for 1-2hrs. The cells were then centrifuged for 1 minute and the pellet resuspended in 500 $\mu$ l 50mM Tris.HCl pH 7.4. Then, 50 $\mu$ l of 5M KAc was added and the tube placed on ice for 1hr before being centrifuged for 15 minutes. The supernatant was then transferred to a fresh tube and one volume of isopropanol added. After mixing, the tube was left for 5 minutes at room temperature before being centrifuged for 10 seconds. The supernatant was discarded and the pellet dried before being resuspended in 300 $\mu$ l of TE pH7.4. The addition of 15 $\mu$ l of 1mg.ml<sup>-1</sup> pancreatic RNA ase and incubation at 37°C for 30 minutes was an optional extra. After this, 30 $\mu$ l of 3MNaAc pH 4.8 and 200 $\mu$ l isopropanol was added, the tube mixed and left for two minutes to precipitate the DNA. The DNA was then centrifuged for 1 minute before being dried and resuspended in 100-300 $\mu$ l of TE.

## 2.6 Transformation techniques

### 2.6.1 Bacterial Transformation (Mandel and Higa, 1970, Cohen and Chang, 1973)

#### Transformation Other Than With M13 Derivatives

The cells were made competent as follows:-

JM101 or JM83 was inoculated into 5ml of L-broth and grown up overnight. 1ml of this was inoculated into 50ml of L-broth in a side-arm flask and incubated until the optical density at 600nm reached 0.2-0.3 on the colourimeter. The cells were then

harvested at 6000rpm in an MSE 18 centrifuge at 4°C for 5 minutes. The supernatant was discarded and the pellet resuspended in 50ml cold sterile 50mM CaCl<sub>2</sub>.10mM Tris.HCl pH 8.0 and then the cells were recentrifuged. Again, the supernatant was discarded and the cells resuspended in 25 ml 50mM CaCl<sub>2</sub>. Tris.HCl pH 8.0 , the cells were then left on ice for 30 minutes. The cells were then recentrifuged and resuspended in 2.5ml Tris.CaCl<sub>2</sub>. The cells could be used immediately or stored for 24 hrs at 4°C. Alternatively, an equal volume of sterile glycerol could be added and the competent cells stored for a number of weeks at -80°C.

The transformation of these competent cells was carried out as follows:-

To the DNA, 100µl of competent cells were added and the tube kept on ice for 45 minutes. The DNA was either 10µl of a plasmid prep. or 30µl of a ligation mixture (see ligation of DNA). The cells were then heat shocked at 42°C for 2 minutes before 1ml of L-broth was added and the cells incubated at 37°C for 1 hour. The cells were then diluted down to 10<sup>-3</sup> and 100µl of each dilution was plated out onto L-agar containing the appropriate antibiotics. Controls were without DNA or DNA which was cut with a restriction enzyme (see R.E. digests) and not ligated. The plates were incubated overnight at 37°C.

### 2.6.2 Transformation With M13 Derivatives (BRL sequencing handbook)

JM101 Competent cells were prepared as above. About two hours before the cells were due to be plated out, 1ml of the original culture was inoculated into 10ml of L-broth and grown at 37°C. To the DNA, 100µl of competent cells were added in an Eppendorf and then kept on ice for 45 minutes. The cells were then heat shocked at 42°C for two minutes. Then 200µl of fresh cells were added along with 10µl of 10mM IPTG and 10µl of 10% X-gal (in 4 imethylformamide). The mixture was then added

to 3ml of molten top agar, mixed, and then poured onto the surface of an L-agar plate. After the top agar had set the plates were incubated overnight at 37°C.

Transformants appeared as either blue plaques (phage without inserted DNA) or white plaques (phages with inserted DNA) on a lawn of bacteria.

### **2.6.3 Transformation of *Saccharomyces cerevisiae* (Beggs 1978)**

This method is based on the production, transformation and regeneration of yeast protoplasts using enzymes to strip away the cell wall.

Yeast from a glycerol culture were inoculated into 5ml of YPD and grown overnight at 30°C. At 4pm the next day, 1ml of this was used to inoculate 200ml of YPD which was grown for 17hrs with shaking. The culture was centrifuged at 5000rpm for 5 minutes at 5°C, the supernatant discarded and the pellet resuspended<sup>in</sup> 100ml of sterile distilled water. The cells were recentrifuged and the pellet resuspended in 35ml of 1.2M sorbitol. 25mM EDTA. 50mM dithiothreitol pH8.0. The cells were incubated at 30°C for 10 minutes before being centrifuged and washed twice in cold 1.2M sorbitol. The cells were then resuspended in 30ml 1.2M sorbitol. 10mM EDTA. 0.1M sodium citrate and 0.3ml (27 units) of glucylase or 0.6ml (of 5mgml<sup>-1</sup>) of lyticase was added. The cells were then incubated for 1-2 hours at 30°C with shaking. After this the cells were centrifuged and washed three times in 1.2M sorbitol and finally resuspended in 15ml 1.2M sorbitol. 10mM CaCl<sub>2</sub>. The cells were again centrifuged and resuspended in 1ml 1.2M sorbitol. 10mM CaCl<sub>2</sub>. Next, 200µl of the cells were transferred to an Eppendorf tube and up to 2µg of DNA was added. The cells were left at room temperature for 15 minutes before the addition of 1ml 20% PEG 4000. 10mM CaCl<sub>2</sub>. 10mM Tris.HCl pH 7.5. The cells were left for no longer than 10 minutes and then they were centrifuged and the pellet resuspended in 100µl of 1.2M sorbitol. 10mM CaCl<sub>2</sub>,

50 $\mu$ l YPD. 1.2M sorbitol. 40 $\mu$ g.ml<sup>-1</sup> leu. The cells were incubated for 30 minutes at 30°C and then diluted to 10<sup>-1</sup> in 1.2M sorbitol. Finally 100 $\mu$ l of cells were added to 6ml of regeneration agar, which was poured onto the surface of a plate agar petri-dish. The agar was allowed to set and then the plate was incubated for 4-5 days at 30°C. Regeneration agar is YMM with 1.2M sorbitol and 3% agar.

Plate agar is YMM with 1.2M sorbitol and 2% agar. With suitable supplements.

#### **2.6.4 Lithium Acetate Transformation Of Yeast (after Ito *et al.*, 1983)**

Yeast were inoculated into 10ml of YPD from a glycerol culture and grown overnight at 30°C with shaking to an O.D. at 600nm of 0.5-0.8. The cells were harvested by centrifugation and washed once in distilled water before being resuspended in 10ml 0.1M lithium acetate in TE pH 8.0. The cells were then incubated at 30°C for 1 hour. The cells were then pelleted and resuspended in 0.4ml of lithium acetate solution. Up to 1 $\mu$ g of DNA was added to 50 $\mu$ l of cells and the tube incubated at 30°C for 30 minutes. The cells were gently resuspended and 0.6ml 40%PEG 4000. 10mM Tris.HCl was added. The cells were incubated for 1hour at 30°C and then heat shocked at 42°C for 5 minutes. The cells were then inoculated into 5ml YPD and incubated overnight. The cells were then pelleted, washed with 0.5ml distilled water and resuspended in 100 $\mu$ l of water. The cells were then plated out on the appropriate YMM plate and incubated at 30°C for upto 5 days or until the transformed colonies appeared.

### **2.7 DNA Manipulation**

#### **2.7.1 Restriction Digests (Maniatis *et al.* 1982)**

RE= Restriction Endonuclease

Restrictions were typically set up as follows:-

10 $\mu$ l (upto 1 $\mu$ g) DNA  
 3 $\mu$ l 10x RE buffer  
 1 $\mu$ l RE (5u typically)  
 16 $\mu$ l Sterile distilled water

37°C for 2 hours

Each RE has a requirement for one of three buffer types (unless otherwise indicated by the manufacturers):-

10x Low Salt	10x Medium salt	10x High salt
0.1M Tris.HCl pH 7.5	0.1M Tris.HCl ph 7.5	0.5M Tris.HCl pH 7.5
0.1M MgCl <sub>2</sub>	0.1M MgCl <sub>2</sub>	0.1M MgCl <sub>2</sub>
10mM DTT	10mM DTT	10mM DTT
	0.5M NaCl	1M NaCl

### 2.7.2 Ligation of DNA (Weiss *et al.*, 1968)

Typically:-

10 $\mu$ l insert DNA (approx. 0.5 $\mu$ g)  
 5 $\mu$ l vector DNA (approx. 0.2 $\mu$ g)  
 3 $\mu$ l 10x ligase buffer  
 1 $\mu$ l T4 DNA ligase (2-5 u)  
 11 $\mu$ l sterile distilled water

Incubated at 15°C overnight

With blunt end ligation more ligase was used.

10x ligase buffer:-

0.66M Tris.HCl pH 7.6

50mM MgCl<sub>2</sub>

50mM DTT

10mM ATP

### 2.7.3 Phosphatase Treatment (Seeburg *et al.*, 1977)

This is used to remove the terminal 5' phosphate from cut vector DNA to stop self religation during ligation experiments.

The digested DNA was made up to 200 $\mu$ l with TE pH 8.0 and an equal volume of phenol:chloroform (1:1) was added. The chloroform used throughout this thesis was actually a 24:1 chloroform:isoamylalcohol solution. The tube was then vortexed and then centrifuged in a microfuge for 3 minutes. The aqueous phase was removed to a clean tube and 1/10 the volume 3M NaAc pH4.8 was added along with 0.5ml ethanol. The contents were mixed and then left at -80°C for 20 minutes to precipitate the DNA. The tube was centrifuged for 10 minutes and the pellet vacuum dried. The pellet was then resuspended in 40 $\mu$ l of TE, to which was added 4 $\mu$ l phosphatase buffer and 1 $\mu$ l phosphatase<sup>(2u)</sup>, and then incubated at 37°C for 30 minutes. Then, 4.8 $\mu$ l of 0.1M nitrilotriacetic acid was added and the tube heated at 70°C for 15 minutes. Next, 200 $\mu$ l phenol:chloroform was added, the tube vortexed and then centrifuged for 3 minutes. The aqueous phase was removed and ethanol precipitated as above. After centrifugation the pellet was vacuum dried and resuspended in 30 $\mu$ l of TE.

#### Phosphatase Buffer:-

0.5M Tris.HCl pH9.0

10mM MgCl<sub>2</sub>

1mM ZnCl<sub>2</sub>

10mM spermidine

#### 2.7.4 Addition of Linkers to DNA (Bahl *et al.*, 1976)

This involves the conversion of the protruding ends left by the action of one RE on a piece of DNA to the recognition site of another RE. This is done by converting the DNA to a blunt ended fragment and then ligating on the appropriate double-stranded linker, followed by digestion with the new R.E.

##### a) Fill in synthesis

This was done as follows:-

13 $\mu$ l	DNA (0.5 - 1.0 $\mu$ g)
2 $\mu$ l	Klenow reaction buffer
4 $\mu$ l	0.5mM dNTP uniform chase
1 $\mu$ l	Klenow fragment DNA polymerase 1U/ $\mu$ l

Uniform chase is 0.5mM 4x dNTP's.

Klenow reaction buffer is:-

100mM Tris.HCl pH 8.5

10mM MgCl<sub>2</sub>

This was incubated in an eppendorf at room temperature for 45 minutes and then heated at 70°C for 5 minutes. Alternatively, radioactive dCTP could be incorporated in order to follow the progress of the reaction.

10 $\mu$ l	DNA
2 $\mu$ l	buffer
2 $\mu$ l	2mM 3xdNTP (no CTP)
4 $\mu$ l	(40 $\mu$ Ci) <sup>32</sup> P-dCTP
1 $\mu$ l	Klenow enzyme

37°C, 15 minutes.

Then, 2  $\mu$ l dNTP uniform chase for 2 minutes followed by heating at 70°C for 5 minutes.

**b) Kinasing the linkers**

1 $\mu$ l	unphosphorylated linkers (0.1 $\mu$ g. $\mu$ l <sup>-1</sup> )
1 $\mu$ l	linker kinase buffer
1 $\mu$ l	10mM ATP
1 $\mu$ l	polynucleotide kinase, 9U/ $\mu$ l
6 $\mu$ l	sterile distilled water

37°C, 1 hour

**Linker Kinase Buffer:-**

0.7M Tris.HCl pH 7.6

0.1M MgCl<sub>2</sub>

50mM DTT

**c) Ligating The Linkers To The Fragment**

20 $\mu$ l	filled in fragment
10 $\mu$ l	kinased linkers
3 $\mu$ l	ligase buffer
2 $\mu$ l	T4 DNA ligase (2-5 U/ $\mu$ l)
4 $\mu$ l	sterile distilled water

15°C, overnight.

The DNA was cut with the appropriate RE and then electrophoresed through an agarose gel (see section on agarose gel electrophoresis) and the fragment purified. It was then ready for ligation into the desired vector.

### 2.7.5 Nick-translating DNA (Maniatis *et al.*, 1982)

This technique allows radioactive label to be incorporated into DNA fragments by nicking the DNA and synthesising duplicate strand in the presence of a radioactively labelled deoxyribonucleotide or dNTP. This is usually  $\alpha$ -<sup>32</sup>P-dCTP. The reaction is set up as follows:-

15 $\mu$ l	DNA
20 $\mu$ l	Nucleotide/buffer solution 1
10 $\mu$ l	$\alpha$ - <sup>32</sup> P-dCTP
10 $\mu$ l	enzyme solution 2
45 $\mu$ l	dist. H <sub>2</sub> O

15°C, 2 hours

Nucleotide/buffer solution 1 and enzyme solution 2 were from the Amersham Kit. While the reaction was taking place, a Sephadex G50 column was set up. A 5cm length of thin rubber tubing was attached to the end of a 5ml plastic pipette and a clip attached. Sephadex G50 in TES pH8 was added and allowed to settle until about 6ml of packed Sephadex formed in the pipette. The Sephadex was then washed through with TES.0.1% SDS.

The reaction mixture was then loaded onto the column and run into the Sephadex. TES.SDS was then used to top up the column as the reaction mixture was allowed run through the Sephadex. Fractions of 0.5ml were collected in Eppendorf tubes and the three most radioactive tubes from the first peak of radioactivity (as determined by the geiger counter) were pooled and their radioactivity determined by the scintillation counter. Prior to use the probe was boiled for ten minutes.

### 2.7.6 Random Priming of DNA (Feinberg and Vogelstein, 1983, 1984)

This technique uses hexadeoxyribonucleotides in all possible permutations in order that they will hydrogen bond to the DNA in question at numerous points along the sequence. The Klenow fragment of DNA polymerase will then synthesize the rest of the fragment incorporating radioactive nucleotides as in nick translation. The reaction was set up as follows:-

OLB buffer	10 $\mu$ l
10mg.ml <sup>-1</sup> BSA	2 $\mu$ l
DNA upto	31 $\mu$ l
$\alpha$ - <sup>32</sup> P-dCTP	(50 $\mu$ Ci) 5 $\mu$ l
Klenow enzyme	2 $\mu$ l
Total	50 $\mu$ l

Incubated at room temperature for 2.5 hours (30-50ng DNA), 5 hours (10-30ng) overnight (less than 10ng). The reaction was stopped by the addition of 200 $\mu$ l of 20mM NaCl. 20mM Tris,Cl pH 7.5. 2mM EDTA. 0.25% SDS. 1 $\mu$ M dCTP. The reaction mixture was run on a column as before.

OLB Buffer is :-

Solution C = 1.25M Tris.HCl. 0.125M MgCl<sub>2</sub> pH8.0 stored at 4°C

Solution A = 1ml solution C + 18 $\mu$ l  $\beta$ mercaptoethanol + 5 $\mu$ l each of dATP, dGTP, dTTP at 0.1M in 3mM Tris.HCl. 0.2mM EDTA pH 7.0. Stored at -20°C.

Solution B = Hexadeoxyribonucleotides in TE at 90 OD units per ml. Stored at -20°C.

These were mixed in the ratio 100:250:150 (A:B:C), to make OLB. This was stored

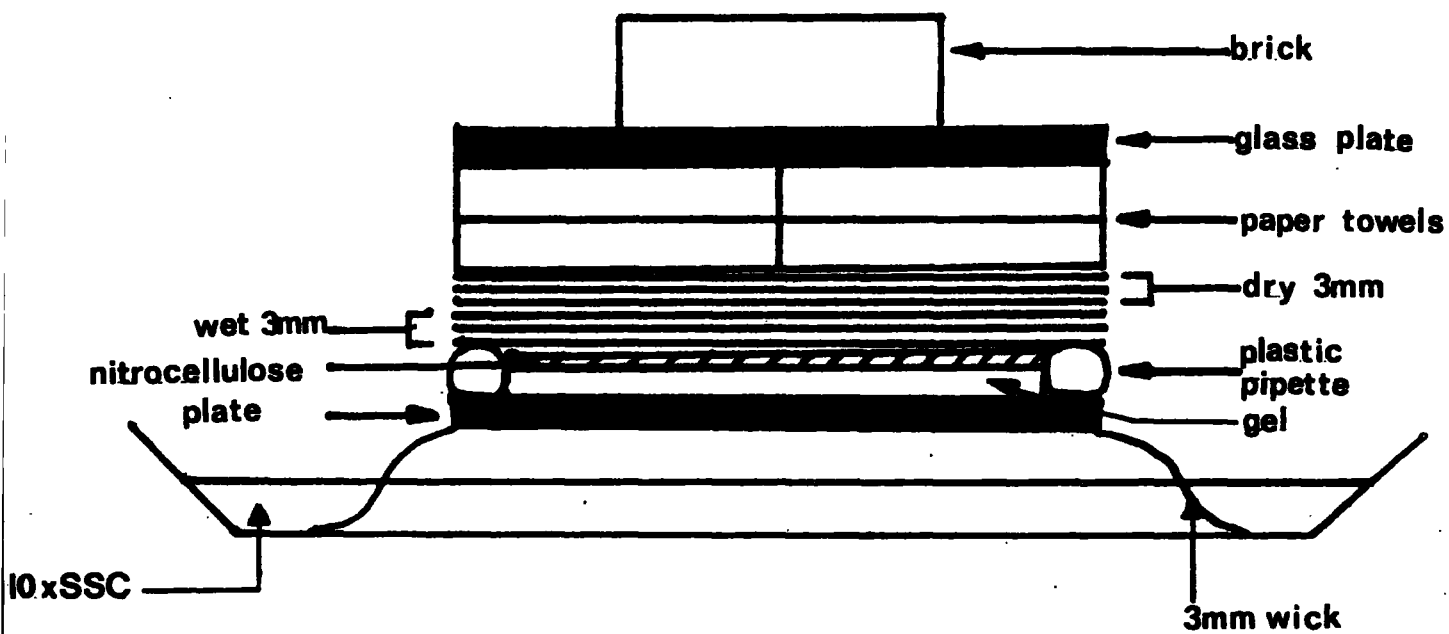
at -20°C and could be kept for upto 3 months.

### **2.7.7 Southern Blotting (Southern, 1975)**

This technique allows DNA fragments containing specific sequences be to located against a background of other DNA fragments. The basic principle of Southern blotting is the transfer of DNA fragments to a nitrocellulose filter from an agarose gel, preserving the pattern of fragments. The DNA is then hybridised *in situ* with a specific radioactively labelled probe DNA fragment. The specificity of the hybridisation reaction can be varied by altering the reaction conditions.

The protocol proceeds as follows:-

The agarose gel was photographed under UV light, if the gel was of total or genomic DNA the gel was soaked for 15 minutes in 1% HCl. The gel was then washed twice with distilled water and then soaked for 45 minutes (for plasmid DNA the process starts here) in denaturation buffer (1.5M NaCl. 0.5M NaOH). The gel was then washed twice in distilled water and then soaked for 45 minutes in neutralisation buffer (3M NaCl. 0.5M Tris.HCl pH 7.0). The gel was then rinsed in 20x SSC (3M NaCl. 0.3M sodium citrate). The gel was then transferred to the blotting apparatus (see figure 2.1) and blotted overnight. The nitrocellulose was removed and rinsed in 3xSSC before being placed between two pieces of 3MM paper and baked in a vacuum oven at 80°C for two hours. The nitrocellulose filter was then incubated at 65°C in prehybridisation buffer for 4 hours.



**Figure 2.1 Southern Blotting Apparatus**  
 Stylised representation of the Southern blotting apparatus.

**Prehybridisation buffer is:-**

20mg PVP, 20mg Ficoll, 20mg BSA, 15ml 3xSSC made upto 100ml with distilled water.

The filter was then removed and incubated overnight at the same temperature in hybridisation buffer to which the <sup>denatured</sup> radioactive probe DNA was added. Hybridisation buffer is the same as prehybridisation buffer but contains in addition 400 $\mu$ l 250mM EDTA and 5ml 10% SDS.

The filter was then washed in 3xSSC. 0.5% SDS 3-4 times or until there was no radioactivity detectable in the wash solution. The filter was then washed once in 3xSSC, dried and exposed to X-ray film. When the film was developed, where the probe had hybridised to the DNA fragments, black bands were seen which allowed the DNA fragments containing the sequence to be identified with reference to the photograph of the agarose gel.

## **2.8 Agarose Gel Electrophoresis (Sharp *et al.*, 1973)**

This technique allows DNA molecules to be separated according to size by their differing electrophoretic mobilities. The concentration of agarose can be altered in order to separate different classes of DNA molecules, raising it to separate small DNA molecules and lowering the concentration to separate large molecules. In this study only 0.7% agarose gels have been used. This concentration is useful for separating plasmid DNA and restriction fragments down to about 0.5kb. Two types of agarose have been used, standard agarose which melts near 100°C and low melting point agarose which melts at 65°C and is useful for isolating DNA fragments. Gels were commonly made as either standard (200ml) gels or mini-gels (30-50ml).

These were made up as follows:-

Large Gel		Mini-gel	
10ml	10x TAE buffer	5ml	10x TBE
1.4g	agarose	0.35g	agarose
180ml	distilled water	45ml	distilled water

Boiled in a microwave oven for four to six minutes

2.5 $\mu$ l 10mgml<sup>-1</sup> ethidium bromide was then added to the mini-gel

The DNA to be electrophoresed was mixed with 1/10th the volume gel dye and then carefully pipetted into the slots left by the comb. The gel tank was filled with the appropriate buffer then connected to the power pack and the gel electrophoresed at 40mA overnight for a large gel and 60mA for 1-2hours for a mini-gel. The inclusion of ethidium bromide in the gel enabled the DNA to be visualised and photographed under U.V. illumination.

10x TAE		10x TBE	
Tris Base	49.4g	Tris Base	108g
EDTA	3.7g	0.5M EDTA	40ml
Etbr (10mgml <sup>-1</sup> )	0.25ml	Boric acid	55g

pH to 7.7 with acetic acid.

No adjustment of the pH was required with TBE. Both buffers were made upto 1 litre

Gel Dye:-

10% SDS	1ml
0.25M EDTA pH 8	2ml
1M Tris.HCl pH 8	0.1ml

Glycerol	5ml
Bromophenol blue	5mg
H <sub>2</sub> O	0.8ml

### 2.8.1 Isolation of DNA from Agarose Gels

Five such methods have been used in this study.

#### a) Freeze Elution (freeze squeeze) (Thuring *et al.* 1975)

The smallest possible fragment of agarose containing the DNA was cut out and placed in a corex tube containing 0.9ml distilled water and 0.1ml 3M NaAc.10mM EDTA. This was left in the dark for 15 minutes with occasional shaking. Meanwhile, a 0.5ml Eppendorf tube was holed in the bottom and plugged with siliconised glass wool, this was then placed in a cap-less 1.5ml eppendorf tube and washed through with 0.5ml sterile distilled water. The agarose slice was then removed from the corex tube and briefly blotted dry with tissue paper. The slice was then put inside the small Eppendorf which was placed at -80°C for 20 minutes. The small Eppendorf was then placed inside the large Eppendorf and the whole assembly centrifuged for 15 minutes at top speed in a microfuge. The small tube was then discarded and the liquid in the large Eppendorf retained. To this was added 5µl 1M MgCl<sub>2</sub>.10% acetic acid, 20µl 3M NaAc pH 4.8 and 1ml ethanol. The contents were mixed and the tube placed at -80°C for 20 minutes. After this the tube was centrifuged for 10 minutes, the supernatant discarded and the pellet resuspended in 180µl TE. The DNA was re-precipitated and the pellet vacuum dried before being resuspended in 20µl TE. If desired, 5µl of this could be run on a mini-gel to check for the presence of the correct DNA fragment.

**b) Isolation Onto DE-81 Paper ( M Watson, personal communication)**

A slit was cut in the agarose immediately ahead of the desired fragment and a suitably sized piece of Whatman DE-81 paper inserted. The current was turned on again until the DNA had bound to the paper (checked under UV illumination). The paper was removed with forceps and rinsed with distilled water. The paper was carefully blotted dry, rolled-up and placed in an Eppendorf tube containing 300 $\mu$ l 1.5M NaCl.TE and incubated at 37°C for 2 hours. The paper and liquid were then centrifuged through a holed small Eppendorf into a large Eppendorf at low speed in a microfuge. The paper was rinsed at high speed with 150 $\mu$ l 1.5M NaCl.TE, all the liquid being collected in the same large eppendorf tube. The liquid was then centrifuged for 2 minutes at high speed and the transferred to a fresh large Eppendorf tube. The DNA was then ethanol precipitated and the pellet resuspended 400 $\mu$ l TE. This was then phenol extracted, ethanol precipitated, centrifuged and the pellet vacuum dried before being resuspended in 20 $\mu$ l of TE. This again could be checked on a mini-gel.

**c) Elution Into A Buffer Well (Hogness, in Maniatis *et al.*, 1982)**

The DNA was electrophoresed until the fragments were well separated and a small well was cut immediately in front of the desired fragment. The gel was put back in the electrophoresis tank and buffer removed until the level was slightly below the top of the gel. The buffer in the well was removed with a pipette and replaced with an equal volume of TE. The current was turned on and the gel electrophoresed at 100mA for 1-2 minutes. The TE was then removed to an Eppendorf tube and the gel examined under UV. The process was repeated until all the desired DNA fragment had been extracted into TE. With practice the total volume of TE could be as low as 400 $\mu$ l. The DNA was then phenol extracted and ethanol precipitated before being

vacuum dried and resuspended in TE.

**d) Low Melting Point Agarose method (1) (M. Watson, personal communication)**

The gel was prepared as usual except that low melting point agarose was used. This will melt at 65°C rather than 100°C. Since the gel is much more fragile than a normal gel, great care was taken when handling the gel. The gel surround and comb were not removed until the gel was immersed in the buffer. Prior to loading the samples, the gel was pre-electrophoresed for 10 minutes. After the DNA had been electrophoresed, the desired fragment was cut out under UV illumination, the smallest possible amount of agarose being removed. The agarose slice was then placed at 65°C, in an Eppendorf until it melted and then two volumes of TE were added and the tube placed at 37°C for 5 minutes. The DNA was phenol extracted twice, chloroform/isoamylalcohol extracted once, before being ethanol precipitated and then vacuum dried. The DNA was resuspended in 20µl of TE or sterile distilled water.

**e) Low Melting Point Agarose Method (2).(Ref. as above)**

The gel was set up and electrophoresed as above and the DNA band removed. The agarose was melted at 65°C in an Eppendorf containing 3 volumes of TE. This caused the agarose concentration to drop to 0.15%. If this was used in a 1:1 ratio with vector DNA solution, then the agarose would not re-gel and the ligation reaction would not be inhibited.

## 2.9 DNA Sequencing

This method is based on the dideoxy chain termination method of Sanger *et al.* (1980). The DNA to be sequenced is cloned into an M13 phage derivative and single stranded DNA is made. To this is annealed a single stranded primer and then the Klenow fragment of DNA polymerase 1 is used to synthesise a complementary strand. The reaction is performed in four tubes each of which contains a mix of 4 deoxynucleotides (dNTP) and one dideoxynucleotide (ddNTP's), one for each nucleotide. Where a ddNTP is incorporated no further chain extension can occur. The four reaction mixtures therefore produce a set of short DNA fragments. A radioactive label is also incorporated and when the fragments are electrophoresed on very thin polyacrylamide gels and an x-ray film exposed, the sequence can be read.

### 2.9.1 Annealing the template to the primer

The s.s.DNA template was produced as in section 2.4. The annealing reaction was typically done as follows:-

s.s.DNA template	5 $\mu$ l
17mer primer	1 $\mu$ l
Klenow buffer	1.5 $\mu$ l
double dist. water	2.5 $\mu$ l

The primer was either complementary to the M13mp9 multiple cloning site or was a synthetic oligonucleotide complementary to an already sequenced part of the cloned DNA, made on an LKB oligonucleotide synthesiser.

This was heated to 85°C in a microfuge tube inside a lead pot, held at that temperature for 5 minutes and then allowed to cool slowly inside the pot. The mixture could

then be stored at  $-20^{\circ}\text{C}$  if necessary.

### 2.9.2 The Sequencing Reaction

The template/primer mix was briefly centrifuged to the bottom of the tube and  $1\mu\text{l}$  ( $10\mu\text{Ci}$ ) of  $[\alpha\text{-}^{35}\text{S}]\text{dATP}$  was added to the rim of the tube and then spun to the bottom.  $1\mu\text{l}$  of Klenow was added and the contents mixed by careful pipetting. This was now called 'the mix'. Four Eppendorf tubes were then prepared (labelled A,G,C,&T) as follows:-

A  $2.5\mu\text{l}$  of mix +  $2\mu\text{l}$   $\text{dA}^{\circ}/\text{ddATP}$

G  $2.5\mu\text{l}$  of mix +  $2\mu\text{l}$   $\text{dG}^{\circ}/\text{ddGTP}$

C  $2.5\mu\text{l}$  of mix +  $2\mu\text{l}$   $\text{dC}^{\circ}/\text{ddCTP}$

T  $2.5\mu\text{l}$  of mix +  $2\mu\text{l}$   $\text{dT}^{\circ}/\text{ddTTP}$

The ddNTP's were made up in distilled water at the following concentrations:-

ddATP 0.1mM

ddGTP 0.3mM

ddCTP 0.1mM

ddTTP 0.5mM

These were mixed <sup>(1:1)</sup> with their respective dNTP<sup>o</sup> solution to produce the mixtures added above.

	A <sup>o</sup>	G <sup>o</sup>	C <sup>o</sup>	T <sup>o</sup>
0.5mM dCTP	20 $\mu\text{l}$	20 $\mu\text{l}$	1 $\mu\text{l}$	20 $\mu\text{l}$
0.5mM dGTP	20 $\mu\text{l}$	1 $\mu\text{l}$	20 $\mu\text{l}$	20 $\mu\text{l}$
0.5mM dTTP	20 $\mu\text{l}$	20 $\mu\text{l}$	20 $\mu\text{l}$	1 $\mu\text{l}$
1x TE	20 $\mu\text{l}$	20 $\mu\text{l}$	20 $\mu\text{l}$	20 $\mu\text{l}$

The four tubes were left at room temperature for 20 minutes before 2 $\mu$ l of chase solution (0.5mM dATP) was added and the tubes left for a further 15 minutes. The reaction was then stopped by the addition of 4 $\mu$ l of formamide dyes:-

100ml formamide mixed with 5g Amberlite mixed bed resin, stirred for 30 minutes and then the resin was filtered off. The formamide was then added to 0.03g xylene cyanol, 0.03g bromophenol blue and 0.75g EDTA.

### 2.9.3 The Sequencing gel

Two sets of 20x40cm glass plates and two sets of 20x38cm plates were thoroughly washed and rendered grease free. One surface of each plate was siliconised with 'Repelcote'. Clean plastic spacers were placed along the long edges of both large plates on the siliconised side. The smaller plates were placed on top of the large plates (siliconised side down) to form a sandwich with the spacers flush with the edges of both glass plates. Waterproof tape was then used to seal the edges of the plates, taking special care around the bottom edge and ensuring no air bubbles were trapped. The top of the plates was left unsealed to admit the gel. The gel was made up as follows:-

Urea	21g
Acryl. stock	7.5ml
TBE	5ml
warm to dissolve urea	
Dist. water to 5 ml	
Degassed. Then,	
TEMED	50ul
10% Ammonium persulphate	300 $\mu$ l

### **Acrylamide Stock**

<b>Acrylamide</b>	<b>38g</b>
<b>Bisacrylamide</b>	<b>2g</b>
<b>Water up to</b>	<b>100ml</b>

Enough for both sets of plates.

The gel was poured using a small beaker or large syringe with the plates at a slight angle so that the gel filled the plates from the bottom corner first and no air bubbles were trapped. The sharks tooth comb was placed upside down in the gel to create a level gel surface. The gels were allowed to set horizontally. When set, the urea was cleaned off the top of the gel with water and the sharks tooth comb reversed so that the teeth protruded into the gel to a depth of 1mm. The tape around the bottom of the gel was removed and two rubber pads (2x3cm) were stuck onto the top of the large plates with grease either side of the comb. The top surface of the small plate and the pads were liberally greased to a depth of about 7cm so that the plates could make an effective watertight seal with the gel tank. The gels were then clamped into the gel tank with an aluminium plate on the outside to distribute the heat generated evenly and so prevent the uneven running of the DNA samples. The top and bottom tanks were filled with 1x TBE and connected up to the power supply. In order maintain a temperature of 55-60°C, the gels were pre-electrophoresed at 1500volts and 60mA until the correct temperature was reached. The four DNA samples were then heated to 95°C for 3 minutes prior to loading. Meanwhile the wells formed by the comb were sparged with a syringe to rid them of leached urea and air bubbles. The hot samples were then loaded into the wells using half of each sample for each gel. The samples were loaded with a microsyringe in the order A,G,C,T. One of the gels was electrophoresed until the first dye front reached the bottom of the gel (running with

the unlabelled primer and the first few bases). The other gel was run until the second dye front had run off the end of the gel. Both gels were then carefully taken apart and the gel itself transferred to 3MM paper and covered with a piece of <sup>cellophane</sup>  $\lambda$ . The gels were then dried in a commercial slab drier (Bio-Rad) for 5 hours.

The gels were then used to expose X-ray film (Fuji RX pre-flashed) in the dark. The X-ray film was then developed and the sequence determined.

## 2.10 Protein Preparation

### 2.10.1 Extraction of Protein from Yeast (1) (J Yarwood, pers. comm.)

The yeast were grown to late log phase in 10ml YPD or YMM; The cells were then centrifuged in pre-weighed centrifuge tubes at 5000 rpm for 5 minutes at 5°C. The cells were then resuspended in 1ml of 1mM <sup>phenyl</sup>  $\lambda$  /methylsulphonyl flouride (PMSF) per gramme of pellet. Also, 1g of glass beads was added per gramme of cells. The cells were then sonicated for 3 minutes (30secs on, 30 secs off, cooling on ice in between) and then centrifuged for 10 minutes at 10000rpm at 5°C. Then, 500 $\mu$ l of the supernatant was added to an equal volume of 2x sample buffer (see section <sup>2.11.1</sup>  $\lambda$  ) and the contents of the tube boiled for 5 minutes. The sample was now ready to load onto a protein gel (see section 10).

### 2.10.2 Extraction of Protein from Yeast (2) (Watson *et al.*, 1988)

The yeast were grown to stationary phase in 10ml of supplemented YMM. The cells were harvested by centrifugation at top speed in a bench-top centrifuge. The supernatant was discarded and the cells resuspended in 100 $\mu$ l of sample buffer containing 1 $\mu$ l of 200 $\mu$ gml<sup>-1</sup> leupeptin and 1 $\mu$ l of 100mM PMSF. The solution was transferred to an Eppendorf and the cells pelleted lightly. An equal volume of glass beads was

added and the tube vortexed 5x15 secs with cooling on ice in between. The tube was then centrifuged at top speed in a microfuge for 3 minutes and the supernatant removed to a fresh tube where it was boiled for 10 minutes prior to loading on a protein gel (see next section).

## 2.11 Polyacrylamide Gel Electrophoresis (Laemmli, 1970)

### 2.11.1 Standard Laemmli Gel

The gel was cast in glass plates as according to the following method:- The plastic spacers were lightly greased with high vacuum grease and then were fitted between the glass plates and the whole assembly clipped together with large bulldog clips. The gels were made according to the recipes below.

Main Gel (17%)		Stacking Gel (3%)	
Acrylamide soln 1	35.4ml	Acrylamide soln 2	2ml
1M Tris.HCl pH8.8	22.5ml	1M Tris.HCl pH6.8	2.5ml
		S.D.W.	14.8ml
Both degassed			
Then:-			
10% SDS	0.6ml	10% SDS	0.2ml
TEMED	20 $\mu$ l	TEMED	20 $\mu$ l
5% Amm.persulph.	1.5ml	20% Amm.persulph.	0.5ml

#### SAMPLE BUFFER

0.2% SDS  
 0.1M Tris-HCL pH6.8  
 0.025% Glycerol

<b>Acrylamide Solution 1</b>		<b>Acrylamide Solution 2</b>	
Acrylamide	30gr.	Acrylamide	30gr.
bisacrylamide	135mg	bisacrylamide	435mg
S.D.W.	upto 100ml	S.D.W.	upto 100ml

An alternative gel recipe used towards the end of the project used the same Acrylamide stock solution for both the stacking and main gels. The concentration of Acrylamide was still 30% but the concentration of bisacrylamide was 0.8%. 10% Ammonium persulphate was used to set both gels, 0.8ml added for the main gel and 0.4ml added for the stacking gel.

Occasionally a 12.5% gel was used which was made in the same way but with only 25.4ml of Acrylamide solution and 10ml of distilled water instead.

The main gel was poured into the plates immediately after the addition of the ammonium persulphate and 1ml of isopropanol was layered onto the surface to exclude oxygen and ensure a smooth surface to the main gel. After the main gel had set, the isopropanol was poured off and the stacking gel was poured. The comb was inserted making sure no air bubbles were trapped. When the stacking gel had set, the gel was clamped into the gel tank. P.A.G.E. buffer (see below) was then poured into the two buffer wells. The protein samples (up to 100 $\mu$ l) were then loaded into the wells using a microsyringe. The gel was electrophoresed at 15mA overnight or 60mA for 6 hours. The gel was then carefully removed from the plates and either used for western blotting (see next section) or placed in 100ml of staining solution and shaken for 3-4 hours. The gel was then washed with some distilled water and then shaken in destaining solution for a further 3-4 hours or until all the stain had been leached out except that in the protein bands. The gel was then dried in one of two ways. The first method involved sandwiching the gel between two layers of wet membrane filter and

then drying under vacuum on a slab gel drier for 48 hours. In the second method, (N. Robinson, personal communication) the gel was incubated in 3% glycerol for 30 minutes before being carefully placed onto a wet piece of membrane filter on a glass plate. A second piece of wet filter was placed on top of the gel and air bubbles were excluded as much as possible. A plastic gel surround was placed around the gel and clamped in place. An angle-poise lamp was then positioned directly over the gel at a distance of 8cm (approx.) and switched on for about 4 hours or until the gel was dry. This second method was not used for Schagger gels (see next section) as they tended to crack.

P.A.G.E buffer		Stain/destain	
Glycine	141g	Methanol	1 litre
Tris base	30g	Acetic acid	140ml
SDS	10g	( kenacid blue R250)	1.8g
S.D.W.	to 1 litre	S.D.W.	to 2 litres

### 2.11.2 Schagger Gels (Schagger and Von Jagow, 1987)

This method involves the same gel casting techniques but the recipes and running of the gel are different. The system was originally designed for separating small molecular weight proteins (less than 10KD) but does give sharpening of all bands below 100KD. The main difference is that the gel system uses Tricine instead of glycine to achieve better stacking and hence better separation of proteins.

After the protein samples were loaded, the gel was electrophoresed at 30 volts for 1 hour and then run at a maximum of 100 volts overnight. The gel was then stained and destained as above and dried in a slab drier or used for western blotting.

Anode buffer		Cathode buffer	
Tris.HCl pH 8.9	0.2M	Tris	0.1M
		Tricine	0.1M
		SDS	0.1%
		pH 8.25 (no adjustment required)	

Gel buffer		Acrylamide stock	
Tris.HCl pH8.45	3M	Acrylamide	48g
SDS	0.3%	Bisacrylamide	1.5g
		dist. water	upto 100ml

Main gel, 16.5%		Stacking gel	
Acrylamide stock	10ml	Acrylamide stock	1ml
Gel buffer	10ml	Gel buffer	3.1ml
80% glycerol	4ml		
dist. water	6ml	dist. water	8.4ml
Degass		Degass	
TEMED	10 $\mu$ l	TEMED	10 $\mu$ l
10% Amm.persulph.	150 $\mu$ l	10% Amm.persulph.	100 $\mu$ l

## 2.12 Western Blotting (Towbin *et al.*, 1979)

This is the semi-dry electroblotter method and firstly needs three buffers to effect the transfer of proteins to the nitrocellulose filter.

Anode buffer no.1	Anode buffer no.2	Cathode buffer
Tris 0.3M	Tris 25mM	Tris 25mM
Methanol 20%	Methanol 20%	Methanol 20%
SDS 0.1%	SDS 0.1%	SDS 0.1%
		6 amino-n-hexanoic acid 40mM
pH 10.4	pH 10.4	pH 9.4

HCl was used to achieve the correct pH.

Six pieces of 3MM paper cut to the same size as the gel along with one piece of membrane filter and the nitrocellulose filter were prepared. Two pieces of paper were soaked in anode buffer no.1, one piece in anode buffer no.2 and three pieces were soaked in cathode buffer, as was the gel. The nitrocellulose and the membrane were soaked in distilled water. The anode and the cathode of the apparatus consisted of two graphite plates which were first washed with distilled water. The two anode buffer no.1 papers were carefully placed on the anodic plate excluding air bubbles, then the piece soaked in anode buffer no.2 was placed on top, again with no trapped air bubbles. Then came the nitrocellulose, the gel, a piece of paper soaked in cathode buffer, the membrane and finally the last two pieces of paper soaked in cathode buffer. No air bubbles were trapped at all. The cathodic plate was then placed on top and the power pack connected up. The transfer took place at 40mA for 1 hour. At the end of this period the assembly was taken apart carefully and the nitrocellulose blot removed for the next stage. The gel could be stained and destained to check if transfer

had been complete.

The blot was then placed in a small plastic lunchbox containing 50ml of 5% Blotto (Johnson *et al.*, 1984):-

nonfat dried milk 30g

10x Tris.salt 60ml

dist. water to 600ml

10x Tris.salt is:-

Tris 24.2g

Salt 45g

pH 7.2 with HCl

Dist. water to 1litre

The box was shaken at 37°C for 1 hour and then washed three times in 5% Blotto 10mins. each time. To 50ml of Blotto, 50µl of affinity purified rabbit anti-vicilin (0.8mg.ml<sup>-1</sup>) was added and the blot incubated as before for 2 hours. The blot was then washed three times in Blotto and then incubated in 50ml Blotto containing 30µl goat anti-rabbit, peroxidase conjugated, IgG (Biorad ltd) at 37°C for a further 2 hours. The blot was then washed three more times and finally washed in 1x Tris.salt. During this last wash, 30µg of diaminobenzidine (DAB) was dissolved in 100ml of 1x Tris.salt (with sonication in a small jeweller's sonicator if necessary) and stored in the dark until needed. The wash solution was drained off the blot, 50 µl of 30% w/v hydrogen peroxide was added to the DAB solution which was then poured onto the blot. If the brown bands appeared faint, 3ml of 1% cobalt chloride was added to enhance the bands, taking care not to let the cobalt chloride turn the whole blot black.

## **2.13 Electron Microscopy of Immuno-Gold labelled Yeast**

Two methods have been used in the course of this study. One method involves cryosectioning yeast and the other involves sectioning resin embedded yeast.

### **2.13.1 Cryosectioning (N.Harris, personal communication)**

Yeast were grown on a YMM plate with the appropriate supplements to give about 100 large colonies (2-3mm diam.) per plate. The yeast were then fixed on the plate for 1 hour in 10ml of the following solution:-

1.25%	glutaraldehyde
3%	paraformaldehyde
0.1M	sodium phosphate buffer pH 7.4
0.1M	sucrose

The plate of cells were then soaked overnight in the same solution except that the sucrose concentration was raised to 1M. The yeast colonies were then picked up on metal stubs and frozen quickly in Freon slush. Frozen sections were then cut on a Sorval MT-2b Microtome and picked up with a wire loop containing transfer drop solution (4% paraformaldehyde. 2.3M sucrose in PBS). The drops were then placed onto a 200 mesh, formvar and carbon coated copper grid. The grid was then placed section side down in a drop of PBS. The grid was then washed by taking it through 5-6 drops of PBS (0.7M NaCl. 50mM Phosphate Buffer pH 7.5)

### **2.13.2 Embedded sections (Brada and Schekman, 1988)**

Yeast were grown in YMM with appropriate supplements until an OD<sub>600</sub> of 1 was reached. The cells were then pelleted in a bench centrifuge and washed once with distilled water. The cells were then fixed for 1 hour in 5ml 2.5% glutaraldehyde. 1.5%

paraformaldehyde. 0.05M <sup>s</sup>Sodium cacodylate buffer pH 7. The cells were washed in distilled water and then incubated at 30°C in YPD. 1.2M sorbitol to which had been added 100µl of glucylase enzyme. Incubation was carried out overnight. The cells were incubated as before in fixer with 1.2M sorbitol for 30 minutes and then in 1% Osmium tetroxide for two hours (optional step). The cells were then embedded in 500µl 2% low melting point agarose and cut into 2mm square pieces. The yeast were dehydrated as follows:-

20% ethanol 1 hour 0°C

50% ethanol 1 hour 0°C

70% ethanol 1 hour -20°C

90% ethanol 1 hour -20°C

100% ethanol 1 hour -20°C

The cells were then incubated overnight in ethanol:LR white resin (1:1) at -20°C. The yeast were then incubated in neat resin for 36 hours with three changes of resin. The yeast were then placed in shallow plastic caps which were filled with resin and a coverslip placed on top excluding air. The resin was then set by baking in an oven overnight at 70°C. The resin discs were then removed from the plastic caps and trimmed with a scalpel blade to reveal a 1mm square cube of embedded yeast. This block was then mounted in the microtome and sections cut. The cut sections were removed onto coated grids by floatation.

### **2.13.3 Immunolabelling of cut sections (N.Harris, personal communication)**

The grids were washed in distilled water and then blocked for 10 minutes in 1% BSA. The grids were then washed in 3 drops of distilled water for 3 minutes each wash. The grids were then incubated for 30 minutes in rabbit anti-vicilin at 1/10 and 1/100

dilutions (in PBS) controls were incubated in PBS only. The grids were then washed in 10 drops of PBS for 2 mins each before being incubated for 30 minutes in a 1/20 dilution of goat anti-rabbit gold labelled antibody (20nm gold particles) in PBS. The grids were again washed in 10 drops of PBS and finally in a stream of distilled water. The grids were then stained for 10 minutes in saturated aqueous uranyl acetate and then washed in a stream of distilled water. The grids could then be stained for 5 minutes in lead citrate and washed in distilled water. The grids were then dried on filter paper and then mounted and viewed in the electron microscope.

## **2.14 Subcellular fractionation**

Two subcellular fractions were purified during this study, yeast vacuoles and yeast microsomes (endoplasmic reticulum and Golgi). In order to test the success and purity of the samples, marker enzymes were assayed. For vacuoles the marker enzyme was carboxypeptidase Y and for microsomes the marker enzyme was NADPH cytochrome C reductase.

### **2.14.1 Preparation of vacuoles (Emter and Wolf, 1984)**

Yeast cells were grown in 50ml of YMM or YPD until an OD<sub>600</sub> of 1.5 was reached and were then centrifuged at 5000rpm for 5minutes at 5°C and washed once in distilled water. The cells were recentrifuged and washed in 0.1M Tris.SO<sub>4</sub> pH 9.2 and then centrifuged again. The pellet was then weighed and 5ml of 0.1M Tris.SO<sub>4</sub> and 185µl of βmercaptoethanol was added per gramme of cells and the cells resuspended. The cells were then incubated at 30°C for 12 minutes before being centrifuged and washed twice in 1M sorbitol. The cells were then resuspended at 2.5ml/g. in 1M sorbitol.05% gluculase (or 0.04% novozyme) and incubated at 30°C for upto 4 hours. The extent to which spheroplasting had occurred was estimated as follows :-

10 $\mu$ l of cells were removed and diluted 1/100 in distilled water, another 10 $\mu$ l was removed and diluted in 1M sorbitol. The optical density of both samples was read at 600nm. The % spheroplasts was calculated as

$$[(A_{600\text{sorb}} - A_{600\text{H}_2\text{O}}) / A_{600\text{sorb}}] \times 100$$

When the cells were more than 75% spheroplasted, they were centrifuged and washed twice in 1M sorbitol. The spheroplasts were then resuspended at 10ml/g. in 12% Ficoll 400 0.1M sorbitol. 10mM Mes.Tris pH 6.8. The spheroplasts were then lysed by repeated passage through a 20ml syringe fitted with a large bore needle. The suspension became viscous when the majority of the cells had been broken. A sample of the lysate was kept for comparison with the purified vacuoles. The lysate was carefully overlaid with 18ml of 7% Ficoll 400 10mM Mes.Tris pH 6.8 and then centrifuged in a swing out rotor in a Sorval centrifuge at 12000 rpm for 35 minutes. The vacuole float was carefully removed and the Ficoll concentration adjusted to 10% with 13% Ficoll 400 10mM Mes.Tris pH 6.8. This was then overlaid with an equal volume of 7% Ficoll 400 10mM Mes.Tris pH 6.8 and centrifuged at 12000 rpm for 20 minutes. The vacuole float was then removed and could be stored at 4°C for 24 hours, after which time the activity of the marker enzymes would have decayed too far to be of use. The vacuoles and lysate sample were tested for the activity of CPY and NADPH cytochrome c reductase activity. Their protein contents were also determined. Aliquots were adjusted to 0.2M Tris.HCl pH 6.8.0.2% SDS with 2x sample buffer and then boiled for 10 minutes and loaded on SDS PAGE for western blotting.

### 2.14.2 Microsome Preparation (Rothblatt and Meyer, 1986)

Yeast cells were grown in YMM at 30°C to an OD<sub>600</sub> of 1.5 and were then centrifuged at 5000 rpm for 5 minutes at 5°C and washed twice in distilled water. They were resuspended in 12ml 0.1M Tris.SO<sub>4</sub>.10mM DTT and incubated at 30°C for 30 minutes. They were then centrifuged and washed twice in 1.2M sorbitol before being resuspended in 12.5ml YPD.1.2M sorbitol.20mM potassium phosphate buffer pH 7.2 to which was added glusulase or novozyme to a concentration of 0.5% and 0.04% respectively. The cells were then incubated at 30°C until more than 75% of the cells had spheroplasted (assayed as in the preparation of vacuoles). The spheroplasts were then layered over 10ml 0.8M sucrose.1.5% ficoll20mM Hepes.KOH pH 7.4 and centrifuged at 3000 rpm for 15 minutes at 4°C. The supernatant was carefully removed and discarded. The pellet was resuspended gently in 10ml homogenisation buffer (0.1M sorbitol.50mM KOAc. 2mM EDTA. 1mM DTT. 20mM Hepes.KOH pH 7.4. 1mM PMSF). The cells were homogenised with 40 strokes in a potter homogeniser (40ml, Wheaton Ltd. USA) with a tight fitting pestle, keeping the homogeniser on ice the whole time. An aliquot of the lysate was kept for later analysis. The rest of the homogenate was layered onto 18ml 1M sucrose.2mM EDTA.20mM Hepes.KOH pH 7.4 and centrifuged at 6500 rpm for 10 minutes at 4°C in a swing out rotor. The supernatant was removed and centrifuged at 22000 rpm for 20 minutes at 4°C. The buff coloured pellet was dissolved in 1ml 0.2M Tris.HCl pH 6.8.20% sucrose. Both the pellet and the lysate sample were assayed for the two marker enzymes and their protein contents measured. Aliquots of both samples were brought to a concentration of 0.2M Tris.HCl .0.2%SDS and boiled for 10 minutes before being loaded onto SDS PAG. .

## 2.14. Carboxypeptidase<sup>S</sup> Y Assay (After Aibara *et al.* 1971)

The assay was set up as follows:-

1M KPO <sub>4</sub> pH 7	100 $\mu$ l
L-amino acid oxidase (2.5 mg.ml <sup>-1</sup> )	50 $\mu$ l
Peroxidase (2mg.ml <sup>-1</sup> )	100 $\mu$ l
5mM MnCl <sub>2</sub>	100 $\mu$ l
dist H <sub>2</sub> O	150 $\mu$ l
10mM Cbz-phe-leu	0.5ml
Dianisidine HCl (2mg.ml <sup>-1</sup> )	50 $\mu$ l
protein extract	50 $\mu$ l

A blank was set up containing all of the above but without the protein extract and with an extra 50 $\mu$ l of water. The assay was left at 37°C for 90 minutes and then the absorbance of the solution was read at 405nm in an LKB Ultrospec. The result was expressed as nmol of leucine per minute per milligramme of protein using a standard curve derived as follows:-

A series of reactions was set up each containing 0.5ml test solution (0.25mg.ml<sup>-1</sup> L-amino acid oxidase. 0.4mg.ml<sup>-1</sup> peroxidase. 0.5mg.ml<sup>-1</sup> MnCl<sub>2</sub> in 0.2M potassium phosphate pH 7.0) to which was added 0.5ml containing 0.01, 0.05, 0.1, 0.15, 0.2, 0.3, 0.4, 0.5, 0.75, 1.0, and 2.0 micromoles of leucine respectively (in 0.2M potassium phosphate buffer pH 7.0). 50 $\mu$ l of (2mg.ml<sup>-1</sup> in distilled water) dianisidine was then added. The volume of each tube was made up to 1.1ml with distilled water and the tubes left for 90 minutes, after which the absorbance at 405nm was recorded.

### 2.14.5 NADPH Cytochrome C Reductase Assay (Polakis *et al.*,1965)

The reaction was set up as detailed below and the absorbance of the solution followed at 340nm until no further change occurred.

Amount in assay	final concentration
100mM pot. phos. buffer pH 6.45 3ml	50mM
250mM EDTA 4 $\mu$ l	0.25mM
16.7mM Potassium cyanide 400 $\mu$ l	1.67mM
3mg.ml <sup>-1</sup> cytochrome C 1mg	0.75mg.ml <sup>-1</sup>
1mM NADPH 400 $\mu$ l	0.1mM
Protein extract 200 $\mu$ l	

The control had no NADPH and no protein (600 $\mu$ l of water instead). The reaction was started by the addition of the NADPH. The amount of enzyme present was calculated using the change in absorbance observed, the time taken for the change and the molar extinction coefficient for NADPH ( $6.22 \times 10^3$ ).

### 2.15 Immunofluorescence of Yeast Cells (Kilmartin and Adams, 1984)

Yeast cells were grown to an OD<sub>600</sub> of 1 in YMM or YPD and then harvested by centrifugation on a bench centrifuge at top speed (3500 rpm). The cells were then washed once in 0.1M potassium phosphate buffer pH 6.5 containing 3% paraformaldehyde and 1% glutaraldehyde. The cells were then incubated in the same buffer for 90 minutes at 25°C. They were then centrifuged and washed three times in 0.1M potassium phosphate buffer. The cells were then spheroplasted in 1.2M sorbitol.0.12M K<sub>2</sub>HPO<sub>4</sub>. 0.033M citric acid pH 5.2 with glucylase or ~~novozyme~~ and monitored as before. The cells were washed three times in 1.2M sorbitol and then applied to poly-

L-lysine coated slides and fixed for 6 minutes in methanol and 30 seconds in acetone at  $-20^{\circ}\text{C}$ . The slides were then washed gently in  $1\text{mg}\cdot\text{ml}^{-1}$   $\text{NaBH}_4$  in PBS (3 x 5 minutes). Rabbit anti-vicilin was then added at a dilution of 1/100 in 1%BSA-PBS and the slides incubated overnight at  $37^{\circ}\text{C}$ . The slides were washed in BSA-PBS (3 x 5 minutes) and then incubated for 12 hours in FITC conjugated goat anti-rabbit Ig-G. The slides were washed as before and mounted in hydromount for viewing under the fluorescent microscope.

## **2.16 Other Biochemical Techniques**

This section details techniques used to analyse proteins extracted from yeast cells. It includes protein assays, purification techniques and enzymatic/chemical partial digestion of the yeast proteins.

### **2.16.1 Ammonium sulphate Precipitation**

10ml of fresh yeast protein extract (see section 2.10) was firstly centrifuged at 20000 rpm in a 50ml centrifuge tube in a Beckman centrifuge at  $4^{\circ}\text{C}$  for 15 minutes to pellet any insoluble material. The exact volume was then measured and the volume made up to 10ml with the same buffer into which the protein had been extracted. The protein solution was then placed in a 50ml clear polythene centrifuge tube with a magnetic 'flea' in the bottom. The tube was then placed in an ice/water slurry in a beaker on top of a magnetic stirrer enabling the protein solution to be stirred continuously. With reference to the table below the appropriate amount of ammonium sulphate was added a few milligrammes at a time to bring the desired % saturation. When all the ammonium sulphate had dissolved, the flea was removed and the tube centrifuged at 12000 rpm for 15 minutes at  $0-4^{\circ}\text{C}$  (without freezing the sample). The supernatant was retained in a second centrifuge tube and the pellet was dissolved

in 1ml SDS sample buffer and then dialysed against 50mM Tris.HCl pH6.8. The dialysate was then centrifuged and the pellet and supernatant retained separately for SDS PAGE. The unprecipitated proteins in the original supernat<sup>ant</sup> could be progressively precipitated with reference to the table below. The final residual supernatant was dialysed against 50mM Tris.HCl pH 6.8 (four changes) and then brought to 0.2% SDS with 2x sample buffer. The pellets and supernatant were analysed by SDS PAGE and western blotting.

Starting % Amm. Sulph.	Desired % Amm. Sulph. Saturation at 0°C						
	And grammes added to 100ml to achieve it						
Saturation	40	50	60	70	80	90	100
0	22.9	29.5	36.6	44.2	52.3	61.1	70.7
40	0	5.9	12.2	19.0	26.2	34.0	42.4
50		0	6.1	12.7	19.7	27.2	35.3
60			0	6.3	13.1	20.4	28.3
70				0	6.6	13.6	21.2
80					0	6.8	14.1
90						0	3.4

### 2.16.2 Cyanogen Bromide Treatment (Gross and Witkop, 1961)

CNBr cleaves proteins <sup>after</sup> every methionine residue and hence can be used to partially map proteins and provide small polypeptides for sequencing. The procedure was carried out as follows:-

Yeast were grown in 10ml YMM to OD<sub>600</sub> of 1-1.5 and then the proteins were ex-

tracted by the glass bead method (section 2.10) into 200 $\mu$ l 50mM Tris.HCl pH 8.6M guanidinium isothiocyanate. 200mM NaCl.1mM PMSF, freshly made. Then, 1ml (5x excess) of acetone was added and the proteins left at -20°C for 1 hour. The precipitated protein was then centrifuged for 10 minutes in a microfuge at top speed, vacuum dried and then redissolved in 200 $\mu$ l of 70% formic acid. This was then placed in a 20ml plastic vial and 1ml of CNBr added, the vial sealed with nescofilm, capped and then left in the dark for 24hours. After this period, 15 volumes of water were added and the contents of the vial frozen slowly in liquid air. The top was then sealed in nescofilm and a small hole pierced in the top. The contents of the vial were then freeze dried under vacuum for 48 hours. The dried material was then dissolved in SDS sample buffer and analysed by SDS PAGE and western blotting.

### 2.16.3 Immunoprecipitation (Croy *et al.* 1980b)

This technique uses anti-vicilin antibodies covalently linked to an inert support, in this case  $\lambda$  S epharose. The linked antibodies can then be used to precipitate vicilin from solution.

Yeast were grown to an OD<sub>600</sub> of 1.5 in 10ml of supplemented YMM and then pelleted in a bench centrifuge. They were then resuspended in 200 $\mu$ l of PBS.1mM PMSF with 0.1% Triton-X-100 and the proteins extracted by grinding against glass beads. The debris was removed by centrifugation in a microfuge and then the supernatant clarified by a further short spin. At this stage 10% SDS was added to bring the concentration to 0.1% (this step was sometimes omitted- see discussion). The protein extract was then boiled for two minutes and allowed to cool on the bench slowly. 5mg of extract anti-vicilin  $\lambda$  S epharose per 100 $\mu$ l was then added and the extract incubated at 4°C with shaking, overnight. The  $\lambda$  S epharose was then removed by centrifugation in a

microfuge and the supernatant removed and kept for later analysis. The Sepharose was then washed three times in PBS (600 $\mu$ l per 100 $\mu$ l of original extract) and finally washed once in PBS:0.1%SDS. The Sepharose was then pelleted and resuspended in 35 $\mu$ l per 100 $\mu$ l SDS sample buffer. The supernatant remaining after the first time the Sepharose was pelleted was brought to 0.2% SDS with 2x sample buffer and both it and the Sepharose solution were boiled for 10 minutes prior to loading onto SDS PAGE and then western blotting.

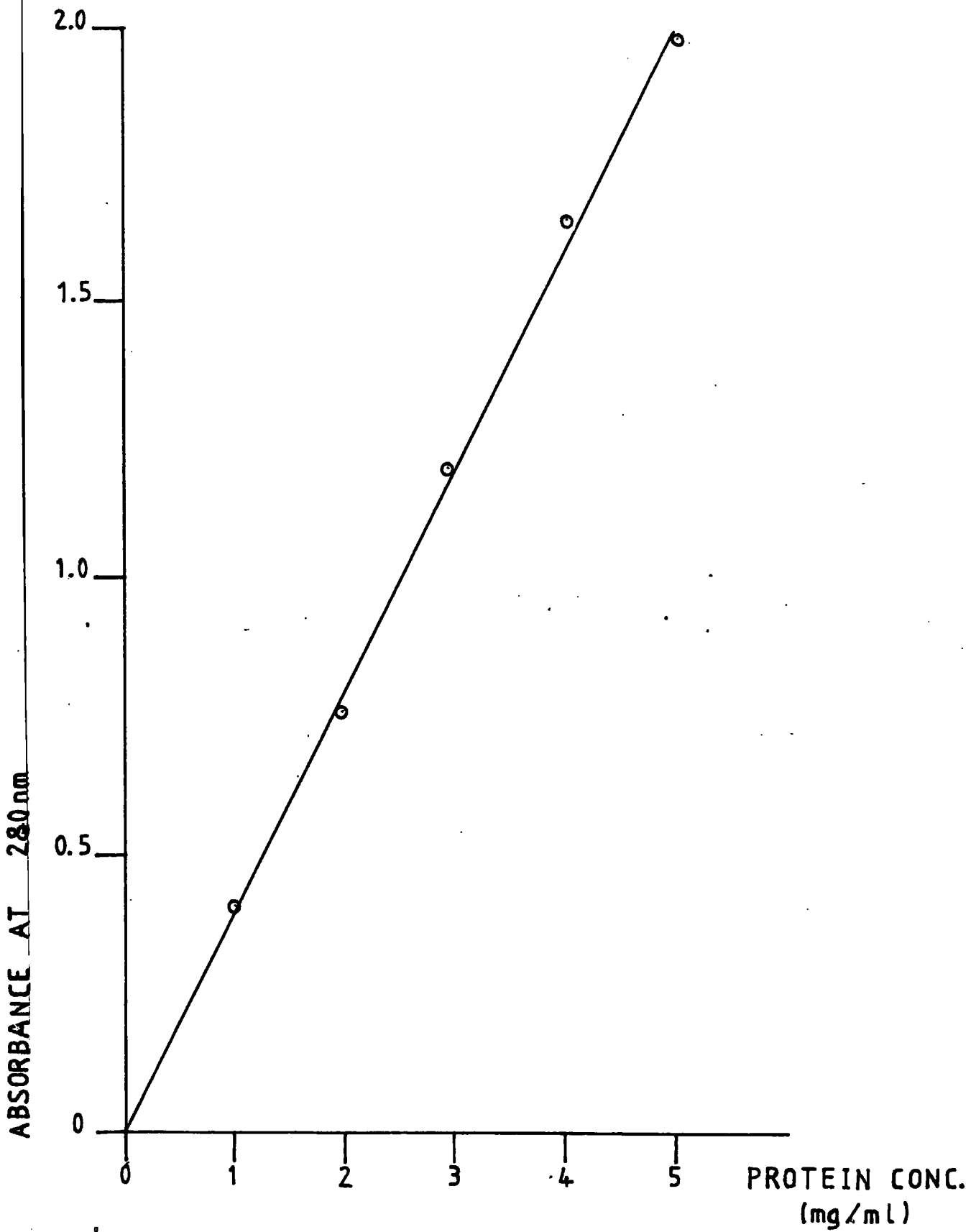
#### 2.16.4 Protein Estimation

Two methods have been used to estimate the amount of protein in solution during this study. The first method has previously been mentioned, that is the measurement of the absorbance of the solution at 280nm (the absorbance measured is that of the aromatic amino acids). This method has the advantage that it is non-destructive however, its accuracy depends on the proportion of aromatic amino acids being similar in different proteins and this is not always the case. A standard curve was constructed using BSA solutions as shown in figure 2.16.1. The second method used was the microbiuret assay which measures the number of peptide bonds. It is a more accurate method but is destructive.

In an Eppendorf tube,

1M NaOH	750 $\mu$ l
Benedicts reagent	50 $\mu$ l
Sterile dist. H <sub>2</sub> O	225 $\mu$ l
Sample	25 $\mu$ l

The samples absorbance at 330nm was measured against a blank containing 25 $\mu$ l of water instead of the protein sample, but with all the other components of the assay.



**Figure 2.16.1 Standard Curve for Protein 1.**  
Standard curve for protein determined by measuring the absorbance at 280nm of standard BSA solutions.

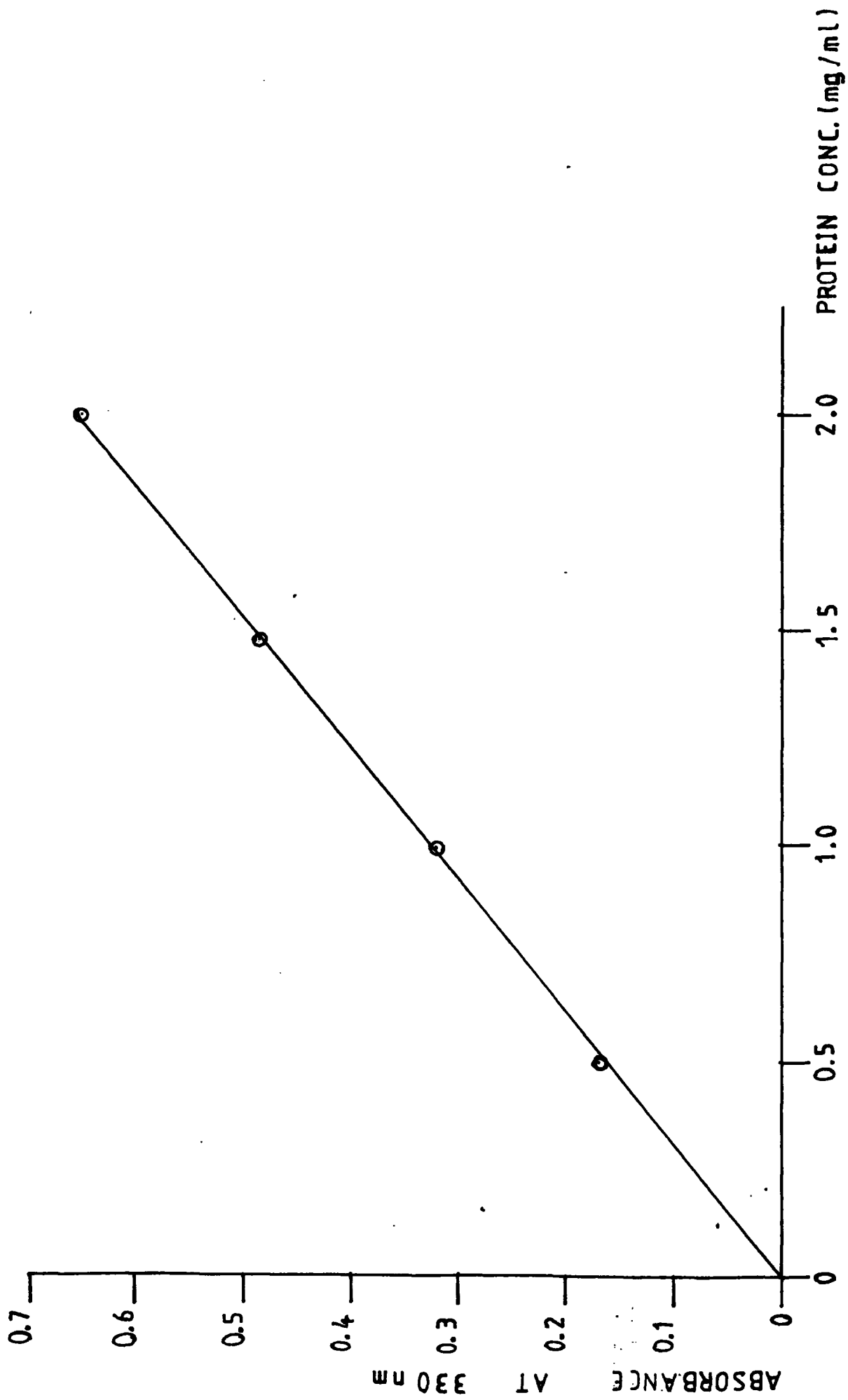


Figure 2.16.2 Standard Curve for Protein 2.  
Standard curve for protein determined using the microbiuret method.

The values obtained were compared to a standard graph (see figure 2.16.2). The graph was constructed using 0, 10, 15 and 20mg.ml<sup>-1</sup>BSA solution and using the above assay.

Benedicts reagent is:- Solution A. 173g trisodium citrate. 2H<sub>2</sub>O, 100g sodium carbonate. 10H<sub>2</sub>O dissolved in 500ml water. Warmed to dissolve. Solution B. 17.3g copper sulphate.5H<sub>2</sub>O dissolved 100ml of water. Solution B was then added to solution A and then made up to 1litre with water.

### **2.16.5 Colony Western Blot (J.Yarwood, personal communication)**

This method allows for the detection of transformed yeast colonies which are expressing a protein of interest. Transformed yeast colonies were plated out on YMM in a square pattern and allowed to grow at 30°C until the colonies were at least 2mm in diameter. The colonies were then transferred to nitrocellulose discs for 5 minutes and then incubated, colony side uppermost, on filter paper discs soaked in 1.0M sorbitol.YPD.0.5% lyticase (or glucylase) at 30°C for 2hours. The discs were then incubated for half an hour at 30°C on filter paper discs soaked in 0.1% SDS.0.2M NaOH.0.5% β-mercaptoethanol and then they were washed in distilled water to remove the cell debris. The nitrocellulose discs were then dried for 30 minutes on 3MM paper. The nitrocellulose discs were then developed as a normal western blot.

### **2.16.6 TCA Precipitation**

TCA was added to the protein solution to bring the concentration to 10% and the solution placed on ice for 30 minutes. The solution was then centrifuged at 20000rpm for 15 minutes. The supernatant was discarded and the pellet washed in 10% TCA. The precipitated proteins were then dissolved in SDS sample buffer. Prior to SDS PAGE and western blotting analysis.

### 2.16.7 N-glycosidase<sup>F</sup> Digestion (Plummer and Tarentino, 1984)

This enzyme removes carbohydrates from glycosylated proteins by attacking the bond between Asn in the Asn-X-Ser sequence and the first N-AcetylGlucose-amine unit attached to it.

The reaction was set up as follows:-

50 $\mu$ l SDS-sample buffer extracted yeast proteins

5 $\mu$ l 250mM EDTA

2 $\mu$ l N-Glycosidase

22 $\mu$ l sterile H<sub>2</sub>O.

37°C for 24 hours

The reaction mixture was then brought to 0.2% SDS with 10% SDS and analysed by SDS-PAGE and western blotting.

## CHAPTER 3. RESULTS

### 3.1 Restriction Mapping of pLG1.63

The plasmid pLG1.63 (shown in figure 3.1.1) was selected from a cDNA library prepared from poly-A<sup>+</sup> RNA isolated from developing pea cotyledons (L.N. Gatehouse, MSc. thesis 1985). It showed specific hybridisation to a cDNA probe (pDUB4) previously shown to encode part of a 47KDa vicilin precursor polypeptide (Lycett *et al.*, 1983a) and had an insert size sufficient to encode a full length vicilin polypeptide. The restriction map of the pLG1.63 was compared to restriction maps of cDNAs of the same type, pDUB4 and pDUB7 (Lycett *et al.* 1983a) since this will confirm that the cDNA shares common restriction sites and may show that it extends further at the 5' and 3' ends. Figure 3.1.1 shows a hybrid restriction map of pDUB4 and pDUB7 showing only the cDNA with the internal *Bgl*II and *Xba*I sites, and the restriction map for the cDNA from pLG1.63 was deduced from the agarose gel photographs shown in figure 3.1.2.

The first gel photograph shows that pLG1.63 has two *Eco*RI fragments, (track 3) one of size 1.6kb which is the cDNA and one of size 2.7kb which is pUC8, the vector into which the cDNA was originally cloned. Since pUC8 has no *Bgl*II or *Xba*I sites, the *Bgl*II (track 4) single digest shows that the cDNA has 2 *Bgl*II sites yielding fragments of size 3.6kb and (very faint band) 0.7kb. The *Xba*I (track 5) digest shows that the cDNA has only one *Xba*I site giving a single fragment of 4.3kb. Of the double digests (tracks 6,7 and 8) only the *Eco*RI/*Xba*I (track 7) digest worked properly in this case and shows only 2 of the expected 3 fragments, the 2.7kb pUC8 fragment and another of about 1kb. The same double digest in gel 2. (track 4) does show the third fragment at about 0.6kb. In the case of gel 2. the other two double digests (tracks 2 and 3)

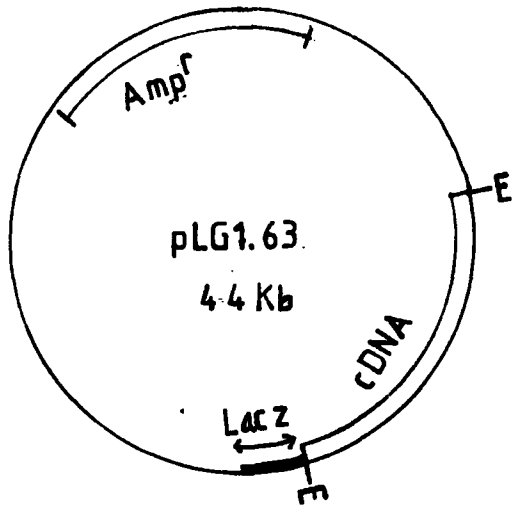
KEY

B = Bgl II

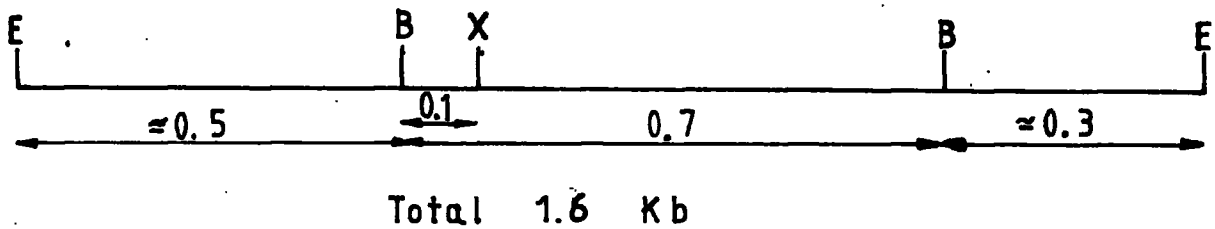
E = EcoRI

M = BamHI

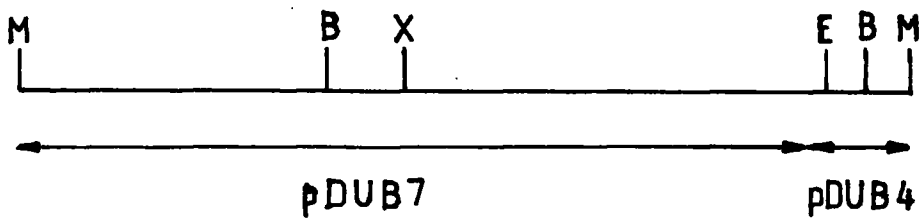
X = Xba I



1)



2)

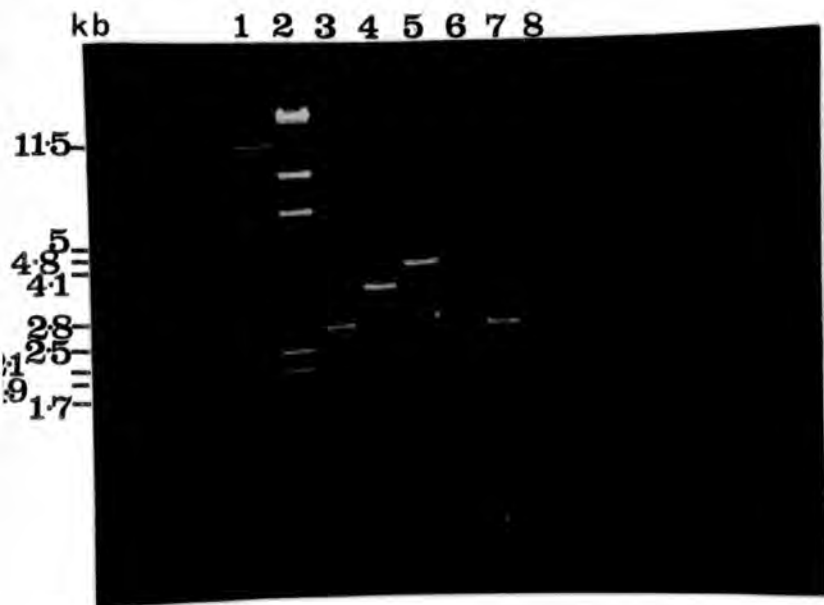


Scale, 1cm=0.1Kb

Figure 3.1.1 Restriction Maps of pLG1.63, pDUB4 and pDUB7

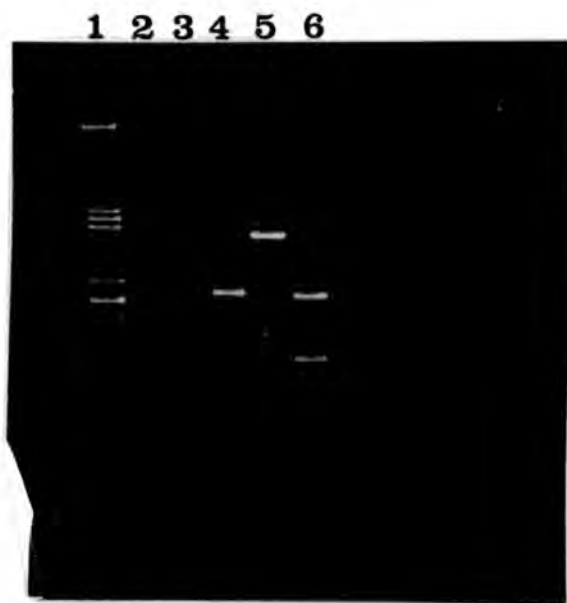
1) pLG1.63

2) Hybrid map of pDUB4 and pDUB7.



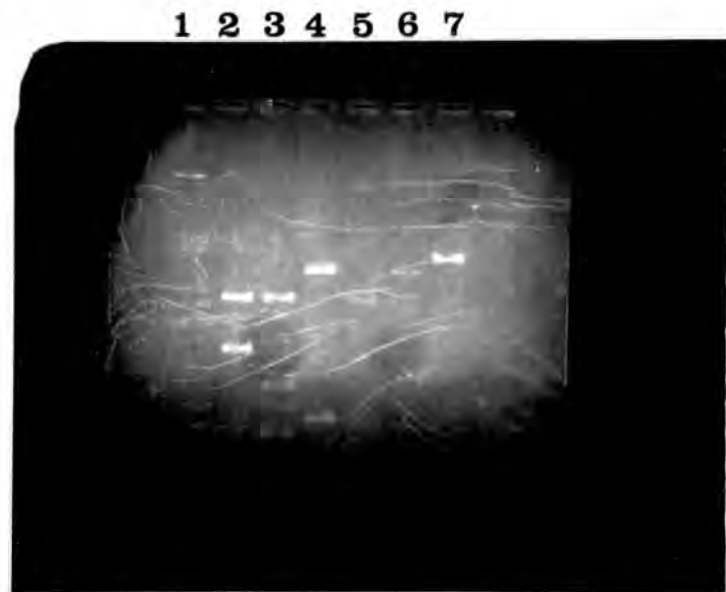
**Gel 1.**

- track 1. phage  $\lambda$  *PstI* digest
- track 2. phage  $\lambda$  *HindIII* digest
- track 3. pLG1.63 *EcoRI* digest
- track 4. pLG1.63 *BglII* digest
- track 5. pLG1.63 *XbaI* digest
- track 6. pLG1.63 *EcoRI/BglII* digest
- track 7. pLG1.63 *EcoRI/XbaI* digest
- track 8. pLG1.63 *BglII/XbaI* digest



**Gel 2.**

- track 1. phage  $\lambda$  *PstI* digest
- track 2. pLG1.63 *EcoRI/BglII* digest
- track 3. pLG1.63 *BglII/XbaI* digest
- track 4. pLG1.63 *EcoRI/XbaI* digest
- track 5. pLG1.63 *BamHI* digest
- track 6. pLG1.63 *BamHI/EcoRI* digest



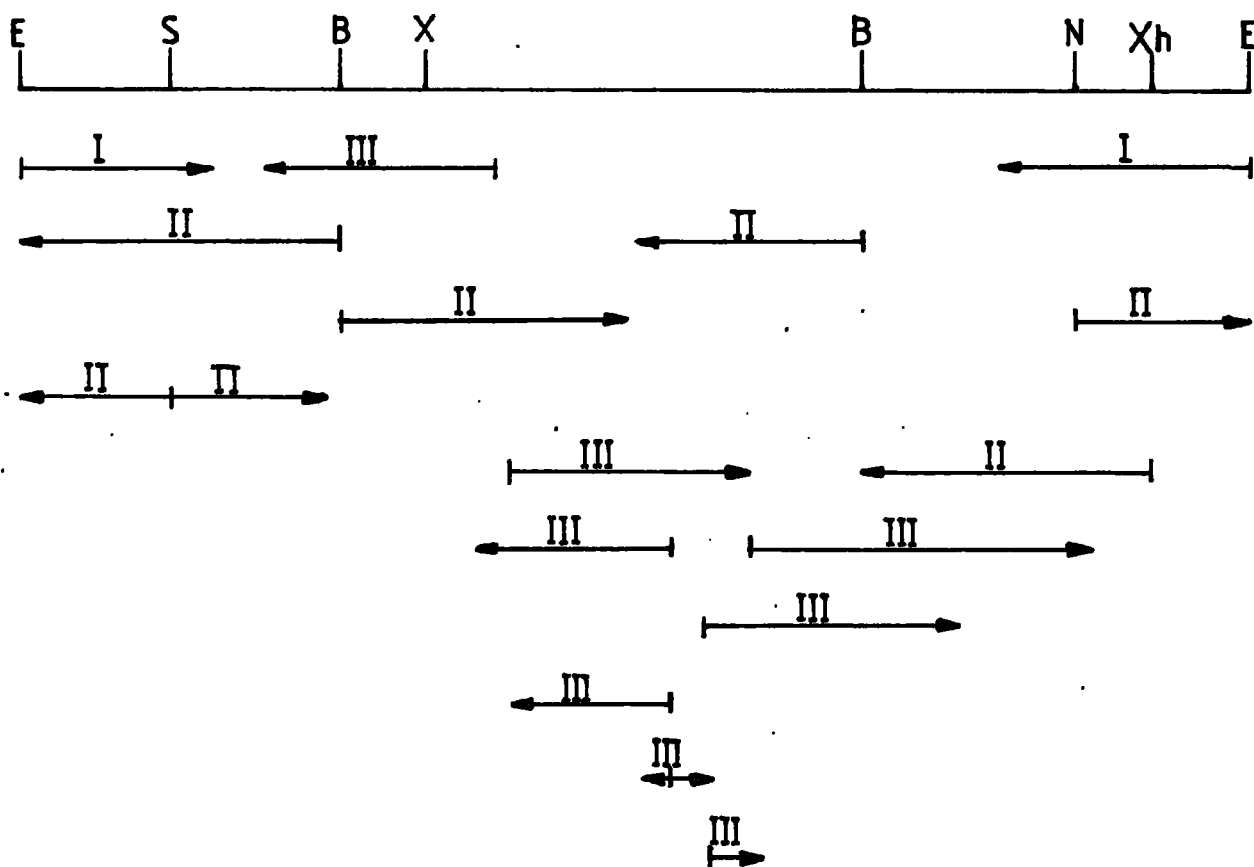
**Gel 3.**

- track 1. phage  $\lambda$  *PstI* digest
- track 2. pLG1.63 *EcoRI* digest
- track 3. pLG1.63 *EcoRI/BglII* digest
- track 4. pLG1.63 *BglII* digest
- track 5. pLG1.63 *EcoRI/XbaI* digest
- track 6. pLG1.63 *BglII/XbaI* digest
- track 7. pLG1.63 *XbaI* digest

**Figure 3.1.2 Restriction Digests of pLG1.63**

Photographs of three agarose gels, loaded with DNA as specified, from which the restriction map of pLG1.63 was deduced.

from which



**Figure 3.2.1 The Sequencing Strategy for pLG1.63**

The key for the diagram is:-

I= Entire cDNA

II= Subcloned restriction fragments

III= Synthetic oligonucleotide primers

E= EcoRI, B=BglII, N= NsiI, S= Ssp, X= XbaI, XH= XhoI.

1 2

ATCCAATCAATATGGCTGCTACTCCAATCAAACCGTTAATGTTGTTGGCAATTGCTTTCCTAGCCTCAGTTTGTGCTCTTCTAGATCCGATCAAGAGAACCCTTTATCTTTAAGTCT 120  
 .....<M A A T P I K P L N L L A I A F L A S V C V S S :R S D Q E N P F I F K S

AACCGATTTCAAACCTTTATGAGAACGAAAACGGTACATTGCTTCTCCAAAAATTTGACAAACGTTCCAAAATATTTGAAAATCTTCAAATACCCTTTTAGAATATAAGTCC 240  
 N R F D T L Y E N E N G H I R L L Q K F D K R S K I F E N L Q N Y R L L E Y K S

AACCTCACACCCTTTTCTCCACAATACACCGATGCCGACTTCATCCTTGTAGTCTTAGTGGGAAAGCCACTCTCACAGTGTGAAATCTAACGATCGAAACTCCTTCAATCTTGAA 360  
 K P H T L F L P Q Y T D A D F I L V V L S G K A T L T V L K S N D R N S F N L E

CGTGGTATGCCATCAAACCTCCCTGCTGGCACTATTGCTTATTTGGTAACCGAGATGACAACGAGGATCTTAGAGTATTAGATCTGCCATCCAGTAAACAAACCCGGTCAATTGCGAG 480  
 R G D A I K L P A G T I A Y L A N R D D N E D L R V L D L A I P V N K P G Q L Q

TCTTCTTATTATCTGGAACCTCAAATCAACCATCATTATTATCTGGATTCAAGAAATATTCTAGAGGCTGCTTTCAATACCAATTACGAGGAGATAGAAAAGTCTTTTABAACAA 600  
 S F L L S G T Q N Q P S L L S G F S K N I L E A A F N T N Y E E I E K V L L E Q

CAGGAACAAGAGCCACAACACAGAAGAAGTCTTAAGGATAGGAGACAAGAGATCAACGAAGAAATGTAATAGTCAAAGTATCAAGGGAACAAATTGAGGAATTGAGCAAAAATGCAAG 720  
 Q E Q E P Q H R R S L K D R R Q E I N E E N V I V K V S R E Q I E E L S K N A K

TCCAGTCCAAAAAAGTGTATCATCAGAACTGACCATTCAACTGAGAAGTCCGAATCCTATCTATTCTAACAAGTTGGCAAAATCTTTGAGATCACCCAGAGAAAAATCAACAA 840  
 S S S K K S V S S E S G P F N L R S R N P I Y S N K F G K F F E I T P E K N Q Q

CTCAAGACTGGACATATTTGTCAATTCTGTGGATATTAAGGAGGGATCTTTATTGTTGCCAACTACAATTCAGAGCAATTGTGATAGTAACTGTTACCAGGAAAAGGAGATTT 960  
 L Q D L D I F V N S V D I K E G S L L L P N Y N S R A I V I V T V T E G K G D F

3  
 GAACCTGTGGTCAAGAAATGAGAACCAGGGAAAAGAAAATGACAAGGAGAGGAAACAAGAAAGAGACAAGCAACAAGTCAACTGTATAGAGCTAAGTTGTCTCCAGGTGATGTT 1080  
 E L V G Q R N E N Q G K E N :D K E E E Q E E E T S K Q V Q L Y R A K L S P G D V

4  
 TTGTGATTCAGCAGGTCAACCCGTTGCCATAAATGCCTCCTCAGATCTCAATCTGATTGGATTTGGTATCAATGCCGAGAACACAAGAGAACTTCTTGCAGGTGAGGAGACAAT 1200  
 F V I P A G H P V A I N A S S D L N L I G F G I N A E N N K R N F L A G E E D N

GTCAATAGTCAAGTAAAGACCAAGTAAAGAGCTTGCAATTCCTGGATCTTCTCATGAGGTTGATAGGCTCTAAGAATCAAAAACAATCTATTTTGCAAATGCTCAGCCTCTGCAA 1320  
 V I S Q V E R P V K E L A F P G S S H E V D R L L K N Q K Q S Y F A N A Q P L Q

AGAGAGTAAAGAACCATCAATAAGGGATCATCTATCTTCAATTCTGGATGCTTTTAATAAGTATATAAAATACTATGATGATGCTATAAAGATATAGCTCATAGTGAAGCAAGGAT 1440  
 R E \*).....

5 5  
 GAATGTCATTCTCTTGAACATAACTCGAGTTTCACTTTTCTACTATGAATAAATAACCAAGAATAAGTTTGTATCCGCGGATAAATAACCAAGAATAAGTTTGTAT(44) 1596  
 .....< poly A+ >.....(polyA+)

**Figure 3.2.2 The DNA Sequence of the Vicilin cDNA**

The sequencing experiments were carried out as specified in Chapter 2. The deduced amino acid sequence is written beneath.

Structural features (underlined) are:-

- 1) Proposed start codon
- 2) Signal peptide cleavage point
- 3)  $\beta$ - $\gamma$  processing site
- 4) Glycosylation signal
- 5) poly adenylation signal

again failed due to the *BglII* digest not being completed first since *BglII* requires a low salt buffer and *EcoRI* and *XbaI* require high salt buffers. Gel 3, though not as clear as gels 1. and 2. shows the *EcoRI/BglII* double digestion (track 3) and gives the expected pUC8 2.7kb fragment and the 3 fragments generated from the internal *BglII* sites in the cDNA. Again, however, the *BglII/XbaI* double digest (track 6) has not worked. These three gels, taken together, do give enough information to construct the restriction map in figure 3.1.1. The *BamHI* and *EcoRI/BamHI* double digest in gel two confirms that the cDNA has no *BamHI* sites. Neither pDUB4 nor pDUB7 have internal *BamHI* sites either.

The restriction mapping has shown that the cDNA insert contained in pLG1.63 has a similar restriction map to other (non full length) cDNAs of the same 47kD type and differs by being longer at both the 5' and 3' ends.

### **3.2 Sequencing of the pLG1.63 cDNA insert**

In order to confirm that the cDNA insert in pLG1.63 is indeed full length and to determine features of the 47KDa vicilin, it was necessary to determine the entire nucleotide sequence. pLG1.63 was digested with *EcoRI* and the DNA electrophoresed on a large agarose gel. The 1.6kb fragment was then isolated from the gel using one of the techniques detailed in Chapter 2. Generally, the 'freeze-squeeze' method was used on ordinary agarose, giving yields of around 50% while the low melting point agarose method yielded 60-70% of original DNA. The isolated fragment was then ligated into *EcoRI* cut, phosphatased, M13mp9 vector and then transformed into competent JM101. When the transformed bacteria were plated out on L-agar with ampicillin, X-gal and IPTG, a mixture of blue and clear plaques were obtained on a lawn of JM101. The clear plaques contained M13mp9 phage DNA with the *EcoRI* fragment inserted into the multiple cloning site. DNA from these clear plaques was

prepared by 'mini-prep' method 1, cut with *EcoRI*, and electrophoresed on a mini-gel. Plaques which showed both the vector and insert were then orientated using an *XbaI* digestion and single stranded DNA prepared from clones of both orientations. This single stranded DNA was then used as template DNA for Sanger dideoxy sequencing as described in Chapter 2. The full sequence of the cDNA was eventually gained using the sequencing strategy shown in figure 3.2.1. The complete sequence of the cDNA is shown in figure 3.2.2 along with the deduced amino-acid sequence underneath. The essential details of the sequence are, firstly the presence of a start codon followed by a 24 amino-acid putative signal peptide. There is a second ATG codon in the position noted by Lycett *et al.* (1983a) which would give a 15 amino-acid signal peptide. The proposed amino-acid sequence of the 24-amino acid putative signal peptide is :-

M A A T P I K P L M L L A I A F L A S V C V S S  
 n n n u n n b n n n n n n n n n n n n n u n u n u u

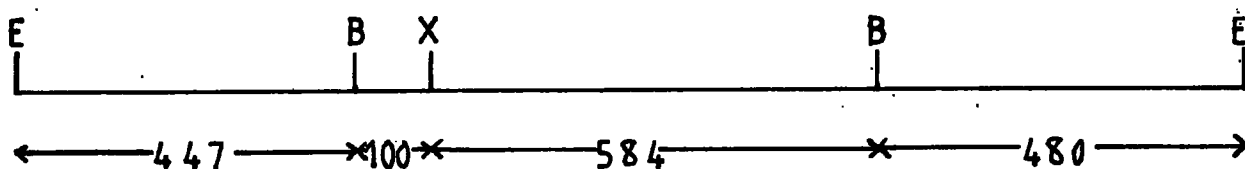
KEY,

n= non-polar

u= uncharged polar

b= basic

As can be seen, the 24 residue signal has an uncharged polar residue and a basic residue before a string of 11 non-polar residues and is 75% hydrophobic whereas the 15 residue signal peptide has no uncharged polar or basic residues before a string of 9 non-polar residues and is 71% hydrophobic. The significance of this data will be discussed in chapter 4 with reference to which constitutes the more ideal signal peptide and the context of the start codon. The signal peptide cleavage point is shown by sequencing to be Ser-Ser:Arg-Ser. The remainder of the coding sequence contains



KEY:-

Scale, 1 cm = 100bp

E = EcoRI

B = BglII

X = XbaI

**Figure 3.2.3 Definitive Restriction map of the pLG1.63 cDNA**

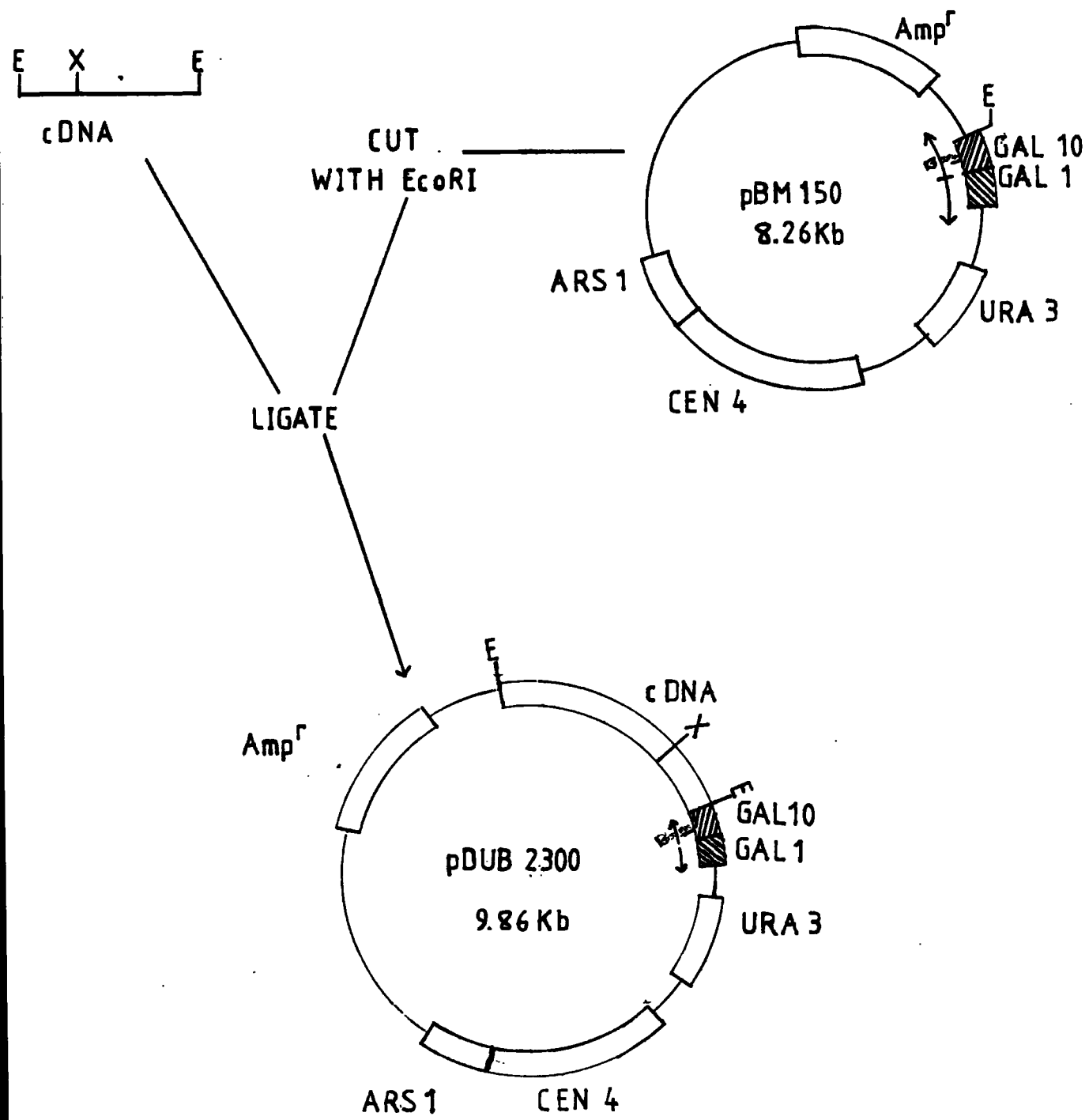
the  $\beta$ - $\gamma$  processing point Glu-Asn:Asp-Lys and, in the  $\gamma$  subunit, the glycosylation signal Asn-Ala-Ser. There are no cysteine residues in the mature polypeptide thus no disulphide bridges can form between the subunits. The sequence also shows the presence of two <sup>polyadenylation</sup> signals (unlike the one noted for the 50k form) and confirms the poly-A tail. The predicted molecular weight of the polypeptide is 49KDa with the signal peptide or 47KDa with the signal peptide removed.

The sequence data confirms the restriction mapping data and therefore the definitive restriction map figure 3.2.3 can be given.

### Expression of Vicilin in Yeast

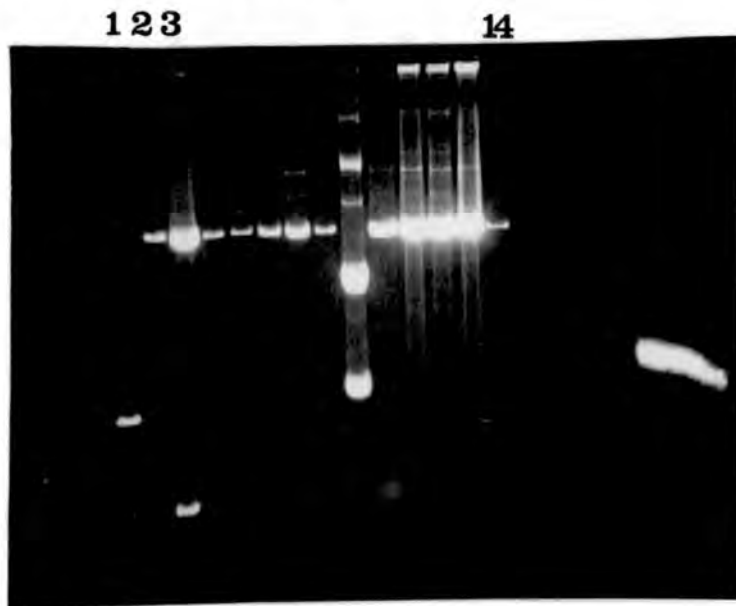
#### 3.3 Construction of pDUB2300

The plasmid pBM150 (Johnston and Davis 1984) is a YCp vector with the structural features shown in figure 3.3.1 (top right hand corner). pBM150 was purified from its *Escherichia coli* host by the large scale plasmid preparation method and the DNA concentration measured at  $31.5\mu\text{g.ml}^{-1}$ . The promoter used is the GAL10 promoter which occurs as part of a divergent promoter system with GAL1. At the 5' end of the GAL10 promoter there is an *EcoRI* site which could be used to express vicilin from the cDNA contained in the *EcoRI* fragment from pLG1.63. The overall strategy for the construction of pDUB2300 is shown in figure 3.3.1. Approximately  $1\mu\text{g}$  of *EcoRI* fragment was ligated into  $0.15\mu\text{g}$  of *EcoRI* cut pBM150 and transformed into competent JM83 cells. The cells were plated out on L-agar plates with ampicillin and 257 transformants obtained. More *EcoRI* fragment was then labelled by nick-translation reaction to obtain a probe for colony hybridisation, which resulted in the identification of 12 putative recombinant colonies. Plasmid DNA from the 12 colonies was prepared according to mini-prep method 1 and analysed by restriction digestion and electrophoresis. Figure 3.3.2 shows two agarose gels, the first shows the twelve

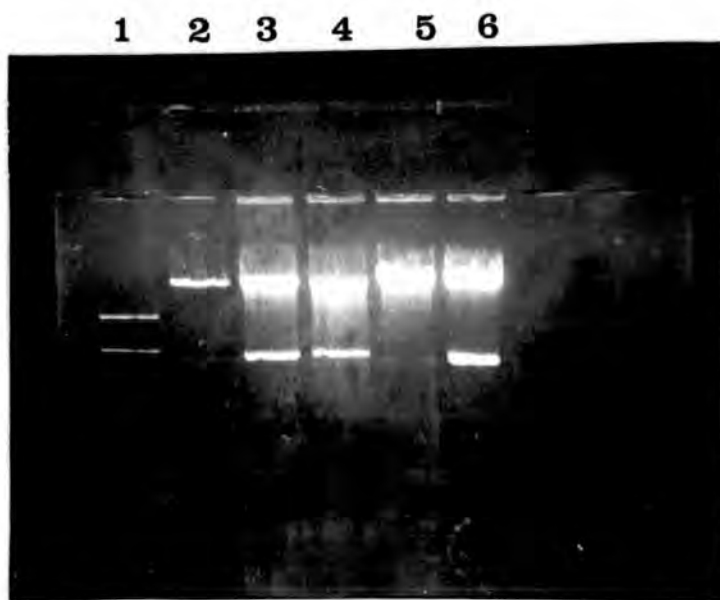


**Figure 3.3.1 Construction of pDUB2300**  
 Whereby the cDNA containing *EcoRI* fragment from pLG1.63 was ligated into the *EcoRI* site of of pBM150.

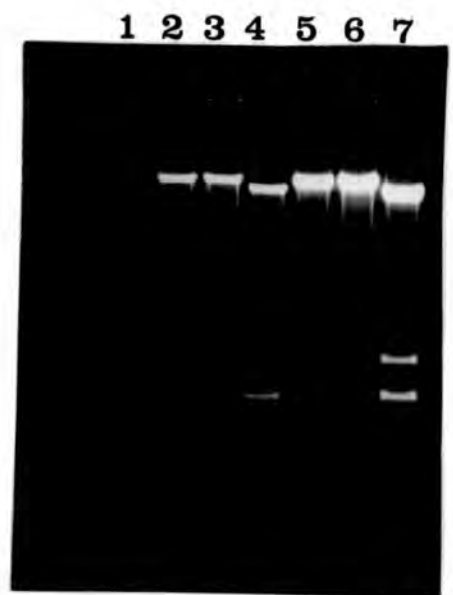
gel 1



gel 2



gel 3



**Figure 3.3.2 Restriction Digests Confirming the Correct Construction of pDUB2300**

The agarose gels shown were loaded as follows:-

Gel 1

Track 1. pLG1.63 *EcoRI* digest

Track 2. pBM150 *EcoRI* digest

Track 3-14 Plasmid DNA from 12 transformants digested with *EcoRI*.

Gel 2

Track 1. pLG1.63 cut with *EcoRI*

Track 2. pBM150 *EcoRI* digest

Track 3. & 4. Transformant no. 1 *EcoRI* digest

Track 5 Transformant no. 6 *EcoRI* digest

Track 6 Transformant no. 12 *EcoRI* digest

Gel 3

Track 1.  $\lambda$  *PstI* digest

Track 2. Transformant no. 1 *XbaI* digest

Track 3. Transformant no. 1 *BamHI* digest

Track 4. Transformant no. 1 *BamHI/XbaI* digest

Track 5. Transformant no. 12 *XbaI* digest

Track 6. Transformant no. 12 *BamHI* digest

Track 7. Transformant no. 12 *BamHI/XbaI* digest

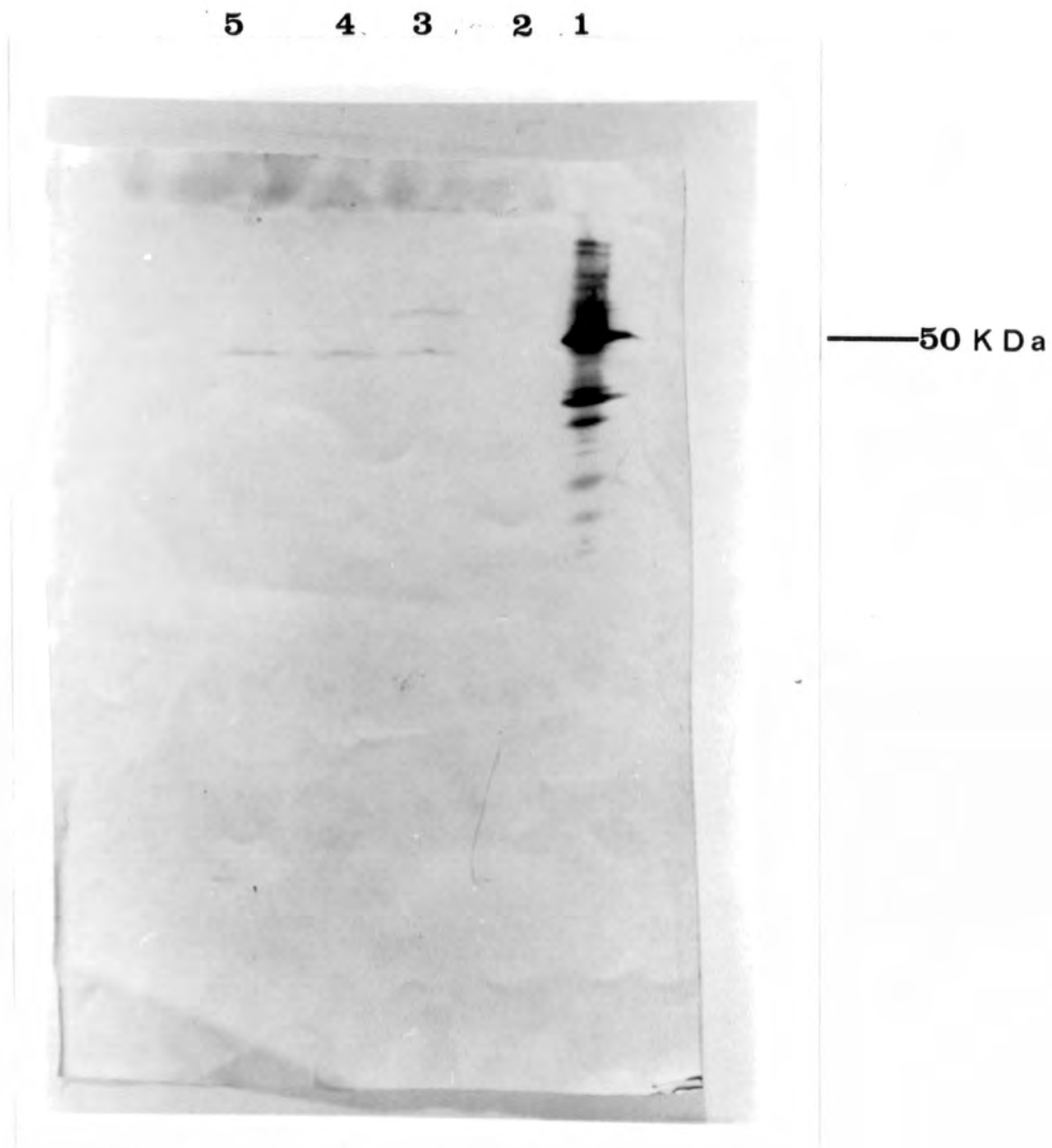
mini-preps cut with *EcoRI* compared to pLG1.63 and BM150 cut with *EcoRI*. Three colonies have the correct fragment, nos. 1,6 and 12. The second photograph shows the orientation of the fragments (for colonies 1 and 12; 6 having been shown not to have the correct fragment on further analysis). pBM150 has one *BamHI* and no *XbaI* site whereas the cDNA has one *XbaI* site and no *BamHI* site. Thus, on digestion with either enzyme singly, only one band is seen with both colony no.1 and no.12 (tracks 2-3 and 5-6). When cut with both enzymes two fragments are seen in the case of colony no.1 (track 4) and three with colony no.12 (track 7), indicating that it is a heterogenous colony. Colony no.1 has the fragment in the correct orientation (see figure 3.3.1).

### **3.4 Expression of Vicilin From pDUB2300 in Yeast**

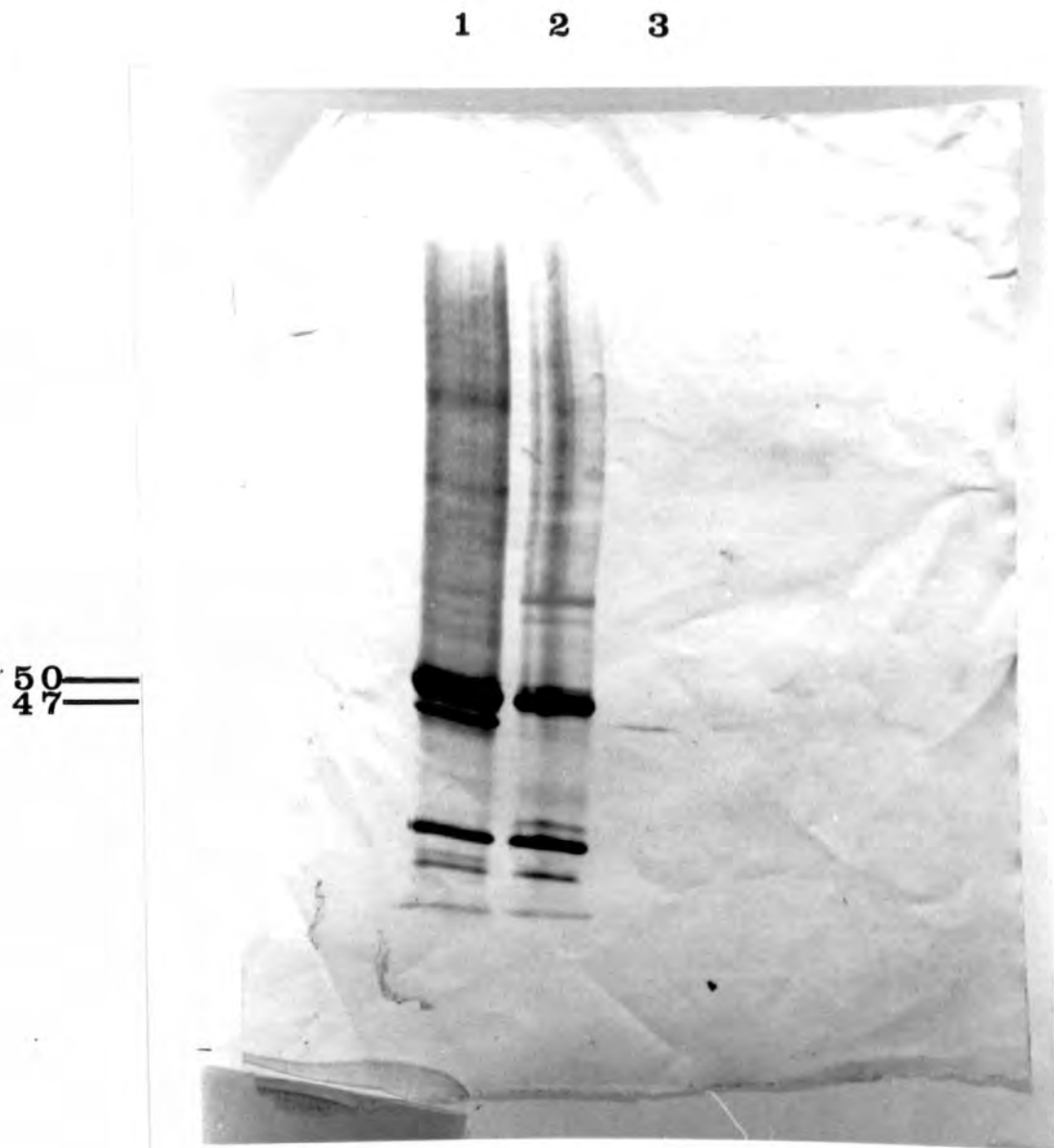
#### **3.4.1 Transformation of Yeast and the initial screening of transformants**

Yeast strains were transformed with pDUB2300, to assess their potential as expression hosts. Strain DBY 746 was transformed with pDUB2300 by the method of Beggs (1978) and selected on YMM His.Trp.Leu. plates. After 5 days, 402 transformants grew, which were replica plated onto YMM plates lacking each of the other marker amino-acids in turn to check that the colonies were true transformants. An attempt was made at extracting plasmid DNA from the yeast but since the plasmid is a YCp and hence in low copy number, no fragments corresponding to the plasmid were observed on an agarose gel. The transformants were then plated onto minimal media agar plates with different carbon sources; 2% glucose, 3% glycerol and 2% galactose. No growth was observed on galactose, very slow growth on glycerol and a normal growth rate on glucose (2-3 days). Selected transformants were then grown in glucose; the cells were pelleted, washed with sterile water and then inoculated into YMM His.Gal.(minimal media with galactose as the carbon source and sup-

plemented with Histidine). In this case one transformant grew very slowly. Protein was extracted from a culture of this transformant by grinding against glass beads in SDS sample buffer and subjected to SDS-PAGE. A western blot showed only the vicilin standard with no vicilin being detected in the yeast extract. The experiment was repeated, using all the cells from the glucose culture to inoculate into YMM His.Gal, and incubating overnight at 30°C. A western blot of extracted protein showed no heterologous vicilin. This was at first thought to be due to a variety of reasons, protein turnover, non-immunoreactivity of the yeast vicilin, RNA degradation, or use of rarely used codons etc. However, the genotype of DBY 746 is *Gal<sup>-</sup>* in common with many other laboratory yeast strains and lacks the GAL4 gene product which is an activator protein for the GAL10 promoter in response to galactose. Therefore we chose a replacement GAL4<sup>+</sup> yeast, GFR167, which could be used to select URA<sup>+</sup> recombinants when transformed by pDUB2300. Transformation was done using the method of Ito *et al.* (1983). Only 62 transformants were obtained but all grew on galactose and were histidine auxotrophs and thus appeared to be true transformants. Two transformed colonies and untransformed GFR167 were grown in YPD, pelleted, washed in water and incubated in YMM His.Gal. for two hours. The proteins were then extracted from the cells using method 2, and subjected to SDS-PAGE and western blotting. No differences in band patterns between the transformed and control yeast were apparent by coomassie blue staining, but on the western blot a very faint band of approx. 50KDa was given by the transformed yeast, suggesting a very low level of vicilin polypeptide. No such band appeared in the untransformed yeast extract. The reason why the level of expression is so low is due to a 14 hour lag period before induction of galactose promoters after glucose repression (J. Gould, personal communication). The use of complete media instead of minimal media could have meant that the plasmid was lost from the culture, however pBM150 is a YCp and



**Figure 3.4.1 Demonstration of the Expression of Vicilin from pDUB2300**  
A western blot taken from a 17% acrylamide gel loaded with the following samples:-  
Track 1. Purified pea vicilin, 100 $\mu$ g  
Track 2. 1mg of protein extracted from untransformed GFR167  
Track 3-5. 1mg of protein extracted from three separate transformed colonies



**Figure 3.4.2 Comparison of Heterologous Vicilin with that from Developing Pea Seeds.**

The acrylamide gel from which this western was taken was loaded with the following samples:-

Track 1. 100 $\mu$ g of protein extracted from 13 day old pea seeds

Track 2. 100 $\mu$ g of protein extracted from 26 day old pea seeds

Track 3. 1mg of protein extracted from transformed GFR167

therefore stably maintained in complete media.

The experiment was then repeated using an overnight culture of transformed yeast in YMM His.Glucose and subculturing 100 $\mu$ l into 5ml YMM His.Gal., incubation was performed overnight and the proteins then extracted as above. Figure 3.4.1 shows a western blot of the extracted proteins. The pea vicilin standard is a little indistinct but the 50k form can be clearly seen. Untransformed GFR 167 gave no reaction, but extracts from three separate transformed colonies all showed an immunoreactive protein of  $M_r$  slightly less than 50000. In one case aggregation of the protein was observed.

### **3.4.2 Molecular weight of Heterologous Vicilin**

Normal pea vicilin extracted from fully developed seeds does not show the 47KDa form as it is processed to lower molecular weight forms. The vicilin expressed in yeast is clearly of lower molecular weight than the 50KDa form, but is it identical to the 47KDa form? To address this question, yeast vicilin was compared on SDS-PAGE with protein extracted from developing pea seeds. Figure 3.4.2 shows a western blot of one of the same extracts used in figure 3.4.1 in comparison with vicilin present in two different stages of developing pea seed meal, the first 13 days after onset of embryogenesis and the second after 26 days. The 13 day extract clearly shows the 47KDa type of vicilin precursor which has disappeared from the 26 day extract. The heterologous vicilin is clearly of higher molecular weight than 47KDa but less than 50KDa. The stained polyacrylamide gel (not shown) showed that the vicilin band could not be distinguished from the background of yeast proteins.

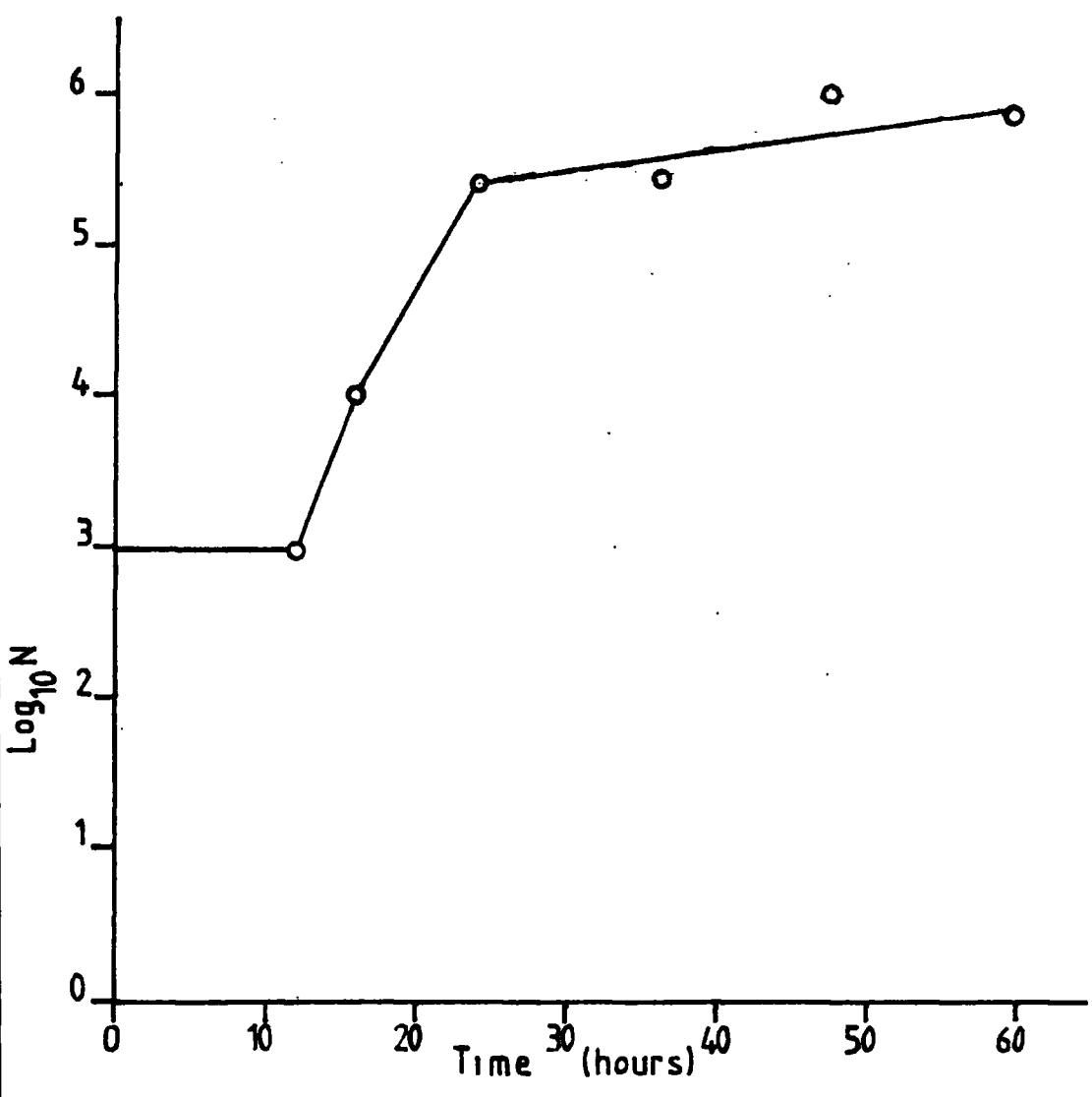


**Figure 3.4.3 Demonstration of Induction of Vicilin Expression by Galactose.**

The western blot was taken from an acrylamide gel loaded as follows:-

Track 1. 100 $\mu$ g of purified pea vicilin

Track 2. 1mg of protein extracted from transformed GFR167 grown in 3% ethanol and induced with galactose.



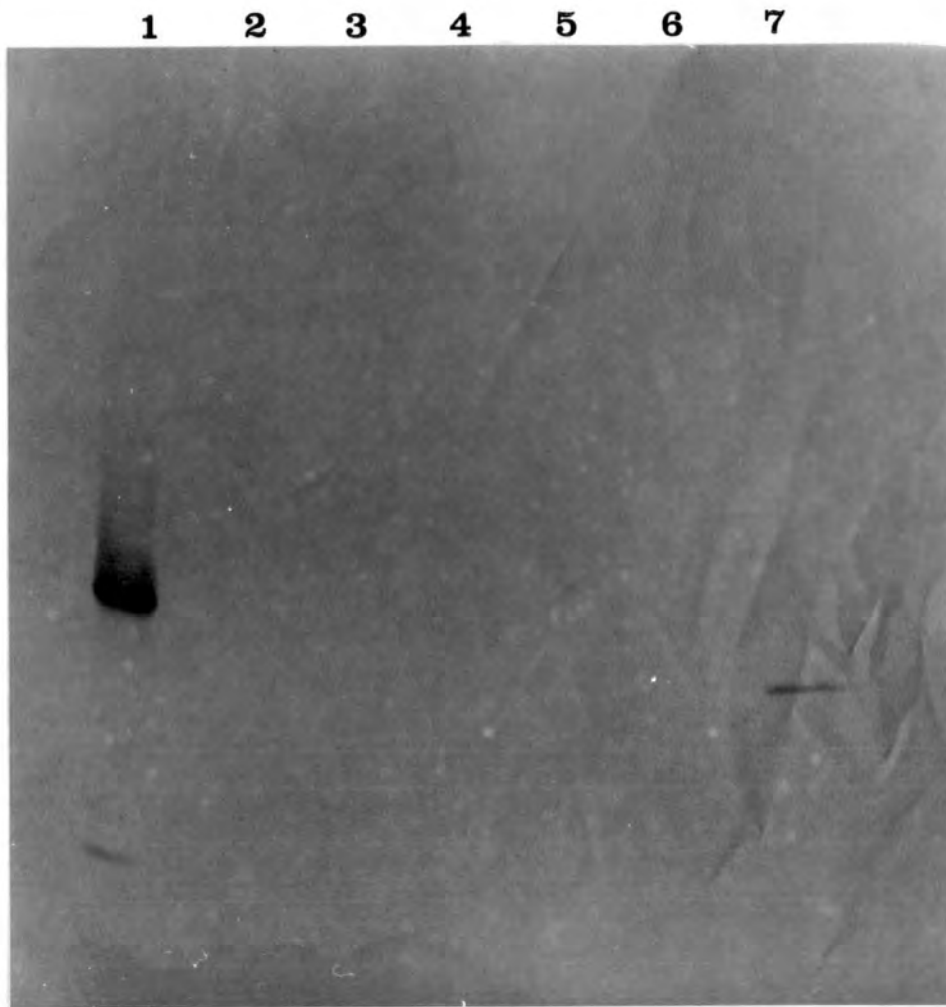
**Figure 3.4.4 Growth Curve for transformed GFR167 1**  
GFR167 was grown in 500ml of 2% galactose minimal media.

### 3.4.3 Induction Kinetics of Vicilin Expression

In order to demonstrate the induction of the GAL10 promoter after growth in non-repressing media, the transformed yeast was inoculated into YMM 3%KAc (pH 4.8) and then incubated at 30°C. The yeast did not grow at all. Growth was achieved in YMM.3% ethanol after 5 days, 10% galactose was then added to bring the final concentration to 2%. The cells were then incubated for 2 hours at 30°C. Figure 3.4.3 shows a western blot of proteins extracted from induced yeast cells, showing clear evidence of vicilin induction. It was then decided to use galactose as the primary carbon source for the majority of further experiments designed to analyse the form of the heterologous vicilin produced. A time course for vicilin induction was measured by inoculating 500ml of YMM His.Gal with a 10ml YMM His.Glucose culture of transformed yeast. 10ml samples were taken at different times as indicated in table 3.4. Protein was extracted from these samples, and frozen until all the samples were taken. Viable counts were done by plating out 100 $\mu$ l samples on YPD plates. The growth curve appears as figure 3.4.4.

Time (hours)	Protein Conc. ( mg.ml <sup>-1</sup> )	Viable Count
12	1.9	9.4x 10 <sup>2</sup>
16	2.3	1x 10 <sup>4</sup>
24	4.6	2.4x 10 <sup>5</sup>
36	4.0	2.7x 10 <sup>5</sup>
48	3	1.07x 10 <sup>6</sup>
60	3	7x 10 <sup>5</sup>

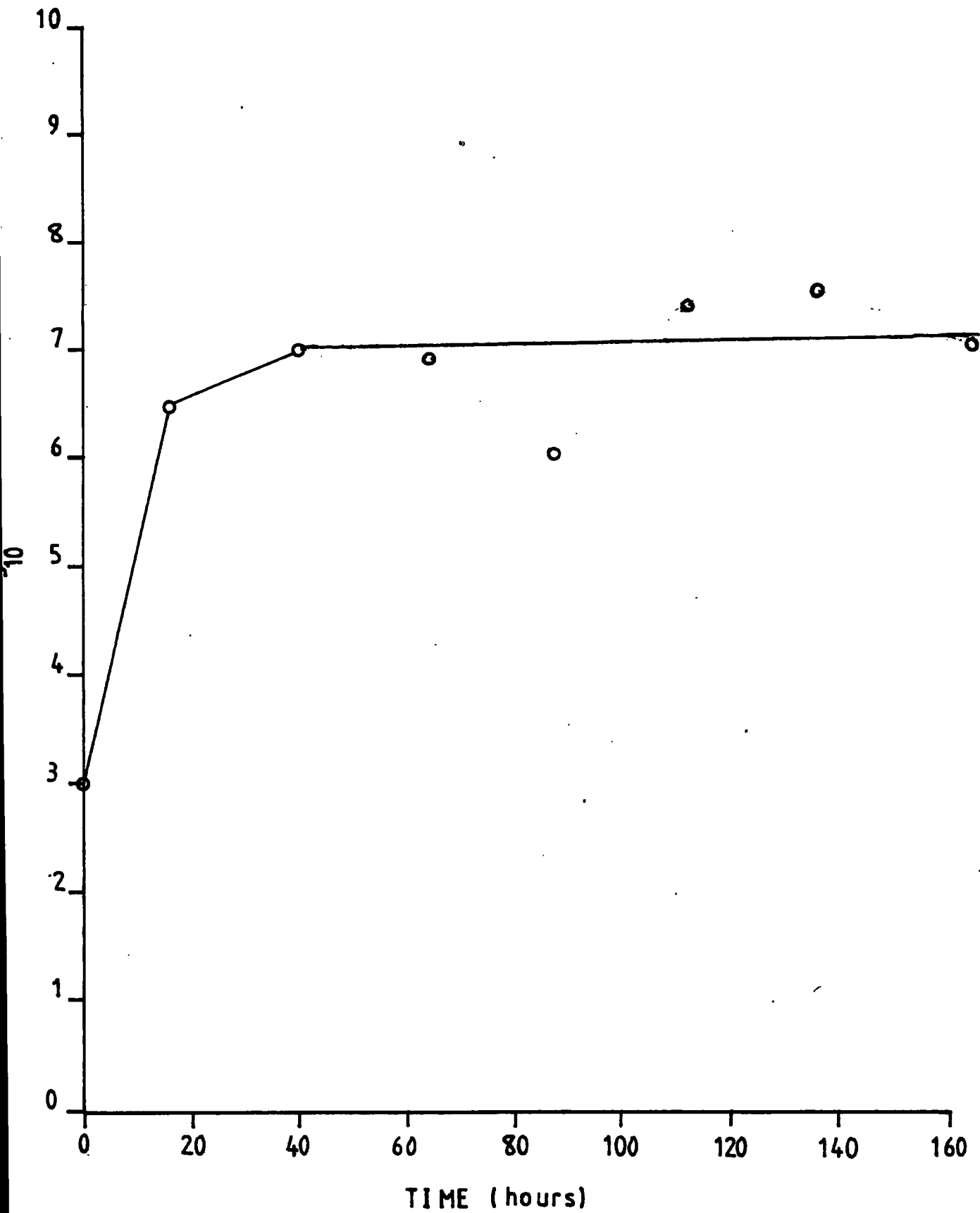
The protein samples were then subjected to SDS-PAGE and western blotted. The western blot appears as figure 3.4.5 and shows that vicilin was only detectable in



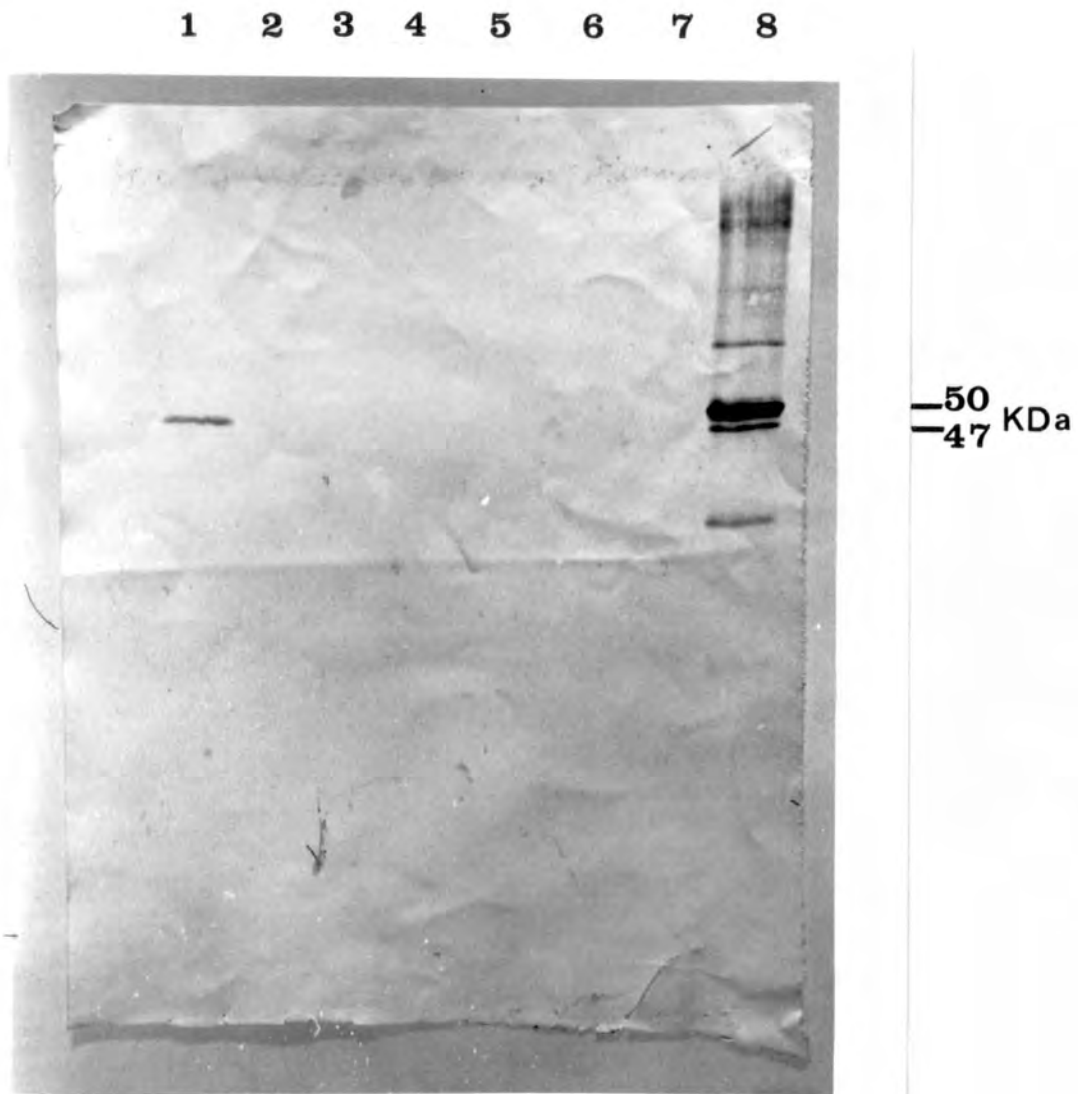
**Figure 3.4.5 Time Course for the Induction of Vicilin Expression 1**

Western blot of protein samples extracted from 10ml of yeast at time intervals shown in table 3.4.

- Track 1. Pea standard vicilin, 100 $\mu$ g
- Track 2. 500 $\mu$ g protein from the 12 hour sample
- Track 3. 500 $\mu$ g protein from the 16 hour sample
- Track 4. 500 $\mu$ g protein from the 24 hour sample
- Track 5. 500 $\mu$ g protein from the 36 hour sample
- Track 6. 500 $\mu$ g protein from the 48 hour sample
- Track 7. 500 $\mu$ g protein from the 60 hour sample



**Figure 3.4.6 Growth Curve for Transformed GFR167 2**



**Figure 3.4.7 Time Course for Transformed GFR167 2**

The western blot shows that all the heterologous vicilin appears in the 16.5 hour sample and does not appear in subsequent samples.

Track 1. 500 $\mu$ g of protein from the 16.5 hour sample.

Tracks 2-7. 500 $\mu$ g proteins from samples (upto 160 hours taken every 24 hours)

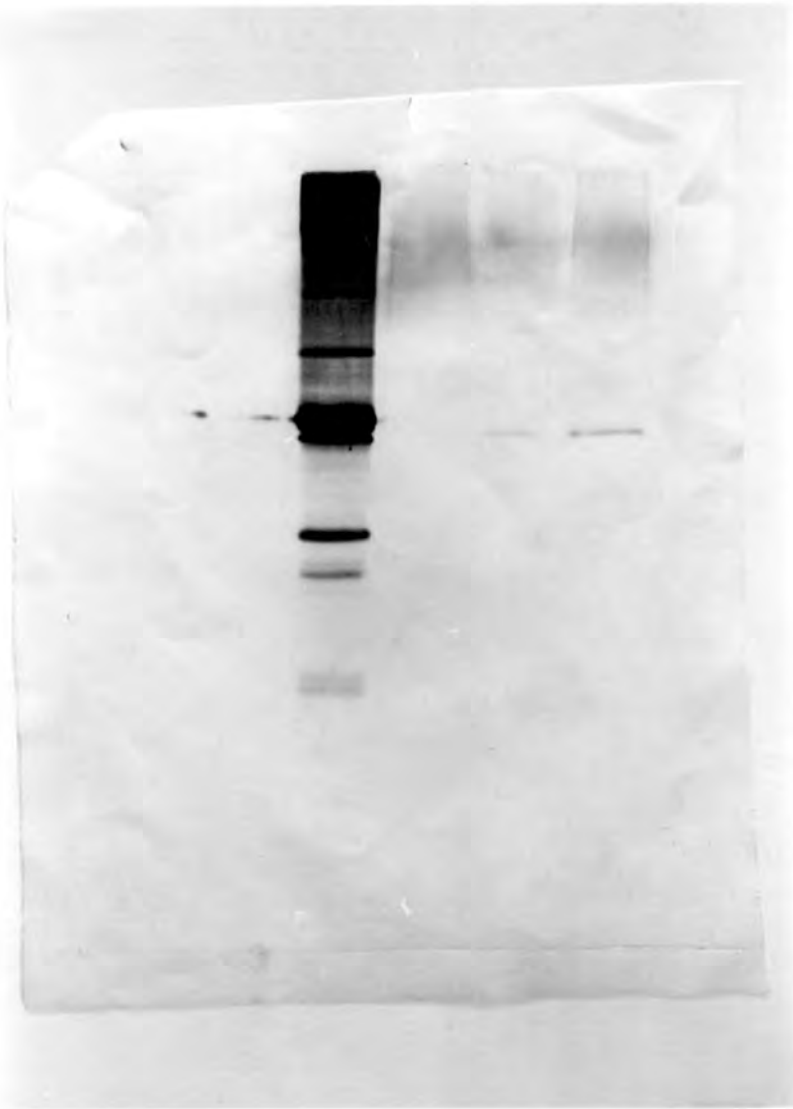
Track 8. pea standard vicilin

the 60 hour sample. This experiment was repeated using a 5ml YPGal culture as an inoculum; in this case the growth curve shows that the yeast grew very much quicker, reaching a higher cell density than in the first experiment (figure 3.4.6) and that all the vicilin appeared in the 16.5 hour sample and then disappeared (figure 3.4.7). The difference between these two results can be explained by the lag period of growth due to glucose repression in the first time course, compared to no glucose repression in the second experiment. The disappearance of vicilin from the later samples in the second experiment is possibly due to degradation during stationary phase of growth.

#### **3.4.4 Yeast Expressed Vicilin is Found in a Particulate Fraction**

The residual culture left at the end of the first induction experiment (section 3.4.3) was used in an experiment designed to indicate the physical state of the yeast vicilin. The cells were pelleted and the proteins extracted with SDS sample buffer and the debris removed by centrifugation. The extract was then dialysed against 50mM TE buffer pH7 overnight and then centrifuged at 20000 rpm for 15 minutes. The pellet was dissolved in SDS sample buffer, and the supernatant mixed with 2x sample buffer to bring the SDS concentration to 0.2%. Both samples were run on an SDS-PAGE gel and western blotted. The blot showed the vicilin to occur exclusively in the pellet fraction, indicating that the vicilin was in an insoluble form (equal amounts of protein were loaded in each track). This interpretation was confirmed when a fresh culture was extracted with sample buffer without SDS, the supernatant kept and the pellet extracted with sample buffer with 1% Triton-X-100 (a non-ionic detergent). The supernatant from this extract was kept, and the pellet extracted with SDS sample buffer. The western blot in figure 3.4.8 shows that only small fraction of the vicilin was extracted into Triton and none at all into the buffer without detergent. Equal amounts of protein were added in each track and the stained gel showed that each

1 2 3 4



**Figure 3.4.8 Vicilin is Associated with a Particulate Fraction**

Western blot showing that the heterologous vicilin can be extracted with Triton-X-100 to a limited extent but not at all when no detergent is present.

Track 1. Pea standard vicilin

Track 2. 1mg of protein extracted into sample buffer without SDS

Track 3. 1mg of protein extracted into sample buffer without SDS but with 1% Triton-X-100.

Track 4. 1mg of protein extracted into sample buffer with SDS

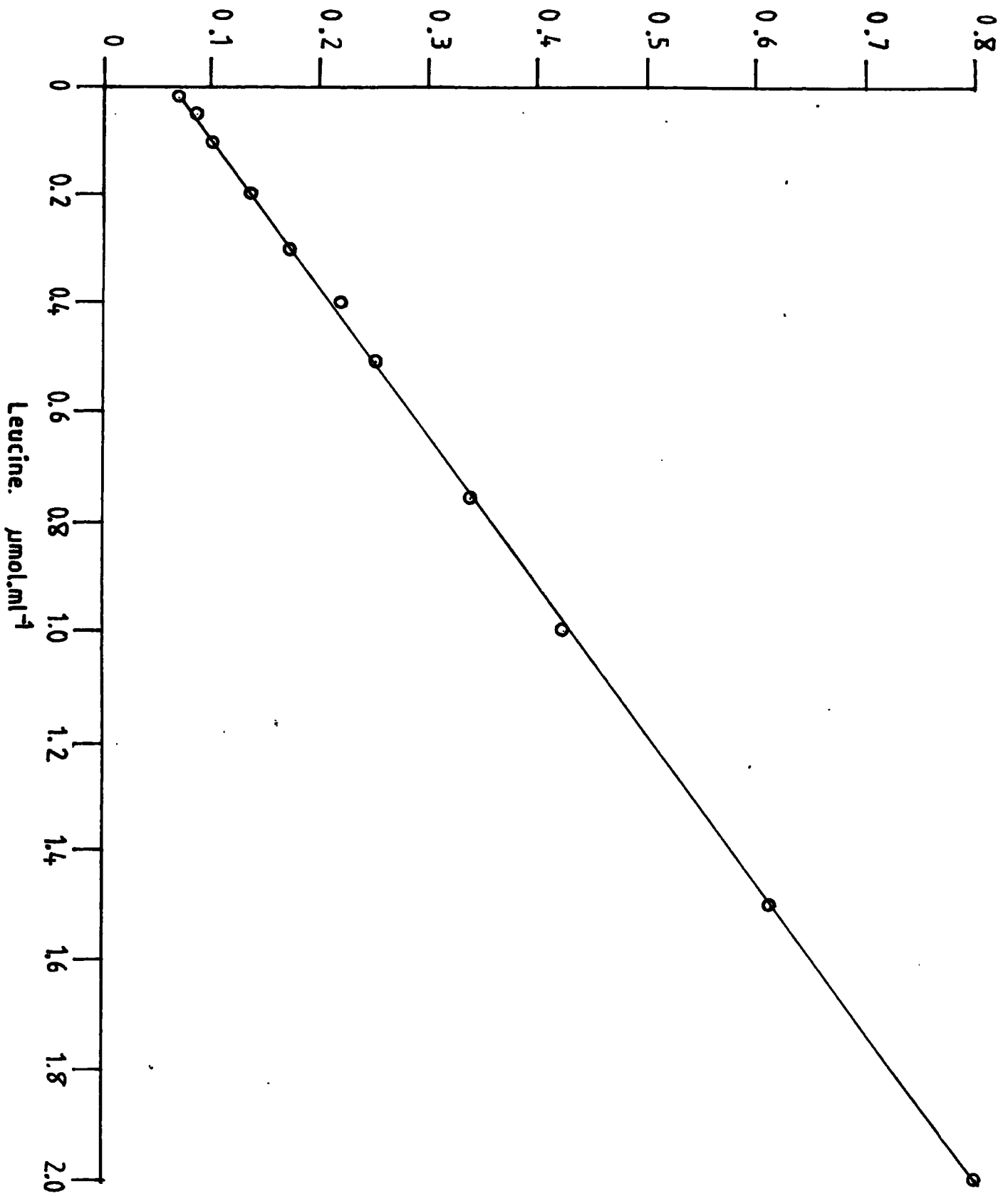
extract had a similar staining pattern. Extracting protein with 2% Triton did not increase the amount of vicilin extracted. This suggested that the yeast was producing vicilin in a membrane bound form or less likely, was sequestering the protein into an organelle or compartment where it could only be extracted using a denaturing detergent like SDS.

### **3.4.5 Subcellular localization of Vicilin**

#### **i) Cell Fractionation**

From the previous experiments it appeared that vicilin was either insoluble or was membrane bound in yeast. To further test this theory attempts were made to purify vacuoles from galactose grown transformed yeast as described in the methods chapter (section 2.14.1). Samples were taken from the lower Ficoll layer containing the crude lysate and from the vacuole float and analysed by SDS-PAGE and western blotting. The fractions were also assayed for CPY, a soluble vacuolar enzyme. This procedure was attempted seven times in all and in only one case was the characteristic cloudy vacuole float seen, but when these were analysed for CPY activity the concentration of enzyme was too low to be accurately measured using the activity graph shown in figure 3.4.9. When equal amounts of protein from the lysate fraction and the 'vacuoles' were loaded onto an SDS gel and then western blotted, only the lysate fraction showed any vicilin (figure 3.4.10). The vacuole of yeast cells grows as the cell ages, but when the cell is about to bud the vacuole fragments. When cell death occurs the vacuole swells up considerably, due to a relaxation of osmotic pressure. However with the advancing age of a culture, the resistance to enzymatic degradation of the cell wall increases. The cells must be caught at a stage of growth when the cell walls aren't too resistant to degradation or the vacuoles too small, i.e. mid to late log phase. The method of vacuole preparation used in this work, or minor variations

ABSORBANCE AT 405 nm



**Figure 3.4.9 Standard Curve for CPY Activity**  
The curve was produced as detailed in section 2.14.1.

1 2 3



**Figure 3.4.10 Location of Vicilin Within a Vacuole Preparation**

Western blot of proteins found in the crude cell lysate and putative vacuole fraction.

Track 1. Pea vicilin

Track 2. 500 $\mu$ g of crude cell lysate proteins

Track 3. 500 $\mu$ g of proteins in putative vacuole fraction

of it, is widely used in many yeast laboratories. However, the vacuoles produced are often of poor quality and purity, and in very low yield. It is also extremely strain dependent (M. Watson and D. Wolf, unpublished observations).

## ii) Immunolocalisation

The next attempt to localise the vicilin involved the use of immunofluorescence (section 2.15). The yeast are fixed to a microscope slide, reacted with anti-vicilin antibodies and then the antigen-antibody complexes are reacted with conjugated fluorescent dye and then visualised using fluorescence microscopy. Four different types of cells were used for this investigation, GFR167, transformed GFR167, transformed GFR167 grown on galactose and JYC3 (a legumin expressing yeast strain from J. Yarwood). The cells were first visualised under light microscopy to check that the cells were intact after fixing (by driving off excess water on a hot plate). On switching to fluorescent illumination, all four cell types fluoresced about equally, indicating that the reaction conditions and washing procedure had not removed non-specific interactions. A new approach was tried where all the reactions were carried out in a microfuge tube and only applied to the slides prior to the addition of the hydromount. In this case the three controls fluoresced less than the galactose grown transformed yeast but the resolution at the highest obtainable magnification, 100x objective and 16x eyepiece, did not reveal any internal structure of the cells and at lower magnification the cells were too small to see any internal structures. Since this procedure had not revealed the association of vicilin with any internal structures, it was decided to use Electron Microscopy in conjunction with Immuno-gold labelling. (see section 3.8)



**Figure 3.4.11 Effect of Tunicamycin on Heterologous Vicilin**

A western blot taken from an acrylamide gel loaded as follows:-

Track 1. Pea vicilin

Track 2. 1mg of proteins extracted from galactose grown, transformed GFR167

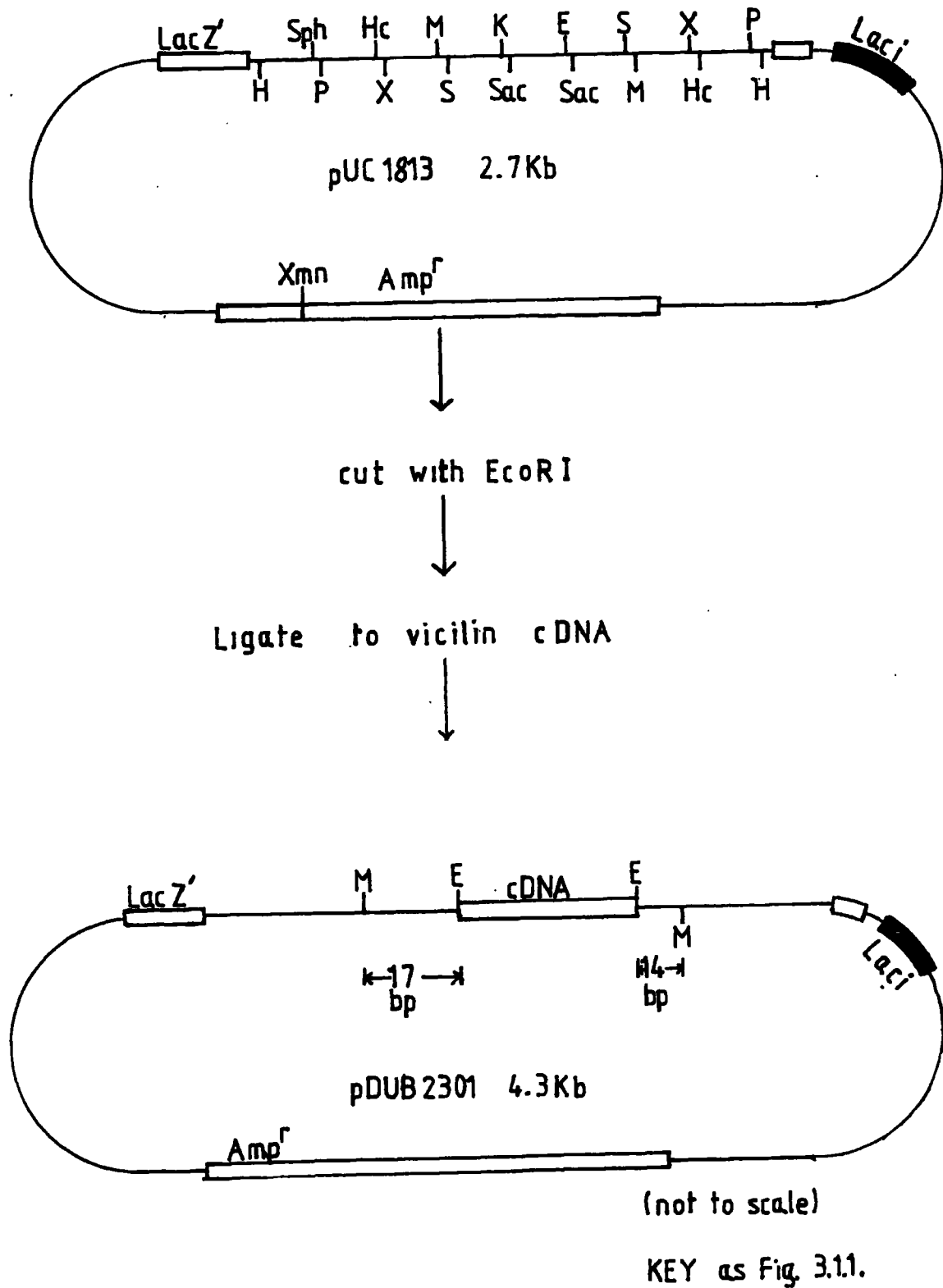
Track 3. 1mg of proteins extracted from transformed GFR167 grown in galactose media with  $10\mu\text{g.ml}^{-1}$  tunicamycin.

### **3.4.6 Effect of Tunicamycin on Heterologous vicilin**

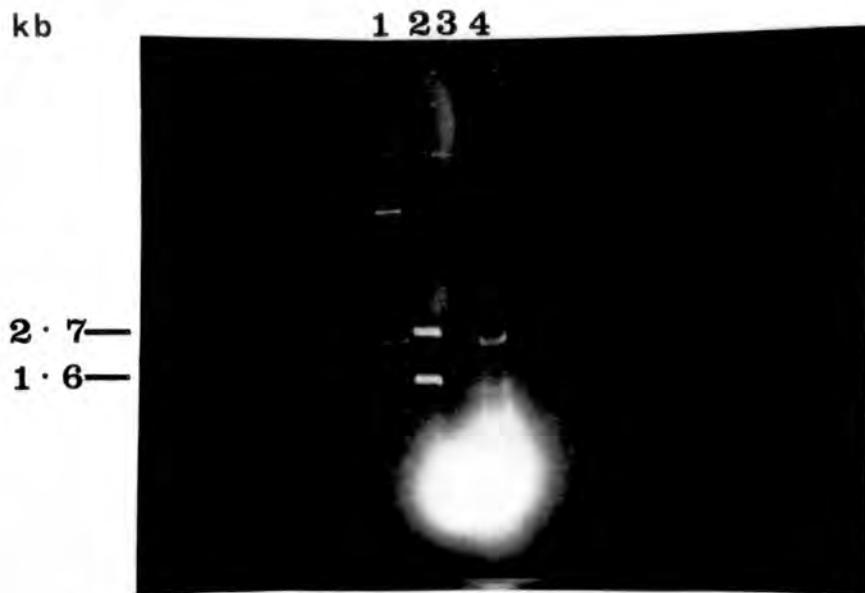
The deduced amino-acid sequence of the 47KDa type vicilin (section 3.2) predicts a single glycosylation site. To determine if the heterologous vicilin is glycosylated, the glycosylation blocking antibiotic Tunicamycin was used. This was added at a concentration of  $10\mu\text{g.ml}^{-1}$  to early log-phase cells growing in YMM His.Gal and growth was allowed to continue until late log-phase, when the proteins were extracted and subjected to SDS-PAGE and then western blotted. Glycosylated and unglycosylated vicilin would be expected to differ in molecular weight by at least 1KDa. Indeed it is suggested that the 16KDa and 12.5KDa vicilin species differ only in that the 16KDa species is glycosylated, therefore the difference in molecular weight could be upto 3.5KDa. This experiment was repeated three times and in all cases no change was noted in the electrophoretic mobility of the treated yeast vicilin compared to that produced without Tunicamycin (figure 3.4.11). This result indicating that the yeast was probably not glycosylating vicilin.

### **3.5 Converting the *EcoRI* cDNA to a *BamHI* Fragment**

In order to study constitutive expression of vicilin in yeast (as opposed to inducible low level expression as described in section 3.4) a suitable promoter was chosen, that of the yeast enzyme phosphoglycerate kinase, the PGK promoter. The vector pMA91 contains a single *BglII* site immediately downstream of the PGK promoter which is suitable for expression of gene inserts. *BglII* generates cohesive ends compatible for ligation with *BamHI* fragments therefore it was necessary to convert the *EcoRI* ended cDNA from pLG1.63 to a *BamHI* fragment.



**Figure 3.5.1 Construction of pDUB2301**  
 Summary of the construction of pDUB2301, showing the ligation of the EcoRI cDNA into the EcoRI site of pUC1813.



**Figure 3.5.2 Restriction Digests Confirming the Correct Construction of pDUB2301**

Agarose gel showing that pDUB2301 contains a BamHI fragment corresponding in size to that expected for the vicilin cDNA.

Track 1.  $\lambda$  PstI digest

Track 2. pDUB2301 cut with BamHI

Tracks 3 & 4 plasmid DNA from 2 other positive clones cut with BamHI

### **3.5.1 Adding BamHI linkers to the cDNA**

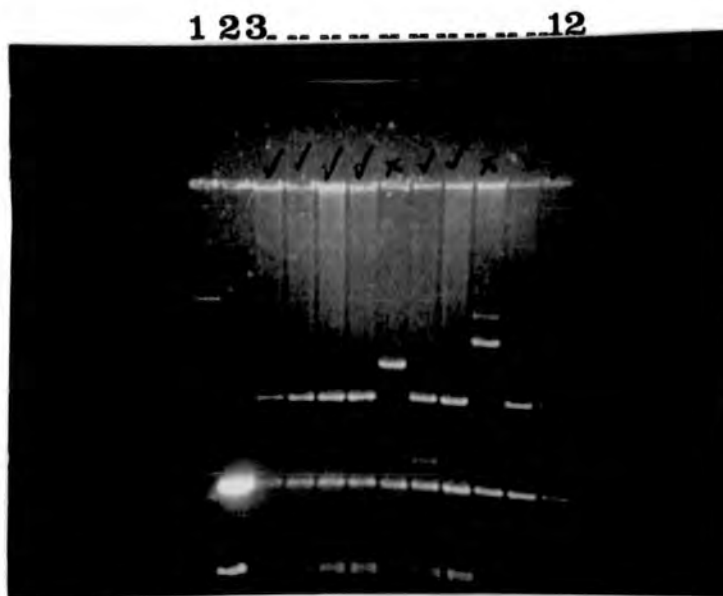
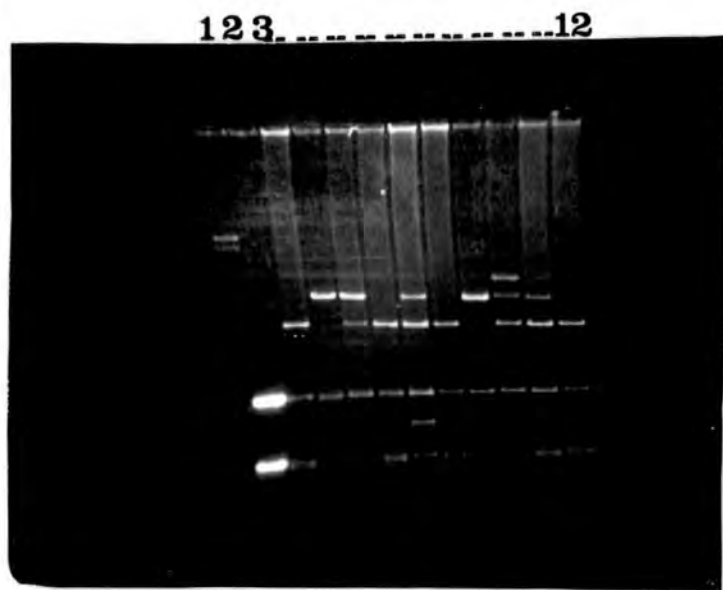
Addition of linkers to the cDNA was attempted four times in all, each time essentially as described in section 2.7.4. In no case was a BamHI ended cDNA fragment recovered. EcoRI to BamHI adaptors were then synthesized by using an Applied Biosystems oligonucleotide synthesizer, but these also failed to produce the desired EcoRI to BamHI conversion. A new hybrid pUC vector was then utilised, pUC1813 (Kay and McPherson, 1987) which dispensed with the need to use synthetic oligonucleotides.

### **3.5.2 Construction of pDUB2301**

Figure 3.5.1 shows the hybrid multiple cloning site of pUC1813 made by ligating together half the cloning site of pUC18 with half of pUC13. The resultant multiple cloning site has a central EcoRI site flanked by pairs of restriction sites one of which is BamHI. The EcoRI fragment from pLG1.63 was ligated into the EcoRI site of pUC1813 and then transformed into JM83. The transformed cells were plated out on X-Gal Amp agar and white colonies selected. Three colonies gave plasmid DNA which when cut with BamHI gave two bands, one of approximately the same size as the cDNA. A large scale plasmid prep was done on one of these colonies and the agarose gel photograph shown in figure 3.5.2 shows a BamHI restriction of the resultant DNA. The construct was checked by digestion with BglII which yielded fragments consistent with the map shown in figure 3.5.1. The plasmid was named pDUB2301, a summary of its construction appears in figure 3.5.1.

### **3.6 Construction of pDUB2302/3**

The plasmid pDUB2301 was cut with BamHI and electrophoresed on a 0.7% agarose gel. The BamHI fragment containing the cDNA was isolated by the elution into a



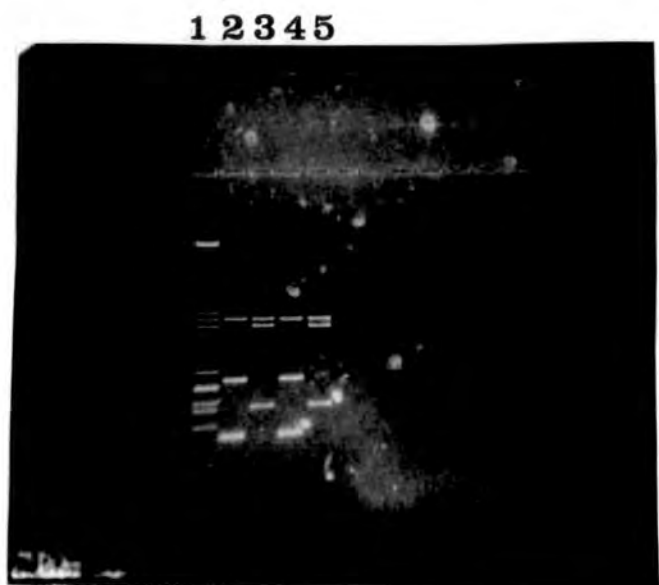
**Figure 3.6.1 Restriction Digests Demonstrating the Cloning of the cDNA into pMA91**

Two agarose gels showing plasmid DNA from 20 transformants cut with *EcoRI*

Track 1.  $\lambda$  *PstI* digest

Track 2. pLG1.63 cut with *EcoRI*

Tracks 3-12 Plasmid DNA from 10 transformants cut with *EcoRI*

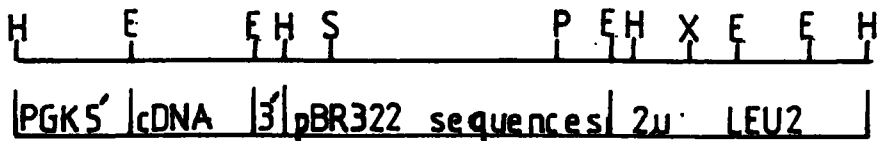
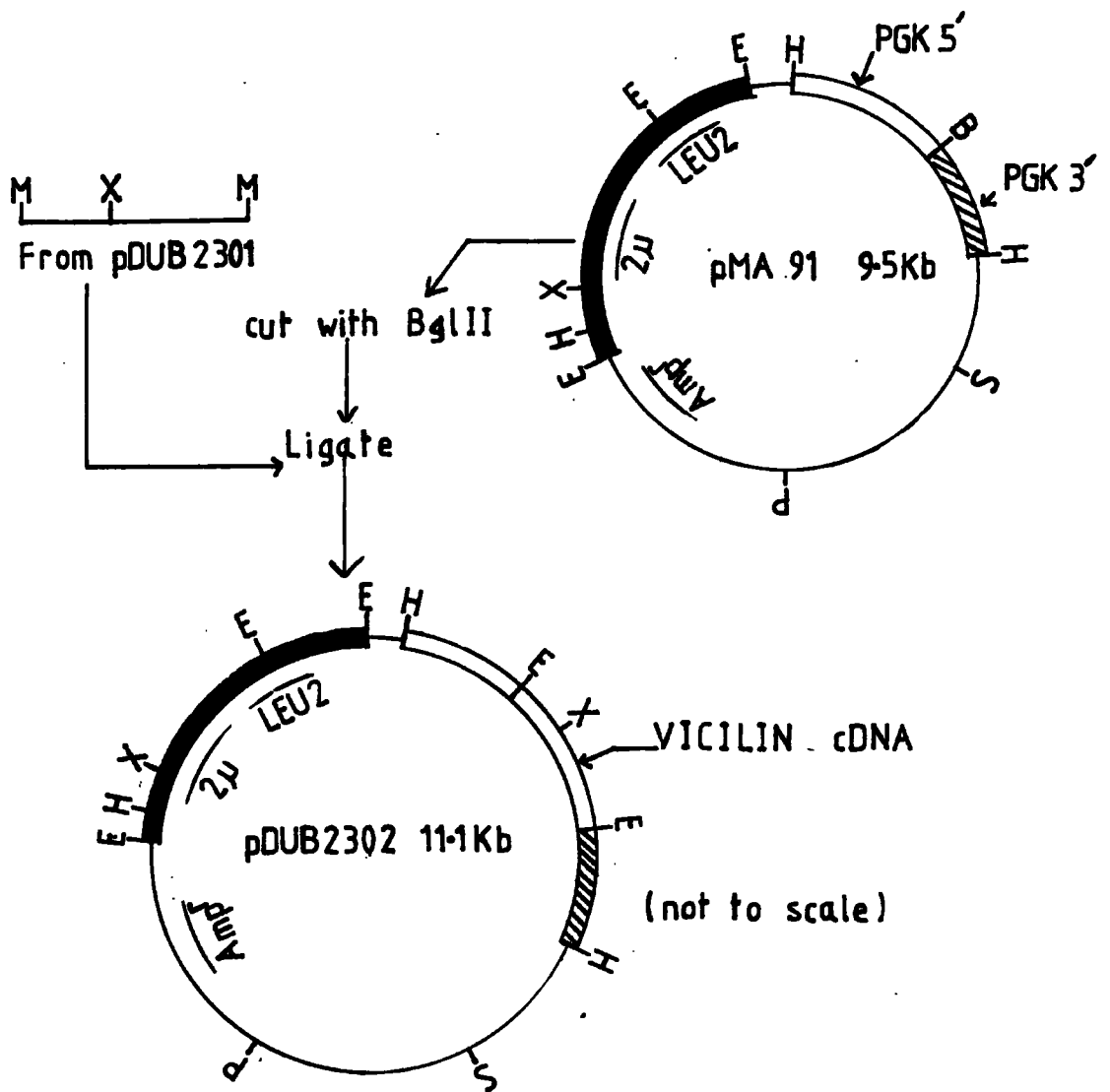


**Figure 3.6.2 Orientation of the cDNA within the Vector**

Agarose gel showing the orientation of the cDNA within pMA91.

Track 1.  $\lambda$  PstI digest

Tracks 2-5. XbaI/SalI double digests of plasmid DNA extracted from 4 positive colonies.



Scale, 1cm = 1Kb

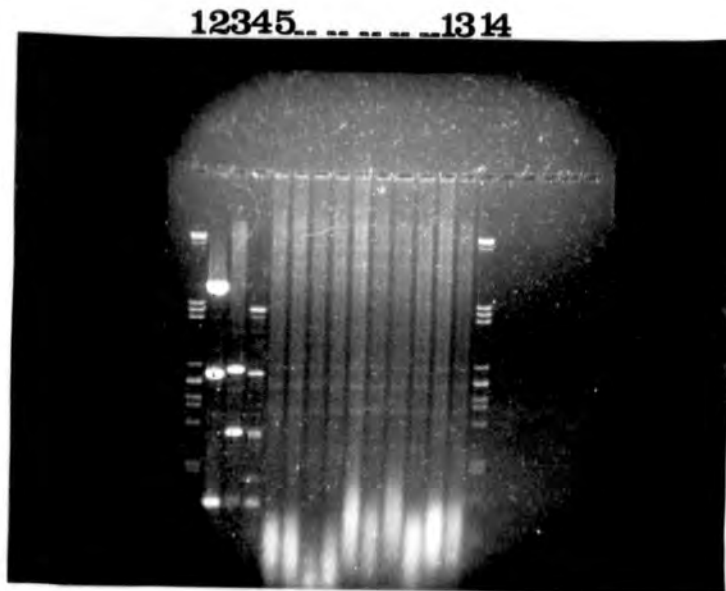
**Figure 3.6.3 Summary of the Construction of pDUB2302/3**  
 The figure also shows a restriction map of pDUB2302.

buffer well method (see section 2.8.1). The yeast vector pMA91 was cut with *BglII* and ligated to the *BamHI* cDNA fragment. *Escherichia coli* strain JM83 was transformed with the ligation mix and plated out on L-Amp agar, producing 1433 colonies. These were replica plated grid-wise onto fresh L-Amp plates and then used for a colony hybridisation experiment. Random priming was used to label the *BamHI* fragment from pDUB2301 with [<sup>32</sup>P]-dCTP to 2.6x10<sup>7</sup> cpm/μg DNA. Out of 1433 colonies, 20 produced dark dots on the resultant autoradiograph. Plasmid DNA was prepared from these by mini-prep. method 2 and the DNA cut with *EcoRI* (the ligation of the *BamHI* fragment into the *BglII* site renders the DNA uncuttable by either enzyme). Figure 3.6.1 shows the *EcoRI* cut DNA in comparison with λ*PstI* DNA and pLG1.63 cut with *EcoRI*. Ticked lanes show mini-preps with the insert, crossed ones have no insert. The fragments were orientated with *XbaI* and *SalI*. *XbaI* cutting asymmetrically once in the cDNA and *SalI* cutting once in the vector only, as shown in figure 3.6.3. Figure 3.6.2 shows the orientation of the fragments in the mini-prep. DNA. Lanes 2 and 4 show the right orientation with respect to the PGK promoter (see figure 3.6.3) and lanes 3 and 5 show the wrong orientation. There is an extra *XbaI* site in pMA91 which is why figure 3.6.2 shows three bands instead of the expected two. Large scale plasmid preps. were done on one correctly orientated plasmid, now called pDUB2302 yielding 130μg.ml<sup>-1</sup>, and one incorrectly orientated plasmid (pDUB2303) yielding 140μg.ml<sup>-1</sup>. Figure 3.6.3 summarises the construction of pDUB2302/3 and shows a restriction map of pDUB2302.

### **3.7 Expression of Vicilin from pDUB2302**

#### **3.7.1 Transformation of *Saccharomyces cerevisiae* and Confirmation of Expression.**

The yeast strain MC16 was used for this work since it had previously been used to



**Figure 3.7.1 DNA Extracted from LEU<sup>+</sup> Yeast Colonies**

The agarose gel was loaded as follows:-

Track 1)  $\lambda$  PstI

Track 2) pMA91 EcoRI

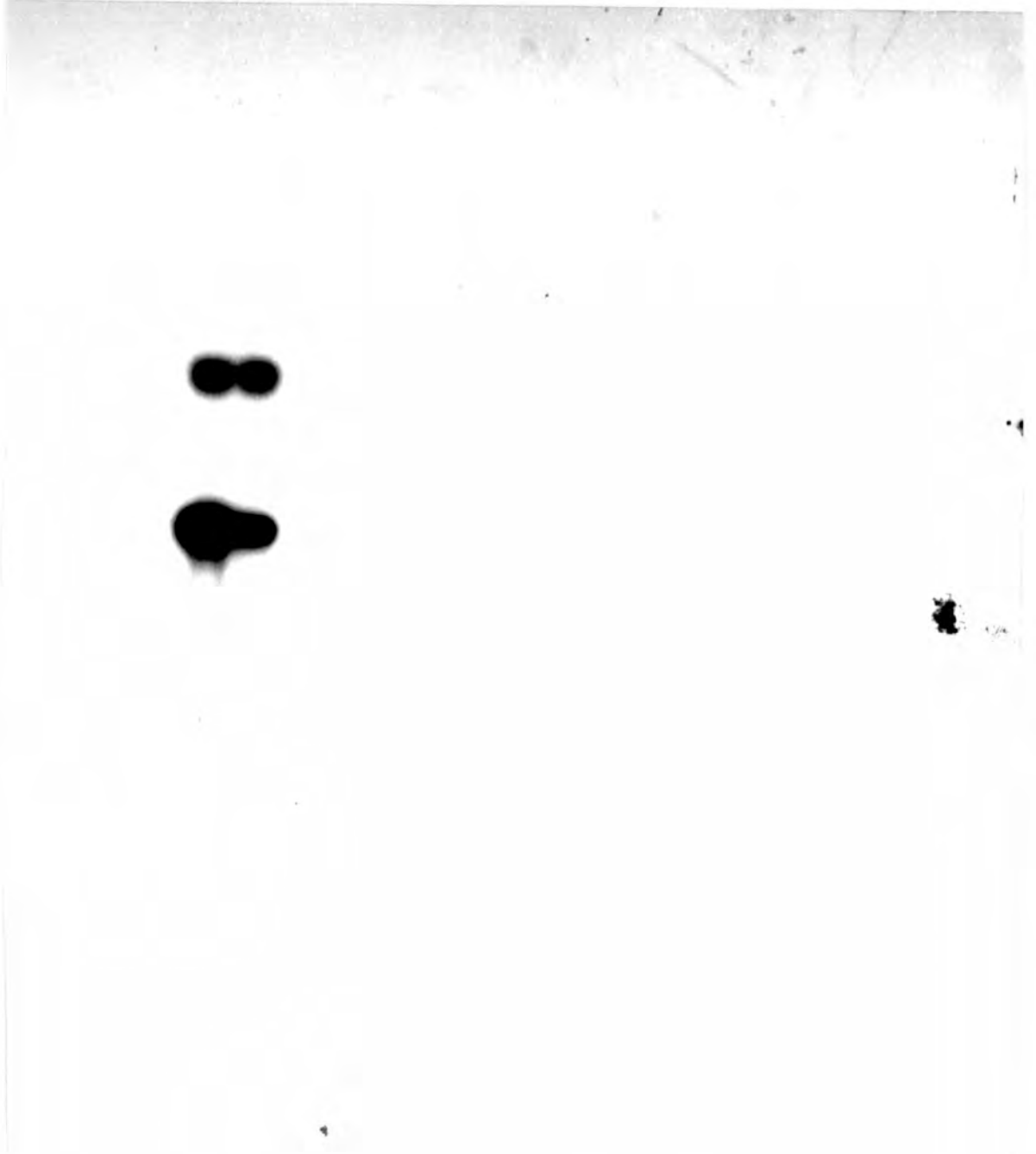
Track 3) pDUB2301 EcoRI

Track 4) pDUB2302 EcoRI

Tracks 5-13) Yeast DNA cut with EcoRI

Track 14)  $\lambda$  PstI

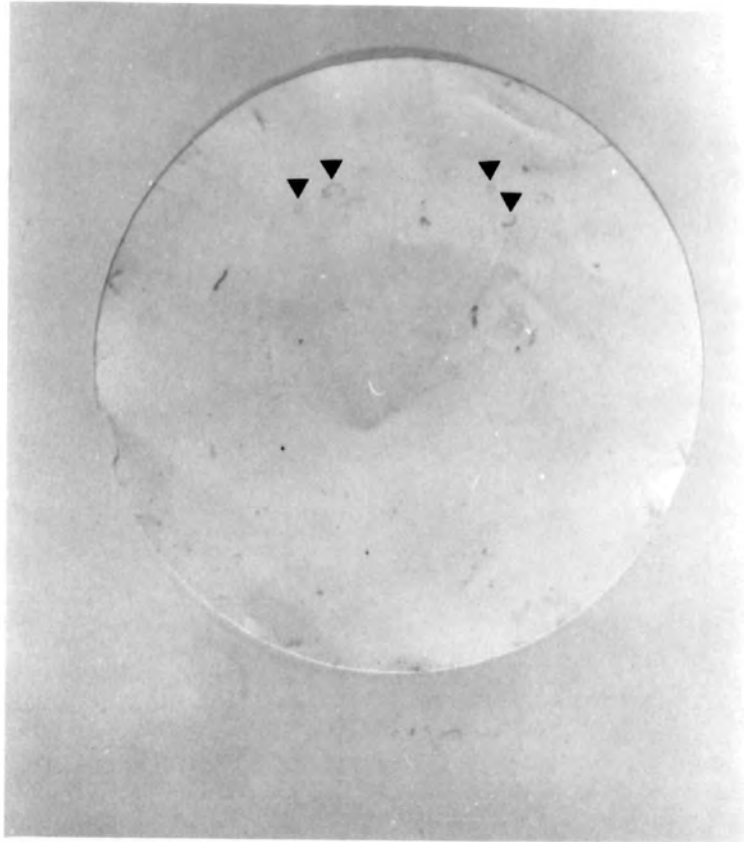
pDUB2301 ECOR1  
pDUB2302 ECOR1



vector

insert

**Figure 3.7.2 Southern Blot of Extracted Yeast DNA**  
Southern blot taken from the agarose gel shown in figure 3.7.1.



**Figure 3.7.3 Colony Western Blot of Transformed MC16**  
The blot shows more than 30 colonies expressing vicilin.

7 6 5 4 3 2 1



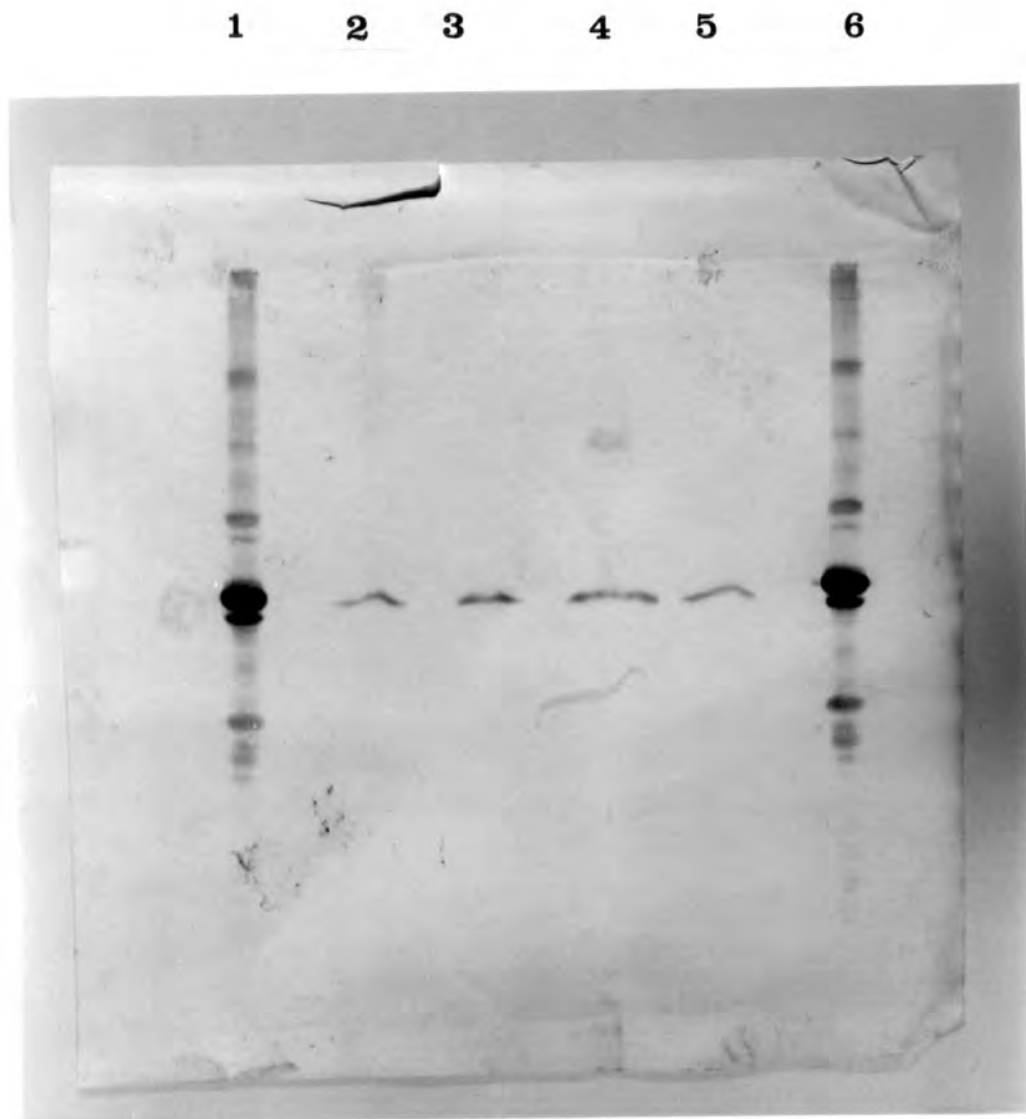
**Figure 3.7.4 Demonstration of Vicil in Expression from pDUB2302**

Western blot of proteins extracted from five colonies transformed with pDUB2302 and one with pDUB2303.

Track 1. Pea standard vicilin.

Track 2-6. Proteins extracted form pDUB2302 transformed yeast

Track 7. Proteins extracted from one pDUB2303 Transformed yeast.



**Figure 3.7.5 Initial Demonstration of the form of Vicilin Expressed from pDUB2302**

Western blot taken from a polyacrylamide gel loaded as follows:-

Tracks 1 & 6 Pea standard vicilin

Track 2 Protein extracted from transf<sup>or</sup>med yeast using sample buffer without detergent.

Track 3 Protein extracted using sample buffer with 1% Triton-X-100 but without SDS.

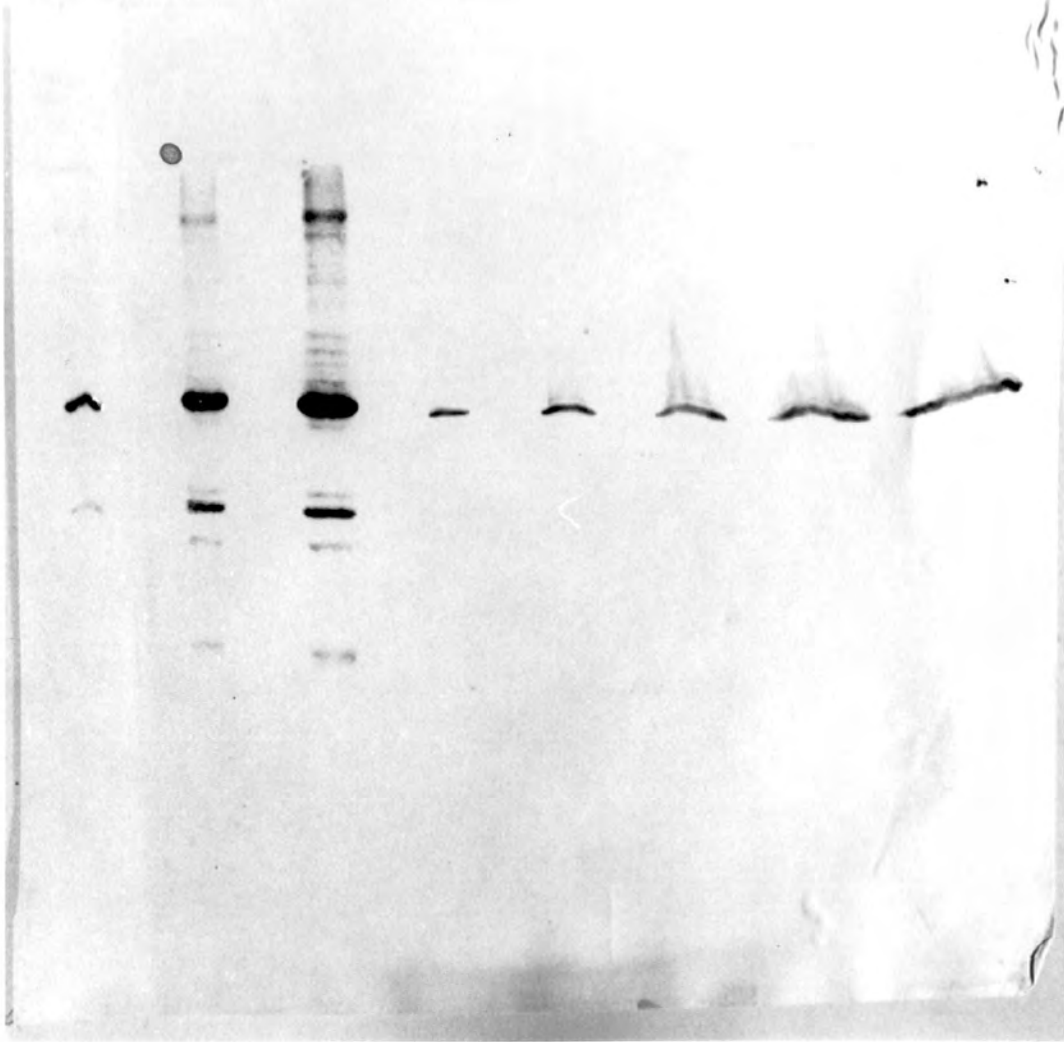
Track 4. Proteins extracted with sample buffer plus SDS.

Track 5. Proteins extracted with SDS sample buffer from a culture of transformed yeast grown in the presence of  $10\mu\text{g.ml}^{-1}$  Tunicamycin.

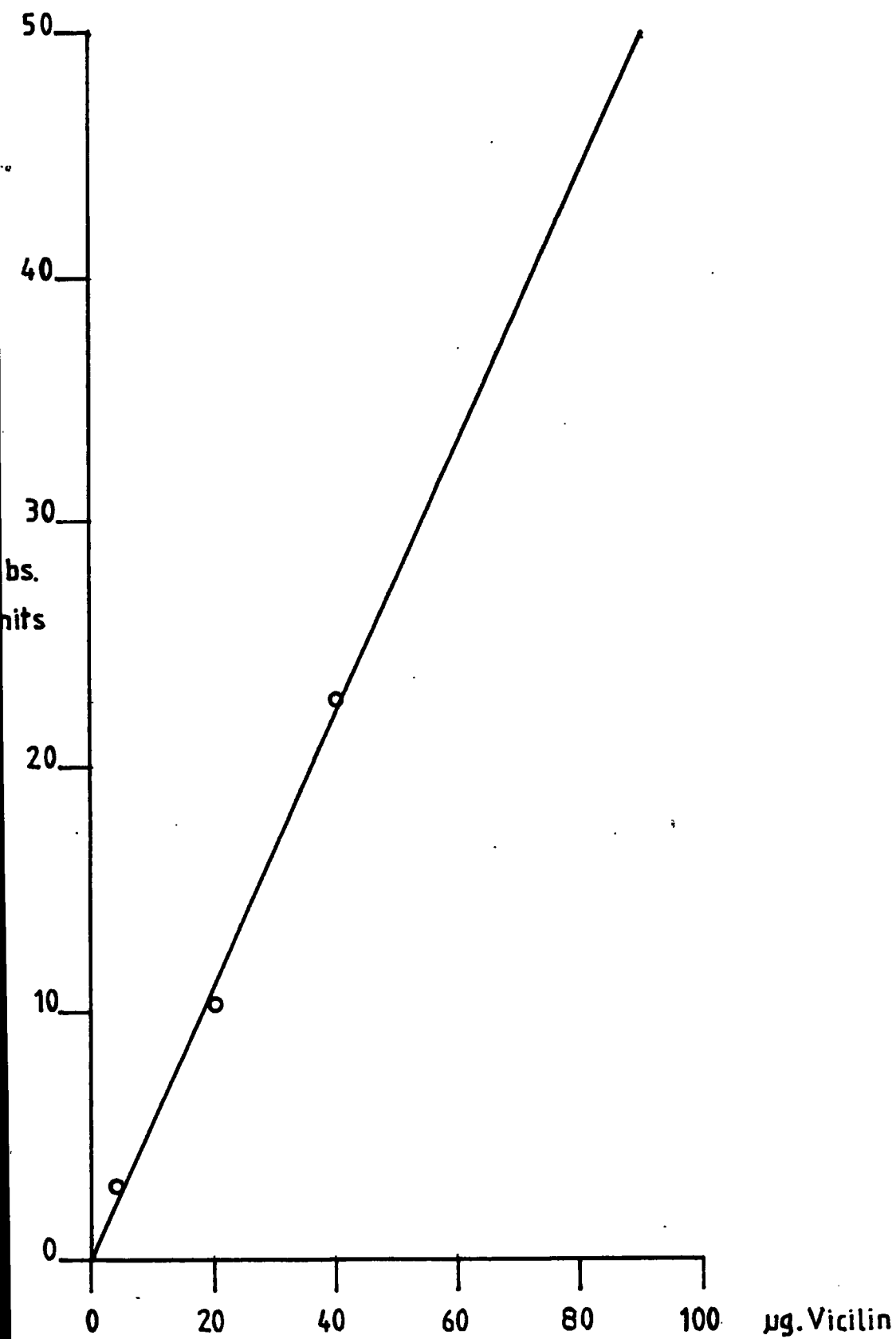
express vicilin using an incomplete cDNA and pMA257 (Watson *et al.* 1988)

MC16 was transformed with both pDUB2302 and pDUB2303 by the method of Ito *et al.* (1983) and the transformed yeast plated out on YMM His.Ade.Lys. Only 10 transformants from each plasmid were obtained. DNA was prepared from these and cut with *EcoRI*. The DNA was then electrophoresed on an agarose gel (figure 3.7.1) and then used for Southern blotting (the probe was the same as that used for the colony hybridisation in section 3.6). The blot (figure 3.7.2) shows that none of the yeast DNA contained the plasmids, it also shows that the probe is contaminated with vector sequences. The transformations were repeated, this time yielding 573 pDUB2302 transformants and 18 pDUB2303 transformants. This time instead of a Southern blot, a colony western blot was performed and more than 30 pDUB2302 transformants proved positive for vicilin (figure 3.7.3). None of the pDUB2303 transformants gave a positive result for vicilin. Five of the positive transformants and one of the pDUB2303 transformants were grown in YPD to late log phase ( $OD_{600}=1.5-2$ ) and protein prepared. SDS-PAGE and western blotting were then performed. Figure 3.7.4 shows the western blot, with all five pDUB2302 transformants expressing vicilin of comparable mobility to the 47000M<sub>r</sub> form of vicilin seen in the standard. Some specific proteolysis is also seen in all five extracts. No vicilin is seen in the pDUB2303 transformed extract. The stained gel showed no difference between the transformed and untransformed protein samples. An initial experiment to determine the physical form of the heterologous vicilin is shown in figure 3.7.5. One transformed, expressing yeast was grown in supplemented YMM and then the proteins were extracted sequentially with Tris.sucrose, then with 1% Triton-X-100.Tris.sucrose and finally with SDS.Tris.sucrose. The results show that roughly equal amounts of vicilin were extractable into each buffer. The fourth extract shown on the gel is of the same strain

1 2 3 4 5 6 7 8



**Figure 3.7.6 Level of Expression of Heterologous Vicilin 1.—Western Blot**  
Western blot taken from an SDS-PAGE gel loaded from left to right as in table 3.7.1.



**Figure 3.7.7 Level of Expression of Heterologous Vicilin 2.-Calibration Curve**

The calibration curve was constructed using the values for pea standard vicilin as shown in table 3.7.1

grown in supplemented YMM with  $10\mu\text{g.ml}^{-1}$  Tunicamycin. The antibiotic had no effect on vicilin produced in yeast.

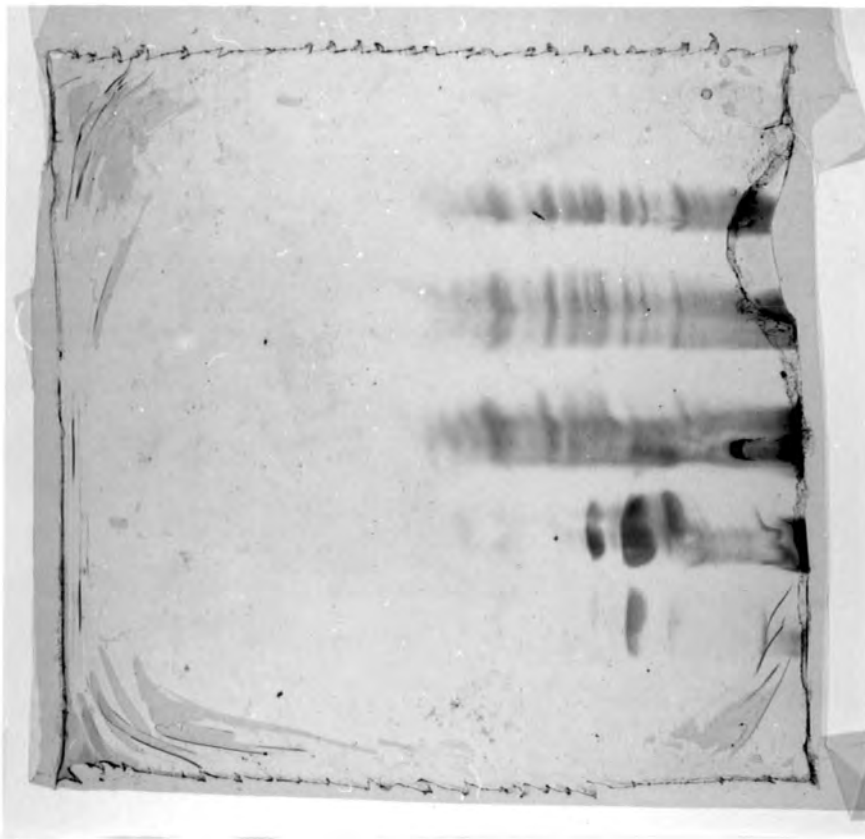
### 3.7.2 Level of Expression of Heterologous Vicilin

Transformed yeast were grown in supplemented YMM to late log phase and the proteins extracted into SDS sample buffer. The protein content was measured at  $17.75\text{mg.ml}^{-1}$ . SDS-PAGE was then performed with the gel loaded as in table 3.7.1. The gel was western blotted and the density of the stained bands determined by an LKB laser densitometer. The total absorbance of each band was determined by multiplying the area of each band by the absorbance per millimeter. The western blot appears as figure 3.7.6 and the graph constructed from the three readings of the vicilin standards appears as figure 3.7.7. The total absorbances for the yeast vicilin bands were plotted on the graph and then the amount of vicilin read off. The results gave an average of 5.5% ( $\pm 0.4$ ) of total protein as vicilin.

Table 3.7.1

$\mu\text{l}$ protein	$\mu\text{g}$ protein	Total Abs.	$\mu\text{g}$ vicilin	% Total Protein
5 yeast	88.7	1.76	3	3.4
10 yeast	173.5	5.85	10.5	5.9
25 yeast	443	13.0	24.25	5.5
50 yeast	887	27.72	50	5.6
100 yeast	1775	49.86	90.5	5.1
2 pea	4	2.85	—	—
10 pea	20	10.205	—	—
20 pea	40	22.64	—	—

The pea standard was  $2\text{mg.ml}^{-1}$  purified vicilin.



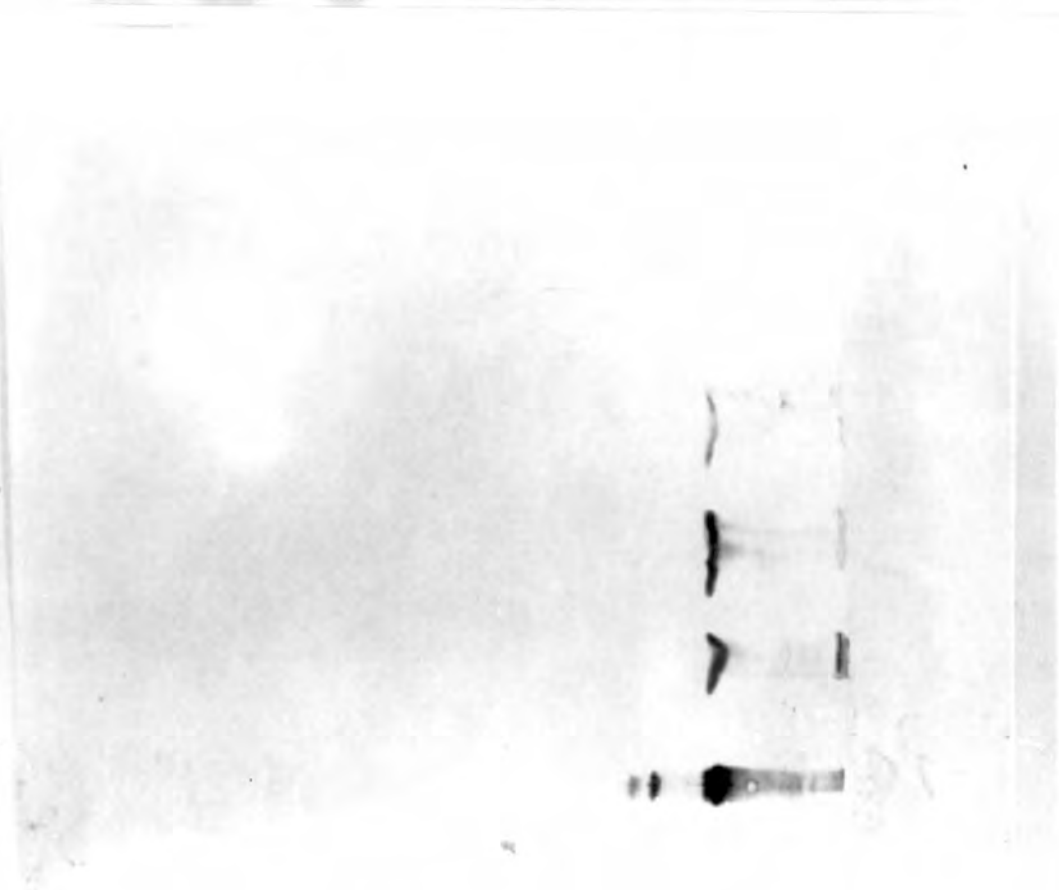
40%

60%

70%

90%

>90%



>90%

90%

70%

60%

40%

SDS

pea

### Figure 3.7.8 Ammonium Sulphate Precipitation of Yeast Proteins

A western blot and polyacrylamide gel loaded with protein samples as detailed in table 3.7.2. The western blot has pea standard vicilin in addition to the yeast protein extracts.

### 3.7.3 Investigation of the form of the heterologous vicilin

When vicilin was expressed in yeast as a soluble cytoplasmic form a two-step purification process was reported (Watson *et al.* 1988). The first step in this was ammonium sulphate precipitation, the vicilin being found in the 45% to 95% pellet. Therefore, ammonium sulphate precipitation was performed on proteins <sup>k</sup>extracted from a 1litre YMM culture of transformed yeast. The protein was first extracted with Tris.sucrose and then the pellet of debris re-extracted with SDS sample buffer. The Tris.sucrose extract was then precipitated as in chapter 2 with concentrations of ammonium sulphate as shown in table 3.7.2. Each pellet was resuspended in 3ml of SDS sample buffer.

Table 3.7.2

Sample	A <sub>330</sub>	mg.ml <sup>-1</sup>	Total Vol.(ml)	Total mg.
SDS extract	0.418	13	20	260
40% pellet	0.486	15	3	45
60% pellet	1.009	31	3	93
70% pellet	0.485	15	3	45
90% pellet	0.374	11.5	3	34.5
90%	0.297	9	25	225

The total available protein was 702.5mg

Therefore 63% was in the Tris.sucrose extract, of which 31% precipitated and 32% remained unprecipitated at 90% Ammonium sulphate saturation.

All samples were brought to 0.2% SDS with 10% SDS and then equal amounts of protein (450  $\mu\text{g}$ ) were subjected to SDS-PAGE and western blotted. Figure 3.7.8 shows the western blot and the stained gel. Vicilin appears in all fractions but by far the largest amount appears to precipitate at 40%. The stained gel has no pea

vicilin standard but does show that the SDS, 40% and 60% samples all look alike, with only a few proteins remaining in the 70-90% fractions. Thus it appears that the vicilin produced from this cDNA is different in its physical properties to that reported by Watson *et al.* (1988). Either the protein is very closely associated with a membrane and co-precipitates with the lipids or it is in a conformation which is still immunoreactive but which is altered in its reaction to ammonium sulphate concentration.

When the proteins were extracted with SDS-sample Buffer an identical result was obtained with all the vicilin precipitating at 40%.

#### **3.7.4 Radio-labelling of Heterologous Vicilin**

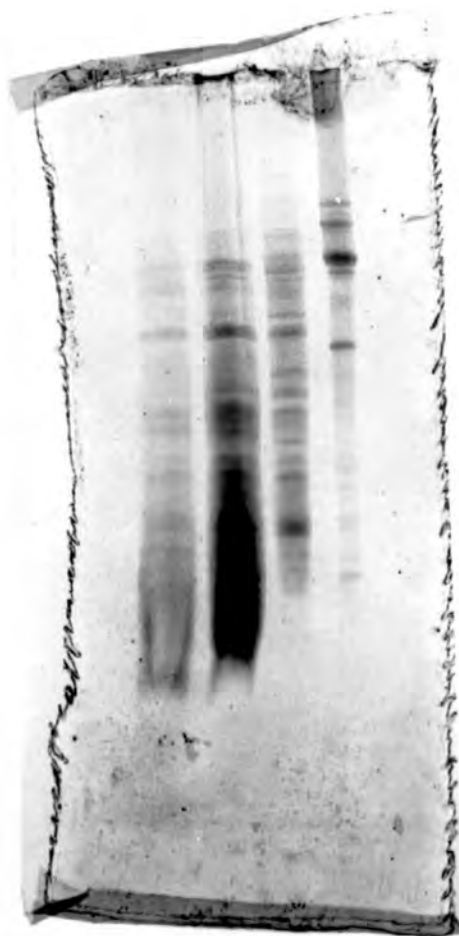
The sequence data presented earlier suggested that if the yeast was incapable of cleaving the vicilin signal peptide then the N-terminal sequence of the heterologous protein would have one or two methionine residues (depending on which AUG served as the initiation codon). No methionine residues occur in the mature protein, so if the yeast was grown in media containing [<sup>35</sup>S] methionine, the vicilin protein would be labelled if the yeast could not remove the signal peptide and unlabelled if it could. An initial experiment grew 50ml cultures of transformed and untransformed MC16 in the presence of 50 $\mu$ Ci of radioactive methionine, extracted the proteins, electrophoresed them on SDS-PAGE, Western blotted the gel and then dried the blot and exposed an X-ray film to it. Figure 3.7.9 shows the stained gel, western blot and the autoradiograph. The first experiment suffered from a lack of vicilin production from the transformed yeast. However, by comparing the gel and the autoradiograph it can be seen that the technique will work ie the dark bands on the autoradiograph correspond to the protein bands on the stained gel. This eliminates the need for fluorography. There are two radioactive proteins in the immediate vicinity of the expected position of the

4 3 2 1



AUTORADIOGRAM

4 3 2 1



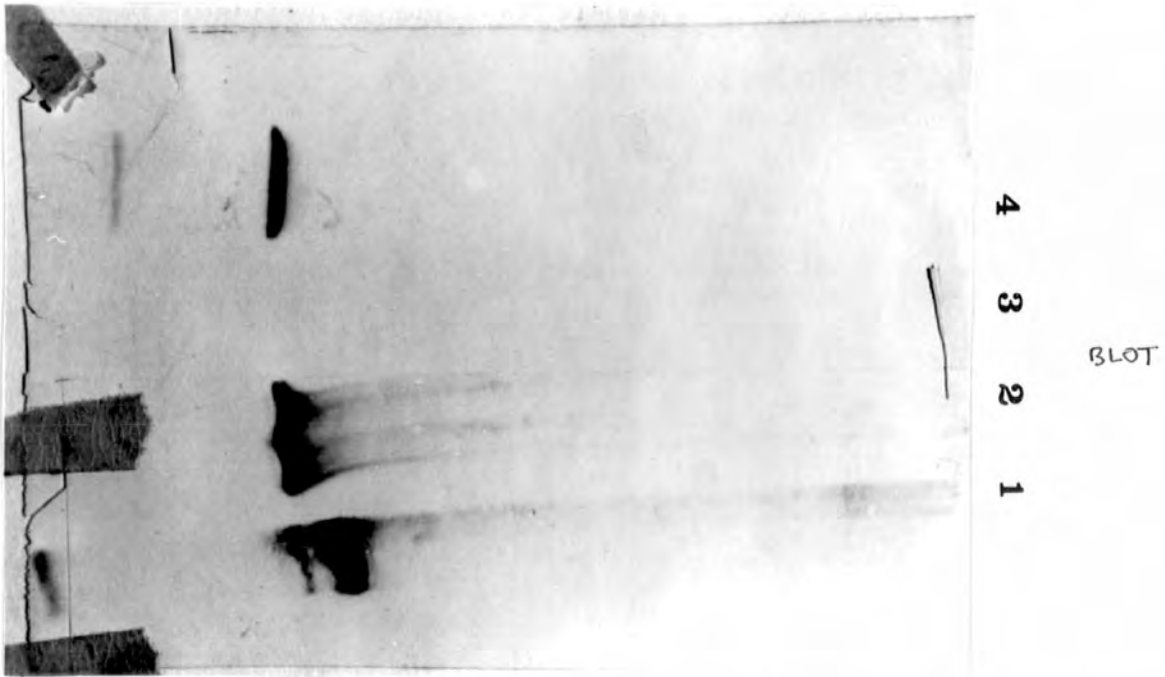
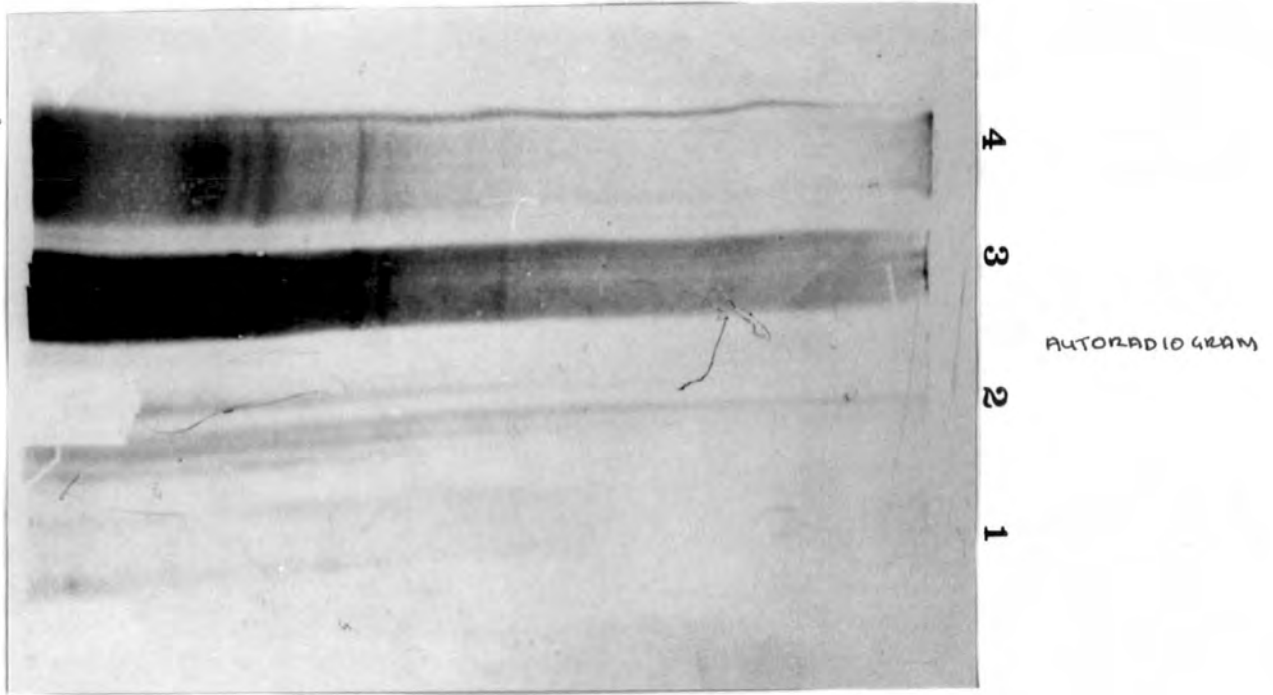
STAINED GEL

**Figure 3.7.9 Labelling of Yeast Proteins with  $^{35}\text{S}$  methionine**

A polyacrylamide gel and autoradiogram showing yeast proteins labelled with  $^{35}\text{S}$ -met.

- Track 1) pea standard vicilin
- Track 2) proteins extracted from untransformed MC16, unlabelled
- Track 3) proteins extracted from untransformed MC16, labelled
- Track 4) proteins extracted from transformed MC16, labelled

vicilin?—



**Figure 3.7.10 Identification of  $^{35}\text{S}$  methionine Labelled Vicilin**

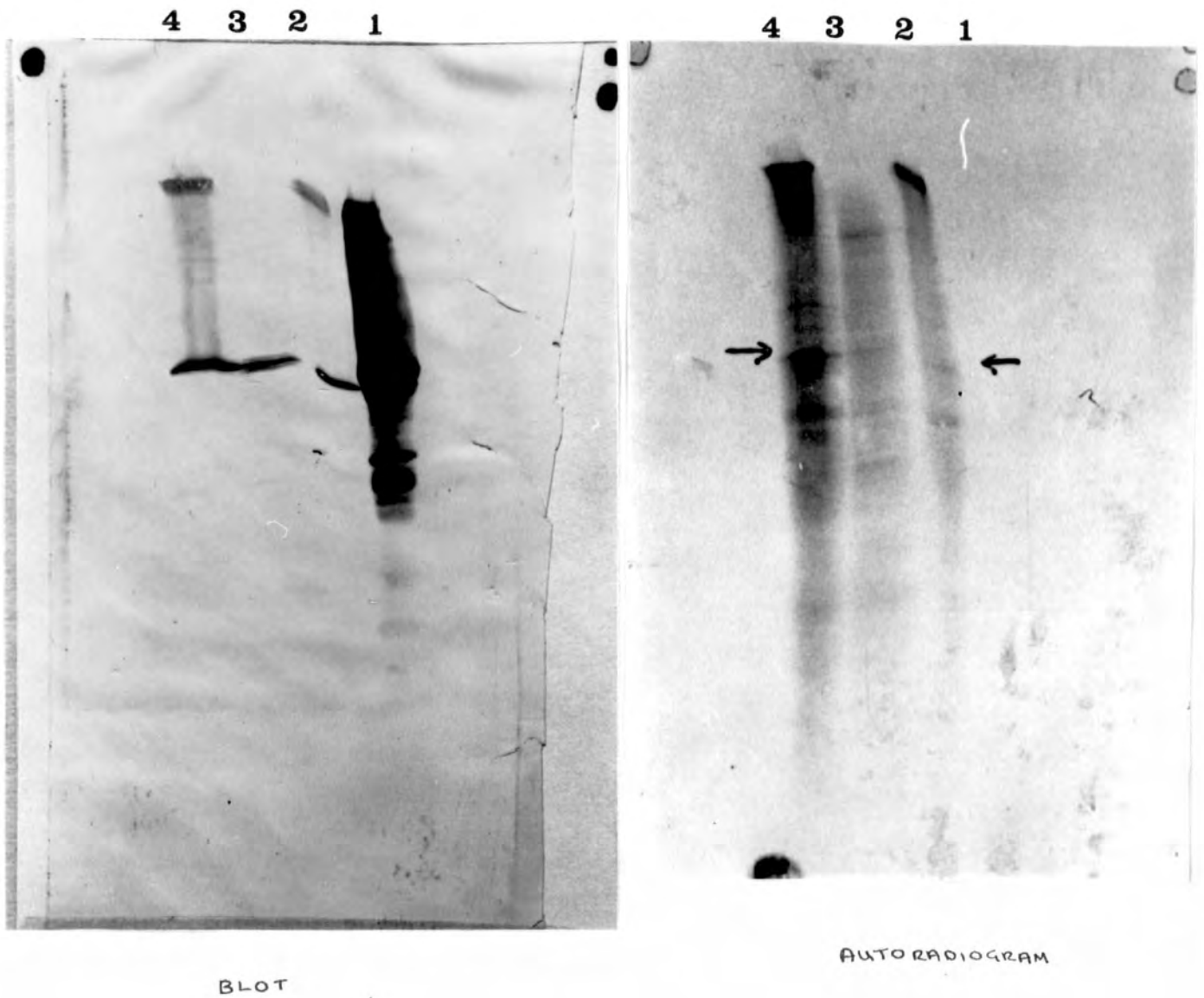
A western blot and autoradiogram taken from a polyacrylamide gel, loaded with protein samples as follows:-

- Track 1) pea standard vicilin
- Track 2) proteins extracted from MC16 transformed with with pDUB2302
- Track 3) protein extracted from untransformed, labelled MC16
- Track 4) proteins extracted from transformed, labelled MC16

yeast produced vicilin which may cause resolution of the vicilin band to be poor.

A second attempt showed restoration of vicilin expression, figure 3.7.10 shows the western blot and the autoradiograph taken from it. In the region of vicilin the two extracts (transformed and untransformed) look as if they have identical banding patterns except that the untransformed yeast appears to be more highly labelled. The upper of the two bands indicated with arrows on the autoradiograph has the same R.F. as the vicilin band on the western blot, 0.74 and has the same shape. On a qualitative basis, the two arrowed bands appear to have different relative abundances in the untransformed yeast extract, with the lower band much darker than the upper band. If the same relative abundance was maintained in the transformed extract then one would expect the upper band to be fainter than the lower band. This is not the case, the upper band is darker than the lower one. This may mean that the yeast is not removing the signal peptide from vicilin and the combined radioactivity of vicilin and a yeast protein of the same mobility (noted on previous gels) give the result seen in figure 3.7.10. In an attempt to gain better resolution and hopefully to separate vicilin from the yeast protein of similar electrophoretic mobility a 10% arylamide gel of the same extracts was performed. This gave fuzzy, indistinct bands on the gel, western blot and autoradiograph and nothing could be interpreted from them.

A later experiment appeared to confound the conclusions of the last experiment. A microsome preparation was performed on radio-labelled yeast (see section 3.7.7). The purified microsomes were subjected to SDS-PAGE together with the lysate fraction and a crude cell extract. The gel was western blotted and an autoradiograph produced. Unfortunately the stained gel cracked on drying and is not available for comparison. The western blot and autoradiograph presented in figure 3.7.11 show that the nearest radioactive protein bands do not have the same R.F. as vicilin and



**Figure 3.7.11 Identification of  $^{35}\text{S}$  methionine Labeled Vicilin?**

A western blot and autoradiogram of  $^{35}\text{S}$ -met labelled yeast proteins, extracted by microsome preparation in comparison with a crude cell extract and lysed spheroplasts.

- Track 1) pea standard vicilin
- Track 2) cell extract
- Track 3) spheroplast lysate
- Track 4) microsomal fraction

1 2 3 4 5 6 7 8 9 10



**Figure 3.7.12 Immunoprecipitation of Yeast Proteins and Cyanogen Bromide Cleavage**

A western blot combining two experiments. Lanes 1-5 show the first attempt at immunoprecipitation and the right hand side of the blot shows the result of cyanogen bromide digestion of pea and yeast vicilin.

- Track 1) crude lysate
- Track 2) Immune precipitate supernatant
- Track 3) blank
- Track 4) blank
- Track 5) immunoprecipitate pellet
- Track 6) pea standard vicilin
- Track 7) microsome fraction
- Track 8) yeast proteins digested with CNBr
- Track 9) pea vicilin digested with CNBr
- Track 10) pea standard vicilin

1 2 3 4



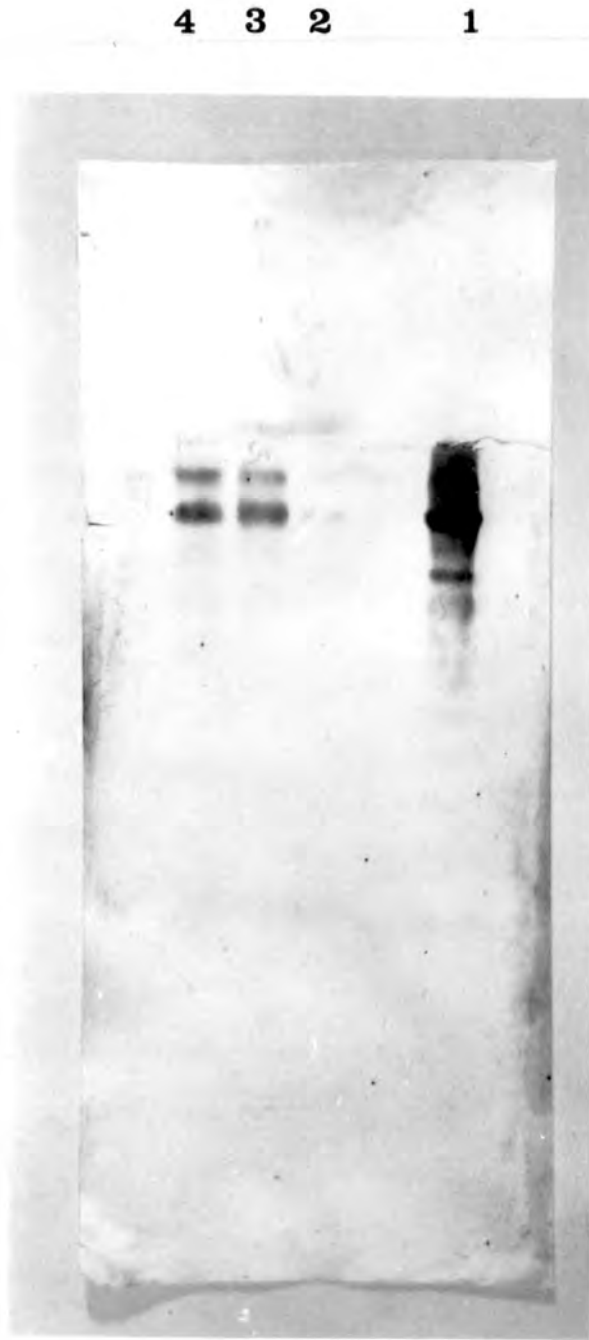
**Figure 3.7.13 Apparent Immunoprecipitation of Vicilin**

The effect of using a Tris-Tricine gel system on immunoprecipitated proteins. The gel from which this western blot was produced was loaded as follows:-

- Track 1) immunoprecipitate
- Track 2) blank
- Track 3) immunoprecipitate, supernatant
- Track 4) pea standard vicilin

one could conclude that the vicilin is not labelled. The ideal situation would be to obtain a gel which shows a single protein band corresponding to a single band on a western blot which would or wouldn't correspond to a radioactive band on an autoradiograph. To achieve this, immunoprecipitation was tried.

In the method used in this work (section 2.16.3) affinity purified anti-vicilin antibodies, covalently linked to sepharose beads (supplied by J. Gatehouse) were allowed to form complexes with vicilin in an extract of yeast proteins. The sepharose: antibody-antigen complexes were removed by centrifugation and the antigens dissociated with SDS. The sepharose: antibodies were pelleted and the supernatant subjected to SDS-PAGE. The first attempt at this failed to precipitate any vicilin, all of it staying in the supernatant (figure 3.7.12, lane 2). A second attempt produced a very smeared image, probably due to not using  $\beta$ -mercaptoethanol which causes the antibody proteins to dissociate and run as discrete polypeptides. Also, this gel confirmed the result of the first attempt in that the antibodies were seen to be dissociated from the sepharose in quite large amounts. In an effort to sharpen up the bands on the gel, a different gel was used, that of Schagger and Von Jagow (1987). This technique uses Tricine instead of glycine as the trailing ion and achieves greater resolution over the range 1 to 100 KDa. it also reduces overloading effects and eliminates the need for urea in resolving proteins below 20KDa. Figure 3.7.13 shows the result of using this gel, which, though better, are still not very clean. Also, the precipitated vicilin appears to run with slower mobility than the 50KDa form of vicilin in the standard. A blot of the same samples which had no extra primary antibody added proved that the band on the western blot with apparent molecular weight of 50KDa is in fact the anti-vicilin IgG. This was confirmed when an extract, immunoprecipitate and supernatant which had very little vicilin in the first place were subjected to SDS-PAGE and western blotted. Figure 3.7.14 shows that the immune-precipitate and super-



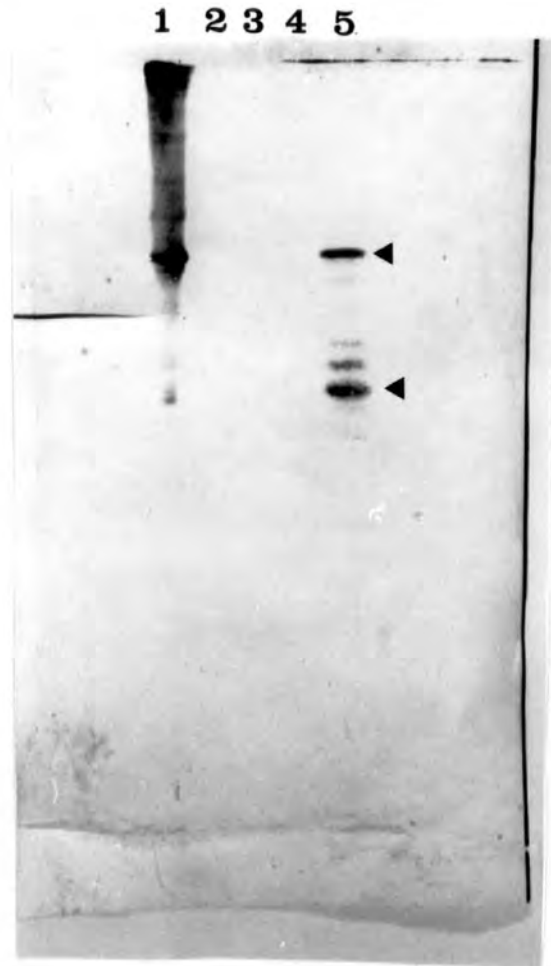
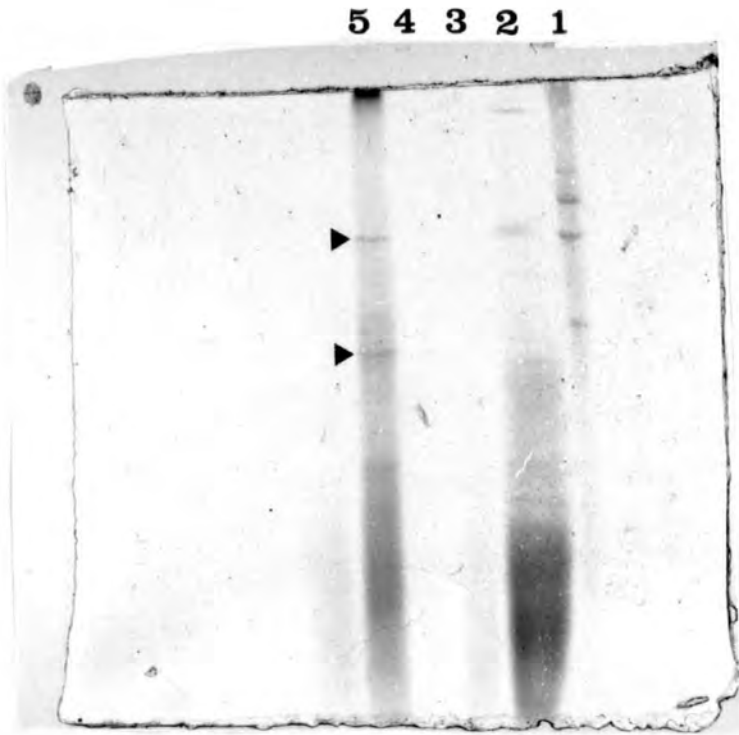
**Figure 3.7.14 Demonstration of Shortcoming of Immunoprecipitation Technique**

A western blot showing that despite there being little vicilin present in the yeast protein extract, the reaction of the 2° antibodies with the anti-vicilin antibodies is equally strong in the supernatant and immunoprecipitate fractions.

- Track 1) pea standard vicilin
- Track 2) crude cell extract
- Track 3) immunoprecipitate, supernatant fraction
- Track 4) immunoprecipitate, precipitated proteins

natant both show up equally strong on the western blot. There is less smear this time because the anti-vicilin Sepharose was washed with distilled water before use. These results indicate that on gels and western blots the presence of uncoupled antibodies is masking any precipitation one might expect to see. However, if the vicilin had an intact signal peptide and was labelled with radioactive methionine then an autoradiogram of an immune-precipitate would show a black band despite the gel and western being masked by the antibodies. This experiment was done and again the yeast failed to produce any vicilin. It did show that although the stained gel showed only the antibodies in the immune-precipitate, the autoradiograph showed detectable amounts of yeast proteins left behind by a faulty washing technique. None of these proteins were immuno-reactive nor corresponded to any known vicilin species. These results show that using the technique described in section 2.16.3 and the anti-vicilin sepharose, no clear immune- precipitation of vicilin was demonstrated.

Another attempt to demonstrate the presence or absence of the signal peptide was by using cyanogen bromide cleavage, which cleaves proteins <sup>after</sup> every methionine residue. If the vicilin signal peptide is intact then cyanogen bromide would cut off 9 amino-acids or one, depending on which AUG is used as the start codon. The experiment was performed as in section 2.16.2 on MC16/pDUB2302 and the result appears in figure 3.7.12 tracks 8,9 and 10. The control vicilin from a microsome preparation (see section 3.7.7) must have been digested by proteases which may have been enriched in the microsome fraction since the track on the western is blank, the next track shows 50 $\mu$ l (2mg total protein approx.) of a fresh extract treated with CNBr and the third, 1mg of pea vicilin treated in the same way. The yeast vicilin shows a distinct doublet more obvious than previously noted but the pea vicilin has all but disappeared, with only the 50KDa form visible confirming the absence of methionines



### Figure 3.7.15 Partial Purification of Vicilin

A polyacrylamide gel and western blot showing that vicilin which has precipitated at 40% Ammonium sulphate saturation, comes out of solution upon dialysis, in a partially purified form.

Track 1) pea standard vicilin

Track 2) 40% Ammonium sulphate precipitated proteins, dialysis supernatant, non-expressing yeast.

Track 3) 40% Amm.sulph. precipitated proteins, dialysis pellet, non-expressing yeast.

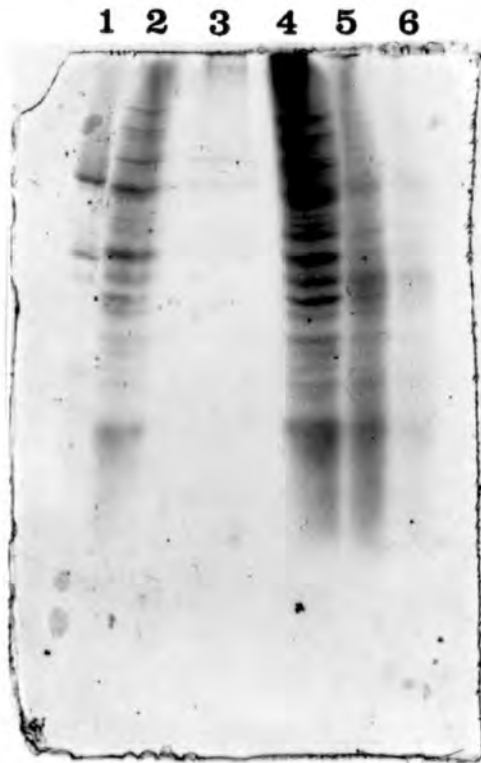
Track 4) as track 2, vicilin expressing yeast.

Track 5) as track 3, vicilin expressing yeast.

in the protein. The doublet could be explained if yeast initiates at the first AUG in a majority of cases but sometimes initiates at the second AUG within the signal peptide explaining the faint doublet seen in some blots. In neither case is the signal peptide cleaved, so on treatment with cyanogen bromide the largest form is cleaved down to the form of the minor species but not all of it has been cleaved i.e. the reaction has not gone to completion therefore the doublet is much more pronounced than usual. This interpretation relies on the gel used being able to resolve a difference of only 9 amino acids corresponding to nearly 1KDa.

### **3.7.5 Partial Purification of the Heterologous Vicilin**

A 40% Ammonium sulphate cut was obtained from two SDS extracts, one from a vicilin expressing strain and the other not expressing vicilin. The pellets were dissolved in 1ml SDS sample buffer and then dialysed against 50mM Tris.Cl pH 6.8 for 48 hours with 4 changes of buffer. The contents of the tubing were then centrifuged at 13500rpm for 10 minutes and then the pellet resuspended in 200 $\mu$ l of SDS sample buffer and the supernatant brought to 0.2% SDS with 10% SDS. Figure 3.7.15 shows an SDS gel and western blot of these protein fractions. The two dialysis pellets are shown to contain a few protein species and are markedly different. The R.F. for the major vicilin band on the western blot is 0.24, identical to that of the most obvious protein band on the transformed yeast pellet track. This protein is absent from the non-expressing yeast. Similarly the other vicilin species visible on the western blot have R.F.'s corresponding to the visible proteins on the gel. The interesting point about this experiment is that the vicilin on the blot can be identified as a discrete, obvious protein band on the stained gel. The presence of so many smaller forms of vicilin in this extract is probably due to non-specific cleavage, even though some of the smaller species appear to be the same size as processed forms of vicilin in the pea

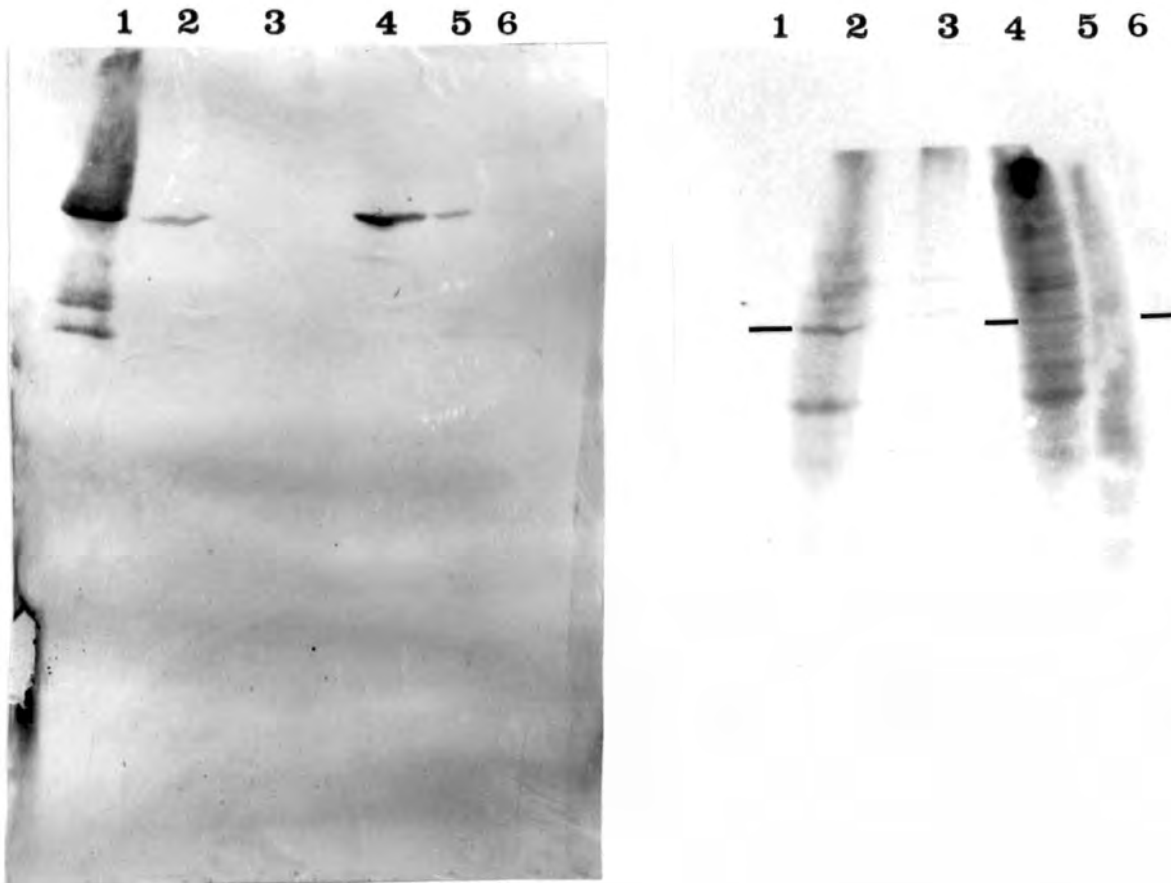


**Figure 3.7.16 Partial Purification of  $^{35}\text{S}$  Labelled Vicilin**

A polyacrylamide gel of  $^{35}\text{S}$ -met labelled yeast proteins.

The gel was loaded as follows:-

- Track 1) pea standard vicilin
- Track 2) crude cell lysate
- Track 3) above 40% Ammonium sulphate proteins
- Track 4) 40% Ammonium sulphate pellet
- Track 5) supernatant after dialysis
- Track 6) pellet after dialysis



**Figure 3.7.17 Western Blot and Autoradiogram of Labeled, Partially Purified Vicilin**

The blot was of a polyacrylamide gel loaded exactly as in figure 3.7.16. The arrows on the autoradiogram indicate radioactive proteins which have the same R.F. as the vicilin band on the western blot.

standard. The reason for this proteolysis may be that in this case the proteins were extracted without the presence of protease inhibitors such as leupeptin or PMSF, a sin of omission rather than choice. The next step was to repeat this experiment, with protease inhibitors, using radioactively labelled yeast. Attempts were made using MC16/pDUB2302 but the expression of vicilin again appeared to have been lost, colony western blots and re-purifying the glycerol stock culture failed to yield any positive colonies. Therefore the GFR167/pDUB2300 yeast was used. The yeast was grown in 5ml of YPGal and the expression was checked by SDS-PAGE and western blotting of extracted proteins. A second 5ml culture was used as an inoculum for 250ml of YMMGal.His with 200 $\mu$ Ci of [ $\alpha$ -<sup>35</sup>S] Methionine and grown at 30°C for 16 hours. Protein was extracted into SDS sample buffer and a 40% Ammonium sulphate precipitation was performed. The precipitate was dissolved in 1ml SDS-sample buffer and dialysed against 50mM Tris.HCl pH 6.8 for 48hours with four changes of buffer. The dialysate was then centrifuged at 13500 rpm for 10 minutes and the pellet dissolved in 200 $\mu$ l of SDS sample buffer. Figure 3.7.16 shows an SDS gel of the various fractions clearly showing a single protein species in the dialysate pellet and supernatant corresponding to vicilin. The autoradiogram taken from this gel showed that the single band was radioactive. This was confirmed when the Western blot shown in figure 3.7.17 was exposed to X-ray film. The black bands indicated with arrows correspond in size, shape and position to the vicilin bands on the blot. Thus this experiment demonstrates that the signal peptide of vicilin is not removed by yeast and probably accounts for the higher molecular weight of the heterologous vicilin compared to the 47KDa form from pea.

### **3.7.6 Glycosylation State of the MC16 Produced Vicilin**

The final aspect of the physical state of the yeast produced vicilin to be investigated



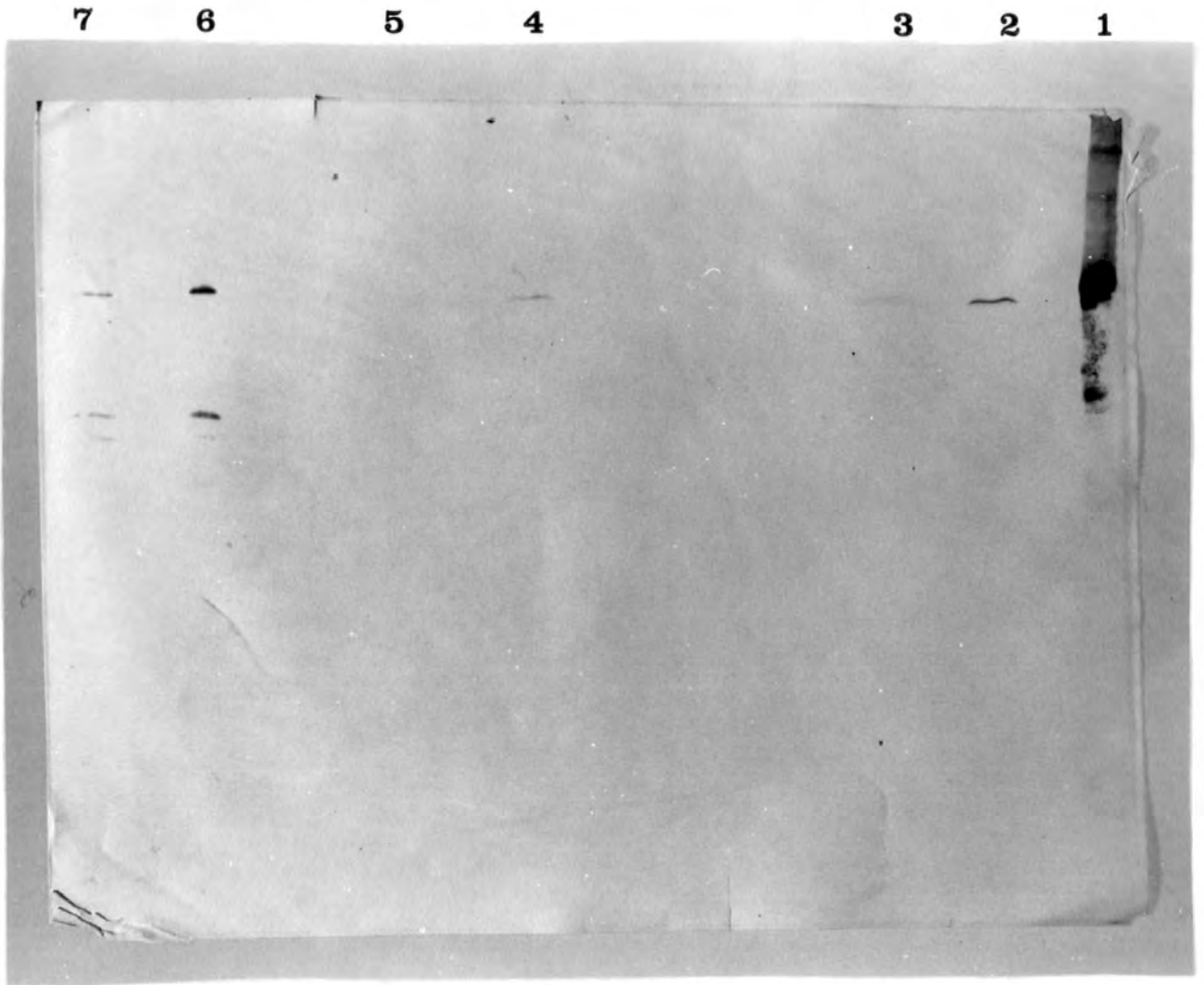
**Figure 3.7.18 1st Demonstration of the Effect of N-glycosidase on Vicilin**

The western blot shows:-

Track 1) pea standard vicilin

Track 2) yeast produced vicilin

Track 3) yeast produced vicilin treated with N-glycosidase



**Figure 3.7.19 2nd Demonstration of the Effect of N-glycosidase on Vicilin**

This western shows:-

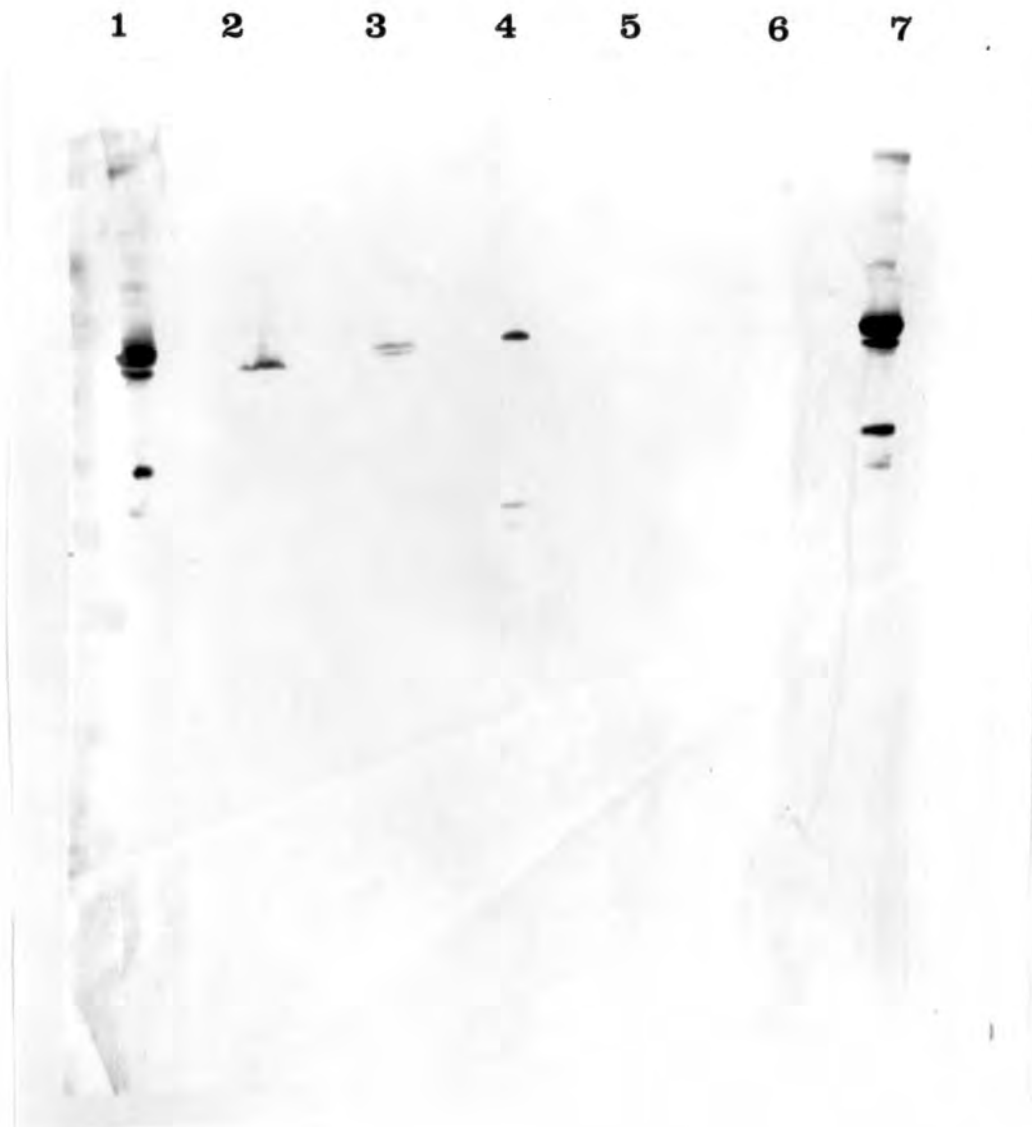
- Track 1) pea standard vicilin
- Track 2) crude cell extract
- Track 3) crude cell extract N-glycosidase treated
- Track 4) cleared lysate
- Track 5) cleared lysate, N-glycosidase treated
- Track 6) vacuole fraction
- Track 7) vacuole fraction, N-glycosidase treated

was glycosylation. We had already shown that tunicamycin had no effect on the vicilin produced from pDUB2300 and pDUB2302 (figure 3.7.5). This result was confirmed by repetition. Another method of detecting glycosylation is to use an enzyme such as Endoglycosidase H or N-glycosidase which cleave sugar moieties from proteins. The first experiment shown in figure 3.7.18 shows no change in mobility of the N-glycosidase treated yeast vicilin compared to untreated vicilin. A second test of the enzyme is shown in figure 3.7.19; in this case the enzyme was used to treat vicilin in three fractions taken from a vacuole preparation (see next section) on the grounds that if there were less variety of protein species and an enrichment of vicilin then the enzyme's action might be more apparent. The blot shows that the lysate and cleared lysate fractions didn't survive the enzymes action possibly indicating that the enzyme was contaminated with proteases. Protein samples running at the edges of the gel may have been distorted and therefore the enzyme treated vacuole fraction appears to have a higher mobility than the untreated sample. Even if the gel hadn't distorted, the amount by which the two samples differ is not large enough to be due to deglycosylation. The difference in molecular weight ought to be in the region of 3.5KDa (corresponding to the difference between the 16KDa and 12.5KDa vicilin subunits. The amount of protein treated with the enzyme is the same as that loaded on the untreated track so it appears that the N-glycosidase may have been contaminated with proteases. Taken together with the tunicamycin results, these results suggest that yeast does not glycosylate vicilin.

### **3.7.7 Subcellular Location of vicilin in MC16**

From the results given so far it is clear that vicilin is not freely soluble in the yeast cytoplasm. The fact that the protein is extracted with SDS, and only to a limited extent with Triton-X-100 suggests that the protein is associated with a membrane or





**Figure 3.7.20 The Occurrence of Vicilin in Three Cell Compartments**

A western blot taken from a polyacrylamide gel showing that vicilin does not occur in either the culture supernatant or the periplasmic space but may occur in the vacuole.

The gel was loaded as follows:-

- Track 1) pea vicilin
- Track 2) crude lysate
- Track 3) cleared lysate
- Track 4) vacuole fraction
- Track 5) culture supernatant proteins
- Track 6) periplasmic proteins
- Track 7) pea vicilin

enclosed by one. The possible locations for vicilin are as follows:-

Culture medium (ie. secreted), periplasm, cell membrane, vacuole, golgi or endoplasmic reticulum.

To check for secretion was relatively simple, a culture was grown up to late log phase and the cells pelleted. The supernatant was removed and TCA precipitated. The precipitate was dissolved in SDS sample buffer to a concentration of  $12\text{mg.ml}^{-1}$  before being loaded onto an SDS gel and then western blotted. No vicilin was seen in the culture supernatant track, whereas it was seen in an SDS extract of the pelleted cells.

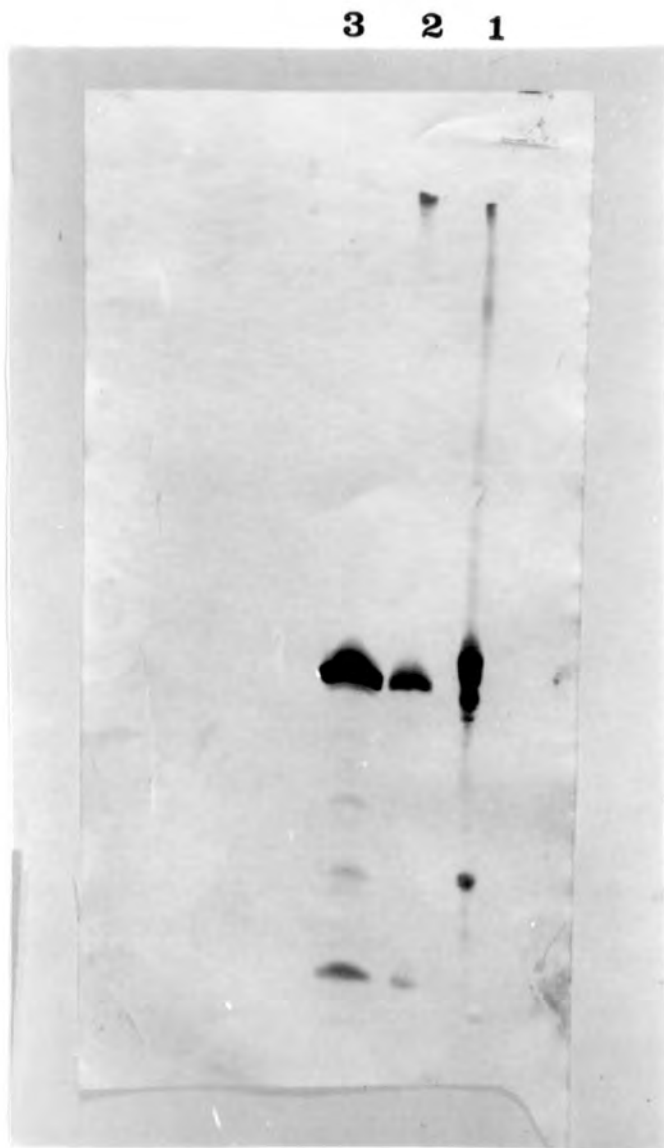
The periplasm could be checked at the same time as vacuoles were purified, since the act of digesting the cell wall with lyticase and pelleting the spheroplasts would release the periplasmic proteins into the supernatant. Again the proteins were TCA precipitated and figure 3.7.20 lanes 5 and 6 show that neither the culture supernatant nor the periplasm contain any vicilin. So it appears that the yeast sequesters the vicilin somewhere inside the cell.

Figure 3.7.20 also shows the result of the first vacuole preparation. Three samples were taken, the cell lysate, the ficoll layer above the debris but below the vacuole layer (called the cleared lysate) and the cloudy vacuole float in the upper ficol layer. The activity of the vacuolar marker enzyme Carboxypeptidase Y was assayed in the lysate and the vacuole layer giving the following specific activities:-

Lysate  $3.8 \text{ nmol/min/mg. protein}$

Vacuoles  $1.55 \text{ nmol/min/mg. protein}$

By comparing the amount of protein in the two fractions, it was clear that in addition to no enrichment of CPY, only 1% of the total activity was recovered in the vacuole



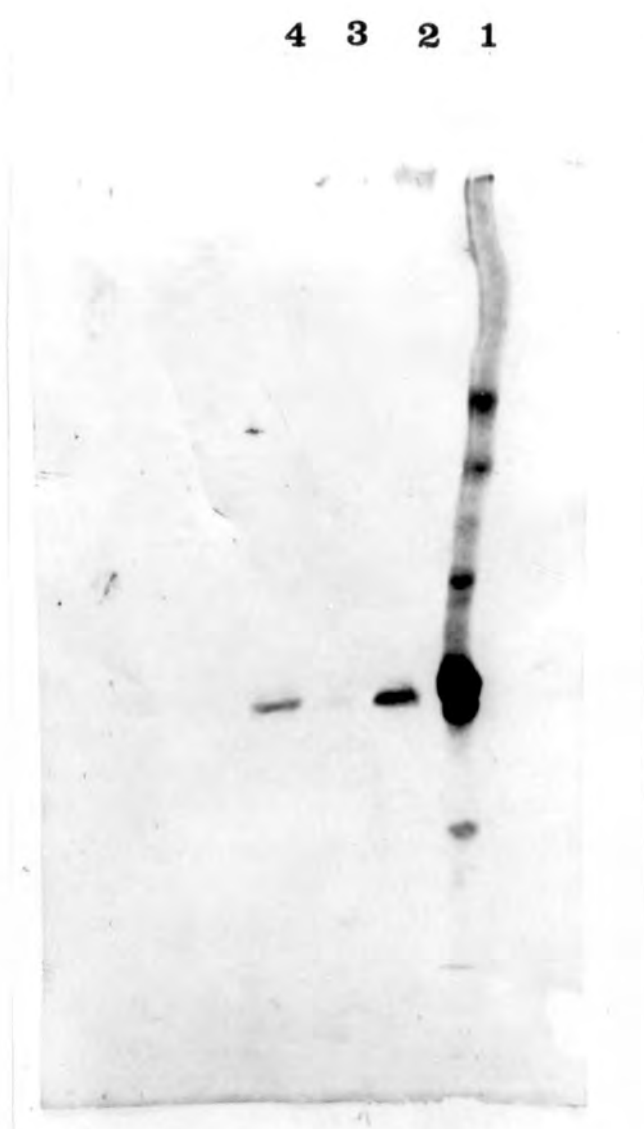
**Figure 3.7.21 Vicilin is Present in the Microsome Fraction**

A western blot showing that vicilin is enriched in purified microsomes. The gel was loaded as follows:-

Track 1) pea standard vicilin

Track 2) crude cell lysate (0.6mg)

Track 3) microsomal fraction (0.6mg)



**Figure 3.7.22 Further Demonstration of Vicilin in the Microsome Fraction**

The gel from which the western was taken was loaded as follows:-

- Track 1) pea standard vicilin
- Track 2) microsomal fraction
- Track 3) 'cloudy layer' (see section 3.7.7)
- Track 4) crude cell lysate

layer. However, from figure 3.7.20 it can be seen that all three fractions contain vicilin, only the vacuole fraction containing any processed forms and only the cleared lysate showing the doublet. Despite showing no enzyme enrichment, the vacuole layer does show enrichment of vicilin, since in the cases of the lysate and the cleared lysate about 1mg of protein was added compared to 375 $\mu$ g of protein in the vacuole sample. Unfortunately the gel 'smiled' so no comparison of size of the bands on the western blot is possible.

A second vacuole preparation failed to yield any cloudy float in the upper ficoll layer; however a third preparation did give a cloudy float but again the specific activity of CPY was very low in the vacuole layer (0.55 nmol/min/mg. protein compared to 13.5 for the lysate). An assay for the enzyme NADPH cytochrome C reductase, an E.R. marker, gave results of 1.6 nmol/min/mg. protein for the lysate and 6 nmol/min/mg.protein in the vacuole sample.

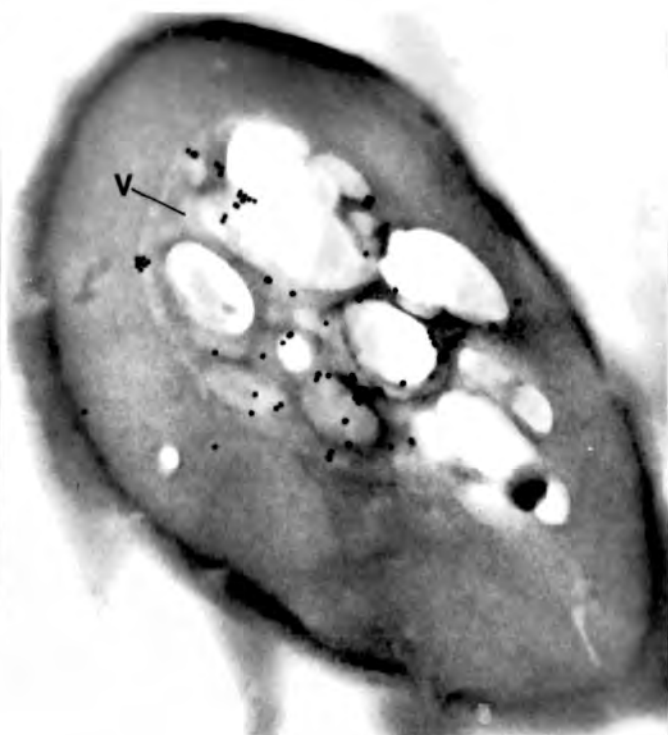
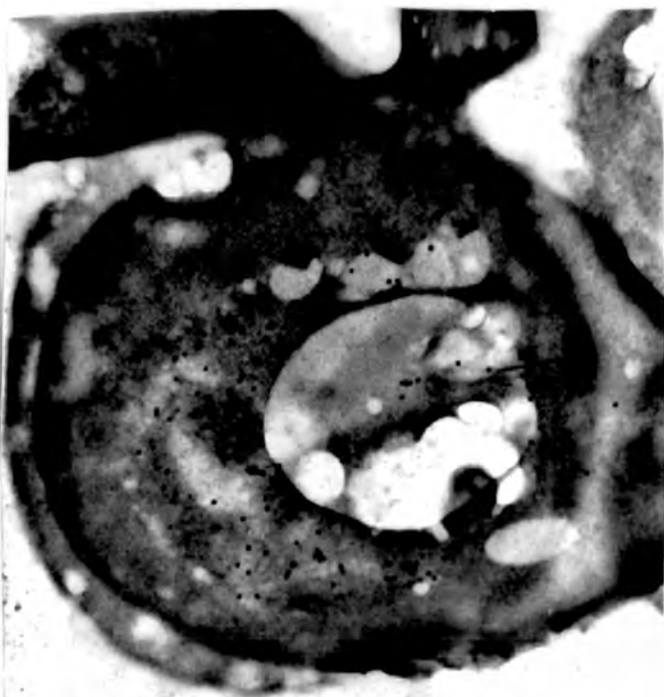
It was then decided to purify microsomes to confirm that vicilin entered the ER. A first attempt at a microsome preparation gave cytochrome C reductase activities of:-

Lysate 0.6 nmol/min/mg. protein

Microsomes 2.5 nmol/min/mg. protein

Enrichment factor 4x

Figure 3.7.21 shows a western blot of the lysate and microsome fractions (600 $\mu$ g) with significant enrichment of the vicilin in the microsome fraction. It also shows one major cleavage product and at least three other minor products. A further microsome preparation yielded a CPY enrichment factor of only 1.5 and a NADPH cytochrome C reductase enrichment of 6.7x. Figure 3.7.22 shows the western blot of the lysate, a cloudy float which may have been vacuoles but which had no CPY activity and the microsome layer again showing significant enrichment of vicilin above



**Figure 3.8.1 Electron Micrographs of Cryosectioned Yeast Cells**

Electron micrographs of immuno-gold labelled GFR167/pDUB2300 cells. The yeast were grown in YMM.Gal. The sections were prepared by cryosectioning.

KEY:-

N= Nucleus

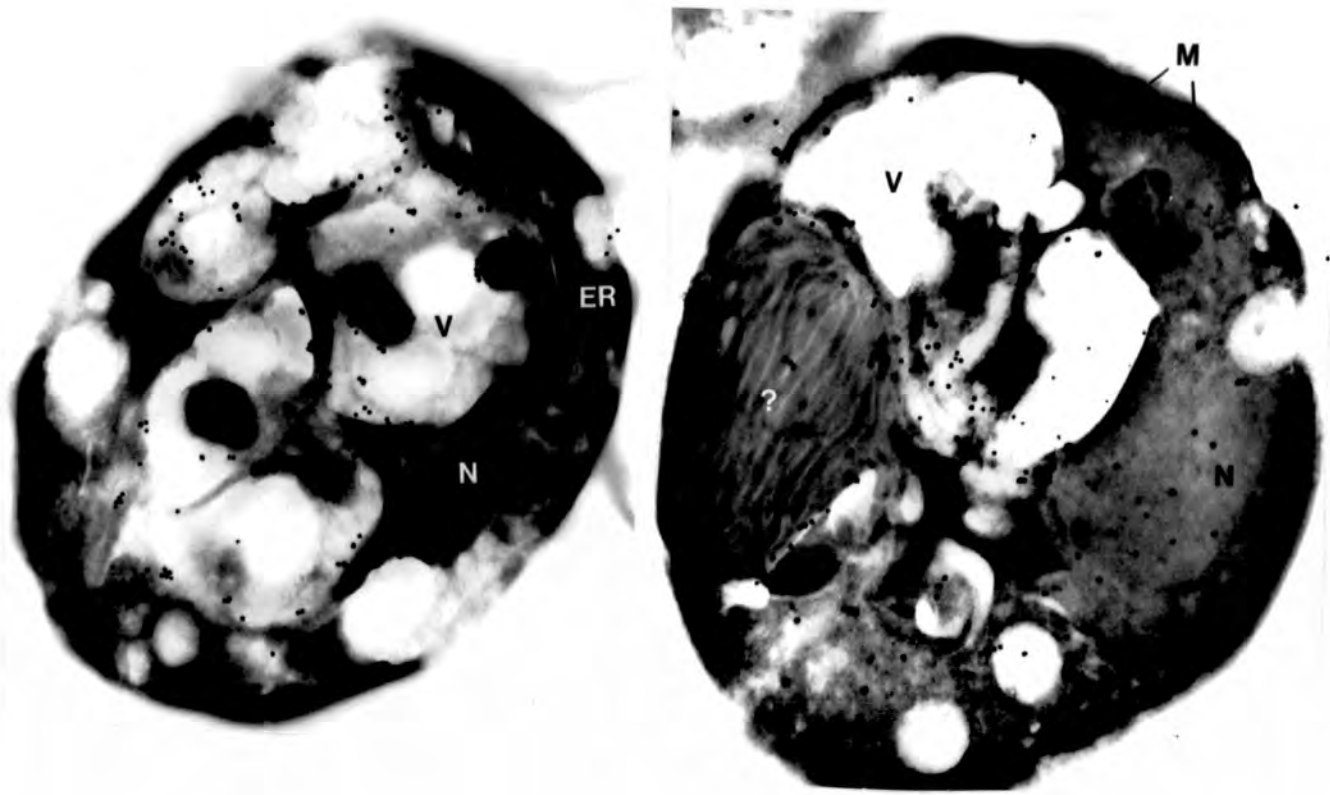
V= Vacuole

ER= Endoplasmic Reticulum

G= Golgi

M= Mitochondria

Magnification= L.H. x25000, R.H. x33000



**Figure 3.8.2**

Further electron micrographs of GFR167/pDUB2300 prepared as above.  
Magnification= L.H. x25000, R.H. x33000

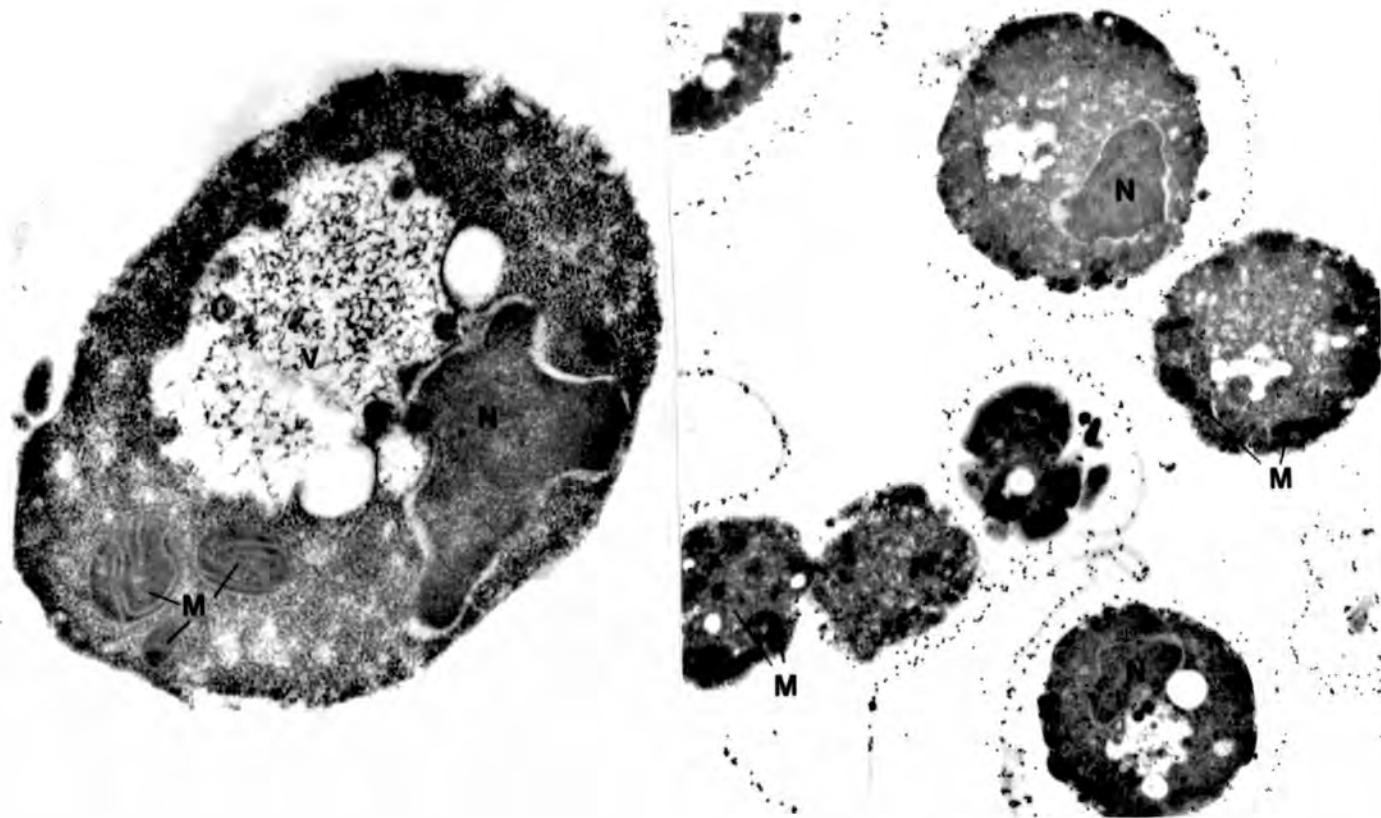
the lysate.

In order to exploit the significant enrichment of vicilin in the microsome fraction and further investigate the presence or absence of the signal peptide, it was decided to purify microsomes from a culture of yeast labelled with radioactive methionine. This was duly done and the enzyme enrichments were 3.8x for CPY and 6.3x for Cytochrome C reductase. Figure 3.7.11 shows the crude cell extract (an aliquot of cells being taken and protein extracted by grinding against glass beads in SDS sample buffer), cell lysate and microsome fractions. The level of vicilin is again boosted in the microsome fraction. The lysate shows a curious triple species. The labeling was discussed in section 3.7.4

Conclusions drawn from these subcellular fractionation experiments will be discussed in chapter 4 in the light of the results presented below on the electron microscopy of transformed yeast.

### **3.8 Electron Microscopy of Immuno-Gold Labelled Yeast**

The first attempts at associating vicilin with a structure or compartment of the yeast cell are shown in figure 3.8.1 and 3.8.2. These cells were GFR167 transformed with pDUB2300 and grown in YMM His.Gal. The sections were prepared by the Cryosectioning method in chapter 2. As can be seen from the pictures the overall preservation of the cells was poor and there are few visible internal structures. The major region of ice damage is in the vacuole area of the cell. The two cells in figure 3.8.1 are typical of those observed in this experiment, with a generally clean background with few or no gold particles outside. The cells themselves have 50-100 gold particles per cell. In these two yeast the gold particles seem to be associated with what is probably the vacuole. The picture on the left shows two yeast on top of one another so it is not completely clear whether some of the gold particles are attached to



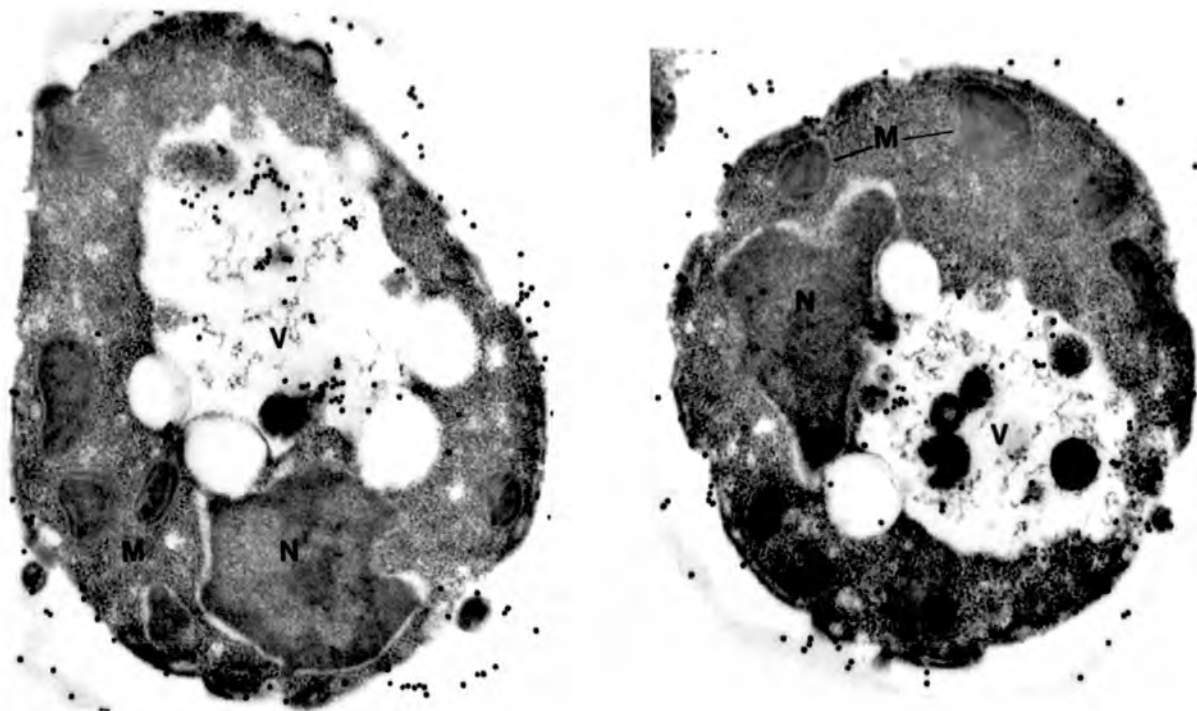
**Figure 3.8.3 Electron Micrographs of Resin Embedded Sections**

MC16/pDUB2302 cells sectioned as described in section 2.13 with the amendments noted in section 3.8. The left hand cell is from a control section to which no 1<sup>o</sup> antibody had been added.

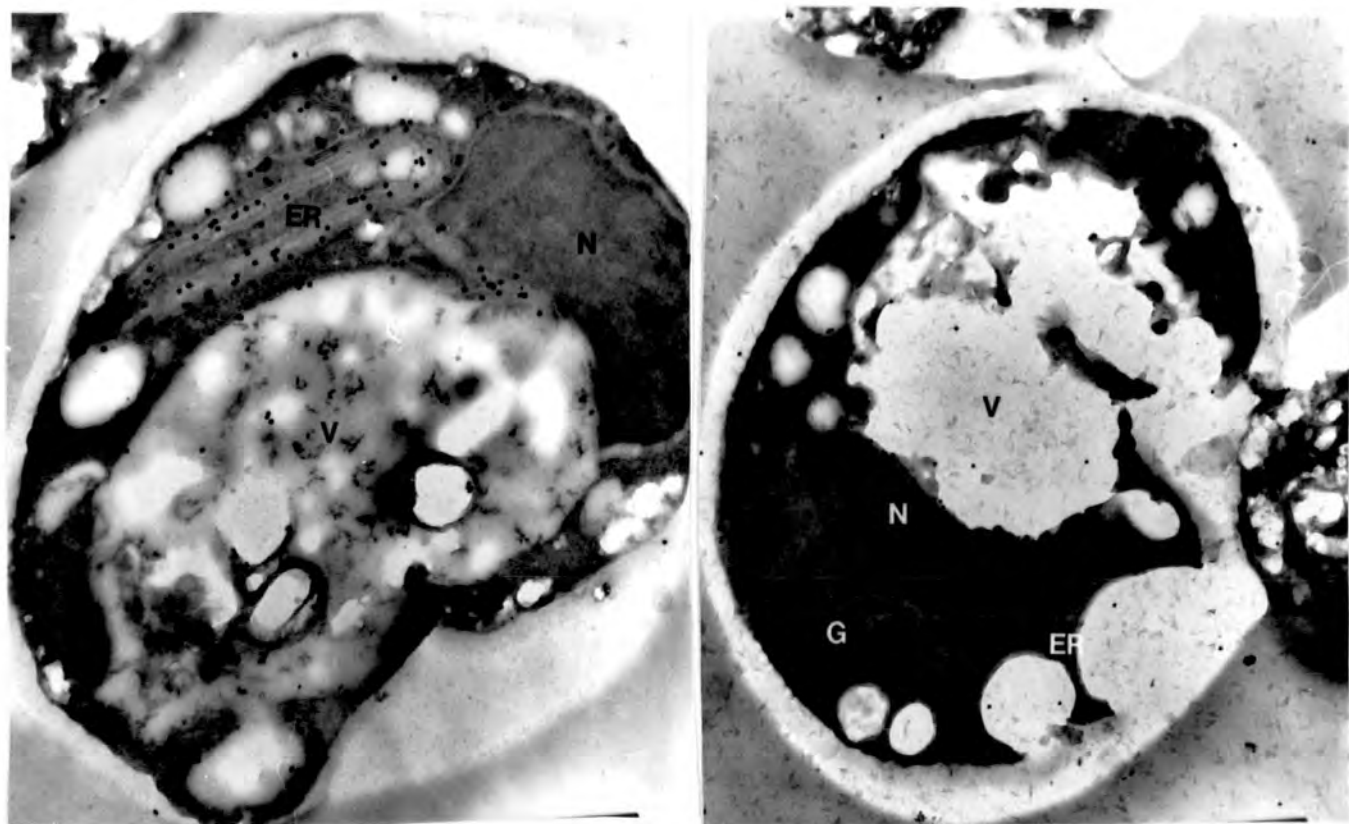
magnification= L.H. x33000, R.H. x11700

the yeast underneath. These two cells were the only examples seen where the vicilin appeared to associate with the vacuole. The majority of the yeast cells resembled the two in figure 3.8.2 in that the gold particles were distributed throughout the cell and did not appear compartmentalised. These two also show some internal structure (the only two cells observed which did), the picture on the left showing long strands of ER and what are probably mitochondria (labelled M). The large membrane structure in the cell on the right is more difficult to identify. The structure bears little resemblance to any structures shown in published electron micrographs of yeast (e.g in Strathern, Jones and Broach 1982) and remains unidentified. Control sections to which no primary antibody were added showed a similar level of preservation of the cells but had few gold particles either in or out of the cells.

By the time the construct pDUB2302 had been transformed into MC16 and expression of vicilin demonstrated and investigated a second method of sectioning yeast had been developed (by N.Harris and M.D. Watson) which differed from that of Brada and Schekman (1988) in certain important aspects. The 20% ethanol step was not used, the cells were spheroplasted before being fixed, sorbitol was included in the fixer for the first four pictures presented not the last two and osmium tetroxide was included only in the last two pictures. Figure 3.8.3 shows one control section to which no primary antibody was added (left side picture) which shows the generally better preservation gained by using the resin embedding method, with the nucleus and vacuole clearly visible and up to five mitochondria apparent, though no ER or Golgi is visible. The picture on the right shows a 11700x magnification of cells to which a 1/10 dilution of anti-vicilin had been added. In this case most of the gold particles are associated with structures at the edges of the cells which are probably the remains of the cell walls with a few particles in the interior of the cells. This was a common occurrence with the sections seen in this particular experiment. Figure 3.8.4

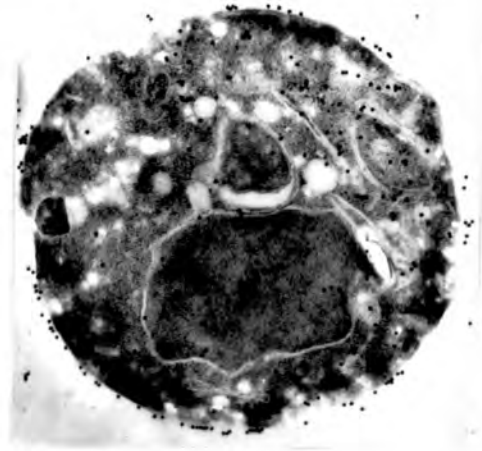
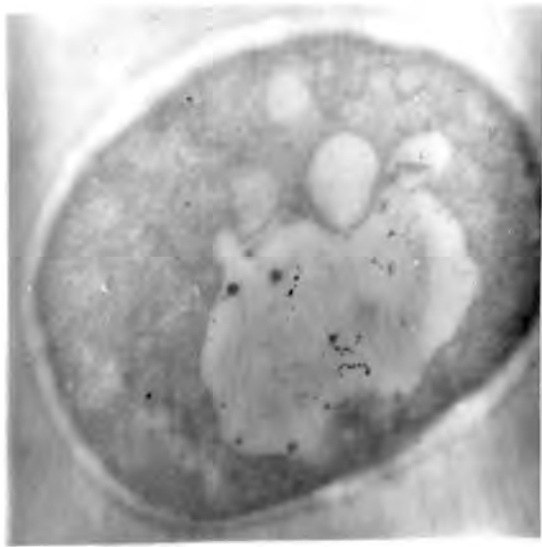


**Figure 3.8.4**  
Further MC16/pDUB2302 cells prepared as above.  
Magnification= both 33000



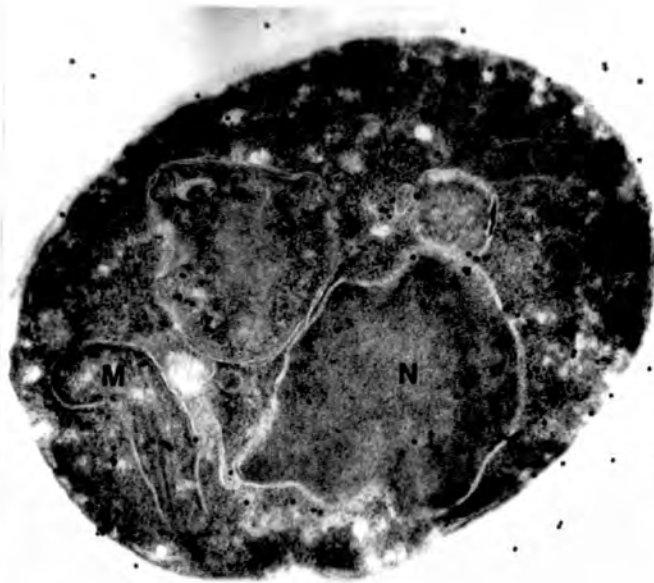
**Figure 3.8.5**

Electron micrographs of two sections with which no sorbitol was used in the agarose embedding step. The sections have been treated with Osmium tetroxide.  
Magnification= L.H. x25000, R.H. x15200



**Figure 3.8.6 Electron Micrographs of Resin Embedded sections**

Electron micrographs of GFR167/pDUB2300 cells, prepared by embedded section method as detailed in section 2.13.2. The cell on the left is from a control section. Magnification= control x33000, others x25000

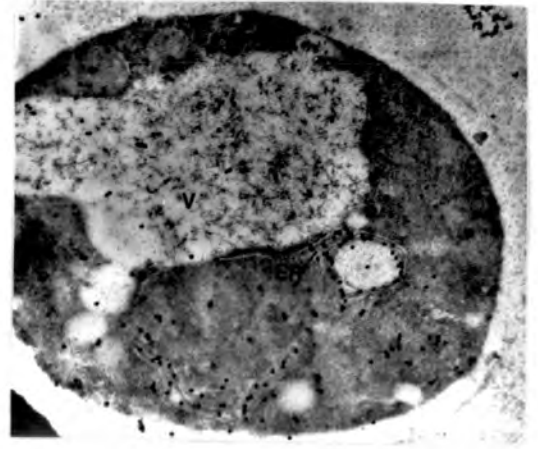
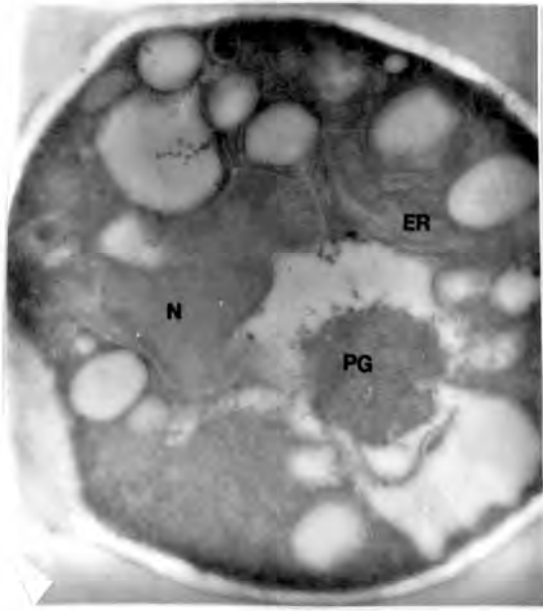


**Figure 3.8.7**

Further electron micrographs of GFR167/pDUB2300 prepared as above.  
magnification= L.H. x25000, R.H. x43000

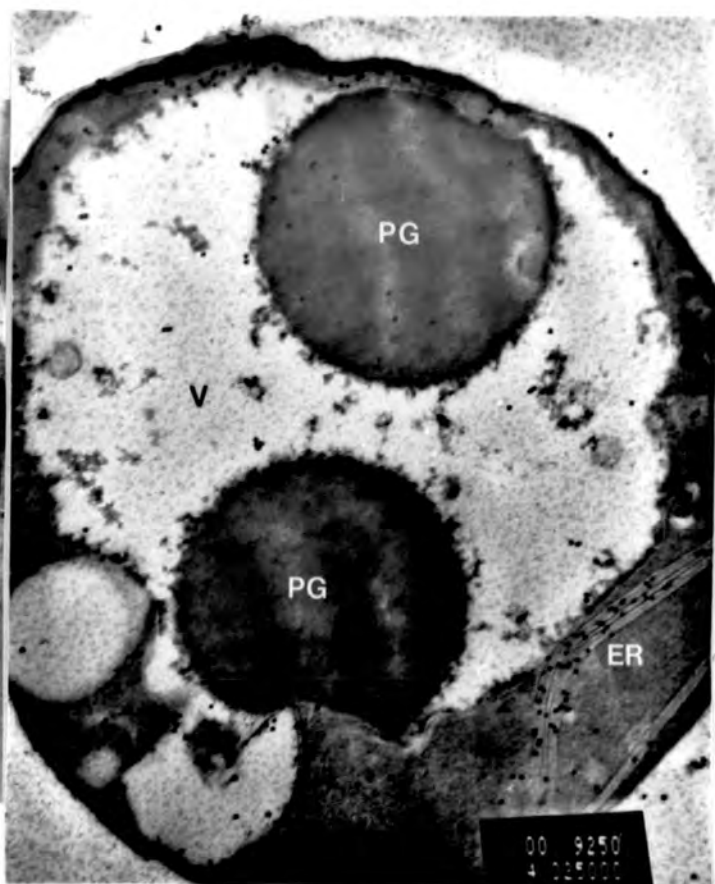
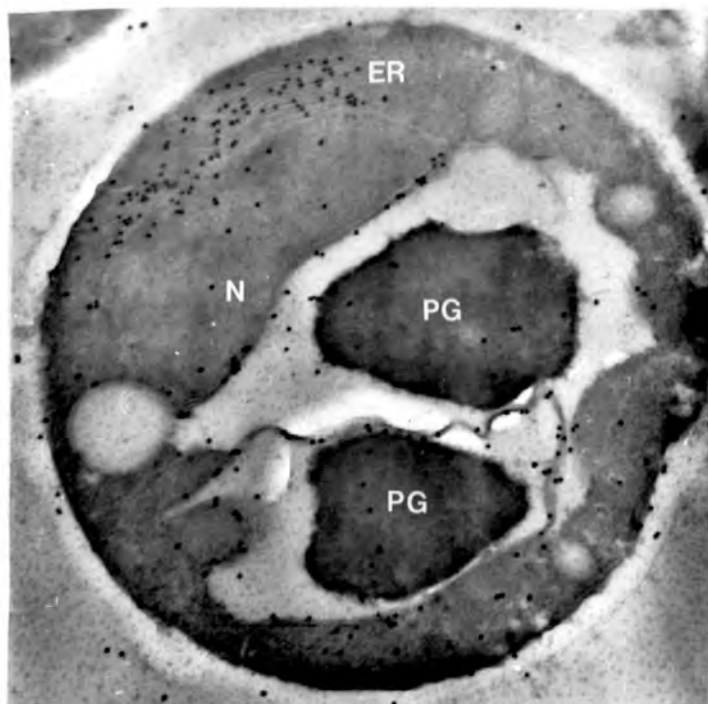
shows two yeast from the same section, again showing the halo of gold particles but with more particles inside the cells, some of which appear in the vacuole. Again, the nucleus, mitochondria and vacuoles are visible but no ER or Golgi. Figure 3.8.5 shows two yeast from a section which omitted the sorbitol but used osmium tetroxide. In this case the preservation of the cells is worse than in the previous pictures, but the osmium has managed to bring out some ER and what are possibly Golgi vesicles. In these yeast, the gold particles do not appear to be associated with the vacuole but with the ER and Golgi. These yeast are both large since they fill the field of view at 25000x and 15200x, whereas the other pictures were of smaller yeast which didn't fill the field of view until 33000x magnification. If the amount of vicilin present in the vacuole represented the true cellular destination of the protein then the larger (older) yeast would be expected to have more vicilin in the vacuole, unless it was being degraded as soon as it arrived there. In the larger cells the only possible association of the gold particles with the vacuole could be those seen around the edges, representing either compressed ER or it is the vacuolar membrane.

Brada and Schekman's method was then applied to GFR167/pDUB 2300 cells grown on galactose, in order to determine whether a lower amount of vicilin expression aided the observation of association with internal structures. The results of this are shown in figures 3.8.6 and 3.8.7. The picture on the left in figure 3.8.6 is a control yeast to which no primary antibody was added, the background is free from gold particles and the cell itself has only one gold particle (the only one seen in over 80 cells observed). The other two cells shown in figure 3.8.6 had a 1/10 dilution of anti-vicilin antibody added and show a high background and the halo effect observed in the last experiment. In these cells the preservation of internal structures is good and either the vacuole has not collapsed this time or has fragmented into the smaller holes seen. The gold particles within the cells do not seem to be associated with any of the ob-



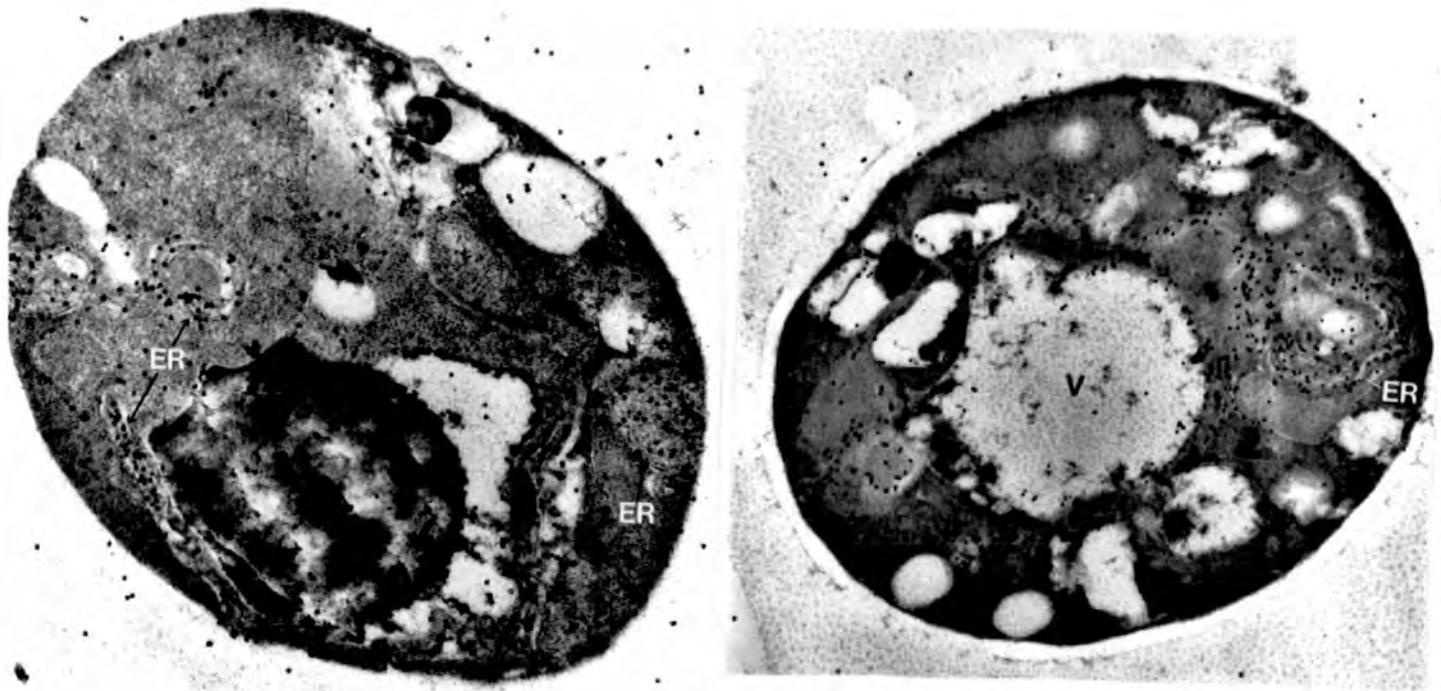
**Figure 3.8.8 Electron Micrographs of MC16/pDUB2302 cells Prepared by the Method of Brada and Schekman (1988)**

MC16/pDUB2302 cells from sections prepared exactly as in section 2.13.2. The cell on the left is from a control section. All are at x25000 magnification.



**Figure 3.8.9**

Further electron micrographs of MC16/pDUB2302 cells. These show the association of vicilin with the ER and possibly the vacuolar membrane.  
Magnification= both x25000

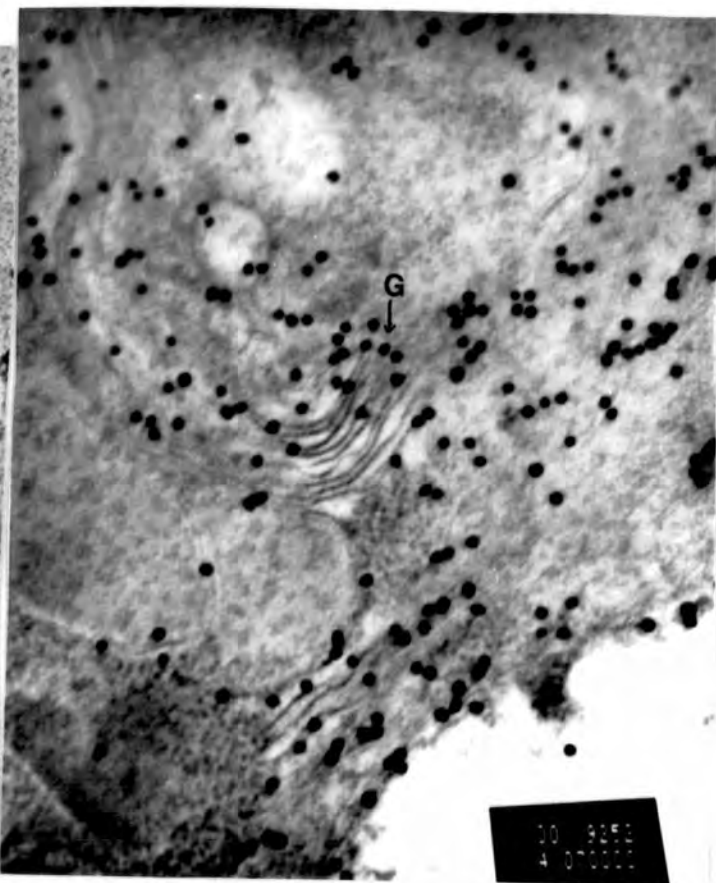
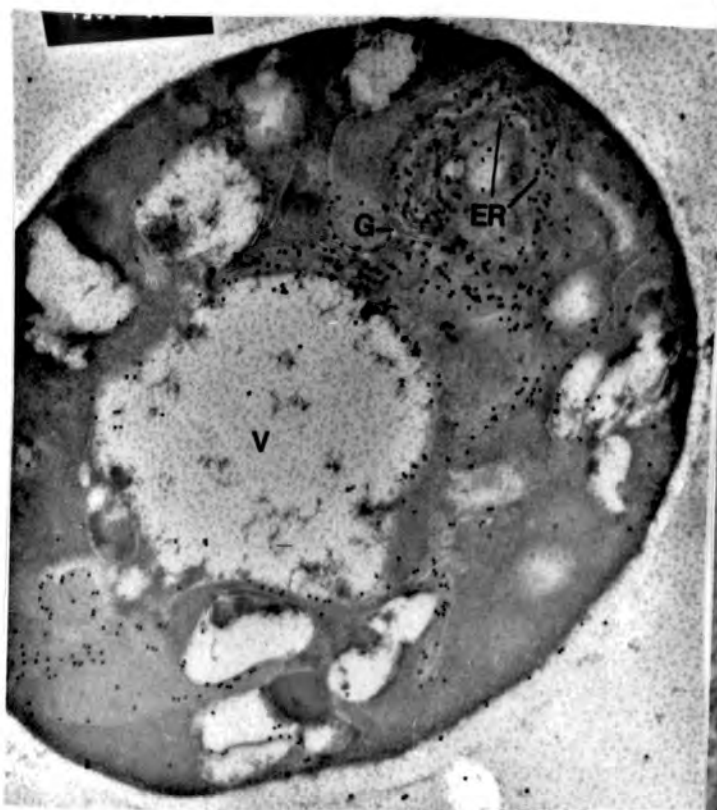


**Figure 3.8.10**

Electron micrographs showing the association of vicilin with what might be Golgi apparatus . Magnifications are x19500 and x15000 left and right respectively.

served internal structures but is at a level substantially above the background. The same can be said for the cell on the left of figure 3.8.7 except that the halo effect is more or less absent but again the gold particles look to be more or less randomly distributed throughout the cell. The cell in the photograph on the right in figure 3.8.7 is representative of the majority of those seen in these sections, the number of gold particles is elevated some 10-20 fold over the background without being associated with any internal structures (unless the membrane bound structure in the centre of the cell is the vacuole, in which case this yeast may provide some evidence that at least some of the vicilin is sequestered into the vacuole).

This technique was then applied to MC16/pDUB2302 cells. Figure 3.8.8 shows three electron micrographs, the one on the left is a control yeast which has no gold particles in the cell or in the background, indeed, none of the control cells had any gold particles. The other two pictures show two yeast cells from a section to which had been added a 1/10 dilution of anti-vicilin, both cells are at 25000x magnification. Both pictures show a fairly high background and generally good preservation of the cells and internal structures. In the case of the cell on the right, the gold particles are definitely associated with the ER but this is less clear in the case of the cell in the centre. The two yeast cells shown in figure 3.8.9 demonstrate the association of the gold particles (and hence the vicilin) with the ER. In the left hand picture the gold particles appear not only associated with the ER but also with what may be the vacuolar membrane. The second picture shows the ER and the gold particles distributed around the outside of the vacuolar region. The two large dark structures in both these cells are polyphosphate granules. The next figure, 3.8.10, shows what may be Golgi as well as extensive ER. The structures indicated with arrows may be Golgi breakdown products (vesicles) or ER derived vesicles. These are again large yeast (19500x and 15200x for left and right respectively) and again there is no concentration of vicilin



**Figure 3.8.11**

Electron micrographs showing a yeast cell where the vicilin may be associated with a golgi stack. The magnified area shows that some of the gold particles are associated with the termini of the stack i.e. vicilin may associated with golgi vesicles.  
Magnification= x19500 and x70000

in the vacuole; however the right hand side yeast does show that the gold particles may be associated with the vacuolar membrane. Figure 3.8.11 shows a yeast and an enlargement of part of it which may show vicilin at the ends of a Golgi stack.

Generally, this last experiment has shown the better preservation of the yeast cells than any of the previous experiments. Sections which had no osmium added showed very poor resolution of the internal structures and none were deemed worth photographing. The background level of gold particles in the sections shown from this last experiment was highly variable, from 100 particles, down to 20 or less in a cell equivalent space. When the background of each cell examined was compared to the number of particles inside the cell, some 40% of the cells were deemed to be not specifically labelled. Of the 60% that were specifically labelled, the number of particles per cell varied from around 20 against a very clean background to more than 100 particles against moderately high or low backgrounds. Of the internal structures of the cells, nuclei and vacuoles were seen in 90% of the cells, mitochondria in around 25% and ER in around 5%, with vicilin always associated with it. Golgi was only seen in the cells presented here. The cells varied in size from very large yeast which filled the observation screen at 30000x magnification to small yeast which didn't fill the screen until 70000x. The larger yeast generally had better preserved structure except those whose vacuole had appeared to swell and cause the cells to rupture. Many cell ghosts were seen too. The presence of damaged cells and ghost outlines of cells probably explains the high background i.e. lots of vicilin released into the environment of the cells.

## CHAPTER 4. DISCUSSION

From the results presented in chapter 3, it is clear that expression of the full length cDNA in yeast results in a polypeptide which is recognisably vicilin (ie it reacts with anti-vicilin antibodies) and has an apparent molecular weight of 49KDa. The equivalent protein extracted from pea seeds has a molecular weight of 47KDa. This thesis has shown that the extra molecular weight can be accounted for by the presence of an uncleaved signal peptide of 24 residues:-

M A A T P I K P L M L L A I A F L A S V C V S S  
n n n u n n b n n n n n n n n n n u n u n u u

In a recent review by Von Heijne (1988), some useful yardsticks for the consensus signal peptide are proposed with which to compare the putative vicilin signal peptide. Firstly, the "ideal" signal peptide should be 15-30 amino-acids in length, vicilin has a signal peptide of 24 residues if the first AUG is the start codon and 15 if the second is the start codon. The signal peptide should have three distinct regions, a positively charged N-region, a central hydrophobic H-region and a polar C-region. In addition the signal peptide should have a low net charge of between -1 and +3. The theoretical 15 a.a. signal peptide would have no discernable positive N-region and no net positive charge. As can be seen from the deduced protein sequence, the putative 24 a.a. signal peptide has a positive N-region provided by the Lysine residue at -18 (relative to the proposed signal peptide cleavage point) making a net charge of +1 for the entire signal peptide. The H-region extends for 11 residues and is then followed by a C-region with 5 out of 7 residues being polar. The border between the H and C-regions in eukaryotes is generally signalled by a ser, pro, gly, glu or a charged residue at -5 or -6, in vicilin there is a ser residue at -6 which could serve as the border. Von Heijne

also states that all naturally occurring signal peptide cleavage points conform to the (-3, -1) rule, that is a small uncharged residue must occur at position -1 and -3. The putative vicilin signal peptide conforms to this rule with a ser residue at -1 and a val residue at -3. Von Heijne also states that a large bulky residue often occurs at -2. Vicilin does not have such a residue but in all other respects conforms to Von Heijne's guidelines.

Von Heijne's guidelines are generalised for eukaryotes and therefore do not give us any specific information about yeast signal peptide processing. When Kaiser *et al.* (1987) replaced the signal peptide of yeast invertase with random DNA sequences and transformed the altered gene back into yeast. They found that many of the random sequences functioned to direct the protein through the secretory pathway but only one of these was efficiently cleaved, the rest remaining intact yet functional. The deduced protein sequences of the functional and nonfunctional signal peptides revealed that in general the functional signals obeyed Von Heijne's guidelines and the (-3, -1) rule. The nonfunctional sequences were in general too charged or were not sufficiently hydrophobic. The one signal peptide that was cleaved was no closer to a concept of an ideal signal peptide than the non-cleaved signals. The environment of the signal peptide processing site must be important in determining whether the signal is cleaved or not, as was demonstrated by Cramer *et al.* (1987). In an earlier paper (1985) they had expressed a cDNA for phaseolin in yeast and reported that the signal peptide was efficiently cleaved and the protein was glycosylated. In the later paper they replaced the phaseolin signal peptide with part or all of that of acid phosphatase (from the PHO5 gene) and reported reduced efficiency in signal peptide processing, despite the hybrid and acid phosphatase signals conforming to Von Heijne's rules. Cramer *et al.* proposed that the environment of the processing

site provided by the N-terminus of the mature polypeptide affected whether the signal peptide was processed or not. That is, yeast's requirements (whatever they are) for efficient processing were met by acid phosphatase and phaseolin but not phaseolin/acid phosphatase hybrids.

It may be that vicilin produced in yeast does not have its signal peptide cleaved because the environment surrounding the cleavage site is hostile to signal peptide processing in yeast. Despite phaseolin and vicilin being homologous over large stretches of their sequence, the signal peptide region is one of the areas where they are not homologous.

The appearance of two protein species in the 49KDa region (previously referred to as a doublet) in some protein preparations and particularly in the cyanogen bromide experiment can be explained as previously described i.e. yeast initiates translation at the first AUG in most instances but in a minority of cases initiates at the second AUG. In neither case is the signal peptide cleaved. Lutcke *et al.* (1987) determined the consensus sequence surrounding the AUG codon in plants and animals:-

Plants:- AACAAUGGC

Animals:- CACCAUG

Vicilin has the following sequences surrounding the two alternative start codons:-

1) UCAAUAUGGC

2) CGUUAUGUU

Taking the A residue of AUG as +1, the preference for G and C in positions +4 and +5 were 85% and 77% respectively in the 61 plant genes studied. Since the first AUG environment in vicilin resembles the plant consensus more closely, I propose that in vicilin the first AUG is the initiation codon and that the signal peptide is the 24 a.a. version. In animals there is an 80% preference for an A base in position

-3 and the first AUG of vicilin has this A at -3. If yeast recognises plant or animal consensus sequences then it is probable that the first AUG is indeed the initiation codon used. Yeast is known to initiate translation at the first transcribed AUG in almost all genes and that when an extra AUG is added 5' to the normal start of translation, normal initiation is drastically reduced (Zitomer *et al.* 1984, Kosak *et al.* 1984a). Results presented here suggest that in the case of vicilin, yeast initiates at the first AUG in most instances but occasionally initiates at the second an observation accentuated by the cyanogen bromide experiment. The removing of 9 amino-acids from the N-terminal end resulting in the doublet being much more obvious, the two protein species being about 1KDa different.

The results also suggest that the conformation of vicilin as produced in yeast is different to pea vicilin and to the vicilin species produced in yeast from an incomplete cDNA (Watson *et al.* 1988). The protein is seen to be relatively insoluble except in detergents like SDS and Triton and precipitates at 40% Ammonium sulphate rather than remaining in the 45-90% supernatant as reported by Lambert *et al.* (1986). It is likely, therefore, that the protein is either assembled or folded in an alternative conformation. In mammals, a 78KDa protein called BiP (Binding Protein) is known to recognise and bind malfolded proteins (Kassenbrock *et al.* 1988) in the E.R. The same protein is known to function in yeast Kotzuksumi *et al.*, (1988). It is part of a group <sup>which includes</sup> Heat shock proteins whose function appears to 'chaperone' newly translated proteins. It has been suggested that BiP seeks out incompletely or incorrectly folded proteins and stops them aggregating. In the case of a mutant or aberrant protein the binding to BiP might be permanent (Pelham, 1988) Whether yeast recognises vicilin as a mutant or aberrant protein one can only speculate, since association with BiP was not determined. The aggregates seen on some western blots were of too low a

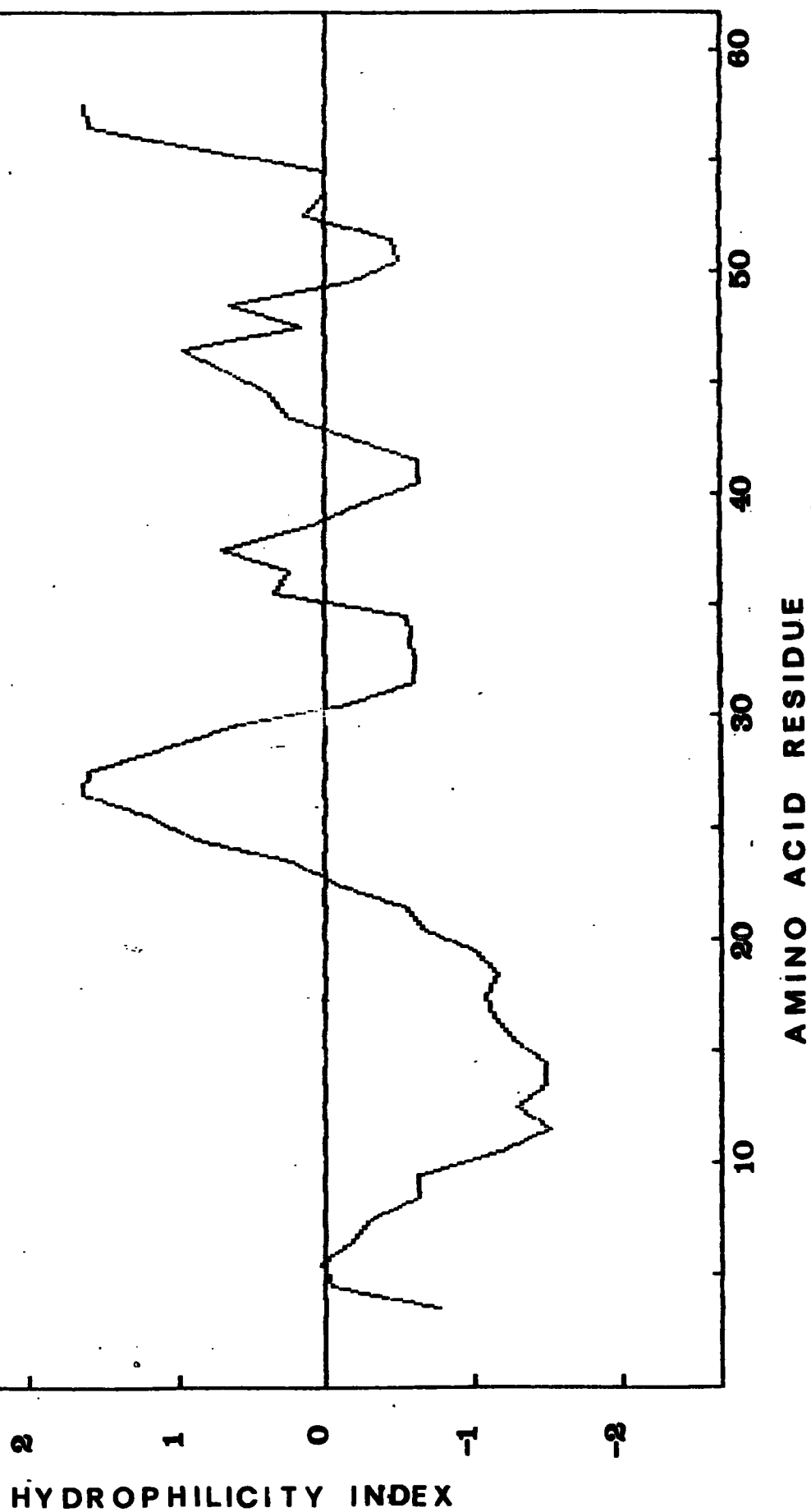
molecular weight to be a BiP/ vicilin complex, since this might be expected to have a molecular weight of 127KDa and, unless the association between the two proteins was irreversible, such a complex would not be seen on an SDS-gel. There is no reason to suppose that vicilin couldn't adopt an alternative conformation in yeast, especially since the signal peptide is known to be intact (folding of vicilin occurs after signal peptide removal in pea, Higgins and Spencer, 1981). There are three possibilities for the location of vicilin within the E.R. area. The signal peptide might be anchored in the E.R. membrane via its large hydrophobic region and the rest of the protein could be either on the cytoplasmic side of the ER membrane or in the lumen of the E.R. The third alternative is that, as in the case of invertase with the random signal peptide sequences, the whole protein including the signal peptide is translocated into the lumen of the E.R. Of these three possibilities the later two are more likely, since a protein anchored by its signal peptide on the cytoplasmic face of the ER would be less likely to remain as such during such procedures as a microsome preparation and we have shown that vicilin is considerably enriched in the microsome fraction. However, the apparent absence of glycosylation could indicate that the bulk of the protein is on the cytoplasmic side of the ER. The fact that vicilin is not apparently glycosylated in yeast does not necessarily favour a lack of or incomplete translocation of vicilin into the lumen of the ER. Tanner and Lehle (1987) stated that in yeast all initial glycosylation events take place in the ER and that only about one third of all eukaryotic glycosylation signals are acted upon. This is affected by the accessibility of the site to the transferase enzymes, the rate of intracellular glycoprotein transport and the rate of protein synthesis. There are two explanations for why vicilin is not glycosylated by yeast, firstly the conformation of the protein may be such that the site is buried within the protein and is therefore inaccessible to the glycosylating enzymes. Secondly, yeast may possess a system whereby the glycosylation of proteins

is prioritised and in this instance the single glycosylation site of vicilin would be of low priority. The fact that when vicilin was produced in low amounts (from pDUB2300) no glycosylation occurred, tends to suggest that the first explanation is probably correct ie. the site is inaccessible. The predicted molecular weight of vicilin from the DNA sequence is 47KDa. The observed molecular weight of native pea vicilin is 47KDa, therefore it would appear that even allowing for inaccuracies in molecular weight determination on SDS-gels, pea probably does not glycosylate vicilin. The yeast expressed vicilin shows a molecular weight of 49KDa, approximately 2KDa of which can be accounted for by the uncleaved signal peptide. So yeast does not appear to be glycosylating vicilin either. Even a single core glycosylation structure (2 N-Acetyl glucosamine + 9 mannose residues) represents about 2KDa. Removal of this by N-glycosidase or blockage with tunicamycin should produce an observable shift in molecular weight on SDS-PAGE, but none such was observed.

Results presented in chapter 3 also showed the presence of lower molecular weight forms of vicilin, usually associated with very high levels of expression or experiments where the extraction of the proteins was separated in time from the electrophoresis of the proteins on SDS-PAGE. In all cases one major proteolysis product was observed, with a molecular weight of about 34KDa. This would correspond exactly to the  $\alpha$ - $\beta$  subunits plus the signal peptide and may indicate that yeast can specifically cleave vicilin. The 12.5KDa polypeptide was never observed and could have been further degraded or is not immunoreactive. The location of the protease(s) responsible for this action is probably the vacuole. From the electron micrographs presented in section 3.8 it can be seen that most of the vicilin is in the ER but that it is occasionally seen to associate with the vacuolar membrane. If this observation is not artefactual then I propose that a small amount of vicilin which reaches the vacuole is that which

is proteolytically cleaved. The protein is probably not targeted specifically to the vacuole but ends up there as it is recognised as a false protein. When vicilin is extracted from the cells it would then be subjected to potentially more extensive proteolysis, especially in the absence of protease inhibitors. Thus the western blot and SDS-PAGE gel presented in figure 3.7.17 represents the fate of the normally uncleaved (ER located) vicilin when exposed to released proteases. The absence of cleaved species on western blots of extracts from pDUB2300 expressed vicilin supports the theories presented above. At such a low level of expression the amount of vicilin which is found in the vacuole will be negligible and wouldn't be detected on western blots. Since no experiments were done without the presence of protease inhibitors, the chance of seeing cleaved forms of vicilin was slight.

Since no secretion of vicilin into the growth medium was detected in either of the two yeast strains used in this study, it can be said that the vicilin signal peptide is sufficient to direct the protein into the yeast secretory pathway but that yeast does not secrete vicilin via a default pathway (as suggested by Rothman, 1987, where yeast will secrete any protein with a functional signal peptide unless it contains other retention signals). Schekman (1985) reviews work done by Schauer (1985) who reported that mutations in the SUC2 gene, resulting in defective signal peptide cleavage of the invertase produced, caused the transport of invertase to the Golgi to be dramatically reduced. Similar results for acid phosphatase were reported by Haguennner-Tsapis and Hinnen (1984). Schekman hypothesised from these results that signal peptide cleavage prevents some proteins associating with a stable component in the ER (perhaps here, Schekman was predicting BiP). Schekman further hypothesised that certain very hydrophobic signal peptides, if they are not cleaved, cause the proteins to be anchored non-specifically to the luminal face of the ER. As shown in figure 4.1 (a



**Figure 4.1 Hydrophilicity Profile of the First 60 residues of the Predicted Sequence of the Vicilin cDNA**

hydrophilicity profile of the first 60 residues of vicilin including the signal peptide) shows that although the signal peptide region is entirely hydrophobic, the extent to which it is hydrophobic is not sufficient to form a membrane spanning domain. A membrane spanning domain requires hydrophilic anchors at either end ( the N-region of the vicilin signal peptide is not sufficiently hydrophilic to act as such an anchor) and would need to be at least 22 residues in length. It is likely therefore that vicilin is translocated into the lumen of the ER complete with its signal peptide intact. The ER is a highly proteinaceous structure and treatment with detergent often results in depletion of lipids but maintains the structure via protein-protein interactions. The results presented here show that vicilin is located in the ER and is only extracted to a small extent with mild detergent and precipitates at 40% ammonium persulphate. This may indicate that vicilin is retained in the lumen of the ER via BiP or interactions with other stable ER components and it is the structure of the ER itself which causes vicilin to be relatively immune to mild detergent treatment.

When the wheat storage protein  $\alpha$ -gliadin was expressed in yeast Neill and co-workers (1987) reported that electron microscopy of the expressing cells had shown enhanced ER and that immuno- ferritin labelling had suggested that the protein was located in the ER, though no photographs were provided. The protein was not secreted. Neither was phaseolin (Cramer *et al.*, 1985), only 0.3% of the total amount synthesized was detected in the growth medium, this being attributed to autolysis and cell leakage. By size comparison on western blots the yeast produced phaseolin appeared identical to bean phaseolin which may indicate that the protein reached the Golgi, though no localisation studies were reported. Coraggio and co-workers (1986) expressed zein in yeast and found only partial signal peptide removal, 3-4 processed forms and no secretion of the protein.

From the fractionation studies presented in chapter 3 it is clear that vicilin is enriched in microsome preparations which are themselves enriched for the microsomal marker enzyme NADPH cytochrome C reductase. The electron micrographs shown in chapter 3 support the fractionation data in that they clearly show vicilin associated with the ER. The vacuole preparations were not conclusive and therefore cannot be said to support the hypothesis that some of the electron micrographs show association of vicilin with the vacuolar membrane. The electron micrograph which shows vicilin in association with what might be Golgi can be compared with the electron micrographs of legumin obtained by Yarwood and co-workers (1987) which suggested that legumin was associated, at least in part with the Golgi. It seems that there is a pattern emerging for the expression of plant storage proteins in yeast. In the examples of storage protein expression discussed here ie phaseolin, zein,  $\alpha$ -gliadin, legumin and vicilin, they are all directed into the yeast secretory pathway yet none are secreted. Yeast's ability to cleave the signal peptide from the storage proteins is variable. The cellular destination appears to be chiefly the ER with some evidence that a proportion of the proteins reach the Golgi. It may be that, lacking an organelle comparable to the protein body of the plant cell, yeast does not recognise the sorting address of these proteins. They are retained in the ER because of some structural effect. Soluble ER luminal proteins are retained by the C-terminal HDEL sequence (Pelham *et al.* 1988). These storage proteins do not have this sequence. Perhaps ER membrane proteins in yeast use a different sorting signal from luminal proteins, or the plant storage proteins are tightly bound to a protein such as BiP which recognises foreign or malfolded proteins (Kozuksumi, *et al.* 1988).

In summary, it has been possible to answer the seven questions set out in the introduction to this thesis:-

**1) Can yeast produce an immunoreactive vicilin species?**

Yes it can and under control of the PGK promoter it can reach 5% cell protein. However, the protein appears to have an altered conformation.

**2) Can yeast recognize the signal peptide and direct the protein into the ER?**

From the evidence presented in this thesis it is not clear whether vicilin enters the yeast ER. Further studies using an *in vitro* translocation system such as dog pancreatic microsomes would clarify this. Protease protection experiments would also indicate whether vicilin is capable of being translocated into the lumen of the ER.

**3) Can yeast cleave the signal peptide accurately?**

From the molecular weight of the vicilin species produced by yeast and from the results of the cyanogen bromide experiment it appears that the putative signal peptide of vicilin is not cleaved in yeast. Though in view of the statement in (2) above, it has not been conclusively shown that vicilin has come into contact with signal peptidase in yeast.

**4) Does yeast glycosylate vicilin?**

From the evidence in this thesis, yeast does not appear to glycosylate vicilin. Though due to the lack of positive controls the possibility still exists that yeast does glycosylate vicilin.

**5) Does yeast possess a protease capable of cleaving vicilin at the correct site?**

Probably not, though some cleavage does occur it is likely that vicilin possesses a chance site or sites for a yeast protease. Some of the cleavage can be attributed to random proteolysis.

**6) What is the subcellular location of vicilin?**

The majority of the protein produced localises in the ER when highly expressed, though in the case of lower level expression (under the control of the GAL10 promoter) vicilin appears randomly distributed throughout the cell. In both cases there is electron microscopic evidence to suggest some association with the vacuole and in one case the Golgi. No vicilin was secreted nor was there any evidence of periplasmic or cell membrane association.

**7) Does yeast assemble vicilin into trimers?**

Though there was some evidence of higher molecular weight aggregates, detected by western blotting, no molecules of equivalent molecular weight to vicilin trimers were detected.

### **Future Work**

As mentioned in the introduction to this thesis, it was hoped that the expression of a complete cDNA for vicilin in yeast would result in the production of provicilin which in turn could be used as a substrate for the pea protease responsible for the cleavage of vicilin at the  $\beta$ - $\gamma$  site. This assay would then be used to isolate the pea protease. As it has turned out, yeast produces only preprovicilin and hence a future experiment would logically be to remove the bases coding for the signal peptide from the cDNA and then ligate the resulting fragment into an expression vector containing an in frame AUG. Such a construct, when transformed into yeast, would hopefully yield cytoplasmic provicilin, which would be relatively easy to purify using the methods of Lambert *et al.* (1986) and Watson *et al.* (1988).

Further experiments to confirm the results presented in this study could be performed on the vicilin expressing strains produced in this study. By a combination of methods such as hydroxylapatite column chromatography, ammonium sulphate precipitation and gel filtration, vicilin from yeast might be purified to enable an N-terminal sequence to be determined which would confirm the presence of the uncleaved signal peptide. Also extracting and running the yeast proteins under nondenaturing conditions might reveal any associations between vicilin molecules (ie assembly into trimers) or associations with a protein such as BiP. It might also be possible to design an experiment which would determine whether vicilin was anchored to the luminal or cytoplasmic face of the ER. Microsomes could be purified and then reacted with a protease for a short time and subjected to SDS-PAGE and western blotting. Protec-

tion form protease digestion would indicate a luminal location.

With a change in protocol and a wider range of marker enzyme assays it will also be possible to produce purified vacuoles and therefore show whether or not vicilin is sequestered there.

## REFERENCES

- Abelson J., (1979), *Ann. Rev. Biochem.* **48** 1035-69.
- Adams A.E.M. and Pringle J.R., (1984), *J. Cell. Biol.* **98** 934-45.
- Aibara S., Hayashi R. and Hata T., (1971), *Agr. Biol. Chem.* **35** 658-66.
- Badenoch-Jones J., Spencer D., Higgins T.G.V. and Millerd A., (1982), *Planta* **153** 201-9.
- Bahl C.P., Marian K.J., Wu R., Slawinsky J. and Narang S.A., (1976), *Gene* **1** 81-92.
- Baker T.A., Sekimizu K., Funnell B.E. and Kornberg A., (1986), *Cell* **45** 53-64.
- Baldari C., Murray J.A.H., Ghiara P., Cesareni G. and Galeotti C.L., (1987), *EMBO J.* **6** 229-34.
- Beach D., Piper M. and Nurse P., (1982), *Mol. Gen. Genet.* **187** 326-29.
- Beggs J.D., (1978), *Nature* **275** 104-9.
- Beggs J.D., van der Berg J., van Ooyen A. and Weissman C., (1980), *Nature* **283** 835-40.
- Bennetzen J.L. and Hall B.D., (1982), *J. Biol. Chem.* **257** 3026-31.
- Bessey E.A., (1950), *The Morphology and Taxonomy of Funghi*, Philadelphia.
- Bird P., Gething M. and Sambrook J., (1987) *J. Cell. Biol.* **105** 2905-14.
- Birnboim H.C. and Doly J., (1979), *Nucl. Acid. Res.* **7** 1513-23.
- Blackburn E.H. and Gall J.G., (1978), *J. Mol. Biol.* **120** 33-53.
- Bloom K.S. and Carbon J., (1982), *Cell* **29** 305-17.
- Botstein D. and Fink G.R., (1988), *Science* **240** 1439-42.
- Bown D., Ellis N.T.H. and Gatehouse J.A., (1988), *Biochem. J.* **251** 717-26.
- Brada D. and Schekman R., (1988), *J. Bacteriol.* **170** 2772-83.
- Breunig K.D., Mackedonski V. and Hollenberg C.P., (1982), *Gene* **20** 1-10.
- Broach J.R., (1981), in *Molecular Biology of the yeast Saccharomyces*, vol.I, eds. J.N. Strathern, E.W. Jones and J.R. Broach, Cold Spring Harour, NY.
- Broach J.R., Atkins J.F., M<sup>c</sup>Gill C. and Chow L., (1979) *Cell* **16** 827-40.
- Broach J.R., Guarascio V.R. and Jayaram M., (1982a), *Cell* **29** 227-34.
- Broach J.R., Guarascio V.R., Misiewicz M.H. and Campbell, (1981) in *Molecular Genetics in Yeast. Alfred Benzon Symposium 16*. Ed. D. von Wettstein *et al.*, Munksgaard, Copenhagen.
- Broach J.R. and Hicks J.B., (1980), *Cell* **21** 501-8.
- Broach J.R., Li Y-Y., Feldman J., Jayaram M., Abraham J., Nasmyth K.A. and Hicks

- J.B., (1983), *C.S.H. Symp. Quant. Biol.* **47** 1165-73.
- Byers B., (1981) in *Molecular Biology of the yeast Saccharomyces*, vol.I, eds J.N. Strathern *et al.*. C.S.H., NY.
- Cabezon T., De Wilde M., Herion M., Loriau R. and Ballen A., (1984), *Proc. Nac. Acad. Sci. USA.* **81** 6594-8.
- Cameron J.R., Loh E.Y. and Davis R.W., (1979), *Cell* **16** 738-52.
- Cameron J.R., Philippsen P. and Davis R.W., (1977), *Nucl. Acid. Res.* **4** 1429-48.
- Casey R., (1979), *Biochem. J.* **177** 509-20.
- Casey R. and Domoney C., (1984), *Phil. Trans. R. Soc. Lond. [Biol.]* **304** 349-58.
- Casey R., Domoney C. and Stanley J., (1984), *Biochem. J.* **224** 661-66.
- Casey R., Sharman J.E., Wright D., Bacon J.R. and Guldager P., (1982), *Qual. Plant. Plant Fd. Hum. Nutr.* **31** 333-46.
- Casey R. and Sanger E., (1980), *Biochem. Soc. Trans.* **8** 657-8.
- Cashmore A.M., Albury M.S., Hadfield G. and Meacock P.A., (1986), *Mol. Gen. Genet.* **203** 154-62.
- Celniker S.E., Swecher K., Srienc F., Bailey J.E. and Campbell J.L., (1984), *Mol. Cell. Biol.* **4** 2455-66.
- Chaleff D.T. and Fink G.R., (1980), *Cell* **21** 227-38.
- Cheng C.Y. and Hitzeman R.A., (1987), *Nucl. Acid. Res.* **15** 643-660.
- Cheng C.Y., Pollock R.A., Hendrick J.P. and Horwich A.L., (1987), *Proc. Nac. Acad. Sci. USA.* **84** 4063-67.
- Chrispeels M.J., Higgins T.J.V., Craig S. and Spencer D., (1982a), *J. Cell. Biol.* **93** 5-14.
- Chrispeels M.J., Higgins T.J.V. and Spencer D., (1982b), *J. Cell. Biol.* **93** 306-13.
- Ciriacy M. and Williamson V.M., (1981), *Mol. Gen. Genet.* 159-63.
- Clarke L. and Carbon J., (1983), *Nature* **305** 23-8.
- Clarke-Walker G.D. and Miklos G.L.G., (1974), *Eur. J. Biochem.* **41** 359-65.
- Clements F.E., (1909), *The Genera of Funghi*, Minniapolis.
- Cohen J.D., Eccleshall T.R., Needleman R.B., Federoff M., Buchferer B.A. and Marmur J., (1980), *Proc. Nac. Acad. Sci. USA.* **77** 1078-82.
- Cohen S.N. and Chang A.C.Y., (1973), *Proc. Nac. Acad. Sci. USA.* **70** 1293-7.
- Cooper T.G., (1982), in *The molecular biology of the yeast Saccharomyces cerevisiae*. eds. Strathearn *et al.*. CSH, NY.
- Coraggio I., Compagno C., Martegani E., Ranz B.M., Sala E., Alberghina L. and

- Viotti A., (1986), *EMBO J.* **5** 459-65.
- Cousens L.S., Shuster J.R., Gallegos C., Ku L., Stempien M.M., Urdea M.S., Sanchez-Pescador R., Taylor A. and Tekamp-Olsen P., (1987), *Gene* **61** 265-275.
- Crabeel M., Hygen R., Cunin R. and Glansdorff N., (1983), *EMBO J.* **2** 205-12.
- Cramer J.H., Lea K., Schaber M.D. and Kramer R.A., (1987), *Mol. Cell. Biol.* **121-28**.
- Cramer J.H., Lea K. and Slightom J.L., (1985), *Proc. Nac. Acad. Sci. USA.* **82** 334-38.
- Crouse G.F., Frischauf A. and Lehrach H., (1983), *Methods in Enzymology* **101** 78-89.
- Croy R.R.D. and Gatehouse J.A., (1985), in *Plant Genetic Engineering*, ed. J.H. Dodds. Cambridge Univ. Press, Cambridge.
- Croy R.R.D., Gatehouse J.A., Evans I.M. and Boulter D., (1980b), *Planta* **148** 57-63.
- Croy R.R.D., Gatehouse J.A., Tyler M. and Boulter D., (1980c), *Biochem. J.* **191** 509-16.
- Croy R.R.D., Lycett G.W., Gatehouse J.A. and Boulter D., (1984a), *Biochem. J.* **218** 795-803.
- Croy R.R.D., Lycett G.W., Gatehouse J.A. and Boulter D., (1984b), *Kulturpflanze* **32** 81-98.
- Cullin C. and Pompon D., (1988), *Gene* **56** 203-17.
- Cullis C., (1976), *Planta* **131** 293-8.
- Dani G.M. and Zakian U.A., (1983), *Proc. Nac. Acad. Sci. USA.* **80** 3406-10.
- Davey R.A. and Dudman W.F., (1979), *Aust. J. Plant Physiol.* **6** 435-7.
- Davey R.A., Higgins T.J.V. and Spencer D., (1981), *Biochem. Int.* **3** 595-602.
- Dehoux P., Ribes V., Sobczak E. and Streek R.E., (1986), *Gene* **48** 155-63.
- Dente L., Cesareni G. and Cartese R., (1983), *Nucl. Acid. Res.* **11** 1645-55.
- Derynk R., Singh A. and Goeddel D., (1983), *Nucl. Acid. Res.* **11** 1819-37.
- Dodson M., Dean F.B., Bullock P., Echols H. and Hurwitz J., (1987), *Science* **238** 964-67.
- Domoney C. and Casey R., (1985), *Nucl. Acid. Res.* **13** 687-99.
- Edens L., Bom I., Ledebuer A.M., Maat J., Toonen M.Y., Visser C. and Verrips C.T., (1984), *Cell* **37** 629-35.
- Emter O. and Wolf D.H., (1984), *FEBS Lett.* **166** 321-5.

- Errede B., Cardillo T.S., Sherman F., Dubois E., Deschamps J. and Wiame J.-M., (1980), *Cell* **22** 427-36.
- Esposito R.E. and Klapholz S., (1981) in *Molecular Biology of the yeast Saccharomyces* vol.I, ed. Strathern *et al.* CSH, NY.
- Evans I.M., Croy R.R.D., Brown P. and Boulter D., (1984), *Planta* **160** 559-68.
- Fangman W.L. and Zakian U.A., (1981), in *Molecular Biology of the yeast Saccharomyces*, vol.I, eds. Strathern *et al.* CSH, NY.
- Feinberg A.P. and Vogelstein B., (1983), *Anal. Biochem.* **132** 6-13.
- Feinberg A.P. and Vogelstein B., (1984), *Anal. Biochem.* **137** 266-7.
- Fitzgerald-Hayes M., Buhler J.M., Copper T.G. and Carbon J., (1982a), *Mol. Cell. Biol.* **2** 82-7.
- Fitzgerald-Hayes M., Clarke L. and Carbon J., (1982b), *Cell* **29** 235-44.
- Fuller R.S., Funnell B.E. and Kornberg A., (1984), *Cell* **38** 889-900.
- Gallwitz D. and Sures I., (1980), *Proc. Nac. Acad. Sci. USA.* **77** 2546-50
- Gatehouse J.A., Croy R.R.D. and Boulter D., (1984b) in *Critical Reviews in Plant Sciences*, vol.I pp287-314. CRC Press, Boca Raton, FLa.
- Gatehouse J.A., Croy R.R.D., Morton H., Tyler M. and Boulter D., (1981), *Eur. J. Biochem.* **118** 627-33.
- Gatehouse J.A., Evans I.M., Bown D., Croy R.R.D. and Boulter D., (1982a), *Biochem. J.* **208** 119-27.
- Gatehouse J.A., Lycett G.W., Croy R.R.D. and Boulter D., (1982b), *Biochem. J.* **207** 629-32.
- Gatehouse J.A., Lycett G.W., Delauney A.J., Croy R.R.D. and Boulter D., (1983), *Biochem. J.* **212** 427-32.
- Gerbaud C., Fournier P., Blanc H., Aigle M., Helot H. and Gerineau M., (1979), *Proc. Nac. Acad. Sci. USA.* **79** 76-80.
- Giniger E., Varnum S.M. and Ptashne M., (1985), *Cell* **40** 767-74.
- Goeddel D.V., Kleid D.G. Bolivar F., Heyneker H.L., Yansura D.G., Crea R., Hirose T., Kraszewski A., Itakura K. and Riggs A.D., (1979b), *Proc. Nac. Acad. Sci. USA.* **76** 106-10.
- Gross E. and Witkop B., (1961), *J. Amer. Chem. Soc.* **83** 1510-11.
- Guarente L., (1984), *Cell* **36** 799-800.
- Guarente L. and Ptashne M., (1981), *Proc. Nac. Acad. Sci. USA.* **78** 2199-203.
- Guerineau M., Grandchamp C. and Slonimski P., (1976), *Proc. Nac. Acad. Sci.*

USA. 73 3030-34.

- Haguennner-Tsapis R. and Hinnen A., (1984), *J. Mol. Cell Biol.* 4 2668-75.
- Hartley J.L. and Donelson J.E., (1980), *Nature* 286 860-65.
- Hattori M. and Sakaki Y., (1986), *Anal. Biochem.* 152 232-238.
- Hereford L., Fahrner K., Woolford Jr. J.L., Rosbah M. and Kasback D.B., (1979), *Cell* 18 1261-72.
- Higgins T.J.V. and Spencer D., (1981), *Plant Physiol.* 67 205-11.
- Hinnen A., Hicks J.B. and Fink G.R., (1978), *Proc. Nat. Acad. Sci. USA.* 75 1929-33.
- Hirano H., Gatehouse J.A. and Boulter D., (1982), *FEBS Lett.* 145 99-102.
- Hitzeman R.A., Hagie F.E., Levine H.L., Goeddel D.V., Ammerer G. and Hall B.D., (1981), *Nature* 293 717-22.
- Hitzeman R.A., Leung D.W., Perry L.J., Kohr W.J., Levine H.L. and Goeddel D.V., (1983), *Science* 219 620-5.
- Hogness D., (1982), in *Molecular Cloning. A Laboratory Manual.* Eds. T. Maniatis, E.F. Fritsch and J. Sambrook. CSH, NY.
- Hollenberg C.P., Degelmann A., Kusterman-Kuhn B. and Royer H.D., (1976), *Proc. Nat. Acad. Sci. USA.* 73 2072-76.
- Hopper A.K. and Hall B.D., (1975), *Genetics* 80 77-86.
- Hsiao C.L. and Carbon J., (1981), *Gene* 15 157-66.
- Huberman J.A., Spotila L.D., Nawotka K.A., El-Assouli S.M. and Davis L.R., (1987), *Cell* 51 473-81.
- Hutchison C.A., Phillips S. and Edgell M.H., (1978), *J. Biol. Chem.* 253 6551-60.
- Ish-Horowicz D., (1982), in *Molecular Cloning.* Eds Maniatis et al.. CSH, NY.
- Itakura K. and Riggs A.D., (1980), *Science* 209 1401-5.
- Ito H., Fukada Y., Muraka K. and Kimura A., (1983), *J. Bacteriol.* 153 163-8.
- Izumoto Y., Sato T., Yamamoto T., Yoshida N., Kikuchi N., Ogawa M. and Matsubara K., (1987), *Gene* 59 151-9.
- Jayaram M., Li Y.-Y. and Broach J.R., (1983), *Cell* 34 95-104.
- Jigami Y., Muraki M., Harada N. and Tanaka H., (1986), *Gene* 43 273-9.
- Jiminez A. and Davis J., (1980), *Nature* 287 869-71.
- Johnson D.A., Gautsch J.W., Sportsman J.R. and Elder J.H., (1984), *Gene Anal. Techn.* 1 3-8.
- Johnson L.M., Bankaitis V.A. and Emr S.D., (1987), *Cell* 48 875-85.

- Johnston M. and Davis R.W., (1984), *Mol. Cell. Biol.* **4** 1440-8.
- Jones R.H., Moreno S., Nurse P. and Jones N.C., (1988) *Cell* **59** 659-67.
- Kassenbrock C.K., Garcia P.D., Walter P. and Kelly R.B., (1988), *Nature* **333** 90-93.
- Kaiser C.A., Preuss D., Grisafi P. and Botstein D., (1987), *Science* **235** 312-7.
- Kay R. and McPherson J., (1987), *Nucl. Acid. Res.* **15** 2778.
- Kearsey S.E., (1983), *EMBO J.* **2** 1571-5.
- Kearsey S.E., (1984), *Cell* **37** 299-307.
- Kemmler W., Peterson J.D. and Steiner D.F., (1971), *J. Biol. Chem.* **246** 6786-91.
- Kikuchi Y., (1983), *Cell* **35** 487-93.
- Kingsman A.J., Clarke L., Mortimer R.K. and Carbon J., (1979), *Gene* **7** 141-52.
- Kilmartin J.V. and Adams A.E.M., (1984), *J. Cell. Biol.* **98** 922-33.
- Klar A.J.S., Strathern J.N., Broach J.R. and Hicks J.B., (1981), *Nature* **289** 239-44.
- Kosak M., (1984a), *Nucl. Acid. Res.* **12** 3873-93.
- Kozutsumi Y., Segal M., Normington K., Gething M.J. and Sambrook J., (1988), *Nature* **332** 462-64.
- Laemmli U.K., (1970), *Nature* **227** 680-5.
- Lambert N., Chambers S.J., Phalp M. and Wright D.J., (1986), *Biochem. Soc. Trans.* **619**.
- Langford C.J., Klinz F.-J., Danath C. and Gallwitz D., (1984), *Cell* **36** 645-53.
- Langford C.J. and Gallwitz D., (1983), *Cell* **33** 519-27.
- Langford C.J., Nellen W., Neissing J. and Gallwitz D., (1983), *Proc. Nac. Acad. Sci. USA.* **80** 1496-500.
- Lindgrens C.G. and Lindgrens G., (1943), *Proc. Nac. Acad. Sci. USA.* **29** 306-308.
- Livingston D.M., (1977), *Genetics* **86** 73-84.
- Lütcke H.A., Chow K.C., Mickel F.S., Moss K.A., Kern H.F. and Scheele G.A., (1987), *EMBO J.* **6** 43-8.
- Lycett G.W., Delauney A.J. and Croy R.R.D., (1983a), *FEBS Lett.* **153** 43-6.
- Lycett G.W., Delauney A.J., Gatehouse J.A., Gilroy J., Croy R.R.D. and Boulter D., (1983b), *Nucl. Acid. Res.* **11** 2367-80.
- Mandel M. and Higa A., (1970), *J. Mol. Biol.* **53** 159-62.
- Maniatis T., Fritsh E.F. and Sambrook J., (1982), Eds. *Molecular Cloning. A Laboratory Manual.* CSH, NY.
- Maniatis T., Jeffrey A. and Kleid G.D., (1988), *Proc. Nac. Acad. Sci. USA.* **72**

1184-8.

- March J.F., Pappin D.J.C. and Casey R., (1988), *Biochem. J.* **250** 911-15.
- Mechler B., Hrisch H.H., Müller H. and Wolf D.H., (1988), *EMBO J.* **7** 1705-10.
- Mellor J., Dobson M.J., Roberts N.A., Tuite M.F., Emtage J.S., White S., Lowe P.A., Patel T., Kingsman A.J. and Kingsman S.M., (1983), *Gene* **24** 1-14.
- Metzger D., White J.H. and Chambon P., (1988), *Nature* **334** 31-6.
- Millerd A. and Spencer D., (1974), *Aust. J. Plant Physiol.* **1** 331-41.
- Mizunaga T., Masayuki I., Ikeda K. & Maruyama Y., (1988), *J. Biochem.* **103** 321-326.
- Moerschell R.P., Tsunasawa S. and Sherman F., (1988), *Proc. Nac. Acad. Sci. USA.* **85** 524-8.
- Moody A.J., Norris F., Norris K., Hansen M.T. and Thim L., (1987), *FEBS Lett.* **212** 302-6.
- Morton H., Evans I.M., Gatehouse J.A. and Boulter D., (1983), *Phytochem.* **22** 807-12.
- Müller H.P., (1983), in *Seed Proteins: Biochemistry, Genetics and Nutritive Value.* Ed. W. Gottschalk and H.P. Müller. 308-51. Martinus Nijhoff, The Hague.
- Muller W., Weber H., Meyer F. and Weissman C., (1978), *J. Mol. Biol.* **124** 343-58.
- Munro S. and Pelham H.R.B., (1986), *Cell* **46** 291-300.
- Murray A.W. and Szostak J.M., (1983b), *Nature* **305** 189-93.
- Nasmyth K.A., Tatchell K., Hall B.D., Astell C. and Smith M., (1981), *Nature* **289** 244-50.
- Neill J.D., Litts J.C., Anderson O.D., Greene F.C. and Stiles J.I., (1987), *Gene* **55** 303-17.
- Ng R. and Abelson J., (1980), *Proc. Nac. Acad. Sci. USA.* **77** 3912-6.
- Oberto J. and Davison J., (1986), *Gene* **40** 57-65.
- Oeser H., (1962) *Archiv. Microbiol.* **44** 47.
- Old R.W. and Primrose S.B., (1985), eds. *Principles of Genetic Manipulation.* Blackwell, Oxford.
- Olson M.V., (1981), in *Genetic Engineering.* Eds J.K. Setlow and A. Hollaender. Plenum Press, N.Y.
- Olson M.V., Loughrey K. and Hall B.D., (1979a), *J. Mol. Biol.* **127** 285-95.
- Orr-Weaver T.L., Szostak J.W. and Rothstein R.L., (1981), *Proc. Nac. Acad. Sci. USA.* **78** 6354-8.

- Osborne T.B., (1924), *The Vegetable Proteins*. Longmans, London.
- Oshiro S., Katsura N., Kitada K. and Gunge N., (1987), *FEBS Lett.* **220** 382-6.
- Palzkill T.G. and Newlon C.S., (1988), *Cell* **53** 441-50.
- Palzkill T.G., Oliver S.G. and Newlon C.S., (1986), *Nucl. Acid. Res.* **14** 6247-64.
- Parkinson J.S. and Huskey R.J., (1971), *J. Mol. Biol.* **56** 369-84.
- Pelham H.R.B., (1986), *Cell* **46** 959-61.
- Pelham H.R.B., (1988), *Nature* **332** 776-77.
- Pelham H.R.B., Hardwick K.G. and Lewis M.J., (1988), *EMBO J.* **8** 1757-62.
- Petes T.D. and Williamson D.H., (1975), *Cell* **4** 249-54.
- Philippsen P., Thomas M., Kramer R.A. and Davis R.W., (1978), *J. Mol. Biol.* **123** 387-404.
- Plummer T.H. and Tarentino A.L., (1984), *J. Biol. Chem.* **256** 10243-6.
- Polakis E.S., Bartley W. and Meek G.A., (1965), *Biochem. J.* **97** 298-302.
- Post L.E., Strycharz G.D., Nomura M., Lewis H. and Dennis P.P., (1979), *Proc. Nat. Acad. Sci. USA.* **74** 1697-1701.
- Price V., Mochizuki D., March C.J., Gosman D., Deely M.C., Klinke R., Clevenger W., Gillis S., Baker P. and Urdal D., (1987), *Gene* **55** 287-93.
- Pringle J.R., (1975), *Mol. Cell. Biol.* **12** 149-184.
- Pringle J.R. and Hartwell L.H., (1981), In *Molecular Biology of the yeast Saccharomyces*. Eds. Strathern *et al.* Vol. I. CSH, N.Y.
- Rine J., Hansen W., Hardeman E. and Davis R.W., (1983), *Proc. Nat. Acad. Sci. USA.* **76** 5596-600.
- Roeder S.G., Farabaugh P.J., Chaleff D.T. and Fink G.R., (1980), *Science* **209** 1375-80.
- Roeder S.G. and Fink G.R., (1980), *Cell* **21** 239-50.
- Rose M., Casadaban M.J. and Botstein D., (1981), *Proc. Nat. Acad. Sci. USA.* **78** 2460-4.
- Rothblatt J. and Meyer D., (1986), *Cell* **44** 619-28.
- Rothman J.E., (1987), *Cell* **50** 521-2.
- Rothstein S.J., Lahners K.N., Lazarus C.M., Baulcombe D.C. and Gatenby A.A., (1987), *Gene* **55** 353-6.
- Ruohonen L., Hackman P., Lehtovaara P., Knowles J.K.C. and Keränen S., (1987), *Gene* **59** 161-70.
- Russel P. and Nurse P., (1986), *Cell* **45** 781-782.

- Rykowski M.C., Wallis J.R., Choe J. and Grunstein M., (1981), *Cell* **25** 477-88.
- Saccardo P.A., (1889), *Sylloge Fungorum Omnium Hucusque Cognitorum*, vol. 8. Pavia.
- St. John T. and Davis R.W., (1979), *Cell* **16** 443-52.
- Sanger F., Coulson A.R., Barrell B.G., Smith A.J.H. and Roe B.A., (1980), *J. Mol. Biol.* **143** 161-78.
- Sato T., Tsunasawa S., Nakamura Y, Emi M., Sakiyama F. and Matsubara K., (1986), *Gene* **50** 247-57.
- Schägger H. and Von Jagow G., (1987), *Anal. Biochem.* **166** 368-79.
- Schauer I., Emr S., Gross C. and Schekman R., (1985), *J. Cell. Biol.* **100** 1664-75.
- Schekman R., (1985), *Ann. Rev. Cell Biol.* **1** 115-43.
- Scherer S. and Davis R.W., (1979), *Proc. Nac. Acad. Sci. USA.* **76** 4951-5.
- Scherer S. and Davis R.W., (1981), *CSH Symp. Quant. Biol.* **45** 584-91.
- Shortle D., Haber J. and Botstein D., (1982), *Science* **217** 371-3.
- Shortle D., Koshland D., Weinstock G.M. and Botstein D., (1982), *Proc. Nac. Acad. Sci. USA.* **77** 5375-9.
- Schultz L.D., Hofman K.J., Mylin L.M., Montgomery G.L., Ellis R.W. and Hopper J.E., (1987), *Gene* **61** 123-33.
- Seeburg P.H., Shine J., Marshall J.A., Baxter J.D. and Goodman H.M., (1977), *Nature* **270** 486-94.
- Sharp P.A., Sugden B. and Sambrook J., (1973), *Biochemistry* **12** 3055-63.
- Sidhu R.S. and Bollon A.P., (1987), *Cell* **54** 175-84.
- Singer S.J., Maher P.A. and Yaffe M.D., (1987), *Proc. Nac. Acad. Sci. USA.* **54** 1015-9.
- Snyder M., Buchman A.R. and Davis R.W., (1986), *Nature* **324** 87-9.
- Som T., Armstrong K.A., Volkert F.C. and Broach J.R., (1988), *Cell* **52** 27-37.
- Southern E., (1975), *J. Mol. Biol.* **98** 503-17.
- Srienc F., Bailey J.E. and Campbell J.L., (1985), *Mol. Cell. Biol.* **5** 1676-84.
- Stinchcomb D.T., Mann C. and Davis R.W., (1982), *J. Mol. Biol.* **158** 157-79.
- Stinchcomb D.T., Struhl K. and Davis R.W., (1979), *Nature* **289** 39-43.
- Strathern J.N., Jones E.W. and Broach J.R., (1982) *The Molecular Biology of the Yeast Saccharomyces cerevisiae*. eds. CSH, NY.
- Strathern J.N., Newlon C.S., Herskowitz I. and Hicks J.B., (1979), *Cell* **18** 309-19.
- Strich R., Woontner M. and Scott J.F., (1986), *Yeast* **2** 169-78.

- Struhl K., Cameron J.R. and Davis R.W., (1976), *Proc. Nat. Acad. Sci. USA.* **73** 1471-5.
- Struhl K. and Davis R.W., (1980), *Proc. Nat. Acad. Sci. USA.* **74** 5255-9.
- Struhl K., Stinchcomb D.T. and Davis R.W., (1980), *J. Mol. Biol.* **136** 291-307.
- Struhl K., Stinchcomb D.T. and Scherer S., (1979), *Proc. Nat. Acad. Sci. USA.* **76** 1035-9.
- Sutton A. and Broach J.R., (1985), *Mol. Cell. Biol.* **5** 2770-80.
- Szostak J.W. and Blackburn E.H., (1982), *Cell* **29** 245-55.
- Tanner W. and Lehle L., (1987), *Biochim. Biophys. Acta* **906** 81-99.
- Tarentino A.L. and Plummer T.H., (1982), *J. Biol. Chem.* **257** 10776-80.
- Tegtmeyer P., Lewton B.A., DeLucia A.L., Wilson V.G. and Ryder K., (1983), *J. Virol.* **46** 151-61.
- Thim L., Hansen M.T., Norris K., Hoegh I., Boel E., Forstrom J., Ammerer G. and Fiil N.P., (1986), *Proc. Nat. Acad. Sci. USA.* **83** 6766-70.
- Thomas M., White R.L. and Davis R.W., (1976), *Proc. Nat. Acad. Sci. USA.* **73** 2294-8.
- Thompson J.A., Schroeder H.E. and Dudman W.F., (1978), *Aust. J. Plant Physiol.* **5** 263-79.
- Thuring R.W.J., Sanders J.P.M. and Borst P., (1975), *Anal. Biochem.* **66** 213-20.
- Tjian R., (1978), *Cell* **13** 165-174.
- Towbin H., Staehelin T. and Gordon J., (1979), *Proc. Nat. Acad. Sci. USA.* **76** 4350-4.
- Tuite M.F., Dobson M.J., Roberts N.A., King R.M., Burke D.C., Kingsman S.M. and Kingsman A.J., (1982), *EMBO J.* **1** 603-8.
- Verbakel J.M.A., Dekker K.A., Rutgens C.A., Pouwels P.H. and Enger-Valk B.E., (1987), *Gene* **61** 207-215.
- Vierra J. and Messing J., (1982), *Gene* **19**, 259-68.
- Volkert F.C. and Broach J.R., (1986), *Gene* **46** 541-50.
- Von Heijne G., (1988), *Biochim. Biophys. Acta* **947** 307-33.
- Wallace R.B., Johnson P.F., Tanaka S., Schold M., Itakura K. and Abelson J. (1980), *Science* **209** 1396-1400.
- Watson M.D., Lambert N., Delauney A.J., Yarwood J.N., Croy R.R.D., Gatehouse J.A., Wright D.J. and Boulter D., (1988), *Biochem. J.* **251** 857-64.
- Weiss B., Jaquemin-Sablon A., Live T.R., Fareed G.C. and Richardson C.C., (1968),

*J. Biol. Chem.* **243** 4543-55.

Wetzel R., Kleid D., Crea R., Heyenber H.L., Yansura D.G., Hirose T., Kraszewski A., Riggs A.D., Itakura K. and Goeddel D.V. (1981), *Gene* **16** 63-71.

Wiedmann M., Wiedmann B., Voigt S., Wachter E., Müller H.G. and Rapoport T.A., (1988), *EMBO J.* **7** 1763-8.

Wiemken A., (1975), in *Methods In Cell Biolgy*. Vol.12. Chapt. 7 99-109.

Williamson V.M., Young E.T. and Ciriacy M., (1981), *Cell* **23** 605-14.

Winge Ö. and Roberts C., (1949), *C.R. Trav. Lab.* **24** 263-315.

Yanagita Y., Abdel-Ghany M., Raden D., Nelson N. and Racher E., (1987), *Proc. Nac. Acad. Sci. USA.* **84** 925-9.

Yarwood J.N., Harris N., Delauney A.J., Croy R.R.D., Gatehouse J.A., Watson M.D. and Boulter D., (1987), *FEBS Lett.* **222** 175-180.

Zaret K.S. and Sherman F., (1982), *Cell* **28** 563-73.

Zaret K.S. and Sherman F., (1984), *J. Mol. Biol.* **177** 107-35.

Zealey G.R., Goodey A.R., Piggott J.R., Watson M.E., Cafferkey R.C., Doel S.M., Carter B.L.A. and Wheals A.E., (1988), *Mol. Gen. Genet.* **211** 155-9.

Zitomer R.S., Walthall D.A., Rymond B.C. and Hollenberg C.P., (1984), *Mol. Cell. Biol.* **4** 1191-1197.

