

Durham E-Theses

The micro-determination of uranium and thorium

John C. Dalton

How to cite:

Dalton, John C. (1954) The micro-determination of uranium and thorium. Doctoral thesis, Durham University.

Use policy

The full-text may be used and/or reproduced, and given to third parties in any format or medium, without prior permission or charge, for personal research or study, educational, or not-for-profit purposes provided that:

- a full bibliographic reference is made to the original source
- a <https://etheses.durham.ac.uk/id/eprint/9312/> is made to the metadata record in Durham E-Theses
- the full-text is not changed in any way

The full-text must not be sold in any format or medium without the formal permission of the copyright holders.

Please consult the [full Durham E-Theses policy](#) for further details.

THESIS

presented in candidature for the degree of

DOCTOR OF PHILOSOPHY

of the University of Durham

by

John C. Dalton, B.Sc., (Dunelm).

entitled

"THE MICRO-DETERMINATION OF URANIUM AND THORIUM"

Being an account of the work carried out at the Londonderry Laboratory for Radiochemistry Durham University, during the period 1950 - 1953 under the supervision of Mr. E.R. Mercer, B.Sc., (from October 1950 to September 1951) and S.J. Thomson B.Sc., Ph.D., A.R.I.C., (from September 1951 to September 1953).



ABSTRACT

Methods are described for the analysis of the uranium and thorium contents of iron and stone meteorites. These elements are present in concentrations of about 10^{-8} gram per gram, and normally the quantity of meteorite available was limited (10 - 50 gram).

Using the fluorimetric method for the microdetermination of uranium, 2×10^{-8} gram Uranium could be determined with an accuracy of 10%.

Thorium estimations were accomplished by α -particle scintillation counting of Thorium C in radioactive equilibrium with the thorium series; the counter had an extremely low background (about 0.9 counts per hour). The Thorium C could be regenerated from the higher members of the thorium disintegration series and it could therefore be determined several times. 10^{-7} gram thorium could be determined with an accuracy of 25%.

A method was developed for the isolation of the uranium from meteorites using a retrograde solvent extraction technique involving nitric acid and diethyl ether. Other chemical procedures evolved, permitted the analysis of both the uranium and thorium in single samples of meteorite. The techniques employed included solvent extractions, co-precipitations and a chromatographic separation of uranium and iron. The quantitative separation of submicrogram quantities of uranium and thorium was also accomplished by precipitating the latter element, with a zirconium carrier, using an organic precipitant. Methods for the removal of traces of uranium and thorium from reagents are also described.

The determinations were correlated with the helium content of the meteorites to calculate their probable ages. The absolute amount of meteoritic helium, together with its isotopic analysis, enabled probable amounts of helium produced independently by cosmic rays and the naturally-occurring radio-elements to be estimated.

Results suggest a probable age for eight meteorites of about 75×10^6 years, while six others appear to have solidified less than one million years ago.

I N D E X .

<u>CHAPTER</u>	<u>TITLE</u>	<u>PAGE</u>
	SUMMARY	
1	INTRODUCTION	1
11	METHODS FOR MICRODETERMINATION OF URANIUM AND THORIUM.	5
111	THE FLUORIMETRIC METHOD FOR THE DETERMINATION OF URANIUM.	11
IV	REVIEW OF SUITABLE METHODS FOR THE SEPARATION OF URANIUM AND THORIUM FROM METEORITES.	29
V	THE ETHER/NITRIC ACID RETROGRADE EXTRACTION METHOD FOR URANIUM DETERMINATION.	34
VI	THE SEPARATION OF URANIUM BY MERCURY-CATHODE ELECTROLYSIS	45
VII	DEVELOPMENT OF THE COMBINED URANIUM/THORIUM METHOD	53
VIII	THE COMPLETE URANIUM/THORIUM PROCEDURE APPLIED TO METEORITES.	73
IX	MEASUREMENT OF URANIUM IN METEORITE SOLUTIONS REMAINING AS RESIDUES FROM THE RADON-THORON METHOD.	83
X	DETERMINATION OF URANIUM AND THORIUM IN STONE METEORITES.	84
XI	ALTERATION OF THE METHOD OF URANIUM/THORIUM SEPARATION.	88
XII	ELECTROCHROMATOGRAPHIC AND CHROMATOGRAPHIC METHOD OF SEPARATING URANIUM AND IRON.	94
XIII	RESULTS AND DISCUSSION.	120
APPENDIX 1	THE FLUORIMETER	137
APPENDIX 11	SCINTILLATION COUNTER	143
	BIBLIOGRAPHY	150
	ACKNOWLEDGEMENTS.	

SUMMARY

Methods are described for the analysis of the uranium and thorium contents of iron and stone meteorites. These elements are present in meteorites in concentrations of about 10^{-8} gram per gram and normally the quantity of starting material available was limited (10 - 50 gram).

The micro-determination of uranium was accomplished using a fluorimetric analytical procedure by which 2×10^{-8} gram of uranium could be determined with an accuracy of 10%. This method required the quantitative extraction of the uranium from the meteorite in a state of extreme purity.

Thorium estimations were performed using an α -particle scintillation counter with an extremely low natural background counting rate (ca. 0.9 counts per hour). The thorium, after isolation from the meteorite was stored in solution until radioactive equilibrium was established throughout the whole of the thorium decay series. The thorium C member was then precipitated as sulphide with thorium B on a lead sulphide carrier, and its α -activity was measured. After three days the thorium B and thorium C had been regenerated to the equilibrium amount and the thorium C could therefore be determined several times. 10^{-7} gram of thorium could be determined with an accuracy of 25%.

A method was developed for the quantitative isolation of the meteoritic uranium in a pure state using the partition of



uranyl nitrate between ether and aqueous nitric acid, in a retrograde extraction. Other chemical procedures evolved, permitted the analysis of both the uranium and thorium in one and the same sample of meteorite. The techniques employed included solvent extractions (removal of uranyl nitrate or ferric chloride into ether), co-precipitations (thorium hydroxide and ammonium diuranate on ferric or aluminium hydroxides, uranyl ferrocyanide on ferric ferrocyanide), a chromatographic separation of uranium and iron, and the electrolytic removal of iron, nickel, chromium, etc., from uranium, using a mercury cathode. The quantitative separation of sub-microgram quantities of uranium and thorium was also accomplished by precipitating the latter element with a zirconium carrier using an organic precipitant.

Uranium²³³ and Uranium-X₁ were employed as tracers for uranium and thorium respectively during the development of new methods of separation. The uranium²³³ was later used in an isotope dilution technique to measure the efficiency of uranium recovery following chromatographic purification.

In all of the separation procedures it was essential that the reagents used should contain the minimum amounts of uranium and thorium in order to obtain the best possible sensitivity and accuracy in the results. Special attention is given to methods of purification of the reagents where this is necessary.

The uranium and thorium contents of the meteorites were

correlated with the helium contents, to calculate the ages of the meteorites. The absolute amount of meteoritic helium, together with its isotopic analysis, enabled probable amounts of helium produced independently by cosmic-rays and the naturally-occurring radio-elements to be estimated.

The results obtained suggest a probable age for eight meteorites of about 75×10^6 years, while six others appear to have solidified less than one million years ago.

Chapter 1.

INTRODUCTION.

Many papers have been published during the last thirty years on the determination of the age of meteorites by the helium method.⁽¹⁾ This method was originally based on the assumption that the helium present in meteorites was the disintegration product of the uranium and thorium content of the meteorites. The radio-active content of the meteorites had therefore to be determined to calculate their ages by the helium method, and this thesis is an account of the work carried out during the past three years on the micro-analysis of uranium and thorium for this purpose.

Some five years ago it had been independently suggested by Bauer⁽²⁾ and Huntley⁽³⁾ that at least part of the meteoritic helium may not have been produced from the radio-activity of uranium, thorium and their disintegration series; they suggested that it had been formed by the interaction of cosmic rays with the meteoritic material while in outer space. Calculations by Le Couteur⁽⁴⁾ suggested that helium thus produced should contain about 30 parts of the isotope He^3 for every 100 parts of He^4 (Radiogenic helium would consist purely of the isotope He^4).

To investigate these processes, mass-spectrometric analyses of meteoritic helium were undertaken a year ago by Paneth

Reasbeck and Mayne⁽⁵⁾. They found that in four of the eleven meteorites so far examined the He^3 : He^4 ratio was between 28% and 31%.⁽⁶⁾ However, in certain other cases, the isotopic ratio was appreciably lower (e.g. the meteorites Bethany (Harvard) and San Martin both had He^3 : He^4 ratios of 17%). If one assumes that the helium produced by the cosmic ray processes has a He^3 : He^4 ratio of 30% one is led to the conclusion that meteorites containing helium of lower isotopic ratios than this have a contribution from radiogenic helium. In such cases as this the determination of the uranium and thorium contents of the meteorites was necessary in order to calculate their ages.

Another problem to which the acquired data may be applied, is the determination of the constancy of the He^3 : He^4 ratio of the cosmic ray helium, after assuming an age for the meteorites and calculating the amount of He^4 produced during this time by the uranium and thorium present. This work was undertaken in collaboration with Reasbeck and Mayne.

This determination is particularly applicable to pallasites (meteorites with both an iron and a stone phase e.g. Brenham Township), in which the age of the stone phase may be independently determined by the potassium/argon method⁽⁷⁾. Assuming that both phases have the same age, the amount of He^4 formed from the uranium and thorium may then be calculated. Potassium/argon age determinations are at present being

carried out in these laboratories.

In addition, the determination of the distribution of trace elements in meteorites, and the comparison of these distributions with those found on earth, are both of geochemical interest, since meteorites represent the only available source of extra-terrestrial matter.

Stone meteorites contain smaller quantities of uranium and thorium than even the most basic rocks, and iron meteorites are still less "contaminated" by these radio-active substances⁽⁸⁾. The determination of such micro-quantities of these elements demanded the use of more sensitive methods than were already available, and the refinement of these methods, together with the development of new techniques, will be described along with details of the methods used for the chemical separation of the elements from the starting material, prior to their measurement.

The average uranium and thorium contents of iron meteorites are respectively 0.7×10^{-8} g./g. and 4.0×10^{-8} g./g., while for stone meteorites these values are 10×10^{-8} g./g. and 50×10^{-8} g./g. These data, coupled with the fact that for most meteorites only limited amounts of starting material are available, mean that not only are extremely sensitive methods of determination required, but also that the methods of extraction employed must involve the use of reagents containing amounts of uranium and thorium appreciably less than the

quantities contained in the meteoritic sample. If any procedure demands the use of reagents containing appreciable amounts of uranium or thorium, methods must be found for the removal of these elements from the reagents.

In the following chapters will be found a discussion of the methods available, and those developed, for the micro-determination of uranium and thorium. Subsequent chapters are devoted to detailed accounts of the extraction procedures used, particular attention being paid to the major problem of the purity of the reagents, and descriptions are given of the methods used for their purification, where necessary.

Chapter 11

METHODS FOR THE MICRO-DETERMINATION OF
URANIUM AND THORIUM

In order to undertake this present problem, methods capable of determining 10^{-8} - 10^{-7} g. of both uranium and thorium had to be developed.

Gravimetric analysis is unsuitable for microgram quantities in this work because of the difficulty in handling these quantities after extraction from the vast excess of meteoritic material, while volumetric methods for both elements are restricted to a lower limit of 10^{-4} g.⁽⁹⁾ . The most sensitive colorimetric method for uranium is that using 8-hydroxyquinoline and it has a lower limit of about 5×10^{-7} g. (ref(9), p118), while using p-dimethylaminoazobenzeneearsonic acid (parasonic acid) one can detect 5×10^{-7} - 5×10^{-4} g. Thorium⁽¹⁰⁾. Neither of these methods is sufficiently sensitive for the present work. Spectrochemical and polarographic methods for the determination of uranium and thorium in 10^{-6} g. quantities are known (ref.(9) p.596), but both methods are unsuitable for sub-microgram analysis.

One technique which can be employed in meteorite analysis is the estimation of the natural radioactivity of the two elements and their disintegration products. A review on the determination of naturally occurring radioactive elements has recently been published by Rodden (11) The counting of

β - particles⁽¹²⁾ or γ - rays from any of the daughter substances must be rejected, since the achieving of sufficiently low natural background effects with the counters, to detect the low activities in question, is a difficult and complicated procedure. The counting of α - particles can, however, be satisfactorily carried out at much lower levels of activity, but here again a difficulty arises from the need to extract from the large amounts of starting material, the appropriate radioactive substance in a form suitable for the counting of the emitted α - particles.

Three different methods of α - particle counting have been adapted for use in uranium and thorium analyses of meteorites in these laboratories. Each will now be discussed in turn.

(1) The ideal method would be one in which there was no self-absorption of the α - particles by the source, and in which α - particles emitted in all directions were counted. This is not possible when a solid source is used but the emanation method using the rare gas member of each of the two series has been employed with some success in this laboratory.⁽¹³⁾ The basis of the method is as follows:-

When the meteorite sample (usually 30g.-100g.) had been dissolved in HCl, and any residue brought into solution with HNO₃ or fusion mixture, 50 mg. of barium chloride, which had been added as a carrier for the radium isotopes, was precipitated as Ba SO₄. The washed precipitate was fused

with an excess of fusion mixture, forming the barium and radium carbonates, which were dissolved in HCl. This solution then contained the radium (Ra^{226}) and thorium -X (Ra^{224}) which were respectively in equilibrium with the uranium and thorium present in the meteorite. Since Th X has a short half-life (3.64 days), it was necessary to carry out the thorium determination as soon as possible. This was done by bubbling nitrogen through the chloride solution and then through an ionisation chamber, at such a rate that the majority of the thoron (Rn^{220} $t_{1/2} = 55$ secs.) atoms, which were carried out of solution as they were formed from ThX, decayed in the chamber. In this way an insignificant number of radon (Rn^{222}) atoms decayed in the chamber. The number of counts in excess of background was a measure of the amount of thorium originally present. Allowance had of course to be made for the fraction of the ThX which decayed between the precipitation of Ba SO_4 and the time of counting. The background of the apparatus was about 30 disintegrations per hour, while 10^{-6} g. thorium gave 6.48 ± 0.4 cts./hr. by this method. The accuracy of the method for 100g. of a meteorite of average thorium content, involved an error of about 10^{-8} g./g. meteorite.

The chloride solution was then stored between two mercury ventils for several days to allow the radon (Rn^{222} $t_{1/2} = 3.84$ days) to approach equilibrium with the radium. The gas was then pumped with nitrogen into the evacuated ionisation chamber

and its disintegrations were counted. Radon equivalent to 10^{-6} g. uranium gave 65 ± 1.5 cts./hr. in excess of background. Here the accuracy for an estimation of a 100g. sample was 10^{-9} g. uranium per g. meteorite. The method was advantageous in that it could be used for large amounts of starting material, as much as 250g. being used for one meteorite of unusually low uranium content.

(2) The second method of α -counting which can be adapted to the present problem, is that employing the counting of tracks in photographic emulsions (nuclear plates)⁽¹⁴⁾. A method was devised⁽¹⁵⁾ involving the extraction of uranium and its evaporation on to a small surface which was then clamped in contact with a piece of Ilford Type C 2 emulsion for a desired period. The plate was then processed, dried and track-counted under a microscope. As little as 10^{-8} g. uranium could be estimated by this method, with an accuracy of about 6%, but in order to do this a period of exposure of 50 days was required. Another difficulty of the method was that the uranium must be in the form of a 'weightless' source, in order to avoid self-absorption of the α -particles, and this proved to be one of the obstacles in using the method.

(3) The third suitable form of α -counting is that achieved by a scintillation technique. This has been used by the author. When an impurity-activated phosphor of zinc sulphide is struck by an α -particle, the phosphor scintillates

and the light produced is allowed to fall up on the photo-sensitive cathode of an electron-multiplier photo-tube. The output from this phototube is amplified and pulses are recorded on an electro-mechanical counter. The normal background of this counter is about 0.9 cts./hr. and with reasonable care this low figure can be maintained for long periods.

Although the counting efficiency of this instrument is lower than that of the radon-thoron apparatus (only about 35% of the α - particles emitted from the source can strike the phosphor, whereas almost all the disintegrations in the ionisation chamber are counted), the background count of the latter was at least 20 times that of the former, and hence the scintillation counter is much more sensitive when working with low activities. One microgram of uranium in this instrument would give 15.3 cts./hr. while the same weight of thorium would give 5.2 cts./hr.

This scintillation technique appears to be the most sensitive method available for micro-determinations of thorium, and was the one finally used. A brief description of the scintillation counter will be found in Appendix 11.

For the determination of uranium, a fluorimetric method is available, which is probably the most sensitive known for that element. The method which is a development of that devised by Hernegger and Karlik⁽¹⁶⁾ lends itself admirably to

the present work, and was the one eventually chosen. A complete description of the method will be found in the following chapter.

The recently described radio-activation analysis method⁽¹⁷⁾ for micro-quantities of uranium would also appear to be potentially useful for meteorite analyses. Its ultimate sensitivity is of the order of 10^{-8} g. uranium, but since the method cannot be used unless the uranium concentration in the material to be irradiated is at least 0.0003% (much higher than the uranium concentration of meteorites), some preliminary enrichment of the uranium would have to be effected before irradiation, and much of the appeal of the method is thus lost.

Chapter 111

THE FLUORIMETRIC METHOD FOR THE
DETERMINATION OF URANIUM

The phenomenon of the fluorescence of uranium salts on exposure to ultra-violet light was first studied by Stokes⁽¹⁸⁾ in 1852. Later investigation of the subject by the Becquerels⁽¹⁹⁾ led indirectly to the discovery of radioactivity in 1896 by H. Becquerel. Examination of the fluorescence showed that it was confined solely to the uranyl compounds, and that the normal oxides and non-oxygenated compounds of uranium did not fluoresce. Further work by Nicholls and Howe⁽²⁰⁾ followed, and in 1926 it was discovered by Nicholls and Slattery⁽²¹⁾ that the intensity of the fluorescence could be considerably increased by the fusion of the uranium compound with certain solids, such as borax, sodium phosphate or sodium fluoride. They showed that of all these substances, sodium fluoride was the one giving the most intense fluorescence. The intensity of the fluorescent light was studied as a function of the concentration of the uranium in the flux. The phenomenon of optimum fluorescence concentration, associated with the name of Bruninghaus⁽²²⁾, was observed, but at lower concentrations than this the fluorescence intensity was approximately proportional to the uranium concentration, even down to one part of uranium in 10^7 parts of NaF. The Bruninghaus maximum occurred at a uranium concentration of

1 in 2000, producing a range of nearly four orders of magnitude over which the relationship was virtually linear.

This phenomenon of the activation effect of uranium was soon utilised as the basis of a method of qualitative detection of traces of uranium by Papish and Hoag⁽²³⁾. They showed that as little as 10^{-10} g. of uranium could be detected visually, by comparison with fused pure sodium fluoride. They also pointed out the need for the absence of certain interfering substances which cause "quenching" of the fluorescence. (A quencher is a term ascribed by Rodden to any ion which diminishes the fluorescence of a phosphor). Papish and Hoag found that the only other element giving a similar fluorescence to that of uranium was niobium, when present as niobic acid.

The first to use this fluorescence property as a quantitative analytical method were Hernegger and Karlik⁽¹⁶⁾ in 1935. Hernegger⁽²⁴⁾ had suggested previously that the method could be adapted for quantitative determinations by measurement of the fluorescence intensity either by means of a photocell arrangement, or alternatively by spectrographic measurements with photographic plates. The former method would be more sensitive, but the latter more specific. Hernegger recorded that by using the fluoromicroscope method of Haitinger⁽²⁵⁾, the difference between a pure NaF phosphor and one containing 10^{-11} g. uranium could be seen with little difficulty. He pointed out that a flat NaF disc was preferable to a spherical

bead, since the former was more easily penetrated by the ultra-violet light.

Hernegger and Karlik first used their method for the determination of uranium in sea-water. The uranium was separated by a precipitation method, and then brought into solution and mixed with 1g. of NaF which was dried, ground in an agate crucible, and made into 25mg. (15%) "pastilles" with a press. The NaF was melted in a platinum wire loop, irradiated with light from a mercury vapour lamp and spectrographs were taken. The plates were examined with a Zeiss Microphotometer and compared with those from standard uranium phosphors. The authors report a good accuracy and reproducibility from 10^{-9} to 5×10^{-6} g. uranium. This method, with various developments has subsequently been used by many other workers, and under reference (26) will be found papers on uranium analyses by the fluorescence method.

Sill and Peterson⁽²⁷⁾ developed a fluorimetric test for uranium in aqueous solution capable of detecting 10^{-5} g. of the element.

Reviews of fluorimetric determinations of uranium have been published by Northup⁽²⁸⁾ and De Mont⁽²⁹⁾.

With the discovery of nuclear fission and the subsequent importance of uranium in the field of atomic energy, a method was required for the rapid and accurate estimation of sub-microgram quantities of uranium. The original method of

Hernegger and Karlik was obviously too tedious for work on large numbers of samples, and a close investigation of its reliability was also required. For this reason much work has recently been done in this field, and several types of fluorimeter have been built, both in this country and in the U.S.A. (ref.(9) p.566-573) ranging from the single adaptation of a Duboseq colorimeter, to the elaborate instrument of Price⁽³⁰⁾, and including one for use in field work designed by Gibb and Evans⁽³¹⁾.

For this present work the following are the criteria for the instrument:-

1. Instrument of high sensitivity (sufficient to detect 10^{-9} g. uranium).
2. Reproducibility of instrument readings at any value to within $\pm 5\%$.
3. Instrument linear in response from 10^{-9} g. to about 10^{-6} g. uranium.
4. Minimum background (i.e. that part of the reading that is not due to uranium fluorescence).

A direct reading objective fluorimeter, conforming to these specifications, has recently been developed at the Atomic Energy Research Establishment at Harwell⁽³²⁾, and the instrument that was built and used by the author for this work was a slightly modified version of the A.E.R.E. Fluorimeter type 1080A⁽³³⁾, built at the Londonderry Laboratories of Radiochemistry. A

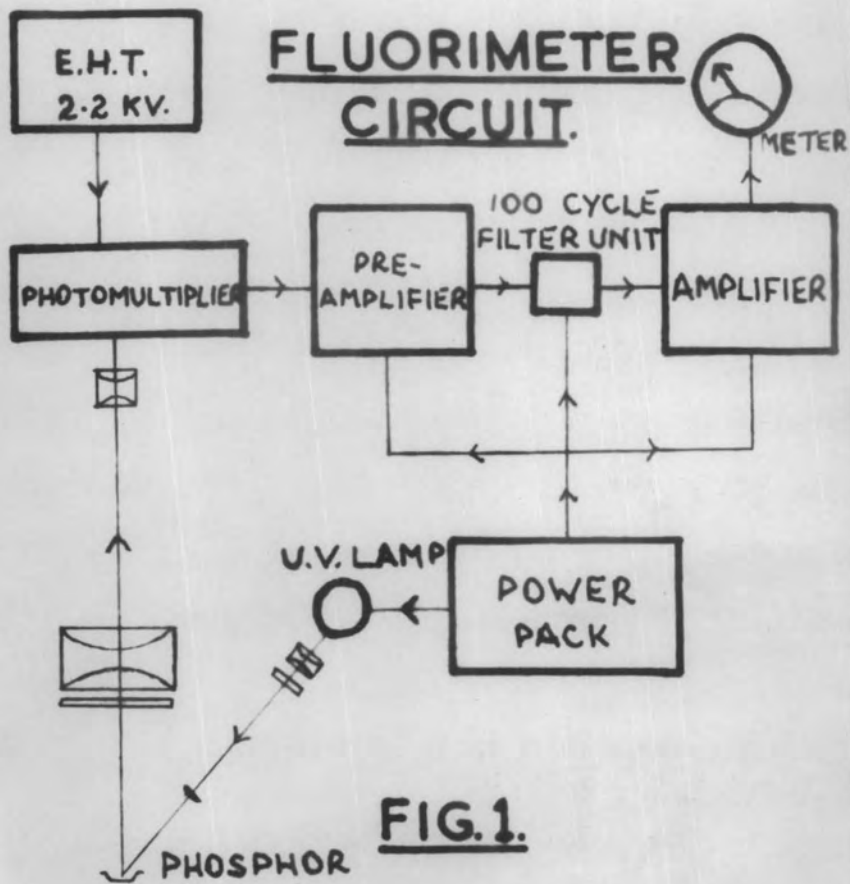

brief description of the instrument will now be given, and a detailed description of the construction, with diagrams, will be found in Appendix 1.

The Fluorimeter.

Ultra-violet light from a mercury vapour lamp impinged upon a sample dish containing NaF which had been fused with the uranium extracted from the sample undergoing analysis. The platinum sample dish and its contained phosphor were locked in a fixed position in the ultra-violet beam by means of a locating device in the turntable sample holder. The light from the phosphor reached a filter which allowed the yellow fluorescent light of uranium in sodium fluoride to pass through, but which cut out any reflected U.V. light. The intensity of the transmitted light was measured by means of a photocell whose output was amplified and then fed to a voltmeter.

A diagrammatic representation of the system is shown in Figure 1.

Preparation of Sodium Fluoride Phosphors and Interference by Contamination and Quenching.

In order to prepare phosphor discs of consistently reproducible fluorescence intensities, a careful standardisation of procedure was required.

There was a wide choice of flux material for the phosphors. For the determination of 10^{-3} g. quantities of uranium, it was necessary that the flux should have a high sensitivity to uranium and that the inherent "background" fluorescence of

the flux should be as low as possible. For this reason many fluxes such as KF, Borax, Na_2CO_3 , KHF_2 , NaKCO_3 and K_2TaF_7 and various mixtures of these substances were unsuitable because of their low sensitivity to uranium or the high fluorescence of their "blanks"⁽⁵⁴⁾. The choice of flux was now limited to either pure sodium fluoride or one of various mixtures of this substance with sodium carbonate. It had already been shown⁽⁵⁵⁾, that mixtures of NaF and Na_2CO_3 had a higher sensitivity to uranium than had pure NaF. For example, a mixture of 95% Na_2CO_3 and 5% NaF gave a fluorescence five times as intense as that from pure NaF when fused with the same quantity of uranium. However, in all cases the addition of Na_2CO_3 to the flux caused a great increase in the "blank" fluorescence. In the case of the above example the mixture had a blank fluorescence fifteen times that of the pure NaF. Since it is the apparent uranium content of the flux, inferred by its background fluorescence, which ultimately sets the lower limit of detection for the method, it is necessary to keep this quantity down to a minimum. Thus pure NaF was used: it had several other advantages over the mixed fluxes. Overton and Williams⁽⁵⁵⁾ had shown that phosphors produced from the mixtures gave results markedly affected by variations of the time and temperature of fusion. Even with carefully standardised conditions, consistent results were difficult to achieve. Phosphors made from the mixtures showed an

appreciable increase in fluorescence with time on being allowed to stand, either in the open or in a dessicator. Pure NaF did not exhibit this effect and gave better reproducibility of readings when standardised conditions were employed.

Fusion of Phosphors.

When the uranium solution to be analysed had been evaporated to dryness in the platinum sample dish (capacity 2 c.c.) under a radiant-heater, a fixed quantity of NaF was added (0.94 ± 0.05 g). This amount of NaF was found to be about the optimum. If less was used, the fluorescence decreased due to insufficient thickness of the phosphor, and if much more was used the dilution of the uranium in the flux also reduced the fluorescence.

In order to fuse the NaF (M.P. $992^{\circ}\text{C}.$) a Meker burner fed with coal-gas and a little compressed air was used. The air-flow was carefully regulated, since if the temperature was too high the flux attacked the platinum and quenching occurred⁽³⁶⁾. During the fusion the dishes were supported on a platinum triangle.

It was found that unless the fusion time was fixed, inconsistent readings were obtained. If insufficient fusion time was allowed, the solid solution of uranium in NaF was not homogeneous, while if too much time was allowed, volatilisation of NaF occurred and also the risk of attack on the platinum

by the flux was increased. In order to fix these conditions, the fusion of the solid was closely observed, and when the last particle was seen to melt the time was noted on a stop-clock, and heating was discontinued after a further 25 seconds. This allowed sufficient time for homogenisation of the melt, without undue prolongation of heating.

After fusing the fluoride the dishes were allowed to cool and these were placed in the instrument, care being taken to prevent dust falling upon them, since it was found that the fluorescence of dust particles could greatly increase the phosphor readings when working near the lower limit of the instrument.

At least five minutes were allowed to elapse between the end of fusion and the actual taking of the reading, in order to allow the phosphor to reach room temperature, since the fluorescence intensity decreased with rise in temperature. After this cooling period, phosphor readings remained constant for several hours, but eventually the uptake of moisture by the hygroscopic flux resulted in changes in readings by as much as 20%. Phosphors of low uranium content (10^{-8} - 10^{-9} g.U) tended to increase in reading, while the readings of phosphors containing 10^{-7} g.U or more, tended to decrease. For this reason standard uranium phosphors could not be kept from day to day for calibration of the instrument; fresh standards had to be prepared whenever determinations were being made.

Individual Brands of Sodium Fluoride.

When investigations of sodium fluoride commenced, it was found that the quality of the substance varied considerably from sample to sample in fluorescence properties, although chemically they were all highly pure.

Previous workers had recommended the products of Messrs. Merck (Rahway, New Jersey) and Messrs. Baker and Adamson (New York), and limited quantities of these were obtained from the A.E.R.E., Harwell. Both brands proved highly satisfactory, their phosphor blanks being respectively equivalent to 3×10^{-9} g. U and 2×10^{-9} g. U per 0.94g. This was sufficiently low to enable the differentiation of pure flux and phosphors containing 10^{-9} g. of added uranium.

The phenomenon of the inherent background fluorescence of fluxes did not appear to be due to the presence of uranium in the flux, since a procedure which was proved to remove uranium from NaF solutions failed to produce a lowering of the blank fluorescences when applied to solutions of several different brands of NaF. This attempted purification procedure is described on p. 76.

Because of the difficulty in obtaining NaF from the U.S.A. several more British brands were tested for use with the method. A sample of B.D.H. NaF Reagent (Specially Pure) was found to have a blank reading equivalent to 5×10^{-9} g. U per 0.94 g; this was only slightly inferior to that from the American brands

and this flux was used for meteorite determinations when the latter were not available.

Investigation of Fluorimeter Characteristics.

A solution of AnalaR uranyl nitrate hexahydrate (Messrs. Hopkins and Williams), which had been standardised gravimetrically, was suitably diluted to give solutions from 1.247×10^{-5} g. U/ml. to 1.247×10^{-8} g. U/ml., for use in the calibration of the instrument.

A phosphor containing 1.247×10^{-6} g. uranium was placed in the instrument, and the position of the ultra-violet lamp was varied until the maximum photocell response was obtained. This gave a reading of 44v on the output voltmeter using the $\times 30$ scale on the range-switch, i.e. 1320 (arbitrary units). (These units will hereafter be referred to as "volts" (v.), since they are obtained by multiplying the reading of the voltmeter by the factor of the range-switch). With a graphitised platinum dish in the sample operating position, the reading of the instrument was equivalent to 0.8×10^{-9} g.U. Hence the "instrument blank fluorescence" was less than that of the purest NaF examined (3×10^{-9} g.U).

On examining the same phosphor in the eight different operating positions of the turntable sample-holder, the readings were all within $1\frac{1}{2}\%$ of the mean and no corrections for misplacements were required.

Testing the Linearity of the Instrument Response.

A series of phosphors were prepared, varying in uranium content from 4×10^{-6} g.U. to 2×10^{-9} g.U. Three phosphors were prepared for each value of uranium content above 4×10^{-8} g. but below this value ten phosphors were made to obtain a better statistical accuracy. When the contribution of the NaF blank fluorescence became appreciable (i.e. $> 5\%$), it was subtracted from the readings to obtain the reading due to added uranium alone. All the calibration results were obtained within 10 hours, retaining a standard phosphor throughout as a check on the constancy of the instrument.

The following table of results was obtained:-

U in 10^{-6} g.	F.R.	U in 10^{-7} g.	F.R.	U in 10^{-8} g.	F.R.	U in 10^{-9} g.	F.R.
-	-	6	675v	6	69.0v	6	6.7v
4	4500v	4	455v	4	47.0v	4	4.3v
2	2260v	2	210v	2	22.0v	2	2.0v
1	1080v	1	110v	1	11.2v	-	-

F.R. = Fluorescence Reading

It can be seen that the relationship between instrument reading and uranium content was linear from 5×10^{-6} g. to 2×10^{-9} g.U. Presumably this relationship would extend somewhat lower than this (at least to 1×10^{-9} g.U.), but statistical errors made it impossible to demonstrate this. The proof of linearity of readings simplified the derivation of results from the instrument. Direct comparison of readings

from a phosphor of unknown uranium content and a standard phosphor (subtracting the contributions of NaF blanks if significant) enabled the unknown quantity to be found.

A series of solutions of known uranium content were "determined" fluorimetrically with the following results:- Aliquots containing 10^{-8} g. - 10^{-6} g.U would be determined with an accuracy of $\pm 3\%$ using the mean of three phosphors, while 2×10^{-9} g.U per sample could be determined with $\pm 10\%$ accuracy by means of a survey of ten phosphors.

Interference with Uranium Fluorescence by Other Elements.

Two possible types of interference with the fluorimetric method had to be considered, firstly, any elements producing a uranium-like fluorescence in NaF, and secondly, elements which quenched fluorescence. The presence of a "quencher" could easily be detected by the addition of known quantities of uranium to the phosphors. Re-fusion and measurement of the increase in instrument reading would indicate the presence of any quencher. An element having a similar fluorescence to uranium in NaF would be more difficult to discover.

Uranium-like Fluorescences.

Papish and Hoag⁽²³⁾ recorded that the only other element which was found to interfere with their qualitative fluorescence test for uranium, was niobium which produced an almost white fluorescence. Rodden (ref.(9).p 127) states that niobium and tantalum fused in NaF produced a uranium-like

fluorescence and quotes the results:- 5×10^{-4} g.Nb. produced the same fluorescence as 3×10^{-7} g.U and 5×10^{-5} g.Ta produced the same fluorescence as 6×10^{-7} g.U⁽³⁷⁾. However, he then suggests that these fluorescences may have been due to the presence of uranium as impurity in the niobium and tantalum, since Price et al.⁽³⁰⁾ examined the effect of Nb,Ta. and many others and concluded that no known element interfered with the determination according to their procedure. It was, however, necessary to investigate the effects of niobium and tantalum on the instrument to be used by the author.

Samples of potassium pentafluoniobate $K_2NbF_5O.H_2O$ and potassium pentafluotantalate K_2TaF_5O were obtained and dissolved in very dilute hydrofluoric acid. Various amounts of these elements were then fused with NaF and the phosphors were examined in the fluorimeter. In the case of niobium it was found that quantities of the element varying from 5×10^{-9} g. to 3×10^{-3} g. produced no noticeable fluorescence (i.e. less than that produced by 10^{-9} g. uranium) and also that these quantities neither enhanced nor quenched the fluorescence of phosphors containing known amounts of added uranium.

Tantalum produced no fluorescence or interfering effect on uranium fluorescence when present from 10^{-8} g. to 10^{-5} g. per phosphor. Quantities of Ta greater than this latter figure began to show signs of fluorescence in the instrument, 10^{-3} g. Ta producing readings equivalent to 8×10^{-8} g. U.

Amounts of Ta between 10^{-5} g. and 10^{-2} g. produced readings proportional to the Ta present, 6×10^{-3} g. Ta being equivalent in fluorescence reading to 6×10^{-7} g. U

Since so much tantalum was required to produce any fluorescence it is unlikely that the phenomenon was in fact due to the tantalum itself, because impurity-activated phosphors normally contain the activator in very great dilution⁽³⁸⁾. The tantalum salt presumably contained traces of uranium. However, even if this was not so, the possibility of such large quantities of Ta being present in meteorites is remote, and extraction procedures designed for the recovery of uranium from meteorites were unlikely to extract such quantities of tantalum. Rankama and Sahama⁽³⁹⁾ quote the tantalum content of meteorites to be 4×10^{-7} g./g. in silicate meteorites and 6×10^{-8} g./g. in iron meteorites, while for niobium these values are respectively 5×10^{-7} g./g. and 2×10^{-7} g./g.

The instrument could therefore be considered specific for uranium.

Quenching of Fluorescence.

Quantities of the order of several micrograms of certain elements produce a considerable lowering of the apparent uranium content of phosphors. Early tests by other workers had shown that the controlling factor was the concentration of the quencher in the phosphor, and not the ratio of the uranium and

quencher concentrations. A fixed amount of a quencher produced a fixed percentage decrease in fluorescence, independent of the uranium content of the phosphor. This led Price⁽³⁰⁾ to devise a dilution technique by which a sufficiently strong solution of uranium with a quencher present, is diluted until the effect of the quencher is negligible, but the concentration of uranium is still sufficient to produce a measurable fluorescence. This technique was unsuitable for meteorite analyses since the amounts of uranium present were so small, that any dilution of it would render its determination impossible.

Measurements of the Tolerance Limits of Quenchers.

The effect of a large number of quenchers on U/NaF phosphors has already been reported by Jacobs⁽³⁴⁾, however, since slightly different conditions prevailed, (he used a flux of 5% NaF and 95% Na KCO₃ and had smaller platinum dishes containing less flux), it was necessary that the tolerance limits of certain quenchers should be known, to determine the degree of purification required in the extraction of the uranium prior to fluorimetry. (The tolerance limit of a quencher is that amount causing only 5% quenching).

The extraction of uranium from iron meteorites (which contain usually > 90% Fe) in a sufficiently pure state for fluorimetric analysis, is complicated by the similarity in the chemical properties of uranium and iron.

To investigate the tolerance limit for iron, a series of phosphors was prepared containing $1.247 \times 10^{-6} \text{g. U}$ and varying amounts of Fe. The following results were obtained:-

Wt. of Fe/phosphor in 10^{-6}g.	0	1	2	5	10	20	50	100	200	500
Scale Reading(v)	1200	1200	1190	1080	1030	1010	890	860	390	250

Thus not more than $2 \times 10^{-6} \text{g. Fe}$ could be tolerated in each phosphor, without appreciable quenching occurring. The intention in each extraction procedure was to finish with the quantitatively separated uranium in solution and to take one-tenth aliquots of this in each phosphor and so estimate the probable error on any result (see p.143). Therefore the final uranium solution should not contain more than $2 \times 10^{-5} \text{g. Fe}$. Jacobs obtained a value of $1 \times 10^{-6} \text{g. Fe}$ as the tolerance limit per phosphor, using phosphors of about half the weight used here.

Another element later used as a carrier for uranium was aluminium. Its quenching effect had therefore to be examined and results will be quoted here. Jacobs had observed that aluminium present in a phosphor to the extent of several micrograms produced an increase in the uranium fluorescence intensity. Then, as the amount of aluminium was increased, normal quenching occurred. This phenomenon of anomalous fluorescence he attributed to the shortening of the wave-length of the fluorescent light because of the presence of aluminium.

This shorter wave-length light was transmitted by the filters, and the photocell, having a greater response at the new wave-length, produced a stronger signal. This phenomenon was not observed by the author as can be seen from the following table of results.

Wt. of Al/phosphor in 10^{-6} g.	0	1	2	5	10	20	50	100	200	500
Scale Reading(v)	1200	1200	1210	1200	1180	1170	1210	1190	1160	1120

Fairly large quantities of Al could therefore be tolerated without any apparent effect on the fluorescence (e.g. 2 mg. Al divided among ten phosphors would produce only 5% quenching). The only fundamental difference between the conditions employed by Jacobs and those used here, was that the flux in the latter case was pure NaF, while in the former it was 5% NaF and 95% Na KCO₃. This fact may account for the difference in results.

Other Interference.

Appreciable quantities of any acid radicals or acidic oxides which are capable of reacting with the molten fluoride, have an adverse effect upon the accuracy and reproducibility of the method, and have to be avoided. Their presence results in either the complexing of part of the NaF (e.g. SiO₂, TiO₂, Nb₂O₅, V₂O₅ and Ta₂O₅) or else its displacement and loss as HF (caused by SO₄). Both these effects result in a change in the apparent uranium concentration in the phosphor if the amount of

NaF lost or complexed is an appreciable fraction of that undergoing fusion. Only SiO_2 and SO_4 were likely to be present in sufficient quantity to cause interference in meteorite analyses and care was always taken to exclude them from the sample to be incorporated in the phosphor.

Bearing in mind all the possible sources of error, and taking due care to avoid them, the method was now ready for use in meteorite analyses. The next chapter will be devoted to a review of possible methods of separation of uranium and thorium from the starting material, prior to fluorimetry.

Chapter IV

REVIEW OF SUITABLE METHODS FOR THE SEPARATION OF
URANIUM AND THORIUM FROM METEORITES.

Introduction.

The quantitative separation from meteorites of sub-microgram quantities of uranium and thorium demanded careful assessment of the available methods which might be suitable for combination and development for the analysis.

Potentially suitable methods will be discussed in the following order:- solvent extraction, co-precipitation, chromatography and electro-deposition.

A detailed review of methods for the isolation of uranium can be found in "Analytical Chemistry of the Manhattan Project" (Edited by C.J. Rodden) pp.14-44. Similar data for thorium can be found in the same book pp.164-182.

(a) Solvent Extraction Methods.

Extraction procedures in general give particularly "clean-cut" separations, and, when dealing with micro-quantities, they can usually effect a more quantitative removal, (by repetition, if necessary), than can precipitations. The method of extracting uranyl nitrate with di-ethyl ether, first used by Peligot⁽⁴⁰⁾ in 1842, proved to be of great value in this work. Uranyl nitrate in micro-quantities may also be extracted with certain other organic solvents, one of the most efficient being

tetrahydroxyivan⁽⁴¹⁾. The chloroform or ether extraction of uranium (IV) cupferrate⁽⁴²⁾ and the aniline extraction of uranyl tannate have both been reported. They both appear to be quantitative when used with milligram or gram quantities of uranium, but do not appear to have been used with sub-microgram quantities and were not investigated by the author.

Solvent extractions of thorium compounds are not widely used because they are not particularly specific (e.g. thorium nitrate may be extracted into ether from nitric acid, using zinc nitrate as a salting-out agent, but if rare earths are present, several of them are removed with it).

The removal of all the meteoritic iron by solvent extraction, without loss of any uranium or thorium, was a valuable technique for use in the present problem. It was achieved by the ether extraction of ferric chloride from aqueous hydro-chloric acid solutions.

A method was developed for the separation of meteoritic uranium in a sufficiently pure state for fluorimetric determination, using solely the effect^{of} the partition of uranyl nitrate between ether and aqueous nitric acid. Such a method for thorium was not possible, and separations were achieved by co-precipitation methods. The ether/nitric acid extraction of uranium suffered from the disadvantage that sometimes dangerous quantities of ether saturated with nitric acid had to be evaporated.

A review on solvent extraction and its applications to inorganic analysis has recently been published by Irving⁽⁴³⁾.

(b) Co-precipitation Methods.

Methods of isolation of uranium by precipitation are very numerous:- e.g. as peroxide with HgO_2 , as sulphide in alkaline solution, as UF_4 , as oxalate and also with organic reagents (cupferron hydroxyquinoline). Thorium can also be isolated by precipitation as peroxide, oxalate, iodate, fluoride etc. and as several organic complexes (e.g. with sebacic acid or m-nitrobenzoic acid). However, by far the most useful co-precipitation in this work was the carrying down of uranium (as ammonium diuranate) and thorium (as hydroxide) together, on either ferric or aluminium hydroxides, using carbonate-free ammonia as the precipitating agent. By this method sub-microgram quantities of the two elements in the determinations could be removed from a large volume of solution, on a relatively small quantity of carrier precipitate. The method had the added advantage that any radium isotopes present remained in solution, (the method of thorium determination demanded the absence of radium).

Separation of uranium and thorium prior to their individual determination was achieved by either of two co-precipitation methods. The first involved the classical sodium hydroxide-hydrogen peroxide treatment in which the uranium remained in

solution as sodium peroxyuranate (with aluminate "hold-back" carrier) while the thorium co-precipitated as peroxide on ferric hydroxide. This method required the use of very large volumes of ether for the subsequent recovery of the uranium from the mother liquor and it was later discarded in favour of the second separation method developed in this laboratory. This involved the co-precipitation of thorium on zirconium carrier by means of an organic reagent which appeared to be specific for these two elements.

A separation of uranium from chromium was required for chromatographic purposes, and this was achieved using ferric ferrocyanide as a carrier for the uranium.

(c) Electro-chromatographic and Chromatographic Methods.

Attempts were made to find a method of separating the meteoritic uranium in a suitably pure state for fluorimetric analysis without employing the method of ether extraction of uranyl nitrate. The possibility of employing the comparatively recent technique of ionography was investigated. The method was potentially useful because a final separation might be achieved without use of reagents and with great simplicity of operation. Preliminary tests showed great promise, but later it became evident that rigorous standardisation of humidity and temperature conditions were required, in order to ensure the success of each separation. When further separations were attempted using a technique by which the humidity and

temperature could be fixed, it was found that the relative rates of migration of the uranium and its iron carrier were such that satisfactory separations could not be obtained.

A new chromatographic technique was then developed. This involved the separation of the uranium from the meteorite on a very small amount of iron hydroxide carrier, following a co-precipitation procedure and the removal of iron by ether extraction. The iron and uranium as chlorides in solution were placed on a filter paper strip, down which flowed ether, saturated with hydrochloric acid. The iron was so efficiently removed by this procedure, that the uranium which remained was in a suitable condition for fluorimetry.

(d) Electro-deposition.

The possibility of removal from solution of the bulk of the metals present in iron meteorites by electro-deposition, promised the separation of the meteoritic uranium without the use of reagents, once the sample had been dissolved. Many metals can be removed almost quantitatively from acid solution using a mercury cathode electrolysis cell. Uranium on the other hand, remains completely in solution. Unfortunately it was found that the removal of the metals was not sufficiently complete to enable the fluorimetric determination of the uranium to be carried out without "quenching" occurring. An ether extraction of the uranium in the final solution was necessary in order to obtain it in a sufficiently pure state for this method of determination.

Chapter V.

THE ETHER/NITRIC ACID RETROGRADE EXTRACTION
METHOD FOR URANIUM DETERMINATION.

Introduction.

It was proposed to develop a method by which uranium could be quantitatively separated from meteorites in a sufficiently pure state for fluorimetric determination, using solely the effect of the partition of uranyl nitrate between di-ethyl ether and aqueous nitric acid.

Discussion.

The specificity of ether/HNO₃ extractions with respect to uranium was evident from the data published by Irving⁽⁴³⁾. He records that when solutions of metal nitrates in 3N HNO₃ are extracted with an equal volume of ether, 65% of the uranium passes into the aqueous phase. The only other metals which should be appreciably extracted are Au^(III) 97%, Co^(IV) 96.8% Th 54.6%, Zr 8% and Cr 15%^(VI). The first four elements named are present only in trace quantities in meteorites and such quantities should not cause interference by quenching in fluorimetric determinations. Chromium, however, is one of the minor constituents of iron meteorites and the amounts extracted by ether would obviously be greater than the fluorimetric tolerance limit. However, since its partition coefficient was about 6 to 1 in favour of the aqueous phase, a retrograde extraction method should effectively reduce the

amount present in the organic phase. This treatment would result in the loss of some uranium from the ether, but re-extraction of this aqueous extract should recover this.

The main constituents of meteorites were reported to be extracted only to a slight extent:- Fe 0.1%, Ni 0.1%, Cu 0.5% and Co 0.2%. It was therefore considered by the author that traces of these substances passing into the ether should be easily removable by retrograde extraction.

According to Bock and Bock⁽⁴⁴⁾ the percentage of uranium extracted by ether increases with increase in HNO₃ concentration in the aqueous phase, to the maximum of 65% at 8N HNO₃. Irving records that the efficiency of the extraction of uranium can be increased by the use of salting-out agents, such as one of the nitrates of ammonium, lithium, sodium, magnesium, calcium etc. Several of these substances are also reported to improve the specificity of the process by retaining in the aqueous phase some elements which are normally partially extracted into the ether. The most efficient salting-out agents are reported to be LiNO₃ and MgNO₃⁽⁴⁴⁾, which produce almost quantitative removal of uranium, even in low HNO₃ concentration. However, since NH₄NO₃ was readily available, containing no noticeable contribution of uranium to the reagent blank, the author decided that this would therefore be the best material for use in micro-analytical work. It should also have the added advantage that the quantities of chromium⁽⁴⁵⁾,

iron and thorium⁽⁴⁴⁾ passing into the ether should be reduced by the NH_4NO_3 . The first two metals must be absent from the final uranium extract because of their quenching effect on the phosphors, while the quantitative retention of thorium in the aqueous phase would be of use if an assay of the total radioactivity in the sample was required.

Using HNO_3 saturated with NH_4NO_3 an extraction efficiency for uranium of 80% has been reported⁽⁴⁶⁾. Three successive extractions should remove over 99% of the uranium.

A publication by the Department of Scientific and Industrial Research⁽⁴⁷⁾ points out that when performing several successive ether extractions of uranium, it is advisable to maintain the high concentration of HNO_3 in the aqueous layer, by adding some conc. HNO_3 between extractions. (Irving records that 42% of the HNO_3 passes into the organic phase on equilibrating 8N HNO_3 with an equal volume of ether).

Other publications relating to the ether extraction of uranyl nitrate are listed under reference 48.

Experimental.

During the time in which the fluorimeter was being built, preliminary tests were carried out to determine the efficiency of ether extraction of uranium when working with 10^{-8} g. quantities of U. U^{233} (α -active, $t_{1/2} = 1.62 \times 10^5$ years), obtained from A.E.R.E., Harwell, was used as a tracer. The U^{233} was later shown to be isotopically pure, by means of the

fluorimeter, and the amounts used in the tests was $\sim 10^{-8}$ g.U. The activity of a standard volume of the U^{235} solution (in HNO_3) was determined, similar volumes were then subjected to ether extraction, and the efficiency of this was found by measurement of the activity recovered.

The counting system used consisted of an ionisation chamber of the parallel-plate type, a head-amplifier, an amplifier, a discriminator, and a scaler. A potential of 1400v. was applied to the chamber. The background count of the system was 1.8 counts per minute and activities of about 100 cts./min. gave ample statistical accuracy when counted for about one hour.

The earliest tests were designed to compare the extraction efficiency with and without high nitrate ion concentration in the aqueous phase. Using dilute HNO_3 with only a little NH_4NO_3 added (i.e. ca 10% w/v), three consecutive ether extractions recovered a total of 40-50% of the total U.

The nitrate ion concentration was then increased by using conc. HNO_3 saturated with NH_4NO_3 . The number of ether extractions was increased to four, to allow for any decrease in efficiency below the optimum reported⁽⁴⁶⁾. Additions of a few mls. of conc. HNO_3 were made between extractions, and the solutions were then boiled before re-extraction to ensure that the uranium was maintained in the hexa-valent state.

After the four extractions had been carried out, the combined ether layers were evaporated in the presence of water,

on a water-bath, until only the aqueous layer remained. This liquid contained a large quantity of HNO_3 , and since traces of ether were still present, great care had to be exercised during the final stages of evaporation, because these two substances tend to react together violently. Oxides of nitrogen are evolved rapidly during this reaction and the resultant frothing could lead to considerable loss of liquid from the vessel. Evaporation was continued by cautiously heating with a burner. Warning that the reaction between ether and HNO_3 was commencing was given when the solution began to turn yellow. If the burner was removed at this point and the solution was stirred vigorously, the reaction could usually be kept under control. If the rate of the reaction did tend to become too great, the addition of cold distilled water reduced the rate of evolution of gases and enabled the evaporation to be continued when the reaction was complete.

The possibility of vacuum desiccation was not investigated, because when one HNO_3 extract from which the ether had been boiled off was left overnight at room temperature it was found to have undergone a violent reaction.

The evaporation was continued almost to dryness and the last few drops were transferred to a platinum source-disc using a glass-dropper; the drops were evaporated to dryness by radiant heat. Any solid NH_4NO_3 present could be volatilised gently with a micro-burner. The Pt disc was then placed in

the ionisation chamber, and the source activity was determined.

The procedure was carried out in triplicate, and the results varied between 95% and 103% extraction efficiency.

After completion of the assembly of the fluorimeter, this procedure was repeated using standard amounts of uranium, at about microgram level, and the extraction efficiency was determined fluorimetrically. Results for several determinations varied from 97% to 102%.

(Note. The apparent efficiencies of extraction of over 100% are due to statistical fluctuations in the measuring techniques).

The Solvent Extraction of Uranium from Meteorites and Steel.

Since meteorites are scarce, and valuable, mild steel was usually used to represent meteorites in the preliminary investigation work, as its composition is similar to that of meteorites.

10g. of steel were dissolved in dil. HNO_3 , and the volume of the solution was reduced by boiling. Conc. HNO_3 and NH_4NO_3 were added and the solution (50ml.) was extracted four times with an equal volume of ether in the manner described. The combined ether extracts were pale yellow in colour and obviously contained appreciable quantities of iron. This ether was shaken with 10 ml. conc. HNO_3 saturated with NH_4NO_3 and most of the coloration passed into the aqueous layer. After three extractions with the $\text{HNO}_3/\text{NH}_4\text{NO}_3$ mixture, the

organic layer was colourless and was evaporated with water. 1.247×10^{-5} g. uranium in solution was then added to the extract (sufficient to "swamp" any natural uranium present). The solution was evaporated to a small volume and diluted to 10 ml. 1 ml. portions were evaporated in the fluorimeter trays and NaF phosphors were prepared. The phosphors were discoloured (yellow) and on examination in the instrument, the readings were lower than those to be expected, showing that quenching had occurred. This was presumably due to the presence of minute droplets of the aqueous phase containing iron, which had been retained in the organic layer. A further refinement of the method was therefore necessary.

20g. of the steel were dissolved in HNO_3 which was then saturated with NH_4NO_3 . The mixture was extracted four times with ether to remove any natural uranium. The metal nitrates present would also assist the salting out of uranium in all of these extractions. The resultant aqueous layer was divided into two equal volumes (60 ml.). To one was added 1.247×10^{-5} g. uranium while the other was used as a reagent blank control. The first solution was extracted four times with 60 ml. volumes of ether in the usual manner. The combined ether layers were extracted three times with 10 ml. portions of conc. HNO_3 saturated with NH_4NO_3 . This removed practically all the iron and presumably a little of the uranium. In order to recover the latter, the resultant 30 ml. of $\text{HNO}_3/\text{NH}_4\text{NO}_3$ solution was

extracted twice with 30 ml. ether. The solution was boiled with addition of conc. HNO_3 before each extraction. This ether was then placed in a 1 l. beaker along with the main ether extract. 200 ml. of distilled water were added, followed cautiously by 25 ml. of .880 NH_4OH solution. It was calculated that this volume of ammonia would form sufficient NH_4NO_3 in situ to saturate the aqueous layer when it was evaporated to 60 ml. The NH_4OH also served to neutralise much of the HNO_3 in the ether and so reduce the risk of any reaction. The mixture was warmed on a water-bath and when no ether remained, the solution was evaporated to 60 ml. The solution, still strongly acid, was extracted four times with ether, as described. The ether was evaporated with water and the aqueous solution was made up to 10 ml. 1 ml. portions were taken for the preparation of NaF phosphors. The whole extraction process was repeated with the "uranium-free" control solution to make allowance for the contribution of any of the reagents used. The difference in the results from the two determinations was due to the added uranium. The apparent extraction efficiency found was $100.0 \pm 2.0\%$. The standard error was obtained from the results of the individual phosphors (see p. 143). Two repeats of the procedure gave the results:- (a) $97.2 \pm 2.0\%$ and (b) $98.4 \pm 2.5\%$.

These figures proved that the uranium had been quantitatively recovered in a sufficiently pure state for

direct fluorimetric determination.

The difference between the results from the blank control extraction and those from pure NaF blank phosphors was due to the uranium present in the reagents. This proved to be sufficiently low to permit micro-analysis by this method. The total uranium content of all the reagents used in an average meteorite extraction was shown to be 1.3×10^{-8} g. U (i.e. when divided into 10 phosphors, the fluorescence increase of each would be less than half of the NaF background fluorescence).

U^{233} Tracer Work.

Although the extraction method was suitable at the 10^{-6} gU level, this did not establish its applicability to solutions containing a total of 3×10^{-8} - 1×10^{-7} g. U. (to be expected in meteorite analyses). In order to do this U^{233} (ca. 1×10^{-8} g) was used as a tracer and this was added to steel purified from its natural uranium content.

The results obtained using the counting equipment previously described, pointed to quantitative extraction, but difficulty was encountered in preparing a thin source on the small Pt. counting disc. (diam. 1 cm.). such that the α - particles did not suffer self-absorption by the source. Attempts to obtain this "weightless" source often led to mechanical loss from the disc and inconsistent results were obtained (85% - 105% recovery). However, when the

scintillation counter later became available, the procedure was repeated and no difficulty was encountered since the source disc was much larger in area (3 cm. diam.) than had been the previous one. The lower background of this counter also led to more accurate results. The extraction efficiencies were (a) $98.5 \pm 1.2\%$, (b) $100.8 \pm 0.7\%$ and (c) $99.6 \pm 0.5\%$.

Later, one slight alteration was made to this procedure. To ensure the absence of any small aqueous droplets, containing quenching ions, from the final ether extract, this ether was extracted three times with 10 ml. portions of conc. HNO_3 saturated with NH_4NO_3 . Any uranium removed from the ether by this process was recovered by two further ether extractions of the 30 ml. conc. HNO_3 .

In every determination, the final uranium solution was checked to ensure that no quenching was occurring. To several of the phosphors a known amount of uranium (ca. 10^{-6}g.) was added. The phosphors were re-fused and examined in the fluorimeter to check that they produced the full expected increase in fluorescence reading.

During meteorite analyses careful note of the exact amounts of reagents used was always made, and these quantities were reproduced for the reagent blanks.

No purification was required for the reagents used in this method. Their uranium content was so low that the method proved highly successful, especially when only a small quantity

of the sample was available (5 -10g.) Using a 10g. sample it was possible to determine uranium contents with an accuracy of 2 to 5 x 10⁻¹⁰g./g. meteorite.

Using this method it was difficult to handle more than 20g. starting material, because of the volumes of ether involved, and when greater amounts than this were available, it was usual to determine both the uranium and the thorium by the combined method.

This combined method (to be described later) enabled determinations to be carried out on 20 - 150g. starting material and both the uranium and thorium in the same sample were determined. This method decreased the chance of any errors in the sampling.

Results obtained by the retrograde extraction method are included in the table of results on p. 121.

Chapter VI

THE SEPARATION OF URANIUM BY MERCURY-
CATHODE ELECTROLYSIS.

Introduction.

It was hoped that it might prove possible to separate the meteoritic uranium in a sufficiently pure state for direct fluorimetric determination by removing the major constituents of the meteorites (i.e. Fe, Ni, Cr, Cu, Co) from sulphuric acid solution by use of a mercury-cathode electrolysis cell. It was discovered, however, that although the uranium did remain quantitatively in the sulphuric acid, the amount of "quencher" ions remaining with it was slightly greater than the tolerance limit for direct fluorimetric analysis. A further purification, in the form of an ether/nitric acid extraction of the uranium, was necessary before the method could be applied to meteorite determinations.

Discussion.

The method of separating certain metals in the form of amalgams was first described in 1880 by Gibbs⁽⁴⁹⁾. However, it is only during the last 10 or 15 years that the method has been applied to any great extent in the field of analytical chemistry. In general, metals below manganese in the electro-motive series can be made to deposit quantitatively in a mercury cathode. Unless extremely high currents are used (6 amps./cm² cathode), uranium remains quantitatively in the

electrolyte⁽⁵⁰⁾. Bennett⁽⁵¹⁾ and Melaven⁽⁵²⁾ employed the method for the separation of uranium and iron, and other examples of the use of the method in this field are listed under reference 53.

A discussion of the various factors controlling the rates of deposition of several elements will be found in "Analytical Chemistry of the Manhattan Project" (pp.511-522), along with a list of the optimum conditions for removal of iron and chromium from uranium. A review of the applications of the mercury cathode has recently been published by Maxwell and Graham⁽⁵⁴⁾.

Experimental.

In preliminary tests a tall 150 ml. beaker was used as the cell. About 20 ml. of mercury were placed in it and a tungsten wire in the side of the beaker acted as the cathode lead; the anode consisted of a platinum foil.

Sulphuric acid is normally used as the electrolyte for mercury-cathode cells. An "artificial" meteorite solution" was prepared by dissolving some ferrous sulphate, and smaller quantities of nickel, chromium, copper and cobalt sulphates in dilute H_2SO_4 . This mixture was then electrolysed in the cell. The electricity supply was drawn either from several accumulators, or alternatively, from a 24v. rectifier. The current and voltage across the cell were controlled by means of a rheostat.

Solid amalgam, which soon began to form on the surface of the mercury, was periodically removed, and fresh mercury was added. A current of 5 amps. was used at a potential of 10-12v. The solution began to decolorise as the metals were removed, and eventually a colourless solution was obtained. A test with NH_4CNS , after addition of H_2O_2 to the electrolyte to oxidise any Fe^{2+} to Fe^{3+} , gave a pink coloration, showing that a small amount of iron had remained in solution.

A sample of steel, representing a meteorite, was then dissolved in dilute H_2SO_4 , the carbon formed being filtered out through glasswool. On electrolysis the amalgam again separated and was removed, but as the separation neared completion, a dark brown deposit began to form on the anode and small scales of it fell off into the solution. Around the anode the solution turned pink, but it decolorised rapidly when the current was switched off. It had been reported⁽⁵⁴⁾ that manganese tended to be deposited incompletely on the anode, and qualitative tests showed that the deposit was manganese. The pink coloration was due to anodic oxidation to permanganate. The formation of this deposit was undesirable, because it was probably manganese dioxide, which has been shown to be an excellent "scavenger" for trace quantities of many elements and it could possibly cause the removal of uranium from the solution.

It was observed that the deposit occurred only when the

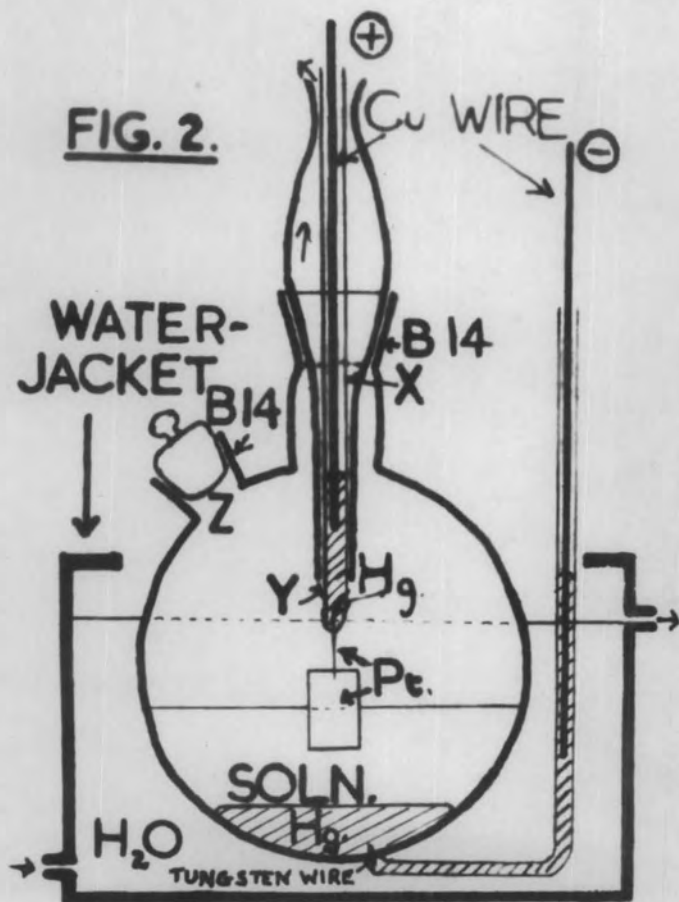

MERCURY-CATHODE
ELECTROLYSIS CELL.

solution became warm, and that when the cell was cooled in a water-jacket, no deposit was formed. Losses by spray were appreciable and so a new cell was designed, in which all the gases were "scrubbed" before escaping (see Fig.2).

Electrolytic gases escaped up through the narrow gap in the "air-leak" (Y), and a "trap" of condensed liquid soon formed at X. All the gases had to pass through this trap and the spray was retained. Amalgam could be removed through the ground joint Z. No anodic deposit formed when the cell was operated in the water-jacket.

Testing the Behaviour of Uranium during Electrolysis.

Microgram quantities of uranium were electrolysed in the cell and fluorimetric analysis showed that the uranium had remained quantitatively in solution. Similar proof was obtained using U^{235} added to solutions of steel.

So far the results had appeared very promising, and it now remained to discover if the "quenching" ions could be removed to below the fluorimetric tolerance limit.

To about 5g. of steel dissolved in dil. H_2SO_4 was added 1.247×10^{-5} g. uranium. The solution was electrolysed for 6 hours, but at the end of this time a trace of iron was still present in the aqueous solution (shown by H_2O_2/NH_4CNS test). Electrolysis was therefore continued overnight.

No trace of iron was found on repeating the test after overnight electrolysis. The solution was evaporated to 10 ml,

and 1 ml. portions were used in the preparation of fluorimeter phosphors (all the H_2SO_4 being driven off before addition of NaF). The phosphors were coloured blue and showed obvious signs of quenching when subsequently "spiked" with known quantities of uranium. However, from the original phosphor readings, and the amount of quenching shown to have occurred, it appeared that the uranium was still present quantitatively.

The colour of the phosphors suggested that the quenching was probably due to manganese not removed by the electrolysis. (Jacobs⁽³⁴⁾ records that 10^{-6} g. Mn/phosphor is sufficient to cause 5% quenching).

Separation of Uranium from Manganese.

The method of precipitating uranium quantitatively on $Al(OH)_3$ from HCl or HNO_3 solutions using carbonate-free ammonia gas had already been used in connection with work described in the following chapter, and since Mn would remain in solution during this precipitation a successful separation of the interfering element was probable.

After overnight electrolysis 10 mg. of Al were added to the final solution and after precipitation as $Al(OH)_3$, it was dissolved in 10 ml. HNO_3 . 0.2 ml portions of this solution were measured fluorimetrically. If none of the uranium had been lost, each phosphor should have contained 2.5×10^{-7} g. U and also 0.2 mg. Al (enough to cause only 5% quenching). However, the results showed that only 15 - 20% of the uranium was present.

The only change in the conditions from those previously used in the successful co-precipitations was the presence of H_2SO_4 instead of HCl or HNO_3 . A check was therefore made on the efficiency of the extraction of U by $Al(OH)_3$ from H_2SO_4 medium. 10 ml. conc. H_2SO_4 were diluted to 100 ml. with H_2O and 1.247×10^{-5} g. U and 10 mg. Al were added. The carbonate-free NH_3 precipitation was carried out and again only 15% of the total uranium was recovered on the precipitate. The readiness of the uranyl ion to form complexes with certain acid radicals, including the sulphate radical, is well known⁽⁵⁵⁾ (the presence of small quantities of SO_4 inhibit the extraction of $UO_2(NO_3)_2$ by ether). It was therefore probable that the same effect was preventing the co-precipitation.

It was therefore necessary to carry out the precipitation in the absence of SO_4 ion. 1.247×10^{-5} g. U in dil. H_2SO_4 was evaporated to dryness in a Pt basin under a radiant heater. The basin was leached several times with HNO_3 to which was then added 10 mg. Al. On precipitating the $Al(OH)_3$ and measuring the amount of uranium carried in the usual way, quantitative recovery was obtained.

The complete procedure, including electrolysis, was then carried through, and when 0.2 ml. portions of the final solution were used to form the phosphors, extraction efficiencies for uranium in three runs were:- $101 \pm 2\%$, $95.5 \pm 2\%$ and $99 \pm 2\%$.

However, if 1/10th of the total uranium extract solution was used in the preparation of each phosphor (as would be the case in a meteorite determination), it was found that quenching occurred to a small extent (10-20%). It was inferred that about 9.1 mg. Fe must have remained in solution (not detected by NH_4CNS when diluted in ca. 100 ml.). If divided among 50 phosphors, this amount of iron would have no effect, but it would cause appreciable quenching if divided among 10 (see p. 26)

It was not possible to electrolyse more than 10g. starting material in the cell, and it could not therefore be expected that measurable increases in fluorescence over the "blank" fluorescence of NaF, would be obtained if the solution was divided into 50 aliquots. However, with starting material of uranium content about 10^{-7} g./g. this method of separation would prove quite satisfactory.

For meteorite analysis a further refinement could have been introduced by extracting the final nitric acid solution with ether. The H_2SO_4 had again to be removed by evaporation followed by the ammonia precipitation of $\text{Al}(\text{OH})_3$, for it was shown that the presence of 1 ml. conc. H_2SO_4 in 60 ml. conc. HNO_3 reduced the efficiency of four consecutive ether extractions from 100% to 10%. Ether extractions of the nitric acid solution following mercury-cathode electrolysis, resulted in quantitative recovery of the uranium in a quencher-free state.

However, the uranium content of the H_2SO_4 was two or three

times greater than that of the reagents used in the ether/ HNO_3 retrograde extraction method, and since the applicability of the later method was not limited by the quantity of starting material it was decided to retain the solvent extraction procedure for meteorite analyses.

For analysis of materials of higher uranium content (10^{-7} - 10^{-5} g./g.), the electrolysis method would be the most satisfactory, since sufficient uranium would be present to divide the electrolysed solution into a large enough number of aliquots to ensure the preparation of quencher-free phosphors. In addition, the higher uranium content of the sulphuric acid would not be such a disadvantage when larger quantities of that element were being determined. The actual chemical working up involved in the electrolytic procedure is much simpler than that in the extraction method.

No meteorites were analysed by this method.

Chapter VII

DEVELOPMENT OF THE COMBINED URANIUM/THORIUM METHOD.

Introduction.

To avoid errors in the determination of "ages", due to variations in helium, uranium and thorium contents at different points in the meteorites, the ideal situation would be one in which these elements were determined in one and the same sample. This was not possible, since the quantities of meteorite which could be used in the helium apparatus were much smaller than those required for uranium and thorium determinations. The best alternative was to reduce the sample to small fragments with a milling machine, mix the sample, and take sufficient for the helium determination, the rest being used for a combined uranium and thorium determination.

The scintillation counter, for thorium determinations was at the time being operated by Mr. J. Golden⁽⁵⁶⁾, and all the development work described in this chapter was done in collaboration with him.

The purpose of the method was to isolate these two elements separately from the whole meteorite sample in a sufficiently pure state for their own methods of determination.

Discussion.

The Method for the Determination of Thorium.

The procedure for the determination of the thorium present,

following its separation will first be discussed:-

The two main factors to be borne in mind before attempting to develop a separation procedure were, firstly, that the amount of thorium required to obtain measurable activity was at least 5×10^{-7} g., and secondly, that the source to be examined should be such that the minimum of self-absorption of the α - particles should occur. These facts meant that the amount of starting material would be greater than 20 g., and that the thorium activity would have to be concentrated on to a small precipitate, of the order of about 2 mg. The task of concentrating this activity directly on to so small a precipitate from a large volume of solution seemed virtually impossible, so an intermediate concentration of the relevant nuclides from the whole sample to the 100 mg. scale was visualised.

THE THORIUM DISINTEGRATION SERIES.

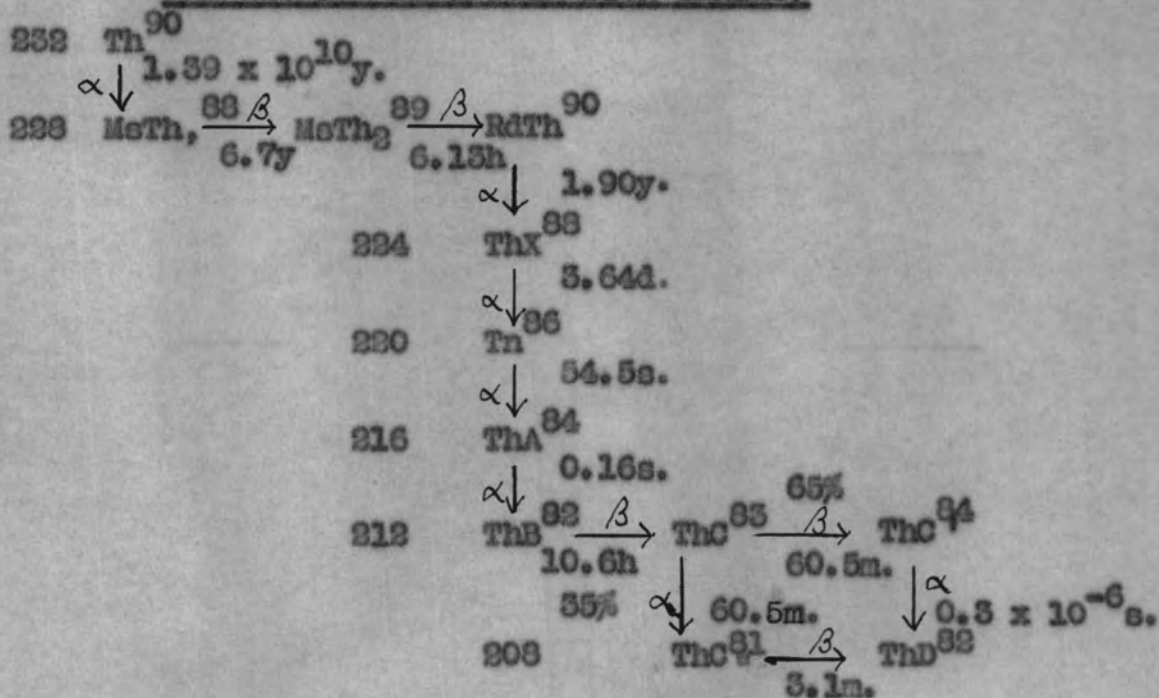

In order to avoid contamination of the counter phosphor by thoron, it was preferable that some member of the series below this element should be used as the source. The α -active Th C member appeared to be most suitable.

If the thorium could be quantitatively extracted from the meteorite by methods of precipitation, etc., the radiothorium (Th^{230}) would naturally accompany it, and on storing the solution for about 1 month the Th X ($t_{1/2} = 3.64$ days) would grow to equilibrium together with the rest of the series:- thoron to Th C. Precipitation of lead as PbS_2 through such a solution should extract the Th B (Pb^{212}) ($t_{1/2} = 10.6$ hr) along with the Th C (Bi^{212}) ($t_{1/2} = 60.5$ min.). This α -active Th C could be measured in the scintillation counter and it would be maintained in equilibrium with its parent Th B and so have an effective half-life of 10.6 hr.

This method would have one extremely valuable feature i.e. the possibility of regeneration of the Th C. The Th X (Ra^{226}) parent could be maintained in solution with a little Ba Cl₂ as hold-back carrier, and after a further 3 days the Th B and Th C would once more have grown to equilibrium and these nuclides could then be redetermined. It would be essential in this process to have the complete absence of the equivalent member of the uranium series, i.e. Ra^{226} , from the solution, otherwise the active deposit members of its series would be precipitated along with the Pb, and interfere with the thorium determination.

Thus any method used for separation of thorium must ensure the complete removal of all radium isotopes. The Th X would then grow, while the radium parent present, ionium (Th^{230}), would regenerate radium with a half-period of growth of 1590 years, and would not interfere.

Investigation of Carriers for Th B.

Preliminary tests with lead iodide showed that a 2 mg. precipitate of lead as PbI_2 could easily be separated and formed into a suitable α - source, but the efficiency of Th B extraction, using excess iodide ion was only 70%; presumably the solubility of PbI_2 (40 mg./100 ml. at 0°C) was too great. PbS is much less soluble (8.6×10^{-5} g./100 ml. at 18°C) but it can give rise to colloidal precipitates which are difficult to separate.

Development by Tracer Techniques.

To test the efficiency of the PbS extraction of Th B the scintillation counter could not be used because the higher activities required for good statistical accuracies would involve the risk of contamination of the counter. The radiation of Th C was therefore used. Tubes containing a solution of radiothorium were placed in a wire frame close to a Geiger counter, so that an appreciable fraction of the γ -rays passed through it. Four tubes, each containing 1 ml. of the $2d$ Th solution, gave the following counts:-

(i) 782 ± 12 c.p.m. (ii) 776 ± 4 c.p.m. (iii) 774 ± 12 c.p.m.
(iv) 770 ± 12 c.p.m. Mean 776 ± 10 c.p.m.

This counting technique was therefore reproducible.

Interference by Other Members of the Thorium Series.

1 ml. of this solution with 2 mg. Pb as acetate, and 1 mg. Ba Cl₂ as hold-back carrier for Th X, were mixed in 0.2 N HCl. H₂S gas was bubbled through the solution, and the precipitate was centrifuged and washed, after which it was dissolved in a little HNO₃ and placed in a counting tube. The test, in duplicate gave the following results:-

(a) 724 ± 12 (b) 738 ± 12 . Mean 731 ± 12 (i.e. $95\% \pm 2\%$).

The initial half-life of these extracts was approximately 11 hr. showing that the Ba Cl₂ had retained the Th X in solution, otherwise the Th C would have decayed with the half-life of Th X rather than that of Th B. However, the decay curves showed that the PbS had carried down Rd Th (and therefore Th²³² itself, if it had been present), since the activity began to increase due to the growth of Th X and the active deposit members of the series including Th C, from the Rd Th.

1 ml. portions of Rd Th solution were similarly extracted with the addition of a little zirconium as hold-back carrier for Rd.Th. The decay curves showed that the Rd Th and Th X were being held up in solution. There was no initial growth period in the counting, proving that the Th C (Bi) had been co-precipitated with the Th B on the PbS.

Conditions for the Precipitation of Thorium B.

Repeats of the above procedure gave extraction efficiencies of $93 \pm 1\%$ and $92 \pm 1\%$ but the free acid

concentration had not been accurately controlled, except to ensure that it was between 0.2 N and 0.4 N HCl.

With precisely 0.35 N HCl quantitative extractions were achieved, but it was thought necessary to investigate the relationship of acid concentration to efficiency of extraction at this point. Using HCl concentration of 0.05 N or less the PbS was precipitated in a form which could not be readily centrifuged. At 0.8 N HCl no Pb was precipitated by H₂S. It was shown that in order to obtain quantitative precipitation of the Th B on the PbS, the acid concentration had to be carefully controlled at 0.3 N.

A series of six consecutive PbS precipitations were carried out on the same thorium solution. Although the Th B was not allowed to grow to equilibrium before precipitation in the case of the first four extractions, these precipitations would still cause their due share of interference, if any, on later extractions. The Th B was allowed to grow to equilibrium before the fifth and sixth precipitations, which were then counted, giving the following results:-

5th Extraction (a) 98 ± 1% (b) 99 ± 1%.

6th Extraction (a) 99 ± 1% (b) 101 ± 1.5%.

It was concluded that no precautions were necessary to prevent the escape of thoron from the open test tubes, as it was found that the Th B was always regenerated to the equilibrium amount.

Since the effective half-life of the precipitate was short, it would be necessary when working with low-activity material from meteorites to standardise the counting time carefully, in order to get comparable results. A suitable technique was to allow 45 min. from the time of precipitation for the preparation of the α - source, before commencing counting, which was then carried on for 16 hours. Counting for periods longer than 16 hrs. is of little value, since by that time over 60% of the activity has decayed. Using this standard technique, the number of counts registered in the 16 hrs. after subtraction of the instrument background for this period, is a measure of the amount of thorium present in the original solution.

The theoretical count to be expected from any α - active member of the thorium series in equilibrium with 10^{-6} g. Th is 15α 's/hr. The geometrical efficiency of the scintillation counter measured with a standard uranium source was 35% and hence the best practical count obtainable from the thorium series would be 5.25α 's/hr./ 10^{-6} g. Th. Calibrations with a source of 9.5450×10^{-6} g. Th. resulted in a mean count of $3.1 \pm 0.13 \alpha$'s/hr./ 10^{-6} g. Th for the 16 hr. calibration; on correction for decay, since precipitation, this yielded the result $5.2 \pm 0.2 \alpha$'s/hr./ 10^{-6} g. Th. The efficiency of the Th B - C source was therefore as high as could be expected.

Separation of Uranium and Thorium from the Starting Material.

The original methods considered which were later

drastically modified, for separating the thorium from the meteorite free from uranium and radium were the following:-

From the acid solution of the meteorite, (in which the iron was to be complexed by means of salicylate ion), 100 mg. of cerium hydroxide would be precipitated, carrying down the thorium (free from interfering Ra), and leaving the salicylate complexed uranium in solution. Tests showed that only 4% of the Ra was carried down and re-dissolving the precipitate followed by its reprecipitation would reduce the carried radium to a negligible quantity. However, the behaviour of the uranium during this procedure was liable to cause some difficulty. If precipitated on the $Ce(OH)_4$ a further separation would have to be carried out, and if it remained complexed in solution its recovery would probably prove difficult. This method was therefore discarded while a procedure for the precipitation of Th in acid solution (without use of complexing agents) was tested:-

Thorium should be precipitated from a 2 N HNO_3 meteorite solution on a carrier of zirconium or cerium iodate, leaving the uranium, radium and major constituents of meteorites in solution. A $Zr(IO_3)_4$ precipitate could be dissolved easily in HCl and could be adjusted to 0.2 N HCl, from which 2 mg. PbS could then be precipitated. The uranium in the parent meteorite solution might then be precipitated as the oxalate using lanthanum as carrier.

Recovery of Uranium from Parent Solution.

Excess oxalate ion was used to precipitate La through a solution of U, since uranyl oxalate is slightly soluble (80 mg./100 ml. at 14°C), but on testing the precipitate it was found to contain < 1% of the available uranium. Since uranyl ferrocyanide is insoluble in neutral solution it was attempted to carry this on a molybdenum ferrocyanide precipitate and then bring the uranium alone into solution with dilute HNO₃, but this also proved disappointing.

Quantitative recoveries of uranium carried on aluminium hydroxide were obtained when the precipitation was carried out with carbonate-free ammonia gas, prepared by distillation over KOH(NH₄OH solution normally contains (NH₄)₂CO₃ which can cause the uranium to remain in solution as a complex). In order to utilise this technique, the iron in the meteorite would first have to be removed. The uranium could then be recovered from the Al(OH)₃ in a sufficiently pure state for fluorimetry by means of an ether/HNO₃ extraction.

Testing the Separate Stages of the Process.

(a) The Zirconium Iodate Precipitation Through a Meteorite Solution.

An "artificial" meteorite solution in 2 N HNO₃ with Ba present (as hold-back carrier for Ra) gave no precipitate with KIO₃. With added ZP, again no precipitate occurred although it was shown that normally Zr (IO₃)₄ was completely precipitated if

the solution was 0.15 N with respect to KIO_3 . It was shown that the presence of iron was the factor which prevented precipitation. The removal of iron was thus again a necessary preliminary stage for the procedure.

(b) The Removal of Iron.

The method of extracting into ether as $HFeCl_4$ from 6.5 N HCl is a useful technique for this separation⁽⁴³⁾. The partition coefficient is about 100 to 1 in favour of the ether, so three extractions should reduce the iron to negligible proportions.

This step makes possible the co-precipitation of both the uranium and thorium on the combined zirconium/aluminium hydroxide carrier, using carbonate-free ammonia, and leaving radium in solution. The aluminium, together with the uranium should then be separable from the zirconium and thorium by means of the "group" procedure using Na_2O_2 and Na OH as reagents.

The zirconium precipitate with the carried thorium could be dissolved, stored for a month and then extracted with PbS , which would then be measured for α - activity in the scintillation counter. The alkali mother liquor on acidification followed by the passing of CO_3 - free NH_3 would precipitate $Al(OH)_3$ carrying the uranium which could then be purified by ether/ HNO_3 extraction prior to fluorimetry.

Testing the Different Stages of the Proposed New Separation.

Discussion.

The behaviour of both uranium and thorium at each stage of

the procedure was tested, using the fluorimeter with 10^{-5} g. quantities of uranium, and using uranium X, as tracer for Th. To use natural thorium measured in the scintillation counter would involve long counting periods in order to obtain good statistical accuracies. If larger quantities of thorium were used, these would then involve the risk of the counter becoming contaminated. Using the γ - radiation of Th C (previously described) would involve a period of growth of several weeks in order to generate the Th X, and to avoid this UX₁ was used as the thorium tracer.

Preparation of a UX₁ solution for Thorium Tracer Work.

UX₁ (Th²³⁴; $t_{1/2} = 24.5$ days) emits weak β - radiation (0.2 Mev) but its daughter UX₂ ($t_{1/2} = 1.14$ min.) emits β - radiation of 2.5 Mev. Thus in any extraction test of UX₁ the UX₂ would be in equilibrium before the completion of the source preparation. UX₁ was prepared from a UO₂(NO₃) 6H₂O solution by adding a little Fe Cl₃ solution followed by NH₄OH until the iron was just precipitated (pH=3). The precipitate was digested with (NH₄)₂CO₃ solution to remove any uranium as complex. (If the initial precipitation had been carried out with (NH₄)₂CO₃, the thorium would also have remained in solution as a complex, whereas Th (OH)₄ does not form a complex on being digested with (NH₄)₂CO₃). The Fe(OH)₃ was then dissolved in HCl.

0.5 ml. of this solution, dried by radiant heat on nickel

trays and measured in a Geiger counter gave:-

(a) 669 ± 9 c.p.m. (b) 654 ± 8 c.p.m. Mean 659 ± 6 c.p.m.

(1) Zirconium as a Carrier for Thorium.

A mixture of 0.5 ml. of UX_1 solution and dil. HCl containing 2 mg. Zr, as $Zr Cl_4$, was prepared and CO_3 - free NH_3 gas was bubbled through until $Zr (OH)_4$ was precipitated. This precipitate was centrifuged off, washed, and prepared as a counting source. The counts obtained were:- (a) 677 ± 9 c.p.m. (b) 638 ± 8 c.p.m. Mean 658 ± 6 c.p.m. This corresponded to $100 \pm 1\%$ of available UX_1 .

(2) The Effect of Ether/6.5 N HCl Extractions on Thorium Chloride.

0.5 ml. of UX_1 solution was dried and the residue dissolved in 6.5 N HCl and this was shaken with equal volumes of ether which had previously been equilibrated with 6.5 N HCl. The aqueous layer was evaporated to smaller bulk to remove most of the HCl, and 2 mg. Zr were added. The solution was diluted and NH_3 was passed to precipitate the $Zr (OH)_4$. The activity of the UX_1 on the $Zr (OH)_4$ was found to be (a) $97 \pm 2\%$ (b) $103 \pm 2\%$ Mean $100\% \pm 2\%$.

No loss of thorium had therefore occurred at this stage.

(3) Testing the Recovery of Thorium after the Na OH/ Na_2O_2 Treatment.

0.5 ml. UX_1 solution with 2 mg. Zr in HCl were treated with 10% Na OH solution, followed by 200 - 300 mg. Na_2O_2 .

The solution was warmed until the effervescence of the peroxide ceased and the mixture was then centrifuged. Recoveries of Ux_3 on the Zr precipitates were:- (a) $95 \pm 1\%$ (b) $100 \pm 1\%$
Mean $97.5 \pm 1\%$.

This stage was also satisfactory.

Uranium Investigations.

1. Testing the Effect of Ether/6.5 N HCl Extractions on Uranyl Chloride.

5×10^{-5} g. U. in 6.5 HCl was shaken with the ether as described in the investigation of thorium in the previous section, and the uranium content of the ether layer was measured fluorimetrically. The ether layer contained (a) $0.15 \pm 0.01\%$ and (b) $0.08 \pm 0.01\%$ of the total available uranium. The uranium had therefore remained almost completely in the aqueous phase. The test was later repeated in the presence of iron and it was found that both the uranium and the thorium remained in the aqueous phase while the iron was extracted.

2. Zirconium Hydroxide as a Carrier for Uranium.

On precipitating 2 mg. Zr with carbonate-free NH_3 in the presence of 1.25×10^{-5} g. U. the mother liquor was analysed and found to contain $0.1 \pm 0.02\%$ of the total uranium. The presence of the rest of the uranium on the precipitate was also shown.

3. Investigation of the Behaviour of Uranium during the NaOH/ Na_2CO_3 Treatment.

A solution of 1.247×10^{-5} g. U in dil. HCl with 2 mg. Zr and 10 mg. Al present, was treated with 10% Na OH solution followed by 200-300 mg. Na_2O_2 . After warming the mixture, the precipitate was recovered by centrifugation and shown to contain < 0.5% of the total uranium. Thus the U was present in the alkaline solution.

Testing the Complete Procedure.

It was now necessary to test the recovery of both U and Th by the complete separation procedure. In order to do this, meteorite solutions from which Ba SO_4 had been precipitated for determination of uranium and thorium by the radon-thoron method were used. Sufficient uranium and thorium were added to "swamp" any natural content of these elements and to give quickly obtainable results. In order to avoid the delay caused by growth to equilibrium of ThX , the thorium was determined by counting the α - particles of Th and Rd Th on the Zr (OH)_4 precipitate. Short counts on this gave little risk of contamination of the counter by thoron.

Experimental.

A sample of the " Ba SO_4 residue" meteorite solution, containing 20g. of meteorite was evaporated to dryness on a water-bath, after the addition of 1.247×10^{-5} g. U and 3.82×10^{-5} g. Th to the solution. The dried salts were dissolved in 100 ml. 6.5 N HCl and shaken three times with an equal volume of ether (previously equilibrated with 6.5 N HCl)

to remove the iron. The third ether extract contained very little iron and a test with $\text{NH}_4 \text{ CNS}$ showed that only milligram quantities of Fe^{+++} remained in the aqueous layer. The aqueous layer was warmed on a water-bath to remove dissolved ether and the bulk of the solution was then reduced by boiling. Water was then added to bring the HCl concentration to between 2 and 3 N, so that no saturation with NH_4^+ salts would occur on passing NH_3 gas. On passing the gas a large amount of pale blue precipitate was formed on reaching neutrality. The precipitate was shown to be ferrous hydroxide. It was therefore necessary to ensure that all the iron present was in the ferric state before the evaporation to dryness.

Oxidation of Ferrous Iron to Ferric.

This oxidation was at first carried out by passing chlorine gas into the solution. It had been thought that if conc. HNO_3 were used to effect the oxidation, it might cause the loss of some uranium into the ether as uranyl nitrate. However, as chloride ion is known to suppress this extraction, tests were made using HNO_3 and it was shown that no loss of uranium occurred. Great care had to be exercised in adding the conc. HNO_3 to the chloride solution; additions of more than 1 or 2 ml. at a time produced a vigorous reaction with formation of nitrosyl chloride and frothing of this would have caused substantial loss from the vessel. When a drop of the

mixture produced no blue coloration on being tested with a drop of potassium ferricyanide solution, the oxidation was known to be complete.

It was shown that the slight precipitate of silica, which appeared on boiling the aqueous layer after ether/HCl extraction of iron, contained (a) < 0.1% and (b) < 0.1% of the total uranium and (a) 1.0% and (b) 0.5% of the total thorium present.

Thorium recoveries from the complete procedure were practically 100%, but for uranium they were only 50-75%. It was shown that the weak link in the method was the NaOH/Na₂O₂ stage.

Development of the Alkali-Peroxide Method of Separation for Uranium and Thorium.

The alkali-peroxide reaction had been carried out as previously described, the mixture being warmed only long enough to reduce the effervescence of the peroxide sufficiently to allow successful centrifugation of the precipitate.

Tests using the technique recommended by Vogel⁽⁵⁷⁾ were then made. The Zr(OH)₄/Al(OH)₃ precipitate was dissolved in the minimum of dil. HCl and was then poured into an equal volume of "20 volume" H₂O₂ rendered strongly alkaline with 10% NaOH solution. The mixture was boiled for 5 minutes, and the precipitate was centrifuged. UX₁ (thorium) recoveries were (a) 98.5 ± 1% and (b) 101.0 ± 0.8%.

The uranium on the precipitate was:- (a) 8.0% and (b) 7.5% of the total.

Two such successive treatments of the precipitate would give complete removal of uranium from the Zr. H_2O_2 is preferable to H_2O_2 from the point of view of lowering the reagent "blank". Noyes and Bray⁽⁵⁸⁾ point out that the peroxyuranate complex formed tends to be destroyed on boiling in the presence of a hydroxide precipitate, explaining the increased amount of U found on the Zr precipitate after 5 minutes boiling. Variations in the results of this vital reaction were found, so it was thoroughly investigated.

(In order to cut out the rather tedious ether/ HNO_3 extraction of uranium for each determination, it was decided to acidify the sodium aluminate-peroxyuranate solution and then precipitate the Al with $CO_3^{=}$ - free NH_3 . If the quenching could be shown to be negligible, the U on the precipitate would be measured directly in the fluorimeter. If this was not possible, the ether / HNO_3 extraction was then carried out.) During these tests it became obvious that the presence or absence of iron was one of the controlling factors for the efficiency of the uranium recovery.

Investigation of the Peroxide Separation in the Presence of Iron

10 ml. of HCl containing 7 mg. Zr, 10 mg. Al, and known amounts of U and Th, were poured into a mixture of "20 vol."

H₂O₂ and 20% Na OH solution. The mixture was boiled for 5 minutes and then centrifuged. Tests on the Al(OH)₃ precipitated by NH₃ after acidifying and boiling the mother liquor showed that U recoveries were always about 10%. If the reaction was allowed to proceed in the cold, and the mixture stood overnight to improve centrifugation, still only about 10% of the total uranium was recovered.

For further testing a "master solution" was prepared containing known amounts of U, Th, Al, Zr and a 10g. meteorite solution from which most of the iron had been extracted. If the master solution was used with 4 times its volume of Na OH/H₂O₂ mixture 10-20% recoveries of uranium were obtained. On increasing this ratio to 6:1 the recoveries were 70-80%. However, when this was repeated with only Zr, Al, U and Th present (i.e. in the absence of the master solution), only 30% uranium recovery was obtained and on increasing the ratio to 10:1, no improvement was found.

Repeating the tests with meteorite solutions containing added U, Th, Zr and Al with a ratio of Na OH/H₂O₂: HCl of 6:1 and boiling the mixture for 5 minutes, the uranium recoveries obtained were:- (a) 85 ± 2% and (b) 86 ± 3%.

Reverting to tests in the absence of meteorite solution poor U recoveries (approximately 30%) were found. The test was repeated with 4.5 mg. Fe present (as Fe Cl₃), and the U recoveries were:- (a) 91 ± 8% (b) 88 ± 7% and 85 ± 5%.

In all tests where 80% or more of the U had been recovered, iron had been present, either from meteorite solutions or with UX_1 solution which had Fe present as a carrier (see p. 63). Low efficiencies of U recovery had been associated with experiments performed in the absence of Fe. Low recoveries in the presence of Fe had occurred when the Na OH/ H_2O_2 : HCl volume ratio was less than 6:1.

As a final check the test was performed with Fe absent and Zr present when the U recoveries were (a) $26 \pm 6\%$ (b) $32 \pm 7\%$, while on substituting Fe for Zr they were (a) $81 \pm 5\%$ and (b) $> 70\%$.

Testing the Aluminium Precipitation.

It was obvious that the method, though promising, was still inadequate, since quantitative recoveries had never been obtained. A test was made on the efficiency of the co-precipitation of U by 10 mg. Al as $Al(OH)_3$ from the acidified solution following Na OH/ H_2O_2 treatment. It was found to be only 70-80% efficient. Another method of extraction of uranium from this solution was therefore needed. In order to keep the solution free from chloride ion (since this represses the efficiency of ether/ HNO_3 extractions of U), the precipitate from the second NH_3 gas treatment (after ether/HCl extraction of Fe) was dissolved in dil. HNO_3 instead of dil. HCl and was treated with the alkali-peroxide reagent. The mother liquor from this was acidified with excess conc. HNO_3

and saturated with NH_4NO_3 . Four extractions of this mixture with ether gave complete recovery of uranium.

When tests of the complete procedure were then carried out, thorium recoveries were, as always, near 100% :- (a) $92 \pm 2\%$ (b) $98 \pm 3\%$. Uranium recoveries were (a) $96 \pm 3\%$ and (b) $100 \pm 3\%$.

Whether the peroxide reaction was carried out in the cold, just brought to the boil, or boiled for 5 minutes, the U recovery was still quantitative. The method of just bringing to the boil was the most suitable, since the cold technique caused difficult centrifugation, while excessive boiling of the solution risked the loss of some uranium by decomposition of the complex on the precipitate.

When Zr alone was present, the precipitate of $\text{Zr}(\text{OH})_4$ first formed on pouring into the alkali, disappeared completely on boiling, and later a whitish granular precipitate was thrown down. This is believed to be a peroxide of zirconium but its constitution does not seem to be known.

Using Fe alone the red-brown particulate precipitate remained throughout the treatment. It is probable that the dissolving of the initial Zr precipitate and its re-precipitation causes the decomposition of the sodium peroxyuranate and the consequent loss of uranium from the solution.

The complete procedure as applied to a typical meteorite will be described in the following chapter, but before the

method could be applied to meteorite analyses it was necessary to purify several of the reagents. A description follows of the methods used for this purification.

Purification of Reagents.

The tolerance limits for reagent contribution in the analysis of a 30g. meteorite sample were about 6×10^{-8} g. U and 3×10^{-7} g. Th. One litre of distilled H₂O, for example contained 3.5×10^{-7} g. Th. Methods for purifying this, and several other reagents, had to be found.

The methods used for these purifications consisted of solvent extraction, co-precipitation of the traces of the "impurities" on carriers, and the re-distillation of some of the liquid reagents. The solvent extractions used were (a) the removal of uranium by ether/HNO₃ extraction and (b) the separation of iron free from U or Th by the ether/HCl extraction of the iron. The co-precipitation of U and Th on Ba CO₃ and use of lanthanum fluoride as a carrier for Th were two important techniques in these purifications.

In Mme. Joliot-Curie's text book⁽⁵⁹⁾ it is recorded that on shaking a thorium solution (in which the disintegration products were in equilibrium) with Ba CO₃, all the members are carried out of the solution except Hs Th₂. This could possibly find application as a method of freeing neutral and alkaline solutions from the thorium series.

40 ml. H₂O with UX₁ (freed from its iron carrier by

ether extraction) as indicator, was shaken for a few seconds with well-washed Ba CO_3 . Only $0.9 \pm 0.3\%$ of the activity remained in solution. On attempting similar separations from the Al and Zr reagents, it was found that these elements were also carried down on the precipitate. This meant that the Ba CO_3 - shaking method could not be used for the purification of these reagents, however it did lead to another use for the method in the removal of uranium from certain reagents.

Treadwell⁽⁶⁰⁾ describes a method of precipitating Fe, Cr and Al as hydroxides and U as $\text{Ba}_2(\text{UO}_2(\text{CO}_3)_3)_3$, with a slurry of Ba CO_3 as the reagent. Stieglitz⁽⁶¹⁾ also describes a separation of the Al and Zn groups by this method. The removal of U from reagents with Ba CO_3 therefore appeared to be possible.

Mixing Ba CO_3 with H_2O containing known amounts of U caused 0.1% of the U to remain in solution. U in H_2O_2 was removed to an extent greater than 99% but it was found that shaking was required in order to remove U from Na OH solution. After 2 minutes shaking 67% of the U remained in solution. After 16 hours, this was reduced to 14%, and after 44 hours shaking only $5.9 \pm 0.4\%$ of the U remained in solution. This technique when applied to A.R. Na OH gave a satisfactory reagent.

Ba CO_3 removed UX_1 from H_2O_2 and Na OH leaving < 1% in solution. The U and Th content of A.R. H_2O_2 was so low that it did not require any treatment before use. Ba Cl_2 reagent

was also freed from U and Th by the Ba CO₃ method.

The Zr(NO₃)₄ salt contained 2.3×10^{-4} g. U/g. Zr and although it was not used in this procedure, it found use in a later separation technique (described in Chapter XI), and its purification is therefore described here. Zr (NO₃)₄ solution in HNO₃, with added NH₄NO₃ present, was shaken 7 times with ether. The Zr was recovered from the aqueous layer by ammonia precipitation. Some of the Zr was also extracted into the ether⁽⁴³⁾, and allowance was made for this when adjusting the volume of the reagent solution. The Zr solution was then shown to contain $< 2 \times 10^{-7}$ g. U/g. Zr.

Removal of Th from the Zr reagent was accomplished by precipitation of the very insoluble Th F₄ on La F₃ carrier. Zr F₄ is soluble and the final solution contained some lanthanum but no fluoride.

The Al reagent was purified in the same manner as the Zr. Fe Cl₃ free from U and Th was obtained from the ether/HCl extractions of meteorites.

Crude conc. HCl contained 0.4×10^{-3} g. U/500 ml. and was satisfactory in this respect, but its Th content was high, 1×10^{-6} g. Th/l. Attempts to purify this by various methods of distillation failed, and it appeared that the thorium was probably being picked up from the glass. As only 300 ml. conc. HCl were usually required for analysis of a 30g. meteorite sample, the Th content of this was just within the tolerance

limit set. Ether equilibrated with 6.5 N HCl did not contain any U or Th because these two elements, if initially present in the ether would both pass into the aqueous layer on equilibrating the two phases.

The following table shows the uranium and thorium contents of the reagents:-

Reagent	U in 10^{-8} g.	Th in 10^{-8} g.	Aliquot Taken
Al Cl ₃	< 1.0	0.7 ± 0.15	10mg.
Ba Cl ₂	0.7 ± 0.1	< 0.4	10mg.
Zr Cl ₄	< 0.2	< 0.9	10mg.
20 vol. H ₂ O ₂	0.16 ± 0.17	1.0 ± 0.6	10ml.
20% Na OH soln.	< 0.2	5.0 ± 1.6	10ml.
H ₂ O.	< 1.0	14 ± 5	1 l.
HCl	0.30 ± 0.10	ca. 50	500ml.

Purification of Sodium Fluoride.

In view of the success of the Ba CO₃ shaking technique, it was applied to the purification of NaF. The relative solubilities of NaF, BaF₂ and Ba CO₃ are 4.22, 0.17 and 0.002g./100ml. H₂O at 20°C. One sample of NaF tested had an exceptionally high background fluorescence (equivalent to 1.5×10^{-6} g.U/g. of NaF). After dissolving some of this and shaking the solution with Ba CO₃, the liquid was evaporated to dryness in a Pt basin and the solid was finely ground in an

agate mortar. Phosphors from this NaF had a blank fluorescence of less than 1% of the original reading. When known amounts of U were added and phosphors were prepared, the latter gave readings of only 60% of the expected value. The sensitivity had therefore also been reduced.

Attempts to purify more suitable brands of NaF were less successful. The blank fluorescence of a batch of B.D.H. NaF was reduced on treatment from 15v. to 5v. but the uranium standard phosphors were again reduced to 60-70% of their normal fluorescence intensity, presumably due to the "quenching" effect of the Ba present. (Jacobs⁽³⁴⁾ quotes the tolerance limit of Ba as 5×10^{-4} g. per phosphor).

It therefore appeared that the blank fluorescence of NaF was probably not due to uranium contained in it, otherwise the treatment with Ba CO₃ should have reduced it by a greater factor. Since B.D.H. NaF, with a blank fluorescence equivalent to 5×10^{-3} g.U per phosphor, was readily available, no purification method for NaF was essential.

Chapter VIII

THE COMPLETE URANIUM/ THORIUM PROCEDURE
APPLIED TO METEORITES

30-100g. of the meteorite sample were dissolved in the minimum of conc. HCl, water being added to retain the metal salts in solution. Any residue which remained was dissolved in HNO₃ or a mixture of HCl and HNO₃. Oxidation of ferrous iron to ferric was effected by the cautious addition of conc. HNO₃ to the hot solution, until on testing a drop of the mixture with freshly prepared K₃Fe(CN)₆ solution no blue coloration was produced. The meteorite solution was then evaporated to dryness on a water-bath, and the residue was dissolved in 6.5 N HCl. After 4 extractions with "equilibrated" ether the aqueous phase was boiled to reduce its bulk. 10 mg. Fe, 20 mg. Al, and 20 mg. Ba were then added as carriers for Th, U and Ra respectively. Carbonate-free NH₃ gas was passed into the solution until it was alkaline. As a precautionary measure against the adsorption of radium or copper (which both interfere in the preparation of the Th B source) the hydroxide precipitate was centrifuged off, dissolved in dilute HCl and reprecipitated with NH₃ gas after addition of 20mg. Ba as "hold-back" carrier for radium. The precipitate, after centrifugation was dissolved in 5-10 ml. dil. HNO₃ and 20mg. Ba were added. The solution was then poured into a mixture of 50ml. 20% Na OH solution and 30ml.

20 vol. H_2O_2 , immediately warmed to the boiling point and rapidly centrifuged.

Purification and Estimation of the Uranium.

The uranium present in the alkaline liquid phase was recovered by boiling the solution with excess conc. HNO_3 and by extraction of the uranyl nitrate so formed four times with 30ml. quantities of ether, after addition of 20g. NH_4NO_3 as salting-out agent. After four ether extractions the extract solution was shaken three times with 10ml. quantities of conc. HNO_3 saturated with NH_4NO_3 to remove any Fe or Cr present in the ether. This 30ml. conc. HNO_3 was then extracted twice with 30ml. ether to recover any uranium lost into the aqueous phase. The total ether extracts were then combined and were evaporated in the presence of 200ml. water which was then carefully reduced in volume and diluted to 10ml. 1ml. portions were evaporated to dryness in the fluorimeter trays and prepared as phosphors with NaF. These phosphors were compared with those prepared from the reagent blank solution and the difference in their fluorescence intensities was a measure of the amount of uranium present. A typical calculation for a meteorite determination is shown in Appendix I.

Estimation of the Thorium.

The $Fe(OH)_3$ precipitated from the $NaOH/H_2O_2$ treatment with its accompanying Th and Ra Th was dissolved in sufficient

HCl to produce a 0.2 N HCl solution when diluted to 25ml. 30mg. Ba as Ba Cl₂ were added as "hold-back" carrier for the Th X which grew to equilibrium in the solution during the next 3 - 4 weeks. 2mg. Pb, as acetate, were then added to the solution and H₂S was then passed until the PbS was precipitated. The suspension was centrifuged and the precipitate was dissolved in warm HCl and transferred to the polystyrene counting disc where it was evaporated by radiant heat with a current of air playing radially on the disc⁽⁶²⁾. 45 minutes after precipitation, the counting was commenced and was continued for a further 16 hours. After 3 days a further PbS precipitation was carried out and normally 5 such Th B-C sources were prepared for each meteorite determination, a similar number being prepared for its reagent blank. A typical calculation is shown in Appendix 11.

Anomalous Results with Initial Th B-C Sources.

When meteorite analyses were commenced, it was observed that the first precipitation of PbS from the stored thorium solution often had an appreciably greater activity than subsequent precipitations. It was also noted that this increased count was most noticeable in the cases where the U content of the meteorite had been appreciable. For example, the counts recorded overnight from the 6 precipitates, from Carbo (46g. with 0.52×10^{-8} g. U/g.) were 125, 46, 43, 51, 55 and 46. In the case of Bethany (Harvard) (40g. with

0.61×10^{-8} g. U/g.) the recorded counts were 149, 77, 87, 82 and 83, while Bethany Amalia (Krants) (28g. with 0.53×10^{-8} g. U/g.) gave 65, 55, 43, 46, and 37 whereas Huonionalusta 11 (23g. with only 0.18×10^{-8} g. U/g.) gave precipitates with counts of 55, 27, 33, 28, 32 and 32.

Under the conditions described it had been shown that no other member of the Th series could interfere and it therefore appeared that some member of another radioactive disintegration series present in the meteorite had been carried down on the PbS.

Since members of the actinium series below Ac X (i.e. Ra²³³) all have very short half-lives (< 1 hr) these would decay during the 1 month growth period of Th X and would not interfere in a PbS precipitate. In addition the short lived members of the active deposit would decay during the source preparation if precipitated on the PbS. In the uranium series, the only active deposit members which could be present 1 month after the removal of radium are Ra D (Pb²¹⁰, $t_{1/2} = 16.5$ yrs.) and Ra F (Po²¹⁰, $t_{1/2} = 140$ days). The former is β -active but the latter is α -active and would probably be present in the final thorium solution after the chemical treatment of the meteorite, and hence would precipitate along with all the Pb isotopes in the first PbS extract.

One of these initial PbS precipitates was therefore retained and counted periodically after the Th B and Th C had

decayed. Its activity was shown to have a half-life of about 130-150 days, which agreed with that of Ra F. In all subsequent determinations the initial PbS precipitate was discarded.

The results obtained from this combined U/Th method are included in the table on p. 121.

The method was later altered in order to reduce the volumes of ether and HNO_3 which were required for the final uranium purification. These volumes were dangerously large and by the introduction of a new method of U/Th separation it was possible to reduce considerably the scale of this extraction. The new separation procedure, which did not entail the use of certain reagents liable to contain uranium or thorium, is described in Chapter XI.

Chapter IX

MEASUREMENT OF URANIUM IN METEORITE SOLUTIONS REMAINING
AS RESIDUES FROM THE RADON-THORON METHOD.

The use of the meteorite "residue" solutions from determinations by the emanation method, in the testing of the combined U/Th method, suggested that if the precipitation of barium sulphate through the solutions had left the uranium and thorium completely in solution, these "residues" could be redetermined by the new method.

It was shown that appreciable amounts of Th (ca. 48%) were removed by the precipitation used for the Radon-Thoron Method, but less than 0.04% of the available uranium was removed by such a procedure. It was therefore possible to analyse the uranium in these samples by removing all the iron with the usual ether/HCl extraction, and then co-precipitating the U on 20mg. of added Al, using carbonate-free NH_3 as reagent. The centrifuged precipitate was dissolved in conc. HNO_3 to which was added NH_4NO_3 , and the uranium was purified by ether extraction. Records of the exact amounts of reagents used in the original working up of the meteorites were available, and these conditions were reproduced for the reagent blank.

Results, in excellent agreement with those found from other methods, were obtained, and are listed in the table on P. 121.

Chapter X.

DETERMINATION OF URANIUM AND THORIUM IN
STONE METEORITES.

No method was so far available for the determination of uranium and thorium in silicious material by the new techniques of fluorimetry and scintillation counting. The new find of a stone meteorite (Akaba⁽⁶⁵⁾), made it especially desirable that such a method should be developed. The author decided that the combined U/Th method, previously described, could probably be successfully adapted for use with stone meteorites.

A sample of olivine was finely powdered and passed through a "100 mesh" sieve after which it was fused with five times its weight of anhydrous sodium carbonate, in the presence of 1.247×10^{-5} g. U and 4.75×10^{-5} g. Th. On cooling, water was added and the insoluble residue was attacked with conc. HCl. The silica was centrifuged off and shown to contain < 1.0% of the total uranium and < 0.5% of the thorium. It was then hoped to precipitate the iron, present in the olivine, with carbonate-free NH_3 , and so carry the uranium and thorium out of solution. On passing the gas into the solution, however, gelatinous Si O_2 aq. was precipitated, and this was difficult to wash. The total efficiency of uranium recovery was 87% and for thorium this figure was 86%.

In order to improve this, the dehydration technique

described by Washington⁽⁶⁴⁾ was examined. After fusion the residue was attacked with H_2O followed by a few mls. of conc. HCl . The mixture was warmed and then evaporated to dryness in a platinum basin on a water-bath. This rendered the $Si O_2$ almost insoluble. The residue was moistened with conc. HCl and then washed out into a beaker with water. The mixture was then boiled until only $Si O_2$ remained, and this was centrifuged off, washed, and shown to contain 0.5% of both the uranium and thorium. The main bulk of solution was re-evaporated in the Pt basin. A few mls. of conc. HCl were again added to the dried salts, followed by the addition of water. After warming, the small amount of $Si O_2$ remaining was centrifuged off, and washings from it together with those from the first $Si O_2$ residue, were combined with the main liquid bulk. The second $Si O_2$ residue was shown to be free from both U and Th.

Carbonate-free NH_3 was then passed into the solution, and the $Fe(OH)_3$ precipitate was centrifuged off. This was dissolved in conc. HCl (8.7N) and then extracted several times with ether which had been equilibrated with 6.5 N HCl . The U and Th remained in the aqueous layer. It was found that if the $Fe(OH)_3$ was dissolved in 6.5 HCl , the acid concentration was lowered too far to give suitable extraction efficiencies of iron (see ref.43). Using 8.7 N HCl , however, the final acid concentration was correct.

After all the iron had been removed 10mg. Fe and 20mg. Al were added to the aqueous layer to act as carriers. These were precipitated in the presence of 20mg. Ba (hold-back carrier for Ra isotopes) by means of NH_3 gas, and the precipitate was dissolved and re-precipitated after the addition of more Ba Cl_2 . No precipitate of silica appeared. The $\text{Na OH/H}_2\text{O}_2$ treatment was then carried out, after which the U was recovered by ether/ HNO_3 extraction and the thorium was stored until the ThX had grown to equilibrium. The results for the recoveries of the two elements were:-

Uranium:- (a) $101\% \pm 3\%$ (b) $98 \pm 2\%$

Thorium:- (a) $97 \pm 2\%$ (b) $99 \pm 3\%$

Using this procedure the U and Th in stone meteorites or in the silicate phase of pallasites (i.e. iron-stone meteorites) could be determined.

Since the U and Th contents of stone meteorites are usually appreciably greater than those of iron meteorites (see p. 3) a smaller quantity of starting material was required for the silicate analyses. 0.5 - 4.0g. of the powdered silicate was normally used in order to obtain a sufficient degree of accuracy, (i.e. about 10% error).

The only new reagent used in this procedure was the anhydrous sodium carbonate. 50g. of this were acidified with conc. HNO_3 , and after addition of NH_4NO_3 the mixture was

extracted three times with ether. It was shown that the U content was $< 3 \times 10^{-10}$ g. U/g. Measurements of the Th content showed $< 1 \times 10^{-9}$ g. Th/g. No purification of this reagent was therefore required.

Results obtained from this method are listed in the table on p.123.

Chapter XI

ALTERATION OF THE METHOD OF
URANIUM/THORIUM SEPARATION

Although the combined uranium/thorium analysis method gave satisfactory and consistent results, it had one practical disadvantage: that was the danger in evaporating the large quantities of ether, containing nitric acid, in the last stage of uranium purification. The total volume of this ether in every determination, including the reagent blank, amounted to nearly 800ml., and its evaporation in the presence of HNO_3 involved considerable risk. The aqueous phase being extracted contained 50ml. of 20% NaOH solution which had been acidified with conc. HNO_3 . Since NaNO_3 was not a sufficiently effective salting-out agent for $\text{UO}_2(\text{NO}_3)_2$, it was also necessary to add some NH_4NO_3 to the solution. To keep these amounts of salts in solution a volume of about 80ml. was required and hence a similar volume of ether was used in each shaking.

It had been shown in previous attempts to reduce the scale of the ether/ HNO_3 extraction, that if the mother liquor from the $\text{NaOH}/\text{H}_2\text{O}_2$ treatment was acidified and then treated with gaseous NH_3 , the $\text{Al}(\text{OH})_3$ precipitate formed carried only 70-80% of the total uranium (see p. 71), hence the extraction of the complete mother liquor had been necessary. It was therefore decided that an alteration of the method of U/Th separation was required to avoid the ether/ HNO_3 risk.

Rao, Murthy and Rao⁽⁶⁵⁾ have reported a separation of uranium and thorium on a milligram scale using m-nitrobenzoic acid. Carrying out the reaction at about 80°C and at pH 2.6 - 2.8, the thorium is quantitatively precipitated as m-nitrobenzoate, while the uranium remains in solution. It was decided to attempt an application of this method to the problem.

Experimental.

Before using this technique with microgram quantities, a suitable carrier for the Th had to be found. Tests were made to discover which other elements would precipitate with m-nitrobenzoic acid under the required conditions. It was found that the usual carriers for Th, viz: Al, Fe, Cr, Ce and La did not precipitate, however, Zr did. Zr m-nitrobenzoate was therefore tested as a carrier for Th, and also to find if such a precipitate was free from any U present in the solution during precipitation.

5mg. Zr and 1.247×10^{-5} g. U were placed in HCl solution and the pH was adjusted until the thymol blue used as indicator was orange. The solution was warmed and a hot 1% solution of the reagent was added. The Zr precipitate was centrifuged off and was shown to contain only 0.5% of the available uranium. Repetitions of this procedure showed 0.4% and 0.5% of the U present on the precipitate. The reaction was therefore satisfactory with respect to the behaviour of the uranium.

A solution of UX_1 was used as a tracer for thorium investigations. 0.1 ml. of this solution when evaporated to dryness gave 157.5 ± 1.5 cts./min in excess of background when examined with a Geiger counter. 1ml. of the solution with 5mg. Zr. was treated with the hot reagent, using thymol blue as pH indicator. After centrifugation the precipitate was dissolved in conc. HCl, and one-tenth of it when measured in a Geiger counter gave 117.6 ± 3.0 cts./min. A repetition of the procedure gave the result 119.7 ± 1.7 cts./min. These were equivalent to recoveries of ca. 85%.

On testing the precipitation in the presence of iron and chromium (these would be present in a meteorite determination), thymol blue could not be used as an indicator, B.D.H. pH paper being used instead. The adjustment of the pH to the correct value for the reaction, without precipitation of $Fe(OH)_3$, (with consequent loss of U and Th), was found to be very difficult. Acetic acid was then used to accomplish this, but the Zr precipitate was smaller in bulk than that previously obtained, and contained only 50% of the UX_1 . (Vogel (ref.(57)p.453) records that acetic acid complexes with Zr and retards its precipitation).

Attempts were then made to find some reagent which would precipitate Th and a carrier in solutions of lower pH, to retain iron in solution. Peracetic acid⁽⁶⁶⁾ is recommended

as a precipitant for Th in acid solutions. In this case Zr could again be used as a carrier, for it is reported⁽⁶⁷⁾ that parasonic acid precipitates Zr in 2N HCl. The reaction was tested in 2N HNO₃, for the following stage for uranium purification was intended to be a small scale ether/HNO₃ extraction of U, and the presence of any chloride would have inhibited this. It was found that Zr did not precipitate with the organic reagent in 2N HNO₃. Since two other possibilities were still open, this technique was abandoned, at least temporarily, until they had been investigated.

Th and Zr are said to precipitate with salicylic acid in buffered acetate solution (ref.(9) p.181), but no precipitate was obtained on testing the reaction with Zr alone, presumably due to the complexing action of the acetate.

It is reported⁽⁶⁸⁾ that Th can be precipitated at pH 0.3 to 1.0 using 1-(*o*-arseno-phenylazo)-2 naphthol- 3:6 disulphonic acid. This reagent was also shown to precipitate Zr in dilute HNO₃ (about 0.2N), and on prolonged boiling with conc.HCl the complex was destroyed and the Zr could then be kept in solution in 0.2 N HCl (i.e. the conditions required for the precipitation of PbS carrier for ThB and ThC). The reaction was then tested in the presence of U and Th to discover if they were efficiently separated.

10mg. Zr and 1.247×10^{-5} g. U together with a few milligrams

of both Fe and Cr were mixed in 0.2N HNO₃. A 5% aqueous solution of the reagent (sodium salt) was added and the strawberry red precipitate was centrifuged off. The solution was boiled with conc. HNO₃ (20ml) and NH₄NO₃ was added as salting-out agent. The mixture was extracted four times with ether, and fluorimetric analysis showed that 99.2 ± 1.5% of the total U present had been recovered. Repetitions of the procedure showed recoveries of 98.8 ± 2.0% and 99.4 ± 2.0%. Examination of the precipitates proved that < 2% of the U had been carried out of solution.

Using U²³⁵ as a tracer instead of natural uranium, the efficiency of U recovery was 97-100% and the precipitates always contained < 2.5% of the available U²³⁵. The technique was therefore satisfactory with respect to uranium.

Tests using UK₁ as a tracer for Th, under the conditions described above, gave results for Th recoveries on the precipitate of:- (a) 98.6 ± 1.5% (b) 101.2 ± 1.6% and (c) 99.3 ± 2.1%.

This method of separating micro-quantities of U and Th was preferable to the original alkali-peroxide method, because the amount of ether/HNO₃ mixture which had to be evaporated was only one quarter of that previously used.

It could not be expected that (with the present stock of reagents) the new method would produce appreciably lower

reagent blanks, because the reagents which were now no longer required (NaOH, H₂O₂, and larger amounts of ether, conc. HNO₃ and NH₄NO₃) had previously been shown to contain negligible quantities of uranium and thorium. However, in cases where the available samples of these reagents were less satisfactory than those used here, the new method would have a distinct advantage. No trace of uranium or thorium could be found in the organic precipitating agent.

Results obtained from this method are shown in the table on p.122.

Chapter XII

ELECTROCHROMATOGRAPHIC AND CHROMATOGRAPHIC METHODS
OF SEPARATING URANIUM FROM IRON.

Discussion.

The ether/nitric acid extraction of uranium was a necessary final step prior to fluorimetry in each of the methods of uranium isolation so far described. Any attempts to avoid using this extraction had led either to incomplete recovery of the uranium (eg. the $Al(OH)_3$ precipitation p. 71), or to the presence of "quenching" ions in the final uranium solution (eg. the mercury cathode electrolysis method Chap.VI). Attempts were now made to find an alternative method for this purification of uranium.

The complete removal of iron by ether/HCl extraction was not possible because in very low concentrations of iron the efficiency of this extraction decreases⁽⁶⁹⁾. On extracting 5ml. of 6.5 N HCl containing $\mu g.$ Fe^{+++} , several times with ether/6.5 N HCl, each of the ten aliquots taken from the final aqueous phase still contained sufficient iron to cause 25% quenching of the phosphors. Two new methods were therefore investigated: electrochromatography and chromatography involving liquid flow.

Electrochromatography.

The initial work on the electromigration of ions had been

**ELECTRO-CHROMATOGRAPHY
BY THE METHOD OF
DURRUM.**

FIG. 6.

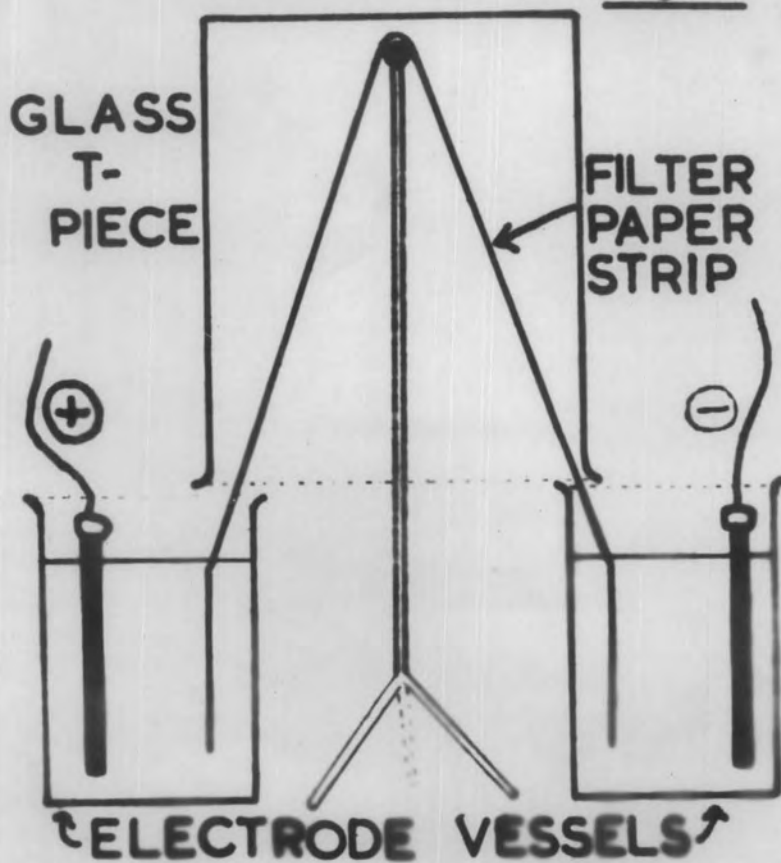

done by investigators whose publications are listed in ref. (70). The first separation utilising electromigration, without liquid flow was carried out by Strain⁽⁷¹⁾ in 1939, when he separated dyes in a column of moist absorbent. Separations of proteins and amino-acids by this method were carried out (see ref. (72).) Durrum⁽⁷³⁾ named the technique electrochromatography and was among the first to use the method for the separation of inorganic ions (see also ref. (74)).

It therefore appeared possible that the small quantity of iron remaining with the uranium after a small-scale ether/HCl extraction could be separated from the uranium if the two elements behaved differently during electrochromatography.

Experimental.

The method of Durrum⁽⁷⁵⁾ was first investigated. A strip of Whatman No.1 filter-paper 3cm. x 25cm. was hung over a glass T-piece (see fig.6), its two ends passing into two electrode vessels (250ml. beakers). The electrolytes used in the protein separations had been various buffer solutions. For this present attempted separation it was necessary that the acidity should be sufficient to prevent hydrolysis of the iron salts, so a buffer solution of pH 3.42 was prepared (190ml. 0.2N CH_3COOH + 10ml. 0.2N CH_3COONa). Carbon rods were used as electrodes and the power-pack used was capable of producing voltages from 50-400v (D.C.) (maximum current was 8 m.a.).

Investigating the Effect of Electrochromatography on Iron.

1mg. Fe in a drop of dil. HCl was placed in the centre of a strip of the paper which was then hung over the T-piece so that the Fe was at the apex. The paper was moistened with buffer solution to within 2-3 cm. of the apex at each side. Capillary attraction then caused the liquid fronts to join at the top. The strip was protected from aerial contamination by an inverted 400ml. beaker, resting across the tops of the two electrode vessels. A current of 2 m.a. was passed for 3 hours at 350v, after which the paper was dried and sprayed with ammonium thiocyanate solution to develop the iron stain. The red coloration indicated that the Fe had migrated 3-4 cm. towards the cathode.

Investigating the Effect of Electrochromatography on Uranium.

The above test was repeated using 2.5×10^{-5} g. uranium (as $UO_2(NO_3)_2$) substituted for the iron. After a similar period of electrolysis, the paper was dried and then sprayed with $K_4Fe(CN)_6$ solution. The brown spot of uranyl ferrocyanide was situated at the origin. It therefore appeared probable that a mixture of Fe and U treated in this way would be separated by migration of the ferric ions from the stationary uranium.

Mixtures of Iron and Uranium.

A mixture of iron and uranium was treated in a similar manner to that described for the separate elements, but the

electrolysis was continued overnight. After drying the paper it was seen that the iron had moved more than halfway towards the liquid surface in the cathode vessel (i.e. about 5 cm. from the origin). The origin was then sprayed with KI solution to reduce any ferric iron to ferrous, and the paper was then resprayed with $K_4Fe(CN)_6$ solution which again showed no movement of the uranium.

Several electrochromatograms of U or U/Fe mixtures were examined by cutting the paper into 8 m.m. strips across its length, the strips then being ignited in fluorimeter trays and phosphors prepared. It was shown that all of the uranium always lay within 2 cm. either side of the origin. Sometimes the peak of the U band was slightly on the anode side and sometimes slightly on the cathode side, presumably depending upon which side of the origin the buffer solution had first reached the apex. (It was attempted to cause the buffer solution to reach the top from both sides simultaneously).

Quantitative Tests with Uranium.

Tests were next carried out to discover if the uranium could be quantitatively recovered from the paper. $1.247 \times 10^{-5} g$ in solution was placed on a 4 x 2 cm. piece of filter-paper which was then air-dried. The paper was placed in a 50ml. beaker with 10ml. conc. HNO_3 and on boiling, the paper formed a homogeneous suspension of minute fibres. The solution was

adjusted to 10ml. and 1ml. portions were evaporated to dryness in fluorimeter trays by radiant heat. The small deposit of carbon formed on the trays disappeared when fusion of the NaF commenced. It was found that $100 \pm 1.5\%$ recovery of the U was obtained and that no "quenching" ions had been introduced into the phosphors by the procedure.

This technique was then applied to an electrochromatographic separation of 1.247×10^{-5} g. U and 2mg. Fe. Quantitative recovery of the uranium was obtained but 25% "quenching" was shown to be occurring in each of the 10 phosphors. This indicated that just over 75% of the iron had been removed from the zone lying within ± 2 cm. of the origin. Longer periods of electrochromatography produced no improvement in these conditions and it was thought that hydrolysis of the stationary Fe had occurred, due to the low acidity. A buffer solution of pH 2.00 (50ml. $\text{NCH}_3\text{COO Na} + 100\text{ml. N HCl}$ diluted to 250ml) was then used, in an attempt to overcome this problem. Difficulty was encountered in keeping the current below 8 m.a. (maximum for the power-pack). The rate of movement of the Fe was lower than that observed with the original buffer solution and it appeared that the current was being carried almost completely by the electrolyte ions (H^+ , Na^+ and Cl^-) and very little movement of iron was taking place.

Other separations were then attempted using alkaline solutions in which the Fe and U were complexed with organic anions (see Strain and Sullivan⁽⁷⁶⁾). Using 4N NH₄OH with either oxalic or salicylic acids as complexing ions some movement of Fe towards the anode was observed, while the U remained stationary, but the efficiency of separation was inferior to that obtained with the sodium acetate/acetic acid buffer solution and the author therefore reverted to this more promising electrolyte for further experiments.

After an "overnight electrolysis" of 1mg. Fe and 1.247×10^{-5} g. U with the original buffer solution, the paper was moistened slightly at the apex and the electrolysis was then continued for a further 3 hours. "Quencher"-free phosphors were obtained but only 75% U recovery was achieved. Tests in which the buffer solution was allowed to flow down a paper strip showed that U and Fe on the strip were rapidly washed from their origin positions. The technique of moistening the paper could not therefore be used, but the drying of the paper appeared to be the cause of the immobility of part of the iron.

Electrochromatograms.

To study the behaviour of the iron during the process of electrochromatography a series of chromatograms of iron were prepared by cutting the paper into 0.8 ins. strips across its length and then measuring the amount of iron in each strip by a

MOVEMENT OF IRON DURING ELECTRO-CHROMATOGRAPHY.

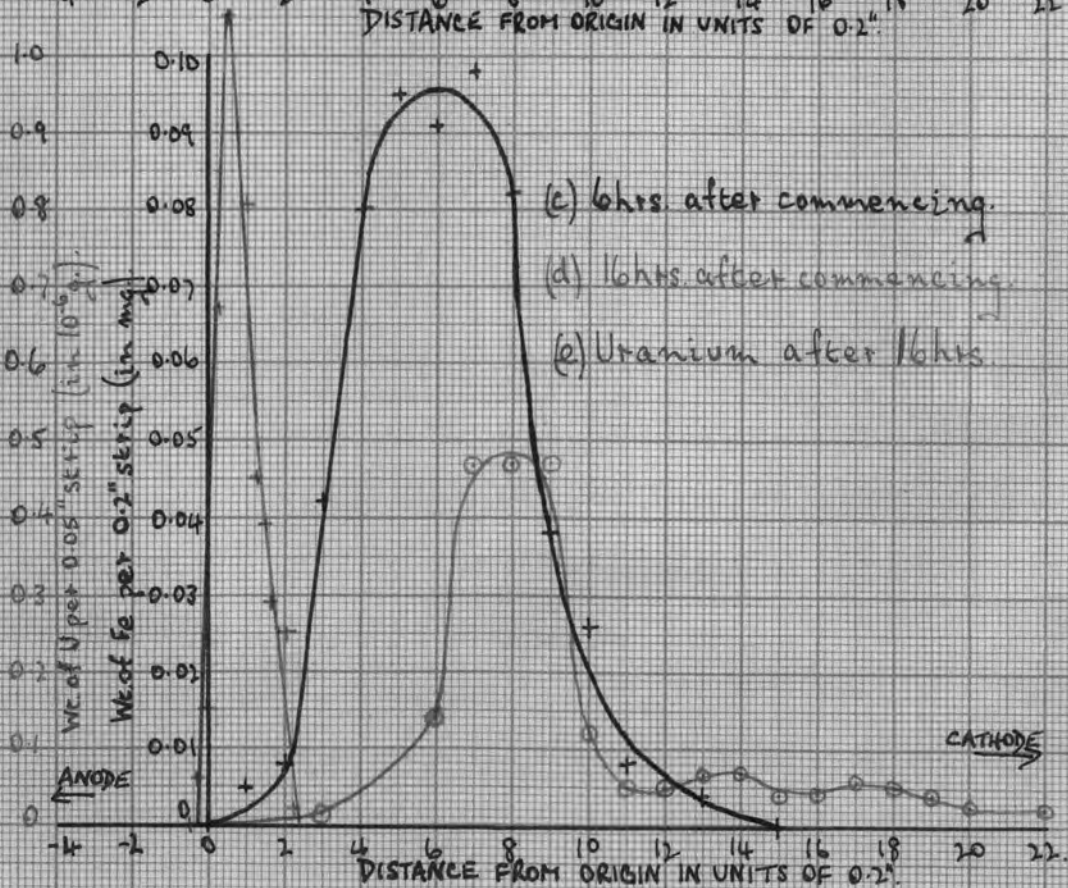
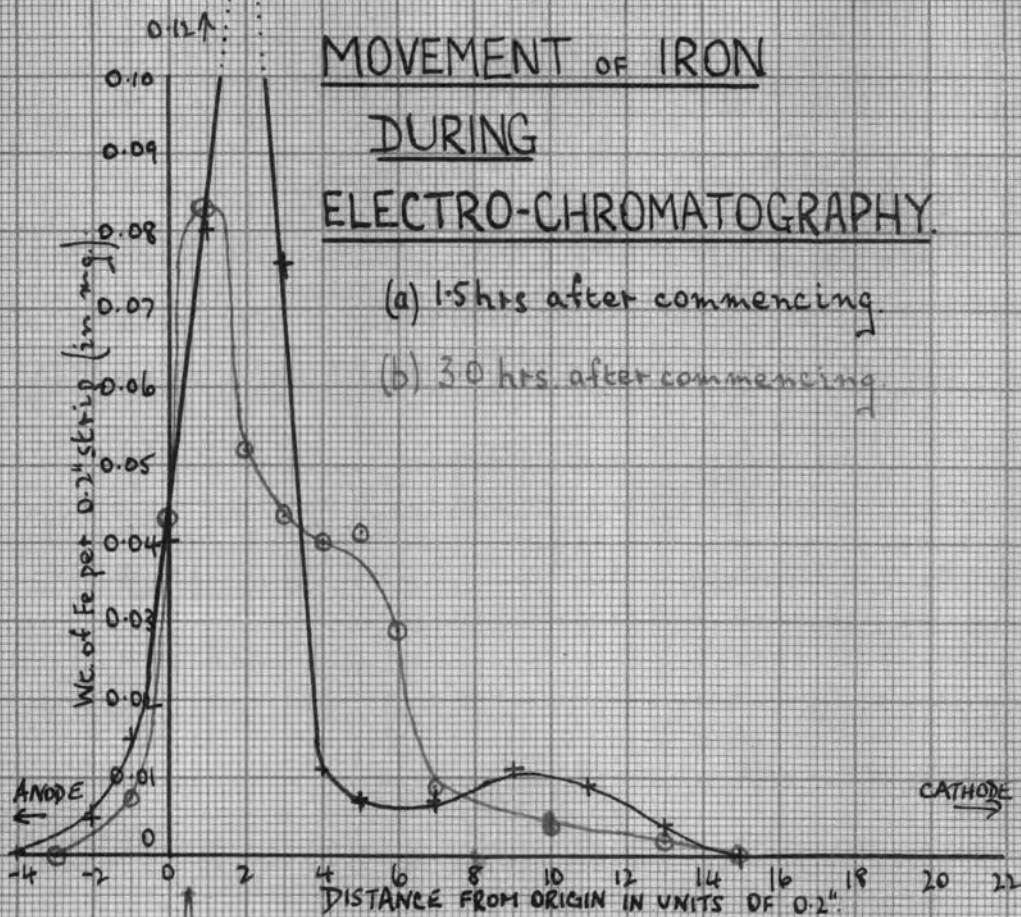

colorimetric method described by Vogel⁽⁷⁷⁾ using thioglycollic acid as the developing agent. The results are shown graphically on the opposite page. It can be seen from the graphs that even after 16 hours electrochromatography, the peak of the iron band was still only 1.5 ins. from the origin and was virtually stationary. During later experiments, when the room temperature was higher, the stationary Fe peak was even closer to the origin and it became impossible to move the Fe more than 0.75 ins. from the origin. The subsequent uranium estimations showed that as much as 50-60% "quenching" was occurring.

The effects observed bore a striking resemblance to those subsequently described by Machebeuf⁽⁷⁸⁾, in a recent paper. He describes how countercurrents due to diffusion of the buffer solution, in replacement of solvent evaporated from the paper, immobilise the migrating ions at points where the effects are equal and opposite. The effect, which is named electro-rheophoresis, results in the formation of bands of the various cations at varying distances from the origin on the cathode side.

Electrochromatography in an Enclosed Space.

To avoid the detrimental effects of this evaporation, the process was carried out in an enclosed vessel. The electrolyte vessels were placed on a large glass plate, through which was drilled a small hole for the wire leads, and the whole cell was

covered with a large bell-jar which made a good greased contact with the glass plate, so preventing air currents inside the system. The air inside was kept saturated with water vapour from a water trough with a cotton-wool wick. Overnight electrochromatography resulted in complete removal of iron from the paper strip into the cathode vessel and the paper was seen to be quite moist. However, on repeating the test with uranium it was found that the uranium also migrated towards the cathode. It was at first thought that this movement may have been due to electrolyte flow along the paper, because the liquid levels in the two electrolyte vessels may have been unequal. This was disproved by making the liquid level in the cathode vessel higher than that in the anode vessel when it was found that the uranium had again moved towards the cathode. The bell-jar was observed to be covered on its inside surface with condensed moisture and the increase in the humidity was apparently the cause of the change in the behaviour of the uranium.

If the previous immobility of the uranyl ion had been due solely to electro-rheophoresis it would be extremely unlikely that the U band would be found exactly at the origin (or even slightly on the anode side, as it sometimes was) and the effect could not therefore be due to the uranyl ion having a slower migration velocity than the ferric ion. Further proof of this



ELECTRO-CHROMATOGRAPHY

BETWEEN GLASS PLATES,

CARBON ELECTRODES

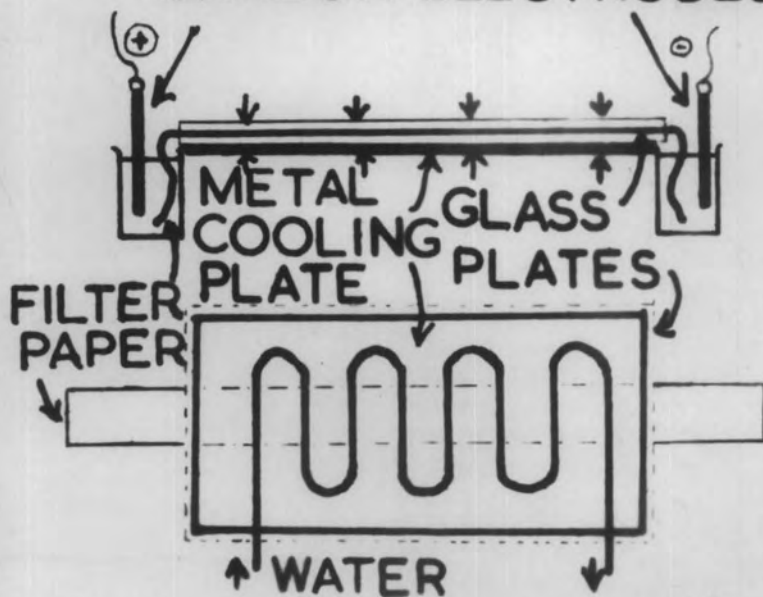

FIG. 8.

was obtained when it was shown that the two substances were moving with similar velocities in the enclosed system. The cause of the immobility of the UO_2^{++} ion in the initial experiments was therefore unknown.

Further attempts to obtain conditions under which the uranium remained stationary while the iron moved a sufficiently great distance from the origin to allow "quencher"-free phosphors to be prepared, proved unsuccessful. Experiments were made in which the water-trough and the cotton-wool wick were removed, also the bell-jar was used supported on small blocks so that the paper was shielded from direct air-draughts but was not entirely enclosed from the outside air. However, these tests were unsuccessful in that they either resulted in the insufficient removal of the Fe from the stationary U, or else the Fe and the U both moved away from the origin and were not separable from one another.

Attempts using the technique of Durrum were therefore abandoned and the apparatus described by Foster⁽⁷⁹⁾ was then used for investigations.

Electrochromatography between Glass Plates.

This technique involved placing the filter-paper strip between two glass plates which rested on a water-cooled metal plate so preventing any rise in temperature during electrochromatography. Foster reports that without the cooling

MOVEMENT OF IRON AND URANIUM DURING ELECTRO-CHROMATOGRAPHY BETWEEN GLASS PLATES.

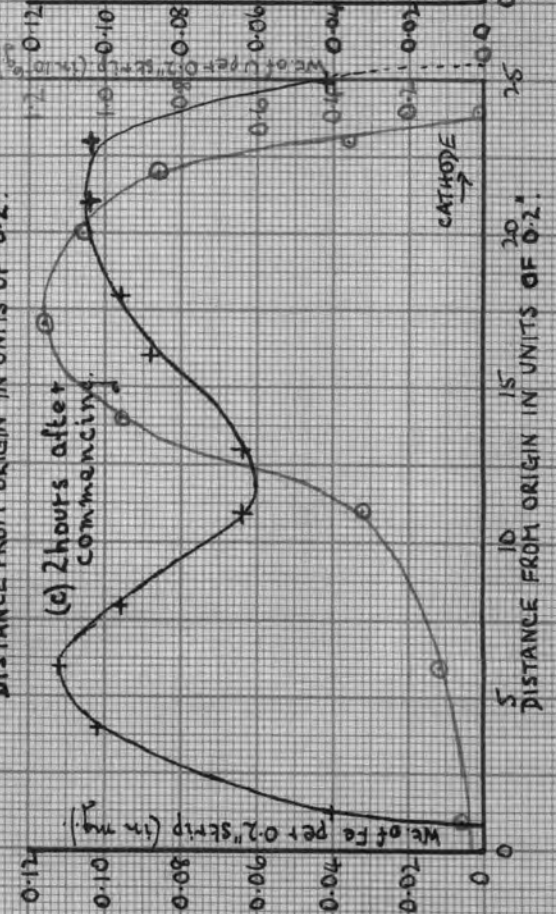
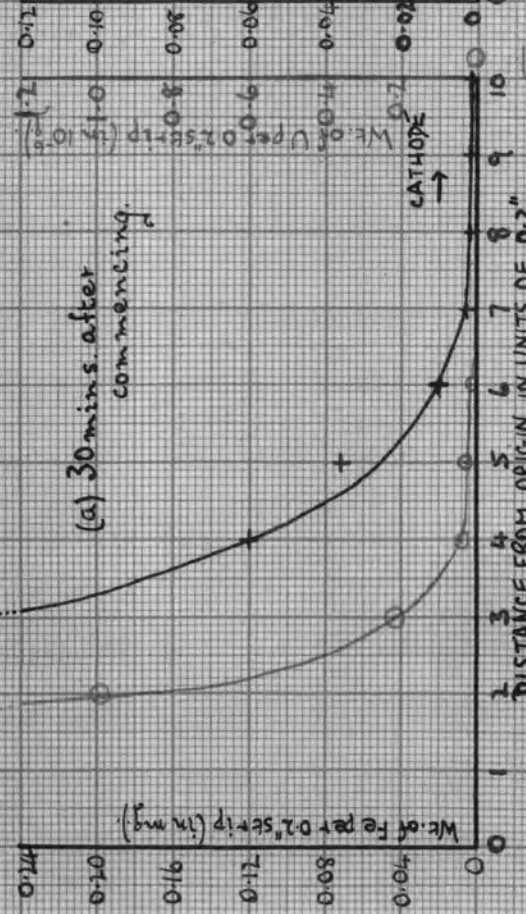
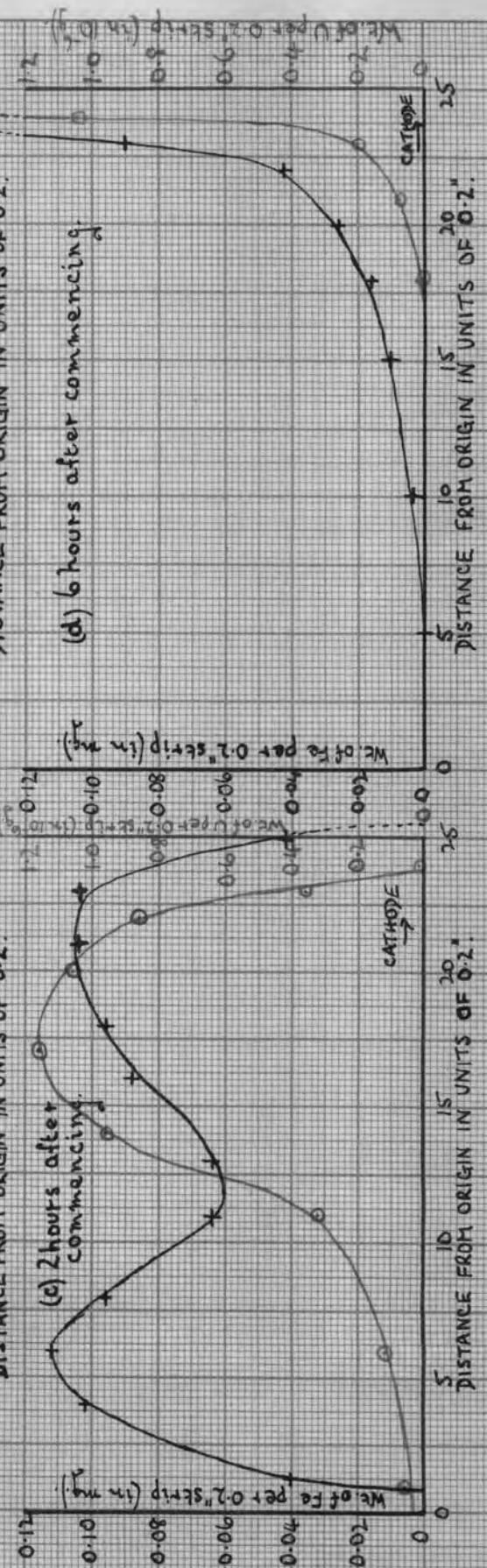
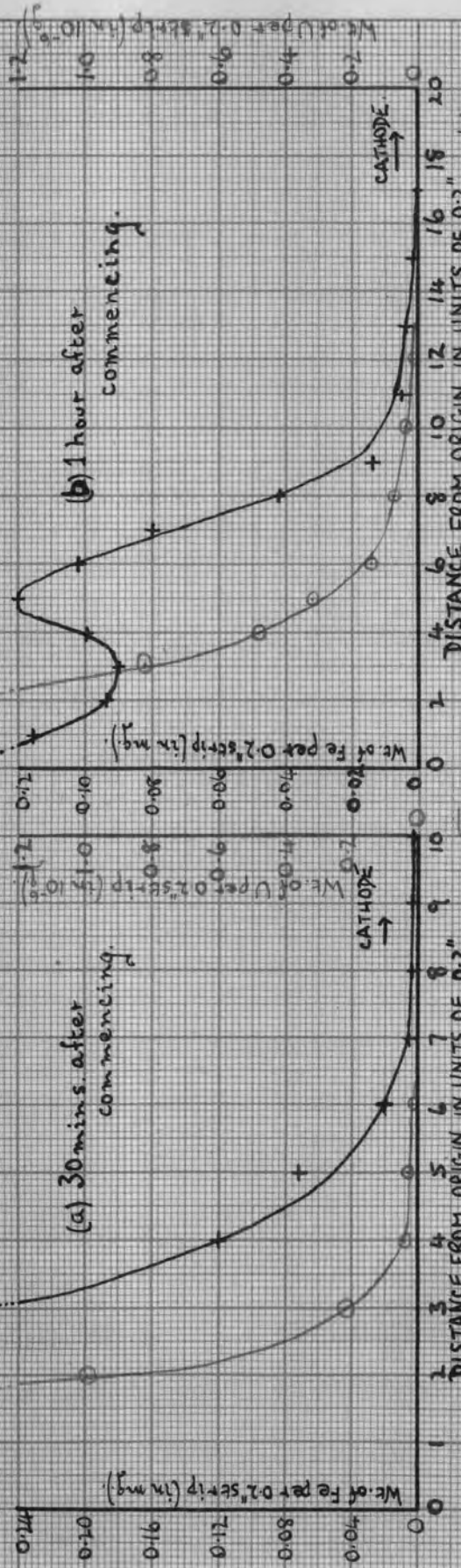

system the temperature rose by 20-25°C. The paper strip was immersed in the buffer solution on each side almost up to the origin line and was then partially dried by compression between two sheets of absorbent paper using a rubber roller. A drop of the iron or uranium solution was applied at the origin and the moist paper was inserted between the glass plates which were then clamped on to the cooling plate. The ends of the filter-paper were dipped into the buffer solution in the electrode vessels. (see Fig.8).

The behaviour of both iron and uranium after varying periods of electrochromatography was studied and results are shown graphically on the opposite page. It can be deduced that complete separation of uranium and iron by this method was not possible because the two elements behaved similarly. Attempts to separate the two elements by the method of electrochromatography were therefore concluded.

Other elements examined by the method of Durrum were Al and Th. It had been thought that the uranium remaining with sub-milligram quantities of Fe after small scale ether/HCl extractions of the latter element might be precipitated with the iron on a small but manageable quantity of $Al(OH)_3$. The behaviour of the Al during the electrochromatography was therefore of interest. Aluminium was used as an indicator for the Al and it was observed that the Al moved similarly to the Fe under the conditions in which the U had remained stationary.

The technique of separating U and Th by electrochromatography had also been attempted, but it was discovered that the Th remained practically stationary with the U using these conditions. 1(-o-arsenophenyl-azo)-2-naphthol-3:6-disulphonic acid had been used as an indicator for the position of the Th. The behaviour of the Th during the glass-plate electrochromatography was not studied.

Solvent-Flow Chromatography.

The separation of uranium from many other elements by the method of solvent-flow chromatography has recently been described by several workers⁽⁸⁰⁾. The technique usually involved the removal of uranium as uranyl nitrate using certain organic solvents (eg. ether, tetrahydroxyvan, ethyl acetate etc.) containing HNO_3 , as the washing-out agent. The process could be carried out either on a column of adsorbent material (eg. cellulose) or on strips of filter paper. The latter method is more suitable for work involving micro-quantities of the substances to be separated and analysed.

The separation of uranium, iron and aluminium has been described by Lacourt, Sommereyns and Soete⁽⁸¹⁾. They used acetone containing 5% HCl as the washing-out agent and the separation was carried out in an atmosphere saturated with benzene. The separation depended upon the different rates of movement of the three substances. However, for

SOLVENT-FLOW CHROMATOGRAPHY



quantitative recoveries in micro-analytical work, the ideal separation would be one in which the substance being studied remained stationary on the column or paper strip, while the other substances were removed by the solvent flow.

The apparently almost complete insolubility of uranium in ether equilibrated with 6.5 N HCl suggested the use of this solvent as a means of separating Fe and U chromatographically. It has already been recorded (p.94) that the complete extraction of Fe with ether/6.5 N HCl could not be successfully carried out. The iron could not be removed below the fluorimetric tolerance limit for 10 phosphors. However, using a continuous flow of the solvent through the extremely small effective volume of the filter-paper strip, it was thought that almost complete removal of iron might be achieved.

Chromatography Using Ether/6.5 N HCl Flow.

A 2 x 25 cm. strip of Whatman No.1 was used as the absorbent and at its centre was placed 1mg. Fe as $FeCl_3$ in dil. HCl. The paper was air-dried and the boundaries of the iron were lightly marked with pencil. One end of the paper was folded over about 2-3 cm. above the Fe boundary and that end was inserted in a 50ml. beaker filled with ether, previously equilibrated with 6.5 N HCl. The liquid was allowed to flow by capillary forces down the paper. It was soon discovered that the rate of evaporation of the ether from the paper was greater than its replacement by flow. It was

necessary to carry out the treatment in a closed system, under a bell-jar (see Fig.7).

When the atmosphere inside the bell-jar became saturated with the solvent, the latter began to flow down the paper strip. On reaching the zone containing the iron, the solvent began to elute the iron. After several hours the yellow band of FeCl_3 was completely below the pencilled starting zone. This part of the paper was cut out and dissolved in hot conc. HNO_3 to which was added 1.247×10^{-5} g. U. The solution was diluted to 10ml., 1ml. portions being used in the preparation of NaF phosphors. When the phosphors were examined fluorimetrically it was shown that they were entirely "quencher"-free and that the amount of Fe which had not been removed from its original position was less than 2×10^{-5} g.

The behaviour of uranium during this procedure had then to be examined.

1.247×10^{-5} g. U (as uranyl nitrate solution) was placed on a strip of filter-paper and the experiment was repeated. The paper was then cut into 0.1" strips across its length and these were analysed fluorimetrically for uranium. It was found that the uranium had remained inside its initial boundaries.

Further tests were carried out using mixtures of iron and uranium, and in all cases the uranium was quantitatively

REMOVAL OF IRON BY SOLVENT-FLOW

CHROMATOGRAPHY.

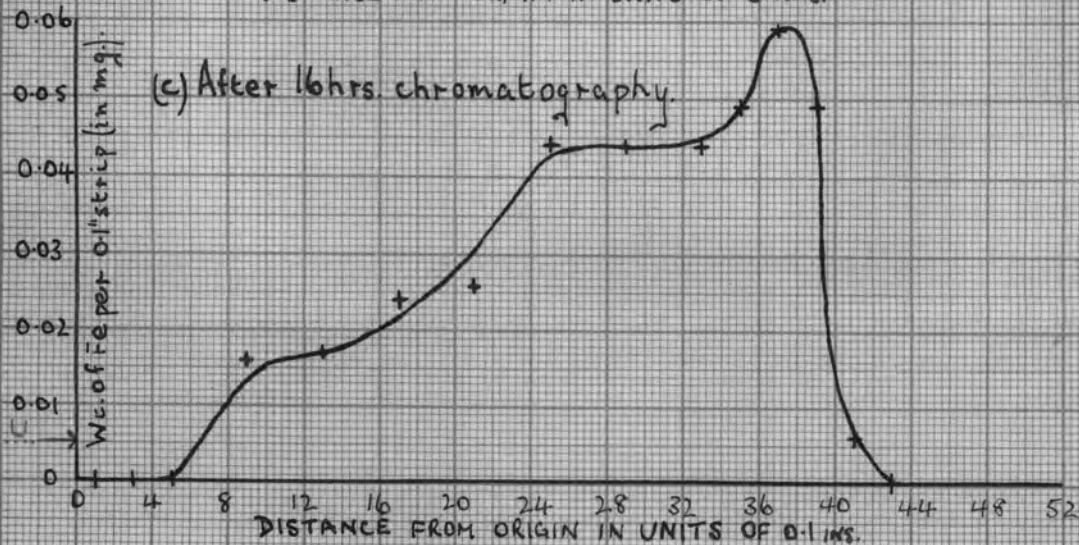
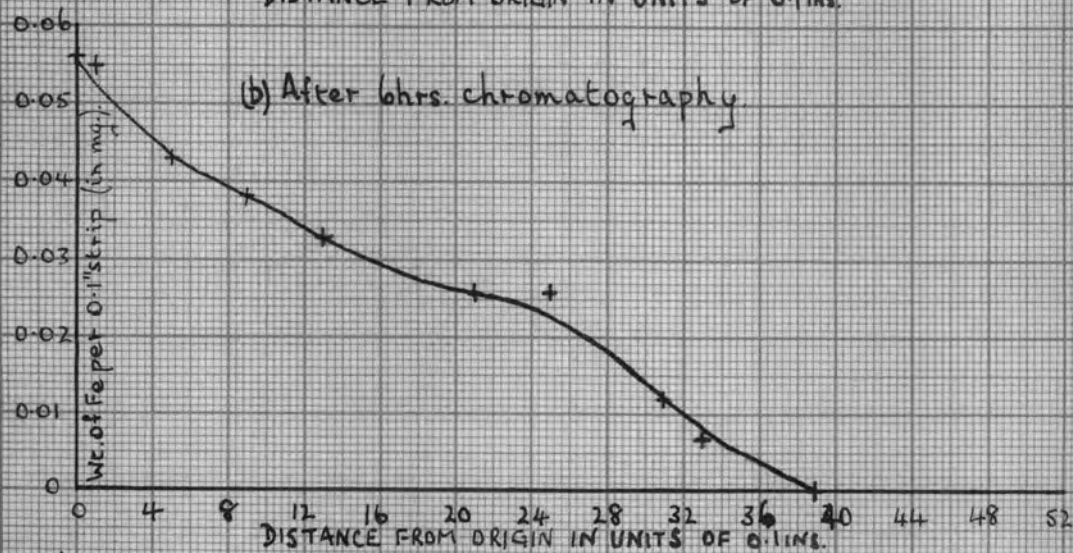
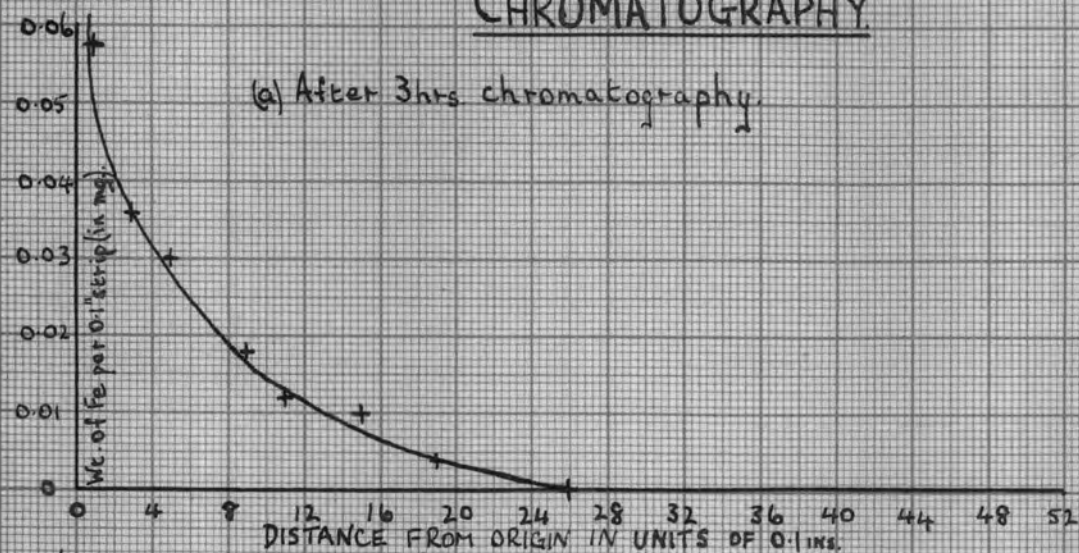

recovered from the paper free from iron quenching.

Recoveries of uranium were:- (a) $99.2 \pm 2.9\%$
(b) $101.9 \pm 1.5\%$. In subsequent tests U^{235} tracer was used in place of natural uranium, to test the validity of the method at the levels of U content at which it was going to be used (i.e. ca. 10^{-8} g. U). Again fully quantitative recoveries were achieved:- (a) $102.8 \pm 1.1\%$ (b) $98.2 \pm 1.7\%$ (c) $96.4 \pm 2.6\%$ (d) $93.2 \pm 1.7\%$.

In each case it was shown that the zone originally occupied by the Fe/ U^{235} mixture was "quencher"-free when dissolved and prepared into 10 NaF phosphors in the presence of known amounts of added uranium.

A series of chromatograms were prepared showing the elution of the Fe by the solvent and these are shown on the opposite page. They were obtained by colorimetric determinations of the Fe content of various strips cut across the paper, using o-phenanthroline as the developer (see Vogel⁽⁷⁷⁾). Results showed that the Fe was completely removed while the U remained stationary on the paper.

The method was now ready for application to actual meteorite determinations provided that a method could be found whereby the uranium could be extracted from the sample on a sufficiently small quantity of iron for the filter-paper treatment.

Separation of Uranium Prior to Solvent Flow Chromatography.

On extracting several mg. of Fe in 5ml. 6.5 N HCl two or three times with an equal volume of ether/6.5 N HCl in a small centrifuge tube, the amount of iron remaining in the aqueous layer was sufficient to produce a small manageable precipitate on being treated with ammonia followed by centrifugation. The centrifuge tube used was specially made with its lower end tapered, but with thick glass walls to withstand the pressures during centrifugation. The upper end was fitted with a B 14 ground glass socket into which fitted a cone stopper so that ether/HCl extractions could be performed in the tube.

5mg. Fe and 1.247×10^{-5} g. U in 3-4ml. 6.5 N HCl were extracted twice with 5ml. ether/6.5 N HCl mixture in the small centrifuge tube. The ether layers were removed using a drawn out glass dropper. Before precipitating the small amount of Fe remaining with CO_3^{H} - free NH_3 gas, the ether dissolved in the aqueous layer had first to be removed otherwise NH_4Cl was precipitated on passing the NH_3 into the solution. This was effected by warming the tube in a water-bath while air was gently blown in through the thin glass-dropper to promote even boiling. The aqueous layer was then diluted to 8ml. (i.e. 2N), with water and the NH_3 gas was passed into it through the glass dropper. The small precipitate was centrifuged and collected in the tip of the tapered tube. The

liquid was poured off and about three drops of dil. HCl were washed round the inside walls of the tube which was then rotated in the centrifuge so that the liquid collected at the bottom of the tube and dissolved the precipitate. This solution was transferred using the dropper to the filter-paper which was air-dried. A further washing of the tube with three drops of dil. HCl was carried out and these were added to the paper. The position of the Fe/U mixture on the paper was marked and chromatographic separation was carried out. Recoveries using 1.247×10^{-5} g. U of known activities of U^{233} were often quantitative but occasionally the efficiency was 80-90%. Presumably the coprecipitation of the U on such a small quantity of $Fe(OH)_3$ was not always quantitative. For analytical work it was necessary that any such losses should be accurately known. The U^{233} tracer solution was therefore used in an isotope dilution technique.

Isotope Dilution Technique Employing U^{233} .

The specific activity of U^{233} is almost 3000 times that of U^{238} . If this tracer is obtained in an isotopically pure state, amounts of it substantially less than those normally found in average meteorite samples, would give sufficient α - activity to be accurately measured. Hence a known activity of U^{233} (ca. 100 cts./min.) could be added to the sample without appreciably increasing the U in the reagent blank, when final

measurements were made fluorimetrically. A known fraction of the final U extract solution could then be measured for α - activity in the scintillation counter (only a negligible fraction of the count obtained would be due to the natural uranium). The efficiency of the U recovery would then be known and the necessary correction could be applied to the fluorimetric results for the total U. All of the methods of U extraction previously described gave consistently quantitative recoveries of U, and therefore there was no need to apply the technique to them. In the case of this chromatographic method the tracer was essential in order to obtain reliable results.

Before using the U^{235} solution it was necessary to prove that the quantity of uranium present in it would not cause a great increase in the reagent blank contribution (since all isotopes of uranium produce fluorescence in NaF phosphors).

Examination of the U^{235} Tracer Solution.

0.1ml. of the U^{235} solution produced sufficient activity to give a high statistical accuracy when measured for a few hours in the scintillation counter. (ca. 140 cts./min.). Assuming an efficiency of 30% for the counter, this was equivalent to 3.22×10^{-8} g. U^{235} /0.1ml. This was highly satisfactory from the point of view of maintaining a low reagent blank. A series of NaF phosphors containing 0.1ml. of the U^{235} solution were prepared and it was found that their U

content was 2.68×10^{-8} g. U/phosphor. This indicated that the tracer was virtually isotopically pure and could be used without risk of increasing the reagent blank.

The use of U^{233} in the scintillation counter involved no risk of contaminating the instrument if sufficient care was observed in avoiding mechanical contact of the source with the exposed parts of the phosphor and its supports. Unlike the three naturally occurring radio-active disintegration series, the artificially produced $4n + 1$ series contains no rare-gas member which might emanate and hence contaminate the counter. No increase in the background of the counter was observed after measurements involving U^{233} .

After performing a determination with a known activity of U^{233} present, that part of the paper containing the uranium was removed and was digested with conc. HNO_3 . One-tenth of it was evaporated on a source-disc, the rest being used for fluorimetric analyses. Difficulty was met with in producing a U^{233} source which was sufficiently "weightless" to produce no self-absorption of the α - particles. Using the polystyrene source discs normally employed with the scintillation counter, this could not be achieved. Platinum discs were therefore used. They had been employed by previous workers⁽⁸²⁾ with the scintillation counter but their α - particle background count (ca. 4α 's/hr.) was not satisfactory for low activity

determinations, whereas when used with U^{235} sources this was no disadvantage. The aliquot of solution was dried by radiant heat on the Pt disc and the carbon deposit was then gently volatilised using a micro-burner. This procedure resulted in reproducible source preparations.

Application to Meteorite Analyses.

As previously explained, whenever possible it was desired to measure both the U and Th content of the meteorite samples. It was therefore intended to utilise the chromatographic separation of U and Fe following the separation of U and Th by the organic reagent method described in Chapter XI.

The mother liquor from this separation contained all of the U, and after boiling with conc. HNO_3 to destroy the organic reagent it was shown that the hydroxide precipitate, obtained on treating this solution with NH_3 gas, contained all the uranium present. This was proved using U^{235} and measuring the activity on an aliquot of the precipitate after removal of the bulk of the Fe by ether extraction and also by fluorimetric analysis of the natural uranium obtained after a small ether/ HNO_3 extraction of the dissolved precipitate. However, the precipitate not only contained a small amount of the meteoritic iron (not removed by previous ether/ HCl extractions), but also nearly all of the chromium from the sample. (Some of the Cr remains in solution after NH_3 precipitation as

complex chromeammine ($\text{Cr}(\text{NH}_3)_6(\text{OH})_3$). This Cr could not of course be removed by either ether/HCl extraction or chromatography, and since its presence with the U would cause "quenching" of the NaF phosphors, a method had to be found for separating U from Cr, so that the only "quenching" substance present with the U would be Fe (which would later be removed by chromatography).

It could not be expected that the Cr could be removed using repeated NH_3 gas treatment by which the chromium remained partially in solution as chrome-ammine, because only a small fraction of the element appeared to be separated in this way.

Chromic salts when treated with excess NaOH solution yield a green solution containing sodium chromite, NaCrO_2 , whereas iron and uranium yield precipitates insoluble in excess of the reagent. However, when Fe^{+++} and Cr^{+++} were both present it was found that NaOH solution failed to give a satisfactory separation, some of the Cr^{+++} being precipitated and some Fe^{+++} remained in solution. It was therefore probable that the uranium would also remain partially in solution during this treatment.

Attempts were then made to remove the chromium as perchromic acid: this acid is soluble in ether. A few mg. Fe and Cr as chlorides with added U^{235} were treated first with NaOH solution and then the mixture was boiled after addition

of Na_2O_2 . The Cr formed sodium chromate. After cooling, ether was added and the mixture was acidified with dil. H_2SO_4 . On shaking, the blue perchromic acid appeared in the ether layer. Although it was shown that less than 1% of the U^{233} was lost during this treatment, the technique was inadequate because the perchromic acid was unstable at room temperature and much of the Cr remained in the aqueous phase.

UO_2^{++} and Fe^{+++} both have ferrocyanides, insoluble in acetic acid, whereas Cr does not yield or precipitate under these conditions. Tests were carried out to discover if the desired separation could be effected by this means.

A solution of 5mg. Fe and several mg. Cr with 0.1ml U^{233} solution present, in dil. HCl, was treated with NH_3 gas, and the resultant precipitate after centrifugation was dissolved in 20ml. 1:1 acetic acid-water mixture. 5ml. of a saturated solution of $\text{K}_4\text{Fe}(\text{CN})_6$ was added. The precipitate required about 10 mins. centrifugation before it was suitably separated, but the mother liquor was then yellow in colour showing that the ferric ferrocyanide (blue) had not redissolved in excess reagent. (If this had occurred the solution would also have been blue).

The precipitate was formed into a slurry with water and one-tenth of it was evaporated on a Pt disc (for scintillation counting). The dry residue was strongly heated with a

burner and the amount of ferric oxide remaining as a source was sufficiently small to permit α - counting without self-absorption. The precipitate was shown to contain:-

(a) $98.2 \pm 0.8\%$ and (b) $100.8 \pm 1.6\%$ of the available U^{235} .

The chromium had been satisfactorily removed.

The problem still remained of how the uranium could be recovered from the precipitate in a suitable state for chromatography. On treating ferric ferrocyanide with caustic alkalis it decomposes to $Fe(OH)_3$ and $K_4Fe(CN)_6$. However on centrifuging of the $Fe(OH)_3$ precipitate and dissolving it in conc. HCl (ready for other extraction of Fe), much $Fe_4(Fe(CN)_6)_3$ remained and this could not of course be removed by ether.

On boiling the $Fe_4(Fe(CN)_6)_3$ precipitate with 1-2ml. of conc. H_2SO_4 complete decomposition of the anion occurs. However, when the acid was cooled and diluted with water, a pale brown precipitate appeared which could not be dissolved, even with hot aqua regia. The precipitate was found to carry between 5 and 10% of the U^{235} when this tracer was present during the reaction. If, however, the conc. H_2SO_4 after cooling was treated cautiously with conc. HCl (about 25ml. in all), the precipitate did not appear, and on further dilution of the mixture with water the salts remained in solution. No blue coloration was seen, the iron being present as $FeCl_3$. The diluted solution was evaporated to 75ml. and then further

diluted to 150ml with H₂O. On passing CO₂^H-free NH₃ gas the ferric hydroxide precipitated; this was centrifuged, dissolved in 5ml. conc. HCl and extracted twice with ether/6.5 N HCl. Experiments with U²³³ tracer present showed that the aqueous phase contained (a) 98.6 ± 0.9% and (b) 98.6 ± 1.9% of the available uranium. These recoveries were satisfactory, as the determinations were to be carried out in the presence of U²³⁵ as a check on the efficiency of recovery in each analysis. Although 1-2ml. conc. H₂SO₄ were present in the 150ml solution from which the Fe(OH)₃ had been precipitated, it appeared that complexing of the uranium did not occur when an excess of HCl was present (cf. p. 50).

Although two stages of the method were not consistently quantitative in their recoveries of uranium, it appeared that well over 50% of the U should be recovered by the complete procedure and any losses could be corrected for, by the isotope dilution technique using U²³³.

Testing the Complete Procedure.

1.247 x 10⁻⁵g. U, 0.1ml. U²³³ solution, 5mg. Fe and several mg. Cr (representing a meteorite solution prior to separation of U and Th) were mixed in 0.2 N HNO₃ (10ml.). (In an actual meteorite determination it is advisable to remove all the Fe by ether extraction, and then add 5mg. Fe at this stage). 10mg. Zr solution was added followed by a 5%

aqueous solution of 1-(o-arsono-phenyl-azo)-2-naphthol-3:6-disulphonic acid. The Zr precipitate was centrifuged off, and the mother liquor was boiled with conc. HNO_3 to decompose the organic reagent. (In meteorite analyses the U^{233} was added after the separation of U and Th. It was known from the previous method that the U was always quantitatively present at this stage, and the addition of high activities of the tracer before removal of the thorium would involve a risk of contamination of the PbS extracts). CO_3^{2-} -free NH_3 gas was then passed into the solution, and the Fe and Cr hydroxides were centrifuged off. These were then dissolved in 1:1 acetic acid-water mixture (20ml.) and 5ml. $\text{K}_4\text{Fe}(\text{CN})_6$ solution (saturated) were added. The mixture was centrifuged for 10 mins. and after decanting the mother liquor, the precipitate was boiled in the centrifuge tube for 2 mins. with 1-2ml. conc. H_2SO_4 . After cooling 25ml. conc. HCl were cautiously added, followed by 100ml. distilled water. The solution was reduced to 75ml by boiling and then was diluted to 150ml. CO_3^{2-} -free NH_3 gas was passed into the solution and the $\text{Fe}(\text{OH})_3$ precipitate was centrifuged off. It was then dissolved in 3-4ml. dil. HCl and transferred with washings to the special small centrifuge tube (capacity 10ml.). NH_3 gas was again passed into this using a long dropping tube and the $\text{Fe}(\text{OH})_3$ (ca. 10mg. Fe) was centrifuged off. This was dissolved in 3-4ml. conc. HCl

(8.7 N), (if 6.5 N HCl was used, the acidity was reduced below the optimum for ether/HCl extraction of Fe). The HCl was shaken twice with 5ml. ether/6.5 N HCl in the tube, using the ground glass stopper. Each ether layer was removed with the glass dropper and the ether dissolved in the aqueous phase was removed by the technique previously described. The aqueous phase was diluted to twice its volume with water, and on passing NH_3 gas into the tube a small precipitate of $\text{Fe}(\text{OH})_3$ (ca. 0.2-0.5mg. Fe) was formed and was centrifuged off. This was dissolved in 2-3 drops of dil. HCl and air-dried (along with washings from the tube) on a strip of filter-paper. The paper was subjected to overnight chromatographic flow, inside a bell-jar and the original zone was cut out and dissolved in conc. HNO_3 . One-tenth of this was evaporated on a Pt disc and its activity was determined in the scintillation counter. The rest was used in the preparation of NaF phosphors.

Recovery of U^{235} was $102.4 \pm 1.8\%$ while fluorimetry showed that $100.9 \pm 1.8\%$ of the uranium had been recovered. Subsequent tests were carried out using only U^{233} to assess the recovery of U at the 10^{-8} g. level. Recoveries were (a) $90.8 \pm 2.4\%$ (b) $102.0 \pm 2.1\%$ and (c) $84.5 \pm 1.2\%$. It was also shown that the U-containing zone of the paper contained less than the tolerance limit of "quenchers".

Although recoveries were not consistently quantitative

a sufficiently high percentage of the uranium was extracted in a "quencher"-free state to enable meteoritic uranium to be determined by this method, providing that the extraction efficiency was checked using U^{235} .

The only new reagents to be used in this procedure were the acetic acid and the $K_4Fe(CN)_6$. No detectable quantity of uranium was found in 200ml. acetic acid, and on performing complete reagent blanks no noticeable increase in their U contents was found, and hence the $K_4Fe(CN)_6$ could not contain measureable quantities of the element.

Only two meteorites were analysed by this method, but both gave results in excellent agreement with those found using other procedures:- (1) Carbo:- (by this method), 0.57 ± 0.03 ; (by previous methods), 0.52 ± 0.02 , 0.45 ± 0.03 and 0.56 ± 0.04 . (2) Savik:- (by this method), 0.23 ± 0.02 ; (by previous methods) 0.25 ± 0.02 , 0.23 ± 0.04 , 0.18 ± 0.02 and 0.21 ± 0.03 . (also 0.20 ± 0.05 and 0.22 ± 0.05 by the radon method⁽⁵⁶⁾).

(All results in 10^{-8} g.U/g. meteorite).

Chapter XIII

RESULTS.

TABLE I Uranium and Thorium Contents of Meteorites and comparison with those obtained by previous workers.

TABLE II Helium Content, He³:He⁴ ratio, and mean Uranium and Thorium contents of certain meteorites.

TABLE III He³ content, and calculated cosmic-ray helium isotopic ratio at several selected "ages" .

TABLE 1
Iron Meteorites

NAME OF METEORITE	THORIUM CONTENT IN 10^{-8} g/g.	
	PEROXIDE SEPARATION	RESULTS BY PREVIOUS WORKERS
SAVIK	< 1.1	< 0.26 < 0.21
AHNIGHTO		
TOCOPILLA	< 1.0	1.9 ± 0.8
TREYSA		
TOLUCA (DURHAM)	< 0.5	< 1.05
SAN MARTIN	10.4 ± 1.47	8.0
BETHANY (AMALIA KRANTZ)	0.92 ± 0.27	
TOLUCA (HAMBURG)	2.38 ± 0.27	
THUNDA		
CARTHAGE		
BRENHAM TOWNSHIP (IRON PHASE)	< 0.7	
MUONIONAIIUSTA 11	< 1.1 0.60 ± 0.33	

URANIUM CONTENT IN 10 ⁻⁸ g./g.			
RETROGRADE EXTRACTION	PEROXIDE SEPARATION	Rn/Tn RESIDUE SOLUTION	RESULTS BY PREVIOUS WORKERS.
0.21 ± 0.03	0.18 ± 0.02	0.25 ± 0.02 0.23 ± 0.04 0.23 ± 0.02 *	0.20 ± 0.05 0.22 ± 0.05
0.56 ± 0.05		0.63 ± 0.08 0.61 ± 0.06	0.21 ± 0.08
	0.72 ± 0.03	0.65 ± 0.05 0.65 ± 0.06	2.3 ± 0.3
		0.69 ± 0.04 0.66 ± 0.04	0.70 ± 0.30
1.00 ± 0.08	0.65 ± 0.05 0.52 ± 0.06	0.50 ± 0.04 0.46 ± 0.04	0.86 ± 0.30
0.77 ± 0.03	0.75 ± 0.04		0.6
	0.53 ± 0.05		
	0.20 ± 0.02		
0.55 ± 0.04			0.8 0.24
0.41 ± 0.03			0.5 0.44
0.06 ± 0.02	0.05 ± 0.02		
	0.20 ± 0.04 0.18 ± 0.01		

TABLE 1

Iron Meteorites

NAME OF METEORITE	8- THORIUM CONTENT IN 10^{-8} g./g.		
	PEROXIDE SEPARATION	Zr/ORGANIC REAGENT.	RESULTS BY PREVIOUS WORKERS
COAHUILA		0.69 \pm 0.26	< 0.95
CARBO	0.63 \pm 0.20	0.68 \pm 0.19	
BETHANY (HARVARD)	2.46 \pm 0.58	0.94 \pm 0.18	
TAMARUGAL		1.60 \pm 0.21	
ARISPE		1.47 \pm 0.22	
HENBURY		2.96 \pm 0.42	
UWET		0.47 \pm 0.21	
BETHANY (LION RIVER)		< 1.5	

(Continued)

URANIUM CONTENT IN 10^{-8} g./g.			
RETROGRADE EXTRACTION	PEROXIDE SEPARATION	Zr/ORGANIC REAGENT	RESULTS BY PREVIOUS WORKERS
		0.40 \pm 0.02	< 0.5
0.45 \pm 0.03 0.56 \pm 0.04	0.52 \pm 0.02	0.57 \pm 0.03 *	
1.14 \pm 0.03	0.61 \pm 0.03	0.78 \pm 0.02	
		0.32 \pm 0.02	
		0.46 \pm 0.02	
		1.07 \pm 0.05	
		0.31 \pm 0.01	
		0.27 \pm 0.02	

* Final U Purification performed chromatographically.

The results obtained by previous workers, and included in the table as comparisons, have been published by Arrol and Jacobi⁽¹³⁾, Golden⁽⁵⁶⁾ and Davis⁽⁸³⁾. All were obtained using the radon-thoron method.

Errors stated are equivalent to σ

Where only a limit is stated for the Th content, this is equivalent to the mean result + 2σ and the chance that the actual Th content is greater than the figure stated is only 5%.

TABLE 1**Stone Meteorites.****(Continued)**

NAME OF METEORITE	Th. CONTENT IN 10^{-8}g./g. (PEROXIDE)	U CONTENT IN 10^{-8}g./g. (PEROXIDE SEPARATION)
BRENHAM TOWNSHIP (Silicate Phase)	5.3 ± 2.4	0.69 ± 0.17
AKABA	6.0 ± 2.1	0.84 ± 0.08
MONZE		4.8 ± 0.8

Terrestrial Iron.

NAME	THORIUM CONTENT IN 10^{-8}g./g. (PEROXIDE SEPH.)	URANIUM CONTENT IN 10^{-8}g./g. (PEROXIDE SEPARATION)
OVIFAK (DISKO)	1.52 ± 0.24	0.45 ± 0.04

TABLE 11

NAME OF METEORITE	He CONTENT in 10^{-6} cc./g.	He ³ :He ⁴ RATIO	U CONTENT in 10^{-8} g./g.	Th CONTENT in 10^{-8} g./g.
TAMARUGAL	23.59	30.9	0.32 ± 0.02	1.60 ± 0.21
CARBO	22.0	28.6	0.52 ± 0.02	0.66 ± 0.19
TOLUCA (DURHAM)	18.9	29.7	0.54 ± 0.04	< 0.5
ARISPE	5.32	27.4	0.46 ± 0.02	1.47 ± 0.22
BETHANY (AMALIA)	3.4	27.8	0.53 ± 0.05	0.92 ± 0.27
SAN MARTIN	1.76	16.8	0.76 ± 0.03	10.4 ± 1.4
HEMBURY	0.88	25.4	1.07 ± 0.05	2.94 ± 0.42
BETHANY (HARVARD)	0.36	17.8	0.84 ± 0.03	1.70 ± 0.38
COAHUILA	0.20	23.3	0.40 ± 0.02	0.69 ± 0.26
UWET	0.17	11.0	0.31 ± 0.01	0.47 ± 0.21
TOLUCA (HAMBURG)	0.16	19.6	0.20 ± 0.02	2.38 ± 0.27
MUONIONALUSTA 11	0.013		0.19 ± 0.01	0.60 ± 0.33
BETHANY (LION RIVER)	0.002		0.27 ± 0.02	< 1.5
SAVIK	< 0.0002		0.22 ± 0.02	< 0.21

TABLE 111

NAME OF METEORITE	He ³ CONTENT IN 10 ⁻⁶ cc./g.	He ³ :He ⁴ RATIO OF COSMIC He.		
		AGE 1.1x10 ⁸ y	AGE 0.9x10 ⁸ y	AGE 0.75x10 ⁸ y
TAMARUGAL	5.59	30.9	30.9	30.9
CARBO	4.87	28.6	28.6	28.6
TOLUCA (DURHAM)	4.34	30.0	30.0	30.0.
ARISPE	1.15	28.3	28.2	28.1.
BETHANY (AMALIA)	0.72	28.9	28.7	28.5
SAN MARTIN	0.25	36.5.	32.7	30.5
HENBURY	0.18	38.3.	35.1	33.1
BETHANY (HARVARD)	0.054	57.0	32.2	27.4

DISCUSSION OF RESULTS

Reliability and Accuracy of Results.

It will be seen from Table 1 that in practically all of the cases where a meteorite was analysed for uranium or thorium on more than one occasion, the agreement between the different results was fairly good, after taking into account the standard deviations stated.

The only serious discrepancy occurs in the case of the meteorite Bethany (Harvard):- U ($\times 10^{-8}$ g./g.) = (a) 1.14 ± 0.03 (b) 0.61 ± 0.05 and (c) 0.78 ± 0.02 ; Th ($\times 10^{-8}$ g./g.) = (a) 2.46 ± 0.58 and (b) 0.94 ± 0.18 . These variations are not altogether surprising, since this meteorite has a heterogeneous structure. The fragment from which the samples were taken for analysis contained a dark brown intrusion. The Widmannstätten figures at each side of it were of different form and orientation. The meteorite also contained several small shiny inclusions which did not exhibit Widmannstätten figures.

Comparison of the results with those obtained using the older radon-thoron method often showed excellent agreement, e.g. Savik and Treysa, although the older method usually led to greater standard deviations, despite the fact that larger amounts of the meteorites were used (50-250g.).

Several other meteorites showed disagreement in the results obtained by the different methods. For example, the

meteorite Topopilla when analysed by the Rn/Tn. method was found to contain $(2.3 \pm 0.3) \times 10^{-8}$ g.U/g. By fluorimetry, after retrograde extraction, its uranium content was found to be $(0.72 \pm 0.03) \times 10^{-8}$ g./g. On examination of the "residue" solution from the Rn/Tn method by the technique described in Chapter IX, the results (0.65 ± 0.05) and $(0.65 \pm 0.06) \times 10^{-8}$ g.U/g. were obtained. Similarly for Ahnighito the results were:- $(0.21 \pm 0.08) \times 10^{-8}$ g.U/g by the Rn/Tn method; $(0.56 \pm 0.05) \times 10^{-8}$ g.U/g. by the fluorimetric method after retrograde extraction; and (0.63 ± 0.08) and $(0.61 \pm 0.06) \times 10^{-8}$ g. U/g. by fluorimetric analysis of the "residue" solution.

It therefore appears that the more sensitive fluorimetric procedure for uranium analysis leads to results which are more accurate and reliable than those previously obtained.

Very few meteorites were analysed for thorium by both the thoron and the scintillation counting methods. In all cases the agreement was quite good, though often only the limit for the maximum thorium content could be stated. Again, in general, the scintillation counter, having a lower natural background count than the ionisation chamber, produced the more accurate results, although usually employing a smaller quantity of starting material.

Uranium Content of Meteorites.

The mean uranium content of the iron meteorites analysed by

Arrol, Jacobi and Paneth⁽¹³⁾(1942) was 0.70×10^{-8} g.U/g. while that obtained by Davis⁽⁸³⁾(1950) was 0.33×10^{-8} g.U/g. The mean uranium content of the twenty iron meteorites in Table 1 was 0.47×10^{-8} g.U/g.

Iron meteorites are therefore much poorer in uranium than are terrestrial minerals. Rankama and Sahama (ref.(39) p.632) quote the uranium content of igneous rocks to be 4×10^{-6} g./g. (Hevesy, 1932), while that of the upper lithosphere is 1×10^{-6} g/g (Tonkeieff, 1946). Silicate meteorites are also quoted as having a mean uranium content of 40×10^{-8} g./g., whereas the silicate meteorites analysed during the present work had a mean content of 2.1×10^{-8} g.U/g. (this figure is based on only three analyses).

Davis⁽⁸³⁾ analysed three pallasites (including Brenham Township) for uranium by the radon method, and in each case he found more uranium in the metal phase than in the olivine phase, e.g. Brenham Township:- (Fe), $(0.79 \pm 0.24) \times 10^{-8}$ g.U/g.; (silicate), 0.09×10^{-8} g.U/g. Using the fluorimetric method the author obtained the following results:- Fe, $(0.06 \pm 0.02) \times 10^{-8}$ g.U/g. and also $(0.05 \pm 0.02) \times 10^{-8}$ g.U/g.; (silicate) $(0.69 \pm 0.17) \times 10^{-8}$ g.U/g.

Thorium Content of Meteorites.

The mean thorium content of iron meteorites found by Arrol, Jacobi and Paneth was 4.0×10^{-8} g.Th/g. whereas the value from

the sixteen meteorites in Table 1 was, 1.79×10^{-8} g./Th/g. The meteorite San Martin had an exceptionally high content (10.4 ± 1.4) $\times 10^{-8}$ g.Th/g.) and on omitting this from the list, the mean thorium content of the others was 1.22×10^{-8} g./g. (It is of interest to note that the thorium content of San Martin found by the thoron method was 8×10^{-8} g./g.).

Silicate meteorites are quoted as having a mean thorium content of $200-400 \times 10^{-8}$ g./g. (Noddack and Noddack (1930) (see ref.(39) p.570), however the two meteorites examined during the present work had a mean thorium content of 5.7×10^{-8} g./g.

Terrestrial minerals are much richer in thorium than iron or stone meteorites. Basic igneous rocks are reported to have a mean thorium content of 390×10^{-8} g./g. while acidic igneous rocks contain 1150×10^{-8} g.Th/g. (Goldschmidt, 1937)

Terrestrial Iron.

The terrestrial iron Ovifak (Disko) (fully described by Bøggild⁽⁸⁴⁾) was analysed for uranium and thorium by the present author. It was found, rather surprisingly, to have these elements present in concentrations very similar to those found in meteorites, viz. $(0.45 \pm 0.04) \times 10^{-8}$ g.U/g. and $(1.52 \pm 0.24) \times 10^{-8}$ g.Th/g.

Sensitivity of the Analytical Procedures Used.

The analysis of the uranium content of iron meteorite s

could be successfully carried out on 10g. of starting material using the retrograde solvent extraction procedure. 2×10^{-8} g. uranium could be estimated with an accuracy of 10% When 20g. or more of the starting material were available, both the uranium and thorium in the sample were determined. 4×10^{-7} g. thorium could be estimated with an accuracy of 15% The amounts of the two elements present in silicate meteorites could be successfully determined using 0.5 - 3.0g. of starting material.

As previously explained, the "background" fluorescence of sodium fluoride is the factor which governs the ultimate sensitivity of the fluorimetric method of uranium analysis. If sodium fluoride of extremely low "background" fluorescence could be procured, the accuracy of the method and its lower limit of uranium detection would be substantially improved.

It is unlikely that the natural background count of the scintillation counter could be appreciably improved, and hence it appears that the thorium content of concentrated hydrochloric acid is the controlling factor on the sensitivity of the method at present. The removal of thorium from this reagent should lead to a definite improvement in the accuracy and sensitivity of the technique.

When sufficient meteorite sample for the determination of uranium only is available, the most suitable method to employ is

the retrograde ether extraction procedure, since the uranium content of the reagents involved is so low. When both the uranium and the thorium are to be analysed, the procedure involving the use of the organic precipitant for thorium, followed by the recovery of uranium by ether/nitric acid extraction is probably the best available technique⁽⁸⁶⁾. The quantity of the ether/nitric acid mixture to be evaporated is decreased to a minimum, and the reagents involved in the separation of the uranium and thorium do not require purification as did those in the original alkali-peroxide procedure.

The chromatographic technique for the separation of uranium and iron using the flow of ether equilibrated with 6.5N hydrochloric acid on filter paper absorbent, could possibly prove to be a useful tool in analytical procedures⁽⁸⁵⁾, although its application to meteorite analysis involves the risk of incomplete recovery of uranium, losses being corrected for by the use of U^{235} in an isotopic dilution technique.

While it was not employed in the analysis of iron meteorites, there is little doubt that the mercury cathode electrolysis procedure would prove to be a highly successful technique when used in conjunction with fluorimetry on starting materials composed of metals removable at a mercury cathode and in which uranium is present in concentration of 10^{-7} to 10^{-5} g./g.

The Age of Meteorites.

Until fairly recent times it had been assumed that the helium contained in meteorites originated entirely from the radioactive disintegration products (α - particles) from the uranium and thorium series. Since the helium content of different meteorites varies considerably (Savik $< 0.0002 \times 10^{-6}$ cc/g. Morden 38.1×10^{-6} cc/g.) while the uranium and thorium contents are fairly constant, the resultant "ages" varied from 0.8×10^6 yrs (Savik) to 6.6×10^9 yr. (Toluca (Durham)).

Following the suggestion by Bauer⁽²⁾ and Huntley⁽³⁾ that the helium may have been produced by the action of cosmic rays on the meteoritic material while in outer space, isotopic analyses of the helium were carried out⁽⁵⁾ and it was found that the helium contained appreciable amounts of He^3 and could not therefore be of purely radiogenic origin. Le Couteur had calculated a $\text{He}^3:\text{He}^4$ ratio of about 30% for this cosmic process and the results obtained varied from 31.5% (Mount Ayliff) to 17.8% (Bethany (Harvard)). These results suggested that many meteorites contained helium of almost purely cosmogenic origin while others (of lower $\text{He}^3:\text{He}^4$ ratio) contained a mixture of cosmogenic and radiogenic helium.

From the knowledge of the uranium, thorium and helium contents of meteorites and the determination of the isotopic composition of the helium, it is not possible to determine

directly the amount of radiogenic helium present (and hence the age) since the exact isotopic ratio of cosmogenic helium is unknown and may not be always constant. Calculation of the quantities of radiogenic He^4 produced in a certain time by the known amounts of uranium and thorium present in certain meteorites, allow the corresponding amounts of cosmogenic He^4 to be determined and hence the isotopic ratio of the cosmic helium may be found. By calculating these ratios for certain assumed ages it is possible to compare the isotopic ratios of the cosmogenic helium of the different meteorites. The assumed "age" which then shows the least variation in these ratios may then be suggested as the probable age of these meteorites.

Table III includes the isotopic ratio of cosmic helium for several meteorites assuming the ages 1.1×10^8 yr., 0.9×10^8 yr. and 0.75×10^8 yr. It can be seen that the smallest "spread" in the $\text{He}^3:\text{He}^4$ ratios corresponds to an age of 0.75×10^8 yrs. (27.4% to 33.1%). A further reduction in the assumed age below 0.75×10^8 yr. would result in a larger spread in the ratios due to the rapidly decreasing values of San Martin and Bethany (Harvard). The probable age of 0.75×10^8 years has therefore been assigned to these meteorites. This age would require a mean cosmic ray flux of only three times the present day intensity to account for all of the helium found in the

"richest" meteorite, Morden. The reason for the variations in the absolute helium content of these meteorites of the same "age" is that the amount of helium produced at any point in the body will depend upon the intensity of cosmic ray flux at that point. The central parts of large meteorites will have been shielded from the radiation by the outer shell and would therefore contain less cosmic helium. During the passage of such a meteorite through the earth's atmosphere it is likely that considerable loss from the outer shell would occur through evaporation or melting and the central part, comparatively helium-"poor" would be found.

It is of interest to note that the variation of helium content (and its isotopic composition) with depth from the surface of the meteorite Carbo has recently been studied⁽⁵⁾. The helium content was 23.05×10^{-6} cc/g. at the surface and decreased steadily to 16.83×10^{-6} cc/g. at the centre (depth 28.5 cm.) and then increased again on passing through the centre. The $\text{He}^3:\text{He}^4$ ratio varied only slightly (26.8% near the surface, and 27.7% at the centre), as was to be expected since the radiogenic helium present made only a very slight contribution to the total helium present (see Table III). This "depth effect" therefore substantiated the hypothesis of the cosmogenic origin of the meteoritic helium.

This still provides no satisfactory explanation for the

three meteorites (Savik, Ahnighito and Muonionalusta 1) found to contain no detectable helium. Since these meteorites were found to contain detectable quantities of uranium and thorium, calculations show that they must have solidified not more than 1×10^6 years ago. One is therefore forced to postulate some additional mechanism in these cases, either a more recent "catastrophy" than that of 0.75×10^6 years ago, or that these meteorites may have re-melted by passing close to the sun.

Similarly the meteorite Bethany (Lion River) contains so little helium (0.002×10^{-6} cc/g.) that even if all its helium is of radiogenic origin, its maximum age is 6.2×10^6 years, and Muonionalusta 11 (0.013×10^{-6} cc./g.) has a maximum age of 43×10^6 years.

Toluca (Hamburg) is a special case in that although it contains sufficient helium to allow determination of its $\text{He}^3:\text{He}^4$ ratio it does not fit in with the group in Table III. After calculating the absolute amounts of He^3 and He^4 and assuming a cosmic ray $\text{He}^3:\text{He}^4$ ratio of 30%, the amount of "radiogenic" helium, and hence the probable age can be found. The resultant age is 53×10^6 years.

The pallasite Brenham Township affords an interesting comparison of two different methods of age determination. The age of the iron phase can be determined by the helium method while that of the stone phase may be found by the potassium/

argon method⁽⁷⁾. Unfortunately the iron phase is very poor in helium (0.02×10^{-6} cc/g.) and its $\text{He}^3:\text{He}^4$ ratio could not be determined. In addition its uranium content was the lowest ever found ($(0.06 \pm 0.02) \times 10^{-8}$ g./g.) and the thorium could only be determined as a limit of ($< 0.7 \times 10^{-8}$ g./g.) Assuming all the helium to be radiogenic this leads to an age of 68×10^6 years (if 0.7×10^{-8} g.Th/g.) or 3.77×10^8 (if no thorium).

Although the isotopic analysis of the argon in the stone phase has not yet been determined, the argon and potassium contents of the olivine phase are known:-(4.4×10^{-5} cc./g. and 4×10^{-3} g.K/g.) This means that Brenham Township has a maximum age of 2.2×10^9 y.

Conclusions.

Since most of the meteorites containing large amounts of helium have been shown to have a $\text{He}^3:\text{He}^4$ ratio of about 50% it appears that the cosmic ray process is chiefly responsible for the production of this helium. Meteorites containing helium of lower $\text{He}^3:\text{He}^4$ ratio produce results leading one to postulate a probable age of 75×10^6 years. A mean cosmic ray flux of three times the present day intensity would be required to produce all the helium in the meteorite of highest helium content during this time.

Several meteorites containing little or no detectable

helium have maximum ages considerably lower than this value, and must either have been formed in a more recent "catastrophy" or else they must have re-melted and again solidified in comparatively recent geological time.

A more detailed account of the age determination work can be obtained from the recent publication ⁽⁸⁶⁾ by those working on this problem in these laboratories.

APPENDIX 1

The Fluorimeter (Type 1080A).

The essential parts of the fluorimeter optical system are shown in Fig.3. The fluorimeter unit can be sub-divided in four parts:- the ultra-violet system, the sample holder and instrument base, the visible light system and the photocell compartment. In addition there are three electronic units (a) a 100 cycle amplifier with range switch and output meter (shown in Fig.4), which amplified the photocell signal prior to measurement, (b) a power unit type 1080A (Fig.5), providing power for both the amplifier and the mercury vapour lamp and (c) a power unit type 1007 providing a stable source of $\pm 2,200$ volts for the operation of the photo-cell.

The Basic Optical System will first be discussed in sections:-

1. The Ultra-Violet System.

The U.V. source used was a G.E.C. Osira 125 watt lamp from which the black glass envelope had been removed. Current for the lamp was supplied through a choke No.2 1832H. The lamp produced light of wavelength in the region of $3650\overset{\circ}{\text{A}}$. Although the $3650\overset{\circ}{\text{A}}$ line is not as efficient in exciting U fluorescence as is the $3130\overset{\circ}{\text{A}}$ line, the former is more suitable for this instrument because the latter wave-length increases background fluorescence and excites rare-earth fluorescence, not found using light of

FIG. 3.

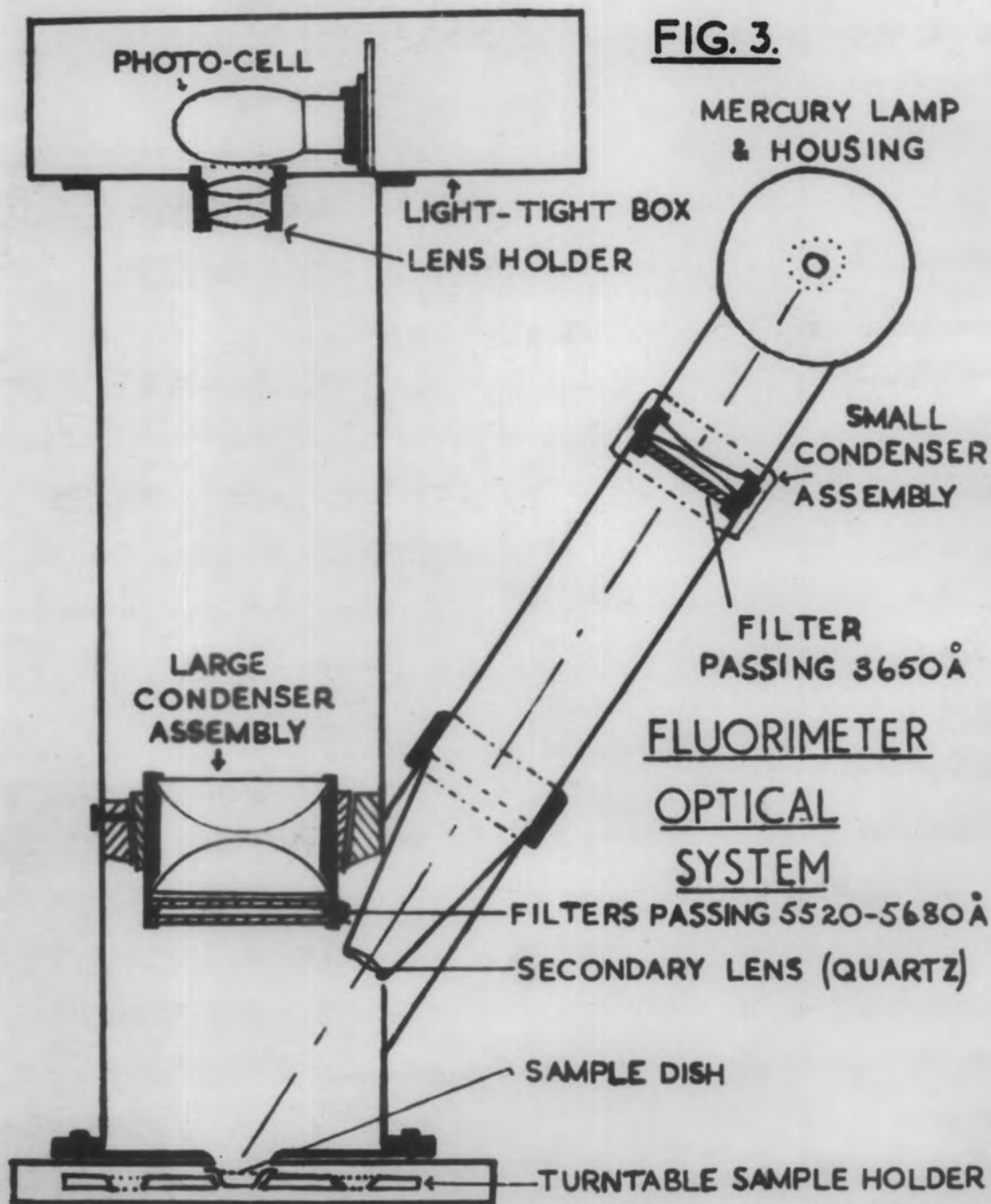

wavelength 3650\AA . The light was filtered through a 4 m.m. thickness of Chance's OX1 glass, which removed light other than in a narrow band of wavelength around 3650\AA . The quartz lenses projected an image of the arc on to the phosphor.

The entire interior surfaces of both the U.V. system and the sample holder compartment were painted with colloidal graphite ("aqua-dag") to reduce their "background" fluorescence.

2. Sample Holder and Instrument Base.

Unlike the A.E.R.E. Fluorimeter which had a sliding bar sample holder, the instrument built in these laboratories had an almost completely enclosed turntable sample holder. It was mounted in a small sheet-metal box which formed the instrument base.

The turntable consisted of a rotating circular brass plate, with eight holes to receive the sample trays. The periphery was knurled to afford a grip for the rubber ring on the turning knob. Eight locating holes, into which fitted a spring loaded plunger, were drilled in the plate to lock it when each sample tray was in its true operating position. Each sample hole was numbered, and an indicator dial showed which hole was in position at the junction of the optical axes of the U.V. and visible light systems. Access for the sample trays was obtained through a hole in the upper base plate, and this hole was covered with a light-tight metal cap. Even when this cap was not in position, no external light could leak into the optical system, but the cap was normally kept in place to prevent dust entering the instrument.

3. The Visible Light System.

Fluorescent light from the phosphor and reflected U.V. light fell on the filter combination mounted in the large condenser assembly. These filters passed only light in the region of 5520\AA to 5680\AA , i.e. the band containing the spectrum of uranium in NaF. The filters consisted of 4 m.m. thicknesses of Chance's OB2 (blue) and Chance's OY13 (yellow) glass. The yellow filter removed all of the U.V. light, but had a high transmission at 5520\AA and longer wave lengths. The blue filter removed some of the band containing the U/NaF spectrum, but completely removed red light. This was important in order to render the instrument specific for U-fluorescence, since several of the rare earths in solid solution in NaF, fluoresce in the red part of the spectrum.

The primary and secondary lenses then projected an image of the phosphor on to the cathode of the photoelectron-multiplier tube. The focussing of this image was achieved by varying the position of the large condenser assembly in its bearing, and this was then held in place by a screw passing through the wall of the instrument.

4. Photo-Cell and Potential Divider.

The photocell was housed in a light-tight box mounted at the top of the main tube of the fluorimeter. The box was provided with a deeply flanged metal lid, and was blackened inside. The photocell was mounted directly above the secondary

lenses with its cathode facing them.

The tube used was an R.C.A. 931A(1P21). Although its maximum response with respect to wavelength did not coincide with the waveband of the uranium spectrum being utilised, the wave-lengths fixed by the filters were such that no other element could interfere, and the sensitivity of the photo-cathode at 5550 \AA was nevertheless much greater than those of other tubes whose peak sensitivity was nearer 5550 \AA . An important factor in the choice of this valve was its extremely high signal-to-dark-current ratio. The dark-current from thermal emission is a difficult problem in high sensitivity fluorimetry, and it may be the controlling factor in the ultimate sensitivity of the instrument. The photocell used in this instrument, had a dark-current equivalent to less than 10^{-10} g.U and was therefore negligible.

Also in the photocell housing, mounted round the base of the valve itself, was a potentiometer network which provided the correct voltages for the photocell dynodes.

Amplifier Range-Switch and Output Meter.

Unlike the original A.E.R.E. Fluorimeter 1080A, whose amplifier was contained in the same housing as the phototube, the amplifier in the Durham instrument was mounted separately in a rack along with the Power Unit 1080A. This resulted in easier access to the amplifier and to the photocell, and also reduced the bulk of the fluorimeter unit.

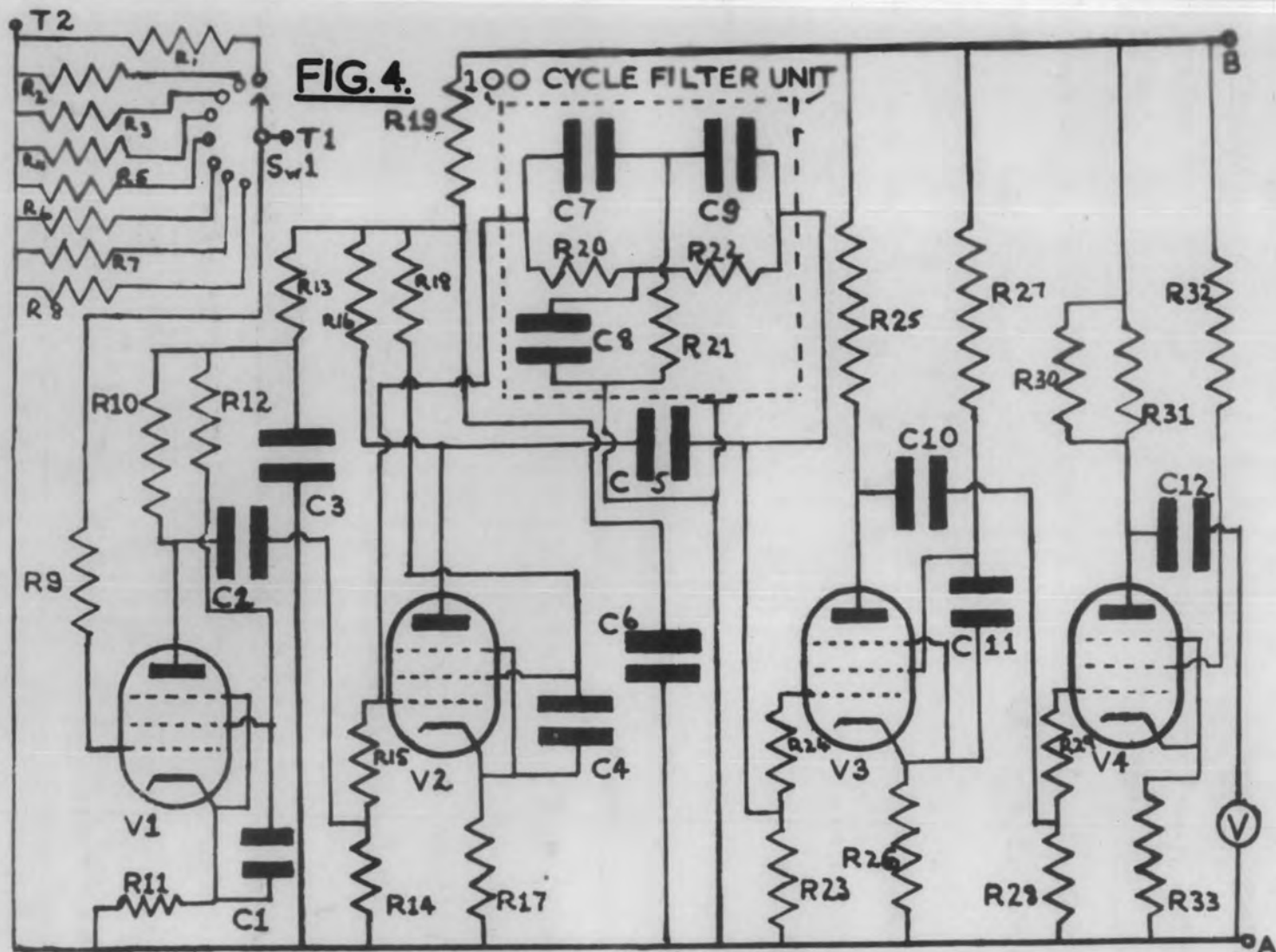

FLUORIMETER AMPLIFIER.

The output of the photocell was fed directly into the amplifier. The photocell anode load formed both the grid resistor of the first valve and also functioned as a range-switch. The anode load was switched in a series:- 0.1, 0.3, 1.0, 3.0, 10, 30, 100, 300, by means of resistors from 1000 ohms to 3.3 megohms, the meter deflections being multiplied by the factor shown on the range-switch indicator. The reason for this choice of ranges was that the amplifier output ceased to be linear above 55v., and the voltmeter being used to measure the output could not be read with sufficient accuracy below 15v. The range-switch was always adjusted so that the meter reading was between these two values. This gave a complete range of from $0.1 \times 15v.$ to $300 \times 55v.$, a factor of over 10,000 representing U concentrations of 10^{-9} - 10^{-5} g. per phosphor.

To reduce thermal noise from the multiplier tube, the amplifier was tuned fairly sharply to 100 cycles, the frequency at which the fluorescent light was interrupted (it would have twice the periodicity of the 50 cycle mains from which the U.V. lamp ran, since the lamp was extinguished at every current zero). Selectivity of amplification was achieved by using a parallel-T-network in a negative feedback circuit, which reduced the amplifier gain at all frequencies other than that selected and a narrow band on either side of it. The overall gain of the amplifier was about 16,000 times.

Power Unit Type 1080A.

This unit provided power to both the 100 cycle amplifier and the U.V. lamp. The amplifier required 4 milliamps at 250v. D.C. and 1-2 amps at 6.3v. A.C. for the valve heaters. Smoothing was very important, as the second harmonic of the mains frequency would have been amplified if present in the H.T. supply. Stabilisation reduced the ripple to less than 2.5mv.

The U.V. lamp required a supply of alternating current through a current limiting device, (choke No. 2.1832H).

Whilst stabilisation of the apparatus against change of performance due to mains variation had been applied as far as possible, the overall stability ratio was low, between 0.5 - 1.0% change of output for 1% change of mains voltage, caused chiefly by the characteristics of the U.V. lamp. For this reason, the whole equipment was operated from an electro-mechanically stabilised mains supply, and no trouble was experienced from mains voltage fluctuations.

(The values of the various components shown in Figs. 4 and 5 can be obtained from the A.E.R.E. Specification Manual. (33)).

Two reports on the design and construction of highly sensitive fluorimeters, including the principles involved, have been published by the United States Atomic Energy Commission (37).

Calculation of Uranium Contents from Fluorimeter Results.

The following is an example of the calculation of the U

content of ^aΛ meteorite from results obtained from the fluorimeter after extraction of U and Th by the combined methods:-

1ml. portions of the U extract solution (10ml) when prepared as NaF phosphors produced the following instrument readings:-

- (1) 31 (2) 29.5 (3) 26 (4) 30 (5) 30 (6) 29.5 (7) 31 (8) 28 (9) 26

The mean is 29.0v.

The deviation of each result from the mean:-

- 2, 0.5, 3, 1, 1, 0.5, 2, 1, and 3.

The squares of these deviations:-

- 4, 0.25, 9, 1, 1, 0.25, 4, 1 and 9.

The Sum of the Square Deviations = 29.5

$$\text{Standard Error} = \sqrt{\frac{1}{n} \frac{\sum \Delta^2}{n-1}} = \sqrt{\frac{29.5}{9 \times 8}} v = \sqrt{0.41} v.$$

$$= 0.64 v.$$

Result = 29.0 ± 0.64 v.

The reagent blank, when similarly treated, produced the following readings:-

- (1) 19.0 (2) 16.5 (3) 15.0 (4) 18.5 (5) 18.5 (6) 17.0 (7) 15.5 (8) 16.0 (9) 16.0.

The mean is 16.9 v.

The deviations from the mean:-

- 2.1, 0.4, 1.9, 1.6, 1.6, 0.1, 1.4, 0.9 and 0.9.

The squares of the deviations:-

- 4.41, 0.16, 3.61, 2.56, 2.56, 0.01, 1.96, 0.81 and 0.81.

The Sum of the Square Deviations = 16.89.

$$\text{The Standard Error} = \sqrt{\frac{16.89}{9 - 1}} \text{ v} = \sqrt{0.235} \text{ v.} = 0.49 \text{ v.}$$

Reagent Blank Result = $16.9 \pm 0.49 \text{ v.}$

$$\begin{aligned} \text{Reading due to meteorite alone} &= 12.1 \pm \sqrt{(0.64)^2 + (0.49)^2} \text{ v.} \\ &= 12.1 \pm \sqrt{0.645} \text{ v} = \underline{12.1 \pm 0.8 \text{ v.}} \end{aligned}$$

The mean of fifteen 1.247×10^{-6} g. U standard phosphors was 1400v.

(Additions of 1.247×10^{-6} g. U to several of the phosphors from both the "meteorite" and "reagent blank" determinations, produced increases in fluorescence readings of ca. 1400v. after re-fusion. This proved that "quenching" ions were absent from both solutions).

The wt. of Tamarugal taken = 33.5367g.

$$\text{Wt. of U/g. Tamarugal} = \frac{(12.1 \pm 0.8) \times 10 \times 1.247 \times 10^{-6}}{1400 \times 33.5367}$$

$$\underline{(0.52 \pm 0.02) \times 10^{-8} \text{ g.U./g.}}$$

APPENDIX 11.

The Scintillation Counter.

An important development in particle counting techniques during the last few years has been the application of the electron-multiplier phototube to the counting of the scintillation produced in suitable phosphors. α - particles, which are the most intensely ionising of the radiations from radioactive materials, produce individual scintillations on an activated zinc sulphide-screen sufficiently bright to be observed visually in a darkened room. This phenomenon was the basis of the spintharoscope, which appeared early in the history of radioactivity⁽⁸⁸⁾.

Blau and Dreyfus⁽⁸⁹⁾ used a ZnS screen and photomultiplier tube, and showed that the output current of the tube increased as an α - source was brought near to the screen, and that this output could be used as a measure of the radiation intensity. It was later shown⁽⁸⁹⁾ that the output pulses produced by the individual scintillations in such a system could be used for the efficient counting of the incident α - particles.

It has been estimated that an α - particle of 2MeV energy produce some 2×10^5 quanta in a ZnS screen. Assuming that 10% of these reach the photo-cathode and the latter emits one electron per 10 photons incident on it, each α - particle results in 2000 electrons leaving the cathode.

From the point of view of this present work, the great advantage of this method lies in the very low natural background counting rates which can be achieved, provided that certain precautions are observed. Background effects associated with thermionic emission from the phototube appear to be entirely negligible and the residual background counting rate of about 0.9 cts./hr. appears to be due to the natural α -particle contamination of the phosphor. To achieve such a low rate all glass and metal components have been eliminated from the α -particle-sensitive region, organic polymer materials (Perspex and Polystyrene) being used exclusively for source mounts, phosphor mount and constructional material. A most important precaution is the minimisation of the volume of air to which the phosphor is exposed, especially when the high voltage is applied to the photocathode; radium active deposit collected from the radon naturally present in air can materially increase the background counting rate if the consideration is overlooked. It has been found⁽⁵⁶⁾ that when the instrument was operated for several weeks in the absence of the source holder, which normally shields the phosphor from the bulk of the air present inside the phototube housing, the background increased to 8 α 's/hr. (The Rn content of air has been shown to be equivalent to 5×10^{-17} g. Rn/cc. air, i.e. ca. 1×10^{-2} α /hr./cc.⁽⁹¹⁾).

The counting system is shown diagrammatically in Fig. 9,

THE SCINTILLATION COUNTER.

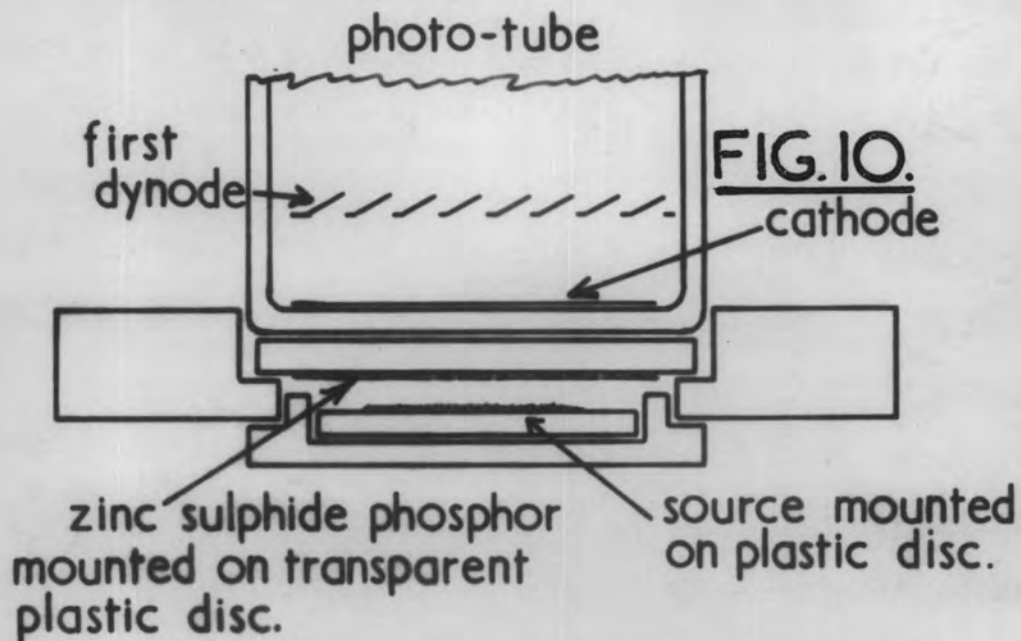
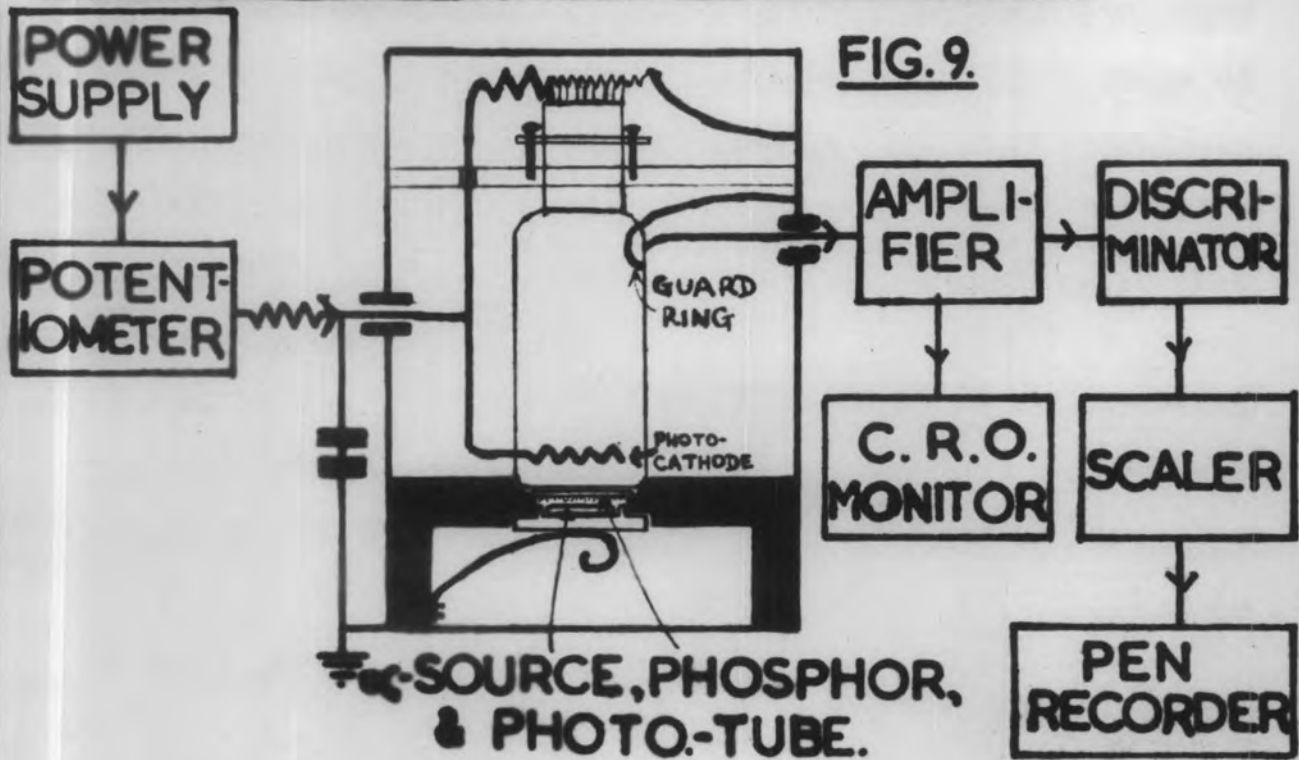

while the detailed drawing of the α -particle-sensitive region is shown in Fig.10. The phototube is housed in a light-tight metal box, the door providing access to the source compartment being interlocked with the high voltage supply, to prevent the tube being energised while the door is open. After exposure to light, the phosphor (silver activated, "nickel-killed" zinc sulphide, type G86, supplied by the Levy West Laboratories, Wembley) showed some slight phosphorescence, but this decayed within a few minutes, and did not, in any case, add materially to the background counting rate.

The phosphor, which is 5cm. in diameter, is prepared by moistening its perspex support with a 5% solution of phosphoric acid in acetone and then shaking the phosphor powder on to it through a fine mesh. The optimum thickness of the powder is $15\text{mg}/\text{cm}^2$. The α -source is evaporated on a polystyrene disc, 3cm in diameter and its plastic holder is held in position by a spring, so that the source is 1-2a.m. from the phosphor.

The multiplier tube (11-stage E.M.I. type 5359) is fed via a smoothing circuit from the E.H.T. power pack, and was operated at -1500v. This voltage is led both to the photocathode (antimony/caesium alloy) and to the dynode pins at the valve base. The pulses from the final anode of the tube are further amplified by a three-stage resistance-capacity-coupled amplifier with negative feed-back, and passed to a pulse-amplitude discriminator

Pulses above the predetermined discriminator level are recorded on an electromechanical counter, and, simultaneously, on a pen recorder (to check the validity of the counts by recording any breakdowns causing several "counts" in quick succession). For counting more active sources, (efficiency tests), the electromechanical counter can be replaced by an electronic scale-of-100 counter.

Calculation of Thorium Contents from Scintillation Counter Results.

The following is a typical example of the calculation of the Th content of a meteorite from results obtained from the scintillation counter after extraction of the U and Th by the procedure using 1-(o-arsono-phenyl-azo)-2-naphthol-3:6-disulphonic acid (Chapter XI):-

After discarding the first FBS extract (containing Po and RaB) the next five extracts gave the following counts (including background) during the 16 hrs. measurement:- 43,36,47,39,42. The total count was 207 in 5 determinations, and since all are in good agreement there could be no suspicion cast upon the validity of any of them (i.e. no losses or contamination appeared to have occurred). The mean result and error were therefore $\frac{207 \pm \sqrt{207}}{5} = 41.4 \pm \frac{14.4}{5} = 41.4 \pm 2.9 \alpha's/16 \text{ hr.}$

The equivalent results for the reagent blank were:- 18,20,15,13,13. Mean $15.8 \pm 1.8 \alpha's/16 \text{ hr.}$

Since the meteorite and its reagent blank were counted

alternately using an instrument whose background remained steady during this period, the difference between the two sets of figures was due to the thorium present in the meteorite.

$$\text{i.e. } 25.6 \pm \sqrt{(2.9)^2 + (1.8)^2} = 25.6 \pm 3.4 \alpha^{\text{ts}}/16 \text{ hr.}$$

Standard Th solutions (9.545×10^{-6} g.Th) gave a mean calibration of $449 \alpha^{\text{ts}}/16$ hrs. after the subtraction of the background count for this period.

The wt. of Th in the meteorite was therefore

$$\frac{(25.6 \pm 3.4) \times 9.545 \times 10^{-6} \text{ g.}}{449.}$$

The meteorite (Tamarugal, 33.5367g.) therefore contained

$$\frac{(25.6 \pm 3.4) \times 9.545 \times 10^{-6} \text{ g. Th/g.}}{449 \times 33.5367}$$
$$= \underline{(1.60 \pm 0.21) \times 10^{-8} \text{ g. Th/g.}}$$

Several recently published reviews of scintillation counters are listed under reference 92. Under reference (93) will be found a method of micro-determination of U and Th in minerals, using a scintillation counter.

BIBLIOGRAPHY.

- (1) Paneth F.A. in collaboration with Gehlen H., Gunther P.L., Urry Wm. D., and Koeck W., Z. Elektrochem., (1928) 34 p.645; *ibid.* (1930) 36 p.727; Nature, (1930) 125 p.490; Naturwisa, (1931) 19 p.164; Z. physikal. Chem. (1931) A. 152 110; *ibid.* Bodenstein- Festband (1931), p.145.
- (2) Bauer, C.A., Phys.Rev., (1947), 72, p.354; *ibid.*, (1948) 74, p.225 and p.501.
- (3) Huntley, H.E., Nature (1948) 161 p.356.
- (4) Le Couteur, K.J., Proc. Phys. Soc. 1950 A.65 p.259.
- (5) Paneth, F.A., Reasbeck, P., and Mayne, K.I., Geochim. et Cosmochim. Acta, (1952) 2 p.300; *idem.*, Nature, (1953) 172 p.200.
- (6) Reasbeck, P., Private communication.
- (7) Gerling E.K., Pavlova T.G., Doklady Akad, Nauk S.S.S.R. (1951) 77 p.85.
- (8) Paneth, F.A., Meteorites, Encyclopaedia Britannica, (1948), 15 p.340.
- (9) "Analytical Chemistry of the Manhattan Project", edited by C.J. Rodden: National Nuclear Energy Series, Div. VIII, Vol.1: McGraw-Hill 1950 pp. 52 and 184.
- (10) Taylor, A.E., and Dillon, R.J., Analyt. Chem., (1952), 24 p. 1624.
- (11) Rodden, C.J., Anal. Chem. (1949) 21 p. 327.
- (12) Zemies, K.E., and Hedvall, J.H., Arkiv. Kemi. Mineral., Geol. (1946) A22 No.25.

- (13) Arrol, W.J., Jacobi, R.B., and Paneth, F.A., Nature (1942), 149 p.235; Arrol, W.J., Ph.D. Thesis, London, (1942); Jacobi, R.B., Ph.D. Thesis, London, (1942); Chackett, K.F., Golden, J., Mercer, E.R., Paneth, F.A., and Reasbeck, P., Geochim et Cosmochim. Acta, (1950) 1 p.3.
- (14) Yagoda, H., and Kaplan, N., Phys. Rev., (1947), 72 p.356.
- (15) Robson, A., Ph.D. Thesis, Durham, (1949).
- (16) Hernegger, F., and Karlik, B., Sitzber. Akad. Wiss. Wien, Math. naturw. Klasse Abt. IIa (1935), 144, p.217.
- (17) Smales, A.A., (1952), Report No. A.E.R.E. C/R, - 930.
- (18) Stokes, G., Phil. Trans., (1852), 142 p.517.
- (19) Becquerel, E., Ann. Chim. Phys., (1859), 55 p.66.
- (20) Nicholls, E.L., and Howe, T.A., Publ. Carnegie, Inst. Wash. (1919), p.298.
- (21) Nicholls, E.L., and Slattery, M.K., J. Optical. Soc. Am., (1926), 12, p.449; *ibid.*, (1926), 13, p.573; *ibid.*, (1929), 19, p.175.
- (22) Bruninghaus, L., Compt. Rend., (1907), 144, p.839.
- (23) Papish, J., and Hoag, L.E., Proc. Nat. Acad. Sci., (1927), 15 p. 726.
- (24) Hernegger, F., Anz. Akad. Wiss. Wien, Math. naturwiss. Klasse (1933), 70, p.15.
- (25) Haitinger, M., Mikrochemie, (1931), 2 p.220.
- (26) Hofmann, J., Sprechsaal (1940), 73 p.153 ; Neuman, W.F., M-1675, No.6. (March 1945); Center, E.J. BMI-JDS 129 (June 1948); Zebrowski, E., and Newton, T.W., MDDC-443

- (Oct. 1946); Coleman, C.F., Report C-4. 381.4, (March 1944);
Nakanishi, N., Bull. Chem. Soc. Japan, (1950), 23 p.161;
Unkovskaya, V., Comptes Rendus (Doklady) de l'Academie des
Sciences de l'URSS (1940), 29, p.380.
- (27) Sill, C.W., and Peterson, H.E., Ind.Eng. News, (1947), 19
p.646.
- (28) Northup, M.A., Ind.Eng. Chem., Anal. Ed., (1945), 17 p.664.
- (29) De Ment, J., Jour. Chem. Educ. (1946), 23 p.213.
- (30) Price, C.R., Ferretti, R.J., and Schwartz, S., C.C.-2985
(June 1945)
- (31) Gibb, T.R.P., and Evans, H.T., Science (1947), 105, p.72.
- (32) Florida, C.D., paper communicated to J. Sci. Instrum.
- (33) A.E.R.E. Catalogue, No. 3-7/5104.
- (34) Jacobs, S., C.R.L./A.E. 54 (April 1950).
- (35) Overton, K.C., and Williams, A.F., C.R.L./A.E.78 (April
1951).
- (36) Zimmerman, J.B., (Ottawa), Rep. T.R.44/50 (April 1950).
- (37) Jones, A.G., and Hanson, W.T., Report Chem. S-563, (Dec.
1944)
- (38) Pringsheim, P., "Fluorescence and Phosphorescence",
(Interscience Publishers, New York), (1949).
- (39) Rankama, K., and Sahama, Th.G.; "Geochemistry", Univ. of
Chicago Press, Chicago, Ill., (1950), p.605.
- (40) Peligot, E., Ann. Chim. Phys., (1842), 5, 7, p.42.
- (41) Arden, T.V., Burstall, F.H., and Linstead, R.P., J.C.S.,
(1949), S.511.

- (42) Auger, V., Compt. Rend., (1920), 170, p.995.
- (43) Irving, H.M., Quart. Rev., (1951), 5, p.200.
- (44) Bock, R., and Bock E., Z. anorg. Chem. (1950), 263, p.146.
- (45) Ato, S., Sci., Pap, Inst. Phys. Chem. Res. Tokyo, (1930), 14, p.287.
- (46) Norstrom, A., and Sillen, L.G., Svensk Kem.Tidskr., (1948) 60, p.227.
- (47) "Handbook of Chemical Methods for the Determination of Uranium in Minerals and Ores", H.M. Stationery Office, London, 1950.
- (48) Hecht, F., and Grunwald, A., Mikrochem. Mikrochim. Acta, (1943), 30 p.279., Short H.G., and Dutton, W.L., Anal.Chem. (1948), 20 p.1073; Hoffman, J.I., Journ. Wash. Acad. Sci. (1948) 38, p.233.
- (49) Gibbs, W., Chem. News, (1890), 42, p.291; idem, Am. Chem. J. (1891), 13, p.571.
- (50) Irvin, N.M., and Russell, A.S., J.C.S., (1932), p.891; Groves, R., and Russell, A.S. J.C.S., (1931), p.2805.
- (51) Bennett, W.R., Jour. Am. Chem. Soc., (1934), 56, p.277.
- (52) Melaven, A.D., Anal. Chem., (1950), 2, p.180.
- (53) Pavlich, A.E., and Sullivan, J.D., Metals and Alloys, (1940), 11 p.56; Chirnside, R.C., Dauncey, L.A., and Proffitt, P.M.C., Analyst, (1940), 65, p.446; idem, ibid., (1943), 68, p.175; Parks, T.D., Johnson, H.O., and Dykken, L., Anal.Chem., (1948), 20, p.148; Furman, H.N., and Bricker,

- C.E., U.S.A.E.C.- MDDC-691. (1948); Furman, Bricker and Mc.Duffie, B., Journ. Wash. Acad. Sci., (1948), 38 p.159.
- (54) Maxwell, J.A., and Graham, R.P., Chem. Rev. (1950), 46 p.471.
- (55) Mundy, R.J., Report A-1022, (Dec. 1945).
- (56) Golden, J., Ph.D. Thesis (1953).
- (57) Vogel, A.I., "Qualitative Analysis", Longmans-Green, London (1947), p.447.
- (58) Noyes, A.A., and Bray, E.C., "Qualitative Analysis for the rare elements". Macmillan, New York (1948), p.421.
- (59) Mme. Joliot-Curie, "Les Radioelements Naturels", Hermann et Cie, Paris, (1946), p.42.
- (60) Treadwell, R.P., and Hall, W.T., Wiley, New York (1937), (9th Edition).
- (61) Stieglitz, T., "The Elements of Qualitative Chemical Analysis", G. Bell, London, (1911), p.193.
- (62) Wright, M.L., Nature, (1951), 168, p.289.
- (63) Paneth, F.A., Geochim-et. Cosmochim. Acta, (1950), 1, p.70.
- (64) Washington, H.S., "Chemical Analysis of Rocks", Wiley, (New York), (1919), p.131.
- (65) Rao, B.R.L., Murthy, T.K.S., and Rao, B.S.V.R., Journ. Ind. Chem. Soc. (1950), 27, p.610.
- (66) Grimaldi, F.S., and Fairchild, J.G., Report A-2507, (June, 1945).
- (67) Fiegl, F., Krumholz, P., and Rajmann, E., Mikrochemie, (1931) 2, p.395.

- (68) Kuznetsov, V.I., Journ. Gen. Chem. U.S.S.R., (1944), 14
p.914.
- (69) Dodson, R.W., Forney, G.J., and Swift, E.H., Journ. Am.
Chem. Soc., (1936), 58, p.2573.
- (70) Kendall, J., Science (1928), 67, p.163; Conden.R., Gordon,
A.H., and Martin, A.J.P., Biochem. J., (1946), 40, p.33;
Butler, J.A.V., and Stephen, J.M.L., Nature, (1947),
160, p.469.
- (71) Strain, H.H., J. Amer. Chem. Soc., (1939), 61, p.1292.
- (72) Durrum, E.L., J. Colloid Sci., (1951), 6, p.274; idem,
J. Am. Chem. Soc., (1951), 73, p.4875; Biserte, G., Biochim.
et Biophys. Acta (1950), 4, p.416.
- (73) Durrum, E.L., Chem. Eng. News (1949), 27, p.601.
- (74) Wieland, T., and Fischer, E., Naturwiss., (1948), 35, p.29;
Gremer, H.D., and Tiselius, A., Biochem. Z. (1950), 220
p.273; Lederer, M., Research, (1951), 4, p.371; McDonald,
H.J., Urbin, M.C., and Williamson, M.B., J. Colloid Sci.
(1951), 6 p.236.
- (75) Durrum E.L., J. Am. Chem. Soc., (1950), 72, p.2943.
- (76) Strain, H.H., and Sullivan, J.C., Anal. Chem., (1951),
23, p.816.
- (77) Vogel, A.I., "Quantitative Inorganic Analysis", Longmans
(2nd Edit.) (1951). p.646.
- (78) Macheboeuf, M., Chem. Weekbl., (1953), 49, p.237.
- (79) Foster, A.B., Chemistry and Industry (1952), No.43, p.1050.

- (80) Lederer, M., Nature, (1949), 163, p.598; Williams, A.F., and Ryan, W., Analyst, (1952), 77, p.257; Sarma, B., Science and Culture, (1950), 16, p.165; see also refs. (41) and (47).
- (81) Lacourt, A., Sommereyns, G., and Soete, J., Mikrochem. Mikrochim. Acta, (1951), 38, p.348.
- (82) Mercer, E.R., Ph.D. Thesis, Durham.
- (83) Davis, G.L., Am.J. Sci. (1950), 248, p.107.
- (84) Bøggild, O.B., Mineralogy of Greenland, (1953). Meddelelser om Grønland (1953) 149 NR.3 p.23.
- (85) Dalton J.C. and Thomson, S.J., Geochim. et Cosmochim. Acta (1953), in the press.
- (86) "Recent Studies on Iron Meteorites", Geochim. et Cosmochim. Acta (1953), 3, pp. 257 - 309.
- Part I. Introduction by Paneth. F.A.
- Part II. Determination of helium content by Checkett, K.F., Reasbeck, P. and Wilson E.J.
- Part III. Determination of uranium and thorium content by Dalton J.C., Golden J., Martin, G.R., Mercer E.R., and Thomson S.J.,
- Part IV. The origin of meteorite helium and the age of meteorites by Martin G.R.
- (87) Pickle, C.B., AECD - 2433 (October 1946).
Price, G.R., AECD - 2677 (April 1948)
- (88) Crookes, W. Proc. Roy. Soc. (1903), 81, p.405. Elster and Geitel, Phys. Zert., (1903), 15, p.437.

- (89) Blau, M., and Dreyfus, B., Rev. Sci. Instr., (1945), 16
p.245.
- (90) Curran, S.C., and Baker, W.R., Rev. Sci. Instr. (1948)
19, p.116.
- (91) Whitehouse, W.J., and Putman, J.L., "Radioactive Isotopes".
(1953) (Oxford Univ. Press), p. 349.
- (92) Birks, J.B., Scintillation Counters, (Pergamon Press),
London, (1953). Curran, S.C., Luminescence and the
Scintillation Counter, (Butterworths), London (1953).
- (93) Chatterjee, S., and Dhar, S., Ind.J.Phys., (1950), 24
p.346.

ACKNOWLEDGEMENTS

I wish to express my deep gratitude to Professor F.A. Paneth, Ph.D., F.R.S. for the privilege of being allowed to work under him at the Londonderry Laboratory for Radiochemistry, for the encouragement he has given throughout the course of this work, and for the meteorite samples used.

It is a pleasure to record my sincere thanks to my supervisors Mr. E.R. Mercer, B.Sc., and S.J. Thomson, B.Sc., Ph.D., A.R.I.C., for the keen and sustained interest which they have shown in this work, and for the sound advice and suggestions which were at all times given.

I acknowledge my debt to Mr. G.R. Martin, B.Sc., A.R.C.S., for many valuable discussions and for the benefit of his wide knowledge in the fields of radiochemistry and electronics.

I am very grateful to J. Golden, B.Sc., Ph.D., for his collaboration in the work involved in Chapter VII.

Finally, I should like to thank Durham County Council Education Committee and the Department of Scientific and Industrial Research for the maintenance grants without which this research could not have been done.

John C. Dalton.

