

Durham E-Theses

Real-time power system security assessment

A. R. Shafie-Pour

How to cite:

Shafie-Pour, A. R. (1989) Real-time power system security assessment. Doctoral thesis, Durham University.

Use policy

The full-text may be used and/or reproduced, and given to third parties in any format or medium, without prior permission or charge, for personal research or study, educational, or not-for-profit purposes provided that:

- a full bibliographic reference is made to the original source
- a <https://etheses.durham.ac.uk/id/eprint/9303/> is made to the metadata record in Durham E-Theses
- the full-text is not changed in any way

The full-text must not be sold in any format or medium without the formal permission of the copyright holders.

Please consult the [full Durham E-Theses policy](#) for further details.

The copyright of this thesis rests with the author.
No quotation from it should be published without
his prior written consent and information derived
from it should be acknowledged.

REAL-TIME POWER SYSTEM SECURITY ASSESSMENT

A THESIS SUBMITTED TO
THE UNIVERSITY OF DURHAM
FOR THE DEGREE OF
PHD

BY

A.R. SHAFIE-POUR

SEPTEMBER 1989

SCIENCE LABORATORY
SCHOOL OF ENGINEERING

THE UNIVERSITY OF DURHAM



25 APR 1991

A.R.SHAFIE-POUR
REAL-TIME POWER SYSTEM SECURITY ASSESSMENT

ABSTRACT

The increasing complexity of modern power systems has led to a greater dependence on automatic control at all levels of operation. Large scale systems of which a power system is a prime example, is an area in which a wide gap exists between theoretical mathematically based research and engineering practice. The research programme at Durham is directed towards bridging this gap by linking some of the available and new theoretical techniques with the practical requirements of on-line computer control in power systems.

This thesis is concerned with the assessment of security of power systems in real-time operation. The main objective of this work was to develop a package to be incorporated in the University of Durham On line Control of Electrical Power Systems (OCEPS) suite to cater for network islanding and analyse the features and the feasibility of a real-time 'security package' for modern energy control centres.

The real-time power systems simulator developed at Durham was used to test the algorithms and numerical results obtained are presented.

ACKNOWLEDGEMENTS

The author wishes to express his sincere thanks and gratitude to his project supervisor, Professor M.J.H. Sterling, for his guidance and encouragement during the development of this project.

I would like to thank my parents without whose support and encouragement this work would not have materialised, and also support of my own family.

I would like to dedicate this work to my parents, Nicola, Danielle, Stephanie and Victoria.

The author also wishes to thank Janet Goodman for typing this thesis.

Hearty thanks go to Dr. M.R. Irving for his time and valuable discussions throughout the project.

LIST OF PRINCIPAL SYMBOLS AND ABBREVIATIONS

1. Network

B', B''	approximate Jacobian matrix
H, J, L, N	Jacobian submatrices of partial derivatives
I	vector of injected nodal current
P	active power
Q	reactive power
P^{SP}	specified power
Q^{SP}	specified reactive power
V	vector of node voltages
Y	admittance matrix = $G + jB$
θ	vector of busbar voltage angles
Z	impedance matrix
C	connection vector
f	modified branch impedance
q_i	Quadrature tap position
P_{ik}	Active power through the phase shifter
PI	performance index
$Z(p)$	overload performance index
Z_v	voltage performance index

2. Subscripts

i, j, k	nodes
$k \in i$	subset of nodes directly connected by branches to node i
t	transpose
o	original
m	modified

3. Other Symbols

Capital letters indicate a vector, lower case indicates a scalar quantity.

Δ	delta
n	number of faults
\sum	sum notation

4. Abbreviations

SCADA	Supervisory Control and Data Acquisition
FDNR	Fast Decoupled Newton Raphson
ACS	Automatic Contingency Selection
AUTOOUT	AUTomatic Contingency Selection OUTput
SECASS	SECurity ASSEssment
SECOUT	SECurity Assessment OUTput
ASA	Automatic Security Assessment

CONTENTS

	Page
INTRODUCTION	1
CHAPTER 1 REAL-TIME CONTROL AND SUPERVISION OF POWER SYSTEMS	9
1.1 Energy Control Centres	9
1.2 Supervisory Control and Data Acquisition (SCADA)	
1.3 Control Systems	15
1.3.1 Simulation Function	16
1.3.2 Topology determination and State Estimation	17
1.3.3 Automatic Generation control (AGC)	19
1.3.4 Economic Despatch (ED)	21
1.3.5 Unit Commitment	22
1.3.6 Load Forecast	24
1.3.7 Emergency Rescheduling	25
1.3.8 Load Shedding	26
1.3.9 Security Assessment	26
1.4 Discussion	29
CHAPTER 2 REAL-TIME SECURITY ASSESSMENT	42
2.1 Introduction	42
2.2 Power System Operating States	43
2.3 Security Functions in System Control	48
2.3.1 Security Monitoring	48
2.3.2 Security Enhancement	51
2.3.3 Security Analysis	52
2.4 Real-Time Security Assessment	55

CHAPTER 3	THEORY OF NETWORK CHANGES	60
3.1	Introduction	60
3.2	Solution to Linear Networks	61
3.3	Theory of Network Changes	65
3.3a	Application of diakoptics to the theory of branch outages	65
3.3b	Development of the algorithm for simultaneous branch outages	70
3.3c	Node addition and removal	79
3.3d	Asymmetry	81
3.3e	Application to non-linear elements	84
3.3f	Split Network	85
3.3g	Node merge	90
CHAPTER 4	APPLICATION OF THE THEORY OF BRANCH OUTAGES TO LOAD-FLOW	91
4.1	Introduction	91
4.2	Summary of fast decoupled load-flow	91
4.3	Automatic Control and Adjustment	96
4.3.1	On-load transformer tap-changing	101
4.4	Transmission-line Outages	102
4.5	Application of the recursive method to load-flow	105
CHAPTER 5	AUTOMATION CONTINGENCY SELECTION (ACS)	109
5.1	Introduction	109
5.2	ACS Techniques	110
5.3	Line Overload Performance Index	117
5.3.1	Analysis of a Single Branch Outage	119

5.3.2	Change of performance index δZ_k due to change of δQ_k - Outage of branch 'k'	121
5.4	Sequence of Compilation	126
5.5	Voltage Violation Performance Index	128
5.5.1	Change of Z_v (δZ_v) due to changes in voltages δV_ℓ^v	129
5.6	Analysis of a single branch outage	132
5.6.1	Effect of a single branch outage on system susceptance	132
5.6.2	Calculation of δV_ℓ	134
5.6.3	Calculation of voltage phase angle	135
5.7	Sequence of Computation	136
CHAPTER 6	NETWORK ISLANDING AND EQUIVALENCING	139
6.1	Introduction	139
6.2	Split network	140
6.3	Theory of Network Islanding	141
6.3.1	Summary of basic algorithm for outage studies	142
6.3.2	Pre-processing for System Separation	145
6.3.3	Islanding	147
6.4	Equivalencing	151
6.5	External Network Equivalencing	159
CHAPTER 7		
7.1	Introduction to Real-Time EMS Integration	162
7.2	OCEPS EMS Software Integration	165
7.3	Numerical Results	167
7.3.1	Test Network	167

INTRODUCTION

The system operator has a vitally important role in successful bulk power system operations. He manages both the production and the transmission of electricity. His objectives include an uninterrupted supply of power, minimum production cost, maximum savings on interchange transactions, safety of field personnel, power delivery without damage to equipment and well co-ordinated maintenance.

To accomplish these, he must have a thorough knowledge of the characteristics of the power system, understand economics, know how to effectively use computer resources, analyse carefully but act quickly and decisively, and survive repetitive work. His mistakes can be costly and very visible while the pounds he saves and the interruptions he avoids go unnoticed.

Power systems are becoming more tightly integrated, complex and the demand for electricity is growing and as a result the system operator's life is becoming more complicated and he is becoming more heavily depended upon.

System operators are not born with the necessary capabilities and until now there have been no comprehensive college programmes to educate them. Still much of the burden of training system operators falls on individual control centres. Excellence in training is essential.

The components of the operator's initial training programme are classroom education (lectures, reading, video tapes, workbooks, discussion covering theory, practical application, operating procedures, reliability standards etc.), field trips (to hear the operator's problems first hand), on-the-job training (by working side by side with an experienced system operator), familiarisation and practice using the control computer. The refresher training and the upgrading of skills includes more classroom education, meetings with other control centre operators and work projects such as forecasting load and generation.

The increasing size and complexity of modern power systems has led to a gradual change in control requirements. The increase in the cost of energy has enhanced the need to seek economic operations, whilst the system complexity has taken the control task beyond the direct abilities of the operators. Simple indications and controls have given way to more sophisticated means of display and analysis, and automatic operation of plant and systems is more common place. It follows that it is necessary to install sophisticated, yet extremely reliable integrated control systems, with complex real-time function. One benefit of integrated simulation management and control software is the ability to provide a useful operator training aid, which includes power system dynamics, telemetering and energy management facilities. Power system simulators are an important operator training tool in today's modern control centres. They provide practical exercise with hypothetical situations such as simulation of emergency

situations, partial blackout and restoration conditions; in understanding how one's power system qualitatively responds under abnormal frequency conditions including interactions of system frequency, governors, prime movers, load shedding, load restoration and tie-line synchronisation. In addition the development and implementation of an integrated simulation and control suite is a pre-requisite of any research establishment with interest in the operational control aspects of generation and transmission systems, since it enables the consideration of realistic environments.

Energy Management Systems (EMS) are part of the integrated control system and typically include functions such as Network Analysis (Topology, state-estimator, bus load forecast), security analysis, load-flows, security constrained economic despatch, interchange scheduling, system load forecast, dispatcher training simulation, network reduction and automatic generation control. Some of these functions are required to run in real-time mode and some in study mode. Although due to the conflicting objectives in operating the system and the peculiarities of generation, load, transmission and distribution facilities of different systems, a standard allocation of tasks and responsibilities to the levels of control is not practical, many EMS systems have similar structures.

Energy Management Systems provide means for the secure, economic operation of electrical power networks and recently with the inclusion of expert system facilities reduces the burden on systems operators.

The final responsibility for the safe, secure and economic operation of the power system rests with the staff in the system control centre. Their capability to carry out their control responsibilities relies heavily on the adequacy of the operation plans and guidance provided to them by planning staff. In the event, system conditions may differ from those expected conditions on which the plans were based, and there is a need to review and revise security plans in the control room environment. This is the function of the on-line security assessment package, which is one of the functions carried out in a modern system control centre.

The general objective of security assessment is to ensure that the power system is operated at the minimum cost necessary to ensure compliance with security standards.

The progression of time in the real-time environment means that there is always a danger of events overtaking the control engineer before a decision has been made. These two factors, require that the on-line security assessment facility be as automatic as possible in terms of picking up nodal demand productions, generator schedules and planned network configuration and as fast as possible in producing results.

As an aid to the network control engineer it is possible to assess the effect of any scheduled or unexpected line or generator outages by means of a fast approximate load-flow method. Unfortunately, even applying the fast decoupled load flow method with efficient updating of outage solutions using

the modified matrix technique, the solution time required for consideration of every possible outage may be excessive. It is, therefore, advantageous to perform a simplified analysis referred to as automatic contingency solution, which determines the subset of possible contingencies predicted to be most severe.

The security assessment phase then proceeds to analyse the intact system and the preselected outage cases one at a time.

Conventional techniques for the assessment of transmission network security normally assume the preselected contingency list will not split the network into islands. Should such a situation arise the approach is usually to restrict analysis to the largest island so created. This approach has serious disadvantages in power systems which are subjected to frequent major outages and for which islanding is a common occurrence.

This dissertation represents fast and accurate techniques for the preselection of contingency lists for transmission line outages. A new technique for the diakoptic solution of the network flow when subjected to configuration changes is presented. Based on the theories described, computer programmes in Fortran language were developed for the real-time security assessment of electrical power networks and were integrated in the On Line Control of Electrical Power Systems (OCEPS) suite at the University of Durham Science Laboratories. A technical paper based on new techniques developed for the security analysis incorporating network islanding was published.

Computer assisted control of electrical power transmission and distribution systems represents a large scale real-time data processing problem and demands an integrated approach to software design and testing. The availability of relatively inexpensive computer hardware and the increasing importance of energy management has led to the wide-spread adoption of sophisticated control systems. Objectives of these schemes include the minimisation of production cost, improvement of the security of supply and the ability to ensure the correct generation of power system plant. Computer based supervisory control and data acquisition systems have been widely used in most power utilities for SCADA and energy management (Chapter 1).

Chapter 2 represents a survey of approaches to the estimation of system security and discusses power system operating states, monitoring and security enhancement.

The solution to linear networks and the theory of network modifications is described in Chapter 3 and is further expanded to non-linear networks in Chapter 4, where the application of the recursive branch outages technique to load flow is investigated.

The automatic contingency selection problem is concerned with developing computer algorithms for quickly identifying those contingencies which may

cause out-of-limit conditions so as to reduce the number of contingencies that need to be evaluated when assessing the power system's security in a real-time environment. Chapter 5 presents an automatic contingency selection algorithm for the determination of all the contingencies that give either voltage or line flow problems when the system is subjected to single line outages.

Power systems are subjected to frequent major outages and network split is a common occurrence. Should such a situation arise the approach is usually to restrict analysis to the largest island so created. Theory of network islanding is described in Chapter 6. The new technique presented is based on diakoptics and overcomes the above disadvantage.

One of the requirements of today's modern power system control centres is to determine equivalents for extensive power systems external to an internal system equipped with a central control computer. These equivalents are needed for different system studies where the internal system is represented in detail and the external system is represented by their equivalent, to simulate the interaction effects of the external system on the internal system for disturbances originating in the internal system. The addition of this facility to an EMS package enhances the security assessment function. A survey of techniques available for network reduction, is presented in Chapter 6 and a new approach is discussed.

Chapter 7 of this thesis represents the numerical results obtained throughout this work and reference is made to overall EMS integration.

CHAPTER 1

REAL-TIME CONTROL AND SUPERVISION OF POWER SYSTEMS

1.1 Energy Control Centres

The increasing size and complexity of modern power systems has led to a gradual change in control requirements. The increase in the cost of energy has enhanced the need to seek economic operations, whilst the system complexity has taken the control task beyond the direct abilities of the operators. Simple indications and controls have given way to more sophisticated means of display and analysis, and automatic operation of plant and systems is more commonplace.

Electricity Authorities operate highly complex generation and distribution networks with an ever-increasing requirement for energy saving and permanency of supply. It follows that it is necessary to install sophisticated, yet extremely reliable control systems to achieve these objectives.

The role of system control under normal operating conditions is to maintain electricity demand and generation continuously in balance, whilst staying within defined levels of frequency and voltage, and whilst maintaining a defined degree of security against unforeseen hazards. Power

station plant must be controlled to cope with a variety of system requirements such as efficiency, frequency regulation, part-load operation and operation with frequent start-ups and shut-down (2 shifting) and at the same time meet such requirements as frequency control, voltage control, real power demand, line-flow constraints, security against disturbances and economic despatch.

To meet these needs, the operator requires a range of computing aids such as load-flow analysis to identify potential constraints and resolve them, state-estimation to identify the system configuration, data redundancy to enable bad data to be eliminated, economic load despatch, contingency analysis, VAR despatch to avoid the risk of voltage collapse.

Electrical power plants are interconnected and require a control point from which frequency and generation can be controlled, especially when control areas are established, and interconnection flows as well as generation are to be monitored, in order to control the amount of interchanged power with other control areas. The information is gathered via telemetry systems.

For control purposes generation and transmission in England and Wales, managed by the CEGB, is divided into 7 Grid control areas each with its own control centre. In addition control is co-ordinated nationally by the National Control Centre. Each area control centre is responsible for switching of circuits within the area, and for meeting demand in the area.

It is also responsible for instructing the switching of circuits between areas, and for optimising, as far as possible, economic operation between areas.

The present method of economic operation is one in which National Control carries out studies 24, 12, 6, 3 and 1 hour ahead to determine which plant is likely to be in merit and required for loading. This plant is then scheduled to be synchronised just before it is needed. The schedules for synchronisation are then issued by Area Control Centres to the power stations.

The advent of automation, array processors, transputers and, on the software side, expert systems, have much to offer system control. In recent years the traditionally manned substation has given way in some locations to unmanned substations controlled by telecommand from an Area Control Room. It is likely, as nationally co-ordinated despatch comes in, that the economic role of Area Control Centres will give way to a switching control role, in which advanced aids will assist the control engineer in the management of the system. Training simulators can be one of enhancing control engineers' ability to deal with emergencies.

The CEGB has approximately 130 power stations with a total generating capacity in excess of 55 GW. Figure (1.1) illustrates the location of the major power stations in the CEGB. The control of the power generation throughout the network is a hierarchical process which commences with a

prediction of the load demand at a Central Control Centre and ends with closed loop controllers which regulate the primary energy source supplied to the generators in response to variations in the desired and actual values of frequency and output power. The hierarchical levels in the control sequence include the long term planning of unit commitment, based on the long term load forecasts, the short term adjustment of the desired levels of generation (economic despatch) based on the short term load forecasts and the desired operating frequency and finally the continual adjustment of the generator regulations by the closed loop controllers.

The CEGB divide the unit commitment and economic despatch problems amongst a National Control Centre and Area Control Centres. The National Control Centre is responsible for determining the overall operating levels throughout the network, while the Area Control Centres are responsible for implementing the levels. Figure (1.2) illustrates the location of the Control Centres in the CEGB. Figures (1.3), (1.4) and (1.5) illustrate CEGB's Super Grid and demands.

1.2 Supervisory Control and Data Acquisition (SCADA) and Data Communication

In order to be able to meet the ever-more stringent operating conditions with the ever-decreasing levels of equipment redundancy, the operator requires up-to-date and accurate information about the state of the entire network. The function of supplying the operator with this information and additional information on the security of system derived by

processing the raw measurements can be provided by an on-line digital computer. Analogue data is scanned periodically in the order of 1 second to a few seconds. Each scan is triggered by the system control centre at the prescribed interval by issuing a request to all remote stations to send in data.

The acquired system information together with state estimation methods provide indication of alarm or abnormal conditions, even with several remote terminations out of service.

The major features of a SCADA software can be:

- Alarm/event acquisition and processing
- Telemetry
- Telecontrol
- Measured acquisition and processing

The use of the special application functions such as load shedding and generator scheduling and control is possible only by virtue of the establishment of a comprehensive supervisory control and data acquisition system. The use of microcomputer-based Remote Terminal Units (RTUs), enables and encourages the acquisition of more alarm information than was possible with older solid-state and electro-mechanical systems. Accordingly, careful attention must be paid to the processing and display of alarms if the operators are to be able readily to identify the information during major system disturbances. The provision of several different alarm

categories, each with a dedicated display, and the extensive use of colour to rank alarms in order of importance, would result in a powerful and comprehensive alarm processing/display facility for control engineers. Operators are made aware of network event within 2-3 seconds of its occurrence.

For telecontrols, the system can employ the common 'check-back-before-operate' feature, or on receipt of a command telegram, the RTU can energise a command relay associated with the circuit breaker to be operated. In the latter, before completing the command process, the RTU initiates a current injection test to confirm that only one relay is primed and on verification, the command process is completed. This interval check at the RTU coupled with Digital Pulse Duration Modulation (DPDM) communications provides adequate security.

Data transmission between the control centre and the substations can be by: Voice Frequency Telegraph (VFT) equipment operating over telephone cable, Power Line Carrier (PLC) and UHF radio facilities. Main and standby channels with full duplex point-to-point communication (for example at 200 baud) can be provided for each RTU where practical, standby channels can be carried on physically separate routes. In the event of a channel failure, channel monitoring equipment can switch communication to the alternative channel.

The communications protocol commonly uses DPDM with information being

transmitted as a message comprising an address block, an information block and a data protection block. The use of DPDM and data protection blocks provides a communications protocol with a very high probability of error detection. The control centre can be provided with the facility to request the message to be re-transmitted, following the detection of errors.

The supervisory control function operates only upon specific operator request and may use the same computer interface, communication channels and RTUs as does the data acquisition system on a time-shared basis. The devices being controlled are mostly circuit breakers, motor operated disconnectors and load tap charging transformers.

1.3 Control Systems

The operational control of electrical power systems can be divided into two major functions; simulation functions and control function. Further, as shown in Figures (1.6) and (1.7), each function comprises of a number of tasks executed in the manner shown in a real-time environment. Throughout the rest of this chapter reference is made to the Energy Management suite (OCEPS) developed at the University of Durham under the supervision of Professor M.J.H. Sterling. Figure (1.8) illustrates the execution time for performing different tasks.

1.3.1 Simulation Function

If operators are to have confidence in and rely on the data being presented to them at the control centre, it is necessary to have some means of verifying the displayed information. Further, to provide reliable and secure operation of the network it is desirable to have means of checking operations in simulated form prior to performing network changes.

Computer assisted control of electrical power transmission and distribution systems represents a large scale real-time data processing problem and demands an integrated approach to software design and testing. The availability of relatively inexpensive computer hardware and the increasing importance of energy management has led to the widespread adoption of sophisticated control systems.^{[1][2]} Objectives of these schemes include the minimisation of production cost, improvement of the security of supply and the ability to ensure the correct operation of power system plant. Testing and validation of analysis and control software may be achieved with the aid of a real-time simulation system.^[3] In this way the performance of energy management software can be evaluated against a realistic model of the network under a range of operating conditions. A secondary benefit of integrated simulation, management and control software is the ability to provide a useful operator training aid, which includes power system dynamics, telemetering and energy management facilities. The development of an integrated simulation and control suite has been found to be essential in order to conduct research into operational control aspects

of generation and transmission systems, since it enables the consideration of realistic environments.

Figure (1.9) shows the major database elements and computational procedures required for simulation. The simulator applies to a non-linear algebraic model of the network in conjunction with a set of low order differential equations representing generator dynamics to produce telemetry information. In order to obtain stable numerical integration at speeds which are consistent with real-time operation, it has been found that the implicit trapezoidal technique combined with sparse Newton-Raphson solution is very suitable.^[4]

1.3.2 Topology determination and State Estimation

A pre-requisite of any power system security monitoring or control scheme is a reliable database in which the raw observations have been systematically processed in order to filter out the effects of uncertainty by inclusion of information on the network structure and measurement accuracy. Any form of filtering implies a loss of information and consequently the complete determination of the system state will require additional measurements with inherent extra cost. For example, the $2R-1$ independent variables consisting of voltage magnitudes E_k ($k=1,n$) and angles θ_k ($k=2,n$) at all buses, are sufficient to determine the static state of an n -bus power system relative to a reference bus where θ_1 , is assumed to be zero. However these measurements are not adequate for dynamic operation in

the presence of measurements errors and possible failure of a section of the real-time data collection equipment. Consequently, more measurements than the number of unknown state variables are needed. The way in which this redundancy is utilised gives rise to various techniques for state estimation which have application in several areas of power system monitoring and control.

State estimation techniques may be broadly divided into two categories, namely static and dynamic estimation.^[5] Static methods mainly have application in determination of load-flow in a transmission network, although the system does not remain in a fixed state, the approximation of steady-state over a short period of time is adequate. This assumption will be valid if the system is subject to relatively low frequency disturbances. Measurement redundancy is essential in this type of application.

Dynamic state estimation on the other hand is normally associated with transient or dynamic stability problem, where the dynamics of elements of the system must be considered and is typified by the integrated power plant problems.

Both static and dynamic estimation only operate successfully provided limits can be set on the statistical properties of transducer and telemetry system. Raw data could consequently first be processed to remove gross errors which would at least delay convergence of the estimator and, at worst, corrupt valid measurements. This pre-processing on raw data is known

as bad data suppression or data validation. The complexity of the algorithms incorporated in data validation software can range from simple limit checks on incoming analog data through to fully structured bad data suppression schemes possibly based on linearised system models.^[6]

In addition to the standard data validation methods of limit checking, consistency checking, exponential smoothing, logical filtering, OCEPS suite includes more sophisticated algorithms based on linear programming which are able to eliminate the majority of bad data values at the topology determination stage.^[7] This considerably reduces the computational burden imposed by bad data detection and elimination during the state estimation process. The data validation program take full advantage of network and linear programming sparsity to achieve the necessary solution and speed.^[8]

If enough well-placed measurements are available in the network, the state estimator problem is well defined and the network is said to be observable. A valid observability determination algorithm is therefore an important component of the estimation subsystem.

1.3.3 Automatic Generation Control (AGC)

The importance of AGC, also known as load frequency control, depends to a large extent on the size and form of a power system.

In large density interconnected systems such as in the UK, AGC is of

less importance than in say the USA, where many separate companies jointly supply power to widely distributed consumers via a network of interconnections or tie-lines. The system regulation coefficient is often a guide to the relative importance of AGC with values ranging from in excess of 2000 MW/HZ for systems similar to that of the UK to 200 MW/Hz more typical of systems in the USA and Africa.

Manual load-frequency control relies on an operating schedule prepared perhaps 24 hours in advance, which indicates that the anticipated demand profile and the corresponding set point changes together with tie-line power exchanges that should be maintained. The continued alteration of the set points needed for close frequency and tie-line control is frequently replaced by alteration of set points at regular intervals according to the schedule. Further corrective action may be applied if the frequency or clock error deviates from a certain band. Each alteration of the set points represents an appreciable step change to the set point which itself introduces a transient frequency disturbance before the desired result is achieved. In order to avoid these transients, the set points must be ramped between their current and desired values over a reasonable time provided successful manual control of both the frequency and the tie-line power exchanges therefore necessitates operator vigilance and changes of the tie-line exchange need special attention.

Computer control schemes have been devised which will automatically compute and implement set point changes and also facilitate smooth

transition between tie-line exchange requirements.^[9] The digital implementation of AGC generally necessitates the sampling of the tie-line power flows and the system frequency, together with control of the governor set points at approximately regular intervals.^[10] Optimal control approach to AGC does not prove very advantageous in practice.^[11]

1.3.4 Economic Despatch (ED)

The complex optimisation problems associated with the control of a power system have been the subject of considerable research. The complexity of the overall control problem, in which the maintenance of supply, quantity and quality is of more importance than economic factors, has resulted in a division of the research into two main areas; network control and operational economics.^[5] Network control, including transmission switching, voltage, power factor, frequency and individual plant control, have necessarily been of prime importance, for without reliability in this field, the consideration of operational economics is of no value. However, once reliable system operation has been achieved, large financial benefits may be accrued from economic allocation of generation.

For a particular load and set of network conditions, an optimal combination of generators can be determined by consideration of the difference in operational characteristics of the plant. Load variation consequently necessitates the calculation of new optimum generation despatches.

When an accurate estimate of the load is available the generator outputs must be allocated so that all operational constraints are satisfied and the production cost is minimised. The time scale of the optimisation permits the separate consideration of two problems, plant ordering phase being typically 4 hours in advance, plant loading or despatch phase normally attempted as frequently as possible, typically every 5-10 minutes.

The simplest ED algorithm is the merit-ordering method. Only a linear or piece-wise linear cost function, upper and lower generator active power limits and the load balance equality can be accommodated. The committed generators are indexed in order of increasing incremental cost, and are initialised at their lower output limit. Generators are then considered for loading to their maximum limit in order of merit until the demand is satisfied. The advantage of the merit order is its simplicity and that there is no difficulty in dealing with large scale problems. The disadvantage is that only simple cost functions may be considered. Other techniques for ED are based on linear programming, quadratic programming, recursive quadratic programming and dynamic despatch. [12][5][13][14].

1.3.5 Unit Commitment

Since the load varies continuously with time, the optimum combination of units may alter during any period. In practice however, one hour is the smallest time period that need be considered, as the start-up and shut-down time for many units is of this order. This plant ordering or unit

commitment phase of operational control thus represents a course running cost optimisation in which units are brought into and taken out of service such that the sufficient generation is always available to meet the system load and to provide spinning reserve. The loss of economy which can result from an incorrect unit commitment schedule may exceed the savings obtained by optimum allocation of generation among synchronised units.

It might at first appear that a merit-order approach is sufficient in which units are brought into service in accordance with their relative cost efficiency, cheaper units being scheduled before less efficient units. However, if an inefficient unit is shut-down when it is no longer required, it will have to be restarted several hours later prior to the next peak load. The saving gained by shutting down the unit is consequently offset by the cost of starting up the unit again.

The main factors influencing the plant ordering decision are:

- (a) The shape of the hourly integrated consumer demand curve
- (b) The relative efficiency of each unit to be shut-down compared with that of the other synchronised units
- (c) The start-up and shut-down costs of each unit.

Unit commitment based on dynamic programming considers standard

operation constraints for thermal units and will schedule hydro-plant in order to satisfy water usage and conservation requirements. The resulting generation schedules ensure that hydro-plant contributes to the economic and secure operation of the network. [5][15]

1.3.6 Load Forecast

The necessity for estimating the power system load expected at some time in the future is apparent when it is remembered that generating plant capacity must be available to balance exactly any network load at whatever time it occurs. In the long term the installation of new plant and network expansion is dependent upon an estimate of the future peak consumer demand up to several years ahead. In the short term the variation of the system load must be known in order that prior warning of output requirements may be given to power stations, enabling limitations on boiler fuel feed rates, and generator rate of change of output constraints, to be observed. Furthermore, the economic schedule for the start-up and shut-down of plant is dependent on an estimate of the network load so that the cost of providing spinning spare capacity for system security can be minimised.

In a power system under automatic computer control it is this short-term projected load that would be used to calculate a generator despatch for which all operating limits were satisfied and the generator cost a minimum. Unfortunately, the consumer load is uncontrollable, although small variations can be effected by frequency control and more

drastically by load shedding. The variation of the load does however exhibit certain daily and yearly pattern variations and the analysis of these forms the basis for several prediction techniques.^{[17][18]}

The method of load prediction using spectral expansion was first proposed by Farmer in 1963.^[16] It has subsequently been the subject of several publications in which the application of the method to an automatic on-line load prediction and scheduling technique (implemented on the South-West region of the CEGB) is discussed in (5).

1.3.7 Emergency Rescheduling

During emergency conditions in which insufficient generation is available to meet system loads or where one or more unexpected plant outages have occurred, it is important to be able to rapidly reschedule generation and allocate the degree of load shedding required. It is vital that this phase of operation should be executed rapidly, and modern computer control systems are increasingly being used in this area.

Under emergency conditions the economic operation of the system has a lower priority than the minimisation of load shedding. However, emergency rescheduling methods which are now available, generally assign artificial costs to each load supply point, and therefore allow a priority order of load shedding and also enable a trade-off between generation rescheduling and load shedding.^[19]

The rescheduling problem is mathematically similar to the economic despatch problem, but the difference in modelling and solution requirements, indicates that separate software facilities are necessary. The sparse quadratic programming algorithm by Chan and Yip, and a second method based on network flow and the 'out of kilter' algorithm are commonly used.^[20]

1.3.8 Load Shedding

Although the emergency rescheduling techniques may give an automatic indication of the required degree and location of load reduction, many applications require a more detailed analysis and further operator interaction before any load shedding takes place. Interactive programs have been developed which assign priorities and allowable load shedding fractions to each consumer demand point.^[21] Load may be reduced in a number of pre-defined stages and operator confirmation is necessary before any load shedding programs in real-time environment may be initiated either manually by operator selection or automatically by the detection of serious under frequency or load/generation imbalance conditions.

1.3.9 Security Assessment

With the present state of the system established through the state estimation program, it is necessary to investigate whether under present operating conditions, the system could withstand the outage of any line, transformer or generator without violation of the loading constraints of the

remaining elements. This is the task of the contingency evaluation program. The contingency evaluation program accepts a list of outages from either a fixed list or from an operator entered list of additional outages. Contingency evaluation is performed in real-time at fixed intervals or at operator's request. During the outage simulation, a table is compiled of all the elements that are overloaded, this information being vital in the derivation of the security constraints which are used in the power rescheduling algorithm.

There are currently two basic approaches to the estimation of future system security and reliability, namely the deterministic approach and the probabilistic approach. The deterministic technique requires that certain calculations such as load-flow, unit commitment and stability studies be made for all conceivable future contingencies. The results of these studies are then reviewed and a judgement is made of whether or not some corrective action is required to maintain adequate system security. However, this technique does not take direct account of the unequal probability of occurrence of each system contingency, and furthermore that the number of ways of reaching undesirable operating states is not constant. Thus, whereas the deterministic approach clearly indicates those operating conditions that would result in breach of system security, it does not supply a consistent criterion for control action, given the results of the contingency tests. Unfortunately, probabilistic methods are not yet widely implemented, since the fundamental prerequisite is a detailed knowledge of a performance of the existing system in terms of failure rates, repair times,

and event probabilities. The introduction of such techniques would therefore normally only be feasible after a prolonged data collection and analysis period and consequently their implementation would not appear relevant as part of an initial power system control package.

Non-linear load-flow techniques are quite time-consuming and costly, especially if many cases are to be studied. The d-c load-flow approach is the fastest technique, but its accuracy is low and does not provide information regarding reactive flow in the system elements. This technique has the advantage of simple data, speed of execution and reasonable storage requirements. It provides the basis for the provision of an outage contingency list, which would be later accepted by an AC security assessment program. [22][23]

The basis of any on-line security assessment scheme is an AC power flow solution. Each cycle of security monitoring and analysis determines the effects of a selected list of outage contingencies on the steady-state operation of the system, making use of real-time data. The program calculates busbar voltages and power flows, using a vector of bus-bar injections and predicted network configuration. In general, the busbar injections are calculated from statistical data obtained on-line or state estimation, loading conditions and interchange schedules. [24][25][26]

Modern security assessment packages should cope with network islanding which could be caused as a result of transmission line outages or as a

result of real-time topology changes in the power system.^[27]

1.4 Discussion

The increasing complexity of modern power systems has led to a greater dependence of automatic control at all levels of operation. The higher levels of control have traditionally relied heavily on human judgement especially in respect of economic factors. However, recent international research experience has shown that centralised computer control is feasible for small scale networks but that costs would rise alarmingly for the implementation of schemes on a national basis. The geographical distribution of the plant presents enormous data gathering and control problems which, for large scale systems, preclude any direct approach to centralised control.

Despite the overall problem complexity many national supply boards are already installing computer control systems for specific, mostly local, functions within the network. Generator start-up, shut-down and control was one of the first areas to be computer controlled, together with boiler and other plant controls. These schemes are however, usually only within a single power station and rely on the manual coordination of the stations to meet national criteria. Their existence does however, facilitate data reduction and simplified control implementation for the co-ordinating control level.

The primary function of an electrical power system is to provide a secure and reliable source of electricity to the consumer. Electricity Authorities operate highly complex generation and distribution networks with an ever-increasing requirement for energy saving and permanency of supply. It follows that it is necessary to install sophisticated, yet extremely reliable control systems to achieve these objectives.

In order to be able to meet the ever-more stringent operating conditions with the ever-decreasing levels of equipment redundancy, the operator requires up-to-date and accurate information about the state of the entire network. The function of supplying the operator with this information and additional information on the security of system derived by processing the raw measurements can be provided by an on-line digital computer.

Throughout this chapter the main functions of a control system package where highlighted. OCEPS suite developed at the University of Durham, not only provides the basis for operator training and future research but is a unique example of an Energy Management System (EMS) package. The co-ordination of the functions mentioned in section 1.3 of this thesis is illustrated through Figures (1.10) and (1.13).

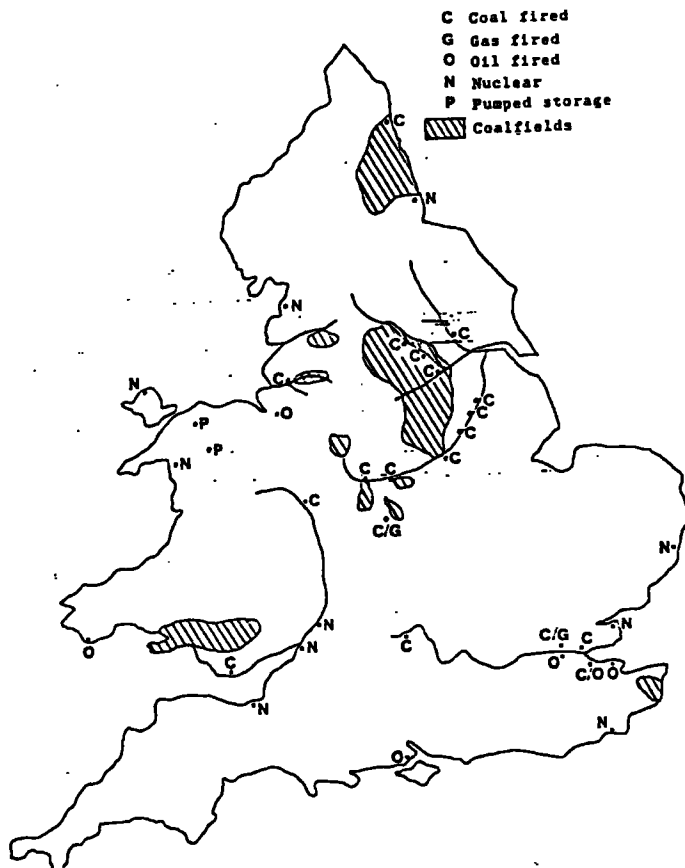

Fig. 1.1: Location of the major power stations in the CEB.



FIGURE 1.2 LOCATION OF THE GRID CONTROL CENTRES

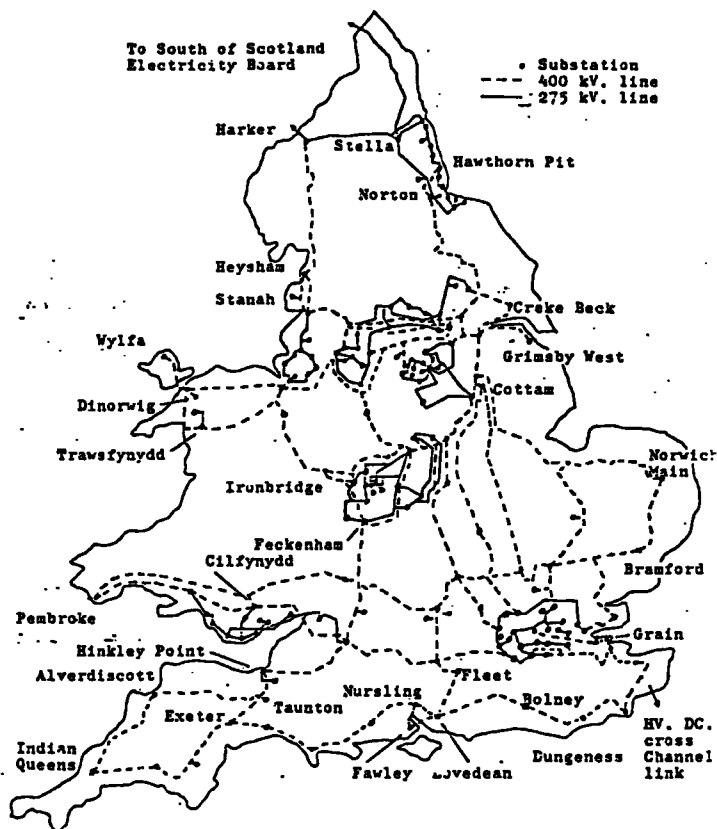

Fig. 1.3: CEGB. Supergrid system

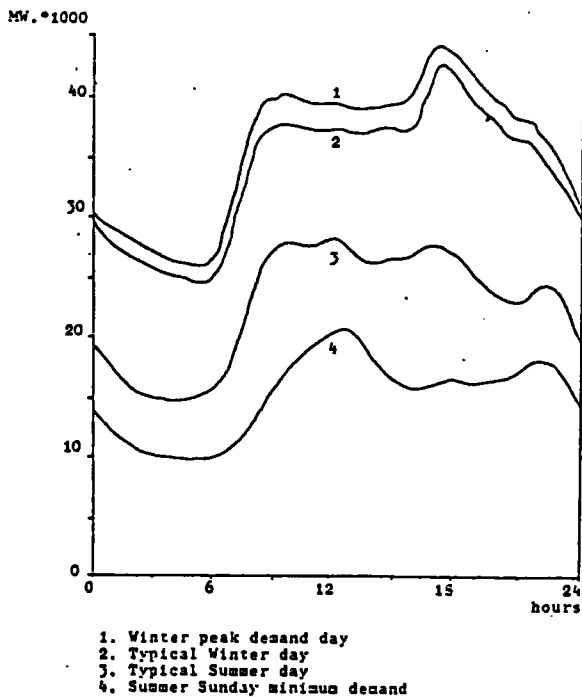

FIGURE 1.4 COMPARISON OF SUMMER AND WINTER DEMANDS ON THE CEGB

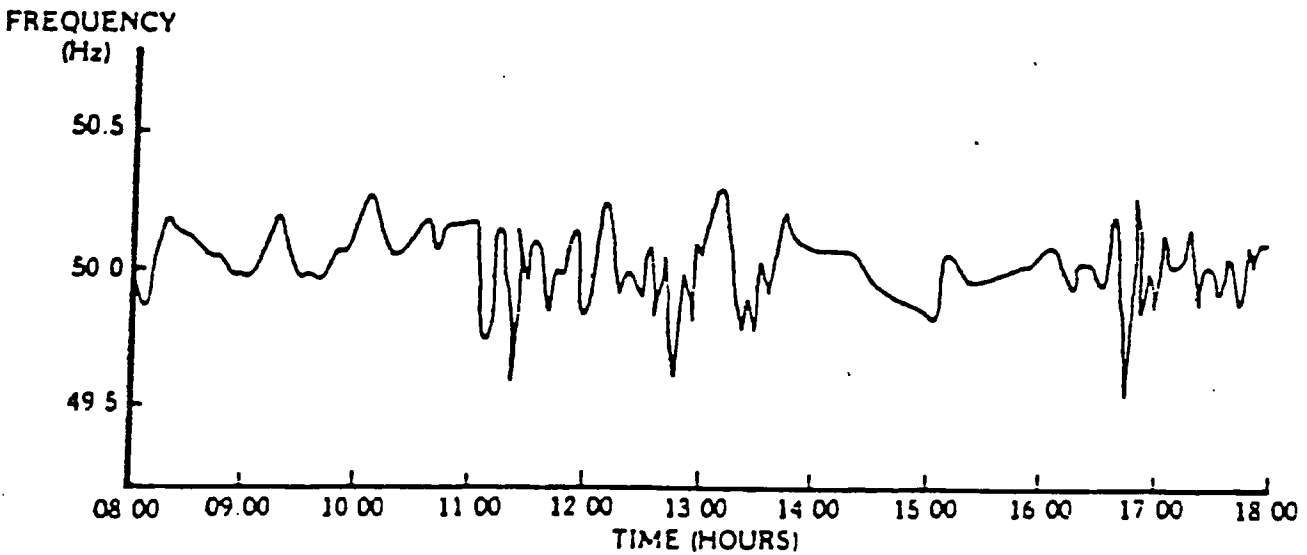
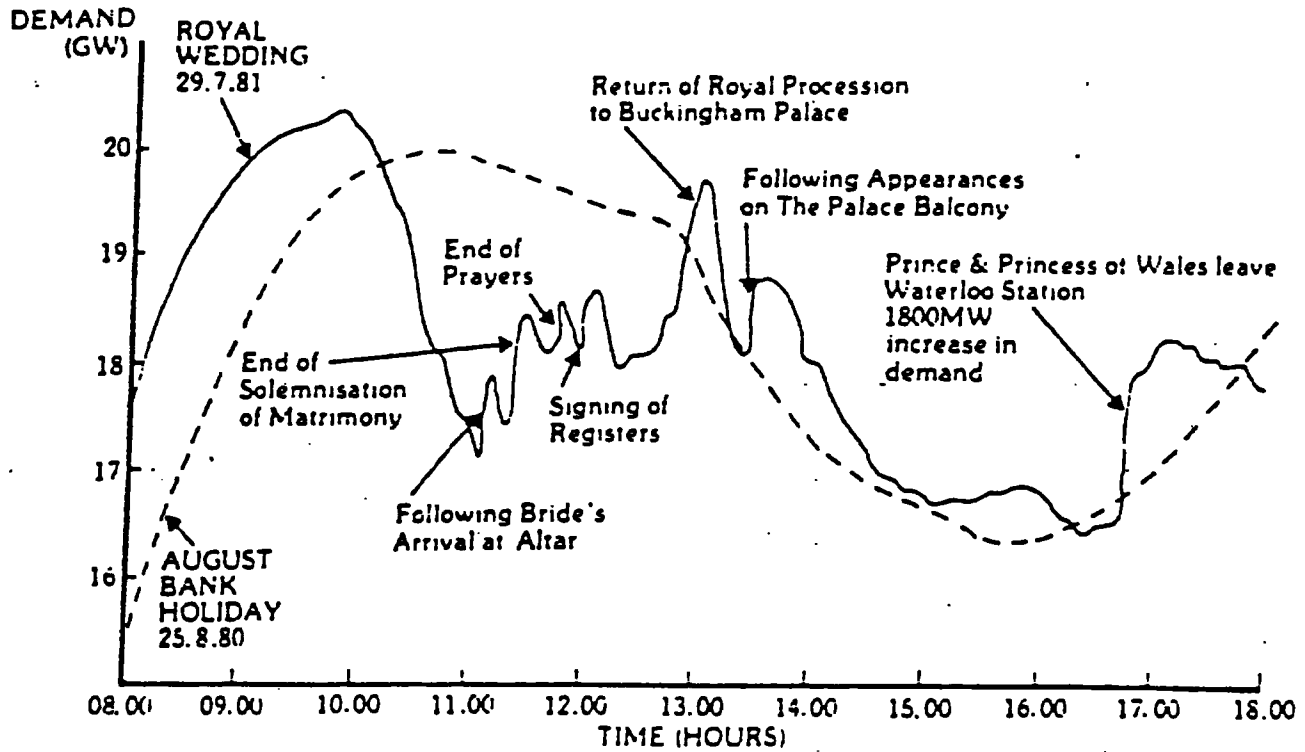

FIGURE 1.5 ILLUSTRATION OF THE EFFECTS OF TELEVISED EVENTS ON THE SYSTEM DEMAND AND FREQUENCY

SIMULATION FUNCTION

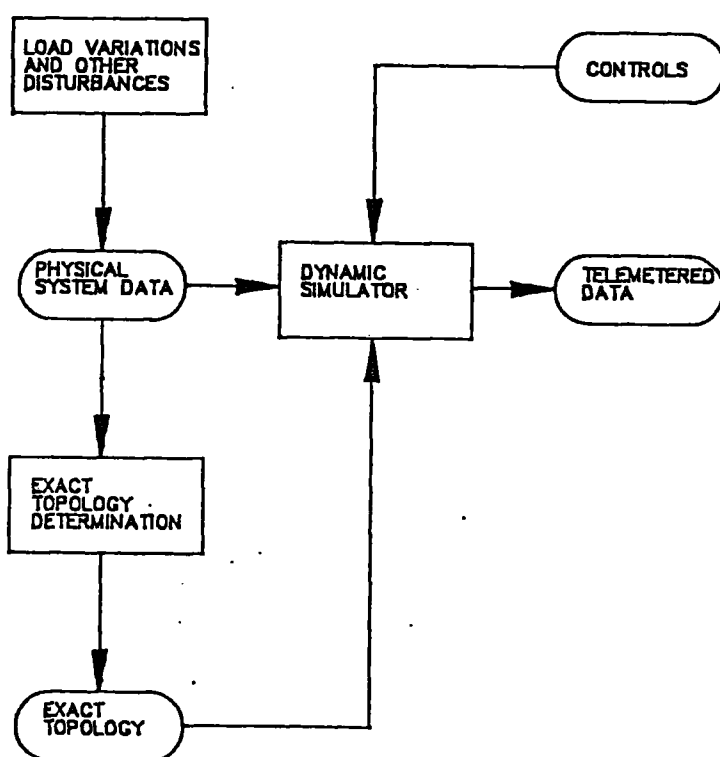

FIGURE 1.6 OPERATIONAL CONTROL OF POWER SYSTEMS
SIMULATION FUNCTION

ANALYSIS AND CONTROL FUNCTION

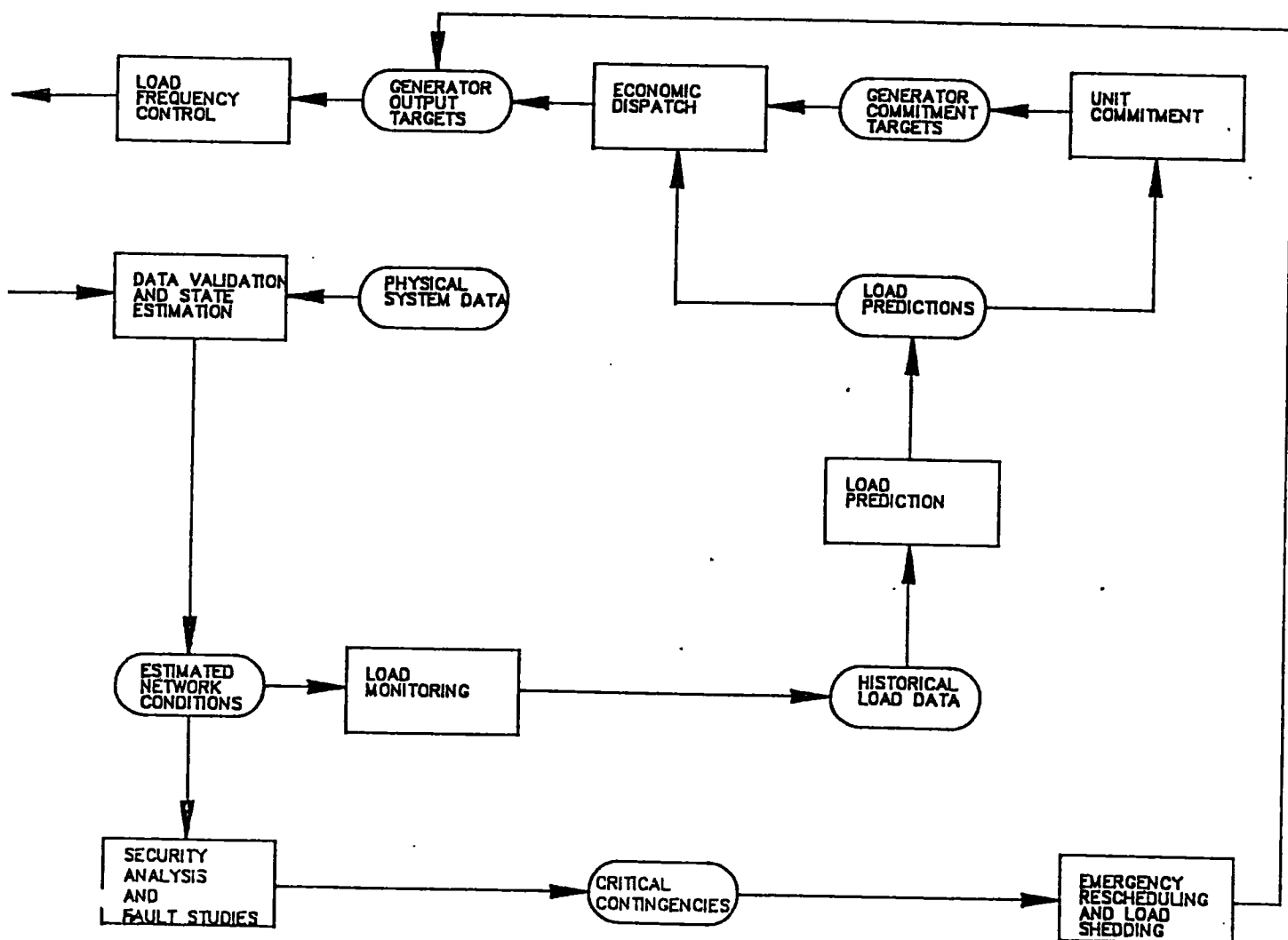

FIGURE 1.7 OPERATIONAL CONTROL OF ELECTRIC POWER SYSTEM
ANALYSIS AND CONTROL FUNCTION

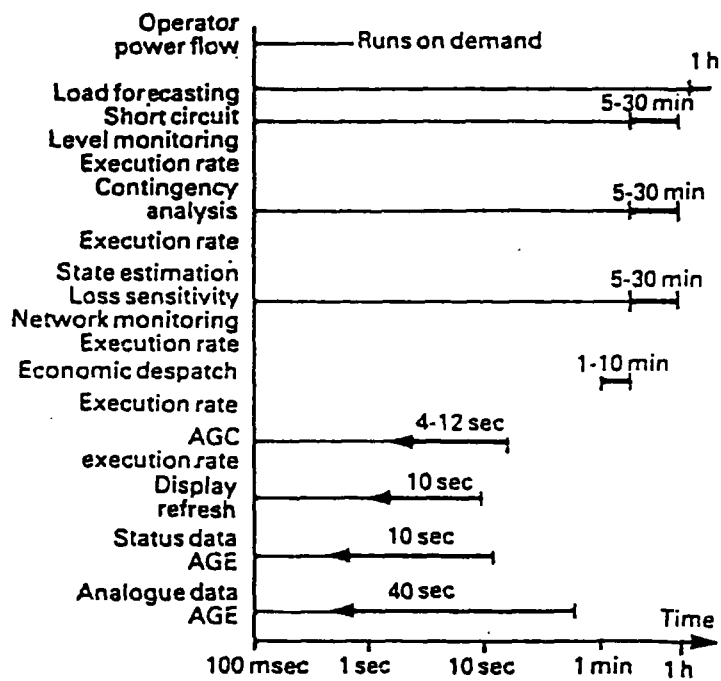

FIGURE 1.8 TYPICAL EXECUTE RATES

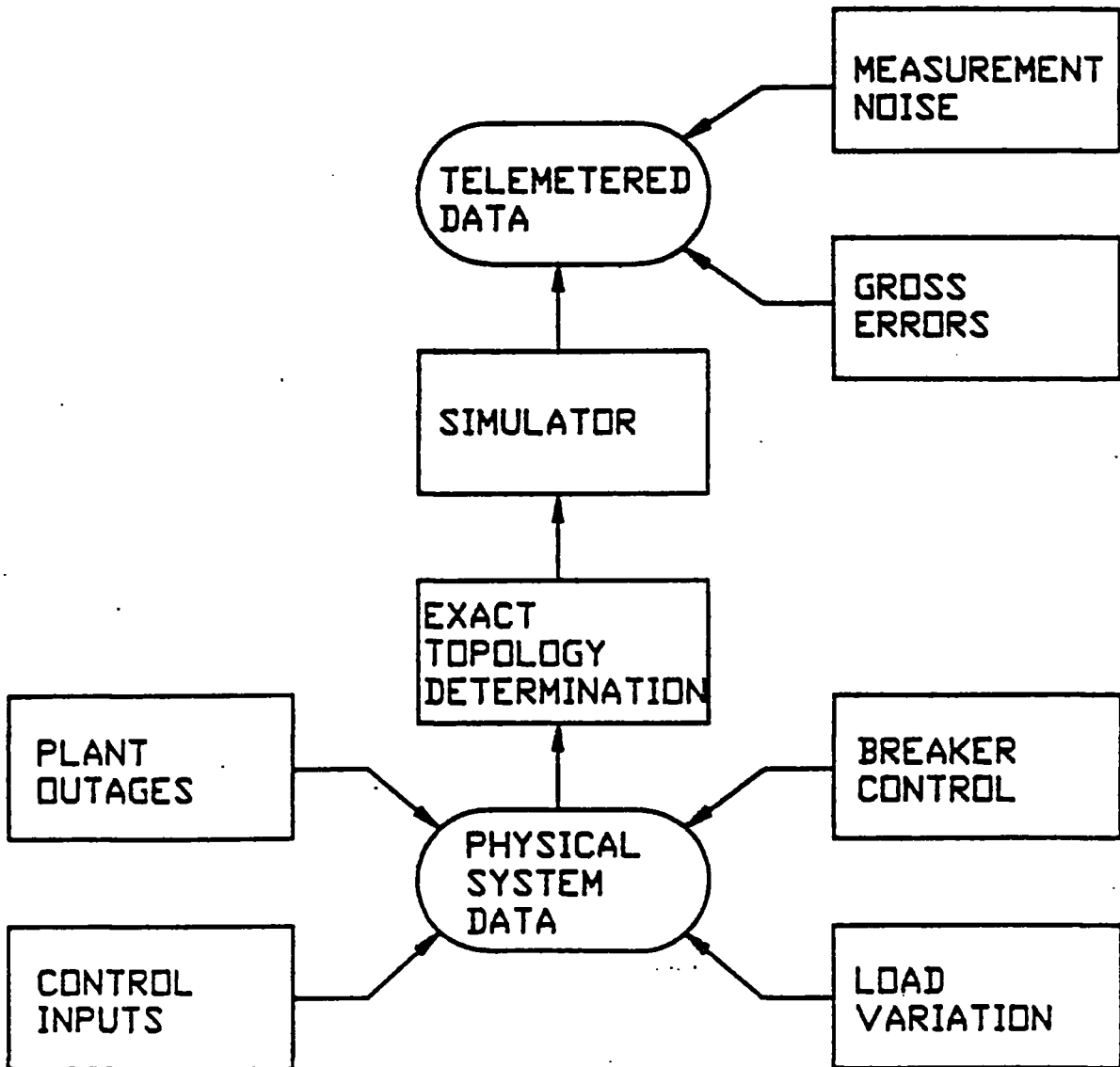

FIGURE 1.9 SIMULATION SUBSYSTEM

OPERATIONAL CONTROL OF ELECTRIC POWER SYSTEMS
OVERVIEW OF MAJOR FUNCTIONAL ELEMENTS

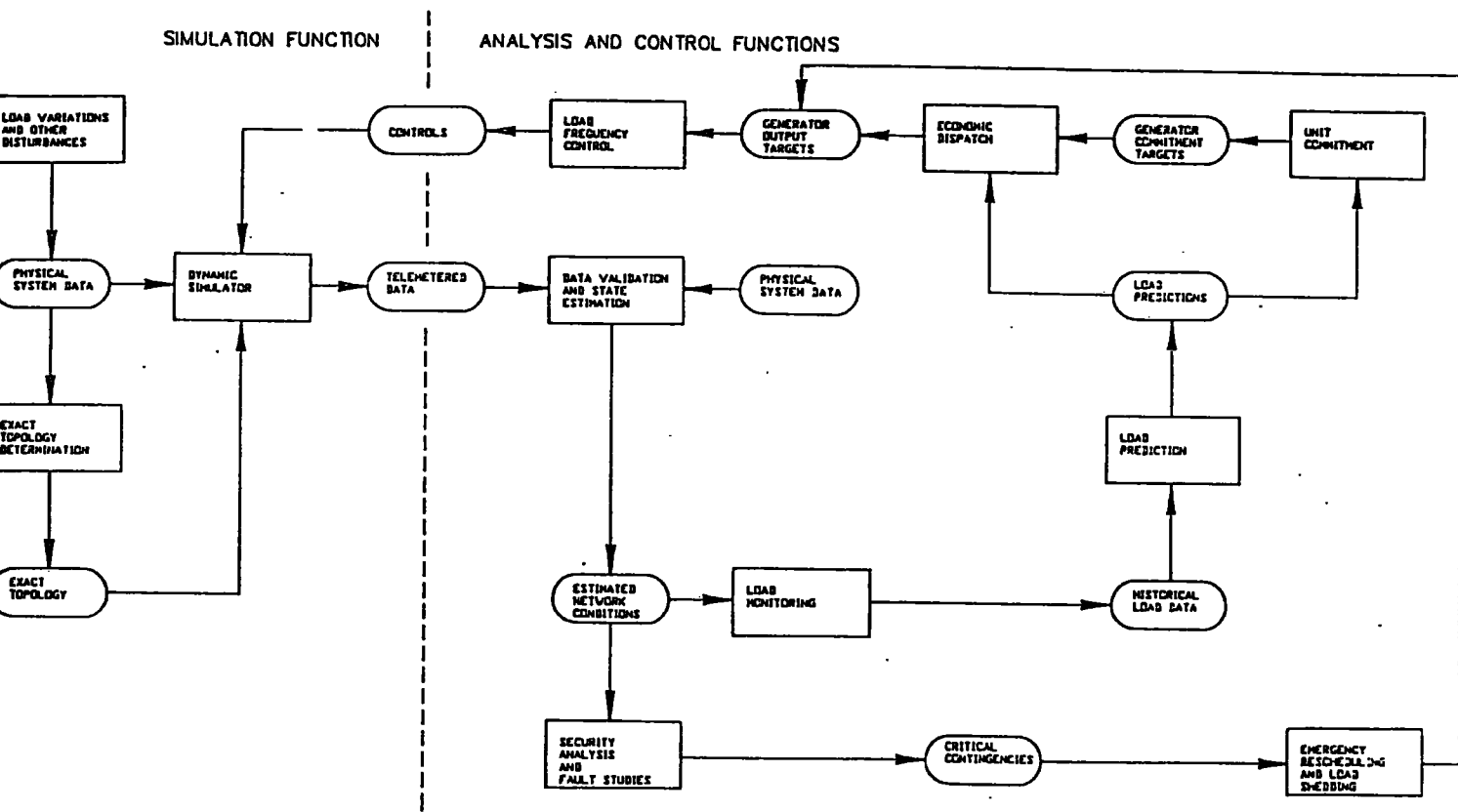

FIGURE 1.10 OPERATIONAL CONTROL OF ELECTRIC POWER SYSTEMS
 OVERVIEW OF MAJOR FUNCTIONAL ELEMENTS

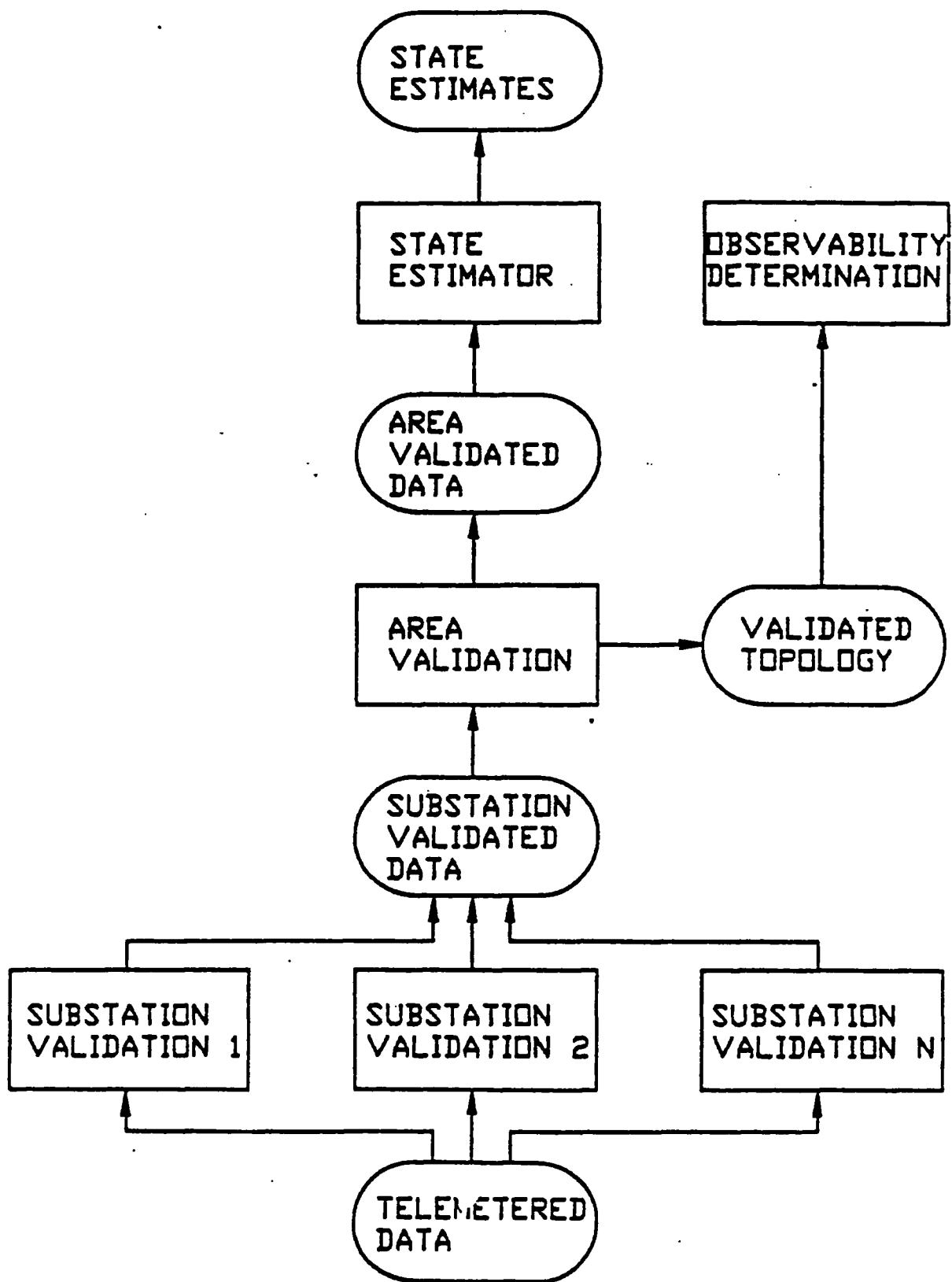

FIGURE 1.11 STATE ESTIMATION AND TOPOLOGY SUBSYSTEM

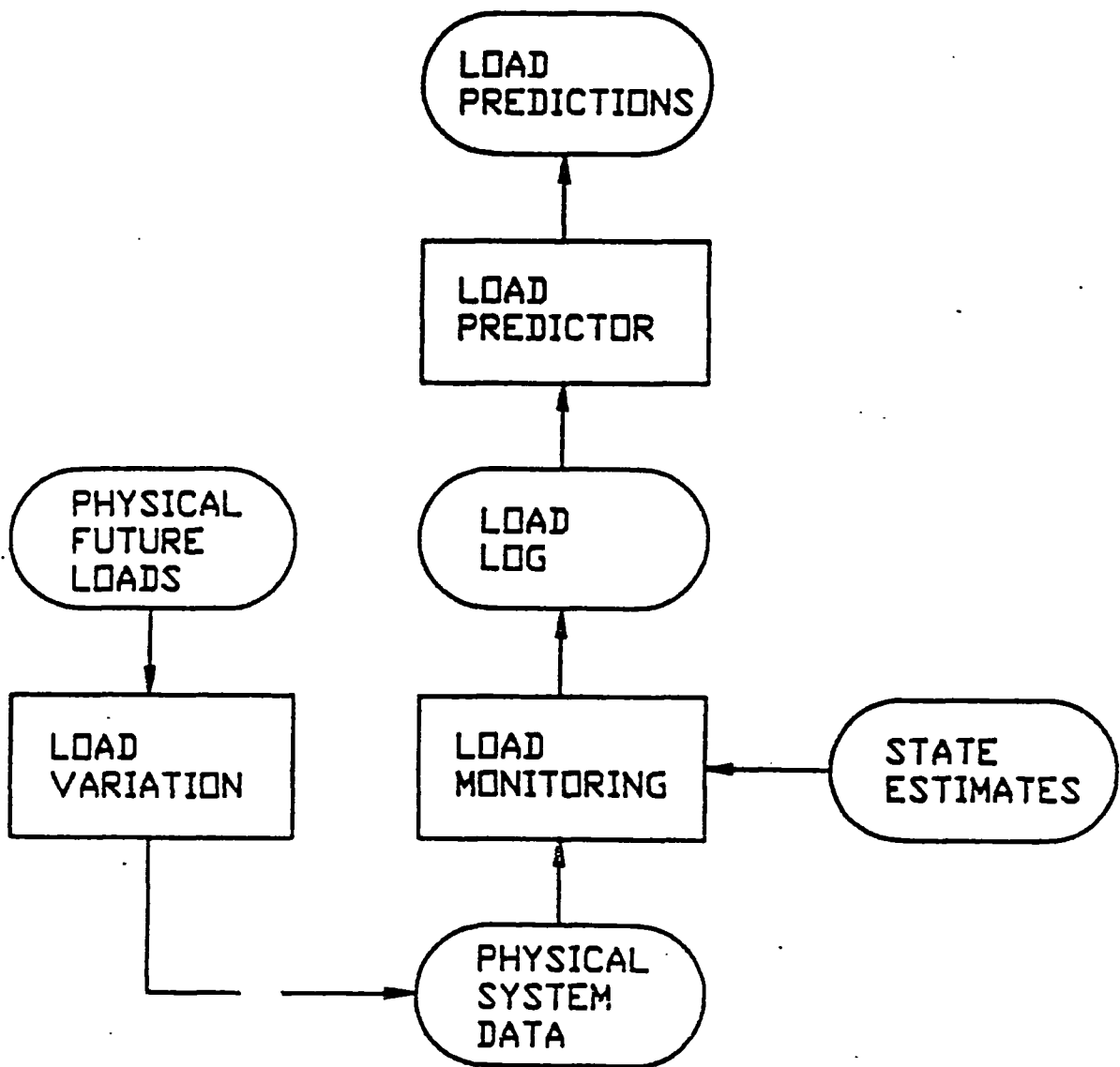

FIGURE 1.12 LOAD MONITORING AND PREDICTION SUBSYSTEM

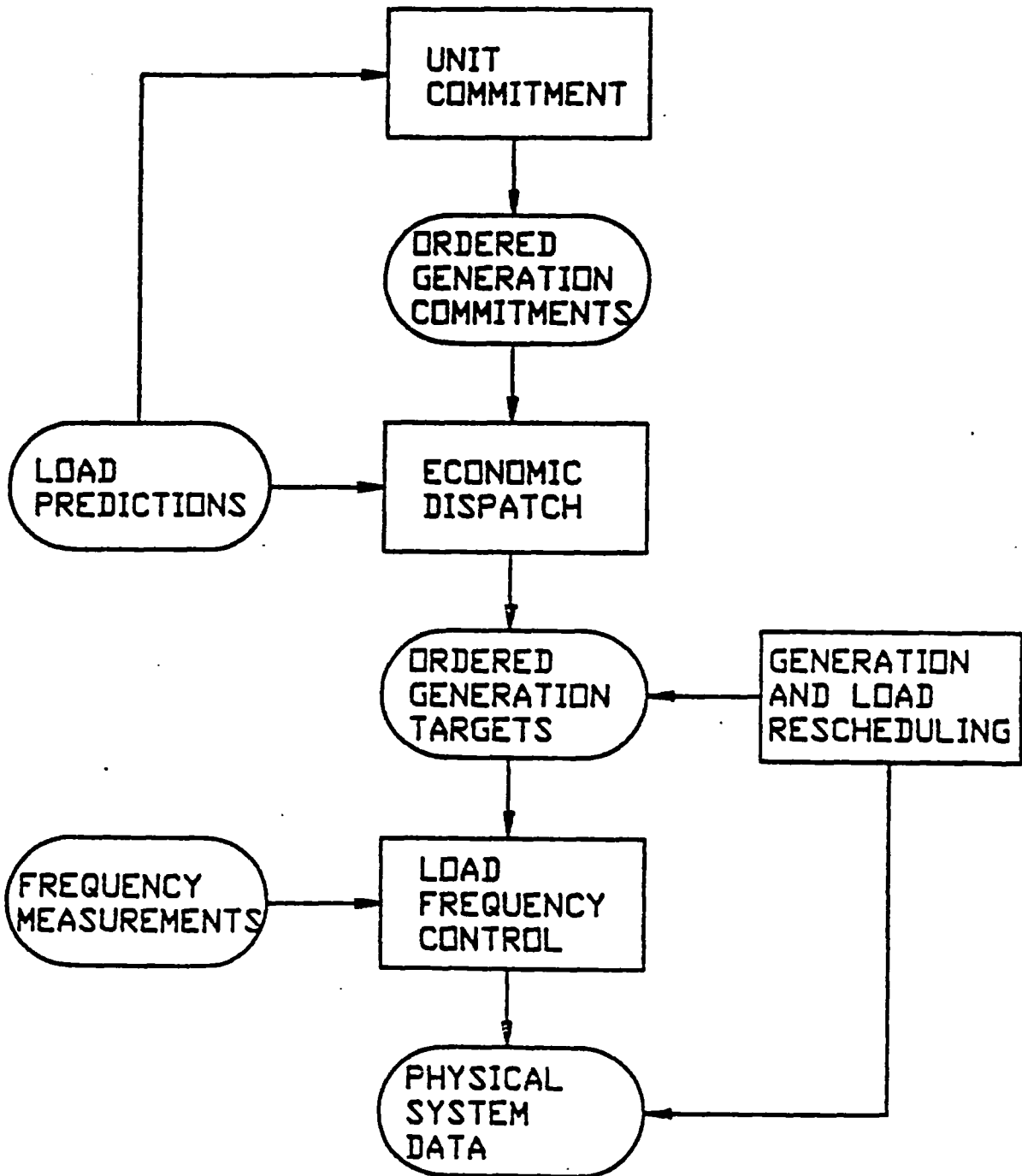

FIGURE 1.13 GENERATION AND LOAD CONTROL SUBSYSTEM

CHAPTER 2

REAL-TIME SECURITY ASSESSMENT

2.1 Introduction

The concept of security can be expressed as the capability to meet demand in terms of availability of enough production and transmission resources to match any load rise and credible but unforecasted outages without exceeding acceptable limits in frequency and voltage drops. [28]

System security studies start in the long-term planning stage when the transmission and generation systems are designed taking into account some contingency situations. However, due to economic considerations, only so much security can be built into a power system. In the short term simulations of the future conditions in the network are carried out in order to assure that the transmission and generation facilities scheduled to be operative are adequate to meet pre-established security requirements. However, the planner cannot predict all possible system configurations and system demands. There is then the necessity of providing additional security analysis and control in the real-time environment.

The purpose of security assessment is to detect and alert operators to insecure and abnormal conditions so that corrective strategy may be planned

and corrective action taken.

This chapter represents a survey of approaches to the estimation of system security and discusses power system operating states, monitoring and security enhancement.

2.2 Power System Operating States

The power system is thought of as being run under three sets of constraints, [29] which are:

- the load constraints
- the operating constraints
- the security constraints

The load constraints simply recognise the prime task in power system operation, namely to meet the load demand. The operating constraints, furthermore, stipulate the objective of using the system components within permissible limits and to meet the quality standard of the system. Overloaded components, bus-voltages outside the tolerances and abnormal frequency deviations are examples of violations of the operating constraints.

Some of the security constraints are magnitude, accessibility and location of operating resources, limits in transmission capacity, etc. The

system is secure if it fulfils the appropriate security constraints in order to meet some contingencies. By means of these three sets of constraints four classes of operating states^{[28][29][30][31]} can be defined as follows:

(a) the normal state

All three sets of constraints satisfied, the objective in this state is to operate the system so as to remain in this state and to allocate generation to minimise total production cost within security.

(b) the alert state

Loading and operating constraints satisfied but existing reserve margins are such that some disturbance would result in a violation of some security constraints. The operating objective in the alert state is to return to the normal state as rapidly as possible.

(c) the emergency state

Operating and security constraints not satisfied, load constraints not necessarily satisfied. The operating objective in this state is to prevent the spread of the emergency and to restore the system to at least the alert state.

(d) the restoration state

Operating constraints satisfied, load and security constraints not satisfied. This is the state of the system following an emergency where the emergency has been stabilised but the establishment of the normal state has not yet been achieved. The operating objective in this state is to restore all services as rapidly as possible and to return to normal state.

The four operating states and the transition between them are shown in Figure (2.1).

The transitions are caused by contingencies and control actions. According to these states, security is defined with respect to a set of random events called the set-of-next-contingencies.

This is a collection of disturbances that could occur. A system is said to be secure if it is in the normal state and none of the contingencies could cause it to enter the emergency state.

As shown in Figure (2.1), the function of the preventive control is to take action to make the system secure. Some centres have programs that can, when they are activated by the operator, produce schedules to eliminate certain limit violations. However, most preventive control is manual.

The function of the emergency control is to take corrective action to

make the system normal. Aside from load shedding, which is done in accordance with precalculated schedules and implemented by under-frequency relays, the operator is usually responsible for all emergency control. The function of the restorative control is to restore service to the system's loads. All restorative decisions are made by the operator.

In the power system control centres the main emphasis has been given to the preventive control.

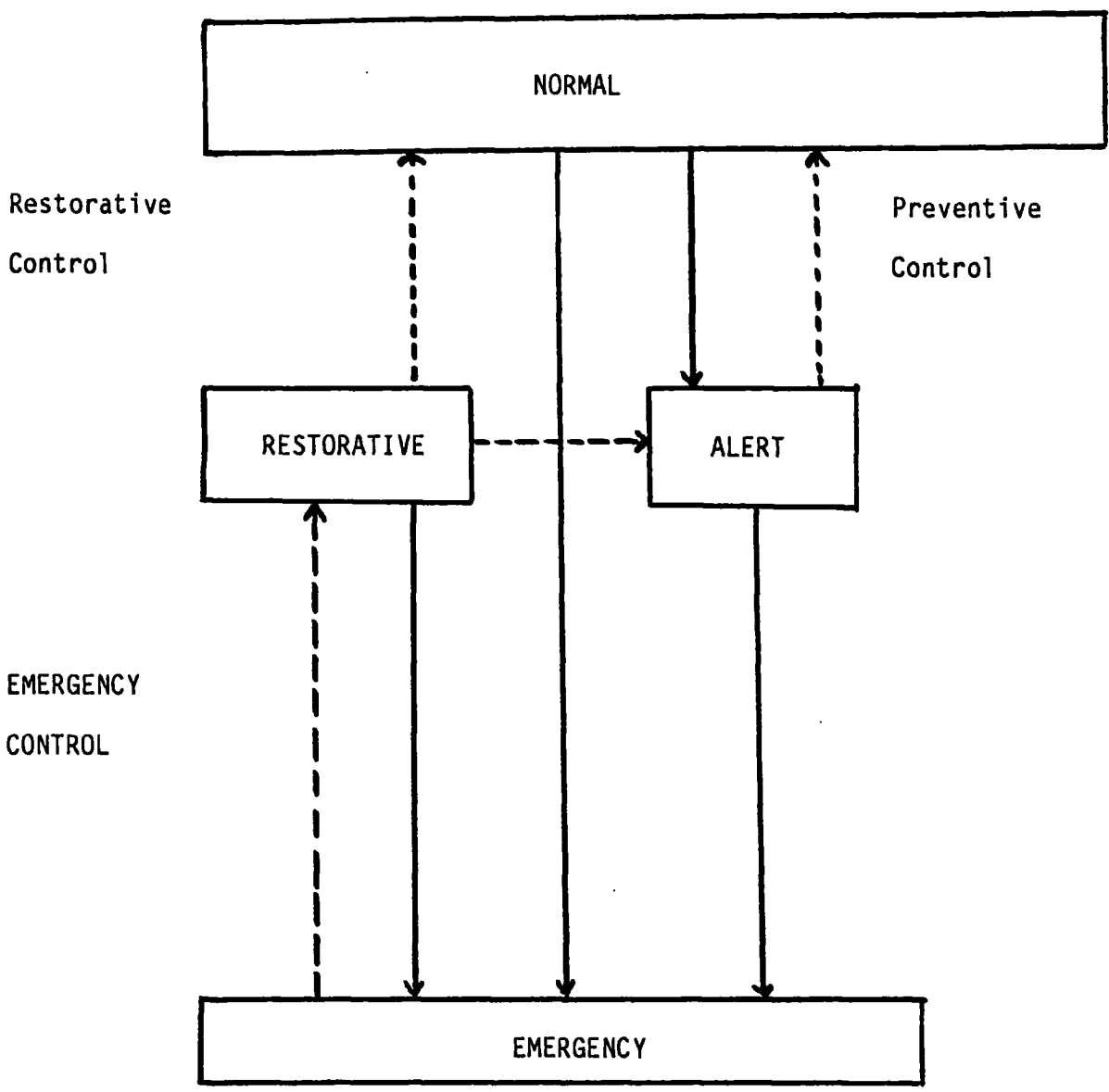

—— transition caused by contingencies
----- transition caused by control action

FIGURE 2.1 - POWER SYSTEM SECURITY STATES

2.3 Security Functions in System Control

Security assessment^{[28][29]} is the process of checking for violation of operating limits on the power system, in its present state or in an anticipated future state, and either in the intact condition or on the occurrence of a likely contingency.

The purpose of contingency assessment is to detect and alert operators to insecure and abnormal conditions so that corrective strategy may be planned and corrective action taken.

There are three basic functions in a secure control system, which are:

- (a) security monitoring
- (b) security enhancement
- (c) security analysis

These are illustrated in Figure (2.2).

2.3.1 Security Monitoring

Security monitoring is the on-line identification of the actual operating state of a system by checking real-time data to determine whether it is in a normal, alert, emergency or restorative state.

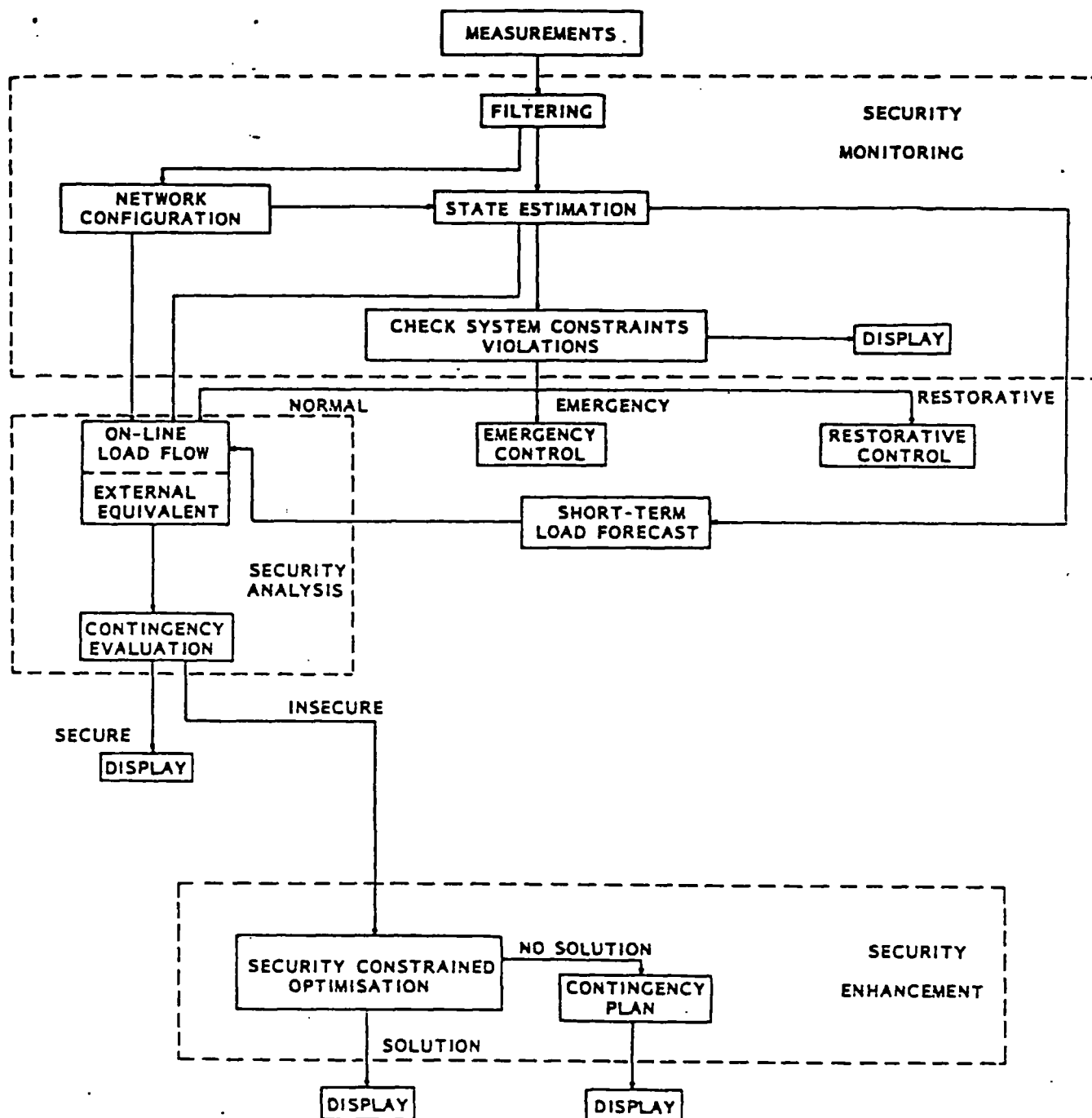

FIGURE 2.2 REAL-TIME SECURITY CONTROL SYSTEM

The first step in security monitoring of power systems is the setting up of a real-time database. The data acquisition function starts with the measurement of the physical quantities in a power system such as bus voltage magnitude, line flows and bus power injections. In addition, data on the status (open or closed) of circuit breakers, and switches are required. The measurements data are telemetered from locations to the control centre computer. Glaringly bad data such as transient excursions in the measured values are rejected by filtering the transmitted data through a simple check of their reasonableness or of the consistency between breaker status and analogue information, or by some smoothing routine. The real-time information about the status of circuit breakers and disconnect switches is systematically processed to determine the network configuration.

Missing and erroneous data occur frequently in the real-time environment. Faced with errors in the measurements, missing measurements, and errors in the transmitted data, the available data must be processed to obtain an estimate of the state variables, the vector of bus voltage magnitudes and phase angles, of the power system; that is the task of the state estimate program.

The following function in security monitoring is the on-line check on the operating limits of the power system based on the calculated values.

2.3.2 Security Enhancement

Security enhancement determines whether the system can be made secure. Basically, it determines what preventive action should be taken to make an insecure system secure, or less insecure.

Preventive action requires an optimisation routine, or optimum power flow. Let us assume that a preventive-action solution can be found optimal or not; since the power system normally is operated at minimum operating cost. System security will have to be obtained at a price. If the cost of the preventive action is small, the operator can place the control in effect. Where the cost is high but the contingent emergency not too severe, the operator may decide not to take any action to improve system security.

If it is not possible to find a preventive-action solution, a contingency plan would be developed by assuming that the contingency has occurred. The objective of this would be to minimise the amount of load to be curtailed, this strategy can be part of an emergency control function.

The definition and objectives of real-time security assessment when the power system is operating under emergency or stressful conditions should be evaluated. Under these conditions, the objectives of operation change from cost minimisation to control of the system to bulk oscillation and return the system to the normal operating state and/or initiate other control actions towards a restorative state to insure against cascading

interruptions and major blackouts. The computer software used in system operations should have the flexibility to reflect these different objectives.

2.3.3 Security Analysis

The reliable and efficient operation of interconnected electric energy systems is an important objective for the nation and a challenging problem for power systems planners and analysts.

Security of a power system is considered to be an instantaneous, time-varying condition that is a function of the system's robustness relative to imminent disturbances.

Security analysis^{[32][33][34]} consists of evaluating the system under various contingencies in order to obtain a measure of system security and providing inputs to enhancements strategies. So, security of a power system is defined with respect to a list of possible transmission line outages and generator outages, called contingencies. As the system conditions change, the contingencies which cause insecure operation may also change.

A framework was established for deterministic steady-state security assessment, in which, the robustness of the system is tested, using a power flow, on a set of selected contingencies. The major components of the classical security assessment in a modern control centre include: state

estimation, topology determination, contingency selection and evaluation, and security control. An in-depth survey of the classical approach was presented by F.F.Wu and S.N.Talukar.^[30]

The deterministic technique requires that certain calculations such as load-flow unit commitment, and stability studies be made for all conceivable future contingencies. The results of these studies are then reviewed and a judgement is made of whether or not some corrective action is required to maintain adequate system security.

However, this technique does not take direct account of the unequal probability of occurrence of each system's contingencies, and furthermore that the number of ways of reaching undesirable operating states is not constant. Thus, when as the deterministic approach clearly indicates those operating conditions that would result in a breach of system security, it does not supply a consistent criterion for control. Hence, the probabilistic approach was considered.

The probabilistic approach is not independent of the deterministic technique but supplies a consistent criterion for control action given the results of the contingencies tests.

Because of uncertainty inherent in the prediction "imminent disturbances", a probabilistic framework for security assessment is more appropriate. Furthermore, most of the major power system break downs are

caused by problems associated with system dynamic response. Hence, dynamic models of the system should be represented in the security assessment.

A framework for probabilistic dynamic security assessment has been presented by F.F.Wu and T.K.Tsai.^[35] The deviation of probabilistic dynamic security assessment is conceptually based on a two-level model of power systems. The first level of the model describes the evolution of the system's structural state. The second level of the model describes the trajectories of system variables associated with component dynamics.^[36] The two levels are coupled.

In the probabilistic dynamic security assessment approach the security of a system is characterised in terms of the steady-state and dynamic security regions. The time to insecurity is used as the measure of system security. A linear vector differential equation can be derived whose solution gives the probability that the time to insecurity is greater than t . The coefficient of the differential equations involve: component failure and repair rates, power generation, load demand and security regions.

Techniques have been developed for obtaining steady-state and dynamic security regions. In the former case one is interested in situations where system configurations are changing. The space of injection, however, is invariant. Hence, the security regions in the space of injection are characterised.^[37]

Since the loss of transient stability is a severe breach of security, in the latter case dynamic security region after a fault is defined in terms of transient stability region. For transient stability analysis, a power system is considered as undergoing changes in configurations from pre-fault, fault-on, to post-fault. If the initial condition for the post-fault system lies in the region of asymptotic stability of a stable post-fault equilibrium, the system is transiently stable. The Liapunov method has been widely used for this analysis. [38][39][40][41]

The usual philosophy, in existing central security control systems, in performing security assessment could be characterised as deterministic in real-time environment. The OCEPS security assessment package is based on the deterministic approach.

2.4 Real-Time Security Assessment

The first stage in the assessment of security is the development of a set of events whose occurrence would be considered to be a breach of security.

In the course of the operation, a power system can be considered to be in transit between different steady-states with smaller time-steps. By means of a few sets of constraints these consecutive states may be classified into a number of operating states, characterising different operating conditions. The sets of constraints can be:

- (a) the load constraints
- (b) the operating constraints
- (c) the security constraints

The load constraints simply recognise the prime task in power system operation, namely to meet the load demand. The operating constraints, furthermore, stipulate the objective of using the system components within permissible limits and to meet the quality standard of the system. These constraints can be:

- (a) voltage at any bus outside working tolerances
- (b) overload of any transmission line or other equipment
- (c) insufficient real or reactive generating capacity

The concept of load and operating constraints might further be used to define the concept of security. Thus, the security of the system equals the capability of the system to meet contingencies, i.e. unplanned events, without violating the load and operating constraints in the remaining system. Such contingencies typically are forced outages or deratings of production units and transmission components or essential deviations from the forecasted load.

To analyse the steady-state security problem, very efficient models and numerical techniques must be applied. For system operations, the Fast Decoupled Newton-Raphson load-flow program can be used as one of several

programs in an automated despatch centre. The program can incorporate the outages according to a contingency list, thus indicating to the system operator the constraint violations that will result from a particular outage. The types of outage considered include single and multiple transmission line outages, load generation or station outage, transformer outages.

The effect of load changes and generation rescheduling can be easily evaluated, [42][43][32] but the outage simulation of a line or transformer is more complex because these contingencies change the system configuration.

The loss of a generator or reduction of generator output may precipitate voltage problems due to an inability to match reactive generation and load. It is therefore necessary to simulate the effect of partial or full generator outages on the power system which may be achieved by means of a load-flow study which has access to the actual state of the power system.

As the system conditions change, the contingencies which cause insecure operation may also change. In the real-time environment it is hardly feasible to perform on-line load-flows for all contingencies to determine how well the system, in its present state, can withstand these contingencies. Methods have been developed to rank contingencies according to the severity of their effects on bus voltages or line flows. On-line load-flows are then performed for each case starting at the top of the list

and stopped when the case does not give problem.

Some automatic contingency selection methods have been proposed. [44][23][45] For each outage considered in turn the results of the load-flow study are checked against the critical limits and any violations are brought to the attention of the operator. Such contingency evaluations are carried out at prespecified intervals and also whenever there is a change in the system.

Figure (2.3) illustrates the typical components of a security assessment software package suitable for the real-time monitoring of electrical power systems.

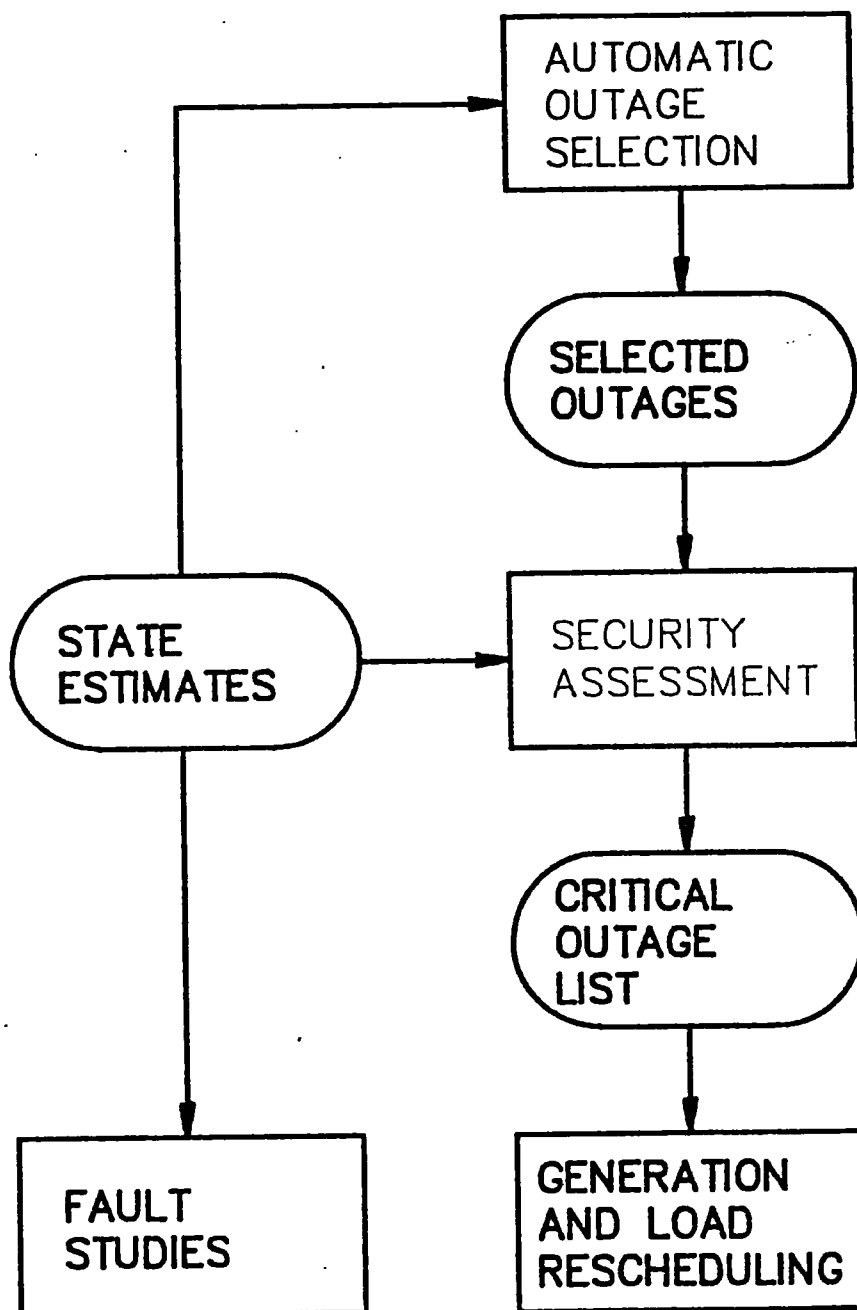

FIGURE 2.3 SECURITY ANALYSIS SUBSYSTEM

CHAPTER 3

THEORY OF NETWORK CHANGES

3.1 Introduction

The basic equations which can lead to the solution of a given network are derived from first principles using Ohm's law and Kirchhoff's laws. The object of the theory of network changes is to obtain the solution to an intact network when it is subjected to modifications. The solution to a linear or non-linear network can be easily obtained from the inverse of the admittance matrix. When the intact network is subjected to branch outages, the theory of simultaneous outages can be applied which determine the new solution from the previous or old solution by modification of the original impedance matrix.

Diakoptics can be used for this purpose where the new solution can be obtained from the original solution in an efficient and organised manner. This chapter represents the theory of network modifications. Initially, the solution to linear networks is investigated. Application of branch outages to non-linear networks is investigated in the following chapter.

3.2 Solution to Linear Networks

The solution to linear network equations may involve the inverse of the bus admittance matrix, Y . There are two methods of approach:

(a) to obtain Z in matrix form

(b) to obtain Z in product form

In the case of the former, the solution is obtained by directly inverting the bus admittance matrix:

$$Y_0 V_0 = I_0 \quad (3.1)$$

$$\therefore V_0 = Y_0^{-1} I_0 \quad (3.2)$$

$$\text{or } V_0 = Z_0 I_0 \quad (3.3)$$

There are many ways of obtaining Y_0^{-1} . One of the simplest and most effective ways of calculating the inverse of large matrices in connection with power system analysis is the generalisation of the elimination process.

It is most easily understood by considering two simultaneous equations:

$$y_{11}v_1 + y_{12}v_2 = i_1 \quad (3.4)$$

$$y_{21}v_1 + y_{22}v_2 = i_2 \quad (3.5)$$

Dividing (3.5) by y_{22} and re-arranging:

$$v_2 = y_{22}^{-1} (i_2 - y_{21}v_1) \quad (3.6)$$

Substituting into the equation (3.4) for v_2 gives:

$$(y_{11} - y_{12}y_{22}^{-1}y_{21}) v_1 + y_{12}y_{22}^{-1}i_2 = i_1 \quad (3.7)$$

The above equation can be written in matrix form with v_2 and i_2 interchanged:

$$\begin{bmatrix} y_{11} & y_{12} \\ y_{21} & y_{22} \end{bmatrix} \cdot \begin{bmatrix} v_1 \\ v_2 \end{bmatrix} = \begin{bmatrix} i_1 \\ i_2 \end{bmatrix}, \quad \begin{bmatrix} y'_{11} & y'_{12} \\ y'_{21} & y'_{22} \end{bmatrix} \cdot \begin{bmatrix} v_1 \\ i_2 \end{bmatrix} = \begin{bmatrix} i_1 \\ v_2 \end{bmatrix}$$

where

$$y'_{11} = y_{11} - y_{12}y_{22}^{-1}y_{21}$$

$$y'_{12} = y_{12}y_{22}^{-1}$$

$$y'_{21} = -y_{21}y_{22}^{-1}$$

$$y'_{22} = y_{22}^{-1}$$

triangular decomposition and the product form of the inverse. The bifactorisation method is a very important recent modification of Gauss elimination. It is particularly suitable for analysing large, sparse systems that have non-zero diagonal elements which predominate over off-diagonal elements that are either symmetrical or, if asymmetrical, have a symmetric sparsity structure. The method combines the triangulation and the product form to express the inverse of a matrix A as the product of 2n matrices:

$$L_m A R_m = U \quad (3.8)$$

$$L_n \dots L_2 L_1 A R_1 R_2 \dots R_n = U \quad (3.9)$$

$$A R_1 R_2 \dots R_n = L_1^{-1} L_2^{-1} \dots L_n^{-1} \quad (3.10)$$

$$A R_1 R_2 \dots R_n L_n \dots L_2 L_1 = U \quad (3.11)$$

$$R_1 R_2 \dots R_n L_n \dots L_2 L_1 = A^{-1} \quad (3.12)$$

where

R = right-hand factor matrices

L = left-hand factor matrices

U = unit matrix

n = order of matrix

For computing, the following rules can be developed:

- 1) $R_{ik}^k = L_{ki}^k$ (only for symmetrical matrices, k column of L_k is identical to the k row of R_k)

$$2) \quad L_{kk}^k = 1/a_{kk}^{k-1}$$

$$3) \quad L_{ik}^k = a_{ik}^{k-1} / a_{kk}^{k-1} \quad i = (k+1), \dots, n$$

$$4) \quad R_{kj}^k = -a_{kj}^{k-1} / a_{kk}^{k-1} \quad j = (k+1), \dots, n$$

$$5) \quad a_{ij}^k = a_{ij}^{k-1} - a_{ik}^{k-1} a_{kj}^{k-1} / a_{kk}^{k-1} \quad \begin{matrix} i = (k+1), \dots, n \\ k = (k+1), \dots, n \end{matrix}$$

Any one column can be obtained from the solution of (3.12) with the right-hand vector set to zero except for unity in the position corresponding to the desired column of the inverse matrix.

3.3 Theory of network changes

3.3a Application of diakoptics to the theory of branch outages^[46]

Assuming that V_0 is known from the solution of the original equations:

$$Y_0 V_0 = I_0 \quad (3.13)$$

where Y_0 represents the original admittance matrix, it is required to find new value V_1 after one branch in the network has been modified. The modification may be addition of branches, removal of branches, or changes in the branch admittances. The procedure to remove branches or to change the

admittance of branches is the same. If a branch is removed which is not mutually coupled to any other branch, the modified bus impedance matrix can be obtained by adding, in parallel with the branches, a link whose admittance is equal to the negative of the admittance of the branch to be removed. If the admittance of an uncoupled branch is changed, the modified bus impedance can be obtained by adding a link in parallel with the branch such that the equivalent admittance of the two branches is the desired value. [47]

From the solution to the original network, the solution to the modified network can be obtained by applying diakoptics. Consider the network shown in Figure (3.1), where only one branch is modified from $y = y_0$ to $y = 0$.

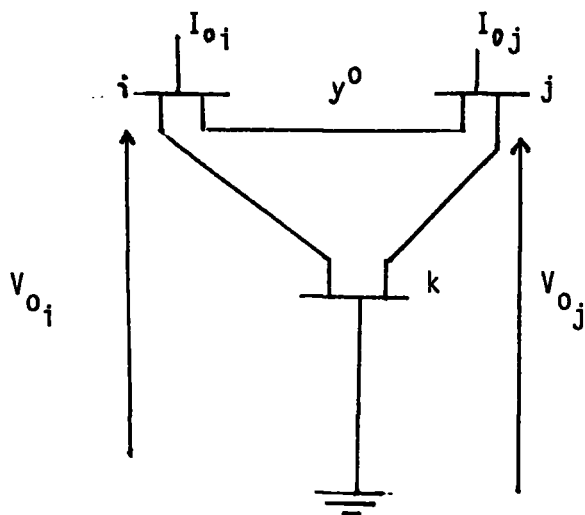

$$Y_0 V_0 = I_0$$

(a) original network

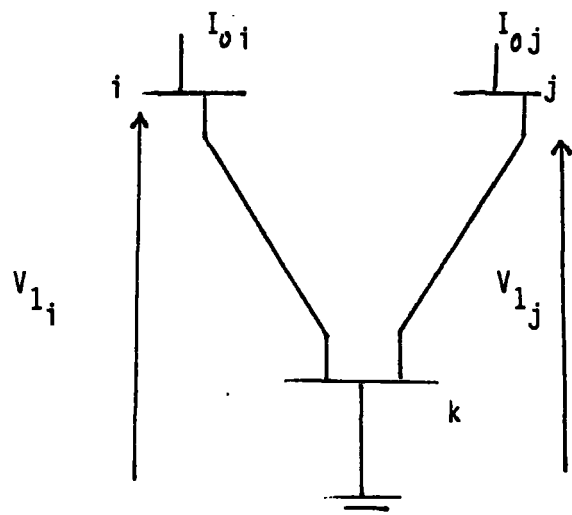

$$Y_1 V_1 = I_0$$

(b) modified network

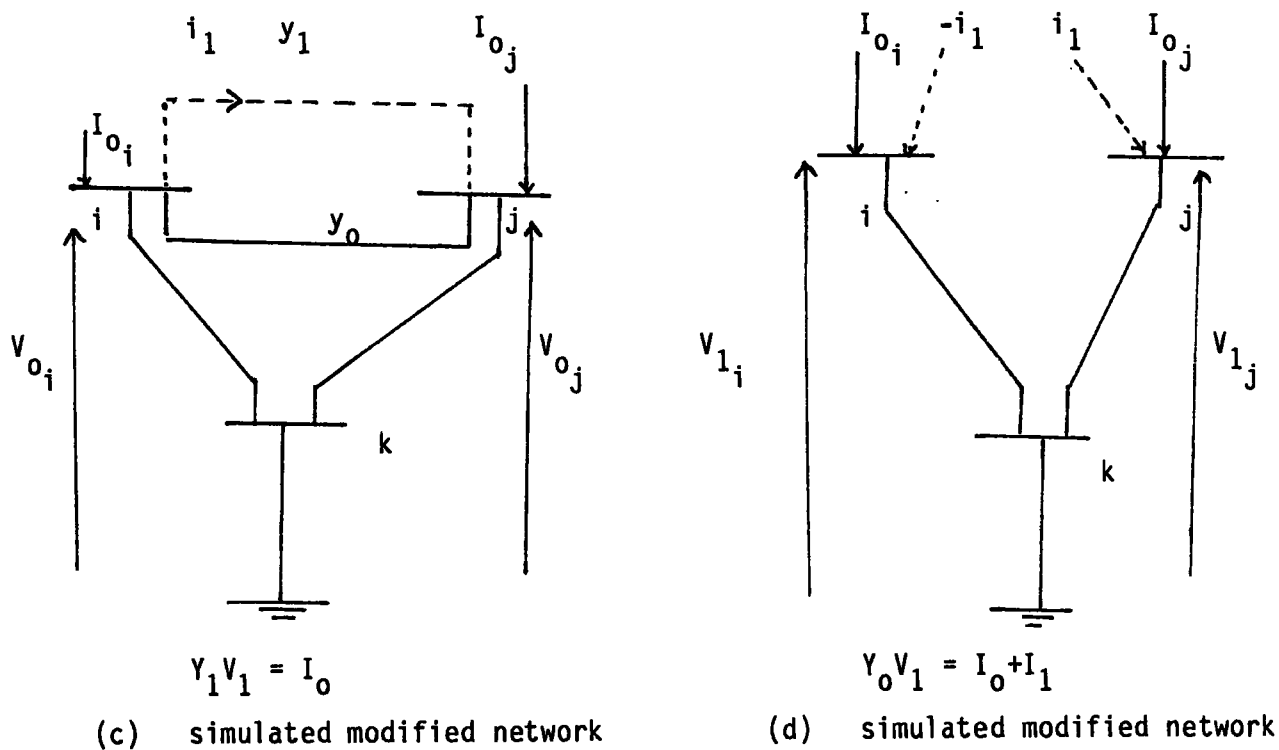

Figure 3.1 Network Changes

For above $y_1 = -y_0$

From Figure (3.1c):

$$i_1 = y_1 (V_{1i} - V_{1j}) \quad (3.14)$$

or in matrix form:

$$i_1 = y_1 C_1^t V_1 \quad (3.15)$$

where

$$C_1^t = \begin{array}{|c|c|} \hline & \begin{array}{cc} i & j \end{array} \\ \hline & \begin{array}{cc} +1 & -1 \end{array} \\ \hline \end{array}$$

(C_1) is referred to as the connection matrix and consists of as many elements as there are nodes. It is established by inspection and has elements +1 (for sending end i), -1 (for receiving end j) and null everywhere else. Hence, multiplication by (C) reduces to simple summation only. From Figure (3.1.d):

$$I_1 = -C_1 i_1 \quad (3.16)$$

(3.15) \rightarrow (3.16):

$$I_1 = -C_1 y_1 C_1^t V_1 \quad (3.17)$$

From Figure (3.1d):

$$Y_0 V_1 = I_0 + I_1 \quad (3.18)$$

$$\therefore V_1 = Z_0 I_0 + Z_0 I_1 \quad (3.19)$$

From Figure (3.1a):

$$V_0 = Z_0 I_0 \quad (3.20)$$

(3.20) \rightarrow (3.19) and (3.17) \rightarrow (3.19):

$$V_1 = V_0 - Z_0 C_1 y_1 C_1^t V_1 \quad (3.21)$$

Multiplying (3.21) by C_1^t :

$$C_1^t V_1 = C_1^t V_0 - C_1^t Z_0 C_1 y_1 C_1^t V_1 \quad (3.22)$$

$$(1 + C_1^t Z_0 C_1 y_1) C_1^t V_1 = C_1^t V_0 \quad (3.23)$$

Let $f_1 = (y_1)^{-1}$

Dividing (3.23) by y_1 :

$$(f_1 + C_1^t Z_0 C_1) y_1 C_1^t V_1 = C_1^t V_0 \quad (3.24)$$

$$\text{Let } d_1 = (f_1 + C_1^t Z_0 C_1)^{-1} \quad (3.25)$$

From (3.24):

$$y_1 C_1^t V_1 = d_1 C_1^t V_0 \quad (3.26)$$

(3.26) \rightarrow (3.21):

$$V_1 = V_0 - Z_0 C_1 d_1 C_1^t V_0 \quad (3.27)$$

Hence, if the solution to the original network (i.e. V_0) and Z_0 are available,

the new solution can be obtained without forming Z_1 .

It can be shown (as in 3.3f) that if $d_1 = 0$ a split network results. The reason is because the new impedance Z_1 becomes singular.

3.3b Development of the algorithm for simultaneous branch outages [37]

It was shown in section (3.3a) that after removing a branch from a network, the new solution would be:

$$V_1 = V_0 - Z_0 C_1 d_1 C_1^t V_0$$

From Figure (3.1b):

$$V_1 = Z_1 I_0 \tag{3.28}$$

From (3.27) and (3.28):

$$V_1 = Z_1 I_0 = Z_0 I_0 - Z_0 C_1 Z_0 C_1 d_1 C_1^t Z_0 I_0$$

$$\therefore Z_1 = Z_0 - Z_0 C_1 d_1 C_1^t Z_0 \tag{3.29}$$

Hence, the solution procedure for single fault can be summarised as:

$$1) \quad X_1 = Z_0 C_1$$

$$2) \quad d_1 = (f_1 + C_1^t X_1)^{-1}$$

$$3) \quad b = d_1 C_1^t V_0$$

$$4) \quad V_1 = V_0 - X_1 b$$

where:

X_1 is the difference of column i and j of Z_0

$C_1^t X_1$ is the difference of element i and j of X_1

$C_1^t V_0$ is the difference of element i and j of V_0

The theory of simultaneous branch outages can be generalised to cater for any number of faults (modifications). For the second outage, Z_0 in (3.27) must be changed to Z_1 to incorporate first outage. It is not necessary to evaluate full Z_1 ; it is sufficient to evaluate $Z_1 C_2$ only. From first outage V_1 , X_1 and d_1 are available.

Multiply (3.29) by C_2 :

$$Z_1 C_2 = Z_0 C_2 - Z_0 C_1 d_1 C_1^t Z_0 C_2 \quad (3.30)$$

$$\text{or } X_2 = W - X_1 a$$

where:

$$\begin{aligned} X_2 &= Z_1 C_2 \\ W &= Z_0 C_2 \\ a &= d_1 C_1^t W \end{aligned}$$

V_2 can be obtained from V_1 :

$$V_2 = V_1 - Z_1 C_2 d_2 C_2^t V_1$$

$$\therefore V_2 = V_1 - X_2 d_2 C_2^t V_1 \quad (3.31)$$

where:

$$d_2 = (f_2 + C_2^t Z_1 C_2)^{-1}$$

$$\therefore d_2 = (f_2 + C_2^t X_2)^{-1} \quad (3.32)$$

Hence, the solution procedure for double simultaneous outage is:

$$1) \quad X_1 = Z_0 C_1$$

$$2) \quad d_1 = (f_1 + C_1^t X_1)^{-1}$$

$$3) \quad b = d_1 C_1^t V_0$$

$$4) \quad V_1 = V_0 - X_1 b$$

$$5) \quad W = Z_0 C_2$$

$$6) \quad a = d_1 C_1^t W$$

$$7) \quad X_2 = W - X_1 a$$

$$8) \quad d_2 = (f_2 + C_2^t X_2)^{-1}$$

$$9) \quad b = d_2 C_2^t V_1$$

$$10) \quad V_2 = V_1 - X_2 b$$

where:

W is the difference of column i and j of Z_0

$C_2^t X_2$ is the difference of element i and j of X_2

$C_2^t V_1$ is the difference of element i and j of V_1

Also:

$$Z_2 = Z_1 - Z_1 C_2 d_2 C_2^t Z_1 \quad (3.33)$$

For the third fault multiply (3.29) and (3.33) by C_3 :

$$Z_1 C_3 = Z_0 C_3 - Z_0 C_1 d_1 C_1^t Z_0 C_3 \quad (3.34)$$

$$Z_2 C_3 = Z_1 C_3 - Z_1 C_2 d_2 C_2^t Z_1 C_3 \quad (3.35)$$

From (3.34):

$$W' = W - X_1 a$$

where:

$$W' = Z_1 C_3$$

$$W = Z_0 C_3$$

$$X = Z_0 C_1$$

$$a = d_1 C_1^t W$$

From (3.35):

$$X_3 = W' - X_2 a$$

where:

$$X_3 = Z_2 C_3$$

V_3 can be written in terms of V_2 (as in (3.27)):

$$V_3 = V_2 - Z_2 C_3 d_3 C_3^t V_2$$

or:

$$V_3 = V_2 - X_3 b \tag{3.36}$$

where:

$$d_3 = (f_3 + C_3^t Z_3 C_3)^{-1}$$

or:

$$d_3 = (f_3 + C_3^t X_3)^{-1} \quad (3.37)$$

$$b = d_3 C_3^t V_2 \quad (3.38)$$

Hence, additional procedures for the third outage are:

$$1) \quad W = Z_0 C_3$$

$$2) \quad a = d_1 C_1^t W$$

$$3) \quad W' = W - X_1 a$$

$$4) \quad a' = d_2 C_2^t W'$$

$$5) \quad X = W' - X_2 a'$$

$$6) \quad d_3 = (f_3 + C_3^t X_3)^{-1}$$

$$7) \quad b = d_3 C_3^t V_2$$

$$8) \quad V_3 = V_2 - X_3 b$$

Also:

$$Z_3 = Z_2 - Z_2 C_3 d_3 C_3^t Z_2 \quad (3.39)$$

For the fourth outage multiply (3.29), (3.33), (3.39) by C_4 ; also, multiplication of (3.33) by C is required. Hence, the additional procedures can be shown to be:

$$1) \quad W = Z_0 C_4$$

$$2) \quad a = d_1 C_1^t W$$

$$3) \quad W' = W - X_1 a$$

$$4) \quad a' = d_2 C_2^t W'$$

$$5) \quad W'' = W' - X_2 a'$$

$$6) \quad a'' = d_3 C_3^t W''$$

$$7) \quad X_4 = W'' - X_3 a''$$

$$8) \quad d_4 = (f_4 + C_4^t X_4)^{-1}$$

$$9) \quad b = d_4 C_4^t V_3$$

$$10) \quad V_4 = V_3 - X_4 b$$

It can be seen from the above that except for the first outage, the rest follow a similar pattern. The process is in a recursive manner. The flow diagram of Figure (3.2) was developed:

$i = 1, n$ where n is the number of outages

$$W = Z_0 C_i$$

For $i \neq 1$

$j = 1, i-1$

$$a = d_j C_j^t W$$

$$W = W - X_j a$$

$$X_i = W$$

$$d_i = (f_i + C_i^t X_i)^{-1}$$

$$a = d_i C_i^t V_{i-1}$$

$$V_i = V_{i-1} - X_i a$$

Figure 3.2 Flow diagram for simultaneous branch modifications

d_i and X_i must be stored for next fault, V_i can be overwritten. a, d, f are single elements, W, Z_0, C, V, X are vectors.

A numerical example is solved in Appendix B to illustrate the application of the recursive method to linear networks.

3.3c Node addition and removal [46]

The network modification process can be used to modify existing branches as well as to network extensions. This can be illustrated from the following example:

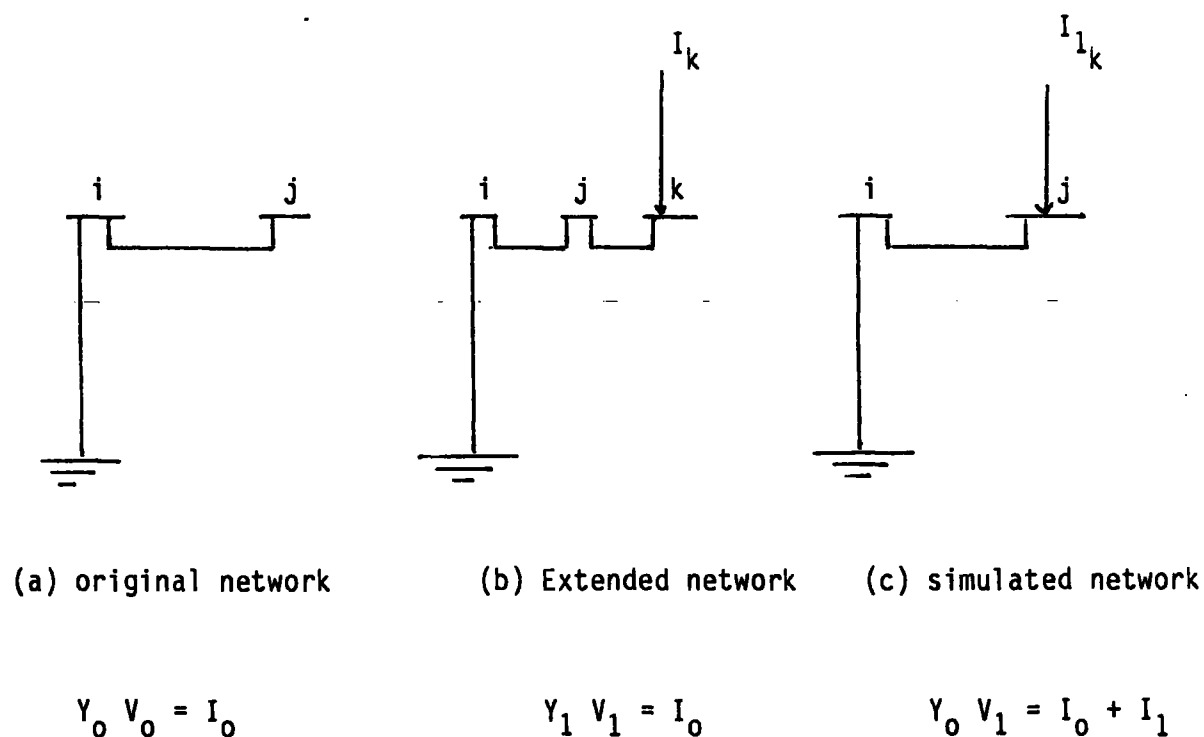

Figure 3.3 Network Extension

From Figure (3.3c):

$$V_1 = Z_0 I_0 + Z_0 I_1 \quad (3.40)$$

From Figure (3.3a):

$$V_0 = Z_0 I_0 \quad (3.41)$$

and

$$I_1 = i_{1_k} \begin{array}{|c|} \hline 1 \\ \hline \end{array} \quad j^{\text{th}}$$

therefore from (3.40):

$$V_{1_1} = V_{a_1} + Z_{1j} I_{1_k}$$

$$V_{1_2} = V_{o_2} + Z_{2j} I_{1_k}$$

.....

$$V_{1_k} = V_{1_k} + y_{kj}^{-1} I_{1_k}$$

where I_{1_k} is known nodal current at node k.

Node isolation is a special case which can be dealt with here. Suppose that

the original network be represented by Figure (3.3b), for which the network solution will be $Y_0 V_0 = I_0$. If branch y be removed, node k will be isolated. This can be simulated by injecting a current equal to $-I_k$ to node j . The new I_1 is:

$$I_1 = I_{1k} \begin{array}{|c|} \hline -1 \\ \hline \end{array} j^{\text{th}}$$

Therefore equation (3.40) can be solved except for v_k .

3.3d Asymmetry (46)

It is sometimes necessary to analyse problems which have asymmetrical coefficient matrix. Such problems arise, for example, when transformers with quadrature taps are represented. In general, such an asymmetry occurs in only few elements but necessitates the calculations and storage of the full coefficient matrix. If symmetry is to be preserved, the asymmetry can be transformed as an injected current and the problem solved iteratively. A better alternative is to be solve the symmetrical problem first and represent the asymmetry as network modifications. This can be illustrated by considering the solution of the following asymmetrical problem:

1	+1	-1	
-1	2		
-1		3	-1
		-1	2

V_{11}
V_{12}
V_{13}
V_{14}

 $=$

1
1
1
1

$$Y_1 V_1 = I_0$$

Restoring symmetry:

1	-1	-1	
-1	2		
-1		3	-1
		-1	2

V_{11}
V_{12}
V_{12}
V_{14}

 $=$

1
1
1
1

 $-2V_{12}$

1

or in general form as:

$$Y_0 V_1 = I_0 + I_1 \quad (3.42)$$

The solution of the asymmetrical problem can now be written as:

$$V_1 = Z_0 I_0 - Z_0 I_1 \quad (3.43)$$

10	5	4	2	1
5	3	2	1	1
4	2	2	1	1
2	1	1	1	1

=

21
11
9
5

=
 $Z_0 I_0$

$$Z^0 I_1 = 2 V_{1_2}$$

10
5
4
2

Therefore: $V_{1_1} = 21 - 2V_{1_2}$ (10)

$$V_{1_2} = 11 - 2V_{1_2} \quad (5)$$

$$V_{1_3} = 9 - 2V_{1_2} \quad (4)$$

$$V_{1_4} = 5 - 2V_{1_2} \quad (2)$$

$$V_{1_1} = 1$$

$$V_{1_2} = 1$$

$$V_{1_3} = 1$$

$$V_{1_4} = 1$$

3.3e Application to non-linear elements (e.g. d.c. links)

If the removed element is non-linear, then the current flowing in it can be defined as:

$$i_1 = f(y_1 V_{1_i} V_{1_j}) \quad (3.44)$$

Compare with (3.14)

From equation (3.19):

$$V_1 = Z_0 I_0 + Z_0 I_1$$

(3.20) (3.19) and (3.16) (3.19):

$$V_1 = V_0 - Z_0 C I_1 \quad (3.45)$$

Multiply (3.45) by C^t

$$C^t V_1 = C^t V_0 - C^t Z_0 C I_1$$

Writing explicitly the i^{th} and j^{th} equations:

$$V_{1_i} = V_{0_i} - (Z_{0_{ii}} - Z_{0_{ij}}) I_1$$

$$V_{1_j} = V_{0_j} - (Z_{0_{ji}} - Z_{0_{jj}}) I_1$$

The above equations, in conjunction with equation (3.44) can be solved as a set of two simultaneous non-linear equations in two variables (V_{1_i} , V_{1_j}) and

hence for I_1 from (3.44). Finally solution for V_1 can be obtained from (3.46):

$$V_1 = V_0 - (Z_{0_i} - Z_{0_j}) I_1 \quad (3.46)$$

3.3f Split Network

As the size of the networks increases, it is possible to tear the network into subdivisions. The solution to the untorn network can be obtained from the solution to the subdivisions. For each subdivision the theory of network changes can be applied and it can be shown that the general equation (3.27) withholds.

When a split network arises as a consequence of a branch outage, each sub-system formed will, independently of the others, cater for the supply of its own loads if possible. The split condition can be easily detected from the calculation of a scalar factor "d" defined for branch outages, as follows:

Consider Figure (3.4) which represents two sub-networks connected by the tie between buses i and j having the admittance equal to Y_{ij} . It is interesting to see what happens when the tie is removed.

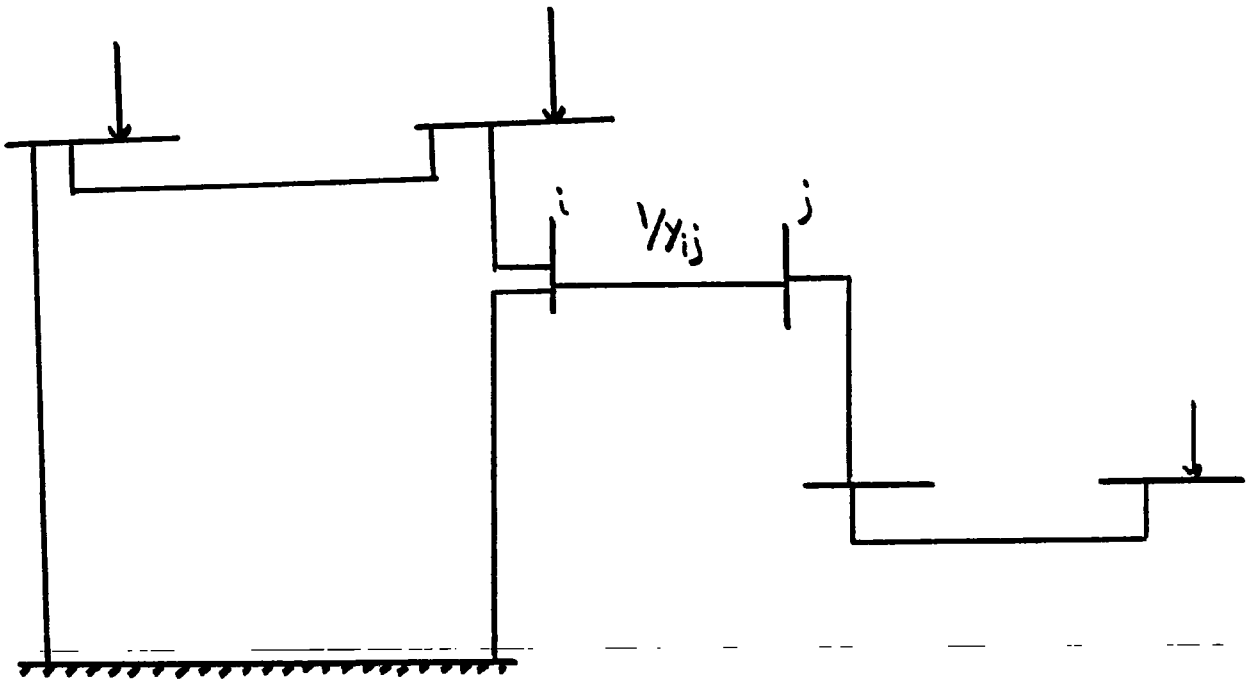

Figure 3.4 Network Interconnection

The equivalent circuit for the above figure can be shown to be as in Figure (3.5)

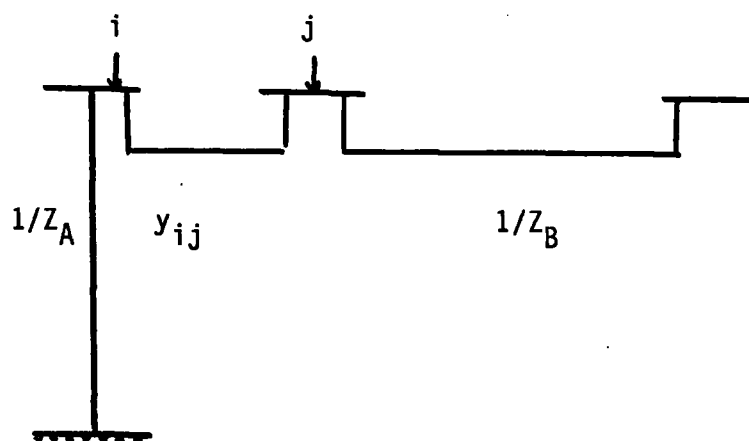

Figure 3.5 Equivalent Circuit

where Z_A and Z_B represent the equivalent impedances of the two sub-networks.

Figure (3.5) is representing the admittance network for which the admittance matrix is:

$$Y = \begin{array}{|c|c|c|} \hline \frac{1}{Z_A} + y_{ij} & -y_{ij} & 0 \\ \hline -y_{ij} & y_{ij} + \frac{1}{Z_B} & -\frac{1}{Z_B} \\ \hline 0 & -\frac{1}{Z_B} & \frac{1}{Z_B} \\ \hline \end{array} \quad (3.47)$$

Hence the impedance matrix would be obtained from the inverse of Y above, as:

$$Z = \begin{array}{|c|c|c|} \hline Z_A & Z_A & Z_A \\ \hline Z_A & Z_A + \frac{1}{y_{ij}} & Z_A + \frac{1}{y_{ij}} \\ \hline Z_A & Z_A + \frac{1}{y_{ij}} & Z_B + \frac{1}{y_{ij}} \\ \hline \end{array} \quad (3.48)$$

However, 'd' as in the theory of branch outages is defined as:

$$1/d = (f + C^t Z_0 C)$$

where:

$$f + C^t Z_0 C = f + Z_{0_{ii}} + Z_{0_{ii}} - 2 Z_{0_{ij}} \quad (3.49)$$

Applying (3.49) to (3.48) yields:

$$1/d = \left(-\frac{1}{y_{ij}} \right) + Z_A + Z_A + \left(\frac{1}{y_{ij}} \right) - 2 \cdot Z_A$$

∴ $1/d = 0$ where for the above $i = 1, j = 2, f = -1/y_{ij}$

Hence, a split network results when $1/d = 0$ (see Appendix 2 for a numerical example).

3.3g Node Merge

When a network is subjected to branch modifications, the effect would be simulated in 'f' where:

$$1/d = f + C^t Z_0 C$$

'f' represents the modified branch impedance as was explained in section (3.3a)

Under short circuit conditions between 2 buses, one bus would reside on the top of another, i.e. the effect can be simulated by adding a line between the shorted buses of impedance $f = 0$.

Hence, when considering short circuits, 'f' in the above equation must be set to zero. The theory of branch modifications withholds, however, equal voltages will be obtained for the corresponding shorted nodes (see Appendix 2 for a numerical example).

CHAPTER 4

APPLICATION OF THE THEORY OF BRANCH

OUTAGES TO LOAD-FLOW

4.1 Introduction

Load-flow calculations are performed in system planning, operational planning and operation/control. For steady state security assessment of the existing and future system, a load-flow solution method capable of computing a large number of single and multiple contingency studies reasonably accurately is necessary, and particularly in the system operations context, it must be fast and efficient. This makes the fast decoupled AC load flow solution ideal for this purpose.

This chapter represents the application of the recursive branch outage routine to load-flow and investigates its speed and accuracy.

4.2 Summary of fast decoupled load-flow^{[48][49]}

If an approximate root x^r of a simple algebraic non-linear equation is known, then a better approximation can be obtained from:

$$x^{r+1} = x^r - f(x^r)/f'(x^r)$$

or:

$$x^{r+1} = x^r - \Delta x$$

where:

$$\Delta x = f(x^r)/f'(x^r)$$

Above is known as Newton-Raphson method and can be extended to a set of simultaneous non-linear equations, in which case

$$\Delta x = J^{-1}F(x^r)$$

The square matrix J is the Jacobian matrix of $F(x)$ whose $(i,k)^{th}$ element is defined as $\partial f_i / \partial x_k$.

To use the algorithm for load-flow solution it is only necessary to write the equations defining the load-flow problem as a set $F(x) = 0$.

The well-known polar power mismatch Newton method is the formal application of the above algorithm for solving non-linear equations (see equations 4.4, 4.5), and constitutes successive solutions of the sparse real Jacobian matrix equation:

For PV and PQ nodes

For PQ only

$$\begin{bmatrix} \Delta\theta \\ \Delta V \end{bmatrix} = J^{-1} \begin{bmatrix} \Delta P \\ \Delta Q \end{bmatrix} \quad (4.1)$$

where $\Delta\theta_i$ and ΔV_i are the corrections for angle and voltage magnitude at node i . The Jacobian matrix of partial derivatives can be divided into four parts as:

$$\begin{bmatrix} \Delta P \\ \Delta Q \end{bmatrix} = \begin{bmatrix} H & N \\ J & L \end{bmatrix} \begin{bmatrix} \Delta\theta \\ \Delta V \end{bmatrix} \quad (4.2)$$

The elements of the Jacobian matrix can be made value symmetrical by re-defining equation (4.2) as:

$$\begin{bmatrix} \Delta P \\ \Delta Q \end{bmatrix} = \begin{bmatrix} H & N \\ J & L \end{bmatrix} \begin{bmatrix} \Delta\theta \\ \Delta V/V \end{bmatrix} \quad (4.3)$$

where the elements of this Jacobian matrix can be obtained by differentiating the mismatch equations given by:

$$\Delta P_i = P_i^{SP} - V_i \sum_{k \in i} (G_{ik} \cos \theta_{ik} + B_{ik} \sin \theta_{ik}) V_k = 0 \quad (4.4)$$

$$\Delta Q_i = Q_i^{SP} - V_i \sum_{k \in i} (G_{ik} \sin \theta_{ik} - B_{ik} \cos \theta_{ik}) V_k = 0 \quad (4.5)$$

For PV-node only (4.4) is required and for slack node no equations are required. However, as an inherent characteristic of any practical power system is the close dependence of active power flows on bus voltage angle and the reactive power flow on bus voltage magnitude, equation (4.3) can be approximated as:

$$\begin{array}{|c|} \hline \Delta P \\ \hline \Delta Q \\ \hline \end{array} = \begin{array}{|c|c|} \hline H & \\ \hline & L \\ \hline \end{array} \begin{array}{|c|} \hline \Delta \theta \\ \hline \Delta V/V \\ \hline \end{array} \quad (4.6)$$

where:

$$H_{ii} = \partial \Delta P_i / \partial \theta_i = Q_i^{SP} + V_i^2 B_{ii}$$

$$H_{ik} = \partial \Delta P_i / \partial \theta_k = -V_i (G_{ik} \sin \theta_{ik} - B_{ik} \cos \theta_{ik}) V_k$$

$$L_{ii} = V_i \partial \Delta Q_i / \partial V_i = -Q_i^{SP} + V_i^2 B_{ii}$$

$$L_{ik} = V_k \partial Q_i / \partial V_k + H_{ik} \quad (4.7)$$

Further approximations in the decoupled Jacobian matrix (4.6) can be made:

$$\cos\theta_{ik} \cong 1$$

$$Q_i \ll B_{ii} V_i^2$$

$$G_{ik} \sin\theta_{ik} \ll B_{ik} \cos\theta_{ik} \quad (4.8)$$

from which the elements of the (4.7) reduce to:

$$\begin{aligned} H_{ii} &= V_i B_{ii} V_i & L_{ii} &= V_i B_{ii} V_i \\ H_{ik} &= V_i B_{ik} V_k & L_{ik} &= V_i B_{ik} V_k \end{aligned} \quad (4.9)$$

or as:

$$\begin{aligned} \Delta P_i / V_i &= V_i B_{ii} \Delta\theta_i + \sum_{\substack{k \in I \\ k \neq i}} B_{ik} V_k \Delta\theta_k \\ \Delta Q_i / V_i &= B_{ii} \Delta V_i + \sum_{\substack{k \in I \\ k \neq i}} B_{ik} \Delta V_k \end{aligned} \quad (4.10)$$

The first equation relates ΔP to $\Delta\theta$; therefore any terms which predominantly affect changes in ΔQ can also be omitted. For example, by setting the voltages on the right-hand side to unity results in:

$$\Delta P/V = B' \Delta \theta$$

$$\Delta Q/V = B'' \Delta V \quad (4.11)$$

The matrix B' and B'' is the negative of the imaginary part of the nodal admittance matrix Y , without the column and row correspondence to the slack node. Faster convergence can be obtained by neglecting the resistance when calculating the terms of B' , hence:

$$\begin{aligned} B'_{ik} &= 1/X_{ik} & B''_{ik} &= X_{ik}/(R_{ik} + X_{ik}) \\ B'_{ii} &= -\sum_{k \neq i} 1/X_{ik} & B''_{ii} &= -\sum_{k \neq i} B''_{ik} \end{aligned} \quad (4.12)$$

Figure (4.1) illustrates the flow chart for the fast-decoupled Newton-Raphson.

4.3 Automatic Control and Adjustment^[49]

A general purpose load-flow program should include the effect of automatic control devices such as on-load transformer taps, phase-shifter, area interchange, as well as upper and lower limits on reactive power generation and voltage limits. Conventionally, adjustments are made at each iterative step by easily programmable logical criteria. The process of correction can also be made using sensitivity factors which relate the

change in a controlling variable to the change produced in the controlled variable.

A transformer with off-nominal tap setting may be represented by an ideal transformer in series with the transformer nominal admittance, as shown in Figure (4.2).

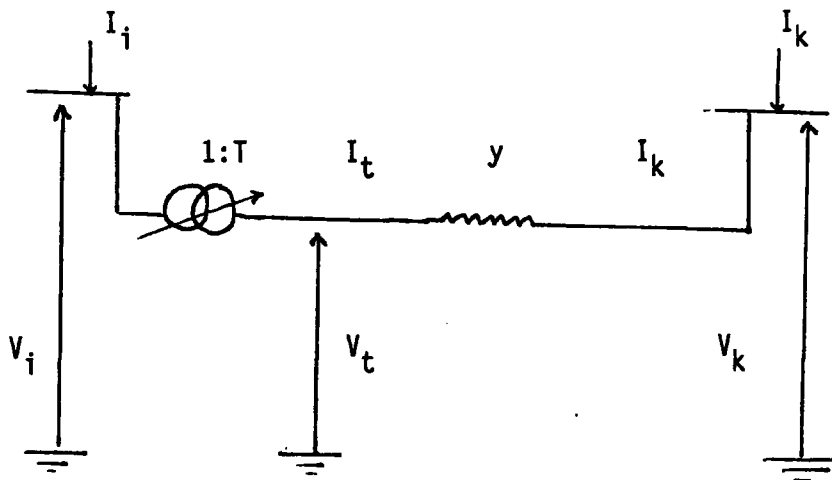

Figure (4.2) Transformer Representation

where:

$$\Gamma = t + jq \quad (4.13)$$

$$\bar{V}_i / \bar{V}_t = \frac{1}{\Gamma} = \frac{\bar{I}_t^*}{\bar{I}_i^*} = \frac{-\bar{I}_k^*}{\bar{I}_i^k} \quad (4.14)$$

therefore:

$$\bar{V}_t = \Gamma \bar{V}_i \quad (4.15)$$

$$\bar{I}_i = -\Gamma^* \bar{I}_k \quad (4.16)$$

$$\text{also } \bar{I}_k = \bar{y} (\bar{V}_k - \bar{V}_t) \quad (4.17)$$

substituting for \bar{V}_t :

$$\bar{I}_k = \bar{y} (\bar{V}_k - \Gamma \bar{V}_i) \quad (4.18)$$

hence:

$$\bar{I}_i = \Gamma^* \bar{y} (\Gamma \bar{V}_i - \bar{V}_k) \quad (4.19)$$

Equations (4.18) and (4.19) can be expressed in matrix form as:

$$\begin{bmatrix} \bar{I}_i \\ \bar{I}_k \end{bmatrix} = \begin{bmatrix} (t^2 + q^2) \bar{y} & -(t+jq) \bar{y} \\ -(t + jq) \bar{y} & \bar{y} \end{bmatrix} \begin{bmatrix} \bar{V}_i \\ \bar{V}_k \end{bmatrix} \quad (4.20)$$

Hence, the elements of the nodal admittance matrix can be modified according to the above. With the complex turns ratio, the Y matrix will no longer be symmetrical. When the off-nominal taps are in-phase, that is $q=0$, a simple equivalent π circuit can be deduced from equation (4.20) and is shown in Figure (4.3).

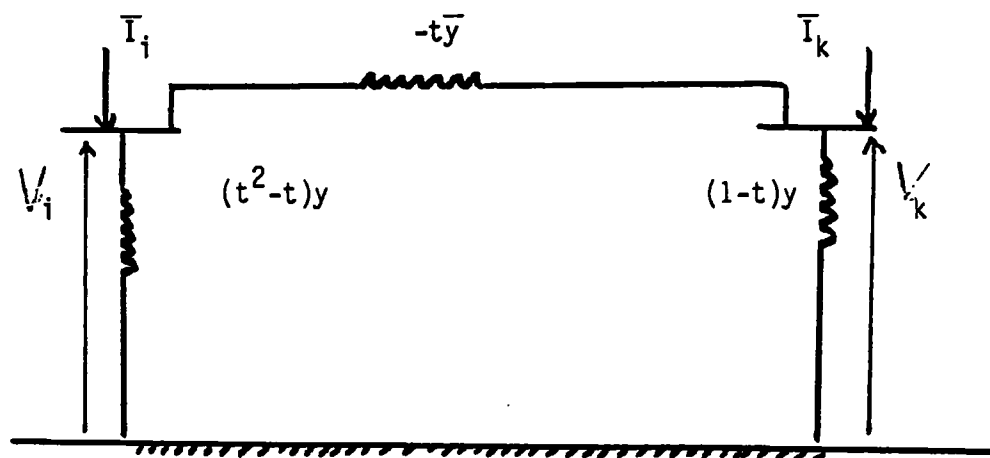

Figure (4.3) In-phase off-nominal taps

For phase shifters, the asymmetry in Y-matrix can be eliminated by representing the effect of asymmetry by an equivalent injected current as follows:

$$\begin{bmatrix} \bar{I}_i \\ \bar{I}_k \end{bmatrix} = \begin{bmatrix} \bar{T} \bar{T}^* \bar{y} & -\bar{T} \bar{y} \\ -\bar{T} \bar{y} & \bar{y} \end{bmatrix} \begin{bmatrix} \bar{V}_i \\ \bar{V}_k \end{bmatrix} + \begin{bmatrix} 2j\bar{q}\bar{y} \bar{V}_k \\ 0 \end{bmatrix} \quad (4.21)$$

which can be represented by a symmetrical π network as shown in Figure (4.4):

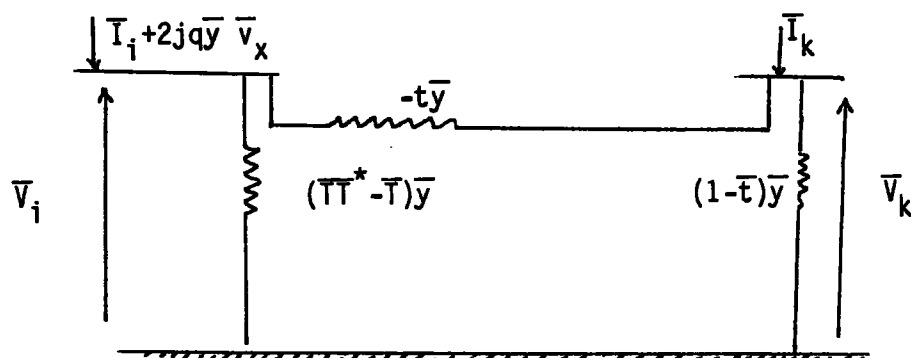

Figure (4.4) Phase Shifter representation

The additional injected current can be treated as additional power source:

$$\bar{S}_i^t = -2j\bar{q}\bar{y}^* \bar{V}_i \bar{V}_k^* \quad (4.22)$$

The phase shifter can be incorporated in the fast decoupled load-flow method as follows:

(a) The calculation of mismatch functions is carried out exactly with admittances as shown by equation (4.21) and adding to the specified power \bar{S}_i^{sp} correction for the asymmetry of the phase-shifter given by equation (4.23).

(b) Representing the phase-shifter in the constant matrix B' and B'' by:

$$B'_{ii} = B'_{kk} = -1/X$$

$$B'_{ik} = B'_{ki} = 1/X$$

$$B''_{ii} = B''_{kk} = -X/(R^2+X^2) \approx -1/X$$

$$B''_{ik} = B''_{ki} = X/(R^2+X^2) \approx 1/X \quad (4.23)$$

4.3.1 On-load transformer tap-changing

An automatic on-load tap-changing transformer usually controls a local bus voltage. Sometimes discrete adjustment in tap steps is used, but more usually the continuous approach is preferred. A conventional adjustment feedback error for a continuous in-phase off-nominal tapping t_i P.U. controlling the voltage of bus k to V_k^{sp} P.U. is:

$$t_i^{new} = t_i^{old} + \alpha (\bar{V}_k^r - \bar{V}_k^{sp}) \quad (4.24)$$



for the tap in quadrature, if present:

$$q_i^{\text{new}} = q_i^{\text{old}} \pm B (P_{ik}^r - P_{ik}^{\text{sp}}) \quad (4.25)$$

where:

t_i = in-phase tap position

q_i = quadrature tap position

P_{ik} = active power through the phase-shifter

α = 1 for fast decoupled Newton-Raphson load-flow

= 0.2 for Gauss-sidal load-flow

For the PV-node i it is usual to calculate Q_i^r to maintain V at V_i^{sp} up to Q_i limit, before adjusting the transformer in-phase tap position if both controls are available.

4.4 Transmission-line Outages

From (4.11) angles and voltages can be obtained for each iteration:

$$\Delta\theta = B'^{-1} \Delta P/V \quad (4.26)$$

$$\Delta V = B''^{-1} \Delta Q/V \quad (4.27)$$

Line outages can be simulated by the adaption of the inverse-matrix modification technique (as in Chapter 3) to B' and B'' as follows. In the most general case, the outage of a line can be reflected in B' by modifying two elements in row k and two in j . The new outage matrix is then:

$$B'_{\text{new}} = B' + b C^t C \quad (4.28)$$

where:

b = line series admittance

c = column vector which is null except for $C_k = 1$ and $C_j = -1$.

Depending on the types of the connected buses, only one row k or j might be present in B' (or B''), in which case either C_k or C_j above is zero, as appropriate. It can be shown that:

$$B'_{\text{new}}^{-1} = B'^{-1} - X d C^t B'^{-1} \quad (4.29)$$

where:

$$d = (f + C^t X)^{-1}$$

and:

$$X = B'^{-1} C$$

$$f = b^{-1} \tag{4.30}$$

The new angles can be found from:

$$\Delta\theta_{\text{new}} = B'_{\text{new}}{}^{-1} \Delta P/V \tag{4.31}$$

Hence, from (4.29) and (4.30), the new angles are found as:

$$\Delta\theta_{\text{new}} = \Delta\theta - B' C d C^t \Delta\theta \tag{4.32}$$

compare with (3.27)

Similarly,

$$\Delta V_{\text{new}} = \Delta V - B'' C d' C^t \Delta V \tag{4.33}$$

where:

$$d' = (f' + C^t X')^{-1}$$

$$X' = B''^{-1} C$$

$$f' = b'^{-1}$$

Also:

$$b = 1/X_{ik}, \quad b' = X_{ik}/(R_{ik}^2 + X_{ik}^2)$$

Mismatch equations also need modifications before the tolerance is checked. Depending on the type of buses involved, the following rules must be obeyed:

(a) If the outage occurs between a slack and a PV bus or between two PV buses, B'' requires no modifications (see equation 4.1).

(b) The connection vector C has elements +1, -1 and null everywhere else. When modifying the angles if the outage include slack bus, zero is placed in the corresponding element of the connection matrix. The same happens when modifying the voltages if the outage occurs between a PV and a PV or slack bus.

4.5 Application of the recursive method to load-flow

As illustrated above, the angles and voltages need to be modified after each iteration and the modifications required, reflect the mismatch equations and B' and B'' . Equations (4.32) and (4.33) are just as (3.27); therefore after each iteration, the old angles and voltages can be modified

by applying the recursive routine. The flow diagram of Figure (4.5) illustrates how this is done. When the convergence is achieved the active and reactive powers at each bus are obtained from:

$$P_i = V_i^2 G_{ii} + V_i \sum_{\substack{k \in I \\ k \neq i}} (G_{ik} \cos \theta_{ik} + B_{ik} \sin \theta_{ik}) V_k \quad (4.34)$$

$$Q_i = -V_i^2 B_{ii} + V_i \sum_{\substack{k \in I \\ k \neq i}} (G_{ik} \sin \theta_{ik} - B_{ik} \cos \theta_{ik}) V_k \quad (4.35)$$

See Appendix 2 for a numerical example.

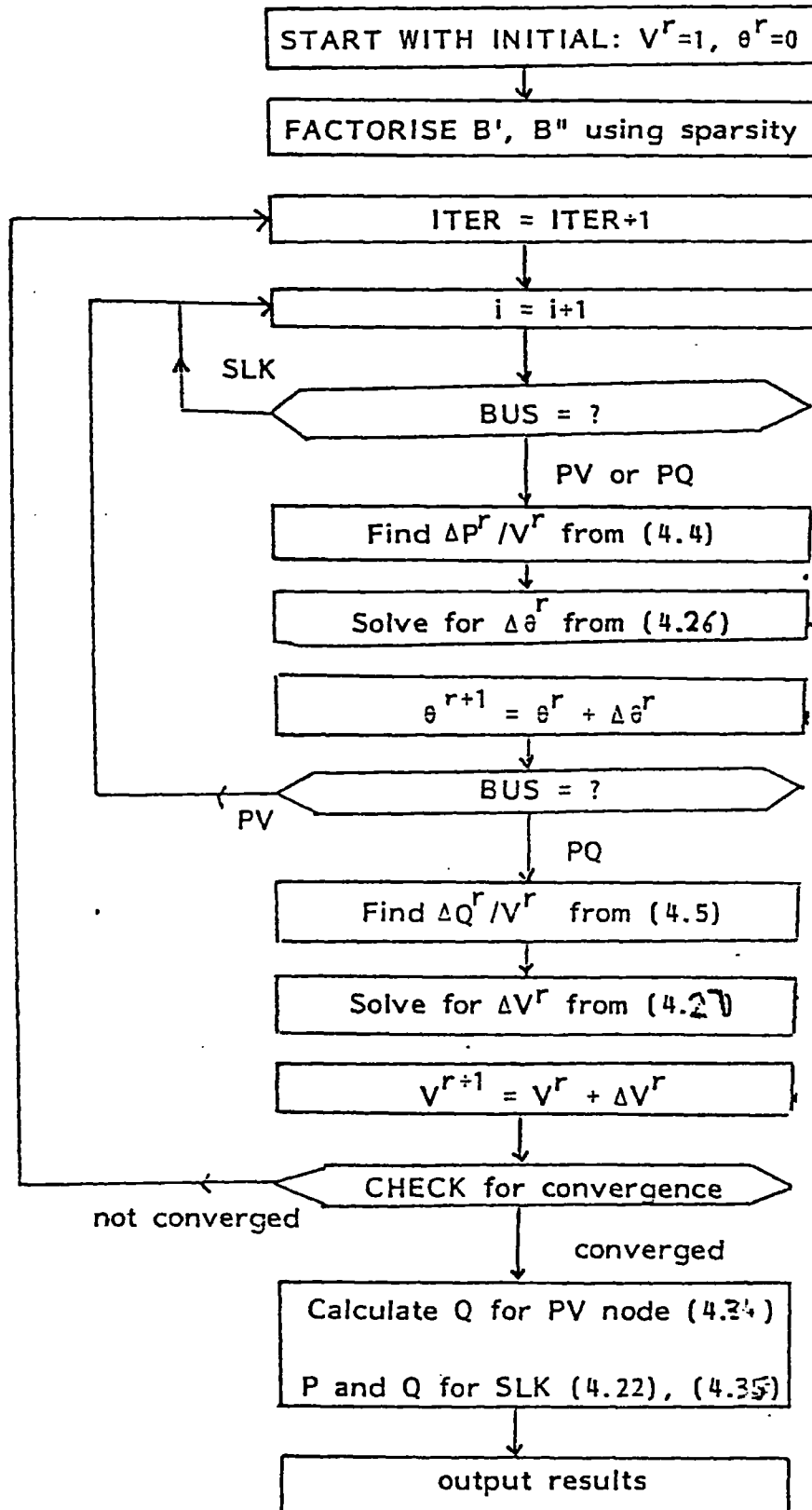

FIGURE 4.1. FLOW DIAGRAM FOR FAST DECOUPLED LOAD FLOW

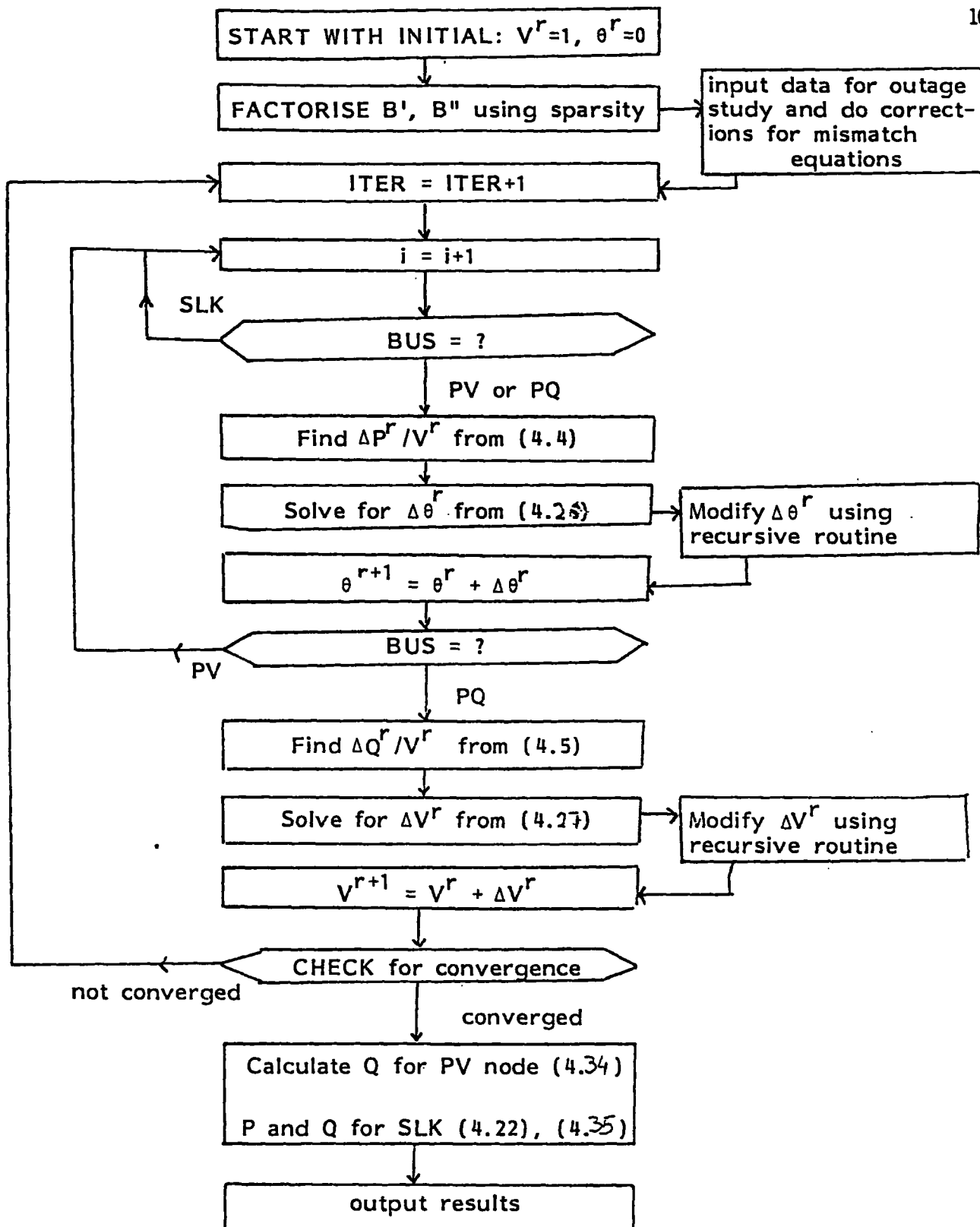

FIGURE 4.5 FLOW DIAGRAM FOR FAST DECOUPLED LOAD FLOW FOR CONTINGENCY STUDIES

CHAPTER 5

AUTOMATIC CONTINGENCY SELECTION (ACS)

5.1 Introduction

Modern energy control centres utilised in electric utility control and monitor schemes are required to provide real-time security assessments. If the potential outage of a line or a generator would result in the overload of another line, then the system is said to be vulnerable, a condition which should be quickly detected for possible corrective rescheduling actions in operation, or for system redesign in planning.

The Automatic Contingency Selection (ACS) problem is concerned with developing computer algorithms for quickly identifying those contingencies which may cause out-of-limit conditions so as to reduce the number of contingencies that need to be evaluated when assessing the power system's security in a real-time environment.

This chapter presents an ACS algorithm for the determination of all the contingencies that give either voltage or line flow problems when the system is subjected to single line outages. The ACS captures all the contingencies

that give out-of-limit conditions and ranks the lines according to the severity that they might cause if the network is subjected to their outage. Initially, a survey of some ACS approaches is presented.

5.2 ACS Techniques

An accepted procedure for on-line steady-state security assessment in present Energy Control Centres is by the evaluation of a large number of contingency cases. However, the computational burden that this procedure places in even the most advanced of present day computer installations has prompted the need for studying procedures for the automatic selection of meaningful contingency cases. The objective is the reduction of the possible cases for consideration and at the same time the determination of a ranking or ordering of these cases according to severity, for further study.

Traditional contingency analysis uses a simple logical rule to classify contingency case results. This logical rule asks if any system components will experience an out-of-limit condition from a particular contingency. If the answer to this question is yes, the case is alarmed, or otherwise noted, for the user; if the answer is no, the case is ignored. The drawback to this technique is the time which must be consumed in calculating the system conditions for each case before a limit check can be made.

To overcome this, contingency selection techniques were developed which attempt to rank the cases by severity so that detailed system conditions

need only be calculated for those cases at the top of the ranking.

The development of a contingency selection technique has two aspects. First, one must develop a straightforward way to compare and rank the severity of one contingency versus another. Past research has concentrated on the use of a Performance Index (PI) which, when calculated for each contingency case, indicates its relative severity. The second aspect in the development of a contingency ranking algorithm is the creation of an algorithm to efficiently calculate the value of the PI for each contingency case. It is desirable to combine these two stages. However, such attempts in the past have resulted in misranking. For ACS, a system performance index is defined. The sensitivity of performance index is used to rank the contingencies according to the severity of their effects on the system performance. This ranked contingency list is used to reduce the number of contingencies which require full contingency analysis solution.

One measure of quality of a performance index is its capture ratio, which is the ratio of the number of truly severe contingency cases to the total number of cases in the top portion of the ranked case list. Other measures can also be used to show the quality of a particular PI.

As to computation, a good contingency selection is not simply a repeated calculation for each contingency case. Instead, if one took as a maximum the time required for execution of a full AC load-flow for each contingency case, then a good contingency selection algorithm ought to be

able to rank all cases in one to five percent of this maximum time.

Most of the existing ACS procedures [50-51] are based on line overload limit violations where PI is expressed as a function of normalised line flows and the use of DC load-flow (P- θ) equations. The voltage limit violations are included by calculating the voltage changes from the linearised load-flow (Q-V) equations. [52] All these methods are useful for analysing single branch outages only. In particular, two approaches based on [53] and [51] are useful for on-line security analysis. These methods are based on DC load-flow analysis and derive a closed form solution for the sensitivity of performance index for an outage of a line. The two algorithms are different in the way they calculate the sensitivity of PI.

Identification of the contingencies that warrant further study by means of full AC-load-flow solution, may be achieved by predicting the values of PI for each line outage and subsequently ranking the contingencies from the most important to the least important (largest and smallest value of PI). The predicted value of PI can be computed either from a Taylor series expansion of the PI as a function of the susceptance of the outaged line, or using the DC-load-flow approach as reported in. [54] The above approaches are summarised in [51].

Ejebe and Wallenberg defined two PIs for voltage analysis. One of the performance indices was defined as a non-linear function of bus voltage deviations. The second index was a modification of the first index to

include the effect of generator MVAR limit violations. They described a procedure for ranking contingencies by computing the sensitivities of performance indices with respect to outages. A gradient technique was used to predict the change in the performance index by using Tellegen's theorem to calculate the terms of the gradient. The imperfections showed up as misrankings of some contingency cases. That is, some contingency cases which should have ranked higher in priority were low on the list and conversely, others which should have ranked low were too high.^[55]

Medicherla and Rastogi developed a contingency solution technique which uses the load curtailment required to raise bus voltages to the pre-contingency level as an indication of the severity of a contingency.^[55] The load curtailment approach can provide a measure of the effect of a contingency level. In this approach the PI for a given contingency is defined as an aggregate sum of load required to be curtailed at the buses to raise bus voltages to the pre-contingency level. The performance indices for all contingencies are computed, and then the contingencies are ranked in order of the decreasing values of PIs. Whereas the performance index defined is of very high quality the calculation of this performance index is computationally not attractive.

One common approach used to obtain the contingency list in today's EMS packages is by considering the base-case solution for a power system network. By considering the violations occurred following the base-case, lines and units will be ranked and subsequently full solutions can be

obtained for further investigation. Whether one obtains the list by considering full AC power-flow or by performing the first iterations of a DC load-flow, neither of these approaches identifies all those contingencies which may cause out-of-limit conditions.

Working in dependent variable spaces, Wasley and Daneshdoost^[56] presented a reliable technique for identifying and ranking line outages which result in the violation of various limits related to power system security. Security limits defined in terms of real-power line flows, generator reactive powers and demand bus voltage magnitudes were considered in normalised sub-spaces and critical contingencies identified by a filtering algorithm using the infinite norm as a performance index. Critical contingencies were then ranked using PIs which were defined in accordance with the sub-space of interest. In the case of real-power line flows, ranking is based on a measure related to distance from the centre of the corresponding security region, whereas in the case of generator reactive powers and demand bus voltage magnitudes, ranking is based on measures related to distances from the boundaries of the corresponding regions. The above approach is not suitable for real-time purposes due to the execution time required to obtain the ranking.

In [50,53] it was mentioned that the performance index in most cases provides a good measure for determining the severity of transmission line contingencies. However, in some instances, particularly when a single line becomes overloaded and at the same time the loading of other lines

decreases, the value of the PI decreases and the overload may not be recognised. This phenomenon has been termed "masking" by the authors of references [50,53]. Irisarri and Sasson⁽⁵⁴⁾ developed an efficient method for automatic contingency selection. Their method is based on the prediction of the value of a system wide performance index for each transmission line outages and the subsequent ranking of the severity of the outages according to the predicted values of the PI. Although their method is based on the work previously reported in references, [50,44] it overcomes the limitations encountered with those approaches. This was achieved through the efficient implementation of the DC-load-flow based selection method proposed in.^[54] To efficiently compute the value of the PI after a line outage, it was shown that only one forward-backward substituting is required per execution of the ranking algorithm, and the storage of two vectors. These lines in the network, need only be updated whenever there is topology changes in the network configuration.

The above approach provides a reliable method for ACS. In^[51], the authors provide means for avoiding the PI masking effect.

Four algorithms most suitable for real-time purposes were tested and compared with the ranking produced by a full AC solution for each contingency, in reference [51]. These were: one full iteration of the fast decoupled load-flow, first-half iteration of DC load-flow, line outage distribution factors based on DC load-flow, sensitivity analysis. It was concluded that from a performance viewpoint the line outage distribution

factors base on DC load-flow is superior. In reference [57], the authors proposed a new algorithm for secondary outages. The authors investigated the feasibility of including the secondary outages of generation/load outages and simultaneous outages of two lines in the overall ACS analysis. This approach is not efficient for real-time Automatic Security Assessment of power systems due to the required execution time, however, as will be presented in later chapters, inclusion of secondary outages could be analysed by providing facilities for the operator to interrupt the Automatic Security Assessment (ASA) and requesting what is termed as mixed outage selection. Subsequent to this study ASA would resume its normal task. None of the existing algorithms investigates the contingency selection for a radial network or even when the outage of a single line could result in a split network, most algorithms automatically assign a high value of PI for the particular lines, which in fact is not true and further the AC load-flow which follows the ACS ignores the lines causing split. Hence no steady-state solution could be obtained, except by performing separate solutions for each sub-network which is not at present an efficient approach.

The ACS algorithm implemented in the OCEPS package incorporates network islanding and is based on the sensitivity of the performance index as in [50]. It is most suitable for real-time security assessment. The algorithm is explained in the next section.

5.3 Line Overload Performance Index

The method described here is based on linearised load-flow (d.c. load-flow), which is then known to be numerically stable and efficient. Here the line overload performance index is defined first.

$$\begin{aligned}
 Z(p) &= \sum_{\ell=1}^L \frac{W_{\ell}}{2} \left[\frac{P_{\ell}}{P_{\ell}^m} \right]^2 \\
 &= (P_1, P_2 \dots P_L) \begin{bmatrix} W_1 / 2P_1^m \\ \vdots \\ W_L / 2P_L^m \end{bmatrix} \begin{bmatrix} P_1 \\ P_2 \\ \vdots \\ P_L \end{bmatrix} \\
 &= \underline{P}_L^T \underline{W}_L \underline{P}_L \tag{5.1}
 \end{aligned}$$

where:

- P_{ℓ} = line flow in line ' ℓ '
- P_{ℓ}^m = maximum capacity of line ' ℓ '
- W_{ℓ} = a weighting factor for line ' ℓ '

L = total number of lines

Alternatively, the performance index can be expressed in terms of θ_ℓ , the phase angle across line ' ℓ '.

$$Z(\theta) = \sum_{\ell=1}^L W_{\ell/2} \left[\frac{P_{\ell/2}^m}{P_{\ell/2}} \right]^2 = \sum_{\ell=1}^L W_{\ell/2} \left[\frac{b_\ell \theta_{\ell/2}}{P_{\ell/2}^m} \right]^2 = \sum_{\ell=1}^L W_{\ell/2} \left[\frac{\theta_{\ell/2}}{K_\ell} \right]^2$$

$$= (\theta_1 \ \theta_2 \ \dots \ \theta_L)$$

$$= \theta_L^T W_\theta \theta_L$$

where:

b_ℓ = susceptance of line ℓ

k_ℓ = $\frac{P_{\ell/2}^m}{b_\ell}$

θ_ℓ = phase difference between its sending bus and receiving bus phase angles.

thus:

$$P_l = b_l \theta_l \quad (5.3)$$

5.3.1 Analysis of a Single Branch Outage

For a change in the susceptance of branch k (i.e. Δb_k), the change in \underline{X} (i.e. the inverse of system susceptance matrix \underline{B}) is as follows:

$$\delta \underline{x} = (\underline{B} + \Delta b_k \underline{m}_k \underline{m}_k^T)^{-1} - \underline{x} = (\underline{B}^{\text{new}})^{-1} - \underline{x} \quad (5.4)$$

where:

\underline{m}_k is a $N \times 1$ incidence vector for line k , having 1 and -1 at the two elements corresponding to the sending bus and receiving bus of line 'k', and zeros for other elements in the vector. Note that $\underline{x} = \underline{B}^{-1}$.

By the matrix inversion lemma^[58]

$$\delta \underline{x} = \eta_k \alpha_k \alpha_k^T \quad (5.5)$$

where

$$\eta_k = \frac{-\Delta b_k}{1 + \Delta b_k x_{kk}} \quad (\text{scalar})$$

$$x_{kk} = \underline{m}_k^T \alpha_k \quad (\text{scalar})$$

$$\alpha_k = \underline{X} \underline{m}_k \quad (\text{Nx1 vector})$$

The corresponding change in θ_ℓ is:-

$$\delta\theta_\ell = \underline{m}_\ell^T \delta\theta_N = \underline{m}_\ell^T (\delta\underline{X} \underline{P}_N) \quad (5.6)$$

where:

$\delta\theta_N = (\delta\underline{X} \underline{P}_N)$ is the change in nodal phase angle.

\underline{P}_N is the nodal power injection.

Substituting equation (5.5) into equation (5.6)

$$\begin{aligned} \delta_\ell &= \underline{m}_\ell^T \eta_k \alpha_k \alpha_k^T \underline{P}_N \\ &= \eta_k (\underline{m}_\ell^T \alpha_k) (\underline{X} \underline{m}_k)^T \underline{P}_N \\ &= \eta_k (\underline{m}_\ell^T \alpha_k) (\underline{m}_k^T \theta_N) \\ &= \eta_k X_{\ell k} \theta_k \end{aligned} \quad (5.7)$$

where:

$\Theta_N = \underline{x} \underline{P}_N$: - d.c. load-flow equation relating bus power injection and bus phase angle.

$\Theta_k = \underline{m}_k^T \Theta_N$ is the phase difference across line 'k'.

$X_{lk} \triangleq \underline{m}_l^T \alpha_k$

5.3.2 Change of performance index $\delta Z_k(\theta)$ due to change of $\delta\theta_l$ and Δb_k - Outage of branch 'k'

From equation (5.2)

$$Z^{new}(\theta) = \sum_{l=1}^L \frac{w_l}{2} \left[\begin{array}{c} b_l^{new} \quad \theta_l^{new} \\ \hline P_l^m \end{array} \right]^2 \quad (5.8)$$

where:

$$b_\ell^{\text{new}} = \begin{cases} b_\ell & \text{when } \ell \neq k \\ b_k + \Delta b_k & \text{when } \ell = k \end{cases}$$

and

$$\theta_\ell^{\text{new}} = \theta_\ell + \delta\theta_\ell$$

Once $Z^{\text{new}}(\theta)$ is found $\sigma Z_k(\theta) = Z^{\text{new}}(\theta) - Z^{\text{old}}(\theta)$ can be calculated

$$\text{with } Z^{\text{old}}(\theta) = \sum_{\ell=1}^L w_{\ell/2} \left[\frac{b_\ell \theta_\ell / P_\ell^m}{P_\ell^m} \right]^2 = \sum_{\ell=1}^L w_{\ell/2} \frac{\theta_\ell^2}{2k_\ell^2} \quad (5.9)$$

substituting b_ℓ^{new} and θ_ℓ^{new} into equation (5.8)

$$\begin{aligned} Z^{\text{new}}(\theta) &= \sum_{\ell=1}^L w_{\ell/2} \left[\frac{b_\ell(\theta_\ell + \sigma\theta_\ell)}{P_\ell^m} \right]^2 + w_{k/2} \frac{(2b_k \Delta b_k + \Delta b_k^2) (\theta_k^{\text{new}})^2}{(P_k^m)^2} \\ &= \sum_{\ell=1}^L w_{\ell/2} \frac{\theta_\ell^2}{2k_\ell^2} + \sum_{\ell=1}^L w_{\ell/2} \frac{2\theta_\ell \sigma\theta_\ell}{2k_\ell^2} + \sum_{\ell=1}^L w_{\ell/2} \frac{\delta\theta_\ell^2}{2k_\ell^2} + R \\ &= Z^{\text{old}}(\theta) + \sum_{\ell=1}^L w_{\ell/2} \frac{2\eta_k \theta_k \chi_{\ell k} \theta_\ell}{2k_\ell^2} + \sum_{\ell=1}^L w_{\ell/2} \frac{\eta_k^2 \theta_k^2 \chi_{\ell k}^2}{2k_\ell^2} + R \\ &= Z^{\text{old}}(\theta) + 2\eta_k \theta_k \sum_{\ell=1}^L w_{\ell/2} \frac{(m_\ell^T \alpha_k)^T \theta_\ell}{2k_\ell^2} + \end{aligned}$$

$$\eta_k^2 \theta_k^2 \sum_{\ell=1}^L \frac{w_{\ell}}{2k_{\ell}^2} (m_{\ell}^T \alpha_k)^T (m_{\ell}^T \alpha_k) + R$$

$$= Z^{\text{old}}(\theta) + 2\eta_k \theta_k \sum_{\ell=1}^L \frac{w_{\ell}}{2k_{\ell}^2} (m_{\ell}^T \chi \ m_k)^T (m_{\ell}^T \theta_n)$$

$$+ \eta_k^2 \theta_k^2 \sum_{\ell=1}^L \frac{w_{\ell}}{2k_{\ell}^2} \alpha_k^T m_{\ell} m_{\ell}^T \alpha_k + R$$

$$= Z^{\text{old}}(\theta) + 2\eta_k \theta_k \sum_{\ell=1}^L \frac{w_{\ell}}{2k_{\ell}^2} m_k^T \chi (m_{\ell} m_{\ell}^T) \theta_n$$

$$+ \eta_k^2 \theta_k^2 \sum_{\ell=1}^L \frac{w_{\ell}}{2k_{\ell}^2} \alpha_k^T (m_{\ell} m_{\ell}^T) \alpha_k + R$$

$$= Z^{\text{old}}(\theta) + 2\eta_k \theta_k m_k^T \chi \sum_{\ell=1}^L \frac{w_{\ell}}{2k_{\ell}^2} m_{\ell} m_{\ell}^T \theta_n$$

$$+ \eta_k^2 \theta_k^2 \alpha_k^T \sum_{\ell=1}^L \frac{w_{\ell}}{2k_{\ell}^2} m_{\ell} m_{\ell}^T \alpha_k + R$$

$$= Z^{\text{old}}(\theta) + 2\eta_k \theta_k m_k^T \chi (m_1 \ m_2 \ \dots \ m_L)$$

$$\begin{bmatrix} w_1/2k_1^2 & & & & \\ & \circ & & & \\ & & w_2/2k_2^2 & & \\ & & & \ddots & \\ & & & & w_L/2k_L^2 \\ & \circ & & & \end{bmatrix} \begin{bmatrix} m_1^T \\ m_2^T \\ \vdots \\ m_L^T \end{bmatrix} \theta_n$$

$$+ \eta_k^2 \theta_k^2 \alpha_k^T (m_1 \ m_2 \ \dots \ m_L)$$

$$\begin{aligned} \dots Z^{\text{new}}(\theta) &= Z^{\text{old}}(\theta) = 2\eta_k \theta_k m_k^T X A W_{\theta} A^T \theta_N \\ &+ \eta_k^2 \theta_k^2 \alpha_k^T A W_{\theta} A^T \alpha_k + R \\ &= Z^{\text{old}}(\theta) + 2\eta_k \theta_k m_k^T X W \theta_N + \eta_k^2 \theta_k^2 \alpha_k^T W \alpha_k + R \\ &= Z^{\text{old}}(\theta) = 2\eta_k \theta_k \theta_k + \eta_k^2 \theta_k^2 t_{kk} + R \end{aligned} \quad (5.11)$$

where

$$\theta_k = m_k^T \theta_N \quad \theta_N = X P_N$$

$$P_N = W \theta_N \quad N \times 1 \text{ vector}$$

$$t_{kk} = \alpha_k^T W \alpha_k \quad \text{Scalar}$$

$$W = A W_{\theta} A^T$$

$$A = (m_1 \ m_2 \ \dots \ m_L)$$

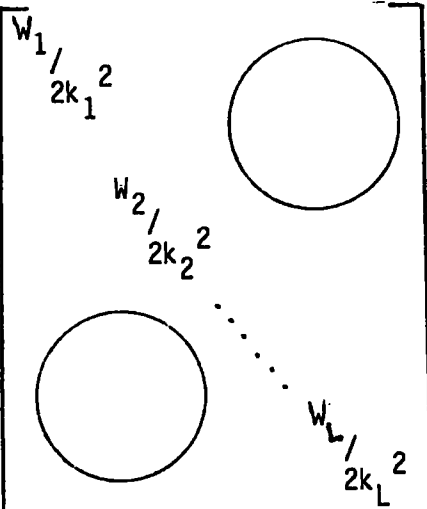
$$W_{\Theta} = \begin{bmatrix} W_1 / 2k_1^2 & & & \\ & W_2 / 2k_2^2 & & \\ & & \dots & \\ & & & W_L / 2k_L^2 \end{bmatrix} \quad (5.12)$$

$$R = \frac{w_k (2b_k \Delta b_k + \Delta b_k^2) (\theta_k^{\text{new}})^2}{2 (p_k^m)^2} \quad (5.13)$$

Now:

$$\begin{aligned} \theta_k^{\text{new}} &= \theta_k + \sigma \theta_k = \theta_k + \eta_k X_{kk} \theta_k \\ &= \frac{\theta_k}{1 + \Delta b_k X_{kk}} \end{aligned} \quad (5.14)$$

and:

$$P_k = b_k \theta_k \quad \sigma Z_k(\theta) = Z^{\text{new}}(\theta) - Z^{\text{old}}(\theta)$$

thus:

$$\delta Z_k(\theta) = \frac{2n_k P_k \theta_k}{b_k} + \frac{t_{kk} n_k^2 P_k^2}{b_k^2} + \frac{W_k}{2} \frac{P_k^2}{P_k^m} \frac{n_k^2}{\Delta b_k} \frac{\Delta b_k}{b_k} \frac{\Delta b_k}{b_k} \quad (5.15)$$

where line 'k' is out, $\delta b_k = -b_k$

$$\delta Z_k(\theta) = \frac{2n_k P_k \theta_k}{b_k} + \frac{t_{kk} n_k^2 P_k^2}{b_k^2} - \frac{W_k}{2} \frac{P_k^2}{P_k^m} \frac{n_k^2}{b_k} \quad (5.16)$$

Equation (5.16) expresses the change of performance index (line overload index) in terms of the parameters t_{kk} , n_k , P_k^m , w_k and b_k of the outage line 'k'.

Among these parameters, t_{kk} and n_k needs preliminary evaluation before $\sigma z_k(\theta)^k$ can be calculated. Parameters t_{kk} and n_k (two vectors of length L) are stored and recalculated only when the base topology changes. Since topology changes are infrequent, this storage scheme saves the calculation of t_{kk} and n_k each time ACS is required, hence speeding up the response of the program.

5.4 Sequence of Computation

The computation steps of the program employing ACS are described as follows:

1. Calculation

$$\underline{X} = \underline{B}^{-1}$$

$$\underline{P}_N = \underline{P}_{bG} - \underline{P}_{bL}$$

$$\underline{Q}_N = \underline{X} \underline{P}_N$$

$$\underline{W} = \underline{A} \underline{W}_\Theta \underline{A}^T$$

$$\underline{P}_N = \underline{W} \underline{Q}_N$$

$$\underline{Q}_N = \underline{X} \underline{P}_N$$

2. For line $k = 1$ to L , calculate the following

$$\Delta b_k = -b_k \quad \text{scalar}$$

$$\underline{q}_k = \underline{X} \underline{m}_k \quad \text{N X I vector}$$

$$\underline{m}_k = (00..1..0.. -1.0) \quad \text{NXI vector}$$

$\uparrow \qquad \qquad \uparrow$
 position position
 IS \qquad \qquad IR

$$x_{kk} = m_k^T \alpha_k \quad \text{scalar}$$

$$t_{kk} = \alpha_k^T W \alpha_k \quad \begin{array}{l} \text{scalar} \\ \text{(stored up as LXI vector for} \\ \text{all)} \end{array}$$

$$\eta_k = \frac{-\Delta b_k}{1 + \Delta b_k x_{kk}} \quad \begin{array}{l} \text{scalar} \\ \text{(stored up as LXI vector for} \\ \text{all)} \end{array}$$

3. Evaluate $\delta Z_k(\theta)$ using equation (5.16) for all k.
4. Ranking δZ_k in descending order according to its value, for all k.
5. Output ranking results. Since δZ_k is an overload index, the first ranked contingency corresponds to the most severe line outage 'k'.

5.5 Voltage Violation Performance Index

The voltage violation performance index is defined as follows:

$$Z_V = \sum_{\ell=1}^{NB} \frac{w_\ell}{2} \left[\frac{V_\ell - V^{SP}}{\Delta V_\ell} \right]^2 \quad (5.17)$$

Where:

W_{ℓ} = a weighting factor for bus ' ℓ '.

V_{ℓ} = voltage magnitude of bus ' ℓ '.

V_{ℓ}^{SP} = specified voltage magnitude of bus ' ℓ '.

ΔV_{ℓ} = maximum allowable deviation of voltage magnitude from the specified value for bus ' ℓ '.

It is clear that the voltage violation performance increases value as more buses have voltage magnitude deviations which exceed the maximum allowable variation.

5.5.1 Change of Z_V (δZ_V) due to changes in voltages δV_{ℓ}

If a single branch outage contingency takes place, all the bus voltages of the system would be changed (δV_{ℓ}). The corresponding change in Z_V can be derived as follows:

Let

$$V_{\ell}^{\text{new}} = V_{\ell} + \delta V_{\ell} \quad (5.18)$$

$$Z_V^{\text{old}} = \sum_{\ell=1}^{NB} \frac{w_{\ell}}{2} \left[\frac{V_{\ell} - V_{\ell}^{SP}}{\Delta V_{\ell}} \right]^2 \quad (5.19)$$

5.6 Analysis of a single branch outage

5.6.1 Effect of a single branch outage on system susceptance

Let \underline{B} define the system susceptance matrix, and denote the outage line as line 'k' having series susceptance b_k and shunt susceptance (charging capacitive susceptance) S_k .

The outage of line 'k' would incur the following changes in \underline{B} .

$$\underline{B}^{\text{new}} = \underline{B} + \underline{M}_k \delta b \underline{M}_k^t \quad (5.22)$$

where

$$\underline{M}_k = \begin{bmatrix} 0 & 0 & 1 \dots 0 & 0 & 0 & 0 & 0 \\ 0 & 0 & 0 \dots 0 & 0 & -1 & 0 & 0 \end{bmatrix}^t \quad \text{NB } n \times 2 \text{ matrix (5.23)}$$

sending receiving
bus location bus location

$$\sigma_b = \begin{bmatrix} -b_k - S_k/2 & b_k \\ b_k & -b_k - S_k/2 \end{bmatrix} \quad \text{2 x 2 matrix (5.24)}$$

Let

$$x = \underline{B}^{-1}$$

then

$$\underline{x}^{\text{new}} = (\underline{B}^{\text{new}})^{-1}$$

i.e.

$$\underline{x}^{\text{new}} = (\underline{B} + \underline{M}_k \delta b \underline{M}_k^t)^{-1}$$

By the matrix inversion lemma (5.18)

$$\begin{aligned} \underline{x}^{\text{new}} &= \underline{B}^{-1} + \underline{B}^{-1} \underline{M}_k \lambda_k \underline{M}_k^t \underline{B}^{-1} \\ &= \underline{X} + \underline{X} \underline{M}_k \lambda_k \underline{M}_k^t \underline{X} \\ &= \underline{X} + \beta_k \lambda_k \beta_k^t \end{aligned}$$

where:

$$\beta_k = \underline{X} \underline{M}_k \quad \text{NB x 2 matrix} \quad (5.25)$$

$$\lambda_k = -(\Pi + \delta b \underline{x}_{kk})^{-1} \underline{b} \quad \text{2 x 2 matrix} \quad (5.26)$$

$$\Pi = \text{2 x 2 unit matrix} = \begin{bmatrix} 1 & 0 \\ 0 & 1 \end{bmatrix} \quad (5.27)$$

$$\underline{x}_{kk} = \underline{M}_k^t \beta_k \quad \text{2 x 2 matrix} \quad (5.28)$$

with δx defined as:

$$\delta x = \beta_k \lambda_k \beta_k^t \quad (5.29)$$

5.6.2 Calculation of δV_k

The calculation of δV_k is based on the decoupled reactive power equation (5.19)

$$\Delta Q_k = -\underline{B}^{\text{new}} \delta V_k \quad (5.30)$$

Expressing δV_k more explicitly

$$\begin{aligned} \delta V_k &= -(\underline{B}^{\text{new}})^{-1} \Delta Q_k \\ &= -\underline{X}^{\text{new}} \Delta Q_k \\ &= -(\underline{X} + \delta \underline{X}) \Delta Q_k \\ &= -\underline{X} \Delta Q_k - \delta \underline{X} \Delta Q_k \end{aligned} \quad (5.31)$$

where ΔQ_k is the mismatch calculation excluding the effect of outage line 'k'.

$$\Delta Q_k = \frac{Q_k^{\text{SP}}}{V_k} + \sum_{j=1}^{\text{NB}} (G_{kj} \sin \theta_{kj} - B_{kj} \cos \theta_{kj}) V_j \quad (5.32)$$

where $G_{\ell j} + j B_{\ell j}$ is the (ℓ, j) th element of the system bus admittance matrix.

At first sight, it might seem this is an iterative algorithm, with calculations iterating between equations (5.32), (5.31) and (5.18), in that order until $\Delta Q = 0$. However, the exact solution for $\delta \underline{V}_\ell$ is not required, but rather the correct ranking of $\delta Z_V = \delta Z_V (\delta \underline{V}_\ell)$. It has been found that the rankings of δZ_V using $\delta \underline{V}_\ell$ calculated at full convergence and the rankings of δW_V using $\delta \underline{V}_\ell$ calculated by a single iteration, are practically identical. Hence, for the present application, equations (5.32) and (5.31) need only be calculated once.

5.6.3 Calculation of voltage phase angle

In the calculation of $\delta \underline{V}_\ell$, the reactive power mismatch ΔQ_ℓ is computed from equation (5.32). It is obvious that this involves the calculations of θ_ℓ and θ_j in order to evaluate $\theta_{\ell j} = \theta_\ell - \theta_j$. The phase angle across the line connecting ℓ and j .

Now defining

$$\theta_\ell^{\text{new}} = \theta_\ell + \delta \theta_\ell \quad (5.33)$$

where:

θ_l is the base case value known prior to the commencement of the present algorithm

$\delta\theta_l$ is the change in bus 'l' voltage angle due to the outage of line 'k'.

Referring to the d.c. load-flow equation (5.17)

$$\theta_l = \underline{X} \underline{P}_l^{SP}$$

thus

$$\delta\theta_l = \underline{\Delta X} \underline{P}_l^{SP} \quad (5.34)$$

This gives the changes in θ_l due to changes in \underline{X} as a result of outage line 'k' where $\underline{\Delta X}$ is defined as equation (5.29).

5.7 Sequence of Computation

The sequence of calculation can be outlined by the following steps.

1. Calculate susceptance \underline{B} and its inverse \underline{X} .
2. For every line $k = 1$ to L , calculate the following:

$$\underline{\delta b} = \begin{bmatrix} -b_k - S_{k/2} & b_k \\ b_k & -b_k S_{k/2} \end{bmatrix} \quad 2 \times 2$$

$$\underline{M}_k = \begin{matrix} 001 \dots 000^t \\ 000 \dots -1000 \end{matrix} \quad \text{NB} \times 2$$

\uparrow \uparrow
 location of IS. location of IR.
 sending bus of receiving bus
 line 'k'. line 'k'.

$$\beta_k = \underline{X} \underline{M}_k \quad 2 \times 2$$

$$\underline{x}_{kk} = \underline{M}_k^t \beta_k \quad 2 \times 2$$

$$\lambda_k = -(\Pi + \underline{\delta b} \underline{x}_{kk})^{-1} \underline{\delta b} \quad 2 \times 2$$

Store λ_k for all k as an $L \times 4$ matrix.

3. For each outage line $k = 1$ to L calculate the following:

(a) Update θ_l

$$\delta \theta_l = \underline{\delta X} \underline{P}_l^{SP} = \beta_k \lambda_k \beta_k^t \underline{P}_l^{SP}$$

$$\theta_l^{new} = \theta_l + \delta \theta_l$$

(b) Calculate $\sin \theta_{ij}$ and $\cos \theta_{ij}$ for all lines $= 1$ to L

$$\sin \theta_{ij} = \sin (\theta_i^{new} - \theta_j^{new})$$

$$\cos \theta_{ij} = \cos (\theta_i^{new} - \theta_j^{new})$$

(c) Calculate ΔQ_ℓ mismatch

$$\Delta Q_\ell = \frac{Q_\ell^{SP}}{V_\ell} + \sum_j^{NB} (G_{ij} \sin \theta_{ij} - B_{ij} \cos \theta_{ij}) V_j$$

For all buses

(d) Calculate δV_ℓ

$$\delta V_\ell = -X \Delta Q_\ell - \delta X \Delta Q_\ell$$

(e) Calculate δZ_{vk}

$$\delta Z_{vk} = (2(V_\ell - V_\ell^{SP}) + \delta V_\ell)^T (W_D) (\delta V_\ell)$$

4. Rank δZ_{vk} for all outage line 'k' in descending order of its magnitude.

5. Output ranking results. Since δZ_{vk} is a voltage violation index, the first ranked contingency corresponds to the most severe line outage 'k'.

CHAPTER 6

NETWORK ISLANDING AND EQUIVALANCING

6.1 Introduction

Conventional techniques for the assessment of transmission network security normally assume that the network to be studied will only be subject to a relatively small number of contingencies simultaneously and furthermore that those contingencies will not split the network into islands. Should such a situation arise the approach is usually to restrict analysis to the largest island so created. This approach has serious disadvantages in power systems which are subjected to frequent major outages and for which islanding is a common occurrence.

In interconnected systems, the results obtained from contingency analysis studies depend strongly on the representation of the neighbouring but unobservable networks. As a possible solution to this fact, at the control centre the observed system, consisting of the internal system, tie-lines and boundary nodes, is represented in its complete form while the unobservable external system is modelled by network equivalents.

This chapter represents a unique approach for the diakoptic solution of the network flow when subjected to configuration changes.

Based on Gauss - elimination, a new method for obtaining network equivalents is presented.

6.2 Split Network

Security assessment analysis has evolved from load-flow techniques and provides a measure of system performance following the occurrence of any of the pre-specified set of contingencies. The selection process is normally implemented by an automatic contingency selection algorithm (ACS) commonly based on DC load-flow. The ACS ranks the outages in order of decreasing severity and those above a certain threshold, which will not split the network into islands, are passed for a detailed network flow analysis.

As the size of the network increases it is possible to tear the network into subdivisions. The solution to the untorn network can be obtained from the solution to the subdivisions. For each subdivision the theory of network changes can be applied and it can be shown that the general equation (3.27) withholds.

When a split network arises as a consequence of a branch outage, each subsystem formed will independently of the others cater for the supply of its own loads if possible. The split condition can be easily detected from

the application of diakoptics to network solution.

The conventional method for simulation of branch outages which cause a split network is based on the introduction of a new reference busbar (slack) and redistribution of active power among the specified generators in each subsystem formed and finally refactorisation of B' and B'' matrices taking into account the existence of a second reference and branch outages.

Section 6.3 of the present chapter describes a new algorithm for the diakoptic solution of the network flow when a split network occurs as a result of a branch outage. The new technique avoids the need to re-order and re-factorise the above matrices. It has been tested using a range of networks and compared with an alternative approach in which the network islands are formulated and solved as separate load-flow problems. From the numerical results obtained it was concluded that the new technique has advantages for application in real-time security assessment.

6.3 Theory of network islanding⁽²⁷⁾

When a split network arises as a consequence of a branch outage, conventionally a new reference busbar is chosen in the island which is not connected to the original system. This busbar can be introduced as an input by the operator or automatically chosen as the busbar which had the biggest active generation prior to the outage. It must be among the generators specified for redistribution of active power. The drawback of such

approaches is the need to introduce the existence of the second reference and the outaged branch in (B') and (B''). In the proposed approach the new reference is chosen automatically, but its existence is not reflected in (B') and (B''), hence the new technique avoids the need to refactorise.

6.3.1 Summary of basic algorithm for outage studies

The application of diakoptics to linear and non-linear networks is summarised:

Assuming that V_0 is known from the solution of the original linear equation:

$$Y_0 V_0 = I_0 \quad (6.1)$$

Where Y_0 represents the original admittance matrix. The new value V_{new} after one branch has been completed can be obtained from:

$$V_{\text{new}} = V_0 - X C^t V_0 \quad (6.2)$$

where C^t = row vector which is null except for

$$C_i = +1 \text{ and } C_j = -1$$

$X = Z_0 C$ is the difference of columns i and j of Z_0

$Z_0 = Y_0^{-1}$ stored in factored form

$C^t V_0 =$ is the difference of elements i and j of V_0

$d = (1/b + C^t X)^{-1}$ a scalar factor

$b =$ line or nominal transformer series admittance.

The above approach is fast, accurate and avoids refactorising Y_0 .

Load-flow is well known as a non-linear problem. The fast decoupled Newton-Raphson (FDNR) load-flow has proved fast, sufficiently accurate and reliable. It is already well documented in chapter 4 and therefore no detailed description will be presented.

The basic model is described by:

$$[\Delta\theta] = [B']^{-1} [\Delta P/V] \quad (6.3)$$

$$[\Delta V] = [B'']^{-1} [\Delta Q/V] \quad (6.4)$$

The numerical technique based on diakoptics developed for line outages can be applied to FDNR after each iteration process in order to obtain new angles and voltages:

$$\text{Step 1: } [\Delta\theta_0] = [B']^{-1} [\Delta P/V]$$

$$\text{Step 2: } x' = [B']^{-1} C$$

$$\text{Step 3: } 1/d' = 1/b' + C^t x'$$

$$\text{Step 4: } [\Delta\theta_{\text{new}}] = [\Delta\theta_0] - d' x' C^t \Delta\theta_0 \quad (6.5)$$

$$\text{where: } b' = 1/x_{ik}$$

For voltages, similar steps to those above can be implemented and the new voltages are:

$$[\Delta V_{\text{new}}] = [\Delta V_0] - d'' x'' M^t \Delta V_0 \quad (6.6)$$

where:

$$x'' = [B'']^{-1} C$$

$$d'' = (1/b' + C^t x'')^{-1}$$

$$b'' = x_{ik} / (R_{ik}^2 + x_{ik}^2)$$

6.3.2 Pre-processing for system separation

Consider Figure (3.4) which represents two islands interconnected by the tie-line between buses i and j . The Thevenin equivalent circuit for the above is shown in Figure (3.5). In Figure (3.5), Z_A , and Z_B are the equivalent impedances of the two islands. The impedance matrix for this circuit is given by:

$$Z_o = \begin{array}{|c|c|c|} \hline Z_A & Z_A & Z_A \\ \hline Z_A & Z_A + \frac{1}{y_{ij}} & Z_A + \frac{1}{y_{ij}} \\ \hline Z_A & Z_A + \frac{1}{y_{ij}} & Z_B + \frac{1}{y_{ij}} \\ \hline \end{array} \quad (6.7)$$

If now the tie-line between buses i and j is to be removed, from equation (6.2) we have:

Step 1: $X = Z_0 C$

$$= \begin{array}{|c|} \hline 0 \\ \hline -1/y_{ij} \\ \hline -1/y_{ij} \\ \hline \end{array}$$

Step 2: $\frac{1}{d} = (1/b + C^t X)$
 $= (-1/y_{ij} + 1/y_{ij})$

therefore: $1/d = 0$

Hence a split network results when $1/d = 0$. Without further calculation by inspection of 'X' obtained from step 1, the buses in each island are identified:

$$\begin{matrix}
 x & = & \begin{matrix} i & 0 \\ j & -1/y_{ij} \\ k & -1/y_{ij} \end{matrix} & \begin{matrix} \text{Island 1 (with the original slack)} \\ \\ \text{Island 2} \end{matrix}
 \end{matrix}$$

When diakoptics is applied to FDNR, following the steps above $1/c$ becomes very small but not identically zero, and further, vector 'X' would not hold absolute zeroes. A sensitivity factor should therefore be specified which is a function of the computer on which the study is implemented.

6.3.3 Islanding

By removing the branch between buses i and j in Figure (3.4), the original network divides into two islands. The original admittance matrices are the following form:

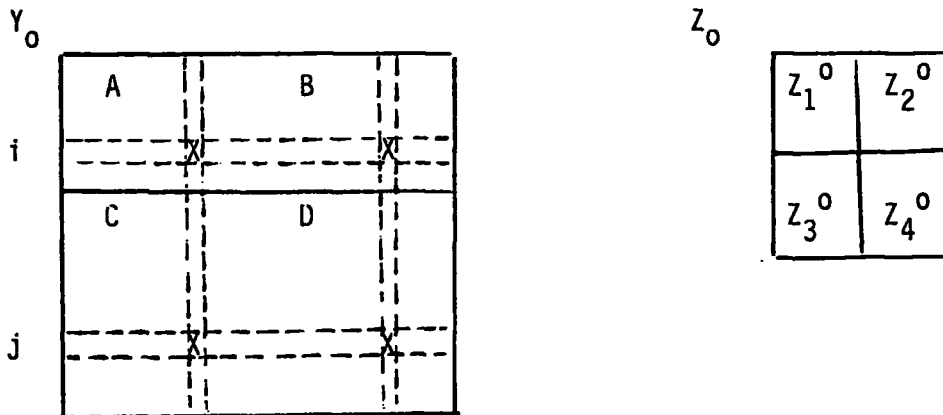

Submatrix $[Z_{o_1}]$ is the impedance matrix of the connected part and $[Z_{o_4}]$ should be modified to obtain the impedance of the second island. In this work, Y_o is assumed symmetrical and since the row elements in submatrix $[B]$ have equal co-factors, the row elements in $[Z_{o_2}]$ are equal.

If i_1, i_2, \dots, i_m represent the injections at the buses of the intact network, the original solution is given by:

$$V_o = Z_o I_o$$

$$\text{or } V_{o_1} = z_{11} i_1 + z_{12} i_2 + z_{13} i_3 + \dots + z_{1j} i_j + z_{1k} i_k + \dots + z_{1m} i_m$$

$$V_{o_2} = z_{21} i_1 + z_{22} i_2 + z_{23} i_3 + \dots + z_{2j} i_j + z_{2k} i_k + \dots + z_{2m} i_m$$

$$V_{o_i} = z_{i1} i_1 + z_{i2} i_2 + z_{i3} i_3 + \dots + z_{ij} i_j + z_{ik} i_k + \dots + z_{im} i_m$$

Where column j, k, n, m are referred to as the buses in the second island.

When the tie-line is removed, the solution to the connected part can be obtained from:

$$V_{\text{new}_1} = V_{o_1} - z_{1j} i_j - z_{1k} i_k \dots - z_{1m} i_m$$

$$V_{\text{new}_2} = V_{o_2} - z_{2j} i_j - z_{2k} i_k \dots - z_{2m} i_m$$

$$V_{\text{new}_i} = V_{o_i} - z_{ij} i_j - z_{ik} i_k \dots - z_{im} i_m$$

A column in $[Z_{o_2}]$ can be chosen, corresponding to the new reference busbar and hence equation (6.8) can be represented at:

$$V_{\text{new}_1} = V_{o_1} - z_{1r} (i_j + i_k + i_m)$$

$$V_{\text{new}_2} = V_{o_2} - z_{2r} (i_j + i_k + i_m)$$

$$V_{\text{new}_i} = V_{o_i} - z_{ir} (i_j + i_k + i_m)$$

In matrix form the above can be represented as:

$$[V_{\text{new}}] = [V_o] - C_1^t [Z_o] C_2^t I_o \quad (6.9)$$

$[V_{\text{new}}]$ gives the solution to the connected part.

where:

$$[V_o] = [Z_o] [I_o]$$

$$C_1^t = \boxed{\quad \quad \quad 1 \quad \quad \quad}$$

$$C_2^t = \boxed{1 \quad 1 \quad \quad 1 \quad 1}$$

C_1^t is zero every but '1' for the new reference busbar. Hence, $C_1^t Z_o$ is a column vector corresponding to the new reference busbar.

C_2^t is zero for island 1 and '1' for island 2. It is set when calculating $[x]$ as in the previous section. $C_2^t I_0$ is a scalar factor. If in the subsystem without the original reference bus, there is no provision for the introduction of a new slack bus, then the reference is taken as the busbar of the new subsystem connected to the outaged branch.

The advantage of applying equation (6.9) to obtain the new solution for the connected network is that it avoids refactorising.

To obtain the solution to the subsystem without the original reference in parallel with the solution of the connected part, the following equation can be applied.

$$[V_{\text{new}}] = [V_0] - C_1^t [Z_0] C_2^t I_0 + C_1 Z^m C_2^t I_0 \quad (6.10)$$

where:

$$Z^m = f(Z_3, Z_1, Z_2)$$

$$Z_1 = 1/y_{r0}$$

$$Z_2 = f(V_{r1r1}/C_2^t I_0) \quad y_{r0} \text{ is the shunt admittance connected to the original reference bus.}$$

$$Z_3 = Z^0 r_0 r_i$$

r_0 refers to the original reference bus and r_i refers to the new reference bus.

The new technique has been applied to many linear and non-linear networks and shown to be efficient, accurate and reliable, and most suitable for the real-time security assessment of electrical power networks. It avoids the need to refactorise [B'] and [B''] and furthermore, modifications to angles are only required after each iteration since PV buses are not represented in [B'']. If automatic tap changers are included in the system, the tap positions on the island with no reference should be set to the initial tap positions, before any modifications are performed.

6.4 Equivalencing

One of the requirements of today's modern power system control centres is to determine equivalents for extensive power systems external to an internal system equipped with a central control computer. These equivalents are needed for different system studies where the internal system is represented in detail, and the external system is represented by their equivalent, to simulate the interaction effects of the external system on the internal system for disturbances originating in the internal system.

The continuing increase in the size and complexity of electric power systems has demanded that a larger number of cases, involving far bigger networks, be analysed in regard to the ability of the system to provide

reliable, secure and economical service. In most cases the system of concern (internal) is a part of a larger interconnection of power pool. It is rather impractical to analyse the entire system in applications involving local control of an area. To overcome this difficulty two approaches have evolved.

1. To break the power system into a reasonable number of subsystems that can be handled separately while the interaction between the subsystems is accounted for. (73)(74)(75)
2. To isolate the area of concern from the rest of the system and construct an equivalent that provides a faithful means for representing the interconnected network beyond the boundaries of the area of concern, rather than providing a way to obtain the overall solution of the entire system. (76)(77)

It is thus desirable, through equivalencing, to develop a representation of the system outside the area of study (extended system) of as low an order as possible while maintaining the essential impact upon the area under study (internal system). It is also required in cases of operational or real-time mode, that these equivalents be identified without knowledge of configuration and state of the external site.

The construction of the equivalents would have to depend mostly on a good model of the internal system and data telemetered from locations within and at the boundaries of the internal system. Furthermore, it is important that the

equivalents be constructed in a minimal amount of time so that they can provide for on-line study modes.

Extended simulations of large power systems with long transmission lines are needed. If such simulations are to be carried out without consuming unreasonable computer resources then better solution algorithms must be available, highly restrictive assumptions must be made regarding system models and/or the effective size of the system must somehow be reduced for solution.

The general approach is to reduce the passive portion of the network. Such a reduction must provide for an accurate representation of real power transfer, and at the same time conserve the reactive response of the internal network. Basically, the interconnected power system is divided into internal and external systems, and the boundary buses are defined as shown in Figure (6.1).

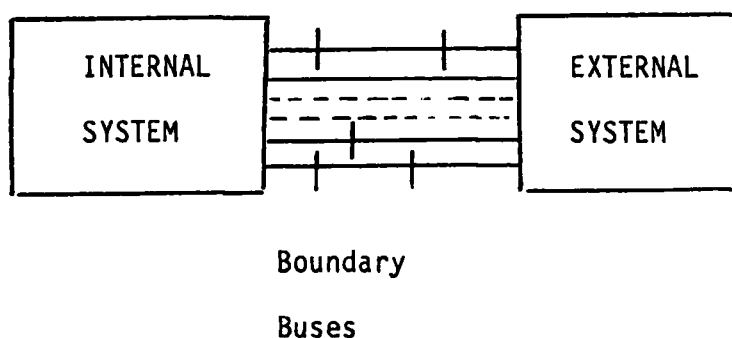

Figure (6.1) Separation between local and external systems

The choice of the boundary buses is such that any large disturbances to be investigated in the internal system would have small effects on the external system.

A good equivalent of the external system was suggested by Ward (78) based on a generalised Norton equivalent theory where the current sources are viewed as constant active and reactive power sources. A similar equivalent can be derived using Thevenin's equivalent theory leading to constant power and reactive power sources behind the equivalent internal impedances at each boundary bus. Either of these equivalents is a static equivalent made of:

1. Equivalent internal source admittances (or impedances) at each boundary bus. For a Norton equivalent these admittances are grounded; while for a Thevenin's equivalent source, creating a fictitious internal equivalent bus.
2. Equivalent transfer admittances (or impedances) between the boundary buses.
3. Equivalent power sources - their sum equals the exchange power scheduled to flow between the internal and external systems.

Ward reduction is based on Gaussian elimination and has been incorporated in most off-line and on-line equivalencing approaches, such as extended Ward

and simplified extended Ward.

The Ward method suffers from poor accuracy when performing security analysis mainly due to problems in the designation of the boundary bus types. Unless a bus actually has a unit, it is not correct to designate it as a PV or PQ bus. What is lacking is a satisfactory way of representing the external system's reactive power response to changes in the study system. References (79-82) list the commonly recognised difficulties of the Ward approach experienced mostly in off-line implementation.

Figure (6.2) illustrates the study system with Ward equivalent.

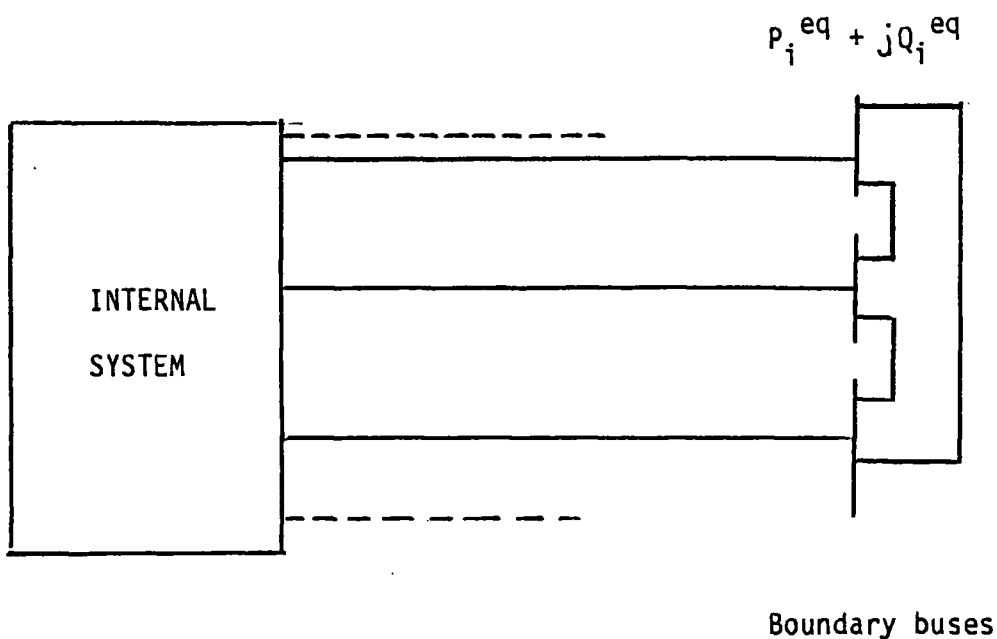

Figure (6.2) Ward Equivalent

In Figure (6.2), the equivalent injection for each boundary bus is given by:

$$P_i^{eq} = V_i^0 \sum_{k \in i} V_k^0 (G_{ik} \cos \theta_{ik}^0 + B_{ik} \sin \theta_{ik}^0)$$

$$Q_i^{eq} = V_i^0 \sum_{k \in i} V_k^0 (G_{ik} \sin \theta_{ik}^0 + B_{ik} \cos \theta_{ik}^0) \quad (6.12)$$

In practical applications, there are various versions and interpretations of the Ward method. In some cases, boundary buses are designed as their original types (83), in others they are considered to be all PV types (76), or are PQ types (84), whereas in others, more complicated heuristic boundary techniques are used (85).

In the extended Ward equivalent each boundary bus is designated as PV or PQ as it actually is. A new fictitious PV bus, with $P_m=0$ and $V_m = V_i^0$ is attached to each PQ boundary bus i , via a fictitious branch of admittance $[Y_i]$, as in Figure (6.3). The new fictitious buses contribute no active power to the system and no reactive power in the base case. However, whenever the study system conditions change, these buses respond with the supply or absorption of reactive power. These can be eliminated altogether if desired by placing an additional injection (83):

$$\Delta P + j\Delta Q = (E_i E_m^* - V_i^2) \cdot Y_i^* \quad (6.13)$$

at each relevant boundary bus.

If Y_i is susceptive equation (6.13) simplifies to:

$$\Delta Q = V_i (V_i - V_i^0) \cdot Y_i \quad (6.14)$$

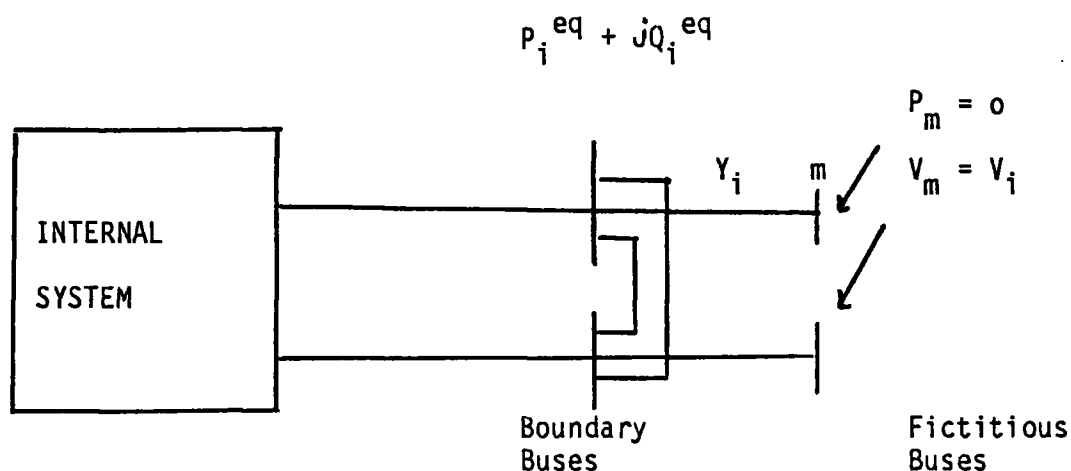

Figure (6.3) Extended Ward Equivalent

If in the extended Ward equivalent method the resistances in the external system be ignored, this gives view to simplified extended Ward equivalent. Though, this method does not provide sufficient accuracy, it guarantees good X/R ratio in the equivalent network; and the process can be performed more economically on a real, rather than, complex matrix.

The reduction technique can be directly applied to fast decoupled load-flow which is used extensively in system security assessment. Basically, the reduction process can be applied to $[B']$ and $[B'']$ matrices to obtain B'^{eq} and B''^{eq} and the equivalent injections at boundary buses are computed from (6.11) and (6.12) using the admittances $jB'_{ik}{}^{eq}$ and $jB''_{ik}{}^{eq}$ respectively for the equivalent branches (83). Then in decoupled load flow solutions, $[B'^{eq}]$ and $[B''^{eq}]$ becomes incorporated into the internal system $[B']$ and $[B'']$ matrices. The equivalent branches susceptances contained in $[B'^{eq}]$ and $[B''^{eq}]$ are used in computing $[\Delta P/V]$ and $[\Delta Q/V]$. The decoupled equivalent retains the advantages of the simplified extended Ward equivalent, however, it requires the storage of two separate susceptible equivalent networks.

From the survey done based on all the above techniques, it was concluded that the extended Ward version is the most accurate (83). The simplified extended Ward method is the next most accurate. This and the decoupled versions sacrifice a little accuracy for certain computational advantages. The non-decoupled versions can be used with any load-flow algorithm.

The method presented in section 6.5, uses Gauss elimination to perform reduction of the passive external network and is an extension to the extended Ward. It provides accurate and reliable results.

6.5 External network equivalencing

As mentioned in the previous section, the extended Ward method of reduction provides the most accurate and reliable results. In this method, following a reduction on the passive external network, equivalent branches will be introduced which connect the boundary buses. In addition, fictitious buses and fictitious admittances connecting the fictitious buses to the boundary buses will be introduced as shown in Figure (6.3).

The fictitious buses can be removed if equivalent injections calculated and added to that at the boundary buses. It was decided to use the Gauss elimination as the basis for the reduction process (see 3.2). In the new approach however, the reduction is not solely performed on the external passive network. Basically, from the solution to the original network (external + internal), the injections (Generation-load) at each bus which is to be reduced will be replaced by its equivalent admittance, except for the boundary buses. Hence, the external network will be transformed into a passive network. At this stage following the rules of Gauss elimination (see 3.2), the equivalent admittances will be obtained. However, the shunt admittances calculated in the reduction process, which are connected to the boundary buses will contribute to the system losses when performing load-flow on the reduced network. Hence, once the equivalent shunt admittances are obtained, these will be replaced by fixed injections, which in terms are added to the original injections at the boundary buses. Figure (6.4) illustrates the steps taken for obtaining solutions to a reduced network.

The advantage of this approach is that all the non-linear loads in the external network can be well represented in the reduction process. To obtain accurate reactive responses, bus matching is performed at the slack bus i.e. keep the active and reactive generation at slack bus constant. This approach was tested on a number of networks and provided accurate results as in extended Ward technique. It is more suitable for power flow analysis, since the contribution of shunt admittances at the fictitious buses are eliminated and in addition the non-linear loads can be more accurately modelled.

Following the reduction process, in order to obtain a better convergence, a test could be added to remove the branches with bad X/R ratios.

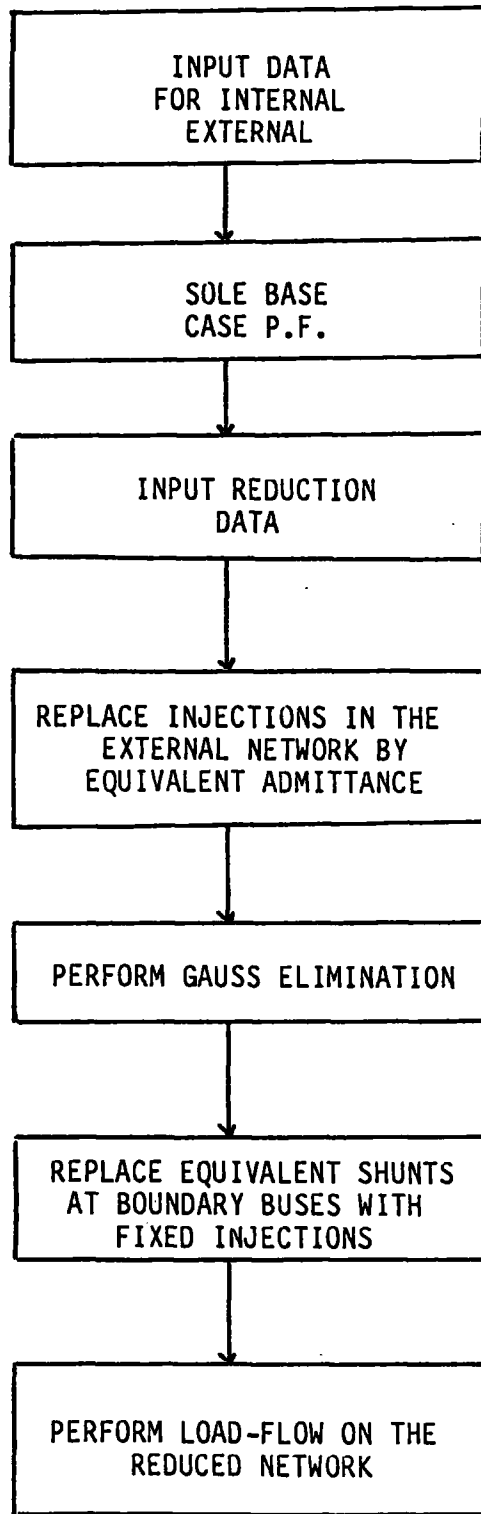

FIGURE (6.4) FLOW CHART FOR SOLUTION TO REDUCED NETWORK

CHAPTER 7

RÉSULTS

7.1 Introduction to Real-time EMS Integration

The extensive growth of interconnected power systems together with the operational complexities and the requirement for improved system management, has led to a greater dependence on automatic control at all levels of operation and the need for control systems with complex real-time functions.

Typically an integrated control system consists of two basic components; Supervisory Control and Data Acquisition (SCADA) function and power system applications function. These functions impose distinctly different processing requirements on the computers in which they operate. [70]

The power system application's function requires mostly a high speed heavy numerical calculation environment which is best handled by a powerful floating point processor and large arrays of contiguous, random access memory. This requirement is generated by such functions as production planning and power network security analysis. The recent inclusion of

operator training simulators imposes an even heavier calculation load on the processors.

Two conceptually different hardware configurations have been developed to handle the processing requirement of an EMS; Centralised Systems and Distributed Processing Systems.^[31]

Centralised systems consist of a main computer or computers which handle all of the EMS functions. Generally, all of the processors in a Centralised System have to handle both SCADA heavy interrupt load and power systems numerical calculations. Distributed processing systems contain multiple processing levels where each level is assigned to a specific machine or set of machines which are optimised for the individual requirements, that is, SCADA heavy interrupt loads and power system numerical calculations can be split into different types of machine.

Throughout the evaluation of SCADA systems, attempts have been made to use distributed processing architectures. These experiments have not been totally successful due to the lack of appropriate technology. But, in recent years, the trend toward broad and diversified processing requirements of utilities has created an even stronger need for the development of effective distributed architecture. As electrical networks grow and become more complex, operators need more sophisticated tools to control them. The technology to distribute the EMS functions is now available.^[72]

Due to the nature of power systems, the information management system is usually hierarchical with data passing from the substations and generating stations through area control centres up to the top of the hierarchy, where global functions such as generation control and network analysis are performed. The downward flow of traffic from system control centres to substations and generating stations is much less in volume than the upward flow and contains the operator commands and system co-ordinating and optimisation controls. The power system application functions normally divide into two areas of real-time and study. The real-time set run automatically on a cyclic basis or on a power system event.

EMS has three major sources of data; telemetered data, network parameters and generation parameters. Conventionally the databases in the system are built using the facilities of a Database Manager and database compiler, which are specific to individual application area.^[70] The defined databases each form a logical independent description, from which any application may draw the required data. For example the network database describes the power network and supports all the network applications such as power flow, and state estimator, the generation database describes the generation characteristics and data and supports the generation applications such as AGC, SCADA database for analog and status obtained from RTUs. The correspondence between the different databases is also built in an off-line mode but updated in real-time if necessary.

During the integrated operation of the system many aspects of the

operation of the system and performance of the individual algorithms are dynamically tested using the simulation facilities. The job of managing and integrating an EMS system is large and complex and requires good software support tools. Once the integration phase is accomplished the performance of the system as a whole (SCADA and EMS) is tested.^[72]

7.2 OCEPS EMS Software Integration

Large scale systems of which a power system is a prime example, is an area in which a wide gap exists between theoretical mathematically based research and engineering practice. The research programme at Durham is directed towards bridging this gap by linking some of the available and new theoretical techniques with the practical requirements of on-line computer control in power systems.

Testing and validation of analysis and control software is achieved with the aid of a real-time simulation system developed at Durham University. In this way the performance of Energy Management software can be evaluated against a realistic model of the network under a range of operating conditions. A secondary benefit of the integrated simulation, measurement and control software is the ability to provide a useful operator training aid, which includes power system dynamics, telemetering and energy management facilities.^[3]

The energy management suite OCEPs developed at Durham divides the

operational control of electrical power systems into two major functions; simulation function and control function. Further, as shown in Figure (1.10) each function comprises of a number of tasks executed in the manner shown. The simulation and control algorithms can either be executed on a single Perkin-Elmer 3230 computer main frame using multi-tasking operation system or the simulation function can be executed on a dedicated Perkin-Elmer 3230 with simulated telemetry and control information transmitted serially to a separate control computer. In general the simulation imposes the major computational load on the system, special multi-microprocessor hardware is being developed to allow real-time response with large systems.

OCEPS security analysis subsystem is divided into the following modules: AUTomatic OUTage selection (AUTOOUT), SECurity ASSEssment program (SECASS), manual OUTAGE selection (OUTAGE), and SECurity assessment OUTput program (SECOUT). In the remaining sections of this chapter numerical results obtained during the course of this research together with the full integration of the security subsystem to the OCEPS suite are presented.

A technical paper was published based on the network islanding technique developed during the course of research at Durham.^[27]

7.3 Numerical Results

7.3.1 Test Network

The test network is illustrated in Figure (7.1) and the associated network data is given in Appendix 3. The University of Durham OCEPS project thirty substation test systems, as the name suggests, includes 30 substations. This network is bus and node orientated. Each bus in a substation is connected via links to other buses in the same substation. By switching operations the number of electrical nodes in a substation can vary. The above network is composed of 72 buses, 41 branches of which 7 are transformers (which include fixed tap, automatic tap changer and phase shifter transformers), 23 loads, 6 generators and 2 shunts.

Outage of transmission lines 16, 13 or 34 will split the above network and hence the contingency selection algorithm gives them the lowest rank (i.e. most harmful).

Network topology changes can be achieved by opening or closing appropriate breakers in the system. The above process (scenario) can also be achieved via a prespecified program. Hence lines, units, loads, transformers, shunts, nodes and buses may be removed or added to the network. The above operation is executed by the system manager via an interactive program.

Protection is an inherent part of the simulator and as a result of an overload, the simulator will trip the appropriate breaker and hence a line or equipment may be taken out of service automatically.

7.3.2 Automatic Contingency Selection (ACS)

The ACS problem is concerned with developing computer algorithms for quickly identifying those contingencies which may cause out-of-limit conditions so as to reduce the number of contingencies that need to be evaluated when assessing the power system's security in a Real-time environment.

Most of the existing ACS procedures are based on line over load limit violations, where the Performance Index (PI) is expressed as a function of normalised line flows and the use of DC load flow equations.^[50,51] The voltage limit violations are included by calculating the voltage changes from the linearised load flow equations.^[52] All these methods are useful for analysing single branch outage only.

In Chapter 5, the techniques commonly used for forecasting the PI and the development of ACS algorithms were compared. Four algorithms most suitable for Real-time purposes were tested and compared with the ranking produced by a full A.C. solution for each contingency.^[57] These were: one full iteration of the fast decoupled load flow, first half iteration of DC load flow, line outage distribution factors based on DC load flow and

finally an algorithm based on sensitivity analysis. In the above reference, it was concluded that from a performance view point the line outage distribution factors based on DC load flow is superior.

Two algorithms have been implemented in OCEPS for ranking line outages in terms of their impact on the real power flows throughout the network, and according to their impact on the bus voltages. The essential components needed in developing each algorithm (as described in Chapter 5) are: a scalar performance index (PI) for ranking the contingencies and a computationally efficient method for evaluating the PI for each contingency. [87,88]

The ACS algorithm developed in Chapter 5 has been applied to IEEE 30 bus test network. The results of ACS were compared with the full A.C. load flow rankings obtained by considering each outage case in turn.

Figure (7.2) illustrates the ACS for line over load contingencies. It can be seen that the ACS ranking is very similar to the full A.C. load flow ranking. All the top 10 contingencies, have been identified correctly by the ACS. Considering the top 20 contingencies, 18 of the A.C. rankings are included, however, line 30 and 37 outages are not included. Instead less severe lines 12 and 35 outages are included. The ACS is nevertheless shown to be entirely satisfactory for most operational purposes.

The voltage violation ACS algorithm discussed in Chapter 5 was then

applied to the test network. The results are compared with the full A.C. load flow rankings obtained from a complete load flow for each line outage with performance index PI evaluated using bus voltage magnitudes (see Figure 7.3). It can be seen that the detailed A.C. load flow ranking profile is very similar to the voltage violation ACS ranking. In the top 10 contingencies only line 41 is missed by ACS. For the top 20 contingency cases, 16 A.C. rankings are included, but lines 4, 7, 28 and 33 are missed out where as the less severe lines 8, 10, 12 and 19 are included.

Detailed studies of voltage magnitudes showed that only line 36 outage involved voltage violation. This line has already been ranked by the voltage violation ACS. Voltage violation ACS consequently proved to be efficient and satisfactory for operational purposes.

The above results confirm the findings in references 50, 53 and 57.

Table (7.1) presents the over load and voltage contingency lists obtained when the above techniques were applied to the 30 bus test network.

In table (7.1), the first column 'RANK' gives the contingency priority. Those with the lower rank have the highest priority for full A.C. solution. The few at the top of the lists (blinking on the terminal screen) are the most critical contingencies and are those which could split the network (lines 13, 15 and 34 as in Figure (7.1)). Further, information about the islands, bus and substation names are provided.

The results obtained from full A.C. power flow solutions (for individual line outages) are shown in tables (7.2 to 7.5). The full A.C. solutions confirmed that the only contingency which could cause voltage and power violations was line 36, which was already in the ACS lists.

The ACS algorithm was enhanced to provide the contingency lists for multiple islands. If due to topological changes, the system is split into multiple islands, the ACS will provide the contingency lists for the multiple islands in parallel. Before building the system admittance matrix, the program automatically assigns references in the islands without the original system reference. The advantage of this approach is that there is no need for re-order and re-factorisation of matrices and hence less computations. Table (7.6) provides the ACS results when the original network was split into two islands.

To simulate the above case, lines 33, 10, 41 in Figure (7.1) were removed out of service prior to the ACS solution.

The column 'ISLAND' in Table (7.6) gives the island number for each branch. From the results shown in this table, it can be seen that if line 37, rank 8 in island 2 is to be completed, it could be more harmful than line 5 rank 9 in island 1, as far as abnormal voltage contingency list is concerned. These informations are vital to the secure operation of the power system.

The information provided by the ACS is also very valuable for the system operators and engineers who monitor the system and evaluate its security continually. The system engineers are normally involved in performing a large number of power flows in order to obtain the answers to a huge number of 'what if' situations. The ACS by far reduces the computational efforts because it highlights the most critical contingencies and ranks them accordingly.

ACS is now an important tool in the contingency analysis subsystem of today's modern Energy Management Systems (EMS).

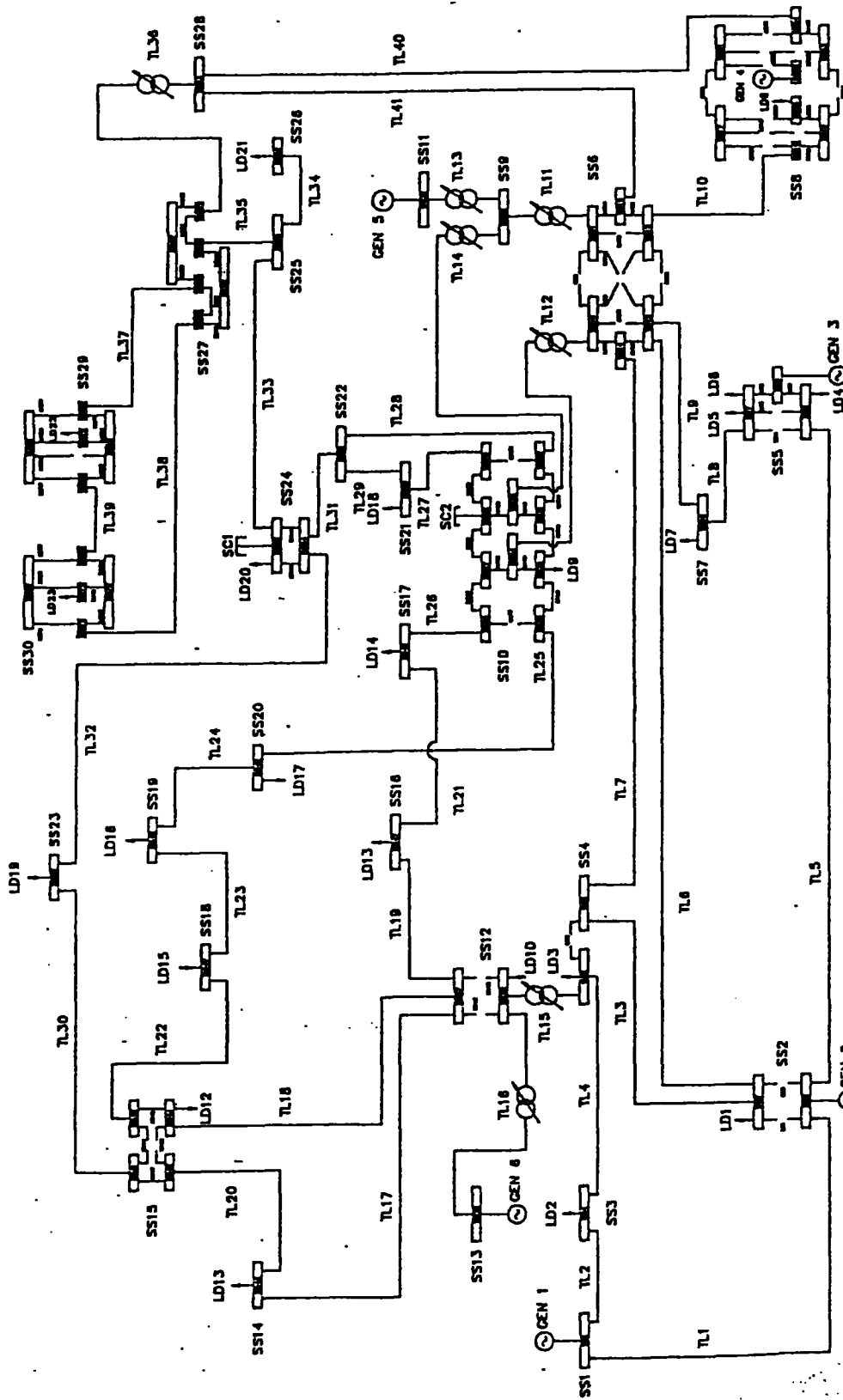

FIGURE (7.1) UNIVERSITY OF DURHAM
OCEPS THIRTY SUBSTATION TEST SYSTEM

Automatic Contingency Selection of Line Overload

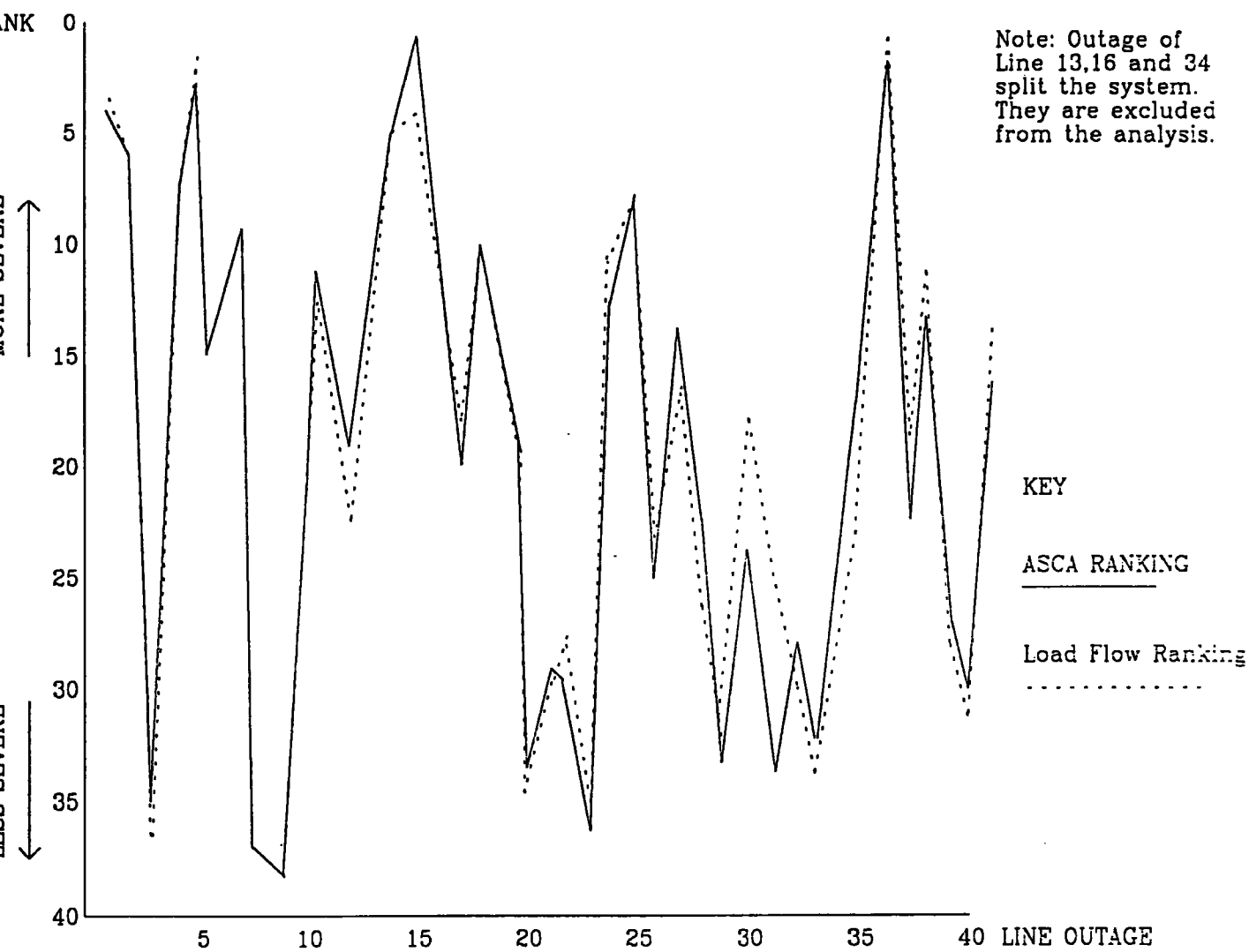

FIGURE (7.2) ACS RESULTS FOR OVERLOAD CONTINGENCIES

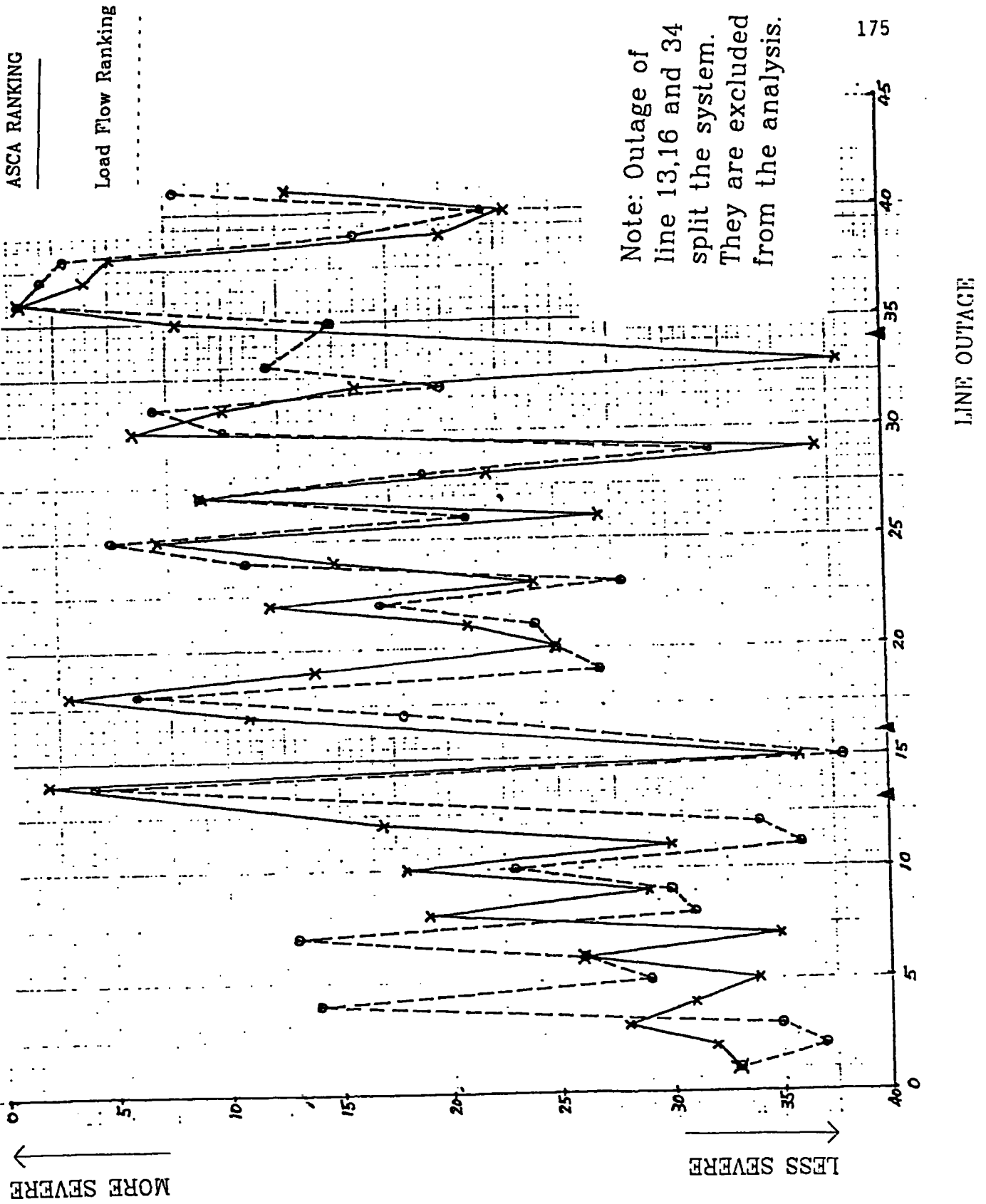

FIGURE (7.3) ACS RESULTS FOR VOLTAGE VIOLATION CONTINGENCIES

OCEPS OUTAGE INPROGRESS R3.0.0

08/02/1985 01:27:17

THE MOST RECENT LISTS

OVERLOAD CONTINGENCY					VOLTAGE CONTINGENCY				
RANK	LINE	ISLAND	BUS	SUB	RANK	LINE	ISLAND	BUS	SUB
1	13	1	25-36	9-11	1	13	1	25-36	9-11
2	16	1	38-39	12-13	2	16	1	38-39	12-13
3	34	1	55-56	25-26	3	34	1	55-56	25-26
4	36	1	63-61	28-27	4	36	1	63-61	28-27
5	19	1	37-45	12-16	5	14	1	25-35	9-10
6	20	1	40-42	14-15	6	15	1	5-38	4-12
7	29	1	50-51	21-22	7	5	1	3-9	2-5
8	33	1	53-55	24-25	8	25	1	33-49	10-20
9	32	1	52-54	23-24	9	26	1	26-46	10-17
10	12	1	10-34	6-10	10	31	1	51-54	22-24
11	22	1	43-47	15-18	11	24	1	48-49	19-20
12	11	1	11-25	6-9	12	4	1	4-5	3-4
13	30	1	41-52	15-23	13	37	1	59-66	27-29
14	17	1	37-40	12-14	14	9	1	12-16	6-7
15	23	1	47-48	18-19	15	35	1	55-62	25-27
16	2	1	1-4	1-3	16	38	1	60-71	27-30
17	28	1	30-51	10-22	17	18	1	37-44	12-15
18	6	1	2-12	2-6	18	27	1	29-50	10-21
19	15	1	5-38	4-12	19	41	1	15-63	6-28
20	7	1	6-14	4-6	20	2	1	1-4	1-3

TABLE (7.1) CONTINGENCY LISTS

OCEPS AUTOMATIC SECURITY ASSESSMENT RESULTS

08/02/1985 00:26:11

SUMMARY OF SECURITY ASSESSMENT RESULTS

VOLTAGE VIOLATION REPORT

LINE OUT	FROM BUS-SUB	TO BUS-SUB	AT BUS-SUB	VOLTAGE(PU)	LIMIT (PU)
36	63- 28	61 - 27	56- 26	0.89362	0.90000
36	63- 28	61 - 27	60- 27	0.88910	0.90000
36	63- 28	61 - 27	65- 29	0.87148	0.90000
36	63- 28	61 - 27	73- 30	0.86162	0.90000

POWER VIOLATIONS REPORT

LINE OUT	FOR LINE	FROM BUS-SUB	TO BUS-SUB	POWER (MW)	LIMIT (MW)
36	31	51 - 22	54- 24	16.17978	16.00000

TABLE (7.2) SECURITY ASSESSMENT VOLTAGE AND
POWER VIOLATION REPORTS

OCEPS AUTOMATIC SECURITY ASSESSMENT RESULTS 08/02/1985 00:26:34
 SECURITY ASSESSMENT SUMMARY THIS IS THE MOST RECENT LIST
 TASK USESE COMBINED OVERLOAD AND VOLTAGE LIST

RANK	LINE	BUS	SUB	OVERLOAD	UNDERVOLTAGE	OVERVOLTAGE
1	36	63-61	28-27	Y	Y	N
2	7	6-14	4- 6	N	N	N
3	14	25-35	9-10	N	N	N
4	12	10-34	6-10	N	N	N
5	37	59-66	27-29	N	N	N
6	33	53-55	24-25	N	N	N
7	38	60-71	27-30	N	N	N
8	20	40-42	14-15	N	N	N
9	30	41-52	15-23	N	N	N
10	32	52-54	23-24	N	N	N

TABLE (7.3) SECURITY ASSESSMENT SUMMARY

OCEPS AUTOMATIC SECURITY ASSESSMENT RESULTS

08/02/1985 00:26:34

LINE FLOW REPORT FOR THE OUTAGE OF LINE 36

** RANK 1 CONTINGENCY**

LINE	BUS	SUB	LIMIT	FLOW	LINE	BUS	SUB	LIMIT	FLOW
1	1- 3	1- 2	130.00	32.69	2	1- 4	1- 3	130.00	19.30
3	2- 6	2- 4	65.00	13.82	4	4- 5	3- 4	130.00	17.18
5	3- 9	2- 5	130.00	34.58	6	2-12	2- 6	100.00	13.71
7	6-14	4- 6	90.00	0.07	8	7-16	5- 7	70.00	-13.68
9	12-16	6- 7	130.00	32.16	10	13-18	6- 8	32.00	-20.25
11	11-25	6- 9	65.00	-2.70	12	10-34	6-10	32.00	7.92
13	25-36	9-11	65.00	-47.78	14	25-35	9-10	65.00	45.09
15	5-38	4-12	65.00	24.61	16	38-39	12-13	65.00	-7.59
17	37-40	12-14	32.00	6.64	18	37-44	12-15	32.00	14.35
19	37-45	12-16	32.00	2.06	20	40-42	14-15	16.00	1.57
21	45-46	16-17	16.00	-0.91	22	43-47	15-18	16.00	2.23
23	47-48	18-19	16.00	-0.41	24	48-49	19-20	32.00	-7.86
25	33-49	10-20	32.00	9.72	26	26-46	10-17	32.00	8.07
27	29-50	10-21	32.00	19.46	28	30-51	10-22	32.00	10.63
29	50-51	21-22	32.00	5.64	30	41-52	15-23	16.00	6.87
31	51-54	22-24	16.00	16.18	32	52-54	23-24	16.00	4.21
33	53-55	24-25	16.00	13.31	34	55-56	25-26	16.00	2.70
35	55-62	25-27	16.00	10.19	36	63-61	28-27	65.00	0.00
37	59-66	27-29	16.00	4.67	38	60-71	27-30	16.00	5.31
39	65-73	29-30	16.00	2.74	40	24-63	8-23	32.00	3.12
41	15-63	6-28	32.00	-3.17					

TABLE (7.4) SECURITY ASSESSMENT LINE FLOW REPORT FOR
OUTAGE OF BRANCH 36

OCEPS AUTOMATIC SECURITY ASSESSMENTS RESULTS

08/02/1985 00:26:34

VOLTAGE REPORT FOR THE OUTAGE OF LINE 36

** RANK 1 CONTINGENCY**

BUS	SUB	HIGH	LOW	VOLTAGE	BUS	SUB	HIGH	LOW	VOLTAGE
1	1	1.100	0.900	1.061	2	2	1.100	0.900	1.047
4	3	1.100	0.900	1.934	5	4	1.100	0.900	1.028
7	5	1.100	0.900	1.012	10	6	1.100	0.900	1.021
16	7	1.100	0.900	1.011	17	8	1.100	0.900	1.011
25	9	1.100	0.900	1.023	26	10	1.100	0.900	0.998
36	11	1.100	0.900	1.080	37	12	1.100	0.900	1.027
39	13	1.100	0.900	1.070	40	41	1.100	0.900	1.010
41	15	1.100	0.900	1.002	45	16	1.100	0.900	1.009
46	17	1.100	0.900	0.997	47	18	1.100	0.900	0.991
48	19	1.100	0.900	0.987	49	20	1.100	0.900	0.989
50	21	1.100	0.900	0.984	51	22	1.100	0.900	0.983
52	23	1.100	0.900	0.979	53	24	1.100	0.900	0.955
55	25	1.100	0.900	0.909	56	26	1.100	0.900	0.894
57	27	1.100	0.900	0.889	63	28	1.100	0.900	1.020
64	29	1.100	0.900	0.871	69	30	1.100	0.900	0.862

TABLE (7.5) SECURITY ASSESSMENT VOLTAGE REPORT FOR THE
OUTAGE OF BRANCH 36

OCEPS OUTAGE IN PROGRESS R3.0.0

10/04/1985 01:27:17

THE MOST RECENT LISTS

OVERLOAD CONTINGENCY					VOLTAGE CONTINGENCY				
RANK	LINE	ISLAND	BUS	SUB	RANK	LINE	ISLAND	BUS	SUB
1	33	2	63-61	28-27	1	36	2	63-61	28-27
2	40	2	24-63	8-28	2	40	2	24-63	8-28
3	35	2	55-62	25-27	3	35	2	55-62	25-27
4	34	2	55-56	25-26	4	34	2	55-62	25-26
5	16	1	38-39	12-13	5	16	1	38-39	12-13
6	13	1	25-36	9-11	6	13	1	25-36	9-11
7	32	1	52-54	23-24	7	26	1	26-46	10-17
8	30	1	41-52	15-23	8	37	2	59-66	25-29
9	18	1	37-44	12-15	9	5	1	3-9	2-5
10	20	1	40-42	14-15	10	15	1	5-38	4-12
11	19	1	37-45	12-16	11	14	1	25-35	9-10
12	23	1	47-48	18-19	12	18	1	37-44	12-15
13	24	1	48-49	19-20	13	31	1	51-54	22-24
14	22	1	43-47	15-18	14	4	1	4-5	3-4
15	11	1	11-25	6-9	15	24	1	48-49	19-20
16	31	1	51-54	22-24	16	6	1	2-12	2-6
17	29	1	50-51	21-22	17	9	1	12-16	6-7
18	15	1	5-38	4-12	18	2	1	1-4	1-3
19	27	1	59-66	27-29	19	38	2	60-71	27-30
20	39	2	65-73	29-30	20	27	1	29-50	10-21

TABLE (7.6) CONTINGENCY LISTS
(NETWORK SPLIT INTO 2 ISLANDS)

7.3.3 AC Security Assessment (SECASS)

The formulation of a mathematical model of a transmission network is a pre-requisite for power systems analysis and control by digital computer. If the interconnections of the n buses of the system, the appropriate model of lines and transformers, and nodal injection data are known, a load flow solution gives all the unknown voltages, power injections and line flows. Mathematically the problem is one of solving a set of simultaneous non-linear algebraic equations. [22][32]

The analysis of security assessment has evolved from load flow techniques and is best thought of as a measure of satisfactory performance of the system following the occurrence of any one of a pre-specified set of contingencies.

Three numerical methods have commonly been applied to the solution of the load flow problem: the Gauss-Seidal method, the Newton-Raphson method and the Fast Decoupled Newton method.

Gauss-Seidal algorithm is inefficient for large networks. The Fast Decoupled load flow method shares many of the properties of the sparse Newton-Raphson approach and has the further advantage of a reduction in computer time and memory loading. This is achieved by neglecting the (weak) coupling effects between phase angles and reactive power and between voltage magnitudes and active power. [28]

The Fast Decoupled method is recommended for application to the majority of power system networks.^[32] However in cases with very high resistance to reactance ratio lines (R/X), as in low voltage distribution networks, it is beneficial to resort to the Newton-Raphson method.

Given a list of hypothetical plant outages assembled either manually or automatically (by the ACS algorithm), it is necessary to execute a series of AC load flow studies to determine whether any limit violations would result from the occurrence of an outage. In order to achieve more rapid solutions where a list of similar networks must be analysed, the Fast Decoupled algorithm has been revised to include the method of modified matrices (Diakoptics). This technique allows solutions for single or multiple branch outages to be obtained without the need for matrix refactorisation when sparsity techniques are applied (see Figure 7.5).

For contingency studies, two methods of approach were considered:

- (i) Repeat load flow solution
- (ii) Application of the recursive Diakoptics method as explained in Chapter 4.

Figures (7.4) and (7.5) represent the above solution methods based on Fast Decoupled Newton-Raphson load flow technique.

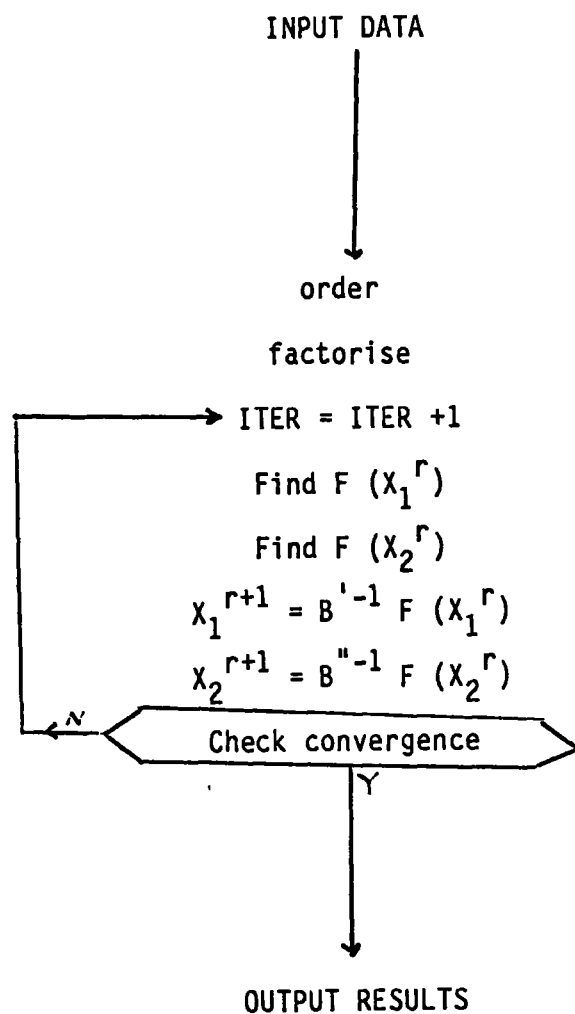

FIGURE (7.4) LOAD FLOW SOLUTION

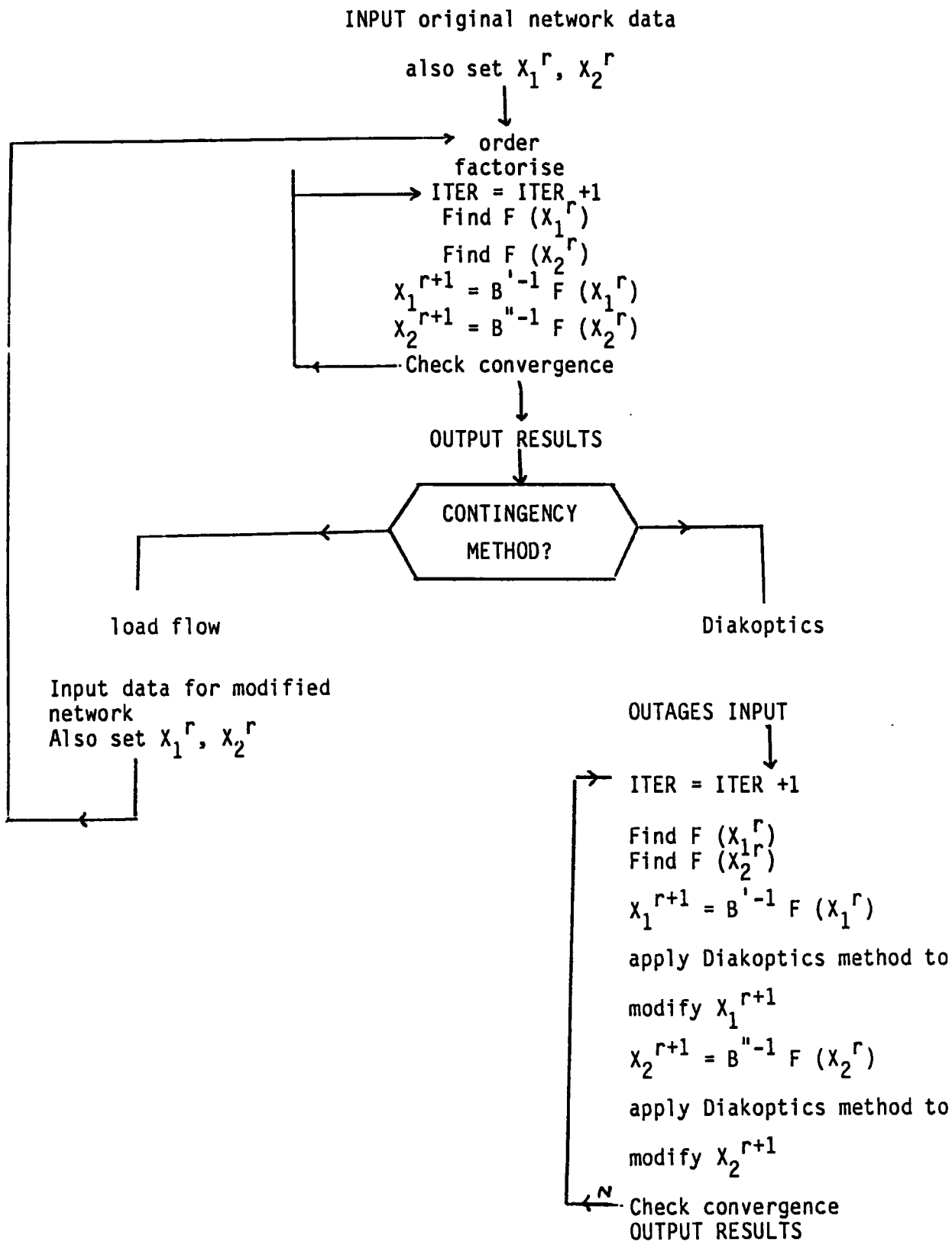

FIGURE (7.5) FLOW DIAGRAM FOR CONTINGENCY STUDIES

As can be seen from the flow diagram of Figure (7.5), when applying the Diakoptics technique there is no need for re-ordering and re-factorising B' and B'' . The total execution times required for the two methods of approach are compared in table (7.7) based on the 30 bus test network and multiple branch outages.

From the results presented it can be seen that the Diakoptics approach provides the same degree of accuracy as the conventional Fast Decoupled Newton-Raphson method. However, when the number of simultaneous branch outages exceeds three, the Fast Decoupled Newton-Raphson method is faster.

The above results confirmed the findings of Stott and Alsac^[32] and provided the basis for further development of the Diakoptics technique in order to obtain network solutions when network splits occur as a result of a branch outage.^[27]

30 BUS TEST NETWORK

	LOAD FLOW		DIAKOPTIC	
	Time (sec)	No. of iterations	Time (sec)	No. of iterations
Base solution	1.101	6	1.101	6
Base solution + single outage	2.061	8	1.903	8
Base solution + double outage	2.092	9	2.073	9
Base solution + triple outage	2.090	9	2.124	9
Base solution + 5th outage	2.135	12	2.805	12

TABLE (7.7) COMPARISON OF RESULTS BASED ON PERKIN-ELMER 3230

7.3.4 Islanding

In Figure (7.6) if the line shown with an asterisk (*) is to be completed, then the network splits into two islands. The conventional approach to obtain the solution to this network is to restrict the solution to the largest island created. This approach has serious disadvantages in power systems which are subjected to frequent major outages and for which islanding is a common occurrence.

The common method to solve the above problem is by solving two separate power flows, one for each island created. The disadvantage of this approach is that it requires the formation of B' and B'' matrices for each island in turn and then to execute two solutions. In addition, as a first step to identify which buses, branches, loads etc. belong to which island, the input data stage requires a considerable amount of data processing.

The theory of network changes (Diakoptics) as commonly applied to the load flow could not be used directly to obtain the solution to the individual islands. The reason is because during the Diakoptics solution a scalar becomes zero when network split takes place and hence numerically the inverse of this scalar is not obtainable (please refer to Chapter 5).

The new technique developed during the course of research at Durham, overcomes the above problem.

As mentioned earlier the new technique is based on the application of Diakoptics to Fast Decoupled Newton-Raphson, and hence it inherits all the associated advantages.

During the development of this new method, it was realised that as a result of one simple mathematical operation, buses, branches etc. in each island will be easily identified (please refer to chapter 5).

Tables (7.8) and (7.9) provide the comparison of results obtained using the new approach based on Diakoptics, and separate power flow solutions, when the network in Figure (7.6) was split due to completion of the branch shown with an asterisk.

The results confirmed that the solution accuracy was similar to Fast Decoupled method, however, the speed of execution was improved by more than 50%. As the size of networks grow, the advantages of utilising the proposed technique became more obvious.

In real-time, topology processing is usually included in the state estimation package in order to construct network connectivity based on the telemetry. Identification of the elements in each island (if islanding occurs) requires a large number of data processing actions. The new method presented in Chapter 5 reduces the required execution time by a large amount and in addition has the advantage of being simple to implement.

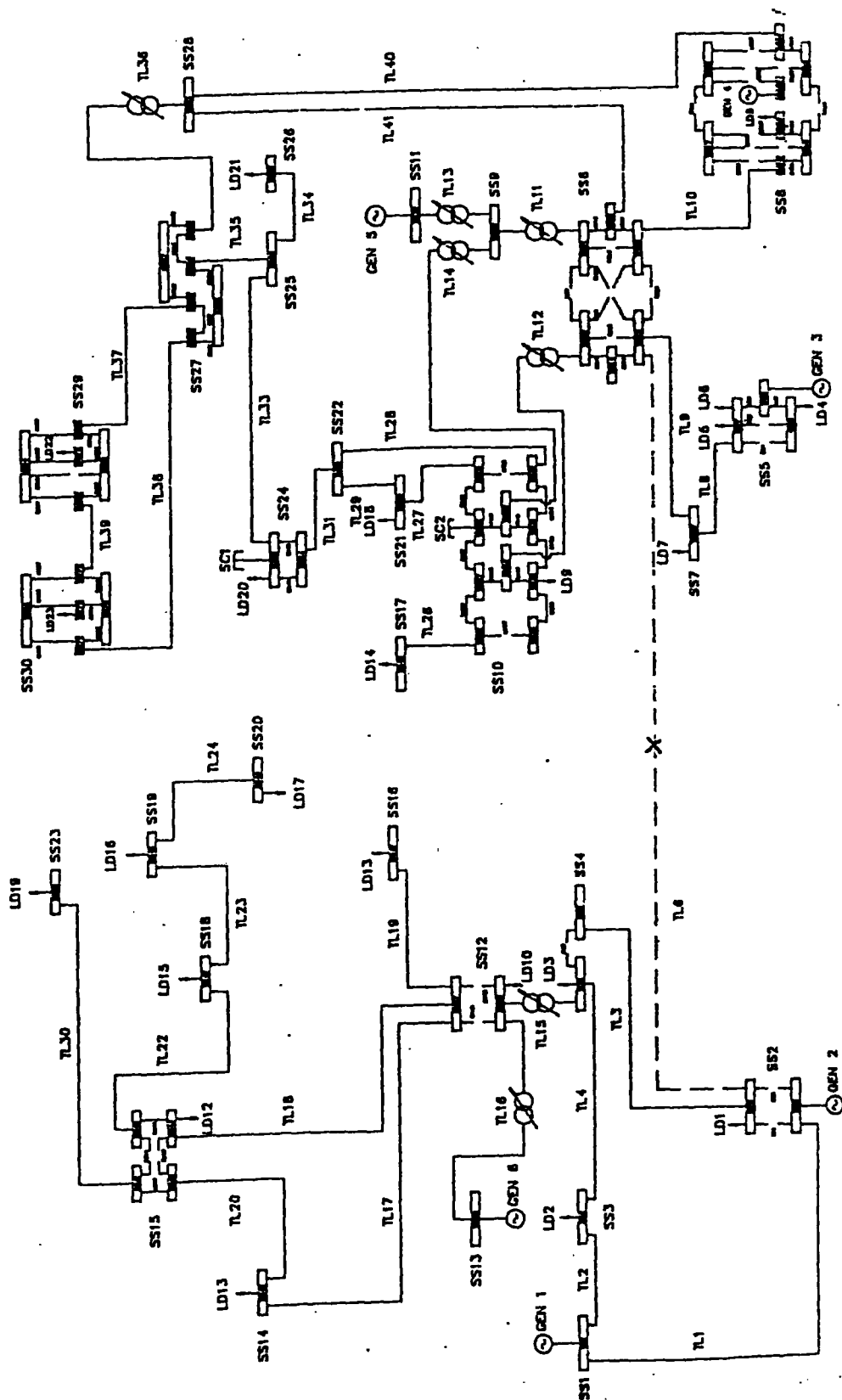

FIGURE (7.6) UNIVERSITY OF DURHAM
OCEPS THIRTY SUBSTATION TEST SYSTEM

	NO. OF ITERATIONS	COMPACTING ORDERING FACTORISING	SOLUTION TIME T1 (sec)	TOTAL TIME T2 (sec)
ISLAND 1 with original slack	4	0.513	0.189	0.702
ISLAND 2	6	0.698	0.425	1.123
DIAKOPTIC TECHNIQUE	6	-	0.712	0.712

TABLE (7.8) RESULTS BASED ON PERKIN-ELMER 3230

GENERATION

BUS NUMBER	MW		MVAR	
	FDNR TECHNIQUE	DIAKOPTIC TECHNIQUE	FDNR TECHNIQUE	DIAKOPTIC TECHNIQUE
1 Slack	40.91	40.90	28.86	28.85
2	40.00	40.00	-13.08	-13.17
5	00.00	00.00	79.13	79.12
13	00.00	00.00	27.03	26.96
8 New Slack	218.90	218.89	5.47	5.44
11	00.00	00.00	26.62	26.62

TABLE (7.9) COMPARISON OF RESULTS

7.3.5 Outages Selection (OUTAGE)

The OUTAGE program allows the operator to edit the contingency list provided in advance by the ACS algorithm (AUTOUT program). In addition OUTAGE program provides facilities for requesting simultaneous outages of branches, shunts, loads and generators output.

The operator can request mixed outages of the above components. As an example, he can request the following scenario: simultaneous outage of lines A and B, addition of lines C and D (if they are already out of service), reduction of loads E and F (in per-unit or percent), and similarly for a few generator outputs.

With respect to units, the operator's request should be within the capability limits of individual unit's output, otherwise appropriate alarm messages will be issued. Loss of unit's outputs will be redistributed amongst the other units only if the "unexpected" option is used. If the reduction in unit outputs are "expected" (according to a defined schedule), then the redistribution will not take place.

Loads and units are ranked with respect to their MW/MVAR levels. Table (7.10) illustrates the results for the case when the output of unit 2 was unexpectedly increased by 0.1 per unit. As can be seen, the output of other units decreased. The redistribution is done by applying the participation factors for the units calculated by the economic despatch program. Table

(7.11) provides the MW, MVAR ranks for loads in the system. Following a load reduction (in per unit or percentage), the loss is redistributed amongst the units.

The outage program is in effect the interface between the operator and the security package. Once the operator selects an outage scenario, via the facilities provided by the OUTAGE program, he can send a message to the SECASS program and request a full AC analysis. During this transition AUTOUT will be paused temporarily, SECASS stops its current execution and performs the study for the operator. At the completion of the analysis a message will be sent directly from SECASS to OUTAGE to inform the user that the study is finished.

Once the results are available, the operator can investigate them by inspecting various displays which will be made available to him by the OUTAGE program. The OUTAGE program is highly interactive and requires no special operator training.

The important function provided by the OUTAGE is simultaneous and mixed outages selection of system components.

OCEPS OUTAGE INPROGRESS R3.0.0

08/02/1985.01:27:17

<u>GENERATOR</u>	<u>BUS----</u>	<u>SUB</u>	<u>ACTIVE POWER</u>
2	3	2	0.674
1	1	1	0.638
4	22	8	0.381
5	36	11	0.378

PLEASE ENTER : GEN.NO., CODE, CHANGE

-- CHANGE : IN % OR PU
 -- CODE := 1 EXPECTED
 = 2 UNEXPECTED

PRESS RETURN TO STOP

2,2,.1PU

OCEPS OUTAGE INPROGRESS R3.0.0

08/02/1985.01:27:38

<u>GENERATOR</u>	<u>MAX. GEN</u>	<u>MIN. GEN</u>	<u>ORIGINAL -P</u>	<u>MODIFIED-P</u>
1	2.00000	0.50000	0.638	0.618
2	1.50000	0.50000	0.674	0.774
4	0.50000	0.10000	0.381	0.341
5	0.50000	0.10000	0.378	0.338

TABLE (7.10) GENERATOR OUTAGES

OCEPS OUTAGE IN PROGRESS R3.0.0

08/02/1985.02:10:43

<u>LOAD-NO.</u>	<u>BUS-----SUB</u>	<u>ACTIVE-LOAD</u>	<u>LOAD-NO.</u>	<u>BUS-----SUB</u>	<u>REACTIVE-LOAD</u>
4	9 5	0.272	8	20 8	0.227
5	7 5	0.236	1	2 2	0.112
8	20 8	0.222	7	16 7	0.091
1	2 2	0.167	18	50 21	0.079
6	7 5	0.166	4	9 5	0.061
7	16 7	0.164	10	38 12	0.056
18	50 21	0.123	5	7 5	0.053
10	38 12	0.080	20	53 24	0.045
23	72 30	0.072	14	46 17	0.042
16	48 19	0.065	6	7 5	0.040
14	46 17	0.064	2	4 3	0.026
20	53 24	0.059	3	5 4	0.026
3	5 4	0.056	16	48 19	0.024
12	44 15	0.055	12	44 15	0.018
9	32 10	0.043	9	32 10	0.017
11	40 14	0.043	21	56 26	0.016
13	45 16	0.024	13	45 16	0.014
21	56 26	0.023	23	72 30	0.014
15	47 18	0.023	11	40 14	0.012
19	52 23	0.022	19	52 23	0.011
2	4 3	0.018	22	67 29	0.007
22	67 29	0.016	15	47 18	0.006
17	49 20	0.016	17	49 20	0.006

PLEASE ENTER THE LOAD CHANGES IN % OR PU
PRESS RETURN TO STOP

ENTER LOAD-NO., ACT-LOAD, REAC-LOAD

TABLE (7.11) LOAD LIST

7.3.6 Security Assessment Output (SECOUT)

The security assessment output program (SECOUT) provides AC solution results as obtained from the security assessment program (SECASS). It has a summary list which provides a quick reference to highlight those contingencies which caused voltage or overload violations. Consequently, the operator can select the appropriate contingency and study in detail the results of security assessment.

If the contingency result list is outdated, the program automatically sends an alarm to inform the operator. The operator can then request the most up to date list. Tables (7.12) to (7.14) illustrate typical SECOUT program contingency output results.

OCEPS AUTOMATIC SECURITY ASSESSMENT RESULTS 08/02/1985.00:26:34
 SECURITY ASSESSMENT SUMMARY THIS IS THE MOST RECENT LIST
 TASK USESE COMBINED OVERLOAD AND VOLTAGE LIST

RANK	LINE	BUS	SUB	OVERLOAD	UNDERVOLTAGE	OVERVOLTAGE
1	36	63-61	28-37	Y	Y	N
2	7	6-14	4-6	N	N	N
3	14	25-35	9-10	N	N	N
4	12	10-34	6-10	N	N	N
5	37	59-66	27-29	N	N	N
6	33	53-55	24-25	N	N	N
7	38	60-71	27-30	N	N	N
8	20	40-42	14-15	N	N	N
9	30	41-52	15-23	N	N	N
10	32	52-54	23-24	N	N	N

TABLE (7.12) SECURITY ASSESSMENT SUMMARY

OCEPS AUTOMATIC SECURITY ASSESSMENT RESULTS

08/02/1985 00:26:34

LINE FLOW REPORT FOR THE OUTAGE OF LINE 36

** RANK 1 CONTINGENCY**

LINE	BUS	SUB	LIMIT	FLOW	LINE	BUS	SUB	LIMIT	FLOW
1	1- 3	1- 2	130.00	32.69	2	1- 4	1- 3	130.00	19.30
3	2- 6	2- 4	65.00	13.82	4	4- 5	3- 4	130.00	17.18
5	3- 9	2- 5	130.00	34.58	6	2-12	2- 6	100.00	13.71
7	6-14	4- 6	90.00	0.07	8	7-16	5- 7	70.00	-13.68
9	12-16	6- 7	130.00	32.16	10	13-18	6- 8	32.00	-20.25
11	11-25	6- 9	65.00	-2.70	12	10-34	6-10	32.00	7.92
13	25-36	9-11	65.00	-47.78	14	25-35	9-10	65.00	45.09
15	5-38	4-12	65.00	24.61	16	38-39	12-13	65.00	-7.59
17	37-40	12-14	32.00	6.64	18	37-44	12-15	32.00	14.35
19	37-45	12-16	32.00	2.06	20	40-42	14-15	16.00	1.57
21	45-46	16-17	16.00	-0.91	22	43-47	15-18	16.00	2.23
23	47-48	18-19	16.00	-0.41	24	48-49	19-20	32.00	-7.86
25	33-49	10-20	32.00	9.72	26	26-46	10-17	32.00	8.07
27	29-50	10-21	32.00	19.46	28	30-51	10-22	32.00	10.63
29	50-51	21-22	32.00	5.64	30	41-52	15-23	16.00	6.87
31	51-54	22-24	16.00	16.18	32	52-54	23-24	16.00	4.21
33	53-55	24-25	16.00	13.31	34	55-56	25-26	16.00	2.70
35	55-62	25-27	16.00	10.19	36	63-61	28-27	65.00	0.00
37	59-66	27-29	16.00	4.67	38	60-71	27-30	16.00	5.31
39	65-73	29-30	16.00	2.74	40	24-63	8-23	32.00	3.12
41	15-63	6-28	32.00	-3.17					

TABLE (7.13) SECURITY ASSESSMENT LINE FLOW REPORT FOR
OUTAGE OF BRANCH 36

OCEPS AUTOMATIC SECURITY ASSESSMENTS RESULTS

08/02/1985 00:26:34

VOLTAGE REPORT FOR THE OUTAGE OF LINE 36

** RANK 1 CONTINGENCY**

BUS	SUB	HIGH	LOW	VOLTAGE	BUS	SUB	HIGH	LOW	VOLTAGE
1	1	1.100	0.900	1.061	2	2	1.100	0.900	1.047
4	3	1.100	0.900	1.934	5	4	1.100	0.900	1.028
7	5	1.100	0.900	1.012	10	6	1.100	0.900	1.021
16	7	1.100	0.900	1.011	17	8	1.100	0.900	1.011
25	9	1.100	0.900	1.023	26	10	1.100	0.900	0.998
36	11	1.100	0.900	1.080	37	12	1.100	0.900	1.027
39	13	1.100	0.900	1.070	40	41	1.100	0.900	1.010
41	15	1.100	0.900	1.002	45	16	1.100	0.900	1.009
46	17	1.100	0.900	0.997	47	18	1.100	0.900	0.991
48	19	1.100	0.900	0.987	49	20	1.100	0.900	0.989
50	21	1.100	0.900	0.984	51	22	1.100	0.900	0.983
52	23	1.100	0.900	0.979	53	24	1.100	0.900	0.955
55	25	1.100	0.900	0.909	56	26	1.100	0.900	0.894
57	27	1.100	0.900	0.889	63	28	1.100	0.900	1.020
64	29	1.100	0.900	0.871	69	30	1.100	0.900	0.862

TABLE (7.14) SECURITY ASSESSMENT VOLTAGE REPORT FOR THE
OUTAGE OF BRANCH 36

7.3.7 Integration of Security Assessment Package to OCEPS

OCEPS' contingency analysis solution approach is divided into two major processes. Contingency screening (AUTOUT program), and full AC contingency processing (SECASS program).

As an aid to the network control engineer, it is possible to assess the effect of any scheduled or unexpected branch outages by means of a fast approximate load flow method. Contingency screening is the first stage of the analysis. This module predicts the number and severity of any overloads or abnormal voltages which may result from the switching operation or breaker status change under consideration. It ranks the harmful contingencies by assigning priority orders. Those with the lower rank order are more likely to cause violations than those with higher rank order.

Screening is a quick way to determine which contingencies are definitely harmless. At present, the list of first ten contingencies will be processed by full AC solution.

The second stage, security assessment, examines those contingencies transferred for full AC solution. The security assessment phase, hence, proceeds to analyse the intact system and the preselected outage cases. The security assessment program is based on fast decoupled Newton-Raphson and for outages simulation it applies Diakoptics as discussed in previous

chapters. This program runs automatically based on a pre-specified execution cycle.

If the network topology changes, the security assessment program will be paused until the new contingency list is evaluated by the screening program.

If the network configuration changes and the intact network split into two, the program assigns automatically a reference bus in subnetwork without the original reference bus. The screening process is also capable of selecting contingency lists under such circumstances.

The new technique developed by the author for network islanding is incorporated in the OCEPS security analysis package. If as a result of a branch outage the network splits into two, then by the application of the new technique the security assessment provides full AC solution for both subnetworks in parallel.

Figures (7.7) through (7.9) illustrate OCEPS coordination of subsystems and the integration of the security assessment package.

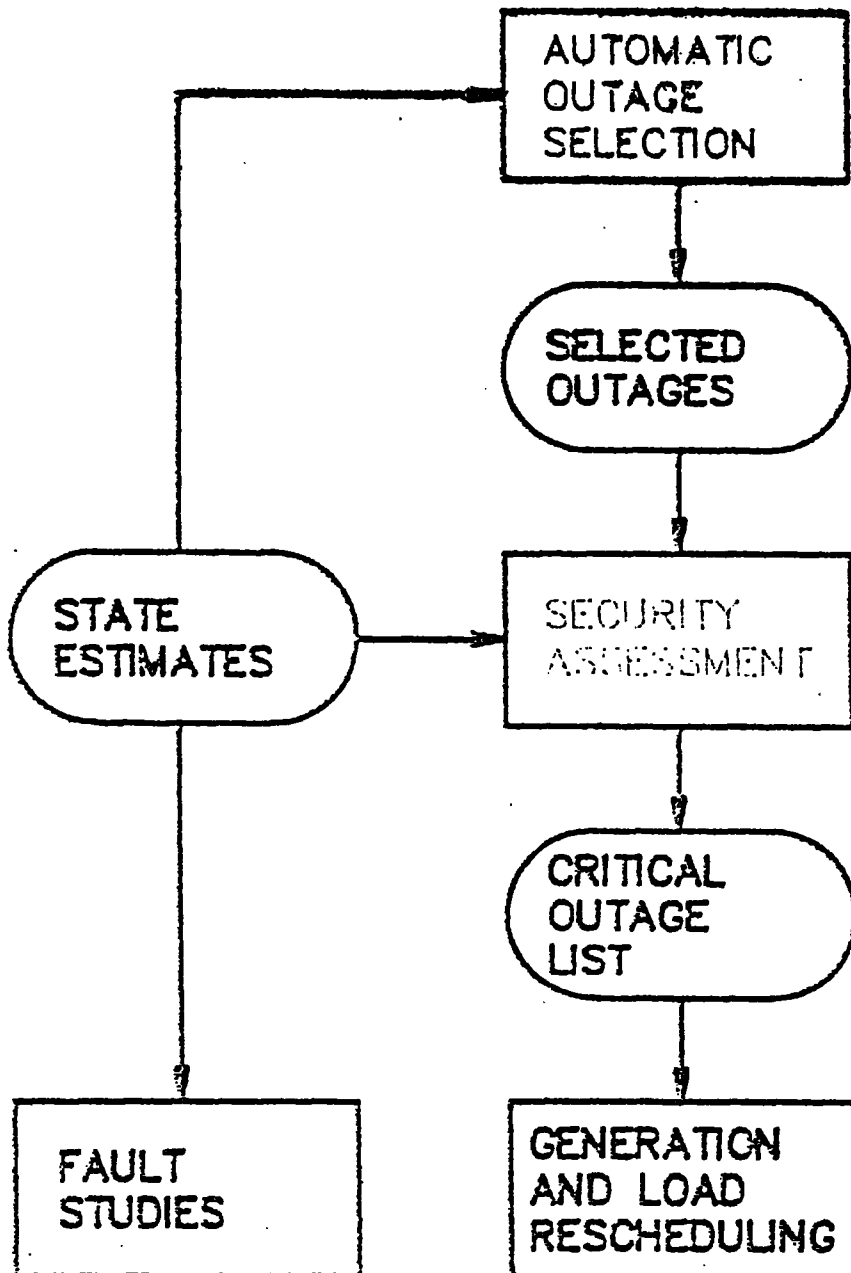

FIGURE (7.7) SECURITY ANALYSIS SUBSYSTEM

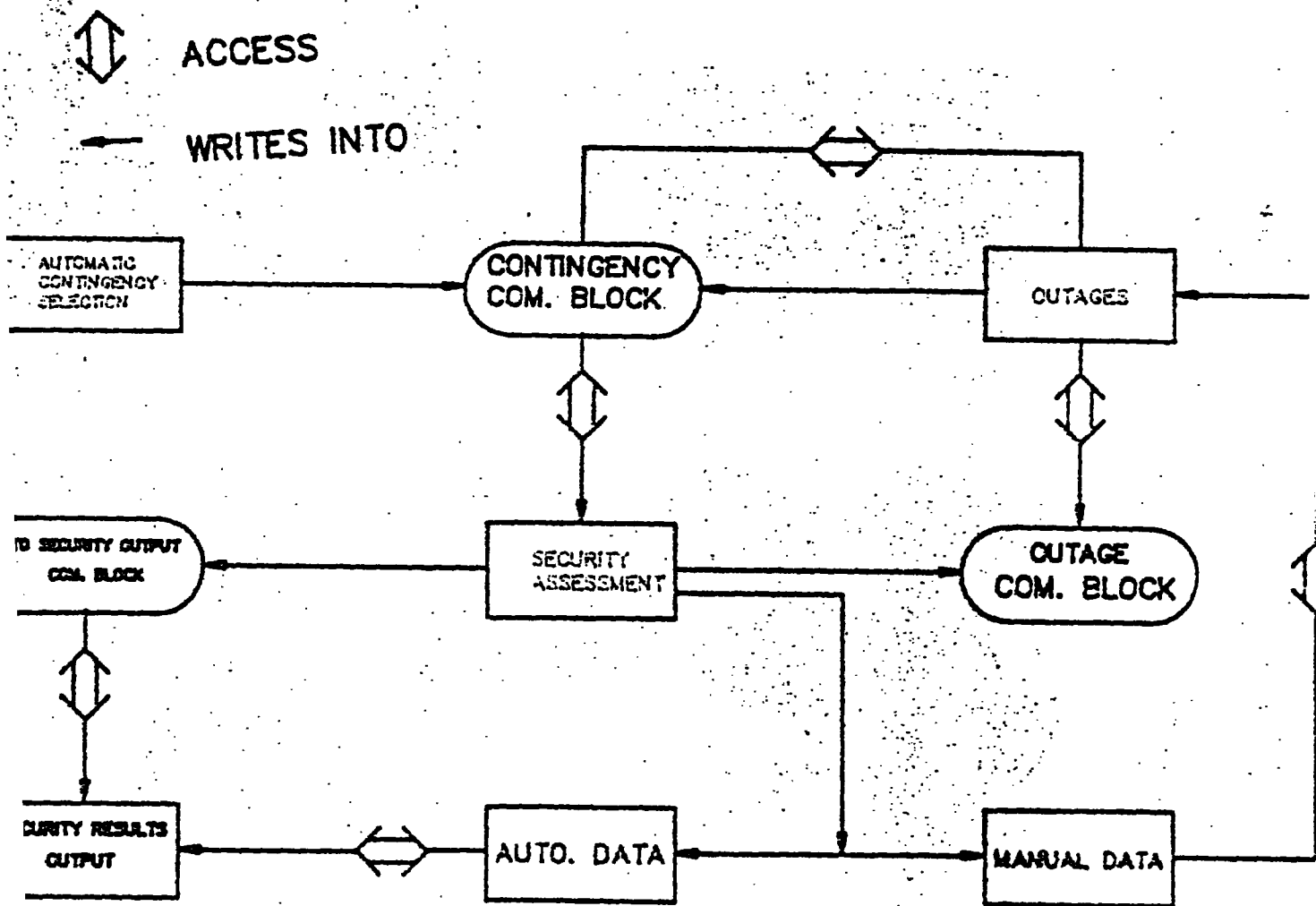

FIGURE (7.8) OVERALL OCEPS SECURITY ASSESSMENT PACKAGE

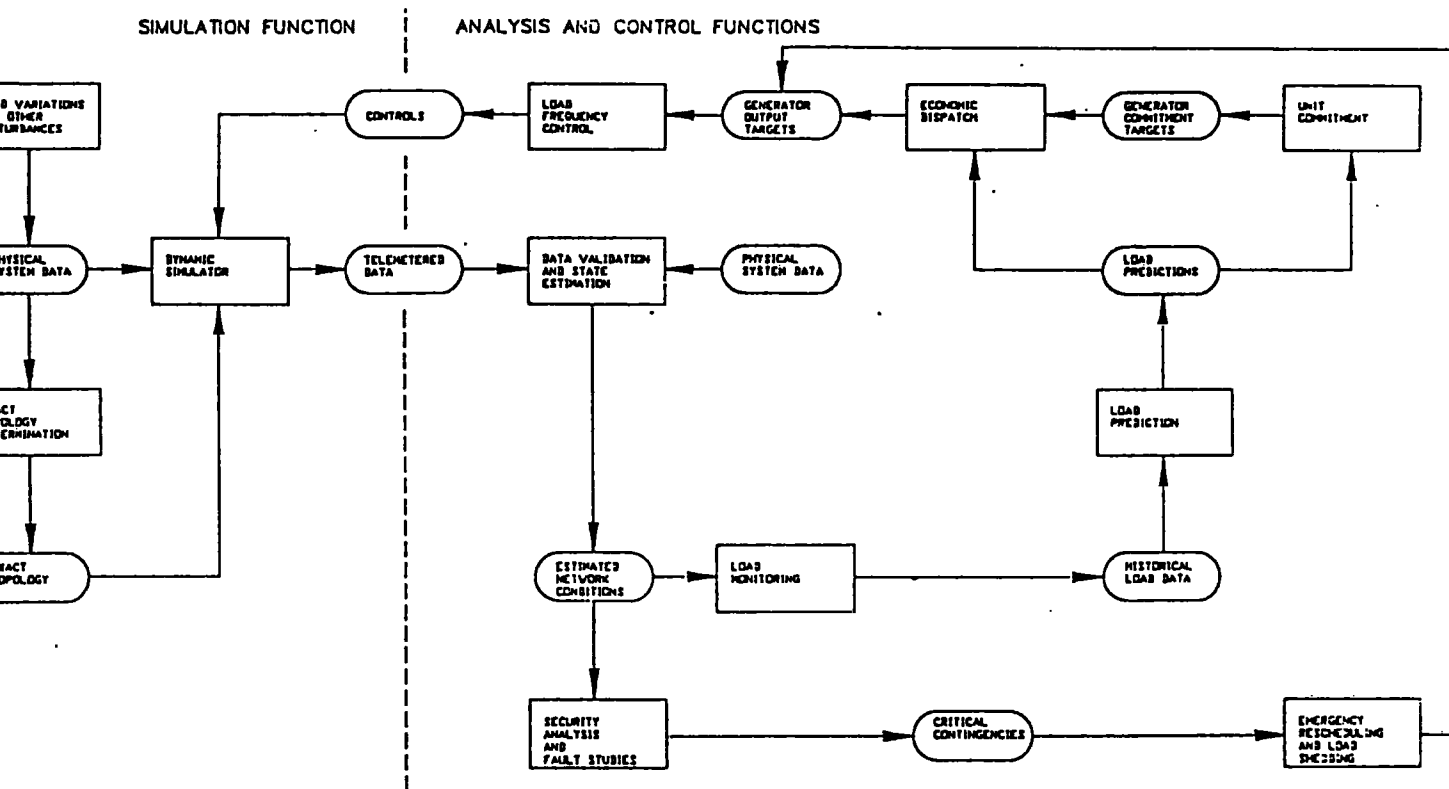

FIGURE (7.9) OPERATIONAL CONTROL OF ELECTRIC POWER SYSTEMS OVERVIEW OF MAJOR FUNCTIONAL ELEMENTS

CHAPTER 8

CONCLUSIONS AND SUGGESTIONS FOR FURTHER RESEARCH

8.1 Conclusions

In this work consideration has been given to the Real-Time Electrical Power Network Security Assessment which is a prerequisite of any on-line control and monitoring scheme and which in itself gives a significant saving of operational cost by providing an indication of system security and information about the power system response after equipment outages have been introduced.

Digital computers are used widely in modern power systems in order to carry out Supervisory Control and Data Acquisition (SCADA) and Automatic Generation Control (AGC). The SCADA function provides a basis for the monitoring and control. Monitoring of limit values, trends and simple means for post-disturbance analysis such as sequence of event recording/replay action and post mortem review are a few examples of the SCADA function. Beyond the SCADA category, a lot of functions deal with system security.

The security of a power system is generally judged in terms of the system's ability to withstand the impact of sudden changes due to the loss of transmission lines, transformers, generators, loads and compensators.

Historically, the load flow is used as a simulation tool when analysing system security. For steady state security assessment of the existing and future system, a general purpose load flow solution method based on the Fast Decoupled Newton Raphson was presented in Chapter 4. The program development takes full advantage of sparsity techniques and simulates automatic tap changers and phase shifters.

The conventional method for simulation of branch outages is based on load flow techniques and requires the refactorisation of system admittance matrices for individual branch outage cases. This method is inefficient for operational purposes in Real-Time environment.

The solution to a linear or non-linear network can be obtained from the inverse of the system admittance matrix. Theory of network changes has been studied in Chapters 3 and 4. As demonstrated in these chapters, the new solution to a network subjected to topological changes, can be obtained from the original solution in an efficient and organised manner via the application of Diakoptic techniques. This theory was further developed to simulate simultaneous branch outages. The technique proved to be efficient (up to 3 simultaneous outages) and most suitable for the Real-Time applications and was successfully applied to the OCEPS security assessment package.

The conventional techniques for assessment of transmission networks security normally assume that the network to be studied will only be

subjected to a relatively small number of contingencies simultaneously and furthermore that those contingencies will not split the network into islands. Should such a situation arise, the approach is usually to restrict analysis to the largest island so created.

The above approach has serious disadvantages in power systems for which islanding is common occurrence. In Chapter 6 a unique approach for the Diakoptic solution of the network flow when subjected to configuration changes was presented. The algorithm proved to be accurate and efficient and most suitable for the online security assessment of power systems.

The above technique was successfully implemented in the OCEPS security assessment subsystem and based on the results obtained, a technical paper was published in the IEE second international conference on power system monitoring and control at Durham 1985.

The common procedure for the security check is to evaluate meaningful contingency cases. If the potential outage results in limit violations, then the system is said to be vulnerable. This system state should be reliably detected for possible corrective rescheduling actions.

In an on-line environment, the computational burden that the above task imposes, does not allow the simulation of all conceivable contingencies. Therefore, security analysis must be restricted to presumable critical cases defined in a contingency list.

In order to reduce the number of contingencies that need to be evaluated when assessing the power system's security in a Real-time environment, an Automatic Contingency Selection (ACS) algorithm based on the fast DC power flow was presented in Chapter 5.

The ACS as implemented in the OCEPS suite, provides the voltage and overload contingency lists when network is subjected to configuration changes (multi-islands). In OCEPS implementation, the ACS is executed automatically according to a pre-selected time step. This package is also event driven and as a result of a configuration change it is automatically triggered to execute.

As discussed in Chapter 7, once the ACS results are available, those above a certain threshold are passed for a detailed network flow analysis which is also executed automatically. The contingency list provided by the ACS can be edited via an interactive program developed and integrated into OCEPS.

The program allows selection of mixed equipment outages and via system messages to the security assessment package, provides AC solutions for further investigation.

The general concept of the organisation and the integration of the network security assessment software package to the OCEPS suite has been

described in Chapter 7. A useful degree of flexibility has been achieved by adopting a modular structure of the package in which the programs communicate with others via task common blocks.

With the development of electrical power industry and the interconnection of isolated power systems, very large power systems are formed. The expansion of the system brings not only the great economical and technical rationality into the system, but also the complexity into the analysis and the computational simulations of the system. The complexity is a great challenge to the static and dynamical analysis and computationally impossible in terms of Real-Time monitoring and control of large scale power systems.

One way to solve the above problem is by using network equivalent techniques. Conventional techniques developed to perform electrical network reduction have been studied in Chapter 5. A new approach for obtaining network equivalents in an off-line environment has been presented in Chapter 6.

8.2 Suggestions for further research work

The following topics related to the Real-Time security analysis discussed in this thesis require further investigation:

- 1 - The theory of network islanding could be further developed to cater for cases when simultaneous outages of branches cause a split or multiple islands.
- 2 - The ACS algorithm could be further developed to include appropriate ranking of loads and generators in the system.
- 3 - Inclusion of bus and station outages in the security package.
- 4 - Simulation of circuit break outages.
- 5 - Detection and provision of appropriate alarms if bus split occurs as a result of switching.
- 6 - Development of one line diagrams (graphics) in order to select contingencies via the one line diagram and also graphical representation of the security assessment results.

- 7 - Development of security assessment algorithms to include the dynamic/algebraic equations of system components in order to provide dynamic response of the system when subjected to equipment outages. With the advance in computer technology such algorithms could soon be implemented in Real-time environments.

Such approaches will be most valuable in systems where islanding is common place.

REFERENCES

1. M.J.H.STERLING and M.IRVING, "Real-time Simulation for the Verification of Advance On-line Control Algorithms", IEE Second International Conference on Power System Monitoring and Control, University of Durham 1986.
2. M.J.H.STERLING, Power System Control, Peter Pergrinus - 1978.
3. M.RAFIAN, M.R.IRVING and M.J.H.STERLING, "A Real-time Power System Simulator", IEE Second International Conference on Power System Monitoring and Control, University of Durham 1986.
4. DOMMEL and N.SATO, "Fast Transient Stability Solutions", IEEE Trans. PAS 91, pp 1643-1650, 1972.
5. Power System Control - internal publication, University of Durham, School of Engineering.
6. G.H.CROUCH and I.F.MORRISON, "Data Validation and Topology Determination for Power System Monitoring and Control", IEEE PES Summer meeting pp 1-9, 1974.
7. M.IRVING, M.STERLING, "Substation Data Validation", PROC. IEE 129, pp 119-122, 1982.
8. M.IRVING, R.OWEN and M.J.H.STERLING, "Power System State Estimation Using Linear Programming", PROC. IEE 125, pp 879-885, 1978.
9. M.J.H.STERLING and H.NICOLSON, "Simulation of a Digital Load - Frequency Control Scheme for Interconnected Systems with Hydro Electric Generation", Dept. of Control Engineering, University of Sheffield 1974.
10. G.E.FOSHA and O.ELGERED, "The Megawatt Frequency Control Problem, a New Approach Via Optimal Control Theory", IEEE Trans. PAS 89, pp 563-571, 1970.
11. F.P.deMELLO, J.UNDRILL, "Automatic Generation Control", Power Technologies Inc., Schenectady, New York.
12. H.NICHOLSON and M.J.H.STERLING, "Optimum Dispatch of Active and Reactive Generation by Qudratic Proqraming", IEEE Trans. PAS 92, pp 644-654, 1973.
13. M.J.H.STERLING, M.IRVING, "Constrained Dispatch of Active Power by Linear Decomposition", PROC. IEE 124, 1977, pp 247-251.

14. M.IRVING, M.J.H.STERLING, "Economic Dispatch of Active Power with Constraint Relaxation", PROC. IEE 1983.
15. A.AYOUB and A.PATTON, "Optimal Thermal Generating Unit-commitment", IEEE Trans. PAS 90, pp 1752-1756, 1971.
16. E.D.FARMER, "A Method of Prediction for Non-stationary Processes and its Application to the Problem of Load Estimation", PROC. IFAC Congress 1963.
17. M.ABOU-HUSSIEN, M.KANDIL, M.TANTNWI, S.FARGHAL, "An Accurate Model for Short Term Load Forecasting", IEEE PAS 100 No. 9, SEPT. 1981.
18. M.MULLER, "Short Term Load Prediction in Electric Power Systems", joint meeting of Austria and Swiss Operational Research Societies, 1980.
19. D.T.Y.CHENG, T.K.HON and M.J.H.STERLING, "Active Power Generation Rescheduling and Load Shedding to Alleviate Overloads or Underloads - a Network Flow Method", Dept. of Engineering, University of Durham, APRIL 1985.
20. S.CHAN and E.YIP, "A Solution of Transmission Limited Dispatch Problem by Sparse Linear Programming", IEEE Trans. PAS Vol 98, No. 3, pp 1044-1053, 1979.
21. M.J.H.STERLING, D.T.Y.CHENG, "An Interactive Load Shedding Technique for Electric Power Systems Control", Dept. of Engineering, University of Durham, FEB. 1983.
22. O.ALSAC, B.STOTT, "Optimal Load Flow with Steady State Security", IEEE PES Summer meeting, EHV/UHV Conf., Vancouver, B.C. Canada, JULY 15-20, 1973.
23. R.G.WASLEY, M.DANESHDOST, "Identification and Ranking of Critical Contingencies in Dependent Variable Space", IEEE PAS Vol. 102, No. 4, APR. 83.
24. A.EKWUE, M.SHORT, "Interactive Security Evaluation in Power System Operation", IEE PROC. Vol. 130, No. 2, MAR. 82.
25. F.VERVLOET, A.BRAMELLER, "AC Security Assessment", PROC. IEE Vol. 122, No. 9, SEPT. 75.
26. G.STAGG and A.PHADKE, "Real-time Evaluation of Power System Contingencies - Detection of Steady State Overloads", IEEE Summer meeting, Los Angeles, California, JULY 12-17, 1970.

27. A.R.SHAFIE-POUR, M.J.H.STERLING, M.IRVING, "Security Assessment Incorporating Network Islanding" IEE Second International Conference on Power System Monitoring and Control, University of Durham 1986.
28. A.BRAMELLER, "Real-time Power System Control", MSC Lecture notes, UMIST, 1979.
29. S.C.SAVULESCU (editor), proceedings of the international symposium, "Computerised Operation of Power Systems", ELSEVIER Publication 1976.
30. F.F.WU, TALUKDAR, "Computer Aided Dispatch for Electric Power Systems", Proceedings of IEEE Vol. 69, pp 1212-1231 OCT. 81.
31. T.E.DYLIACCO, "System Security, the Computer's Role", IEEE Spectrum, pp 43-50 JUNE 78.
32. B.STOTT, O.ALSAC, "Fast Decoupled Load-flow", IEEE PES Summer Meeting and EHV/UHV Conf. Vancouver, Canada, JULY 15-20, 1973.
33. L.ROY, N.RAO, "Real-time Monitoring of Power Systems Using Fast Second Order Method", IEE PROC. Vol. 130, No. 3, MAY 83.
34. G.C.CONTAXIS, B.PAPDIAS, C.DELKIS, "Decoupled Power System Security Dispatch", IEEE TRANS. Vol. PAS 102, No. 9, SEPT. 83.
35. F.F.WU and Y.K.TSAI, "Probabilistic Dynamic Security Assessment of Power Systems", Part I and Part II, technical memorandum No. UCB/ERL M81/64, Electronic Research Laboratory, University of California, BERKELEY, CA, 1981.
36. F.F.WU, Y.K.TSAI and Y.X.YU, "Probabilistic Dynamic Security Assessment", submitted for publication, IEEE PAS 1981.
37. F.F.WU and KUMAGAI, "Limits on Power Injection for Security Constrained Power Flow", PROC. IEEE International Symposium on Circuits and Systems, APRIL 81, Chicago, pp 755-758.
38. R.J.KAYE, F.F.WU, "Stability Region in the Pre-fault State Space", PROC. IEEE International Symposium on Circuits and Systems, APRIL 81, Chicago, pp 936-938.
39. R.J.KAYE and F.F.WU, "A Method of Deriving Dynamic Security Regions of Power Systems", 20th IEEE Conf. on Decision and Control, DEC. 81, Sandiego.
40. A.R.BERGEN and D.J.HILL, "A Structure Preserving Model for Power System Stability Analysis", IEEE TRANS. PAS Vol. 100, JAN. 81, pp 25-35.

41. D.J.HILL and A.R.BERGEN, "Stability Analysis of Multi-machine Power Networks with Frequency Dependent Loads" Technical memorandum No. UCB/ERL M81/5 Electronic Research Laboratory, University of California, BERKELEY, CA, DEC. 80.
42. F.G.VERVLOET, A.BRAMELLER, "AC Security Assessment", PROC. IEE Vol. 122, No. 9, SEPT. 1975.
43. M.S.SACHDER, S.A.IBRAHIM, "A Fast Approximation Technique for Outage Studies in Power System Planning and Operation", IEEE PES Summer meeting and EHV/UHV Conf. VANCOUVER Canada July 73.
44. T.F.HALPIN, R.FISCHL, R.FINK, "Analysis of Automatic Contingency Selection Algorithms", IEEE TRANS. PAS Vol. 103, No. 5, May 1984.
45. "Automatic Contingency Selection", Technical memorandum, University of Durham, School of Engineering 1981.
46. "Numerical Analysis", A.BRAMELLAR, 1979 MSL Lecture notes, UMIST, power system laboratory.
47. Computer methods in power system analysis, G.W.STOTT and A.H.ELABIAD, MacGraw Hill Series in electronic systems.
48. G.Z.BEN-YAACOV, G.M.JNE and K.STRUWIG, "Fast Decoupled Load Flow for Security Assessment", automatic control in power generation, distribution and protection, edited by J.F.HERBIT.
49. Load-flow, J.P.BICKFORD, Academic notes for MSC Course in power systems, UMIST 1982.
50. G.C.EJEBE and B.F.WOLLENBURG, "Automatic Contingency Selection", IEEE TRANS. PAS Vol. 98, No. 1, JAN/FEB. 79 pp 97-103.
51. G.B.IRISARRI and A.M.SASSON, "An Automatic Contingency Selection Method for On-line Security Analysis", IEEE Power Engineering Society Summer meeting 1980.
52. F.ALBUYEH, A.BOSE and B.HEATH, "Reactive Power Considerations in Automatic Contingency Selection", record PICA Conf. papers, Philadelphia, May 81.
53. T.A.MIKOLINNAS and B.F.WOLLENBERG, "An Advanced Contingency Selection Algorithm", IEEE TRANS. PAS Vol. 100.
54. G.IRISARRI, D.LEVENER and A.M.SASSON, "Automatic Contingency Selection For On-line Security Analysis, Real-time Tests", IEEE TRANS. PAS Vol. 98, pp 1552-1559 SEPT/OCT. 79.

55. T.K.MEDICHERLA, S.C.RASTOGI, "A Voltage Criterion Based Contingency Selection Technique", IEEE Vol. PAS 101, No. 9, pp 3523-3532, SEPT. 82.
56. R.G.WASLEY and M.DARESHDOOST, "Identification and Ranking of Critical Contingencies Independent Variable Space", IEEE, PES 1982 Summer meeting.
57. S.VERMUI and R.E.USHER, "On-line Automatic Contingency Selection Analysis", IEEE PES 1982, Summer meeting.
58. A.S.HOUSEHOLDER, Principles of numerical analysis, Mac Graw Hill, BY 1953.
59. SASSON, A.M. 1970 "Decomposition Techniques Applied to Non-linear Programming Load Flow Method", IEEE PAS, Vol. 89, pp 78-82.
60. UNDRIL,, J.M. and HAPP, H.H. 1969, "Multi Computer Configurations and Diakoptics: Real Power Flow in Power Pools", IEEE PAS, Vol. 88, pp 789-796.
61. UNDRILL, J.M. and HAPP, H.H., "Automatic Sectionalisation of Power System Networks for Network Solutions", 1970 TP50-PWR, T-PAS 71 JAN-FEB., pp 46-53.
62. DEVILLE, T.A. and SCHWEPPE, F.C. July 9-14 1972 "On-line Identification of Interconnected Network Equivalentents from Operating Data", IEEE PES Summer meeting, San Francisco, CA.
63. VERMURI, S., HILL, E.F, BALASUBRAMANIAN, R., JAN 28-FEB 2 1973 "A Note of Static Equivalent Circuits of Power Systems" IEEE PES Winter meeting, New York, NY.
64. WARD, J.W. 1949 "Equivalent Circuits for Power Flow Studies", Trans AIEE, Vol. 68, pp 373-383.
65. MONTICELLI, S. DECKMANN, A. GARCIA, B. STOT, "Real-time External Equivalentents for Static Security Analysis", IEEE PAS Vol. 98, No. 2, MARCH/APRIL 79.
66. G.CONTAXIS and A.S.DEBS, "Identification of External Equivalentents for Steady State Security Assessment", IEEE PAS Summer meeting, Mexico City, JULY 1977.
67. W.F.TINNEY and W.L.POWELL, "The REI Approach to Power Network Equivalentents", PROC. IEEE PICA Conference, Toronto, pp 314-320, 1977.
68. F.L.ALVARDO and E.H.ELKONYALY, "Reduction in Power Systems", IEEE PAS Summer meeting, Mexico City, JULY 1977.

69. H.DURAN and N.ARVANTIDIES, "Simplification for Area Security Analysis: a New Look at Equivalence", IEEE Trans. Power App, Vol. PAS 91, pp 670-679, MAR/APR. 72.
70. B.BARAZESH, J.W.LLOYD and W.D.WILSON, "Integration of Modern Real-time Energy Management Systems", Second International Conference on Power System Monitoring and Control, Durham 1986.
71. A.CREW, C.A.LYNCH "The Development of a Distributed Architecture Energy Management System", IEE Second International Conference on Power System Monitoring and Control, 8-11 JULY 1986, Durham, pp 211-216.
72. M.J.STERLING, M.R.IRVING, "Real-time Simulation for the Verification of Advance On-line Control Algorithms", IEE Second International Conference on Power System Monitoring and Control, 8-11 JULY 1986, Durham, UK.
73. SASSON, A.M.. 1970 "Decomposition Techniques Applied to Non-linear Programming Load-flow Method", IEEE Trans. on Power Apparatus and Systems, Vol. 89, pp 78-82.
74. UNDRILL, J.M. and HAPP, H.H., 1969 "Multi-computer Configurations and Diakoptics: Real Power Flow in Power Pools", IEEE Trans on power App and System Vol. 88, pp 78-796.
75. UNDRILL, J.M. and HAPP, H.H., "Automatic Sectionalisation on Power Systems Networks for Network Solutions" 1970 T-PAS 71 JAN-FEB., pp 46-53.
76. PARSON, E.K. JULY 14-19, 1974 "Network Equivalents for On-line Systems", presented at IEEE PES Summer meeting and Energy Resources Conference, Anaheim, CA.
77. DURAN, M. and ARVANTICIDES, N.V. JAN. 31, FEB. 5, 1971 "Simplifications for Area Security Analysis: a New Look at Equivalents", paper 71 TP54-PWR, presented at the IEEE Winter power meeting, BY.
78. WARD, J.W., 1949, "Equivalent Circuits for Power Flow Studies", Trans, AIEE, Vol. 68, pp 373-383.
79. G.CONTAXIS and A.S.DEBS, "Identification of External Equivalents for Steady-state Security Assessment" presented at 1977 IEEE PAS Summer meeting, Mexico City, JULY 1977.
80. T.E.DY LIACCO, K.A.NAMARAO and S.C.SAVULESCU, "An On-line Topological Equivalent of a Power System", ibid.
81. W.F.TINNEY and W.L.POWELL, "The REI Approach to Power Network Equivalents", PROC. IEEE PICA Conf. Toronto, pp 314-320 MAY 1979.

82. F.L.ALVARDO and E.H.ELKONYALY, "Reduction in Power Systems", presented at 1977 IEEE PAS Summer meeting, Mexico City, JULY 1977.
83. MONTICELLI, S.DEKMANN, A.GARCIA, B.STOTT, "Real Time External Equivalents for Static Security Analysis", IEEE Trans on PAS Vol. PAS-98, No. 2, MAR/APR. 1979.
84. D.DENZEL, N.GRAF and J.VERSTEGE, "Practical User of Equivalents for Unobservable Networks in On-line Security Monitoring", Power Systems Computation Conf. Cambridge, SEPT. 1975.
85. L.W.EMARK, "Computational Implementation of On-line Load Flow" presented at 1977 IEEE PAS Summer meeting, Mexico City, JULY 1977.
86. A.C. Security Assessment, F.G.VERVLOET, A.BRAMELER, PROC, IEEE, Vol. 122, No. 9, SEPT. 1975.
87. M.J.H.STERLING and D.T.Y.Cheng, "Automatic Contingency Selection", Department of Engineering, University of Durham, 1982.
88. M.J.H.STERLING and D.T.Y.Cheng, "Voltage Violation Automatic Contingency Selection" Department of Engineering, University of Durham, 1982.

APPENDIX 1
TECHNICAL PAPER

TRANSMISSION NETWORK SECURITY ANALYSIS INCORPORATING NETWORK ISLANDING

A R Shafie-Pour, M J H Sterling and M R Irving

University of Durham, UK

ABSTRACT

Conventional techniques for assessment of transmission network security normally assume that the network to be studied will only be subject to a relatively small number of contingencies and furthermore that those contingencies will not split the network into islands. Should such a situation arise the approach is usually to restrict analysis to the largest island created. This approach has serious disadvantages in power systems which are subjected to frequent major outages and for which islanding is a common occurrence.

This paper presents a new technique for the diakoptic solution of the network flow when subjected to configuration changes. The technique is shown to be applicable to the automatic selection of system contingencies and the subsequent a.c. security assessment for these contingencies. In the diakoptical method the solution for the individual islands is found using the sparse factors of the intact network matrices by means of additional forward and backward substitutions and since it avoids the need to reformulate and factorise the network matrices it is most suitable for real-time security assessment.

INTRODUCTION

Security assessment analysis has evolved from load-flow techniques and provides a measure of system performance following the occurrence of any of a pre-specified set of contingencies. The selection process is normally implemented by an automatic contingency selection algorithm (ACS) commonly based on d.c. loadflow (1,2). The ACS ranks the outages in order of decreasing severity and those above a certain threshold, which will not split the network into islands, are passed for a detailed network flow analysis. The conventional method for simulation of branch outages which cause a split network is based on the introduction of a new slack busbar and redistribution of active power among the specified generators in each subsystem formed and finally refactorisation of $[B']$ and $[B'']$ matrices taking into account the existence of a second reference and the branch outaged.

The present paper describes a new algorithm for the diakoptic solution of the network flow when a split network occurs as a result of a branch outage. The new technique avoids the need to reorder and refactorise $[B']$ and $[B'']$ matrices. It has been tested using a range of networks and compared with an alternative approach in which the network islands are formulated and solved as separate load flow problems. From the numerical results obtained it can be seen that the new technique has advantages for application in real time security assessment.

SUMMARY OF BASIC ALGORITHM FOR OUTAGE STUDIES

The application of diakoptics to linear and non-linear networks is summarised.

Assuming that V_0 is known from the solution of the original linear equation

$$Y_0 V_0 = I_0 \quad (1)$$

where Y_0 represents the original admittance matrix. The new value V_{new} after one branch has been completed can be obtained from

$$V_{new} = V_0 - CXM^T V_0 \quad (2)$$

where

$$[M]^T = \begin{matrix} \text{row vector which is null except for } M_i = +1 \text{ and} \\ M_j = -1 \end{matrix}$$

$$X = \begin{matrix} Z_0 M \text{ is the difference of columns } i \text{ and } j \\ \text{of } Z_0 \end{matrix}$$

$$Z_0 = \begin{matrix} Y_0^{-1} \text{ stored in factored form} \end{matrix}$$

$$M^T V_0 = \begin{matrix} \text{is the difference of elements } i \text{ and } j \text{ of} \\ V_0 \end{matrix}$$

$$C = \begin{matrix} (1/b + M^T X)^{-1} \text{ a scalar factor} \end{matrix}$$

$$b = \begin{matrix} \text{line or nominal transformer series} \\ \text{admittance.} \end{matrix}$$

The above approach is fast, accurate and avoids refactorising Y_0 .

Load flow is well known as a non-linear problem. The fast decoupled Newton-Raphson (FDNR) loadflow has proved fast, sufficiently accurate and reliable (3). It is already well documented and therefore no detailed description will be presented. The basic model is described by:

$$[\Delta\theta] = [B']^{-1} [\Delta P/V] \quad (3)$$

$$[\Delta V] = [B'']^{-1} [\Delta Q/V] \quad (4)$$

The numerical technique based on diakoptics developed for line outages can be applied to FDNR after each iteration process in order to obtain new angles and voltages:

$$\text{Step 1: } [\Delta\theta] = [B']^{-1} [\Delta P/V]$$

$$\text{Step 2: } X' = [B'']^{-1} M$$

$$\text{Step 3: } 1/C' = 1/b' + M^T X'$$

$$\text{Step 4: } [\Delta\theta_{new}] = [\Delta\theta_0] - C^T X'^T M^T \Delta\theta_0 \quad (5)$$

$$\text{where } b' = 1/X'_{ik}$$

For voltages, similar steps to those above can be implemented and the new voltages are:

$$[\Delta V^{new}] = \Delta V^0 - C^T X'^T M^T \Delta V^0 \quad (6)$$

where

$$X' = [B'']^{-1} M$$

C_1^1 is zero everywhere but '1' for the new reference busbar. Hence $C_1^1 Z_0$ is a column vector corresponding to the new reference busbar. C_2^1 is zero for island 1 and '1' for island 2. It is set when calculating [X] as in the previous section. $C_2^1 I_0$ is a scalar factor. If

in the subsystem without the original reference bus, there is no provision for the introduction of a new slack bus, then the reference is taken as the busbar of the new subsystem connected to the outaged branch.

The advantage of applying equation (9) to obtain the new solution for the connected network is that it avoids refactoring [Y₀].

To obtain the solution to the subsystem without the original reference in parallel with the solution of the connected part, the following equation can be applied:

$$[V^{new}] = [V_0] - C_1^1 [Z_0] C_2^1 I_0 + C_1^m Z^m C_2^1 I_0 \quad (10)$$

where

$$Z^m = (z_3, z_1, z_2)$$

$$z_1 = 1/y_{r0} \quad y_{r0} \text{ is the shunt admittance connected to the original reference bus}$$

$$z_3 = (V_{r1r1}/C_2^1 I_0)$$

$$z_2 = Z_{r1r1}^0$$

r_0 refers to the original reference bus and r_1 refers to the new reference bus. The above can be applied directly to automatic contingency selection algorithms which are based on dc loadflow.

APPLICATION TO AC LOAD FLOW

When a split network arises as a consequence of a branch outage, conventionally a new reference busbar is chosen in the island which is not connected to the original system. This busbar can be introduced as an input by the operator or automatically chosen as the busbar which had the biggest active generation prior to the outage. It must be among the generators specified for redistribution of active power. The drawback of such approaches is the need to introduce the existence of the second reference and the outaged branch in [B'] and [B'']. It is consequently proposed that the new reference is chosen automatically, but as explained in the previous section, its existence is not reflected in [B'] and [B'']. Hence, there is no need to refactorise.

The new technique was applied to FDNR according to the flow diagram shown in Fig (2). Since PV buses are not included in [B''], no modification is required to be performed after voltages are obtained in each iteration.

The new technique has been applied to many linear and non-linear networks and shown to be accurate and reliable. In Fig (3) if the tie-line between bus 2 and bus 6 is removed, the intact network divides into two islands. The new technique has been applied to obtain the network solutions for both islands in parallel and compared with those obtained using two separate loadflows. The results are given in Table (1). It should be noted that the times shown for the conventional approach exclude the required time for data input. The loadflow results are compared in Table (2). Table(3) and table(4) illustrate the test data network.

	NO. OF ITERATIONS	COMPACTING ORDERING FACTORISING TIME (sec)	SOLUTION TIME (sec)	
			T1	T2
ISLAND 1 with original slack	4	0.515	0.189	0.702
ISLAND 2	6	0.698	0.425	1.123
DIAKOPTIC TECHNIQUE	8	-	0.712	0.712

TABLE (1) - Results based on PERKIN-ELMER 3230
T1 and T2 are as shown in Fig.(3)

BUS NUMBER		GENERATION			
		MW		MVAR	
		FDNR TECHNIQUE	DIAKOPTIC TECHNIQUE	FDNR TECHNIQUE	DIAKOPTIC TECHNIQUE
1	Slack	40.91	40.90	26.86	26.85
2		40.00	40.00	-13.00	-13.17
3		00.00	00.00	79.13	79.12
13		00.00	00.00	37.83	36.96
8	New Slack	218.00	218.00	5.47	5.44
11		00.00	00.00	26.82	26.82

TABLE (2) - Comparison of results

CONCLUSION

When a split network arises as a consequence of a single branch outage, the above technique based on the diakoptical solution of network flows has been shown to be efficient, accurate, fast and most suitable for the real time security assessment of electrical power networks. It avoids the need to refactorise [B'] and [B''] and furthermore, modifications to angles are only required after each iteration. If automatic tap changers are included in the system, the tap positions on the island with no reference should be set to the initial tap positions, before any modifications are performed.

REFERENCES

- 1 T.A. Mikolinnas, B.T. Wollenberg. "An advanced contingency selection algorithm", IEEE Trans. on Power Apparatus and Systems, Vol. PAS-100, No. 2, Feb. 1981, pp. 608-617.
- 2 S. Vermuri, R.E. Usler. "On-Line automatic contingency selection algorithm", IEEE Trans. on Power Apparatus and System, Vol. PAS-102, pp. 346-354, Feb. 1983.
- 3 B. Scott, O. Alsac. "Fast decoupled load flow" IEEE Trans. on Power Apparatus and System, PAS-93, 1974, pp. 859-867.

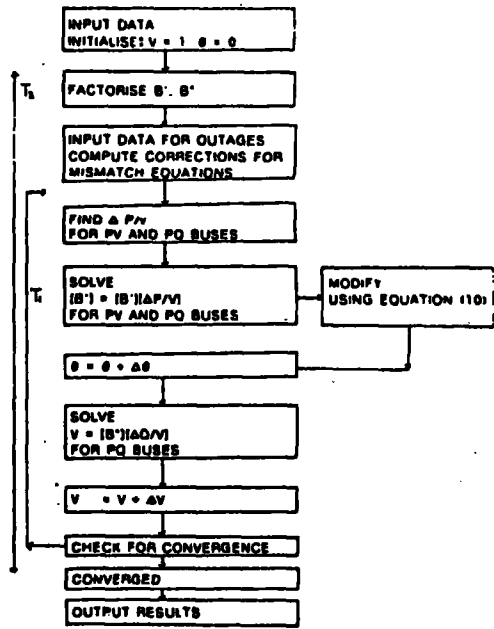
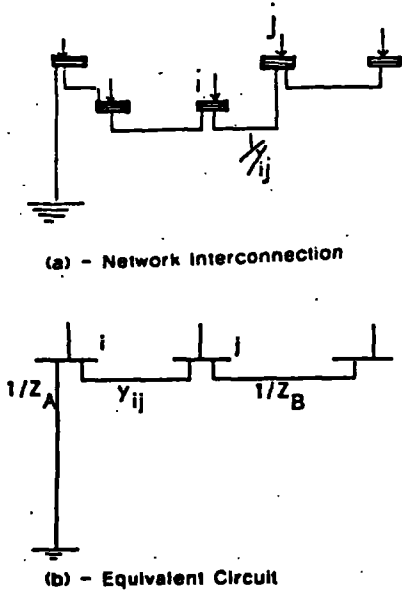

Figure (1) - Network Interconnection

Figure (2) - Flow diagram for the implementation of islanding in FDNR.

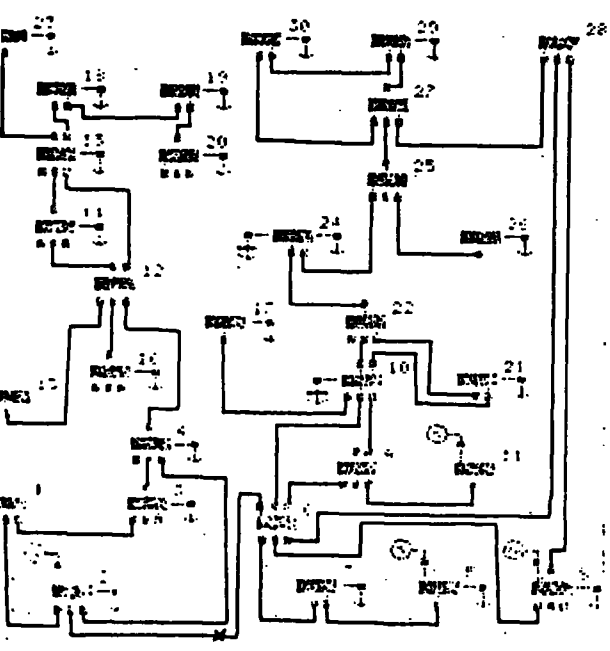

Figure (3) - Test Network

LINE DESIGNATION	R pu	X pu	SUSC pu
1 2	0.0192	0.0375	0.0000
1 3	0.0452	0.1852	0.0204
2 4	0.0570	0.1737	0.0184
3 4	0.0132	0.0379	0.0042
2 6	0.0581	0.1763	0.0187
5 7	0.0460	0.1160	0.0102
6 7	0.0267	0.0920	0.0000
6 8	0.0120	0.0420	0.0000
4 8	2.0000	0.2080	0.0000
6 10	0.0000	0.2080	0.0000
9 11	0.0000	0.2080	0.0000
9 10	0.0000	0.1100	0.0000
4 12	0.0000	0.2560	0.0000
12 13	0.0000	0.1400	0.0000
12 14	0.1231	0.2539	0.0000
12 15	0.0662	0.1304	0.0000
12 16	0.0945	0.1987	0.0000
14 15	0.2210	0.1997	0.0000
15 18	0.1070	0.2185	0.0000
18 19	0.0830	0.1292	0.0000
19 20	0.0340	0.0680	0.0000
10 17	0.0324	0.0945	0.0000
10 21	0.0349	0.0749	0.0000
10 22	0.0727	0.1489	0.0000
21 22	0.0116	0.0236	0.0000
15 23	0.1000	0.2020	0.0000
22 24	0.1150	0.1790	0.0000
24 25	0.1695	0.3292	0.0000
25 26	0.2544	0.3600	0.0000
25 27	0.1693	0.2987	0.0000
28 27	0.0000	0.3960	0.0000
27 29	0.2198	0.4153	0.0000
27 30	0.3202	0.6027	0.0000
29 30	0.2399	0.4533	0.0000
8 28	0.0630	0.2000	0.0214
6 28	0.0169	0.0599	0.0055
10 10	0.0000	-5.260	0.0000
24 24	0.0000	-23.00	0.0000

TABLE (3) - Impedance and line charging data.

BUS NUMBER	VOLTAGE (pu)	GENERATION		LOAD	
		MW	MVAR	MW	MVAR
1	1.0000	00.00	00.00	00.00	00.00
2	1.0430	40.00	00.00	21.70	12.70
3	0.0000	00.00	00.00	2.40	1.20
4	0.0000	00.00	00.00	7.60	1.60
5	1.0100	00.00	00.00	94.20	19.00
6	0.0000	00.00	00.00	00.00	00.00
7	0.0000	00.00	00.00	22.80	10.90
8	1.0700	00.00	00.00	30.00	30.00
9	0.0000	00.00	00.00	00.00	00.00
10	0.0000	00.00	00.00	3.80	2.00
11	1.0820	00.00	00.00	00.00	00.00
12	0.0000	00.00	00.00	11.20	7.50
13	1.0710	00.00	00.00	00.00	00.00
14	0.0000	00.00	00.00	6.20	1.60
15	0.0000	00.00	00.00	8.20	2.50
16	0.0000	00.00	00.00	3.50	1.80
17	0.0000	00.00	00.00	9.00	5.80
18	0.0000	00.00	00.00	3.20	0.90
19	0.0000	00.00	00.00	9.50	3.40
20	0.0000	00.00	00.00	2.20	0.70
21	0.0000	00.00	00.00	17.30	11.20
22	0.0000	00.00	00.00	00.00	00.00
23	0.0000	00.00	00.00	3.20	1.60
24	0.0000	00.00	00.00	6.70	6.70
25	0.0000	00.00	00.00	00.00	00.00
26	0.0000	00.00	00.00	3.50	2.30
27	0.0000	00.00	00.00	00.00	00.00
28	0.0000	00.00	00.00	00.00	00.00
29	0.0000	00.00	00.00	2.40	0.90
30	0.0000	00.00	00.00	10.60	1.90

TABLE (4): Operating conditions.

APPENDIX 2
NUMERICAL RESULTS

APPENDIX 2
NUMERICAL EXAMPLES

The Appendix is devoted to a few numerical examples and deals with:

A2.1 application of the recursive method to linear networks

A2.2 split network

A2.3 node merge

A2.4 application of the direct method to linear networks.

A2.1 Application of the recursive method to linear network

Consider the network shown below, where the injected real currents are shown at each node and the real part of the admittance is also given:

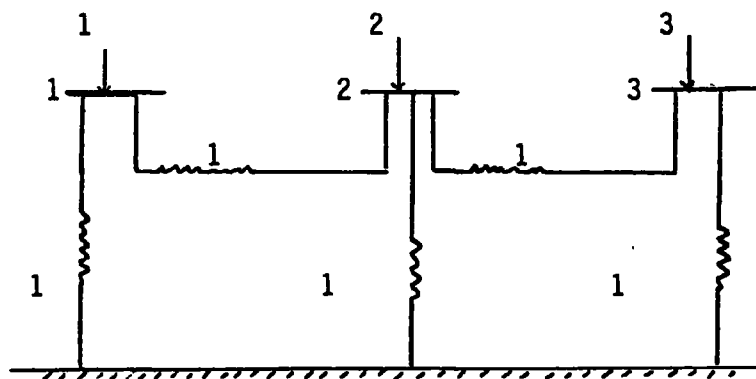

Figure (a) - Simple real linear network

For the above network the original impedance matrix Z_0 can be shown as:

$$Z_0 = \frac{1}{8} \begin{array}{|c|c|c|} \hline 5 & 2 & 1 \\ \hline 2 & 4 & 2 \\ \hline 1 & 2 & 5 \\ \hline \end{array} \quad (1)$$

and the original voltages as v_0 .

$$V_0 = Z_0 I_0 = \frac{1}{8} \begin{array}{|c|c|c|} \hline 5 & 2 & 1 \\ \hline 2 & 4 & 2 \\ \hline 1 & 2 & 5 \\ \hline \end{array} \begin{array}{|c|} \hline 1 \\ \hline 2 \\ \hline 3 \\ \hline \end{array} = \begin{array}{|c|} \hline 3/2 \\ \hline 4/2 \\ \hline 5/2 \\ \hline \end{array} \quad (2)$$

Now suppose that network of Figure (a) is subjected to three simultaneous branch outages as follows:

- 1) remove the branch between node 1 and the reference (node zero)
- 2) then add a branch between node 1 and node 3
- 3) then remove the branch between node 3 and the reference (node zero)

Hence the connection matrix and the modified branch impedance for each of the above faults would be:

$$(i) \text{ for the first fault } C_1 = \begin{array}{|c|} \hline 1 \\ \hline 0 \\ \hline 0 \\ \hline \end{array} \quad f_1 = -1$$

$$(ii) \text{ for the second fault } C_2 = \begin{array}{|c|} \hline 1 \\ \hline 0 \\ \hline -1 \\ \hline \end{array} \quad f_2 = +1$$

(iii) for the third fault $C_3 = \begin{bmatrix} 0 \\ 0 \\ 1 \end{bmatrix}$ $f_3 = -1$

see Figure (b).

We want to find the new voltages after each fault.

1. Fault number 1 - the procedure is as follows:

a) Find $Z_0 c_1$ i.e. different of column 1 and zero of Z_0 -

To simulate column zero of Z_0 we add a row and a column to Z_0 with all elements set to zero, i.e.

	column 1			
$Z_0 =$	5/8	2/8	1/8	0
	2/8	4/8	2/8	0
	1/8	2/8	5/8	0
	0	0	0	0

$$X_1 = Z_0 C_1 = \frac{1}{8} \begin{bmatrix} 5 \\ 2 \\ 1 \\ 0 \end{bmatrix} - \begin{bmatrix} 0 \\ 0 \\ 0 \\ 0 \end{bmatrix} = \frac{1}{8} \begin{bmatrix} 5 \\ 2 \\ 1 \\ 0 \end{bmatrix}$$

b) Find $C_1^T X_1$, i.e. different of elements 1 and zero of X_1 -

$$X_1 = \begin{bmatrix} 5/8 \\ 2/8 \\ 1/8 \\ 0 \end{bmatrix}$$

element zero 0

$$\dots C_1^t X_1 = 5/8 - 0 = 5/8$$

c) Find $d_1 = (f_1 + C_1^t X_1)^{-1}$

$$d_1 = (-1 + 5/8)^{-1} = -8/3$$

d) Find $C_1^t V_0$, i.e. difference of element 1 and zero of V_0 -

To simulate element zero of V_0 add a row to V_0 set to zero:

$$V_0 = \begin{array}{|c|} \hline 3/2 \\ \hline 4/2 \\ \hline 5/2 \\ \hline \text{element zero} & 0 \\ \hline \end{array}$$

$$\dots C_1^t V_0 = 3/2 - 0 = 3/2$$

e) Find $b_1 = d_1 C_1^t V_0$

$$b_1 = (-8/3)(3/2) = -4$$

f) Hence

$$V_1 = V_0 - X_1 b_1$$

$$= \begin{array}{|c|} \hline 3/2 \\ \hline 4/2 \\ \hline 5/2 \\ \hline \text{element zero} & 0 \\ \hline \end{array} - \begin{array}{|c|} \hline 5/8 \\ \hline 2/8 \\ \hline 1/8 \\ \hline \text{element zero} & 0 \\ \hline \end{array} (-4) = \begin{array}{|c|} \hline 4 \\ \hline 3 \\ \hline 3 \\ \hline \text{element zero} & 0 \\ \hline \end{array}$$

2. Fault number 2

a) $W = Z_0 C_2 =$ difference of column 1 and 3 of Z_0

$$W = \begin{array}{|c|} \hline 5/8 \\ \hline 2/8 \\ \hline 1/8 \\ \hline \text{---} \\ \hline 0 \\ \hline \end{array} - \begin{array}{|c|} \hline 1/8 \\ \hline 2/8 \\ \hline 5/8 \\ \hline \text{---} \\ \hline 0 \\ \hline \end{array} = \begin{array}{|c|} \hline 4/8 \\ \hline 0 \\ \hline -4/8 \\ \hline \text{---} \\ \hline 0 \\ \hline \end{array}$$

b) Find $a = d_1 C_1^t W$

where $C_1^t W$ is the difference of elements 1 and zero of W

.. $C_1^t W = 4/8$

.. $a = (-8/3)(4/8) = -4/3$

c) Find $X_2 = W - X_1 a$

$$X_2 = W = \begin{array}{|c|} \hline 4/8 \\ \hline 0 \\ \hline -4/8 \\ \hline \text{---} \\ \hline 0 \\ \hline \end{array} - \begin{array}{|c|} \hline 5/8 \\ \hline 2/8 \\ \hline 1/8 \\ \hline \text{---} \\ \hline 0 \\ \hline \end{array} (-4/3) = \begin{array}{|c|} \hline 4/3 \\ \hline 1/3 \\ \hline -1/3 \\ \hline \text{---} \\ \hline 0 \\ \hline \end{array}$$

d) Find $d_2 = (f_2 C_2^t X_2)^{-1}$

$C_2^t X_2 =$ difference of element 1 and 3 of X_2

.. $C_2^t X_2 = 4/3 + 1/3 = 5/3$

.. $d_2 = (1 + 5/3)^{-1} = 3/8$

e) Find $b = d_2 C_2^t V_1$

$C_2^t V_1 =$ difference of element 1 and 3 of V_1

.. $C_2^t V_1 = 4 - 3 = 1$

.. $b = (3/8)(1) = 3/8$

f) Find $V_2 = V_1 - X_2 b$

$$\dots V_2 = \begin{array}{|c|} \hline 4 \\ \hline 3 \\ \hline 3 \\ \hline \text{---} \\ \hline 0 \\ \hline \end{array} - \begin{array}{|c|} \hline 4/3 \\ \hline 1/3 \\ \hline -1/3 \\ \hline \text{---} \\ \hline 0 \\ \hline \end{array} (3/8) = \begin{array}{|c|} \hline 28/8 \\ \hline 23/8 \\ \hline 25/8 \\ \hline \text{---} \\ \hline 0 \\ \hline \end{array}$$

3. Fault number 3

a)

$$W = Z_0 C_3 = \begin{array}{|c|} \hline 1/8 \\ \hline 2/8 \\ \hline 5/8 \\ \hline \text{---} \\ \hline 0 \\ \hline \end{array}$$

b) Find $a = d_1 C_1^t W$

$$C_1^t W = 1/8$$

$$\dots a = (-8/3)(1/8) = -1/3$$

c) Find $W = W - X_1 a$

$$W = \begin{array}{|c|} \hline 1/8 \\ \hline 2/8 \\ \hline 5/8 \\ \hline \text{---} \\ \hline 0 \\ \hline \end{array} - \begin{array}{|c|} \hline 5/8 \\ \hline 2/8 \\ \hline 1/8 \\ \hline \text{---} \\ \hline 0 \\ \hline \end{array} (-1/3) = \begin{array}{|c|} \hline 1/3 \\ \hline 1/3 \\ \hline 2/3 \\ \hline \text{---} \\ \hline 0 \\ \hline \end{array}$$

d) Find $a = d_2 C_2^t W$

$$C_2^t W = 1/3 - 2/3 = -1/3$$

$$a = (3/8)(-1/3) = -1/8$$

e) Find $X_3 = W - X_2 a$

$$W_3 = \begin{bmatrix} 1/3 \\ 1/3 \\ 2/3 \\ \hline 0 \end{bmatrix} - \begin{bmatrix} 4/3 \\ 1/3 \\ -1/3 \\ \hline 0 \end{bmatrix} (-1/8) = \begin{bmatrix} 1/2 \\ 3/8 \\ 5/8 \\ \hline 0 \end{bmatrix}$$

f) Find $d_3 = (f_3 + C_3^t X_3)^{-1}$

$$C_3^t X_3 = 5/8$$

$$\dots d_3 = (-1 + 5/8)^{-1} = -8/3$$

g) Find $b = d_3 C_3^t V_2$

$$C_3^t V_2 = 25/8$$

$$\dots b = (-8/3)(25/8) = -25/3$$

Find $V_3 = V_2 - X_3 b$

$$V_3 = \begin{bmatrix} 28/8 \\ 23/8 \\ 25/8 \\ \hline 0 \end{bmatrix} - \begin{bmatrix} 1/2 \\ 3/8 \\ 5/8 \\ \hline 0 \end{bmatrix} (-25/3) = \begin{bmatrix} 23/3 \\ 18/3 \\ 25/3 \\ \hline 0 \end{bmatrix}$$

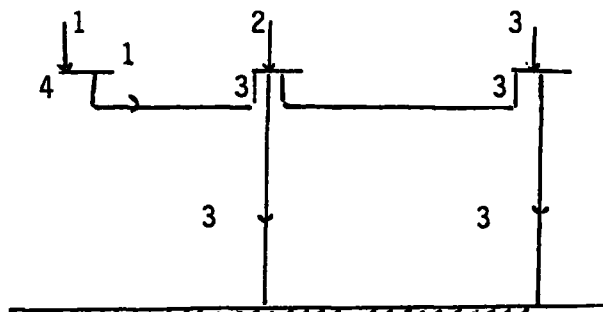

Figure (b1) After first fault

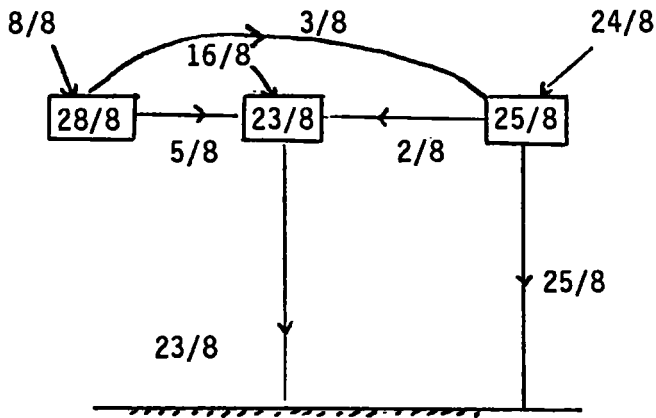

Figure (b2) After second fault

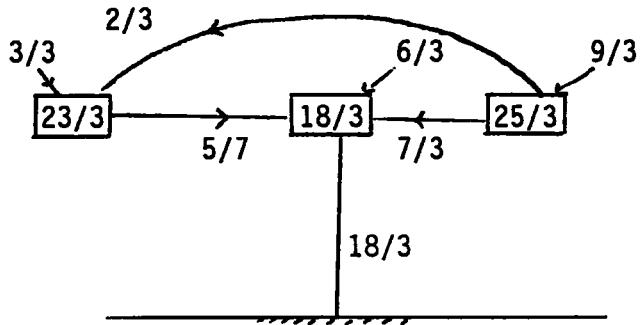

Figure (b3) After the 3rd fault

Figure (b) Network Changes

A2.2 Split Network

It was explained previously that if $1/d = 0$, it indicates a split network. To show this is true consider the following network:

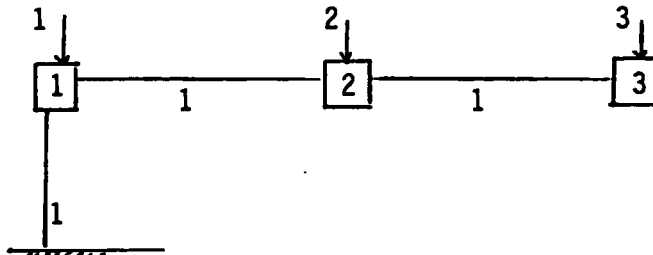

figure (c)

If now the branch between nodes 1 and 2 be removed (which causes split) we investigate what happens to d .

For the above network:

$$X_0 = \begin{array}{|c|c|c|} \hline 1 & 1 & 1 \\ \hline 1 & 2 & 2 \\ \hline 1 & 2 & 3 \\ \hline \end{array}$$

But:

$$1/d = f + C^t x$$

$$1/d = f + C^t Z_0 C$$

$$1/d = f + X_{11} + X_{22} - X_{12} - X_{21}$$

$$1/d = -1 + 1 + 2 - 1 - 1 = 0$$

A2.3 Node Merge

Consider Figure (a) for which Z_0 and V_0 are as in (1) and (2). If a short circuit occurs between nodes 2 and 3, then the network reduces to that of Figure (d).

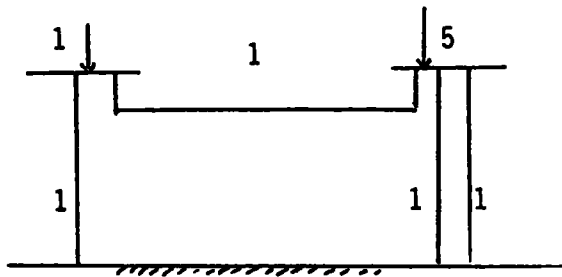

Figure (d) Node Merge

For the above network it can be shown that:

$$x^m = 1/5 \quad \begin{array}{|c|c|} \hline 3 & 1 \\ \hline 1 & 2 \\ \hline \end{array}$$

$$\text{and } V^m = \begin{array}{|c|} \hline 8/5 \\ \hline 11/5 \\ \hline \end{array} \quad \text{where } l = \begin{array}{|c|} \hline 1 \\ \hline 5 \\ \hline \end{array}$$

V^m can be obtained from the application of the recursive method to the original network, i.e. Figure (a), by setting $f=0$ as follows:

$$C = \begin{array}{|c|} \hline 0 \\ \hline +1 \\ \hline -1 \\ \hline \end{array}$$

$$x = Z_0 C = 1/8$$

$$\begin{bmatrix} 1 \\ 2 \\ -3 \end{bmatrix}$$

$$C^T V^0 = -1/2$$

$$C^T x = 5/8$$

$$d = (f + C^T x)^{-1} = (0 + 5/8)^{-1} = 8/5$$

$$\dots V^m = V^0 - d C^T V^0 x = \begin{bmatrix} 3/2 \\ 4/2 \\ 5/2 \end{bmatrix} - (8/5)(-1/2) \frac{1}{8} \begin{bmatrix} 1 \\ 2 \\ -3 \end{bmatrix}$$

$$\dots V^m = \begin{bmatrix} 8/5 \\ 11/5 \\ 11/5 \end{bmatrix} \text{ as obtained previously. As can be seen, voltages at nodes 2 and 3 are given as equal amounts.}$$

A2.4 Application of the direct method to linear networks

The following formula holds in general:

$$(A + XUY)^{-1} = A^{-1} X (U^{-1} + Y A^{-1} X)^{-1} Y A^{-1} \quad (A1)$$

This formula can be considered as a method for building the inverse of $(A + X U Y)$ from the inverse of A .

In applications to networks equation (A1) is applied in the following form:

$$\text{New } Z = Z_0 - Z_0 C (f + C^t Z_0 C)^{-1} C^t Z_0 \quad (A2)$$

where

Z_0 = impedance matrix of the original network

f = diagonal m by m matrix of impedances of the m branches added to the network (of -ve sign if the branch removed).

C = connection matrix ($m \times n$) of elements +1 or -1 or zero.

A numerical example is solved to illustrate the application of the equation (A2) to linear networks. It can also be applied to non-linear problems.

If the current injections at each node is known, then the new voltages would be obtained from the original voltages:

$$\text{new } V = V_0 - Z_0 C (f + C^t Z_0 C)^{-1} C^t V_0$$

Hence, the procedure is as follows:

- 1) $X = X_0 C$
- 2) $L = C^t X$
- 3) $d = (f + L)^{-1}$
- 4) $M = C^t V_0$

$$X_0 = \begin{array}{|c|c|c|} \hline 1 & 1 & 1 \\ \hline 1 & 2 & 2 \\ \hline 1 & 2 & 3 \\ \hline \end{array}$$

The new impedance matrix Z_m can be shown to be:

$$X_m = \begin{array}{|c|c|c|} \hline 1 & 1 & 1 \\ \hline 1 & 2 & 2 \\ \hline 1 & 2 & 7/3 \\ \hline \end{array} \quad (4)$$

Thus Z_m can be obtained from:

$$X_m = Z_0 - Z_0 C (f + C^t Z_0 C)^{-1} C^t Z_0 \quad (5)$$

(as in Appendix A)

where:

$$C = \begin{array}{|c|c|} \hline 0 & 0 \\ \hline +1 & +1 \\ \hline -1 & -1 \\ \hline \end{array}$$

and f is diagonal ($m \times m$) matrix of impedance of the m branches added to the network:

$$f = \begin{array}{|c|c|} \hline 1 & 0 \\ \hline 0 & 1 \\ \hline \end{array}$$

Hence:

$$1) \quad Z_0 C = \begin{array}{|c|c|} \hline 0 & 0 \\ \hline 0 & 0 \\ \hline -1 & -1 \\ \hline \end{array}$$

$$2) \quad C^t Z_0 C = \begin{array}{|c|c|} \hline 1 & 1 \\ \hline 1 & 1 \\ \hline \end{array}$$

$$3) \quad (f + C^t Z_0 C)^{-1} = \begin{array}{|c|c|} \hline 2/3 & -1/3 \\ \hline -1/3 & 2/3 \\ \hline \end{array}$$

$$4) \quad C^t Z_0 = \begin{array}{|c|c|c|} \hline 0 & 0 & -1 \\ \hline 0 & 0 & -1 \\ \hline \end{array}$$

$$5) \quad (f + C^t Z_0 C)^{-1} C^t Z_0 = \begin{array}{|c|c|c|} \hline 0 & 0 & -1/3 \\ \hline 0 & 0 & -1/3 \\ \hline \end{array}$$

$$6) \quad Z_0 C (f + C^t Z_0 C)^{-1} C^t Z_0 = \begin{array}{|c|c|c|} \hline 0 & 0 & 0 \\ \hline 0 & 0 & 0 \\ \hline 0 & 0 & 2/3 \\ \hline \end{array}$$

7) From equation 5:

$$\dots \quad Z_m = \begin{array}{|c|c|c|} \hline 1 & 1 & 1 \\ \hline 1 & 2 & 2 \\ \hline 1 & 2 & 3 \\ \hline \end{array} - \begin{array}{|c|c|c|} \hline 0 & 0 & 0 \\ \hline 0 & 0 & 0 \\ \hline 0 & 0 & 2/3 \\ \hline \end{array}$$

$Z_m =$

1	1	1
1	2	2
1	2	7/3

which is as that shown in (4) earlier.

APPENDIX 3
TEST NETWORK DATA

NO	MAG (P.U.)	ANG (RAD.)	GEN (MW)	LOAD (MW)	GEN (MVAR)	LOAD (MVAR)
1	1.0616	0.0000	63.81	0.00	26.53	0.00
2	1.0454	-0.0172	67.45	16.68	27.05	11.23
4	1.0262	-0.0361	0.00	1.81	0.00	2.60
5	1.0184	-0.0426	0.00	5.63	0.00	2.57
7	0.7909	-0.1009	0.00	67.39	0.00	15.36
15	1.0134	-0.0478	0.00	0.00	0.00	0.00
16	0.9984	-0.0762	0.00	16.38	0.00	9.09
24	1.0081	-0.0413	38.08	22.22	2.74	22.74
25	1.0170	-0.0433	0.00	0.00	0.00	0.00
30	0.9876	-0.0822	0.00	4.32	0.00	1.68
36	1.0310	0.0282	37.89	0.00	34.62	0.00
37	0.9828	-0.0949	0.00	8.04	0.00	5.56
39	0.9826	-0.0949	0.00	0.00	0.00	0.00
40	0.9729	-0.1042	0.00	4.26	0.00	1.22
41	0.9719	-0.1031	0.00	5.55	0.00	1.75
45	0.9796	-0.0934	0.00	2.36	0.00	1.40
46	0.9812	-0.0885	0.00	6.44	0.00	4.19
47	0.9684	-0.1052	0.00	2.27	0.00	0.61
43	0.9687	-0.1038	0.00	6.51	0.00	2.39
49	0.9726	-0.0992	0.00	1.59	0.00	0.58
50	0.9777	-0.0395	0.00	12.32	0.00	7.92
51	0.9779	-0.0896	0.00	0.00	0.00	0.00
52	0.9668	-0.1035	0.00	2.17	0.00	1.12
53	0.9661	-0.0994	0.00	5.89	0.00	4.52
55	0.9724	-0.1011	0.00	0.00	0.00	0.00
56	0.9599	-0.1061	0.00	2.31	0.00	1.62
60	0.9828	-0.0988	0.00	0.00	0.00	0.00
63	1.0083	-0.0511	0.00	0.00	0.00	0.00

--- LINE FLOW ---

LINE NO	SENDG NO	BUS REC NO	BUS	REAL POWER (MW)	REACT POWER (MVAR)	LINE LOSS (MW)	LINE LOSS (MVAR)
1	1	2	1	33.0	14.1	0.509	-4.935
2	1	1	1	33.0	19.1	0.509	-4.935
3	1	2	1	24.4	12.4	0.353	-3.035
4	1	1	1	24.4	15.4	0.353	-3.035
5	1	2	1	18.0	11.0	0.242	-3.133
6	1	1	1	18.0	12.0	0.242	-3.133
7	1	2	1	22.0	13.0	0.036	-0.630
8	1	1	1	22.0	16.0	1.162	0.546
9	1	2	1	21.5	12.5	0.340	-2.932
10	1	1	1	21.5	15.5	0.340	-2.932
11	1	2	1	20.0	12.0	0.034	-0.811
12	1	1	1	20.0	15.0	0.195	-1.525
13	1	2	1	15.6	9.6	0.374	-0.572
14	1	1	1	15.6	13.6	0.045	-0.762
15	1	2	1	11.5	7.5	0.000	0.016
16	1	1	1	11.5	11.5	0.000	0.333
17	1	2	1	6.0	4.0	0.000	4.677
18	1	1	1	6.0	9.0	0.000	2.162
19	1	2	1	3.0	3.0	0.000	1.564
20	1	1	1	3.0	6.0	0.000	0.000
21	1	2	1	0.0	0.0	0.000	0.000
22	1	1	1	0.0	0.0	0.000	0.000
23	1	2	1	0.0	0.0	0.000	0.000
24	1	1	1	0.0	0.0	0.000	0.000
25	1	2	1	0.0	0.0	0.000	0.000
26	1	1	1	0.0	0.0	0.000	0.000
27	1	2	1	0.0	0.0	0.000	0.000
28	1	1	1	0.0	0.0	0.000	0.000
29	1	2	1	0.0	0.0	0.000	0.000
30	1	1	1	0.0	0.0	0.000	0.000
31	1	2	1	0.0	0.0	0.000	0.000
32	1	1	1	0.0	0.0	0.000	0.000
33	1	2	1	0.0	0.0	0.000	0.000
34	1	1	1	0.0	0.0	0.000	0.000
35	1	2	1	0.0	0.0	0.000	0.000
36	1	1	1	0.0	0.0	0.000	0.000
37	1	2	1	0.0	0.0	0.000	0.000
38	1	1	1	0.0	0.0	0.000	0.000
39	1	2	1	0.0	0.0	0.000	0.000
40	1	1	1	0.0	0.0	0.000	0.000
41	1	2	1	0.0	0.0	0.000	0.000
42	1	1	1	0.0	0.0	0.000	0.000
43	1	2	1	0.0	0.0	0.000	0.000
44	1	1	1	0.0	0.0	0.000	0.000
45	1	2	1	0.0	0.0	0.000	0.000
46	1	1	1	0.0	0.0	0.000	0.000
47	1	2	1	0.0	0.0	0.000	0.000
48	1	1	1	0.0	0.0	0.000	0.000
49	1	2	1	0.0	0.0	0.000	0.000
50	1	1	1	0.0	0.0	0.000	0.000
51	1	2	1	0.0	0.0	0.000	0.000
52	1	1	1	0.0	0.0	0.000	0.000
53	1	2	1	0.0	0.0	0.000	0.000
54	1	1	1	0.0	0.0	0.000	0.000
55	1	2	1	0.0	0.0	0.000	0.000
56	1	1	1	0.0	0.0	0.000	0.000
57	1	2	1	0.0	0.0	0.000	0.000
58	1	1	1	0.0	0.0	0.000	0.000
59	1	2	1	0.0	0.0	0.000	0.000
60	1	1	1	0.0	0.0	0.000	0.000
61	1	2	1	0.0	0.0	0.000	0.000
62	1	1	1	0.0	0.0	0.000	0.000
63	1	2	1	0.0	0.0	0.000	0.000
64	1	1	1	0.0	0.0	0.000	0.000
65	1	2	1	0.0	0.0	0.000	0.000
66	1	1	1	0.0	0.0	0.000	0.000
67	1	2	1	0.0	0.0	0.000	0.000
68	1	1	1	0.0	0.0	0.000	0.000
69	1	2	1	0.0	0.0	0.000	0.000
70	1	1	1	0.0	0.0	0.000	0.000
71	1	2	1	0.0	0.0	0.000	0.000
72	1	1	1	0.0	0.0	0.000	0.000
73	1	2	1	0.0	0.0	0.000	0.000
74	1	1	1	0.0	0.0	0.000	0.000
75	1	2	1	0.0	0.0	0.000	0.000
76	1	1	1	0.0	0.0	0.000	0.000
77	1	2	1	0.0	0.0	0.000	0.000
78	1	1	1	0.0	0.0	0.000	0.000
79	1	2	1	0.0	0.0	0.000	0.000
80	1	1	1	0.0	0.0	0.000	0.000
81	1	2	1	0.0	0.0	0.000	0.000
82	1	1	1	0.0	0.0	0.000	0.000
83	1	2	1	0.0	0.0	0.000	0.000
84	1	1	1	0.0	0.0	0.000	0.000
85	1	2	1	0.0	0.0	0.000	0.000
86	1	1	1	0.0	0.0	0.000	0.000
87	1	2	1	0.0	0.0	0.000	0.000
88	1	1	1	0.0	0.0	0.000	0.000
89	1	2	1	0.0	0.0	0.000	0.000
90	1	1	1	0.0	0.0	0.000	0.000
91	1	2	1	0.0	0.0	0.000	0.000
92	1	1	1	0.0	0.0	0.000	0.000
93	1	2	1	0.0	0.0	0.000	0.000
94	1	1	1	0.0	0.0	0.000	0.000
95	1	2	1	0.0	0.0	0.000	0.000
96	1	1	1	0.0	0.0	0.000	0.000
97	1	2	1	0.0	0.0	0.000	0.000
98	1	1	1	0.0	0.0	0.000	0.000
99	1	2	1	0.0	0.0	0.000	0.000
100	1	1	1	0.0	0.0	0.000	0.000

9USSAR VOLTAGE REAL POWER REACT POWER
 NO MAG ANG GEN LOAD GEN LOAD
 (P.U.) (RAD.) (MW) (MW) (MVAR) (MVAR)

1	1.0616	0.0000	64.95	0.00	26.99	0.00
2	1.0454	-0.0175	67.45	16.68	23.39	11.23
4	1.0249	-0.0370	0.00	1.81	0.00	2.60
5	1.0163	-0.0437	0.00	5.63	0.00	2.57
7	0.9906	-0.1011	0.00	67.39	0.00	15.36
15	1.0130	-0.0477	0.00	0.00	0.00	0.00
16	0.9980	-0.0762	0.00	16.38	0.00	9.09
24	1.0081	-0.0402	38.03	22.22	1.62	22.74
25	1.0116	-0.0541	0.00	0.00	0.00	0.00
30	0.9772	-0.0996	0.00	4.32	0.00	1.62
36	1.0810	0.0179	37.80	0.00	37.40	0.00
37	0.9740	-0.1091	0.00	8.04	0.00	5.56
39	0.9738	-0.1090	0.00	0.00	0.00	0.00
40	0.9620	-0.1205	0.00	4.26	0.00	1.22
41	0.9582	-0.1205	0.00	5.55	0.00	1.75
45	0.9700	-0.1090	0.00	2.35	0.00	1.40
46	0.9710	-0.1054	0.00	6.44	0.00	4.19
47	0.9558	-0.1229	0.00	2.27	0.00	0.51
48	0.9567	-0.1215	0.00	6.51	0.00	2.39
49	0.9612	-0.1169	0.00	1.59	0.00	0.58
50	0.9628	-0.1100	0.00	12.32	0.00	7.92
51	0.9616	-0.1112	0.00	0.00	0.00	0.00
52	0.9434	-0.1275	0.00	2.17	0.00	1.12
53	0.9299	-0.1322	0.00	5.89	0.00	4.52
55	0.8869	-0.1681	0.00	0.00	0.00	0.00
56	0.8731	-0.1741	0.00	2.31	0.00	1.62
60	0.8687	-0.1890	0.00	0.00	0.00	0.00

7.3 0.3433 -0.2237 0.00 7.25 0.00 1.36

--- LINE FLOW ---

LINE NO	SENDG NO	BUS REC NO	BUS	REAL POWER (MW)	REACT POWER (MVAR)	LINE LOSS (MW)	LINE LOSS (MVAR)
1	2	1	2	4.01	1.03	0.315	-4.917
1	2	1	2	1.02	0.35	0.353	-2.996
1	2	1	2	0.26	0.35	0.264	-3.109
1	2	1	2	0.09	0.35	0.092	-0.611
1	2	1	2	1.16	0.41	1.162	0.545
1	2	1	2	0.34	0.57	0.340	-2.930
1	2	1	2	0.02	0.57	0.020	-0.858
1	2	1	2	0.19	0.57	0.197	-1.521
1	2	1	2	0.37	0.57	0.375	-0.568
1	2	1	2	0.05	0.57	0.051	-0.742
1	2	1	2	0.00	0.64	0.000	0.021
1	2	1	2	0.00	0.64	0.000	0.710
1	2	1	2	0.00	0.64	0.000	5.033
1	2	1	2	0.00	0.64	0.000	2.938
1	2	1	2	0.00	0.64	0.000	2.368
1	2	1	2	0.00	0.64	0.000	0.000
1	2	1	2	0.04	0.64	0.041	0.085
1	2	1	2	0.11	0.64	0.115	0.226
1	2	1	2	0.03	0.64	0.003	0.007
1	2	1	2	0.03	0.64	0.003	0.003
1	2	1	2	0.02	0.64	0.002	0.006
1	2	1	2	0.02	0.64	0.002	0.004
1	2	1	2	0.01	0.64	0.001	0.002
1	2	1	2	0.02	0.64	0.024	0.047

```

*****
SECURITY ASSESSMENT UNDER *****
THE OUTAGE OF LINE 36 CONNECTING BUS 63 AND BUS 61 *****
*****
VOLTAGE LIMIT VIOLATION REPORT
-----
BUS 55 VOLTAGE AT 0.8369(P.U.) BELOW LIMIT 0.9000(P.U.)
BUS 36 VOLTAGE AT 0.8731(P.U.) BELOW LIMIT 0.9000(P.U.)
BUS 60 VOLTAGE AT 0.8687(P.U.) BELOW LIMIT 0.9000(P.U.)
BUS 65 VOLTAGE AT 0.8523(P.U.) BELOW LIMIT 0.9000(P.U.)
*****
POWER FLOW LIMIT VIOLATION REPORT
-----
***** NO VIOLATION OF POWER FLOW LIMIT ENCOUNTERED ALONG ANY LINE ***
*****
LOAD FLOWS FOR THE OUTAGE OF LINE 19 CONNECTING BUS 37 AND BUS 45
*****

```

Line	Loss	Loss
1	0.158	0.340
2	0.097	0.199
3	0.004	0.009
4	0.052	0.105
5	0.356	0.554
6	0.029	0.060
7	0.381	0.665
8	0.027	0.040
9	0.132	0.252
10	0.000	0.000
11	0.056	0.106
12	0.105	0.198
13	0.022	0.041
14	0.003	-4.343
15	0.001	-1.330
TOTAL LOSS =	4.911	-9.075

 BUSBAR DATA

BUSBAR NO	VOLTAGE MAG (P.U.)	VOLTAGE ANG (RAD.)	GEN (MW)	REAL POWER LOAD (MW)	GEN (MVAR)	REACT POWER LOAD (MVAR)
1	1.0616	0.0000	63.80	0.00	26.42	0.00
2	1.0454	-0.0172	67.45	16.63	26.89	11.23
4	1.0264	-0.0362	0.00	1.81	0.00	2.60
5	1.0187	-0.0427	0.00	5.63	0.00	2.57
7	0.9909	-0.1009	0.00	67.39	0.00	15.36
15	1.0134	-0.0473	0.00	0.00	0.00	0.00
16	0.9984	-0.0762	0.00	16.38	0.00	9.09
24	1.0081	-0.0412	38.08	22.22	2.70	22.74
25	1.0163	-0.0430	0.00	0.00	0.00	0.00
30	0.9863	-0.0318	0.00	4.32	0.00	1.68
36	1.0310	0.0286	37.80	0.00	34.95	0.00
37	0.9852	-0.0954	0.00	8.04	0.00	5.56
39	0.9350	-0.0953	0.00	0.00	0.00	0.00
40	0.9749	-0.1046	0.00	4.26	0.00	1.22
41	0.9735	-0.1033	0.00	5.55	0.00	1.75
45	0.9738	-0.0913	0.00	2.35	0.00	1.40
46	0.9736	-0.0377	0.00	6.44	0.00	4.19
47	0.9690	-0.1052	0.00	2.27	0.00	0.61
48	0.9687	-0.1037	0.00	6.51	0.00	2.39
49	0.9725	-0.0990	0.00	1.59	0.00	0.58
50	0.9766	-0.0891	0.00	12.32	0.00	7.92
51	0.9769	-0.0893	0.00	0.00	0.00	0.00
52	0.9676	-0.1035	0.00	2.17	0.00	1.12
53	0.9658	-0.0993	0.00	5.89	0.00	4.52

60	0.7827	-0.0963	0.00	0.00	0.00	0.00
63	1.0033	-0.0511	0.00	0.00	0.00	0.00
65	0.9685	-0.1145	0.00	1.64	0.00	0.68
73	0.9604	-0.1257	0.00	7.25	0.00	1.36

--- LINE FLOW ---

LINE NO	SENDG NO	BUS REC	BUS	REAL POWER (MW)	REACT POWER (MVAR)	LINE LOSS (MW)	LINE LOSS (MVAR)
1	2	1	1	38.973	14.207	0.309	-4.935
1	2	1	1	30.663	11.137		
1	2	1	1	24.317	11.204	0.331	-3.090
1	2	1	1	18.456	11.304		
1	2	1	1	18.706	11.267	0.240	-3.188
1	2	1	1	22.672	11.205		
1	2	1	1	22.592	11.336	0.085	-0.631
1	2	1	1	42.211	16.236	1.162	0.544
1	2	1	1	27.040	16.284		
1	2	1	1	22.260	16.284	0.340	-2.934
1	2	1	1	21.540	18.18		
1	2	1	1	15.040	18.18	0.035	-0.309
1	2	1	1	20.340	19.238		
1	2	1	1	20.538	19.238	0.196	-1.525
1	2	1	1	20.340	24.48		
1	2	1	1	15.281	24.48	0.374	-0.572
1	2	1	1	11.299	24.48		
1	2	1	1	11.299	24.48	0.045	-0.762
1	2	1	1	11.299	24.48		
1	2	1	1	11.299	24.48	0.000	0.015
1	2	1	1	11.299	24.48		
1	2	1	1	11.299	24.48	0.000	0.341
1	2	1	1	11.299	24.48		
1	2	1	1	11.299	24.48	0.000	4.717
1	2	1	1	11.299	24.48		
1	2	1	1	11.299	24.48	0.000	2.191
1	2	1	1	11.299	24.48		
1	2	1	1	11.299	24.48	0.000	1.522
1	2	1	1	11.299	24.48		
1	2	1	1	11.299	24.48	0.000	0.000
1	2	1	1	11.299	24.48		
1	2	1	1	11.299	24.48	0.062	0.121
1	2	1	1	11.299	24.48		
1	2	1	1	11.299	24.48	0.000	0.000
1	2	1	1	11.299	24.48		
1	2	1	1	11.299	24.48	0.001	0.001
1	2	1	1	11.299	24.48		
1	2	1	1	11.299	24.48	0.007	0.015

44	0.000	44	0.021	0.041
43	0.000	43	0.085	0.189
42	0.000	42	0.037	0.096
41	0.000	41	0.074	0.160
40	0.000	40	0.038	0.078
39	0.000	39	0.000	0.000
38	0.000	38	0.007	0.014
37	0.000	37	0.007	0.014
36	0.000	36	0.055	0.085
35	0.000	35	0.003	0.006
34	0.000	34	0.005	0.010
33	0.000	33	0.022	0.033
32	0.000	32	0.023	0.043
31	0.000	31	0.000	0.736
30	0.000	30	0.043	0.082
29	0.000	29	0.081	0.153
28	0.000	28	0.017	0.032
27	0.000	27	0.014	-4.306
26	0.000	26	0.016	-1.271
25	0.000	25		
24	0.000	24		
23	0.000	23		
22	0.000	22		
21	0.000	21		
20	0.000	20		
19	0.000	19		
18	0.000	18		
17	0.000	17		
16	0.000	16		
15	0.000	15		
14	0.000	14		
13	0.000	13		
12	0.000	12		
11	0.000	11		
10	0.000	10		
9	0.000	9		
8	0.000	8		
7	0.000	7		
6	0.000	6		
5	0.000	5		
4	0.000	4		
3	0.000	3		
2	0.000	2		
1	0.000	1		
TOTAL LOSS =			3.761	-12.728

***** SECURITY ASSESSMENT UNDER *****
 THE OUTAGE OF LINE 19 CONNECTING BUS 37 AND BUS 45 *****

VOLTAGE LIMIT VIOLATION REPORT

*** NO VIOLATION OF VOLTAGE LIMIT ENCOUNTERED AT ANY BUS ***

POWER FLOW LIMIT VIOLATION REPORT

*** NO VIOLATION OF POWER FLOW LIMIT ENCOUNTERED ALONG ANY LINE ***

***** LOAD FLOWS FOR THE OUTAGE OF LINE 14 CONNECTING BUS 25 AND BUS 35 *****

FAST DECOUPLED NEWTON-RAPHSON LOAD FLOW CONVERGED IN 4 ITERATIONS

 BUSBAR DATA

BUSBAR NO	VOLTAGE MAG (P.U.)	ANGLE (RAD.)	GEN (MW)	REAL POWER LOAD (MW)	GEN (MVAR)	REACT POWER LOAD (MVAR)
1	1.0616	0.0000	64.57	0.00	30.13	0.00
2	1.0454	-0.0170	57.45	16.69	34.63	11.23
4	1.0197	-0.0367	0.00	1.81	0.00	2.50
5	1.0105	-0.0433	0.00	5.63	0.00	2.57
7	0.9890	-0.0992	0.00	67.39	0.00	15.36
15	1.0100	-0.0438	0.00	0.00	0.00	0.00
16	0.9956	-0.0732	0.00	16.33	0.00	9.09
24	1.0081	-0.0389	38.08	22.22	13.77	22.74
25	1.0423	0.0307	0.00	0.00	0.00	0.00
30	0.9006	-0.1627	0.00	4.32	0.00	1.68
36	1.0310	0.1006	37.80	0.00	21.39	0.00
37	0.9421	-0.1426	0.00	8.04	0.00	5.56
39	0.9419	-0.1426	0.00	0.00	0.00	0.00
40	0.9276	-0.1567	0.00	4.26	0.00	1.22
41	0.9211	-0.1577	0.00	5.55	0.00	1.75
45	0.9185	-0.1547	0.00	2.36	0.00	1.40
46	0.9015	-0.1636	0.00	6.44	0.00	4.19
47	0.9041	-0.1703	0.00	2.27	0.00	0.61
48	0.8966	-0.1748	0.00	6.51	0.00	2.39
49	0.8969	-0.1726	0.00	1.59	0.00	0.58
50	0.8941	-0.1673	0.00	12.32	0.00	7.92
51	0.3957	-0.1662	0.00	0.00	0.00	0.00
52	0.9104	-0.1622	0.00	2.17	0.00	1.12

LINE NO	SENDG NO	BUS REC NO	BUS	REAL POWER (MW)	REACT POWER (MVAR)	LINE LOSS (MW)	LINE LOSS (MVAR)
56	0.9213	-0.1497		0.00	2.31	0.00	1.62
60	0.9605	-0.1291		0.00	0.00	0.00	0.00
63	1.0025	-0.0502		0.00	0.00	0.00	0.00
65	0.9459	-0.1455		0.00	1.64	0.00	0.68
73	0.7376	-0.1574		0.00	7.25	0.00	1.36

--- LINE FLOW ---

LINE NO	SENDG NO	BUS REC NO	BUS	REAL POWER (MW)	REACT POWER (MVAR)	LINE LOSS (MW)	LINE LOSS (MVAR)
1	1	2	1	38.0	19.2	0.305	-4.946
1	2	1	2	38.0	19.2	0.401	-2.779
1	2	1	2	35.0	12.0	0.332	-2.877
1	2	1	2	35.0	12.0	0.106	-0.563
1	2	1	2	35.0	12.0	1.155	0.523
1	2	1	2	35.0	12.0	0.340	-2.920
1	2	1	2	35.0	12.0	0.000	-0.917
1	2	1	2	35.0	12.0	0.210	-1.478
1	2	1	2	35.0	12.0	0.385	-0.526
1	2	1	2	35.0	12.0	0.018	-0.854
1	2	1	2	35.0	12.0	0.000	3.317
1	2	1	2	35.0	12.0	0.000	4.461
1	2	1	2	35.0	12.0	0.000	3.358
1	2	1	2	35.0	12.0	0.000	0.000
1	2	1	2	35.0	12.0	0.000	5.490
1	2	1	2	35.0	12.0	0.000	0.000
1	2	1	2	35.0	12.0	0.059	0.122
1	2	1	2	35.0	12.0	0.198	0.391
1	2	1	2	35.0	12.0	0.133	0.281
1	2	1	2	35.0	12.0	0.011	0.010

FAST DECOUPLED NEWTON-RAPHSON LOAD FLOW CONVERGED IN 3 ITERATIONS

-----BUSBAR DATA-----

BUSBAR NO	VOLTAGE MAG (P.U.)	VOLTAGE ANG (RAD.)	GEN (MW)	REAL POWER LOAD (MW)	GEN (MVAR)	REACT POWER LOAD (MVAR)
1	1.0616	0.0000	53.79	0.00	26.52	0.00
2	1.0454	-0.0172	67.45	16.63	27.04	11.23
4	1.0262	-0.0361	0.00	1.81	0.00	2.60
5	1.0184	-0.0426	0.00	5.63	0.00	2.37
7	0.9909	-0.1009	0.00	67.39	0.00	15.36
15	1.0134	-0.0478	0.00	0.00	0.00	0.00
16	0.9984	-0.0762	0.00	16.35	0.00	9.09
24	1.0031	-0.0413	38.03	22.22	2.74	22.74
25	1.0169	-0.0433	0.00	0.00	0.00	0.00
30	0.9876	-0.0822	0.00	4.32	0.00	1.68
36	1.0810	0.0283	37.80	0.00	34.64	0.00
37	0.9829	-0.0949	0.00	8.04	0.00	5.56
39	0.9827	-0.0949	0.00	0.00	0.00	0.00
40	0.9743	-0.1047	0.00	4.26	0.00	1.22
41	0.9715	-0.1029	0.00	5.55	0.00	1.75
45	0.9796	-0.0934	0.00	2.36	0.00	1.40
46	0.9812	-0.0885	0.00	6.44	0.00	4.19
47	0.9682	-0.1051	0.00	2.27	0.00	0.61
48	0.9635	-0.1037	0.00	6.51	0.00	2.39
49	0.9727	-0.0991	0.00	1.59	0.00	0.58

LINE NO	SENDG NO	BUS REC NO	REAL POWER (MW)	REACT POWER (MVAR)	LINE LOSS (MW)	LINE LOSS (MVAR)
52	0.7883	-0.1033	0.00	0.17	0.00	1.12
53	0.2660	-0.0993	0.00	5.89	0.00	4.52
55	0.9723	-0.1011	0.00	0.00	0.00	0.00
56	0.9597	-0.1061	0.00	2.31	0.00	1.62
60	0.9828	-0.0988	0.00	0.00	0.00	0.00
63	1.0083	-0.0511	0.00	0.00	0.00	0.00
65	0.3685	-0.1145	0.00	1.64	0.00	0.68
73	0.9604	-0.1257	0.00	7.25	0.00	1.36

--- LINE FLOW ---

LINE NO	SENDG NO	BUS REC NO	REAL POWER (MW)	REACT POWER (MVAR)	LINE LOSS (MW)	LINE LOSS (MVAR)
1	1	2	993	197	0.309	-4.935
1	2	1	38.684	-19.131		
1	3	1	-24.401	-15.325	0.332	-3.085
1	4	1	-133.030	-15.411		
1	5	1	-182.691	-12.220	0.242	-3.184
1	6	1	-225.575	-12.422	0.086	-0.630
1	7	1	-48.050	-13.633		
1	8	1	-42.050	-11.687	1.162	0.546
1	9	1	-21.151	-12.827	0.340	-2.932
1	10	1	-15.151	-12.617	0.034	-0.811
1	11	1	-20.527	-12.424	0.195	-1.525
1	12	1	-20.527	-15.065	0.374	-0.572
1	13	1	-31.030	-15.388	0.045	-0.762
1	14	1	-11.220	-11.729	0.000	0.016
1	15	1	-22.011	-11.330	0.000	0.333
1	16	1	-6.011	-9.436	0.000	4.679
1	17	1	-5.798	-24.635	0.000	2.163
1	18	1	-5.798	-25.650	0.000	1.562
1	19	1	-5.798	-14.309	0.000	0.000
1	20	1	-5.798	-13.219	0.000	0.000
1	21	1	-5.798	-10.219	0.025	0.053
1	22	1	-5.798	-4.152		
1	23	1	-5.798	-1.521		
1	24	1	-5.798	-1.521		
1	25	1	-5.798	-1.521		
1	26	1	-5.798	-1.521		
1	27	1	-5.798	-1.521		
1	28	1	-5.798	-1.521		
1	29	1	-5.798	-1.521		
1	30	1	-5.798	-1.521		
1	31	1	-5.798	-1.521		
1	32	1	-5.798	-1.521		
1	33	1	-5.798	-1.521		
1	34	1	-5.798	-1.521		
1	35	1	-5.798	-1.521		
1	36	1	-5.798	-1.521		
1	37	1	-5.798	-1.521		
1	38	1	-5.798	-1.521		
1	39	1	-5.798	-1.521		
1	40	1	-5.798	-1.521		
1	41	1	-5.798	-1.521		
1	42	1	-5.798	-1.521		
1	43	1	-5.798	-1.521		
1	44	1	-5.798	-1.521		
1	45	1	-5.798	-1.521		
1	46	1	-5.798	-1.521		
1	47	1	-5.798	-1.521		
1	48	1	-5.798	-1.521		
1	49	1	-5.798	-1.521		
1	50	1	-5.798	-1.521		

 LOAD FLOWS FOR THE OUTAGE OF LINE 15 CONNECTING BUS 5 AND BUS 33

FAST DECOUPLED NEWTON-RAPHSON LOAD FLOW CONVERGED IN 4 ITERATIONS

 BUSBAR DATA

BUSBAR NO	MAG (P.U.)	VOLTAGE ANG (RAD.)	REAL POWER GEN (MW)	LOAD (MW)	REACT POWER GEN (MVAR)	LOAD (MVAR)
1	1.0616	0.0000	64.93	0.00	23.63	0.00
2	1.0454	-0.0183	67.45	16.63	24.95	11.23
4	1.0305	-0.0356	0.00	1.81	0.00	2.60
5	1.0237	-0.0421	0.00	5.63	0.00	2.57
7	0.9905	-0.1042	0.00	67.39	0.00	15.36
15	1.0125	-0.0532	0.00	0.00	0.00	0.00
16	0.9976	-0.0807	0.00	16.33	0.00	9.09
24	1.0081	-0.0474	38.03	22.22	6.14	22.74
25	1.0042	-0.0715	0.00	0.00	0.00	0.00
30	0.9626	-0.1247	0.00	4.32	0.00	1.58
36	1.0810	0.0009	37.80	0.00	41.26	0.00
37	0.9024	-0.1734	0.00	8.04	0.00	5.56
39	0.9022	-0.1733	0.00	0.00	0.00	0.00
40	0.8980	-0.1780	0.00	4.26	0.00	1.22
41	0.9053	-0.1735	0.00	5.55	0.00	1.75
45	0.9226	-0.1571	0.00	2.36	0.00	1.40
46	0.9465	-0.1376	0.00	6.44	0.00	4.19
47	0.9160	-0.1664	0.00	2.27	0.00	0.61
48	0.9248	-0.1594	0.00	6.51	0.00	2.39

LINE NO	SENDG NO	BUS REC NO	BUS	REAL POWER (MW)	REACT POWER (MVAR)	LINE LOSS (MW)	LINE LOSS (MVAR)
51	0.9507	-0.1531		0.00	0.00	0.00	0.00
52	0.9140	-0.1632		0.00	2.17	0.00	1.12
53	0.9322	-0.1448		0.00	5.69	0.00	4.52
55	0.9526	-0.1343		0.00	0.00	0.00	0.00
56	0.9398	-0.1395		0.00	2.31	0.00	1.62
60	0.9718	-0.1243		0.00	0.00	0.00	0.00
63	1.0059	-0.0583		0.00	0.00	0.00	0.00
65	0.9574	-0.1403		0.00	1.64	0.00	0.68
73	0.9492	-0.1518		0.00	7.25	0.00	1.36

--- LINE FLOW ---

LINE NO	SENDG NO	BUS REC NO	BUS	REAL POWER (MW)	REACT POWER (MVAR)	LINE LOSS (MW)	LINE LOSS (MVAR)
1	1	2	1	40.00	13.00	0.332	-4.868
2	1	1	2	40.00	13.00	0.293	-3.267
3	1	1	3	17.00	0.00	0.184	-3.379
4	1	1	4	21.00	1.00	0.075	-0.670
5	1	1	5	49.00	1.00	1.210	0.748
6	1	1	6	24.00	1.00	0.401	-2.744
7	1	1	7	33.00	1.00	0.163	-0.365
8	1	1	8	19.00	2.00	0.175	-1.574
9	1	1	9	35.00	6.00	0.353	-0.632
10	1	1	10	10.00	1.00	0.034	-0.799
11	1	1	11	8.00	1.00	0.000	0.197
12	1	1	12	22.00	3.00	0.000	1.340
13	1	1	13	27.00	5.00	0.000	5.573
14	1	1	14	37.00	1.00	0.000	4.049
15	1	1	15	6.00	0.00	0.000	0.000
16	1	1	16	0.00	0.00	0.000	0.000
17	1	1	17	0.00	0.00	0.000	0.000
18	1	1	18	0.00	0.00	0.000	0.000
19	1	1	19	0.00	0.00	0.000	0.000
20	1	1	20	0.00	0.00	0.000	0.000
21	1	1	21	0.00	0.00	0.000	0.000
22	1	1	22	0.00	0.00	0.000	0.000
23	1	1	23	0.00	0.00	0.000	0.000
24	1	1	24	0.00	0.00	0.000	0.000
25	1	1	25	0.00	0.00	0.000	0.000
26	1	1	26	0.00	0.00	0.000	0.000
27	1	1	27	0.00	0.00	0.000	0.000
28	1	1	28	0.00	0.00	0.000	0.000
29	1	1	29	0.00	0.00	0.000	0.000
30	1	1	30	0.00	0.00	0.000	0.000
31	1	1	31	0.00	0.00	0.000	0.000
32	1	1	32	0.00	0.00	0.000	0.000
33	1	1	33	0.00	0.00	0.000	0.000
34	1	1	34	0.00	0.00	0.000	0.000
35	1	1	35	0.00	0.00	0.000	0.000
36	1	1	36	0.00	0.00	0.000	0.000
37	1	1	37	0.00	0.00	0.000	0.000
38	1	1	38	0.00	0.00	0.000	0.000
39	1	1	39	0.00	0.00	0.000	0.000
40	1	1	40	0.00	0.00	0.000	0.000
41	1	1	41	0.00	0.00	0.000	0.000
42	1	1	42	0.00	0.00	0.000	0.000
43	1	1	43	0.00	0.00	0.000	0.000
44	1	1	44	0.00	0.00	0.000	0.000
45	1	1	45	0.00	0.00	0.000	0.000
46	1	1	46	0.00	0.00	0.000	0.000
47	1	1	47	0.00	0.00	0.000	0.000
48	1	1	48	0.00	0.00	0.000	0.000
49	1	1	49	0.00	0.00	0.000	0.000
50	1	1	50	0.00	0.00	0.000	0.000
51	1	1	51	0.00	0.00	0.000	0.000
52	1	1	52	0.00	0.00	0.000	0.000
53	1	1	53	0.00	0.00	0.000	0.000
54	1	1	54	0.00	0.00	0.000	0.000
55	1	1	55	0.00	0.00	0.000	0.000
56	1	1	56	0.00	0.00	0.000	0.000
57	1	1	57	0.00	0.00	0.000	0.000
58	1	1	58	0.00	0.00	0.000	0.000
59	1	1	59	0.00	0.00	0.000	0.000
60	1	1	60	0.00	0.00	0.000	0.000
61	1	1	61	0.00	0.00	0.000	0.000
62	1	1	62	0.00	0.00	0.000	0.000
63	1	1	63	0.00	0.00	0.000	0.000
64	1	1	64	0.00	0.00	0.000	0.000
65	1	1	65	0.00	0.00	0.000	0.000
66	1	1	66	0.00	0.00	0.000	0.000
67	1	1	67	0.00	0.00	0.000	0.000
68	1	1	68	0.00	0.00	0.000	0.000
69	1	1	69	0.00	0.00	0.000	0.000
70	1	1	70	0.00	0.00	0.000	0.000
71	1	1	71	0.00	0.00	0.000	0.000
72	1	1	72	0.00	0.00	0.000	0.000
73	1	1	73	0.00	0.00	0.000	0.000

0.013	0.016	0.013	0.016
0.169	0.397	0.169	0.397
0.023	0.057	0.023	0.057
0.037	0.074	0.037	0.074
0.077	0.154	0.077	0.154
0.266	0.595	0.266	0.595
0.163	0.426	0.163	0.426
0.100	0.215	0.100	0.215
0.054	0.112	0.054	0.112
0.000	0.001	0.000	0.001
0.032	0.064	0.032	0.064
0.113	0.184	0.113	0.184
0.091	0.185	0.091	0.185
0.068	0.116	0.068	0.116
0.023	0.034	0.023	0.034
0.091	0.174	0.091	0.174
0.000	1.366	0.000	1.366
0.044	0.084	0.044	0.084
0.063	0.157	0.063	0.157
0.017	0.032	0.017	0.032
0.013	-4.282	0.013	-4.282
0.031	-1.216	0.031	-1.216
TOTAL LOSS =		4.879	-7.169

***** SECURITY ASSESSMENT UNDER *****
 THE OUTAGE OF LINE 15 CONNECTING BUS 5 AND BUS 33 *****

VOLTAGE LIMIT VIOLATION REPORT
 BUS 40 VOLTAGE AT 0.8980(P.U.) BELOW LIMIT OF 0.9000(P.U.)

POWER FLOW LIMIT VIOLATION REPORT

*** NO VIOLATION OF POWER FLOW LIMIT ENCOUNTERED ALONG ANY LINE ***

 LOAD FLOWS FOR THE OUTAGE OF LINE 29 CONNECTING BUS 50 AND BUS 51

FAST DECOUPLED NEWTON-RAPHSON LOAD FLOW CONVERGED IN 3 ITERATIONS

 BUSBAR DATA

BUSBAR NO	VOLTAGE MAG (P.U.)	VOLTAGE ANG (RAD.)	GEN (MW)	REAL POWER LOAD (MW)	GEN (MVAR)	REACT. POWER LOAD (MVAR)
1	1.0616	0.0000	63.79	0.00	26.53	0.00
2	1.0454	-0.0172	67.45	16.68	27.04	11.23
4	1.0262	-0.0361	0.00	1.81	0.00	2.60
5	1.0184	-0.0426	0.00	5.63	0.00	2.57
7	0.9909	-0.1009	0.00	67.39	0.00	15.36
15	1.0134	-0.0478	0.00	0.00	0.00	0.00
16	0.9984	-0.0762	0.00	16.38	0.00	9.09
24	1.0081	-0.0413	38.08	22.22	2.71	22.74
25	1.0169	-0.0433	0.00	0.00	0.00	0.00
30	0.9875	-0.0821	0.00	4.32	0.00	1.68
36	1.0810	0.0283	37.80	0.00	34.65	0.00
37	0.9828	-0.0949	0.00	8.04	0.00	5.56
39	0.9826	-0.0949	0.00	0.00	0.00	0.00
40	0.9730	-0.1042	0.00	4.25	0.00	1.22
41	0.9720	-0.1032	0.00	5.55	0.00	1.75
45	0.9796	-0.0934	0.00	2.36	0.00	1.40
46	0.9311	-0.0985	0.00	6.44	0.00	4.19
47	0.9685	-0.1053	0.00	2.27	0.00	0.61
48	0.9687	-0.1038	0.00	6.51	0.00	3.39

LINE NO	SENDG NO	BUS REC NO	BUS	REAL POWER (MW)	REACT POWER (MVAR)	LINE LOSS (MW)	LINE LOSS (MVAR)
50	0.9770	-0.0909		0.00	12.02	0.00	1.272
51	0.9787	-0.0904		0.00	0.00	0.00	0.00
52	0.9671	-0.1037		0.00	2.17	0.00	1.12
53	0.9667	-0.0998		0.00	5.89	0.00	4.52
55	0.9728	-0.1014		0.00	0.00	0.00	0.00
56	0.9603	-0.1064		0.00	2.31	0.00	1.62
60	0.9831	-0.0989		0.00	0.00	0.00	0.00
63	1.0083	-0.0511		0.00	0.00	0.00	0.00
65	0.9689	-0.1146		0.00	1.64	0.00	0.68
73	0.9608	-0.1253		0.00	7.25	0.00	1.36

--- LINE FLOW ---

LINE NO	SENDG NO	BUS REC NO	BUS	REAL POWER (MW)	REACT POWER (MVAR)	LINE LOSS (MW)	LINE LOSS (MVAR)
1	1	2	1	38.9807	4.1977	0.309	-4.935
1	1	2	1	24.4671	12.330	0.332	-3.085
1	1	2	1	18.0931	18.209	0.242	-3.183
1	1	2	1	22.5274	13.449	0.085	-0.630
1	1	2	1	42.3030	16.286	1.162	0.546
1	1	2	1	22.3050	16.286	0.340	-2.932
1	1	2	1	21.5099	7.898	0.034	-0.811
1	1	2	1	15.0357	0.425	0.195	-1.525
1	1	2	1	20.2327	6.449	0.374	-0.572
1	1	2	1	7.6320	6.372	0.045	-0.762
1	1	2	1	2.9035	1.796	0.000	0.016
1	1	2	1	2.9035	1.796	0.000	0.333
1	1	2	1	2.9035	1.796	0.000	4.681
1	1	2	1	2.9035	1.796	0.000	2.164
1	1	2	1	2.9035	1.796	0.000	1.564

1	0.003	0.005
2	0.001	0.000
3	0.005	0.011
4	0.003	0.006
5	0.001	0.001
6	0.001	0.001
7	0.001	0.001
8	0.001	0.001
9	0.001	0.001
10	0.001	0.001
11	0.001	0.001
12	0.001	0.001
13	0.001	0.001
14	0.001	0.001
15	0.001	0.001
16	0.001	0.001
17	0.001	0.001
18	0.001	0.001
19	0.001	0.001
20	0.001	0.001
21	0.001	0.001
22	0.001	0.001
23	0.001	0.001
24	0.001	0.001
25	0.001	0.001
26	0.001	0.001
27	0.001	0.001
28	0.001	0.001
29	0.001	0.001
30	0.001	0.001
31	0.001	0.001
32	0.001	0.001
33	0.001	0.001
34	0.001	0.001
35	0.001	0.001
36	0.001	0.001
37	0.001	0.001
38	0.001	0.001
39	0.001	0.001
40	0.001	0.001
41	0.001	0.001
42	0.001	0.001
43	0.001	0.001
44	0.001	0.001
45	0.001	0.001
46	0.001	0.001
47	0.001	0.001
48	0.001	0.001
49	0.001	0.001
50	0.001	0.001
51	0.001	0.001
52	0.001	0.001
53	0.001	0.001
54	0.001	0.001
55	0.001	0.001
56	0.001	0.001
57	0.001	0.001
58	0.001	0.001
59	0.001	0.001
60	0.001	0.001
61	0.001	0.001
62	0.001	0.001
63	0.001	0.001
64	0.001	0.001
65	0.001	0.001
66	0.001	0.001
67	0.001	0.001
68	0.001	0.001
69	0.001	0.001
70	0.001	0.001
71	0.001	0.001
72	0.001	0.001
73	0.001	0.001
74	0.001	0.001
75	0.001	0.001
76	0.001	0.001
77	0.001	0.001
78	0.001	0.001
79	0.001	0.001
80	0.001	0.001
81	0.001	0.001
82	0.001	0.001
83	0.001	0.001
84	0.001	0.001
85	0.001	0.001
86	0.001	0.001
87	0.001	0.001
88	0.001	0.001
89	0.001	0.001
90	0.001	0.001
91	0.001	0.001
92	0.001	0.001
93	0.001	0.001
94	0.001	0.001
95	0.001	0.001
96	0.001	0.001
97	0.001	0.001
98	0.001	0.001
99	0.001	0.001
100	0.001	0.001

TOTAL LOSS = 3.758 -12.761

***** SECURITY ASSESSMENT UNDER *****
 THE OUTAGE OF LINE 29 CONNECTING BUS 50 AND BUS 51 *****

VOLTAGE LIMIT VIOLATION REPORT
 VOLTAGE LIMIT VIOLATION ENCOUNTERED AT ANY BUS ***
 POWER FLOW LIMIT VIOLATION REPORT

 LOAD FLOWS FOR THE OUTAGE OF LINE 5 CONNECTING BUS 3 AND BUS 9

FAST DECOUPLED NEWTON-RAPHSON LOAD FLOW CONVERGED IN 5 ITERATIONS

 BUSBAR DATA

BUSBAR NO	VOLTAGE MAG (P.U.)	VOLTAGE ANG (RAD.)	REAL POWER GEN (MW)	REAL POWER LOAD (MW)	REACT POWER GEN (MVAR)	REACT POWER LOAD (MVAR)
1	1.0616	0.0000	69.13	0.00	30.29	0.00
2	1.0454	-0.0133	67.45	16.68	7.99	11.23
4	1.0192	-0.0567	0.00	1.81	0.00	2.60
5	1.0098	-0.0677	0.00	5.63	0.00	2.57
7	0.8938	-0.2349	0.00	67.39	0.00	15.36
15	1.0021	-0.0843	0.00	0.00	0.00	0.00
16	0.7507	-0.1507	0.00	16.38	0.00	9.09
24	1.0081	-0.0809	38.08	22.22	34.12	22.74
25	1.0101	-0.0781	0.00	0.00	0.00	0.00
30	0.9796	-0.1166	0.00	4.32	0.00	1.68
36	1.0810	-0.0060	37.80	0.00	38.16	0.00
37	0.9751	-0.1251	0.00	8.04	0.00	5.56
39	0.9749	-0.1251	0.00	0.00	0.00	0.00
40	0.9651	-0.1351	0.00	4.26	0.00	1.22
41	0.9639	-0.1345	0.00	5.55	0.00	1.75
45	0.9717	-0.1254	0.00	2.33	0.00	1.40
46	0.9732	-0.1223	0.00	6.44	0.00	4.19

LINE NO	SENDG NO	BUS REC	BUS	REAL POWER (MW)	REACT POWER (MVAR)	LINE LOSS (MW)	LINE LOSS (MVAR)
49	0.96947	-0.1239		0.00	1.00	0.00	0.00
50	0.9696	-0.1239		0.00	12.32	0.00	7.92
51	0.9698	-0.1240		0.00	0.00	0.00	0.00
52	0.9586	-0.1362		0.00	2.17	0.00	1.12
53	0.9576	-0.1336		0.00	5.39	0.00	4.52
55	0.9635	-0.1367		0.00	0.00	0.00	0.00
56	0.9509	-0.1413		0.00	2.31	0.00	1.62
60	0.9738	-0.1353		0.00	0.00	0.00	0.00
63	0.9996	-0.0831		0.00	0.00	0.00	0.00
65	0.9594	-0.1512		0.00	1.64	0.00	0.68
73	0.9512	-0.1627		0.00	7.25	0.00	1.36

--- LINE FLOW ---

LINE NO	SENDG NO	BUS REC	BUS	REAL POWER (MW)	REACT POWER (MVAR)	LINE LOSS (MW)	LINE LOSS (MVAR)
1	2	1	4	32.0350	16.3377	0.239	-5.145
1	2	1	5	37.065	17.6394	0.656	-1.730
1	2	1	3	36.448	15.6246	0.750	-1.601
1	2	1	4	35.473	13.0337	0.175	-0.362
1	2	1	5	40.000	0.000	0.000	0.000
1	2	1	2	40.000	0.000	0.000	0.000
1	2	1	3	44.903	10.2042	1.207	-0.260
1	2	1	4	42.334	6.4032	0.216	-0.160
1	2	1	5	42.334	15.5226	2.736	5.153
1	2	1	3	70.320	15.5331	2.456	5.922
1	2	1	4	89.390	10.5589	0.030	-0.805
1	2	1	5	11.303	1.6811	0.000	0.050
1	2	1	3	11.303	1.5044	0.000	0.276
1	2	1	4	11.303	1.8749	0.000	5.136
1	2	1	5	11.303	1.5501	0.000	2.185

1	0.065	0.127
2	0.002	0.005
3	0.000	0.000
4	0.002	0.005
5	0.004	0.008
6	0.000	0.000
7	0.020	0.040
8	0.084	0.187
9	0.028	0.074
10	0.077	0.165
11	0.039	0.081
12	0.000	0.000
13	0.006	0.012
14	0.058	0.090
15	0.001	0.002
16	0.006	0.010
17	0.022	0.033
18	0.021	0.040
19	0.000	0.084
20	0.044	0.156
21	0.017	0.032
22	0.013	-4.256
23	0.009	-1.269
TOTAL LOSS =	.9.103	6.812

 SECURITY ASSESSMENT UNDER 3 AND BUS 9
 THE OUTAGE OF LINE 5 CONNECTING BUS 5
 VOLTAGE LIMIT VIOLATION REPORT
 BUS 7 VOLTAGE AT 0.8938(P.U.) BELOW LIMIT OF 0.9000(P.U.)

 LOAD FLOWS FOR THE OUTAGE OF LINE 33 CONNECTING BUS 53 AND BUS 55

FAST DECOUPLED NEWTON-RAPHSON LOAD FLOW CONVERGED IN 3 ITERATIONS

 BUSBAR DATA

BUSBAR NO	VOLTAGE MAG (P.U.)	ANGLE (RAD.)	GEN REAL POWER (MW)	LOAD REAL POWER (MW)	GEN REACT POWER (MVAR)	LOAD REACT POWER (MVAR)
1	1.0616	0.0000	53.81	0.00	26.60	0.00
2	1.0454	-0.0172	67.45	16.68	27.11	11.23
4	1.0261	-0.0361	0.00	1.81	0.00	2.60
5	1.0183	-0.0426	0.00	5.63	0.00	2.57
7	0.7909	-0.1009	0.00	67.39	0.00	15.36
15	1.0134	-0.0478	0.00	0.00	0.00	0.00
16	0.9984	-0.0762	0.00	15.33	0.00	9.09
24	1.0081	-0.0412	38.08	22.22	2.20	22.74
25	1.0161	-0.0437	0.00	0.00	0.00	0.00
30	0.9858	-0.0823	0.00	4.32	0.00	1.68
36	1.0310	0.0280	37.30	0.00	35.09	0.00
37	0.9812	-0.0955	0.00	8.04	0.00	5.56
39	0.9310	-0.0954	0.00	0.00	0.00	0.00
40	0.9710	-0.1047	0.00	4.26	0.00	1.22
41	0.9697	-0.1035	0.00	5.55	0.00	1.75
45	0.9779	-0.0940	0.00	2.35	0.00	1.40

*** NO VIOLATION OF POWER FLOW LIMIT ENCOUNTERED ALONG ANY LINE ***

 LOAD FLOWS FOR THE OUTAGE OF LINE 25 CONNECTING BUS 33 AND BUS 49

FAST DECOUPLED NEWTON-RAPHSON LOAD FLOW CONVERGED IN 3 ITERATIONS

---BUSBAR DATA---

BUSBAR NO	MAG (P.U.)	VOLTAGE ANG (RAD.)	GEN (MW)	REAL POWER LOAD (MW)	REACT GEN (MVAR)	POWER LOAD (MVAR)
1	1.0616	0.0000	64.20	0.00	26.97	0.00
2	1.0454	-0.0173	67.45	16.63	27.37	11.23
4	1.0253	-0.0364	0.00	1.81	0.00	2.60
5	1.0173	-0.0430	0.00	5.63	0.00	2.57
7	0.9908	-0.1008	0.00	67.39	0.00	15.36
15	1.0132	-0.0473	0.00	0.00	0.00	0.00
16	0.9932	-0.0759	0.00	16.38	0.00	9.09
24	1.0081	-0.0410	38.03	22.22	3.28	22.74
25	1.0182	-0.0393	0.00	0.00	0.00	0.00
30	0.9903	-0.0760	0.00	4.32	0.00	1.68
36	1.0810	0.0322	37.80	0.00	33.95	0.00
37	0.9754	-0.1037	0.00	8.04	0.00	5.56
39	0.9752	-0.1036	0.00	0.00	0.00	0.00
40	0.9628	-0.1163	0.00	4.26	0.00	1.22
41	0.9579	-0.1173	0.00	5.55	0.00	1.75

LINE NO	SENDG NO	BUS REC NO	REAL POWER (MW)	REACT POWER (MVAR)	LINE LOSS (MW)	LINE LOSS (MVAR)
47	0.9571	-0.1505	0.00	2.27	0.00	0.01
48	0.9272	-0.1482	0.00	6.51	0.00	2.39
49	0.9262	-0.1492	0.00	1.59	0.00	0.58
50	0.9795	-0.0845	0.00	12.32	0.00	7.92
51	0.9793	-0.0851	0.00	0.00	0.00	0.00
52	0.9574	-0.1113	0.00	2.17	0.00	1.12
53	0.9650	-0.0997	0.00	5.89	0.00	4.52
55	0.9704	-0.1015	0.00	0.00	0.00	0.00
56	0.9578	-0.1065	0.00	2.31	0.00	1.62
60	0.9815	-0.0992	0.00	0.00	0.00	0.00
63	1.0080	-0.0508	0.00	0.00	0.00	0.00
65	0.9672	-0.1149	0.00	1.64	0.00	0.58
73	0.9591	-0.1262	0.00	7.25	0.00	1.36

--- LINE FLOW ---

LINE NO	SENDG NO	BUS REC NO	REAL POWER (MW)	REACT POWER (MVAR)	LINE LOSS (MW)	LINE LOSS (MVAR)
1	1	2	39.0789	14.094	0.310	-4.931
2	1	4	35.099	12.808	0.344	-3.033
3	1	2	24.755	8.795	0.255	-3.137
4	1	5	19.054	7.243	0.093	-0.619
5	1	2	22.859	8.662	0.093	-0.619
6	1	4	46.138	16.894	1.160	0.536
7	1	2	22.107	10.358	0.337	-2.940
8	1	2	21.760	8.444	0.337	-2.940
9	1	5	12.307	5.891	0.023	-0.846
10	1	2	20.407	6.977	0.023	-0.846
11	1	6	37.359	13.508	0.197	-1.521
12	1	7	37.359	13.508	0.375	-0.567
13	1	8	37.359	13.508	0.043	-0.768
14	1	2	11.351	4.255	0.000	0.045
15	1	4	11.351	4.255	0.000	0.045
16	1	2	5.158	1.910	0.000	0.242
17	1	4	5.158	1.910	0.000	0.242
18	1	2	5.158	1.910	0.000	0.242
19	1	4	5.158	1.910	0.000	0.242
20	1	2	5.158	1.910	0.000	0.242
21	1	4	5.158	1.910	0.000	0.242
22	1	2	5.158	1.910	0.000	0.242
23	1	4	5.158	1.910	0.000	0.242
24	1	2	5.158	1.910	0.000	0.242
25	1	4	5.158	1.910	0.000	0.242
26	1	2	5.158	1.910	0.000	0.242
27	1	4	5.158	1.910	0.000	0.242
28	1	2	5.158	1.910	0.000	0.242
29	1	4	5.158	1.910	0.000	0.242
30	1	2	5.158	1.910	0.000	0.242
31	1	4	5.158	1.910	0.000	0.242
32	1	2	5.158	1.910	0.000	0.242
33	1	4	5.158	1.910	0.000	0.242
34	1	2	5.158	1.910	0.000	0.242
35	1	4	5.158	1.910	0.000	0.242
36	1	2	5.158	1.910	0.000	0.242
37	1	4	5.158	1.910	0.000	0.242
38	1	2	5.158	1.910	0.000	0.242
39	1	4	5.158	1.910	0.000	0.242
40	1	2	5.158	1.910	0.000	0.242
41	1	4	5.158	1.910	0.000	0.242
42	1	2	5.158	1.910	0.000	0.242
43	1	4	5.158	1.910	0.000	0.242
44	1	2	5.158	1.910	0.000	0.242
45	1	4	5.158	1.910	0.000	0.242
46	1	2	5.158	1.910	0.000	0.242
47	1	4	5.158	1.910	0.000	0.242
48	1	2	5.158	1.910	0.000	0.242
49	1	4	5.158	1.910	0.000	0.242
50	1	2	5.158	1.910	0.000	0.242
51	1	4	5.158	1.910	0.000	0.242
52	1	2	5.158	1.910	0.000	0.242
53	1	4	5.158	1.910	0.000	0.242
54	1	2	5.158	1.910	0.000	0.242
55	1	4	5.158	1.910	0.000	0.242
56	1	2	5.158	1.910	0.000	0.242
57	1	4	5.158	1.910	0.000	0.242
58	1	2	5.158	1.910	0.000	0.242
59	1	4	5.158	1.910	0.000	0.242
60	1	2	5.158	1.910	0.000	0.242
61	1	4	5.158	1.910	0.000	0.242
62	1	2	5.158	1.910	0.000	0.242
63	1	4	5.158	1.910	0.000	0.242
64	1	2	5.158	1.910	0.000	0.242
65	1	4	5.158	1.910	0.000	0.242
66	1	2	5.158	1.910	0.000	0.242
67	1	4	5.158	1.910	0.000	0.242
68	1	2	5.158	1.910	0.000	0.242
69	1	4	5.158	1.910	0.000	0.242
70	1	2	5.158	1.910	0.000	0.242
71	1	4	5.158	1.910	0.000	0.242
72	1	2	5.158	1.910	0.000	0.242
73	1	4	5.158	1.910	0.000	0.242
74	1	2	5.158	1.910	0.000	0.242
75	1	4	5.158	1.910	0.000	0.242
76	1	2	5.158	1.910	0.000	0.242
77	1	4	5.158	1.910	0.000	0.242
78	1	2	5.158	1.910	0.000	0.242
79	1	4	5.158	1.910	0.000	0.242
80	1	2	5.158	1.910	0.000	0.242
81	1	4	5.158	1.910	0.000	0.242
82	1	2	5.158	1.910	0.000	0.242
83	1	4	5.158	1.910	0.000	0.242
84	1	2	5.158	1.910	0.000	0.242
85	1	4	5.158	1.910	0.000	0.242
86	1	2	5.158	1.910	0.000	0.242
87	1	4	5.158	1.910	0.000	0.242
88	1	2	5.158	1.910	0.000	0.242
89	1	4	5.158	1.910	0.000	0.242
90	1	2	5.158	1.910	0.000	0.242
91	1	4	5.158	1.910	0.000	0.242
92	1	2	5.158	1.910	0.000	0.242
93	1	4	5.158	1.910	0.000	0.242
94	1	2	5.158	1.910	0.000	0.242
95	1	4	5.158	1.910	0.000	0.242
96	1	2	5.158	1.910	0.000	0.242
97	1	4	5.158	1.910	0.000	0.242
98	1	2	5.158	1.910	0.000	0.242
99	1	4	5.158	1.910	0.000	0.242
100	1	2	5.158	1.910	0.000	0.242

LINE NO	SENDG NO	BUS REC NO	REAL POWER (MW)	REACT POWER (MVAR)	LINE LOSS (MW)	LINE LOSS (MVAR)
47	0.9663	-0.1058	0.00	2.27	0.00	0.61
48	0.9667	-0.1044	0.00	6.51	0.00	2.39
49	0.9706	-0.0998	0.00	1.59	0.00	0.58
50	0.9753	-0.0900	0.00	12.32	0.00	7.92
51	0.9753	-0.0901	0.00	0.00	0.00	0.00
52	0.9653	-0.1037	0.00	2.17	0.00	1.12
53	0.9610	-0.0992	0.00	5.89	0.00	4.52
55	0.9842	-0.0998	0.00	0.00	0.00	0.00
56	0.9718	-0.1047	0.00	2.31	0.00	1.62
60	0.9906	-0.0967	0.00	0.00	0.00	0.00
63	1.0092	-0.0511	0.00	0.00	0.00	0.00
65	0.9764	-0.1121	0.00	1.64	0.00	0.68
73	0.9684	-0.1232	0.00	7.25	0.00	1.36

--- LINE FLOW ---

LINE NO	SENDG NO	BUS REC NO	REAL POWER (MW)	REACT POWER (MVAR)	LINE LOSS (MW)	LINE LOSS (MVAR)
1	1	2	33.92	14.19	0.309	-4.935
1	2	4	24.81	15.43	0.334	-3.080
1	2	3	44.77	18.31	0.243	-3.178
1	2	4	30.90	12.33	0.087	-0.629
1	2	5	22.58	10.54	1.162	0.544
1	2	6	22.53	10.37	0.339	-2.934
1	2	7	22.53	10.37	0.033	-0.815
1	2	8	22.53	10.37	0.196	-1.525
1	2	9	22.53	10.37	0.374	-0.572
1	2	10	22.53	10.37	0.046	-0.760
1	2	11	22.53	10.37	0.000	0.012
1	2	12	22.53	10.37	0.000	0.358

POWER FLOW LIMIT VIOLATION REPORT
 *** NO VIOLATION OF POWER FLOW LIMIT ENCOUNTERED ALONG ANY LINE ***

 LOAD FLOWS FOR THE OUTAGE OF LINE 32 CONNECTING BUS 52 AND BUS 54

FAST DECOUPLED NEWTON-RAPHSON LOAD FLOW CONVERGED IN 3 ITERATIONS

 BUSBAR DATA

BUSBAR NO	VOLTAGE MAG (P.U.)	ANGLE (RAD.)	GEN REAL POWER (MW)	LOAD REAL POWER (MW)	GEN REACT POWER (MVAR)	LOAD REACT POWER (MVAR)
1	1.0616	0.0000	63.79	0.00	26.53	0.00
2	1.0454	-0.0172	67.45	16.63	27.03	11.23
4	1.0262	-0.0362	0.00	1.81	0.00	2.60
5	1.0184	-0.0427	0.00	5.63	0.00	2.57
7	0.9909	-0.1009	0.00	67.39	0.00	15.36
13	1.0134	-0.0477	0.00	0.00	0.00	0.00
16	0.9984	-0.0761	0.00	16.33	0.00	9.09
24	1.0081	-0.0411	38.03	22.22	2.74	22.74
25	1.0169	-0.0430	0.00	0.00	0.00	0.00
30	0.9375	-0.0817	0.00	4.32	0.00	1.63
36	1.0810	0.0286	37.80	0.00	34.65	0.00
37	0.9533	-0.0962	0.00	8.04	0.00	5.56
39	0.9331	-0.0962	0.00	0.00	0.00	0.00
40	0.9736	-0.1060	0.00	4.26	0.00	1.22

LINE NO	SENDG NO	BUS REC NO	REAL POWER (MW)	REACT POWER (MVAR)	LINE LOSS (MW)	LINE LOSS (MVAR)
47	0.2688	-0.1066	0.00	2.27	0.00	0.61
48	0.5689	-0.1045	0.00	6.51	0.00	2.39
49	0.9730	-0.0996	0.00	1.59	0.00	0.58
50	0.9775	-0.0884	0.00	12.32	0.00	7.92
51	0.9776	-0.0884	0.00	0.00	0.00	0.00
52	0.9679	-0.1089	0.00	2.17	0.00	1.12
53	0.9656	-0.0960	0.00	5.89	0.00	4.52
55	0.9718	-0.0990	0.00	0.00	0.00	0.00
56	0.9593	-0.1040	0.00	2.31	0.00	1.62
60	0.9823	-0.0975	0.00	0.00	0.00	0.00
63	1.0053	-0.0508	0.00	0.00	0.00	0.00
65	0.9630	-0.1132	0.00	1.64	0.00	0.68
73	0.9599	-0.1244	0.00	7.25	0.00	1.36

--- LINE FLOW ---

LINE NO	SENDG NO	BUS REC NO	REAL POWER (MW)	REACT POWER (MVAR)	LINE LOSS (MW)	LINE LOSS (MVAR)
1	1	2	38.9550	14.2066	0.309	-4.936
2	1	4	34.8307	19.3129	0.333	-3.083
3	1	4	24.4497	15.4035	0.242	-3.181
4	1	5	18.7349	11.3894	0.087	-0.630
5	1	5	22.6037	15.4336	0.087	-0.630
6	1	5	28.0349	16.2294	1.161	0.542
7	1	5	42.7910	22.2536	0.339	-2.936
8	1	5	22.7910	16.2294	0.339	-2.936
9	1	5	14.7910	10.2016	0.033	-0.215
10	1	5	14.7910	10.2016	0.033	-0.215
11	1	5	20.3543	12.5316	0.196	-1.524
12	1	5	20.3543	12.5316	0.196	-1.524
13	1	5	30.9254	18.0519	0.374	-0.571
14	1	5	30.9254	18.0519	0.374	-0.571
15	1	5	11.2344	6.5307	0.045	-0.761
16	1	5	11.2344	6.5307	0.045	-0.761
17	1	5	2.3449	1.7143	0.000	0.017
18	1	5	2.3449	1.7143	0.000	0.017
19	1	5	2.3449	1.7143	0.000	0.017
20	1	5	2.3449	1.7143	0.000	0.017
21	1	5	2.3449	1.7143	0.000	0.017
22	1	5	2.3449	1.7143	0.000	0.017
23	1	5	2.3449	1.7143	0.000	0.017
24	1	5	2.3449	1.7143	0.000	0.017
25	1	5	2.3449	1.7143	0.000	0.017
26	1	5	2.3449	1.7143	0.000	0.017
27	1	5	2.3449	1.7143	0.000	0.017
28	1	5	2.3449	1.7143	0.000	0.017
29	1	5	2.3449	1.7143	0.000	0.017
30	1	5	2.3449	1.7143	0.000	0.017
31	1	5	2.3449	1.7143	0.000	0.017
32	1	5	2.3449	1.7143	0.000	0.017
33	1	5	2.3449	1.7143	0.000	0.017
34	1	5	2.3449	1.7143	0.000	0.017
35	1	5	2.3449	1.7143	0.000	0.017
36	1	5	2.3449	1.7143	0.000	0.017
37	1	5	2.3449	1.7143	0.000	0.017
38	1	5	2.3449	1.7143	0.000	0.017
39	1	5	2.3449	1.7143	0.000	0.017
40	1	5	2.3449	1.7143	0.000	0.017
41	1	5	2.3449	1.7143	0.000	0.017
42	1	5	2.3449	1.7143	0.000	0.017
43	1	5	2.3449	1.7143	0.000	0.017
44	1	5	2.3449	1.7143	0.000	0.017
45	1	5	2.3449	1.7143	0.000	0.017
46	1	5	2.3449	1.7143	0.000	0.017
47	1	5	2.3449	1.7143	0.000	0.017
48	1	5	2.3449	1.7143	0.000	0.017
49	1	5	2.3449	1.7143	0.000	0.017
50	1	5	2.3449	1.7143	0.000	0.017
51	1	5	2.3449	1.7143	0.000	0.017
52	1	5	2.3449	1.7143	0.000	0.017
53	1	5	2.3449	1.7143	0.000	0.017
54	1	5	2.3449	1.7143	0.000	0.017
55	1	5	2.3449	1.7143	0.000	0.017
56	1	5	2.3449	1.7143	0.000	0.017
57	1	5	2.3449	1.7143	0.000	0.017
58	1	5	2.3449	1.7143	0.000	0.017
59	1	5	2.3449	1.7143	0.000	0.017
60	1	5	2.3449	1.7143	0.000	0.017
61	1	5	2.3449	1.7143	0.000	0.017
62	1	5	2.3449	1.7143	0.000	0.017
63	1	5	2.3449	1.7143	0.000	0.017
64	1	5	2.3449	1.7143	0.000	0.017
65	1	5	2.3449	1.7143	0.000	0.017
66	1	5	2.3449	1.7143	0.000	0.017
67	1	5	2.3449	1.7143	0.000	0.017
68	1	5	2.3449	1.7143	0.000	0.017
69	1	5	2.3449	1.7143	0.000	0.017
70	1	5	2.3449	1.7143	0.000	0.017
71	1	5	2.3449	1.7143	0.000	0.017
72	1	5	2.3449	1.7143	0.000	0.017
73	1	5	2.3449	1.7143	0.000	0.017

*** NO VIOLATION OF VOLTAGE LIMIT ENCOUNTERED AT ANY BUS ***

POWER FLOW LIMIT VIOLATION REPORT

*** NO VIOLATION OF POWER FLOW LIMIT ENCOUNTERED ALONG ANY LINE ***

