

Durham E-Theses

Free and protein amino acids of vicia faba l

A.E. Kipps

How to cite:

Kipps, A.E. (1972) Free and protein amino acids of vicia faba l. Doctoral thesis, Durham University.

Use policy

The full-text may be used and/or reproduced, and given to third parties in any format or medium, without prior permission or charge, for personal research or study, educational, or not-for-profit purposes provided that:

- a full bibliographic reference is made to the original source
- a <https://etheses.durham.ac.uk/id/eprint/9273/> is made to the metadata record in Durham E-Theses
- the full-text is not changed in any way

The full-text must not be sold in any format or medium without the formal permission of the copyright holders.

Please consult the [full Durham E-Theses policy](#) for further details.

UNIVERSITY OF DURHAM

FREE AND PROTEIN AMINO ACIDS OF VICIA FAB A L.

A Thesis submitted
for the degree of
Doctor of Philosophy

by

A.E. KIPPS

Department of Botany

June 1972



ABSTRACT

Sources of carbon for the developing fruits of Vicia faba L. variety triple white were investigated.

Attached leaves and pods were allowed to photosynthesise in [^{14}C]-labelled carbon dioxide. Leaves, pods and seeds were extracted separately with trichloroacetic acid. Amino acid and radioactive analyses were carried out on both the trichloroacetic acid soluble (non-protein) and insoluble (protein) fractions.

Quantitative analysis of 90 min leaf photosynthesis indicated that a proportion of new photosynthate is rapidly exported from the leaf. Retention in the leaf of some labelled carbon was demonstrated during a 16 hour chase period. Evidence for protein synthesis from newly formed photosynthate is presented, together with evidence for the rapid turnover of such protein. Labelled amino acids and sugars were shown to be present in the petiole of a leaf photosynthesising in [^{14}C] - CO_2 . Leaves near the plant base contributed carbon to xylem sap amino acids. The bloom node leaf was shown to export preformed sugars and amino acids to the developing (20-35 day old) pod and seeds. Some translocate from the leaf entered the seed directly, but more than half was metabolised in the pod before being re-exported to the seeds.

Pod photosynthesis was shown to involve labelling patterns like those of leaf photosynthesis, but to provide the seed with a different, and partly complementary, set of amino acids. Seeds were shown to have a carbon source during the night when transpiration and photosynthesis are negligible. The likelihood of stem tissue functioning as this carbon source is discussed.

Bleeding sap from decapitated plants was analysed, and its relationship to xylem sap discussed. Sap contribution to the developing seeds is considered. Quantitative estimates are made of the carbon contribution from leaves and pods to seeds, and these are compared with the results of other workers.

Seeds are shown to be capable of amino acid synthesis and interconversion, particularly of compounds readily synthesised from respiratory intermediates. Protein synthesis in leaves, pods and seeds is demonstrated, and the nature of the seed protein is discussed.

CONTENTS

	Page
INTRODUCTION	1
MATERIALS	13
ABBREVIATIONS	22
METHODS	23
1. Growth of plant material	24
2. Collection of bleeding sap	24
3. Plant extraction	25
4. [¹⁴ C] - CO ₂ feeding	27
5. Tests for nitrite and nitrate	29
6. Removal of amino acids with amberlite resin	30
7. Dansylation of amino acids and the separation of the products by thin layer chromatography	30
8. Thin layer electrophoresis and chromatography	31
9. Kjeldahl nitrogen determination	40
10. Autoanalysis of amino acid mixtures	41
11. Radioactive counting	46
12. Autoradiography	47
DERIVATION OF METHODS	
1. Collection of bleeding sap	49
2. Preparation of plant extracts	49
3. A marker for thin layer electrophoresis	59
4. The Technicon Autoanalyser	60
PRELIMINARY RESULTS	62
1. Automatic amino acid analysis	63
2. Kjeldahl nitrogen determination	65
3. Plant extraction procedure	70

Contents continued.....

	Page
4. Protein hydrolysis	70
5. Radioactivity measurement	75
6. Calculations and errors	84
RESULTS	91
PRELIMINARY EXPERIMENTS WITH BLEEDING SAP	92
1. Diurnal variation in sap volume	93
2. Qualitative sap analysis	94
3. Diurnal variation in sap composition	100
4. Incorporation of ^{14}C into sap	105
PRELIMINARY EXPERIMENTS WITH LEAVES PHOTOSYNTHESISING IN ^{14}C - CO_2	115
5. Preliminary experiment in ^{14}C - CO_2 feeding	116
6. Leaf photosynthesis and export of labelled photosynthate into the petiole	121
7. Photosynthesis of the bloom node leaf and export of labelled photosynthate into the pod and seed	131
SOURCES OF CARBON FOR THE DEVELOPING POD AND SEED	151
8. Pod photosynthesis	152
9. Bloom node leaf photosynthesis	159
QUANTITATIVE ANALYSIS OF RADIOACTIVE AMINO ACIDS	167
10. Leaf photosynthesis	168
DISCUSSION	181
APPENDICES	233
1. Curve fitting	234
2. Counting errors	236
3. Sample analysis - pod and seed amino acids	237
4. Activity results expressed per sample	238
BIBLIOGRAPHY	241
ACKNOWLEDGMENTS	

INTRODUCTION

As little as twenty years ago it was believed that biosynthesis of nitrogen compounds in plants took place largely in the leaves. Roots were thought to contribute to the process only in the absorption of nitrate and nitrite from the soil and its secretion into the translocation channels. The leaves were pictured as reducing the incoming nitrate to ammonia which was then combined with carbon taken up in photosynthesis to form amino acids and other nitrogenous compounds. Export of preformed amino acids via the phloem then supplied the rest of the plant. In the last two decades this picture has been modified considerably.

In 1960 Bollard was able to write:

"No longer is it possible to picture translocation in plants as consisting simply of an upward movement of absorbed mineral elements in the xylem and a downward movement of elaborated nutrients in the phloem It is clear now that the idea of nitrate being the main form in which nitrogen is transported through the plant will have to be abandoned. Even in the few species where appreciable nitrate occurs in the xylem sap, considerable amounts of organic nitrogenous compounds are also found".

In fact, as early as 1927 it had been reported that nitrate could be detected in apple only in the smallest roots (Thomas, 1927), and in this species reduction of



nitrate was assumed to occur immediately after absorption. It has since been shown that, in apple and many other species, nitrogen is translocated through the xylem largely as amino acids and amides. Bollard (1953, 1957a) showed that tracheal sap of apple contained most of its nitrogen as glutamine, asparagine and aspartic acid. These substances were also shown to be present in high concentration in the bleeding sap of pea (Wieringa and Bakhuis, 1957; Pate, 1962), lupin (Pate and Greig, 1964), tomato and cucumber (Van Die 1958, 1959a) and numerous other unrelated plants (Bollard 1957b, 1957c). Amino acids and amides were not the only nitrogenous substances found in sap, and in some species they were not even the major ones. Citrulline was a major component in some species such as Alnus sp. and Nothofagus sp. (Bollard, 1959), and allantoin and allantoic acid were shown to be important in species of Acer and others. (Mothes and Englebrecht, 1952). Other nitrogenous compounds reported in sap include N-acetylornithine, γ aminobutyric acid, azetidine-2-carboxylic acid, and numerous amino acids (McKee, 1962). Homoserine has been identified in pea sap. (Bakhuis, 1957; Pate, 1962). Many of these compounds are readily broken down and their nitrogen re-used by the plant tops, but this need not always be the case. Dawson (1942) demonstrated that nicotine is synthesised in the roots of the tobacco plant and then exported to the shoot where it is not, apparently, further metabolised.

It had been demonstrated earlier (Stout and Hoagland,

1939) that upward movement of salts from roots took place in the xylem, and the concept of roots as organs for the absorption of mineral ions was well accepted. The realisation that complex organic compounds were exported from the roots introduced a new concept of the complexity of root metabolism. Considerable work was done to investigate the fate of the nitrate absorbed by roots.

Nitrate is reduced in plant tissue by an NADH-dependent enzyme, nitrate reductase. This enzyme has been reported present in many plant tissues, including broad bean leaves (Oji and Izawa, 1969). The relevant literature has been reviewed by Kessler (1964) and Beevers and Hageman (1969). Evidence for the reduction of nitrite to ammonia has been provided by Sanderson and Cocking (1964b), and the synthesis of glutamic acid from α -ketoglutaric acid and ammonia is well documented. (Van Die, 1959b; Bergersen, 1963; Kennedy, 1966).

Nitrate reduction has been shown to be affected by a wide range of environmental conditions, and these are assumed to have their effect on the enzyme nitrate reductase. This is supported by considerable experimental evidence. Nitrate reductase is substrate inducible and requires light, molybdenum and carbon dioxide as well as nitrate for its induction in some species (Kannangara and Woolhouse, 1967; Afridi and Hewitt, 1964; Hageman and Flesher, 1960; Ferrari and Varner, 1969). In other plants, light enhanced enzyme induction, but absence of light did not completely

prevent it. (Candela, Fisher and Hewitt, 1957; Beevers, et al, 1965. These last authors suggested that light has its effect on nitrate reductase by enhancing uptake of nitrate.

In a number of species, nitrate reductase activity has been shown to be higher in shoots than in roots, in the presence of adequate supplies of nitrate. Hageman and Flesher (1960) reported that nitrate reductase activity was 80% lower in root extracts of corn seedlings than in extracts of the shoots. Other authors were unable to detect nitrate reductase at all in roots (Beevers and Hageman, 1969). Candela, Fisher and Hewitt (1957) demonstrated that in cauliflower plants nitrate reductase activity was extremely low in roots under the same conditions which produced high activities in shoots. These results were uncorrected for the effects of nitrite reductase activity which was shown to be low in aerial parts and high in roots. Could this have accounted for the apparently low nitrate reductase activities? Vaidyanthan and Street (1959) demonstrated that, in extracts of tomato roots, nitrate reductase activity could not be demonstrated due to the presence of an NADH oxidase. Addition of a substrate for this enzyme allowed demonstration of nitrate reductase. These root extracts were shown to contain a second system which affected nitrate reduction in vitro. Other workers also have demonstrated high nitrate reductase activities in roots (Wallace and Pate, 1965; Mifflin, 1957; Sanderson and Cocking, 1964a).

Nitrate reductase is, then, at least potentially present in the root and shoot tissues of many plants. Its activity is closely related to nitrogen metabolism, and positive correlations between leaf nitrate reductase, protein content and crop yield have been demonstrated for maize. (Zieserl et al, 1963). The enzyme has a very short half-life (about 4h) and its induction is readily prevented by the usual inhibitors of protein synthesis. (Beevers et al, 1965; Stewart, 1968). These features and the rapid fluctuations which can be detected in nitrate reductase activity reflect the existence of an effective in vivo regulatory mechanism.

Klepper and Hageman (1969) have shown that nitrate reductase can be extracted from apple leaves, stems, petioles and roots, and it appears that, given adequate nitrate levels, all parts of the apple plant have the capacity to utilise nitrate. This appears to be a direct contradiction of the earlier work of Thomas (1927) and Bollard (1953, 1957, 1960) who demonstrated that neither apple foliage or apple sap contained nitrate. Pate (1965) has explained the first anomaly in pointing out that the appearance of nitrate in foliage is an unusual event. Nitrate reductase levels are generally high enough to keep nitrate levels very low. Bollard (1957c) has demonstrated that plants may contain nitrate in the foliage when it is not detectable in the sap. Thus very low sap nitrate concentrations may be sufficient to account for the nitrate reductase levels measured by Klepper and Hageman.

The proportion of nitrate which is reduced in the roots or in the leaves must vary with the conditions of plant growth. Reduction in the two situations will frequently coexist, and hence the aerial parts of the plant will be required to metabolise nitrate (with the formation of glutamate) and also the organic nitrogen compounds synthesised in the roots. The proportion of the two sources will vary with the particular plant and with the experimental conditions used. (Wallace and Pate, 1967).

In nodulated leguminous plants the larger part of the plant nitrogen is taken up by fixation from the atmosphere, except under conditions of excessive nitrogen fertilisation. Pate (1965) has shown that the products of symbiotic nitrogen fixation in the pea are comparable with the products of nitrate reduction in the roots. At low nitrate concentrations in the culture medium, nitrate never enters the sap and nitrate reductase is not found in the shoot. At higher levels of nitrate the organic nitrogen compounds and free nitrate are present together in the sap. Nitrogen so supplied to the shoot is then further metabolised, with the formation of protein, nucleic acid and other nitrogenous plant constituents.

It appears to be generally agreed that the first stable organic products of nitrogen fixation or nitrate reduction are glutamic acid and glutamine. This was convincingly demonstrated using [^{15}N] - nitrate and ammonium salts by Yemm and Willis (1956). They allowed

excised barley roots to assimilate the labelled nitrogen source, and demonstrated primary synthesis of glutamine. Whole barley seedlings were shown to incorporate [^{15}N] - ammonia into glutamic acid and glutamine. (Cocking and Yemm, 1961). The combination of ammonia with α ketoglutarate to produce glutamic acid is mediated by the enzyme glutamic dehydrogenase. This enzyme has been reported from numerous plant tissues including legume seedlings (Damodaran and Nair, 1938), oat coleoptiles (Berger and Avery, 1944), corn leaves (Bulen, 1956) and from Vicia faba chloroplasts (Givan et al, 1970). The enzyme from corn leaves was extracted, rigorously characterised, and shown to be substrate specific. Other amination reactions have also been reported, such as the formation of alanine and aspartic acid by amination of pyruvic acid and oxalacetic acid respectively, but the possibility of the involvement of transamination in these instances has not been ruled out. No unequivocal demonstration of the necessary enzymes has been repeated since earlier suggestions of their occurrence. (McKee, 1962). Bergersen (1971) has reviewed the biochemistry of symbiotic nitrogen fixation in legumes, and demonstrates that, here too, glutamate is the primary organic product.

The other amino acids, besides glutamic acid, which are found in xylem sap are presumed to arise from glutamate by transamination. (Kennedy 1966a, 1966b). Metabolism of some of the more complex nitrogenous sap

constituents has been reviewed by Bollard (1959). Roots and shoots have, then, a common starting point for their major nitrogen metabolism. Biosynthetic pathways for other amino acids from glutamate have been reviewed by a number of authors (Meister, 1965; Steward and Pollard, 1957; Fowden, 1967; Davies, 1968) and will be discussed in detail later.

The discovery, that an extract from a plant organ is able in vitro to synthesise a given compound or, indeed, that the intact organ will make use of an exogenously supplied precursor to synthesise that compound, is not necessarily evidence that the biochemical pathway so revealed is operative in the undisturbed plant. It does, however, provide strong evidence of the synthetic potential of the plant organ. Similarly, the presence in an organ of a given compound is not evidence that it was synthesised there. Substances, translocated into an organ from elsewhere may effectively suppress their own synthesis in that organ. Such repression, by feedback or end product enzyme inhibition, is a familiar phenomenon in bacterial systems (Monod, 1963; Pierard, 1966; Adelberg and Umbarger, 1953). It has also been demonstrated in plants (Oaks, 1963, 1965a, 1966; Oaks and Beevers, 1964; Bonner and Huang, 1962; Bonner, Huang and Gilden, 1963). Oaks has also shown that some amino acids are not extensively metabolised in plants, and that due to amino acid conservation and enzyme repression, the extensive interconversions of amino acids assumed to be prevalent

in plant tissues may be of minor importance. (Oaks, 1965b, 1965c). This work was done with the developing root of a maize seedling, which is extensively supported by the metabolism of the endosperm. Similar dependence on seed reserves has been demonstrated for barley embryos (Kent and Brink, 1947) and Datura embryos (Sanders and Bierkholder, 1948). Such conditions of minimal metabolism of amino acids may equally well exist in any part of the plant which receives a large proportion of its nutrient from elsewhere.

The considerable increase in nitrogen content during development of the seeds of legumes and cereals has been well documented, and it has long been recognised that the developing fruits and seeds draw on other parts of the plant for the supplies of nitrogen used in their growth. McKee (1962) summarises a lot of the early quantitative work. It was shown before the turn of the century that, in a fruiting plant, the nitrogen in the seeds rises at the expense of nitrogen in the leaves, stems and seed pods. In general, the total amount of nitrogen lost by the rest of the plant is much less than that gained by the seeds, and the difference must be supplied by the roots or root nodules after the onset of fruiting. (Maskell and Mason, 1930; Hay et al, 1953). The metabolism of the developing fruit must, then, be affected, if not controlled, by the substances supplied to it by the rest of the plant. In leguminous plants in particular, the fruits are green and capable of photosynthesis (Flinn and Pate, 1970),

and this too must contribute to their metabolism.

Changes in total nitrogen and in nitrogenous and other components of seeds during development have been studied by a number of workers (Bisson and Jones, 1932; Bourdon and Quillet, 1958; Hyde, 1952; Raacke, 1957; Grzesiuk et al, 1962; Davis, 1966; Flinn and Pate, 1968; Briarty, Coult and Boulter, 1969). An increase in protein nitrogen and a decrease in soluble nitrogen was seen to accompany seed maturation. The developmental process was readily divisible into stages, and those of Briarty, Coult and Boulter (1969) are typical for legumes. These workers characterised their developmental stages by electron microscopy of the developing cotyledons of Vicia faba, and the resulting subdivisions are comparable with those obtained by analysis of the seed. In Phase I, the developing zygote undergoes mitosis up to the point at which mitotic frequency falls off rapidly (25 days). At the end of Phase I the cotyledons are about 0.8mm diameter and the ovule is mostly comprised of its integuments. In Phase II (25-35 days) the cotyledons become extensively vacuolated and increase in water content up to 87%. The integuments, now recognisable as a testa, still form a large part of the seed. In Phase III, protein masses deposit in the vacuoles and protein bodies, containing vicilin and legumin are formed. The testa hardens and the cotyledons begin to dry out. Phase IV is the final water loss, hardening and ripening of the seed. Grzesiuk et al (1962) suggests that Phase II is associated with embryo protein

formation and they record low soluble nitrogen levels concomitant with increase in albumin protein. Phase III is associated with synthesis of RNA (Wheeler and Boulter, 1967), synthesis of new ribosomes (Briarty, Coult and Boulter, 1969) and increase in vicilin and legumin protein (Davis, 1966; Raacke, 1957; Grzesiuk et al, 1962) - the time of major accumulation of insoluble reserves.

The biosynthetic pathways in the developing seed have been rather less thoroughly investigated, and will be given in detail in the Discussion Section. Numerous enzymes have been located in fruit and seed extracts and some interconversions of labelled materials have been demonstrated.

Sources of carbon for the developing pod and seed have been investigated by a number of workers using labelled substances applied to 'source' leaves. The concept of a growing fruit as a 'sink' for translocated substances is a familiar one. (Maskell and Mason, 1930; Linck and Seedia, 1962; Carr and Wardlaw, 1965; Hansen, 1970; Flinn and Pate, 1970). The bloom node leaf has been shown by these workers to be particularly important in the nutrition of its subtended fruit, although other leaves doubtless contribute as well. Flinn and Pate (1970) have shown that the leaf at the lowest reproductive node of field pea plants and the pod at that node donate to the seeds about two thirds of the carbon required for ripening. The root system also must provide nitrogen and some carbon to the

growing fruit. In broad bean the development of the lowest fruits coincides with the senescence of the lowest leaves of the plant. Feeding the plants with liquid fertiliser delays but does not prevent this senescence. Export from such ageing leaves probably also contributes, at least indirectly, to the developing seeds. The significance of senescence of plant organs has been reviewed by Yemm (1956).

The present work aims to investigate the forms of carbon translocated into developing seeds and pods of Vicia faba L. and their short term products in the fruit. Amino acids are ^{14}C -labelled via photosynthesis in $[\text{}^{14}\text{C}] - \text{CO}_2$ in an attempt to cause minimum disturbance to the intact plant system. The contributions to the fruit of leaf and pod photosynthesis are investigated, and the xylem sap composition determined. The biosynthesis of amino acids in these plant organs is discussed. The contribution of carbon from senescent organs is not investigated.

MATERIALS

1. Plant material

Vicia faba L. variety triple white was used in all experiments. Seeds were obtained from William Strike Ltd., Durham.

2. Chemicals

Except for those listed below, chemicals were obtained from British Drug Houses (BDH) Ltd, and were of analytical grade.

Amino acid standard mixture (Technicon)

Amino acid standard mixture (Eel)

Acetone (Fisons, laboratory reagent)

Brij 35 solution (Technicon)

Cellulosepulver MN 300 (Machery Nagel & Co.)

L- β 3,4-dihydroxyphenylalanine (Sigma, A.R.)

Indanetrionehydrate (ninhydrin)(Fisons, A.R.)

Kieselgel H nach Stahl (Merck)

2-methoxyethanol (Hopkins and Williams Ltd,
laboratory reagent)

Norleucine standard solution (Technicon)

BDH, laboratory reagents

diphenylamine	aniline
chloroform	ether
formic acid	methanol
methyl ethyl ketone	phloroglucinol
n-propanol	n-propyl acetate
pyridine	thiodiglycol

Radioactive chemicals

[^{14}C] - Sodium carbonate was obtained in two batches from the Radiochemical Centre, Amersham.

Batch 1 specific activity 55.0mCi/mMole
radioactive conc. 2.0mCi/cm³

Batch 2 specific activity 58.6mCi/mMole
radioactive conc. 1.0mCi/cm³

[U- ^{14}C] sucrose was also obtained from Amersham
specific activity 600mCi/mMole
radioactive conc. 0.1mCi/cm³

Planchets, 21mm internal diameter, were obtained from Gallenkamp.

3. Solutions

All water used had been distilled in glass.

a. Solutions used for plant extraction

- (i) 5% (w/v) trichloroacetic acid (TCA)
- (ii) chloroform: methanol (2:1; v/v)
- (iii) phenol: acetic acid: water (1:1:1; w/v/v)

b. Solutions used in [^{14}C] - CO₂ feeding experiments

- (i) 0.1% (v/v) lactic acid
- (ii) 1N sodium hydroxide (pellets)
- (iii) plasticine-vaseline mixture - This was prepared by stirring small quantities of white paraffin wax into a lump of plasticine, until the mixture was easily spreadable with a glass rod.

c. Tests for nitrite and nitrate

(i) 0.5% (w/v) aminosulphonic acid

(ii) sulphanilic acid

() 10g sulphanilic acid was dissolved by warming
in 100 cm³ 30% (v/v) acetic acid

(iii) α -naphthylamine-acetic acid

0.03g α -naphthylamine was boiled in 70 cm³ water.
The colourless solution was decanted from the
blue-violet residue and mixed with 30 cm³
glacial acetic acid.

d. Thionin marker

A saturated solution, 1% (w/v) of thionin (Ehrlich,
Michrome Number 215) in 95% (v/v) ethanol was prepared.

e. Electrophoresis buffer for TLE/TLC method

acetic acid, glacial	57 cm ³	
formic acid, 90% (v/v)	17 cm ³	
distilled water to	1000 cm ³	pH 2.0

f. Chromatography solvents for TLE/TLC method

(i) methyl ethyl ketone	350 cm ³
pyridine	75 cm ³
water	75 cm ³
acetic acid	10 cm ³
(ii) n-propanol	360 cm ³
water	180 cm ³
n-propyl acetate	60 cm ³
acetic acid	12 cm ³
pyridine	3 cm ³

These amounts were used in the large (10 x 25 x 25cm) Shandon Chromatank. 13 plates in a stainless steel rack could then be chromatographed at one time.

g. Ninhydrin reagent for amino acids

cadmium acetate	1.0g
water	100 cm ³
acetic acid, glacial	20 cm ³
acetone	1000 cm ³

1g ninhydrin was dissolved in 112 cm³ of the above stock solution, and the mixture used when fresh.

The reagent is that of Blackburn (1965).

h. Reagents for sugar and acid detection

(i) aniline hydrogen phthalate reagent

aniline	9.15 cm ³
phthalic acid	16g
n-butanol	490 cm ³
diethyl ether	490 cm ³
water	20 cm ³

The mixed reagent is stable for some months.

(ii) phloroglucinol reagent

phloroglucinol 0.7% (w/v) in acetone	9 vol.
trichloroacetic acid, 40% (w/v)	1 vol.

The reagent is freshly mixed immediately before use.

(iii) aniline-diphenylamine reagent

aniline, 1% (v/v) plus	
diphenylamine, 1% (w/v) in acetone	10 vol.
phosphoric acid, 85% (v/v)	1 vol.

The reagent is freshly mixed, and any amine phosphate

precipitate redissolved by the addition of a few drops of water.

(iv) bromocresol blue, 1% (w/v), adjusted to pH 6.0

i. Kjeldahl nitrogen determinations

(i) mixed indicator solution

methyl red 33 mg

bromocresol green 66 mg

ethanol, 98% (v/v)

The indicators were dissolved in a small volume of the ethanol, and the solution made up to 100 cm³.

(ii) boric acid/mixed indicator solution

10g boric acid was dissolved in 200 cm³ 98% (v/v) ethanol and 700 cm³ distilled water added. 10 cm³ mixed indicator was added and then 0.1N sodium hydroxide solution until the indicator colour was grey-blue.

The whole was made up to 1 litre with distilled water.

(iii) potassium hydroxide/sodium thiosulphate reagent.

potassium hydroxide 300g

sodium thiosulphate
(Na₂S₂O₃·5H₂O) 50g

The potassium hydroxide was dissolved in 600 cm³ distilled water and the solution boiled gently for 20 min to remove ammonia. When cool, the thiosulphate was added and the mixture made up to 1 litre with water.

(iv) Water-soluble fixative (Conway, 1957)

To 10 parts by weight of powdered gum acacia were added 15 volumes of water, 5 volumes of glycerol and 5 volumes of saturated potassium carbonate solution.

The water was added slowly to the gum acacia, the mixture being ground in a large mortar to hasten the solution of the gum. The glycerol and potassium carbonate were then stirred in. The mixture was allowed to stand overnight when the dark viscous fluid was separated from the froth and stored in a stoppered vessel.

(v) thymol-blue, cresol-red mixed indicator for titration of carbonate to the bicarbonate stage (Vogel, 1962).

thymol blue	0.1% (w/v) solution of the sodium salt	3 vol.
cresol red	0.1% (w/v) solution of the sodium salt	1 vol.

This indicator changes from yellow to violet at pH 8.3.

j. Solvents for polyamide chromatography

(i) first dimension
formic acid, 1.5% (w/v)

(ii) second dimension
acetic acid 30 cm³
benzene 270 cm³

(iii) third dimension
n-butylacetate 280 cm³
methanol 14 cm³
acetic acid 14 cm³

(iv) cleaning solvent
ammonia (conc.) 90 cm³
acetone 1500 cm³
water 1400 cm³

k. Solutions for planchet preparation

(i) cetyltrimethylammonium bromide, 0.2% (w/v), dissolved in water by stirring for some hours over gentle heat.

(iv) polyvinyl alcohol, 1.0% (w/v), dissolved in water by stirring over heat.

l. Autoanalyser reagents

(i) 4N sodium acetate buffer, pH 5.5.

sodium acetate, anhydrous	1640g
acetic acid, glacial	500 cm ³
distilled water to 5 litres.	

The sodium acetate was slowly dissolved in about 3 litres of the water. The cooled solution was transferred to a 5 litre volumetric flask, the acetic acid added, and the mixture diluted to volume. The reagent was filtered and stored in a dark bottle.

(ii) 0.6% buffered ninhydrin reagent

ninhydrin	20g
methylcellosolve	1500 cm ³
4N sodium acetate buffer	300 cm ³
distilled water to 3 litres.	

The reagents were dissolved in the order given.

(iii) 0.002M hydrazine sulphate solution

hydrazinium sulphate	0.780g
distilled water to 3 litres.	
sulphuric acid, a trace to acidify.	

- (iv) buffer stock solution
- | | |
|------------------------------|------|
| citric acid, monohydrate | 420g |
| sodium hydroxide (pellets) | 165g |
| distilled water to 2 litres. | |

The reagents were dissolved in the order given, and the solution stored in a refrigerator.

- (v) equilibration buffer, pH 3.15, 0.1M citrate, 0.2N Na⁺
- | | |
|------------------------------|---------------------|
| buffer stock solution | 400 cm ³ |
| Brij 35 solution | 40 cm ³ |
| distilled water to 4 litres. | |

The buffer was titrated to pH 3.15 with 6N hydrochloric acid, before being made up to volume. Octanol was added as preservative.

- (vi) buffer 1, pH 3.25, 0.1M citrate, 0.2N Na⁺, 4% MCS
- | | |
|------------------------------|---------------------|
| buffer stock solution | 400 cm ³ |
| methyl cellosolve (MCS) | 160 cm ³ |
| Brij 35 solution | 40 cm ³ |
| distilled water to 4 litres. | |

The pH was adjusted as above.

- (vii) buffer 2, pH 4.25, 0.1M citrate, 0.2N Na⁺
- | | |
|------------------------------|---------------------|
| buffer stock solution | 400 cm ³ |
| Brij 35 solution | 40 cm ³ |
| distilled water to 4 litres. | |

The pH was adjusted as above.

- (viii) buffer 3, pH 7.5, 0.1M citrate, 1.2N Na⁺
- | | |
|-----------------------|---------------------|
| buffer stock solution | 400 cm ³ |
| sodium chloride | 236g |

(viii) cont'd.....

Brij 35 solution 40 cm³

distilled water to 4 litres.

The pH was adjusted with 2N sodium hydroxide solution.

ABBREVIATIONS

The following abbreviations are used in the text, and where appropriate are explained when first encountered.

CYS cystine; ASP aspartic acid; ASN asparagine;
GLN glutamine; GLU glutamic acid; SER serine;
THR threonine; PRO proline; ALA alanine;
DOPA dihydroxyphenylalanine; VAL valine;
MET methionine; TYR tyrosine; TRP tryphophan;
ILE isoleucine; LEU leucine; PHE phenylalanine;
GLY glycine; ARG arginine; HIS histidine;
LYS lysine; γ AB γ aminobutyric acid; α AB α amino-
butyric acid; β ALA β alanine; OH-PRO hydroxyproline;
GLUC NH₃ glucosamine.

TLE/TLC thin layer electrophoresis followed by thin
layer chromatography - method described in text.

PAW phenol: acetic acid: water, 1:1:1 (w/v/v)

MCS methyl cellosolve

DNS-CL dimethylaminonaphthalene-5-sulphonyl chloride
(dansyl chloride)

METHODS

1. Growth of plant material
2. Collection of bleeding sap
3. Plant extraction
4. [^{14}C] - CO_2 feeding
5. Tests for nitrite and nitrate
6. Removal of amino acids with amberlite resin
7. Dansylation of amino acids and the separation
of the products by polyamide thin layer chromatography
8. Thin layer electrophoresis and chromatography
9. Kjeldahl nitrogen determination
10. Autoanalysis of amino acid mixtures
11. Radioactive counting
12. Autoradiography

1. Growth of plant material

Bean seeds for experiments under glass were sown directly into pots of untreated garden soil and watered only with tap water until the onset of flowering. All plants were grown under lights (mercury vapour lights in Durham and fluorescent tubes in Reading) for a 14h day. After the onset of flowering, plants which were to be grown to maturity in pots were fed at weekly intervals with the recommended dilution of Boots red liquid fertiliser.

Plants to be grown outdoors in Reading were sown outside in March without the use of seed boxes.

Flowers on a single peduncle were labelled when the first flower opened, and this was called day 1 in the life of the pod. It took up to five days for a whole bunch to open, and, as any of the flowers in the bunch could give rise to the pod at that node, pod ages were known to within five days. All flowers on glasshouse-grown plants were pollinated with a paint brush as they opened.

2. Collection of bleeding sap

Bleeding was initiated by decapitation of the plant just below the first node, using a sharp razor blade. In early experiments the sap was collected as it formed on the cut surface, using a capillary Pasteur pipette. Later, the sap was allowed to collect in tubes made from 'Parafilm' to fit the stump, and sealed to the stump with white paraffin wax. Bleeding was allowed

to continue for 1h periods and the sap was then removed from the tube using a graduated 100 μ l Terumo microsyringe. Longer collection periods were never used, in order to minimise any chance of abnormal root catabolism contributing to the sap composition. Sap was stored at -20° prior to analysis.

3. Plant extraction

The plant tissue was frozen by immersion in liquid nitrogen and then weighed. After thawing, leaves and pods were chopped roughly with scissors and ground with the minimum volume of ice cold 5% (w/v) trichloroacetic acid (TCA). In preliminary experiments the grinding was done by hand in a small glass mortar, but in later work a Gallenkamp glass-in-glass homogenizer was used. Seeds were always crushed and ground by hand in the mortar owing to the difficulty in rinsing the suspension from the grinding tube. Slurries were rinsed with the minimum volume of 5% TCA into centrifuge tubes and allowed to stand at 0° - 4° overnight.

After centrifuging for 10 min (full speed, small MSE centrifuge, c. 3000g) the supernatants were decanted into boiling tubes and the pellets resuspended in 5% TCA (1.5-2.0cm³ per g tissue) for 30 min. The centrifuging and 30 min extraction were repeated three times, giving five extractions in all. The pooled supernatants were washed 6 times with an equal volume of ether, to remove TCA. For small volumes this was

done in the boiling tube, using a pipette to remove the upper ether layer. For large volumes the washing was done in separating funnels. Ether was finally removed by gentle warming in a water bath. The TCA-free extracts were frozen at -10° for several days and then evaporated to dryness in vacuo. The samples were stored dry until required and then taken up in water using 1.0cm^3 for every 0.5g fresh weight of tissue in the sample, to the nearest 0.5cm^3 . This was the TCA SOLUBLE FRACTION. For autoanalysis, these samples were subjected to a mild hydrolysis to convert glutamine and asparagine to glutamic and aspartic acids. 1cm^3 of plant extract was mixed with 1cm^3 2N hydrochloric acid in a pyrex tube which was then sealed under vacuum as described below for protein hydrolysis. The thawed sample was hydrolysed at 110° for 3h, and the sample applied to the autoanalyser column without removal of acid. (Boulter, 1966).

The pellets remaining after TCA extraction were washed in the centrifuge tube six times with acetone, three times with chloroform-methanol (2:1; v/v) and once more with acetone. The almost colourless residues were allowed to dry for at least a week in the air before weighing to give the EXTRACTED WEIGHT of the sample. 50-100mg of air dried pellet was accurately weighed into a pyrex tube and 4.0cm^3 6N hydrochloric acid pipetted on top. After stretching the tube to a capillary near the top, the acid was frozen by immersion in liquid nitrogen. The tube was evacuated, using an NGN rotary piston pump, to less than 0.05 mm Hg (McCleod Guage), and sealed under

vacuum. After thawing, the mixture was placed in an air oven at 110° for 24h to hydrolyse the protein. (Moore and Stein, 1963). Samples were stored, sealed, at 0° - 4° until required for analysis. The hydrochloric acid was then removed by rotary evaporation to dryness at 40° , and the dry residue was taken up in water and made up to 5cm^3 in a volumetric flask. This was the TCA INSOLUBLE FRACTION.

4. $[^{14}\text{C}] - \text{CO}_2$ feeding

The plant or organ to be fed was enclosed in a polythene bag which was sealed around the stem, petiole or peduncle by tying with cotton into a plug of plasticine-vaseline mixture. A measured volume of $[^{14}\text{C}]$ -sodium carbonate was injected through the polythene into one of the bag corners. An equivalent volume of lactic acid solution was injected on to the carbonate and the hole in the bag was sealed with masking tape. At the end of the feeding period, excess sodium hydroxide solution ($1\text{cm}^3, 1\text{N}$) was delivered on to the acid to absorb the carbon dioxide in the bag.

Either $150\mu\text{Ci}$ or $75\mu\text{Ci}$ $[^{14}\text{C}] - \text{CO}_2$ was fed to plants and different sizes of bag were used for the two amounts. These conditions are summarised in Table 1. The bag volumes are very approximate so that the calculations serve only as a guide to the specific activity of $[^{14}\text{C}] - \text{CO}_2$ in the bags.

$[^{14}\text{C}] - \text{CO}_2$ feeding was usually terminated at 3h, or before. By 3h there was considerable

Table 1. $[^{14}\text{C}] - \text{CO}_2$ feeding

$[^{14}\text{C}] - \text{CO}_2$ batch	1	2
Dimensions of bag (cm)	25 x 38	18 x 23
Bag volume (approx.) (cm^3)	1500	350
$\therefore [^{12}\text{C}] - \text{CO}_2$ in bag (μmole)	20	5
$[^{14}\text{C}] - \text{Na}_2\text{CO}_3$ added (μl)	75	75
$[^{14}\text{C}]$ (μCi)	150	75
$[^{14}\text{C}] - \text{CO}_2$ released (μmole)	2.7	1.3
total CO_2 (μmole)	23	6
specific activity CO_2 ($\mu\text{Ci}/\mu\text{mole}$)	7	12

The bags described were thin polythene ones and were recommended by the Radiochemical Centre, Amersham, as being suitable for feeding these activities of $[^{14}\text{C}] - \text{CO}_2$.

condensation on the inside of the bag and the enclosed leaf had frequently become flaccid.

5. Tests for nitrite and nitrate

NITRITE

One drop of the test solution was mixed on a spot plate with a drop each of sulphanilic acid solution and α -naphthylamine-acetic acid solution. The formation of a red colour indicates the presence of nitrite (Feigl, 1954).

NITRATE

Nitrites were removed from the test solution by mixing a drop of the solution with a drop of 0.5% (w/v) aminosulphonic acid solution. A drop of each of sulphanilic acid solution and α -naphthylamine-acetic acid solution was added. On addition of a few mg of zinc dust, a red colouration indicates the presence of nitrate (Feigl, 1954).

6. Removal of amino acids from solution using
amberlite resin

The method was obtained from a University of Cambridge, Department of Biochemistry practical schedule, which was a modification of the method of Partridge (1949a).

The test solution was either poured through a short column of Amberlite LR 120(H) resin, or shaken with the resin in a specimen tube. Washing the resin with water then gave a solution free of amino acids. Solutions treated in such a manner were shown to give a negative reaction with ninhydrin.

7. Dansylation and polyamide thin layer
chromatography

The method is that of Woods and Wang (1967).

The sample was transferred to a 30 x 6mm test tube and dried in a dessicator in vacuo (<0.5mm Hg) in the presence of sodium hydroxide pellets and Analar concentrated sulphuric acid (about 10 min). 10 μ l of a 0.1M solution of sodium bicarbonate was added to each tube and this dried as before. DNS-Cl (2.5 mg/cm³ in acetone) was premixed with an equal volume of deionized water, and 10 μ l of this reagent added to the sample. The tube was sealed with parafilm and placed in an oven at 37^o for 1h. The mixture was again dried in vacuo before being taken up in 10 μ l 95% (v/v) ethanol.

5 μ l sample was spotted on each side of a polyamide sheet with a 1 μ l microcapillary, the origin being placed under a hairdryer (hot). The tube was washed with 10 μ l 1M ammonium hydroxide solution and the washings were spotted on the same sheet as before. 1 μ l of a standard solution of DNS- amino acids was applied to one side of the sheet. A number of sheets were placed on a rack consisting of two end sheets of stainless steel 17 x 17cm with a 7cm long stainless steel rod at each corner. The sheets were kept apart by spacers on the rods, and one end sheet fastened on to the frame with nuts on the rods. The sheets were subjected to chromatography.

1st dimension: 35 min
2nd dimension: 40 min
3rd dimension: 40 min.

The third dimension was run in the same direction as the second dimension, to resolve the hydrophilics, after examination of the first two dimensions. The sheets were dried for 30 min in a hot air stream between each dimension. The dry sheets were viewed under U.V. light and the fluorescent spots identified relative to the standards. A typical separation is illustrated in Results, Fig. 3-1.

8. Thin layer electrophoresis and chromatography

The method is that of Bielecki and Turner (1966), slightly modified for use with the Shandon cooled plate electrophoresis tank.

Thin layer plates, 20 x 20cm, were spread, using a Shandon hand spreader, with a 250 μ m layer of mixed cellulose and silica gel. 12.5g Macherey and Nagel MN 300 cellulose, 5.0g Merck silica gel H and 100cm³ water were homogenised together for 30 sec, allowed to stand for 30 sec, homogenised again for 30 sec, allowed to stand for a further 60 sec, and then spread. The plates were allowed to set before being moved and then were completely dried at 35° overnight. Extract, 10-100 μ l, was applied near one corner of the layer as a band about 2.5cm long, and dried with a hairdryer. A spot of thionin marker solution was dried on the opposite end of the same origin. The plate is illustrated in Fig. 1. The plate was sprayed with formic-acetic buffer, pH 2.0, taking care not to saturate the origin, and any excess buffer was removed by blotting with paper towelling.

Wicks were prepared by soaking in buffer a 20cm long strip of dialysis tubing, previously slit along one edge, and folding this tubing over the folded edge of a prebuffered, doubled, 20 x 10cm strip of Whatman 3MM chromatography paper. The uncovered edge of the combined wick was dipped into the buffer in the electrode vessel of the electrophoresis tank, and the wick was folded on to the edge of the wet thin layer plate. The dialysis tubing was pressed firmly against the layer and a 20 x 1cm glass strip placed on top. The two glass strips then supported another 20 x 20cm glass plate (which acted as a weight to hold the wicks

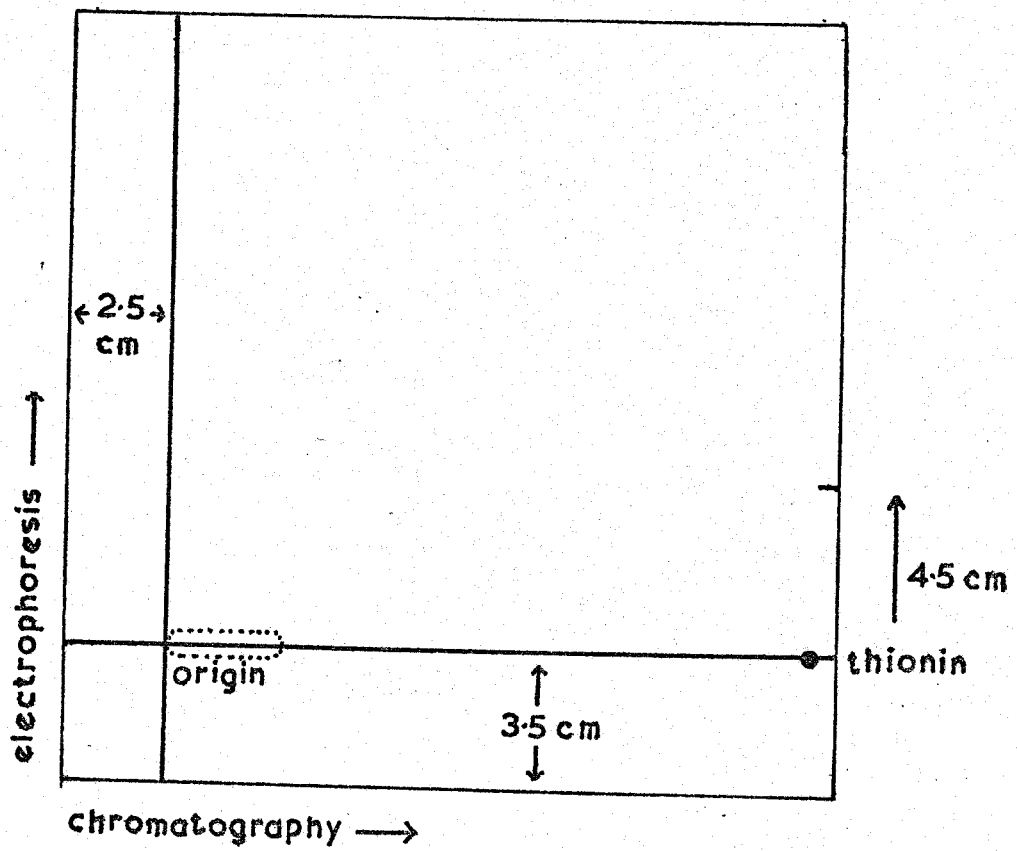

Fig. 1. Thin layer plate for 2-dimensional separation of amino acids.

The method is described in the text.

against the layer and also prevented evaporation from the surface of the layer. Running tap water was used for cooling. 1000V (10-20mA) was applied until the thionin marker had migrated 4.5cm (25-35 min). The plate was then removed from the tank and blown dry in the hot air stream from an industrial drier adapted for plate drying by the attachment to the nozzle of a closed cylinder of steel with a 20cm x 2mm slit on one side.

Prior to chromatography the electrophoretically produced bands were reduced to spots on the 2.5cm origin by dipping the plate into a tank of distilled water to within 1cm of the ends of the bands. The ascending water front was allowed to rise to the 2.5cm origin, when the plate was removed from the tank, blotted, and blown dry in the direction of the subsequent chromatography. For the chromatographic separation in the second dimension, the plate was chromatographed twice, first in methylethylketone-pyridine-water-acetic acid (70:15:15:2, by vol.) for 1.5h to separate threonine and glutamic acid and to remove interfering substances, and then in n-propanol-water-n-propylacetate-acetic acid-pyridine (120:60:20:4:1, by vol.) for 4h for the major separation. The plates were dried after each chromatography in the air draught in the fume cupboard. The plates were sprayed with ninhydrin reagent to detect amino acids or with aniline diphenylamine, aniline hydrogen phthalate or phloroglucinol reagents for sugars.

Sugars moved in chromatography only and were spread

out along the electrophoresis origin - the sugar and organic acid region of the chromatogram. Sugar mobilities, expressed as Rf relative to alanine, are listed in Table 2. Distances moved by amino acids were measured in both dimensions from the origin to the leading edge of the spot. Mobilities relative to alanine are listed in Table 3. An attempt was made to quantify the variation in amino acid mobilities with amino acid concentration, using standard mixtures of amino acids at each of three concentrations. The results, presented in Table 4, indicate very small variation in mobility. Variations in mobility for plant extract analyses were much larger.

Detection of sugars and amino acids on thin layers

Amino acids were detected by spraying with ninhydrin reagent. After spraying, the plate was blown dry in the air draught of a fume cupboard and then stored overnight in the dark. After a preliminary inspection to locate proline (which becomes dull brown on heating) the plate was heated to 80° for 15-20 min. This treatment revealed β -alanine and γ -aminobutyric acid which did not react with the reagent in the cold, unless present in high concentration.

Sugars were detected with one of three reagents:

(i) aniline hydrogen phthalate: the plate was sprayed with the reagent and then heated at 100° for 5 min. Sugars reacted to give brown spots.

(ii) phloroglucinol: the plate was sprayed with freshly mixed reagent and then heated to 105-110° for a few

minutes. Ketopentoses yield strong green colours and other ketoses yield pale yellow-browns with an intense green or yellow fluorescence in U.V. light.

(iii) aniline diphenylamine: the plate was sprayed with freshly mixed reagent and heated to 90-100° for a few minutes. Sugars react to yield green, blue, brown or pink colours which aid identification.

Table 2. Sugar distances on thin layers

	Distance(cm)	Aniline diphenylamine colour
rhamnose	13.6	yellow-grey
glucose	9.6	blue-grey
galactose	9.1	blue-grey
sucrose	8.6	pink-brown
fructose	10.3	pink
raffinose	5.7	purple
glucuronic acid	5.8	brown

2µg samples of each sugar were subjected to chromatography as in the TLE/TLC method. Distances were measured from the origin to the leading edge of the spot. Alanine distance was 7.7cm.

Table 3. Amino acid mobilities on thin layers

	Chromatography	Electrophoresis
CYS	0.34 ± 0.01	0.67 ± 0.01
ASP	0.63 ± 0.01	0.66 ± 0.01
ASN	0.63 ± 0.01	0.76 ± 0.01
GLN	0.76 ± 0.01	0.72 ± 0.01
GLU	0.86 ± 0.01	0.70 ± 0.01
SER	0.82 ± 0.01	0.85 ± 0.01
THR	0.97 ± 0.00	0.76 ± 0.01
PRO	1.02 ± 0.00	0.65 ± 0.01
DOPA	1.07 ± 0.01	0.51 ± 0.02
ALA	1.00	1.00
VAL	1.29 ± 0.00	0.81 ± 0.01
MET	1.34 ± 0.01	0.71 ± 0.01
TYR	1.29 ± 0.01	0.60 ± 0.01
PHE	1.46 ± 0.02	0.62 ± 0.04
TRP	1.39 ± 0.02	0.55 ± 0.01
ILE	1.45 ± 0.01	0.74 ± 0.02
LEU	1.51 ± 0.01	0.72 ± 0.02
GLY	0.79 ± 0.00	0.15 ± 0.01
LYS	0.42 ± 0.03	1.34 ± 0.03
HIS	0.45 ± 0.02	0.18 ± 0.02
ARG	0.59 ± 0.02	1.21 ± 0.04
γAB	1.06 ± 0.01	1.30 ± 0.02
αAB	1.15	0.88
βALA	0.90 ± 0.00	1.39 ± 0.03
OH-PRO	0.92 ± 0.01	0.58 ± 0.01
GLUC NH ₃	0.83 ± 0.02	0.93

Mobilities were determined using the distances from the origins to the leading edges of the amino acid spots. Mobilities given are means of up to ten samples. Spots were identified by running amino acid samples in small groups with alanine until all the spots in the standard mixture were known. A typical separation is illustrated in Results, Fig. 2-1.

Table 4a. Amino acid mobilities in TLE/TLC

	Chromatography		
	1 μ g	3 μ g	6 μ g
CYS	0.34(0.010)	0.32(0.015)	0.37(0.010)
ASP	0.64(0.010)	0.60(0.028)	0.64(0.000)
ASN	0.60(0.010)	0.62(0.036)	0.61(0.017)
GLN	0.73(0.010)	0.73(0.023)	0.73(0.010)
GLU	0.85(0.014)	0.84(0.029)	0.86(0.014)
SER	0.83(0.010)	0.82(0.009)	0.83(0.010)
THR	0.96(0.049)	0.98(0.010)	0.97(0.010)
PRO	1.02(0.014)	1.02(0.010)	1.02(0.014)
DOPA	1.04(0.010)	1.07(0.023)	1.05(0.000)
ALA	1.00	1.00	1.00
VAL	1.33(0.024)	1.33(0.012)	1.32(0.014)
MET	1.37(0.028)	1.38(0.024)	1.34(0.022)
TYR	1.34(0.022)	1.34(0.020)	1.31(0.022)
TRP	1.41(0.032)	1.42(0.030)	1.39(0.022)
ILE	1.48(0.032)	1.47(0.023)	1.45(0.024)
LEU	1.48(0.028)	1.51(0.024)	1.45(0.020)
PHE	1.52(0.032)	1.47(0.040)	1.48(0.026)
GLY	0.77(0.000)	0.77(0.013)	0.78(0.010)
ARG	0.44(0.024)	0.59(0.023)	0.49(0.024)
HIS	0.38(0.010)	0.52	0.53(0.026)
LYS	0.56(0.024)	0.46(0.031)	0.61(0.030)
γ AB	0.88(0.024)	1.08(0.022)	1.08(0.017)
BALA	1.09(0.017)	0.87(0.022)	0.89(0.014)

Mean mobilities relative to alanine are given with the standard deviations in brackets. 6 plates at each concentration were subjected to TLE/TLC.

Table 4b. Amino acid mobilities in TLE/TLC

	Electrophoresis		
	1 μ g	3 μ g	6 μ g
CYS	0.63(0.010)	0.65(0.031)	0.63(0.000)
ASP	0.63(0.010)	0.63(0.050)	0.61(0.010)
ASN	0.70(0.010)	0.73(0.015)	0.70(0.000)
GLN	0.67(0.014)	0.69(0.026)	0.66(0.014)
GLU	0.71(0.010)	0.72(0.018)	0.71(0.000)
SER	0.83(0.014)	0.84(0.013)	0.83(0.000)
THR	0.76(0.010)	0.77(0.023)	0.76(0.000)
PRO	0.66(0.014)	0.67(0.038)	0.66(0.000)
DOPA	0.51(0.014)	0.51(0.050)	0.52(0.000)
ALA	1.00	1.00	1.00
VAL	0.81(0.010)	0.82(0.020)	0.83(0.000)
MET	0.72(0.020)	0.71(0.027)	0.71(0.000)
TYR	0.62(0.020)	0.62(0.032)	0.63(0.000)
TRP	0.50(0.026)	0.51(0.041)	0.53(0.000)
ILE	0.63(0.022)	0.79(0.021)	0.64(0.000)
LEU	0.78(0.014)	0.77(0.021)	0.80(0.000)
PHE	0.76(0.020)	0.63(0.032)	0.77(0.000)
GLY	1.14(0.017)	1.12(0.016)	1.13(0.000)
ARG	1.35(0.049)	1.28(0.076)	1.41(0.028)
HIS	1.27(0.035)	1.27	1.34(0.010)
LYS	1.30(0.036)	1.40(0.058)	1.31(0.022)
γ AB	1.37(0.057)	1.42(0.061)	1.38(0.036)
BALA	1.36(0.054)	1.44(0.079)	1.40(0.041)

Mean mobilities relative to alanine are given with the standard deviation in brackets. 6 plates at each concentration were subjected to TLE/TLC.

9. Kjeldahl nitrogen determination

The method used was that of Thurman and Boulter (1966). About 30mg of the air dried insoluble plant fraction was weighed accurately into a pyrex tube (50 x 16mm). 10mg mercuric oxide and 0.75g of potassium sulphate were added, followed by 0.5cm³ 36N sulphuric acid. The cake of potassium sulphate was dissolved by gentle heating and the test tube was placed in a hole (17mm diameter) in a cylindrical aluminium block (13cm diameter x 7cm) and heated by means of gas to 387°. After charring was complete the mixture was heated for a further 30 min when the test tube was removed from the block and allowed to cool for 3 min. 3cm³ water was added dropwise and the precipitate dissolved by gentle heating. The solution was then quantitatively transferred to a 10cm³ volumetric flask. A reagent blank was subjected to the same digestion procedure.

Ammonia was determined using Conway units which had been cleaned as described by Conway (1957). 1cm³ of boric acid-mixed indicator reagent was pipetted into the centre well of the unit and 1cm³ of the digest solution into the outside compartment. The lid of the unit was smeared with water-soluble fixative (Conway, 1957) and then placed over the unit leaving a small gap. 1cm³ potassium hydroxide-sodium thiosulphate reagent was pipetted into the outer compartment, the lid was moved to cover the unit, and the solutions were mixed by gentle tilting. After

16-17h on the bench, the boric acid in the centre well was titrated against standard 0.02N sulphuric acid, using a Conway burette and stirring with a fine glass rod. The first permanent pink colour of the indicator was taken as the end point.

0.02N sulphuric acid was prepared from analar concentrated acid and standardised against standard sodium carbonate solution using thymol blue-cresol red mixed indicator. (Vogel, 1962).

10. Autoanalysis of amino acids

Autoanalysis of amino acids in plant extracts was carried out using a new Technicon short column autoanalyser. Hydrolysed samples, of both soluble and insoluble fractions, were separated into their constituent amino acids in 3h runs.

The sample (10-400 μ l containing 0.2 - 5.0 μ moles total amino acids) was loaded manually on the top of a 30cm column of C3 resin. The resin, packed in a 35 x 0.6cm glass column, was maintained at 60 $^{\circ}$ with a Haake bath connected to the column water jacket. Buffers were introduced stepwise via a Technicon automatic column shutdown programmer and were pumped with a Technicon positive displacement pump at a flow rate of 0.56 cm³ min⁻¹. This caused a back pressure of 300-400 p.s.i. The column effluent was introduced, via an A10 fitting, directly into a stream of hydrazine sulphate reagent, segmented with bubbles of nitrogen.

The analytic system consisted of a Technicon

autoanalyser proportioning pump III; cartridge (comprising three six turn mixing coils (170-0103), two nitrogen bubblers (177-B004-01 and 177-B004-02) and a cell counter wash valve); a 95° fixed temperature heating bath fitted with 12m x 2.4mm coils whose arms were reduced to 1.6mm; an RSS colorimeter recording at 570 and at 440m μ ; and a standard two pen recorder. The cell counter wash valve was used manually to select either the segmented hydrazine and external standard stream or the segmented hydrazine and column effluent stream. All these items are described in the Technicon parts list. The flow diagram is illustrated in Fig. 2. 1.6mm internal diameter glass was used wherever possible for connections, and otherwise 0.030 tygon.

The buffers, whose composition has already been described, were run as follows:

pH	3.25	40 min
	4.25	35 min
	7.50	75 min

The pH of buffers 1 and 2 was critical to 3 decimal places, very slight changes having a marked effect on the elution pattern. The pH's given were chosen for optimum separation of serine and threonine, and of cystine and valine. If the time of buffer 1 is increased by 5-10 min cystine is eluted as a broad, flat peak, well separated from both alanine and valine. This method was not used in the present work as cystine was present in very small quantities in most samples

and so could be more accurately determined as a short sharp peak on the front of buffer 2. The pH of buffer 3 was not critical and could be varied between pH 6.5 and 8.0 without markedly affecting the elution pattern.

The column was regenerated with 0.2N sodium hydroxide for 5 min and equilibrated with pH 3.15 buffer for 15 min. Cleaning the analytical system is described in the standard Technicon procedure (Instruction Manual, AAA-1, 1967).

Charts were integrated by hand by measuring peak height, and peak width at half height, to the nearest 0.5mm. The product of these measurements was used as peak area. Colour factors for each amino acid were determined using standard mixtures. An internal standard of known concentration was included in all runs. For protein hydrolysates norleucine was used, but for soluble amino acid extracts this was not possible as dihydroxyphenylalanine runs on top of norleucine. In these runs taurine was used as internal standard. A standard analysis chart is included in the back cover of the thesis.

For the determination of specific activities of amino acids, the column effluent was split at the bottom of the column. One portion of the stream ($0.36 \text{ cm}^3 \text{ min}^{-1}$) was directed into the analytical system as usual. The other portion ($0.20 \text{ cm}^3 \text{ min}^{-1}$) was segmented with nitrogen ($0.03 \text{ cm}^3 \text{ min}^{-1}$) and drawn off through the proportioning pump to a fraction

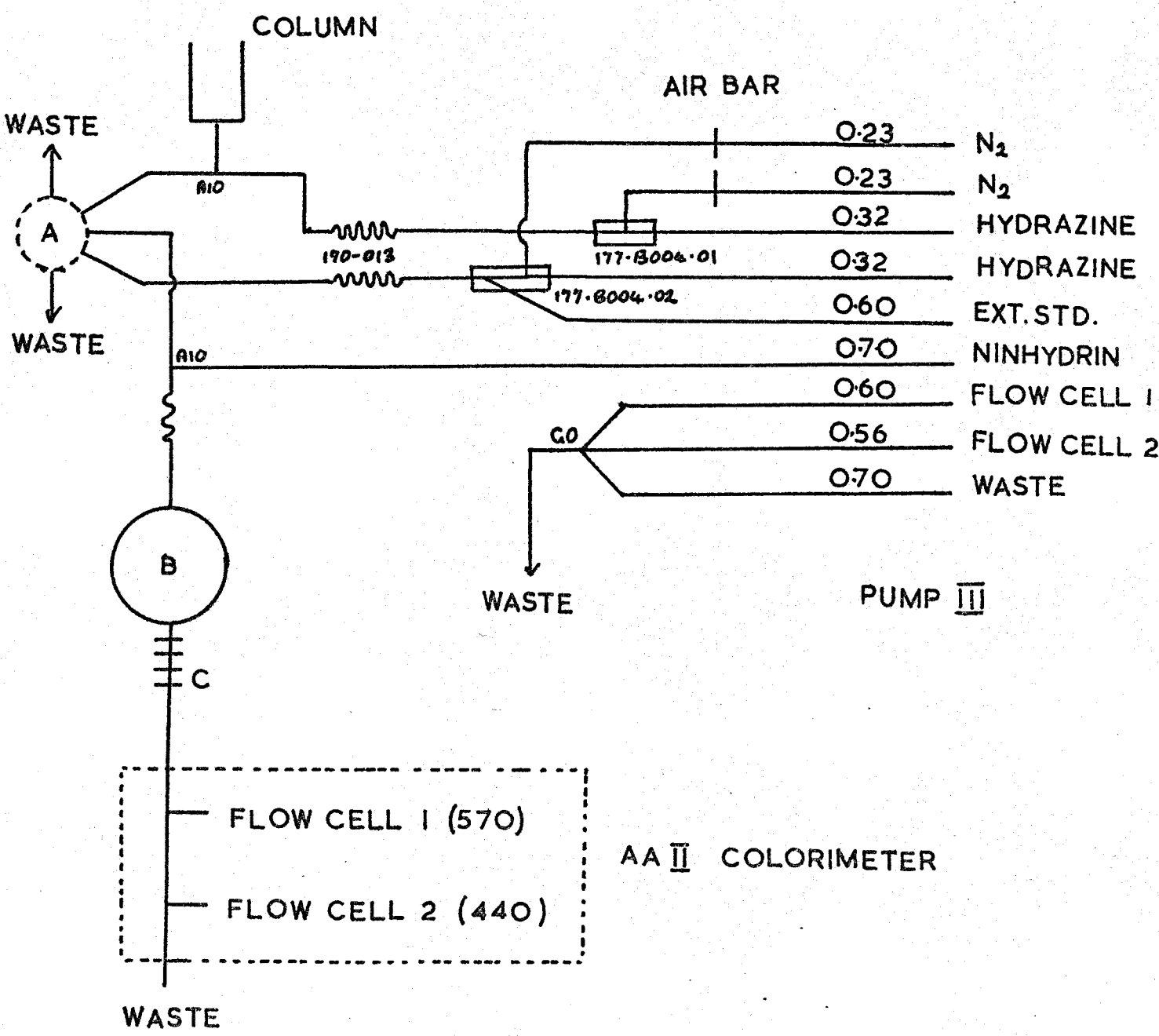

A : CELL COUNTER WASH VALVE
 B : 95° HEATING BATH

Fig. 2. Flow diagram for Autoanalyser system.

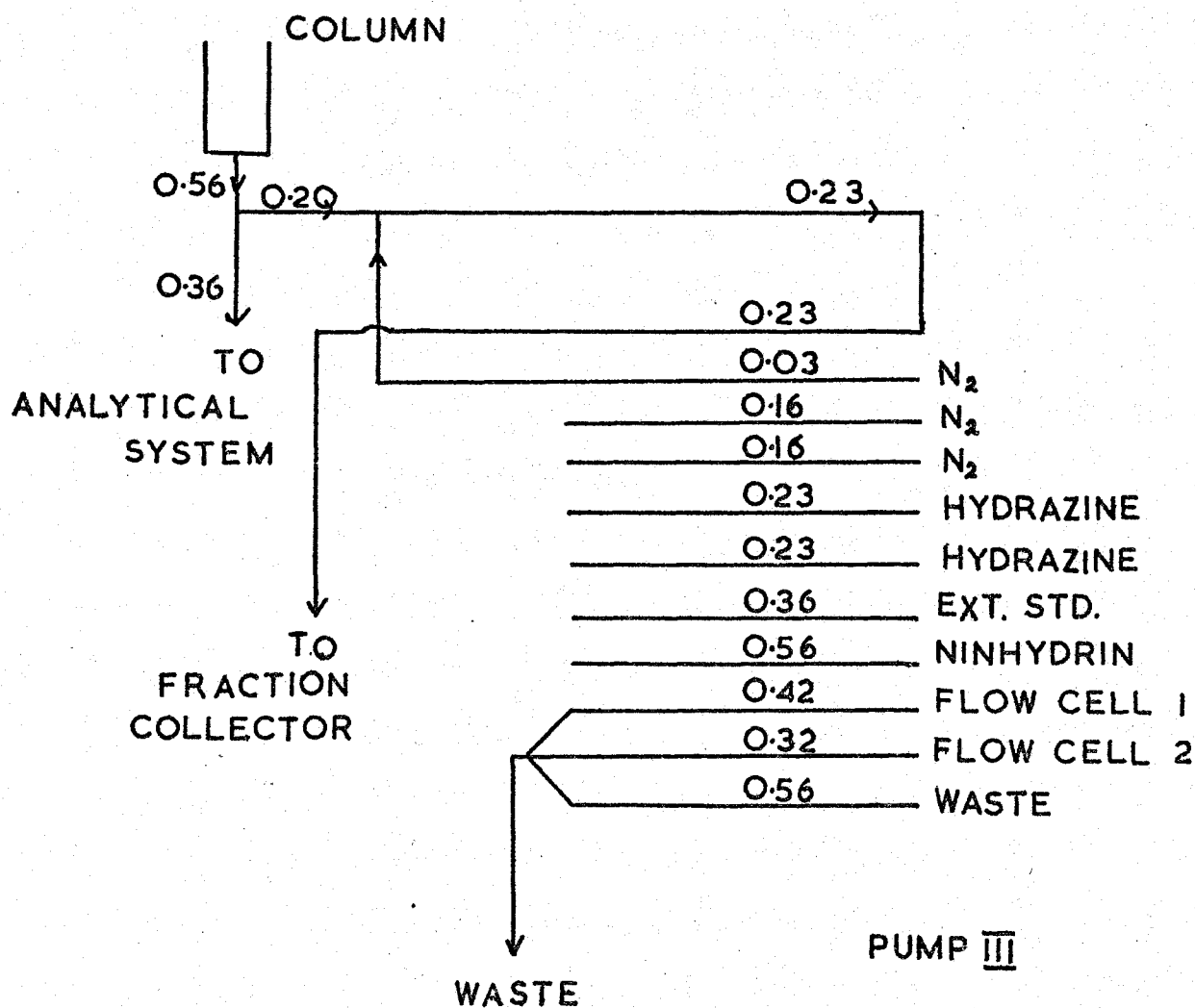

Fig. 3. Modified pump manifold for the autoanalyser system. The column effluent is split as it emerges from the column. $0.20\text{cm}^3/\text{min}$ is segmented with $0.03\text{cm}^3/\text{min}$ nitrogen and drawn off through the pump to the fraction collector. The remaining effluent is injected into the modified analytical system.

collector, where 1 min fractions for counting were collected directly on planchets. For counting low specific activities, maximum column loadings were used (up to 0.25 μ mole of each amino acid). This involved reduction of colorimeter sensitivity (to about 0.5) and alteration of the proportioning pump manifold. The new manifold is illustrated in Fig. 3.

11. Radioactive counting

Planchets were prepared for counting by a modification of the method of Newton (1957).

A disc of lens tissue, cut to fit the 21mm diameter aluminium planchet, was placed on the planchet together with one drop of each of 0.2% (w/v) cetyltrimethyl-ammonium bromide, and 1% (w/v) polyvinyl alcohol. 0.20cm³ sample was pipetted on top using a 0.20cm³ capillary pipette, and the preparation was dried under an infra red lamp.

Dry planchets were counted with a thin end window Geiger-Müller tube in a lead castle connected to an IDL (Isotopes Developments Ltd., Berkshire) scalar 1700. Samples were prepared in duplicate and each planchet was counted twice. The mean of the four results thus obtained was used in all further calculations. All samples were counted at least to the first of 1000 counts or 1000 sec, and no samples were counted for less than 60 sec. Background was counted for 30 min. Using this method, the standard deviation on the count for a sample was always less

than 4%. Errors are discussed later.

For the determination of specific activity of samples subjected to autoanalysis, fractions of column effluent (0.2cm^3) were collected directly on to planchets prepared as described previously. After drying, these samples were counted for 10 or 20 min on a Tracerlab spectro/matic gas flow counter. These samples were not duplicated and background was determined from the 'baseline' of the series of counts.

Counter characteristics are described in Preliminary Results.

12. Autoradiography

Autoradiographs were prepared of samples separated into components by TLE/TLC on thin layer plates, using Ilford Red Seal X-ray film. The film, $16.5 \times 21.6\text{cm}$, was fixed to the plate using wooden spring clothes pegs, and the plate was then wrapped in a brown envelope and two black polythene bags with the open ends alternating. The whole was stored in the dark for 10, 20 or 30 days for radioactivities of 1000-2000, 100-1000, or 50-100 cpm per plate, respectively. (IDL scalar 1700). The film was developed for 5 min in Phen-X X-ray developer (Ilford) and fixed in Ilfofix. The film was washed in running water for 2-12h, and when dry, matched against the sprayed thin layer plate. Plates and autoradiographs were recorded by tracing on to thin paper.

DERIVATION OF METHODS

1. Collection of bleeding sap
2. Preparation of plant extracts
3. A marker for thin layer electrophoresis
4. The Technicon Autoanalyser

1. Collection of bleeding sap

Collection of sap from plant stumps is described by Wieringa and Bakhuis (1957), Bollard (1960) and Pate (1962). The rubber tubing described by these authors for the collection of sap from decapitated pea plants was found to damage bean stem tissue to the extent that no bleeding occurred. The 'parafilm' tube used in the present experiments was sealed by hand and eased over the stump, which had previously been smeared with white paraffin wax. The 'parafilm' and white paraffin wax were tested for amino acid elution from or contribution to the sap as follows:

0.5cm³ of each of two standard mixtures of amino acids containing 1.0 and 0.1µmole per cm³ of each amino acid was placed in a parafilm tube sealed on to the end of a glass rod with white paraffin wax. After 1h the samples and the original solutions, were dried down and analysed by dansylation and polyamide thin layer chromatography. No differences between the tested samples and the controls were observed. Since the parafilm and white paraffin wax contributed no detectable amino acids to the standard mixture, it was assumed that they would contribute nothing to the sap.

2. Preparation of plant extracts

The extraction method is based on that of Bagdasarian et al (1964), modified for use in

centrifuge tubes rather than sintered glass filters. An extraction in centrifuge tubes for microorganisms is described by Newton (1957).

a. Selection of method. Two extraction methods were compared:

(i) 0.531g (fresh weight) of leaf was cut with scissors into a glass mortar and ground with 2cm^3 5% TCA, transferred to a centrifuge tube and placed in ice for 1h. After centrifuging for 10 min ($\sim 3000g$), the supernatant (extract 1) was decanted and the pellet resuspended in 2cm^3 5% TCA for 30 min - extract 2. The extraction was repeated twice. $60\mu\text{l}$ of each extract was spotted on to 3MM chromatography paper, dried, and dipped in ninhydrin reagent. The paper was heated, using a hairdryer, for 20 min to develop the ninhydrin colour. Spot 3 was very faint; 4 was colourless. The pooled extracts were ether washed, evaporated to dryness and taken up in 1cm^3 water. $50\mu\text{l}$ lots of this solution were subjected to TLE/TLC in triplicate.

(ii) 0.528g (fresh weight) of leaf was ground with $0.5-1.0\text{cm}^3$ 10% cold TCA and a little sand, filtered by suction through a sintered glass filter of porosity 2 and the filtrate collected (extract 1). The pellet was returned to the mortar and reground with $0.5-1.0\text{cm}^3$ 5% TCA, four times. $30\mu\text{l}$ of each filtrate was spotted on paper and stained with ninhydrin as before. Spot 5 was colourless. The extracts were pooled, concentrated and subjected to TLE/TLC as before.

All six thin layer plates revealed that the extracts contained the same amino acids in closely comparable concentrations. In fact, the concentration differences between replicates of the one sample were at least as great as those between samples. The two methods were assumed to have comparable extraction power.

With further use, method (ii) proved to be impracticable because sintered glass filters blocked faster than they could be cleaned.

b. The time for the first extraction in method (i) was varied as follows:

Twelve similar leaf samples weighing 0.4-0.7g were picked from node 6 of glasshouse-grown plants and extracted according to method (i). The time of the first extraction was varied, with 6 samples having a 1h extraction and 2 samples having each of 2h, 6h and 24h extractions. TLE/TLC, as before, revealed only minor differences between the extracts with as much variability between the six 1h extractions as between those extracted for different times.

Time of first extraction was, then, assumed to be unimportant, within these limits, and reproducibility was shown to be adequate for at least qualitative comparison of extracts on plates.

c. The number of extractions necessary was determined as follows:

Seven leaf samples weighing 0.4-0.8g were extracted as in method (i), using seven extracts of each.

30 μ l of each extract was spotted, on to a thin layer plate, and, after spraying with ninhydrin, colour was allowed to develop overnight in the dark. Heating to 80 $^{\circ}$ for a few minutes then produced the results listed in Table 5. In only one case did the fifth extract produce a coloured spot, and the sixth and seventh extracts contained no detectable amino acids.

Five extractions were routinely used.

Extraction volumes were 1.5-2.0cm³ per g fresh weight of tissue.

Table 5. Ninhydrin colour for repeated extractions

Sample Fresh wt.(g)	Extracts						
	1	2	3	4	5	6	7
0.57	10+	4+	+	f	-	-	-
0.52	10+	4+	+	f	-	-	-
0.52	10+	4+	+	f	-	-	-
0.49	10+	4+	+	f	-	-	-
0.54	10+	4+	+	f	-	-	-
0.54	10+	4+	+	f	-	-	-
0.72	10+	4+	+	+	f	-	

f = faint, - = absent, + = 4xf

d. Breakdown of amino acids and amides by 5% TCA was investigated as follows:

1cm³ aliquots of solutions of alanine, asparagine and glutamine (0.1mg/cm³) were each mixed with 1cm³

10% (w/v) TCA and the mixtures allowed to stand overnight at 0-4°. The TCA was removed by ether washing and the solutions freeze-dried. The residues were taken up in 2cm³ water and their concentrations compared with those of the original solutions by aspiration through the external standard line of the Technicon autoanalyser. Calibration curves produced by dilution of the untreated solutions are shown in Fig. 4. The concentrations of test solutions are compared with their theoretical values in Table 6. Reductions in concentration occurred in all of the tested solutions. These reductions were 10% for asparagine, 12% for alanine and 14% for glutamine.

Table 6. TCA breakdown of amino compounds

	Optical Density (autoanalyser)				Concentration Decrease	
	1	2	3	MEAN	(mg/cm ³)	%
ASN	43.4	43.4	44.8	43.9	0.045	10
ALA	61.5	64.5	57.6	61.2	0.044	12
GLN	46.7	48.8	54.5	50.0	0.043	14

Solutions of asparagine, alanine and glutamine were treated with 5% TCA, ether washed and then freeze-dried. The dry residues were taken up in water such that the final concentrations would be 0.05 mg/cm³ if no loss had occurred. The concentrations were determined from the calibration curves in Fig. 4.

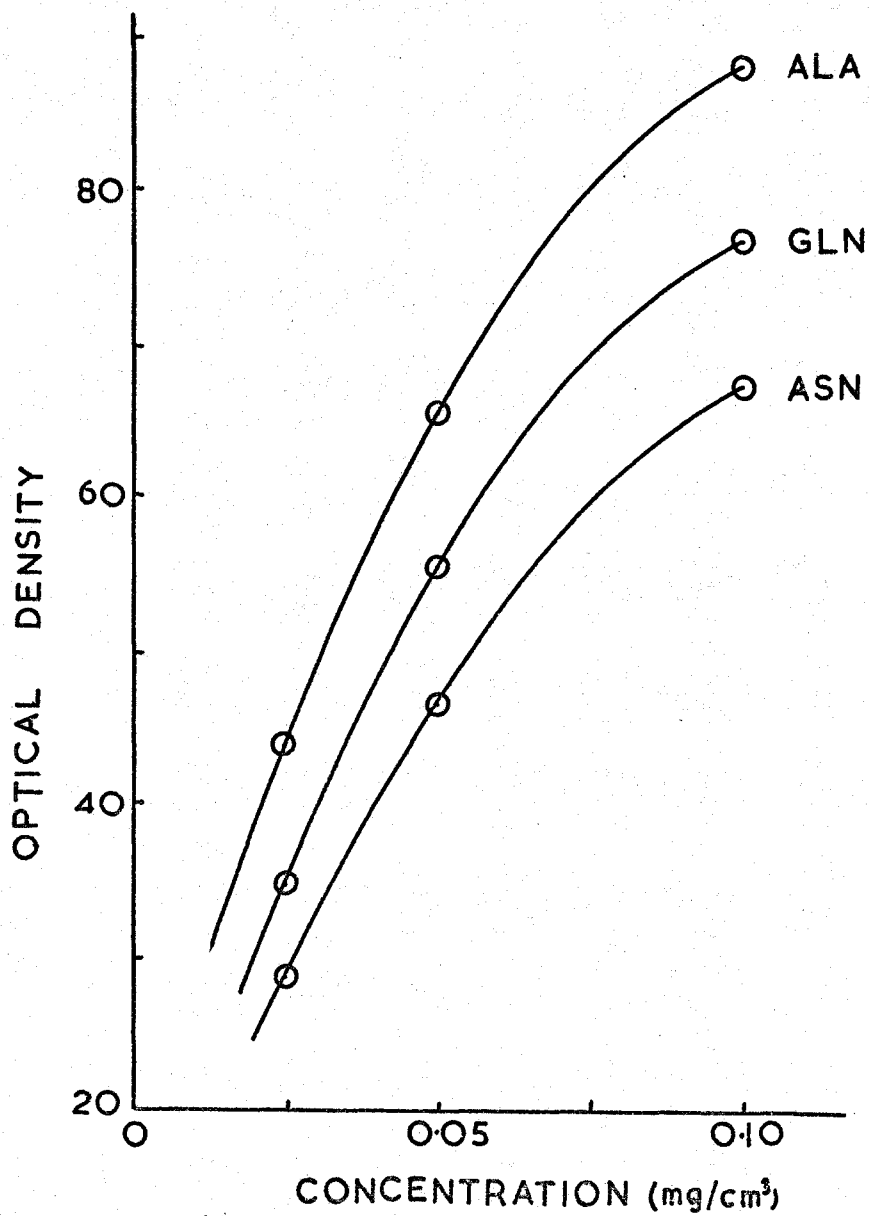

Fig. 4. Calibration curves for external standards. The standard solutions were aspirated through the external standard line of the autoanalyser, and the chart readings (optical density) plotted against concentration. The lack of linearity is due to saturation of the ninhydrin colour and is not a characteristic of the instrument.

e. Pellet extraction with phenol-acetic acid-water

Bagdasarian et al (1964) extracted the nitrogenous components from their dry leaf pellets with phenol-acetic acid-water, (PAW) 1: 1: 1 (w/v/v). This method was compared with simple hydrolysis of the pellet.

(i) Number of extractions necessary.

Insoluble fractions (pellets) were prepared from four leaf samples of fresh weight 0.4-0.6g. The pellets were suspended in 1cm^3 PAW and left at 0° overnight. After centrifuging (10 min, full speed small MSE, $\sim 3000\text{g}$) the pellets were resuspended in PAW for 30 min. Six extracts of each pellet were collected. The extracts were evaporated to dryness in a rotary evaporator at 40° , and phenol was removed by repeated addition of water followed by evaporation to dryness. The evaporation flasks were rinsed twice with 0.5cm^3 6N hydrochloric acid, and the rinsings were transferred to a pyrex tube for hydrolysis in the normal way. $10\mu\text{l}$ of the hydrolysed extracts was spotted on to a thin layer plate, sprayed with ninhydrin and left overnight before heating at 100° for 20 min. Colour development is recorded in Table 7. In no sample did the sixth extract give a positive ninhydrin reaction.

These results show considerable between sample variation. In order to avoid this, in further work the PAW extracts were pooled in a pyrex tube, rotary evaporated directly from this tube, hydrolysed in the tube, and then the acid removed by rotary evaporation from the tube. This improved reproducibility.

Table 7. Ninhydrin reaction with PAW extracts

Fresh weight of sample(g)	Extracts					
	1	2	3	4	5	6
0.45	4+	4+	+	f	f	-
0.51	6+	2+	+	+	f	-
0.58	2+	+	f	f	-	-
0.50	2+	2+	+	f	-	-

ninhydrin colour: f = faint, + = 4xf, - = absent.

Extracts 1-6 were successive PAW extracts of dried leaf pellets. The phenol was removed and the pellets hydrolysed before spotting and staining with ninhydrin.

(ii) Comparison of PAW extraction with simple pellet hydrolysis.

A pellet prepared from mature seeds was ground in a mortar until homogeneous and four 10mg samples were accurately weighed. Samples 1 and 2 were weighed directly into pyrex tubes for hydrolysis. Samples 3 and 4 were weighed into centrifuge tubes and extracted five times with PAW. The extracts were hydrolysed as described above. Samples 1 and 3 were hydrolysed for 24h; 2 and 4 were hydrolysed for 72h. The hydrolysates were analysed by autoanalyser and the results are listed in Table 8. All four samples were closely comparable, although there were greater differences between the 24h and 72h hydrolyses for samples 1 and 2 than for 3 and 4. It is to be expected

Table 8. Amino acids in seed protein extracted by two methods

	1	2	3	4
ASP	0.110	0.129	0.093	0.108
THR	0.038	0.048	0.037	0.042
SER	0.055	0.045	0.059	0.057
GLU	0.160	0.188	0.162	0.156
PRO	0.052	0.052	0.042	0.045
GLY	0.081	0.090	0.071	0.079
ALA	0.057	0.067	0.059	0.069
CYS	0.019	0.019	0.020	0.020
VAL	0.052	0.067	0.049	0.057
MET	0.002	0.012	0.005	0.005
ILE	0.040	0.055	0.037	0.048
LEU	0.074	0.090	0.071	0.074
TYR	0.026	0.033	0.020	0.020
PHE	0.031	0.043	0.029	0.030
HIS	0.026	0.026	0.020	0.025
LYS	0.067	0.083	0.048	0.059
ARG	0.040	0.076	0.049	0.054
AMINO-N(μ g)	16.3	16.8	14.8	14.2
Kjeldahl-N(μ g)	17.1	17.1	17.7	17.7

Amino acid quantities are expressed in μ moles per mg insoluble seed fraction. The four treatments were as follows:

1. 24h hydrolysis of dry pellet
2. 72h hydrolysis of dry pellet
3. 24h hydrolysis of PAW extract of dry pellet
4. 72h hydrolysis of PAW extract of dry pellet

Amino-N was determined by summing the amino acids.

Kjeldahl-N was determined for 1 and 2 directly on the pellet, and for 3 and 4 on the PAW extract of the pellet.

that more amino acid breakdown will occur in hydrolysis of a crude sample.

The weight of nitrogen per mg sample was calculated from the amino acid analysis and from a Kjeldahl digestion of similar extracts. These figures are included in Table 8. Since ammonia was not estimated in the autoanalysis, these figures must be low by an amount representing amide nitrogen. There is much better agreement between the nitrogen determinations for samples 1 and 2 than for 3 and 4.

Simple hydrolysis of pellets was used in all later experiments.

3. A marker for thin layer electrophoresis

A number of dyes thought to carry a positive charge at pH 2 were run in electrophoresis as described in the TLE/TLC method. Mobilities were recorded and the dry plate was immersed in distilled water to test the effect of the elution bath. A fast moving dye which did not smear when immersed in water was required. The results are given in Table 9, as distances moved by dye spots for a lysine distance of 14.4cm.

Thionin was selected as an appropriate marker. Thionin (Ehrlich), Michrome number 215, has a molecular weight of 264 and is obtained as the chloride, $C_{12}H_{10}N_3SCl$. An approximately 1%, (w/v), solution in 95% (v/v) ethanol was prepared, and about 5 μ l used as marker.

Table 9. Mobilities of dyes in electrophoresis

Dye	Distance(cm)	Elution bath
toluidine blue	0.7	no change
methyl violet	1.3	no change
malachite green	1.4	smear
thionin	3.2, 1.7	no change
iodine green	-3.0	no change
methylene blue	0.9	smear
methyl green	1.2	no change

The dyes were dissolved in appropriate solvents and subjected to pH 2 electrophoresis for 35 min at 1KV as described in the TLE/TLC method. In this time lysine moved 14.4cm.

4. The Technicon Autoanalyser

The autoanalyser used in this work was developed during three months work in the Chertsey Laboratories of Technicon Instrument Company Limited. The column, resin, analytical system and buffer concentrations of the first two buffers had already been established by Mr. R. Jay of Technicon. Under his guidance I established the concentration of Buffer 3 and also developed the modified system for use with the fraction collector.

The pH and sodium concentration of buffer 3 were varied in order to minimise the time taken to elute the basic amino acids from the column. The

combinations used are listed in Table 10. Increasing the pH of the low molarity buffer had no effect on elution time, in the pH range 6.0-8.0. When the sodium concentration of the buffer was increased to 1.2M and the pH was above 6.1 (6.5 or over) the basic amino acids were eluted in 60 min. For the high molarity buffer, changing the pH between 6.5 and 8.0 had no effect on elution time.

The buffer finally chosen was pH 7.5, 1.2M Na⁺, and using this it was shown that the usual order of lysine and histidine was reversed. Basics were then eluted in the order histidine, lysine, ammonia, arginine.

Table 10. Effect of pH and sodium concentration on elution time of basic amino acids.

Buffer pH	Na ⁺ molarity	Time for elution of basic amino acids (min)
6.0	0.37	140
6.5	0.37	140
7.5	0.37	140
8.0	0.37	140
8.0	0.80	140
8.0	1.20	60
6.1	1.20	100
6.5	1.20	60
7.0	1.20	60
7.5	1.20	60

The buffers were prepared as described in 'Solutions'. pH was varied by titration with 2N sodium hydroxide. Na⁺ molarity was varied by using different amounts of sodium chloride. Elution times are for the 30cm column of the Technicon Autoanalyser.

PRELIMINARY RESULTS

1. Automatic amino acid analysis
 - (i) Integration of analyser charts
 - (ii) Reproducibility of analysis

2. Kjeldahl nitrogen determination
 - (i) Reproducibility of titration
 - (ii) Reproducibility of digestion
 - (iii) Variability of sampling

3. Plant extraction procedure - soluble fraction
 - (i) Reproducibility

4. Protein hydrolysis
 - (i) Reproducibility
 - (ii) Effect of hydrolysis time

5. Radioactivity measurement
 - (i) Scalar 1700, Isotope Developments Ltd.
 - (ii) Summary of errors for Scalar 1700
 - (iii) Tracerlab spectro/matic Gas Flow Counter
 - (iv) Summary of errors for Gas Flow Counter
 - (v) Autoradiography

6. Calculations and Errors
 - (i) cpm/mg
 - (ii) $\mu\text{Ci}/\text{mg}$
 - (iii) $\mu\text{mole}/\text{mg}$
 - (iv) $\mu\text{Ci}/\mu\text{mole}$
 - (v) plant variability
 - (vi) curve fitting
 - (vii) computing.

1. Automatic amino acid analysis

(i) Integration of analyser charts

The Autoanalyser II system used produced a continuous (not dotted) plot on linear chart paper. The peaks had to be integrated by hand and so three methods of hand integration were compared with integration by the Technicon Integrator-Calculator. Six identical samples of an amino acid standard mixture were analysed and the charts sent to the Botany Department, Durham, for automatic integration on the Integrator-Calculator. Using the same baselines, the charts were integrated three more times.

(a) Integration by planimeter - each measurement was repeated until the result was reproducible.

(b) Integration by hand - the length in mm of each of the horizontal chart lines inside the peak was measured and the lengths added. This effectively divided the peak into rectangles measuring 1.0 x 1.25mm, the number of these rectangles under the peak being used to represent the area.

(c) The peaks were treated as triangles. The peak height and peak width at half height were measured to the nearest 0.5mm. The product of these two numbers was used to represent peak area.

Colour factors were determined for each amino acid for each integration method and these were averaged for the six charts. The mean colour factors and their standard errors are presented in Table 11.

Table 11. Colour factors by different integration methods

	Integrator	Planimeter	Hand	h _{xw}
ASP	0.97 ± 0.010	0.96 ± 0.025	0.99 ± 0.013	1.02 ± 0.020
THR	0.98 ± 0.020	0.98 ± 0.031	0.99 ± 0.020	1.00 ± 0.024
SER	0.90 ± 0.017	0.87 ± 0.028	0.90 ± 0.014	0.98 ± 0.019
GLU	0.94 ± 0.014	0.93 ± 0.023	0.94 ± 0.013	0.98 ± 0.016
PRO	N.D.	0.47 ± 0.024	0.52 ± 0.026	0.52 ± 0.017
GLY	0.89 ± 0.010	0.87 ± 0.025	0.90 ± 0.014	0.92 ± 0.020
ALA	0.97 ± 0.032	0.95 ± 0.039	0.98 ± 0.028	0.99 ± 0.040
CYS	1.26 ± 0.062	1.23 ± 0.046	1.29 ± 0.034	1.29 ± 0.018
VAL	0.87 ± 0.026	0.80 ± 0.025	0.83 ± 0.013	0.95 ± 0.015
MET	1.45 ± 0.057	1.38 ± 0.053	0.43 ± 0.048	1.48 ± 0.056
ILE	0.97 ± 0.014	0.94 ± 0.027	0.99 ± 0.013	0.98 ± 0.018
LEU	0.90 ± 0.014	0.85 ± 0.019	0.89 ± 0.013	0.88 ± 0.016
TYR	0.90 ± 0.000	0.87 ± 0.024	0.83 ± 0.025	0.88 ± 0.017
PHE	0.86 ± 0.014	0.85 ± 0.026	0.87 ± 0.014	0.86 ± 0.009
HIS	0.82 ± 0.014	0.80 ± 0.021	0.83 ± 0.018	0.83 ± 0.044
LYS	0.78 ± 0.000	0.77 ± 0.021	0.79 ± 0.005	0.83 ± 0.027
ARG	0.80 ± 0.030	0.80 ± 0.027	0.80 ± 0.026	0.85 ± 0.026

The four methods of integration are described in the text. Norleucine was used as an internal standard and colour factors were determined as equal to

$$\frac{\text{area norleucine peak}}{\text{area of amino acid peak}}$$

for equal quantities (in μmoles) amino acid.

of norleucine and the

For all colour factors except that of cysteine, the errors were smallest for integration by hand and largest when peak area was measured by planimeter. The Integrator-Calculator and height x width methods produced errors of similar sizes. The planimeter method was discarded. Integration by hand was too time consuming for routine use, and so charts were integrated using peak area = height x width. This method reduced by at least half, as compared with any other method, the error on the colour factor of cysteine. Cysteine is eluted as a very tall spiky peak which is difficult to integrate by most methods.

(ii) Reproducibility of Autoanalysis

Reproducibility of autoanalysis can be estimated from the standard errors in Table 11. Errors vary from 1.6% of the mean for valine to 5.3% for histidine, but for most amino acids the standard error on the colour factor is about 2%.

2. Kjeldahl nitrogen determination

(i) Microdiffusion in Conway units - reproducibility of titration

Aliquots of standard solutions of ammonium sulphate were set up in triplicate for microdiffusion in Conway units. After titration with standard sulphuric acid, the apparent concentrations of the ammonium sulphate solutions were calculated, and are listed in Table 12,

together with their standard errors. The titration results yielded values for the apparent normalities of the ammonium sulphate solutions which were very close to the actual normalities. Standard error of titration was in all cases less than 1%.

Table 12. Microdiffusion in Conway units of standard ammonium sulphate solutions

Normality of (NH ₄) ₂ SO ₄	Mean titre H ₂ SO ₄ (cm ³)	Apparent normality of (NH ₄) ₂ SO ₄
0.0100	0.477±0.008	0.0100±0.0001
0.0050	0.235±0.002	0.0049±0.0001
0.0025	0.119±0.002	0.0025±0.0001

1cm³ samples of the ammonium sulphate solutions were left to diffuse in the Conway unit for 17h. Titration with standard 0.021N sulphuric acid produced the above results. Means are of six titrations.

(ii) Reproducibility of digestion

The Kjeldahl digestion and titration was performed on samples of dried milk, which was chosen for the purpose as it could readily be ground to a fine homogeneous powder. Sampling error could thus be minimised.

Six samples of dried milk were accurately weighed and subjected to microdigestion as described in Methods.

Microdiffusion and titration of the resulting solutions revealed that the powder contained 4.5-5.0% nitrogen. These results are presented in Table 13. The percentages of nitrogen were calculated by substitution in the equation

$$\%N = 10 \times \frac{V_2 - V_1}{1000} \times NA \times \frac{14.01}{Wg} \times 100$$

where V_2 is the volume in cm^3 of H_2SO_4 used in titration of the sample

V_1 is the H_2SO_4 titre in cm^3 for the blank

NA is the normality of the acid

Wg is the weight in gram of the sample.

This relationship can readily be derived from the method details and the equations for the microdiffusion and titration.

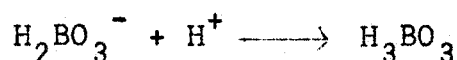
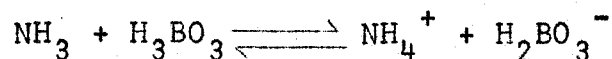

The error on the percentage of nitrogen, determined by this method, is about 1.5% of the mean. This is smaller than the 2% error on the calculated normality of ammonium sulphate solutions, for comparable sulphuric acid titre. It is, then, concluded that the error in the Kjeldahl determination of nitrogen is of the order of 2% and is principally due to titration errors.

Table 13. Percentage nitrogen in replicate samples of dried milk.

Weight of sample(mg)	Mean titre H_2SO_4 (cm ³)	% Nitrogen in sample	Mean % Nitrogen
11.7	0.245 ± 0.005	4.64	
13.0	0.266 ± 0.002	4.73	
14.2	0.302 ± 0.007	4.91	
13.7	0.296 ± 0.005	5.00	
11.9	0.251 ± 0.002	4.87	
12.8	0.277 ± 0.010	5.01	4.85 ± 0.073

'Mac' instant low fat skimmed milk was used in these digestions. Titration of the digest solutions with standard 0.0165N sulphuric acid yielded the above results. Multiplication by the usual factor of 6 to convert %N to % protein (Thurman and Boulter, 1966), gives a value only slightly below the 30% protein claimed for this product by the manufacturer. Mean titres of sulphuric acid are obtained from four titrations of the one digest solution.

(iii) Sampling error for insoluble plant fractions

Six samples of an insoluble seed fraction were subjected to analysis by Kjeldahl digestion and determination of ammonia. Percentage nitrogen in each sample is listed in Table 14. The mean percentage nitrogen in the insoluble seed fraction was 2.84 ± 0.18 . The error in the determination was 6%. This is larger than the titration errors determined for the method, and the difference must be related to sampling error.

Insoluble plant fractions were not, in general, homogeneous, but contained particles of two sizes. Fine particles were mixed with fibrous material, and the proportions of the two in a sample could possibly determine its protein content. This would particularly be so if the fibrous material were partly cellulose and the fine particles were precipitated cytoplasmic protein.

Table 14. Percentage nitrogen in an insoluble seed fraction

Weight of sample(mg)	Mean titre H_2SO_4 (cm ³)	%N	Mean % N
31.4	0.361	3.38	
31.0	0.272	2.58	
31.6	0.233	2.17	
33.0	0.362	3.23	
30.6	0.278	2.67	
34.3	0.351	3.01	2.84 ± 0.18

The samples were all weighed from the one insoluble seed fraction prepared from a number of mature, but not stored, seeds. Mean titres of H_2SO_4 are from three titrations.

3. Plant extraction procedure - reproducibility

Nine similar leaves at nodes 7-9 were harvested at different times during 12h. Their soluble and insoluble fractions were prepared and analysed for amino acid content by autoanalysis. The results for the soluble fraction are presented in Table 15. No pattern of variation with time of day could be detected, and so calculation of means and errors could be used to estimate variability of plant material and of extraction procedure.

The standard error on the mean amount of amino acid in the fraction was different for different amino acids, but mostly in the range 15-20%. This is considerably larger than the error in autoanalysis, and represents the total variability in leaf material and extraction procedure for the soluble fraction.

4. Protein hydrolysis

(i) Reproducibility

The insoluble fractions of the leaves described in part 3 were hydrolysed for 24h and the hydrolysates analysed by autoanalyser. The results are presented in Table 16. Almost all the standard errors are in the

Table 15. Amino acid analysis of soluble leaf fractions

TIME OF DAY	10.30	11.30	12.00	12.30	14.00	14.30	15.00	15.30	16.00	MEAN
ASP	0.086	0.081	0.059	0.085	0.098	0.085	0.068	0.160	0.120	0.094 ± 0.010
THR	0.019	0.020	N.D.	0.024	N.D.	0.017	0.017	0.056	0.016	0.024 ± 0.005
SER	0.046	0.036	0.061	0.072	0.094	0.044	0.050	0.186	0.067	0.073 ± 0.015
GLU	0.124	0.096	0.092	0.132	0.124	0.110	0.078	0.245	0.113	0.124 ± 0.019
PRO	0.021	0.026	0.031	0.021	0.032	0.039	0.030	0.046	0.015	0.029 ± 0.003
GLY	0.049	0.053	0.051	0.079	0.038	0.045	0.051	0.157	0.060	0.068 ± 0.012
ALA	0.044	0.029	0.028	0.039	0.056	0.040	0.035	0.100	0.038	0.045 ± 0.007
VAL	0.013	0.014	0.012	0.020	0.036	0.017	0.015	0.047	0.013	0.021 ± 0.004
ILE	0.006	0.005	0.005	0.008	0.018	0.006	0.008	0.024	N.D.	0.010 ± 0.003
LEU	0.009	0.008	0.007	0.019	0.027	0.007	0.008	0.044	0.004	0.015 ± 0.004
DOPA	0.221	0.363	0.032	0.530	0.255	0.203	0.221	0.368	0.249	0.271 ± 0.046
TYR	0.026	0.021	0.015	0.022	0.017	0.005	0.015	0.037	0.019	0.020 ± 0.003
PHE	0.008	0.012	0.009	0.019	0.022	0.008	0.015	0.027	0.011	0.015 ± 0.002
YAB	0.021	0.013	0.012	0.017	0.015	0.026	0.017	0.037	0.013	0.019 ± 0.003
HIS	0.006	0.007	0.007	0.016	0.013	0.007	0.004	0.025	0.008	0.010 ± 0.002
LYS	0.014	0.013	0.015	0.032	0.030	0.009	0.016	0.028	0.014	0.019 ± 0.003
ARG	0.004	0.003	0.002	0.004	0.004	0.002	0.003	0.004	0.004	0.003 ± 0.000

ND. = not determined.

Amino acid quantities are in μ moles per mg extracted weight of leaf. Each analysis is of an extract of a single leaf from nodes 7, 8 or 9 on glasshouse grown plants with 15-20 nodes. Analyses were done with the Technicon autoanalyser. The values for aspartic and glutamic acids include their amides.

Table 16. Amino acid analysis of leaf protein

	10.30	11.30	12.00	12.30	13.00	15.00	15.30	16.00	MEAN
ASP	0.389	0.357	0.435	0.313	0.310	0.293	0.425	0.375	0.362 ± 0.019
THR	0.267	0.240	0.320	0.200	0.234	0.218	0.285	0.235	0.250 ± 0.014
SER	0.285	0.253	0.315	0.230	0.237	0.215	0.311	0.271	0.265 ± 0.013
GLU	0.414	0.382	0.465	0.329	0.372	0.310	0.425	0.380	0.385 ± 0.018
PRO	0.256	0.229	0.252	0.256	0.182	0.222	0.282	0.262	0.243 ± 0.011
GLY	0.467	0.444	0.519	0.382	0.397	0.411	0.500	0.440	0.445 ± 0.017
ALA	0.347	0.327	0.435	0.313	0.322	0.291	0.418	0.368	0.353 ± 0.018
CYS	0.028	0.043	0.018	0.020	0.021	0.024	0.033	0.020	0.026 ± 0.003
VAL	0.243	0.262	0.287	0.217	0.238	0.192	0.276	0.233	0.244 ± 0.017
MET	0.045	0.039	N.D.	0.036	0.039	N.D.	0.055	0.043	0.043 ± 0.003
ILE	N.D.	0.218	0.270	0.198	0.206	0.107	0.272	0.221	0.213 ± 0.021
LEU	0.331	0.308	0.366	0.286	0.302	0.246	0.386	0.303	0.316 ± 0.016
TYR	0.141	0.126	0.152	0.124	0.121	0.122	0.162	0.133	0.135 ± 0.005
PHE	0.139	0.191	0.255	0.190	0.201	0.171	0.241	0.215	0.200 ± 0.013
HIS	0.096	0.079	0.113	0.094	0.096	0.086	0.133	0.112	0.101 ± 0.006
LYS	0.256	0.235	0.294	0.220	0.224	0.195	0.287	0.241	0.266 ± 0.012
ARG	0.171	0.170	0.220	0.168	0.160	0.152	0.218	0.187	0.181 ± 0.009

N.D. = not determined.

Amino acid quantities are given in μ mole per mg extracted weight of leaf. Each analysis is of the insoluble fraction of a single leaf at nodes 7, 8 or 9 on glasshouse grown plants. Analyses were by Technicon Autoanalyser.

region of 5% or 6% of the mean amount of amino acid. Cysteine and isoleucine are more variable at 10-12%.

These errors are markedly less than those for the soluble amino acids from the same leaves. It is to be expected that the leaf protein will not vary with environmental conditions as much as will the soluble leaf amino acids, and this is probably reflected in the result. Extraction conditions are also more constant for the insoluble fraction, and this doubtless affects the variability of analysis.

The 5% or 6% error in the mean amount of amino acid is very close to the 6% error in mean percentage nitrogen determined for the Kjeldahl digestion. This indicates that in both these instances the chief errors may be sampling errors.

(ii) The effect of hydrolysis time

Replicate samples of insoluble leaf fraction were hydrolysed for each of three hydrolysis times and a mean amino acid composition calculated from the replicates at each time. From this data (Table 17), the decomposition factor for each amino acid was calculated. Multiplication of the values obtained by the standard 24h hydrolysis by their respective decomposition factors produces a more accurate estimate of the amino acid content of the sample. Decomposition factors were determined as follows:

Table 17. Amino acids in leaf protein hydrolysed for different times

	2 ^h	72h	144h	Decomposition factor
ASP	0.122 ± 0.006	0.113 ± 0.022	0.117 ± 0.008	1.017
THR	0.070 ± 0.003	0.067 ± 0.008	0.066 ± 0.004	1.013
SER	0.063 ± 0.001	0.059 ± 0.007	0.060 ± 0.002	1.015
GLU	0.136 ± 0.013	0.115 ± 0.015	0.127 ± 0.002	1.055
PRO	0.069 ± 0.002	0.047 ± 0.018	0.061 ± 0.003	1.030
GLY	0.124 ± 0.008	0.119 ± 0.014	0.129 ± 0.007	1.000
ALA	0.110 ± 0.008	0.103 ± 0.011	0.121 ± 0.004	1.081
CYS	0.016 ± 0.001	0.023 ± 0.002	0.019 ± 0.002	1.312
VAL	0.084 ± 0.006	0.074 ± 0.008	0.097 ± 0.002	1.154
MET	0.019 ± 0.001	0.013 ± 0.003	0.014 ± 0.001	1.052
ILE	0.061 ± 0.003	0.060 ± 0.005	0.072 ± 0.001	1.180
LEU	0.112 ± 0.006	0.105 ± 0.010	0.124 ± 0.008	1.108
TYR	0.037 ± 0.003	0.038 ± 0.002	0.046 ± 0.003	1.242
PHE	0.061 ± 0.004	0.062 ± 0.005	0.060 ± 0.009	1.000
HIS	0.028 ± 0.001	0.021 ± 0.004	0.023 ± 0.002	1.071
LYS	0.076 ± 0.003	0.073 ± 0.011	0.077 ± 0.012	1.000
ARG	0.055 ± 0.004	0.053 ± 0.008	0.065 ± 0.007	1.128

Amino acid quantities are in $\mu\text{moles/mg}$. Each figure is a mean of three replicate samples of leaf insoluble fraction hydrolysed for the times given. The calculation of decomposition factors is described in the text.

(a) If the amino acid content of the sample decreased with increasing hydrolysis time, amino acid breakdown was assumed, and extrapolation to zero time was used to determine the best value for the amino acid.

eg. serine

amount at 24h	0.063 μ mole
amount at 0h	0.064 μ mole
decomposition factor = 1.015	

(b) If the amino acid content of the sample increased with increasing hydrolysis time, then delayed release of amino acids from peptides was assumed, and the 144h value taken as the best.

eg. valine

amount at 24h	0.084 mole
amount at 144h	0.097 mole
decomposition factor = 1.154	

Decomposition factors for leaf protein hydrolysate are given in Table 17.

5. Radioactivity measurement

(i) IDL Scalar 1700

The characteristics of the counter and the operating voltage to be used were determined by varying the high voltage and measuring cpm for a sample planchet. The threshold voltage and counting plateau were located (Table 18). The threshold voltage was between 0.46 and 0.48 KV. 0.52KV was chosen as operating voltage, this

being on the counting plateau and less than the maximum permissible voltage for the Geiger-Muller tube.

Table 18. Characteristics of the IDL Scalar 1700

Voltage(KV)	Time(sec)	Counts	cpm
0.44	600.0	0	0
0.46	600.0	0	0
0.48	600.1	7373	737
0.50	610.2	16265	1599
0.52	645.4	16894	1571
0.54	664.8	17968	1622
0.56	600.0	16362	1636
0.58	613.0	16742	1639

Counting errors, pipetting errors and counter efficiency were determined by counting known amounts of ^{14}C sucrose. Replicate planchets at each of four radioactive concentrations were prepared by dilution from a new bottle of [^{14}C] - sucrose solution. Each planchet was counted six times and the counting error was determined. The mean cpm for each set of replicate planchets were averaged, and the error on the new mean used as an estimate of pipetting error plus counting error. (Table 19).

All planchets were counted for 100.0 sec, which was sufficient to record more than 1500 counts for all but the 0.001 μCi samples. Counting errors ranged from

Table 19. Counting errors for the scalar 1700
and Geiger-Muller tube

^{14}C (μCi)	cpm	mean counting error	mean cpm
1.0	38375.5 \pm 46.1		
	39376.8 \pm 80.9		
	38324.3 \pm 43.3		
	36214.8 \pm 28.1		
	37264.2 \pm 37.1	49.4 \pm 7.7	37908.6 \pm 440.9
0.1	7389.3 \pm 37.7		
	7275.5 \pm 33.1		
	7447.5 \pm 16.2		
	7135.5 \pm 26.6		
	7089.5 \pm 23.6		
	7119.0 \pm 27.0	27.4 \pm 3.1	7242.7 \pm 61.9
0.01	944.8 \pm 11.7		
	983.5 \pm 12.8		
	979.8 \pm 16.0		
	956.0 \pm 8.9		
	958.0 \pm 13.1		
	979.8 \pm 13.6	12.7 \pm 1.0	967.0 \pm 6.6
0.001	118.3 \pm 4.7		
	124.7 \pm 3.3		
	121.5 \pm 2.9	4.0 \pm 0.7	121.5 \pm 4.5

All samples were counted for 100.0 sec. Each cpm value is a mean of six countings of one planchet. The counting error and mean counts are means of the six mean cpm values. ^{14}C was supplied as sucrose solution.

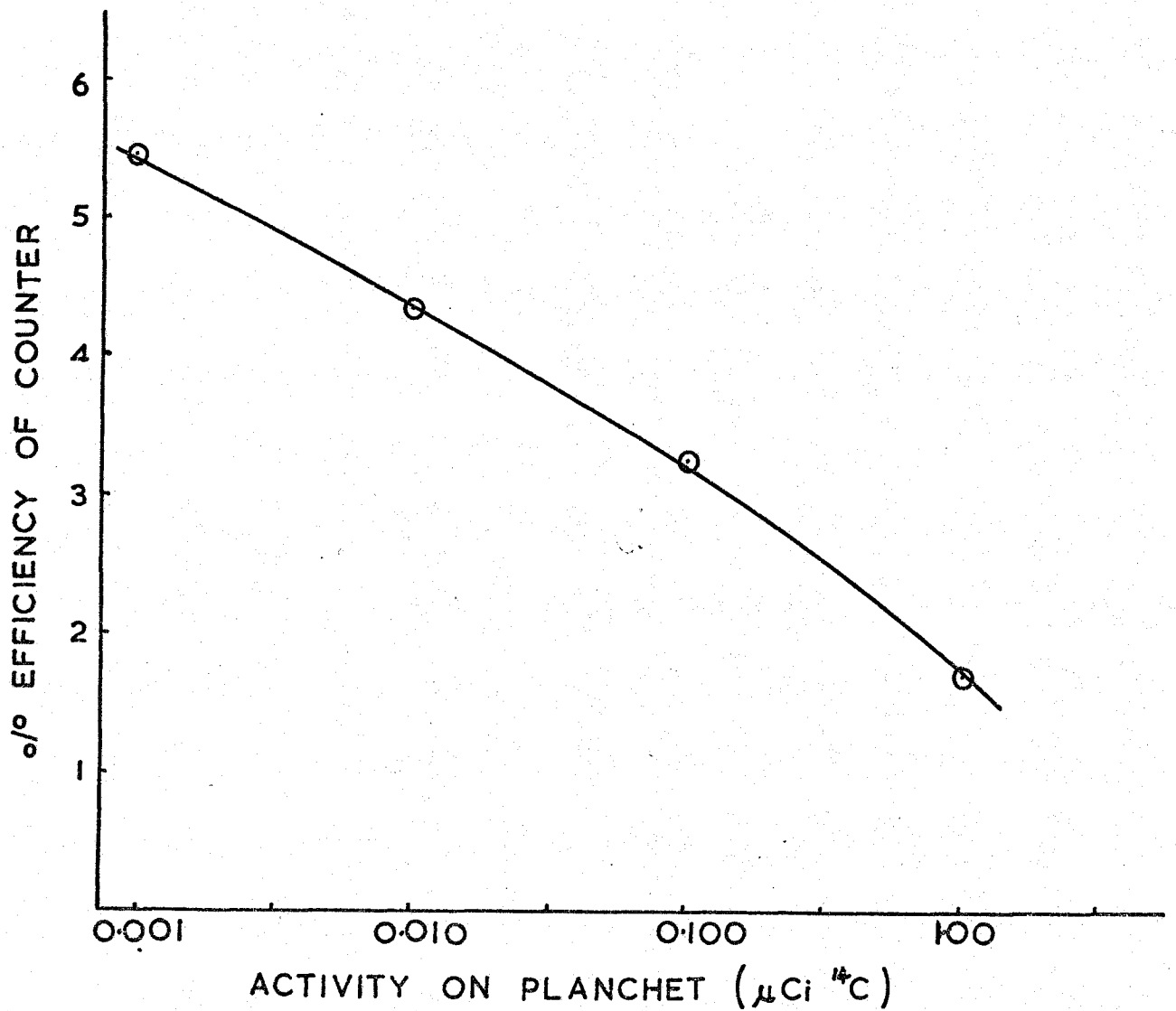

Fig. 5. Counting efficiency of scalar 1700. $[^{14}\text{C}]$ - sucrose solution was pipetted on to planchets and counted, each planchet six times. The values are means from six planchets (36 counts) except for the 0.001 value, which is a mean of 12 counts.

0.2% for 1.0 μ Ci to 3.0% for 0.001 μ Ci. Pipetting errors were 1.0% for 1.0 μ Ci and 5.0% for 0.001 μ Ci.

Background was usually counted for 4000 sec, and never for less than 1800 sec. Background was generally 23-27cpm. Errors on the background count are considered in detail later. (Part 6, Errors).

Efficiency was determined from the figures in Table 19. A plot of efficiency against the logarithm of activity was linear over most of this range (Fig.5).

(ii) Summary of errors for IDL Sclar 1700

All planchets were prepared in duplicate and both duplicates were counted twice. The four results thus obtained were averaged and the mean used in any further calculations. All planchets were counted to the first of 1000 sec or 1000 counts.

From Table 19 it can be seen that for counts over 1000 cpm, counting errors and pipetting errors amount to about 1% of the cpm. In all tables of data determined using the scalar 1700 an approximate estimate of this error is given. (See also, Part 6, Errors).

(iii) Tracerlab spectro/matic Gas Flow Counter

A standard planchet was counted with every set of sample planchets on the gas flow counter. Repeated 20 min counts of this standard recorded 29261 ± 89 counts. (6 measurements). This reveals a counting error of about 0.5%. Repeated counting of background produced a

a mean background count of 6.6 ± 0.1 cpm (18 measurements). Background ranged from 5.2-7.2 cpm.

Six planchets at each of four radioactive concentrations were each counted once for 20 min. Pipetting and counting error and counter efficiency were calculated from the results (Table 20). In all cases errors are 1.0-1.5%, this being more than the counting error described above by an amount which must represent the pipetting error.

Efficiencies were calculated and shown to be neither linear nor log-linear over this range. The efficiency figures in Table 20 were used to plot a graph of counts per 20 min against efficiency. From this curve the efficiency Table 21 was produced, and these figures used in any further calculations. Linear interpolation between the figures in Table 21 was used to find the best value of the efficiency.

(iv) Summary of errors

Counting errors were always less than 2% of the cpm. The effect of error on the background count is considered in Part 6 (Errors).

(v) Autoradiography

Quantitation from autoradiographs was not attempted due to lack of appropriate equipment.

Under the conditions used in these experiments, autoradiography was more sensitive than Gas Flow Counting

Table 20. Counting errors using the Tracerlab Gas Flow Counter

$^{14}\text{C}(\mu\text{Ci})$	cpm	mean cpm	% efficiency
0.0010	207.0		
	214.2		
	207.0		
	200.9		
	200.7		
	197.3	204.5 ± 2.5	9.2
0.0005	106.8		
	103.1		
	105.4		
	103.4		
	105.6		
	109.1	105.6 ± 0.9	9.5
0.00025	58.3		
	60.8		
	58.3		
	57.8		
	58.1		
	56.1	58.2 ± 0.6	10.5
0.000125	32.4		
	32.4		
	32.8		
	32.1		
	30.1		
	33.3	32.2 ± 0.4	11.6

The radioactive planchets were prepared by dilution from a new bottle of [^{14}C] - sucrose solution. Each planchet was counted once for 20 min using the gas flow counter. The standard planchet for this set of samples produced 58911 counts in 20 min.

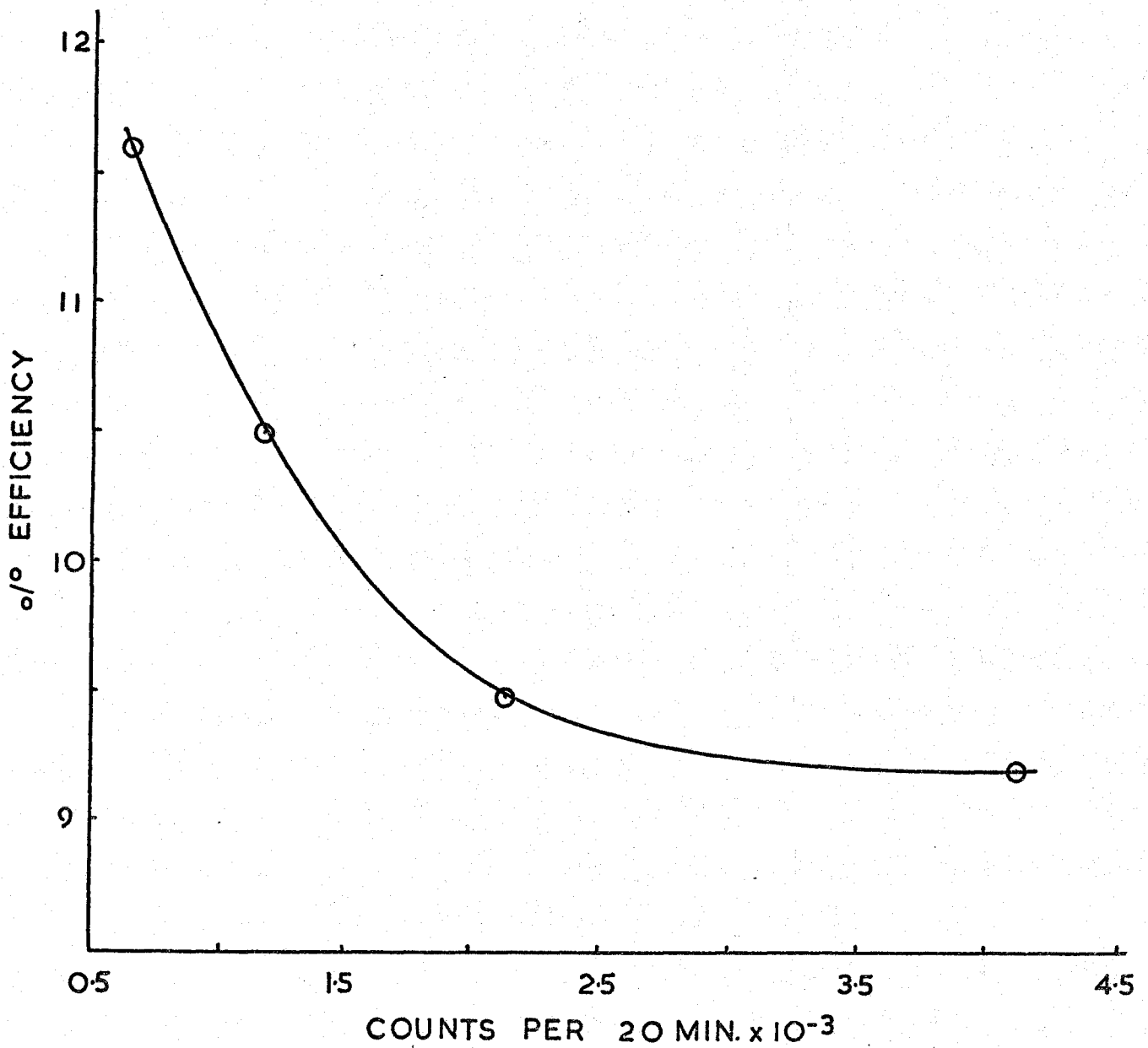

Fig. 6. Efficiency curve for Gas Flow Counter.
Each value was calculated from a mean cpm for six planchets.
The data is given in Table 20.

Table 21. Efficiency of Tracerlab Gas Flow Counter

<u>Counts per 20 min</u>	<u>% Efficiency</u>
500	11.90
750	11.30
1000	10.76
1250	10.31
1500	10.00
1750	9.74
2000	9.55
2250	9.45
2500	9.38
2750	9.33
3000	9.29
3250	9.25
3500	9.23
3750	9.21
4000	9.20

These figures were produced by reading from Fig. 5.
Linear interpolation between these figures was used
in calculations.

of autoanalyser fractions. Both methods were limited by the amount of sample which could be analysed. Autoradiography was able to detect less than 0.4×10^{-4} μ Curies ^{14}C in 36 days exposure.

Some typical autoradiographs are illustrated in Fig. 84.

6. Calculations and Errors

Weighing errors and errors in measuring time are considered sufficiently small to be disregarded.

(i) cpm per mg extracted weight of sample

If COUNT = mean planchet count (4 measurements),
corrected for background

TIME = time of counting in minutes

HSV = hydrolysis sample volume (cm^3)

PSV = planchet sample volume (cm^3)

SV = total sample volume (cm^3)

HSW = hydrolysis sample weight (mg)

SW = total extracted weight of sample (mg)

Then, for an insoluble fraction,

$$\text{cpm/mg} = \frac{\text{COUNT}}{\text{TIME}} \times \frac{\text{HSV}}{\text{PSV}} \times \frac{1}{\text{HSW}}$$

and, for a soluble fraction,

$$\text{cpm/mg} = \frac{\text{COUNT}}{\text{TIME}} \times \frac{\text{SV}}{\text{PSV}} \times \frac{1}{\text{SW}}$$

Errors include both pipetting errors and counting errors on both sample and background, and amount to about 2% for each.

∴ Error in COUNT = counts ± 2% - Background ± 2%.

This error is shown in Appendix 2 to be always between 2% and 10% for counts greater than 1.5 times the background.

eg. An insoluble fraction.

COUNTS = 2874, 3046, 3464, 3218
 BACKGROUND = 23cpm (153 counts in 400 sec)
 TIME = 400 sec
 HSW = 64.6 mg
 HSV = 5.0 cm³
 PSV = 0.2 cm³
 MEAN COUNTS = 3150.5
 MEAN CPM = 473
 MEAN CPM - BACKGROUND = 450 = $\frac{\text{COUNT}}{\text{TIME}}$

$$\therefore \text{cpm/mg} = 450 \times \frac{5.0}{0.2} \times \frac{1}{64.6} = 174.0$$

Error on COUNT = 2%, since count is more than five times as big as the background (see Appendix 2).

$$\therefore \text{cpm/mg} = 174.0 \pm 3.4$$

The counting error used in tables of Results is calculated in this manner.

(ii) µCi per mg extracted weight

If COUNT = sum of counts (minus background) on all
 planchets corresponding to one amino acid
 TIME = time in minutes for which each planchet
 was counted

- E = efficiency of counter at the time of counting that amino acid
 S = counts produced by standard in time TIME when counting that amino acid
 E_s = measured efficiency of counter
 S_s = counts produced by standard in time TIME when measuring E_s
 ASV = analyser sample volume.

Then,

$$\frac{E}{S} = \frac{E_s}{S_s}$$

$$\therefore E = \frac{E_s}{S_s} \times S$$

$$\text{cpm in sample} = \frac{\text{COUNT}}{\text{TIME}}$$

$$\text{disintegrations per min in sample} = \frac{\text{COUNT}}{\text{TIME}} \times \frac{100}{E}$$

$$= \frac{\text{COUNT}}{\text{TIME}} \times 100 \times \frac{S_s}{E_s \times S}$$

but $1\mu\text{Ci} = 3.7 \times 60 \times 10^4$ disintegrations per min.

$$\therefore \mu\text{Ci in sample} = \frac{\text{COUNT}}{\text{TIME}} \times 100 \times \frac{S_s}{E_s \times S} \times \frac{1}{3.7 \times 60 \times 10^4}$$

but the sample counted was only 0.20/0.56 of the whole analyser sample. Thus, using symbols as in (i), for an insoluble fraction,

$$\mu\text{Ci/mg} = \frac{\text{COUNT}}{\text{TIME}} \times 100 \times \frac{S_s}{E_s \times S} \times \frac{1}{3.7 \times 60 \times 10^4} \times \frac{0.56}{0.20} \times \frac{\text{HSV}}{\text{ASV}} \times \frac{1}{\text{HSW}}$$

Errors include sample counting error, background counting error and counting errors on the standards.

Counting error on the standards = 0.3%.

$$\therefore \text{Counting error on } \frac{S_s}{S} = 2 \times 0.3\% = 0.6\%$$

Error in COUNT is generally 4%-6% since counts are generally at least two or three times the background.

Then the total error on the $\mu\text{Ci}/\text{mg}$ determination is about 5%-7%.

(ii) $\mu\text{mole per mg extracted weight}$

μmole data were obtained from autoanalyser peak integrations, and the errors for the individual amino acids are calculable from Table 11. In general errors were $\pm 2\%$.

(iv) $\mu\text{Ci per } \mu\text{mole}$

The error on the calculation of $\mu\text{Ci}/\text{mole}$ of an amino acid (i.e. specific activity) is the sum of the errors on the two parts.

From part (ii) above, error on $\mu\text{Ci}/\text{mg} = 5-7\%$

From part (iii) above, error on $\mu\text{mole}/\text{mg} = 2\%$

\therefore error on $\mu\text{Ci}/\text{mole} = 7-9\%$

(v) Plant variability and variability of extraction

In any calculations where the result is said to be typical of a group of plants, the error represented by plant variation must be taken into account.

Variability of insoluble fraction = 6%

Variability of soluble fraction = 15%-20%.

(vi) Curve fitting

a. Straight line, $y = ax + b$

The best straight line through a series of n points, $x_i y_i$, was determined using the expressions,

$$\text{gradient} = \frac{n \sum x_i y_i - \sum x_i \sum y_i}{n \sum x_i^2 - (\sum x_i)^2} = a$$

$$\text{intercept} = \frac{\sum y_i - a \sum x_i}{n} = b$$

These expressions are derived in Appendix 1. The goodness of fit was expressed as a fit factor, this being the sum of the squares of the distances of the points from the line, measured parallel to the y axis, for each value of x_i .

$$\text{i.e. fit factor} = \frac{\sum (y_i - (ax_i + b))^2}{n}$$

b. Exponential curve, $y = K(1 - e^{-ax})$

If 'a' were known, then $(1 - e^{-ax})$ would be a function of x such that if

$$X = 1 - e^{-ax}$$

$$y = KX$$

Then the best straight line, $y = KX$ could be determined and its gradient would be K .

Approximate values for 'a' can be determined since, when y approaches K,

$$e^{-ax} = 0$$

But, $e^{-5} = 0$, approximately

∴ for y = K, approximately

$$-ax = -5, \text{ approximately}$$

$$a = \frac{5}{x}$$

x can be determined, since it is the value on the x axis which corresponds to the point where the curve approaches the horizontal. A range of values of 'a' which are near this approximation can thus be chosen for each set of data.

For each value of 'a', $1 - e^{-ax}$ was calculated for each value of x, and the value of K which produced the minimum fit factor was determined. This gives a fit factor for each value of 'a', and the value of 'a' with the lowest fit factor was taken as the best. This value of 'a' has a corresponding value of K, and so the best curve is completely described.

The goodness of fit is again expressed in the fit factor.

c. Refitting curves.

When a curve had been fitted to a set of points, any points which were further than three times the fit factor from the curve were discarded. The curve was

then refitted to the remaining points and a second fit factor computed for these points only. This second fit factor is the one quoted in Results.

(vii) Computing

Whenever possible, calculations were done on the University of Reading Elliot 4130 computer. Programs were in FORTRAN and included curve fitting, histogram plotting, and most arithmetic calculations.

RESULTS

PART ONE: Preliminary experiments with bleeding sap.

PART TWO: Preliminary experiments with leaves
photosynthesising in [^{14}C] - CO_2 .

PART THREE: Sources of carbon for the developing
pod and seed

PART FOUR: Quantitative analysis of radioactive
amino acids

PART ONE:

Preliminary experiments with bleeding sap

1. Diurnal variation in sap volume
2. Qualitative sap analysis
3. Diurnal variation in sap composition
4. Incorporation of ^{14}C into sap

1. Diurnal variation in sap volume

When groups of 20-30 plants were decapitated at intervals during a 36h period, variation was evident in the volumes of bleeding sap collected from the cut surfaces. The proportion of cut plants which produced bleeding sap also varied during this interval, being maximum in the middle of the day and minimum at night. Fig. 1-1, 1-2 and 1-3 illustrate mean sap volumes collected in three such experiments, with the details of temperature variation and the light - dark regime during the experimental period.

The bleeding pattern appears to be diurnal. In the November data (Fig. 1-1), the maximum bleeding occurred at noon on both days. This was 4h after the lights were switched on, and in both cases preceded the daily temperature maximum. The minimum was not investigated on this occasion. The March data (Fig. 1-2) indicated that the plants did not bleed for a period at night. Again there was a bleeding maximum in the middle of the day. The four samples recorded in Fig. 1-3 were collected from plants grown under different lighting conditions. During the cold weather the lights were turned on at 3.00 a.m. to prevent the glasshouse from freezing. This had the effect of keeping the temperature minima and maxima, at about the same times of day as in the previous experiments. Although only four samples were collected, it could be seen that the diurnal pattern of bleeding had been altered. The maximum sap volume was produced at or before 6.30 a.m., $3\frac{1}{2}$ h after the

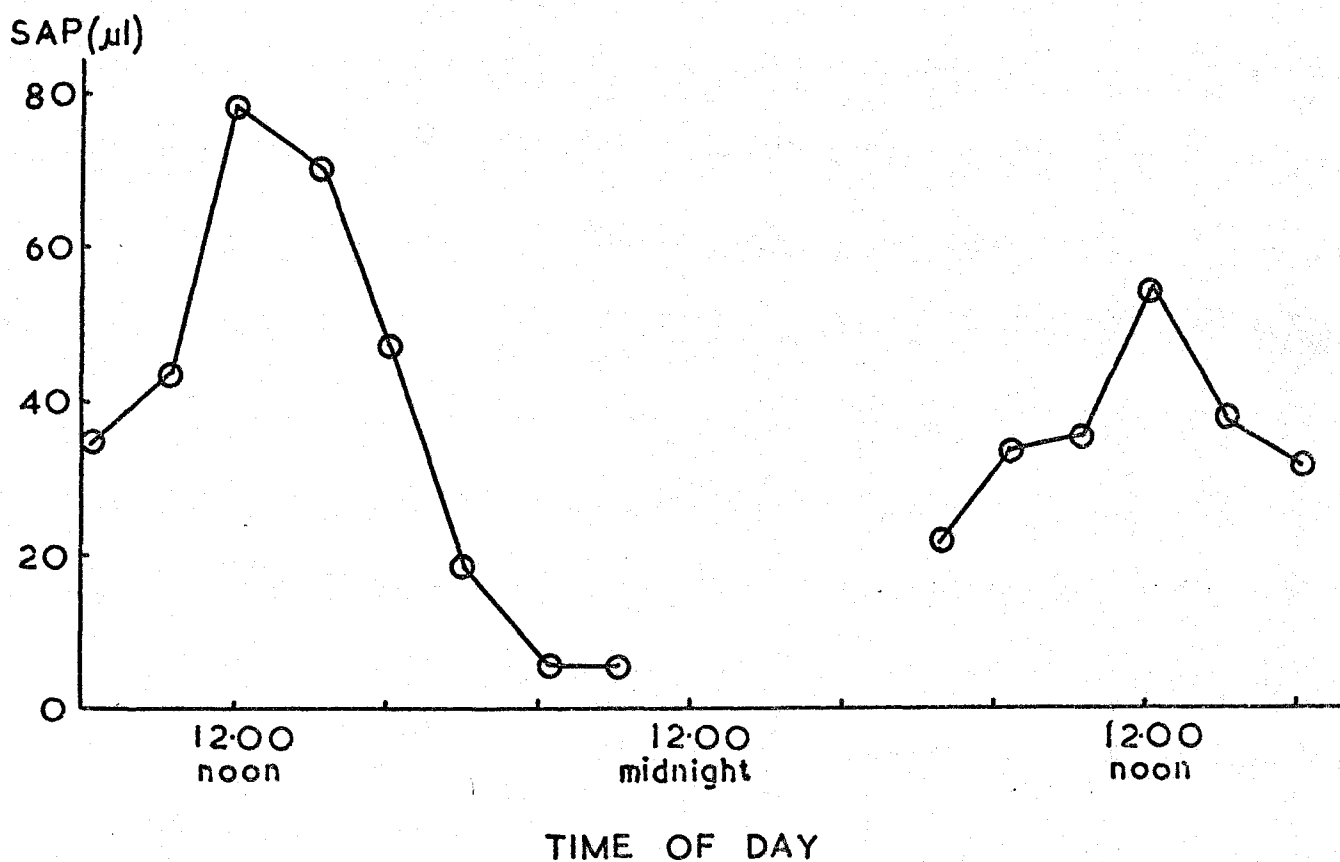
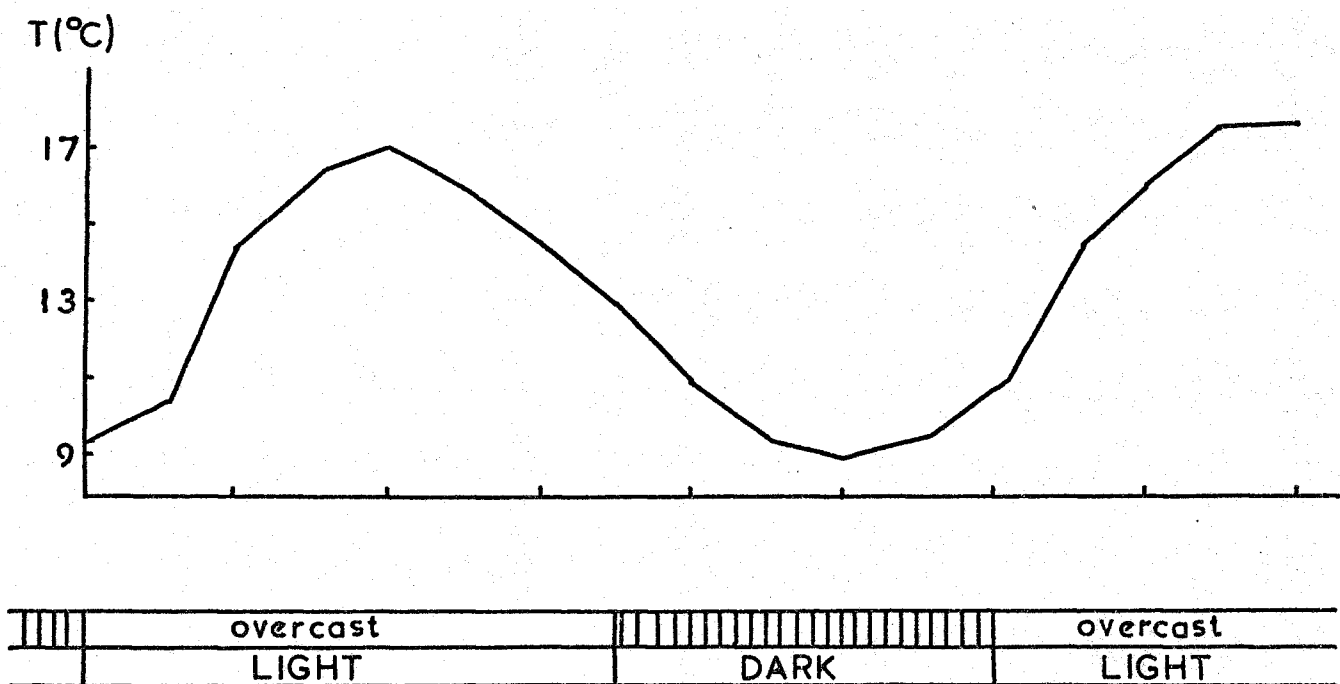

Fig. 1-1. Variation in light, temperature, and mean volume of sap collected in one hour. Sap volumes are means of volumes from 20-30 plants grown in a glasshouse in Durham in November, 1968. Temperature readings were taken from a thermohydrograph chart.

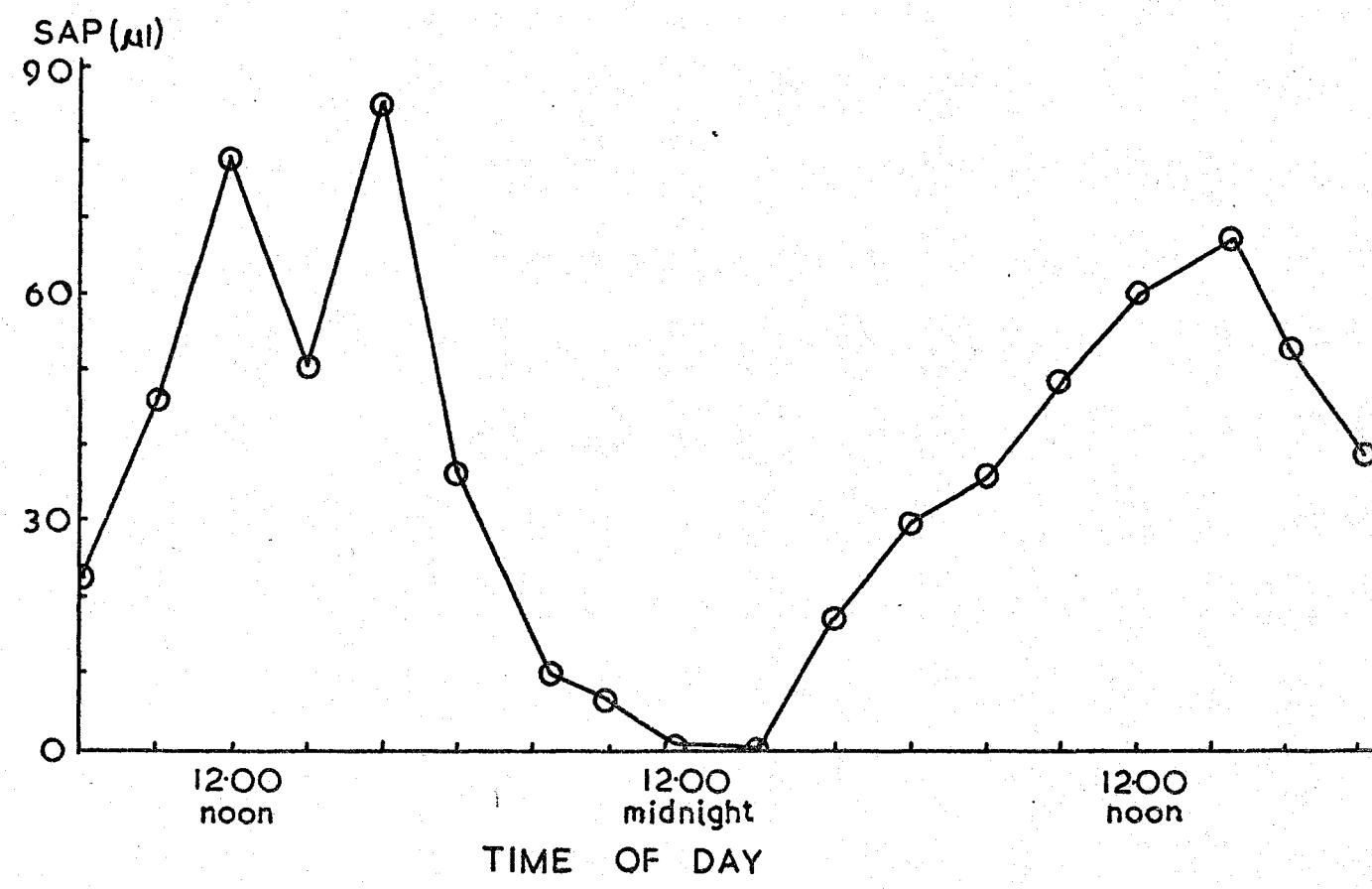
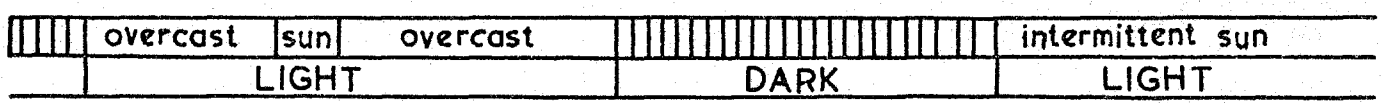
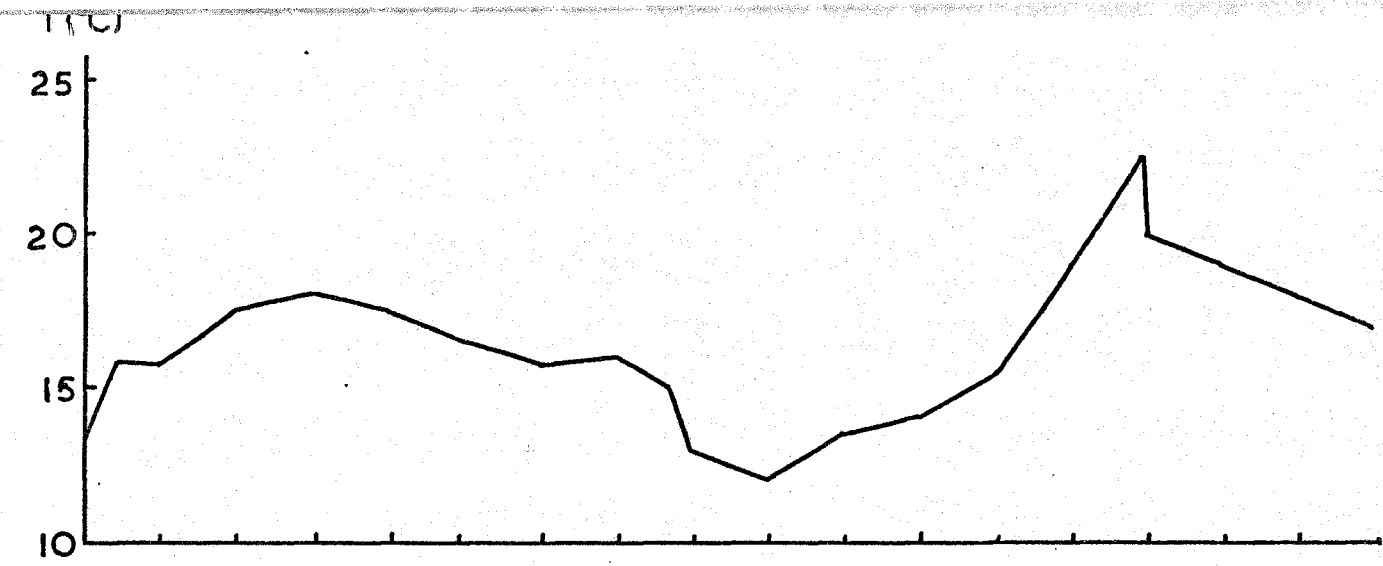

Fig. 1-2. Variation in light, temperature and volume of sap collected in one hour. Sap volumes are means of volumes from 10-30 plants grown in a glasshouse in Durham in March 1969. Temperature readings were taken from a thermohydrograph chart.

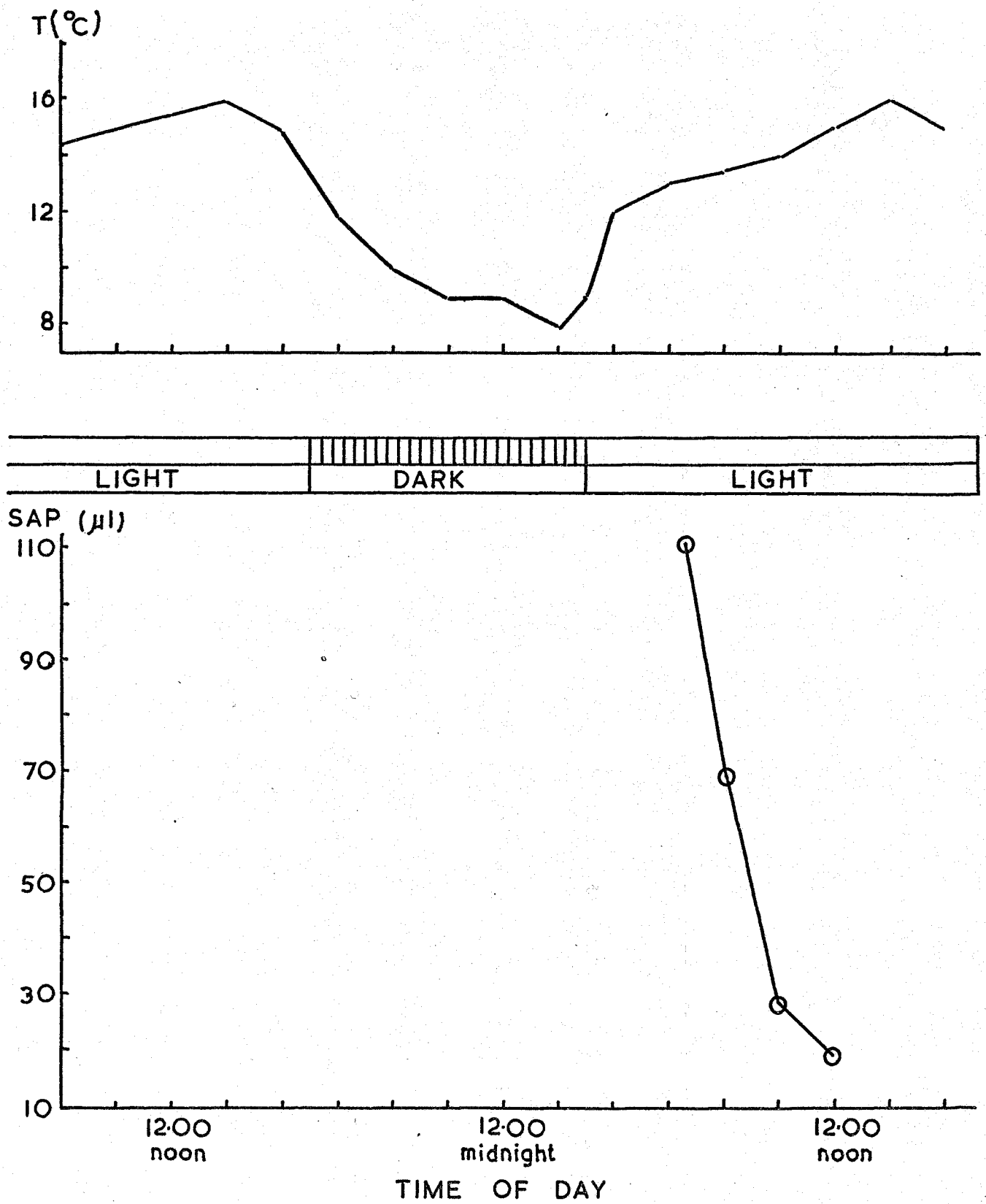

Fig. 1-3. Variation in temperature and light, and some bleeding sap volumes collected during the time interval. Sap volumes are means of 10-12 samples collected in a glasshouse in Durham in October 1969.

lights were turned on.

The diurnal rhythm of bleeding thus appears to be not directly dependent on air temperature or humidity. (Humidity varied inversely with temperature in the glasshouse). All three sets of plants were routinely watered between 9.00 and 10.00 a.m., so that soil moisture was probably not an important variable under these conditions. The light-dark regime, however, does seem to affect the timing of the bleeding maximum. This is suggested, not only by the samples in Fig. 1-3 but also by the second peak at 16.00h on the first day of bleeding in Fig. 1-2. The light period that day was continuously dull and overcast, except for about $1\frac{1}{4}$ hours bright sunshine starting at 13.00h. Again, bright light preceded the bleeding maximum, in this case by about 3h.

The phenomenon was not further investigated.

2. Qualitative sap analysis

- (i) NITRITE. Freshly collected sap gave a weakly positive reaction for nitrites when tested with sulphanic acid and α -naphthylamine
- (ii) NITRATE. After removal of nitrites, fresh sap gave a weakly positive reaction for nitrate
- (iii) SUGARS. Sap subjected to TLE/TLC produced two brown spots on the electrophoresis origin, when sprayed with aniline hydrogen phthalate, and two spots which

fluoresced yellow under U.V. light, when sprayed with phloroglucinol reagent.

Sap subjected to chromatography as in the TLE/TLC method and sprayed with aniline diphenylamine reagent was shown to contain traces of fructose, glucose and sucrose. These were present in 50 μ l sap at about one tenth of the amount in the 2 μ g sugar standard, as estimated by eye.

Table 2-1. Sugars in sap

STANDARDS	DISTANCE	COLOUR	SAP	
			DISTANCE	COLOUR
fructose	10.3	pink	10.0	pink
glucose	9.6	blue-grey	9.4	blue-grey
galactose	9.1	blue-grey		
sucrose	9.6	pink-brown	9.6	pink-brown

Distances are in cm from the origin. The chromatography was with two solvents successively in one direction, as in the TLE/TLC method. The sugars were located with aniline diphenylamine reagent.

(iv) AMINO ACIDS. Sap, spotted on to paper and sprayed with ninhydrin reagent, produced a dark purple colouration indicating the presence of amino acids.

A two dimensional separation of 100 μ l sap by the TLE/TLC method is illustrated in Fig. 2-1. Aspartic acid, asparagine, glutamic acid and glutamine accounted for 80-90% of the sap amino acid content. All other amino

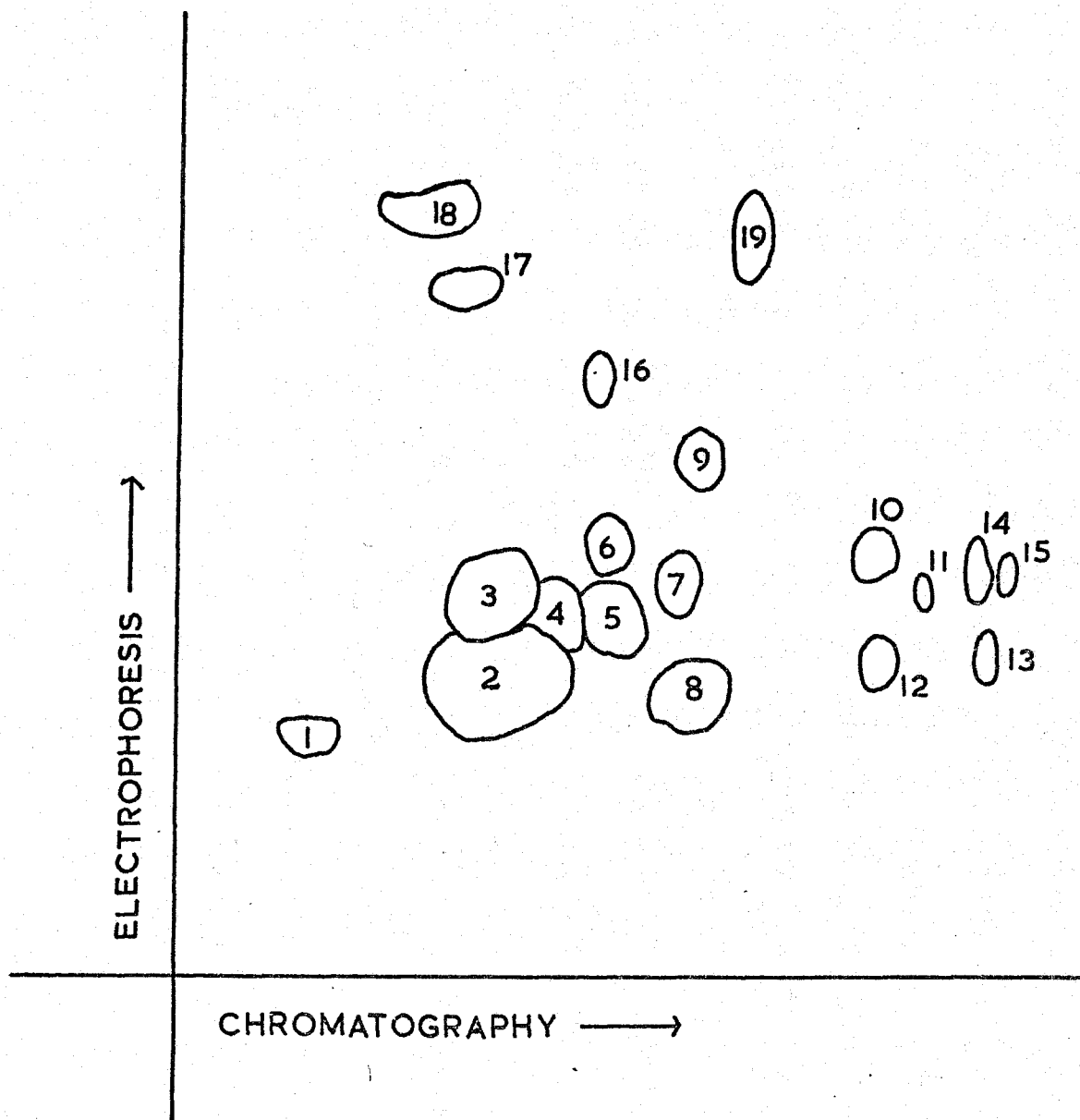

Fig. 2-1. Two dimensional thin layer separation of bleeding sap. The spots were located with ninhydrin reagent.
 1 cys, 2 asp, 3 asn, 4 gln, 5 glu, 6 ser, 7 thr, 8 dopa,
 9 ala, 10 val, 11 met, 12 tyr, 13 phe, 14 ile, 15 leu, 16 gly,
 17 arg, 18 lys, 19 γ AB.

acids except lysine, γ -aminobutyric acid and dihydroxyphenylalanine were present in trace amounts only.

(v) ACIDS. Amino acids were removed with amberlite 1R120(H). The residual solution gave a negative ninhydrin reaction. 50 μ l of this solution spotted on to paper and sprayed with bromocresol blue produced a dark yellow spot on a green background - indicating the presence of acids.

3. Diurnal variation in sap composition

Analysis of the sap samples illustrated in Fig. 1-1 revealed small variations in amino acid composition (Table 3-1). Both concentrations and volumes were lower on the second day than on the first.

The principal amino acid components of the sap were asparagine, glutamine, aspartic acid, and an unknown U_8 . U_8 ran ahead of tyrosine on the vertical axis of the chromatogram illustrated in Fig. 3-1. Thin layer analyses (TLE/TLC) suggest that U_8 could be dihydroxyphenylalanine. Arginine, methionine and tryptophan were not detected in any of these samples, although arginine was later shown to be present in sap. U_5 , U_6 , U_7 and U_9 ran close to positions normally associated with dipeptides. U_7 and U_9 were detectable only in late afternoon and early morning samples. This may be simply a reflection of variation in overall sap concentration, or it could be that the plant roots export small quantities of these substances only at night.

Table 3-1. Variation in amino acid content of sap samples, as revealed by dansylation

	8.15	10.15	12.00	16.00	18.00	20.15	22.00	6.30	8.15	10.15	12.00	14.00	16.00
ASN	8+	8+	8+	8+	10+	8+	8+	8+	8+	2+	6+	6+	6+
GLN	2+	2+	2+	2+	2+	2+	2+	2+	2+	tr	2+	2+	+
ASP	4+	4+	4+	4+	4+	4+	4+	4+	4+	2+	2+	2+	2+
GLU	+	str	str	str	str	+	+	tr	tr	tr	tr	tr	tr
HIS	str	+	+	+	+	+	+	2+	2+	str	str	str	+
VAL	+	2+	2+	2+	2+	+	+	2+	2+	+	+	+	+
LYS	str	+	+	2+	2+	+	+	2+	+	+	+	+	+
PHE	tr	str	str	+	+	str	+	+	+	str	tr	tr	str
GLY	-	tr	-	tr	tr	ftr	tr	ftr	ftr	-	-	-	ftr
ALA	tr	str	tr	str	str	str	str	str	tr	tr	tr	tr	str
PRO	tr	tr	tr	tr	str	tr	str	str	tr	tr	tr	tr	tr
LEU	tr	str	str	+	+	str	+	+	+	str	tr	tr	tr
ILE	tr	str	str	+	+	str	+	+	+	str	tr	tr	tr
U ₁	tr	tr	-	tr	tr	tr	tr	tr	ftr	-	tr	ftr	tr
U ₂	tr	str	tr	tr	+	str	2+	+	str	-	tr	tr	str
U ₃	tr	tr	tr	tr	tr	tr	tr	ftr	ftr	tr	-	-	tr
U ₅	tr	-	-	-	-	-	-	-	-	-	-	ftr	-
U ₆	tr	str	-	-	-	-	-	-	-	-	-	-	-
U ₇	-	tr	-	-	tr	-	tr	tr	ftr	-	-	-	-
U ₈	4+	4+	4+	4+	6+	6+	6+	6+	6+	3+	3+	3+	3+
U ₉	-	-	-	-	ftr	ftr	+	ftr	-	-	-	-	-

- absent; ftr faint trace; tr trace; str strong trace; + (2xstr)
 The positions of the unknowns are illustrated in Fig. 3-1.
 Each sample was 5 μ l of sap, subjected to dansylation and
 polyamide thin layer chromatography. The samples were collected
 in March in the glasshouse in Durham and their pattern of
 bleeding is illustrated in Fig. 1-1.

Table 3-2. Total amino acids in sap

TIME OF DAY	SAP CONCENTRATION	MEAN SAP VOLUME	MEAN AMINO ACID WEIGHT
	mg/cm ³	μl/plant/h	μg/plant/h
8.15	0.44	35	15.4
12.00	0.27	79	21.4
14.15	0.39	71	27.7
16.00	0.31	48	14.3
18.00	0.30	19	5.6
20.15	0.50	6	0.3
22.00	0.26	6	0.2

Mean volumes are for 20-30 plants. Sap concentrations were determined by aspiration of samples through the external standard line of the amino acid analyser, and by comparison of the optical density values with an alanine standard. The samples were collected in the glasshouse in Durham and their bleeding pattern is illustrated in Fig. 1-1.



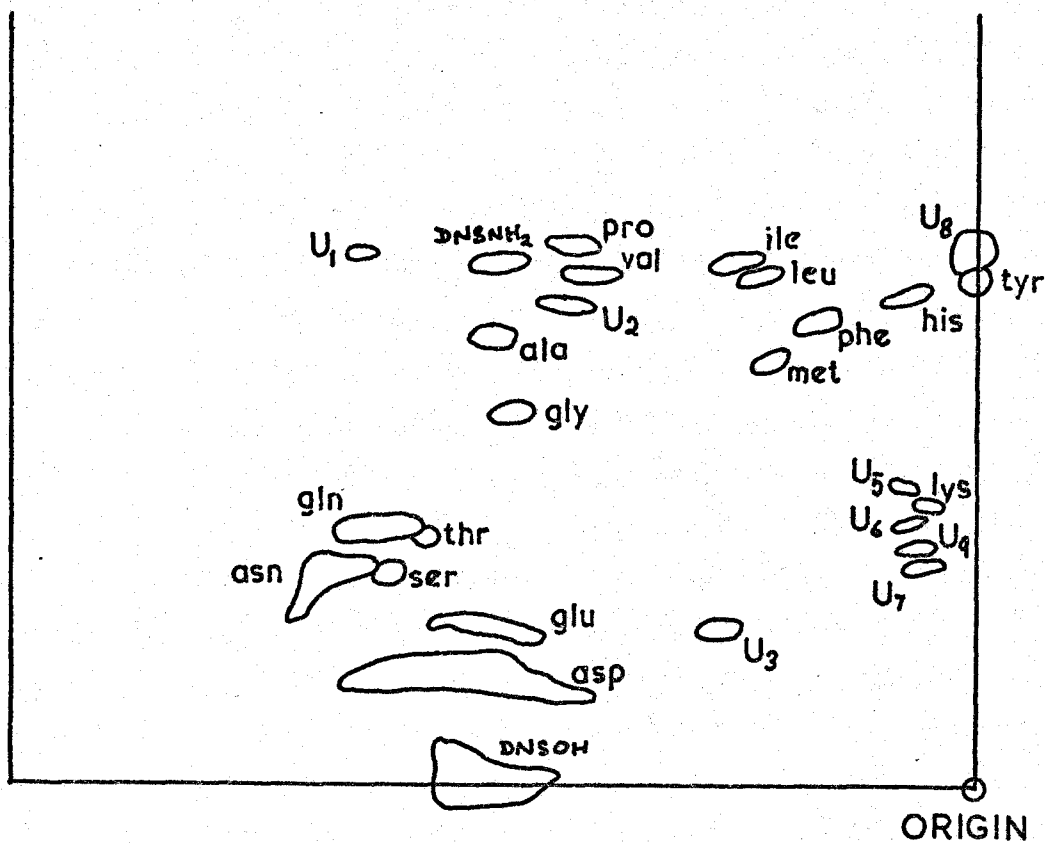

Fig. 3-1. Polyamide thin layer chromatography of dansyl amino acids prepared from a sap sample. 5 μ l samples were used. Serine and threonine were partially obscured by glutamine and asparagine. U₅, U₆, U₇ and U₉ are possibly dipeptides.

Determination of total amino acid concentration in sap revealed no obvious pattern of variation during the day. However, the mean weight of amino acids exuded per plant per h was shown to increase to a maximum near the bleeding maximum and to decrease with the sap volume later in the day (Table 3-2). These results imply that the extra sap produced at times of maximum bleeding reflects not merely extra water in the transpiration stream, but also extra amino acid exported by the root system.

4. Incorporation of ^{14}C into sap

When [^{14}C] - CO_2 was fed to the lowest leaf of 3-leaf plants for 3h, label could be detected in sap collected from plants cut at the end of the first hour. Radioactivity in the sap increased during the remaining 2h. These results are presented in Table 4-1.

Comparable amounts of radioactivity were obtained in the sap by feeding the [^{14}C] - CO_2 to the whole tops of 4-leaf plants. When feeding was discontinued after 3h, label could still be detected in the sap after 23h, at about one quarter of the 3h activity. (Table 4-2).

The amino acids were removed from a labelled sap sample with amberlite 1R120(H) and the residual solution was shown to contain 63% of the original radioactivity (Table 4-3). This distribution of label was also seen when labelled sap was analysed by TLE/TLC followed by autoradiography. The samples described in Table 4-2 were all shown to contain ^{14}C in aspartic acid, asparagine and glutamine, and in no other amino acids. The sugar and organic acid region of the chromatogram had fogged the autoradiograph at least as much as had the amino acid region. The same compounds appeared labelled in all six samples, although the fogging caused by 100ul sap was considerably fainter for the 23h sample. A tracing of the 1h sample is shown in Fig. 4-1.

The mobilities of the ninhydrin negative radioactive spots 20, 21, 22 and 23 is compared, in Table 4-4, with mobilities of known sugar standards. Colour reactions

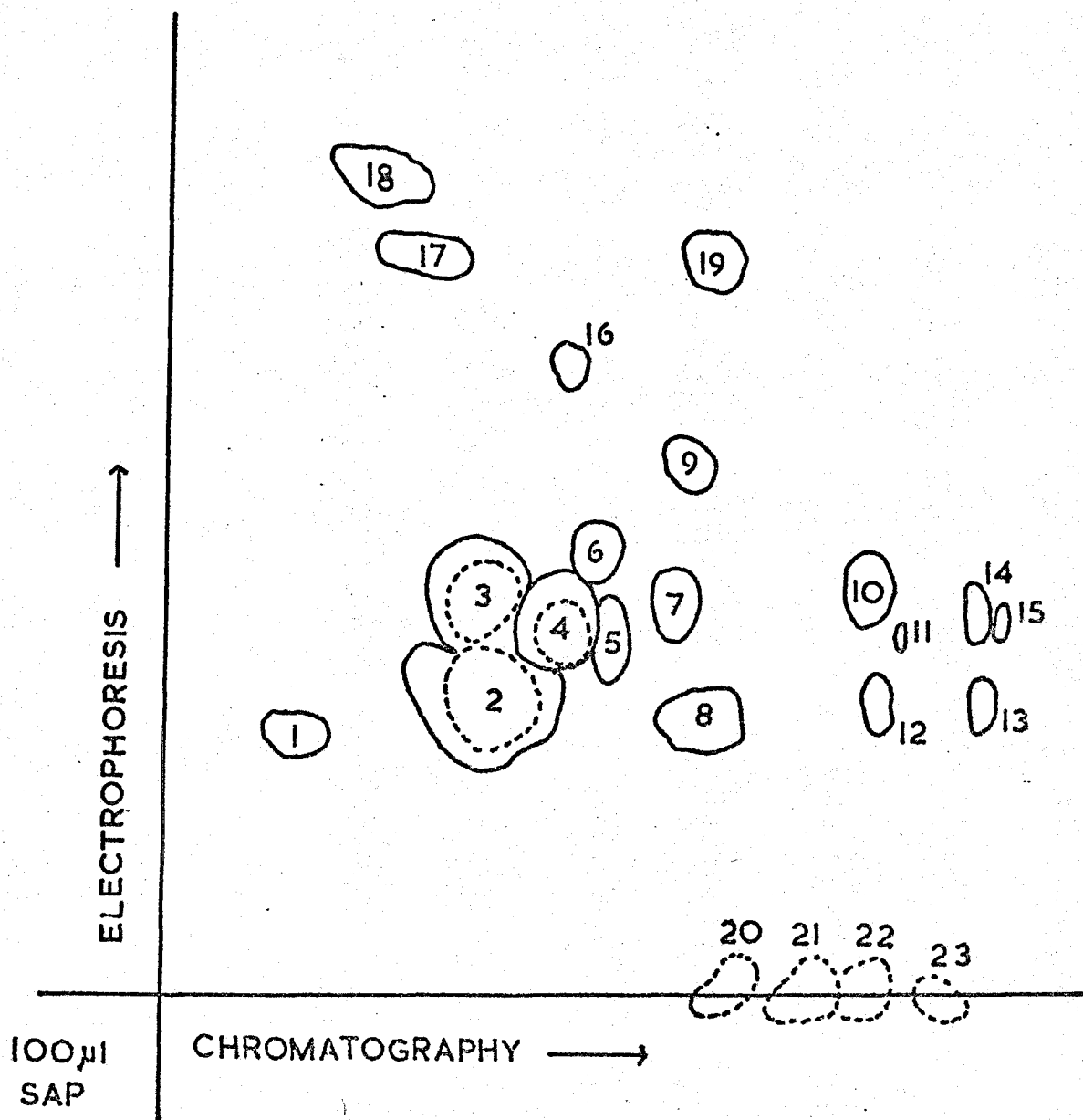

Fig. 4-1. Superimposed tracings of a thin layer separation of sap and the autoradiograph prepared from it. Spots 20-23 are in the sugar and organic acid region of the chromatogram. Amino acids are: 1 cys, 2 asp, 3 asn, 4 gln, 5 glu, 6 ser, 7 thr, 8 dopa, 9 ala, 10 val, 11 met, 12 tyr, 13 phe, 14 ile, 15 leu, 16 gly, 17 arg, 18 lys, 19 γ AB.

Table 4-1. Appearance of ^{14}C in bleeding sap

TIME(min)	SAP VOLUME(μl)	CPM PER SAMPLE	CPM PER μl
15	168	1	0.0
45	36	5	0.1
60	21	16	0.8
75	200	216	1.1
90	190	75	0.4
105	216	205	0.9
120	110	119	1.1
150	68	155	2.3
180	103	212	2.1

The sap samples were each collected from a single 3-leaf plant. [^{14}C] - CO_2 was fed to the lowest leaf of the plant for the time given. The plant was then excised below this leaf and sap allowed to collect for 1h. The whole sample was transferred to a planchet for counting. Counting errors were 2% - 3% for all samples after 90 min. The 75 min sample had a 10% counting error, and the 15, 45 and 60 min samples a 20% - 30% counting error.

Table 4-2. Appearance of ^{14}C in bleeding sap

TIME (hours)	SAP VOLUME (μl per plant)	CPM PER PLANT	CPM PER μl
1	123	709	0.72
2	79	289	0.87
3	64	473	0.81
5	112	658	0.65
7	94	465	0.55
23	76	150	0.22

Each sap volume is a mean calculated for volumes from 10-12 4-leaf plants. $[^{14}\text{C}] - \text{CO}_2$ was fed to the whole plant tops for 3h by enclosing the plant pots (containing 5-6 plants) in a polythene bag and releasing the labelled CO_2 inside the bag. Sap was collected for 1h and 100 μl was used for counting. Counting errors were 2%-3%.

Table 4-3. Distribution of ^{14}C in sap

	CFM	NINHYDRIN
200 μl sap	134 \pm 5	purple
200 μl sap without amino acids	84 \pm 3	colourless

Amino acids were removed by pipetting the sap on to a small quantity of amberlite LR120(H). The resin was washed 4 times with 3 drops water and the washings were dried on to a planchet. The planchets were stained with ninhydrin, after counting, to ensure that amino acids had been removed from the sap.

Table 4-4. Mobilities of sugars in sap

SAP SAMPLES								STANDARDS
SPOT	1	2	3	5	7	23	MEAN	
23	1.49	1.47	1.52	1.53	1.53	1.48	1.50	?
22	1.33	1.36	1.37	1.36	1.39	1.32	1.36	FRUCTOSE 1.34
21	1.24	1.25	1.22	1.24	1.23	1.20	1.23	GLUCOSE 1.25
20	1.08	1.07		1.10	1.05	0.99	1.06	SUCROSE 1.12

The samples are those described in table 4-2, and are referred to by their collection time in hours. Mobilities, for chromatography as in the TLE/TLC method, are given in terms of alanine (1.00). The distances moved by the radioactive spots were measured on the autoradiograph and divided by the distance moved by the alanine spot on the corresponding chromatogram. Spot 23 did not react with the colour reagents for sugars.

with phloroglucinol and aniline diphenylamine supported the suggestion that spots 20, 21 and 22 contain sucrose, glucose and fructose respectively. 23 gave no colour reaction with the sugar reagents.

When plants were grown in pots to the 20-30 leaf stage and allowed to branch once near the base, label could be introduced into the sap by feeding [^{14}C] - CO_2 to the side shoot. In this way it was possible to label sap on fruiting plants where the lowest leaves had abscised. Plants fed [^{14}C] - CO_2 in this manner for 6h had more ^{14}C per ul in sap collected after 24h than in that collected at the end of the 6h feeding period. This contrasts with the situation described in Table 4-2 for 4-leaf plants, where the label detectable in the sap was greater at the end of the feeding period than at 2, 4 and 20h later. The greater time to reach maximum ^{14}C output in the sap probably reflects the larger size of the root system of the 20-leaf plant.

Extracts of leaves, fruit and stem from the same plants also contained more ^{14}C in the 24h samples than in the 6h ones. The internode immediately above the side shoot contained more label than the internode immediately below the lowest fruiting node, in both samples. The ratio of cpm in the upper internode to cpm in the lower internode was similar for the two plants. This implies that an equal proportion (about 25%) of the sap stream is removed by the two plants between the two internodes which were sampled.

The leaf subtending the lowest pod was approximately equally labelled in the two plants, suggesting that the

leaf pool was quickly saturated by the sap ^{14}C . The pod and seed soluble fractions were appreciably more labelled after 24h than after 6h. Incorporation of ^{14}C into pod and seed insoluble fractions was very slight, even after 24h. In no case were the plant extracts radioactive enough for the labelled constituents to be identified. These results are summarised in Table 4-5.

Table 4-5. Distribution of label in plants fed [^{14}C] - CO_2 through a side shoot near the base

SOLUBLE FRACTION

SAP (cpm/ μl)	0.75	5.98	SAP (cpm/ μl)
INTERNODE 2-3			INTERNODE 1-2
(cpm/mg fresh wt)	0.11	0.34	(cpm/mg fresh wt)
INTERNODE 13-14			INTERNODE 14-15
(cpm/mg fresh wt)	0.08	0.27	(cpm/mg fresh wt)
LEAF NODE 14			LEAF NODE 15
(cpm/mg extracted wt)	5.91	3.78	(cpm/mg extracted wt)
POD NODE 14			POD NODE 15
(cpm/mg extracted wt)	1.40	4.68	(cpm/mg extracted wt)
SEEDS NODE 14			SEEDS NODE 15
(cpm/mg extracted wt)	1.71	11.02	(cpm/mg extracted wt)
POD NODE 15			
(cpm/mg extracted wt)	1.36		
SEEDS NODE 15			
(cpm/mg extracted wt)	2.72		

INSOLUBLE FRACTION

POD NODE 14			POD NODE 15
(cpm/mg extracted wt)	0.64	8.81	(cpm/mg extracted wt)
SEEDS NODE 14			SEEDS NODE 15
(cpm/mg extracted wt)	0.13	2.92	(cpm/mg extracted wt)
POD NODE 15			
(cpm/mg extracted wt)	0.23		
SEEDS NODE 15			
(cpm/mg extracted wt)	0.00		

Plants were fed $150\mu\text{Ci}$ [^{14}C] - CO_2 by enclosing a side shoot, below the lowest harvested internode, in a polythene bag in the usual way, for 6h. At 6h and at 24h after the start of feeding one plant was decapitated below the side shoot and sap collected for 1h. The rest of the plant was cut up and extracted as described in the

Legend to Table 4-5 continued.....

table. The fruit, all of age 30-35 days, had small seeds with thick fleshy testas, except for the 6h, node 14, sample. In this case the pods were more developed and the testas had become thin.

Counting errors are about 20% for all insoluble fractions and for soluble fractions containing less than 2 cpm/mg. Errors for the remaining samples are about 6%.

PART TWO:

Preliminary experiments with leaves
photosynthesising in $[^{14}\text{C}] - \text{CO}_2$

5. Preliminary experiment in $[^{14}\text{C}] - \text{CO}_2$ feeding
6. Leaf photosynthesis and export of labelled photosynthate into the petiole
7. Photosynthesis of the bloom node leaf and export of labelled photosynthate into the pod and seed.

5. Preliminary [^{14}C] - CO_2 feeding experiment

[^{14}C] - CO_2 was fed to leaves subtending 17 day old pods and, after 3h feeding, ^{14}C was detectable in the TCA soluble fractions of both the leaf and pod. A small amount of label was also present in the internodes immediately above and below the node of attachment of the fed leaf. 21h later ^{14}C was still present in the leaf, pod and internodes. During that time the amount in the soluble fractions of the leaf had been reduced by about half and that in the pod had increased more than 3 times. At both 3h and 24h, appreciably more label was found in the internode below than in the internode above the fed leaf. (Table 5-1).

Autoradiography of leaf extracts revealed ^{14}C in most soluble amino acids at 3h. Asparagine, dihydroxyphenylalanine and basic amino acids alone were unlabelled. Of these, the first two were labelled at 24h. At 3h, fogging of the autoradiograph was strong for cystine, aspartic acid, serine, glutamine, glutamic acid, glycine, alanine, tyrosine and phenylalanine. After 24h only aspartic acid, glutamic acid, glutamine, tyrosine and phenylalanine were strongly labelled. The ninhydrin negative region of the chromatogram along the line of the electrophoresis origin (the 'sugar and organic acid region') was very heavily labelled for both extracts. Table 5-2 describes this distribution of ^{14}C in the leaf soluble fraction.

In the 3h pod sample, the soluble fraction contained

most of its ^{14}C in three ninhydrin negative spots on the electrophoresis origin of the chromatogram. These were identified as sucrose, glucose and fructose (Table 5-3). Only very faint traces of label were detected in amino acids - in aspartic acid, glutamic acid, alanine, tyrosine, and serine. After 24h almost all the soluble amino acids of the pod contained some label, and a number of ninhydrin negative compounds were labelled as well.

Sucrose, glucose and fructose appeared heavily labelled on all the chromatograms of stem internode extracts. At 3h, these were the only labelled substances detectable in the internode above the fed leaf, but at 24h this internode also contained very small quantities of ^{14}C in asparagine, aspartic acid, glutamine, and glutamic acid. The internode below the fed leaf contained trace quantities of labelled amino acids at both 3h and 24h. Asparagine was labelled in neither internode at 3h, and in both at 24h.

The sugar and organic acid regions of the leaf extract chromatograms caused such heavy fogging of the autoradiographs that individual spots could not be resolved. The presence of the sugars, which were detected labelled in other extracts, could not then be ascertained with certainty.

Table 8-1. Distribution of ^{14}C from a leaf photosynthesising in $[^{14}\text{C}] - \text{CO}_2$

	3h	24h
LEAF, NODE 15	3098 \pm 61	1497 \pm 29
POD, NODE 15	513 \pm 10	1703 \pm 34
INTERNODE, 15-16	74 \pm 2	104 \pm 2
INTERNODE, 14-15	562 \pm 11	292 \pm 6

Activities are expressed in cpm per mg fresh weight of sample. Soluble fractions only were counted. Two plants were used. These were grown, in the glasshouse in Durham, to 20-30 nodes. $150\mu\text{Ci}$ was fed for 3h, from 10.30 to 13.30, to leaves subtending 20-25 day old pods. The 3h sample was harvested immediately after removal of the feeding chamber. The 24h sample was left in unlabelled air for another 21h. Nodes are numbered from the plant base.

Table 5-2. Distribution of ^{14}C from a leaf photosynthesising in $[\text{}^{14}\text{C}] - \text{CO}_2$

	leaf		pod		internode above		internode below	
	3h	24h	3h	24h	3h	24h	3h	24h
CYS	++	+		+				
ASP	++	++	+	+		+	+	
ASN		+		+		+		+
GLN		++		+		+	+	+
GLU	++	++	+	+		+	+	+
SER	++	+		+			+	
THR	+	+						
DOPA		+		+				
ALA	++	+	+	+				
VAL	+	+		+				
MET								
TYR	++	++	+	+				
PHE	++	++		+				
LEU	+							
ILE	+							
GLY	++							
BASICS								
γ AB	+	+		+				
NON-AMINO	++	++	++	++	++	++	++	++

= absent; + = weak label; ++ = strong label;

The experimental conditions are described in the legend to Table 5-1. The extracts were all made by grinding once with 5% TCA and were, therefore, incomplete, particularly for the leaf and pod tissues. 40 μ l samples, corresponding to about 5 μ g tissue, were used on each chromatogram. Autoradiographs were exposed for 3 days.

Table 5-3. Sugars in pod and internode extracts -
mobilities

	pod		internode above		internode below		MEAN	STANDARDS	
	3h	24h	3h	24h	3h	24h			
a)	1.36	1.29	1.36	1.44	1.38	1.37	1.37	FRUCTOSE	1.34
b)	1.23	1.20	1.27	1.33	1.28	1.23	1.26	GLUCOSE	1.25
c)	1.12	1.09	1.15	1.09	1.18	1.03	1.11	SUCROSE	1.12

Mobilities are expressed in terms of alanine (1.00) by measuring the distance moved by the unknown (on the autoradiograph) and dividing by the alanine distance (from the chromatogram).

6. Leaf photosynthesis and export of labelled photosynthate into the petiole

When [^{14}C] - CO_2 was fed to the oldest leaves of 3-leaf plants, the ^{14}C was incorporated into both the TCA-soluble and TCA-precipitated (insoluble) fractions. Total ^{14}C in the leaf extracts was plotted against time, and linear and exponential curves were fitted to the points.

Fit factor for linear curve = 46.99

Fit factor for exponential curve = 41.77

The two fit factors are not dissimilar, and the exponential curve is the better fit. Thus the data is best described by

$$y = K (1 - e^{-ax})$$

where $K = 2413.54$

$$a = 0.004$$

Then, when y is 99% of K

$$e^{-ax} = 0.01$$

$$\therefore 0.004x = \ln 0.01$$

$$\therefore x = 1200$$

Therefore, the saturated leaf will contain ^{14}C at an activity of 2414 cpm per mg, and it will take 1200 min. to become 99% saturated. This assumes that all parts of the leaf which will become labelled contain some activity at the end of the experimental period. Conversely, the calculated saturation applies only to those parts of the leaf which are labelled during the experimental period.

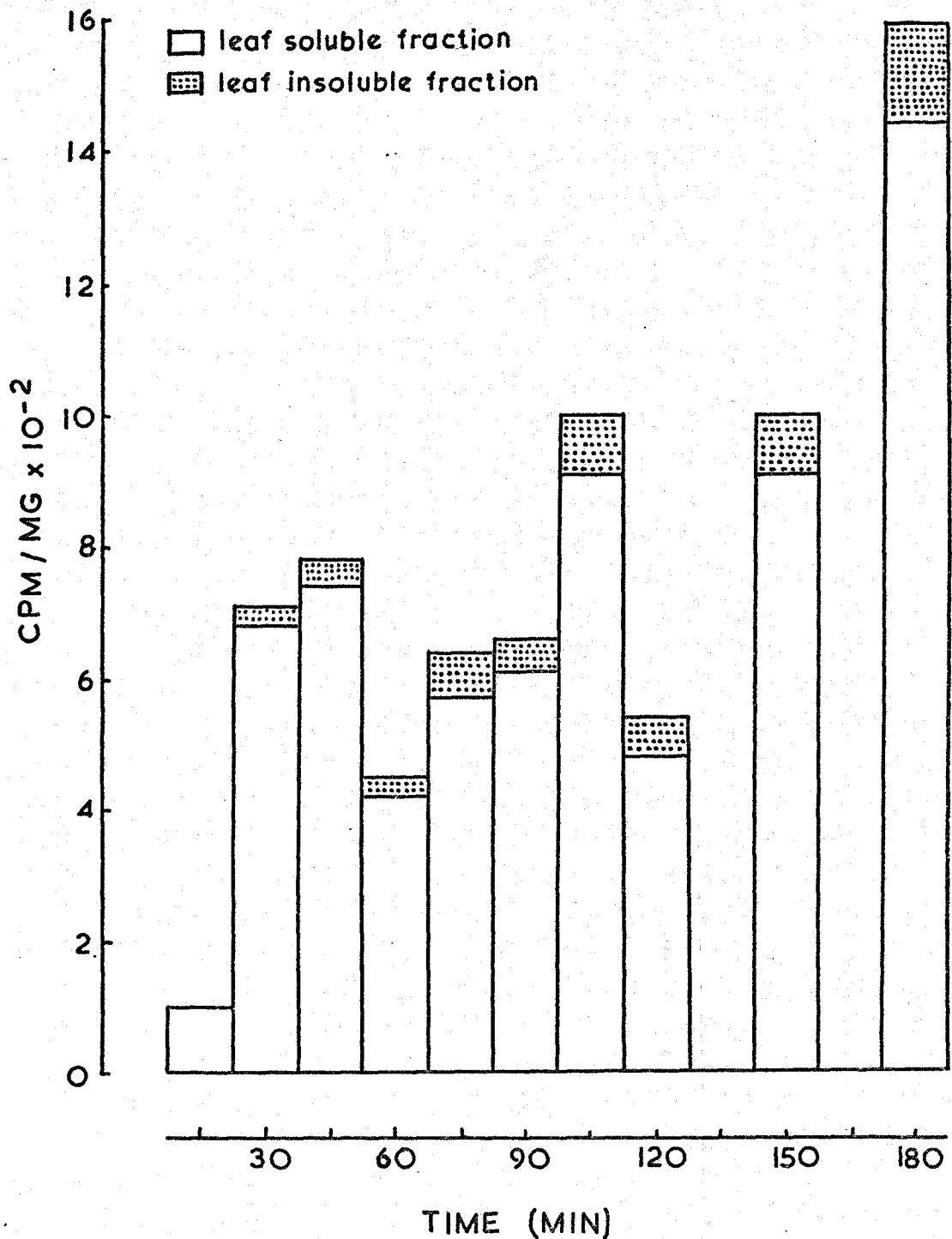

Fig. 6-1. The distribution of ^{14}C between the soluble and insoluble fractions of a leaf. Ten leaves, the oldest on 3-leaf plants, were each fed $150 \mu\text{Ci } [^{14}\text{C}] - \text{CO}_2$. One leaf was harvested at each of the times given, which are in minutes after 10.00 a.m., the start of feeding. Samples were counted using the IDL Scalar 1700. Counting errors were about 3%.

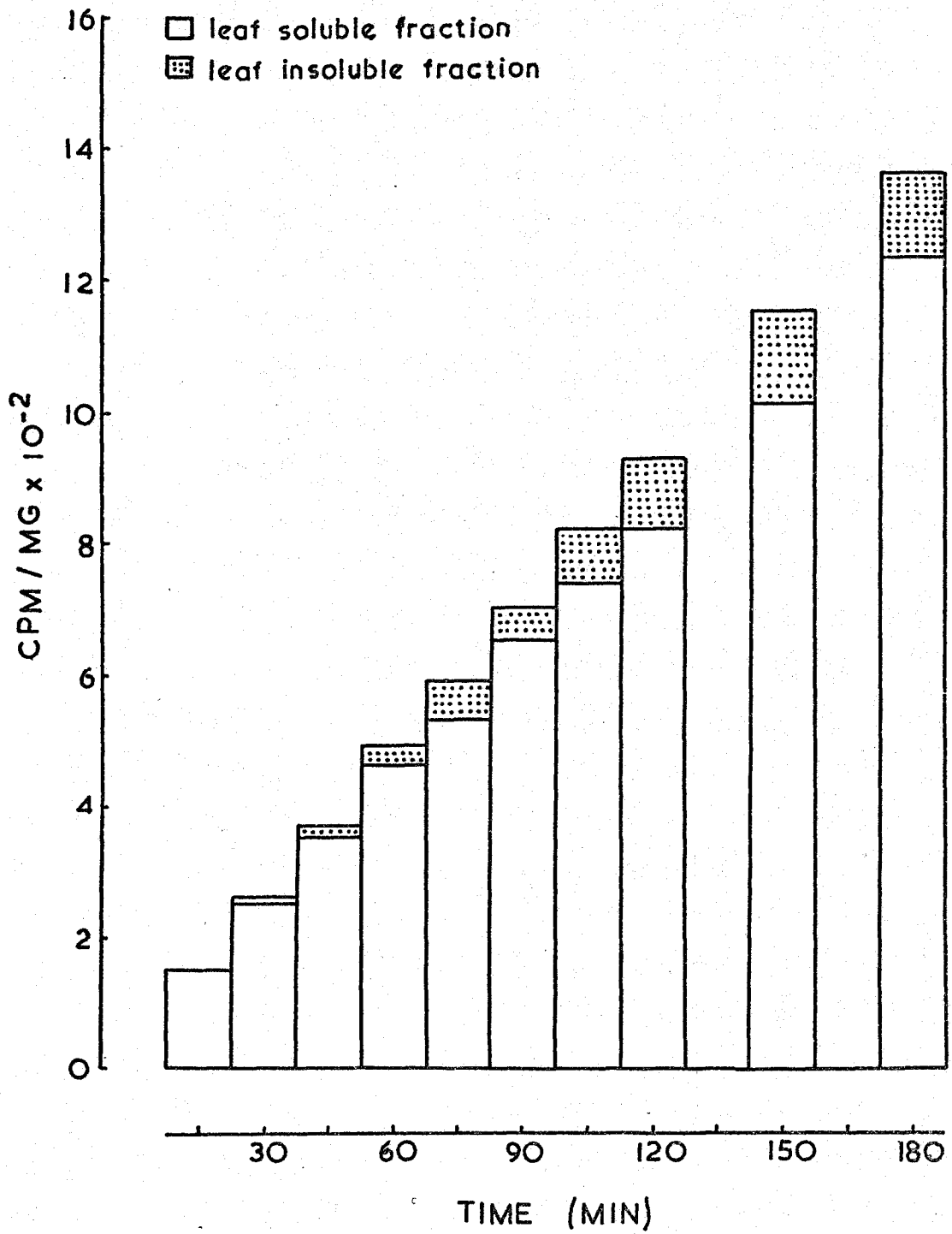

Fig. 6-2. The distribution of ^{14}C between the soluble and insoluble fractions of a leaf. This histogram was obtained from Fig. 6-1 by adjusting the histogram totals to lie upon an exponential curve (see text).

The experimental period is only 0.15 of the time to 99% saturate the leaf, and this accounts for the similarity between the two fit factors. The first section of an exponential curve is almost linear. The exponential curve is illustrated as the histogram totals in Fig. 6-2.

The distribution of ^{14}C between the soluble and insoluble leaf fractions is illustrated in Figs. 6-1 and 6-2. Fig. 6-2 was obtained from Fig. 6-1 by adjusting the histogram totals to lie upon the exponential curve and scaling the contents of each histogram column. Incorporation of ^{14}C into the two fractions can be seen from Fig. 6-2 to be approximately linear. ^{14}C in leaf protein did not reach a measurable level until 30 min. after the start of feeding, and it then increased in a linear manner for the rest of the 3h. The soluble leaf fraction showed no sign of becoming saturated with ^{14}C during this time interval.

The leaf petioles, which had been smeared with plasticine-vaseline mixture to exclude $[^{14}\text{C}] - \text{CO}_2$ and prevent photosynthesis, contained ^{14}C in the soluble fraction after 15 min. (Table 6-1). The total activity in the petiole increased for the whole 3h of the experiment. A very small quantity of ^{14}C was incorporated into the petiole insoluble fraction, but not until the 120 min. sample. The low activity of the insoluble fraction suggests that most of the soluble petiole ^{14}C was being translocated through the petiole and not being absorbed by it.

Table 8-1. ^{14}C distribution in petioles

TIME AFTER START (min)	SOLUBLE FRACTION	INSOLUBLE FRACTION	TOTAL
15	0.4	0.0	0.4
30	2.8	0.3	3.1
45	1.6	0.0	1.6
60	2.9	0.0	2.9
75	8.5	0.2	8.7
90	2.8	0.5	3.3
105	5.8	0.6	6.4
120	11.5	1.2	12.7
150	58.3	2.3	60.6
180	14.3	1.3	15.6
MEAN PLANCHET COUNT			
15	600	450	
30	1200	450	
150	2800	450	
MEAN ERROR (PERCENTAGE)			
15	10	34	
30	4	34	
150	2	34	

Activities are expressed in cpm per mg extracted weight of petiole. Background was 23cpm. Errors were calculated as described in Preliminary Results, section 6(i). The leaves were fed ^{14}C - CO_2 for 180 min and the petioles, which had been smeared with plasticine-vaseline to exclude gases, were harvested individually at the times given. The extracts were counted using the IDL scalar 1700.

When the activity in the petiole is expressed per mg of leaf to which it was attached, the pattern of export of labelled materials becomes more evident. This assumes that, for petioles of similar sizes, the translocation channels will be of comparable volume. For constant rate of export from a leaf, ^{14}C per petiole is then equal to ^{14}C per unit time. Fig. 6-3 illustrates that after a lag phase of 30-45 min, ^{14}C per petiole increases linearly. This linear increase must represent a linear increase in ^{14}C in that leaf pool which is active in export of photosynthate from the leaf. The lag phase must represent the time taken to saturate the precursors of this active leaf pool. Saturation of the petiole is not approached during the 3h experiment. This is, perhaps, to be expected as leaf saturation is not approached during this time interval.

If the data in Fig. 6-1 are used to calculate the net uptake of ^{14}C by the leaf, per h, it is seen that the 30 min sample has a higher net uptake than any other, and that the 45 min sample is also large (Table 6-2). These figures can be accounted for, since export from the leaf into the petiole is very small until the 45 min sample (Fig. 6-3) and so net ^{14}C uptake by the leaf must appear larger. This does not account for the small value for the 15 min sample.

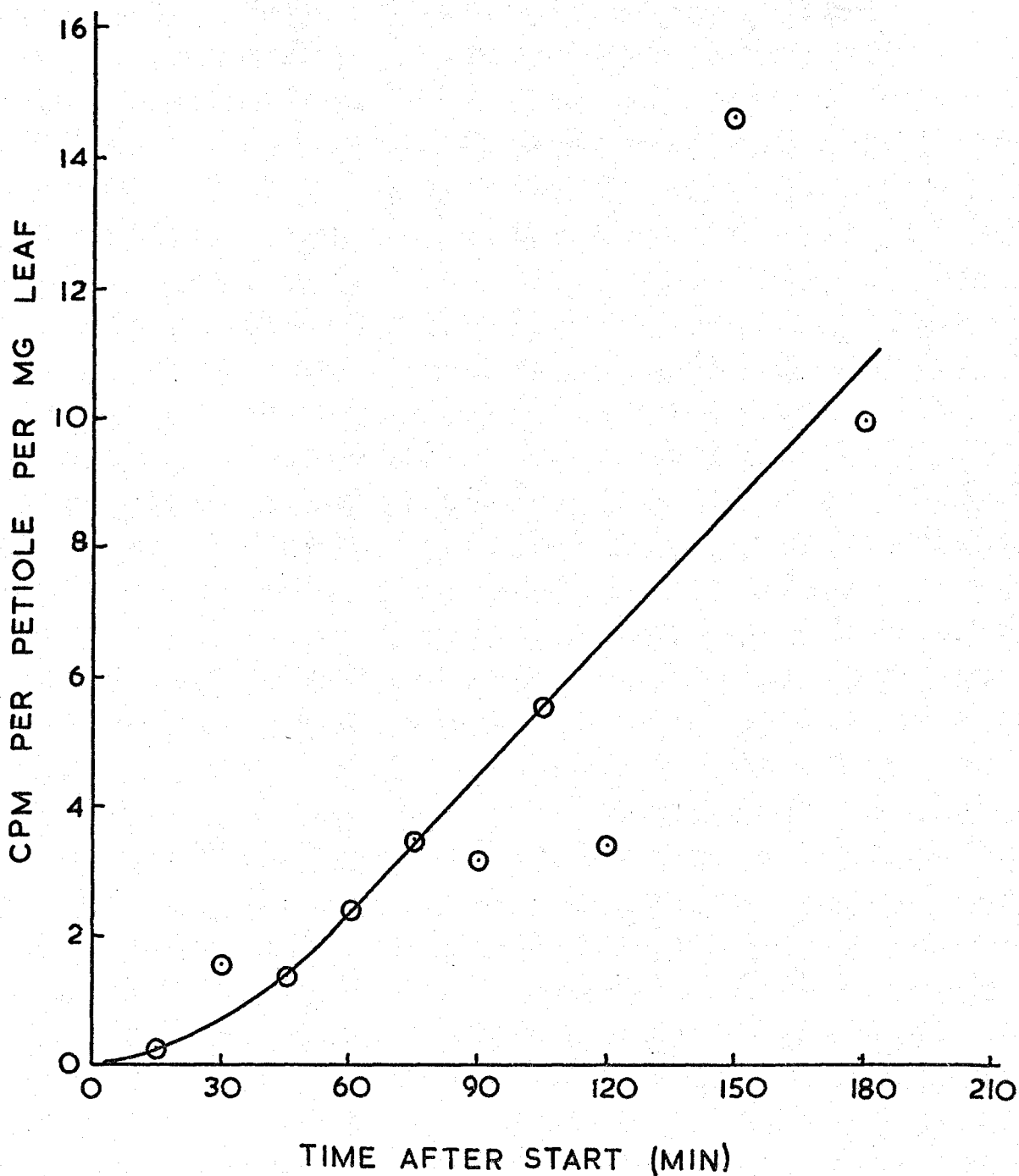

Fig. 6-3. ^{14}C in the petioles of leaves photosynthesising in $[\text{}^{14}\text{C}] - \text{CO}_2$. The leaves were fed $[\text{}^{14}\text{C}] - \text{CO}_2$ for 180 min and the petioles were smeared with plasticine-vaseline to exclude gases. Each sample is a single petiole and was counted using the IDL Scalar 1700. Errors are discussed in the legend to Table 6-1.

Table 3-2. ^{14}C uptake by the leaf

TIME(min)	15	30	45	60	75	90	105	120	150	180
UPTAKE (cpm per h)	428	1436	985	443	490	888	571	272	411	529

Uptake = activity in leaf \times 60/time of ^{14}C - CO_2 feeding (min). The leaves were fed ^{14}C - CO_2 for the whole 180 min.

Autoradiography of leaf extracts revealed that at least 90% of soluble ^{14}C was in ninhydrin negative compounds which ran in the sugar and organic acid regions of the chromatogram. No attempt was made to identify these. At 15 min, ^{14}C was also detected in dihydroxy-phenylalanine, aspartic acid, serine and glycine. All but the first of these remained radioactive throughout the 3h. At 75 min glutamic acid, tyrosine and phenylalanine became labelled, and these six amino acids retained most of the amino acid label throughout the rest of the experiment. These labelled amino acids were among the most concentrated soluble amino acids in the leaf. Cystine and glutamine, also present in high concentration, were labelled only weakly. Dihydroxy-phenylalanine, which accounted for about 50% of the amino acid in the leaf soluble fraction, was similarly weakly labelled.

Serine was the first leaf protein amino acid to appear labelled (at 30 min), followed by alanine and glycine (45 min). Tyrosine, phenylalanine and aspartic acid in protein were labelled in the 105 min sample.

All these protein amino acids were labelled in the soluble leaf fraction, but not all the labelled soluble amino acids gave rise to detectable quantities of labelled protein amino acid (Table 6-3).

Autoradiography of petiole extracts showed that the detectable ^{14}C was almost entirely in sugars or organic acids. Serine and glycine were labelled at 30 min and serine retained the label, which gradually decreased, until 105 min. The remaining autoradiograph fogging was never well resolved, and the [^{14}C] sugars and/or organic acids were not identified (Table 6-3).

Leaves subtending 25-30 day old pods were fed [^{14}C] - CO_2 for 1h, in a like manner and soluble petiole extracts were subjected to autoradiography. Six labelled compounds were detectable in the extracts - serine, glycine, sucrose, glucose, fructose and an unknown moving just ahead of fructose on the electrophoresis origin. Almost half the label was in sucrose. Glucose and fructose appeared to contain similar amounts of label, at about half the activity of the sucrose. Serine and glycine were weakly labelled by comparison.

Table 6-3. ^{14}C in leaf and petiole amino acids

PETIOLE
SOLUBLE FRACTION

LEAF
INSOLUBLE FRACTION

SOLUBLE FRACTION

TIME	SOLUBLE FRACTION						LEAF						INSOLUBLE FRACTION						PETIOLE SOLUBLE FRACTION											
	15	30	45	60	75	90	105	120	150	180	15	30	45	60	75	90	105	120	150	180	15	30	45	60	75	90	105	120	150	180
CYS																														
ASP	+		+	+	+			+	+	+		+																	+	
ASN						+																								
GLN						+																								
GLU					+	+		+	+	+		+																		
PRO																														
DOPA	+			+																										
SER	+	+	+	+	+			+	+	+		+																	+	+
THR																														
ALA				+																									+	
VAL																														
MET																														
TYR						+			+	+																			+	+
PHE						+			+	+																			+	+
ILE																														
LEU																														
GLY	+	+	+	+	+			+	+	+		+																	+	+
ARG																														
HIS																														
LYS																														
γ AB																														

= no label + = labelled.

The leaves were fed $[^{14}\text{C}] - \text{CO}_2$ for 180 min. The experimental conditions are described in the legends to Figs. 6-1 and 6-3.

7. Photosynthesis of the bloom node leaf and export of labelled photosynthate into the pod and seed

When the bloom node leaves subtending 20-25 day old pods were allowed to assimilate [^{14}C] - CO_2 for 3h, and leaves and pods were harvested at intervals for another 16h, a small transfer of ^{14}C from leaf to pod was detected. The total ^{14}C in the leaf-pod system fell from 576 cpm/mg at 1h to 98 cpm/mg after 19h from the start of [^{14}C] - CO_2 feeding. Variability between samples was large so that although it can be said that the system lost 400-500 cpm/mg during the 18h after the first sample, precise values cannot, with any meaning, be assigned to the individual samples.

In the 1h sample the ^{14}C was restricted to the leaf and present in both the soluble and insoluble fractions. By 3h, a significant amount of ^{14}C was present in the soluble fraction of the pod, but label was not detected in the insoluble pod fraction until the 7h sample. This distribution of ^{14}C in the leaf-pod system is illustrated as a histogram in Fig. 7-1. An expanded histogram showing the distribution of ^{14}C in the leaf samples only (Fig. 7-2) is almost exactly the same shape as the histogram for the whole system. This emphasises the fact that the 20-25 day old pod had only a small effect on this leaf-pod system, and that only a small part of the ^{14}C exported from the leaf was finally found in the pod.

Autoradiography of pod and leaf extracts revealed

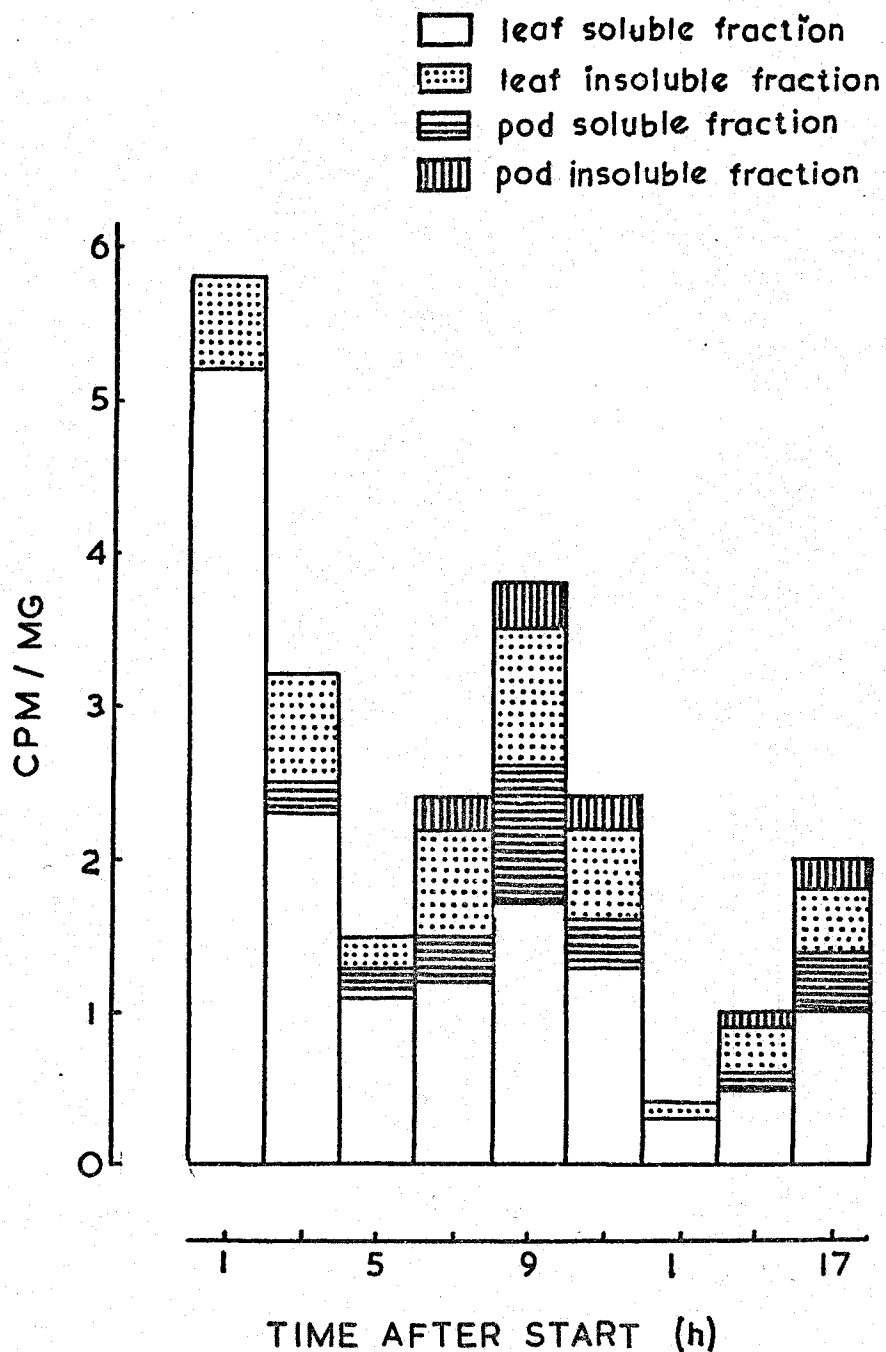

Fig. 7-1. Distribution of ^{14}C in a leaf and pod system. Each sample was the extract from a single plant grown outdoors in Reading in the summer of 1970. The plants were grown to about 15 nodes, and these samples were the leaf and pod at nodes 12, 13 and 14. The pods were 20-25 days old. Feeding of $[^{14}\text{C}] - \text{CO}_2$ was from 11.00 - 14.00. The seeds were very small (1-2mm long) and were extracted with the pod. Samples were counted using the IDL scalar 1700. Counting errors were 2-3% for soluble fractions and 4-6% insoluble fractions.

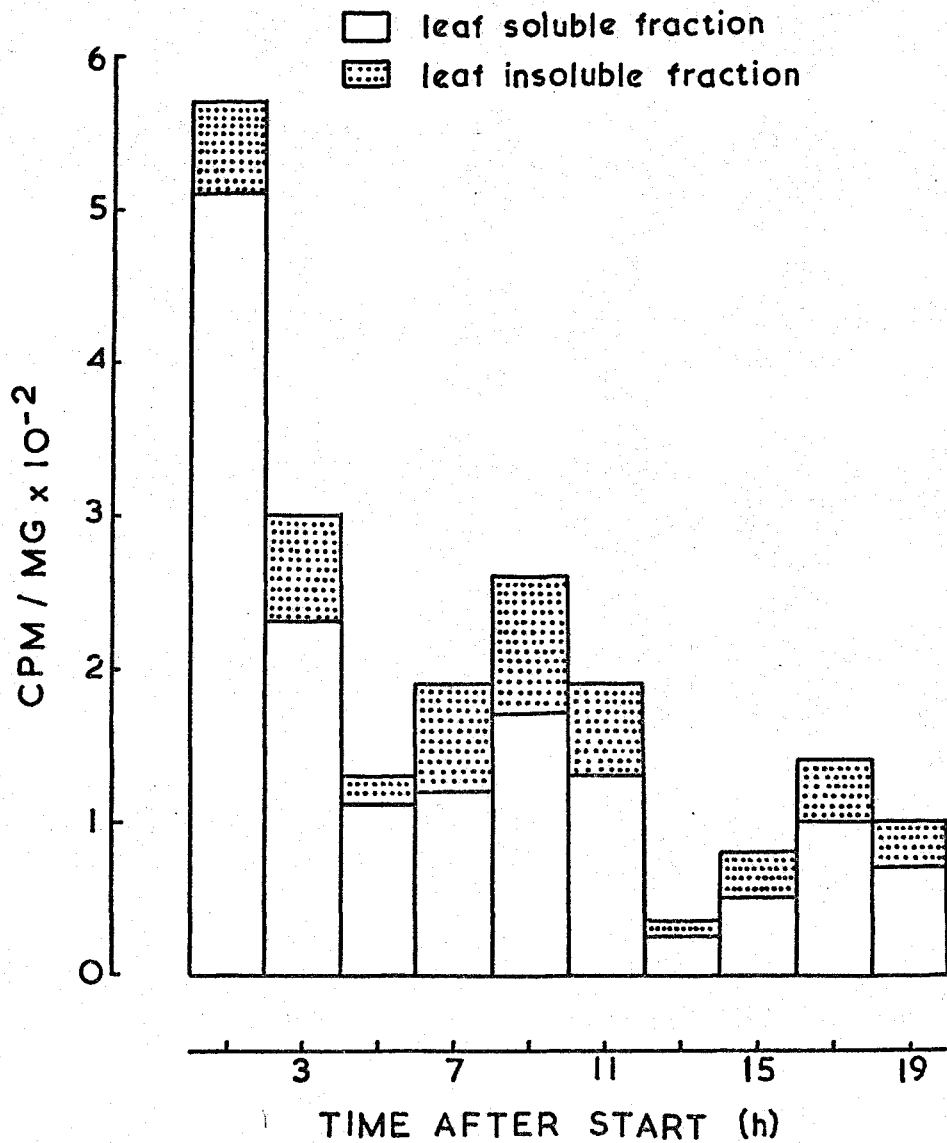

Fig. 7-2. Distribution of ^{14}C in the leaf of a leaf and pod system.

The leaves subtended 20-25 day old pods at nodes 12, 13 or 14 of a 15 node plant. The experimental conditions are described in the legend to Fig. 7-1.

that a considerable portion of the ^{14}C in all samples was in ninhydrin negative compounds. No labelled amino acids were detected in pod protein and only six amino acids in the pod soluble fraction became labelled (Table 7-1). After 1h $[^{14}\text{C}] - \text{CO}_2$ feeding, the only $[^{14}\text{C}]$ - amino acid in the pod was dihydroxyphenylalanine and this accounted for about half of the detectable ^{14}C . At 3h tyrosine was as strongly labelled as dihydroxyphenylalanine and traces of label were present in serine and alanine. Tyrosine and dihydroxyphenylalanine remained the most heavily labelled amino acids for the rest of the 19h, and trace quantities of label were detected in glutamic acid and glutamine as well as in serine and alanine. The ninhydrin-negative radioactive compounds in the soluble pod fraction contained about half of the label (as estimated from intensity of autoradiograph fogging) throughout the experiment. The labelled region was never resolved into spots and so its sugar components were not identified, but could have included sucrose, fructose and glucose, as in earlier pod samples. The insoluble fractions of leaf and pod, after 7h, contained an unidentified ninhydrin-negative substance which moved on the electrophoresis origin to the chromatography front. This substance must have contained most, if not all, of the ^{14}C recorded for the insoluble pod fraction.

These pods had been damaged slightly by a storm about two days before the experiment, and many of the unused pods of equivalent age developed no further, but

Table 7-1. Distribution of ¹⁴C in amino acids of a leaf pod system

TIME(h)	LEAF									POD											
	SOLUBLE FRACTION			INSOLUBLE FRACTION			SOLUBLE FRACTION			SOLUBLE FRACTION											
	1	3	5	7	9	11	13	15	17	19	1	3	5	7	9	11	13	15	17	19	
CYS																					
ASP	+	+	+	+	+						+	+									
ASN																					
GLN																+					+
GLU	+	+	+	+	+											+					+
SER	+	+	+	+	+											+					+
THR																+					
PRO																					
DOPA																					
ALA	+	+	+	+	+																
VAL																					
MET																					
TYR																					
PHE																					
ILE																					
LEU																					
GLY																					
LYS																					
ARG																					
SALA																					
*AB																					
OTHER	+	+	+	+	+																

= absence, + = presence of label. [¹⁴C] - CO₂ was fed for the first 3h of the experiment to the leaves which subtended 20-25 day old pods. The experimental conditions are described in the legend to Fig. 7-1. The pod insoluble fraction contained no radioactive amino acids.

withered and aborted. Thus the pods used may have not been actively growing, and this may account for the marked difference between these results and those in the Preliminary experiment (section 5.), which were of a comparable age.

A number of soluble leaf amino acids became labelled and a considerable proportion of leaf radioactivity was incorporated into leaf protein. At 1h, ^{14}C was detectable in soluble aspartic acid, glutamic acid, serine and alanine, but at 3h only cystine, asparagine, dihydroxyphenylalanine, leucines and basic amino acids were unlabelled. By 2h after the end of $[\text{}^{14}\text{C}] - \text{CO}_2$ feeding, the amount of label in soluble amino acids was markedly reduced. The small amount of label present from 5h onwards was mostly in aspartic and glutamic acids. In contrast, the label in the sugar and organic acid regions of the chromatograms remained strong for all extracts, first showing signs of lessening in the 13h sample.

Most of the amino acids in the leaf protein were labelled by 7h and remained so until the end of the experiment. Exceptions were glutamic acid, which was not labelled before the 19h sample and cystine, proline and arginine which were not labelled at all. Cystine and proline are present in small quantities in leaf protein and so any ^{14}C may have been undetectable. Arginine and glutamic acid are major amino acids in the protein.

When $[^{14}\text{C}] - \text{CO}_2$ was fed to leaves subtending 30-35 day old pods, ^{14}C was seen to be transferred from the leaf into the pod and its seeds. The total ^{14}C in the leaf, pod and seed system rose to 720 cpm/mg extracted weight of sample at the end of the 3h feeding period, and then fell to 250 cpm/mg 6h later. From 11h to 19h the total ^{14}C in the system rose again until at 19h it reached 840 cpm/mg. The difference between these minimum and maximum activities is considerably greater than the 100-200 cpm/mg variation between plants (as in Fig. 7-1). The distribution of ^{14}C between the various parts of the system is illustrated in Fig. 7-3. Fig. 7-4 is a histogram of the leaf samples alone, and is quite different from the histogram for the whole system. In the leaf, the total ^{14}C decreased rapidly after $[^{14}\text{C}] - \text{CO}_2$ feeding ended, and then remained almost constant at 180-240 cpm/mg. The pod made a considerable contribution to the total ^{14}C in the system, unlike the 20-25 day pod in Figs. 7-1 and 7-2. A closer examination of Fig. 7-3 reveals that the increase in cpm/mg after the 11h sample is accounted for almost entirely by an increase in the activity of the soluble seed fraction. This rose from 113 cpm/mg at 9h to 606 cpm/mg at 19h. During this time interval the soluble pod fraction activity fluctuated between 6 and 18 cpm/mg.

The leaf insoluble fraction had its maximum activity of 101 cpm/mg at the end of the feeding period. After this it fluctuated between 20 and 50 cpm/mg for the rest

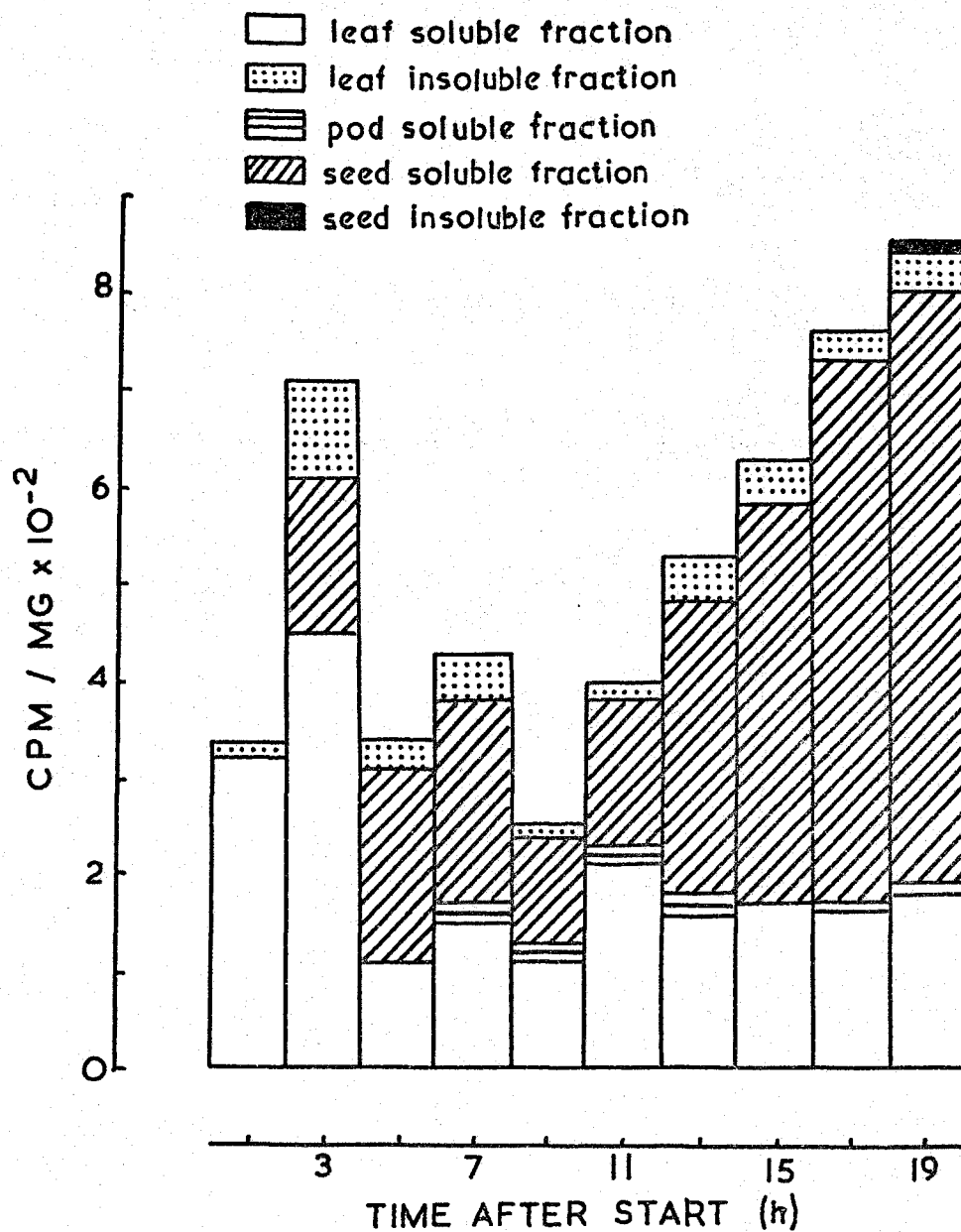

Fig. 7-3. Distribution of ^{14}C in a leaf-pod-seed system. Leaves at nodes 7-11 on 15 node plants were fed $150\mu\text{Ci}$ $[\text{}^{14}\text{C}] - \text{CO}_2$ for 3h from 12.15-15.15 in the summer of 1970. The leaves and the 30-35 day old pods which they subtended were harvested at intervals during 19h. Pods and seeds were extracted separately. Each sample was a single plant. Extracts were counted using the IDL scalar 1700. Counting errors were 2-3% for soluble fractions, 4% for insoluble leaf fractions, and 30-40% for insoluble pod and seed fractions.

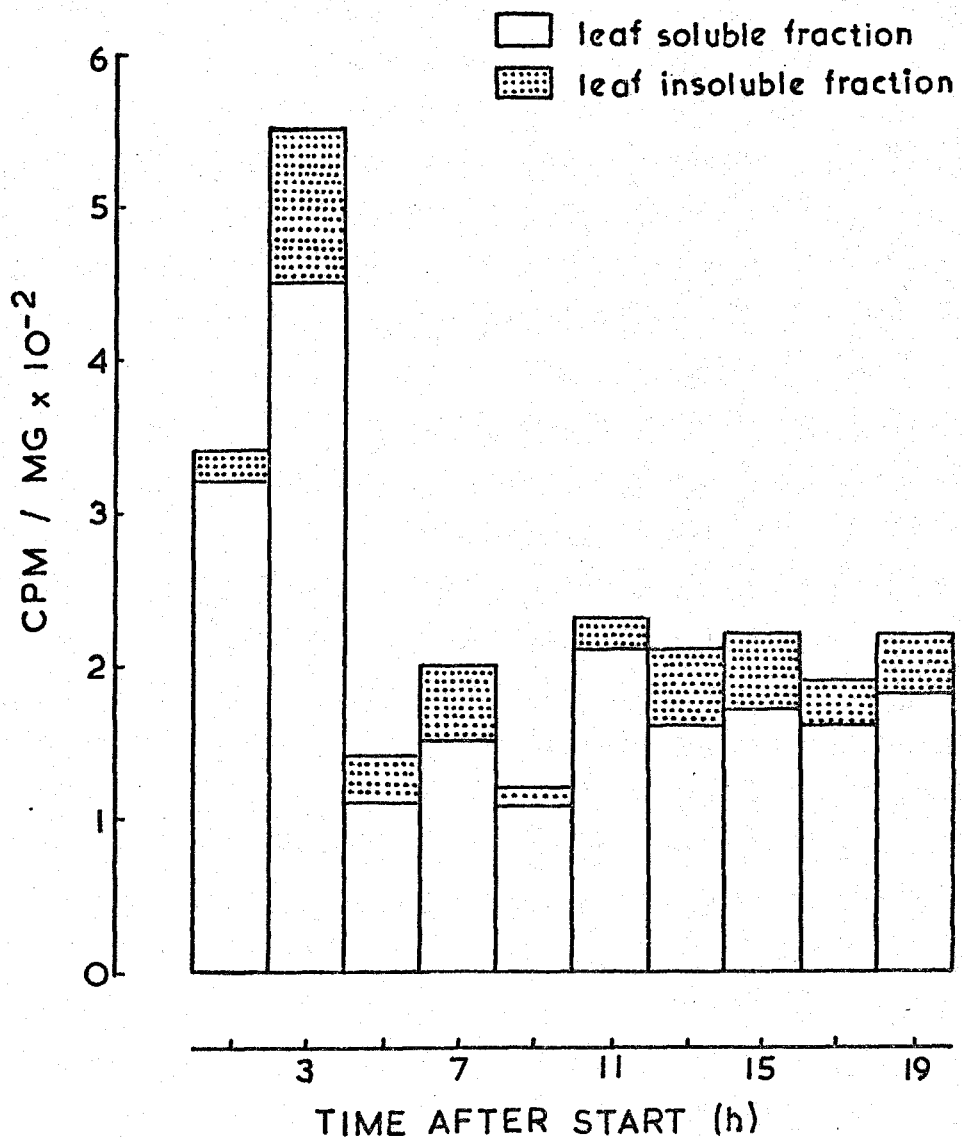

Fig. 7-4. Distribution of ^{14}C in the leaf of a leaf-pod-seed system. The leaves, at nodes 7-11 on 15 node plants grown outdoors in Reading in the summer of 1970, subtended 30-35 day old pods. $150\mu\text{Ci } [^{14}\text{C}] - \text{CO}_2$ was fed to the leaves for 3h from 12.15 to 15.15. Errors are described in the legend to Fig. 7-3.

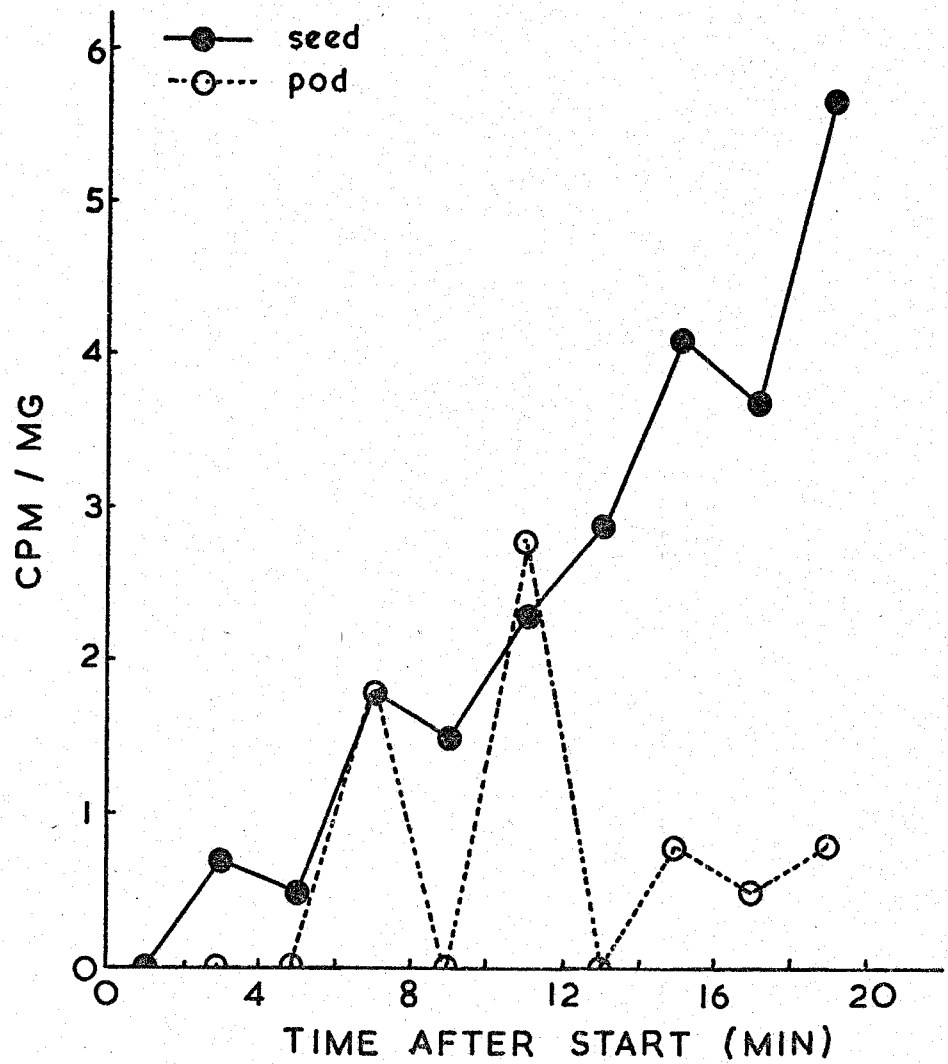

Fig. 7-5. ^{14}C in the insoluble fractions of pod and seed. The pods were 30-35 days old and were fed ^{14}C for 3h via their subtending leaf. The experimental details are described in the legend to Fig. 7-3.

of the 19h. ^{14}C incorporated into the pod insoluble fraction was very low and variable, having a maximum of 3 cpm/mg at 11h. Insoluble ^{14}C in the seed was also very low but increased steadily throughout the experiment, reaching 6 cpm/mg at 19h. These values, too low to be shown on Fig. 7-3, are plotted on an expanded scale in Fig. 7-5.

Autoradiography did not detect any radioactive amino acids in the pod and seed extracts. Maximum loadings of soluble fractions contained 50-100 cpm per chromatogram and this was sufficient only to fog the sugar and organic acid areas of the autoradiographs. Any radioactive soluble amino acids were present in pods and seeds below the detectable level, and the marked increase in soluble activity in the seed must have been due almost entirely to sugars and/or organic acids. These compounds were not resolved. Maximum chromatogram loadings of insoluble fractions contained 3-6 cpm per chromatogram, and thus had no effect at all on the autoradiograph, even after 6 weeks exposure.

All the soluble pod fractions contained radioactive compounds which were not resolved in autoradiography. They moved on the electrophoresis origin and had a mean chromatography Rf. relative to alanine of 1.29. At least in the later samples the radioactive area contained more than one substance which could have included the sugars glucose (Rf. 1.25) and sucrose (Rf. 1.12), but probably not fructose (Rf. 1.34) until after 9h. (Table 7-2). The chromatograms of seed soluble fractions from 3h

Table 7-2. Mobilities of the ninhydrin negative radioactive spot on chromatograms of soluble fractions

	1	3	5	7	9	11	13	15	17	19	MEAN
pod	1.28	1.23	1.27	1.28	1.33	1.28	1.28	1.32	1.30	1.35	1.29 (1-19h)
seed	-	1.21	1.23	1.27	1.41	1.28	1.31	1.31	1.31	1.33	1.32 (7-19h)

The experimental conditions are described in the legend to Fig. 7-3. Rf's were calculated by dividing the distance to the front of the radioactive spot (measured on the autoradiograph) by the distance moved by alanine (on the chromatogram).

onwards contained a similar unresolved radioactive area with a mean Rf relative to alanine of 1.22 at 3h and 5h, and of 1.32 from 7h to 19h. These correspond approximately to glucose, possibly with sucrose at 3h and 5h, and to fructose, probably with glucose and sucrose in the later samples. Since the mobilities of sugars in chromatography are notoriously variable, and other radioactive substances may have been present as well, these interpretations must be treated with caution. In the pod samples at least the analysis can be justified by comparison with earlier results (Section 1.), but in the seed samples the radioactive area was a single, large and symmetrical spot and its interpretation as a number of sugars is open to doubt. The mobilities of the fronts of the radioactive areas are listed in Table 7-2.

Radioactive amino acids in the leaf fractions are listed in Table 7-3. At 1h almost all the soluble amino acid ^{14}C was in serine, but by 3h aspartic acid, glutamic acid, glutamine, threonine and alanine were as heavily labelled. From 5h, aspartic acid and serine were the most heavily labelled amino acids in all samples. The sugar and organic acid region of the chromatogram caused at least 90% of the autoradiograph fogging, for these extracts. In the insoluble fractions the only ninhydrin negative radioactive substance was the unknown which moves on the electrophoresis origin to the chromatography front. This was also present in the soluble fractions of these leaves. The first protein amino acids to be detectably labelled were serine, alanine, phenylalanine

Table 7-3. ^{14}C distribution in leaf amino acids

	SOLUBLE FRACTION										INSOLUBLE FRACTION									
	1	3	5	7	9	11	13	15	17	19	1	3	5	7	9	11	13	15	17	19
CYS																				
ASP	+	+	+	+	+	+	+	+	+	+										
ASN																				
GLN	+	+	+	+						+	+									
GLU	+	+	+	+	+	+	+	+	+	+					+			+	+	+
SER	+	+	+	+	+	+	+	+	+	+	+	+	+	+	+	+	+	+	+	+
THR		+		+	+	+	+	+	+	+					+			+	+	+
PRO																				
DOPA	+	+	+	+	+	+	+													
ALA	+	+	+	+	+	+	+	+	+	+	+	+	+	+	+	+	+	+	+	+
VAL		+													+	+		+	+	
MET																				
TYR		+													+	+	+		+	+
PHE	+	+	+	+	+	+	+		+	+	+	+	+	+	+	+	+	+	+	+
ILE		+													+	+	+		+	+
LEU															+	+	+			
GLY	+	+													+	+	+	+	+	+
ARG															+					
HIS																				
LYS		+													+			+		
βALA																				
γAB		+				+	+	+	+	+										
OTHER	+	+	+	+	+	+	+	+	+	+	+	+	+	+	+	+	+	+	+	+

= absent + = present (radioactivity)

The leaves were fed $[^{14}\text{C}] - \text{CO}_2$ for the first 3h from 12.15 - 15.15. The experimental conditions are described in the legend to Fig. 7-3.

and glycine (at 1h). By 3h most of the amino acids which became labelled during the 19h were radioactive. Glutamic acid, arginine and lysine, all present in high concentration in the protein, were labelled only faintly in these extracts. Other unlabelled amino acids were present in small quantities only. The distribution of ^{14}C in the soluble amino acids bore very little relation to its distribution in protein amino acids.

$[^{14}\text{C}] - \text{CO}_2$ was fed to leaves subtending 20-25 day old pods for 3h and the leaves, pods and seeds were extracted 21h later. ^{14}C was detected in all extracts. Variability between the trace samples was considerable, the largest total ^{14}C for the system being almost twice the smallest. Means, standard errors and percentage errors are given in Table 7-4. Autoradiography of extracts revealed ^{14}C amino acids in leaf, pod and seed protein. (Table 7-5). The pattern of labelling in leaf protein was like that seen previously (Tables 7-1 and 7-3). Pod and seed proteins were weakly radioactive with the label distributed fairly evenly among the radioactive amino acids.

Table 7-5. ^{15}C amino acids in protein

INSOLUBLE FRACTIONS			
	leaf	pod	seed
CYS			
ASP	+		+
GLU	+		+
SER	+	+	+
THR	+		+
PRO			
ALA	+	+	+
VAL	+	+	+
MET			+
TYR	+	+	+
PHE	+	+	+
ILE	+	+	
LEU	+	+	+
GLY	+	+	+
BASICS	+		

= absence of label, + = presence of label.

The leaf, which subtended a 20-25 day old pod, was fed [^{14}C] - CO_2 for 3h. The leaf, pod and seed were harvested 21h later. The experimental conditions are described in the legend to Table 7-4.

$[^{14}\text{C}] - \text{CO}_2$ was fed to leaves subtending 22-27 day old pods for 3h, and ^{14}C was detected in both soluble and insoluble fractions of pods and seeds harvested at 3, 6 and 12h after the start of feeding. (Table 7-6). The changes in total ^{14}C in the pod and seeds after the 3h sample are similar in size to the chance variations obtained with the three replicate samples described in Table 7-4. Thus, the only significant change in activity of the pod and seed fractions after 3h may be the increase in ^{14}C in the seed insoluble fractions. Other differences represent fluctuation rather than increase.

Autoradiography did not detect any labelled amino acids in the pod insoluble fractions where the only radioactive compound was the unknown on the electrophoresis origin and chromatography front. This substance was also labelled in the seed insoluble fractions, but in neither pod nor seed soluble fractions. Seed protein amino acids were first detectably labelled at 6h when nine amino acids were radioactive. At 12h, only aspartic and glutamic acid, serine and phenylalanine were labelled. (Table 7-7). The pod and seed soluble fractions were all very heavily labelled over the whole sugar and organic acid area of the chromatograms. In the pod, amino acid labelling was strongest in tyrosine in all three samples. In the seed soluble fractions, γ -aminobutyric acid was the only labelled amino acid to acquire its label after the first sample. Apart from increasing intensity of labelling, the autoradiograph pattern changed very little between the 3 samples.

Table 7-6. ^{14}C distribution in the pod and seeds of a leaf-pod-seed system

	SOLUBLE		INSOLUBLE		TOTAL
	pod	seed	pod	seed	
3h	365	932	86	36	1419
6h	368	1882	146	266	2661
12h	203	714	81	125	1123

Activities are expressed in cpm/mg extracted weight of sample. $75 \mu\text{Ci } [^{14}\text{C}] - \text{CO}_2$ was fed to leaves at node 7 of glasshouse grown plants, for 3h. At 3h, 6h and 12h after the start of feeding, the 22-27 day old pods, subtended by the leaves, were harvested. Each sample is a single pod and its seeds. Extracts were counted using the IDL scalar 1700. Counting errors were less than 4%.

Table 7-7. ^{14}C amino acids in 22-27 day old pods and seeds

	POD			SEEDS					
	SOLUBLE			SOLUBLE			INSOLUBLE		
	3	6	12	3	6	12	3	6	12
CYS		+		+	+	+			
ASP		+	+	+	+	+		+	+
ASN		+							
GLN		+		+	+	+			
GLU	+	+	+	+	+	+		+	+
SER	+	+		+	+			+	+
THR									
PRO									
DOPA	+	+	+	+	+	+			
ALA	+	+	+	+	+	+		+	
VAL						+		+	
MET									
TYR	+	+	+	+	+	+		+	
PHE				+	+	+		+	+
ILE									
LEU									
GLY								+	
BASICS								+	
YAB									
BALA									
OTHER	+	+	+	+	+	+		+	+

= absence, + = presence of label.

^{14}C - CO_2 was fed to leaves subtending 22-27 day old pods for 3h. The pods were harvested at 3, 6 and 12h after the start of feeding. Experimental details are given in the legend to Table 7-6.

PART THREE:

Sources of carbon for the developing
pod and seed

8. Pod photosynthesis
9. Bloom node leaf photosynthesis

8. Pod photosynthesis

When [^{14}C] - CO_2 was fed directly to 25-35 day old pods, uptake of ^{14}C into the pod was observed. During the 3h feeding period, total ^{14}C in the pod and seeds rose rapidly and then remained more or less constant at 1200-1300 cpm per mg. Linear and exponential curves fitted to the data had fit factors of 129.51 and 50.90, respectively. The data was best described by the curve

$$y = k(1 - e^{-ax})$$

where $K = 1337.17$

$a = 0.023$

The pods could, then, be expected to approach saturation in 4.5-5.0h.

The distribution of ^{14}C in the pod and seed system is shown in Fig. 8-1. Fig. 8-2 was obtained from Fig. 8-1 by fitting the histogram totals to the calculated exponential curve, and then scaling the contents of each histogram column. The histograms illustrate the fact that ^{14}C in the soluble pod fraction fluctuated rather than increased after about 75 min [^{14}C] - CO_2 feeding. The ^{14}C in the insoluble pod fraction did not increase after 105 min. In both pod and seeds increase of label in the soluble fraction preceded that in the insoluble fraction. The soluble seed fraction was first appreciably labelled at 75 min, and the insoluble seed fraction at 165 min. Seed samples collected after the end of the feeding period

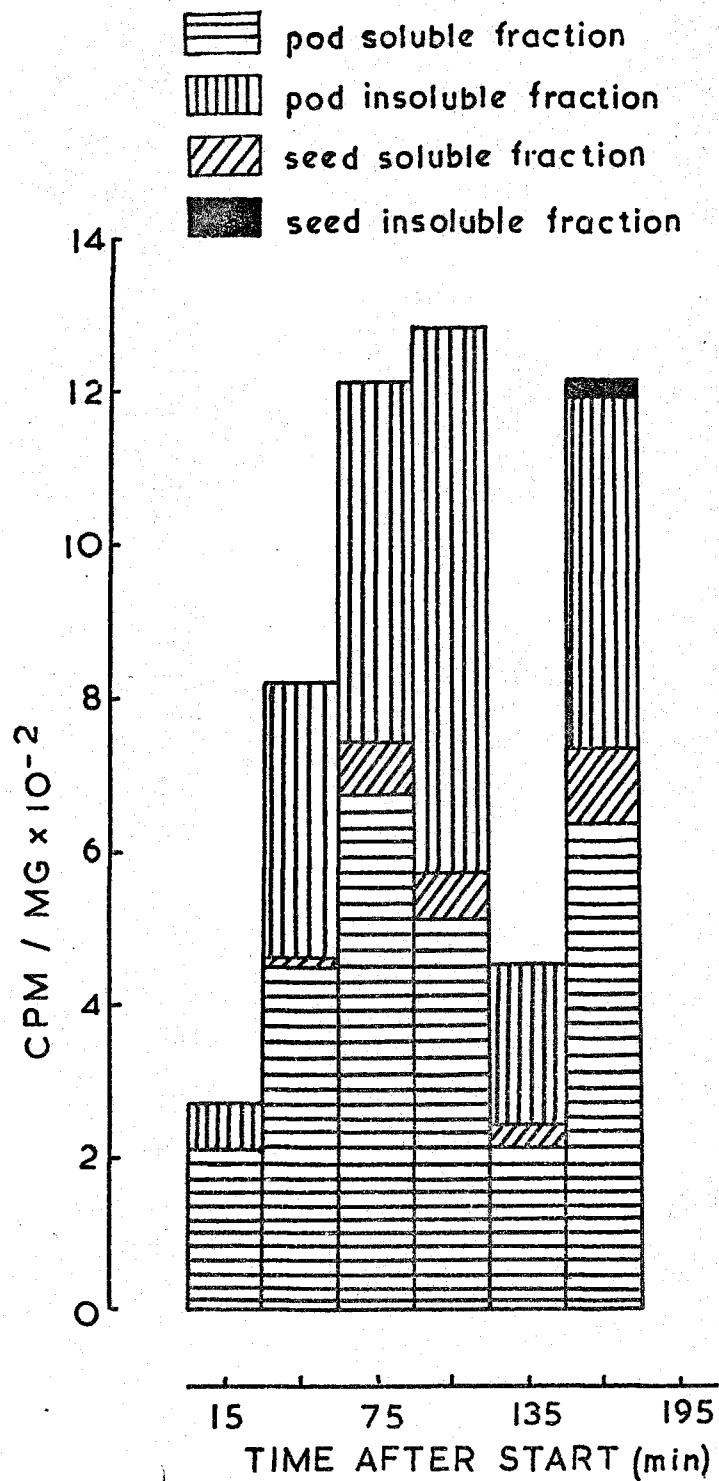

Fig. 8-1. Distribution of ^{14}C in pods and seeds. Plants were grown in the glasshouse in Reading until June 1971. $75 \mu\text{Ci } [^{14}\text{C}] - \text{CO}_2$ was fed directly to the 25-35 day old pods at nodes 10-13 on 20-25 leaf plants. Feeding was continued for 3h. Each sample is the extract from a single pod and its seeds. Extracts were counted using the IDL scalar 1700. Counting errors were about 2% for all samples except the seed insoluble fraction where they were about 10%.

legend as Fig.8-1

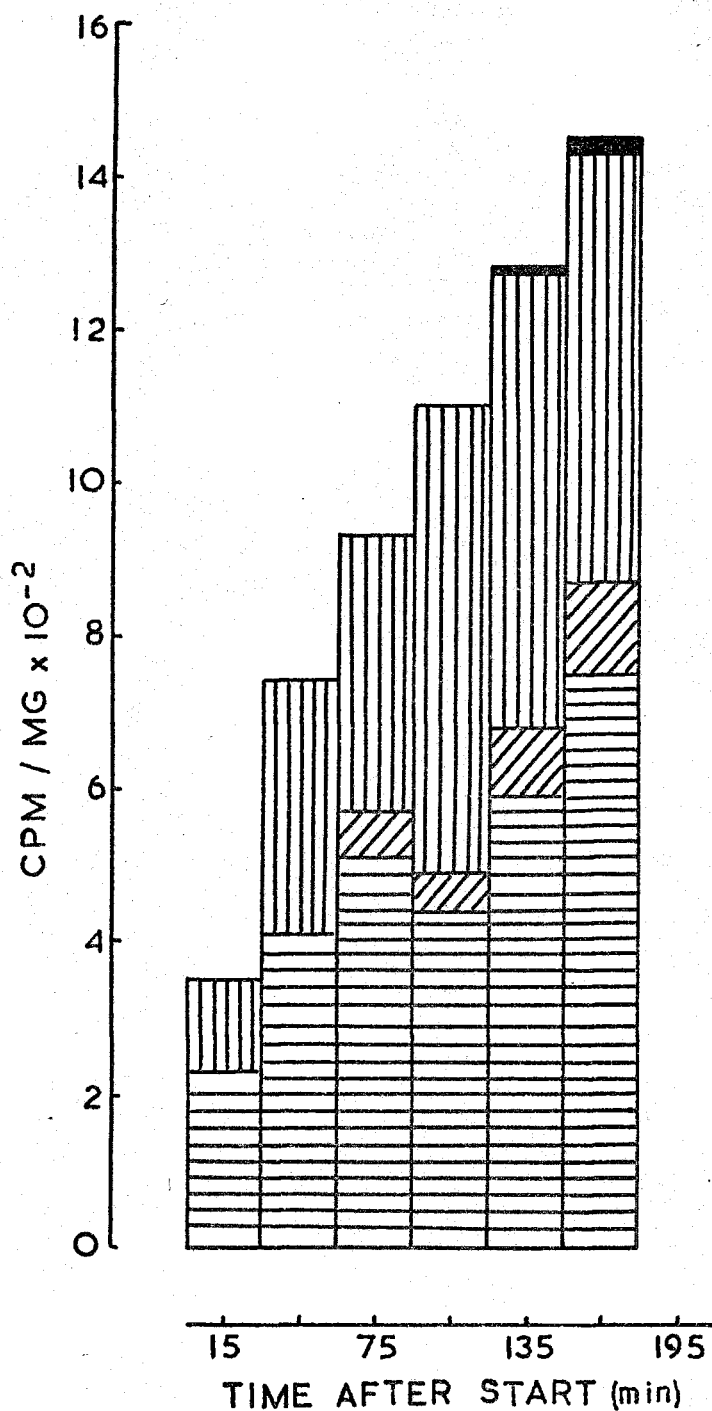

Fig. 8-2. Distribution of ¹⁴C in pods and seeds. This figure was obtained from Fig. 8-1 by fitting the histogram totals to the calculated exponential curve (see text), and scaling the histogram columns.

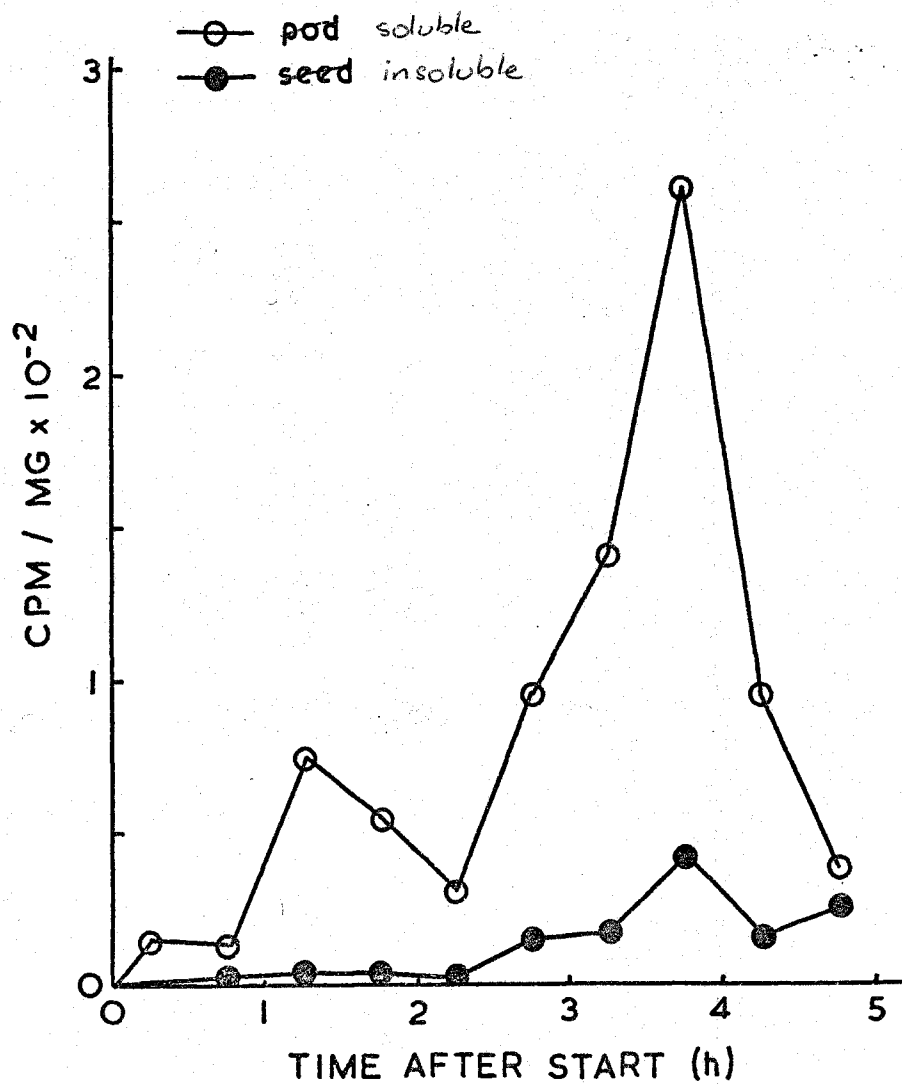

Fig. 8-3. Distribution of ^{14}C in the ^{soluble and} insoluble fractions of ~~pod and~~ seeds.

$[^{14}\text{C}] - \text{CO}_2$ was fed directly to the 25-35 day old pods for 3h. Experimental details are given in the legend to Fig. 8-1.

showed continued increase in total ^{14}C until the 3.75h sample, followed by a marked decrease, (Fig. 8-3). By 5h, the ^{14}C in the soluble seed fraction had fallen below its value at the end of the feeding period, while the ^{14}C in the seed insoluble fraction did not show a corresponding decrease. The 45-75 min delay in the loss of ^{14}C from the soluble seed fraction, after the end of $[^{14}\text{C}] - \text{CO}_2$ feeding is of comparable size with the 45-75 min interval after the start until the soluble seed fraction showed its first increase in ^{14}C . This suggests that only recent photosynthate is exported by the pod to its seeds.

Autoradiography of the soluble pod extracts revealed that the activity was divided approximately equally between ninhydrin positive and ninhydrin negative substances. The labelling pattern was not unlike that of the photosynthesising leaf, at least in its major components. (Tables 6-3, 8-1). In early samples most label was found in aspartic acid, serine and alanine. By 105 min tyrosine was also heavily labelled. Label in dihydroxyphenylalanine was very weak at first, but increased steadily during the 3h. Label was always present in small quantities in glycine, although glycine was present in only trace amounts in these pod extracts. Label was never detected in asparagine or glutamine although pods contain these amides in high concentration. The labelled ninhydrin negative compounds ran in the sugar and organic acid region of the chromatogram.

Incorporation of ^{14}C into pod protein was rather

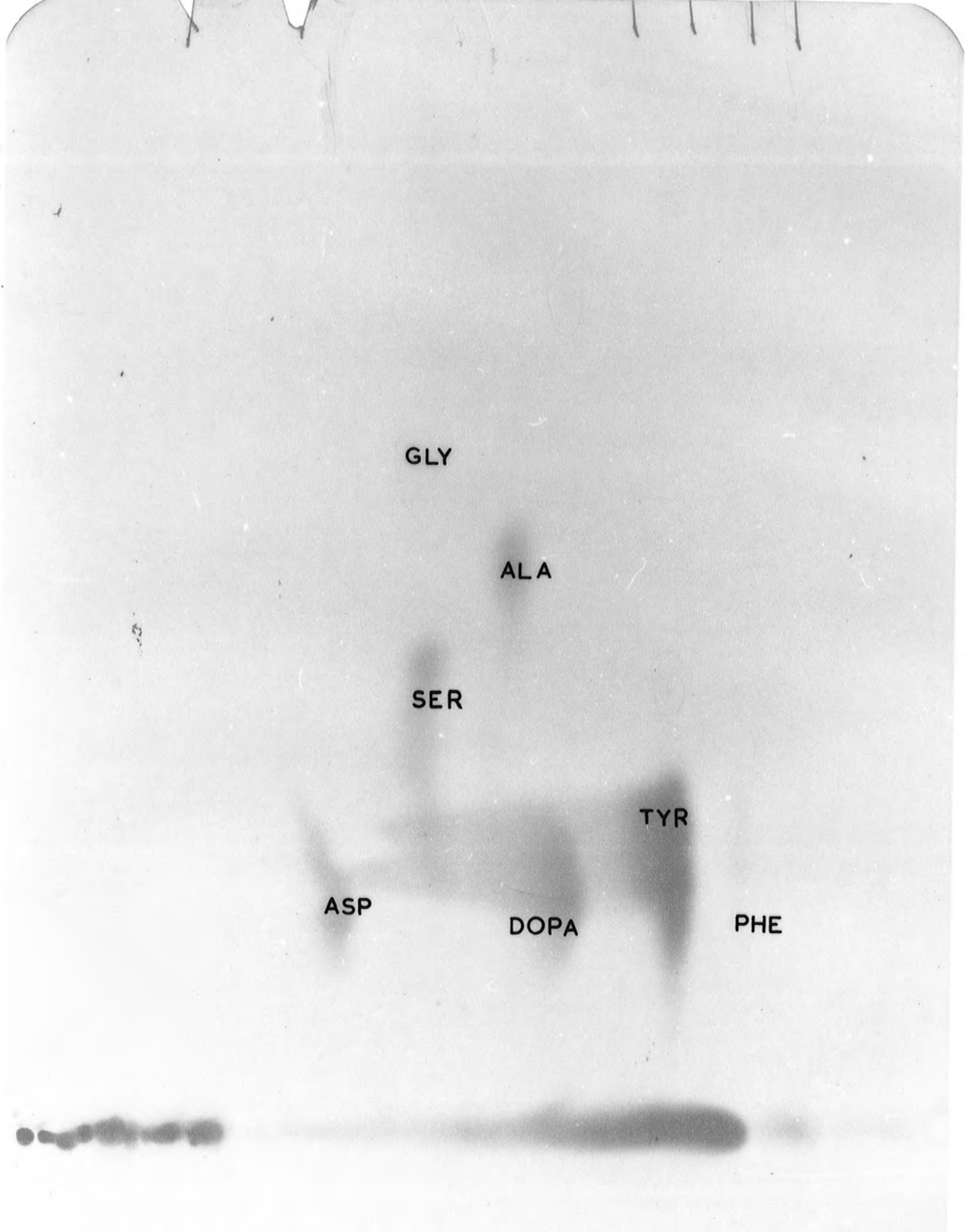

Fig. 8-5 POD SOLUBLE FRACTION AFTER 165 MIN. —
SEE TABLE 8-1.

GLY

ALA

SER

ASP

TYR

PHE

Fig. 8-4 POD SOLUBLE FRACTION AFTER 15 MIN. -
SEE TABLE 8-1.

Table 8-1. Distribution of ^{14}C in pod and seed amino acids

	POD						SEED															
	SOLUBLE			INSOLUBLE			SOLUBLE			INSOLUBLE												
	15	45	75	105	135	165	15	45	75	105	135	165	195	225	255	285	165	195	225	255	285	
CYS																						
ASP	+	+	+				+										+					+
ASN																						
GLN																						
GLU				+																		+
SER				+																		+
THR																						
PRO																						
DOPA	+																					
ALA	+																					
VAL																						
TYR	+																					
PHE	+																					
ILE																						
LEU																						
GLY	+																					
BASICS																						
YAB																						
OTHER	+																					

+ = presence, = absence of label.

^{14}C - CO_2 was fed directly to 25-30 day old pods which were harvested at the times given (in min.). Experimental details are described in the legend to Fig. 8-1.

different from that in the leaf. Tyrosine and phenylalanine were the first labelled protein amino acids, followed by serine and glycine in the 45 min sample and alanine at 75 min. Other amino acids were never as strongly labelled as these. The ninhydrin negative compound listed in Table 8-1 was the unknown which runs on the electrophoresis origin to the chromatography front.

In the soluble seed fraction at 75 min most of the ^{14}C was in aspartic acid, with smaller quantities in the other amino acids sugars, and/or organic acids. These latter included spots with mobilities like those of fructose, glucose and sucrose. Other labelled ninhydrin negative compounds with lower Rf values were present as well. By the end of the 5h asp contained only a trace of ^{14}C and glutamic acid, glutamine, alanine and serine were most strongly labelled. ^{14}C incorporation into protein was restricted to seven amino acids for the first 4h of the experiment. Label was never detected in threonine or alanine, both present in the protein in large amounts and both labelled in the soluble seed fraction.

9. Bloom node leaf photosynthesis

$[^{14}\text{C}] - \text{CO}_2$ was fed for 3h to leaves subtending 25-30 day old pods and during the subsequent 3h ^{14}C was detected in all extracts of the leaves, pods and seeds. (Table 9-1). The total ^{14}C in the leaf-pod-seed system increased steeply between the 40 and 90 min samples, and then decreased again just as steeply. This was mostly due to a rise and fall in the leaf ^{14}C . This pattern is more reminiscent of that illustrated in Fig. 7-4, for loss of ^{14}C from a leaf-pod-seed system at the end of the feeding period, than of any of the data produced during continuous feeding. It is indicated that the plants did not take up $^{14}\text{C} - \text{CO}_2$ after the 90 min sample, perhaps due to stomatal closure in response to saturation of the atmosphere in the feeding bag.

For the two samples taken during $[^{14}\text{C}] - \text{CO}_2$ uptake an approximate description of the leaf photosynthesis was obtained, as follows:

$$y = K(1 - e^{-ax})$$

$$\text{when } x = 40, y = 4261 \quad \therefore 4261 = K(1 - e^{-a40})$$

$$x = 90, y = 16845 \quad \therefore 16845 = K(1 - e^{-a90})$$

Simplifying, we obtain

$$5 \ln K = 9 \ln(K - 4261) - 4 \ln(K - 16845)$$

This equation may be solved for K by trial and error.

We find

$$K = 70,000$$

Substituting in the original equations,

$$a = 0.003$$

When the leaf is almost saturated, y is 99% of K .

Then,

$$e^{-ax} = 0.01, a = 0.003$$

$$x = 1533.$$

The leaf would, then, reach saturation (of the parts containing label at 90 min) after about 1500 min.

At 90 min it was nearly 25% saturated.

The calculated time until saturation is comparable with the time determined for the leaves in section 6. (1200 min). The very much higher value for K (70,000 as compared with 2,400) reflects the more active photosynthesis of these leaves.

At the end of the 90 min feeding period the total activity in the system decreased rapidly, and from 150 min to 330 min it remained approximately constant at 9000-10,000 cpm/mg. Activity decreased slightly in the last sample at 360 min. The samples at 125 min and 270 min were considerably less active in ^{14}C uptake than any of the others and so are disregarded in the following discussion.

The leaf fractions were strongly labelled throughout the 6h, no marked loss of ^{14}C occurring after the 150 min sample. The pod soluble fraction reached 400 cpm/mg at 90 min and fluctuated rather than changed after this time. The pod insoluble fraction took rather longer, 150 min, to approach its maximum

Table 9-1. Distribution of ^{14}C in a leaf-pod-seeds system

TIME AFTER START (min)	LEAF		POD			SEED		TOTAL
	SOLUBLE	INSOLUBLE	SOLUBLE	INSOLUBLE	SOLUBLE	INSOLUBLE		
40	3588	673	3	2	1	1	4267	
90	13314	3531	412	24	148	2	17431	
125	2291	536	146	10	140	4	3126	
150	6352	1758	466	93	401	11	9281	
180	5043	1045	1506	505	1494	56	9647	
245	6603	-	356	99	1199	53	-	
270	735	143	53	14	97	6	1047	
300	7304	1665	62	47	783	58	9920	
330	4967	1929	673	195	1170	136	9070	
360	4062	1208	693	171	1057	92	7282	
MEAN PLANCHET COUNT	50,000	5,000	5,000	2,000	8,000	1,000		
MEAN ERROR	2%	2%	2%	2%	2%	6-10%		

Activities are expressed in cpm per mg extracted weight of sample. Plants were grown in a glasshouse in Reading until July 1971 when they had 20-25 leaves. $75\ \mu\text{Ci}$ [^{14}C] - CO_2 was fed for 3h to leaves at nodes 7-10 subtending 25-30 day old pods. No [^{14}C] - CO_2 was taken up after 90 min. Each sample is the extract from a single plant. Extracts were counted using the IDL scalar 1700, and counting errors are given above.

activity and variability masked any trends after this time. By 245 min the seeds had absorbed more soluble ^{14}C per mg than had the pod and the level remained higher for the rest of the 6h. Variability between plants was least evident in the seed insoluble fraction where the cpm per mg increased fairly steadily for the whole 6h.

Autoradiography of extracts revealed that more than half of soluble activity in leaf, pod and seeds was in ninhydrin negative compounds. In all cases the radioactive areas were not fully resolvable into spots, but at least in leaves and pods probably included sucrose, glucose and fructose. Insoluble fractions all contained the radioactive unknown which runs on the electrophoresis origin to the chromatography front. In leaf, pod and seed some ^{14}C was incorporated into insoluble amino acids before the end of the 6h. (Table 9-2).

All the amino acids in leaf protein became labelled, and some very strongly, although valine, methionine and basic amino acids were never detected labelled in the soluble fraction. This data is discussed quantitatively in section 10. At 90 min most of the soluble amino acid ^{14}C in the pod was in serine and alanine, and these amino acids contained less than 5% of the total soluble ^{14}C . Glutamic acid, glutamine and tyrosine were the only other soluble amino acids to become as strongly labelled. Aspartic acid, asparagine, dihydroxyphenylalanine, valine and

γ -aminobutyric acid were all present in the pod soluble fraction at equal or greater concentrations than the labelled compounds (see appendix), but were labelled weakly or not at all. Glycine, which was present in trace quantities only, was labelled in two samples. In the pod protein, serine, glycine, alanine, tyrosine and phenylalanine contained most ^{14}C . These are the same amino acids which were strongly labelled in pod protein after pod photosynthesis. Serine and alanine were the only ^{14}C amino acids detectable in the seed before the 180 min samples. At 180 min label appeared in numerous soluble seed amino acids. This coincided with a marked overall increase in the amount of amino acid ^{14}C . Label then remained predominantly in serine, alanine, glutamic acid and glutamine for the remainder of the 6h. Serine and alanine were also the most strongly labelled amino acids in seed protein, with tyrosine and phenylalanine being the only others with more than trace amounts of label.

Table 9-2a. Distribution of ^{14}C in the leaves of a leaf-pod-seed system

TIME(min)	LEAF						INSOLUBLE										
	40	90	125	150	180	240	300	360	40	90	125	150	180	270	300	330	360
CYS	+	+	+	+	+	+	+	+	+	+	+	+	+	+	+	+	+
ASP	+	+	+	+	+	+	+	+	+	+	+	+	+	+	+	+	+
ASN																	
GLN							+										
GLU	+	+	+	+	+	+	+	+	+	+	+	+	+	+	+	+	+
SER	+	+	+	+	+	+	+	+	+	+	+	+	+	+	+	+	+
THR	+	+	+	+	+	+	+	+	+	+	+	+	+	+	+	+	+
PRO																	
DOPA																	
ALA	+	+	+	+	+	+	+	+	+	+	+	+	+	+	+	+	+
VAL																	
MET																	
TYR	+	+	+	+	+	+	+	+	+	+	+	+	+	+	+	+	+
PHE	+	+	+	+	+	+	+	+	+	+	+	+	+	+	+	+	+
ILE	+	+	+	+	+	+	+	+	+	+	+	+	+	+	+	+	+
LEU																	
GLY	+	+	+	+	+	+	+	+	+	+	+	+	+	+	+	+	+
BASICS																	
7AB	+	+	+	+	+	+	+	+	+	+	+	+	+	+	+	+	+
OTHER	+	+	+	+	+	+	+	+	+	+	+	+	+	+	+	+	+

= absence, + = presence of label.

The leaves, which subtended 25-30 day old pods, were fed $[^{14}\text{C}] - \text{CO}_2$ for 3h, but took it up for only 90 min.

For details see Table 9-1.

Table 9-2b. Distribution of ^{14}C in the pod of a leaf-pod-seed system

CYS	POD										OTHERS			
	SOLUBLE					INSOLUBLE								
TIME(min)	90	125	150	180	240	300	330	360	150	180	240	300	330	360
CYS	+													
ASP														
ASN														
GLN														
GLU														
SER														
THR														
PRO														
DOPA														
ALA														
VAL														
MET														
TYR														
PHE														
ILE														
LEU														
GLY														
BASICS														
YAB														
OTHERS														

-, absence, + = presence of label

^{14}C - CO_2 was fed to the bloom node leaf for 3h, but was only taken up for 90 min. The pods were 25-30 days old. For experimental details see the legend to Table 9-1.

Table 9-2c. Distribution of ^{14}C in the seeds of a leaf-pod-seed system

	SEEDS												
	SOLUBLE						INSOLUBLE						
TIME(min)	90	125	150	180	240	300	330	360	180	240	300	330	360
CYS				+	+	+	+	+				+	+
ASP				+	+	+	+	+			+	+	+
ASN				+	+	+							
GLN				+	+	+	+						
GLU				+	+	+	+				+	+	+
SER				+	+	+	+	+			+	+	+
THR								+					
PRO								+					
DOPA													
ALA				+	+	+	+	+			+	+	+
VAL				+	+			+				+	+
MET												+	+
TYR				+	+	+	+	+			+	+	+
PHE				+	+			+			+	+	+
ILE													+
LEU												+	+
GLY				+	+	+	+	+			+	+	+
BASICS													+
YAB													
OTHERS				+	+	+	+	+			+	+	+

* absence, + = presence of label.

^{14}C - CO_2 was fed to the bloom node leaf for 3h, but was only taken up for 90 min. The pods were 25-30 days old. For experimental details see the legend to Table 9-1.

PART FOUR:

Quantitative analysis of
radioactive amino acids

10. Leaf photosynthesis

10. Leaf photosynthesis

The leaf samples described in section 9 were analysed for amino acids and ^{14}C per amino acid as described in Methods. This was the only whole set of samples containing sufficient protein ^{14}C for analysis in this manner. The results of the amino acid and radioactive analyses are presented in Tables 10-1 to 10-4. The data in these tables is directly comparable with the autoradiograph data in Table 9-2. In general the two analyses agree, but the autoradiography appears to be slightly more sensitive. In part, at least, this must be due to the policy of ignoring peaks in the planchet counting data which were not higher than twice the baseline count. The changes with time in the activity of the more strongly labelled amino acids are illustrated in Figs. 10-1 to 10-5. The total uptake of ^{14}C into soluble and protein amino acids is plotted in Fig. 10-5. From these figures it is evident that the incorporations of ^{14}C - serine, alanine, glycine, tyrosine and phenylalanine into protein all followed a similar pattern, and this pattern is different from that shown by glutamic and aspartic acids.

The former group of amino acids (group A) follows the same pattern of ^{14}C incorporation as is seen in the graph of incorporation into total amino acids. The ^{14}C in both soluble and insoluble fractions rose steeply to the 90 min sample (effective end of feeding

Table 10-1. Soluble amino acids in leaves

	40	90	125	150	245	270	300	330	360
ASP	0.086	0.081	0.059	0.085	0.098	0.085	0.068	0.160	0.120
THR	0.019	0.020	ND	0.024	ND	0.017	0.017	0.056	0.016
SER	0.046	0.036	0.061	0.072	0.094	0.044	0.050	0.186	0.067
GLU	0.124	0.096	0.092	0.132	0.124	0.110	0.078	0.245	0.113
PRO	0.021	0.026	0.031	0.021	0.032	0.039	0.030	0.046	0.015
GLY	0.049	0.053	0.051	0.079	0.068	0.045	0.051	0.157	0.060
ALA	0.044	0.029	0.028	0.039	0.056	0.040	0.035	0.100	0.038
VAL	0.013	0.014	0.012	0.020	0.036	0.017	0.015	0.047	0.013
ILE	0.006	0.005	0.005	0.008	0.018	0.006	0.008	0.024	ND
LEU	0.009	0.008	0.007	0.019	0.027	0.007	0.008	0.044	0.004
DOPA	0.221	0.363	0.032	0.530	0.255	0.203	0.221	0.368	0.249
TYR	0.026	0.021	0.015	0.022	0.017	0.005	0.015	0.037	0.019
PHE	0.008	0.012	0.009	0.019	0.022	0.008	0.015	0.027	0.013
YAB	0.021	0.013	0.012	0.017	0.015	0.026	0.017	0.037	0.013
HIS	0.006	0.007	0.007	0.016	0.013	0.007	0.004	0.025	0.008
LYS	0.014	0.013	0.015	0.032	0.030	0.009	0.016	0.028	0.014
ARG	0.004	0.003	0.002	0.004	0.004	0.002	0.003	0.004	0.004

Amino acid quantities are in umoles per mg extracted weight of leaf. Aspartic and glutamic acid quantities include their amides. Times are in minutes after 10.00 a.m., the start of [^{14}C] - CO_2 feeding. The leaves subtended 25-30 day old pods and are the samples which are described in the leaf-pod-seeds system in Tables 9-1 and 9-2. Variability of the samples is estimated in Table 15 of Preliminary Results. Autoanalyser errors are approximately 2%.

Table 10-2. Protein amino acids of leaves

TIME(min)	40	90	125	150	180	300	330	360
ASP	0.389	0.357	0.435	0.313	0.310	0.293	0.425	0.375
THR	0.267	0.240	0.320	0.200	0.234	0.218	0.285	0.235
SER	0.285	0.253	0.315	0.230	0.237	0.215	0.311	0.271
GLU	0.414	0.382	0.465	0.329	0.372	0.310	0.425	0.380
PRO	0.256	0.229	0.252	0.256	0.182	0.222	0.282	0.262
GLY	0.467	0.444	0.519	0.382	0.397	0.411	0.502	0.440
ALA	0.347	0.327	0.435	0.313	0.322	0.291	0.418	0.368
CYS	0.028	0.043	0.018	0.020	0.021	0.024	0.033	0.020
VAL	0.243	0.262	0.287	0.217	0.238	0.192	0.276	0.233
MET	0.045	0.039	0.053	0.036	0.039	0.035	0.055	0.043
ILE	ND	0.218	0.270	0.198	0.206	0.167	0.272	0.221
LEU	0.331	0.308	0.366	0.286	0.302	0.246	0.386	0.303
TYR	0.141	0.126	0.152	0.124	0.121	0.122	0.162	0.133
PHE	0.139	0.191	0.255	0.190	0.201	0.171	0.241	0.215
HIS	0.096	0.079	0.113	0.094	0.096	0.086	0.133	0.112
LYS	0.256	0.235	0.294	0.220	0.224	0.195	0.287	0.241
ARG	0.171	0.170	0.220	0.168	0.160	0.152	0.218	0.187
TOTAL N (µmoles)	5.039	4.806	5.959	4.488	4.658	4.113	6.018	5.057

Mean total N 69.7 ± 3.3

Kjeldahl N 81.0 ± 0.9

Amino acid quantities are in µmoles per mg extracted weight of leaf. Nitrogen is measured in ug per mg extracted weight of leaf. Times and experimental conditions are as in Tables 9-1 and 9-2. Variability of samples is estimated in Table 16 of Preliminary Results. Autoanalyser errors are approximately 2%.

Table 10-3. ^{14}C in soluble amino acids of leaves

TIME	40	90	125	150	240	270	300	330	360
ASP	1.27	3.73	0.30	2.59	2.31	0.03	1.42	2.10	1.12
SER	5.93	14.60	1.94	4.33	1.13	0.04	0.66	2.45	0.29
GLU	1.35	3.27	0.25	1.67	4.01	0.11	2.17	4.40	1.15
PRO	0.0	0.19	0.0	0.0	0.63	0.08	0.17	0.26	0.04
GLY	0.74	4.95	0.75	2.95	2.97	0.06	1.38	5.19	0.52
ALA	0.64	1.51	0.34	0.64	0.36	0.02	0.49	0.31	0.11
VAL	0.0	0.66	0.10	0.44	0.40	0.12	0.37	0.85	0.11
ILE	0.16	1.37	0.12	0.0	0.20	0.0	0.30	0.23	0.0
LEU	0.0	0.0	0.0	0.0	0.11	0.0	0.09	0.11	0.12
DOPA	0.0	0.0	0.0	0.0	0.02	0.0	0.03	0.01	0.0
TYR	0.05	0.94	0.09	0.34	0.72	0.0	0.06	0.16	0.04
PHE	0.12	1.25	0.09	0.59	0.63	0.0	0.29	0.70	0.09
γ AB	0.37	3.47	0.19	0.17	0.66	0.0	0.65	0.86	0.10
HIS	0.0	0.21	0.0	1.05	0.30	0.0	0.09	0.27	0.01
LYS	0.05	0.17	0.0	0.06	0.0	0.0	0.0	0.0	0.03
UNI	ND	0.49	0.07	0.0	0.0	0.06	0.08	0.0	0.05
UN2	ND	0.30	0.12	0.26	0.38	0.08	0.33	2.09	0.25
TOTAL	11	47	4	15	5	1	9	23	4
^{14}C in SAMPLE	65	500	34	173	175	9	194	124	90

Amino acid activities are given in μCi per g extracted weight of leaf. Total ^{14}C is the sum of the amino acid activities. Sample ^{14}C is calculated from the cpm/mg for the whole sample (Table 9-1). Serine activity includes that of threonine. UNI and UN2 are unknowns eluted under the ammonia base-line rise. Experimental details are as in the legends to Tables 9-1 and 10-1. Samples were counted on the Tracerlab gas flow counter. Counting errors were always less than 10% and generally 2-4%.

Table 10-4. ^{14}C in protein amino acids of leaves

TIME	40	90	125	150	130	300	330	360
ASP	0.11	0.46	0.13	0.46	0.48	1.13	1.56	1.60
SER	0.81	8.24	0.87	2.18	2.53	3.01	2.93	4.26
GLU	0.0	0.09	0.0	0.08	0.10	0.35	0.36	0.67
GLY	0.74	7.77	0.95	2.28	2.27	3.00	2.76	3.78
ALA	0.21	1.17	0.20	0.57	0.46	0.55	1.24	1.44
CYS	0.03	0.34	0.0	0.0	0.03	0.05	0.09	0.0
VAL	0.0	0.0	0.0	0.09	0.0	0.10	0.0	0.10
MET	0.03	0.0	0.0	0.04	0.0	0.08	0.0	0.0
ILE	0.02	0.37	0.02	0.0	0.0	0.13	0.12	0.09
LEU	0.0	0.16	0.02	0.0	0.0	0.0	0.19	0.20
TYR	0.04	1.14	0.07	0.18	0.11	0.18	0.13	0.27
PHE	0.03	0.56	0.05	0.14	0.10	0.11	0.11	0.30
HIS	0.04	0.19	0.0	0.02	0.0	0.0	0.0	0.07
LYS	0.05	0.42	0.04	0.05	0.0	0.08	0.13	0.20
ARG	0.07	0.82	0.04	0.10	0.13	0.32	0.26	0.20
TOTAL	2.2	21.7	2.4	6.2	6.4	5.5	9.9	13.2
^{14}C in SAMPLE	7	48	6	23	12	21	24	14

Experimental details are described in the legends to Tables 9-1 and 10-1. Samples were counted on the Tracerlab gas flow counter. Counting errors were always less than 10% and generally 5-6%. Amino acid activities are in μCi per g extracted weight of leaf. Total ^{14}C is the sum of the amino acid activities. Sample ^{14}C is calculated from the cpm/mg for the whole sample (Table 9-1). Serine activity includes that of threonine.

period) and then dropped almost as steeply as it rose. The activity of the 150 min sample was not very different from the 40 min one. After 150 min the ^{14}C in the soluble fraction decreased slowly while the insoluble fraction became slowly more radioactive. In most cases the change in ^{14}C in the two fractions was similar, and one can visualise that soluble ^{14}C -amino acid was being incorporated into protein. The rapid decrease in ^{14}C in both fractions after 90 min cannot be accounted for by exchange between the two fractions. The ^{14}C here lost must have been removed from the leaf - by export or by respiration.

Incorporation of ^{14}C into soluble aspartic acid followed much the same pattern as incorporation into group A amino acids, although loss of ^{14}C after 90 min was not as steep. Soluble glutamic acid followed a very different pattern, rising steeply to about 3 μCi per g at 90 min and then oscillating between 1.0 and 4.5 μCi per g for the rest of the experiment. This oscillation is similar in size to the estimated 20% variability between samples, and can perhaps be accounted for in this manner. Insoluble glutamic and aspartic acids did not show the dramatic increase in activity during the first 90 min. In both cases activity rose less steeply to a plateau where it remained between the 90 and 180 min samples, and began to rise again before the 300 min sample. Since no sample is recorded between 180 and 300 min it cannot be established whether or not the second rise in activity was associated with

removal of the feeding chamber. Incorporation of ^{14}C into protein between 300 and 360 min is noticeable for all amino acids.

Of the less strongly labelled protein amino acids, cystine, isoleucine, leucine, lysine and arginine followed a pattern of ^{14}C incorporation similar to that of group A, discussed above. Valine and methionine alone did not show a peak of activity at 90 min.

The proportion of total activity in amino acids was about 10% for the soluble fraction and 30% or more for the insoluble fraction. Both percentages tended to increase towards the end of the 6h. Variability in total uptake was high. From the figures in Tables 10-3 and 10-4 some details of the leaf system can be calculated, very approximately.

For a leaf weighing 0.05g (extracted weight),

Activity at 90 min = 548 $\mu\text{Ci/g}$
 = 24 μCi per leaf

Activity at 150 min = 196 $\mu\text{Ci/g}$
 = 10 μCi per leaf.

- .°. In 60 minutes, ^{14}C loss from leaf is 10 μCi
- .°. In 90 minutes, ^{14}C loss would have been 15 μCi
- .°. In 90 minutes, the leaf must have removed 24 + 15, i.e. 39 μCi ^{14}C from the feeding chamber - over half of the supplied [^{14}C] - CO_2 .

An estimate of the metabolic pool size for an amino acid taking up ^{14}C can be obtained by fitting an exponential curve to the ^{14}C analysis data. Division of the μCi per g data by the specific activity of the source carbon would convert the data to μmoles of carbon

at the same specific activity as the source. However, since only two samples were obtained during ^{14}C uptake into amino acids, this method could not be applied with any accuracy to the present data. The amount of amino acid labelled at 90 min can, however, be determined and compared with the total amino acid in that sample.

For example,

At 90 min serine contained $14.6\mu\text{Ci } ^{14}\text{C}$ per g.

∴ Amount of serine labelled at the same specific activity as the applied $[^{14}\text{C}] - \text{CO}_2$ is

$$\frac{14.6}{12} \mu\text{moles carbon}$$

$$\text{i.e. } \frac{14.6}{12 \times 3} \mu\text{moles serine per g extracted weight}$$

$$\text{i.e. } 0.41 \mu\text{moles serine per g extracted weight}$$

But from Table 10-1, the leaf contains 140 μmoles of serine per g in its soluble fraction. A very small part of the total leaf serine is affected by 90 min photosynthesis in $[^{14}\text{C}] - \text{CO}_2$ and this is so for all the amino acids.

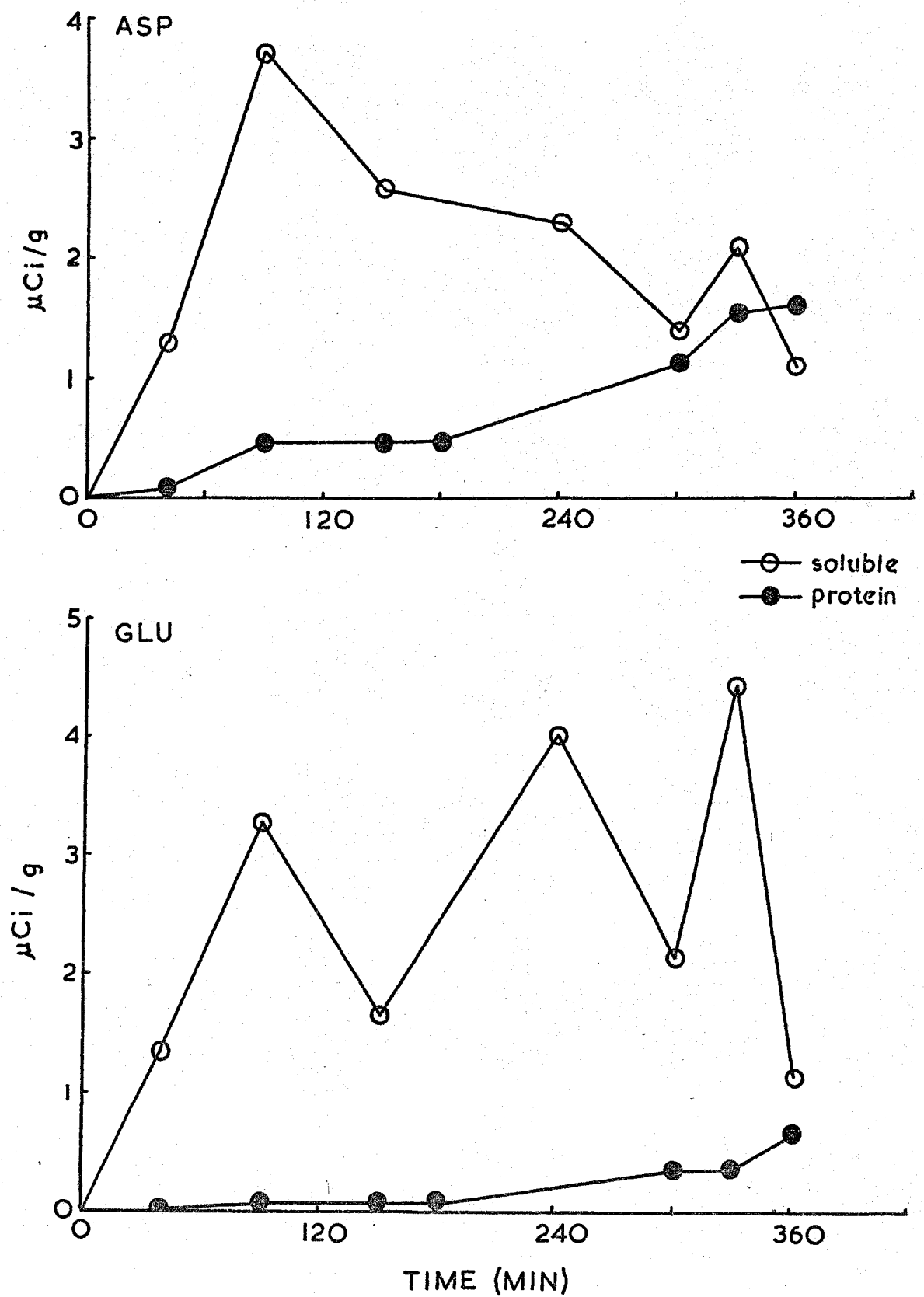

Fig. 10-1. ^{14}C in soluble and protein amino acids of leaves. The leaves were fed $75 \mu\text{Ci } [^{14}\text{C}] - \text{CO}_2$ for 3h, but took it up only for 90 min. Feeding began at 10.00 a.m. and times are in minutes after the start. Experimental conditions are described in the legend to Table 9-1. Errors are estimated in the legends to Tables 10-3 and 10-4.

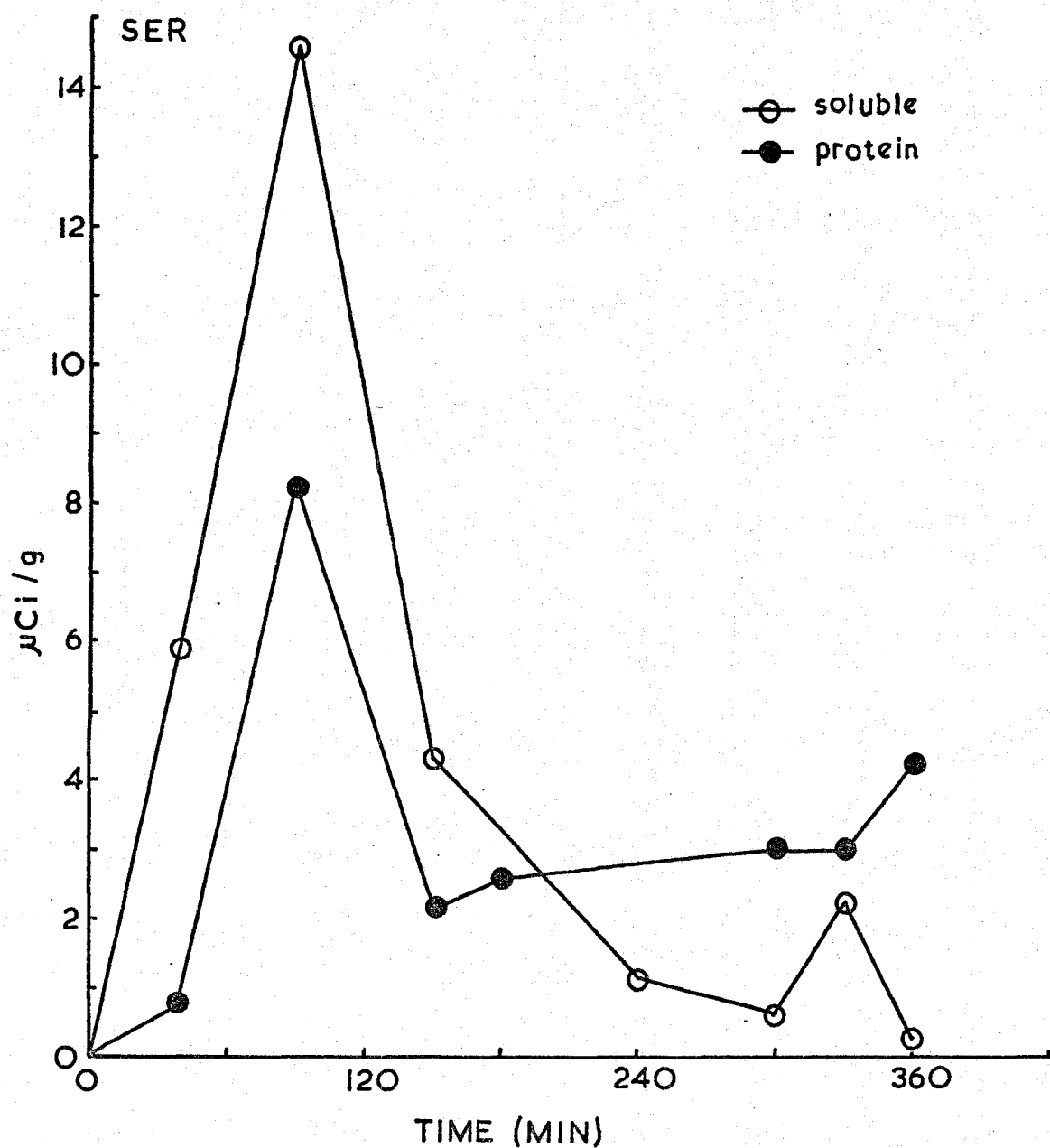

Fig. 10-2. ^{14}C in soluble and protein amino acids of leaves. The leaves were fed $75 \mu\text{Ci } [^{14}\text{C}] - \text{CO}_2$ for 3h, but took it up only for 90 min. Feeding began at 10.00 a.m. and times are in minutes after the start. Experimental conditions are described in the legend to Table 9-1. Errors are estimated in the legends to Tables 10-3 and 10-4.

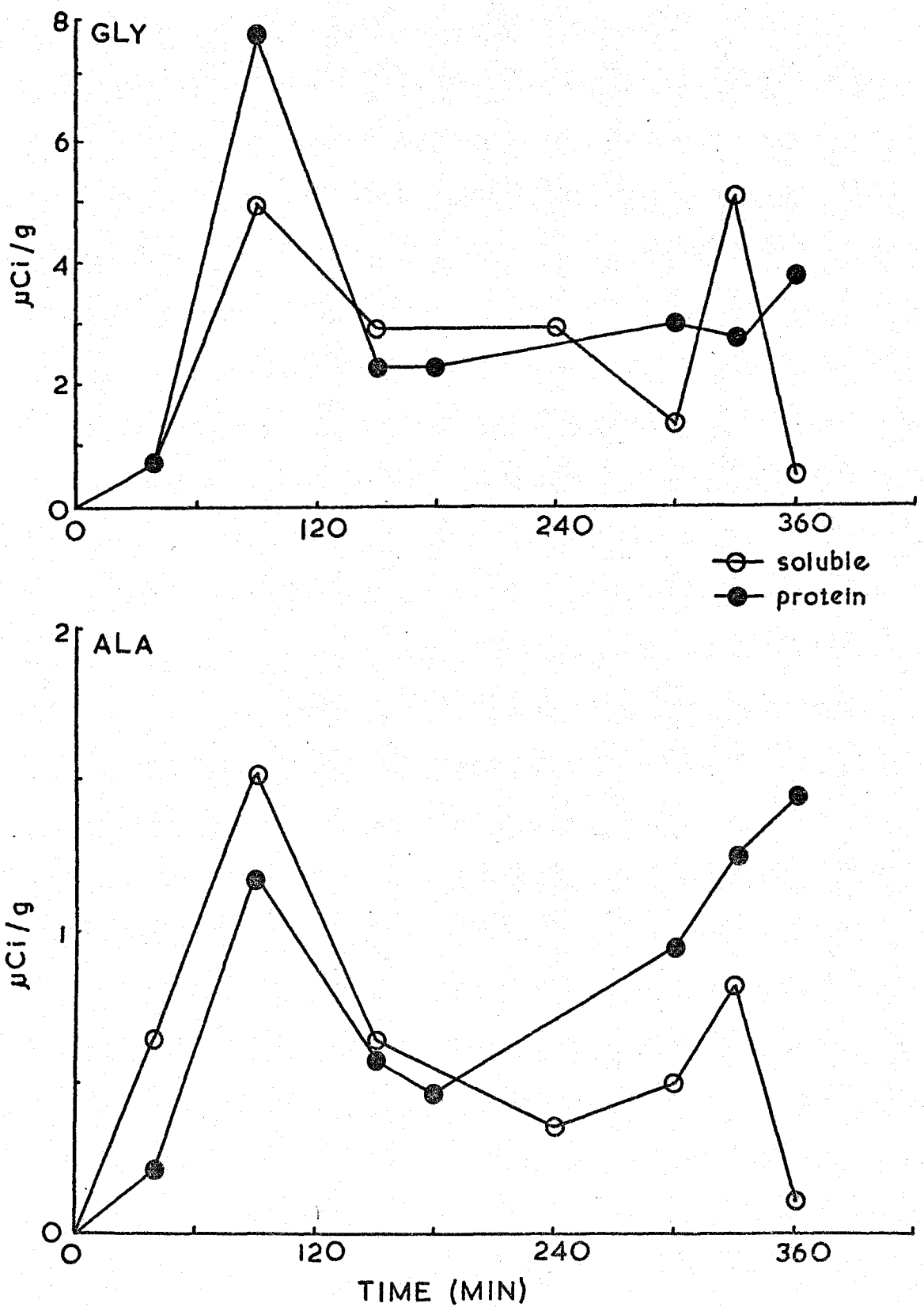

Fig. 10-3. ^{14}C in soluble and protein amino acids of leaves. The leaves were fed $75 \mu\text{Ci } [^{14}\text{C}] - \text{CO}_2$ for 3h, but took it up only for 90 min. Feeding began at 10.00 a.m. and times are in minutes after the start. Experimental conditions are described in the legend to Table 9-1. Errors are estimated in the legends to Tables 10-3 and 10-4.

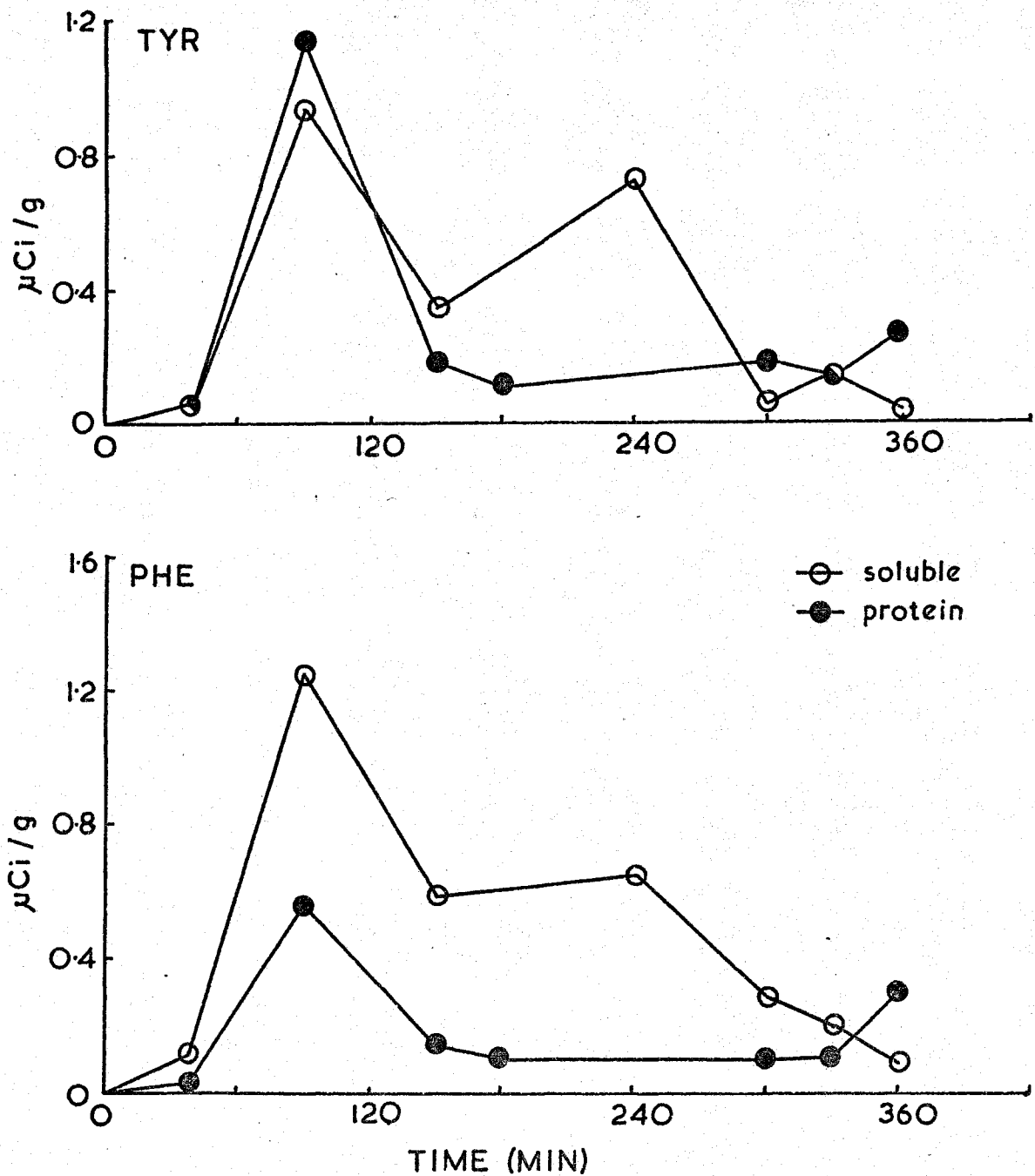

Fig. 10-4. ^{14}C in soluble and protein amino acids of leaves. The leaves were fed $75 \mu\text{Ci } [^{14}\text{C}] - \text{CO}_2$ for 3h, but took it up only for 90 min. Feeding began at 10.00 a.m. and times are in minutes after the start. Experimental conditions are described in the legend to Table 9-1. Errors are estimated in the legends to Tables 10-3 and 10-4.

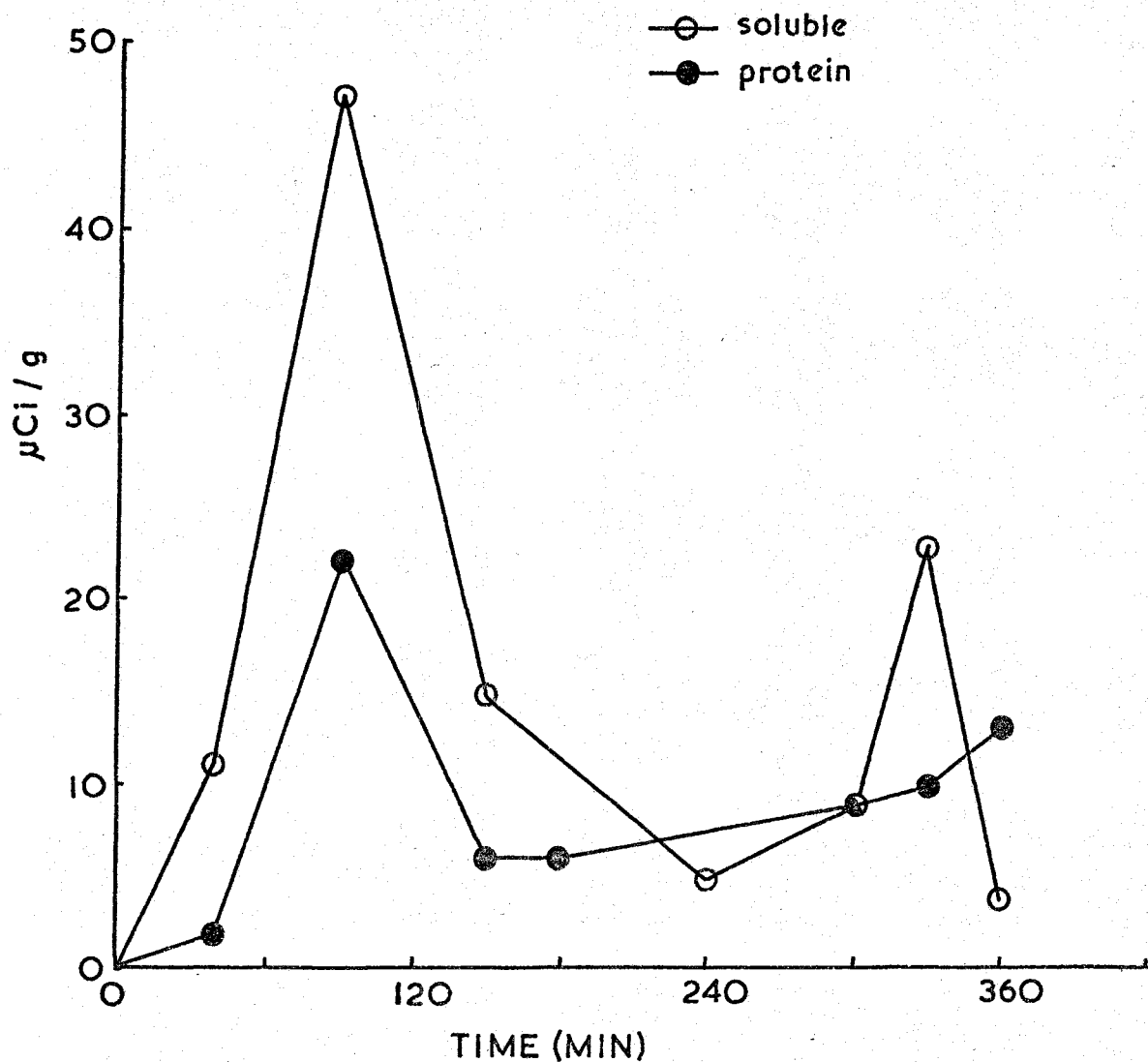

Fig 10-5. Total ^{14}C in leaf amino acids. The leaves were fed $75 \mu\text{Ci } [^{14}\text{C}] - \text{CO}_2$ for 3h, but took it up only for 90 min. Feeding began at 10.00 a.m. and times are in minutes after the start. Experimental conditions are described in the legend to Table 9-1. Errors are estimated in the legends to Tables 10-3 and 10-4.

DISCUSSION

In all the experiments here described, except those involving collection of sap, single plants were sampled. This was done in order to minimise the use of radioactive materials, and in the belief that more information would be obtained from ten consecutive individual samples, than from three or four more widely spaced samples containing two or three replicates. Variability between plants was high, and the fitting of curves to experimental data has been used in an attempt to overcome this variability and simplify the interpretation of results. In the two continuous feeding experiments where leaf and pod photosynthesis were studied, uptake of ^{14}C - CO_2 was found to be exponential, and the properties of the system were analysed in detail. In the pulse-feeding experiments, results were complicated by the simultaneous movement of ^{14}C into and out of the different parts of the system, and the fitting of a simple curve to the data was no longer meaningful.

The system studied was the developing broad bean fruit between its 20th and 35th day of growth. Davis (1966) has discussed the problem of ageing fruits in terms of days after pollination in the light of studies of embryo formation by Rau (1951). Flowers open within one day of the start of embryo growth, and this event can quite reasonably be called day 1 in the life of the fruit. However, considerable variation is observed in the subsequent rate of maturation of the pod and seeds,

and age in days is not always a reliable estimate of its physiological age.

Robertson et al (1962) describes how seed development is affected by a number of environmental factors. Briarty, Coult and Boulter (1969) define the broad bean fruit that they study as 'mid-season fruit' because of the varying rate of maturation with time of year, weather, etc. This variability is not surprising in the light of work such as that of Steward et al (1959) in which it is shown that the chemical composition of plants depends markedly on photoperiod, temperature, mineral nutrients, diurnal variations and interactions between these factors. Therefore it is important, for comparative discussion, to determine the physiological age of the fruits being studied.

Protein formation in the broad bean fruit has been analysed in detail by Davis (1966) and Briarty, Coult and Boulter (1969). Davis describes the appearance of the growing pod at different stages of development. At 20 days pods were 8cm long, swollen, spongy to touch, and the seeds were not apparent. At 32 days the pods were 17cm long, hardening and beginning to reveal the seeds as bumps. At 48 days the 26cm long pods were hard, green and beginning to dry. Analysis of the protein in seeds taken from these pods demonstrates that each pod type just mentioned falls into one of the three phases of development described by Briarty, Coult and Boulter (1969), which are summarised in the Introduction to this thesis. In the present work, the

20-25 day old pods described in Fig. 7-1 are like the 20 day old pods of Davis (1966) and must be at the end of Phase I of development. The seeds were very small and were nearing the end of the rapid mitotic phase. The 30-35 day old pods described in Fig. 7-3 were aged between the 32 day and 48 day pods described by Davis. The testas were no longer thick and fleshy and the seeds were hard. These samples must have been at the beginning of Phase III and undergoing rapid accumulation of insoluble reserves. All other fruits used in this work were alike physiologically, although they varied in age from 25 to 35 days. The seeds had fleshy testas and small, about 8mm long, cotyledons. The pods were 7-10cm long. These were younger than the 32 day old pods described by Davis and must have been in Phase II of development. Protein formation in the seeds of these samples must have been chiefly albumins, i.e. structural and metabolic protein. Accumulation of legumin and vicilin would not have begun. (Davis, 1966).

Amino acid metabolism has been extensively studied during the last two decades, and biosynthetic pathways for almost all the amino acids found in plants are known. Many of these pathways have been demonstrated to operate in tissues from a number of plant species. Others are assumed to be operative by comparison with animals or microorganisms. Amino acid biosynthesis has been reviewed by Meister (1965), and in plants by McKee (1962), Fowden (1967), Davies (1968), Mifflin (1973).

Nitrogen enters into organic combination via ammonia,

either from nitrate or nitrite or from atmospheric nitrogen in root nodules. Glutamic acid and glutamine are the primary products of root nodule fixation. (Kennedy, 1966; Cocking and Yemm, 1961). Glutamic acid is the primary product from nitrate reduction (Beevers and Hageman, 1969). The combination of ammonia with α -ketoglutarate to produce glutamic acid is catalysed by glutamic dehydrogenase, an enzyme which has been isolated from a number of plant tissues (see Introduction). Glutamic acid is the only amino acid for which a dehydrogenase is known in higher plants, and so nitrogen must enter other amino acids by transamination from glutamic acid.

Transamination was first reported in muscle tissue by Braunstein and Kritzmann (1937) and shortly afterwards in 'vegetable materials' by Kritzmann (1939). Transaminations have been reported from a large number of plant tissues and shown to transfer the amino group of most amino acids to α -ketoglutaric acid. Wilson, King and Burris (1964) used three independent methods to demonstrate the presence in plants of transaminases which would transfer the amino group from each of seventeen amino acids to α -ketoglutaric acid. Alanine has been shown to be synthesised by transamination of pyruvic acid with aspartic acid in peas (Virtanen and Laine, 1938) and of pyruvic acid with glutamic acid in wheat germ (Cruickshank and Isherwood, 1958) and mung bean mitochondria (Bone and Fowden, 1960). Aspartic acid is synthesised by transamination from oxaloacetic

acid in cauliflower (Ellis and Davies, 1961), oat seedlings (Albaum and Cohen, 1943), wheat germ (Cruickshank and Isherwood, 1958) and mung bean (Bone and Fowden, 1950). The last two groups of workers demonstrated that the alanine-glutamic acid and aspartic acid glutamic acid transaminases were different enzymes. Transamination to either α ketoglutaric acid or oxaloacetic acid from γ -hydroxyglutamic acid, γ -methylene glutamic acid, β -hydroxyaspartic acid, cysteic acid and cysteine sulphinic acid was demonstrated for cauliflower by Ellis and Davies (1961). An aromatic amino acid transaminase from mung bean was isolated and shown to transaminate tyrosine or phenylalanine with α ketoglutarate or pyruvate by Gamburg and Weller (1963). γ -methylene-glutamic acid and γ -methylglutamic acid have been shown by Fowden and Done (1953) to transaminate with α ketoglutaric acid, pyruvic acid and oxaloacetic acid at comparable rates to the other amino acids in ground nut seedlings. Transamination is the last step in the formation of many amino acids, including valine, leucine, isoleucine, as well as those described above (Rudman and Meister, 1953; Adelberg and Umbarger, 1953).

Transamination of pyruvate appears to be one of the main synthetic pathways to alanine, but Smith, Bassham and Kirk (1961) suggested that alanine is formed also by reductive amination of phosphoenolpyruvate formed in photosynthesis. β alanine has been shown to be formed by transamination from malonic semialdehyde in Pseudomonas (Nishizuka et al 1959). Evidence for the presence of β -ala- α -ala transaminase has also been

obtained for Lactobacillus sp. (Roberts et al 1953) and plant tissues. (Davies, Giovanelli and Ap Rees, 1964). These authors also report the formation of β alanine by decarboxylation of aspartic acid in bacteria and in extracts of squash fruit.

Aspartic acid is biosynthesised by transamination of oxaloacetic acid which arises, either from the tricarboxylic acid cycle or by carboxylation of phosphoenolpyruvate. Withdrawal of oxaloacetic acid from the TCA cycle would inhibit the respiratory function of the cycle, and so the alternative route is the generally accepted pathway. All the enzymes involved in the carboxylation have been found in plants and the results of a number of labelling studies have confirmed that aspartic acid is biosynthesised in this manner. (Gibbs, 1951; Tchen and Vennesland, 1955; Bandurski and Greiner, 1953). However, experiments with feeding labelled acetate to wheat plants indicate that the TCA cycle is important in supplying carbon skeletons to the dicarboxylic amino acids (Bilinski and McConnell, 1957), and so, either the TCA cycle is operative in more than one separate metabolic pool, one of which does not fulfil the respiratory function, or else some of the intermediates in the cycle can interchange with other pools which thereby would become labelled from fed acetate. It has also been suggested that some aspartic acid must be formed by a C2 + C2 (Thunberg) condensation, since aspartic acid labelled in carbon atoms 2 and 3 is produced in broad bean leaves photosynthesising in $[^{14}\text{C}] - \text{CO}_2$

(Nelson and Krotkov, 1956). Other workers have confirmed this labelling pattern (Davies, Hanford and Wilkinson, 1959), but details of the reactions have not been established.

Asparagine is formed from aspartic acid by reactions analogous to glutamine synthesis. Asparagine synthetase has been reported in extracts of lupin seedlings and wheat germ (Webster and Varner, 1955). Other workers have reported ^{14}C labelling patterns which indicate that asparagine is biosynthesised from aspartic acid. (Bidwell, 1963). Glutamine synthetase has been more exhaustively studied than asparagine synthetase. Elliott (1951) demonstrated glutamine synthesis in extracts of lupin seedlings, and Webster (1953) showed that glutamine is formed from glutamic acid in a wide variety of plants including bean seedlings. Other workers (Levintow et al 1955; Loomis, 1959) have shown that glutamine synthetase catalyses the glutamyl transfer reaction, glutamine + hydroxylamine \rightarrow γ -glutamethylhydroxamate + ammonia as well as the conversion of glutamic acid to glutamine.

Other amino acids which are synthesised directly from glutamate include γ -aminobutyric acid, proline and arginine. Decarboxylation of glutamic acid to produce γ -aminobutyric acid has been demonstrated in legumes (Fowden, 1954; Kulkarnie and Sohonie, 1956) and barley (Beevers, 1951). The enzyme, glutamic decarboxylase, has been purified and characterised (Schales, Mims and Schales, 1946). γ -aminobutyric acid has been shown to

transaminate with α -ketoglutaric acid forming succinic semialdehyde in Aspergillus fumigatus and E. coli (Roberts et al, 1953). Steward, Bidwell and Yemm (1956) showed that γ -aminobutyric acid supplied to carrot root tissue culture was converted readily to glutamic acid and glutamine but was not synthesised from these amino acids. This suggests that γ -aminobutyric acid is not simply an end product of glutamate decarboxylation but also an important metabolite, donating carbon to metabolism.

The formation of proline from glutamic acid in higher plants has been frequently demonstrated. (McConnell, 1959, Meister et al, 1957). The synthetic pathway via glutamic semialdehyde and Δ^1 -pyrroline-5-carboxylic acid has been demonstrated in *Neurospora* (Vogel and Bonner, 1954) and evidence for its existence in plants is strong (Mann and Smithies, 1955; Meister et al, 1957). The involvement of acetylated intermediates is suggested by the work of Morris, Thompson and Johnson (1969) who demonstrated that N-acetylglutamate donates carbon to proline.

Arginine is generally accepted to be biosynthesised from glutamic acid via ornithine and citrulline in the Krebs and Hensleit (1932) urea cycle. The amino acids associated with this pathway have been reported from many plant species including wheat, barley and watermelon (Kasting and Delwiche, 1955), jack bean (Walker and Myers, 1953), peas (Davison and Elliot, 1952), tree sap (Bollard, 1957) and alder (Miettinen and Virtanen, 1952).

A number of authors have demonstrated close metabolic relationships between ornithine, citrulline and arginine in plants. (Skinner and Street, 1954; Fries, 1953; Bone, 1959; Racusen and Aronoff, 1954). Acetylated intermediates have been shown to participate in arginine synthesis (Maas, Novelli and Lipman, 1953; Dougall and Fulton, 1967) and it is likely that this pathway normally operates in plants. Both labelled ornithine and arginine are utilised by plants with the formation of labelled glutamate and proline (Naylor, 1959) and the apparent reversal of expected arginine synthesis is interpreted as being due to flooding of the metabolic pools with the exogenously supplied metabolite. Citrulline is synthesised from ornithine and carbamyl phosphate (Jones, Spector and Lipmann, 1955; Glasziou, 1956). Carbon fixation in the presence of carbon dioxide, ammonia and ornithine can occur, with carbamyl phosphate acting as carbamyl group donor (Bone, 1959). Citrulline and aspartate then react to form arginosuccinate which is broken down by arginosuccinase to arginine and fumarate (Ratner, et al, 1953). This enzyme has been shown to be widely present in plant tissue (Davison and Elliott, 1952; Walker and Myers, 1953). All the other enzymes of the cycle have also been found in plants (Mifflin, 1973).

Homoserine and threonine are biosynthesised from aspartic acid. The formation of homoserine via β aspartyl phosphate and aspartic- β -semialdehyde was first described in detail for yeast by Black and Wright (1955) who characterised the enzymes involved. The conversion has

also been demonstrated in E. coli (Abelson, 1954) and in a number of plant species (Naylor et al, 1958; Dougall and Fulton, 1967b; Dunham and Bryan, 1971). The enzyme systems have been described for pea seedlings by Sasatka and Inagaki (1960), and shown to resemble the yeast enzymes. The conversion of homoserine to threonine in plants has been demonstrated (Naylor et al, 1958; Dougall and Fulton, 1967b; Dunham and Bryan, 1971). In yeast, this conversion has been shown to involve two enzymatically controlled reactions (Watanabe et al, 1955), but the details in higher plants have not been elucidated.

Two distinct pathways for lysine biosynthesis exist. In yeast (Strassman and Weinhouse, 1953; Weber et al, 1964), a pathway beginning with the condensation of acetyl-coenzyme A and α -ketoglutaric acid results in the production of α -amino adipic acid which is converted to lysine. The enzymatic evidence for this pathway is reviewed by Broquist and Trupin (1966). This pathway has also been demonstrated in a number of other fungi. In E. coli aspartic- β -semialdehyde enters reactions leading to diaminopimelic acid and a specific decarboxylase acts to give lysine (Edelman and Gilvarg, 1961); Gilvarg, 1962) Considerable evidence has been accumulated which suggests that the diaminopimelate pathway operates in higher plants, although under some conditions or in some species there is evidence for the functioning of the amino adipate pathway. This literature is reviewed by Mifflin (1973).

The formation of histidine in Neurospora crassa has been shown to involve the conversion of imidazoleglycerol

phosphate in two steps to histidinol which is converted directly to histidine. The enzymes controlling these reactions have been characterised (Ames and Mitchell, 1955; Ames, 1957a, b; Ames and Horecker, 1956). Work with E. coli suggests a similar pathway (Westley and Ceithaml, 1956). It has also been shown that the amide nitrogen of glutamine is incorporated preferentially into N1 of histidine, while N3 originates most readily from adenine (Neidle and Waelsh, 1959). In Salmonella typhimurium imidazoleglycerol phosphate is similarly converted to histidine and is shown to be formed in a number of steps from phosphoribosyl AMP (Ames and Martin, 1964). In this case, all ten steps of the synthesis have been identified with one of the nine genes of the histidine operon. Little is known of histidine biosynthesis in higher plants except that histidinol (Dougall and Fulton 1967b) and imidazoleglycerol phosphate would appear to be intermediates (Seigel and Gentile, 1966; Davies, 1971).

Aromatic amino acid biosynthesis has recently been reviewed by Yoshida (1969). The biosynthetic pathway in microorganisms is well established. Condensation of phosphoenolpyruvate and erythrose phosphate (arising from glutamate breakdown) gives rise in a number of steps to shikimic acid, chorismic acid and then prephenic acid. Conversion of prephenic acid to phenyl pyruvic acid or p-hydroxyphenylpyruvic acid, followed by transamination, gives rise to phenylalanine or tyrosine respectively. Trypophan arises from chorismic acid via anthranilic acid and indole-3-glycerol phosphate. Considerable evidence

for the operation of this pathway in plants has been published (McCalla and Neish, 1959; Gamborg and Neish, 1959; Yoshida and Towers, 1963) and a number of the enzymes concerned have been identified (Yoshida, 1969; Mifflin, 1973). There is, however, evidence that this is not the only pathway to tyrosine and phenylalanine in plants, and the involvement of quinic acid in the alternate biosynthesis has been demonstrated (Weinstein et al, 1961). Dihydroxyphenylalanine, which is present in large quantities in Vicia faba is formed from tyrosine, probably by direct hydroxylation catalysed by phenolase. The reaction has not been studied in detail and other pathways from tyrosine may also be operative (Pridham, 1965).

The sulphur containing amino acids, cysteine and methionine, are synthesised in microorganisms by the combination of sulphide or, perhaps, thiosulphate with serine or homoserine. The cysteine or homocysteine produced gives rise to methionine. (Nakamura and Sato, 1960; Horowitz, 1947; Meister, 1965). Cysteine can be formed by plant enzymes by the reaction of o-acetyl serine with H₂S. Serine is relatively inactive in this reaction (Giovanelli and Mudd, 1967, 1968; Morris and Thompson, 1968). The formation of o-acetyl serine has not been demonstrated. A number of pathways to methionine have been demonstrated in plants. Transsulphuration of either o-acetylhomoserine or o-succinyl homoserine to cystathionine, followed by its conversion to homocysteine has been demonstrated in spinach extracts by Giovanelli and Mudd (1966, 1971). The direct sulphuration of o-

acetylhomoserine to homocysteine has also been shown to take place in spinach extracts. (Giovanelli and Mudd, 1967).

The pathway of isoleucine and valine biosynthesis was established using mutants of E. coli and N. erassa (Wagner et al, 1958), and the same sequence of intermediates demonstrated for isoleucine synthesis in Phaseolus radiatus seedlings (Satyanarayana and Radhakrishnan, 1962). The deamination of threonine by threonine deaminase yields α -ketobutyrate which condenses with acetaldehyde and, in a number of steps, yields isoleucine. Analogous reactions where pyruvate replaces the α ketobutyrate yield valine. Leucine is synthesised from α ketoisovalerate, the immediate precursor of valine. This close metabolic relationship between leucine and valine has been often demonstrated in plants, the formation of valine and leucine from labelled acetate being a common occurrence. (Arreguin et al, 1951). The enzymatic evidence for these biosynthetic pathways in plants is summarised by Mifflin (1973).

Serine and glycine are readily interconvertible by a reversible reaction requiring tetrahydrofolic acid and catalysed by serine hydroxymethylase. (Blakley, 1958; Huennekens et al, 1958). Glycine is synthesised in plants from glycolic acid. The enzyme which reversibly oxidises glycolic acid to glyoxylic acid is present in a wide variety of plants, but absent in dark grown plants and in roots. (Zelitch and Ochoa, 1953; Tolbert and

Cohen, 1953). In wheat and barley the major products of glycolic acid metabolism are glycine and serine (Tolbert and Cohen, 1953). Experiments with [^{14}C]-formate and [^{14}C] glycine in wheat plants indicate that serine is formed by condensation of formate, or its carbon atom, with glycine, or its C-2. (McConnell and Bilinski, 1959). Tolbert (1955) also demonstrated incorporation of carbon from [^{14}C]-formate into the β -carbon of serine. Numerous workers report that serine and glycine are readily labelled in [^{14}C] - CO_2 photosynthesis, and that either serine or glycine can be labelled first. This indicates that serine cannot always be synthesised from glycine. Tolbert (1963) demonstrated that both serine and glycine are synthesised from photosynthetic intermediates by the glycolate pathway, or, more directly, from phosphoglycerate and glycerate. The two routes are partly located in leaf peroxisomes and form a carbon cycle from and back to the photosynthetic carbon cycle. As much as half of the carbon fixed in photosynthesis may flow through this system, en route to sugars (Tolbert, 1963). The peroxisomes are permeable to serine and glycine, and the glycine-serine interconversion enzymes are found elsewhere in the cell.

These biosynthetic pathways can account completely for the observed labelling of amino acids in the present work, and are summarised diagrammatically in Figs. 11-1 and 11-2.

Labelled carbon was introduced into the bean leaves

by allowing photosynthesis to occur in the presence of $[^{14}\text{C}] - \text{CO}_2$. The products of such photosynthesis, particularly in the short term, have been extensively studied. (Calvin and Benson, 1948, 1949; Bassham et al, 1950; Vernon and Aronoff, 1950; Aronoff and Vernon, 1950; Aronoff, 1951; Gibbs, 1951; Kandler and Gibbs, 1956). In the present work, serine and glycine were always among the first soluble leaf amino acids to be labelled, and remained strongly labelled during the $[^{14}\text{C}] - \text{CO}_2$ feeding period. This is in agreement with their biosynthesis from intermediates of the photosynthetic carbon fixation cycle. The channelling of almost half the photosynthetically fixed carbon through glycine and serine via the glyoxylate cycle would account for the uniformly high activities of these amino acids. Aspartic acid labelled in leaves could have arisen from Krebs cycle intermediates labelled through sugar breakdown, or from direct fixation of $[^{14}\text{C}] - \text{CO}_2$ into oxalacetic acid from phosphoenolpyruvate. Tyrosine and phenylalanine, always strongly labelled, would also arise from phosphoenol-pyruvate. Threonine must have acquired its label from aspartic acid, cysteine indirectly from serine, and proline, glutamine and γ aminobutyric acid from glutamic acid, and dihydroxyphenylalanine from tyrosine by the pathways already described.

Incorporation of ^{14}C into leaf amino acids was not constant, but varied under the different experimental conditions employed. Dihydroxyphenylalanine was labelled in mature leaves photosynthesising outdoors (Table 7-3)

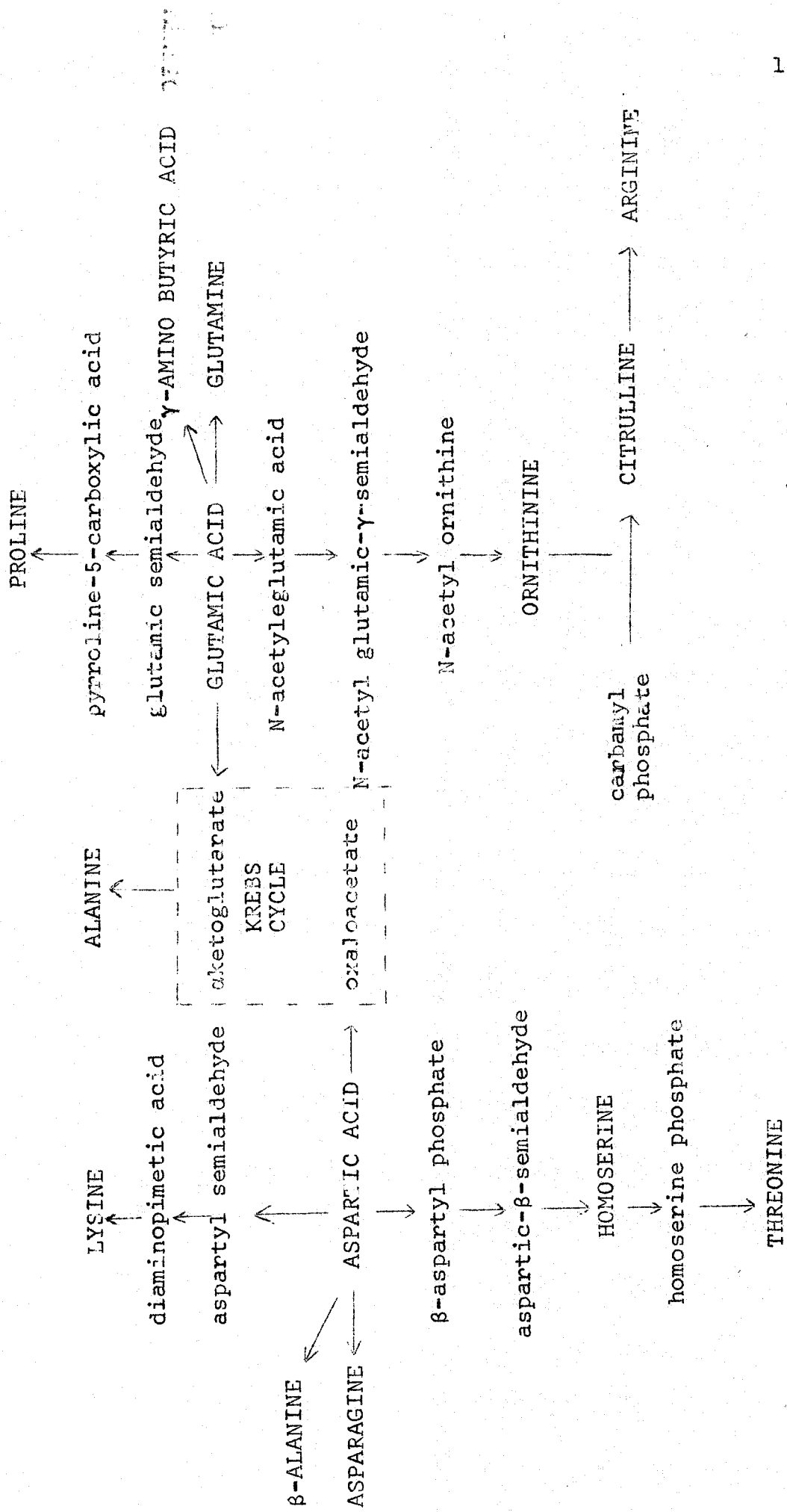

Fig. 11-1 Biosynthetic pathways

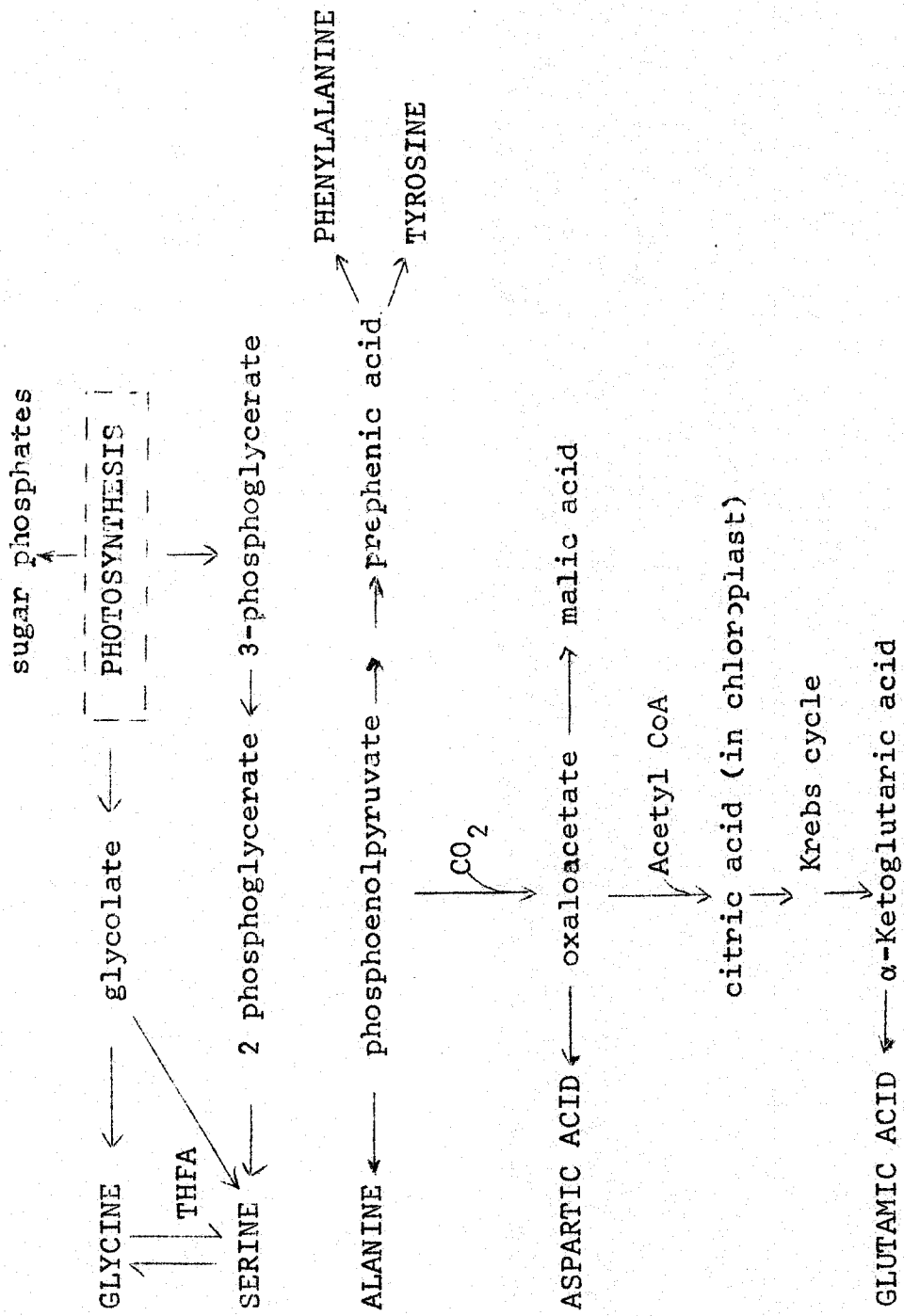

Fig. 11-2 Photosynthesis of amino acids

but not in younger, but fully expanded, leaves on similar plants on the same day. (Table 7-1). Dihydroxyphenylalanine was never labelled in leaves on glasshouse grown plants. Cysteine was detected labelled in only one experiment (Table 9-2) but, being present in the leaf in very small quantities, its label could readily have been undetectable without a large difference in its specific activity. This is so for all the amino acids present in leaves in low concentration - methionine, leucine, isoleucine, arginine and histidine. However, asparagine, glutamine, valine, lysine and dihydroxyphenylalanine were present in the soluble leaf fractions in high concentrations, were rarely detected labelled, and then only weakly. If these substances were synthesised in these leaves, the synthesis must have taken place at a point very remote from carbon fixation in photosynthesis. Mature leaves import very little, if any, assimilate from other parts of the plant shoot (Thrower, 1962; Thaine, Ovenden and Turner, 1959) and so, under normal conditions of growth, they must synthesise or conserve any necessary substances not provided by the xylem sap. In the bean the sap contains large quantities of aspartic acid, asparagine and glutamine, and it may be that the asparagine and glutamine in the sap is sufficient to supply the needs of the leaf and to prevent their synthesis in the leaf. Lysine, valine and dihydroxyphenylalanine are also present in sap, in lower concentrations, and it is possible that the same argument applies. The literature contains descriptions of a number of such situations. Vernon and

Aronoff (1950) showed that in soybean leaves, short term photosynthesis labels alanine, serine and glycine, and that although the plants contain large amounts of asparagine or aspartic acid (depending on the history of the plant) these do not become labelled. Pate (1966) showed for field pea plants that leaf photosynthesis in $[^{14}\text{C}] - \text{CO}_2$ introduced label into leaf protein chiefly in glycine, serine and alanine, and that these amino acids were not labelled when the ^{14}C was supplied through the transpiration stream in the normal components of the bleeding sap. Similarly, in the shoot apex of field pea, amino acids in the transpiration stream supplied carbon to protein through a set of amino acids essentially complementary to those supplied by the photosynthesising upper leaves of the plant. Oaks (1966) showed for maize root tips that asparagine normally supplied to the root tip from the endosperm via the transport system was not synthesised in the root tip although extensively incorporated into protein there. In all these cases, control of the synthesis of asparagine is implicated. The results do not distinguish between feedback inhibition of enzyme activity and feedback repression of enzyme synthesis as the control mechanism. Isolation and characterisation of the enzymes involved would be necessary to distinguish between these mechanisms, and such work has not been done for asparagine synthesis. Lysine and valine have been shown to be subject to feedback inhibition in some plants (Mifflin, 1973).

Protein synthesis during photosynthesis has been demonstrated by a number of workers including Racusen and Aronoff (1954). In the bean, synthesis of leaf protein was very evident, and all the amino acids labelled in the leaf soluble fraction were also labelled in the protein. However, valine, methionine, proline, leucine, lysine and arginine were labelled in leaf protein before they were detected labelled in the soluble fraction. This suggests that either these amino acids are incorporated into protein as soon as they are synthesised (c.f. Steward, Bidwell and Yemm, 1956) or that the amino acid pool from which amino acids are taken for protein synthesis is very small and isolated from the rest of the soluble leaf pool of that amino acid. It also demonstrates that these six amino acids are synthesised in the leaf which does not, then, depend on the transpiration stream for its whole supply of these compounds. The data suggests that photosynthesis supplies the leaf with valine, methionine, proline, leucine, lysine and arginine for protein synthesis, and the transpiration stream or protein breakdown in the leaf supplies these amino acids, or their precursors, to the soluble leaf pool.

A very small part of the total leaf amino acids is labelled by photosynthesis in $[^{14}\text{C}] - \text{CO}_2$ in these experiments. In the young plant, (Table 6-3), serine, glycine and alanine appeared to reach maximum specific activity after 60 min $[^{14}\text{C}] - \text{CO}_2$ uptake. Aspartic acid, glutamic acid, tyrosine and phenylalanine were

still increasing in activity at 3h. These leaves, at node 3, had two large leaflets and were green and healthy although pale in comparison with the leaves at node 10 on the older plants described in Table 9-1. Both leaves would have reached [^{14}C]-saturation in 1000-1500 min of [^{14}C] - CO_2 uptake, but the leaves on the older plant would have contained 25-30 times as much ^{14}C per mg leaf, at saturation. This difference is perhaps in enhanced density of chloroplasts and therefore photosynthetic capacity of the older leaf, but direct measurements of photosynthetic rate would be necessary to confirm this. In any case, the time course of labelling in the two sets of leaves appears to be comparable, and so serine, glycine and alanine in the mature leaf should have been saturated with ^{14}C at 90 min or at least soon after. At this time, less than 1% of the total soluble pools of serine, glycine and alanine were labelled. This is a very different result from that of Smith, Bassham and Kirk (1961) for algal cultures. They found that alanine became saturated with ^{14}C from photosynthesis in 20-30 min and at this time, nearly half the soluble alanine pool was labelled. The difference reflects, perhaps, the more complex pool structure of the leaves of higher plants. In the algae, amino acids represented 32% of carbon fixation, but in the bean it was not more than 10%. Other workers, who have fed [^{14}C] - CO_2 to leaves for comparable time intervals, either have not investigated the soluble leaf fraction (Pate, 1966) or have not expressed their results



in a form such that the proportion of the amino acid pool affected by the label can be calculated (Hellebust and Bidwell 1963a, 1963b, 1964).

At the end of [^{14}C] - CO_2 uptake, label in both soluble and insoluble fractions in leaves decreased quickly. (Fig. 7-4, Table 9-1). This suggests rapid respiration or export from the leaf of newly formed photosynthate. There are numerous reports in the literature which demonstrate that assimilate exported from leaves is always from recent photosynthesis (Hellebust and Bidwell, 1963b; Eschrich 1966; Khan and Sagar, 1969), and this doubtless accounts for part of the decrease in the soluble fraction. Respiration of newly formed sugars and conversion of soluble to insoluble compounds must account for the rest of the ^{14}C loss from soluble fractions. Individual soluble amino acids also showed rapid loss of ^{14}C (Table 10-3). indicative of their high rates of turnover. This decrease in [^{14}C]- soluble amino acids was not paralleled by an increase in ^{14}C in the corresponding protein amino acid. In fact, the protein amino acids lost label almost as steeply as the soluble fraction at this time (Table 10-4). Later in the experiment, between 5h and 6h from the start of ^{14}C uptake, a transfer of ^{14}C from the soluble to the insoluble fraction was evident, and suggests incorporation of free amino acids into protein. Steward, Bidwell and Yemm (1958) demonstrated for carrot root tissue cultures that the free amino acids of the tissue are not the immediate precursors of protein, protein

amino acids being synthesised from carbohydrate and nitrogen residues at the site of their incorporation into protein. However, Oaks (1965b) showed that leucine is incorporated into maize root tip protein at the expense of soluble leucine, and Zielke and Filner (1971) demonstrated reincorporation of amino acids into protein after they had been released into the soluble amino acid pool. These differences in interpretation must reflect differences between tissues in the sizes of the protein precursor amino acid pools. Very small, isolated protein precursor pools would account for the results of Steward (1958) and also for the leaf protein which was rapidly labelled and destroyed in the present leaves. Larger protein precursor pools must have been present in the root tips studied by Oaks and for the protein synthesis observed in the bean leaf between 5 and 6h after the start of ^{14}C uptake.

These results suggest that ^{14}C from photosynthesis is incorporated into two types of protein - one which is synthesised and broken down very rapidly, and another which turns over much more slowly. The first appears to be labelled rather directly from newly formed photosynthate, perhaps in the chloroplast; the second is formed from the soluble amino acid pool of the leaf, possibly at a point in the cell remote from the synthesis of the first. Turnover of protein in leaves and other tissues has been frequently reported. Earlier work gave evidence for the existence of a protein cycle (Chibnall, 1954; Chibnall and Wiltshire, 1954; Steward, Bidwell

and Yemm, 1956; Steward, Thompson and Pollard, 1958). Later work has attempted to determine turnover rates of protein. Mandelstam (1960) showed that protein turnover in growing bacteria was very small, but could be increased at least 5-fold by transferring the culture to a medium unsuitable for rapid growth. Racusen and Foote (1962) determined protein turnover rates in aged, detached bean leaves and found turnover of 0.7% per h and 1.1% per h for protein, glycine and serine respectively. Hellebust and Bidwell (1963b, 1964) calculated turnover rates for growing and nongrowing leaves of wheat, snapdragon and tobacco. Turnover was shown to be higher for rapidly growing leaves than for nongrowing leaves - the opposite to the situation found in bacteria. They found turnover rates of 0.4-0.5% for rapidly growing secondary wheat leaves, 0.2-0.3% for nongrowing primary wheat leaves, 0.1-0.15% for expanding tobacco leaves, and negligible turnover of protein in mature tobacco leaves. Turnover rates of individual proteins have been determined for inducible enzymes such as nitrate reductase (Schneider et al, 1968; Heimer and Filner, 1971; Zielke and Filner, 1971) and invertase (Bacon et al, 1965; Edelman and Hall, 1965; Glasziou et al, 1966). Nitrate reductase appears to have a half life of about 4h, and invertase is shown to have a half life of 2h in sugar cane tissue and rather more (0.5-1.0 days) in washed slices of beet and artichoke roots.

Trewavas (1972) determined the rates of protein synthesis and degradation in Lemna minor by measuring

amounts of methionine bound to RNA and to protein, and showed that the half life of protein methionine under optimum growth conditions is about 7 days. Alteration of the growth medium from the optimum markedly increased the rate of protein turnover and the half life of protein methionine was reduced to about 2 days. These results are directly comparable with Mandelstam's conclusions for bacteria, but quite unlike those for plant leaves (Hellebust and Bidwell, 1963b, 1964) where rapid growth is associated with rapid protein turnover. This may reflect differences in the metabolism of the organisms used. It has been suggested that in bacteria mRNAs turn over rapidly and protein slowly, whereas in plants mRNA is stable and proteins turn over faster. Alternatively, protein turnover associated with photosynthesis may be under different control than that associated with metabolic pools permeable to exogenous substrates. Trewavas's work demonstrates unequivocally that rates of protein turnover vary markedly with the conditions of growth of the organisms, and this may account for discrepancies between rates observed by different workers.

In the present work, the turnover rate of protein serine during photosynthesis is about 0.1% per h. This is a minimum estimate since it is calculated from Table 10-4, assuming that the serine in protein has a specific activity equal to that of the source carbon dioxide, an assumption based on the derivation of this protein from new photosynthate. The turnover rate of

the more slowly labelled protein is very much less than 0.1%. These results indicate that, even in mature leaves, some protein turnover does occur, at least under the conditions of the present experiments. This turnover would, however, be undetectable in samples collected much more than 1h after the end of [^{14}C] - CO_2 photosynthesis, and this may account for the lack of detection of protein turnover in mature leaves by Hellebust and Bidwell (1963b). They subjected their leaves to 1h respiration analysis at the end of the period of photosynthesis in [^{14}C] - CO_2 . The samples for analysis were collected after this time, and as in the present experiments, the protein ^{14}C was very low. The specific activity of the carbon dioxide collected in respiration analysis was higher than that of any of the substances extracted from the leaf in the first sample. They suggested that the respired carbon dioxide must have come from an isolated pool of high specific activity sugars, but the present work indicates that protein labelled in photosynthesis probably also contributed ^{14}C to the carbon dioxide. The contribution of protein carbon to respired carbon dioxide is reported by a number of workers including Yemm (1950) and Steward et al (1958).

In the last experiment described here (Tables 9-1, 10-3, 10-4) [^{14}C] - CO_2 uptake was terminated prematurely, presumably due to stomatal closure. Labelled carbon dioxide from respiration would have been unable to escape from the leaf, and would thus be expected to be

metabolised. There is little conclusive evidence of this in the data. It is possible that fixation of endogenous [^{14}C] - CO_2 into aspartic acid accounts for the rather slow (by comparison with other amino acids) loss of ^{14}C from aspartic acid, after the end of ^{14}C uptake, but without more detailed kinetic data this suggestion cannot be substantiated. Aspartic and glutamic acids behaved rather differently from the other labelled amino acids. They were both rapidly labelled in the first 90 min of photosynthesis, after which activity in aspartic acid decreased more slowly than in the other amino acids, and activity in glutamic acid continued to increase until 330 min. Glutamic acid may have been labelled via hexose respiration. Leaf hexose was always strongly labelled in the leaf and this may have accounted for the prolonged uptake of ^{14}C into glutamate. Neither aspartic nor glutamic acids showed rapid uptake of ^{14}C into protein. Slow labelling of protein aspartic and glutamic acids from leaf photosynthesis in [^{14}C] - CO_2 was reported by Hellebust and Bidwell (1963a). They suggested that this reflected the slow rates of labelling of the protein precursor pools of these amino acids, due to their formation via Krebs cycle intermediates, remote from the photosynthetic process. Both aspartic and glutamic acid were incorporated in small amounts into leaf protein during the first 90 min of the present experiment. Their activity in protein then remained constant but began to rise again at 300 min. If the plateau between

90 and 300 min (Fig. 10-1) was not an effect of the prevention of leaf photosynthesis, then it suggests that aspartic and glutamic acids are first incorporated into a small pool of protein, and that penetration into another compartment of the cell was necessary before more protein could be labelled.

The rapid turnover of soluble amino acids without their incorporation into protein (Figs. 10-2, 10-3, 10-4) has not been accounted for. These amino acids could be converted into other substances, e.g. serine and glycine converted to carbohydrate via the glyoxylate cycle, and these substances exported from the leaf or respired. They could be exported from the leaf without conversion.

There are numerous reports in the literature of the presence of amino acids in phloem exudate. Eschrich (1963) found asparagine, aspartic acid, glycine, glutamine, glutamic acid, alanine, arginine and citrulline in phloem sap from Cucurbita ficifolia. Peel and Weatherley (1959) demonstrated the presence of ten amino acids in phloem sap of Salix viminalis and showed that these varied with the time of year. Tammes and Van Die (1966) determined nitrogen in phloem sap of Yucca flaccida and showed that it moved chiefly as amino acids and amides. Phloem sap was not investigated in the present work, but extracts of petioles of leaves photosynthesising in $[^{14}\text{C}] - \text{CO}_2$ did contain radioactive serine and glycine. These were the most heavily labelled soluble amino acids in the leaf, and thus the absence

of other labelled amino acids in the petiole extracts may merely reflect that their radioactive concentration there was too low for detection by the methods used. Since amino acids are known constituents of phloem exudate, and have been shown to move out of leaves in the phloem (Eschrich and Hartman, 1969), the serine and glycine labelled in these petioles is assumed to be moving out of the leaf. This translocation would, then, contribute to the decrease in soluble leaf amino acids. This assumption is supported by the early appearance of labelled serine in the fruit at the same node as the fed leaf, along with other amino acids which are strongly labelled in the leaf. (Table 9-2). If the serine had been formed in the fruit from labelled, translocated sugars, then amino acids more closely related to sugar metabolism (e.g. glutamic acid, glutamine) would be expected to be labelled also, and this was not the case. Recently, Pate has shown that phloem sap collected from petioles and stems of pea contains high levels of amino acids in almost correctly balanced proportions for direct incorporation into protein. This stream of amino compounds is regarded as being an important source of nitrogen for the plant meristems (Pate, 1968), developing seeds (Flinn, 1969), and the distal region of the root system (Oghoghorie and Pate, 1972).

The petioles of leaves photosynthesising in $[^{14}\text{C}] - \text{CO}_2$ contained labelled sucrose, fructose and glucose as well as amino acids and these also were among the first labelled substances to appear in the fruit

(Table 5-3). These three labelled sugars have also been reported in the stems of soybean plants photosynthesising in [^{14}C] - CO_2 , and their translocation away from the labelled leaf was described (Vernon and Aronoff, 1951). However, analyses of sieve tube exudates, obtained from bleeding plants and from aphid stylets, demonstrate that hexoses are not transported in the phloem and that sucrose is the principal form of carbohydrate translocated by most plants. (Zimmerman, 1960; Eschrich, 1970). The glucose and fructose labelled in the petiole must then have been stationary there, and formed from the sucrose in the petiolar cells. Similarly, the glucose and fructose in the fruit must have been formed from translocated sucrose on arrival in the fruit. Such inversion of sucrose by acid invertase has been described by many authors. The enzyme appears to be located in the cell wall tissue of many plants and plant organs (Eschrich, 1970) including corn coleoptiles (Kivilaan et al., 1967), fruit stalk tissue of Zea mays (Shannon, 1972; Shannon and Dougherty, 1972) and bean pod tissue of Phaseolus vulgaris where an intra-cellular alkaline invertase was also found (Sacher, 1966). The present results suggest that inversion of sucrose occurs in petioles and in stem tissue as well as in the developing fruit of Vicia faba.

Exchange of substances in the translocation channels with the tissues through which they are being translocated has been convincingly demonstrated. Hill (1963) found that the stem of Salix cuttings temporarily stored

labelled translocate, and later released it back into the phloem tissue. Ho and Peel (1969) showed that the storage cells of the willow stem contributed between 10 and 25% of moving sugars, depending on the degree of previous accumulation in the storage cells. Biddulph and Cory (1965) demonstrated radial loss of labelled assimilate from the phloem of the red kidney bean plant, using autoradiography of stem tissue. Fleshy stems and petioles, such as rhubarb and sugar beet petioles are major sinks for translocated assimilate, with about 3% of the translocate being absorbed by the petiolar tissue. (Geiger et al, 1969). Much smaller proportions of translocate, about 0.8%, are found to leak from the phloem tissue in the stem of the soybean plant (Evans et al, 1963), which is likely to be comparable with the present work. The function of such storage of translocate in stem and petiole tissue is suggested by Geiger et al (1969) to be the buffering of the sucrose concentrations in the phloem during times of fluctuating assimilation. Such buffering has been demonstrated by Hill (1963) who showed that stem cells near the base of a willow stem released sugars into the phloem to compensate for losses from the phloem caused by aphids feeding on the stem near the top.

The fate of assimilate translocated from leaves has been studied in some detail, and shown to be related to the proximity of 'sinks'. The present work shows considerable transfer of carbon from the bloom node leaf to its subtended pod, a phenomenon which has been reported

by many workers, and in many plant species. Linck and Sudia (1962) showed that 90% of carbon translocated from the bloom node leaf of Pisum sativum was recoverable from the growing, 12 day old, carpel and ovules. Carr and Wardlaw (1965) found that 49% of the carbon assimilated by the flag leaf blade of wheat moved to the grain, during the time of maximum grain expansion. Translocation of assimilates into growing cotton balls has been demonstrated by Maskell and Mason (1928, 1930) and Brown (1968). Hansen (1970) has described the translocation of sorbitol from the fruit spur leaf to the fruit of apple, and the subsequent rapid metabolism of the translocate. Flinn and Pate (1970) showed that developing field pea seeds are dependent on their bloom node leaves for about one third of their total supply of carbon. It is, then, generally accepted that the leaf at the bloom node supplies carbon directly to the fruit at that node with other leaves probably also contributing carbon in smaller quantities. None of these leaves are totally committed to the fruit, as they also export assimilate to the rest of the plant. (Flinn and Pate, 1970). Mature leaves import very little of this assimilate, unlike developing leaves which export nothing and import large amounts of carbon until they are at least half expanded. (Thaine et al, 1959; Thrower, 1962). Assimilate exported by leaves near the plant apex supplies the apex almost exclusively. Leaves near the plant base export principally to the roots, and the leaves in between translocate some assimilate

in each direction. (Thaine et al, 1959; Thrower, 1962; Biddulph and Cory, 1965; Pate, 1966). This pattern of translocation accounts for the observation in the present work, that similar amounts of label are recovered in sap from 3 to 4 leaf plants fed [^{14}C] - CO_2 through the lowest leaf and through the whole plant top.

Developing roots and apices, then, receive constant supplies of photosynthate from proximal leaves, and in many species this photosynthate is translocated chiefly as sucrose. In the roots the carbon from broken down sucrose combines, as α ketoglutaric acid, with nitrogen fixed in nodules or absorbed as nitrate. The glutamic acid and glutamine so formed transaminates with oxaloacetic acid forming aspartic acid and asparagine. These processes have already been discussed. Such root biosynthesis, from photosynthate supplied by the shoot, must be responsible for a large part of the organic compounds supplied to the shoot in the xylem sap.

Xylem sap is collected from herbaceous species as bleeding sap forced by root pressure from the vessels of decapitated plants. Some of the work on xylem sap has been mentioned in the Introduction to this thesis, and so the present discussion will be limited to the results obtained in the present work, and literature related directly to these results.

Exudation of sap from cut stumps shows a diurnal periodicity which has also been described for sunflower (Grossenbacher, 1939), tomato (Arisz et al, 1951; van Andel, 1953; Van Die, 1959a) and field pea (Pate, 1962).

A number of workers (Van Andel, 1953; Vaadia, 1960; Pate, 1962) have demonstrated a relationship between this periodicity and the ion content of the exudate, and have implicated ion secretion into the xylem as the causative agent. The effect of light in enhancing exudation and controlling the timing of the periodicity was observed in the present work and is also discussed by Pate (1962). Considerable evidence supports the view that exudation from root systems is related to the synthetic activities of the root and, in a legume, the root nodules. Correlations between illumination of plant tops and activity of nitrogen fixation in nodules have been drawn by many workers (Virtanen et al 1955; Bach et al, 1958; Bergersen, 1971) and the role of photosynthate translocated from the plant tops has been implicated (Bach et al, 1958; Virtanen et al 1955; Pate and Greig, 1964).

The periodicity in volume of sap exuded from the cut stump is accompanied, but not always exactly matched, by a periodicity of amino acid concentration in the exudate (Van Die 1959a, 1959b; Pate, 1962). These periodicities are evident whether the sap is collected over a long period of time from the one group of plants, as in the work of Van Die, or in short collection periods consecutively from a number of groups of plants, as in the present work (Table 3-2) and that of Pate (1962). Removal of the plant shoot removes transpirational forces and any downward translocation of metabolites into the root. Thus, a short collection period is more likely than a

long one to produce exudate of composition qualitatively similar to the sap of the intact xylem. However, sap collected over several days from one group of plants reveals, by its changes in composition, some of the processes associated with sap formation in the intact plant. Van Die (1959b, 1960) demonstrated that prolonged bleeding depleted α ketoglutaric acid from the roots and bleeding sap of the tomato plant, and that disappearance of α ketoglutaric acid was correlated with decrease of amino acids in the sap. α ketoglutaric acid did not decrease in roots with no nitrogen source, and sap amino acid concentration remained low. Some amino acid was always present in the sap and this exhibited the usual periodicity. Van Die suggested that this low level of sap amino acid originated from proteolysis in root cells. He demonstrated that glutamine and proline in sap, roots and stem increased with increasing ammonium fertilisation of the roots, and that the concentrations of other amino acids did not change (Van Die, 1961). This suggested that glutamine and proline were synthesised using the applied nitrogen, and the other amino acids originated in another manner. Labelled photosynthate introduces label into aspartic acid, asparagine and glutamine in bleeding sap from Vicia faba and into these amino acids and homoserine in the field pea (Pate, 1962). Other sap amino acids are not labelled. If this is not a concentration effect, then it too suggests different origins for the labelled and the unlabelled amino acids.

The absence of label in glutamic acid must imply that the pool of glutamate into which nitrogen is fixed in the root nodules is small and isolated from the amino acid exudation pool. Direct evidence for the origin of the unlabelled amino acids has not been obtained, nor has evidence been produced for their existence in xylem sap of intact plants.

There is considerable evidence for the existence of the major amino acid components of xylem sap in intact plants. Changes in the glutamine concentration of bleeding sap were correlated with changes in glutamine in stem tissue for tomato plants. (Van Die, 1961). Appearance of label in amides and amino acids in bleeding sap was correlated with appearance of label in the same compounds in the nodules and lower portion of the stem of field pea (Pate, 1962; Pate, Walker and Wallace, 1965). In the present work, the absence of labelled asparagine in the stem near the leaf photosynthesising in $[^{14}\text{C}] - \text{CO}_2$ after 3h exposure to the label, and its presence 21h later (Table 5-2) correlates with the usual appearance by this time of labelled asparagine in the bleeding sap (Fig. 4-1). Lesser components of the sap which do not become labelled from photosynthate, and which show little variation in concentration are not possible to demonstrate in this manner. It is interesting to note the presence in the root exudate from Vicia faba of dihydroxyphenylalanine, an amino acid which occurs in high concentration in most parts of the broad bean plant.

In the present work, non amino substances in sap were investigated only if they became labelled from photosynthate. The unidentified ninhydrin negative substance in the sap could have been either an organic acid, or a sugar present in very low concentration. The presence of organic acids in bulk sap was demonstrated by qualitative tests, but no attempt at identification was made. Van Die (1959b) found a number of organic acids in bleeding sap from tomato roots. α ketoglutaric acid was present as a major component in sap from newly cut stumps, but had decreased markedly in concentration after six hours bleeding from a stump. This decrease was accompanied by a decrease in the root α ketoglutarate pool and in the sap amino acids. Kating and Eschrich (1964) also noted this decrease in α ketoglutarate and amino acids in xylem sap from Cucurbita sp. They applied [^{14}C]-bicarbonate to the plant roots and, rapidly, label appeared in amino acids and organic acids of the sap. The label decreased with longer sap collection times. The α ketoglutarate was suggested to arise from sucrose translocated from leaves (Van Die, 1960). Other sap organic acids were present in the tomato plant in smaller amounts, and their concentrations varied very little during prolonged bleeding.

In herbaceous plants, xylem sap is generally accepted as being free, or almost free, of carbohydrate (Pate, 1962). In the present work it required repeated spraying of increasingly concentrated samples of sap before the sugars, glucose, fructose and sucrose, could be identified.

These substances were present in very low concentrations, although highly radioactive, containing almost half the sap ^{14}C , and it is suggested that they represent recently formed photosynthate and its derivatives. Their presence in the sap is supposed to be derived from exudation from cut cells, probably phloem tissue, of the stem, and the likelihood of their being xylem-translocated substances seems very small.

Introduction of label into the sap of a fruiting plant and its recovery in the fruit proved impracticable in the present experiments since, even with a 6h feeding period, the amount of ^{14}C recovered from the plant was too low for individual labelled compounds to be identified. Longer feeding periods were not attempted since this would have required the development of a suitable feeding chamber. The contribution of the xylem sap components to the metabolism of the shoot and fruit was not determined. Such an investigation for vegetative shoots has been carried out by Pate, Walker and Wallace (1965) who fed labelled, diluted bleeding sap to detached plant shoots and observed its subsequent metabolism. Pate (1966) showed that this contribution to the shoot of carbon from xylem sap was essentially complementary to the amino acid carbon synthesised in situ.

Reduction in concentration of sap as it ascends the stem is suggested by the activities of stem segments in Table 4-5. Such a reduction in concentration was demonstrated unequivocally by Brennan, Pate and Wallace (1964) when they collected bleeding sap from petioles of

field pea. They concluded that a considerable portion of the nitrogen in the xylem sap is absorbed by the tissues of the stem, and that asparagine is absorbed more intensively than other sap components. Thus, the xylem sap reaching a fruit high on the plant may not have the same composition as that collected from the root system.

We are now in a position to consider the various sources of carbon for a fruit developing on a broad bean plant. The respective contributions of leaf photosynthesis, fruit photosynthesis and root metabolism to the developing pod are summarised in Fig. 11-3. Evidence for many of the points illustrated, even if only indirect evidence, has been obtained in the present work. However, the strongest evidence for the illustrated interrelations of shoot and root in carbon and nitrogen metabolism comes from the work of Pate et al with the field pea, and has already been discussed. The carbon sources revealed in this discussion must form the basis for any biosynthetic activity in the growing fruit, and at least potentially, exert a control over all such activity.

When [^{14}C] - CO_2 was fed to the bloom node leaf subtending young, phase I pods, sucrose, glucose and fructose were the first labelled substances to be detected in the pod (Table 5-3). Labelled amino acids were also present in the soluble fraction of the pod, at first in trace amounts and later in higher concentrations (Table 5-2, Table 7-1). The low uptake of ^{14}C by the pods growing outdoors as compared with those in the glasshouse

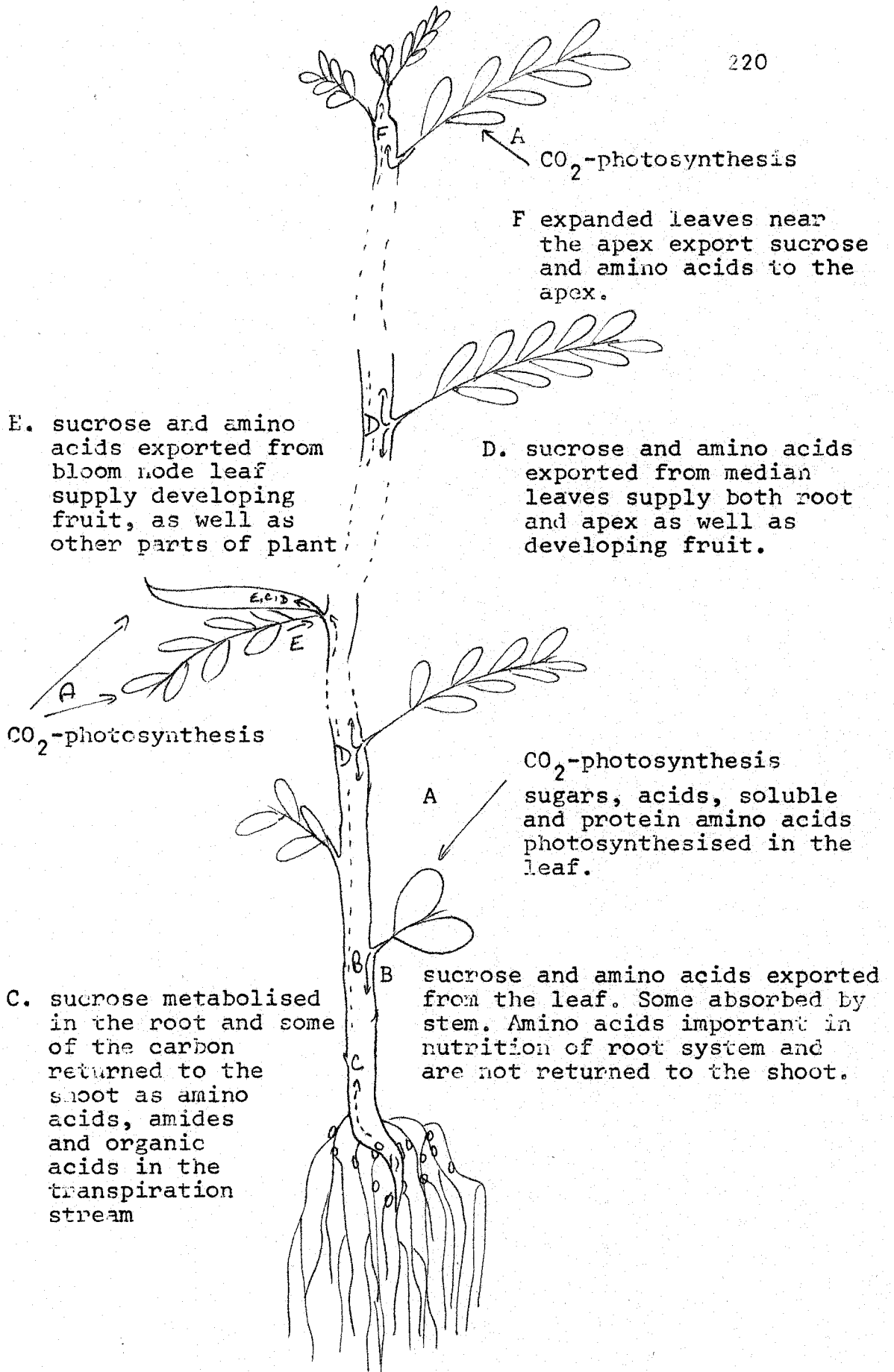

Fig. 11-3. Fruiting plant of Vicia faba

must be attributable in part to the different environmental conditions, but the emphasis on dihydroxyphenylalanine metabolism in the outdoor pods indicates that this is not the only factor. Dihydroxyphenylalanine was generally labelled weakly in other soluble pod fractions, but never more strongly than tyrosine. Dihydroxyphenylalanine metabolism is related to, although not directly involved in, the metabolism of melanin in these tissues, and melanin production occurs in damaged or senescent tissue. (Andrews and Pridham, 1967). As already suggested in the Results section, these pods were probably abortive. The experiment was not repeated, and so, although the young pod is evidently active in importing translocate from the bloom node leaf, further conclusions as to the normal metabolism of such pods are not justified.

^{14}C uptake by the 35-day-old, phase III pods followed a rather different pattern. Leaves export photosynthate within a short time of its synthesis, or store it until export during senescence, as discussed previously. It may be seen from Table 7-3 that the photosynthesising leaf had exported all its labelled photosynthate by 2h after the end of $[^{14}\text{C}] - \text{CO}_2$ feeding. Label appeared in the pod within 90 min of the start of $[^{14}\text{C}] - \text{CO}_2$ photosynthesis, and so one would expect that the fruit would cease to increase in activity within about 4h after the end of ^{14}C uptake by the leaf. The fruit activity did remain essentially constant between 2h and 8h after the end of ^{14}C uptake, as expected, but then it began to rise again.

The original loss of ^{14}C from the bloom node leaf was not matched by an equal increase in ^{14}C in the pod, and some of the activity must have been lost from the system by respiration, or exported to other parts of the plant. The late increase in pod activity must then indicate that those other parts of the plant receiving ^{14}C from the leaf, later remobilised them and supplied them to the pod. The leaves were at nodes 7-11 on 15 node plants, and would be expected to supply both the roots and the apex with some translocate, as already discussed. The apex retains such carbon, over the time intervals being considered. The roots reexport photosynthate in the transpiration stream. However, the observed increase in pod carbon is taking place between 23.00 and 7.00 hours when the transpiration of the plant is minimal and could not be expected to supply large amounts of carbon to the plant shoot. The substances arriving in the pod and seeds during this time were non-amino compounds, and this also supports the contention that they were not supplied via the xylem. Such results can only indicate that labelled sugars, stored elsewhere than in the fed leaf, are remobilised during the night to supply the fruit. That the stem might be the site of such storage and remobilisation is indicated by the work of Peel and Weatherly (1962) who showed that with the change from light to dark, the source of sugar for phloem translocation in Salix sp. changed from leaf to stem tissue. This indicates an important role for the stem

in the carbon economy of the plant. Stems have also been reported to accumulate nitrogen compounds from xylem sap, (Van Die, 1961; Brennan, Pate and Wallace, 1964) and it is possible that these substances too contribute to the carbon remobilised from stem tissue during the night. Further experimental work is necessary to confirm this.

That some of the carbon exported by the photosynthesising leaf was incorporated into the soluble and insoluble fractions of the phase III seeds is clearly shown in Figs. 7-3 and 7-5. However, labelled carbon was not detectable by autoradiography in soluble and protein amino acids in extracts of these seeds, probably because of dilution of radiocarbon by the already large seed pools of soluble and protein-bound amino acids. Younger fruits were investigated in order to establish the seed size in which radiocarbon dilution would be small enough that the labelled compounds could be detected by the present methods. The 25-30 day old, phase II fruits were found to be suitable (Tables 7-5, 7-7).

The phase II fruits studied during 6h import of photosynthate from a leaf became labelled in both pod and seed insoluble fractions between 40 min and 90 min photosynthesis in $[^{14}\text{C}] - \text{CO}_2$. In both cases serine and alanine were the most strongly labelled amino acids. The early presence of labelled serine in the seed soluble fractions indicates that this amino acid may have been translocated directly from the leaf to the seed, passing through vascular tissue all the way. In this context

it is interesting that Davis (1966) found no conversion of exogenously supplied glycine to serine in the broad bean seed, although the conversion did take place in the pod. It is possible that sufficient serine is translocated to the seed to inhibit its synthesis in the seed. Alanine was not detected labelled in petiole extracts, and so would be expected to be only weakly labelled in the pod and seed tissue if it were derived entirely from translocated alanine. Thus the alanine is suggested to arise by transamination of pyruvic acid formed from translocated sugar which was present in large quantity in both pod and seed. Glutamic acid, glutamine and tyrosine, also labelled strongly in the early pod extracts, must arise similarly from sugar breakdown products. Alanine, glutamic acid, tyrosine and phenylalanine have been shown to be formed in *Datura* seeds from a supply of sucrose and nitrate. (Lewis et al, 1970).

Early seed soluble fractions contained label in sugars, serine and alanine only, but at 180 min, 90 min after the first labelled sample, the soluble seed activity increased steeply and almost all the amino acids which were labelled in the pod became labelled in the seed. When ^{14}C was fed directly to the pod, there was a 75 min delay before ^{14}C was detected in the seed (Fig. 8-3). This is comparable with the time between the first appearance in the pod of label from the leaf and the sudden increase in the soluble seed activity in the same experiment. It is suggested that the numerous amino acids labelled in the 180 min sample were derived

from the pod. This being so, more than two thirds of the carbon from the leaf entered the seed after metabolism in the pod. No amino acids were labelled in the seed which were not also labelled in the soluble or protein fraction of the pod. Thus it is not necessary to hypothesise any major metabolic conversions within the seed, except perhaps the formation of alanine from sugars.

Pod photosynthesis labelled essentially similar compounds in the soluble pod fraction as leaf photosynthesis did in the leaf, but the pod exported different amino acids to the seed, at least over the time interval investigated. [^{14}C] -aspartic acid was the major labelled amino acid appearing in the seed during pod photosynthesis. Label in glutamic acid, glutamine and alanine in the seed increased at the expense of aspartate carbon. The conversion of aspartate to oxaloacetate, followed by cycling of carbon in the Krebs cycle is the obvious pathway for the conversion (Fig. 11-1). The results could equally well be accounted for by the incorporation of aspartate into seed protein simultaneously with accumulation in the seed of other amino acids from the pod or from sugar metabolism, but aspartic acid was only weakly labelled in seed protein and hence the former explanation is preferred. Quantitative analysis would be necessary to resolve the problem. The seed, then appears to be capable of fairly extensive interconversions of amino acids, and particularly those involving respiratory pathways (Krebs cycle, sugar metabolism). Seeds are known to have a high respiration rate (Flinn and Pate, 1970), the carbon dioxide so produced

being recycled in the fruit by pod photosynthesis.

Pod protein became labelled strongly in tyrosine, phenylalanine, glycine, serine and alanine from both leaf photosynthesis and pod photosynthesis. As in the leaf, glutamic and aspartic acids and basic amino acids were labelled only weakly, in spite of being present in the protein in amounts similar to the labelled amino acids. This may be due, as suggested by Hellebust and Bidwell (1963a) for leaves, to larger protein precursor pools for these amino acids. It is tempting to wonder whether these protein precursor pools are more readily penetrated by amino acids from xylem sap than by photosynthate. This could apply equally well in leaves, and is in line with the demonstration by Pate (1966) that xylem sap provided carbon to protein in apices of field pea through amino acids of the aspartic and glutamic acid families.

It is to be expected that the amount of xylem sap entering an organ will be directly related to the transpiration rate of that organ, and thus organs such as mature leaves will receive an excess of substances from the xylem and must reexport a proportion of these. (Bollard, 1960). The transpiration rate of a seed enclosed in a pod cannot be high, and one would expect, then to find very little dependence of the seed on the xylem sap stream. This seems to be borne out by the labelling of aspartic and glutamic acid family amino acids in the seed from carbon taken up in pod

photosynthesis. In this context, it is worthy of note that the seed is the only part of the Vicia faba shoot which contains no dihydroxyphenylalanine. Dihydroxyphenylalanine is present in bleeding sap and, therefore, probably in xylem sap. If then, dihydroxyphenylalanine does enter the seed in the xylem sap, it must be either reexported, or else broken down. It may be that the xylem sap stream makes its chief contribution to the seed after its components have been recycled in the pod - in the same way as some of the carbon from leaf translocate appears to be metabolised in the pod before entering the seed.

Pod photosynthesis incorporated carbon into seed protein chiefly in aspartic acid, glutamic acid, serine, tyrosine, phenylalanine and glycine. Leaf photosynthesis labelled serine, alanine, tyrosine and phenylalanine most strongly. Threonine and proline were the only amino acids unlabelled from either carbon source, but valine, isoleucine, and leucine, all present in seed protein in amounts greater than or equal to tyrosine (see Appendix 3) were only weakly labelled. Threonine and proline are synthesised from aspartate and glutamate respectively, and possibly arise from pod metabolism of xylem sap, along with some of the seed aspartic and glutamic acids and their amides. Iso-leucine arises from threonine, and valine and leucine from pyruvate. The weak label in the last two, at least, of these is not readily explained. There remains the possibility of prior storage of these amino acids in, for example, the pod and

their mobilisation for use in seed protein formation as required. This would suggest minimal turnover of these amino acids. (c.f. Oaks, 1966). Davis (1966) demonstrated that, between day 26 and day 38 (phase II) in broad bean fruit, there is a decrease in glycine, tyrosine, lysine and arginine in the pod concomitant with an increase of glycine, tyrosine and lysine in the seed. It is reasonable to suppose that these substances had been stored in the pod for translocation to the developing seed. They are not, however, closely related, metabolically, to the unlabelled amino acids above. Alternative stores of amino acids could occur in the seed coat or in the developing cotyledons themselves. Any such stores might provide to the seed sufficient of an amino acid to inhibit its synthesis in the seed. This would not necessarily preclude the occurrence of normal synthesis of these amino acids at other times in the life of the fruit. Of course, the present study views only a few hours in the life of the pod, during which time only certain proteins will be synthesised and only certain substrates used. The unlabelled amino acids in the present experiment may be present in low concentration in the currently synthesised protein, or in high concentration in temporary storage pools not detectable in studies such as those of Davis (1966). In the absence of detailed quantitative data, such conclusions from the present work must be considered with caution.

The proteins being synthesised in these phase II fruits must be chiefly albumins and must include some of

the many enzymes active in the fruit at this time. Davis (1966) showed that phase II broad bean seeds synthesise a number of albumin proteins, as revealed by acrylamide gel electrophoresis, and that the number of these proteins increases to a maximum between day 29 and day 49. Flinn and Pate (1968) showed that in seeds of field pea, albumins are synthesised in large quantity in phase II and globulins are not synthesised until phase III. A similar pattern was demonstrated for Phaseolus vulgaris seeds by Hall et al, 1972.

The production of albumins in quantity during phase II of seed growth is indicative of considerable change in the metabolism of the seed, and is probably associated with preparation of vacuoles and synthetic machinery for the deposition of storage protein. Numerous enzyme activities have been detected in extracts of developing and mature seeds (Dey and Pridham, 1968; Rinne, 1969; Morris et al, 1970; Moore, 1969), and it is likely that the increase in albumin protein would be associated with increase in activities of some of these proteins.

In seeds of Ricinus communis, an enzyme catalysing the synthesis of ricinoleic acid from oleic acid is absent (or inactive) in young developing seeds, mature seeds and germinating seeds, but present in developing seeds older than about 25 days. (Yamada and Stumpf, 1964; Galliard and Stumpf, 1966). Although such results appear not to have been described for legumes, it is likely that a similar situation exists. A combination of gel electrophoresis and autoradiography of ^{14}C -labelled seed

proteins might yield interesting results in this situation.

It is evident that the developing seed depends markedly on the rest of the plant for its carbon supplies. The seed is green for most of its time of development, and it is thus potentially photosynthetic. Flinn and Pate (1970) showed that seeds of field pea were unable to photosynthesise significantly, but pointed out that other leguminous seeds which contain more chlorophyll than those of field pea, may have a greater photosynthetic efficiency.

The present experiments were not designed with a view to investigating the amounts of carbon supplied to the seed from different sources, but the results may be used to obtain a very rough estimate of carbon transfer. If the activity results for the leaf-pod-seed systems (Table 9-1, Fig. 7-3) and the pod-seed system (Fig. 8-1) are recalculated on a per leaf and per pod basis (Appendix 4), rate of transfer of carbon into the seeds per pod can be calculated. These are necessarily minimum figures, as they assume that the specific activity of the carbon entering the seed is that of the fed $[^{14}\text{C}] - \text{CO}_2$, and while this may be a reasonable approximation for new photosynthate, in other cases it is likely that the actual specific activity will be rather smaller. These calculated values are presented in Table 11-1. It is interesting to note that the stem at night feeds a comparable amount of carbon to the seed as does the leaf on the same plant during the day.

Table 11-1. Carbon sources for the seed

Source of ^{14}C	^{14}C uptake into the seeds per pod	
	cpm/h	$\mu\text{moles/h}$
(a) pod photo-synthesis (Fig. 8-1)	2,300	0.002
(b) leaf photo-synthesis (Table 9-1)	20,000	0.023
(c) leaf photo-synthesis (Fig. 7-3)	3,000	0.005
stem, at night (Fig. 7-3)	2,000	0.003

The data were calculated from the figures and tables given, re-expressed on a per sample basis in Appendix 4. They are maximum mean values in each case.

(a) and (b) were plants grown indoors and under artificial lights. (c) were plants grown outdoors, and which took up much less $[^{14}\text{C}] - \text{CO}_2$ than did the plants in (a) and (b). The value for the stem at night is likely to be low due to dilution of translocate during storage in the stem.

The results indicate that, for the glasshouse grown plants, leaf photosynthate supplies a much larger proportion of carbon to the seed than does the pod. The pod is still growing at this time and it is therefore likely that it retains a great deal of photosynthate for its own metabolism.

Within the limits of accuracy of these results, they agree with the findings of other workers. Lewis et al (1970, 1971) showed for Datura stramonium seeds that the bulk of the amino acids incorporated into the seed protein were derived from carbon exported by leaves in the proximity of the fruit. In general, 6-10 times as much seed protein amino acid was derived from leaf photosynthesis as from metabolism of sucrose in the fruit. Flinn and Pate (1970) showed that, during the life of the fruit of the field pea, the leaflets supply a greater proportion of the carbon required by the seeds than do the pods. Pods were found to export no carbon when very young (up to 10 days) and to export steadily increasing amounts to the seed until levelling off at about 25 days. The pod never exported as big a proportion of its fixed carbon as did the leaf.

The complexities of interrelationships of the carbon sources for the seed have been indicated rather than analysed, suggested rather than proved. This is perhaps inevitable in a preliminary study which has attempted to broadly assess several aspects of the problem. It is hoped that the present work will form a basis for further, more detailed investigations of the metabolism surrounding the development of the seed in Vicia faba.

APPENDIX

1. Curve fitting
2. Counting errors
3. Sample analyses - pod and seed amino acids
4. Activity results expressed per sample

APPENDIX ONE - Curve fitting

Straight line, $y = ax + b$.

For each value of x there is an observed value of y .
On the straight line, for each value of x there is
a calculated value of y . For the best straight line
the sum of the squares of (y observed - y calculated)
will be minimum.

$$y_{\text{calc}} = a x_{\text{obs}} + b$$

$$\begin{aligned} \Sigma (y_{\text{obs}} - y_{\text{calc}})^2 &= \Sigma (y_{\text{obs}} - (ax_{\text{obs}} + b))^2 \\ &= \Sigma (y_i - ax_i - b)^2 \end{aligned}$$

Differentiating with respect to a ,

$$\frac{\partial}{\partial a} \Sigma (y_i - ax_i - b)^2 = \Sigma 2(y_i - ax_i - b)(-x_i) = 0$$

$$\therefore \Sigma x_i (ax_i + b - y_i) = 0 \quad (1)$$

Differentiating with respect to b ,

$$\frac{\partial}{\partial b} \Sigma (y_i - ax_i - b)^2 = \Sigma 2(y_i - ax_i - b) = 0$$

$$\therefore \Sigma (y_i - ax_i - b) = 0 \quad (2)$$

$$\text{from (1), } a \Sigma x_i^2 + b \Sigma x_i - \Sigma x_i y_i = 0$$

$$\text{from (2), } \Sigma y_i - a \Sigma x_i - b \Sigma 1 = 0$$

$$\therefore b = \frac{\Sigma y_i - a \Sigma x_i}{n}$$

$$a = \frac{n \Sigma x_i y_i - \Sigma x_i \Sigma y_i}{n \Sigma x_i^2 - (\Sigma x_i)^2}$$

APPENDIX TWOCounting errors

(Ref. Section 6(i) + 6(ii), Preliminary Results).

$$\text{COUNT} = \text{counts} - \text{background}$$

$$\text{Error in COUNT} = \text{counts} \pm 2\% - \text{background} \pm 2\%$$

Then, the maximum error, E_{max} , is given by

$$E_{\text{max}} = \frac{2}{100} x + \frac{2}{100} B$$

where $x = \text{counts}$, $B = \text{background}$.

Then, the relative error, E , is given by

$$E = \frac{2/100 (x+B) \cdot 100}{x-B}$$

$$\therefore 2(x+B) = (x-B)E$$

$$2x + 2B = Ex - EB$$

$$x(2-E) = -B(2+E)$$

$$\frac{B}{x} = \frac{2-E}{2+E} = \frac{E-2}{E+2}$$

Then, for $x = 1.5B$, $E = 10\%$

$$x = 2B, E = 6\%$$

$$x = 3B, E = 4\%$$

$$x = 4B, E = 3\%$$

APPENDIX THREE

Table A1. Pod and seed analyses

	POD SOLUBLE	SEED SOLUBLE	SEED INSOLUBLE
ASP	0.729	0.200	0.362
THR	0.013	0.076	0.211
SER	0.032	0.064	0.247
GLU	0.113	0.351	0.366
PRO	0.008	0.141	0.156
GLY	0.011	0.026	0.314
ALA	0.031	0.557	0.314
CYS	0.0	0.0	0.0
VAL	0.012	0.044	0.241
MET	0.0	0.0	0.049
ILE	0.004	0.018	0.186
LEU	0.0	0.010	0.398
DOPA	0.907	0.0	0.000
TYR	0.111	0.010	0.092
PHE	0.010	0.014	0.136
γ AB	0.009	0.523	0.000
HIS	0.004	0.028	0.071
LYS	0.006	0.061	0.225
ARG	0.0	0.036	0.191

Amino acid quantities are in μ moles per sample, i.e. μ moles per pod, and μ moles per seeds per pod. The fruits were all in phase II of growth and are the samples described in Table 9-1. Autoanalyser errors are $\pm 2\%$. Since the analyses are of 1-3 samples only, they are only representative of the population of samples with a certainty of $\pm 20\%$.

APPENDIX FOUR

Table A2. Distribution of ¹⁴C in the leaf-pod-seed system illustrated in Fig. 7-3

TIME AFTER START(h)	LEAF		POD		SEEDS		SEED UPTAKE cpm/h
	SOLUBLE	INSOLUBLE	SOLUBLE	INSOLUBLE	SOLUBLE	INSOLUBLE	
1	64999	4511	3331	0	121	0	120
3	87970	19790	9973	0	8521	360	3000
5	28073	7129	6448	0	10805	188	2200
7	31174	10101	21534	2474	11017	675	1700
9	48705	4703	13423	0	5970	391	710
11	33991	3788	20544	3297	7815	794	780
13	43670	15059	9828	0	15058	2251	1300
15	64831	18300	8253	1353	20879	3416	1600
17	54804	8800	13358	677	28834	4634	2000
19	45520	9120	20089	1291	30558	3872	1800

Activities are in cpm per sample, i.e. per leaf, per pod, and per seeds per pod. Experimental details are given in the legend to Fig. 7-3.

Table A-3. Distribution of ^{14}C in the pod-seed system illustrated in Fig. 8-1.

TIME AFTER START(min)	POD		SEED		SEED UPTAKE cpm/h
	SOLUBLE	INSOLUBLE	SOLUBLE	INSOLUBLE	
15	67040	18837	302	450	
45	276724	221050	466	195	882
75	410140	286191	4855	279	2800
105	363023	510058	5495	484	2100
135	124145	122439	2018	164	2400
165	377669	277957	4639	810	2000

Activities are in cpm per pod. Experimental details are given in the legend to Fig. 8-1.

Table A-4. Distribution of ^{14}C in the leaf-pod-seed system described in Table 9-1.

TIME AFTER START(min)	LEAF		POD		SEEDS		SEED UPTAKE cpm/h
	SOLUBLE	INSOLUBLE	SOLUBLE	INSOLUBLE	SOLUBLE	INSOLUBLE	
40	390000	73150	1254	780	86	126	300
90	697700	185000	226000	12920	13100	197	8,800
125	128300	30000	56520	3703	6875	192	3,400
150	548000	147500	124000	24760	16490	434	6,800
180	415500	86070	399300	133900	55740	2086	19,000
245	541700	-	102500	28470	48310	2150	12,000
270	50130	9765	22780	5634	11330	663	27,000
300	561000	127900	257800	24640	274100	20370	59,000
330	263200	102200	324600	94000	56720	6595	12,000
360	293700	87330	360800	88760	90480	7895	16,000

Activities are in cpm per sample. Experimental details are given in the legend to

Table 9-1.

BIBLIOGRAPHY

- ABELSON, P.H. (1954). J. Biol. Chem. 206, 335-343
Amino acid biosynthesis in Escherichia coli:
isotopic competition with ^{14}C -glucose.
- ADELBERG, E.A., UMBARGER, H.E. (1953). J. Biol. Chem.
205, 475-482. Isoleucine and valine metabolism in
Escherichia coli. V. α ketoisovaleric acid metabolism.
- AFRIDI, M.M.R.K., HEWITT, E.J. (1964). J. Exp. Bot.
15, 251-271. The inducible formation and stability of
nitrate reductase in higher plants. I. Effects of
nitrate and molybdenum on enzyme activity in cauliflower.
- AFRIDI, M.M.R.K., HEWITT, E.J. (1965). J. Exp. Bot.
16, 628-645. The inducible formation and stability of
nitrate reductase in higher plants. II. Effects of
environmental factors, antimetabolites and amino acids
on induction.
- ALBAUM, H.G., COHEN, P.P. (1943). J. Biol. Chem. 149,
19-27. Transamination and protein synthesis in
germinating oat seedlings.
- AMES, B.N. (1957a). J. Biol. Chem. 228, 131-143.
Biosynthesis of histidine: D-erythroimidazoleglycerol
phosphate dehydrase.
- AMES, B.N. (1957b). J. Biol. Chem. 226, 583-593.
Biosynthesis of histidine: histidinol phosphate phosphatase.
- AMES, B.N., HORECKER, B.L. (1956). J. Biol. Chem. 220,
113-128. Biosynthesis of histidine: imidazoleacetol
phosphate transaminase.
- AMES, B.N., MARTIN, R.G. (1964). Ann. Rev. Biochem. 33,
235-258. Biochemical aspects of genetics; the operon.

- AMES, B.N., MITCHELL, H.K. (1955). J. Biol. Chem. 212, 687-696. Biosynthesis of histidine: Imidazoleglycerol phosphate, imidazoleacetol phosphate and histidinol phosphate.
- ANDREWS, R.S., PRIDHAM, J.B. (1967). Phytochem. 6, 13-18. Melanine from dopa-containing plants.
- ARISZ, W.H., HELDER, R.J., VAN NIE, R. (1951). J. Exp. Bot. 2, 257-298. Analysis of the exudation process in tomato plants.
- ARONOFF, S. (1951). Arch. Biochem. Biophys. 32, 237-248. Metabolism of soybean leaves. III. The organic acids produced in short time photosynthesis.
- ARONOFF, S., VERNON, L. (1950). Arch. Biochem. 28, 424-439. Metabolism of soybean leaves I. The sequence of formation of soluble carbohydrates during photosynthesis.
- ARREGUIN, B., BONNER, J., WOOD, B.J. (1951). Arch. Biochem. Biophys. 31, 234-247. Studies on the mechanism of rubber formation in the Guayule. III. Experiments with isotopic carbon.
- BACH, M.K.; MAGEE, W.E., BURRIS, R.H. (1958). Pl. Physiol. 33, 118-124. Translocation of photosynthetic products to soybean nodules and their role in nitrogen fixation.
- BACON, J.S.D., MACDONALD, J.R., KNIGHT, A.H. (1965). Biochem. J. 94, 175-182. The development of invertase activity in slices of the root of Beta vulgaris L., washed under aseptic conditions.
- BAGDASARIAN, M., MATHESON, N.A., SYNGE, R.L.M., YOUNGSON, M.A. (1964). Biochem. J. 91, 91-105. New procedures for isolating polypeptides and proteins from tissue.
- BAKHUIS, J.A. (1957). Nature 180, 713. Homoserine in bleeding sap of pea plants.

- BANDURSKI, R.S., GREINER, C.M. (1953). J. Biol. Chem. 204, 781-786. The enzymatic synthesis of oxalacetate from phosphoenol pyruvate and carbon dioxide.
- BASSHAM, J.A., BENSON, A.A., CALVIN, M. (1950). J. Biol. Chem. 185, 781-787. The path of carbon in photosynthesis. VIII. The role of malic acid.
- BEEVERS, H. (1951). Biochem. J. 48, 132-137. An L-glutamic acid decarboxylase from barley.
- BEEVERS, L., HAGEMAN, R.H. (1969). Ann. Rev. Pl. Physiol. 20, 495-522. Nitrate reduction in higher plants.
- BEEVERS, L., SCHRADER, L.E., FLESHER, D., HAGEMAN, R.H., (1965). Pl. Physiol. 40, 691-697. The role of light and nitrate in the induction of nitrate reductase in radish cotyledons and maize seedlings.
- BERGER, J., AVERY, A.S. Jr., (1944). Am. J. Bot. 31, 11-19. Glutamic and isocitric acid dehydrogenases in the Avena coleoptile and the effect of auxins on these enzymes.
- BERGERSEN, F.J. (1965). Aust. J. Biol. Sci. 18, 1-9. Ammonia - and early stable product of nitrogen fixation by soybean root nodules.
- BERGERSON, F.J. (1971). Ann. Rev. Pl. Physiol. 22, 121- Biochemistry of symbiotic nitrogen fixation in legumes.
- BIDDULPH, O., CORY, R. (1965). Pl. Physiol. 40, 119-129. Translocation of ^{14}C -metabolites in the phloem of the bean plant.
- BIDWELL, R.G.S. (1963). Can. J. Bot., 41, 1623-1638. Pathways leading to the formation of amino acids and amides in leaves.

- BIDWELL, R.G.S., BARR, R., STEWARD, F.C. (1964). *Nature* 203, 367-373. Protein synthesis and turnover in cultured plant tissue: sources of carbon for synthesis and the fate of the protein breakdown products.
- BIELESKI, R.L., TURNER, N.A. (1966). *Anal. Biochem.* 17, 278-293. Separation and estimation of amino acids in crude plant extracts by thin layer electrophoresis and chromatography.
- BILINSKI, E., MCCONNELL, W.B. (1957). *Can. J. Biochem. Physiol.* 35, 357-363, 364-371. Studies on wheat plants using ^{14}C compounds. III. The utilisation of acetate for amino acid biosynthesis. IV. Distribution of ^{14}C in glutamate, aspartic and threonine arising from acetate-1- ^{14}C and acetate-2- ^{14}C .
- BISSON, C.S., JONES, H.A. (1932). *Pl. Physiol.* 7, 91-105. Changes accompanying fruit development in the garden pea.
- BLACKBURN, S. (1965). The determination of amino acids by high voltage paper electrophoresis. In 'Methods of Biochemical Analysis' 13 pl. (Interscience).
- BLAKLEY, R.L. (1958). *Nature* 182, 1719-1722. Interaction of formaldehyde and tetrahydrofolic acid and its relation to the enzymic synthesis of serine.
- BOLLARD, E.G. (1953). *Nature* 171, 571-572. Nitrogen metabolism of apple trees.
- BOLLARD, E.G. (1957a). *Aust. J. Biol. Sci.* 10, 279-287. Composition of the nitrogen fraction of apple tracheal sap.
- BOLLARD, E.G. (1957b). *Aust. J. Biol. Sci.* 10, 288-291. Nitrogen compounds in tracheal sap of woody members of the family Rosaceae.
- BOLLARD, E.G. (1957c). *Aust. J. Biol. Sci.* 10, 292-301. Translocation of organic nitrogen in the xylem.

- BOLLARD, E.G. (1959). Urease, urea and ureides in plants. In 'Utilisation of nitrogen and its compounds by plants' S.E.B. symposium XIII, p. 304. (Cambridge University Press).
- BOLLARD, E.G. (1960). Ann. Rev. Pl. Physiol. 11, 141-166. Transport in the xylem.
- BONE, D.H. (1959). Pl. Physiol. 34, 171-175. Metabolism of citrulline and ornithine in mung bean mitochondria.
- BONE, D.H., FOWDEN, L. (1960). J. Exp. Bot. 11, 104-115. Transamination and the oxidation of some amino acids by mung bean mitochondria.
- BONNER, J., HUANG, R.G. (1962). Can. J. Bot., 40, 1487-1497. Chromosomal control of enzyme synthesis.
- BONNER, J., HUANG, R.G., GILDEN, R.V. (1963). Proc. Natl. Acad. Sci. U.S. 50, 893-900. Chromosomally directed protein synthesis.
- BOULTER, D. (1966). An introduction to automatic amino acid analysis with plant extracts. In 'Techniques in amino acid analysis' ed. D.I. Schmidt, p. 95. (Technicon Instruments Co. Ltd., Chertsey, England).
- BOURDON, D., QUILLET, M. (1958). C.R. Acad. Sci. 247, 504-506. Sur l'évolution des galactosides pendant les periodes de formation et de germination des graines de Soja hispida.
- BRAUNSTEIN, A.E., KRITZMANN, M.G. (1937). Nature 140, 503-504. Formation and breakdown of amino acids by intermolecular transfer of the amino group.
- BRENNAN, H., PATE, J.S., WALLACE, W. (1964). Ann. Bot. 28, 527-540. Nitrogen containing compounds in the shoot

- system of Pisum arvense. I. Amino compounds in the bleeding sap from petioles.
- BRIARTY, L.G., COULT, D.A., BOULTER, D. (1969). J. Exp. Bot. 20, 358-372. Protein bodies of developing seeds of Vicia faba.
- BROWN, K.J. (1968). Ann. Bot. 32, 703-713.
Translocation of carbohydrate in cotton: movement to the fruiting bodies.
- BROQUIST, H.P., TRUPIN, J.S. (1966). Ann. Rev. Biochem. 35, 231-274. Amino acid metabolism.
- BULEN, W.A. (1956). Arch. Biochem. Biophys. 62, 173-183.
The isolation and characterisation of glutamic dehydrogenase from corn leaves.
- CALVIN, M., BENSON, A.A. (1948). Science 107, 476-480.
The path of carbon in photosynthesis.
- CALVIN, M., BENSON, A.A. (1949). Science 109, 140-142.
The path of carbon in photosynthesis. IV. Intermediates in sucrose synthesis.
- CALVO, J.M., KALYANPUR, M.G., STEVENS, C.M. (1962). Biochem. 1, 1157-1161. 2-isopropylmalate and 3-isopropylmalate as intermediates in leucine biosynthesis.
- CANDELA, M.I., FISHER, E.G., HEWITT, E.J. (1957). Pl. Physiol. 32, 280-288. Molybdenum as a plant nutrient. X. Some factors affecting the activity of nitrate reductase in cauliflower plants grown with different nitrogen sources and molybdenum levels in sand culture.
- CARR, D.J., WARDLAW, J.F. (1965). Aust. J. Biol. Sci. 18, 711-719. The supply of photosynthetic assimilates to the grain from the flag leaf and ear of wheat.

- CHIBNALL, A.G. (1954). *New Phytol.* 53, 31-37. Protein metabolism in rooted runner bean leaves.
- CHIBNALL, A.C., WILTSHIRE, G.H. (1954). *New Phytol.* 53, 38-43. A study with isotopic nitrogen of protein metabolism in detached runner bean leaves.
- COCKING, E.C., YEMM, E.W. (1961). *New Phytol.* 60, 103-116. Synthesis of amino acids and proteins in barley seedlings.
- CONWAY, E.J. (1957). 'Microdiffusion and Volumetric Error' (Crosby, Lockwood and Sons Ltd., London).
- CRUICKSHANK, D.H., ISHERWOOD, F.A. (1958). *Biochem. J.* 69, 189-195. Glutamic-alanine and glutamic-aspartic transaminases of wheat germ.
- DAMODARAN, M., NAIR, K.R. (1938). *Biochem. J.* 32, 1064-1074. Glutamic acid dehydrogenase from germinating seeds.
- DAVIES, D.D. (1968). Metabolism of amino acids in plants. In 'Nitrogen metabolism in plants' Ed. H.J. Hewitt and C.V. Cutting. (Academic Press, London) p. 125.
- DAVIES, D.D., GIOVANELLI, J., AP REES T. (1964). 'Plant Biochemistry' (Blackwell Scientific Publications, Oxford).
- DAVIES, D.D., HANFORD, J., WILKINSON, A.P. (1959). The metabolism of aspartic acid, serine and glycine in higher plants. In S.E.B. symposium XIII p. 353. (Cambridge University Press).
- DAVIES, M.E. (1971). *Phytochem.* 10, 783-788. Regulation of histidine biosynthesis in cultured plant cells: evidence from studies on amitrole toxicity.
- DAVIS, O.J. (1966). Ph.D. Thesis, University of Liverpool. 'Studies on the nitrogen metabolism of developing seeds of Vicia faba L'.

- DAVISON, D.C., ELLIOTT, W.H. (1952). *Nature* 169, 313-314.
Enzymic reaction between arginine and fumarate in plant and animal tissues.
- DAWSON, R.F. (1942). *Am. J. Bot.* 29, 66-71.
Accumulation of nicotine in reciprocal grafts of tomato and tobacco.
- DEY, P.M., PRIDHAM, J.B. (1968). *Phytochem.* 7, 1737-1739.
Multiple forms of α galactosidase in Vicia faba seeds.
- DOUGALL, D.K., FULTON, M.M. (1967a). *Pl. Physiol.* 42, 387-390. Biosynthesis of protein amino acids in plant tissue culture. III. Studies on the biosynthesis of arginine.
- DOUGALL, D.K., FULTON, M.M. (1967b). *Pl. Physiol.* 42, 941-945. Biosynthesis of protein amino acids in plant tissue culture. VI. Isotope competition experiments using glucose-U- 14 C and potential intermediates.
- DUNHAM, V.L., BRYAN, J.K. (1971). *Pl. Physiol.* 47, 91-97. Synergistic effects of metabolically related amino acids on the growth of a multicellular plant. II. Studies of 14 C amino acid incorporation.
- EDELMAN, J.C., GILVARS, C. (1961). *J. Biol. Chem.* 236, 3295-3299. Isotope studies on diaminopimetic acid synthesis in Escherchia coli.
- EDELMAN, J.C., HALL, M.A. (1965). *Biochem. J.* 95, 403-410. Enzyme formation in higher plant tissues. Development of invertase and ascorbate-oxidase activities in mature storage tissue of Helianthus tuberosus.
- ELLIOTT, W.H. (1951). *Biochem. J.* 49, 106-112. Enzymic synthesis of glutamine.

- ELLIS, R.J., DAVIES, D.D. (1961). *Biochem. J.* 78, 615-623, 624-630. Glutamic-oxaloacetic transaminase of cauliflower. I. Purification and specificity. II. Kinetics and mechanism of action.
- ESCHRICH, W. (1963). *Planta(Berl.)* 60, 216-224. Der Phloemsaft von Cucurbita ficifolia.
- ESCHRICH, W. (1966). *Planta (Berl.)* 70, 99-124. Translokation ¹⁴C-markierfer Assimilate im Licht und im Dunkelm bei Vicia faba.
- ESCHRICH, W. (1970). *Ann. Rev. Plt. Physiol.* 21, 193-214. Biochemistry and fine structure of phloem in relation to transport.
- ESCHRICH, W., HARTMANN, T. (1969). *Planta (Berl.)* 85, 213-227. Translokation und biochemisches Verhalten von D-und L-Phenylalanin bei Vicia faba.
- EVANS, N.T.S., EBERT M., MOORBY, J. (1963). *J. Exp. Bot.* 14, 221-231. A model for translocation of photosynthate in the soybean.
- FEIGL, F. (1954). 'Spot tests. I. Inorganic applications' (Elsevier Publishing Co., Netherlands).
- FERRARI, T.E., VARNER, J.E. (1969). *Pl. Physiol.* 44, 85-88. Substrate induction of nitrate reductase in barley aleurone layers.
- FLINN, A.M., PATE, J.S. (1968). *Ann. Bot.* 32, 479-95. Biochemical and physiological changes during maturation of the fruit of the field pea (Pisum arvense L.).
- FLINN, A.M., PATE, J.S. (1970). *J. Exp. Bot.* 21, 71-82. A quantitative study of carbon transfer from pod and subtending leaf to the ripening seeds of the field pea (Pisum arvense).
- FLINN, A.M. (1969). Ph.D. Thesis, University of Belfast, (quoted in Oghoghorie and Pate, 1972).

- FOLKES, B.F., YEMM, E.W. (1956). *Biochem. J.* 62, 4-11.
The amino acid content of the proteins of barley grains.
- FOWDEN, L. (1954). *J. Exp. Bot.* 5, 28-36.
The enzymic decarboxylation of γ -methyleneglutamic acid by plant extracts.
- FOWDEN, L. (1965). Origins of the amino acids. In 'Plant Biochemistry', ed. J. Bonner and J.E. Varner. (Academic Press, London).
- FOWDEN, L. (1967). *Ann. Rev. Pl. Physiol.* 18, 85-106.
Aspects of amino acid metabolism in plants.
- FOWDEN, L., DONE, J. (1953). *Nature* 171, 1068-1069.
A new transamination reaction.
- FRIES, N. (1953). *Physiol. Plant*, 6, 292-300.
Limiting factors in the growth of the pea seedling root.
- GALLIARD, T., STUMPF, P.K. (1966). *J. Biol. Chem.* 241, 5806-5812. Fat metabolism in higher plants. XXX Enzymatic synthesis of ricinoleic acid by a microsomal preparation from developing Ricinus communis seeds.
- GAMBORG, O.L., NEISH, A.C. (1959). *Can. J. Biochem. Physiol.* 37, 1277-1285. Biosynthesis of phenylalanine and tyrosine in young wheat and buckwheat plants.
- GAMBORG, O.L., WETTER L.R. (1963). *Can. J. Biochem. Physiol.* 41, 1733-1740. An aromatic amino acid transaminase from mung bean.
- GEIGER, D.R., SAUNDERS, M.A., CATALDO, D.A. (1969). *Pl. Physiol.* 44, 1657-1665. Translocation and accumulation of translocate in the sugar beet petiole.

- GIBBS, M. (1951). *Pl. Physiol.* 26, 549-556.
The position of ^{14}C in sunflower leaf metabolites after exposure of leaves to short period photosynthesis and darkness in $^{14}\text{CO}_2$.
- GILVARG, C. (1962). *J. Biol. Chem.* 237, 482-484.
The branching point in diaminopimetic acid synthesis.
- GIOVANELLI, J., MUDD, S.H. (1966). *Biochem. Biophys. Res. Commun.* 25, 366-371. Enzymatic synthesis of cystathionine. by extracts of spinach requiring o-acetylhomo-serine or o-succinylhomo-serine.
- GIOVANELLI, J., MUDD, S.H. (1967). *Biochem. Biophys. Res. Commun.* 27, 150-156. Synthesis of homocystine and cysteine by enzyme extracts of spinach.
- GIOVANELLI, J., MUDD, S.H. (1968). *Biochem. Biophys. Res. Commun.* 31, 275-280. Sulphuration of o-acetylhomoserine and o-acetylserine by two enzyme fractions from spinach.
- GIOVANELLI, J., MUDD, S.H. (1971). *Biochem. Biophys. Acta* 227, 654-670. Transsulphuration in higher plants. Partial purification and properties of β cystathionase of spinach.
- GIVAN, C. V., GIVAN, A.L., LEECH, R.M. (1970).
Pl. Physiol. 45, 624-630. Photoreduction of α -ketoglutarate to glutamate by Vicia faba chloroplasts.
- GLASZIOU, K.T. (1956). *Aust. J. Biol. Sci.* 9, 253-262.
Metabolism of arginine in Serratea marcescens.
I. carbamyl-adenosine diphosphate phosphoferase.
- GLASZIOU, K.T., WALDRON, J.C., BULL, T.A. (1966).
Pl. Physiol. 41, 282-288. Control of invertase synthesis in sugar cane.

- GROSSENBACHER, K.A. (1939). Am. J. Bot. 26, 107-109.
Autonomic cycle of rate of exudation of plants.
- GRZESIUK, S., MIERZWINSKA, T., SÓJKA, E. (1962).
Soviet Plant Physiology (transl. Fiziologiya Rastenii)
9, 544-552. On the physiology and biochemistry of
seed development in broad bean.
- HAGEMAN, R.H., FLESHER, D. (1960). Pl. Physiol. 35,
700-708. Nitrate reductase activity in corn seedlings
as affected by light and nitrogen content of nutrient
media.
- HALL, T.C., MCLEESTER, R.C., BUSS, F.A. (1972).
Phytochem. 11, 647-649. Electrophoretic analysis
of protein changes during the development of the
french bean fruit.
- HANSEN, P. (1970). Physiol. Plant. 23, 564-573.
¹⁴C studies on apple trees. V. Translocation of
labelled compounds from leaves to fruit and their
conversion within the fruit.
- HAY, R.E., EARLEY, E.B., DETURK, E.E. (1953). Pl. Physiol.
28, 606-621. Concentration and translocation of
nitrogen compounds in the corn plant (Zea mays) during
grain development.
- HEIMER, Y.M., FILNER, P. (1971). Biochim. Biophys. Acta
230, 362-372. Regulation of the nitrate assimilation
pathway in cultured tobacco cells. III. The nitrate
uptake system.
- HELLEBUST, J.A., BIDWELL, R.G.S. (1963a). Can. J. Bot.
41, 969-983. Protein turnover in wheat and
snapdragon leaves.
- HELLEBUST, J.A., BIDWELL, R.G.S. (1963b). Can. J. Bot.
41, 985-994. Sources of carbon for the synthesis of
protein amino acids in attached photosynthesising
wheat leaves.

- HELLEBUST, J.A., BIDWELL, R.G.S. (1964). *Can. J. Bot.* 42, 1-12. Protein turnover in attached wheat and tobacco leaves.
- HILL, G.P. (1963). *Ann. Bot.* 27, 79-87.
The sources of sugars in sieve tube sap.
- HO, L.C., PEEL, A.J. (1969). *Physiol. Plant.* 22, 379-385.
The relative contributions of sugars from assimilating leaves and stem storage cells to the sieve tube sap in willow cuttings.
- HOROWITZ, N.H. (1947). *J. Biol. Chem.* 171, 255-264.
Methionine synthesis in Neurospora. The isolation of cystathionine.
- HUENNEKENS, F.M., OSBORN, M.J., WHITELEY, H.R. (1958). *Science*, 128, 120-124.
Serine hydroxymethylase.
- HYDE, T.G. (1952). *Proc. Roy. Soc. Edinburgh* 65, 299-316. Nitrogen metabolism in Pisum sativum.
- JONES, M.E., SPECTOR, L., LIPMANN, F. (1955). *J. Am. Chem. Soc.* 77, 819-820. Carbamyl phosphate, the carbamyl donor in enzymatic citrulline synthesis.
- JUNGWIRTH, C., GROSS, S.R., MARGOLIN, F., UMBARGER, H.E. (1963) *Biochem.* 2, 1-9. Biosynthesis of leucine. I. The accumulation of β -carboxy- β -hydroxy isocaproate by leucine auxotrophs of Salmonella typhimurium and Neurospora crassa.
- KANDLER, O., GIBBS, M. (1956). *Pl. Physiol.* 31, 411-412.
Asymmetric distribution of ^{14}C in the glucose phosphates formed during photosynthesis.

- KANNANGARA, C.G., WOOLHOUSE, H.W. (1967). *New Phytol.* 66, 553-561. The role of carbon dioxide, light and nitrate in the synthesis and degradation of nitrate reductase in leaves of Perilla frutescens.
- KASTING, R., DELWICHE, C.C. (1955). *Pl. Physiol.* 32, 471-475. The presence of ornithine cycle amino acids in some higher plants.
- KATING, H., ESCHRICH, W. (1964). *Planta (Berl.)* 60, 598-611. Aufnahme Einbau und Transport von ^{14}C im Cucurbita ficifolia. II. Applikation von bicarbonat ^{14}C über die Wurzel.
- KENNEDY, I.R. (1966). *Biochim. Biophys. Acta* 130, 285-294, 295-303. Primary products of symbiotic nitrogen fixation. I. Short term exposures of serratella nodules to $^{15}\text{N}_2$. II. Pulse labelling of serratella nodules with $^{15}\text{N}_2$.
- KENT, N., BRINK, R.A. (1947). *Science* 106, 547-548. Growth in vitro of immature *Hordeum* embryos.
- KESSLER, E. (1964). *Ann. Rev. Pl. Physiol.* 15, 57-72. Nitrate assimilation by plants.
- KHAN, A., SAGAR, G.R. (1969). *Ann. Bot.* 33, 763-779. Changing patterns of distribution of the products of photosynthesis with respect to time and age of leaf.
- KIVILAN, A., BEAMAN, T.C., BANDURSKI R.S. (1961). *Pl. Physiol.* 36, 605-610. Enzyme activities associated with cell wall preparations from coleoptiles.
- KLEPPER, L., HAGEMAN, R.H. (1969). *Pl. Physiol.* 44, 110-114. The occurrence of nitrate reductase in apple leaves.

- KREBS, H.A., HENSELEIT, K. (1932). Hoppe-Seyl Z. 210, 33. (quoted in Naylor, 1959).
- KRITZMANN, M.G. (1939). Nature 143, 603-604.
The enzyme system transferring the amino-group of aspartic acid.
- KULKARNI, L., SOHONIE, K. (1956). Nature 178, 925.
Glutamic acid decarboxylase in legumes.
- LEVINTOW, L., MEISTER, A., HOGEBROOM, G.H., KUFF, E.L. (1955). J. Am. Chem. Soc. 77, 5304-5308. Studies on the relationship between the enzymic synthesis of glutamine and the glutamyl transfer reaction.
- LEWIS, O.A.M., NEIMAN, E.J., MUNZ, A. (1970). Ann. Bot., 34, 843-848. Origin of amino acids in Datura stramonium seeds.
- LINCK, A.J., SUDIA, T.W. (1962). Experientia 18, 69-70.
Translocation of labelled photosynthate from the bloom node leaf to the fruit of Pisum sativum.
- LOOMIS, W.D. (1959). Pl. Physiol. 34, 541-546.
Amide metabolism in higher plants. III. Distribution of glutamyl transferase and glutamine synthetase activity.
- MAAS, W.K., NOVELLI, G.D., LIPMANN, F. (1953). Proc. Natl. Acad. Sci. U.S. 39, 1004-1008. Acetylation of glutamate by extracts of Escherichia coli.
- MANDELSTAM, J. (1960). Bacteriol. Rev. 24, 289-308.
The intracellular turnover of protein and nucleic acids and its role in biochemical differentiation.
- MANN, P.J.G., SMITHIES, W.R. (1955). Biochem. J. 61, 89-100. Plant enzyme reactions leading to the formation of heterocyclic compounds. I. The formation of unsaturated pyrrolidine and piperidine compounds.

- MASKELL, E.J., MASON, T.G. (1928). *Ann. Bot.* 42, 189-253, 571-636. Studies on transport of carbohydrates in the cotton plant.
- MASKELL, E.J., MASON, T.G. (1930). *Ann. Bot.* 44, 657-688. Studies on the transport of nitrogenous substances in the cotton plant. V. Movement to the boll.
- MCCALLA, D.R., NEISH, A.C. (1959). *Can. J. Biochem. Physiol.* 37, 531-536. Metabolism of phenylpropanoid compounds in Salvia. I. Biosynthesis of phenylalanine and tyrosine.
- MCCONNELL, W.B. (1959). *Can. J. Biochem. Physiol.* 37, 933-936. Studies on wheat plants using ^{14}C labelled compounds. X. The incorporation of glutamate-1- ^{14}C .
- MCCONNELL, W.B., BILINSKI, E. (1959). *Can. J. Biochem. Physiol.* 37, 549-555. Studies on wheat plants using ^{14}C compounds. IX. Radioactivity of wheat following injection of formate- ^{14}C and glycine-1- ^{14}C , with special reference to serine labelling.
- MCKEE, H.S. (1962). 'Nitrogen metabolism in plants'. (Clarendon Press, Oxford).
- MEISTER, A. (1965). 'Biochemistry of the amino acids' (second edition, Academic Press, New York).
- MEISTER, A., RADHAKRISHNAN, A.N., BUCKLEY, S.D. (1957). *J. Biol. Chem.* 229, 789-800. Enzymatic synthesis of L-pipecolic acid and L-proline.
- MIETTINEN, J.K., VIRTANEN, A.I. (1952). *Physiol. Plant.* 5, 540-557. The free amino acids in the leaves, roots and root nodules of the Alder (Alnus).
- MIFLIN, B.J. (1967). *Nature* 214, 1133-1134. Distribution of nitrate and nitrite reductase in barley.

- MIFLIN, B.J. (1973). in 'Amino acid biosyntheses and its control in plants' ed. Milbourne. (Academic Press, to be published 1973).
- MONOD, J., CHANGEUX, J., JACOB, F. (1963). J. Mol. Biol. 6, 306-329. Allosteric proteins and cellular control systems.
- MOORE, S., STEIN, W.H. (1963). Chromatographic determination of amino acids by the use of automatic recording equipment in 'Methods in Enzymology VI' ed. S.P. Colowick and N.O. Kaplan. p. 819. (Academic Press, New York).
- MOORE, T.C. (1969). Phytochem. 8, 1109-1120. Comparative net biosynthesis of indoleacetic acid from tryptophan in cell free extracts of different parts of Pisum sativum plants.
- MORRIS, C.J., THOMPSON, J.F., and JOHNSON, C.M. (1969). Pl. Physiol. 44, 1023-1026. Metabolism of glutamate and N-acetylglutamate in leaf discs and cell free extracts of higher plants.
- MORRIS, G.F.I., THURMAN, D.A., BOULTER, D. (1970). Phytochem. 9, 1707-1714. The extraction and chemical composition of aleurone grains (protein bodies) isolated from seeds of Vicia faba.
- MOTHES, K., ENGELBRECHT, L. (1952). Flora(Jena) 139, 586-597. Über Allantoinsäure und Allantoin.
- TARO NAKAMURA, RYO SATO (1960). Nature 185, 163-164. Cysteine-S-sulphonate as an intermediate in microbial synthesis of cysteine.
- NAYLOR, A.W. (1959). Interrelations of ornithine, citrulline and arginine in plants in S.E.B. symposium. XIII. p. 193. (Cambridge University Press).

- NAYLOR, A.W., RABSON, R., TOLBERT, N.E. (1958).
Physiol. Plant. 11, 537-547. Aspartic-¹⁴C-acid
metabolism in leaves, roots and stems.
- NEIDLE, A., WAELSCH, H. (1959). J. Biol. Chem. 234,
586-591. The origin of the imidazole ring of
histidine in Escherichia coli.
- NELSON, C.D., KROTKOV, A. (1956). Can. J. Bot. 34, 423-433.
Metabolism of ¹⁴C amino acids and amides in detached leaves.
- NEWTON, B.A. (1957). J. Gen. Microbiol. 17, 708-717.
Nutritional requirements and biosynthetic capabilities
of the parasitic flagellate Strigomonas oncopelti.
- YASUTOMI NISHIZUKA, MASAZUMI TAKESHITA, SIGERU KUNO,
OSAMU HAYAISHI (1959). Biochim. Biophys. Acta 33,
591-593. β -alanine- α -alanine transaminase of
Pseudomonas.
- OAKS, A. (1963). Biochim. Biophys. Acta 76, 638-641.
The control of amino acid synthesis in maize root tips.
- OAKS, A. (1965a). Can. J. Bot. 43, 1077-1082.
The regulation of nitrogen loss from maize endosperm.
- OAKS, A. (1965b). Pl. Physiol. 40, 142-149. The soluble
leucine pool in maize root tips.
- OAKS, A. (1965c). Pl. Physiol. 40, 149-155. The effect
of leucine on the biosynthesis of leucine in maize
root tips.
- OAKS, A. (1966). Pl. Physiol. 41, 173-180. Transport
of amino acids to the maize root.
- OAKS, A., BEEVERS, H. (1964). Pl. Physiol. 39, 37-43.
The requirement for organic nitrogen in Zea mays embryos.

- OGHOGHORIE, C.G.O., PATE, J.S. (1972). *Planta* (Berl.) 104, 35-49. Exploration of the nitrogen transport system of a nodulated legume using ^{15}N .
- OJI, J., IZAWA, G. (1969). *Plant & Cell Physiol.* 10, 743-749. Flavine nucleotide nitrate reductase from broad bean leaves.
- PARTRIDGE, S.M. (1949). *Biochem. J.* 44, 521-527.
Displacement chromatography on synthetic ion exchange resins
- PATE, J.S. (1962). *Plant & Soil* 17, 333-356. Root exudation studies on the exchange of ^{14}C -labelled organic substances between the roots and shoot of the nodulated legume.
- PATE, J.S. (1966). *Ann. Bot.* 30, 93-109. Photosynthesising leaves and nodulated roots as donors of carbon to protein of the shoot of the field pea (*Pisum arvense* L.)
- PATE, J.S. (1968). Physiological aspects of inorganic and intermediate nitrogen metabolism in 'Nitrogen metabolism in plants' ed. E.J. Hewitt and C.V. Cutting. p.219 (Academic Press, London).
- PATE, J.S., GREIG, J.M. (1964). *Plant and Soil* 21, 163-184. Rhythmic fluctuations in the synthetic activities of the nodulated root of the legume.
- PATE, J.S., WALKER, J., WALLACE, W. (1965). *Ann. Bot.* 29, 475-493. Nitrogen containing compounds in the shoot system of *Pisum arvense* L. II. The significance of amino acids and amides released from nodulated roots.
- PEEL, A.J., WEATHERLEY, P.E. (1959). *Nature* 184, 1955-1956. Composition of sieve tube sap.
- PEEL, A.J., WEATHERLEY, P.E. (1962). *Ann. Bot.* 26, 633-646. Studies in sieve tube exudation through aphid mouthparts: the effects of light and girdling.

- PIÉRARD, A. (1966). *Science* 154, 1572-1573. Control of the activity of Escherichia coli carbamoyl phosphate synthetase by antagonistic allosteric effectors.
- PRIDHAM, J.B. (1965). *Ann. Rev. Pl. Physiol.* 16, 13-36. Low molecular weight phenols in higher plants.
- RACUSEN, D.W., ARONOFF, S. (1954). *Arch. Biochem. Biophys.* 51, 68-78. Metabolism of soybean leaves. VI. Exploratory studies in protein metabolism.
- RACUSEN, D.W., FOOTE, M. (1962). *Pl. Physiol.* 37, 640-642. Protein turnover in bean leaf discs.
- RATNER, S., PETRACK, B., ROCHOVANSKY, O. (1953). *J. Biol. Chem.* 204, 95-113, 115-125. Biosynthesis of urea. V. Isolation and properties of arginosuccinic acid. VI. Enzymatic cleavage of arginosuccinic acid to arginine and fumaric acid.
- RAU, M.A. (1951). *Phytomorphology* 1, 80-86. Development of the embryo in some species of the Papilionaceae.
- RINNE, R.W. (1969). *Pl. Physiol.* 44, 89-94. Biosynthesis of fatty acids by a soluble extract from developing soybean cotyledons.
- ROBERTS, E., AYENGAR, P., POSNER, I. (1953). *J. Biol. Chem.* 203, 195-204. Transamination of γ -aminobutyric acid and β -alanine in microorganisms.
- ROBERTSON, R.N., HIGHKIN, H.R., SMYDZUK, J., WENT, F.W. (1962). *Aust. J. Biol. Sci.* 15, 1-15. The effect of environmental conditions on the development of pea seeds.
- RUDMAN, D., MEISTER, A. (1953). *J. Biol. Chem.* 200, 591-604. Transamination in Escherichia coli.

- SACHER, J.A. (1966). Pl. Physiol. 41, 181-189.
The regulation of sugar uptake and accumulation in
bean pod tissue.
- SANDERS, M.E., BURKHOLDER, P.R. (1948). Proc. Natl. Acad.
Sci. U.S., 34, 516-526. Influence of amino acids on
growth of Datura embryos in culture.
- SANDERSON, G.W., COCKING, E.C. (1964). Pl. Physiol. 39,
416-422, 423-431. Enzymic assimilation of nitrate in
tomato plants. I. Reduction of nitrate to nitrite.
II. Reduction of nitrite to ammonia.
- SASAKA, K., INAGAKI, H. (1960). Mem. Res. Inst. Food Sci.
Kyoto Univ. 14, 42. (quoted in Fowden, 1965).
- SATYANARAYANA, T., RADHAKRISHNAN, A.N. (1962). Biochim.
Biophys. Acta 56, 177-199. Biosynthesis of valine and
isoleucine in plants.
- SCHALES, O., MIMS, V., SCHALES, S.S. (1946). Arch. Biochem.
10, 455-465. Glutamic acid decarboxylase of higher plants.
I. Distribution, preparation of clear solutions, nature of
prosthetic group.
- SCHRADER, L.E., RITENOUR, G.L., EILRICH, G.L., HAGEMAN, R.H.
(1968). Pl. Physiol. 43, 930-940. Some characteristics
of nitrate reductase from higher plants.
- SHANNON, J.C. (1972). Pl. Physiol. 49, 198-202.
Movement of ^{14}C -labelled assimilates into kernels of
Zea mays L. I. Pattern and rate of sugar movement.
- SHANNON, J.C., DOUGHERTY, C.T. (1972). Pl. Physiol. 49,
203-206. Movement of ^{14}C -labelled assimilates into kernels
of Zea mays. II. Invertase activity of the pedicel and
placento-chalazal tissues.
- SIEGEL, J.N., GENTILE, A.C. (1966). Pl. Physiol. 41,
670-672. Effect of 3-amino-1,2,4-triazole on histidine
metabolism in algae.

- SKINNER, J.C., STREET, H.E. (1954). *New Phytol.* 53, 44-67. Studies on the growth of excised roots. II. Observations on the growth of excised groundsel roots.
- SMITH, D.C., BASSHAM, J.A., KIRK, M. (1961). *Biochim. Biophys. Acta* 48, 299-313. Dynamics of the photosynthesis of carbon compounds. II. Amino acid synthesis.
- STEWART, F.C., BIDWELL, R.G.S., YEMM, E.W. (1956). *Nature* 178, 734-738, 789-792. Protein metabolism, respiration and growth.
- STEWART, F.C., BIDWELL, R.G.S., YEMM, E.W. (1958). *J. Exp. Bot.* 9, 11-49, 285-305. Nitrogen metabolism, respiration and growth of cultured plant tissue.
- STEWART, F.C., CRANE, F., MILLAR, K., ZACHARIUS, R.M., RABSON, R., MARGOLIS, D. (1959). Nutritional and environmental effects on the nitrogen metabolism of plants. S.E.B. Symposium XIII p. 148. (Cambridge University Press).
- STEWART, F.C., THOMPSON, J.F., POLLARD, J.K. (1958). *J. Exp. Bot.* 9, 1-10. Contrasts in the nitrogenous composition of rapidly growing and non-growing plant tissues.
- STEWART, G.R. (1968). *Phytochem.* 7, 1139-1142. The effect of cycloheximide on the induction of nitrate and nitrite reductase in Lemna minor L.
- STOUT, P.R., HOAGLAND, D.R. (1939). *Am. J. Bot.* 26, 320-324. Upward and lateral movement of salt in certain plants as indicated by radioactive isotopes of K, Na and P absorbed by roots.
- STRASSMAN, M., WEINHOUSE, S. (1953). *J. Am. Chem. Soc.* 75, 1680-1684. Biosynthetic pathways. III. The biosynthesis of lysine by Torulopsis utilis.

- TAMMES, P.M.L., VAN DIE, J. (1966). Kon. Ned. Akad. Wet. 69, 655-653. Studies on phloem exudation from Yucca flaccida Haw.
- TCHEN, T.T., VENNESLAND, B. (1955). J. Biol. Chem. 213, 533-546. Enzymatic carbon dioxide fixation into oxalacetate in wheat germ.
- THAINE, R., OVENDEN, S.L., TURNER, J.S. (1959). Aust. J. Biol. Sci. 12, 349-372. Translocation of labelled assimilates in the soybean.
- THOMAS, W. (1927). Science 66, 115-116. The seat of formation of amino acids in Pyrus malus.
- THOMPSON, J.F., MOORE, D.P. (1968). Biochem. Biophys. Res. Commun. 31, 281-286. Enzymatic synthesis of cysteine and s-methyl-cysteine in plant extracts.
- THROWER, S. (1962). Aust. J. Biol. Sci. 15, 629-649. Translocation of labelled assimilates in the soybean. II. The pattern of translocation in intact and defoliated plants.
- THURMAN, D.A., BOULTER, D. (1966). The determination of proteins. In 'Proceedings of the 4th Amino Acid Colloquium' pp. 1-6.
- TOLBERT, N.E. (1955). J. Biol. Chem. 215, 27-34. Formic acid metabolism in barley leaves.
- TOLBERT, N.E. (1963). 'Photosynthetic mechanisms in green plants'. Nat. Acad. Sci. Res. Counc. Publ. 1145, 648-662. (quoted in Tolbert, 1971).
- TOLBERT, N.E. (1971). Ann. Rev. Pl. Physiol. 22, 45-74. Microbodies - peroxisomes and glyoxysomes.

- TOLBERT, N.E., COHEN, M.S. (1953). J. Biol. Chem. 204, 639-648, 649-654. Activation of glycolic acid oxidase in plants. Products formed from glycolic acid in plants.
- TREWAVAS, A. (1972). Pl. Physiol. 49, 40-46.
Determination of the rates of protein synthesis and degradation in Lemna minor.
- VAADIA, Y. (1960). Physiol. Plant. 13, 701-717.
Autonomic diurnal fluctuations in rate of exudation and root pressure of decapitated sunflower plants.
- VAIDYANATHAN, C.S., STREET, H.E. (1959). Nature 184, 531-533. Nitrate reduction by aqueous extracts of excised tomato roots.
- VAN ANDEL, O.M. (1953). Acta Bot. Neerl. 2, 445-521.
The influence of salts on the exudation of tomato plants.
- VAN DIE, J. (1958). Kon. Ned. Akad. Wet. 61, 572-578.
On the occurrence of α keto acids and organic nitrogen compounds in xylem exudates of cucumber and tomato plants.
- VAN DIE, J. (1959a). Kon. Ned. Akad. Wet. 62, 50-58.
Diurnal rhythm in the amino acid content of xylem exudate from tomato plants bleeding under constant environmental conditions.
- VAN DIE, J. (1959b). Kon. Ned. Akad. Wet. 62, 505-517.
On the synthesis of carboxylic and amino acids in the roots and their transport to aerial parts of the tomato plant.
- VAN DIE, J. (1960). Kon. Ned. Akad. Wet. 63, 230-238.
Studies on the role of sugars and α ketoglutaric acid in the formation and secretion of amino acids by bleeding tomato root systems.
- VAN DIE, J. (1961). Kon. Ned. Akad. Wet. 64, 375-382.
Synthesis and translocation of glutamine and related substances to the tomato plant.

- VERNON, L.P., ARONOFF, S. (1950). Arch. Biochem. 29, 179-189. Metabolism of soybean leaves. II. Amino acids formed during short term photosynthesis.
- VERNON, L.P., ARONOFF, S. (1952). Arch. Biochem. Biophys. 36, 383-398. Metabolism of soybean leaves. IV. Translocation from soybean leaves.
- VIRTANEN, A.I., LAINE, T. (1939). Nature 141, 748-749. Biological synthesis of amino acids from atmospheric nitrogen.
- VIRTANEN, A.I., MOISIO, T., BURRIS, R.H. (1955). Acta Chem. Scand. 9, 184-186. Fixation of nitrogen by nodules excised from illuminated and darkened pea plants.
- VOGEL, A.I. (1962). 'A text book of quantitative inorganic analysis'. (Longmans, London).
- VOGEL, H.J., BONNER, D.M. (1954). Proc. Natl. Acad. Sci. U.S. 40, 688-694. On the glutamate-proline-ornithine interrelation in Neurospora crassa.
- WAGNER, R.P., RADHAKRISHNAN, A.N., SNELL, E.E. (1958). Proc. Natl. Acad. Sci. U.S. 44, 1047-1053. The biosynthesis of isoleucine and valine in Neurospora crassa.
- WALKER, J.B., MYERS, J. (1953). J. Biol. Chem. 203, 143-152. The formation of arginosuccinic acid from arginine and fumarate.
- WALLACE, W., PATE, J.S. (1965). Ann. Bot. 29, 655-671. Nitrate reductase in the field pea (Pisum arvense L.)
- WALLACE, W., PATE, J.S. (1967). Ann. Bot. 31, 213-228. Nitrate assimilation in higher plants with special reference to the cocklebur (Xanthium pennsylvanicum, Wallr.)

- WATANABE, Y., KONISHI, S., SHIMURA, K. (1955).
J. Biochem. (Tokyo) 42, 837. (quoted in Fowden, 1965).
- WEBER, M.A., HOAGLAND, A.N., KLEIN, J., LEWIS, K. (1964).
Arch. Biochem. Biophys. 104, 257-266. Biosynthesis
of α -ketoacilpic acid by extracts of bakers yeast.
- WEBSTER, G.C. (1953). Pl. Physiol. 28, 724-727.
Enzymatic synthesis of glutamine in higher plants.
- WEBSTER, G.C., VARNER, J.E. (1955). J. Biol. Chem. 215,
91-99. Aspartate metabolism and asparagine synthesis
in plants.
- WEINSTEIN (1961). Contrib. Boyce Thompson Inst.
21, 201-14. (quoted in Soshida, 1969).
- WESTLEY, J., CEITHAML, J. (1956). Arch. Biochem. Biophys.
60, 215-225. Synthesis of histidine in Escherichia coli.
I. Biochemical mutant studies.
- WIERINGA, K.T., BAKHUIS, J.A. (1957). Plant and Soil
8, 254-262. Chromatography as a means of selecting
effective strains of Rhizobia.
- WILSON, D.G., KING, K.W., BURRIS, R.H. (1964).
J. Biol. Chem. 208, 863-874. Transamination reactions
in plants.
- WOODS, K.R., WANG, K.T. (1967). Biochim. Biophys. Acta
133, 369-370. Separation of dansyl aminoacids by
polyamide layer chromatography.
- MITSHIRO YAMADA, STUMPF, P.K. (1964). Biochem. Biophys.
Res. Commun. 14, 165-171. Enzymic synthesis of
ricinoleic acid by extracts of developing Ricinus
communis seeds.

- YEMM, E.W. (1950). Proc. Roy. Soc. B136, 632-649.
Respiration of barley plants. IV.
- YEMM, E.W. (1956). The metabolism of senescent leaves
in Ciba Foundation Colloquia on Ageing, Vol. 2, p.202.
- YEMM, E.W., WILLIS, A.J. (1956). New Phytol. 55, 229-252.
The respiration of barley plants. IX. The metabolism
of roots during the assimilation of nitrogen.
- SEIICHI YOSHIDA (1969). Ann. Rev. Pl. Physiol. 20, 41-62.
Biosynthesis and conversion of aromatic amino acids in
plants.
- SEIICHI YOSHIDA, TOWERS, G.H.N. (1963). Can. J. Biochem.
Physiol. 41, 579-586. Synthesis of ^{14}C -shikimic acid
in Pinus resinosa from some ^{14}C labelled compounds.
- ZELITCH, I., OCHOA, S. (1953). J. Biol. Sci. 201, 707-718,
719-726. Oxidation and reduction of glycolic and
glyoxylic acids in plants. I. Glycolic acid oxidase.
II. Glyoxylic acid oxidase.
- ZIELKE, H.R., FILNER, P. (1971). J. Biol. Chem. 246,
1772-1779. Synthesis and turnover of nitrate reductase
induced by nitrate in cultured tobacco cells.
- ZIESERL, J.F., RIVENBARK, W.L., HAGEMAN, R.H. (1963).
Crop. Sci. 3, 27-32. Nitrate reductase activity,
protein content and yield of four maize hybrids at
varying plant populations.
- ZIMMERMANN, M.H. (1960). Ann. Rev. Pl. Physiol. 11,
167-190. Transport in the phloem.

ACKNOWLEDGMENTS

I wish to thank my supervisor, Professor D. Boulter, for his considerable help and guidance during the present work. I am indebted to Professor V.H. Heywood for the provision of laboratory space in the Botany Department of the University of Reading, and to Dr. F.B. Hora, without whose help the change of departments would have been much more difficult. I would like to express my appreciation of all the advice and practical assistance given by the technical and academic staff of both departments.

I thank the Science Research Council for the award of a studentship, and the Technicon Instrument Co. Ltd., for their considerable help during the time spent in their laboratories. I thank them also for the loan of an autoanalyser system, without which much of the present work would have been impossible.

I wish to acknowledge the assistance of my husband, who taught me all the mathematics and computer programming involved in this work, and to thank him for his unfailing help.



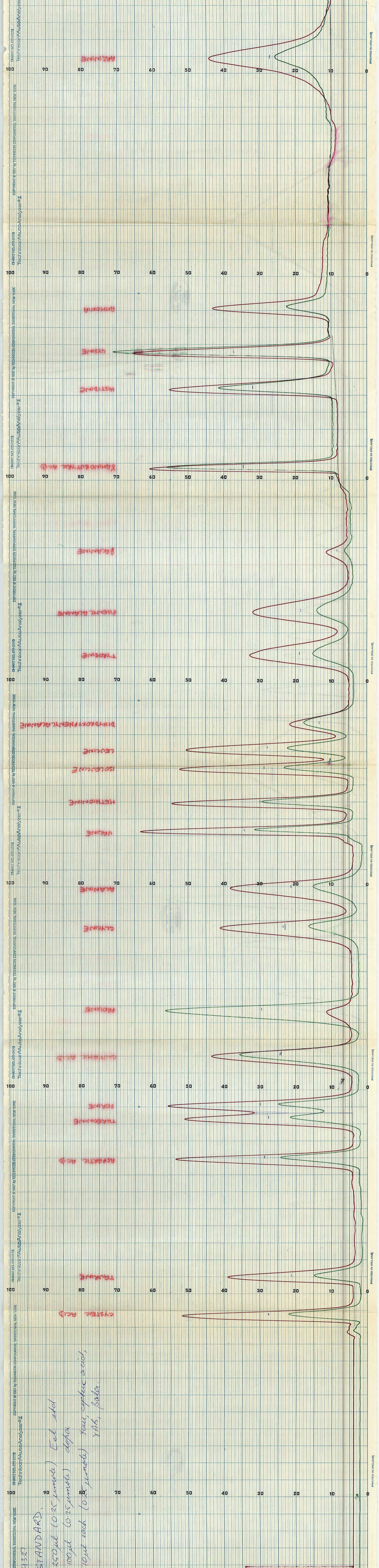

CHART NO. 01073
Technicon AutoAnalyzer II

CHART NO. 01073
Technicon AutoAnalyzer II

CHART NO. 01073
Technicon AutoAnalyzer II

CHART NO. 01073
Technicon AutoAnalyzer II

CHART NO. 01073
Technicon AutoAnalyzer II

CHART NO. 01073
Technicon AutoAnalyzer II

CHART NO. 01073
Technicon AutoAnalyzer II

CHART NO. 01073
Technicon AutoAnalyzer II

CHART NO. 01073
Technicon AutoAnalyzer II

CHART NO. 01073
Technicon AutoAnalyzer II

CHART NO. 01073
Technicon AutoAnalyzer II

CHART NO. 01073
Technicon AutoAnalyzer II

CHART NO. 01073
Technicon AutoAnalyzer II

CHART NO. 01073
Technicon AutoAnalyzer II

CHART NO. 01073
Technicon AutoAnalyzer II

CHART NO. 01073
Technicon AutoAnalyzer II

CHART NO. 01073
Technicon AutoAnalyzer II

CHART NO. 01073
Technicon AutoAnalyzer II

CHART NO. 01073
Technicon AutoAnalyzer II

CHART NO. 01073
Technicon AutoAnalyzer II

CHART NO. 01073
Technicon AutoAnalyzer II

CHART NO. 01073
Technicon AutoAnalyzer II

CHART NO. 01073
Technicon AutoAnalyzer II

CHART NO. 01073
Technicon AutoAnalyzer II

CHART NO. 01073
Technicon AutoAnalyzer II

STANDARD.
250µl (0.25 µmole) Each std
100µl (0.25 µmole) dupes
10µl each (0.25 µmole) four, captaic acid,
γ-AB, β-ala.

CHART NO. 01073
Technicon AutoAnalyzer II

CHART NO. 01073
Technicon AutoAnalyzer II

CHART NO. 01073
Technicon AutoAnalyzer II

CHART NO. 01073
Technicon AutoAnalyzer II

CHART NO. 01073
Technicon AutoAnalyzer II

CHART NO. 01073
Technicon AutoAnalyzer II

CHART NO. 01073
Technicon AutoAnalyzer II

CHART NO. 01073
Technicon AutoAnalyzer II

CHART NO. 01073
Technicon AutoAnalyzer II

CHART NO. 01073
Technicon AutoAnalyzer II

CHART NO. 01073
Technicon AutoAnalyzer II

CHART NO. 01073
Technicon AutoAnalyzer II

CHART NO. 01073
Technicon AutoAnalyzer II

CHART NO. 01073
Technicon AutoAnalyzer II

CHART NO. 01073
Technicon AutoAnalyzer II

CHART NO. 01073
Technicon AutoAnalyzer II

CHART NO. 01073
Technicon AutoAnalyzer II

CHART NO. 01073
Technicon AutoAnalyzer II

CHART NO. 01073
Technicon AutoAnalyzer II

CHART NO. 01073
Technicon AutoAnalyzer II

CHART NO. 01073
Technicon AutoAnalyzer II

CHART NO. 01073
Technicon AutoAnalyzer II

CHART NO. 01073
Technicon AutoAnalyzer II

CHART NO. 01073
Technicon AutoAnalyzer II

PRINTED IN IRELAND