

Durham E-Theses

Measurements of atmospheric point discharge currents

J.W. Milner

How to cite:

Milner, J.W. (1960) Measurements of atmospheric point discharge currents. Doctoral thesis, Durham University.

Use policy

The full-text may be used and/or reproduced, and given to third parties in any format or medium, without prior permission or charge, for personal research or study, educational, or not-for-profit purposes provided that:

- a full bibliographic reference is made to the original source
- a <https://etheses.durham.ac.uk/id/eprint/9122/> is made to the metadata record in Durham E-Theses
- the full-text is not changed in any way

The full-text must not be sold in any format or medium without the formal permission of the copyright holders.

Please consult the [full Durham E-Theses policy](#) for further details.

Measurements of Atmospheric Point Discharge Currents.

by

J.W. Milner B.Sc.

Presented in candid^dature for the degree of
Doctor of Philosophy.

September 1960.



ABSTRACT

Investigations of the behaviour of point discharge currents down an earthed point mounted at the height of surrounding trees are described. Simultaneous measurements of the potential gradient at the ground to windward of the point, point discharge current, and windspeed at the point indicate that the current can be represented by the expression

$$I = k (W + C) (F - M) \text{ where}$$

I is the point discharge current

W is the windspeed

F is the potential gradient

M is the onset value of the potential gradient and

k and C are constants.

This is in direct agreement with the results of Chalmers and Kirkman (1957) for a point on a high mast and considering what has been said by Chalmers (1957) the results suggest that the current flowing down points in all conditions can be represented by the equation

$$I = A (V - V_0) (W^2 + C^2 V^2)^{\frac{1}{2}} \text{ where}$$

I and W are as above



V is the potential of the air surrounding the point

V_0 is the onset potential and

A and c are constants.

Measurements of point discharge currents down a tree indicate that for a fixed windspeed the current can be represented by

$$I = a (F - M)$$

and that other things being equal the current down the tree is only one tenth of the current down the point. This suggests that estimations of charge brought down by point discharge based on the equivalence of a point and tree would have to be greatly modified.

Laboratory experiments were carried out to test the practicability of measuring currents down trees by a transformer method and currents of 5 microamps were measured with ease. The sensitivity could be greatly improved and it is suggested that this is a possible method of measuring point discharge currents down trees.

C O N T E N T S

	Page No.
Chapter 1 Introduction	
1 The Nature of Point Discharge Current	1
2 Naturally Occurring Point Discharge and Weather Conditions Producing It.	3
3 Point Discharge Currents down Artificial Points	6
4 Point Discharge Currents down Natural Objects	9
5 Laboratory Measurements of Point Discharge Currents	13
6 Relevance of the Study of Point Discharge Currents	14
7 Conclusions.	17
Chapter 2 Object of Research and Choice of Method of Investigation	
1 Object of Research	19
2 Potential Gradient, Point Discharge Current, and Windspeed	20
3 Point Discharge Current down the Tree	22
4 Automatic Recording	25
5 Summary	26
Chapter 3 The Apparatus	
1 The Agrimeter	28
2 The Point	31
3 The Anemometer	32
4 The Tree Electrodes	32
5 The Field Mills	34
6 Automatic Recording	37
7 The Recording Room and Site of Apparatus	40
Chapter 4 Performance and Calibration of Apparatus	
1 The Agrimeter	42
2 The Point	43
3 The Anemometer	44
4 The Tree Electrodes	44
5 The Field Mills	45
6 Automatic Recording	46
7 Analysis of Records	47
Chapter 5 Results Obtained With The Point	
1 Summary of Recordings Taken	49
2 Point Discharge Current, Potential Gradient and Windspeed	50
3 Effect of Wind Direction and Weather Conditions	52
4 Discussion and Conclusions	53

Chapter 6 Results Obtained from the Tree	Page No.
1 Results with the Electrodes	57
2 Results with the Field Mills	59
3 Conclusions	60
Chapter 7 Preliminary Experiments for Detecting Point Discharge Current by a Transformer Method	
1 Introduction	62
2 The Apparatus	63
3 Experimental Procedure and Results	67
4 Conclusions	70
Suggestions for Further Work	72
Acknowledgements	74
References	75.

CHAPTER ONE.

Introduction

1. The Nature of Point Discharge Current.

If a sharp conducting point is in a high electric field, then this field becomes concentrated at the point and if it is high enough a current will flow down the point. This current is produced by either of two processes, depending on whether the electric field is negative or positive, and is known as point discharge current.

Positive point discharge current occurs when the point is negative with respect to its surroundings and positive charge flows into the point. The current begins to flow when the field near the point is great enough for a positive ion to gain sufficient energy to produce at least one secondary electron as the ion is accelerated towards the point. This positive ion already exists in the electric field and is produced by some

external agency. The newly produced electron is accelerated away from the point and produces new ions by colliding with neutral molecules, the ejected electrons continuing the process of ionisation. The number of electrons produced increases with distance from the point until the field becomes too weak to cause ionisation. The electrons attach themselves to neutral molecules as they slow down forming negative ions, which produce a negative space charge, and leaving behind a cloud of positive ions near the point. The positive space charge moves inwards under the influence of the field, greatly increasing the field near the point and therefore increasing the amount of ionisation. At the same time the field outside this space charge is so reduced that very little ionisation can take place. When the positive space charge is very close to the point the current begins to decrease since the distance between the point and the space charge is now too small for an ion to be accelerated to a high enough energy to cause ionisation by collision. The space charge enters the point and, as the last ions are entering, the field again rises to its original high value, the remaining ions are accelerated and the whole process starts again. It can be seen therefore that the point discharge current is a pulsed direct

current. The amount of charge transferred in each pulse is about 10^{-10} coulomb, the frequency of the pulses depending on the magnitude of the current. For example for a point discharge current of one microamp the frequency is about ten kilocycles per second.

Negative point discharge current occurs when the point is positive with respect to its surroundings and negative charge flows into the point. The process is similar to that for positive current, the current again being pulsed. The discharge in this case is started by an electron or negative ion and the pulses tend to be much less regular than in positive point discharge current.

2. Naturally Occurring Point Discharge and Weather Conditions Producing It.

Point discharge current can be produced quite easily in the laboratory, but it may be asked whether it occurs naturally in the atmosphere and if so, what sort of weather conditions cause electric fields high enough to produce it.

In fine weather there is a potential gradient at the earth's surface which is of the order of 200 volts per metre. That is,

if the earth's surface is taken to be at zero potential, then the potential of the atmosphere increases by 200 volts for every metre increase in height. Naturally occurring objects such as trees projecting from the earth's surface cause the lines of force to converge, producing an increased electric field. For example a tree fifteen metres high will at its top be at a potential of 3000 volts below that of the surrounding air since the tree is at earth potential and the potential gradient is 200 volts per metre in fine weather. This potential difference produces an electric field around the top of the tree, but is not great enough to cause point-discharge. If, however, a cloud passes overhead which is very highly charged electrically, then it may produce a potential gradient at the earth's surface very much greater than the fair weather value, and it may be great enough to start point discharge from projecting objects. This does in fact occur, and point discharge currents can easily be detected during thunderstorms and heavy showers. The type of cloud sufficiently charged to cause point discharge is usually the cumulo-nimbus cloud, but occasionally point discharge currents are observed during conditions of continuous rain from nimbo-stratus clouds.

Although not strictly-relevant, it is of interest here to discuss briefly the nature and formation of a cumulo-nimbus cloud. The cumulo-nimbus cloud normally occurs in cold front conditions. The cold air stream of the cold front strikes a region of heated air causing it to rise. The water vapour in the rising air condenses, and a cloud of the cumulus type is formed. If the conditions are right, then this cumulus cloud will grow laterally and vertically until a cumulo-nimbus cloud develops. This cloud will be of great thickness, limited lateral extent, and inside it there will be a considerable amount of turbulence; it is often characterised by having a flat, anvil shaped top to it. The electrical structure of the cloud is that it is negatively charged at the base, positively charged at the top, and often there is a localised positive charge near the centre of the base. Several theories have been put forward as to how this charge separation occurs and have been discussed and compared by Chalmers (1958). As yet there is no completely satisfactory theory. The charge at the base of the cloud is sufficient to produce potential gradients of several thousand volts per metre at the earth's surface. These clouds give conditions suitable for measurement of point discharge currents

for periods of the order of thirty minutes or one hour.

3. Point Discharge Currents down Artificial Points.

Most of the research work which has been carried out on point discharge currents in atmospheric electricity has been concerned with currents flowing down elevated artificial conducting points. Relatively little work has been carried out in the study of point discharge currents down natural objects. The work which has been done on artificial points shows that the point discharge current depends on the potential gradient to the windward of the point and on the windspeed at the point. This is what one would expect since the potential gradient determines the electric field around the point and the wind assists in the removal of ions. The actual relationship between current, potential gradient and windspeed seems to depend somewhat on the locality of the point and the experimental procedure adopted since different workers have discovered differing relationships.

Whipple & Scrase (1936), Chiplonkar (1940), Hutchinson (1951) and Yriberry (1954) discovered a relationship of the form :-

$$I = A (F^2 - M^2) \text{ where :-}$$

I = point discharge current in micro amps.

F = potential gradient at earth's surface in volts per metre

M = value of potential gradient at onset of point discharge, and

A = a constant.

Chalmers (1952) deduced such a relationship as that above theoretically, but assuming that a single point can be considered as one of a rectangular array of points over a wide area.

Windspeed is neglected. Incidentally, Chiplonkar found that a four point discharger brought down less current than a single point. Chalmers & Mapleson also found that an eight point discharger was only half as efficient as a single point.

Chalmers & Mapleson (1955) obtained the following relationship using a tethered balloon :-

$$I = 0.015 W^{\frac{1}{4}} (Fh)^{\frac{7}{4}}$$

I & F are as before

W = windspeed in metres per second, and

h = height of the balloon, therefore of the point, in metres.

They also deduced the following equation theoretically :-

$$I = K W^{3-q} (Fh)^{q-1}$$

q being $\frac{11}{4}$ and K, 0.015 for their balloon experiments.

Kirkman & Chalmers (1957) using a point on a mast 27 metres and 34 metres high found a relationship of the form :-

$$I = K (W + C) (F - M) \text{ where}$$

I, W, F & M are as before and

K & C are constants.

Chapman (1956) deduced theoretically that the relationship between point discharge current, potential gradient, and windspeed should be of the form :-

$$I = A (V - V_0) v \text{ where}$$

V is the potential of the point relative to its surrounds,

v is the velocity with which the ions are removed from the neighbourhood of the point and A & V_0 are constants.

Chalmers (1957) re-analysed the results of Mapleson and Kirkman and found that by suitably choosing the constants their results could be presented in a relationship very similar to that of Chapman. In fact Chalmers presented their results in the same form as Large and Pierce (1957) presented theirs, namely :-

$$I = A (V - V_0) (W^2 + c^2 V^2)^{\frac{1}{2}}$$

the expression $(W^2 + c^2 V^2)^{\frac{1}{2}}$ is the vector sum of the wind and ionic velocities and is the equivalent of v in Chapman's formula.

Maund (1958), using the same apparatus as Kirkman, obtained

results confirming Kirkman's, and also showed that point discharge current can be measured indirectly by observing the effect of the ions from the point on the potential gradient at the ground.

4. Point Discharge Currents down Natural Objects.

Very little work seems to have been carried out in the investigation of point discharge currents down natural objects, especially trees. Schonland (1928) mounted a small tree, a thornbush, on insulators and measured the flow of current to earth by means of a galvanometer. He found that his small tree, which was about twelve feet high, gave point discharge currents in high potential gradients, and that the current, potential gradient relationship was roughly similar to that of a point. The amount of current flowing down the tree was considerably smaller than that down a point of similar height for the same value of the potential gradient.

Kirkman (1956) fixed two conducting bands, about fifteen feet apart, round a lime tree which was about fifty feet tall. He shorted out the section of the trunk between these bands with a low resistance galvanometer. In doing this he hoped to measure

the point discharge currents flowing down the tree directly without harming the tree in any way. He did not succeed in making any accurate quantitative measurements, but he observed that the current very approximately followed the potential gradient. He also observed that the tree had a lower onset value of the potential gradient than had a point of the same height in a neighbouring tree, but that when the point and the tree were giving point discharge current, the point gave about twice as much current as the tree. The zero position of the tree current indicator varied considerably and often the current down the tree oscillated, especially during heavy rain. When these oscillations occurred there was no relationship at all between the current and the potential gradient.

Maund (1958) while making observations on an isolated point at the top of a mast, detected point discharge from a line of nearby trees. He at first rejected some of his results because the charge from these trees was affecting one of his potential gradient measuring instruments, but he later re-analysed these results and found the potential gradient to windward and leeward of the line of trees. He then investigated the relation between point discharge current and potential gradient. He obtained two

curves, one from results taken in December, and the other for results taken in May, and in both cases the current varied more or less linearly with potential gradient. There was one notable difference between the curves however, and it was that their gradients differed in the ratio of about three to one. For the December results the current rose much more rapidly with the potential gradient than for the May results. The only observable difference between these two occasions was that in December the trees had shed their leaves whereas in May all but one of the trees were in full leaf.

From these observations, although insufficient in number to attempt a quantitative analysis, he drew the following conclusions:-

a. There may be a similar current-potential gradient relationship to that for a single point and

b. The current-potential gradient relationship seems to be affected quite substantially by the profile of the tree, which, if it is deciduous varies from summer to winter.

However since one of the trees was not in leaf in his May results, Maund suggests that all the point discharge current may be from this tree; the difference in the two curves was not

due to windspeed because this was the same for both occasions. He bases this suggestion on his results for an isolated tree which are mentioned below.

Maund also attempted to measure point discharge currents down an isolated tree indirectly. The tree which he selected was an isolated sycamore in the middle of the fairways of the local golf course. He intended to measure the current indirectly by making simultaneous measurements of the potential gradient to windward and leeward of the tree, and of the windspeed. However he only had three occasions of disturbed weather in which he could take measurements and the results he obtained are briefly summarised in the following conclusions which he made :-

- a) For his isolated tree the point discharge current is less than one microamp for potential gradients of up to ± 7000 volts per metre.
- b) The tree, which was in full leaf, acts very much differently from an artificial point of similar height and exposure.

So it seems that all that is known so far about point discharge currents down trees is that the current increases as the potential gradient increases, and that a point gives far more point discharge

current than a tree of similar height under the same conditions.

5. Laboratory Measurements of Point Discharge Currents.

As stated earlier, point discharge currents can be produced quite easily in the laboratory. Laboratory point discharge is basically the same as naturally occurring point discharge.

The current from a point to a plane was found by Warburg (1899) to obey a relationship of the form :-

$$I = C V (V - V_0) \text{ where}$$

I = current

V = voltage

V_0 = voltage at which point discharge commences, and

C = a constant depending on the gas, the gap between the point and plane, and the sharpness of the point.

Starr (1940) showed that the onset of point discharge depended very much on the nature of the point and that discharge from all but very sharp points causes radio interference.

These laboratory results cannot, however, be applied to naturally occurring point discharge, mainly because in the atmosphere one electrode is the point and the other is the cloudbase. This is on a far larger scale than can even

approximately be reproduced in the laboratory. However the basic similarities remain; for example, the pulsed nature of the current, the dependence on voltage, the dependence on the shape of the point etc.

6. Relevance of the Study of Point Discharge Currents.

It may be asked at this point what is the relevance of the study of point discharge currents in the general topic of atmospheric electricity? The basic problem of atmospheric electricity is to account for the maintenance of the negative charge which the earth possesses. It is believed that point discharge currents play a large part in this. Early measurements of point discharge currents were solely to estimate how much charge is brought down by this process in disturbed weather, but more recently the investigation of point discharge has become an interesting field of study in itself, see for example the work of Large & Pierce (1955).

The earth and the electrosphere are two concentric conducting surfaces with a potential difference of about 3×10^5 volts between them. The atmosphere lies between these two surfaces and has a columnar resistance of about 2×10^{17} ohms

per square metre. As a result of the large potential difference and the finite conductivity of the atmosphere there is an air-earth current of the order of 10^{-12} amperes per square metre bringing positive charge to the earth. One would expect that this positive charge would soon cancel the earth's negative charge, but this is not the case. In fact the earth's negative charge rarely varies, so there must be other processes bringing negative charge to earth. Apart from the conduction current just described, charge is brought to earth in three ways, by precipitation currents, by point discharge currents, and by lightning flashes. For the earth's charge to remain constant then the effects of these four processes must cancel one another out. Several people have tried to estimate the charge brought to earth by these processes, for example Wormell (1930) at Cambridge, Chalmers & Little (1947) at Durham, Chalmers (1949) at Kew, and Wait (1950) who made an estimate for the whole of the earth's surface. All of these except Wait found an excess of negative charge brought to earth and they were of the opinion that this neutralised the excess positive charge in the non-stormy polar regions. In all their calculations the most uncertain element was the estimation of

the contribution of point discharge currents. It has already been shown that there is a great deal of difference between single and multiple artificial points, and that there is a great deal of difference between these and single trees or groups of trees. Estimates, therefore, based on measurements made with single points will not be very reliable. Chalmers (1952) has shown on theoretical grounds that the amount of point discharge caused by a thundercloud is practically independent of the nature of the surface of the earth beneath it. This surprising result will affect Wait's estimate considerably since storms occurring over the oceans will also produce point discharge currents. This will increase his estimate of negative charge brought down by point discharge.

Positive charge is brought to earth by point discharge as well as negative charge and measurements made by Wormell (1927 and 1930), Whipple & Scrase (1936), Chiplonkar (1940), and Chalmers & Little (1947) with artificial points show an excess of negative to positive charge in the ratio of about 2 : 1. The contribution of point discharge, then, is to bring negative charge to earth, and this plus the negative charge added by lightning flashes must cancel out the positive charge added by

precipitation and conduction currents. - Because of the relative scarcity of lightning flashes it is highly probable that point discharge currents play a very important part in the maintenance of the earth's negative charge.

7. Conclusions.

There exists a great deal of data on the nature of point discharge current, and of its variation with potential gradient and windspeed for single artificial points. For a single isolated point the relationship between current, potential gradient, and windspeed is of the form :-

$$I = A (V - V_0) (W^2 + C^2 V^2)^{\frac{1}{2}}$$

which is very similar to Chapman's Formula.

For a point which is at a similar height to surrounding trees a relationship of the form :-

$$I = A (F^2 - M^2)$$

is obtained, neglecting windspeed. This is in agreement with Chalmers' calculation for a rectangular array of points.

Very little is known about the behaviour of point discharge currents down trees, except that an isolated tree is not equivalent to an isolated point of the same height. The following

differences are known :-

- a) The onset value of the potential gradient is much higher for a tree than for a point.
- b) The current down a tree is much smaller than the current down a point for the same values of potential gradient and windspeed.
- c) The onset value of the potential gradient varies with the time of the year owing to the seasonal change in a tree's profile.

In order to estimate the part played by point discharge in the maintenance of the earth's negative charge, much more needs to be known about the nature of such currents in trees, and a reliable, accurate method of measuring the current in a tree is needed.

Simultaneous measurements of current down a tree and a point at a similar height would also be of interest in the comparison of trees with artificial points.

CHAPTER TWO.

Object of Research & Choice of Method of Investigation.

1. Object of Research.

As stated in the conclusion of the last chapter, very little is known about the behaviour of point discharge currents flowing down natural objects, mainly trees. The purpose of the present research is to increase this knowledge and, if possible, to obtain some quantitative measurements. A further object of the research is to continue measurements made with an artificial point mounted just above tree level.

In view of these objects it will be realised that the quantities which need to be measured are :-

- a) the potential gradient,
- b) point discharge current down the artificial point,
- c) Windspeed at the point,

- d) point discharge current down the tree, and
- e) wind direction.

2. Potential Gradient, Point Discharge Current, and Windspeed.

Point discharge current depends upon the potential gradient at the ground to windward of the point and upon the windspeed at the point. Measurements which have been taken neglecting windspeed resulted in a relationship where the point discharge current depended upon the square of the potential gradient. When windspeed has been taken into account a linear relationship was obtained for any particular value of the wind velocity. If any further observations are to be made then it is necessary that measurements be taken of the potential gradient and the windspeed.

In order to conduct an investigation of this nature simultaneous measurements of the potential gradient, point discharge current, and windspeed need to be taken. Ideally instantaneous values of these three variables should be taken but in practice it is found convenient to average each variable over a short period of time, say half a minute. The reason for this is that the different recording instruments often have different response times and that there are sometimes short delays

between a change in potential gradient and the corresponding change in current for example. Averaging over short periods of time tends to even out the spurious irregularities which always occur in the observation of natural phenomena. These irregularities also make it necessary to have a large number of observations which can be analysed statistically. If the quantities under observation are recorded photographically then all the quantities can be on the same film and this greatly facilitates the analysis of the results, since this can be executed at leisure, long after the observations have been made if necessary.

The point discharge current was measured directly, the potential gradient by means of an "agrimeter", and the windspeed by means of an anemometer. Each of these instruments gave finally a direct current which was measured with mirror galvanometers and recorded photographically.

It was necessary to know the wind direction when observations were being made to ensure that the potential gradient was being measured to the windward of the point and not to the leeward since ions liberated from the point affect

the potential gradient at the ground. When this happens the point discharge current becomes the independent variable and the potential gradient the dependent variable instead of vice-versa. As has been mentioned in the previous chapter this effect can be utilised, but it is simply an inconvenience in this part of the research.

The wind direction was noted visually or else was obtained from the nearby observatory. It was unnecessary to have it continuously recorded with the other data on the photographic recording paper.

3. Point Discharge Current down the Tree.

Point discharge current flowing down a tree may be measured in two ways, namely directly or indirectly.

a) Direct Measurement.

To measure the current directly a method similar to that used by Kirkman (1956) needs to be employed. In such a method electrical contact is made with the conducting part of the tree, the sapwood, and the current flowing down the tree is by-passed through a galvanometer. This method at first sight appears to be very simple, but in practice there are contact potentials to

be accounted for which can be quite large and can vary considerably. The effect of these contact potentials is to cause a current to flow through the galvanometer even when there is no point discharge current and the result is a "zero", which varies as the contact potential varies.

It was decided to use this method and to try to find a means of making contact with the sapwood which resulted in as steady a contact potential as possible.

b) Indirect Measurement.

Maund (1958) attempted to measure currents flowing down trees by observing the effect on the potential gradient at ground level of the stream of ions liberated in the point discharge.

Davis & Standring (1947) calculated that the potential gradient at the ground due to an infinite line of ions is given by :-

$$E = \frac{i}{2\pi \epsilon_0 Vh} \left(1 + \frac{d}{\sqrt{d^2 + h^2}} \right)$$

where E = potential gradient due to ions immediately beneath the ion stream in volts per metre.

i = point discharge current in microamperes

V = velocity of ions in metres-second⁻¹

h = height of stream of ions in metres

d = distance of point of observation from source of ions in metres. The source in the calculation was an artificial point but the source in the present investigation is a tree.

In most cases V is simply the wind velocity. For a tree h would have to be estimated and d can be made any convenient value.

If the potential gradient is measured to windward (E_u) and leeward (E_d) of the tree then $E = E_u - E_d$; and if the windspeed is measured also then i can be obtained from the equation above.

Maund showed that if d was less than $\sqrt{3k}$ then the effect of the ions diffusing from the straight line to a cone was negligible and that if d was also small, quite large changes in wind direction could be tolerated.

Maund was unable to make many measurements using this method, so it was decided if possible to continue his work in estimating currents flowing down trees in this way.

Another method of measuring the current indirectly would be

to make the tree the primary of a transformer and to detect the e.m.f. induced in a secondary coil wrapped round the trunk of the tree. It was decided to conduct some preliminary laboratory measurements using this method to see if it would be practicable. This experiment was to be conducted in the intervals between the occurrence of suitable weather conditions for the other experiments and is described in a separate chapter.

A third possible method of measuring the current indirectly may be to use a Hall Effect Magnetometer. This was developed by Whitlock (1960). He could detect currents of slightly less than 10~~00~~, but perhaps with further research this could be reduced. Owing to lack of time this method was not studied, but it may well be a useful topic for some future research worker.

4. Automatic Recording.

Weather conditions suitable for producing point discharge current do not occur very frequently, and when they do the occasion can be at any time of day, or night. If the apparatus has to be switched on and off by hand then the operator will have to be constantly beside his apparatus otherwise many suitable events will be missed. Needless to say this is undesirable so

it was decided, if possible, to develop a technique of switching the apparatus on and off automatically. The apparatus must switch itself on when the potential gradient begins to rise to values capable of producing point discharge, and must switch itself off again when the potential gradient returns to normal values.

Automatic recording had been attempted previously but with little success. In the present research it appeared from the very outset that unless a method could be perfected the number of results available would be very small indeed, so automatic recording of results is imperative.

5. Summary.

The following apparatus was used for measuring the various quantities spoken of in section 1 of this chapter. The different types of instruments were chosen simply because they were either already available or were of a well-proved design and could be constructed with confidence. They were :-

- a) the Agrimeter for measuring the potential gradient to windward of the tree supporting the artificial point,

- b) the Point, which was well insulated from its support and connected directly to earth through a galvanometer,
- c) the Anemometer for measuring the windspeed at the point,
- d) suitable electrodes for measuring the current down the tree directly.

ii two field mills to make the necessary potential gradient measurements for detecting the current indirectly, and

- e) the wind direction was noted either from a home-made wind vane or from the nearby observatory.

All the apparatus is described in detail in the next chapter.

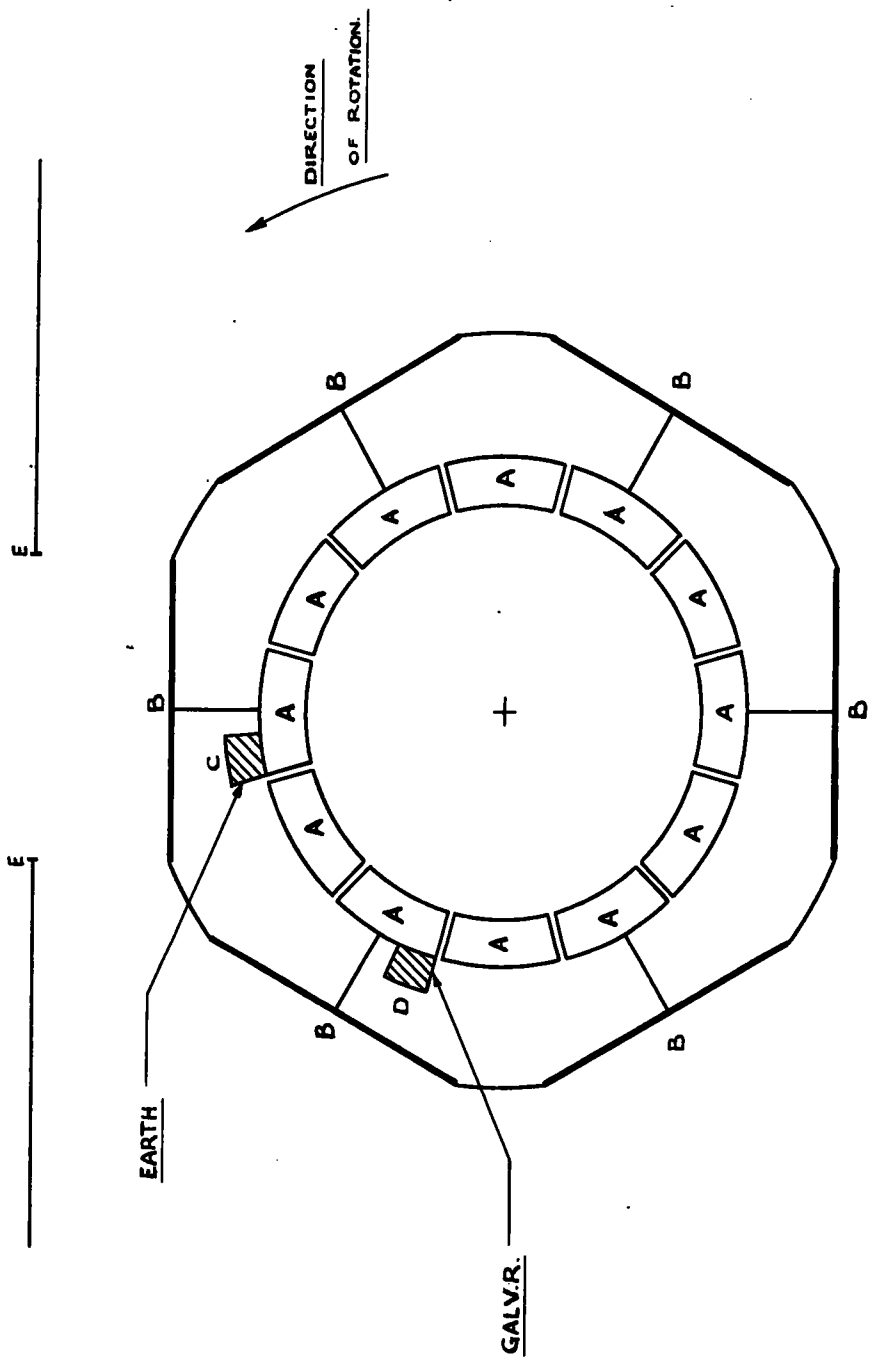

Fig 1. The Agrimeter.

CHAPTER THREE

The Apparatus

1. The Agrimeter

As stated already, the agrimeter was used for measuring the potential gradient at the ground to windward of the discharging point. An end elevation is given diagrammatically in Fig 1 and a photograph of the agrimeter as it was used in this present research in Fig 2. This particular instrument is described in detail by Chalmers (1953) and the way in which it works is as follows :-

E (Fig 1) is an earthed plate in the plane of the surrounding earth and has an aperture in it the size of the collecting plates B. Each collecting plate is insulated from its neighbours and is connected to a segment of the commutator A. The assembly of collecting plates rotates as shown, being driven at constant speed by a powerful induction motor. When a collecting plate comes opposite the aperture in E, the plate is earthed by the carbon brush C and, acting like the electrophorus the plate has a bound charge produced by the



Fig 2. The Agrimeter.

lines of force of the earth's vertical potential gradient. As the plate rotates contact with C is broken and then the bound charge flows to earth through a highly sensitive galvanometer when contact is made with a second carbon brush D.

It can be seen then that the earth's electric potential gradient produces an intermittent direct current. The magnitude of this current is directly proportional to the magnitude of the potential gradient. When the potential gradient changes sign the current changes sign also.

The original casing of the agrimeter was rather open and when it was raining the insulation of the collecting plates frequently broke down. After a few weeks' use it became apparent that more efficient casing was needed. A new case therefore was made of aluminium bolted onto a welded steel framework, it was much more effective and the insulation did not break down until after prolonged periods of heavy rain.

The agrimeter needed to be earthed as efficiently as possible, and the best way of doing this was found to be by driving a long copper pipe into the ground and making all earth connections to this. Even so, due to contact potentials

the agrimeter was at a slight potential with respect to earth. This resulted in a small "zero" output which varied from time to time. To keep a check on the zero an earthed plate covered the aperture in E automatically every five minutes. The earthed plate was also used to check the calibration of the agrimeter by putting a known voltage on it.

The original plate mechanism was separate from the agrimeter casing and the result was that the height of the plate above the agrimeter collecting plates varied whenever the mechanism was moved. When the height varied the calibration of the agrimeter seemed to vary also. To overcome this, when the new case was made the plate mechanism was made part of the casing. The case and plate mechanism are seen in Fig 2. The large aluminium sheet which can be seen was used to make the agrimeter as near as possible in the plane of the earth's surface.

As stated above, the current was measured with a very sensitive mirror galvanometer. An Ayrton shunt was used with the galvanometer enabling a wide range of potential gradient values to be recorded. The component values in the Ayrton

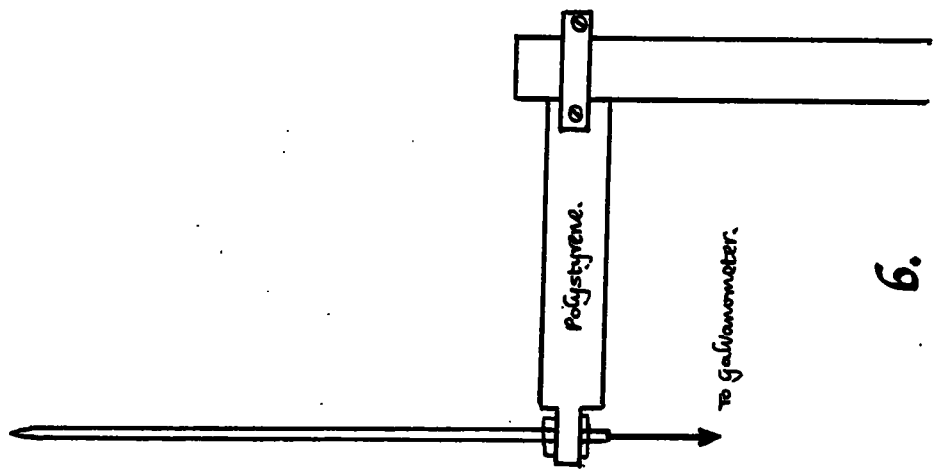

6.

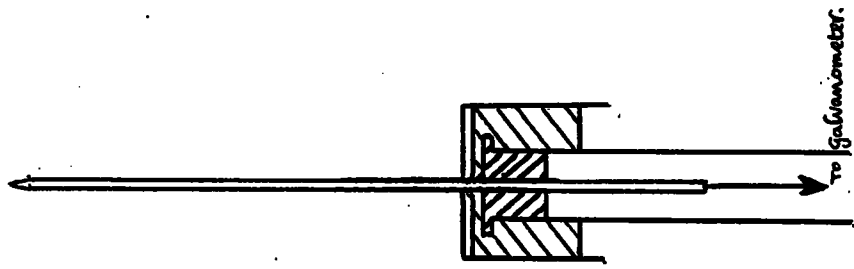

a.

 Paraffin Wax.

 Tufnol.

Fig. 3. The Points.

Shunt were so chosen that recordings could be made without having to change sensitivity any more often than was absolutely necessary.

An Ayrton Shunt was used with the galvanometers of all the recording instruments.

2. The Point.

Two points were used and for the sake of completeness both are shown in Fig 3. The first type (Fig 3a) was discarded because the insulation broke down quite easily in wet weather. The reason for this was that owing to its construction the area of insulating material was quite small and was rather easily covered with a film of water or traversed by spiders' webs.

The second type (Fig 3b) had a much larger area of insulating material and the high insulation was maintained even in the most adverse weather conditions.

The current from the point went directly to earth through a galvanometer. A circuit was arranged to pass a calibrating current through the galvanometer when required and to use the same galvanometer to check the insulation of the point. This

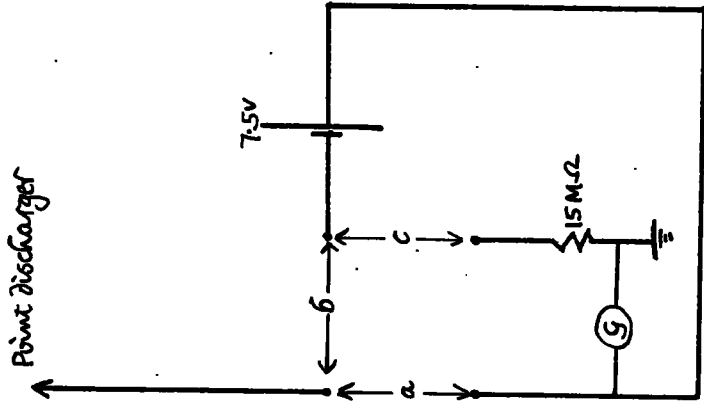

- a. Record current
- b. Test insulation
- c. Calibrate galvanometer

Fig 4. Point circuit

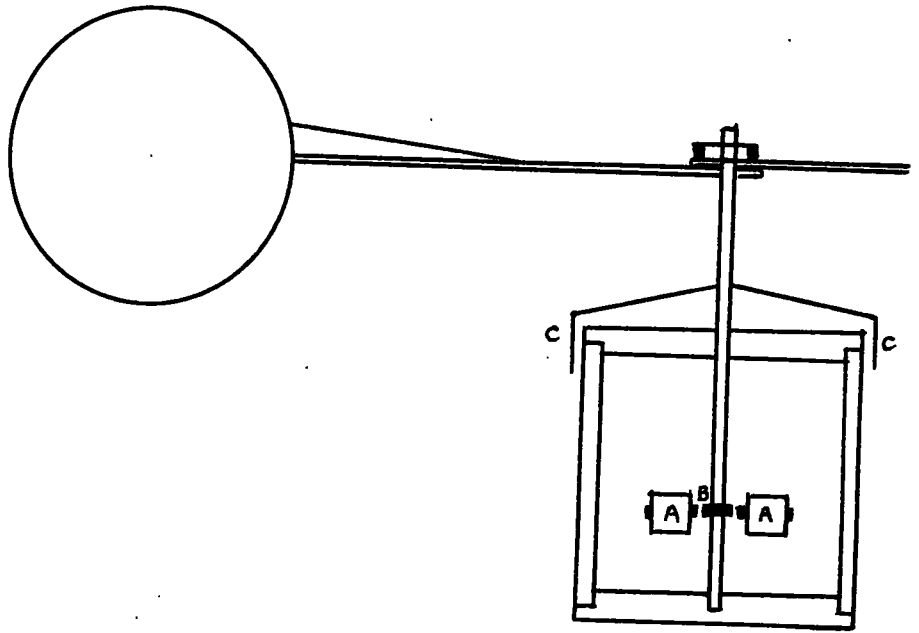

A $1000\ \Omega$ coils

B Bar magnet

C Perspex umbrella

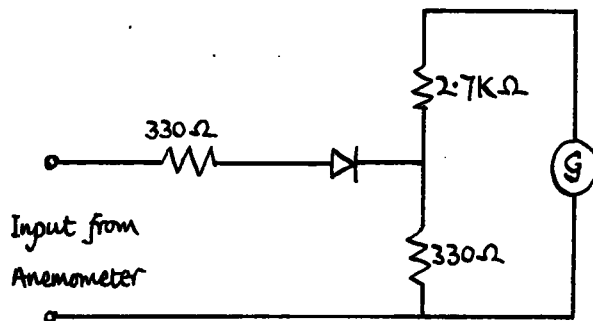

Fig.5. Anemometer and Rectifier



Fig 6. The Point and Anemometer.

circuit is shown in Fig 4.

3. The Anemometer.

The anemometer was of the three cup generator type. A small magnet was mounted on the axle carrying the three cups, and as it rotated it generated an alternating e.m.f. in two 1000 ohm coils from an old relay. This e.m.f. was rectified and passed through a galvanometer in the usual way.

A diagram of the anemometer and rectifier circuit is shown in Fig 5.

The anemometer had been calibrated by a previous research worker in the wind tunnel of the National Coal Board at Longbenton, Newcastle upon Tyne.

Fig 6 is a photograph of the point and anemometer mounted in the tree.

4. The Tree Electrodes.

After some preliminary experiments it was found that the best way of making electrical contact with the sapwood was by using mercury. A hole was drilled into the tree trunk to a depth of about five centimetres. A glass tube was inserted

into the hole and was filled with mercury. A wire dipped into the mercury completed the contact. The glass tube was sealed off with putty to prevent the mercury from flowing away and being wasted, and was protected by means of an aluminium can. A diagram of an electrode formed in this way is given in Fig 7.

At first two of these electrodes, one five metres above the other, were inserted into a lime tree. Due to the erection of telegraph poles etc. these contacts were later removed to a more isolated chestnut tree. To begin with two electrodes were used as before, one three metres above the other and the resistance of the section of the tree was measured to be 4000 ohms. Later two pairs of electrodes were used and the resistance only dropped to 3000 ohms. Since the resistance of the galvanometer which shorts out the section of the tree between the electrodes is only five ohms, it would have been quite satisfactory to use one electrode at each level.

The galvanometer circuit was so arranged that a calibrating current could be passed through the galvanometer, and that the galvanometer could be disconnected and the resistance of the tree periodically checked with an AVOMeter to ensure that the tree was not sealing itself off against the mercury.

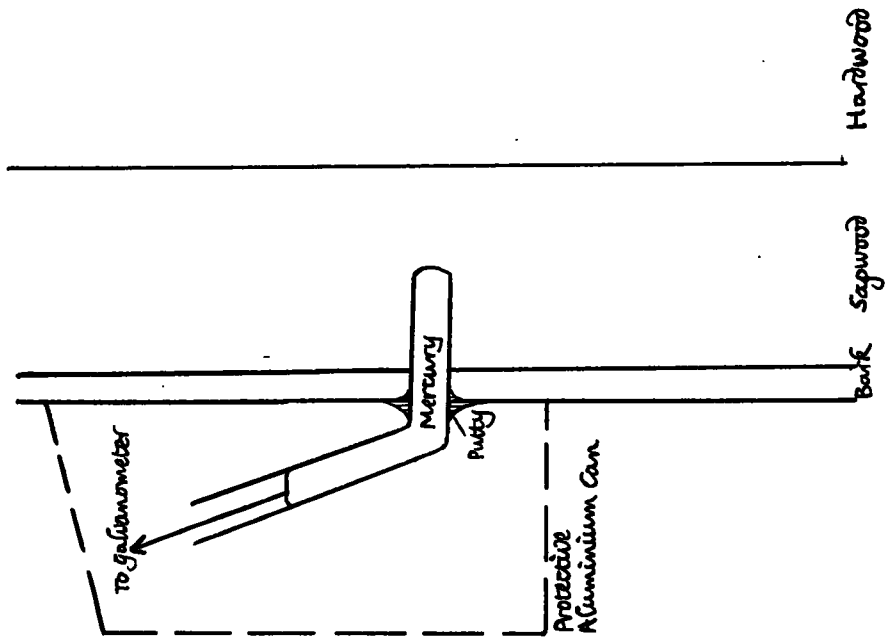

Fig. 7. Tree Electrode

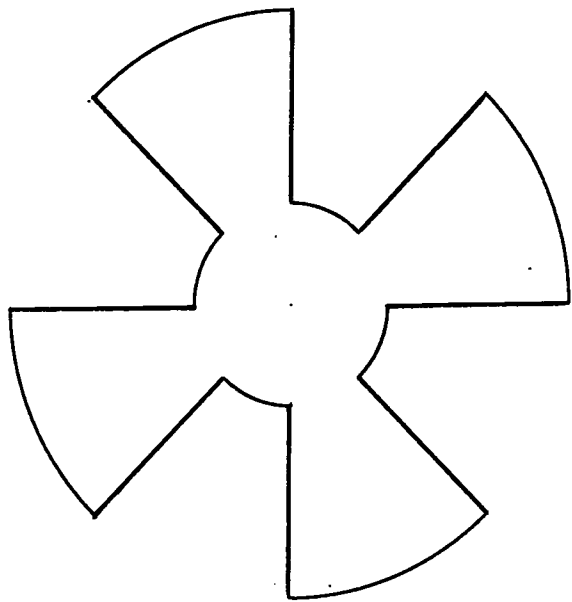

Fig. 8. Field Mill Vane

In measuring the current in this way it is assumed that the major part of the current flows through the sapwood. Since it is the sap of the tree which makes it conducting and not the wood, this assumption is justified.

Mercury was chosen for this because it was found that :-

- a. It gave as good an electrical contact as the brass screws used by Kirkman (1956) and any other material that was tried,
- b. It was not sucked into the tree as was water or any aqueous solution, and
- c. After the electrode had been installed for a week or so and had settled down the contact potentials were fairly steady and caused the "zero" to vary only slightly in the time taken for an average recording.

5. The Field Mills

The Agrimeter is extremely simple both in design and in use, its only disadvantage being its bulkiness. A Field Mill is much smaller and as a result much more portable, so it was decided that the potential gradient measurements for detecting the point discharge current down a tree should be made with Field Mills.

The Field Mills which were made and used were of the conventional quadrant vane type normally used in this research department. Sign discrimination of the potential gradient was unnecessary since this could be easily determined from the agrimeter or from the sign of the point discharge current down the artificial point.

Each Field Mill was in two parts, the Head Unit and the Amplifier Unit. Two identical Field Mills were used,

a. The Head Unit

The Head Unit contained the two vanes, the earthed rotor and insulated stator, an electric motor for driving the rotor, a cathode follower to enable a long cable to be used to carry the signal to the amplifier, and a power supply for the cathode follower.

Each vane, shaped as shown in Fig 8, was cut from brass and then chromium plated to prevent corrosion and contact potentials.

Each electric motor was a mains operated shaded-pole induction motor. Originally they had plain bearings but when they had worn out they were replaced by ball-bearings.

The circuit for the cathode followers and power supplies

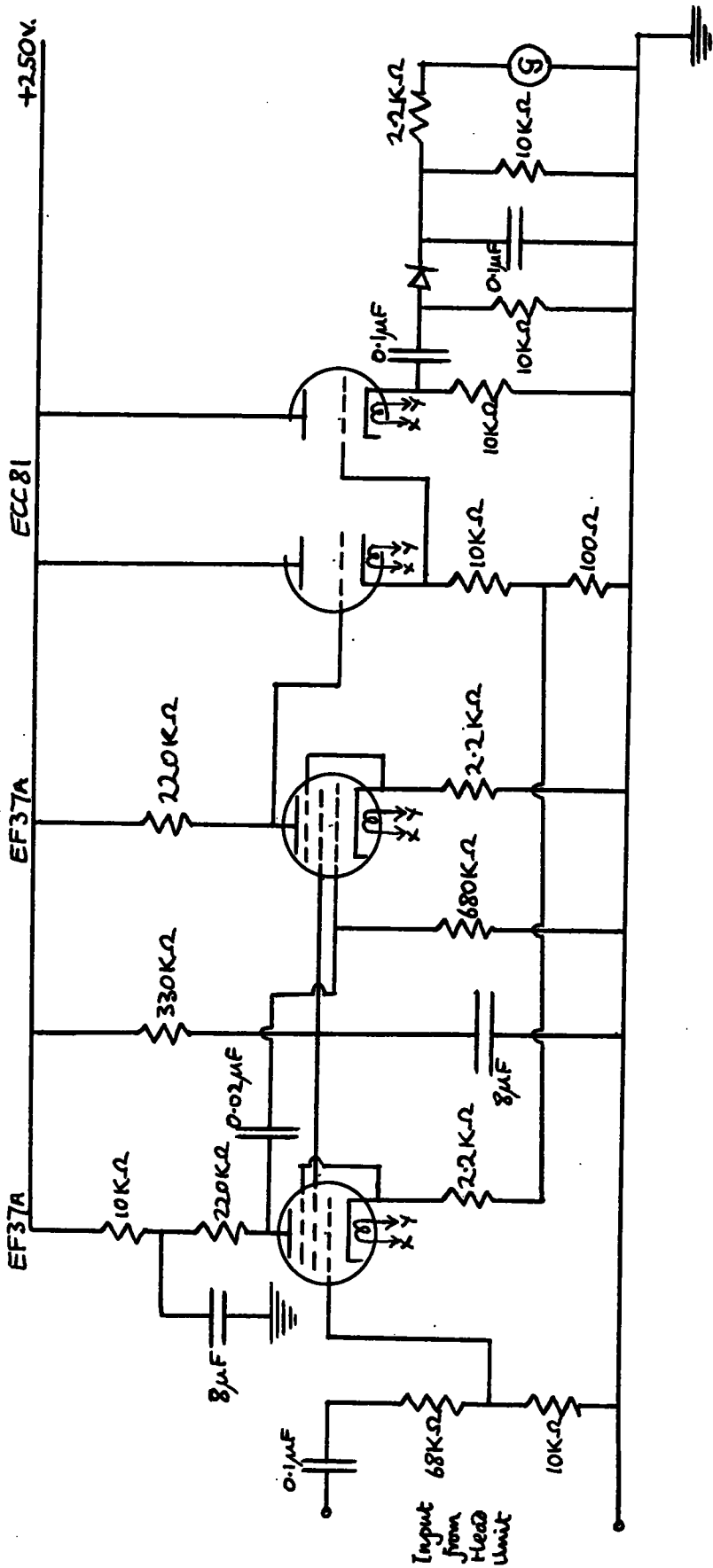

Fig. 10. Field Mill Amplifier.

is given in Fig 9. The cathode follower was screened from the power supply and the motor was screened from both, in this way mains pickup was eliminated.

Two cables were required, a three-core mains cable to and a co-axial signal cable from each head unit.

b. The Amplifier Unit.

The signal from each head unit was fed into an amplifier, the circuit of which is given in Fig 10. The input to the first grid is as shown so that it would take an exceptionally high potential gradient to overload the amplifier. Negative feedback is applied to the cathode of the first stage from the cathode of the third stage and the overall gain is 100 times. The output is rectified and passed through a galvanometer as shown. The sensitivity is adjusted by the Ayrton Shunt on the galvanometer. The zero output of the mills was so low on the sensitivity range normally used that the "zeros" on the records were found by simply shorting the galvanometers.

A stabilised power supply (Fig 11.) was used for the amplifiers. The circuit is quite conventional and in operation the ripple on the H.T. was five millivolts in 250

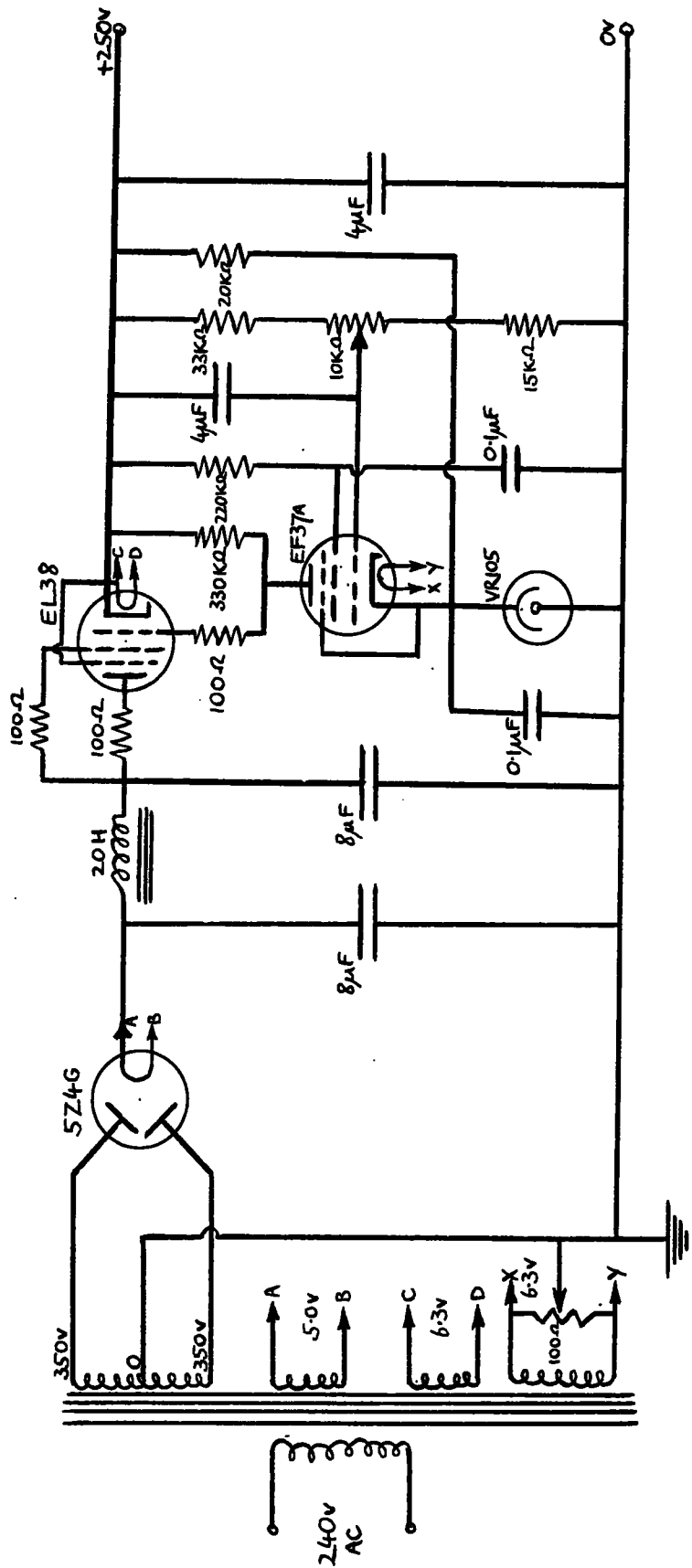

Fig. 11. The Stabilised Power Supply.



Fig 12. Field Mill Head Unit.

volts and the output remained steady at 250 volts as the input from the mains was varied from 215 to 300 volts.

A "humdinger" was connected across the heater supply to the amplifiers. This consisted of a 100 ohm potentiometer the slider of which was earthed. When adjusted, the hum induced from the valve heaters was reduced to negligible proportions.

At first the field mill head units were mounted upside down on small portable stands, but later were fixed, in the same running position, to the eaves of two convenient research huts.

Fig 12 is a photograph of one of the field mill head units as they were used in the final operating conditions.

6. Automatic Recording

At the beginning of this research, the apparatus was left switched on permanently and the various quantities were recorded on a slow spiral drum camera. In this way every occasion of point discharge would have been recorded.

However it was soon realised that the traces on the paper would become hopelessly confused if any overlapping occurred so it was decided to use an ordinary recording camera and to develop a method of switching the apparatus on and off

automatically whenever point discharge took place.

The agrimeter and the field mills were left running continuously and the equipment which needed to be switched on was simply the galvanometer lamps and the camera motor.

It was decided eventually that a photo-electric method would be used for the automatic switching. A galvanometer of normal sensitivity was connected in series with the highly sensitive galvanometer used with the agrimeter. A beam of light was reflected from the mirror of this galvanometer and focussed on the sensitive area of a Mullard OCP 71 photo-transistor. The beam of light was adjusted so that it was about one centimetre wide, and the galvanometer was arranged so that when the potential gradient was zero the centre of the beam was on the photo-cell. When the potential gradient rose in value, the beam of light would eventually cease to shine on the photocell and there would be a change in current in the photocell circuit. Because of the positioning of the beam for zero potential gradient, this would happen when the potential gradient rose high enough positively or negatively. The change in current was sufficient to operate a sensitive

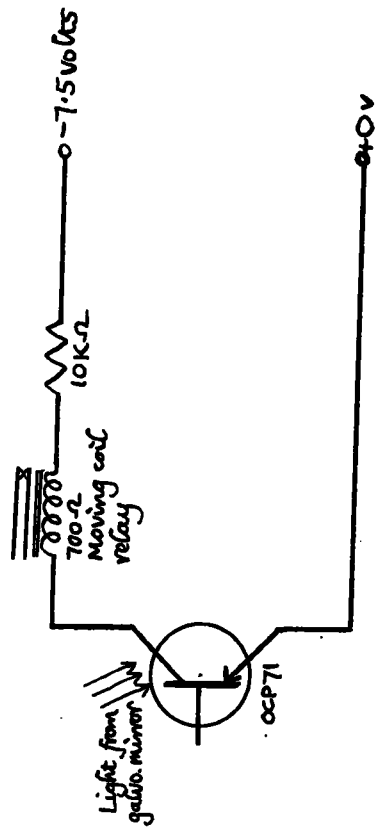

Fig.13. The Photo-transistor Circuit.

moving-coil relay. The lamp and galvanometer were adjusted so that the relay switched at ± 400 volts-metre⁻¹, since point discharge was found to occur at about ± 600 volts-metre⁻¹. The circuit used with the photo-transistor was extremely simple and is given in Fig 13. One great advantage of the photo-transistor was the smallness of its sensitive area which enabled the light to be focussed upon it accurately.

For convenience the rest of the automatic switching system is shown in the form of a block diagram (Fig 14). The moving coil relay in the photocell unit 1 operated a relay, 2, having four sets of heavy duty contacts. Relay 2 then brought 3,4,5, & 6 into operation. 3 & 4 are the galvanometer lamps and camera motor respectively. 5 is a further relay which switched off the lamp shining on the photo-cell every five minutes. This was timed to coincide with the plate which covered the agrimeter every five minutes. If this had not been arranged then the apparatus would have switched itself off every time the agrimeter automatically recorded zero potential gradient. Relay 5 only switched the photocell lamp on and off when the apparatus was on. 6 is an

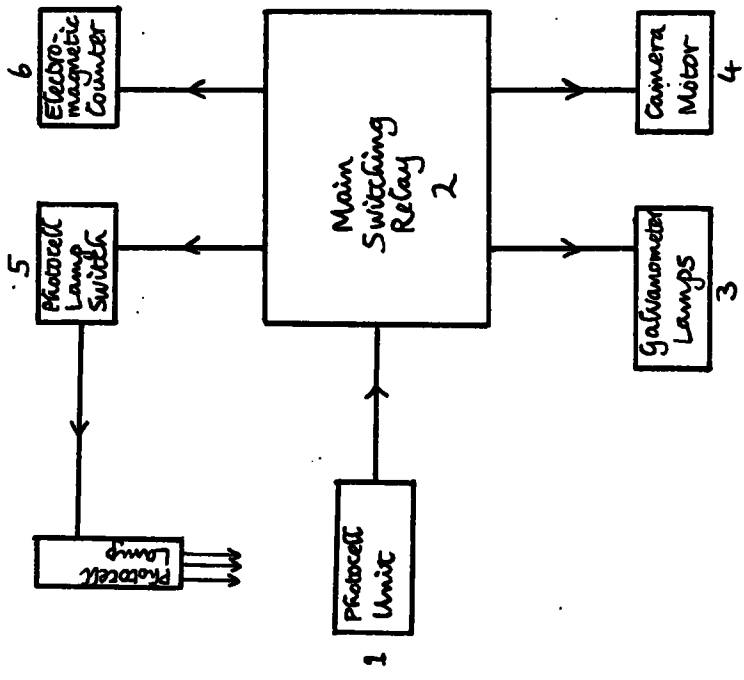

Fig.14. Block Diagram of Automatic Switching System

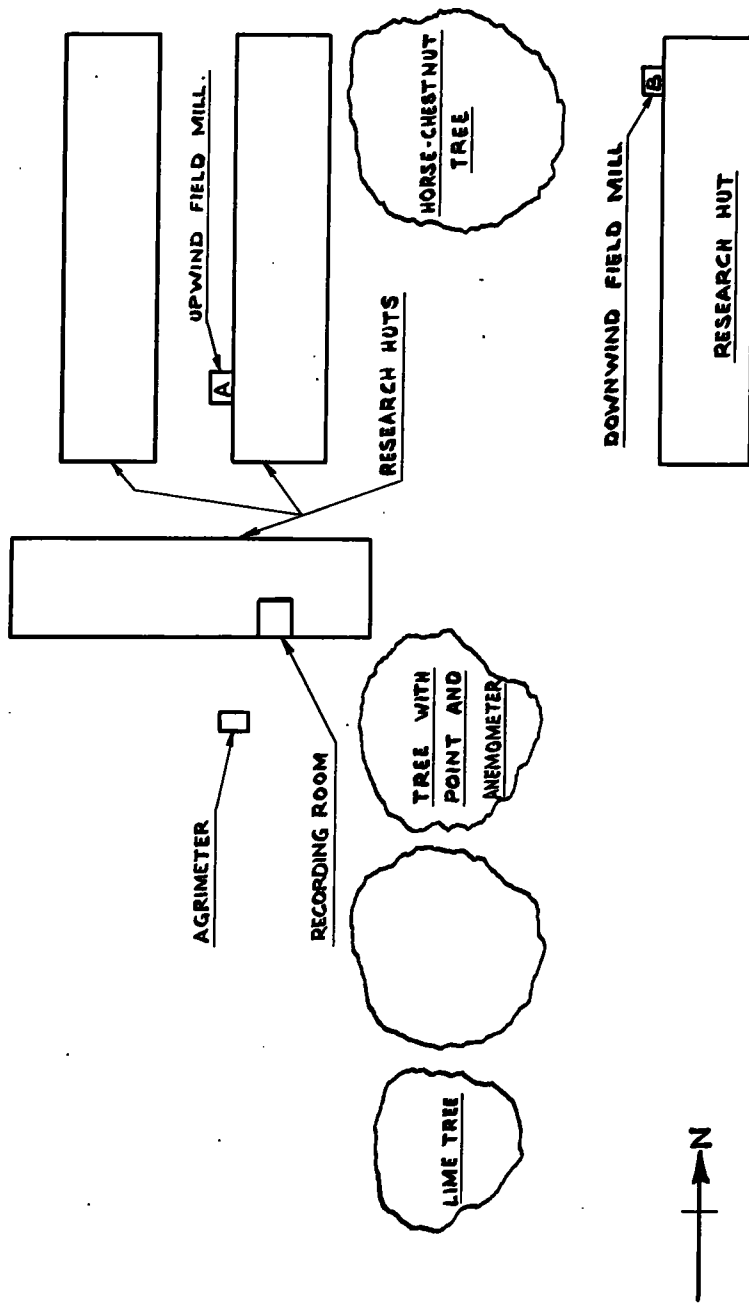

Fig 15. Sketch of the Site.

electromagnetic counter which was operated every half-minute by an electric clock. The purpose of this was to indicate if a recording had been made and, if so, how long it had lasted.

7. The Recording Room and Site of Apparatus.

The galvanometers, lamps, camera, field mill amplifiers etc., were all housed in a small darkroom. The Ayrton shunts, or sensitivity switches, for the various galvanometers were all mounted on one panel for convenience. The relays and electromagnetic counter for the automatic switching system were fixed on another panel and the switches for operating the agrimeter plate mechanism on a third. These three panels were mounted on the walls of the recording room in order to save table space which was needed for the galvanometer lamps and the camera. The galvanometers stood on a pillar which was isolated from the room floor and had its own foundation separate from that of the building thus ensuring freedom from vibration.

Fig 15 is a sketch of the site used for the apparatus. It was hoped to use the lime tree for measuring natural point discharge currents, but owing to the erection of some

telegraph poles it became impossible to position the field mills suitably. Eventually the mercury electrodes were transferred to the horse chestnut tree and the field mills were placed as shown. The chimney of a power-house possessed a lightning conductor, and if the wind was southerly point discharge ions from it would mask the true potential gradient at the agrimeter. A wood to the south-west of the site was on a hill and composed of tall trees, so for the same reason most results taken in south-west winds would be unsuitable. It can be seen that the most suitable wind directions were west to north-west, fortunately the prevailing wind direction was westerly.

The calibration and actual performance of the apparatus are described in detail in the next chapter.

CHAPTER FOUR.

Performance and Calibration of the Apparatus.

1. The Agrimeter.

Except for one occasion when one of the collector plates fractured, the agrimeter worked satisfactorily for the whole of the period of research. Occasionally the bearings had to be greased and the spaces in between the commutator segments had to be freed from carbon. A thorough overhaul was needed only once after two and a half years of continuous running. The greatest inconvenience was the breaking down of the insulation between the collecting plates during periods of prolonged heavy rain. It is difficult to see how this could be remedied without radically changing the whole instrument.

The agrimeter was calibrated by covering it with a large plate at a height of about 50 cms, and putting a series of voltages on this plate. The calibration curves were linear on all sensitivities. The recording paper when developed had

graduations on it formed by an engraved scale mounted in the camera, and using these graduations the calibration was as follows:-

Sensitivity Switch Position 1		= Short galvanometer
Sensitivity Switch Position 2	1 division	= 174 volts.metre ⁻¹
Sensitivity Switch Position 3	1 division	= 87 volts.metre ⁻¹
Sensitivity Switch Position 4	1 division	= 43.5 volts.metre ⁻¹
Sensitivity Switch Position 5	1 division	= 8.7 volts.metre ⁻¹

The small plate gave, with a potential of 120 volts on it, a deflection equivalent to 2900 volts.metre⁻¹ which on sensitivity 4, the one always used for this research was 67 divisions.

2. The Point.

The insulation of the point rarely broke down even in the most adverse weather conditions. Normally the resistance between the point and earth was infinite and in heavy rain went down to about 20 megohms. The resistance only twice became less than this when the point was covered with snow.

The point galvanometer was calibrated in the usual way by passing known currents through it. The calibration curve, of course was linear.

There were two sensitivity ranges in the ratio 10:1.

On high sensitivity 40 divisions = 1 μ A

On low sensitivity 4 divisions = 1 μ A

3. The Anemometer.

The calibration curve of the anemometer is given in Fig 16. The anemometer worked satisfactorily and the bearings never seemed to stick due to corrosion etc. Although the official starting speed was 1.5 metres.sec⁻¹ it was found that little confidence could be placed in measurements of speeds below 3 metres.sec⁻¹.

4. The Tree Electrodes.

After the electrodes had been inserted into the tree for about seven days or so the contact potentials settled down and remained steady and small. The resistance between the electrodes was checked daily and it was found that it took the tree about four months to seal itself against the electrodes. It was necessary then to renew them from time to time.

The galvanometer was calibrated by passing known currents through it. As for the point galvanometer there were two sensitivity ranges in the ratio 10:1.

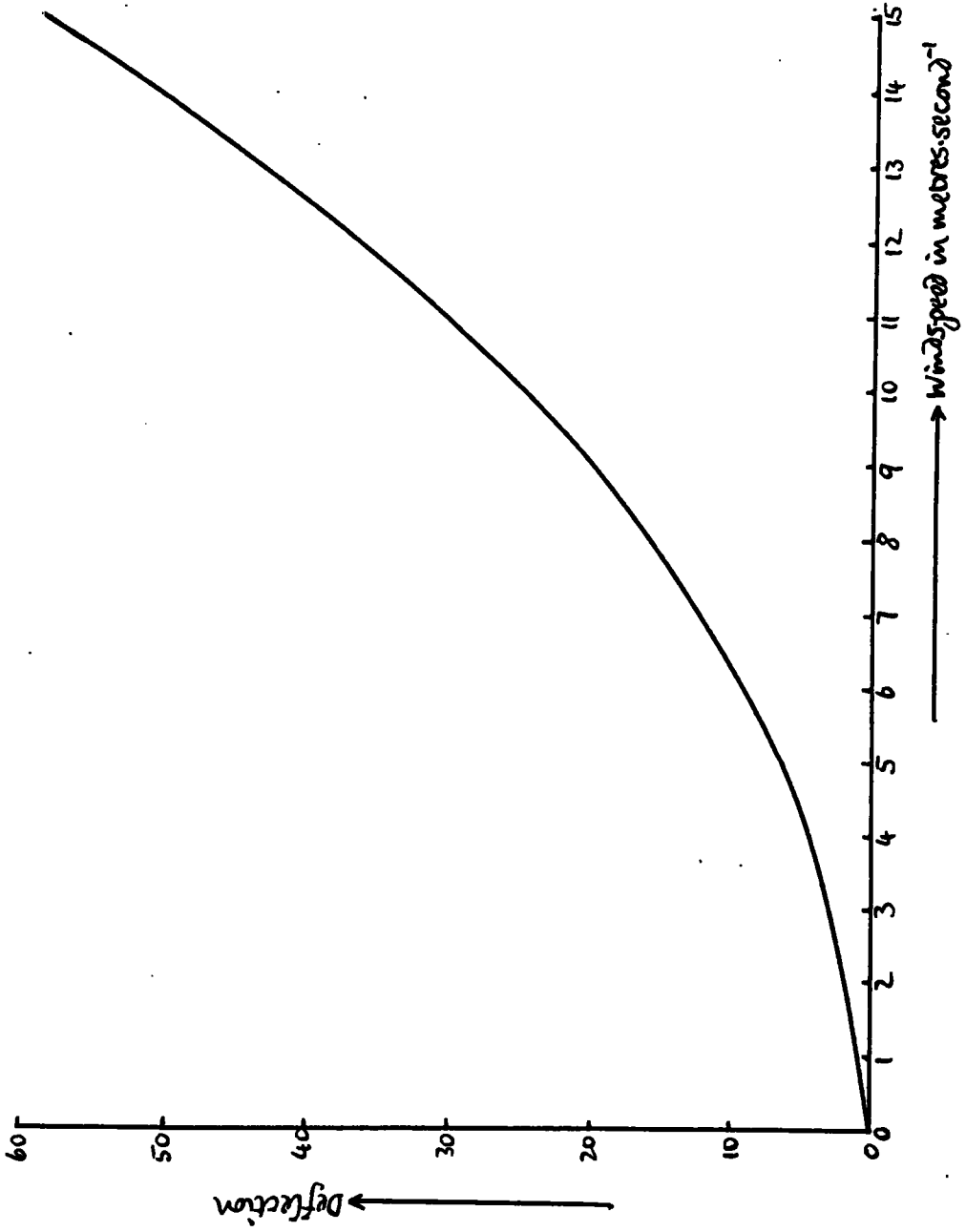

Fig 16 Anemometer Calibration

On high sensitivity 28 divisions = 1 μ A

On low sensitivity 2.8 divisions = 1 μ A

5. The Field Mills.

The field mills were not quite satisfactory in their operation. Electrically they gave no trouble whatsoever, but the bearings of the driving motors repeatedly seized until eventually they wore out. However after the original bearings had been replaced by ball races the mills were much more reliable.

The mills were originally calibrated against the agrimeter and were mounted on small portable stands. The calibration curves are given in Figs 17 & 18. Mill A was used to the windward of the tree and Mill B to the leeward. The curved section of the curves is due to non-linearity in the characteristics of the rectifiers at very low currents. It was not possible, however, to use the mills on the portable stands; instead they were fixed to the eaves of two research huts. This would alter the exposure factor and, therefore, the calibration of the field mills. There was not time to wait for conditions of high potential gradient to re-calibrate them so it was decided to stick to the calibration curves given, remembering that any results would be

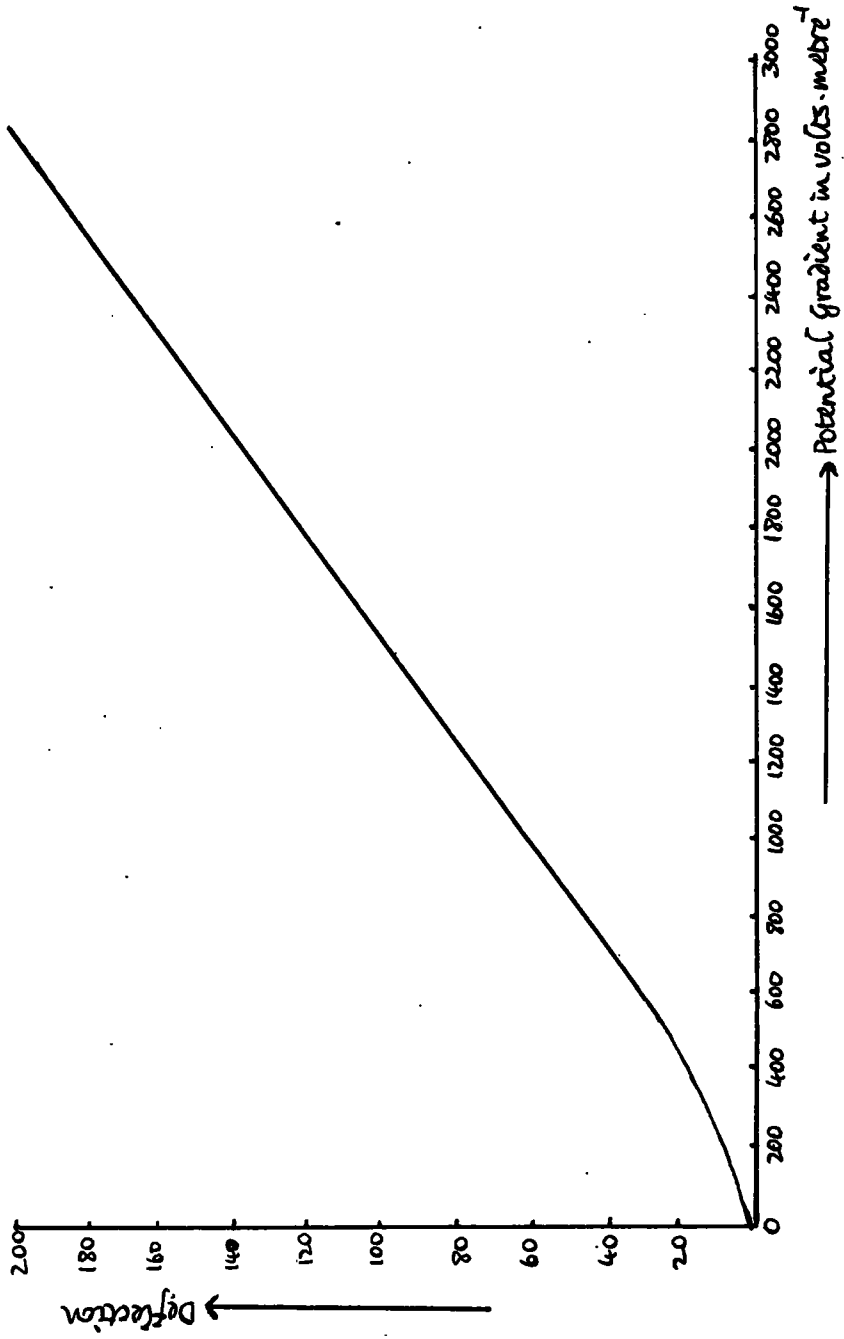

Fig 17 Mill A Calibration

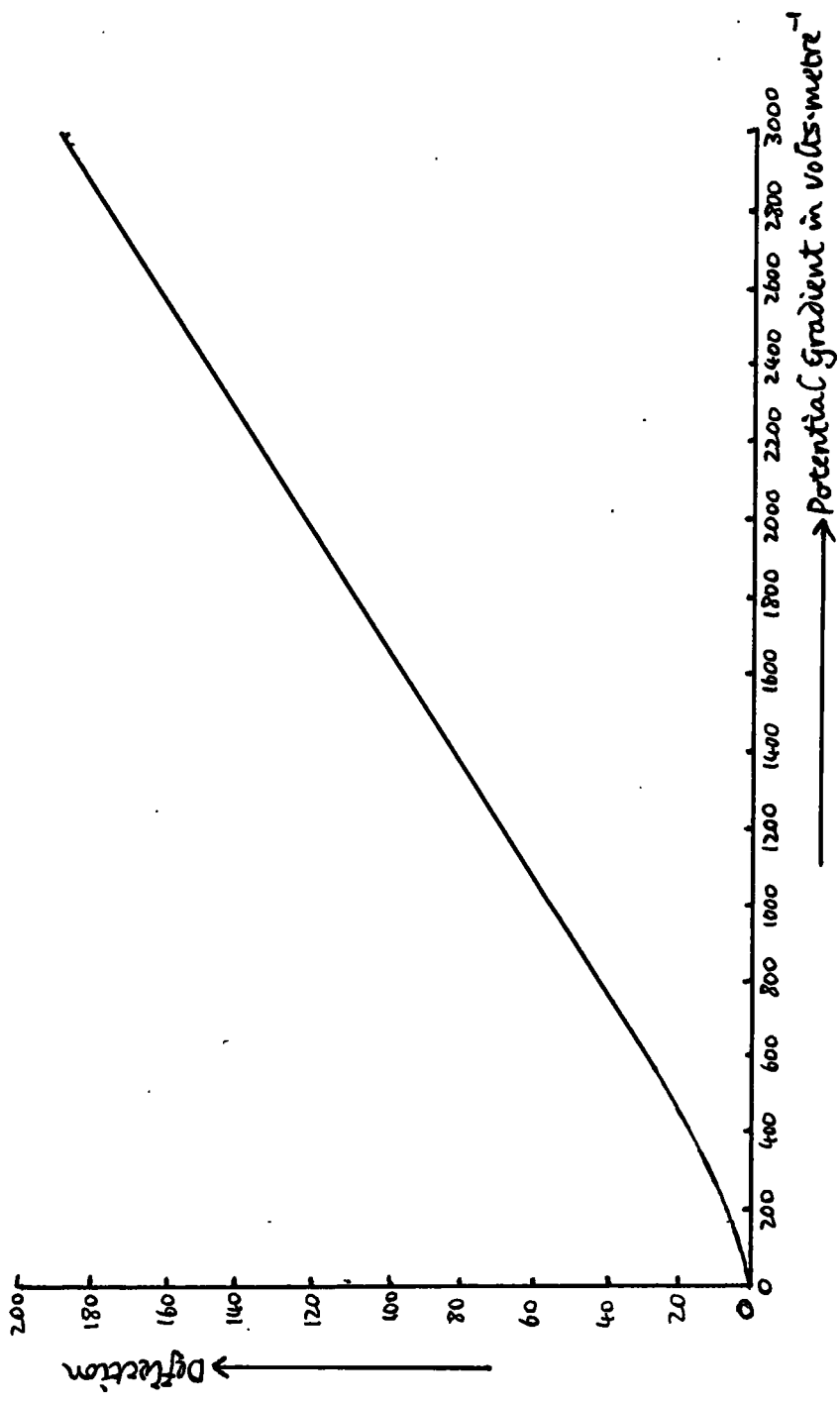

Fig 18 Mill B Calibration

liable to a systematic error. At the very least the field mills could be used to check that the tree current galvanometer was recording point discharge current and not some other phenomenon. The method of calibration was first to use a small plate with known voltages on it and after this to compare the mills with the agrimeter in conditions of high potential gradient. The small plate gave a relative calibration and comparison with the agrimeter made the calibration absolute.

6. Automatic Recording.

The photocell and relay system worked perfectly well throughout the period of research. Occasionally the bulb in the lamp shining on the photocell would burn out and result in some photographic recording paper being wasted. Such happenings were kept rare by running the lamp at slightly less than its rated wattage thus lengthening its life considerably.

The procedure for using the automatic system was as follows:-

- a. The camera was loaded with paper
- b. The apparatus was set at the required sensitivities
- c. The number on the counter was noted

Then if a record had been taken :-

- d. The number on the counter was re-noted
- e. The wind-direction was obtained from the nearby observatory
- f. The zeros of the various instruments were recorded, and
- g. The paper was removed from the camera and developed in the usual way.

If this system was adhered to and the apparatus was functioning correctly then all the results obtained could be treated with confidence.

7. Analysis of Records.

Figs 22 and 24 are examples of records obtained. The graduated scale in front of the camera is reproduced on the photographic paper by means of a fogging lamp. These graduations were always used for measuring the deflections of the various traces, this being much more convenient than using a rule.

The various quantities were averaged over half-minute periods . The periods were marked on the recording paper by switching a fogging lamp on for two seconds every half minute. This produced the dark vertical lines which can be seen in the illustrations.

The analysis was carried out by first of all noting the

sensitivities of the instruments, wind-direction, and, if possible, weather conditions. Then the deflections were recorded and finally changed into actual values by referring to the calibration curves.

CHAPTER FIVE

Results Obtained with the Point

1. Summary of Recordings Taken.

The apparatus was ready for use in March 1958 and was used until the end of August 1960. About twenty occurrences of high potential gradients were recorded during this period, all of which except for two or three were recorded automatically. Only nine of these recordings were suitable for analysis. Five gave negative potential gradients and currents all at the same windspeed, the other four gave positive potential gradients and currents at varying windspeeds.

Included in the records were four occurrences of point discharge currents flowing down the tree. These were all at the same time of the year, so it was not possible to study the variation of point discharge characteristics with the season of the year.

The highest potential gradient recorded was 2500 volts per metre, the values of the current and windspeed being 12 microamps and 5-6 metres per second respectively. These were the highest values used in the analysis of the results.

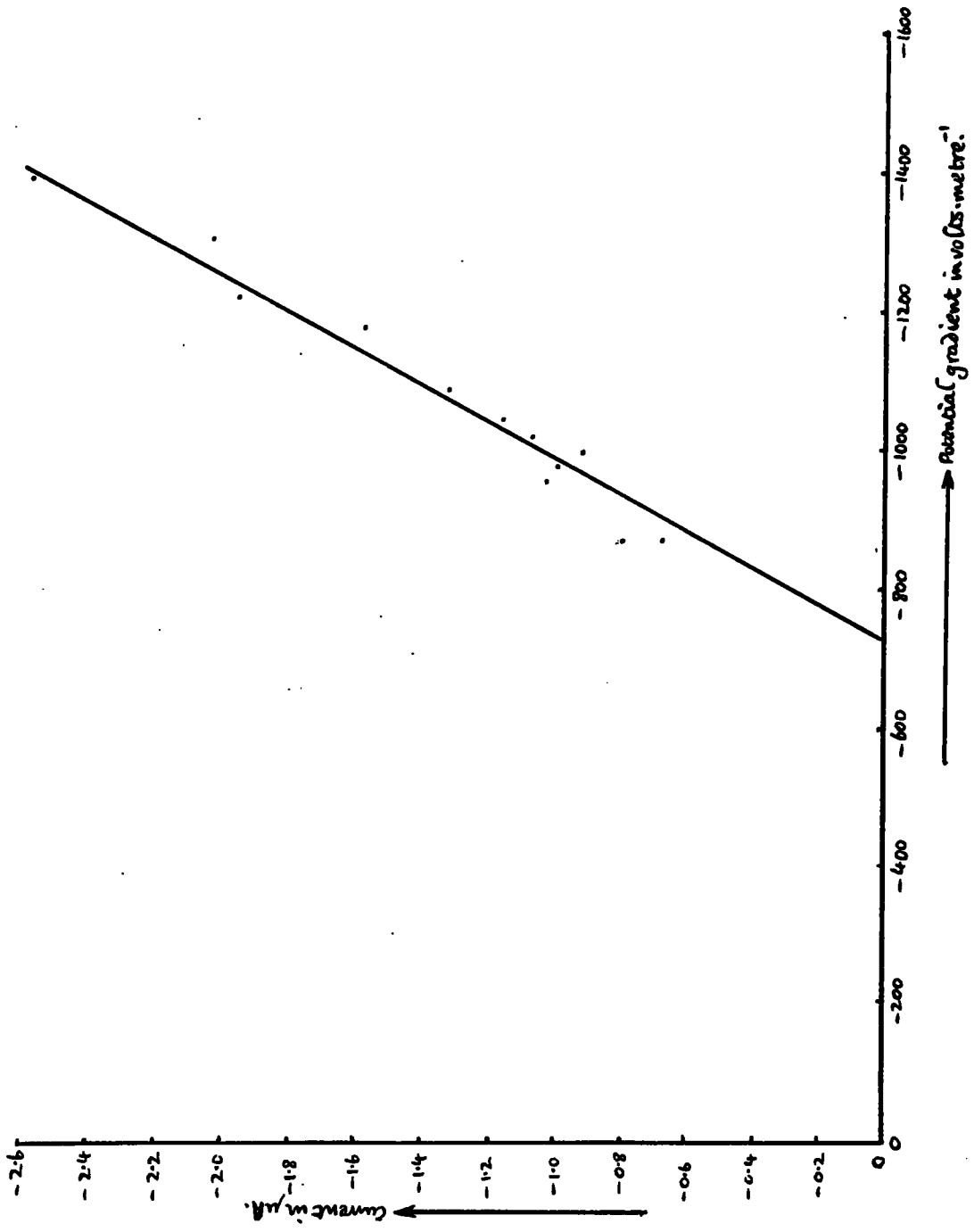

Fig 19. Negative Point Discharge versus Potential gradient.

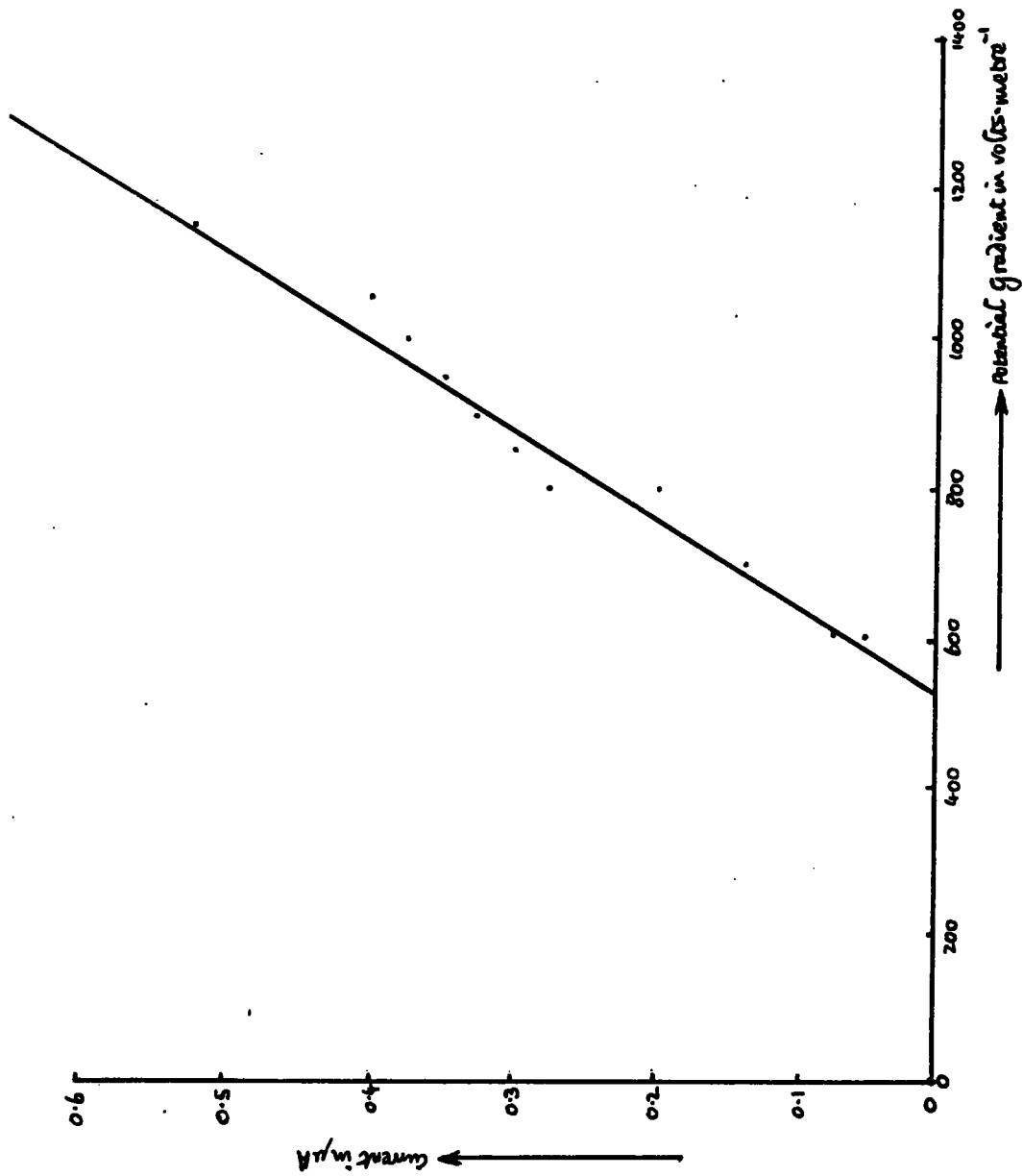

Fig 20. Positive Point Discharge versus Potential Gradient.

2. Point Discharge Current, Potential Gradient and Windspeed.

For all windspeeds the relation between point discharge current and potential gradient was linear. For any particular windspeed the relationship was of the form :-

$$I = a (F - M) \text{ where}$$

I = the current

a = a constant

F = the potential gradient and

M = onset value of the potential gradient.

Figs 19 and 20 are examples of the curves which were obtained. Other things being equal the negative point discharge currents were slightly greater than the positive. For zero windspeed the value of a, the slope of the current versus potential gradient curve, was 0.0011 microamps per volt per metre for negative currents and 0.00073 microamps per volt per metre for positive currents. The value of M was not the same for positive and negative potential gradients, negative currents always starting at higher values of the potential gradient than positive currents. The mean values of M were -900 volts per metre and +600 volts per metre but these could vary considerably even on the same record.

It was found that the value of a depended on the windspeed, but the results available were too few to definitely ascertain the

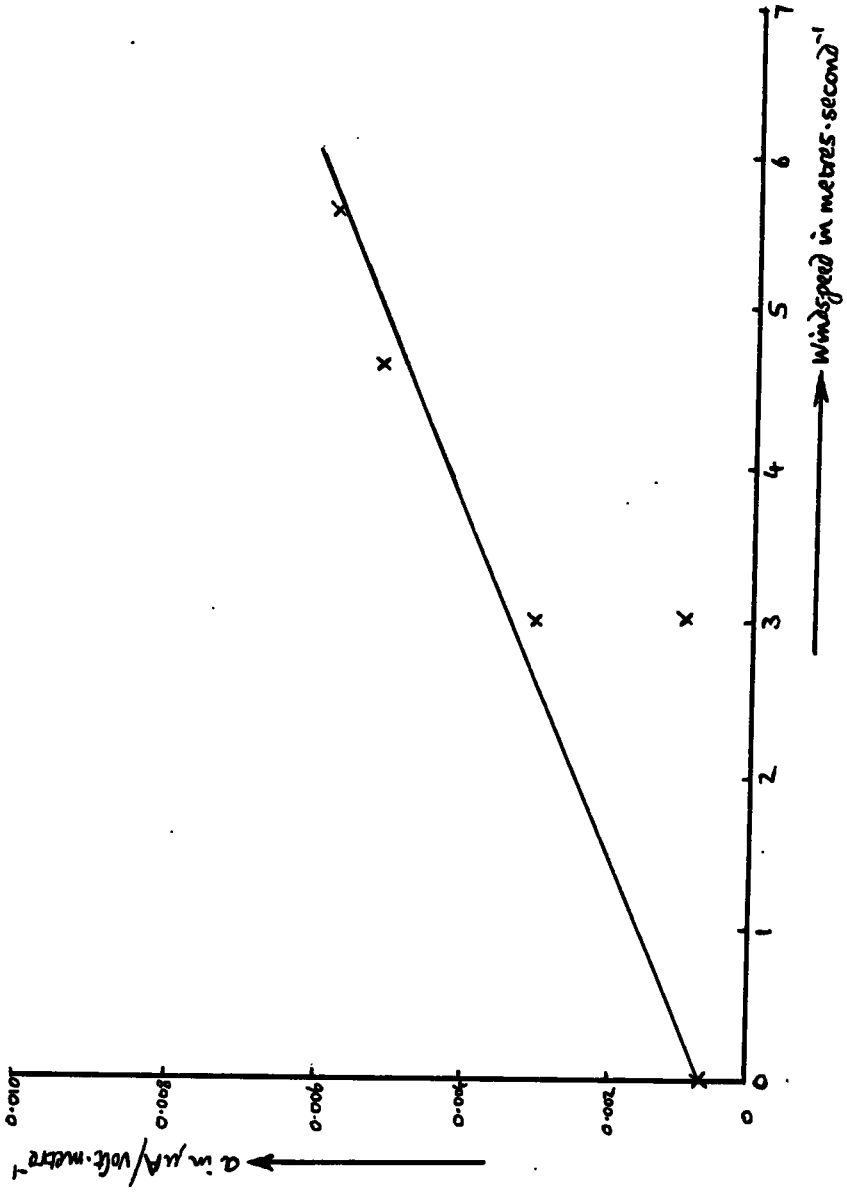

Fig 2.1. Variation of "a" with Windspeed.

effect of windspeed quantitatively. Five values of a were obtained and were :-

Windspeed (metres per second)	a (microamps per volt per metre)
0	0.00073
3	0.001
3	0.003
4.6	0.0051
5.6	0.0057

These values when plotted (Fig. 21) were found to lie close to a straight line except for one of the two values obtained for a windspeed of 3 metres-second⁻¹.

The results suggest that for a point at tree top height and for positive potential gradients the relationship between point discharge current, potential gradient, and windspeed is of the form

$$I = k (W + C) (F-M) \text{ where,}$$

I, F & M are as before

W = windspeed and

k and C are constants

If it were not for the fact that this equation is in agreement with the results of Chalmers and Kirkman (1957), the amount of data available would not justify its assertion. However since the results

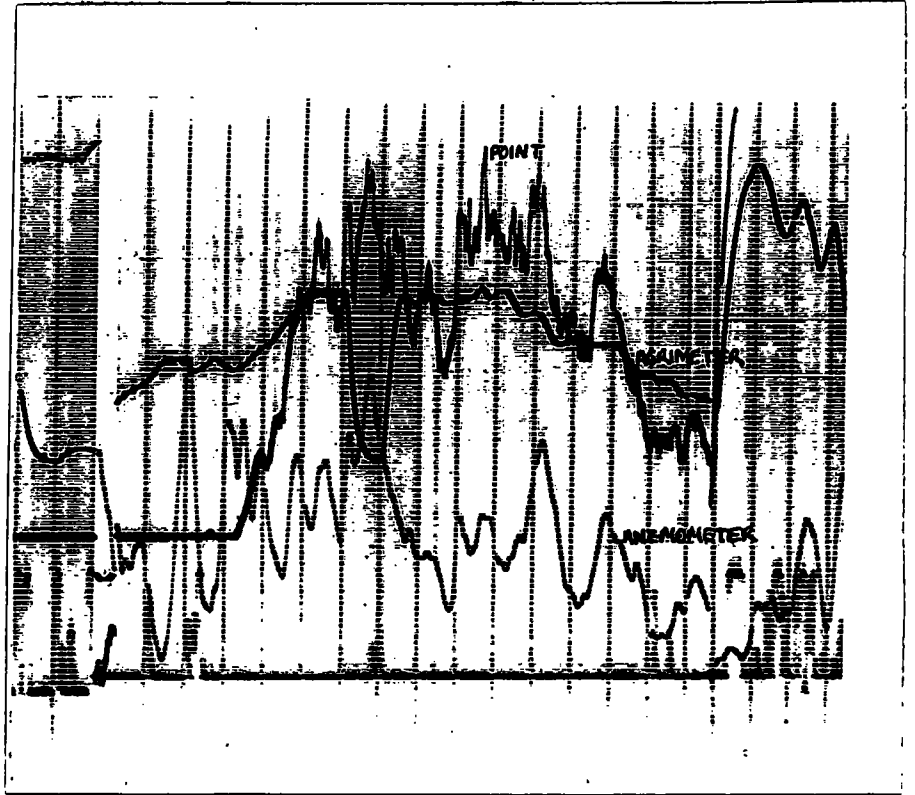

Fig 22. Record Showing Variation of Current with Windspeed.

do agree it seems logical to conclude that the relation between point discharge current, potential gradient, and windspeed is of the form given above for points at tree-top height as well as for points mounted on high masts.

Substituting for k, C and M, the equation obtained for positive currents and potential gradients was :-

$$I \mu A = 0.00098 (W + 0.75) (F-600) \text{ ----- EQ.1.}$$

It can only be claimed that this equation holds for values of F up to 2500 volts per metre and for values of W up to 5.6 metres per second, these being the highest recorded values.

One or two records were obtained in which it was possible to see the point discharge current varying with the windspeed while the potential gradient remained fairly steady. Such periods were too short to attempt an analysis but they served to illustrate the effect of windspeed. An example of such a record is given in Fig. 22.

3. Effect of Wind Direction and Weather Conditions.

If the wind direction was such that space charge from surrounding trees passed over the agrimeter then the correlation between point discharge current and potential gradient broke down completely. On

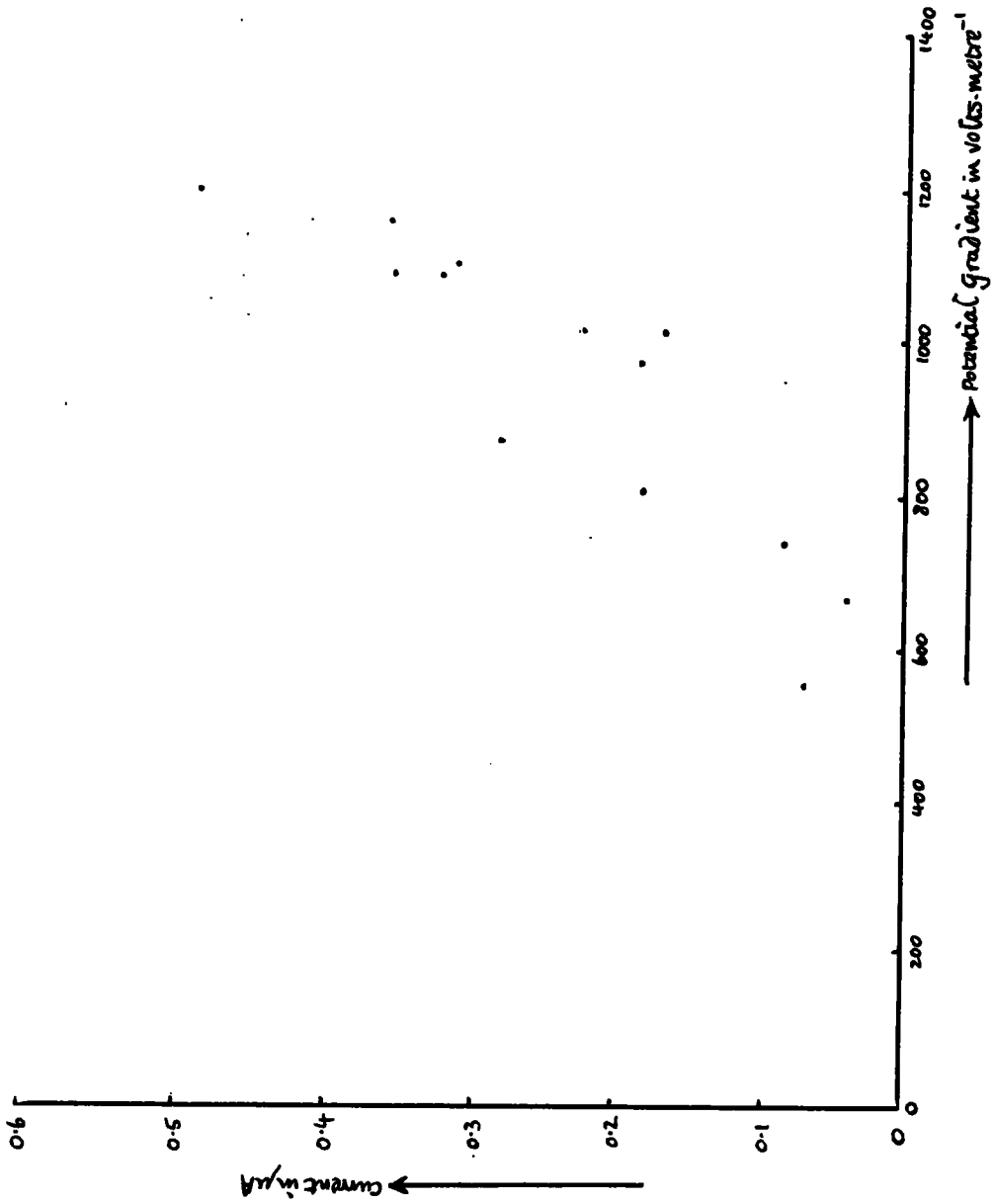

Fig 23 Results taken in a Snow Shower.

the other hand if the wind was blowing in exactly the opposite direction to that desired, it was then apparent that the potential gradient was dependent on the point discharge current. In low windspeeds it was possible to see the time delay as ions from the point drifted over the agrimeter, also the values of the potential gradient were lower than would be expected for the size of the current. In some cases the effect of the ion stream was great enough to reverse the sign of the potential gradient at the ground.

The effect of snow was to destroy the correlation between the current and the potential gradient, or at least to increase the scatter of the results. Fig. 23 is the result of a record taken in a snow shower and a comparison with Figs. 19 and 20 illustrates how the correlation has degenerated. This is probably due to the drifting about of patches of space charge.

Heavy rain normally had little effect, except that if prolonged it caused the agrimeter to break down. Very heavy rain seemed to have the same effect as snow, i.e. to cause the breakdown of the correlation. This may be due to the production of space charge by splashing at the ground.

4. Discussion and Conclusions.

Chalmers (1957) found that the results of previous workers

could be represented by the formula :-

$$I = A (V - V_0) (W^2 + c^2 V^2)^{\frac{1}{2}}$$

if the values of A, V_0 and c^2 were suitably chosen.

The values of A, V_0 and c^2 are given as

	A	V_0	c^2
Large & Pierce (1957)	1.6×10^{-11}	7×10^3	8×10^{-9}
Chalmers & Mapleson (1955)	6.5×10^{-11}	2.5×10^3	8×10^{-8}
Chalmers & Kirkman (1957)	6×10^{-12}	8×10^3	2×10^{-9}
Chapman (1956)	1.4×10^{-11}		

V , the potential of the air round the point, is measured in volts, W in metres per second and I in amperes.

In the present research the height of the point was about 15 metres, so assuming the potential gradient does not alter with height and knowing that $M = 600$ volts per metre, $V_0 = 9000$ volts. If I is expressed in amperes and instead of F , V the potential of the air around the point is used then equation 1 above becomes

$$I = 6.5 \times 10^{-11} (W + 0.75) (V - 9 \times 10^3) \text{ ----- EQ.2.}$$

giving $A = 6.5 \times 10^{-11}$ and $V_0 = 9 \times 10^3$. These seem to be in

good agreement with the values in the above table. Considering the scarcity of the results it is difficult to see how c^2 could be estimated.

It can be said then that the results obtained probably agree with those of Chalmers & Mapleson (1955) with their balloon experiments, Chapman (1956) with his wind-tunnel experiments, Large & Pierce (1957) with their artificially produced point discharge, and with those of Chalmers & Kirkman (1957) with their mast experiments.

The results differ, however, from those of all previous workers with points at tree-top height. Whipple & Scrase (1936), Chipionkar (1940), Hutchinson (1951), and Yriberry (1954) all obtained a relationship of the form :-

$$I = A (F^2 - M^2)$$

but none of them measured the wind velocity, and the divergence of their results from those obtained in the present work seems to have been best explained by Kirkman (1956). He suggests that with a limited number of results and a few high values of the windspeed occurring with high potential gradients the dependence of I on F^2 could easily be suggested. This suggestion is very plausible since the higher potential gradients are usually associated with

the more turbulent weather conditions.

Chalmers (1952) deduced a square law relationship theoretically, but in his calculations he ignored the windspeed, saying that the primary cause in the removal of ions was the electric field. However it seems as if his equation is included in the general equation :-

$$I = A (V - V_0) (W^2 + c^2 V^2)^{\frac{1}{2}}$$

since if $W = 0$ this reduces to a square law expression.

In conclusion then it can be asserted that for a point at tree top height the relation between point discharge current, potential gradient and windspeed is of the form :-

$$I = k (W + C) (F - M)$$

which is in direct agreement with the results of Chalmers & Kirkman (1957) and considering what has been said by Chalmers (1957) this result strongly suggests that the expanded Chapman formula :-

$$I = A (V - V_0) (W^2 + c^2 V^2)^{\frac{1}{2}}$$

holds for point discharge currents from points under all conditions.

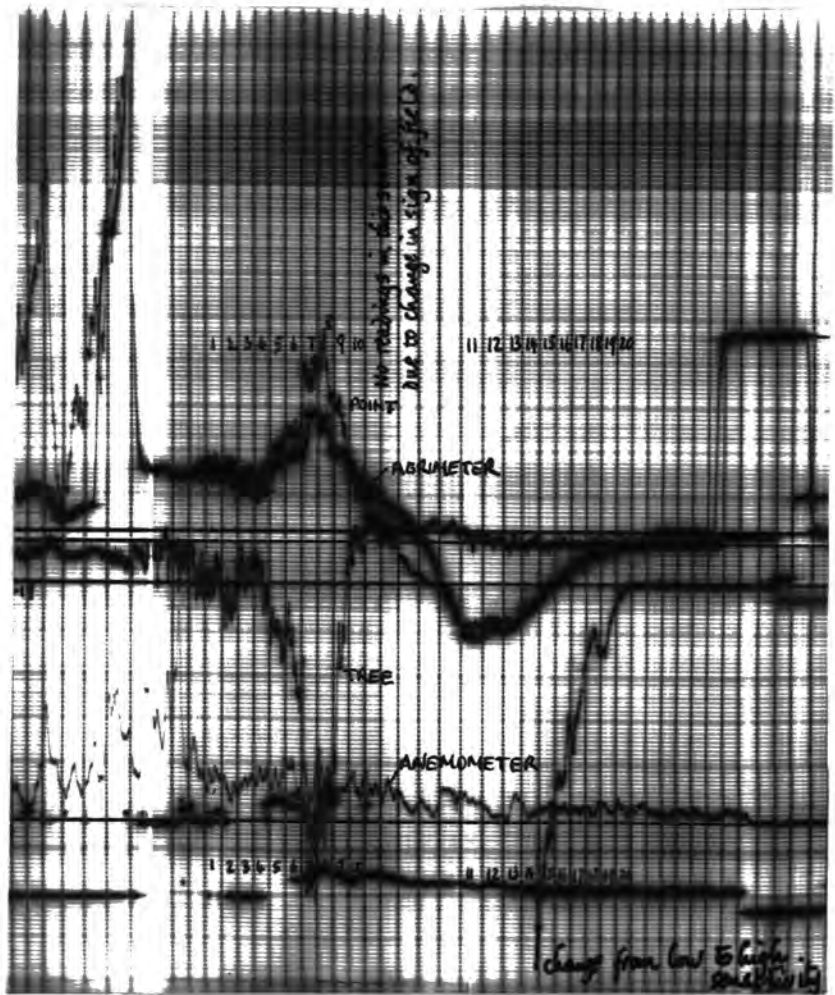

Fig 24. Record Showing Point Discharge Current Down the Tree.

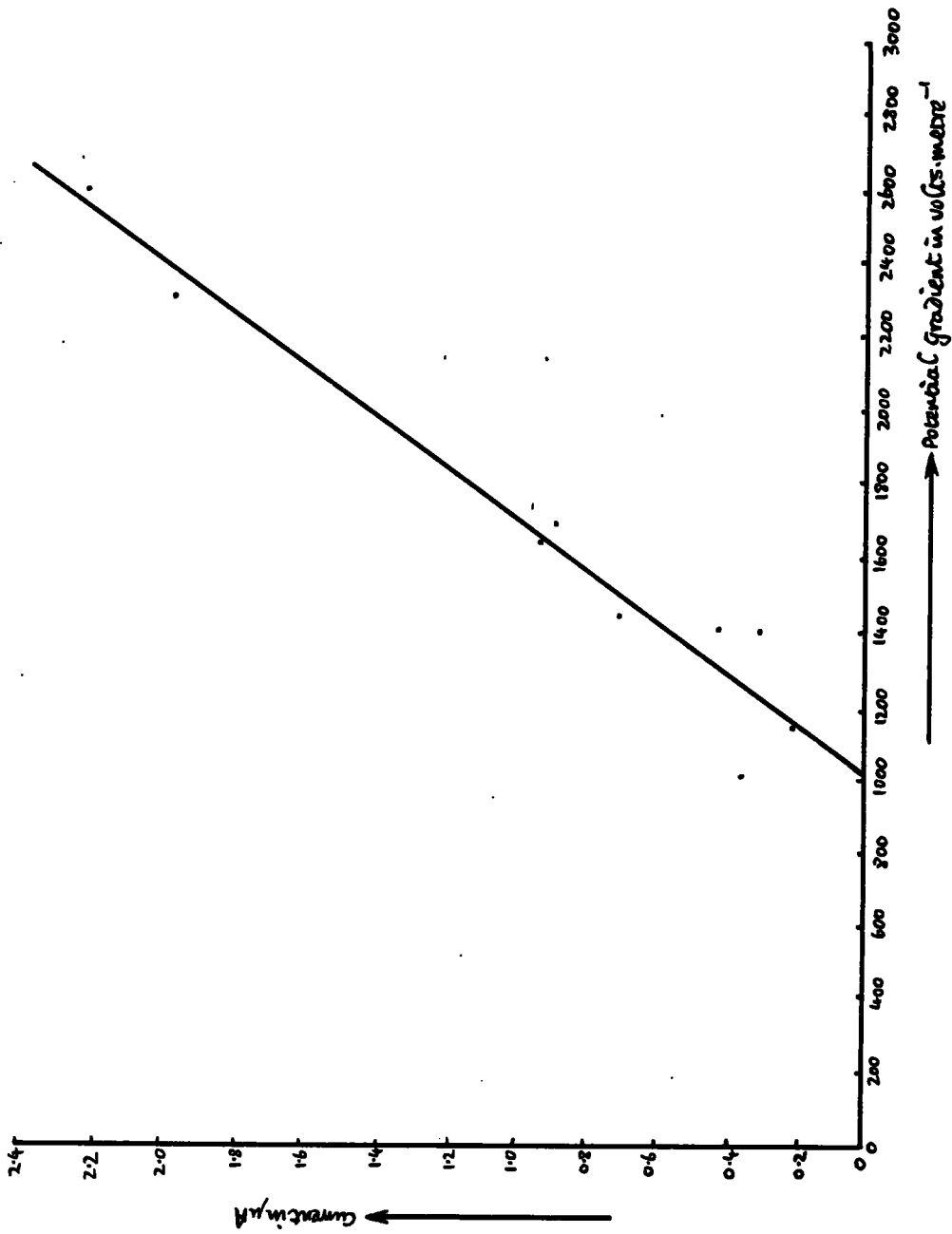

Fig 25. Potential gradient versus Current down the Tree.

CHAPTER . SIX.

Results Obtained from the Tree.

1. Results with the Electrodes.

Only five records were obtained of currents flowing down the tree. One of these was obtained when the electrodes were in the lime tree, the others were obtained with the electrodes in the horse chestnut tree, only the first mentioned of these records was suitable for analysis.

Fig 24 is a photograph of the one suitable record, and Fig 25 shows the relationship between the potential gradient and point discharge current flowing down the tree which is linear as for current flowing down the point. The windspeed as measured at the point was 5.6 metres per second.

The onset value of the potential gradient for the lime tree was 1000 volts per metre, the value for the point being 600 volts

per metre. The horse chestnut tree was smaller than the lime tree and consequently had an even higher value of the onset potential gradient.

At any instant the current flowing down the point was about ten times greater than the current flowing down the tree. This was not due to the method employed in measuring the current since the majority, if not all, of the current flowed through the low-resistance galvanometer.

It was not possible to determine the effect of the windspeed, even qualitatively. On one record it was quite easy to see the effect of the wind on the current flowing down the point, but the current down the tree seemed to be unaffected. Two explanations suggest themselves, one is that the current is unaffected by the windspeed, the other is that the windspeed as measured at the point does not represent the windspeed around the tree. The second of these seems more likely since the wind near ground level is very erratic both in direction and in velocity, especially when buildings, trees, etc present an irregular surface.

Two other effects were observed; one was that with the horse chestnut tree the trace of the current on the records was

much smoother than the trace of the current down the point. Probably the reason for this is that local fluctuations in potential gradient and windspeed immediately affect the small region around the point, whereas the tree being much larger would not detect such local variations. The other effect was observed with the lime tree and the horse chestnut tree. At fairly regular intervals of the order of half-a-minute short bursts of charge would be recorded, the galvanometer acting almost as a ballistic galvanometer. This happened regularly, especially when the potential gradient was near the onset value, but was never observed with the point.

The "oscillations" described by Kirkman (1956) never occurred with the electrodes neither did the sudden large changes in the "zero". It is suggested that these phenomena were largely a result of his using brass screws for the electrical contacts.

2. Results with the Field Mills.

Three records were obtained with the field mills positioned on either side of the horse chestnut tree. On one of these records the wind direction was such that the leeward field mill B was measuring the effect of ions from the point, On the other

two the current flowing down the tree was never greater than 0.25 microamp and could only just be detected as slight irregularities in the trace of the down-wind field mill.

On the record in which Mill B was detecting ions from the point, a sudden change in point discharge current of 1.25 microamps produced a change in the potential gradient of only 300 volts per metre. This is approaching the limit of the sensitivity of the apparatus. If smaller currents are to be measured then the field mills would have to be calibrated very accurately and carefully, also the windspeed and wind-direction would have to be measured more carefully, the windspeed as measured at the point being most inadequate.

3. Conclusions.

The current-potential gradient relationship is the same as for a point of similar height for any particular windspeed, namely :-

$$I = a(F-M)$$

Other things being equal the current flowing down a tree is one tenth of that down a point of similar height. This will affect considerably estimations on the contribution of point

discharge in the charge replacement process in which trees are assumed to be as efficient as points in the amount of charge they bring down.

Height for height the value of the onset potential gradient is greater for a tree than for a point which is to be expected since the profile of a tree is much less sharp than that of a point.

The electrodes measured the currents flowing down the tree much more simply than the two field mills. The same difficulty was encountered as by Maund (1958) who found it difficult to measure currents of less than one microamp. The chief disadvantage of using the field mills apart from their lack of sensitivity is that they detect all the space charge present instead of just that from the tree on which measurements are being made.

These results, unfortunately, are no significant advance on what is known already except that a point and tree have been compared, and that in the mercury electrodes a simple and reliable means of measuring the current directly has been discovered. A further method of measuring the current is suggested in the next chapter.

C H A P T E R S E V E N

Preliminary Experiments for Detecting Point Discharge Currents by a Transformer Method.

1. Introduction.

In chapter 2 section 3 it was suggested that point discharge current flowing down a tree may possibly be measured by detecting the magnetic field produced by the current.

If the current flowing down the tree is I amps, and the radius of the tree is r metres, then the magnetic field produced around the tree is H, where

$$H = \frac{I}{2\pi r} \text{ ampere turns per metre,}$$

assuming for the moment that the current is flowing down the centre of the tree. Since the current is pulsed the magnetic field also will be pulsed. If r is about 0.4 metre, then for a current of one microamp., H is approximately 3×10^{-7} ampere turns per metre and for a current of one tenth of a microamp H is about 3×10^{-8} ampere turns per metre. Any method for detecting fields of this size will have to be extremely sensitive, the most obvious being to use a toroid

around the trunk of the tree and to measure the e.m.f. induced in it by the pulsed magnetic field. If the toroid has a high permeability core the magnetic field will be increased considerably and so also will be the e.m.f.

It was not possible to calculate the size of this e.m.f. very satisfactorily except to say that it would be of the order of a few microvolts, so it was decided to conduct some laboratory experiments to test the feasibility of this method of point discharge current measurement.

The e.m.f. would have to be amplified and then recorded in some way. It was decided that in such preliminary work as this it would be quite satisfactory to make all measurements on a cathode ray oscillograph. It can be seen then that all that was required for these experiments was

- a. a suitable toroid, and
- b. a high gain, low noise level amplifier.

This chapter is a description of the apparatus which was constructed and the results which were obtained with it.

2. The Apparatus.

a. The Toroid

A small toroidal core was purchased and a coil wound

on to it. The core was laminated and made from Permalloy "C" which has an initial permeability of 20,000. The "initial permeability" is that for very low magnetic fields. There is a metal, Permalloy "Super C", which has an even higher permeability of 60,000 but this was unobtainable for this experiment. The dimensions of the core used were :-

Inside diameter	=	6.3 cm
Outside diameter	=	11.5 cm
Width	=	1.3 cm

The number of turns on the core was 450, the resistance of the coil being 1.3 ohms and its inductance 230 microhenries.

The coil needed to be screened from all external magnetic fields, especially the 50 c.p.s. field radiated from the electricity mains. If the coil was left open to these stray fields the e.m.f. induced in it was sufficient to overload the amplifier. A "mumetal" box complete with lid was obtained and the coil was completely enclosed in it. This was sufficient to eliminate the effects of all unwanted magnetic fields.

b. The Amplifier

Since the amplifier was needed to measure very small

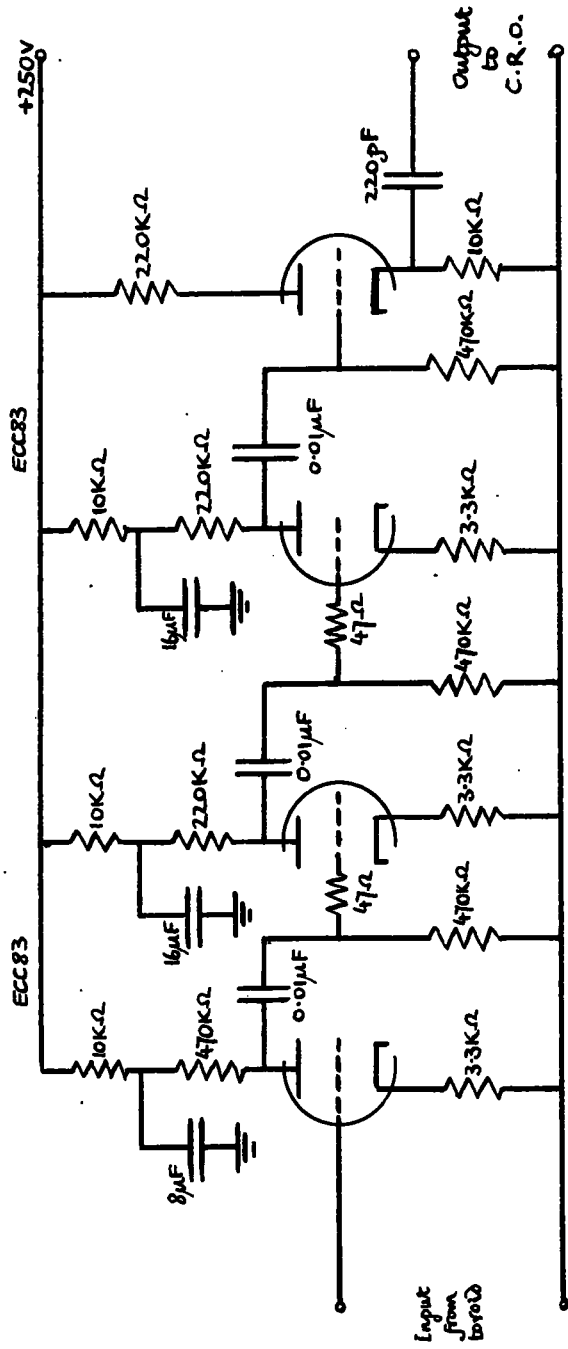

Fig 2.6 . The Amplifier.

signals of the order of a few microvolts an instrument with a high gain and low noise level was needed.

Three amplifier circuits were tried, two using pentodes and one using triodes. The first consisted of two amplification stages and although low noise AF pentodes were used the noise level of the amplifier was considerable. In the second circuit three stages of amplification were used with negative feedback in the first stage but this resulted in very little improvement. Finally triodes were used instead of pentodes and this circuit, given in Fig 26, consisted of three amplification stages and a cathode follower output stage. The noise level in the final amplifier was much smaller and a smaller signal could be detected, even so the performance left much to be desired but it was decided that it would be suitable for the intended experiments. The H.T. to each stage was decoupled and the 47 ohms "grid-stoppers" were introduced to cut down the risk of any instability causing the amplifier to oscillate.

The 220 pF D.C. blocking condenser in the output of the cathode follower also served to attenuate frequencies below one kilocycle per second, reducing the annoyance caused by

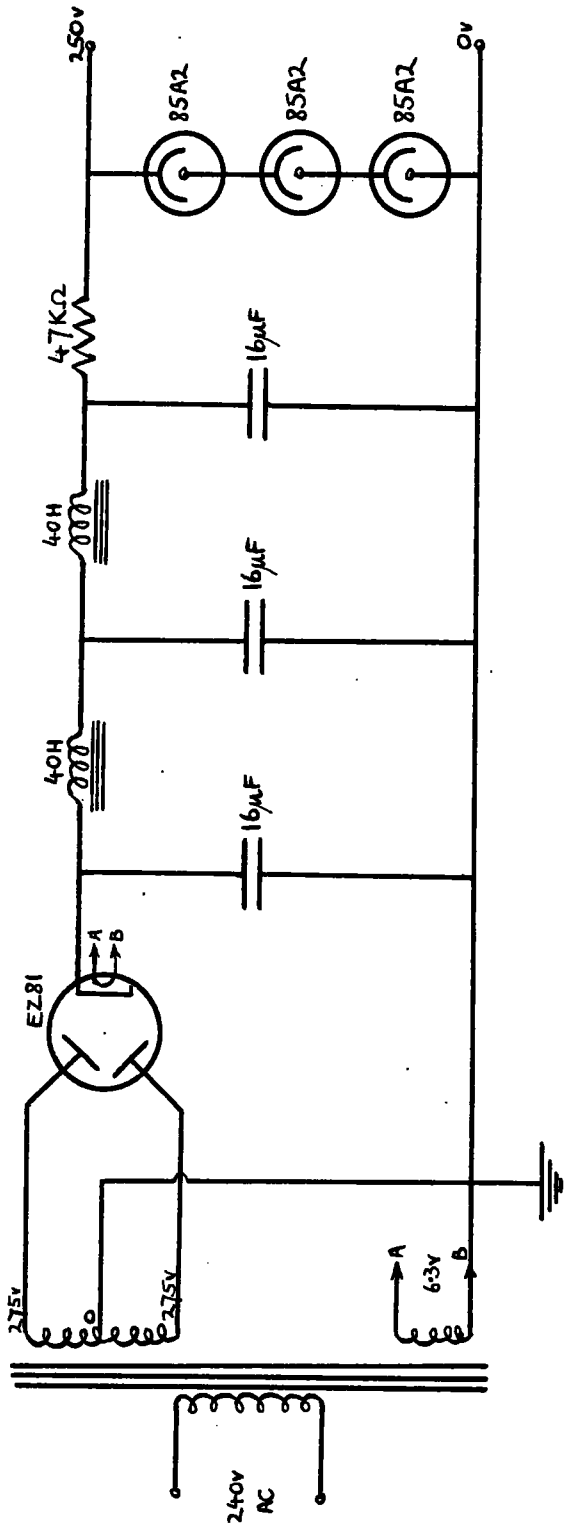

Fig 27. The Power Supply.

50 c.p.s. pick-up, if any. 50 c.p.s. pick-up was completely eliminated by using accumulators for the valve heaters instead of the usual 6.3 volts AC.

The performance of the amplifier was as follows, all AC voltages being measured peak to peak on a cathode ray oscillograph. The gain was 6,500 times and the noise level was 40 - 50 millivolts. The smallest detectable signal was 4 - 5 microvolts and the largest signal which could be applied before cut-off occurred was 0.5 millivolt when the output was about 3 volts.

c. The Amplifier Power Supply.

As stated already accumulators were used for the heaters of the amplifier valves. The H.T. was provided from a stabilised power supply the circuit of which is given in Fig 27. As can be seen a double filter was used for smoothing and three 85A2 neon tubes were used for stabilisation. The maximum stabilised current that could be taken from the supply was 5 mA. The amplifier required 250 volts at 3 mA. The ripple on the H.T. was too small to be measured on the cathode ray oscillograph and in any case did not affect the performance of the amplifier in any way.

3. Experimental Procedure and Results.

The apparatus being built the experiments were carried out as follows.

First a ten-turn primary coil was wound on top of the larger coil on the toroidal core. An AC current from a beat frequency oscillator was passed through the primary, and represented the point discharge current flowing down the tree. A megohm resistor was put in series with the primary coil across the terminals of the oscillator and the output from the oscillator in volts was interpreted as the same number of microamps flowing in the primary.

With this arrangement the following experiments were performed :-

a. Frequency Measurements

In chapter 1, section 1 it says that the frequency of the point discharge current pulses depends on the size of the current. The purpose of the present experiment is to measure the size of the current only and not its frequency, so it was decided to measure the frequency response of the coil and amplifier. This was done by keeping the current in the primary

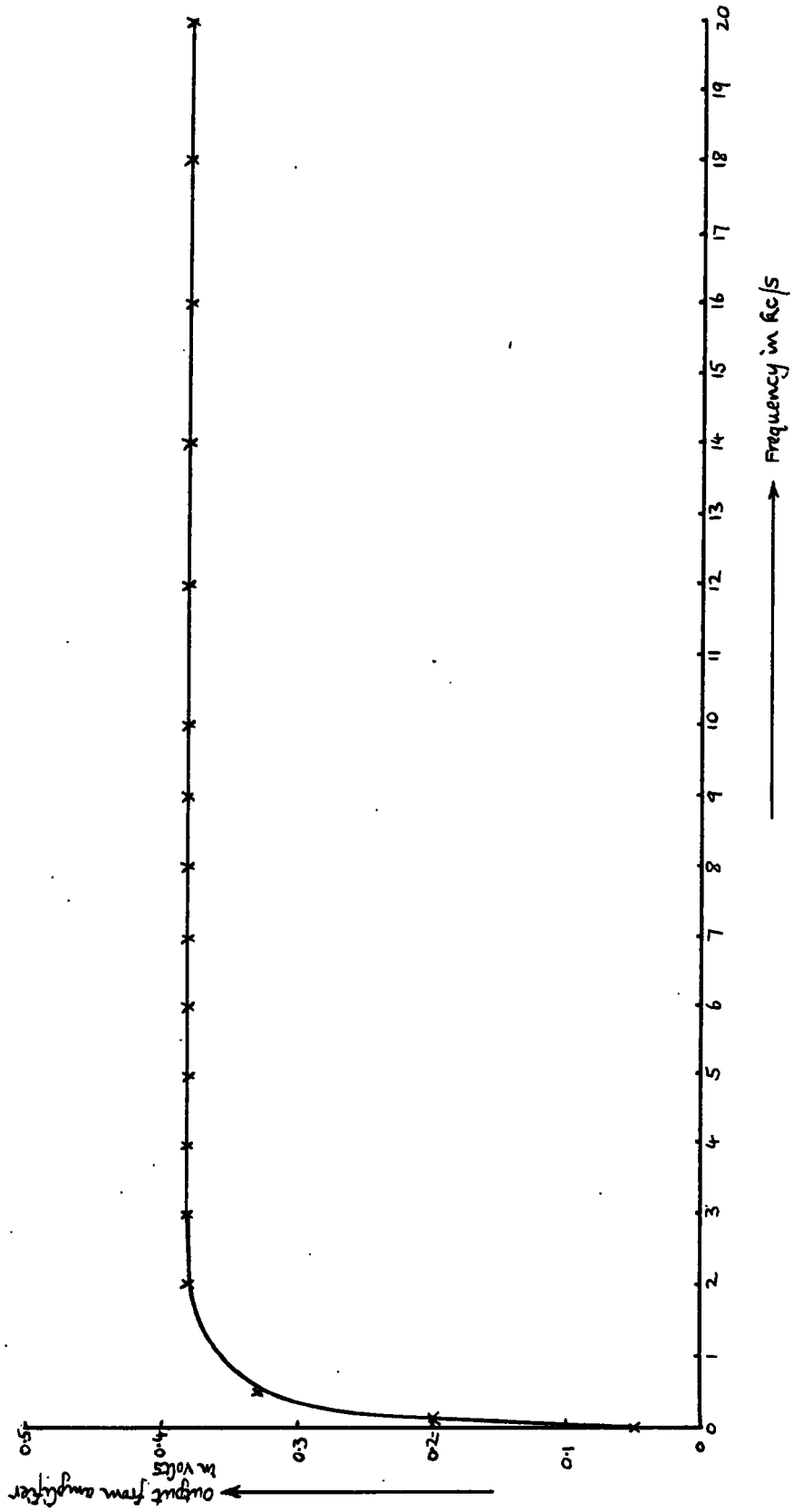

Fig 2.8. Frequency Response of Coil and Amplifier.

coil constant, varying the frequency throughout the entire range of the oscillator, and measuring the output from the amplifier on the cathode ray oscillograph.

The current was kept constant at 50 microamps, and the frequency was varied from 100 c.p.s. to 20 kc.p.s., the latter being as high as the oscillator would go. The result is shown in Fig 28. From 2 - 20 kc.p.s. the output is steady, at 0.38 volt falling to 0.36 volt at 1 kc.p.s. The rapid fall in output below this frequency is due to the 220 pF capacitor mentioned earlier. The range in frequency 1 - 20 kc.p.s. represents values of the point discharge current from 0.1 - 2.0 microamps. The low-frequency response can easily be extended so this system is certainly quite suitable for measuring a current whose frequency varies with its magnitude.

b. Sensitivity Measurements.

Having measured the frequency response it was now necessary to determine the sensitivity of the coil. In this case the frequency of the current was kept constant, though in view of what has just been said this was unimportant, and the output from the amplifier was measured as the current through the

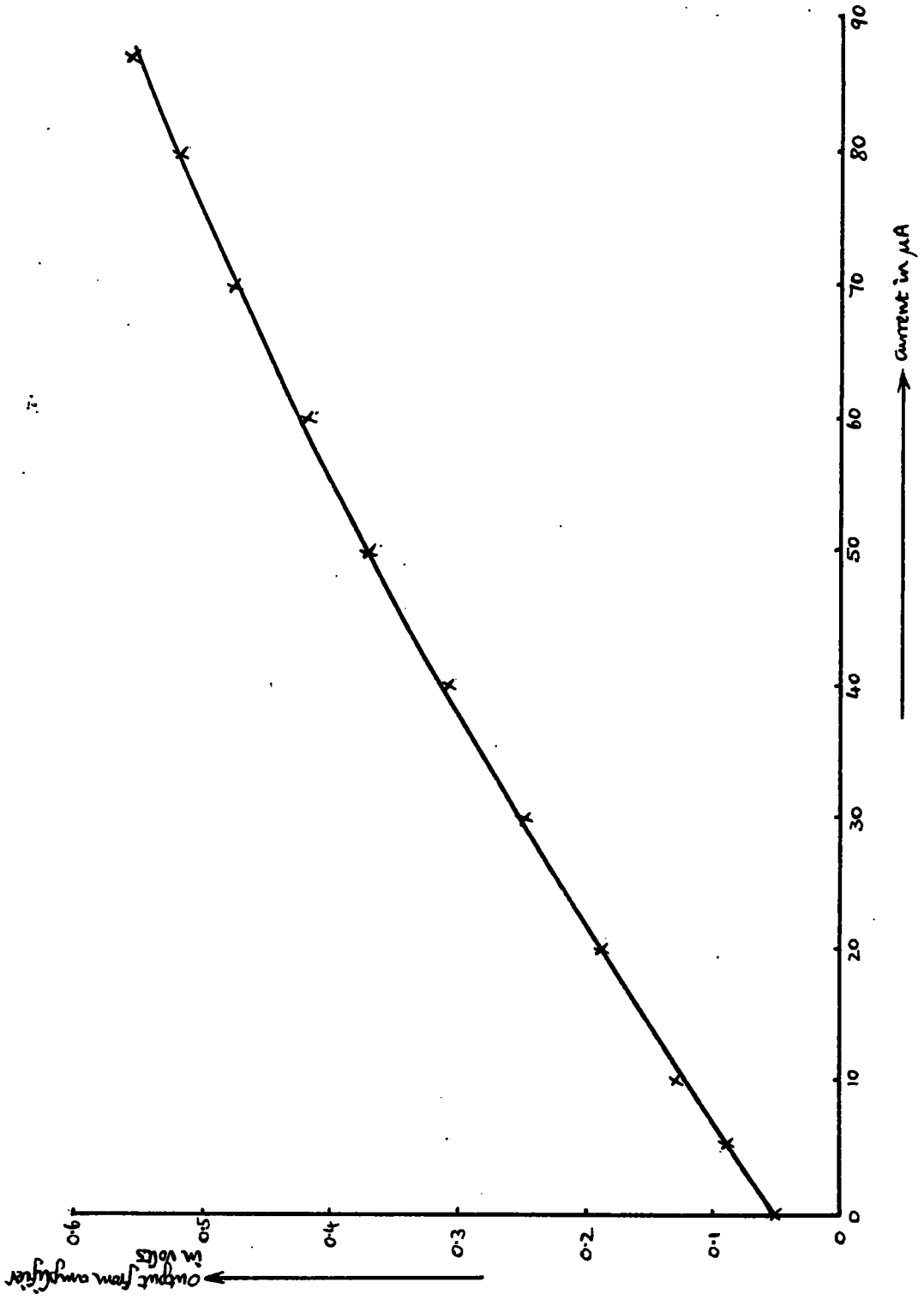

Fig 29. Sensitivity of Coil and Amplifier.

primary was varied. The current started at a high value and was gradually decreased until the waveform on the screen of the oscillograph merged into the noise of the amplifier.

The frequency was kept constant at 5 kc.p.s. With the megohm in series with the primary the maximum current that could be produced was 87 microamps giving an output from the amplifier of 0.56 volt. The current was gradually reduced until at 3 microamps the wave-form merged into the amplifier noise. The relation between the current through the primary and the output from the amplifier is shown in Fig 29, and can be seen to be a smooth curve.

The result then is that currents as small as 3 microamps can be detected, and currents of 5 microamps and greater can be measured quite easily.

c. Point Discharge Measurements.

An 8 kV supply was available so it was decided to detect, if possible, some actual point discharge pulses. Unfortunately it was found that 8 kV was sufficient to produce only a small point discharge current and it was not possible to produce anything greater than the noise level of the amplifier.

4. Conclusions.

The sensitivity of the system is quite high, and could be improved. The primary at the moment is ten turns, whereas the tree with the current flowing down it is equivalent to half a turn, so to obtain the present sensitivity the number of turns in the toroid would have to be increased from 450 to 9,000. Point discharge currents down trees are usually less than one microamp, so for the system to be of any use its sensitivity would have to be stepped up by a factor of twenty or thirty. Amplifiers can be made to detect signals of one microvolt, and Permalloy "Super C" could be used for the toroidal core instead of Permalloy "C". These two factors would produce an increase in sensitivity of about ten times. The coil around a tree would be considerably bigger than the one used in this experiment so it would not be difficult to increase the number of turns considerably. However there is a limit to this because a stage would be reached where the effect of the resistance and inductance of the coil would be to destroy the induced e.m.f.

It may be possible to construct an amplifier of the required

sensitivity by using an electrometer valve first stage followed by several stages of transistor amplification.

Although it seems as though this method can be used for measuring point discharge currents there are two grave disadvantages. The first is putting the toroid round the tree and winding all the turns onto it. The second is that the coil would have to be magnetically screened with a "mumetal" case and this could be exceedingly awkward. If these two disadvantages can be overcome then it seems as though this method could be used for detecting point discharge currents and it would be at least as reliable as using two field mills.

Suggestions for Further Work.

It has been shown that the relationship obtained by Kirkman (1956), namely :-

$$I = k(W + C) (F-M)$$

using a point on a mast also holds for a point mounted at tree-top height. It would be useful to continue collecting data to see if the formula

$$I = A(V-V_0) (W^2 + c^2 V^2)^{\frac{1}{2}}$$

holds for points in all conditions.

It has also been shown that the mercury electrodes are more sensitive than the field mills for measuring point discharge currents down trees, it is now necessary to greatly increase the amount of information available. The site used is not really satisfactory and if apparatus could be permanently located round a tall isolated tree it would not be so difficult to obtain reliable information.

It would be worthwhile to consider developing the transformer method of measuring point discharge currents down trees. If this method can be perfected then one can be sure of measuring the whole of the current flowing instead of just knowing that the majority is being measured as with the electrodes.

Acknowledgements.

The author wishes to thank his supervisor Dr. J.A. Chalmers who was always at hand to give help and advice.

The author is also grateful to Professor G.D. Rochester for the research facilities which were available and is indebted to D. Jobling, M. Cutter and other members of the laboratory staff for their help in constructing apparatus.

Fellow research students were a constant source of help and diversion, especially during the long periods between thunderstorms.

Finally, thanks are due to D.S.I.R. for the research scholarship awarded from 1957 to 1960.

References.

- Chalmers J.A. (1949) "Atmospheric Electricity" (Oxford, Clarendon Press).
- Chalmers J.A. (1952) J. Atmosph. Terr. Phys. 2 pp 292 - 300.
- Chalmers J.A. (1952) J. Atmosph. Terr. Phys. 2 pp 301 - 305.
- Chalmers J.A. (1953) J. Atmosph. Terr. Phys. 4 pp 124 - 128.
- Chalmers J.A. (1957) J. Atmosph. Terr. Phys. 11 pp 301 - 302.
- Chalmers J.A. (1958) Geofis. Pura e Appl. Milano 41 pp 189 - 193.
- Chalmers J.A. & Kirkman J.R. (1957) J. Atmosph. Terr. Phys. 10 pp 258 - 265.
- Chalmers J.A. & Little E.W.R. (1947) Terr. Mag. Atmos. Elect. 52 pp 239 - 260.
- Chalmers J.A. & Mapleson W.W. (1955) J. Atmosph. Terr. Phys. 6 pp 149 - 159.
- Chalmers J.A. & Maund J.E. (1960) Quart. J. Roy. Met. Soc., 86 pp 85 - 90.
- Chapman S. (1956) Report C.A.L. 68.
- Chiplonkar M.W. (1940) Proc. Ind. Acad. Sci. A. 12 p 50.
- Cobine J.D. "Gaseous Conductors" Chapter 8, section 8:18.
- Davis R. & Standring W.G. (1947) Proc. Roy. Soc. A. 191 pp 304 - 322.

- Hutchinson W.C.A. (1951) Quart. J. Roy. Met. Soc.,
77 pp 627 - 632.
- Kirkman J.R. (1956) Durham Ph. D. Thesis.
- Large M.I. & Pierce E.T. 1955 Quart. J. Roy. Met. Soc.,
81 pp 92 - 95.
- Large M.I. & Pierce E.T. 1957 J. Atmosph. Terr. Phys.
10 pp 251 - 257.
- Maund J.E. (1958) Durham Ph. D. Thesis.
- Petterson S. "Introduction to Meteorology".
- Schonland B.F.J. (1928) Proc. Roy. Soc. A. 118 pp 252 - 262.
- Starr E.C. (1940) A.I.E.E. Tech. Paper. May 1940
pp 40 - 118.
- Trichel G.W. (1938) Phys. Rev. 54 pp 1078 - 1084.
- Wait G.R. (1950) Arch. Met. Vien. A. 3 pp 70 - 76.
- Warburg E. (1899) Ann. Phys. Lipz. 67 p 69.
- Whipple F.J.W. & Scrase F.J. (1936) Geophys. Mem. Lond.
68 pp 1 - 20.
- Wormell T.W. (1927) Proc. Roy. Soc. A. 115 pp 443 - 455.
- Wormell T.W. (1930) Proc. Roy. Soc. A. 127 pp 567 - 590.
- Whitlock W.S. (1960) Nature 185 p 302.
- Yriberry A.J. (1954) Acta. Sci. San. Miguel Obs. de Fis.
Cos. No. 2.

