

Durham E-Theses

The iodous sulphates

Cyril Argument

How to cite:

Argument, Cyril (1944) *The iodous sulphates*. Doctoral thesis, Durham University.

Use policy

The full-text may be used and/or reproduced, and given to third parties in any format or medium, without prior permission or charge, for personal research or study, educational, or not-for-profit purposes provided that:

- a full bibliographic reference is made to the original source
- a <https://etheses.durham.ac.uk/id/eprint/9113/> is made to the metadata record in Durham E-Theses
- the full-text is not changed in any way

The full-text must not be sold in any format or medium without the formal permission of the copyright holders.

Please consult the [full Durham E-Theses policy](#) for further details.

ADSORPTION AT THE INTERFACE BETWEEN TWO FLUIDS.

WITH SPECIAL REFERENCE TO THE ADSORPTION
OF FIVE DYES AT A MERCURY-WATER
INTERFACE.

THESIS.

Part II.

Presented in candidature for the degree of

Doctor of Philosophy

of the University of Durham

by

Cyril Argument

B.Sc.

entitled

Adsorption at the Interface between Two Fluids.

With special reference to the adsorption

of five dyes at a mercury-water

interface.

Being an account of the work carried out during
the Session 1938 - 9 at the Science Laboratories,
Durham University, (Durham Division), under the
direction of Dr. C.W. Gibby, M.Sc., A.I.C.

Contents.

	<u>Page.</u>
<u>Publication.</u>	-
<u>Introduction.</u>	-
<u>Chapter I.</u> Historical	1.
<u>Chapter II.</u> Preliminary Investigations.	13.
Adsorption at the Chlorobenzene-water interface.	
Interfacial tension measurements.	17.
Adsorption at the mercury-water interface.	20.
<u>Chapter III.</u> Experimental.	24.
Adsorption measurements.	24.
Interfacial tension measurements.	31.
Calculation of adsorption coefficients.	37.
Purity of Substances used.	38.
<u>Chapter IV.</u> Drop Numbers, Interfacial Tensions and Calculated Adsorptions.	41.
Measured Adsorptions etc.	51.
<u>Chapter V.</u> Consideration of Results.	57.
General observations.	
Discrepancies between theoretical and measured values of adsorption coefficients.	58.
Nature of Adsorbed layers.	59.
<u>Summary.</u>	-
<u>Bibliography.</u>	-
<u>Acknowledgements.</u>	-

Illustrations.

	Page.
<u>Figure I.</u> Apparatus used in Preliminary work on adsorption at the chlorobenzene-water interface.	13.
<u>Figure II.</u> Apparatus used in Preliminary work on adsorption at the mercury-water interface.	20.
<u>Figure III.</u> Apparatus finally adopted for determination of adsorption at the mercury-water interface.	24.
<u>Figure IV.</u> Graph of $F/\text{Log } \frac{v}{r^3}$ relationship.	33.
<u>Figure V.</u> Automatic Drop counting device.	36.
Graph of Interfacial tension/Concn. relationship for all five dyes.	50.
Adsorption curves for Methylene Blue.	52.
Adsorption curves for Congo Red.	53.
Adsorption curves for Bordeaux Extra.	54.
Adsorption curves for Indigo Carmine X.	55.
Adsorption curves for Solway Ultra Blue B.	56.
<u>Figure VI.</u> Formulae for dyes used.	59.

109. *Adsorption at the Interface between Two Fluids. Part III. The Adsorption of Five Dyes at a Mercury–Water Interface.*

By C. W. GIBBY and C. ARGUMENT.

The adsorptions of methylene-blue, Congo-red, Bordeaux extra, indigo-carmin X, and Solway ultra-blue B at mercury–aqueous solution interfaces have been measured. In each case the adsorption passes through a maximum as the concentration increases, and is always positive. Interfacial-tension measurements have also been made, and values of the adsorption calculated from them by means of Gibbs's equation. These are not in agreement with the measured values, and are in some cases negative.

IN Parts I and II (J., 1936, 119, 1306) the adsorptions of certain dyes at water–organic liquid interfaces were measured, and compared with those calculated by means of Gibbs's equation, $\Gamma = -c(d\sigma/dc)/RT$, from measured values of interfacial tensions.

The present report deals with the adsorptions, at the mercury–water interface, of three of these same dyes, Congo-red, Bordeaux extra, and methylene-blue, and also of two

FIG. 1.

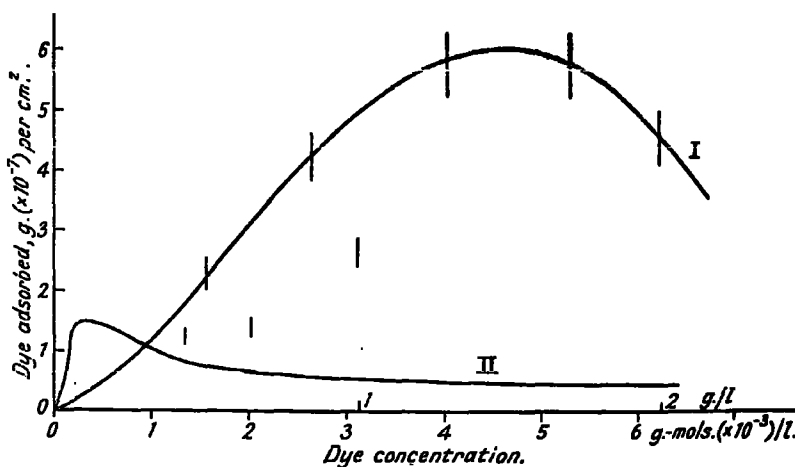

I. *Methylene-blue (measured).*
 II. *Methylene-blue (theoretical).*

others, indigo-carmin X (the potassium salt of indigotin-5 : 5'-disulphonic acid) and Solway ultra-blue B (the sodium salt of 1-amino-4-anilinoanthraquinone-2-sulphonic acid). The last two were chosen to include two types of structure, indigoid and anthraquinonoid, not previously studied. Attempts to carry out measurements of this type for the mercury–water interface seem to be limited to those of Patrick (*Z. physikal. Chem.*, 1914, **86**, 545), whose determinations are only comparative.

With all five dyes the measured adsorption passes through a maximum with increasing concentration (Figs. 1, 2, 3; Table I). A similar phenomenon was observed in many of the cases previously studied (*loc. cit.*), though both the adsorbing liquid and the experimental method were entirely different.

The areas of interface per molecule adsorbed at the concentration of maximum adsorption are shown in Table II, together with the approximate areas of the molecules, found by drawing projections of their outlines to scale on a plane, as in Parts I and II. It has been assumed that the molecule of Solway ultra-blue B is coplanar, hence the area estimated in this case is a maximum value. The ratios of the two sets of values suggest considerable orientation of the molecules at the interfaces. The difference between the ratios for Congo-red and Bordeaux extra is striking, as the structures of these two dyes are closely related.

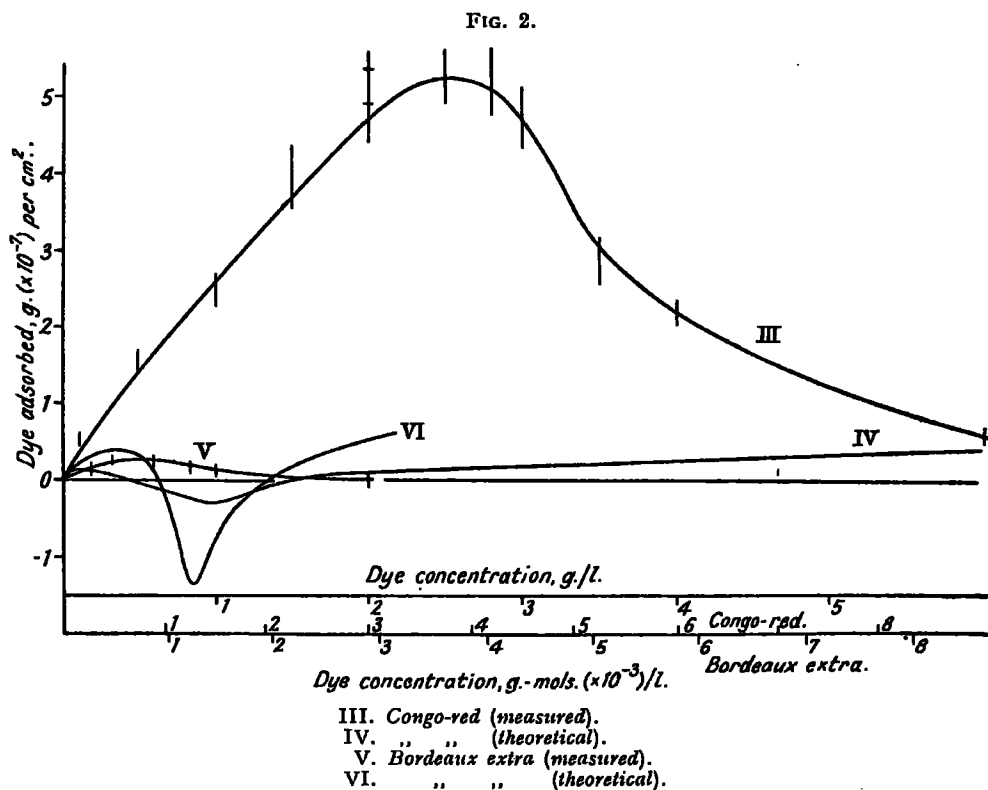

TABLE I.

Initial concn., g./l.	Surface area $\times 10^{-4}$, cm^2 .	Adsorption coeff. $\times 10^7$, g./ cm^2 .	Initial concn., g./l.	Surface area $\times 10^{-4}$, cm^2 .	Adsorption coeff. $\times 10^7$, g./ cm^2 .	Initial concn., g./l.	Surface area $\times 10^{-4}$, cm^2 .	Adsorption coeff. $\times 10^7$, g./ cm^2 .
Methylene-blue.								
0.425	2.15	1.4 ± 0.1	0.850	1.55	4.1 ± 0.4	1.710	1.40	5.8 ± 0.6
0.500	1.61	2.1 ± 0.2	1.000	2.11	2.6 ± 0.3	2.000	1.16	4.6 ± 0.5
0.650	1.74	1.6 ± 0.2	1.300	1.33	5.7 ± 0.6			
Congo-red.								
0.125	1.61	2.5 ± 0.3	2.000	1.87	53.5 ± 5.4	3.000	1.57	47.8 ± 4.8
0.250	2.06	5.7 ± 0.6	2.000	2.34	49.0 ± 5.0	3.500	1.41	29.1 ± 2.9
0.500	1.61	15.2 ± 1.5	2.500	1.40	54.0 ± 5.4	4.000	1.96	22.2 ± 2.2
1.000	1.32	24.5 ± 2.5	2.800	1.74	53.0 ± 5.3	6.000	1.18	5.7 ± 0.6
1.500	1.36	39.3 ± 4.0						
Bordeaux extra.								
0.100	3.05	0.9 ± 0.1	0.500	1.54	3.7 ± 0.4	1.000	1.56	1.1 ± 0.1
0.200	3.80	1.4 ± 0.1	0.600	1.70	2.3 ± 0.2	2.000	1.45	0.8 ± 0.1
0.330	1.91	2.4 ± 0.2	0.730	1.77	1.6 ± 0.2			
Indigo-carmin.								
1.110	1.50	0.9 ± 0.1	2.810	1.30	2.8 ± 0.3	6.000	1.33	1.5 ± 0.2
1.730	1.46	1.4 ± 0.1	4.000	1.56	2.5 ± 0.3	7.700	0.84	1.7 ± 0.2
2.500	1.42	2.2 ± 0.2	5.000	1.48	2.0 ± 0.2			
Solway ultra-blue.								
0.300	2.08	0.8 ± 0.1	1.850	1.96	2.4 ± 0.2	3.300	1.61	1.7 ± 0.2
0.700	2.84	1.4 ± 0.1	2.400	1.43	2.2 ± 0.2	3.860	1.85	1.3 ± 0.1
1.000	1.29	1.8 ± 0.2	2.800	1.27	1.8 ± 0.2	5.000	1.56	1.1 ± 0.1

TABLE II.

	Actual area, \AA^2 .	Area of interface per molecule at maximum adsorption, \AA^2 .
Methylene-blue	140	53
Congo-red	192	2
Bordeaux extra	153	33
Indigo-carminc	168	27
Solway ultra-blue	176	28

FIG. 3.

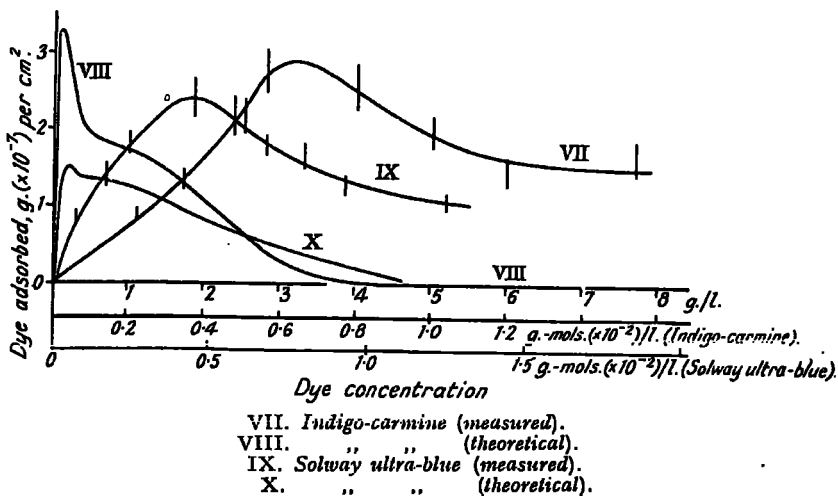

Interfacial tensions between mercury and aqueous solutions of the dyes have been determined by a drop-number method, and are shown in Fig. 4 and Table III. Exact agreement between measured adsorption and that calculated from the form of Gibbs's equation quoted above is not to be expected, on account of the latitude in evaluating $d\sigma/dc$, the use of concentrations instead of activities, and of factors such as the influence of electrical double layers, of which Gibbs's equation takes no account. The values of the interfacial tensions and of the adsorption coefficients calculated from them are nevertheless

FIG. 4.

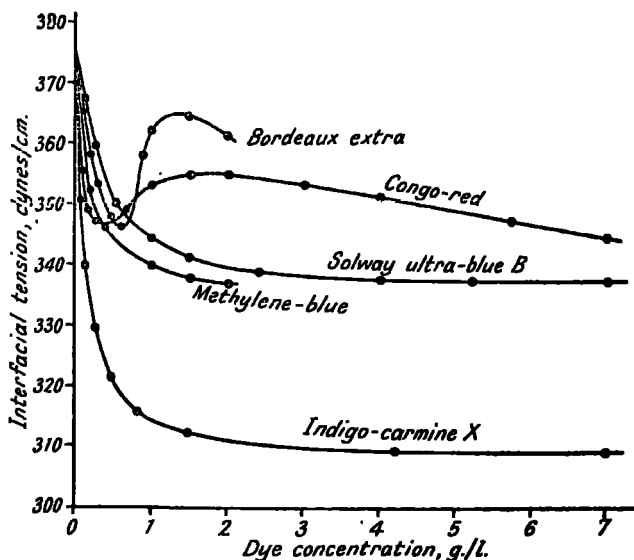

TABLE III.

Concn., g./l.	Drop no.	σ , dynes/cm.	Concn., g./l.	Drop no.	σ , dynes/cm.	Concn., g./l.	Drop no.	σ , dynes/cm.
Methylene-blue.								
0.000	208	374	0.200	222	352	1.000	230	340
0.100	215	363	0.400	226	346	2.000	232	337
Congo-red.								
0.000	208	374	0.250	225	347	2.000	220	354
0.022	213	366	0.500	225	347	3.000	221	353
0.044	216	361	0.750	224	348	4.000	222	351
0.063	220	354	1.000	221	352	5.700	225	347
0.125	224	348	1.500	220	354	7.000	227	344
Bordeaux extra.								
0.000	208	374	0.400	223	350	1.000	216	361
0.050	212	368	0.500	225	347	1.500	214	364
0.100	214	365	0.600	226	346	2.000	218	361
0.200	218	358	0.750	225	347			
0.300	221	353	0.910	218	358			
Indigo-carmine.								
0.000	208	374	0.500	244	322	2.800	254	310
0.063	223	350	1.000	249	316	4.200	254	310
0.125	230	340	1.500	251	313	7.000	254	310
0.250	238	329	2.000	253	311			
Solway ultra-blue.								
0.000	208	374	0.500	223	359	4.000	232	337
0.050	210	371	1.000	227	344	5.000	232	337
0.100	212	368	1.500	229	341	7.000	232	337
0.200	217	360	2.400	231	339			

recorded (Table III, Fig. 4; Figs. 1, 2, 3) because of the great discrepancies between the latter and the measured values. With methylene-blue, Solway ultra-blue B, and indigo-carmine X the interfacial tension falls with increasing concentration to a practically constant value, leading to a "theoretical" adsorption curve of the same form as that found by measurement, though of different dimensions. In this they resemble the behaviour of methyl-orange, Congo-red, and Bordeaux extra when adsorbed on benzene, chlorobenzene, and light petroleum. For the last two dyes the interfacial tension-concentration curves show two inflexions, similar to those found for the surface tension of laurylsulphonic acid and quoted by McBain and Mills ("Report on Progress of Physics," 1938, 5, 30, where references are given to other tension curves which reach or pass through a minimum). These lead to "theoretical" values for the adsorption which change from positive to negative and again from negative to positive with increasing concentration. This change of sign is independent of the use of concentrations instead of activities in Gibbs's equation, and of errors in assessing the numerical magnitude of $d\sigma/dc$. In none of the cases investigated do the curves representing the "theoretical" and measured adsorptions coincide at small concentrations, as would be the case if the only cause of the discrepancy were the omission of activity coefficients. No evaluation of possible activity coefficients could be carried out, therefore, as was done for methylene-blue (on chlorobenzene), Congo-red (on benzene), and Orange-II (on light petroleum) in Part II.

EXPERIMENTAL.

Adsorption Measurements.—Mercury stored in a reservoir *A* (Fig. 5) fell in a very rapid stream of small drops through a fine jet *B*, dipping below the dye solution contained in the inclined tube *C*. The drops moved slowly down to the syphon *D*, through which they passed as a sludge, aided if necessary by gentle stirring with a glass rod, and fell into a beaker *E*. The stability of the drops was such that in all the recorded experiments, except some of those with the most dilute solutions, very little coalescence could be detected in the syphon *D*. In some cases, particularly with Bordeaux extra, the drops remained stable for as long as two months, and coalescence of the mercury could be brought about only by centrifuging at high speed. In the cases of greatest stability the mixture of mercury and solution was uniformly semi-solid,

and only after centrifuging could a distinct layer of solution be seen on top of the mercury. The volume of the mercury used was measured directly, centrifuging being carried out first if necessary. The volume of the solution carried through with the mercury was that that added from a burette to keep a constant level in the graduated neck *F*. The difference in concentration between the original solution and that in *E* was measured in a tintometer. It was found necessary to centrifuge the solution again before comparison, to remove a large number of extremely minute drops of mercury, probably secondary drops formed at the jet, which otherwise produced a spurious deepening of the tint. The size of the mercury drops was found by catching a number of them on a lightly greased glass plate held under the surface of a solution a short distance below the jet. The diameters were then measured on the calibrated eyepiece scale of a microscope. A large majority of the drops were of uniform diameter within 2%, and very little variation was caused by changes in the concentrations of the solutions, the drops not being formed under quasi-equilibrium conditions, as was the case in the measurement of interfacial tensions. The values so obtained, of the order of 0.02 cm., were confirmed by measurements on drops caught on greased plates as they emerged from the syphon *D*, and on others which had been flowing for some time down a gentle slope. Different times of contact between the mercury and the solution were ensured by using alternately two adsorption tubes of different lengths, 45 and 60 cm., and by varying the angle of slope. In the majority of the experiments recorded the time of contact was 1.5–2 mins. The drop sizes were varied by using different

FIG. 5.

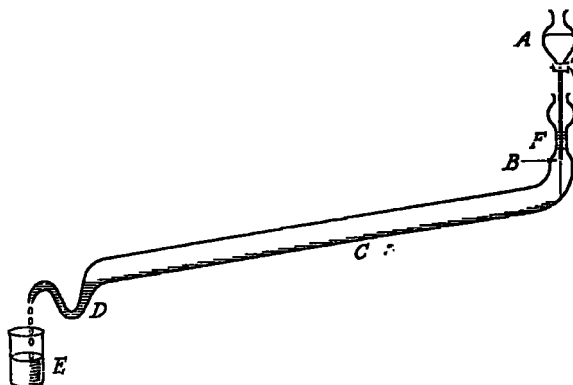

jets. As variation in these factors produced no corresponding variation in the results, it was concluded that the interfaces were saturated. All measurements were carried out at approximately 17°.

Interfacial Tensions.—The drop pipette used for the determination of drop numbers against the dye solutions was made from fine-gauge capillary tubing, blown out into a bulb of 1.206 c.c. capacity, measured between two constrictions formed above and below it. The lower constriction was of such a size that about 10 mins. were required to fill the bulb with mercury from below by evacuating from above with a pump. The average radius, measured along several diameters with a travelling microscope, was 0.0400 ± 0.0002 cm. The falling drops were counted automatically, as in previous work, and an average of several successive readings with each solution was taken when exact agreement to 1 drop was not obtained. The values of σ and $d\sigma/dc$ were calculated (as in Parts I and II) from smoothed curves of drop number plotted against concentration. No difference in drop number for a single solution was found by altering the time of formation of the drops from 4 to 20 secs. The time of formation used was 12–15 secs.

Materials.—The mercury was purified at frequent intervals by the method of Russell and Evans (J., 1925, 127, 2221). The methylene-blue, Congo-red, and Bordeaux extra were from the samples used in Parts I and II. The indigo-carmin and Solway ultra-blue had been purified by Messrs. Imperial Chemical Industries, Ltd. (to whose Research Department of the Dyestuffs Group we are indebted for the gift of these and other dyes) and were not further treated. All solutions were made in distilled water.

THE DURHAM COLLEGES IN THE UNIVERSITY OF DURHAM,
DURHAM.

[Received, February 19th, 1940.]

Introduction.

This research was undertaken as a continuation of the work carried out by Dr. C.C. Addison, during the sessions 1934 - 5 - 6, under the direction of Dr. C.W. Gibby. It is concerned with adsorption at liquid-liquid interfaces and in particular with the discrepancies between observed values for adsorption coefficients and those calculated from interfacial tension measurements using the Gibbs equation in the following form :-

$$\gamma = \frac{-\sigma}{RT} \cdot \frac{d\sigma}{dc}$$

Chief prominence has been given to adsorption at the mercury-water interface but some of the preliminary experiments were carried out with the chlorobenzene-water and benzene-water interfaces.

A large proportion of earlier work has been directed towards the study of adsorption at solid surfaces from either gaseous or liquid media; this being quite natural in view of the immediate industrial importance of such phenomena. Owing to the essentially irregular nature of the surfaces involved (e.g. charcoal, textiles etc.,) only a very approximate determination of the surface area can be made in such cases. Hence, the necessarily approximate nature of all results derived therefrom suggests that the translation of these results into terms of molecular thicknesses at the interfaces is scarcely justifiable.

Other investigators have studied the adsorption, at gas-liquid interfaces, of very large molecules which remain in the surface either

because they are only partly soluble in the liquid layer; or because they can produce there a layer so stable that it is capable of independent existence.

Unique advantages are possessed by the experimental study of adsorption at liquid-liquid interfaces in that a more quantitative investigation is possible. It has been found possible, in recent researches, to investigate the influence of the polar natures of either the adsorbent, or the adsorbate, or both, on the extent of the adsorption.

With due regard to the thermal agitation of the molecules in the surface region, the liquid-liquid interface may be considered to be as plane as is physically possible; in which case it will offer no resistance to whatever orienting forces the molecular attractions may set up.

The concentration of any solute at the interface between two other media can be regarded from a purely chemical or a purely physical standpoint as laid down below.

In the former conception there is a natural tendency for some molecules to concentrate on the interface where, because of their polar structure they may be attracted across the boundary surface although not sufficiently to be soluble in that medium. In the case of long fatty acid molecules on the air-water interface, the adsorbate may not be completely soluble in the aqueous layer and this tendency, together with the lateral cohesive forces between the hydrocarbon molecules themselves causes the adsorbate to spread out

on the surface in a film in a definite orientation. This film can behave as a two dimensional gaseous or liquid film according to the magnitude of the lateral pressure on it.

The latter conception considers adsorption as being due to a physical cause, and regards it as a mechanical movement towards the minimum potential energy of the system which its presence at the interface would produce. The lowering of the surface tension is readily visualised in terms of the molecular distribution caused by the various molecular attractions. If water molecules have a greater attraction for one another than for the solute present it follows that the latter will proceed to the boundary surface. Since surface tension is determined by the attractions between molecules in the actual surface, the smaller mutual attraction between solvent molecules in the surface, due to the concentration of solute there, must bring about a corresponding drop in surface tension.

Although the two aspects of adsorption referred to above are very closely related, experimental evidence of previous workers and that obtained in this particular study have shown that a large adsorption is not reflected to nearly the same extent in the drop in interfacial tension.

On the contrary, certain solutes, whose interfacial tension-concentration curves are similar are found to be adsorbed to widely different extents. Again, it is found that the variations of adsorption with concentration of solute need not follow even a similar course in such cases.

Gibbs' conception of Adsorption.

Willard Gibbs, who studied the influences of surfaces of continuity upon the equilibrium of heterogeneous masses, deduced a direct relationship between the quantity of any substance adsorbed in the region of an interface, and the change in the potential brought about by its movement from the homogeneous phase to the boundary.

The original form in which Gibbs stated his relationship has been altered by other workers to a form more applicable to practical use :-

$$\gamma = \frac{c}{RT} \cdot \frac{d\sigma}{dc}$$

This is the form in which it has been used throughout this work in attempting to correlate observed values for adsorption with the corresponding theoretical values.

The quantity γ , or the adsorption coefficient, having the same dimensions as $\frac{c}{RT} \cdot \frac{d\sigma}{dc}$; viz mass per unit area, does not represent a concentration excess over that of the homogeneous portion of the solution beyond the range of surface influences, but an actual mass attached to unit area of the interface. The volume in which this adsorbed mass is distributed is immaterial, since the surface layer was considered by Gibbs in his derivation as extending to a thickness great enough to include all such adsorbed matter.

As pointed out by previous workers, this form of Gibbs' equation was intended to apply only to adsorption of a single component from a solution in which its behaviour is ideal with respect to

concentration i.e. in which the actual concentration can be equated with the thermodynamic concentration or activity.

It can not, therefore, apply to solutions in which micelle formation or any comparable set of conditions is known to be present. Furthermore, the Gibbs relationship is not concerned with the possible influences on adsorption of electrical effects at the interface or of direct chemical affinities.

Finally, it can be seen that Gibbs' relationship gives a value for the adsorption coefficient depending upon the change of interfacial tension and hence may be either positive or negative according to whether the solute lowers or raises the interfacial tension. Reference to this will be made later in some interesting comparisons between the adsorptions calculated from interfacial tension data and the actual observed adsorption values obtained by direct experimental means. Discrepancies between the parallel series of figures are shown clearly and it is suggested that they arise because the ideal conditions assumed in the derivation of Gibbs' equation are not realised in practice and that the phenomenon of adsorption is governed by other factors than interfacial tensions.

Chapter 1.

HISTORICAL.

This chapter deals generally with previous experimental work relevant to the present research. The adsorption on solid surfaces from gaseous and aqueous media has hitherto received a great deal of attention for reasons already indicated, but, being scarcely relevant to the present investigation, it need receive no more than mention in this review.

The review of actual individual experimental details and formulae involved has been deferred until the appropriate later sections.

References are quoted in the bibliography.

Conclusions which have been drawn by previous workers with regard to surface orientation of molecules, layer thicknesses, the actual nature of the adsorbed layers etc., depend on an original estimation of the mass of the substance adsorbed on a known area of surface.

This data seems usually to have been obtained by one of two methods :-

(a) By accepting the validity of Gibbs' equation for the particular conditions employed and calculating adsorption values from available interfacial tension data.

(b) By actual experimental determination.

The data obtained by the first of these methods seems to have been

determined without adequate proof of the relationship over a sufficient range of concentration. In experimental work, especially in that due to Dr. Gibby and Addison, the deviations of observed values for adsorptions from those calculated via Gibbs' relationship have been so marked that the calculated values can have little practical significance. This conclusion is fully supported throughout present work.

The second method may be relied upon within the limits of experimental error (which are however variable) and it is the results of such determinations which have received the greatest attention here.

Previous Experimental Determinations of Adsorption at liquid-liquid interfaces.

Two chief experimental methods have been used; the one involving investigation of emulsions and the other, the moving bubble method, in which streams of single bubbles carry their adsorbed material into separate collecting reservoirs.

(I) The Emulsion Method.

This was developed during research on stabilising of soap solutions. The amount adsorbed emulsifying agent was measured by examination of the continuous phase before and after the emulsification.

Since Langmuir (1) and (2) and W.D. Harkins, E.C.H. Davies and G.L. Clark (3) suggested that emulsion stability was due to an oriented monomolecular layer of adsorbed material, a considerable amount of work has been done.

E.L. Griffin (4) studied emulsions of kerosene with solutions of sodium oleate and stearate, and found an approximately monomolecular layer at the interface. Similar results were obtained by P.A. Van der Meulen and W. Riemann (5) and (6) for toluene emulsified in sodium ricinoleate and oleate solutions.

W.D. Harkins and N. Beeman (7) worked with finer emulsions than had previously been used, and they found that the amount of various oleates adsorbed on very fine octane drops was more than sufficient to form a monomolecular layer.

E.K. Fischer and W.D. Harkins (8) made further measurements of the adsorption of soaps at an oil-water interface. The total surface area was obtained by direct microscopic measurement of the oil particles, and the quantity of soap adsorbed by chemical means. They concluded that an emulsion is stabilised by either expanded or condensed monomolecular layers of the emulsifying agent.

H.M. Cassel (9) in developing a theory of adsorption on curved surfaces, suggested that emulsions can be stable only if the interfacial densities of the emulsifying films for the surfaces of larger curvature are greater than for those of lesser curvature. Deductions from the theory are in qualitative agreement with experimental data.

(II) The Moving Bubble-Method.

This method for determining adsorption at liquid-liquid interfaces was first used by W.C. Lewis (10) who by this means examined the adsorption of a range of solutes at the interface

between their aqueous solutions and a hydrocarbon oil. Similar adsorption coefficients were obtained with large drops and with emulsion droplets; and it was therefore concluded that the surface of even the droplets was sufficiently plane, when considered in terms of molecular dimensions, to exhibit normal adsorption phenomena.

The adsorption of sodium glycocholate was measured by passing drops of oil up a tower containing its aqueous solution. The adsorbed material was collected in a reservoir at the top of the column. The drop pipette method was used to measure the change of interfacial tension with concentration, and also to estimate the excess concentration in the reservoir due to the adsorption. Results indicated an adsorption of the order of 100 times that calculated from interfacial tension data.

Adsorption coefficients for Congo Red, Methyl Orange, and caustic soda were obtained by the emulsion method. The oil was emulsified in the solutions, and the fall in bulk concentrations was measured by taking drop numbers through the emulsion. Experiments again indicated adsorptions of 10 to 20 times the calculated figures. Lewis attributed this discrepancy to the electrical double layer and other effects not taken into account by the Gibbs' Equation.

In a further extension of his experiments to the study of non-electrolytes and inorganic salts, Lewis (11) estimated adsorbed material gravimetrically. For silver nitrate and potassium, barium and copper chlorides, the actual adsorption was again from 10 to 20 times the calculated amount. Only in the case of emulsification of

a hydrocarbon oil in a solution of caffeine, were observed figures for adsorption of the same order as those predicted by the Gibbs' equation.

Lewis' results cannot, however, be considered from anything but a qualitative point of view as he generally records only one measurement for each substance. Because of this the accuracy of his experimental data cannot be estimated with certainty. It should be noted, in this connection, that a comparison of experimental results with those figures predicted by the Gibbs' relationship requires an extensive investigation of a wide concentration range. This is necessary because of the possibility of excellent agreement at a particular concentration, whilst in general there may be little or no correspondence between the two sets of data.

Patrick (12) whose work is more closely related to the present investigation, measured the interfacial tensions of mercury against aqueous solutions of mercurous sulphate, neofuchsin, salicylic acid, morphine hydrochloride, picric acid and caffeine by the drop-weight method. He found that the mass of the mercury drop was independent of the rate of formation, a minimum time limit of one second for the formation of each drop being sufficient to ensure equilibrium.

Adsorption experiments were carried out on the aforementioned substances; but these were of an approximate nature. A fine shower of mercury droplets was sprayed down a tower up which was passing a current of solution. This spray was obtained by forcing mercury by a head of pressure through a series of fine scratches in a ground glass connection. The adsorbed material was collected

in a reservoir at the bottom of the tower, where the mercury droplets coalesced with a layer of mercury. In each experiment a constant mass of mercury was allowed to flow, and the solute removed from the tower was estimated colorimetrically. Results indicated that adsorption increased with concentration according to the relation found for solid surfaces, except for morphine and caffeine, when no adsorption was found.

No attempts were made to estimate the size of the droplets, and thus the surface area, or to prove that the mercury surface was completely saturated; and hence the results have only qualitative significance.

Nonaka (13),(14), investigated the adsorption of soaps at the benzene-water and toluene-water interfaces, and found a greater adsorption value than corresponded to a monomolecular layer. He suggested that the layer may be in unimicellular form.

K.M. Seymour, H.V. Tartar and K.H. Wright (15) also investigated the adsorption of sodium oleate at benzene-water interfaces. The oleate solution was prepared by saponification of pure oleic acid with a slight excess of caustic soda. The system is complicated by the fact that the oleic acid dissolves in benzene.

Aqueous and benzene solutions of oleic acid were therefore left in contact for about two weeks to reach equilibrium, and these media were used in the adsorption experiments. The moving bubble method of determination was used; the drops passed up an inclined tube,

over a bend at its upper extremity, down a narrower tube just large enough at accomodate the drops, and finally into a reservoir. This reservoir contained the coalesced benzene drops with the minimum of bulk soap solution. The adsorbed mass was found by estimation of the excess sodium in the aqueous layer. The quantity adsorbed was more than 20 times that required for a monomolecular layer when calculated from the oleic acid gain, but only five times the monomolecular quantity when calculated from the sodium gain. This indicates that considerable hydrolysis must have taken place in the solution. Furthermore, errors from drainage of adsorbed material from the benzene drops, must have arisen; and from the adsorption of oleic acid from the benzene side of the interface.

C.W. Gibby and C.C. Addison (16),(17), in work on adsorptions at liquid-liquid interfaces of which the present investigation is a continuation, studied the adsorption of Methylene Blue, Orange II, Methyl Orange, Congo Red and Bordeaux Extra at benzene-water, chlorobenzene-water, and petroleum ether-water interfaces. The determinations were made by the moving bubble method in which the bubbles traversed a vertical column of aqueous dyestuff and coalesced in a reservoir. The adsorbed material was estimated by change in concentration of the reservoir solutions determined colorimetrically.

Interfacial tension measurements for the same systems were made by the drop weight method and the observed adsorption figures compared with those calculated by the use of the Gibbs' Equation.

Considerable deviations from calculated figures were noted

throughout and were ascribed to the action of factors not considered by Gibbs' in the derivation of his relationship, but not to the action of any one factor.

Two types of concentration-adsorption curve were found, differing according to the adsorbate, but independent of the interface. The adsorptions of Methylene Blue and Orange II rose to a maximum and remained there up to the highest concentrations used. The adsorptions of Congo Red, Bordeaux Extra and Methyl Orange passed through a maximum and returned to or towards zero at higher concentrations, thus having the qualitative features of a Gibbs' curve.

The numerical value of the adsorption reached in the case of Methylene Blue and Orange II was the same whether benzene or chlorobenzene was used; whilst for Congo Red or Methyl Orange the influence of polar strength of the adsorbent was outstanding. Bordeaux Extra showed anomalous behaviour, and adsorption on petroleum ether was consistently small throughout.

Methylene Blue and Orange II on benzene and chlorobenzene interfaces formed approximately monomolecular layers. The adsorption curves for the other three dyes, although similar to those required by Gibbs' Equation, could also be accounted for qualitatively by assuming selective adsorption of single molecules.

Methyl Orange and Congo Red, at maximum adsorption, formed sparse monomolecular layers on benzene, but on chlorobenzene their layers were found to be approximately two molecules thick.

Calculated adsorptions involving the use of Gibbs' Equation.

Schofield and Rideal (18) (19) (20) studied the kinetic theory of surface films, and calculated adsorption values for a number of substances over a range of concentration. From these values they calculated the area A occupied by a molecule on the interface. Following Langmuir's original method, the authors applied the gas laws $PV = RT$ to two dimensional layers, by substituting A for V , and F for P , where F , the lateral pressure experienced by the adsorbed molecules, is represented by the fall in the interfacial tension. The expression FA/RT was graphed against F , for a range of long chain fatty acids, and curves similar to those given by imperfect gases were obtained.

Wynne-Jones (21) pointed out that the values obtained by Schofield and Rideal for alcohol represent the total amount at the interface, not the excess. He recalculated the figures assuming a finite thickness of layer but his assumptions were regarded by the previous authors as being unsound thermodynamically.

These results are interesting as an extension of the kinetic theory to two-dimensional layers, but since the original adsorption figures were based on Gibbs' relationship, they can be of no real significance until proved by quantitative experiment.

R. Dubrisay (22)

This investigation was concerned with changes in drop numbers of benzene in soap solutions, on addition of electrolytes. The adsorption of soap on the benzene-solution interface was calculated

and the author suggested that the presence of electrolytes increased the amount of soap adsorbed. (Due possibly to enhanced electrostatic attractions).

Harkins & Wampler (23) measured activity coefficients of n-butyl alcohol and other organic solvents in aqueous solutions by freezing point methods, and employed the results in the calculation of adsorption. The results indicated monomolecular adsorption.

Butler & Wightman (24) also investigated the surface tensions of water-alcohol systems, using the maximum bubble pressure method. The calculated adsorption corresponded to slightly more than a monomolecular layer of alcohol molecules.

J.L. Shereshefski (25)

This worker applied Gibbs' Equation to the somewhat unusual case of a one component system. He suggested that the surface of a liquid in contact with its own vapour is neither a continuous transition nor an abrupt change, but that an adsorbed layer of vapour, denser than the vapour but less dense than the liquid, provides the transition.

By applying Gibbs' Equation to the change in surface tension and vapour density with temperature, he was able to calculate the thickness of this adsorbed transitional layer. He concluded that it was rather less than one molecule thick.

J.W. Belton (26) (27) (28).

This investigator carried out work of a slightly different nature and measured the surface tensions of binary liquid

mixtures containing benzene. The surface tensions of the benzene-acetic acid, benzene-carbon disulphide, and benzene-carbon tetrachloride systems was found by the maximum bubble pressure and the adsorptions calculated. An interesting feature of the results is that for the benzene-acetic acid system an adsorption-concentration curve with two maxima was obtained, with a point of zero adsorption between the two maxima. This will be referred to later in discussion of adsorption values calculated from interfacial tension data in this present work.

J.W. Belton (29) continued the above work, this time on the systems $C_6H_6 - CS_2 - H_2O$ and $C_6H_6 - ACOH - H_2O$. For the first mentioned system, application of the Gibbs' Equation to the interfacial tension data (by maximum bubble pressure method) showed that the adsorption of benzene at the liquid-vapour interface increased to a maximum and then decreased, whilst that of CS_2 at the liquid-liquid interface decreased with increasing benzene concentration.

In the system benzene-acetic acid-water, acetic acid was found to be adsorbed at each interface; the amounts adsorbed at the liquid-liquid and aqueous layer-air interfaces passing through a maximum when acetic acid concentration in the aqueous layer was 2M. The amount adsorbed at the benzene layer-air interface increased with increasing acetic acid concentration throughout the range of concentration investigated.

These calculations should form the basis of a comparative investigation if a satisfactory experimental technique could be evolved for direct determination of the adsorption. However, it is considered that adsorption data which are entirely dependent on the validity of

the Gibbs' equation have little importance and should always have the support of some practical justification.

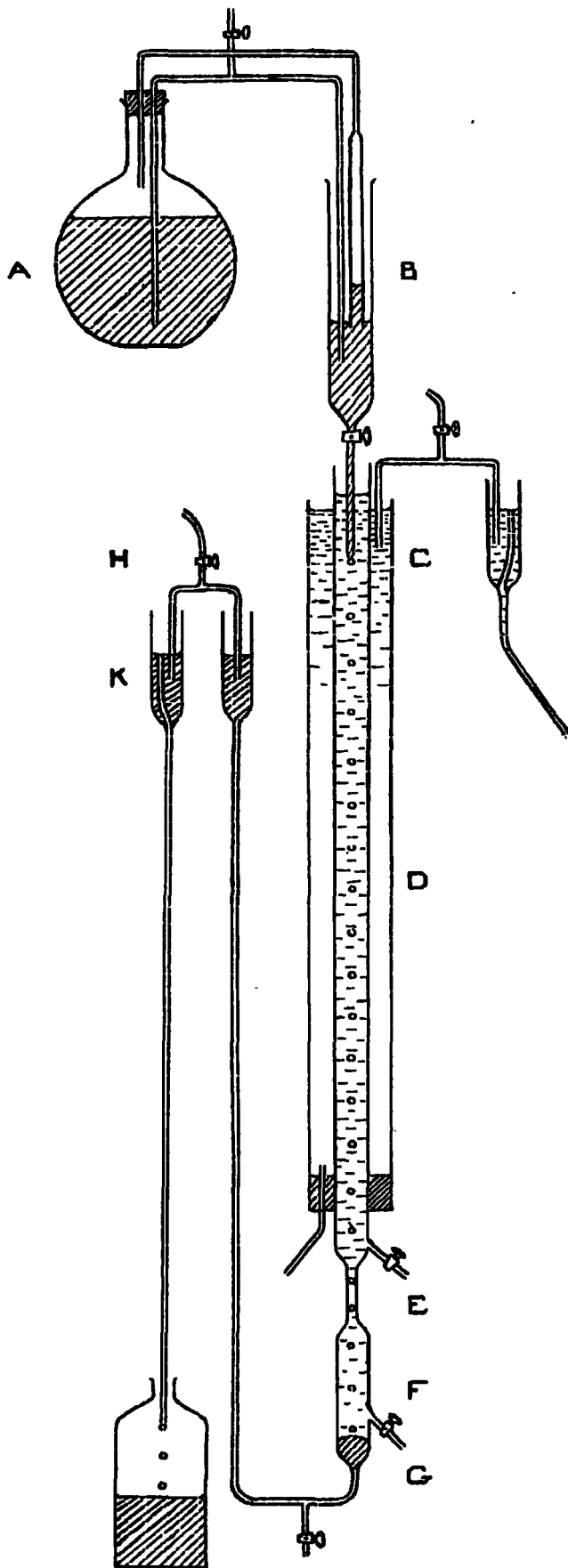

FIGURE I.

Chapter 2.

PRELIMINARY INVESTIGATIONS.

(a) Adsorption at the chlorobenzene-water interface.

(I) Apparatus.

In these initial experiments the apparatus closely resembled that used by Drs. C.W. Gibby and C.C. Addison in their work on the adsorption of dyestuffs at the chlorobenzene-water interface. The apparatus is shown in Figure I opposite and was operated as set out below :-

The chlorobenzene (B.D.H. "Purified") was contained in a 4 litre flask at A and maintained, by the siphon arrangement shown, a constant head of pressure at B. From here it fell in a uniform stream of drops 4 - 5" apart from a jet C immersed in the aqueous solution of the adsorbate. This aqueous solution was contained in a water jacketed column D about four feet in length which narrowed at its lower end to a constriction about 4" long and just large enough to accommodate the drops. After passing through this constriction the drops coalesced at the chlorobenzene surface G in the bottom of the reservoir F in which the adsorbed material would then collect. The chlorobenzene passed through only one tap in the constant pressure head and this was lubricated sparingly with Apiezon grease at its outer extremities only. The chlorobenzene overflowed through a siphon H, and by adjusting the movable limb K, the level of the interface G could be kept constant. In filling the apparatus chlorobenzene was added down H till the surface was at G as shown; the chlorobenzene and

aqueous solution then being added down their respective limbs at such a rate that the chlorobenzene-aqueous solution interface was maintained at G.

The average duration of a run was not less than 24 hours, in which time 4 - 5 litres of chlorobenzene passed through the apparatus in drops of about 0.1 ccs. volume. The average area of surface exposed during such a run was about 4 square metres. The rate of flow was maintained very steadily and checked, at intervals, by timing the drops on a stop-watch. The number of drops and total volume of chlorobenzene passing in any given time served immediately as a source of data for the surface area exposed during the run.

To provide a test of completion of adsorption during the passage through the solution, a second column D of $1\frac{1}{2}$ ft. greater length was used in an otherwise duplicate apparatus which was used alternatively with the initial apparatus.

(II) Cleaning of apparatus.

Since chlorobenzene drops readily clogged the constricted tube unless this was very thoroughly cleaned, it was found necessary after each run to "bubble"-clean the apparatus with nitric acid and ethyl alcohol.

(III) Estimation of adsorbed material.

Since all solutions which it was proposed to investigate were colourless, concentration changes were determined by the use of a Rayleigh refractometer, purchased with the aid of a grant from the

Durham Colleges Research Fund.

For the adsorbates used the instrument had a sensitivity of approximately 0.08 gram/litre per scale division which meant a limiting accuracy of the order of 0.01 gram/litre concentration change detectable by this method. Calibration curves of concentration against band displacement were constructed and enabled the concentration of the reservoir solutions to be rapidly determined.

(IV) Temperature Control.

The apparatus was water-jacketed as shown in Figure I and this was found to maintain the solution in D at approximately $17^{\circ} \pm 1^{\circ}\text{C}$. throughout in a small room provided with continuous central heating.

(V) Particular adsorbates used.

The apparatus was intended for the investigation of adsorption, at the chlorobenzene-water interface, of sulphonic acids and sulphonates whose molecular structure was simpler than that of the dyestuffs used by Drs. C.W. Gibby and G.C. Addison, viz:- Orange II, Bordeaux Extra, Congo Red and Methyl Orange.

To begin with, benzene sulphonic acid, sodium benzene sulphonate and sodium sulphanilate were chosen as possible adsorbates, being readily obtainable in a state of purity.

The adsorbate solution and the chlorobenzene were mutually saturated by shaking together and standing for 24 hours before using as were all solutions examined in the refractometer.

In no case was any change in concentration of the reservoir

solution noted in experiments with single drops and surface areas of about 5 square metres. The jet size was then adjusted so that a mist of drops showered down the tower. The diameter of these droplets was found to be very uniform and of the order of μm . when measured on the scale of a travelling microscope. Here, instead of the time of contact being 10 - 15 seconds, it was as great as 45 - 50 seconds and the area exposed was some 90 - 100 square metres per run.

Although a range of concentrations from 0 - 10 grms/litre was investigated in each case there was no detectable adsorption and it appeared probable that there was an upper limit for the adsorption of 10^{-9} grms/cm² above which it would be detected by the method described.

It should be pointed out here that it would be incorrect to infer that there was no adsorption, since the great readiness with which all these solutions froth indicates a very decided lowering of surface tension at the air-water interface, at least.

(VI) Adsorption of dimethylaniline at the benzene-water interface.

An attempt was made to detect adsorption, in the same apparatus, by dropping water down the tower through benzene solutions of dimethylaniline. Concentration comparisons were again carried out by the refractometer method and the solutions used were mutually saturated.

Reliable results were not obtained but it was considered that there was no very appreciable adsorption detectable but conclusions were

complicated by refractometer measurements on dimethylaniline solutions which darkened on exposure to light and air.

(VII) Testing the apparatus for diffusion:

During the preliminary experiments on adsorption at the mercury-water interface attempts were made to use a further modification of Addison's apparatus and it was here found that the stirring effect of the mercury drops was very great and caused very considerable back diffusion from the collecting reservoir. This will be discussed more fully later but the result of this discovery was an investigation of the stirring effect in the case of chlorobenzene drops.

It seems doubtful to what extent the back diffusion was disproved by Addison. In comparative tests during the present work it was found that a dyestuff solution in the lower reservoir had diffused through the whole apparatus within $\frac{1}{2}$ hour when drops were falling at the rate of 60 per minute which was comparable with Addison's conditions.

The time occupied by one of the adsorption runs in this, and in Addison's work, was roughly 24 hours so that it seems feasible to say that there may be more adsorption in this work than is indicated and also that the order of Addison's results may be low and that the form of his curves may be somewhat incorrect.

(b) Interfacial tension measurements :-

The interfacial tensions between chlorobenzene and aqueous solutions of benzene sulphonic acid and sodium benzene sulphonate were determined by the drop weight method and the drops were counted by an

automatic device similar to that used by Drs. Gibby and Addison, and described later.

Considerable difficulty was experienced in obtaining reproducible results with a glass jet. These glass jets were made by carefully grinding down the end of a capillary tube. In most cases the edge so obtained was not fine enough nor was the capillary of uniform circular section. It also appears that the effective radius of the jet cannot be taken as that of the inside if the glass becomes slightly wetted with chlorobenzene before the start of the experiment.

Metal jets made of brass were found to be much more satisfactory. A truer hole was obtained together with a finer edge. The difference between the inside and outside diameters of the jet was no greater than the actual experimental error in measuring either. With jets of this type it was found quite possible to reproduce recorded figures for the interfacial tensions between water and pure organic liquids.

The drop number of B.D.H. "Purified" chlorobenzene against distilled water using a metal jet was 272 where the effective volume of the pipette was 29.02 ccs. and the radius of the jet was 0.0592 cms. The corresponding value of interfacial tension was therefore 37.4 dynes/cm.

The drop numbers were then taken against solutions of sodium benzene sulphonate over a range from 0 - 10 gms/litre. The maximum drop number recorded was 274 at 10 gms/l. Thus there is no appreciable change in interfacial tension with increase of concentration and it is

not practicable to calculate adsorption figures.

Further drop numbers were taken against benzene sulphonic acid solutions made by dilution of a 32% B.D.H. solution. The range of concentrations investigated was 0 - 25 gms/litre and an appreciable change in interfacial tension was recorded. Because of the comparatively high concentrations under consideration it was necessary to apply correction for the difference in density between the sulphonic acid solutions and water. The results of this survey were plotted to give a drop number/ concentration curve from a smoothed version of which interfacial tensions were calculated and plotted to give an interfacial tension/concentration curve from whose slope values of $\frac{d\sigma}{dc}$ at various concentrations were read off and used in calculation of theoretical adsorptions by substitution in Gibb's equation

$$\Gamma = \frac{-\sigma}{RT} \cdot \frac{d\sigma}{dc}$$

The complete summary of results is given in Table I.

Although the range of concentration did not extend far enough to cover the full range of adsorption coefficients it was found impossible to complete the range in the time available. It appears that the adsorption coefficient follows a typical Gibb's curve and, after passing through a maximum returns to or towards the zero value again.

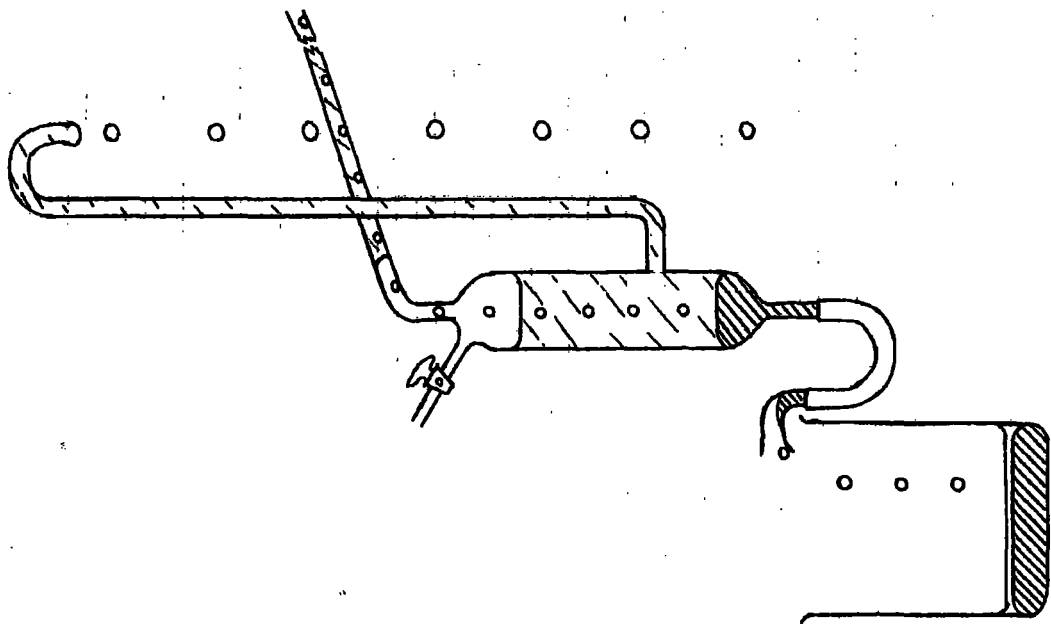

FIGURE II.

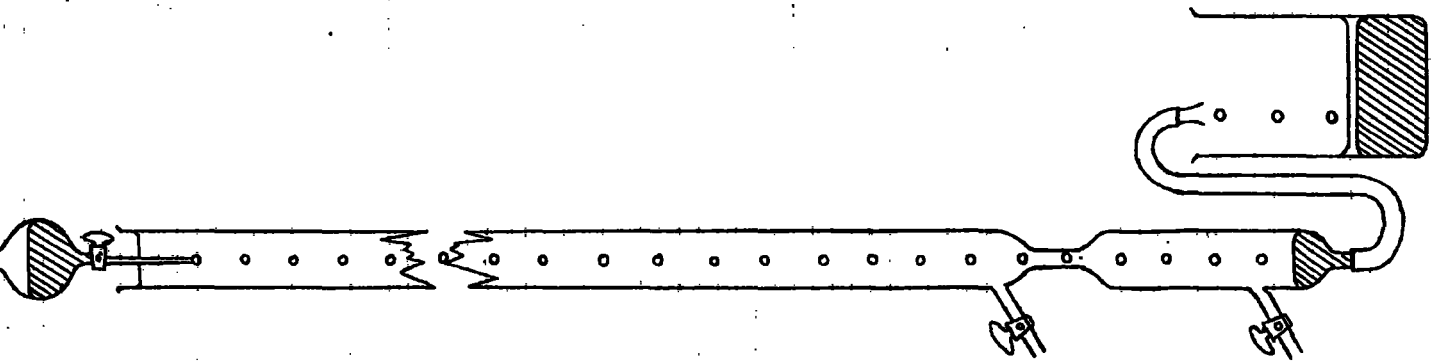

TABLE I.

Concn. Gms/L.	Drop No.	σ in dynes/cm.	$\frac{d\sigma}{dc}$	density soln.- density water	Calculated Γ 10^{-8} gms/cm ²
0.00	272	37.4	1.55	0.0000	0.000
0.50	277	36.7	1.09	0.0002	0.35
1.00	280	36.3	0.95	0.0004	0.61
2.00	286	35.4	0.77	0.0008	1.0
4.00	296	34.0	0.57	0.0016	1.5
8.00	309	32.2	0.38	0.0032	2.0
16.00	323	29.9	0.22	0.0064	2.3
25.60	328	28.4	0.12	0.0102	1.99

(c) Adsorption at the mercury - water interface.

Because this investigation is primarily concerned with comparisons between calculated and observed values of the adsorption coefficients, attention was transferred to the mercury-water interface in an effort to find a suitable measurable adsorption.

A fine jet of mercury liberated under a solution of Methylene Blue resulted in the stabilisation of the droplets formed and a great reluctance on their part to coalesce after several hours. This seemed to indicate that some surface influence was responsible and encouraged further work.

The apparatus used in first experiments was a much simplified form of that used for the chlorobenzene work and is shown in Figure II opposite which is self explanatory. As already mentioned, before

using this apparatus it was tested for back-diffusion from the reservoir due to the stirring effect of the rapid stream of mercury drops and the slight but continual oscillation of the mercury surface in the lower reservoir.

A little dyestuff was placed in the reservoir and the apparatus cautiously filled with water. When the mercury stream was turned on the stirring was so very violent that the whole apparatus was uniformly coloured in 5 minutes and would be sufficient to reduce considerably any concentration change in the lower reservoir, if not to completely nullify it.

Hence, it seemed that unpublished work of L.W. Turner which had been based on the use of this apparatus was of little numerical value, but the fact that there were any figures obtainable at all was remarkable enough, and showed that adsorptions must be quite appreciable.

On this basis it was decided that if the diffusion effect could be eliminated then valuable data could be obtained for comparison with adsorption values calculated from interfacial tension data obtained by the drop weight method.

Several attempts were made in the design of the apparatus to prevent this back-diffusion. The first was the insertion of strings of baffles in the upper portion of the adsorption tower, but this was quite ineffective as numerous small eddies were set up.

The fact that small drops of mercury remain stable in dyestuff

solutions for long periods suggested a method in which a stream of such drops could be run down a gentle slope and thence into a reservoir. The great problem still remained that of getting the droplets into the reservoir on a lower level without causing stirring effects; and, after experimenting with several designs of apparatus, it was finally decided that the direct drop into the reservoir was quite impracticable; no matter how gently it was made.

The next method tested was with an apparatus in which the mercury, in single drops passed through an air-lock. The upper portion of the apparatus was a tube of $\frac{1}{2}$ cm. internal diameter and 4 metres in length. The total fall in head over this distance was not more than 25 cms. which gave a slope which was just sufficient to maintain a steady flow of drops. The reservoir, shown in Figure II, was sealed to the lower end of this long Z shaped upper portion. The apparatus was filled with dyestuff solution and an air-lock was then blown in at A. If the mercury, after running through the solution of the adsorbate in B, fell through this air-lock commencing at C, there could be little chance of back-diffusion.

It was found, however, that the great difficulty was the lack of stability of the air-lock which, due to the constant transfer of liquid across the lock by the drops, could not be prevented from moving steadily up the tube above B. To overcome this increase in the bulk of the solution in the reservoir a siphon of adjustable height was fixed to the reservoir at D in order to remove this solution as it entered. This worked satisfactorily for short periods

until slight irregularities in the mercury flow upset the balance of levels and the air began its upward movement. Besides this difficulty the solution carried over by the drops caused so great an increase in the bulk of the reservoir solution that determination of concentration changes was, of necessity, much less accurate.

The method finally decided upon, and described in detail in the following chapter, involved the great stability of a fine stream of mercury drops after passage through the dyestuff solutions. The drop size was found to remain uniform and coalescence to be infrequent. The reluctance of an accumulation of such drops to flow through narrow tubes enabled the sludge to be removed progressively by a slow siphoning system to an entirely separate reservoir for examination. As will be described later, the sludge had invariably to be centrifuged at high speed to bring about complete separation of the mercury from "bound" solution.

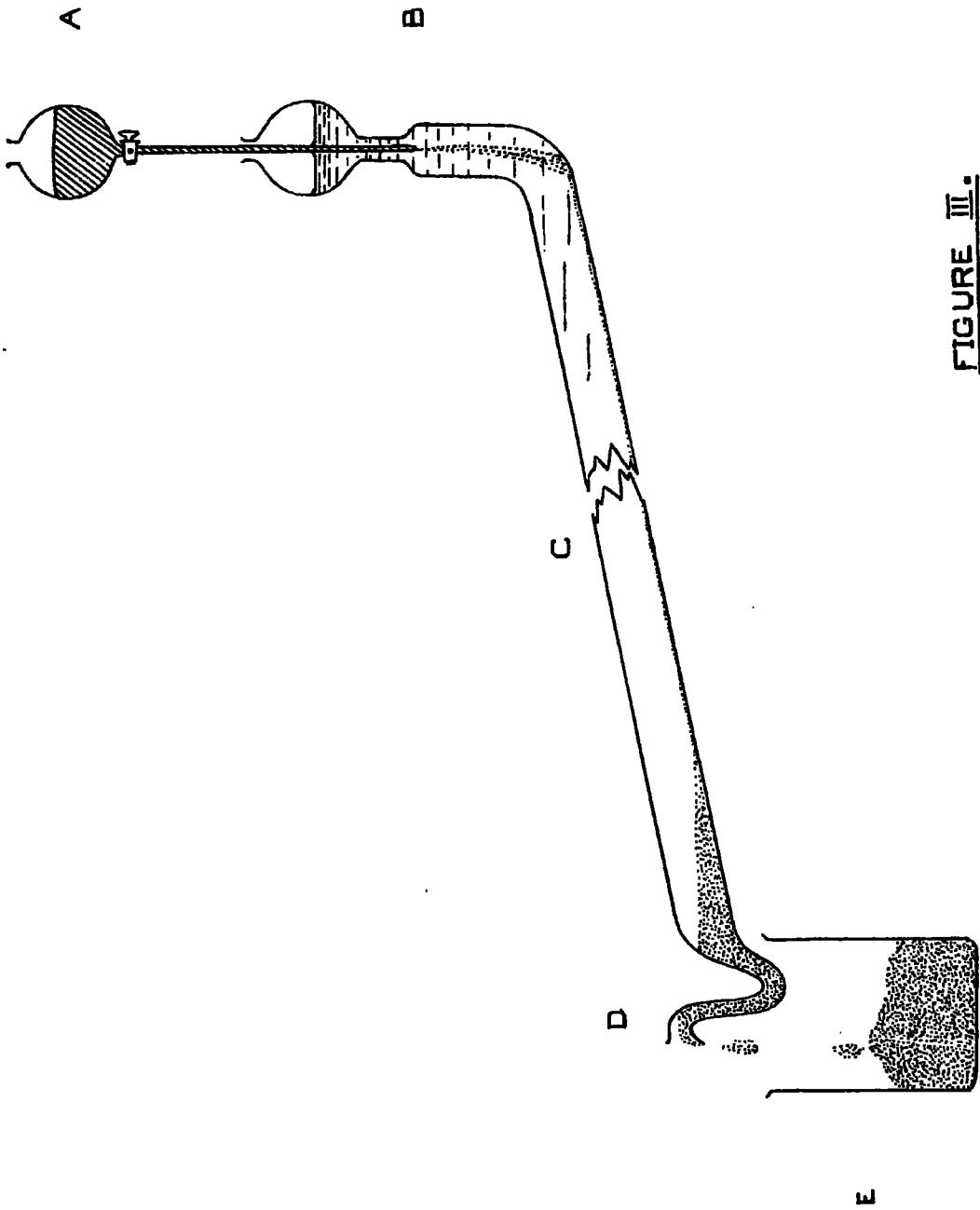

FIGURE III.

Chapter 3.

EXPERIMENTAL.

(I) Adsorption Measurement.

The apparatus finally decided upon for the experimental determination of adsorptions of dyestuffs is shown in Figure III opposite.

Mercury, stored in a reservoir A fell in a very rapid stream of small droplets through a fine jet B, dipping below the dye solution contained in the inclined tube C. This tube was about 3 cms. internal diameter and some 50 cms. in length after the bend. At the upper extremity of the vertical portion of C a bulb-shaped reservoir served as a capacity vessel in filling and in displacement of dye solution due to accumulation of mercury sludge at the lower end of the tube.

The jet was suspended in a vertical position in the tube and the mercury droplets flowed on to the bend in C from which they passed downwards in a continuous uniform stream until they reached the lower end. Here, the tube was drawn down and attached to a narrower tube of about 0.5 cms. internal diameter, which was bent to form a syphon and had to be adjusted, from time to time, for bend and size until, when the stream of mercury droplets was flowing regularly down C the accumulation of sludge emptied itself regularly by the siphon D into the receiver E. When working steadily the levels of mercury in D adjusted themselves so as to balance the head of solution in C. This difference in levels was never as great as would have appeared necessary at first sight, owing to the restricted flow of the mercury sludge.

In some cases no amount of adjustment could make the sludge pass over freely without constant attention and in such cases its passage was encouraged by gentle stirring with a fine glass rod worked piston-fashion in D.

The stable "froth" or "sludge" carried with it, into E, a considerable amount of solution and it was in this solution that the change of concentration over and above the initial concentration in C was sought.

In most cases except those involving the very dilute dyestuff solutions the rate of coalescence of the mercury sludge was slow and it was found necessary to centrifuge the total content of the reservoir for about 10 minutes in order to effect a complete separation of mercury and solution. The total bulk of the solution passed over in the froth was measured by filling up to a graduation mark on the neck of C at the beginning of each experiment and replenishing from a burette as the solution was carried over. Having centrifuged the contents of the reservoir the volumes of the two components could be measured and the aqueous solution checked against the volume added from the burette. This check was necessary in order to ascertain whether or not there was any measurable evaporation of the solution from the reservoir over the period of the experiment. No evaporation was ever detected. The volume of mercury was measured in a graduated cylinder after centrifuging with a maximum error of $\frac{1}{2}\%$.

Properties of the mercury "sludge".

The "sludge" was of a semi-solid, spongy, nature possessing a pale pastel tint due to the film of dyestuff solution. The spongy mass could be poked about and showed no sign of the rapid recovery so typical of ordinary clean mercury. The stability was such that in all the recorded experiments, except some of those with the most dilute solutions, very little coalescence could be detected in the syphon tube D. In some cases, notably when considering Bordeaux Extra, samples of sludge were observed to be perfectly stable after standing for over 2 months and coalescence could only be brought about by centrifuging at high speed.

In different strengths of dyestuff solution and with different dyestuffs the stability was very variable and this factor set the limits to the concentrations which could be investigated and also to the actual dyestuffs suitable for this type of work. For example Methyl Orange used in earlier work by Drs. Gibby and Addison was found to produce only very unstable droplets in the higher concentration ranges. For a really stable film which had to be assisted over into the reservoir, as already described, the sludge of droplets would pile up like so much lead shot and poured to a uniform level only very slowly.

Adjustment of the Apparatus to ensure saturation of the Mercury Surface.

(1) Two tubes were used in the experiments on each dyestuff, being worked with successive concentrations throughout the range. The two tubes were 45 and 60 cms. in length respectively. This variation in

time of contact of droplets with aqueous solutions should have had a decided effect on the series of adsorption data if both tubes had not been of adequate length.

(2) Various jets were used, and, since they were so fine as to be of random size when made, a variation in size was inevitable during some early runs when breakages were frequent and unavoidable. In recorded runs, two jet sizes were used and showed no effect on the form of the results.

(3) The angle of slope on the tube A could be varied at will and thus the time during which any section of the stream was in contact with the solution. The average time for passage of any portion of the stream through the apparatus was between $1\frac{1}{2}$ and 2 minutes.

Thus it will be seen that at any stage in the experiment, should unsaturation occur it should show itself in irregularities in the values of the adsorption coefficients obtained and in a complete lack of reproducibility. No such difficulties were encountered and it was concluded that at all times saturation was achieved.

Determination of area of mercury surface exposed.

The jets used in production of the droplets were very fine and were drawn from fine capillary tubing. The drop was also measured, on emergence of the stream under the solution in question, by allowing the stream to fall on to a thinly-greased microscope slide. The drops so caught on the slide were examined in a microscope fitted with a micrometer scale. Great regularity in size of droplets was a feature of such examinations and it was interesting to note that

any larger drops which were detected possessed diameters which were $\sqrt[3]{2}$ and $\sqrt[3]{3}$ times as great as those of the majority of droplets. This observation indicates that the drop size is such that they lie on the greased plate in a spherical form and show no measurable tendency to flatten out as would larger drops; even after 2 or 3 drops have coalesced.

A further noteworthy observation was the fact that there was no measurable change in droplet size from a particular jet with change of concentration of the dyestuff solution. This seems to indicate that the droplets are formed too rapidly in such a spray for there to be any surface equilibria established.

Samples of the droplets were also taken from streams which had been flowing for some time down a gentle slope and from others which were emerging from the overflow of the apparatus itself. The drops from all sources were found to have the same dimensions, to be very regular and coalescence was negligible at the concentrations chosen for this work. The error in measurement in the drops was of the order of 2%. The drop size which was found to be most easily obtained whilst being of great stability, was found to be about 0.2 mm. diameter.

From the diameter of droplets so examined and from the total volume of mercury passed over in any experiment the area of surface exposed could be readily determined with an error of some 2%.

Examination of Reservoir Solutions.

The concentration of the reservoir solution was determined

colorimetrically by means of a Bausch & Lomb tintometer, this being found more suitable than the Du Bosck instrument used by Drs. Gibby and Addison.

In an effort to eliminate part of the experimental error, namely that due to the human element, which is imperative in colour matching, it was thought best to work with a constant comparison tint for each dye. This necessitated the dilution of reservoir solutions in most cases and adjustment of depths of solution in both limbs of the apparatus in other cases.

Throughout, the depths of the two solutions under comparison were adjusted by dilution so as to be of the same order of concentration and by so doing it was estimated that the experimental error was limited to an outside maximum of 5%. Greatest facility of matching was found with blue dyes and least with red and in the former case, therefore, the experimental error may have been considerably less than 5%.

Calculation of an Adsorption Coefficient.

Let droplet radius = r cms.

Total adsorbent = V ccs.

Then total surface exposed = $\frac{3V}{r}$ cms²

In this particular case :-

Average droplet radius = 0.0112 cms.

Total mercury used = 58 ccs.

Hence surface exposed = $\frac{3V}{r} = 1.56 \times 10^4$ cms².

Initial concentration of dyestuff	=	1.0 gms/litre.
Reservoir " " "	=	$\frac{15}{13} \times 1.0$ gms/litre.
Change in " " "	=	.154 gms/litre.
Volume of reservoir solution	=	11.0 ccs.
Hence total dyestuff adsorbed	=	1.69×10^{-3} gms.
Herefore adsorption coefficient	=	$\gamma = \frac{1.69 \times 10^{-3}}{1.56 \times 10^4}$
	=	<u>1.08×10^{-7} gms/cm² .</u>

Total Experimental Error.

It will be seen that three sources of experimental error have been noted.

(1) Measurement of droplet radius.

In setting an average value for this a large number of readings were taken . The maximum and minimum figures were always within 2% of the accepted average. The amount of coalescence was extremely small but was, of course, indeterminate. The total effect of these two factors on estimation of surface areas exposed is not estimated as being more than about 3%.

(2) The volume of mercury used in any experiment was measured after centrifuging the reservoir contents and an accuracy within $\frac{1}{2}$ % could be claimed.

(3) The largest source of error seemed to be in the determination of the concentration of the reservoir solution. Blank experiments with ranges of concentration indicated an average error of some 5%.

Hence it may be assumed that the absolute maximum of experimental

error was $\pm 8 - 10\%$. From observations of series of results however it seems unlikely that this figure was often realised; since curves drawn from the experimental figures are, on the whole, too smooth. However, this maximum figure for the experimental error is quoted in the tables of results and shown by the "limit - lines" on the graphs.

(II) Interfacial tension measurements.

Theoretical Considerations:

Interfacial tensions of dye solutions against mercury have been measured by the drop weight method in which the mercury was allowed to fall from a jet of fine capillary through the dye solution under test. The drop is held by surface tensional forces, and hence the greater the tension the larger will the drop become before it falls. The drop number from a fixed volume of mercury enables the drop size to be obtained in any solution.

The method is commendable for its accuracy and reproducibility and, in conjunction with an automatic counting device described later, was very convenient for this work. However, despite its extensive use the theory connecting drop weight with interfacial tension is not perfectly clear. Results are obtained only by employment of standardisation factors for known liquids and solutions. This is due to the complexity of the dynamic process of drop release. Guye & Perrots (30), who photographed drop releases, showed that only a part of the liquid outside the jet is released as a drop. Part is retained and part follows as a minute drop in the wake of the larger

one. It will be seen that it is difficult to cover such a process by any empirical laws. The secondary drop has been noted both here and in the adsorption work itself and is very minute indeed.

Tate (31) suggested that :

$$W = 2\pi r\sigma$$

where W = drop weight and r = jet radius, but this simple relationship was rapidly disproved as were several other static formulae unsuitable for a dynamic process such as this.

A dynamic conception of a falling drop, which must take into account the size of the drop at the point where it breaks away, and the fraction of the bulk which falls, is more nearly satisfied by the Lohnstein-Kohlrausch (32) formula which states that :-

$$g = r\sigma\phi$$

where g = drop weight and r = radius of the drop and ϕ is a function of $\frac{r}{a}$ where $a^2 = \frac{2\sigma}{\rho}$ (ρ = density).

A value for σ is assumed and $\frac{r}{a}$ is calculated. A linear relation given by Kohlrausch yields ϕ directly. The value of g calculated from $r\sigma\phi$ is compared with the value obtained by experiment and therefore may by trial be given the value such as to make the calculated and observed values identical.

Lewis (loc. cit.) used this method in calculation of theoretical adsorption coefficients using Gibb's Equation but in this work the more comprehensive figures of Harkins & Brown (33) were used.

Like Lohnstein these workers found that the drop weight

$$\begin{aligned}
 W &= \text{a function of } \frac{r}{a} \\
 &= 2\pi r \sigma f(r/a)
 \end{aligned}$$

They also point out that $f(r/a)$ is also a function of $r/\sqrt[3]{V}$ where V is the volume of one drop

$$\text{Therefore } W = 2\pi r \sigma \phi(r/\sqrt[3]{V})$$

$$\text{If } F \text{ is a function of } \frac{V}{r^3} \text{ such that } F = \frac{1}{2\pi \phi(r/\sqrt[3]{V})}$$

$$\text{Then } \sigma = \frac{mg_x}{r} F \text{ where } m = \text{the mass of the drop.}$$

Table II is an extract, over the relevant range, from the tables connecting $\frac{V}{r^3}$ and F given by Harkins & Brown, and obtained by standardisations against liquids of known properties. Using these σ may be evaluated in conjunction with the graph given in Figure IV.

Table II.

$\frac{V}{r^3}$	$F.$
5000	0.172
250	0.198
58.1	0.215
24.6	0.2256
17.7	0.2305

Example of calculation of Interfacial tension.

The interfacial tension of mercury against pure water is worked out at a temperature of 20° C. The necessary densities are from the International Critical Tables.

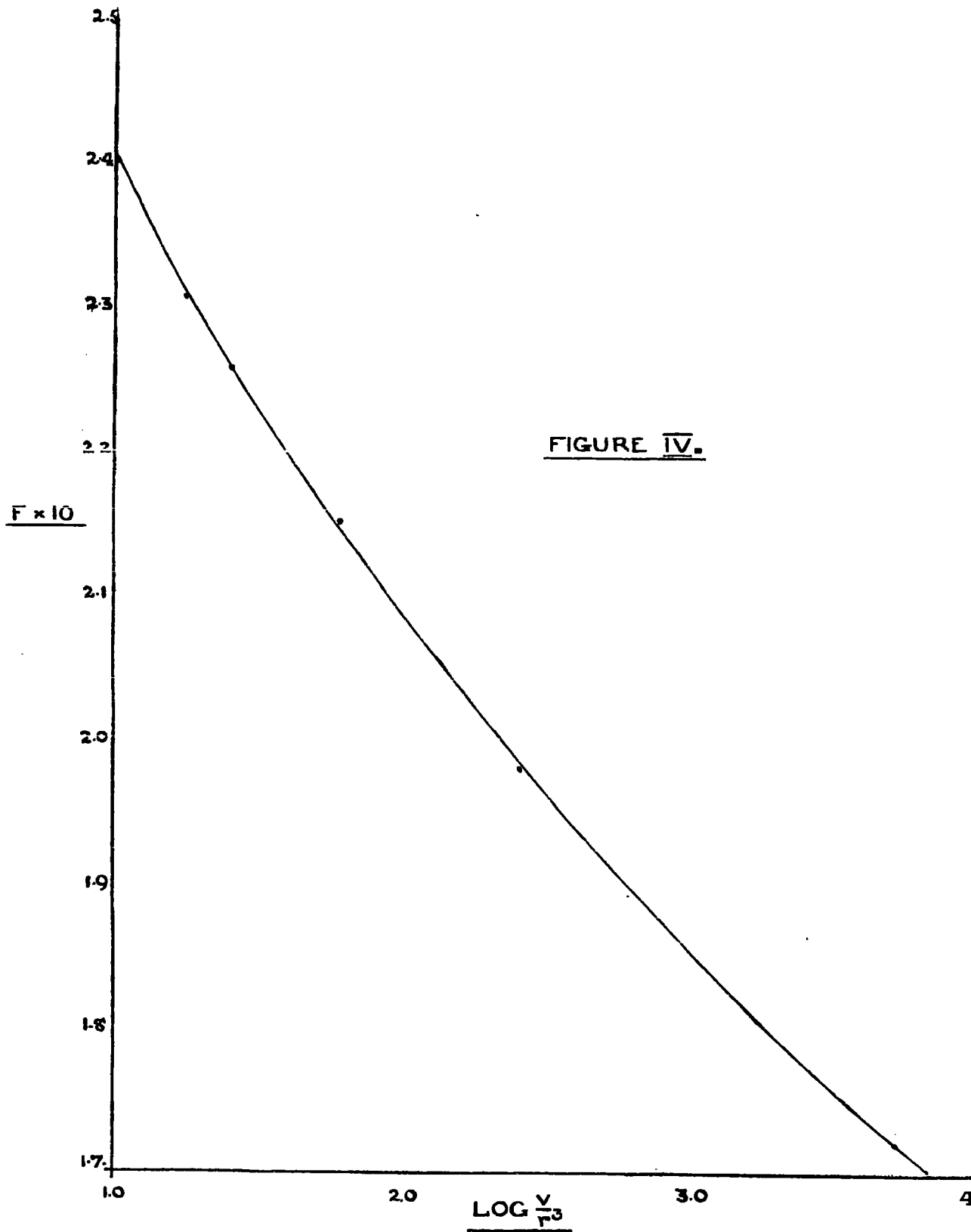

FIGURE IV.

$$\begin{aligned}
 \text{Radius of jet} &= 0.040 \text{ cms.} \\
 \text{Volume of pipette} &= 1.206 \text{ ccs.} \\
 \text{Drop Number} &= 208 \\
 \begin{array}{l} 20^\circ \text{ C} \\ d \\ \text{H}_2\text{O} \end{array} &= 0.9980 \text{ gms/cc.} \\
 \begin{array}{l} 20^\circ \text{ C} \\ d \\ \text{Hg} \end{array} &= 13.5437 \text{ gms/co.} \\
 d_{\text{Hg}} - d_{\text{H}_2\text{O}} &= 12.546 \\
 \text{So that } \frac{V}{r^3} &= \frac{1.206}{208 \times (0.04)^3} \\
 \text{And } \text{Log } \frac{V}{r^3} &= 1.9570
 \end{aligned}$$

Hence from Figure IV showing relation between F & $\text{Log } \frac{V}{r^3}$

$$\begin{aligned}
 F &= 0.2099 \\
 \text{So that } \sigma &= \frac{mgF}{r} \\
 &= \frac{1.206 \times 12.546 \times 981 \times 0.2099}{208 \times 0.040} \\
 &= \underline{\underline{374.4 \text{ dynes per cm.}}}
 \end{aligned}$$

This figure compares well with the 375.0 dynes/cm. obtained by Harkins & Brown J.A.C.S. 1920, 42, 2543.

Experimental Procedure:

The drop pipette used in this work was constructed from a piece of fine-gauge capillary tubing blown out into a bulb of 1.206 ccs. capacity, measured between two constrictions formed above and below it. (See Figure V.) The lower constriction was of such a size that about 10 minutes were required to fill the bulb with mercury from below

by evacuating from above with a "Hyvac" pump. This lower constriction was made so fine in order to control the rate of formation of the drops. Its suitability had to be tested by trial and error with frequent adjustments before a time of formation of 12 - 15 seconds per drop was obtained. The volume of the bulb was obtained by weighing the mercury content between the constrictions.

The jet itself was formed by a perfectly clean break of the fine capillary of which the tube was formed. Its surface and uniformity were examined by means of a travelling microscope and by this means also the radius was measured. Taken across several diameters the average value was found to be 0.0400 ± 0.0002 cms.

Rate of flow of mercury from the pipette.

In his original experiments, Tate (31) quoted 40 seconds for each drop release as the minimum time for reproducible results. Other investigators such as Lewis (loc. cit.) and Lord Rayleigh (34) found this unnecessary, and Lewis suggested 12 - 15 seconds per drop as a necessary time minimum. This minimum of 12 seconds was also considered necessary by Addison (loc. cit.).

In this present work no difference in drop number for a single solution was found by altering the time of formation of the drops from 4 to 20 seconds. The average time of formation used was 12 to 15 seconds as this was most suitable for operation of the automatic counter.

Temperature control.

All drop numbers were taken at $20^{\circ} \pm 1^{\circ}$ C. and it was found by

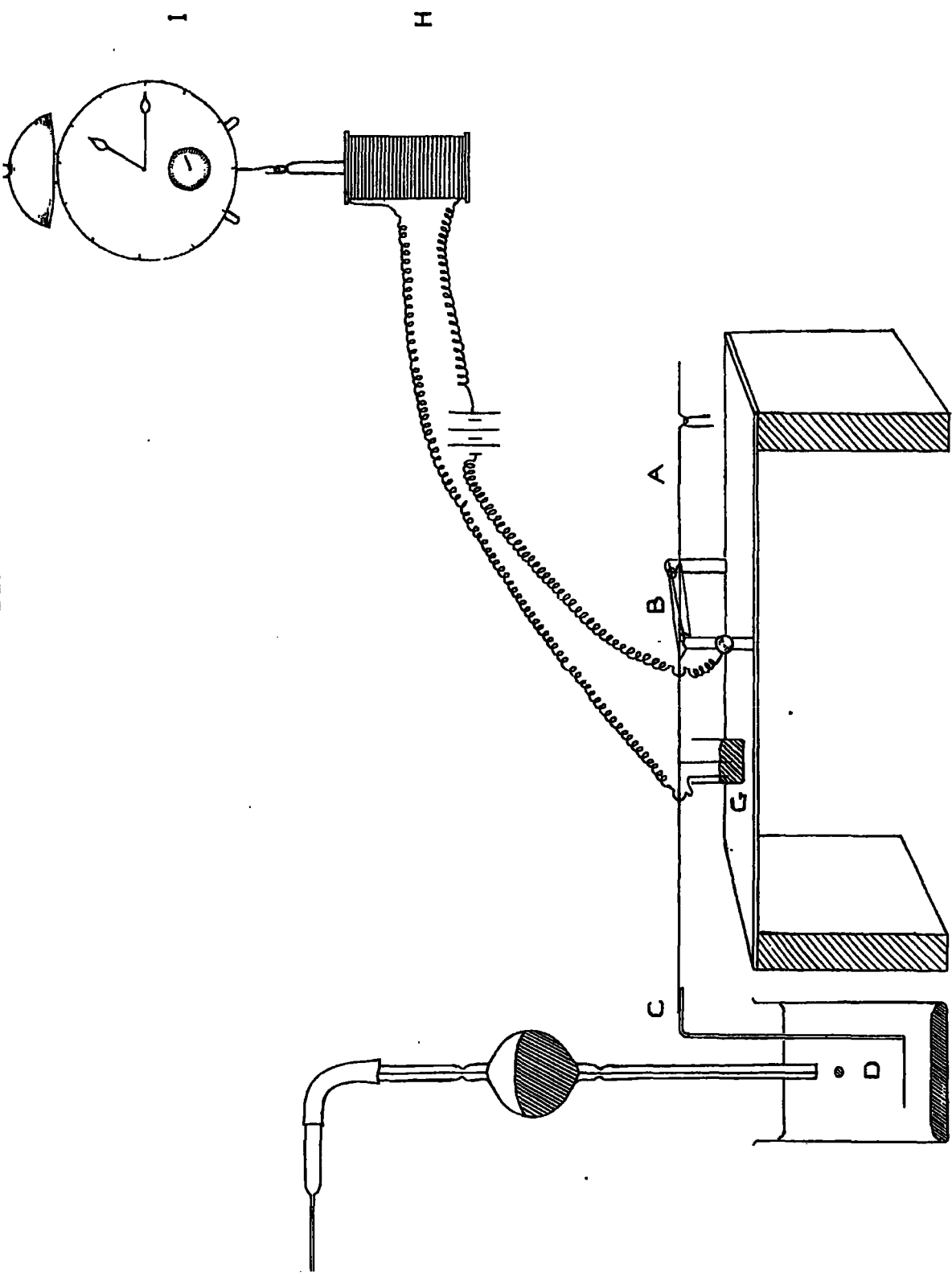

FIGURE V.

experiment that such a latitude has no measurable effect on the drop number for any particular solution.

Automatic Counting Device: (See Figure V).

This was based on that used by Drs. Gibby & Addison (loc. cit.) and which was described in the Journal of Scientific Instruments Vol. XII No. 6. June 1935. The large numbers of drops to be counted made an automatic not only desirable but necessary to ensure accuracy.

A beam A made of light gauge aluminium wire was suspended at B by means of a fine strand of copper wire round which it was looped. At C was attached, by means of Shellac, a thin glass rod less than one mm. in diameter, to which a microscope cover glass D was sealed. A platinum wire was firmly twisted to A between B and C and when C was depressed by a drop falling on D this wire made contact with the mercury surface in G. The resultant closing of the electrical circuit caused the operation of a small electromagnet H, the plunger of which was attached directly to the escapement lever of an alarm clock I. The balance wheel of the clock was removed, and the second hand found to tick 100 times per revolution. A suitably graduated scale was therefore fitted and the minute hand consequently read in hundreds of drops.

It was found essential that the glass rod attached at C should be very fine or frequent readjustments of balance riders on A was necessary on account of the increasing up thrust due to accumulation of mercury beneath the dyestuff solution.

Some slight trouble was experienced with fouling of the platinum contact but otherwise the device worked satisfactorily for numerous complete runs without attention.

Several drop counts were made with each particular concentration of dyestuff solution and in most cases exact agreement was obtained. Where this was not the case the average was taken.

(II) Calculation of Theoretical Adsorption Values:

The theoretical adsorption coefficients according to Gibb's Equation were calculated as follows:-

The values of σ and $\frac{d\sigma}{dc}$ were calculated by constructing smoothed drop number/concentration curves for each dyestuff in turn. The values of $\frac{d\sigma}{dc}$ were read off directly from the $\sigma - c$ curves by laying a fine wire on the curves at a series of points. These slopes were graphed against concentration and a smooth curve drawn through the points. The values of $\frac{d\sigma}{dc}$ required for substitution in Gibb's Equation were read off directly from this curve for each dyestuff.

In the calculations each dyestuff is assumed to be present in its simple molecular form as there is no complete data available on the variation of degree aggregation with concentration.

Example :

$$\gamma = - \frac{c}{RT} \cdot \frac{d\sigma}{dc}$$

Considering the interfacial tension curve for Congo Red against mercury :-

$$c = 0.05 \text{ gms/litre or } 5 \times 10^{-5} \text{ gms/cc.}$$

$$R = \frac{2 \times 4.2 \times 10^7}{\text{Molecular wt.}} \text{ ergs/gram of solute}$$

$$T = \text{Absolute temperature} = 293^\circ \text{ A or } 20^\circ \text{ C.}$$

$$\begin{aligned} \text{From smoothed curve } \frac{d\sigma}{dc} &= -250 \text{ dynes/cm. per gm/litre.} \\ &= -2.5 \times 10^5 \frac{\text{dynes/cm.}}{\text{gms/cc.}} \end{aligned}$$

$$\begin{aligned} \text{Substituting these values, } \sigma &= \frac{5 \times 10^{-5} (-2.5 \times 10^5) \times 696 \text{ gms/cm}^2}{2 \times 4.2 \times 10^7 \times 290} \\ &= \underline{\underline{3.58 \times 10^{-7} \text{ gms/cm}^2.}} \end{aligned}$$

(IV) Purity of Substances used.

(a) Dyestuffs.

The Methylene Blue, Congo Red, and Bordeaux Extra were from samples used by Dr. C.C. Addison in previous work on adsorption at the benzene-water and chlorobenzene-water interfaces which had been purified as below.

Methylene Blue.

This was originally a laboratory stock sample in which the most probable impurities would be sodium and zinc chlorides with which the commercial dyestuff is salted out. No residue on ignition proved the absence of all possible inorganic impurities except zinc salts which may volatilise. Addison decolourised a solution of the dye by reduction to the leuco base with sodium hydrosulphite. This solution on treatment with ammonium sulphide gave only sulphur. The dye was therefore assumed to be pure.

Congo Red.

The dye; from laboratory stock, was treated in a hot Soxhlet

apparatus with absolute alcohol for a period of two days to remove any organic impurities of simpler constitution which may have been soluble in alcohol. The dye itself was only very slightly soluble. On applying the chromyl chloride test, the dye was found to contain traces of chloride. It was therefore treated in a manner advised by C. Robinson & H.A.T. Mills (35), by salting out with sodium acetate. This was repeated three times, after which no trace of chloride was to be found. The acetate was removed by boiling with absolute alcohol and washing the filtrate well with absolute alcohol. This was repeated four times when no acetate could be detected by the cacodyl test. Drop numbers were taken on the purified sample and were found to lie in the drop number/concentration curve for the unpurified material.

Bordeaux Extra.

This sample was prepared for Addison's work by Messrs. I.C.I. (Dyestuffs) Ltd., of Blackley and was purified by the method used for Congo Red.

Indigo Carmine and Solway Ultra Blue B.

These two dyestuffs were especially obtained for this work from Messrs. I.C.I. (Dyestuffs) Ltd., Blackley, and were purified by them. The author wishes to take this opportunity of recording his thanks to the Research Department of the Dyestuffs Group for the gift of these dyes.

No further treatment was given to these two dyes.

(b) Mercury.

The method of purification was that described by Russell & Evans (36) in which mercury was shaken vigorously with a normal solution of ferric sulphate in twice normal sulphuric acid until the surface of the mercury broke into bubbles. The ferric salt was then removed by washing with distilled water until there was no trace of ferric iron detectable in the washings after vigorous shaking. Finally the mercury was dried by filtering through Whatman filter paper.

(c) Water.

A previous investigation of the purity of the distilled water from normal laboratory stocks had shown that there was no detectable tin or lead content and that the copper content was of the order of 1 part in seven million which was considered sufficiently low as to have no effect on the results obtained. The specific conductivity was checked against a "Megger" earth tester and found to be approximately 8×10^{-6} mhos. so that this water could hardly contain sufficient of any impurity to influence the adsorption figures.

All results for interfacial tension determinations and for measured adsorption coefficients are tabulated in the following chapter in which graphical representation is also included.

Chapter 4.

1. Drop Numbers, Interfacial Tensions and Calculated Adsorptions.

(a) Methylene Blue.Interfacial Tensions.

Concentration Gms./Litre.	Drop Number.	Interfacial Tension Dynes/Cm.
0.0	208	374
0.1	215	363
0.2	222	352
0.4	226	346
1.0	230	340
2.0	232	337
3.2	233	336
4.0	234	335

Calculated Adsorption Values.

Concentration Gms./Litre.	$\frac{d\sigma}{dc}$ dynes/Cm/Gm/Lt.	σ Gms./Cm ² $\times 10^7$
0.05	ca. -130	0.75
0.10	-125	1.49
0.15	- 71	1.42
0.20	- 56	1.34
0.3	- 30.4	1.11
0.4	- 18.5	0.88
0.5	- 12.9	0.77
1.0	- 4.8	0.57
1.5	- 2.4	0.43
2.0	- 1.8	0.44

(b) Congo Red.Interfacial Tensions.

Concentration Gms./Litre.	Drop Number.	Interfacial Tension Dynes/Cm.
0.00	208	374
0.022	213	366
0.044	216	361
0.063	220	355
0.125	224	349
0.250	225	347
0.500	225	347
0.750	224	348
1.000	221	352
1.500	220	354
2.000	220	354
3.000	221	353
4.000	222	351
5.700	225	347
7.000	227	344

(b) Congo Red continued.Calculated Adsorption Values.

Concentration Gms./Litre.	$\frac{d\sigma}{dc}$ dynes/Cm/Gm/Lt.	γ Gms./Cm ² 10 ⁷
0.00	ca.	--
0.05	-250	3.58
0.10	- 38	1.08
0.20	- 13	0.74
0.25	- 8.0	0.57
0.30	- 5.0	0.43
0.35	- 2.0	0.20
0.40	----- 0.0 -----	----- 0.0 -----
0.50	3.5	-0.5
0.60	6.2	-1.07
0.70	8.5	-1.7
0.80	9.5	-2.2
0.90	10.5	-2.7
1.00	10.6	-3.0
1.10	8.5	-2.7
1.20	5.5	-1.9
1.30	3.2	-1.2
1.40	1.5	-0.6
1.50	----- 0.0 -----	----- 0.0 -----
1.60	-0.4	0.2
1.70	-0.8	0.4
1.80	-1.2	0.6
2.00	-1.4	0.8
2.50	-1.75	1.3

(c) Bordeaux Extra.Interfacial Tensions.

Concentration Gms./Litre.	Drop Number.	Interfacial Tension dynes/Cm.
0.00	208	374
0.05	212	368
0.10	214	365
0.20	218	358
0.30	221	353
0.40	223	350
0.50	225	347
0.60	226	346
0.75	225	347
0.91	218	358
1.00	216	361
1.50	214	365
2.00	216	361

(c) Bordeaux Extra continued.Calculated Adsorption Values.

Concentration Gms./Litre.	$\frac{d\sigma}{dc}$ dynes/Cm/Gm/Lt.	γ Gms./Cm ² $\times 10^7$
0.0	ca. $-\infty$	0.0
0.02	-117	0.67
0.05	- 95.5	1.37
0.10	- 74.1	2.13
0.20	- 54.0	3.09
0.30	- 40.0	3.45
0.40	- 30.1	3.61
0.50	- 21.5	3.08
0.60	- 6.0	1.04
0.63	----- 0.0 -----	----- 0.0 -----
0.70	16.0	-3.2
0.75	36.0	-7.7
0.80	73.0	-11.6
0.85	77.0	-13.7
0.90	50.0	-12.8
1.00	28.0	- 8.0
1.10	15.2	- 4.7
1.20	7.2	- 2.5
1.30	2.0	-0 .74
1.35	----- 0.0 -----	----- 0.0 -----
1.50	-4.2	1.8
1.60	-5.8	2.66
1.80	-7.5	3.85
2.0	-9.0	5.15

(d) Indigo Carmine X.Interfacial Tensions.

Concentration Gms./Litre.	Drop Number.	Interfacial Tension Dynes/Cm.
0.00	208	374
0.63	223	350
0.125	230	340
0.25	238	329
0.50	244	322
1.00	249	316
1.50	251	313
2.0	253	311
2.8	254	310
4.2	254	310
7.0	254	310

(d) Indigo Carmine X continued.Calculated Adsorption Values.

Concentration Gms./Litre.	$\frac{d\sigma}{dc}$ dynes/Cm/Gm/Lt.	γ Gms./Cm ² $\times 10^7$
0.02	-350	1.43
0.05	-200	2.05
0.10	-130	2.65
0.15	-105	3.24
0.20	- 70	2.86
0.30	- 33.5	2.15
0.40	- 23.0	1.88
0.50	- 19.0	1.94
0.60	- 15.2	1.86
0.70	- 12.5	1.80
0.80	- 10.9	1.80
0.90	- 9.8	1.81
1.00	- 8.4	1.72
1.20	- 6.8	1.66
1.40	- 5.5	1.57
1.60	- 4.0	1.31
1.80	- 3.4	1.25
2.00	- 2.5	0.98
2.20	- 2.0	0.90
2.40	- 1.4	0.69
2.80	- 0.5	0.24
4.00	0.0	0.0

(e) Solway Ultra Blue B.Interfacial Tensions.

Concentration Gms./Litre.	Drop Number.	Interfacial Tensions Dynes/Cm.
0.000	208	374
0.050	210	371
0.100	212	368
0.20	217	360
0.50	223	350
1.00	227	344
1.50	229	341
2.40	231	339
4.00	232	337
5.00	232	337
7.00	232	337

(e) Solway Ultra Blue B. continued.Calculated Adsorption Values.

Concentration Gms./Litre.	$\frac{d\sigma}{dc}$ dynes/Cm/Gm/Lt.	γ Gms./Gm ² $\times 10^7$
0.0	-100	0.0
0.1	- 80.0	1.30
0.2	- 50.0	1.60
0.3	- 30.0	1.46
0.4	- 20.0	1.30
0.5	- 17.0	1.38
0.6	- 14.6	1.42
0.7	- 12.3	1.40
0.8	- 10.8	1.40
0.9	- 9.4	1.37
1.0	- 8.2	1.31
1.1	- 7.2	1.28
1.3	- 5.6	1.18
1.5	- 4.5	1.09
2.0	- 2.8	0.89
2.5	- 1.7	0.67
3.0	- 1.1	0.53
3.5	- 0.6	0.32
4.0	- 0.13	0.21
5.0	ca. 0.0	0.0
6.0	0.0	0.0
7.0	0.0	0.0

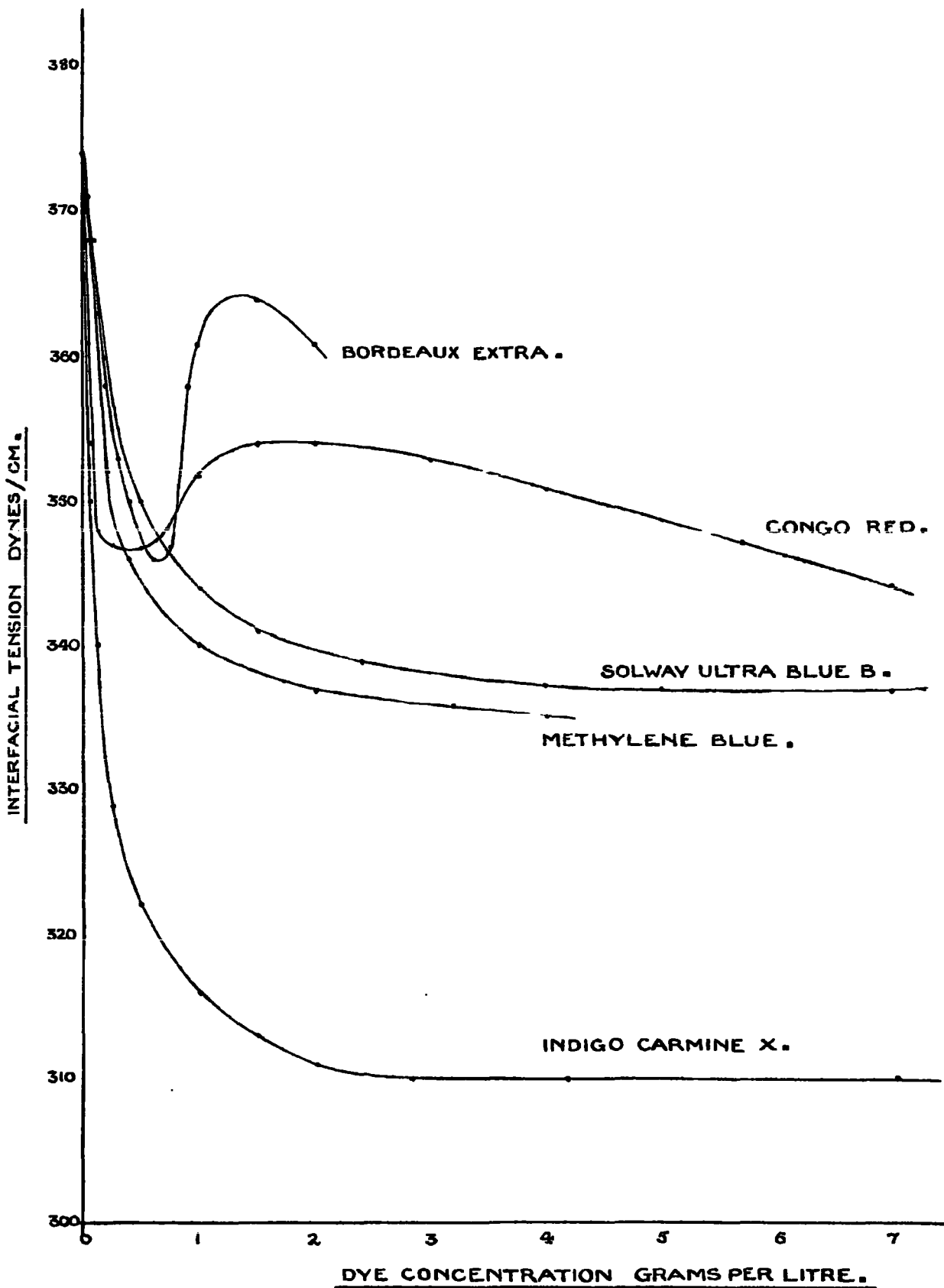

2. Measured Adsorptions etc.

DYE ADSORBED GMS $\times 10^{-7}$ PER CM².

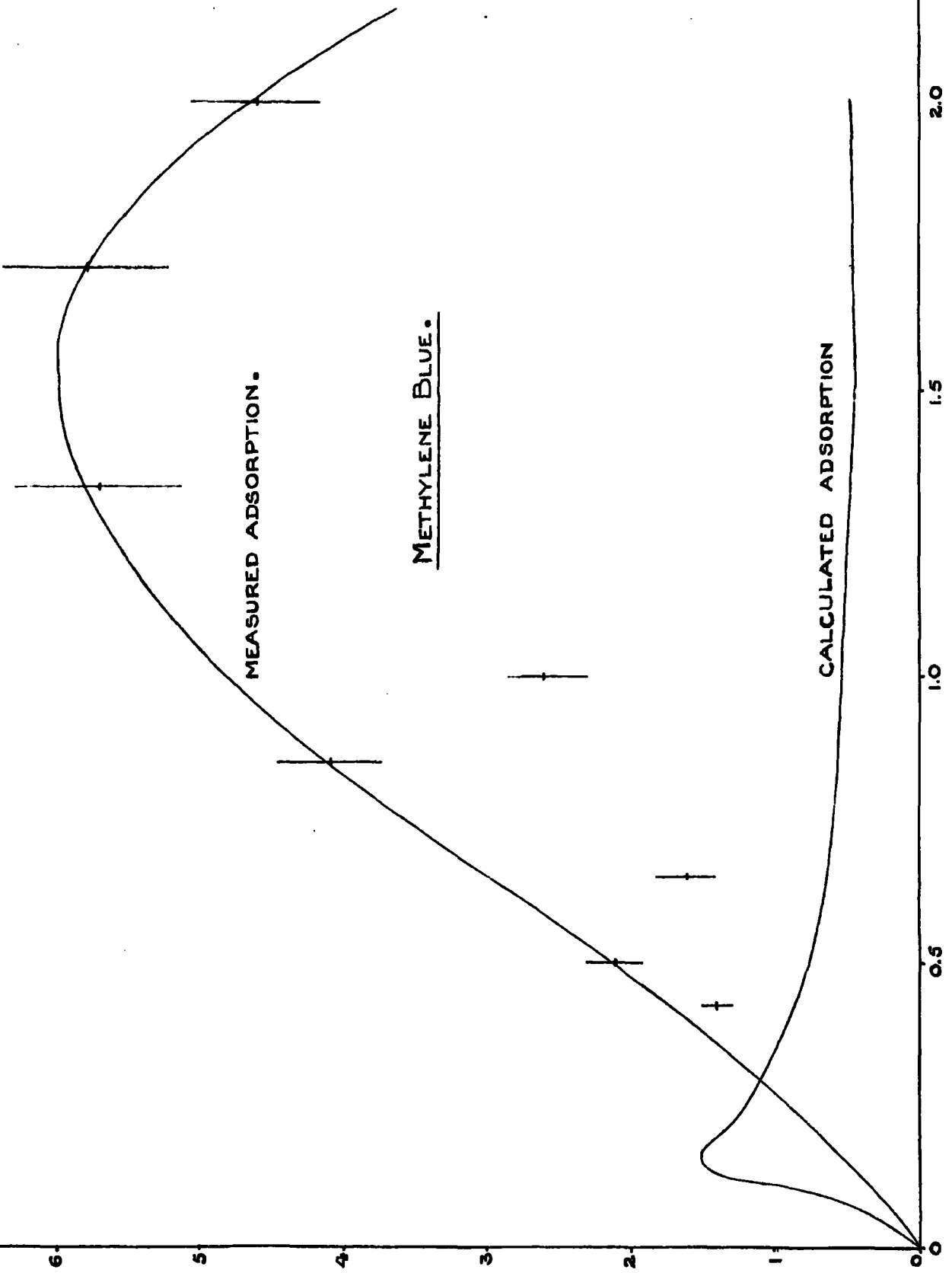

MEASURED ADSORPTION.

METHYLENE BLUE.

CALCULATED ADSORPTION

DYE CONCENTRATION GMS PER LITRE.

2.0

1.5

1.0

0.5

0

6

5

4

3

2

1

1. Summary of Results for Methylene Blue Experiments.

Initial Concn. Gms./Lt.	Vol. of Hg. used in ccs.	Drop Radius cms.	Area of Hg. cm ² 10 ⁻⁴	Vol. of res ^r Soln ccs.	Change in Concn. of res ^r Soln Gms./Lt.	Total Wt. of Dyestuff adsorbed 10 ³	Adsorption Coefficient Gms./Cm ² 10 ⁷
0.425	82.4	0.0115	2.15	10.5	.29	3.04	1.4 ± 0.1
0.500	61.7	0.0115	1.61	12.0	.28	3.37	2.1 ± 0.2
0.650	66.7	0.0115	1.74	11.5	.24	2.76	1.6 ± 0.2
0.850	59.5	0.0115	1.55	10.6	.58	6.16	4.0 ± 0.4
1.000	81.0	0.0115	2.11	13.0	.42	5.46	2.6 ± 0.3
1.300	51.0	0.0115	1.33	12.5	.61	7.52	5.7 ± 0.6
1.710	53.8	0.0115	1.40	11.0	.74	8.11	5.8 ± 0.6
2.000	44.4	0.0115	1.16	12.3	.43	5.29	4.6 ± 0.5

CONGO RED.

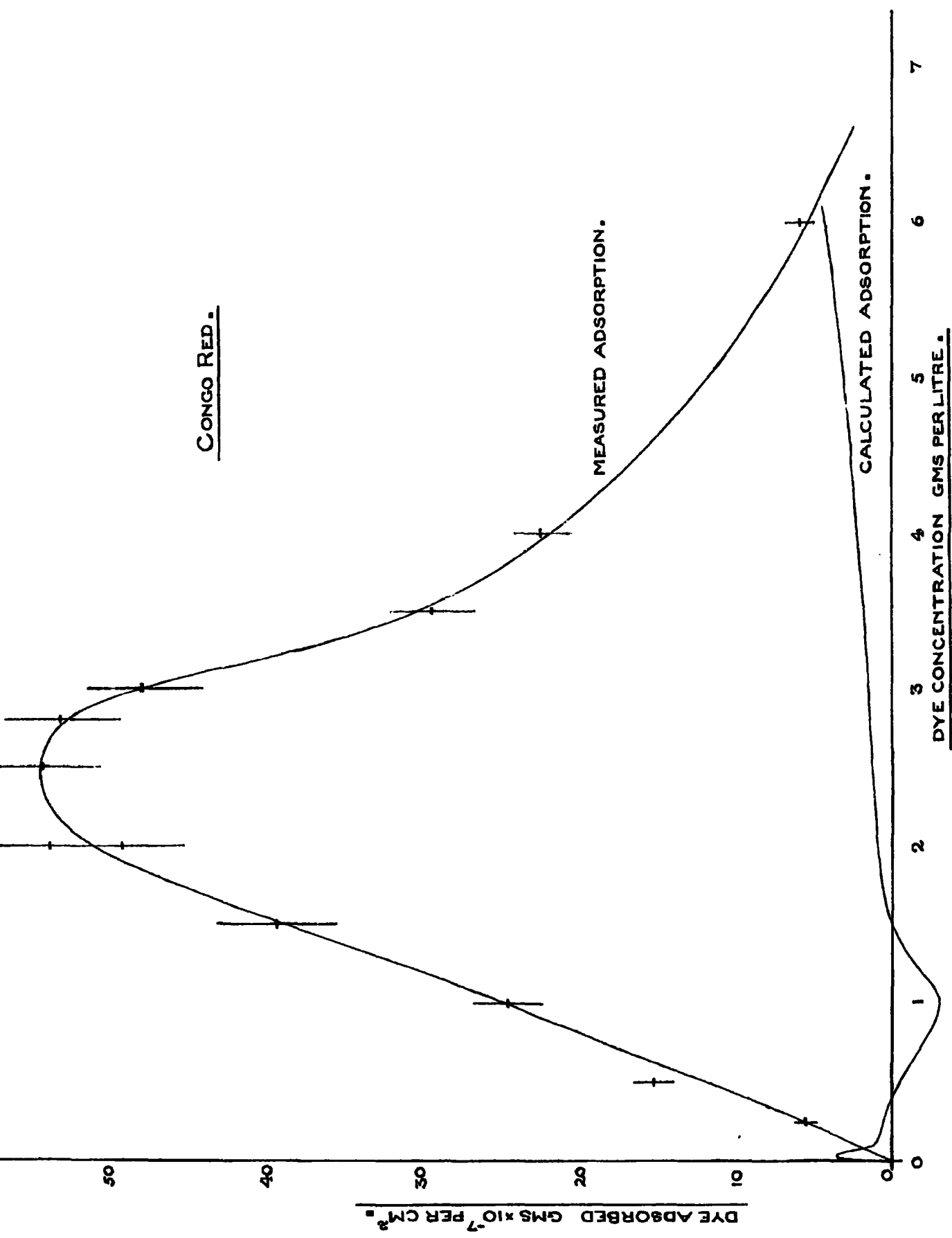

MEASURED ADSORPTION.

CALCULATED ADSORPTION.

DYE CONCENTRATION GMS PER LITRE.

DYE ADSORBED GMS x 10⁻⁷ PER CM².

2. Summary of Results for Congo Red Experiments.

Initial Concn. Gms./Lt.	Vol. of Hg. used in ccs.	Drop Radius cms.	Area of Hg. cm ² 10 ⁻⁴	Vol. of res ^r Soln. ccs.	Change in Concn. of res ^r Soln. Gms./Lt.	Total Wt. of Dyestuff adsorbed 10 ³	Adsorption Coefficient Gms./Cm ² 10 ⁷
0.125	60.0	0.0112	1.61	11.2	0.369	4.13	2.56 ± 0.3
0.25	77.0	0.0112	2.06	21.9	0.537	11.75	5.70 ± 0.6
0.50	60.0	0.0112	1.61	11.8	2.08	24.5	15.20 ± 1.5
1.00	83.5	0.0192	1.32	10.8	3.00	32.4	24.50 ± 2.5
1.50	87.0	0.0192	1.36	12.4	4.31	53.5	39.3 ± 4.0
2.00	69.5	0.0112	1.87	12.5	8.0	100.0	53.5 ± 5.4
2.0	87.0	0.0112	2.34	14.2	8.1	115.0	49.0 ± 5.0
2.5	89.0	0.0192	1.40	12.8	5.9	75.5	54.0 ± 5.4
2.8	65.0	0.0112	1.74	12.8	7.2	92.0	53.0 ± 5.3
3.0	100.0	0.0192	1.57	13.0	5.76	75.0	47.8 ± 4.8
3.5	90.0	0.0192	1.41	12.6	3.25	41.0	29.1 ± 2.9
4.0	73.0	0.0112	1.96	15.1	2.88	43.5	22.2 ± 2.2
6.0	75.5	0.0192	1.18	10.6	0.63	6.68	5.66 ± 0.6

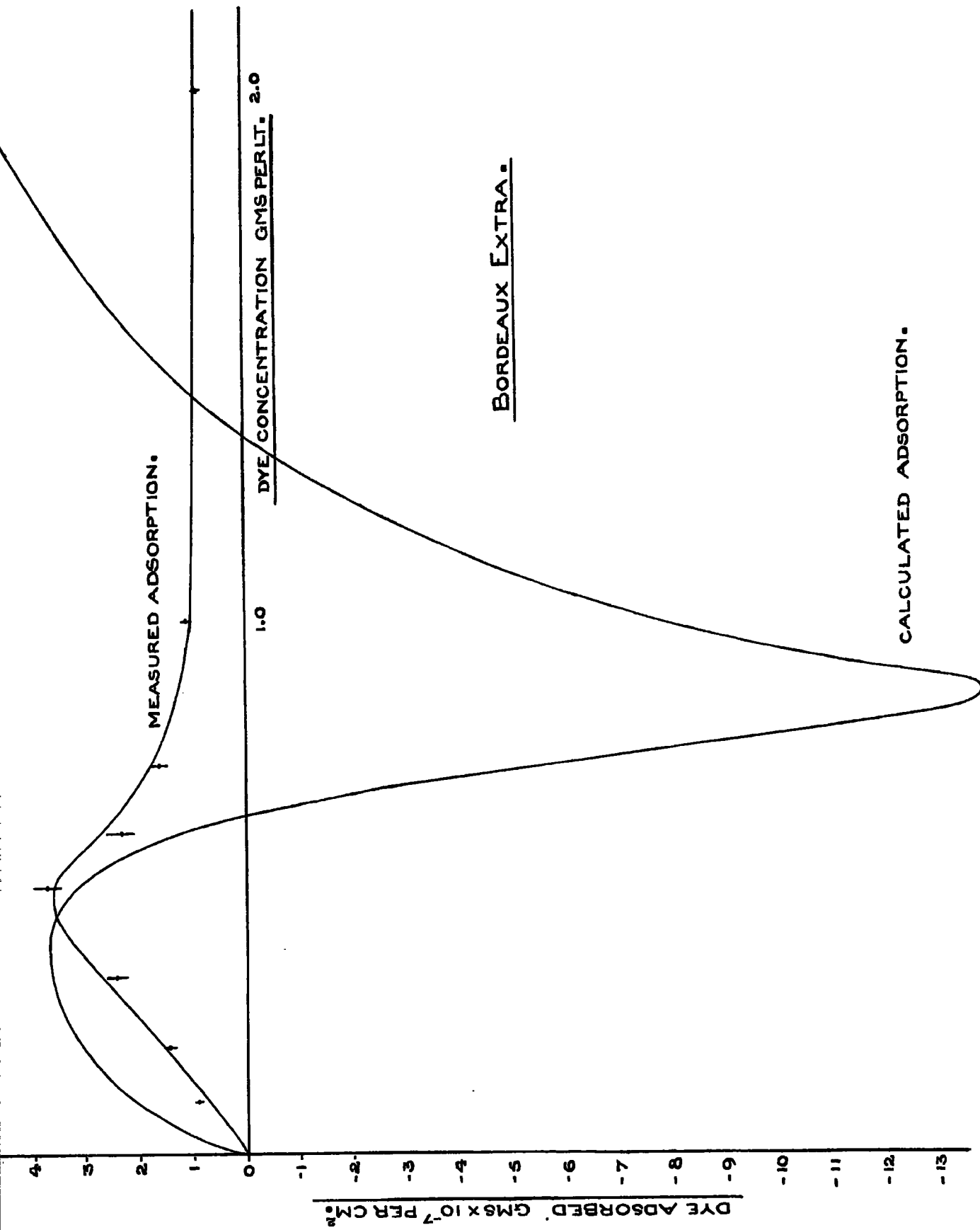

3. Summary of Results for Bordeaux Extra Experiments.

Initial Concn. Gms./Lt.	Vol. of Hg. used in ccs.	Drop Radius cms.	Area of Hg. cm^2 10^{-4}	Vol. of res ^r Soln. ccs.	Change in Concn. of res ^r Soln. Gms./Lt.	Total Wt. of Dyestuff adsorbed 10^5	Adsorption Coefficient Gms./ Cm^2 10^7
0.1	117.0	0.0115	3.05	10.4	0.28	2.91	0.9 ± 0.1
0.2	146.0	0.0115	3.80	10.4	0.52	5.4	1.4 ± 0.1
0.33	73.0	0.0115	1.91	13.5	0.34	4.6	2.4 ± 0.2
0.50	59.0	0.0115	1.54	10.0	0.57	5.7	3.7 ± 0.4
0.60	65.0	0.0115	1.70	11.7	0.34	3.98	2.3 ± 0.2
0.73	66.0	0.0112	1.77	12.4	0.231	2.87	1.6 ± 0.2
1.00	58.0	0.0112	1.56	11.0	0.154	1.69	1.1 ± 0.1
2.00	54.0	0.0112	1.45	12.0	0.10	1.20	0.8 ± 0.1

INDIGO CARMINE.

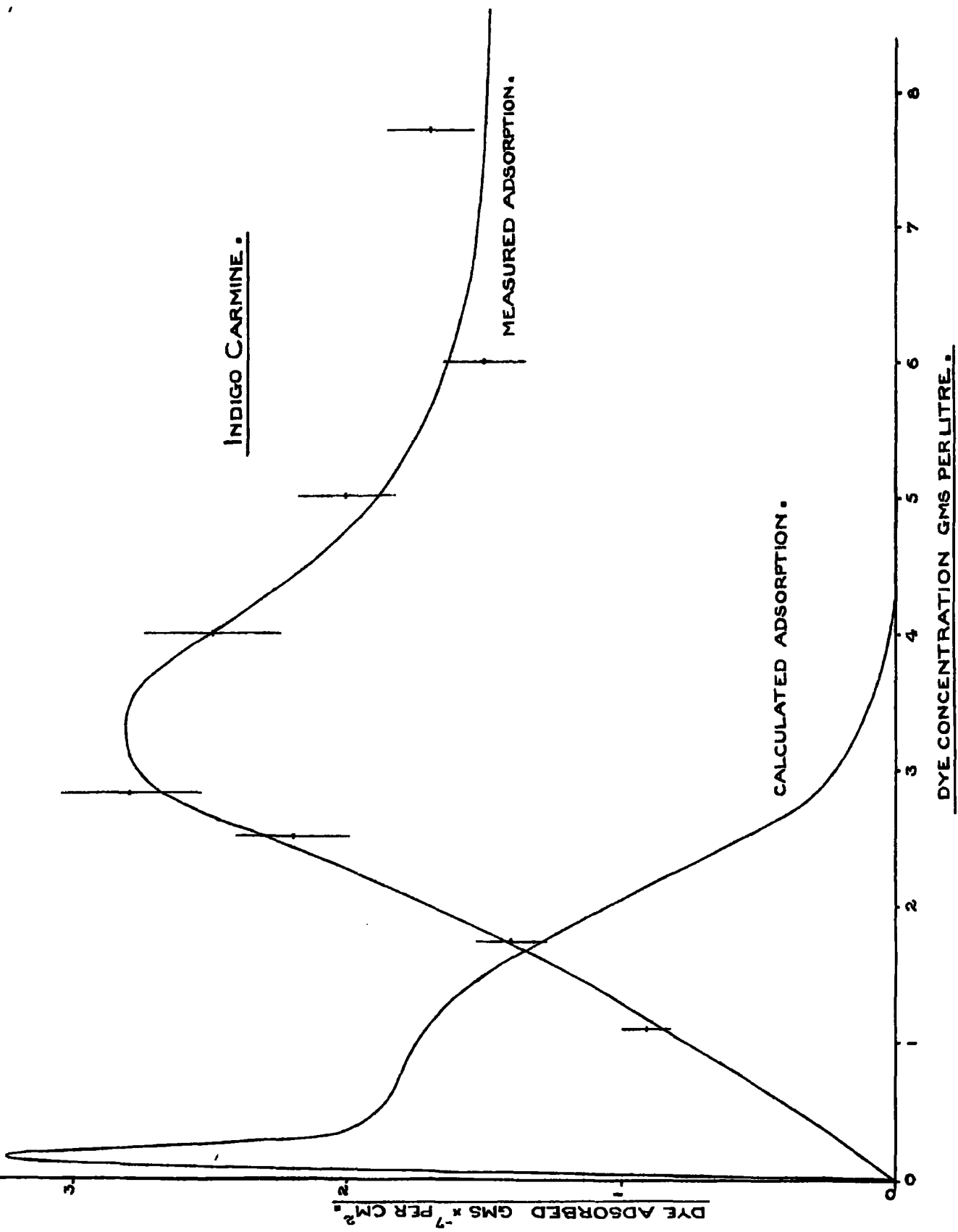

4. Summary of Results for Indigo Carmine X Experiments.

Initial Concn. Gms./Lt.	Vol. of Hg. used in ccs.	Drop Radius cms.	Area of Hg. cm ² 10 ⁻⁴	Vol. of res ^r Soln ccs.	Change in Concn. of res ^r Soln Gms./Lt.	Total Wt. of Dyestuff adsorbed 10 ³	Adsorption Coefficient Gms./cm ² 10 ⁷
1.11	56.0	0.0112	1.50	10.5	0.13	1.37	0.9 ± 0.1
1.73	54.5	0.0112	1.46	10.5	0.20	2.1	1.4 ± 0.1
2.5	53.0	0.0112	1.42	10.3	0.30	3.09	2.2 ± 0.2
2.81	48.0	0.0112	1.50	9.4	0.38	3.58	2.8 ± 0.3
4.0	58.0	0.0112	1.56	10.1	0.38	3.84	2.5 ± 0.3
5.0	55.0	0.0112	1.48	10.2	0.29	2.96	2.0 ± 0.2
6.0	49.5	0.0112	1.33	10.8	0.19	2.05	1.5 ± 0.2
7.7	31.5	0.0112	0.84	7.0	0.20	1.4	1.7 ± 0.2

SOLWAY ULTRA-BLUE.

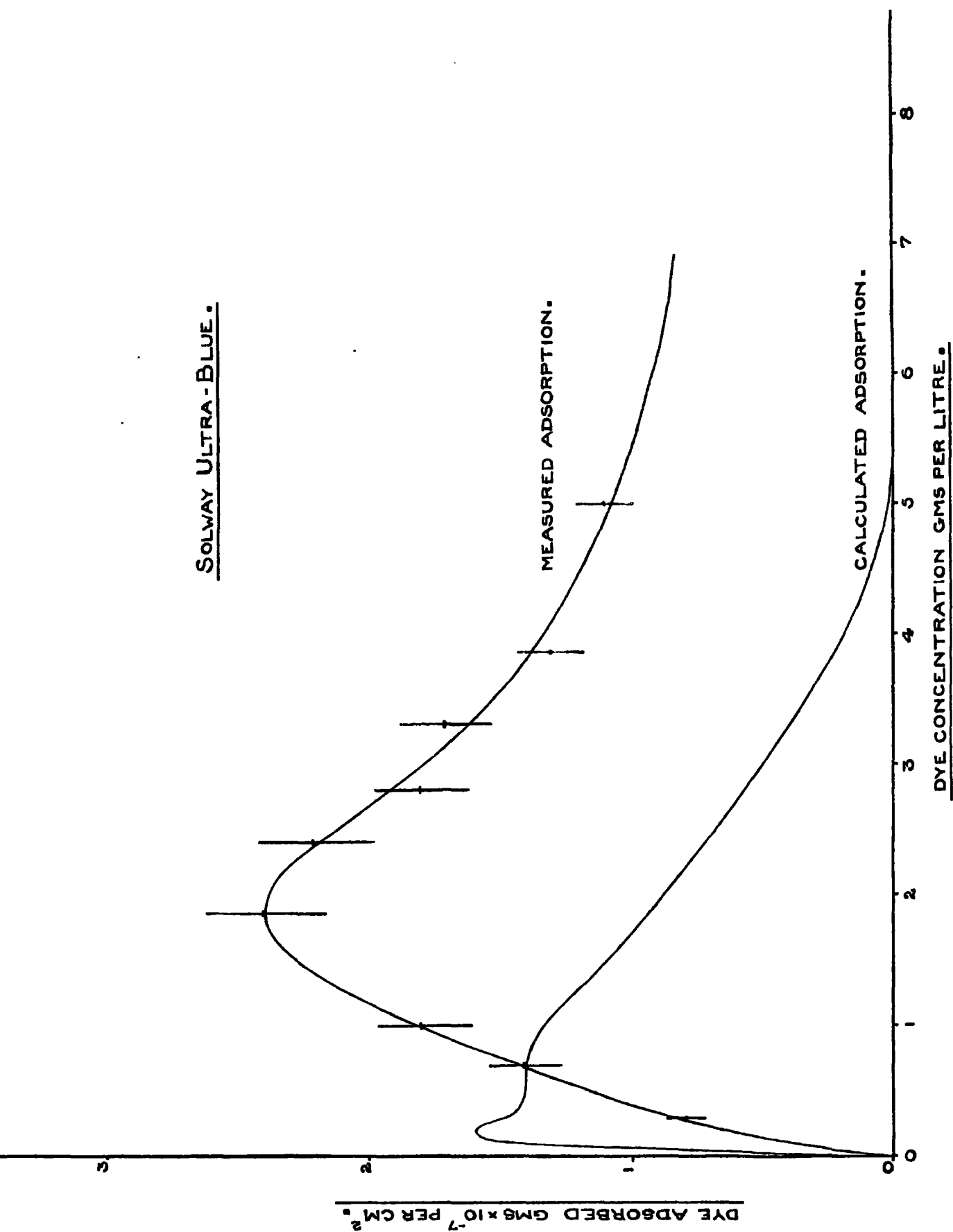

5. Summary of Results for Solway Ultra Blue B Experiments.

Initial Concn. Gms./Lt.	Vol. of Hg. used in ccs.	Drop Radius cms.	Area of Hg. cm ² 10 ⁻⁴	Vol of res ^I Soln ccs.	Change in Concn. of res ^I Soln Gms./Lt.	Total Wt. of Dyestuff adsorbed 10 ³	Adsorption Coefficient Gms./Cm ² 10 ⁷
0.3	90.0	0.013	2.08	7.9	0.21	1.66	0.8 ± 0.1
0.7	123.0	0.013	2.84	10.2	0.39	3.98	1.4 ± 0.1
1.0	56.0	0.013	1.29	15.3	0.15	2.30	1.8 ± 0.2
1.85	73.0	0.0112	1.96	10.6	0.45	4.76	2.4 ± 0.2
2.4	62.0	0.013	1.43	10.8	0.288	3.11	2.2 ± 0.2
2.8	55.0	0.013	1.27	10.6	0.22	2.34	1.8 ± 0.2
3.3	60.0	0.0112	1.61	10.8	0.24	2.58	1.7 ± 0.2
3.86	69.0	0.0112	1.85	11.5	0.215	2.47	1.3 ± 0.1
5.0	58.0	0.0112	1.56	10.4	0.164	1.70	1.1 ± 0.1

Chapter 5.

CONSIDERATION OF RESULTS.

(a) General Observations:

It is evident from the curves in the previous chapter that, with all the dyestuffs investigated, the measured adsorption passes through a maximum with increasing concentration. A similar phenomenon was observed in many of the cases considered by previous workers although the adsorbate, the adsorbent and the experimental procedure were entirely different. (16), (17).

With methylene-blue, solway ultra-blue B, and indigo carmine X the interfacial tension between mercury and aqueous dye solution falls with increasing concentration to a practically constant value, leading to "theoretical" adsorption curves of the same form as those found experimentally; though, of course, varying in order of magnitude. In this they resemble the behaviour of methyl-orange, Congo red and bordeaux extra when adsorbed on benzene, chlorobenzene and light petroleum. In the case of Congo red and Bordeaux extra however, the interfacial tension-concentration curves show two points of inflexion similar to those found by McBain and Mills (36) when considering the surface tension-concentration relationship for lauryl sulphonic acid.

Interfacial tension-concentration curves of this type lead to "theoretical" adsorption curves which change from positive to negative and again from negative to positive with increasing concentration. Such change of sign is quite independent of the use

of the concentration term in place of activity in the Gibbs' equation and of errors in assessing the numerical magnitude of $\frac{d\sigma}{dc}$.

(b) Discrepancies between "theoretical" and measured adsorption values.

In view of the graphical method by which the values of $\frac{d\sigma}{dc}$ were assessed from σ/c curves it was not to be expected that there could be exact agreement between the measured and calculated values of Γ' . Furthermore, in the simplified form of Gibbs' equation used throughout this work the activity term was replaced by concentration. Had this been the only cause of discrepancy then the "theoretical" and measured adsorption curves would have coincided at low concentrations when the two terms can be regarded as wholly interchangeable. Such was not however found to be the case and consequently no estimate of "activity coefficients" is possible in this work.

Previous workers have observed considerable electric charges on droplets of adsorbent, as evidenced by the strong repulsive forces between adjacent droplets and in particular by the divergence of paths of two droplets falling freely through adsorbate solution. Such phenomenon have been observed in this work and it may well be that the great stability of such small droplets as were under examination was due in some measure to this static charge. No account is taken of the existence and influence of electrical double layers by the Gibbs' equation, though they must necessarily exert considerable influence on the nature of adsorbed layers. It has been shown by previous workers in this field that the extent of adsorption is greatly influenced by the electronic structure of both the adsorbate and the adsorbent; thus

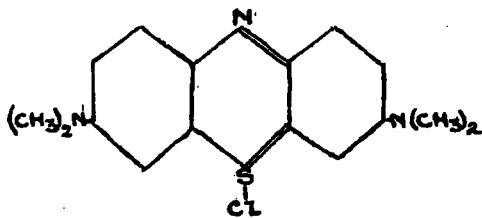

METHYLENE BLUE •

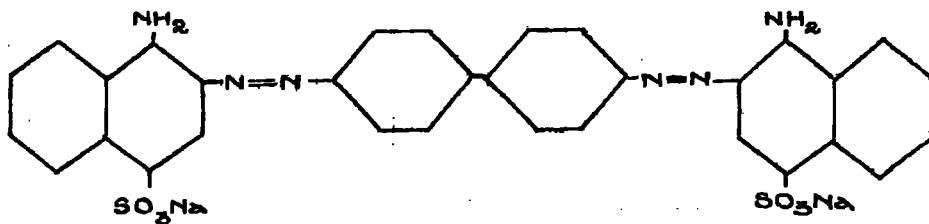

CONGO RED •

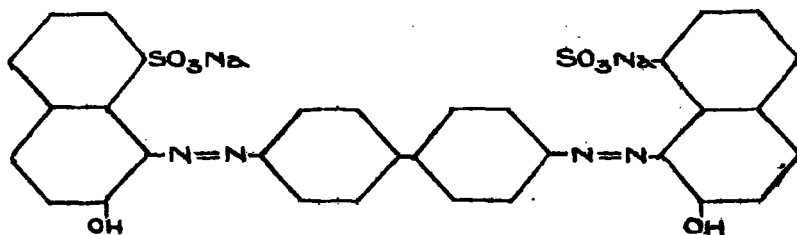

BORDEAUX EXTRA •

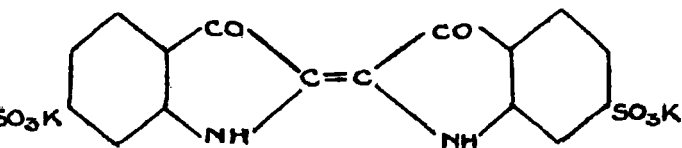

INDIGO CARMINE X •

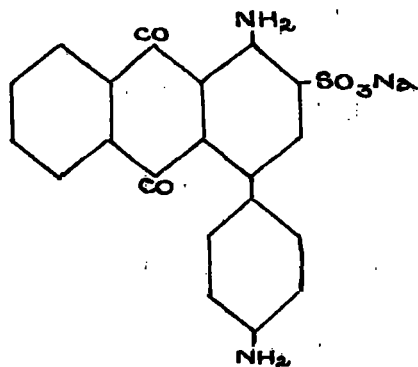

SOLWAY ULTRA BLUE B •

FIGURE VI •

indicating a definite orientation of the adsorbate at the interface.

(c) Nature of Adsorbed Layers.

The five dyestuffs considered in this work and whose formulae are given in Figure VI opposite were drawn to scale from the data of Sidgwick and Bowen (37) on the assumption that the ring structures were coplanar. The area was also taken to be that of a straight sided polygon drawn closely round the projection. The above two approximations will make it obvious that the calculated areas should be considered to be maximum values. It is improbable, however, that any system of close packing of the molecules in the adsorbed layers could utilise all the inter-group spacings and, furthermore, the atomic movement within the molecule itself will tend to forbid such extremely intimate contact.

The actual area of interface occupied per simple molecule in the region of maximum adsorption was calculated for each dyestuff as shown below in the case of Methylene Blue:-

Maximum Adsorption coefficient for Methylene Blue = 6.0×10^{-7} gms/cm².

Molecular weight of dye = 320

$\therefore \frac{6.0 \times 10^{-7}}{320}$ gm. molecules of dye occupy 1 sq. cm.

and therefore occupy 10^{16} sq. Å.

Hence one molecule of dye occupies $\frac{320 \times 10^{16}}{6.0 \times 10^{-7} \times 6.06 \times 10^{23}}$ sq. Å

≈ 9 sq. Å

The values obtained in this manner are collected in Table III together with the areas observed experimentally. The ratio of area calculated to area observed gives a direct measure of the

average thickness of the adsorbed layer at maximum adsorption if the molecules are so orientated as to present the maximum area to the interface. It is well recognised however that such an orientation may not be the one taken up and that end-on presentation as is conceived for the fatty acids at the oil-water interface, may well exist.

It is worthy of note that the ratio of calculated to observed area is very much greater in the case of Congo red than it is with Bordeaux extra although structurally the two dyestuffs are very closely related.

Table III.

	Calculated Area \AA^2	Observed area at maximum adsorption \AA^2	Ratio.
Methylene Blue.	140	9	16:1
Congo Red.	192	2	96:1
Bordeaux Extra.	153	33	4.6:1
Indigo Carmine X.	168	27	6.2:1
Solway Ultra Blue B.	176	28	6.4:1

It is also of significance that the ratio of calculated to observed area varies widely, and this would hardly be the case if the smaller area occupied per molecule were to be explained only on the basis of close packing in the end-on positions.

Close packing in the "end-on" position is not to be overlooked however since there may well be strong attractions between the mercury and the highly polar inorganic groupings of dyestuffs.

Returning to the consideration of the inter-dependence of the interfacial tension and adsorption it may be suggested that what relationship there is, is by no means as simple as has been supposed and is not free from secondary and conflicting influences.

It cannot be that adsorption is the sole cause of lowering of interfacial tension, since it is possible to have extremely pronounced lowering of interfacial tension at points where adsorption is found to be very slight and apparently insufficient to cause appreciable saturation of the interface.

In a paper by A.E. Alexander (38) the author considers that the above experimental results are invalidated by virtue of the formation of insoluble mercury salts, to which he attributes the stability of the mercury droplets and the semi-solid nature of collections of such droplets. It is not considered that this is a final criticism since no observation of any "scum" on the mercury surface was ever made in this work. Although there was definitely a change in the appearance of the mercury in this form (attributable to the intimate association with the dyestuff solution) the clean gleam of mercury surface was ever present, even after some weeks in the case of the high stability in Congo red solutions. This statement applies equally to the microscopic examination of the mercury surface during drop-radius determinations.

Alexander also states that, even in the case of micelle-forming adsorbates, when concentrations are very low and the simple molecule concentration approaches the stoichiometrical concentration; the theoretical and observed adsorption curves coincide. He cites three

examples from Addison's work in support of this but neglects twelve other examples in which there is no sign of such coincidence. If this author's criticisms of the "falling droplet" method of investigation are sincere then surely the results embodied in his three examples will be as much in question as the twelve examples which he neglects. In this particular work, as has already been pointed out, the two curves do not coincide for any dyestuff studied at any concentration, despite the fact that Methylene blue and Bordeaux extra at least are believed to be present mainly in the form of simple molecules at the concentrations here investigated (39).

It is not clear why, according to Alexander, the formation of micelles should imply complete disappearance of adsorption although it is fully realized that a reduction in both the effective particulate concentration and in the dipole concentration will proceed as micelle formation increases.

Summary.

The adsorption of Methylene blue, Congo red, Bordeaux extra, Indigo carmine X and Solway ultra-blue B, from aqueous solutions of each has been measured at the mercury-water interface at 17° C. The interface was provided by a stream of droplets falling through the dyestuff solution. The adsorbed material was estimated colorimetrically in a Bausch and Lomb tintometer. Interfacial tensions of the same systems have been measured and from these theoretical adsorptions calculated by way of the Gibbs' adsorption equation.

$$\gamma = - \frac{c}{RT} \cdot \frac{d\sigma}{dc}$$

In all five dyes studied the measured adsorption passes through a maximum with increasing concentration which is in agreement with several examples previously published by other workers although the experimental technique and materials under consideration differed widely.

Exact agreement between measured adsorptions and those calculated from the Gibbs' equation was not expected in view of the latitude in evaluating $\frac{d\sigma}{dc}$ from σ/c curves, the use of concentrations instead of activities, and of factors such as the influence of electrical double layers of which Gibbs' equation takes no account. The discrepancies between the two sets of values are nevertheless striking.

In the case of Methylene blue, Solway ultra-blue B, and Indigo carmine X the form of the "theoretical" adsorption curve is the same as that of the measured curve though of different dimensions. In the

case of Congo red and Bordeaux extra however the interfacial tension/
concentration curve has two inflexions which lead to "theoretical"
values for the adsorptions which change from positive to negative and
then back to positive as the concentration increases. Such a change
is independent of the use of concentrations instead of activities in
calculating adsorptions from Gibbs' equation and of errors in
assessing $\frac{d\sigma}{dc}$. In none of the cases investigated do the curves for
theoretical and measured adsorptions coincide at low concentrations as
would be the case if the only reason for the discrepancies were to be
found in the omission of the activity coefficients.

Bibliography.

- (1) Langmuir. Chem. Met. Eng. 15, 468, 1916.
- (2) Langmuir. J.A.C.S. 39, 1848, 1917.
- (3) W.D. Harkins, E.C.H. Davies & G.L. Clark. J.A.C.S. 39, 541, 1917.
- (4) E.L. Griffin. J.A.C.S. 45, 1648, 1923.
- (5) Van der Meulen & W. Riemann. J.A.C.S. 46, 876, 1924.
- (6) Van der Meulen & W. Riemann. J.A.C.S. 47, 2507, 1925.
- (7) W.D. Harkins & M. Beeman. J.A.C.S. 51, 1674, 1929.
- (8) E.A. Fischer & Harkins. J. Phys. Chem. 86, 1932.
- (9) H.M. Cassel. J. Phys. Chem. 1938, 42 - 475 - 482.
- (10) W.C. Lewis. Phil. mag. 15, 499, 1908.
- (11) W.C. Lewis. Phil. mag. 17, 466, 1909.
- (12) Patrick. Zeit. Phys. Chem. 86, 545, 1914.
- (13) Nonaka. J. Chem. Soc. Ind. Japan. 31, 297, 1928.
- (14) Nonaka. J. Chem. Soc. Ind. Japan. 32, 115, 1929.
- (15) A.M. Seymour, H.V. Tartar & K.H. Wright. J. Phys. Chem. 38, 839, 1934.
- (16) C.W. Gibby & C.C. Addison. J.C.S. 119 - 127, 1936.
- (17) C.W. Gibby & C.C. Addison. J.C.S. 1306 - 1313, 1936.
- (18) Schofield & Rideal. Proc. Roy. A. 109, 1925.
- (19) Schofield & Rideal. Proc. Roy. A. 110, 1926.
- (20) Schofield & Rideal. Phil. mag. 13, 806, 1932.
- (21) Wynne-Jones. Phil. mag. 12, 907, 1931.
- (22) R. Dubrisay. Compt. Rend. 182, 1217, 1926.
- (23) Harkins & Wampler. J.A.C.S. 53, 850, 1931.
- (24) Butler & Wightman. J.C.S. 2089, 1932.

- (25) J.L. Shereshefski. J. Phys. Chem. 36, 1271, 1932.
- (26) J.W. Belton. Trans. Farad. Soc. 31, 1642, 1935.
- (27) J.W. Belton. Trans. Farad. Soc. 31, 1413, 1935.
- (28) J.W. Belton. Trans. Farad. Soc. 31, 1648, 1935.
- (29) J.W. Belton. Trans. Farad. Soc. 35, 1354-1361, 1939.
- (30) Guye and Perrot. Arch. Sci. Phys. Nat. Geneva. 15,178,1903.
- (31) Tate. Phil. Mag. 27, 176, 1864.
- (32) Lohnstein. Ann. der Physik. 1906, 20, 798, 237, 606,
21, 1030, 22, 191.
- (33) Harkins and Brown. J.A.C.S. 499, 1909.
- (34) Rayleigh. Phil. Mag. 48, 321, 1899.
- (35) C. Robinson and H.A.T. Mills, Proc. Roy. Soc. A. 131,576 & 596,
1931.
- (36) McBain and Mills. Report on Progress of Phys. 1938, 5, 30.
- (37) Sidgwick and Bowen. Ann. Reports. 1931, 28, 402.
- (38) A.E. Alexander. Trans. Farad Soc. 1942, 38, 248.
- (39) Robinson. Farad. Soc. Discussion, 1935, P.250.

Acknowledgements.

I wish to take this opportunity of recording my sincere and grateful thanks to Dr. C.W. Gibby, M.Sc., Ph.D., who suggested this line of investigation and under whose supervision this work has been carried out. I am glad to have been his collaborator, and his timely guidance and cheerful encouragement have been directly responsible for the progress of this work to its present stage.

I am indebted to Professor F.A. Paneth for permission to make full use of the facilities of the Science Department of the Durham Division at all times, and to the Staff of the laboratories for their helpful co-operation.

I should like to express to the various members of the Laboratories Lecturing Staff and in particular to Dr. W.A. Waters, M.A., Ph.D., my appreciation of their interest and constructive criticism which have always been apparent and which have been invaluable in this work.

I am again, indebted to the University Authorities for the provision of the Rayleigh refractometer used in the preliminary investigations and to Messrs. I.C.I. (Dyestuffs) Ltd., for the gift of dyes used in this work.

Finally, I express my gratitude to the Principal, Rev. Canon E.F. Braley, M.A., LL.D. and the Governors of the College of the Venerable Bede, whose assistance has done much to make this work possible.

Cyril Argument.