

Durham E-Theses

Energy flow through a population of oribated mites

A. Russell-Smith

How to cite:

Russell-Smith, A. (1974) Energy flow through a population of oribated mites. Masters thesis, Durham University.

Use policy

The full-text may be used and/or reproduced, and given to third parties in any format or medium, without prior permission or charge, for personal research or study, educational, or not-for-profit purposes provided that:

- a full bibliographic reference is made to the original source
- a <https://etheses.durham.ac.uk/id/eprint/8948/> is made to the metadata record in Durham E-Theses
- the full-text is not changed in any way

The full-text must not be sold in any format or medium without the formal permission of the copyright holders.

Please consult the [full Durham E-Theses policy](#) for further details.

ENERGY FLOW THROUGH A POPULATION OF
ORIBATID MITES.

A. Russell-Smith.

Submitted as part of the requirements for
the degree of M.Sc. in Ecology.



CONTENTS

	Page
Introduction	1
The habitat	2
Temperature measurements	4
Population studies	4
Size class distribution	6
Bomb calorimetry	7
Length/weight relationships	8
Egg production	9
Incubation period	10
The calculation of growth in the population	10
Respiration	14
Methods	15
Calculation of the respiratory energy losses of the population	16
Ingestion	18
The quantification of the energy budget	19
Discussion	20
Summary	29
References	32
Acknowledgements	34

ENERGY FLOW THROUGH A POPULATION OF ORIBATID MITES

Introduction

Although oribatid mites form a numerically important part of the soil ecosystem, few studies have been made of their role in the energetics of the ecosystem. However, two recent papers have been published on the energetics of oribatids (Englemann, 1961; Berthet, 1964). In both cases whole communities are considered, and Englemann concentrates particularly on assimilation while Berthet estimated only the respiratory energy losses of the mite community. In the work described here an attempt was made to assess the energy flow through a species population over a six month period in woodland soil. The species concerned was Damaeus geniculatus (L.) Koch, a large species which occurred in sufficient numbers in the woodland litter to make a study of its energetics relatively simple. Owing to the limited time available attention was focussed on population changes, respiratory energy losses and growth. In addition an attempt was made to estimate ingestion rates. From the figures for energy loss due to respiration and energy of growth, the energy assimilated was derived from the equation:

$$A = R + P$$

where

A = energy assimilated

R = respiratory energy losses

P = energy of production (growth)

It was hoped originally to carry out a similar study for 'Nothrus sylvestris' Nic., a smaller species but one that occurred in greater numbers

than D.geniculatus in this woodland. However, the absence of respiratory data and the lack of an estimate of mortality made this impossible.

The habitat

The study was carried out in a birch/alder wood at Wynyard, nr. Sedgefield, Co.Durham, about 17 miles S.E. of Durham City (O.S. 1 inch sheet 85, Grid ref. 425/294). The dominant tree was alder (Alnus glutinosa Gaertn) with birch (Betula pendula Roth) and sycamore (Acer pseudoplatanus L.) occurring at about 10% frequency in each case. The shrub layer consisted chiefly of bramble (Rubus fruticosus L. sensu lato) and male fern (Dryopteris filix-mas agg.). A mixed herb layer was present in which Dog's mercury (Mercurialis perennis L.) and Rose-bay willowherb (Chamaenerion augusti-folium (L.) Scon.) were frequent. Other species present included:

Crataegus monogyna (Jacq.)

Salix cinerea L.

Ranunculus bulbosus L.

Viola riviniana Rohb.

Oxalis acetosella L.

Geum urbanum L.

Rosa canina agg.

Epilobium montanum L.

Circaca lutetiana L.

Holcus mollis L.

Deschampsia caespitosa L.

Poa sp. L.

A fairly well developed moss layer was present in which Mnium hornum Hedw. and Pellia epiphylla (L.) Corda were abundant. The following species were also found:

Mnium undulatum Hedw.

Mnium punctatum Hedw.

Atrichium undulatum (Hedw.) P. Beauv.

Fissidens bryoides Hedw.

Dicranella heteromalla (Hedw.) Schp.

Thuidium tamariscinum (Hedw.) B. & S.

Eurhynchium praelongum (Hedw.) Hobn

Plagiothecium sylvaticum (Brid) B. & S.

Lophocolea heterophylla (Schrad.) Dum.

The soil profile was examined by taking 4, one foot deep cores at random in the area sampled. A poorly developed layer of litter and raw humus was present, varying in depth from 0 to 3 cms. Only where rhizomes of the male fern (Dryopteris filix-mas agg.) had penetrated deeply and subsequently decayed was humus found below this depth. Beneath this humus, a layer of clay loam was found which varied from 12 to 20 cms in depth. This loam then graded almost imperceptibly into a grey boulder clay which formed the B horizon. Drainage in the wood was poor, and on several occasions during the sampling period the water table was found to be only one inch below the surface.

Temperature measurements

Soil temperature measurements were taken at regular intervals in order that corrections due to changes in temperature could be made to the respiratory rate of the mites at different seasons. The method used was the sucrose inversion technique (Berthet, 1960) which is based on the principle that the rate of inversion of a sucrose solution is temperature dependent when the pH is constant.

For each measurement six temperature tubes were buried at a depth of two to three cms in the litter of the wood. Each tube contained concentrated sucrose solution plus a buffer and a small quantity of formalin to prevent fungal or bacterial growth. Each set of tubes was then left in the field for a period of one month. Over each monthly period two tubes containing an identical solution of sucrose were kept in the constant temperature room at 27°C.

The optical rotation of the solution in each tube, including those kept in the constant temperature room, was determined in a polarimeter at the beginning and end of each monthly period. The mean temperature in each month was then calculated using the formulae in appendix I. The results were plotted as change in temperature against time (Fig. 1). The mean temperature over the whole six month period was found to be 9°C.

Population studies

In order to estimate the standing crop and changes in biomass of the mite populations a sampling programme was carried out. The area sampled was an 18 x 20 M rectangle which was subdivided into ninety 2 M side squares. Thirty samples were taken twice monthly, each sample being taken at random

from within one of the 2 M side squares. Since a total of 12 separate sets of 30 samples were taken, each 2 M side square was sampled four times, and 360 samples were taken in all.

The sampling unit was a soil core 3 cms deep and 3.8 cms in diameter, having a surface area of 11.35 cms². Each core was held in a bakelite cylinder and was then transported to the laboratory in a polythene bag. The mites were extracted from the cores in a MacFadyen high gradient extractor. This extractor depends on the action of heat and desiccation in driving the mites from the soil, and has been fully described by Block (1966), who found that for oribatids in mineral soil the extraction efficiency was 77%. The samples were extracted for 72 hours, during which time the temperature at the surface of the sample rises from room temperature (c. 15-20°C) to 115°C. The mites that emerged were preserved in 70% alcohol and were then identified and counted under a binocular microscope.

For each set of 30 samples the mean number per sample of total mites, oribatids and Damaeus geniculatus was calculated, and from these figures the number of each group per square metre calculated (Tables 1-3). These results were plotted graphically on a monthly basis (Figs 2, 3). From Figure 2 it can be seen that the numbers per square metre of both mites in general and oribatids in particular were low in February and rose sharply, reaching a peak in May, after which the numbers fell again. In both cases the increase in numbers between February and May was approximately three-fold. There was also a small, synchronous fall in numbers in both the total mite population and the oribatids in April. In the case of Damaeus geniculatus, on the other hand, it can be seen (Fig. 3) that whereas the general pattern of the

population trend is similar to that of the oribatids as a whole, the peak in numbers does not occur until June, and its numbers are nearly constant in April and May.

Size class distribution

A sample of Damaeus geniculatus was taken every month, and their lengths measured to assess the proportion of animals of different size classes in the population. These measurements were used in the calculation of growth and respiratory energy loss of the population. To obtain sufficient animals to make the measurements significant, large samples of soil and leaf litter were extracted over a five day period in Tullgren funnels. The mites were preserved in alcohol, and at least 40 individuals were measured in each sample.

The measurements were made using a monocular microscope fitted with a micrometer eyepiece. A mite to be measured was placed on its dorsal surface on a microscope slide and its length measured between the tip of the rostrum and the posterior margin of the opisthosoma. The mites measured were then divided into arbitrary size classes, the limits of which were 0.1 mm apart. Measurements of animals below 1.0 mm length were not made, since throughout most of the period of study recovery of such animals from the Tullgren funnels were so low as to be of little value statistically. The results of these measurements are shown in Table 4. The results thus obtained were plotted as histograms of percentage frequency of each size class in each month (Fig. 4).

As can be seen from the histograms the ratio of nymphs to adults is low in February and March, and builds up gradually until it reaches a peak

in June and July, when nymphs represent 40% of the total population. It is clear from the high proportion of nymphs in the smallest size class (1.0-1.1 mm) that hatching commences in May, a conclusion which is borne out by the population figures (Table 3). A number of anomalies are to be seen in the size frequency distributions, particularly the absence of nymphs of length 1.3-1.4 mm in June and also the absence of the largest nymphs (1.4-1.5 mm) in February and June. It is likely that these anomalies were due to the small size of the samples measured.

Bomb calorimetry

In order that growth could be compared with respiratory energy loss a common energy unit, the calorie, was used. Determinations of the calorific value of the tissues of D.geniculatus were made using a micro-bomb calorimeter (Phillipson, 1964). A small sample, in the form of a pellet of known weight, is placed in the bomb calorimeter which is then filled with oxygen to 30 atmospheres pressure. The sample is ignited by passing a discharge from a condenser through a fine platinum wire which is in contact with the pellet. The heat produced by the combustion of the sample is detected by a ring of thermocouples on which the bomb rests, and the change in potential so produced is monitored by a recording galvanometer.

The bomb was first calibrated using pellets of Benzoic acid having a known calorific value of 6,324 calories per gramme. The calibration constant for this bomb was found to be 0.0721 millivolts per calorie.

Material whose calorific value was to be determined was first dried in a vacuum oven at 60°C for 24 hours. The dried material was finely ground in a small mortar and pestle and formed into small pellets in a pelleting

press. The pellets were dried for a further 24 hours before combustion and then weighed as rapidly as possible on an Oertling balance sensitive to 0.002 milligrammes. They were then burned in the bomb calorimeter as described above.

Unfortunately, owing to the small size of the animals, sufficient material was available to carry out only three separate determinations. The results are shown below.

	Weight of pellet (mg)	Calorific value (calories/gramme)
1.	13.896	5,023
2.	12.556	4,729
3.	14.160	4,897

These values fall within 5% of one another and the mean value of 4,883 calories/gramme was taken as the calorific value of D.geniculatus.

Length/Weight relationships

In order to estimate growth a relationship was obtained between the length and the wet weight of D.geniculatus. Individuals were measured as previously described and weighed on an Oertling balance sensitive to 0.002 milligrammes. Each individual was first dried for 5 seconds on a piece of filter paper to remove excess moisture, and then weighed as rapidly as possible. In the case of nymphs which normally have soil adhering to their dorsal surfaces, the animals were first cleaned using a needle and fine camel hair brush under a binocular microscope.

When length was plotted against wet weight a smooth curve was obtained. To derive a direct relationship between the two, length was plotted against the logarithm of wet weight and a regression calculated for the points

obtained (Fig. 5). The regression formula for this line was

$$Y = - 1.42X + 1.7$$

To establish growth in terms of biomass a relationship between wet weight and dry weight of the organisms was needed. Individual animals were first weighed in the manner described above and then dried in small tubes for 48 hours at 60°C in a vacuum oven. They were then placed in a desiccator and re-weighed as rapidly as possible. A graph of wet weight against dry weight of D.geniculatus was then plotted and a regression calculated for the points obtained (Fig. 6). The regression equation for this line was

$$Y = 0.33X - 0.0062$$

It can be seen from Figures 5 and 6 that the correlations between the calculated regressions and the observed values for D.geniculatus were very good indeed, and it was therefore thought unnecessary to calculate correlation co-efficients for these regressions.

Egg production

Egg production by D.geniculatus was estimated in the field in the following way. Thirty adult individuals, ten from each adult size class, were placed in 10 cm Petri dishes on moist filter paper. An adequate supply of food in the form of decaying alder and birch leaves was added, and the lids were then sealed on. The Petri dishes were buried in the litter of the wood for a period of 34 days. They were then re-examined and the number of eggs laid, including those that had hatched, was counted. The results are shown overleaf.

No.of animals	Time	No.of eggs laid	Mean no./animal
30	39 days	50	0.046/day

This value of 0.046 eggs laid per adult individual per day was used in the calculation of the total number of eggs laid by the population over the whole six month period.

Incubation period

To estimate the length of the egg period of D.geniculatus in the laboratory, freshly laid eggs were cultured in small tubes on damp filter paper at 10°C. For a total of 66 eggs laid between the 3rd and 22nd March the mean egg period was found to be 11 days with a maximum of 14 days and a minimum of 9 days.

The calculation of growth in the population

A consideration of the size class distribution (Fig. 4) and the fact that female animals were carrying eggs throughout the period of observation indicate that young were being born into the population throughout the period of observation. This introduces a number of problems in assessment of increase in tissue production, the most important of which is that there is frequently a decrease in the mean weight of an individual from one sample to the next. Also because new individuals may enter the population at any time, a survivorship curve cannot be computed in the normal way. Thus any estimate of growth due to animals that died between successive sampling times could only be an approximation.

The standing crop of D.geniculatus was first calculated. From the previously computed length/wet weight and wet weight/dry weight relationship the mean dry weight of individuals in each size class was calculated. The

numbers of animals in each size class in each month were then multiplied by the mean dry weight for that size class, and the figures summed to give the standing crop in each month (Table 5). The mean weight of an individual was then calculated for each month and, as can be seen from the table, there is a decrease in the mean weight of surviving animals over the whole period February to July. This is undoubtedly due to a 'dilution effect' on the standing crop produced by young individuals, since whereas the standing crop increases approximately two-fold over this period the number of animals nearly trebles.

The method adopted here for the assessment of growth due to surviving animals over the whole time period was as follows. By inspection of the numbers in each size class and their respective weights it was found that the only size classes in which the aforementioned dilution effect was not observed were the last two (1.5-1.7 mm). Since no young individuals were entering these size classes, the increase in mean weight in these two size classes was 0.0088 mg per individual (Table 6). The overall growth of the 216 surviving individuals will therefore be:

$$0.0088 \times \frac{7}{2} \times 216 = 6.6528 \text{ mg/M}^2$$

where $\frac{7}{2}$ is based on half the number of size classes.

The method used for estimating the growth due to animals that died was adopted from that used by Saito (1965). He derived this component of growth from the following expression:

$$\frac{\Delta N}{\Delta t} \times \frac{1}{2} \times \frac{\Delta W}{\Delta t}$$

where $\frac{\Delta N}{\Delta t}$ = the decrease in numbers per unit time calculated from the survival curve

$\frac{\Delta W}{\Delta t}$ = the mean growth rate of an individual per unit time, calculated as the differences between consecutive mean weights in each sample

As has already been pointed out the form of the monthly size class distributions does not allow a survival curve to be calculated in the normal way. However, using the known egg laying rate for D.geniculatus and the regression of total numbers of adults present over the whole period, a crude survivorship curve can be calculated on the assumption that

- (a) all eggs are laid at the beginning of the sampling period
- (b) the total number of adults present in the largest size class (1.6-1.7 mm) represent the survivors of these eggs.

Clearly neither of these assumptions is entirely correct, but at least they provide a crude method of estimating the growth due to animals that died.

From the calculated egg laying rate of 0.046 eggs per adult individual per day, the total number of eggs laid by the 923 adults present over the whole 172 day period of study was calculated as:

$$0.046 \times 923 \times 172 = 7,303$$

It was assumed for the purpose of this study that this number of eggs was in fact laid and that the total number of individuals in the largest size class represented the survivors of these eggs (that is, the sum of individuals in the 1.6-1.7 mm size class in each month). From the monthly size class distributions and the monthly population figures the total number of animals in each size class was calculated and plotted on a logarithmic scale (Fig. 7).

Since it has been assumed that the summed numbers in the largest size class represent survivors of all the eggs laid by the adult population, the X axis of this graph must in fact represent time. It can be seen that the numbers in each size class do not in fact fall on a smooth curve. However, it was found that a regression plotted through the points for the adult size classes (1.4-1.7 mm) cut the Y axis at a point (A) corresponding to the 7,303 eggs laid. This regression is shown as line AB on Figure 7, the equation for which is

$$Y = -0.015X + 3.71$$

Since there was a reasonable correspondence between the number of eggs assumed to be laid and the regression of numbers of total adults present, this regression was used as a crude survivorship curve in calculation of mortality.

From this regression it was found that 1,679 animals entered the 1.0-1.1 mm size class and that the number surviving to the 1.6-1.7 mm size class was 211. The number that died over the whole period was

$$1,679 - 211 = 1,468$$

Using the increase in mean weight of 0.0088 x 3.5 mg already obtained for surviving animals (p.11), growth due to animals that died was calculated as

$$\begin{aligned} 0.0088 \times 3.5 \times 1,468 \times 0.5 \text{ mg} \\ = 0.0308 \times 734 \text{ mg} \\ = 22.607/M^2 \end{aligned}$$

The total growth of the population per square metre will therefore be:

$$6.6528 + 22.6072 \text{ mg} = \underline{29.26 \text{ mg/M}^2}$$

This growth was then converted to calories in order to compare it with the respiratory energy losses of the population. This was done by multiplying the growth in milligrammes by the calorific value for D.geniculatus previously determined.

$$\text{growth} = 29.26 \times 4.883 \text{ cal} = 142.87 \text{ cal/M}^2$$

Respiration

Studies of the respiratory rate of Damaeus geniculatus were undertaken to estimate the energy dissipated in respiration by the population over the period of study. The respirometer used with D.geniculatus was a constant pressure capillary respirometer; a modification of the Kirk-Smith respirometer. This is shown in Figure 8. The experimental chamber (see inset, Fig. 8) consisted of a length of P.V.C. tubing (1) with an internal diameter slightly smaller than the external diameter of the capillary tube (5) and to which a floor of P.V.C. (2) was fitted. A small tube of soda-lime was placed in the chamber (3) to absorb carbon dioxide while the chamber was lined with moist filter paper (4) to maintain a high humidity. The experimental chamber A was connected to the capillary tube B with a constant internal bore of 0.675 mm and fitted with a scale, F. The capillary was connected via a connecting tube C to a large closed chamber D which reduced the pressure changes acting on the capillary tubing. The intake of oxygen was recorded by the movement of a small bubble of paraffin, E, in the capillary tube. Any changes in pressure or temperature were recorded by a blank tube set up in exactly the way described above, but lacking an experimental animal.

Methods

A group of animals (usually 2-4) was weighed on a torsion balance sensitive to 0.01 mg. They were then introduced to the chamber A which was connected to the capillary B. A small bubble of paraffin was introduced to the top of the capillary which was then connected to the chamber D. The respirometer was allowed to equilibrate for at least 1 hour in a constant temperature room at either 5 or 10°C. The initial readings of both the experimental and blank chambers were taken and the apparatus allowed to operate for 24 hours, 12 hours in the light and 12 hours in the dark. The final readings of the capillaries were then taken and the oxygen consumption calculated from the equation:

$$R = \frac{A-B \times \pi r^2}{\text{No. of individuals}} \text{ mm}^3/\text{individual}/24 \text{ hours}$$

Where A = depression of bubble in experimental capillary (mm)

B = depression of bubble in blank capillary (mm)

r = radius of capillary (mm)

Although this respirometer was found to give consistent results with D. geniculatus and other larger organisms (particularly the isopod, Trichoniscus), no readings could be obtained for the smaller Nothrus sylvestris.

Respiratory measurements were made at 5° and 10°C. The animals used were first acclimatized at the temperature at which measurements were made for at least 48 hours to ensure that respiration occurred under conditions at least approximating to those of the environment.

The results of the respiratory measurements at each temperature were then plotted as oxygen consumed in cubic millimetres per individual per day

against wet weight (Figs 9, 10). The curves obtained were then transformed to square roots and regressions calculated for the points obtained (Fig. 11). The regression equation for respiration at 5°C was

$$Y = 1.2096X + 0.1358$$

and at 10°C $Y = 2.2352X + 0.6745$

As can be seen from Figure 11 the regressions at 5°C and 10°C cross and it was therefore decided to take a mean regression for all the points at both temperatures (line AB on Fig. 11) and use this in the calculation of energy losses of the population as a whole.

Calculation of the respiratory energy losses of the population

The mean respiratory rate of an individual of each different size class was calculated from the regression of respiratory rate against mean wet weight. The consumption of oxygen by the standing crop in each month was then calculated by summing the oxygen consumption due to the animals of all size classes present in any one month. These results are set out in Table 7. The total respiration per metre squared due to the animals that survived the whole period was therefore calculated as:

$$\frac{892.6578 \times 30}{1000} \text{ ml } O_2/M^2 = 27.6724 \text{ ml } O_2/M^2$$

where 892.6578 is the total oxygen consumption per day of animals in each size class in each month and 30 is the number of days in each month.

An estimate of the respiratory energy losses due to animals that died between the beginning and end of the whole period was also needed. From the survivorship curve it was known that 1,468 animals died over this period.

The mean wet weight of these animals was 0.4417 mg. (assuming that mortality was constant in each size class), and from the regression of respiratory rate against wet weight the mean respiratory rate was found to be $0.504/\text{mm}^3/\text{individual}/\text{day}$. The quantity of oxygen consumed by the animals that died over the whole period will then be:

$$\begin{aligned} & 0.504 \times 1,468 \times 172 \times 0.5 \text{ mm}^3 \text{ O}_2/\text{M}^2 \\ & = \frac{740 \times 86}{1000} \text{ ml O}_2/\text{M}^2 \\ & = 63.6416 \text{ ml O}_2/\text{M}^2 \end{aligned}$$

Where 0.504 = the mean respiratory rate of an individual in mm^3/day

$1,468$ = the total number of individuals that died

172 = the total number of days

0.5 is based on a constant mortality rate

The total quantity of oxygen consumed by both animals that survive and those that die will therefore be:

$$63.6724 + 27.6724 = 91.3448 \text{ ml O}_2/\text{M}^2$$

To compare these figures with growth, a common unit must be used, the calorie. The calorific value of a given quantity of oxygen respired by an organism can be obtained if the R.Q. is known. Since no R.Q. is available for D.geniculatus, the value for a resting insect, 0.82, will be used (Roeder, 1963). This gives an oxy-calorific value of 4.8 calories per millilitre of oxygen consumed. The total energy respired by the population over this six month period will therefore be:

$$91.3448 \times 4.8 = \underline{438.45 \text{ calories}/\text{M}^2}$$

Ingestion

An estimation of ingestion rate of adult D.geniculatus was made under near natural conditions as follows. Decaying leaves of alder (Alnus glutinosa) and birch (Betula pendula) were dried for 48 hours at 60°C. Discs of tissue were cut from these with a cork borer and weighed on a torsion balance sensitive to 0.01 mg. Equal numbers of discs of each type of leaf were re-wetted and positioned at random on moist filter paper in 10 cm Petri dishes.

Thirty adult animals, 10 from each adult size class, were placed in the Petri dishes which were sealed and buried in the leaf litter of the wood for a period of 39 days. At the end of this period the Petri dishes were collected again and the discs of tissue dried and reweighed. The loss in weight was recorded and the mean ingestion rate for each size class and for adults as a whole calculated (Table 8).

Using the mean figure of 0.00827 mg of leaf ingested per individual per day, and applying this to the whole population, an estimate can be derived for the ingestion of the population as a whole. The ingestion due to the standing crop in each month was first calculated by multiplying the number of animals present by the daily ingestion rate and the number of days they were present (Table 9). Thus the standing crop ingests 322.1119 mg of leaf tissue/M² over the six month period. From the survivorship curve it was known that 1,468 animals died in this period. The ingestion due to these animals will be:

$$\begin{aligned}
 &= 0.00827 \times 1,468 \times 172 \times 0.5 = 12.1403 \times 86 \text{ mg/M}^2 \\
 &= \underline{1,044.0658} \text{ mg/M}^2
 \end{aligned}$$

The total ingestion for this period will therefore be:

$$1,044.0658 + 322.7119 \text{ mg/M}^2 = \underline{1366.7777} \text{ mg/M}^2$$

The mean calorific value for decayed birch leaves was found to be 5,346 cal/gramme and that for decayed alder leaves 5,373 cal/gramme (Hughes, personal communication). Using the mean of these two values, 5,359 cal/gramme, the total energy ingested by the population was:

$$1,366.77 \times 5.359 = \underline{7324.5} \text{ cal/M}^2$$

The quantification of the energy budget

Having obtained estimates of energy ingested (E), energy respired (R) and energy of growth (P), we can substitute in equations (1) and (2) below to obtain indirect estimates of energy assimilated (A) and energy excreted (F):

$$E = A + F \quad (1)$$

$$A = R + P \quad (2)$$

where

$$E = 7,324 \text{ cal/M}^2$$

$$R = 438 \text{ cal/M}^2$$

$$P = 143 \text{ cal/M}^2$$

$$A = 438 + 143 \text{ cal/M}^2$$

$$\underline{582} = 438 + 143 \text{ cal/M}^2$$

Using this figure 582 cal/M² for assimilation and substituting in equation (1) above

$$7,324 = 582 + F \text{ Cal/M}^2$$

$$F = 7,324 - 582 \text{ cal/M}^2 = 6,642 \text{ cal/M}^2$$

From these figures it was found that:

assimilation as a percentage of ingestion equals 7.94%

growth as a percentage of assimilation equals 24.57%

respiration as a percentage of assimilation equals 75.43%

Discussion

As Phillipson (1967) has pointed out, energetics studies on any species populations present two major areas of study:

- (a) the estimation of changes in population size
- (b) the fate of energy entering the population

Normally changes in population size in themselves do not provide sufficient information to draw up a detailed energy budget and an estimation of two other parameters, natality and mortality, is needed. The fate of energy entering the population (energy ingested) is completely described by the following equations:

$$E = A + F$$

and $A = R + P$

where $E =$ energy ingested $R =$ energy respired

$A =$ energy assimilated $P =$ energy of production

$F =$ energy egested

Ideally all of these parameters should be separately estimated in any single study, but in the present case time limitation prevented this. In this study it was decided to concentrate on changes in population size, respiratory energy losses and growth. In addition more approximate estimates were made of ingestion and mortality.

The habitat was sampled on a stratified random basis to avoid aggregation of samples due to chance. The size of the sampling unit was 11.35 cm², which is close to the 10 cm² advocated by MacFadyen (1963) for patchily

distributed micro-arthropods in woodland soils. One possible source of error in the monthly estimation of numbers was that the soil was sampled only to a depth of 3 cm. However, it was thought that this error was minimal since the soil below this level was a very stiff clay-loam difficult for a large mite such as D.geniculatus to penetrate, and in any case Belbids are known to be inhabitants of the F and H layers (Kuhnelt, 1961).

Although no statistical analysis of the spatial distribution of the animals was made in this study it was clear that D.geniculatus showed an aggregated distribution in this habitat. In those months (March and June) where tests were made the variance was found to be considerably greater than the mean, while in a large number (c.20%) of the samples in which it occurred more than one individual was present.

The extractor used was a model of the MacFadyen high gradient extractor. This produces a very high gradient of heat and humidity between the soil core and the aluminium cylinder into which the mites are extracted. Although Block (1966) found that this extractor has a 77% efficiency in the extraction of oribatids from mineral soil, it is not clear from his paper whether he used adults alone, or both adults and nymphs in testing his extraction apparatus. In the present study very few larvae or protonymphs were obtained and it is suggested that the extraction efficiency, with regard to D.geniculatus at least, was very much lower for nymphs than for adults.

The number of mites present in the woodland soil showed a clear seasonal variation in this study. Both the total mite community and oribatid mites showed low numbers in February, rising to a peak in May and thereafter

falling again. Strenzke (1952) found in N.Germany that maxima of oribatids were normal in May and December and minima in February and August. Block (1963), working on high altitude moorland soils, found a similar situation with maxima in May and December. Both these findings accord well with the limited findings of this paper. On the other hand, Evans (1955) found that in Sitka spruce forest the cryptostigmatids showed population maxima in February and November and a minimum in August. MacFadyen (1952), working on fen soil, found a similar pattern with a maximum in February but also a lesser maximum in May and December for some species. D.geniculatus itself showed a minimum in February rising sharply in March, and then remaining fairly constant until June when there was a peak, after which numbers fell again. Block (1963) worked on a closely related species, Damaeus clavipes, on high altitude moorland soils and found a peak in numbers in July and August. It is suggested that the difference in timing of the population peak is possibly due to the later onset of breeding on the high altitude moorland associated with lower temperatures during the spring and early summer.

It has been shown by Wiegert (1962) that the calorific value of the tissues of an organism can vary with age, sex, reproductive condition and season. It follows that in order to obtain complete information on the calorific content of the tissues of an animal population, measurements should be made on both sexes, and on all life stages at different seasons.

Unfortunately the very small size of mites meant that there was only a small quantity of material available for calorimetry in this study, and the three determinations made were on a mixture of adults and nymphs taken from the whole six month period. However, the fact that the three values obtained

were within five per cent of one another indicates that the mean value of 4,883 calories/gramme is a reasonable estimate of the calorific content of the population as a whole.

The estimation of the growth of the population involved the following data:

- (a) a length-wet weight relationship
- (b) a wet weight-dry weight relationship
- (c) a monthly size class distribution

A clear relationship was obtained between the length and the wet weight of this mite. It is of interest to note that Englemann (op.cit) could find no relationship between either length or volume and wet weight in the 24 oribatids, including one species of Damaeus, which he studied. For these 24 species he derived the relationship:

$$\text{Log weight (mg)} = 1.32 (\text{log length} + \text{log width}) - 5.87$$

He thus suggested from this that weight was a function of surface area rather than volume and explained this on the assumption that exoskeleton and its attached muscles comprise the majority of the weight of a mite. If this is so of mites, one would expect the same relationship to hold for many insects and Crustacea. Normally however a satisfactory relationship is found between the wet weight and the length of arthropods.

The wet weight-dry weight relationship was found to be a direct one, dry weight being 0.325 x wet weight.

A size class distribution was obtained for each month by measuring the length of at least 50 animals in each sample. The animals were extracted in Tullgren funnels and it was noted that nymphs formed a very low proportion

of the total except in June and July. It was thought likely that this extractor had a low efficiency with regard to nymphs, and that they were not properly represented in the size class distributions. However, it was clear from the rise in numbers of nymphs in May and June that breeding occurred in these months, giving rise to a peak in numbers in June.

In the calculation of the growth of the population the size class distributions and the total numbers present in each month were used to tabulate the numbers present in each size class in each month. These figures were then used in conjunction with the mean dry weight of animals of each size class to calculate the standing crop in each month. The change in mean weight of an individual from month to month was calculated, and it was found that over the whole period there was a fall in mean weight due to the increase in numbers of small animals. By inspection of the monthly size class distribution it was found that animals 1.5 mm long and upwards did in fact show an increase in mean weight; this increase was therefore applied to the whole population in the calculation of growth.

To obtain an estimate of growth due to animals that died, a survivorship curve was needed to assess mortality. In the case of oribatid mites which produce more than one generation each year, and in which the generations overlap, it is not possible to calculate a survivorship curve from field data alone by the normal methods. A further complication is that the observations on age structure of the population extended over only a six month period. However, a crude survivorship curve was constructed from the monthly age structure data and the calculated number of eggs laid, using the following assumptions:

- (a) Mortality was constant throughout the period of study and did not deviate significantly from a Deevey Type II survivorship curve.
- (b) For the purpose of simplification all eggs could be considered as laid at the beginning of the period of study (i.e. in February).
- (c) Animals that hatched from these eggs and survived the whole six month period had all reached maturity.

The method used was first to sum the numbers of animals in each size class in each month and to plot these total numbers in each size class on a logarithmic scale (Fig. 7). It is clear from this figure that there is no clear trend for the numbers in every size class; however, a regression calculated through the last three points on the graph (line AB on Fig. 7) was found to cut the Y axis at a point (A) corresponding to the logarithm of the number of eggs laid. The latter figure was computed from the daily egg laying rate of adults confined in the field over a period of one month. Because there was a good correlation between the number of eggs laid and the regression on total adults present over the whole period, this regression was used as a crude survivorship curve.

Because the egg laying rate was likely to be an over-estimate for at least the first three months of this period, and because assumption (c) was not necessarily valid (i.e. the animals may have a longer development period), the estimate of mortality was probably too high. However, despite the assumptions made it does provide an approximate means of estimating growth due to animals that died from the limited data available. Further, if the survivorship curve obtained at least approximates to that which actually exists under field conditions, it lends support to the belief that the

Tullgren funnel extraction technique is highly inefficient at extracting oribatid nymphs.

The growth due to animals dying was found to be 3.66 times the growth due to survivors, and was a measure of the high mortality rate. The growth in milligrams was then multiplied by the calorific value for D.geniculatus tissues already obtained to get the energy of growth.

The respirometer used in the estimation of respiratory rates in D.geniculatus has already been described. It was found that there were three likely sources of error in these measurements:

- (1) the reading of the depression of the paraffin drop
- (2) slight variations in the bore of the capillary tube
- (3) differences in the volumes of the experimental and blank chambers

All of these sources of error could in fact be eliminated by using 0.1 mm bore thermometric capillary tubing connected by ground glass joints to 1 ml flasks, the volume of which had been determined by titration. Such capillary tubing would give a much larger depression per unit volume of oxygen taken up than that used here. This was just fine enough to give readings with D.geniculatus, but when tried with smaller species of mites gave no readings at all. Also for ideal conditions the apparatus should be immersed in a water bath thermostatically controlled to within 0.1°C of the required temperature.

Despite the possible errors inherent in the apparatus used, the results obtained were reasonably consistent. However, on plotting the square root of respiratory rate against the root of wet weight the regressions calculated at 5 and 10°C respectively were found to cross. This may have

No. of animals dying x mean respiratory rate x $\frac{1}{2}$

The mean respiratory rate was taken as the respiratory rate of an animal of mean weight in the population as a whole. Here again the respiratory energy losses of animals dying were considerably higher than those surviving, being in the ratio 2.5:1.

In order to compare respiratory energy loss with energy of growth the volume of oxygen utilized was converted to calories consumed by multiplying by an oxycalorific equivalent of 4.8 cal/ml O_2 .

Experiments were carried out to estimate the ingestion rate of adult D.geniculatus under near-natural conditions. Animals were allowed to feed on decaying birch and alder leaves and the amount ingested during July was obtained gravimetrically. This feeding rate was then applied to the population as a whole. The estimate is liable to be too high for two reasons:

- (1) the adult ingestion rate is normally higher than that of young.
- (2) the leaf material was infected with fungi probably carried as spores by the mites themselves. This would account for some of the loss in weight of the leaves.

Because the ingestion rate obtained was too high, probably by a factor of at least two, the assimilation percentage will probably be too low. Englemann (1961) found assimilation amongst the oribatids he studied to be 20% of ingestion using a radio-tracer method. As has been mentioned previously, the estimation of growth in this study is probably too high, and Englemann found growth to be only 4% of assimilation. However, this figure is low compared with other estimates of growth in terrestrial invertebrate herbivores and it may prove on more careful examination that

the figure for oribatids in general lies somewhere between the 4% obtained by Englemann and the 24% found in this study.

Summary

- (1) An attempt was made to assess energy flow through a population of the oribatid mite Damaeus geniculatus in the soil of a birch-alder wood, over a six month period. Estimates were made of the population density, energy ingested, energy respired and energy laid down in growth.
- (2) A sampling programme was carried out using a MacFadyen high gradient extractor to extract the mites from the cores. Populations of both mites in general and oribatids in particular were found to be low in February, rising to a peak in May and then falling again until July. The population of D.geniculatus followed the general trend for that for oribatids as a whole, but the peak in numbers came in June and numbers were relatively constant between March and May.
- (3) Monthly size class distributions were determined on the basis of length of animals extracted from bulk samples in Tullgren funnels. A relationship between length and wet weight was derived which took the form:

$$\text{Length (mm)} = 1.42 \times \log \text{ wet wt.} + 1.7$$

The relationship between wet weight and dry weight of the organisms was found to be:

$$\text{Dry weight (mg)} = 0.33 \times \text{wet weight (mg)} - 0.0062$$

- (4) The calorific value of the tissues of D.geniculatus was determined using a miniature bomb calorimeter. Sufficient material was available to obtain only three determinations, the mean value for which was 4,833 calories per gramme.

- (5) The egg production rate of adult D.geniculatus was estimated under semi-natural conditions. A rate of 0.046 eggs/adult individual/day was found.
- (6) The growth of the population as a whole was calculated using the increase in dry weight over the whole period calculated from the size class distributions and the relationship between size class and dry weight. The growth of animals that died was estimated using a crude survivorship curve derived from the egg laying rate and the regression of total numbers of adults present. Growth was estimated as 29.26 mg/M² and when converted to calories this was found to equal 142.87 calories/M².
- (7) In order to estimate respiratory energy losses of the population, studies were made of the respiratory rate of D.geniculatus using a simple capillary respirometer. Measurements were made at 5 and 10°C after previous acclimatization of the animals at the required temperature. The results were expressed as respiratory rate against wet weight of the animals, and the raw data was then transformed to square roots. Since the regressions calculated at the two temperatures crossed a mean regression for all the points was calculated. The relationship took the form:
- $$\text{root respiratory rate} = 1.7224 \times \text{root wet weight} - 0.2513$$
- (8) The respiratory energy losses of the population as a whole were calculated using the monthly size class distributions and the weight specific respiratory rates obtained. Respiration due to animals that died was calculated from the crude survivorship curve previously mentioned. It was found that the population consumed 91.3448 ml of oxygen/M² and that using an oxy-calorific value of 4.8 this was equivalent to 438.45 calories/M².

(9) The ingestion rate of D.geniculatus was estimated under near natural conditions using as food discs of decayed alder and birch leaves. A mean ingestion rate of 0.00827 mg per individual per day was found. From this the total ingestion of the population was calculated as 1,367 mg/M² of leaf tissue or 7,324.5 calories/M².

(10) The energy budget was quantified as follows. Ingestion 7,324 cal/M². Respiration 438 cal/M² and growth 143 cal/M². By difference it was found that faecal production equalled 6,642 cal/M² and assimilation equalled 582 calories/M². On the basis of these figures assimilation represents 7.94% of ingestion, growth represents 24.57% of assimilation and respiration equals 75.43% of assimilation.

(11) The results were discussed and possible sources of error pointed out. Comparisons were made between the results obtained here and those obtained by other workers on terrestrial arthropods.

References

- Baker, E.W. and Wharton, G.W. (1952) An introduction to Acarology. Macmillan, New York.
- Berthet, P. (1960) La mesure ecologique de la temperature par determination de la vitesse d'inversion du Saccarose. *Vegetatio*, IX, 197-207.
- Berthet, P. (1964) L'activite des oribatides d'une chenaie. *Mem.Inst. Roy.Sci.Nat.Belg.*, 152, 1-152.
- Block, W. (1963) Studies on the acarina of moorland areas. Unpublished Ph.D. thesis, University of Durham.
- Block, W. (1966) Some characteristics of the MacFadyen high gradient extractor for soil micro-arthropods. *Oikos*, 17, 1-9.
- Evans, G.O. (1950) Study of the soil fauna of a Sitka spruce plantation at Ampthill in Bedfordshire. Unpublished. In Evans et al (1961) *The terrestrial Acari of the British Isles*. Vol.I. (B.M.(N.H.), London).
- Englemann, M.D. (1961) The role of soil arthropods in the energetics of an old field community. *Ecol.monogr.*, 31, 221-38.
- Grainger, J.N.R. (1956) Effects of changes of temperature on the respiration of certain Crustacea. *Nature, Lond.*, 178, 930-31.
- Kuhnelt, W. (1961) *Soil biology with special reference to the animal kingdom*. Faber and Faber, London.
- MacFadyen, A. (1952) The small arthropods of a molinia fen at Cothill. *J.Anim.Ecol.*, 21, 87-117.

been due to inaccuracies in the measurements themselves, but it was thought more likely to be due to the fact that very few measurements were made on animals of the smallest size classes. This could cause an alteration in the slope of one or both of the regressions. Because the two regressions crossed it was decided to calculate a mean respiratory rate for all the points obtained. This will therefore represent the respiratory rate of the animals at 7.5°C, which is close to the mean soil temperature of 9°C measured over the period considered.

The animals whose respiratory rate was measured were first acclimatized for at least 48 hours at the temperature at which measurements were made. Although the effect of acclimatization on the respiratory rate of oribatids has not been studied, it is known that with some arthropods sudden changes in temperature can produce over-compensation in the respiratory rate (Grainger, 1956). Berthet (1964) found that the sixteen species of oribatid mites whose respiratory rate he investigated without previous acclimatization showed Q_{10}^c values ranging from 3 to 6 with a mean value of approximately 4. These values are all fairly high, and although no Q_{10} can be calculated from the data presented here the relative slope of the regressions for respiration at 5 and 10°C would indicate a value for the Q_{10}^c closer to 2 than 4. Whatever the Q_{10} may be, there is a good case for investigating the effect of acclimatization on the respiratory rate of oribatids.

The respiratory energy losses of the population as a whole were calculated from the regression of respiratory rate on wet weight and the numbers in each size class in each month. The respiratory energy losses of the animals that died was calculated from the survivorship curve as:

- MacFadyen, A. (1963) Animal ecology. Aims and methods. 2nd ed.
Pitman and Sons, London.
- Michael, A.D. (1884-88) British Oribatidae. Vols 1-2. Roy.Soc.London
- Phillipson, J. (1964) A miniature bomb calorimeter for small biological samples. *Oikos*, 15, 130-39.
- Phillipson, J. (1967) Invertebrates reproducing more than once in a lifetime. [in press]
- Saito, S. (1965) Structure and energetics of the population of Ligidium japonicum (Isopoda) in warm temperate forest ecosystems. *Jap.J.Ecol.*, 15, 47-55.
- Strenzke, K. (1952) Untersuchungen über die Tiergemeinschaften des Bodens. Die oribatiden und ihre Synusien in dem Boden Norddeutschlands. *Zoologica*, 104.
- Wiegert, R.G. (1964) Population energetics of meadow bugs (Philaenus spumarius) as affected by migration and habitat. *Ecol. Monogr.*, 34 (2), 225-41.
- Willman, C. (1931) Moosmilben oder oribatiden (Cryptostigmata). In *Dahl.Die Tierwelt Deutschlands*, 22.

Acknowledgements

I wish to thank Dr. J. Phillipson, my supervisor, for constant advice and encouragement during this study.

My thanks are also due to Mr. Gordon Allen for advice on the use of the bomb calorimeter, to Mr. Malcolm Hughes for kindly providing calorific values for birch and alder leaves, and to Mr. R. Wignarajah who made available his soil temperature measurement quoted in this work.

This study was carried out whilst I was in receipt of a postgraduate grant from East Suffolk County Council.

TABLE 1

Mean number per sample and number per M^2 of total mites

Month	February	March	April	May	June	July
No./sample	8.58	20.10	18.68	25.90	19.41	19.03
No./ M^2	7,555	17,708	16,457	22,818	17,100	16,766

TABLE 2

Mean number per sample and number per M^2 of oribatids

Month	February	March	April	May	June	July
No./sample	4.61	13.72	13.13	19.20	13.35	12.27
No./ M^2	4,062	12,083	11,568	16,915	11,757	10,806

TABLE 3

Mean number per sample and number per M^2 of Damaeus geniculatus

Month	February	March	April	May	June	July
No./sample	0.09	0.28	0.26	0.27	0.35	0.25
No./ M^2	75	247	229	234	304	216

TABLE 4

Monthly size class distribution of Damaeus geniculatus

Month	February		March		April		May		June		July	
Size class (mm) ₆	N	A	N	A	N	A	N	A	N	A	N	A
1.0-1.1	1.49	-	3.10	-	4.47	-	5.0	-	11.66	-	25.20	-
1.1-1.2	2.98	-	7.36	-	1.49	-	22.0	-	11.66	-	3.25	-
1.2-1.3	2.98	-	1.05	-	4.47	-	22.0	-	5.0	-	1.63	-
1.3-1.4	4.48	-	3.10	-	0	-	11.0	-	13.33	1.66	4.89	-
1.4-1.5	-	26.87	2.10	37.89	5.97	34.33	15.30	16.92	-	23.33	4.06	28.45
1.5-1.6	-	47.77	-	29.47	-	32.83	-	25.46	-	23.33	-	24.39
1.6-1.7	-	13.32	-	15.78	-	16.42	-	22.32	-	10.0	-	8.14

All figures as % of total in each month

N = nymphs

A = adults

TABLE 5

Standing crop and change in standing crop of D.geniculatus

Month	Standing crop per M ² (mg)	Change in mean weight in animal (mg)	
February	14.7153		
March	45.8320	-0.0107	Overall change in mean weight per animal -0.0424 mg
April	43.9569	+0.0064	
May	45.2506	+0.0015	
June	46.6945	-0.0348	
July	33.2308	+0.0002	

TABLE 6

Numbers, biomass and mean weight of animals 1.5-1.7 mm length

Overall increase in mean weight = 0.0088 mg

Month	Numbers	Biomass (mg)	Mean weight (mg)	Change in wt.
February	46	10.6279	0.2310	
March	112	26.9507	0.2406	+0.0096
April	113.	27.1434	0.2402	-0.0004
May	111	28.4343	0.2562	+0.0160
June	102	24.1759	0.2370	-0.0192
July	69	16.5483	0.2398	+0.0028

TABLE 7

Oxygen consumed in cubic millimetres per day by animals of each size class in each month

Size class	1.0-1.1	1.1-1.2	1.2-1.3	1.3-1.4	1.4-1.5	1.5-1.6	1.6-1.7	Total
February	0.1122	0.2964	0.5202	1.6128	12.7880	34.2216	10.7200	60.2512
March	0.8975	2.6676	0.7803	3.2256	62.5632	69.3938	41.8080	181.3360
April	1.1220	0.5928	2.6010	0.0000	58.7328	71.2950	40.7360	175.0796
May	1.3464	0.7419	1.3005	10.4832	47.8800	56.0854	55.7440	173.5805
June	3.9240	5.1870	3.9015	18.5472	45.3264	67.4926	33.2320	177.6137
July	6.0588	1.0374	1.5606	4.4352	44.0496	49.4312	18.2240	124.7968
							Total	892.6572

TABLE 8

Ingestion in D.geniculatus

Size class (mm)	1.4-1.5	1.5-1.6	1.6-1.7	Mean
Total ingestion	3.57 mg	2.89 mg	2.48 mg	2.98 mg
Mean ingestion	0.357	0.289	0.248	0.298
Ingestion/day	0.0092	0.0074	0.0063	0.0083

TABLE 9

Ingestion of the standing crop of D.geniculatus

Month	No.of animals	Time	Ingestion (mg)
February	75	19	11.7847
March	247	31	63.3234
April	229	30	56.8149
May	234	31	59.9906
June	304	30	75.4224
July	216	31	55.3759
Total ingestion			322.7119

Appendix I

Calculation of temperatures by the sucrose inversion technique

Where t = time period in days
 α_0 = initial rotation value of solution
 α = final rotation value of solution
 β_0 = rotation value for completely inverted sucrose

Calculation of field temperature

$$K'_T = \frac{1}{t} \log \frac{\alpha_0 - \beta_0}{\alpha - \beta_0}$$

K'_T = inversion constant

$$T = \frac{5.854}{17,28778 - \log K'_T}$$

Where T = temperature °Absolute = $T^\circ\text{C} - 273.2$

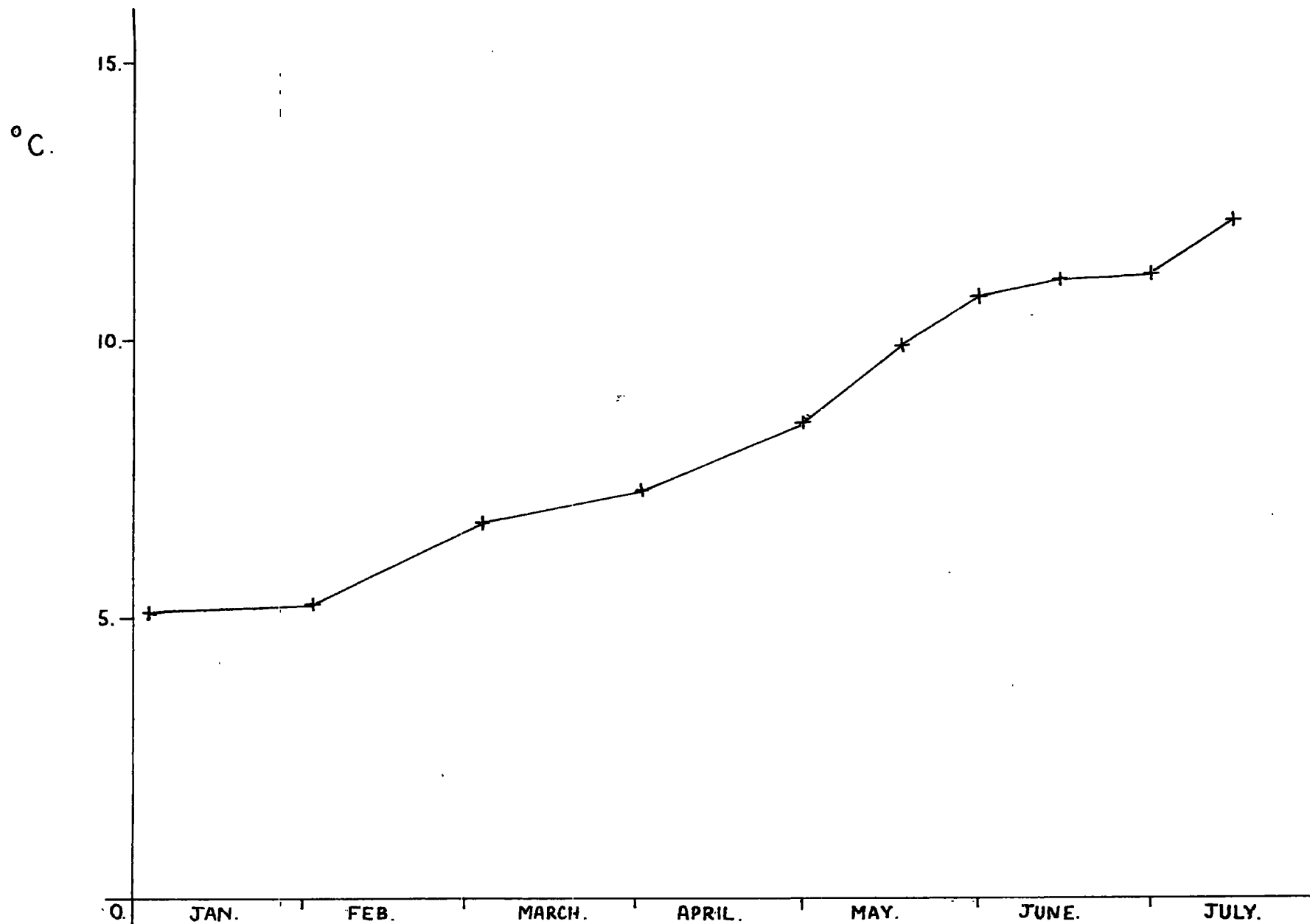

FIGURE 1. TEMPERATURE. 1967.

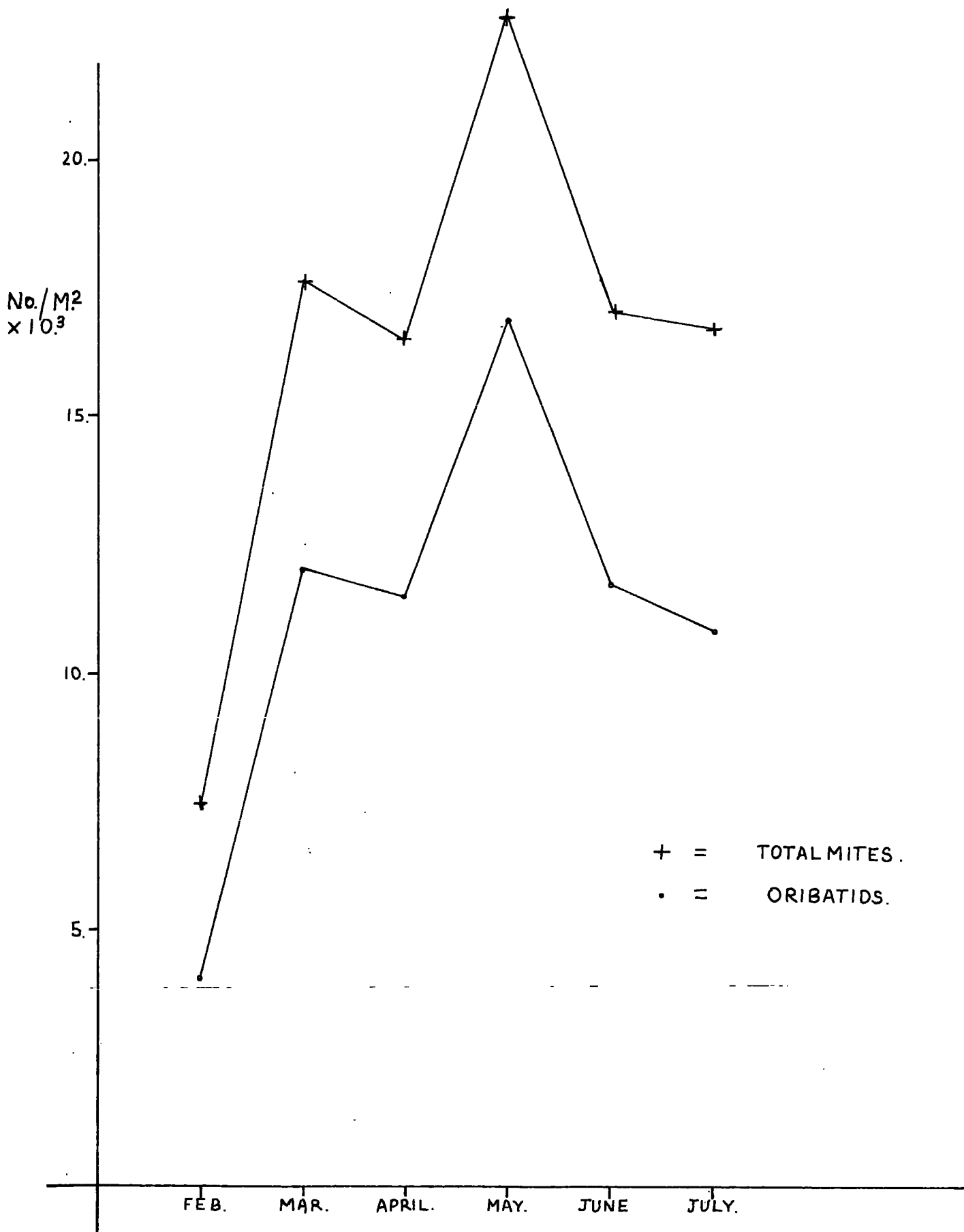

FIGURE 2. MONTHLY POPULATION FIGURES.

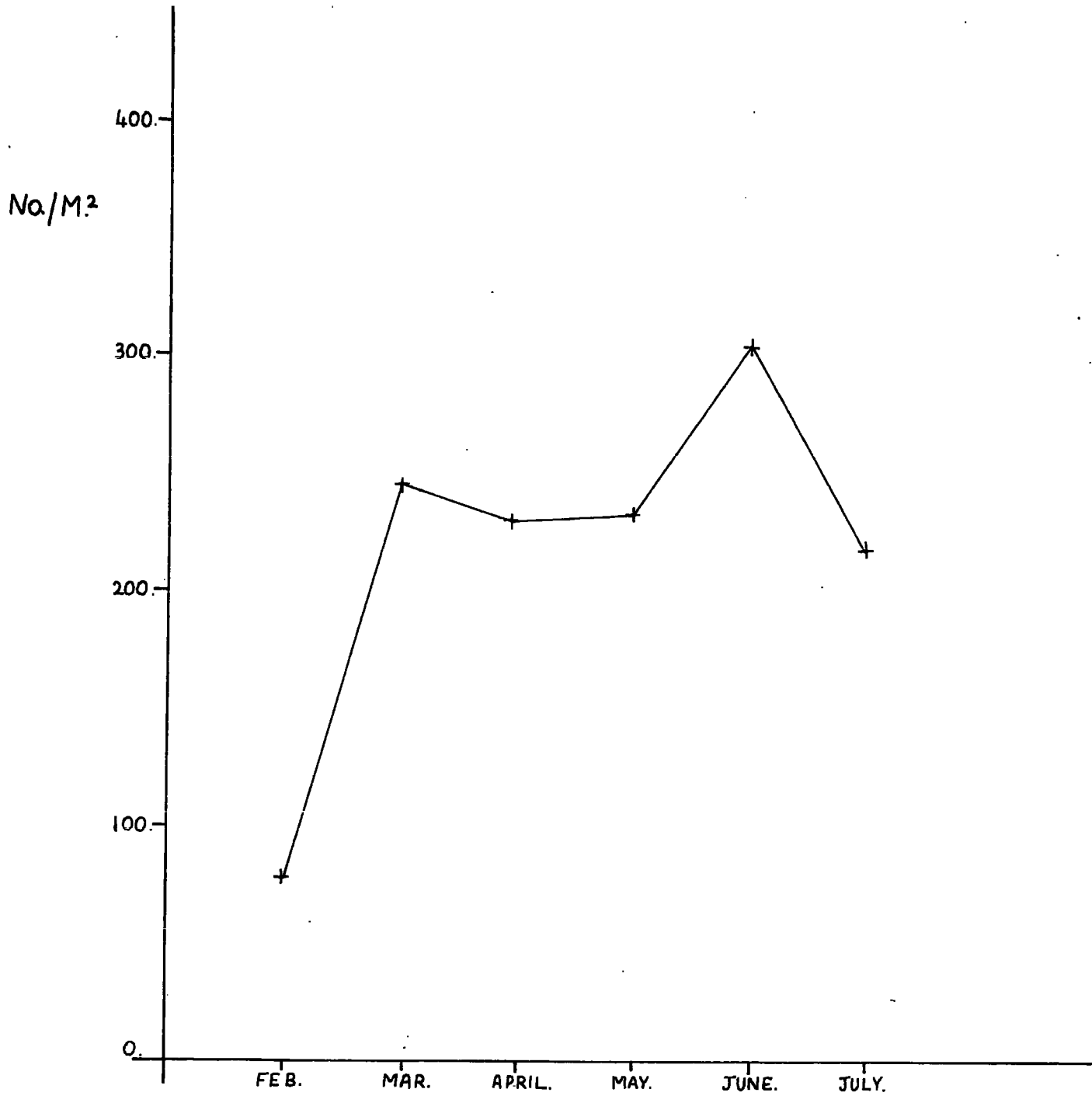

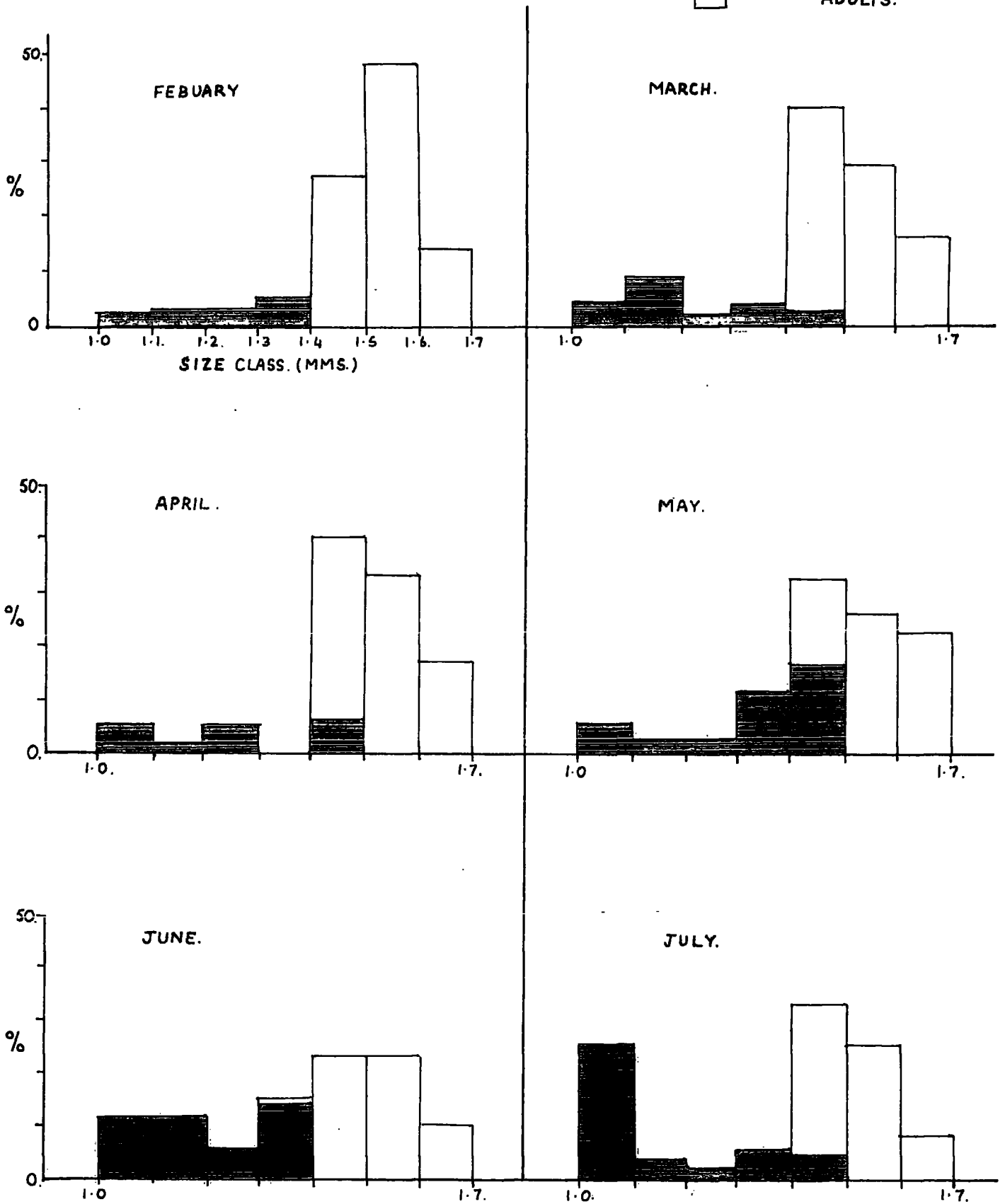

FIGURE 3.

MONTHLY POPULATION FIGURES FOR *D. GENICULATUS*.

FIGURE 4.
 SIZE CLASS DISTRIBUTIONS FOR *D. GENICULATUS*.

 NYMPHS.
 ADULTS.



RELATIONSHIP BETWEEN LENGTH AND LOG. WET WEIGHT IN D. GENICULATUS.

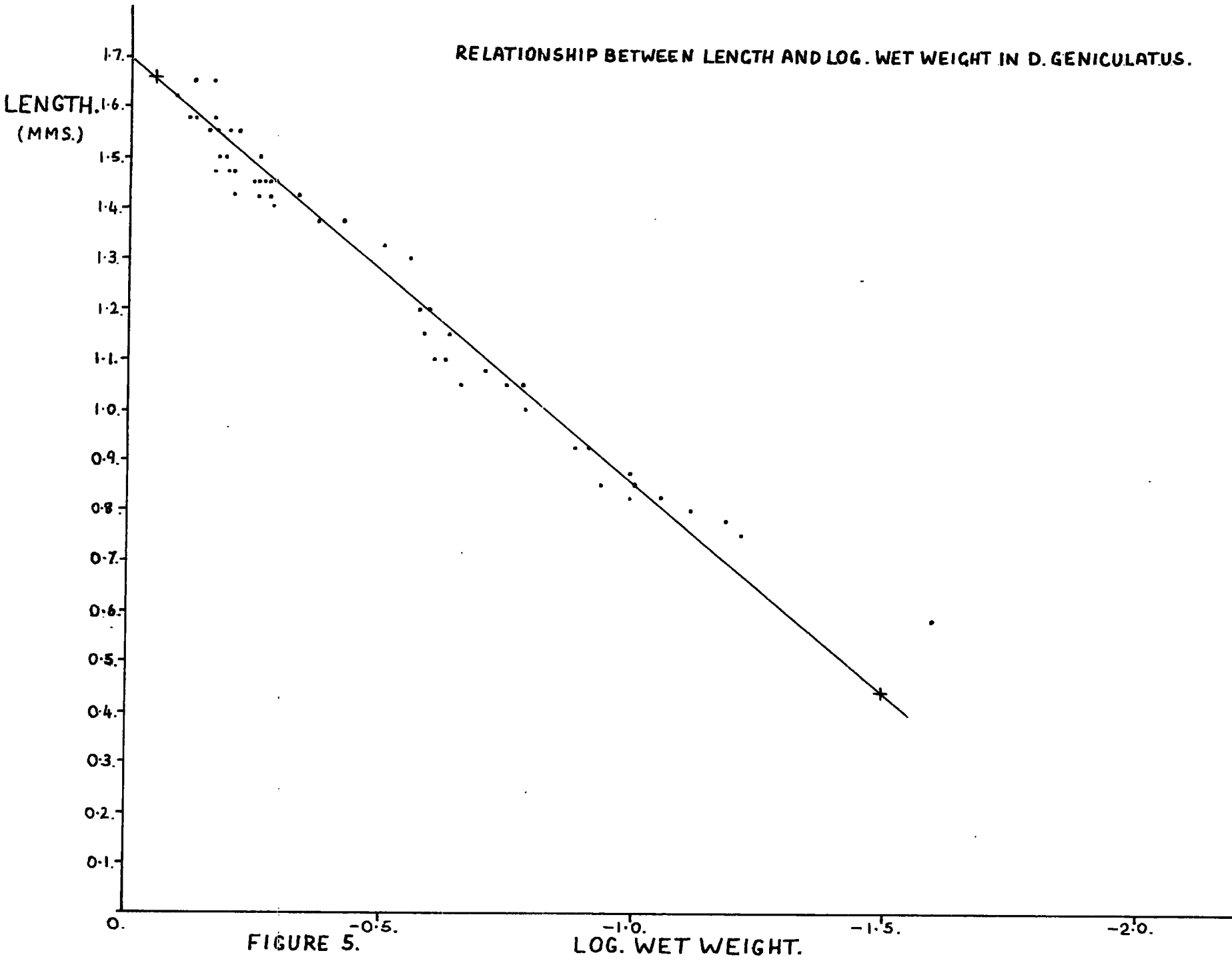

RELATIONSHIP BETWEEN WET WEIGHT AND DRYWEIGHT OF *D. GENICULATUS*.

DRY WEIGHT.
(MGS.)

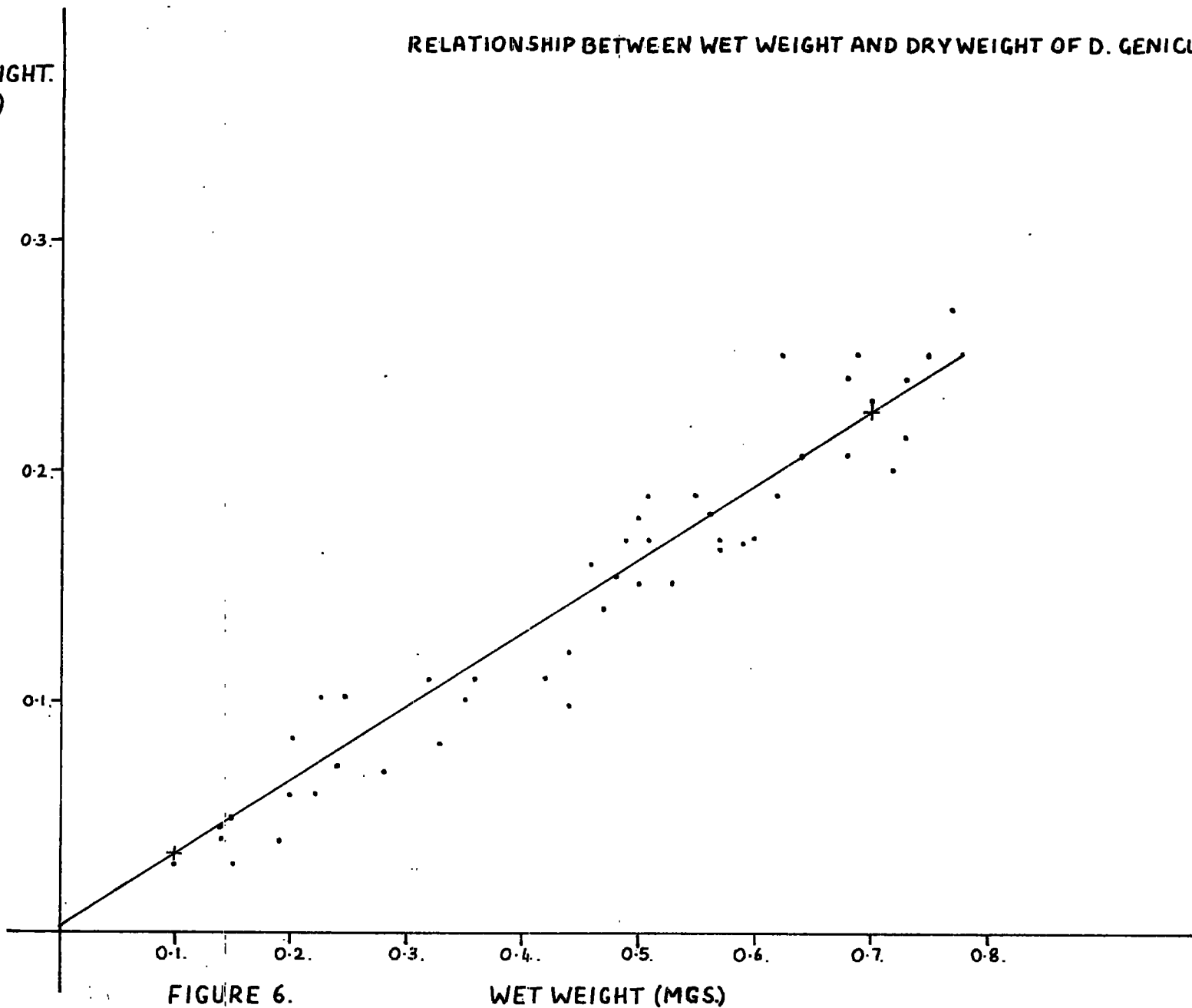

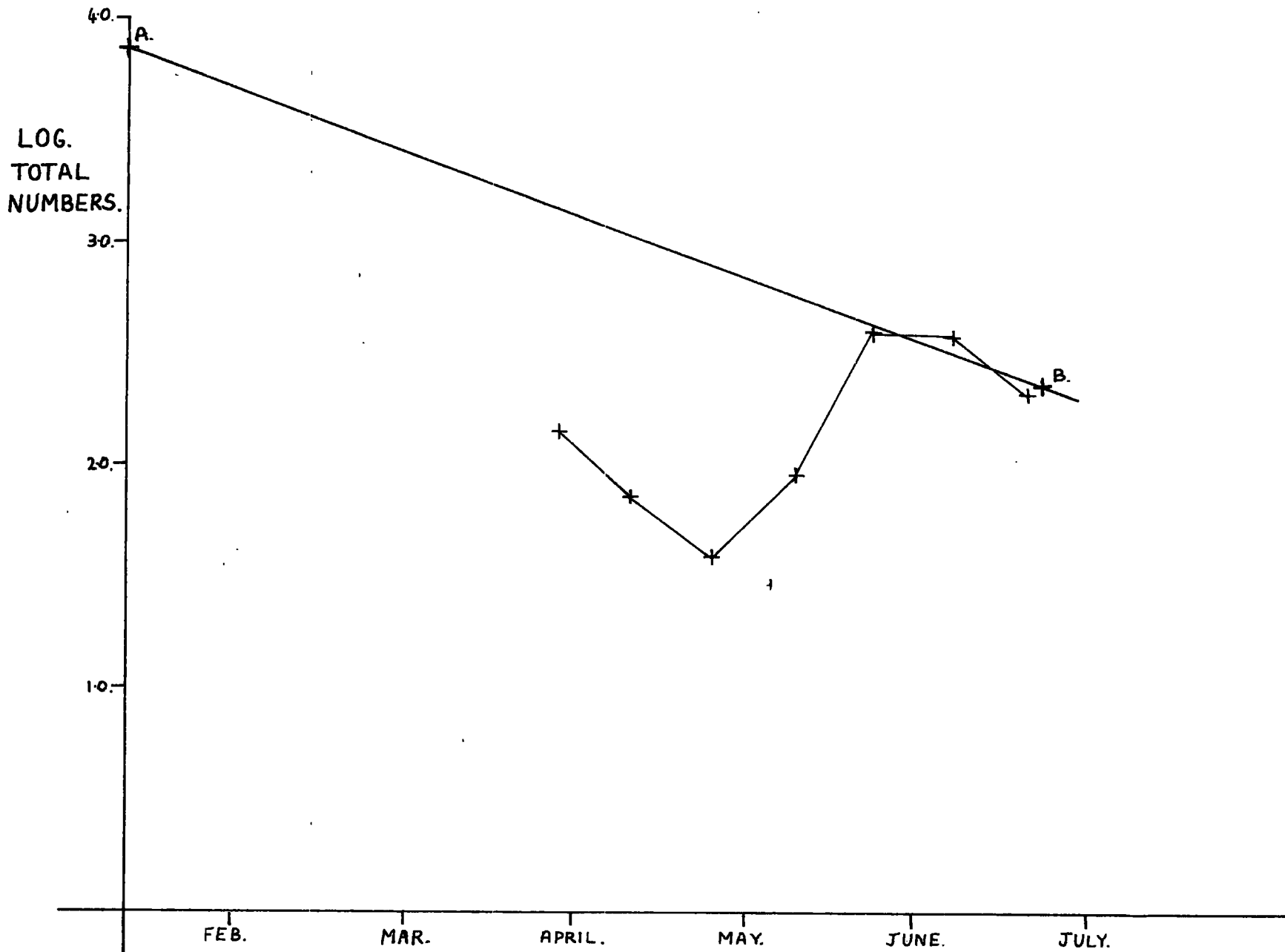

FIGURE 7.

TOTAL NUMBERS OF *D. GENICULATUS* IN EACH SIZE CLASS.

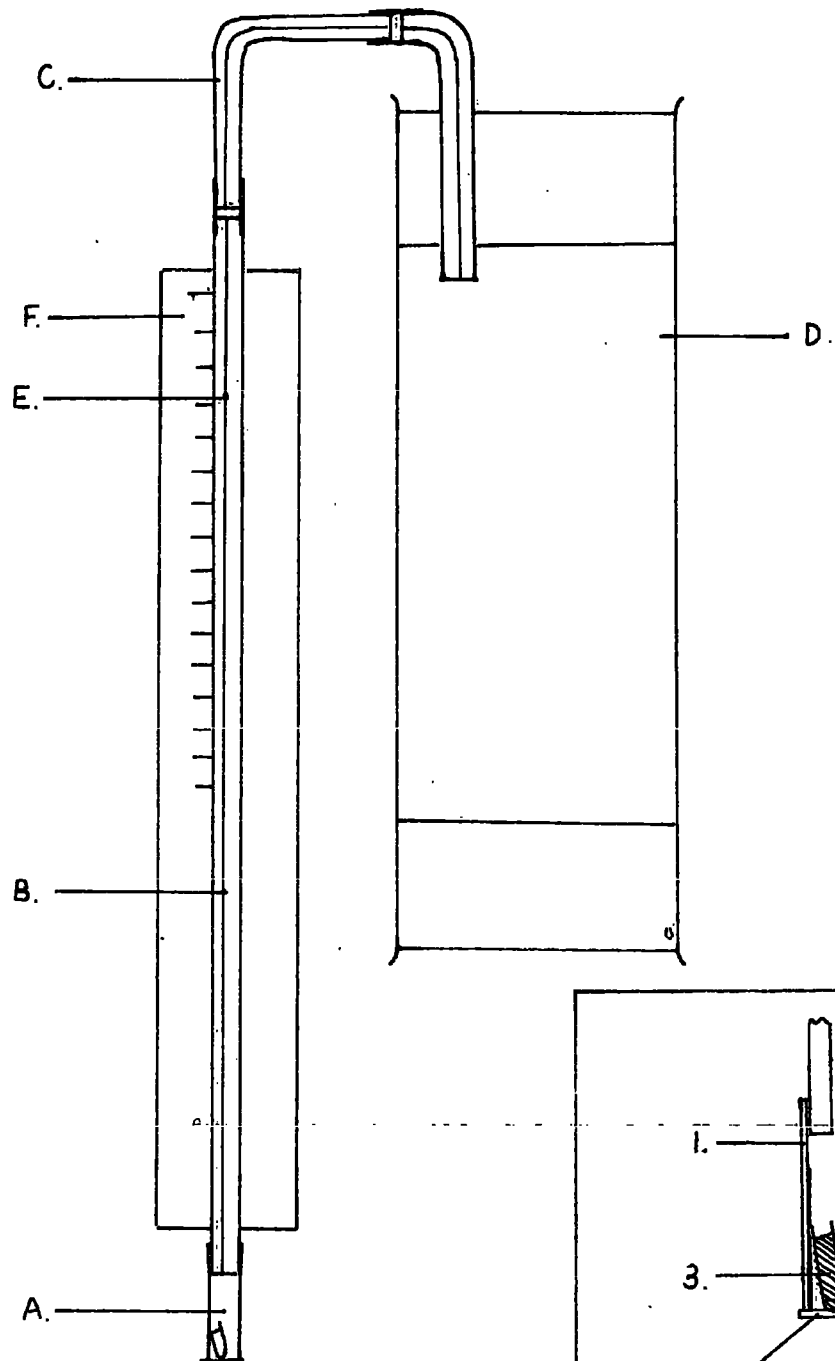
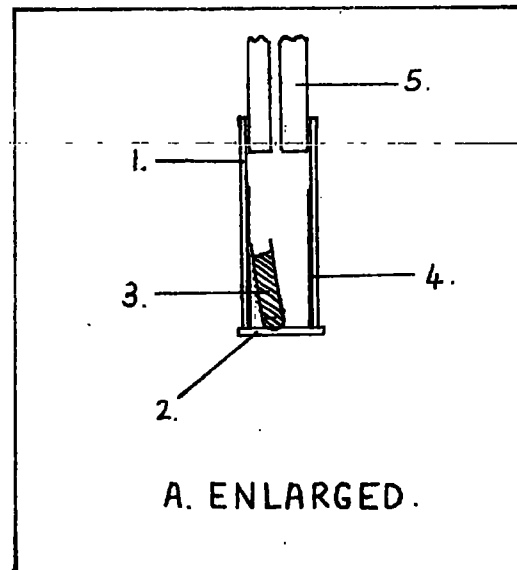

FIGURE 8. CAPILLARY RESPIROMETER.
FOR EXPLANATION SEE TEXT.



A. ENLARGED.

FIGURE 9.

RESPIRATORY RATE AS A FUNCTION OF WET WEIGHT AT 5°C.
IN *D. GENICULATUS*.

O₂ UPTAKE
MM³/24 H.

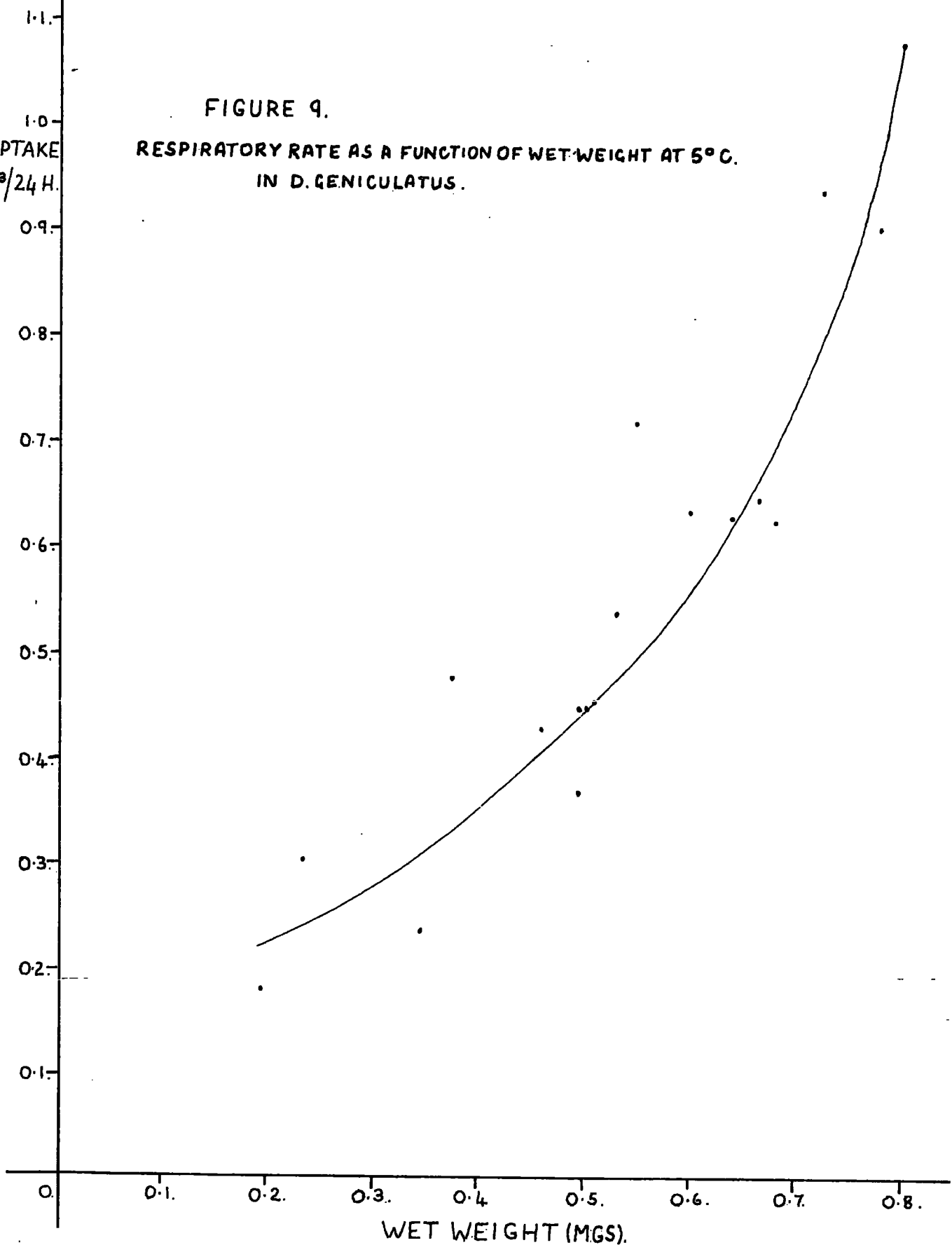

O₂ UPTAKE.

FIGURE 10.
RESPIRATORY RATE AS A FUNCTION OF WET WEIGHT AT 10°C.
IN *D. GENICULATUS*.

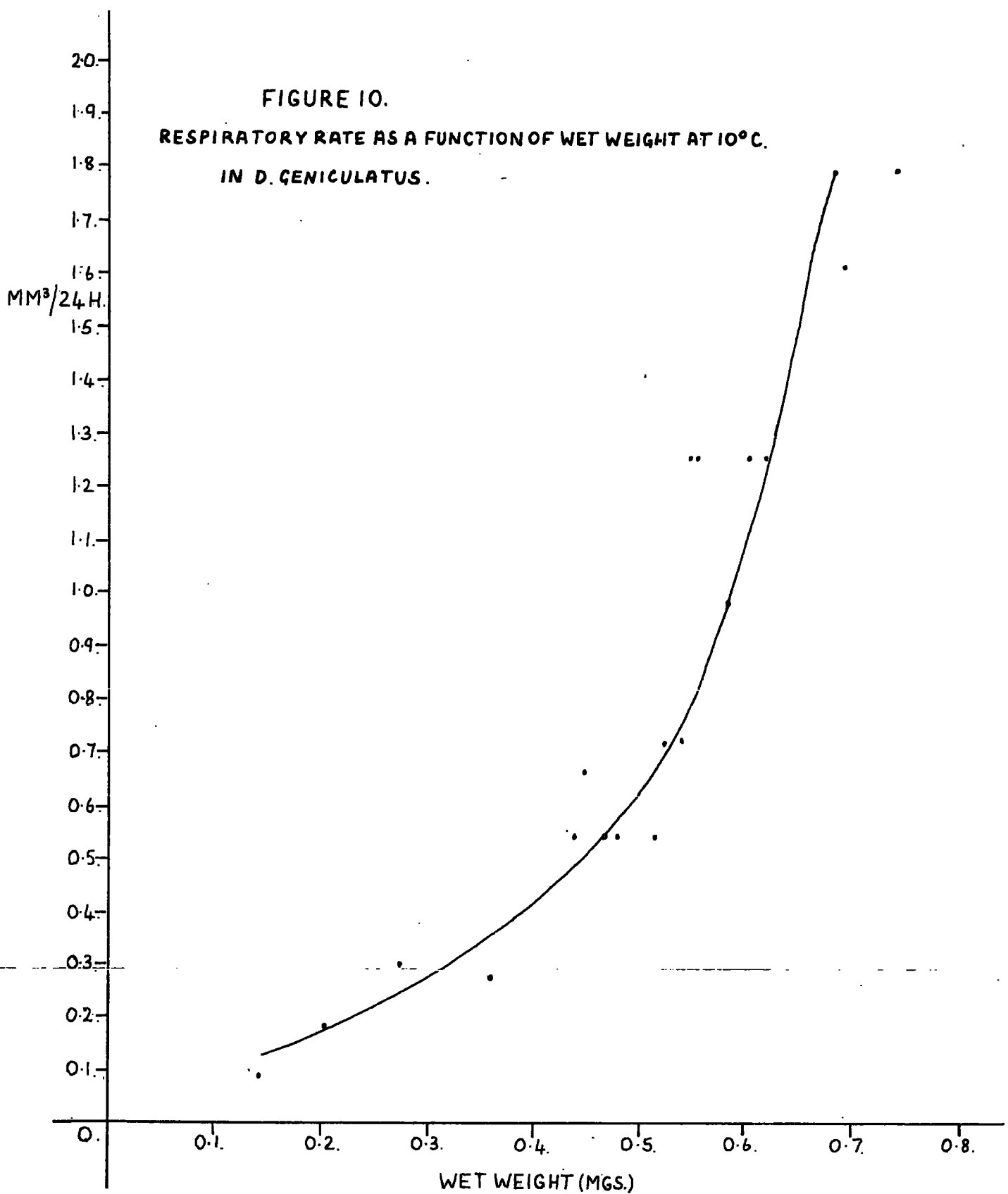

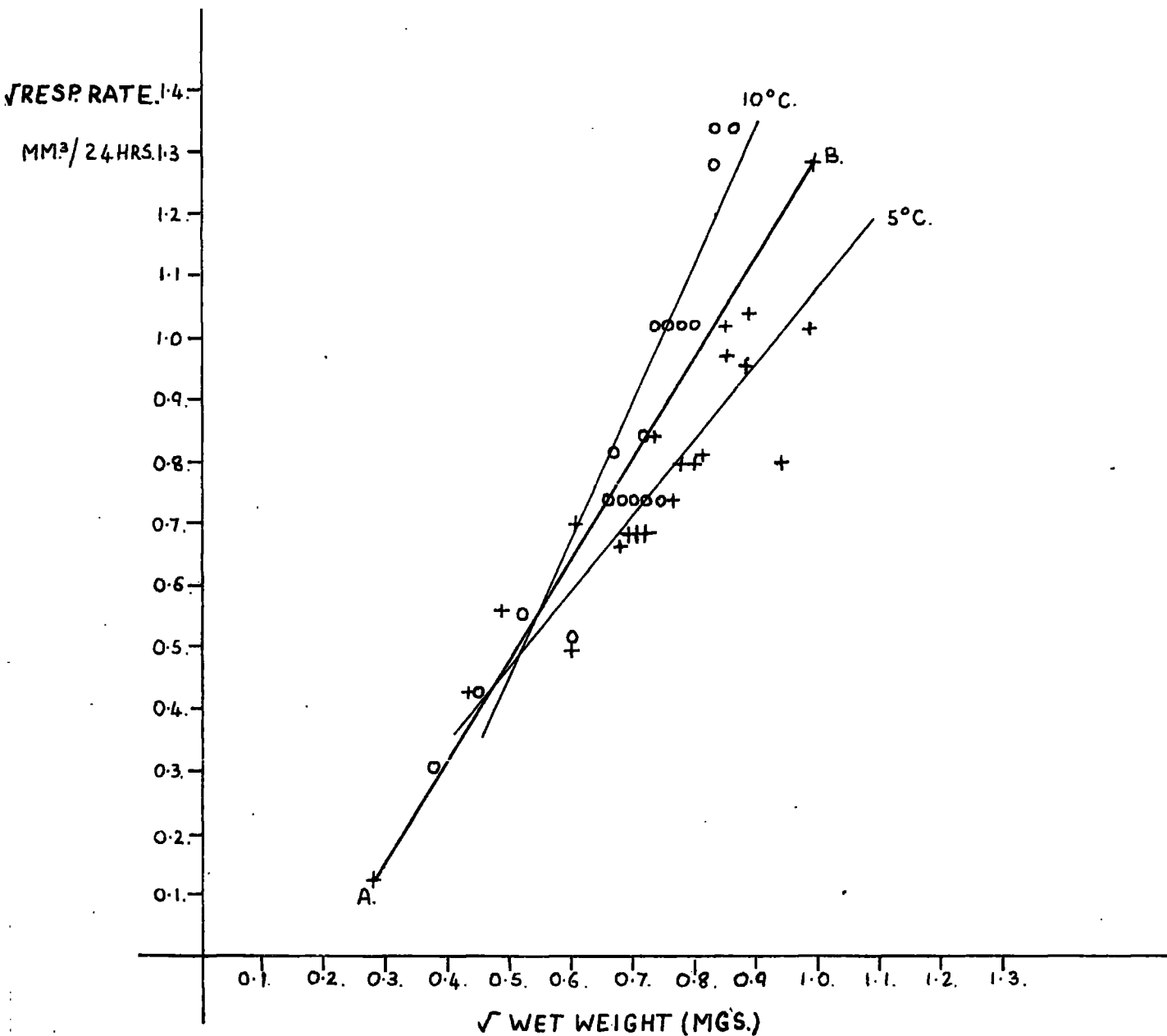

FIGURE II.

REGRESSIONS OF $\sqrt{\text{RESPIRATORY RATE}}$ AGAINST $\sqrt{\text{WET WEIGHT}}$ AT 5° AND 10°C.

FOR *D. GENICULATUS*.

o 10°C.
 + 5°C.