

Durham E-Theses

Investigations into cyclic chlorofluoro compounds

Peter Johncock

How to cite:

Johncock, Peter (1959) Investigations into cyclic chlorofluoro compounds. Doctoral thesis, Durham University.

Use policy

The full-text may be used and/or reproduced, and given to third parties in any format or medium, without prior permission or charge, for personal research or study, educational, or not-for-profit purposes provided that:

- a full bibliographic reference is made to the original source
- a <https://etheses.durham.ac.uk/id/eprint/8830/> is made to the metadata record in Durham E-Theses
- the full-text is not changed in any way

The full-text must not be sold in any format or medium without the formal permission of the copyright holders.

Please consult the [full Durham E-Theses policy](#) for further details.

DURHAM COLLEGES IN THE UNIVERSITY OF DURHAM

A THESIS

entitled

INVESTIGATIONS INTO CYCLIC CHLOROFLUORO COMPOUNDS

submitted by

PETER JOHNCOCK, B.Sc.

(University College)

A candidate for the degree of Doctor of Philosophy

1959.

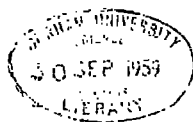

ACKNOWLEDGEMENTS

The work recorded in this thesis was carried out under the direction of Dr. W.K.R. Musgrave and I should like to express my thanks to him for continual help and encouragement. I should like to thank also, the Durham Colleges for the award of a Research Studentship, Mr. A. Wiper for technical assistance in the work described in the analytical section, J. Feeney and Dr. L.H. Sutcliffe of Liverpool University for the nuclear magnetic resonance determinations, and the Imperial Smelting Corporation for samples of decafluoro- and nonafluoro- cyclohexanes.

CONTENTS

	<u>Page Numbers.</u>
Title page	i
Acknowledgements	ii
Contents	iii
Summary	v
<u>CHAPTER 1</u>	
<u>Introduction</u>	
Chlorofluorocyclohexanes	
- preparation.	2
- reactions.	12
References.	19
<u>CHAPTER 2</u>	
<u>Discussion of the experimental work and the results</u>	
The reaction between chlorine tri- fluoride and benzene in the vapour phase.	23
Reaction mechanism.	29
The reaction between chlorine tri- fluoride and benzene in the vapour phase.	37
Reactions between perchlorofluoro- cyclohexanes and	
- lithium aluminium hydride.	45
- zinc dust/n-butyl alcohol.	48
- potassium graphite.	51
- phenyl lithium and phenyl sodium.	55
References.	60
<u>CHAPTER 3</u>	
<u>Gas-liquid partition chromatography</u>	
Description of apparatus.	63
References.	71

Page Numbers

<u>CHAPTER 4</u>	<u>Experimental work</u>	
	Infra-red spectroscopy, molecular weight and boiling point determinations.	73
	The reaction between chlorine trifluoride and benzene in the vapour phase.	74
	The reaction between hexachlorobenzene and cobalt trifluoride in the vapour phase.	90
	Reactions between perchlorofluorocyclohexanes and	
	- lithium aluminium hydride.	113
	- zinc dust/n-butyl alcohol.	122
	- potassium graphite.	127
	- phenyl lithium.	133
	- phenyl sodium.	138
	References.	141
 <u>CHAPTER 5</u>	 <u>Analytical Section</u>	
	<u>The determination of chlorine and fluorine in organic compounds.</u>	
	Summary.	143
	Introduction.	144
	Discussion.	152
	Experimental.	155

SUMMARY

The purpose of the work was to investigate the nature and the reactivity of the products obtained in the vapour phase fluorination of benzene with chlorine trifluoride under conditions chosen to increase the amount of more highly fluorinated material formed. The fraction B.Pt., 55-135°C., although quite complex, consisted predominantly of unchanged benzene and the products, isomeric mixtures of perchlorofluorocyclohexanes of general formula $C_6F_{12-n}Cl_n$, $n = 1$ to 4, and chlorobenzene, which were isolated by gas chromatography. These products accounted for about 20% of the total reaction product. In addition the presence of a very small amount of p-chlorofluorobenzene was confirmed.

To characterise the perchlorofluorocyclohexanes formed in the above reaction and also to obtain better yields, the vapour phase fluorination of hexachlorobenzene with cobalt trifluoride was carried out and only perchlorocyclohexanes of general formula $C_6F_{12-n}Cl_n$, $n = 1$ to 5, were obtained which were easily separated by distillation.

The reactivity of the perchlorofluorocyclohexanes was examined by reactions with lithium aluminium hydride, zinc dust- n-butyl alcohol, potassium graphite, phenyl lithium and phenyl sodium.

Because of the extreme stability of the highly fluorinated cyclohexanes, a new method was sought for quantitatively converting organically bound fluorine and chlorine to halide ion. The biphenyl-sodium-dimethoxy ethane complex was found to accomplish this easily and quickly at room temperature. The cation exchange method for determining inorganic halide was then modified accordingly.

CHAPTER 1.

Introduction

INTRODUCTION

Perhalocyclohexanes containing fluorine and chlorine

Chlorofluorocyclohexanes have generally been made by the 'Metallic Fluoride' process; cobalt trifluoride, argentic fluoride, manganic fluoride, ceric fluoride and plumbic fluoride have been used in this way. Liquid phase reactions with antimony pentafluoride and bromine trifluoride, the vapour phase fluorination of benzene with chlorine trifluoride and the direct chlorination of suitable fluorine containing compounds have also been used.

The Metallic Fluoride Process

The organic vapour, with or without nitrogen, is passed over the heated metal fluoride in a suitable reactor. Two types of reactor have been used, both of which will be briefly described.

In the first, or Static Method, the fluorinating agent is placed in a thin layer inside a long rectangular reactor. No attempt is made to agitate the metallic fluoride, hence the term static. This method was used by McBee and his co-workers in the fluorination of chlorobenzenes.

In the second method the fluorinating agent is placed in a cylindrical reactor and agitated by means of paddles attached to a rotating axial shaft. This type of reactor

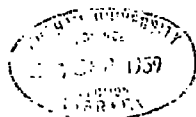

was originally used by Fowler et al.¹ in the large scale fluorination of hydrocarbons, and was subsequently adopted by Barbour, Barlow and Tatlow,² who demonstrated that in the fluorination of a large number of hydrocarbons on a laboratory scale, smoother reactions occurred and higher yields of fluorinated products were obtained than with the static method. Tatlow and co-workers used this method in the fluorination of chlorobenzenes.

The metal fluorides are formed exothermically and so the heat evolved in their reaction with an organic compound is often much less than in the corresponding reaction using elementary fluorine. Thus if we consider the heats of reaction for the replacement of a carbon-hydrogen by fluorine using cobalt trifluoride and fluorine,¹ we have

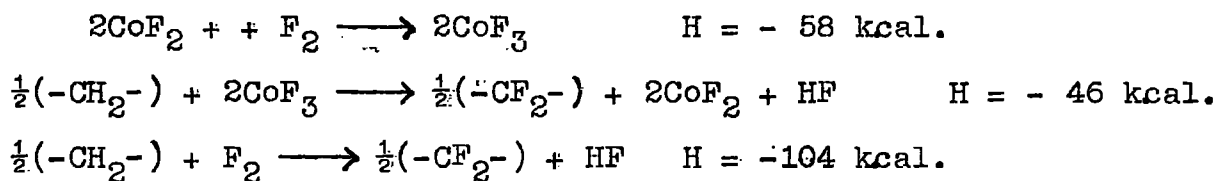

The carbon-carbon bond energy is 80 k.cal. Although the heat of reaction is still considerable less extensive decomposition is likely to occur. Except for a few, not very successful, pre-war attempts to fluorinate directly chlorobenzenes,^{3,4,5} all subsequent fluorinations have been carried out with metallic fluorides.

The extent of fluorination induced by these reagents

depends on a number of factors such as reactor temperature, contact time, the fluorinating agent used and the degree of reagent exhaustion. Optimum conditions must be found for each starting material.

In the fluorination of polychlorofluoroheptanes⁶ and unsaturated fluoro and fluorochloro- compounds of the type C_7HF_{13} , $C_7HF_{12}Cl$ and $C_7HF_{11}Cl_2$ ⁷ with cobalt trifluoride, it was observed that double bonds were saturated, hydrogen replaced and that the chlorine was difficult to remove completely. A similar observation had been made at Birmingham.⁸ McBee et al.⁶ also noted that argentic fluoride was more potent in removing chlorine than was cobaltic fluoride under comparable conditions.

Since these observations were made, mono-, di- and hexa-chlorobenzenes have been fluorinated and from the products cyclic $C_6F_{11}Cl$, cyclic $C_6F_{10}Cl_2$ and cyclic $C_6F_9Cl_3$ characterised. Reference is made to the formation of cyclic $C_6F_8Cl_4$ and cyclic $C_6F_7Cl_5$ in the fluorination of hexachlorobenzene but no yields or physical constants are quoted. This would seem due to the fact that workers have been more interested in the higher fluorine containing compounds because of their possible commercial value and have recycled intermediate products to achieve this result.^{9,10,11}

Fluorination of chlorobenzenes

The fluorination of chlorobenzenes has been carried

out by McBee and co-workers at Purdue University in America and by Tatlow and co-workers at Birmingham University. Since both schools have fluorinated o-dichlorobenzene using different type reactors and metallic fluorinating reagents it might be interesting to consider their methods in detail and to compare their results in tabular form.

Lindgren and McBee⁹ employed a series of six static-type reactors graded at successively higher temperatures containing argentic fluoride, since in this way initially formed partially fluorinated products were less susceptible to break down but as their fluorine content increased their ability to withstand further fluorination without degradation at higher temperatures increased.

147 gms. of o-dichlorobenzene were passed through the six reactors graded at temperatures from 118°C. to 200°C. The product obtained, after purging the system with nitrogen, was recycled, the reactors being graded from 196°C. to 325°C. The products from two such runs were combined and again recycled, the reactors being graded from 288°C-335°C. The weight of argentic fluoride was such that 50% of the 'available fluorine' was sufficient to perfluorinate the organic structure.

In the same patent the fluorination of o-dichlorobenzene in two reactor units containing manganic fluoride is described. 292 gms. of o-dichlorobenzene were passed through the two units containing 20 moles of manganic fluoride

at 230°C. The product was recycled twice, at 400°C. and at 450°C, the system being purged with nitrogen and the manganic fluoride regenerated at the end of each cycle.

Tatlow and Worthington⁸ fluorinated o-dichlorobenzene in a Fowler-type reactor at 350°C. in a simple one stage process with cobaltic fluoride, such that less than 50% of the 'available fluorine' was needed to perfluorinate the compound.

Products formed and yields

	Wt. of start- ing mater- ial g.	Fluor- inating agent	Products formed	Yield g.
Lindgren & McBee	294	AgF ₂	cyclic C ₆ F ₁₁ Cl	50
			cyclic C ₆ F ₁₀ Cl ₂	15
Lindgren & McBee	292	MnF ₃	cyclic C ₆ F ₁₁ Cl	96
			cyclic C ₆ F ₁₀ Cl ₂	115
Tatlow & Worthington	278	CoF ₃	cyclic C ₆ F ₁₁ Cl	96
			cyclic C ₆ F ₁₀ Cl ₂	99
			cyclic C ₆ F ₉ Cl ₃	27.5

It will be observed that Tatlow and Worthington isolated cyclic C₆F₉Cl₃, i.e. that liberated chlorine was capable of re-entering organic structures.

Certainly as far as simplicity of operation and yields

are concerned the Fowler reactor is to be preferred.

The Birmingham School which has investigated the nature of the products more fully, in a later paper¹² refute their earlier belief that the cyclic $C_6F_{10}Cl_2$ consisted mainly of the 1,2-dichloro isomer, thus p-dichlorobenzene formed a cyclic $C_6F_{10}Cl_2$ product with similar physical characteristics. It is now realised that the isomeric forms of a chlorofluorocyclohexane have very similar physical properties. Cyclic $C_6F_{10}Cl_2$ isomers can however be reduced to the corresponding decafluorocyclohexane derivatives with lithium aluminium hydride, compounds which, because of differences in the extent of intermolecular hydrogen binding have different boiling points and so may be resolved. In this way the cyclic $C_6F_{10}Cl_2$ formed was shown to be a mixture of isomers.

Tatlow and Worthington⁸ obtained a 14% yield of cyclic $C_6F_{11}Cl$ in the fluorination of chlorobenzene with cobaltic fluoride at 350°C.

Fluorination of hexachlorobenzene

Lindgren and McBee⁹ fluorinated hexachlorobenzene in a single unit static-type reactor with plumbic fluoride at 300°C. in a one stage process and obtained an 8% yield of cyclic $C_6F_9Cl_3$. They mention that cyclic $C_6F_8Cl_4$ and cyclic $C_6F_7Cl_5$ may also be prepared but no details are given.

McBee, Robb and Ligett¹⁰ also report the formation of considerable amounts of cyclic $C_6F_9Cl_3$ in the single stage fluorination of hexachlorobenzene with ceric fluoride at 350-400°C. and that recycling of the product gave a substantial proportion of cyclic C_6F_{12} .

Liquid Phase Reactions

1. Antimony pentafluoride

Antimony pentafluoride fluorinates hexachlorobenzene to form unsaturated or saturated chlorofluorocyclohexanes depending on the reaction conditions.

McBee, Wiseman and Bachman¹³ heated hexachlorobenzene and antimony pentafluoride in a reaction flask from room temperature to 125°C. and obtained 1,2-dichlorooctafluorocyclohexene in 60% yield. In a later paper¹⁴ it is reported that by carrying out the reaction at 150°C. the yield of this compound is increased to 87%. McBee et al.¹⁴ also report that trifluoromethylpentachlorobenzene when heated with antimony pentafluoride at 150°C. yields the unsaturated compounds cyclic C_6F_9Cl and cyclic $C_6F_8Cl_2$, and that with a longer reaction time and higher temperatures, 100-360°C, the saturated cyclic $C_6F_9Cl_3$ is formed as well as cyclic C_6F_9Cl and cyclic $C_6F_8Cl_2$.

2. Bromine trifluoride and antimony pentafluoride

McBee, Lindgren and Ligett¹⁵ fluorinated hexachlorobenzene with bromine trifluoride at moderate temperatures and obtained a product of average composition $C_6Br_2Cl_4F_6$ which was further

fluorinated with antimony pentafluoride and a product of average composition $C_6BrCl_4F_7$ formed. No attempt was made to resolve this product, it was simply dehalogenated as such with zinc dust and ethyl alcohol. The perfluorocyclic-compounds C_6F_6 , C_6F_8 and a number of unsaturated chlorofluorocyclic-compounds C_6F_7Cl , $C_6F_8Cl_2$, $C_6F_6Cl_2$, $C_6F_7Cl_3$ and $C_6F_5Cl_3$ were isolated. Physical constants were recorded, but no attempt was made to realise their configurations.

Addition of chlorine to unsaturated perfluoro-compounds

This approach, although obviously with restricted use does allow the preparation of perhalo-compounds of known configuration.

Bryce and Simons¹⁶ first reported the addition of chlorine to perfluorocyclohexene. This was repeated by Tatlow and Worthington⁸ who added liquid chlorine to cyclic C_6F_{10} in a sealed tube irradiated with a mercury arc lamp. In a subsequent paper¹⁷ it was shown that, provided configuration was retained in the molecule when reduced with lithium aluminium hydride to the corresponding dihydro-compound, whose configuration was deduced from dipole measurements and the dehydrofluorination products, that cis addition of the chlorine had predominantly occurred. The 1,3-perfluorocyclohexadiene¹⁸ and perfluorobenzene³⁴ similarly add chlorine forming 1,2,3,4-tetrachlorooctafluorocyclohexane and cyclic $C_6F_6Cl_6$ respectively.

Of minor importance is the fact that perfluorobicyclohexyl when passed through a heated tube with chlorine at 550°C . gives cyclic $\text{C}_6\text{F}_{11}\text{Cl}$.¹⁹ This reaction only occurs with compounds containing the cyclic carbon atom bonded to a tertiary carbon atom, thus cyclic $\text{C}_6\text{F}_{11}\cdot\text{CF}(\text{CF}_3)_2$ reacts similarly but cyclic $\text{C}_6\text{F}_{11}\cdot\text{CF}_3$ and cyclic $\text{C}_6\text{F}_{11}\text{C}_2\text{F}_5$ do not. A homolytic split of the bond linking the tertiary bonded carbon atoms is postulated since under the experimental conditions the chlorine molecule is hardly dissociated.

Chlorofluorocyclohexanes

Very little work has been done on the preparation of chlorofluorocyclohexanes containing hydrogen. Although a controlled vapour phase reaction between benzene and the very reactive chlorine trifluoride yields such compounds,²⁰ the product is very complex and resolution tedious. Cuthbertson and Musgrave²¹ found that the selective replacement of halogens in simple halogen substituted cyclohexanes and cyclohexenes with fluorine using milder reagents was generally impossible. Addition of chlorine to fluorobenzenes has also been attempted but yields of isolated products are usually small.^{22,23,24.}

Reaction between benzene and chlorine trifluoride

Banks and Musgrave²⁰ allowed chlorine trifluoride and benzene diluted with nitrogen to react within the meshes of a copper packing contained in a reactor maintained at 260°C .

A complex product was obtained which could only be resolved with the aid of a sixty plate concentric tube column and preparative scale vapour phase chromatography. The perhalo-cyclohexanes $C_6F_{10}Cl_2$, $C_6F_9Cl_3$ and the fluorochloro-cyclohexanes $C_6H_6F_5Cl$, $C_6HF_9Cl_2$, $C_6H_2F_8Cl_2$ and $C_6H_3F_7Cl_2$ were isolated. No unsaturated products were isolated.

Cuthbertson and Musgrave²¹ obtained 1.Cl.1F-cyclohexane by the action of hydrofluoric acid with or without catalysts, such as boron trifluoride, aluminium trichloride and stannic chloride, on 1.Cl-cyclohexene. The action of this reagent and others such as potassium fluoride in glycol, antimony trifluoride and mercuric fluoride on 1.1.2-trichlorocyclohexane, 1.2-dibromocyclohexane and 1.2-dichlorocyclohexene-1 gave no isolatable products.

Chlorination of fluorobenzenes

Van der Linden²² obtained a fluoroheptachlorocyclohexane of unknown constitution by treating fluorobenzene with liquid chlorine in sunlight. Germano and Séchaud²⁴ passed gaseous chlorine into fluorobenzene in ultra violet light at room temperature, a smooth reaction occurred and from the product small amounts of a cyclic $C_6H_5Cl_6F$ and a cyclic $C_6H_4Cl_7F$ were isolated. The latter compound had a boiling point similar to Van der Linden's product and was identical with a product obtained by chlorinating p-chlorofluorobenzene under similar conditions. It was consequently assigned the structure 1F-1.2.3.4.4.5.6-heptachlorocyclohexane.

Finger et al.²³ attempted the exhaustive photochemical chlorination of tetrafluorobenzene and isolated small amounts of a material corresponding to the formula $C_6H_2Cl_6F_4$.

Nield, Stephens and Tatlow²⁵ reacted pentafluorobenzene and liquid chlorine in a sealed tube in ultra violet light and obtained 1.2.3.4.5.6-hexachloro 1.2.3.4.5-pentafluorocyclohexane in good yield.

Reactions of chlorofluoro-cyclohexanes

The perhalocyclohexanes are very stable, heat resistant compounds. Chemically they are very unreactive and reported reactions are restricted to reductions and dehalogenations. Chlorofluorocyclohexanes containing hydrogen can undergo dehydrohalogenation. Fluorocyclohexanes have been extensively dehalogenated forming hitherto unknown perfluoro aromatic, perfluorocyclohexadiene and perfluorocyclohexene compounds and their derivatives.

Tatlow and Worthington⁸ investigated the reactivity of the chlorine atom in cyclic $C_6F_{11}Cl$. It was extremely stable and underwent none of the normal alkyl halide reactions, thus treatment with aqueous sodium hydroxide, aqueous-alcoholic sodium or cuprous cyanides, potassium and silver acetates in glacial acetic acid, magnesium turnings in ether, phenyl magnesium bromide, and sodium iodide in acetone had no effect. Sodium and magnesium metals under drastic conditions caused degradation.

The replacement of chlorine with hydrogen in cyclic $C_6F_{11}Cl^8$ and cyclic $C_6F_{10}Cl_2^{12}$ occurs easily and completely with lithium aluminium hydride in ether. However the fluorocyclohexanes are better obtained by fluorinating benzene with cobalt trifluoride and a little will be said about their reactions later.

The susceptibility to dehalogenation of adjacent halogen atoms in a mixture of bromochlorofluoro-cyclohexanes has already been mentioned (see page 9). In a subsequent patent²⁶ McBee and co-workers report that

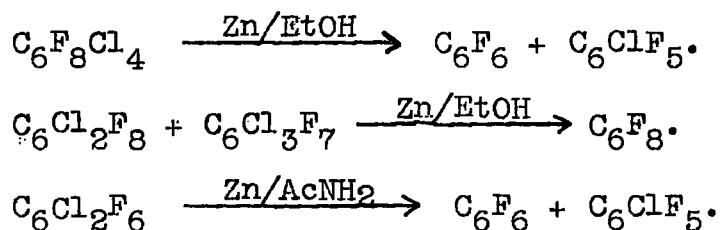

together with the dehalogenation of bromofluorocyclohexanes of different mean formula to similar products.

Very little work has been reported on the dehydrohalogenation of chlorofluorocyclohexanes, largely due to the difficulty in forming specific compounds²¹ and also the difficulty in separating the complex products in less specific reactions.²⁰

Germano and Sechaud²⁴ reported that F.1-heptachloro-1.2.3.4.4.5.6-cyclohexane was aromatised easily with sodium methoxide in methyl alcohol to F.1-tetrachloro-2.3.4.6-benzene, whilst Thompson, Tarrant and Bigelow²⁷ observed that both chlorine and fluorine were eliminated from cyclic

$(CF_3)_2 \cdot C_6H_3ClF_4$ and cyclic $(CF_3)_2C_6H_3ClF_2$ by treatment with alcoholic potassium hydroxide. Banks and Musgrave²⁰ found similarly that fluorochlorocyclohexanes containing hydrogen lost both fluorine and chlorine when treated with N.alcoholic potash and Cuthbertson and Musgrave that acid or alkaline hydrolysis of 1Cl.1F-cyclohexane resulted in the removal of both fluorine and chlorine to the extent of 50% of the total halogen present in the molecule.

Fluorocyclohexanes.

Dehydrofluorination has been extensively applied in the structural investigations of fluorocyclohexanes. Before this statement is expanded a little should be said about direct fluorocyclohexane preparation for two reasons.

1. The great importance of fluorocyclohexanes as a source of fluorocyclo-hexenes, -hexadienes and -benzenes.
2. The reduction of the irresolvable cyclic $C_6F_{10}Cl_2$ isomers to the corresponding resolvable $C_6F_{10}H_2$ derivatives of known configuration has allowed its isomeric distribution to be ascertained.

Although McBee and Robb²⁸ obtained cyclic $C_6F_8H_4$ by fluorinating benzene with plumbic fluoride at 200°C. and Fear and Thrower²⁹ the unsaturated cyclic compounds $C_6F_8H_2$ and $C_6F_7H_3$ by fluorinating benzene with manganic fluoride at 200-300°C., by far the most important is the very detailed and thorough work of the Birmingham School in its systematic investigation of the products formed in the fluorination of

benzene with cobaltic fluoride.

Benzene was fluorinated in the vapour phase with cobaltic fluoride at approximately 150°C . and a complex mixture of fluorocyclohexanes of general formula $\text{C}_6\text{F}_{12-n}\text{H}_n$, $n = 1$ to 4 obtained.^{2.17} The products were separated by fractional distillation controlled by analytical scale vapour phase chromatography, and preparative scale vapour phase chromatography. All isomeric forms, structural and stereometric, of cyclic $\text{C}_6\text{F}_{10}\text{H}_2$ have been isolated and characterised as well as some of the trihydro- and tetrahydro-fluorocyclohexanes.^{17.30.31}

Cyclic $\text{C}_6\text{F}_{11}\text{H}$ when refluxed with 50% aqueous potassium hydroxide gives an 82% yield of cyclic C_6F_{10} .⁸

The mild and more vigorous dehydrofluorination of the cyclic $\text{C}_6\text{F}_{10}\text{H}_2$ isomers have been used by Tatlow and his co-workers to determine the structure of these compounds.^{17.31} The unsaturated products formed were separated by preparative scale vapour phase chromatography and characterised by their acid oxidation products, or if of previously determined structure, by their physical constants and infra red spectra.

It seems certain that with fluorocyclohexanes the chair form is preferred and that the small hydrogen atoms, when possible, occupy axial positions. In the decafluorocyclohexanes each structural isomer should have two stereo forms, one with two axial hydrogen atoms and the other with one axial and one equatorial hydrogen atom. The former should be more

easily dehydrofluorinated than the latter since both positions are available for attack by base at the outset in the orientation most favourable for elimination to occur. According to the presence or absence of the possible dehydrofluorination products, cyclic C_6F_8 -1.4-diene, cyclic C_6F_8 -1.3-diene, cyclic $1H-C_6F_9H$, cyclic $3H-C_6F_9H$ and cyclic $4H-C_6F_9H$, and their intensity, with mild or more vigorous dehydrofluorination by aqueous potassium hydroxide, structures are assigned.

The above structures were tested by relating them to two nonafluorocyclohexanes shown by their dehydrofluorination products to be $1H.2H.4H-C_6F_9H_3$ isomers.³¹ Partial dehydrofluorination of both yielded cyclic $3H.4H-C_6F_8H_2$ which was oxidised to $3H.4H$ -hexafluoroadipic acid. The acid could be resolved by means of its brucine salt which indicated that the adjacent hydrogen atoms in the original cyclic $C_6F_9H_3$ were trans w.r.t. each other. The relative rates of partial dehydrofluorination allowed one isomer to be assigned the stereo configuration $1Ha/2Ha:4Ha$ - and the other $1Ha:4He/2Ha-C_6F_9H_3$.

Each of these nonafluorides was farther fluorinated with cobaltic fluoride in a small tubular static reactor and in each case only the expected decafluorides were formed. Both independent approaches were completely consistent.

Dipole measurements confirmed the structures assigned. Subsequent papers^{35,36} report similar structure studies on

further cyclic $C_6F_9H_3$ isomers and some cyclic $C_6F_8H_4$ isomers.

An interesting method of dehydrofluorinating fluorocyclohexanes has been used by Banks³⁷ following a suggestion by Dr. W.K.R. Musgrave. The dehydrofluorinations were carried out with the anion exchange resin amberlite I R A-400(OH). Apparently dehydrofluorinations can be carried out at lower temperatures and with less chance of degradation. Thus cyclic $C_6F_{11}H$ when shaken with a 10% excess over the theoretical amount of resin in a stainless steel vessel at 90° gave an 86% yield of cyclic C_6F_{10} . In this reaction the resin is partly denatured, however, with a 100% excess of resin at 50°C. or using a solvent such as carbon tetrachloride or methylcyclohexane at 20°C. almost quantitative conversions to cyclic C_6F_{10} are obtained and the resin can be regenerated. Similar examples quoted are the dehydrofluorination of cyclic 1H.4H- $C_6F_{10}H_2$ and cyclic 1H.3H- $C_6F_{10}H_2$ to mixtures of cyclic dienes and monoenes and cyclic 1H.2H.4H- $C_6F_9H_3$ to a mixture of cyclic C_6F_6 , dienes and monoenes. Attempts to carry out the dehydrofluorination with catalytic amounts of resin at higher temperatures (150°C.) gave only slight conversions.

In the same communication the pyrolytic dehydrofluorination of cyclic $C_6F_{11}H$ at 700-800°C. in a nickel or copper reactor to an 80-90% yield of cyclic C_6F_{10} is reported. Similarly cyclic 1H.3H- $C_6F_{10}H_2$ and cyclic 1H.4H- $C_6F_{10}H_2$ gave

a mixture of products containing cyclic C_6F_{10} , cyclic C_6F_6 and higher boiling materials together with the dehydrofluorination products cyclic C_6F_8 -1.3-diene, cyclic C_6F_8 -1.4-diene and cyclic C_6F_9H .

REFERENCES

1. FOWLER et al., Ind. Eng. Chem., 293, 39, 1947.
2. BARBOUR, BARLOW and TATLOW, J. App. Chem., 127, 1952.
3. BANCROFT and WHEARTY, J. Phys. Chem., 3121, 35, 1931;
Proc. Natl. Acad. Sci., 183, 17, 1931.
4. BIGELOW and PEARSON, J.A.C.S., 2773, 56, 1934.
5. FUKUHARA and BIGELOW, ibid., 427, 60, 1938.
6. McBEE et al., Ind. Eng. Chem., 310, 39, 1947.
7. COUPER et al., ibid., 346.
8. TATLOW and WORTHINGTON, J.C.S., 1251, , 1952.
9. LINDGREN and McBEE, C.A., 5375, 44, 1950; U.S.P.,
2,480, 081, Aug. 1949.
10. McBEE, ROBB and LIGETT, C.A., 5375, 44, 1950; U.S.P.,
2,493,007, Jan. 1950.
11. STILMAR, C.A., 9079, 45, 1951; U.S.P., 2,553,217, May
1951.
12. ROYLANCE, TATLOW and WORTHINGTON, J.C.S., 4426, 1954.
13. McBEE, WISEMAN and BACHMAN, Ind. Eng. Chem., 415, 39,
1947; U.S.P., 2,459,783; C.A., 3844, 43, 1949.
14. McBEE et al., Natl. Nuclear Energy Serv., Div. VII, 1,
Ppn., Props. and Technol. of Fluorine and Organic
Fluoro Compounds., 1951, 783-8; C.A., 46, 7987.
15. McBEE, LINDGREN and LIGETT, Ind. Eng. Chem., 378, 39,
1947.
16. BRYCE and SIMONS, J.A.C.S., 4017, 23, 1951.

17. SMITH and TATLOW, J.C.S., 2505, 1957.
18. EVANS and TATLOW, *ibid.*, 3779, 1954.
19. BARLOW and TATLOW, *ibid.*, 4695, 1952.
20. BANKS and MUSGRAVE, BANKS, Ph.D. Thesis, Durham, 1956.
21. CUTHBERTSON and MUSGRAVE, CUTHBERTSON, Ph.D. Thesis,
Durham, 1956.
22. VAN der LINDEN, *Rec. Trav. Chem.*, 282, 55, 1936.
23. FINGER et al., J.A.C.S., 145, 73, 1951.
24. GERMANO and SECHAUD, *Helv.*, 1343, 37, 54.
25. NIELD, STEPHENS and TATLOW, J.C.S., 169, 1959.
26. McBEE, LINDGREN and LIGETT, C.A., 8675, 46, 1952;
U.S.P., 2, 586, 364.
27. THOMSON, TARRANT and BIGELOW, J.A.C.S., 2187, 68,
1946.
28. McBEE and ROBB, C.A., 2975, 45, 1951; U.S.P., 2, 583,
132.
29. FEAR and THROWER, *J. App. Chem.*, 353, 5, 1955.
30. EVANS, GODSELL, STEPHENS, TATLOW and WISEMAN,
Tetrahedron, 183, 2, 1958.
31. GODSELL, STACEY and TATLOW, *ibid.*, 193.
32. EVANS and TATLOW, J.C.S., 1184, 1955.
33. EVANS and TATLOW, *Vapour Phase Chromatography*,
Butterworths, London 1956, p. 256.
34. GODSELL, STACEY and TATLOW, *Nat.*, 199, 178, 1956.
35. STEPHENS, TATLOW and WISEMAN, J.C.S., 148, 1959.

36. NIELD, STEPHENS and TATLOW, *ibid.*, 159.
37. BANKS, private communication.

CHAPTER 2.

Discussion of the experimental work
and the results

The reaction between benzene and chlorine trifluoride in the vapour phase

The lower boiling material, formed in the reaction between chlorine trifluoride and benzene in the vapour phase using more drastic conditions (a slightly higher $\text{ClF}_3:\text{C}_6\text{H}_6$ ratio and a much lower nitrogen dilution) than were used by Banks (Ph.D. thesis, Durham 1956), was a good deal simpler in composition than the corresponding material examined by Banks and consisted mostly of the perhalogenated products, cyclic $\text{C}_6\text{F}_{11}\text{Cl}$, cyclic $\text{C}_6\text{F}_{10}\text{Cl}_2$, cyclic $\text{C}_6\text{F}_9\text{Cl}_3$, cyclic $\text{C}_6\text{F}_8\text{Cl}_4$ and chlorobenzene. Evidence is produced which questions Bank's conclusions that chlorobenzene was a trace product and that the isomers of $\text{C}_6\text{H}_4\text{ClF}$ were formed to a larger extent.

Bank's investigated the reaction between benzene and chlorine trifluoride in the vapour phase at 260°C . when the chlorine trifluoride and benzene in a molar ratio of 1.85:1, and diluted with nitrogen, were allowed to react within the meshes of a copper packing contained in an iron reactor at 260°C . A complex product, with about 20% unreacted benzene was obtained and this was separated with a 60 plate concentric tube column into a number of azeotropes; no pure compounds were thus obtained. Gas chromatography was then becoming known and this technique was used to resolve the lower boiling azeotropes, B.Pt. $< 130^\circ\text{C}$. into their components. Cyclic $\text{C}_6\text{F}_{10}\text{Cl}_2$, cyclic $\text{C}_6\text{F}_9\text{Cl}_3$, chlorofluorocyclohexanes contain-

ing hydrogen and the aromatic derivatives, chlorobenzene and a mixture of the isomers of chlorofluorobenzene were thus obtained.

Bank's obtained cyclic $C_6F_{10}Cl_2$ (0.0012 moles/mole of reacted benzene) from an azeotrope formed with benzene, B.Pt. $79.5^\circ C$. (op. cit., pp. 37, 133, 141). This azeotrope contained another component to which the formula $C_6F_{10}Cl_2$ was also assigned. Unless it is the isomer 1.1-dichlorodecafluorocyclohexane whose formation has not yet been observed, the formula is incorrect, since it has been impossible to resolve a mixture of all other isomers on any of the column packings so far used. Cyclic $C_6F_{10}Cl_2$ was also present in a complex fraction, B.Pt. 55- $79.5^\circ C$. (op. cit. pp. 53, 137).

Cyclic $C_6F_9Cl_3$ (0.0023 moles/mole of reacted benzene) was present in a complex azeotrope, B.Pt., $129.5^\circ C$. (op. cit., pp. 43, 138, 142) and a tedious chromatographic procedure was required to isolate it.

The method which Banks used to decompose his products for halogen estimation - fusion with sodium in a nickel bomb - was found to be most unreliable with polyfluorocyclohexanes and invariably gave low answers because of the incomplete decomposition of the sample. Considerable trouble was experienced by the present worker in the halogen estimation of these compounds until the present method of

decomposing them with the biphenyl-sodium-dimethoxy ethane complex was applied. This work is fully described in Chapter 5 .

Banks isolated materials, to which, based purely on halogen analytical figures, the formula $C_6HCl_2F_9$, $C_6H_2Cl_2F_8$ and $C_6H_3Cl_2F_9$ were assigned; dehalogenation and infra-red evidence were consistent with saturation and the presence of hydrogen. However, the analytical figures were low and so the compounds were reanalysed. The values obtained were not completely in agreement with the suggested formula, and analytical gas chromatography in each case showed the presence of a second component (present to about 5-10%). Also, the materials of assigned formula $C_6F_8Cl_2H_2$ and $C_6F_7Cl_2H_3$ had the same retention time and were probably much the same in composition; incidently, this was indicated by Banks own infra-red evidence. All of these compounds had a lower retention time than cyclic $C_6F_9Cl_3$ and were not isolated from my reaction product.

It was realised that the approach to the problem might be simplified considerably with the following modifications:

1. Making more use of preparative scale gas chromatography to isolate pure compounds after the product had been separated into suitable fractions with a less efficient fractional distillation. In this way, the distribution of a component in different azeotropes as occurred with

Banks more efficient distillation would not occur.

2. By simplifying the product; an attempt was made to increase the amount of more highly fluorinated material by using more drastic conditions.

The simplification in the composition of the product obtained by this second modification allowed the use of gas chromatography to be highly successful in its preparative resolution.

The reaction product was prepared by Dr. W.K.R. Musgrave and table I compares the reaction conditions which he used compared with those of Banks. The reaction temperature was in both cases 260°C.

TABLE I.

	C_6H_6 feed rate moles/hr.	ClF_3 feed rate moles/hr.	ClF_3 : C_6H_6 molar ratio	$N_2(1)$ l./hr.	$N_2(2)$ l./hr.
Banks	0.248	0.460	1.85:1	4	24
Musgrave	0.236	0.476	2.01:1	4.7	10.9

$N_2(1)$ Nitrogen flow rate through the benzene vapouriser.

$N_2(2)$ Nitrogen flow rate through the centre annular space of the concentric tube burner.

(See Banks, op. cit. p. 75).

Musgrave used a slightly higher $ClF_3:C_6H_6$ ratio and a much lower nitrogen dilution.

The product so obtained was fractionated through a 20 plate column and two fractions, B.Pt. 55-85°C. and B.Pt. 85-135°C., were collected. The former should have contained any cyclic $C_6F_{10}Cl_2$ and the latter any cyclic $C_6F_9Cl_3$. Higher boiling product was not examined.

Fraction, B.Pt. 55-85°C.

This fraction was much simpler than the corresponding fractions investigated by Banks and consisted of only three components which were easily and completely separated on a 10 g. scale by gas chromatography. They were identified by analysis and physical constants as cyclic $C_6F_{11}Cl$, cyclic $C_6F_{10}Cl_2$ and benzene. The recovered benzene was of the order of 30% of that initially reacted. A highly efficient fractional distillation column is required to separate benzene and fluorobenzene and with a 20 plate column, these compounds distil over together,³⁸ also they have similar retention times on a firebrick-dinonyl phthalate packing, which was used to resolve this fraction, and fluorobenzene if formed, would be present in the benzene cut. An infra-red spectrum showed that fluorobenzene was not present. Banks came to the same conclusion after an unsuccessful attempt to characterize any fluorobenzene formed chemically.

Fraction, B.Pt. 85-135°C.

This fraction was quite complex in composition yet consisted predominantly of three components. These were each

isolated in pure form by a slightly more tedious gas chromatographic operation and characterised as cyclic $C_6F_9Cl_3$, chlorobenzene and cyclic $C_6F_8Cl_4$. In addition, the presence of p-chlorofluorobenzene in the chlorobenzene was confirmed by an infra-red spectrum. The infra-red spectra of intermediary fractions, which generally consisted of several components, were also examined but neither the o- or the m-chlorofluorobenzene isomer were detected. The spectra also indicated that the remaining constituents were almost completely saturated and contained hydrogen and that some other aromatic product was probably present.

It is unlikely that the chlorofluorobenzene isomers were formed to such large extent, or the chlorobenzene to such small extent in Banks reaction product. It would seem that the analytical figures obtained were fortuitous since it is impossible to separate chlorobenzene, p-chlorofluorobenzene and certain highly fluorinated material with the packing he used and that the interpretation of the infra-red spectrum is unreliable since it was not realised that chlorobenzene was a possible component. Also, Banks was unable to characterise his chlorofluorobenzene isomers chemically.

Table 2 gives the extent to which compounds were isolated from the product investigated.

TABLE 2.

Compound	Formation (moles/mole of reacted benzene)
$C_6F_{11}Cl$	0.00872
$C_6F_{10}Cl_2$	0.0400
$C_6F_9Cl_3$	0.0383
$C_6F_8Cl_4$	0.0293
C_6H_5Cl	0.0561
p-Cl.F-benzene*	0.0043

* Calculated from the chromatographic peak area relative to that of chlorobenzene and assuming their thermal conductivities to be equal.

Theoretical considerations

Vapour Phase Fluorination

Bigelow and Fukuhara⁵ caused benzene and fluorine, diluted with nitrogen, to react in the vapour phase over a copper gauze packing at 90°C. The degradation products CF_4 , C_2F_6 , C_3F_8 , C_4F_{10} , cyclic C_5F_{10} together with cyclic $C_6F_{11}H$ and C_6F_{12} and the dimer $C_{12}F_{22}$ were isolated. The formation of these products was explained in terms of atomic chain reactions in which the aromaticity was destroyed first by the addition of fluorine and this was followed by the processes of further addition, substitution, fragmentation and polymerisation. The fact that these processes occurred concurrently and successively was demonstrated by the isolation of such products as cyclic $C_6H_5F_4(CF_3)_3$; cyclic

$C_6H_2F_5(CF_3)_3$ and $C_6H_2F_7(CF_3)_3$ from the mild fluorination of the highly deactivated compound 1,3,5-tris-(CF_3)₃-benzene over a close copper packing. In the fluorination of these and other deactivated aromatic compounds,^{39,40} no aromatic products were isolated. Aromatic systems have been directly fluorinated by other workers,^{41,42} and again no aromatic products were isolated. These reaction products were not examined with the intensity of Bigelow and co-workers yet it seems safe to assume that aromatic derivatives were not formed.

A number of aromatic systems have been fluorinated in the vapour phase with the milder metallic fluoride reagents. No aromatic products were isolated which again might have been due to insufficiently close examination since a private communication⁴³ has revealed that small amounts of fluoro-benzene and polyfluoro-benzene derivatives were formed in the vapour phase fluorination of benzene with cobalt trifluoride.

Vapour Phase Chlorination

Wibaut and his co-workers have extensively investigated the vapour phase halogenation of monohalogenated benzenes. It was found that in the chlorination of chlorobenzene⁴⁵ and the bromination of fluoro-, chloro-, and bromobenzenes^{44,46} with a pumice or charcoal catalyst, that the substitution product changed from ortho and para to meta

at 400-450°C. Thus in the bromination of bromobenzene⁴⁶ at 400°C., 20% ortho, 23% meta and 57% para and at 450°C., 20.5% ortho, 54.5% meta and 25% para were formed. In the presence of ferric bromide or copper bromide as catalyst, this change in substitution type did not occur. Olah, Pavlath and Varsanyi⁴⁷ investigated the chlorination of fluorobenzene from 260-680°C. in a silica tube in the absence of catalysts and also observed a change in substitution type, thus at 260°C., 17% ortho, 32% meta and 66% para and at 500°C., 9% ortho, 58% meta and 33% para were formed.

Both the purely cationoid substitution of halogen in monohalogenated benzenes to give exclusively ortho and para derivatives, and the fact that a monosubstituted benzene, irrespective of the nature of the substituent, gives mainly the ortho and para derivatives by reaction with radicals, are well explained by the electronic theory of valency.⁴⁸ The change in substitution type observed at high temperatures was attributed by Waters⁴⁹ to the direct reaction with halogen atoms produced by the thermal decomposition of the halogen at these temperatures. Presumably at lower temperatures, the catalytic production of free radicals and, possibly in the presence of polar catalysts, cationoid attack give rise to normal ortho and para substitution. The story as far as vapour phase halogenation is concerned, however, is still by no means clear but we can conclude that at 260°C.,

radical substitution of halogen in a monohalogenated benzene readily occurs and that the p-derivative is predominantly formed.

The reason why the reaction between benzene and atomic fluorine leads to addition is readily perceived from the heat of reaction calculated from the bond energies given by Pauling.⁵⁰

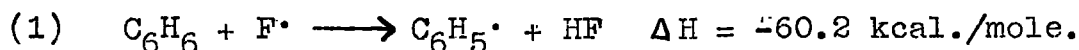

The energy liberated is easily sufficient to break down the benzene resonance energy of 39 kcals./mole. Compare the similar reaction with chlorine atoms.

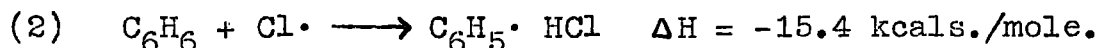

Reaction with chlorine trifluoride

Chlorine trifluoride, which has a heat of formation of 42 kcals/mole⁵¹ can be regarded as intermediary in fluorinating power between elementary fluorine and cobalt trifluoride and this accounts for the more orderly reaction with less degradation which is observed, compared with the corresponding direct fluorination of benzene.

Banks explained the complexity and nature of his reaction product by atomic chain reactions in an analagous manner to the direct fluorination of benzene. The following primary dissociations were postulated.

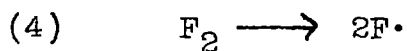

The formation of chlorofluorocyclohexanes then occurred as follows, writing $\text{X}\cdot$ for a halogen atom.

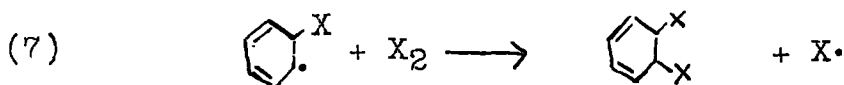
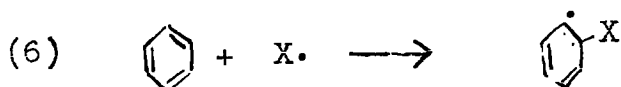

with further addition and substitution. Such a mechanism yielded a complex mixture of products in which a molecular formula was capable of being present as numerous structural isomers. These processes must have occurred extremely rapidly to form saturated products since no unsaturated materials were isolated and a large amount of unreacted benzene was recovered. From earlier arguments it would seem that $\text{X} = \text{F}$ is mainly responsible for step (6).

The formation of benzene derivatives was explained in a similar manner by Banks.

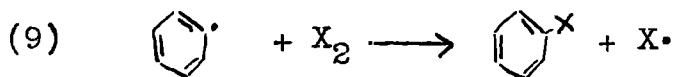
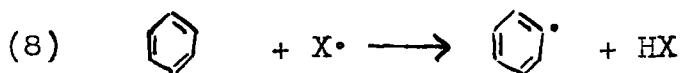

which was followed by further substitution.

It has already been mentioned that the formation of these compounds to the extents stated by Banks is questionable. Also, because of the large amount of energy liberated, step (8) where $X = F$ is doubtful.

In the reaction product investigated by the present worker, chlorobenzene and p-chlorofluorobenzene were formed to the extent 0.056 moles and 0.0043 moles/mole of reacted benzene respectively.

The formation of chlorobenzene is readily explained by steps (8) and (9) where $X = Cl$.

The homogenous exchange of fluorine between $H^{18}F$ and ClF_3 vapours is said to proceed by an intermediate non-ionic activated complex, $HClF_4$.⁵² Further, the exchange of fluorine atoms between fluorine and hydrogen fluoride is negligible below a $100^\circ C.$, yet above $200^\circ C.$ it is rapid. This has been attributed partly to heterogeneous catalysis by the metal fluoride coating in the reactor and partly to homogenous gas exchange.⁵²

Nuclear substitution of fluorine might occur by a similar complex intermediate. Also as previously stated, chlorobenzene is activated for radical substitution and the para-derivative is predominantly formed. Steric factors, also, would be expected in this case to accentuate p^u-substitution.

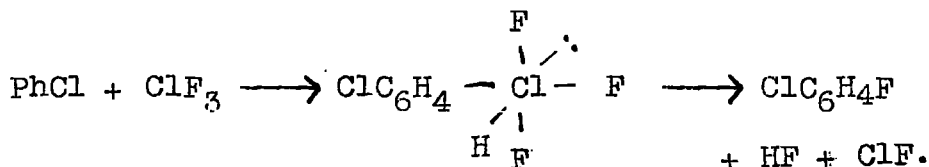

An alternative source of aromatic material suggested by Banks, but regarded as unlikely, was the dehydrohalogenation of suitable chlorofluorocyclohexanes. As Banks pointed out, the small amount of unsaturated material formed refutes this. Another reason, however, lies in the fact that all polyhalogenated benzene derivatives, which contain three or less hydrogen atoms would have had to have been formed from chlorofluorocyclohexanes containing six or more hydrogen atoms. Trihalogenated benzenes could only be formed from the dehydrohalogenation of addition compounds of the type $C_6H_6X_6$ and Bigelow³⁹ has reported that compounds such as $C_6H_3F_4(CF_3)_3$ and $C_6H_2F_5(CF_3)_3$ formed by the addition of fluorine to 1.3.5-tris- $(CF_3)_3$ -benzene show no tendency to aromatise, and this was attributed to trans addition of the fluorine. The formation of chlorobenzene and p-chlorofluorobenzene in such a manner would seem impossible.

Future work

The amounts of perhalogenated-cyclohexanes and halogenated benzene derivatives isolated account for about 20% of the reacted benzene and from a consideration of the ClF_3 : C_6H_6 reactant ratio of 2.01:1 the higher boiling material will consist of chlorofluorocyclohexanes containing hydrogen and possibly polyhalogenated benzene derivatives and polymeric product. The resolution of the 85-135°C. fraction has been relatively easy since the isomers of a perhalogenated cyclo-

hexane containing chlorine and fluorine are not resolved by gas chromatography. The number of possible isomers of a chlorofluorocyclohexane containing hydrogen in which there are three variable species is very large, also, the presence of hydrogen will allow chromatographic resolution. These two factors will make the separation of the higher boiling material a formidable task. The best approach will probably be an efficient fractionation controlled by gas chromatography as has been done at Birmingham in the resolution of their complex fluorocyclohexane product.

A more intense search for polyhalogenated aromatic material and biphenyl or halogenated biphenyl is necessary as the isolation of these is important from a mechanistic point of view. The unlikely formation of benzene derivatives by dehydrohalogenation of suitable chlorofluorocyclohexanes in the working-up process can be checked easily by not bringing the reaction product into contact with a basic medium.

The reaction between hexachlorobenzene and cobalt trifluoride
in the vapour phase

Although the vapour phase reaction between chlorine trifluoride and benzene gave chlorofluorocyclohexanes of formula, $C_6F_{12-n}Cl_n$, $n = 1$ to 4 , the yields of these compounds were low and the isolation of cyclic $C_6F_9Cl_3$ and cyclic $C_6F_8Cl_4$ was tedious. The method did, however, have the advantage that the starting material, benzene, was cheap and that no intermediate generation of a fluorinating agent was necessary. It is also likely that the yields of these compounds can be further increased by suitably changing the reaction conditions.

An obvious starting material for the preparation of perhalocyclohexanes containing chlorine and fluorine is hexachlorobenzene. This compound has already been fluorinated in the vapour phase with the metallic fluorinating reagents, lead tetrafluoride⁹ and ceric fluoride¹⁰ but little information is available on these reactions. It was therefore decided to investigate the vapour phase fluorination of hexachlorobenzene with cobalt trifluoride, a potent and readily available reagent.

Hexachlorobenzene was fluorinated with cobalt trifluoride in a Fowler type reactor at $350^\circ C$. and chlorofluorocyclohexanes of general formula $C_6F_{12-n}Cl_n$, $n = 1$ to 5 , were obtained. The compound cyclic $C_6F_7Cl_5$ had not previously been characterised.

The main factors influencing the extent of fluorination in the metallic fluoride process are, the rate of fluorination, contact time, reactor temperature and the degree of the reagent exhaustion.⁵³ The extent in the variation of these factors in the present fluorination will be considered.

Rate of introduction and contact time

The only effective method found of discharging the hexachlorobenzene into the reactor-bubbling nitrogen through the boiling liquid contained in a copper pot had the disadvantage that it was impossible to do this at a steady controlled rate. A rough idea only was obtained from the rate at which the product emerged into the glass trap and attempts were made to control this by adjusting the nitrogen flow rate and the oil bath temperature and this was reasonably successful. Between 45 g. (0.158 moles) and 80 g. (0.281 moles) of hexachlorobenzene were fluorinated per hour, but the actual rate of introduction probably varied considerably during a run. This did not seem to have an undue effect on the yields. The contact time was of the order of one or two minutes.

Reactor temperature

The reaction temperature was controlled at $350 \pm 30^{\circ}\text{C}$. in an orderly reaction, although occasional spurts of

hexachlorobenzene into the reactor caused temperature increases of the order of 50°C. or so.

Degree of reagent exhaustion

Sufficient hexachlorobenzene was passed into the reactor so as to use about 50% of the available fluorine (a product of approximate composition $C_6F_9Cl_3$ was always formed). Attempts to fluorinate more hexachlorobenzene gave rise to blockage of unreacted starting material in the reactor outlet lead.

A further variable to be taken into consideration, and not to be found in nickel reactors, was that the cobalt trifluoride became diluted with ferric fluoride formed by the action of chlorine trifluoride on the mild steel paddles during the regeneration of the cobalt trifluoride. This was disadvantageous in that:

1. Excessive corrosion of the paddles resulted in an incomplete stirring of the reactor space and fluorinating reagent tended to pack against the reactor surface.
2. The bulk of the material in the fluorinator increased and aided blockage.

Altogether 13 runs were carried out but during this time the reactor was stripped down twice and the weight of effective fluorinating reagent replaced each time reduced, thus allowing less hexachlorobenzene to be fluorinated.

Table 3 records; A, the maximum amount of hexachlorobenzene which could be fluorinated during a run; B and C, the weights of cobalt trifluoride and ferric fluoride in the reactor respectively (the latter value refers to the weight immediately after repacking the reactor and did of course increase as the number of runs carried out increased; D, the available fluorine; E, the weight of fluorine required to convert the corresponding weight of hexachlorobenzene to a product of average composition $C_6F_9Cl_3$; and F, the percentage available fluorine used assuming that cobalt trifluoride was the only effective fluorinating agent.

TABLE 3.

Run No.	A(g.)	B*(g.)	C(g.)	D(g.)	E(g.)	F. %
1 to 4	120	935	-	164	72	44
5 to 9	100	623	267	102 ✓	60	58
10 to 13	80	445	476	73	48	65

* A conversion of $CoF_2 \longrightarrow CoF_3$ of 85% is assumed.

Resolution of the reaction product.

The product was examined by gas chromatography; a kieselguhr-silicone grease packing showed 5 peaks, a kieselguhr-apiezon I packing would not resolve the first two of these peaks and gave 4 peaks. The product was completely

resolved with a 20 plate concentric tube column and five wax-like solids, which were characterised as cyclic $C_6F_{11}Cl$, cyclic $C_6F_{10}Cl_2$, cyclic $C_6F_9Cl_3$, cyclic $C_6F_8Cl_4$ and cyclic $C_6F_7Cl_5$, obtained. An analysis of the small amount of distillation residue indicated that some cyclic $C_6F_6Cl_6$ was present. Of these, cyclic $C_6F_7Cl_5$ had not previously been characterised. The isomer 1.2.3.4-tetrachlorooctafluorocyclohexane¹⁸ has been reported but its B.Pt. was quoted under reduced pressure. No other products were isolated. Table 4 gives the extent to which the above products were obtained.

TABLE 4.

Compound	Conc. ⁿ of compound in moles/mole of C_6Cl_6	
	Distillation of product from runs 1 to 4.	Distillation of product from runs 5 to 13.
$C_6F_{11}Cl$		0.023
$C_6F_{10}Cl_2$	0.125	0.159
$C_6F_9Cl_3$	0.215	0.286
$C_6F_8Cl_4$	0.216	0.196
$C_6F_7Cl_5$	0.042	0.041

All isomers of each molecular formula are of course present, and as has also been observed by other workers,¹² have very similar physical properties, thus they distil over as a unit and as yet no method has been found of separating them.

Product distribution

The product distribution for the combined product of each run and in runs 10 and 12 for the product formed in the first and second halves of the fluorination were determined from the ratio of the chromatographic peak areas after these had been standardised with a mixture of known composition. The values obtained and other relevant run data are given in table 5.

Considering the considerable variation in the rate of fluorination during a run and from run to run and the increasing dilution of the cobalt trifluoride with ferric fluoride* as the run number increased, the fairly steady distribution of products is quite remarkable.

The concentration of cyclic $C_6F_9Cl_3$ is much the same in all runs except for run 9 in which a blockage occurred and the stirrer ceased to operate. There is a tendency for the concentration of cyclic $C_6F_8Cl_4$ to decrease as the the run number increases with a corresponding increase in concentration of cyclic $C_6F_{10}Cl_2$, which is rather surprising considering the increasing dilution of the cobalt trifluoride with ferric fluoride.

Considering the variation of the product distribution within a particular run, no great trend is apparent, indeed,

* Dr. R.E. Banks (private communication) has indicated that ferric fluoride is quite ineffective for fluorinating benzene at 220-650°C.

in run 10 the product distribution in the first half of the fluorination is much the same as in the second half and in run 12 only a slight tendency to form more less-fluorinated material as the fluorination proceeds is observed. It would seem that the fluorination of the hexachlorobenzene is practically complete within a localised zone of the reactor and that little further fluorination of the resultant product occurs.

Theoretical considerations

In the reaction investigated only chlorofluorocyclohexanes of formula $C_6Cl_{12-n}F_n$, $n = 6$ to 11, were obtained and the reaction can be represented by the stoichiometric equation.

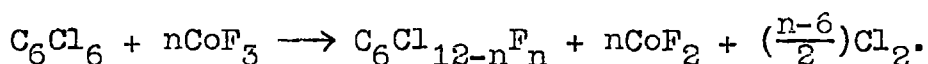

The mechanism by which this process occurs is still not clear, but probably involves a direct reaction between the organic molecule and the cobalt trifluoride. This is supported by the fact that 'direct fluorination' occurs in a more orderly manner, with less breakdown and polymerisation, when the reaction takes place within the meshes of a copper⁵⁴ or better silver-, gold-, nickel- or cobalt- plated copper packing.^{41,55.} This has been attributed partly to the intermediate formation of the higher metal fluoride which is the effective fluorinating reagent, besides the rapid dissipation of heat away from the reaction centre by the packing.

TABLE 5.

Fluorination of C_6Cl_6 with CoF_3

Run No.	C_6Cl_6 Fed in g.	Reaction time (mins.)	C_6Cl_6 Feed ⁶ g./hr.	Wt. of Product g.	Percentage distribution of product (by wt.).				
					Peak I	Peak II	Peak III	Peak IV	Peak V
1	106	120	53	115.5	6.0	20.5	40.3	30.2	3.0
2*	105	90	70	110	21.9		38.2	31.7	8.2
3*	125	120	62	132	27.5		36.3	31.9	4.4
4*	125	120	62	136	19.9		36.4	36.0	7.6
5	97	120	48	104	2.6	21.2	41.0	27.5	7.6
6	91	100	55	97	2.7	23.2	40.0	27.7	6.3
7	97	120	48	104	1.6	16.9	39.8	33.8	8.0
8	93	105	60	101	4.5	26.8	40.1	22.9	5.6
9	76	60	76	70	2.2	9.0	33.9	39.3	15.6
10(a)	101	60	67	34	5.5	31.3	39.9	21.4	1.8
10(b)		30		56	5.6	29.9	40.4	22.3	1.9
11	84	90	56	85	7.7	30.3	39.0	21.0	2.1
12(a)	85	60	46	36	6.5	28.4	38.9	22.2	4.0
12(b)		50		51	3.5	24.7	39.8	26.6	5.3
13	80	60	80	78					

* Kieselguhr-apiezon L packing was used, in all other cases a kieselguhr-silicone grease packing was used.

Reactions between chlorofluorocyclohexanes and lithium aluminium hydride

Tatlow and Worthington⁸ and Roylance, Tatlow and Worthington¹² first reported that cyclic $C_6F_{11}Cl$ and cyclic $C_6F_{10}Cl_2$ were easily converted to the corresponding fluorocyclohexanes with lithium aluminium hydride. Reactions with this reagent generally involve the displacement of a highly electronegative group, usually nitrogen, oxygen or a halogen and the accession of a hydrogen atom to the electron deficient centre.⁵⁶ Such a mechanism in the above reactions is encouraged by the strong +I effect of the fluorine atoms.⁵⁷

Attempts were made to convert the isomeric mixtures of chlorofluorocyclohexanes obtained in the reactions already described to the corresponding fluorocyclohexanes which could be separated and so some insight gained into the isomeric distribution of these products. Only in the case of the cyclic $C_6F_{10}Cl_2$ was this approach successful.

Dichlorodecafluorocyclohexanes

The isomeric mixtures of cyclic $C_6F_{10}Cl_2$, obtained from the reactions between hexachlorobenzene and cobalt trifluoride, and benzene and chlorine trifluoride, were each converted to the corresponding decafluorocyclohexanes which were separated by gas chromatography. Table 6 lists the extent to which the various isomers were

formed. They were characterised by physical constants, analysis, and in the case of the 1H/3H-decafluorocyclohexane by nuclear magnetic resonance.

TABLE 6.

Compound	Reduction of cyclic $C_6F_{10}Cl_2$ from ClF_3 and C_6H_6 (A)		Reduction of cyclic $C_6F_{10}Cl_2$ from CoF_3 and C_6Cl_6 (B)	
	Yield moles/ mole of cyclic $C_6F_{10}Cl_2$.	% Yield from C_6H_6 .	Yield moles/ mole of cyclic $C_6F_{10}Cl_2$.	% Yield from C_6Cl_6 .
1H/2H- $C_6F_{10}H_2$			0.020	0.3
1H/3H- $C_6F_{10}H_2$	0.183	0.74	0.263	3.7
1H:4H- $C_6F_{10}H_2$	0.131	0.52	0.134	1.9
1H:3H- $C_6F_{10}H_2$	0.079	0.31	0.095	1.4
1H:2H- $C_6F_{10}H_2$	0.167	0.67	0.228	3.2

The reductions were carried out in ether and 1H/2H- $C_6F_{10}H_2$ and ether have the same retention times with the stationary phase, dinonyl phthalate, which was used to separate the products. The presence of an isomer in the ether cut was not realised when reduction A was carried out and consequently the 1H/2H-isomer was not identified. 1H/2H-decafluorocyclohexane was shown to be present in an ether fraction from reduction B by gas chromatography using the stationary phase, apiezon L. The yield quoted was estimated from the fluorine content

of the mixture. Considering the similarity in the product distribution for the two reductions, there is good reason to suppose that the 1H/2H-isomer was formed to a similar extent in reduction A. The yields of products obtained in reduction A are generally lower and this can be attributed to the chromatographic system used at that time.

An interesting point which emerged from this work was that it was impossible to conclude from published information whether material obtained in both reductions was the 1H/4H- or the 1H/3H- decafluorocyclohexane. Gas chromatography (kieselguhr-tricresyl phosphate) resolves these isomers,³⁰ yet in each case, a single peak of the same retention time was obtained. J. Feeney and L.H. Sutcliffe of Liverpool University found that the nuclear magnetic spectra of both samples were identical and fitted the 1H/3H-isomer perfectly, which was estimated as being present to greater than 90%. The absence of the 1H/4H-isomer is rather surprising since Evans et al.³⁰ reported its formation in the fluorination of benzene with cobalt trifluoride and also from the reduction of the cyclic $C_6F_{10}Cl_2$ obtained in the fluorination of o-dichlorobenzene with cobalt trifluoride.

Trichlorononafluorocyclohexanes

The reduction of cyclic $C_6F_9Cl_3$ with lithium aluminium hydride in ether gave only a few per cent of cyclic

$C_6F_9H_3$ and the product was mostly a complex mixture of mono- and dichloro- nonafluorocyclohexanes. A two-stage reduction in ether in which an intermediate product of average composition $C_6F_9Cl_{1.24}H_{1.76}$ was reacted with more lithium aluminium hydride proceeded little further. The reaction was also carried out at a higher temperature with tetrahydrofuran as the solvent but again the reduction was incomplete. Analytical gas chromatography showed peaks corresponding to authentic cyclic $C_6F_9H_3$ isomers, however, the predominant component was n-butyl alcohol formed in the reduction of the solvent under the drastic conditions used

Tetrachlorooctafluoro- and pentachloroheptafluorocyclohexanes

These compounds gave complex mixtures of chlorofluoro-cyclohexanes containing one, two and three chlorine atoms.

Dehalogenations with zinc dust/n-butyl alcohol

McBee and his co-workers have dehalogenated bromo-chlorofluoro-cyclohexane mixtures (see introduction) and the dehalogenation of cyclic $C_6F_8Cl_4$ with zinc dust/ethyl alcohol gave perfluoro-benzene and chloropentafluoro-benzene.²⁶

Cyclic $C_6F_8Cl_4$ and cyclic $C_6F_7Cl_5$ were dehalogenated with zinc dust in n-butyl alcohol. This solvent was chosen so that the expected more volatile dehalogenated

products could be separated by distillation. The products were obtained in pure form by gas chromatography and were characterised by their physical constants, analysis, and infra-red spectroscopy.

Tetrachlorooctafluorocyclohexane

Table 7 lists the products isolated and their yields. Gas chromatography showed that very small amounts of other products were formed, but these were not isolated.

TABLE 7.

Compound	Yield moles/ mole cyclic $C_6F_8Cl_4$	% yield from C_6Cl_6
(1) C_6F_8 -1:4-diene	0.223	4.6
(2) 1H- C_6F_7H -1:4-diene	0.044	0.9
(3) C_6F_6	0.191	3.9
(4) C_6F_7H	0.061	1.3
(5) C_6F_7Cl	0.088	1.8

The products (4) and (5) were obtained as a mixture which was only resolved with a kieselguhr-apiezon L packing and a preparative column was not available. The molecular weight, analytical and infra-red evidence, however, were entirely consistent with such a mixture.

Reactions with zinc dust in which a chlorine atom is replaced by a hydrogen atom have been reported by other workers.

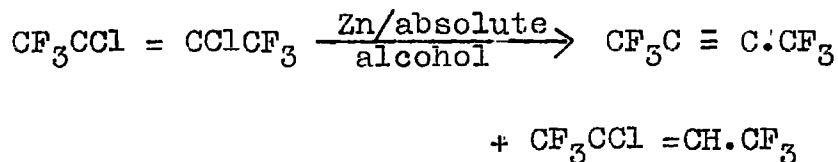
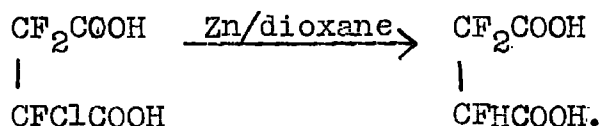
Henne and Finnegan⁵⁸Raasch, Miegel and Castle⁵⁹

It will be observed that no octafluorocyclohexa-1:3-diene was formed. Presumably under the reaction conditions, the compound was further dehalogenated to perfluorobenzene.

Pentachloroheptafluorocyclohexane

Table 8 lists the products isolated and their yields

TABLE 8

Compound	Yield moles/mole of cyclic $\text{C}_6\text{F}_7\text{Cl}_5$	% yield from C_6Cl_6
C_6F_6	0.652	2.7
$\text{C}_6\text{F}_5\text{Cl}$	0.068	0.29
$\text{C}_6\text{F}_5\text{H}$	0.037	0.16

The presence of pentafluorobenzene was inferred from an infra-red spectrum of one of the fractions obtained. Analytical gas chromatography gave a single peak, yet the infra-red spectrum indicated quite strongly

that n-butyl alcohol was also present. Some sort of interaction between these two compounds must have occurred since pure n-butyl alcohol had a different retention time.

Reactions with potassium graphite

Kingston and Glockling⁶⁰ have carried out a number of reactions between potassium graphite (KC_8) and organic halides, including aryl- and benzyl-halides, in methylcyclohexane and cyclohexane as solvents. The work is still being developed, yet the nature of the products is explained by free radical mechanisms in which the extents of dimerisation and side reactions depend on the stability of the free radical $R\cdot$ formed in the reaction

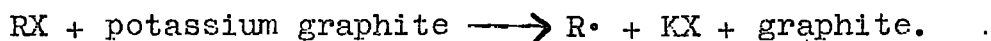

The lamellar compound KC_8 , which is formed by the absorption of potassium by graphite, is similar to the addition compounds formed between alkali metals and aromatic hydrocarbons in suitable solvents (see p.149), in that in both cases, the ionisation electrons of the alkali metal are delocalised over an aromatic system which is potentially a powerful electron transfer reagent. Although the solvation energies must be taken into consideration when considering the stability of the alkali metal- aromatic hydrocarbon complexes, graphite has

a much higher electron affinity (a work function of 100 k.cals/g. atom) than the aromatic hydrocarbons (electron affinities of ~ 20 k.cals/mole) and is potentially the weakest reducing reagent.*

It was considered that reactions between cyclic $C_6F_9Cl_3$ and potassium graphite would give some insight into the possibility of using aromatic hydrocarbon anions, under suitable conditions, for dehalogenating chloro-fluorocyclohexanes to chlorofluoro-benzene and -cyclohexadiene derivatives. The most reactive of these, the biphenyl-sodium-dimethoxyethane complex has been used to decompose these compounds and other polyfluoro-organic compounds quantitatively in the semi-micro determination of chlorine and fluorine (see chapter 5).

Three exploratory reactions in methylcyclohexane at $110^\circ C.$ were carried out with different reactant ratios and the extent of halogen extraction was determined. Table 9 lists the results.

Even with a large excess of potassium graphite, the extent of halogen extraction was relatively small. A reaction on a larger scale under conditions similar to reaction 3 yielded only traces of perfluorobenzene,

* Coates, Organo-metallic compounds, 2nd Edition, Methuen, in print. Taken from a lecture given by Professor Coates in Durham.

TABLE 9.

	KC ₈ : cyclic C ₆ F ₉ Cl ₃ molar ratio	Reaction time (hrs.)	% halogen ex- tracted	
			F	Cl
1.	6.2:1	8	5.3	11
2.	13.4:1	8	12	22.4
3.	26 :1	20	28.6	46.7

which was detected by gas chromatography, and unchanged starting material. The low fluorine and chlorine content of a small amount of residue obtained after the removal of the solvent, indicated that the expected reaction with the solvent had also occurred. The amount of material accounted for in the reaction was very low and this was attributed to, adsorbtion on the graphite, losses incurred during the distillation of the solvent, and decomposition. A reaction was also carried out without a solvent, but an extremely vigorous reaction with reaction flame, occurred. The fluoride and chloride content of the aqueous extract indicated that ~ 70% decomposition had occurred. A small amount of dehalogenated material, perfluorobenzene (2.7%), and octafluorocyclohexa-1:4-diene (4%), detected by gas

chromatography and infra-red spectroscopy, was obtained.

Lack of time prevented a more exhaustive investigation of this topic using the hydrocarbon anions. The results do indicate, however, that although dehalogenated products are produced, extensive side reactions with solvent and with the soluble complexes, the aromatic hydrocarbon, are likely to occur. An additional factor is that the alkali metal aromatic hydrocarbon complexes can only be obtained in concentrations of ~ 1 molar, and large amounts of aromatic hydrocarbon are required as ballast. This latter disadvantage has been overcome by Muller and Roscheisen⁶¹ who used catalytic amounts of tetraphenylethylene in tetrahydrofuran as solvent to act as a sodium carrier in the Wurtz reaction of benzyl halides to the corresponding dimers. Whether this approach will be successful in dehalogenating chlorofluorocyclohexanes is doubtful.

While this work was being carried out, Gethin, Patrick, Stacey and Tatlow⁶² reported the defluorination of perfluoro-cyclohexane and -cyclohexane homologues to perfluoro-benzene and the corresponding-benzene homologues simply by passing them over a clean metal surface (iron or nickel) at 400-600°C. Chlorofluorocyclohexanes should be even more susceptible to this process and in the case of the higher chlorine containing compounds, there should be a good chance of obtaining chloropentafluorobenzene.

The reaction between cyclic $C_6F_{11}Cl$ and phenyl lithium
and phenyl sodium

Tatlow and Worthington⁸ reported that cyclic $C_6F_{11}Cl$ was most unreactive and would not form or react with a Grignard reagent. It was considered, however, that reactions might occur with the more reactive, organo-lithium and -sodium reagents. The only reported formation of a perfluoroorgano-lithium compound is C_3F_7Li ⁶³ formed from C_3F_7I and $MeLi$ at $-74^\circ C$. The compound was hydrolysed to C_3F_7H and on warming lithium fluoride was eliminated to give $CF_3CF=CF_2$. No perfluoroorgano-sodium compounds have been reported.

Reactions were carried out between cyclic $C_6F_{11}Cl$ and 5% excesses of phenyl lithium and phenyl sodium at room temperature with the intention of forming perfluorocyclohexene and possibly coupling products. Table 10 lists the products and yields formed in these reactions.

TABLE 10.

	Reaction with C_6H_5Li Yield moles/mole $C_6F_{11}Cl$.	Reaction with C_6H_5Na Yield moles/mole $C_6F_{11}Cl$.
unchanged $C_6F_{11}Cl$	0.431	0.351
C_6F_{10}	-	0.058
C_6H_5Cl	0.528	0.478
$C_6H_5 \cdot C_6F_9$	0.119	0.084
C_6H_6	0.075	-
Residue*	0.110	0.094

* A molecular weight of 400 was assumed in calculating these concentrations.

The products formed in the reaction with phenyl lithium were separated by gas chromatography and identified by physical constants and infra-red spectroscopy. A new compound, B.Pt., 177.2°C. , n_{D}^{20} 1.4185, whose analysis and molecular weight corresponded to the formula $\text{C}_6\text{H}_5\cdot\text{C}_6\text{F}_9$, was isolated. The formation of this coupling product seemed quite specific. An infra-red spectrum showed the monosubstituted aromatic C-H stretching frequency⁶⁴ at 3062 cm.^{-1} and an absorption at 1689 cm.^{-1} was rather lower than the absorption region ($1745\text{--}1755\text{ cm.}^{-1}$) given by Burdon and Whiffen for the -CF=CF- stretching frequency in fluorocyclohexenes (see p.83), however, this shift could be due to conjugation,⁶⁵ i.e. the phenyl group is linked to a double-bonded carbon atom. An attempt was made to oxidise the compound to the dibasic acid, and although oxidation occurred to an appreciable extent as indicated by the formation of manganese dioxide, the results were inconclusive. This possibly could be attributed to the position of the phenyl group. Lack of time prevented further investigation. The products in the reaction with phenyl sodium, which was carried out on a smaller scale, were identified by gas chromatography and infra-red spectroscopy. The yields were estimated from chromatographic peak areas and the halogen analysis of fractions.

Although the reaction between cyclic $\text{C}_6\text{F}_{11}\text{Cl}$ and

phenyl lithium was the more intensely examined, the reaction with phenyl sodium yielded similar products and yields, and the mechanisms were probably the same.

The predominant reaction was a halogen-metal exchange which involved exclusively chlorine, no fluorobenzene was isolated, M = Li or Na.

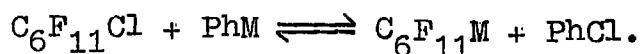

This is in accordance with other workers' findings,⁶⁶ in that fluorine does not undergo halogen-metal exchange at all. Also the equilibrium position depends on the relative electronegativities of the two organic groups, and in the above case would be expected to be on the right. In each case about 40% cyclic $\text{C}_6\text{F}_{11}\text{Cl}$ was recovered unchanged and another 30-40% was unaccounted for. This can be attributed to the inherent instability of the cyclic $\text{C}_6\text{F}_{11}\text{M}$ at the reaction temperature, which decomposed to give volatile fluorocarbons which were lost during the reaction. Thus $\text{C}_6\text{F}_{11}\text{COOH}$ is unstable in aqueous solution and gives C_6F_{10} (30%) and a complex mixture of fluorocarbons.⁶⁷ C_6F_{10} , an expected decomposition product, was only detected in the reaction with phenyl sodium. No free $\text{C}_6\text{F}_{11}\text{M}$ was present when the reaction mixture was hydrolysed, since $\text{C}_6\text{F}_{11}\text{H}$ was not detected, however, a small amount of benzene was isolated.

The formation of the $C_6H_5C_6F_9$ probably resulted from a coupling reaction between the organo-metallic compound and perfluorocyclohexene. This can be checked by reacting these two compounds.

The low fluorine content of the small amount of residue indicated that three molecules of the organo-metallic compound had coupled per molecule of cyclic $C_6F_{11}Cl$ and/or defluorination had occurred with a smaller coupling ratio.

By carrying out these reactions with a molar ratio of $2PhM:C_6F_{11}Cl$, at room temperature, the yield of $C_6H_5.C_6F_9$ should be increased to $\sim 20\%$. The reactions should also be carried out at $-78^\circ C.$, at which temperature, the $C_6F_{11}M$ should be more stable and hydrolysis would give cyclic $C_6F_{11}H$, and reactions with ketones and aldehydes, alcohols.

Reactions with other organo-metallic reagents, n-butyl lithium,⁶⁶ n-amyl sodium,⁶⁸ etc. might also lead to interesting results.

Future Work

The ways in which the various topics might be extended have been described in the appropriate parts of the discussion. It should be stressed, however, that as far as the compounds, cyclic $C_6F_{12-n}Cl_n$, $n = 2$ to 5 , are concerned, one is dealing with complex mixtures of isomers and the only likely profitable reactions are

those which produce a limited number of products, namely dehalogenations. There seems to be very little prospect, as yet, of separating these chlorofluorocyclohexane isomers, and in the case of the compounds $C_6F_{12-n}Cl_n$, $n = 3$ to 5, of determining the isomeric distributions chemically.

REFERENCES

38. BANKS & MUSGRAVE, J.C.S., 1482, 1956.
39. BIGELOW & GILBERT, J.A.C.S., 2411, 72, 1950.
40. TOMPSON, TARRANT & BIGELOW, *ibid.*, 2187, 68, 1946.
41. MUSGRAVE & SMITH, J.C.S., 3021, 1949.
42. HASZELDINE & SMITH, *ibid.*, 2689, 1950.
43. TATLOW, private communication.
44. WIBAUT, van de LANDE, & WALLAGH, *Rec. Trav. Chim.*,
794, 52, 1933.
45. *Idem*, 65, 56, 1937.
46. Van LOON & WIBAUT, *ibid.*, 815.
47. OLAH, PAVLATH & VARSANYI, J.C.S., 1825, 1957.
48. DEWAR, *Electronic Theory of Organic Chemistry*,
Oxford University Press, 1949, pp. 163, 278.
49. WATERS, *Trans. Faraday Soc.*, 745, 37, 1941.
50. PAULING, *The Nature of the Chemical Bond*, Cornell
University Press, 1940, p. 53.
51. SCHMITZ & SCHUMACHER, *Naturforsch*, 2a, 362, 1947.
52. CLARK, *Chemical Reviews*, 887, 1958.
53. BRICE, *Fluorine Chemistry Vol. I*, Ed. J.H. SIMONS,
Academic Press: Inc., New York, 1950, p. 428.
54. BIGELOW, CALFIE & MILLER, J.A.C.S., 198, 59, 1937.
55. CADY et al., *Ind. Eng. Chem.*, 290, 39, 1947.
56. TREVOY and BROWN, J.A.C.S., 1675, 71, 1949.
57. DEWAR, *op. cit.*, p. 70.

58. HENNE and FINNEGAN, J.A.C.S., 298, 71, 1949.
59. RAASCH, MIEGEL and CASTLE, *ibid.*, 2698, 1959.
60. KINGSTON and GLOCKLING, private communication.
61. MULLER and ROSCHEISEN, Ber., 543, 90, 1957.
62. GETHIN, PATRICK, STACEY and TATLOW, Nature, 588,
1959.
63. PIERCE, McBEE and JUDD, J.A.C.S., 474, 76, 1954.
64. BELLAMY, *Infra-red Spectra of Complex Molecules*,
Methuen, 1958, p. 65.
65. *Idem.*, p. 40.
66. GILMAN and JONES, *Organic Reactions*, Adams, Vol. VI,
Chapter 7, Wiley, 1951.
67. BRYCE and SIMONS, J.A.C.S., 4016, 73, 1951.
68. LIDSTONE and MORRIS, Chem. and Ind., 560, 1958.

CHAPTER 3.

Gas-liquid partition chromatography

Gas Chromatography

Gas chromatography has been particularly useful in the identification and separation of chlorofluorocyclohexanes, fluorocyclohexanes and their derivatives.^{20,21,33.} In many cases, compounds of this type have very similar properties and form azeotropes and so cannot be separated in any other way. Consequently this technique has been used extensively, both analytically and for preparative separations, in the present work.

The system first used, system A, which was as described by Cuthbertson and Musgrave,⁶⁹ had a glass thermal conductivity detector with 0.2 mm, 60 ohm resistance, nickel filaments. The column was heated to the desired temperature and the detector was always kept at room temperature. The carrier gas used was nitrogen and its flow rate was controlled by two Edward's high vacuum valves, one at the column inlet and the other at the trapping system exit. The general lay-out of the system is shown in diagram 1. Compounds of the type, chlorobenzene, B.Pt. 132°C, and cyclic C₆F₉Cl₃, B.Pt. 141°C, could be separated on this system provided the pressure drop across the column was large and the outlet pressure low. Cuthbertson²¹ and Banks²⁰ also prevented condensation of high boiling materials by having a low outlet pressure. Presumably under these conditions the emergent vapour occupies a larger volume than it does with lower pressure drops and its vapour pressure never

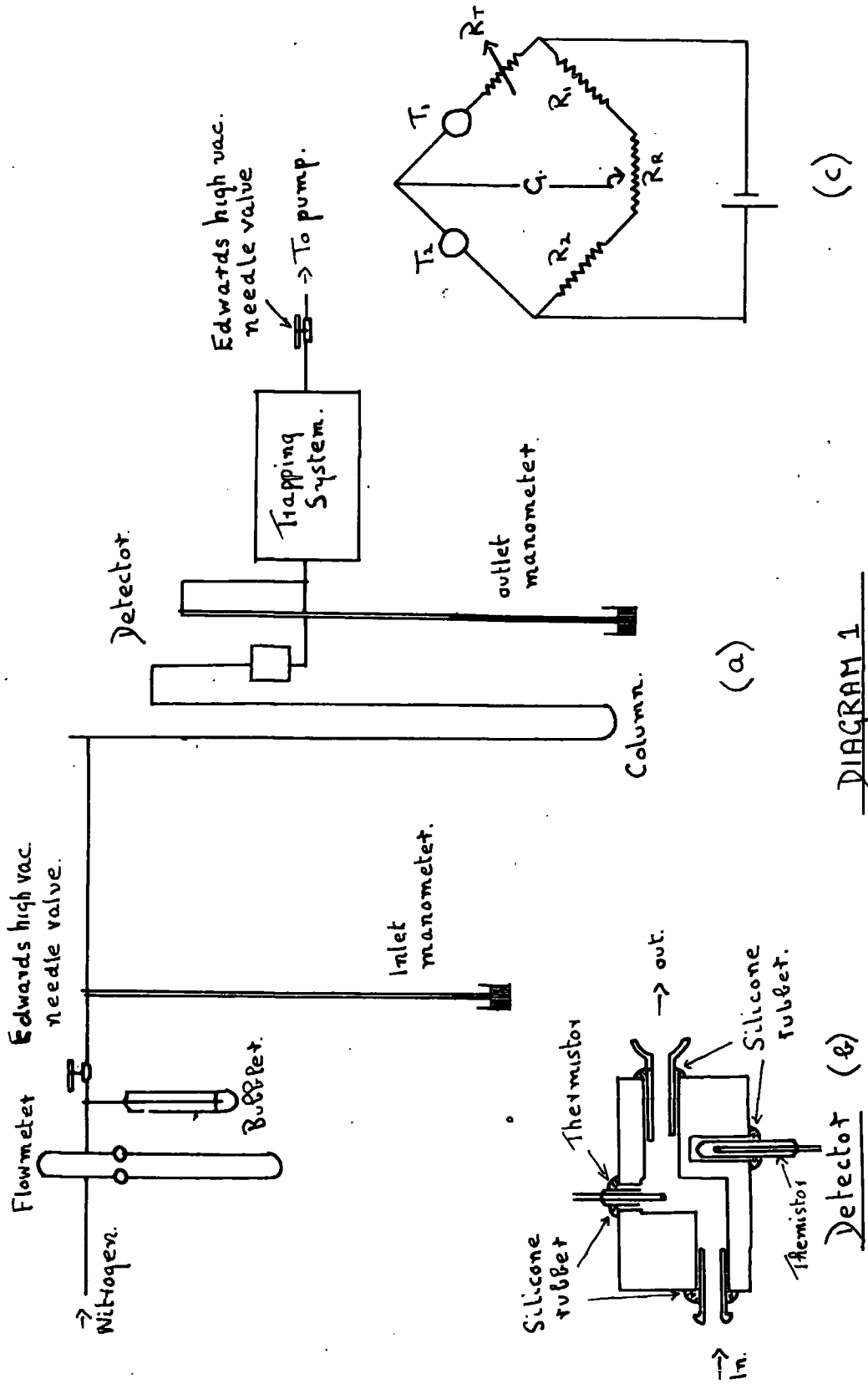

DIAGRAM 1

exceeds its saturated vapour pressure at room temperature.

System B, in which both the column and the detector were heated, was a necessary development of system A and the compounds mentioned above and those of higher boiling point could be separated more efficiently. The column and the detector were heated in a heating cabinet* which allowed analytical and preparative columns to be conveniently interchanged (diagram 2a). The trapping system was much more compact in design than used in system A and incorporated a three-way tap, F, and two two-way taps, G, and H, (diagram 3). The shorter leads from the detector to the condensation traps decreased the dead-space volume and the extent of diffusion between adjacent peaks before they were trapped out. These leads were conveniently heated with a heating tape when high boiling materials were being separated.

The glass detector operated quite well at room temperature but when the need arose to heat it, it was found impossible to obtain a stable system. Consideration of alternative detectors which would be stable at higher temperatures (the decision was largely influenced by cost and simplicity of operation), led to the thermistor type of thermal conductivity detector being used. Thermistor

* Thanks are accorded to Mr. R.N. Mobbs for developing this heating arrangement.

a, B, c, d : Ball joints.
A, B, C, D, E : B.19 joints.

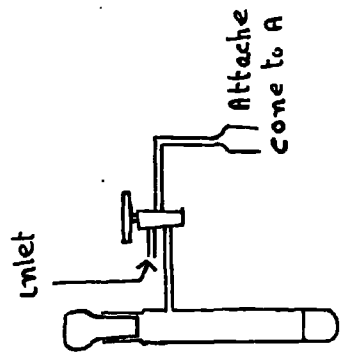

Injection System
(c).

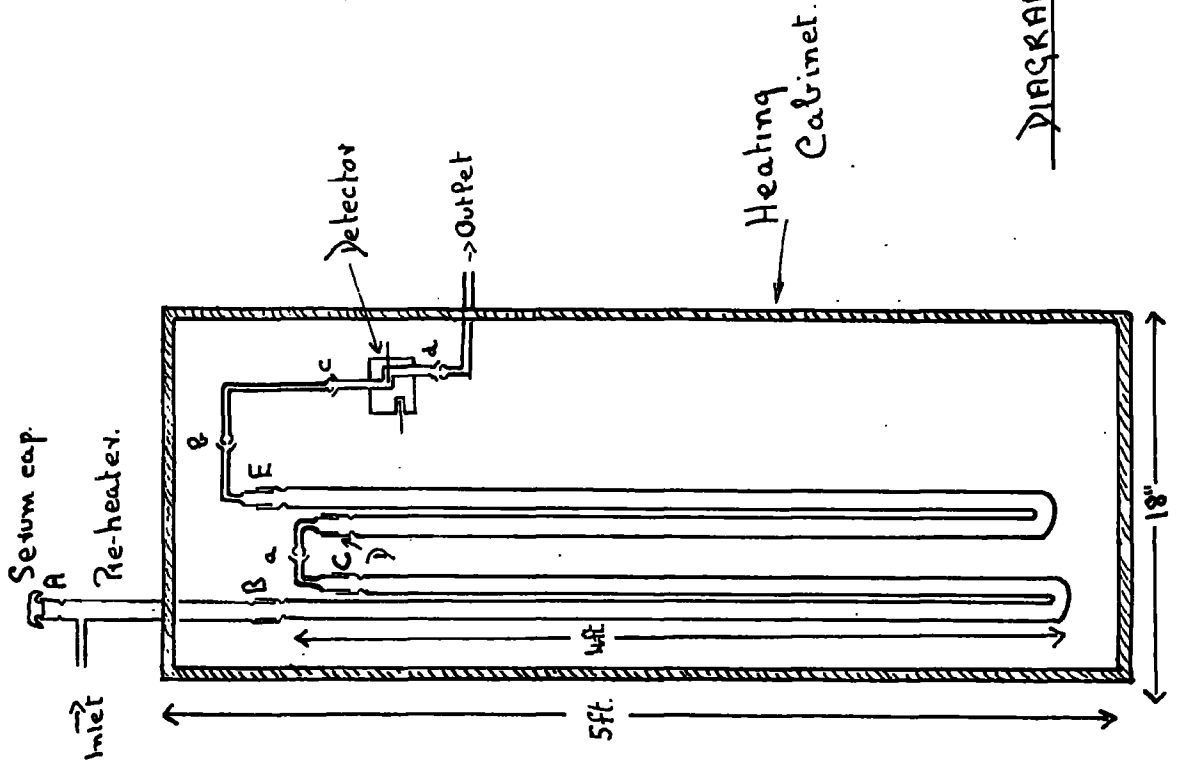
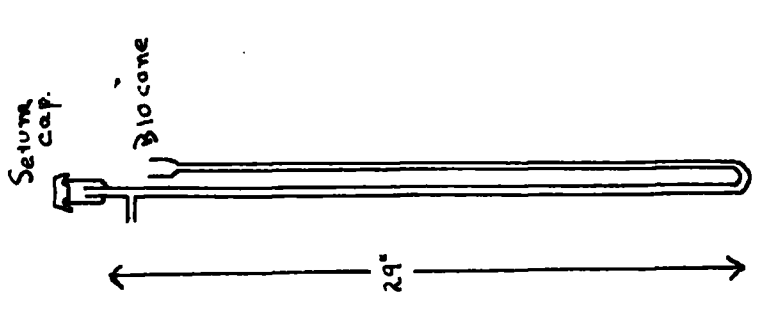
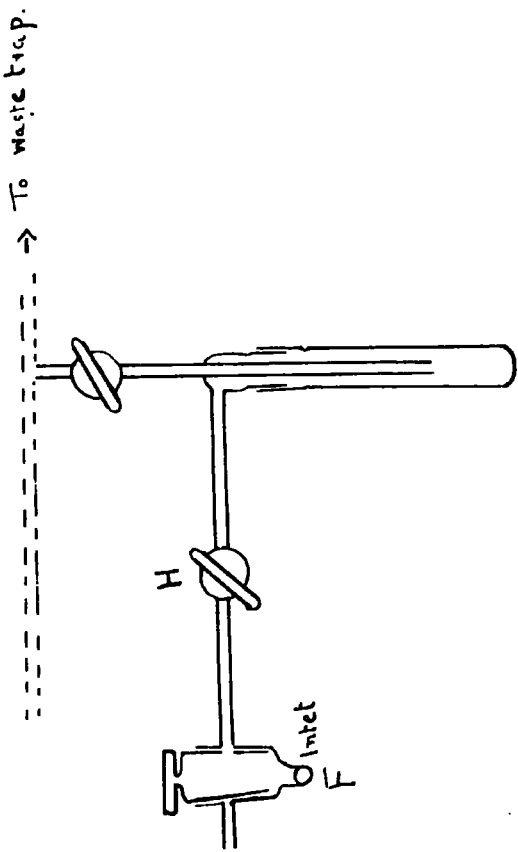
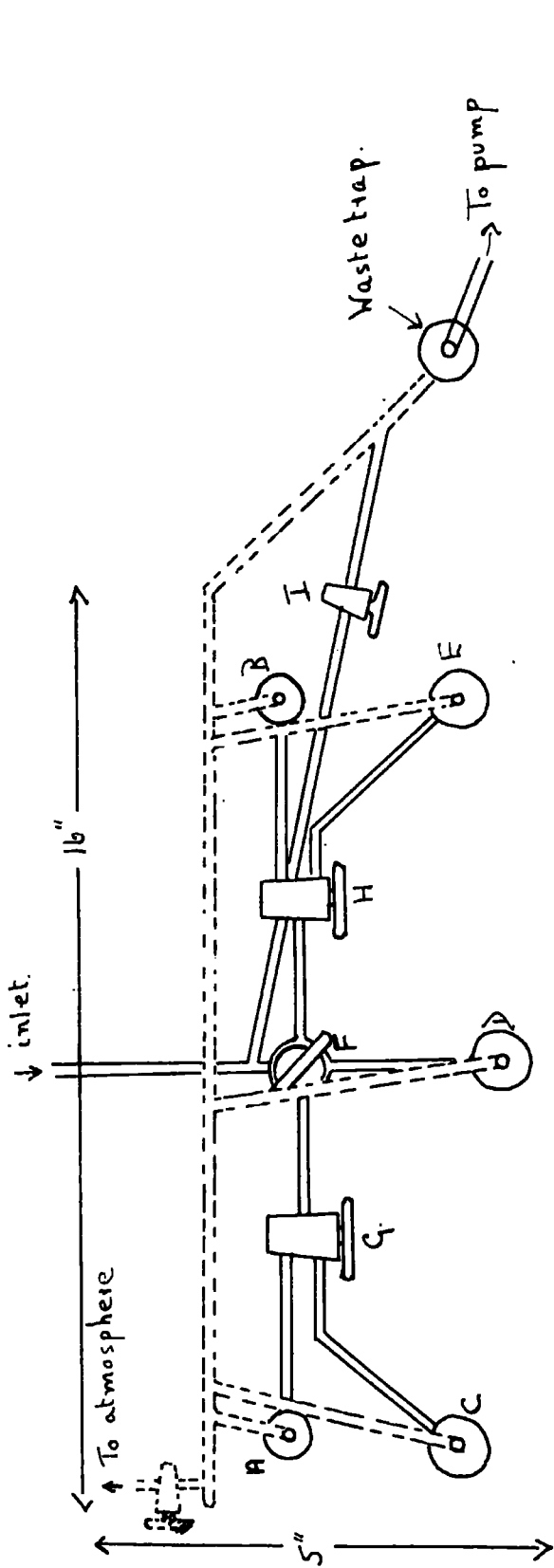

DIAGRAM 2



Analytical column.
(8)

(a)



Trap B - Side view.

Top View.

- A, B : B1H traps.
- C, D, E : B.24 traps.
- G, H : Two-way taps
- F : Three-way tap (Bottom entry).
- I : one-way tap to allow bypassing of trapping system.

DIAGRAM 3

detectors have been used in commercial apparatus, made in the United States of America by the Perkin-Elmer Corporation⁷⁰ and have also been described by Ambrose and Collerson,⁷¹ Davies and Howard⁷² and Browning and Watts.⁷³ Such detectors have a high sensitivity, have been used at elevated temperatures and are simpler to make than the hot-wire type. A thermistor detector, as described by Musgrave,⁷⁴ has been used successfully in this department at temperatures from room temperature to 190°C. and has an average life of several months.

The thermistors were sealed in position in a copper block with a cold-curing silicone rubber (Midland Silicones Ltd.), (diagram 18). If type A thermistors were used, that in the nitrogen stream had its bead exposed by cutting off the lower part of the glass envelope. There was no need to pass nitrogen past the reference thermistor as this did not add to the stability of the system and it was simply sealed into a hole in the copper block. Type P thermistors, which were matched and had a thin glass protective film coating the thermistor bead, were also used but they showed no advantage over the A type. The resistance of a thermistor, initially 2000 ohms at room temperature, was not completely reversible with temperature, and changes in resistance of the order of 20 to 30% on returning to room temperature were not exceptional. This was not critical, however, and the deficient resistance was made up with a 500 ohm, wire wound, variable resistance,

R_T . The other two arms of the Wheatstone circuit were 60 ohm carbon type resistors. The circuit was balanced with a helical potentiometer and driven by a 2V. battery (diagram 1c). Changes in the thermal conductivity of the nitrogen stream caused by an emergent vapour were recorded in the early stages of the work with a galvanometer and later with a Sunvic automatic recorder.

The column operating conditions and the packings used for both analytical chromatograms and preparative separations are given in the appropriate places in the thesis.

Columns

All analytical columns were 5 ft. long x 5 mm. internal diameter pyrex U tubes (diagram 2b) except for the 6½ ft. x 6 mm. column packed with kieselguhr-apiezon L which was also used for semi-micro preparative work.

The preparative columns were of two types, 8 ft. long x 2.3 cm. i.d. or 2.5 cm. i.d. pyrex U tubes and 8 ft. long x 1" diameter copper U tubes which were either used alone or joined into 16 ft. long columns in the form of double U tubes.

Column packings

Inert supports. Two types of inert support were used:

1. Kieselguhr (Celite 545, Johns Manville Co. Ltd.).
2. Firebrick (Johns Manville C.22).

The firebricks were crushed and sieved to 40-60 mesh and fine material removed by sedimentation. 100 g. quantities were made into a slurry with 4 l. of water in a 5l. beaker and the supernatant suspension poured off after five minutes. The residue after two further such treatments and having been filtered off was dried in an oven at 140°C.

Stationary phases

The following stationary phases were used:

Analytical columns: dinonyl phthalate, dinonyl phthalate + 10% by weight of stearic acid, florube 1, florube 3, silicone grease, apiezon L and tricresyl phosphate.

Preparative columns: dinonyl phthalate and silicone grease.

Preparation of the packing

A ratio of 10:4 by weight of inert support to stationary phase was always used. The stationary phase was dispersed onto the support by agitation in a medium of ether and the ether was then allowed to evaporate. Final traces of ether were removed by actually operating the column.

The packing was introduced into the column and allowed to settle into position by gently tapping the column with a piece of pressure tubing. The analytical columns each contained about 17 g. of packing. Given below are the weights of packings which the various preparative columns contained.

Column	Packing	Weight of packing (g.)
8 ft. x 2.3 cm. pyrex	Kieselguhr-D.N.P.	340
16 ft. x 2.3 cm. pyrex	Kieselguhr-D.N.P.	700
8 ft. x 2.5 cm. pyrex	Kieselguhr-silicone grease	650
16 ft. x 1" copper	Firebrick-D.N.P.	1500

Introduction of samples

Analytical samples (4 to 6 drops, \approx 0.02 mls) were injected through the serum cap with a 1 ml. Summit syringe.

Preparative samples (B.Pt. $>$ 80°C.) were injected through the serum cap with a 1 ml. Summit syringe and vapourised onto the column by heating the pre-heater with a bunsen burner. Low boiling samples (samples containing much ether etc.), especially if the column was being operated at temperatures much above their boiling points, were better distilled out of the injection system (diagram 2c.) onto the column; the nitrogen stream was switched off during this operation and on again immediately after. The direct injection of such samples into the nitrogen stream led to 'blow-back' and the loss of material.

REFERENCES

69. CUTHBERTSON and MUSGRAVE, J. App. Chem., 99, 7,
1957.
70. PHILLIPS, Gas chromatography, Butterworths, 1956,
p. 42.
71. AMBROSE and COLLERSON, J. Sci. Inst., 323, 32,
1955.
72. DAVIES and HOWARD, Chem. and Ind., 25, 1956.
73. BROWNING and WATTS, Anal. Chem., 24, 29, 1957.
74. MUSGRAVE, Chem. and Ind., 46, 1959.

CHAPTER 4.

Experimental work

Infra-red Spectroscopy

Infra-red spectroscopy was used extensively in the identification of products. The spectra were obtained with a Grubb Parsons double beam grating spectrometer, model G.S.2a using the liquid film technique for liquid films (generally < 0.01 cm. thick) between potassium bromide discs.

Molecular Weights

Victor Meyer's method was used. It was found impossible to maintain the apparatus at a constant temperature with the electrical heating system described by Banks, op. cit., p. 115 and the conventional method of achieving this with a liquid of suitable boiling point (aniline or quinoline) was used. Values obtained for standard substances were consistently 2-3% high.

Boiling Points

All boiling points quoted for compounds separated by preparative scale gas chromatography were determined using a micro-Schleiermacher apparatus as described by James and Phillips and the method was accurate to $\pm 0.4^{\circ}\text{C}$.

The reaction between chlorine trifluoride and benzene
in the vapour phase*

1555 mls. of benzene were caused to react with chlorine trifluoride diluted with nitrogen in the vapour phase at 260°C. Altogether nine runs were carried out and details of these are given in table 11. The apparatus used and the experimental procedure were as described by Banks, op. cit., p. 65. A total of 2036 mls. of product, density 1.40, was obtained.

The product was fractionated through a 20 plate column packed with $\frac{1}{8}$ " single turn, Fenske glass helices and two boiling fractions, 690 mls., B.Pt. 55-85°C. and 410 mls., B.Pt. 85-135°C. collected. The complexity of these fractions was examined by gas chromatography to determine the possibility of resolving them on a preparative scale. Material distilling at a temperature greater than 135°C. was not investigated.

Fraction, B.Pt. 55-85°C.

Several column packings were used: kieselguhr-dinonyl phthalate, - dinonyl phthalate + 10% by weight of stearic acid, -florube-1 and -florube-3. Kieselguhr-dinonyl phthalate gave the best resolution and the chromatogram consisted of

* The actual fluorination was carried out by Dr. W.K.R. Musgrave.

three well separated peaks (diagram 4). Crushed firebrick⁷⁶ has been recommended as a superior inert support to kieselguhr and the efficiencies of analytical columns packed with firebrick-dinonyl phthalate and kieselguhr-dinonyl phthalate were examined. The firebrick did give a better resolution and retained a drier appearance when treated with the stationary phase, however, contrary to the above report the firebrick required a larger pressure drop for a particular flow rate (diagram 5). Because of the first two advantages a firebrick-dinonyl phthalate packing was used to separate this fraction on a preparative scale.

A 16 ft. x 1" copper column packed with 1500 g. of material was used with chromatographic system A. (See chapter 3).

The column temperature was 100°C., the pressure drop 62 cms. and the nitrogen flow rate 160 mls./minute.

70 g. (in 10 g. fractions) gave: (1) monochloro-undecafluorocyclohexane (3.3 g., 7-11 mins.*), n_D^{45} 1.297 (Found: F, 66.1; Cl, 11.3. Calc. For $C_6F_{11}Cl$: F, 66.0; Cl, 11.2%), for which Tatlow and Worthington⁸ gave n_D^{45} 1.301; (2) dichlorodecafluorocyclohexane (16 g., 19-30 mins), n_D^{45} 1.330 (Found: F, 56.6; Cl, 21.5. Calc. for $C_6F_{10}Cl_2$: F, 57.1, Cl, 21.3%), for which Tatlow and Worthington, *ibid.* gave n_D^{45} 1.332; and (3) benzene (43.3 g., 31-70 min.), an

* This refers to the time during which the material was collected and will be assumed in future.

TABLE 11.

Fluorination of C_6H_6 with ClF_3 .

(i) C_6H_6 Feed g./hr.	(ii) ClF_3 Feed g./hr.	$ClF_3:C_6H_6$ ratio Wt.:Wt.	N_2 (1) l./hr.	N_2 (2) l./hr.	Temps. on Reactor °C.	Length of run hr. min.	C_6H_6 Fed in g.	ClF_3 Fed in g.	Amount Product g.	Density of Product g./ml.	Amount of Product mls.	Amount of C_6H_6 in mls.		
(i)	18.6	45	2.39	4.8	10.4	270 210	8	40	163	387	300	1.30	230	185
(ii)	19.0	46.3	2.44	4.8	10.9	260 240	8	20	158	386	360	1.33	270	180
(iii)	17.1	40.7	2.38	5.0	10.9	250 250	8	30	145	346	325	1.35	240	165
(iv)	18.1	47.8	2.64	4.3	10.7	250-350 220-350	8	45	158	418	330	1.49	221	180
(v)	17.3	40.8	2.36	4.7	11.4	260 250	8	10	141	333	250	1.43	175	160
(vi)	19.2	44.8	2.34	4.7	11.4	250 250	7	45	149	347	330	1.43	230	170
(vii)	19.1	45.1	2.36	4.5	10.4	250 260	8	30	163	383	360	1.44	250	185
(viii)	18.8	43.6	2.32	4.5	10.7	250 260	7	30	141	327	300	1.43	210	160
(ix)	18.2	42.3	2.32	5.0	10.2	250 230	8	10	149	345	300	1.43	210	170
Total:							1367	3272	2855	1.40	2036	1555		

N_2 (1) Nitrogen flow rate through the benzene vapouriser.

N_2 (2) Nitrogen flow rate through the centre annular space of the concentric tube burner.

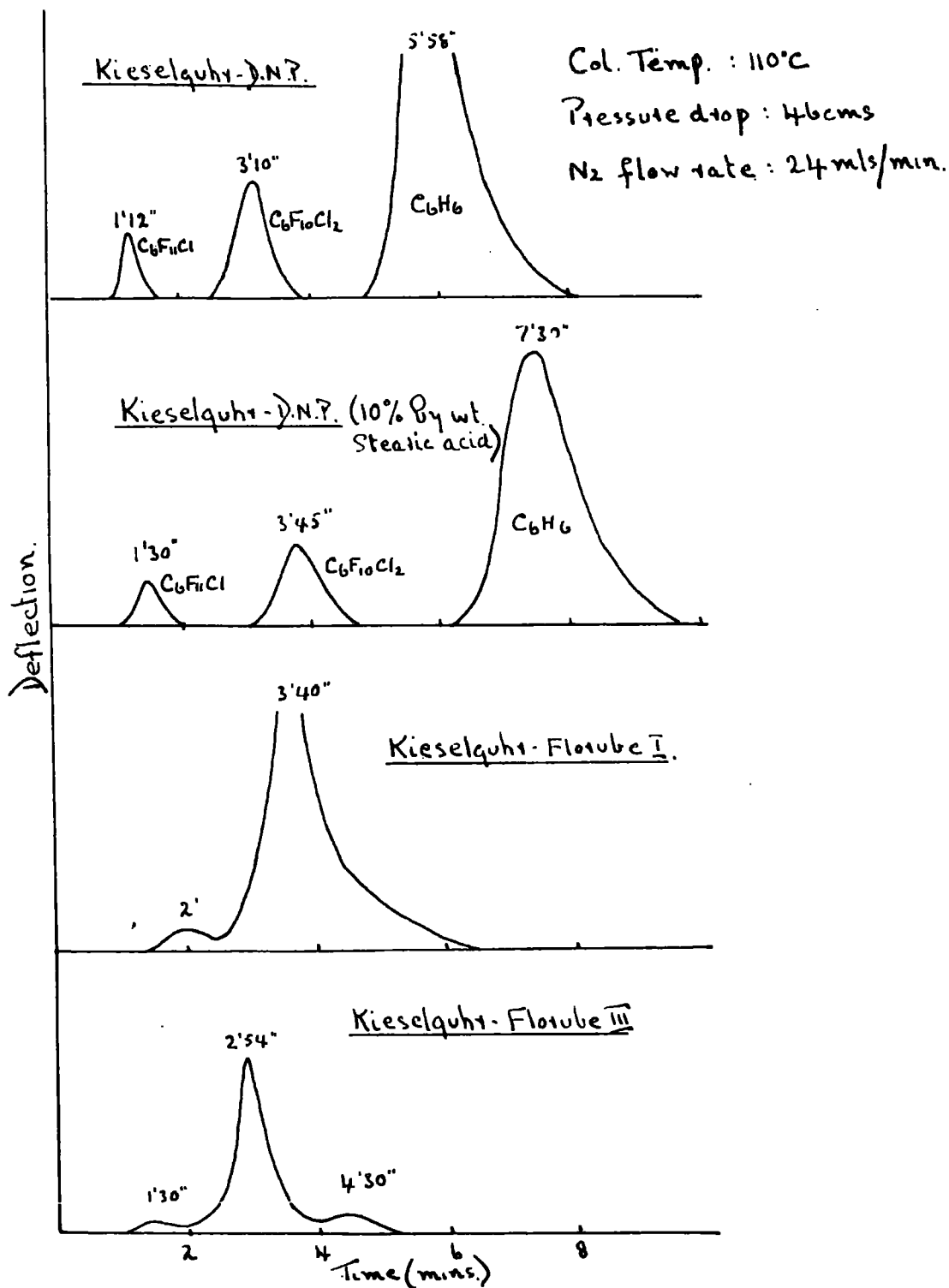
DIAGRAM 4.FRACTION, B.Pt. 55-85°C (ClF₃ on C₆H₆).

DIAGRAMS.Firebrick-Dinonyl phthalate

Col. Temp. : 110°C

Pressure drop : 40 cms.

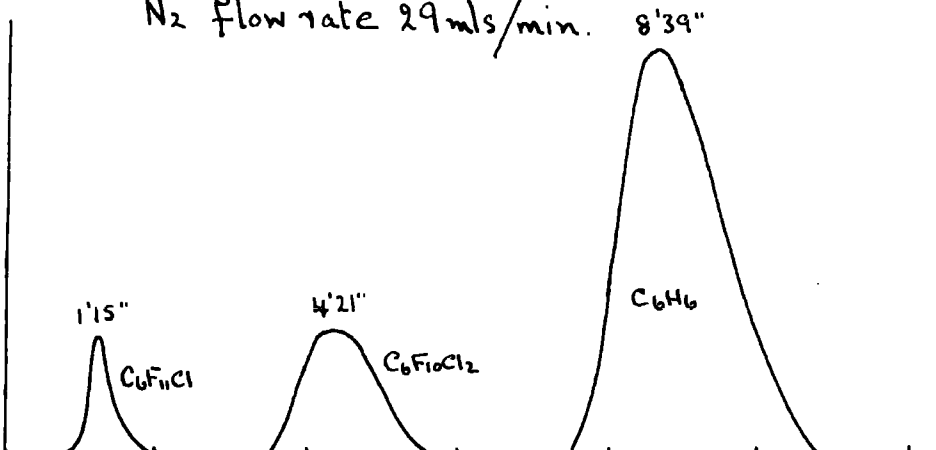
N₂ flow rate 29 ml/min.Kieselguhr-Dinonyl phthalate.

Col. Temp. : 108°C

Pressure drop : 22 cms.

N₂ flow rate 29 ml/min.

Deflection.

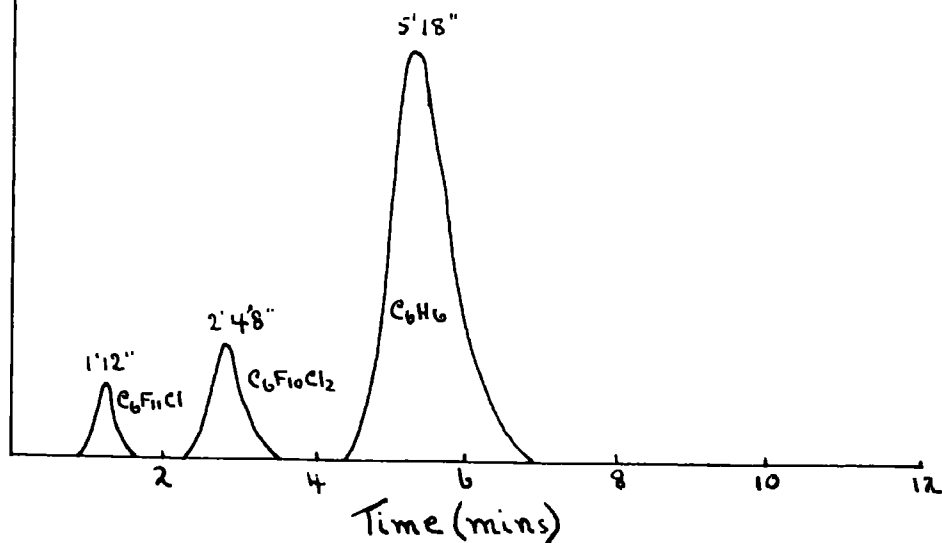

infra-red spectrum of which was identical with authentic benzene. The infra-red spectrum also showed that no fluorobenzene was present.

Fraction, B.Pt. 85-135°C.

A chromatogram for 0.5 mls. of this fraction on the 16 ft. x 1" copper column packed with firebrick-dinonyl phthalate was obtained and although quite complex, consisted predominantly of three major components (diagram 6). Attempts were made to separate them using this column.

The column temperature was 140°C., the pressure drop 70 cms. and the nitrogen flow rate 160 mls./minute.

12 mls. (20 g.) in two runs were separated into five fractions: Cut 1 (6.5 g., 32-50 mins.); Cut 2 (1.0 g., 50-80 mins.); Cut 3 (3.4 g., 80-107 mins.); Cut 4 (6.5 g., 107-160 mins.); and Cut 5 (1.5 g., 160-240 mins.). All of the cuts were colourless liquids and analytical chromatograms are given for them in diagrams 7 & 8 . Because of the greater complexity of these fractions, each will be considered in turn.

Cut 1, n_D^{20} 1.373 (Found: F, 48.4; Cl, 28.9%, F:Cl ratio of 3.14:1). The chromatogram consisted of a single peak with a small inflexion at its base. 1.4 g. were recycled through the column (conditions as above) and a middle cut, a wax-like solid, collected which was cyclic $C_6F_9Cl_3$ (0.8 g.), n_D^{45} 1.363

DIAGRAM 6

FRACTION, B.Pt. 85-135°C.

16ft. x 1" copper column packed with Firebrick-D.N.P.

0.5ml sample.

Col. Temp.: 138°C

Pressure drop: 66cms.

N₂ flow rate: 140mls/min.

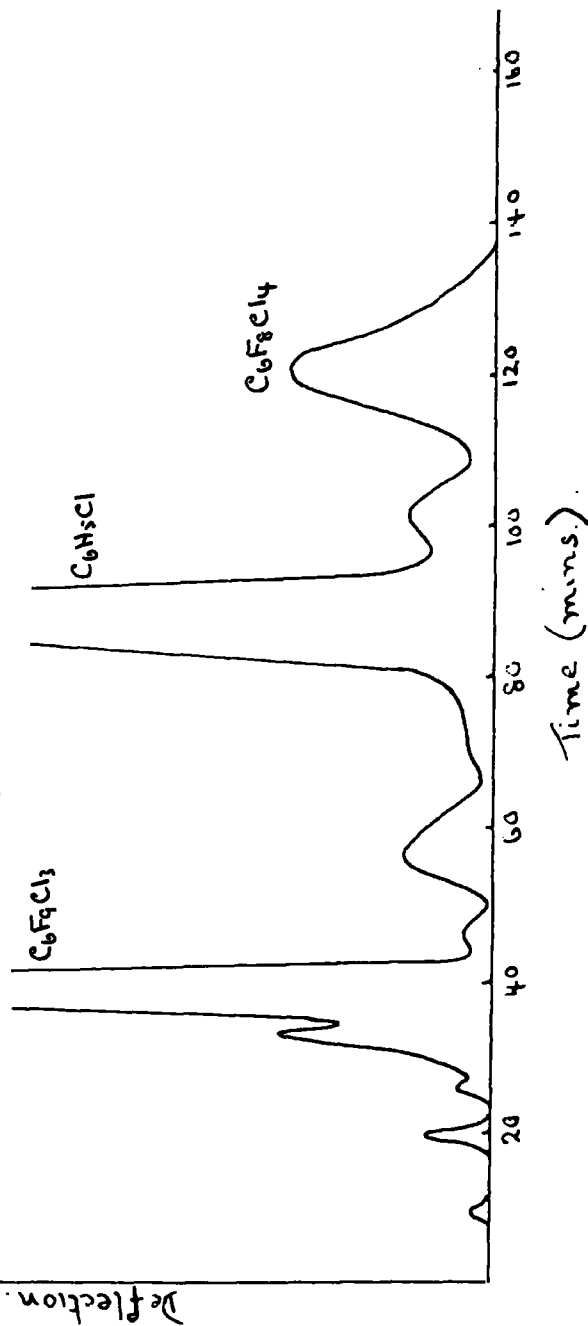

DIAGRAM 7

FRACTION, B.Pt. 85-135°C. (ClF₃ on C₆H₆)

Kieselguhr-dinonyl phthalate

Col. Temp. : 125°C

Pressure drop : 25cms.

N₂ flow rate : 18mls/min.

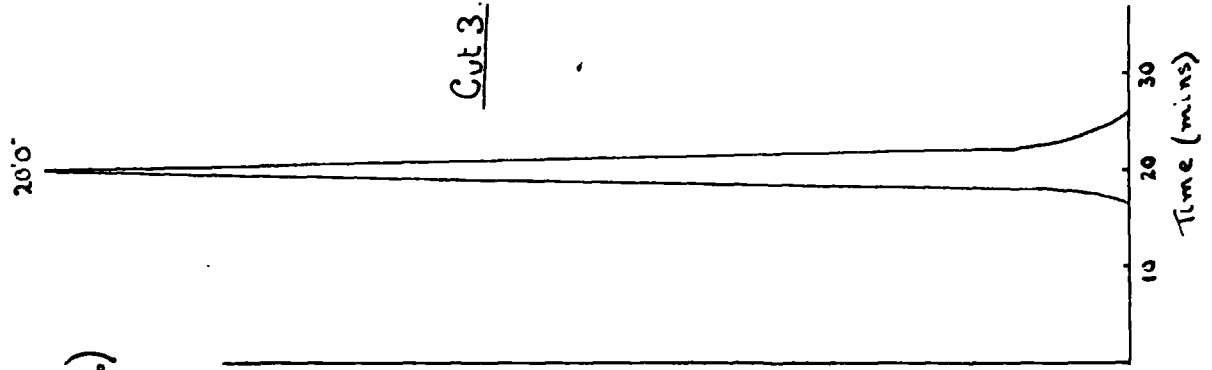
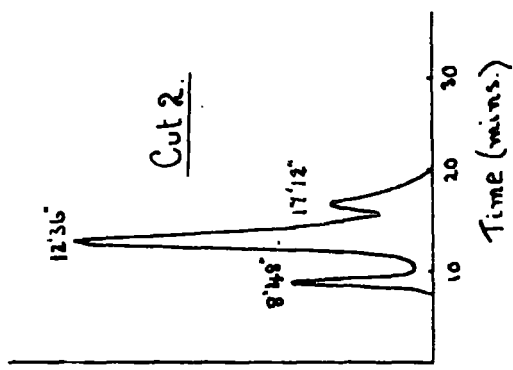
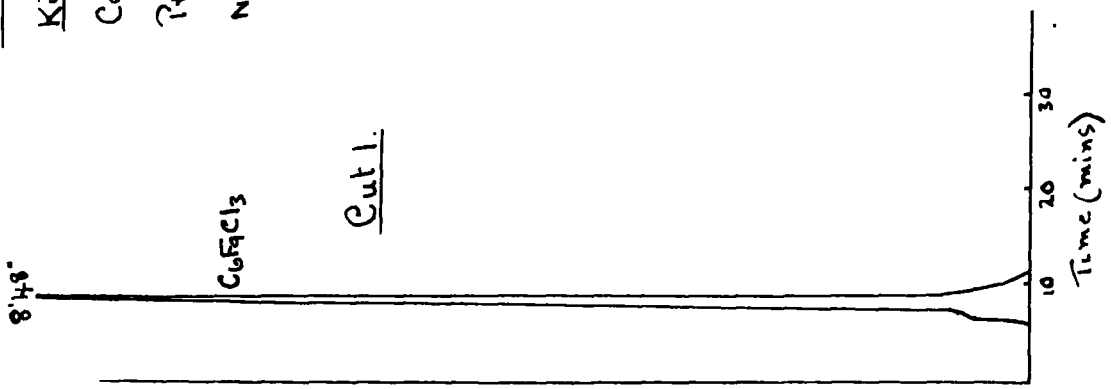

DIAGRAM 8

FRACTION, B.Pt. 85-135°C (C1F3 on C6H6)

Kieselguhr - dinonyl phthalate

Col. Temp : 141°C

Pressure drop : sms.

N₂ flow rate : 20mls/min.

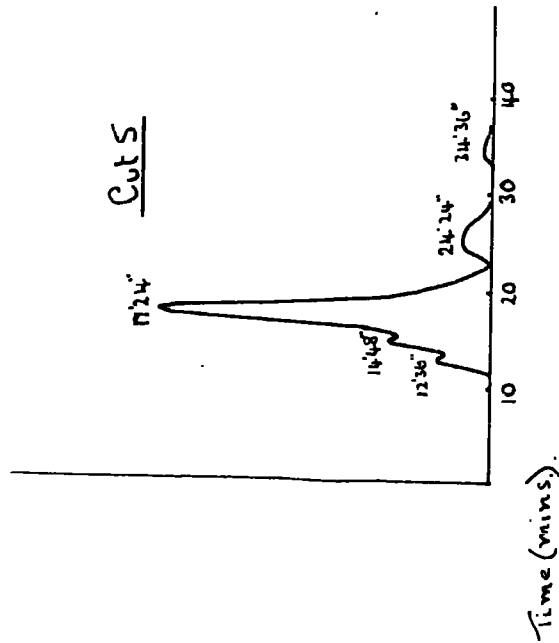
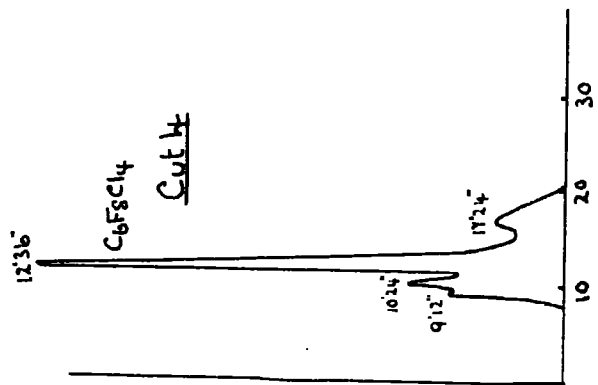
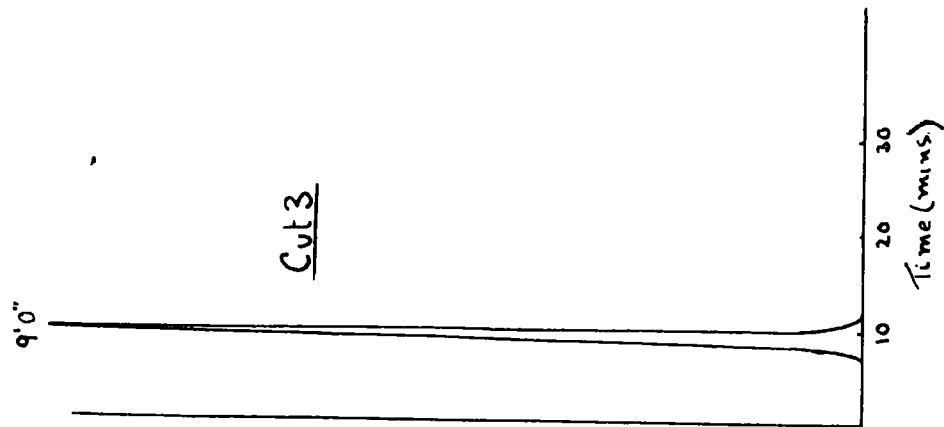

(Found: F, 48.8; Cl, 30.6. Calc. for $C_6F_9Cl_3$: F, 48.9; Cl, 30.5%), for which Tatlow and Worthington, *ibid.*, gave n_D^{45} 1.363.

Cut 2, n_D^{20} 1.402 (Found: F, 41.1; Cl, 29.8%, F:Cl ratio of 2.58:1). The chromatogram consisted of three overlapping peaks. An infra-red spectrum* showed weak absorption at 1733 cm^{-1} and fairly strong absorption at 2967 cm^{-1} ; this indicated that the material was mostly saturated and contained hydrogen. A weak absorption at 1477 cm^{-1} suggested that a small amount of aromatic material might be present; no o- or m-chlorofluorobenzene was present.

Cut 3, n_D^{20} 1.507 (Found: F, 8.1; Cl, 30.1%, F:Cl ratio of 2.00:1. The chromatogram consisted of a single peak, yet the analytical figures corresponded to no definite compound. The peak could not be resolved with either kieselguhr-silicone grease or -tricresyl phosphate packings. Kieselguhr-apiezon L, however, resolved it into one major peak and several overlapping small ones. The peaks of retention

* Burdon and Whiffen⁷⁷ have measured the $-C=C-$ stretching frequencies in various fluorinated six-membered ring olefines in the vapour phase and have reported that $-CF=CF-$ absorbs strongly at $1745-1755\text{ cm}^{-1}$, $-CF=CH-$ strongly at $1722-1733\text{ cm}^{-1}$, and $-CH=CH-$ weakly at 1688 cm^{-1} so that in the last case saturation can be confused for unsaturation. Dienes give two bands, at $1777-1734\text{ cm}^{-1}$ and $1741-1635\text{ cm}^{-1}$. Steele and Whiffen⁷⁸ report that, for saturated fluorocyclohexanes the $-C-H$ stretching frequency occurs at $2968-2984\text{ cm}^{-1}$, for mono-olefines at $2961-3104\text{ cm}^{-1}$ and polyenes at $3087-3113\text{ cm}^{-1}$.

times 23' 36" and 27' 24" corresponded exactly to p-chlorofluorobenzene and chlorobenzene respectively (diagram 9).

The fraction was further resolved using a 2 m. x 6 mm. i.d. column packed with kieselguhr-apiezon L. The column temperature was 128°C, the pressure drop 11.5 cms. and the nitrogen flow rate 26 mls./minute. 0.8 g. (15 runs) gave: cut i (0.14 g., 0-25 mins.), (Found: F, 30.5; Cl, 26.9%, Cl:F ratio 2.12:1). An analytical chromatogram (diagram 9) showed that this cut was complex and consisted of seven overlapping peaks. An infra-red spectrum (diagram 10) showed that besides containing chlorobenzene (absorbtion at 465, 685, 703 cm^{-1}) and p-chlorofluorobenzene (absorbtion at 498, 634 cm^{-1}), that the o- and m-chlorofluorobenzene isomers were not present. These isomers have characteristic strong absorbptions at 443, 679 and 444, 673 cm^{-1} respectively.⁷⁹ Very weak absorbtion in the region 1742 cm^{-1} and medium absorbtion at 2971 cm^{-1} indicated that the remaining material was saturated and contained hydrogen although a fairly strong absorbtion at 1490 cm^{-1} suggested that other aromatic product might have been present; cut ii, chlorobenzene (0.430 g., 25-34 mins.), (Found: Cl, 30.3; F, 1.7. Calc. for $\text{C}_6\text{H}_5\text{Cl}:\text{Cl}$, 31.5%). An infra-red spectrogram was identical with that of authentic chlorobenzene except for weak bands at 497, 633 and 826 cm^{-1} which were characteristic

DIAGRAM 9

FURTHER RESOLUTION OF CUT 3

Kieselguhr - Apiezon h.

Col. Temp. : 128°C

Pressure drop : 11.5 cms.

N₂ flow rate : 26 ml/min.

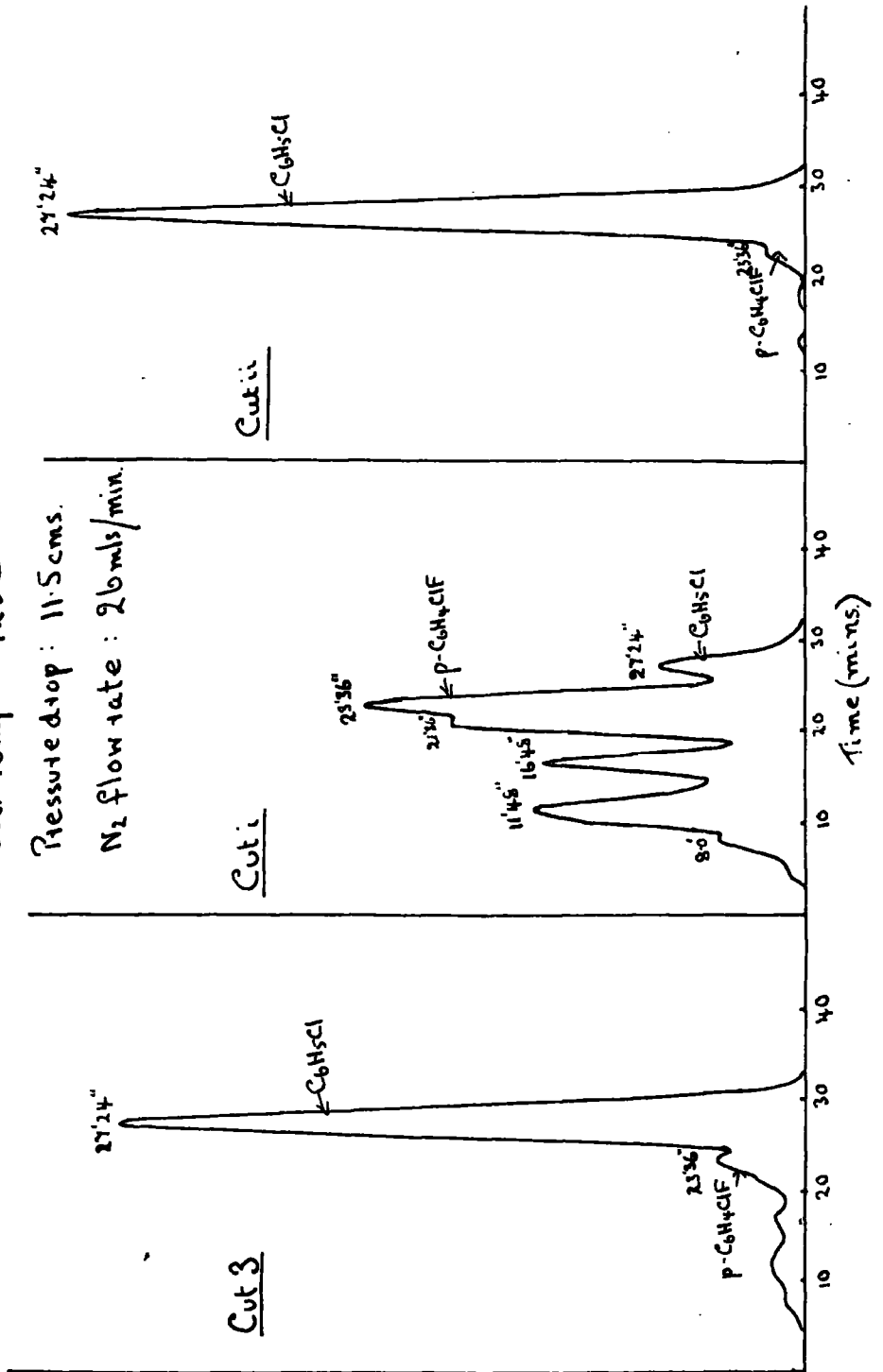
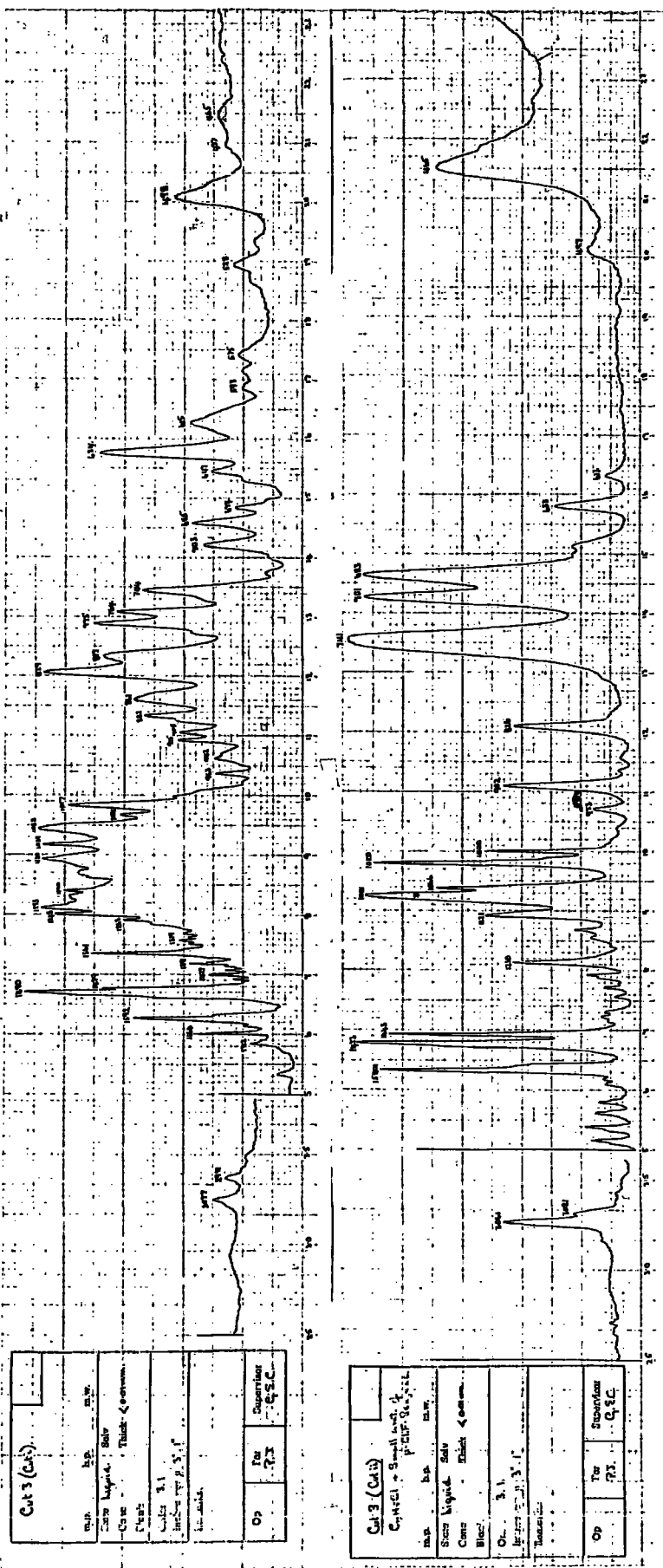

DIAGRAM 10



Cat's (cat)	
m.p.	b.p.
State	Color
Op.	For P.I.
	Sinterizer C.P.C.

Cat's (cat)	
m.p.	b.p.
State	Color
Op.	For P.I.
	Sinterizer C.P.C.

strong absorbtions for p-chlorofluorobenzene (diagram 10). The low recovery was due to the inefficient trapping system, the design of which was such that vapour was condensed out in the liquid phase and continually being pumped during the operation of the column (See Chambers, Ph.D. thesis, Durham 1959).

Cut 4, (Found: F, 38.5; Cl, 35.7%, F:Cl ratio of 2.01:1).

The chromatogram consisted of a single large peak and three small ones. The fraction was further resolved using an 8 ft. x 2.5 cm. i.d. column, packed with kieselguhr-silicone grease (650 g.) with chromatographic system B (see chapter 3). The column temperature was 125°C., the pressure drop 15 cms. and the nitrogen flow rate 170 mls./minute.

4.5 g. (in two runs) gave: cut i (1.4 g., 0-80 mins.), n_D^{25} 1.425 (Found: F, 37.0; Cl, 30%, F:Cl ratio of 2.30:1). An analytical chromatogram showed that this cut was complex and consisted of six overlapping peaks. An infra-red spectrum showed very weak absorbtion at 1754 cm^{-1} and medium absorbtion at 2971 cm^{-1} indicating that the material was saturated and contained hydrogen. Weak absorbtion at 440 cm^{-1} showed that o- and m-chlorofluorobenzene, if present, were so in negligible amounts, although absorbtion at 1484 cm^{-1} suggested that aromatic material might have been present; cut ii, cyclic $\text{C}_6\text{F}_8\text{Cl}_4$ (2.6 g., 80-87 mins.), n_D^{60} 1.389 (Found: F, 40.5; Cl, 38.7, Calc. for $\text{C}_6\text{F}_8\text{Cl}_4$:

DIAGRAM II

FURTHER RESOLUTION OF CUT H.

Kieselgohr - Apiezon L.

Col. Temp. : 155°C.
Pressure drop : 7 cms.
N₂ flow rate 5 mls/min.

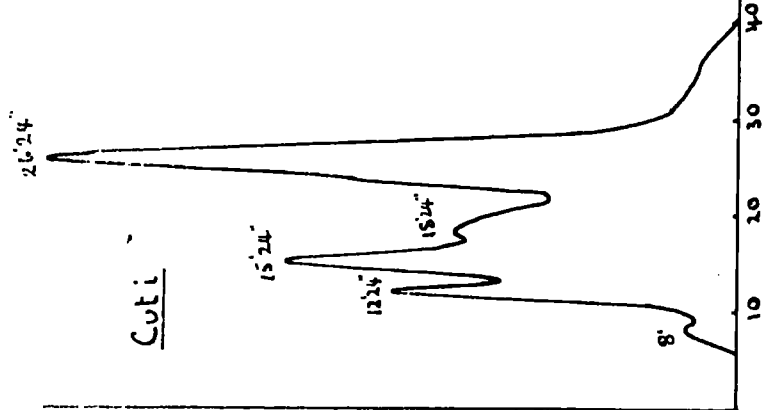

Cut i

Col. Temp. : 165°C.
Pressure drop : 16.5 cms.
N₂ flow rate : 33 mls/min.

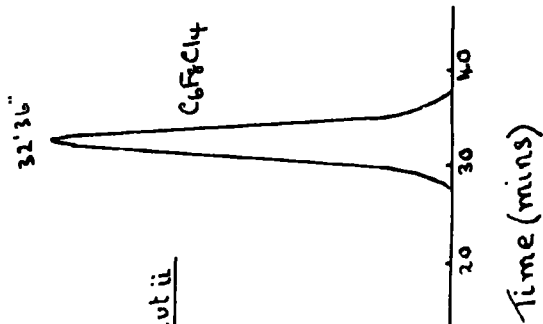

Cut ii

C₆F₈Cl₁₀

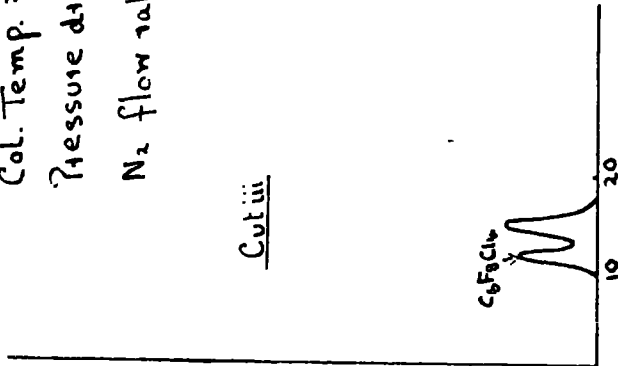

Cut iii

F, 41.5; Cl, 38.8%), Cyclic $C_6F_8Cl_4$ from CoF_3 and C_6Cl_6 had n_D^{60} 1.387 and cut iii, (0.2 g., 97-120 mins.), n_D^{20} 1.433 (Found: F, 34.1; Cl, 40.7%, F:Cl ratio of 1.56:1).

Cut 5, n_D^{20} 1.433 (Found: F, 35.5; Cl, 36.7%, F:Cl ratio of 1.81:1). The chromatogram consisted of five peaks. An infra-red spectrum showed no absorption between 1713 and 1777 cm^{-1} and had a medium absorption at 2967 cm^{-1} which indicated that the material was saturated and contained hydrogen. Absorption at 1484 cm^{-1} suggested that aromatic material might have been present.

Analysis of Bank's compounds

Banks suggested formula	Calc.		Found	
	F%	Cl%	F%	Cl%
$C_6HCl_2F_9$	54.3	22.5	53	22.5
$C_6H_2Cl_2F_8$	51.2	23.9	52.5	19.3
$C_6H_3Cl_2F_7$	47.7	25.4	48.0	24.0

Analytical chromatograms on an apiezon L column at 103°C. showed that each of these compounds contained a second component present to about 5-10%. Also the compounds of assigned formula $C_6H_2Cl_2F_8$ and $C_6H_3Cl_2F_7$ gave major peaks of the same retention time which had similar shaped inflexions at their bases.

The reaction between hexachlorobenzene and cobalt trifluoride
in the vapour phase

Hexachlorobenzene was fluorinated with cobalt trifluoride in the vapour phase at 350°C. in a one cycle process. The hexachlorobenzene was discharged into the reactor by bubbling a slow stream of nitrogen through the boiling liquid and the products were condensed out in a single glass trap which was cooled in an acetone-drikold mixture.

Apparatus

Before the described system of introducing the hexachlorobenzene into the reactor was used, attempts were made to do this by bubbling nitrogen through the boiling liquid contained in a glass flask, however it was found impossible to make a suitable glass to metal joint at the necessary temperature of 350°C; an aluminium cone fitting into a pyrex socket, a glass-copper petrol union joint with a teflon washer and a glass-metal joint sealed with silica cement were each tried and rejected since the glass always cracked at the joint. A copper pot was eventually used.

The lay-out of the fluorinating system is shown in diagram 12. The hexachlorobenzene was contained in a copper pot (diagram 13 &.), which had a nitrogen inlet lead and outlet lead proceeding via a pre-heater to the reactor, and which could be heated on a silicone oil bath. The temperature of the lead from the copper pot to the pre-heater and the latter

DIAGRAM 12

— indicates - copper-copper union joint.

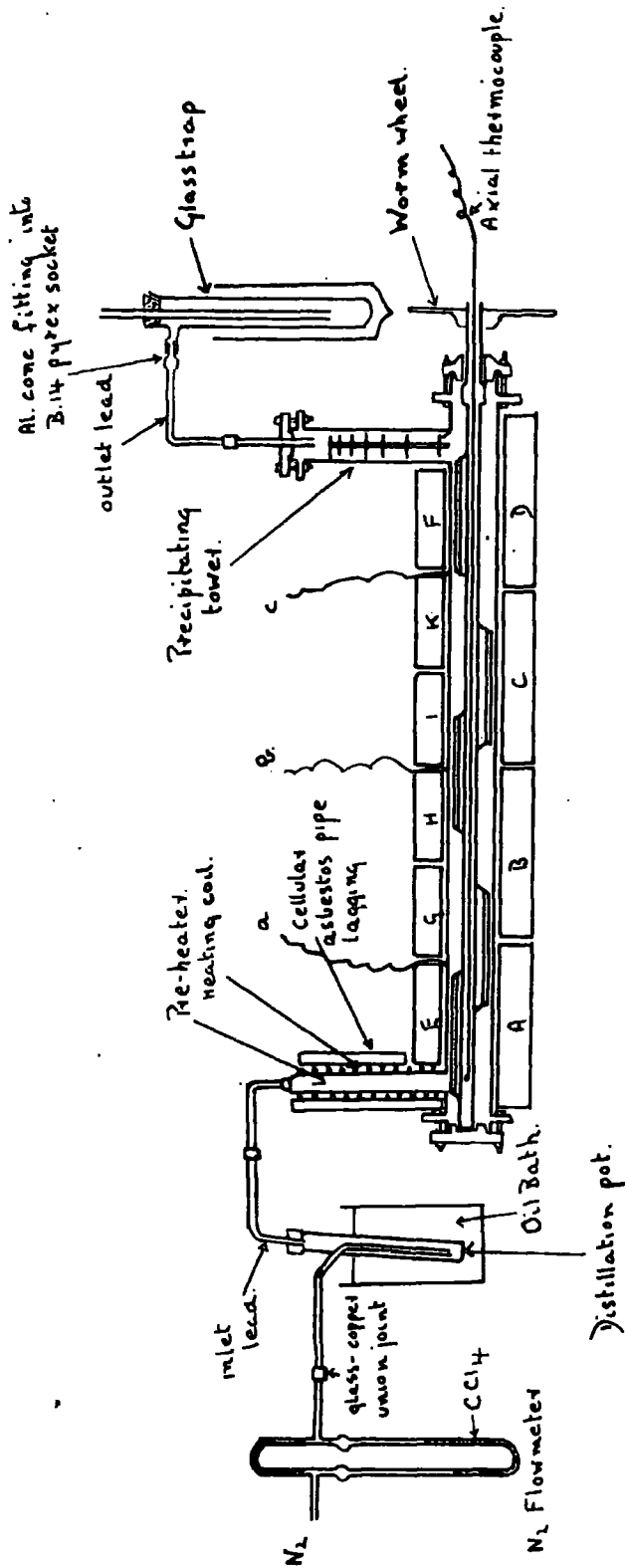

Fluorinating Apparatus.

DIAGRAM 13

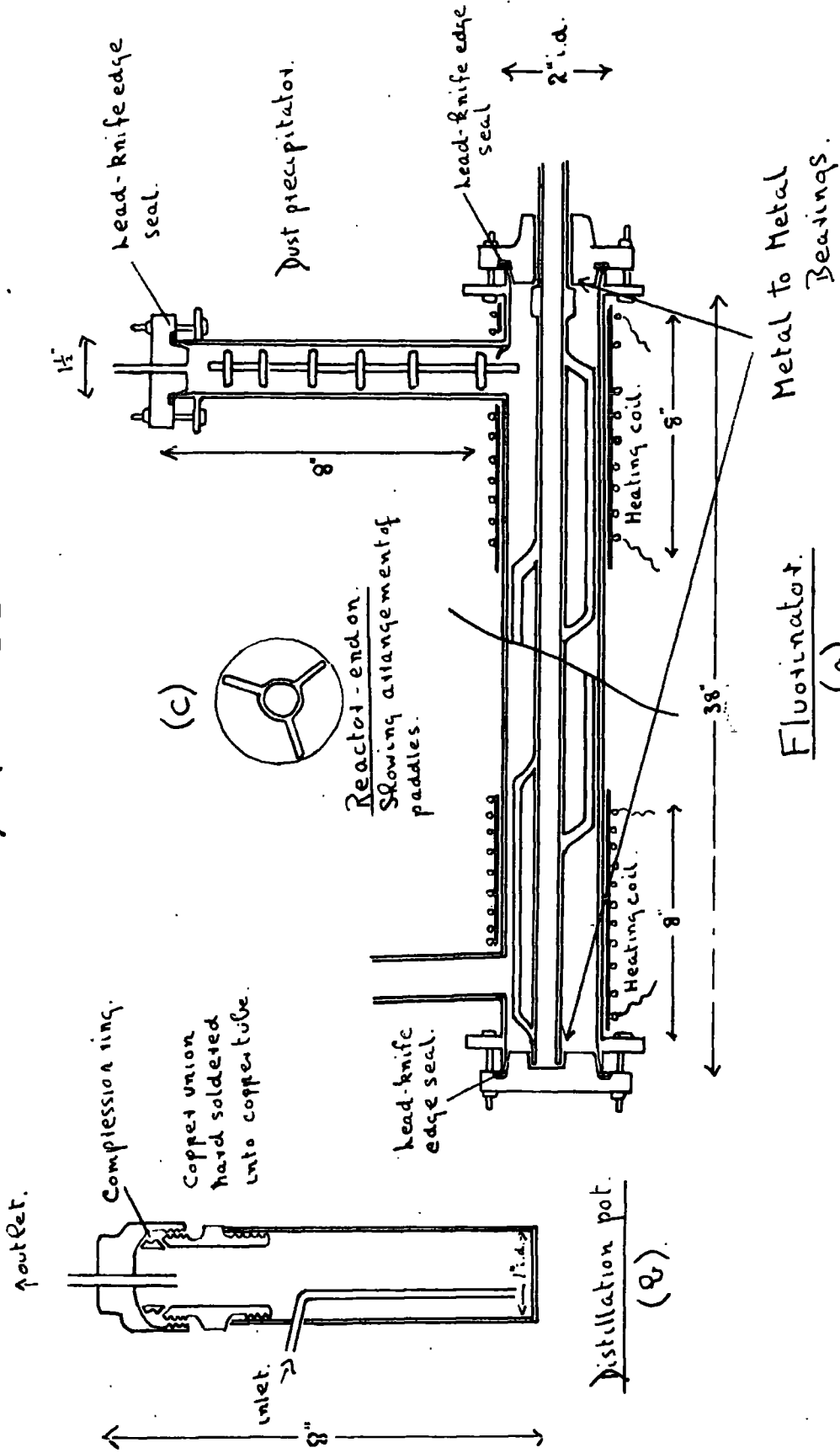

were maintained at 400°C. with a heating tape and a 250 watt wire heater respectively; an iron-constantan thermocouple was silver-soldered to the pre-heater.

The reactor, which was a modification of that described by Massingham et al.,⁸⁰ was a steel cylinder 3 ft. long x 2" internal diameter, with the pre-heater already mentioned at one end and a dust-precipitating tower at the outlet end (diagram 13a). Both ends of the reactor were closed with bolted steel discs and had lead to knife edge seals. These discs supported the stirring mechanism on metal to metal bearings as shown in the diagram. The stirring mechanism consisted of an axial shaft made from 0.7" diameter, $\frac{1}{8}$ " thick steel tubing along the axis of which a thermocouple, inside a glass sheath, could be moved to give the temperature at any part of the reactor; to the shaft were welded several 6" long mild steel paddles, successively at 120°C. and overlapping by about half their length, so that when the system was rotated practically all of the reactor space was swept (diagram 13c). The stirrer was driven, through a worm wheel, by a $\frac{1}{4}$ h.p. low gear electric motor at about four revolutions per minute. A copper tube led from the dust precipitating tower to the glass trap and the copper-glass joint was a B.14 aluminium cone screwed onto a copper base which fitted into a pyrex socket. The dust-precipitating tower and the outlet lead were maintained at 200°C. with a heating tape.

Heating the reactor

80-20 vacrom wire, 4.26 ohms per yard, was used to make all the filament heaters.

The reactor was heated from below with 4 x 750 watt heaters (diagram 12, A, B, C, and D), each independently controlled by a simmerstat. The heaters consisted of moulded firebricks inlaid with 70 ohm coiled wire filaments (diagram 14b). In the fabrication of these heaters the adjacent filaments were insulated with asbestos strips, held in position with a moist magnesia packing and covered with a double thickness of moist asbestos paper. The heaters were dried overnight in an oven at 180°C. To reach the required temperature of 350°C. at the ends of the reactor it was necessary to supplement these heaters, since if the simmerstats were switched on for more than 55% of the time they burnt out. Wire was coiled round a double thickness of asbestos rope (diagram 14a) and two such heaters, 100 ohm, 500 watts were wrapped round the body of the reactor at the inlet and outlet ends (diagram 13a) and connected in parallel with the respective lower heaters. The top of the reactor was insulated with similar moulded bricks and the removal of these at the appropriate point allowed sudden temperature increases to be controlled. The two top end bricks could also be used as 250 watt heaters.

The temperature at the outside surface of the reactor was measured by four equally spaced iron-constantan thermocouples which were silver-soldered to the reactor body

DIAGRAM IV.

Vacuum wire wound on asbestos rope.



(a)

Asbestos strips to insulate adjacent filaments.

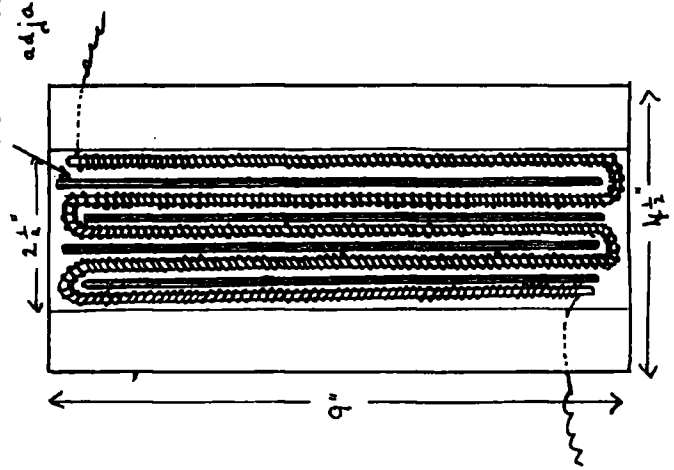

Top view

3 layers of asbestos paper.

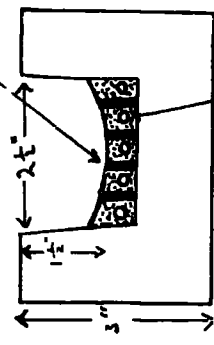

Magnesia packing.

End view.

(b)

Firebrick heater.

(diagram 12, a, b, c, and d). These outer thermocouples were useful for adjusting the starting conditions, but during a run they were insensitive to changes in temperature in the body of the reactor which were easily observed with the sliding axial thermocouple.

Cobalt trifluoride preparation

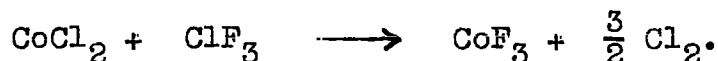

1300 g. (10 moles) of anhydrous cobalt dichloride were charged into the reactor and heated to a temperature of 200°C. Chlorine trifluoride was metred through a flow-meter (see Banks, op. cit., p. 68 for its construction) at a rate of about 20 g. per hour and passed until the emergent gas stream spontaneously ignited an acetone droplet. The chlorine trifluoride was not diluted with nitrogen during this operation. After the cobalt trifluoride had been generated any residual chlorine trifluoride in the reactor was swept out in a stream of nitrogen. The conversion to cobalt trifluoride was of the order of 85% and hence the available fluorine about 164 g.

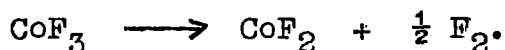

Fluorination procedure

Hexachlorobenzene (120 to 80 g.) was introduced into the copper pot and the apparatus set up as previously described. The temperature along the reactor was about 350°C.

The oil bath temperature was increased to 350°C. and a slow stream of nitrogen (2 to 6 l./hr.) commenced. The product soon emerged into the drikold-acetone cooled glass trap in the form of yellow oily droplets and copious white fumes and the rate at which this occurred was controlled by adjusting the oil bath temperature and the nitrogen flow rate. In some runs the product formed in the first and second halves of the fluorination were collected separately.

As the run proceeded a localised hot zone passed along the reactor. The temperature increases were readily detected with the axial thermocouple and in an orderly reaction were restricted to about 30°C., however, sometimes spurts of hexachlorobenzene shot into the reactor and were responsible for temperature rises of the order of 50°C. The arrival of the hot zone at the end of the reactor was an indication that the effective available fluorine had been utilised. A run was complete in 1½-2 hrs. Any product remaining in the reactor was swept out in a stream of nitrogen which was passed for a further ½ hr.

The product was allowed to reach room temperature and was a yellow solid-liquid mixture with a strong smell of chlorine. It was allowed to stand for a few hours, washed twice with alkaline sulphite solution, then several times with warm water (as it tended to solidify at room temperature) and was dried with magnesium sulphate. The product was a white wax-like solid.

When a run had been completed the cobalt trifluoride was regenerated with chlorine trifluoride as previously described.

After the cobalt trifluoride had been initially prepared, four runs (1,2,3, and 4) were carried out smoothly in which a total of 493 g. of product was obtained from 461 g. of starting material. If more than 120 g. of hexachlorobenzene were charged into the reactor during a run the blockage of unreacted material occurred in the outlet tubes. During the regeneration of the cobalt trifluoride for the fifth run, the stirrer mechanism broke down. The reactor was stripped down and examination showed that extensive corrosion of the stirrer axis and the paddles had occurred, causing the fracture of the former. The heavy corrosion of the paddles resulted in an incomplete stirring of the reactor space and a layer of fluorinating reagent was tightly packed against the surface of the reactor. The weight of solid material in the reactor had increased to 1500 g. because of the formation of ferric fluoride. A new stirrer was made, the fluorinator reassembled and 1000 g. of sieved fluorinating mixture re-introduced into the reactor. The effective fluorinating power was decreased and it was not possible to fluorinate more than 100 g. of hexachlorobenzene per run without causing the blockage of unreacted material in the outlet tube. Four further runs were completed (runs 5,6, 7 and 8), but during run 9 the stirrer ceased to operate and this run was carried out without agitation. 476 g. of product from

454 g. of hexachlorobenzene were obtained in this period. Examination showed that the fluorinating reagent had moved to one end of the reactor and had blocked the stirring mechanism, further, extensive corrosion of paddles had occurred and the weight of solid material had increased to 1400 g. Certain paddles were replaced and 1000 g. of sieved material re-charged into the reactor. Not more than 80 g. of hexachlorobenzene could now be fluorinated per run. Five further runs were completed and 340 g. of product obtained from 350 g. of starting material. During the regeneration of the cobalt trifluoride for a further run, the axial shaft again fractured and so the amount of product obtained was considered sufficient.

Table 12 gives the reaction conditions for a typical run (run 12).

Chromatographic examination of the product

The combined product for each run, and for runs 10 and 12, the product formed in the first and second halves of the fluorination, were examined by gas chromatography. A kieselguhr-silicone grease packing was usually used and in every case the chromatogram showed only five peaks. A kieselguhr-apiezon L packing was sometimes used (runs 2,3,4) but did not resolve the first two of these peaks. These chromatograms are shown in diagrams 15 to 19 .

After the pure compounds corresponding to these peaks

TABLE 12 (Run 12)

93 g. of C_6Cl_6 introduced into the reactor.

Time (min.)	Oil Bath temp. °C.	Thermocouple readings				N_2 flow rate l./hr.
		a	b	c	d	
		345	355	360	350	
0	341	350	355	350		
10	346	353	355	350	350	2.8
20	350	357	360	350		
30	350	360	360	350		3.4
40	350	365	350	350	345	4.0
50	350	375	340	340		
60	350	370	350	340	340	

Trap changed - 36 g. of product collected.

70	356	360	365	345		7.2
80	358	355	365	365	350	
90	358	350	350	365	355	
100	360	345	350	345	355	
120	360	345	350	340		

- 51 g. of product collected.

A total of 87 g. was thus collected.

DIAGRAM 15

DIAGRAM 16Kieselguhr - Silicone grease.

Column temp. : 192°C

Pressure drop : 69 cms.

N₂ flow rate : 30 mls./min.

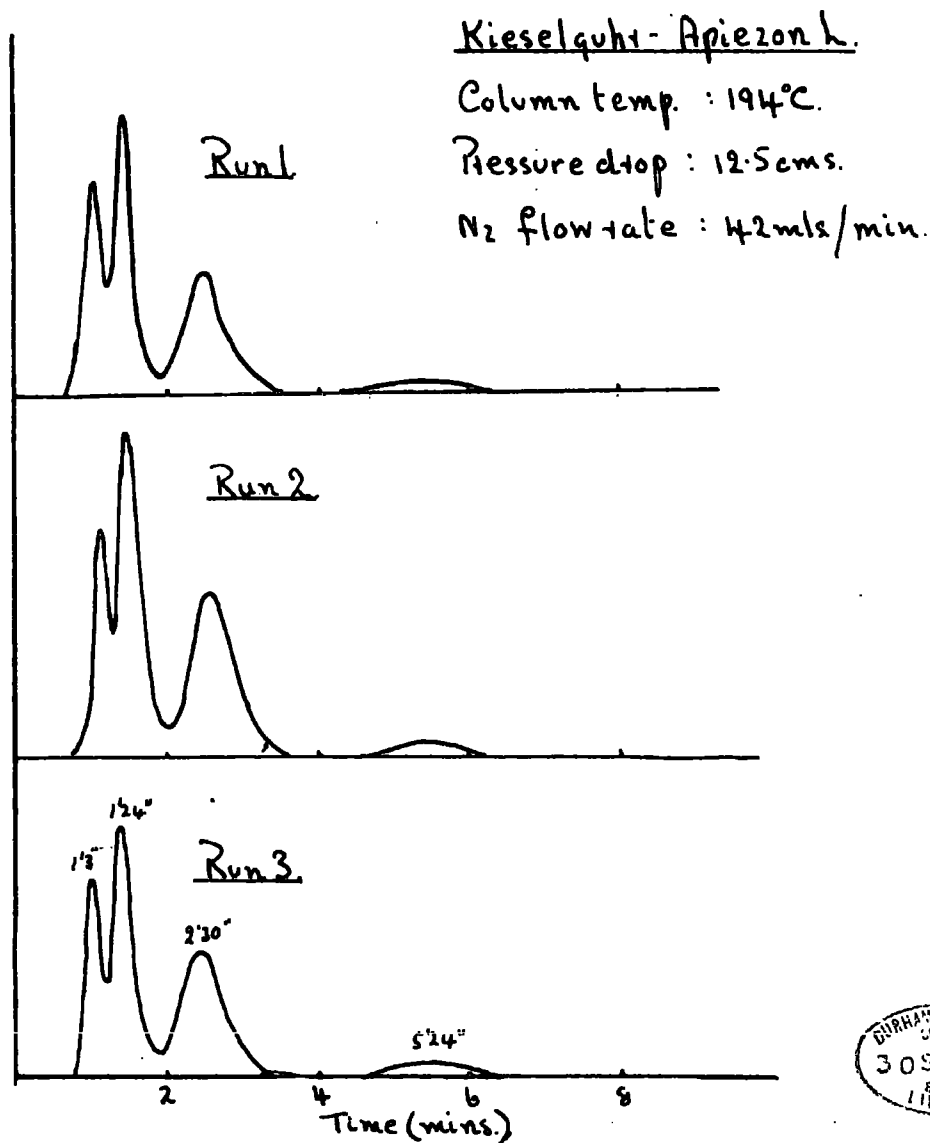
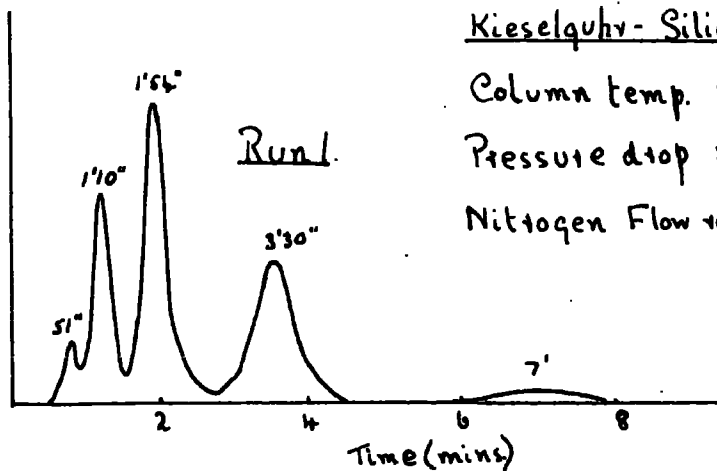
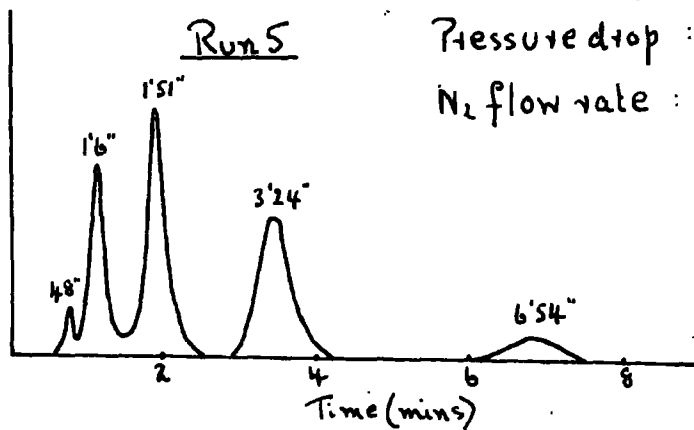
Column temp. : 196°C

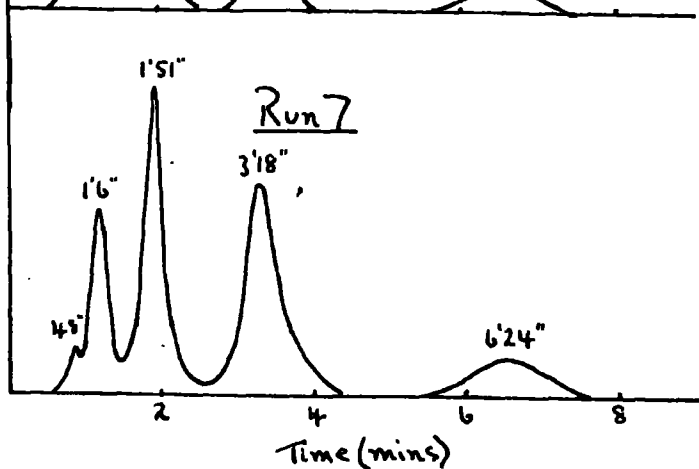
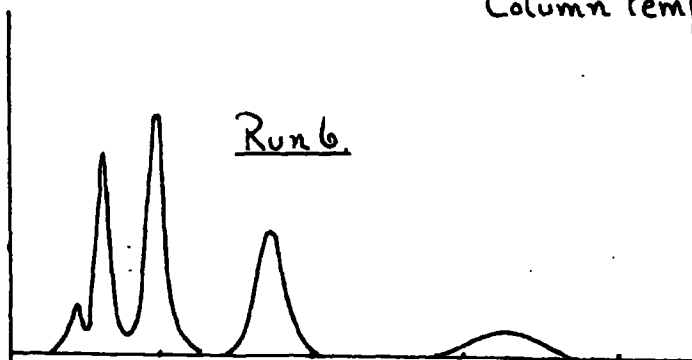

DIAGRAM 17

Kieselquhar - Silicone grease.

Column Temp : 194°C

Pressure drop : 70cms.

N₂ flow rate : 25mls./min.

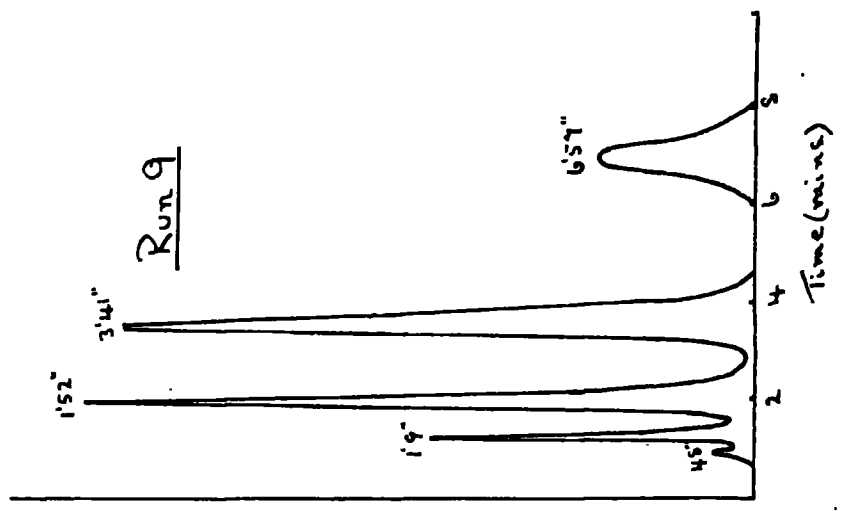
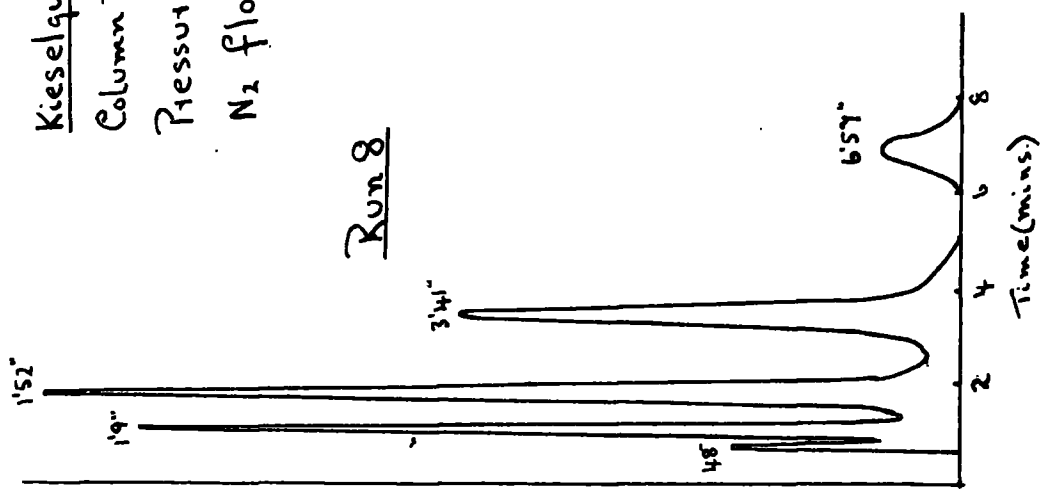

DIAGRAM 18

Kieselguhr - Silicone grease

Column temp. : 184°C

Pressure drop : 35.5cms

N₂ flow rate : 20mls./min.

Run 10(i)

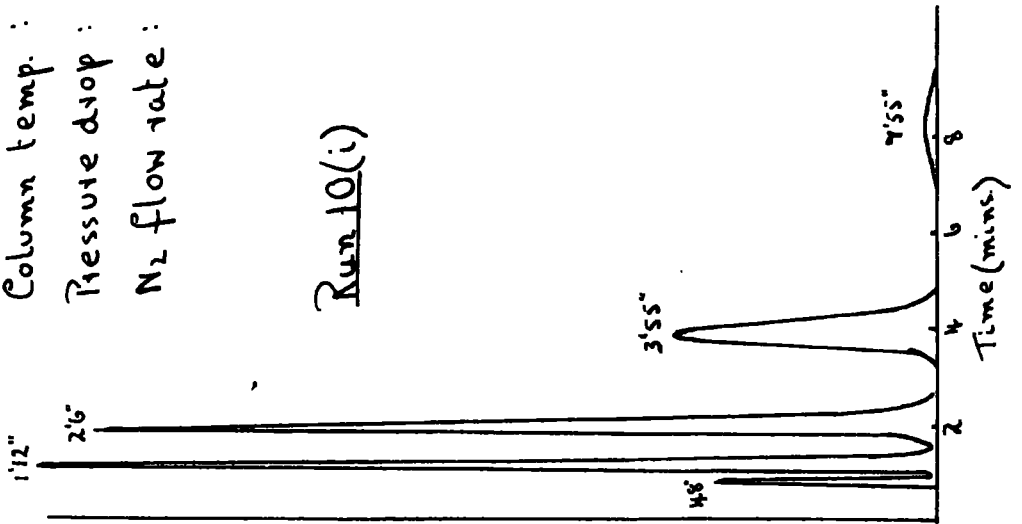

Run 10(ii)

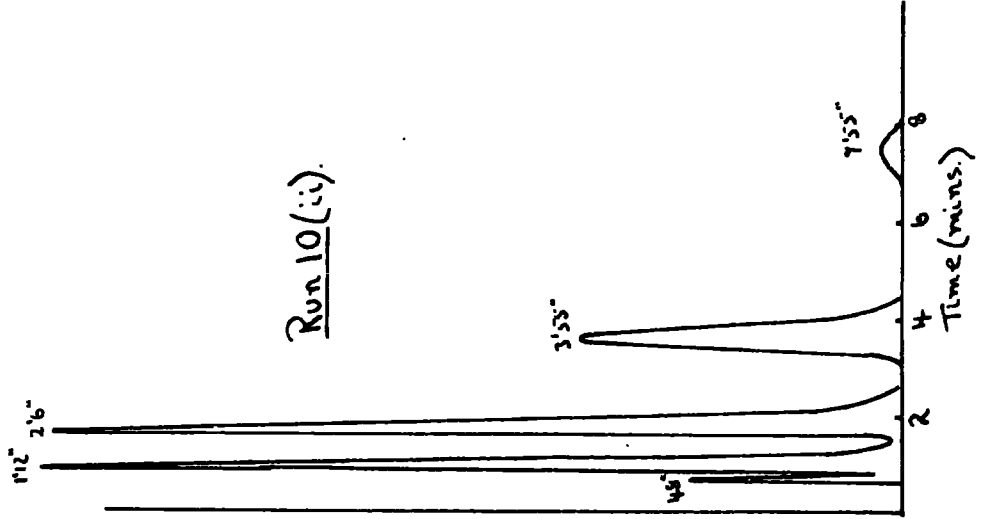

DIAGRAM 19

Kieselquarz - Silicone grease

Column temp. : 187°C

Pressure drop : 35.5 cms.

Nitrogen flow rate : 20 ml/min. 2'6"

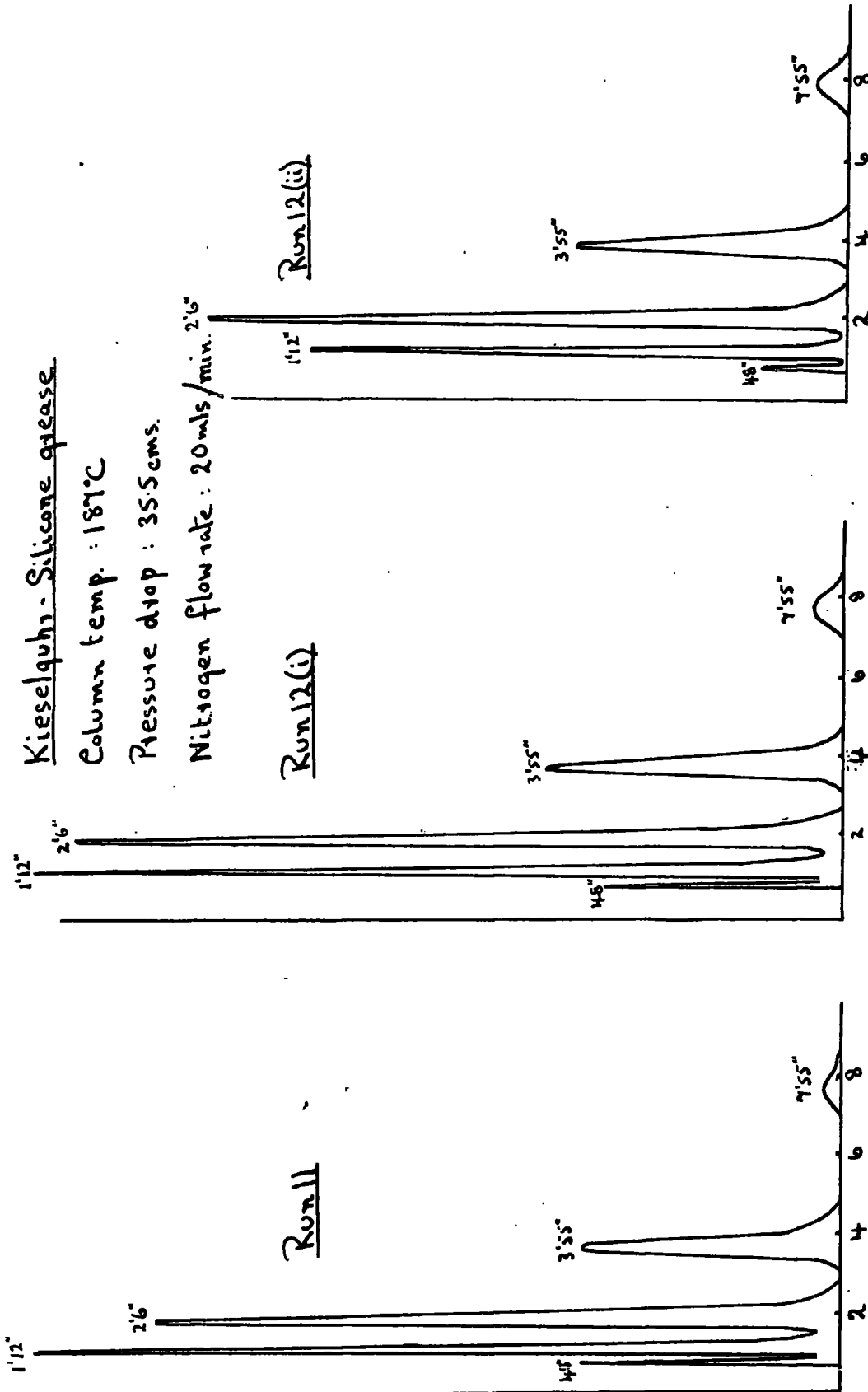

had been separated by fractional distillation and shown to be $C_6F_{12-n}Cl_n$, $n = 1$ to 5 , a standard mixture was made and a chromatogram of this allowed the peak areas* to be related to actual concentrations. Table 13 gives the correction factors by which the peak areas were multiplied.

TABLE 13.

Peak 1 ($C_6F_{11}Cl$)	Peak 2 ($C_6F_{10}Cl_2$)	Peak 3 ($C_6F_9Cl_3$)	Peak 4 ($C_6F_8Cl_4$)	Peak 5 ($C_6F_7Cl_5$)
1.27	1.08	1.00	0.88	0.84

The product distribution for the various runs together with other relevant information is given in table 5 .

Distillation of the product

In the distillation of this and other reaction products a concentric tube column was used, the design of which is shown in diagram 20 . The column was cleaned, set up and operated as described by Banks (op. cit. p. 98).

Testing the column

The efficiency of the column was determined at atmospheric pressure using the standard n-heptane-methyl cyclohexane test mixture of Bromiley and Quiggle.⁸¹ The composition of

* The peak areas,⁸² obtained by multiplying peak heights x half-band widths, were more accurately measured by projecting the chromatograms onto a screen.

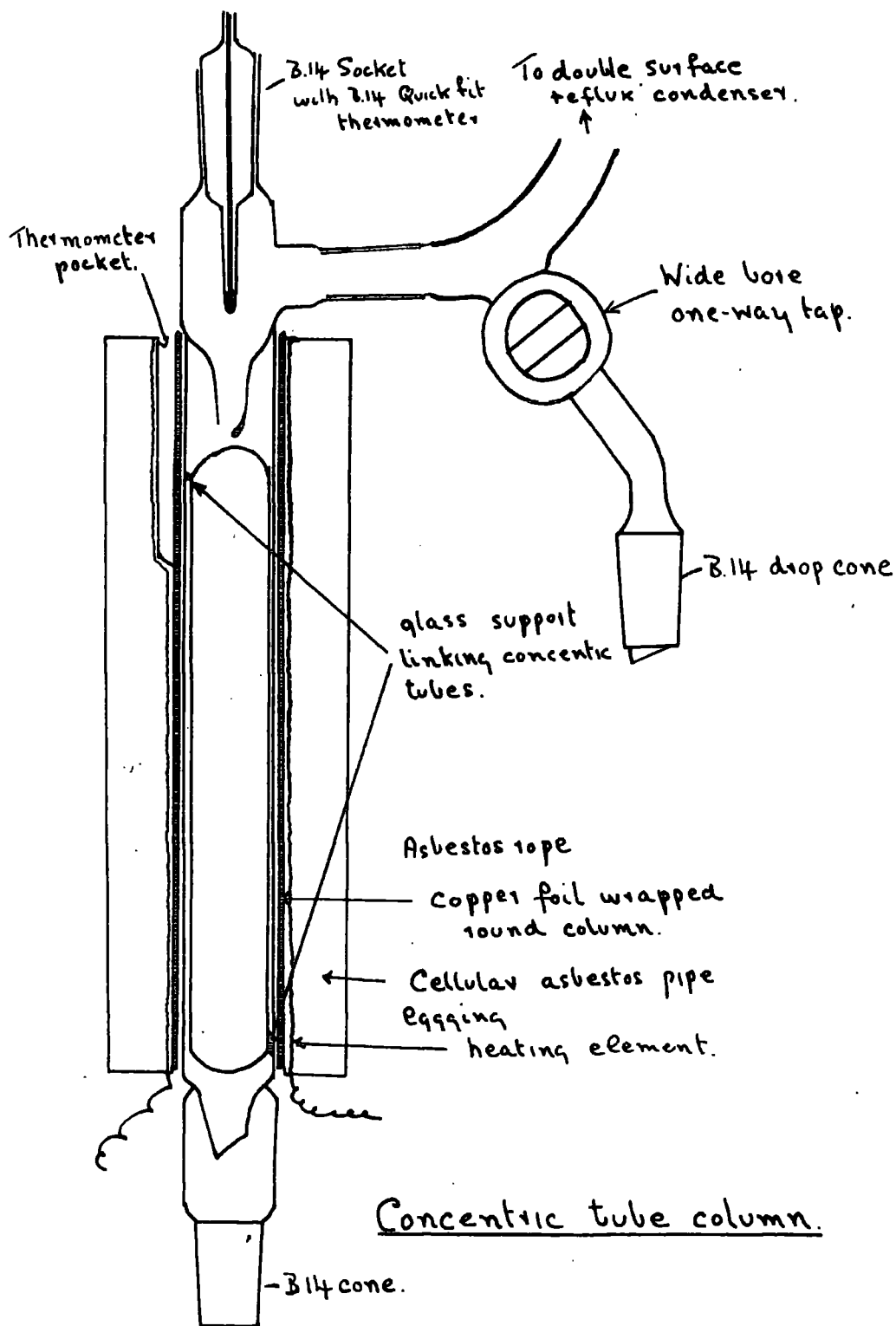

DIAGRAM 20

distillate and distilland was found from their respective refractive indices and the platage of the column read off from the table of refractive index against theoretical plates constructed by Lecky and Ewell.⁸³

n_D^{20} distillate	n_D^{20} distilland	Theoretical platage
1.4040	1.4158	22

Distillation of the product

Distillation 1.

460 g. of product from runs 1 to 4 were fractionated. The reflux rate* was approximately 20:1 and about 20 g. of distillate per hour were collected. As the distillation proceeded the distillate solidified in the take off tube and this was prevented by heating this part of the apparatus with a heating tape. The collecting pot was graduated in mls. and the still head temperature was recorded for each 2 mls. of distillate collected. The course of the distillation is shown in diagram 21. Table 14 records the boiling ranges, refractive indices and weights of the various flats obtained. All of the flats were wax-like solids.

* The reflux rate is defined as the rate at which material is returned to the column to the rate at which material is taken off.

Curve for distillation I

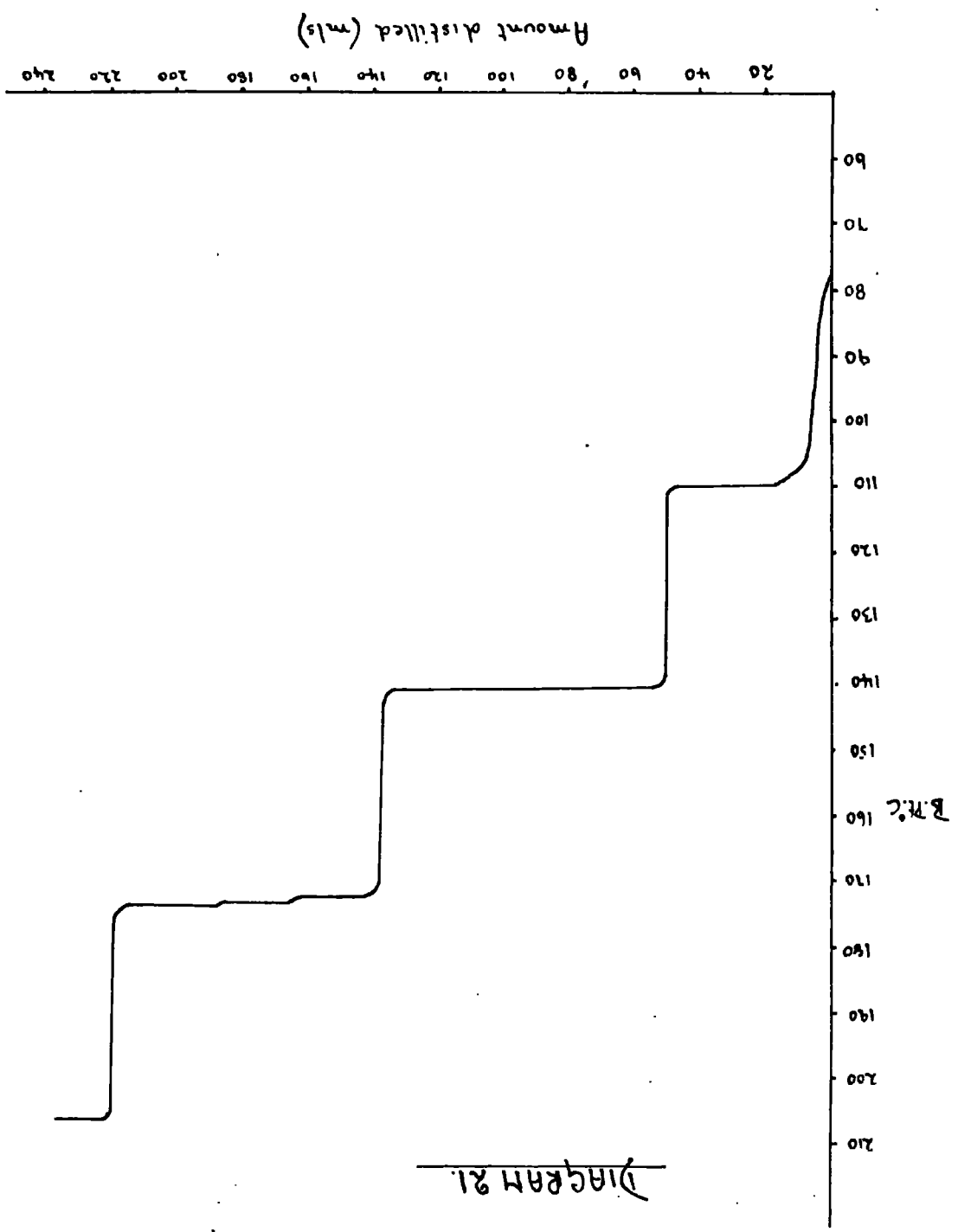

Diagram 21.

TABLE 14

Flat No.	B.Pt °C./754 mm.	n_D	Size of fraction (g.)	Wt. per 100 g. of C_6Cl_6 (g.)
1	109-109.8	1.329 ⁴⁵	67.2	146
2	140.8-141	1.361 ⁴⁵	121.2	263
3	172-174.2	1.387 ⁶⁰	127.5	277
4	207-207.8		26.0	56.4

Residue 5 g., Intermediary fraction 87.3 g.

Recovery: 93%.

Distillation 2.

810 g. of product from runs 5 to 13 and 87 g. of intermediary fractions from distillation I were fractionated. Table 15 gives details of the distillation.

TABLE 15

Flat No.	B.Pt. °C.	n_D	Size of fraction (g.)	Wt. per 1000g. of C_6Cl_6 (g.)
1	79.5-79.7/761 mm.	1.297 ⁴⁵	23.2	26
2	109.1-110.1/767 mm.	1.330 ⁴⁵	165	186
3	140.8-141.2/758 mm.	1.362 ⁴⁵	310.9	350
4	173.8-175.3/767 mm.		223	252
5	208.7-209.2/758 mm.		49	55

Residue 16 g.; Intermediary fraction 78 g.

Recovery: 96%.

Characterisation of the boiling fractions

Fractions, B.Pt. 79.5-79.7°C./761 mm., n_D^{45} 1.297 was cyclic $C_6F_{11}Cl$ (Found: F, 65.7; Cl, 11.3. Calc. for $C_6F_{11}Cl$: F, 66.0; Cl, 11.2%). Tatlow and Worthington⁸ gave for cyclic $C_6F_{11}Cl$, B.Pt. 79.4-80.1°C./754 mm., n_D^{45} 1.301.

Fraction, B.Pt. 109.1-110.1°C./767 mm., n_D^{45} 1.330, was cyclic $C_6F_{10}Cl_2$ (Found: F, 57.1; Cl, 21.2, M. 341. Calc. for $C_6F_{10}Cl_2$: F, 57.0; Cl, 21.4%, M. 334). Tatlow and Worthington⁸ gave B.Pt. 109.6-110.2°C./746 mm., n_D^{45} 1.332 for this compound.

Fraction, B.Pt. 140.8-141.2°C./758 mm., n_D^{45} 1.362 was cyclic $C_6F_9Cl_3$ (Found: F, 48.6; Cl, 30.6, M. 357. Calc. for $C_6F_9Cl_3$: F, 48.9; Cl, 30.4%, M. 349.5). Tatlow and Worthington⁸ gave B.Pt., 140.7-141.2°C./758 mm., n_D^{45} 1.363 for this compound.

Fraction, B.Pt. 173-175.3°C./767 mm., n_D^{60} 1.387 was cyclic $C_6F_8Cl_4$ (Found: F, 41.2; Cl, 38.8, M. 376. Calc. for $C_6F_8Cl_4$: F, 41.5; Cl, 38.8%, M. 366).

Fraction, B.Pt. 208.7-209.2°C./758 mm. was cyclic $C_6F_7Cl_5$ (Found: F, 35.0; Cl, 46.3, M. 397. Calc. for $C_6F_7Cl_5$: F, 34.8; Cl, 46.4%, M. 382.5).

Residue

The residue was distilled over in a straight distillation

and a white wax-like solid collected (11 g.). A tar remained.

Distillate (Found: F, 29.2; Cl, 51.0, F:Cl ratio of 1.07:1. Calc. for $C_6F_6Cl_6$: F, 28.6; Cl, 53.4%).

Reactions with lithium aluminium hydride

The reductions were carried out as described by Tatlow and Worthington⁸ and Roylance, Tatlow and Worthington.¹²

Solvents: Solvent ether was distilled over phenyl magnesium bromide and stood over sodium wire. Tetrahydrofuran was distilled over potassium in the presence of the ketyl of benzophenone and similarly stored.

Decafluorocyclohexanes from dichlorodecafluorocyclohexanes

obtained from hexachlorobenzene and cobalt trifluoride: A suspension of 2.4 g. (0.063 moles) of powdered lithium aluminium hydride and 26 g. of ether were placed in a 3N.100 ml. flask fitted with a dropping funnel, mechanical stirrer and a reflux condenser with a drikold-acetone cooled cold-finger above the normal water condenser. The flask contents were kept at 0°C. whilst 20 g. (0.060 moles) of cyclic $C_6F_{10}Cl_2$ in 2 g. ether were added during $1\frac{1}{4}$ hours with stirring. The reaction was continued at room temperature for a further hour and then under ether reflux for three hours. The reaction product was cooled to 0°C. and kept at this temperature whilst 20 mls. of dilute sulphuric acid were carefully added followed by 40 mls. of 25% sulphuric acid. When the solution became clear (2 or 3 hours) the ethereal layer was separated and the aqueous layer extracted twice with 10 ml. portions of ether. The combined ethereal layers were dried with magnesium sulphate and filtered. Distillation

through a 20 plate concentric tube column* gave, after removal of the ether (i) (0.5 g.) B.Pt. 34.8-69°C. (Found: F, 35.6%). Analytical gas chromatography (kieselguhr-apiezon L, column temperature 85°C., nitrogen flow rate 30 mls./minute) gave two peaks of retention times 2'6" and 3'54" which corresponded to authentic samples of 1H/2H-decafluorocyclohexane (supplied by the Imperial Smelting Corporation) and ether respectively. Kieselguhr-dinonyl phthalate or -trimesyl phosphate packings at 60°C. did not give a clean resolution of these compounds; (ii) Residue (15 g.). A straight distillation of this gave 14 g. of a white, wax-like solid which was an isomeric mixture of decafluorocyclohexanes (Found: F, 71.7. Calc. for $C_6F_{10}H_2$: F, 71.9%). Analytical gas chromatography (diagram 22a) showed five peaks. The mixture was separated on a 16 ft. x 2.3 cm. i.d. column packed with kieselguhr-dinonyl phthalate (700 g.) and chromatographic system B. The column temperature was 92°C., the nitrogen flow rate 160 mls./minute and pressure drop 20 cms. Peak I was present in trace amounts and was not isolated. It had the same retention time as ether and 1H/2H-decafluorocyclohexane and was probably a mixture of these. 12 g. in three runs gave (a) peak II, 1H/3H-deca-

* All fractionations in subsequent experiments were carried out using this column.

DIAGRAM 22Product from $C_6F_{10}Cl_2$ & $LiAlH_4/Et_2O$.Kieselquartz-Dinonyl phthalate.Column temp.: $102^\circ C$. N_2 flow rate: 28 ml./min.

P.D.: 30 cms.

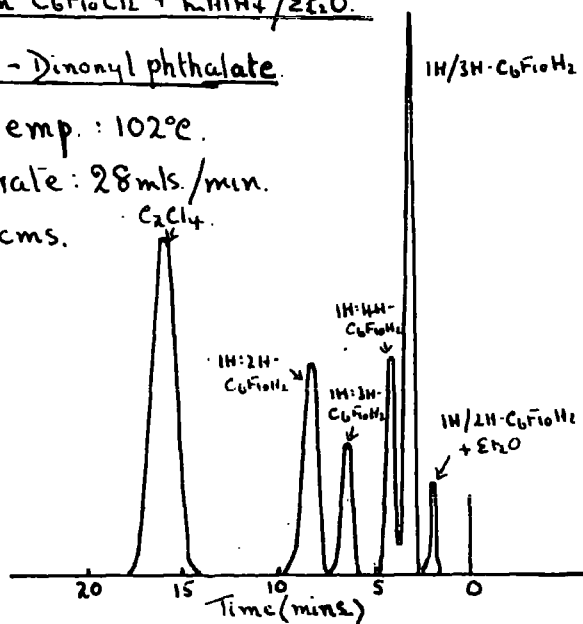

(a).

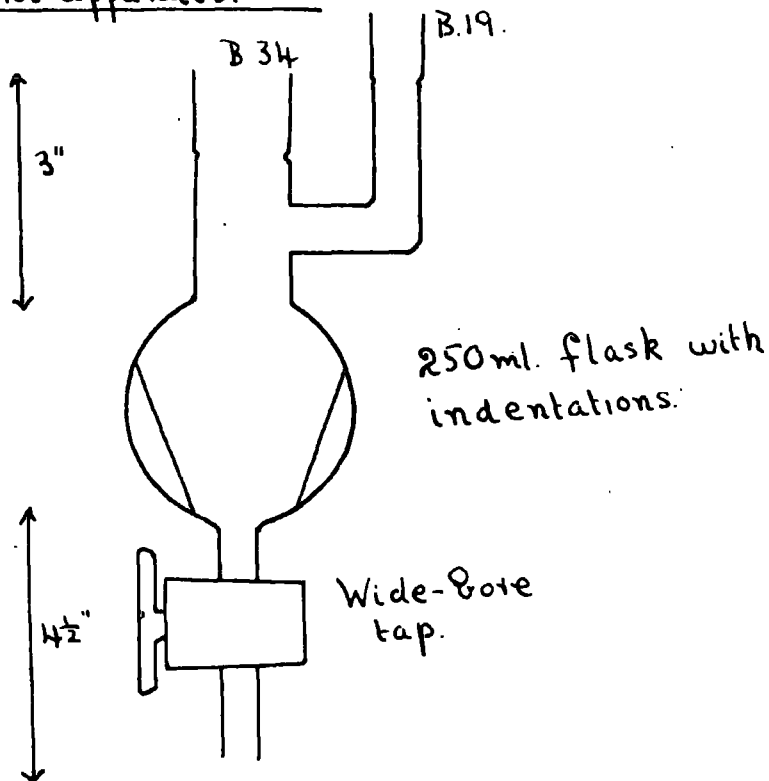
Lithium shot apparatus.

(b).

fluorocyclohexane (3.5 g. 30-40 mins.) B.Pt. 79°C .,
 M.Pt. $34-36.7^{\circ}\text{C}$., for which Evans et al.³⁰ gave B.Pt. 78°C .
 These authors reported that 1H/3H- and 1H/4H-decafluoro-
 cyclohexanes could not be resolved with a kieselguhr-
 dinonyl phthalate packing but could be separated with a
 kieselguhr-tricresyl phosphate packing. Both isomers have
 the same boiling point. Analytical gas chromatography
 (kieselguhr-tricresyl phosphate, col. temperature 55°C .)
 gave a single peak with no inflexion. J. Feeney and L.H.
 Sutcliffe of Liverpool University were provided with a
 sample of this material and by nuclear magnetic resonance
 showed that it consisted predominantly of the 1H/3H-isomer;
 (b) peak III, 1H:4H-decafluorocyclohexane (1.8 g., 42-60
 mins.) B.Pt. 85.4, M.Pt. $39-41^{\circ}\text{C}$. for which Evans et al.³⁰
 gave B.Pt. 86°C ., M.Pt. $40-41^{\circ}\text{C}$.; (c) peak IV, 1H:3H-deca-
 fluorocyclohexane (1.3 g. 68-84 mins.) B.Pt. 90.8°C .,
 M.Pt. $45-48^{\circ}\text{C}$. for which Evans et al.³⁰ gave B.Pt. 89°C .;
 (d) peak V, 1H:2H-decafluorocyclohexane (3.1 g. 90-130 mins.)
 B.Pt. 90.9°C . M.Pt. $46-49.2^{\circ}\text{C}$. for which Roylance, Tatlow
 and Worthington¹² gave B.Pt. $91-92^{\circ}\text{C}$., M.Pt. 46°C .

Decafluorocyclohexanes from dichlorodecafluorocyclohexanes

obtained from benzene and chlorine trifluoride: The

reaction was carried out exactly as described above. 14.5 g.

(0.0435 moles) of cyclic $C_6F_{10}Cl_2$ and 1.9 g. (0.050 moles) of lithium aluminium hydride in 42 g. of ether yielded, after the removal of practically all of the ether, 9 g. of residue. This was separated by gas chromatography (16 ft. x 1" copper column packed with firebrick-dinonyl phthalate and chromatographic system A, column temperature $95^\circ C.$, pressure drop 50 cms., nitrogen flow rate 160 mls./minute). 9 g. in two runs gave: (i) (2.1 g.) (Found: F, 71.7. Calc. for $C_6F_{10}H_2$: F, 71.9%). Analytical gas chromatography (kieselguhr-tricresyl phosphate, column temperature $55^\circ C.$) gave a single peak with no inflexion which had the same retention time as 1H/3H-decafluorocyclohexane (see previous reaction); (ii) (1.5 g.) (Found: F, 71.8%); (iii) (0.9 g.) (Found: F, 71.3%); (iv) (1.9 g.) (Found: F, 71.5%). Fractions (ii), (iii) and (iv) had the same retention times as peaks III, IV, and V of the previous experiment and were 1H:4H-, 1H:3H- and 1H:2H-decafluorocyclohexanes respectively. It is now realised that any 1H/2H-decafluorocyclohexane formed would have been trapped out with the ether present, unfortunately this was not examined at the time.

The reaction between cyclic $C_6F_9Cl_3$ obtained from hexachlorobenzene and cobalt trifluoride and lithium aluminium hydride in ether: The reaction was carried out as previously described. 20 g. (0.057 moles) of cyclic $C_6F_9Cl_3$ and 5 g. (0.132 moles, 3 times theoretical) of lithium aluminium

hydride in 60 g. of ether were stirred at room temperature for 3 hours and then under ether reflux for 18 hours. Distillation of the ethereal layers through a 20 plate column, after ether removal, gave (i) (2.3 g.) B.Pt. up to 111°C.; (ii) (2.8 g.). B.Pt. 111-117°C. (Found: F, 56.4; Cl, 14.5. Calc. for $C_6F_9Cl_{1.24}H_{1.76}$: F, 57.9; Cl, 15.2%) (iii) (7.3 g.) residue (Found: F, 53.5; Cl, 17.3; Calc. for $C_6F_9Cl_{1.56}H_{1.44}$: F, 53.4; Cl, 17.3%). All fractions were liquids. Analytical gas chromatography (kieselguhr-dinonyl phthalate, col. temp. 103°C.) showed that each of these fractions were complex and consisted of several overlapping peaks. Fraction (i) contained some ether and separation of this by preparative scale gas chromatography (16 ft. x 2.3 cm. i.d. column, kieselguhr-dinonyl phthalate, col. temp. 100°C.) gave 1.9 g. of a colourless liquid (Found: F, 59; Cl, 8.8; Calc. for $C_6F_9Cl_{0.72}H_{2.28}$: F, 63.1; Cl, 9.2%). These fractions were not investigated further.

The attempted two stage reduction of cyclic $C_6F_9Cl_3$ from hexachlorobenzene and cobalt trifluoride with lithium aluminium hydride: 20 g. (0.057 moles) of cyclic $C_6F_9Cl_3$ and 3 g. (0.087 moles) of lithium aluminium hydride (2 times theoretical) in 26.4 g. of ether were stirred at room temperature for 1 hour and then under ether reflux for 4½ hours.

Fractionation through a 20 plate column of the ethereal layers, after ether removal, gave 15.5 g. residue which in a straight distillation yielded 14.6 g. of a colourless liquid (Found: F, 59.0; Cl, 13.4. Calc. for $C_6F_9Cl_{1.09}H_{1.91}$: F, 60.4; Cl, 13.7%). 14.6 g. (0.051 moles) and 1.1 g. (0.029 moles) of lithium aluminium hydride (2 times theoretical) in 26 g. of ether were stirred under ether reflux for 6 hours. Fractionation of the ethereal layers through a 20 plate column after ether removal, gave (i) (3.6 g.) B.Pt. 95-109°C. An accident resulted in the loss of this material; (ii) (8.3 g.) residue (Found: F, 58.9; Cl, 11.2, $C_6F_9Cl_{0.92}H_{2.08}$ contains: F, 61.4; Cl, 11.7%).

The reaction between cyclic $C_6F_9Cl_3$ obtained from hexachlorobenzene and cobalt trifluoride and lithium aluminium hydride in tetrahydrofuran: 20 g. (0.057 moles) cyclic $C_6F_9Cl_3$ and 6.52 g. (0.172 moles) lithium aluminium hydride (4 times the theoretical amount) in 90 g. of tetrahydrofuran were stirred at room temperature for 3 hours and then under reflux for 16 hours. The flask contents were cooled to 0°C. and 100 mls. of dilute sulphuric acid were added carefully, the aqueous volume was made up to about 400 mls. and extracted with 4 x 50 mls. of ether. The ethereal layers were dried with magnesium sulphate and distillation through a 20 plate column, after the removal of the ether, gave; (i) (2.3 g.)

B.Pt. 66-109°C. (Found: F, 25.8; Cl, 1.0%); (ii) (4.1 g.)
 B.Pt. 109-112°C. (Found: F, 29.4; Cl, 2.9%); (iii) (2.0 g.)
 B.Pt. 112-114°C. (Found: F, 25.0; Cl, 1.9%); (iv) (3 g.)
 residue (Found: F, 22.7; Cl, 3.0%). Analytical gas
 chromatography (kieselguhr-dinonyl phthalate, temperature
 102°C., nitrogen flow rate 20 mls./minute) gave the following
 peaks for these fractions. The figures in parentheses refer
 to peak heights (inches). (i) 6'24" (>> 7), 10' (1.2), 11'36"
 (5), 14'24"* (.9), 20'12" (.7), 24'48" (.2), (ii) 6'48"* (.7),
 11'36" (>7), 14'24"* (.7), 20' (1.4), 24'36" (.9), 33'12"*
 (.2); (iii) 11'36" (>> 7), 20' (.8), 24'36" (1.3), 32' (.5),
 40' (.1). The peak with retention time 6'24" in fraction
 (i) was tetrahydrofuran. The peak, retention time 11'36"
 was the major component in all fractions and was isolated
 chromatographically from (iii). 2.0 g. fraction (iii)
 (8 ft. x 2.3 cm. i.d. column, kieselguhr-dinonyl phthalate
 (340 g.) and chromatographic system B col. temperature 100°C.,
 nitrogen flow 150 mls./minute) gave n-butyl alcohol (0.8 g.)
 n_D^{20} 1.399, B.Pt. 114.5°C., for which the literature gave
 n_D^{20} 1.399, B.Pt. 117.7°C. An authentic mixture of $C_6F_9H_3$
 isomers supplied by the Imperial Smelting Corporation gave
 peaks with retention times, 6'48", 11'36", 14'36", 17'12",
 33'24" and 45'. The peaks marked with an asterisk are
 possible $C_6F_9H_3$ isomers.

Reaction between cyclic $C_6F_8Cl_4$ obtained from hexachloro-
benzene and cobalt trifluoride and lithium aluminium hydride

in ether: 20 g. (0.054 moles) cyclic $C_6F_8Cl_4$ and 4.8 g. (0.126 moles) lithium aluminium hydride (over 2 times theoretical) in 52 g. ether were stirred at room temperature for 2 hours and then under ether reflux for 12 hours.

Distillation of the ethereal layers, after ether removal, gave; (i) (0.8 g.) B.Pt. up to $120^{\circ}C$. (Found: F, 25.8; Cl, 6.1%, F:Cl ratio of 7.9:1), this fraction contained some ether; (ii) (4.0 g.) B.Pt. $120-138^{\circ}C$. (Found: F, 51.3; Cl, 15.3%, F:Cl ratio of 6.20:1); (iii) (8.3 g.) residue (Found: F, 48.8; Cl, 23.9%, F:Cl ratio of 3.81:1).

Reaction between cyclic $C_6F_7Cl_5$ obtained from hexachloro-
benzene and cobalt trifluoride and lithium aluminium hydride

in ether: 10 g. (0.026 moles) cyclic $C_6F_7Cl_5$ and 2.5 g. (0.066 moles) lithium aluminium hydride (over 2 times theoretical) in 26 g. of ether were stirred at room temperature for 1 hour and then under ether reflux for 8 hours.

Distillation of the ethereal layers, after ether removal, gave; (i) (0.3 g.) B.Pt. up to $145^{\circ}C$. (Found: F, 21.8; Cl, 6.8%, F:Cl ratio of 6.02:1), this fraction contained ether; (ii) (2.4 g.) B.Pt. $145-170^{\circ}C$. (Found: F, 43.4; Cl, 23.4%, F:Cl ratio of 3.46:1); (iii) (2.9 g.) residue (Found: F, 40.6; Cl, 29.7%, F:Cl ratio of 2.55:1).

Dehalogenations with zinc dust/n-butyl alcohol.

Zinc dust 200 g. of commercial zinc dust were treated with 500 mls. of 10% sulphuric acid and allowed to stand for $\frac{1}{2}$ hour, when the supernatant solution was poured off. The zinc was washed several times with distilled water until the supernatant solution gave no precipitate with barium chloride. After washing twice with acetone, the zinc dust was dried under vacuum at 80°C .

n-butyl alcohol this was dried with magnesium sulphate and distilled through an 8" helices packed column. B.Pt. 117°C .

The reaction between cyclic $\text{C}_6\text{F}_8\text{Cl}_4$ obtained from hexachlorobenzene and cobalt trifluoride and zinc dust/n-butyl alcohol:

83 g. (1.28 moles) zinc dust (8 times theoretical amount) and 72 g. n-butyl alcohol were placed in a 250 ml. 3N. flask fitted with a dropping funnel, mechanical stirrer and a reflux condenser with a drikold-acetone cooled cold-finger above the normal water condenser. 30 g. (0.082 moles) of cyclic $\text{C}_6\text{F}_8\text{Cl}_4$ in 10 g. n-butyl alcohol were added over a period of 4 hours to the flask contents heated on an oil bath at 80°C . and the reaction allowed to continue at that temperature for a further 5 hours. The reaction product was fractionated through a 20 plate column and gave; (i) octafluorocyclohexa-1:4-diene (3 g.) B.Pt. $56-56.5^{\circ}\text{C}$., n_D^{18} 1.3185 (Found: F, 66.9. Calc. for C_6F_8 :F, 67.8%), for which

Evans and Tatlow¹⁸ gave B.Pt. 57-58°C., n_D^{18} 1.318. and McBee et al.¹⁵ B.Pt. 56-57°C., n_D^{20} 1.315; (ii) (2.6 g.) B.Pt. 56.5-78.5°C.; (iii) (3.6 g.) B.Pt. 78.5-80°C.; (iv) (3.1 g.) B.Pt. 80-82°C.; (v) (3.5 g.) B.Pt. 82-110°C.; (vi) (2.8 g.) B.Pt. 110-116°C. Analytical gas chromatography (kieselguhr-dinonyl phthalate, column temperature 111°C., nitrogen flow rate 30 mls./minute) showed that fractions (ii)-(vi) were quite complex. The retention times and peak heights, in parentheses, for the components of each fraction are listed below.

Fraction (ii)	Fraction (iii)	Fraction (iv)	Fraction (v)	Fraction (vi)
1'24"(>>8)				
2'(5.4)	2'(.7)			
2'36"(2.5)	2'36"(4.4)	2'36"(5.5)	2'36"(2.9)	
3'36"(2)	3'36"(4.7)	3'36"(4.4)	3'36"(1.4)	
		4'12"(1.1)	4'12"(1.8)	
			5'24"(.9)	
6'24"(.05)	6'24"(.15)	6'24"(2)	6'24"(1.1)	6'24"(3.9)
			10'36"(.9)	10'36"(.15)
			12'48"(.25)	12'48"(.2)

Fractions (ii), (iii) and (iv) were combined and separated by gas chromatography (16 ft. x 2.3 cm. i.d. column, kieselguhr-dinonyl phthalate (700 g.) and chromatographic

system B, column temperature 79°C., nitrogen flow rate 175 mls./minute, pressure drop 19 cms.). 9.3 g. in three runs gave; (a) octafluorocyclohexa-1:4-diene (1.1 g.) n_D^{18} 1.318; (b) (0.75 g.) (Found: F, 63.1; Cl, 1.0. Calc. for C_6F_7H : F, 64.6%). An infra-red spectrum gave absorption at 3093, 1767 and 1718 cm^{-1} , and the carbon-hydrogen and diene vibrational stretching frequencies have been reported at 3097 and 1771, 1721 cm^{-1} respectively for 1H-heptafluorocyclohexa-1:4-diene;^{77.78} (c) (2.75 g.) n_D^{20} 1.350 (Found: F, 58.2; Cl, 9.3, M. 233. Calc. for C_6F_7H : F, 64.6, M. 206 and calc. for C_6F_7Cl : F, 55.4; Cl, 14.8%, M. 240). Analytical gas chromatography (kieselguhr-dinonyl phthalate) gave a single peak, however (kieselguhr-apiezon L, column temperature 60°C., nitrogen flow rate 24 mls./minute) gave two peaks at 3' and 4'3" of relative areas 1:2.3. An infra-red spectrum gave absorptions at 3093 and at 1767 m.,* 1730 s., 1698 s., and 1681 m. cm^{-1} . The analytical figures, molecular weight, doublet absorption in the diene region and carbon-hydrogen absorption at 3093 cm^{-1} suggest that this fraction is a mixture of a heptafluorocyclohexadiene and a chloroheptafluorocyclohexadiene. Hydrogen fluoride was liberated on standing. (d) perfluorobenzene (2.9 g.) B.Pt. 79°C., n_D^{20} 1.377 (Found: F, 60.2; Cl, 1.3. Calc. for C_6F_6 : F, 61.3%). Birchall and Haszeldine⁸⁴ gave B.Pt. 80-81°C., n_D^{20} 1.3777 for this compound. Fraction (v) which

* m and s indicate medium and strong band respectively.

was very complex was not separated and fraction (vi) consisted predominantly of n-butyl alcohol (retention time 6'24").

The reaction between cyclic $C_6F_7Cl_5$ obtained from hexachlorobenzene and cobalt trifluoride and zinc dust/n-butyl alcohol:

The reaction was carried out as described above. 25 g.

(0.0654 moles) of cyclic $C_6F_7Cl_5$ in 10 g. of n-butyl alcohol were added over 4 hours to 86 g. (1.32 moles) of zinc dust in 71 g. of n-butyl alcohol at 80°C. and the reaction was continued for a further 5 hours at that temperature.

Fractionation of the reaction product through a 20 plate column gave: (i) (7 g.) B.Pt. 78-79°C.; (ii) (2.5 g.) B.Pt. 79-101°C.; (iii) (2.5 g.) B.Pt. 101-110°C.; and (iv) (2 g.) B.Pt. 110-117°C. Analytical gas chromatography (kieselguhr-dinonyl phthalate, column temperature 111°C., nitrogen flow rate 30 mls./minute) gave the following peaks, the retention times and peak heights (in parentheses) are listed.

Fraction (i)	Fraction (ii)	Fraction (iii)	Fraction (iv)
2'24"(.1)	2'24"(.3)		
3'36"(6)	3'36"(6)	3'36"(.5)	
4' (.2)	4' (1.6)	4' (.4)	
6'24"(.1)	6'24"(.15)	6'24"(1.6)	6'24"(4.6)
		10' (2.3)	10' (.8)

Fraction (i) was separated by gas chromatography (16 ft. x 2.3 cm. i.d. column packed with kieselguhr-dinonyl phthalate (700 g.) and chromatographic system B., column temperature 82°C., nitrogen flow rate 190 mls./minute) 1.8 g. gave perfluorobenzene (1.65 g.) B.Pt. 79.5°C., n_D^{20} 1.377 (Found: F, 60.3. Calc. for C_6F_6 : F, 61.3%) for which the literature (loc. cit.) gave n_D^{20} 1.377, B.Pt. 80^o 81 C. Fraction (ii) was similarly resolved and 2.5 g. gave; (a) perfluorobenzene (1.5 g.) n_D^{20} 1.377; and (b) (0.5 g.) (Found: F, 46.3%). Analytical gas chromatography (kieselguhr-dinonyl phthalate, column temperature 84°C., nitrogen flow 22 mls./minute) gave two peaks, 9' (0.15) and 11'24" (1.9), the former had the same retention time as perfluorobenzene. An infra-red spectrum was very similar to authentic n-butyl alcohol in the 4000-2857 cm^{-1} region and gave the broad band due to hydrogen bonded hydroxyl at 3382 (3333), CH_3- at 2971 (2959) and 2879 (2868) and $-CH_2-$ at 2930 (2930) cm^{-1} . The figures in parentheses refer to pure n-butyl alcohol. In addition there was a sharp absorption at 3096 cm^{-1} and a strong doublet at 1527 and 1508 cm^{-1} . Nield, Stephens and Tatlow reported absorptions associated with the benzene ring for pentafluorobenzene at 1535 and 1512 cm^{-1} and Steele and Whiffen the carbon-hydrogen absorption at 3102 cm^{-1} . Gas chromatography (kieselguhr-apiezon L, column temperature 90°C., nitrogen flow 25 mls./minute) gave a single peak at

8'6" with an inflexion on the near side (n-butyl alcohol had a retention time of 10'42" with these column conditions). It would appear that interaction between pentafluoro-benzene and n-butyl alcohol has resulted in a single chromatographic peak. Fraction (iii) was separated by gas chromatography (column as above, column temperature 106°C, nitrogen flow rate 180 mls./minute). 2.5 g. gave 1.2 g. of material which contained a little n-butyl alcohol (the other major component of this fraction, R.T. 6'24"). Recycling yielded chloropentafluorobenzene (0.9 g.), B.Pt. 107.5°C., n_D^{20} 1.421 (Found: F, 45.0; Cl, 16.9. Calc. for C_6F_5Cl : F, 46.9; Cl, 17.5). McBee et al.²⁶ gave B.Pt. 122-123°C., n_D^{20} 1.4256 for this compound. An infra-red spectrum gave the absorption associated with the benzene ring at 1511 cm^{-1} . The low analytical figures were due to a small amount of n-butyl alcohol ($\approx 4\%$).

Reactions under nitrogen

All subsequent reactions were carried out under oxygen free nitrogen (see Fieser⁸⁶ for the general technique).

Reactions with potassium graphite

Potassium graphite (KC_8) was prepared as described by Kingston and Glockling (private communication) after the method of Podall, Foster and Giraitis.⁸⁷ It is formed exothermically according to the equation

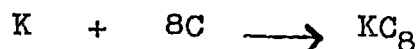

and sparks in air. The potassium and graphite (synthetic B.D.H.) were caused to react in the proportions given by the equation. The graphite was contained in a glass flask fitted with a mechanical stirrer and an 8" air condenser, and heated to 280-300°C. on a lead bath and kept within this temperature range whilst the potassium was gradually added in small pellets. The reaction proceeded via an intermediate blue compound (KC_{16}) and with the addition of more potassium turned a reddish-brown. After the potassium was added, stirring was continued for a farther 10 minutes and the potassium graphite allowed to cool to room temperature.

Solvent Methylcyclohexane was distilled over potassium and stood over sodium wire.

Reactions between potassium graphite and cyclic $C_6F_9Cl_3$

Three exploratory reactions were carried out using different reactant ratios. The experimental procedure was as follows. The cyclic $C_6F_9Cl_3$ and methylcyclohexane were contained in a 3N flask fitted with a mechanical stirrer and a reflux condenser with a drikold-acetone cooled cold-finger above the usual water condenser. The potassium graphite, in a separate flask, was transferred in the solid state via polyvinyl chloride tubing into the reaction vessel which was at room temperature. The amount of heat liberated during the addition of the potassium graphite

increased as the ratio of KC_8 : cyclic $C_6F_9Cl_3$ used increased. After the potassium graphite was added, the reaction was continued at $\sim 100^\circ C.$ for some time. The reaction product was then cooled to $0^\circ C.$ and de-ionised water (~ 30 mls.) added carefully and the mixture filtered under suction. The residue was agitated twice with water. The filtrates were collected and the organic and aqueous layers separated. The former was examined by gas chromatography and the latter made up to a known volume and the halide ion determined. The figures in parentheses give the percentage of the total halogen extracted.

Reaction 1. $KC_8:C_6F_9Cl_3$ molar ratio of 6.2:1.

Potassium graphite (5.8 g., 0.043 moles) and cyclic $C_6F_9Cl_3$ (2.41 g., 0.0069 moles) in methylcyclohexane (8.8 g.) were heated at $105^\circ C.$ for 8 hours.

The aqueous layer contained fluoride ion, 0.063 g. (5.3%) and chloride ion, 0.081 g. (11.0%).

Organic layer. Analytical gas chromatography (kieselguhr-silicone grease, column temperature $91^\circ C.$, nitrogen flow 15 mls./minute) gave two peaks which corresponded to methylcyclohexane, 5'8" and cyclic $C_6F_9Cl_3$, 10'6". The relative peak areas were 6:6:1.

Reaction 2. $KC_8:C_6F_9Cl_3$ molar ratio of 13.4:1.

Potassium graphite (10.5 g., 0.078 moles) and cyclic $C_6F_9Cl_3$ (2.03 g., 0.0058 moles) in methylcyclohexane (10.5 g.)

were heated at 105°C. for 8 hours.

The aqueous layer contained fluoride ion, 0.119 g. (12%) and chloride ion, 0.139 g. (22.4%).

Organic layer. Analytical gas chromatography (column and conditions as above) gave two peaks which corresponded to methylcyclohexane, 5'8" and cyclic $C_6F_9Cl_3$, 10'6". The relative peak areas were 9.8:1.

Reaction 3. $KC_8:C_6F_9Cl_3$ molar ratio of 26:1.

Potassium graphite (20 g. 0.148 moles) and cyclic $C_6F_9Cl_3$ (2 g., 0.0057 moles) in methylcyclohexane (17 g.) were heated at 100°C. for 20 hours.

The aqueous layer contained fluoride ion, 0.280 g. (28.6%) and chloride ion, 0.285 g. (46.7%).

The organic layer was dried (magnesium sulphate), fractionated through a 22 plate column, and the first 0.4 g. of distillate collected. Analytical gas chromatography (kieselguhr-dinonyl phthalate, column temperature 81°C., nitrogen flow rate 20 mls./minute), gave peaks at 1'24" (0.1), 3'54" (0.15), 4'36" (0.1) and 6'30" (8). Figures in parentheses refer to peak heights. The peaks at 4'36" and 6'30" corresponded to perfluorobenzene and methylcyclohexane. The other peaks were not identified.

Since only traces of dehalogenated material were detected in reaction 3, a reaction was repeated with the intention of examining any high boiling material formed. The reaction was carried out as previously described except

that a mercury sealed stirrer was used.

Potassium graphite (50 g., 0.37 moles) and cyclic $C_6F_9Cl_3$ (5 g., 0.0143 moles) in methylcyclohexane (54 g.) were heated at $110^\circ C.$ for 16 hours. The organic layer was dried ($MgSO_4$) and fractionation through a 20 plate column gave; (i) (1.5 g.) B.Pt. up to $99^\circ C.$ Analytical gas chromatography (kieselguhr-dinonyl phthalate, column temperature $96^\circ C.$, nitrogen flow rate 16 mls./minute) gave peaks at 2'36" (0.35), 6'24" (0.7) and 9' (7). Figures in brackets refer to the peak heights. The peaks at 6'24" and 9' corresponded to perfluorobenzene and methylcyclohexane respectively; (ii) bulk of solvent; (iii) residue (2 g.). This in a straight distillation gave; (a) distillate (1.3 g.) - oil bath temperature taken up to $220^\circ C.$ (Found: F, 19.1, Cl, 17.8% F:Cl ratio 2.01:1). Analytical gas chromatography (kieselguhr-dinonyl phthalate, column temperature $108^\circ C.$, nitrogen flow rate 28 mls./minute) gave two peaks which corresponded to methylcyclohexane and cyclic $C_6F_9Cl_3$. A kieselguhr-silicone packing at $192^\circ C.$ gave no high boiling peaks. The analytical figures indicated that other more highly chlorinated material was also present; (b) residual tar (0.6 g.) (Found: F, 22.7; Cl, 8.9. F:Cl ratio of 4.8:1).

The recovery from these reactions using a solvent was very low, yet even with a large excess of potassium

graphite, it was apparent that a fair proportion of starting material remained unchanged. A reaction was therefore carried out without a solvent.

The apparatus used was as previously described except that a trap cooled in liquid air was placed beyond the water condenser and a mercury sealed stirrer was used. Cyclic $C_6F_9Cl_3$ (15 g., 0.0425 moles) was added to potassium graphite (50 g., 0.37 moles) over a period of about 10 minutes. Much heat was evolved and a reaction flame was observed during the addition. The reaction mixture was cooled in an ice bath. The reaction was continued at $130^\circ C.$ for 6 hours and during this time 3 g. of material collected in the trap. The reaction was continued a further day at $180^\circ C.$ but no more volatile material was collected. Gas chromatography (kieselguhr-dinonyl phthalate, column temperature $98^\circ C.$, nitrogen flow rate 21 mls./minute) gave 4 peaks at 2'12" (0.20), 4'18" (0.23), 12'30" (0.11) and 29'6" (1). The figures in parentheses refer to the relative peak areas in terms of peak 4. Peaks 1, 3 and 4 had the same retention times as authentic samples of octafluorocyclohexa-1:4-diene, perfluorobenzene and cyclic $C_6F_9Cl_3$, peak 3 was not identified. An infra-red spectrum gave the C_6F_8 -1:4-diene, diene absorption at 1744 cm.^{-1} (1742) and the aromatic perfluorobenzene absorption at 1530 cm.^{-1} (1527). The figures in parentheses are values for authentic samples. Assuming equal thermal conductivities for these products, C_6F_8 -1:4-diene, C_6F_6 ,

and cyclic $C_6F_9Cl_3$ are present to the extent 0.34 g., 0.19 g., and 1.72 g. respectively. The solid residue was transferred via polyvinyl chloride tubing into a Soxhlet extractor and extracted with ether for two days. The ether extract was evaporated and a residue (0.6 g.) remained. This in a straight distillation gave a distillate (0.3 g.) (Found: F, 34.3; Cl, 23.7. F:Cl ratio of 2.71:1) and a residual tar. Water was carefully added to the graphite but no heat was given off (the potassium evidently having been utilised), and was continuously extracted for two days. The aqueous extract was made up to a known volume and the halide ion determined. It contained fluoride ion 4.1 g. (62.7%) and chloride ion 2.87 (70.7%).

The reaction between cyclic $C_6F_{11}Cl$ and phenyl lithium

Lithium shot. Petroleum oil (high boiling fraction), lithium metal which was cut up into suitable pieces, and a little oleic acid, were introduced into the apparatus shown in diagram 22b. The apparatus was fitted with a mechanical stirrer, not shown in the diagram, and the operation was carried out under argon. The oil was heated to boiling and the lithium was dispersed with fairly vigorous stirring. The stirring was discontinued after about 10 minutes and the apparatus was allowed to cool to room temperature. The oil was run off, and the

lithium shot washed two or three times with ether, it could then be washed directly into the reaction vessel.

Phenyl lithium was prepared as described by Gilman and Jones.⁶⁶ Redistilled phenyl bromide (13 g., 0.0828 moles) in dry ether (~ 30 mls.) was gradually added to lithium shot (2 g., 0.28 moles) in ether (~ 40 mls.) contained in a 3N flask fitted with a dropping funnel, mechanical stirrer and a Friedrich condenser. The solution soon turned brown and a good ether reflux was maintained during the addition (cooling with an ice bath when necessary). After stirring for a further half hour, the solution was transferred via polythene tubing, which contained a glass wool plug, into a 100 ml. graduated dropping funnel. Volume of solution (73 mls.) and strength as determined by titration with acid (1.06N). Yield 93%.

Cyclic $C_6F_{11}Cl$ (20 g., 0.0633 moles) in ether (35 g.) was contained in a 3N flask fitted with a dropping funnel, mercury sealed stirrer, and a reflux condenser with a drikold-acetone cooled cold-finger above the normal reflux condenser. The solution of phenyl lithium (65 mls., 0.0689 moles) was added over about 20 minutes. Heat was given off, and the reaction mixture was cooled with an ice bath. Stirring was continued for a further $\frac{1}{2}$ hour at room temperature. Dilute sulphuric acid (100 mls.)

was added carefully, then conc. sulphuric acid (5 mls.), and after half an hour two clear layers had formed. The ethereal layer was separated and the aqueous layer extracted once with ether (15 mls.). The ethereal layers were combined, dried (magnesium sulphate), filtered and fractionated through a 20 plate column to give; (i) bulk of ether. B.Pt. 33-36°C. Analytical gas chromatography (kieselguhr-dinonyl phthalate, column temperature 50°C., nitrogen flow rate 17 mls./minute) gave two peaks at 3' and 5'36", which corresponded to cyclic $C_6F_{11}Cl$ and ether respectively. No cyclic C_6F_{10} , R.T. 1'36" was present. Cyclic $C_6F_{11}H$ had the same retention time as ether, yet a kieselguhr-tricresyl phosphate packing (column temperature 52°C.) resolved them, no cyclic $C_6F_{11}H$ was detected. The amount of cyclic $C_6F_{11}Cl$ present in the ether fraction was calculated from the relative peak areas after they had been related to concentrations with a mixture of known composition. The correction factors were (ether peak area x 1) and (cyclic $C_6F_{11}Cl$ peak area x 2.15). Amount of cyclic $C_6F_{11}Cl$ thus calculated (8.64 g.). In addition a sample was separated by gas chromatography (16 ft. x 2.3 cm. i.d. column, kieselguhr-dinonyl phthalate and chromatographic system B, column temperature 47°C., nitrogen flow 150 mls./minute). (Found: F, 66.6; Cl,

11.1. Calc. for $C_6F_{11}Cl$: F, 66.1; Cl, 11.2%); (ii) residue (12.1 g.). A straight distillation at atmospheric and reduced pressures yielded; (a) (4.4 g.) B.Pt. up to $150^{\circ}C./A.P.$; (b) (3.4 g.) B.Pt. $60^{\circ}-120^{\circ}C./10$ cms.; (c) (1.18 g.) B.Pt. up to $120^{\circ}C./1$ cm.; (d) residual brown oil (2.4 g.) (Found: F, 33.6. Calc. for $(C_6H_5)_3C_6F_9$: F, 36.1%)

Fraction (a). Analytical gas chromatography (kieselguhr-silicone grease, column temperature $135^{\circ}C.$, nitrogen flow rate 17 mls./minute) gave four peaks at 1'48", 3', 6'36" and 14'48". No bromobenzene, R.T. 11'36", was present. 4.4 g. were separated by gas chromatography (8 ft. x 2.5 cm. i.d. column packed with kieselguhr-silicone grease and chromatographic system B, column temperature $127^{\circ}C.$, nitrogen flow 150 mls./minute) and gave; (i) ether and cyclic $C_6F_{11}Cl$; (ii) (0.3 g.) n_D^{20} 1.494. An infra-red spectrum showed that it consisted predominantly of benzene. No fluorobenzene, which had the same retention time, was present; (iii) chlorobenzene (2.4 g.) n_D^{20} 1.522, for which the literature gave n_D^{20} 1.524. An infra-red spectrum was identical with authentic chlorobenzene; (iv) (0.4 g.) n_D^{20} 1.419, a sweet smelling liquid (Found: F, 52.2%).

Fraction (b). Analytical gas chromatography (column and conditions as above) gave two peaks at 6'36" and 15', and 1.5 g. separated by gas chromatography (column and

conditions as above) gave (i) chlorobenzene (0.6 g.) n_D^{20} 1.525 and; (ii) sweet smelling liquid (0.8 g.), B.Pt. 177.2°C . n_D^{20} 1.4185 (Found F, 52.5. M. 316, Calc. for $\text{C}_{12}\text{H}_5\text{F}_9$: F, 53.4% M. 320). An infra-red spectrum gave a sharp absorption at 3062 cm.^{-1} (monosubstituted aromatics absorb at $\sim 3058\text{ cm.}^{-1}$).⁶⁴ The compound decolourised potassium permanganate in acetone.

Fraction (c). 1.1 g. was introduced onto the preparative column (column and conditions as above) but only 0.2 g. of the sweet smelling liquid was collected. No other material came off the column even though the temperature was raised to 179°C .

Oxidation with aqueous permanganate - carried out as described by Nield, Stephens and Tatlow.⁸⁵ Fraction (b) (1.4 g. containing suspected C_6H_5 . C_6F_9 (0.76 g.)), potassium permanganate (1.4 g.) and sodium bicarbonate (3 g.) in water (100 ml.) were shaken at room temperature for 93 hours. Starting material (1.16 g.), characterised by gas chromatography, was recovered. No acid was isolated.

Oxidation with Potassium permanganate in acetone⁸⁸ The recovered material from the previous reaction was added to potassium permanganate (1 g.) in 100 mls. of acetone (distilled over alkaline permanganate and dried with magnesium sulphate), and after shaking, left for $\frac{3}{4}$ hour. Water (100 mls.) was added and a copious brown precipitate was observed. The acetone was taken

off under reduced pressure and the aqueous solution acidified, decolourised with sulphur dioxide, and extracted continuously with ether for 20 hours. The ethereal extract was dried (magnesium sulphate), filtered and most of the ether distilled off. The residue was transferred to a sublimation apparatus and all volatile material at $150^{\circ}\text{C.}/2\text{ mm.}$ taken off. The small residue was dissolved in ether, the solution filtered and aniline (redistilled) added. A white precipitate was formed, which was filtered off and dried (50 mg.). The material started to decompose at $\sim 180^{\circ}\text{C.}$ (Found: F, 31.8. E.Wt. 277. Calc. for $\text{C}_4\text{F}_8(\text{COOH})_2 \cdot 2\text{PhNH}_2$: F, 31.9, E.Wt. 238 and for $\text{C}_4\text{F}_7\text{Ph.}(\text{COOH})_2 \cdot 2\text{PhNH}_2$: F, 24.9%. E.Wt. 267).

The reaction between cyclic $\text{C}_6\text{F}_{11}\text{Cl}$ and phenyl sodium

Phenyl sodium was made as described by Gilman, Pacewitz and Baine.⁸⁹ Metallic sodium (0.86 g., 0.0374 moles) was dispersed in toluene (6 g.) as described on page 156. After cooling, it was transferred to a 50 ml. flask fitted with a dropping funnel, mechanical stirrer and a Friedrich condenser. Phenyl chloride (1.8 g., 0.016 moles) in toluene (1.8 g.) was added over about 20 minutes, heat was evolved and the reaction mixture darkened. The temperature was kept below 40°C. Stirring was continued at room temperature for 2 hours. The phenyl sodium

was transferred over a period of 15 minutes, via polythene tubing, into the reaction vessel which contained cyclic $C_6F_{11}Cl$ (5 g., 0.0158 moles) in toluene (5 g.) and was fitted with a mechanical stirrer and a reflux condenser with an acetone-drikold cooled trap attached. Heat was evolved during the reaction and the temperature was kept below $\sim 30^\circ C$. The stirring was continued for a further hour and water (50 ml.) added. The organic layer was separated, dried (magnesium sulphate) and filtered. During the reaction, volatile material (2.7 g.) had condensed in the cold-trap. Analytical gas chromatography (kieselguhr-dinonyl phthalate, column temperature $93^\circ C$., nitrogen flow rate 30 mls./minute) gave 3 peaks at 48", 1'12" and 13'12" of relative areas 0.27:1.8:1, which corresponded to decafluorocyclohexene, cyclic $C_6F_{11}Cl$ and toluene. The cyclic C_6F_{10} was checked at a lower column operating temperature ($44^\circ C$.). An infra-red spectrum showed the double-bond absorption of cyclic C_6F_{10} at 1745 cm.^{-1} , Burdon and Whiffen gave 1746 cm.^{-1} . Assuming equal thermal conductivities for these components, the concentrations are cyclic C_6F_{10} (0.24 g.), cyclic $C_6F_{11}Cl$ (1.6 g.) and toluene (0.88 g.). The organic layer was fractionated through a 22 plate column and gave;

(i) (1.5 g.) B.Pt. $65-107^\circ C$. Analytical gas chromatography (kieselguhr-dinonyl phthalate, showed two peaks at 1'12" (cyclic $C_6F_{11}Cl$), and 13'12" (toluene), of relative areas

0.12:1. Assuming equal thermal conductivities cyclic $C_6F_{11}Cl$ (0.16 g.) was present; (ii) bulk of toluene and; (iii) residue (3 g.). A straight distillation gave the successive fractions; (a) (1.3 g.) (Found: F, 3.8; Cl, 4.4%); (b) (0.7 g.) (Found: F, 7.2; Cl, 7.2%); (c) (0.3 g.), silicone oil bath at $220^{\circ}C$. (Found: F, 42.0; Cl, 5.4%); and (d) residual brown oil (0.6 g.) (Found: F, 31.4; Cl, 1.2%). Analytical gas chromatography (kieselguhr-silicone grease, column temperature $185^{\circ}C$., nitrogen flow 18 mls./minute) showed that fractions (a), (b) and (c) each gave the same three peaks at 1'48", 2'36" and 4'7" which corresponded to toluene, chlorobenzene and the suspected $C_6H_5 \cdot C_6F_9$ obtained in the reaction between phenyl lithium and cyclic $C_6F_{11}Cl$. An infra-red spectrum showed all the absorptions of authentic chlorobenzene and the suspected $C_6H_5 \cdot C_6F_9$. The amounts of chlorobenzene and suspected C_6F_9Ph present in fractions (a), (b) and (c), as calculated from the halogen analytical figures were

	chlorobenzene (g)	suspected $C_6H_5 \cdot C_6F_9$ (g.)
fraction (a)	0.18	0.093
fraction (b)	0.16	0.094
fraction (c)	0.51	0.236

REFERENCES

75. JAMES and PHILLIPS, J.C.S., 1606, 1953.
76. DIMBAT, PORTER and STROSS, Anal. Chem., 290, 1956.
77. BURDON and WHIFFEN, Spectrochim. Acta, 139, 12, 1958.
78. STEELE and WHIFFEN, Tetrahedron, 181, 3, 1958.
79. HARRIS, NARASIMHAM and NIELSON, J. Chem. Phys., 433, 1232, 24, 1956.
80. MASSINGHAM et al., J. App. Chem., 221, 2, 1952.
81. BROMILEY and QUIGGLE, Ind. Eng. Chem., 1136, 35, 1935.
82. PHILLIPS, op. cit., p. 63.
83. LECKY and EWELL, Ind. Eng. Chem., Anal. Ed., 544, 12, 1940.
84. BIRCHALL and HASZELDINE, J.C.S., 13, 1959.
85. NIELD, STEPHENS and TATLOW, ibid, 166, 1959.
86. FIESER, Experiments in Organic Chemistry, Heath and Company, 1955, p. 267.
87. PODAL, FOSTER and GIRAITIS, J. Org. Chem., 82, 1958.
88. BURDON and TATLOW, J. App. Chem., 293, 8, 1958.
89. GILMAN, PACEWITZ and BAINE, J.A.C.S., 1517, 62, 1940.

CHAPTER 5.

Analytical section

The determination of chlorine and fluorine
in organic compounds

SUMMARY

The quantitative reduction of organically bound chlorine and fluorine in stable highly fluorinated organic compounds to inorganic halide has been found to proceed quickly and smoothly at room temperature using the diphenyl-sodium-dimethoxy ethane complex. The inorganic halide can then be determined, as described in the preceding paper in this series,¹ making use of a cation exchange resin. This work has been published. See, Johncock, Musgrave and Wiper, *The Analyst*, 245, 84, 1959.

INTRODUCTION

Until recently in this department the semi-micro determination of fluorine and chlorine in organic compounds has been carried out according to the method of Banks, Cuthbertson and Musgrave.¹

Although Samuelson² mentioned the use of an anion exchange resin for the separation of fluoride, chloride and iodide ions from each other, and Osborn³, the conversion of inorganic fluoride by a cation exchange resin to hydrofluoric acid which could be titrated directly, Banks, Cuthbertson and Musgrave were the first workers to realise the advantages offered by the application of a cation exchange resin in allowing the total halogen in an organic compound to be determined by alkalimetry.

The organic compound, containing about 10 mg. of halogen, was decomposed with sodium in a nickel bomb, such as described by Belcher and Tatlow,⁴ at 600-700°C. and the inorganic halides formed taken up in 100 mls. of solution. The salts were converted to their corresponding acids by passage through a column containing the cation exchange resin, amberlite IR-120 (H), chosen because of its good exchange rate, high exchange capacity and no great tendency to change its volume on conversion from one form to another. The total halide content of a 10 ml. aliquot was determined by titration with alkali using methyl red screened with

methylene blue as indicator. The chloride was directly estimated by neutralisation of a second aliquot with the exact amount of alkali, evaporation of the solution to an optimum chloride concentration of about 2 mg. per 10 mls. and titration with silver nitrate using dichloro-R-fluorescein as indicator. This indicator can be used successfully since it is operating in a solution of pure halides; the only condition under which the indicator functions. The fluoride is found by difference. Nitrogen could be determined as cyanide in the fusion solution by the method of Deniges⁵ provided the organic compound did not contain oxygen. In the chloride determination, cyanide was removed by treating the fusion solution with aqueous formaldehyde solution.⁶ Cyanate was converted by the cation exchange resin to cyanic acid which decomposed to ammonia and carbon dioxide; the former was retained on the column and did not interfere and the latter could be removed by boiling the solution.

Eger and Yarden⁷ at the same time as Banks, Cuthbertson and Musgrave, and in a subsequent paper^{7a}, determined fluorine in organic compounds by decomposing them with sodium peroxide in a modified Parr bomb, simply used the cation exchange resin, amberlite IR-120 (H), to remove the excess sodium ions and titrated with thorium nitrate using sodium alizarin sulphonate as indicator. These workers said that the method was applicable to other halogens besides fluorine

and that chloride and bromide could be determined in the same solution but no details were given. It is surprising that the acid was not titrated directly with alkali.

Zenin⁸ separated fluoride ions from solution by retaining them on a column of the thorium salt of the cation exchanger, sulphonated coal resin, and extracted them with ammonia or alkali. The fluoride was determined by titration with thorium nitrate, and colorimetrically, but these methods were not accurate and the fluosilicic acid method had to be resorted to.

If a cation exchange resin is not used, the fluoride must be determined either volumetrically by titration of the fusion solution with thorium nitrate using sodium alizarin sulphonate as indicator - a reaction which is non-stoichiometric and requires a comparative colour technique⁹ - or by using the lengthier gravimetric procedure¹⁰ in which lead chloro-fluoride is precipitated. Both methods give good results in the hands of experienced analysts. As far as chloride is concerned, a direct titration of the neutralised fusion solution with silver nitrate is impossible because of the large nitrate ion concentrations, and the longer indirect methods of Brown and Musgrave⁶ or Belcher, Macdonald and Nutten¹¹ must be used.

It is thus apparent that provided a quantitative decomposition to the inorganic halides is obtained, the

use of a cation exchange resin allows simple and direct estimation of the chloride and fluoride.

In our experience when dealing with more stable fluorine containing compounds of the type benzotrifluoride, chlorofluorocyclohexanes and fluorocyclohexanes, decomposition with sodium or potassium at 650°C. in a nickel bomb was often incomplete; at 700-750°C., low figures were still obtained and farther trouble arose in that 'bomb blowing' was frequent. At these higher temperatures softening of the nickel occurred and after a bomb had blown, pitting of the nickel at the nickel-copper washer interface was apparent. This latter effect could be eliminated by refacing the nickel surface after every two decompositions.

Ma, in his review of the micro determination of fluorine in organic compounds¹² lists the numerous variations of bombs, reagents and temperatures recommended for the decomposition of organic fluorine compounds. Obviously, the recommendations of different workers depend on the range of compounds which they have considered, even so, it is apparent that the more stable fluorine compounds require extremely high temperatures at which the limitations of the bomb, certainly from a constructional point of view, are severely tested. Belcher⁴, decomposed organic fluorine compounds with sodium or potassium in a nickel

bomb at 600°C. for 1 hour, Savchenko¹³ recommended a temperature of 900°C. Korshun, Klimorva and Chumachenko¹⁴ used a steel bomb heated at 800°C. for 1 hour. Ma and Gwirtsman,¹⁵ decomposed samples in a Parr micro bomb and specified a copper washer; sodium was used for mono- and potassium for poly-fluoro compounds; and the bomb was simply heated with a bunsen burner for 15 minutes. Organic fluorine compounds have also been frequently decomposed by catalytic oxidation at high temperatures. Clark,¹⁶ effectively decomposed mono- and di-fluoro compounds by catalytic oxidation in a quartz combustion tube containing platinum foil at 900°C; Clark and Rees,¹⁷ said that some polyfluoro-compounds required a temperature of 1150°C. and Freier and co-workers¹⁸ advocated this temperature for all polyfluoro-compounds. Belcher,¹⁹ employed a platinum micro combustion tube which could withstand high temperatures but which was opaque and pliable.

It is thus apparent that a simpler method of quantitatively decomposing polyfluoro-organic compounds would be very desirable, and we found that the sodium biphenyl- demethoxy ethane complex accomplishes this, quickly, at room temperature. The method essentially follows that progressively developed by Benton and Hamill,²⁰ Pecherer, Gambrill and Wilcox²¹ and Ligett²² for the decomposition of organic compounds containing halogen other than fluorine.

Vaughn and Nieuwland,²³ using sodium in liquid ammonia,

first attempted the reduction of organic halogen to halide in solution. The method, however, was of limited application because of the sparing solubility of many compounds in liquid ammonia.

In 1936, Scott, Walker and Hansley²⁴ showed that concentrated solutions of the addition compounds of sodium with biphenyl, naphthalene and other aromatic hydrocarbons could be prepared in suitable solvents. As far as really concentrated solutions of sodium biphenyl or naphthalene complexes, of the order of 1 to 2 g. atoms of sodium per litre of solution, were concerned, only dimethyl ether and dimethoxy ethane could be used. These complexes contained 1 g. atom of sodium dissolved per mole of hydrocarbon and further uptake of sodium was difficult. The solutions contain hydrocarbon anions, potentially a powerful source of electrons, and consequently excellent reducing agents.

The possibility of using these complexes as electron transfer reagents in the reduction of organic halogen to halide was first realised by Benton and Hamill²⁰ who used a 0.5 M solution of the sodium naphthalene-dimethoxy ethane complex. The organic compound containing chlorine or bromine, if liquid, was sealed in a thin walled glass tube, which was placed in a separating funnel and excess of the complex added. On shaking, the bulb broke, and a vigorous reaction ensued which the workers regarded as almost instantaneous.

The excess reagent was decomposed and the halide extracted with water. The aqueous extracts after acidification were titrated potentiometrically with silver nitrate. Solid samples were dissolved in a small amount of toluene before being treated with the reagent. A blank experiment was also carried out. Good results were obtained for a number of mono and polychloro or polybromo- compounds. However, compounds such as p-chloro-aniline, containing a reactive hydrogen atom, formed insoluble unreactive salts and low results were obtained. Also, compounds containing nitro-groups proved difficult and hexabromobenzene and 2,2-difluoroheptane did not react at all.

Pecherer, Gambrill and Wilcox,²¹ after preliminary experiments with the sodium complexes of naphthalene and anthracene and the ketyl from benzophenone in dimethoxy ethane, concentrated on the sodium biphenyl complex for the estimation of ethylene halides in petroleum. Hoitzink et al,²⁵ recently have measured the reduction potentials of a number of hydrocarbons and their univalent anions with reference to biphenyl, the one of lowest electron affinity, in dimethoxy ethane. The naphthalene anion is only less reactive than that of biphenyl in this series. Pecherer et al. successfully extended the method to a number of aliphatic and aromatic compounds containing chlorine or bromine. This reagent was not restricted

to the decomposition of organic compounds with only non-reactive groups, thus p-chlorophenol was successfully analysed. The reaction was generally complete within the shortest time studied, namely 10 minutes. Their technique was much the same as that of Benton and Hamill except that a 1% solution of the sample in benzene was treated with excess 0.5 M reagent.

Ligett,²² expanded the above authors' work into a simple analytical procedure and also developed a convenient method of preparing the reagent and for storing it over considerable periods. Ligett advocated a number of solvents:- Toluene, benzene, ether or other water immiscible solvent for dissolving the sample before the decomposition with excess 1.3 M sodium biphenyl- dimethoxy ethane complex. Complete solution of the sample was essential. If this could not be achieved at room temperature, refluxing was recommended and sometimes even refluxing with the reagent itself; under these circumstances more reagent was required because of its decomposition at higher temperatures. A blank was carried out under identical conditions. After extraction with water and nitric acid the halide was determined by the Volhard technique. All those compounds for which Benton and Hamill found the sodium naphthalene-dimethoxy ethane complex uneffective were successfully analysed by Ligett. Provided samples were completely

soluble the reaction was probably instantaneous; compounds which formed insoluble intermediates required a longer time. The analysis of fluorine containing compounds was not attempted.

Ma,¹² in the review already referred to, mentions that Benett and Debrecht²⁶ reported the general applicability of the sodium biphenyl-dimethoxy ethane complex for the speedy complete reduction of organically bound fluorine but no detailed procedure was published.

Application of the Sodium biphenyl- dimethoxy ethane complex for estimating organically bound fluorine

Discussion

Since during the preliminary work in the application of this method, dimethoxy ethane was unavailable for the reagent preparation, and as Sezerat,²⁷ who although using dimethoxy ethane, reported that tetrahydrofuran might be used instead, the preparation of sodium biphenyl was first attempted in this solvent. Sezerat also advocated the use of oleic acid to facilitate the sodium dispersion formation which was used in the reagent preparation. However, as Ligett pointed out, and as we confirm, the use of dispersive aids encourages emulsion formation during the aqueous extraction making a clean separation impossible. Another reason why it is particularly important not to add oleic acid in our case, is that, since the total halogen

is determined by alkalimetry, buffering at the end point would occur. Attempts to make a molar solution of the complex in tetrahydrofuran were unsuccessful, and although the reaction started almost immediately, the sodium dispersion soon coagulated forming a honeycomb structure which settled in the bottom of the flask. The preparation of the complex in dimethoxy ethane proceeded smoothly.

Contrary to Ligett,²² it was found that neither toluene, benzene nor petroleum spirit were suitable solvents for the organic sample since emulsion formation occurred during the aqueous extraction even though no dispersion aids were used in the sodium dispersion formation. Ligett's clean extraction from these solvents might have been due to the fact that he extracted with dilute nitric acid. Ether formed no emulsion, but, because of its volatility, much loss of material occurred on venting the separating funnel after shaking. Di-isopropyl ether suffered none of the above disadvantages and was a suitable solvent for our organic compounds.

Samples were quite conveniently weighed in a gelatin capsule and the top removed before introduction into the di-isopropyl ether. 10 mls. of the reagent was added; no more was necessary under our conditions. Periodic use of the reagent in the same storage bottle was found

uneconomical since the residue after using 3 or 4 10 mls. portions tended to thicken and become less effective, presumably due to reaction with the atmosphere. More than 10 mls. of reagent was then necessary to achieve the permanent green colour but for some reason inconsistent results were obtained. The trouble was eliminated by carrying out the analyses in 'batches of ten' and using all of the reagent in one bottle at one session. This was also advantageous in that only one blank determination per bottle of reagent was required. The reaction was usually complete within 10 minutes and the halides extracted with water and made up to a known volume.

The presence of organic material in the aqueous extract necessitated a slight modification of the Banks, Cuthbertson and Musgrave¹ technique. These workers regenerated the resin for re-use after having passed an aliquot of their fusion solution through the column. It was found, however, that the passage of our halide solutions denatured the column and that the use of regenerated resin gave inconsistent results. This was eliminated by simply using fresh resin each time.. Quantitative results were obtained using a minimum of 5 g. of resin.

10 c.c.s. of solution is approximately 0.1 N w.r.t. Na^+

5 g. of amberlite IR-120 (H) \equiv 7 mls. NNa^+

Therefore there is a good excess of resin.

The use of polythene for the anion exchange column was not necessary and pyrex apparatus was used.

The method has been found applicable to a number of stable polyfluoro-compounds such as chlorofluorocyclohexanes, fluorocyclohexanes and perfluorocyclohexa-dienes. The decomposition proceeded smoothly and quickly at room temperature.

Attempts were made to analyse telomers of general formula $CF_3(CF_2)_nI$, $n \gg 7$ and polytetrafluoroethylene but no suitable solvents could be found. Refluxing in a tetrahydrofuran-di-isopropyl ether mixture, in which slight solubility was apparent, before treatment with the reagent, or even refluxing with excess of the reagent, gave maximum fluorine figures of only about 15% of the expected values.

Experimental

Preparation of the sodium biphenyl-dimethoxy ethane complex

Reagents

Toluene - sulphur free toluene was distilled over sodium.

Dimethoxy ethane - was distilled twice over potassium, the second time in the presence of the ketyl of benzophenone. B.Pt., 66-68°C.

Biphenyl - was recrystallised once from meths. and pumped dry under vacuum. M.Pt. 70-71°C.

Sodium dispersion - 60 g. (2.61 g. atoms) of sodium and 60 g. of toluene were placed in a 2N 250 c.c. specially indented flask, to prevent swirling, with a nitrogen inlet, and outlet via a vertical air condenser, down the centre of which was freely suspended the rod of the dispersator. The toluene was gently refluxed and the dispersator ran at near maximum speed for 15 minutes. The heating and dispersator were turned off and the dispersion allowed to cool to room temperature.

Complex Preparation - essentially as described by Ligett²² and Sezerat.²⁷

The sodium dispersion was transferred to a 2 l. 3N flask fitted with a dropping funnel, mechanical stirrer and reflux condenser. The system was under nitrogen. The total toluene concentration was made up to 300 mls. and 750 mls. of dimethoxy ethane added. With steady stirring, 400 g. (2.6 moles) of biphenyl in 500 mls. of dimethoxy ethane were added over a period of 2 hours. The reaction started after about 5 minutes and the solution turned first green and finally black; heat was evolved and the temperature was kept below 30°C. by cooling in an ice-water-bath. Stirring was continued for a further hour and the solution allowed to stand overnight. The reagent was transferred to 100 ml. bottles stoppered with corks holding aluminium foil seals and stored in a refrigerator at 0°C.

There was no sign of any residual sodium in the reaction flask.

Analytical procedure

Reagents

Sodium hydroxide solution 0.02 N.

Silver nitrate solution 0.01 N.

Mercuric oxycyanide solution - 20 g. of mercuric oxycyanide were shaken with 1 litre of distilled water and the solution neutralised approximately with 0.1 N sulphuric acid with methyl red - methylene blue as indicator, and filtered into a brown glass bottle.

Sodium chloride solution 0.01 N.

sulphuric acid solution 0.01 N.

Indicators

Methyl red-methylene blue; see Banks, Ph.D. thesis, Durham 1956, p. 189.

Dichloro-R-fluorescein; 0.1 g. in 100 mls. of 70% alcohol.

Experimental

20 mls. of di-isopropyl ether (B.D.H. technical) were placed in a separating funnel fitted with a rubber bung. The organic sample containing 10-20 mg. of halogen was weighed out in a gelatin capsule and the top removed before introduction into the solvent and the bung replaced. Complete solubility was essential for a successful

decomposition. 10 mls. of the reagent (≈ 1.0 M) were added and the separating funnel carefully shaken; the system was vented by removing the bung. It was usually necessary to shake intermittently for 4 or 5 minutes to obtain complete miscibility and for the solution to retain a permanent green colour showing that excess of the reagent was present. No more than 10 mls. of the reagent was necessary to achieve this. After standing for a further 5 minutes, the halides were extracted with 3 x 20 mls. of water - all water used for making up the decomposition solutions and subsequent treatments of them had been passed through a 'Deminrolit' column - and the aqueous extracts made up to 100 mls. A blank experiment was carried out under identical conditions.

A 10 mls. aliquot was passed through the cation exchange resin column containing 5 g. of amberlite IR-120 (H) resin and eluted with 60 mls. of water added in successive amounts of 15 mls. The eluate was heated to boiling and immediately cooled.

If fluorine or chlorine were present alone

The solution was simply titrated with standard 0.02 N. NaOH solution using methyl red-methylene blue (3:2 drops) as indicator.

If fluorine and chlorine were present

The total halogen content was determined as above

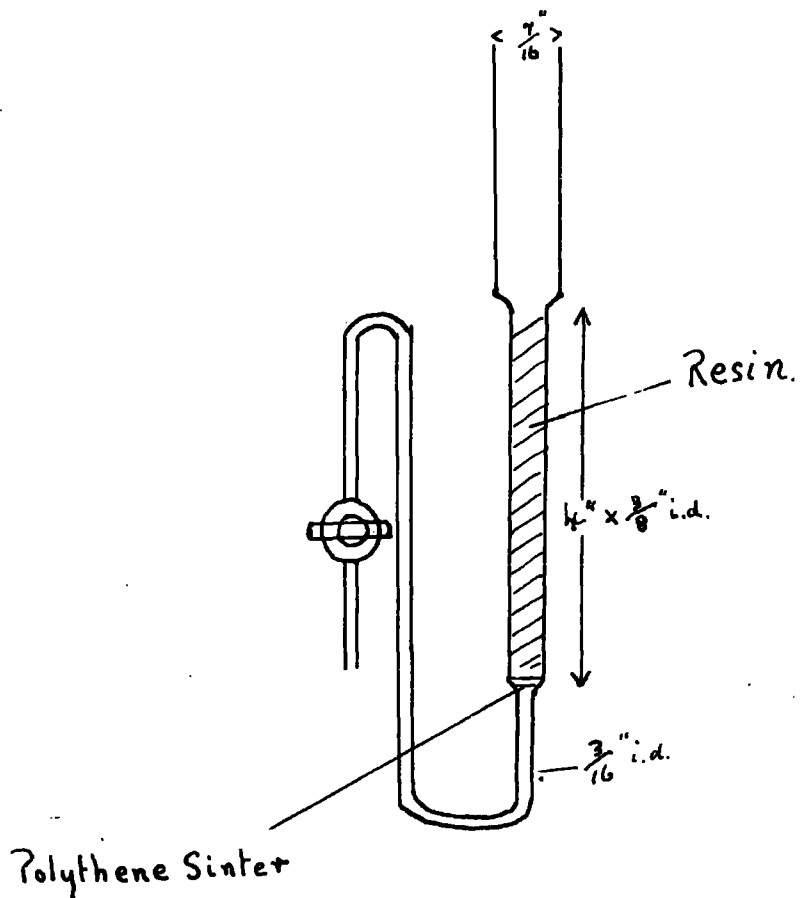
DIAGRAM 23RESIN' EXCHANGE COLUMN.

and a second aliquot, after passage through the column, neutralised with the exact amount of alkali. The solution was evaporated down to an approximate chloride concentration of 2 mg. per 10 mls. solution and titrated with 0.01 N silver nitrate solution using dichloro-R-fluorescein as indicator.

Alternatively, after neutralisation with methyl red-methylene blue (3:2 drops) as indicator, the chloride in the same solution could have been determined by the mercuric oxycyanide method as described by Belcher et al.¹¹

If nitrogen was present

10 mls. of the decomposition solution was treated with 3 mls. of aqueous formaldehyde solution and allowed to stand for 30 minutes. The halide could then be estimated as previously described.

Results

<u>Standard compounds</u>	Found		Calculated	
	% Cl	% F	% Cl	% F
$C_7H_5F_3$ Benzotrifluoride		39.0		39.0
C_6H_5F fluorobenzene		19.9		19.7
$C_7H_5O_2N_2F_3$ 3-nitro-4-aminobenzotri- fluoride		27.5		27.6
$C_{11}H_9O_2NClF_3$ 2-chloro-5-trifluoro- methylacetoacetanilide	13	20.9	13.1	21.1
$C_9H_8O_4NF_3S$ 3-amino-4-sulphonyl- benzotrifluoride		20.1		20.1
$C_6F_{10}H_2$ dihydrodecafluorocyclohexane		71.6		72.0
$C_6F_9H_3$ trihydrnonafluorocyclo- hexane		69.6		69.5
<u>Research compounds:</u>				
$C_6F_{11}Cl$ monochloroundecafluoro- cyclohexane	11.3	65.7	11.2	66.0
$C_6F_{10}Cl_2$ dichlorodecafluoro- cyclohexane	21.2	57.1	21.4	57.1
$C_6F_9Cl_3$ trichlorononafluoro- cyclohexane	30.6	48.6	30.4	48.9

<u>Results</u> (continued)	Found		Calculated	
	% Cl	% F	% Cl	% F
$C_6F_8Cl_4$ tetrachlorooctafluoro- cyclohexane	38.4	41.6	38.8	41.5
$C_6F_7Cl_5$ pentachloroheptafluoro- cyclohexane	46.3	35.0	46.4	34.8
$C_{19}H_{34}P_2PdBrF_3$ Bis(triethylphosphine) p-trifluoro- methyl-phenyl-bromo palladium	(Br)13.7	9.9	(Br)14.1	10.0

REFERENCES

1. BANKS, CUTHBERTSON AND MUSTRAVE, Anal. Chim. Acta, 442, 13, 1955.
2. SAMUELSON, Ion exchangers in Analytical Chemistry, John Wiley and Sons, New York, 1953, p. 178.
3. OSBORN, Analyst, 220, 78, 1953.
4. BELCHER AND TATLOW, *ibid.*, 593, 76, 1951.
5. DENIGES, Compt. rend., 1078, 117, 1893.
6. BROWN AND MUSGRAVE, Anal. Chim., Acta, 29, 12, 1955.
7. EGER AND YARDEN, C.A., 13018, 49, 1955; Bull. Research Council Israel, 305, 4, 1954.
- 7a. EGER AND YARDEN, Anal. Chem., 512, 28, 1956.
8. ZENIN, Hidrokhim Materialy, 115, 22, 1954; C.A., 14568, 49, 1955.
9. BELCHER, CLARK, CALDAS AND MACDONALD, Mikrochim. Acta, 283, 3, 1953.
10. BELCHER, CALDAS AND CLARK, Analyst, 602, 77, 1952.
11. BELCHER, MACDONALD AND NUTTEN, Mikrochim. Acta, 104, 4, 1954.
12. MA, Anal. Chem., 1557, 1958.
13. SAVCHENKO, Zhur. Anal. Chim., 355, 10, 1955.
14. KORSHUN, KLIMORVA AND CHUMACHENKO, *ibid.*, 358, 10, 1955.
15. MA AND GWIRTSMAN, Anal. Chem., 140, 29, 1952.
16. CLARK, *ibid.*, 659, 23, 1951.

17. CLARK AND REES, Illinois State Geol. Survey, Rept. Invest. 659, 1951.
18. FREIER AND co-workers, Anal. Chem., 146, 27, 1955.
19. BELCHER, private comm. to MA, *ibid.*, 1557, 1958.
20. BENTON AND HAMILL, *ibid.*, 269, 20, 1948.
21. PECHERER, GAMBRIL AND WILCOX, *ibid.*, 311, 22, 1950.
22. LIGETT, *ibid.*, 748, 2, 1954.
23. VAUGHN AND NIEUWLAND, Ind. Eng. Chem., Anal. Ed., 274, 3, 1931.
24. SCOTT, WALKER AND HANSLEY, J.A.C.S., 2442, 58, 1936.
25. HOITJINK, de BOER, van der MEY and WEYLAND, Rec. Trav. Chim., 487, 75, 1956.
26. BENETT AND DEBBRECHT, 131st Meeting, A.C.S., Miami, Fla., April 1957, Abstracts, p. 24B.
27. SEZERAT, Annal. Pharm. Franz., 745, 13, 1955.

