

# Durham E-Theses

---

## *Tracer studies on the solid state*

John Neil Sherwood

### How to cite:

---

Sherwood, John Neil (1959) Tracer studies on the solid state. Doctoral thesis, Durham University.

### Use policy

---

The full-text may be used and/or reproduced, and given to third parties in any format or medium, without prior permission or charge, for personal research or study, educational, or not-for-profit purposes provided that:

- a full bibliographic reference is made to the original source
- a <https://etheses.durham.ac.uk/id/eprint/8809/> is made to the metadata record in Durham E-Theses
- the full-text is not changed in any way

The full-text must not be sold in any format or medium without the formal permission of the copyright holders.

Please consult the [full Durham E-Theses policy](#) for further details.

TRACER STUDIES ON THE SOLID STATE

Thesis

submitted for the degree of

Doctor of Philosophy

of the

University of Durham

by

JOHN NEIL SHERWOOD, B.Sc., A.R.I.C.

Bede College

25th May, 1959.



## ABSTRACT

A study of self-diffusion in anthracene single crystals has been carried out using a radioactive tracer technique.

A method was developed for the growth of large single crystals of anthracene from the melt, starting from the Bridgman technique. On to one surface of the crystals was evaporated a deposit of anthracene - 9 - carbon-14, prepared by a seven stage synthesis from barium 14-carbonate, and the crystals and their deposits were heated at constant temperatures in the range 150°-190°C for periods up to 230 hours. The crystals were then sectioned parallel to the initial active face, using a calibrated, hand operated, lathe. The quantity of radioactive material which had diffused into each section was determined by quantitative combustion of the sections to carbon dioxide in an "Empty Tube" rapid combustion apparatus, followed by the determination of the disintegration rate of this gas in a gas counting tube, using carbon disulphide as charge transfer agent. Penetration was found up to a depth of  $4 \times 10^{-2}$  cms.

It was found that two concurrent diffusion processes were occurring in the crystal. One of these involved only a small proportion of the total diffusing activity and may represent diffusion along intersecting dislocations in the crystal. The second process involved most of the diffusing activity and was thought to represent bulk diffusion in the crystal. The temperature

dependence of the diffusion coefficient for the second process is given by the equation

$$D = (1.31 \pm 1.13) \times 10^{11} e^{-(42,400 \pm 1,200)/RT} \text{ cms.}^2 \text{ per second}$$

The pre-exponential factor and activation energy for this process are unusually high. This leads to the conclusion that a co-operative diffusion phenomenon is occurring in the crystal, in which diffusion occurs by way of vacant lattice sites, and that the loosening or premelting of from four to six molecules occurs in the neighbourhood of the vacancy during diffusion.

This is one of the few studies of self-diffusion in molecular crystals.

## ACKNOWLEDGEMENTS

It is a pleasure to express my sincere gratitude to my supervisor, Dr. S. J. Thomson, for his continued interest in this work and for his help, advice and encouragement.

I would also like to thank Mr. G. R. Martin of the Londonderry Laboratories for Radiochemistry, Durham University, for many helpful discussions, and Professor J. Monteath Robertson of Glasgow University for providing me with laboratory facilities during my final year, and to gratefully acknowledge the help of: Mr. K. T. B. Scott, Dr. R. Lapage and Dr. S. K. Hutchinson of the A.W.R.E., Aldermaston, Miss A. M. G. Macdonald of Birmingham University, and Dr. E. Clar and Dr. K. C. Campbell of Glasgow University.

I am indebted to the Council of the Durham Colleges and to the Gas Council for maintenance grants received during my studies.

Finally I should like to thank my wife for her help in the preparation of the diagrams for this thesis.

*John N. Sherwood.*

## CONTENTS

	Page
INTRODUCTION	1
CHAPTER I. EXPERIMENTAL TECHNIQUES	
1. The Growth of Single Crystals of Anthracene	14
2. The Synthesis of Anthracene - 9 - Carbon-14	49
3. The Deposition of Radioactive Anthracene on the Crystal Surface	59
4. The Diffusion Experiments	67
5. The Crystal Sectioning Technique	78
6. The Determination of Radioactivity in the Crystal Sections	85
7. The Combustion of the Crystal Sections	88
8. The Internal Gas Counting of Carbon-14	100
CHAPTER II. THE RESULTS OF THE DIFFUSION EXPERIMENTS	
1. Experiments carried out to determine the Rates of Diffusion Perpendicular to the Cleavage (001) Plane	115
2. Experiments carried out to determine the Rates of Diffusion in a Direction Parallel to the Cleavage (001) Plane	126
3. Experiment to determine the Rate of Surface Diffusion	128

	Page
CHAPTER III. INTERPRETATION OF RESULTS	
1. The Choice of a Diffusion Equation	129
2. Interpretation of the Experimental Results	136
3. Calculation of the Diffusion Equation for Self-Diffusion in Anthracene	141
4. The Rate of Self-Diffusion Parallel to the Cleavage Plane in Anthracene	142
CHAPTER IV. DISCUSSION OF THE RESULTS	
1. Summary of Previous Work	144
2. The Experimental Expression for the Self-Diffusion in Anthracene	154
3. Comparison of the Pre-exponential Factor for Self-Diffusion in Anthracene with Values determined for other Molecular Solids	157
4. Calculation of the Pre-exponential Factor for Self-Diffusion in Anthracene	159
5. The Calculation of the Entropy Factor associated with Self-Diffusion	166
6. The Activation Energy for Self-Diffusion in Anthracene	170
7. The Rapid Diffusion in Anthracene	174
8. The Absence of Surface Diffusion on Anthracene Crystals	176
9. Conclusions	177
Future Work	178

REFERENCES

180

APPENDICES

- I Experimental Details concerning the Determination  
of Absorption Spectra
- II Calculation of the Constants for the Arrhenius type  
Equation for Self-Diffusion in Anthracene
- III The Calculation of the Diffusion Coefficient

## LIST OF FIGURES

Figure		Facing page
1.	Diagram of the Temperature Gradient.	17
2.	The Crystal Growing Oven.	21
3.a.	The Thermostat Circuit.	
b.	The Heating Circuit.	23
4.	The Crystal Growing Tubes.	27
5.	The Capillary of the Crystal Growing Tube.	32
6.	U.V. Spectra of the Anthracene in the Range a. 270-300 $m\mu$ ., b. 400-460 $m\mu$ ..	37
7.	U.V. Spectrum of the Purified Anthracene in the Range 290-390 $m\mu$ ..	38
8.	A Photograph of the Zone Refining Tube.	41
9.	The Distillation Apparatus.	43
10.	The Distillation Effect in the Crystal Growing Tube.	44
11.	The Laue Diffraction Pattern of Anthracene.	48
12.	Synthesis of Anthracene - 9 - Carbon-14.	50
13.	The Carbonation Apparatus.	51
14.	The Evaporator.	61
15.	A Diagram of the Crystal and Deposit.	66
16.	The Autoclave.	68
17.	The Crystal Holder.	72
18.	The Crystal Holding Device.	82

Figure		Facing page
19.	Plan of the Lathe.	83
20.	Block Schematic Diagram of the High Vacuum Apparatus.	90
21.	The High Vacuum Apparatus - The Combustion Section.	90
22.	The High Vacuum Apparatus - The Counter Filling Section.	103
23.	The Gas Counting Tube Characteristic.	108
24.	Variation of the Counter Characteristic with Internal Pressure.	109
25.	Graph to show Variation of Count Rate with Internal Pressure for the Gas Counting Tube.	111
26.	Diffusion Profile for Crystal A.	118
27.	Diffusion Profile for Crystal I.	118
28.	Diffusion Profile for Crystal C.	119
29.	Diffusion Profile for Crystal F.	119
30.	Graph of $\log_{10} A$ versus $\bar{x}^2$ for Crystal I.	130
31.	Crystal and Deposit.	131
32.	Graph of $\log D$ versus $\frac{1}{T}$ .	142
33.	Position of the Anthracene Molecules in the Unit Cell.	163
34.	Graph of $\log_{10} D$ versus $\frac{T_m - T}{T}$ .	169

## INTRODUCTION

The quantitative study of diffusion in solids can be said to have been initiated in 1896 when Roberts-Austen measured the rate of diffusion of gold in lead (1). After the discovery that diffusion proceeded at a measurable rate in solids, it was realised that such experiments might provide information about the basic metallurgical processes such as the carburisation of steel, cold welding and alloying from metal powders, some of which had been known, if not understood, for centuries. Not only was this aim realised, but many more useful metallurgical processes were discovered and, even more fundamental than this; a great deal of information was obtained about the physics of crystals (2). It was from this beginning that this subject has grown and since the beginning of this century diffusion studies have been made in almost all types of solids.

After the initial work in metallic systems, many hundreds of which have been studied, the field was extended to include ionic crystals (2) and later still a few studies were carried out in valence (3-5) and inorganic molecular crystals (6-8).

Although a number of direct determinations of the diffusion coefficients for ionic solids have been made, measurements in this type of solid have been mainly carried out by the study of the related process of conductivity. Such studies have helped in the elucidation of the mechanisms by which diffusion occurs in solids



and have give rise to theories of the defect solid state (2). <sup>2</sup>

The value of ionic crystals for such studies is that it is possible to generate defects which aid diffusion in these crystals, e.g. the incorporation of altermvalent ions in an ionic crystal lattice results in the generation of an equivalent number of vacancies, in order that electrical neutrality should be maintained in the crystal. The study of ionic crystals by direct and conductimetric methods has also led to a better understanding of the effect of crystalline fine structure on the diffusion process.

The experimental determination of diffusion in solids is usually made by studying the rate of movement of one component into or out of the bulk of a second. Many techniques have been devised for this measurement and these can be divided into two types, those which provide an overall picture of diffusion from the beginning to the end of the experiment, and those which involve the determination of the concentration gradient resulting from diffusion of one component into a second. The latter process is more useful in that it can reveal the existence of several concurrent diffusion processes which may be occuring in the solid, whereas the former measurement yields only an overall diffusion coefficient representing the combination of all processes occuring in the solid.

Examples of the former process are the diffusion of gases out of solids (9), and the diffusion of metals with relatively high vapour pressures at the temperature of the experiment out of alloys (e.g. zinc in  $\alpha$  brass (10)). The rates of diffusion are measured

by collecting the gases at the surface and measuring them volumetrically or, alternatively, changes in concentration are found by measuring the loss in weight of the sample in the case of more volatile metals.

Radio-active tracers have also been used to determine rate of diffusion in studies where the concentration gradient is not required. In addition to the obvious methods related to the examples quoted in the previous paragraph there are two worthy of special note. The Hahn Emanation technique (26) measures the rate of escape at the crystal surface of emanation from decaying radio-active material included in the solid. This rate can be related to the self diffusion coefficient for the components of the lattice. The second method (11) makes use of the fact that radiations from radio-active substances are absorbed in solids. A radio-active material is deposited on the crystal surface and an initial count is taken. As diffusion of the radio-active material into the crystal proceeds, the radiations from the diffused material will be absorbed, and the count rate at the same surface will decrease. From the measurement of this decrease of count rate with time, the rate of penetration can be calculated.

The method in which the concentration gradient is determined unfortunately involves the destruction of the crystal during the determination, which means that a different crystal is required for each experiment. This of course raises the question as to whether all the crystals used are comparable in properties. This is an

experimental difficulty which cannot be overcome. It is here 4 that the conductimetric studies which can be made with ionic crystals are advantageous because one crystal can be used for a number of studies, though even here re-application of the electrodes and continued heating and cooling may change the crystals.

The direct measurement of the diffusion coefficient by measuring the concentration gradient is usually carried out as follows:- The two components, which may be identical for self-diffusion studies, or which may differ, are placed in intimate contact and the temperature of this couple raised to a point where measurable penetration will occur in a reasonable time. On completion of this diffusion period the couple is accurately sectioned, parallel to the initial plane of contact, by use of a grinding machine, lathe, or microtome, and each section, which is in the form of shavings or powder, assayed for the diffusing material.

In this way a profile of concentration of the solute versus the depth of penetration can be built up, from which, using the integrated form of Fick's equation corresponding to the geometry of the initial state, the diffusion coefficient can be calculated.

The method adopted for preparing the diffusion couple will, of course, depend upon the physical properties of the materials concerned. In some cases it has been found adequate to press the faces of two crystals together or to press the powder of one component on to the surface of another. Somewhat more intimate contact can be achieved by deposition of one component upon the other from saturated solution, by fusion of the common faces, or, where the

vapour pressure of one component is sufficiently high, by evaporation under vacuum. The author believes the last named method to be the best where applicable, because this presents less possibility of damage to a non-metallic crystal surface and is most likely to result in epitaxial deposition which, especially in the study of self-diffusion, is to be preferred. Metallic crystals are not as susceptible to such damage and these and other methods such as welding and electroplating have been used.

In many of the earlier determinations, and in experiments where a reasonable quantity of material diffuses into the crystal, the normal techniques of chemical analysis have been used to separate the components and to determine the concentration of the diffusing material in cut sections. In a greater number of cases however the concentration of the diffusing species is low and this method is inaccurate. In some such cases the techniques of spectroscopic analysis have proved accurate and useful (12).

Some alloys are known to have resistance to attack by certain chemical reagents and this resistance depends upon their composition. In some cases where alloys are formed a series of tests on each section using such reagents has resulted in a determination of the approximate concentration (13).

Physical properties such as conductivity (14), cathodic emission (15), photo emission (16), and hardness (17), have all been shown to depend upon the purity of the specimen and the presence of even small amounts of impurity in some cases is enough to cause quite

a large change in these properties. These properties have also been related to composition in some cases and used for the determination of the concentration of the diffusing species in a section of the heat-treated diffusion couple.

A method of widespread application, and one of the most successful methods of all for the experimental evaluation of diffusion, is the use of radio-active tracers (2). Here use can be made of the highly sensitive methods of radiation detection to determine the concentration of the diffusing radio-active species. In this way accuracy of measurement can be obtained, even when the penetration distance is very small and also when the concentration of the radio-active species is small. With the more widespread availability of natural and artificial radio isotopes, this technique has come more and more into prominence and is probably the most widely used method at the present time. For the measurement of self-diffusion (where movement of a lattice component in its own lattice is studied) the tracer technique presents the only possible direct method of study and the tracer self-diffusion studies have made valuable contributions to the better understanding of the solid state and the elucidation of the structure of crystalline solids. The isotope effect in such a study is very small in most cases, and the rate of diffusion of an isotope can be regarded as the same as that of the inactive constituent of the solid under study.

The diffusion coefficients calculated from these experimental results are found to vary with absolute temperature according to an

$$D = D_0 e^{-E/RT} \quad - - - - - 1$$

where  $D$  is the diffusion coefficient at temperature  $T$  and  $R$  the gas constant.  $D_0$  and  $E$  are substantially constant for particular systems.  $E$  is taken as the energy of activation for the process. That the latter constant should be related to the mechanism by which diffusion occurs is obvious, as it will represent the energy required to move an atom or ion from one equilibrium position in the solid to the next, but it is also accepted that the value of the pre-exponential factor which is contained in  $D_0$  will also depend upon this mechanism.

Attempts have been made to formulate theoretical expressions (18,19) for these two constants from which theoretical values for the diffusion coefficient could be calculated, assuming the commonly accepted mechanisms of diffusion in solids (i.e. by way of vacancies in the lattice, interstices, or by the direct exchange of neighbouring atoms, molecules, or ions (2b)). It was hoped that the comparison of these theoretical values with those determined experimentally would show the most probable path by which diffusion was taking place. This approach has had a certain success where it was possible to carry out the theoretical calculations (18), but it is thought that a more exhaustive theoretical treatment is necessary before such a method for determining the diffusion mechanism is finally accepted. In the case of ionic crystals probable mechanisms have been discovered by studying the effect of the generation of

certain defects upon the diffusion rates.

Most studies of diffusion have been confined to metals and ionic solids because of the various methods available for study and comparison in these cases. In spite of the great attention given to the solid state in general very little attention has been paid to the study of valence and molecular crystals.

The study of diffusion in valence crystals has been reported for two cases, germanium (3), and natural (4) and artificial (5) graphite. Work on the former substance was no doubt inspired by its valuable semi-conducting properties and the need to discover all the relevant properties of the solid state. In both these cases accurate determinations were carried out and an attempt was made to formulate a mechanism for the diffusion process by comparison of theoretical and experimental values for the constants in the diffusion equation as described above.

Comparatively little information exists concerning the diffusion process in molecular solids and in view of this scant information it was decided to explore this field and to carry out a tracer study of self diffusion in a molecular solid.

The first recorded investigation of diffusion in a molecular solid is that of Cremer (6) who determined the Arrhenius type equation, (equation 1), for self diffusion in solid hydrogen from kinetic data obtained from the study of the ortho-para conversion in solid hydrogen. The constants in Cremer's equation are of rather limited accuracy

because of the very small temperature range in which the measurements were made ( $11^{\circ}$ - $13^{\circ}$ K), also such a measurement will only provide an overall diffusion equation which would not indicate the existence of more than one diffusion process.

Later tracer studies by Cuddeback and Driekamer (7) of self-diffusion in ortho rhombic sulphur, and by Nachtrieb and Handler (8) of the same process in  $\alpha$  white phosphorus, proved that diffusion in this type of compound did occur. In both cases evidence was found for the existence of two diffusion processes but each group of workers suggested different explanations of the mechanisms of the diffusion process in each case.

The results of these two tracer studies are open to criticism because of the methods adopted in the preparation of the specimens. In the second case (8) the samples used were compressed powders and with such samples it is difficult to visualize the extent to which such a specimen resembles a single crystal. It has been shown (2b) that the results of self-diffusion experiments using polycrystals can be a useful indication of the approximate value of self-diffusion in crystals when single crystals are not available, but the constants in the Arrhenius equation are found to vary with degree of polycrystallinity, no doubt because the numerous boundaries between crystallites provide a very large number of short circuiting paths for diffusion.

In the former case (7) single crystals were used but these were grown from solution, a method which may allow the inclusion of solvent

in the crystal lattice during growth, and which could affect the diffusion process.

There was therefore a need to carry out a tracer diffusion study using a single crystal of high purity grown from the melt or vapour phase in order to ascertain whether the effects described by the previous workers are still found in such a crystal.

No tracer diffusion studies have been attempted using crystals of organic molecular solids and what information is available has been derived from nuclear magnetic resonance (N.M.R.) studies.

Andrew and Eades (2) whilst carrying out a N.M.R. study of solid cyclohexane found evidence that wholesale molecular movement was occurring near its melting point. They ascribed this motion to self diffusion and calculated the activation energy for this process. Later, a comparison between N.M.R. self diffusion data for solid sodium (21) with that obtained from a tracer study (22) showed good agreement and supported Andrew and Eades's proposal. Following this discovery Waugh (23) using N.M.R. data, obtained previously, calculated the Arrhenius type equation for solid methane.

Other studies (24) however show no onset of molecular motion, but such evidence must not be taken to mean that molecular motion is completely absent. The N.M.R. Technique is rather limited in its application to such problems because it will only detect self diffusion when this motion is rapid enough to be detected instantly, and it is here that the tracer technique is superior because this measures the

summation of all movements over the period of the experiment and will therefore detect a much slower rate of movement.

The lack of information about this particular class of solids and the need for tracer studies using single crystals of molecular solids led to the decision to attempt to open up this field of study of self diffusion in single crystals of organic compounds.

The main objects of such a study were thought to be:

1. To ascertain initially whether diffusion does occur,
2. If this is the case, to determine whether diffusion occurs by one process or by the combination of several concurrent processes,
3. To determine the magnitude of the energy of activation for these processes,
4. To compare the results with those of N.M.R. studies, if such studies have been attempted on the substances used,
5. To determine the mechanisms by which the diffusion processes occur and whether these provide any information regarding disorder in the crystal.

There was no obvious substance to choose for the present study because all nuclear magnetic resonance measurements, with which the results could be compared, had been carried out on substances which were liquid or gaseous at room temperatures (20,23) or in solids at low temperatures (24) where self diffusion was not apparent. The

choice of specimen was therefore dictated by the requirements of the experiment.

The basic requirements were thought to be:

1. The substance used should have a fairly high melting point so that as wide a temperature range as possible could be used for the measurements.
2. That it should have a comparatively low vapour pressure at elevated temperatures so that losses by evaporation on heating should be low.
3. It should be easy to obtain pure in reasonably large quantities and when pure should be stable to oxidation or other chemical change.
4. It should be possible to synthesise a radio-active form of the substance.
5. It should be possible to grow large single crystals of the substance.

This last requirement is probably the most important of all.

The consideration of these requirements led to the choice of anthracene, because its high melting point ( $217^{\circ}\text{C}$  (25)) promised a wide range of temperature in which measurements could be made, large single crystals of the pure material had been grown for scintillation counting experiments and a method was devised for synthesising a radio-active form of anthracene labelled with  $^{14}\text{C}$ . In addition to these properties the vapour pressure was not high compared to other

similar suitable organic solids.

The details of the experimental work are given in the following chapter.

CHAPTER I

EXPERIMENTAL TECHNIQUES

## EXPERIMENTAL TECHNIQUES

1. The Growth of Single Crystals of Anthracene

The numerous experimental techniques for the growth of single crystals of chemical elements and compounds can be divided under three main headings:

1. growth from the vapour phase.
2. growth from a saturated solution.
3. growth from the melt.

All of these methods have been successfully employed in the growth of crystals of organic compounds, but the size and nature of the crystals produced vary with the method adopted and the experimental requirements of the crystals must be considered before a method of growth is chosen.

The present study required that:

1. the crystals grown should be approximately  
 $1 \times 1 \times 0.5 \text{ cms}^3$  in size,
2. the rate of growth should be fairly rapid,
3. the crystals should be very pure.

The growth of organic crystals from the vapour phase in general results in the slow growth of very thin crystals (26-29) which would be unsuitable for a tracer diffusion study and hence this method can be neglected.

Very large crystals indeed have been produced by growth from saturated solutions but this method also proved unsuitable for the present purposes because of the conditions required for growth. The limiting factor (30) in growth from solution is the solubility of the solid in the solvent used and, in order that tolerable growth rates will result, solubilities of 20-50% by weight are required. The solubility of anthracene in organic solvents is very much less than this and because the rate of growth from solution decreases rapidly with decreasing solubility such a method would have proved unfavourable in the present case. A second important reason which also leads to the rejection of this method is the possible inclusion of solvent in the crystal lattice during growth; the presence of which could affect the process of diffusion.

The third method, growth from the melt, has none of the disadvantages mentioned above. By this method large single crystals can be grown at a reasonable rate and, as the crystals can be grown under vacuum or in an inert atmosphere if necessary, the purity of the crystal depends upon the purity of the starting material alone. For these reasons the method of growth from the melt was considered for use in the present study.

Numerous reports (31-42) have been published over the past decade on the growth of very large single crystals of organic compounds from the melt for the purpose of studying chemical and physical properties of these substances in the solid state. Not the least of these studies have been the measurements of semi-

conductivity and the potentialities of such crystals as scintillators for use in radiation analysis. Anthracene proved to be an excellent material for this latter purpose and as a result several reports of the growth of large single crystals of this substance have been published (36-42). The availability of this information led in part to the adoption of anthracene as the subject of the present study.

There are three general methods of growth of crystals from the melt which are the basis of all reported techniques:

1. The Kyropoulos method (43,44)
2. The moving vessel technique (35,42,46-48)
3. The stationary vessel technique (34,35,45).

In the Kyropoulos method a seed crystal of the substance, attached to a water cooled chuck is partly melted into a bath of the molten substance contained in a furnace. The chuck and crystal are slowly and uniformly withdrawn and surface tension effects cause the surface of the melt to be drawn up with the seed. As the cooler regions of the furnace above the melt are reached, the material solidifies. If the correct rate of withdrawal is chosen the melt crystallises epitaxially upon the lattice of the seed crystal and a top shaped "boule" of single crystal results.

So far as the author is aware the Kyropoulos method has never been used for the preparation of single crystals of organic compounds because of the practical difficulties involved in isolating the apparatus to prevent aerial oxidation of the molten material and losses by volatilisation.

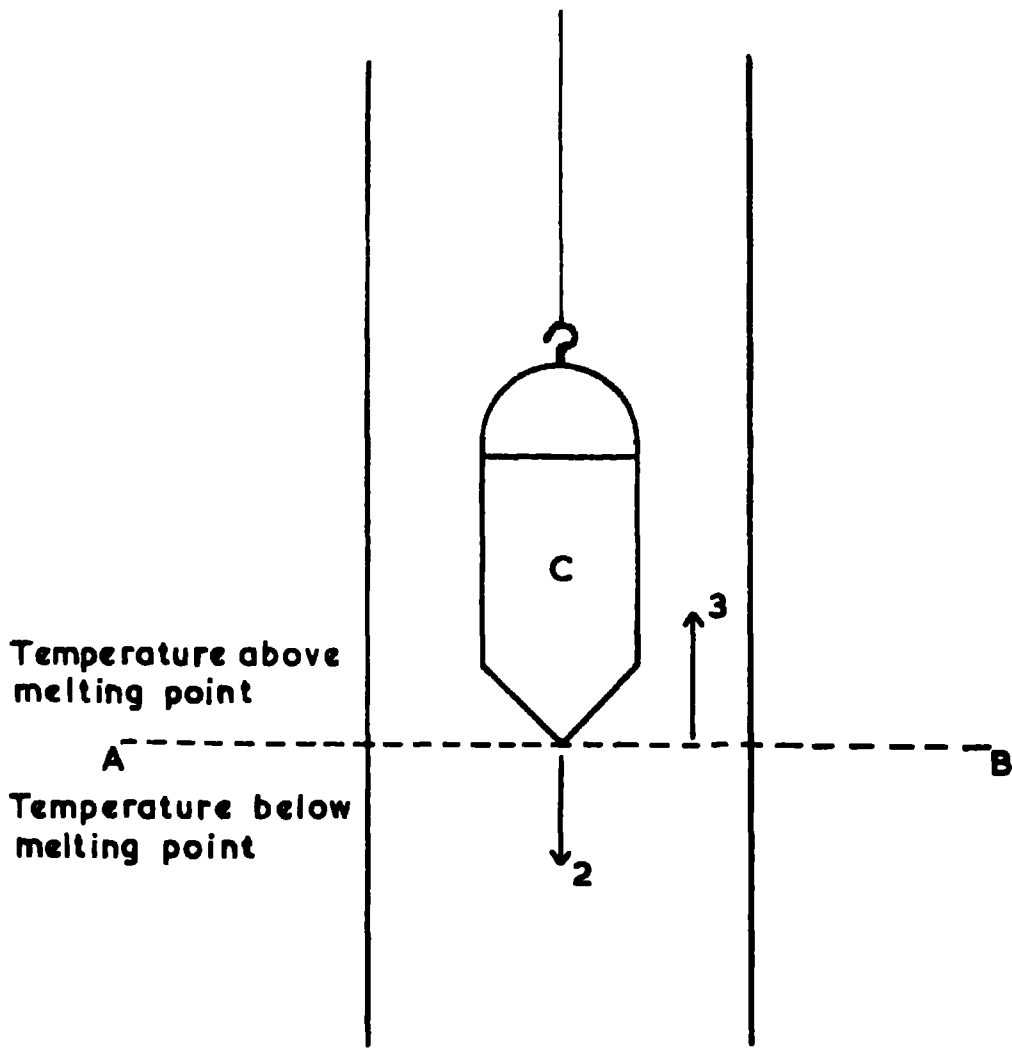

FIG. I. DIAGRAM OF THE TEMPERATURE GRADIENT.

In the other two methods (2 and 3 above) the melt can be completely isolated during the growth process, under vacuum or inert gas pressure, in a closed vessel, and hence both these methods are suitable for consideration as methods for the growth of organic crystals.

Both methods require the construction of a growth oven in which a temperature gradient with horizontal isothermals can be maintained. The temperature gradient usually involves a transition from 20-30° above the melting point to an equivalent point below the melting point. The two methods differ in the use of this temperature gradient.

Figure 1 represents diagrammatically such a gradient in which AB is the isothermal corresponding to the melting point. The material, in the tube C, is placed in the upper part of the gradient and allowed to melt.

In method 2 the vessel containing the molten material is attached to a lowering mechanism and slowly lowered down the gradient in the direction of the arrow 2. As the tip of the tube crosses the isothermal AB crystallisation occurs, and continued lowering leads to the growth of these crystals up the tube, the solid/melt interface always lying on the isothermal AB.

Method 3 can almost be regarded as the converse of this because, in this case, the vessel containing the melt, C, is kept stationary during growth and the temperature gradient is slowly and evenly cooled by the controlled reduction of the heating input. As

cooling occurs the isothermals in the furnace move up the crystallisation vessel (in the direction of the arrow 3 in figure 1) at a rate proportional to the rate of cooling of the furnace and crystallisation and growth occurs as the isothermal AB passes slowly up the tube.

Although both these methods have been successfully used for the growth of single crystals of organic compounds (34,35,42,46-48) there are limitations to the static method (44) and it was considered better in principle to construct a crystal growing oven in which a steady temperature could be maintained and to lower the crystal growing vessel mechanically. It was this type of oven which was constructed and used for the growth of the anthracene crystals for use in this study.

As the work proceeded it became apparent that this design had many advantages because of the slow rates of growth necessary for the successful production of large single crystals of anthracene and the difficulty of seeding the single crystals. Using this basic method it was also found possible to construct an unlagged crystal growing oven in which the crystals could be watched during growth, a feature which later proved time saving and which would have been impossible had method 3 been employed.

#### 1. a. The Crystal Growing Ovens.

The temperature gradient necessary for crystal growth by the moving vessel technique is usually established between two heaters mounted on a tube and separated by a short distance. The ovens

are usually heated electrically but in the cases of the lower melting solids boiling vapour (32) and heated liquids (35) have been used. Whether the tube supporting the heaters should be a good or bad conductor of heat seems to be of little consequence.

Very little indication is given in the literature of the optimum slope of the temperature gradient to use and descriptions vary between two extremes, those which advocate a gradual change between the upper and lower limits (46,49) and those which produce a very steep gradient which is almost a sharp discontinuity between the upper and lower temperature limits (36).

It was therefore necessary to determine the optimum temperature gradient by experiment and the first crystal growing oven was constructed in such a way that this gradient could be varied. Electrical heating was used and the arrangement of the furnace was similar to that used by Leininger (49).

Two electrical heaters of resistance 94 ohms and 140 ohms were wound, twelve inches apart, upon a four inch diameter iron tube. The heaters were wound using 15.7 ohms per yard "Nichrome" heating tape and were insulated from the iron pipe by asbestos paper. The slope of the temperature gradient could be varied by adjusting the input to the heaters and conduction of heat along the iron supporting pipe ensured that a linear gradient was produced. The tube and heaters were supported (the lower resistance heater uppermost) in a large drum and the drum packed with magnesia asbestos lagging for thermal

insulation. The two heaters were connected in parallel and operated from a constant voltage A.C. stabilised supply. Temperature control was effected by use of a thermostat and regulating circuit similar to that shown in figure 3.a.

At first the experiments in crystal growth met with little success because of the impurity of the anthracene used. The crystals produced were very dark in colour and all were polycrystalline in nature.

As the purity of the anthracene was increased it became obvious that there were two factors which might effect the growth of the crystal, the rate of growth, i.e. the rate of lowering of the tube containing the melt, and the slope of the temperature gradient.

In the initial experiments a gradual gradient was used (upper heater  $T = 220^{\circ}\text{C}$ , lower heater  $T = \text{room temperature}$ ) and a fairly rapid rate of lowering (5 mms per hour). Under these circumstances a mass of polycrystals was always produced. These parameters were varied separately and it was found that (a) there was a critical lowering rate of 1-2 mms per hour, above which polycrystals were always produced, and (b) much better crystals were produced when steep temperature gradients were used. At this time a growth tube with a capillary drawn out at its end (figure 4.b.) was being used. Following these experiments it was decided to construct a crystal growing oven in which a very steep temperature gradient could be produced.

A big disadvantage of the type of furnace described above was

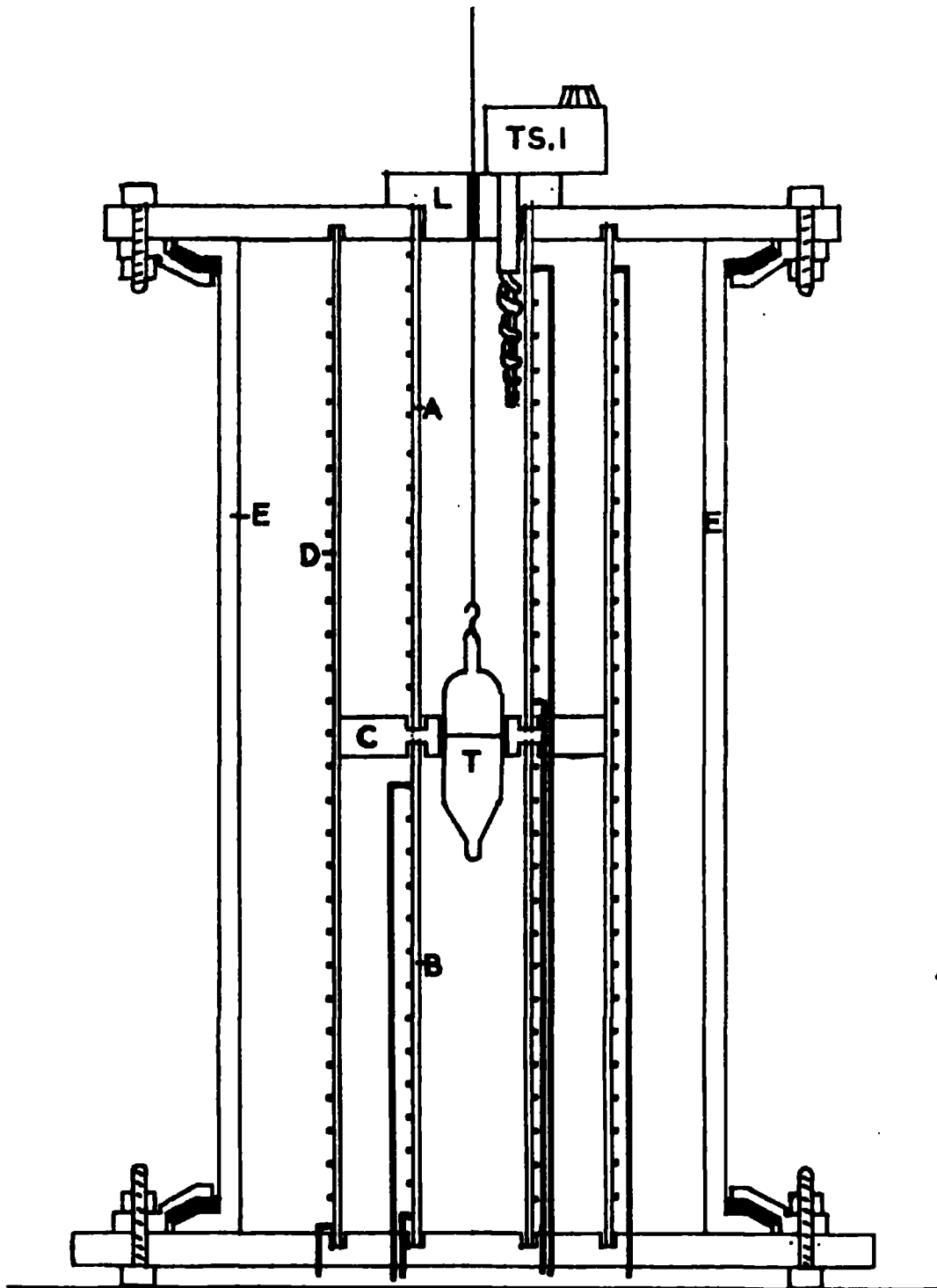

FIG.2. THE CRYSTAL GROWING OVEN.

that it was not possible to see the crystal during the period of growth. The only way in which the growing crystal could be studied was to withdraw the crystallisation vessel from the oven during growth and replace it quickly. This was found to have a very bad effect on the growth of any single crystal which may have formed and this practice was discontinued and complete growth allowed to occur before removal. Using the slower rates of growth found to be necessary for the production of good quality crystals, periods of 8-10 days were required to complete crystal growth. In cases where polycrystals and not single crystals were formed in the early stages of growth a considerable part of this time was wasted and the second oven was therefore constructed in such a way that the growing crystal could be studied in the oven. This was done by using pyrex glass for the heater formers. A second advantage of this design was that very little heat conduction would take place along the glass and therefore this aided the establishment of a very steep temperature gradient. A diagram of the oven is shown in figure 2.

Two heating coils A and B of resistance 80 ohms and 130 ohms respectively, were wound from 33 ohm per yard "Nichrome" heating tape (0.025" x .002") on the two 2 inch diameter pyrex glass tubes A and B. The heaters were wound with the coils closer together at the lower ends in order that an even temperature could be maintained along as much of the length of the coil as possible. The two coils were separated by a "Sindanyo" asbestos baffle C, the central hole of which was just large enough to admit the crystal growth tube T to

the lower half of the oven. The outside diameter of C was cut to 2.6 inches so that a third pyrex glass tube D of that internal diameter would slip over this and lie concentrically with A and B. On D was uniformly wound an 100 ohm heating coil using similar wire to that used for A and B.

The tubes A, B and D were supported at top and bottom by two circular "Sindanyo" sheets, and were enclosed by the thick walled, twelve inch diameter, pyrex glass pipe E. In the upper "Sindanyo" sheet was cut a hole two inches in diameter so that access could be gained to the oven. When the oven was in use this hole was closed by means of a lid L, which also served as a support for the thermostat T.S.1. The crystal growth tube T was supported by a fine wire which passed through a small hole in this lid.

The oven was protected from draughts by enclosing it in a hard-board box which also served as a support for the control panel for the heaters and the lowering mechanism. The growing crystal could be viewed through a small hole in the front of the box.

#### Operating Circuit.

The heaters A and B were arranged in parallel and operated from a 250 v. A.C. stabilised mains. Control of these heaters was by series rheostats  $R_1$ ,  $R_2$ ,  $R_3$  (figure 3b), which were adjusted so that the temperatures of the two heaters were approximately  $10^\circ$  below that required (upper heater  $240^\circ\text{C}$ , lower heater  $190^\circ\text{C}$ ). Heater D was used as a control coil to raise the temperature of the oven to that required and to maintain constant temperature. The current for

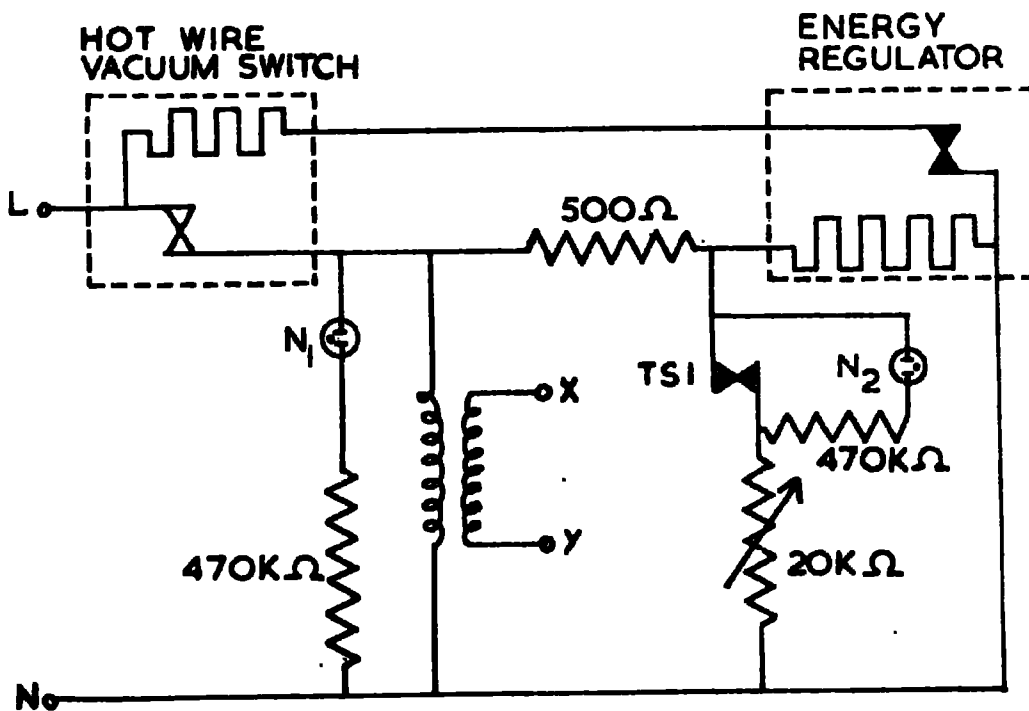

FIG.3a. THE THERMOSTAT CIRCUIT.

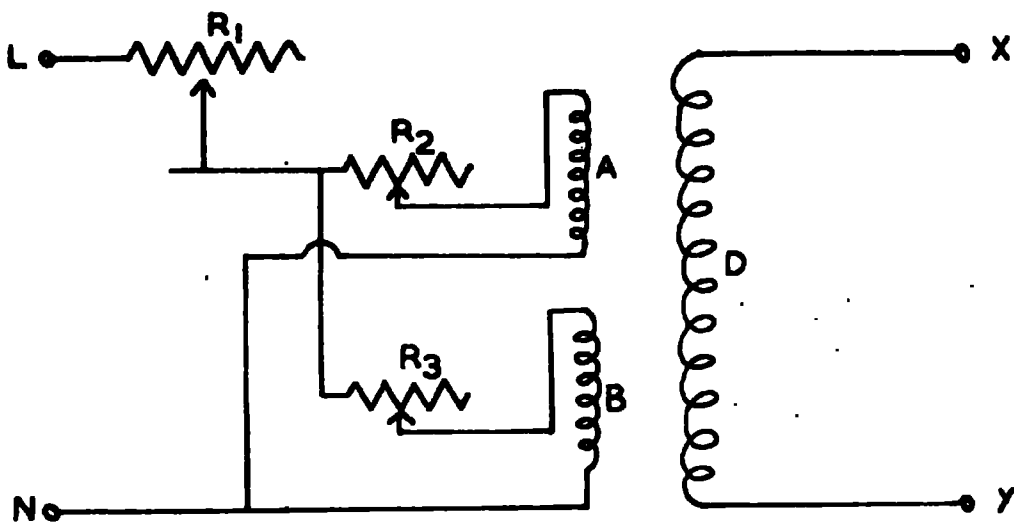

FIG.3b. THE HEATING CIRCUIT.

this control coil was supplied through a "Sunvic" circuit F102/3M, depicted in figure 3.a., incorporating a Sunvic normally closed thermostat T.S.1, energy regulator, and hot wire vacuum switch. Connections to heater D were made via terminals X and Y (figures 3.a. and b.).

Several different positions in the oven were tried for the thermostat T.S.1. but it was found that the circuit operated most successfully when the thermostat was in the position indicated in figure 2 and small fluctuations in the temperature of the oven were readily adjusted by the controlling circuit.

The thermostat circuit operated as follows:-

When the oven temperature fell below the required value the thermostat contacts closed causing the energy input to the circuit, controlled by the energy regulator and hot wire vacuum switch, to be increased, the current passing in cycles as the energy regulator contacts were opened and closed by its controlling circuit. The cycling on/off time was determined by the position of the control knob of the regulator. As the system warmed up the thermostat contacts opened showing that the oven was above temperature. The effect of the opening of the contacts on the input circuit was to reduce the cycling on/off time and the system cooled until the thermostat contacts again closed and the cycle was repeated. The thermostat and energy regulator were set so that very fine control of the input resulted and the drift above and below the equilibrium temperature was small. Under these conditions the temperature

remained effectively constant. The neon indicators  $N_1$  and  $N_2$  showed when the energy regulator and thermostat contacts, respectively, were open and aided the accurate setting of the control circuit. This method of control proved very effective indeed and after the initial work in setting the circuit no more trouble was experienced in the temperature control of the oven.

It was found possible using this circuit of three coils to maintain a constant temperature for a distance of 2-3 inches on either side of the baffle C (figure 2). The temperature above being  $240^{\circ}\text{C}$  and below  $190^{\circ}\text{C}$ , thus the temperature gradient was  $50^{\circ}\text{C}$  over the thickness of the baffle ( $\sim 0.5$  inches). In this way a very steep gradient indeed was produced.

This design of oven proved very successful indeed. The fact that crystal growth could be recommenced if a single crystal was not initiated saved a great deal of valuable time and also with the better crystal growing tubes evolved during the crystal growth programme and the purer anthracene which was produced during the latter stages of the work, some extremely fine crystals were produced using this oven.

#### 1.b. The Rate of Lowering of the Crystal Growing Tube.

In determining the rate at which the crystal growing tube is to be lowered down the temperature gradient it is necessary to ascertain the rate of growth of the crystal from its melt. This rate of growth will provide an upper limit to the rate of lowering, since a more rapid rate will result in the advance of the

solidification front below the isothermal corresponding to the melting point, with subsequent rapid crystallisation and the formation of polycrystals. It is therefore essential to measure this rate of growth before single crystals can be successfully grown.

It is reported that for the satisfactory growth of organic crystals the rate of lowering of the crystal growing vessel should not exceed 1-2 mms. per hour (35). This value indicates that the rate of growth of organic crystals is very much less than that of metals, where rates of growth of up to 20 mms. per minute have been quoted (50), but is similar to that of ionic crystals, where rates of 1-4 mms. per hour have been reported (44,51). In the present study experiments were carried out to determine whether such a slow rate of growth was necessary and to ascertain whether any improved crystal quality could be achieved by the use of lowering rates less than 1-2 mms. per hour.

The crystal growing tube was lowered down the temperature gradient by means of a suitably geared down synchro-clock motor with a projecting axle. The wire supporting the vessel was wound around the axle. A series of interchangeable axles of differing diameters allowed the rate of lowering to be varied in the range 0.5-6 mms. per hour.

Preliminary experiments in which the rate was varied showed, in agreement with Scott, Hutchinson and Lapage (35), that rates of lowering greater than 1-2 mms. per hour always resulted in the formation of polycrystals whereas lower rates than this value were

inevitably successful. Further experiments showed that no improvement in crystal quality resulted from the use of slower lowering rates than this critical value.

Previous workers (35) have shown that with some designs of growing vessel a reorientation of the crystal occurs during the growth process. It was shown by them that the crystal produced after reorientation had occurred was always polycrystalline in nature, but that it was not possible to detect this until the crystal had been removed from the tube. It has been suggested (35), that polycrystalline growth occurs because the rate of growth of the crystal on the face presented to the melt after reorientation has occurred, is slower than that on the original face, and that in this way the rate of lowering becomes greater than the rate of growth with the resultant formation of polycrystals as described above. It would appear that slower lowering rates might obviate this change to polycrystallinity and it was with this purpose that a lowering rate of one half the critical value was adopted, i.e. 0.5-1 mms. per hour.

It was later discovered that reorientation did occur during the growth of anthracene crystals in some types of crystal growing tube but this never resulted in the formation of polycrystals and it is believed that this was because of the low lowering rate used.

The experiments carried out to examine the effect of the variation of lowering rate were not extensive and were merely intended to lead to a stage at which crystals of reasonable quality could be produced.

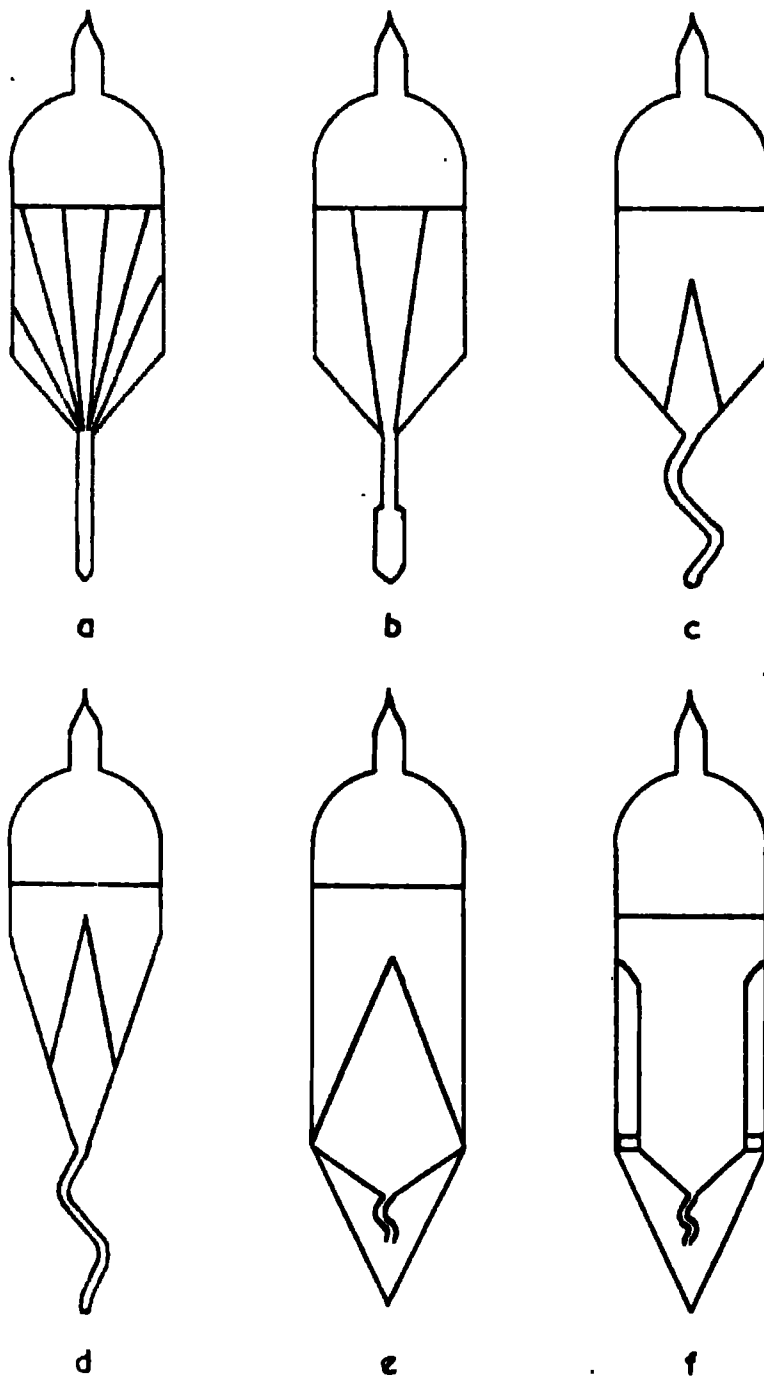

FIG. 4. THE CRYSTAL GROWING TUBES.

### 1.c. The Initiation of the Single Crystal.

The initiation of the seed crystal for growth, a factor which seems to present little difficulty with other types of solids, is a real problem in the case of organic crystals. A method devised by Tammann (52) at the end of the last century for the growth of crystals, was to seed from a long capillary attached to the lower end of the crystallisation tube. This type of tube is depicted in figure 4.a. and was used for the initial experiments of the present study.

The sealed pyrex glass tube containing the anthracene was suspended in the upper part of the oven, above the baffle  $\theta$ . (figure 2), until the anthracene had melted and filled the lower part of the tube and the capillary. The tube was then quickly withdrawn and the lower end of the capillary cooled so that a small mass of polycrystal was formed in the tip. The tube was replaced and its height in the oven adjusted until the tip of the capillary tube was just below the isothermal corresponding to the melting point. The oven and crystal growing tube were allowed to come to equilibrium. When this state was attained a small amount of solid polycrystalline anthracene remained at the tip of the capillary tube, the rest of the anthracene in the crystal tube being molten. The lowering motor was switched on and the crystal tube lowered slowly down the temperature gradient in the oven. As it descended the small crystals grew up the capillary and into the wide tube.

Some workers (46) have reported that this design of tube aids the formation of one single crystal in the upper wider tube; others

disagree with this (49) and report multiple crystal growth.

In the present work it was found impossible to produce less than twelve small crystals side by side in the upper tube surrounded by polycrystalline anthracene. The result of such an experiment is depicted in figure 4.a.

In an effort to reduce this number of crystals, several experiments were carried out using a crystal growing tube of the type shown in figure 4.b. with a small bulb at the lower end of the capillary. It was hoped that the use of a bulb at the tip would allow the greater expansion of the crystallite seeds during the first part of their growth and hence increase the possibility that only one crystal seed would arrive under the mouth of the capillary tube, grow up, and seed the molten mass in the upper wider tube. A limited amount of success resulted from this adaptation and it was found possible to reduce the number of crystals formed in the upper tube to about six. The most successful attempt however only produced three crystals and it was obvious that further modification of the growth tube would have to be made before one single crystal could be initiated and grown in the wider part of the tube.

The crystals obtained at this stage were of very good quality but were rather small for the requirements of the present study.

Whilst attempting to grow large single crystals of Stilbene by a similar growth technique Scott, Hutchinson and Lapage (35), found that by bending the capillary as shown in figure 4.c. a single crystal was inevitably initiated at the upper end of the capillary

and this seeded the molten material in the upper wider tube.

It would appear that the bends in the capillary tube must help in some way to remove all but one of the original crystallites during the growth of the polycrystalline mass up the capillary tube, leaving this one single crystal to grow to the top and seed the melt.

This method was applied to the growth of anthracene and several experiments were carried out using this type of tube. It was found that a single seed of anthracene was produced at the upper end of the bent capillary on each occasion.

Now that this aim had been achieved and it was known that a single crystal was generated on each occasion it was possible to study the growth of this seed crystal into the melt in the upper tube.

When, in each of these experiments with the bent capillary, the crystal was examined on removal from the tube it was found that the single crystal rapidly gave way to polycrystals and that the appearance of the tube was similar to that depicted in figure 4.c. A narrow wedge of single crystal had been formed and this was surrounded by a polycrystalline mass. The very low rate of lowering was used and it was thought unlikely that the lowering rate was exceeding the growth rate, if this was the case no single crystal would have been produced at all, and that it was more likely to be the result of local cooling on the shoulders of the crystal tube on each side of the capillary causing nucleation and subsequent growth of polycrystals. The polycrystals formed in this way would grow more rapidly than the single crystal and therefore increase in size

at the expense of the single crystal. This would result in the formation of a cone of single crystal surrounded by polycrystalline anthracene as was found in this case. This local cooling could perhaps have occurred as a result of small temperature fluctuations in the oven.

It was however possible that, although the lowering rate did not exceed the rate of growth of the crystal in a vertical direction, the rate of spread of the crystal into the wider tube, from the capillary, was much slower than this and hence, whilst the single crystal seed continued to grow upwards it did not grow outwards before the shoulders of the tube had descended below the melting point isothermal, and thus polycrystals formed rapidly in the super cooled melt on each side of the single crystal and acted in the above mentioned manner.

In order to allow more gradual growth of the seed into the wider tube a vessel of type 4.d. was used in several experiments. It was found that although some contribution to the formation of polycrystals did arise from the latter cause, nucleation of polycrystals still occurred and thus this must arise from local cooling in the oven. In an effort to eliminate the formation of polycrystals the capillary was mounted on a baffle which rested loosely in the crystallisation vessel (figure 4.e.).

This modification resulted in the formation of a much larger wedge of single crystal but nucleation of polycrystal now took place around the top of the baffle cone. The resulting crystal is shown

in figure 4.e. This experiment supported the view that nucleation occurred as the result of local cooling at the walls of the tube because in this case the single crystal had completely filled the wide part of the tube. It seemed that the anthracene surrounding the cone had acted as a thermal insulator on the material within during growth. In order to make the maximum use of this possible protective effect a tube of the type figure 4.f. was constructed in which the growing crystal was surrounded by anthracene.

This type of tube therefore combines all the desirable features of all the previous tubes, the bent capillary, which aids in the selection of a single crystal for growth, the thermal insulation effect of the surrounding anthracene, and the gradual shape of the cone which obviates "corner" effects as the single crystal spreads into the wider tube. The inclusion of all these factors proved to be the key to the problem of design of the vessel.

This design of vessel proved to be a complete success and using this it was found relatively easy to grow single crystals which completely occupied the central tube of the crystal tube.

As the research into the design of the vessel proceeded so did the improvement in the purity of the anthracene and, using the very pure anthracene produced in the final stages of the work, crystal boules 4 cms. long x 2.5 cms. diameter were obtained, which completely occupied the inner tube of the crystal growing vessel. These large single crystals had a beautiful blue fluorescence and were quite large enough for the present purposes.

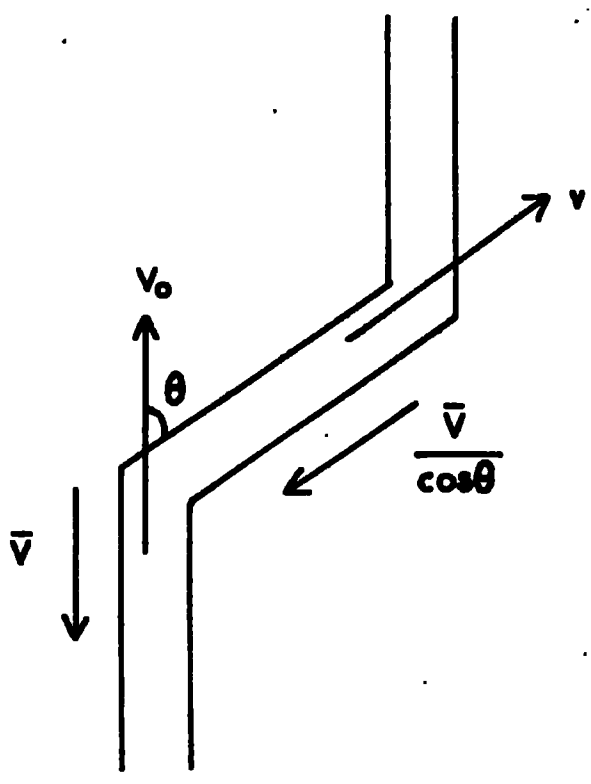

FIG.5. THE CAPILLARY OF THE CRYSTAL GROWING TUBE.

In the previous section it was stated that the crystals can be grown with the cleavage plane (001 plane) vertical or horizontal. This change of orientation only occurs when a tube with a bent capillary is used, the straight capillary always yielding crystals orientated with the cleavage (001) plane vertical. It can perhaps be assumed then that the growth rate is greater with the cleavage plane vertical and also that reorientation occurs in the "zig zag" of the capillary. That this latter is the case has been proved for other materials (35) by comparing the orientation of the crystals at the upper and lower ends of the zig zag capillary.

Three factors will decide whether the crystal will grow with the cleavage plane vertical or horizontal.

1. The rate of lowering which will be equal to the rate of movement of the freezing level.
2. The rates of growth along the two crystal axes.
3. The angles of the bends in the capillary tube.

Scott, Hutchinson and Lapage (35) explain the conditions as follows:

If  $\bar{v}$  = the rate of movement of the freezing level

$v_0$  = maximum rate of growth of the crystal

$v$  = maximum rate of growth along the inclined limb with the (001) plane vertical

$\theta$  = angle of inclination of the capillary to the vertical,

then if

$v > \frac{\bar{v}}{\cos \theta}$  there will be no change in orientation

$v < \frac{\bar{v}}{\cos \theta} < v_0$  conditions are favourable for this change

but if

$\frac{\bar{v}}{\cos \theta} > v_0$  polycrystalline growth will result.

Scott, Hutchinson and Lapage (35) found that the reorientation process resulted in the formation of polycrystals. In this study it was found that perfect crystals were produced no matter what the final orientation of the crystal and hence it was not necessary to determine accurately these limiting conditions. It can be said however that a tube with  $\theta \approx 45^\circ$  always produced reorientation and  $\theta < 45^\circ$  inevitably resulted in the growth of a crystal with the cleavage plane vertical. It was found that crystals grown with the cleavage plane horizontal were easier to shape and in the latter stages of the work an effort was usually made to produce growth with this orientation.

#### 1.e. Purification of the Anthracene.

The initial attempts to grow crystals were carried out using commercially available pure anthracene (B.D.H. Blue Fluorescent). The powdered anthracene was sealed in the crystal growing tube (type 4.a.) under the vacuum or an inert atmosphere and crystal growth attempted as described in section 1.c. In spite of these precautions against oxidation, etc., very dark brown crystals were produced, no doubt the result of impurity in the starting material. A small quantity of this impure material was purified chromatographically and

used for crystal growth. Very much clearer crystals were obtained and it became obvious that purity of the starting material was one of the principle factors in the growth of single crystals and it was necessary to find a method for the preparation of extremely pure anthracene. It was not until this had been achieved that any marked improvement in the quality of the crystals grown was noticed.

Previous workers in this field had used one of two methods for the purification of anthracene, one, a lengthy recrystallisation process involving as one of its steps a co-distillation with ethylene glycol (33), and the second Chromatography (28). It was found possible to set up a continuous flow chromatographic purification apparatus which would produce adequate quantities of pure material for the initial stages of the work and thus this method of purification was adopted at the beginning of this study.

(a) Chromatographic Purification.

A continuous flow chromatographic column similar to that used by Leininger (33,49) for the purification of organic compounds was used for this purpose. The column was packed with grade 1 alumina and 40°-60°C petroleum ether was used as the elutriant.

Before the column was packed the alumina (B.D.H. for chromatographic purposes) was refluxed for two hours with 50% acetic acid to remove all alkaline impurities and then washed with distilled water until the washings gave no acid reaction. The washed alumina was dried at 200°C on a glass tray and bottled while still warm. Prior

to use it was graded by dye adsorption tests (53) and if not Grade I was reheated until a positive test was obtained.

The column 1.5 inches diameter and four feet long was packed with the dry alumina and the petroleum ether passed for 24-48 hours before the column was used to allow the alumina to settle. The column was tapped at intervals during this period, in order to release air bubbles and air channels trapped during the packing.

Continuous elution was achieved as follows:-

The column was attached at the lower end to a large flask containing the petroleum ether. The solvent in the flask was boiled and the vapour ascended by way of a side arm to the top of the column where it was condensed and allowed to fall on to the alumina. The liquid petroleum ether then passed down the column into the flask. A "head" of the liquid approximately six inches high was usually built up at the top of the column.

When the column was ready for use the anthracene was placed on top and the elution with petroleum ether commenced. The column was wrapped with thick paper to exclude light and a slow current of nitrogen gas was passed through the apparatus to stop diffusion in of atmospheric oxygen. These precautions were found to be necessary because the anthracene is very readily oxidised on the column, in presence of sunlight, to anthraquinone. This reaction can readily be detected because the white alumina column becomes yellow.

The anthracene was found to pass through the column rapidly and the several impurities were absorbed on the column. These

adsorbed impurities eventually separated into coloured bands as elution was continued.

The solution of anthracene passed into the boiler at the base of the column. When the solution became saturated, the anthracene crystallised out in flakes which had a bright blue fluorescence and could be removed when required.

The anthracene purified by this method was of excellent purity but the rate of production was slow. As improvements were made in crystal growing techniques larger crystal growing tubes were used, and, although two chromatographic columns were operated together, the rate of production of pure anthracene by this method was inadequate. The columns needed constant attention, it being difficult on occasions to determine when break through of impurities was about to occur, and needed repacking every 8-10 days. The overall rate of production by this method was approximately 40-50 gms. pure anthracene per week. When this method of purification was abandoned approximately 100 gms. of the pure material were required per week and it was decided to purify the anthracene by successive recrystallisations, a method which had the advantage that a large amount of material could be purified in a fairly short time.

(b) Purification by Recrystallisation.

Hutchinson and Lepage (42) had purified commercial anthracene for the purpose of growing scintillator crystals by the following series of processes.

1. Recrystallisation from acetic acid.

I = B.D.H. anthracene  
 C = Chromatographically pure anthracene.  
 F = Final pure anthracene.

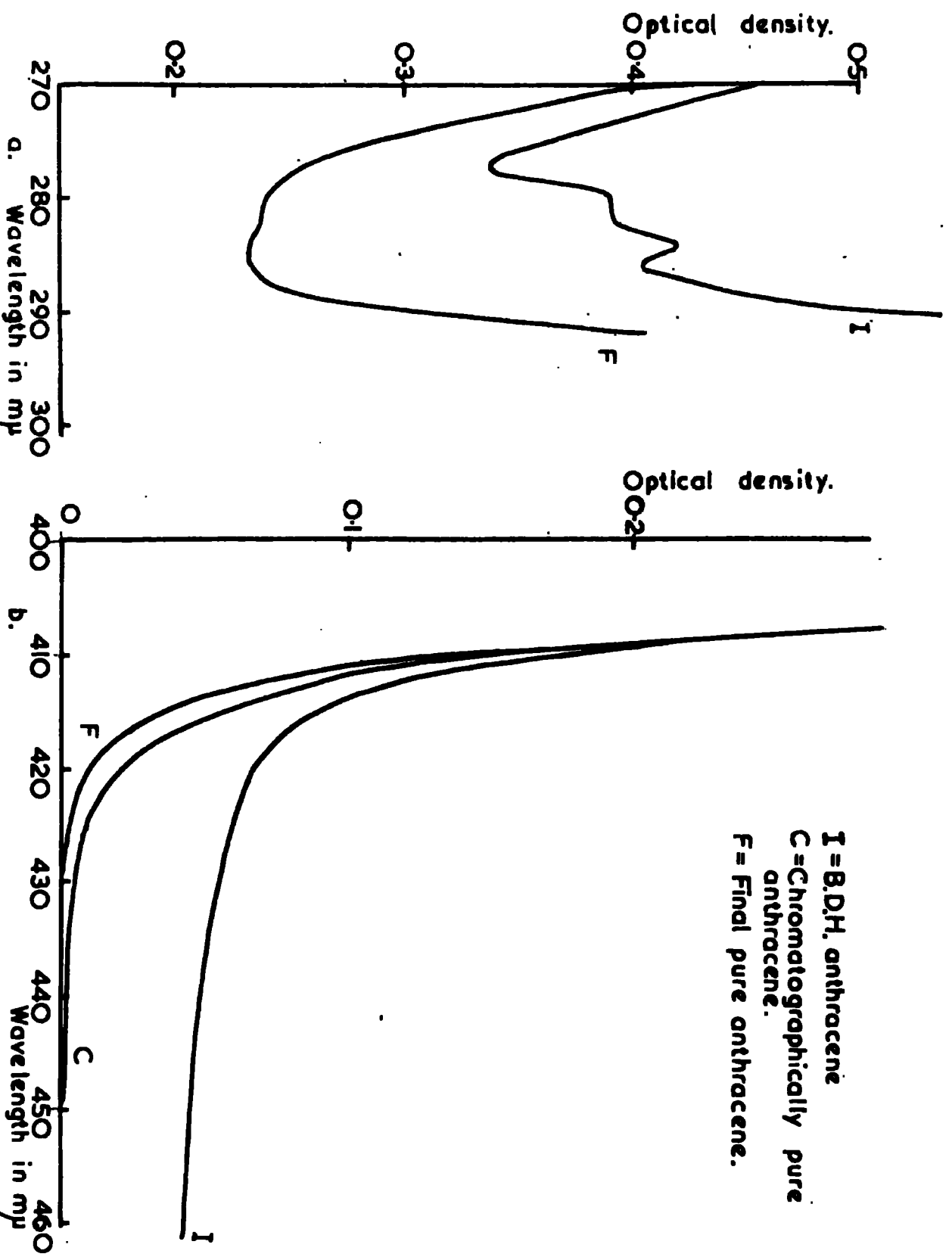

FIG. 6. U.V. SPECTRA OF THE ANTHRACENE IN THE RANGE a. 270 - 300. b. 400 - 460.

2. Distillation under reduced pressure (three times).
3. Recrystallisation from acetic acid.
4. Recrystallisation from toluene.

Hutchinson and Lapage examined their starting material spectroscopically and found that the impurities present were naphthacene, perylene and carbazole together with some unidentified yellow impurity.

Spectroscopic examination of the impure anthracene (B.D.H. blue fluorescent) used in the present study showed that absorption occurred in parts of the spectrum where little or none would be expected if the anthracene were pure, and where absorption would be expected if the above mentioned impurities were present. These regions were 270-300 $\mu$ . and 400-460 $\mu$ . As a result of this it was decided to attempt to use this method for the purification of this anthracene.

The improvement in the quality of the material was checked at each stage in the purification process by measurement of the U.V. absorption spectrum using a Unicam S.P. 500 spectrophotometer. The spectra of the initial and final materials are depicted in figure 6.a. and b. Figure 6.a. depicts the decrease in absorption of light in the region in which the carbazole impurity should be apparent (270-300 $\mu$ ) and figure 6.b. that region where naphthacene and perylene impurity would cause absorption (400-460 $\mu$ ). In figure 6.b. is included the absorption spectrum of the chromatographically purified material in the range 400-460 $\mu$ . and it can be seen that

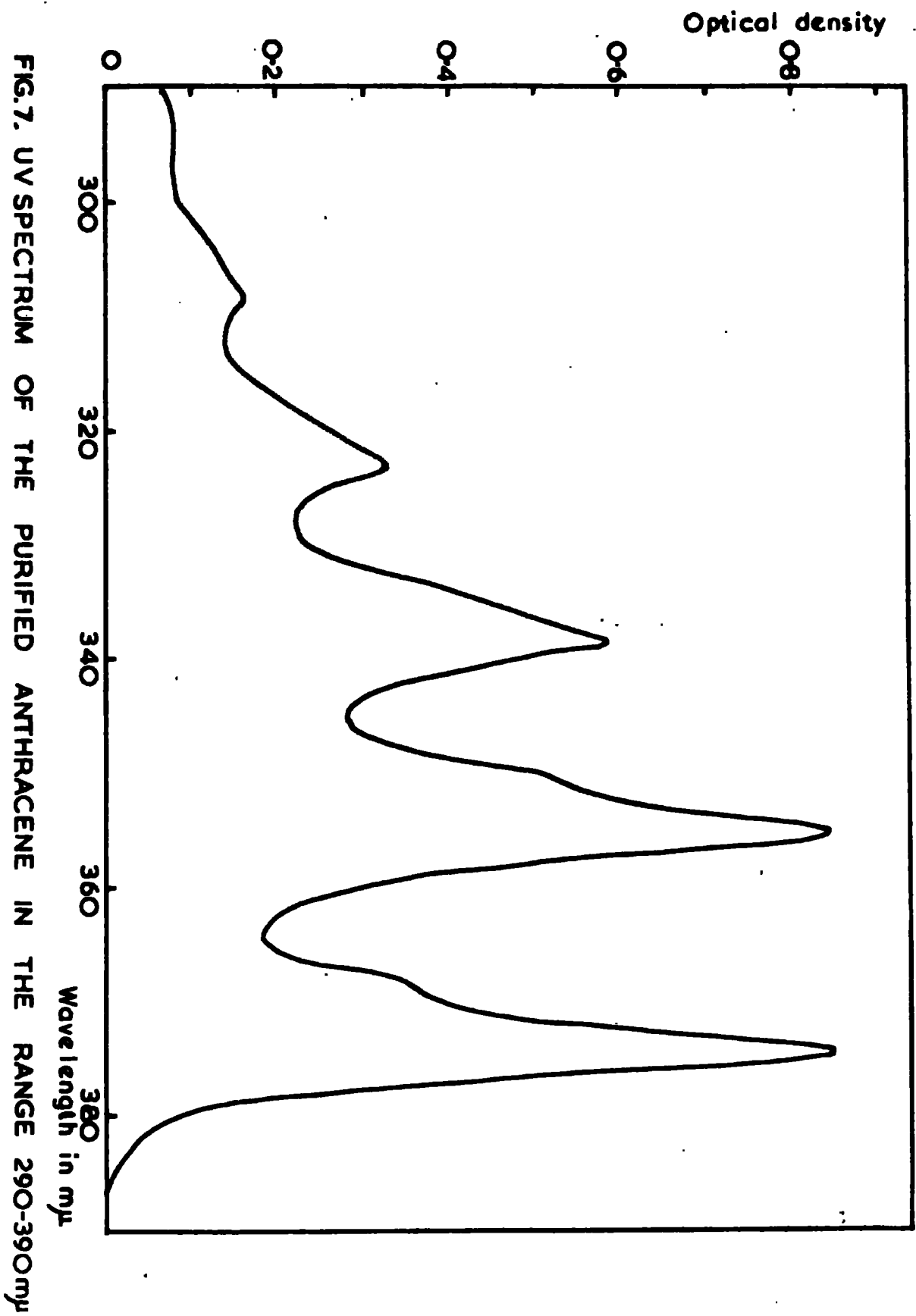

the pure anthracene obtained by this second purification process was purer than that obtained by chromatographic purification.

The spectroscopic study was not carried out quantitatively but the results showed, in agreement with Hutchinson and Lapage (42), that the initial recrystallisation from acetic acid removes the greater part of the carbazole present, the distillation, the naphthacene and perylene and the second recrystallisation completed the removal of the carbazole. That the above was the case was assumed by comparison with the work of Hutchinson and Lapage (42) and Merrick (55). The yellow impurity reported by Hutchinson and Lapage was not detected. The final recrystallisation from toluene, used by those workers, to remove the yellow impurity, was continued however because it helped to remove a considerable amount of acetic acid from the crystals. The greater part of the acetic acid adhering to the crystals following the second recrystallisation was removed by standing the recrystallised anthracene over solid caustic soda in a desiccator for 24 hours.

The pure anthracene produced by this method was in the form of white flakes which fluoresced blue in daylight. -- The U.V. absorption spectrum of the final product in the range 290-380  $m\mu$  compares well with that reproduced by Friedel and Orchin (54) for pure anthracene and is depicted in figure 7.

The experimental details for the measurement of the U.V. spectra are given in Appendix I.

The quality of the crystals produced using this pure anthracene

was very much better than those grown from the chromatographically purified material, showing that this second method had resulted in the production of very much purer anthracene, and using this material it was found possible to detect the cooling effects which affected crystal growth (described in the previous section), and to develop the design of the crystal growing vessel.

When the growing vessel type 4.f. had been evolved and all major faults in crystal growth eliminated another factor concerning the purity of the anthracene became apparent. When the crystal was removed from the crystal tube (figure 4.f.) after growth it was seen that, after the seed crystal had been initiated at the upper end of the capillary tube, and growth had continued into the upper wider tube, the apparently perfect crystal gave way to an increasing density of faults, cracks and striations. It appeared as if the impurities remaining in the anthracene were concentrating in the melt until a limit was attained where they started to crystallise out and to disrupt the crystal lattice. The quality of the crystal at the top of the vessel was very poor indeed compared to that at the bottom. This concentration of impurities in the melt can be likened to the process of purification by zone melting (56). This observation led to the consideration of the technique of zone refining for the purification of the anthracene. It was obvious that some improvement in purity of the anthracene had resulted from a related process during the growth of the crystal and it was therefore likely that zone refining would result in the

production of anthracene of comparable purity to that in the lower half of the growing tube after growth.

(c) Zone Refining.

Few reports of the application of this technique to the purification of organic compounds exist (57,58). One of these (57) deals with the large scale purification of naphthalene and this method was adopted for the purification of anthracene.

Powdered anthracene was packed into a thick walled pyrex tube. The tube was evacuated and the anthracene melted down to form a compact mass. This process was repeated until a column of anthracene approximately 50 cms. long was obtained. The tube was then attached to a high vacuum apparatus and evacuated for at least two hours at "sticking" vacuum in order to remove all traces of oxygen. Shorter evacuation periods resulted in incomplete removal of oxygen as was shown by the charring of the anthracene on subsequent melting. The evacuation complete, 12 cms. mercury pressure of argon gas was admitted to the tube and the tube sealed off. This pressure of inert gas was necessary to prevent "bumping" of the molten anthracene.

The sealed tube was held vertically in a stand and a small cylindrical heater, of diameter slightly greater than the tube, and approximately 2 cms. in length, was suspended over the tube so that, at the commencement of the experiment, the heater was level with the upper surface of the anthracene. The heater was wound from 2 yards of Nichrome resistance tape (33 ohms per yard), on a pyrex glass former. The input was controlled by a variac operated from the 250

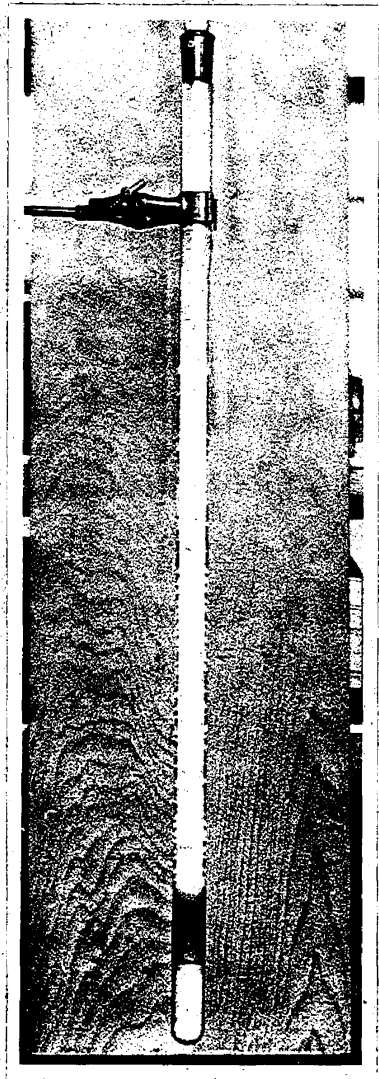

FIG.8. A PHOTOGRAPH OF THE ZONE REFINING TUBE.

volt A.C. mains supply, and the heater was attached to a lowering mechanism.

The temperature of the heater was adjusted to approximately 250°C. When the anthracene at the top of the tube had melted the lowering mechanism was started and the heater lowered down the tube at the rate of 2.5 cms. per hour. As the heater passed down the tube the anthracene below it melted and the molten anthracene above it solidified, with the result that a band of molten anthracene 3-4 cms. wide was produced which passed down the anthracene column at a rate equal to the passage of the heater. When the heater reached the lower end of the column it was automatically returned to the top and the cycle recommenced.

The impurities present in the anthracene concentrated in the melt and passed down the column with the molten band. Each successive pass pushed these impurities lower and the result was an enhancement in the purity of the anthracene in the upper end of the column. It was determined that after about ten passes of the heater the anthracene in the upper three-quarters of the tube was of higher purity than that produced by the previous two methods. A photograph of a zone refining tube on completion of purification is depicted in figure 8.

No more information about the purity of the anthracene could be gained from U.V. spectroscopic methods but the quality of the crystals grown served as an excellent indication of the high purity of the anthracene purified by this method. The crystals produced showed

none of the zone cooling effects noted in the previous samples during growth and were single and free from striations and other features associated with the presence of fairly large quantities of impurity in the crystal. The crystals were singular throughout the length of the growing vessel and crystals grown from this zone refined material were used for the diffusion measurements.

The success of this method of purification led to its adoption and all the material for the latter stages of the work was purified in this manner.

#### 1.f. The Filling of the Crystal Growing Tubes

In early experiments (using tubes type, figure 4.a. and b.) the crystal growing vessels were filled with powdered anthracene, evacuated, and sealed under vacuum. This method was not very successful because a considerable number of small particles were included with the anthracene and these tended to block the capillary at the lower end and hence hinder growth.

The larger particles were removed as follows:

After the crystal growing tube had been filled with powdered anthracene a glass tube with two constrictions was glass-blown on to the upper end. The complete tube was evacuated and sealed at the upper of the two constrictions. The sealed tube was inverted and suspended in a tube furnace and the anthracene allowed to melt. The larger particles fell to the bottom and were easily tapped into the space between the sealed and open constrictions. When all this unwanted solid had been removed in this way the second constriction

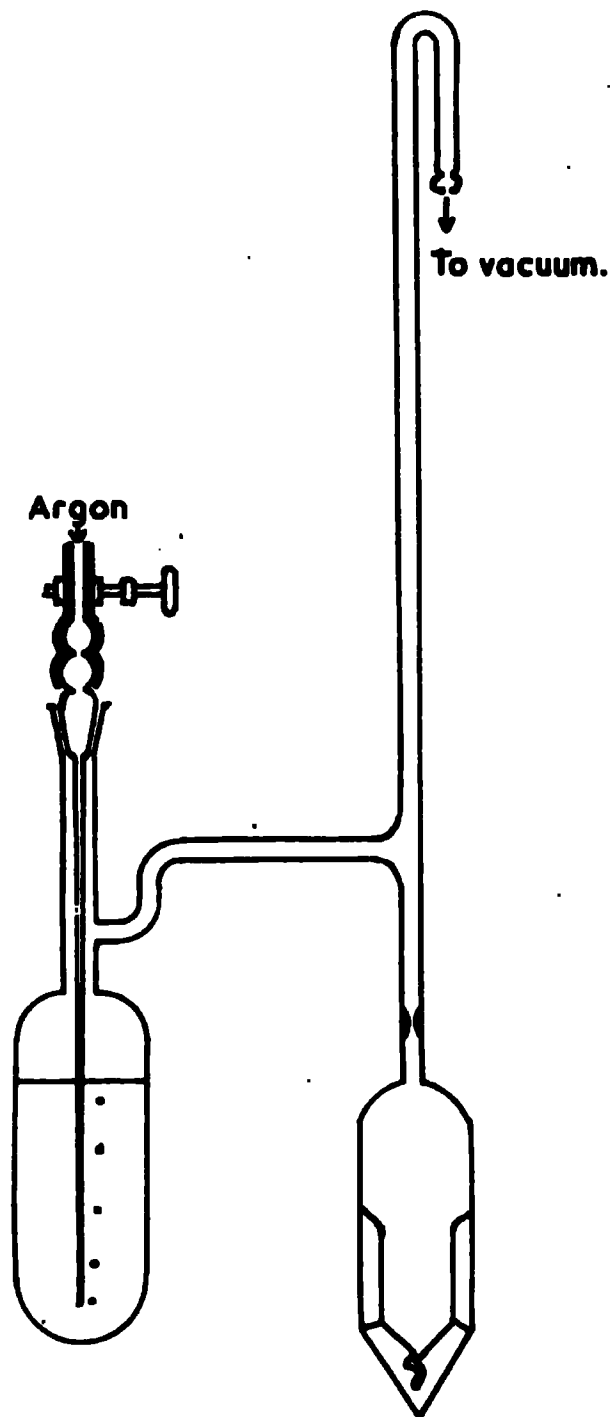

**FIG.9. THE DISTILLATION APPARATUS.**

was sealed and the particles trapped.

This technique removed the possibility of capillary blockage during growth but still left a considerable number of smaller, floating particles which could cause nucleation and spoil single crystal growth. In order to remove all such particles, both large and small, it was found necessary to distill the anthracene, under reduced pressure, into the crystal growing tube (32,35). The apparatus used for this purpose is depicted in figure 9.

The anthracene in the flask was melted under an atmosphere of argon gas. When this was complete the pressure in the apparatus was reduced to 12 cms. mercury pressure of argon and maintained at this value by means of the argon bleed. The anthracene distilled quite rapidly into the crystal growing tube under these conditions.

It was found necessary to heat the connecting tubes of the apparatus with a hand torch during the distillation to reduce the possibility of blockage of these tubes by anthracene, which tended to solidify in the cooler parts of the apparatus. Some anthracene solidified in the air condenser during distillation and this was melted into the crystal growing tube at the end of the distillation.

This technique was found to be very useful in eliminating all small particles which could cause nucleation and was used for filling the tubes types, figure 4.c, d, e. and f.

Anthracene undergoes quite a large contraction on solidification and because of this it was found necessary to fill tubes of type f. (figure 4) so that the central tube was always covered with anthracene

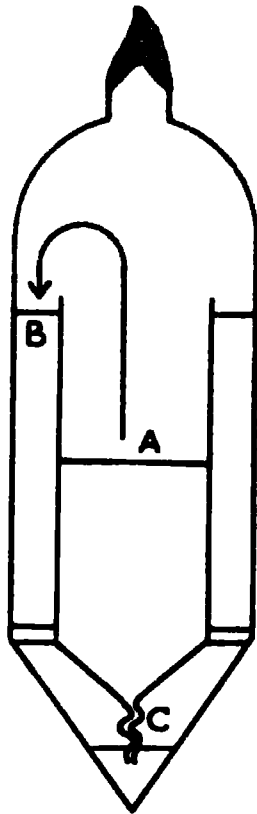

FIG.10. THE DISTILLATION EFFECT IN THE CRYSTAL GROWING TUBE.

during the crystal growth. If this was not done it was found that when the crystal growing tube was suspended in the crystal growing oven distillation of the molten anthracene took place from the central tube to the outside tube (A to B, figure 10), no doubt as a result of the different vapour pressures of anthracene vapour over each surface. Before crystal growth had commenced, this distillation had little effect because equilibrium could be maintained by flow through the capillary G. However, when the growing crystal had blocked the capillary this was not possible and the level of molten anthracene in the outside space rose at the expense of that contained in the central tube. This distillation now caused two undesirable effects:

1. the production of a smaller crystal than anticipated because of the loss of anthracene from A.
2. the stirring of the melt in A as the level B rose to the top of the central tube and overflowed into A.

As it was found that better crystals could be grown from a placid melt this latter effect was extremely harmful to good crystal growth, and distillation was carefully avoided, in the way indicated above.

When the tubes had been filled they were attached to a high vacuum line, and evacuated at "sticking" vacuum for at least two hours. At the end of this period of time 12 cms. mercury pressure of argon gas was added to the tube and the tube sealed off. The small pressure of inert gas was included to avoid "bumping" which

always occurred when the anthracene was melted under lower pressures than 8 cms. mercury.

#### 1. g. The Annealing of the Crystals after Growth.

Organic crystals are, in general, very susceptible to thermal shock and must be treated with extreme care to prevent damage from this source. During the initial attempts at crystal growth the crystal growing tube was allowed to descend slowly to the bottom of the furnace, which was at air temperature, and was gradually cooled in this way. This method proved very time consuming, periods of up to fifteen days being required to complete the growth of one crystal, and a well lagged, electrically heated, tube furnace was constructed to anneal the crystals in the crystal growing vessel after removal from the oven.

The annealing furnace was wound from 2 yards of 33 ohms per yard Nichrome heating tape on an iron former 2 inches in diameter and 8 inches long, previously wrapped with asbestos paper for electrical insulation. The iron former was supported in a large tin and well lagged with magnesia-asbestos lagging. Control was effected by means of a Sunvic energy regulator operated from the 250 volt A.C. mains.

As soon as crystal growth was complete, the tube containing the crystal was transferred from the growth oven to the annealing furnace, which had previously been heated to the temperature of the crystal ( $\approx 180^{\circ}\text{C}$ ), and was annealed at this temperature for two to three days. Annealing served to ease strain in the crystal. At the end

of this period the furnace and the crystal were slowly cooled to room temperature by gradual and regular reduction of the energy regulator setting over a period of approximately 48 hours. In order to ensure that each crystal had a similar history all crystals grown for use in the diffusion experiments were annealed in exactly the same way.

#### 1.h. Removal of the Crystals from the Tube and Crystal Shaping.

After the crystal had been annealed and cooled to room temperature, the crystallisation vessel was carefully broken open and the crystal "boule" removed. The crystal thus obtained was cylindrical in shape and similar in cross section to the internal tube of the crystallisation vessel. Plates of crystals were required for the diffusion experiments and hence some shaping of the crystal "boule" was necessary.

It was decided to use the (001) plane of the crystal as the zero face for the initial diffusion experiments because this coincided with the cleavage plane (59) and was easily located.

Examination of that end of the "boule" which had broken away from the seed crystal at the upper end of the capillary tube showed the angle of the cleavage plane to the axis of the cylinder of crystal. By pressing a razor blade against the crystal at this angle the crystal was made to cleave apart. In this way the crystal was cut into sections with parallel faces approximately 0.75 cms. thick. Only those sections cut from the lower two-thirds of the

crystal cylinder were used in the experiments. The reason for this was that it was thought that any remaining impurity in the anthracene used for crystal growth would have concentrated in the upper third and in this way reproducible specimens could be obtained.

Cleavage of the anthracene crystal is well defined but a smooth flat surface was rarely obtained and it was found necessary to polish the cleaved face before the crystal was used in the experiments. For convenience the other faces of the crystal were cut square with a sharp razor blade and these were not polished.

Small pieces of crystal adhering to the cleaved surface were removed with a razor blade and the surface ground flat by rubbing on a glass plate, using fine carborundum powder lubricated with distilled water as abrasive. Grinding in this way produced a flat matt surface which could be polished with benzene to produce a mirror-like finish. Attempts were made to polish these surfaces with metal polish but the alcohol contained in the polish attacked the crystal surface and caused longitudinal cracks in the crystal. The approximate size of the finished crystals was  $1.5 \times 1.5 \times 0.5 \text{ cms}^3$ .

In order to determine whether the anthracene crystal exhibited diffusion anisotropy it was desired to carry out two experiments, at two different temperatures, to measure the rates of diffusion in the plane parallel to the cleavage plane. (The crystals prepared above were to measure rates of diffusion perpendicular to the cleavage plane.) There is no definite cleavage in any other plane than the (001) plane and some difficulty was experienced in determining the

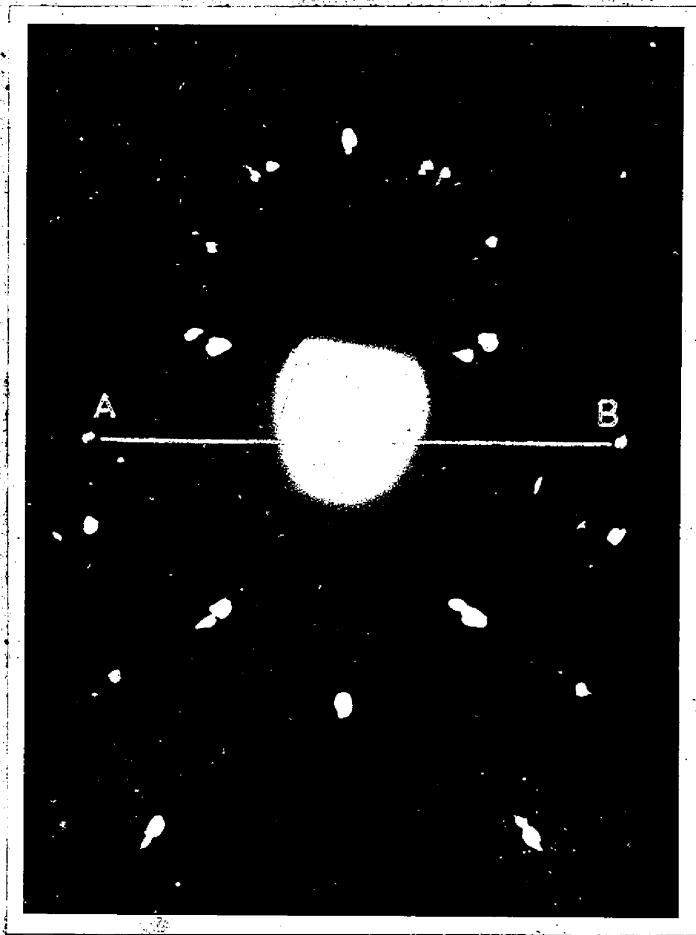

FIG.II. THE LAUE DIFFRACTION PATTERN OF ANTHRACENE.

direction. It was finally decided that it was not possible to select another crystal axis for the measurements and that some arbitrary choice would have to be made. In order that the results of the two experiments carried out in this plane should be in relation to one another it was, however, desirable that they should be carried out so that diffusion proceeded in a similar direction in each case. That this was the case was ensured in the following manner:

Before shaping, a large anthracene crystal was set up with the cleavage plane normal to an "X" ray beam and the resultant Laue diffraction pattern recorded on a photographic plate behind the crystal. A very characteristic and unsymmetrical pattern, a photograph of which is shown in figure 11, was obtained.

The position of the crystal relative to the Laue pattern was known in each case and hence, by comparing the crystal with the diffraction pattern, the crystals could all be shaped so that the initial face from which diffusion was measured was orientated in exactly the same direction in each case.

The direction chosen corresponded to the line AB on figure 11.

The crystal and diffraction pattern were compared and a line drawn on the cleaved crystal surface which would correspond to a line parallel to AB on the pattern. A razor blade was placed on the crystal surface and a cut made parallel to this line and at right angles to the cleaved surface. This cut face was taken as the zero face for the diffusion experiments carried out in the

direction parallel to the cleavage plane.

Rather more trouble was experienced in the preparation of these crystals for the measurement of diffusion parallel to the cleavage plane and attempts to cut the crystal to the size required with a razor blade inevitably resulted in the fracture of the crystal. It was found necessary to take a crystal approximately 1.5 cms. cube and to reduce it to the size required by rubbing the face opposite to that cut as described above, with coarse emery paper. When the crystal had been reduced in this way to  $1.5 \times 1.5 \times 0.75$  cms<sup>3</sup>, the cut face and that opposite to it were polished in the manner described above.

All crystals used in the attempt to measure diffusion anisotropy in anthracene were photographed with an "X" ray beam, the initial surface determined and polished as described above.

The crystals, after polishing, were colourless and transparent, exhibiting a blue fluorescence in direct daylight. Some of the thicker crystals appeared to have a faint yellow colour which the author believes results from the optical properties of the crystal rather than the presence of impurities. The specimens used for the diffusion experiments were tested for singularity by examination with the polarizing microscope and were free of all striations and visible imperfections.

## 2. The Synthesis of Anthracene - 9 - Carbon 14

There are certain special features connected with the synthesis of radio-active materials which make them different in some ways to

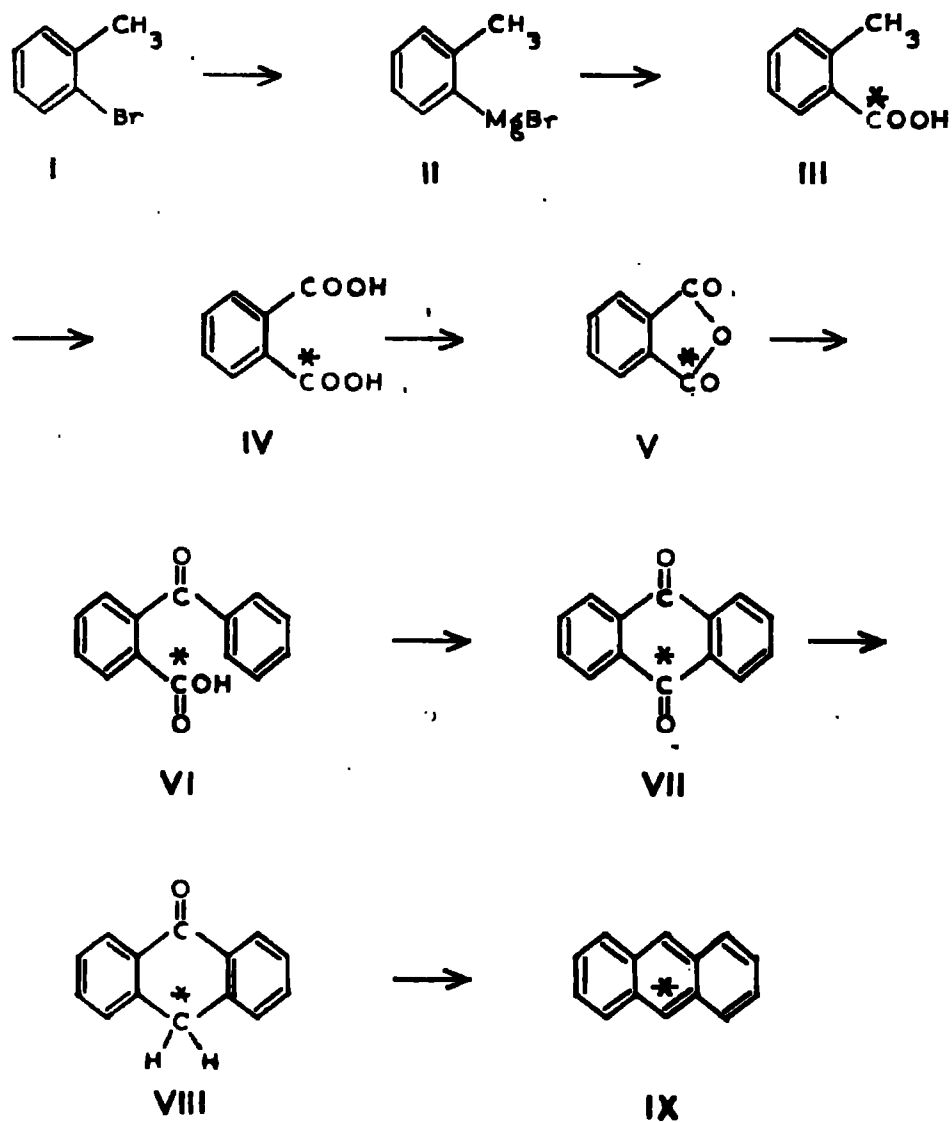

FIG.12. SYNTHESIS OF ANTHRACENE-9-CARBON-14.

routine organic syntheses:

- (a) The starting materials are unusual.
- (b) The result of this is that the synthesis is often long.
- (c) The materials are costly.
- (d) The synthetic route adopted must have fairly high yields at each stage and the amount of dilution of the radioactivity throughout the synthesis must be small, so that the specific activity of the radioactive compound is kept high.

Although some labelled organic compounds are available these are costly and the usual approach to a radio-active synthesis is the introduction of the carbon-14 from barium 14-carbonate or potassium 14-cyanide.

The synthesis adopted for the present work was more or less a classical synthesis of anthracene and was based, except in the final stages, upon a synthesis described by Stevens and Holland (60). Barium 14-carbonate was used as the source of carbon-14 and as this was introduced during the early stages of synthesis great care was taken to ensure that maximum possible yields were obtained at each stage.

Figure 12 shows an outline of the synthesis, each stage of which is described in detail below. The Roman numerals after the various compounds refer to figure 12.

2.a. o - Toluic acid (III)

o - Toluic acid - carbonyl - carbon-14 (III) was prepared by

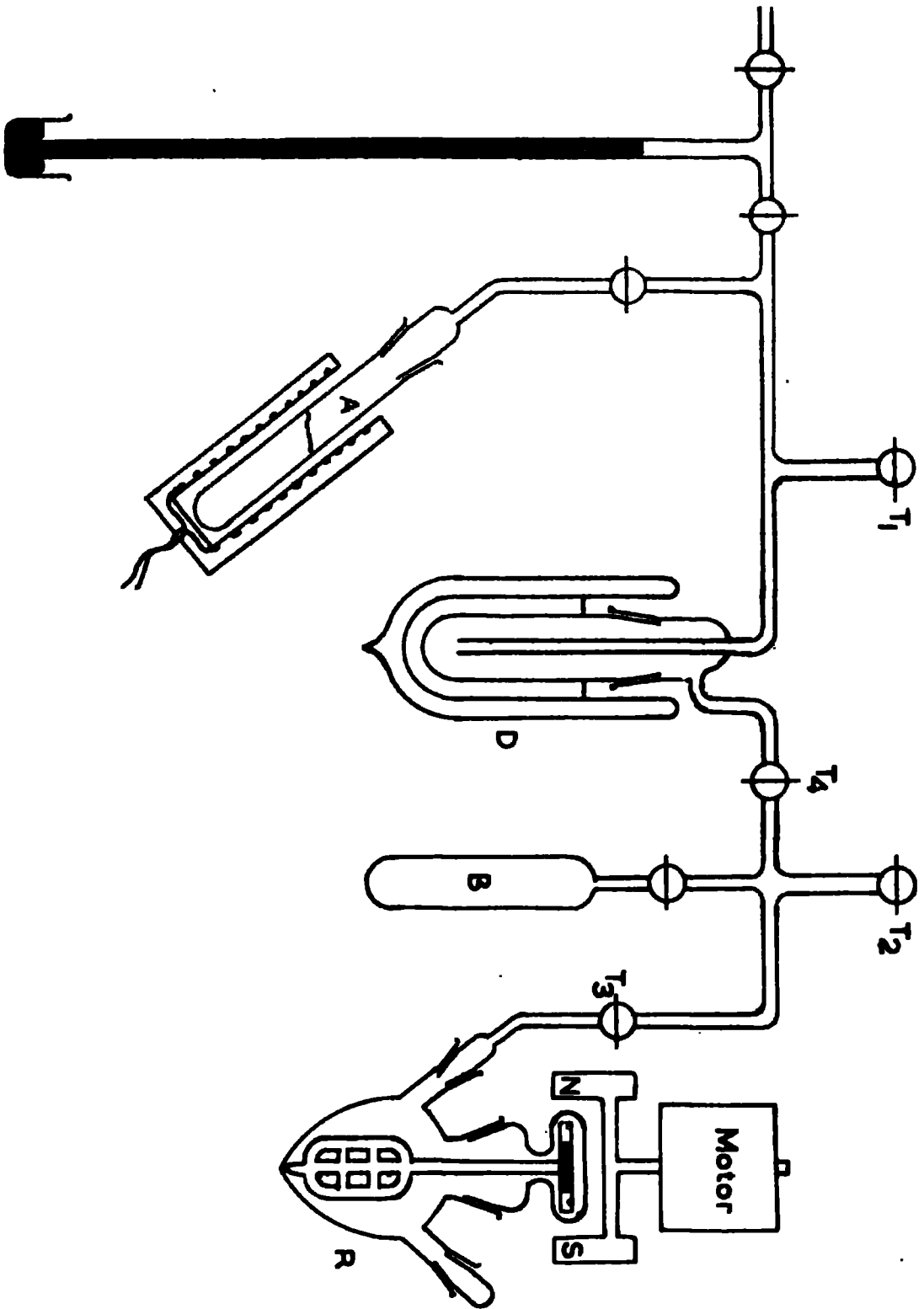

FIG.13. THE CARBONATION APPARATUS.

carbonating a four-fold excess of Grignard reagent (II) obtained from o - bromotoluene (I) with 10 millimoles of labelled carbon dioxide. This reaction was carried out in a high vacuum apparatus, the procedure adopted being similar to that described by Dauben, Reid and Yankwich (61) with slight modifications. The carbonation apparatus is depicted in figure 13.

The Grignard reagent was prepared (62) from 1 gm. magnesium and 6.8 gms. of o - bromotoluene using 100 mls. of dry di-ethyl ether as solvent. The reaction was carried out under an atmosphere of dry nitrogen to prevent oxidative and hydrolytic losses.

The magnesium was placed in a round bottomed flask provided with a stirrer, together with 50 mls. of the ether. Half the o - bromotoluene was added and the mixture refluxed for half an hour to start the reaction. A small crystal of iodine was inevitably needed to initiate the reaction. At the end of this time the heater was removed, the stirrer started and the rest of the o - bromotoluene, dissolved in 50 mls. of ether, added slowly over a period of half an hour. The reaction was allowed to proceed with stirring until the rate slackened. Finally the mixture was refluxed to complete the reaction.

When the reaction was complete 10 mls. of the ether solution were taken by pipette (which had previously been flushed out with nitrogen) and were decomposed in 50 mls. of water. Ten mls. of standard 2N sulphuric acid were added and the mixture shaken to decompose the precipitated basic magnesium bromide. The ether layer

52  
was removed and the aqueous solution warmed on a hot plate to complete the decomposition. Care was taken that the temperature did not exceed 60°C, as above this temperature decomposition of the magnesium bromide occurs. The solution was cooled and titrated against standard 2N sodium hydroxide using methyl orange as indicator. The yield of the Grignard reagent was calculated and was usually greater than 90%

The remaining solution of the Grignard reagent was transferred by pipette to the reaction flask R of the high vacuum apparatus (figure 13) which had previously been flushed with nitrogen ready for the transfer.

The transfer complete, the apparatus was isolated and the ether solution of the Grignard reagent frozen with liquid nitrogen. The taps  $T_1$ ,  $T_2$ , to the vacuum line, were then opened, and the apparatus evacuated, to "sticking" vacuum. When this state was attained  $T_1$  and  $T_2$  were closed and the solution in R allowed to warm to  $-25^\circ\text{C}$  by replacing the liquid nitrogen bath with an acetone/ice bath at that temperature. This allowed any nitrogen "frozen in" during the rapid freezing of the solution to escape. The solution was then frozen again and the apparatus re-evacuated.

When "sticking" vacuum had again been attained the apparatus was isolated from the main vacuum line. The reaction vessel was isolated from the rest of the apparatus by closing tap  $T_3$  and the carbon-14 dioxide was prepared.

Ten mgms. of barium 14-carbonate containing 2 millicuries of

radioactivity were obtained from the Radiochemical Centre.

This radio-active material was diluted with 1.97 gms. of inactive barium carbonate.

The labelled carbon dioxide was prepared by heating an intimate mixture of the 1.97 gms. of barium carbonate with 18 gms. of lead chloride to 350°C in the pyrex tube A (90). The preparation was carried out under vacuum.

The evolution of the carbon dioxide from this mixture is rapid and quantitative at this temperature. The volume evolved was determined by studying the pressure produced in the apparatus during the process. The gas was passed through a trap D, cooled with an acetone/solid carbon dioxide bath, to remove any condensable matter which may have been present, and was collected in the storage bulb B which was surrounded by liquid nitrogen.

Attempts to prepare the carbon dioxide by reaction of concentrated sulphuric acid and barium carbonate (61) always resulted in low yields of the final product (less than 30% yield). The author believes this low yield to be the result of rapid reaction of the Grignard reagent with impurities present; probably traces of water, which initiate the rapid decomposition of the Grignard reagent before reaction with carbon dioxide will occur. This effect was not eliminated by the inclusion of the trap D, cooled with an acetone/solid carbon dioxide bath.

When evolution of carbon dioxide was complete tap T<sub>4</sub> was closed. Tap T<sub>3</sub> was then opened and the liquid nitrogen bath removed from around the storage bulb B. The carbon-14 dioxide was allowed to

condense on to the surface of the frozen ether solution in the reaction flask R. When this was complete Tap  $T_3$  was closed and the solution in the flask allowed to warm to  $-25^{\circ}\text{C}$ . The reaction mixture was stirred vigorously for 30 minutes whilst the Grignard reagent reacted with the carbon dioxide. The freezing, melting and stirring cycle was repeated twice, by which time the reaction was complete and the solution was allowed to warm to room temperature. The reaction vessel was removed from the apparatus.

The reaction mixture was hydrolysed by pouring it on to a mixture of ice and dilute sulphuric acid. The o-toluic acid liberated in this way dissolved in the ether layer and was separated. The ether layer was extracted with four 10 mls. portions of N. sodium hydroxide. The alkaline extract was cooled to  $0^{\circ}\text{C}$  and the o-toluic acid precipitated by adding concentrated hydrochloric acid. The o-toluic acid was filtered, washed and recrystallised from hot water. 0.891 gms. of o-toluic acid were obtained, melting point  $104^{\circ}\text{C}$  (pure  $104^{\circ}-5^{\circ}\text{C}$ ) (72).

#### 2.b. Phthalic acid (IV)

The o-toluic acid was converted to phthalic acid by the oxidation of a solution of the acid in a three-fold excess of N. sodium carbonate, with a 10% excess of 5% potassium permanganate solution (63). The reaction mixture was heated on a water bath at  $60^{\circ}-70^{\circ}\text{C}$  for ten hours.

At the end of this period the excess permanganate was destroyed by the addition of ethyl alcohol and the solution filtered from the precipitated manganese dioxide.

The colourless filtrate was transferred to an evaporating <sup>55</sup> basin and the volume reduced to about 5 mls. by heating the solution in a current of air. The concentrated solution was cooled and the acid precipitated by addition of concentrated hydrochloric acid. The phthalic acid was filtered at the pump.

A more complete recovery of the labelled phthalic acid was effected by dissolving a small quantity (0.5 gms.) of inactive compound in the hot filtrate. A second quantity of less active material was obtained on cooling. The combined acids were recrystallised from water. A yield of 0.75 gms. of radioactive phthalic acid was obtained, melting point  $206^{\circ}\text{C}$  (pure  $207^{\circ}\text{C}$ ) (72). The total weight including the inactive material was 1.25 gms.

#### 2.c. o-Benzoyl Benzoic acid (VI).

The conversion of phthalic acid to o-benzoyl benzoic acid was made via phthalic anhydride (V). Phthalic anhydride was prepared (64) from the parent acid by refluxing it with four times its weight of freshly distilled thionyl chloride for three hours. When refluxing was complete three successive portions of benzene were distilled from the anhydride to free it from excess thionyl chloride, and the purified anhydride recrystallised from benzene. Long needle like crystals were obtained in approximately 96% yield.

o-Benzoyl benzoic acid (VI) was prepared (65) from this compound by a Friedal-Craft type reaction using 5 mls. benzene and 1.9 gms. freshly sublimed anhydrous aluminium trichloride. The phthalic anhydride and the benzene were placed in a small round bottomed flask and the finely ground aluminium trichloride added slowly. A

reflux condenser was attached and the reaction mixture allowed to stand at room temperature for one hour. At the end of this time the reaction mixture was refluxed on a water bath for a further two hours. The apparatus was carefully dried prior to use and the reflux condenser provided with a drying tube at the upper end, in order that atmospheric moisture could not enter the system.

On completion of the reaction the crude acid was dissolved in dilute ammonium hydroxide and the mixture filtered. The ammoniacal solution was cooled and the acid precipitated by addition of concentrated hydrochloric acid. The acid precipitates as an oil which solidifies on being allowed to stand. It was filtered and recrystallised from water. The final yield of pure material was 1.188 gms. and the melting point  $93^{\circ}\text{C}$  (pure  $93^{\circ}\text{C}$ ) (72).

#### 2.d. Anthraquinone (VII)

The preparation of anthraquinone (66) was accomplished by refluxing the o-benzoyl benzoic acid with 60 mls. 96% sulphuric acid, on an oil bath at  $120^{\circ}\text{C}$  for two hours. On completion of the reaction the contents of the flask were poured into an excess of water. The anthraquinone precipitated as a slurry which was digested on a hot plate. It was then filtered and washed well with dilute ammonia to remove traces of unchanged acid. This product was recrystallised from glacial acetic acid and dried at  $120^{\circ}\text{C}$ . The yield was 1.020 gms. and the melting point  $286^{\circ}\text{C}$  (pure  $286^{\circ}\text{C}$ ) (72).

Stevens and Holland (60) recommend a two stage reduction of anthraquinone to anthracene via anthrone (VIII). It was found by the author however that although the reduction to anthrone (67) proceeds rapidly and well (yield 95%), that of anthrone (68) rarely yielded more than 10% of very impure anthracene.

The possibility of reduction of the anthraquinone direct to anthracene was suggested by Dr. E. Clar (69). This method was attempted and although the final yield of anthracene was low (40-50%) it was a great improvement upon the method suggested by Stevens and Holland and was adopted for the final stage of synthesis.

The anthraquinone from the previous preparation was heated under reflux with 6 gms. zinc dust and 20 mls. of pyridine. 5 mls. of 80% acetic acid were added to the refluxing mixture over a period of three hours. Reaction was complete when the colour of the solution, which was originally yellow, faded, a change which took approximately three hours.

When this change was complete the reaction solution was decanted into 100 mls. 5% hydrochloric acid. A zinc chloride-hydroxy anthracene complex was precipitated. The zinc residues were washed with a little water and pyridine and the washings added to the acidic solution. The precipitate was boiled for twenty minutes and allowed to stand overnight in a refrigerator.

Next day the complex was filtered at the pump, washed with water and finally with ammonium hydroxide solution. This latter reagent destroys the complex and removes the zinc chloride. The washings

and mother liquors were evaporated down to increase the yield of material.

Excess ammonium hydroxide was not removed from the decomposed complex because it hinders the possible formation of zinc chloride which may still be present as an impurity and could have a degradative effect during the sublimation process.

The residue after decomposition of the complex was dried and sublimed in a high vacuum system. The sublimed product was recrystallised from toluene. Beautiful blue flakes of anthracene (melting point  $217.5^{\circ}\text{C}$  (pure  $217^{\circ}\text{C}$ )) (72) were obtained. The yield was 0.400 gms.

#### 2.f. Activity of the Specimen

The initial sample of barium 14-carbonate contained two millicuries of radioactivity. The final product, 0.277 gms. of anthracene - 9 - carbon 14 had a specific activity of 0.6 microcuries/mgm.

The relative amounts of product at each stage in the synthesis and the yield in each stage are given in table I.

Table I. The percentage yields of the compounds obtained at each stage of the synthesis

Compound	Weight gms.	Yield %
2.a. o-Toluic acid (III)	0.891	65
2.b. o-Phthalic acid (IV)	0.750	69
2.c. o-Benzoyl Benzoic acid (VI)	1.188	70
2.d. Anthraquinone (VII)	1.020	94
2.e. Anthracene (IX)	0.400	46

### 3. The Deposition of Radioactive Anthracene on the Crystal Surface.

It is desirable that the radioactive material should be deposited on the crystal surface in such a way that the deposit is a continuation of the crystal lattice. There are two methods which have been used in other branches of this field of research to produce such an epitaxial deposit which are applicable to the present case:

1. Deposition from saturated solution.
2. Evaporation of the solid on to the surface in a vacuum.

There are two major objections to the first of these. Earlier in this thesis it was pointed out that some solvents, when used for solvent polishing, caused cracks in the crystal surface. One explanation of this could be that the cracking was the result of thermal shock due to local cooling as the solvent evaporated. There is therefore a possibility that similar effects could result from the evaporation of the solvent, following the application of the saturated solution to the crystal surface. These cracks, if produced, could provide a short circuit path for the penetration of the material into the crystals.

The second objection is the possibility that the solution may "creep" round the sides of the crystal and deposit the radioactive substance there as well as on the intended face, again causing interference with the diffusion experiments.

The above objections do not arise in consideration of the second method, providing that care is taken in the design of the evaporation apparatus to obviate the possibility of deposition on other faces

than that desired, This is easier to arrange for the evaporation method than for deposition from saturated solution, and because of this advantage it was decided to investigate the possibility of using this latter method for the present study.

Preliminary experiments carried out to determine whether anthracene could be evaporated in this way showed this method to be practicable, and it was found that powdered anthracene evaporated readily from a small hot plate on to a cooler surface placed immediately above it, to form a satisfactory deposit. These experiments were not carried out under vacuum, but the results were promising and a high vacuum apparatus was constructed for the evaporation of the anthracene, as it was thought that evaporation in vacuum would result in even better deposits being formed.

### 3.a. The Evaporation Apparatus.

The main requirements of this apparatus were:

1. A small heater from which the radioactive sample could be evaporated.
2. The distance from the heater to the crystal should be low so that a large portion of the evaporated material would reach the crystal surface.
3. Some feature should be included to confine the radioactive material so that it could be easily recovered at the conclusion of the experiments.
4. The crystal should not be subject to thermal shock from the proximity of the heater.
5. The evaporated anthracene should be deposited in a

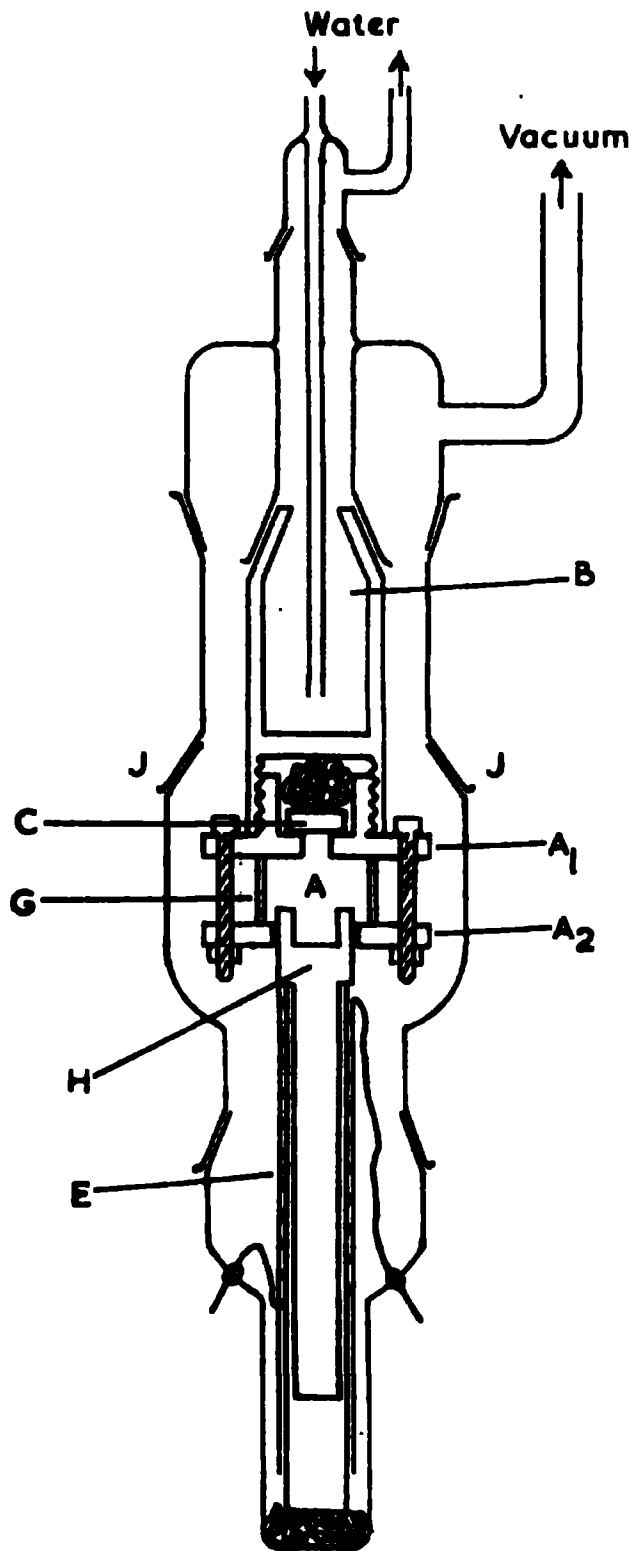

FIG.14. THE EVAPORATOR.

well defined area on the crystal surface and that it should be prevented from depositing on any other surface during this process.

6. The apparatus could be readily taken apart for cleaning and for the replacement of the crystal.

With these major requirements in mind the glass and metal high vacuum apparatus depicted in figure 14 was constructed for the evaporation of the radioactive anthracene on to the crystal surface.

The apparatus was designed in two parts, the lower portion of which contained the heater and the upper, the crystal in a holder. In each half of the evaporator the ground joints were held together with Apiezon high vacuum wax W100. The apparatus could be readily taken apart at ground joint J which was greased with Apiezon N. high vacuum grease, for ease of separation after each evaporation.

The brass crystal holder A consisted of an upper and lower flange  $A_1$  and  $A_2$ . The upper flange  $A_1$ , which had a hole 1.2 cms. diameter in its base, was screwed into the bottom of the cold finger B. On this flange rested the crystal C. The space between the crystal and B was packed with silver wool which served a dual purpose. Firstly, when the flange was screwed home the silver wool pressed the crystal against the base of the flange and prevented the passage of vapour between the crystal and the flange. This removed the possibility of deposition of radioactive anthracene on any other part of the crystal surface than the area defined by the hole in the flange. Secondly, it provided excellent thermal contact between

the crystal and the bottom of B. Through B was passed cold water which helped to maintain the crystal and the brass flange A at a constant temperature. The lower flange was attached to the upper by four long screws and separated from it by means of a pyrex glass tube G of diameter 2 cms. and depth 1 cm., through which the evaporation could be watched. The hole in the lower flange was just large enough for the head of the hot plate H to pass through.

The lower portion of the apparatus consisted of a hot plate H and an electrical heating coil E wound on a pyrex glass former from 33 ohms. per yard "Nichrome" resistance tape (total resistance 60 ohms.). Connections to the heating coil were provided by two tungsten to glass seals in the surrounding wall. The hot plate H was an aluminium rod, the end of which had been turned to form a small cup. The hot plate slipped inside the glass former of the heating coil as shown in the diagram. When the joint J was sealed the cup of the hot plate passed through the hole in the lower flange of the crystal holder to lie, enclosed by the circular glass window G, about 2-3 mms. from the crystal in the holder. In this way the requirement that the heater and sample should be only a small distance from the crystal surface was met, and also, the evaporating anthracene was confined to the volume of the glass tube G.

### 3.b. The Evaporating Technique.

A crystal was placed in the holder and packed with silver wool. The holder was then screwed into position in the base of the cold finger, so that the crystal was pressed tightly against the face

of the holder.

The charge of anthracene - 9 - carbon-14 was placed in the cup of the heater and apparatus assembled. The tap to the vacuum line was opened and the evaporator evacuated at "sticking" vacuum for two hours. At the end of this period the apparatus was isolated from the vacuum line and the heater terminals connected to the 250 volt A.C. mains through a variac. The input to the heater was adjusted to 0.30 amps and the heater allowed to warm up over a period of 30 minutes. At the end of this time the temperature of the hot plate was just below that required for rapid evaporation of the radioactive anthracene. The temperature attained was 80°C. The input was then increased to 0.35 amps which caused a sudden increase of the temperature of the hot plate to 110°C, the temperature required for rapid evaporation of the anthracene. Rapid evaporation of the anthracene from the cup of the hot plate occurred and anthracene was deposited upon the face plate of the crystal holder and the wall of the surrounding glass tube as well as on the crystal surface. The rate of evaporation was approximately 2 mgm. of anthracene per minute. This input (0.35 amps) was applied for about 5-10 minutes depending upon the size of the original charge and was then increased to 0.40 amps to complete the evaporation process.

It was found that a much better deposit resulted from the above rate of evaporation than from slower rates. Slower rates of evaporation usually lead to the formation of dense whisker like growth from the surface and not an even deposit over the surface of the crystal.

### 3.c. The Nature of the Deposit.

Microscopic examination of the crystal surface after deposition of the radioactive anthracene showed that the deposit formed a transparent raised step on the surface of the crystal, of diameter equal to the hole in the face plate of the crystal holder. The surface of this raised portion was in most cases covered with a mass of smaller crystals which had grown out from the surface of the deposit.

A blank experiment was carried out to determine whether the raised step was the result of deposited anthracene or whether it was caused by pressure of the crystal against the face plate, accompanied by heat from below. This experiment was carried out with no anthracene in the cup of the hot plate and it was found that, even after periods of several hours at maximum heater temperature, no such step was formed. It was therefore concluded that the transparent step formed on the surface was the deposited anthracene. That the deposit was formed epitaxially on the surface was shown by examination of the crystal and the deposit with the polarizing microscope.

A very good test of the epitaxial nature of the deposit was supplied by several experiments in which inactive anthracene was evaporated on to the surface of a polycrystalline specimen in which the crystallites were quite large. A transparent raised deposit was produced as described above. When the crystal and deposit was viewed under the polarizing microscope and the crystal rotated,

alternate light and dark areas could be seen when the separate crystallites were orientated so that extinction of the beam of polarized light resulted. It was found that the evaporated deposit followed the same pattern of extinction as the underlying crystallites. All the single crystals and deposits used for the experiments were examined in this way.

Whereas the greater part of the radioactive material was found to be deposited epitaxially, a small fraction always grew out from the surface of the deposit in the form of "whiskers". The number of whiskers formed seemed to vary with the experiment and could not be said to be the same in all cases. Removal of the whiskers by slight rubbing showed that an epitaxial deposit had always been produced underneath. In all cases some of the whiskers were removed in this way. Attempts were made to eliminate the formation of these whiskers by varying the rate of evaporation of the anthracene, but it was found that slower rates of evaporation lead to the formation of more whiskers, and faster rates produced no marked difference.

It was later shown that the epitaxial deposit beneath the whiskers was sufficiently large to produce the diffusion of a measurable amount of radioactivity into the crystal, and because of this the evaporations were carried out in the above described manner and no attempt at further improvement was made.

The amount of radioactive anthracene deposited on the crystals used for the diffusion experiments varied from 2 mgms. to 15 mgms. depending upon the quantity of radioactivity required in the surface

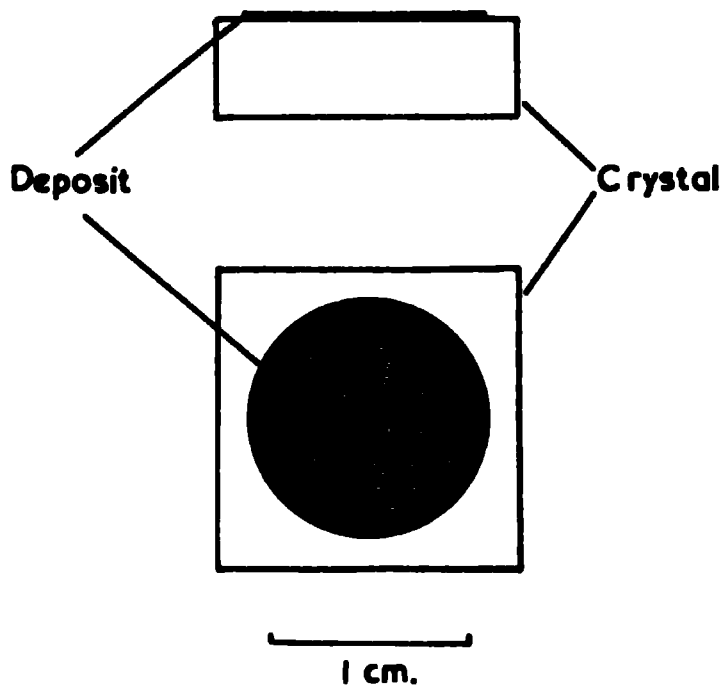

**FIG.15. A DIAGRAM OF THE CRYSTAL AND DEPOSIT.**

deposit. All crystals and deposits were examined under the polarizing microscope before use and it was found that in all cases a good epitaxial deposit was produced.

### 3.d. Approximate Thickness of the Deposit.

The presence of the whiskers on the crystal surface prevented an accurate measurement of thickness of the deposit by use of a microscope. An effort was made to relate the deposit thickness to the amount of radioactive material evaporated from the cup of the hot plate by determining the weight of the deposit per weight evaporated.

It was found that the approximate weight of the deposit was 0.04 mgms. per mgm. of anthracene evaporated from the hot plate.

Now Radius of the deposit = 0.6 cms.

Volume occupied by the deposit =  $\pi \times (0.6)^2 \times t$  cms<sup>3</sup>.

where t = thickness of the deposit in cms.

density of anthracene = 1.25 gms. per cc. (87).

$t = \frac{0.04 \times 10^{-3}}{1.25 \times \pi \times 0.36}$  cms. per mgm. anthracene evaporated.

$t = 2.8 \times 10^{-5}$  cms. per mgm. anthracene evaporated.

Although the amount of anthracene evaporated on to the crystals varied, the most usual weight evaporated was 8 mgms. and thus this weight would result in a deposit approximately  $2 \times 10^{-4}$  cms. thick.

The diameter of the deposit was 1.2 cms. and the size of the crystals approximately  $1.5 \times 1.5 \times 0.5$  cms<sup>3</sup>. Figure 15 shows a diagram of a crystal and deposit.

The major difficulties experienced in the diffusion experiments arose from the relatively high vapour pressure of anthracene. Solid anthracene has a vapour pressure of 1 mm. at 150°C. and this rises rapidly to 40 mms. at the melting point (217.0°C ~~(70)~~). Such a high vapour pressure implies that, under normal conditions, the rate of evaporation of anthracene at these temperatures would be high and, in a diffusion experiment, would result in the loss of anthracene from the crystal and also the loss of radioactivity from the deposit.

The magnitude of the former loss was shown in an experiment in which a crystal of the same size as those to be used in the diffusion experiments, was heated at 100°C under atmospheric pressure. The crystal suffered a 90% loss in weight over a period of 24 hours. It was proposed to carry out diffusion experiments at temperatures up to the melting point and as the rate of evaporation would increase with temperature it was obvious that this difficulty would have to be overcome.

The loss of radioactive anthracene from the surface could effect the experiments in two ways:

1. The radioactive material, following evaporation during the diffusion experiments, could be deposited on other faces of the crystal thus rendering the subsequent experimental results meaningless, because, in addition to measuring the amount of radioactivity which had diffused into the crystal from the original deposit, that which

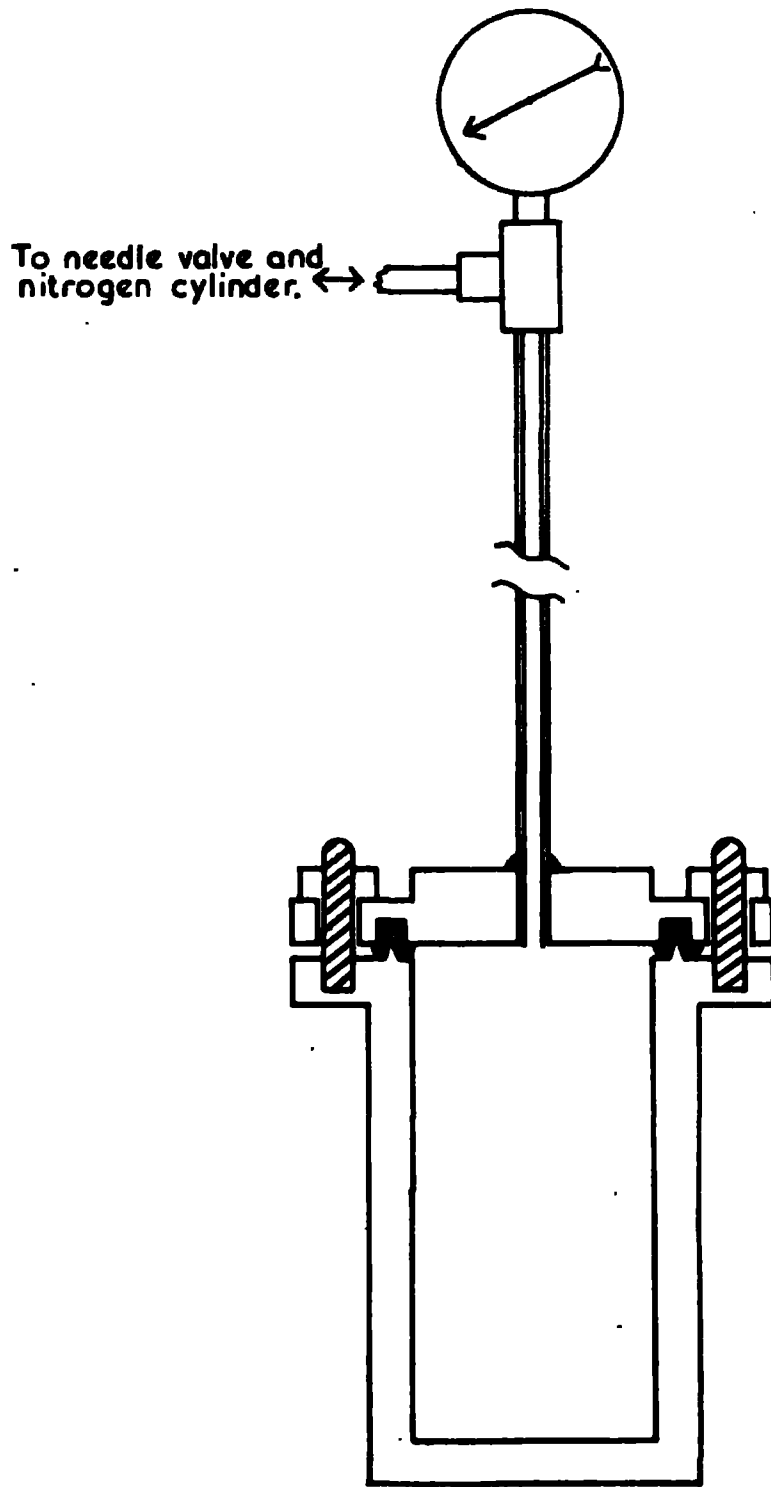

FIG.16. THE AUTOCLAVE.

had been deposited on the other crystal faces during the heating process would also be measured.

2. If the loss of the radioactive deposit was rapid then measurement would be made of the rate of diffusion from a source of diminishing strength and some difficulty would be found in formulating a diffusion equation for this process.

For these reasons it was necessary to reduce the rate of evaporation to as low a value as possible.

4.a. The Reduction of large scale losses of anthracene during the diffusion experiments.

Large scale losses of anthracene were reduced by carrying out the experiments under a pressure of inert gas in a steel autoclave, a diagram of which is depicted in figure 16. The vessel of the autoclave which was made from a solid steel bar had an internal diameter of 2.5 inches and a depth of 6 inches. The wall thickness of the vessel was 0.5 inches.

In the lid of the autoclave, which was of similar thickness to the wall of the vessel, was drilled a hole in which was welded a thick wall brass tube 10 inches long which projected upwards from the lid. To the upper end of this brass tube was attached a pressure gauge which indicated the pressure in the autoclave when in use. Gas was admitted to the autoclave directly from a large cylinder. The connections from the autoclave to the cylinder were made by thin bore copper tubing and union connections, and the pressure in the autoclave when in use was maintained by a high

pressure needle valve.

The lid was held to the bomb by eight 5/16" nuts and bolts, the bolts being welded into the bomb. A gas tight seal was made as follows:

On the top of the vessel was a lip which fitted into a circular groove in the lid. Before the lid was placed in position molten lead was run into the circular groove and allowed to solidify. The lid was then placed over the projecting bolts and the nuts screwed on and uniformly tightened. As the lid was drawn to the vessel in this way the lip on the vessel "bit" into the lead ring. The seal so formed proved very effective indeed at pressures up to 300 lbs. per sq. in. and temperatures up to 250°C. The inert gas used during the experiments was oxygen free nitrogen (supplied by the British Oxygen Gases Ltd.).

Experiments carried out with the autoclave proved that applied pressure could successfully reduce the large scale loss of anthracene, even at temperatures near the melting point, to a point where the losses involved would probably have no effect on the diffusion experiments.

Preliminary experiments on the measurement of the rates of self-diffusion in anthracene showed that, in order that the periods of heating for the crystals should not be too long, it would be necessary to use temperatures greater than 150°C. It was found by experiment, using the upper pressure limit of the apparatus (250 lbs. per sq. in.), that the rate of loss of anthracene from a crystal in

the autoclave was negligible at 150°C but increased at higher temperatures. The rate of loss of anthracene became critical at 190°C where, after the period required to produce measurable diffusion into the crystal (~50 hours), a piece of the crystal not much greater in size than the width of the deposit remained. If it is assumed that the radioactive material from the deposit only diffuses normally to the initial surface and in the cylinder of diameter equal to the diameter of the deposit, then it could perhaps be said that even this loss of anthracene at 190°C would not affect the experiment as that part of the crystal involved in the diffusion experiment still remained. It is thought therefore that the large scale losses of anthracene can be said not to affect the diffusion experiments at temperatures up to 190°C under pressure of 250 lbs. per sq. in. of inert gas.

There now remains the question as to how loss of radioactivity from the deposit, which will be at the same rate as from the rest of the crystal can be reduced. The dangers of such loss have been pointed out above and in order to minimise these effects in experiments at those temperatures where, even under pressure, the loss of anthracene is rapid, it is obvious that the deposit must be protected in some way. The way in which this was achieved is described in the following section.

#### 4.b. The Protection of the Radioactive Deposit.

Initially, attempts were made to protect the deposit by evaporating inactive anthracene on to the surface of the deposit. This

method proved unsuccessful, probably as a result of the presence of whiskers on the surface of the deposit, and losses of radioactivity during heating, from a crystal treated in this way were still high because of the impossibility of complete coverage.

Next a method was attempted in which two crystals, each with a radioactive deposit, were pressed face to face with the deposit between the common faces. It was not possible however to attain a good enough degree of contact between the crystals and losses of radioactivity on heating were still rather high. It was decided that if such a method was to be used some way of sealing off the common faces would have to be found.

An attempt to weld the crystals together at the edges with a heated wire failed because, when the wire was hot enough to melt the anthracene the sudden local heating at the touch of the wire cracked the crystal and spoiled it.

A more delicate technique attempted, was to hold the crystal on either side of a loop of resistance wire through which an electric current was passed. The current was gradually increased until the wire loop was hot enough to melt into the crystal and seal off the volume round the deposit. An excellent seal was produced in this way but the crystal surface was spoiled as it was difficult to separate the crystals without breakage after the experiment.

In the most successful method attempted for the protection of the deposit two crystals were placed deposit to deposit on either side of a "Teflon" washer which surrounded the deposits, and were

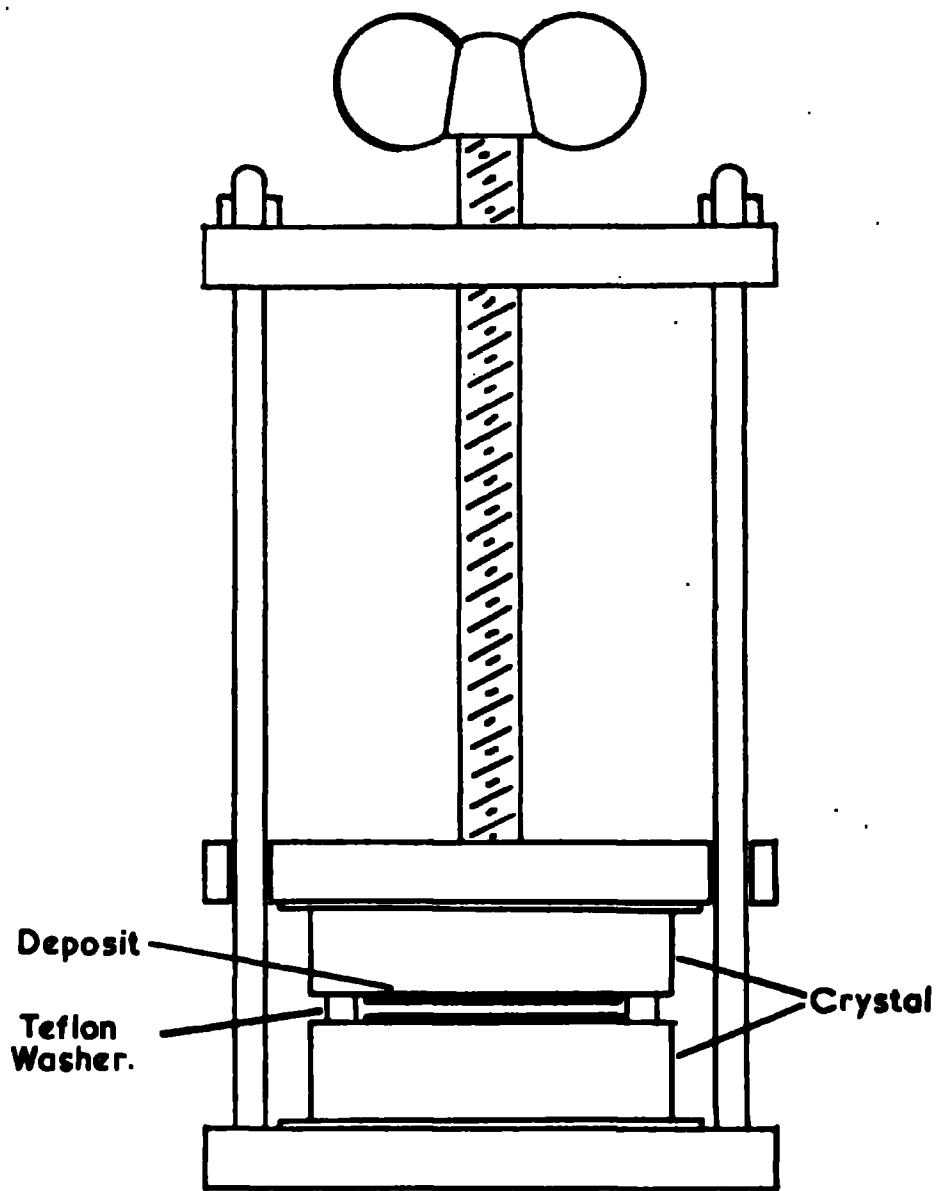

FIG.17. THE CRYSTAL HOLDER.

pressed together in a small press as depicted in figure 17.

Enough pressure was exerted to press the washer against the surface of the crystals and seal off the volume containing the deposits. In the heating experiments the crystals and washer, still in the press, were sealed inside the autoclave. The washer provided an excellent seal and reduced the losses of radioactive anthracene considerably.

It was found necessary to separate the crystals from the brass pressure device during the experiments by thin glass slips as there was a tendency for the crystals to stick to the metal on heating.

There was still some loss of radioactive material from the surface but this was very much lower than from the open crystal and this method was adopted for the protection of the radioactive deposit during the heat treatment of the crystals.

#### 4.c. Losses of Radioactivity during the Experiments.

The activity of the surface deposit was measured before and after the heat treatment of the crystals using a thin end windowed Geiger-Muller counting tube (type G.M.4) in a conventional lead castle arrangement. The results of these experiments are given in Table II where they are compared with the percentage of the total activity which has penetrated into the crystal during the diffusion experiment.

It will be seen that a decrease in surface activity resulted in each case. Comparison of this decrease with values for the total activity which has diffused into the crystal during the

Table II. The decrease in radioactivity of the surface deposit during the diffusion experiments

Crystal	Activity counts per minute		Percentage decrease in surface activity	Percentage decrease in surface activity due to penetration <sup>2</sup>
	Initial <sup>1</sup>	Final <sup>1</sup>	%	%
A	1183	972	18	20
B	1769	1558	12	9
C	3055	2659	13	3
D	2531	437	83	-
E	2120	620	71	-
F	2563	2180	15	-
G	1230	900	27	16
H	1763	720	59	2
I	2883	2578	11	35
J	2199	2099	5	3
M	2138	2115	1	63
N	2275	1955	14	<1
O	3896	3169	19	4
P	4276	3619	11	<1
Q	2924	2458	16	6
R	5510	3364	39	-
S	4339	4639	0	-
T	4824	3618	25	16

1. Measured with an end window G.M. tube.

2. Calculated from the results of the gas counting experiments given in tables IXb-XVIIb.

experiment (Chapter II, Tables IXb-XVIIb) showed that in most cases the loss of surface activity was greater than would be expected from the diffusion of radioactive material into the crystal, and hence this decrease must in part represent a loss from the surface.

It was previously stated that the deposit consisted of two portions, an epitaxial deposit, and "whiskers", which grew out of the surface of this deposit. The effect of heating on such a deposit would be the more rapid evaporation of the "whiskers" because of their higher surface area, accompanied by the slower evaporation of the epitaxial portion. It was also stated above that the number of whiskers varied in each case and hence it would be expected that, if this loss was representative of the rapid evaporation of the whiskers, the percentage loss should vary in crystals heated at the same temperature. Reference to Table II shows this to be the case and the author proposes that this large scale loss represents the rapid evaporation of some of the "whiskers" from the surface of the deposit.

Such a loss would not affect the diffusion rate as the controlling factor in this process will be the epitaxial deposit and hence the effect of the loss of whiskers on the diffusion process was negligible.

Other evidence for the loss being representative of evaporation of the whiskers is shown in cases where the loss is great. Such a loss should correspond to a large fraction of whiskers in the

deposit and hence only a thin epitaxial deposit. It will be shown later that the concentration of diffused activity in the crystal depends upon the quantity of radioactive material on the surface, thus the above conditions should result in a low level of radioactivity in the crystal. That a large surface loss was accompanied by a low level of diffused activity in the crystal was shown by the preliminary experiments (Chapter II, Experiment 1) and by crystals D and E which, although they were not sectioned accurately because of this loss were shown to have only a very low level of diffused activity, and hence these experiments support the suggestion made above. In spite of the fact that losses of radioactivity from such a cause would not affect the total strength of the diffusion source it was possible that the radioactive material which evaporated from the initial surface would deposit on other faces of the crystal. An attempt which was made to measure surface diffusion showed that this was not the case and the radioactivity on the crystal surface was confined to the deposit alone which might be expected if it is considered that the crystal is under isothermal conditions.

The surface diffusion measurements referred to above were made using a crystal with a line deposit of radioactive anthracene. The crystal surface with the line deposit was scanned with a thin end windowed G.M. counting tube mounted over a narrow slit. The crystal was moved underneath the slit on a screw carriage. No movement of the radioactivity on the surface was found to have occurred

even after heating for 160 hours at 150°C, and although some loss of radioactivity from the surface was observed during this time (15%) none was observed to deposit elsewhere on the surface, the experimentally determined profile of radioactivity on the surface remaining the same over this period.

This method of detection was far less sensitive than that used for the bulk diffusion measurements and hence may not have detected small amounts of radioactivity deposited on the surface, therefore, as an added precaution a thin section of anthracene was removed, with a razor blade, from each of the four faces of the crystal at right angles to the initial face prior to sectioning the crystal, thus removing entirely possibility of contamination from this source.

#### 4.d. The Experimental Technique.

A well lagged, electrical furnace in which the bomb could be enclosed was constructed. Temperature control of the furnace was effected by a circuit similar to that described previously (figure 3.a.) and was such that the temperature of the furnace could be controlled to an accuracy of  $\pm 0.5^\circ$ .

The furnace was set to the required temperature and the sealed autoclave placed in, and attached to, the nitrogen cylinder. The pressure in the autoclave was raised to 200 lbs. per sq. in. and released to help remove the air which was present after sealing. After this process had been repeated twice the pressure was raised

to 100 lbs. per sq. in. and the autoclave allowed to attain the temperature of the furnace, a process which usually took 3-4 hours. When the required temperature had been reached the pressure, which had increased on heating to 150-160 lbs. per sq. in. was boosted to 250 lbs. per sq. in. by admitting gas from the cylinder and the apparatus was allowed to stand for the period of the experiment. Slow leakage of gas from the autoclave inevitably occurred during the course of the experiment and it was found necessary to admit more gas at least once per day to maintain the pressure in the range 200-250 lbs. per sq. in.

On completion of the experiment the autoclave, still at full pressure, was taken out of the furnace and allowed to cool. The pressure was then released and the crystals which were in the small press removed.

The experimental error in the determination of the heating period, i.e. that time of the heating and cooling process, during which the rate of diffusion could be considered rapid enough to have some effect upon the measured value, is considered to be less than 30 minutes. This period of time represents the sum of the times before and after the experiment when the temperature of the autoclave was within 20-30°C of the required temperature, and was less than 1% of the time when the furnace was at maximum temperature in each case. It was assumed that zero time was that time when the required temperature was attained and that the experiment

was completed when the autoclave was removed from the oven.

Preliminary experiments to determine the temperature inside the autoclave during heating, indicated that the temperature of the crystal would be determined by the temperature of the lower part of the wall. These experiments were carried out as follows:

The autoclave was placed in the hot furnace and a temporary lid placed over the top. A calibrated thermocouple was attached to the side of the bomb so that contact with the wall was maintained but also so that it could be moved up the wall. The temperature of the wall was taken at regular small intervals from bottom to top. This reading was compared with that given by a second calibrated thermocouple moved inside the autoclave. It was found that, when the autoclave had reached thermal equilibrium, the two thermocouples gave a similar reading at each point and that the temperature inside the autoclave was equal to that of the wall. The temperature was shown to be uniform for a distance of 4 inches from the lower end of the autoclave. Above this region the temperature decreased gradually.

The temperature of the lower wall of the autoclave, and hence the crystal, was measured during the diffusion experiments using an accurately calibrated iron/constantan thermocouple, attached to the wall of the autoclave at the same height from the bottom of the autoclave as the enclosed crystal.

The thermocouple was checked for consistency of reading before

Table III. The temperature variation during a typical  
experiment

Trial Experiment No. 1.

	Time hours	Temperature °C		Time hours	Temperature °C
1st day	17.30	151.5	3rd day	10.30	153.0
	19.00	151.5		12.30	153.5
	20.30	153.0		15.00	152.5
	21.15	152.5		17.00	152.0
2nd day	10.00	153.0	4th day	10.30	153.0
	11.15	153.0		11.15	152.5
	12.00	153.5		12.30	152.0
	13.30	152.5		15.30	153.0
	15.00	152.5		18.30	152.5
	16.15	152.0		21.30	153.0
	17.15	152.5			
	21.00	152.5			

Temperature variation =  $151.5^{\circ} - 153.5^{\circ}\text{C}$

∴ mean temperature =  $152.5^{\circ}\text{C}$

Thermocouple Check

Thermocouple reads  $150^{\circ}\text{C}$

N.P.L. Thermometer reads  $150^{\circ}\text{C}$

and after each experiment and small deviations were corrected. Table III shows the temperature variation for a typical experiment. The readings were taken at irregular intervals over a period of 76 hours.

#### 4.e. Periods of Diffusion.

Preliminary experiments indicated that diffusion periods of about 3 days at 150°C was required. Subsequent more accurate experiments showed this figure to be rather low, the resulting penetration being small, and the time was increased accordingly. The periods of diffusion were varied with temperature in order that the shortest possible heating period was used at the higher temperatures, so that the loss of anthracene as a result of evaporation of the crystal was reduced to a minimum. The temperatures and periods of diffusion for each experiment are given in Table IV.

Table IV. The temperatures and diffusion periods for each experiment.

Experiment	1	2	3	4	5	6	7	9	10
Temperature °C	150	152.5	177	177	189.6	153.5	160	160	174
Diffusion Period hours	60	79	45.5	79.5	49	231	219	170	88

On removal from the autoclave crystals were checked for loss in weight and radioactivity and sectioned as described below.

#### 5. The Crystal Sectioning Technique.

The quantity of radioactive material which has diffused into the crystal during the heating period can be determined in two ways:

1. The decrease in radioactivity at the initial face, as the radioactive material penetrates into the crystal, can be studied.
2. The crystal can be sectioned parallel to the initial face and the concentration of activity in each section determined.

The former method makes use of the fact that radioactive radiations are absorbed in solids and hence, as the radioactive material penetrates into the crystal, the radiations will no longer reach the surface and the total activity at the surface will be reduced. A surface count before and after heating will therefore indicate the quantity of radioactive material which has diffused into the crystal during the heating period.

This method is rather limited in practice because it presents only an average picture of the diffusion process over the period of the experiment and yields only one overall diffusion coefficient.

The use of such a method for the present study was thought to be inadvisable because, in addition to the above limitation, the  $\beta$  radiation emitted by carbon-14 has a very low energy ( $E_{\beta \text{ max}} = 0.156 \text{ Mev. (89)}$ ) and therefore the corrections for self absorption and back scattering which have to be applied will be very large and also the method of detection used in this technique, an end windowed counter or similar arrangement must be used, is not very sensitive for the detection of such small activity changes in soft

$\beta$  radiation as were expected in the present study and this method was rejected.

The technique involving the sectioning of the crystals is of wider application than the above because, after sectioning the most suitable method available can be used for the determination of the diffused radioactivity in each section, and thus in the present study the most sensitive method of detecting the low energy  $\beta$  radiation from carbon-14 can be used.

A further advantage of the second method is that it results in the determination of the diffusion profile of radioactive material which has diffused into the crystal. This diffusion profile can often indicate whether one, or several different, diffusion processes are occurring in the crystal and thus, in addition to being more adaptable to the detection of soft  $\beta$  radiation this method is likely to furnish a greater amount of information about the diffusion process than the first technique and for these reasons this method was adopted for use in the present study.

The three methods most commonly used for the sectioning of crystals are:

1. Microtoming (71)
2. Grinding (3)
3. Turning on a lathe (73).

In the first method the crystal is fastened in the chuck of a microtome and aligned with the knife edge, or broken glass edge,

usually by an optical method. A piece of transparent adhesive 81  
tape is stuck to the upper surface of the crystal and the knife  
moved across the crystal at the correct depth of cut. The cut  
section, which is sometimes in the form of powder adheres to the  
tape and is not spread about on impact of the knife and lost.

Attempts were made to section the anthracene crystals using this  
instrument but it was found that the crystal inevitably fractured  
on impact of the knife and also, only a small fraction of the resulting  
powder adhered to the tape. After a number of attempts to section  
the crystals in this way this method was abandoned.

Grinding is usually carried out by rubbing the face of the  
crystal against a small piece of abrasive paper. In this way the  
thin section of the crystal is removed as a powder which sticks to  
the rough surface of the abrasive paper. Although this method  
could be most successfully used with most types of crystal, and  
precision apparatus could be constructed to measure the thickness  
of crystal removed, there are two objections to its use in the  
present case. Firstly, it would be difficult to remove the powder  
from the abrasive paper and the section would probably have to be  
counted, whilst still on the paper, under an end windowed counting  
tube. As stated previously this method is not suitable for the  
detection of small quantities of low energy  $\beta$  radiation. Secondly,  
if such a counting method was used small variations in the thick-  
ness of the material on the abrasive paper would, because of the  
large self absorption corrections involved, spoil the accuracy of

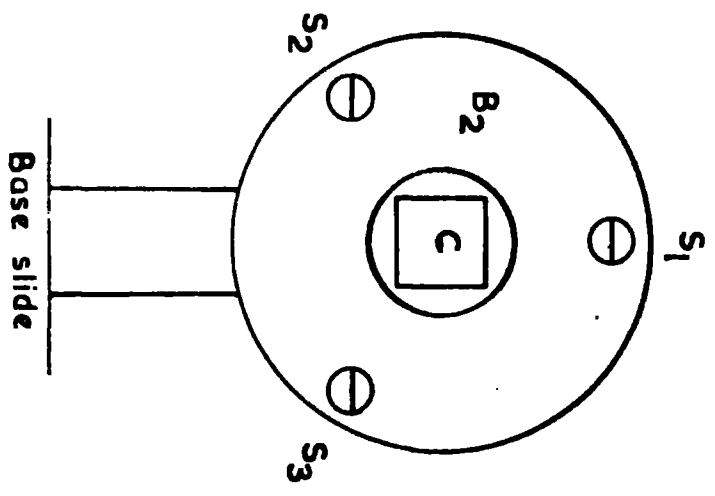
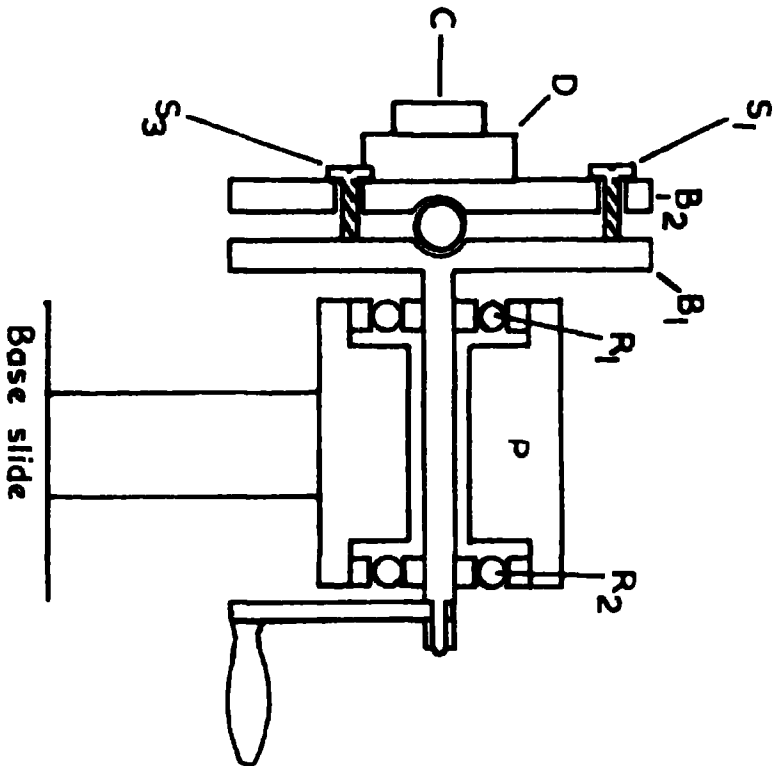

FIG.18. THE CRYSTAL HOLDING DEVICE.

the soft  $\beta$ . counting and successive counts may not be comparable. <sup>82</sup>

There is also more possibility of contamination of one slice by material from the preceding slice in this method than in the other two.

The third method was found to be the most satisfactory for the present study because, when attempts were made to section the anthracene crystals on a large machine lathe, it was found that the crystals could be accurately and easily sectioned. Each section was "turned off" as a fine powder which could all be collected on a piece of black paper held under the crystal, and was then available for counting by any suitable method. Although some of the powder from the cut section adhered to the crystal surface and cutting tool, the possibility of contamination of subsequent slices could be eliminated by carefully removing this powder with a small brush. A special, hand operated, lathe was constructed for the sectioning of the radioactive crystals because of the danger of contamination of more generally used equipment by radioactive material. The crystal was rotated by hand because this method of operation allowed a greater degree of control to be exercised over the section cutting than that allowed by other methods.

#### 5. a. The Lathe.

The lathe, a plan of which is shown in figure 19, was constructed from the base and cross feed slides of a small machine lathe. At one end of the base slide was mounted the crystal holding device depicted in figure 18.

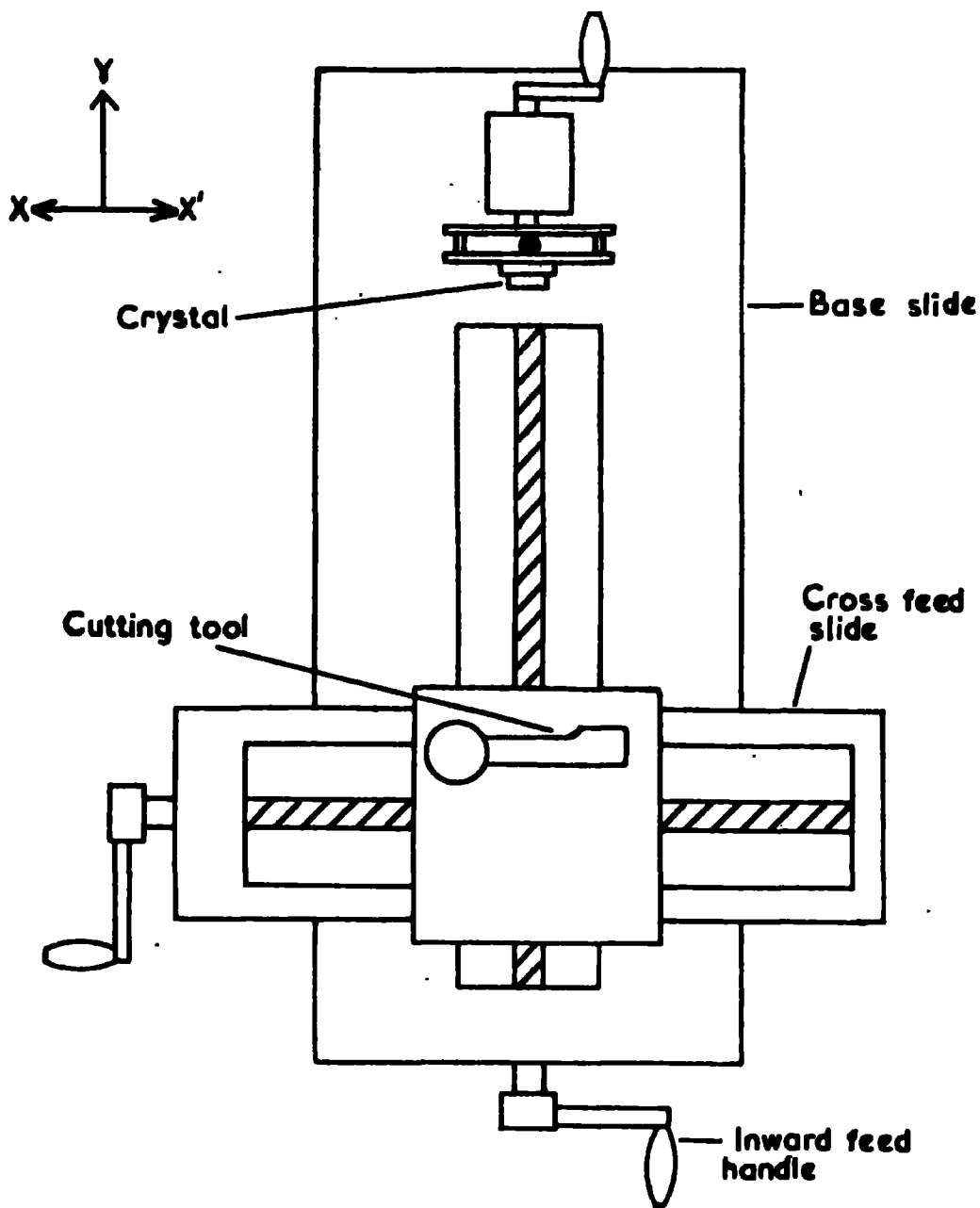

FIG.19. PLAN OF THE LATHE.

The crystal holding device consisted of a brass plate  $B_1$  mounted on an axle A which was held in ball races  $R_1$ ,  $R_2$  fixed in the pillar P. The free end of the axle was attached to a small handle which could be used to turn the brass plate. Attached to the brass plate  $B_1$  was a second brass plate  $B_2$  which acted as the crystal holder.  $B_2$  was separated from  $B_1$  by a steel ball and attached to it by three screws  $S_1$ ,  $S_2$ ,  $S_3$ . The angle of  $B_2$  could be adjusted by use of the three screws,  $B_2$  pivoting on the steel ball. In the centre of the front face of  $B_2$  was fixed a small "Polythene" disc D to which was attached the crystal C. The purpose of the "Polythene" disc was to raise the crystal above the heads of the screws so that these did not interfere with the cutting tool during sectioning.

The cutting tool, a conventional lathe tool, was mounted on the cross feed slide. The base slide allowed movement of the cutting tool into the crystal and the cross feed slide, movement of the tool across the face of the crystal.

#### 5.b. The Sectioning Technique.

The crystal was stuck on to the "Polythene" disc with a low melting wax and the three levelling screws adjusted until the face of the crystal was perpendicular to the axis of rotation of the crystal. The cutting tool was then moved towards the crystal (direction Y, figure 19), using the base feed slide, until the cutting edge of the tool was almost coincident with the face of the

crystal. The tool was withdrawn to the side (direction X), using the cross feed slide, and again moved towards the crystal, a small distance at a time, moving the tool across the face of the crystal (in the  $XX^1$  direction) after each forward (Y) movement until a faint scratch on the crystal surface indicated that the edge of the cutting tool was coincident with the surface.

Attached to the handle of the inward feed (base slide) was a dial, calibrated in degrees, to indicate the number of turns made by the handle during the sectioning of the crystal, from this the thickness of each section removed could be determined. It was calculated, from the pitch of <sup>the</sup> inward screw feed, that one degree on the dial was equivalent to a movement of the tool of  $11.8\mu$ .

When the edge of the cutting tool was coincident with the face of the crystal the dial was set to zero and sectioning was commenced.

It was found necessary to section the crystal by cutting into the crystal from the edge ( $XX^1$  direction), in this way a smooth cut was always produced. Attempts to cut from the face of the crystal (Y direction) always resulted in the fracture of the crystal at the edges. The cutting tool was withdrawn to the side and advanced a distance equal to the thickness of the section to be cut. The crystal was rotated at a speed of approximately 60 r.p.m. and the tool moved slowly into the crystal from the edge. The section was turned off as a fine powder which was collected on a piece of black paper held under the crystal. The powder was transferred to a

small platinum boat and was stored in a desiccator until required. The crystal surface was very carefully cleaned with a camel hair brush before and after each cut was made, to prevent the contamination of subsequent sections. The camel hair brushes, several of which were kept for this purpose, were also carefully cleaned before use.

After the crystal had been cleaned the tool was advanced and the next section cut.

#### 6. The Determination of Radioactivity in the Crystal Sections

The radioactive isotope of carbon of mass 14 used in these experiments decays by the emission of a  $\beta$  particle to form the stable nitrogen isotope of mass 14. The very long half life of carbon-14, 5600 years (89), makes it a very suitable tracer in reactions involving carbon because, in the course of any particular study, no measurable decay of the isotope will have occurred and as in addition to this it forms a non-radioactive daughter substance no decay corrections are necessary to the determined activity of the product and this can be directly compared with that of the starting state. These properties have led to the widespread use of this isotope for the study of reactions and processes which involve carbon.

The very low energy of the  $\beta$  radiation ( $E_{\beta \text{ max}} = 0.156 \text{ Mev.}$  (89)) from carbon-14 makes substances labelled with this isotope safe to handle, providing reasonable precautions are taken to avoid

direct contact with the labelled material. This low energy however causes some difficulties in the detection of the  $\beta$  radiation from carbon-14 and, when it is required to determine the activity of carbon-14 labelled compounds, a method appropriate for the detection of soft  $\beta$  radiation must be used. This is particularly the case when samples of very low specific activity are to be measured.

Of the several methods available for the counting of carbon-14, the counting of this isotope in the solid state is probably the most widely used. The accuracy of the method is however severely limited by the large corrections which must be made for self absorption and back scattering of the low energy  $\beta$  radiation, and this will be unsuitable for the counting of samples of very low specific activity.

Greater accuracy can be attained by the internal counting of the radioactive species in the form of a gas or by the use of scintillation counting techniques. The latter method, which requires the availability of specialised equipment, involves the dissolution of the sample in a liquid scintillator, such as terphenyl. Interaction of the radiation from the sample with the scintillator results in the emission of light which can be detected by the photo sensitive electrode of a photomultiplier tube placed close to the solution and recorded by an electronic counting device. This method is very sensitive for the detection of low energy radiation:

such as that emitted by carbon-14 because a large proportion of the radiation emitted will be detected and recorded.

The gas counting technique requires the conversion of the sample to a gas of suitable characteristics for use as a G.M. tube filling. After preparation, this gas is transferred to a counting tube and is counted internally. The great advantage of this method is that almost all the activity inside a cylindrical cathode is recorded and this can be arranged to be almost 100% of that introduced. In cases where the total activity of the specimen is low this method of counting therefore provides a method of measuring the total radioactivity of the sample and can be regarded as a highly sensitive method of  $\beta$  radiation detection. This method is rather more convenient than the scintillation counting method because conventional counting and scaling equipment can be readily modified for use with this type of counting tube.

It was expected that the low rates of diffusion, characteristic of the type of solid under study and the specific activity of the radioactive anthracene deposited on the crystal, would result in the diffusion of only a relatively small amount of radioactivity into the crystal. It was therefore advantageous to choose as sensitive a method as possible for the detection and assaying of this activity, and one which would count as much as possible of the radioactivity present in each slice. The last discussed method satisfied these requirements and was used for the determination of

the radioactivity of the crystal sections. Several comprehensive accounts of the gas counting of carbon-14 in the form of carbon-14 dioxide have been published (74-78). Organic compounds can be readily and quantitatively converted to carbon dioxide by controlled oxidation and thus this gas is an obvious choice as the counter filling gas when the activity of carbon-14 labelled compounds is to be determined by this method. The sections of the anthracene crystals were therefore converted to carbon dioxide and counted in this manner.

The method used for the quantitative combustion of anthracene to carbon dioxide is described in detail in the following section and the technique used for the counting of this gas described in section 8.

#### 7. The Combustion of the Crystal Sections.

The most commonly used method for the quantitative combustion of organic materials is that devised by Pregl (79). In this method the organic compound is vapourized in a slow stream of oxygen and carried by this stream over heater copper oxide where quantitative oxidation occurs. The oxidation products, usually carbon dioxide and water, are carried forward by the oxygen stream and can be condensed by passing the gases through a trap surrounded by a suitable coolant or absorbed on suitable solid reagents. This method although very reliable has the disadvantage that very long periods are required to complete the combustion of macro amounts of organic

substances and there are inherent errors involved in the method, such as the contamination of the copper oxide, which can be reduced but not eliminated.

The desire for a more rapid method of combustion lead Belcher and Spooner (81) to invent the "Empty Tube" method. In this method the rate of combustion is considerably increased without any loss of accuracy. The combustion of the sample is carried out in an empty quartz reaction tube which is maintained at a temperature of 900°C for 25 cms. of its length. The sample is vapourized in a fast stream of oxygen and is carried into the heated tube, by the stream, and is oxidised. The heated tube is provided with baffles (80) to ensure the mixing and complete combustion of the organic vapour and oxygen. The products of combustion are carried away into the stream and can be removed in the same way as described above.

A critical comparison of this method with the Pregl method (82) has shown that the errors involved are less than those found with Pregl's Universal filling and that the method can be confidently used for the combustion of all types of organic compounds.

The great advantage of the Empty Tube method is that a combustion of 10 mgms. of material can be completed in 15-20 minutes compared with an hour for the same amount of material by the Pregl method. In the present study it was necessary to burn and "count" a number of sections of the crystal in as short a time as possible and because of the apparent reliability and speed of the "Empty Tube" method it seemed ideal for use in the present case. The possibility

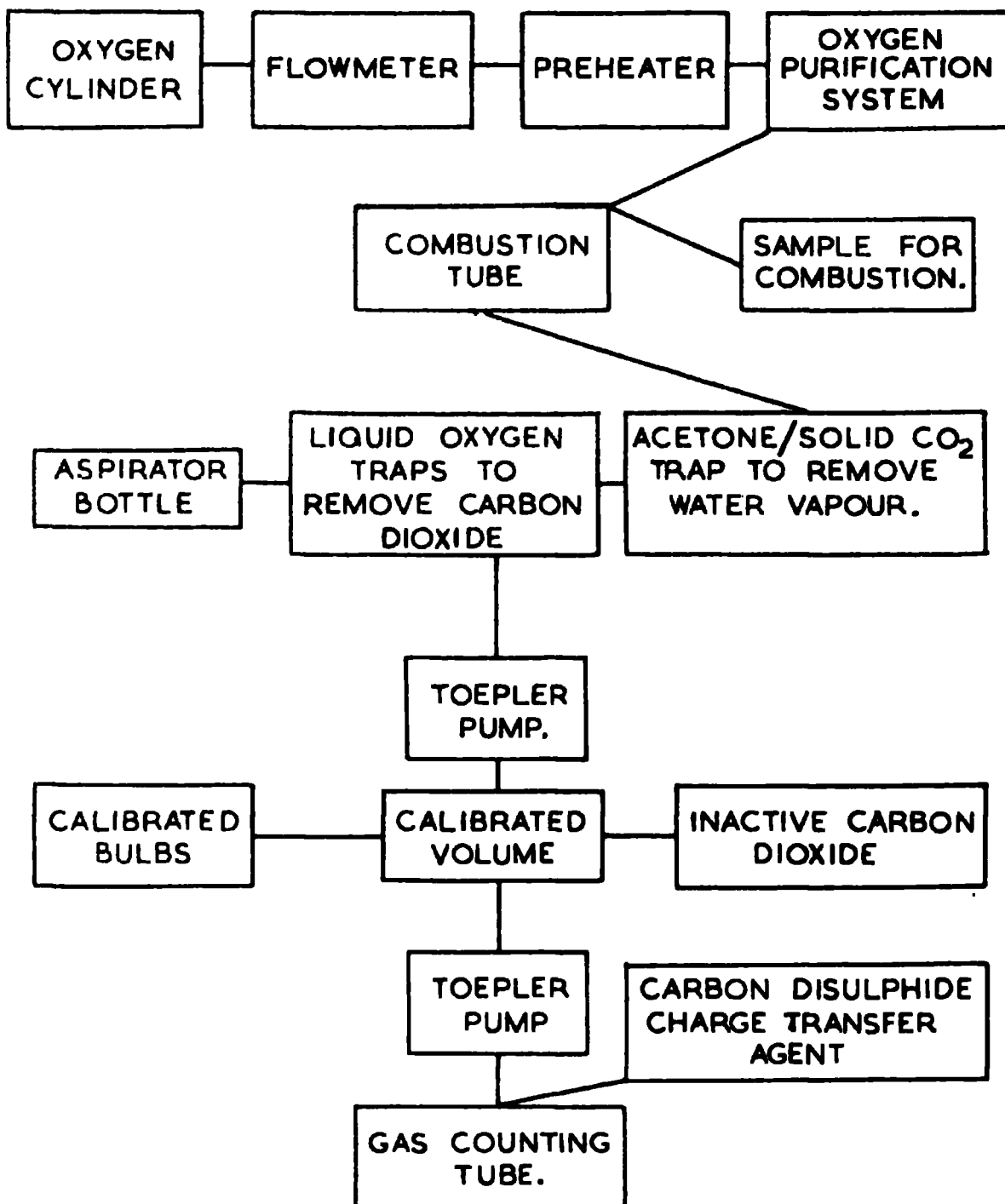

FIG.20. BLOCK SCHEMATIC DIAGRAM OF THE HIGH VACUUM APPARATUS.

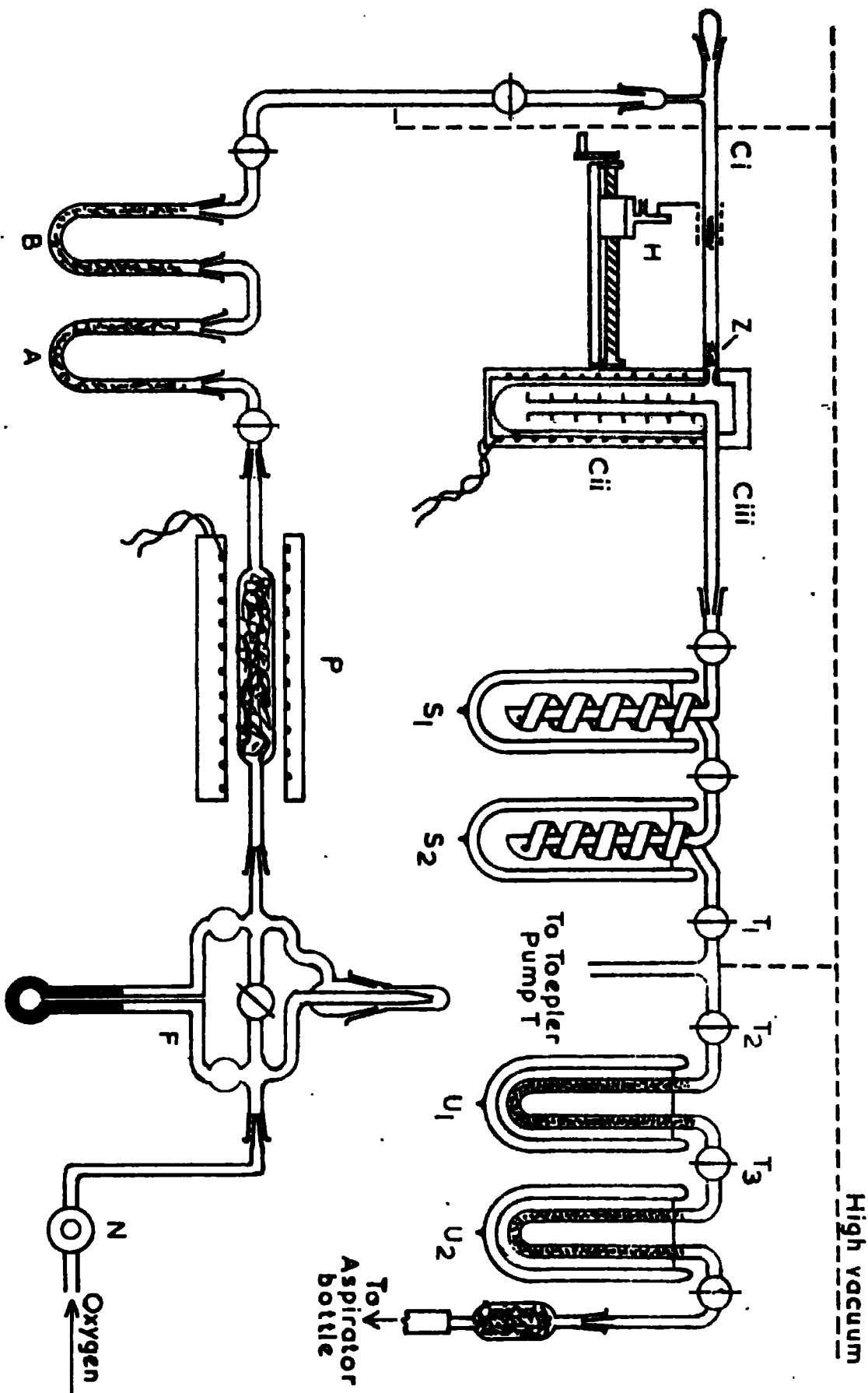

FIG. 21. THE HIGH VACUUM APPARATUS - THE COMBUSTION SECTION.

of its use was investigated and it was found to be suitable for this study. The experimental method was adapted slightly for use in conjunction with a high vacuum apparatus and the apparatus and technique as used are described below.

#### 7.a. The combustion apparatus.

A high vacuum apparatus was built for the combustion of the anthracene crystal sections and the filling of the gas counting tube with the resulting carbon dioxide. The principle features of the complete apparatus are depicted in the block schematic diagram shown in figure 20. This present section describes that part of the high vacuum apparatus used for the combustion of the anthracene. A line drawing of the combustion apparatus is shown in figure 21.

The majority of taps and standard joints incorporated in the apparatus were greased with Apiezon N high vacuum grease. Those taps and joints near the Furnaces were greased with Silicone grease. Each section of the combustion apparatus is described in detail below.

##### (i) Oxygen purification system.

The oxygen used for the combustions was supplied in large cylinders by British Oxygen Co. Ltd. The gas as obtained from the cylinder is likely to contain traces amounts of organic matter, water and perhaps carbon dioxide and was purified as follows. (The letters refer to figure 21.)

Primary control of the gas flow was effected by a reducing valve attached to the oxygen cylinder. The flow of the gas into

the apparatus was monitored by the flow meter F and fine control of the rate of flow was achieved by the use of a needle valve N. After passing through the flowmeter the gas passed through the preheater P, which consisted of a silica tube, 25 cms. long, packed with platinised asbestos and maintained at a temperature of  $700^{\circ}\text{C}$  by means of a "Kanthal".tube furnace. The temperature of the furnace was measured by means of a calibrated chromel/alumel thermocouple held inside the furnace. The purpose of this preheater was to oxidise any organic matter present in the oxygen to carbon dioxide and water.

Any carbon dioxide and water present, either in the original gas or as a result of this passage through the preheater, was next removed by passage of the gas through two U-tubes A and B containing soda asbestos and anhydrous respectively.

A third U-tube packed with granulated manganese dioxide is sometimes included to remove traces of nitrogen oxides which may be present in the gas stream (83). This reagent was not included in the present apparatus because the type of oxygen used has been shown to be free of such impurity (84).

The gas, after purification, passed into the combustion tube.

(ii) The Combustion Tube.

The combustion tube C was supplied by Messrs. Baird and Tatlock Ltd. and was the standard type of tube issued with the "B.T.L. Rapid Micro Combustion Apparatus".

The tube, made of clear quartz glass, was mounted in the apparatus in a horizontal position. (It is shown in the vertical plane in figure 21 for the convenience of the illustration.) It consisted of a 9 mm. bore tube C(i) with the oxygen inlet situated 3 cms. from the open end. The inlet and the open end were fitted with B.14 ground joints for attachment to the apparatus and closure respectively. The sample to be burned was placed in this arm of the tube. A small bunsen burner H was mounted under the tube so that the sample could be vapourized into the gas stream. The bunsen could be moved the length of the tube.

The combustion chamber C(ii), 2.5 cms. internal diameter and 19 cms. long, was fused to C(i) 2 cms. from the flattened end. The outlet to the chamber consisted of a 9 mm. bore tube in which 5 baffle plates 2.2 cms. in diameter were blown. This outlet tube proceeded from the rounded end of the wide tube to 2 cms. from the flattened end, where it was attached by means of a ring seal and protuded outwards for a length of 18 cms. and was attached to the next section of the apparatus by a B.14 cone and socket.

The combustion chamber C(ii) was enclosed in a Kanthal tube furnace and was maintained at 900°C during the combustion experiments. The furnace temperature was measured by means of a calibrated chromel/alumel thermocouple, which was attached to the tube inside the furnace.

(iii) The Condensation of the combustion products.

Using a similar apparatus but incorporating a Pregl combustion tube, Thomson and Walton (85) have shown that the water vapour and carbon dioxide resulting from combustion could be quantitatively trapped in a glass spiral containing 1 metre of glass tubing, immersed in a liquid oxygen bath. In the present case a very much faster flow of oxygen was being used (75 mls. per minute) and it was found that a similar spiral to that used by Thomson and Walton was insufficient to remove all the combustion products, and a more extensive condensation system had to be used, to ensure that the condensable gas did not pass through the system.

Water vapour was removed by condensation in the spiral  $S_1$  which was surrounded with an acetone/solid carbon dioxide bath at  $-78^\circ\text{C}$ . This one trap served to remove quantitatively all water vapour produced by combustion.

After removal of the water vapour from the gas stream the gases were passed through a series of traps ( $S_2$ ,  $U_1$ ,  $U_2$ ) immersed in liquid oxygen to remove the carbon dioxide present.

Initially an attempt was made to remove the carbon dioxide by condensation in the spiral  $S_2$  alone. The dimensions of  $S_2$  were similar to those of  $S_1$ , used for the removal of water vapour. This proved inadequate however and only 92-95% recovery of the carbon dioxide was obtained showing losses of 5-8% assuming quantitative combustion of the samples used. Some improvement was made by

adding the first U-trap and losses were reduced by this to 0-3%.

The final addition of the second U-trap and the packing of both with glass beads resulted in the quantitative condensation of all the carbon dioxide formed by combustion.

From the end of the condensation system the oxygen was led into an aspirator bottle initially full of water and a check on the rate of flow of the gas made by measuring the rate of expulsion of water from the aspirator bottle. The maintenance of a steady rate of flow was found to be essential to the good performance of the combustion apparatus.

#### (iv) Oxygen Flow Rate

For the semi-micro combustion of organic compounds by the "Empty Tube" technique Ingram and Lonsdale (86) have suggested that a rate of flow of oxygen of 150 mls. per minute should be used and for micro-combustion a rate of 50 mls. per minute. Experience with the apparatus in the form used in the present study showed that the optimum flow rate was 75 mls. per minute. Higher and lower rates than this produced lower yields of carbon dioxide from combustion than expected. The author believes that because of the size of the sample used (2-10 mgms.) the lower flow rates resulted in incomplete combustion in the hot zone of the combustion tube, and higher rates in incomplete condensation of the carbon dioxide formed.

When smaller samples were used (< 2 mgms.) it was found that quantitative combustion was still attained if the flow rate was

reduced to 50 mls. per minute and this flow rate was used in such cases.

It was found that fluctuations of the oxygen flow rate during the course of the experiment resulted in incomplete combustion and hence very accurate measurement and control of the flow rate was necessary. The method of control used in the present apparatus has been described above.

#### 7.b. The Experimental Technique.

When the two furnaces had attained the working temperature the oxygen flow was commenced and regulated to the flow rate appropriate to the weight of the sample to be burned (usually 75 mls. per minute). The sample, in a platinum boat, was placed in arm C(i) of the combustion tube at a distance of 5 cms. from the entrance to the combustion chamber and the end of the tube closed. The coolants were placed around the condensation traps.

The small bunsen burner H, mounted under the tube C(i) and attached to a wire gauze wrapped round this tube was moved into position just behind the boat. The gas was ignited and the flame adjusted so that it was just not luminous and so that the tip of the flame was playing on the wire gauze. The burner could be moved the length of the tube C(i) by a screw arrangement, the gauze moving with the bunsen burner.

When the gauze had been heated to a dull red heat the bunsen burner was moved up to the handle of the platinum boat and the

anthracene in the boat sublimed on to the walls of the tube.

When this operation was complete the burner was moved slowly towards the furnace driving the anthracene before it into the combustion chamber.

During the combustion of highly volatile substances a carbon fog is sometimes formed when volatilizing the sample from the boat. This carbon fog would, if allowed, pass through the hot zone of the combustion tube and be lost. This possibility is prevented by placing a plug of silica wool  $Z$  at the entrance to the combustion chamber to trap these particles. These can then be oxidised to carbon dioxide before the completion of the experiment by heating the silica wool plug to red heat in the oxygen stream.

When the anthracene had been driven into the combustion chamber, a procedure which should take 5-10 minutes, the burner was returned to a position beneath the platinum boat and the flame adjusted to give maximum heat. After the boat had been heated for about one minute the burner was moved steadily towards the entrance of the combustion chamber heating the tube to a dull red heat as it passed. The burner was allowed to stand under the silica wool plug and the plug was heated to red heat for one minute to oxidise any carbon which may have been trapped there. The bunsen was then extinguished and the oxygen flow continued for two minutes to sweep any residual combustion products out of the combustion chamber. The oxygen flow was then arrested and all the taps on the apparatus closed.

With the liquid oxygen baths still in position, the taps  $T_1$ ,  $T_2$

and  $T_3$  were slowly opened to the main vacuum line and the traps  $S_2$ ,  $U_1$  and  $U_2$  were evacuated to "sticking vacuum". When this state was attained this section was isolated from the main vacuum line and the liquid oxygen baths removed from the three traps. The condensed carbon dioxide evaporated rapidly and was transferred by means of the Toepler pump T to the volume V of the counter filling apparatus (figure 22). The volume of V had been previously calibrated by gas expansion methods using the bulb Q (itself calibrated by weighing with mercury) as a standard volume.

When transfer was complete the mercury in Toepler pump T was raised to cut off X. The mercury in Toepler pump T was raised to cut off E before the transfer was commenced. The pressure of the gas in the volume V, registered on the manometer  $M_1$ , was then read, using a cathetometer and the N.T.P. volume of the carbon dioxide could be calculated. The yield of carbon dioxide from the combustion of the anthracene sample was then determined by comparing this value with that calculated for quantitative conversion of the anthracene to carbon dioxide.

The carbon dioxide was then transferred to the counting tube and the activity measured. The technique used for the filling of the counting tube is described in section 8.c.

#### 7.c. Results of the Combustion Experiments.

The above described technique for the combustion of anthracene and measurement of the resultant carbon dioxide proved to be

Table V. Yields of Carbon Dioxide

Weight of anthracene sample mgms.	Volume of carbon dioxide (theoretical) mls. N.T.P.	Volume of carbon dioxide (measured) mls. N.T.P.	Yield %
2.0	3.5	3.5	100
2.5	4.4	4.5	102
2.6	4.6	4.6	100
2.8	4.9	4.9	100
3.3	5.7	5.8	102
3.4	6.0	5.9	99
4.9	8.7	8.7	100
4.9	8.7	8.8	101
5.1	9.2	9.3	101
5.6	9.8	9.8	100
7.4	13.1	13.3	101
8.7	15.3	15.4	100
9.2	16.1	15.7	98
9.4	16.6	16.6	100
11.7	21.0	21.6	103
17.8	32.0	31.4	98

extremely successful. The results of a number of typical combustions are given in Table V.

The small variation in the yield of carbon dioxide can be ascribed to the error in measuring the volume of the product. Since 100% yield was obtained in the combustion of every crystal section there was no possibility of isotope effects occurring during the combustions.

#### 7.d. Blank Experiments.

As the yield of carbon dioxide from the combustion of the anthracene was measured volumetrically, blank experiments were carried out to determine whether any source of error in this measurement would arise from contamination of the oxygen stream, or slow leakage of the apparatus during the course of the combustion.

The apparatus was switched on and the furnaces allowed to attain maximum temperature. The coolants were placed around the condensation traps and the oxygen flow maintained at 75 mls. per minute for a period of 6 hours. At the end of this period the gas which had condensed in the traps was transferred to the calibrated volume and measured. In this period, 0.7 mls. (N.T.P.)<sup>of</sup> condensable gas was collected. This volume of gas corresponded to the accumulation of 0.04 mls. during the period of combustion and as at least 4 mls. of carbon dioxide were being collected as a result of the combustions this error was considered to be negligible.

#### 7.e. Contamination of the combustion apparatus by carbon-14.

After transfer of the carbon dioxide, and before the next

combustion was commenced, the combustion tube and condensation traps were evacuated at "sticking vacuum". No contamination of the tube by radioactive material was ever found to have occurred after the section had been evacuated for 5-10 minutes, even after the combustion of highly active samples. In the initial experiments, tests for contamination were made by carrying out the combustion of a small amount of inactive anthracene following the combustion of each radioactive sample. The results of one such check are shown in table VI.

Table VI. Test for radioactive contamination of the Combustion Apparatus

	Specific activity in counts per min. per cm. mercury pressure of carbon dioxide in counting tube
Background	75.2
Slice No. 1	2736
Inactive sample	72.4
Slice No. 2	383
Inactive sample	72.8
Slice No. 3	110
Inactive sample	70.9
Background	69.6

The difference in the background counts can be attributed to the fact that this particular experiment was carried out over a period of two days. It will be seen from the results of this particular

experiment that no contamination occurred at all.

100

After evacuation, pure oxygen was allowed into this section of the apparatus and allowed to flow at the required rate for 5 minutes before the next combustion was commenced so that steady conditions were achieved.

#### 7.f. Conclusions.

The speed at which a combustion and determination can be carried out using this apparatus renders it invaluable to the present study. This speed coupled with the fact that quantitative conversion to carbon dioxide is readily obtained, a factor which would eliminate possible isotope effects during combustion, renders the technique suitable for all determinations of the isotopic content of organic materials used in tracer studies, and much superior to the slower Pregl method.

Although in the present study use has been made of the apparatus to determine carbon-14 content, the author believes that the technique could be readily extended for use in the determination of tritium in tritiated organic compounds, by the inclusion of some method for the reduction of the water vapour trapped in spiral  $S_1$  to hydrogen.

#### 8. The Internal Gas Counting of Carbon-14.

The need for a simple and sensitive method for the determination of carbon-14 led to the consideration of the possibility of counting the species inside a counter in the form of a gas. This technique results in a counting efficiency of almost 100% and obviates the many errors involved in the counting of carbon-14 in the solid form.

The most suitable gas for this purpose would appear to be <sup>101</sup> carbon dioxide because the carbon-14 labelled specimen can be easily and quantitatively converted to this gas and also the relative weight of carbon in the gas is fairly high. There are, however, some objections to the use of this gas but these can be overcome.

Carbon dioxide has been extensively used as an ionisation chamber filling and is a very useful gas for this purpose because of its high collision cross section to low energy electrons, and its inability to form negative ions by electron attachment. On the other hand it has a great tendency to form positive ions which behave peculiarly on collision with metal surfaces. When these positive ions collide with the cathode, to which they are attracted, there is a great tendency to extract two electrons and form a negative ion. This process will of course give rise to spurious counting effects and therefore must be reduced in some way. Before negative ion formation will occur, the ionisation potential of the molecule plus the electron affinity of the molecule must exceed twice the work function of the cathode surface (76). For carbon dioxide the ionisation potential = 14.4 volts and the electron affinity = 3.8 volts, therefore the work function of the cathode must be less than 9.1 volts. The usual cathode metals, copper, silver and brass, have a work function of 4-5 volts and with these metals the probability that a negative ion will be formed on impact with the cathode is



reduced to  $10^{-5}$ - $10^{-4}$  negative ions per positive ion. The forma<sup>102</sup>-  
tion of these negative ions cannot however be eliminated completely.  
Some method must therefore be employed whereby the ion can be  
prevented from reaching the cathode.

It has been shown (76) that the cumulative ionisation from the  
discharge initiated by the ionising particle results in the formation  
of a positive ion sheath around the central wire anode. This sheath  
lowers the electric field between the electrodes and discharge ceases.  
The positive sheath is then expelled from the anode and attracted  
towards the cathode. As it traverses the gap, it will suffer  
approximately  $10^5$  collisions with neighbouring gas molecules and if  
there is mixed with the carbon dioxide a gas, the ionisation poten-  
tial of which is less than that of the main gas, then there will be  
a very high probability that collision will result in the formation  
of new ions at the expense of the charge on the carbon dioxide ion,  
and thus the carbon dioxide ion will be prevented from reaching the  
cathode.

A study of possible charge transfer gases by Brown and Miller  
(76) has shown carbon disulphide to be the most efficient gas for  
this purpose and also that excellent counter characteristics can be  
obtained with carbon dioxide - carbon disulphide filled counters.

#### 8.a. The gas counting tube.

The counting tubes were constructed from pyrex glass in the  
form usually adopted for "gas counting".

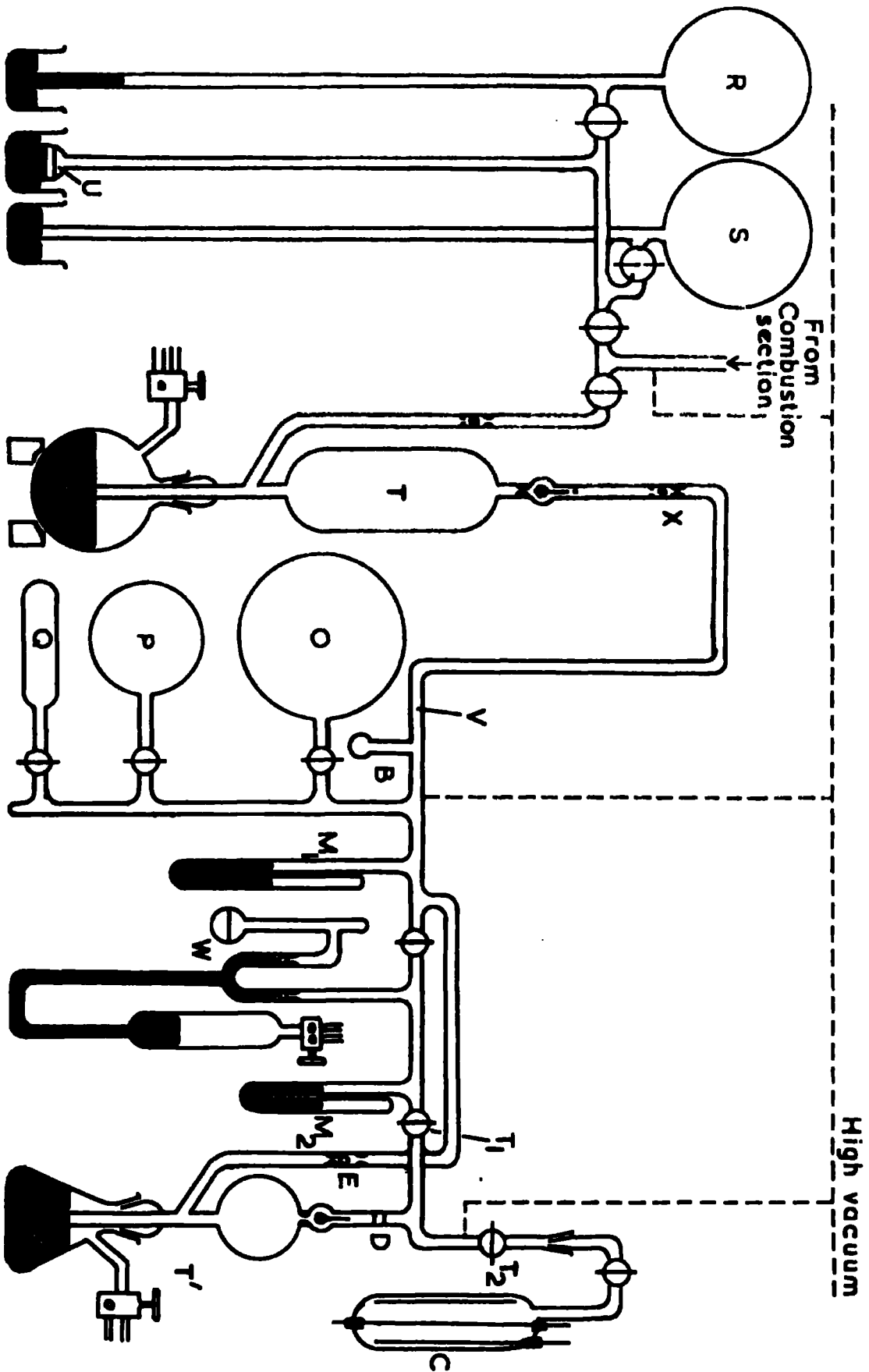

FIG.22. THE HIGH VACUUM APPARATUS - THE COUNTER FILLING SECTION.

The cathode of the counting tube was a polished copper cylinder 12 cms. long and 2 cms. internal diameter. An axial tungsten wire (100  $\mu$  diameter) served as the anode. Prior to assembly the wire and cylinder were polished to remove all points which could give rise to discharges at the high voltages at which the tube operates. The anode and cathode were mounted in a glass tube by means of tungsten to glass seals. The tube was filled by way of a 2 mm. bore vacuum stopcock, greased with Apiezon N high vacuum grease.

Before use the tube was evacuated at high vacuum and heated under vacuum to remove all adsorbed material from the cathode and anode.

One particular tube was characterised and used for all experiments to ensure reproducibility of counting.

#### 8,b. The counter filling apparatus.

The filling of the gas counting tube was carried out on a section of the high vacuum apparatus (figure 20) part of which, the combustion apparatus, was described in section 7.a. The essential features of the counter filling apparatus are shown in figure 22, and are described below.

The radioactive gas from the combustion apparatus was transferred to the calibrated section V of the counter filling apparatus by means of the Toepler pump T. The pressure of gas in V could be read on the manometer  $M_1$ , by means of a cathetometer. Attached to

V were four large bulbs, three of which O, P and Q, are shown in the diagram. The volumes of these bulbs were approximately 50 mls., 500 mls., 800 mls. and 1,000 mls., and the volume of V was 110 mls. These bulbs were used for reducing the pressure of gas in V by expansion, or for storage of radioactive gases. The radioactive gas in V could be diluted with inactive carbon dioxide contained in the storage bulbs R and S. The counter C, into which could be passed carbon disulphide from the vent W, was filled with the radioactive carbon dioxide from V by means of the Toepler pump T<sup>1</sup>.

The inactive carbon dioxide in bulbs R and S was prepared by evaporation of solid carbon dioxide ("Drikold"). The gas was passed over anhydrone, to remove traces of water, and passed into the bulbs by way of the No. 4 porosity sinter U. Traces of air which may have been included were removed by condensing the carbon dioxide on the wall of the bulbs, and pumping the non-condensable gases away. This inactive gas was used to dilute specimens, the activity of which was too high to be measured by the counting tube and electronic circuit, and also to increase the volume of samples which were too small to be counted directly.

Whenever the samples of radioactive gas were diluted with inactive carbon dioxide the gas mixture was condensed into the small bulb B by surrounding it with liquid oxygen. This was to ensure that the gases were thoroughly mixed. The volume of inactive gas added on such occasions was calculated from the changes of pressure indicated by the manometer M<sub>1</sub>.

When the radioactive gas in V was ready for transfer to the counting tube, the counter C and ventill W were evacuated to sticking vacuum and isolated from the main vacuum line. The carbon disulphide, which was contained in the reservoir of the ventill was frozen by placing a bath of liquid oxygen around it. The ventill was lowered and the frozen carbon disulphide allowed to warm until the manometer  $M_2$  indicated that the pressure of carbon disulphide vapour in the counting tube was approximately 2 cms. mercury. The ventill was closed and the counter isolated from the ventill by closing the tap  $T_1$ .

The active gas contained in the calibrated volume V was then transferred to the counting tube by five strokes of the Toepler pump  $T^1$ . When the transfer was complete the carbon dioxide/carbon disulphide mixture was stirred by raising and lowering the level of the mercury in the pump. The mercury was finally raised to the cut off D, which was a No. 4 porosity sintered disc.

The relative volumes of the counter section and the calibrated volume V had been determined previously, and the pressure of gas in the counter could be determined from the pressure which the sample of gas had exerted when it occupied the volume V.

In order that the pressure of carbon dioxide in the counting tube should exceed 8 cms. mercury, a value found to be the minimum required for reliable working of the counting tube, it was necessary that the pressure of gas in the volume V should be greater than 5

cms. mercury. The pressure of gas in V was therefore adjusted to 6-7 cms. mercury before it was transferred to the counting tube. This adjustment was made by expanding the gas from V into the calibrated bulbs, if the pressure was greater than this value, or by diluting it with inactive carbon dioxide, if the pressure was too low; sometimes a combination of both these methods was necessary. In most cases a sample of anthracene was burned which yielded a volume of carbon dioxide which, when transferred to V, exerted a pressure of 6-7 cms. mercury and this adjustment was avoided.

When the counting tube had been filled it was isolated from the apparatus by closing tap  $T_2$  and was transferred to a lead castle. The sample was counted.

#### 8.c. The Counting Circuit.

Several modifications had to be made to the type of counting circuit used for routine counting experiments with conventional G.M. counting tubes, because of the particular characteristics of carbon dioxide gas counting. These modifications were occasioned because:

1. the counter was non self quenching and an external circuit for this purpose had to be included.
2. the working voltage range of the tube was in the region of 2,300 volts upwards, and it was necessary to use a power pack which produced a higher voltage than that normally used (2,000 volts maximum). An Ecko Power Unit type N5706 which provided a maximum output voltage of 3,000 volts, was used in the circuit. The threshold voltage of the counting tube varies with the pressure of the gas

in the tube and the above power unit allowed the counting of samples of internal pressures up to 18-20 cms. mercury.

3. in order that the positive sheath should have time to diffuse away from the anode after the discharge produced by the radiation, it was necessary to increase the "dead time" for the external quenching circuit. to approximately 1,000  $\mu$  secs, by modifying the "time constant" of the type 110A probe unit used. This modification involved the replacement of one of the resistors used to control the dead time of the circuit, by one rated at 15 M. ohms. After this modification had been made the "dead" time of the circuit was determined by the method of superposition of sources and found to be 1150  $\mu$  secs.

4. the counter characteristics obtained, even after this increase in dead time, had rather short, steep, plateaux. These characteristics can be improved by feeding an increased voltage to the grid of the valve in the quenching circuit. Henson (75) suggests that an increase in voltage of 120 volts will result in an increase in the pulse height by 100 volts and the plateau length by 50 volts.

This increase was effected by breaking the mains lead to the probe unit and inserting a high tension battery such that the voltage increases by 120 volts. The battery was replaced when the output voltage fell below 100 volts.

In agreement with Henson it was found that improved counter characteristics resulted.

Pulses from the tube were recorded on a Dynatron Scaling Unit

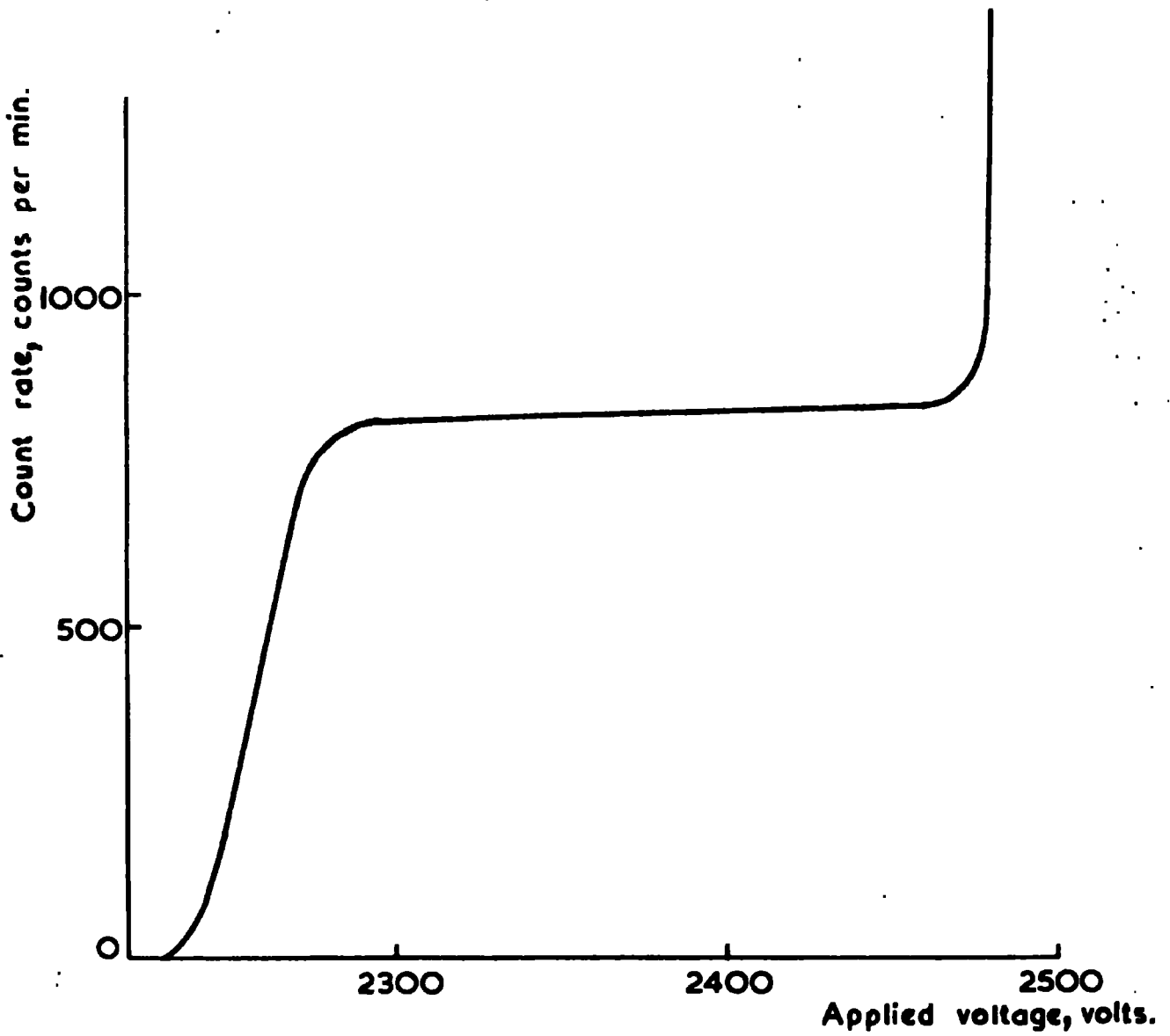

FIG.23. THE GAS COUNTING TUBE CHARACTERISTIC.

type 1009d and were read on a scale of 100 and a recorder. 108

When the above modifications had been made the counter was capable of measuring count rates of up to 3000 counts per minute. If attempts were made to count specimens of higher activity the counter went into a continuous discharge.

#### 8.d. Counter characteristics.

The counter was filled in the manner described in section 8.c., inserted in the lead castle and the terminals connected to the H.T. supply. The electronic apparatus was switched on and was allowed to stand for 20 minutes before use.

The counter characteristics were determined in two ways.

1. Using an inactive filling and an external  $\gamma$  radiation source.
2. Using an active filling.

In both cases the applied voltage was slowly increased until the threshold voltage was attained and then the counter rate determined, to an accuracy of 1%, at intervals of 25 volts until the counter "raced".

Graphs were drawn of the activity in counts per minute versus applied voltage. A typical result is shown in figure 23.

It was found that the counter characteristics obtained by either of the above methods were similar.

When the pressure of carbon dioxide in the tube was greater than 8 cms. mercury, plateaux of approximate length 150 volts and of slope approximately 2% per 100 volts were obtained.

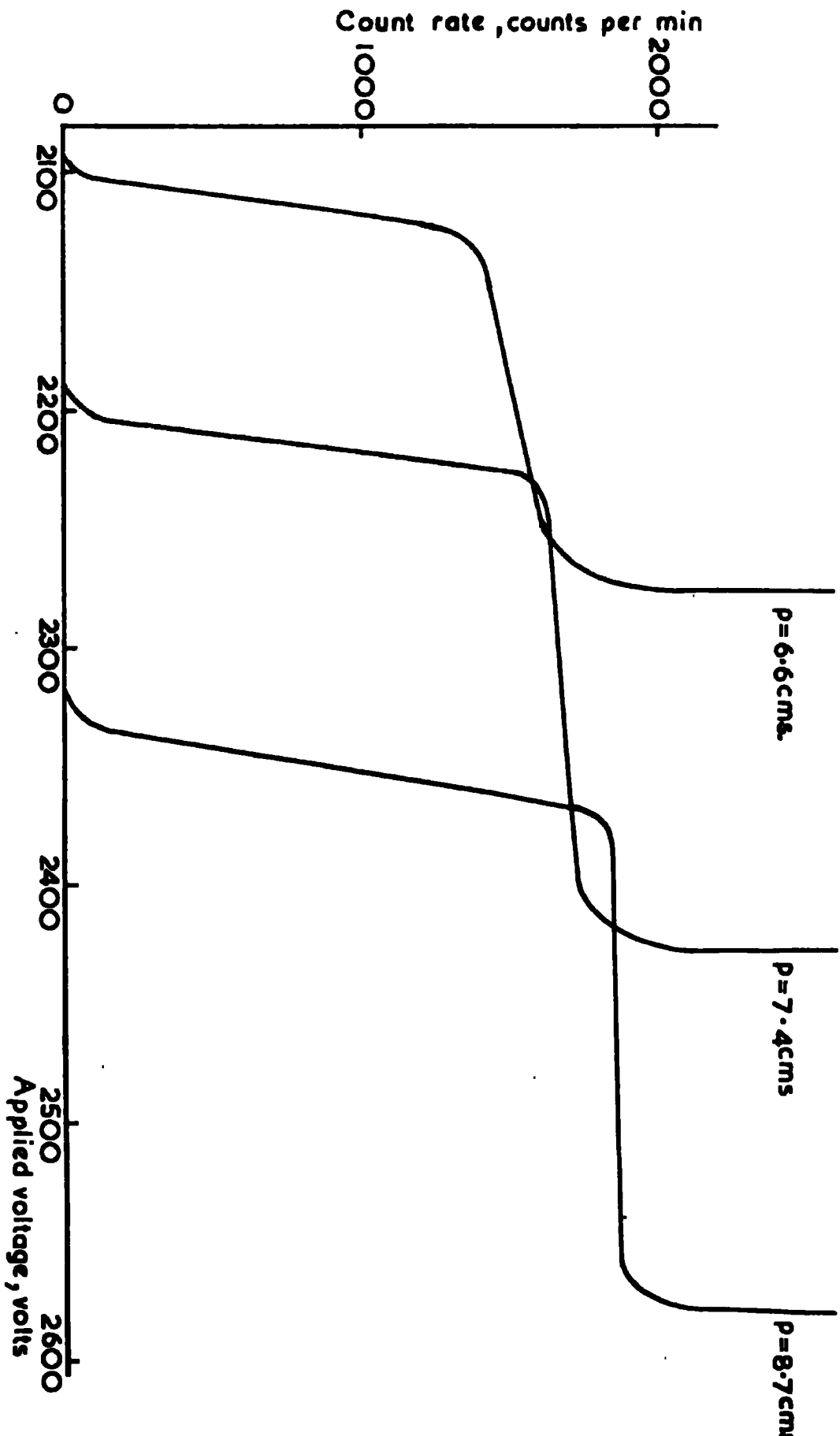

FIG. 24. THE VARIATION OF COUNTER CHARACTERISTIC WITH INTERNAL PRESSURE.

8.e. Conditions used for the measurement of the count rate of the active samples.

After the introduction of the sample to the counter it was placed in the lead castle and the length of the plateau determined, by increasing the applied voltage and observing the difference between the threshold and "racing" voltages. This was usually approximately 200 volts. The voltage was then adjusted to 100 volts above the threshold voltage and the count rate measured.

The count rate of all specimens was measured to an accuracy of at least 1% (i.e. a total of 10,000 counts).

8.f. Effect of the Internal Pressure on the Counting rate and counter characteristics.

Before the counter could be used for comparative experiments it was necessary to determine how variations in the pressure of the radioactive gas contained in the counter would affect the reliability and reproducibility of the observed count rate.

A series of experiments were carried out in which the counter was filled to different pressures with <sup>the</sup> some samples of radioactive gas and the counter characteristics determined as described above. Some of the results are reproduced in figure 24.

The main features of the characteristics were that, as the internal pressure was increased

- (i) the threshold voltage increased.
- (ii) the slope of the plateaux decreased and the length of the plateaux increased.

(iii) the count rate of the sample, as indicated 110

by a position one-third of the way along the plateau, increased.

(i) The variation in threshold voltage has been reported by other workers (74-78) and this has been found to have no effect at all on the reproducibility of the count rate.

(ii) It is essential that a counter should have a characteristic with a fairly long plateau and that the slope of this plateau should be reasonably low. If the slope is steep, then small variations in working voltage will result in large variations in the measured activity of the sample and hence the counter is not reliable. In the present case it was found that counter characteristics with steep plateaux were obtained at low values of the internal pressure. As the pressure was increased, the slope of the plateaux decreased, and the length increased until at internal pressures of 8 cms. mercury and above, the slopes of the plateaux were approximately 2% per 100 volts, a value of the slope usually accepted as producing reliable and reproducible count rates. It was obvious therefore that filling pressures of greater than 8 cms. mercury should be used if reliable results were to be obtained. This lower limit of the filling pressure for use with this type of counter is in accord with the value suggested by Brown and Miller (76). Brown and Miller also found that reliable and comparable results were obtained with internal pressures as high as 40 cms. mercury. Although it was not possible to measure count rates at such high pressures in the present

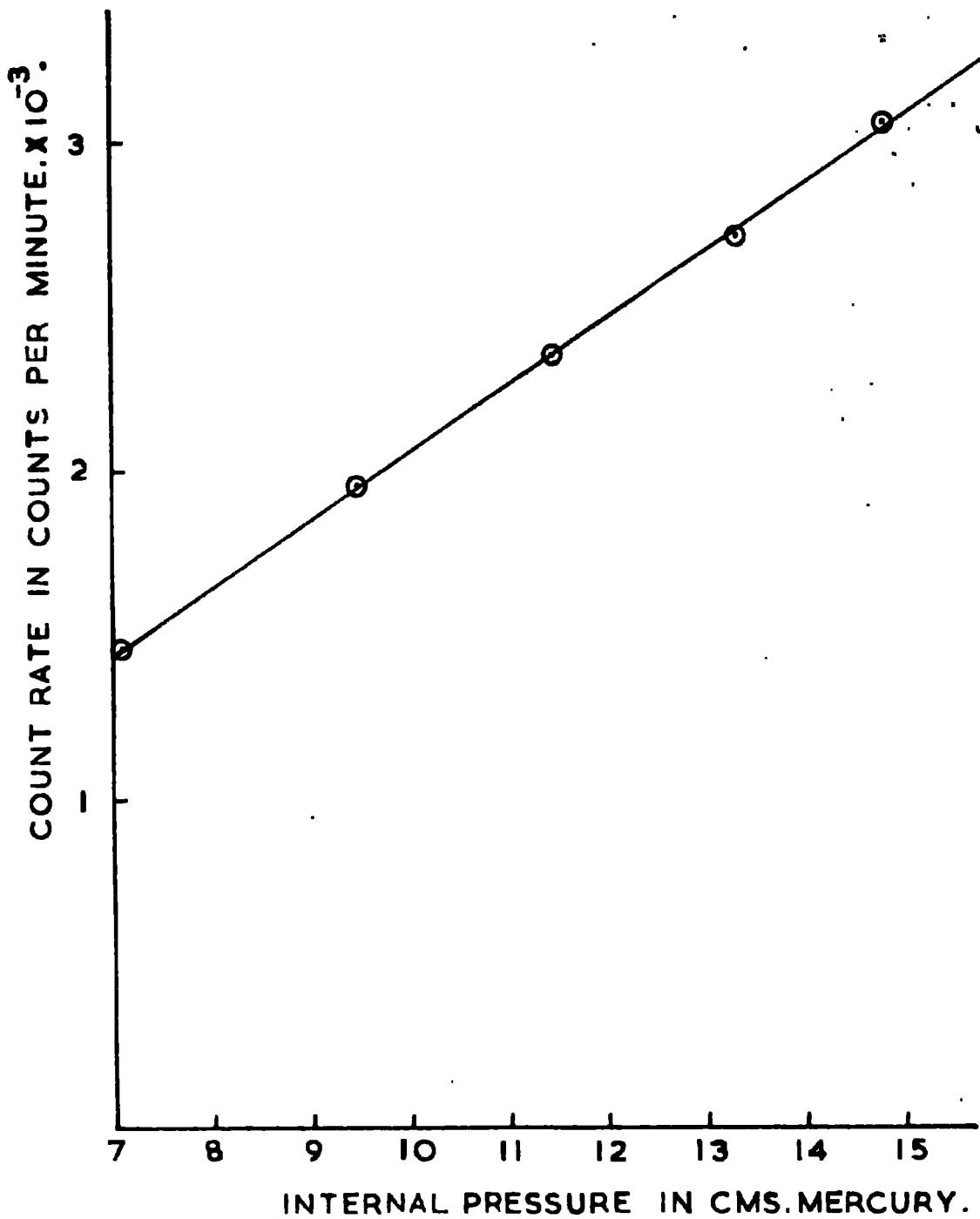

FIG.25. GRAPH TO SHOW VARIATION OF COUNT RATE WITH INTERNAL PRESSURE FOR THE GAS COUNTING TUBE.

case , because of the upper limit of the high voltage supply (3000 volts), measurements using internal pressures of up to 15 cms. mercury showed that reproducible results were obtained in the range 8-15 cms. mercury pressure and all measurements were made in this range.

(iii) A variation in the count rate of the sample with the filling pressure would be expected, because an increase in pressure corresponds to a greater number of radioactive molecules in the counter, and hence a higher count rate would result. If this were the only reason for an increase in count rate with internal pressure then a linear relationship should exist between these variables, and for any particular sample the specific activity in counts per minutes per cm. mercury pressure would be constant. It was possible however that the increase in pressure could affect the counter in some other way. It was therefore necessary to examine the variation of count rate with internal pressure for a particular sample of the gas, to determine if the counting tube was reliable over a range of pressures.

The counting tube was filled to various pressures with the same sample of radioactive gas, and accurate measurement of the count rate for each pressure was made in the way described in section 8.c. The results are plotted in figure 25. It was found that the count rate varied linearly with the pressure of gas in the counting tube.

This indicated that the counting tube was reliable over the range measured and it could be used for the determination of the activities of the samples in the present work. All activities were

expressed as specific activities in the units quoted above and, as these were directly related to the concentration of radioactivity in the original sample of anthracene, were used as a measure of this concentration in the diffusion calculations.

#### 8.g. Background counting rates.

The background rates were measured by filling the counting tube, in the way described above, but with inactive carbon dioxide. The operating voltage of the counting tube was determined as described in section 8.e. An external  $\gamma$ -ray source was sometimes used to determine the length of the plateau.

The values of the background rate were fairly constant. Table VII shows some of these values which were determined over a period of several months. All counts were measured to 1% accuracy.

Table VII. Background Counting Rates measured during the experiments.

#### Background counting rates in counts per minute

71.4	68.6	68.0
69.7	69.9	69.3
70.3	70.5	68.7
71.1	68.1	70.2
70.0	70.6	71.3
68.2	68.3	70.7
68.8	72.7	71.4
67.8	70.6	66.7
70.1	69.8	70.1
67.8	69.7	67.8

In any particular experiment the variation in the background rate was

rarely more than  $\pm 2$  counts per minute. It was therefore 113  
assumed that the variation in this rate in any one day would be  
negligible and only one measurement of the background rate was made  
per day.

#### 8.h. Retention of carbon-14 dioxide in the counting tube.

The counting tube and filling section were evacuated to sticking  
vacuum following each determination. After this had been carried  
out no evidence was ever found of contamination of the apparatus  
by carbon-14. This possibility was checked by the combustion of  
inactive material, especially after very active specimens had been  
measured, and the count rates of such samples were always similar  
to the background rates (Table V). The small variation in the  
background counting rates (Table VII) over the several months during  
which the apparatus was being used also shows that no contamination  
of the filling section and counting tube ever occurred during this  
period.

#### 8.i. Conclusions.

The internal gas counting of carbon dioxide has been found to  
be successful and reliable with counter fillings of 2 cms. mercury  
pressure of carbon disulphide and pressures of carbon dioxide  
varying from 8-15 cms. The counting tube characteristics obtained  
were similar to those observed by previous workers with this type  
of tube and had plateaux of length 150 volts and slope 2% per 100  
volts.

No contamination of the counting tube, or high vacuum apparatus, by carbon-14 was ever detected after reasonable precautions to avoid this possibility had been taken.

## CHAPTER II

### THE RESULTS OF THE DIFFUSION EXPERIMENTS

## THE RESULTS OF THE DIFFUSION EXPERIMENTS

1. Experiments carried out to determine the rates of diffusion perpendicular to the cleavage (001) plane.

This chapter deals with the details of the deposition of the radioactive material and the behaviour of the deposit on being heated. The results of the sectioning of the crystals and the subsequent determination of the specific activity of each slice are given. The radioactive anthracene used in all experiments was calculated to have a specific activity of 0.6 microcuries per milligram.

The conditions for the initial experiment were obtained by determining the approximate depth of penetration of activity into a crystal, previously used in the attempt to determine the rates of surface diffusion. This crystal had been heated at 100°C for 87 hours and at 150°C for 58 hours. It was shown by cutting sections with a razor blade and determining the specific activity of each slice that some penetration had occurred to a depth of about  $10^{-2}$  cms. If the diffusion is an activated process, the greater part of this penetration would have occurred during the 150°C heating period and, as the penetration was small, it seemed that very little had occurred at the lower temperature. As a result of this determination it was decided to carry out the initial experiment at 150°C.

Two mgms. of radioactive anthracene were placed in the evaporator and evaporated on to the crystal surface to give a deposit of approximate weight 0.08 mgms. This was carried out for each of two crystals. The crystals were heated in the diffusion furnace for 60 hours, under a pressure of 150 lbs. per sq. in. of nitrogen gas. The changes in the crystal during the experiment are recorded in Table VIII.

Table VIII. Effect of heating of crystals 1 and 2

	initial	final
Crystal 1	816	206
Crystal 2	982	820

\* All counts of the crystals and deposits were made using a thin end windowed counting tube, type G.M.4.

It can be seen that a considerable amount of activity was lost from the surface of crystal 1 during the heating period. The reason for this loss is discussed in Chapter I and the loss is assumed to be due to bad deposition of the active material. The change in count rate over the heating period was much lower for crystal 2 and this change might reasonably be expected to result from diffusion of the radioactive anthracene into the crystal.

Sectioning of the crystals and measurement of the activity which had penetrated into the crystals showed that, in the case of crystal 1 the concentration of activity was very low indeed and because this low activity would have necessitated disproportionately long counting

times few sections of this crystal were cut.

The experiment was more successful in the case of crystal 2 and it was found that measurable activity had penetrated to a depth of approximately  $3 \times 10^{-2}$  cms.

In view of the comparative success of this first experiment it was decided to carry out a more accurate experiment at the same temperature, using a bigger deposit of radioactive anthracene in order to increase, if possible, the activity arising from diffusion into the crystal.

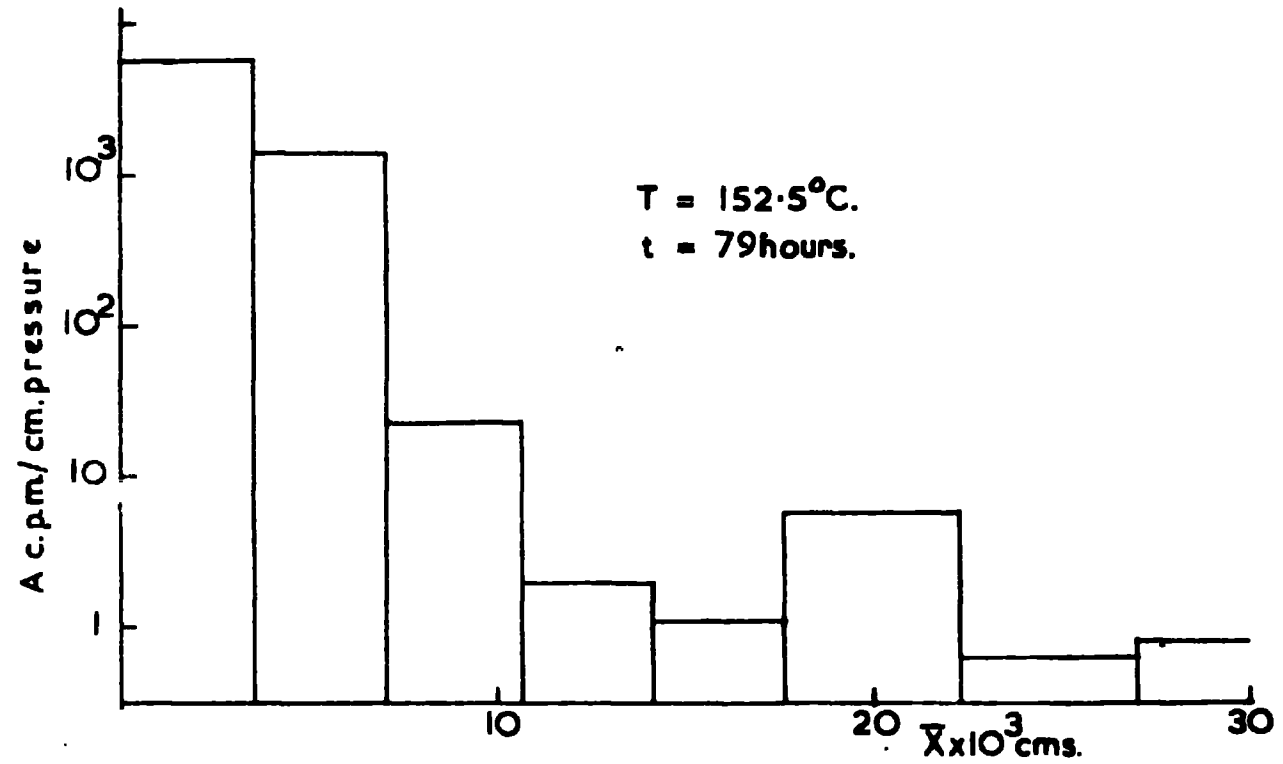

FIG. 26 DIFFUSION PROFILE FOR CRYSTAL A.

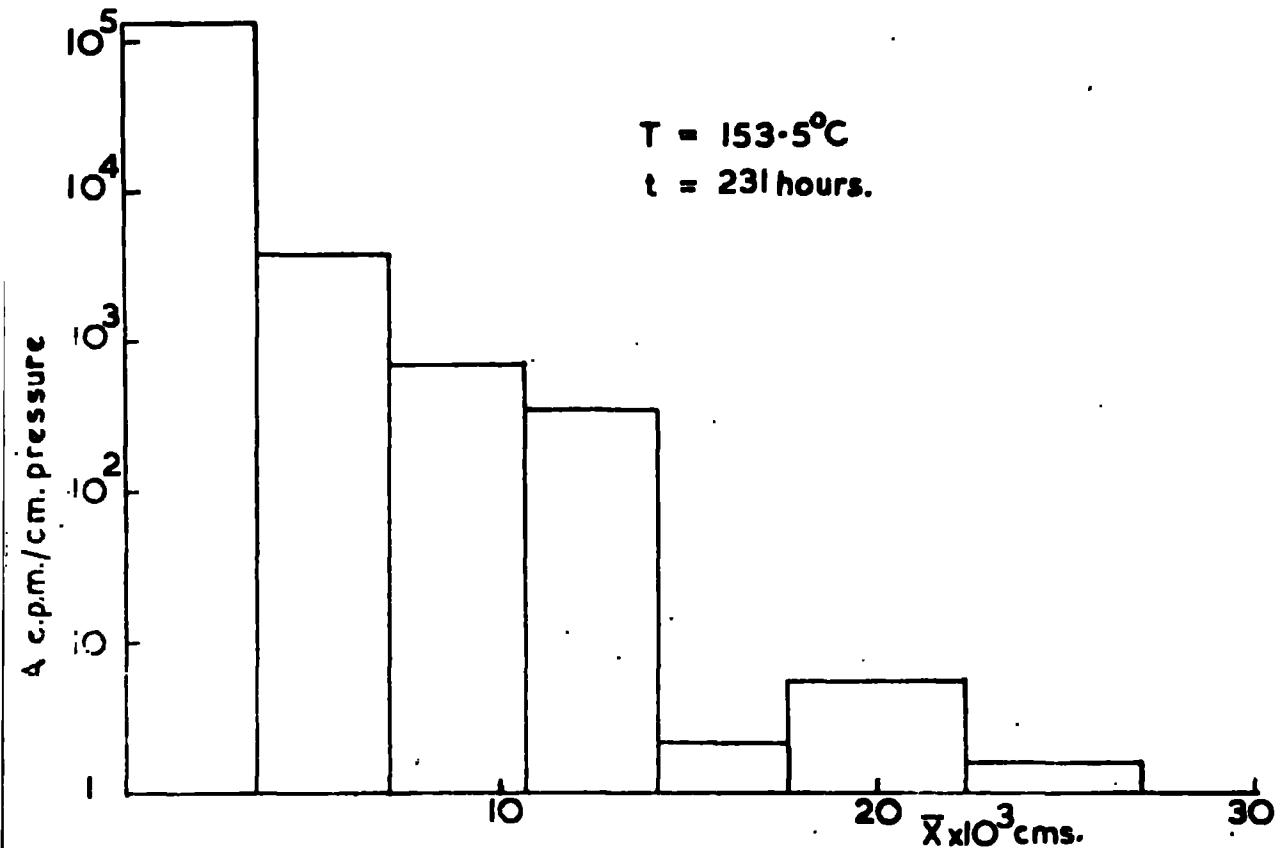

FIG. 27. DIFFUSION PROFILE FOR CRYSTAL I.

Table IXb. Penetration of Activity into the crystals A and B

No. of crystal section	Thickness of section cms. $\times 10^3$	Depth of centre of section $\bar{x}$ cms. $\times 10^3$	$\bar{x}^2$ cms. $^2$ $\times 10^6$	Specific Activity of carbon dioxide A counts per minute per cm. pressure	$\text{Log}_{10} A$
<b>Crystal A</b>					
1	3.53	1.76	3.10	5431 $\pm$ 15	3.74
2	3.53	5.29	28.02	1373 $\pm$ 9	3.14
3	3.53	8.82	77.84	22.78 $\pm$ 0.33	1.36
4	3.53	12.34	152.5	2.01 $\pm$ 0.20	0.30
5	3.53	15.87	251.9	1.15 $\pm$ 0.15	0.06
6	4.70	19.99	399.7	5.90 $\pm$ 0.15	0.77
7	4.70	24.69	609.5	0.63 $\pm$ 0.10	-0.20
8	4.70	29.39	864.6	0.82 $\pm$ 0.07	-0.09
9	4.70	34.09	1162.0	0.82 $\pm$ 0.07	-0.09
<b>Crystal B</b>					
1	3.53	1.76	3.10	20610 $\pm$ 188	4.31
2	2.35	4.70	22.14	2078 $\pm$ 8	3.32
3	3.53	7.64	58.45	39.77 $\pm$ 0.84	1.60
4	3.53	11.17	124.8	6.35 $\pm$ 0.22	0.80
5	3.53	14.70	216.2	10.25 $\pm$ 0.19	1.01
6	5.87	19.41	376.7	-	-
7	4.70	24.70	610.1	3.12 $\pm$ 0.07	0.49
8	4.70	29.40	864.6	0.86 $\pm$ 0.13	-0.07
9	4.70	34.11	1164	0.20 $\pm$ 0.06	-0.70

On to two crystals A and B was evaporated 0.15 and 0.20 mgms. of radioactive anthracene. The crystals were mounted in the holder and placed in the pressure vessel in the furnace and the temperature raised to 152.5°C. The pressure was increased to 150 lbs. per sq. in. and the crystals heated for 79 hours. The results of the experiment are given in Table IXa.

Table IXa. Effect of heating the crystals A and B

Activity of the deposit in counts per minute

	initial	final
A	1183	972
B	1769	1558

The loss in activity was small and the activity in the sections showed that penetration had taken place. Some evaporation however did occur for radioactive anthracene was deposited on the cooler parts of the pressure vessel.

Figure 26 shows the diffusion profile for Crystal A. The ordinate is plotted on a logarithmic scale because of the very high values of the specific activity.

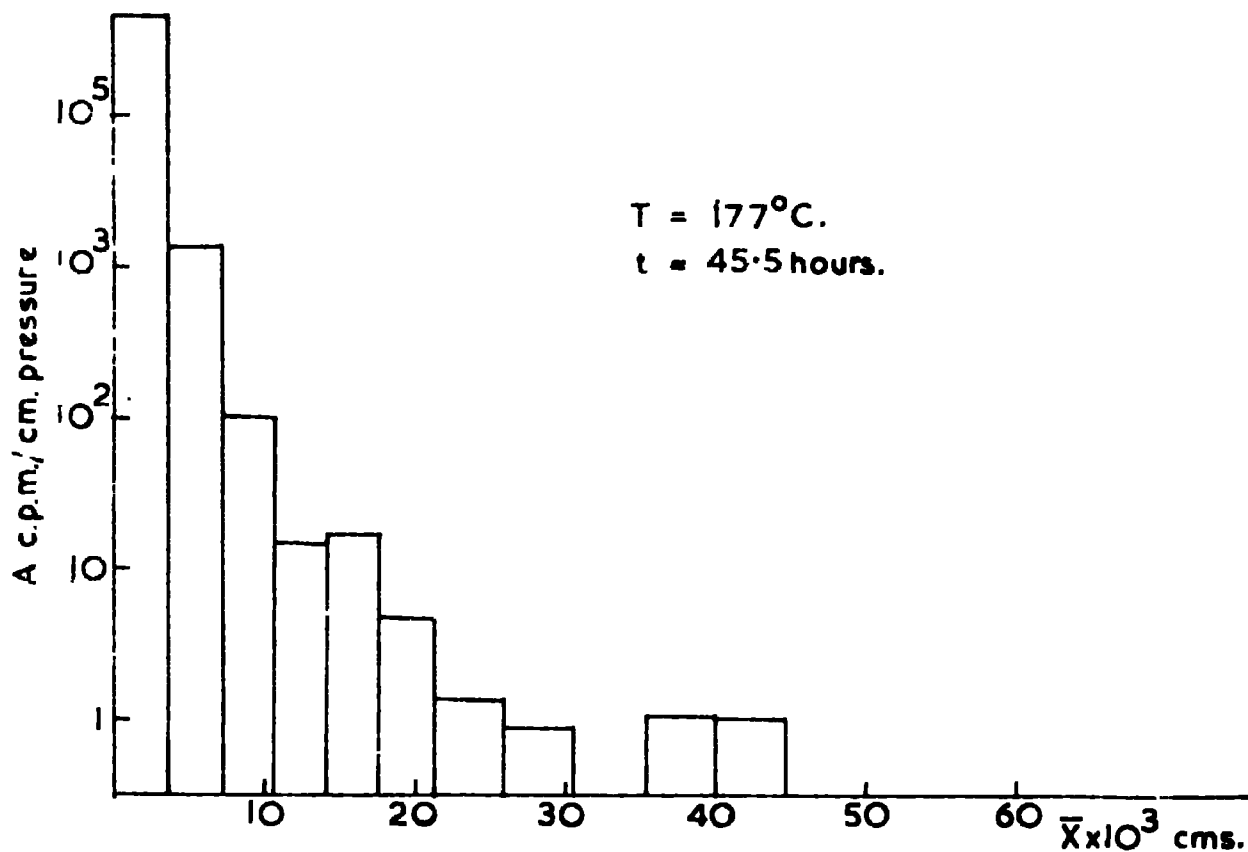

FIG.28. DIFFUSION PROFILE FOR CRYSTAL C.

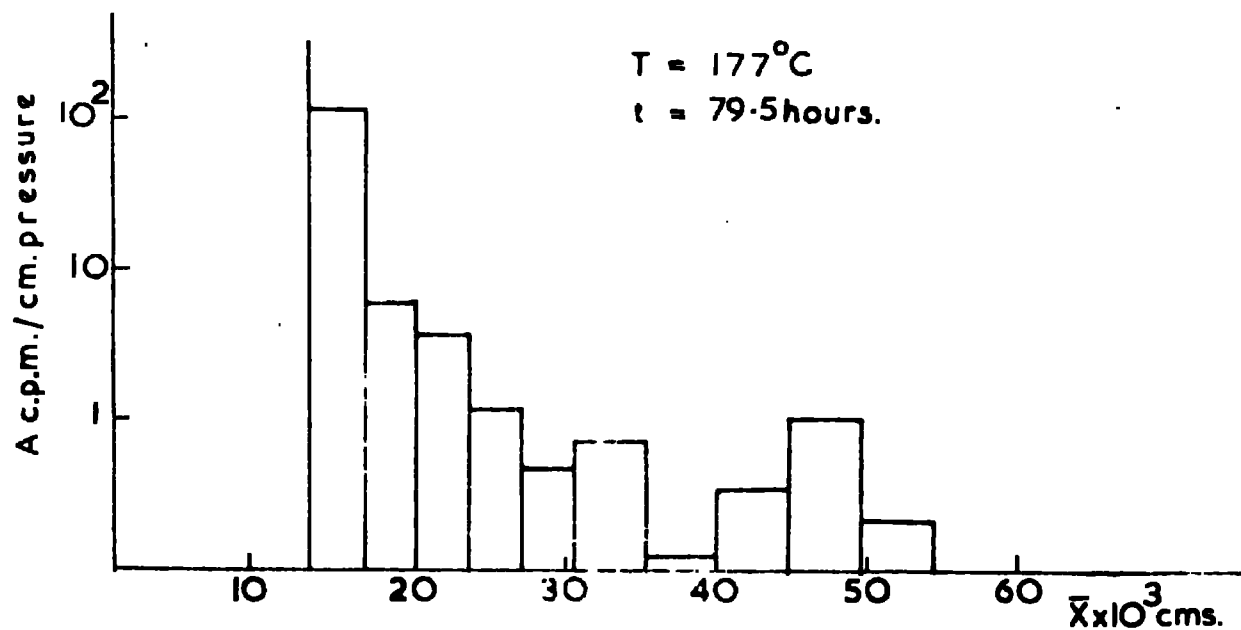

FIG.29. DIFFUSION PROFILE FOR CRYSTAL F.

Table Xb. Penetration of Activity into the crystal C

No. of crystal section	Thickness of section cms. x $10^3$	Depth of centre of section $\bar{x}$ cms, x $10^3$	$\bar{x}^2$ cms. <sup>2</sup> x $10^6$	Specific Activity of carbon dioxide A counts per minute per cm. pressure	$\log_{10} A$
1	3.53	1.76	3.10	48138 ± 435	4.68
2	3.53	5.29	28.02	~1345	~3.13
3	3.53	8.82	77.84	100.7 ± 2.4	2.00
4	3.53	12.34	152.5	15.11 ± 0.42	1.18
5	3.53	15.87	251.9	16.66 ± 0.17	1.22
6	3.53	19.40	376.4	4.78 ± 0.29	0.68
7	4.70	23.51	552.7	1.31 ± 0.12	0.12
8	4.70	28.22	796.4	0.88 ± 0.09	-0.06
9	4.70	-	-	-	-
10	4.70	37.63	1416.0	1.07 ± 0.09	0.03
11	4.70	42.34	1793.0	1.04 ± 0.11	0.02

2.5 mgms. of radioactive anthracene was evaporated on to each of crystals C and D. The crystals were heated at 177°C for 45.5 hours. In this experiment the pressure was maintained at 200-250 lbs. per sq. in. during the heating process in order to minimise losses from the crystal, due to the increased vapour pressure of anthracene at this higher temperature. This pressure was adopted as a standard during the remaining experiments.

The effect of heating the crystal is shown in Table Xa.

Table Xa. The effect of heating the crystals C and D.

	Activity of the deposit counts per minute		Total weight of the crystal mgms.	
	initial	final	initial	final
C	3055	2659	774.0	616.5
D	2531	437	503.0	416.3

Reference to the above table will show that the deposit on crystal D must have been badly formed. This was again indicated by the considerable loss of activity from the deposit during the heating of the crystal. Because of the low final activity, crystal D was not sectioned. An inaccurate experiment which was carried out to determine the total activity which had diffused into crystal D showed this activity to be only slightly greater than the background counting rate. In the case of crystal C however the comparatively small loss showed that a well formed deposit resulted from the evaporation.

The diffusion profile for crystal C is drawn in figure 28.

Because of the failure of the experiment because of the poor deposit on crystal D, the experiment at this temperature was repeated, with a longer period of heating in order that greater penetration of the activity would result.

Crystals E and F, on to each of which had been evaporated 0.25 mgms. of radioactive anthracene, were heated at 177°C for 79.5 hours. The pressure in the vessel was maintained at 200-250 lbs. per sq. in. during the experiment. The effect of the heating at this temperature on the crystals is recorded in Table XIa.

Table XIa. The effect of heating on crystals E and F

	Activity of the deposit counts per minute		Total weight of the crystal mgms.	
	initial	final	initial	final
E	2120	620	441.6	-
F	2563	2180	591.6	-

The decrease in activity in the case of crystal E was again so great that the concentration of activity in the crystal would be small and the crystal was not sectioned. The activity which had diffused into crystal E was later shown to be very low and only slightly greater than the background counting rate, thus indicating that the epitaxial deposit must have been small. Crystal F appeared to have had a well formed deposit. On removal of the crystals from the oven breakage occurred from the opposite face to the deposit. For this reason a final weight is not given in Table

Table XIb. Penetration of Activity into the crystal F

No. of crystal section	Thickness of section $\text{cms.} \times 10^3$	Depth of centre of section $\bar{x}$ $\text{cms.} \times 10^3$	$\bar{x}^2$ $\text{cms.}^2 \times 10^6$	Specific Activity of carbon dioxide A counts per minute per cm. pressure		$\text{Log}_{10} A$
1 & 2	12.93	-	-	-	-	-
3	3.53	14.70	216.2	114.90 ±	1.50	2.06
4	3.53	18.23	332.4	6.16 ±	0.17	0.79
5	3.53	21.76	473.6	3.85 ±	0.24	0.59
6	3.53	25.28	639.5	1.20 ±	0.17	0.08
7	3.53	28.82	830.6	0.49 ±	0.15	-0.31
8	4.70	32.93	1084	0.71 ±	0.16	-0.15
9	4.70	37.63	1416	0.13 ±	0.01	-0.89
10	4.70	42.34	1793	0.34 ±	0.10	-0.47
11	4.70	47.04	2213	1.01 ±	0.12	0.00
12	5.87	52.33	2738	0.21 ±	0.09	-0.68

XIa because a true final weight could not be obtained.

Crystal F was sectioned and the results are given in Table XIb. The first two slices were spoiled because the crystal fractured as sectioning was commenced.

The results are plotted as  $\log_{10} A$  versus  $\bar{x}$  in figure 29 and can be compared with those for crystal C on the same page. This comparison shows the increase in penetration with increase of heating time, the temperature being the same for both crystals. Comparison of figures 26 and 29 shows the effect of increase of temperature on the overall penetration. The heating period for both these experiments was 79 hours but the temperature differs (A 152.5°C and F 177°C). It will be seen that for crystal A (figure 26) the penetration is lower than for crystal F (figure 29) showing that the rate of diffusion has increased with increasing temperature.

Crystals G and H after the deposition of approximately 0.2 mgms. radioactive anthracene on each were heated for 49 hours at a temperature of 189.0°C under a pressure of 200-250 lbs. per sq. in.

Table XIIIa. Effect of heating on crystals G and H

	Activity of the deposit counts per minute		Total weight of the crystal mgms.	
	initial	final	initial	final
G	1230	900	368.2	-
H	1763	720	313.4	-

Again no final weight is given because of crystal breakage on the back surface on removal from the pressure holder, however, in this case the anthracene loss was considerable. At the end of the experiment little more was left of the crystal than a cylinder of diameter equal to that of the Teflon separating washer. Because of the method used to protect the deposit very little loss appeared to have occurred from the face. The losses of radioactivity are comparable with other experiments.

If it is assumed that penetration occurs normal to the initial plane alone then this loss of anthracene will not have affected the diffusion process, providing that no great loss of activity has occurred from the deposit.

The loss of anthracene at this temperature was so great that it was decided that no purpose would be served in attempting to carry out experiments at higher temperatures with the existing

Table XIIIb. Penetration of Activity into crystals G and H

No. of crystal section	Thickness of section cms. <sub>3</sub> x 10 <sup>3</sup>	Depth of centre of section $\bar{x}$ cms. <sub>3</sub> x 10 <sup>3</sup>	$\bar{x}^2$ cms. <sub>3</sub> <sup>2</sup> x 10 <sup>6</sup>	Specific Activity of carbon dioxide A counts per minute per cm. pressure	Log <sub>10</sub> A
<b>Crystal G</b>					
1	4.70	2.35	5.5	34550 ± 102	4.54
2	4.70	7.05	49.8	5628 ± 13	3.75
3	4.70	11.76	138.2	48.48 ± 0.54	1.69
4	4.70	16.46	270.8	19.61 ± 0.33	1.29
5	4.70	21.16	447.7	23.31 ± 0.36	1.37
6	4.70	25.86	668.8	4.03 ± 0.02	0.61
7	4.70	30.56	933.9	7.04 ± 0.17	0.85
8	4.70	35.26	1243	2.15 ± 0.20	0.33
9	4.70	39.97	1598	1.01 ± 0.19	0.01
10	4.70	-	-	-	-
11	4.70	49.37	2437	0.30 ± 0.20	-0.52
<b>Crystal H</b>					
1	4.70	2.35	5.5	1223 ± 9	3.09
2	4.70	7.05	49.8	5.96 ± 0.68	0.78
3	4.70	11.76	138.2	2.08 ± 0.24	0.32
4	4.70	16.46	270.8	12.81 ± 0.38	1.11
5	7.04	22.35	499.5	0.96 ± 0.16	-0.02
6	5.87	28.80	830.7	0.32 ± 0.27	-0.50
7	5.87	34.68	1203	0.74 ± 0.16	-0.13
8	5.87	40.56	1647	0.13 ± 0.01	-0.89

apparatus. It was decided to limit the experiments to the 123  
temperature range 150°-190°C.

Both crystals were sectioned and the results are given in  
Table XIIb.

Table XIIIb. Penetration of Activity into crystals I and J

No. of crystal section	Thickness of section $\text{cms.} \times 10^3$	Depth of centre of section $\bar{x} \text{ cms.} \times 10^3$	$\bar{x}^2 \text{ cms.}^2 \times 10^6$	Specific Activity of carbon dioxide A counts per minute per cm. pressure	$\text{Log}_{10} A$
<b>Crystal I</b>					
1	3.53	1.76	3.10	129414 ± 266	5.11
2	3.53	5.29	28.02	3899 ± 0.6	3.59
3	3.53	8.82	77.84	726.7 ± 3.5	2.86
4	3.53	12.34	152.5	44.46 ± 0.59	1.65
5	3.53	15.87	251.9	2.10 ± 0.34	0.32
6	4.70	19.98	399.2	5.60 ± 0.26	0.75
7	4.70	24.69	609.6	1.58 ± 0.18	0.20
8	4.70	-	-	-	-
9	4.70	34.09	1162	1.93 ± 0.19	0.29
10	4.70	-	-	-	-
11	4.70	43.49	1891	2.54 ± 0.19	0.41
<b>Crystal J</b>					
1	4.70	2.35	5.5	2678 ± 49	3.44
2	4.70	7.05	49.8	24.37 ± 0.52	1.39
3	4.70	11.76	138.2	11.72 ± 0.36	1.07
4	4.70	16.46	270.8	32.26 ± 0.50	1.51
5	4.70	21.16	447.7	5.43 ± 0.31	0.74
6	4.70	25.86	668.8	-	-
7	4.70	30.56	933.9	0.13 ± 0.17	-0.89
8	4.70	35.27	1243	0.75 ± 0.22	-0.12

In view of the low penetration of activity observed in experiment 1 and the dissimilarity between the diffusion profiles for these crystals and those of subsequent experiments, it was decided to carry out another experiment at this temperature and to increase the amount of radioactive anthracene deposited on the crystals, and the heating period. Thus crystals I and J on each of which had been deposited 0.2 mgms. of radioactive anthracene were heated for 231 hours at 153.5°C under a pressure of 200-250 lbs. per sq. in.

Table XIIIa. Effect of heating on crystals I and J

	Activity of the deposit counts per minute		Total weight of the crystal mgms.	
	initial	final	initial	final
I	2883	2578	473.2	340.4
J	2199	2099	388.1	-

On removal from the oven crystal J broke, in such a way that the active portion of the crystal may have been affected and any result calculated in the case of J must be regarded with suspicion. The loss of activity in the case of I was comparable with previous experiments and was indicative of a good deposit.

The diffusion profile for crystal I, plotted in figure 27, can be compared with that for crystal A on the same page. In both these cases the temperature of the experiment was approximately the same and the increased penetration resulting from diffusion over the longer heating period for crystal I can be seen.

Table XIVb. Penetration of Activity into crystals M and N

No. of crystal section	Thickness of section cms. $\times 10^3$	Depth of centre of section $\bar{x}$ cms. $\times 10^3$	$\bar{x}^2$ cms. $\times 10^6$	Specific Activity of carbon dioxide per cm. pressure	$\text{Log}_{10} A$
<b>Crystal M</b>					
1	4.70	2.35	5.5	33330 $\pm$ 93	4.52
2	3.53	6.47	41.7	1403 $\pm$ 4	3.15
3	3.53	9.99	99.8	648 $\pm$ 2.67	2.81
4	3.53	13.52	182.7	143.8 $\pm$ 1.49	2.16
5	3.53	17.04	290.4	30.03 $\pm$ 0.63	1.48
6	3.53	20.57	423.1	8.57 $\pm$ 0.32	0.93
7	3.53	24.10	580.8	6.22 $\pm$ 0.25	0.79
8	3.53	27.62	761.8	3.51 $\pm$ 0.51	0.55
<b>Crystal N</b>					
1	4.70	2.35	5.5	36750 $\pm$ 105	4.57
2	3.53	6.47	41.7	1.59 $\pm$ 0.24	0.20
3	3.53	9.99	99.8	-	-

## Experiment 7.

The results of this experiment in which crystals K and L were heated for 149 hours are not reliable because of a failure in the temperature measuring system. This was recalibrated before the next experiment.

## Experiment 8.

Crystals M and N each with a deposit of 0.2 mgms. of radioactive anthracene were heated at 160°C for 219 hours, under a pressure of 200-250 lbs. per sq. in.

Table XIVa. Effect of heating of crystals M and N

	Activity of the deposit counts per minute		Total weight of the crystal mgms.	
	initial	final	initial	final
M	2138	2115	234	179
N	2275	1955	321	237

The losses of activity were small and it was assumed that the deposits were well formed. The crystals were sectioned.

In the case of N the activity which penetrated into the crystal was much lower than would be expected from the value of surface activity given in Table XIVa. The only reason which can be forwarded is that the original deposit was badly formed. As can be seen from Table XIVb the concentration of radioactive anthracene in the crystal was so small that very long counting times were necessary to achieve the desired accuracy and the sectioning of crystal N was concluded at this stage.

Table XVb. Penetration of Activity into crystals O, P and Q

No. of crystal section	Thickness of section cms. x $10^3$	Depth of centre of section $\bar{x}$ cms. x $10^3$	$\bar{x}^2$ cms. x $10^6$	Specific Activity of carbon dioxide A counts per minute per cm. pressure	$\text{Log}_{10} A$
<b>Crystal O</b>					
1	3.53	1.76	3.10	2384 ± 4.1	3.38
2	3.53	5.29	28.02	6.26 ± 0.31	0.80
3	3.53	8.82	77.84	1.98 ± 0.40	0.30
4	3.53	12.34	152.5	1.54 ± 0.22	0.19
<b>Crystal P</b>					
1	3.53	-	-	-	-
2	3.53	5.29	28.02	11835 ± 32	4.07
3	3.53	8.82	77.84	91.60 ± 0.99	1.96
4	3.53	12.34	152.5	61.80 ± 0.73	1.79
5	3.53	15.87	251.9	59.65 ± 0.82	1.78
6	3.53	19.40	376.7	87.10 ± 0.13	1.94
7	3.53	22.92	525.3	21.37 ± 0.47	1.33
<b>Crystal Q</b>					
1	3.53	1.76	3.10	3927 ± 9	3.59
2	3.53	5.29	28.02	91.6 ± 0.90	1.96
3	3.53	8.82	77.84	79.27 ± 0.83	1.90
4	3.53	12.34	152.5	46.80 ± 0.52	1.67
5	3.53	15.87	251.9	31.28 ± 0.37	1.50
6	11.76	-	-	-	-
7	4.70	31.74	1007	13.28 ± 0.23	1.12
8	9.40	-	-	-	-
9	4.70	45.84	2101	8.60 ± 0.26	0.94

2. Experiments carried out to determine the rates of diffusion in a direction parallel to the cleavage (001) plane

Two experiments were carried out to ascertain whether any diffusion anisotropy existed in this crystal. Because of the difficulties in sectioning the crystal in this orientation the results must be regarded only as indicative of the order of magnitude of the rate of diffusion in this direction. The experiments were carried out in triplicate.

Experiment 9.

Deposits of approximately 0.25, 0.3 and 0.3 mgms. of radioactive anthracene were evaporated on to crystals O, P and Q respectively. The crystals were heated at 160°C for 170 hours under the usual conditions of pressure. The results were as follows.

Table XVa. Effect of heating on crystals O, P and Q

	Activity of the deposit counts per minute		Total weight of the crystal mgms.	
	initial	final	initial	final
O	3896	3169	563	497
P	4276	3619	373	306
Q	2924	2458	304	249

The above information indicated that the deposits were well formed during the evaporation.

Table XVIb. Penetration of Activity into crystals R and S

No. of crystal section	Thickness of section $\text{cms.} \times 10^3$	Depth of centre of section $\bar{x} \text{ cms.} \times 10^3$	$\bar{x}^2 \text{ cms.}^2 \times 10^6$	Specific Activity of carbon dioxide A counts per minute per cm. pressure	$\text{Log}_{10} A$
------------------------	--	---	--	--	---------------------

Crystal R

1	-	-	-	-	-
2	3.53	5.29	28.02	518.2 ± 2	2.71
3	3.53	8.82	77.84	153.3 ± 1.2	2.19
4	3.53	12.34	152.5	60.1 ± 0.71	1.78
5	3.53	15.87	251.9	56.5 ± 0.63	1.75

Crystal S

1	3.53	1.76	3.10	4475 ± 15	3.65
2	3.53	5.29	28.02	433.9 ± 1.9	2.64
3	3.53	8.82	77.84	107.3 ± 4.8	2.03
4	3.53	12.34	152.5	67.90 ± 0.74	1.83
5	3.53	15.87	251.9	73.37 ± 0.74	1.87
6	3.53	19.40	376.7	84.57 ± 0.80	1.93
7	3.53	22.92	525.3	62.5 ± 0.62	1.80

On to the surface of crystals R, S and T were evaporated approximately 0.45, 0.4 and 0.45 mgms. respectively. The three crystals were heated at 174°C for 88 hours. The pressure was maintained at 200-250 lbs. per sq. in.

Table XVIa. Effect of heating on crystals R, S and T

	Activity of the deposit counts per minute		Total weight of the crystal mgms.	
	initial	final	initial	final
R	5510	3364	927	735
S	4339	4639	738	608
T	4824	3618	713	633

Crystal T was badly cracked during the heating process and was discarded.

The result of sectioning crystals R and S and the subsequent counting are given in Table XVIb.

An experiment was carried out to determine whether it was possible to detect surface diffusion on the cleaved surface of an anthracene single crystal.

A line deposit of radioactive anthracene was evaporated on to the centre of a cleaved crystal face and attempt was made to follow the diffusion along the surface with the apparatus previously described (Chapter I, section 4.c.).

After heating the crystal and deposit for periods of

87 hours at 100°C

58 hours at 150°C

it was found that no apparent movement had occurred. Surface diffusion is found to be more rapid than bulk diffusion for most solids and it is thought that some movement should have resulted from the 150°C heating for the above period of time.

The experiments were discontinued at this stage and it was found impossible to carry out further experiments for longer heating periods and at higher temperatures at a later time.

CHAPTER III

INTERPRETATION OF THE RESULTS

## Interpretation of the Results

1. The choice of a diffusion equation.

The experimental results of diffusion experiments carried out under similar conditions to the present study, have usually been interpreted from the viewpoint that the deposit is "infinitely" thin compared to the overall depth of diffusion. The activity of such a source would be diminished by diffusion immediately the experiment is commenced and the experimental conditions should be adjusted so that the diffusing activity does not reach the far extremity of the crystal during the experiment.

When such conditions are applied to the experiment the diffusion process is represented by the following solution of the diffusion equation (2,91)

$$C = \frac{Q}{(2\pi Dt)^{\frac{1}{2}}} e^{-x^2/4Dt} \quad \text{-----} \quad 2$$

C represents the concentration of the activity located at a depth x in the crystal after time t, D the diffusion coefficient and Q the total activity deposited on the surface. It can be seen that the expression is symmetrical with respect to x and approaches zero when x approaches infinity for all t's > 0.

Taking logarithms to base 10 of the above expression the following equation is obtained.

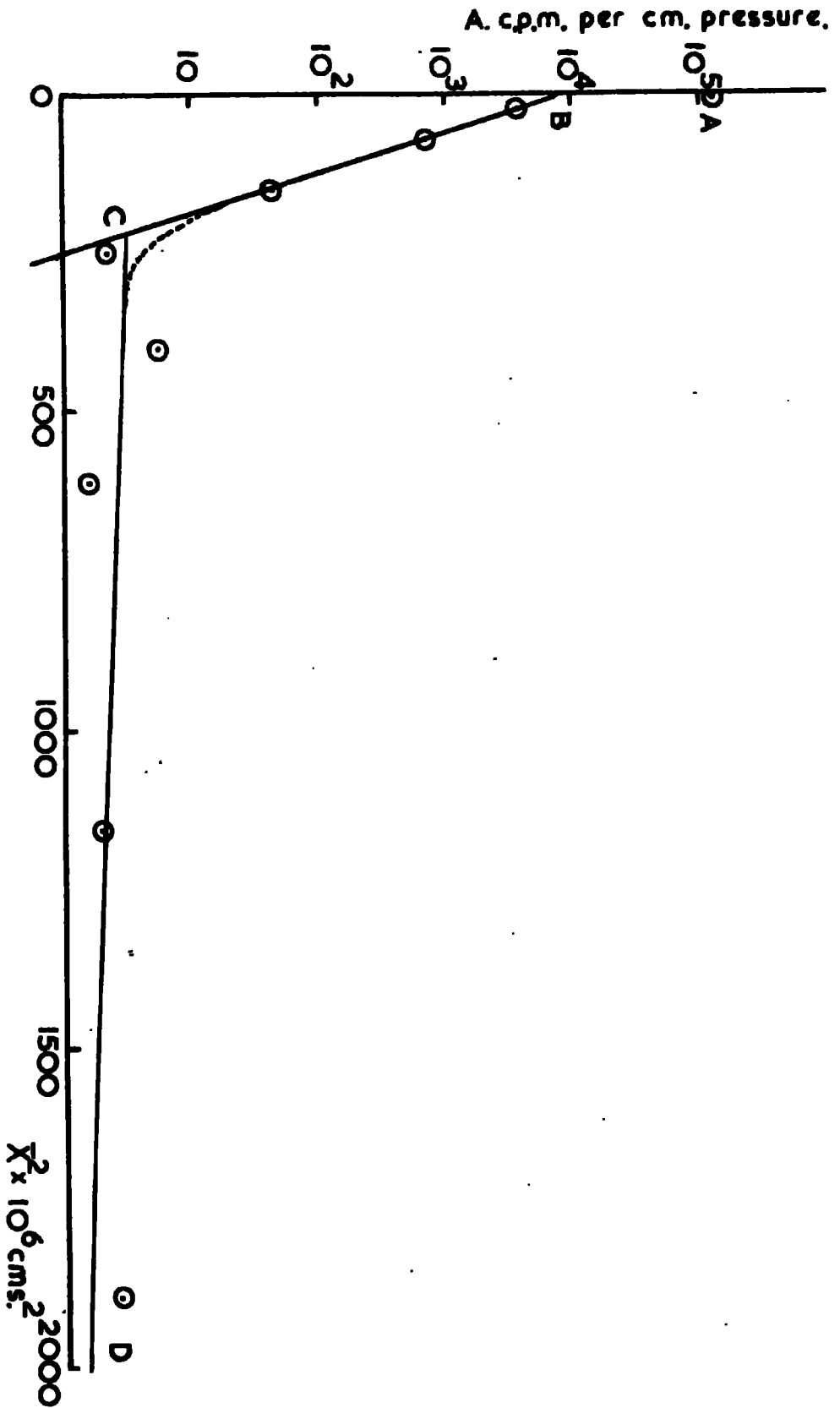

FIG.30. GRAPH OF LOG<sub>10</sub> A versus  $X^2$  FOR CRYSTAL I.

$$\log_{10} c = \log_{10} \frac{Q}{(2\pi Dt)^{1/2}} - \frac{x^2}{4Dt} \cdot \log_{10} e \quad \text{--- 3}$$

It will be seen from equation 3 that if equation 2 correctly describes the diffusion process under consideration, then a plot of the logarithm of the concentration of the diffusing species (in this case the specific activity of the anthracene - 9 - carbon-14 present) at any depth  $x$ , versus the square of that depth ( $x^2$ ) should result in a straight line graph of slope

$$- \frac{\log_{10} e}{4Dt}$$

The heating period  $t$  is known from experiment and hence the diffusion coefficient can be calculated from the slope of this line.

Figure 30 depicts such a plot for one of the experiments carried out in this study and it can be seen that it does not conform to the linear relationship expected from equation 3. This graph is typical for the majority of the experiments.

If the experimental points are regarded from the point of view of the above equations, (i.e. straight lines are expected from a plot of equation 3) one could regard them as composing two straight lines, BE and CD on the diagram, and that the point A is anomalous in that it is high. From the geometry of the crystal and deposit it would be expected that this first point should be high in all cases.

The reason is as follows:-

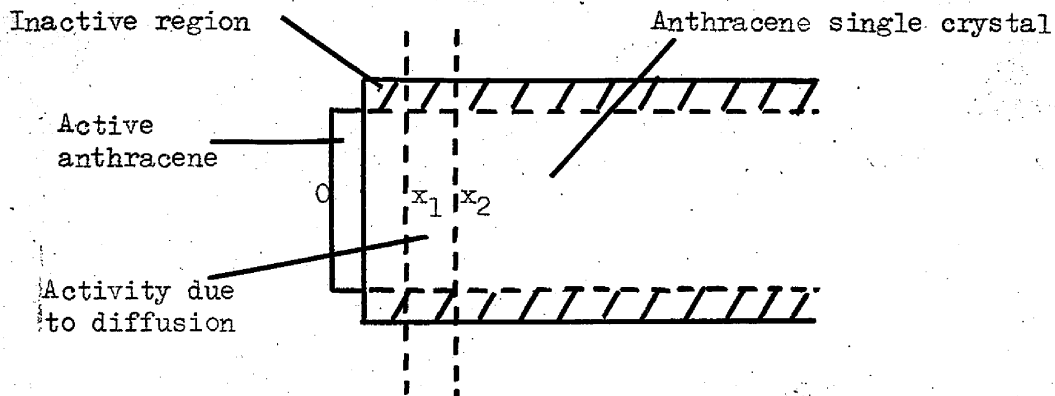

Fig. 31 The Crystal and Deposit

Figure 31 represents the crystal and deposit. 0 on the surface of the deposit is the origin of the sectioning process and  $ox_1$ ,  $x_1 x_2$ , the thickness of the first and second sections respectively.

If it is assumed that diffusion into the crystal takes place only in the cylinder of diameter equal to the diameter of the deposit it will be seen that the first section will consist of the deposited radioanthracene (diluted with a little inactive anthracene from back diffusion) plus the radioanthracene which has diffused into the crystal as far as  $x_2$ , with the inactive material surrounding it.

The second section  $x_1 x_2$  will consist of diffused radioanthracene and surrounding inactive material, as will subsequent sections. It will be seen from the above diagram that, whereas sections 2 onwards will contain equal amounts of inactive anthracene at the edges thus making their specific activities comparable, section 1 will contain an excess amount of radioanthracene. Because

of this the specific activity of section 1 should be high compared to subsequent sections and hence on all graphs the first point should be "high" compared to subsequent points. In spite of the fact that the initial point can be accounted for there is, at this stage, no reason to assume that the remaining experimental points are best represented by two straight lines because it can also be said that all the points (neglecting A for the above reasons) lie on a curve (the dotted line in figure 30). If this were the case, then it is obvious that equation 2 does not describe the present diffusion process and that more consideration should be given to the possibility that other conditions apply to the integration of the diffusion equation than those quoted above, and that some other equation to describe the diffusion process is necessary.

The former explanation of the experimental points can be justified however and the existence of two straight lines could be accepted as evidence of two concurrent diffusion processes, one, represented by the portion CD, more rapid than the other (BC).

There are then two possible explanations of the type of curve depicted in figure 30 and before the experiments can be analysed it is necessary to come to some conclusion on these alternatives.

In practice an infinitely thin deposit cannot be evaporated on to a crystal surface. Also such a deposit of radioactive material would not give high enough counting rates in the crystal, after diffusion, to enable accurate determination of the radioactivity to be made in a reasonable time, unless an extremely radioactive sample

were used. It should however be possible to approximate to an <sup>133</sup> infinitely thin deposit in cases where the penetration of activity is large compared to the deposit thickness. An upper limit must however exist where the deposit can no longer be considered to be infinitely thin and in cases where the thickness is comparable with the depth of penetration other boundary conditions will apply in the integration of the diffusion equation and a different solution will result.

There exist three other possible descriptions which could perhaps be applied.

(a) Where the deposit and crystal are infinite, or very large in extent compared to the overall depth of diffusion and the deposit can be described as an "extended initial distribution of concentration" (2,91). The solution of the diffusion equation in this case is

$$C = \frac{C_0}{2} \operatorname{erfc} \frac{x}{2(Dt)^{1/2}} \quad \text{--- 4}$$

where in addition to the previously mentioned abbreviations  $C_0 =$  the initial concentration in the deposit. In this case:-

$$C = C_0, \quad x < 0 \quad \text{and} \quad C = 0, \quad x > 0 \quad \text{when} \quad t = 0$$

and  $C = C_0/2 \quad x = 0 \quad t > 0.$

It would be expected that, in cases where this equation held, the concentration at the interface between the deposit and the crystal would be constant throughout the experiment and equal to half the initial concentration applied.

(b) In which the deposit is finite in extent and the crystal infinite or very large in extent, and that during the experiment the diffusing species fails to reach the boundary of the crystal but at the same time back diffusion from the crystal does reach the boundary of the deposit. Diffusion in such a case is represented by the equation (2,91)

$$C = \frac{C_0}{2} \left( \operatorname{erf} \frac{h + x_1}{2(Dt)^{\frac{1}{2}}} + \operatorname{erf} \frac{h - x_1}{2(Dt)^{\frac{1}{2}}} \right) \dots \dots \dots 5$$

where  $h$  represents the deposit thickness.

(c) Where the source can be regarded as of constant concentration. This can readily be discounted in the present case because back diffusion of inactive anthracene from the crystal will immediately lower the concentration of the diffusing activity and hence such a condition could not hold. An actual experiment involving the use of these conditions could perhaps be devised, studying the rate of diffusion into an anthracene crystal of radioactive anthracene from a large volume of radioactive anthracene vapour.

The other two possibilities (a) and (b) can perhaps be ruled out by comparison of the deposit thickness and the overall depth of diffusion.

In a case where microscopic examination of the radioactive material deposited on the crystal surface showed that a comparatively small number of "whiskers" had resulted, it was possible to calculate that approximately 0.04 mgms. of the active anthracene was deposited

per 1 mgm. evaporated from the heater in the evaporator. The diameter of the deposit was limited by the size of the template in the evaporator and hence is known. From this data it was possible to calculate that deposit should be approximately  $2 \times 10^{-4}$  cms. thick. This would represent a maximum thickness because, in most cases, some of the evaporated anthracene forms whiskers on the surface. If it is assumed that the decrease in surface activity referred to in tables VIII, IXa and XVIa is due to the rapid evaporation of the whiskers during the heating of the crystals, then the remaining material must be mostly an epitaxial deposit which will take part in the diffusion. In most cases this loss was less than 50% of the total and it can perhaps be said that the deposit thickness was actually  $1-2 \times 10^{-4}$  cms. thick.

Reference to tables IXb-XVIIb will show that the penetration depth of the major portion of the activity which has diffused into the crystal is not less than  $25 \times 10^{-3}$  cms. in the more accurate determinations and the diffused activity continues to be measurable, with a lesser degree of accuracy, in all cases, to the end of the experimental determination, in which case the overall penetration should be regarded as greater than  $40 \times 10^{-3}$  cms. It can be said then, that the depth of penetration is more than 100 times greater than the deposit thickness. It must be emphasised that this is not an accurate value but it does at least indicate the order of magnitude of the ratio of the deposit thickness to the depth of penetration.

This difference immediately rules out the possibility of alternative mechanism (a) where the essential conditions would appear to be that the extension of each component of the diffusion couple should be equally large. Similarly if alternative (b) is applied in this case, the deposit thickness  $h$  is very much smaller than the penetration depth, in fact, so small that it can be assumed that

$$h + x \approx x \quad \text{and} \quad h - x \approx -x$$

within the limits of experimental accuracy for most values of  $x$ , and hence the expression becomes meaningless, i.e. equation 5 becomes

$$C = \frac{C_0}{2} \left( \operatorname{erf} \frac{x}{2(Dt)^{\frac{1}{2}}} + \operatorname{erf} -\frac{x}{2(Dt)^{\frac{1}{2}}} \right) \quad \text{--- -- 51}$$

and as  $\operatorname{erf}(-z) = -\operatorname{erf}z$  the equation 51 reduces to zero if we make the above assumption.

Because of this large difference between the approximate deposit thickness and the overall depth of penetration, it was decided that the process is best described by equation 2 and that the deposit can be regarded as approximating to an "instantaneous" plane source.

## 2. Interpretation of the Experimental Results

Now that it has been decided that the deposit can be regarded as an infinitely thin source and that the diffusion process should be represented by equation 2 it remains to account for the deviations from linearity in the graphs of  $\log_{10} A$  versus  $x^2$ . Equation 3 indicates that such a plot should yield a linear graph, from the slope of which it should be possible to calculate the diffusion coefficient.

137

Because of this predicted linearity it seems reasonable to attempt to draw straight lines through the experimental points as suggested at the beginning of the previous section. This was carried out (figure 30) and it was seen that the results were as follows:- two linear portions BC and CD and a point A, the initial point, which lay above CB produced. The position of point A was accounted for on consideration of the geometry of the diffusion couple. Before proceeding with the calculation it is necessary to account for the existence of the two linear portions when one only is predicted from equation 3.

Reference to figures 26-29 and to tables IXb-XVIb will show that the overall activity represented by the portion CD is very small compared to that of BC and it would appear that CD represents a small scale phenomenon compared to BC.

It is to be expected that the process which involves the penetration of the greatest amount of the initial activity should be bulk diffusion and it is suggested that the portion BC represents this process. CD must then be the result of some small scale secondary effect.

There are two possible explanations of CD.

1. That it is the result of contamination during the experiment.
2. That it is a concurrent, more rapid diffusion process than BC.

In the present study the author is inclined to reject the 138  
former explanation. Several reasons have been forwarded by other  
workers in this field to account for the presence of a "tail" to the  
diffusion curve by contamination. Mapother, Crooks and Maurer (92)  
discovered such a "tail" in their studies of self diffusion in sodium  
chloride, in cases where the heating periods were low and little  
penetration resulted. They ascribed this to contamination during  
their sectioning experiments. Feldman et al (4) claimed that  
contamination occurred during the application of the radioactive  
deposit. In this latter case carbon-14 was applied in the form of  
a slurry to compressed graphite specimens and the possibility that  
the slurry would penetrate pores in the specimen is very likely.

Both these explanations are not thought to apply in the present  
case because the use of single crystals, and the method of applica-  
tion of the deposit rule out the latter possibility and the care  
taken to ensure that transfer of activity did not occur during  
sectioning the former. The crystal was scrupulously and carefully  
cleaned before and after each section was cut.

One further source of possible contamination in this type of  
experiment arises from the evaporation of the radioactive deposit on  
to other faces of the crystal than that under study, during the  
application of the deposit and during the heating process. The  
attempt to determine the existence of surface diffusion on anthracene  
crystals showed this latter process to be unlikely but this possibi-

lity was eliminated completely by trimming the edges of the . 139  
crystal after deposition, and after the heating process before  
sectioning was commenced.

In view of these precautions the author believes that the  
tailing of the graph (i.e. CD, figure 30) is more likely to be the  
result of a more rapid diffusion process.

Williams and Slifkin (93) have reported that such rapid  
diffusion processes do occur, in addition to the bulk diffusion  
process, in the cases of low temperature diffusion of rare earth  
tracers in lead and silver, and of gold in silver. Presumably the  
term "low temperature diffusion" implies cases in which a low degree  
of penetration results. Hart (94) has demonstrated theoretically  
that this is the case, and he suggests that all diffusion studies  
in single crystals should yield a value for the diffusion coefficient  
a few per cent. high, because of rapid diffusion along dislocations in  
the crystals. Their work will be discussed in the next section.

If this is the case then the portion of the graph BC will  
represent the linear combination of this process and the bulk diffu-  
sion process. The ideal treatment of the results would involve --  
treating the two curves separately and subtracting the contributions  
of CD from BC. Unfortunately the values of the specific activity  
represented by CD are very low and the scatter of the experimental  
points, and their low accuracy, render such a calculation impossible.  
In most cases it is not possible to state with any accuracy that the

experimental points in this part of the curve obey a linear equation. A straight line was however drawn to comply with equation 3. This acceptance of linearity in this part of the graph is thought to be not unreasonable.

In one case where the linearity of CD was reasonably well defined, it was shown by least squares calculation that, if the process represented by CD was subtracted from that represented by BC, no difference was made, within the limits of experimental error, to the value of the diffusion coefficient calculated on the basis that BC represented a single process. As a result of this calculation it was decided to neglect the "tail" and to determine the values of the diffusion coefficient from the portion BC of the curve. These values are regarded as being values for the bulk diffusion process in anthracene.

When the experimental results for experiment 1, crystals A and B, were plotted according to equation 3 it was found that, whilst the curves were similar in most respects to those of other crystals, the initial points lay on the straight lines corresponding to BC (figure 30) and not above it. This apparent anomaly is believed to result from the fact that very low penetration of radioactivity occurred in this case, because of the comparatively low heating period, and that, when the results are plotted in the above manner, the slope of the initial line (corresponding to BC, figure 30) is steep and for this reason it is not possible to distinguish whether

the initial point lies above this line or not. In other respects these curves were similar to those of other crystals and were treated in the same way for the calculation of the diffusion coefficient.

### 3. Calculation of the Diffusion equation for self diffusion in anthracene.

Values of the diffusion coefficient for self diffusion in anthracene were calculated from the slope of the steep linear portion (BC) of the  $\log_{10}A$  versus  $x^2$  curve for each experiment. The slopes were calculated from the experimental points by the method of mean least squares. The results are given in Table XVII.

Table XVII

Crystal	Diffusion Coefficient D cms. per second	Heating Temperature T°K	perpendicular to the (001) plane Temperature $\frac{10^3}{T} \text{K}^{-1} \times 10^3$
A	$1.732 \times 10^{-11}$	425.5	2.356
B	$1.679 \times 10^{-11}$	425.5	2.356
I	$9.067 \times 10^{-12}$	426.5	2.350
M	$2.286 \times 10^{-11}$	433	2.309
C	$1.873 \times 10^{-10}$	450	2.222
F	$1.113 \times 10^{-10}$	450	2.222
G	$4.188 \times 10^{-10}$	462	2.165
H	$4.188 \times 10^{-10}$	462	2.165

The Arrhenius type equation, equation 1, for the variation of the diffusion coefficient with absolute temperature can be written in logarithmic form

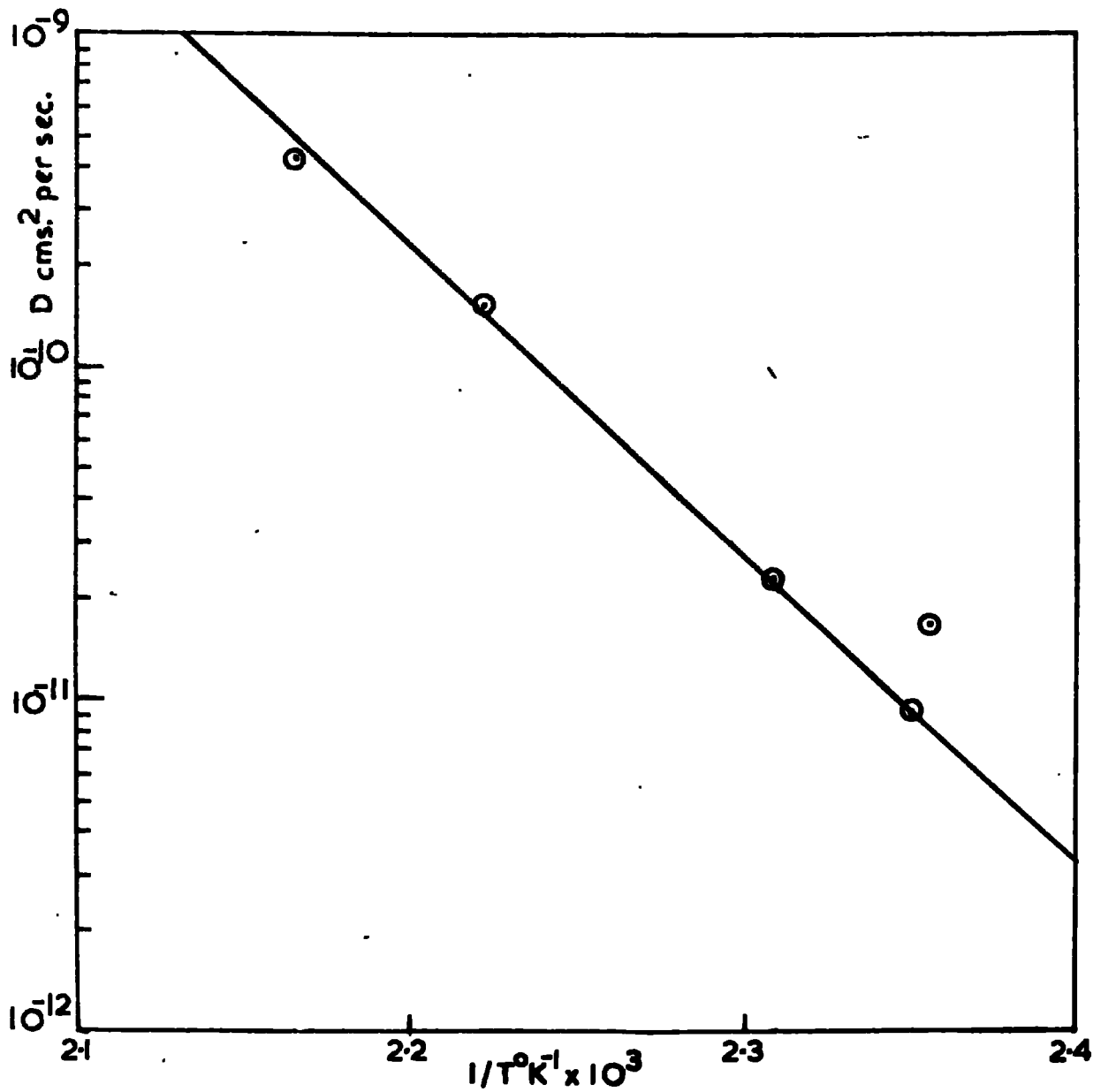

FIG. 32. GRAPH OF  $\text{LOG}_{10} \bar{D}$  versus  $1/T$ .

$$\log_{10} D = \log_{10} D_0 - \frac{E}{R} \log_e \frac{1}{T} \quad \text{--- 11}$$

It will be seen that if  $\log_{10} D$  is plotted versus  $\frac{1}{T}$  a straight line should be obtained, from the slope and intercept of which,  $E$  and  $D_0$  can be calculated. Figure 32 represents such a plot for the present study.

The points on the graph are the mean of all experimental values for a given temperature. The point at  $\frac{1}{T} = 2.356 \times 10^{-3} \text{ } ^\circ\text{K}^{-1}$  is neglected, because in this case the penetration of activity was small and this point is considered to be less accurate than subsequent measurements. The slope and intercept of this line were determined by a least squares calculation, and from these values were calculated the constants of the Arrhenius type equation. The results of this calculation show that the diffusion coefficient for self diffusion in anthracene varies with the absolute temperature according to the equation

$$D = (1.31 \pm 1.13) \times 10^{11} e^{-\frac{42,400 \pm 1200}{RT}} \quad \text{--- 6}$$

cms.<sup>2</sup> per second

The calculation is shown in Appendix II.

#### 4. The Rate of Self Diffusion parallel to the cleavage plane in anthracene

When the analysis of Fick's laws is extended into three dimensions the existence of diffusion anisotropy in crystals is suggested.

Anthracene is an anisotropic crystal and the possible existence of this phenomenon lead to the attempt to measure the rates of

diffusion in a second direction.

143

Two experiments were carried out such that diffusion proceeded in a direction parallel to the cleavage (001) plane and the results interpreted in the manner previously described. The diffusion profiles had the same characteristics as those for experiments on diffusion perpendicular to the (001) plane. The results of mean least squares determinations are given in Table XVIII.

Table XVIII

Diffusion Coefficients parallel to the (001) plane

Crystal	Diffusion coefficient D cms. <sup>2</sup> per second	Heating temperature T°K
O	$1.122 \times 10^{-10}$	433
P	$1.466 \times 10^{-10}$	433
Q	$8.103 \times 10^{-11}$	433
R	$1.457 \times 10^{-10}$	447
S	$4.165 \times 10^{-10}$	447

It will be seen that the diffusion coefficients obtained vary over quite a wide range at each temperature and hence must be regarded with suspicion. The experimental difficulties involved in these particular experiments suggest that any results should be regarded as approximate results. It can be said however, that within the limits of experimental error, the values can be regarded as comparable with the corresponding values of the diffusion coefficient obtained in the previous section, and on this basis the existence of diffusion anisotropy must be doubted. More accurate determinations may however show up the fallacy of this statement.

CHAPTER IV

DISCUSSION OF THE RESULTS

## DISCUSSION OF THE RESULTS

1. Summary of Previous Work

Before the present work was commenced the direct measurement of self diffusion in molecular solids had been carried out in only three cases. The systems investigated were solid hydrogen (6), ortho-rhombic sulphur (7) and  $\alpha$  white phosphorus (8). It will be seen that there is little basis for comparison and correlation of results in this class of solids alone and previous workers have been forced to rely upon knowledge gained in the study of metals and ionic crystals in order to attempt to explain their results. They have found that although by doing this some indication of the mechanisms can be obtained, much more work in this field is necessary before any absolute determinations of mechanisms and theory of diffusion in this class of compound can be made.

The first account of the determination of <sup>a</sup>diffusion coefficient in a molecular solid was published by Cremer (6) in 1938. Cremer assumed that the kinetics of the ortho-para conversion in solid hydrogen is bimolecular in character and becomes diffusion controlled at low concentrations of the parahydrogen. Working on the basis of this assumption he calculated the self diffusion coefficient of solid hydrogen near its melting point and showed it to increase with temperature according to the equation



They state that, of the methods of deposition of the radio<sup>146</sup> active material, the former gave a superior degree of contact. This method of deposition is thought by the present author to be of doubtful reliability and where other methods are available, such as that of evaporation, it is best avoided. The objection is on the grounds that considerable damage to a crystal surface can result from the attack of solvent and the local cooling resulting from rapid evaporation of such a solvent. It is not possible to assess whether this was the case in the work on sulphur, as the report is brief, but it can perhaps be assumed that the results obtained by both methods were comparable as the authors imply that they used both evaporation and deposition from solution.

Cuddeback and Driekamer (7) discovered that a rapid rise in the diffusion coefficient occurred 30° below the transition point to monoclinic sulphur. Their interpretation of this phenomenon was that, at the lower temperatures, the radioactive species diffuses through the crystal by a normal vacancy mechanism and that diffusion varies with temperature according to the expression

$$D = 8.32 \times 10^{-12} e^{-3080/RT} \text{ cms.}^2 \text{ per second} \text{ --- 8}$$

The authors suggest that this represents diffusion perpendicular to the (111) plane. At temperatures approaching the transition point to monoclinic sulphur diffusion in the direction parallel to the (111) plane becomes important and diffusion anisotropy becomes apparent. The measured diffusion rates in this upper temperature range are regarded as the combination of two diffusion processes

along different axes. Analysis of this region yields the 147  
expression for diffusion parallel to the (111) plane as

$$D = 1.78 \times 10^{36} e^{-7800/RT} \text{ cms.}^2 \text{ per second} - - - 9$$

The great increase in the activation energy for the process is ascribed to the greater jump distance in this direction.

This explanation seems quite reasonable and the magnitude of the constants in the two equations can perhaps be said to be similar to values of the comparable constants for the self diffusion of bismuth (96) which is also reported to show diffusion anisotropy. Very few examples of this phenomenon have been discovered and little is known of the process. Rhombic sulphur is anisotropic in nature and might be expected to exhibit such diffusion anisotropy.

After the work of Cuddeback and Drickamer a similar study was made by Nachtrieb and Handler (8) using  $\alpha$ -white phosphorus. This material was chosen because it has a cubic crystalline form and hence would not be expected to show evidence of anisotropy in diffusion. A tracer technique was employed, and again evidence of two diffusion processes obtained. One process which occurs singly at temperatures below 35°C, the second process becoming important at temperatures from 35°C to the melting point (44.2°C). Their analysis of the diffusion profile yields the following expression for the temperature dependence of the diffusion coefficient.

$$D = 1.07 \times 10^{-3} e^{-9400/RT} + 2 \times 10^{46} e^{-80600/RT} \text{ cms.}^2 \text{ per second} - 10$$

The second term on the right hand side of the equation being negligible at temperatures below 35°C.

In a previous paper Nachtrieb and Handler (97) showed that for cubic metals there was a correlation between the activation energy for diffusion  $E_d$  and the latent heat of fusion  $L_f$ , viz.

$$E = C L_f \quad \text{--- -- -- -- -- 11}$$

where C is a constant and equal to 16.5. In the ensuing discussion they propose that in crystals where this correlation obtains, diffusion occurs by the random walk of relaxed vacancies and that the value of the constant depends upon the structure of the material concerned. Phosphorus forms cubic crystals and has a latent heat of fusion of 601 cal. per mole, therefore on this basis the activation energy for diffusion should be 9920 cal. per mole, which agrees reasonably well with the experimental value of 9400 cal. per mole for self diffusion below 35°C.

Thus Nachtrieb and Handler interpret the lower temperature diffusion process as the random walk of relaxed vacancies and conclude that  $P_4$  and its vacancies are the diffusing species.

On the assumption that the second term in the expression also represents bulk diffusion the authors propose that some large scale co-operative phenomenon comes into prominence at 35°C. They show, on the basis of Zener's theory of the pre-exponential factor <sup>(D.)</sup>  $D_0$  (18), that this second process possesses a very large entropy factor and hence that the process involves many times the Avogadro number of molecules. Because of this the more simple mechanisms for diffusion such as direct interchange, and interstitial diffusion can be ruled out and the authors propose a large scale co-operative mechanism

involving disordered or premelted regions in the solid.

It would be expected then that a gradual transition from solid state diffusion to liquid state diffusion might occur as the melting point is approached. Evidence for such a transition has been reported for diffusion in Indium (98) near the melting point, but the region of transition is much smaller than in the case of phosphorus.

Further experiments by Nachtrieb and Lawson (99) on the effect of hydrostatic pressure on diffusion in phosphorus, show that increase of pressure decreases the rate of diffusion, and provides evidence that lattice disordering on a comparatively large scale begins well below the melting point.

Nachtrieb and Handler (8) suggest that perhaps the processes described as diffusion anisotropy in bismuth and sulphur could also perhaps be explained in this way.

There must however remain some doubt as to whether the results obtained by Nachtrieb and Handler can be said to express the rate of movement in a single or polycrystal. The measurements were made upon polycrystalline specimens formed by compression of powder, and until further work is carried out upon the effect of the degree of compression of the powder upon the final state of the diffusion specimen, very little can be said upon this question. Previous experiments with metallic crystals have shown that polycrystalline specimens do present an approximate picture of behaviour in the

single crystal state (2). In a polycrystalline specimen however, the possibility of grain boundary diffusion must always be considered, and this could give values of the diffusion coefficient higher than those obtained in single crystal specimens if this effect is not detected and allowance made for its effect upon the bulk diffusion process.

Another source of information concerning the diffusion process in solids is the magnetic resonance study of organic solids (20,24, 100). Several such studies have been carried out on organic solids but only two have yielded any definite information on this topic (20,23).

It is found in these studies that the onset of molecular motion in the crystal causes a narrowing of the resonance line width. In some cases it was found that, near the melting point, this line width narrowed to zero, indicating very rapid translational motion in the solid. It was proposed by Andrew and Eades (20) that this translational motion in the crystal was self diffusion. Later work by Norberg and Slichter (21) on the nuclear magnetic resonance of sodium yielded values for the diffusion coefficient comparable with the results of a tracer study by Nachtrieb et al (22). This information gave some confirmation to Andrew and Eades's statement that the process was self diffusion.

As a result of these studies it has been calculated that the activation energy for self diffusion in cyclohexane is 8000 cal. per mole, a value stated to be consistent with a vacancy mechanism for

Table XIX. The Pre-exponential Factors and Activation Energies for self diffusion in molecular solids

		Pre-exponential Factor $D_0$ cms. <sup>2</sup> per second	Activation Energy cals.per mole
Methane	(23)	$7 \times 10^{-6}$	1500
Cyclohexane	(20)	-	8000
Hydrogen	(6)	$\sim 10^{-7}$	790
o-Rhombic Sulphur	(7)	a. $8.3 \times 10^{-12}$	3080
		b. $2 \times 10^{36}$	78000
α White Phosphorus	(8)	a. $1.07 \times 10^{-3}$	9400
		b. $2 \times 10^{46}$	80600

a represents the constants for the process which occurs at lower temperatures, and, b, for the process which becomes important as the melting point is approached.

diffusion (20), and it has been shown that self diffusion in solid methane (23) varies with temperature according to the equation

$$D = 7 \times 10^{-6} e^{-1500/RT} \text{ cms.}^2 \text{ per second} \text{ - - - - - 12}$$

Similar studies on solid benzene, naphthalene, and anthracene, at temperatures up to room temperature (24) have revealed no evidence of translational motion. This may however become apparent in naphthalene and anthracene at higher temperatures.

It should be understood that for translational motion to be detected during nuclear magnetic resonance studies the frequency of movement of the diffusing molecules from one lattice site to the adjoining empty site must be of the same order as the resonance line width frequency, i.e. the nuclear magnetic resonance method provides an instantaneous measure of movement. On the other hand a tracer study may detect a diffusion process which proceeds at a much lower rate than this, as it yields a sum of all movements during the period of the experiment.

Five studies therefore have been made on molecular solids which have yielded information about self diffusion. The results of these five studies are summarised in Table XIX. The tracer studies show evidence that in molecular solids two concurrent diffusion processes occur one of which only becomes apparent as the melting point of the solid is approached. One group of workers suggest that this is the result of diffusion anisotropy, the others that it is the result of two different bulk diffusion mechanisms.

The remaining three non-tracer studies can be taken as giving an overall picture of diffusion in the solid and could be regarded as representing one of two possibilities:

- (a) a single diffusion process, or
- (b) the sum of two concurrent diffusion processes for solids near the melting point.

The present author is of the opinion that the latter possibility is unlikely. When the pre-exponential factors for diffusion in these solids are examined, it is seen that the values for hydrogen and methane, no value is given for cyclohexane, are nearer to the values found for sulphur and phosphorus, where diffusion is thought to be by vacancy diffusion, than to the value expected by the linear combination of the high and low temperature processes.

Many theories have been postulated regarding the significance of the pre-exponential factor (101) and its bearing upon the mechanism whereby the diffusion process occurs. The activation energy should also help in the elucidation of the mechanism because it represents the ease with which the diffusing molecule moves through the lattice and hence the value of the activation energy should depend upon the path by which the movement occurs.

It has been possible in the case of some metals, to calculate values of the pre-exponential factor and the activation energy for the various mechanisms by which diffusion could take place. These values have been compared with the experimental value in order to

determine the most likely mechanism by which diffusion in the solid occurs. This method has met with a certain amount of success in some cases. The lack of the necessary physical data for the molecular crystals studied, render it impossible to carry out comparable calculations. Comparison of the experimental values can however be made with values calculated for metals. Calculation of the pre-exponential factor for metallic systems yields values of the order of  $0.1-10$  (8). If it is accepted that something out of the ordinary is occurring in the higher temperature terms of the sulphur and phosphorus self diffusion equations and that the low temperature terms are representative of normal bulk diffusion then the range of values of the pre-exponential factor is

$$D_0 = 10^{-12} - 10^{-3} \text{ cms. per second,}$$

a wide range, but sufficiently different to the values calculated for metals to suggest that this system should perhaps not be compared with the metallic system. It should be added that the experimental values for the metals do not all lie within the theoretical range.

One point which should be noted is that these values are comparable with pre-exponential factors for liquid diffusion (102). This leads to speculation about the nature of the mechanism and the possibility of a link between self diffusion in molecular solids and their liquids.

In metallic systems several correlations have been found between the activation energy and constants which might be expected to have

some association with the diffusion mechanism. Whereas such correlations may not show the same agreement for molecular crystals as for metals it may be that in the class of molecular solids alone some comparison can be made.

One such correlation mentioned previously (97), suggests a linear relationship between the activation energy for diffusion and the latent heat of fusion. This was shown to hold for phosphorus in the same way as for cubic metals but, as it involves a structural factor and is thought to be related to cubic metals alone it would not be widely applicable. Further work may however show that other crystal classes have a similar interrelationship.

Other correlations which should have a more widespread application are those relating the activation energy and the latent heat of sublimation, and the activation energy and the melting temperature. These will be discussed at a later stage when the case of anthracene will be included.

## 2. The Experimental Expression for Self Diffusion in Anthracene.

The experimental determination of the rate of self diffusion in anthracene in the temperature range  $150^{\circ}$ - $190^{\circ}$ C shows evidence of two concurrent diffusion processes. The more rapid of these processes was very difficult to characterise, because the penetration of only a very small proportion of the deposited radioactive anthracene was involved, and the resulting count rate was so low that the errors involved in the counting experiments rendered its analysis impossible.

The second, slower, process was very well defined and involved almost all of the diffusing activity. It was shown that the variation of diffusion coefficient for this process with absolute temperature could be represented by the following equation

$$D = (1.31 \pm 1.13) \times 10^{11} e^{-(42,400 \pm 1,200)/RT} \text{ cms.}^2 \text{ per second.} \cdot 6$$

It now remains to attempt to formulate the mechanism by which these processes occur, and if possible, to correlate the behaviour of this solid with the existing information about the other molecular solids.

The discovery that two concurrent diffusion processes occur in anthracene suggests a similarity between the diffusion processes in this solid and those in sulphur and phosphorus (7,8). In order to make such a comparison the more rapid diffusion process found in anthracene must be compared to those described as vacancy diffusion processes in these other solids. The author is however inclined to the opinion that this diffusion process constitutes a different type of diffusion to those described in the previous section. A study of these publications led to the conclusion that in sulphur and phosphorus both processes must be regarded as fairly large scale processes, each involving a fairly large proportion of the active material diffusing into the bulk of the crystal, otherwise they would not have been so easily detected. When the secondary process becomes apparent, each must affect the other to a marked extent, because the overall result of the combination of these two processes

is a sudden elevation in the value determined for the diffusion<sup>156</sup> coefficient. This is shown by a discontinuity in the  $\log_{10} D$  versus  $\frac{1}{T}$  plot for these solids. The discontinuity occurs at the temperature at which the penetrated activity due to the second process achieves sufficient magnitude to affect the first process.

In anthracene the opposite is the case, and the activities resulting from the rapid diffusion process are too small to affect greatly the apparent rate of the slower major process. Because of the comparatively small scale effect of the rapid process it is proposed that it represents diffusion along intersecting dislocations in the crystal. This process will be discussed later in the thesis.

Thus only one major self diffusion process is observed in the anthracene crystal and it is thought that this can be considered to represent diffusion through the bulk of the crystal. It must be remembered however, that the measurements were carried out in only a very limited temperature range, and that the extension of this range may reveal that there is actually more than one bulk diffusion process in anthracene and that the one observed in this study is the predominant process in the temperature range studied.

If it is accepted that the major diffusion process represents bulk diffusion in the crystal then this process can be compared with other studies made by previous workers in this field. A comparison of the pre-exponential factor and energy of activation with those

for other molecular solids may yield some evidence for the mechanism of the diffusion process in anthracene.

### 3. Comparison of the pre-exponential factor for Self Diffusion in Anthracene with values determined for other molecular solids.

Studies of self diffusion in molecular solids have revealed the existence of two types of bulk diffusion process, one involving diffusion via vacant lattice sites in the solid and the other, a process which becomes apparent as the melting point of the solid is approached. The experimental values for the pre-exponential factor  $D_0$  obtained in these studies are given in Table XIX.

The values of the pre-exponential factor for what is considered to be vacancy diffusion in these solids are small and lie in the range  $10^{-12}$ - $10^{-3}$  cms.<sup>2</sup> per second. The experimental value of the pre-exponential factor for anthracene is very much higher than this ( $10^{11}$  cms.<sup>2</sup> per second) and therefore this suggests that something other than normal vacancy diffusion is taking place in anthracene.

The other type of diffusion which was found to occur in sulphur and phosphorus near the melting points is characterised by very large experimental values of the pre-exponential factor ( $10^{36}$  and  $10^{46}$  cms.<sup>2</sup> per second). These are much higher than that of anthracene and again it would appear that the mechanism of diffusion in anthracene will be by a different process than these, however, it is possible that a similar process to these upper temperature processes may occur in anthracene but perhaps on a smaller scale than in phosphorus.

The two explanations put forward to account for these very<sup>158</sup> high values of the pre-exponential factor for diffusion in sulphur and phosphorus near the melting point are diffusion anisotropy (7), and pretransitional effects in the crystal (8).

The former explanation is not thought to apply to self diffusion in anthracene because an attempt to determine whether diffusion anisotropy was detectable in this solid indicated that this was probably not the case. The experimental accuracy of the method adopted was however low, and more accurate experiments may show this conclusion to be wrong.

The pretransitional effects described by Nachtrieb and Handler are probably more likely to account for the high value of the pre-exponential factor. These effects involve large scale premelting in the crystal just below the melting point and subsequent diffusion by way of these liquid like clusters. This process was suggested to account for the very high entropy factor for diffusion which is found for the upper temperature diffusion mechanism in phosphorus. In the case of anthracene the  $\log_{10} D$  versus  $\frac{1}{T}$  plot gives a straight line over the temperature range of the experiments. This indicates that the mechanism which is appropriate must exist over the temperature range  $150^{\circ}$  to the melting point, a range of  $70^{\circ}$  compared to that of  $10^{\circ}$  for the range in which the second, upper, temperature process is predominant in phosphorus. Such a wide range might be said to eliminate this possible mechanism, but it is possible that if such pretransitional effects did exist in anthracene and they were

on a much smaller scale than in phosphorus, that is if fewer molecules were involved, then it might be expected that it could predominate over a somewhat wider temperature range. A smaller scale co-operative process of this type might also be expected to have a pre-exponential factor higher than that for normal vacancy diffusion but lower than that quoted for diffusion in white phosphorus near the melting point. This possibility will be discussed later.

In spite of the disagreement between the pre-exponential factor for self-diffusion in anthracene and those for vacancy diffusion in other molecular solids, the possibility cannot be neglected that the experimental expression does represent a normal vacancy diffusion process and that the apparently high experimental value for the pre-exponential factor is characteristic of anthracene. It is therefore interesting to attempt to calculate a value of this factor for anthracene and to compare it to the experimentally obtained value.

#### 4. Calculation of the Pre-exponential Factor for Self-Diffusion in Anthracene.

Several attempts (103) have been made to calculate theoretical equations for self-diffusion in solids. These expressions were in the main part formulated for metals and ionic crystals, and it is doubtful whether they are strictly applicable to molecular solids, but, even if this is the case, it may be possible, by application of these methods of calculation to the case of anthracene, to obtain

an approximate value of the pre-exponential factor for self diffusion in this solid. 160

One of the more recent attempts was made by Zener (18) who, using a statistical mechanical approach, calculated that, for diffusion in metals

$$D = ca^2 \nu e^{\Delta S/k} e^{-E/RT} \quad \text{--- 13}$$

where, in addition to previously defined terms,

$c$  = a constant, the value of which depends upon the mechanism whereby diffusion occurs and is related to the availability of adjacent sites to which the atom can move.

$a$  = the jump distance.

$\nu$  = the frequency of vibration of the moving atom or molecule in the direction of movement.

$\Delta S$  = the entropy change involved in movement.

$k$  = the Boltzmann constant.

This method of calculation has proved quite promising in its use, but so far it has been applied to only a few cases of diffusion in metals and cannot be said to have widespread application.

The calculation is based upon the concept that the entropy of diffusion is associated with the deformation of the lattice on diffusion. Zener suggests that the entropy is related to the activation energy for diffusion by an equation

$$\Delta S \approx \beta \cdot \frac{E}{T_m} \quad \text{--- 14}$$

where  $T_m$  is the melting temperature,  $\Delta S$  and  $E$  are the entropy and activation energy for the process, and  $\beta$  a constant for the particular substance, which is related to the temperature coefficient of the elastic modulus.

Doubt has been expressed as to whether such an assumption, i.e. that the whole of the entropy of the process is associated with the deformation of the lattice on diffusion, is correct and it is thought that this approach is perhaps a little oversimplified.

A search of the available literature revealed that no work had been carried out on the measurement of the temperature coefficient of the elastic modulus of anthracene and hence a calculation of the above type was impossible. Similar problems arise in consideration of the other calculations mentioned above (103) which render their use for the calculation of a value for the pre-exponential factor impossible.

A more general, if somewhat less rigorous approach to the problem of diffusion in solids is based upon classical rate theory (104) and it is possible by application of this theory to the problem of diffusion in solids to calculate an approximate value for the pre-exponential factor for self diffusion in anthracene.

Rate theory leads to an equation of the following form for diffusion in solids

$$D = a^2 \nu e^{-E/RT} \quad \text{--- -- -- -- --} \quad 15$$

where  $a$  = the distance between successive equilibrium positions.

$\nu$  = vibrational frequency of the molecule in the direction



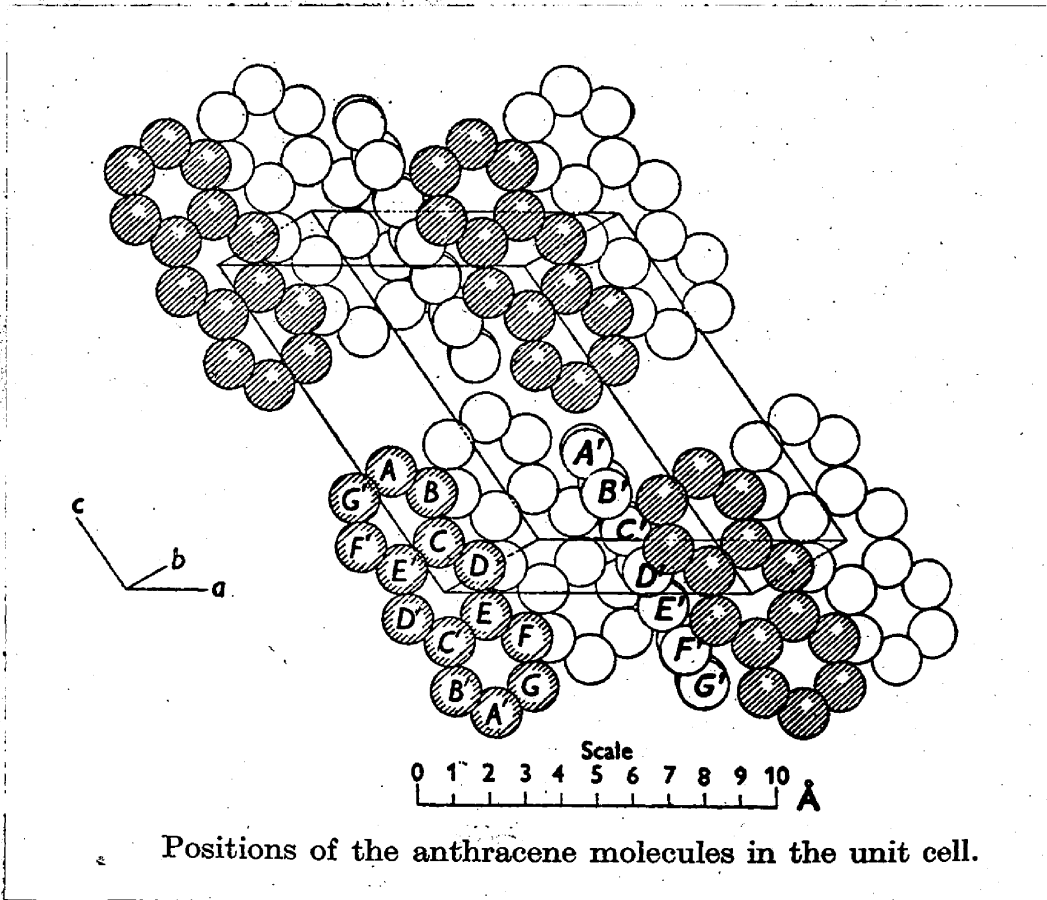

FIG. 33.

If  $\theta_0$  represents the Debye Characteristic temperature at the absolute zero then

$$\nu = \frac{3}{4} \cdot \frac{\theta_0 \cdot k}{h} \text{ ----- 17}$$

where  $k$  and  $h$  are Boltzmann's and Planck's constants respectively.

$\theta_0 = 108^\circ\text{K}$  (106).

$$\therefore \nu = \frac{3}{4} \times 108 \times \frac{1.38 \times 10^{-16}}{6.62 \times 10^{-27}} \text{ sec.}^{-1} \text{ ----- 17}^1$$

and  $a = 11.06 \times 10^{-8}$  cms. in the direction of the (001) plane (105), i.e. along the  $c$  axis of the crystal. Figure 33 represents the arrangement of the anthracene molecules in the unit cell.

Thus we have

$$D_0 = 123 \times 10^{-16} \times \frac{3}{4} \times 108 \times \frac{1.38}{6.62} \times 10^{11} \text{ cms.}^2 \text{ per second}$$
$$D_0 = 2.08 \times 10^{-2} \text{ cms.}^2 \text{ per second ----- 18}$$

The calculation which leads to equation 15 does not take into account the possibility of limiting conditions to diffusion. The calculated value for the pre-exponential factor therefore represents unlimited diffusion in the solid and hence the maximum value that the pre-exponential factor can have. Thus it is necessary to consider what effect the various possible diffusion mechanisms will have upon this value.

The more generally accepted mechanisms for diffusion in solids are, diffusion by direct interchange of neighbouring atoms, diffusion via vacancies in the lattice and diffusion via interstitial positions. To these can be added the ring mechanism of Zener (18).

Diffusion by direct interchange can occur with any neighbouring

atom of molecule. In the anthracene crystal, if movement 164  
 along the "c" axis alone is considered, each molecule in the OAB  
 plane will have 4 nearest neighbours and thus these are 4 equivalent  
 movements the molecule could make, only one of which is possible,  
 and thus the value of the pre-exponential factor calculated in  
 equation 18 will be reduced by this amount and

$$D_0 \text{ direct interchange} = \frac{1}{4} \times 2.08 \times 10^{-2} \text{ cms.}^2 \text{ per second}$$

$$= 5.20 \times 10^{-3} \text{ cms.}^2 \text{ per second} \text{ - - - 19}$$

In other classes of solids however this mechanism is usually  
 rejected on energetic grounds and as there is no reason why it  
 should occur in molecular solids when it does not in others, it will  
 not be considered here.

The ring mechanism of Zener is related to the direct interchange  
 mechanism. Zener proposed that the direct interchange mechanism  
 could be likened to two atoms in a ring changing places by rotation  
 of the ring, and showed that by increasing the size of the ring to  
 include four atoms a resultant lowering of the activation energy by  
 40% was achieved. Consideration of Zener's argument shows that the  
 factor c in equation 13 is integral for this mechanism and thus it  
 might be expected that an increase in the above value for  $D_0$  would  
 result if this mechanism were considered; however such a factor  
 will not increase the calculated value by more than one power of ten.  
 Zener has also concluded from his analysis that such a mechanism  
 might only operate for metal lattices with a body centred cubic  
 structure and hence it is unlikely that this mechanism could be

considered to apply to the case of anthracene.

165

The remaining two mechanisms will both limit the movement of the diffusing particle and hence will result in a reduction of the calculated value of the pre-exponential factor. The limitations, which are similar in the case of both mechanisms, are that diffusion must occur to an adjacent lattice site or interstitial position and, in order that diffusion will occur, this site or position must be empty. Thus the calculated value of the pre-exponential factor for diffusion by direct interchange will be reduced by a factor equal to the probability that the site or position will be empty. This will be equal to the fraction of vacancies in the crystal or the fraction of empty interstitial sites in the crystal, whichever mechanism is considered. These factors will both be fractional and hence the actual value of the pre-exponential factor for these mechanisms will be smaller than that calculated for the direct interchange mechanism.

Methods have been formulated for the calculation of these fractions (107) but these methods require the knowledge of physical data for the anthracene crystal which is unavailable, and hence the calculation of the pre-exponential factors for the above mechanisms is impossible. It can however be concluded that for vacancy and interstitial diffusion in anthracene the pre-exponential factors associated with these processes will be less than  $5 \cdot 20 \times 10^{-3}$  cms.<sup>2</sup> per second, and hence might lie in the range of experimental values

found for the pre-exponential factors for vacancy diffusion in other molecular solids. 166

It can also be seen that the experimentally determined value for the pre-exponential factor for bulk diffusion in anthracene is much bigger than the calculated value for diffusion by a vacancy or interstitial mechanism and hence a more complex diffusion mechanism must exist in this solid.

#### 5. The Calculation of the Entropy Factor Associated with self-diffusion in Anthracene.

The more precise calculations of the diffusion equation by Zener (18) and Le Claire (108) involve the consideration of free energy changes in the diffusion process. This effectively results in the replacement of the term  $E$  in equation 15 by  $\Delta G$ , the change in free energy associated with diffusion, and hence in the subsequent incorporation of an entropy term in the expression for the pre-exponential factor  $D_0$ . If Le Claire's treatment is applied to the present case then an expression for  $D_0$  can be obtained, which contains the entropy term referred to above, and the comparison of this expression with the experimentally determined value for  $D_0$  should result in the calculation of the entropy involved in the diffusion process. Le Claire's treatment is as follows:

If it is considered that the most likely method of self diffusion in anthracene is the vacancy mechanism, then if  $\Delta G_1$  is the change in free energy involved in the formation of a vacancy, the concentration of vacancies in the crystal is

$$V = e^{(-\Delta G_1/RT)} \quad \text{-----} \quad 20$$

Let us assume that forward movement for diffusion can only take place along lines parallel to the  $c$  axis, then each molecule in the plane OAB has four near neighbours (see figure 33). It will be seen later that this simplification does not affect the argument.

Now

$$D = \frac{\alpha a^2}{\tau} \quad \text{-----} \quad 21$$

where  $D$  is the diffusion coefficient,  $\alpha$  a geometric factor depending upon the lattice, in this case  $\alpha = \frac{1}{6}$ , and  $\tau$  is the average time of successive jumps of each molecule. In the anthracene crystal the probability that a molecule has a neighbouring vacant site into which it can move will be  $6V$  and hence, if  $n$  is the jump rate into vacant sites

$$\frac{1}{\tau} = 6Vn \quad \text{-----} \quad 22$$

$$\text{and } n = \nu e^{(-\Delta G_2/RT)} \quad \text{-----} \quad 23$$

where  $\nu$  is the vibration frequency of the molecule and  $\Delta G_2$  is the isothermal work required to move a molecule from its equilibrium position to the top of the potential barrier separating it from the neighbouring equilibrium position. The appropriate combination of the above equations leads to the expression

$$D = a^2 \nu e^{(\Delta S_1 + \Delta S_2)/R} \cdot e^{-(\Delta H_1 + \Delta H_2)/RT} \quad \text{-----} \quad 24$$

The terms  $(\Delta S_1 + \Delta S_2)$  and  $(\Delta H_1 + \Delta H_2)$  can be identified with the entropy change  $\Delta S$  and activation energy  $E$  associated with vacancy

$$D_0 = a^2 \nu e^{\Delta S/R} \text{ - - - - - 25}$$

The term  $a^2 \nu$  has already been evaluated when attempting to determine the theoretical value of  $D_0$  from rate theory calculations (equations 17, 18) and it will therefore be seen that

$$D_0 = 2.08 \times 10^{-2} e^{\Delta S/R} \text{ - - - - - 26}$$

The value obtained by experiment for  $D_0$  was  $1.31 \times 10^{11}$  cms.<sup>2</sup> per second and equating this with equation 25 we have

$$\begin{aligned} 2.08 \times 10^{-2} e^{\Delta S/R} &= 1.31 \times 10^{11} \\ e^{\Delta S/R} &= 6.30 \times 10^{12} \end{aligned}$$

$$\frac{\Delta S}{R} = 29.47 \text{ and } \Delta S = 58.4 \text{ cal. per degree - - - - 27.}$$

and thus in spite of any simplification in the calculation of  $D_0$ , it can be seen that the entropy change for self diffusion in anthracene by a vacancy mechanism is surprisingly large. This very large value for the entropy factor is suggestive of a diffusion process in the crystal in which many molecules are involved. A similar suggestion was put forward by Nachtrieb and Handler (8) when considering the case of diffusion in white phosphorus near the melting point. In this case they found an even higher entropy factor than that above. They proposed that about 130 molecules were involved in the diffusion process and that a premelted region of this size was formed in the crystal. This proposal is in agreement with the concepts of Eyring who points out in his book "The Kinetic Theory of Liquids" (109) that elements of fluidity exist in crystals near the melting point, and

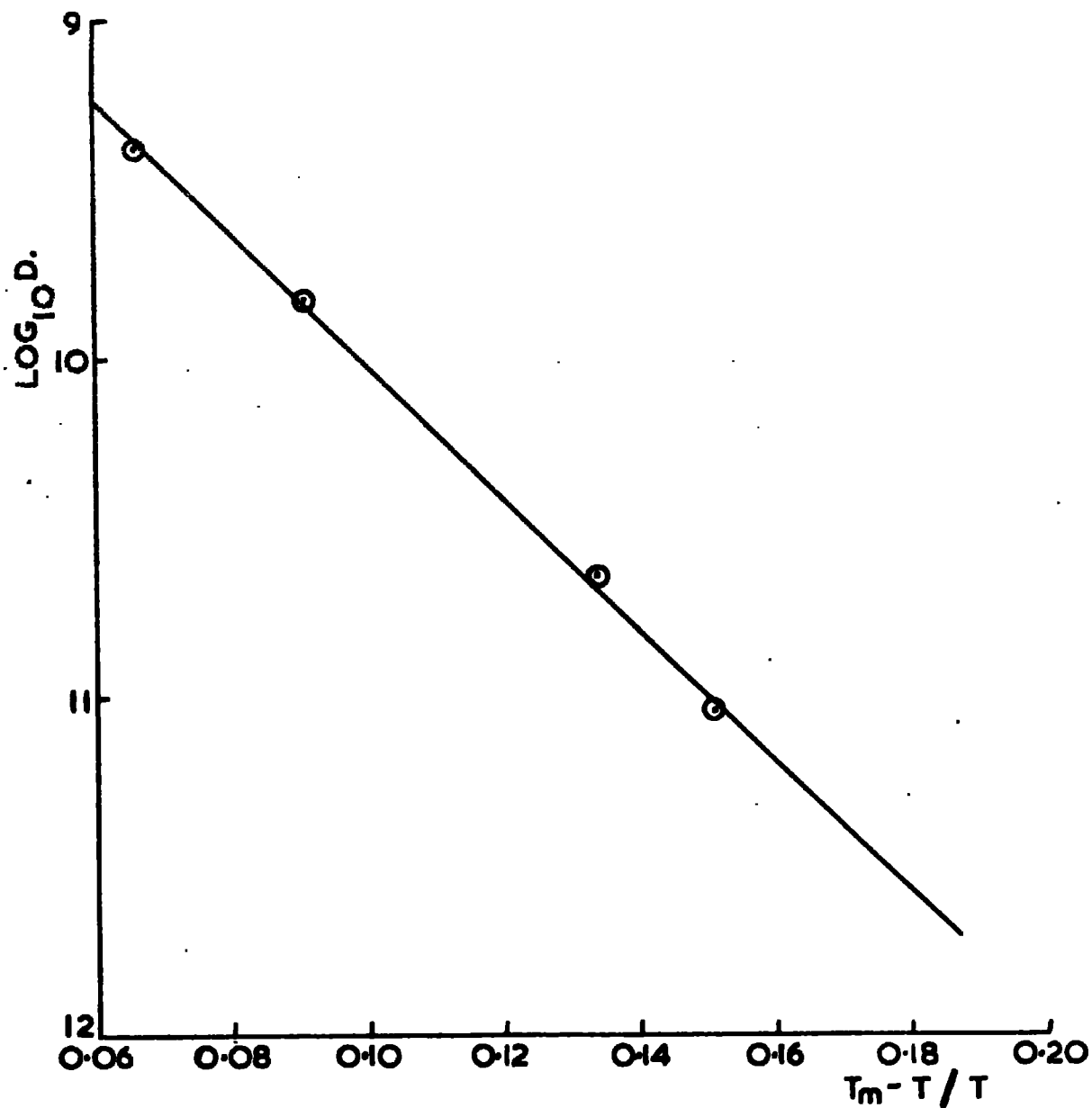

FIG.34. GRAPH OF  $\text{LOG}_{10} D$  versus  $\frac{T_m - T}{T}$ .

that the smallest number of molecules required to form such a liquid like region in the solid is 150 molecules (110). Nachtrieb and Handler in their treatment suggest that the free energy of formation of an n molecular disordered or premelted cluster at any temperature T is given by

$$\Delta F_n = nL_f(1-T/T_m) \text{ - - - - - 28}$$

where  $L_f$  is the latent heat of fusion and  $T_m$  the melting temperature, and that on this supposition the diffusion coefficient will be

$$D = K e^{-\left(\frac{nL_f(T_m-T)}{RTT_m}\right)} \text{ - - - - - 29}$$

The logarithmic form of this equation is

$$\log_{10} D = \log_{10} K - \frac{nL_f(T_m-T)}{RTT_m} \log_{10} e \text{ - - - - - 30}$$

and thus a plot of  $\log_{10} D$  versus  $(T_m-T)/T$  should be linear. Figure 34 represents this plot for the experimental results obtained in the present study and it will be seen that this is the case. The slope of the line corresponds to a value of  $n = 6$ .

This value for the number of molecules involved in the diffusion process is much lower than that quoted by Nachtrieb and Handler for the size of the premelted clusters in white phosphorus, and thus diffusion in anthracene cannot be said to proceed by any large scale melting in the crystal, but more probably by the loosening of a number of molecules in the vicinity of the diffusing molecule.

The entropy of melting for anthracene will be given by

$$\Delta S = \frac{L_f}{T_m} = \frac{6890}{490} \approx 14 \text{ cal. per degree - - - - 31}$$

and the entropy for the diffusion is about 58 cal. per degree, on this basis then some loosening or melting of about four molecules of anthracene would be predicted. This figure is about the same as that derived for the number of molecules associated with the diffusion process above and indicates that this interpretation is fairly consistent.

Thus the probable diffusion mechanism seems to be, not a process dependent upon large scale fusion of the type proposed by Nachtrieb and Handler for self diffusion in white phosphorus, but a process dependent upon a vacancy mechanism in which the large entropy of activation results from a loosening of the lattice in the neighbourhood of the vacancy, during the diffusion process, to the extent of about four to six molecules.

6. The Activation Energy for Self Diffusion in Anthracene.

An accurate calculation of the activation energy required for diffusion by the various mechanisms in anthracene is not possible, but it is possible to obtain an order of magnitude of the energy required for diffusion by these mechanisms, and in this way some information about the diffusion process in anthracene can be gained.

Studies of diffusion in metals has shown that for the usually accepted mechanisms for self diffusion

E direct interchange } E vacancy } E interstitial

and there is no reason to suspect that a similar order should not exist for molecular solids. Of these three mechanisms, that of

direct interchange will not be considered for reasons given previously. Another mechanism which should perhaps be considered however is the "Relaxion" mechanism proposed by Nachtrieb and Handler (97). These authors suggest that the formation of a vacancy is followed by the inward relaxation of atoms or molecules around the vacancy to form a small region of disorder in which the rate limiting molecular movements occur. This inward relaxation process is associated with a negative energy of formation and thus the overall energy required to form the "relaxion" will be less than that to form a vacancy alone and hence the energy of activation for movement of such a defect would be less than that required for vacancy diffusion.

Mott and Gurney (107) have shown that the energy of activation for self-diffusion by a vacancy mechanism in a molecular solid should be approximately equal to the latent heat of sublimation of the solid, since this will be the amount of energy required to form a vacancy in the lattice. It can be said therefore that energy of activation for vacancy diffusion in anthracene is 23,300 cal. per mole and that for the alternative mechanisms will be less than this.

The experimentally determined activation energy for self diffusion in anthracene is 42,400 cal. per mole, almost twice that expected from diffusion by a vacancy mechanism and therefore the other possible mechanisms can be rejected.

Since the experimentally determined activation energy is so much higher than the latent heats of sublimation and fusion, it seems

likely that more than one molecule is taking part in the diffusion process and, considering the mechanism proposed in the last section, it seems reasonable to suggest that a vacancy mechanism accompanied by the loosening, or premelting of four to six molecules in the neighbourhood of the vacancy during diffusion, would give the necessary high activation energy.

It should also be pointed out that a large activation energy for self diffusion in anthracene might be expected, on the basis that diffusion along the length of the carbon chain in an organic crystal would become more and more difficult as the length of the chain was increased, until, when the chain was very long, as in a linear polymer, diffusion along the chain direction would be impossible. In the present study diffusion was measured along the long chain of the molecules of anthracene and hence a high activation energy is not unexpected. It is not possible to determine the magnitude of this effect in anthracene, but, if the vacancy mechanism suggested above is accepted, the major part of the activation energy required for movement of the vacancy will arise from the energy required for the formation of the vacancy and the energy required to premelt or loosen the molecules in the lattice; and hence it seems unlikely that any major contribution to the activation energy for diffusion would come from this source in the present case.

It is difficult to compare the activation energies for self diffusion in other molecular solids with the present study, because no direct comparison is possible. In studies of metallic solids

Table XX. Comparison of the Energies of Activation for Self-Diffusion in molecular solids with their latent heats of fusion and sublimation, and their melting temperatures

	Energy of Activation E cal.s.per mole	Latent heat of Fusion L <sub>f</sub> cal.s.per mole	Latent heat of sublimation L <sub>g</sub> cal.s.per mole	Melting Temperature T <sub>m</sub> °K	$\frac{E}{L_f}$	$\frac{E}{L_g}$	$\frac{E}{T_m}$
Anthracene	42,400	6890 (25)	23,300 (112)	490 (25)	5.8	1.72	81
Cyclohexane	8,500 (20)	620 (25)	10,200 (25)	280 (25)	13	0.83	30
Hydrogen	790 (6)	28 (114)	216 (113)	14 (114)	28	3.66	49
Methane	1,500 (23)	196 (25)	1,990 (25)	89 (25)	7.6	0.75	17
Phosphorus	9,400 (8)	605 (111)	14,040 (118)	317 (114)	15.5	0.67	30
Sulphur	3,080 (7)	300 (115)	-	366 (114)	10.3	-	8

Average values of these ratios determined for metals

16.5 0.65 38  
(8) (101a)(101a)

however, various correlations have been discovered between the <sup>173</sup> energy of activation for self diffusion and the latent heats of sublimation (101) and fusion (8) and the melting temperature (101) of the solids studied. The prevalent mechanism in the solids studied was thought to be via vacancies. It may not be that molecular solids would show the same correlations as metals but it is interesting to see whether any similar correlation holds. These are depicted in Table XX.

The values of the activation energy for self diffusion in sulphur and phosphorus near the melting point are not included and thus with the exception of anthracene the activation energies quoted are those for what is thought to be diffusion by a vacancy mechanism.

It will be seen that very little correlation at all exists, except perhaps in the column  $\frac{E}{L_s}$ . Here the values of the ratio for cyclohexane, methane and phosphorus are similar and comparable with that value found for diffusion in metals. This may mean that energy of activation for self diffusion in a molecular solid is better represented by a fraction (approximately 0.75) of the latent heat of sublimation and not by the latent heat itself. The values for hydrogen and anthracene do not agree with this but, in the case of hydrogen, the value for the activation energy is of limited accuracy as a result of the very narrow temperature range in which the measurements were carried out, and it has already been suggested that something other than normal vacancy diffusion is occurring in anthracene. This particular comparison does not help in the

determination of the diffusion mechanism except that it suggests<sup>174</sup> the possibility that in a co-operative mechanism, the contribution to the activation energy of diffusion from the energy required to form a vacancy, might be less than the latent heat of sublimation, thus leaving an even bigger balance of energy to be accounted for by the possible loosening of the lattice.

No definite conclusions can be drawn from the above comparison and it is suggested, as stated previously, that the high value of the activation energy can best be explained on the basis that diffusion is by a vacancy mechanism, and that movement of the vacancy is accompanied by a loosening of the lattice so that several molecules are taking part in the diffusion process.

#### 7. The Rapid Diffusion Process in Anthracene.

It was proposed, because of the comparatively low values of diffused activity resulting from this rapid process, that this process is characteristic of some small scale diffusion phenomenon in the crystal. This cannot be the result of grain boundary diffusion because single crystals of anthracene were used for all experiments. The author believes that it may be the result of diffusion along intersecting dislocations in the crystal. Such a process would be expected to proceed at a faster rate than bulk diffusion. The magnitude of the process will depend upon the relative concentration of dislocations in the crystal. Since the area of these dislocations presented to the radioactive deposit at the surface of the crystal will be small, compared to the total cross sectional area of the

crystal on which the deposit is evaporated, it could be expected that such a process would involve only a very small fraction of the total deposited radioactivity compared to that available for the bulk diffusion process.

Evidence for the existence of this type of process has been reported for diffusion in metals where the total penetration due to bulk diffusion is small.

Williams and Slifkin (93) noted this effect whilst studying the rates of diffusion of Rare Earth tracers in silver and lead. In order to determine whether such a phenomenon was only characteristic of the system they were studying they carried out further experiments in a "more well-behaved system", that of diffusion of gold in silver single crystals. The same effect was reported for low values of penetration and they showed that diffusion coefficients calculated from the initial portion of their diffusion profiles (equivalent to the portion BC in figure 30 in the present case) were in agreement with values obtained by previous workers, within the experimental error.

They also report that Hart (94) suggests that low temperature diffusion measurements in single crystals should yield values of the diffusion coefficient elevated a few per cent. by the effect of dislocations, and state that Tomizuka (116) has demonstrated this effect for the diffusion of antimony in silver.

Williams and Slifkin attribute this tailing effect to diffusion along dislocations.

Such a scheme of diffusion would be characterised by lower<sup>176</sup> energies of activation and greater rapidity of movement than bulk diffusion. Experimental difficulties made it impossible to determine these values in the present study and a new design of experiment would have been necessary for the elucidation of this process.

Mention was made earlier in this thesis of such a "tail" for sodium chloride self diffusion studies (92). In this case the workers attributed the cause of this tail to contamination during the sectioning process. The above information leads one to wonder whether perhaps a reassessment of their statement should be made.

#### 8. The absence of surface diffusion on anthracene crystals.

It was pointed out in the section containing experimental results that surface diffusion was investigated and found to be non-existent at the temperatures employed. It should be pointed out that studies at higher temperatures may show this process to be present. It is usually found that surface diffusion is more rapid than bulk diffusion and, as measurable bulk diffusion occurs at 150°C, it is peculiar that no evidence of surface movement was discovered.

Similar work by Hoedless (117) who attempted to study surface self diffusion using cleaved sodium chloride crystals also yielded a negative result. It is thought that the absence of surface diffusion is probably a function of the surface structure of the crystals. Unfortunately time did not permit a more exhaustive

study of this process.

177

### 9. Conclusions.

The tracer method of studying self diffusion in the solid state shows that self diffusion does occur in this molecular crystal.

In the temperature range studied evidence was found that two diffusion processes were occurring in the crystal, one of which accounted for most of the observed diffusion; the second was a very small scale process.

The major diffusion process, which can be represented by the equation

$$D = (1.31 \pm 1.13) \times 10^{11} e^{-(42,400 \pm 1200)/RT} \text{ cms.}^2 \text{ per second}$$

was found to possess an unusually high entropy factor. This high value of the entropy factor leads to the conclusion that a co-operative diffusion phenomenon involving four to six molecules is taking place in the crystal.

The activation energy for this diffusion process was also unexpectedly high, and this again can be ascribed to a co-operative phenomenon in which more than one molecule is participating.

The probable diffusion mechanism appears to be a process dependent upon a vacancy mechanism which is accompanied by a loosening of the crystal lattice in the neighbourhood of the vacancy to the extent of four to six molecules, and not as might be expected a process dependent upon large scale premelting.

The minor process may be the result of diffusion of the radioactive material along intersecting dislocations in the crystal.

In the further study of the major process it is thought that the temperature range of the measurements should be extended to higher temperatures, to ascertain whether any large scale premelting effects become apparent nearer the melting point than already investigated; and also, a study of self diffusion in molten anthracene should be carried out to determine whether any sharp boundary exists between the rates of diffusion in the liquid and solid states. More accurate experiments should be carried out to determine the rates of diffusion parallel to the (001) plane in anthracene, in order to ascertain whether diffusion anisotropy can be detected in this way. The possibility of a nuclear magnetic resonance study of anthracene should be investigated so that the results of such a study can be compared with those of the present tracer study.

The primary problem associated with the minor process is to prepare a sample of radioactive anthracene of much higher specific activity, in order that this process can be investigated at lower temperatures. The possibility of generating dislocations in the crystals by irradiation, or the incorporation of impurity, should be considered, in order to determine whether an increase in the concentration of these defects has a significant effect upon the magnitude of this minor process.

A determination of the temperature coefficient of the elastic modulus for anthracene would enable a value for the pre-exponential factor to be calculated from Zener's equation (equation 13) which could be compared with the present results.

A more detailed study of surface diffusion on anthracene <sup>179</sup>  
single crystals should be made so that this apparently anomalous  
behaviour can be examined.

These studies should also be extended to other molecular  
solids in order that the results of such studies can be compared  
with each other, and a better understanding of the diffusion process  
in these solids can be achieved.

## REFERENCES

1. Roberts-Austen, Phil. Trans., 1896, 187A, 393
2. a Barrer, Diffusion in and through solids, Cambridge University Press, Cambridge, 1951.  
b Jost, Diffusion, Academic Press, New York, 1952.
3. Letaw, Slifkin and Portenoy, Phys. Rev., 1956, 102, 636
4. Feldman, Goedell, Dienes and Gossen, J. Appl. Phys., 1952, 23,  
1200
5. Kanter, Phys. Rev., 1957, 107, 655
6. Cremer, Z Phys. Chem., 1938, B39, 445
7. Cuddeback and Drickamer, J. Chem. Phys., 1951, 19, 790
8. Nachtrieb and Handler, J. Chem. Phys., 1955, 23, 1187
9. Barrer, Reference 2a, p. 306 (23) gives a list of references
10. Dunn, J. Chem. Soc., 1926, 2973
11. Von Hevesy, Trans. Faraday Soc., 1938, 34, 841
12. Seith and Perretti, Z. Elektrochem., 1936, 42, 570
13. Fraenkel and Houben, Z. Anorg. Chem., 1921, 116, 1
14. Jost, Reference 2b, p. 212
15. Langmuir, J. Franklin Inst., 1934, 217, 543
16. Bosworth, Proc. Roy. Soc., 1935, 150A, 58
17. Gray, The Defect Solid State, Interscience Pub., New York,  
1957, p. 87
18. Zener, Imperfections in Nearly Perfect Crystals, Ed. W. Shockley  
Wiley and Sons, New York, 1952, p. 289.

19. Barrer, Reference 2a., p. 305 181
20. Andrew and Eades, Proc. Roy. Soc., 1953, A216, 398
21. Norberg and Slichter, Phys. Rev., 1951, 83, 1074
22. Nachtrieb, Catalano and Weil, J. Chem. Phys., 1952, 20, 1185
23. Waugh, *ibid.*, 1957, 26, 966
24. Andrew, *ibid.*, 1950, 18, 607
- Rushworth, *ibid.*, 1952, 20, 920
25. Timmermans, Physico-Chemical Constants of Pure Organic Compounds, Elsevier, New York, 1950
26. Buckley, Crystal Growth, Wiley and Sons, New York, 1951
- Lawson and Neilson, Preparation of Single Crystals, Butterworths, London, 1958.
27. Dawson and Vand, Proc. Roy. Soc., 1951, 206A, 555
28. Craig and Hobbins, J. Chem. Soc., 1955, 2317
29. Brandstätter, Z. Elektrochem. 1952, 56, 968
30. Holden, Discuss Faraday Soc., 1949, 5, 312
31. Fruhling, Ann. Physique, 1951, 6, 401
32. Mohoičič, Reports Slovenian Acad. Sci.Arts, 1953, 1, 77
33. Curran, Luminescence and the Scintillation Counter, Butterworths, London, 1953
34. Roussett, and Lochet, J. Physique, 1942, 3, 146
35. Scott, Hutchinson and Lapage, A.W.R.E. Report No.04/53, 1953
36. Mette and Pick, Z. Physik, 1953, 134, 566
37. Bell, Phys. Rev., 1948, 73, 1405

38. Feazel and Dixon-Smith, Rev. Sci. Instr., 1948, 19, 817 182
39. Ross, Proc. National Electronics Conference, 1950, 6, 531
40. Deutsch, Nucleonics, 1948, 2, 58
41. Sangster, M.I.T. Technical Report on Electronics No.55, 1952
42. Hutchinson and Lapage, A.W.R.E. Report No.073/54, 1954
43. Kyropoulos, Z.Anorg. Chem., 1926, 154, 308  
Z.Physik, 1930, 63, 849
44. Menzies and Skinner, Discuss. Faraday Soc., 1949, 5, 306
45. Stober, Z. Krist, 1925, 61, 299
46. Bridgman, Proc. Amer. Acad. Arts Sci., 1925, 60, 303
47. Hendricks and Jefferson, J. Opt. Soc. Amer., 1933, 23, 299
48. Baret et al., C.E.A. Report No.74, 1951
49. Leininger, Rev. Sci Instr., 1952, 23, 127
50. Goss and Weintroub, Nature, 1951, 167, 349  
Proc. Phys. Soc., 1952, 65B, 561
51. Stockbarger, Discuss. Faraday Soc., 1949, 5, 294, 299
52. Tammann, Reported in reference 35
53. Cassidy, Adsorption and Chromatography, Interscience Pub.,  
New York, 1951, p.158
54. Friedel and Orchin, U.V. Spectra of Aromatic Compounds,  
Wiley and Sons, New York, 1951
55. Merrick, Private Communication
56. Pfann, Solid State Physics, 1957, 4, 423
57. Herington, Handley and Cook, Chem. and Ind., 1956, 292

58. Handley and Herington, Chem. and Ind., 1956, 304
59. Porter and Spiller, The Barker Index of Crystals, Heffer, Cambridge, 1956, Volume II, part 3, M2877
60. Stevens and Holland, Science, 1950, 112, 718
61. Dauben, Reid and Yankwich, Analyt. Chem., 1947, 19, 828
62. Gilman et al., J. Amer. Chem. Soc., 1929, 51, 1579
63. Weith, Ber., 1874, 7, 1058
64. MacMaster and Ahmann, J. Amer. Chem. Soc., 1928, 50, 145
65. Rubridge and Qua, ibid., 1914, 36, 733
66. Gleason and Dougherty, ibid., 1929, 51, 310, ibid., 1930, 52, 1024
67. Meyer, Org. Synth., 1941, 1, 60
68. Martin, J. Amer. Chem. Soc., 1936, 58, 1438
69. Clar, Private communication
70. Handbook of Chemistry and Physics, Chemical Rubber Publishing Co., Cleveland, Ohio, 1955, p. 2220
71. a. Laurent and Bénard, J. Phys. and Chem. Solids, 1957, 3, 7  
b. Cuddeback and Drickamer, J. Chem. Phys., 1951, 19, 790
72. Handbook of Chemistry and Physics, Reference 70, p. 696-1216
73. Okkerse, Phys. Rev., 1956, 103, 1246
74. Rohringer and Broda, Z. Natureforsch, 1953, 8b, 159
75. Henson, Brit. J. Appl. Phys., 1953, 4, 217
76. Brown and Miller, Rev. Sci. Instr., 1947, 18, 496

77. Audric and Long, D.S.I.R. Report No.CRL/AE51 184
78. Eidenoff, *Analyt. Chem.*, 1950, 22, 529
79. Milton and Waters, *Methods of Quantitative Micro Analysis*  
(2nd Edit.), Edward Arnold, London,  
1955, p.61
80. Belcher and Ingram, *Analyt. Chim. Acta*, 1950, 4, 118
81. Belcher and Spooner, *J. Chem. Soc.*, 1943, 313
82. Ingram, *Analyst*, 1948, 73, 548
83. Belcher and Ingram, *Analyt. Chim. Acta*, 1950, 4, 401
84. Cameron, Private Communication
85. Thomson and Walton, *Trans. Faraday Soc.*, 1957, 53, 821
86. Ingram and Lonsdale, *Chem. and Ind.*, 1956, 276
87. *Handbook of Chemistry and Physics*, Reference 70, p. 739
88. Margenau and Murphy, *Mathematics of Physics and Chemistry*,  
Van Nostrand, New York, 1956, p.519
89. Strominger, Hollander and Seaborg, *Rev. Mod.Phys.*, 1958,  
30, 585
90. Stevens, Private Communication
91. Crank, *Mathematics of Diffusion*, Clarendon Press, Oxford, 1956
92. Mapother, Crooks and Maurer, *J. Chem. Phys.*, 1950, 18, 1231
93. Williams and Slifkin, *Phys. Rev. Letters*, 1958, 1 No.7
94. Hart, Reported in Reference 93.
95. Jost, Reference 2b, p.111
96. Seith, *Z. Elektrochem.*, 1933, 39, 538

- 185
97. Nachtrieb and Handler , Acta Metallurgica, 1954, 2, 797
98. Eckart and Drickamer , J. Chem. Phys., 1952, 20, 13
99. Nachtrieb and Lawson , ibid., 1955, 23, 1193
100. Andrew , Report on the Conference on Crystalline Solids,  
Physical Society, 1954, p.60
- 101.a, Le Claire , Progress in Metal Physics, Volume I, Butterworth,  
London, 1949, p.306
- b. Idem , Progress in Metal Physics, Volume IV, Pergamon, London,  
1953, p.306
102. Jost , Reference 2b, p.436
103. Barrer, Reference 2a, p.305
104. Glasstone, Laidler and Eyring Theory of Rate Processes,  
McGraw-Hill, New York, 1951
105. Cruikshank , Acta. Cryst., 1957, 10, 470  
 , ibid., 1956, 9, 915  
Robertson , Rev. Mod. Phys., 1958, 30, 155
106. Cruikshank , ibid., 1958, 30, 163
107. Mott and Gurney , Electronic Processes in Ionic Crystals,  
Clarendon Press, Oxford, 1940, Chapter II.
108. Le Claire, Reference 101b, p.306
109. Frenkel, Kinetic Theory of Liquids, Clarendon Press, Oxford,  
1946, Chaps. III and VII
110. Idem, ibid., p.390
111. Young and Hildebrand, J. Amer. Chem. Soc., 1942, 64, 839
112. Stevens, J. Chem. Soc., 1953, 2973

113. Jost , Reference 95.

186

114. Handbook of Chemistry and Physics, Reference 70, pages 2129 and  
425-628

115. Landolt-Bornstein , Physikalishe-Chemische Tabellen,  
Springer-Verlag, Berlin, 1923

116. Tomizuka , Reported in reference 93

117. Hoodless , Ph.D. Thesis, Durham, 1957

118. Dainton and Kimberley , Trans. Faraday Soc., 1950, 46, 912

**A P P E N D I C E S**

## APPENDIX I

### Experimental details concerning the determination of Absorption Spectra (55)

The determinations were all carried out with a Unicam S.P. 500 Spectrophotometer.

#### A. 270-300m $\mu$

35 mgms. of the sample were accurately weighed into a small beaker of weight approximately 1 gm. This small beaker containing the sample was placed in a larger one containing about 125 mls. of normal heptane, and the anthracene dissolved in the cold by continuous stirring using a magnetic stirrer. The solution was then transferred to a 200 mls. standard flask care being taken to remove all the solution from the beakers with fresh normal heptane and the solution made up to the mark. The measurement of the absorption spectrum of the solution was usually taken shortly after the solution had been prepared, but if this was not possible the solution was stored in the dark until required.

The absorption spectrum of the solution was measured using 1 cm. silica cells. Three readings were taken and averaged at intervals of 2 m $\mu$ . A matched cell containing solvent only was used as the zero density standard of comparison.

### B. 400-460 m $\mu$

0.500 gms. of the sample were weighed into a small beaker weighing approximately 12 gms. The sample was washed through a funnel into a 100 mls. standard flask with 50 to 60 mls. toluene and dissolved by continuous stirring in the cold, using a magnetic stirrer. The solution was made up to the mark with toluene, the flask having previously been re-calibrated to allow for the volume of the rotor. The solution was transferred to a 10 cms. absorption cell by means of a 10 mls. pipette and the optical density measured, from 400 to 460 m $\mu$ . Readings were taken at intervals of 2 m $\mu$ , three readings being taken and averaged at each wave length. A matched cell containing solvent only was used as the zero density comparison cell.

It is essential, between determinations, to clean the 10 cms., cylindrical type, absorption cells very thoroughly with concentrated sulphuric acid. It has been found that washing with organic solvents was not sufficient to give consistent cell constants.

### C. 260-390 m $\mu$

When measurements in this range were required the solutions used for section A were diluted ten times.

## APPENDIX II

### Calculation of the constants for the Arrhenius Type Equation for self-diffusion in Anthracene

The logarithmic form of the Arrhenius type equation is

$$\log_{10} D = \log_{10} D_0 - \frac{E}{R} \log_{10} e \cdot \frac{1}{T} \quad \text{---} \quad 1^1$$

and a plot of  $\log_{10} D$  versus  $\frac{1}{T}$  should be linear. This was the case for the experimental values determined in this present study, and this appendix shows the least mean squares calculation which was used to determine the best straight line which could be fitted to these experimental points.

In the following tables the terms  $\log_{10} D$  and  $\frac{1}{T}$  are represented as y and x respectively. Where two values were obtained for any particular temperature these have been averaged. The experimental values for crystals A, B and J have been omitted as these are thought to be inaccurate. The reasons for their omission have been given previously.

The remaining abbreviations have their usual meaning (88).

y	x x 10 <sup>3</sup>	x <sup>2</sup> x 10 <sup>6</sup>	xy x 10 <sup>3</sup>
-11.043	2.350	5.523	-25.951
-10.641	2.309	5.332	-24.570
-9.826	2.222	4.937	-21.834
-9.378	2.165	4.687	-20.303
$\Sigma = -40.888$	9.046	20.479	-92.668

$$n = 4$$

$$\begin{aligned}
 m &= \frac{\Sigma x \Sigma y - n \Sigma xy}{(\Sigma x)^2 - n \Sigma x^2} \\
 &= \frac{(9.046 \times 10^{-3} \times -40.888) - 4(-92.668 \times 10^{-3})}{(9.046 \times 10^{-3})^2 - (4 \times 20.479 \times 10^{-6})} \\
 &= \frac{(-369.873 + 370.672)}{(81.830 - 81.916)} \times 10^3 \\
 &= -\frac{0.799}{0.086} \times 10^3 = -9.291 \times 10^3 \\
 c &= \frac{\Sigma x \Sigma y - \Sigma y \Sigma x^2}{(\Sigma x)^2 - n \Sigma x^2} \\
 &= \frac{(9.046 \times 10^{-3} \times -92.668 \times 10^{-3}) - (-40.888 \times 20.479 \times 10^{-6})}{-0.086 \times 10^{-6}} \\
 &= \frac{-838.275 + 837.345}{-0.086} \\
 &= \frac{0.930}{0.086} = 10.814
 \end{aligned}$$

Goodness of fit:-

y	x x 10 <sup>3</sup>	mx	mx + c	d = y - (mx+c)	d <sup>2</sup>
-11.043	2.350	-21.834	-11.020	-0.023	0.000529
-10.641	2.309	-21.453	-10.639	-0.002	0.000004
-9.826	2.222	-20.645	-9.831	+0.005	0.000025
-9.378	2.165	-20.115	-9.301	-0.071	0.00541
$\Sigma$				-0.095	0.005968

$$\begin{aligned}
 r_e &= 0.6745 \left[ \frac{\Sigma d^2}{n-2} \right]^{\frac{1}{2}} = 0.6745 \left[ \frac{59.68 \times 10^{-4}}{2} \right]^{\frac{1}{2}} \\
 &= 0.6745 (29.84 \times 10^{-4})^{\frac{1}{2}} \\
 &= 0.6745 \times 5.463 \times 10^{-2} \\
 &= 0.0369
 \end{aligned}$$

$$D = n \Sigma x^2 - (\Sigma x)^2 = 0.086 \times 10^{-6}$$

$$\begin{aligned}
 \text{error in } m = \Delta m &= r_e \left( \frac{n}{D} \right)^{\frac{1}{2}} = 0.0369 \left[ \frac{4}{0.086 \times 10^{-6}} \right]^{\frac{1}{2}} \\
 &= 0.0369 \cdot (46.511 \times 10^6)^{\frac{1}{2}} \\
 &= 0.0369 \times 6.82 \times 10^3 \\
 &= 0.252 \times 10^3
 \end{aligned}$$

$$\begin{aligned}
 \text{error in } c = \Delta c &= r_e \left( \frac{\Sigma x^2}{D} \right)^{\frac{1}{2}} = 0.0369 \left[ \frac{20.479 \times 10^{-6}}{0.086 \times 10^{-6}} \right]^{\frac{1}{2}} \\
 &= 0.0369 \times (2.381 \times 10^2)^{\frac{1}{2}} \\
 &= 0.0369 \times 15.543 \\
 &= 0.574
 \end{aligned}$$

the equation to the line is

$$y = -(9.291 \pm 0.252) \times 10^3 x + (10.814 \pm 0.574)$$

Comparing this equation with equation 1<sup>1</sup> above we have

$$\log_{10} D_0 = 10.814 \pm 0.574$$

$$\text{and } \frac{E}{R} \log_{10} e = (9.291 \pm 0.252) \times 10^3$$

$$D_0 = (1.31 \pm 1.13) \times 10^{11} \text{ cms.}^2 \text{ per second}$$

$$E = 42,400 \pm 1,200 \text{ cal. per mole.}$$

Therefore the Arrhenius Type equation for self diffusion in anthracene is

$$D = (1.31 \pm 1.13) \times 10^{11} e^{-42,400 \pm 1,200/RT} \text{ cms.}^2 \text{ per second.}$$

### APPENDIX III

#### The Calculation of the Diffusion Coefficient

The logarithmic form of the diffusion equation which represents the process of diffusion in the present case is

$$\log_{10}C = \log_{10} \frac{Q}{2(\pi Dt)^{\frac{1}{2}}} - \frac{\log_{10}e}{4Dt} x^2 \text{ - - - - - } 3$$

and a plot of  $\log_{10}C$  (in this case the specific activity) versus  $x^2$  should be linear. This was the case and the diffusion coefficient was calculated from the slope of this line

$$\text{i.e. slope} = \frac{-\log_{10}e}{4Dt}$$

This appendix shows a typical calculation. The slope was calculated by the least mean squares method using those points which lay on the steep initial portion of the experimental plot of equation 3. The following calculation is for crystal C.

In the calculation the terms  $\log_{10}A$  and  $x^2$  are represented by  $x$  and  $y$  respectively.

$x \times 10^6$	$y$	$x^2 \times 10^{12}$	$xy \times 10^6$
77.84	2.00	6059	155.7
152.5	1.18	23256	180.0
251.9	1.22	63454	307.3
376.4	0.68	141677	256.0
552.7	0.12	305477	66.3
$\Sigma = 1411.3$	5.20	539923	965.3

$$n = 5$$

$$\begin{aligned}
 m &= \frac{\Sigma x \Sigma y - n \Sigma xy}{(\Sigma x)^2 - n \Sigma x^2} = \frac{(14.11 \times 10^{-4} \times 5.20) - (5 \times 9.65 \times 10^{-4})}{(14.11 \times 10^{-4})^2 - (5 \times 53.99 \times 10^{-8})} \\
 &= \frac{(73.37 - 48.25) \times 10^{-4}}{(199.09 - 269.95) \times 10^{-8}} \\
 &= - \frac{25.12}{7.09} \times 10^3 \\
 &= - 3.54 \times 10^3
 \end{aligned}$$

$$- \frac{\log_{10} e}{4Dt} = - 3.54 \times 10^3$$

and in this case  $t = 45.5$  hours

$$D = \frac{0.4343}{4 \times 3.54 \times 10^3 \times 45.5 \times 3600} = 1.873 \times 10^{-10} \text{ cms.}^2 \text{ per second.}$$

