

Durham E-Theses

The effects of abnormal stimulation on the judgement of visual direction

William B Templeton

How to cite:

Templeton, William B (1969) The effects of abnormal stimulation on the judgement of visual direction. Doctoral thesis, Durham University.

Use policy

The full-text may be used and/or reproduced, and given to third parties in any format or medium, without prior permission or charge, for personal research or study, educational, or not-for-profit purposes provided that:

- a full bibliographic reference is made to the original source
- a <https://etheses.durham.ac.uk/id/eprint/8798/> is made to the metadata record in Durham E-Theses
- the full-text is not changed in any way

The full-text must not be sold in any format or medium without the formal permission of the copyright holders.

Please consult the [full Durham E-Theses policy](#) for further details.

THE EFFECTS OF ABNORMAL STIMULATION ON
THE JUDGEMENT OF VISUAL DIRECTION.

William B. Templeton.

A Thesis presented for the Degree of
Doctor of Philosophy.



ACKNOWLEDGEMENTS.

I gratefully acknowledge the contribution of Professor P. McEwen who first interested me in these problems, and of Professor I. P. Howard and all the other colleagues and students with whom I have discussed them.

ABSTRACT.

Spatially oriented behaviour is to a considerable extent calibrated by reference to stimulus norms and invariant relationships between inputs from different stimulus channels. Three sorts of experimental disruption of these normal relationships in the field of direction perception are examined and experiments are reported which attempt to elucidate the mechanisms underlying the behavioural reaction to them in humans.

The first two examples concern the visual perception of verticality and frontal plane tilt. The first is an examination of Gibson's concept of normalization and negative after-effect in spatial dimensions. A review is made of several attempts to subsume the behaviour which this theory was designed to explain under more elementary principles. The most serious of these attempts - that of Köhler and Wallach - is the subject of a series of experiments which are reported and from which it is concluded that the attempt must be considered a failure and that the postulation of some mechanism genuinely characteristic of the spatial dimension is required to explain the behaviour.

The second issue is the role of non-visual gravitational cues in the visual judgment of the direction of gravity. The historical dispute about the relative importance of visual and postural cues is outlined. Then attention is focussed on the contribution of the various types of postural cue and it is concluded that some

investigators have seriously misinterpreted the role of vestibular information. An experiment is reported in which the two main factors known to have disruptive effects on spatial behaviour - tilt of the visual field and tilt of the subject - are shown to have their effects considerably attenuated by the presence of vestibular cues.

The third example concerns the disruption of azimuth-oriented behaviour by modification of the normal correlation between spatial inputs in two modalities. A critical scrutiny is made of theories concerning the location of the adaptive change in response to such disruption. A corollary of one of the theories - that active movement is necessary for adaptation - is tested and rejected in a series of experiments, and these in addition provide some evidence for an alternative theory.

CONTENTS.

	<u>Page.</u>
INTRODUCTION.	1
I: NORMALIZATION AND TILT AFTER-EFFECT.	4
Experiment 1(a)	34
Experiment 1(b)	40
Experiment 1(c)	45
Experiment 1(d)	49
Experiment 1(e)	61
II: POSTURAL AND VISUAL-FRAME EFFECTS ON THE VISUAL VERTICAL.	70
Experiment 2.	96
III: ADAPTATION TO PRISMATIC DISPLACEMENT.	118
Experiment 3(a)	171
Experiment 3(b)	177
Experiment 3(c)	182
CONCLUSION.	189
BIBLIOGRAPHY.	191

INTRODUCTION.

The attribution of importance in biology to concepts of a natural balancing tendency or "equilibrium seeking" has been traced back at least as far as Hippocrates. Following the stress laid by Bernard (1859) on the constancy of the "milieu interieur" Cannon's (1932) concept of homeostasis became a central principle in the study of living systems and more recently similar ideas have gained currency in the physical sciences (e.g. Wiener, 1948).

It is scarcely surprising that psychology has not remained immune to these influences and indeed a measure of their pervasiveness is the suggestion by Fletcher (1942) that psychology should take over the principle of homeostasis as its own and the remark by Davis (1958) that this principle as a model for behaviour "presents itself in rivalry with the time-honoured formula of stimulus-response". Its critical importance is apparent all the way from low-level demonstrations that effort modulation is used to maintain human performance fairly constant in distracting situations (C. G. Seashore, 1951) right up to the grand models of motivation and personality of Freud, Lewin and the drive-reduction learning theorists. It underpins the concept of perceptual constancy and is implied by much gestaltist writing on perception.

Irrespective of the validity of these applications of the principle of homeostasis, which have usually involved the idea of a natural equilibrium which when it is disturbed, the organism seeks to re-establish, there can be little doubt that in the interaction of man at least, with his sensory world, many responses are structured on the basis of salient points on sensory dimensions of properties of objects with high ecological frequencies and of normally invariant relations among environmental variables. The importance of invariant relations has been stressed most notably by Gibson (1957, 1966) while the most comprehensive study of the significance of norms or anchor points in single dimensions has been carried out over the last twenty years by Helson (1964).

Whether or not one wishes to view all motivated behaviour as aimed at restoration of an equilibrium, there is no doubt that prolonged exposure to deviations from sensory norms or alterations of invariant sensory relations do have important and characteristic consequences for behaviour. It is the purpose of this dissertation to contribute a little to the elucidation of the mechanisms whereby these behavioural consequences are produced in the field of spatial behaviour. Such effects have been studied in several areas of spatial behaviour, for example the experiments of Howard and Templeton

(1964a) and Gogol (1956) in binocular depth perception. But attention will here be focussed on the perception of direction. The first two examples involve the judgement of visual verticality. Historically a distinction has been drawn between the effects on ongoing behaviour of concurrent abnormal stimulation and those of prolonged prior abnormal stimulation, but it is questionable whether this is a fundamental distinction (see for example Ganz's 1966 theory of figural after-effects). At any rate the first example concerns the effects of concurrent abnormal visual stimulation, the second those of prior abnormal visual and postural stimulation. The third and final example concerns the effect on azimuth directional behaviour, specifically finger pointing to a visual target, of an abnormal relationship between visual and motor-kinaesthetic inputs.

It should be stressed that the term "abnormal" here refers only to statistical deviation from an expected value without any implication of artificiality. Thus non-alignment of the long axis of the body with the direction of gravity is abnormal whether it is induced by lying on one's side or by spinning in a centrifuge, and poking about at the bottom of transparent water with the tip of a stick involves sensory relationships just as abnormal as those in pointing at a visual target while wearing displacing prisms.

I: Normalization and Tilt After-Effect.

Gravity is the most significant of all the environmental features to which man orients himself. Under normal conditions it is virtually constant, both in strength and direction and affects practically every aspect of man's overt behaviour.

Man has a mid-body axis which is normally kept in line with the direction of gravity; any disturbance is corrected by many complex postural reflex mechanisms. Thus rotation of the eyes or the head or the whole body in the frontal plane is a significant stimulus factor influencing orientation behaviour. Furthermore man lives in an environment of objects and surfaces which typically maintain a constant relationship to gravity and provide a visible frame of reference for his behaviour. But this frame may itself be tilted, which adds a further significant variable.

Most if not all behaviour directly involving gravity can be reduced to either eye torsion, setting or judging the orientation of the body or part of the body with respect to gravity, or setting or judging the orientation of an external line with respect to gravity either by sight or by touch. In the next chapter we shall be concerned with the visual version of the latter task and with the closely

related task, which may or may not involve gravity, of setting or judging an external line in relation to a body axis, in this case setting a line parallel with the mid-body axis. We shall be concerned with the relative contributions to this behaviour of the visual and postural stimulus determinants referred to above. This chapter on the other hand deals with the way in which visual gravitational judgments are influenced by the orientation of lines in a previously exposed field.

The setting of a visual line to the apparent vertical has been an extremely popular task among investigators; under normal circumstances it can be performed with great accuracy, average unsigned deviations being typically one degree or less, see Howard and Templeton (1966, p. 179), and relatively small treatment effects can thus easily be detected.

Gibson (1933) reported that a curved or bent line-segment suffers an apparent change during continuous fixation in the direction of becoming straight, and thereafter an objectively straight line appears curved or bent in the opposite direction. These phenomena were named "adaptation" and "negative after-effect" respectively. Gibson avoided the term "successive contrast" because it might imply an after-effect without the correlative adaptation which he

regards as the basic process involved. These findings were confirmed by Bales and Follansbee (1935). Later it was demonstrated that similar effects can be obtained using tilted lines, i.e. inspection of a line tilted somewhat from the vertical or horizontal leads to a progressive lessening of the apparent tilt and to subsequent perception of an objectively vertical or horizontal line as tilted in the opposite direction (Vernon, 1934; Gibson and Radner, 1937). It must be noted that these adaptation effects are only partial: the discrepancy (tilt, curvature, etc.) decreases but does not disappear, reaching a plateau after about two minutes. The shift of apparent tilt may be about two or three degrees; after inspection a ten degree line looks eight degrees, two degrees looks vertical and vertical looks like minus two degrees. The effect does not apply to the visual field as a whole but is mainly limited to the region previously occupied by the stimulus-line (Gibson, 1937a). This localization is said to show that the effects, though analogous to judgement-contrast, are not illusions of judgement. They are also subject to interocular transfer but again only between corresponding areas of the two retinae and in this case the magnitude of the effects is reduced.

Gibson looks upon shape (curvature) and direction (tilt) as the immediate sensory qualities of a line and the phenomena under discussion he regards as analogous to sensory adaptation. He seeks an explanation in the nature of the perceptual process itself. In support of Koffka (1922) Gibson argues that every sense quality falls on a dimension of some type and it is possible to speak of a stimulus and a sensation only so long as one means a point on a scale. A sensory dimension is functionally "all of a piece"; the series is "a discriminatory unit".

Helson (1964) has demonstrated similar effects in several other dimensions, including weight and brightness. When the subject is asked to categorize a series of stimuli he adopts a norm or indifference point which is usually approximated by the geometric mean of the series. But when he is frequently exposed during the series to a background stimulus to which he does not have to respond and which deviates from this norm, the norm itself tends to be shifted in the direction of the anchoring stimulus.

But there are different types of series. Gibson's adaptation applies only to "opposition series", i.e. sensory dimensions with centrally placed "norms" or indifference regions from which deviations in either direction mean increased intensity of one of the two opposed qualities represented on the dimension. Linear shape (curvature) and direction (tilt) are two such dimensions, independent of

one another. The effects are well known in the case of skin temperature. "Chromatic adaptation operates so as to shift the hue which is evoked by any stimulus in the direction of the complementary of the adapting stimulus" (Troland, 1930). The facts of light and dark adaptation also fit into this framework. In the case of movement the negative after-effect is well known and has been given detailed study (Wohlgemuth, 1911; Spigel, 1965) but Gibson (1937b) shows that adaptation also occurs; a moving stimulus tends to slow down during prolonged fixation, i.e., there is an apparent shift towards the norm of motionlessness. Several of these effects have been demonstrated in the tactile-kinaesthetic modality, by Gibson (1933) for curvature and by Thalman (1922) for movement. Specifically excluded are distance, duration, pressure, visual size and olfactory intensity; all examples of "intensive series", i.e., ones which vary from zero to an extreme in one direction only.

The norms of the opposition series are defined statistically as the most frequent and prolonged condition in the organism's environment. Horizontal and vertical lines are norms in this sense. Usually such norms correspond with the norms of the appropriate psychological dimensions, e.g., objective and apparent vertical correspond closely for most subjects. Hence, since these norms are anchoring

points for the whole of their respective dimensions, the stimulus dimension and the sensory dimension coincide. With perception of an abnormal quality, however, a gradual shift in the correspondence between the two dimensions occurs, tending to the point where the subjective norm corresponds to the present stimulus. The objective norm must now correspond to a point on the sensory scale somewhat displaced away from the original stimulus, e.g., an objectively vertical line is reported as tilted away from the line to which the subject has previously adapted. This constitutes the negative after-effect, a mere by-product of the adaptation or normalization process.

There are several oppositional dimensions of visual space: (a) Tilt or rotation of a line from the vertical or horizontal in the frontal or sagittal plane; rotation of a line in the horizontal plane from the pointing-straight-ahead position or from the frontal-parallel position. (b) Translation of a point from the median plane to left or right; translation of a point from eye level up or down. (c) Departure from straightness by curvature or bending in the frontal plane or in depth. The present discussion will deal mainly with tilt in the frontal plane.

Gibson does not put forward a physiological explanation though he suspects that the process is "characteristic of the whole projection system from end-organ to cortex". More

often (e.g., 1937b) he sees the adaptation as a striving towards equilibrium in a field which includes both organism and environment, a process designed to keep the experiential norm coincident with the norm of external conditions - the state which involves the least output of energy.

Since the original reports of tilt adaptation several attempts have been made, in the interests of parsimony, to demonstrate that it does not require a separate principle but can rather be explained either as a by-product of another process, such as eye-torsion or size-constancy scaling or as a special case of another phenomenon, notably visual-frame shifts, simultaneous contrast or figural after-effects. The first four of these attempts will be briefly discussed, then the final one - that of the satiation theorists - will be analysed in more detail and several experiments relevant to its evaluation will be reported.

Tilt adaptation and eye-torsion.

Ogle (1950) suggested that tilt adaptation might be due to the eye's rotating about the visual axis in an attempt to keep the normally vertical meridian of the retina parallel with the main lines of the visual field, which are now tilted. Vertical lines subsequently presented before the eyes have time to return to their normal orientation will stimulate non-vertical retinal meridians and will be judged accordingly. Howard and Templeton (1964b) tested this theory by measuring the torsional position of the eye before and after the subject had inspected a 10° tilted line for ten seconds. The measuring technique used could reliably record movements of 0.2° , yet no significant change of torsional position could be detected which was in any way related to the orientation of the stimulus line. Under the same conditions of viewing tilt after-effects of about two degrees were recorded from the same subjects.

It has been known for some time that visual objects rotating in the frontal plane about the visual axis induce eye torsion in the same direction (Noji, 1929; Brecher, 1934). Howard and Templeton confirmed this effect, recording a maximum torsion of 1.3° , but failed to find any difference depending on whether the line rotated away from or towards the vertical. They concluded that the vertical has no special significance for eye movements.

Greenberg (1960) has claimed that a stationary tilted frame does induce eye-torsion but even if this is true, and Greenberg's measurement procedure involved a moving line which may have contaminated his results, Howard and Templeton have certainly demonstrated tilt adaptation in conditions where torsion does not occur.

Size-constancy scaling.

Although not directly concerned with tilt adaptation Coren and Festinger's (1967) contribution is too important theoretically to be omitted from the present discussion. It has always seemed a puzzle that normalization and tilt after-effect should be processes whereby perception changed over time in the direction of non-iridicality. This contrasts with the case of optical illusions, which typically tend to disappear over time. Then Coren and Festinger suggested what in retrospect seems an obvious alternative interpretation - curves, tilted lines etc, initially appear more deviant from their norm than they really are and normalization is a truly adaptive reduction of this excess deviation, with the after-effect on the norm itself an admittedly non-iridical by-product. In fact their argument is presented wholly in the context of curvature adaptation rather than tilt.

They overcame the problem of measuring how curved a curved line looks by matching the height (tip to tip) and the width (apex to midpoint of an imaginary line joining the tips) against variable straight lines presented nearby. The results confirmed that the width of the curve was initially overestimated and over time tended to become more correctly estimated, whereas the height estimates remained approximately correct throughout. It was suggested that

the reason for the initial excessive apparent curvature was that the figure was judged to be rotated in depth - just as the Ponzo figure's converging straight lines are taken to be parallel lines receding in depth so a curve is taken to be a curve of smaller radius rotated in depth so that the tips of the curve are the parts closest to the subject.

The analogy was tested by the method which has become familiar in the context of the constancy theory of illusions - a binocularly viewed light was matched in depth to various parts of a monocularly viewed luminous curve. The results confirmed that the tips were judged significantly closer than the rest of the figure and moreover the amount of rotation in depth was approximately the amount required to account for the apparent change in radius of curvature when the illusion had been measured.

This is the most striking development in thinking about normalization for many years and it could be applied to the bent line effects with even more a priori plausibility than to curvature. But the tilted line effects present more of a problem. On the theoretical side there is no obvious bias in a tilted line towards one particular depth interpretation. One could argue on ecological grounds that most tilted proximal stimuli are projections of actually horizontal lines and that structural visual environment tends to occur below rather than above eye level, so that the tops of

tilted lines should be judged as farther away than the bottoms. Nevertheless it is difficult to see what effect such a depth interpretation would have on judgements of frontal-plane tilt. One might deduce that tilted lines should be judged to be closer to the horizontal and while this might cover normalization to the vertical it could not account for the apparently very similar normalization to the horizontal.

On the experimental side there are also difficulties in measuring the change in apparent tilt of a line over time, chiefly the fact that any other line used in the measurement procedure may itself influence the effect. In this laboratory attempts have been made to use an outline circle (radially symmetrical and therefore presumably ineffective) centred on the midpoint of the tilted line. The subject matches the diameter of the circle to the horizontal distance between the ends of the line. Results so far have been equivocal and the task is clearly a difficult one.

At present the conclusion must be that there is little prospect of extending a three-dimensional explanation to the tilt effects, and pending confirmation of Festinger's results with curved lines it would seem prudent to continue to assume that all of the Gibson effects have a common explanation. It will be ironic if the bent-line effect,

previously thought to be a special case of the tilted-line effect, turns out to be a manifestation of the same mechanism as the curved-line effect, and quite different from the tilted line effect.

Tilt adaptation and shifts of the visual frame.

There is clearly at least a superficial resemblance between Gibson's tilt adaptation and the reports by Wertheimer and by Witkin that optically tilted rooms appear to right themselves after a period of observation. On the other hand Gibson, Held, Morant and others have pointed to important differences. In the first place adaptation is usually only about two or three degrees, whereas frame shifts may be complete for angles up to about 25° (Wertheimer, 1912; Witkin, 1949b; Bellar and Morant, 1963).

Secondly, Gibson claimed that adaptation was largely restricted to the site of the inspection figure whereas it is generally thought that frame effects transfer to all parts of the visual field. In fact, neither of these statements is beyond dispute. The experiment used by Gibson to confirm the restricted nature of his effect involved the inspection of three lines side by side, two vertical lines and a middle one which was tilted. Of three vertical test lines in corresponding positions, only the middle one appeared tilted. Morant and Mikaelian (1960) point out that this demonstrates only that different inspection lines can produce differential effects in different parts of the field, not that the after-effect is restricted

to the part of the field corresponding to the position of the inspection figure. Similarly they interpret Gibson's failure to observe an after-effect in a test field consisting of an ordinary room only as evidence that the after-effect does not manifest itself when a strong vertical-horizontal frame of reference is present. They reported their own experiment in which a tilted inspection-line and a vertical test-line were exposed either in the same location or in different locations, seven degrees of visual angle apart. The two conditions produced after-effects of 1.52° and 1.09° respectively, demonstrating a considerable degree of transfer over this short distance at least. Morant and Mikaelian neglected to mention another experiment of Gibson (1933) in which he found 25% transfer of a curvature after-effect over 5.7° of visual angle. Gibson's claim was that most of the effect, not all of it, is localized.

Nor is there any evidence that frame shifts do in fact transfer to all parts of the retina. The experiment subjecting half the retina to prism distortion with the other half blanked out has yet to be done. In short, with neither half of the necessary argument established, areal restriction cannot be used to separate tilt after-effects from visual-frame shifts.

A further apparent difference between the two sets of phenomena lies in the supposed dependence of visual-frame shifts on active locomotion and manipulation during inspection. Mikaelian and Held (1964) for example reported an experiment in which subjects wearing rotating prisms moved about either actively or passively in a hallway in which cues to the prism-induced distortion could be camouflaged by means of luminous spheres. Passive inspection produced a Gibson-type after-effect in the ordinary hallway but not when the spheres were present. Active inspection, on the other hand, produced large effects in both conditions, almost the full 20° of prism rotation in the case of the ordinary hallway. Similarly Rekosh and Held (1963) and Held and Rekosh (1963) found that under certain conditions active movement may be required to induce curvature after-effects.

Thus there is no doubt that active movement is an important factor in these situations and it may actually be necessary for adaptation to large rotations of the field of view. On the other hand, Wertheimer, Köffka and Witkin all reported complete or almost complete adaptation to large rotations apparently without any need for active movement. The solution may emerge from a closer analysis of the nature and amount of active movement which is significant, and it may appear that such movement could easily

have occurred spontaneously in the classical experiments. This issue appears a more likely one to separate tilt after-effects from frame shifts.

Finally it is clear from Gibson's theory that tilt adaptation should be absent for some inspection-line orientation intermediate between vertical and horizontal. (The precise location of this null point will be considered later; it is not important for the present discussion.) Gibson and Radner (1937) and Culbert (1954) found that this was the case although Köhler and Wallach (1944) did not. On the other hand, frame shifts typically involve fields of familiar normally vertical objects and there is no reason for the effect to reverse at any orientation; indeed Wertheimer obtained the original effect with a field tilted 45° . As would be expected from this analysis, 45° tilt of a field of objects affects the apparent verticality of a line whereas similar tilt of a field of parallel straight lines does not (Morant and Beller, 1965). Similarly the two fields when tilted 15° produce congruent effects while at 75° they produce opposed effects: a field of lines adapts to the nearest main axis taking all other line orientations in the same direction, while a field of normally upright objects always adapts to the vertical.

In summary then, the balance of evidence would favour treating tilt adaptation and frame shifts as different phenomena, the former being a small effect of inspection of tilted lines whose direction is determined by the nearest main axis and whose magnitude is not increased by active movement, the latter a large and uni-directional effect of inspection of a rotated field of familiar mono-oriented objects, whose magnitude may be increased by active movement.

Tilt adaptation and simultaneous contrast.

Apart from the temporal factor there appears to be a strong analogy between tilt adaptation and the well-known alteration in apparent tilt suffered by a vertical line which is superimposed on a field of parallel tilted lines (Hoffmann and Bielschowsky, 1909; Krantz, 1936; Kleint, 1936). This analogy would be even stronger if it were accepted that the tilt after-effect is a special case of the figural after-effect, as a strong case has recently been made for regarding figural after-effects and simultaneous contrast as manifestations of the same basic process, with after-images providing the temporal link (Taylor, 1962; Ganz, 1966).

Despite Gibson's emphatic denial that his effects were the same as simultaneous contrast all the evidence he cites in fact tends to strengthen the analogy. If the after-effects were due to after-images of the inspection-figure it would be expected that their strength would depend on the length of the inspection period, and would never be as great as that of the simultaneous effects. Nor is interocular transfer of the effects good evidence against the after-image theory since monocular after-images persist when the affected eye is shut and may influence the appearance of stimuli seen with the other eye.

If, on the other hand, the independence of tilt adaptation from figural after-effects could be established it would be much more plausible that they were also independent of simultaneous contrast, with the latter still perhaps providing the mechanism underlying figural after-effects.

If, on the other hand, tilt adaptation is eventually shown to be related to simultaneous contrast then a new explanation for the latter phenomenon recently advanced by Brosgole and Cristal (1967) would become relevant to tilt adaptation. These authors are actually writing about the "rod-and-frame effect" in which a tilted visual frame surrounding a visual line affects its apparent orientation. This phenomenon will be considered in more detail in the next chapter where it is used as an index of the effectiveness of gravitational cues, but it seems indistinguishable from simultaneous tilt contrast and the suggested explanation of the rod-and-frame effect can be assumed to apply also to the latter effect.

Brosgole and Cristal report a series of experiments designed to show that the rod-and-frame effect can be analysed as a series of apparent linear displacements of segments of the target line in a manner similar to the Roelofs (1935) effect of the azimuth position of a background

on the apparent median plane. In these experiments the target vertical line consisted only of two terminal points, and each point was accompanied by a frame consisting of two short vertical lines, as shown in Fig. 11. The two frames were offset so that imaginary lines joining the centres of their constituent lines would be parallel and tilted like a Witkin frame. In one condition both points and both frames were simultaneously visible and the subject adjusted the points to apparent verticality; in the second condition the points were adjusted to the apparent straight ahead singly in alternation, each bounded by its own frame only, so that the display on any one trial lacked any tilt component. They found that the resulting constant errors were similar in magnitude and direction in the two conditions and were significantly correlated over subjects. They also showed that with a conventional Witkin rod-and-frame the usual effect was significantly reduced if the frame was surrounded with an annulus, thereby tending to eliminate the conditions for the Roelofs effect but leaving the tilt characteristics of the situation unchanged. Thirdly, tilt could be removed by having the frame slowly oscillate vertically behind a narrow horizontal slit while the subject continuously maintained a target point at the apparent straight ahead. The results were similar when the horizontal slit was removed so that the whole of the oscillating tilted

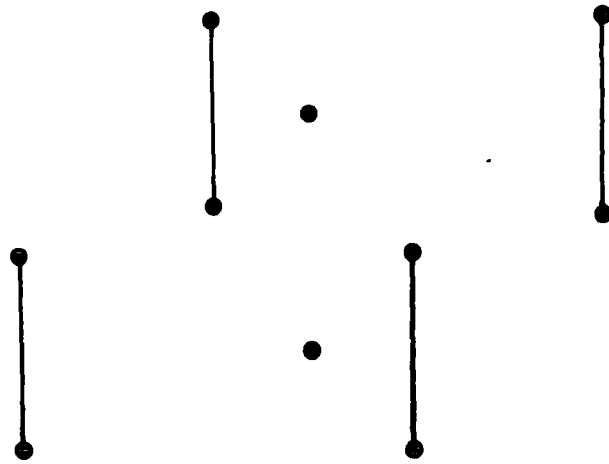

A

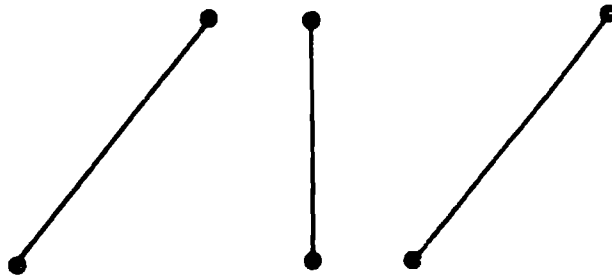

B

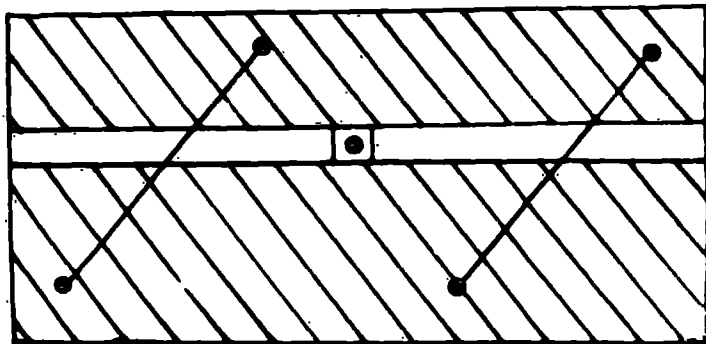

C

Fig. 1.1

Stimulus displays used by Brosgole and Cristal (1967).
 A. Rod-and-frame without tilt component.
 B. Conventional rod-and-frame.
 C. Vertically oscillating frame and target point.

frame was continuously visible. Finally they found that the rod-and-frame effect was significantly greater if the rod was confined to the lower half of the visual field than if it was in the upper half of the field, so that the best fit for the apparent upright, as generated by a tilted frame, is a bent rather than a straight line - a situation which would be difficult to predict from theories involving a general tilting of visual space.

Tilt adaptation and figural after-effects.

Köhler and Wallach (1944) considered that Gibson's adaptation effects were a special case of a broader class of effects based on a mechanism which they called satiation. This theory depends on an "electrotonic" spread of the striate-cortex process produced by an inspected stimulus, which shifts the peak activity induced by a subsequently presented test stimulus and hence produces an apparent repulsion of the latter away from the location of the inspection stimulus. There have been several alternative theoretical formulations (Osgood and Heyer, 1952; Taylor, 1962) but the predictions are similar and the basic phenomena are well established (McEwen, 1958).

There is a theoretical problem as to whether satiation can straightforwardly predict a change in apparent orientation of a test line which intersects the trace of a previously inspected line. A straightforward application of the displacement principle would suggest that as one travelled along the test line starting at its intersection with the inspection line the degree of displacement should increase rapidly to a maximum and then tail off slowly to a point of zero displacement at some distance from the intersection. But if the test line is to remain apparently straight and be apparently displaced away from the inspection line then of course it must suffer an increasing linear

displacement over its whole length rather than a decreasing displacement over most of its length. It would thus only be by concentrating on a short segment closer to the intersection that an increase in apparent angular separation could be predicted from the displacement principle. But of course it may be just this segment which is critical in judging the orientation of the line. The issue can be clarified only by further research.

However, if one makes the normal assumption that the satiation mechanism can produce the required change in orientation of a test line there are still a number of possible operational tests of the claim that satiation can account wholly for the Gibson effects. These are usually treated as separate issues but they resolve ultimately to the question of how the effect varies as a function of the orientation of the test line and the inspection line. The orientation of the inspection line will be considered first.

This issue concerns the special significance of the norm in Gibson's theory. No normalization can be expected when a vertical line is inspected and therefore no after-effect on the apparent orientation of a tilted line can be expected. Under satiation theory, on the other hand, such effects should be symmetrical, inspection of a vertical line having as much effect on a tilted test line as inspection of a tilted line on a vertical test line, since

the critical variable is simply the angular separation between test and inspection lines and no special status is ascribed to any particular orientation. Hence any apparent repulsion of a tilted test line by a vertical or horizontal inspection line can only be a figural after-effect whereas both theories predict an apparent repulsion of a vertical or horizontal line by a tilted inspection line. It follows that if the tilt after-effect does occur as an independent process the two effects may combine in the second case to give a larger after-effect than that observed in the first case. If on the other hand the figural after-effect is the only process then the effects in the two cases should be the same size.

Köhler and Wallach (1944) carried out this experiment and found that with two lines, one vertical (or horizontal) and the other tilted 10° from the vertical (or horizontal) it made no difference to the size of the apparent displacement which was made inspection - and which test-figure. However, they used only one subject apart from themselves, and in view of the theoretical importance of the issue the experiment was repeated on a larger scale and is reported as experiment 1(a).

On the question of the orientation of the test line interest has focussed principally on three points. Given an inspection line tilted somewhat from the vertical what is its effect on (a) a test line identical to the inspection line, (b) a test line somewhat more tilted than the inspection line, and (c) a horizontal test line?

The case where test and inspection lines are identical is the case of normalization which is of course the cornerstone of Gibson's theory but cannot be predicted from satiation theory. However, although normalization is often reported by subjects (e.g. Gibson and Radner, 1937; Morant and Mistovich, 1960) it is extremely difficult to demonstrate rigorously and quantitatively. The obvious method of asking the subject how many degrees a single line appears to be tilted before and after a period of inspection is pointless because judgments away from the main anchoring points of the scale are relatively imprecise and freely chosen response categories tend to change in five-degree steps at best which is hardly sufficient to detect a change of two degrees. In addition later judgments are no doubt influenced by earlier ones when only one line is used in the experiment. The alternative method is to embed the inspection line in a series of test lines and ask for magnitude estimates of the whole series. In this case one cannot be sure that the

presence of the other test lines does not contaminate the primary effect. However, an attempt along these lines was one of the purposes of experiment 1(d).

A second procedure is to ask for parallelism judgments of a comparison figure located in a region of the field thought to be unaffected by the tilt adaptation. In view of the uncertainty about the degree of transfer of the effect this must be a perilous procedure. Prentice and Beardslae (1950) exposed a three-inch inspection figure at 10° from the vertical on one side of the fixation point and subsequently a similar test figure the same distance on the other side. The subject reported whether the test figure appeared more or less tilted than the inspection figure had been. The reported normalization was about two degrees and the fact that this was not altered by making the square frame twice as large nor indeed by dispensing with it altogether was claimed as evidence against contamination by figural after-effects. Nor was there any effect of a parallelogram frame with its vertical sides parallel with the test and inspection lines - a condition in which supposedly no satiation effects would be predicted.

But Heinemann and Marill (1954) argued that figural after-effects could be differentially operative even with a parallelogram frame since the density of satiation is greater within acute angles than within obtuse ones. They

themselves repeated the experiment using various tilt combinations of lines and frame, and found only a saturation effect - the inspection lines appeared to align themselves with the frame. These problems of frame intrusion have been avoided in all the experiments reported by the author in this chapter by presenting only lines which lie on a radius or diameter of a circular aperture.

Held (1963) used a similar procedure involving test/inspection and comparison figures on opposite sides of the fixation point, and reported a normalization effect, but Morant (private communication) has been unable to reproduce the results. In any case these techniques can detect only that portion of the effect which does not transfer over the distance between the two figures and Morant and Mikaelian reported a 66% transfer of a tilt after-effect across seven degrees of visual angle.

Another technique, not without its own problems, is to ask for alignment judgments of the two halves of the diameter of a circle centred on the fixation point before and after inspection of one of the component radii of the diameter. In addition, two diameters placed symmetrically about and close to the vertical can be used to test for simultaneous normalization in opposite directions - an effect not easily predictable from either theory. This approach has been investigated in experiments 1(b) and (c).

When we look at the case of test lines tilted in the same direction and to a greater extent than the inspection line there once again seems to be a clear cut issue. The prediction from satiation theory must be that lines more tilted than the inspection figure will, like lines less tilted than it, be apparently displaced away from its location, i.e. lines more and less tilted than the inspection figure will be apparently displaced in opposite directions. Gibson on the other hand holds that scales tend to be displaced as a complete unit so the effects should be approximately equal and in the same direction for all test lines. Figure 1.2 shows in general terms the displacement as a function of the orientation of local test lines as predicted from each theory separately. It is clear that even if the two functions are combined there should be at least a sudden fall in the magnitude of the effect at the location of the inspection figure. A study based on this reasoning is reported as experiment 1(d).

Finally the test line may actually be the main axis at right angles to the one near which the inspection line falls. In the case, for example, of an inspection line tilted 10° anti-clockwise from the vertical it seems clear that adaptation theory would require that a horizontal line, like a vertical line or any other line, should be apparently displaced in a clockwise direction. This effect on the more

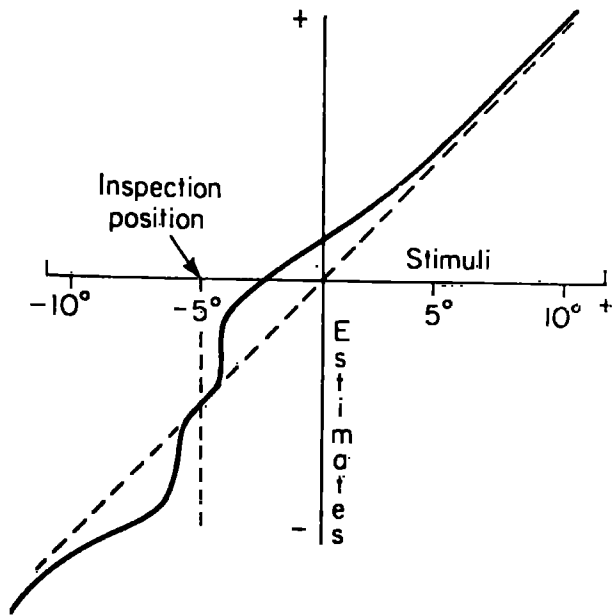

(a)

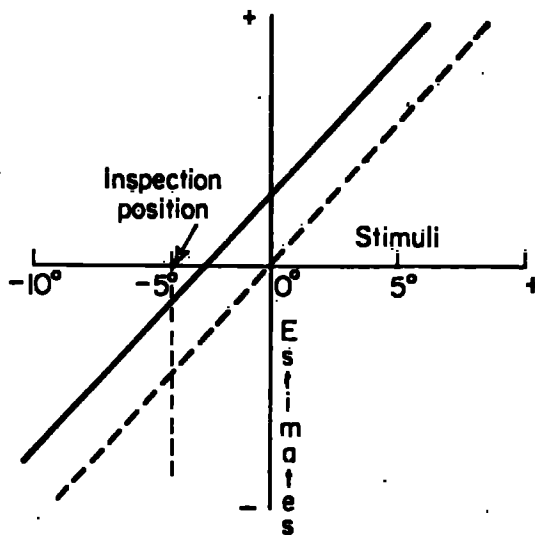

(b)

FIG 1.2

The predicted scale shifts in absolute judgments of inclination after inspection of a line tilted to -5° according to (a) Köhler and (b) Gibson

distant main axis is known as the "indirect effect". If there is any prediction from satiation theory it must be in the opposite direction, viz. that the horizontal should suffer an apparent anti-clockwise rotation since this would make it more nearly normal to the inspection line which is the steady state for the relative orientation of two intersecting lines according to this theory.

As with most of the issues in this area conflicting results have been reported. Gibson and Radner (1937) and Morant and Mistovich (1960) observed the indirect effect whereas Köhler and Wallach (1944) and Prentice and Beardslee (1950) did not. Those who have found it report it to be about half the size of the corresponding direct effect, the size difference being interpreted by Gibson as "play between the axis", by Morant as due to the summation of the tilt adaptation and figural after-effects (opposed in the case of the indirect effect, in agreement in the case of the direct effect).

Experiment 1(e) provides clear-cut confirmation of the occurrence of the indirect effect. Since the data for this experiment was collected Morant and Harris (1965) have reported a more comprehensive study which incidentally confirms the occurrence of the indirect effect. They made predictions about how apparent displacement of a vertical test line would vary as a function of inspection-line

orientation on the basis of (a) satiation theory, (b) adaptation theory and (c) the algebraic sum of the functions generated by the two predictions. These predicted functions are shown in figure L3 together with Morant and Harris's empirical results. The observed curve appears to match well the general shape of the combined function; in particular, the curve does cross the zero axis, demonstrating the "indirect effect" and establishing the presence of a Gibson-type process, and the cross-over point is not at 45° . This last feature could indicate that the vertical norm is stronger than the horizontal norm, but Gibson has found that the reverse is true and Morant and Mistovich (1960) that they are of equal strength. So the assumption of Morant and Harris that it indicates the operation of a satiation process is probably justified, although the smaller extent of the indirect effect might be due simply to a lack of complete transfer of the adaptation process - a "play" between the axis.

Fig. 1.3 Negative after-effect on the vertical as a function of inspection-line orientation (Morant and Harris, 1965).

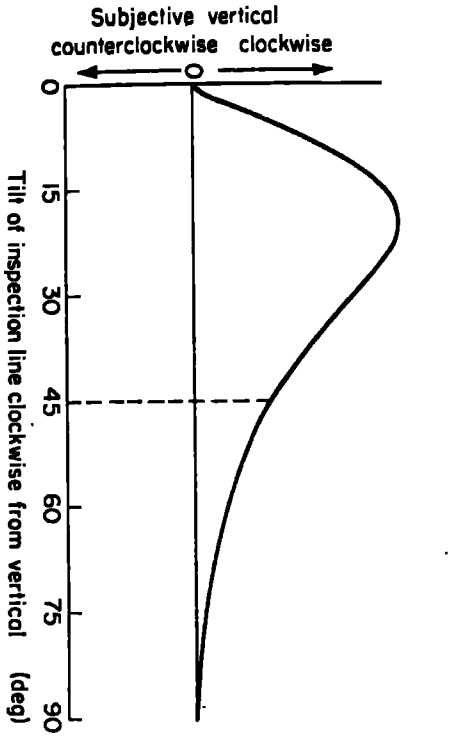

Hypothesized effects of 'satiation' process.

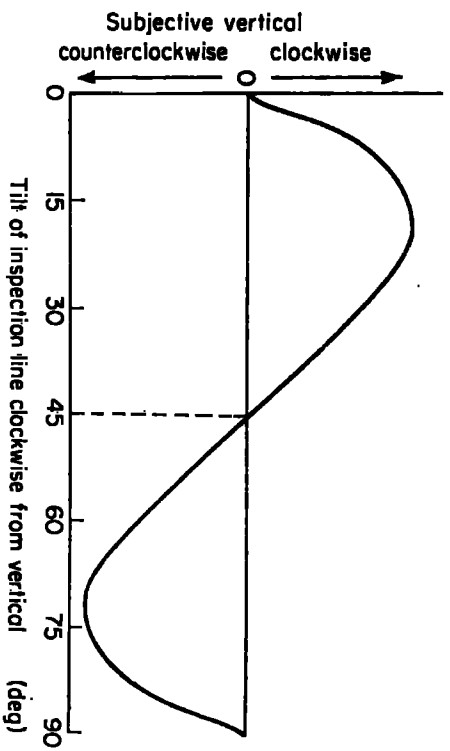

Hypothesized effects of 'adaptation' process.

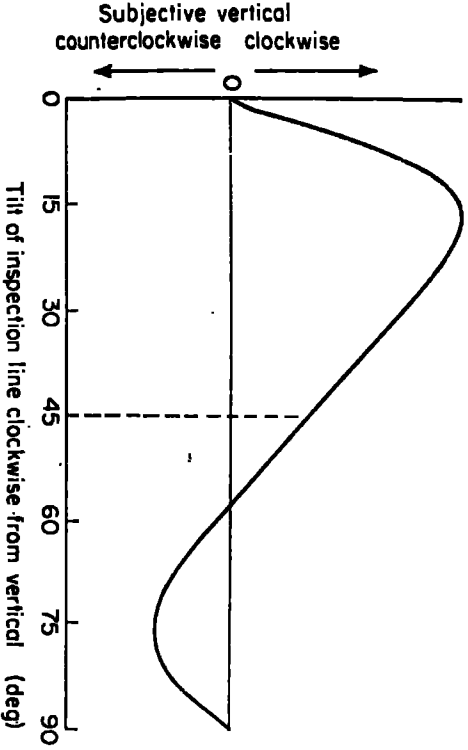

Algebraic summation of 'satiation' and 'adaptation' effects.

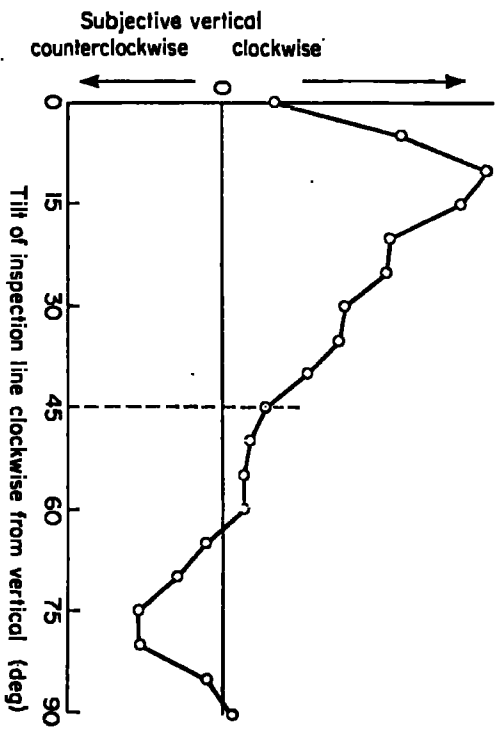

Measured amount of tilt after-effect for increasing amounts tilt of the inspection line.

EXPERIMENT 1(a).

This experiment was concerned with testing the symmetry of the effects of a vertical line and a tilted line on one another. Such symmetry would be taken as strong evidence that the vertical norm has no special significance in the explanation of tilt after-effects, which would then appear simply as special cases of the figural after-effect.

Method.

A split-beam tachistoscope was used, one channel carrying the inspection figure and the other the test figure (and in Part II the comparison figure). Each stimulus consisted of an 11 inch, 60w. strip-light pivoted about its centre and reduced to give a line of light 0.08 in. wide. Both test and inspection figures had small opaque fixation points at their centres and were located in such a way that, when both figures were illuminated, their fixation points coincided. The subject had his head clamped and viewed the figures in a dark field from a distance of 40 inches.

In each of the two parts of the experiment a forced choice, constant stimulus method was used, first under control conditions and later with the inspection figure present. In Part I the test figure appeared alone in one of five positions separated by half-degree steps from one

degree clockwise to one degree counter-clockwise about the vertical and the subject had to respond that it appeared wither clockwise or counter-clockwise relative to the vertical. In Part II, due to the imprecision of absolute judgments of tilted lines, a comparison figure was presented tilted 10° counter-clockwise and located four inches to the left of the test figure, which in this case varied from nine to eleven degrees counter-clockwise, again in half-degree steps. The subject responded according to whether the test line appeared to be tilted clockwise or counter-clockwise relative to the comparison line.

In each Part the initial control condition consisted of five one-second presentations of the test figure (and comparison-figure in Part II) in each of its five orientations, in random order. Between presentations there was a five-second dark period with no figure visible. Then followed a sixty-second period during which only the inspection figure (in Part II a vertical line, in Part I a line tilted 10° clockwise) was visible and fixated. This was immediately followed by the post-test which consisted of a repeat of the 25 trials of the pre-test with the single difference that the inspection figure was fixated during the five-second inter-trial interval.

The subjects were 10 undergraduates most of them new to studies in this area and all ignorant of the purpose of the experiment. All appeared in both parts of the experiment, half of them in each of the two possible orders. The parts were separated by several days.

Results and Discussion.

The total number of clockwise responses was counted for each subject in each condition of each part of the experiment and the means are shown in Table 1.1.

Table 1.1.

Mean number of 'clockwise' responses.

	<u>Part I.</u>	<u>Part II.</u>
Pre-test	14.5	9.4
Post-test	3.5	3.5
Difference	11.0	5.9

In Part I the inspection figure was tilted clockwise so either of the effects under consideration should produce a tendency for stimuli near the vertical to be seen as tilted relatively counter-clockwise and hence a decreased number of "clockwise" responses in the post-test. Similarly in Part II the vertical inspection-figure is oriented clockwise relative to the test-figure positions and so a figural

after-effect would be manifested in a tendency for the test-lines to appear more tilted (counter-clockwise) and hence again a decrease in the number of "clockwise" responses. The differences of 11 and 5.9 are thus both in the expected direction and are significant by t-test for correlated means at the .001 and .01 levels respectively. But the difference of 5.1 between the two effects also is significant, at the .02 level. Thus it appears that in addition to the satiation component, present in both effects, there is an additional effect operating when the inspection line is tilted rather than vertical and we can conclude that on this issue there is no confirmation of the satiation theorists claim to subsume entirely the tilt effects.

One possible criticism of this experiment is that the use of a comparison figure and judgments of apparent parallelism in Part II invalidates the direct comparison of the two parts. The similarity of the variances in the two situations suggests, however, that the tasks are quite comparable. It could also be argued that the comparison figure as well as the test figure might be affected by the process of the inspection figure. But satiation produced by the inspection figure, while it would cause the test figure to appear more tilted than it really was, could only have the opposite effect on the comparison figure - only in the

special case where the test and inspection lines actually cross does the apparent angular separation increase; in other cases that part of the test figure which is closer to the position of the inspection figure suffers greater apparent repulsion, thereby reducing the apparent angular separation of the lines.

If the test line retains its linearity during the apparent displacement then of course it is strictly impossible for it to undergo a different displacement depending on whether or not it intersects the path of the inspection line since the latter case is merely an extension of the former, and this points up the confusion discussed in the introduction to the section on "Tilt adaptation and figural after-effects" as to whether satiation theory can actually predict a change in the orientation of a test line.

Use of a comparison figure in Part I, on the other hand, is precluded by the probability that the Gibson effect transfers at least to some extent and would therefore tend to be partialled out through the inspection figure's having a similar effect on both test and comparison figures. Indeed, Köhler and Wallach's use of a comparison figure in Part I is the most likely explanation for their failure to obtain a difference between the two situations.

The response-count in Table 1.1 suggests that the two effects may be of similar magnitude since the numbers of responses representing apparent displacements in the two parts are in the ratio of almost 2:1. Unfortunately it is not possible to derive from the data a more precise estimate of their relative magnitudes based on the P.S.E.'s; the effects in both parts were so large relative to the range of the test-stimuli that the extrapolation required to estimate median points in the post-test conditions could only be the wildest guess. In any case evaluation of the effects by subtraction of this sort requires the assumption that they are additive, an assumption made extremely difficult to test by the apparent impossibility of devising a condition in which the Gibson effect might be expected to occur alone.

EXPERIMENT 1(b).

This experiment was an attempt to demonstrate normalization under adverse conditions. It will be convenient here to describe the experiment first and provide the theoretical rationale later.

Method.

A three-channel mirror tachistoscope was used. The stimulus material was a series of black eight-inch-high figures drawn on white cards which were front illuminated in the instrument and viewed at an optical distance of 40 inches. The apex of the V was always in the centre of the circular field and served as a fixation point. The apex angles ranged from 38° to 44° in steps of two degrees. The figures could be presented either as V's or inverted V's, always symmetrically about the vertical. For one set of readings the test/inspection figure was a single 40-degree V presented in one channel of the tachistoscope. In the other channel appeared an inverted V comparison figure with the apices of the two figures exactly in register. The third channel permanently held a card bearing only a black fixation point, also in register with the apices. The two figure-carrying channels were simultaneously illuminated for a half-second every five seconds and for the remainder of this period the fixation point only was visible.

The subject was instructed to fixate on the point throughout the experiment and when he briefly saw a figure like a multiplication cross to indicate by vertical movement of a post-office switch whether the top or bottom angle of the cross appeared larger. There were fifty trials with each of the five sizes of comparison inverted-V appearing ten times in random order.

Immediately after this pre-test series the subject fixated the test/inspection V for 60 seconds and then without delay the post-test series commenced. This was identical with the pre-test series except that during the five-second inter-trial intervals the subject continued to fixate the test/comparison figure instead of just the fixation point.

Thus the subject judged the angular size of a 40° V in relation to an inverted-V presented directly below it and either the same size or two or four degrees larger or smaller than it, and the judgments were made before and after inspecting the 40° V for one minute. For half the subjects the test/inspection figure was an inverted V and the comparison figures erect V's.

Subjects were ten undergraduate volunteers, naive as to the purpose of the experiment.

Rationale.

In this situation the predictions from satiation theory are that (i) the arms of the comparison angles will undergo an apparent displacement away from the position of the previously inspected angle, making the comparison angles appear smaller than they otherwise would, and possibly (ii) that the test/inspection angle will suffer an apparent growth as it is inspected due to the denser area of satiation within the angle. Although not made explicit by Köhler and Wallach it seems clear that their satiation principle would demand this latter effect due to greater density of satiation within inspection figures (Hebb, 1949) but the empirical results are equivocal (Köhler and Wallach, 1944; Walthall, 1946; Ikeda and Obonai, 1953; Duncan, 1960). In the case of either of these predictions the result would be an apparent growth of the test/inspection angle relative to the comparison angles.

The prediction from adaptation theory is less clear-cut. Each arm of the inspected angle alone would tend to normalize to the vertical during inspection. But Gibson's original formulation and more recent work by Rich and Morant suggest that the perceptual scale of tilt is relatively rigid and therefore when both arms of the angle are inspected each should neutralize the normalization of the other and

no change in the apparent size of the angle could be expected. It may be, however, that the scale is not completely rigid and that both arms could normalize, at least to some extent, simultaneously.

The experiment was therefore regarded as a test of normalization under the most adverse conditions and a significant apparent shrinkage of the test/inspection angle would have been regarded as the first clear-cut demonstration of the phenomenon.

Results and Discussion.

The number of "top larger" responses was counted for each subject for both pre-test and post-test series. The comparisons indicated that six subjects reported the comparison figure as the larger more frequently in the post-test series than in the pre-test thereby indicating a probable apparent shrinkage of the inspected figure. However, three of the subjects showed a change in the opposite direction while the final subject yielded no change. A t-test revealed no significant overall change in judgment.

Although the trend of the results is thus in favour of the adaptation hypothesis, no definite conclusion can be drawn. In view of the uncertainty as to whether one can expect simultaneous bilateral tilt adaptation it may be that the test was too stringent. Accordingly, a further

experiment was designed, incorporating the present conditions together with an opportunity for unilateral normalization.

EXPERIMENT 1(c).Method.

The apparatus and procedure were similar to the previous experiment. But the inspection figure was either the fixation point alone, or a line extending from the fixation point at angle of ten degrees clockwise from the vertical, or two such lines symmetrically placed about the vertical to form an angle of 20° . In all cases the test figure consisted of a line 10° clockwise from the vertical (i.e. coincident with the unilateral inspection figure or one of the lines of the bilateral inspection figure), together with a line which was actually or almost its extension below the fixation point. The task was to say whether the lower, variable line deviated to right or to the left of the true extension of the upper line. Performance was found to be more precise on this task than on the previous one and so the steps separating the five positions of the lower line were only one half-degree in size.

The subjects were 18 undergraduate volunteers. Each participated in all three conditions, with three subjects being assigned to each of the six possible sequences of conditions. At least 15 min. of normal visual stimulation intervened between conditions.

Results.

The number of "left" responses was counted for each subject in each half of each of the three conditions and a split-plot analysis of variance was performed on this data, as shown in Table 1.2.

Table 1.2 analysis of variance of the number of left responses in experiment 1(c).

Source.	S.S.	d.f.	M.S.
Sequences	272	5	54
Subjects within sequences	698	12	58
Subjects (sub-total)	970	17	
Conditions	60	2	30
Conditions x sequences	109	10	10.9
Conditions x subjects within sequences	271	24	11.3
Halves	3	1	3
Halves x sequences	18	5	3.6
Halves x subjects within sequences	52	12	4.3
Conditions x halves	24	2	12
Conditions x halves x sequences	86	10	8.6
Conditions x halves x subjects within sequences	192	24	8
Pooled subject interactions	515	60	8.6
Within subjects (sub-total)	815	90	
Total	4085	107	

3.5^{xx}

The three subject interactions were compared using progressive F-tests, none of which reached significance at the 10% level, and were consequently pooled to provide a single error term for all within-subject effects. Except for conditions no effect approaches significance. The insubstantial magnitude of the halves and conditions x halves terms is particularly noteworthy; any difference between the conditions was presumably established by the original period of inspection and then maintained but not increased by the inter-trial topping-up periods.

Individual comparisons among the conditions were made using Dunnett's (1955) test for comparing several means with a control. The unilateral condition mean (8.86) differs from the control condition mean (7.11) at the 2% level using a one-tailed t. In the case of the bilateral condition there are contradictory predictions and a two-tailed test is appropriate. This mean (8.42) does not differ from the control mean at the 5% level. A change in the choice of one or two-tailed tests would not affect the significance levels of these comparisons. It should be pointed out, however, that a set of planned orthogonal comparisons would indicate that the difference between the control and the other two conditions is significant at the 1% level while the latter do not differ significantly from one another, a good example of the ambiguity inherent in the use of individual comparisons.

Discussion.

Once again, as in the earlier experiment, the evidence regarding the effect of inspecting a V is equivocal. The evidence does, however, suggest that the presumed satiation hypothesis of an apparent expansion of an inspected V can be discarded. But statistical argument about the significance of the shift in the opposite direction is made pointless by a glance at Figure 1.4 where the average psychophysical functions are shown for the three conditions. Not only the statistically equivocal bilateral condition but even the unilateral condition, clearly significant in terms of response count, reveals a mean shift in P.S.E. (by linear interpolation) of less than one half of one degree: a good example of the coincidence of statistical significance and empirical triviality. This experiment must therefore be counted as a further failure to demonstrate normalization.

FIG 1 4 PSYCHOPHYSICAL FUNCTIONS IN EXPERIMENT 1 (C)

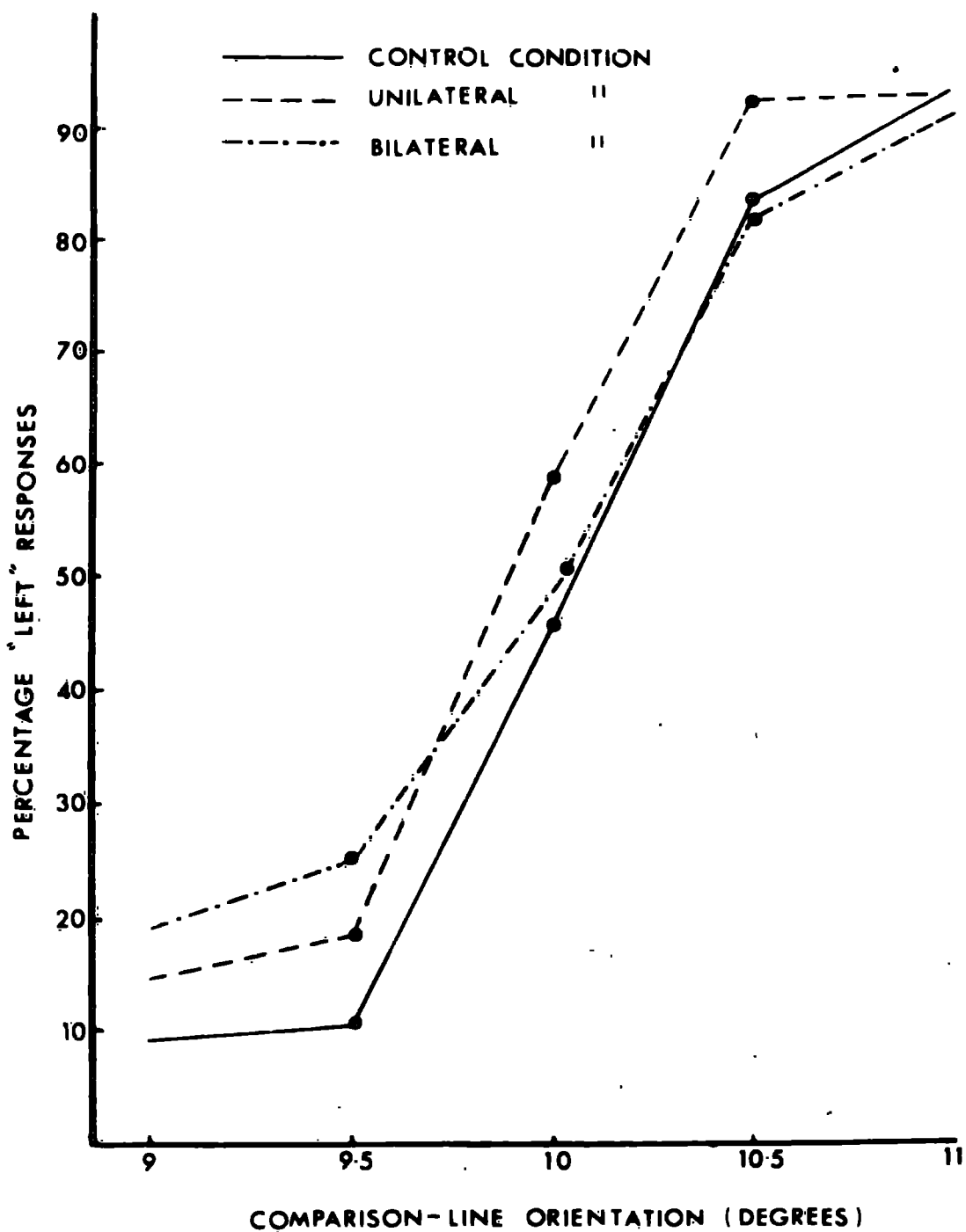

EXPERIMENT 1(d).

In this experiment magnitude estimates of frontal plane tilt were obtained in an effort to find a more sensitive index of normalization and also to explore the tilt after-effect as a function of the orientation of test lines.

Method.

The apparatus was similar to that used in the two previous experiments - a split beam tachistoscope with one channel carrying a fixation point and, where appropriate, an inspection figure, the other a test figure. All figures consisted of black diameters drawn on a circular white card with a fixation point at the centre; nothing else was visible to the subject. There were ten test figures consisting of single diameters which varied in two-degree steps from -9° (anti-clockwise) to $+9^{\circ}$ (clockwise) about the vertical. The thirty trials were divided into three blocks with each test figure being presented once in each block in an order independently randomized from block to block and condition to condition. The test exposures were one second each and were separated by five seconds, during which the inspection figure was visible. The seven conditions corresponded to seven inspection figures - single diameters at -15° , -5° , $+5^{\circ}$, or $+15^{\circ}$, two diameters simultaneously

presented at $+15^\circ$ and -15° ($\pm 15^\circ$) or at $+5^\circ$ and -5° ($\pm 5^\circ$), and finally the control condition with only the fixation point in the white circular field.

Each of the seven subjects - all undergraduates naive about the purpose of the experiment - served in all seven conditions in a unique order determined by a 7 x 7 Latin square. Conditions were separated by about 5 minutes during which the subject carried on normal visual behaviour with the room lights on. The initial instructions to the subjects were simply to fixate throughout the session and to respond to each test-stimulus presentation with a number which should be proportional to the apparent tilt of the line from the vertical, a negative number for anti-clockwise tilt, a positive one for clockwise tilt. "For example, if you called a particular anti-clockwise line 'minus six' then you would call a line which was tilted the same amount in the opposite direction 'plus six' and one which was half-way between that and the vertical 'plus three'". Subjects were urged once they had settled on a scale to try to maintain consistency of meaning of the numbers throughout the experiment. In fact, perhaps biased by the instruction example, all subjects used either five or six as their maximum numbers, positive or negative.

Results.

The estimates in the first of the four blocks in each condition tended to be rather wild and were not used in the analysis. Thus when the behaviour reflected in the analysis began the subject had already been exposed to the inspection figure for 50 seconds, and to the test figures for a half-second each. This omission was not detrimental to the objects of the experiment since the main interest was in condition comparisons rather than time trends (block comparisons).

The data analysed in Table 1.3 are thus the estimates of the ten stimuli by the seven subjects in the three blocks of each of the seven conditions.

Table 1.3.

Analysis of variance of magnitude estimates of tilt in experiment 1(d). The F-ratio for each for each term is the ratio of its mean square to that of the succeeding term.

Source.	S.S.	d.f.	M.S.	F
Subjects	296.23	6	49.37	
Conditions	315.46	6	52.58	16.90 ^{xxx}
Conditions x Subjects	111.88	36	3.11	
Stimuli	6360.14	9	706.68	399.00 ^{xxx}
Stimuli x Subjects	95.71	54	1.77	
Blocks	3.13	2	1.56	9.18 ^{xx}
Blocks x Subjects	2.05	12	0.17	
Conditions x Stimuli	139.06	54	2.58	5.86 ^{xxx}
Conditions x Stimuli x Subjects	143.79	324	0.44	
Conditions x Blocks	5.65	12	0.47	1.27 N.S.
Conditions x Blocks x Subjects	26.43	72	0.37	
Stimuli x Blocks	13.06	18	0.73	2.35 ^{xx}
Stimuli x Blocks x Subjects	33.47	108	0.31	
Conditions x Stimuli x Blocks	25.59	108	0.24	0.96 N.S.
Conditions x Stimuli x Blocks x Subjects	161.26	648	0.25	
Total	7732.90	1469		

The significant blocks and stimuli x blocks effects were unexpected but are irrelevant to the present discussion; they presumably indicate that the form of the subjective scale alters over time but this is true for all conditions since the three-way interaction is not significant. Hence the effect of primary interest here - the conditions x stimuli interaction - apparently does not vary from one block of trials to another.

The conditions x stimuli interaction is highly significant and its form is illustrated in figures 1.5 - 1.10 where the subjective scale for each of the six experimental conditions (solid circles) is shown together with that for the control condition (outline circles). There is clearly a tendency for an apparent displacement away from the side on which inspection figures lie, at least for stimuli located on the same side as the inspection figure.

Before investigating this further we must look in some detail at the control condition. The trends in this condition are analysed in Table 1.4.

FIG.1.5 ESTIMATES IN CONTROL (o)
AND +5°(●) CONDITIONS

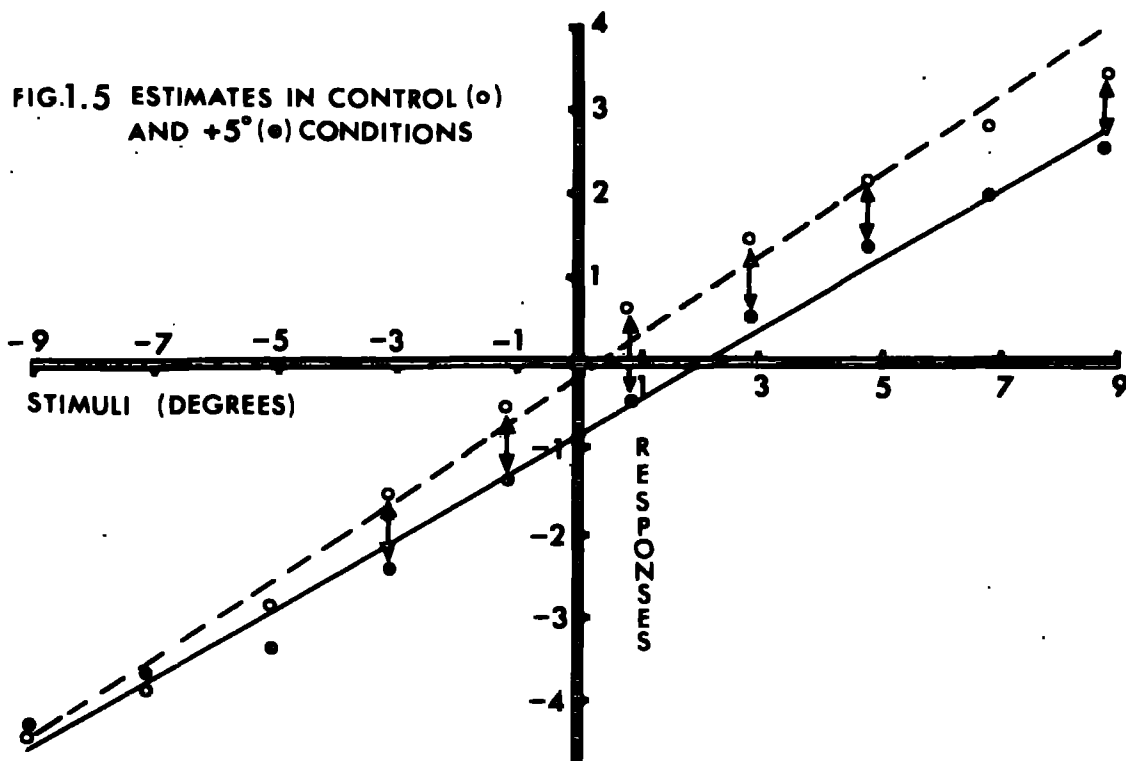

FIG.1.6 ESTIMATES IN CONTROL (o)
AND +15°(●) CONDITIONS

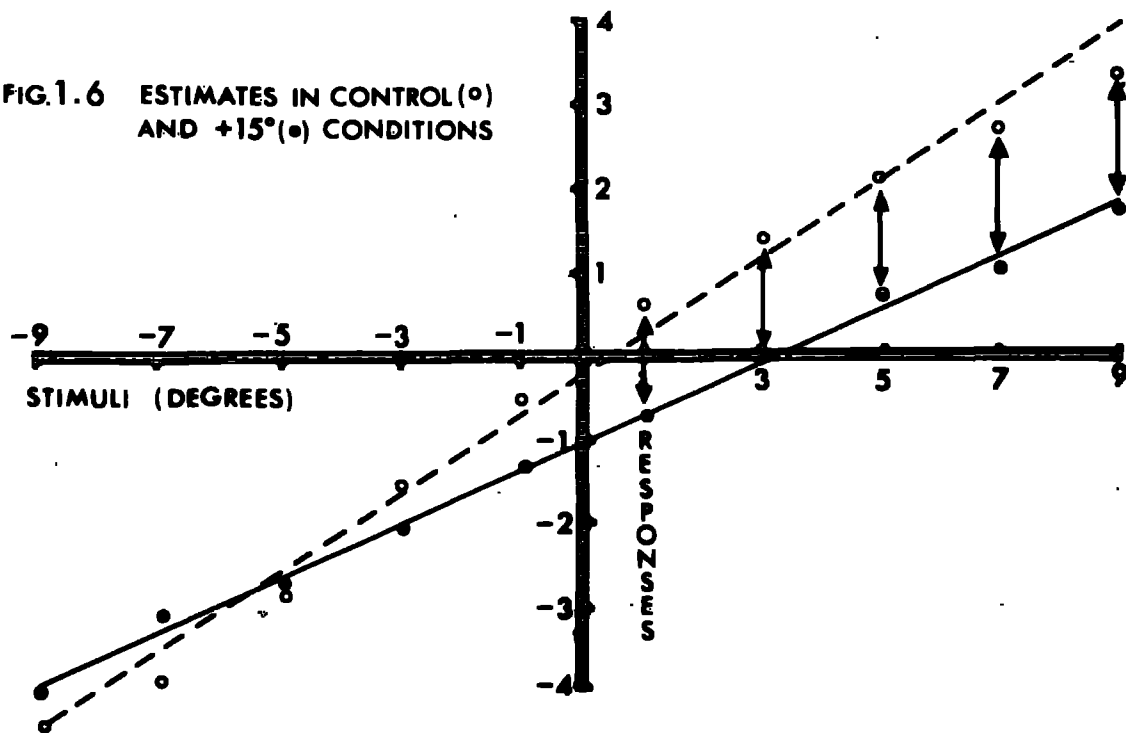

FIG. 1.7 ESTIMATES IN CONTROL (○) AND -5° (●) CONDITIONS

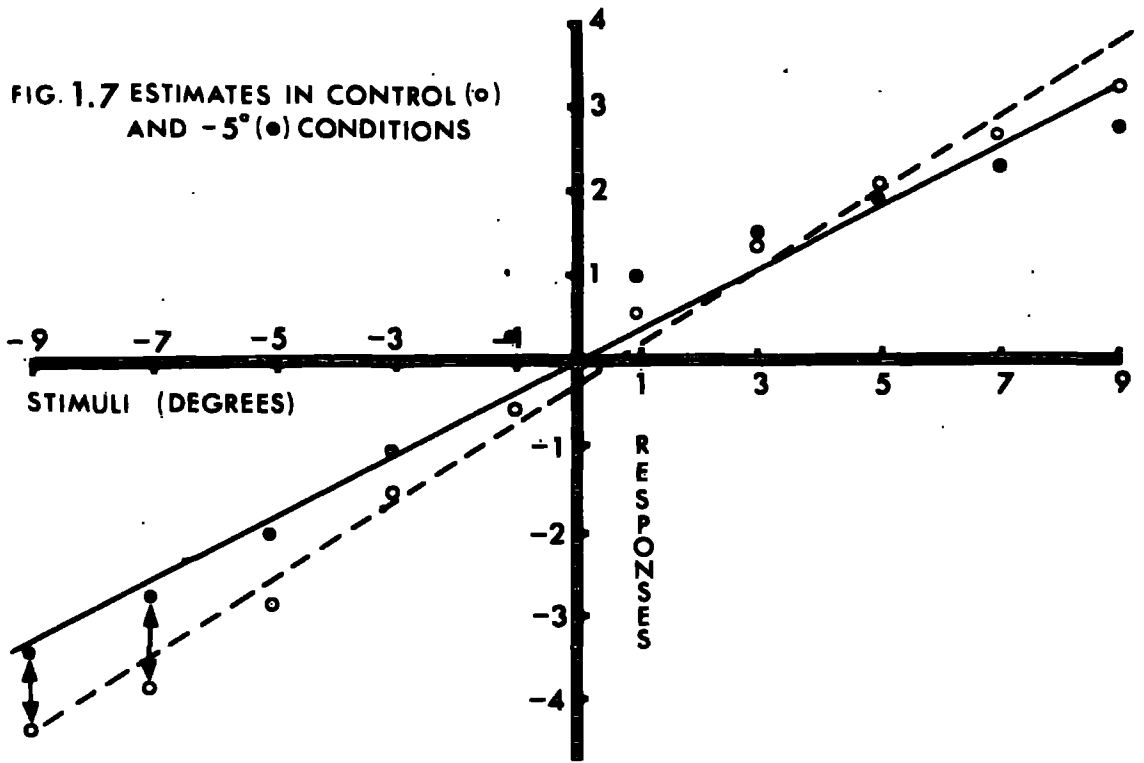

FIG. 1.8 ESTIMATES IN CONTROL (○) AND -15° (●) CONDITIONS

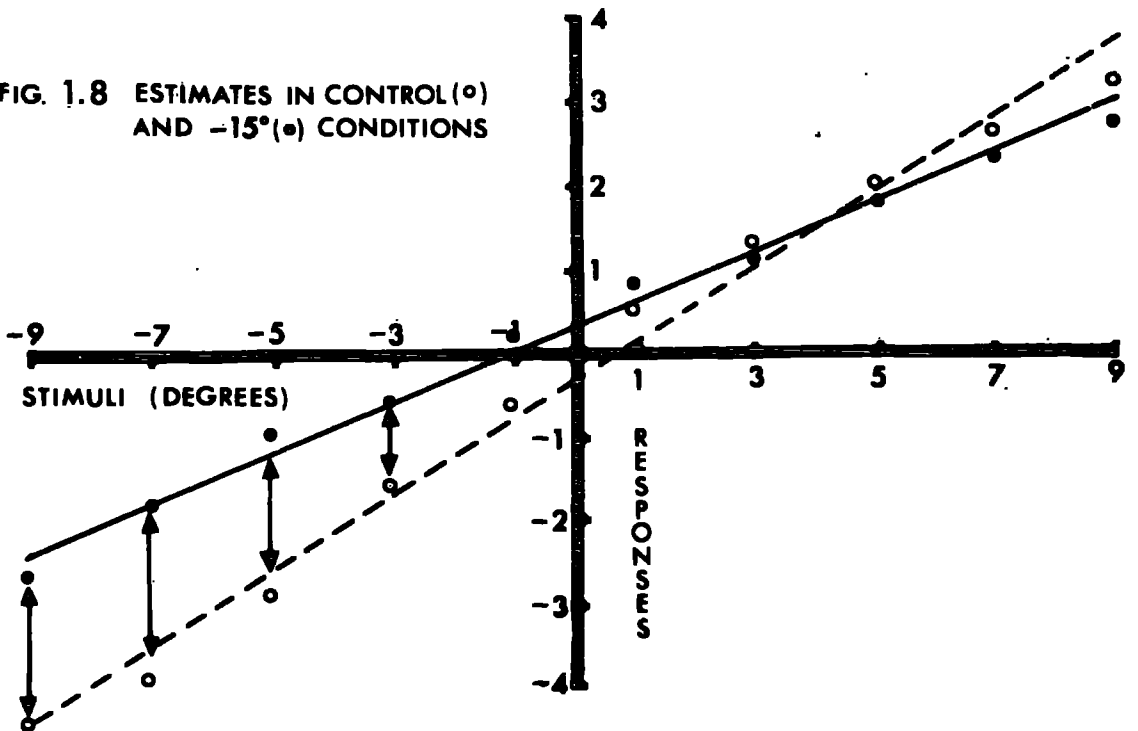

FIG.1.9 ESTIMATES IN CONTROL (○)
AND $\pm 5^\circ$ (●) CONDITIONS

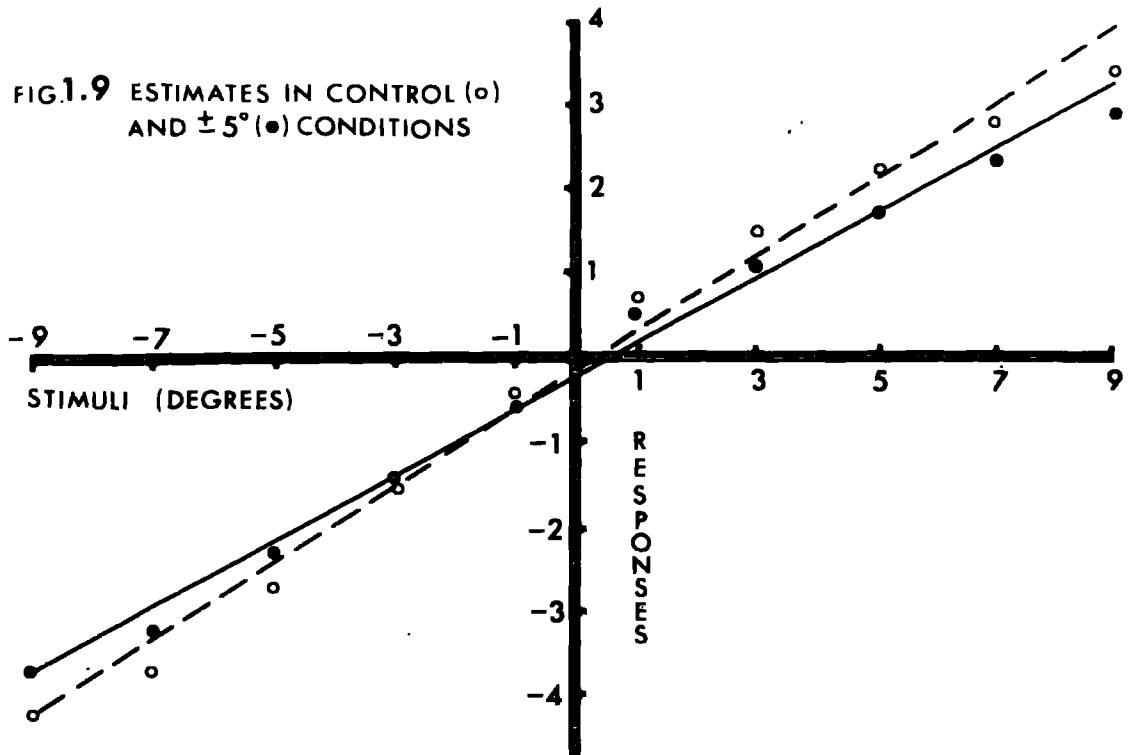

FIG.1.10 ESTIMATES IN CONTROL (○)
AND $\pm 15^\circ$ (●) CONDITIONS

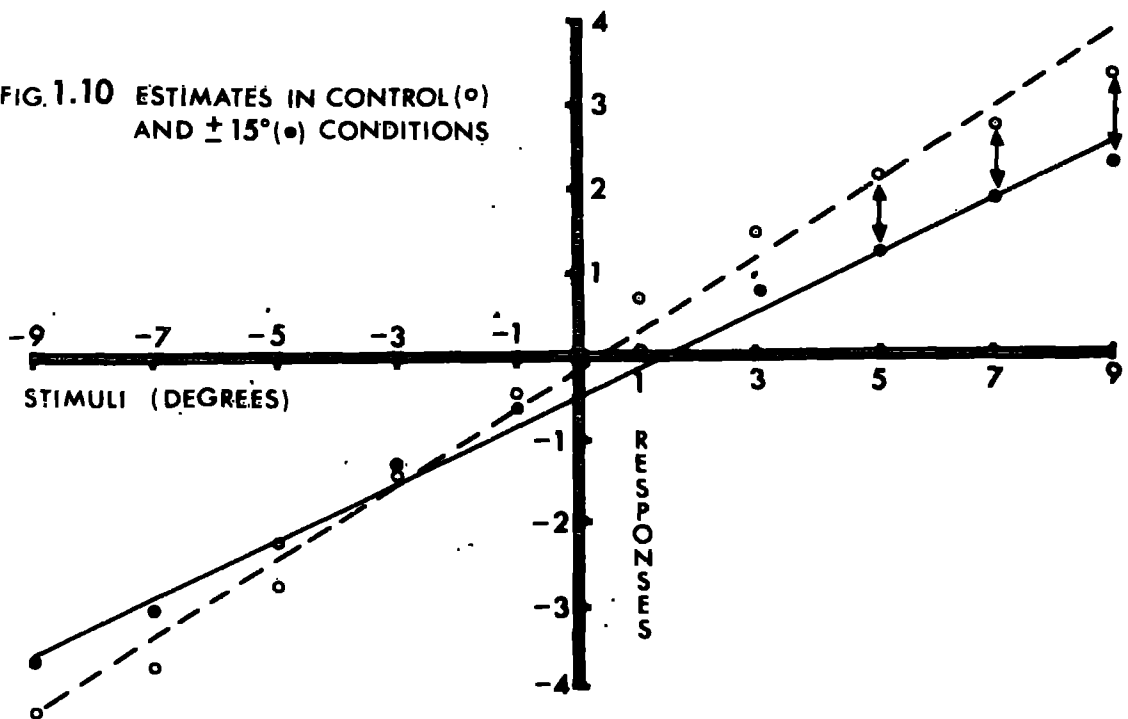

Table 1.4.

Trend analysis of mean estimates of stimuli in the control condition.

Source.	S.S.	d.f.	M.S.	F
Stimuli	1383	9	153.7	244 ^{XXX}
Linear trend	1364	1	1364	2165 ^{XXX}
Quadratic trend	9.5	1	9.5	15.1 ^{XXX}
Cubic trend	5.4	1	5.4	8.6 ^{XX}
Residual trend	4.5	6	0.75	1.2 N.S.
Error	239.5	378	0.63	

Since these trend effects represent comparisons among the stimulus means for a particular condition, the error term is the weighted mean of the error terms for stimuli and for stimuli x conditions viz. stimuli x subjects and stimuli x conditions x subjects.

Although linear trend accounts for almost 99% of the stimuli sums of squares, due to the smallness of the error term the quadratic and cubic components are also highly significant. These higher-order trends are quite noticeable in the plotted data but the fact that they are seen to a greater or lesser extent in the other conditions as well suggests that they are inherent properties of the scaling process in this situation. This conclusion is strengthened by the trend analysis of the conditions x stimuli interaction shown in Table 1.5.

Table 1.5.

Trend analysis of the conditions x stimuli interaction.
(Error term is the error term for the interaction viz.
conditions x stimuli x subjects).

Source.	S.D.	d.f.	M.S.	F
Conditions x Stimuli	139.1	54	2.6	5.9 ^{xxx}
Linear trend differences	104.9	6	17.5	39.7 ^{xxx}
Quadratic trend differences	15.2	6	2.5	5.8 ^{xxx}
Residual trend differences	19.0	42	0.45	1.0 N.S.
Error	143.8	324	0.44	

This shows that although the quadratic trend also differs significantly between conditions, 75% of the conditions x stimuli interaction is accounted for by differences in linear trend. Further investigation of the significant differences in quadratic trend reveals no apparent relationship with the characteristics of the inspection figures: the magnitudes of negative curvature of the conditions in descending order are -5, control, ± 15 , ± 5 , -15, +15, +5, with the latter two having negligible curvature.

Accordingly, in view of the fact that the curves predicted from satiation theory either alone (Figure 1.2) or in combination with adaptation theory clearly suggest significant cubic or higher-order differences and that there is no evidence for such differences, attention was focussed

on the predominant differences in linear trend.

These demonstrate a clear relationship with inspection figure characteristics as is shown in Figures 1.5-1.10 where the best-fitting straight line for each condition is paired with that for the control condition.

Also indicated in these figures are the differences between data points which are significant at the .01 level (two-tailed). These result from applying Dunnett's (1955) test for the comparison of K means with a control to the difference between each experimental condition and the control at each test-stimulus position.

The picture that emerges from this data is that all of the original hypotheses are contradicted in important respects. Contrary to the satiation-theory predictions there is normalization of test figures in the same location as inspection figures. This is strongly implied in the $+15^{\circ}$ and -15° conditions, and shown directly in the $+5^{\circ}$ and -5° conditions, though in the latter it just fails to reach significance. The magnitude of the effect in the two 5° conditions can be estimated at two degrees by calculating that the response made to the 5° inspection stimulus in the control condition is, in the appropriate experimental condition, made to a stimulus of just over 7° and the response made to the 5° stimulus during inspection is made in the control condition to a stimulus of just over 3° .

The $\pm 5^\circ$ condition shows a tendency towards simultaneous bilateral normalization, again in contradiction to satiation theory; but as in experiments 1(b) and (c), not significant. This effect is also implied in the ± 15 condition.

In addition, effects on test stimuli more tilted than the inspected stimulus should be markedly different from those on stimuli less tilted. But examination of the relevant 7° and 9° stimulus positions in the 5° conditions reveals no evidence of either a reversal of the direction of the effect as required by satiation theory, or even a reduction in the size of the effect, which would be compatible with the combined operation of the two mechanisms.

It seems therefore that, rather surprisingly, there is no evidence in the data for the operation of satiation process as envisaged by Köhler and Wallach. On the other hand, it seems doubtful that Gibson's theory can account for much of the data pattern either. Certainly there is normalization and the apparent displacement is in the same direction for all stimuli on the same side of vertical as the inspection figure, whether more or less tilted than it. But in all four unilateral conditions the effect declines to zero a few degrees on the other side of vertical from the inspection figure. (Indeed, they all show an actual reversal of the effect though in no case does the reversed effect reach significance.) Such a reduction in the effect

would of course be predicted by the two-factor theory, but not to zero, and in any case the two-factor theory would seem to be ruled out by the evidence discussed earlier.

In fact, the linear trend of these effects if taken at face value, creates serious problems. In the 5° conditions it seems inconceivable that the displacement is larger for test stimuli more tilted than the inspection figure. Similarly in the 15° conditions extrapolation of the linear trends would lead to an implausibly large normalization effect on the appropriate 15° stimulus. Extrapolation in the other direction, on the other hand, would imply a reversed effect or at least a zero effect on test lines tilted more than a few degrees on the opposite side of vertical to the inspection figure, whereas it is now well established that effects are in the same direction for test stimuli as far away even as the horizontal (the indirect effect).

These anomalies cannot be the result of exposure to the series of test lines since this influence was present also in the control condition and is therefore partialled out from the difference scores. The addition of the inspection figures to the stimulus series, on the other hand, alters drastically the effective stimulus distribution and could produce purely semantic effects on the apparent subjective scale. As Campbell, Lewis and Hunt (1958) and others

have pointed out the interpretation of context effects in judgment is always ambiguous. They can be regarded "either as distortions of identity judgments which are independent of the specific details of the response system allowed, or as semantic effects limited to the specific response system employed in the method of single stimuli". This has tended to be a rather neglected possibility in studies where the attention is focussed on perceptual mechanisms rather than response biases. However, the present study used a dimension with a strong subjective reference point external to the specific range of stimuli on display, and the choice of response range was subject rather than experimenter controlled; both of these conditions have been shown to severely reduce context effects on judgment (Fillenbaum, 1961) the reduction presumably affecting mainly the semantic rather than the perceptual components of the effects. The only improvement which could be made in future studies is to modify the instructions with a view to tying the subjects' responses more closely to angular degrees.

For the present we must assume that the data reflect the operation of a genuine input-encoding mechanism and the most plausible view would seem to be that the apparent linear trend masks an actual pattern in which effects are maximal at the site of the inspection figure and remain high for several degrees on either side of it. If this were the case

it should become clear if the experiment were repeated using a wider range of test lines.

This would still leave unexplained the rapid decline of the effect to zero or beyond on the other side of the vertical from the inspection figure. This pattern is so marked and consistent that it is difficult to escape the conclusion that what we are dealing with here is a new effect, similar in some respects to Gibson's adaptation but much more localized. Such an effect would consist basically of normalization of an inspected line carrying with it only lines within ten or twenty degrees on either side of it, with more tilted inspection lines giving a larger effect and influencing the apparent orientation of a wider range of test lines. The question of what particular conditions give rise to this effect rather than true Gibsonian negative after-effect is one for future investigation, and the apparent non-occurrence of figural after-effects also remains a puzzle. But it is noteworthy that the mechanism suggested here could more easily encompass simultaneous bilateral normalization for the existence of which this experiment, like the two previous ones, provides weak but consistent support.

The conclusion mainly relevant to the theme of this chapter, however, is that in this situation one can record normalization and adaptation-like processes which depend on the relationship of inspected lines to main axis rather than merely on the separation of test and inspection lines and which are thus independent of satiation effects.

EXPERIMENT 1(a).

The purpose of this experiment was to demonstrate the occurrence of the "indirect effect" - the influence on apparent verticality of inspection lines close to the horizontal.

Apparatus.

A tachistoscope was used which had two viewing channels, each 40 inches long and of 16 inch square cross-section, set at right angles to one another. A front-silvered mirror of approximately equal reflectance and transmission was mounted at 45 degrees between the channels. The inspection pattern appeared in one channel, the test pattern in the other. Their exposure was controlled by two electronic timers.

The inspection pattern consisted of a white cardboard disc, 10 inches in diameter with a black inspection point at its centre. It was filled with a series of black parallel lines one sixteenth of an inch wide and one eighth of an inch apart. It was mounted centrally in the end wall of the viewing channel. Illumination was provided by two 11 inch, 60 watt strip-lights mounted vertically on the walls of the channel six inches from the end. Over this six inches the floor and walls of the channel were lined with mirror to diffuse the light. The disc could be rotated about its centre so that the lines were horizontal or tilted 10 degrees

clockwise or anti-clockwise from the horizontal. The two latter positions could also be alternated on successive trials by means of solenoids operated by the timers. This change-over of the inspection pattern always occurred when the test pattern was exposed, so that the subject never saw the movement.

Mounted in the end wall of the other channel was the test figure, a single strip-light pivoted about its centre. It was completely covered with cardboard except for a single strip ten inches long and one sixteenth wide. When illuminated this strip appeared as a narrow line of light in a dark field. It had a black fixation spot at its midpoint. The setting of the line was by manual control through a reduction mechanism of 80:1. The dial on the control knob was marked with five points. The five points indicated the angular position of the line - vertical and one and two degrees each way from the vertical.

The fixation points on the two patterns were superimposed when illuminated simultaneously. A single flexible rubber eye-piece was mounted externally on the box and centrally to the viewing channels. A cardboard stop, close to the eye, restricted the field of view in each channel to the size and shape of the circular inspection pattern. The tachistoscope was mounted on a rigid table whose surface was set truly horizontal.

The experimenter had five keys corresponding to the five positions of the test figure and these were wired to a recorder which stamped the digits one to six. Another two-way switch was placed convenient to the subject and wired to the first two channels of the recorder. The sixth channel was used as a spacer and was automatically pulsed after each trial by a unit controlled by the timers.

Procedure.

The subject was seated on a stool close to the tachistoscope. He pressed his left eye against the flexible rubber eye-piece so that all extraneous light was excluded. He was asked to adjust his position until the black spot in the middle of the array of horizontal lines was centred in the circular field of his eye-piece. He was told that there would always be such a spot in the centre of the field and he must constantly fixate it throughout the experiment. He would be shown the horizontal lines for a period of six seconds; then they would be replaced by a single near-vertical line with a black spot at its mid-point. This would be exposed for only one half second and he must indicate immediately, by means of the switch, which way it appeared to be tilted from the vertical. The sequence would then be repeated.

There were three series of trials in which the inspection lines were orientated as follows:

- (i) Horizontal - 50 trials.
- (ii) Ten degrees clockwise and ten degrees anti-clockwise, from the horizontal, on alternate trials - 100 trials.
- (iii) Ten degrees clockwise - 50 trials.

A minute's rest was allowed between the series and also half-way through series (ii).

The order of conditions was standardized for all subjects, as only the inspection figure in series (iii) could be expected to build up a unidirectional satiation which might cause systematic errors in subsequent series.

During each six-second inspection period the experimenter set the test line to one of its five positions: vertical and one degree or two degrees clockwise or anti-clockwise from vertical. In series (i) and (iii) each position was presented ten times in random order. In series (ii) the set of 50 even trials and the set of 50 odd trials each consisted of 10 presentations of each position in random order. The programme was arranged in this way so that the 50 readings which had been preceded by the clockwise (or anti-clockwise) inspection figure, could later be extracted and would still form a series in which the figure had been presented 10 times in each of its five positions.

Results.

The conditions used in the analysis were the result of the manipulations described above. The respective inspection figures were:

1. Ten degrees anti-clockwise mixed (i.e. presented in alternation with 10° clockwise).
2. Horizontal control.
3. Ten degrees clockwise mixed (i.e. presented in alternation with 10° anti-clockwise).
4. Ten degrees clockwise.

Each subject made 50 judgments in each condition and the number of "clockwise" responses was counted for each subject in each condition.

For the indirect effect to manifest itself fixation of a line tilted anti-clockwise from the horizontal not only must displace an objectively horizontal line in a clockwise direction (the direct effect) but must also displace in the same direction lines close to the vertical. Hence, there should be more clockwise responses following inspection of an anti-clockwise figure (condition 1) and fewer clockwise responses following inspection of a clockwise figure (conditions 3 and 4) as compared with the number of clockwise responses following inspection of a horizontal figure (condition 2). Table 1.6 shows the analysis of variance performed on the results.

Analysis of variance was performed on these means:

Table 1.6.

Analysis of variance for clockwise responses.

Source.	Degrees of Freedom.	Sums of Square.	Estimated Variance.	F
Conditions	3	2999	1000	74 p .001
Subjects	9	883	98.1	
Residual	27	364	13.5	
Total	39	4246		

The conditions term is very highly significant and would still be even if the degrees of freedom for the Geisser-Greenhouse conservative test were substituted. The theoretical predictions of differences among the means are clear and so we can perform a set of orthogonal comparisons as shown in Table 1.7.

Table 1.7.

Orthogonal comparisons among means of "clockwise" responses.

	10° anti-clockwise mixed.	Horizontal control.	10° clockwise mixed.	10° clockwise.	F ratio.
Mean.	31.8	26.0	20.1	8.4	
Comparison I	+3	-1	-1	-1	103 ^{xxx}
Comparison II		+2	-1	-1	68 ^{xxx}
Comparison III			+1	-1	51 ^{xxx}

All three comparisons are very highly significant. The first one establishes the effect of the anti-clockwise mixed condition in increasing the number of "clockwise" judgments

of near vertical lines. The second shows that the two clockwise conditions produce a decreased number of "clockwise" responses compared with the control; and the third one shows that this effect is significantly greater in the unmixed than in the mixed condition. All effects are thus in the direction predicted by adaptation theory and contrary to that predicted by satiation theory, so the "indirect effect" has been demonstrated.

Thus we have demonstrated Gibson's indirect effect. The mean points of subjective verticality and their P.E.'s were computed using Urban's constant process to derive the median of the best-fitting ogive (Table 1.8).

Table 1.8.

Mean points of subjective verticality and their probable errors, in degrees from the vertical, positive figures representing anti-clockwise deviations.

Inspection figure.	10° anti-clockwise mixed.	Horizontal control.	10° clockwise mixed.	10° clockwise
Mean point of subjective verticality.	0.81	0.12	- 0.54	- 2.34
Probable error.	0.15	0.13	0.13	0.17

The size of the indirect effect is calculated as 2.46 degrees, the differences between the means of the control condition and the condition where the inspection figure was

tilted 10° from the horizontal throughout. The magnitude of the effect makes it doubtful whether the corresponding direct effect, had it been measured, would have been twice as large, as reported by Gibson and Radner and Morant and Mistovich.

The mixed conditions yield smaller but significant direct effects of 0.69° (anti-clockwise condition) and 0.66° (clockwise condition).

The "mixed" conditions were included in the experiment partly as a trial for what was thought to be a promising new technique whereby one might study the effect of short inspection periods without recourse to the long rest intervals between trials which are needed to avoid the effects of a cumulative build-up of satiation over a series of short identical inspections. What the technique demonstrates of importance in the present experiment is that the observed effect is not simply a successive-contrast phenomenon - since the mixed condition yields a smaller displacement - but is a genuinely time dependent process. The parallel with the previous experiments is interesting. There the tendency was for simultaneous presentation of "incompatible" inspection figures to result in a diminished version of the effect of either one of them alone, while here the same thing results from alternation of the inspection figures.

General Conclusions.

This series of experiments together with the results of other workers which have been reported seem to make it clear that, at least in the dimension of frontal-plane tilt, there is a process similar to that envisaged by Gibson and independent of figural after-effects. A non-normal stimulus comes, over time, to appear more like the "norm"; it produces an effect on a normal stimulus which is not reciprocated by the normal stimulus; and other stimuli in the same dimension are also affected. It is clear from the classical work and from the magnitude of the indirect-effect obtained here that under certain conditions this generalized effect remains relatively undiminished even for stimuli in orientations as far removed as possible from the inspection figure. Under other conditions, however, the decline in the magnitude of the effect can be quite sharp as shown by the results of experiment 1(d) and by the tentative evidence for simultaneous bilateral normalization.

Notwithstanding these differences the evidence is clearly in favour of tilt after-effects which involve higher-order psychophysical mechanisms than figural after-effects and successive contrast which may eventually both be explained by a fairly immediate transformation of input, involving perhaps after-image and lateral inhibition as suggested by Taylor (1962) and Ganz (1966).

II: Postural and Visual-Frame Effects on the Visual Vertical.

This chapter concerns the visual judgment of the orientation of lines with respect either to gravity or to the body mid-line and the way in which it is influenced by concurrent visual and postural stimulation.

Changes in the direction of gravity with respect to the body have been induced either by tilting the subject or by spinning him in a human centrifuge. Despite recent controversy in the literature (Witkin, 1952; Howard and Templeton, 1963; Witkin, 1964; Howard and Templeton, 1966, p. 174 ff.) in this account the two procedures will be treated as equivalent for the specified purpose.

The A- and the E- effects.

The A-effect was accidentally discovered by Aubert (1861). He noticed that when he looked at a vertical streak of sunlight in an otherwise dark room, if he tilted his head to one side the streak appeared to tilt in the opposite direction. The maximum effect was about 45° when his head was tilted to 135° from vertical, and decreased to zero when his head was upside down. The visibility of other objects such as furniture in the room destroyed the effect, which took several seconds to reappear when darkness was restored or after tilting the head rapidly from the vertical.

Although his informal observations suggested that at least initially we judge correctly the tilted position of our heads, Aubert concluded that after a time we come to underestimate the degree of tilt of our heads and that this is the explanation of the effect. The implication is that we judge the angle between head position and visual line correctly, and therefore apparent line orientation is subject to the error in judging head orientation. How such a delayed phenomenon could produce the fairly immediate A-effect is not clear.

Müller (1916) made a further study of the effect of posture on the apparent orientation of visual targets and found that while some subjects always reported the A-effect most were subject to it only at large degrees of head tilt, and at small degrees reported the opposite effect - a truly vertical line appears tilted in the same direction as the head. This latter effect Müller called the E-effect. Similar individual differences were reported by Passey and Ray (1950). Bourdon (1906) and Bauermeister (1964) found the relatively small E-effect with a suggested maximum at about 30° of head tilt, changing over to the much larger A-effect at about 50° or 60° of head tilt.

Sandström (1954, 1956) found a more complex situation with some subjects showing the A-effect and some the E-effect throughout, some showing the E-effect for small head tilts

and the A-effect for large, but others having the opposite pattern.

Other studies have shown that when subjects are passively tilted away from the vertical their perception of the visual vertical (or horizontal) is subject to constant errors (Miller, Fragly, van den Brink, and Graybiel, 1965; Werner, Wapner and Chandler, 1951; and Thomas and Lyons, 1966).

Lyons and Thomas (1968) found that pigeons trained to peck at a vertical line tended to generalize to a 30° tilted line when the floor on which they were tested was tilted up to 36° in the same direction, i.e. they displayed an A-effect.

Day and Wade (1966) found that when the subject is returned to vertical after two or three minutes of head tilt, the apparent visual vertical is shifted in the direction of the prior head tilt, i.e. an after-effect corresponding to the A-effect. Wade (1968) found that for all his conditions this after-effect was in the opposite direction to the original effect obtained during the tilting.

There is some evidence for an analogue of the E-effect in the sagittal plane (Schubert and Brecher, 1934). The E-effect also seems to predominate in the tactile-kinaesthetic modality according to many investigators, although Sachs and Mellor (1903) reported an A-effect.

It is now well established that a normal response to lateral tilting of the head is a more or less marked counter-torsion of the eyes, i.e. the eyes tend to maintain their orientation with respect to gravity (Howard and Templeton, 1966, p. 49 f.f.) and Aubert (1861) and Nagel (1896) among others, considered this countertorsion as a possible explanation of the A-effect. However, since the eyes rotate less far than the head, the image of a vertical line will rotate on the retina in the opposite direction to the head tilt but less far than it would in the case of a torsionless eye system, and it seems clear that the effect of countertorsion should therefore be to make a vertical line appear tilted in the same direction as the head, i.e. the E-effect rather than the A-effect. In any case Fischer (1927, 1930a and b) found no clear relationship between countertorsion and the constant error in setting a line to the vertical.

Aubert's suggestion that his effect was due to under-estimation of head tilt resulting from somesthetic and vestibular adaptation was challenged by Nagel (1898) and more recently by Bauermeister (1964) and McFarland, Wapner, and Warner (1962) who all claimed that the displacement of the body away from the vertical is in fact overestimated. This, like countertorsion would explain the E-effect rather than the A-effect and in fact these investigators found that up to about 60° of body tilt the postural overestimation increased

and there was a predominant E-effect. The fact that the amounts of the two effects were not congruent may have been due to what appears to be a rather indirect measure of apparent posture - the setting of a visual rod to apparently parallel the mid-body axis. However, beyond 60° of body tilt the postural overestimation continued to increase while E-effect fell to zero and gave way to the opposite, A-effect.

Nagel (1896) found that the A-effect was not altered by the application of counterweights to the head or of electric current to the musculature of the neck. But a potential applied to the side of the erect head itself produced a marked change in judgment of the visual vertical. It also produced feelings of dizziness and of falling towards the side of the cathode, thus supporting Nagel's view that these visual effects of posture depend on the vestibular system and not on kinaesthesia.

However, more recent evidence has complicated the picture. It appears that visual constant errors can be affected by counterweights (Kleint, 1937; Schneider and Bartley, 1962) or by unilateral noise or electrical muscle stimulation (Wapner, Warner and Chandler, 1951; Chandler, 1961).

Naylor (1963) found that although auditory and muscular stimulation did induce characteristic effects on the apparent visual vertical these were not consistently related to the

sidedness of stimulation. And Aarens and Goldenberg (1964) found that the effects of unilateral Galvanic stimulation depend on the location and polarity of the electrodes and they speculate that the differences result from differential effects of the stimulus on the muscular, vestibular and oculomotor systems.

Visual and postural factors.

Despite the inconsistencies in the studies of the A- and E-effects it seems clear that visual direction is often strongly influenced by postural factors. Nevertheless, this issue has in the past generated considerable controversy. Koffka (1926) the strongest proponent of the "pure vision" school argued that the directions of visual space are determined by the main lines of the field. In its strongest interpretation this case is clearly false - otherwise setting a line to appear vertical in an otherwise dark room would be impossible since the line would be accepted as vertical (or perhaps horizontal?) wherever it happened to first become visible to the subject. In fact, it seems clear from the examples he cites that what Koffka meant was that visual objects which are known, perhaps by experience, to be vertical or horizontal are accepted as such irrespective of their actual orientation. For example a vertical house on a sloping lawn may be reported as a tilted house on a horizontal lawn; on travelling on a mountain railway the trees appear tilted with reference to the actually tilted window frame, but on putting one's head out of the window the trees revert to vertical, and later it is the trees against which the window frame is judged to be tilted; finally Wertheimer's (1912) experiment is interpreted as indicating that a visually tilted room containing familiar objects will come to appear vertical.

Apart from the wealth of empirical evidence which contradicts this view, as a theory it seems inadequate in that there is no obvious principle whereby conflicts are resolved, for example why is the lawn accepted as horizontal rather than the building being accepted as vertical, why is the window frame initially accepted as vertical rather than the trees and what is critical about the experience which later reverses this resolution?

An approach to this problem of predicting relative strengths of various visual cues was made by Kleint (1936) who used a vertical and a tilted frame and found that the frame occupying the larger proportion of the visual field was typically accepted as vertical. For example, when looking out of the window of a tilted room the subject will accept the room as vertical when he is far from the window but will reverse his decision as he approaches the window and more of the outside scene becomes visible. The "part-space" appears appropriately tilted, but it also in turn affects the orientation of the "full-space" to some extent. Such "mutual induction" has also been demonstrated in the third dimension of visual space (Werner, 1938; Howard and Templeton, 1964a).

Koffka's chief opponents Gibson and Mowrer (1938) take a somewhat less extreme view, that the visual vertical is "determined by visual factors and gravitational factors

acting jointly, with orientation to gravity, however, as the more decisive factor..... and the primary factor genetically", (p. 303). They match every anecdote of Koffka, for example citing Helmholtz's (1962, vol. 3, p. 250) report that on a ship the cabin initially appeared vertical and a hanging barometer seemed to sway but that after a time the barometer appeared vertical and the cabin seemed to sway.

They tried to argue that the apparent tilt of the trees in the mountain-railway example could have been due to a pure contrast effect as in the Zollner illusion where a vertical line appears tilted when superimposed on a field of parallel tilted lines. However, it is not clear that the Zollner illusion is a pure contrast effect, i.e. that the tilted field does not tend to be accepted as vertical; and Koffka clearly reported that the window frame appeared upright. Nor does this interpretation account for the reversal which occurred when the trees were accepted as upright and the window frame appeared tilted.

Gibson repeated Wertheimer's experiment using either a mirror or rotating prisms and found that although the room came to appear more "natural" it never ceased to look tilted. And Boring (1952) had his subjects set a line to the vertical when a background window pattern was tilted to either the same side or the opposite side to the body. He found that constant errors were unaffected by the direction of tilt of the frame.

Reese (1953) found that the constant error of setting a rod to the vertical increased with increasing room tilt, but only up to a room tilt of 5° - 10° beyond which there was a gradual reduction of error, i.e. an increasing reliance on postural cues.

Gibson and Mowrer finally concluded that "Visual lines are not in their own right stimuli for orientation. If the eyes rolled at random with the head, if the organism could not be oriented to gravity, a vertical line of stimulation on the retina would be neurologically meaningless". This statement is either false, if it means that an organism lacking-non-visual postural apparatus could not use direct visual information about the direction of gravity, such as plumb-lines; or it is trivial, if it means that the only way to judge the relationship between the orientation of a visual line and that of the unseen body is either to know the orientation of both with respect to gravity or to know the successive relationships in the line-eye-head-body chain.

However, despite weaknesses in Gibson's critique of Koffka it seems clear that any strong interpretation of the latter's theory is ruled out by the facts of the A-and E-effects and by Neal's (1926) finding that a line can be set to the vertical no more accurately with a frame present than in the dark, even after an hour's testing in the dark.

It seems equally difficult to substantiate as a universal

principle that postural factors dominate visual, and indeed Gibson (1952) later conceded that the real task is to explore the interaction between visual and postural factors rather than to ask which of them is dominant. He stressed the important distinction between situations where the two factors co-vary, as when the subject tilts his head, and those where their relationship alters, as when special lenses are worn or the subject sits in a centrifuge with a normally oriented environment remaining visible. In the latter case there are two alternative response modes and which is chosen depends on attitude, sex, etc. and may not be of fundamental theoretical interest.

An important series of experiments which helped demolish the supposed preponderance of postural factors was reported by Asch and Witkin (1948 a and b). They studied Wertheimer's tilting mirror situation and an actually tilted model room, using the objective method of setting a line to vertical or to parallel with the body. In general the results showed a marked effect of visual frame and this swamped any effect of tilting the subject. But there were marked individual differences in response style which became the focus of attention in the later work of these authors.

The experiment in this series which is here of most immediate interest is one in which Witkin and Asch (1948) used a visual square frame which was tilted 28° to left or

right in the subjects' frontal plane. The subjects were either upright or tilted 28° to the left and had to set a rod of similar size to the frame, to the apparent vertical. The rod and frame were the only visible objects present. The results were similar to those of the other experiments and Witkin and Asch concluded that the visual frame is much more potent than postural factors; an upright visual frame limits the effect of body tilt to about three degrees (compared with eight degrees in the absence of the frame); whereas the frame effect itself is about six degrees for an upright observer compared with nine degrees when body tilt opposes the frame-effect and twelve degrees when it reinforces it.

These results clearly conflict with those of Boring's apparently similar experiment referred to above. A number of suggestions have been put forward to account for the difference. Mann (1952) thought that Boring's frame might not have been sufficiently articulated to show an effect and he repeated the experiment using a complete tilting room as the frame. He found little effect of tilting only the subject but a substantial effect of tilting the room particularly when the subjects were tilted in the opposite direction, although the effects of the frame were in general smaller than those recorded by Asch and Witkin. It should be noted here that these failures to find effects of body tilt are not inconsistent with the A- and E-effects since the latter occur in the absence of a visual frame.

Further evidence which could be interpreted as showing that visual effects increase with increasing stimulus complexity is provided by Weiner (1955 a). The subject was either erect or tilted 28° and had to set to the vertical either a rod, a square or a cube from a starting position of 28° . He found that settings in general deviated in the direction of the starting position - the tilt after-effect - and away from the direction of body tilt - the E-effect. But whereas the postural effect declined, the visual effect increased with increasing stimulus complexity. Unfortunately it is not clear whether this is a comparable situation to the others, in which a constant stimulus is judged against a background or frame of changing complexity; in addition, Weiner presents his results in terms of errors averaged "without regard to sign", a measure which confounds constant and variable errors but which the author interprets throughout as constant error.

On the other hand Curran and Lane (1962) found that visual cues contribute more than postural factors to the position of the apparent vertical, even when they are few and dimly illuminated, suggesting that Boring's results are unlikely to be due solely to weakness of the visual frame.

A further suggestion to account for the differences between Boring's and Witkin and Asch's results concerns training. Mann and Boring (1953) found that naive subjects

produced larger errors than trained and carefully instructed subjects, particularly when the room was tilted. But Witkin (1953) pointed out that the instructions he and Asch had used corresponded to those given to Mann and Boring's sophisticated group and so the differences could not be explained in this way.

Other studies on the effect of training are reported by Bitterman and Worchel (1953) who found that blindfolded sighted subjects are less resistant than subjects blind from birth to the disruptive effects of body tilt on setting a rod to the vertical by hand, and concluded that postural factors, while genetically prior, could become through training less important than visual factors. Witkin (1948) and Weiner (1955 b) found that certain types of training, for example teaching subjects about the nature of postural cues, could produce a greater reliance on and more valid interpretation of postural input, resulting in a less disruptive effect of body tilt. On the other hand Elliott and McMichael (1963) failed to improve performance by means of training and concluded that the inability to make valid use of postural cues is "a stable and durable deficit".

In view of the multiplicity of factors which may influence frame-and-posture-dependence - subject selection, training and instructions, relative strength of cues and duration of exposure - it is perhaps not surprising that two studies like Witkin and Asch's and Boring's should produce conflicting results.

The Nature of Postural Cues.

When one comes to look at the various sources of information which could aid the stationary animal in orienting itself and which have been previously lumped together as "postural cues" one can distinguish three broad classes: (a) input to the utricles which could provide information regarding the position of the head with respect to gravity, (b) differential pressure inputs from those parts of the body in contact with supporting surfaces, and from the viscera, which could give information about the gravitational orientation of the body as a whole, (Gray and Malcolm, 1950; Gray and Matthews, 1951; Cohen, 1964), and (c) motor-kinaesthetic inputs which could give information about either the gravitational orientation of the whole body, for example the generalized strain on one side of the body when it is tilted to the other side, or the relationship of body parts, for example the fact that the eyes are rotated in the head or the head tilted on the trunk. Considering the neck system, receptors in the joint capsules of the cervical vertebrae have been shown to play an important role in maintaining spatial orientation (Cohen, 1961; McCouch, Deering, and Ling, 1951). Malfunction of the sternomastoid muscle has also been associated with vertigo (Weeks and Travell, 1955; Gray, 1956). The only one of these groups of postural inputs whose loss is relatively easy to study is utricular function,

but the evidence is scanty. The only clearly defined utricular reflex in man is counter-torsion, the tendency of the eyes to retain their orientation during lateral head tilt. During actual tilting of the head a large effect may be observed but when the head is stopped in a tilted position this rapidly decreases to about six degrees for head tilts of 60° to 120° (Schöne, 1962). The large temporary torsion is thought to be a function of the labyrinths while the residual effect must depend on the utricles and is absent when the experiment is carried out with the head tilted 90° forwards or backwards (Mulder, 1897; Merton, 1956, 1958; Davies and Merton, 1958). Also the amount of torsion is a function of the magnitude of the lateral force in a human centrifuge (Woellner and Graybiel, 1958, 1959) and is non-existent in deaf-mutes (Kompanejetz, 1925). Bilateral loss of vestibular function is accompanied by an immunity to motion sickness and an inability to stand upright or to maintain stability while swimming, and unilateral loss by considerable distress and disorientation (Howard and Templeton, 1966) but the only effect which is permanent is the immunity to motion sickness, and it seems likely that most of these effects are due to vestibular canal loss rather than utricle loss. Wing (1963) was unable to record any consistent potential changes in the mammalian vestibular ganglion in response to head tilt and suggested that the utricle is largely

vestigial in higher mammals, where vision and kinaesthesia are dominant in posture control. And Birren (1945) claimed that vestibular thresholds, as measured by reflex-eye-movement thresholds, are much too high to account for the correction of normal sway in erect blindfolded subjects. Even pigeons when deprived of vestibular apparatus have normal leg and wing reflexes (Mittelstaedt, 1964).

Temporary effective loss of utricular function can be produced by immersing the subject in water and this increases the mean error of setting a rod visually to the vertical (Stigler, 1912; Schock, 1959; Whiteside, 1960; Brown, 1961). However, this procedure also drastically affects somesthetic and kinaesthetic input, and Garten (1920) found that while immersion affected the performance of normal subjects in setting their bodies to the vertical in a tilting chair, anaesthetizing the skin areas in contact with the chair, by cooling the buttocks, had no effect; nor were subjects with defective inner ears less accurate than normals; he therefore concluded that kinaesthesia, rather than somesthesia or vestibular function, was critical in posture maintenance. Arendts (1924) confirmed the unimportance of somesthesia by using local anaesthesia. Mann, Berthelot-Berry, and Dauterive (1949) found that padding the chair to reduce touch sensations did increase error but this may have been due to greater relaxation inhibiting body movements from which the subject normally

derives information. Recent evidence generally suggests that labyrinthine defects do not markedly affect postural abilities, at least after an initial period of adaptation to the damage (Thetford and Guedry, 1952 a and b; Clark and Graybiel, 1963).

Vestibular Involvement in A- and E-effects.

Turning specifically to the A- and E-effects the most reasonable expectation might appear to be that the influence of the utricles, if anything, should be in the direction of reducing these postural effects on visual direction, through providing additional information about the true orientation of the head. However, most workers who have studied the effect of loss of vestibular function appear to have operated on the quite different expectation that if there is vestibular involvement then vestibular loss should result in destruction of the A- and E-effects; that this does not occur has accordingly been taken as evidence of the unimportance of vestibular function. This reasoning seems to assume that when the head or body is tilted the vestibular input is subject to some special error which indirectly results in false visual direction; in the absence of vestibular input, control would pass to other postural systems presumably giving veridical information, and the visual errors would disappear. Part of this assumption was made explicit by Witkin and Asch (1948) when they explained their finding that the frame effect was greater when the body was tilted, by suggesting that postural cues were most valid when the body is erect. Feilchenfeld (1903) and Bárány (1921) recorded A-effects from congenitally deaf subjects, and Fischer (1950b) reported an E-effect from a subject with unilateral vestibular loss and an A-effect from another with bilateral loss.

The usual conclusion from this sort of result has been that vestibular cues are not important in the judgment of visual direction. More recently, however, a few workers have taken the view that the vestibular system where operative should be a factor tending to reduce error effects in visual direction. Miller and Graybiel (1966) tested normal and labyrinthine-defective subjects on setting a target to horizontal either sitting upright, lying on their sides, or with their heads inverted, and with or without a visible background of objects giving strong viridical cues to vertical and horizontal. All of these postures allow potential utricular information about the direction of gravity. Not surprisingly both groups were extremely accurate in all postures provided the visual background was present. In the head-inverted condition both groups showed a small but similar decrement when the visual background was removed; but it is difficult to base any conclusion on this condition since there is considerable uncertainty about otolithic function in such a posture. In the recumbent position loss of visual background produced a marked decrement (16° of average absolute deviation) in the normals, but a very much larger one (28°) in the labyrinthine-defectives. (According to the authors these figures are a measure of the Λ -effect since in this posture all the deviations were in the same direction.) Finally in the upright posture loss of visual background produced a small but significant decrement but only for the

labyrinthine-defectives. Similar results were found in a second experiment in which the same groups in the same postures had to maintain the target apparently horizontal throughout successive periods when the visual background was either present or absent; the fluctuations during the dark periods were termed "rotary autokinesis". Miller and Graybiel conclude that their evidence contradicts any claim that the utricles operate to produce error in localization associated with head (body) tilt".

In addition Mann (1951) claimed that his patient with VIII'th nerve paralysis had a larger-than-normal A-effect, but this may have been due to what appear to be unusually small effects in his control group.

Clark and Graybiel (1967) on the other hand failed to find any consistent effect of several combinations of head and body tilt on the visual vertical in either normal or defective subjects; they concluded that the vestibular information was unnecessary for accurate performance, which is consistent with the evidence cited earlier for the slight effect that vestibular loss has upon general posture control. This study was unusual in that instead of being forced passively into position, the subjects actively and without external support produced and maintained head tilt and body tilt, which was merely monitored by the experimenter. The resulting increase in motor-kinaesthetic and tactile information may have been sufficient to permit accurate performance

with or without the vestibular system.

Another attempt to reinstate vestibular input as valid rather than error-producing information was made by Wade (1968) who used the technique of combining sets of cues in co-operation or opposition rather than studying the effects of the pathological loss of a particular set. He argued that head tilt alone involves otolith and neck stimulation, while tilting of the trunk alone involves neck and trunk stimulation. His subjects made visual verticality judgments either while tilted or immediately on being returned to the upright position after two minutes of tilt. Table 2.1 shows the tilt conditions, the supposed sensory systems in which change occurs, and the magnitude (in degrees) and direction of the effects and after-effects. All conditions involved

Table 2.1.

Wade's (1968) model of the influence of posture on the visual vertical, and obtained results.

<u>Condition.</u>	<u>Sensory changes involved.</u>		<u>Effect.</u>	<u>After-effect.</u>
RHT	+o	+n	-4.1	1.5
LHT	-o	-n	4.7	-2.1
RBT	+o	+t	-3.7	0.8
LBT	-o	-t	3.4	-1.4
RTT	-n	+t	1.4	-1.0
LTT	+n	-t	-0.9	0.7

30° of tilt and + represents right. Thus the immediate effects in the head-and-body-tilt conditions represent the E-effect, and the after-effect is in all cases of opposite sign to the effect and in most cases considerably smaller. His argument is that since these are the systems which alter when the particular tilt occurs, a resulting decrement in performance must be due to failure of one or both systems. For example, head tilt gives consistently larger effects and after-effects than body tilt and therefore the neck system must be more "potent" (i.e. weak) than the trunk system (the otolith changes being common to both head and body tilt). This is confirmed by the trunk-tilt conditions which involve neck and trunk systems in opposition and where the effects and after-effects are consistently in the direction expected on the basis of the neck changes.

Wade's data does not give any direct indication of the role of the otolith system but it is clear that he regards it as a constancy-maintaining factor and considers the neck and trunk systems to be responsible for all the after-effects, mainly on the grounds that the oculogravic illusion, which is regarded as an index of otolith function, shows no adaptation over time (Clark and Graybiel, 1962, 1966). Hazlewood and Singer (1969) have recently reported a similar experiment using judgments of kinaesthetic verticality and giving similar results - large E-effects in head-and-body-tilt conditions but not in trunk-tilt conditions.

Another method of eliminating gravitational cues is to have the subject supine (or prone) so that the direction of gravity is orthogonal to the plane of rotation of the horizontal line which the subject attempts to align with the long axis of his body. Unlike the use of labyrinthine-defective subjects but like the approximation of weightlessness by immersion, this procedure renders inoperative not only the utricles but also the complex of tactile-kinaesthetic cues to the direction of gravity.

Rock (1954) had his subjects set a line parallel with or at right angles to the long axis of the head when supine. Constant errors were in both directions and ranged up to nine degrees, and standard deviations ranged from two to six-and-a-half degrees with a mean of four. Rock judged this an accurate performance and concluded that the loss of gravitational cues was not serious. This appears to be totally unwarranted. The task is a relatively simple one involving only two links (the orientation of the line on the retina and of the eye in the head); in any case it is not known how accurate performance is in the erect posture and no control group was used.

The supine posture was also used by Brosgole and Cristal (1967) in a recent attack on the now almost universal view that visual and postural cues interact to determine the visual vertical, that for example a tilted frame in conflict

with the postural cues of an erect observer produces a compromise change in felt orientation which in turn gives rise to a modified conception of visual space. They point out that there is here an implicit assumption that the visual vertical is directly determined by the felt orientation of the body and yet it is precisely this link which has never been studied - how gravity, which gives information only about the orientation of the body, can be used in the judgment of the orientation of a target which is sensed only visually. In addition the interactionist view would seem to require a similar sized change in apparent body orientation, whereas Passey (1950) found that the maximum effect of a visual frame on the apparent body vertical was about two degrees.

Broscole and Cristal suggest the alternative view that the rod-and-frame effect is a purely visual phenomenon and that any small postural effect is a result rather than the cause of the visual change. They report a series of experiments elaborating their visual analysis of the rod-and-frame effect and these have already been reviewed in the chapter on tilt adaptation. Of more immediate interest here is another experiment in which they compared performance on the Witkin rod-and-frame test when the subjects were erect and supine and the task was to align the rod with the long axis of the body. They found mean effects of the frame of 7° and

9.7° in the two conditions, and although this difference is not significant they seem to think it requires an explanation. They say the deterioration in the supine posture, and in the tilted postures used by other workers is due not to the absence of gravitational cues or their conflict with visual ones but simply to the fact that subjects are in an unfamiliar situation. They claim without formal evidence that the deterioration does not occur when the subject is standing and the display is on the floor or the ceiling, and judge these situations to be familiar ones in which useful gravitational cues are lacking. This seems a very poor argument for the unimportance of postural cues, particularly in view of the equivocal results and the weakness of the concept of "unfamiliarity".

In view of the uncertain results of these studies the present experiment was designed to compare performance in the erect and supine postures and to study the relative susceptibility in the two postures to the common errors in verticality judgments - the effects of head tilt and of a tilted visual frame.

EXPERIMENT 2.Apparatus.

The display visible to the subject consisted simply of a pair of parallel 4.25 inch lines of light (the frame) set at eye level with their centres horizontally separated by nine inches. Midway between the frame lines another line of light (the test line) 3.5 inches long rotated in the frontal plane about its own centre. These lines, which were mounted approximately 18 inches from the subjects eyes, consisted of one-eighth slits milled in metal plates, the two plates carrying the frame slits being fastened to a partition in the rectangular wooden apparatus box and the circular plate carrying the test slit being free to rotate flush with the same partition. This circular plate protruded about one inch through the ceiling of the box and half degree protractor marks on its rim allowed its angular position to be read off against a reference line on the outside of the box. The subject viewed binocularly with his face pressed against a rubber mask mounted in the end of the box.

Using a small number of pilot subjects the back-illumination of the slits was adjusted until (a) the frame slits appeared approximately half as bright as the test slit and (b) nothing else became visible inside the box during a period twice as long as a typical experimental session.

Close to the position of the face mask a system of chin-rest and temple clamps was mounted on the box so that the subjects head would maintain a constant relationship to the box as the latter was rotated in the fronto-parallel plane. Either the right or the left-hand bottom edge of the box could be lifted and a standard wooden block inserted to give the box an inclination of 20 degrees. The reliability of this procedure was ensured by the use of stops to prevent horizontal slipping of either block or box. The whole box and block system stood on a platform which could be racked up or down to match the height of individual subjects when standing erect.

In another condition the subject lay in a supine position on a mattress with his body aligned by eye with two parallel lines drawn on the floor. The box now stood on its front end and was lowered until the mask pressed on the subject's face and the chin-rest-temple-clamp system could be secured. The fronto-parallel rotation - now about a vertical axis - was achieved by means of stops fastened to the platform on which the box rested.

In both erect and supine conditions two bars extending sagittally towards the subject from the platform supporting the apparatus were adjusted to press on the subject's shoulders and maintain them level even when the head was tilted.

The experimenter rotated the disc by hand and the dangers inherent in this procedure were minimized by instructing the experimenter not to watch the angular scale while the disc was in motion. The experimenter developed a smooth rotation technique in which one hand took over the work before the other hand reached the end of its transit. In any case the slit was small relative to the disc so that any irregularities of motion at the rim would in linear terms be considerably demagnified at the extremities of the line of light.

The two parallel frame lines were fixed at 20° counter-clockwise relative to the sides of the box and therefore relative to the subject's head. Thus when the subject's head was tilted to the right the frame was parallel with his body axis, when the subject's head was upright on his body the frame was 20° to the left, and when the subject's head was tilted to the left the frame was 40° to the left relative to his body axis.

Subjects.

Fourteen subjects were used, seven male and seven female. They were aged from twenty to thirty and were undergraduates, postgraduates and staff from the Department. All subjects reported clear vision of the stimulus display with optical correction if normally used, and all subjects passed the Worchel test of standing on one leg for five seconds while

blindfolded. Two candidates were rejected for failure on this test. No subject had knowledge of the purpose of the experiment.

Procedure.

Apart from the screening tests described above no special pre-experimental procedures or precautions were undertaken. The room lights but not the display lights were on while the subject was positioned and secured.

The instructions were as follows:

"The experiment is concerned with finding out how well you can set a line parallel to the midline of your body when you are standing up and when you are lying down. Sometimes the box to which your head is attached will be tilted a little and I want you to relax and let your head go along easily with the box and keep it in the final position of the box without straining. The three lines you saw before "(in the screening test)" will sometimes be there and sometimes only the centre line. In any case I want you to disregard the two outer lines and concentrate on the centre one. On each trial it will start in a very tilted position and I shall move it back towards the upright. I want you to tell me as soon as it appears to be parallel to the midline of your body, that is parallel to a

line extending from a point midway between your shoulders to a point between your feet. When you tell me I shall leave it on for a second or two and you can make further adjustments if you are not satisfied, but I must tell you that in this sort of task snap judgments are usually the best".

There were twelve conditions since the frame could be either on or off (F, NF) the subject could be either erect or supine (E, S) and his head could be either upright on his body or tilted left or right (HU, HL, HR). With only seven subjects of each sex it was not possible completely to counter-balance the order of conditions, but there was an attempt to approximate this as closely as possible. Approximately half of each sex group (four males and three females) were given the six E conditions first, the other half the six S conditions. Approximately half of the resulting groups (one or two subjects) were given NF before F conditions in both E and S conditions, the other half F before NF. Finally each subject was assigned an order of head tilt conditions which was the same for all four frame and posture conditions, so that each of the twelve possible orders of head tilt was used at least once and not more than twice. Preliminary scrutiny of the results in terms of condition order revealed negligible effects and this factor was not included in the final analysis.

The conditions followed each other as rapidly as was allowed by the necessary alterations to the apparatus, and the whole experiment lasted about one hour. Each subject made eight determinations under each of the twelve conditions, with the test line being initially positioned between 30° and 50° to the right on half the trials, to the left on the other half.



Results.

The data for analysis consisted of the algebraic mean (constant error) and the standard deviation of the eight determinations made on each subject under each condition. Table 2.2. shows these two measures averaged over the seven subjects in each sex group.

The means and standard deviations were separately analysed in two split plot designs with sex as a between-subjects factor and repeated measures on posture, head-tilt and frame. The analyses are shown in Table 2.3.

Table 2.2.

Average means (upper line) and standard deviations (lower line) in degrees for all groups and conditions. Anti-clockwise deviations are positive.

		ERECT.						SUPINE.					
		FRAME			NO FRAME.			FRAME.			NO FRAME.		
		HL	HU	HR	HL	HU	HR	HL	HU	HR	HL	HU	HR
MALE		4.09	2.84	-0.79	2.09	1.90	0.14	15.63	5.39	-3.79	12.57	1.61	-6.50
		1.08	0.68	0.91	1.46	0.73	1.42	2.08	1.50	1.75	1.81	1.04	2.26
FEMALE		3.69	1.34	-0.21	2.17	0.79	1.03	15.21	7.59	-3.06	9.60	2.69	-3.30
		1.48	0.89	1.27	1.35	0.66	1.58	3.08	1.33	2.58	2.89	1.52	3.67
TOTAL		3.89	2.10	-0.5	2.13	1.35	0.52	15.42	6.49	-3.42	11.09	2.15	-4.9
		1.28	0.79	1.09	1.41	0.70	1.50	2.58	1.42	2.17	2.35	1.28	2.97

Table 2.3.

Analysis of variance of standard deviations and constant errors in experiment 2.

Source.	d.f.	<u>Standard deviations.</u>		<u>Constant errors.</u>	
		M.S.	F.	M.S.	F.
Sex	1	9.08	4.1 NS	1.60	NS
Subjects within sex	12	2.23		26.98	
Posture	1	41.77	45.9 ^{xxx}	348.60	17.2 ^{xx}
Posture x sex	1	3.90	4.3 NS	8.15	NS
Posture x subjects within sex	12	0.91		20.30	
Frame	1	0.90	NS	156.21	12.0 ^{xxx}
Frame x sex	1	0.03	NS	0.00	NS
Frame x subjects within sex	12	0.72		13.02	
Head	2	14.24	23.6 ^{xxx}	1453.51	46.9 ^{xxx}
Head x sex	2	1.35	NS	18.07	NS
Head x subjects within sex	24	0.60		30.99	
Posture x frame	1	0.00	NS	88.89	8.2 ^x
Posture x frame x sex	1	1.55	7.2 ^x	1.68	NS
Posture x frame x subjects within sex	12	0.22		10.90	
Posture x head	2	1.69	NS	731.64	24.5 ^{xxx}
Posture x head x sex	2	0.75	NS	17.88	NS
Posture x head x subjects within sex	24	0.57		29.92	

Continued overleaf

Table 2.3. (Continued)

Source.	d.f.	<u>Standard</u> <u>deviations.</u>		<u>Constant</u> <u>errors.</u>	
		M.S.	F.	M.S.	F.
Frame x head	2	2.20	NS	32.39	5.5 ^x
Frame x head x sex	2	0.19	NS	5.51	NS
Frame x head x subjects within sex	24	1.06		5.88	
Posture x frame x head	2	0.49	NS	1.20	NS
Posture x frame x head x sex	2	0.03	NS	6.25	NS
Posture x frame x head x subjects within sex	24	0.72		4.11	
Total	167				

One, two and three asterisks represent significance at the .05, .01 and .001 levels respectively.

Sex is tested against subjects within sex, and the 21 within subject terms are divided into groups of three such that the final term in each group, an interaction involving subjects within sex is the appropriate error term for the other two terms in the group. There is in each analysis some scope for pooling error terms but this would not in fact alter the significance level of any F-ratio and it is therefore unnecessary. Nor are the significance levels reduced by substitution of the degrees of freedom associated with the Geisser-Greenhouse conservative test which allows

for asymmetry of the variance-covariance matrix in repeated-measures designs. This is because the fixed factors and their mutual interactions already have only one or two degrees of freedom and so reducing them to one degree of freedom as required by the Geisser-Greenhouse test has at most a very small effect.

Analysis of standard deviations.

It is clear that the presence or absence of the frame used in this experiment had no direct effect on the variability of settings. On the other hand standard deviations are about one degree larger in the supine than in the erect posture, the respective means being 2.13° and 1.14° , and this difference is highly significant. Also highly significant is the difference of almost a degree between head upright (1.05°) and head tilted (1.91° and 1.92° for HL and HR respectively).

There is a tendency throughout for men to be less variable than women but this is significant only when subjects are supine and deprived of a visual frame, when the difference is one degree. This accounts for the marginally significant sex x frame x posture interaction as shown in Table 2.4.

Table 2.4.

The sex x frame x posture interaction of standard deviations: means and tests of simple main effects of sex.

	M	F	M.S.	Error M.S.	F ratio (1, 48 d.f.)
EF	0.89	1.23	1.2	1.02	N.S.
ENF	1.20	1.20	0.0	1.02	N.S.
SF	1.78	2.33	3.1	1.02	N.S.
SNF	1.70	2.69	10.3	1.02	10.1 ^{xx}

The error M.S. for these simple main effects of sex is the weighted average of the separate error terms for sex, sex x frame, sex x posture, and sex x frame x posture and has 48 degrees of freedom because each of these component error terms has 12 degrees of freedom.

Analysis of constant errors.

As can be seen from Table 2.3 there is no significant difference in constant error between the sexes either overall or in any individual condition. However, the main effects of the three treatment variables are significant as are all the two-way interactions among them, and so it is these interactions which must be interpreted. The relationship among the three factors is shown in Fig. 21. The most significant effect is the head x posture interaction and this is further

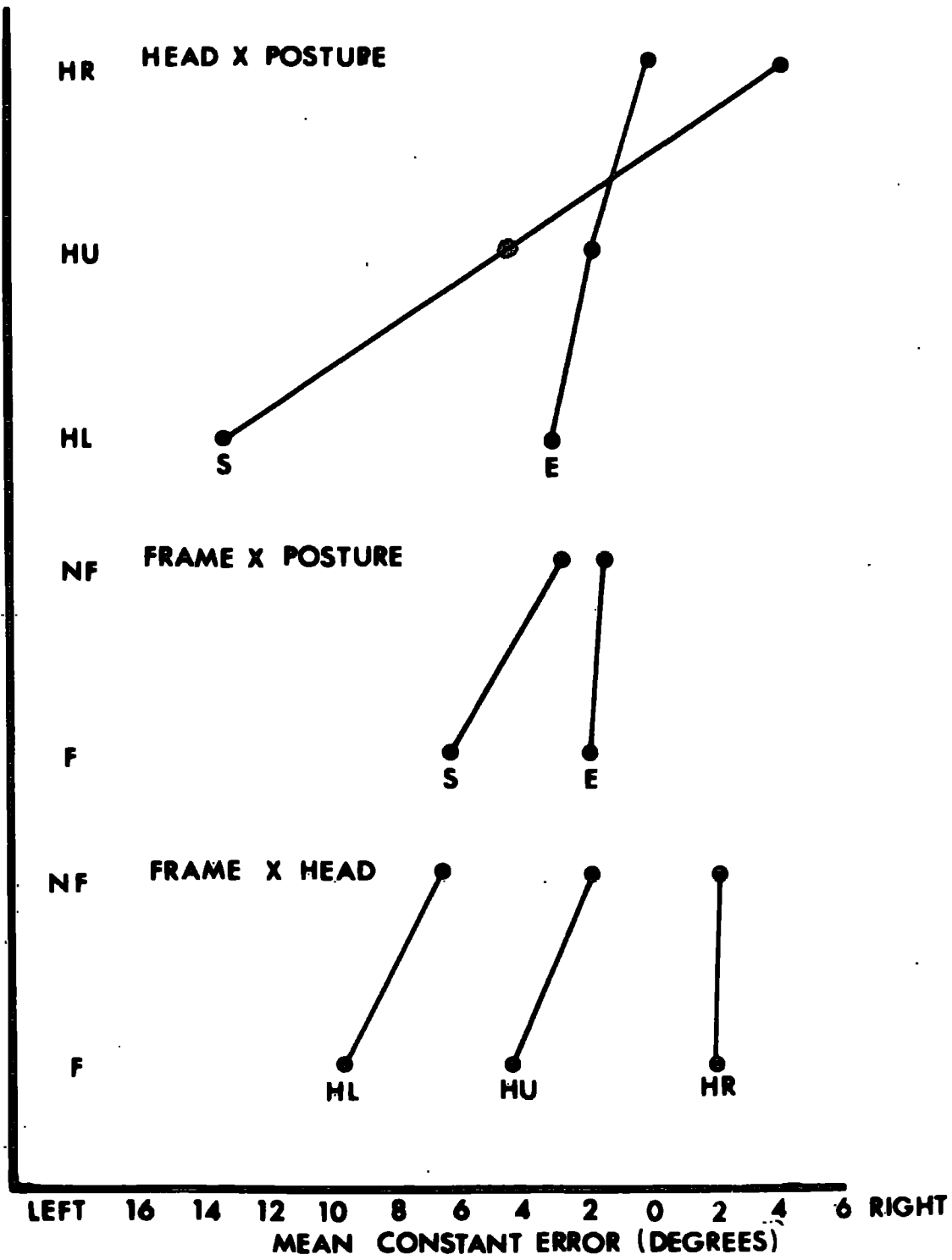

FIG 2.1 TWO-WAY INTERACTIONS OF CONSTANT ERRORS

analysed in Table 2.5 into the simple main effects of head tilt for the two postures separately.

Table 2.5.

The head x posture interaction of constant errors: means and tests of the simple main effects of head tilt.

	HL	HU	HR	M.S.	Error M.S.	F Ratio (2,48 d.f.)
Erect	3.01	1.73	0.01	83.4	30	N.S.
Supine	13.26	4.32	-4.16	2125	30	70 ^{xxx}

The error M.S. is the weighted average of the error terms for head and head x posture, each with 24 degrees of freedom.

This indicates that whereas there is a small non-significant tendency for judgments to follow head position (A-effect) in the erect posture, when the subject is supine this effect is highly significant (at least 8.5 degrees). The same conclusion would of course follow from an analysis of posture differences at the various head positions, which would show that whereas posture makes no significant difference with head upright, supine judgments are significantly more positive (left) when the head is tilted left and significantly more negative (right) when the head is tilted right than erect judgments.

The frame x posture interaction is analyzed in Table 2.6.

Table 2.6.

Frame x posture interaction of constant errors: means and tests of simple main effects of frame presence.

	F	NF	M.S.	M.S. Error	F-ratio (1, 24 d.f.)
Erect	1.83	1.33	6.0	12	NS
Supine	6.16	2.78	241	12	20 ^{xxx}

The error M.S. is the weighted mean of the error M.S. for frame and for frame x posture, each of which has 12 degrees of freedom.

It will be recalled that the frame is always 20° to the left of the head position and the overall tendency of settings to be more positive in frame than in no-frame conditions thus represents a tendency for the subject to adopt the visual frame as his norm of uprightness. But whereas this tendency is small and insignificant in the erect posture, when the subject is supine it becomes a highly significant difference of 3.4° .

Finally the head x frame interaction as analyzed in Table 2.7 indicates, rather surprisingly that the frame effect is not significant in the head right condition, i.e. when the frame itself is vertical, but the head effect is significant whether or not the frame is present. The error term for frame effects is the weighted mean of the error terms for frame,

with 12 d.f. and for frame x head with 24 d.f.; the error term for head effects is the weighted mean of the error terms for head, with 24 d.f. and for frame x head with 24 d.f.

Table 2.7.

Head x frame interaction of constant errors: means and tests of simple main effects of frame and head.

	F	NF	M.S.	M.S. Error.	F-ratio (1, 36 d.f.)
HL	9.66	6.61	130	8.26	15.7 ^{xxx}
HU	4.30	1.75	91	8.26	11 ^{xx}
HR	-1.96	-2.19	1	8.26	N.S.
M.S.	947	544 ^{xxx}			
M.S. Error.	18.4	18.4			
F-ratio (2, 48 d.f.)	52 ^{xxx}	30 ^{xxx}			

Discussion.

A few minor points will be disposed of first, before proceeding to the major findings. Witkin (1949) introduced the concept of field-dependency as a basic personality variable, the original purpose of which was to account for the large individual differences in the frame effect. He claimed specifically that women are more field dependent than men which meant that they are less able to make use of postural information to counter the influence of a misleading visual frame, and are more disoriented by head tilt. Sandstrom (1956) on the other hand found no sex differences in the effect of head tilt on apparent visual verticality. The present results clearly support Sandstrom, there being no sex differences in constant error, due either to head or frame orientation, although female variability tended to be greater throughout, and significantly so in the supine position with no visual frame.

In the basic control condition (erect, no frame, head upright) the average standard deviation 0.7° is probably comparable with earlier investigators' variability measures of one degree or a little more, since they typically used average unsigned deviations which include constant as well as variable error.

Cohen and Tepas (1958) reported a mean control constant error of 2.3° anti-clockwise, but such observations should be treated with scepticism since they can so easily be induced by slight irregularities of apparatus or subjects posture. In the present study control constant errors ranged from zero up to 3.3° anti-clockwise, while Gibson and Radner's ranged up to two degrees in either direction.

The increase in variability with head tilt confirms earlier findings (e.g. Mann, Berthelot-Berry, and Dauterive, 1949). On the other hand, Neal's (1926) report that the presence of a visual frame does not affect consistency was also confirmed, though presumably this applies only to relatively unstructured frames.

The predominance of the A-effect in the present study - in the supine posture only two of the fourteen subjects produced an E-effect in one of the four possible conditions - merely adds confusion to the problem of specifying the conditions under which the two effects occur, since it contradicts the idea that E-effects occur for small degrees of head tilt. The present experiment used a head tilt within eight degrees of that found by Witkin and Asch (1948) to give a maximal E-effect!

Finally there are no clear implications concerning the old controversy about the relative magnitudes of frame - and

head-tilt effects since this issue has usually been discussed in the context of available gravitational cues and in this condition neither of the effects was significant in the present study. It can only be reported that in the supine condition the frame effect averaged about 3.5° while the average A-effect was about five degrees larger. But without some way of comparing the independent variables any conclusion based on this difference would seem pointless.

The major finding of the study, however, is that although the data show a small frame-effect and A-effect in the erect posture these are not significant, whereas the corresponding effects for supine subjects are large and highly significant. This effect of loss of direct gravitational information is also reflected in the standard-deviation data. This is therefore the first report of a case in which both of the common sources of error in verticality judgments - frame effect and head-tilt affect - have been found to be significant only in the presence of gravitational cues. This pattern is shown clearly in Fig. 2.2 in which constant errors are shown separately for erect and supine conditions, the conditions being ordered along the abscissa according to the location of the means of their supine versions. The dramatic suppression of constant error in the erect conditions is clearly evident. The figure also shows the fairly consistent doubling of standard

FIG 2.2
CONSTANT ERRORS AND STANDARD
DEVIATIONS FOR ERRECT AND
SUPINE CONDITIONS

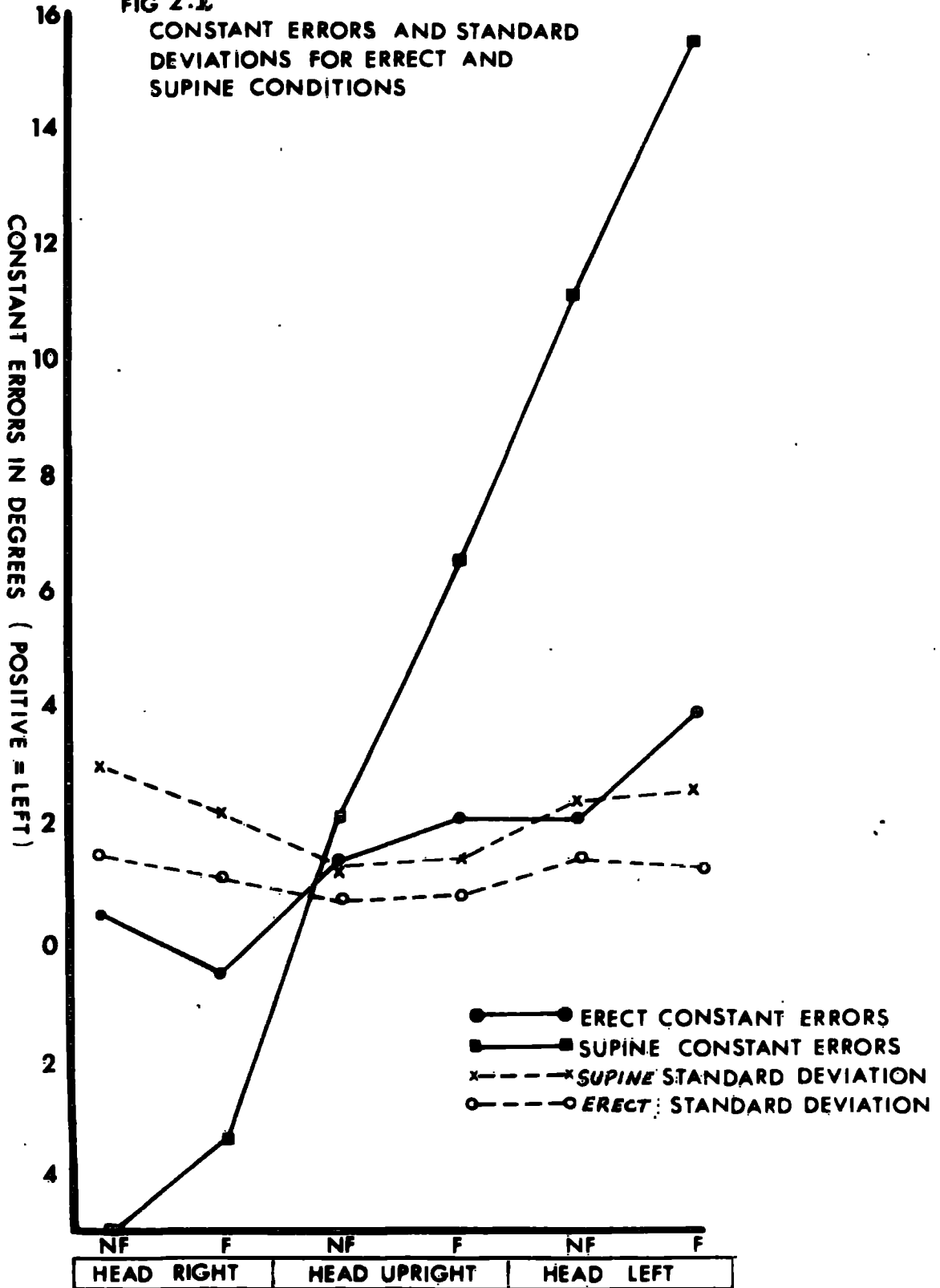

deviations which is caused by loss of gravitational cues.

Figure 2.3 shows a schematic representation of the major factors involved in the various conditions. In order to carry out the task of relating line orientation to trunk orientation the system must presumably have information about the relationship of the line to the eye-head complex and about the relationship of the latter to the trunk. In the erect conditions information is potentially available about the relationship of gravity to both head and trunk separately thus augmenting the information about their mutual relationship and so reducing error. In the frame conditions the frame can be visually related to both the line and the eye-head system. It is possible that the first of these relationships is critical for the frame effect, i.e. it is purely visual as suggested by Brosgole and Cristal. But this would not explain the large difference between erect and supine conditions in the size of the effect. It seems more likely that in sighted people part of the postural control system depends on a more or less continuous monitoring of the relationship between eye-head and a normally vertical-horizontal visual frame. (Evidence for a similar system of control for the straight-ahead resting position of the eyes has been reported by Craske and Templeton, 1968.) The information from a misleading visual frame will thus combine with the veridical

Fig. 2.3 Schematic model of sensory sources in experiment 2.

1 ERECT - NO FRAME

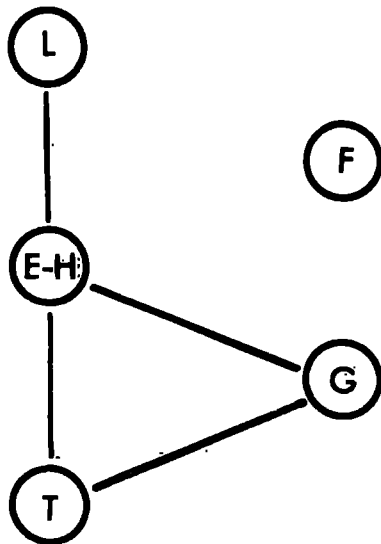

2 ERECT - FRAME

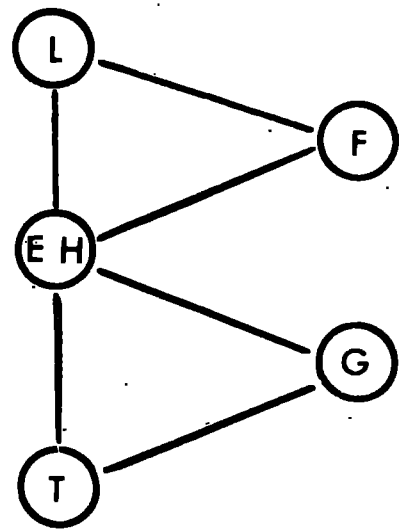

3 SUPINE - NO FRAME

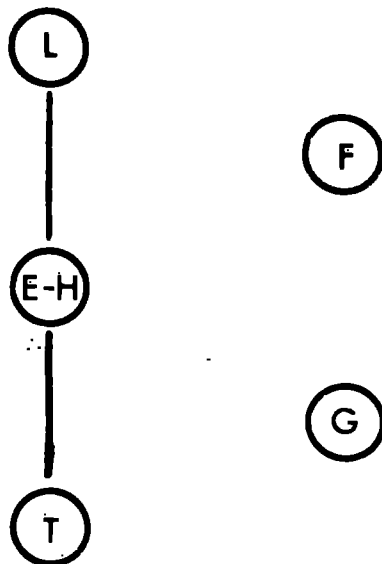

4 SUPINE - FRAME

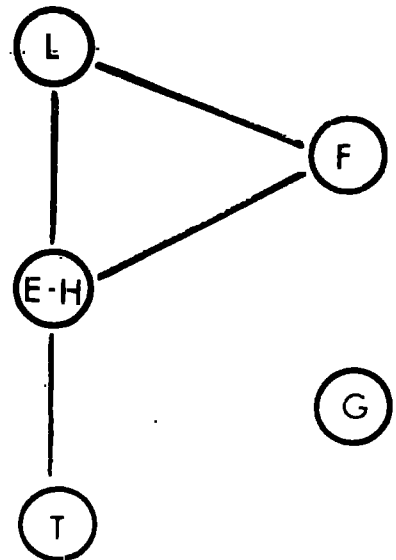

kinaesthetic information to produce a faulty apparent orientation of head on trunk except when the kinaesthetic information is supported by gravitational cues to head orientation. This assumed effect of visual-frame tilt on apparent head orientation has never been adequately tested. But Passey (1950) reported an effect of a visual frame on apparent body orientation with a maximum of about two degrees, so it seems possible that a corresponding head effect might be an important factor in the frame effects of three or four degrees found in the present study.

In this analysis eye and head have been combined into a single element as though the relationship between them was fixed. This is not the case particularly when the head is tilted, as attested by the eye-torsion literature. As pointed out earlier the effect of eye torsion should be in the direction of the E-effect or presumably a reduction in the size of the A-effect. Since torsion with the head stationary in a tilted position is probably a utricular effect this is another possible mechanism whereby gravitational cues reduce the effect of head tilt in the erect conditions. The problem about this interpretation is that if a situation could be devised similar to the present one but yielding predominantly E-effects then it would have to be predicted that eye torsion would act to increase the effect of head tilt in the erect conditions.

This study does not directly indicate the nature of the gravitational cues which produce this effect but vestibular input is likely to be important in view of the parallel suppression of the head-tilt effect in normals compared with labyrinthine-defectives reported by Miller and Graybiel (1966). If this is true then it is further evidence against the views either that the vestibular system is vestigial or that it is subject to characteristic errors which are responsible for the effects of head tilt on verticality judgments. The relatively small long-term effects of vestibular loss on general posture control may indicate only that other cues can take over the functions normally performed by the vestibular system.

The fact that the error effects are not only reduced in the erect posture but reduced to statistical insignificance is probably related to the small amount of head-and body-support afforded by the apparatus - the same explanation as was suggested for Clark and Graybiel's (1967) failure to find any A- or E-effect in labyrinthine-defective or normal subjects.

III: Adaptation to Prismatic Displacement.

There are many methods whereby the normal relationship between sensory systems or between a sensory and a motor system can be altered. It can be done either by the use of external devices - lenses, pseudophones, etc. - or by surgical re-arrangement of the anatomical distribution of peripheral innervation - tendon crossing, nerve transposition, reversal of a limb in its socket. Taub (1968) makes a strong case, based on phylogenetic correlation, that the responses to these distortions can be regarded as a very closely related group of processes. After reviewing the evidence he concludes that there is apparently no ability to compensate for either visual inversion or reversal of the direction of action exerted by limb antagonists below the class mammalia. The higher mammals are able to compensate for both types of re-arrangement, while rats, a lower mammalian order, display a transitional amount of compensation for nerve and muscle reversal and are apparently able to compensate for visual inversion also. A possible criticism of the visual inversion work is that the studies on mammals have invariably used optical devices, but a recent study by Albert (1966) showing compensation in rats, used the surgical procedures more commonly employed with the lower forms.

Although there is a strong assumption in much of this work both surgical (e.g. Sperry, 1951) and optical (e.g. Held and Bossom, 1961) that it has direct implications for neonatal development of sensory-motor co-ordination this connection is by no means self-evident. The present discussion will disregard these wider implications and treat as a process of interest in its own right the adaptation of humans to prism displacement - the process which has been by far the most popular with experimenters.

The most obvious consequence of wearing displacing spectacles is the disturbance of visually guided behaviour, such as pointing. Movements towards objects will be directed towards that position in space whence the displaced optical array would normally emanate. If the pointing limb is in view, the person will correct his initial mistake and be able to guide it visually to the target. If, on the other hand, the error is not made evident until the termination of the pointing movement, it can still be corrected at the next attempt.

Human subjects, given time and knowledge of results are able to adapt their movements to simple visual displacements or rotations. There has apparently never been any disagreement about this fact since the classical experiment by Stratton (1897) who wore an inverting reversing device for seven days. He recorded in great detail the gradual

process of adaptation to the disturbance as he went about his everyday life. Unfortunately he used no systematic tests of co-ordination. Similarly the long series of experiments by Erisman and Köhler (see Kottenhoff, 1957 a and b; Köhler, 1964) relied largely on phenomenological reports from subjects. The most significant aspects of the reports concerned the gradual reduction in the deliberate and conscious thinking required to achieve an appropriate movement and, secondly, the fact that success at one skill apparently did not transfer to others.

The gradual automatization of skills is a common experience, and the specificity of learning in this situation has been further stressed by Taylor (1962) whose subject wore reversing spectacles each morning over a pre-tracted period, and by Rhule and Smith (1959 a and b). This latter work is puzzling in several respects. The four groups of subjects were asked to write rows of a's, triangles and dots under four conditions: normal vision and normal kinaesthetic orientation, normal vision with inverted kinaesthetic feedback, inverted vision with normal kinaesthetic feedback, and inverted vision with inverted kinaesthetic feedback. By "inverted kinaesthetic feedback" was meant upside down writing movements. How anyone can write a row of dots, or even a triangle upside down is not made clear. Nor is it clear why upside down writing movements should be regarded as inverted kinaesthetic feedback, which properly

would involve an anatomical reversal of the kinaesthetic nerves in relation to the motor supply and vision. All that is reversed in drawing something upside down is the pattern of motor-movements normally associated with the particular shape. The letter 'a' was the only one of Rhule and Smith's shapes which is obviously associated with a particular orientation of movements.

Their only measures of performance were the times during which the pen was in contact with the paper (manipulation time) and the time it was not in contact with the paper (travel time). No measures were taken of the quality of the shapes produced. It is well known in mirror drawing experiments, that time can be 'traded' against errors. A measure of either alone is no indication of the rate of learning. It can be seen from an illustration in Smith and Smith's book (1962, p. 136) that the quality of performance was abysmal on the first day of the experiment. If the subjects were told to work as fast as possible, and we are not told what they were asked to do, their learning would not have been reflected at all in the time measures which were used.

There seems little reason, therefore, to trust any of the results which these authors present, and this applies to most of the results in the book by Smith and Smith: especially when many of their results contradict what one can find out easily from casual observation. For instance,

they found that there was little if any difference in people's ability to draw 'a' and upside down 'a'. Anyone trying these two tasks is immediately aware that it is much more difficult to draw an upside down 'a', but one learns in a few minutes to become fairly proficient. The time scale of averaged scores on each day for ten days, which Rhule and Smith used, fails to disclose the learning which must take place here.

From the conditions where vision was inverted, it was concluded that the effects of inversion were greater in tasks of increasing complexity. The triangle showed the most effect of inversion, the dots least. That the dots would show least effect should surely have been obvious before the experiment started, and to say that the triangle shows most effect, because it is the most complex shape, is meaningless in the absence of any independent measure of complexity. Rhule and Smith concluded that learning was specific to each shape. Their conclusion would carry more weight if they had tested whether training on one letter improved the ability to write other letters under similar distorting conditions. They did find, however, that training to read upside down writing did not transfer to writing with visual inversion, but in view of the crude measure they used, even this finding cannot be accepted as a fact.

These experiments were repeated using a closed-circuit television camera and monitor. The subject saw his hand and the visual target in the monitor only. But the hand was actually off to one side where it could be photographed whereas the monitor was directly in front of the subject, thus inducing a large unwanted and unnecessary visual-kinaesthetic discordance. They analyzed the relative disturbing effect on drawing dots, a's, and triangles, of inverted, reversed, and inverted-reversed vision. Performance speed was most affected by inverted viewing, next by inverted-reversed, and least by reversed viewing. They concluded that this order reflects the order in which all skills are affected by these respective disturbances. This conclusion is completely unwarranted. Two of the shapes they used, dots and triangles (), are bilaterally symmetrical, so that reversal could not be expected to disrupt performance. It is not stated whether the order of drawing the rows of shapes was specified to the subjects, but in any case, inversion of the visual field would not disturb this aspect of performance, whereas reversal would.

Smith and Smith (pp. 180 - 183) also used a star-tracing task. This is the correct way to study the relative effects of the various types of distortion, for the figure is just as symmetrical one way as the other. They still found that inversion produced the greatest disturbance, and reversal

least. They found, contrary to commonsense expectation, that movements in a particular dimension were not disturbed most by displacement in that dimension. For instance, those portions of the star figure which ran left to right were not most disturbed by left-right reversal of vision. This result is unacceptable for it is based on time measures only.

These studies do not lead to any important theoretical conclusions, except that the effects of various types of distortion on various kinds of movement are highly specific, and one's faith in even this conclusion is shaken when one considers the crude measure used. Smith and Smith interpret their findings in terms of their neurogeometric theory, which is not directly relevant to the present discussion but is analyzed in Howard and Templeton (1966).

The gradual improvement in performance with reversing and/or inverting spectacles which was a major feature of the studies of Stratton and Köhler was confirmed by Ewart (1930) and Snyder and Pronko (1952) using a variety of tasks, including card sorting, mirror tracing, pointing to visual targets, and pegboard filling, and a variety of conditions and periods of exposure to the distortion.

Peterson and Peterson (1938), and Snyder and Pronko (1952) found that the visual-motor habits learned whilst wearing distorting spectacles were retained when the subjects

were again tested with the spectacles after a period of several months of normal viewing.

Reversing and inverting spectacles produce a complex pattern of disturbances to sensory-motor co-ordination, eye and head movements, and the polarity of familiar objects, and this is the main reason why the classical work, even those studies using systematic tests, was theoretically sterile and fell into disrepute. The workers producing significant studies in recent years have less ambitiously limited themselves to the simpler distortions produced by displacing mirrors or prisms. In addition to relative simplicity this approach has the advantage that relearning is quicker, being typically measured in minutes rather than days, and so the experimental conditions are more easily controlled.

Wooster's (1923) experiment will be described in some detail since, although no important positive conclusions follow from it, it is generally regarded as setting the style for modern experimentation and it illustrates many of the procedures and problems encountered in the spate of studies which the past decade has produced. She studied the effects of wearing prisms which displaced the visual world 21 degrees to the right. In the various experiments, 72 subjects were tested. Each subject was tested while

wearing the prisms for a short period on each of ten days or until the effects of the distortion had been overcome, if less than ten days.

The subjects had to make rapid movements of the right arm towards the position of one of several small round discs. Normally, the arm and hand were hidden from view. In one condition, no knowledge of results was provided, at least not deliberately. In other conditions, information regarding the true position of the disc was potentially available to the subject, in one of several forms. The disc emitted a sound in one condition. In another, the subject was allowed to move his finger until it touched the disc. In a third condition, the tip of the finger could be seen when the localizing response had been made. Finally, the tip of the other index finger was used as the target, and the subject was allowed to touch it if he made the correct localizing response.

After ten days of practice, Wooster found that, even with no knowledge of results, accuracy had increased until the subject's mean deviation from true localization was 40.5 per cent less than the deviation on the first day. She suggested that there was "unconscious adaptation of the reaching movements to the new kinaesthetic stimuli from the eye muscles". Presumably what is meant here is that the subject's body faced the true position of the

visual target, while the eye was directed to its displaced position, and that gradually the subject came to behave as if he were looking straight ahead - the well known after-effect of asymmetrical eye position on the apparent median plane (Fischer, 1915; Kiss, 1921; Goldstein and Riese, 1923; Werner, Wapner, and Bruell, 1953). It is a pity that this factor was not controlled by making the displaced visual targets symmetrical in the visual field of some of the subjects. A stronger possibility, however, is that the effect was a true effect of compensation for intersensory conflict since it disappeared when head movements were prevented and it is known that compensation occurs with a fairly rich visual environment provided head movements are permitted (Bossom, 1964).

The sound of the disc buzzer was found not to contribute towards increased accuracy of pointing, even when the buzzer could be both seen and heard. When subjects were allowed to slide their finger along until they touched the disc or when they were allowed to see their finger, there was a rapid improvement in accuracy. The most rapid improvement occurred, however, when the visual target was the tip of the other index finger and the subject was allowed to touch it. In this last condition, however, the subject could have performed correctly by disregarding visual information, because he could 'feel' the position of the target. The

task would have been a purely kinaesthetic-motor one and, as such, would have involved no distortion of sensory input.

The most important way in which this technique has been altered in recent work is that attention is typically no longer paid to the actual changes in behaviour during the exposure or training period since if the subject is aware of his errors he will presumably, and is often encouraged to, correct them deliberately. So changes taking place during this phase are of trivial importance since there is no way of telling when the corrections cease to be deliberate and become, in some sense, automatic. Accordingly in recent studies the point of interest has been the change in performance on a test localization task which precedes and succeeds the training task, being sometimes quite similar to it, sometimes not, and often performed with the optical displacing device removed.

These procedures present their own difficulties. If the prisms remain in place throughout and the tasks are similar then the subject may, in the post-test, merely continue to do what he has been trained to do in the exposure phase whether or not the change in behaviour has become automatic. If on the other hand the tasks are very different then the extent of the real underlying changes may be underestimated since it may reasonably be expected that the

degree of transfer of the changes, whether deliberate or automatic will be related to the similarity of the tasks, (Freedman, Hall and Rekosh, 1965). This is important especially for those who attempt to analyze the adaptive change into its component processes. It is easy to assume, for example, that a change in the "felt position" of the hand used in training can be equally well measured by having the subject use that hand to point straight ahead in the dark, or by having him point at that hand using the other "untrained hand". In fact the first task may show a greater effect simply because the same arm is active which was active during training.

The danger of underestimation of the magnitude of the underlying change is also present when the goggles are removed for pre -and post-tests, since one can easily envisage the operation of a strong conditioning effect. Whether consciously or not the subject in effect says "These goggles were the reason I was making the errors initially; now that they are removed I can revert to pointing naturally". This danger is of course greatest when the experiment involves a series of repeated test and training sessions; indeed J. G. Taylor (1962) reported that his subject became able in time to switch immediately from one mode of behaviour to the other, merely by putting on or taking off the goggles. The tactile stimuli from the goggles and the change in shape

of visual field can of course easily be controlled, for example by wearing goggles throughout but substituting plain glass for the prisms. But incidental effects of looking through prisms, such as colour fringes and apparent curvature (Ogle, 1951; Taylor, 1966) are possible discriminative stimuli, and can probably be eliminated only by using a more cumbersome mirror system.

In order to overcome these difficulties Howard and Templeton (1966) suggested a new "shaping" technique in which variable prisms are used to gradually increase the optical displacement so that each step of the change is within the normal range of error of the subject's control pointing. Ideally, with this procedure the subject can be trained to a stage at which he is pointing a long way from the optical position of the target without having any awareness of the change. The problem of conscious correction is thus eliminated and with it the need for pre-and post-tests, and the time course of adaptation and extinction can be studied in detail under various conditions.

The other major divergence from the pattern set by Wooster's work is that whereas most workers still, like Wooster, require subjects to perform an actual task during training, the errors made providing the error-corrective feedback, an important body of work has involved only inspection of the hand through prisms while it executes a series

of fairly random movements. This procedural divergence has theoretical implications which will become clear in the discussion of reafference theory.

A high proportion of the large body of work reported in the late fifties and the sixties has been provoked by the two major theoretical formulations which have been advanced in this field, the one associated mainly with Held, the other with Harris. Epstein's (1967) observation about Harris's theory that it is concerned with what changes during adaptation rather than with how or why it changes applies to some extent to Held's theory as well. Both workers begin with an assumption about the site of the adaptive change and from Held's particular assumption there follows a corollary that self-produced movement is an essential condition for adaptation. The work which has been reported for the most part falls into two classes, tests of Held's corollary and investigations, mostly stemming from Harris's work, of the locus of the adaptive shift, the latter work, by implication at least, involving Held's basic assumption. Accordingly, the significance of self-produced movement will be examined first since although logically derivative it has been treated by many workers as an independent hypothesis.

The Importance of Reafference for Adaptation.

The minimal conditions which all workers would agree to be necessary for adaptation to take place are that there must be a conflict between spatial information provided by two modalities, that this conflict must be in some sense apparent to the system (thereby excluding intra-model effects like that of asymmetry of gaze as discussed in the analysis of Wooster's work) and that there must be a suitable way of measuring the change which distinguishes it from the trivial adaptation of conscious correction (the problem discussed in the previous section). Beyond that the major dispute has been about the importance of generating the error information by means of active self-produced movement.

Stratton, Köhler, Wooster and other early workers stressed the importance of active movements in the adaptation of movements to optical distortions. However, von Holst (1954) was the first to formulate the basis for a definite hypothesis. On the basis of his observations on insects and fish, in which he re-arranged the visual input, he concluded that the important thing in visual-motor co-ordination is the relation of actively produced movements of the body or parts of the body to changes in the pattern of stimulation of the sense organs which these movements produce. Such changes in sensory stimulation consequent upon self-produced movement he called "reafference".

Stimulation of the sense organs produced solely by changes in the external world were called "exafference". An animal capable of orientating itself must be capable of distinguishing between reafferent and exafferent stimulation. It does this by making use of information from the neural centres which control the movements of the parts of its body. The changes in the stimulation of the exteroceptors which a given pattern of muscular innervation would normally produce is 'allowed for' in processing the information from the exteroceptors. This idea has something in common with Helmholtz's theory of unconscious inference.

Held applied this hypothesis to the case of visual-motor adaptation and reported experimental evidence which is claimed to support it. The schematized process which he proposes is shown in figure 3.1. It is similar to the one proposed by von Holst except for the addition of the "Correlation Storage". The skeletal muscle represents any motor system that can be a source of reafferent visual stimulation. In Held's words, "...the reafferent visual signal is compared (in the Comparator) with a signal selected from the Correlation Storage by the monitored efferent signal. The Correlation Storage acts as a kind of memory which retains traces of previous combinations of concurrent efferent and reafferent signals. The currently monitored efferent signal is presumed to select the trace combination

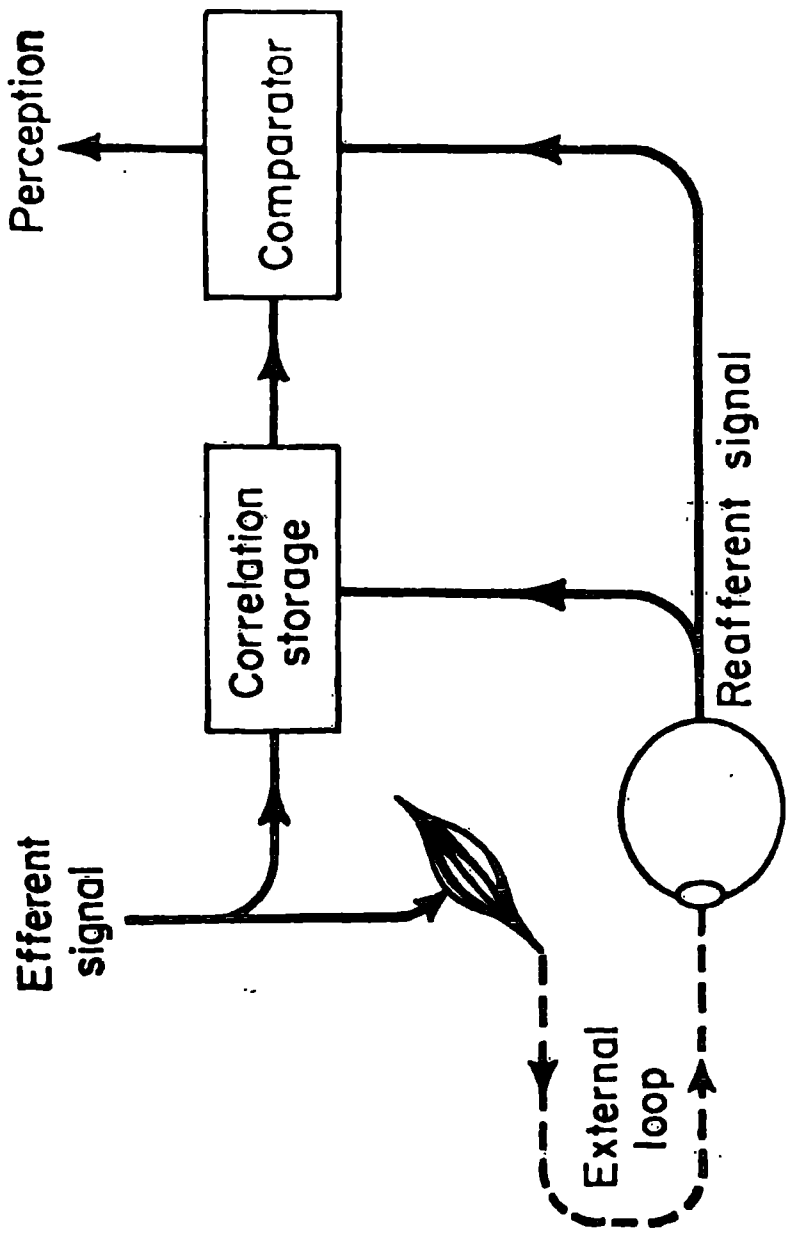

FIG. 3.1 Schematized process assumed by Held to underlie the consequences of rearrangement, neonatal development, disarrangement, and privation on visual-motor coordination.

containing the identical efferent part and to activate the reafferent trace combined with it. The resulting revived reafferent signal is sent to the Comparator for comparison with the current reafferent signal. The outcome of this comparison determines further performance". (Held, 1961, p. 30).

Held thus sees the significant effect of optical distortion to be a deviation of the sensory consequences of motor commands from those expected on the basis of past experience. Adaptation is consequently the establishment of a new set of expectations, a recorrelation of motor commands and sensory consequences. Motor commands are clearly essential to this process, hence the corollary that self-produced movement is a necessary condition for adaptation.

Held's basic procedure was to compare the effectiveness of self-produced movement with passive movement in the re-adaptation of visual-motor co-ordination to a displaced visual input in adult human subjects. The experiments reported in Held and Hein (1958) Held and Schlank (1959) and Held and Freedman (1963) are typical. They used an apparatus described by Held and Gottlieb (1958), in which a mirror is used to occlude vision of the hand and arm and to present a target square. The subject was first asked to mark a sheet of paper under the mirror at

the mirror-image positions of the four corners of the square. The mirror was then replaced by a prism and the subject was allowed to see his hand through the prism for three minutes while the hand was motionless, moved passively from side to side, or moved actively by the subject. Only the active movement condition led to any significant shift in the mean position of aim when the subject was again asked to point with the unseen hand at the corners of the reflected target figure. The active training had led to a change in the relationship between the visual location of the targets and the localizing movements made to touch them, and Held and Hein concluded that reafference was necessary for such a change to take place. The failure of Weinstein, Sersen, and Weinstein (1964) to produce any adaptation even with an active condition was probably due to an experimental artifact as Held and Schlank (1964) point out. Weinstein et al. certainly produced adaptation with active training in other studies (Weinstein, Sersen, Weisinger, and Fisher, 1964; Weinstein, Sersen, Fisher, and Weisinger, 1964).

The first thing to be said about Held's theory is that, as Rock (1966) has pointed out, it uses reafference for a very different purpose from that of Von Holst. Whereas Von Holst was concerned with the problem of how an animal categorizes movement stimulation (e.g. retinal image flow or the brushing of fur or whiskers) as caused by the animal's

own movement with respect to a stationary environment (i.e. reafferently) or by the actual movement of an object in the environment (i.e. exafferently). This is the direct forerunner of the recent growth of interest in the problem of human detection of visual movement and displacement during different types of eye movement (e.g. Matin, Pearce, Matin, and Kibler, 1965; Wallach and Lewis, 1965, Stoper, 1967; Steinbach and Held, 1968).

But Held has assigned to reafference in prism displacement a very different purpose from this function of discounting movement stimulation. In Held's hand-wagging experiments the hand continues to be seen to move whether it moves actively or passively. In fact, the primary effect of displacing prisms is not an alteration in the correlation between commanded and seen movement at all; when one moves one's arm one foot to the left the arm's image as seen through the prisms also moves one foot to the left (this is not precisely true since the prism produces somewhat different displacements in different parts of the field, but this is certainly not what Held was talking about). What is primarily altered is the relationship not between commanded and seen movement but that between felt and seen position. Felt position, at least in limbs, is given primarily by joint proprioception; it certainly cannot be given by monitored motor outflow since such a system could not

compensate for load changes, which the limbs, in contrast to the eyes, are required to do. Held's model does not contain information about limb proprioception and is therefore irrelevant to the problem of adaptation to visual-propriocceptive discordance. The only aspect of prism-wearing to which Von Holst's theory would appear directly relevant is adaptation to changes in the rate or direction of displacement of the retinal image produced by head movements. Another problem for which it would be suitable is that of a subject denied direct information about the loading on his limbs; such a subject would have to compensate his movements for load changes on the basis of the discrepancy between motor commands and their sensory consequences.

If there is thus no obvious justification for extending Von Holst's ideas to the problem of prism adaptation then the prestige and supporting evidence of the theory does not transfer automatically to Held's model. Granted this lack of external support and the suggested irrelevance of the model, the self-produced-movement corollary appears a priori unlikely to be correct. Confronted with a conflict between two normally correlated sources of spatial information the subject might reasonably be expected to use any available information as a basis for resolving the conflict. "Information of any sort with respect to the altered state of the system may serve as a basis for adaptation" (Wohlwill, 1966).

The surprising thing at first sight about the arm-wagging experiments of Held and his associates is not the difference between active and passive groups but the fact that either of the groups learned anything. The subjects were not required during exposure to carry out any task which would have demanded a resolution of the visual-proprioceptive conflict of which they may or may not have been aware. And so it is not surprising that even the active group achieved an adaptation of only about one third of the amount of the optical displacement.

Wertheimer and Arena (1959) were surprised that they observed a much larger and more rapid adaptation (40% with a 20 second exposure) but their training procedure involved placing crosses in visible squares so the subjects were required to deliberately correct their movements. But even this procedure did not produce full adaptation, presumably because the pointing hand was visible throughout its movement and the task could therefore be carried out under visual control alone, thereby making the demand for a resolution of the conflict weaker than it need be.

It seems very likely that the superiority of active training conditions found by Held is due to richer viridical proprioceptive information or more attention being paid to it, thereby sharpening the intersensory conflict. But to say that proprioception may be different when a limb is actively rather than passively moved is very different

from postulating a discrepancy between motor commands and sensory consequences. This raises a major point about Held's inferences from his data. The experiments described above involved a comparison of active and passive movement during exposure but the test sessions involved only an active task. If active proprioception is different then the reason why passive training did not influence the active test may be that any recalibration of passive proprioception was swamped by the original calibration of those proprioceptive components peculiar to activity. In any case, the evidence of adaptation obtained from a test situation is, in general, likely to be related to the similarity between test and exposure conditions.

Finally there is the logical point that Held has chosen one or two specific situations in which adaptation appears to depend on self-produced movement of all adaptation.

In the light of Held's failure to explore the potential of exafference an attempt was made to devise a situation in which the bias would be reversed in favour of exafference by providing the subject with both the motivation and the opportunity to alter his behaviour during training.

The results of experiment 3(a) show that under these conditions there is a degree of adaptation comparable with that observed by Held and his associates in their active conditions.

This conclusion is strengthened by other recent evidence that adaptation can occur following passive movement (Singer and Day, 1966 a and b) and even without a task in conditions similar to those used by Held (Pick and Hay, 1965; Singer and Day, 1966 b).

It might appear that the fact that self-produced movement is not necessary for the dissipation of adaptive changes in behaviour (Bossom and Hamilton, 1963; Hamilton, 1964; Hamilton and Bossem, 1964) constitutes an argument against reafference theory. But, as Epstein (1967) points out, variables necessary for the establishment of a state may play no part in its disruption. In fact, massed practice seems to affect acquisition and extinction in opposite directions (Kimble, 1961).

Although it is often invoked as a contaminating factor in other studies few workers have deliberately attempted to produce adaptation by means of visual stimulation from parts of the body other than the reaching arm or finger. But again the results have confirmed the non-essential character of self-produced movement for adaptation.

Wallach, Kravitz, and Lindauer (1963) used two tests, pointing to a visual target and judging when a visual target was straight ahead. Both tests showed an adaptive change of about 35% of the prism displacement after the subject had stood for ten minutes looking down at his legs through the prisms. Another experiment in which a subject lay supine and looked down at his feet produced paradoxical results. In a situation where the proprioceptive and assumptional cues to the position of the feet should be weaker the apparent straight ahead shifted by a much greater 65% whereas the change in the pointing test was not significant, and this despite the fact that a change in the apparent visual straight ahead should normally be a sufficient condition for a change in pointing to a visual target (Rock, 1966).

Hein (1965) attributed the positive results of Wallach, Kravitz, and Lindauer to a postural after-effect resulting from the asymmetrical position taken up by the head and trunk in order to view the legs through prisms. He closely replicated the results by having his subjects adopt such a posture but without any intersensory conflict. Another factor which Wallach et al. did not control was the asymmetrical direction of gaze while the legs were being viewed. All of these factors were controlled in experiment 3(b) which eliminated head movement while the standing subject

gazed at his feet through prisms. The test - setting the eyes straight ahead - showed a substantial effect which a control condition showed was not due to the asymmetrical gaze.

The other sort of procedure used to provide support for the reafference principle is typified in the experiment by Held and Bossom (1961). Subjects wore eleven-degree displacing prisms while they either walked along a road or were pushed along it in a wheelchair for one hour. The sequence of visual stimulation was thus similar for the two groups but in only one did it depend on self-produced movement. Before and after this exposure the subjects with prisms on set their bodies so that a light appeared to be in their median plane. The prismatic distortion of eleven degrees was reduced by just over one degree after exposure, but only in the case of the walking subjects. Similar experiments have produced similar results for tilt adaptation (Mikaelian and Held, 1964) and curvature adaptation (Held and Rekosh, 1963; Rekosh and Held, 1963).

In this situation it seems clear that in the absence of vision of the subject's own body the major potential source of information is the changed relationship between the felt progression of locomotion and the seen progression of visual stimulation. As one progresses forward in a straight line the retinal image of the environment moves outward from a distant point on the line of progression (Gibson, 1950). When wearing prisms this centre of the expansion pattern is displaced to one side of the straight ahead. A point which is truly straight ahead will at a distance appear displaced to one side but as the linear

magnitude of the displacement decreases as the point is approached it comes closer and closer to the optical straight ahead. This progressive change in visual stimulation would be compatible with locomotion along a curved path of an observer with normal vision.

Held's theory seems more relevant to this situation than to the hand viewing one since here the important discrepancy is between movement and its visual consequences, but again the movement information is certainly not derived wholly from monitored motor-outflow.

It follows from the above analysis that whether or not the subject resolves the conflict by a change in the apparent visual direction of objects would seem to depend on how well he knows the direction of his locomotion; if the motor-vestibular - tactile stimulation complex presumably responsible for this information is weak then the conflict - of which the subject might not even become aware - can easily be resolved by the assumption that the path of his locomotion is curved, and this mode of resolution has never been tested for. This seems likely to be the crucial distinction between the active and the passive subjects in this situation: the active subjects have more information about their true direction of locomotion and so are forced to resolve the conflict by a change in visual judgments of direction.

If the passive subjects were allowed to control their own movements the difference might well disappear with both groups showing adaptation of visual direction. This reveals an important ambiguity in Held's position. It is not clear precisely how close, or direct, or natural the relationship between movement and its sensory consequences has to be in order to qualify as correlated reafference. For example if the two arms were mechanically linked in such a way that active movement of one produced passive movement of the other in the opposite direction, would the sensory feedback from the passive arm be reafferent or not? Or, in this case, is the stimulation resulting from propelling oneself in a wheel-chair - or even an automobile - reafferent in the same sense as that resulting from walking? Held does not specify the necessary conditions for reafference except indirectly by implication from his experiments. For example Held, Efstathiou, and Greene (1966) found that a time-delay of 270 m.sec. in the feedback loop was sufficient to prevent adaptation and therefore presumably to preclude true reafference. Significant reduction of adaptation is also reported when during exposure the subject continually tries to move his arm against a countervailing force so that the actual movement is in the direction opposite to that intended (Held, 1968). The force in this case was presumably completely countervailing,

i.e. negligibly modifiable by the subject, but it might have been such that the subject though never able to move his arm in the intended direction could nevertheless control the rate of movement in the opposite direction by the effort which he made. This, like the time delay situation, is a case of complete, though unusual correlation, but it is not clear whether it would qualify as reafference.

Weinstein, Sarsen, Fisher, and Weisinger designed a test of Held's hypothesis in which they seemed to cope with this ambiguity by allowing several different interpretations of reafference. They employed the same method of testing the apparent straight ahead as Held and Bossom. During the exposure period all subjects sat in wheelchairs and either propelled themselves or were pushed along a corridor for one hour. There were four conditions: passive, in which the subject was wheeled around; move-only, in which the subject moved the wheels but the experimenter steered the chair; direct-only in which a blindfolded experimenter pushed the chair but the subject steered it; and move-and-direct in which the subject provided both the locomotion and the direction. These conditions were designed to separate the directional or decision making aspects of active movement from the actual movement itself. Weinstein et al.'s interpretation of Held's position demanded adaptation only in the conditions where their subject provided the locomotion

whereas they themselves predicted that it should occur only in the conditions where he directed the movement, presumably on the grounds suggested above that the subject has more information about his true direction of movement. Under the alternative interpretation that reafference requires a "natural" relationship between movement and its sensory consequences, Held would predict adaptation in none of the conditions. This interpretation is suggested by Held and Mikaelian's (1964) experiment in which "passive" subjects controlled their own wheelchair and showed no adaptation while "active" walking subjects did adapt.

In fact Weinstein et al. found adaptation in all four conditions though it was greater in the two in which subjects controlled the steering. These data clearly conflict with those of Held and Bossom but in fact this experimental arrangement is so uncontrolled that there are several possible differences which could explain the disagreement. Held and Bossom claim that their subjects could not see their own bodies but neither Held and Mikaelian nor Weinstein et al. make clear whether their subjects could.

Indeed, it is not clear what effect viewing the body would have: it would certainly produce a further visual-preprioceptive conflict which could explain the adaptation found in all of Weinstein et al.'s conditions (Wertheimer and Arena, 1959, and Craske and Templeton, 1968 have shown

that the briefest glimpse of part of one's own body can be effective). But sight of the body and the wheel-chair could equally be the explanation for the absence of adaptation in the case of Held and Mikaelian's wheelchair subjects, for they could have stayed on course and avoided collisions by means of continuous visual guidance based on the spatial relationships between the wheelchair and the surroundings since these visual relationships would be little distorted by the prisms.

Similarly none of these studies controlled for the asymmetry of the visual field which results from wearing prisms and which was discussed in connection with Wooster's experiment. Nor did any of them control for the effect of movement itself; it is well known that adaptation occurs with a subject who is permitted head movements but is otherwise immobile (Bossom, 1964; Taub, Goldberg, Bossom, and Berman, 1966). In any case there could be any number of uncontrolled differences between the groups of subjects used in these experiments: walking probably inherently involves more head movement than riding in a wheelchair, and subjects who are either walking or propelling their own chair are probably more motivated to attend to and resolve spatial conflicts.

As Howard and Templeton (1966) point out, several of these criticisms apply equally to Held and Hein's (1963) experiment with a mechanically linked pair of kittens. As always with Held's experiments a situation is devised in which active animals learn better and it is concluded that activity is essential to learning before any attempt is made to discover whether different conditions might obliterate the difference. The odds are stacked against the passive animal from the start.

In general then the wheelchair situation seems much too cumbersome to allow proper control of the information sequence reaching the subject. In order adequately to test Held's hypothesis in a situation which does not involve arm pointing one would require a subject who is passive but who is nevertheless forced to commit himself to a spatial judgment which is then clearly shown to be in error. A subject is presumably attentive to an object which is approaching him and tends to judge whether or not it will hit him and if so on what part of his body and he is presumably surprised and so made aware of spatial conflict if his judgment turns out to be erroneous. Such a situation is the basis of experiment 3(c), and the results show once again that given sufficient information and motivation a passive subject will demonstrate at least some adaptation.

This result takes the conclusion from experiments 3(a) and (b) and from Singer and Day (1966a) a stage further - adaptation can occur not only in passive subjects and subjects without skeletal movement but even in subjects who are not making eye movements. This study showing adaptation to visual-tactile discrepancy is neatly complemented by two more recent experiments showing adaptation to visual-auditory conflict (Kalil and Freedman, 1967) and to tactile-auditory conflict (Freedman and Wilson, 1967) again in an immobile subject. The exposure condition in this last study involved merely repeated tapping on the subject's hand with a sounding loudspeaker.

The conclusion therefore from all these studies and from the experiments reported below must be that there are myriad possibilities for producing adaptation in a subject who is not engaged in relevant self-produced motor activity. He can be allowed to see his own stationary body or his passively moved hand or objects coming towards him and colliding with him or failing to collide with him. Craske (1967a) even found adaptation when the subject pointed to visual targets during training but received kinaesthetic rather than visual error feedback - his errors were corrected by passive movement of the unseen limb by the experimenter.

In the light of this evidence there has been some modification of Held's views but the most recent statements from the reafference theorists reveal some confusion about the role of active movement. "Active movement with its accompanying sensory feedback is an essential condition for adaptation under circumstances in which no other important source of error information is available", (Held, 1968). And "Self-produced movements of a subject experiencing rearranged vision have been shown to be a sufficient condition for partial adaptation and they appear to be a necessary condition for full and exact compensation", (Held and Hein, 1967).

Howard and Templeton (1966) suggested that the necessary conditions for adaptation might be opportunity, in the sense of information definitely getting through about the conflict, and motivation, in the sense of a task requiring for its successful performance a resolution of the conflict. As indicated above, however, there is some evidence that a specific task may not be necessary, and the interpretation of adaptation as a learning phenomenon, to be discussed below, suggests strongly that opportunity is the only necessary criterion since sensory discordance carries with it its own motivational properties.

Adaptation as a Learning Phenomenon.

The central problem which has been neglected by most theories of adaptation is "Why does adaptation occur?" Theoretical issues have mainly concerned the conditions which facilitate adaptation or the site of the changes which occur in adaptation. But they leave us with an intersensory conflict or an efference-reafference discrepancy without suggesting why it should be resolved (Epstein, 1967). Interpretation of adaptation as a learning phenomenon might supply the missing link since learning implies reinforcement and motivation.

Several of the earlier workers in this field, e.g. Wooster (1923) and Snyder and Pronko (1952) have regarded some sort of learning as an important component of the process of prism adaptation. The most elaborate analysis along these lines was advanced by J. G. Taylor (1962) who argued that spatially oriented behaviour consists of sets of stimulus-response connections established through early learning. When vision is subsequently transformed the old visual-motor relations lead to mislocalization and are therefore subject both to extinction due to lack of reinforcement and to suppression due to punishment. At the same time new co-ordinations appropriate to the altered vision are rewarded, thereby acquiring strength. This approach, entirely in terms of primary reinforcement processes, provides an adequate account of the results of the

classical work on either displacing ~~or~~ reversing/inverting prisms. In these cases subjects either interacted freely with their environment or were given specific tasks, after which they were permitted knowledge of their errors; the nature of the reward and punishment was clear.

Two aspects of more recent work, however, appear to dispose of such a simple learning interpretation. In the first place Held's series of studies have demonstrated adaptation in situations where lack of co-ordination did not appear to be punished: nor correct co-ordination rewarded: subjects merely watched their environment as they moved about it or watched more or less random movements of their optically displaced hands. In the second place, those studies designed to undermine the relevance of Held's reafference principle by showing adaptation in the absence of subject movement (Experiments 3(a), (b) and (c); Singer and Day, 1966; Wallach, Kravitz, and Lindauer, 1963; Freedman and Wilson, 1967; Kalil and Freedman, 1967) make it unlikely that if there is learning it is of sensory-motor connections.

Taub (1968) has attempted to strengthen the learning interpretation to encompass these cases in the time-honoured manner of reinforcement theorists in difficulty - by invoking secondary reinforcement. Due to their having led in the past to mislocalization and subsequent punishment certain

conditions, notably intersensory discordance, acquire a secondary negative character. The subject from a very early age learns to escape from or terminate such noxious conditions before they can lead to mislocalization. In the case of intersensory discordance the noxious situation is terminated by intersensory recalibration (i.e. change in judgment) which is the learned response; hence the lack of need for subject movement. The system has merely to be made aware of the discordance in any effective way and the recalibration will result. Furthermore, the recalibration will consist not of a compromise between the conflicting sources of information, which would typically still lead to mislocalization, but of a dominance of that source which has proved itself the more stable and accurate in the past, in the human case generally vision. A compromise solution may be apparent (e.g. Rekosh and Freedman, 1967) but only at an intermediate stage of adaptation.

Taub, Goldberg, Bossom, and Berman (1966) have shown directly the importance of the relative strengths of modalities. They trained deafferented monkeys to point accurately with unseen hands, and gave them a 24-hour period of prism exposure with free head movements but no sight of the body. After-effects initially were 100% of prism displacement in the deafferents but only 39% in normal controls, showing that if the subordinate modality in

a conflict is weakened, adaptation is more rapid. Similarly Rakosh and Freedman (1967) have shown that in a condition of prism-induced visual-auditory conflict if the auditory information is attenuated by ear-muffs then there is a shift in both auditory and visual localization; without auditory attenuation the adaptation is almost entirely visual.

This last example makes it clear that the question of how the conflict is resolved is not wholly one of inherent dominance but depends also on which modality has been experimentally altered.

Thus on this view the old habits of judgment result in noxious discordance which in turn provides the information necessary for subsequent modification of these habits. It is not unusual in learning theory for one and the same stimulus to serve as a reinforcement for earlier responses and a discriminative stimulus for subsequent responses (e.g. Haviow and Lang, 1965).

The fact that adaptation occurs even in an immobile animal no longer rules out a learning interpretation since in the past decade a wide range of learning phenomena have been shown to occur after administration of curariform agents which prevent overt skeletal movement (e.g. Black, 1965; Miller and Di Cara, 1967).

Epstein (1967) propounds a view which while much less fully elaborated than Taub's probably has similar implications. "The presence of conflict or discrepancy may be a precondition for adaptation..... the need to eliminate conflict is the motivational basis for the changes observed in adaptational experiments.... Precedents for these assumptions may be found in more general discussions of conflict (e.g. Miller, in Koch, 1959; Festinger, 1957)".

The only other attempt to apply learning theory principles to adaptation is Baily and Singer's (1967) analogy with sensory preconditioning (Seidel, 1959) but the details are very elusive and will not be pursued here.

The Site of the Adaptive Change.

Although the aspect of Held's theory which has generated most controversy and research is his claim that self-produced movement is necessary for adaptation, this claim in fact follows from the more basic assertion that what changes during adaption are the connections between efference and reafference, in effect adaptation is a change in visual-motor co-ordination. In this respect Held has been followed by Festinger, Ono, Burnham, and Bamber (1967) but has been largely by-passed by the great majority of studies done in the sixties and concerned with the problem of what adapts during adaptation.

Harris 1963(a) listed six possible mechanisms which could underly a change in pointing to a visual target. The first possibility is "conscious correction". There is of course no doubt that this occurs but, as was pointed out earlier, most experimenters are aware of this and take steps to exclude it so it is unlikely to be a viable general explanation of adaptation. Secondly, it is possible that the apparent egocentric location of the visual target alters due to a change in specifically visual localization. Or its apparent location may alter as part of a more general "shift in perceptual axis" which produces a change in the localization of all targets, however sensed. Held's view

that there is a change in visual-motor correlation is also a possibility. The fifth mechanism suggested by Harris is "motor learning", the establishment of new muscular responses to a particular perceived target location. Finally there may be a "proprioceptive change" a change in the judged location of the unseen hand with respect to the body.

Harris also listed a set of transfer tests which would be useful in deciding between these possibilities and applied them in a number of experiments (Harris, 1963 a and b). He used an exposure period of three minutes during which the subject wore 20-dioptre laterally displacing prisms and was required to point repeatedly with seen hand to a visual target. He used four different tests applied with normal vision before and after exposure. In one the subject pointed with unseen hand to each of five visual targets. In the second the subject judged when a sound source was straight ahead with his eyes shut. The third involved pointing at the sound source again with eyes shut. And finally he was required to point straight ahead with eyes shut. The three pointing tasks used both hands alternately.

The main finding was that the judgment of the straight ahead position of the sound source showed no effect, but the other three tests showed an adaptive shift and to

similar extents provided the trained hand was used. In addition the shift in the first test was the same size for all five target positions. The absence of intermanual transfer seems to rule out either a change in visual localization or a general "shift in perceptual axis". The shift in pointing to the auditory target rules out Held's visual-motor recorrelation. Harris also considers that the motor learning hypothesis is excluded by the fact that the change in pointing to the visual target used in training transferred fully to the other four visual targets which had not been used and which demanded different movements. This possibility is ruled out easily and more decisively by the common procedure of alternating starting positions for test pointings, since the motor-system can presumably alter its commands in ways like "make a larger movement" but not like "make a larger movement from the left but a smaller movement from the right". In fact, some workers have reported a dependence of the effect on starting position (Sekular and Bauer, 1966).

If we exclude "conscious correction" this leaves only proprioceptive change and this is what Harris concluded was the operative mechanism - "a change in the felt position of the arm relative to the body..... The person comes to feel that his hand is where it looks as if it is" (Harris, 1963b, p. 813). This of course fits well with the common view that

"Vision completely dominates touch" (Rock and Harris, 1967; see also Rock, 1965; Rock and Victor, 1963; Nielson, 1963; Hay, Pick and Ikeda, 1965).

More direct evidence is presented in a second experiment (Harris, 1963a) in which the test consisted of productions by the subject of various intermanual distances specified by the experimenter. Motor learning was excluded by allowing only passive movements of the trained limb. The results showed a marked change in the productions which was compatible with the expected adaptive shift in the trained arm.

McLaughlin and Rifkin (1965) confirmed that the change in pointing straight ahead in the dark is of similar magnitude to the change in pointing at visual targets.

A further decisive test showed significant shifts when the trained arm was used to point to the stationary untrained arm with eyes shut (Efstathiou and Held, 1964) although their other finding that this adaptive shift is significantly smaller than that manifested in pointing to visual targets - is difficult to account for on the proprioceptive-change hypothesis. But Hamilton and Hillyard (1965) and Craske and Gregg (1966) have shown very similar shifts in pointing to visual targets and to the untrained hand.

Kravitz and Wallach (1966) found a change in judged limb position when the subject was exposed to displaced

vision of his passively vibrated hand. And Craske (1966a) had subjects point at the shoulder, elbow, and wrist of the trained arm when the training involved pointing to visual targets with a straight rigid arm. There was a considerable change in the apparent position of the wrist a smaller change at the elbow and no change at the shoulder. These shifts were compatible with a change in the judged angular orientation of the arm, measured from the shoulder. In another experiment this angular change was shown to correlate highly with the adaptive shift in pointing to visual targets.

The change in pointing to auditory targets following visual rearrangement training found by Harris has been confirmed by Pick and Hay (1964) and McLaughlin and Bower (1965a). Craske (1966b) confirmed the reverse hypothesis, viz. that adaptation to auditory-proprioceptive discordance transfers to a task of pointing to visual targets. During training the subject had to point to an auditory target and in order to "assist" him in the task he had to use another auditory source which he believed to be in the same location and attached to his finger-tip but which was in fact displaced several inches from this finger tip. It has also been shown that adaptation to auditory rearrangement -

this time the sound source which the subject carried had its apparent direction altered by a pair of false pinnae offset by 20° - transfers to pointing straight ahead in the dark (Freedman, Gardos, and Rekosh, 1966).

A further prediction which might be made from the proprioceptive change hypothesis is that there should be an adaptive change in pointing to the remembered location of targets with the trained hand but not with the untrained. Efstathiou and Held (1964) failed to find such an effect in the trained arm but Hamilton and Hillyard (1965) did record adaptation though not as great as in pointing to visual targets. Craske (1967a) used a sample of skilled pianists and failed to find an after-effect in the task of pointing to middle C without vision. He suggested that highly skilled movements like this may no longer depend on information about starting position but depend solely on a standard motor-outflow pattern. But any localizing movement must surely depend not only on the motor pattern but also on knowledge, either direct or assumed, about the starting position of the limb. Craske's explanation would be plausible if he had used a standard starting position but in fact, very sensibly, he made a point of varying the starting position from trial to trial. His result remains paradoxical. Kennedy (1969) however, has confirmed

that adaptation in pointing to the remembered location of targets occurs in the trained, but not in the untrained arm.

Finally the evidence of Bossom and Hamilton (1963) that split-brain monkeys show interocular transfer of prism adaptation seems in retrospect compatible with the hypothesis of a change in felt position of the arm.

It was noted above that Hamilton (1964) lent support to Harris's position by reporting a lack of intermanual transfer of the adaptive shift in pointing to visual targets. But this was true only when the subject's movements were restricted. With free head movements, on the other hand, the adaptive shift was manifested in the untrained as well as the trained arm although significantly reduced in size. Hamilton sought to extend the proprioceptive change hypothesis by suggesting that there were two components of the adaptation process, the change in apparent relationship between arm and trunk and a change in that between head and trunk, with the latter for some unexplained reason, occurring only when the head was free to move.

The other obvious explanation for intermanual transfer is a change in visual localization probably mediated by a change in apparent direction of gaze. This suggestion goes back to Helmholtz. This alternative is perhaps less plausible in Hamilton's case since the presence of adaptation in

the untrained arm seems to depend on the presence of head movements and it is even more difficult to explain why this factor should catalyze a change in felt eye position than why it should produce a change in felt head position. But Hamilton rejects it even in another experiment where subjects lay on their backs and effects were manifested in pointing with all four limbs; the question of head movements was not involved. His rejection of this possibility was mainly on the erroneous grounds that the eye has no position sense to be altered. But of course the evidence shows simply that the eye's position sense is not proprioceptive in the normal sense but rather based on monitoring of motor outflow to the eye muscles (see Howard and Templeton, 1966).

In another of the rare cases where intermanual transfer was found when the exposure consisted simply of viewing the hand through prisms (Kalil and Freedman, 1966a) it was confirmed that there occurred also a shift in the position in which the eyes are judged to be straight ahead (Kalil and Freedman, 1966b). Other cases are McLaughlin and Bower (1965b) McLaughlin, Rifkin, and Webster (1966) and McLaughlin and Webster (1967). These authors also found no effect when the untrained arm pointed to the apparent straight ahead but confirmed the oculomotor nature of the change by demonstrating a shift in the position of the visual target which was judged to be straight ahead.

The finding of Cohen (1967) that intermanual transfer occurs if the subject sees his finger only at the termination of a pointing movement and not if he sees it throughout the movement, remains unexplained.

It thus seems clear that even in exposure conditions where the only conflict is between seen and felt positions of the hand or arm, the observed adaptation seems to require the assumption of a change in judged relationship between head and eyes or head and trunk, in addition to the change in felt arm position which is undoubtedly the primary component of adaptation in these situations.

But it is in the other sort of situation - locomotion while wearing prisms - that the eye or head component becomes most prominent. In these situations pointing with both hands is affected (Bossom, 1964; Bossom and Held, 1957; Cohen, 1963; Hamilton, 1964; Harris, 1963a; Held and Bossom, 1961; Pick and Hay, 1964) and so also is egocentric orientation (Bossom and Held, 1957; Bossom, 1959; Held and Bossom, 1961; Held and Mikaelian, 1964; Pick and Hay, 1964).

Similarly in the case of inspecting one's own body through prisms, Wallach, Kravitz, and Lindauer (1963) concluded that the technique seemed to produce an altered evaluation of visual direction, Craske (1967b) found a change in the apparent straight ahead position of gaze,

an effect confirmed in experiment 3(b). And Hay and Pick (1966) found changes in both head and eyes.

When the shift is in the judged head orientation one would expect a congruent change in both visual and auditory localization whereas if it was in the judged direction of gaze only, there should be no change in auditory localization. This test was used by Rekosh and Freedman (1967) although they did not interpret their results in this way. Harris (1965) admitted that these factors could be operating in some situations but he did not seem to realize that the visual changes which they mediate appear to be the central factor in unrestricted experimental conditions.

Yet another possible component of adaptation is suggested by the work of Cohen (1966) who found that the adaptive shift generated by pointing to foveal targets in training transferred to peripheral test targets but there was no transfer in the opposite direction. A possible explanation would be that the change in the first situation involved either arm or direction of gaze and hence affected all test targets; in the second situation it may have been the retinal space values which altered, i.e. what the subject learned may have been that the target was stimulating a point closer to or farther away from the fovea than it actually was. In this case there

would be no reason to expect foveal targets to be affected. It seems in the context of prism adaptation to have been generally tacitly assumed that retinal space values are unalterable, but in fact there are several well established phenomena such as figural after-effects, pseudo-fovea and anomalous correspondence with monocular diplopia which appear to involve just such a change in local sign. This would seem a fruitful field for further investigation.

Harris and Harris (1965) have speculated that the sort of mechanisms we have been considering can be used to explain the long-term adaptation to reversing and inverting spectacles used in the classical work of Stratton and Köhler. There are two problems here. The question of differences between the effects of displacing prisms and the more complex disturbances caused by the other devices is beyond the scope of this discussion, but Hay and Pick (1966) have thrown some light on the other question, of whether the evidence found in the relatively short-term experiments discussed above can be generalized to situations involving long-term exposure, even with only displacing prisms.

Hay and Pick had their subjects wear 20-dioptre prisms for periods ranging from 144 hours to 40 days. At various times during these periods they tested them on

six tests involving respectively eye-hand, eye-ear eye-head, ear-hand, ear-head, and head-hand co-ordination. Briefly, the results indicated that early in the exposure period all the tests except ear-head (designed to control for changes in the auditory system) showed adaptive shifts but that after about 12 hours the effects in the tests involving the proprioceptive change (ear-hand and head-hand) began to diminish whereas those involving visual localization (eye-hand, eye-ear, eye-head) showed sustained adaptation. Hay and Pick suggest that the trend of adaptation is characterized by an initial, rapid, transitory change in the proprioceptive system, followed by a stable change in visual localization. This makes good sense: vision is inherently dominant over proprioception, so when it is displaced visual capture occurs almost immediately but in the long-run the subject must encounter a multitude of cues which bring home to the nervous system the true situation - that it is vision which is giving erroneous information and it is therefore more economical to recalibrate the visual input. By analogy one would expect that in a visual-auditory conflict the auditory system would alter initially and would remain altered if the conflict was produced by auditory re-arrangement, but would return to normal, to be replaced by a long-term visual change if it was audition which had been re-arranged. Hay and Pick's experiment is an excellent model for future long-term studies.

The evidence then seems strongly in favour of the naive view that if a subject comes to point inaccurately to a visual target then he has changed his mind either about where the visual target is or about where his arm is. Apart from this there is no evidence for a change in the visual-motor relationship as such, and it was the assumption that this was the basis of adaptive shifts that forced Held to assign so much importance to the reafference principle. If reafference is important in facilitating adaptation and there is as yet no good evidence to the contrary then its importance must rest on other grounds than its role in Held's model, as has been suggested above.

Thus adaptation to spatial sensory conflict appears to consist of a change in the judged relationship between parts of the body - between arm and body, between eye and head, possibly between head and neck and possibly even between different parts of the retina. Even the M.I.T. group say in a recent publication that adaptation consists of "a new spatial relationship between movements of two or more parts of the body oriented in relation to a common target". (Efstathiou, Bauer, Greene, and Held, 1967). An altered interpretation of proprioceptive information from the arm joints seems to characterize the restricted hand-wagging and finger-pointing laboratory experiments, and visual change based on neck or eyes the freer locomotion

situations, but the detailed specification of the conditions under which the various components manifest themselves and how they alter with respect to one another over time remain as problems for future research. The most likely factor to be of importance seems at present the relative richness of the various classes of information which are in conflict. Vision for example is less likely to dominate when the whole body is visible rather than just the hand, or when the subject has been wearing prisms for some time and has encountered many types of cue, all contradicting the information furnished by vision.

EXPERIMENT 3(a).

The purpose of this experiment was to test whether given both opportunity and motivation subjects would adapt to prismatic distortion even in the absence of reafferent information, in this case when the subject's movements were passive.

Method.

Throughout the experiment the subject stood at a table with his head clamped in a head-rest. His right forearm was firmly secured in a horizontal cradle designed to keep the arm rigid from elbow to index fingertip. The cradle rotated horizontally about the vertical axis through the subject's elbow. It could be rotated either by active movement of the subject's arm or by means of a motor. The angular position of the cradle could be read off a scale attached to the pivot bearing. The subject's arm and the cradle were normally concealed by a screen which could be withdrawn to permit the subject to view his fingertip.

Throughout the experiment the subject wore rotating prisms which displaced the field of view about 13° to his left. The visual targets were two identical brass rods which could be individually raised into the subject's field of view or lowered out of sight. They were located 27°

apart on the horizontal arc of a circle centred on the subject's elbow and with a radius somewhat longer than the subject's forearm. Their optical positions (taking account of the prisms) were at equal distances on either side of the median plane of the head. Due to the spatial separation of head and elbow, the 13° optical displacement as measured from the head corresponded to a displacement of 12.5° for the right target (A) and 9.5° for the left target (B) as measured from the elbow.

The pre-test consisted of six active pointings to each target without knowledge of results; the first two pointings to each target were disregarded. The pre-test was immediately followed by the training session during which the subject was several times instructed to keep his arm "completely passive". Movement was by means of the motor and the subject instructed the experimenter when he was satisfied that he was pointing at whichever of the targets was visible; the screen was withdrawn and the subject could see his fingertip in its true relationship to the target; his arm was then returned by a circuitous route to the starting position for the next trial. Although the subject was not permitted to move his finger while the target light was on, he was encouraged to make deliberate correction of his pointing error on subsequent trials. Training was continued to an arbitrary criterion of ten

successive trials on none of which the pointing deviated from the true position of the target in the direction of its optical position by more than the magnitude of the optical displacement. This criterion was in all cases reached by about the sixteenth trial. Finally the post-test consisted of four active pointings to each target under the same conditions as the pre-test but with instructions to point "normally and naturally" without the deliberate adjustments characteristic of the training session.

In all three sessions the two targets and four starting positions, two to the left and two to the right, were balanced and presented in random order. Sixteen subjects were used, mainly undergraduate volunteers.

Results and Discussion.

Table 3.1 shows the optical displacement of each target as measured from the elbow together with the mean difference in pointing positions between the pre-test and the post-test.

Table 3.1.

Optical displacement, and mean pointing position at the end of training and on post-test as deviations from pre-test pointing positions, and ratio of pre-test - post-test difference to optical displacement.

Optical Displacement	Target A. 12.5°	Target B. 9.5°
Mean difference of pre- and post-test pointings	4.0°	3.2°
Adaptation ratio	.32	.34
Mean difference of pre-test and final training level	8.6°	8.5°

The overall difference between pre- and post-test settings is $3.6^{\circ} \pm 0.4^{\circ}$ which is of course significantly greater than zero. This change, approximately one third of the optical displacement, demonstrates that substantial and significant adaptation can occur in the absence of active-movement and hence reafferent feedback during

training, provided the subject is forced to use the other information available about the distortions.

The interpretation of this result depends on two crucial assumptions, that the arm was really passive during training and that the subject did not make deliberate corrections during the post-test. Only instruction was used to ensure passivity, as was also the case when Held and Hein (1958) failed to obtain adaptation. The only evidence available about the subject's attitude during the post-test is that of verbal report together with the fact that post-test pointing positions were quite different from the last four pointings to each target in the training session (see Table 3.1). It is well known that asymmetrical stimulation can induce its own characteristic after-effects. In this experiment the visual stimulation was approximately symmetrical about the median plane and the expected shift in pointing from pre-test to post-test was away from the median plane, i.e., in the direction opposite to that which would be expected of an adaptation of the pointing itself.

Finally, a possible suggestive aspect of the results is the difference between amounts of adaptation for the two targets such that the adaptation ratio is a constant one-third. This might suggest differential adaptation in different parts of the field, but such is made rather implausible by the fact that this difference is not reflected in the final level of training.

This experiment was carried out before the feasibility of establishing the location of adaptation had become apparent and so it is impossible to specify the actual mechanism which produced the adaptation. Such an analysis would require for example that adaptation be tested in both hands to decide between a change in the interpretation of limb proprioception (the more likely alternative) and a more generalized change in apparent head orientation or direction of gaze. In retrospect it also appears unfortunate that a passive test condition was not included in view of the criticism levelled against Held that one of the reasons he did not find adaptation in his passive conditions was that the position sense of the active arm is different and stronger and since the elements it does not share with passive position have not been recalibrated it does not show any affect as a result of passive training.

EXPERIMENT 3(b).

The purpose of this experiment is to determine whether changes in spatial behaviour occur when a motionless observer gazes down at his feet through displacing prisms, and whether such changes result from the intersensory conflict.

Method.

The subject sat in front of a T.V. camera which was focussed on his left eye. Between the eye and the camera, and 7.5 cms. from the corneal surface, was a 15 cm. x 20 cm. beam-splitter, inclined at 45° to the horizontal (see Fig. 3.2). A featureless white ceiling at an optical distance of 137 cm. was illuminated by a number of reflector spot-lights with a uniform luminance of 250 foot lamberts, and performed the dual function, by reflection at the beam-splitter, of illuminating the eye and providing the subject's visual field; the extent of this field was equal to an excursion of 90° in the horizontal direction, and 22° in the vertical. Head position was kept constant by means of a wax bite. The image of the eye was magnified x 10 at the monitor screen. The screen incorporated a plastic millimetre scale oriented either vertically or horizontally, and the position of the eye could be measured against this scale by means of a set square. This could be translated parallel to the scale until its edge formed a tangent to the iris of the imaged eye.

Fig. 3.3

The decay of the post-exposure effect.

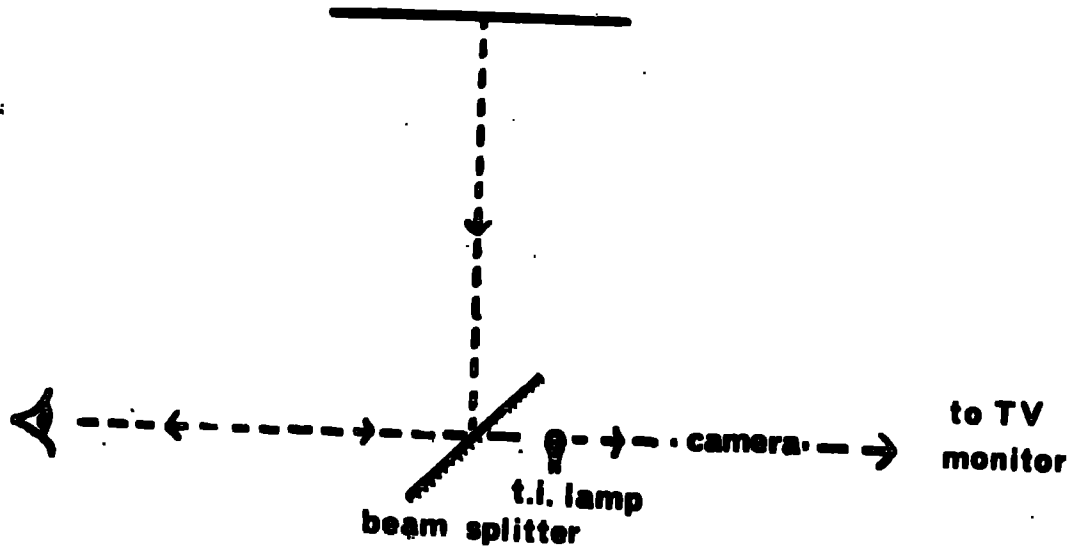
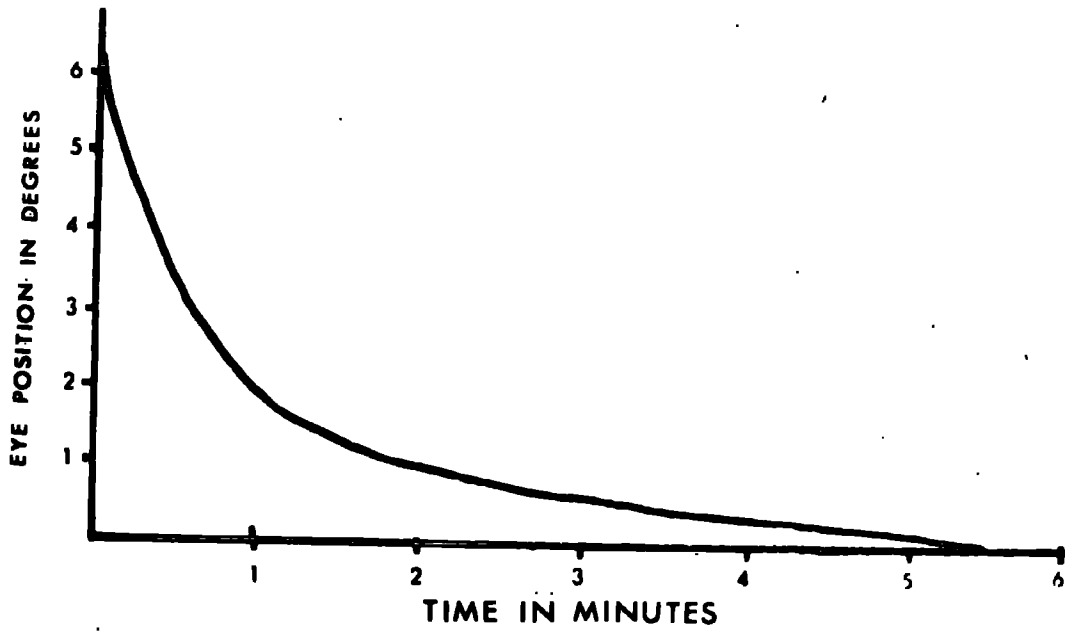

Fig. 3.2

Schematic side view of measurement apparatus.

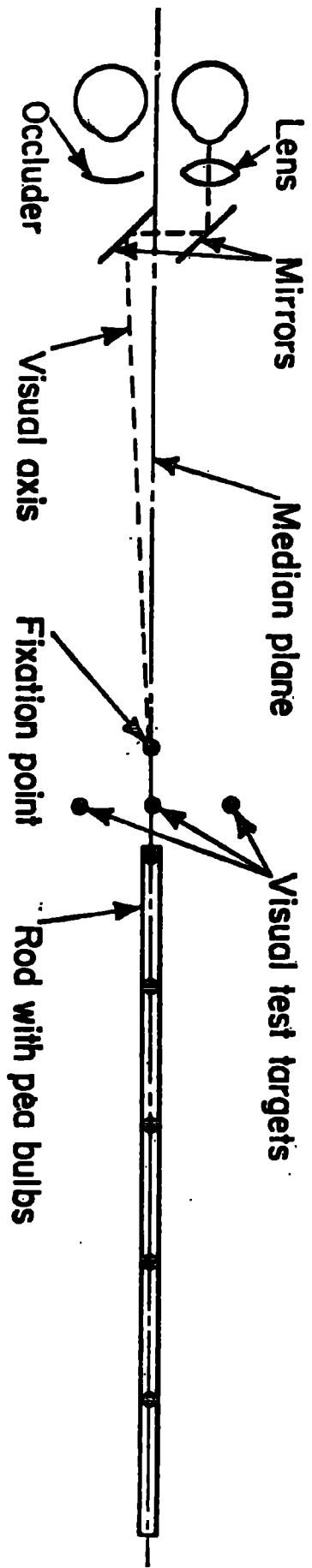

Fig. 3.4

Apparatus used in experiment 3.3.

Before a set of readings, the subject switched on a tungsten-iodine 100 watt bulb mounted 23 cm. in front of his eyes in the median sagittal plane. Binocular fixation was maintained until the small grid filament became clearly distinguishable; the bulb was switched off, and the subject could see the small after-image projected on the illuminated ceiling, which appeared normal to the subject's forward direction of gaze and at a distance of 137 cm. This was repeated at intervals of a few minutes so that a clear after-image was maintained. This normally involved missing out one reading.

Readings of the eye's position were taken every ten seconds, and between readings the subject kept his eyes shut. When the signal was given for a reading, the subject attempted to set his eyes straight ahead and then opened his lids. The after-image was seen projected on the ceiling, and where this first appeared, it was voluntarily locked for the duration of the reading, (1 - 2 seconds). This 'locking' could easily be achieved by preventing the after-image gliding over the texture of the ceiling surface.

It was found that by occasionally executing a rapid series of blinks the subject could maintain a sharp after-image without interfering with the measurement procedure.

During the exposure condition the subject stood looking down at his feet through 25 dioptre prisms for a period of 15 minutes. Head was held in the median sagittal plane by means of a dental wax bite, his chin rested on his chest and his forehead on a head-rest. His feet were dimly illuminated in an otherwise dark room and he could reduce the illumination to compensate for dark adaptation by means of a variac suitably to hand.

Such a condition clearly involves a conflict of information regarding the position of the feet, between vision on the one hand and the vestibular-proprioceptive system on the other. After a short time the conflict is resolved in favour of the latter - the feet are reported to appear directly below the subject's eyes.

After the exposure condition the prisms were removed and the subject found his way with eyes shut to the measurement apparatus; when he was seated he opened his eyes and proceeded to generate the after-image. Readings were then taken as described, once every ten seconds. During the measurement procedure it was ensured that the subject saw no part of his own body at any time.

Results.

The experiment involved a series of eye-position readings, then the 15 minute exposure and then a resumption of eye-position readings taken every ten seconds. Typical results for one subject are shown in fig. 3.3. The data points at ten-second intervals virtually all lie along the line. The baseline is the mean of the pre-exposure readings. The readings begin at about 6.5 degrees which strongly suggests that if readings had begun immediately after the exposure period they would have shown complete adaptation to the eleven-degree prism displacement.

The decay of the effect to baseline level normally took about five minutes compared with the decay period of 15 minutes recorded by Hamilton and Bossom (1964) with a quite different exposure condition. These decay times are of interest in that they show that, whatever may be the necessary conditions for the establishment of new spatial habits, the old overlearned structure is re-established quite rapidly and apparently without any need for spatial information. On the other hand even the briefest glimpse of the subject's own body or hand causes an immediate and dramatic destruction of the effect.

The head and body were held stationary in this experiment and a control condition in which the eyes fixated a

point 30° from the median sagittal plane produced no effect. Hence Hein's (1965) criticisms of Wallach et. al. (1963) should not apply in the present case.

In another condition the feet were seen through two dove prisms which rotated the optical array by about 30° . But no change in the torsional position of the eye was detected, nor indeed was there any change reported in the apparent orientation of the feet, despite the fact that adaptation has been found to occur in this situation (Ebenholtz, 1966).

The main conclusion from the experiment is that adaptation, as measured by the apparent straight ahead position of the eyes can result from the intersensory conflict generated when an immobile observed looks at his own feet through displacing prisms.

EXPERIMENT 3(c).

The purpose of the experiment was to determine whether, in an observer without either skeletal or eye movements, adaptation of pointing behaviour can result from a purely exafferent conflict, in this case between apparent track of a visually displaced approaching object and the tactile information about where it collides with the observer.

Method.

Figure 3.4 shows the layout of the apparatus. The optical device consisted of two parallel mirrors which displaced the light from objects 2 inches to the left before it entered the left eye. Mirrors were used rather than prisms, because they do not introduce any apparent curvature, tilt, or color fringes. The displacement is parallel rather than angular, which is essential for the purpose; with prismatic angular displacement the apparent displacement reduces to zero as the viewed object comes towards the subject. Mirrors have one disadvantage: they lengthen the optical path and hence reduce the apparent size (or increase the apparent distance) of the visual target. This means that where a series of visual targets is used, as in this experiment, the apparent distance between the targets is distorted and visuomotor co-ordination will be disturbed accordingly. This disadvantage was overcome by introducing

a lens system which magnified the displaced visual image to a size corresponding to its distance.

The rod consisted of a rigid wooden bar, the first 14 inches of which had five pea bulbs countersunk into the top surface at intervals of $3\frac{1}{2}$ inches. The rod was mounted horizontally in the sagittal plane and could be moved towards the centre of the subject's lips. As seen through the mirrors, however, it appeared as if it would hit the face 2 inches to the left of the mouth. Nothing could be seen but the lights on the rod and a stationary fixation point. The lights used as visual targets in the test condition were three fine 1-inch high light slits displaced 2 inches apart in the frontal plane at a distance of 17 inches from the subject. The centre light was in the subject's objective median plane.

The subject's head was clamped in a headrest, the right eye was always occluded.

Each of the 20 subjects (10 male, 10 female) were subjected to two conditions.

In Condition I, the subject was asked to look through the optical device and point to the target light. These appeared one at a time in random order, 20 times in all. The subject was allowed to fixate the slit displayed, and the hand could not be seen. This initial test established the pretraining deviation of the subject's pointing in

relation to the displaced visual targets. He was then told to remain still and to fixate a light just above the rod, 12 inches away. The rod was then moved from a distance of 14 inches until it hit the subject on the lips. This was repeated 20 times. The subject was then immediately retested on the pointing task.

In Condition II, the same procedure was employed except that in the training, the rod did not quite touch the subject. The order of conditions was alternated over the subjects with an interval of at least one week between conditions.

Table 3.2.

Mean error in inches of pointing at target optically displaced 2 inches laterally, before and after being touched and not being touched.

	Not Being Touched	Being Touched
Before	1.94	2.15
After	1.88	1.51
Adaptation	0.06	0.64

Results.

The results are set out in Table 1. The "being-hit" training procedure produced a significant mean change in pointing of 0.64 ± 0.16 inches towards the actual position of the target lights, i.e., about one third of the displacement. This difference is significant, $t(19) = 3.9$, $p < .001$.

The "not-being-hit" condition produced no significant mean change in pointing. The size of the effect did not differ between sexes, nor between hands, though it tended to be larger for the right hand. Nor did the effect vary in size from the first to the last set of 10 judgments.

Discussion.

These results show that discordant exafferent stimulation of an inactive subject leads to some adaptation of pointing towards displaced visual targets. The effect could not have been due solely to the visually asymmetrical position of the rod, for this was present in Condition II, where no adaptation occurred. The tactile stimulation was symmetrical, so that there was no need to have a control condition where the subjects were touched without being able to see the rod. Apparently all active movement was prevented, even convergence of the eyes. The subject was

thus more completely passive than in the "passive" conditions of Held and his associates and so once again the conclusion seems clear that provided the subject has information about sensory conflict there is the possibility of resolution.

But there is some doubt about the actual mechanism responsible for the adaptation. Since the "change in judged direction of gaze" theory gained prominence it has seemed likely that it could explain this result. The eye was fixating a light actually above the rod in the median plane and was therefore pointing at a virtual image two inches to the left of the median plane. In the course of training the subject came to regard his eye as pointing further to the right, i.e. closer to the median plane, since an object directly below his point of fixation continually hit him in the mouth. Visual targets would thus be apparently displaced to the right which would account for the change in pointing behaviour.

It now appears to the author that there is a serious flaw in this argument and that the testing of an alternative theory could uncover a new form of adaptation. The inconsistency in the subject's suggested view of the situation late in training is that he sees a rod passing below a point somewhat to the left of his median plane which later strikes him at a point in his median plane

but during its visible travel to that point it moves only from right to left across his field of view. This is normally an impossibility. The only way, normally, an object can follow a linear path from right to left across the visual field and then strike the observer in the mid line is if the object is viewed only by the right eye. So it seems possible that the way in which the subject constructs a consistent view of the situation is by changing his assumption about which eye he is using. This theory would equally well account for the change in pointing behaviour. Some support is lent to its possible operation in the present experiment by the accident that the mirrors were two inches apart so that the left eye was receiving what would have almost been the normal uninterrupted view of the right eye.

No doubt when one eye is occluded a subject is, initially at least, well aware of which eye it is. But the essential lability of utrocular discrimination is amply demonstrated by the finding of Templeton and Green (1968) that a situation can be devised in which subjects are unable to report, even after training with feedback, which eye is receiving a stimulus. It is therefore proposed to incorporate the techniques developed in that study in an extensive repeat of the adaptation experiment using different degrees and directions of displacement, in order

to test whether, even under very special conditions we are capable of resolving anomalous sensory inputs by effectively transferring inputs from one eye to the other.

CONCLUSION.

Writing specifically about haptic space but with more general relevance Gibson (1966) states "clearly the three axis of behavioural (sic) space must be anchored to environmental space if behaviour is to be adaptive and perception correct. This can be accomplished only if there is some sort of calibrating of the input from each sensory system with other information. The haptic straight ahead must be the same as the visual straight ahead. The haptic vertical must coincide with the visual vertical. The body horizontal must coincide with the visual horizontal.

"How such a calibration is accomplished in the brain is a problem. But there are experiments to suggest that a recalibration occurs when prolonged abnormal information is imposed on a perceptual system, and this may help us to understand the process.

"There seems to be two logical possibilities. A perceptual system..... might normalize itself by some averaging process over time, taking the mean of its inputs as the criterion of straight ahead, of vertical, and of horizontal. Or the brain might compare its inputs with those of another perceptual system,..... taking the other information as the criterion for recalibration. The former

process would be one that occurs within the system; the latter would be one of reducing a discrepancy between systems, or what psychologists have called a 'conflict of cues' between senses..... Perhaps both processes can occur - both spontaneous normalizing and cross-sensory reduction of discrepancy".

These are the two processes with which this thesis has been concerned. In Chapter I we reviewed the evidence concerning the normalizing process in one spatial dimension and presented evidence that it was indeed an independent process and not simply a by-product of some more fundamental visual phenomenon. Chapter II looked at the same dimension from the point of view of the interplay of cross-model influences which determine its calibration and specifically the manner in which the process is affected by the loss of relevant gravitational information. Gibson's second process was the subject of Chapter III which concerned the mutual calibration of visual and proprioceptive systems. We looked at various ways in which the recalibration occurs when the systems give conflicting information and presented evidence in support of the conclusion that the process is probably determined simply by the nature of the information given by the two systems and is not crucially dependent on any special condition such as self-produced movement.

BIBLIOGRAPHY.

- AARONS, L., and GOLDENBERG, L., 1964. Galvanic stimulation of the vestibular system and perception of the vertical. *Percept. mot. Skills*, 19, 59 - 66.
- ALBERT, D. J., 1966. Rotation of the visual field in the rat. Unpublished manuscript, reported in Taub (1968).
- ARNDTS, F., 1924. Zur Frage nach der Lagewahrnehmung dienenden Sinnes functionen. *Pflug. Arch. ges. Physiol.*, 204, 539 - 540.
- ASCH, S.E., and WITKIN, H. A., 1948a. Studies in space orientation: I. Perception of the upright with displaced visual fields. *J. exp. Psychol.*, 38, 325 - 337.
- ASCH, S. E., and WITKIN, H. A., 1948b. Studies in space orientation: II. Perception of the upright with displaced visual fields and with body tilted. *J. exp. Psychol.*, 38, 455 - 477.
- AUBERT, H., 1861. Eine scheinbare bedeutende Drehung von Objekten bei Neigung des Kipfes nach rechts oder links. *Virchows Arch.*, 20, 381 - 393.
- BAILY, J. S. and SINGER, G., 1967. Behavioural compensation through information feedback and transformed visual input. *Psychol.*, 19, 49 - 53.
- BALES, J. F. and FOLLANSBEE, C. L., 1935. The after-effect of the perception of curved lines. *J. exp. Psychol.*, 18, 499 - 503.
- BARANY, R., 1921. Zur Klinik und Theorie des Eisenbahn - Nystagmus. *Arch. Augenheilk.*, 87, 139 - 142.
- BAUERMEISTER, M., 1964. Effect of body tilt on apparent verticality, apparent body position, and their relation. *J. exp. Psychol.*, 67, 142 - 147.
- BELLER, H. K. and MORANT, R. B., 1963. Adaptation to prismatically rotated visual fields. Typescript from authors.
- BERNARD, C., 1859. Lecons sur les proprietes physiologiques et les alterations pathologiques des liquides de l'organisme. Paris: Balliere.

- BIRREN, J. E., 1945. Static equilibrium and vestibular function. *J. exp. Psychol.*, 35, 127, 133.
- BITTERMAN, M. E., and WORCHEL, P., 1953. The phenomenal vertical and horizontal in blind and sighted subjects. *Amer. J. Psychol.*, 66, 598 - 602.
- BLACK, A. H., 1965. Cardiac conditioning in curarized dogs: the relationship between heart rate and skeletal behavior. M. W. Prokasy (Ed.) *Classical Conditioning - a Symposium*. New York: Appleton-Century-Crofts.
- BORING, R. O., 1952. The effect of visual stimulus variables upon the perception of the visual vertical. Proj. No. NM.001.063.01.28. U.S. Nav. Sch. aviat. Med., Pensacola, Fla.
- BOSSOM, J., 1959. Complete recovery of accurate egocentric localization during prolonged wearing of prisms. Paper read to East. Psychol. Assoc.
- BOSSOM, J., 1964. Mechanisms of prism adaptation in normal monkeys. *Psychon. Sci.*, 1, 377 - 378.
- BOSSOM, J., and HAMILTON, C. R., 1963. Interecular transfer of prism-altered co-ordinations in split-brain monkeys. *J. comp. physiol. Psychol.*, 56, 769 - 774.
- BOSSOM, H., and HELD, R., 1957. Shifts in egocentric localization following prolonged displacement of the retinal image. Paper read to Amer. Psychol. Ass., New York.
- BOURDON, B., 1906. Sur le role de la tete dans la perception de l'espace. *Rev. Philos.*, 61, 526 - 529.
- BRECHER, G. A., 1934. Die optokinetische Auslösung von Augenrollung und rotatorischem Nystagmus. *Pflüg. Arch. ges. Physiol.*, 234, 13 - 28.
- BROSGOLE, L., and CRISTAL, R. M., 1967. Role of phenomenal displacement on the perception of the visual upright. *Percept. Psychophysics*, 2, 179 - 188.
- BROWN, J. L., 1961. Orientation to the vertical during water immersion. *Aerosp. Med.*, 32, 209 - 217.

- CAMPBELL, D. T., LEWIS, N. A., and HUNT, W. A., 1958. Context effects with judgmental language that is absolute, extensive and extra-experimentally anchored. *J. exp. Psychol.*, 55, 220 - 228.
- CHANDLER, A., 1961. The effect of monaural and binaural tones of different intensities on the visual perception of verticality. *Amer. J. Psychol.*, 74, 260 - 265.
- CLARK, B., and GRAYBIEL, A., 1962. Visual perception of the horizontal during prolonged exposure to radial acceleration on a centrifuge. *J. exp. Psychol.*, 63, 294 - 301.
- CLARK, B., and GRAYBIEL, A., 1963. Perception of the postural vertical in normals and subjects with labyrinthine defects. *J. exp. Psychol.*, 65, 490 - 494.
- CLARK, B., and GRAYBIEL, A., 1966. Perception of the visual horizontal in normal and labyrinthine defective observers during prolonged rotation. *Amer. J. Psychol.*, 79, 608 - 612.
- CLARK, B., and GRAYBIEL, A., 1967. Egocentric localization of the visual horizontal in normal and labyrinthine defective observers as a function of head and body tilt. *Percept. Psychophysics.*, 2, 609 - 611.
- COHEN, H. B., 1966. Some critical factors in prism adaptation. *Amer. J. Psychol.*, 79, 285 - 290.
- COHEN, L. A., 1961. Role of eye and neck proprioceptive mechanism in body orientation and motor co-ordination. *J. Neurophysiol.*, 24, 1 - 11.
- COHEN, L. A., 1964. Human spatial orientation and its critical role in space travel. *Aerosp. Med.*, 35, 1054 - 1057.
- COHEN, M., 1967. Continuous versus terminal visual feedback in prism after-effects. *Percept. Mot. Skills*, 24, 1295 - 1302.
- COREN, S., and FESTINGER, L., 1967. An alternative view of the "Gibson normalization effect". *Percept. Psychophysics*, 2, 621 - 626.
- CORREIA, M. J., HIXSON, W., and NIVEN, J. I., 1965. Otolith shear and the visual perception of force direction: Discrepancies and a proposed resolution. *USN AMI NASA Jt. Rep.*, No. 951.

- CRASKE, B., 1966a. Change in transfer function of joint receptor output. *Nature* 210, 764 - 765.
- CRASKE, B., 1967a. An analysis of human adaptation to prismatically displaced vision. Unpublished Ph.D. Dissertation.
- CRASKE, B., 1967b. Adaptation to prisms: change in internally registered eye-position. *Br. J. Psychol.*, 58, 329 - 335.
- CRASKE, B., and GREGG, S. J., 1966. Prism after-effects: Identical results for visual targets and unexposed limb. *Nature*, 212, 104 - 105.
- CRASKE, B., and TEMPLETON, W. B., 1968. Prolonged oscillation of the eyes induced by conflicting position input. *J. exp. Psychol.*, 76, 387 - 393.
- CULBERT, S. S., 1954. Directional after-effects following systematic distortion of the visual field. *J. Psychol.*, 37, 81 - 93.
- CURRAN, C. R. and LANE, H. L., 1962. On the relations among some factors that contribute to estimates of verticality. *J. exp. Psychol.*, 64, 295 - 299.
- DAVIES, T., and MERTON, P. A., 1958. Recording compensatory rolling of the eyes. *J. Physiol.*, 140, 27 - 28.
- DAVIS, R. C., 1958. The domain of homeostasis. *Psychol. Rev.*, 65, 8 - 13.
- DAY, R. H. and WADE, N. J., 1966. Visual spatial after-effect from prolonged head-tilt. *Science*, 154, 1201 - 1202.
- DUNCAN, C. P., 1960. Effect of self satiation on perceived size of a visual figure. *J. exp. Psychol.*, 60.
- DUNNETT, C. W., 1955. A multiple comparison procedure for comparing several treatments with a control. *J. Amer. Statist. Assoc.*, 50, 1096 - 1121.
- EBENHOLTZ, S. M., 1966. Adaptation to a rotated visual field as a function of degree of optical tilt and exposure time. *J. exp. Psychol.*, 72, 629 - 634.
- EFSTATHIOU, A., BAUER, J., GREENE, M. and HELD, R., 1967. Altered reaching following adaptation to optical displacement of the hand. *J. exp. Psychol.*, 73, 113 - 120.

- EPSTATHIOU, A. and HELD, R., 1964. Cross-modal transfer of adaptation to eye-hand rearrangement. Paper presented to the East Psychol. Assoc.
- ELLIOTT, R., and McMICHAEL, R. E., 1963. Effects of specific training on frame dependence. *Percept. mot. Skills*, 17, 363 - 367.
- EPSTEIN, W., 1967. *Varieties of Perceptual Learning*. New York: McGraw-Hill.
- EWERT, P. H., 1930. A study of the effects of inverted retinal stimulation upon spatially co-ordinated behavior. *Genet. Psychol. Monog.*, 7, 177 - 363.
- FEILCHENFELD, H., 1903. Zur Lageschätzung bei seitlichen Kopfnigungen. *Z. Psychol. Physiol. Sinnesorg.*, 31, 127 - 150.
- FESTINGER, L., 1957. *A Theory of Cognitive Dissonance*. New York: Harper and Row.
- FESTINGER, L., ONO, H., BURNHAM, C. A. and BAMBER, D., 1967. Efference and the conscious experience of perception. *J. exp. Psychol.*, 74, 1 - 36.
- FILLENBAUM, S., 1961. The effect of a remote anchor upon judgement with a salient within-series stimulus - object and with a free choice of scale. *Amer. J. Psychol.*, 74, 602 - 606.
- FISCHER, B., 1915. Der Einfluss der Blickrichtung und Änderung der Kipfstellung (Halsreflex) auf der Baranyshen Zeigversuch. *Jb. Psychiat. Neurol.*, 35, 155 - 158.
- FISCHER, M. H., 1927. Messende Untersuchungen über die Gegenrollung der Augen und die Lokalisation der scheinbaren Vertikalen bei seitlicher Neigung (des Kopfes, des Stammes and des Gesamtkörpers). I. Neigungen bis zu 40°. *v. Graefes Arch. Ophthal.*, 118, 633 - 680.
- FISCHER, M. H., 1930a. Messende Untersuchungen über die Gegenrollung der Augen und die Lokalisation der scheinbaren Vertikalen bei seitlicher Neigung des Gesamtkörpers bis zu 360°. II Mitteilung. Untersuchungen an Normalen. *v. Graefes Arch. Ophthal.*, 123, 476 - 508.

- FISCHER, M. H., 1930b. Messende Untersuchungen über die Gegenrollung der Augen und die Lokalisation der scheinbaren Vertikalen bei seitlicher Neigung des Körpers, Kopfes und Stammes: III Mitteilung. Untersuchungen an einem Ertaubten mit Funktionsuntfähigkeit beider Vestibular - apparatus und einem einseitig Labyrinthlosen. V. Graefes Arch., Ophthalm., 123, 509 - 531.
- FLETCHER, J. M., 1942. Homeostasis as an explanatory principle in psychology. Psychol. Rev., 49, 80 - 87.
- FREEDMAN, S. J., GARDOS, G., and REKOSH, J. H., 1966. There's more to perception than meets the eye. Paper read at East. Psychol. Ass., New York.
- FREEDMAN, S. J., HALL, S. B., and REKOSH, J. H., 1965. Effects on hand-eye co-ordination of two different arm motions during adaptation to displaced vision. Percept. mot. Skills, 20, 1054 - 1056.
- FREEDMAN, S. J. and WILSON, L., 1967. Compensation for auditory rearrangement following exposure to auditory-tactile discordance. Percept. mot. Skills, 25, 861 - 866.
- GANZ, L., 1966. Mechanism of the figural after-effects. Psychol. Rev., 73, 128 - 150.
- GARTEN, S., 1920. Über die Grundlagen unserer Orientierung im Raum. Abh. sächs. Ges (Akad.) Wiss., 36, 431 - 510.
- GIBSON, J. J., 1933. Adaptation, after-effect and contrast in the perception of curved lines. J. exp. Psychol., 16, 1 - 31.
- GIBSON, J. J., 1937a. Adaptation, after-effect, and contrast in the perception of tilted lines: II. Simultaneous contrast and the areal restriction of the after-effect. J. exp. Psychol., 20, 553 - 569.
- GIBSON, J. J., 1937b. Adaptation with negative after-effects. Psychol. Rev., 44, 222 - 244.
- GIBSON, J. J., 1950. The Perception of the Visual World. Boston: Houghton - Mifflin.

- GIBSON, J. J., 1952. The relation between visual and postural determinants of the phenomenal vertical. *Psychol. Rev.*, 59, 370 - 375.
- GIBSON, J. J., 1957. Optical motions and transformations as stimuli for visual perception. *Psychol. Rev.* 64, 288 - 295.
- GIBSON, J. J., 1966. *The Senses Considered as Perceptual Systems.* London: Allen and Unwin.
- GIBSON, J. J., and MOWRER, O. H., 1939. Determinants of the perceived vertical and horizontal. *Psychol., Rev.*, 45, 300 - 323.
- GIBSON, J. J., and RADNER, M., 1937. Adaptation, after-effect, and contrast in the perception of tilted lines. I. Quantitative studies. *J. exp. Psychol.*, 20, 453 - 467.
- GOGEL, W. C., 1956. The tendency to see objects as equidistant and its inverse relationship to lateral separation. *Psychol. Monogr.*, 70, 1 - 17.
-
- GOLDSTEIN, K., and RIESE, W., 1923. Über induzierte Veränderungen des Tonus (Halsreflexe, Labyrinthreflexe und ähnliche Erscheinungen). III. Blickrichtung und Zeigerversuch. *Klin. Wschr.*, 2, 2338 - 2340.
- GRAY, J. A. B., and MALCOLM, J. L., 1950. The initiation of nerve impulses by mesenteric Pacinian corpuscles. *Proc. roy. Soc. ser. B.*, 137, 96 - 114.
- GRAY, J. A. B., and MATTHEWS, P. B. C., 1951. A comparison of the adaptation of Pacinian corpuscles with the accommodation of its axon. *J. Physiol.*, 114, 454 - 464.
- GRAY, L. P., 1956. Extralabyrinthine vertigo due to cervical muscle lesions. *J. Laryng*, 70, 353 - 360.
- GREENBERG, G., 1960., Visual induction of eye torsion, as measured with an after-image technique, in relation to visual perception of the vertical. Ph. D. Diss., Duke Univ.
- HAMILTON, C. R., 1964. Intermanual transfer of adaptation to prisms. *Amer. J. Psychol.*, 77, 457 - 462.

- HAMILTON, C. R., and BOSSOM, J., 1964. Decay of prism after-effects. *J. exp. Psychol.*, 67, 148 - 150.
- HAMILTON, C. R., and HILLYARD, S. A., 1965. Alterations in position sense following eye-hand adaptation to deflected vision. Typescript.
- HARRIS, C. S., 1963a. Adaptation to displaced vision: A proprioceptive change. Ph. D. Diss., Harvard Univ.
- HARRIS, C. S., 1963b. Adaptation to displaced vision: Visual, motor, or proprioceptive change? *Science*, 140, 812 - 813.
- HARRIS, C. S., 1965. Perceptual adaptation to inverted, reversed and displaced vision. *Psychol. Rev.*, 72, 419 - 444.
- HARRIS, C. S., and HARRIS, J. R., 1965. Rapid adaptation to right-left reversal of the visual field. Paper read at Psychon. Soc.
- HAY, J. C., and PICK, H. L., Jr., 1966. Visual and proprioceptive adaptation to optical displacement of the visual stimulus. *J. exp. Psychol.*, 71, 150 - 158.
- HAY, J. C., PICK, H. L., Jr., and IKEDA, K., 1965. Visual capture produced by prism spectacles. *Psychon. Sci.*, 2, 215 - 216.
- HAZELWOOD, V., and SINGER, G., 1969. Kinaesthetic orientation judgments during lateral head, body and trunk tilt. *Percept. Psychophysics*, 5, 141 - 142.
- HEBB, D. O., 1949. *The Organization of Behavior*. New York: Wiley.
- HEIN, A., 1965. Postural after-effects and visual-motor adaptation to prisms. Paper read at East. Psychol. Assoc. Atlantic City.
- HEIN, A., and HELD, R., 1962. *A Neural Model for labile sensori motor, coordinations in Biological Prototypes and Synthetic Systems*. New York: Plenum Press.
- HEINEMANN, E. G., and MARILL; T., 1954. Tilt adaptation and figural after-effects. *J. exp. Psychol.*, 48, 468 - 472.

- HELD, R., 1961. Exposure history as a factor in maintaining stability of perception and coordination. *J. nerv. ment. Dis.*, 1932, 26 - 32.
- HELD, R., 1963. Localized normalization of tilted lines. *Amer. J. Psychol.*, 76, 146 - 148.
- HELD, R., 1968. Plasticity in sensorimotor coordination. In Sandford S. J., *The Neuropsychology of Spatially Oriented Behavior*. Dorsey Press.
- HELD, R., and BAUER, J. A., 1967. Visually guided reaching in infant monkeys after restricted rearing. *Science*, 155, 718 - 720.
- HELD, R. and BOSSOM, J., 1961. Neonatal deprivation and adult rearrangement: complementary techniques for analysing plastic sensory-motor coordinations. *J. comp. physiol. Psychol.*, 54, 33 - 37.
- HELD, R., EFSTATHIOU, A., and GREENE, M., 1966. Adaptation to displaced and delayed visual feedback from the hand. *J. exp. Psychol.*, 72, 887 - 891.
- HELD, R., and FREEDMAN, S. J., 1963. Plasticity in human sensorimotor control. *Science*, 142, 455 - 462.
- HELD, R., and GOTTLIEB, N., 1958. Technique for studying adaptation to disarranged hand-eye coordination. *Percept. mot. Skills*, 8, 83 - 86.
- HELD, R., and HEIN, A., 1958. Adaptation of disarranged hand-eye coordination contingent upon re-afferent stimulation. *Percept. mot. Skills*, 8, 87 - 90.
- HELD, R., and HEIN, A., 1963. Movement-produced stimulation in the development of visually guided behaviour. *J. comp. physiol. Psychol.*, 56, 872 - 876.
- HELD, R., and HEIN, A., 1967. On the modifiability of form perception. In W. Wathen-Dunn (Ed.) *Models for the Perception of Speech and Visual Form*. Cambridge, Mass.: M.I.T. Press.
- HELD, R., and MIKAELIAN, H., 1964. Motor-sensory feedback versus need in adaptation to rearrangement. *Percept. mot. Skills*, 18, 685 - 688.

- HELD, R., and REKOSH, J., 1963. Motor-sensory feedback and the geometry of visual space. *Science*, 141, 722 - 723.
- HELD, R., and SCHLANK, M., 1959. Adaptation to disarranged eye-hand coordination in the distance - dimension. *Amer. J. Psychol.*, 72, 521 - 527.
- HELD, R., and SCHLANK, M., 1964. An attempt that failed to reproduce a study of disarranged eye-hand coordination. *Percept. mot. Skills*, 19, 301.
- HELMHOLTZ, H. von, 1962. *Treatise on Physiological Optics*. New York: Dover.
- HELSON, H., 1964. *Adaptation Level Theory*. New York: Harper and Row.
- HNATIOW, M., and LANG, P. J., 1965. Learned stabilization of heart rate. *Psychophysiology*, 1, 330 - 336.
- HOCHBERG, J., 1963. On the importance of movement-produced stimulation in prism-induced after-effects. *Percept. mot. Skills*, 16, 544.
- HOFMANN, F. B., and BIELSCHOWSKY, A., 1909. Über die Einstellung der Scheinbaren Horizontalen und Vertikalen bei Betrachtung eines von schrägen Konturen erfüllten Gesichtsfeldes. *Pflüg. Arch. ges. Physiol.*, 126, 453 - 475.
- HOWARD, I. P., CRASKE, B., and TEMPLETON, W. B., 1965. Visuomotor adaptation to discordant ex-afferent stimulation. *J. exp. Psychol.*, 70, 189 - 191.
- HOWARD, I. P., and TEMPLETON, W. B., 1963. A critical note on the use of the human centrifuge. *Amer. J. Psychol.*, 76, 150 - 152.
- HOWARD, I. P., and TEMPLETON, W. B., 1964a. The effect of steady fixation on the judgment of relative depth. *Quart. J. exp. Psychol.*, 16, 193 - 203.
- HOWARD, I. P., and TEMPLETON, W. B., 1964b. Visually-induced eye torsion and tilt adaptation. *Vis. Res.*, 4, 433 - 437.

- HOWARD, I. P., and TEMPLETON, W. B., 1966. Human Spatial Orientation. London: Wiley.
- ISKEDA, H., and OBONAI, T., 1953. The quantitative analysis of figural after-effects III on satiation. Jap. J. Psychol., 24.
- KALIL, R., and FREEDMAN, SANFORD, J., 1967. Compensation for auditory re-arrangement in the absence of observer movement. Percept. mot. Skills, 24, 475 - 478.
- KALIL, R. E. and FREEDMAN, S. J., 1966a. Intermanual transfer of compensation for displaced vision. Percept. mot. Skills, 22, 123 - 126.
- KALIL, R. E., and FREEDMAN, S. J., 1966b. Persistence of ocular rotation following compensation for displaced vision. Percept. mot Skills 22, 135 - 139.
- KENNEDY, J. M., 1969. Prismatic displacement and the remembered location of targets. Percept. Psychophysics, 5, 218 - 220.
- KIMBLE, G. S., 1961. Helgard and Marquis' Conditioning and Learning. New York: Appleton-Century-Crofts.
- KISS, J., 1921. Über das Vorbeizeigen bei forciertem Seitwärtsschauen. Z. ges. Neurol. Psychiat., 65, 14 - 17.
- KLEINT, H., 1936. Versuche über die Wahrnehmung. Z. Psychol., 138, 1 - 34.
- KLEINT, H., 1937. Versuche über die Wahrnehmung. Z. Psychol., 140, 109 - 138.
- KOFFKA, K., 1922. Perception: an introduction to Gestalt theory. Psychol. Bull, 19.
- KIFFKA, K., 1935. Principles of Gestalt Psychology. Routledge and Kegan Paul, London.
- KOHLER, I., 1964. The formation and transformation of the perceptual world (Trans. by Fiss, H.). Psychol. Issues, 3, Monogr. 12.
- KÖHLER, W., and WALLACH, H., 1944. Figural after-effects: an investigation of visual processes. Proc. Amer. Phil. Soc., 88, 269 - 357.

- KOMPANEJEV, S., 1925. On compensatory eye movements in deaf mutes. *Acta oto-laryng.*, Stockh., 7, 323.
- KOTTENHOFF, H., 1957a. Situational and personal influences on space perception with experimental spectacles. I. Prolonged experiments with inverting glasses, *Acta. Psychol.*, Hague, 13, 79 - 97.
- KOTTENHOFF, H., 1957b. Situational and personal influences on space perception with experimental spectacles. II. Semi-prolonged tests with inverting glasses. *Acta Psychol.*, Hague, 13, 151 - 161.
- KRANTZ, F., 1930. Experimentell strukturpsychologische Untersuchungen über die Abhängigkeit der Wahrnehmungswelt vom Persönlichkeitstypus. *Z. Psychol.*, 16, 105 - 214.
- KRAVITZ, J. M., and WALLACH, J., 1966. Adaptation to displaced vision contingent upon vibrating stimuli. *Psychon. Sci.*, 6, 465 - 466.
- LYONS, J., and THOMAS, D. R., 1968. Influence of postural distortion on the perception of visual vertical in pigeons. *J. exp. Psychol.*, 76, 120 - 124.
- MANN, C. W., 1951. The effects of auditory-vestibular nerve pathology on space perception. *J. exp. Psychol.*, 42, 450 - 456.
- MANN, C. W., 1952. Visual factors in the perception of verticality. *J. exp. Psychol.*, 44, 460 - 464.
- MANN, C. W., BERTHELOT-BERRY, N. H., and DAUTERIVE, H. J., 1949. The perception of the vertical: I. visual and non-labyrinthine cues. *J. exp. Psychol.*, 39, 538 - 547.
- MANN, C. W. and BORING, R. O., 1953. The role of instruction in experimental space perception. *J. exp. Psychol.*, 45, 44 - 48.
- MATIN, L., PEARCE, D., MATIN, E., and KIBLER, G., 1965. Visual perception of direction in the dark: roles of local sign, eye movements and ocular proprioception. *Vision Res.*, 6, 453 - 469.
- MCCOUGH, G. P., DEERING, I. D., and LING, T. H., 1951. Location of receptors for tonic neck reflexes. *J. Neurophysiol.*, 14, 191 - 195.

- McEWEN, P., 1958. Figural After-effects. Brit. J. Psychol. Monogr. Suppl., 31.
- McFARLAND, J. H., WAPNER, S., and WERNER, H., 1962. Relation between perceived location of objects and perceived location of one's own body. Percept. mot. Skills, 15, 331 - 341.
- McLAUGHLIN, S. C., and BOWER, J. L., 1965a. Auditory localization and judgments of straight ahead during adaptation to prism. Psychon. Sci., 2, 283 - 284.
- McLAUGHLIN, S. C. and BOWER, J. L., 1965b. Selective inter-manual transfer of adaptive effects during adaptation to prism. Psychon. Sci., 3, 67 - 70.
- McLAUGHLIN, S. C. and RIFKIN, K. I., 1965. Change in straight ahead during adaptation to prism. Psychon. Sci., 2, 107 - 108.
- McLAUGHLIN, S. C., RIFKIN, K. I., and WEBSTER, R. G., 1960. Oculomotor adaptation to wedge prisms with no part of the body seen. Percept. Psychophysics, 1, 452 - 458.
- McLAUGHLIN, S. C., and WEBSTER, R. G., 1967. Changes in straight-ahead eye position during adaptation to wedge prisms, Percept. Psychophysics, 2, 37 - 44.
- MERTON, P. A., 1958., Compensatory rolling movements of the eyes. Proc. R. Soc. Med., 52, 184 - 185.
- MERTON, P. A., 1956. Compensatory rolling movements of the eye. J. Physiol., 132, 25 - 27.
- MIKAELIAN, H., and HELD, R., 1964. Two types of adaptation to an optically-rotated visual field. Amer. J. Psychol., 77, 257 - 263.
- MILLER, E. F., FREGLY, A. R., van den BRINK, G, and GRAYBIEL, A., 1965. Visual localization of the horizontal as a function of body tilt up to $\pm 90^\circ$ from gravitational vertical. NSAM - 942. NSA R-93. School Aviat. Med. Pensacola, Fla.
- MILLER, E. F. and GRAYBIEL, A., 1966a. Magnitude of gravito inertial force, and independent variable in egocentric visual localization of the horizontal. J. exp. Psychol., 71, 452 - 462.

- MILLER, E. F., and GRAYBIEL, A., 1966b. Role of the ololith organs in the perception of horizontality. *Amer. J. Psychol.*, 74, 24 - 37.
- MILLER, N. E., 1959. Liberalization of basic S-R concepts: extension to conflict behavior, motivation and social learning. M. S. Koch (Ed.), *Psychology, a Study of a Science*. Vol. II. New York: McGraw-Hill.
- MILLER, N. E., and DI CARA, L. V., 1967. Instrumental learning of heart-rate changes by curarized rats: shaping and specificity to discriminative stimulus. *J. comp. physiol. Psychol.*, 63, 12 - 19.
- MITTELSTAEDT, H., 1964. Basic control patterns of orientation homeostasis. *Symp. Soc. exp. Biol.*, 18, 365 - 385.
- MORANT, R. B., and BELLER, H. K., 1965. Adaptation to prismatically rotated visual fields. *Science* 148, 530 - 531.
- MORANT, R. B., and HARRIS, J. R., 1965. Two different after-effects of exposure to visual tilts. *Amer. J. Psychol.*, 78, 218 - 226.
- MORANT, R. B., and MIKAELIAN, H. H., 1960. Inter-field tilt after-effects. *Percept. mot. Skills*, 10, 95 - 98.
- MORANT, R. B., and MLSTOVICH, M., 1960. Tilt after-effects between the vertical and horizontal axes. *Percept. mot. Skills*, 10, 75 - 81.
- MULDER, M. E., 1897. De la rotation compensatrice de l'oeil en cas d'inclination a droit ou a gauche de la tete. *Arch. Ophtal.*, Paris, 17, 465 - 474.
- MÜLLER, G. E., 1916. Über das Aubertsche Phänomenon. *Z. Psychol. Physiol. Sinnesorg.*, 49, 109- 246.
- NAGEL, W. A., 1896. Über kompensatorische Raddrehungen der Augen. *Z. Physiol. Psychol. Sinnesorg.*, 12, 331 - 354.
- NAGEL, W. A., 1898. Über das Aubertsche Phänomen und verwandte Täuschungen über die vertikale Richtung. *Z. Psychol. Physiol. Sinnesorg.*, 16, 373 - 398.
- NAYLOR, G. F. K., 1963. Effects of stress on the perception of direction. *Aust. J. Psychol.*, 15, 17 - 28.

- NEAL, E., 1926. Visual localization of the vertical. *Amer. J. Psychol.*, 37, 287 - 291.
- NIELSEN, T. I., 1963. Volition: a new experimental approach. *Scand. J. Psychol.*, 4, 225 - 230.
- NOJI, R., 1929. Über optisch erzwungene parallele Rollungen der Augen. *v. Graefes Arch. Ophthal.*, 122, 562 - 571.
- OGLE, K. N., 1951. Distortion of the image by prisms. *J. opt. Soc., Amer.*, 41, 1023 - 1028.
- OSGOOD, C. E. and HEYER, A. W., 1952. A new interpretation of figural after-effects. *Psychol. Rev.*, 59, 98 - 118.
- PASSEY, G. E., 1950. The perception of the vertical: IV. Adjustment to the vertical with normal and tilted visual frames of reference. *J. exp. Psychol.*, 40, 738 - 745.
- PASSEY, G. E., and RAY, J. T., 1950. The perception of the vertical: X. Adaptation effects in the adjustment of the visual vertical: Jnt. Rep. No. 17. U.S. Nav. Sch. ~~aviat. Med. Res. and Rulane Univ.~~
- PETERSON, J., and PETERSON, J. K., 1938. Does practice with inverting lenses make vision normal. *Psychol. Monogr.*, 50, No. 225, 12 - 37.
- PICK, H. L., Jr., and HAY, J. C., 1964. Adaptation to prismatic distortion. *Psychon. Sci.*, 1, 199 - 200.
- PICK, H. L., and HAY, J. C., 1965. A passive test of the Held re-reference hypothesis. *Percept. mot. Skills*, 20, 1070 - 1072.
- PICK, H. L., Jr., HAY, J. C., and PABST, J., 1963. Kinaesthetic adaptation to visual distortion. Paper read at Midwest. *Psychol. Ass. Chicago.*
- PRENTICE, W. C. H., and BEARDSLEE, D. C., 1950. Visual 'normalization' near the vertical and horizontal. *J. exp. Psychol.*, 40, 355 - 364.
- REESE, E. P. (Ed.), 1953. Summary Rep. No., SDC 131-1-5. *Psychophysical Res. Unit, Mt. Holyoke College.*
- REKOSH, J. H., and FREEDMAN, S. J., 1967. Errors in auditory direction finding after compensation for visual re-arrangement. *Percept. Psychophysics*, 2, 466 - 468.

- REKOSH, J. H., and HELD, R., 1963. Visual-spatial distortion produced by the sensory feedback accompanying locomotion. Paper read to the East. Psychol. Ass.
- RHULE, W., and SMITH, K. U., 1959a. Effect of visual pre training in inverted reading on perceptual-motor performance in inverted visual fields. *Percept. mot. Skills*, 9, 327 - 331.
- RHULE, W., and SMITH, K. U., 1959b. Effects of inversion of the visual field on human motions. *J. exp. Psychol.*, 57, 338 - 343.
- ROCK, I., 1954. The perception of the egocentric orientation of a line. *J. exp. Psychol.*, 48, 367 - 374.
- ROCK, I., 1965. Adaptation to a minified image. *Psychon. Sci.*, 2, 105 - 106.
- ROCK, I., 1966. *The Nature of Perceptual Adaptation*. New York, Basic Books.
- ROCK, I., and HARRIS, C. S., 1967. Vision and touch. *Sci. Amer.* 216, 96 - 104.
- ROCK, I., and VICTOR, J., 1963. Vision and touch: an experimentally created conflict between the two senses. *Science*, 143, 594 - 596.
- ROELOFS, C. O., 1935. Optische Lokalisation. *Arch. Augenheilk.*, 109, 395 - 415.
- SACHS, M., and MELLER, J., 1903. Untersuchungen über die optische und haptische lokalisation bei Neigungen um eine sagittale Achse. *Z. Psychol., Physiol. Sinnesorg.*, 31, 89 - 109.
- SANDSTRÖM, C. I., 1954. A note on the Aubert Phenomenon. *J. exp. Psychol.*, 48, 209 - 210.
- SANDSTROM, C. I., 1956. Sex differences in tactile-kinaesthetic and visual perception of verticality. *Quart. J. exp. Psychol.*, 8, 1 - 7.
- SCHNEIDER, C. W., and BARTLEY, S. H., 1962. A study of the effects of mechanically induced tension of the neck muscles on the perception of verticality. *J. Psychol.*, 54, 245 - 248.

- SCHOCK, G. J. D., 1959. Perception of the horizontal and vertical in simulated sub-gravity conditions. AFMDC Tech. Rep. 59 - 13. Holloman AFB, New Mexico.
- SCHÖNE, H., 1962. Über den Einfluss der Schwerkraft auf die Augenrollung und auf die Wahrnehmung der Lage im Raum. Z. vergl. Physiol., 46, 57 - 87.
- SCHÖNE, H., 1964. On the role of gravity in human spatial orientation. Aerospace Med., 35, 764 - 772.
- SCHÖNE, H., PARKER, D.E., and MORTAG, H. G., 1967. Subjective vertical as a function of body position and gravity magnitude. Naturwissenschaften 54, 288.
- SCHUBERT, G., and BRECHER, G. A., 1934. Über optische Lokalisation und Augenstellung bei Vor-Rückwärtsneigung oder exzentrischer Rotation des Körpers. Z. Sinnesphysiol., 65, 1 - 26.
- SEASHORE, R. H., 1951. Work and motor performance. In Stevens, S.S. (Ed.) Handbook of Experimental Psychology. New York: Wiley.
- SEIDEL, R. J., 1959. A review of sensory preconditioning. Psychol. Bull. 56, 58 - 73.
- SEKULER, R. W., and BAUER, J. A., Jr., 1966. Adaptation to prismatic displacements: Hand position and target location. J. exp. Psychol., 72, 207 - 212.
- SINGER, G., and DAY, R. A., 1966a. The effects of spatial judgments on the perceptual after-effect resulting from prismatically transformed vision. Austr. J. Psychol., 18, 63 - 70.
- SINGER, G., and DAY, R. A., 1966b. Spatial adaptation and after-effect with optically transformed vision: effects of active and passive responding and the relationship between test and exposure responses. J. exp. Psychol., 71, 725 - 731.
- SMITH, K. U., and SMITH, W. M., 1962. Perception and Motion. Philadelphia and London. Saunders.
- SNYDER, F. W., and PRONKO, N. H., 1952. Vision with Spatial Inversion. Wichita, Kansas. McCormick-Armstrong.

- SPERRY, R. W., 1951. Mechanisms of neural maturation. In S. S. Stevens (Ed.) *Handbook of Experimental Psychology*. New York: Wiley 1951.
- SPIGEL, I. M., 1965. *Readings in the Study of Visually Perceived Movement*. New York: Harper and Row.
- STEINBACH, M. J., and HELD, R., 1968. Eye tracking of observer-generated target movements. *Amer. Assoc., advancement Sci.*, 161, 187 - 188.
- STIGLER, R., 1912. Versuche über die Beteiligung der Schwereempfindung an der Orientierung des Menschen im Raume. *Arch. ges. Physiol. Bonn*, 148, 573 - 584.
- STOPER, A. E., 1967. Vision during pursuit movement: the role of oculomotor information. Unpublished Ph.D. dissertation, M.I.T.
- STRATTON, G. M., 1897. Vision without inversion of the retinal image. *Psychol. Rev.*, 4, 463 - 481.
- TAUB, E., 1968. Prism compensation as a learning phenomenon: a phylogenetic approach in Sandford S.J.: *The Neuropsychology of Spatially Oriented Behavior*. Homewood, Ill.: The Dorsey Press.
- TAUB, E., GOLDBERG, I. A., BOSSOM, J., and BERMAN, A. J., 1966. Deafferentation in monkeys: adaptation to prismatic displacement of vision. Paper read at Eastern Psychol. Ass., New York.
- TAYLOR, J. G., 1962. *The behavioral basis of perception*. New Haven, Conn.: Yale Univer. Press.
- TAYLOR, J. G., 1966. The prism illusion: a function of dislocated equivalence classes. *Percept. mot. Skills*, 22, 219 - 232.
- TAYLOR, M. M., 1962. Figural after-effects: A psychophysical theory of the displacement effect. *Canad. J. Psychol.*, 16, 247 - 277.
- TEMPLETON, W. B., and GREEN, F. A., 1958. Chance results in utrocular discrimination. *Quart. J. exp. Psychol.*, 20, 200 - 203.

- THALMAN, W. A., 1922. The after-affect of movement in the sense of touch. Amer. J. Psychol. 33.
- THETFORD, P. E., and GUEDRY, F. E., 1952a. The postural vertical in unilaterally labyrinthectomized individuals. Proj. No. NM.001.063.01.26. Joint Rep. No. 26. U.S. Nav. Sch. aviat. Med., Pensacola, Fla.
- THETFORD, P. E., and GUEDRY, F. E., 1952b. Judgment of the postural vertical during exposure to a misleading visual framework in unilaterally labyrinthectomized subjects. Proj. No. NM.001.063.01.27. Joint Rep. No. 27. U.S. Nav. Sch. aviat. Med., Pensacola, Fla.
- THOMAS, D. R., and LYONS, J., 1966. The interaction between sensory and tonic factors in the perception of the vertical in pigeons. Percept. Psychophysics 1, 93 - 95.
- TROLAND, L. T., 1930. *Psychophysiology: Vol. II Sensation.* New York: Van Nostrand.
- VERNON, M. D., 1934. The perception of inclined lines. Brit. J. Psychol., 25, 186 = 196.
- VON HOLST, E., 1954. Relations between the CNS and the peripheral organs. Brit. J. animal Behav., 2, 89 - 94.
- WADE, N. J., 1968. Visual orientation during and after lateral head, body, and trunk tilt. Percept. Psychophysics, 3, 215 - 219.
- WALLACH, H., KRAVITZ, J. H., and LINDAUER, J., 1963. A passive condition for rapid adaptation to displaced visual direction. Amer. J. Psychol., 76, 568 - 578.
- WALLACH, H., and LEWIS, C., 1965. The effect of abnormal displacements of the retinal image during eye movements. Percept. Psychophysics 1, 25 - 29.
- WALTHALL, W. J., Jr., 1946. The Köhler effect. Amer. J. Psychol., 59, 152 - 5.
- WAPNER, S., WEINER, H., and CHANDLER, K. A., 1951. Experiments on sensory-tonic field theory of perception: I. Effect of extraneous stimulation on the visual perception of verticality. J. exp. Psychol., 42, 341 - 343.

- WEEKS, V. D., and TRAVELL, J., 1955. Postural vertigo due to trigger areas in the sternocleidomastoid muscle. *J. Pediat.*, 47, 315 - 327.
- WEINER, M., 1955a. The effects of differentially structured visual fields on the perception of verticality. *Amer. J. Psychol.*, 68, 291 - 293.
- WEINER, M., 1955b. Effects of training in space orientation on perception of the upright. *J. exp. Psychol.*, 49, 367 - 373.
- WEINSTEIN, S., SERSEN, E. A., FISHER, L., and WEISINGER, M., 1964. Is re-reference necessary for visual adaptation? *Percept. mot. Skills*, 18, 641 - 648.
- WEINSTEIN, S., SERSEN, E. A., and WEINSTEIN, D. S., 1964. An attempt to replicate a study of disarranged eye-hand coordination. *Percept. mot. Skills*, 18, 629 - 632.
- WEINSTEIN, S., SERSEN, E. A., WEISINGER, M., FISHER, L., and RECHLIN, M., 1964. Total adaptation to prismatic displacement in the absence of re-reference. *Typescript*.
- WERNER, H., 1938. Binocular depth contrast and the conditions of the binocular field. *Amer. J. Psychol.*, 51, 489 - 497.
- WERNER, H., WAPNER, S., and BRUELL, J. H., 1953. Experiments on sensory-tonic field theory of perception: VI. Effect of position of head, eyes, and of object on position of the apparent median plane. *J. exp. Psychol.*, 46, 293 - 299.
- WERNER, H., WAPNER, S., and CHANDLER, K. A., 1951. Experiments on sensory-tonic field theory of perception: II. Effect of supported and unsupported tilt of the body on the visual perception of verticality. *J. exp. Psychol.*, 42, 346 - 350.
- WERTHEIMER, M., 1912. Experimentelle Studien über das Sehen von Bewegung. *Z. Psychol. Physiol. Sinnesorg.*, 61, 161 - 265.
- WERTHEIMER, M., and ARENA, A., 1959. Effect of exposure time on adaptation to disarranged hand-eye coordination. *Percept. mot. Skills*, 9, 159 - 164.
- WHITESIDE, T. C. D., 1960. The effect of weightlessness on some postural mechanisms. *Aerosp. Med.*, 31, 324.



- WIENER, N., 1948. *Cybernetics*. New York: Wiley.
- WING, M. E., 1963. The response of the otolith organs to tilt. *Acta oto-laryng.*, 56, 537 - 545.
- WITKIN, H. A., 1948. The effect of training and of structural aids on performance in three tests of space orientation. Rep. No. 80. Washington D.C. Civil Aeronautics Administration.
- WITKIN, H. A., 1949b. The nature and importance of individual differences in perception. *J. Perx.*, 18, 145 - 170.
- WITKIN, H. A., 1949a. Perception of body position and of the position of the visual field. *Psychol. Monogr.*, 63, No. 302.
- WITKIN, H. A., 1952. Further studies of perception of the upright when the direction of the force acting on the body is changed. *J. exp. Psychol.*, 43, 9 - 20.
- WITKIN, H. A., 1953. Comment on 'The role of instruction in experimental space orientation'. *J. exp. Psychol.*, 46, 135 - 136.
- WITKIN, H. A., 1964. Uses of the centrifuge in studies of the orientation of space. *Amer. J. Psychol.*, 77, 499 - 501.
- WITKIN, H. A., and ASCH, S. E., 1948. Studies in space orientation: IV. Further experiments on perception of the upright with displaced visual fields. *J. exp. Psychol.*, 38, 762 - 782.
- WOELLNER, R. C., and GRAYBIEL, A., 1958. Reflex ocular torsion in healthy males. Proj. NM.17.01.11, Subtask 1, Rep. No. 47, U.S. Nav. Sch. aviat. Med., Pensacola, Fla.
- WOELLNER, R. C., and GRAYBIEL, A., 1959. Counterrolling of the eyes and its dependence on the magnitude of gravitational or inertial force acting laterally on the body. *J. appl. Physiol.*, 14, 632 - 634.
- WOHLGEMUTH, A., 1911. On the after-effect of seen movement. *Brit. J. Psychol. Monogr. Suppl.*, No. 1.
- WOHLWILL, J. F., 1966. Perceptual learning. *Ann. Rev. Psychol.*, 17, 201 - 232.
- WOOSTER, M., 1923. Certain factors in the development of a new spatial coordination. *Psychol. Monogr.*, 32, No. 4, (Whole No. 146).