

Durham E-Theses

Studies on the sensory systems of certain freshwater pulmonate molluscs

P. R. Benjamin

How to cite:

Benjamin, P. R. (1968) Studies on the sensory systems of certain freshwater pulmonate molluscs. Doctoral thesis, Durham University.

Use policy

The full-text may be used and/or reproduced, and given to third parties in any format or medium, without prior permission or charge, for personal research or study, educational, or not-for-profit purposes provided that:

- a full bibliographic reference is made to the original source
- a <https://etheses.durham.ac.uk/id/eprint/8780/> is made to the metadata record in Durham E-Theses
- the full-text is not changed in any way

The full-text must not be sold in any format or medium without the formal permission of the copyright holders.

Please consult the [full Durham E-Theses policy](#) for further details.

STUDIES ON THE SENSORY SYSTEMS OF
CERTAIN FRESHWATER PULMONATE MOLLUSCS

by

P.R. Benjamin, B.Sc. (Liverpool)

Being a thesis presented in candidature for the degree
of Doctor of Philosophy of the University of Durham,
July 1968.

St. Cuthbert's Society,

Durham.



ACKNOWLEDGEMENTS

I should like to thank Dr. C.J. Duncan for all his help and encouragement during the course of this research and for kindly reading the thesis manuscript.

I am grateful for the help and advice which I received from Mr. A. Peat in the electron microscope work.

I should also like to thank Miss K. Flower, Mr. D. Snaith and Mr. D. Kelly for technical assistance.

I am indebted to the Science Research Council for financial support during the three year research period and to Professor D. Barker for the facilities he provided for me in his department.

CONTENTS

	page
<u>GENERAL INTRODUCTION</u>	1.
<u>SECTION 1 ANATOMY</u>	6.
INTRODUCTION	6.
METHODS	9.
a. <u>In vivo</u> observations.	9.
b. Light microscopy.	10.
c. Electron microscopy.	12.
RESULTS	13.
a. The osphradium.	13.
i. <u>In vivo</u> observations.	13.
ii. Low power structure.	18.
iii. Relationship between cell diameter and the diameter of the shell.	30.
b. Neurones in the left pallial nerve.	33.
c. Central nervous organisation.	40.
d. Osphradium - electron microscope studies.	43.
CONCLUSIONS AND DISCUSSION	84.
The osphradium	84.
Organisation of neurones in <u>Planorbarius</u>	85.

CONTENTS (contd.)

	page
<u>SECTION 2</u> <u>ELECTROPHYSIOLOGY</u>	87.
INTRODUCTION	87.
METHODS	93.
a. Electrophysiological apparatus.	93.
b. Recording techniques and preparations.	93.
RESULTS	100.
a. Central nervous system.	100.
b. Pallial nerve recordings.	105.
c. The osphradium.	109.
CONCLUSIONS AND DISCUSSION	116.
<u>SECTION 3</u> <u>BEHAVIOUR</u>	120.
INTRODUCTION	120.
METHODS	123.
a. Ciliary currents.	123.
b. Y mazes.	124.
c. Anaesthetisation and operations.	127.
d. Respiratory behaviour.	129.
RESULTS	129.

CONTENTS (contd.)

	page
a. Ciliary currents.	129.
b. Chemoreception.	133.
c. Respiratory behaviour.	135.
CONCLUSIONS AND DISCUSSION	137.
<u>SECTION 4 LIPID BODIES</u>	139.
INTRODUCTION	139.
METHODS	141.
RESULTS	142.
CONCLUSIONS AND DISCUSSION	152.
<u>GENERAL CONCLUSIONS AND DISCUSSION</u>	161.
<u>SUMMARY</u>	171.
<u>PUBLICATIONS</u>	175.
<u>REFERENCES</u>	176.

GENERAL INTRODUCTION

Most of the work which will be described in this thesis is concerned with the structure and function of a small organ, the osphradium, present in freshwater snails of the Pulmonata, Gastropoda. It was hoped to compare the osphradium of the Pulmonata with the similarly named organ in other groups of the Mollusca. Two species of snail have been used, Planorbarius corneus L. and Lymnaea stagnalis L. After initial examination of the organ in the two species, Planorbarius was found to be most useful for electrophysiological and behavioural experiments and this animal has been used exclusively in these aspects of the work. The original objectives have been extended to discover other possible sites of chemoreceptive importance, and a preliminary study of the organisation and electrophysiology of nerve cells from various parts of the central and peripheral nervous system has been made. In addition a detailed examination has been carried out of the fine structure of the so-called lipid bodies present in neurones of the osphradial ganglion.

Osphradia or homologous structures are said to occur in all groups of molluscs except the Aplacophora, Scaphopoda, nudibranchs, terrestrial pulmonates and dibranchiate cephalopods (Charles, 1966).

The organs are typically situated near the ctenidia in the pallial cavity. They are elongate strips of epithelial tissue consisting of ciliary, secretory and supposedly sensory cells. The osphradium in freshwater pulmonates is rather different from this basic type. It is a small tubular structure, consisting of a blindly-ending canal, with a basal ganglion of nerve cells (Lacaze-Duthiers, 1872; Bernard, 1890; Demal, 1955). Whether this organ is homologous with other known osphradia is uncertain.

The function of the osphradium in the Mollusca has been the subject of some discussion but it is now generally accepted to be a sense organ. This conclusion is based upon the position of the organ in the line of the inhalent current (Yonge, 1947), the presence of neurosensory elements (Bernard, 1890; Dakin, 1912; Demal, 1955) and behavioural experiments carried out by various workers (Copeland, 1919; Henschel, 1932; Wölper, 1950; Brown and Noble, 1960; Michelson, 1960). The modality of sensory function has, however, remained in doubt. Hulbert and Yonge (1937) and Yonge (1947) have favoured a sedimentary-detecting function based upon the circumstantial evidence of size and development of the organ in relation to the degree of sedimentation to which the animal is exposed in its environment. Most experimental evidence obtained from prosobranch species, however, has supported a chemoreceptor function. Behavioural evidence, using choice chamber and

excision techniques, implicated the osphradium in chemoreception (Copeland, 1918; Wölper, 1950; Brown and Noble, 1960) but the most conclusive evidence has been obtained by Bailey and Laverack (1963, 1966) in the marine prosobranch, Buccinum undatum. These authors were able to record electrical responses in the supra-intestinal ganglion, which were the result of adding chemical substances to the osphradium. The osphradium was behaviourally sensitive to probe stimuli but gross mechanical deformation was necessary to stimulate electrical activity. The organ was insensitive to inert particles of various sizes.

The only experimental results which indicate a possible function for the osphradium of a freshwater pulmonate are those of Michelson (1960). He found that the ability of Australorbis to orientate towards food substances was lost in animals in which the osphradium had been cauterized. These results suggest that the pulmonate osphradium, like that of the prosobranch type, may have a chemoreceptor function.

In the present study the osphradium of the pulmonates has been investigated using several different approaches.

The structure of the organ has been examined, using light and electron microscope techniques (SECTION 1). These studies have been linked with in vivo observations of the behaviour of

the organ and its responses to the application of chemicals and particle suspensions (SECTION 3).

The second approach has been an electrophysiological one (SECTION 2). Electrical activity has been recorded in the osphradial ganglion and attempts have been made to stimulate activity by addition of suitable substances to the mouth of the organ. By this means it was hoped that direct evidence for the role of the osphradium could be obtained. This recording also yielded evidence concerning the organisation of a peripheral ganglion in the Pulmonata and this was correlated with anatomical evidence (SECTION 1). These results were compared with anatomical and electrophysiological studies of nerve cells from other parts of the peripheral nervous system and with electrical activity recorded from brain cells.

The last approach has been behavioural. The ability of freshwater snails to orientate towards food substances has been investigated. Substances which attracted the snails were tested for their ability to stimulate the osphradium in electrophysiological experiments. In order to discover sites of chemoreception in the snails, the orientation experiments were repeated with animals in which the osphradium had been cauterised and with animals in which the tentacles had been removed. The results obtained with the osphradialectomised animals were correlated with the electrophysiological

experiments. The osphradialectomised group of animals were also tested for their ability to carry out lung-ventilation behaviour. Because of the position of the osphradium at the base of the pneumostomal folds, Lacaze-Duthiers (1872) had suggested that it might be involved in this process.

By these various techniques it was hoped that the function of the osphradium might be determined and its role in the life of the animal ascertained.

SECTION 1 ANATOMY

INTRODUCTION

Most of the work on the cytology and organisation of nerve cells in the Mollusca has been carried out on the central nervous system. In the Gastropoda the early work has been restricted to a small number of species, especially to animals of the genus Helix (Legendre, 1907; Schmalz, 1914; Kunze, 1921; Hanström, 1928; Bæcker, 1932). Kunze (1921) made a detailed study of neurones within the brain of Helix, which included a cytochemical investigation of individual cell bodies. Hanström (1928) summarised a long series of experiments in which he was able to trace the axons of neurones in the brain and tentacles of several pulmonate species. Recent studies have increased the information concerning the cytochemistry and organisation of the gastropod central nervous system (Bullock, 1961; Nisbet, 1961; Smith, 1966; Dorsett, 1967). A much more complete picture of brain structure has emerged with the aid of electron microscopy. Gerschenfeld (1962) examined the neuro-pile in the visceral ganglion of Aplysia, and Rosenbluth (1963) extended this to a study of the whole ganglion. Amoroso, Baxter, Chiquoine and Nisbet (1964) carried out a detailed analysis of the

brain and peripheral nerves of the pulmonate, Archachatina marginata. All these studies have revealed a common plan of structure within the ganglia of the various groups which have been investigated.

The peripheral system, which consists of those nerve cell bodies situated outside the main central ganglia, has been examined anatomically in only a few cases. These peripheral cells may be divided into two main groups: (a) Those with an obvious sensory function, usually associated with the epithelium of the body wall, and (b) others which occur throughout the lengths of nerves whose axons do not appear to pass outside the nerve itself.

Nisbet (1961) has described isolated sensory neurones in the body wall of Archachatina, and ganglia which probably have a sensory function occur in the tentacles of stylommatophoran pulmonates (Hanström, 1928; Lane, 1962, 1964). The osphradium of many groups of molluscs consists of nerve cell bodies associated with an epithelium and evidence has been accumulating which suggests that they have a sensory function (Bailey and Laverack, 1963, 1966). Lacaze-Duthiers (1872) first described the osphradium of freshwater pulmonates with its canal and associated neurones. He also noticed other groups of nerve cells which occurred in the peripheral nervous system; these were particularly obvious where several nerves formed a junction.

Isolated nerve cell bodies were shown to be present in peripheral nerves of pulmonates by Schlote (1955, 1957). His electron micrographs (Schlote, 1957) were the first to show the fine structure of peripheral nerves in the Mollusca. More recently, other, sensory structures, have been investigated in the electron microscope. Barber (1966) worked out the fine-structure of the statocyst in Octopus and several other workers have investigated the ultrastructure of eyes in gastropods. (Eakin and Brandenburger, 1965; Eakin, 1967; Westfall, Dennis and Eakin, 1967).

Isolated reports of neurone cell diameters for gastropods occur in the literature but there are few analyses of cell type and size for whole ganglia (Bullock and Horridge, 1965). Only one attempt has been made to relate the size of neurone cell bodies to the weight of the animal (Arvanitaki and Tchou, 1942).

In the present study neurones from various parts of the nervous systems of Planorbarius corneus and Lymnaea stagnalis have been investigated. The structure of the osphradium has received special attention. It was hoped that examination of the structure would provide evidence concerning the organ's supposed sensory function and also yield information about the nature of nerve cell organisation in a peripheral ganglion. A conflict of opinion had occurred in earlier papers concerning the innervation of the osphradial canal

epithelium (Bernard, 1890; Demal, 1955) and, in order to investigate this more thoroughly, it was necessary to extend the light microscopy analysis to an electron microscopic study of the organ.

METHODS

Specimens of Planorbarius corneus were obtained from an animal suppliers; Lymnaea stagnalis have been mostly collected from ponds in the vicinity of Durham, although specimens of this snail have also been obtained from commercial sources. The snails were kept in charcoal-filtered tapwater, with added calcium carbonate, in a cold room at a temperature of about 12° C. The animals were fed on fresh lettuce which they readily consume. If the water in the tanks was changed regularly, then lively specimens were available at any time. The snails have been kept for periods of up to 1 year. Only active specimens have been used for histological work, their diameter of shell varying between 1 and 3 cms.(both species).

a. In vivo observations.

Observations of the central nervous system and the nerves originating from it were made from the dorsal side. The shell was carefully removed and the animal transferred to a bath of Ringer (Pantin, page 47, 1948). The brain was exposed by making a dorsal incision in the head,

pinning the buccal mass forward and pulling the gut through the perioesophageal nerve ring, after it had been sectioned in the region behind the brain. In Planorbarius, the left pallial nerve could be followed from its origin in the left pallial ganglion, and by carefully pulling aside the body wall, the osphradium revealed. Neurones in the brain could be readily observed under the low power of a zoom microscope, and identification of isolated and grouped cells in peripheral nerves was possible because their presence was marked by pigment.

Repeated examination of the osphradial ganglion showed that certain large cells on the dorsal side, close to the origin of the osphradial nerve, could be recognised in all ganglia. Measurements of three cells were made by micrometer eyepiece in vivo and these values were correlated with the size of the shell, its diameter at the widest point being determined by means of callipers. A series of animals of gradually increasing diameter were measured in this way.

b. Light microscopy.

The brain, left pallial nerve and osphradium of Planorbarius corneus and Lymnaea stagnalis have been prepared for sectioning and examination in the light microscope. Brains were removed and

quickly transferred to fixative; portions of the left pallial nerve were carefully exposed and transferred in a similar manner. In early experiments the osphradium was dissected almost completely from its surrounding tissue except for a portion of the body wall around its aperture. It was found that this technique tended to damage the larger nerve cells and the epithelium, so in later experiments the osphradium was left in position and a larger piece of tissue containing the organ was prepared for sectioning.

Various fixatives have been tried: Bouin, Susa, Stieve's, Gilson's, and 70% alcohol. The best results were obtained with Gilson's and Stieve's fixatives and these were used after initial trials. All tissues were fixed for about 24 hours, dehydrated through an ethanol series, cleared in chloroform and embedded in paraffin wax. The blocks were serially sectioned at 5 μ , stained, and mounted in DPX. A number of different stains have been tried. The most commonly used have been Heidenhain's Iron Haematoxylin (sometimes with Orange G as counterstain) and Ehrlich's Haematoxylin with Eosin as counterstain. Azan and Masson's trichrome stains have also been tried. In order to obtain a more complete picture of the cells in the various ganglia of the snails, photographs have been taken of 5 μ serial sections passing through the whole of a particular ganglion. Individual cell bodies were traced and measurements made of

greatest cell diameter. They were classified firstly on the basis of size, and secondly on the number of axons they possessed. This analysis has been carried out on one series of sections from the left pallial ganglion, two series from the osphradial ganglion and two series of sections of the left pallial nerve. The type and number of cells which sent axons to the osphradial epithelium were also noted in the series of the osphradial ganglia.

c. Electron microscopy.

The osphradium was dissected undamaged from living snails under Ringer and transferred to fixative. For the electron microscope work only Planorbarius has been used. The best fixation medium was found to be unbuffered osmium tetroxide which gave a good general fixation. The osphradium was quickly transferred to an aqueous 1% solution of this substance and fixed for one hour at 4° C. The organ was given several washes of distilled water, dehydrated through an ethanol series up to absolute alcohol and passed through a series of propylene oxide/Araldite mixtures, until only Araldite was present. The Araldite was left to harden for several days at 48° C. (Peat and Whitton, 1967). Sections of about 600-800 Å thickness were taken, using glass knives, on an LKB ultratome. The technique was to take several grids of sections, examine them in the electron

microscope and move some μ down the block and take more sections until the whole block was cut. By this method it was possible to obtain an idea of the structure along the entire length of the organ.

The sections were examined in an EM 6B electron microscope at about 60 kv. Beforehand they were stained with lead citrate (Reynolds, 1963) or sometimes with uranyl acetate, followed by lead citrate. Washing with distilled water afterwards removed excess stain.

RESULTS

a. The osphradium.

i. In vivo observations.

Most of the observations will refer to Planorbarius; only differences in structure of the osphradium in Lymnaea will be recorded.

The osphradium of Planorbarius is about 0.5 mm. long, that of Lymnaea usually a little shorter. The organ in Planorbarius is situated on the left side of the anterior mantle, close to the base of the folds of the pneumostome. The osphradium in Lymnaea is similarly positioned, but on the right side of the animal. If the shell is removed and the anterior fold of the mantle lifted back, the aperture of the osphradium can be seen under the low power of a dis-

Fig. 1. An anterior view of the snail, Planorbarius corneus, L. with the shell removed and the anterior mantle of the shell pinned back to show the position of the osphradial aperture.

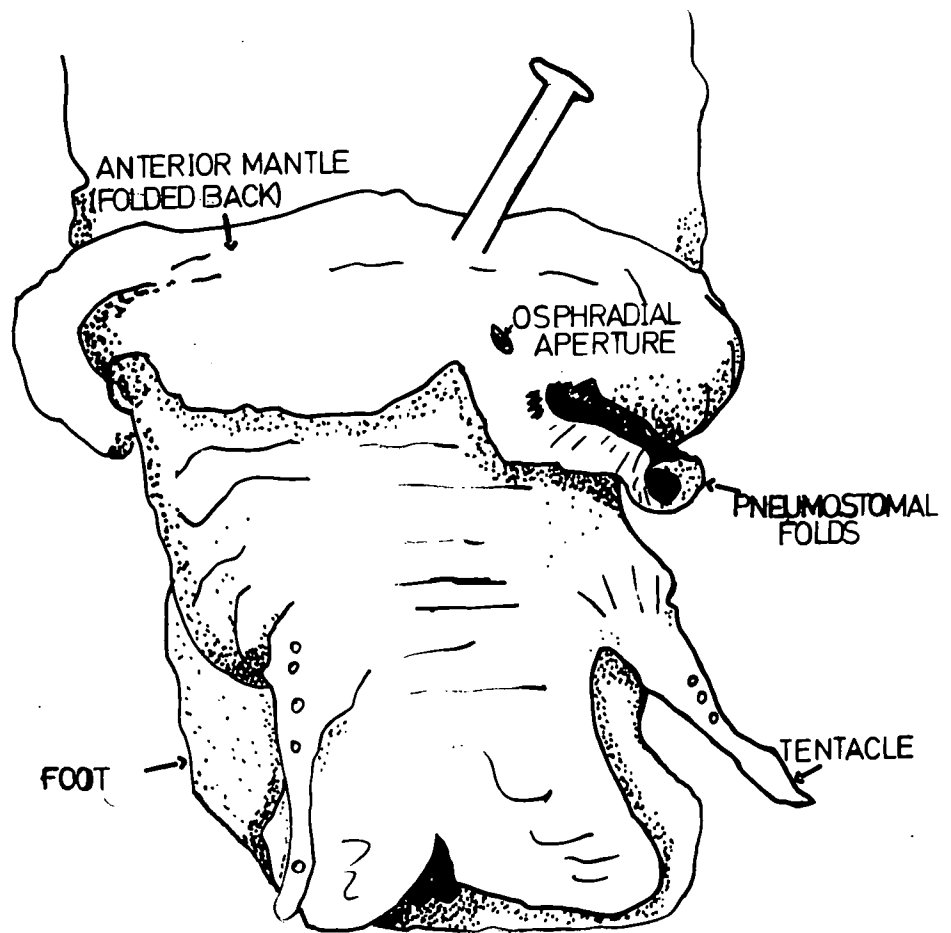

POSITION OF THE OSPHRADIUM
IN PLANORBARIUS

secting microscope. It appears as a small slit surrounded by an oval lip of tissue (fig. 1.). The aperture may be obscured if the body wall around the aperture is contracted. Ciliary activity can be observed on the lip of the osphradium. The body wall below the aperture can be pulled carefully aside to reveal the osphradial canal and ganglion. The osphradia of both species consist of a blindly ending canal, surrounded by a basally situated ganglion of nerve cells. The canal is bifid in Lymnaea, whereas in Planorbarius it is a simple tube. The rear portions of the canal in Lymnaea appear as small humps on the dorsal surface of the ganglion. The whole organ in this species is more pear-shaped than that of Planorbarius. The ganglion region extends over a large part of the canal, whereas in the case of the ramshorn snail the ganglion is more basally situated, leaving a large part of the canal uncovered. In both species the canal close to the mantle surface is wider than the canal in the ganglion region. A short osphradial nerve leads from the rear of the osphradial ganglion to the main pallial nerve. The whole organ is covered by a sheath of connective tissue whose thickness increases with the age of the snail. Certain larger nerve cells are organised superficially on the surface of the ganglia. The cells contain pigment which gives them a red colour in Planorbarius and a predominantly yellow colour in Lymnaea. Squash preparations of

Fig. 2. Diagram of the anterior nervous system of Planorbarius
corneus showing the brain and nervous connections to
the osphradium.

ag, abdominal ganglion
an, aortic nerve
apn, anterior pallial nerve
bc, buccal connective
cg, cerebral ganglion
cn, columellar nerve
icn, inferior cervical nerve
iln, inferior labial nerve
lpn, left pallial nerve
mpn, median pallial nerve
on, optic nerve
os, osphradium
pag, pallial ganglion
pdg, pedal ganglion
pg, pleural ganglion
pn, penial nerve
rpn, right pallial nerve
scn, superior cervical nerve
sn, splanchnic nerve
sln, superior labial nerve
vpn, ventral pallial nerve

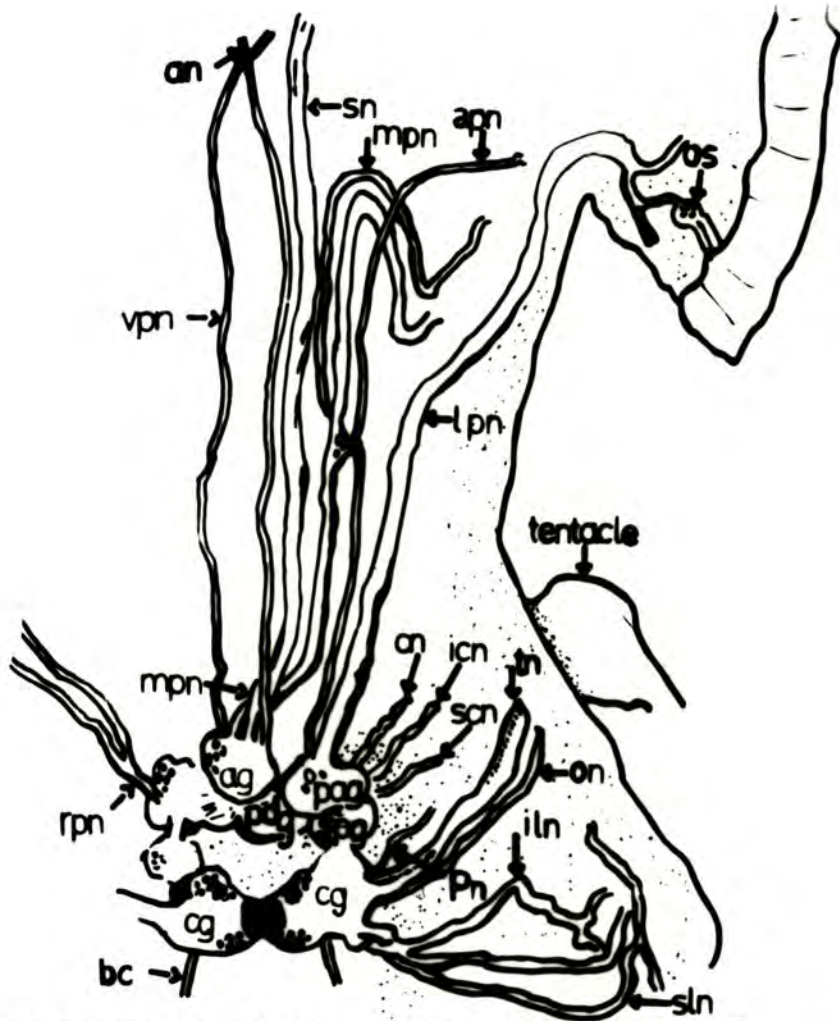

DISSECTION OF THE ANTERIOR
NERVOUS SYSTEM OF PLANORBARIUS
(DORSAL VIEW)

Fig. 3. L.S. osphradium of Planorbarius corneus showing the osphradial ganglion and canal.

bw, body wall

ca, canal

co, connective tissue capsule

cr, ciliated region of the osphradial epithelium

cs, connective tissue strand

ico, inner connective tissue capsule.

n, neuropile

ne, neurone cell body

og, osphradial ganglion

se, secretory region of the osphradial epithelium

sr, sensory region

Stained with Heidenhain's Iron Haematoxylin with orange G. counterstain.

50µ



the osphradial ganglion show that the pigment is contained within discrete "grains" which probably correspond to the lipid bodies of other molluscs (Arvanitaki and Chalazonitis, 1961). The osphradial ganglion of Planorbarius can easily be observed against the black body wall tissue and for this reason the organ in Planorbarius was used in preference to that of Lymnaea in the electrophysiological work, when it was important to be able to observe individual nerve cell bodies.

The general arrangement of the nervous system of Planorbarius and Lymnaea has been described by Lacaze-Duthiers (1872) and it was found in the present work that his analysis was largely accurate (fig. 2), although there are variations in the exact organisation of nerves from individual to individual. The organisation of nerves in the osphradial region of Planorbarius is shown in figure 15. This is the most common arrangement, but it may vary in detail.

ii. Low power structure(see fig. 23).

Examination of serial sections of the organ show that the connective tissue capsule surrounding the osphradium is a continuous layer enclosing both the canal region and the basal ganglion. In addition, there is an inner capsule surrounding the canal epithelium inside the ganglion (fig. 3). Strands of tissue connect the inner and outer capsules in the ganglion region (fig. 3). The capsule can be seen to contain elongate strands of smooth muscle with a large

Fig. 4. T.S. osphradium of Planorbarius corneus showing sensory region of the canal and some neurones from the osphradial ganglion.

c, cilia

ca, canal

ne, neurone

og, osphradial ganglion

sc, secretory cell

se, secretory epithelium

sr, sensory region of the osphradial canal

Stained with Heidenhain's Iron Haematoxylin.

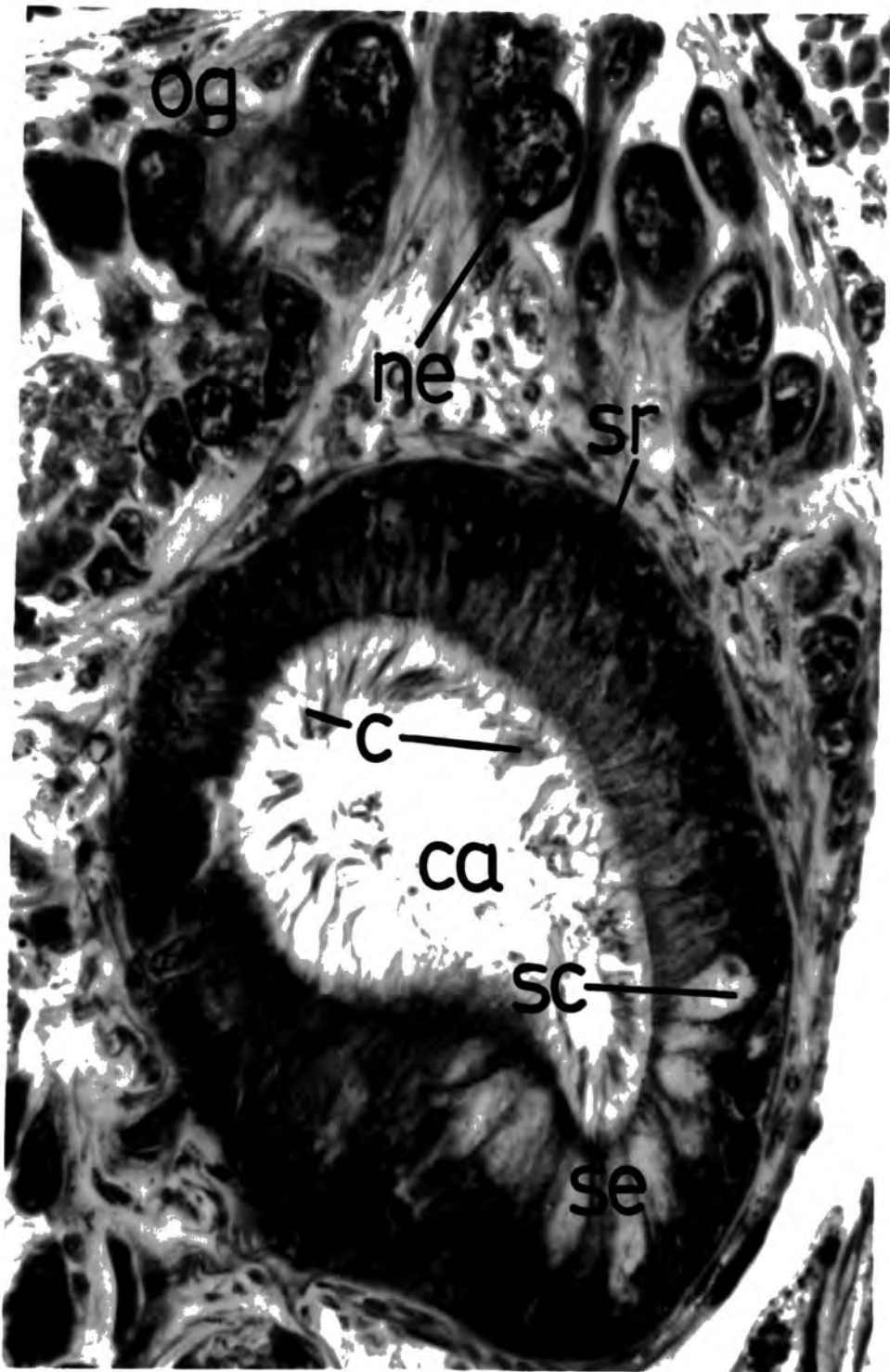

Fig. 5. T.S. osphradial canal of Planorbarius showing the secretory epithelial region.

c, cilia

ca, canal

cc, ciliated cell

co, connective tissue capsule

sc, secretory cell

Stained with Heidenhain's Iron Haematoxylin.

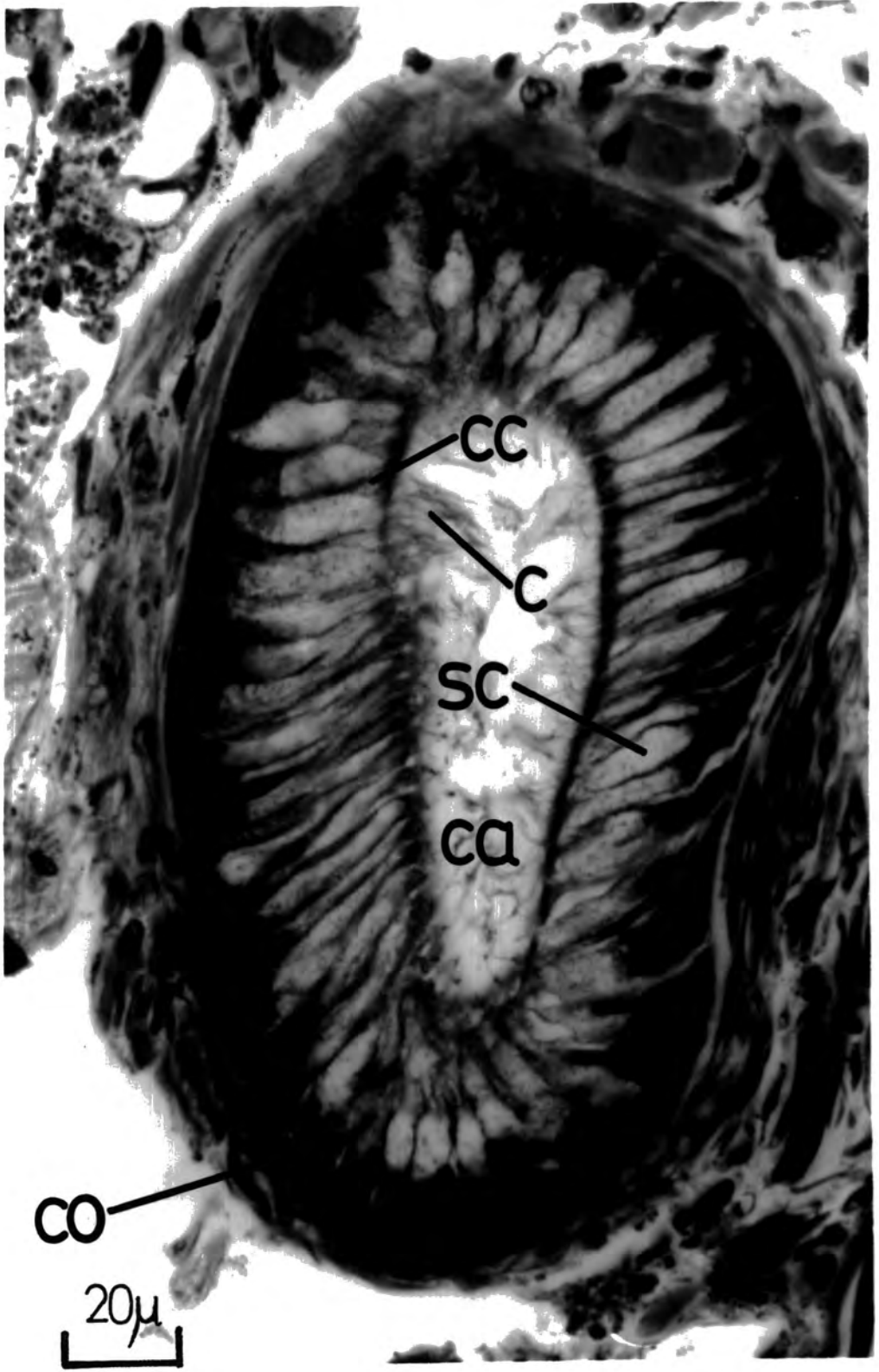

CC

C

SC

CA

CO

20μ

number of nuclei apparent (figs. 5-7). The organ lies in a fluid-filled pocket and it is connected to the surrounding body wall by numerous strands of connective tissue. Observations of serial sections of the osphradium showed that fibres from neurones in the ganglion region underneath the epithelium penetrate the inner connective tissue capsule (fig. 10). The processes are of an axonal rather than a dendritic nature and will be considered as such. Dendrites arising from the soma are unknown in molluscan neurones so far examined in the light or electron microscope (Bullock and Horridge, 1965). It is not clear from the 5 μ sections in the light microscope whether the axons innervate cells in the epithelium or form primary sensory processes. Recent work on molluscan neurones suggests that the second arrangement is most likely (Nisbet, 1961). The axons are only apparent in the region of the canal epithelium which is surrounded by the ganglion and this region has been termed the sensory region of the canal.

The distribution of cells in the osphradial canal epithelium in different parts of the canal has allowed the identification of three regions. The basal sensory region consists mainly of ciliated cells with a few secretory cells (fig. 4). The nuclei of the ciliated cells never extend above half the distance from the base to the apical region bounding the canal. The thickness of the epithelium is of the

Fig. 6. T.S. of the osphradial canal of Planorbarius corneus
in the ciliary region just below the osphradial
aperture.

c, cilia

ca, canal

cc, ciliated cells

sc, secretory cells

Stained with Heidenhain's Iron Haematoxylin.

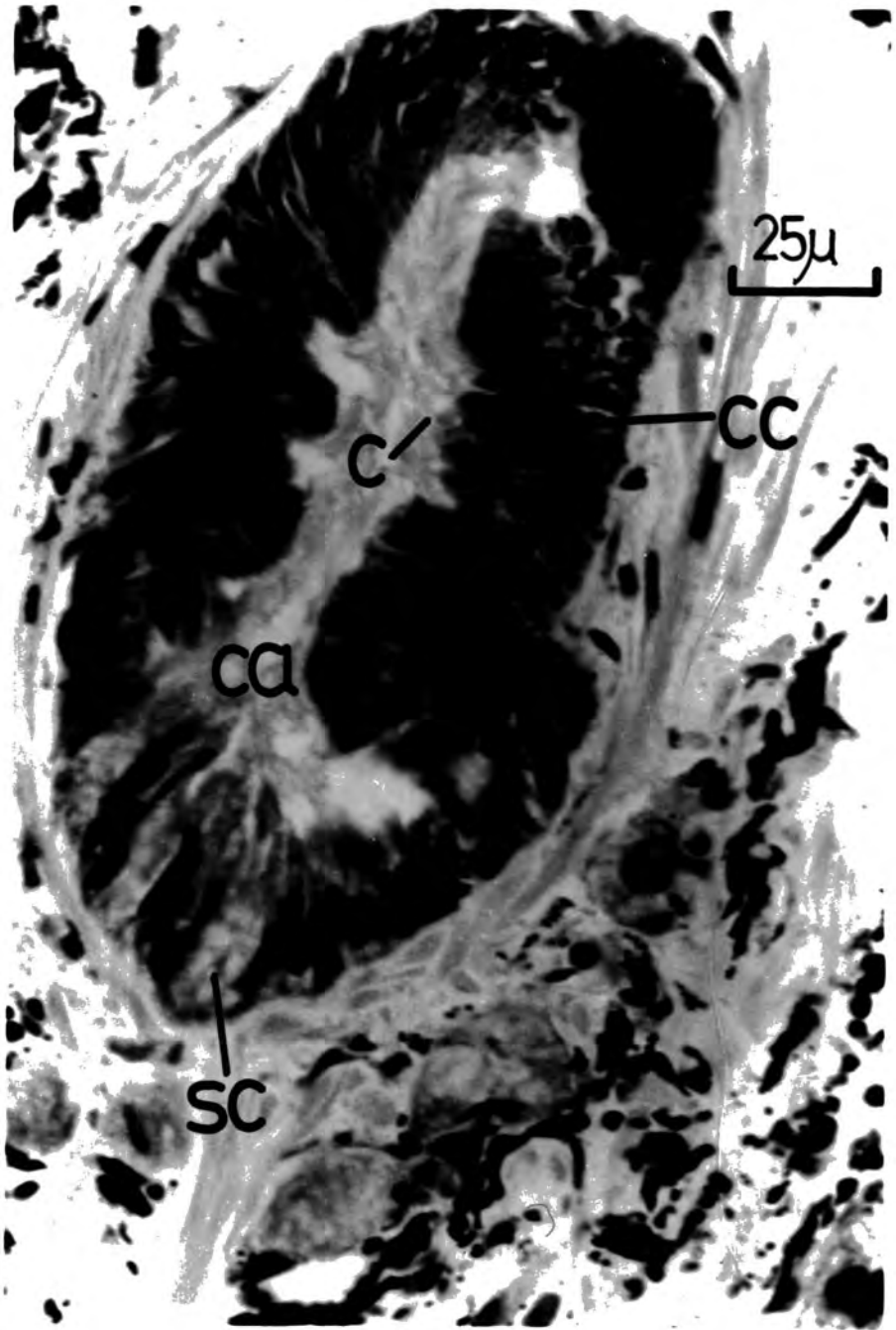

Fig. 7. Oblique section through the osphradial canal of Planorbarius showing the boundary between the secretory and ciliated regions of the osphradial canal.

c, cilia

ca, canal

co, connective tissue capsule

cr, ciliary region of the osphradial canal

se, secretory region of the osphradial epithelium

Stained with Heidenhain's Iron Haematoxylin.

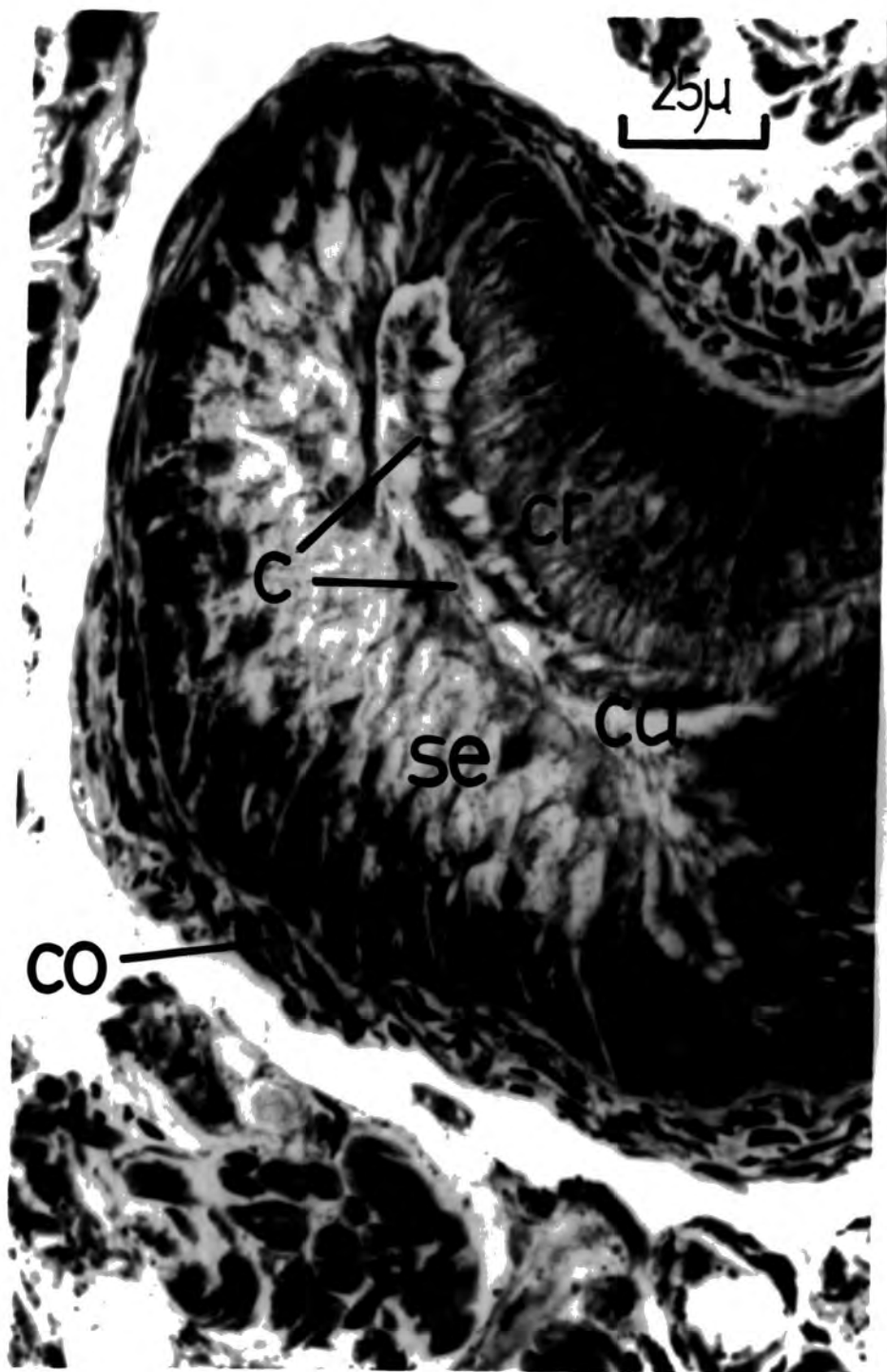

order of 30 μ and the cells have numerous cilia which can be of length equal to the thickness of the epithelium. Because of their length these cilia appear to occupy a large part of the canal lumen of this region (fig. 4). Observations on the living organ had shown the active beating of cilia in the basal canal area.

The second division of the canal, the middle or secretory region, is readily differentiated from the first (figs. 4, 5, 8). Figure 8 shows the change from a region consisting mainly of ciliated cells to one which has a preponderance of secretory cells. These latter cells have a bulbous appearance and, when stained with Heidenhain's Iron Haematoxylin, appear almost colourless, having basal nuclei and containing round globules of a presumed secretory nature. Similar cells are present in other parts of the animal and form a normal part of the epithelium of many molluscan tissues (Duncan, 1956). Ciliated cells are also present in small numbers and appear in section as triangles of tissue in the region of the epithelium adjacent to the canal. These cells are small in number (figs. 5, 8) and this is reflected in the number of cilia observed in the lumen of the canal. The width of the canal is similar to that of the sensory region, about 30 μ , but as the third and most distal region to the ganglion is reached the canal begins to widen, especially in the area underneath the osphradial aperture. The walls of the canal become more folded

Fig. 8. L.S. osphradium of Planorbarius contrasting the cell types of the sensory and secretory regions of the osphradial epithelium. The number of cilia in the lumen of the sensory region of canal is much greater than that of the secretory region.

c, cilia

ca, canal

cc, ciliated cell

co, connective tissue capsule

og, osphradial ganglion

sc, secretory cell

se, secretory canal epithelium

sr, sensory canal epithelium

Stained with Heidenhain's Iron Haematoxylin.

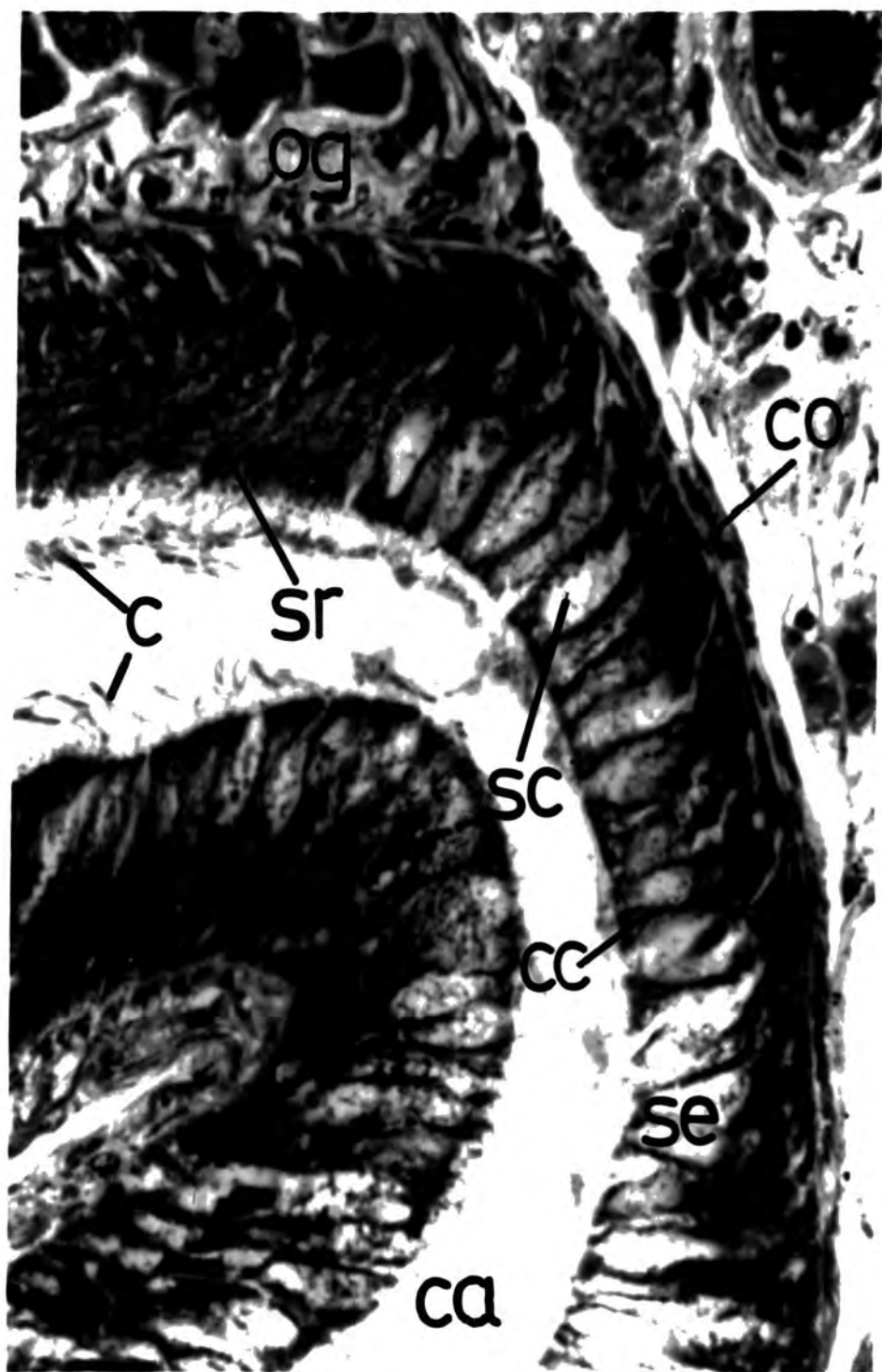

20 μ

Fig. 9. L.S. through the osphradial ganglion of Planorbarius showing a bipolar sensory neurone.

b, bipolar neurone

co, connective tissue sheath

cc, ciliated cells

n, neuropile of the osphradial ganglion

nu, nucleus

Stained with Heidenhain's Iron Haematoxylin with orange G. as counterstain.

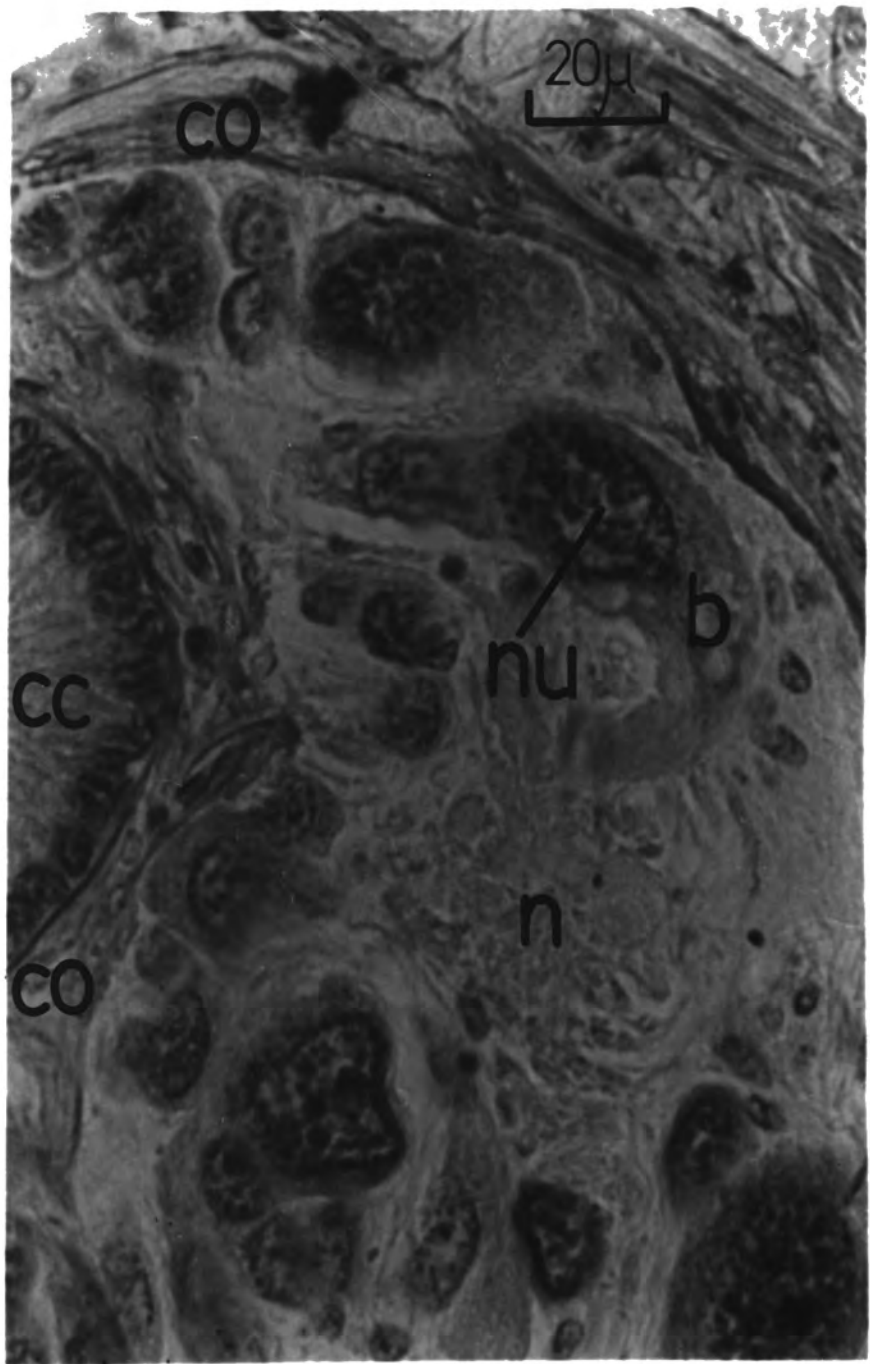

(fig. 6) and the structure of the epithelium becomes similar to that of the mantle around the aperture.

This region of the canal, following after the secretory region and next to the osphradial aperture, has been termed the ciliary region. In structure it is similar to the sensory region, consisting of ciliated cells and a small number of secretory cells (fig. 6). The transition from the secretory to the ciliated region is quite obvious (fig. 7). As the lip region is approached the secretory cells become more numerous and the epithelium consists of ciliary cells interspersed by numerous secretory cells.

The overall organisation of the neurones in the osphradial ganglion is similar to that of the central nervous ganglia of other pulmonate molluscs (Nisbet, 1961; Smith, 1966). The nerve cell bodies are arranged around the periphery of the ganglion and a neuropile of nerve axons is apparent at the centre (fig. 3). The nuclei of the osphradial neurones fill a large part of the soma (figs. 3, 9, 11). The neurones, in some regions, are arranged into distinct groups separated from neighbouring cells by connective tissue strands. This is particularly evident in the regions where the inner and outer capsules of the ganglion meet (see fig. 3). Whether this has any functional significance is not known. Monopolar (figs. 10, 11), bipolar (fig. 9) and multipolar neurones

Fig. 10. L.S. ganglion region of the osphradium of Planorbarius.

Two nerve cell bodies have axons which penetrate the epithelium of the osphradial canal.

ax, axon

bw, body wall

ca, canal

m, monopolar neurone

og, osphradial ganglion

sr, sensory epithelium

Stained with Heidenhain's Iron Haematoxylin.

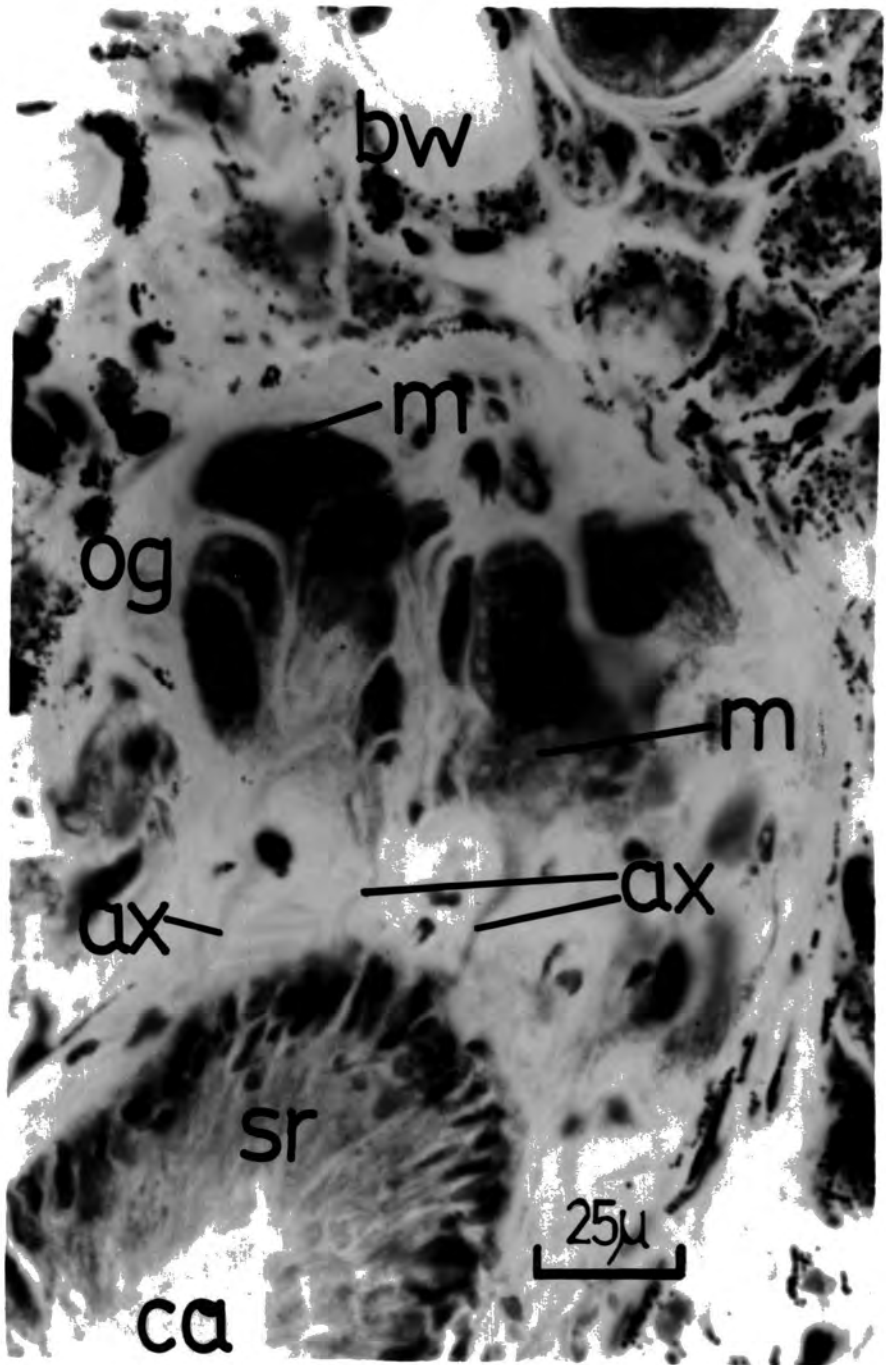

Fig. 11. Section through the osphradial ganglion of Planorbarius
corneus showing two types of neurone, multipolar and
monopolar cells.

n, neuropile

m, monopolar neurone

mu, multipolar neurone

Stained with Heidenhain's Iron Haematoxylin.

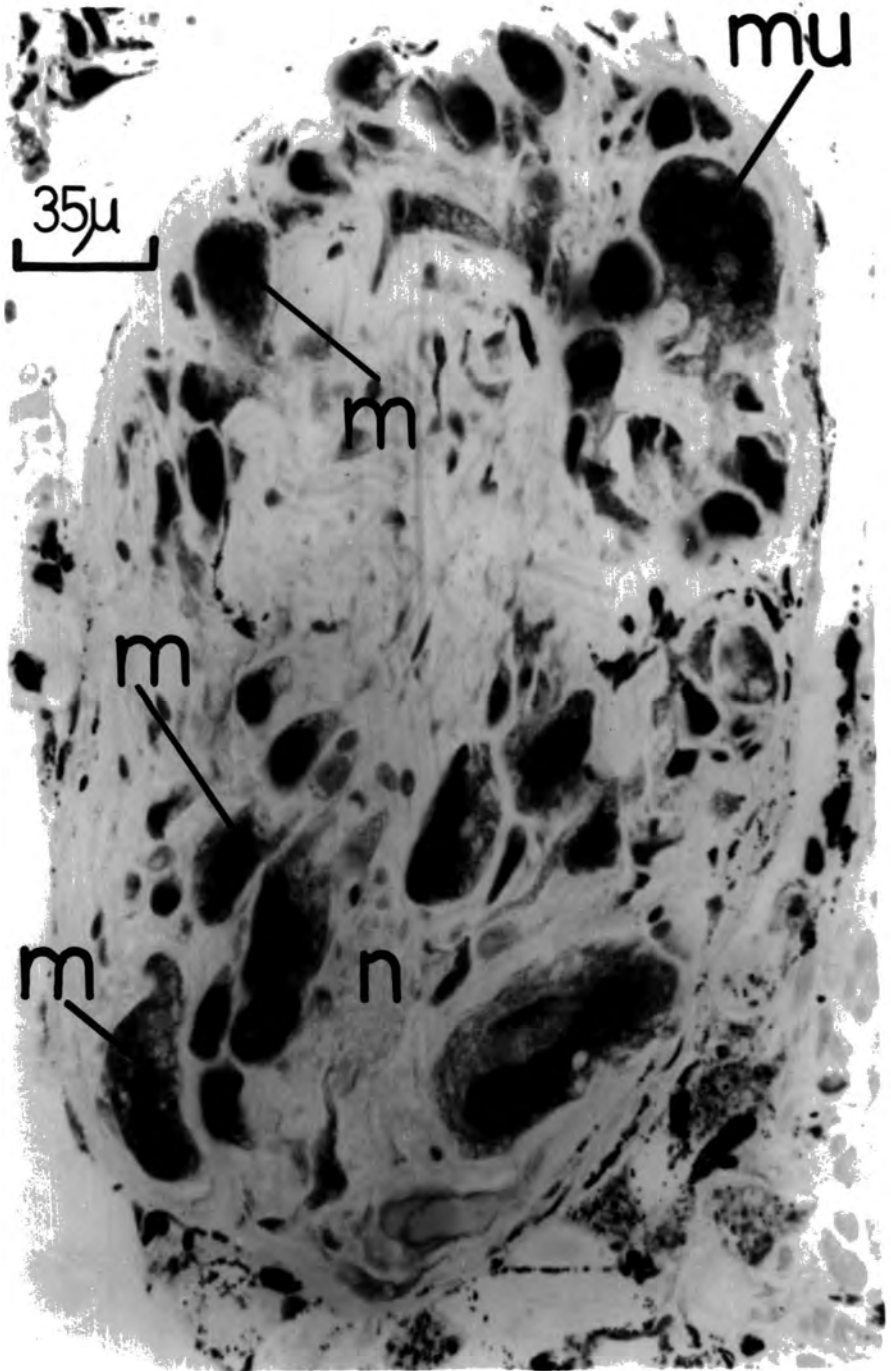

(fig. 11) are present in the osphradial ganglion. The most common types observed are the monopolars, with the bipolars and multipolars much less frequently present (figs. 12, 13). The two latter types ~~often~~ send processes to the osphradial epithelium (figs. 12, 13). When monopolar neurones have been observed with processes terminating in the epithelium they are usually multiterminal. All cell bodies have at least one axon penetrating the central osphradial neuropile. Only about a sixth of the neurones appear to send processes into the canal epithelium (figs. 12, 13). This is probably a conservative estimate, as only cells with the cell body and its axon in the same section were counted. The histograms (figs. 12, 13) show that the most common cell diameter is from 10-20 μ with about half this number from 20-30 μ . Only a few cells reach 80 μ in diameter, which agrees with in vivo measurements of the same cells measured by eyepiece micrometer.

iii. Relationship between cell diameter and the diameter of the shell.
(see fig. 14)

The two diameters show a roughly linear relationship over the lower ranges of shell size considered (fig. 14), but above about 2.5 cms. in diameter this relationship breaks down. At this point the neurone diameters fluctuate around a maximum or even decrease in size (cell 3, fig. 14).

Fig. 12. The neurone cell bodies of the osphradial ganglion of Planorbarius have been counted and classified according to maximum cell diameter and the number of axons possessed.

"Canal Neurones" are those nerve cell bodies which send processes into the osphradial canal epithelium.

ANALYSIS OF NERVE CELLS IN THE OSPHRADIAL GANGLION OF PLANORBARIUS

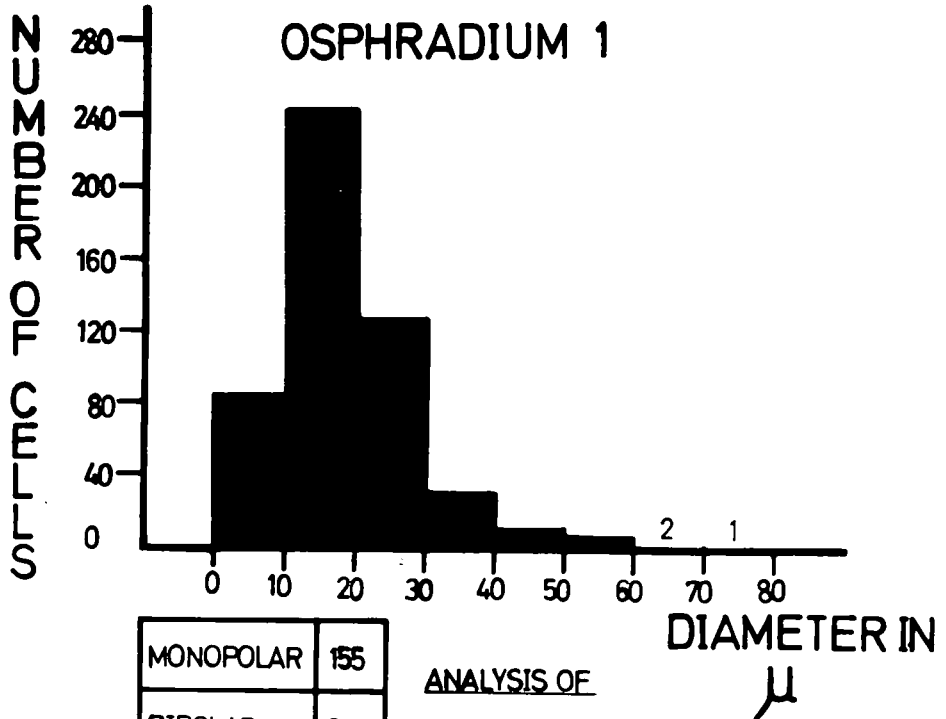

MONOPOLAR	155
BIPOLAR	85
MULTIPOLAR	34
UNCLASSSED	224

ANALYSIS OF
CELL TYPE

TOTAL NEURONES = 498

MONOPOLAR	17
BIPOLAR	34
MULTIPOLAR	22
UNCLASSSED	11

ANALYSIS OF CELL TYPE
FOR "CANAL" NEURONES

TOTAL NEURONES = 84

Fig. 13. Analysis of the neurones from the osphradial ganglion of Planorbarius, based upon largest cell diameter and number of axons.

ANALYSIS OF NEURONES IN PLANORBARIUS

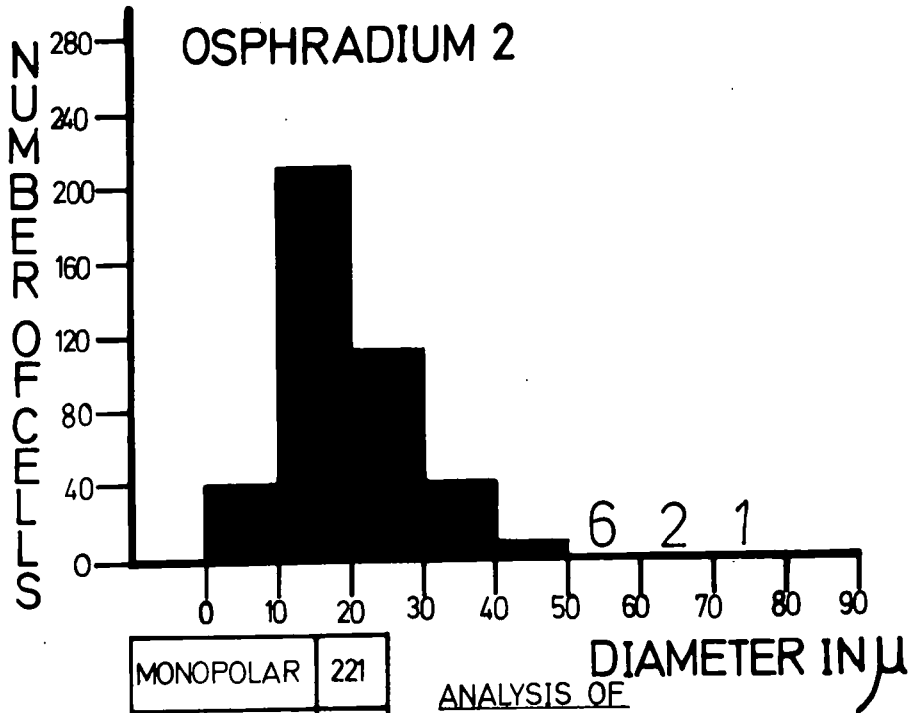

MONOPOLAR	221
BIPOLAR	76
MULTIPOLAR	31
UNCLASSED	92

ANALYSIS OF
CELL TYPE

TOTAL=420

MONOPOLAR	24
BIPOLAR	29
MULTIPOLAR	12
UNCLASSED	4

ANALYSIS OF CELL
TYPE IN "CANAL" NEURONES.

TOTAL=69

b. Neurones in the left pallial nerve.

Groups of nerve cell bodies in the peripheral nervous system of pulmonates are sometimes organised into ganglia which appear to have a sensory function, eg. in the neurones of the osphradium. Other nerve cell bodies occur in the nerves of an animal such as Planorbarius which have no obvious sensory function and these may occur in groups or as isolated cell bodies. They are marked in the nerves by their pigment and those organised into groups are the easiest to observe. Lacaze-Duthiers (1872) had noticed a group of these cells at the junction of the median pallial and the anterior pallial nerve in Planorbarius and this was also seen in the present study (fig. 2). Those nerve bodies commonly organised into groups or small ganglia usually occur at the junction of several nerve fibres and a group such as this has been observed at a junction of the pallial nerve, which occurs close to the mantle in the region of the pulmonary cavity (fig. 15). Individual cells can be observed, and in sections examined in the light microscope the cells are usually of the multipolar type. They are arranged in a clump (fig. 18) and an analysis of cell type and diameter (fig. 19) in two preparations indicated the presence of 11 cells in both cases. In the sections labelled as animal No. 3 all the cells were of the multipolar type.

Fig. 14. The relationship between shell diameter and nerve cell diameter in the osphradial ganglion of Planorbarius.

Each point is the measurement from a single snail.

ANALYSIS OF NERVE CELLS IN PLANORBARIUS

VARIATION IN THE DIAMETER OF THREE OSPHRADIAL NEURONES WITH DIAMETER OF SHELL

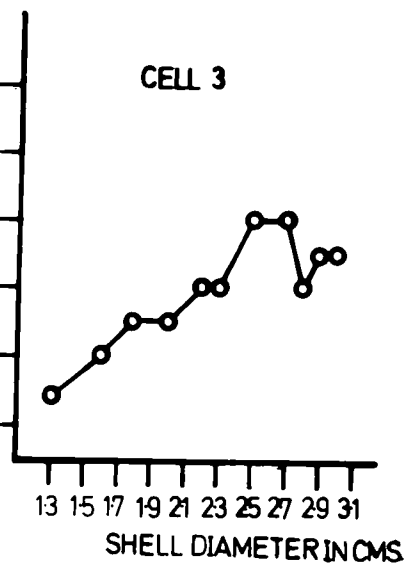
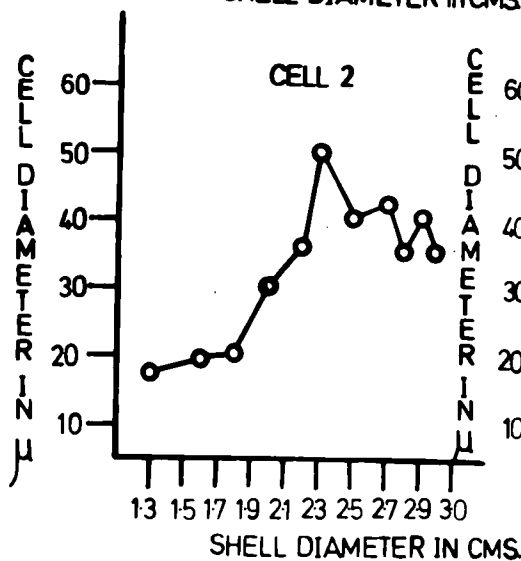
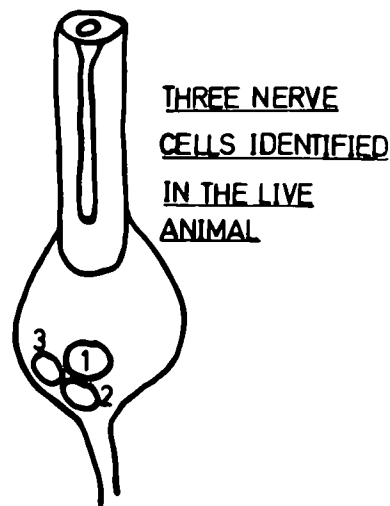
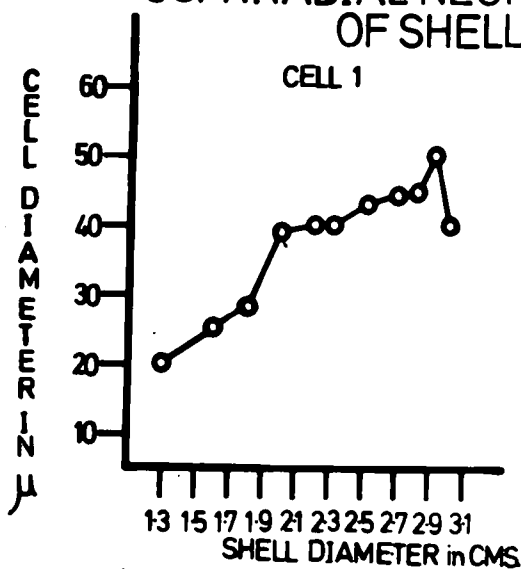
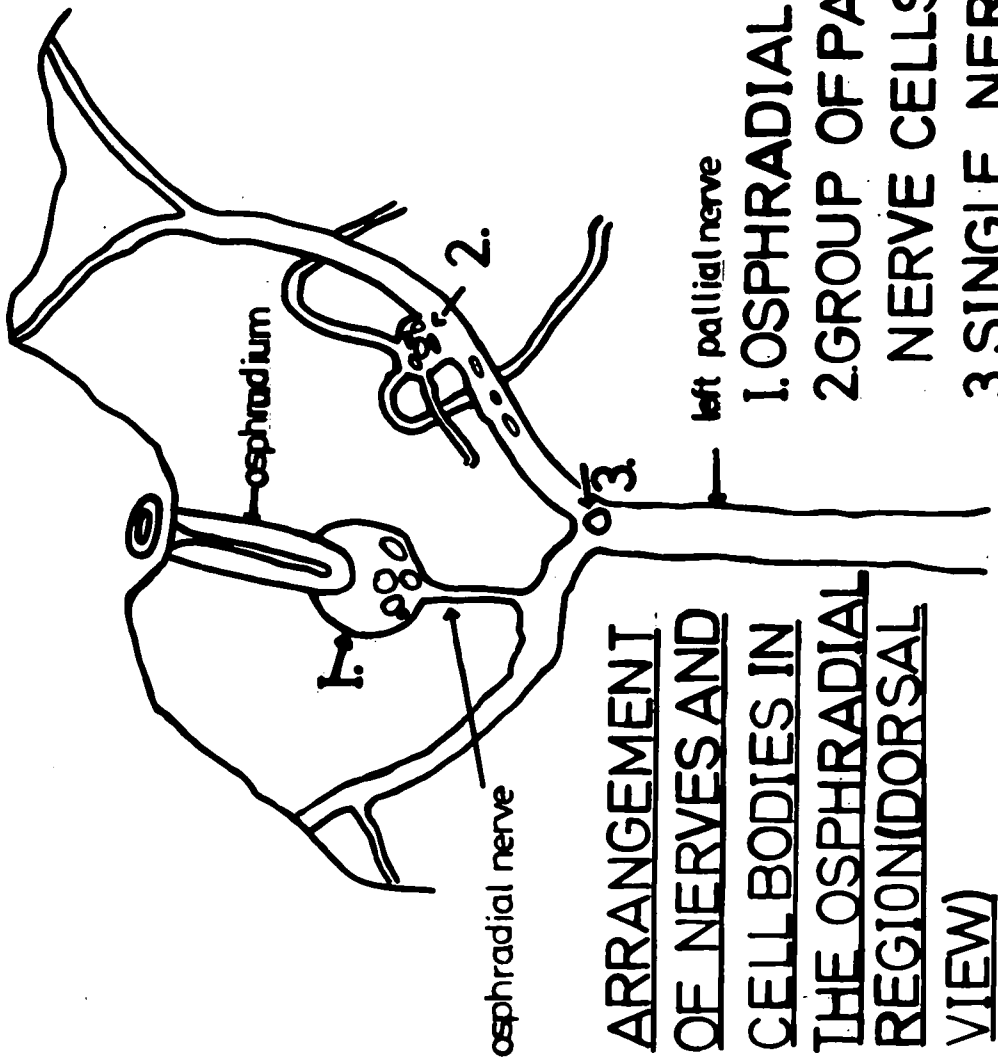

Fig. 15. This diagram shows the arrangement of the nerves in the region of the mantle close to the base of the pneumostomal folds. (SEE Fig. 1).
Cell bodies in positions 1, 2 and 3 were penetrated by microelectrodes (SECTION 2).



ARRANGEMENT OF NERVES AND CELL BODIES IN THE OSPHRADIAL REGION (DORSAL VIEW)

- 1. OSPHRADIAL GANGLION
- 2. GROUP OF PALLIAL NERVE CELLS
- 3. SINGLE NERVE CELL

The cell diameters showed a spectrum of diameter ranging from 10 μ to 50 μ . with 4 cells of 20-30 μ and 4 of 40-50 μ . In animal No. 4 the range of diameter is similar, with maximum size being recorded at 60 μ . The most common diameter is between 10-20 μ and, in this preparation, all the cells except two are multipolar, the other cells being monopolar. All the axons from these cells pass into the nerve itself; none has been observed to pass outside the nerve into the body wall.

Other cells are not arranged in a ganglion-like manner but occur as isolated cells (fig. 16), or are arranged in a series along the inside of the nerve (fig. 17). The cell shown in figure 16 is typical of the isolated cell type found in various parts of the left pallial nerve. The cells in figure 17 are arranged in series along the nerve and in this case five monopolar cells are present. In figure 19 the cells observed in two series of serial sections of the left pallial nerve have been listed and in animal No. 1 the cells are all of the monopolar type varying in diameter from 25-35 μ . The cells of animal No. 2 are also monopolar but their range of size is larger varying from 20-55 μ .

Fig. 16. An isolated monopolar nerve cell from the left pallial nerve of Planorbarius. The cell possesses two terminals.

bw, body wall

mb, monopolar, biterminal cell

p, small branch of pallial nerve distal to position 2 of figure 15

Stained with Heidenhain's Iron Haematoxylin and Orange G.

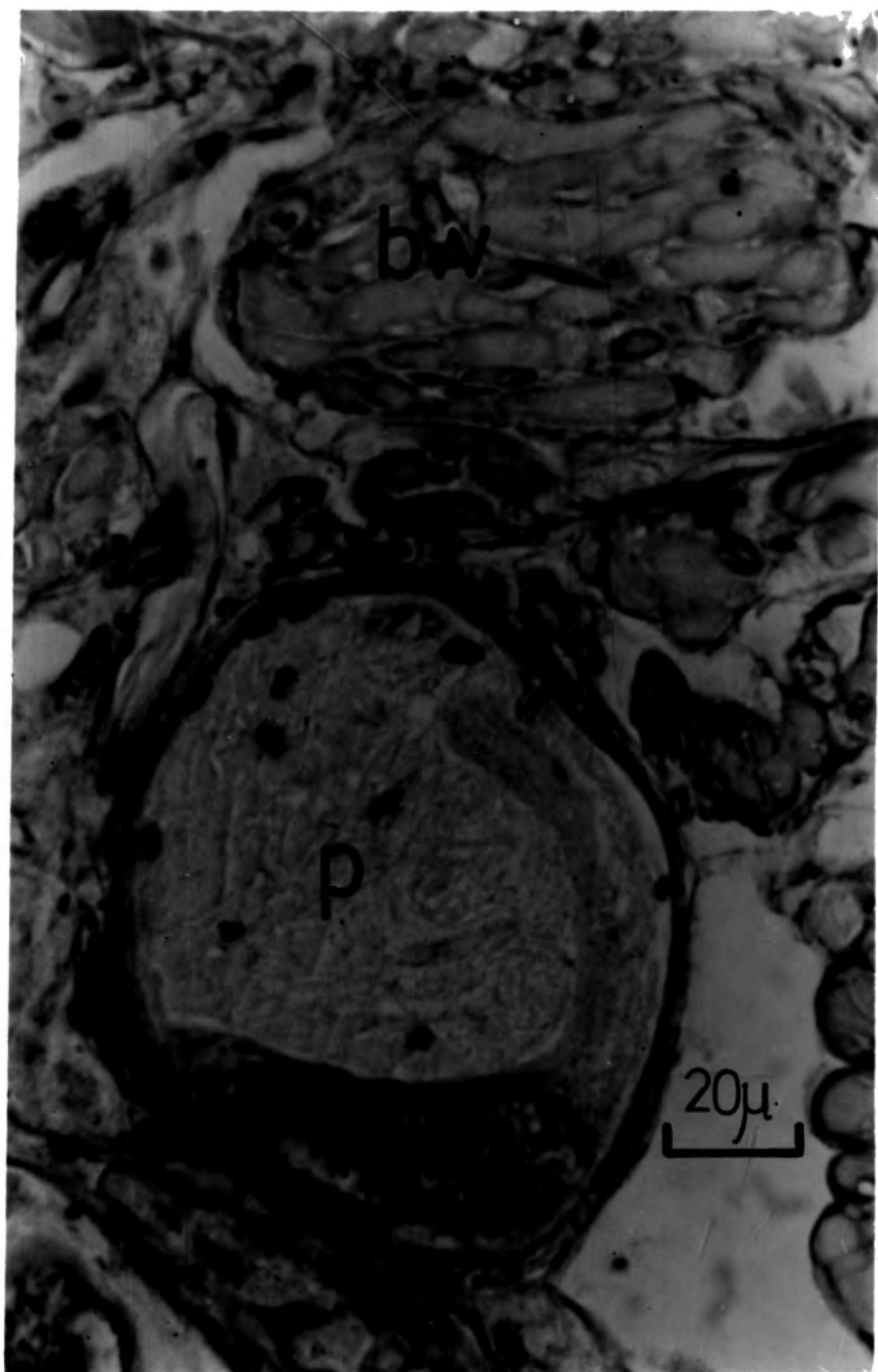

Fig. 17. Monopolar neurones from the left pallial nerve of Planorbarius. The 5 cells are arranged in series along the inside of the nerve. Their single axons do not pass outside the main nerve trunk.

ax, axon

bw, body wall

m, monopolar neurone

nu, nucleus of nerve cell body

p, left pallial nerve

Stained with Heidenhain's Iron Haematoxylin.

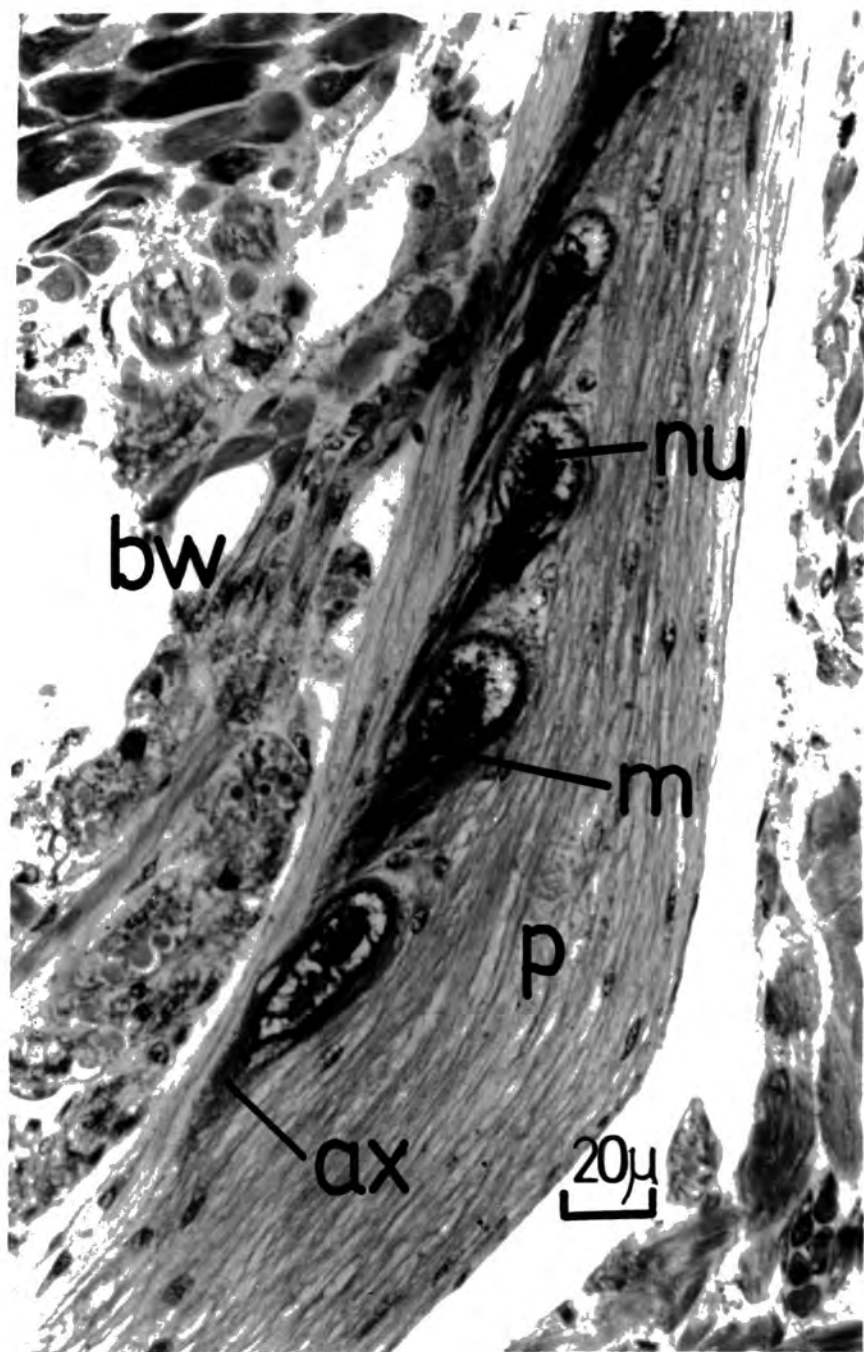

Fig. 18. Multipolar neurone cell bodies from the left pallial nerve of Planorbarius. These cells are three of the clumped neurones represented in figure 15 at position 2.

bw, body wall

con, connective tissue sheath nucleus

mu, multipolar neurone

nu, nucleus.

p, branch of left pallial nerve

Stained with Heidenhain's Iron Haematoxylin.



c. Central nervous organisation.

The following description is mainly concerned with the left pallial ganglion of Planorbarius, but the basic organisation of cells is similar for the other ganglia of the brain.

The left pallial ganglion is approximately spheroidal in shape, and it has passing into it the connectives from the left pleural and visceral ganglia plus two nerves - the left pallial nerve and the left anterior pallial nerve (fig. 2). It has one lobe which is situated on the left side of the ganglion (fig. 21). The neurone cell bodies are arranged around the periphery of the ganglion in the characteristic molluscan pattern (fig. 20). From the cell bodies the axons pass into the central neuropile. The nucleus fills a large part of the nerve cell body and is often irregular in shape (fig. 21); a central nucleolus can be observed in many cells. The cells of the pallial ganglion are predominantly monopolar, sometimes the axon possesses more than one terminal close to the soma; occasionally a multipolar or bipolar cell has been observed (fig. 22). The cell size analysis shows that the most common diameter is in the 10-20 μ range, with just below half this number in the 0-10 and 20-30 μ ranges. Few cells are above 50 μ in diameter, although one cell larger than 100 μ was recorded. This histogram of the distribution

Fig. 19. Analysis of isolated and clumped neurones from the left pallial nerve of Planorbarius. The isolated cells occur at various points along the nerve but the clumped cells are specifically those of position 2, figure 15 in both animals.

ANALYSIS OF NERVE CELLS IN PLANORBARIUS

ANIMAL

1	TYPE	DIAMETER IN μ
	M	25
	M	33
	M	25
	M	20
	M	35
	M	25

SINGLE CELLS
FROM THE LEFT
PALLIAL NERVE
(POSITION 3)

ANIMAL

2	M	50
	M	20
	M	55
	M	40

LEGEND

M = MONOPOLAR
BI = BIPOLAR
MU = MULTIPOLAR

GROUPED CELLS IN THE LEFT PALLIAL GANGLION (POSITION 2)

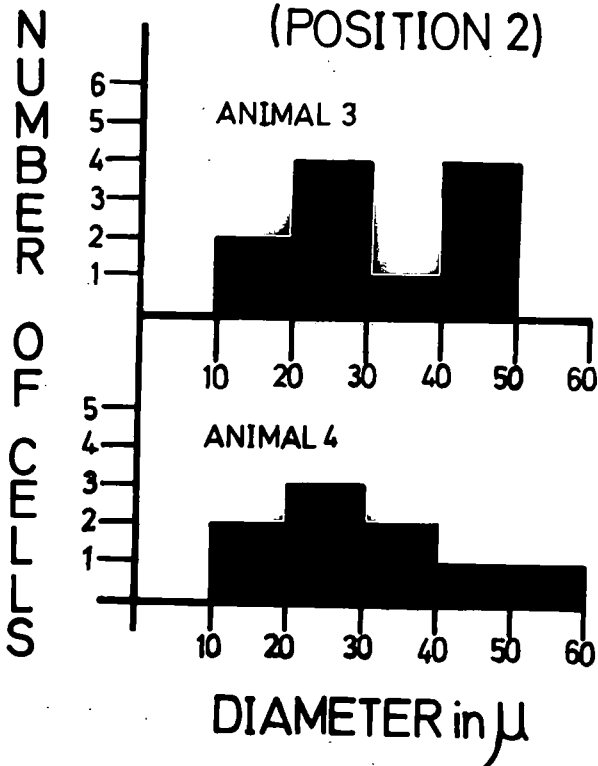

M	0
BI	0
MU	11

M	3
BI	0
MU	8

Fig. 20. Section through the left pallial ganglion of Planorbarius, showing the organisation of cell bodies in the rind of the ganglion.

ax, axon

co, connective tissue sheath

m, monopolar neurone

n, neuropile

Section stained with Heidenhain's Iron Haematoxylin.

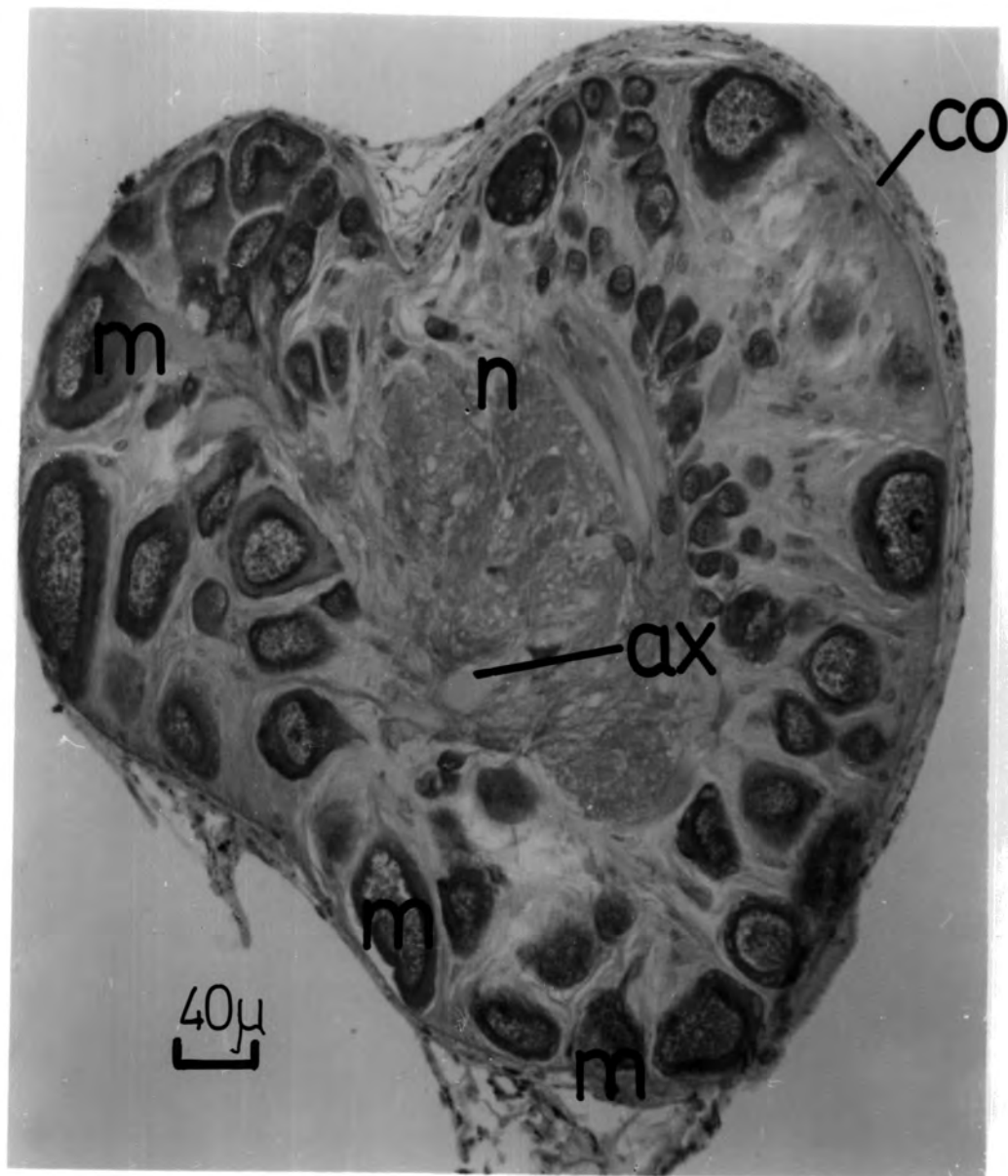

of cell diameter in the pallial ganglion closely resembles the corresponding analysis obtained in the osphradial ganglion (cf. figs. 12, 13).

d. Osphradium - electron microscope studies.

Nerve cell bodies.

These cells are arranged in the rind of the osphradial ganglion of Planorbarius and have processes which enter either the neuropile or the epithelium of the osphradial canal. A typical soma (fig. 24) is oval shaped, largely filled by its nucleus. The nucleus is folded and contains a large nucleolus (fig. 24). The usual organelles, such as mitochondria, are apparent in the cytoplasm of the neurone cell body and in the axon region close to the soma. Most nerve cells in the rind of the osphradial ganglion have a single axon which enters the neuropile of the ganglion (fig. 24), but about a fifth of the cells are so-called "canal" neurones (fig. 25) which have axons passing to the osphradial canal. The neurone in figure 25 possesses numerous lipid bodies (Chou, 1957) of varying structure. Often associated with larger neurones are smaller "satellite" neurones (fig. 25). This type of cell was described by Nisbet (1961) in Archachatina. The plasma membranes of the cells are in close proximity to one another.

Fig. 21. Higher power section of a lobe of the left pallial ganglion showing the organisation of neurones. The nucleus fills a large part of the nerve cell body and is often irregular in shape. Connective tissue strands invade the ganglion at several points.

ax, axon

co, connective tissue capsule

cs, connective tissue strand

m, monopolar neurone

n, neuropile

nu, nucleus of nerve cell body

Section stained with Heidenhain's Iron Haematoxylin.

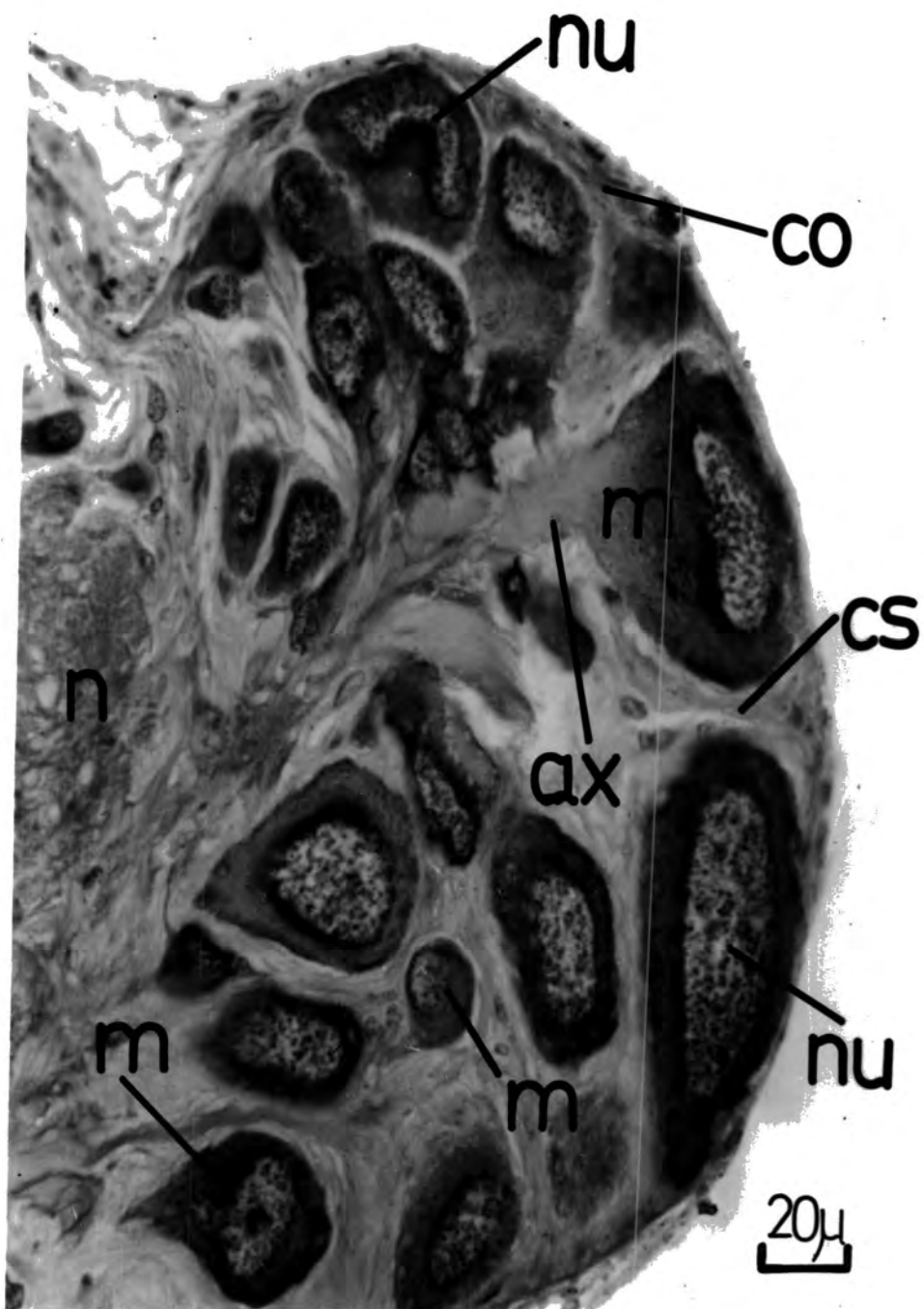
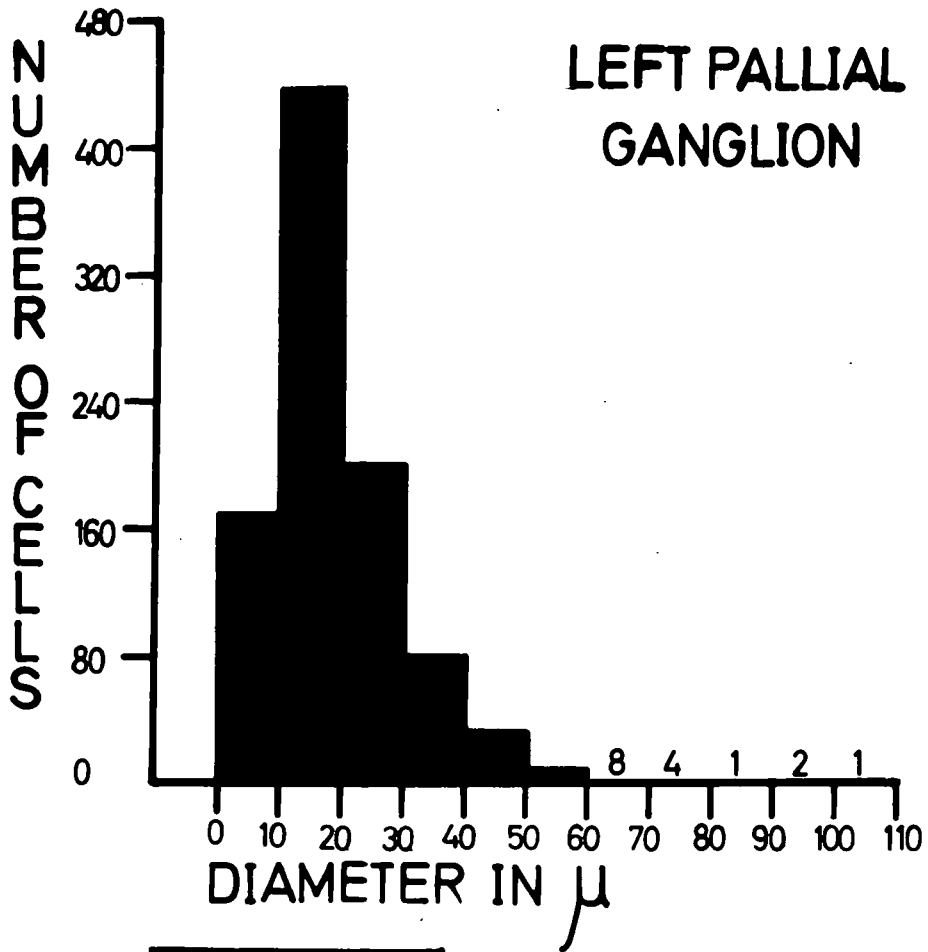

Fig. 22. Analysis of neurones from the left pallial ganglion of Planorbarius. The cells are divided on the basis of largest cell diameter and number of axons.

ANALYSIS OF NEURONES IN PLANORBARIUS.



MONOPOLAR	889
BIPOLAR	8
MULTIPOLAR	15
UNCLASSIFIED	44

ANALYSIS OF
CELL TYPES

TOTAL NEURONES = 956

At higher power the cytoplasm of the soma of the osphradial neurones is similar in appearance to that of central nervous neurones described by other workers (Rosenbluth, 1963; Amoroso et al., 1964; Zs-Nagy, 1965). The cytoplasm is filled with elongate vesicles surrounded by endoplasmic reticulum of the smooth type (fig. 26). Other types of vesicle are obvious, and particularly prominent are those up to 0.25μ in diameter which often contain a dense granular centre. Sometimes their outer membrane is broken. Other vesicles are associated with the Golgi apparatus (fig. 28). This organelle has been apparent in all neurones examined. Dense centred granules of about 0.1μ in diameter, often observed to be secreted from the Golgi membranes of other molluscs, are a common feature of the osphradial neurones. Mitochondria are very numerous and are usually of elongate form with cristae emerging from their lateral walls (fig. 27). They may reach large size and organelles of up to 6μ in length are frequently observed. As in the case of central neurones of molluscs (eg. Rosenbluth, 1963), the soma of peripheral nerve cells do not appear to have dendritic processes. Intersomal synapses have not been observed, either of the "electrotonic" or conventional types.

Fig. 23. Diagram of a longitudinal section of the whole osphradium of Planorbarius as revealed by light microscope techniques.

b, bipolar neurone

c, connective tissue capsule

cc, ciliated region of the canal epithelium

m, monopolar neurones

n, neuropile

sc, sensory region of the canal epithelium

sec, secretory region of the canal epithelium

DIAGRAM OF THE OSPHRADIUM
OF
PLANORBARIUS.
(LONGITUDINAL
SECTION)

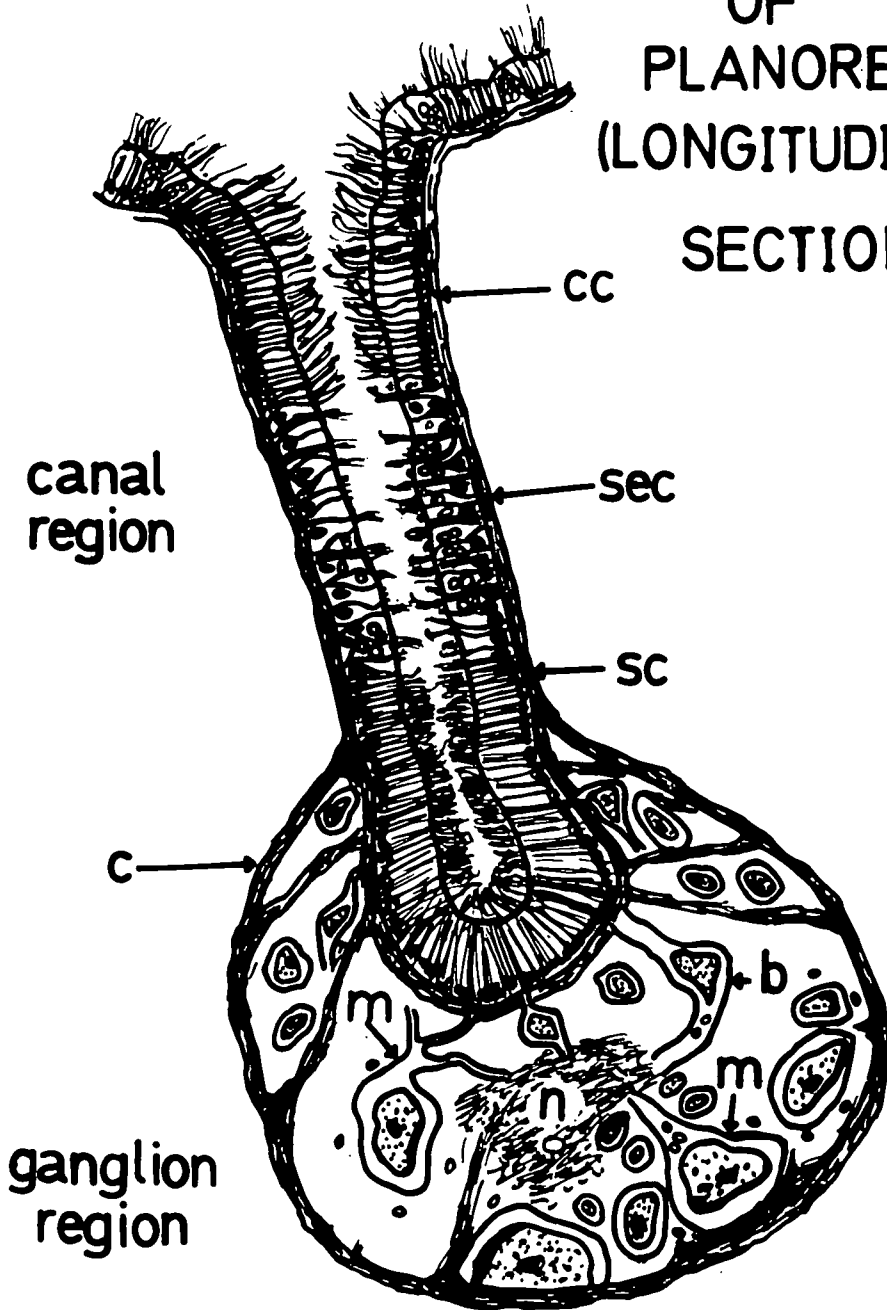

Fig. 24. Low power electron micrograph of a small neurone
from the rind of the osphradial ganglion of Planorbarius.

ax, axon

gl, glial cell

lb, lipid body

mi, mitochondrion

nu, nucleus

nuc, nucleolus

s, neurone soma

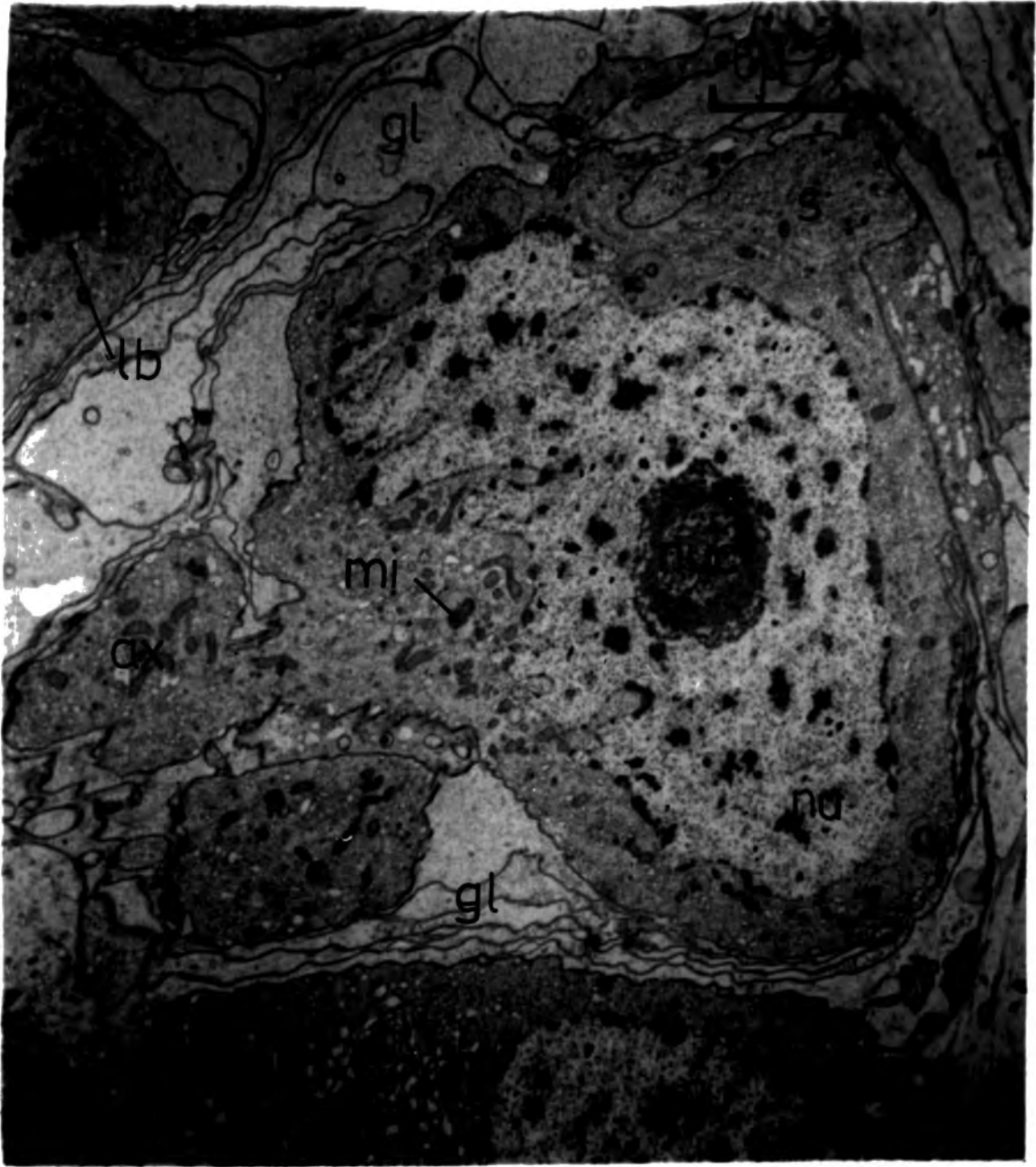

Glial cells.

In the rind of the osphradial ganglion the nerve cell bodies are surrounded by the glial cells (figs. 24, 25). The clear cytoplasm of these cells allows them to be readily observed, contrasted against the electron dense cytoplasm of the neurone cell bodies. Processes of glial cells can also be observed among the axons of the ganglion neuropile (fig. 31). The arrangement of the glial processes is such that the neurone soma or axon may be surrounded by several layers of glial cell formed by the elongate strands of this tissue (fig. 24). The glial cells are of one type only which seems to be the usual situation in the molluscan ganglia so far examined (eg. Rosenbluth, 1963; Amoroso *et al.*, 1964) unlike some ~~insect~~ ^{crustacean} ganglia where several types may be recognised (Hámori and Horridge, 1966).

At various points in the glial cells, complexes of intracellular organelles are observed. Each complex consists of an irregularly shaped nucleus, a single gliosome, a number of mitochondria, vesicles and membrane fragments (figs. 30, 31). Particularly prominent are the so-called "curled" membrane fragments (fig. 29). They have the appearance of a vesicle which has broken open. This variety may be up to 4 μ in diameter but all sizes down to 0.2 μ occur. Filamentous material is often seen in glial cells (fig. 29), both in the region of the nucleus and in the glial strands, some distance away.

Fig. 25. Montage of neurone cell body from the osphradial ganglion of Planorbarius. Its position suggests that it is a "sensory" neurone with processes which penetrate the osphradial canal epithelium.

ax, axon

co, connective tissue matrix

gl, glia.

lb, lipid body

mi, mitochondrion

nu, nucleus of nerve cell body

sc, "satellite" neurone

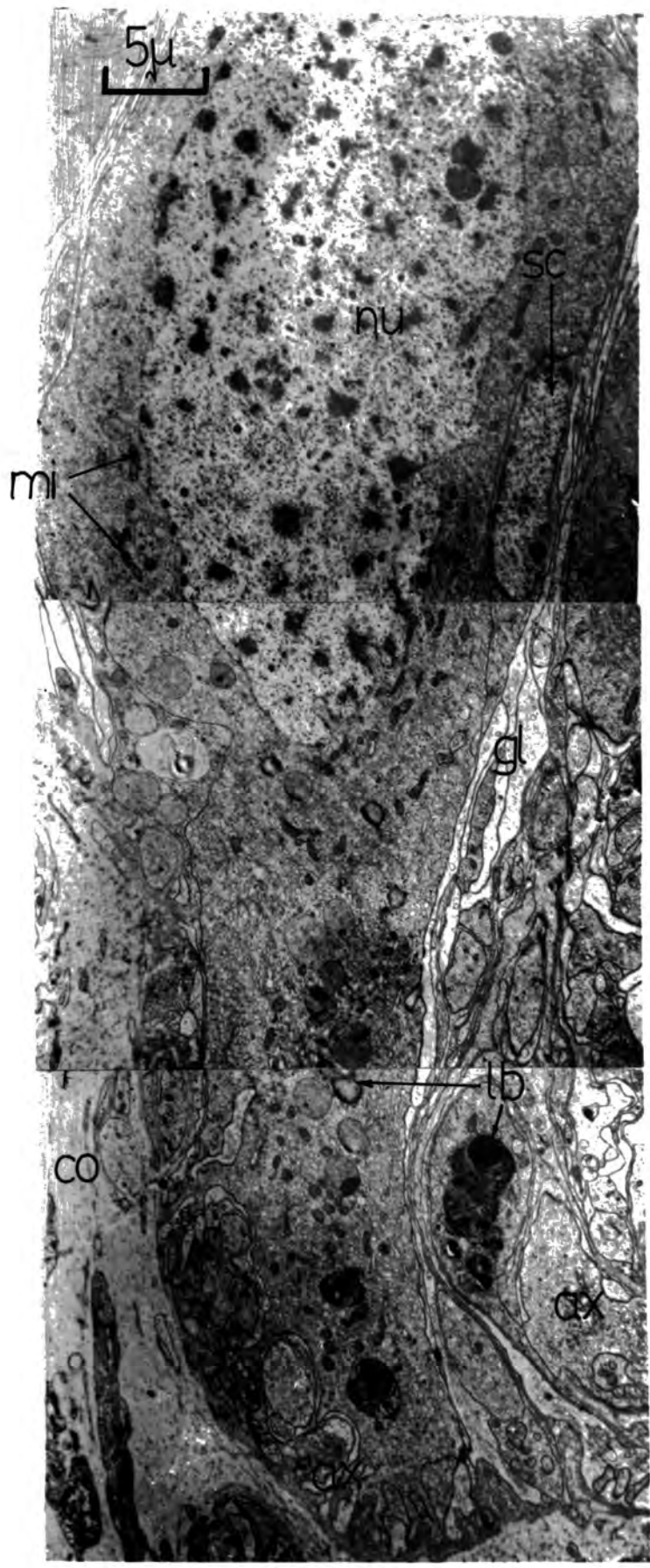

Fig. 26. Electron micrograph showing the contents of the cytoplasm in a neurone from the osphradial ganglion of Planorbarius. Glial invasions of the cell are apparent.

g, Golgi apparatus

nu, nucleus of the neurone

nm, nuclear membrane

nt, neurotubule

mi, mitochondrion

pm, plasma membrane of the neurone

ser, smooth endoplasmic reticulum

si, glial invasion of the neurone soma

v, vesicle

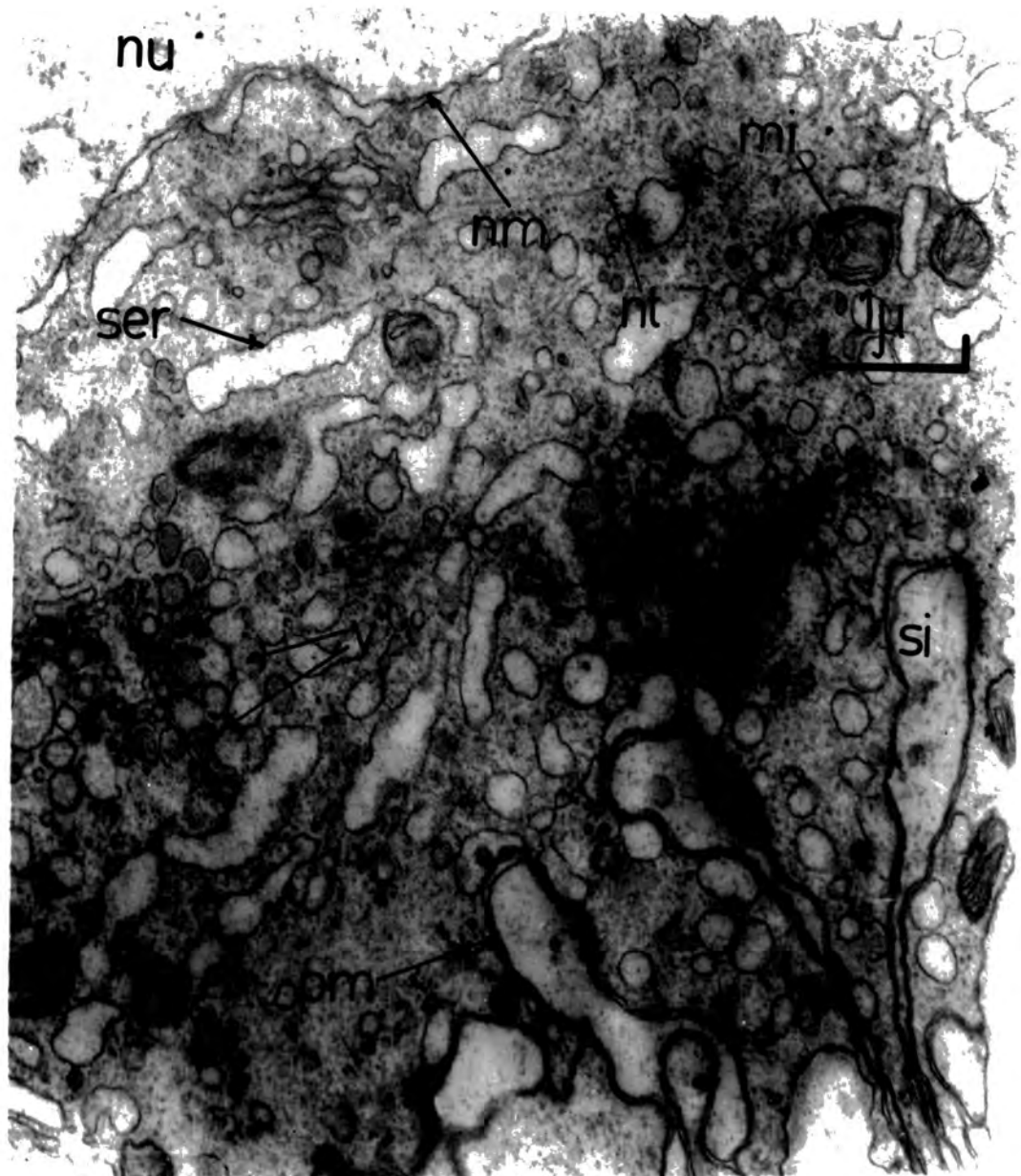

Glial invasions of nerve axons were first described in the electron microscope by Schlote (1957) in the intestinal nerve of Helix. He showed that they are a common feature of molluscan peripheral nerves. Since then they have been described in a number of molluscan species (Batham, 1961; Amoroso et al., 1964). Bullock (1961) suggests that they increase the effective internal surface area of the axon.

The neuropile.

In the neuropile it is possible to recognise several different types of axon based upon their diameter and contents, although some of these contents are common to all fibres. The appearance of the axons from the fibres close to the soma is similar to that of the nerve cell body itself (fig. 24). Portions of this type of fibre can readily be observed in many parts of the neuropile (fig. 31). Most of the nerve axons are not of this type. The largest type of nerve fibre (fig. 31) is up to 12 μ in diameter and can be as small as 6 μ . They are only few in number. The fibre shown in the top right hand corner of figure 31 is about 12 μ in diameter and may be considered to be in the "giant" category. Very few fibres have been observed in molluscs of this size (Bullock and Horridge, 1965). These axons in the osphradium are characterised by their sparcity of

Fig. 27. High power electron micrograph of a neurone from the osphradial ganglion of Planorbarius showing the folded nature of the nucleus caused by "invasions" of the cell cytoplasm.

mi, mitochondrion

ni, invasion of the nucleus by somal cytoplasm

nm, nuclear membrane

nu, nucleus

rer, rough endoplasmic reticulum

s, soma

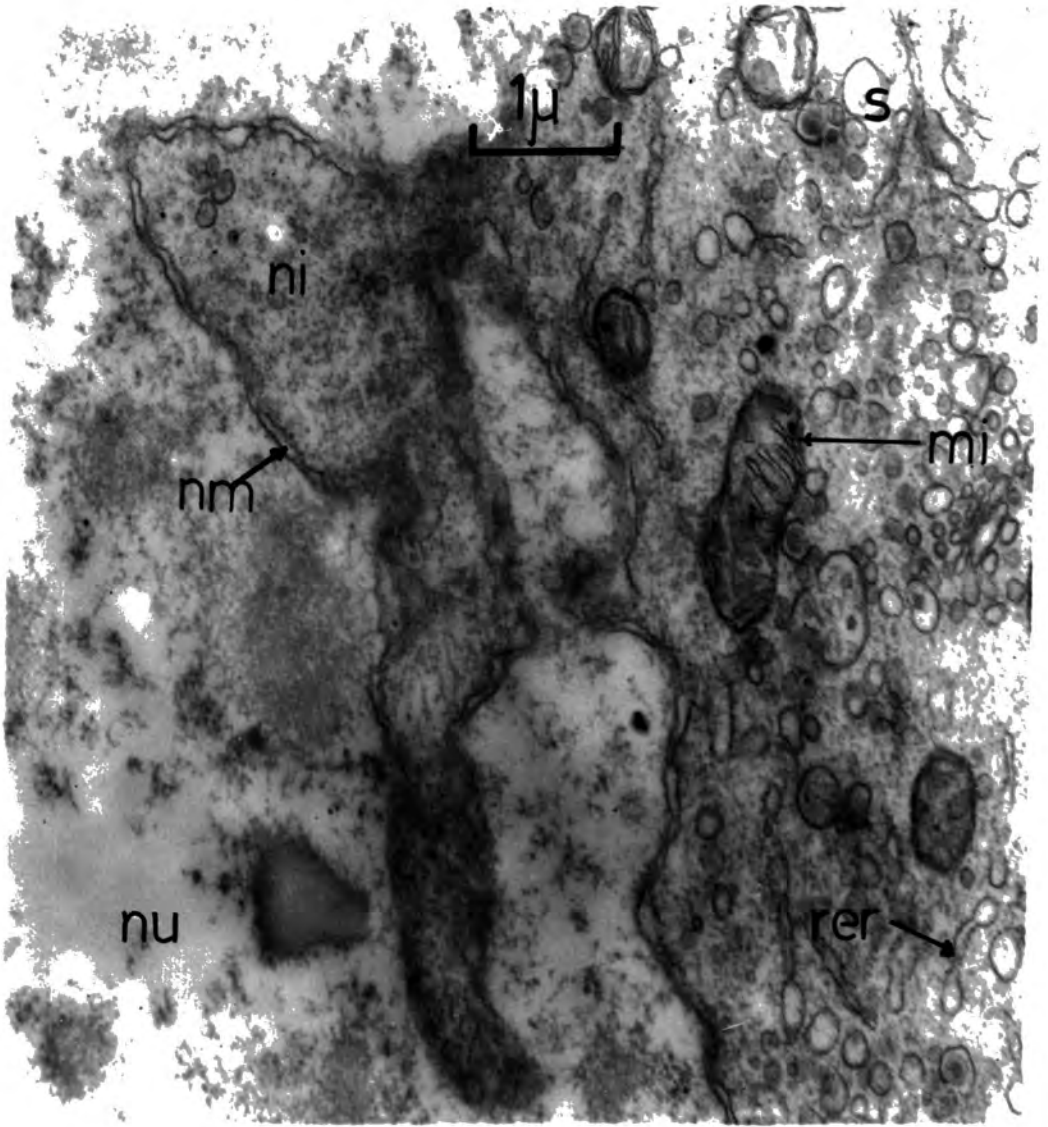

Fig. 28. High power electron micrograph of the Golgi apparatus of an osphradial neurone from Planorbarius.

gl, glial cell

gm, Golgi membranes

gv, Golgi vesicles

mi, mitochondrion

pm, plasma membrane

s, soma

ser, smooth endoplasmic reticulum

v, vesicles

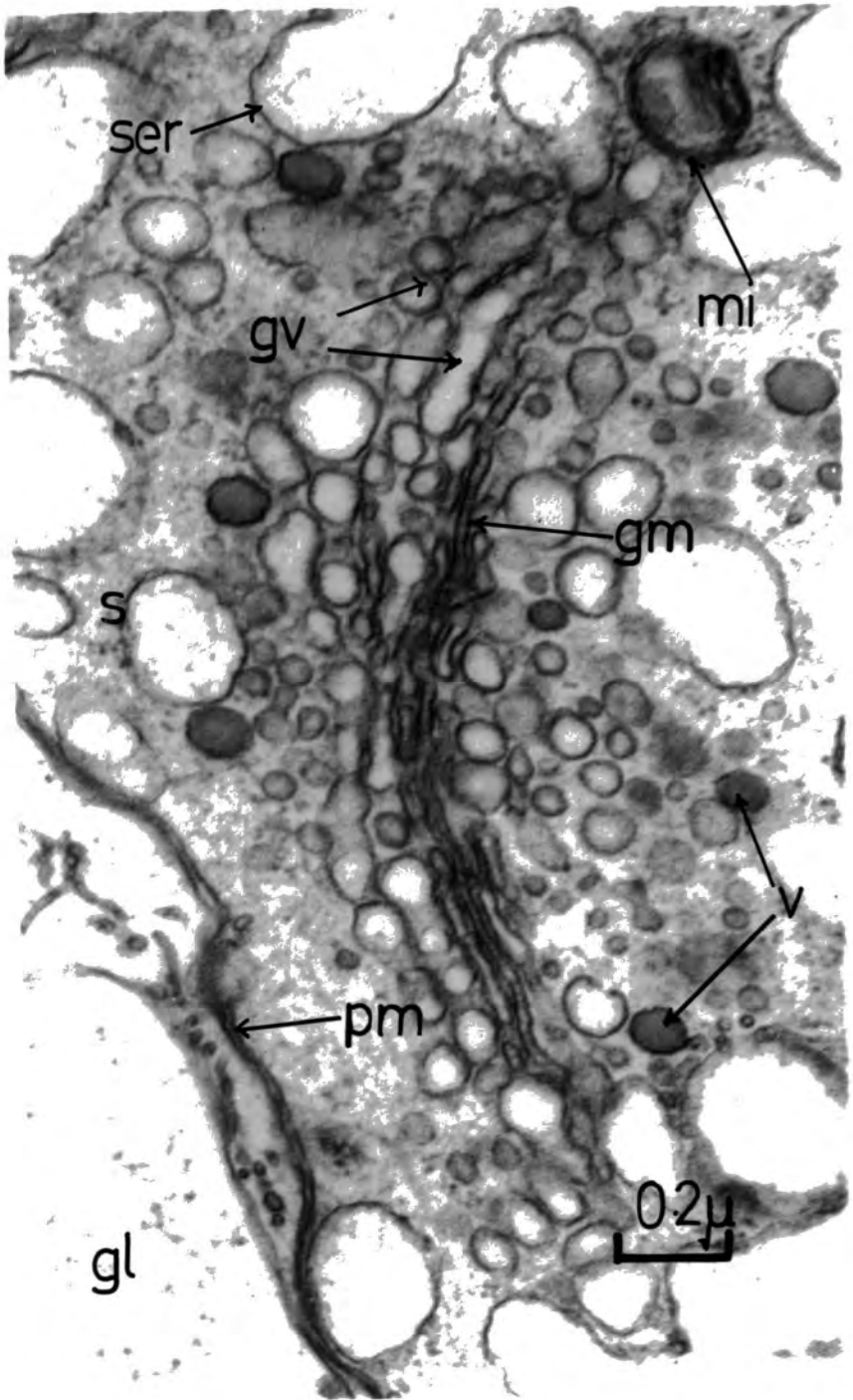

organelles, and by the fingers of glia which invade them. The general cytoplasm of the fibre is uniformly fine-grained and contains only granules of structureless nature.

More common than the last type of fibre are the medium sized fibres (fig. 32). These are of maximum diameter in the region of 7μ and may be as small as 2μ . The general cytoplasm is less electron dense than the large fibres (fig. 32). Areas of electron dense granules are interspersed with electron-transparent patches. Mitochondria, when present, are of very small size, less than 0.2μ in length. Membrane fragments of variable structure are the most common feature, these seldom reach 0.5μ in diameter. Occasionally a dense centred elementary granule is observed (fig. 32). On one occasion, in a region where medium sized axons were common, a fibre containing large numbers of mitochondria and clear vesicles has been observed (fig. 33). This may represent a synaptic region, but the size of the vesicles (up to 0.2μ in diameter) and the fact that many are of the dense centred granular variety, suggests that this is not the case. Generally interaxonal synapses are most common in smaller fibres which have a different cytoplasmic appearance.

These small fibres range in diameter from about 3μ down to less than 1μ . In this type of axon small clear vesicles and large numbers of granules of the dense centred type are apparent (figs. 34, 35).

Fig. 29. Electron micrograph of a glial cell from the osphradial ganglion of Planorbarius showing organelles in the region of a glial nucleus.

cmf, "curled" membrane fragment

d, double-walled vesicles

fm, fibrous material

gp, glial cell process

mi, mitochondrion

nm, nuclear membrane.

nu, nucleus

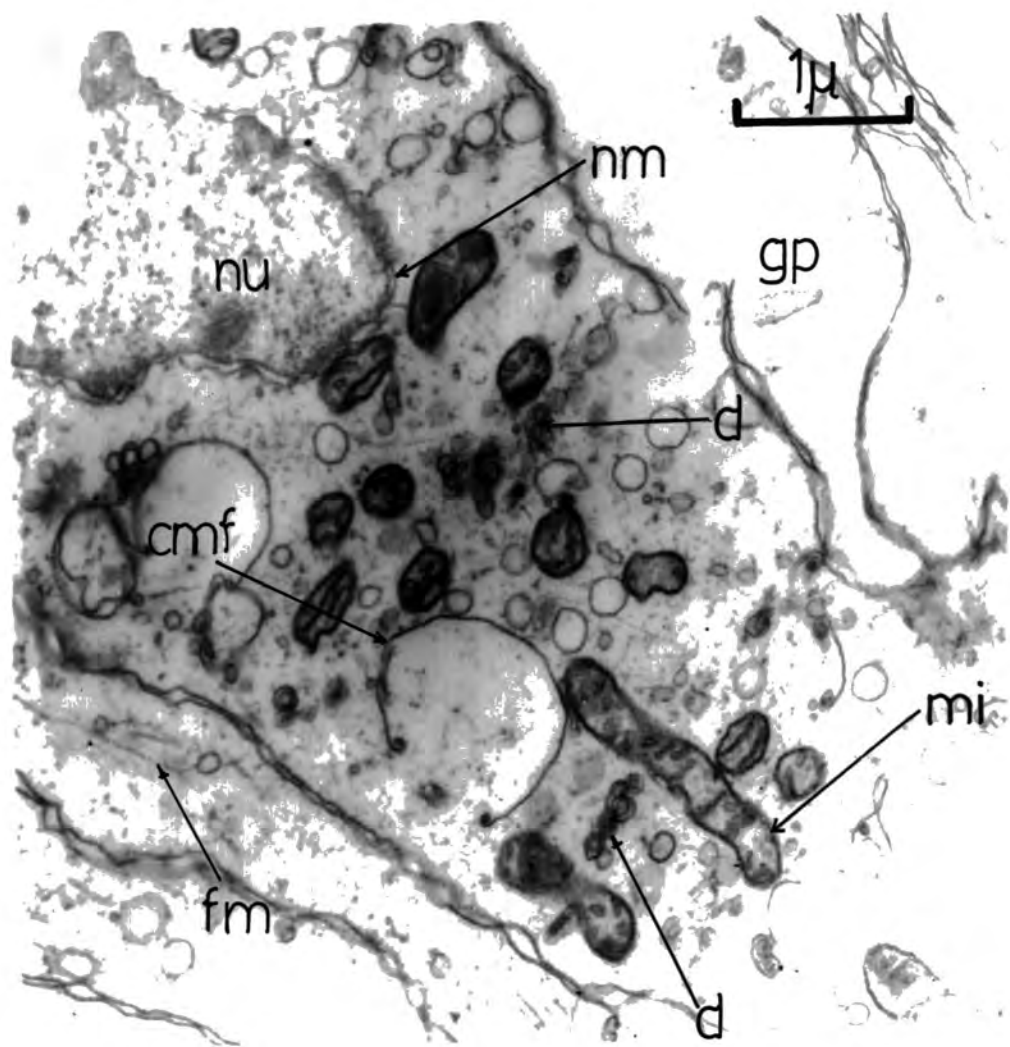

Fig. 30. Electron micrograph of a glial cell from the osphradial ganglion of Planorbarius showing a gliosome.

cmf, curled membrane fragment

d, double-walled vesicle

gl, glial cell

glio, gliosome

mi, mitochondrion

nu, nucleus

nm, nuclear membrane

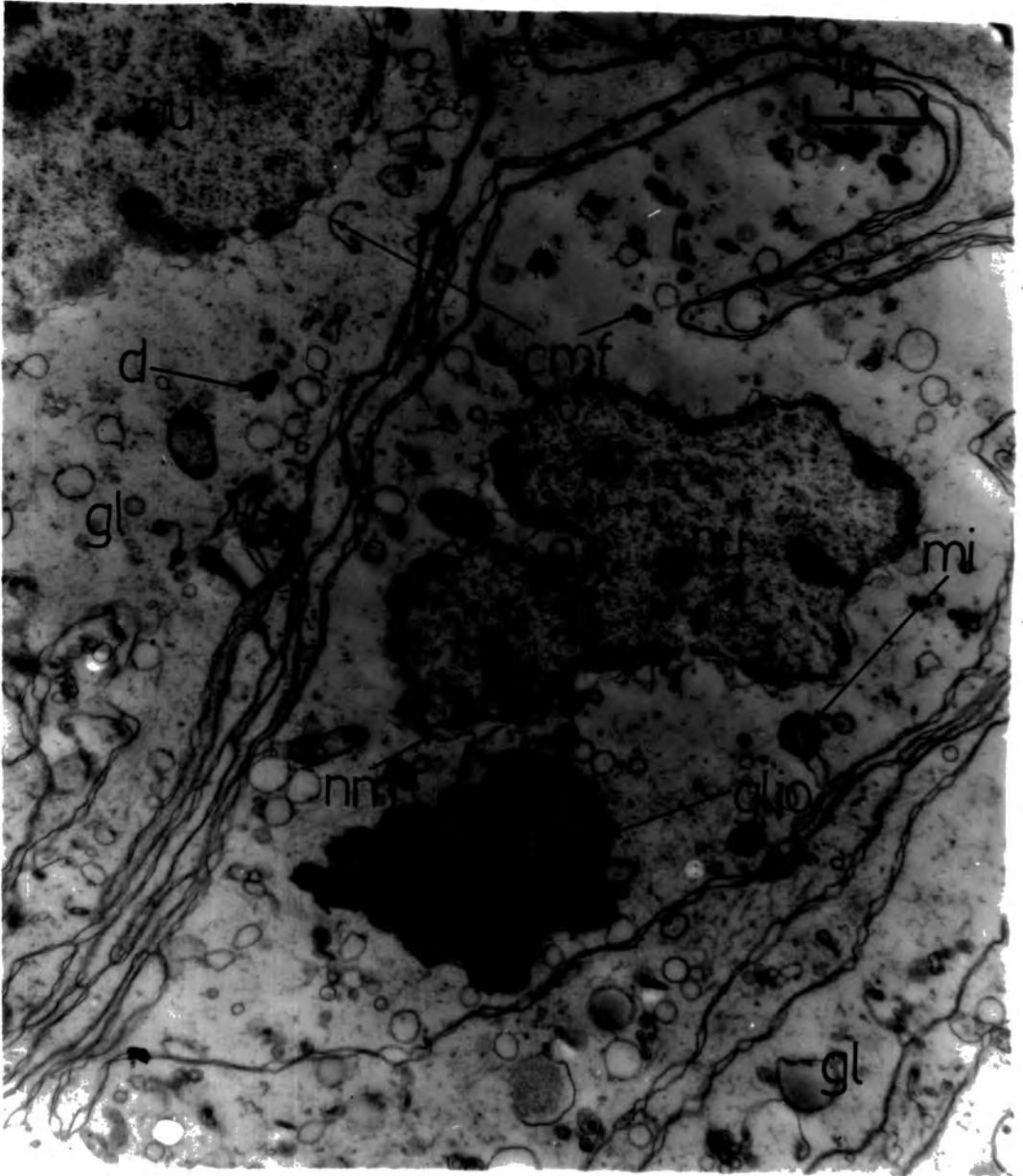

Fig. 31. Electron micrograph of the neuropile region of the oosphradial ganglion of Planorbarius showing a large neurone fibre and invasions by glial strands. A sub-fibre is delimited by a glial strand in the top part of the centre fibre.

ax, axon

gi, glial invasion

gl, glial cell

lnf, large nerve fibre

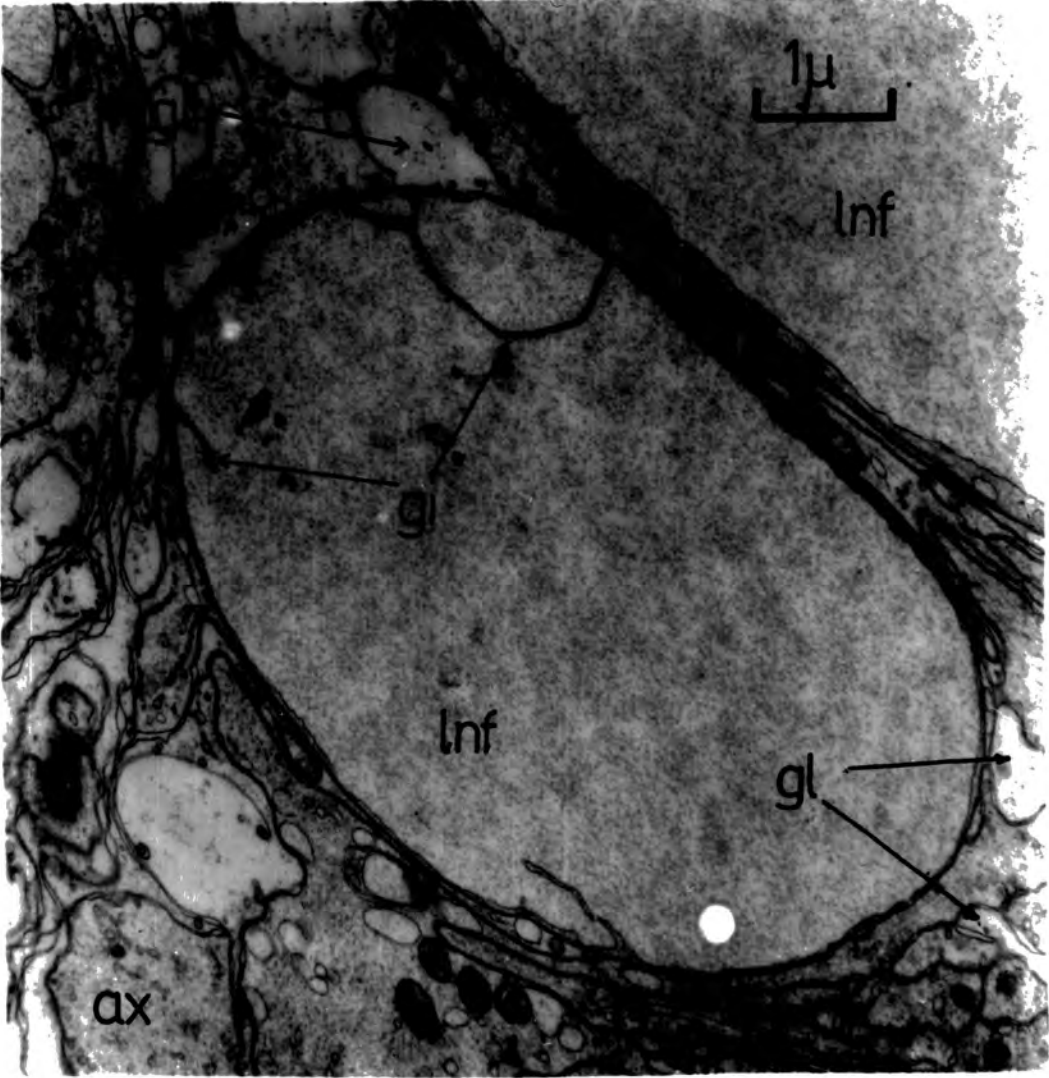

These fibres often contain neurotubules (fig. 34) which normally appear in L.S. as long strands about 0.05μ in diameter and up to several μ in length. In transverse section they appear to have a tubular form consisting of a membrane surrounding a central electron transparent region. Sometimes a thicker variety of neurotubule has been observed (fig. 34) which is often organised in a stack-like manner. Other types which are spirally orientated have been observed. Neurotubules do not seem to be present in the other types of nerve fibre described, although they occur in small numbers in the soma of the nerve cells and in the axon close to the cell body. At high magnification the dense centred granules of the small fibres are seen to be surrounded by a unit membrane (fig. 35). They vary in diameter from just less than 0.1μ to about 0.15μ . The clear vesicles are about 0.05μ in diameter and are also surrounded by a unit membrane (fig. 35). Gerschenfeld (1962) described similar structures in the synaptic regions of the visceral ganglion of Aplysia and other authors have shown their presence in small fibres from the central nervous system of other molluscs (Amoroso, et al., 1964). In some sections an accumulation of vesicles and granules is organised on either side of two adjacent axon membranes (fig. 35). These may represent interaxonal synaptic regions by analogy with known vertebrate synapses, although in the present case pre- or post-synaptic

Fig. 32. Electron micrograph of a section through the neuro-
pile region of the osphradial ganglion of Planorbarius
showing medium sized nerve fibres.

eg, dense centred granule

mf, membraned inclusion

mi, mitochondrion

nf, medium sized nerve fibres

snf, small nerve fibre

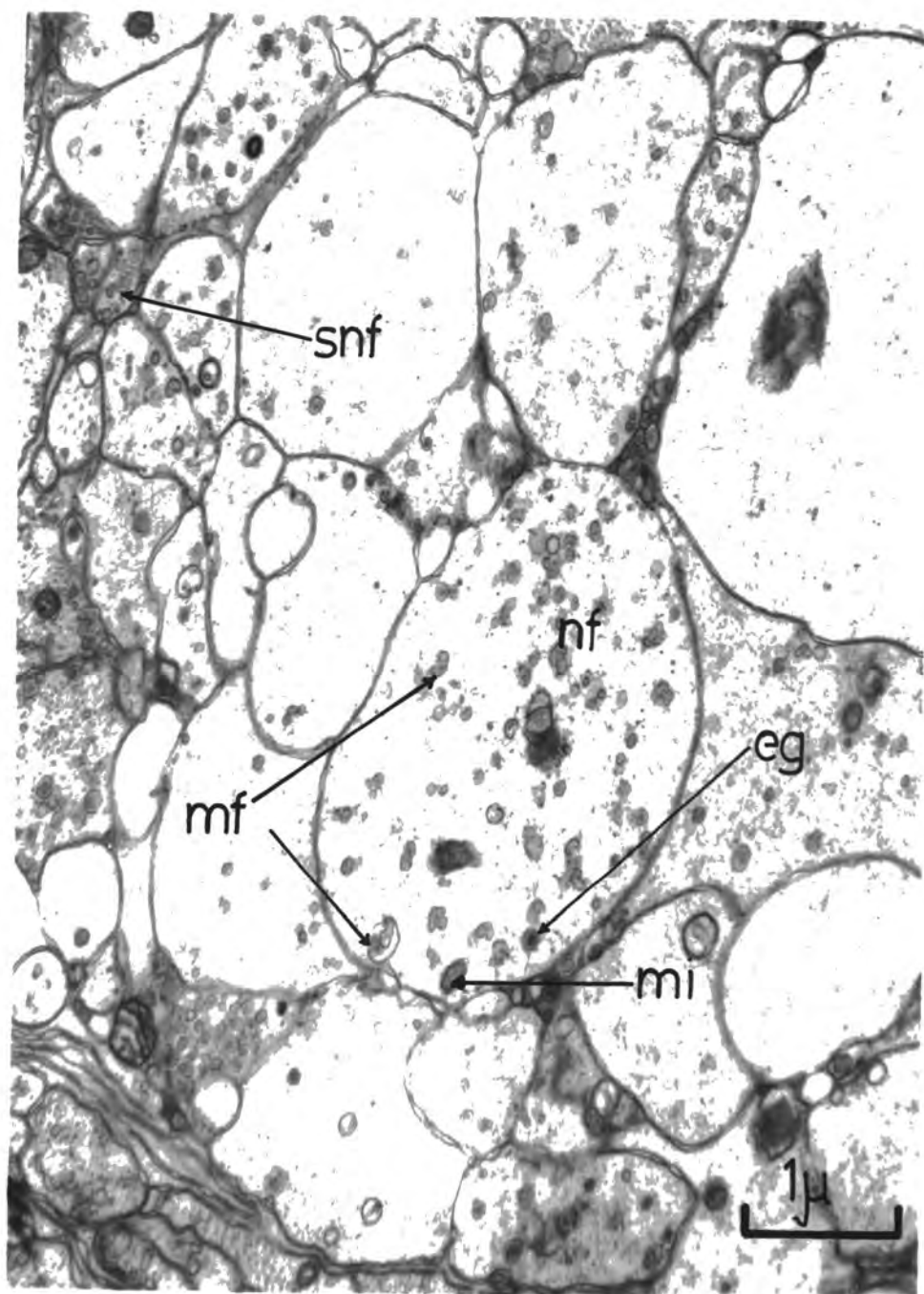

Fig. 33. Electron micrograph of the neuropile region of the osphradial ganglion of Planorbarius showing a medium sized nerve fibre filled with vesicles and mitochondria.

mf, membrane fragment

mi, mitochondrion

mv, membraned body plus vesicles

eg, dense centred granules

x, possible sub-fibre

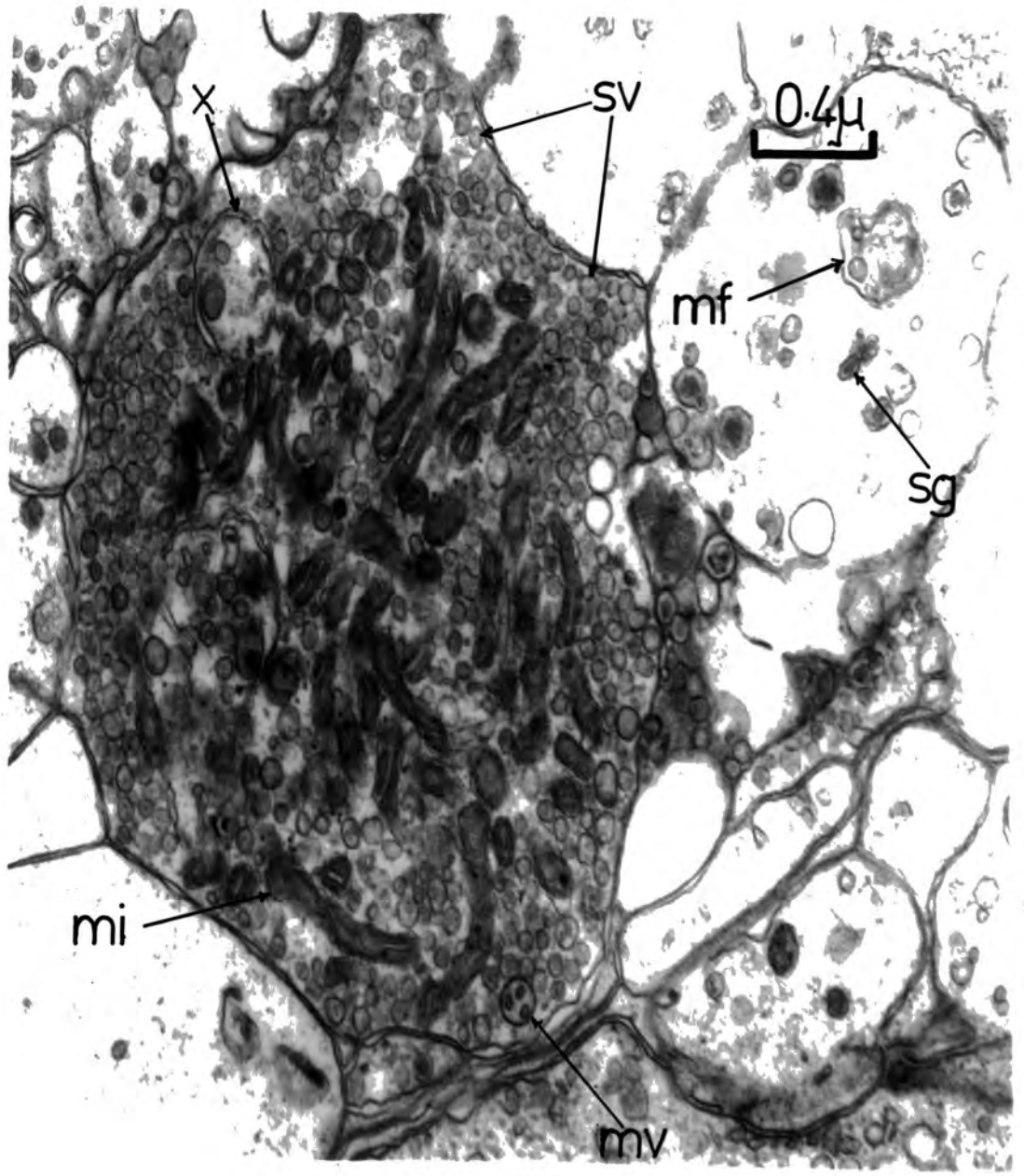

Fig. 34. High power electron micrograph of small nerve fibres in the osphradial ganglion neuropile of Planorbarius.

eg, dense centred granule, often termed "elementary neurosecretory granule".

egb, elementary neurosecretory granule with broken membrane

mi, mitochondrion

nt, neurotubule

snf, small nerve fibre

sv, small vesicles

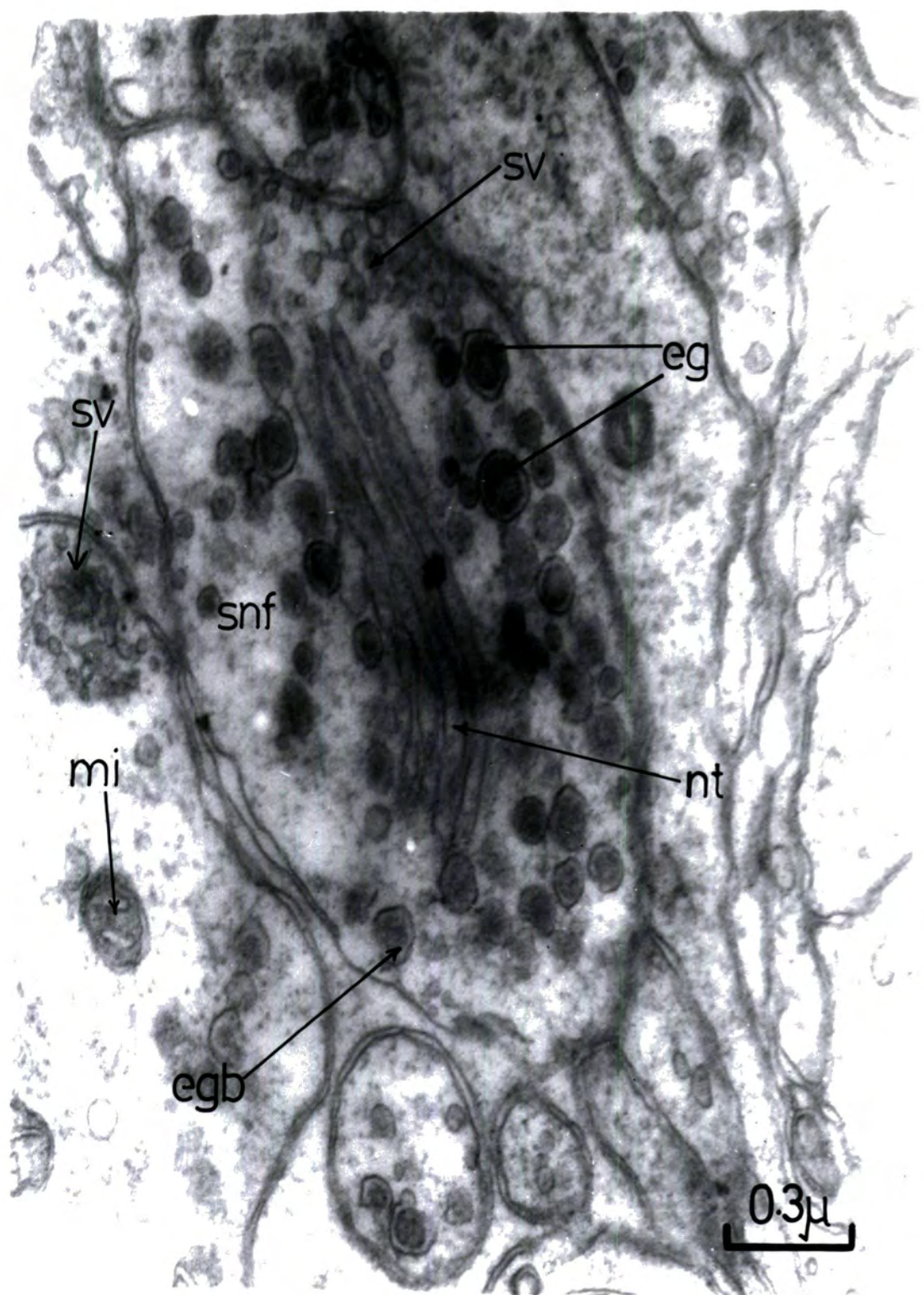

sv

eg

sv

snf

mi

nt

egb

0.3μ

regions are difficult to determine. Tauc (1960) has shown by electrophysiological techniques that the synapses in Aplysia are situated down the axons about 1 mm. from the soma and this is consistent with the position of interaxonal synapses found in several molluscan structural studies. The dense centred granules are often presumed to be transmitter substance which have been secreted by the Golgi apparatus and passed into the synaptic regions (Scharrer, 1966).

Nervous elements in the connective tissue capsule.

These are observed in the osphradium as single elements passing across the connective tissue into the canal epithelium (fig. 36) or occur as bundles of fibres forming a distinct nerve trunk (fig. 44). Individual nerve fibres often contain neurotubules, dense centred granules and vesicles. In addition to these fibres the connective tissue which surrounds the canal forward of the ganglion also contains cells which have the appearance of small neurone cell bodies (fig. 38). These cells with nerve fibres and glial tissue do not seem to have been observed by other workers (eg. Rosenbluth, 1963). This complex of tissue is contained within a capsule which has its own basement membrane, separate from the one which surrounds the base of the canal epithelium. The cells illustrated in figure 38 are situated in the connective tissue which surrounds the secretory region of the canal

Fig. 35. High power electron micrograph of the neuropile in the osphradial ganglion of Planorbarius. Between two small fibres is an interaxonal synapse.

eg, elementary neurosecretory granule

nt, neurotubule

snf, small nerve fibre

sv, synaptic vesicle

sy, synapse

u, unit membrane

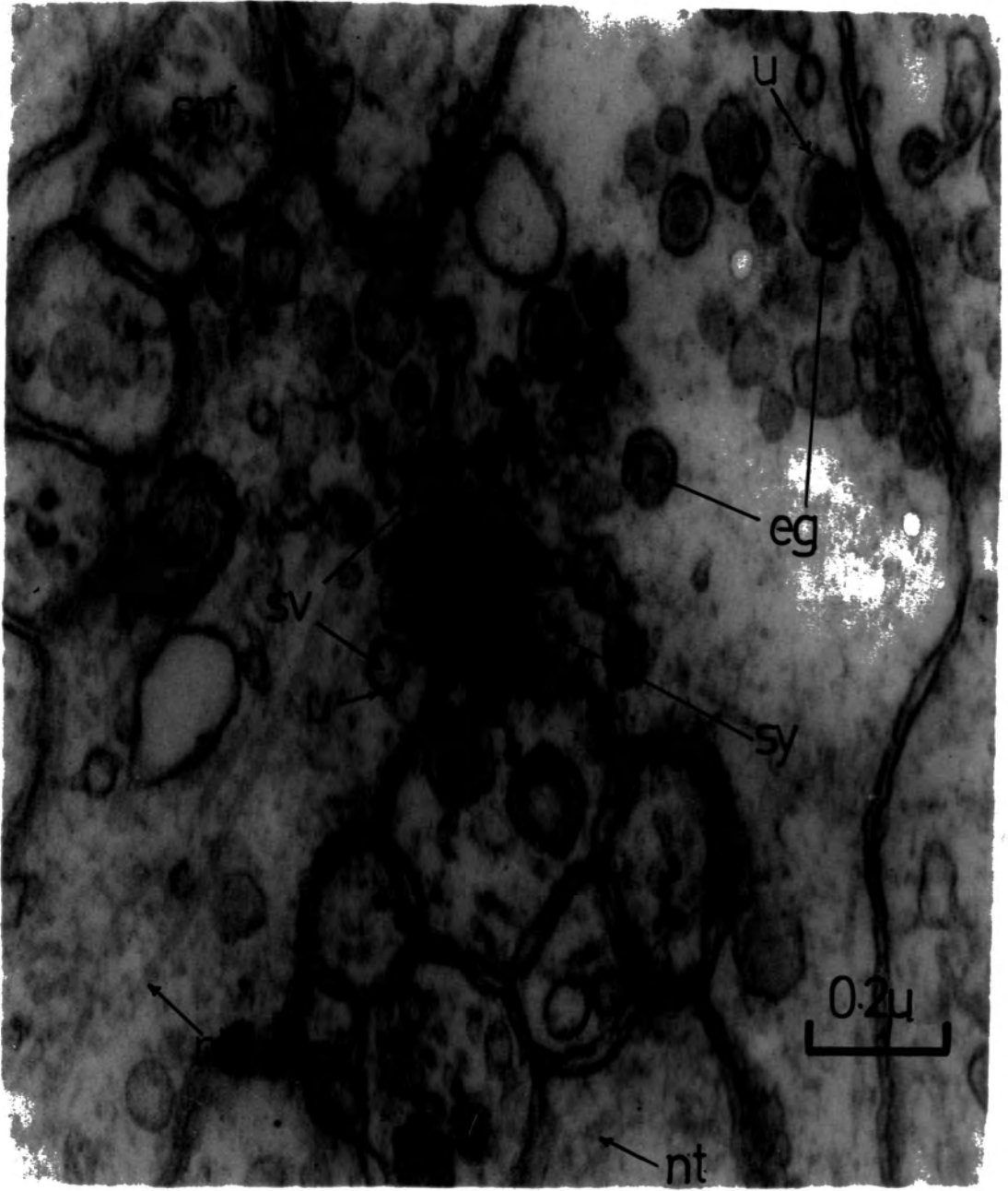

Fig. 36. Electron micrograph of a nerve fibre crossing the inner connective tissue sheath of the osphradial ganglion and penetrating the osphradial epithelium of Planorbarius. The nerve process contains numerous neurotubules which allow it to be distinguished from other epithelial components.

cc, ciliated cell

col, collagen

mi, mitochondrion

nf, nerve fibre

np, nerve process

nt, neurotubule

v, vesicles

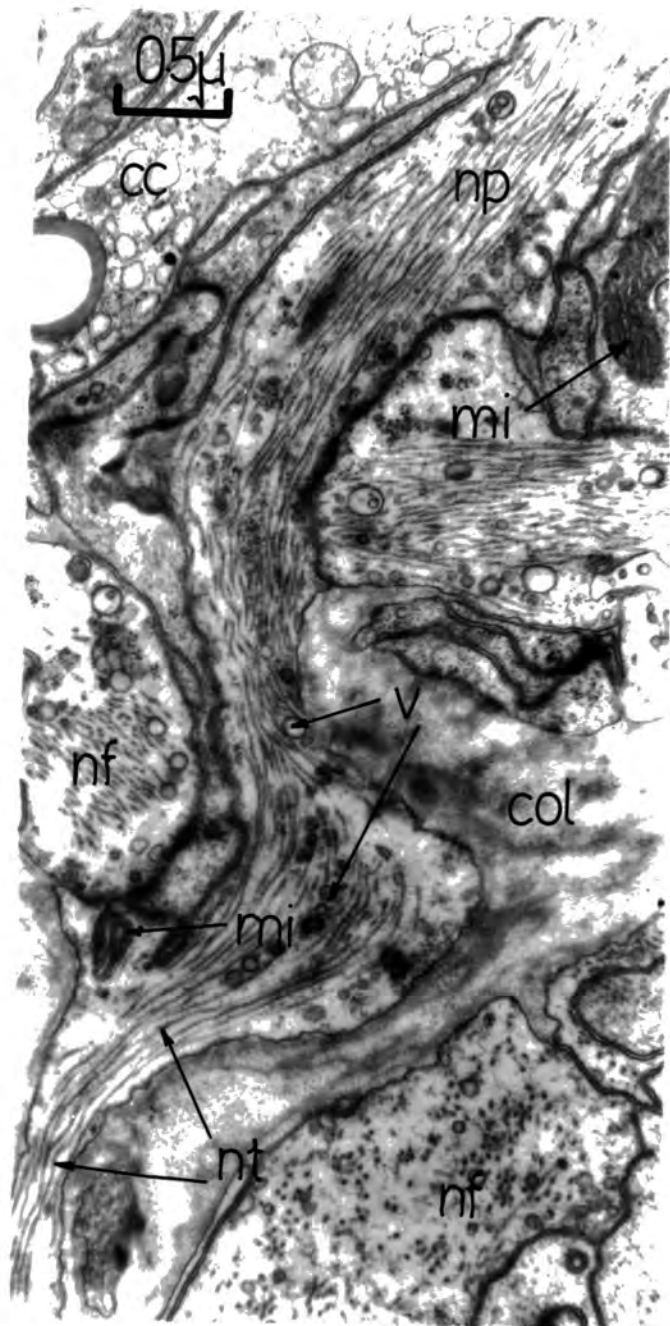

epithelium. Three cells are apparent. The central cell (s1) has a cytoplasm similar in appearance to that of the neurones of the ganglion region. It has processes which intermingle with the cell s2. Cells s2 and s3 have cytoplasm which are lighter in appearance than s1. Whether these represent a different cell type from s1 is not clear. Cell s3 is continuous with the nerve fibre ax3 and this fibre is surrounded by tissue which strikingly resembles the glial processes of the ganglion region. It is possible that the pigment which can be observed in the canal region of the osphradium is contained within these neurones.

Sensory axons.

The nerve processes which penetrate the epithelium from nerve cell bodies in the ganglion possess numerous neurotubules. This allows them to be distinguished from other constituent cells of the epithelium. They have only been observed in the canal region which corresponds to the sensory epithelium of the light microscope sections. The axons terminate at the surface of the epithelium adjacent to the canal. They have never been observed to innervate any cells in the epithelium, either at the base of this layer or towards the apical surface. They thus form free nerve endings in contact with the contents of the canal. Besides neurotubules they contain numerous small

Fig. 37. Electron micrograph of a free nerve ending in the osphradial epithelium of Planorbarius. The nerve process is situated between two ciliated cells and is distinguished by the presence of neurotubules.

c, cilium

ca, osphradial canal

cc, ciliated cell

de, possible desmosome

mi, mitochondrion

ne, nerve process

nt, neurotubule

v, vesicles

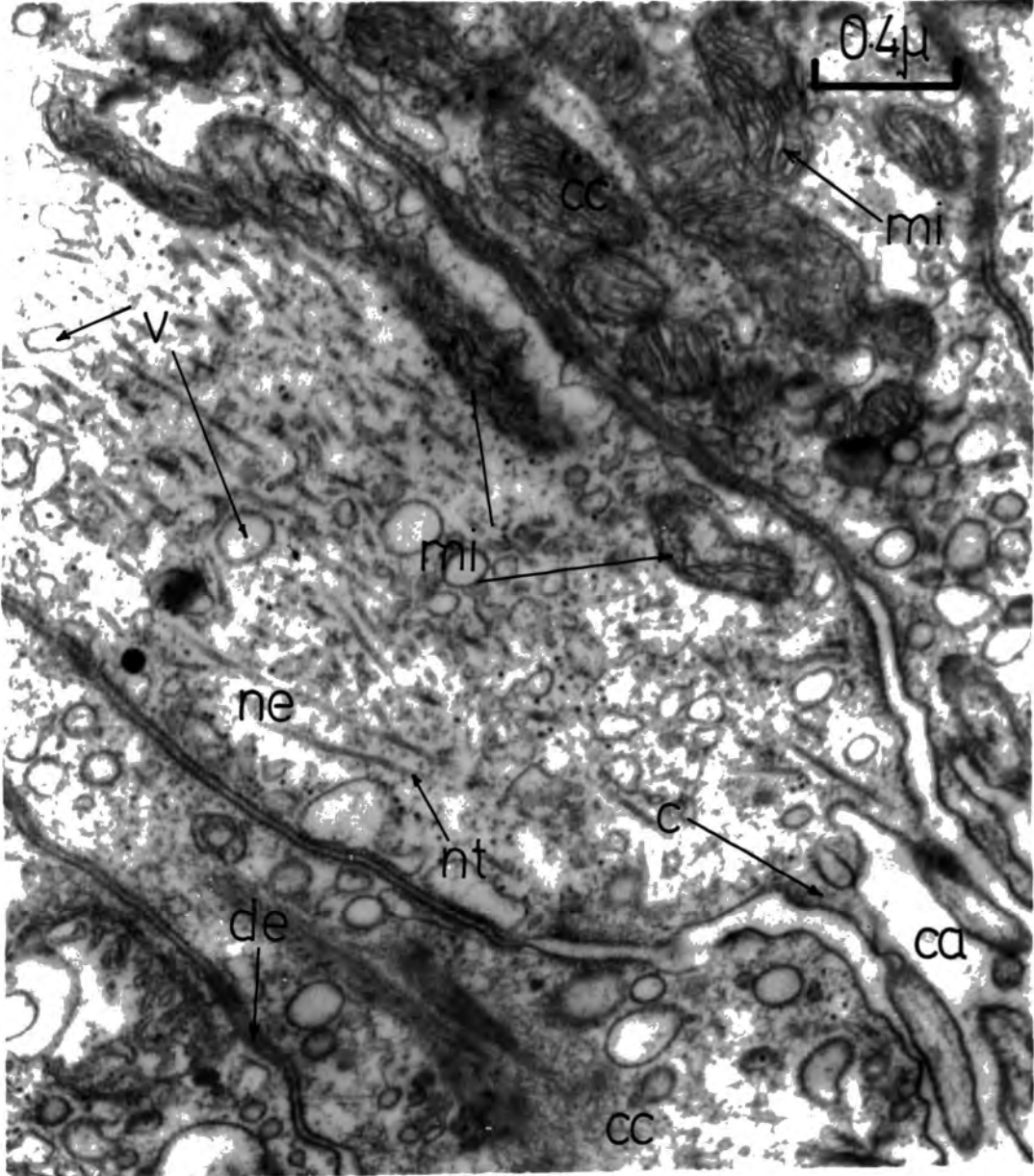

Fig. 38. Electron micrograph of a group of three neurones contained within a capsule situated in the connective tissue which surrounds the secretory region of the osphradial epithelium of Planorbarius.

Cells, s1, s2 and s3

ax3 is a process from the nerve cell body of s3

bm, basement membrane

gl, glial cell

nf, nerve fibre

nu, nucleus

sm, smooth muscle



vesicles (fig. 36) and small mitochondria which are particularly prominent below the apical membrane surface (fig. 37), although their number is usually less than in the adjacent ciliated cells (compare the ciliated cell in the top of fig. 37 with the sensory process below it). They always possess cilia or microvilli on their apical surface. The free surface of the nerve fibre is always just below the average level of the epithelial cilia border and occurs within a small pit. The adjacent ciliated cells tend to overlap the nerve ending (fig. 37). As a rule olfactory endings in vertebrates tend to be elevated from the epithelium (Gray and Watkins, 1965; Reese, 1965) as do the lateral line endings in the frog tadpole (Jande, 1966). The sensory endings of the statocyst in Octopus appear to be on the same level as the rest of the sensory epithelium (Barber, 1966).

The connective tissue capsule.

The nervous content of the connective tissue capsule has already been discussed. In light microscope sections numerous muscle fibres were apparent and these have also been observed in the electron microscope (figs. 38-40). The smooth muscle fibres are arranged typically in long strands and within each strand it is possible to observe the individual muscle fibrils. Associated with the contrac-

Fig. 39. Electron micrograph of connective tissue cells from the osphradial ganglion of Planorbarius. The main cell present is elongate and spindle shaped. It may be a fibroblast.

col, collagen

fib?, fibroblast

fm, fibrous material

gl, glial cell

mi, mitochondrion

nu, nucleus

om, oval mass

pg, pigment granule

rer, rough endoplasmic reticulum

sm, smooth muscle

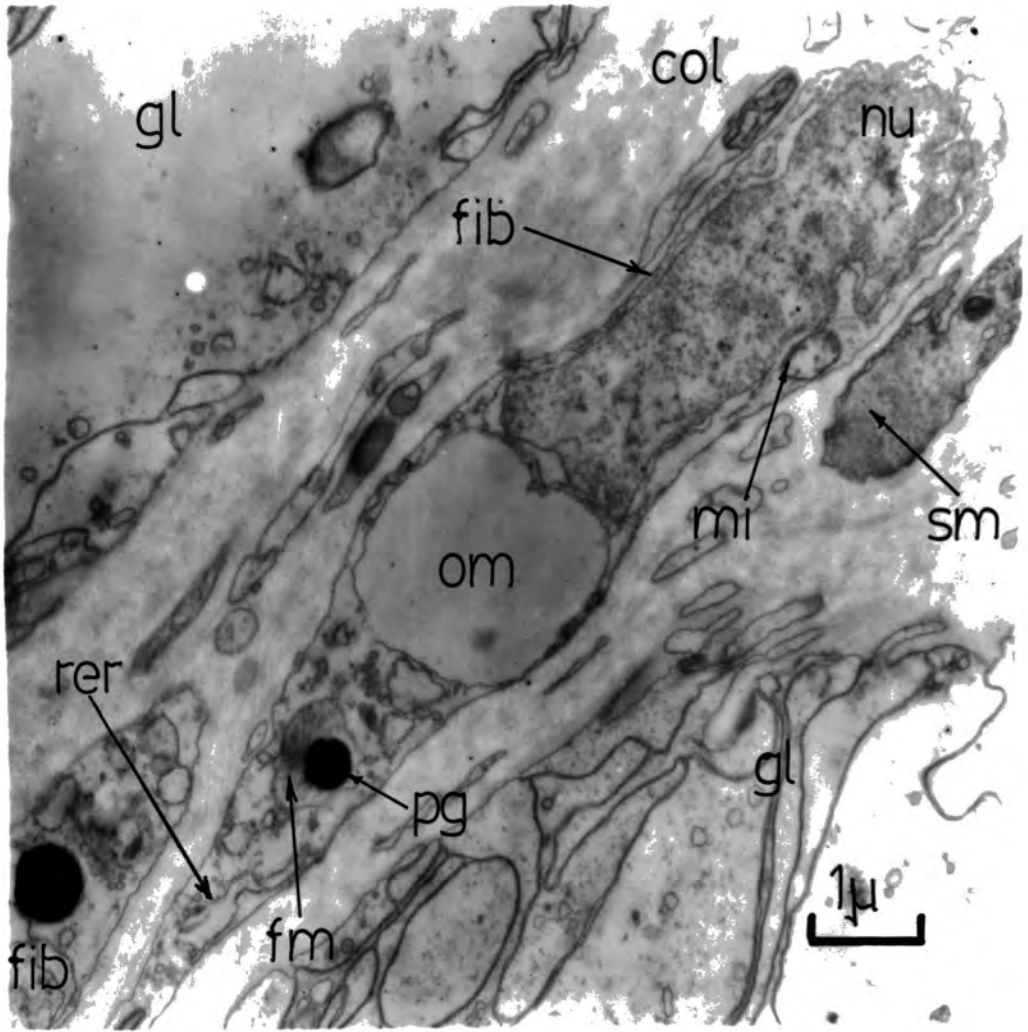

Fig. 40. Electron micrograph of a connective tissue cell from the osphradial ganglion of Planorbarius.

br, branch of cell

mi, mitochondrion

nu, nucleus

nuc, nucleolus

sm, smooth muscle fibre

v, vesicles

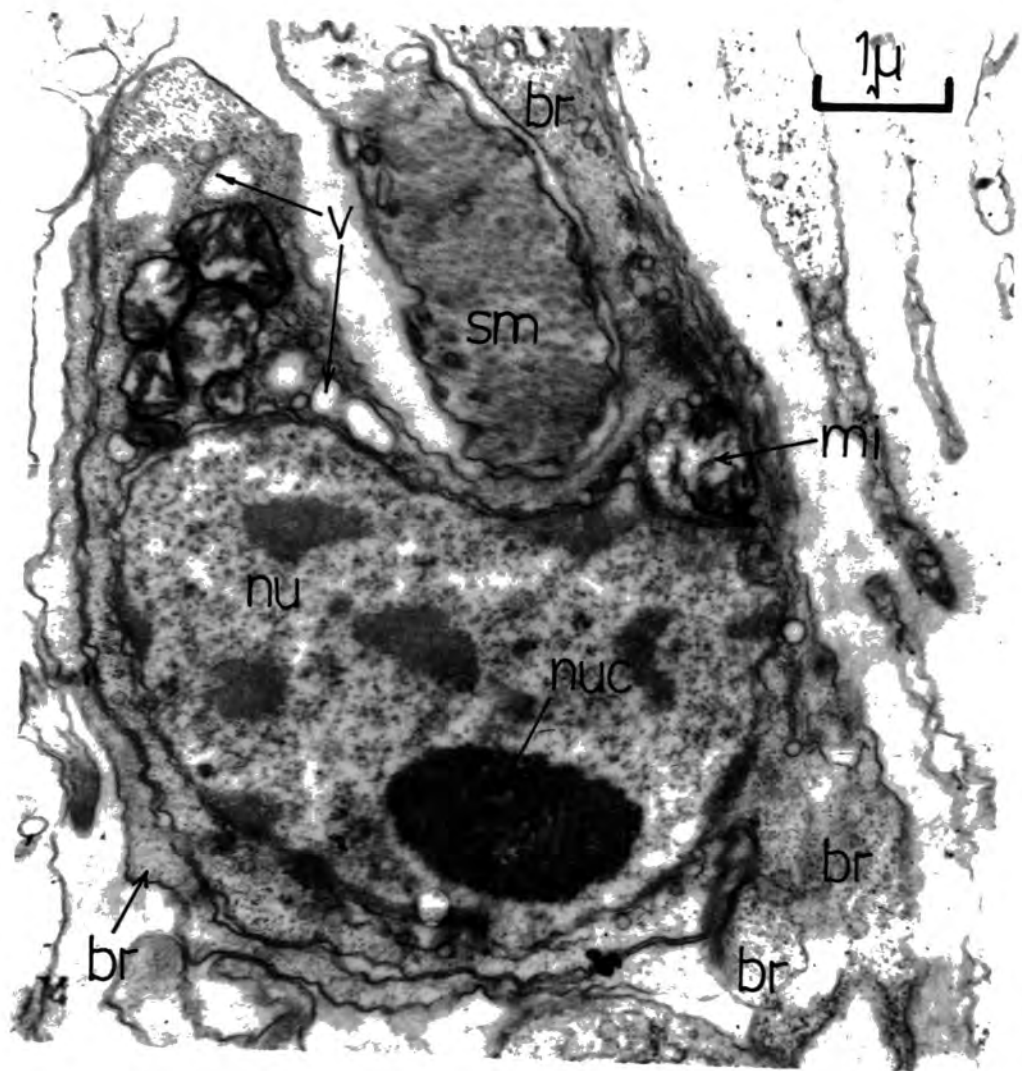

tile elements of the cells are areas of sarcoplasm which contain mitochondria and vacuoles (figs. 39, 44). The ground substance of the connective tissue contains fibrils (presumably collagen), plus two other types of cell. One type, the most common, is an elongate spindle-shaped cell (fig. 39) which is similar to the fibroblasts described by Schlote (1957) in Helix. If they are the formative cells of the connective tissue then they are unlike the "pore" cells which Plummer (1966) has described in the connective tissue capsule of Archachatina central nervous system. The cell, illustrated in figure 39, has a large nucleus which fills about a half of the cell. The cytoplasm around its borders contains a number of vesicles and a mitochondrion. Below the nucleus is a heart-shaped mass of structureless material. The rest of the cell contains rough endoplasmic reticulum and an area separated from the rest of the cytoplasm, which contains fibrous material and an electron dense pigment granule. This fibrous material resembles the collagen fibres in the surrounding cytoplasm which suggests that the cell is secreting this material. The second type of cell (fig. 40) is less frequent than the first and bears some resemblance to the pore cells of Plummer (1966) in that it contains a number of large vesicles. These cells are irregularly shaped, having processes whose cytoplasm is of a granular nature; the nucleus fills a large part of the cell.

Fig. 41. Electron micrograph of ciliated epithelium from the osphradium of Planorbarius. This section is from the osphradial canal close to aperture of the organ.

c, cilia

er, endoplasmic reticulum

g, Golgi apparatus

li, lysosome

mi, mitochondrion

mic, microvillus

nu, nucleus

v, vesicle

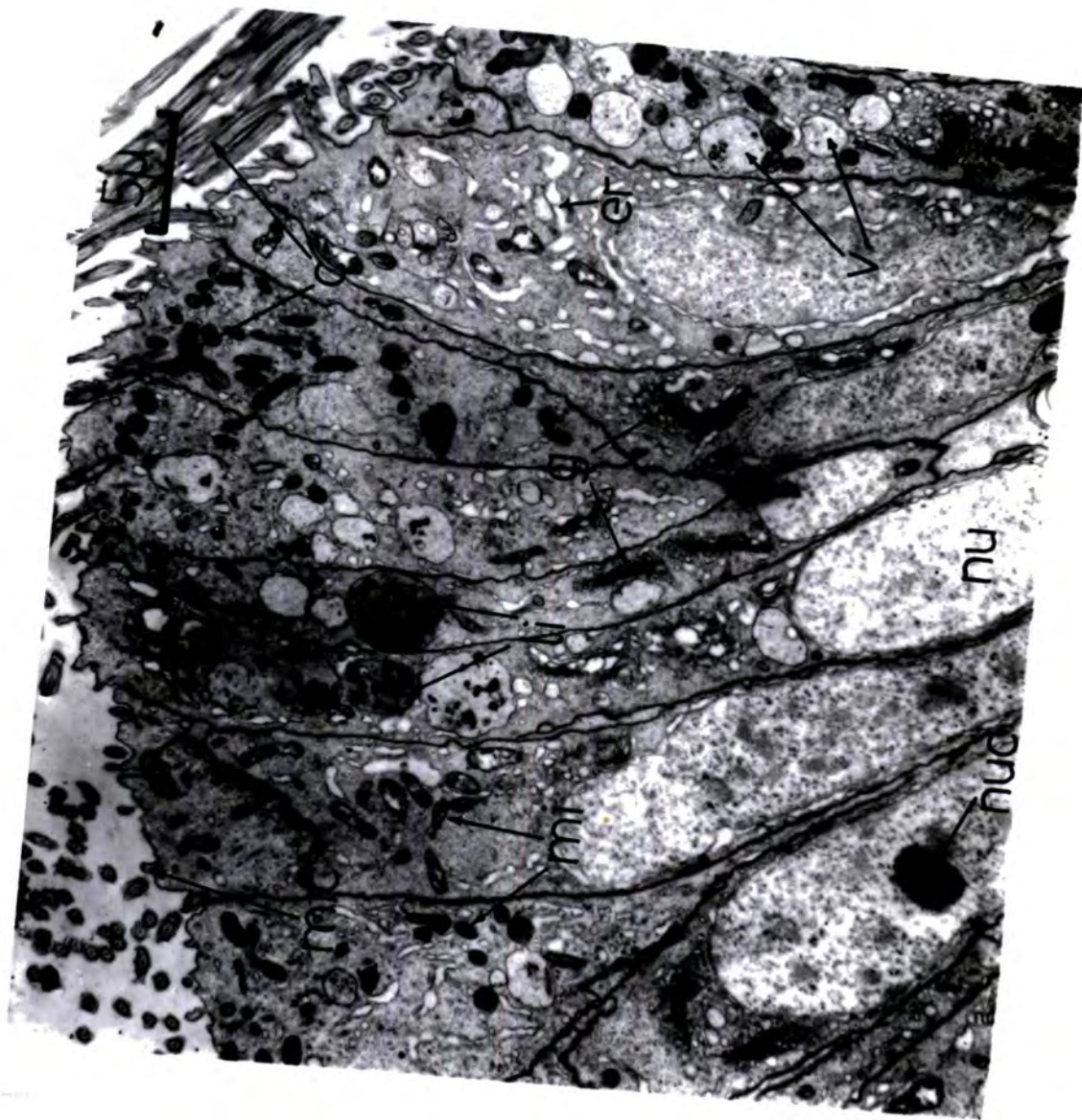

Fig. 42. Electron micrograph of the sensory epithelium of the osphradium in Planorbarius. A free nerve-ending is situated between two ciliated cells.

c, cilium

ca, osphradial canal

cb, basal body of a cilium

cc, ciliated cell

cp, basal plate of a cilium

cr, ciliary rootlet

mi, mitochondrion

mic, microvillus

ne, nerve-ending

v, vesicle

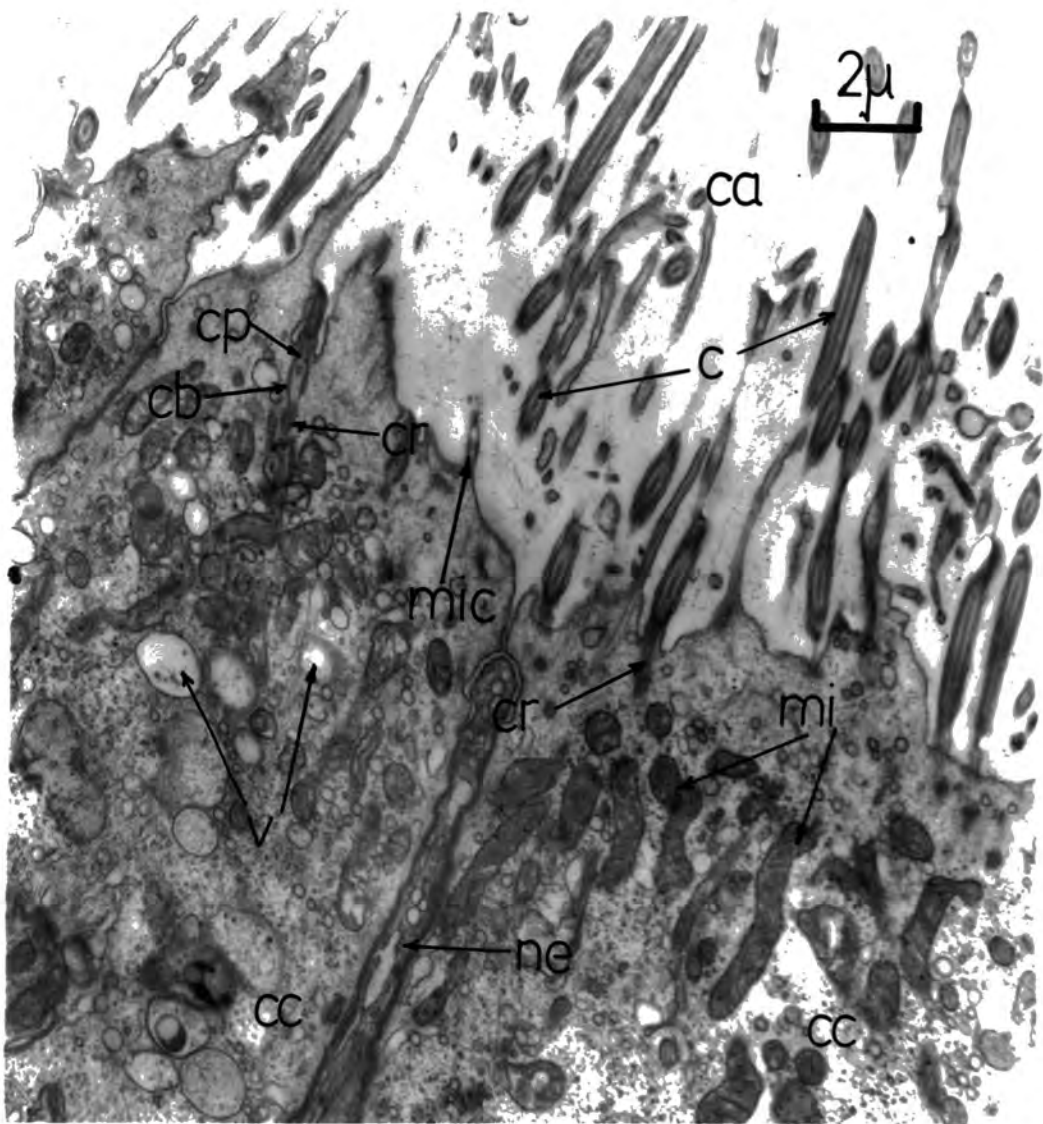

Large mitochondria are another prominent feature. The significance of this type of cell is not clear.

The canal epithelium.

The organisation of the canal epithelium was investigated in the light microscope and, on the basis of cell type, the canal was divided into three regions. Examination of the canal epithelium in the electron microscope has confirmed these light microscope results.

The nerve processes of the sensory region have already been described. Apart from these endings the region consists almost exclusively of ciliated cells. The ciliated cells of this region and other parts of the epithelium are similar and the description applies for all areas. The nucleus of these cells (fig. 41) is elongate and fills the lower part of the cell almost completely. Each cell contains several sets of Golgi apparatus arranged around the nucleus. The cells contain an extensive system of endoplasmic reticulum and vesicles from about 0.1μ to 2μ in diameter. Mitochondria are present throughout the cytoplasm but are particularly evident in the area below the ciliated border of the cells adjacent to the canal (fig. 42). The cilia are kinocilia and have a typical 9 plus 2 banded structure. They possess the usual basal body, plate

Fig. 43. Electron micrograph of a secretory cell from the osphradial canal epithelium of Planorbarius.

c, cilium

ca, osphradial canal

cc, ciliated cell

mi, mitochondrion

mic, microvillus

sc, secretory cell

sva, secretory vacuole

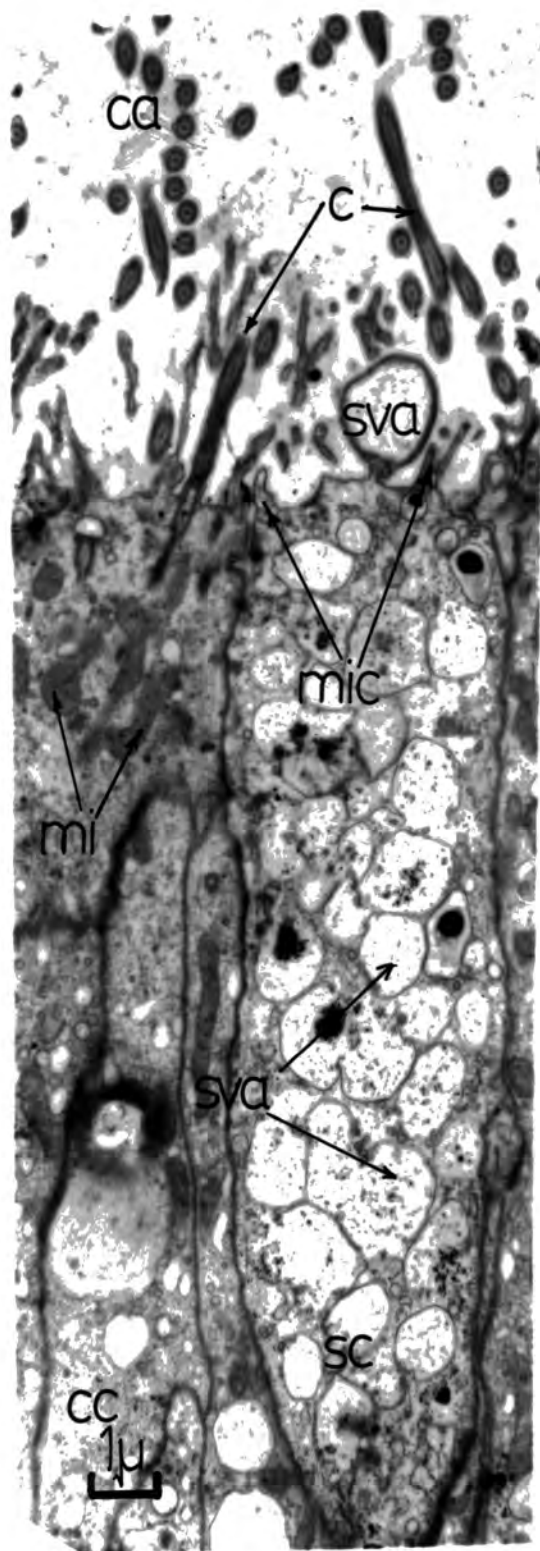

Fig. 44. Electron micrograph of the basal region of secretory cells from the osphradial epithelium of Planorbarius.

bm, basement membrane

cc, ciliated cell

col, collagen.

fb, folded base of secretory cell

fib, fibroblast

li, lysosome

mi, mitochondrion

nu, nucleus

nf, nerve fibre bundle

pg, pigment granule

rer, rough endoplasmic reticulum

sc, secretory cell

sm, smooth muscle

sva, secretory vacuole

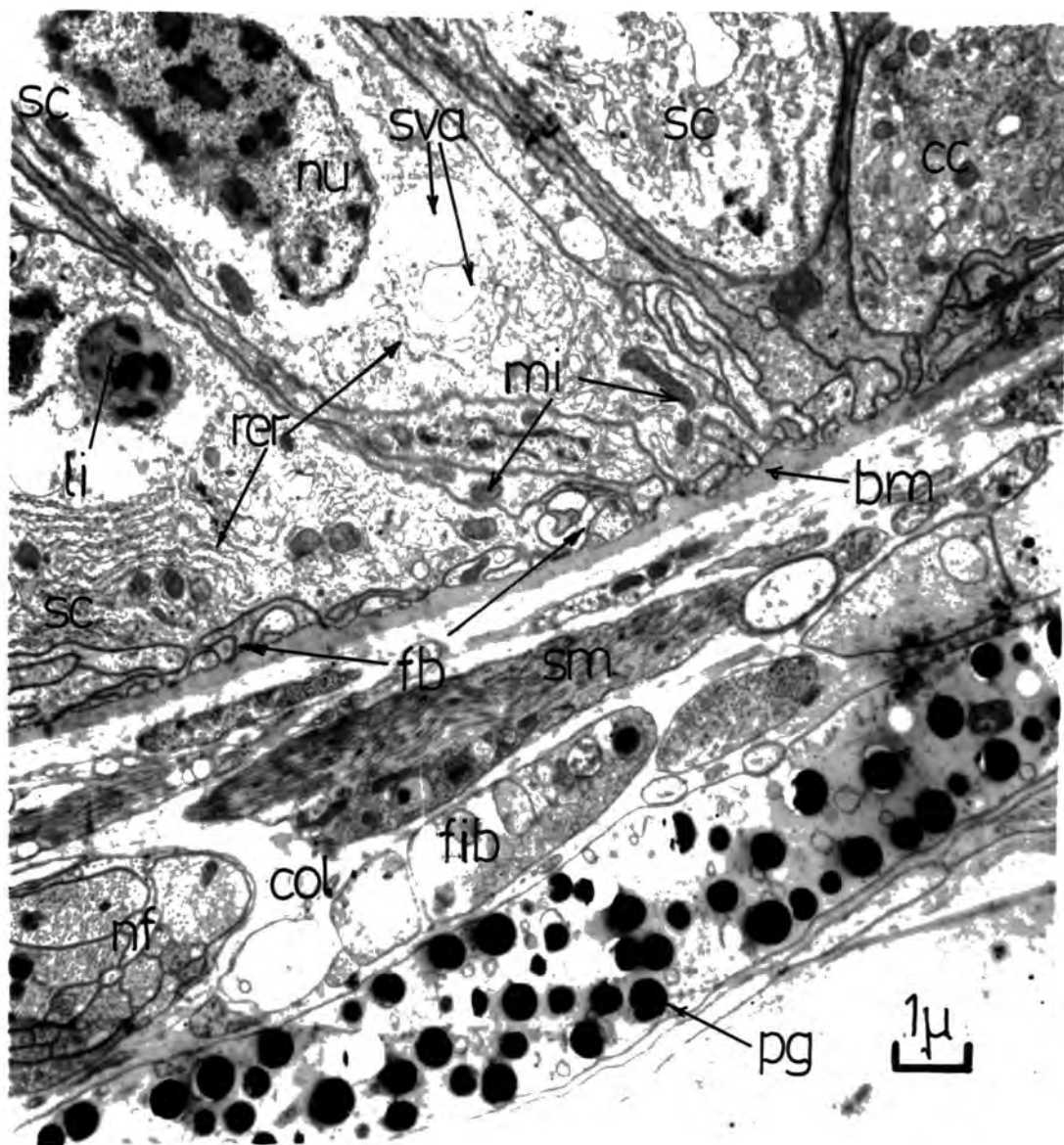

and rootlet, although the rootlet is not as long, for example, as the lateral cilia of the ctenidium in bivalves (Fawcett and Porter, 1954). Cilia from different cells in a similar plane of section have rootlets which point in the same direction suggesting unidirectional beating. The cilia from cells on the lip of the osphradium may be as long as 20 μ . Those from further down the canal are shorter and are only a few μ long. All the ciliated cells possess microvilli which are as long as 10 μ and usually possess a broad base surmounted by one or two finger-like projections (fig. 42).

Secretory cells are observed in all regions of the canal epithelium but are most numerous in the so-called secretory region. The cells of this region are all of one type and are similar to the type I mucocytes of the salivary glands of Lymnaea stagnalis (Boer, Bonga and van Rooyen, 1967). The cells possess a basal nucleus (fig. 44) which is surrounded by extensive rough endoplasmic reticulum. In this basal part of the cell there are few mitochondria and these are rarely above 1 μ in length. This network of endoplasmic reticulum gives way to cytoplasm in the apical portions of the cells which is dominated by the presence of large vacuoles (fig. 43). These secretory vacuoles, which are up to 3 μ in diameter, often contain patches of "fluffy" material which may be polysaccharide. The apical surface of the cell possesses numerous microvilli but never cilia.

Fig. 45. Montage of electron micrographs showing a "basal cell" from the osphradial epithelium of Planorbarius.

ap, apical process

bc, basal cell

bi, basal body inclusion

bm, basement membrane

bw, membrane whorl

co, collagen

di, dense inclusion

mi, mitochondrion

sc, secretory cell

sm, smooth muscle fibre



sc

dip

iq

mq

co

2μ

sc

mi

bm

sm

di

The cell in figure 43 is releasing some of its contents into the osphradial canal. It is presumed that a portion of plasma membrane surrounding the supposed secretory product is being "budded off" from the cell surface prior to release of its contents into the canal. These vesicles have been observed on the surface of this type of secretory cell in several instances but membrane fragments have never been recognised within the canal itself.

A second type of secretory cell is found in the osphradial canal close to the aperture of the organ and is also common in the mantle around the aperture. It is similar in appearance to the granular cells found in the salivary duct of Lymnaea stagnalis (Boer, Bonga and van Rooyen, 1967). Like the cells in Lymnaea the cell apices are usually covered by horizontal expansions of ciliated cells; mitochondria are few in number (fig. 46). The cytoplasm of the basal parts of the cells are dominated by the presence of endoplasmic reticulum (fig. 46). Large masses of structureless secretory material are present in the apical regions of the cell. The nucleus is basal and irregularly shaped. A dense body is often situated below the nuclear region (fig. 46); this does not seem to have been observed in the granular cells of Lymnaea salivary gland. A mechanism of release for the secretory material of this type of secretory cell has not been suggested by structural observations.

Fig. 46. Electron micrograph of a secretory cell in the osphradial epithelium of Planorbarius.

am, amorphous mass

cc, ciliated cell

co, connective tissue capsule

db, dense body

er, endoplasmic reticulum

mi, mitochondrion

nu, nucleus

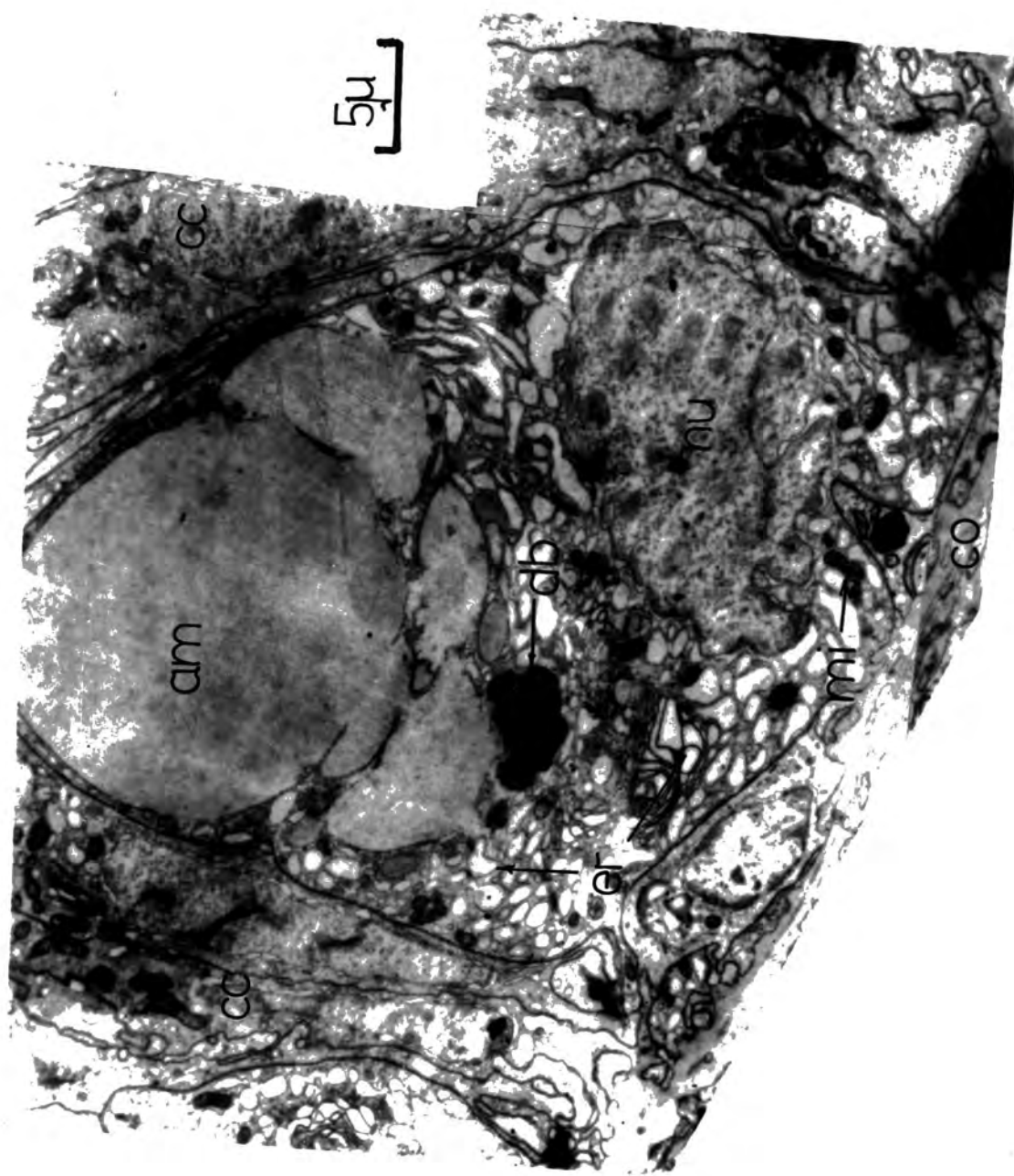

The basal cell is a third type of epithelial cell which is restricted to the secretory region of the osphradial canal. These cells were not seen in light microscope sections. They are of variable shape, usually elongate, flattened cells (fig. 45), with a characteristic apical process. This process does not appear to reach the canal although this is not easy to determine with certainty. Basal cells always contain large oval bodies containing membranes organised in a circular, whorled arrangement. Associated with the membranes is granular electron dense material often arranged along the membrane whorls (fig. 45). Other dense inclusions may be present inside these subcellular organelles. The general cytoplasm of the basal cells is lighter than that of the surrounding secretory cells and contains little endoplasmic reticulum and only a small number of mitochondria. The nucleus occupies only a small part of the cell. The function of this type of cell is not obvious from these observations. They do not appear to be nervous in origin and are not associated with extra-epithelial structures. Barber (1966) has observed a basal cell in the epithelium of the statocyst of Octopus, and Jande (1966), the so-called dark cells in the basal regions of the lateral line organs of the frog tadpole. The latter author suggests that the cells have a "support" function.

Fig. 47. Reconstruction of the fine structure of the osphradial epithelium of Planorbarius. The region is that overlapping both the sensory and secretory portions of the canal epithelium.

DIAGRAM OF THE FINE STRUCTURE
OF THE EPITHELIUM IN THE OSPHRADIUM

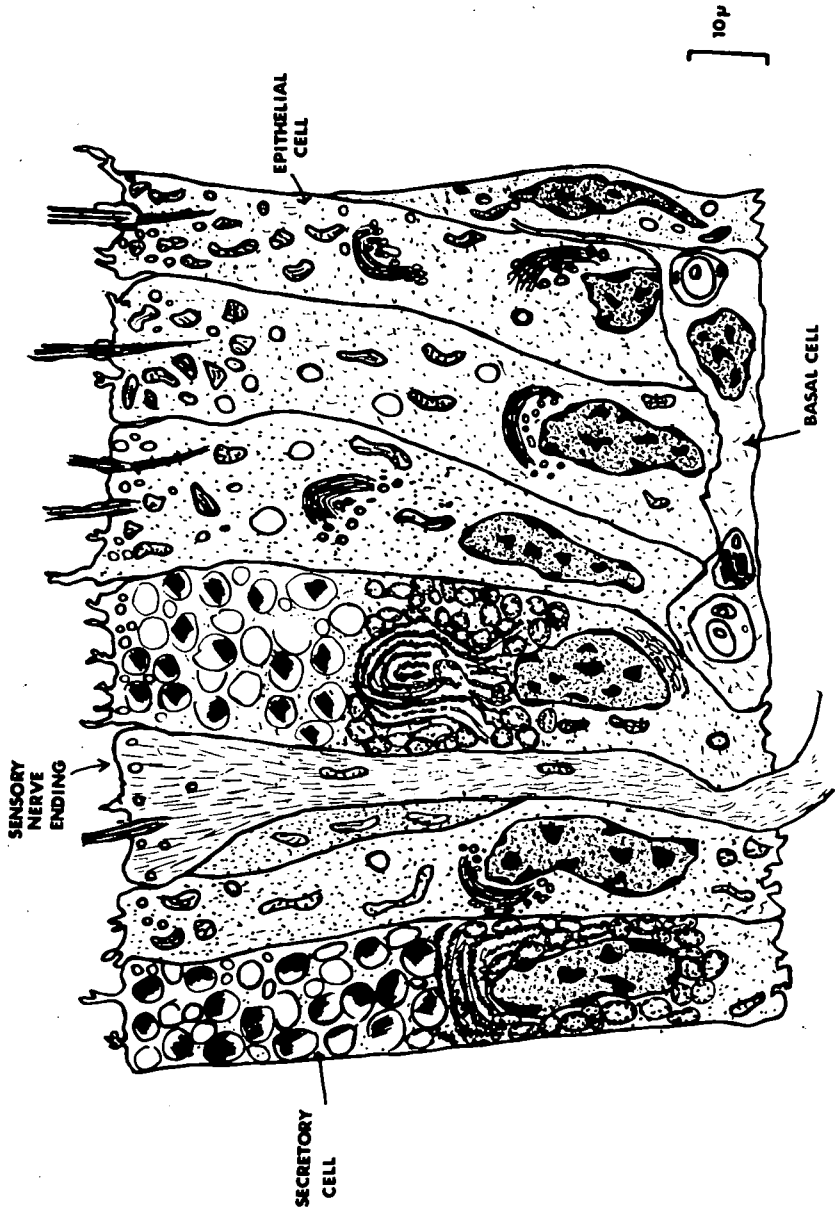

CONCLUSIONS AND DISCUSSION

The osphradium.

The light-microscope structure of the pulmonate osphradium is summarised in figure 23 and the electron microscope studies in figure 47. The anatomy agrees essentially with the description of Bernard (1890) and Demal (1955). Bernard (1890) stated that the secretory cells were mainly restricted to the region of the osphradial epithelium close to the osphradial aperture, although Demal correctly analysed the secretory region as being mainly in the mid-region of the osphradial canal. Both authors observed monopolar, bipolar and multipolar neurones, but Demal (1955) did not record any cell bodies above 30 μ in diameter. The nervous innervation of the osphradial epithelium was not clear from the work of Bernard but Demal states that neurones in the ganglion send processes to "neuroepithelial cells" which he presumed were sensory. The electron micrographs in the present study show that the nerve cell bodies have axons which penetrate the epithelium in the basal regions of the canal and form primary nerve endings. No evidence for the innervation of any of the epithelial cell types by nerve cells in the osphradial ganglion has been obtained. The previous authors did not distinguish different types of secretory cells.

or observe the basal cells of the present study.

The organ has a secretory role but the presence of mucus secreting cells, not directly innervated by nervous elements would suggest that these cells may be associated with the role of the ciliated cells as carriers of extracellular material (see SECTION 3). The presence of free nerve endings strongly suggests a sensory function. Possible roles in chemoreception or sediment detection will be considered in SECTIONS 2 and 3.

The overall anatomical organisation can be compared with other osphradia, eg. that of the prosobranchs. Dakin (1912) described the osphradium of Buccinum which possessed all the cell types described in the pulmonates. The osphradium in Buccinum, however, is situated in the mantle cavity directly in line with the inhalent current through this cavity, whereas the pulmonate osphradium is situated outside the mantle cavity although it still receives a strong supply of the medium from around the animal (SECTION 3). In the case of Buccinum a chemoreceptor function seems most likely (Bailey and Laverack, 1963, 1966), although a particle-detecting function (Yonge, 1947) cannot be ruled out.

Organisation of neurones in Planorbarius.

The neurones of the left pallial ganglion are organised in a manner which is similar to that of other molluscan ganglia examined (Smith,

1966), and electrophysiology studies in this preparation (SECTION 2) and other preparations (eg. Hughes and Tauc, 1961, 1963) suggest that the ganglia are capable of complex integrative function. The organisation of the osphradial ganglion is also complex. It contains a large number of nerve cell bodies which are organised in a manner which is similar to that of the central nervous system. The presence of synapses in the osphradial neuropile suggests that the cells of the osphradial ganglion are capable of complex interactions on a purely local basis. It is probable that the ganglion is capable of integrative and local reflex function. It is known that the osphradium of Planorbarius is capable of local movements (SECTIONS 2 and 3). It is also possible that the integrative role may be concerned with the processing of sensory information which presumably feeds in via those neurones of the osphradial ganglion which have sensory processes in the osphradial epithelium. Peripheral integration and "sorting" of information is well-known in such phenomena as "lateral inhibition" (eg. in Limulus eye).

On the other hand, groups of cells in other parts of the nervous system (eg. the grouped cells of figure 15) are clearly of different function. It is not certain whether cells of this type are capable of local interactions and their function is unknown.

SECTION 2 ELECTROPHYSIOLOGY

INTRODUCTION

Much of the electrophysiological work in the Mollusca has been concentrated on the central nervous system of a small number of species which possess giant nerve cells. A relatively small amount of work has been concerned with sensory structures and almost none with other accessory ganglia and peripheral nerve cell bodies. Two types of gastropods have been investigated more than any others - terrestrial pulmonates of the genus, Helix, and various species of the opisthobranch, Aplysia. Neurone cell bodies from Aplysia reach a size of 800 μ in large specimens and much work since 1960 has been carried out on giant cells from the visceral ganglion of this species. The early work of Hughes and Kerkut (1956) had showed that complex spike activity was a feature of electrical activity recorded from the brain of slugs. More recently, the membrane properties of single nerve cells in Onchidium brain have been measured by Hagiwara (1959), and Tauc (eg. 1955a, 1955b, 1962) has extensively investigated the various types of spike activity found in Aplysia giant nerve cells, and the sites of spike initiation. The sensitivity of the electrical

activity of snail neurones to various external factors such as temperature (eg. Kerkut and Taylor, 1956; Kerkut and Ridge, 1962), pH (Chalazonitis and Takeuchi, 1966), oxygen and carbon dioxide concentration (Chalazonitis, 1961) and light (summarised, Arvanitaki and Chalazonitis, 1961), has been investigated. Using species of Helix, Kerkut et al. have elucidated the ionic basis of resting and action potentials in snail central neurones (Kerkut and Walker, 1961a; Kerkut and Thomas, 1965; Kerkut and Meech, 1966, 1967; Kerkut and Gardner, 1967).

The size of neurones in molluscs and their accessibility has led several groups of workers to examine the effects of chemical agents on the electrical activity of snail neurones. The sensitivity of Helix neurones to acetylcholine and 5-hydroxytryptamine (5-HT) has been tested by Kerkut and Walker (1961b) and evidence obtained for a possible role in synaptic transmission. These substances have been isolated from snail brains by Kerkut and Cottrell (1963). Gerschenfeld and Tauc (1961) had ionophoretically added acetylcholine to Aplysia neurones and indicated that some cells were depolarised by acetylcholine (D-cells), whilst others were hyperpolarised (H-cells). The phenomenon of desensitisation observed in vertebrate nerve cells was apparent in both H and D type cells (Tauc and Bruner, 1963). Kerkut and Thomas (1964)

showed that the hyperpolarising effect of acetylcholine could be associated with the inward movement of chloride ions (and to a lesser extent the movement of potassium ions outwards). The generation of Inhibitory post-synaptic potentials (IPSP) was thought to be mediated by the same ions. A non-cholinergic type of inhibition has also been observed in some cells from Cryptomphallus (Gerschenfeld, 1964) and this has been associated with a permeability change to potassium (Gerschenfeld and Chariandini, 1965). Gerschenfeld and Stefani (1965, 1966) have investigated the effects of 5-HT on nerve cells identified by Gerschenfeld and Tauc (1964) as being sensitive to this drug (the so-called CILDA cells). The small number of cells which responded to 5-HT always showed a depolarisation. These neurones were also D-sensitive to acetylcholine although the site of action of the two drugs appeared to be different. Glutamate when ionophoretically added to snail neurones caused a depolarising or hyperpolarising effect on different cells (Gerschenfeld and Lasansky, 1964). The possible combinations of drug and cell would suggest that the chemically mediated organisation of synapses in the neuropile is enormously complex.

The organisation of nerve cells within the central nervous system of molluscs has been investigated by electrophysiological methods. Turner and Nevius (1951), Horridge (1958) and Nisbet (1961)

have studied the transmission of impulses across the molluscan ganglion. The technique has been to stimulate afferent fibres, usually by mechanical deformation of the body wall, and to record the resulting impulses in nerves leading from the central ganglion. Alternatively, the nerves and ganglia have been stimulated electrically and the resulting activity recorded at different points in the nervous system. These studies provided information concerning the general organisation of pathways but not the relationship between particular cells (because of the large number of units involved). Hughes and Tauc (1961, 1963) have combined stimulating techniques with intracellular recording to study the branching of a particular cell. The techniques of peripheral stimulation and recording in the brain have been continued by Bailey (1966) in Buccinum and Dorsett (1967) has plotted the pathways of certain cells in the brain of Tritonia. Kandel, Frazier and Coggeshall (1967) have recently discovered a group of cells in Aplysia whose "bursting" activity is mediated by IPSPs from a single cell in another part of the same ganglion.

The presence of isolated cell bodies in the nerves radiating from the central nervous system is well-known in molluscs. When sections of nerve isolated from any central or body wall connections were tested for electrical activity in a number of pulmonate species

by Duncan (1961), multiple units of a spontaneous nature could be recorded. No intracellular recordings from this type of cell have been made.

Recordings of electrical activity originating from sensory sources are relatively rare. Barth (1964) recorded intracellular potentials from the eye of Hermissenda and Kennedy (1960) has discovered a photosensitive nerve fibre in Spisula. Mechanical sensitivity is a feature of a number of species examined. Turner and Nevius (1951) showed that the stretching of the foot of Agriolimax caused bursts of spike activity in the pedal nerves. More recently, Laverack and Bailey (1963) have demonstrated three types of stretch response in Buccinum and also recorded the electrical responses of the animals to discrete probe stimuli. This type of tactile response has been shown in other preparations (Horridge, 1958; Nisbet, 1961; Hughes and Tauc, 1962). Responses to chemicals have only rarely been recorded electrophysiologically. Bailey and Laverack (1963, 1966) have been able to record activity in the supra-intestinal ganglion of Buccinum when the osphradium of this animal was stimulated chemically. In an isolated preparation of supra-intestinal ganglion plus osphradium they have demonstrated that extracts of Mytilus on which the animal feeds, could elicit spike activity in various parts of this ganglion. Nervous activity

could also be stimulated by chemicals such as glutamate and succinate.

The aims of the present study have been twofold. Electrical activity has been recorded in the central and peripheral nervous system of Planorbarius in order to compare types of activity from the various parts of the nervous system and to correlate these with anatomical studies (SECTION 1). Preliminary work has been carried out to test the responses of central neurones to addition of drugs known to affect electrical activity in other snails. The sensitivity of brain neurones to light has also been investigated.

The second main aim has been to determine a sensory function for the osphradium. Experiments have been carried out to determine the effects of adding various substances to the mouth of the osphradium whilst at the same time recording intracelluarly from osphradial neurones. A preparation of brain plus osphradium with the left pallial nerve intact has also been investigated to discover whether osphradially stimulated activity could be recorded in the nerve cells of the brain. In view of the previously suggested functions for the osphradium suitable chemical and mechanical stimuli were tried.

METHODS

a. Electrophysiological apparatus.

Glass micropipettes have been used for intracellular recording and a small amount of external recording has been carried out using silver/silver chloride bipolar electrodes. The micropipettes were pulled on a commercial electrode puller whose heating element was adjusted so that medium-length tips of 10-20 megohms were produced. The electrodes were filled with 3 M KCl after boiling in methanol and distilled water in the conventional manner.

The circuit for intracellular recording (fig.48) consisted of a cathode follower leading directly to a Tektronix 502A oscilloscope. For external recording it was necessary to include an A.C. pre-amplifier in the circuit and this meant that signals down to about 15 μ volts could be detected.

b. Recording techniques and preparations.

The recording electrodes were arranged around a dissection bath whose contents could be viewed through a zoom binocular microscope. The preparations were immersed in Ringer solution and the cells remained in good condition for several hours. A flow system was arranged so that the Ringer could be changed without disturbing the preparation. The Ringer was made up from a formula given by

Fig. 48. Diagram showing the circuit used for intracellular and extracellular electrophysiological recording from neurones in Planorbarius.

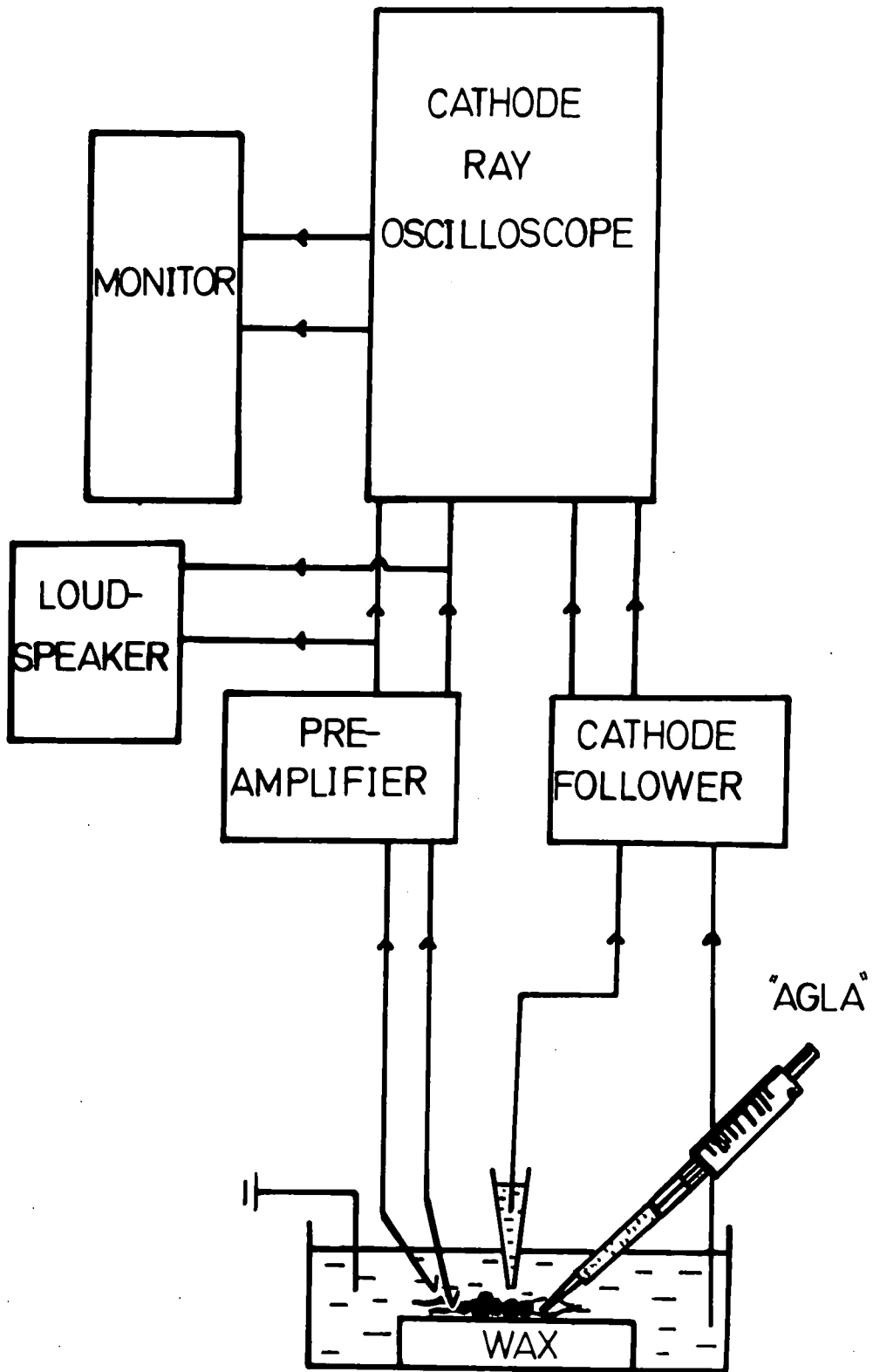

Pantin (1948 p. 67). This solution had been used by Duncan (1961) in electrophysiological work on several species of freshwater pulmonates.

Intracellular recordings were made from the brain, osphradial ganglion and neurone cell bodies in the left pallial nerve. The external recordings were made from the left pallial nerve in attempts to record afferent activity from the osphradium.

For experiments carried out on the brain, the dissection technique described in SECTION 1, was used for exposing the contents of the head cavity. Attempts to record intracellular activity with the brain intact were very difficult because of the constant movements of the body wall of the animal. Therefore most of the recording was carried out on preparations of isolated brain with the nerves entering it severed as far from the brain as possible. For penetration of cell bodies using glass electrodes it was necessary to either mechanically remove the sheath from around the brain or soften it using a chemical technique. The latter method, using a non-specific fungal protease, was found to be most satisfactory and was also used for softening the connective tissue capsule over nerves in the left pallial nerve and the osphradial ganglion. Normal electrical activity was unaffected by addition of protease, treated cells maintained their resting potential and any spike activity for

as long as untreated cells. Willows (1965) had used a similar enzyme to soften the connective tissue sheath around the ganglion of several species of nudibranch molluscs. The technique for penetration of a selected cell was to lower the electrode until it just touched the surface of the nerve cell body. This was indicated by deformation of the cell surface and by recording of a surface potential. Sometimes negatively going spikes could be observed. Often the contact with the neurone surface was enough to gain cell penetration, but sometimes it was necessary to tap the bench before this could be achieved.

A similar technique was used for neurones in the left pallial nerve and cells of the osphradial ganglion. Both types of cell were penetrated by microelectrodes and their types of activity examined. The preparation for recording from both types of cell was the same. A dissection of the osphradial region of the mantle (fig. 15) revealed not only the osphradial ganglion but also cells of the clumped and isolated types (fig. 15 POSITIONS 2 and 3). Recordings in the whole animal with just the shell removed were impossible for more than a short period of time, due to the movements of the body wall around the recording area. An isolated preparation was more satisfactory. A portion of body wall containing the osphradium and about 2 cms of pallial nerve was dissected from the whole animal

and pinned firmly to a wax block. Further dissection of the osphradial region yielded a preparation which was suitable for intracellular recording and also provided a length of pallial nerve long enough for external recording, using silver/silver chloride electrodes.

After initial examination of electrical changes taking place in the neurones of the osphradial ganglion, attempts were made to discover a sensory role for the organ. Various substances were added to the aperture of the osphradium whilst simultaneous recording was being made from single cells in the osphradial ganglion. An "Agla" micrometer device was used for this addition. It was arranged in series with a hypodermic syringe barrel and mounted on a micromanipulator. This apparatus was also used for addition of softening enzyme to the preparation and allowed the addition of discrete amounts of protease to particular neurones under examination.

The behavioural work (SECTION 3) had indicated that the animals were attracted to certain substances, such as algal extracts, leaf extracts and milk. In order to test a possible chemoreceptor function for the organ these substances were added to the osphradial preparation. Algae such as Potomageton, and oak and elm leaves were homogenised in Ringer solution until they were reduced to particulate form suitable for addition via the Agla pipette.

The substances were added to the surface of the mantle so that they would be carried over the mouth of the osphradium by the ciliary currents normally active in this region (SECTION 3). Thus the experiments consisted of an initial penetration of an osphradial neurone by microelectrode and observations of any "basic" activity with no obvious stimulus present, followed by addition of individual substances; the sequence being Ringer, Ringer plus stimulant, Ringer. The last addition of Ringer was to wash any remaining stimulus away.

A specific chemoreceptor function associated with reproductive behaviour was tested by addition of penis extract. Snails were brought into reproductive phase by transfer to clean, filtered tap-water and kept at 15° C. This stimulated penis extrusion and copulatory behaviour and resulted in the laying of eggs. Penis plus accessory organs were removed from snails in reproductive condition, homogenised in Ringer solution and tested on the isolated osphradial preparation, in the manner described above.

A particle detecting hypothesis was tested by addition of 1 μ particles of alumina. This substance does not normally attract snails in Y maze experiments and earlier trials had shown that 1 μ particles of this substance will penetrate into the osphradial canal (SECTION 3). It was therefore considered to be a suitable

substance for mechanical stimulation of the osphradium.

Experiments to test for specific chemical substances were also tried. Bailey and Laverack (1963, 1966) had shown that the osphradium of Buccinum was particularly sensitive to glutamate and a large number of experiments was carried out in the present study using this substance. It was necessary to avoid any response to acidity, so suitable quantities of TRIS buffer were added to the glutamate to produce a solution of pH 7. Other amino acids common in plants were also tried.

The sensitivity of the osphradium to inorganic ions such as sodium, calcium and chloride were tested and also the organ's response to acid and alkaline solutions of various pH.

A small number of experiments has been carried out to see if the neurones of the osphradium were particularly sensitive to temperature, implicating the organ in a temperature receptor role. recordings were made from the same cell when the temperature of the Ringer bathing the preparation was varied.

In addition to experiments using external electrodes on the pallial nerve and intracellular recording from the osphradium, a third type of electrophysiological approach was tried. A preparation of osphradium plus brain was isolated and arranged so that substances could be added to the osphradium whilst simultaneous intracellular recordings were being made from the left pallial ganglion of the brain.

RESULTS

a. Central nervous system.

Intracellular recordings have been made from various parts of the central nervous system of Planorbarius corneus. Many cells show rhythmic spike activity which is characteristic of isolated molluscan central nervous neurones (Kerkut and Ridge, 1962; Willows, 1965). Others are silent and, although spikes may be initiated by electrode penetration, these disappear after a few seconds.

The resting potential recorded in most cells is around the 50 mV. level, although resting potentials as low as 20 mV. and as high as 80 mV. have been found. In autoactive cells negatively going spikes can be recorded on the surface of the cell. After penetration, the full resting potential is usually quickly re-gistered and the spikes show a full size of about 70 mV. from the base line with a 15-20 mV. positive overshoot from the zero potential before penetration. The shape of the spike is typically molluscan showing a prepotential with a slow build of about 15-20 mV. and a fast spike phase with a negative afterpotential (figs. 49, 50). Cells showing spike activity are common on the dorsal surface of the abdominal and pallial ganglia and in the smaller cells of the cerebral ganglia.

Fig.49. Intracellular spike activity recorded from neurones on the dorsal side of the left pallial ganglion of Planorbarius.

The neurone in the top trace is firing continuously but with unequal spike intervals.

The middle trace shows a cell with a constant interspike interval.

The bottom trace illustrates the firing of a neurone whose resting potential is constantly fluctuating, spikes being generated at the peak of the depolarisation phase of the cycle.



PALLIAL GANGLION

IRREGULAR

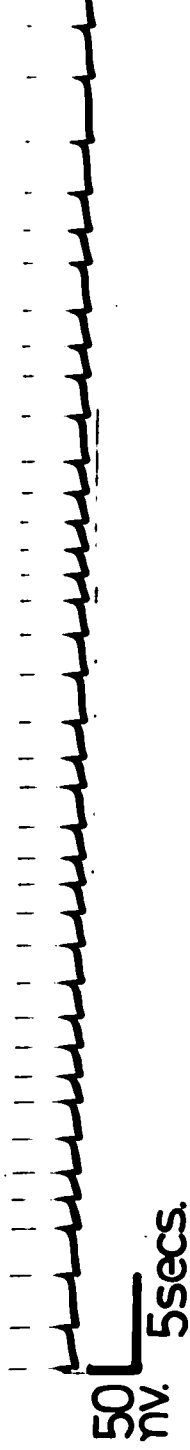

REGULAR

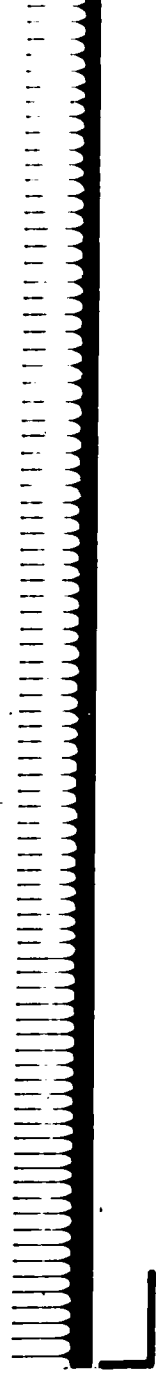

GROUPED



Fig. 50. Intracellular recordings of spike activity from single cells in the abdominal ganglion of Planorbarius.

The top trace shows a cell firing continuously with approximately equal spike interval.

The cell of the middle trace is much more irregular.

The bottom trace cell shows spike activity with superimposed IPSP input.

ABDOMINAL GANGLION

REGULAR



50
mv.

5secs.

IRREGULAR



I.P.S.P.



Spike activity has several different patterns (figs. 49, 50). Some cells fire continuously and this activity may be of very regular frequency or less so (the so-called irregular cells in fig. 49). A less common type of activity is the "burst" or grouped spike discharge. This latter type of cellular activity is characterised by wide, regular fluctuations in baseline potential with spikes being generated at a depolarisation level of about 15 mV. above the resting level. The number of spikes generated at each peak may vary in number, (between 6 and 8 in fig. 49, bottom trace), and the time between spikes increases as the last spikes in the grouped discharge are considered. In some cells excitatory post-synaptic potentials have been recorded and these never show a size greater than about 15 mV. Another type of baseline activity observed in other molluscan neurones (Chalazonitis, 1961) is the inhibitory post-synaptic potential. These often occur in autoactive cells of Planorbarius and appear as transient hyperpolarisations superimposed on the oscilloscope trace (fig. 50). Their frequency is not related to spike discharge in any obvious manner.

A small number of experiments has been carried out to test the sensitivity of Planorbarius brain neurones to acetylcholine (c.f. Kerkut and Walker, 1961; Gerschenfeld and Tauc, 1961). The H and D cells of other preparations are also present in the brain of this

Fig. 51. Responses of abdominal neurones to the applications of external factors. Intracellular recording from single cells on the dorsal aspect of the ganglion.

Upper two traces show the response of a 'D cell' to two different concentrations of acetylcholine.

Bottom two traces show a cell which is sensitive to the onset and cessation of white incident light.

The onset of light caused inhibition of spike activity and the cessation caused a burst of spikes or excitation.

ABDOMINAL GANGLION

ACETYL CHOLINE 10^{-5} M.



ACETYL CHOLINE 10^{-7} M.



LIGHT-ON RESPONSE



LIGHT-OFF RESPONSE



snail. Figure 51 shows a typical D-cell response to the addition of the drug. Responses were obtained down to a concentration of 10^{-8} M.

Cells in the abdominal ganglion have been found which are sensitive to the onset and cessation of incident white light (c.f. Arvanitaki and Chalazonitis, 1961). Some cells are inhibited by the onset of light and excited by its cessation (fig. 51) and others respond in the reversed manner. Inhibition was often accompanied by inhibitory post-synaptic potentials.

b. Pallial nerve recordings.

In a small number of experiments it has been possible to record intracellular activity from single cells in the left pallial nerve. The cell shown in position 3 of figure 15 was superficial on the pallial nerve and recordings have been made from it for short periods. This cell usually shows spike activity which appears to be generated from within the soma of the cell. Sectioning of the nerve connections around it did not affect its activity. The spikes were similar to those from the central nervous system with a gradual prepotential build-up and the usual 70 mV. spike followed by a negative after-potential.

Most recordings, however, have been made from the clumped nerve

Fig. 52. Intracellular recordings from the clumped cells present in the left pallial nerve of Planorbarius (cells shown in position 2 of figure 15).

Top trace shows a cell which is firing in an irregular manner and which shows EPSP input.

Bottom two traces show two fast repetitively firing cells.

LEFT PALLIAL NERVE-CLUMP

IRREGULAR+E.P.S.P.



50
mv. 5secs.

REGULAR



FAST IRREGULAR



cells of position 2 (fig. 15). These cells, which are up to 60 μ in diameter, form a group of 11 cells (see SECTION 1) and it was possible to record from a number of neurones in the same preparation (fig. 52). In preparations in which the connections with the brain were severed, most of the cells showed spike activity. Only occasionally was a cell found which was silent. The most common type of activity was that shown in the top trace of figure 52. The cells showed a continuous discharge, but the spikes were irregular and not particularly patterned. They were of the usual 70 mV. size but showed no prepotential. The negative afterpotential was present in these spikes as normal. Also common in these cells were excitatory post-synaptic potentials, never reaching a size above 10-15 mV. The lack of prepotential in the spikes suggests that the soma is being activated by an extra-somal depolarising potential. Autoactive cells are also present in the clumped cells of the left pallial nerve (fig. 52). Some of these autoactive cells are very regular in their discharge patterns but others are irregular. No inhibitory post-synaptic potentials have been recorded from any of these clumped cells of the left pallial nerve. Whether the cells are synaptically connected within the clump is not clear from these simple recording techniques or from the anatomical studies (SECTION 1).

Fig. 53. Intracellular recordings from three cells in the osphradial ganglion of Planorbarius.

The three neurones are from the same preparation and show similar rates of firing.

OSPHRADIAL GANGLION

CELL 1



50
mv. 5secs.

CELL 2



CELL 3



c. The osphradium.

Attempts to record afferent activity in the osphradial nerve or left pallial nerve using bipolar silver electrodes were unsuccessful. Intracellular recordings have, however, been made from cells of the osphradial ganglion. The cells which have been penetrated most easily are those situated on the dorsal side of the osphradial ganglion around the point of entry of the osphradial nerve into the organ. These cells may be as large as 70 μ in diameter (SECTION 1) in the biggest snails and could be readily observed under the high power of the zoom microscope. Cells of smaller size, less superficially situated, have also been frequently penetrated. It was usually possible to record from upward of ten cells in any one osphradial preparation. The largest cells could be penetrated more than once without any noticeable fall in resting potential. These cells were used extensively during the attempts to stimulate the osphradium by addition of substances to the osphradial aperture. The spike activity, which was always present, was maintained for periods of several hours with little fall off in frequency.

Intracellular recordings made from every part of the ganglion showed regular spike activity. The activity recorded was of a continuous rhythmic type, the spike shape being typical of cells from the brain and pallial nerve cell bodies. Different cells from the

Fig. 54. Intracellular recordings from the osphradium of Planorbarius.

Addition of glutamate to the osphradial aperture.

The glutamate was buffered with TRIS buffer to give a solution of pH 7.

Uppermost trace. Control addition of TRIS. There is no change in spike frequency with the addition of this substance.

Bottom three traces show the addition of three different concentrations of buffered glutamate. The arrows or double base line indicate the point of addition. In each case an increase in frequency has been recorded but this has been interpreted to indicate movement of the electrode within the cell.

OSPHRADIAL GANGLION

0.05M TRIS

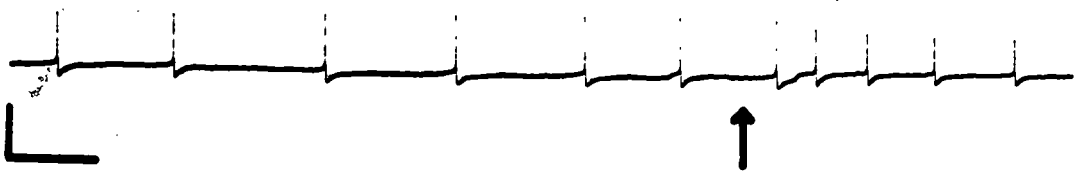
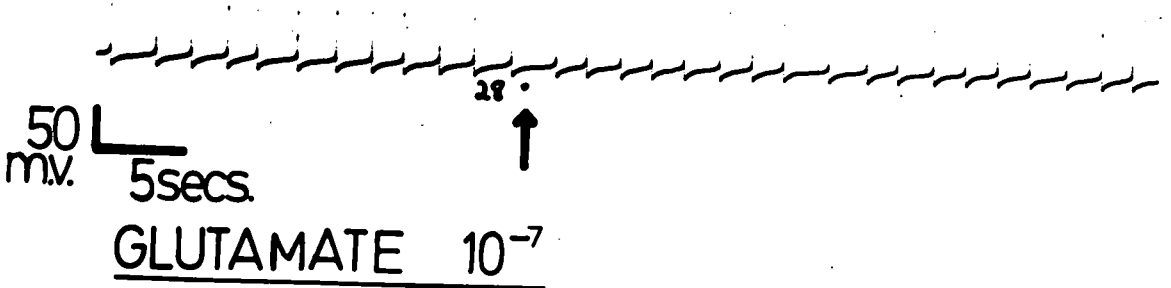

GLUTAMATE 10^{-5}

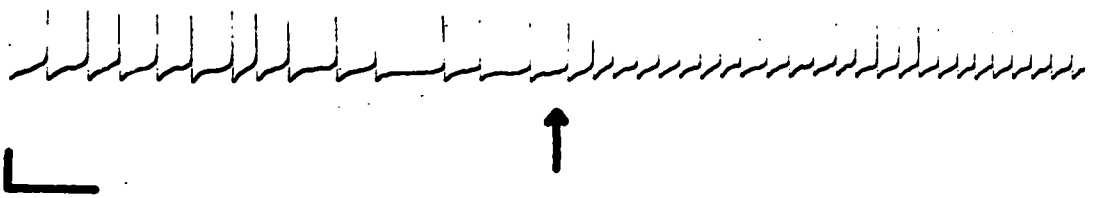

GLUTAMATE 10^{-3}

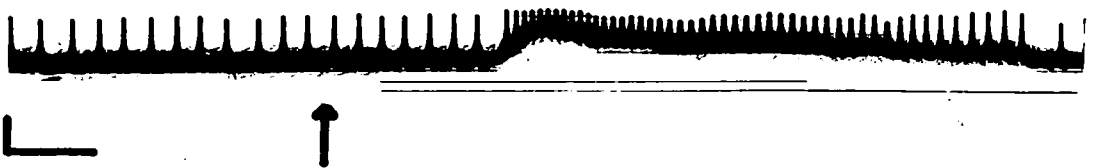

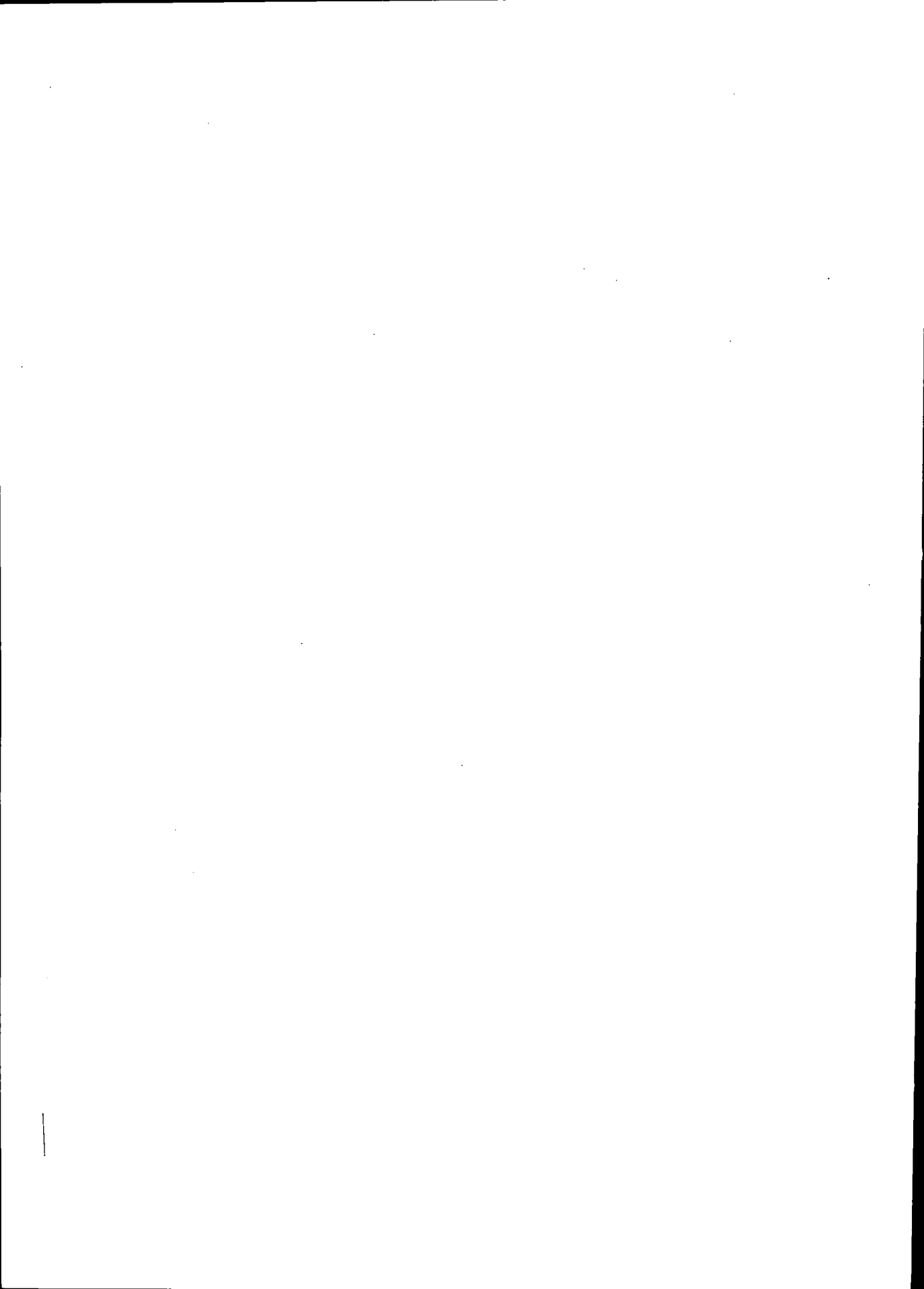

same preparation showed a similar rate of firing (fig. 53). Those cells in figure 53 all fire at about 46 spikes per minute. Different preparations kept at the same temperature also showed a similar rate of firing. Early experiments were carried out on the isolated osphradium plus the brain but it was found that the activity of the osphradial neurones was unaffected by section of the left pallial nerve. No efferent activity from the brain or pallial nerve has been recorded in osphradial neurones. Most of the later experiments have been carried out with the left pallial nerve severed close to the brain.

Addition to the osphradial aperture of food substances which had been shown to attract the snails in Y maze experiments (SECTION 3) failed to elicit any change in the firing rate of the osphradial neurones (fig. 56). No receptor potentials or post-synaptic activity were recorded.

Neutral solutions of common amino-acids had no repeatable effects on osphradial neurone activity. Glutamate had the effect of causing a contraction of the body wall and the osphradium and in consequence the recording electrode was either disturbed or dislodged completely from the neurones (fig. 54). Glutamate has been implicated in neuromuscular transmission in Helix (Kerkut, Leake, Shapira, Cowan and Walker, 1965) and the effects observed in the present experiments

Fig. 55. Intracellular recordings from the osphradial ganglion of Planorbarius.

Top two traces show recordings from the same cell when the temperature of the bathing Ringer was increased from 13° C to 23° C. There is an approximate doubling in the frequency of firing which yields a Q 10 of about 2.

Bottom traces show the responses of two cells in the same preparation to the addition of penis extract. The arrows indicate the point of addition. There is no change in frequency which accompanies the addition of this substance.

OSPHRADIAL GANGLION

TEMPERATURE 13°C



50
mv. 5secs.

TEMPERATURE 23°C

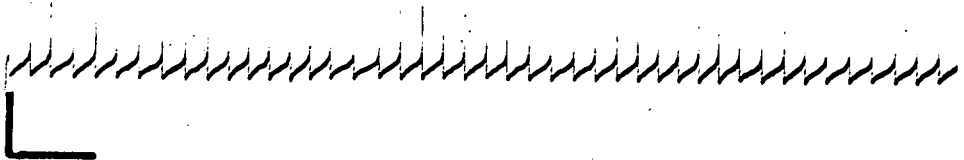

PENIS EXTRACT

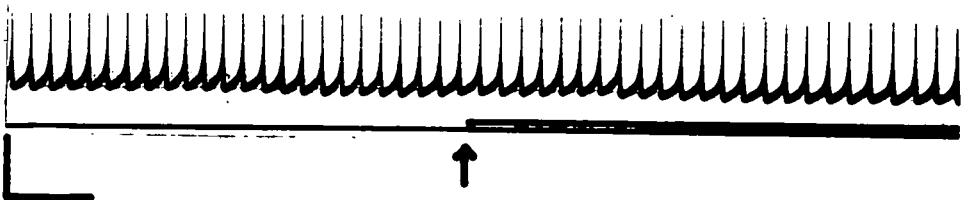

PENIS EXTRACT

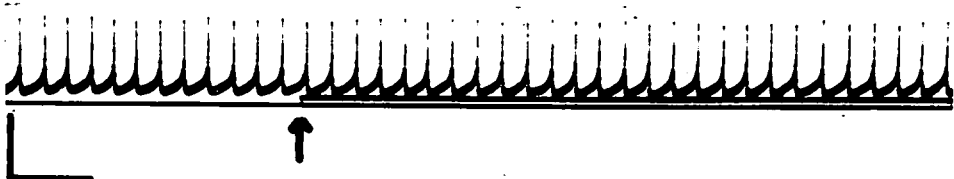

may be attributed to this role. The preparations were sensitive to concentrations of glutamate down to 10^{-8} M. The muscular tissue of the mantle and osphradium is also sensitive to cations such as sodium and calcium and no genuine osphradial stimulations were achieved with inorganic ions. Additions of Ringer adjusted to a pH of up to 2 on either side of neutral caused only a withdrawal of the body wall and osphradium.

Extracts from the genitalia of reproductively active snails also caused no response (fig. 55).

A particle detecting function was tested by addition of alumina particles, of maximum size 1μ , to the osphradial aperture. These did not affect the activity of the osphradial neurones.

The osphradial neurones were not particularly sensitive to temperature. An increase in temperature of about 10° C caused an increase in spike frequency (fig. 55) but not sufficient to suggest that temperature reception could be a primary function for the osphradium ($Q_{10}^{0-10} = 2$). The experiments in which activity in the central nervous system was monitored whilst the osphradium was stimulated peripherally, confirmed the results of the direct recordings. Substances were added to the osphradial aperture and recordings simultaneously made from cells in all parts of the left pallial ganglion. Figure 57 shows an experiment in which milk was

Fig. 56. Responses of the osphradial ganglion of Planorbarius to the addition of leaf extract, alumina particles and milk.

The arrows indicate the addition of the substances.

No changes in spike frequency have been recorded.

OSPHRADIAL GANGLION

50
mv. — 5 secs.

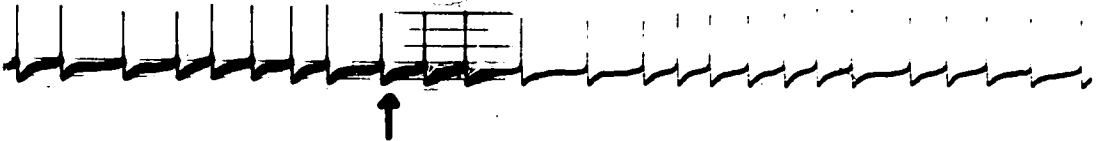

LEAF EXTRACT

L

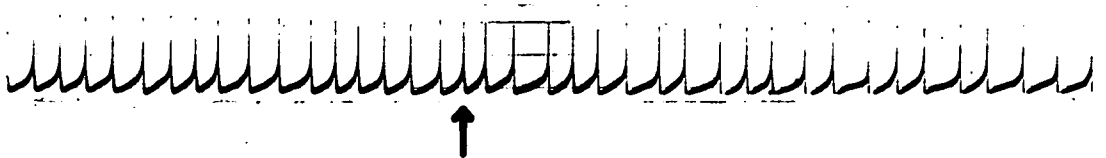

ALUMINA PARTICLES

L



MILK

Fig. 57. Intracellular recordings from the left pallial ganglion of Planorbarius whilst milk is being added to the osphradium.

The preparation consists of the osphradium in an isolated piece of body wall tissue with the brain attached via the left pallial nerve.

Recordings from three active cells. No change in frequency is recorded.

LEFT PALLIAL GANGLION
OSPHRADIUM+MILK PLUS OSPHRADIUM

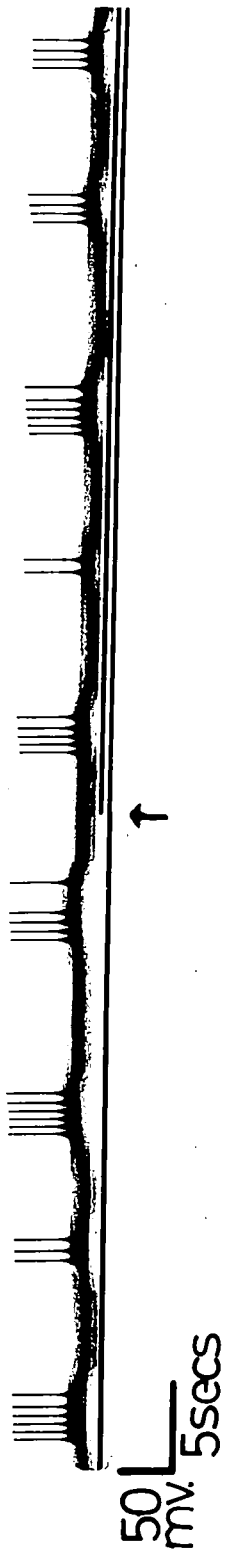

OSPHRADIUM+MILK



OSPHRADIUM+MILK

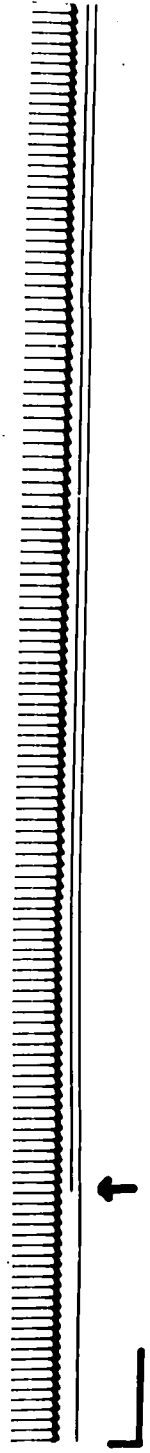

tested. Three different cells are shown, each having a different type of rhythmic spike activity. No changes in activity in the left pallial ganglion have been recorded which could be associated with stimulation of the osphradium.

CONCLUSIONS AND DISCUSSION

Neurones from the isolated brain of Planorbarius have similar electrical properties to those recorded in molluscs by other workers (eg. Arvanitaki and Chalazonitis, 1955; Kerkut and Walker, 1961). Willows (1965) recorded resting potentials in the isolated brains of several nudibranch molluscs and obtained a range of values from 30-80 mV. These are similar to the resting potentials recorded in the present study. Kerkut and Walker (1961) pointed out that active cells in Helix brain show a maximum resting potential of about 50 mV. Action potentials in Planorbarius are of the order of 70 mV. overall size and this is again characteristic of molluscan central neurones. No intracellular recordings have previously been made from osphradial ganglia or isolated cells similar to those in left pallial nerve of Planorbarius. Only a small number of intracellular recordings has been made from nerve cell bodies known to be sensory in function. Barth (1964) succeeded in recording intra-

cellular spikes and resting potentials in the retinal neurones of the eye of Hermisenda. It seems probable from these recordings in Hermisenda and from recordings in the peripheral nerve cell bodies of Planorbarius that the cell bodies of peripheral neurones in these molluscs have similar properties to central neurones.

The rhythmic spike activity present in isolated brains of Planorbarius, which seemed to be independent of any input, has often been termed "spontaneous" in other isolated molluscan brain preparations. The mechanism of the phenomenon is not clear, although it necessarily requires regular depolarisation and repolarisation of the neuronal membrane (Kennedy, 1966). Recent work by Willows (1967) in nudibranchs suggests that so-called spontaneously active cells are much less common in intact brains than in isolated preparations.

From the small number of experiments carried out it seems that H and D acetylcholine sensitive cells, present in other species of molluscs investigated (eg. Kerkut and Walker, 1962), are also present in Planorbarius. The preliminary experiments investigating the light sensitivity of brain cells in the present study suggest that white light affects the electrical activity of Planorbarius neurones in a similar way to Aplysia (Arvanitaki and Chalazonitis, 1961). Kennedy (1960) showed that a peripherally located nervous

element in the lamellibranch, Spisula solidissima was sensitive to light and that the shadow response of the animal was mediated by this peripheral element. Whether the light sensitivity of Aplysia or Planorbarius neurones is important in normal animals is unknown. Stephens and Stephens (1966) have reported that photoperiodically stimulated egg laying in Helix aspersa is independent of the presence of eyes. This sort of response could be mediated by light-sensitive neurosecretory cells in the brain (see SECTION 4).

Recordings from single cells, individually situated in the pallial nerve of Planorbarius revealed cells which fired in a rhythmic manner. The significance of this sort of activity is difficult to account for in a single cell. Recordings from grouped cells also revealed spike activity; some of this appeared to be autogenic but most of it resulted from activation of the soma from distantly initiated axonal spikes (as no prepotential was recorded). These spikes still occurred after connections with the central nervous system had been severed. Whether the activation was due to post-synaptic activity within the clumped group of cell bodies itself or from activity of other peripherally situated units is not clear. Other experiments, involving stimulation and recording techniques are required to determine the source of spike and EPSP activity in these clumped cells. It is possible that small groups

of cells of this type may act as simple integrating centres which control some aspect of local activity in a similar way to the cardiac ganglion of the lobster (Bullock and Terzuola, 1957). Molluscs have the ability to carry out locally organised reflex actions.

Electrophysiological experiments on the osphradium have not revealed a function for the organ, nor have they confirmed any duality of function in the osphradial ganglion which had been suggested by anatomical studies (SECTION 1). It is possible that cells have been penetrated which have no connection with an osphradial sensory function being neither primary sensory neurones or second order neurones connected with the former by interaxonal synapses. This seems unlikely in view of the large number of cells penetrated. The significance of the regularly firing cells in the osphradium is not clear, although this sort of activity would make the output of the cells more sensitive to applied depolarisation or hyperpolarisation. To understand the relationship of the various nerve cells within the osphradial ganglion it would be necessary to carry out further studies using stimulating and recording electrodes. The insensitivity of the osphradium to addition of food substances was confirmed by the behavioural experiments of SECTION 3.

SECTION 3 BEHAVIOUR

INTRODUCTION

Early attempts to discover sites of chemosensitivity in gastropod molluscs have been mainly anatomical. Kohn (1961) has emphasised that the large majority of more recent investigations concerned with the experimental analysis of chemoreceptive ability has been of a behavioural nature. Commonly, orientation experiments have been allied with extirpation techniques to determine areas of the animal which are sensitive to this modality. Only a small number of experiments has been carried out using an electrophysiological approach (SECTION 2).

Charles (1966) states that the cephalic tentacles are the most important sites of "contact" chemoreception in the gastropod molluscs, supplementing any sensory nerve endings in the buccal region and the foot. Agersborg (1922, 1925) has obtained evidence that the oral tentacles and rhinophores of nudibranchs are sensitive to chemicals; the tentacles are most sensitive to this modality and are involved in detecting substances in small concentrations. In another opisthobranch, Aplysia, Frings and Frings (1965) showed that the receptors involved in chemoreception were situated on the tentacles rather than the rhinophores. The rhinophores do not appear to play a role

in the characteristic food responses of Aplysia to its food-plant, Uca. Rhinophores are not present in the prosobranch or pulmonate gastropod groups. In the stylommatophoran pulmonates a second pair of oral tentacles is present which Charles (1966) says possesses gustatory receptors. Piéron (1908) reported that the anterior edge of the foot of Lymnaea stagnalis was a primary site of "contact" chemoreception. Copeland (1918) showed that the siphon, tentacles and anterior foot of Nassarius were sensitive to chemicals. Extirpation experiments, however, indicated that a region close to the bases of the siphon was the most important site involved in the feeding response to Fundulus extract. Removal of the tentacles did not destroy the feeding responses of Nassarius or Busycon. In Viviparus the olfactory ability also appears to be normal in animals in which the tentacles have been removed (Wölper, 1950).

The osphradium is found within the mantle cavity of aquatic prosobranch molluscs, and some opisthobranchs, but is outside the mantle cavity in aquatic pulmonates. The work of Copeland (1918) implicated the organ of the carnivorous prosobranch Busycon in chemoreception. Using extirpation techniques he showed that the movement of the animals towards fish extract was dependent on the presence of at least part of the osphradium. The work of Wölper (1950), Brown and Noble (1960) and Burke (1964) has confirmed

Copeland's results for other prosobranch species. Bailey and Laverack (1963, 1966) have obtained addition^{al} evidence from electrophysiological work that chemoreception is the primary function of the osphradium of prosobranch molluscs. The only direct evidence of a role for the osphradium of pulmonates comes from the behavioural work of Michelson (1960). Again a chemoreceptive function was suggested.

It is apparent that chemoreception is not restricted to one particular organ in gastropod molluscs, and in the present study attempts have been made to determine the site of chemoreceptive ability in Planorbarius corneus. Experiments have been carried out to ascertain whether these herbivorous animals could be attracted towards complex substances in Y mazes and the effect of removal of tentacles and destruction of the osphradium was tested to see if "normal" behaviour was affected. In the case of the osphradium it was hoped to correlate these behavioural results with the electrophysiological experiments described in SECTION 2.

Further behavioural experiments were carried out to see if extirpation of the osphradium affected the ability of the snails to carry out lung ventilation behaviour. (that the organ might be concerned in this type of behaviour was suggested by Lacaze-Duthiers, 1872).

Other results which are recorded in this section are concerned with the behaviour of the osphradium itself in intact animals and in isolated preparations of body wall. The ciliary currents on the mantle epithelium in the osphradial aperture region and within the canal of the organ have also been investigated.

METHODS

a) Ciliary currents.

It is possible to observe the beating of cilia in molluscs simply by viewing the surface of an epithelium under the low-power of a microscope. Tracts of cilia are indicated by a flickering effect and this can be observed against the blue background of the mucus which is always associated with the cilia. Observations of ciliary currents are made easier by using some particle which is carried by the tracts in a particular direction; thus it is possible to ascertain any region towards which the main beat of the ciliary rows is being directed, and whether the various rows of cilia are being co-ordinated to produce a general "flow" of water movement. Carmine particles were tried initially but it was found that these tended to clump together and it was not easy to determine the size of particle being carried. More satisfactory results were obtained using alumina

particles which could be obtained in guaranteed sizes from 1-20 μ in diameter. 1 μ alumina particles were added to the dorsal side of the head behind the tentacles and their movements over the dorsal head and osphradial regions recorded. After the initial observations of particle movements around the mouth of the osphradium the mantle behind this aperture was removed to reveal the osphradial canal. It was thus possible to ascertain whether particles were carried into the osphradium. Removal of the osphradium and the production of a squash preparation allowed a more detailed analysis to be made.

The same type of experiments was carried out on the isolated osphradial preparation used for the electrophysiological experiments (SECTION 2) in order to determine whether the ciliary currents were beating in a similar manner to those of the intact preparation. Experiments were carried out with the central nervous system attached and with the left pallial nerve sectioned to estimate the effects of possible efferent activity on the beating of the ciliary currents in the osphradial canal or outside.

b. Y mazes.

Eight Y mazes were constructed from perspex with the dimensions shown in figure 58. The width of the channel ensured that animals

Fig. 58. Y maze used in chemosensory orientation experiments
with Planorbarius.

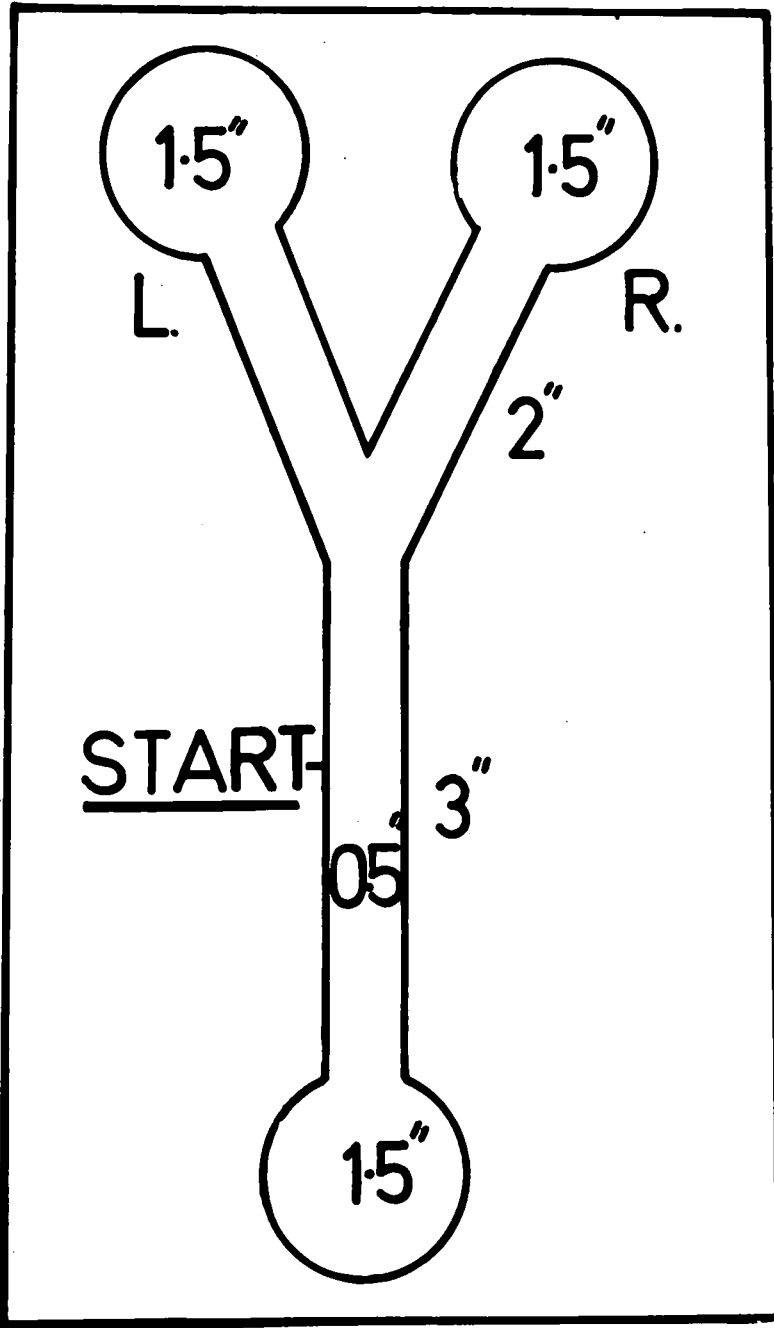

Y MAZE

of various sizes could be accommodated. An average-sized animal of about 2 cm. length had only small lateral clearance which meant that there was little room to manoeuvre. This ensured that the animals usually crawled forwards.

Animals which had recently ventilated were used for the trials. Thus they were in the correct buoyancy condition for the normal depth of about 0.5 cm. of water in the mazes. This meant that the snails did not require to carry out ventilation behaviour during the course of an average run of about a quarter of an hour. The snails were divided into groups of sixteen and numbered. It was convenient to carry out 64 trials in one day, and thus a day's experiment consisted of running each snail of a particular group four times, the mazes being baited twice left and twice right. Snails were selected for the preferred buoyancy condition and the bait positioned in a pre-determined random sequence. If the snail had not moved after 20 minutes from the start position in the maze (fig. 58) then it was returned to the storage tank. After each set of trials the mazes were washed in hot water and set up for a new series of experiments. A particular trial was considered complete when the whole shell of the animal had entered one of the short arms of the Y maze. The following substances were used as baits - 10^{-3} M glutamate, milk, a mixture of rotting leaves (Oak and Elm), lettuce, Cladophora and

Potamogeton crispus. The plant material was homogenised in filtered water until a particulate suspension was obtained. The milk was fresh cows milk used straight from the commercially supplied bottle and the glutamate solution was prepared from powder dissolved in filtered tap water and was unbuffered.

Attempts to determine the site of chemosensitivity in the animals by extirpation were preceded by preliminary experiments to see if feeding movements could be elicited in the snails by pipetting leaf homogenate onto various parts of the animal.

c. Anaesthetisation and operations.

A technique for the anaesthetisation of Planorbarius has been developed. Lever, Jager and Westerveld (1964) used a technique based upon a combination of nembutal, carbon dioxide, and M.S.222 which proved satisfactory for operations on the brain of Lymnaea stagnalis. The same technique used with Planorbarius was less successful and produced high mortality rates. A technique which uses nembutal and carbon dioxide alone has been used. Active snails were placed in a 0.1% solution of veterinary (60 mg/ml) nembutal in filtered tapwater at 27°C. They were left for ten minutes, and then flushed with carbon dioxide using a porous block for a further ten minutes. The animals were then suitable for operations.

After this treatment the animals were either extended completely out of the shell or relaxed enough to be easily manipulated in a position to reveal the osphradial opening, which was observed under the low power of a binocular microscope. A hot needle was used to destroy the canal of the osphradium. It was important not to break the surface of the mantle because this caused a loss of blood. Animals which were injured in this way did not recover. It seems that Planorbarius, unlike Lymnaea, cannot lose blood without causing death. Another group of snails was prepared in which the mantle in the region of the osphradium was damaged but not the osphradium itself, and a third group was allowed to recover from the anaesthetisations without injury. All the animals were active after a few hours but were not used in the Y mazes until fully active; this was usually after a week. Examination of a snail which had been osphradialectomised after two days showed that the tissue over the osphradium had healed to leave a scar on the surface. In the short time which elapsed between the operations and maze experiments the osphradium did not appear to regenerate itself (Copeland, 1918, had reported that marine prosobranchs could regenerate their osphradia after several months).

The tentacles were removed under anaesthesia by cutting them at their base, close to the head.

d.) Respiratory behaviour.

The ventilation behaviour of Planorbarius in filtered tapwater was studied when the air pressure above the water was increased (Jones, 1964a, 1964b). The animals were contained in a gas jar connected to a compressed air supply, pressure changes being monitored by a mercury manometer. Normal animals and osphradialectomised animals were used.

RESULTS

a.) Ciliary currents.

Observations of young specimens of Planorbarius indicated that the ciliary currents on the anterior mantle of the snails draw a water current from some distance in front of the animal. The passage of motile protozoa is affected by this ciliary activity at a distance of up to 1 cm. away from the snails. The main water current is backwards over the head, and up and under the anterior shell (fig. 59). This means that there is a constant movement of water in the region adjacent to the anus and osphradium. The volume of this space is also affected by the locomotion of the animals. This consists of

Fig. 59. Results of experiments with alumina particles to discover the ciliary currents over the osphradial region of the anterior mantle of Planorbarius.

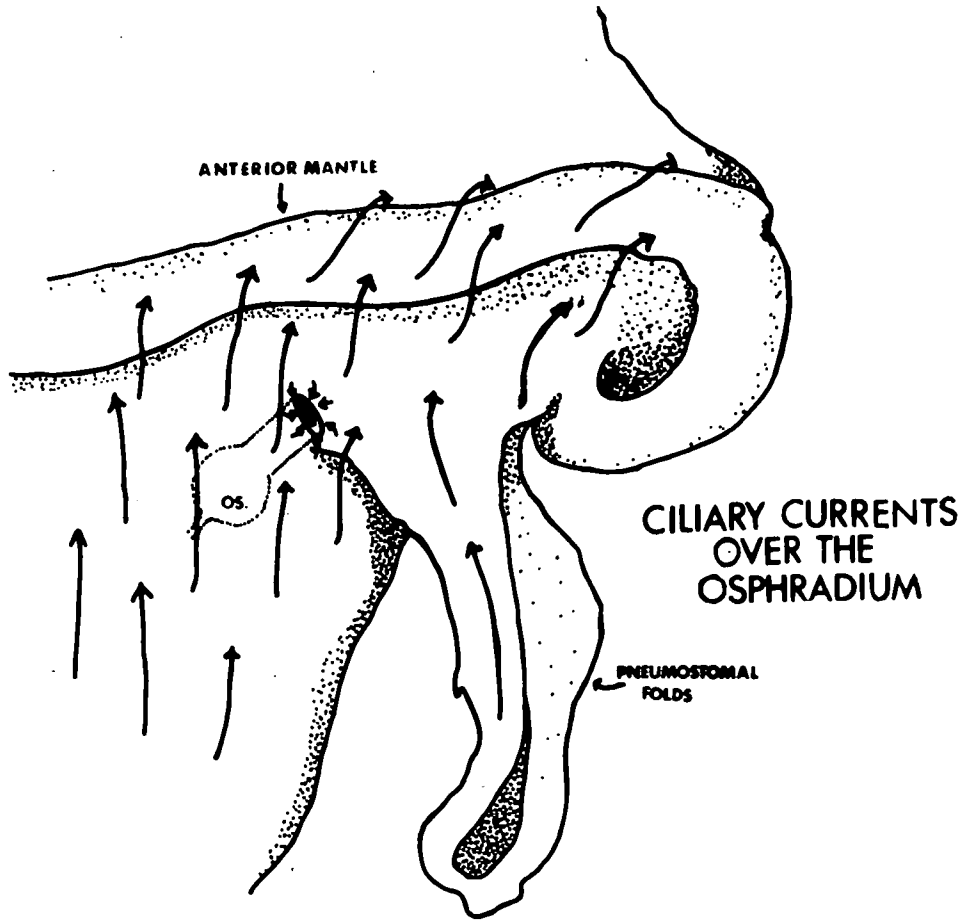

a forward movement of the head and foot followed by the lifting over of the visceral mass and shell during the second stage of the locomotary cycle. When the foot is forward the volume between the osphradium and the shell is small, but when the visceral mass moves anteriorly this volume increases. This cycle would cause a constant movement of water in the osphradial region.

Addition of alumina particles gave results which are summarised in figure 59. Apart from the current of water carrying material over the osphradial aperture and up over the lip of the mantle there is a subsidiary current caused by the cilia in the osphradial canal. This is primarily inward. After addition of 1μ particles of alumina and removal of the mantle epithelium, examination of the contents of the osphradial canal showed that particles were being carried inwards, some of them to the basal region of the canal. Examination of the mouth of the osphradium in the intact preparation showed that the particles were enmeshed in strings of mucus. These strands were carried over the lips of the aperture and could be observed to penetrate the mouth of the osphradium. 5μ particles caused a rather different response. They were also carried in strings over the lips of the osphradium and entered the broad region of the canal just below the aperture, but then they were immediately rejected by muscular contractions of the canal.

Sometimes they would be carried repeatedly towards the mouth of the osphradium but were always rejected. The muscular nature of the osphradium has already been mentioned (SECTION 1) and the "contraction" response seems to be an important behavioural property of the organ. Sometimes the response occurs "spontaneously" without stimulation.

The ciliary currents in the osphradial region were re-examined in the isolated preparation used for the electrophysiological recordings. Even when the nervous connections with the brain had been severed the cilia both around the osphradium and within the ciliated canal were, apparently, beating normally. Also the contraction response could be elicited when the connection to the central nervous system via the left pallial nerve had been severed. In SECTION 2 it was noted that the contraction response could be stimulated by other noxious stimuli, for instance acidic solutions and tactile stimuli. Glutamate also has the same effect and this probably reflects its role in neuromuscular transmission (Kerkut, Leake, Shapira, Cowan and Walker, 1965).

Addition of alumina particles to the tentacles showed the presence of rows of cilia beating in a manner which caused a strong current of particles to be carried from the tip of the tentacles downwards to the base of the tentacle and from there

over the lateral regions of the head. Severing of the tentacle nerve did not alter this activity in isolated tentacle preparations.

b. Chemoreception.

Observations on specimens of Planorbarius corneus kept in the laboratory showed that they will feed on plant material, such as lettuce and rotting oak and elm leaves. If a homogenate of rotting leaves was placed in one part of an otherwise empty tank then snails, placed randomly, could be found feeding on it after a few minutes. This behaviour was particularly evident if the snails had been starved for a few days. Feeding movements of the pharynx and radula could be induced by squirting extracts of plant substances towards the head. The mouth regions were particularly sensitive to squirted extracts, but animals could also be induced to turn towards food by addition of this substance to the dorsal part of the head in the tentacular region. The foot was less sensitive but occasional turning responses could be elicited by stimulation of the anterior foot region. Such responses have been termed "contact" responses (Kohn, 1961). However, because of the extensive ciliary activity on the head it is not certain from these experiments which part of the animal is being stimulated.

The Y maze results have been analysed using the Chi-squared

Fig. 60.

Summary of bait tests with *Planorbarius corneus*

1. Orientation of snails towards various
possible food substances

Baits	No. of snails entering		χ^2	Attracted?
	Baited Well	Empty Well		
Milk	123	55	12.4	Yes
Rotting Leaves	94	34	27.2	Yes
<u>Cladophora</u>	43	18	9.4	Yes
Lettuce	48	16	16.3	Yes
Glutamate 10 ⁻³ M	31	33	0.01	No
<u>Potamogeton</u>	75	59	5.0	No

Chi-squared values greater than 6.635 (P = 0.01) have been considered as significant.

test with Yates' adjustment for small samples. Values greater than 6.635 were considered to be significant ($P = 0.01$). The results shown in figure 60 indicate that milk, rotting leaves, Cladophora and lettuce would attract the snails. The best results with lettuce leaves could be obtained if the lettuce had first been allowed to float on the surface of snail tanks in the aquarium for a few days. This suggests that bacterial or algal growth may be the primary attractant and this is confirmed by the good results obtained with Cladophora. The freshwater plant Potamogeton did not attract the animals significantly. 10^{-3} M glutamate, which Bailey and Laverack (1963, 1966) had shown would stimulate the osphradium of Buccinum in an electrophysiological preparation, did not attract the snails in the present experiments.

Control snails which had been anaesthetised but were undamaged, orientated in a significant manner towards lettuce as did the sham operated group (fig. 61). Animals in which the osphradium had been destroyed, also moved towards the lettuce ($P = 0.01$), but those without tentacles were unable to detect this substance.

c. Respiratory behaviour.

Jones (1961, 1964b) had shown that buoyancy was a factor which determines whether a snail would carry out respiratory or diving

Fig. 61.

Summary of bait tests with *Planorbarius corneus*

2. The effects of extirpation of various organs on the orientation of snails towards lettuce extract

Extirpation Group	No. of snails entering		χ^2	Attracted?
	Baited Well	Empty Well		
Undamaged Group	44	20	8.3	Yes
Sham operated	49	14	18.4	Yes
Osphradialectomised	43	21	5.9	Yes
Tentacles removed	37	27	0.63	No

Chi-squared values greater than 6.635 have been taken as significant.

behaviour. By adjusting the pressure of air above an enclosed volume of water which contained snails, he could artificially stimulate either type of behaviour. Experiments of this type have been repeated successfully with Planorbarius. If the osphradium was destroyed and the experiments repeated with osphradialectomised animals, then the behaviour was completely normal. The animals could be induced to move towards the surface if the pressure of air was increased by one atmosphere and diving followed release of this pressure.

CONCLUSIONS AND DISCUSSION

The region in which the osphradium of Planorbarius is situated receives a constant supply of water from in front of the animal and the osphradium is able to sample this water. It is probable that the osphradial canal is emptied by means of a contraction or flushing response. Thus material from the water reaches the base of the osphradial canal where nerve endings occur (SECTION 1).

The Y maze experiments indicate that the animals are able to orientate towards various complex plant substances, but that destruction of the osphradium does not alter this ability. These results do not agree with those of Michelson (1960) who found that

if the osphradium of Australorbis glabratus was destroyed by cauterisation, then the ability of the animals to orientate towards algal extract was lost. These results do, however, agree with the electrophysiological experiments of SECTION 2.

The tentacle ablation experiments suggest that the main site of chemoreception is in these structures. Removal of both tentacles affected the ability to seek food. Sensory nerve cells have been reported in the tentacles of basommatophoran pulmonates (Hanström, 1928) and these could represent the primary receptor sites for chemoreception. Ciliary currents on the tentacles carry water currents from the tip of the tentacles towards the base and presumably carry chemical stimulants over these primary sensory endings in the tentacular epithelium.

Ventilation behaviour is normal in osphradialectomised animals which suggests that the organ is not concerned with this process.

Thus the behavioural evidence does not clarify the role of the osphradium but does support the negative finding of electrophysiological evidence concerning a function in chemoreception.

SECTION 4 LIPID BODIES

INTRODUCTION

There have been a number of studies on the cytochemical inclusions of molluscan neurones using different experimental approaches. Chou (1957) and Chou and Meek (1958) carried out cytochemical investigations into the subcellular organisation of neurones from the central nervous system of Helix aspersa. They showed that the neurones contained lipid bodies which varied in their staining properties. Chou suggested a sequence of development which Chou and Meek correlated with structural changes revealed by the electron microscope. Other, more recent, investigations showed that these lipid bodies occur in a number of molluscan species (Chalazonitis and Lenoir, 1959; Amoroso, Baxter, Chiquoine and Nisbet, 1964; Zs-Nagy, 1964; Simpson, Bern and Nishioka, 1966; Lane, 1966). Lane⁽¹⁹⁶⁶⁾ has suggested that the lipid bodies resemble vertebrate lysosomes in their staining properties.

Another group of workers has stained sections of molluscan central nervous systems with the neurosecretory stains paraldehyde-fuchsin and chrome-haematoxylin. Lever, Kok, Meuleman and Joosse (1961) have used the chrome-haematoxylin technique to identify

neurosecretory material in the central nervous system of Lymnaea stagnalis and they showed that the pleural ganglia contained a large number of cells which stain positively with this technique. Hekstra and Lever (1960) had earlier demonstrated the importance of the pleural ganglia in maintaining water balance in the same species, and Lever, Jansen and de Vlieger (1961) in an extension of this work concluded that the neurosecretory cells were an important factor in this process. Boer (1965), in a detailed analysis of neurosecretory phenomena in Lymnaea stagnalis, correlated the neurosecretory staining results with known intracellular inclusions of snail neurones and showed that the "yellow" lipid bodies which Chou (1957) had described in Helix aspersa would stain positively with paraldehyde-fuchsin in one group of central neurones.

Arvanitaki and Chalazonitis (1961) have been interested in the effects of light on the electrical activity of neurones in the visceral ganglion of Aplysia. They have demonstrated the presence of two pigments within the lipid bodies of these cells which gave the neurones their characteristic orange colour in the living state. The pigments have been identified as a carotene-protein and a haem-protein, and their absorption spectra have been measured. If the neurones were illuminated with light of wavelength similar

to that of the absorption peaks of the two pigments, then the electrical activities of the cells were affected. Changes which presumably take place within the lipid bodies could affect the electrical characteristics of the plasma membrane which surrounds the whole cell. Arvanitaki and Chalazonitis (1961) thought that this was similar in some respects to the photo-activation of plant cells by light.

Lipid bodies are present in the osphradial neurones of Planorbarius (SECTION 1). In the present study the fine structure of the organelles will be considered in greater detail and the results will be interpreted in an attempt to explain the work discussed above.

METHODS

The techniques for removal and preparation of the osphradium for sectioning and examination in the electron microscope have been described in SECTION 1. All the material examined has been stained with lead citrate alone (Reynolds, 1963). After initial low power identification of the lipid bodies within the neurones of the ganglion region most of the more detailed examination has been carried out in the 20-30K magnification range.

RESULTS

The lipid bodies were present in most of the neurones of the osphradium. They occur mainly in the region below the nucleus and in the axons close to the soma. Those shown in figure 62 are in a portion of axon close to the cell body of a large neurone from the rind of the osphradial ganglion. The distribution of these organelles in a whole cell body is seen in figure 25. The lipid bodies vary in length from 0.7-5.0 μ and in width from 0.5-2.0 μ . These dimensions are similar to those recorded by Chalazonitis and Lenoir (1949) in Aplysia. As Chou and Meek (1957) had observed, the lipid bodies have a variety of structural forms which may be interpreted to form a sequence of events. Analysis of a large number of cells has revealed the existence of forms not observed by the above authors or subsequently by McGee-Russell (1964). As well as a gradual build-up of material inside an originally simple sac, forms have been observed which suggest a breakdown phase when the lipid bodies contents are released into the neurone cytoplasm.

The first stages in the suggested sequence are simple sacs possibly formed from areas of neuronal cytoplasm enclosed by portions of the endoplasmic reticulum. No early stage lipid bodies

Fig. 62. Electron micrograph of a neurone from the osphradial ganglion of Planorbarius. Several lipid bodies are apparent with a number of large mitochondria close by.

dg, dense granules

er, endoplasmic reticulum

g, glial cell

lb, lipid body

mi, mitochondrion

nc, nerve cell body

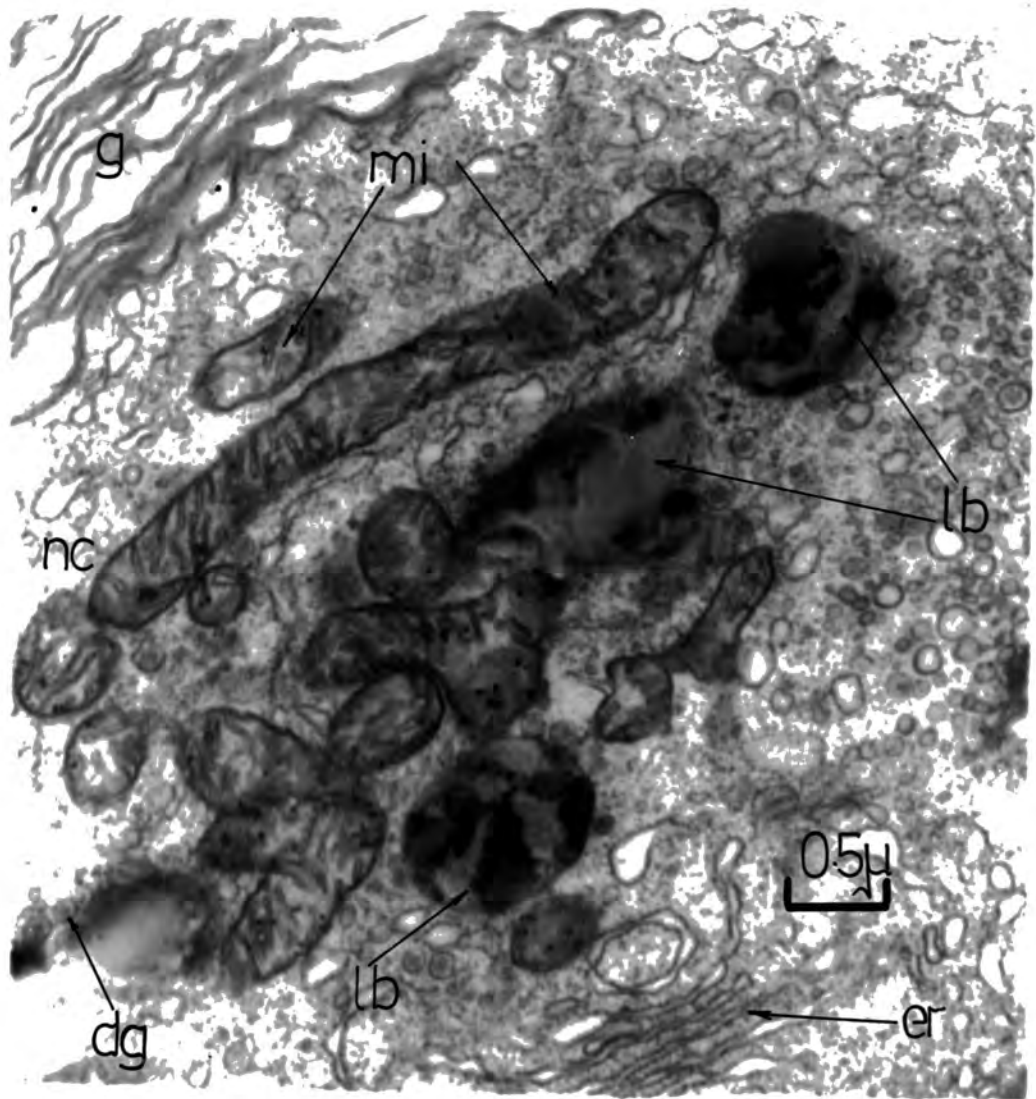

Fig. 63. Electron micrograph of an early stage in the lipid body cycle. The lipid body contains a number of structureless granules and a single-membraned sac of larger size. The general cytoplasm of the lipid body is similar to that of the outside neuronal cytoplasm.

er, endoplasmic reticulum

lb, lipid body

min, membraned inclusion

n, nucleus

sg, structureless granule

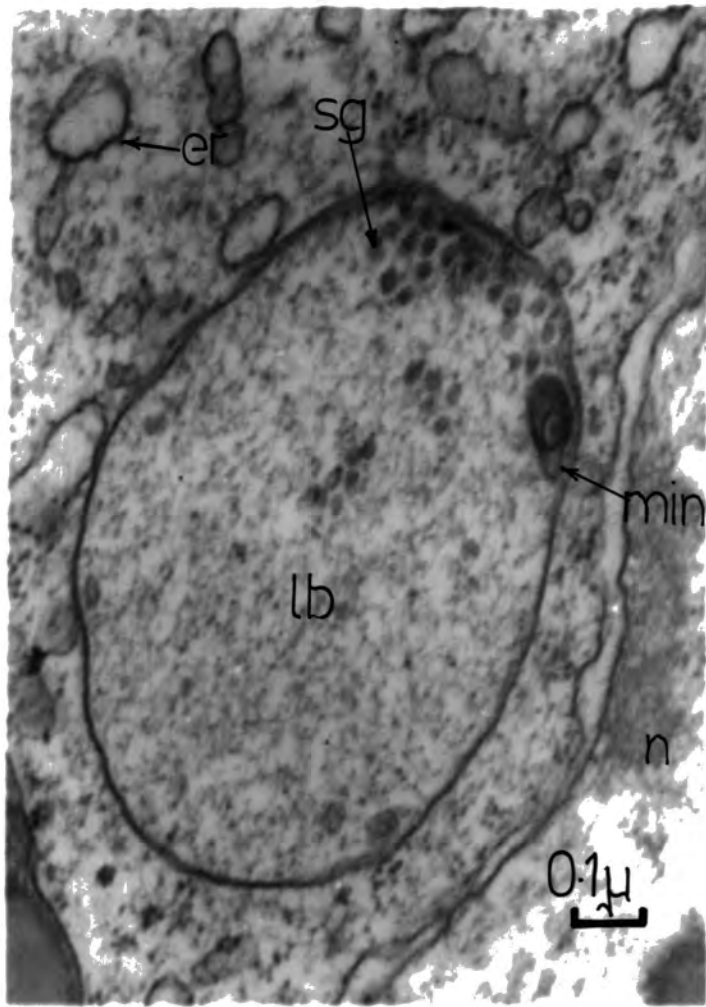

have been observed in the region of the Golgi apparatus to suggest an origin from this source. They are surrounded by a single membrane and their cytoplasm has a similar appearance to that of the outside neuronal cytoplasm (fig. 63). These sacs often contain granules of two types which are also common in the general cytoplasm of the neurones (fig. 64). The granules of the first type are about 0.05μ in diameter with no discernible structure, and are uniformly electron dense (fig. 63 s.g.). The second type of granule is larger, being about 0.1μ in diameter and consisting of a dense central region surrounded by a lighter area, the whole granule being enclosed by a definite membrane (fig. 64 d.g.). This type of "elementary secretory granule" is often associated with neurosecretion, and similar granules are known to be secreted from the Golgi apparatus in other molluscs (Amoroso et al., 1964). Similar granules have also been described in the synaptic regions of the neuropile in Aplysia (Gerschenfeld, 1962).

The later stages of the lipid body cycle are characterised by the presence of complex internal structures (figs. 64-67). Stacks of unit membrane arranged in lamella form are a prominent feature (fig. 64) and in a stage where the lipid body is packed with membranes and filaments these membranes often closely envelop oval areas of structureless material (fig. 65). Filamentous material

Fig. 64. Electron micrograph of an early-stage lipid body which contains a number of structureless granules, a dense centred granule and a membrane lamella. The neuronal cytoplasm contains a number of dense centred granules and the endoplasmic reticulum is arrayed in a manner which would be suitable for forming a new lipid body(A).

dg, dense centred granule

er, endoplasmic reticulum

lb, lipid body

m, membrane lamella

nc, neuronal cytoplasm

sg, structureless granule

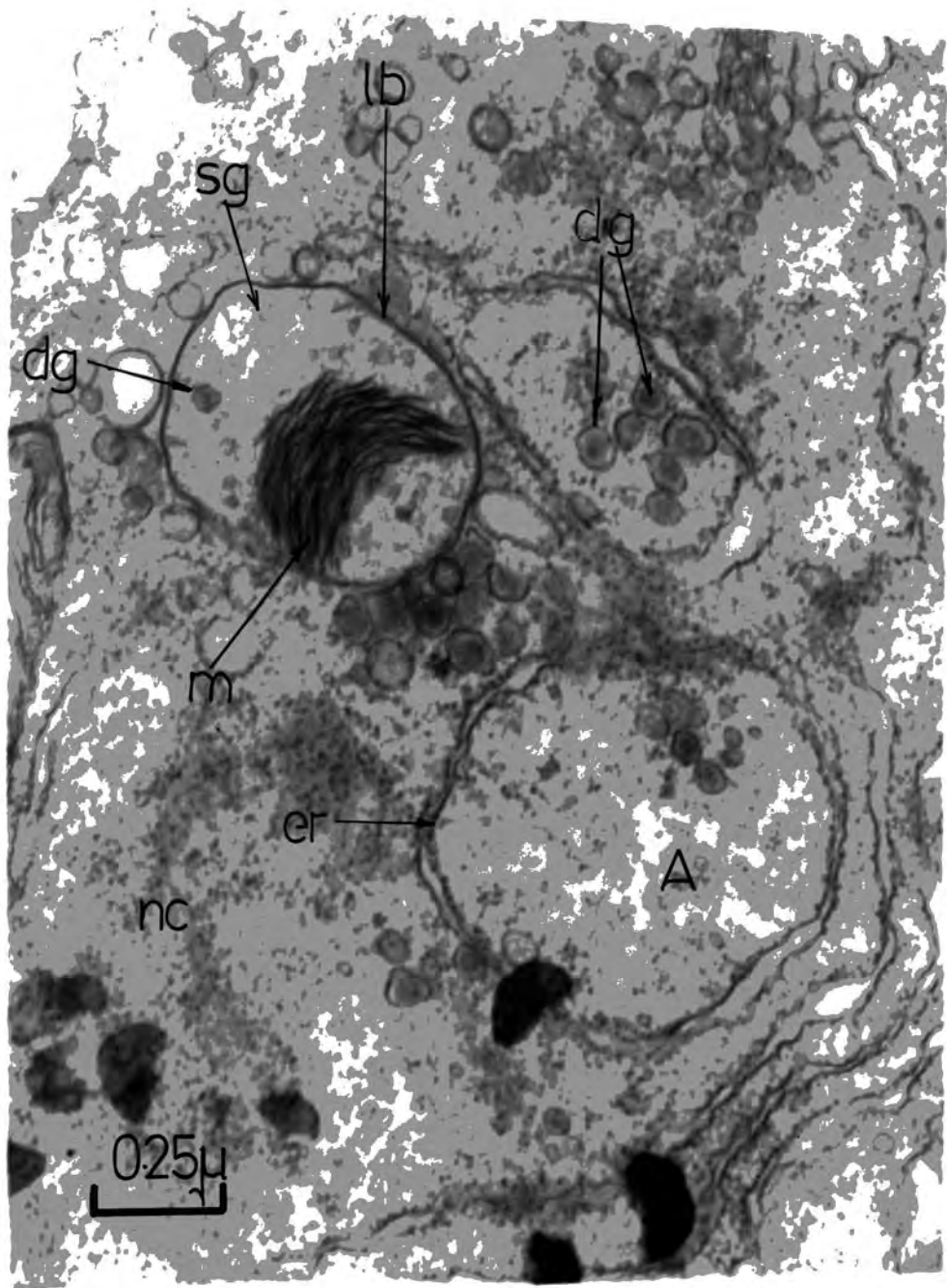

Fig. 65. An electron micrograph of a mature lipid body whose contents are largely filamentous. Membrane lamellae are associated with oval areas of secretory material.

b, break in the lipid body membrane

er, endoplasmic reticulum

f, filamentous material

m, membrane lamella

n, nucleus of neurone

sm, secretory material

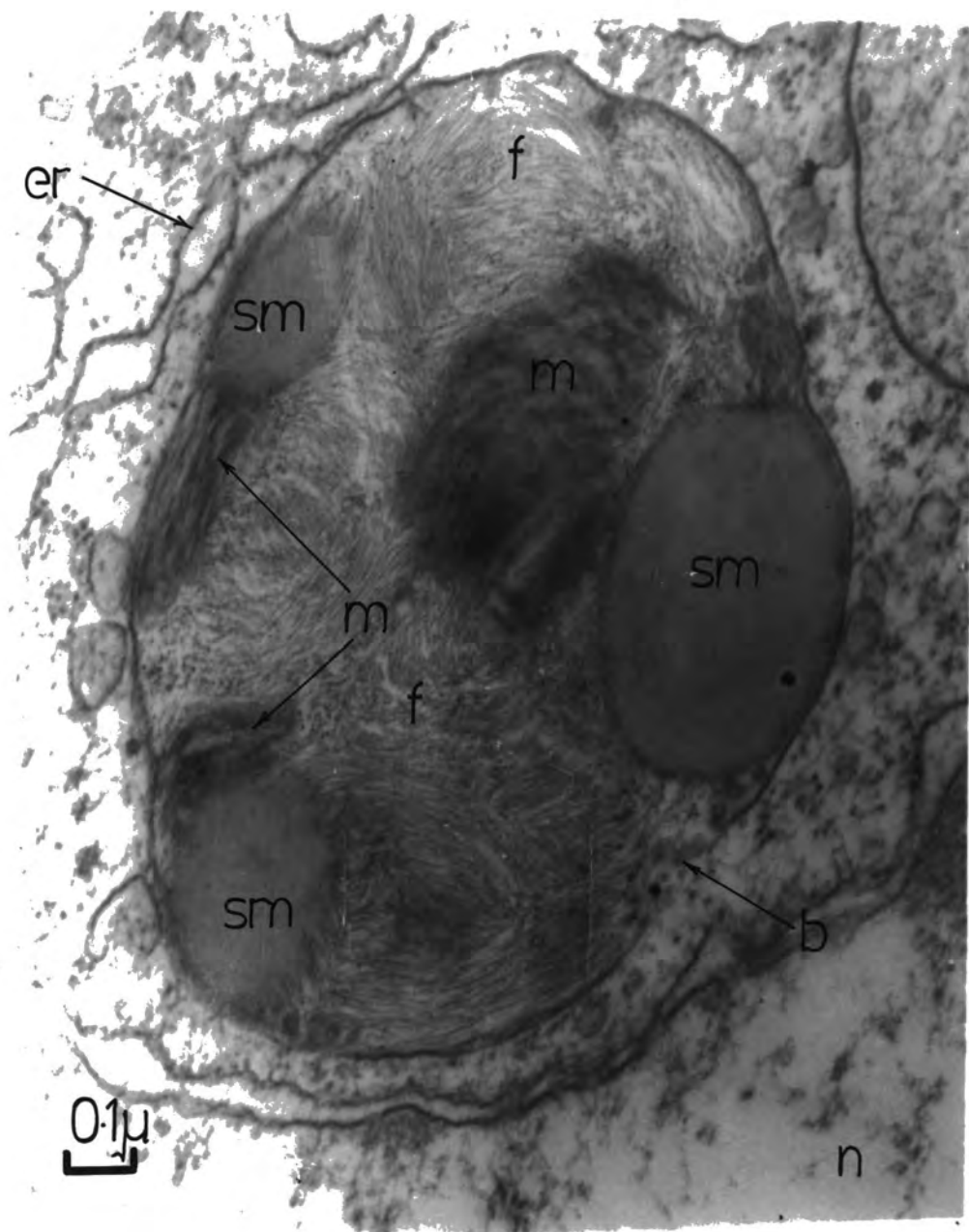

Fig. 66. A lipid body which contains a large amount of secretory material. A break in the lipid body membrane is apparent.

b, break in the lipid body membrane

er, endoplasmic reticulum

f, filamentous material

m, membrane lamella

mi, mitochondrion

mv, multivesicular body

nc, nerve cell soma

sm, secretory material

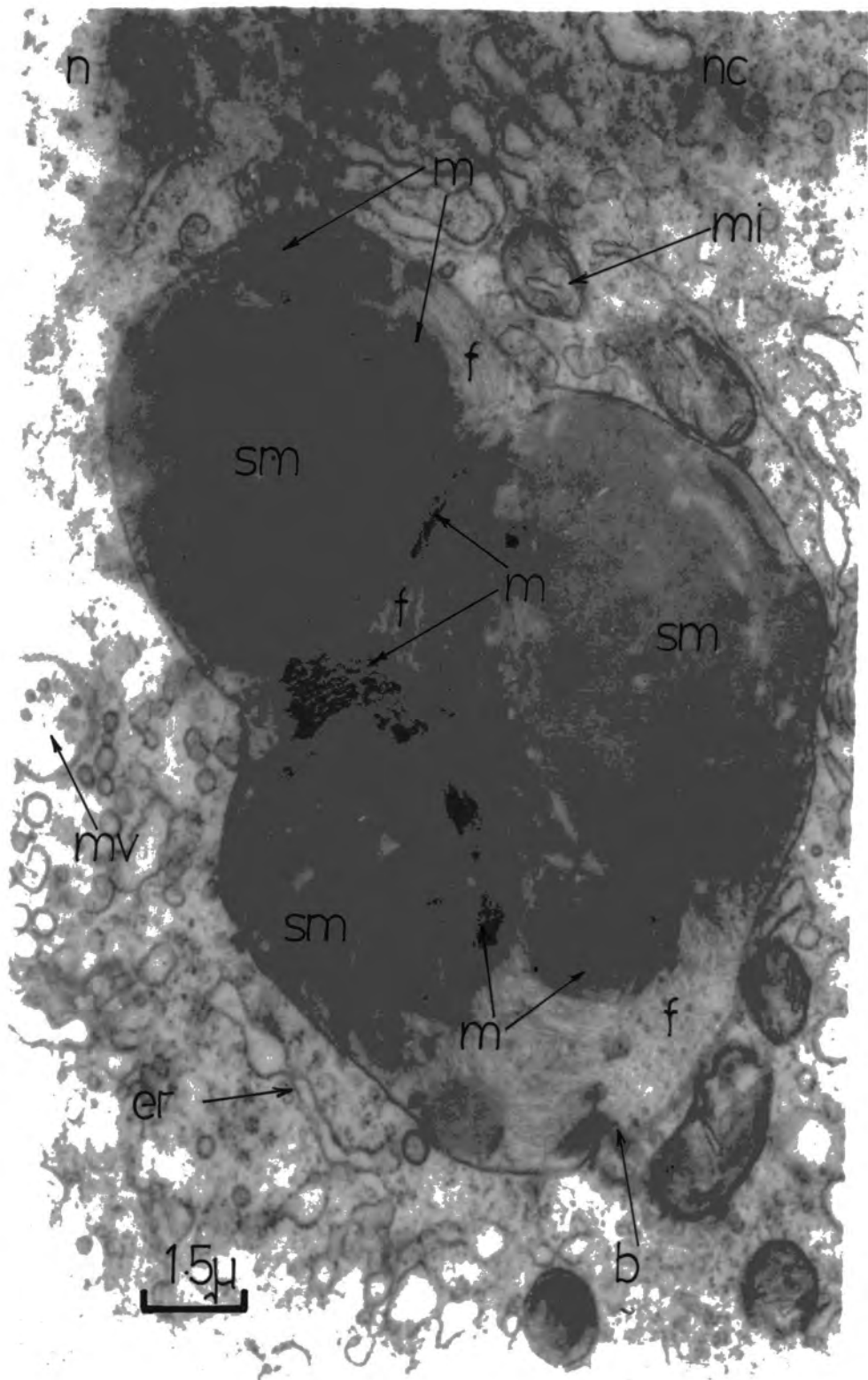

fills a large part of the lipid body shown in figure 65, and groups of filaments are arranged at various planes to one another. In transverse section the filaments appear as granules, about 80 Å in diameter.

The structureless material is usually situated at the edge of the lipid body under the surrounding membrane. There may be several regions of this material and they tend to give the lipid bodies an irregular shape (fig. 66). They increase in size until they fill almost the whole volume of the lipid body (fig. 66). The smallest observed structureless mass has been 0.2 μ in diameter and the largest about 2.5 μ . The oval areas are thought to be secretory products of the membranes, and this is supported by other histochemical evidence (Meek and Lane, 1964). The filamentous elements and membrane lamellae fill a much smaller volume of the lipid body by this stage.

During the transition of the lipid bodies from the early stages (fig. 63), up to the stage represented by figures 65 and 66, there is an increase in diameter from about 1.0 μ to 5.0 μ .

The stages which have reached the largest size often show breaks in their surrounding membrane (figs. 65 and 66); sometimes this membrane appears to be totally absent (fig. 67). It is suggested that when the membrane breaks down, the lipid body contents

Fig. 67. An electron micrograph of a lipid body which has lost its outer membrane and whose contents are being released into the general neuronal cytoplasm.

er, endoplasmic reticulum

f, filamentous material

m, membrane lamella

mi, mitochondrion.

nc, nerve cell cytoplasm

nt, neurotubule

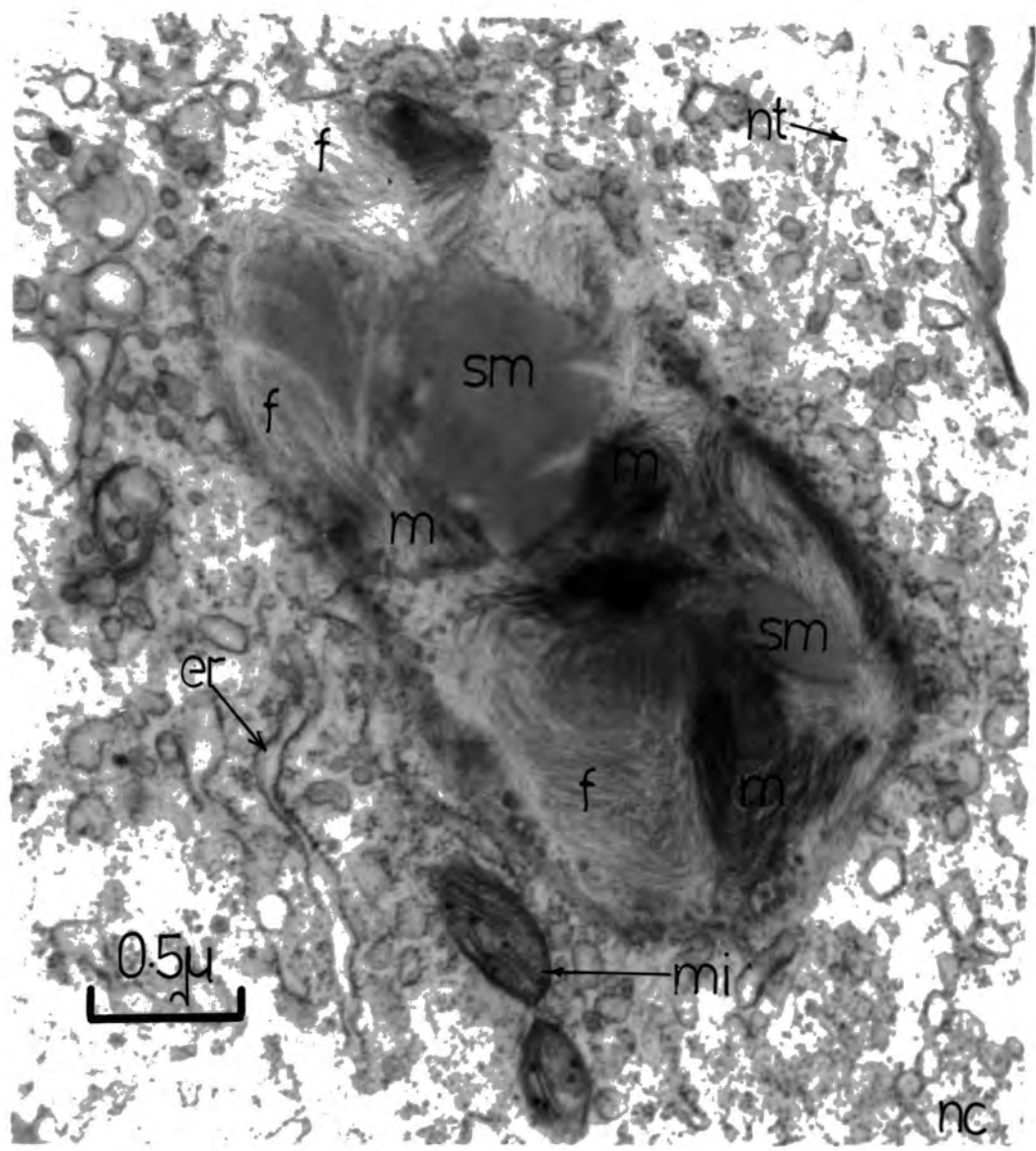

Fig. 68. Electron micrograph of a lipid body whose entire contents have been lost, leaving a small amount of residual secretory material and fragments of membrane and scattered filaments.

er, endoplasmic reticulum

f, filaments

mi, mitochondrion

mr, membrane fragment

p, particle clump

sg, structureless granule

smr, secretory material remnant

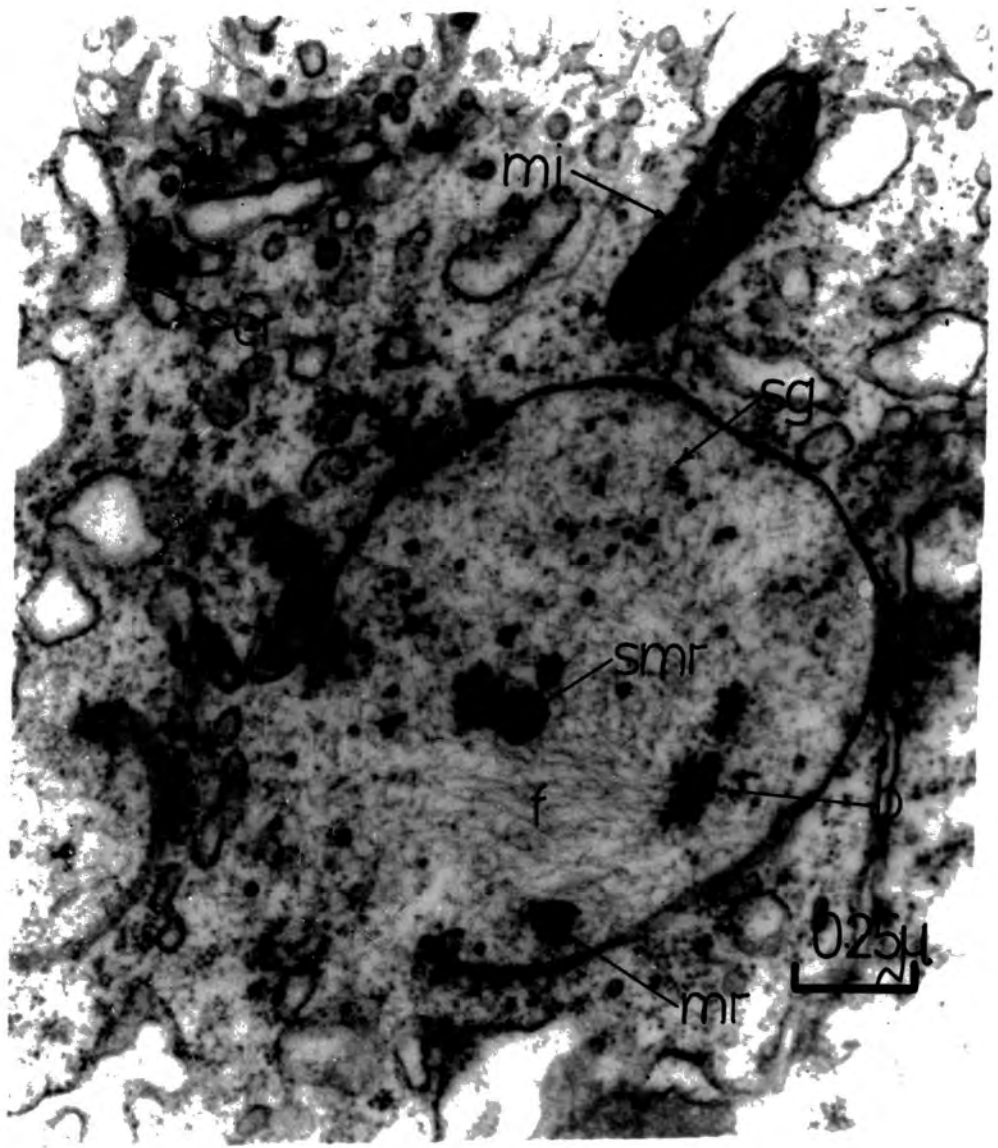

are released into the soma and thence into the axon, because fragments of lipid body containing only portions of lamellae and filaments have often been observed (fig. 68) in the axon region close to the soma. Areas of secretory material are also present in these late lipid body stages, usually of small size, about 0.2μ in figure 68.

The cytoplasm of early and late stages of the lipid bodies described here have a similar overall cytoplasmic appearance (compare figs. 63 and 68), but the last stages are clearly distinguished by the presence of small quantities of membrane and scattered filaments.

CONCLUSIONS AND DISCUSSION

The above sequence of changes which consist of a gradual build-up of material within a lipid body and its eventual release into the cytoplasm can be correlated with the results of other workers.

Chou (1957) and Chou and Meek (1958) postulated a series of changes in lipid body structure and cytochemical staining properties, analysing their results in terms of three stages of development. Some of the staining properties were common to all lipid bodies. Sudan black produced a similar positive staining reaction

for all stages and it was clear that lipid content was a common property. The first stage in Chou's sequence was the "colourless" globules which are similar in structure to the "immature" lipid bodies of the osphradial neurones in Planorbarius corneus (fig. 63). They consisted of a single membraned sac with little internal structure and Chou thought that they contained only triglycerides. This is compatible with the secretory hypothesis which suggests that this stage represents the enclosure of a portion of the neuronal cytoplasm by endoplasmic reticulum, before the elaboration of more complex structures.

The "blue" globules were the second stage of Chou's sequence. They are similar to the "mature" lipid bodies of the osphradial neurones in Planorbarius which are dominated by complex membrane lamellae and fibrous material. Chou found that the lipid present in this case was largely phospholipid. The triglycerides of the "immature" lipid bodies have been superseded by phospholipid which agrees biochemically with the presence of the membrane lamellae. Electron histochemistry by Meek and Lane (1964) showed that the membranes stain positively for thiamine pyrophosphatase and inosine diphosphatase whilst the oval masses of secretory material had little enzymic activity. Acid phosphatase activity was also most prominent in the membrane lamellae. The synthetic activity

of the membranes, reflected in the enzyme staining properties is therefore producing the inert secretory material.

The "yellow" globules are the final stage in Chou's lipid body sequence in Helix aspersa. He identified the pigment as a carotene and this gave the globules their yellow colour in the living state. They were characterised by the presence of large quantities of amorphous structureless material and on the secretory hypothesis represent the stage just before release of this secretory product into the neurone cytoplasm. They contain much less membrane or fibrous material than the "blue" granules and this was reflected by their enzyme-staining properties. Acid phosphatase activity was restricted to the remaining membrane lamellae in Helix and in this "yellow" globule stage the lipid bodies showed little thiamine pyrophosphatase or inosine diphosphatase activity (Meek and Lane, 1964). These lipid bodies of Helix often had breaks in their surrounding membrane, similar to those of Planorbarius osphradial neurones of the present study. In addition to the substances described above, the "yellow" globules of Helix contained mixed lipids, some carbohydrate and a little protein (Chou, 1957). Chemical changes have continued to increase the complexity of the lipid bodies in the final phase before breakdown.

The last part of the cycle described in Planorbarius osphradial neurones has not been observed by the above workers. After release of the lipid body contents into the neuronal cytoplasm it has been shown that only fragments of the surrounding membrane can be observed. Within the fragments, filaments and remnants of membrane and secretory material are often observed. The remaining contents appear to be similar to the main body of neuronal cytoplasm and it is unlikely that they would stain differently. Thus Chou (1957) in his light-microscope histochemistry of Helix neurones had not revealed the presence of these last stages.

It seems that the evidence of this first group of workers agrees with the secretory hypothesis. The work of the second has provided additional information. Thus Chou (1957) had identified the pigment of Helix aspersa as a carotene and located it in the lipid bodies. Arvanitaki and Chalazonitis (1961) have described a two pigment system in the neurones of Aplysia. They discussed experiments in which they extracted the lipid bodies from Aplysia neurones and examined the chemical and optical properties of the pigments present in them. They identified these as a haem-protein and a carotene protein, and also demonstrated the presence of a succinoxidase system in the lipid bodies (Chalazonitis and Arvanitaki, 1956). Arvanitaki and Chalazonitis (1961) discussed the results of

experiments which were concerned with the effects of light on the electrical activity of the neurones. The spike activity could be altered by incident white light, but a much greater effect could be obtained by using monochromatic light of wavelength equal to that of the absorption bands of either one of the two pigments. The authors likened the "artificial" effects of light on molluscan neurones to the photoactivation of chloroplasts in plant cells. Arvanitaki and Chalazonitis (1949) had shown that illumination could also cause a spike discharge in a plant cell, Nitella. In both systems the light-sensitive structure consisted of membrane lamellae on which enzymes were organised, the essential feature of each system being the presence of a photosensitive pigment. In plant cells the photoactivation is linked with a complex system of enzymes, culminating in the production of energy-rich compounds. The ability of the lipid bodies to affect the electrical properties of the neurone plasma membrane, even though it is an "artificial" effect, also suggests a highly organised system.

The lipid bodies show, in their structural and biochemical properties, affinities with other cell organelles. The membranes of the "mature" stages stain heavily for acid phosphatase and thiamine pyrophosphatase. This, coupled with structural similarities, has suggested to Lane (1966) that the lipid bodies belong to the same

group of organelles as the lysosomes of vertebrate cells. The results obtained by Arvanitaki and Chalazonitis (1961) which are discussed above, and the presence of other enzymes such as adenosine triphosphatase and succinoxidase, do not agree with the definition of classical lysosome content defined by ^{de} Duve (1966) although he has emphasised that lysosomes may form a much wider group of functional structures than was previously thought. Properties such as acid phosphatase and adenosine triphosphatase staining are also possessed by the Golgi apparatus (Lane, 1966), and the membrane lamellae of both the Golgi apparatus and lipid bodies are similar. Both have been associated with secretory material. The presence of pigments and succinoxidase activity is a feature held in common with mitochondria. The lipid bodies have properties in common with other subcellular organelles, but their combination of features seems to be unique.

A secretory function has been postulated, and the work of a third group of workers provides evidence that neurosecretory products of snail neurones may be concerned with a physiological process outside the nervous system. This sort of function is well known in vertebrates, and Gabe (1966) has discussed methods of identification of this neuroendocrine material within neurones in invertebrates and vertebrates. Two stains have been commonly used

to identify secretory material in nerve cells, namely chrome-haematoxylin and paraldehyde-fuchsin. These have often been called "neurosecretory" stains although they may stain other material. Bern (1962) has emphasised that a neurosecretory function cannot be attributed to nerve cells on cytochemical evidence alone.

A number of experiments have been carried out on molluscan neurones to identify neurosecretory material by the above staining techniques. It is not clear in many experiments if any particular subcellular particle is being stained. Krause (1960), however, has identified granules in neurones of the central nervous system of Helix pomatia which resemble in size and distribution the lipid bodies which have been discussed. They varied in size from 0.4 - 5.8 μ , with the smaller granules being stained the most heavily. Lever, Kok, Meuleman and Joosse (1961) stained sections of the central nervous system of Lymnaea stagnalis with chrome-haematoxylin and recorded secretory activity in all ganglia except the pedals. The staining is abundant below the nuclear region and passes into the axons of the neurones. Boer (1965) has repeated this work in Lymnaea in great detail. He has attempted to analyse the staining areas in terms of known molluscan subcellular inclusions. He showed that granules which he thought were equivalent to Chou's "yellow" globules stained positively in one group of cells for

paraldehyde-fuchsin, and he interpreted another group of granules which stained negatively with neurosecretory stains as being similar either to the "colourless" or to the "blue" globules of Chou (1957). In Lymnaea stagnalis the presence of chrome-haematoxylin staining material has been correlated with the physiological control of water balance. A large number of nerve cells in the pleural ganglion of this species had stained positively using this technique (Lever, Kok, Meuleman, and Joosse, 1961) and Hekstra and Lever (1960) had shown that these ganglia were important in water balance. Lever, Jansen and de Vlieger (1961) extended these experiments. If the pleural ganglia were removed, the animals gained water and swelling could be observed, but if extracts of pleural ganglia were injected into the animals, they returned to their normal weight. Removal of the right pleural ganglion upset water balance more than the left, and this could be correlated with the presence of a much larger number of chrome-haematoxylin-positive cells in the right ganglion. They concluded that release of secretion from the pleural ganglia can affect the water content of the snails' tissues.

It is probable that at least one stage, the "mature" lipid bodies of the postulated secretory cycle, stain for neurosecretory material, and this has been correlated with a physiological function in Lymnaea. It seems that in some cells, at least, the lipid bodies are associated with neurosecretion.

The neurones in the osphradium which have processes passing into the epithelium contain lipid bodies and this raises the possibility of neurosecretory products being secreted via the osphradial canal to the outside of the animal. This suggests a possible secretory role for the osphradium which could be connected with the production of intraspecific control factors or pheromones. This sort of substance is well-known in insects (Butler, 1967) and recently a growth-inhibiting substance has been reported in molluscs (Berrie and Visser, 1963). This possibility needs to be investigated further using physiological techniques.

GENERAL CONCLUSIONS AND DISCUSSION

The object of the present study was to investigate the structure and function of the pulmonate osphradium. This has been extended to include preliminary investigations of the structure and function of other parts of the nervous system and, in addition, attempts to locate sites of chemoreception in the snails has included a behavioural investigation into the role of the tentacles in food detection.

Examination of the structure of the osphradium in the light and electron microscopes and observations of the organ in vivo suggest that it has a sensory function. Ciliary currents on the anterior mantle enable particulate material from in front of the animal to be carried to the region of the osphradial aperture. This, coupled with the circulation of water under the anterior shell caused by the locomotory movements of the animal, indicated that the organ could be an important sampler of the medium, even though it appears to be badly positioned for this function. The ciliary currents of the osphradial epithelium enable samples of water to enter the canal and particles of about 1μ can be carried to the blind end of the canal, whereas larger particles are rejected by a muscular contraction of the osphradial walls. This is a purely local reflex, elicited even when connections to the central nervous system are severed. This

contraction response occasionally occurs when no obvious stimulant is present. As the primary ciliary current in the osphradial canal is inward it would seem that this muscular extrusion of the contents of the osphradial canal forms the main mechanism for evacuating the canal's contents. The electron microscope has revealed the presence of primary nerve endings in only the basal portion of the osphradial canal. Thus any component of the canal's contents would have to be carried to this region before a sensory response could be elicited. The ability of the organ to reject particles of above 5μ in diameter prevents blocking of the osphradial canal (which is about 30μ in the basal regions). The small size of the free nerve endings and their situation in depressions of the epithelial surface means that only objects of limited size could act as a stimulus. The significance of the bifid canal arrangement in Lymnaea is not clear.

The presence of a ganglion associated with ciliated epithelium in pulmonate osphradia immediately suggested a sensory function to other workers (Lacaze-Duthiers, 1872; Bernard, 1890), but it is apparent from the present study that the osphradial ganglion is a complicated structure, with other than sensory neurones, comparable in complexity with the ganglia of the central nervous system. In fact, only a fifth of all the neurones in the osphradial ganglion

are directly concerned with a sensory function, i.e. those sending axons to the epithelium of the osphradial canal. Although this figure is probably a conservative estimate, many cells are certainly monopolar, sending axons only to the neuropile, in a manner characteristic of the central nervous system. This does not preclude them from a role in a sensory integrative function, because interaxonal synapses are present within the neuropile of the osphradial ganglion. It could be, however, that the osphradial ganglion has more than just a sensory function, perhaps concerned with control of local reflex activity. Molluscs have the ability to carry out locally organised movements in the absence of the central nervous system.

Straightforward intracellular recording has not revealed any evidence which would suggest a dual function for the osphradial ganglion. All cells uniformly show spike activity. No post-synaptic activity has so far been recorded which would suggest either sensory or motor input for any of the cells. Sectioning of the pallial nerve connection to the brain does not affect the spike activity in the osphradial neurones, and no efferent activity originating from the brain has ever been recorded.

Thus the variety of spike and synaptic activity present in isolated preparations of the brain is not apparent in the osphradial

ganglion. This sort of activity in the brain has already been well characterised in other isolated molluscan central nervous systems (Tauc, 1955; Chalazonitis, 1961; Willows, 1965) and the brain of Planorbarius shows similar patterns and types of spike activity to these other preparations. No intracellular recordings have previously been made from the isolated and clumped cells of the peripheral nervous system of a pulmonate. Duncan (1961) had demonstrated that these cells could show regular spike activity and this was confirmed in the present study. In addition EPSPs have been recorded from the clumped cells in the pallial nerve of Planorbarius. It would be interesting to investigate the structure of cells of the clumped type with the electron microscope to see if interaxonal synapses were present. Further study using stimulation techniques is necessary to see if a simple ganglion of this type possesses the characteristics of more complex systems.

The experiments of Michelson (1960) with Australorbis had implicated the osphradium of freshwater pulmonates in chemoreception but repeating his experiments, using similar Y maze and extirpation techniques, has not confirmed these results. Planorbarius could still orientate towards food substances even after removal of the osphradium. The food substances also failed to stimulate the isolated osphradial preparation when simultaneous intracellular recordings were being

made from the osphradial neurones. This was also true of other substances, glutamate for instance, which Bailey and Laverack (1963, 1966) had found would stimulate the prosobranch osphradium. Mechanical stimuli provided by addition of alumina particles also failed to elicit a response in the osphradial neurones. This was similar to the results of Bailey and Laverack (1963, 1966). In fact, although the osphradium in Planorbarius is sensitive to mechanical stimuli, as shown by the contraction response, this does not seem to be reflected in the electrical activity of neurones in the osphradial ganglion. All attempts to stimulate the osphradium in the electrophysiological experiments have failed.

This suggests two main possibilities. Either the osphradium of freshwater pulmonates has a different function to the prosobranch type which seems to be a chemoreceptor, and may not be homologous with it, or the recordings so far made are from neurones which are not concerned with a sensory function in the osphradium. As Bullock and Horridge (1965) point out, it is difficult to decide whether the osphradia of the various molluscan groups are homologous. The osphradia of the gastropod groups outside the Pulmonata have a similar position and structure and have been classified as chemoreceptors, usually on the basis of behavioural studies (Copeland, 1918; Henschel, 1922; Brock, 1936; Wölper, 1950; Brown and Noble, 1960). The organ

in the pulmonates is rather different in form, being tubular rather than ctenidia-like. The position of the organ outside the mantle cavity is also different. The basic cell types are, however, similar. No other osphradium has been examined in the electron microscope, but the division of the osphradial epithelium in Buccinum into ciliated, secretory and sensory regions (Dakin, 1912) is similar to the organisation in freshwater pulmonates. The osphradia of Planorbarius and Buccinum are both capable of co-ordinated movements in response to local stimulation. The nervous connection to the central nervous system comes from the visceral-pleural-parietal complex in both animals, and it is obvious in these two species that the nervous organisation in the osphradial ganglion is complex. The observation of Bullock and Horridge (1965) that the osphradial ganglion may represent "merely a cluster of primary cell bodies without relay of independent reflex function" seems to be unjustified in the light of the present work. The conversion of the mantle in the freshwater pulmonates to a lung and its involvement in respiratory activity has obviously affected the position and organisation of the pallial organs and this is reflected in the structure and position of the osphradium. Yonge's suggestion that the osphradium might be concerned with particle detection (Yonge, 1947) was based partly on the supposition that it was important for prosobranchs to detect

sediment within the mantle cavity, to prevent blocking or fouling. This argument is clearly irrelevant for pulmonate molluscs whose mantle cavity has been converted into a lung and whose pallial organs no longer reside within it (Yonge did not consider the freshwater pulmonates in his argument).

If the structures are homologous then the chemoreceptive function of the osphradium is not universal. The lack of sensitivity of the pulmonate osphradium to chemoreceptive or mechanoreceptive stimuli suggests that the osphradium has some other function. In the search for another receptive modality, the effects of pH, temperature, inorganic ions and application of reproductive extracts have been tried with no success. Ventilation behaviour is unaffected by removal of the organ and a connection with this sort of behaviour seems unlikely.

The total lack of consistent responses to the above factors raises the second possibility, that the intracellular neurone recordings have been made from cells which are not involved with a sensory function of the organ. The inter-relationship of neurones in the osphradium has still to be determined. The anatomy had suggested a possible dual function for the organ, but this was not reflected in the electrophysiological recordings. In view of the well known convergence of sensory pathways in the central nervous system

of molluscs (Bailey, 1966), it seems unlikely that stimulation of the osphradium would not have been recorded in the present experiments. The ganglion of the osphradium has all the complexity, including interaxonal synapses, of the brain and it would seem probable that, in view of the large number of recordings made, any stimulation of the osphradium would have been detected. It is, perhaps, possible that the isolated preparation was unable to sample the environment in the normal manner. However, addition of particles and observation of their presence in the canal would suggest that this was not the case.

From the small number of experiments carried out it seems likely that the tentacles are important in chemoreception in freshwater pulmonates. Removal of these structures had the effect of destroying the ability of the snail to orientate towards food substances which normally attracted the snails. It was also shown that the lips of the snails and the anterior foot were sensitive to high concentrations of added food substance. If the tentacles are important in detecting food, it would seem unnecessary for a browsing herbivore, such as Planorbarius, to have another chemoreceptive centre such as the osphradium, although this organ could be detecting a more specific chemical substance (eg. the presence of predators or pheromones).

If it is considered that the above results represent a genuine negative conclusion, then it is necessary to consider other possible functions for the osphradium of freshwater pulmonates. It is possible that the organ is sensitive to another factor of the environment not so far investigated, the partial pressure of oxygen or carbon dioxide in the water, for example. Further experiments need to be carried out to test this hypothesis.

Another possibility is that the organ has a secretory or effector function. In this context the electron microscope analysis of the lipid bodies in the osphradial neurones may be relevant. It has been suggested that these bodies have a secretory function. An analysis of the various structural forms of the lipid bodies has been considered and a series of changes postulated which represent a gradual build-up of material inside the organelle, followed by release of this secretion into the soma and axon of the neurones. The evidence of other workers from several fields supports this hypothesis. This raises the possibility of a secretory role for the free nerve endings of the osphradial epithelium. It is possible that the osphradium could be involved in the release of intraspecific population control factors, or other secretions which are normally termed pheromones. Berrie and Visser (1963) have isolated a substance which acts as a growth inhibitor in freshwater snails. This possibility needs to

be investigated. Attractants involved in sexual behaviour are well known in insects (Butler, 1967).

The problem of the function of the pulmonate osphradium therefore remains unsolved. A sensory function still appears to be the most likely answer but another effector function remains to be investigated.

SUMMARY

The structure and function of the pulmonate osphradium has been investigated, using anatomical, electrophysiological and behavioural techniques. Planorbarius corneus L. has been used mostly but the anatomy of the organ in Lymnaea stagnalis L. has also been studied.

The osphradium was situated in the anterior mantle close to the base of the pneumostomal folds. The organ was about 0.5 mm. long and consisted of a blindly-ending, tubular canal with a basal ganglion of nerve cells. The epithelial layer of the osphradial canal contained ciliated, secretory and basal cells. The ciliated cells occurred along the entire length of canal and in the living state the cilia were beating continuously. The secretory cells also occurred along the entire canal epithelium but were more numerous in the central region. The nerve cell bodies of the osphradial ganglion sent processes through the epithelial layer to make contact with the contents of the osphradial canal in only the basal canal regions. The osphradial ganglion was arranged in typical molluscan fashion with a central neuropile and cortex of cell bodies. Within the ganglion monopolar, bipolar and multipolar neurones were observed. Bipolar cells often sent one axon to the neuropile and one to the epithelium; these were

therefore most likely to be sensory cells. The majority of the osphradial neurones were not directly concerned with perception and may have another role, perhaps concerned with the organisation of local reflexes. Interaxonal synapses occurred in the neuropile and this suggested that the osphradial ganglion had an integrative role. The organisation of the osphradial ganglion was comparable in complexity to the ganglia of the central nervous system although the large majority of brain neurones were monopolar. Other clumped or single cells in the left pallial nerve of Planorbarius showed less complex organisation.

A main water current over the osphradial aperture was provided by a mass of ciliated cells which were situated on the anterior mantle. In addition to this general current, the ciliated cells in the osphradial canal provided local movements by which 1μ particles could be carried to the base of the canal where the area of supposedly sensory endings occurred. Larger particles of 5μ or more were rejected by a "contraction response". This local reflex could be elicited by noxious stimuli such as acids and was stimulated by neutral glutamate, a known neuromuscular transmitter in molluscs. This contraction response probably formed the main mechanism for evacuation of the contents of the osphradial canal.

Attempts to record afferent activity in the osphradial or left pallial nerves of Planorbarius, using bipolar silver electrodes have failed. However, intracellular recordings have been made from the osphradial neurones. Spike activity of 30-40 spikes/minute were recorded, the frequency of discharge being similar in different cells of the same preparation. No post-synaptic activity or receptor potentials have been recorded in the osphradial neurones. The variety of spike and post-synaptic activity recorded in the brain neurones of Planorbarius was not apparent in the osphradial ganglion. A possible dual function for the osphradium, suggested by anatomical work, was not confirmed by simple electrophysiological recording techniques from many differently positioned osphradial neurones.

Food substances which attracted the snails in Y mazes failed to elicit electrical changes in the osphradial neurones when added to an isolated preparation of the organ. No responses were obtained to the addition of inert particles. Central expression of osphradial activity could not be obtained by addition of the above substances to the osphradium and recording in the left pallial ganglion of the brain. Normal orientation towards food substances by osphradialectomised snails in Y mazes, provided further evidence that the osphradium was not involved in food detection. In the search for another receptive

modality the effects of pH, temperature and inorganic ions were tried on the osphradium, but without positive results. Extracts of the reproductive system of copulating snails also failed to stimulate the organ. Respiratory behaviour was unaffected by the destruction of the osphradium.

Whether the osphradia in the various groups of the Mollusca were homologous was considered to be uncertain. If the organs were homologous then the chemoreceptive ability of the prosobranch osphradium could not be a universal function for the organ. As no sensory function for the pulmonate osphradium was discovered it was necessary to consider an effector function. A fine structural analysis of lipid bodies in osphradial nerve cell bodies suggested that these organelles may secrete substances into the axons. The presence of lipid bodies in the neurones innervating the osphradial canal epithelium may mean that the osphradium was secreting some substance into the external medium.

The problem of the function of the pulmonate osphradium therefore remained unsolved. A sensory function still seemed most likely but another effector role remained to be investigated.

PUBLICATIONS

Some parts of this thesis have been accepted for publication.

Bailey, D.F. and Benjamin, P.R. (1968). Anatomical and electrophysiological studies on the gastropod osphradium. Symp. zool. Soc. Lond. 23:263-268.

Benjamin, P.R. and Peat, A. (1968). A secretory role for the lipid bodies of molluscan neurons. J. comp. Neurol. (in press).

REFERENCES (WORLD LIST)

Agersborg, H.P.K. (1922). Some observations on qualitative chemical and physical stimulations in nudibranchiate mollusks with special reference to the role of the "rhinophores". J. exp. Zool. 36:423-444.

Agersborg, H.P.K. (1925). The sensory receptors and the structure of the oral tentacles of the nudibranchiate mollusk Hermissenda crassicornis (Eschscholtz 1831) syn. Hermissenda opalescens Cooper 1862, 1863. Acta zool., Stockh. 6:167-182.

Amoroso, E.C., Baxter, M.I., Chiquoine, A.D. and Nisbet, R.H. (1964). The fine structure of neurones and other elements in the nervous system of the giant african land snail Archachatina marginata. Proc. Roy. Soc. B. 160:167-180.

Arvanitaki, A. and Chalazonitis, N. (1949). Catalyse respiratoire et potentiels bioélectriques. Archs. Sci. physiol. 3:303-338.

Arvanitaki, A. and Chalazonitis, N. (1961). Excitatory and inhibitory processes initiated by light and infra-red radiations in single identifiable nerve cells (giant ganglion cells of Aplysia). In Nervous Inhibition (ed. E. Florey). 194-231 Pergamon Press: Oxford.

Arvanitaki, A. and Tchou, S.H. (1942). Les lois de la croissance relative individuelle des cellules nerveuse chez l'aplysie. Bull. Histol. Tech. micr. 19:244-256.

Bäcker, R. (1932). Die Mikromorphologie von Helix pomatia und einigen anderen Stylommatophoren. Ergebn. Anat. Entw. Gesch. 29:449-585.

Bailey, D.F. (1966). Aspects of the neurophysiology of Buccinum undatum L. (Gastropoda) II. Central organisation. J. exp. Biol. 44:149-161.

Bailey, D.F. and Laverack, M.S. (1963). Central nervous responses to chemical stimulation of a gastropod osphradium. Nature, Lond. 200:1122-1123.

Bailey, D.F. and Laverack, M.S. (1966). Aspects of the neurophysiology of Buccinum undatum. I. Central responses to stimulation of the osphradium. J. exp. Biol. 44:131-148.

Barber, V.C. (1966). The fine structure of the statocyst of Octopus vulgaris. Z. Zellforsch. mikrosk. Anat. 70:91-107.

Barber, V.C., Evans, E.M. and Land, M.F. (1967). The fine structure of the eye of the mollusc Pecten maximus. Z. Zellforsch. mikrosk. Anat. 76:295-312.

- Barth, J. (1964). Intracellular recording from the photoreceptor neurones in eyes of a nudibranch mollusc (*Hermisenda crassicornis*). Comp. Biochem. Physiol. 11:311-315.
- Batham, E.J. (1961). Infoldings of nerve fibre membranes in the opisthobranch mollusc *Aplysia depilans*. J. biophys. biochem. Cytol. 9:490-492.
- Bern, H.A. (1962). The properties of neurosecretory cells. Gen. Endocrinol. Suppl. 1:117-132.
- Bernard, F. (1890). Recherches sur les organes palléaux des gastéropodes prosobranches. Ann. Sci. nat. Zool. Ser. 7. 9:88-404.
- Berrie, A.D. and Visser, S.A. (1963). Investigations of a general growth-inhibiting substance affecting a natural population of freshwater snails. Physiol. Zool. 36:167-173.
- Boer, H.H. (1965). A cytological and cytochemical study of neurosecretory cells in Basommatophora with particular reference to *Lymnaea stagnalis*. Arch. néerl. Zool. 16:313-386.
- Boer, H.H., Bonga, S.E.W. and van Rooyen, N. (1967). Light and electron microscopical investigations on the salivary glands of *Lymnaea stagnalis* L. Z. Zellforsch. mikrosk. Anat. 76:228-247.

Brown, A.C. and Noble, R.G. (1960). Function of the osphradium in Bullia (Gastropoda). Nature, Lond. 188:1045.

Bullock, T.H. (1945). Problems in the comparative study of brain waves. Yale J. biol. Med. 17:657-679.

Bullock, T.H. (1961). On the anatomy of the giant neurons of the visceral ganglion of Aplysia. In Nervous Inhibition (Ed. E. Florey) Pergamon: Press: Oxford.

Bullock, T.H. and Horridge, G.A. (1965). Structure and function in the nervous system of invertebrates. W.H. Freeman: San Francisco.

Bullock, T.H. and Terzuola, C.A. (1957). Diverse forms of activity in the somata of spontaneous and integrating ganglion cells. J. Physiol., Lond. 138:341-364.

Burke, W.R. (1964). Chemoreception by Tegula funebris (Mollusca: Gastropoda). Veliger 6 Suppl:17-20.

Butler, G.C. (1967). Insect pheromones. Biol. Revs. 42:42-87.

Charles, G.H. (1966). Sense organs (less Cephalopods). In Physiology of the mollusca Vol. II. (ed. K.M. Wilbur and C.M. Yonge). Academic Press: New York.

Chalazonitis, N. (1961). Chemopotentials in giant nerve cells (Aplysia fasciata). In Nervous Inhibition (ed. E. Florey) Pergamon Press: Oxford.

Chalazonitis, N. and Arvanitaki A. (1956). Chromoprotéide et succinoxydase dans divers grains isolables du cytoplasme neuronique. Archs. Sci. physiol. 10:291-299.

Chalazonitis, N. and Lenoir, J. (1959). Ultrastructure et organisation du neurone d'Aplysia. Bull. Inst. océanogr. Monaco. 1144:1-11.

Chalazonitis, N. and Takeuchi, H. (1966). Application microélectrophorétique locale d'ions H^+ et variations des paramètres bioélectrique de la membrane neuronique (Neurones géants d'Helix pomatia). C. r. Séanc. Soc. Biol. 160:610-617.

Chou, J.T.Y. (1957). The chemical composition of lipid globules in the neurones of Helix aspersa. Q. Jl. Microsc. Sci. 98:59-64.

Chou, J.T.Y. and Meek, G.A. (1958). The ultrafine structure of lipid globules in the neurones of Helix aspersa. Q. Jl. Microsc. Sci. 99:279-284.

Copeland, M. (1918). The olfactory reactions and organs of the marine snails Alectrion obseleta (Say) and Busycon caniculatum (Linn.). J. exp. Zool. 25:177-227.

Dakin, W.J. (1912). Buccinum (The Welk). L.M.B.C. Mem. 20.

Démal, J. (1955). Essai d'histologie comparée des organes chémorécepteurs des gastéropodes. Mém. Acad. r. Belg. Cl. Sci. 29:1-87.

Dorsett, D.A. (1967). Giant neurons and axon pathways in the brain of Tritonia. J. exp. Biol. 46:137-151.

Duncan, C.J. (1956). Ph.D. Thesis. Univ. Lond.

Duncan, C.J. (1961). Spontaneous activity in the isolated nerves of pulmonate molluscs. Comp. Biochem. Physiol. 3:42-51.

de Duve, C. and Wattiaux, R. (1966). Functions of lysosomes. Ann. Rev. Physiol. 28:435-492.

Eakin, R.M. (1965). Development of the lens of the snail, Helix aspersa. Amer. Zool. 5:709-710.

Eakin, R.M. and Brandenburger, J.L. (1967). Differentiation in the eye of a pulmonate snail Helix aspersa. J. Ultra. Res. 18:391-421.

Eakin, R.M., Westfall, J.A. and Dennis, M.J. (1967). The fine structure of the eye of a nudibranch mollusc. Hermissenda crassicornis. J. Cell Sci. 2:349-358.

Fawcett, D.W. and Porter, D.R. (1954). A study of the fine structure of ciliated epithelia. J. Morphol. 94:221-282.

Fernandez, J. (1966). Nervous system of the snail Helix aspersa. I. Structure and histochemistry of the ganglionic sheath and neuroglia. J. comp. Neurol. 127:157-181.

Frings, H. and Frings, C. (1965). Chemosensory basis of food-finding and feeding in Aplysia juliana (Mollusca Opisthobranchiata). Biol. Bull. mar. Lab., Woods Hole. 128:211-217.

Gabe, M. (1966). Neurosecretion. Pergamon Press: Oxford.

Gerschenfeld, H.M. (1962). Submicroscopic basis of synaptic organization in gastropod nervous systems. In Electron Microscopy, vol. II (ed. S.S. Breese, Jr.) Pergamon Press: Oxford.

Gerschenfeld, H.M. (1964). A non-cholinergic synaptic inhibition in the central nervous system of a mollusc. Nature, Lond. 203:415-416.

Gerschenfeld, H.M. and Chariandini, D.J. (1965). Ionic mechanism associated with non-cholinergic synaptic inhibition in molluscan neurones. J. Neurophysiol. 28:710-723.

Gerschenfeld, H.M. and Lasansky, A. (1964). Action of glutamic acid and other naturally occurring amino-acids on snail central neurones. Int. J. Neuropharmacol. 3:301-314.

Gerschenfeld, H.M. and Stefani, E. (1965). 5-Hydroxytryptamine receptors and synaptic transmission in molluscan neurones. Nature, Lond. 205:1216-1218.

Gerschenfeld, H.M. and Stefani, E. (1966). An electrophysiological study of 5-Hydroxytryptamine receptors of neurones in the molluscan nervous system. J. Physiol., Lond. 185:684-700.

Gerschenfeld, H.M. and Tauc, L. (1961). Pharmacological specificities of neurones in an elementary nervous system. Nature, Lond. 189:924-925.

Gerschenfeld, H.M. and Tauc, L. (1964). Différents aspects de la pharmacologie des synapses dans le système nerveux central des Mollusques. J. Physiol., Paris. 56:360-361.

Gray, E.G. and Watkins, K.C. (1965). Electron microscopy of taste buds in rat. Z. Zellforsch. mikrosk. Anat. 66:583-595.

Hagiwara, S. and Saito, N. (1959). Voltage-current relations in nerve cell membrane of Onchidium verruculatum. J. Physiol., Lond. 148:161-179.

Hámori, J. and Horridge, G.A. (1966). The lobster optic lamina. IV Glial Cells. J. Cell Sci. 1:275-280.

Hanström, B. (1928). Vergleichende Anatomie des Nervensystems der wirbellosen Tiere. Springer: Berlin.

Hekstra, G.P. and Lever, J. (1960). Some effects of ganglion-extirpations in Lymnaea stagnalis. Proc. K. ned. Akad. Wet. Amsterdam, C 63:271-282.

Horridge, G.A. (1958). Transmission of excitation through the ganglia of Mya (Lamellibranchiata). J. Physiol. Lond. 143:553-572.

Hughes, G.M. and Kerkut, G.A. (1956). Electrical activity in a slug ganglion in relation to the concentration of Locke solution. J. exp. Biol. 33:282-294.

Hughes, G.M. and Tauc, L. (1961). The path of the giant cell axons in Aplysia depilans. Nature, Lond. 191:404-405.

Hughes, G.M. and Tauc, L. (1963). An electrophysiological study of the anatomical relations of two giant nerve cells in Aplysia depilans. J. exp. Biol. 45:469-486.

Hulbert, G.C.E.B. and Yonge, C.M. (1937). A possible function of the osphradium in the Gastropoda. Nature, Lond. 139:840.

Jande, S.S. (1966). The fine structure of lateral-line organs of frog tadpoles. J. Ultrastruct. Res. 15:496-509.

Jones, J.D. (1961). Aspects of respiration in Planorbis corneus L. and Lymnaea stagnalis L. (Gastropoda: Pulmonata). Comp. Biochem. Physiol. 4:1-29.

Jones, J.D. (1964a). The role of haemoglobin in the aquatic pulmonate, Planorbis corneus. Comp. Biochem. Physiol. 12:283-295.

Jones, J.D. (1964b). Respiratory gas exchange in the aquatic pulmonate, Biomphalaria sudanica. Comp. Biochem. Physiol. 12:297-310.

Kandel, E.R., Frazier, W.T. and Coggeshall, R.E. (1967). Opposite synaptic actions mediated by different branches of an identifiable interneuron in Aplysia. Science, N.Y. 155:346-349.

Kennedy, D. (1960). Neural photoreceptors in a lamellibranch mollusc. J. gen. Physiol. 44:277-299.

Kennedy, D. (1966). The comparative physiology of invertebrate central neurones. In Advances in Comparative Physiology and Biochemistry vol. II (ed. O. Lowenstein). Academic Press: New York.

Kerkut, G.A. and Cottrell, G.A. (1963). Acetylcholine and 5-Hydroxytryptamine in the snail brain. Comp. Biochem. Physiol. 8:53-63.

Kerkut, G.A. and Gardner, D.R. (1967). The role of calcium ions in the action potential of Helix aspersa neurones. Comp. Biochem. Physiol. 20:147-162.

Kerkut, G.A. and Meech, R.W. (1966). The internal chloride concentration of H and D cells in the snail brain. Comp. Biochem. Physiol. 19:819-832.

Kerkut, G.A. and Meech, R.W. (1967). The effect of ions on the membrane potential of snail neurones. Comp. Biochem. Physiol. 20:411-430.

Kerkut, G.A., Leake, L.D., Shapira, A., Cowan, S., and Walker, R.J. (1965). The presence of glutamate in nerve-muscle perfusates of Helix, Carcinus and Periplaneta. Comp. Biochem. Physiol. 15:485-502.

Kerkut, G.A. and Ridge, R. (1962). The effect of temperature changes on the activity of the neurones of the snail Helix aspersa. Comp. Biochem. Physiol. 5:283-295.

Kerkut, G.A. and Taylor, B.J.R. (1956). Effect of temperature on the spontaneous activity from the isolated ganglia of the slug, cockroach and crayfish. Nature, Lond. 178:426.

Kerkut, G.A. and Thomas, R.C. (1964). The effect of anion injection and changes in the external potassium and chloride concentration on the reversal potentials of the IPSP and acetyl-choline. Comp. Biochem. Physiol. 11:199-213.

Kerkut, G.A. and Thomas, R.C. (1965). An electrogenic sodium pump in snail nerve cells. Comp. Biochem. Physiol. 14:167-183.

Kerkut, G.A. and Walker, R.J. (1961a). The resting potential and potassium levels of cells from active and inactive snails. Comp. Biochem. Physiol. 2:76-79.

Kerkut, G.A. and Walker, R.J. (1961b). The effects of drugs on the neurones of the snail Helix aspersa. Comp. Biochem. Physiol. 3:143-160.

Kohn, A.J. (1961). Chemoreception in the gastropod molluscs. Am. Zool. 1:291-308.

Krause, E. (1960). Untersuchungen über die Neurosekretion im Schlundring von Helix pomatia. Z. Zellforsch. Mikrosk. Anat. 51:748-776.

Kunze, H. (1921). Zur Topographie und Histologie des Centralnervensystems von Helix pomatia. Z. wiss. Zool. 118:25-203.

Lacaze-Duthiers, H. (1872). Du système nerveux des mollusques gastéropodes pulmonés aquatiques et d'un nouvel organe d'innervation. Archs. Zool. exp. gén. 1:97-168.

Laduron, P., de Potter, W., Belpaire, F. (1966). Storage of labelled nor-adrenaline in lysosomes. Life Sci. 5:2085-2094.

Land, M.F. (1966). Activity in the optic nerve of Pecten maximus in response to changes in light intensity, and to pattern and movement in the optical environment. J. exp. Biol. 45:83-100.

Lane, N.J. (1962). Neurosecretory cells in the optic tentacles of certain pulmonates. Q. Jl. microsc. Sci. 103:211-226.

Lane, N. J. (1964). Localisation of enzymes in certain secretory cells of Helix tentacles. Q. Jl. microsc. Sci. 105:49-60.

Lane, N.J. (1966). The fine-structural localisation of phosphatases in neurosecretory cells within the ganglia of certain gastropod snails. Am. Zool. 6:139-157.

Laverack, M.S. and Bailey, D.F. (1963). Movement receptors in Buccinum undatum. Comp. Biochem. Physiol. 8:289-298.

Legendre, R. (1907-1908). Contribution à la connaissance de la cellule nerveuse d'Helix pomatia. Archs. Anat. microsc. 10:287-554.

Lever, J. Jansen, J. and de Vlieger, T.A. (1961). Pleural ganglia and water balance in the freshwater pulmonate Lymnaea stagnalis.

Proc. K. ned. Akad. Wet. C 64:532-542.

Lever, J., Kok, M., Meuleman, E.A. and Joosse, J. (1961). On the location of Gomori-positive neurosecretory cells in the central ganglia of Lymnaea stagnalis. Proc. K. Ned. Akad. Wet. Amsterdam C 64:640-647.

Lever, J., Jager, J.C. and Westerveld, A. (1964). A new anaesthetisation technique for freshwater snails, tested on Lymnaea stagnalis. Malacologia 1:331-337.

Meek, G.A. and Lane, N.J. (1964). The ultrastructural localisation of phosphatases in the neurones of the snail, Helix aspersa.

Jl. Roy. Microsc. Soc. 82:193-204.

Michelson, E.H. (1960). Chemoreception in the snail Australorbis glabratus. Am. J. trop. Med. Hyg. 9:480-487.

Nisbet, R.H. (1961). Some aspects of the structure and function of the nervous system of Archachatina (Calachatina) marginata (Swainson).

Proc. Roy. Soc. B. 154:267-287.

- Palay, S.L. (1960). The fine structure of the secretory neurons in the preoptic nucleus of the goldfish (Carassius auratus). Anat. Rec. 138:417-443.
- Pantin, C.F.A. (1948). Notes on microscopical technique for Zoologists. Cambridge University Press: Cambridge.
- Peat, A. and Whitton, B.A.W. (1967). Environment effects on the structure of the blue-green alga Chlorogloea fritschii. Archs. Mikrobiol. 57:155-180.
- Plummer, J.M. (1966). Collagen formation in Achatinidæ associated with a specific cell type. Proc. malac. Soc. Lond. 37:189-198.
- Piéron, H. (1908). Le sens chimique des limnés. Compt. Ren. Assoc. France Avanc. Sci. 2:603-608.
- Reynolds, E.S. (1963). The use of lead citrate at high pH as an electron opaque stain in electron microscopy. J. Cell Biol. 17:208-212.
- Reese, T.S. (1965). Olfactory cilia in the frog. J. Cell Biol. 25:209-230.
- Rosenbluth, J. (1963). The visceral ganglion of Aplysia californica. Z. Zellforsch. mikrosk. Anat. 60:213-236.

Scharrer, E. (1966). Principles of neuroendocrine integration. In Endocrines and the central nervous system. Ass. Res. Nerv. Ment. Dis. 43:1-35.

Schlote, F.W. (1955). Die Erregungsleitung im Gastropodennerven und ihr histologisches Substrat. Z. vergl. Physiol. 37:373-415.

Schlote, F.W. (1957). Submikroskopische Morphologie von Gastropodennerven. Z. Zellforsch. mikrosk. Anat. 45:543-568.

Schmalz, E. (1914). Zur Morphologie des Nervensystems von Helix pomatia. Z. wiss. Zool. 111:506-568.

Simpson, L., Bern, H. and Nishioka, R.S. (1963). Inclusions in the neurons of Aplysia californica (Cooper, 1863) (Gastropoda Opisthobranchiata). J. comp. Neurol. 121:237-257.

Simpson, L., Bern, H. and Nishioka, R.S. (1966). Survey of the evidence for neurosecretion in gastropod molluscs. Am. Zool. 6:123-138.

Smith, B.J. (1966). The structure of the central nervous system of the slug Arion ater L., with notes on the cytoplasmic inclusions of the neurons. J. comp. Neurol. 126:437-451.

Stephens, G.J. and Stephens, G.C. (1966). Photoperiodic stimulation of egg laying in the land snail, Helix aspersa. Nature, Lond. 212:1582.

Tauc, L. (1955a). Étude de l'activité élémentaire des cellules du ganglion abdominal d'aplysie. J. Physiol., Paris 47:769-792.

Tauc, L. (1955b). Divers aspects de l'activité électrique spontanée de la cellule nerveuse du ganglion abdominal de l'aplysie. C. r. Séanc. Soc. Biol. 240:672-674.

Tauc, L. (1960). The site of origin of the efferent action potentials in the giant nerve cell of Aplysia. J. Physiol. Lond. 152:36P-37P.

Tauc, L. (1962). Identification of active membrane areas in the giant neuron of Aplysia. J. gen. Physiol. 45:1099-1115.

Tauc, L. and Bruner, J. (1963). Desensitization of cholinergic receptors by acetylcholine in molluscan central neurones. Nature, Lond. 198:33-34.

Turner R.S. and Nevius, D.B. (1951). The organisation of the nervous system of Ariolimax columbianus. J. comp. Neurol. 94:239-256.

Willows, A.O.D. (1965). Giant nerve cells in the ganglia of nudibranch molluscs. Comp. Biochem. Physiol. 14:707-710.

Willows, A.O.D. (1967). Behavioural acts elicited by stimulation of single, identifiable brain cells. Science, N.Y. 157:570-574.

Wölper, C. (1950). Das osphradium der Paludina vivipara.

Z. vergl. Physiol. 32:272-286.

Yonge, C.M. (1947). The pallial organs in the aspidobranch
Gastropoda and their evolution throughout the Mollusca. Phil.

Trans. Roy. Soc. B 232:443-518.

Zs-Nagy, I. (1965). Electron-microscope observations on the
cerebral ganglion of the freshwater mussel (Anadonta cygnaea)

Ann. Biol. Tihany 31:147-152.

ADDITION.

Henschel, J. (1932). Untersuchungen über den chemischer Sinn von

Nassa reticulata. Wiss. Meeresuntersuch. 21:131-159.

3 MAY 1969