

Durham E-Theses

*Ecological investigations of some plant communities
in the cow green area of upper Teesdale*

Clive Marshall

How to cite:

Marshall, Clive (1971) Ecological investigations of some plant communities in the cow green area of upper Teesdale. Doctoral thesis, Durham University.

Use policy

The full-text may be used and/or reproduced, and given to third parties in any format or medium, without prior permission or charge, for personal research or study, educational, or not-for-profit purposes provided that:

- a full bibliographic reference is made to the original source
- a <https://etheses.durham.ac.uk/id/eprint/8728/> is made to the metadata record in Durham E-Theses
- the full-text is not changed in any way

The full-text must not be sold in any format or medium without the formal permission of the copyright holders.

Please consult the [full Durham E-Theses policy](#) for further details.

ECOLOGICAL INVESTIGATIONS OF SOME PLANT COMMUNITIES
IN THE COW GREEN AREA OF UPPER TEESDALE

by

Clive Marshall, B.Sc. Hons. (Dunelm)

being a thesis submitted for the degree of
Doctor of Philosophy in the University of Durham

July 1971

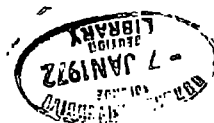

The contents of this thesis are, apart from any text reference to published work, entirely the product of my own research and have not been submitted for the candidature for any other degree or diploma.

Two papers of joint authorship are bound in the back of this thesis but only material that was my own contribution to these publications has been included in the text.

C. Marshall

Clive Marshall

July 1971

ACKNOWLEDGEMENT

I wish to thank Professor D. Boulter for the facilities provided in the Botany Department, Durham University, Dr. D.J. Bellamy for his supervision, and the I.C.I. Teesdale Trust for financing this research.

C. Marshall

July 1971

PLATE I

Eroding "sugar limestone"



ABSTRACT

The flora of Upper Teesdale contains a large number of "relict" species of disjunct geographical distribution. Why is this rich assemblage of species present in Teesdale?

It was assumed that arctic alpine and other rare species, supposedly intolerant of competition, were able to survive in the face of lowered competition from typically lowland species.

This study was designed to test this hypothesis by answering three questions:

- (i) What are the communities?
- (ii) What is their productivity (as a general measure of competition)?
- (iii) What are the reasons for this level of production?

Initial analyses on Widdybank Fell indicated the importance of Limes convergens situations, sharp zones of biotic and abiotic transition, as key habitats for many of the rarities.

Detailed phytosociological analyses of a grid matrix on Widdybank Fell, produced an optimum classification of vegetation units. These communities contained many rare species and the affinities of these units with continental phytosociological groups was considered. The distribution of the quadrats of these communities on the grid was compared with abiotic variables.

The productivity, in this context used as a general measure of competition, of those communities delimited in the phytosociological analyses and other sites was determined. A single species increment cropping technique was developed to determine the net annual aerial standing crop of the communities considered. A composite picture of community dynamics in terms of vertical biomass distribution, net annual aerial production and mineral flux was obtained.

The rare species were found to be most common in the communities studied that were of low net annual aerial production, particularly those of less than $150 \text{ gm/m}^2/\text{per annum}$.

The importance of grazing and climate in maintaining these low levels of production was emphasised by exclosure and cold frame experiments. Chemical analysis indicated the importance of the highly calcareous sugar limestone soils and indicated that high zinc levels appeared to coincide with low production.

INDEX TO TEXT

	<u>Page</u>
Title	i
Acknowledgement	iii
Abstract	iv
Index to text	v
List of Figures	vi
List of Tables	ix
List of Plates	xiii
Nomenclature	xiv
<u>PART I</u> INTRODUCTION	1
A. The Abiotic	4
B. The Biotic	5
<u>PART II</u> THE VEGETATION OF THE STUDY AREA	
A. Transect Analysis	12
B. Investigation of a boundary situation	16
<u>PART III</u> SELECTION OF COMMUNITIES FOR DETAILED ECOLOGICAL STUDY	
A. Ordination	28
B. Classification	34
C. Polythetic agglomerative methods	36
D. Discussion of Results of Analysis	38
<u>PART IV</u> PRODUCTION STUDIES	
A. Sites	48
B. Harvest Methods	50
C. Detailed consideration of Species	56
D. Synthesis	78
E. Vertical Biomass Distribution	79
F. What limits the Productivity of these Communities	81
<u>PART V</u> CONCLUSION	89
<u>APPENDIX I</u> PLANT AND SOIL ANALYSIS	98
<u>APPENDIX II</u> THE "DOING" SCALE	101
<u>BIBLIOGRAPHY</u>	102

LIST OF FIGURES

1. Upper Teesdale
2. Geology of Upper Teesdale
3. The distribution of annual rainfall in the Tees Valley
4. A general classification of the main vegetation types occupying the high ground of Upper Teesdale
5. A Slapestone Sike Transect (1) illustrating topography, group analysis units and 'H' value graph
6. The eight synecological groups determined in the Slapestone Sike transect (1) by Group Analysis
7. Total Calcium, Sodium, Potassium and organic material of soil samples along Slapestone Sike Transect (1)
8. Normal and Inverse association analysis of Slapestone Sike Transect (2)
9. Nodal Analysis of Slapestone Sike Transect (2)
10. Noda superimposed on Slapestone Sike Transect (2)
11. Upper Slapestone Sike. Orientation of grid of quadrats
12. Upper Slapestone Sike. Location of quadrats on grid
13. Upper Slapestone Sike. Grid Topography
14. pH gradient along Slapestone Sike Transect (3)
15. Multidimensional gradient analysis indicating the position of quadrats on environmental gradients
16. The variance attributable to the first fifteen principal components

17. Quadrat distribution on Principal Components Axes 1 and 2
18. Pattern of soil calcium on the vegetational ordination
19. Pattern of soil organic material on the vegetational ordination
20. Pattern of soil exchangeable calcium on the vegetational ordination
21. Pattern of soil exchangeable potassium on the vegetational ordination
22. Distribution of Tofieldia pusilla and Sesleria caerulea on the vegetational ordination
23. Group analysis dendrogram
24. Normal association analysis dendrogram
25. Inverse association analysis dendrogram
26. Ward's Hierarchic Fusion Method dendrogram
27. Relationship between the clusters derived from Normal Association Analysis and Group Analysis in terms of common quadrats
28. Relationship between the clusters derived from the iterative relocation procedure and Ward's Method in terms of common quadrats
29. Relationship between the clusters derived from the iterative relocation procedure and normal association analysis in terms of common quadrats
30. The arrangement of the quadrat groups derived from Group Analysis and Association Analysis on the grid map
31. The arrangement of the quadrat groups derived from Relocation after Ward's Analysis
32. Ordination of groups obtained by Normal Association Analysis and Group Analysis

33. Ordination of groups obtained by Ward's Method and Relocation (8 clusters)
34. Ordination of groups obtained by Relocation (6 Cluster and 4 Cluster)
35. Ordination and map of the component quadrats of the 6 Clusters derived by Relocation
36. Distribution of Exchangeable Calcium on grid
37. Distribution of organic material in soil on grid
38. Distribution of soil water under "normal conditions" on grid
39. Carex lepidocarpa Graph illustrating the effect of increasing the sample size to decrease the error margin of the mean
40. Eriophorum angustifolium "Mean" individual aerial standing crop through 1969 growing season at Upper Slapestone, Lower Slapestone and Nameless/Red Sike sites
41. Eriophorum angustifolium Graph of standing crop per m² for 1968 and 1969
42. Carex panicea "Mean" individual aerial standing crop through 1969 growing season at Upper Slapestone, Lower Slapestone, and Nameless/Red Sike
43. Carex lepidocarpa "Mean" individual aerial standing crop through 1969 growing season at Upper Slapestone, Lower Slapestone and Nameless/Red Sike
44. Sorting categories for vertical biomass distribution
45. Vertical biomass distribution in August 1969 at Upper Slapestone Sedge Marsh, Upper Slapestone Agrostis-Fescue grassland and Lower Slapestone Sike Sedge Marsh

LIST OF TABLES

1. Some of the rarities in the "Teesdale assemblage"
2. Climatic data for Widdybank Fell
3. The floristic composition of clusters as segregated by Group Analysis
4. The floristic composition of clusters as segregated by Normal Association Analysis
5. 'Two way' table incorporating Normal and Inverse Analysis groups
(see sleeve for Table 5).
6. The floristic composition of clusters at the six cluster stage as segregated by the Iterative Relocation Procedure
7. Eriophorum angustifolium, aerial standing crop per "mean" individual at Upper Slapestone Sike Site.
8. Eriophorum angustifolium, aerial standing crop per "mean" individual at Lower Slapestone Sike Site.
9. Eriophorum angustifolium, aerial standing crop per "mean" individual at Red Sike Site.
10. Eriophorum angustifolium Standing crop for Upper Slapestone Sike site during 1969 growing season
11. Eriophorum angustifolium Standing crop for Lower Slapestone Sike site during 1969 growing season
12. Eriophorum angustifolium Standing crop for Red Sike site during 1969 growing season
13. Eriophorum angustifolium Growth increment for 1969 at the three sites
14. Carex panicea Mean aerial dry weights of individual plants from sample populations of three wetland sites
15. Carex panicea Mean number of individuals per metre² from sample populations of three wetland sites

16. Carex panicea Concentration of Potassium, Calcium, Magnesium, Sodium and Zinc in dead and live material from three sites
17. Carex panicea Standing crop for three sites through 1969 growing season
18. Carex panicea Net aerial production and net mineral flux for 1969 growing season
19. Carex lepidocarpa Mean aerial dry weights of individual plants from sample populations of three wetland sites
20. Carex lepidocarpa Mean concentration of Potassium, Calcium, Magnesium and Sodium in dead and live material from three sites
21. Carex lepidocarpa Aerial standing crop for three wetland sites through 1969 growing season
22. Narrow Leaved Grasses & Sedges Mean aerial dry weights per 10 individual plants from sample populations of two wetland sites, and concentrations of certain elements in the plant tissue
23. Narrow Leaved Grasses & Sedges Aerial Standing Crop for two wetland sites through 1969 growing season
24. Carex nigra Mean aerial dry weight of individual plants from populations sampled through growing season from two wetland sites
25. Carex nigra Mean concentrations of Potassium, Calcium, Magnesium and Sodium in dead and live material from two sites
26. Carex nigra Aerial Standing Crop for two wetland sites through 1969 growing season
27. Equisetum sp. Mean aerial standing crop per m² at Lower Slapstone Sike through 1969 growing season
28. Agrostis canina Mean aerial standing crop per m² in Lower Slapstone Sike through 1969 growing season
29. Eleocharis quinquefolia Mean aerial standing crop per metre square in Upper Slapstone Sike through 1969 growing season
30. Juncus articulatus Mean aerial standing crop per metre² in Nameless/Red Sike and Upper Slapstone Sedge sites through 1969 growing season

31. Kobresia simpliciuscula Mean aerial standing crop per metre² in Upper Slapestone Sedge site and Upper Slapestone calcareous grassland site through 1969 growing season
32. Sesleria caerulea Mean aerial standing crop per m² in Upper Slapestone Calcareous Grassland Site throughout 1969 growing season
33. Carex capillaris Mean aerial standing crop in Upper Slapestone Calcareous Grassland Site through 1969 growing season
34. Festuca ovina Mean aerial standing crop for Upper Slapestone Calcareous grassland site and Upper Slapestone Agrostis-Fescue grassland site for 1969 growing season
35. Agrostis tenuis Mean aerial standing crop for Agrostis-Fescue grassland site for 1969 growing season
36. Selaginella selaginoides Mean aerial standing crop for Upper Slapestone Sedge Marsh and Upper Slapestone Bent-Fescue Grassland
37. Bryophytes Mean concentrations of certain ions
38. Bryophytes Estimated increment for 1969 growing season
39. Sedge Site increments
40. Grassland Site increments
41. Net above ground production at each site with distribution of rarities
42. Cold Frame Experiment. October standing crop of Agrostis-Fescue grassland from within cold frame and from ungrazed sward
43. a & b Floristic composition of unfenced springhead hummocks and adjacent fenced hummocks on Widdybank Fell
44. Net aerial production for 1969 growing season and Zinc concentrations for dead and live leaves of Eriophorum angustifolium and Carex lepidocarpa for three wetland sites in Upper Teesdale
45. The rare species found in, and associated with, the six clusters derived by relocation with main abiotic trends

46. Summary of Mineral standing crop and uptake area
47. Biomass produced per gram of calcium, magnesium and potassium at each site
48. Concentration of Calcium in dried material from sedges and grasses at various sites
49. Concentration of Potassium in dried material of Carex panicea and Sesleria caerulea at various sites

LIST OF PLATES

- I Eroding "sugar limestone".
- II Outcrop of "sugar limestone" on Widdybank Fell.
- III Locally, there was a sharp differentiation between the relatively unbroken expanse of moorland on Widdybank Fell and the pattern of hay meadows, pastures and coniferous plantations in the Tees Valley below.
- IV A "limes convergens" situation.
- V Upper Slapstone production study area.
- VI Nameless/Red Sike production study area.
- VII Cold Frame Experiment. Bent-Fescue grassland sample (i) from within cold frame and (ii) from ungrazed sward.
- VIII Cold Frame Experiment. Cirsium palustre from (i) within cold frame, and (ii) ungrazed sward.

NOMENCLATURE

Species have been named according to the nomenclature adopted in the following:

- i) Vascular Plants Clapham, Tutin and Warburg (1962).
- ii) Bryophytes Watson (1963).
- iii) Lichens The Lichenologist, Vol. 3.

Phytosociological nomenclature follows Lohmeyer (1962), unless otherwise stated.

In the text all Latin plant names are underlined with continuous lines, e.g. Eriophorum angustifolium.

Phytosociological nomenclature is differentiated by a broken line, e.g. Scheuzerio-Caricetea Fuscae.

PART I

INTRODUCTION

The flora of Upper Teesdale contains a large number of species, the populations of which are outliers of their normal geographical range (Pigott, 1956). Upper Teesdale is, in fact, one of the series of 'refugia' which is particularly rich in species which show disjunct distributions across the British Isles (Table 1).

Although their distributions are now disjunct, there is much evidence that many of these species were much more widespread in the past. For example late glacial deposits near Darlington have yielded fossil remains of Arctostaphylos uva-ursi, Dryas octopetala, Helianthemum canum, Selaginella sp., Thaliotrum alpinum and Juniperus sp. (Blackburn, 1952). Sub-fossil material of Potentilla fruticosa, Draba incana, Dryas octopetala and Helianthemum have been found near London and seeds of Minuartia stricta have been tentatively identified from a late glacial deposit in Ireland (Mitchell, 1953).

The Teesdale assemblage may therefore be interpreted as "relict", fragments of a flora which was widespread in Britain some 10,000 to 12,000 years ago (Godwin and Walters, 1967).

The development of this original flora, late and early post-glacial, has provoked much speculation. There have been two main arguments.

The first favoured the rare species as periglacial survivors, stating that during the last glaciation there may have been some unglaciated areas in the Pennines. It would have been on the inhospitable peaks of these nunataks that the plants would have weathered the ice age.

The alternative argument maintains that, as the glacial ice masses receded, the bulk of the flora immigrated from the warmer south.

Whatever the correct explanation for their initial presence in the area may be, there is also the problem of explaining their persistence over a span of more than 10,000 years of climatic change; change which has transformed an open glacial landscape into one dominated by closed woodland and subsequently by blanket peat (Turner^{d Hewatson.}, 1970).

TABLE 1

Some of the rarities in the "Teesdale assemblage"

Continental Southern

Helianthemum canum

Continental Northern

Carex ericetorum

Northern Montane

Equisetum variegatum
Juncus alpino-articulatus
Potentilla fruticosa
Primula farinosa
Viola rupestris

Oceanic Northern

Armeria maritima

Arctic-Alpine

Carex capillaris
Dryas octopetala
Juncus triglumis
Kobresia simpliciuscula
Minuartia stricta
Minuartia verna
Polygonum viviparum
Saxifraga aizoides
Thalictrum alpinum
Tofieldia pusilla

Alpine

Gentiana verna

The contemporary climate of the high western boundary of Upper Teesdale is marginally sub-arctic (Manley 1942) but the climate of the main area in which the Teesdale rarities are found is much less extreme and differs but little from that of other large stretches of the Pennines.

Why then is this rich assemblage of species present only in Upper Teesdale?

The abundance of arctic alpine plants in gardening catalogues indicates that many of these plants can be grown at lower altitudes in drier situations with much longer growing seasons than occur in the "sub-arctic wastes" of Upper Teesdale. However it is an essential prerequisite that the successful alpine garden is well weeded and hence the arctic and arctic alpine plants are kept free of interference from other species which are better adapted to the lowland climate.

In Teesdale many of the rarities do grow in open conditions where the total vegetation cover may be less than a third of the ground area and hence competition or interference must be low.

However, the continued existence of these skeletal communities and the contemporary stabilisation of communities forming 100% cover but rich in both "relict" species and their lowland competitors demands an explanation. It would seem that either the Teesdale relict populations are less sensitive to "competition" and/or their lowland competitors are less vigorous in the region under consideration.

What are the main abiotic differences between a typical lowland garden where these species may be grown only in the absence of "competition" and the fells of Upper Teesdale where they grow, and must have grown for a long period, in competition with the more widespread lowland species?

The importance of competition or at least the lack of it in arctic alpine communities has been discussed widely (Coombe and White 1951, Pigott 1956), but there is little empirical evidence.

This difficult question of determining quantitatively a general measure of competition has been approached by Bellamy and Tickle (1964). They indicated that the Teesdale rarities were confined to plant communities whose net annual aerial production was less than 150 g dry wt per metre square.

In order to check this figure and extend our knowledge of the structure of the communities a detailed study was undertaken and the results of this investigation form the basis of this thesis.

To summarise, the basic hypothesis was that there existed in Upper Teesdale a complex of "unique" vegetation types characterised by low levels of primary production. These "low production" communities offered niches in which competitive effects were low, and in which the "Teesdale rarities" were able to survive.

The project was designed to test this hypothesis by answering four main questions:

- 1) What are these vegetation types?
- 2) What is their productivity?
- 3) What determines their level of productivity?

Due to the planned destruction of part of the vegetation on Widdybank Fell, Upper Teesdale, by the construction of the Cow Green Reservoir, the study was confined to the area that was to be submerged, thus providing an opportunity for "destructive" research.

A. THE ABIOTIC

(i) Geology and Soils

Upper Teesdale occupies a central position in northern England, being situated in the Pennines between the Vale of Eden and the Lake District to the west, and the Durham coal measures to the east (Figure 1).

The River Tees rises at over 2,000 feet and curves in a general south westerly direction until it is forced to skirt round the base of Widdybank Fell beneath the scarp face of Cronkley Scar.

Widdybank Fell is largely composed of sedimentary rocks of the Carboniferous Lower Limestone Group. These consist of a sequence of hard light coloured limestones, shales and sandstones; the Melmerby Scar limestone predominating with a thickness of over 130 feet (Johnson 1965).

The transgressive Great Whin Sill, a hard quartz dolerite, was intruded into this sequence and baked the surrounding limestone into a coarsely crystalline marble (Figure 2). When exposed this marble disintegrates and crumbles eventually to form the granular "sugar limestone" (Plate I). Only in this region of the British Isles is sugar limestone found and here large outcrops are restricted solely to Cronkley and Widdybank Fell (Plate II).

Many of the more interesting plant communities and the rare species are associated with the sugar limestone and the soils derived from it. The pedogenic processes of these soils will therefore be briefly considered.

Jenny (1958) considered soils to be the product of five pedogenic factors; parent material, climate, organisms, topography and time. Parent material and climate predominate in the production of limestone soils in the British Isles.

In the vicinity of the sugar limestone outcrops, the soils show little or no differentiation into horizons, only a complex intermixture of roots, dark humic material and coarse limestone granules. The

Fig. 1

Upper Teesdale

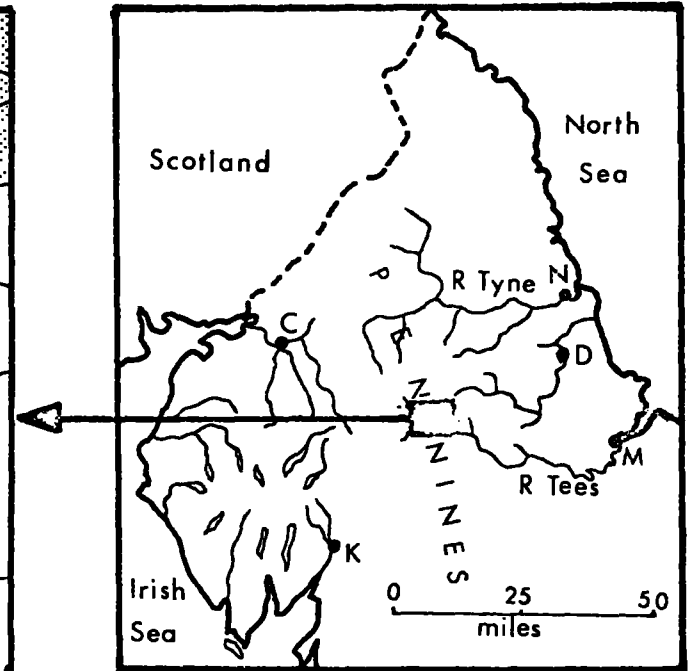
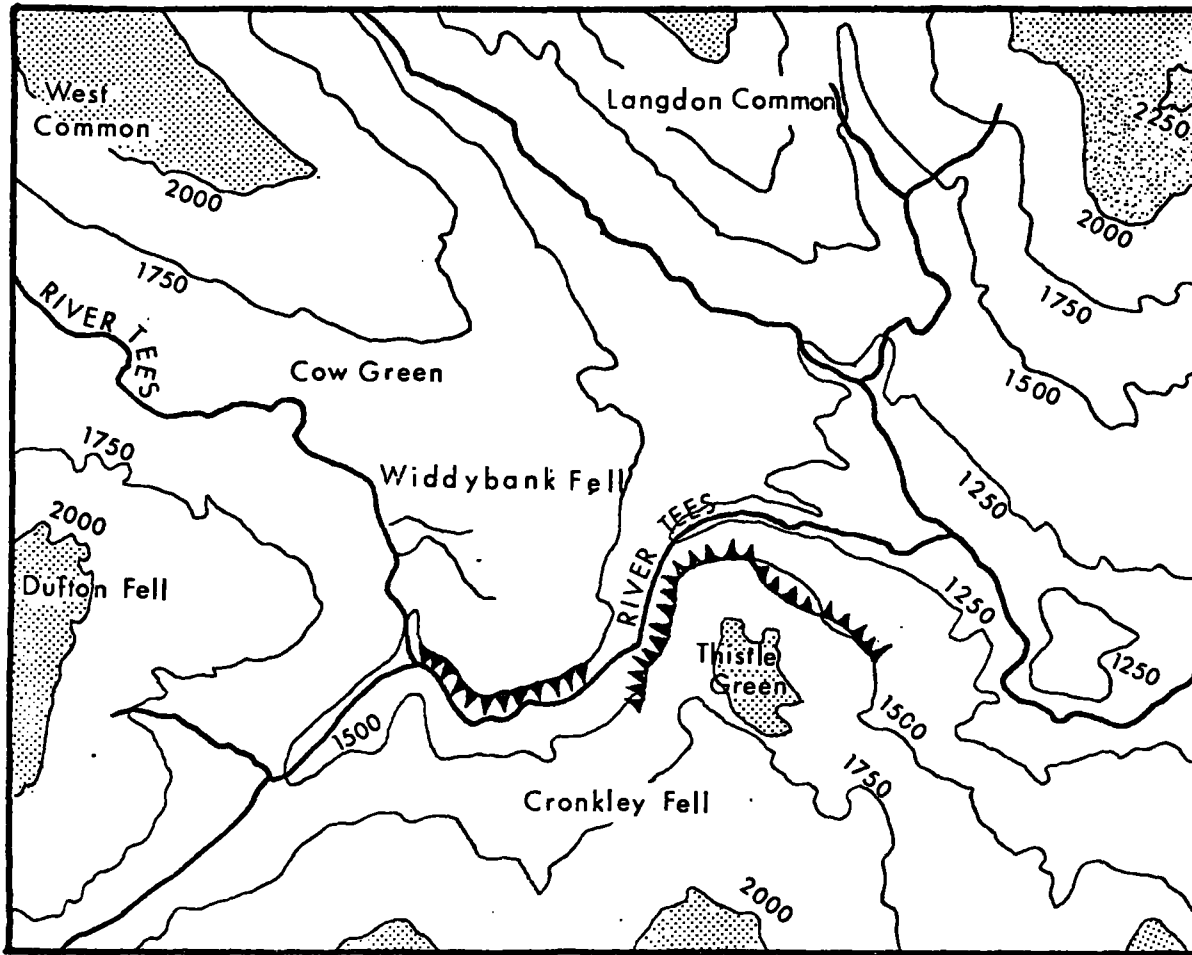

 Cliff

 Land over 2000ft

SCALE 1:63360



Fig. 2 Geology of Upper Teesdale
(after Johnson 1965)

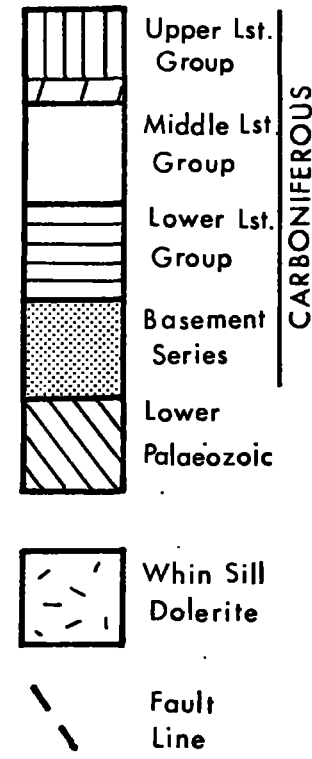
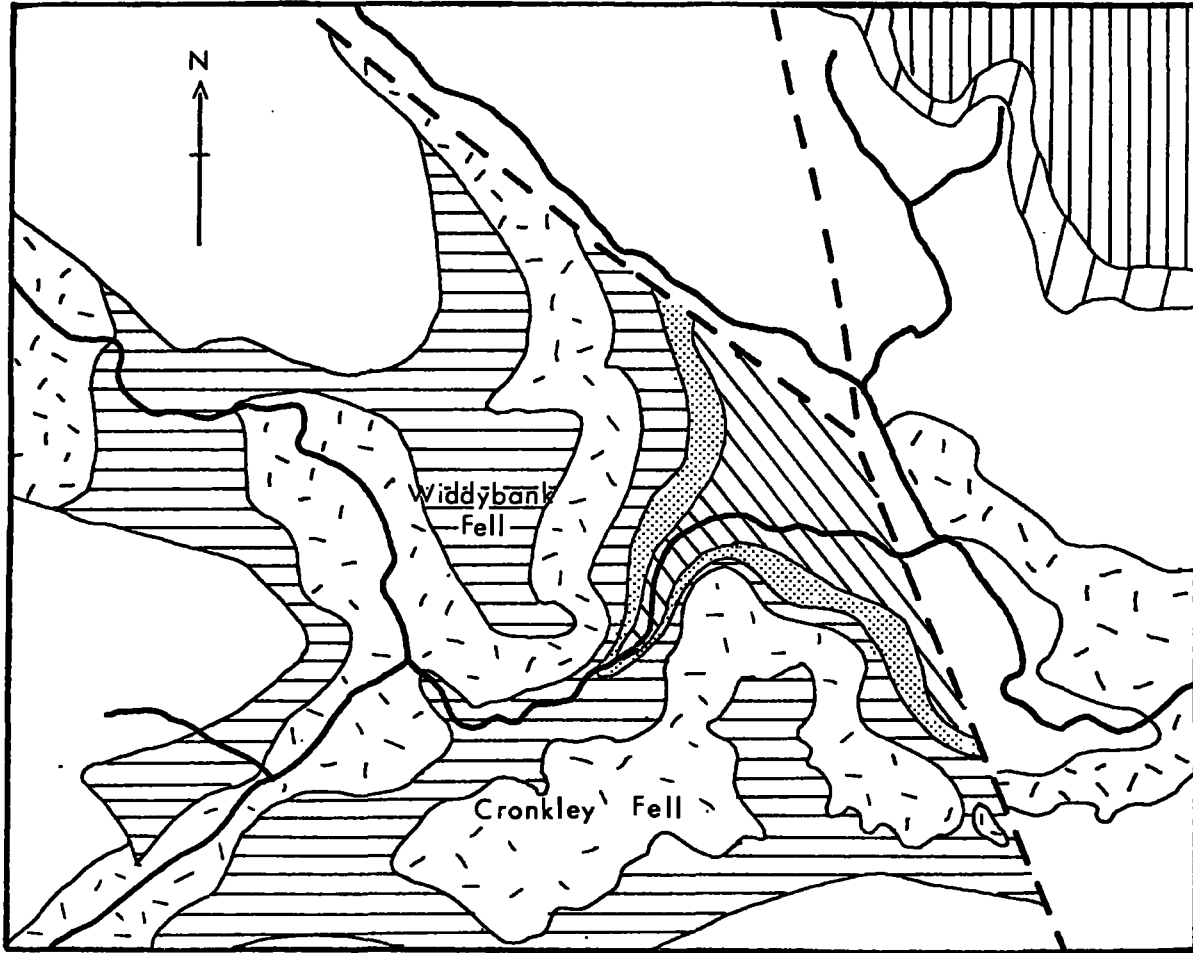

SCALE 1:63360

PLATE II

Outcrop of "sugar limestone" on Widdybank Fell



undifferentiated soils on sand dunes have been termed silicate syrosem and similarly Shimwell (1969) proposed the term calcareous syrosem to describe this undifferentiated limestone soil type in Teesdale.

The accumulation of humus to form an Ao horizon, together with some leaching, has resulted in the formation of rendzinas and brown rendzinas. The activities of large populations of moles, Talpa, have contributed to the erosion, and have also reassorted the profiles overlying the sugar limestone so that the rendzinas have diffuse boundaries with humus widespread through the profile.

Much of Widdybank Fell has been covered by glacial drift deposits and where boulder clay has sealed off the sugar limestone from the pedogenic process humus iron podsols have developed, and in shallow basins, where drainage has been impeded, up to 4 metres of peat have developed over the calcareous drift (Shimwell 1969).

Gleying is restricted on Widdybank Fell to small areas where the Fell meets the flood plain of the river, and extends a little way up the streams or sikes.

(ii) Climate

Manley (1942) studied the western boundary of Upper Teesdale and formed "a conception of an excessively windy and pervasively wet autumn, a variable and stormy winter with long spells of snow cover, high humidity and extremely bitter winds alternating with brief periods of rain and thaw. April has a mean temperature little above freezing point and sunny days in May are offset by cold polar air, while the short and cloudy summer is not quite warm enough to support the growth of trees. Throughout the year indeed the summits are frequently covered in cloud."

He labelled the climate of the high western ridge "subarctic" but emphasised the marginal nature of this upland climate by saying that a "relatively slight increase in the frequency of anticyclonic summer

weather would allow a rise in mean temperature almost sufficient to permit growth of trees."

Table 2 shows the months with mean daily minimum temperatures below 0°C and also mean monthly temperatures. Manley indicated that owing to the flatness of the annual mean temperature curve, a slight increase in elevation was accompanied by a remarkably large decrease in length of the growing season. The number of months with a mean daily minimum below 0°C is indicative of the period throughout which snow may lie. Indeed Radforth (1962) included Upper Teesdale in his "active frost" zone where microtopography is influenced by solifluction and erosive phenomena associated with freezing conditions.

The rainfall is high enough to be conducive to peat formation. - ref

Glasspoole (1952) mapped the distribution of rainfall in the Tees Valley (Figure 3). The annual rainfall increases rapidly westward from less than 30 inches (76 cm.) near the coast to 55 inches (140 cm.) on Cronkley Fell and Widdybank Fell. This increases to over 70 inches (180 cm.) on the summit of Mickle Fell and the high ground near Cross Fell.

Rainfall at study area

TABLE 2

Climatic data for Widdybank Fell
(based on 1968, 69 and 70 records only)

	Mean Monthly Precipitation (cms.)	Mean Monthly Temperature (°C)	Months with mean daily minimum below 0°C
January	14.6	1.1	*
February	18.3	2.8	*
March	20.8	1.1	*
April	11.4	1.6	-
May	9.6	4.4	-
June	10.5	10.6	-
July	7.2	12.2	-
August	6.5	12.2	-
September	18.2	10.0	-
October	13.3	9.4	-
November	19.1	1.7	*
December	9.9	- 0.4	*

159.1

(62.1)

Fig. 3 The distribution of annual rainfall in the Tees Valley
(after Glasspoole 1932)

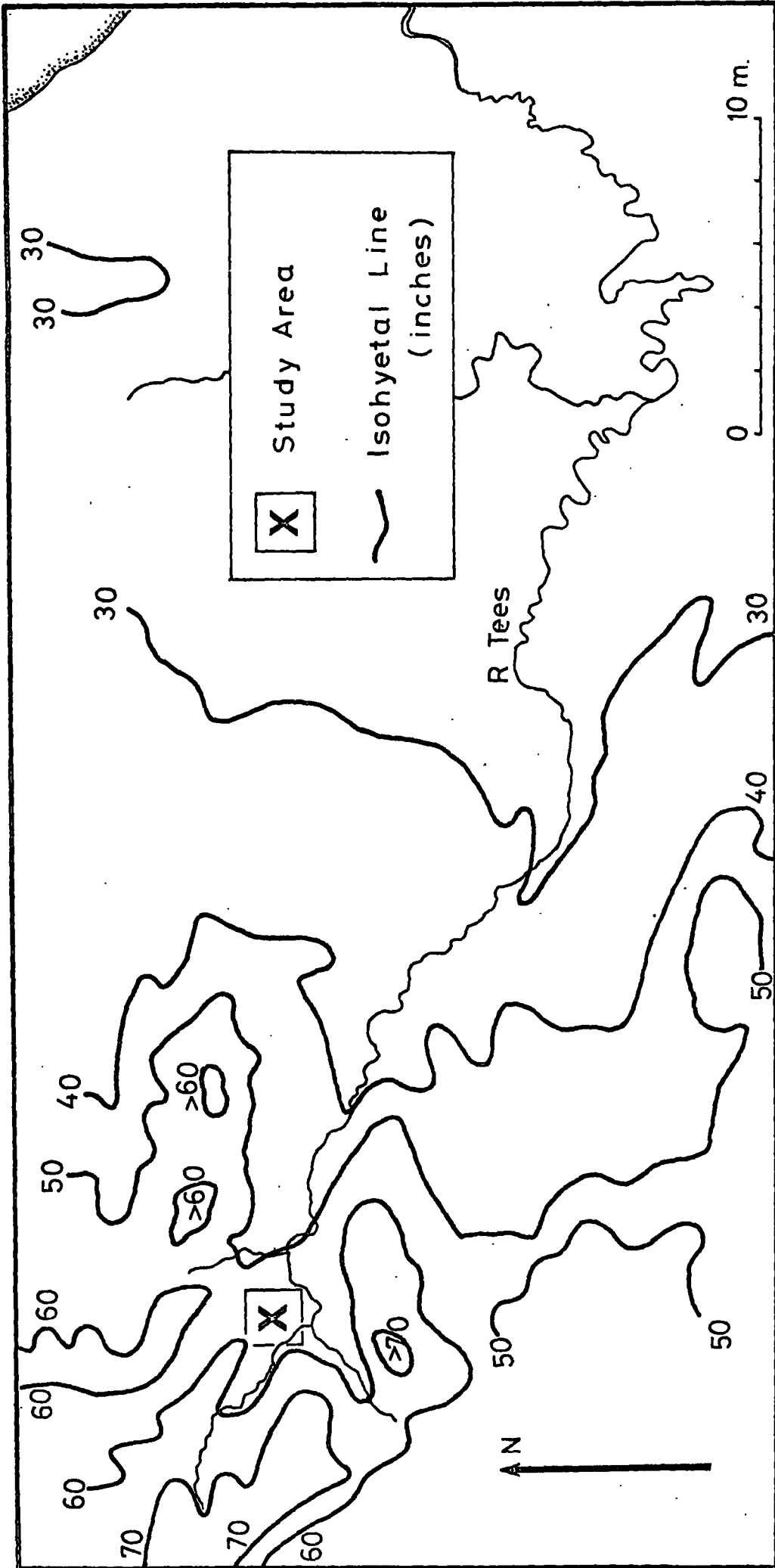

B. THE BIOTIC

General Vegetation of Upper Teesdale

The uplands of the Northern Pennines are covered for their greater part by "dreary and monotonous" moorlands (Tansley 1911) which contrast markedly with the rich, green vegetation of the lower slopes and valleys. This difference is accentuated by agricultural settlement of the lower land. Locally, there is a sharp differentiation between the relatively unbroken expanse of moorland on the top of Widdybank Fell, occupying the foreground in Plate III, and the pattern of hay meadows, pastures and coniferous plantation on the floor of the Tees valley to the west of the Fell.

The situation is further complicated in the Widdybank Fell area by the relatively "lush" vegetation which penetrates in calcareous flushes high into the moorland zone.

Although the Upper Teesdale flora is probably more widely known than that of any area in Britain there have been few attempts to describe its phytosociology, as opposed to the distributions of individual species. Bradshaw and Clark (1967) have produced a classification of the vegetation of the higher ground which is summarised in Figure 4. The main vegetation types they delimit will be briefly considered here.

(1) Blanket Bog

Much of the upland area of the Pennines up to 2,500 ft. lies buried beneath a blanket of acid peat of varying depth, particularly in flat areas or slopes of low gradient. The growth of various species of Sphagna is encouraged under these conditions of low runoff, and under the prevailing climatic conditions peat formation has occurred. A typical flora including the following species has developed:

PLATE III Locally, there was a sharp differentiation between the relatively unbroken expanse of moorland on Widdybank Fell and the pattern of hay meadows, pastures and coniferous plantations in the Tees Valley below.

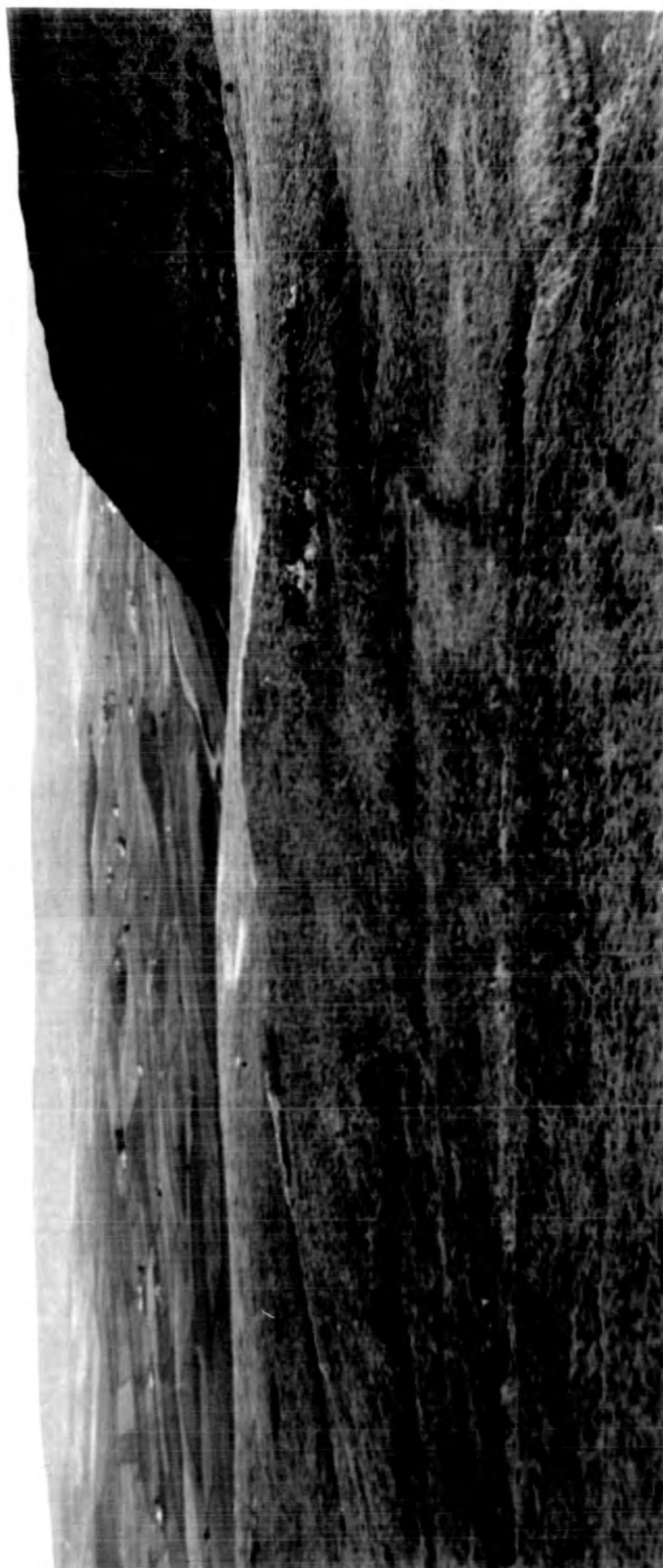

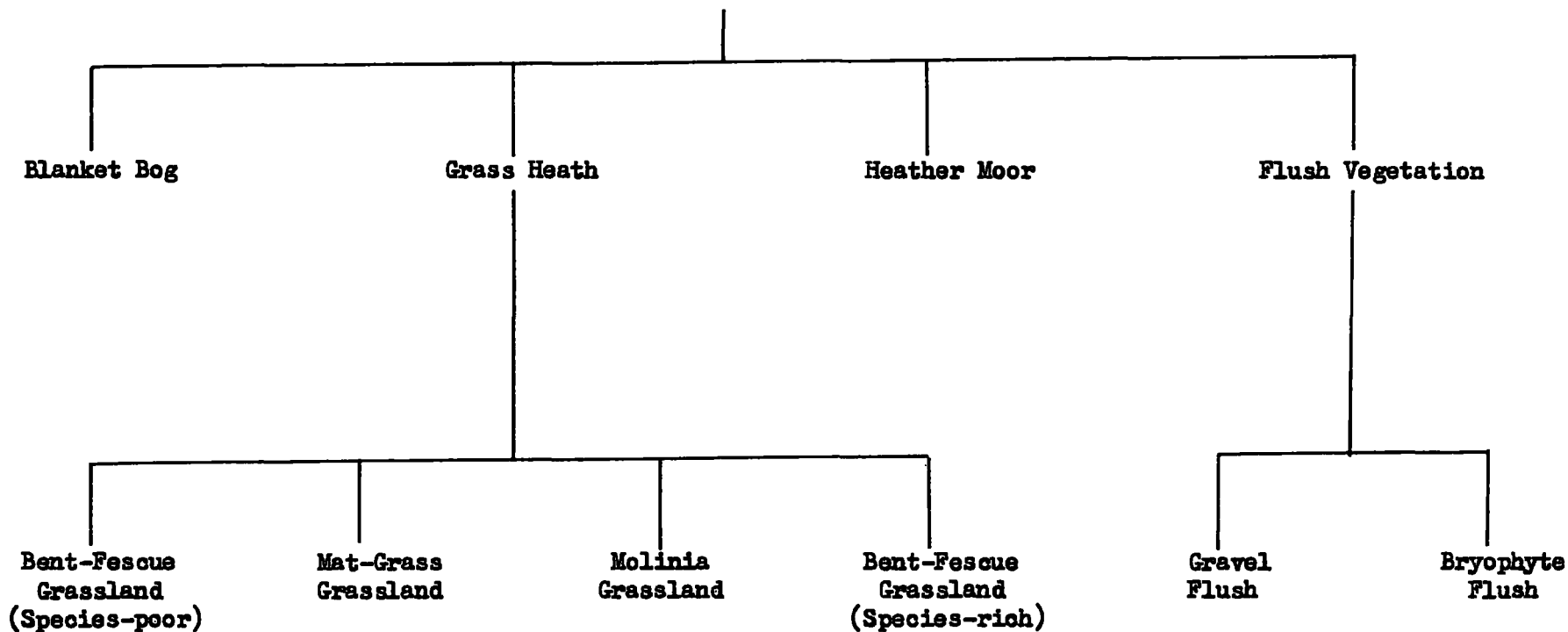

Fig. 4 A general classification of the main vegetation types occupying the high ground of Upper Teesdale
(after Bradshaw and Clark 1965)

Sphagnum spp.Drosera rotundifoliaNarthecium ossifragumCalluna vulgarisErica tetralixEriophorum angustifoliumEriophorum vaginatumTrichophorum caespitosum

This formation is synonymous with the Cotton-grass associations of Tansley (1911), the Eriophoretum Vaginatii and the Eriophoretum Angustifolii, as well as the Calluno-Eriophoretum of McVean and Ratcliffe (1962). The top of Widdybank Fell is covered by large tracts of this formation and it is interesting to note that the only known station in England for Betula nana occurs there.

(ii) Heather Moor

This dwarf shrub heath is dominated by heather and is found in the better drained, leached acid soils. Its floristic composition is variable, depending on the intensity of grazing and burning, but the main species are:

Calluna vulgarisVaccinium myrtillusVaccinium vitis-idaeaErica cinereaDeschampsia flexuosaPotentilla erectaHypnum cupressiformePleurozium schreberiDicranum scopariumLophocolea bidentata

This group is synonymous with the Bilberxy Moor associations of Tansley (1911), the Vaccinietea Myrtilli, and the Vaccinium myrtillus heath of Bridgewater (1970) typical of northern Britain and upland Wales.

Where this moor abuts on to grass heath and the soil is calcareous a floristically richer variant has developed. This species rich heather moor is more heterogeneous in nature than the typical heather moor, and has the following additional species:

Empetrum nigrumLophozia floerkiiPtilidium ciliareHylocomium splendensCladonia arbusculaFestuca ovinaRhytidiadelphus loreusCampanula rotundifoliaPolygala vulgarisThymus drucei

This vegetation in the vicinity of Slapestone Sike, on Widdybank Fell, grades off into species rich grass heath; this transition accompanied by the introduction of such species as Gentiana verna.

(iii) Grass heath

In Teesdale these formations are generally anthropogenic (Bradshaw and Clark, 1965) and their structure depends upon grazing pressure, soil base status and soil-moisture regime. The three main kinds of grassland typical of the low base status will be considered first before the species-rich grassland of the calcareous tracts.

(iv) Species-poor Bent-Fescue Grassland

This is typified by the following combination of species:

Agrostis tenuisFestuca ovinaA. caninaAnthoxanthum odoratumPotentilla erectaGalium saxatileViola rivinianaLuzula campestrisRhytidiadelphus squarrosusHylocomium splendens

This type of vegetation is widespread in the British Isles and is one of the most important pasture types of rough grazing in the Southern Uplands, Northern England and Wales. These grasslands tend to occur on dry pedsollic loams and are extensive on the boulder clay of Widdybank Fell.

(v) Mat-Grass Grassland

This grassland is similar to the preceding type except that Agrostis and Festuca species are replaced by Nardus stricta, Juncus squarrosus and Deschampsia flexuosa. This formation is typical of the wetter and more heavily grazed sectors of the Fell and is again restricted to what are, from a botanical point of view, base poor substrata.

(vi) Molinia Grassland

This has the following assemblage:

<u>Molinia caerulea</u>	<u>Juncus squarrosus</u>
<u>Carex panicea</u>	<u>C. flacca</u>
<u>C. echinata</u>	<u>C. pulicaris</u>
<u>C. dioica</u>	<u>C. nigra</u>
<u>Juncus articulatus</u>	

These occur in even wetter and more acid conditions, frequently on anaerobic gleyed soils.

These preceding vegetation types generally do not support a rich flora, nor many of the rare and peculiar species for which Teesdale is famous. They will therefore be considered no further at this stage, although they cover a large proportion of Widdybank Fell and the Cow Green area.

The limestone outcrops, however, make up for their spatial restriction by supporting a varied and interesting flora associated with the species rich Bent-Fescue grassland and the flush vegetation.

(vii) Species-rich Bent-Fescue Grassland

These grasslands grow on both metamorphosed and unaltered limestone and the following assemblage represents the typical species composition:

<u>Festuca ovina</u>	<u>Helictotrichon pratense</u>
<u>Koeleria cristata</u>	<u>Carex caryophyllea</u>
<u>Briza media</u>	<u>C. capillaris</u>
<u>Carex ericetorum</u>	<u>Gentianella amarella</u>
<u>Galium pumilum</u>	<u>Kobresia simpliciuscula</u>
<u>Helianthemum chamaecistus</u>	<u>Linum catharticum</u>
<u>Minuartia verna</u>	<u>Thymus drucei</u>
<u>Viola riviniana</u>	<u>Campanula rotundifolia</u>
<u>Plantago lanceolata</u>	<u>Plantago maritima</u>
<u>Ditrichum flexicaule</u>	<u>Viola rupestris</u>
<u>Rhytidium rugosum</u>	<u>Tortella muralis</u>
<u>Rhacomitrium canescens</u>	and others
<u>Sesleria caerulea</u>	

(viii) Flush Vegetation

The vegetation falling into this category generally occupies areas subject to periodic flooding and is situated either directly on limestone or in the path of runoff or drainage water from limestone.

Species occupying these wet habitats included:

<u>Carex lepidocarpa</u>	<u>Pinguicula vulgaris</u>
<u>C. panicea</u>	<u>Primula farinosa</u>
<u>Eriophorum angustifolium</u>	<u>Tofieldia pusilla</u>
<u>Equisetum variegatum</u>	<u>Festuca rubra</u>
<u>Selaginella selaginoides</u>	<u>Eleocharis quinqueflora</u>
<u>Euphrasia micrantha</u>	<u>Saxifraga aizoides</u>
<u>Campylium stellatum</u>	<u>Catoscopium nigratum</u>
<u>Ctenidium molluscum</u>	<u>Fissidens adianthoides</u>
<u>Philonotis calcarea</u>	and others.

PART II

THE VEGETATION OF THE STUDY AREA

A. TRANSECT ANALYSIS

As a basis for the study a transect was laid down on the north-facing slope of Slapestone Sike, Widdybank Fell.

This sike drains a partially peat-covered catchment and cuts down through the overlying glacial drift into the Melmerby Limestone beneath. The soils of this valley form a catena from peat-covered drift down through various admixtures to limestone, becoming progressively wetter downslope due to seepage from the limestone aquifers draining into the sike.

The transect was orientated at rightangles to the main drainage axes of the sike. It started in sedge marsh vegetation on the damp calcareous gravels on the banks of the stream and progressed upslope away from the stream's influence. The sedge marsh graded into damp grassland which in turn gave way to herb-rich heathland on a more siliceous soil. This covered one of the main 'gradients' of vegetation variation on Widdybank Fell.

Method of Transect Analysis

Presence or absence of the plant species were recorded in contiguous $\frac{1}{4} \times \frac{1}{4}$ m square quadrats along the belt transect. Soil samples were collected from each quadrat and analysed (for method see Appendix 1).

The floristic data was then sorted using Crawford and Wishart's Group Analysis technique (1967). To determine whether the groups so obtained represented more nearly stages in a continuum or individual plant communities in their own right, the floristic data was subjected to a further analysis aimed at detecting major discontinuity or heterogeneity in the data; this was the 'H' value analysis, as described by Van de Maarel 1968.

This sensitive method was employed to locate the exact position and nature of these boundaries. That is the heterogeneity between contiguous $\frac{1}{2} \times \frac{1}{4}$ metre quadrats was obtained using the differential

occurrence of species. The frequency of occurrence of the species in the two constituent $\frac{1}{4} \times \frac{1}{4}$ metre halves being used as a measure of species significance. This leads to the equation

$$H = \frac{1}{2} \sum_{i=1} \frac{P(ia) - P(ib)}{P \text{ max}}$$

where $P(ia)$ is the performance of the i th species in quadrat a etc.

H values for such transects are then amenable to graphical representation.

Results

The resultant 'H' profile indicated an acute peak on the graph at a position 4 m along the transect (Figure 5) implying that there was a spatially abrupt change in the floristic composition at that point. A picture therefore emerged of the sedge marsh communities being sharply separated from a sedge rich grassland. The remainder of the graph showed a variable and 'disturbed' form; the peaks on the 'graph' were of a much lower amplitude indicating a spatially more gradual change.

The complementary group analysis produced eight synecological groups (Figure 6) and subsequently their ecological relationships were analysed along the following simple environmental scalars, soil organic content, total calcium, magnesium, sodium and potassium.

Fuller details of the group analysis are given below in the thesis.

The sedge marsh community was composed of a mosaic of three similar groups, D, H and G, typified by the high percentage occurrence of such species as Carex panicea, Carex lepidocarpa, Juncus articulatus, Bryum pseudotriquetrum, Drepanocladus fluitans, Philonotis fontana and the absence of the species typical of the grassland further up the transect, Festuca ovina, Ctenidium molluscum and Hylocomium splendens (Figure 6).

The first part of the document discusses the importance of maintaining accurate records of all transactions. It emphasizes that proper record-keeping is essential for the integrity of the financial system and for the ability to detect and prevent fraud.

Financial Reporting and Transparency

The second part of the document focuses on the requirements for financial reporting. It outlines the standards for transparency and the need for timely and accurate disclosure of financial information to stakeholders.

The third part of the document addresses the role of internal controls in ensuring the reliability of financial data. It discusses how strong internal controls can help identify and mitigate risks before they become significant issues.

Internal Controls

Conclusion

In conclusion, the document highlights the critical importance of financial reporting and internal controls in maintaining the trust and confidence of the public in the financial system.

It is the responsibility of all financial institutions and their regulators to ensure that these standards are strictly followed and that any violations are promptly addressed.

The document also notes that ongoing monitoring and improvement of these systems are necessary to adapt to the changing landscape of financial markets and emerging risks.

By adhering to these principles, the financial system can continue to serve the economy effectively and maintain its reputation for integrity and stability.

The document concludes by expressing confidence that the measures outlined herein will contribute to a more robust and transparent financial system for the future.

Thank you for your attention to these important issues. We look forward to continued collaboration in promoting the highest standards of financial reporting and internal controls.

Respectfully,
[Signature]

The document is intended to provide a clear and concise overview of the key requirements and expectations for financial reporting and internal controls. It is not intended to constitute legal advice or a substitute for professional counsel.

For more information or to request a copy of the full document, please contact the appropriate regulatory authority or the relevant financial institution.

We appreciate your commitment to the integrity and transparency of the financial system and your cooperation in implementing these standards.

Thank you for your attention to these important issues. We look forward to continued collaboration in promoting the highest standards of financial reporting and internal controls.

The document is intended to provide a clear and concise overview of the key requirements and expectations for financial reporting and internal controls. It is not intended to constitute legal advice or a substitute for professional counsel.

For more information or to request a copy of the full document, please contact the appropriate regulatory authority or the relevant financial institution.

We appreciate your commitment to the integrity and transparency of the financial system and your cooperation in implementing these standards.

Thank you for your attention to these important issues. We look forward to continued collaboration in promoting the highest standards of financial reporting and internal controls.

The document is intended to provide a clear and concise overview of the key requirements and expectations for financial reporting and internal controls. It is not intended to constitute legal advice or a substitute for professional counsel.

For more information or to request a copy of the full document, please contact the appropriate regulatory authority or the relevant financial institution.

We appreciate your commitment to the integrity and transparency of the financial system and your cooperation in implementing these standards.

Fig. 5 Slapestone Sike Transect (1)
Topography, Group Analysis and 'H' value graph

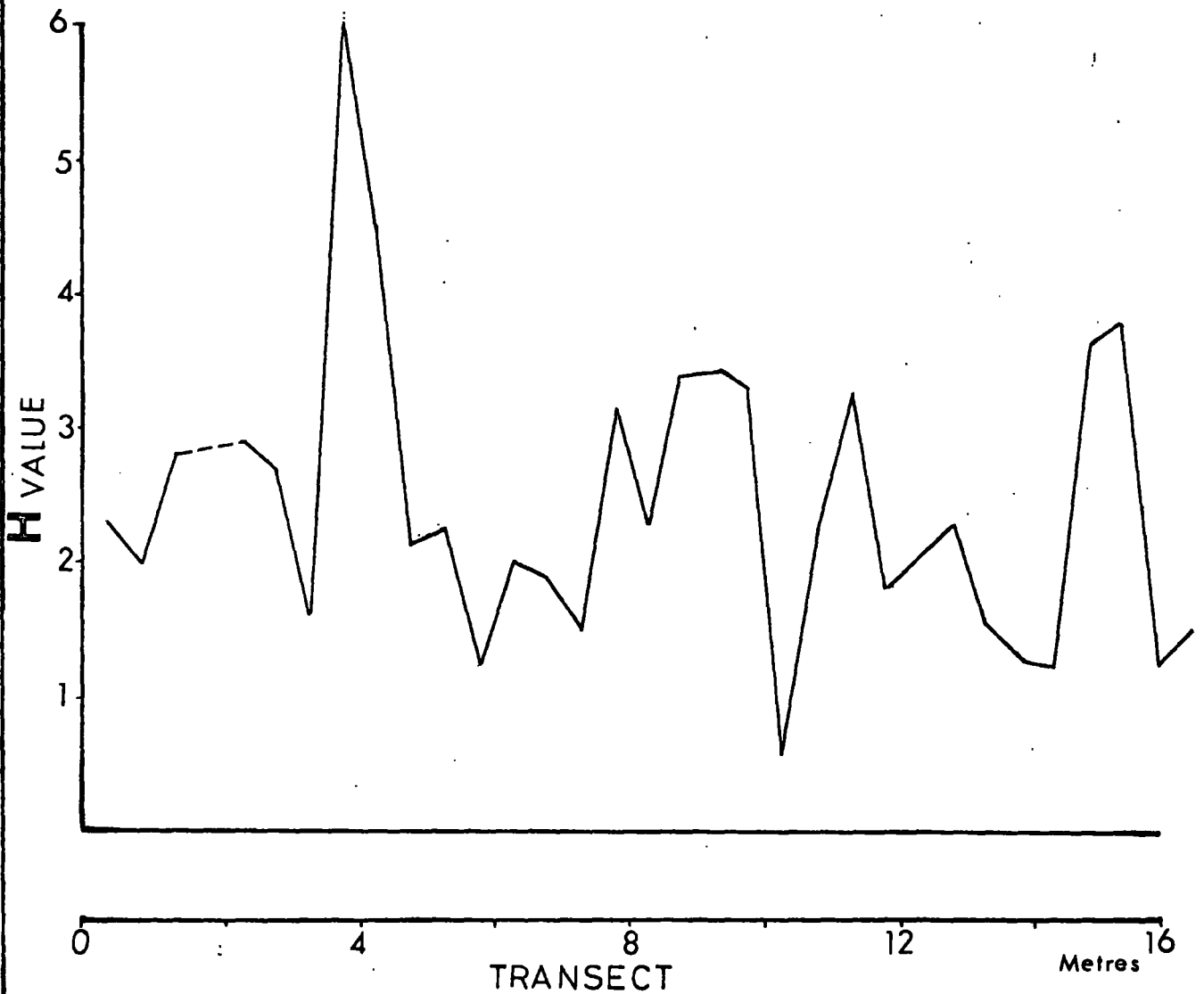
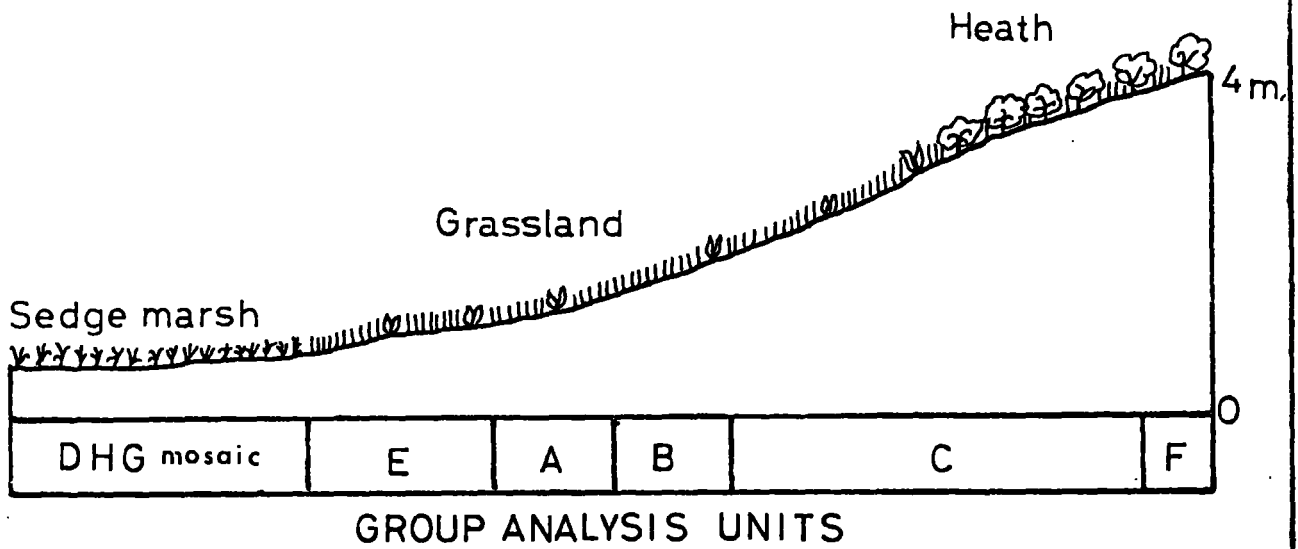

Fig. 6 Slapestone Sike Transect (1)

The eight synecological groups determined by Group Analysis

<u>Species</u>	<u>Groups</u>	<u>H</u>	<u>G</u>	<u>D</u>	<u>E</u>	<u>A</u>	<u>B</u>	<u>C</u>	<u>F</u>
Pellia epiphylla		33	100						
Agrostis canina		67	50						
Sagina nodosa		33	50						
Philonotis fontana		100	100	50					
Kobresia simpliciliscula		67	50	100					
Drepanocladus fluitans		100	100	100					
Bryum pseudotriquetrum		100	100	100	20				
Riccardia pinguis		67	100	100	20				
Pinguicula vulgaris		33	100	50	20				
Eriophorum angustifolium		100	100	100	100	100			
Equisetum variegatum		100	50	50	100		67		
Juncus articulatus		100	100	100	100	67	67		
Carex lepidocarpa		100	100	100	100	100	67		
Carex panicea		100	100	100	100	100	100		
Selaginella selaginoides		33		50	80	100	100		
Breutelia chrysocoma					20	100	67		
Racomitrium lanuginosum					80	100			
Tofieldia pusilla					20	100	100		
Carex capillaris					100	67	100		
Ctenidium molluscum					100	100	67		
Peltigera aphosia				50	80	100	100		
Cornicularia aculeata					40	33	33	15	
Prunella vulgaris		100			100	100	100	7	
Thymus drucei				100	100	100	100	76	
Potentilla erecta				100	100	100	100	100	
Minuartia verna						33	100	7	
Viola lutea						33	100	69	
Rhytidiadelphus triquetrus							100	15	
Cerastium holosteoides							33	7	
Festuca ovina					80	100	100	100	100
Hypnocomium splendens						100	100	100	100
Cladonia arbuscula							67	92	100
Agrostis tenuis							100	100	50
Galium saxatile							67	100	100
Rhytidiadelphus loreus								54	100
Pleurozium schreberi								100	50
Campanula rotundifolia								69	100
Anthoxanthum odoratum								69	100
Calluna vulgaris								46	100
Hypnum cupressiforme								38	100
Polytrichum juniperinum								24	50
Carex ericetorum								15	100
Thuidium tamariscinum								7	50
Plantago maritima			50		20				
Fissidens adiantoides			50		20				
Cardamine pratensis				50					
Lophocolea bidentata				100					
Polygala vulgaris					40				
Riccardia multifida					20				
Cephalozia bicuspidata					20				
Nardus stricta					20				
Rhytidiadelphus squarrosus								54	
Luzula campestris								24	
Dicranum scoparium								62	
Bazzania trilobata								24	
Certraria islandica						33		15	
Viola riviniana								7	
Armeria maritima		33					33		
Ditrichum flexicaule									

(Figures quoted refer to percentage occurrence of species in groups).

These sedge marsh groups occur to the left of the peak on the differential profile diagram, whereas to the right of the peak there follows a group of five contiguous quadrats designated group E. This was distinguished by the presence of Festuca ovina, Potentilla erecta, Thymus drucei and Ctenidium molluscum together with some sedge species and Bryophytes from the groups D, H and G.

The sharp margin of the wet sedge marsh community not only marks vegetational discontinuity but also marks a zone of sudden environmental transition; the limit of periodic inundations from the swollen watercourse after torrential rain. The scouring effect of this vigorous flushing also led to preferential erosion of the humus and litter that had accumulated since the previous inundation, as well as exposure and/or deposition of limestone granules at and below the top flood-water level. This was reflected in the chemical analyses (Figure 7) where the soil showed a very sudden decline from relatively high levels of calcium (200 mg/g soil) and sodium (2.5 mg/g soil) in the sedge marsh groups D, H and G, to a much lower level in group E where calcium was 10 mg/g soil and sodium 0.5 mg/g soil. These low levels were continued through the other groups A, B, C and F, the valley side. The dramatic drop of these two elements took place in the immediate vicinity of the 4 m mark of the transect and clearly corresponds closely to the large floristic difference expressed in the profile.

As the levels of Calcium and Sodium in the soil fell, so the proportion of organic material increased from 10 to 50% of the total dry weight of the soil. This higher level of organic material decreased near the 10 m level of the transect, but the corresponding increase in organic material was made up largely of siliceous rather than calcareous material.

The floristic composition of group A is distinguished from group B by the high presence of Tofieldia pusilla and Rhacomitrium lanuginosum

Fig. 7 Slapstone Sike Transect (1)

Total Calcium, Sodium, Potassium and organic material of soil
samples

TOTAL CALCIUM AND SODIUM IN SOIL

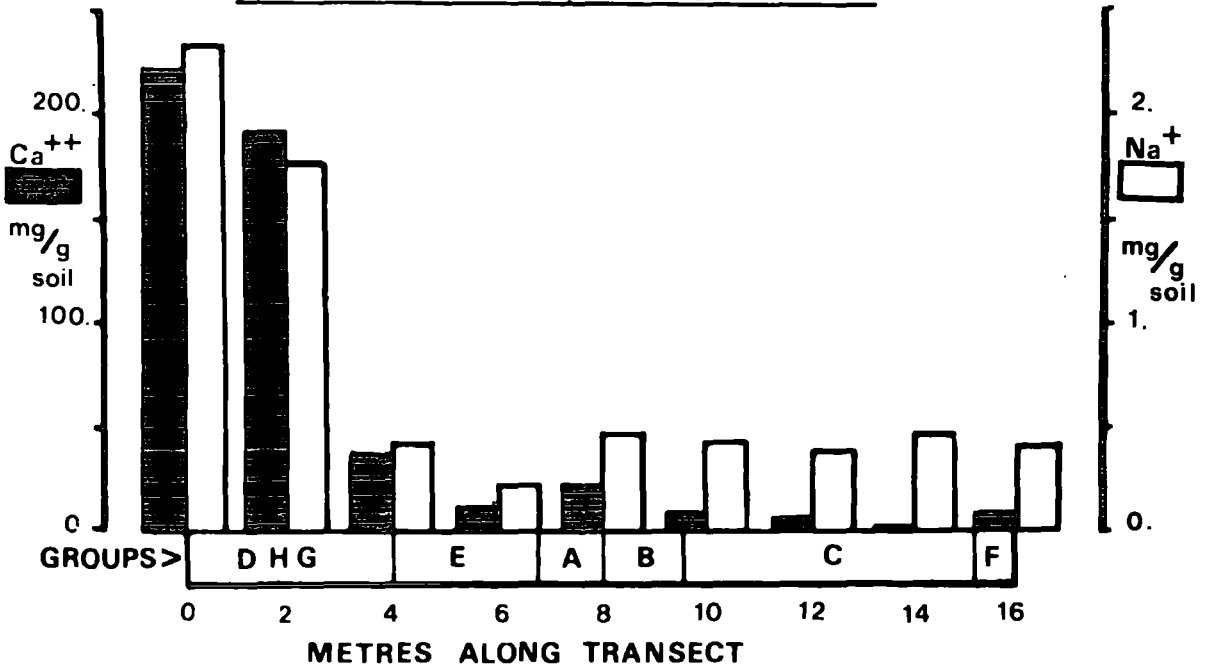

ORGANIC MATERIAL AND POTASSIUM IN SOIL

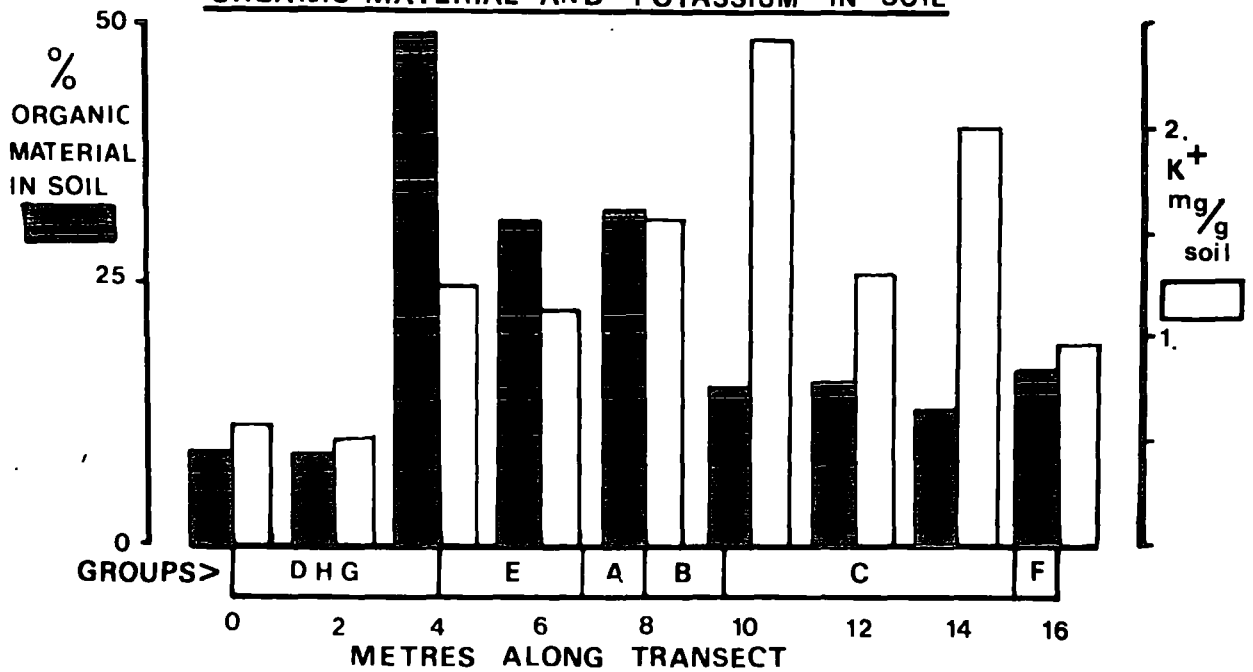

whereas B was typified by Rhytidiadelphus triquetrus, Viola lutea and ~~and~~ Agrostis tenuis.

Groups A and B were distinguished from the next group, C, by such species as Breutelia chrysocoma and Minuartia verna. Group B blended with group C which continued for most of the remainder of the transect. This vegetational continuity was reflected in the comparative constancy of the environmental scalars although within this latter group a physiognomic change associated with the presence of Calluna vulgaris occurred in the last four metres of the transect. The appearance of a Chaemophyte in an otherwise essentially homogenous community did not appear to be paralleled by change in any of the soil factors previously mentioned. The density of the heather near the top end of the transect precluded the full development of associated herbs such as Prunella vulgaris.

The 4 metre boundary therefore is real both biotically and abiotically. Associated with this sharp boundary situation and its surrounding area were some of the "Teesdale Rarities". The occurrence of such species as Tofieldia pusilla, Carex capillaris and Plantago maritima in this vigorous zone of transition is noteworthy. This raised the question do some of the rarities find suitable habitats in such unstable areas where a wealth of environmental variables mingle together?

B. INVESTIGATION OF A BOUNDARY SITUATION

To investigate the possibility of such boundary situations being a key habitat for the rarities, a different approach was applied to determine the character and significance of the sociological groupings, as well as delimiting these groups and their boundaries. To this end another transect was laid down the side of Slapestone Sike, as in the previous analysis, but the upper quadrats of this belt crossed calcareous grassland before entering the species rich heath.

The presence or absence of each species was recorded as before for each quadrat along the transect, there being 33 quadrats of dimensions 25 x 25 cm.

The raw data was subjected to normal, inverse, and nodal analysis (Williams & Lambert, 1959, 1961, and Lambert & Williams, 1962).

Normal analysis compares the homogeneity of quadrats based on their species content, and divides them into related quadrat groups. Using this method the quadrats were split into two groups which were as dissimilar as any two sections of the population could be with reference to a single species (see Figure 8). In this case the first division was based on Carex lepidocarpa (species reference No. 2). Those quadrats with this species (+2) went to form one group of 18 quadrats and those without (-2) formed the other group of the remaining 15 quadrats.

The first group, typified by the presence of Carex lepidocarpa, occupied the lower part of the transect, being subject to periodic flooding, whereas the other group were above the level attained by floodwater.

This divisive procedure was repeated, the group containing Carex lepidocarpa split into one large group of 16 quadrats containing Kobresia simpliciuscula, and a small group of two quadrats without this plant.

Similarly the first group without Carex lepidocarpa was split

Fig. 8 Slapestone Sike Transect (2)

Normal (upper) and Inverse (lower) association analysis

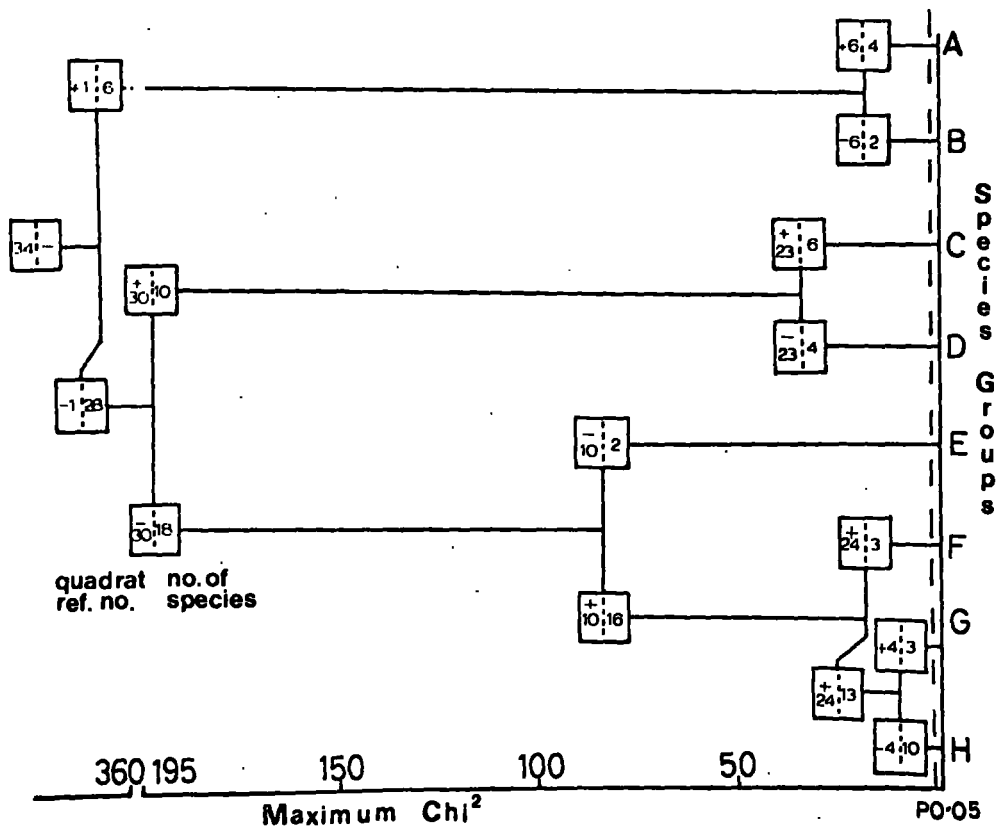
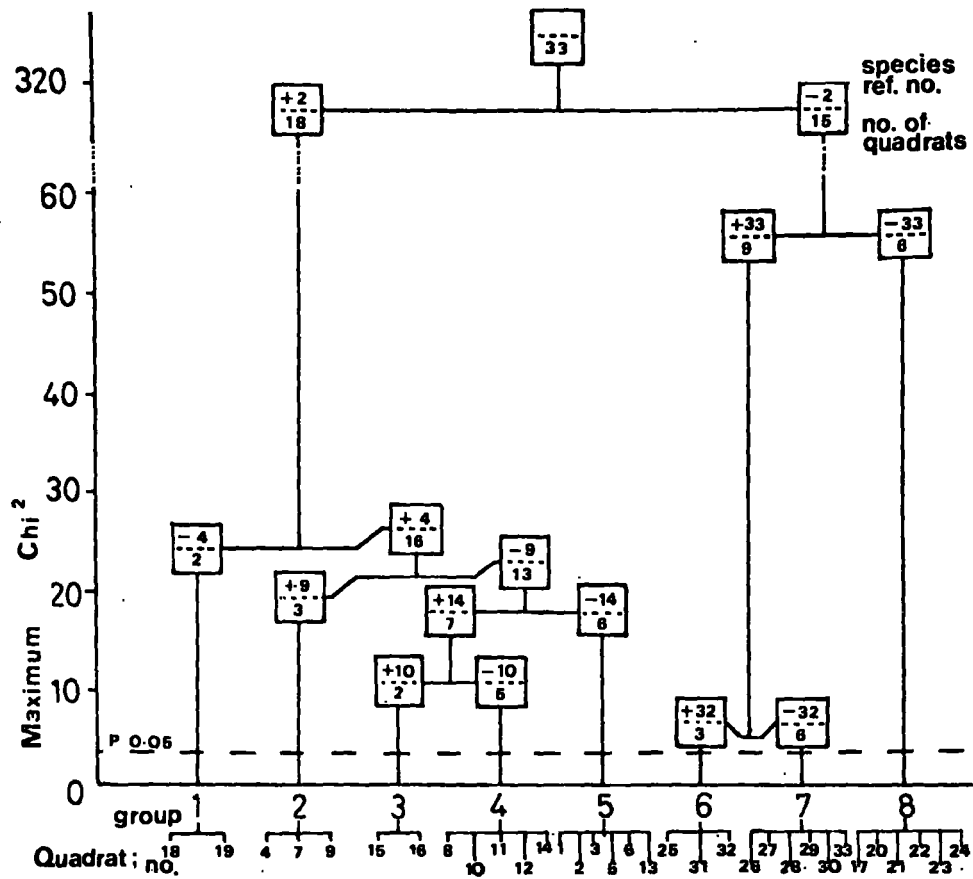

according to the presence or absence of Rhytidiadelphus loreus and the resultant groups continually re-divided until the predetermined stopping level ($p = 0.05$) was reached.

The resultant eight groups of floristically defined quadrats theoretically formed meaningful ecological entities.

Inverse analysis aimed at dividing the species data in order to produce sociologically meaningful groups. The manipulation of the raw data in this procedure was the same as for normal analysis, except that the species are treated as were quadrats, and the quadrats as were the species. Again eight groups were derived before the stopping level was attained.

The combination of the floristically defined quadrats (from normal analysis) and the social groups of species (from inverse analysis) was advocated by Lambert & Williams (1962) to produce a nodal analysis. In nodal analysis the combination and re-defining of these two initial analyses, normal and inverse, produced a doubly defined set of units or noda of differing quantitative and qualitative definition. The noda are defined statistically as full noda, major sub-noda of high rank, major sub-noda of low rank, and minor sub-noda in descending order of significance.

In Figure 9 the quadrat groups have been arranged horizontally and the species groups vertically to clarify the relationships of the noda in general abstract terms. Two main types of vegetation have been delimited in both sociological and spatial contexts. Type 1 is defined by the following full noda:-

4/12, 4/1, 4/7

These contained Juncus articulatus, Kobresia simpliciuscula, Carex panicea and Carex lepidocarpa; all species typical of the Alpine sedge-marsh Order Tofieldietalia and the last named species C. lepidocarpa is

Fig. 9 Slapestone Sike Transect (2)

Nodal Analysis

ref. no.	SPECIES	QUADRATS group ref. no.																																
		4				5					2			3		1		8					6			7								
		12	8	10	11	14	1	2	3	5	6	13	7	9	4	15	16	18	19	23	24	20	2/	22	17	31	32	25	26	27	28	29	3	33
A	4 KOBRESIA SIMPLICIUSCULA	4/12				4/1					4/7			4/15		-/18																		
	1 CAREX PANICEA	4/12				4/1					4/7			4/15		-/18																		
	2 C. LEPIDOCARPA	4/12				4/1					4/7			4/15		-/18																		
E	13 PRUNELLA VULGARIS	13/12												13/15																				
	14 CAMPYLIIUM STELLATUM	13/12												13/15																				
B	5 CTENIDIUM MOLLUSCUM	5/12				5/1					5/7			5/15		5/18		: 6/23 :																
	6 POTENTILLA ERECTA	5/12				5/1					5/7			5/15		5/18		: 6/23 :																
	GIOMINUARTIA VERNA													10/15																				
H	17 CLADONIA IMPEXA													15/15		18/18																		
	18 RHACOMITRIUM LANUGINOSUM													15/15		18/18																		
	19 EUISETUM VARIEGATUM													15/15		18/18																		
	20 PLANTAGO MARITIMA													15/15		18/18																		
D	21 RICCARDIA PINGUIS													15/15		18/18																		
	31 PLEUROZIUM SCHREBERI																						31/28											
	32 CALLUNA VULGARIS																						-/31											
F	26 RHYTIDIADELPHUS SQUARROSUS										9/7																							
	9 CAMPANULA ROTUNDIFOLIA										9/7																							
	25 PSEUDOSCLEROPODIUM PURUM																																	
C	27 THUIDIUM TAMARISCINUM																						14/37											
	4 POLYTRICHUM JUNIPERINUM																						14/37											
C	29 GALIUM SAXATILE															-/18																		
	23 RHYTIDIADELPHUS LOREUS															-/18																		
	15 THYMUS DRUCEI															-/18																		
	22 FESTUCA OVINA															-/18																		
	12 SESLERIA CAERULEA															-/18																		
	24 HYLOCOMIUM SPLENDENS															-/18																		

a "charakterarten" of the Alliance Eriophorion Latifolii of that Order.

The other extreme, type 2, was strongly defined by the noda:-

$24/23$, $24/31$, $24/28$.

These contain Hylocomium splendens, Sesleria caerulea, Festuca ovina, Thymus drucei and, except in noda 24/31, Galium saxatile with Rhytidiadelphus loreus. This group of grassland species was rather heterogenous from the synsystematic viewpoint showing affinities to the Orders Seslerietalia, Nardetalia, or Brometalia.

A transition zone separated these two principal types and was characterised by many major and minor sub-noda and the absence of full noda representative of either extreme type.

These sub-noda constituted a distinct abrupt definable boundary zone directly comparable to the first transect, Figure 5, a zone of instability only 1 metre wide. Figure 10 shows the noda superimposed on the actual transect.

Lambert & Williams (1962) noted that minor sub-noda which were only weakly defined were best omitted. However, in this instance, their presence was obviously intrinsic to the nodal constitutions of the communities, and, more particularly, to the boundary zone between them. Therefore they have been retained to form the focal part of the analysis.

As the full noda of the grassland vegetation type approached the boundary zone their social structure broke down until one minor sub-nodum remained, containing only Rhytidiadelphus loreus. This unit was intermingled with a minor sub-nodum which resulted from a similar degradation of the full noda of the sedge marsh approaching from the other side of the boundary. All the tension zone quadrats were therefore defined in weak fashion, and it was in the sub-noda of these quadrats that certain species reached a level of statistical social significance. These

Fig. 10

Slapstone Sike Transect (2)

Noda superimposed on transect

KEY

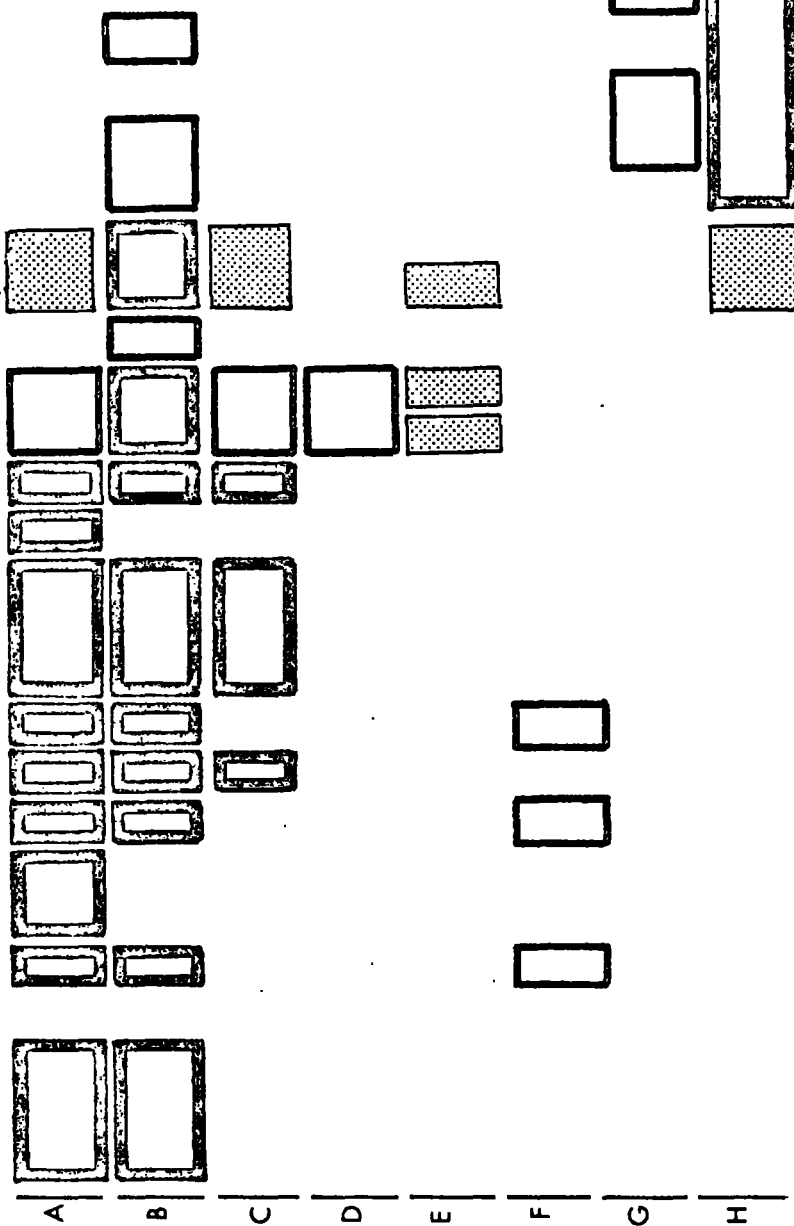
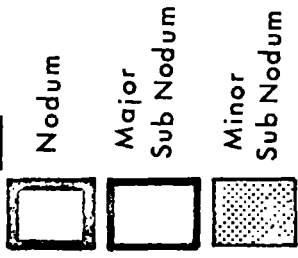

Species

Groups

Transect

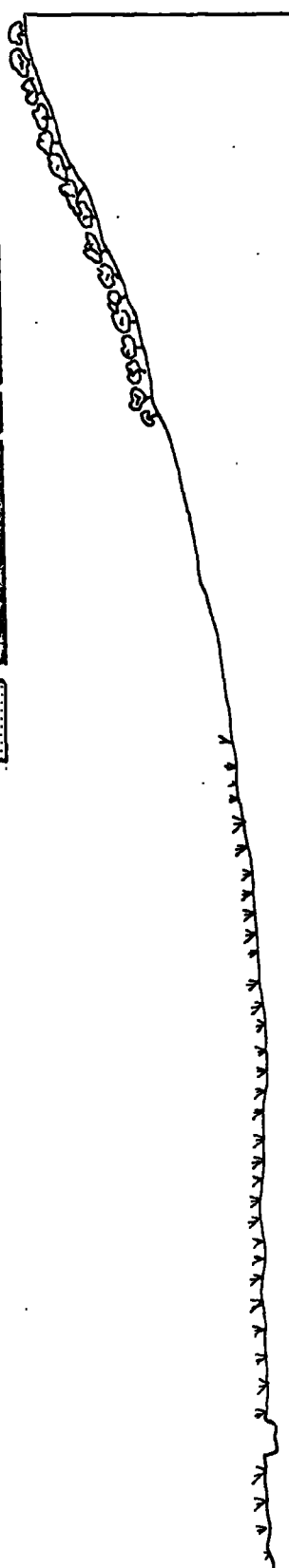

Quadrats

1	2	3	4	5	6	7	8	9	10	11	12	13	14	15	16	17	18	19	20	21	22	23	24	25	26	27	28	29	30	31	32	33
---	---	---	---	---	---	---	---	---	----	----	----	----	----	----	----	----	----	----	----	----	----	----	----	----	----	----	----	----	----	----	----	----

species include Equisetum variegatum, Plantago maritima and Minuartia verna.

These are all members of the "Teesdale rarities" which are more widespread in the British Isles, being typical of open skeletal pioneer communities, Plantago maritima, as a component of the Juncetalia Maritimae of Saltmarsh, Equisetum variegatum of the Scheuzerio-Caricetea Fuscae of montane flush and dune slack, and Minuartia verna typical of the Violetalia Calaminariae of heavy metal spoil heaps. In this zone of instability they exist together in a closed community with complete plant cover.

This phenomenon is not restricted to Slapestone Sike. Pigott (1956) described the chief habitat of Minuartia stricta together with Minuartia verna and Saxifraga aizoides as a narrow zone around the base of Gymnostomum recurvirostrum hummocks in open gravel flushes. Minuartia stricta also occurs along Red Sike on Widdybank Fell in a closed Bryophyte turf which forms a distinct boundary zone between the flushed vegetation of the sike and the bank above the normal level of flowing water.

Perhaps the classic examples of boundary zone species are the mosses Paludella squarrosa, Cinclidium stygium and Cam^fptothecium nitens. Although widespread in the arctic (Nyholm 1954-65) their relict localities in Teesdale and elsewhere are typical of a transition zone between association Erico-Sphagnetalia and the Tofieldietalia. This is a zone of abrupt ecological transition where the nutrient poor came into contact with the nutrient rich and is indeed dominated by it.

The effect of drainage in changing the water regime, thus leading to the disappearance of these species, has been used to explain their loss from many relict localities (Bellamy et al 1969). This upsetting of the balance would change the dynamics of the system and would lead to domination by one of the end state communities, with irrevocable loss or movement of the boundary habitat.

At this stage of the investigation the probable importance of boundary situations in the contemporary existence of the Teesdale rarities was therefore indicated.

The importance of boundary situations was thus indicated. A discussion of some of the more theoretical aspects will therefore be included here.

These zonations or boundary areas bear directly on important aspects of community organisation, especially along apparently continuous environmental gradients. The position and social status of the peculiar species in the Teesdale assemblage is of relevance when considering their persistence in their present disjunct localities as well as delimiting more closely the phytosociological distinctions of the various community types.

In the above study the boundary zones were considered as separators of adjacent systems or communities of differing constitution. Boundary definition used the full information structure of both systems, and was dependent not only on the scale of the system, but also the scale of observation.

Sharp vegetation boundaries have been referred to as ecotones, and diffuse boundaries as ecocline. The term ecocline has connotations of experimental taxonomy and the less ambiguous terms proposed by Van Leeuwen (1966) will be used throughout; Limes convergens denoting sharply defined boundaries, and Limes divergens, diffuse boundaries.

These two extreme boundary forms are associated with characteristic vegetation patterns. The limes convergens shows coarse granulation and has sharp, easily discernible lines of demarcation (Plate IV) between the two opposing vegetation types. Characteristically this vegetation consists of large numbers of plants belonging to relatively few species distributed in a relatively homogeneous manner. Although spatially stable, the life circumstances in these areas have high degrees of temporal instability in

PLATE IV

A limes convergens situation



that there are great environmental fluctuations. Examples of this general disturbance are fluctuations from wet to dry, salt water to fresh water, and nutrient poor to nutrient rich. Weed communities and salt marshes are often linked with this type of situation, these communities falling into the associations of the synsystematic classes of Plantaginetea Tx. and Prsg. 1950, and Thero-Salicornietea Strictae Tx. 1954.

The features of the limes convergens contrast strongly with the fine granulation and faint lines of demarcation typical of the limes divergens situation. These latter gradal situations tend to be rich in species, though only a few individuals of each species may be present. Internal conditions tend to be stable in that the plants are not subjected to massive or rapid environmental change. This type of boundary typically occurs as a gradual transition between two extreme end states and is commonly found in rich marshlands, dune slacks and scrubby moorland edges. Communities characteristic of these situations are not readily referable to synsystematical units, chiefly because these zones have been little studied from a synsystematical viewpoint due to their inherent heterogeneity.

The location of many of the Teesdale rarities in boundary situations, both of the limes divergens and limes convergens type, was evident from the above study. It is suggested that "limes" situations may have been important local refugia in the past during periods of climatic change and especially during the forest maximum.

However the occurrence of certain rarities in homogeneous (and sociologically well defined) communities not directly referable to boundary situations remains to be investigated. Kobresia simpliciuscula as an integral component of a full nodum in the transect association analysis described above affords one such example.

It was therefore decided that the next step must include a more detailed study of the vegetation to obtain a more rigorous definition of the communities, especially those which would form the focus of the production studies.

PART III

SELECTION OF COMMUNITIES FOR DETAILED ECOLOGICAL STUDY

The occurrence of the rarities is not solely restricted to the boundary situations described in the previous section. These plants also appear as components of the major vegetation types.

It was proposed therefore to conduct a more rigorous investigation into the types of vegetation found in a specific area with a view to

- a) determining classificatory units produced by a variety of methods
- b) comparing these units to determine their floristic and spatial interrelationships
- and c) correlating the relationships of the groups so produced with selected environmental parameters.

The aim was to determine and delimit exactly what units of vegetation should be studied in the subsequent work.

Availability of resources limited the scope of the investigation both in geographical and temporal aspects. Conflict arose between the need for observation, of a general nature over the whole valley, and specific, detailed analysis over a small area.

A compromise was adopted, a site being selected which was spatially restricted, but containing many vegetation types.

The traditional view of the community emphasises homogeneity and stability. Whittaker (1956) comments that it is impossible to substantiate the existence of homogeneity in plant communities by statistical means.

More or less homogeneous communities are recognised by the trained eye of the plant sociologist (pers. comm. R. Tüxen), (Dahl and Hadac 1949). Minute floristic differences evidenced by certain species combinations are detected by the "sociological eye" (Looman 1964) which is developed by the "right intuitive feeling by experience". However it is difficult to detect homogeneity without the experience allowing the development of this "sociologischer Blick" (Becking 1957).

Together with the subjective choice of stands and the distinguishing of vegetation units by a "process of successive approximation" (Poore 1955), the conventional phytosociological methods have proved "a difficult pill to swallow" for many Anglo-American ecologists.

The difficulty of defining a general model for a wide range of applications and for all types of data, together with the advent of widespread computer facilities has resulted in a plethora of numerical classificatory methods. Initial vegetation sampling and classification 'stopping' rules remain arbitrary, but electronic data processing ^(E.D.P) removes subjective decisions from the synthetic stages.

The following constraints were considered in data selection and processing.

- i) The raw data should reflect the attributes of the vegetation sampled in both spatial and social contexts.
- ii) The raw data should be easily gathered in the field and should be devoid of approximations.
- iii) In the interests of economy and the limitations of current E.D.P. facilities the population size and the number of attributes of each member of the population should each not exceed eighty. (In fact the population size, the species, did exceed 80 in this study and programmes were modified.)

The Methods

The methods used were chosen to demonstrate the affinities between the objects under consideration. These objects were either species or vegetation samples, quadrats.

The methods selected were:

- i) Group Analysis
- ii) Association Analysis, Normal
- iii) Association Analysis, Inverse
- iv) Ward's Hierarchic Fusion Method

- v) Iterative Relocation Procedure
- vi) Principal Components Analysis

These were available as selected options in Wishart's CLUSTAN 1A suite of programmes (1969).

The methods have a common aim in that clusters or groups of objects may be produced.

Clustering is the systematic sorting of these objects, be they species or quadrats, into groups according to the computational rules of the method used. The resultant groupings will be referred to as groups or clusters throughout the text.

The Site

A site was selected that contained various floristic assemblages, characteristic of those described by Bradshaw and Clarke (1965) in a spatially limited area.

This area was located on the north west facing slope of Slapestone Sike, Widdybank Fell. The sike itself appeared to be the principal influence on the physical geography of the site. This small stream has its main drainage axis orientated in a general east-west direction and runs from the top of Widdybank Fell into the River Tees. In its short passage from the felltop to the river it cuts down through the Melmerby Limestone of the Lower Limestone Group, forming a series of small waterfalls. Immediately below this series the rate of descent slackens as the stream flows in the bed of a small valley. The study site was located on the side of this valley.

Vegetation Sampling

A grid was laid to enable systematic sampling. The location of this grid is shown in Figure 11, the grid being composed of a 10 x 8 matrix of quadrats which were labelled as in Figure 12.

Fig. 11

Upper Slapstone Sike

Orientation of grid of quadrats

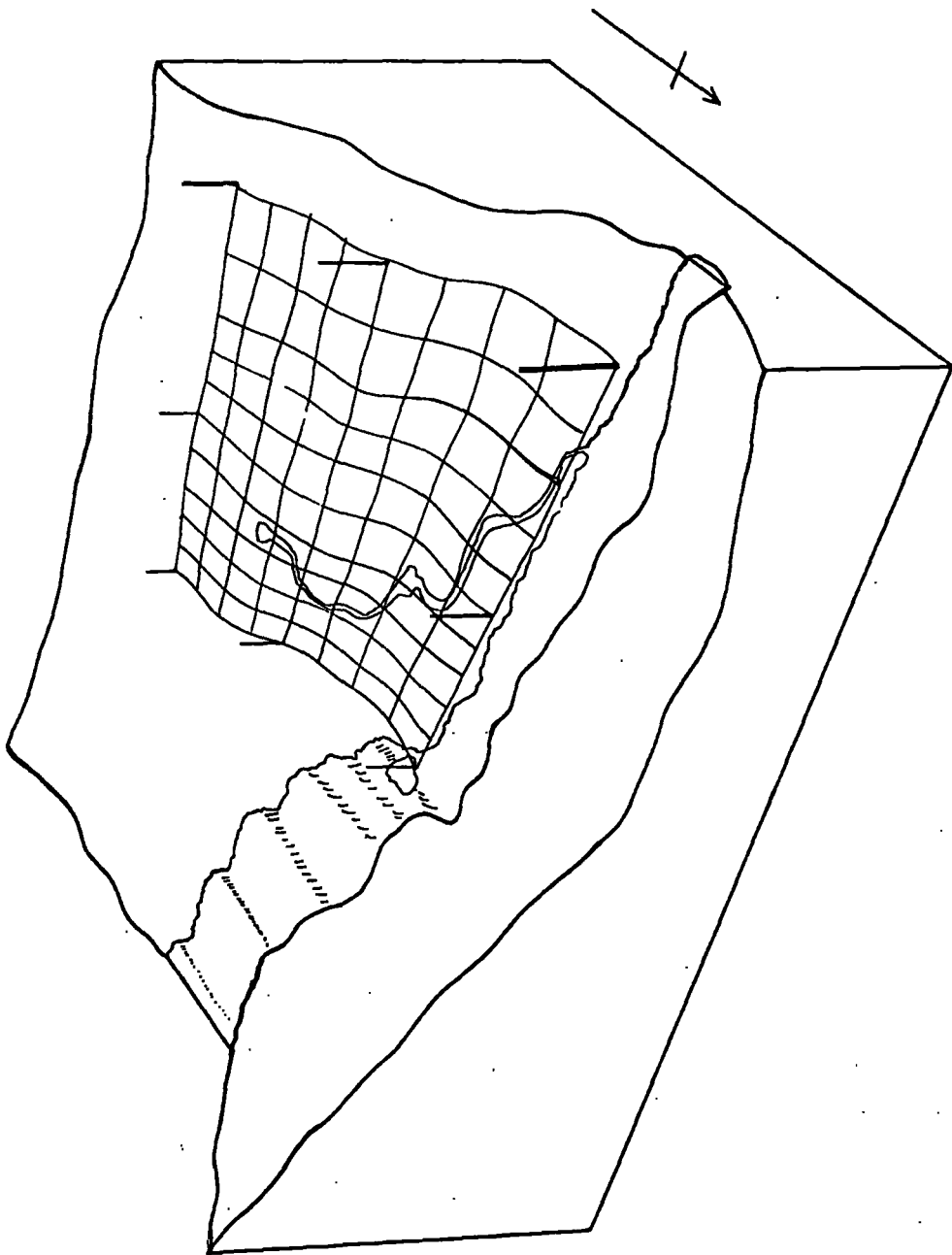

Fig. 12

Upper Slapestone Sike

Location of quadrats on grid

71	72	73	74	75	76	77	78	79	80
61	62	63	64	65	66	67	68	69	70
51	52	53	54	55	56	57	58	59	60
41	42	43	44	45	46	47	48	49	50
31	32	33	34	35	36	37	38	39	40
21	22	23	24	25	26	27	28	29	30
11	12	13	14	15	16	17	18	19	20
1	2	3	4	5	6	7	8	9	10

A hand-drawn wavy line starts at cell (64) and ends at cell (8). The line passes through the following cells: (64), (54), (44), (34), (24), (15), (16), (17), (18), (19), (8).

An important problem relating to vegetation sampling is the original choice of quadrat size. Changing the size of the quadrat can alter the magnitude of the measure of association between species and quadrats and may change the sense of the association (Greig-Smith 1964, Gimingham 1966 and Yarranton 1966). Lambert and Williams (1962) proposed that the quadrat size should be large in relation to the plants.

The quadrat size chosen was 2 x 2 m square. Not only was this area large enough to contain most species of the vegetation type in which the quadrat was situated but it also allowed efficient cover of a relatively large area in a short time. (To cover the grid area with 1 x 1 m square quadrats would have required three hundred and twenty quadrats)

The species present in each quadrat were listed and a comprehensive survey of the floristic assemblage was made.

Presence and absence criteria alone were used, thus avoiding the use of subjective estimates of cover/abundance.

Any plant not readily identifiable in the field was returned to the laboratory for investigation. The site was visited at various times of the year as certain species were more readily identifiable in flower or fruit.

A raw table of the 89 species encountered x 80 quadrats was then drawn up. This matrix of 5,120 cells formed the basic data which was then subjected to analysis.

Environmental Sampling

Grid topography

The grid was surveyed with an "Autoset" level and a 25 cm interval contour map was prepared (see Figure {3})

Soil Sampling

Soil cores were taken from each quadrat of the grid on the same day under uniform weather conditions and were returned to the laboratory for analysis.

Fig. 13 Upper Slapstone Sike
Grid Topography

Scale
1:200

TOPOGRAPHY
(25 cm CONTOURS)

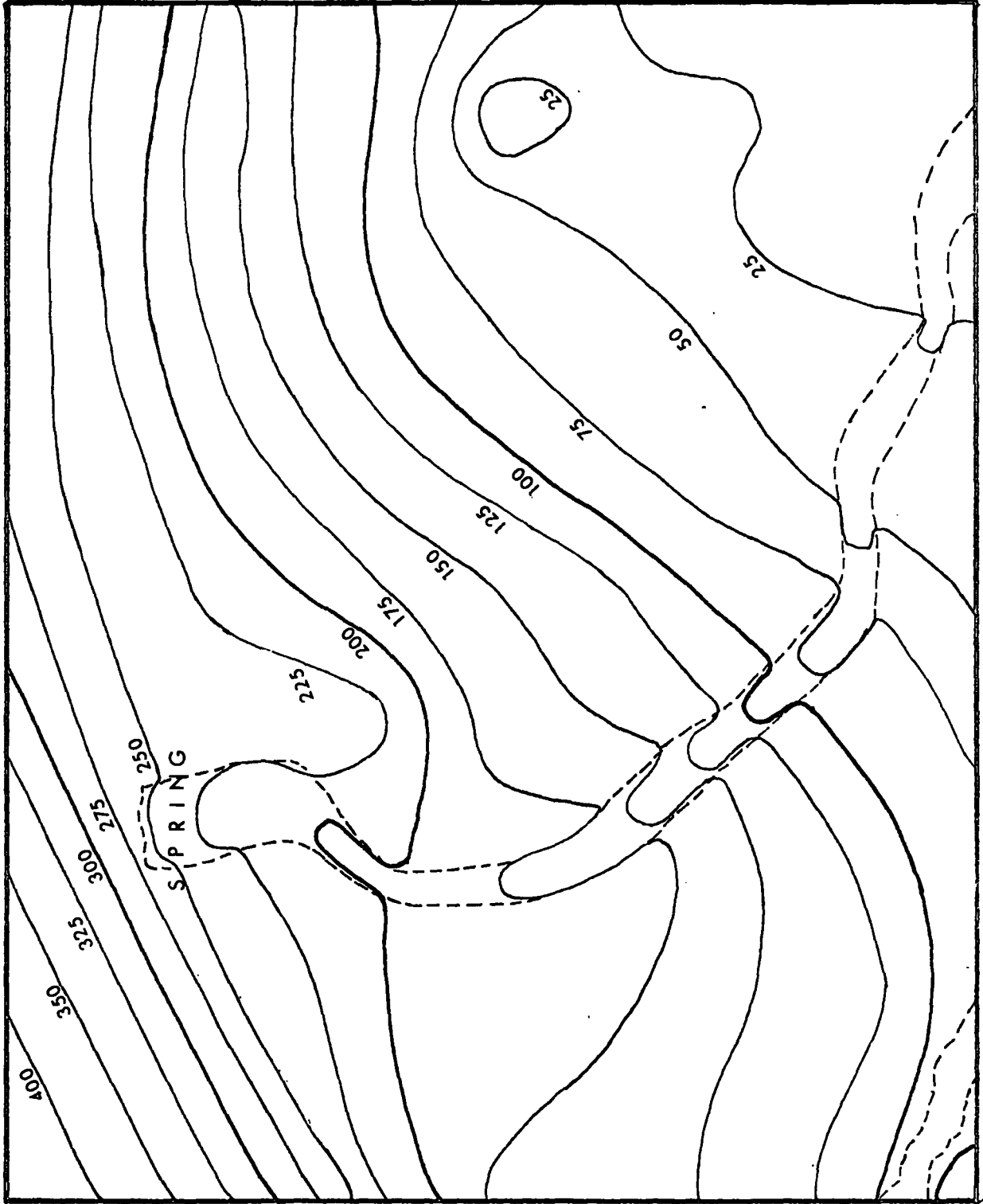

Two cores were taken from every quadrat, each being 7.5 cm in diameter and 10 cm in depth (soil depth allowing).

The following analyses were carried out (see Appendix 1):

- i) Soil water content at time of sampling.
- ii) Soil organic content.
- iii) Exchangeable cations
 - a) Potassium
 - b) Magnesium
 - c) Sodium
 - d) Calcium
 - e) Lead
 - f) Zinc
- iv) Total cations
 - a) Potassium
 - b) Magnesium
 - c) Sodium
 - d) Calcium
 - e) Phosphate

Contour maps of some of these factors were drawn.

Four extreme soil types were recognisable, each the product of its own peculiar geological or topographic features. These were:

- i) Wet sugar limestone soils.
- ii) Dry sugar limestone soils.
- iii) Podsoles derived from boulder clay.
- iv) Organic soils verging on 'fen' peat.

Although these extreme soil types were prevalent, intermediate types predominated to constitute a basically catenal situation.

A. ORDINATION

(i) Direct Gradient Analysis

(a) Linear Gradient Analysis

A pH transect (Figure 14) indicated that major vegetation types could be separated on the basis of soil hydrogen ion concentrations, the sedge marsh was characteristic of zones exceeding pH 5.5, grassland between pH 4.5 - 5.5 and heathlands in areas below pH 4.5. However the two belts of grassland showed only superficial similarities to each other, thus demonstrating the limitation of linear analyses on any single chosen axis.

(b) Multidimensional Gradient Analysis

The complex relationships inherent in vegetation require multi-dimensional methods of representation (Whittaker 1952, 1956, Greig-Smith 1964, Kershaw 1964).

The most direct method of analysing vegetation is by sampling several independently derived environmental gradients using them as co-ordinates.

The relationship between the quadrats on the grid were compared by direct gradient analysis with linear axes derived from soil moisture content (on the day of sampling), the percentage organic material of total soil sample by weight and exchangeable soil calcium.

Although the above factors are not unrelated, they were convenient parameters and from initial observations and analysis appeared closely related to vegetation types associated with them.

The position of each quadrat, when plotted on these axes (Figure 15) indicated an almost continuous range of variation from a wet, organic soil with low calcium through intermediate stages to an extreme high calcareous soil with little organic material.

Fig. 14 pH gradient along Slapestone Sike Transect (3)

	Sedge marsh	Grass	S.M	Grass land	Heath
pH	> 5.5	4.5 - 5.5	> 5.5	4.5 - 5.5	< 4.5

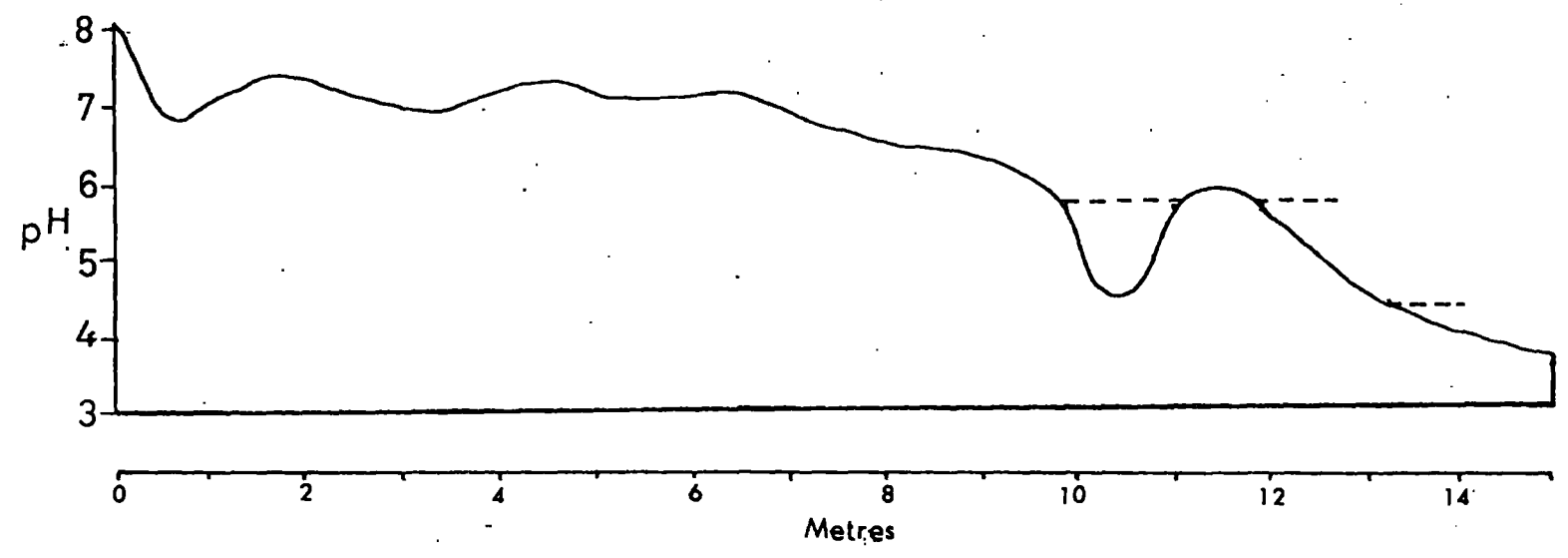
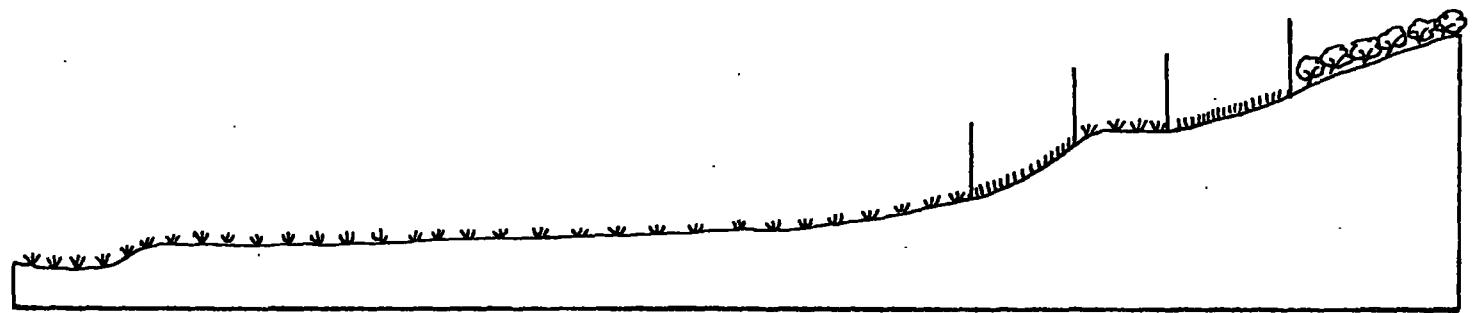
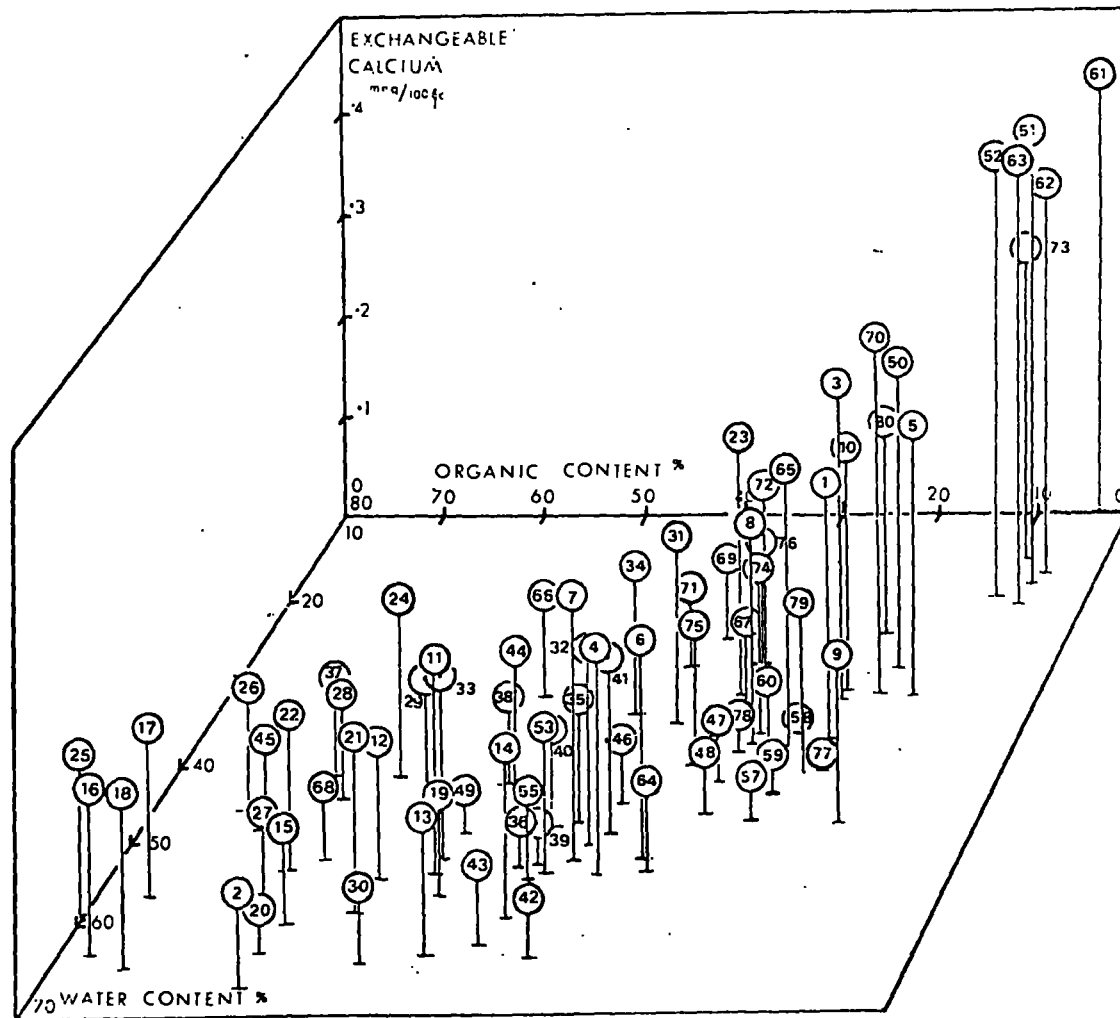

Fig. 15 Multidimensional gradient analysis indicating the
position of the quadrats on environmental gradients



A discontinuity separated off the dry calcareous quadrats on sugar limestone, Nos. 51, 52, 61, 52 and 73. Does this discontinuity represent an artifact induced by the relatively large quadrat size (smaller quadrats may have "bridged that gap"), or does this disjunction emphasise the discrete and peculiar nature of the Teesdale sugar limestone soils?

It is not implied that the distributions of quadrats in this three dimensional pattern of soil calcium, soil water and organic matter is functionally independent of plant communities, but that the measurements and ordination are derived independently from a consideration of vegetation pattern.

The correspondence between the environmental and the floristic data may indicate the degree of validity of the respective analyses.

The nearest neighbours floristically to quadrat 61 (from K-linkage lists preparatory to Principal Components Analysis, see below) were quadrats 63, 51, 62 and 73. The correspondence of this particular combination of quadrats was emphasised independently in the direct gradient analysis. Here a peculiar flora corresponds with the peculiar edaphic conditions.

This coincidence between floristic and environmental attributes indicating a close relationship does not occur so clearly throughout the remainder of the ordination.

In this case direct ordination was shown to be inadequate as it became apparent that the quadrats that were proximate, on a direct environmental ordination, were not necessarily floristically similar to each other. This is perhaps a result of inadequate initial choice of axes.

(ii) Indirect Gradient Analysis

Let it be presupposed that the plants themselves are the best measure of the environment not only in terms of individual species response but also their distributional overlaps, that is, the pooled response of all the species performances. Then their mutual associations and interactions suggest that measurements of correlation or of association would reveal natural aggregations.

A technique of axis construction designed to achieve an efficient ordination of individuals is Principal Components Analysis.

Principal Components Analysis

This variant of factor analysis summarises the information content of a matrix whose elements, distances and angles define the spatial relationships between ecological entities.

The vegetation (quadrats) may be considered as a set of vectors in the vegetational space, if the dimensions are the species encountered. A continuum would be represented in this model by a single cluster of points representing the continuously changing community.

If the points are clusters in several groups restricted to limited portions of the abstract space without intermediate points discrete community types may be recognised. These discrete communities may, however, be difficult to assess in terms of significance and definition.

The problem is that there is no single way of objectively subdividing such a model or validating the apparent clusters unless they are grossly isolated.

The approach to the problem of investigating the relationships of the sample of vegetation encompassed within the grid was considered along the following path:

- i) Production of a principal components model.
- ii) Examination of the cluster(s) produced using a variety of methods to test validity of the group(s).

The Analysis

The stand data of the grid was ordinated using options from CLUSTAN 1A suite of programmes (Wishart 1969).

This entailed constructing a similarity matrix from which the principal component axes were valuated. The coefficient of similarity in this case was a measure of the squared Euclidian distance between each pair of quadrats based on their species content.

The percentage variance accounted for by each of the first five components together with their cumulative percentage variance is shown below:

<u>Principal component</u>	<u>% variance</u>	<u>Cumulative variance</u>
1	17.4	17.4
2	7.8	25.2
3	5.4	30.6
4	4.4	35.0
5	4.1	39.1

The variance attributed to each of the first fifteen axes was represented graphically in Figure 16. The highest variance values were accounted for by the first and second axes and these produced the greatest spread of the quadrats based on their floristic content.

The first two principal axes accounted for 25% of total variance.

The distribution of the eighty quadrats on these two axes is shown in Figure 17. In general each quadrat was in relatively close proximity to its geographical neighbour on the original grid and the whole complex of quadrats constitutes a large cluster with local areas of high density but no major discontinuity.

A picture emerges of a continuum of floristic variation with three main extremes represented by quadrats 80, 34 and 8.

Individual species distributions and various edaphic characteristics were then considered in relation to the principal component analysis.

Fig. 16 The variance attributable to the first fifteen
principal components

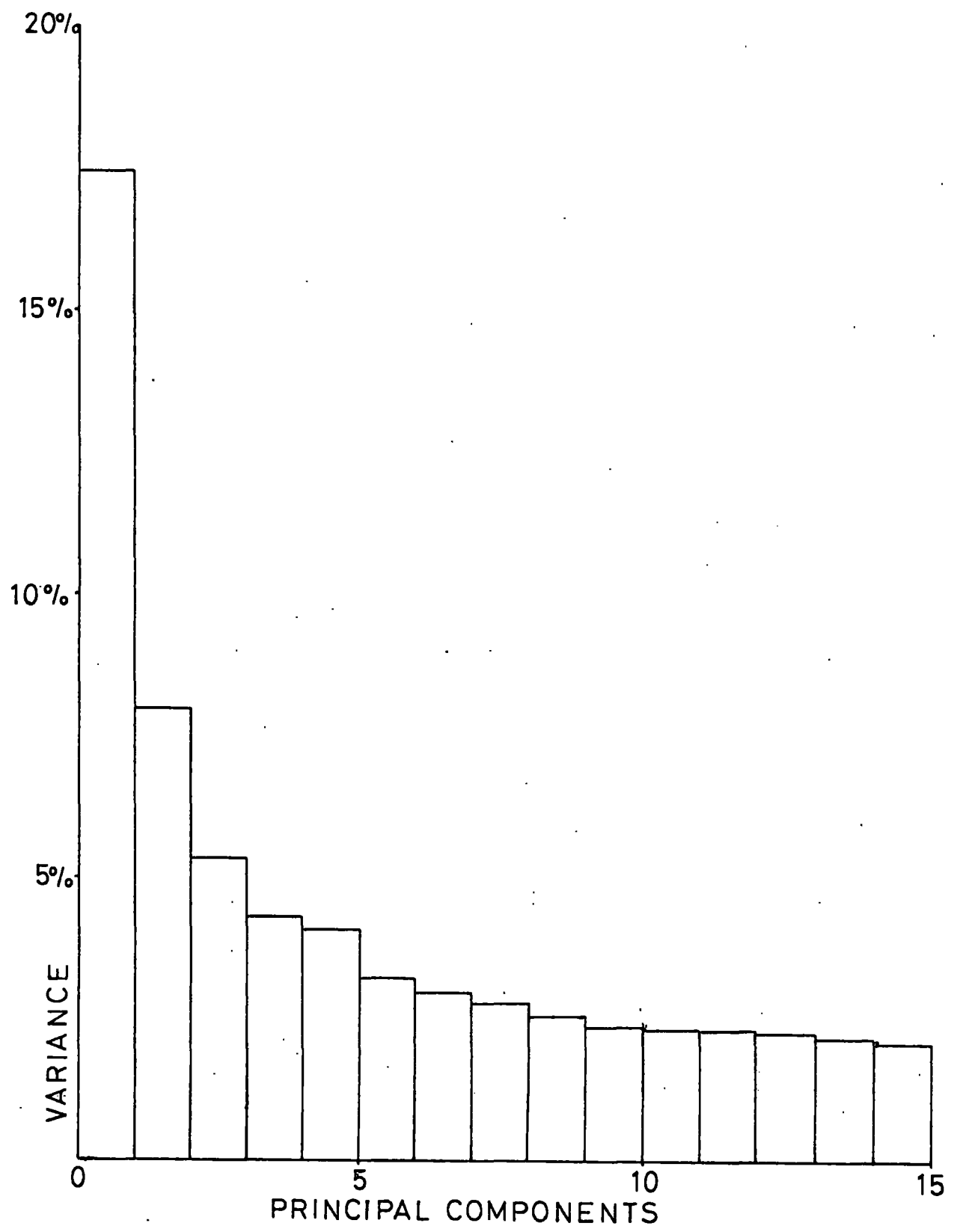
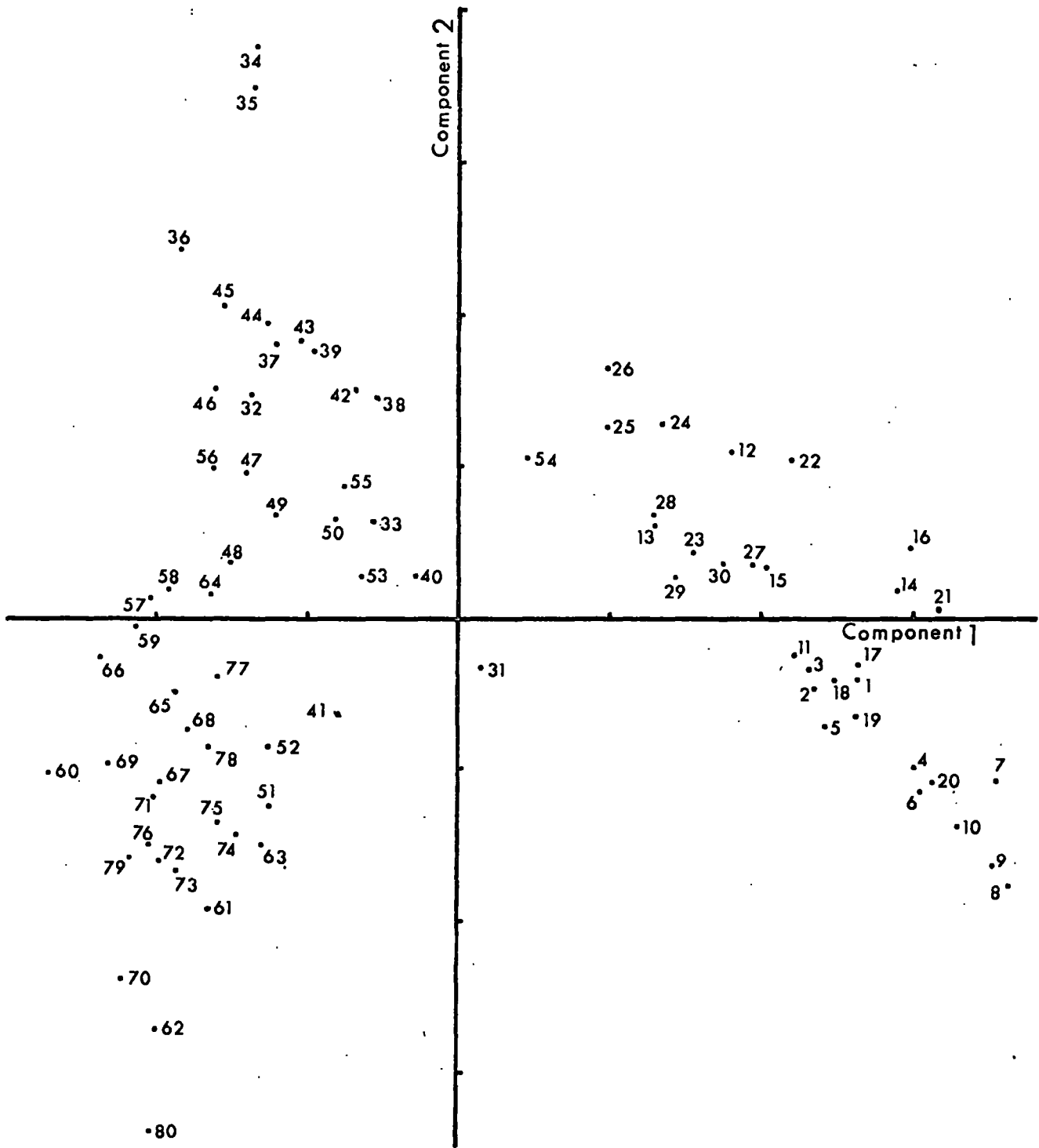

Fig. 17 Quadrat distribution on Principal Components
Axes 1 and 2



A trend existed of high soil moisture to the right of the model with many quadrats with more than 50% by weight of water in their soil (Figure 18). Whereas to the extreme left of the model there were quadrats of low moisture content.

Soil organic content shows a similar distribution to soil moisture (Figure 19).

Exchangeable calcium in the soil samples appeared to correlate with the second principal component, the high values being restricted to the lower quadrats on the model (Figure 20).

Three edaphic extremes are therefore recognisable on the model:

- (i) calcareous, dry soils with little organic content.
- (ii) calcareous, damp soils with little organic content.
- (iii) soils relatively low in calcium and high in organic material.

Exchangeable potassium did not appear to be a major factor contributing to or at least associated with the floristic variation encountered on the grid (Figure 21).

A few species showed a wide tolerance and were found over the whole range of quadrats irrespective of the edaphic properties. These species included Selaginella selaginoides and Potentilla erecta, however most species were limited to particular quadrat groups, e.g. Tofieldia pusilla and Sesleria caerulea (Figure 22).

Other species show a bimodality of occurrence with respect to this particular model, Kobresia simpliciuscula occurring at both wet and dry calcareous extremes.

This heterogeneous area therefore constituted a vegetational continuum which could be correlated with certain environmental variables. Further the distribution of species in this continuum was not continuous and although certain species may have been restricted to certain portions of the model, it was difficult to determine clustering of discrete units of quadrats.

Fig. 18

Pattern of Soil Calcium on vegetational ordination

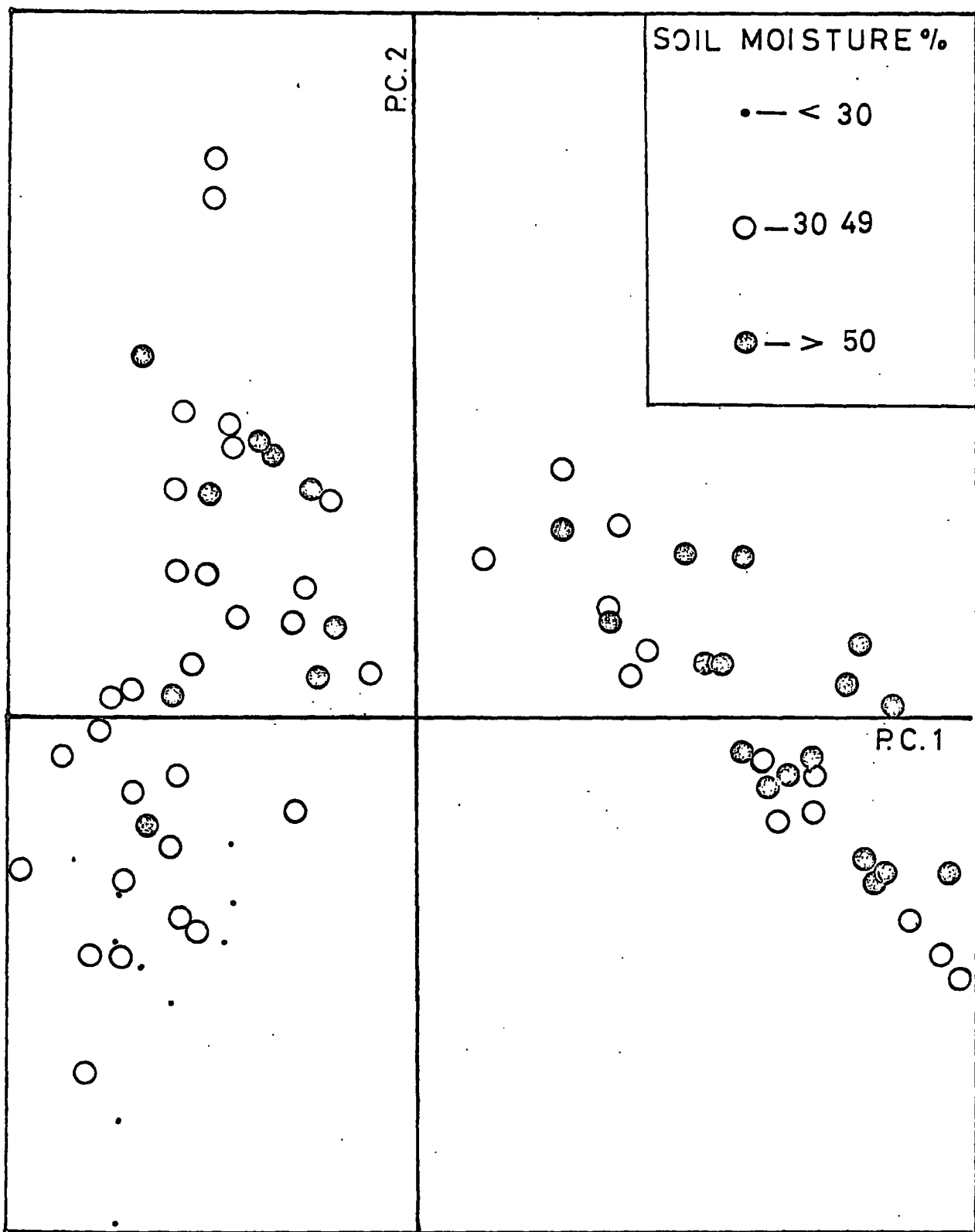

Fig. 19 Pattern of soil organic material on the vegetational
ordination

ORGANIC MATERIAL

% of total dry wt.
of soil

◦ - < 20

○ - 20-29

○ - 30-39

○ - 40-49

○ - > 50

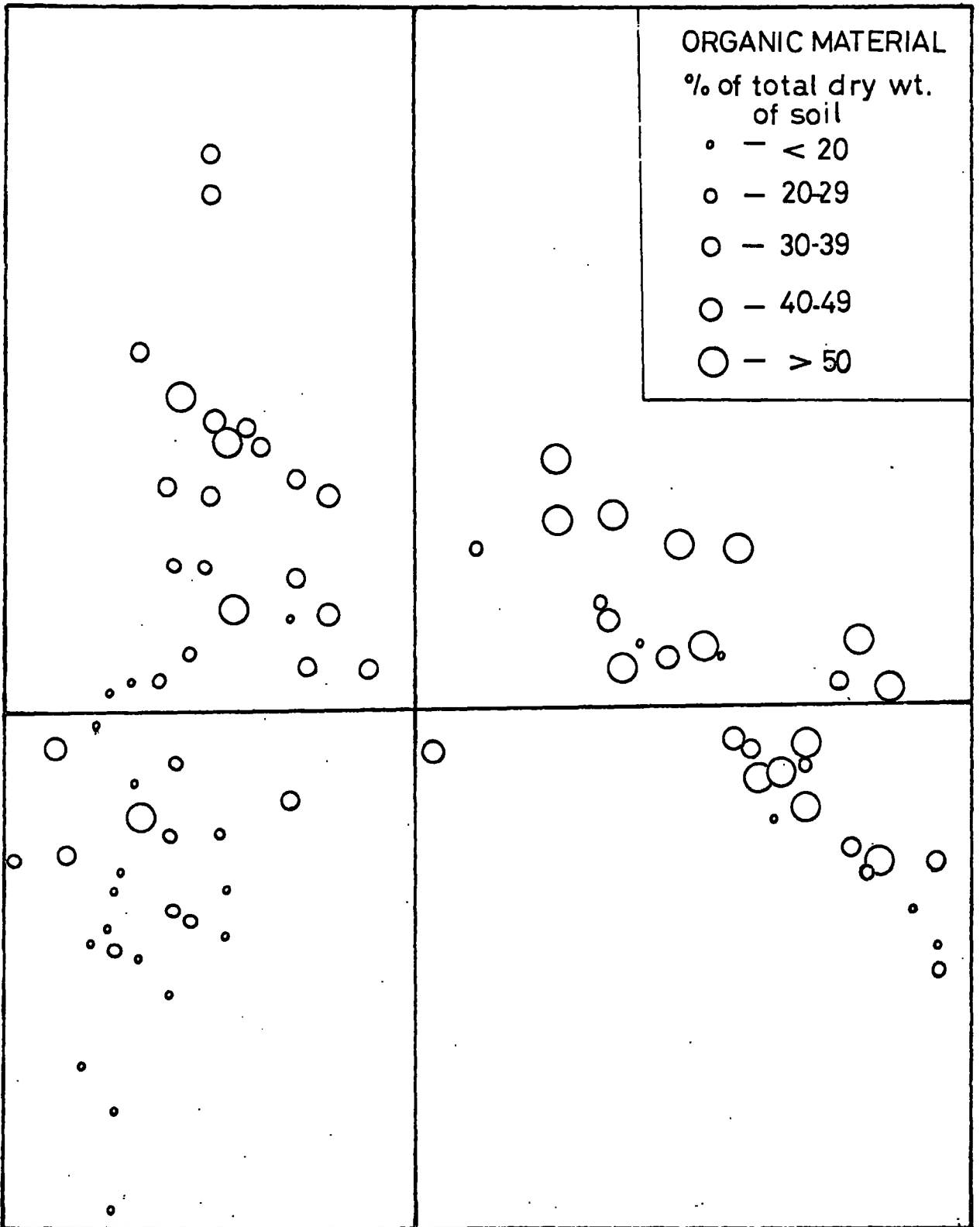

Fig. 20 Pattern of soil exchangeable calcium on the
vegetational ordination

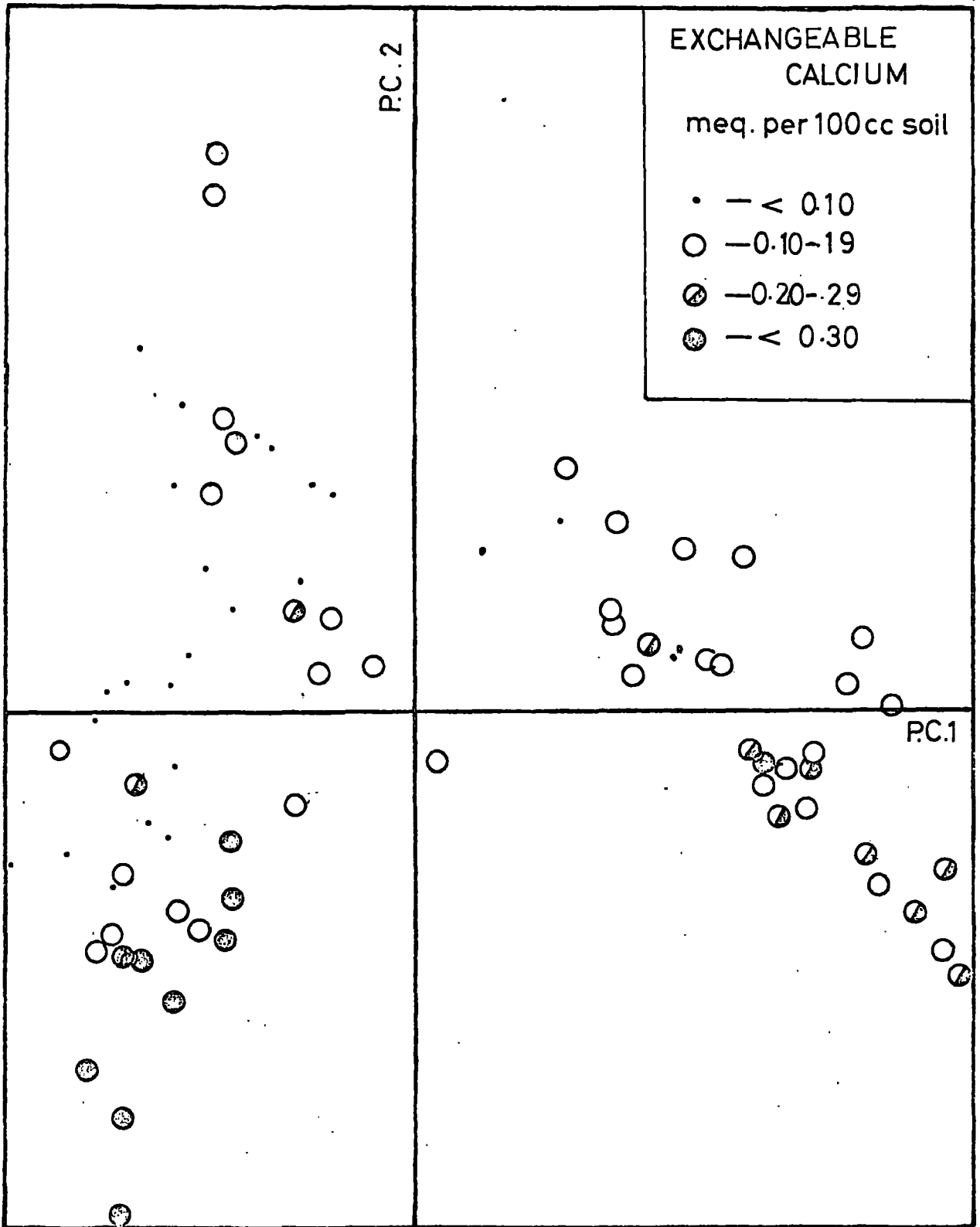

Fig. 21 Pattern of exchangeable potassium on the
vegetational ordination

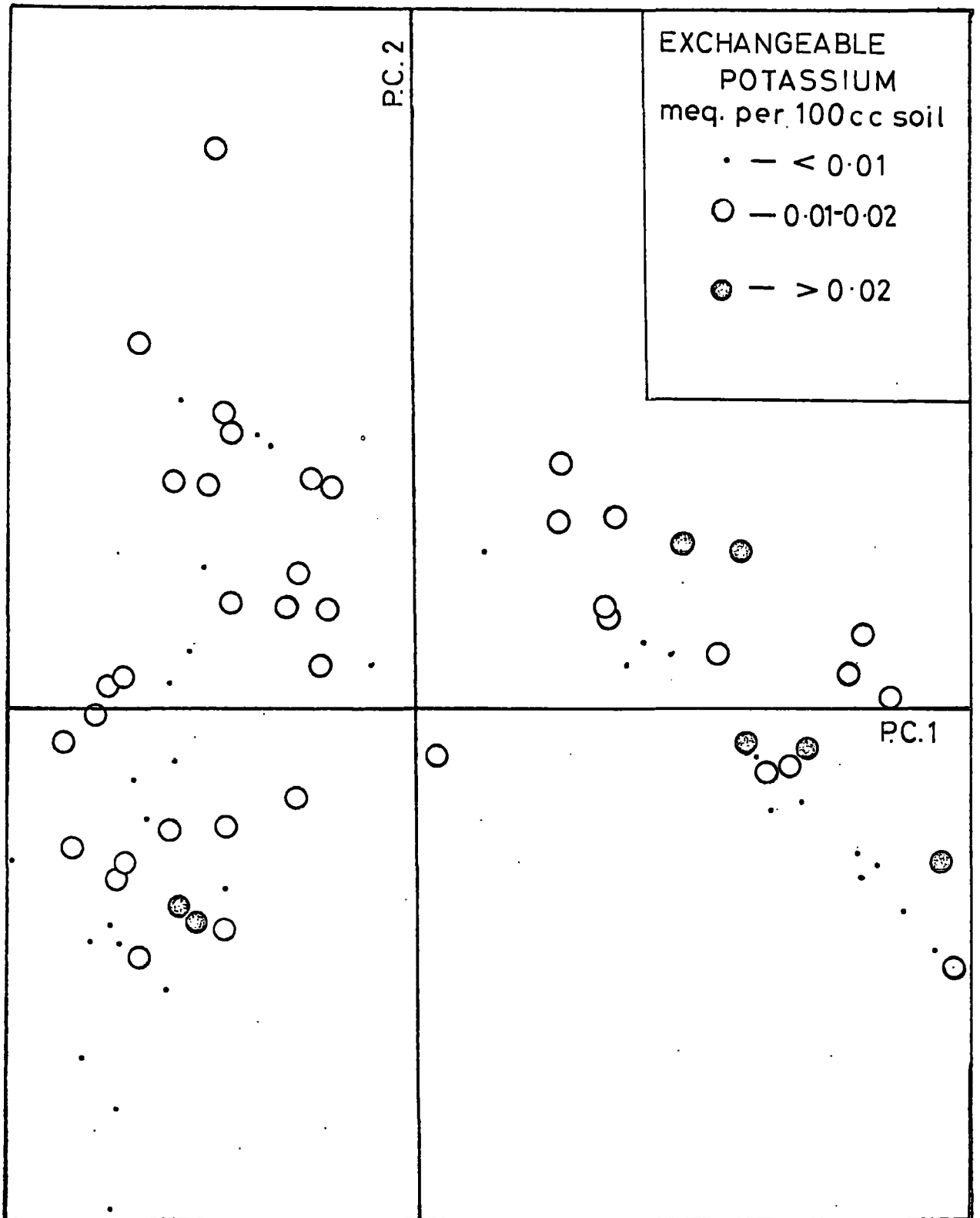
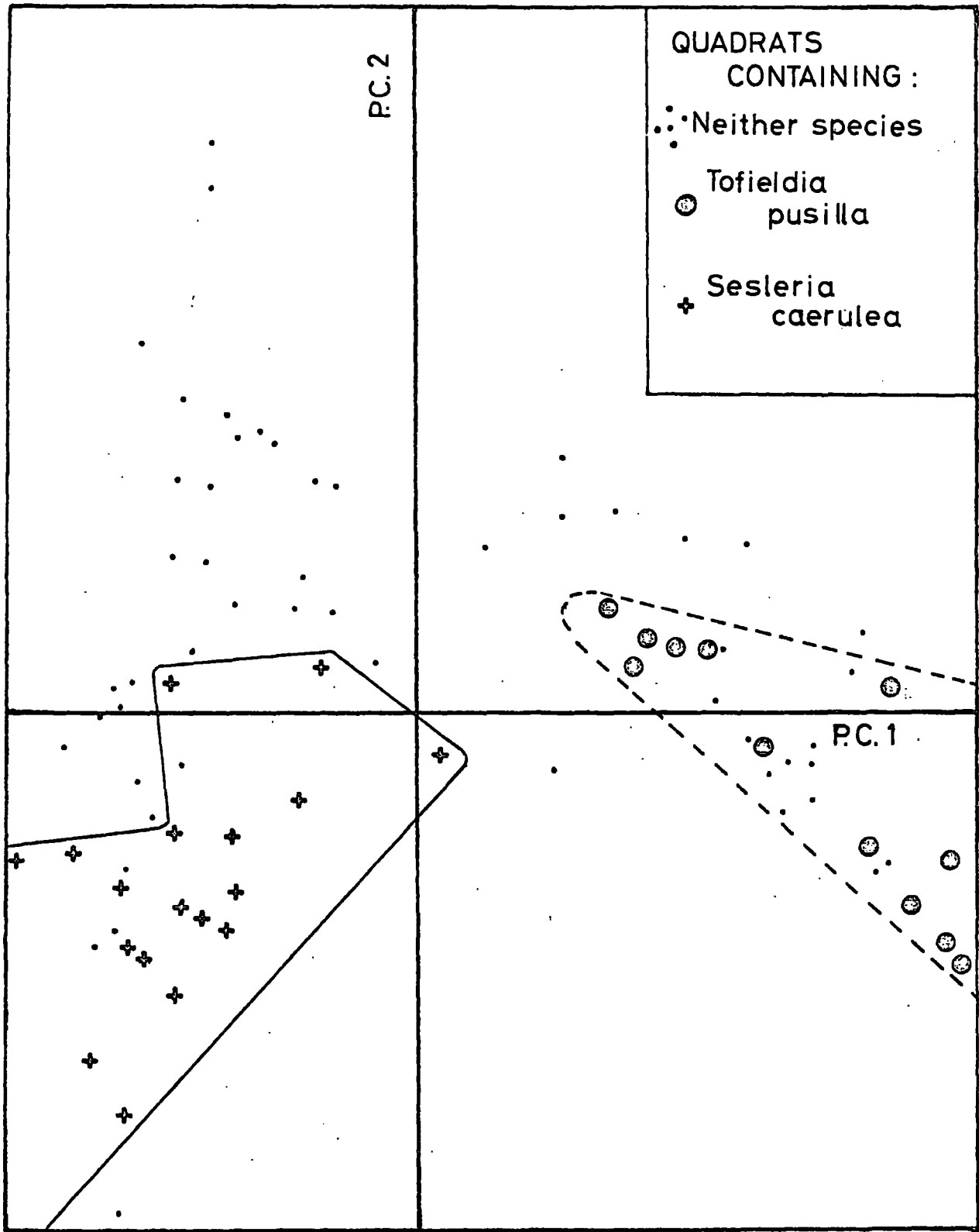

Fig. 22 Distribution of Tofieldia pusilla and Sesleria caerulea on the vegetational ordination



The quadrats were therefore classified into discrete functional units more amenable to general description and consideration than the wide range of variables of the ill-defined continuum using the following methods.

B. CLASSIFICATION

Monothetic Divisive Procedures

These approaches were adopted first since each divisive step is diagnosed by the presence or absence of a particular species and thus provides a useful guide to delineation of the resultant groups.

(i) Group Analysis

Although a monothetic divisive procedure, this method attempts to locate groups of coincident species. Species gregarity, not homogeneity, is the main criterion used, the species richness being assessed in addition to floristic similarity (Crawford and Wishart 1967).

The floristic composition of the 8 clusters resulting from this analysis is recorded in Table 3 where species occurring in more than 33% of a cluster are recorded. These groups will be considered in the discussion.

The defining species of each cluster may be seen by referring to Figure 23.

(ii) Association Analysis

Association analysis accepts heterogeneity as commonplace if not universal, but is designed to abstract relatively homogenous groups by an objective statistical technique. This predilection to produce homogeneous units may lead to overclassification (Gittins 1965). Crawford and Wishart (1967) indicated that, where vegetation is changing rapidly, much of it could be expected to be in a transitional state and this process may find homogeneity where it does not exist and result in over classification.

Normal Analysis

This entails dividing the total quadrat assemblage in groups of quadrats that are more homogeneous with regard to species content.

The χ^2 coefficient was used and Yate's correction, for small

TABLE 3

The floristic composition of clusters as segregated
by Group Analysis
(only species with a presence of 3% or more are listed)

<u>CLUSTER 1</u>	<u>% presence</u>		<u>% presence</u>
Carex panicea	100	Cardamine pratensis	62
Ctenidium molluscum	100	Primula farinosa	62
Carex lepidocarpa	100	Eleocharis quinqueflora	52
Equisetum variegatum	100	Carex capillaris	52
Potentilla erecta	100	Philonotis fontana	52
Euphrasia micrantha	100	Plantago maritima	47
Juncus articulatus	100	Tofieldia pusilla	42
Prunella vulgaris	95	Anthoxanthum odoratum	42
Eriophorum angustifolium	95	Thymus drucei	42
Selaginella selaginoides	85	Kobresia simpliciuscula	42
Festuca rubra	81	Carex pulicaris	38
Pinguicula vulgaris	76	Linum catharticum	38
Sagina nodosa	71	Briza pseudotriquetrum	38
<u>CLUSTER 2</u>			
Linum catharticum	100	Carex panicea	60
Tortella tortuosa	100	Galium sternerii	60
Anthoxanthum odoratum	100	Gentiana verna	60
Cladonia arbuscula	100	Pleurozium schreberi	60
Campanula rotundifolia	100	Cornicularia aculeata	40
Selaginella selaginoides	100	Kobresia simpliciuscula	40
Sesleria caerulea	100	Calluna vulgaris	40
Festuca ovina	100	Hylocomium splendens	40
Carex caryophyllea	80	Rhacomitrium lanuginosum	40
Thymus drucei	80	Certraria islandica	40
Potentilla erecta	80	Polytrichum commune	40
Plantago maritima	60	Viola canina	40
<u>CLUSTER 3</u>			
Thymus drucei	100	Carex capillaris	66
Carex panicea	100	Carex pulicaris	66
Potentilla erecta	100	Agrostis tenuis	66
Euphrasia micrantha	100	Bellis perennis	55
Pleurozium schreberi	100	Campanula rotundifolia	44
Festuca ovina	100	Carex lepidocarpa	44
Selaginella selaginoides	100	Prunella vulgaris	44
Galium sternerii	100	Viola canina	44
Rhytidiadelphus loreus	66	Trifolium repens	44
Hylocomium splendens	66	Juncus squarrosus	33
Thuidium tamariscinum	33	Calluna vulgaris	33
Cladonia chlorophea	33	Dicranum scoparium	33
Equisetum arvense	33		

CLUSTER 4

	<u>% presence</u>		<u>% presence</u>
Carex panicea	100	Ctenidium molluscum	71
Juncus articulatus	100	Carex lepidocarpa	71
Euphrasia micrantha	100	Agrostis canina	71
Selaginella selaginoides	100	Carex pulicaris	57
Thymus drucei	100	Galium sternerii	57
Potentilla erecta	100	Carex capillaris	57
Eriophorum angustifolium	85	Bellis perennis	42
Prunella vulgaris	85	Festuca rubra	42
Festuca ovina	85		

CLUSTER 5

Carex panicea	100	Carex lepidocarpa	41
Euphrasia micrantha	100	Carex capillaris	41
Selaginella selaginoides	100	Ctenidium molluscum	41
Thymus drucei	91	Viola canina	33
Potentilla erecta	91	Eriophorum angustifolium	33
Prunella vulgaris	66	Calluna vulgaris	33
Festuca ovina	66	Kobresia simpliciuscula	33
Linum catharticum	50	Carex pulicaris	33
Galium sternerii	50	Rhacomitrium lanuginosum	33

CLUSTER 6

Festuca ovina	100	Campanula rotundifolia	58
Potentilla erecta	91	Agrostis tenuis	58
Selaginella selaginoides	91	Rhytidiadelphus loreus	58
Cladonia arbuscula	75	Thymus drucei	50
Pleurozium schreberi	75	Sesleria caerulea	33
Galium saxatile	66	Carex panicea	33
Calluna vulgaris	66	Hylocomium splendens	33

CLUSTER 7

Festuca ovina	100	Sesleria caerulea	50
Selaginella selaginoides	100	Galium saxatile	50
Anthoxanthum odoratum	100	Kobresia simpliciuscula	37
Cladonia arbuscula	87	Koeleria cristata	37
Potentilla erecta	87	Linum catharticum	37
Pleurozium schreberi	75	Thymus drucei	37
Campanula rotundifolia	75	Agrostis tenuis	37
Calluna vulgaris	75	Viola lutea	37

CLUSTER 8% presence% presence

<i>Carex panicea</i>	100	<i>Equisetum arvense</i>	50
<i>Euphrasia micrantha</i>	100	<i>Calluna vulgaris</i>	50
<i>Selaginella selaginoides</i>	100	<i>Agrostis tenuis</i>	50
<i>Festuca ovina</i>	100	<i>Prunella vulgaris</i>	33
<i>Potentilla erecta</i>	100	<i>Juncus squarrosus</i>	33
<i>Pleurozium schreberi</i>	100	<i>Hylocomium splendens</i>	33
<i>Thymus drucei</i>	100	<i>Trifolium repens</i>	33
<i>Galium saxatile</i>	83	<i>Nardus stricta</i>	33
<i>Rhytidiadelphus loreus</i>	66	<i>Linum catharticum</i>	33
<i>Campanula rotundifolia</i>	50	<i>Deschampsia caespitosa</i>	33
<i>Polytrichum commune</i>	50		

Fig. 23 Group analysis dendrogram

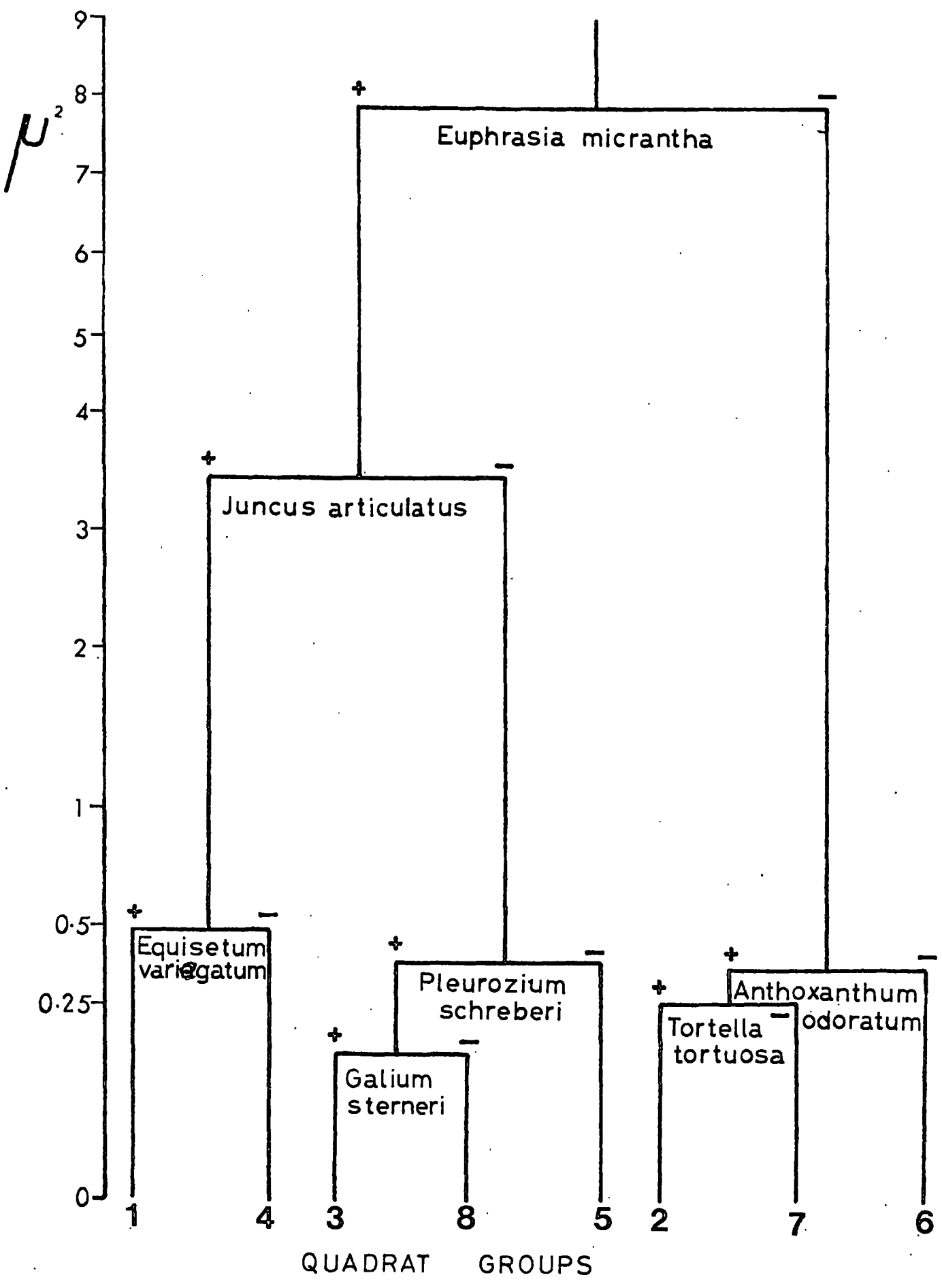

populations, was not considered necessary. The method follows that of Williams and Lambert's (1959) but division was automatically terminated at the eight cluster stage.

The hierarchical division stages of the normal association analysis are illustrated together with their diagnostic species in Figure 24 and the resultant clusters are tabulated in Table 4. These results will be considered in the discussion.

Inverse Association Analysis

To complement the normal association analysis and to produce doubly defined units an inverse association analysis was carried out on the same basic data. The same termination procedure was adopted as for the normal analysis, that is division ceased after the definition of eight clusters. Figure 25 illustrates these seven divisions of the species into eight species clusters.

The groups produced by association analysis were complete in themselves, but it is an inherent limitation of the method that it gives little information about their relationships. Further details of the relationships between the groups obtained by normal and inverse analysis were obtained from a two-way table relating quadrat clusters to species cluster. Table 5 is composed of cells derived horizontally by sets of species delimited by the inverse analysis and vertically by groups of quadrats derived by normal analysis. (see sleeve for Table 5).

The cells themselves could then be identified directly by the reference letters and numbers of their definitive species and quadrats. These cells are entities in their own right and form the basis of a new and modified matrix which will be considered later.

TABLE 4

The floristic composition of clusters as segregated
by Normal Association Analysis
(only species with a presence of 3% or more are listed)

<u>CLUSTER 1</u>	<u>% occurrence</u>		<u>% occurrence</u>
<i>Carex lepidocarpa</i>	100	<i>Sagina nodosa</i>	75
<i>Prunella vulgaris</i>	100	<i>Primula farinosa</i>	69
<i>Ctenidium molluscum</i>	100	<i>Eleocharis quinqueflora</i>	69
<i>Carex panicea</i>	100	<i>Plantago maritima</i>	56
<i>Potentilla erecta</i>	100	<i>Tofieldia pusilla</i>	56
<i>Eriophorum angustifolium</i>	100	<i>Cardamine pratensis</i>	56
<i>Euphrasia micrantha</i>	100	<i>Agrostis canina</i>	50
<i>Pinguicula vulgaris</i>	100	<i>Kobresia simpliciuscula</i>	50
<i>Festuca rubra</i>	94	<i>Philonotis fontana</i>	44
<i>Equisetum variegatum</i>	94	<i>Bryum pseudotriquetrum</i>	38
<i>Juncus articulatus</i>	94	<i>Carex capillaris</i>	38
<i>Selaginella selaginoides</i>	81	<i>Anthoxanthum odoratum</i>	38
 <u>CLUSTER 2</u>			
<i>Festuca ovina</i>	100	<i>Tortella tortuosa</i>	57
<i>Campanula rotundifolia</i>	100	<i>Calluna vulgaris</i>	57
<i>Selaginella selaginoides</i>	100	<i>Anthoxanthum odoratum</i>	57
<i>Carex panicea</i>	100	<i>Gentiana verna</i>	57
<i>Cladonia arbuscula</i>	100	<i>Kobresia simpliciuscula</i>	57
<i>Sesleria caerulea</i>	100	<i>Polytrichum commune</i>	57
<i>Thymus drucei</i>	100	<i>Hylocomium splendens</i>	57
<i>Linum catharticum</i>	100	<i>Euphrasia micrantha</i>	43
<i>Potentilla erecta</i>	72	<i>Cornicularia aculeata</i>	43
<i>Galium sternerii</i>	72	<i>Viola canina</i>	43
<i>Pleurozium schreberi</i>	72	<i>Galium saxatile</i>	43
<i>Plantago maritima</i>	72	<i>Rhacomitrium lanuginosum</i>	43
<i>Carex caryophyllea</i>	57		
 <u>CLUSTER 3</u>			
<i>Sesleria caerulea</i>	100	<i>Gentiana verna</i>	60
<i>Thymus drucei</i>	100	<i>Heliathemum chamaecistus</i>	60
<i>Festuca ovina</i>	100	<i>Anthoxanthum odoratum</i>	60
<i>Carex panicea</i>	100	<i>Carex caryophyllea</i>	60
<i>Selaginella selaginoides</i>	100	<i>Prunella vulgaris</i>	40
<i>Kobresia simpliciuscula</i>	100	<i>Carex lepidocarpa</i>	40
<i>Euphrasia micrantha</i>	80	<i>Galium sternerii</i>	40
<i>Rhacomitrium lanuginosum</i>	80	<i>Nardus stricta</i>	40
<i>Linum catharticum</i>	80	<i>Calluna vulgaris</i>	40
<i>Viola canina</i>	60		

CLUSTER 4

	<u>% occurrence</u>
Thymus drucei	100
Carex panicea	100
Selaginella selaginoides	100
Potentilla erecta	100
Festuca ovina	100
Euphrasia micrantha	84
Agrostis tenuis	68
Rhytidiadelphus squarrosus	68
Pleurozium schreberi	68
Hylocomium splendens	58

% occurrence

Equisetum arvense	53
Galium saxatile	47
Galium sternerii	47
Juncus squarrosus	47
Viola canina	37
Prunella vulgaris	37
Campanula rotundifolia	37
Carex capillaris	37

CLUSTER 5

Potentilla erecta	100
Carex panicea	100
Eriophorum angustifolium	100
Selaginella selaginoides	100
Euphrasia micrantha	100
Prunella vulgaris	93
Ctenidium molluscum	93
Thymus drucei	86
Carex lepidocarpa	79
Juncus articulatus	79
Carex capillaris	72
Agrostis canina	72

Carex pulicaris	64
Galium sternerii	50
Cardamine pratensis	50
Equisetum variegatum	50
Festuca rubra	43
Sagina nodosa	43
Bellis perennis	43
Peltigera aphosa	36
Festuca ovina	36
Philonotis fontana	36
Linum catharticum	36

CLUSTER 7

Carex capillaris	100
Carex panicea	100
Carex lepidocarpa	100
Euphrasia micrantha	100
Potentilla erecta	100
Ctenidium molluscum	100
Thymus drucei	100
Selaginella selaginoides	100
Kobresia simpliciuscula	100
Linum catharticum	100
Prunella vulgaris	50
Sagina nodosa	50
Tofieldia pusilla	50
Bryum pseudotriquetrum	50
Pinguicula vulgaris	50
Plantago maritima	50
Juncus articulatus	50

Carex pulicaris	50
Festuca rubra	50
Juncus triglumis	50
Riocardia pinguis	50
Cardamine pratensis	50
Tortella tortuosa	50
Hypnum cupressiforme	50
Cirsium palustre	50
Equisetum variegatum	50
Pseudoscleropodium purum	50
Campanula rotundifolia	50
Calluna vulgaris	50
Bellis perennis	50
Rhytidiadelphus loreus	50
Pleurozium schreberi	50
Festuca ovina	50

CLUSTER 8

	<u>% occurrence</u>
<i>Festuca ovina</i>	100
<i>Selaginella selaginoides</i>	100
<i>Pleurozium schreberi</i>	100
<i>Cladonia arbuscula</i>	100
<i>Calluna vulgaris</i>	100
<i>Potentilla erecta</i>	100
<i>Campanula rotundifolia</i>	83

% occurrence

<i>Galium saxatile</i>	75
<i>Agrostis tenuis</i>	58
<i>Rhytidiadelphus loreus</i>	50
<i>Koeleria cristata</i>	42
<i>Anthoxanthum odoratum</i>	42
<i>Hylocomium splendens</i>	33

CLUSTER 6

<i>Sesleria caerulea</i>	100
<i>Cladonia arbuscula</i>	100
<i>Festuca ovina</i>	100
<i>Linum catharticum</i>	100
<i>Potentilla erecta</i>	100
<i>Kobresia simpliciuscula</i>	80
<i>Anthoxanthum odoratum</i>	80
<i>Selaginella selaginoides</i>	80
<i>Galium sternerii</i>	60

<i>Campanula rotundifolia</i>	60
<i>Pleurozium schreberi</i>	60
<i>Calluna vulgaris</i>	60
<i>Gentiana verna</i>	40
<i>Tortella tortuosa</i>	40
<i>Thymus drucei</i>	40
<i>Carex caryophyllea</i>	40
<i>Certraria islandica</i>	40

Fig. 24

Normal association analysis dendrogram

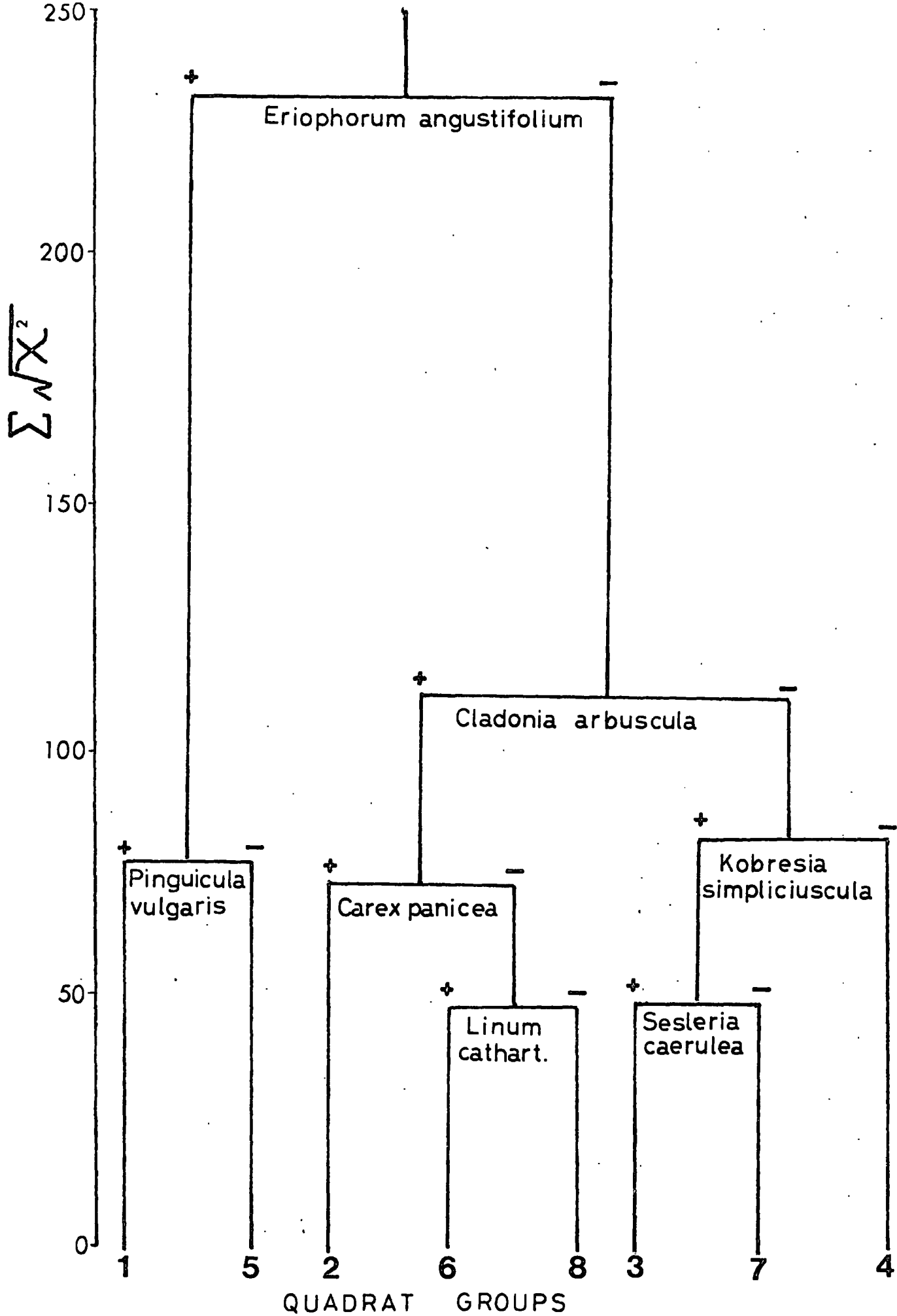
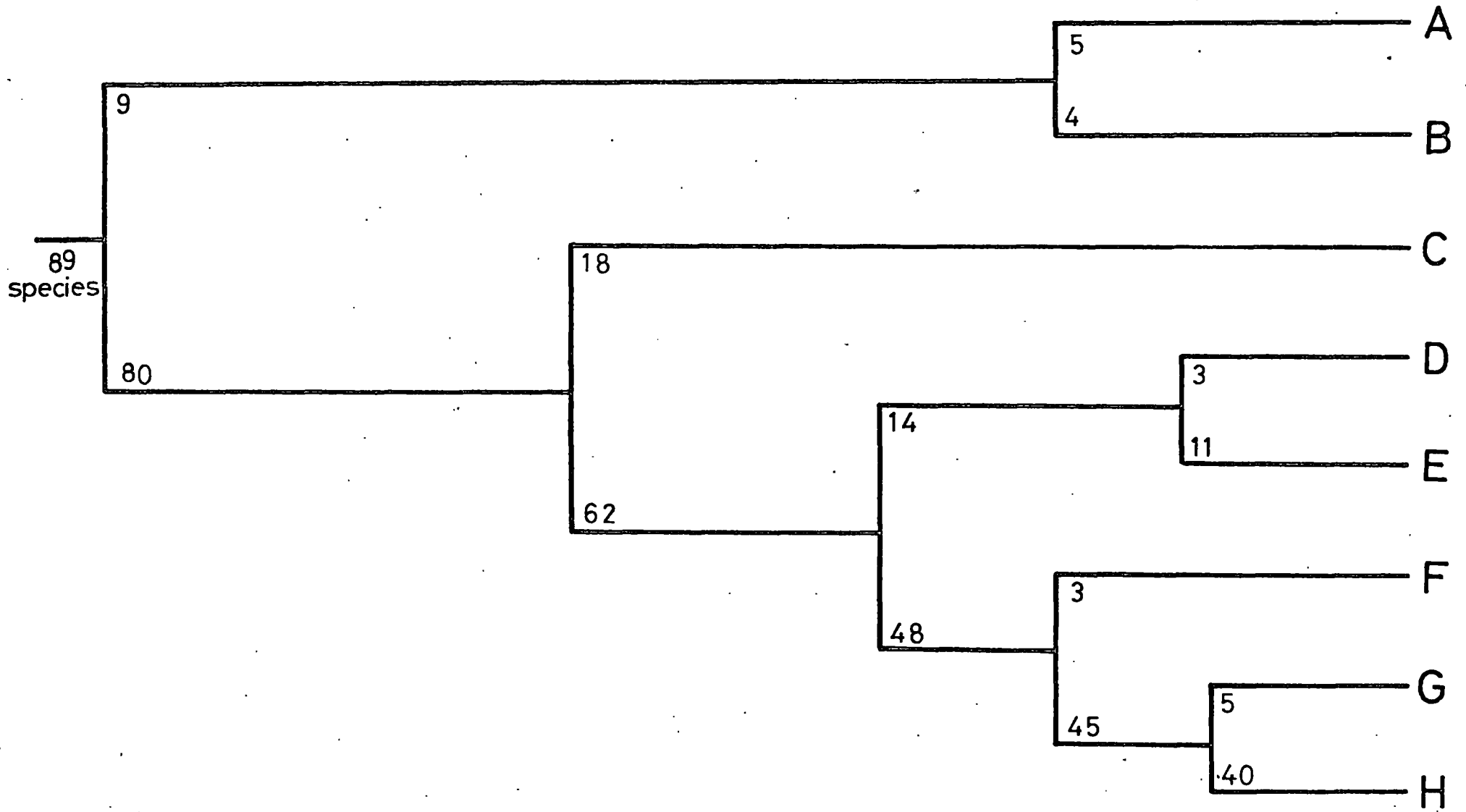

Fig. 25 Inverse association analysis dendrogram



C. POLYTHETIC AGGLOMERATIVE METHODS

(i) Ward's Hierarchic Fusion Method

In the analysis of the grid data using this method (Wishart 1969) there were initially 80 clusters each representing a single quadrat. In each of (80-1) fusion steps those two clusters which were most similar were fused.

The initial measurement of 'similarity' between the quadrats was derived from a coefficient of squared Euclidean distance. Each quadrat was represented by a point in an 89 dimensional Euclidean space (there were 89 attributes or species) whose co-ordinates were the values of the 89 variables. The Euclidean distance between any two points is an accepted measure of the similarity between those two points (quadrats).

The 79 fusion steps are illustrated in Figure 26. A computer printout of the eight cluster stage was obtained but these groups are not reproduced here as they were submitted to a refining procedure, "Iterative Relocation".

(ii) Iterative Relocation Procedure (Wishart 1969)

The eight clusters derived from the Ward's analysis were used as the starting point.

During one relocation scan each quadrat was considered in turn and its affinity with each of the eight clusters was computed. Where the similarity between a quadrat and its parent cluster was not so great as the similarity between that quadrat and an adjacent cluster, then the program moved that quadrat to the new cluster. The centroids of the two clusters involved were recalculated to allow for this change.

The population was repeatedly scanned until no quadrats were relocated during one full scan, at which stage a local optimum for the eight clusters had been obtained.

To compensate for the possibility of overclassification, i.e. the

Fig. 26

Ward's Hierarchic Fusion Method dendrogram

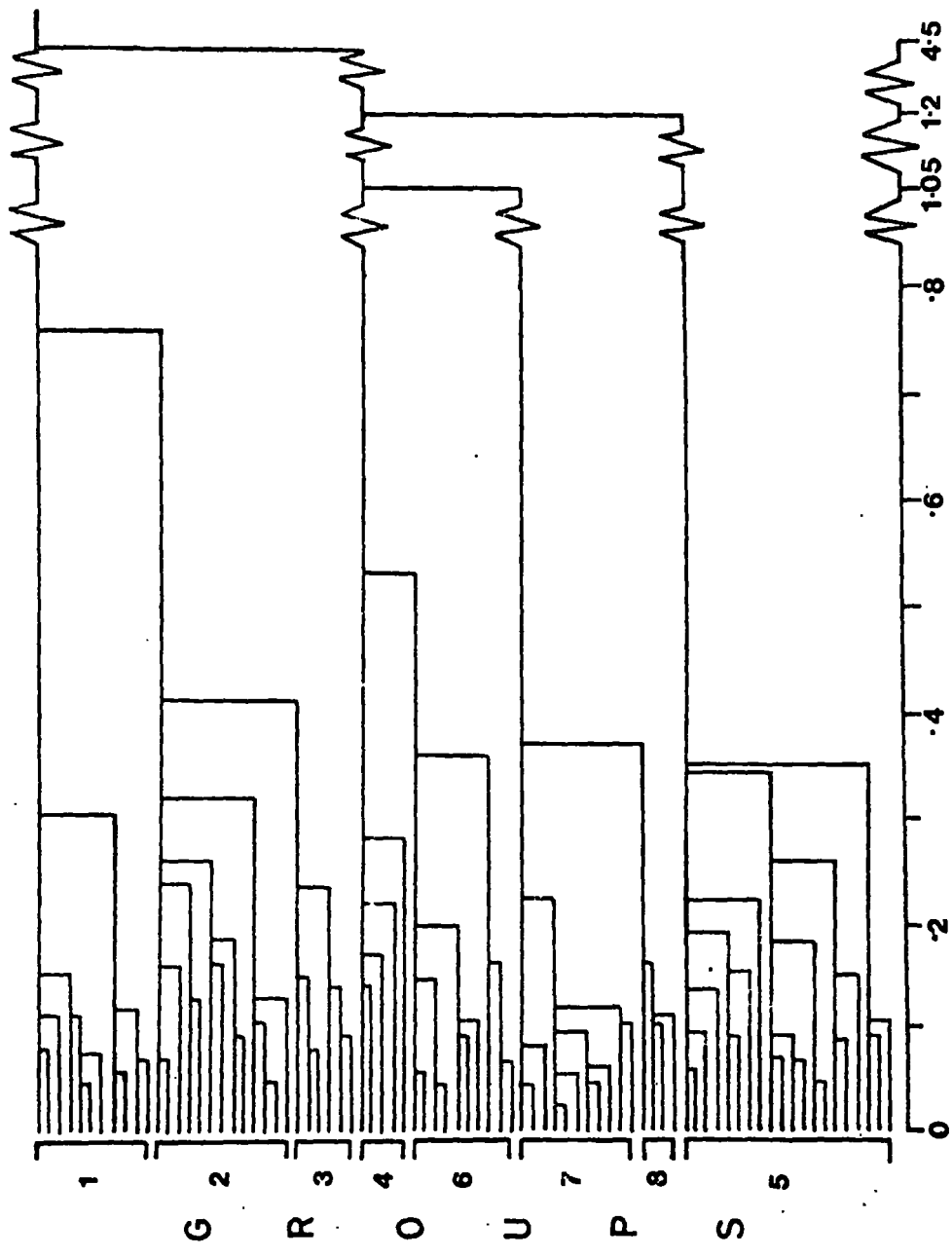

COEFFICIENT

eight clusters may have been an oversensitive result not necessarily meaningful in an ecological context, a fusion procedure for the clusters was adopted using the iterative relocation program.

The similarities were computed between all pairs of clusters and those two which were the most similar were fused, thereby reducing the classification to seven clusters.

The relocation phase was repeated, and a local optimum for the seven clusters was obtained. These fusion and relocation phases were repeated until only one cluster remained.

Computer printouts were obtained listing the species composition of the clusters at each local optimum. These will be discussed later.

D. DISCUSSION OF RESULTS OF ANALYSIS

The grid has been examined by a variety of methods. It remains to test the validity of the clusters derived from these methods.

(i) Comparison of Cluster Analysis Results

Initially the clusters derived from the various analyses were compared on theoretical grounds alone before consideration of the ecological and sociological implications.

The relationships between the clusters derived from different analyses were simply demonstrated by a consideration of the quadrats that composed the respective clusters. Matrices were constructed that indicated how the quadrats contained within each cluster of one analysis compared with those delimited in another.

In no case did clusters derived from the normal association analysis coincide exactly with that obtained from the group analysis (Figure 27). Although both methods are monothetic divisive procedures the group analysis tends to form groups of wider ecological amplitude than the relatively homogeneous units derived from association analysis.

There was a greater similarity between the groups obtained by the two polythetic agglomerative procedures even though one method (Figure 28) was based on a measure of interstand distance and the other was a method of delimitating spheroid clusters.

The correspondence between the association analysis and the results of the iterative relocation procedure was closer than that between the two divisive methods but not as close as the similarities of the results from the two agglomerative methods (Figure 29).

The arrangements of the groups of quadrats on the ground map of the grid show the fragmentary nature of the group analysis clusters as compared to the more extensive quadrat groups shown by the association analysis (Figure 30) and the relocation 8 cluster stage (Figure 31).

Fig. 29

Relationship between the Clusters derived from the Iterative Relocation Procedure and Normal Association Analysis in terms of common quadrats

CLUSTER NO.	RELOCATION							
	1	2	3	4	5	6	7	8
1	12	4						
5		7	6	1				
2		1		1				
4				5	14			
3				2		3		
7						3		4
8							12	
6						2		3

Fig. 30 The arrangement of the quadrat groups derived from
Group Analysis and Association Analysis on the grid map

NO. OF CLUSTERS

GROUP ANALYSIS

ASSOCIATION ANALYSIS

2

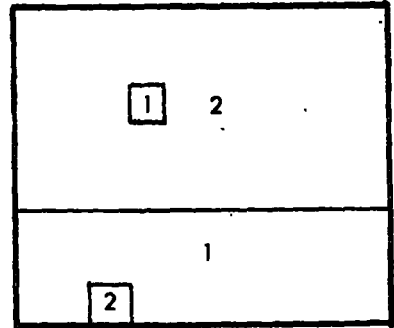
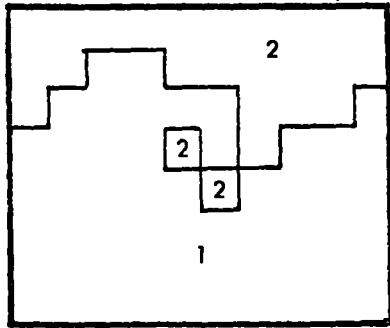

4

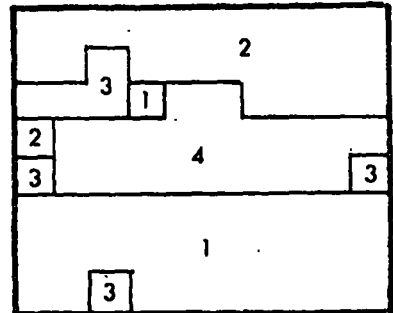
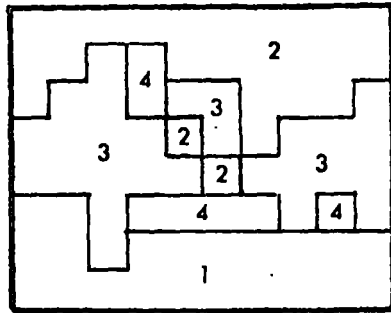

6

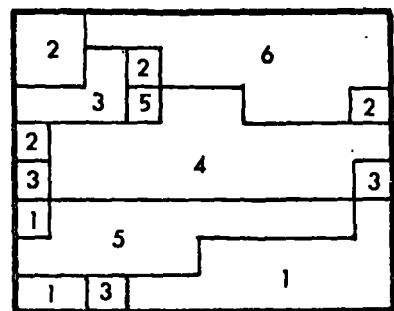
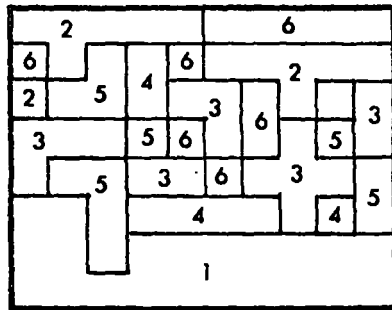

8

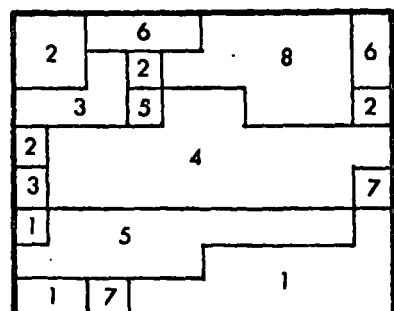
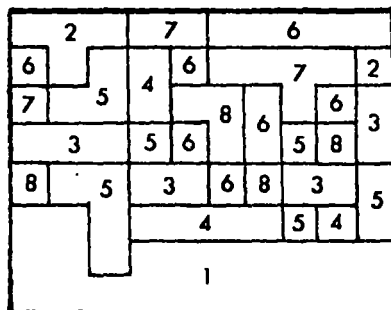
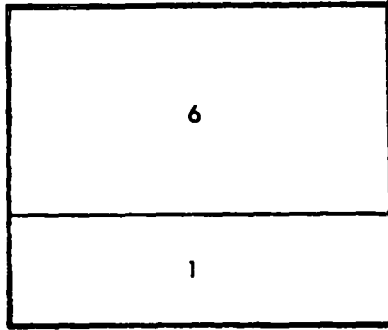

Fig. 31 The arrangement of the quadrat groups derived
from Relocation after Ward's Analysis

RELOCATION AFTER
WARD'S ANALYSIS

NO OF
CLUSTERS

2



4

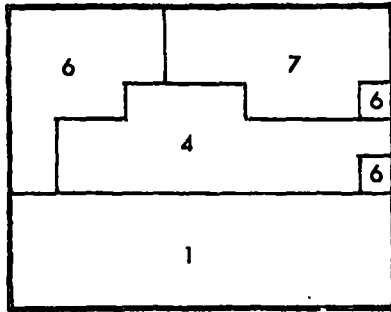

6

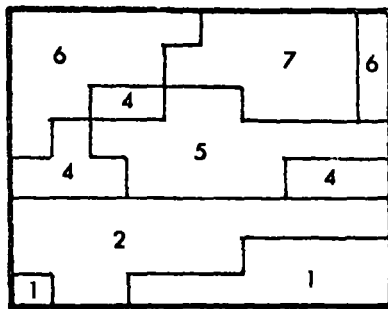

8

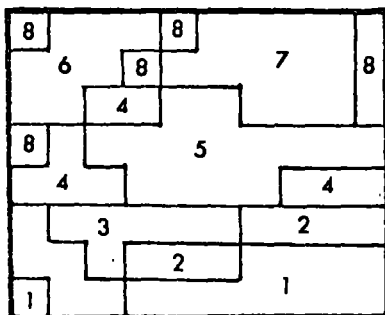

The above analysis gave an indication as to the relative similarities between the results of the various methods, but gave no indication of the definition of each cluster. Definition, in this context, is taken to imply a combination of two factors. The first pertains to the insularity of each cluster. What is the degree of overlap if any with other groups? The second is a reflection of the range of variation encountered within each group, the within group heterogeneity.

Crawford and Wishart (1968) have described a means of representing the variance both within and between the terminal groups by an ordination procedure.

The principal components analysis as previously described was used as a base graph. The points on that graph which correspond to those quadrats of a particular group or cluster can be compared with the points obtained from another group, since the within group heterogeneity and between group homogeneity is demonstrated by the spread and affinity of the points. This may be shown symbolically by plotting a circle for each group whose centre is the mean position of the group's points and the radius the standard deviation of the points' radii from the group mean. It follows that providing the efficiency ratio is reasonably high, the size of each circle provides an indication of the heterogeneity of the corresponding group while the distance between circles shows the groups' mutual homogeneity.

The efficiency ratio is equivalent to the percentage of variance which is explained by the plane of the graph. In the principal components analysis, the first two axes accounted for 25% of the variance, a not unusual level in vegetation analyses, indicating that the plane of the graph is a suitable base.

It follows that the smaller the diameter of each group's circle and the greater the distance separating them, the better the classification.

A program was used (Wishart 1969) that enabled direct plotting by

computer with the use of an on-line digital plotter.

The eight clusters produced by each of the classificatory techniques were put to this form of analysis and the resultant graphs are represented in Figures 32 and 33. Each cluster is diagnosed according to its original reference number.

When the normal association analysis clusters are compared with the group analysis clusters it becomes apparent that the variation between the groups is maximised (distance between circles) and the variation within the groups minimised (radii of circles) in the former, while the latter presents a view of a more diffuse conglomeration of groups.

The superiority of the polythetic agglomerative techniques becomes apparent when Figure 33 is examined. Ward's method showed eight groups with minimum within group variation and maximum between group variation, indicating a good classification.

The relocation procedure, although producing a more exacting classification from a theoretical point of view, did not approach the clarity of the Ward's method groups when illustrated on the plane between principal components one and two.

The progressive resolution of the eight relocated clusters during the agglomerative procedure from the six cluster stage to the four cluster stage is illustrated in Figure 34.

It is apparent that at the three cluster stage the variation between groups is maximised and from a genetic point of view three main types of vegetation are concerned, clusters 1, 4 and the fusion product of 6 and 7. However at this stage the variation within each group is maximised as indicated by large diameter circles and in fact a reasonable compromise is attained in the six cluster relocation phase where there are three pairs of clusters, each cluster with minimum internal variation, but each pair relatively disjunct from its neighbours.

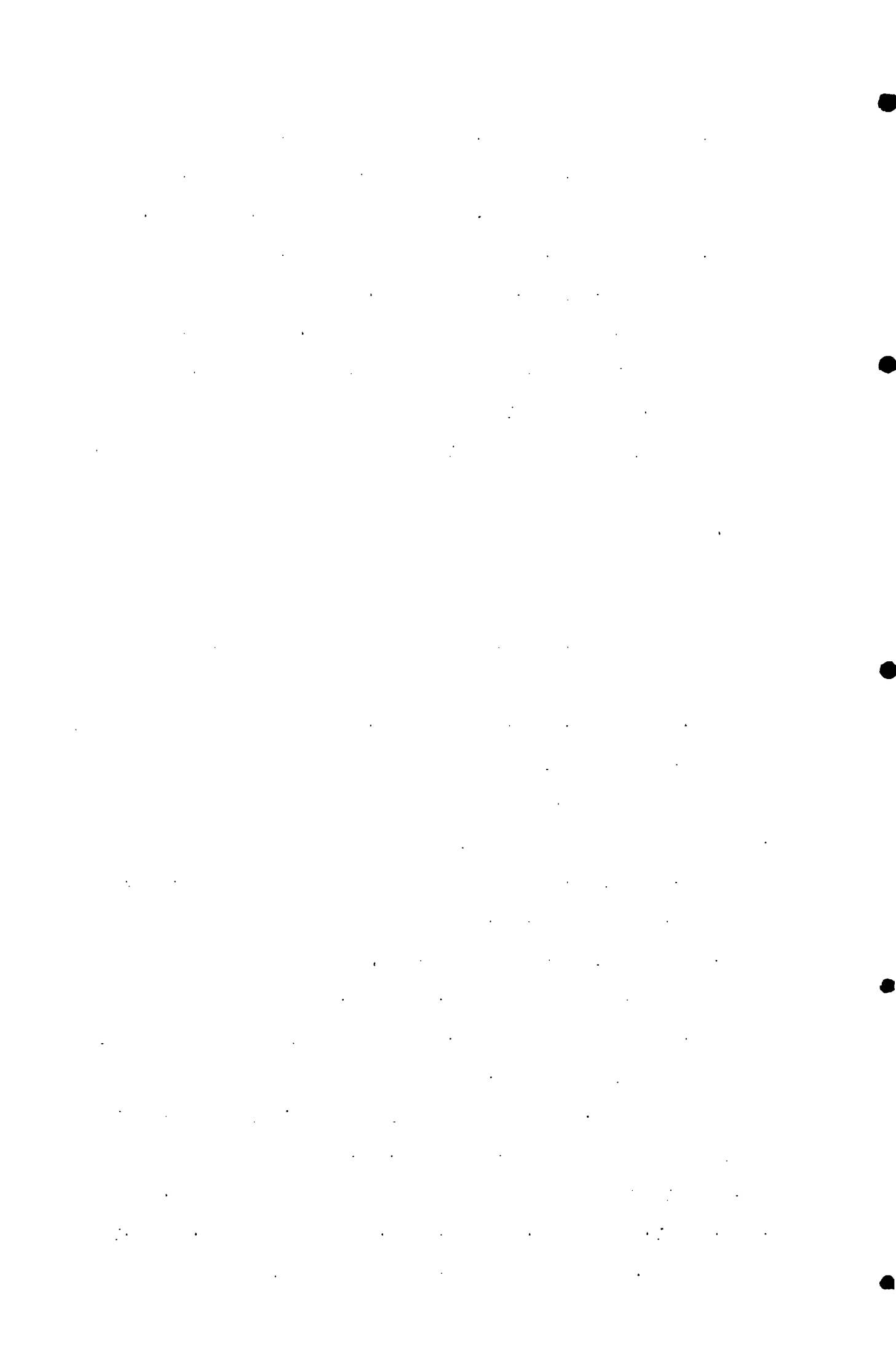
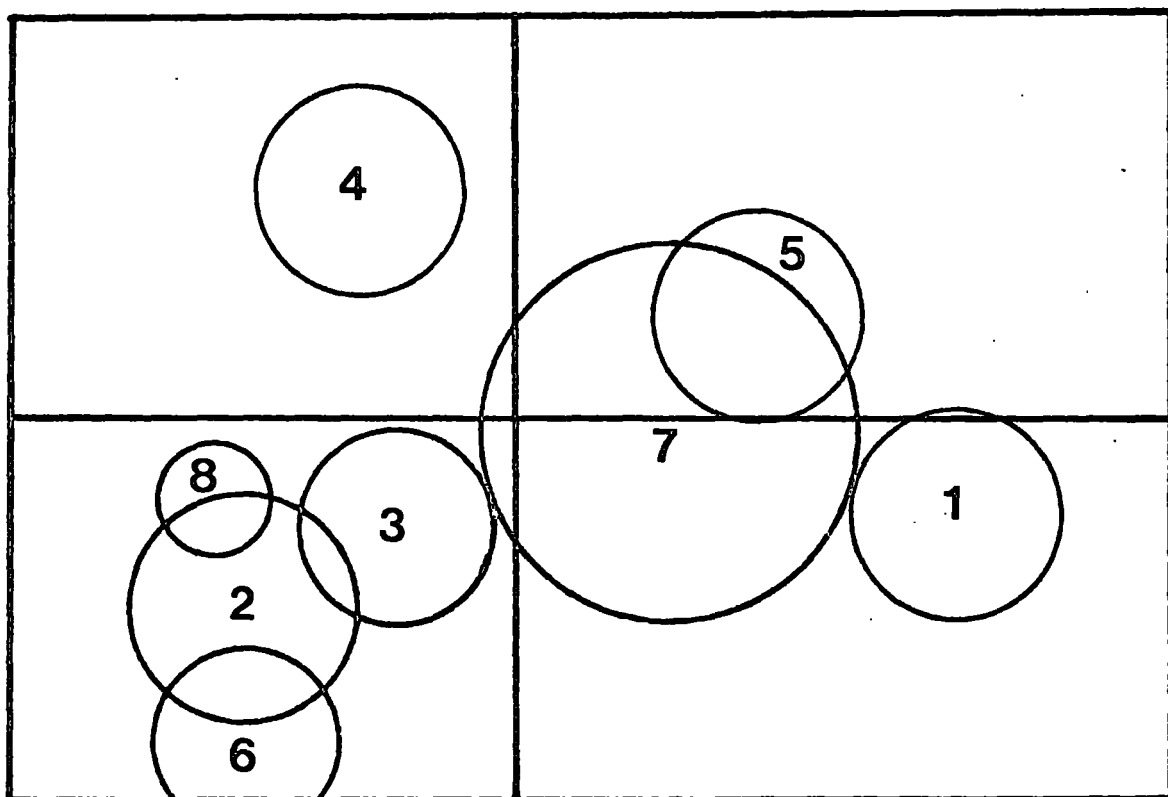

Fig. 32 Ordination of groups obtained by Normal Association
Analysis and Group Analysis

NORMAL ASSOCIATION ANALYSIS



PRINCIPAL COMPONENT 1

GROUP ANALYSIS

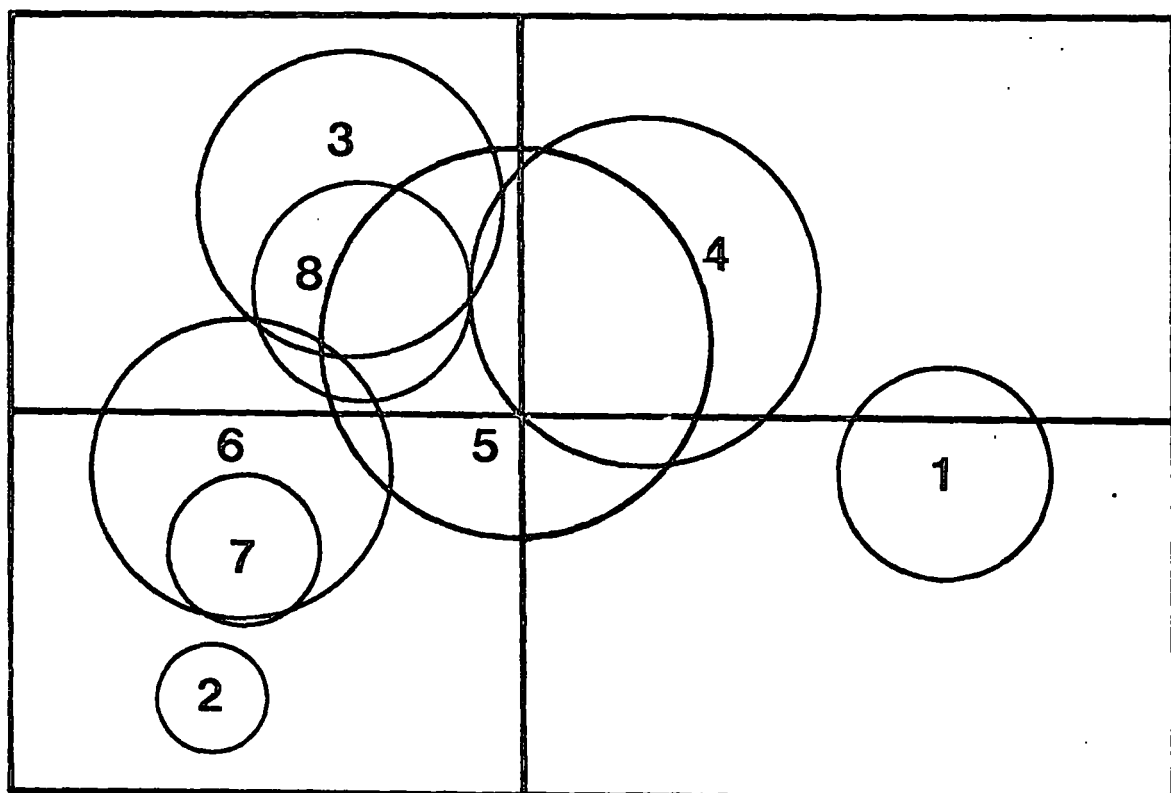

PC 1

Fig. 33 Ordination of groups obtained by Normal
Association Analysis and Relocation

WARD'S METHOD

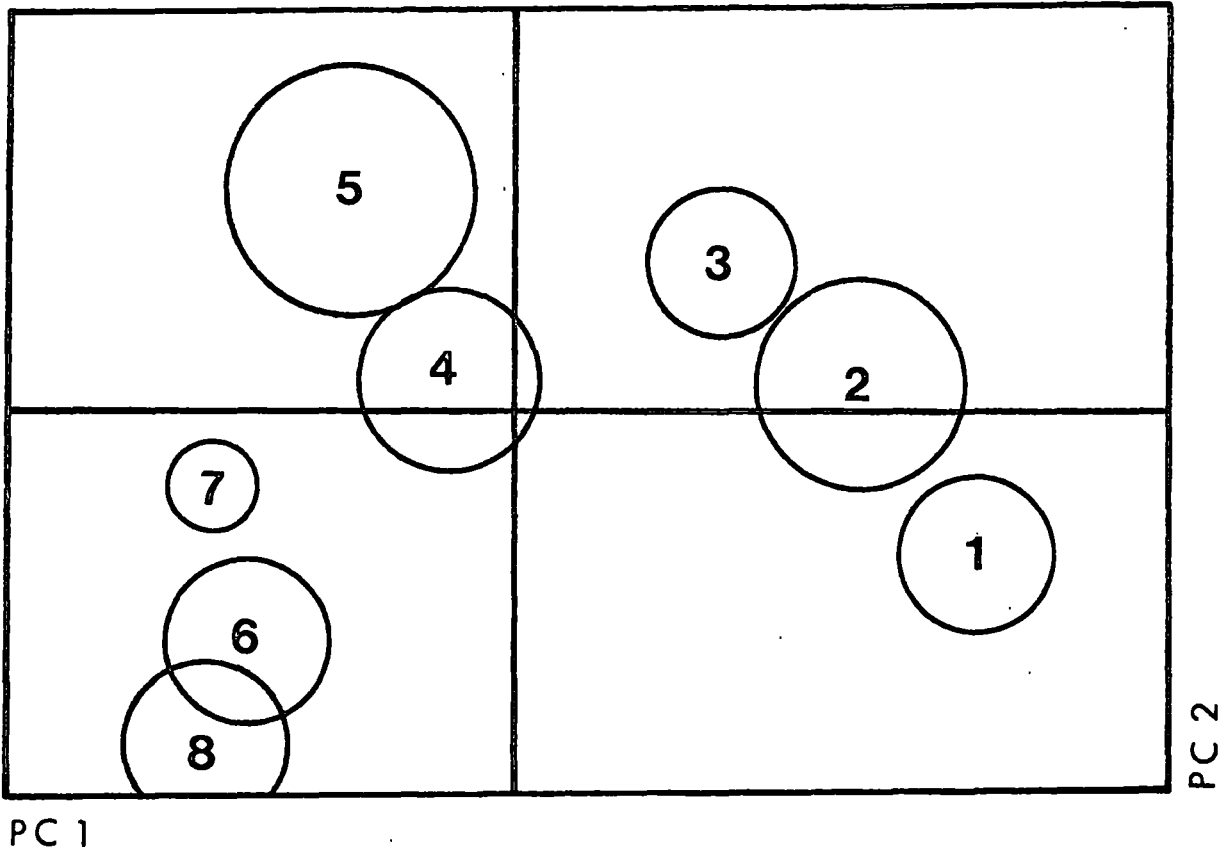

RELOCATION 8 CLUSTERS

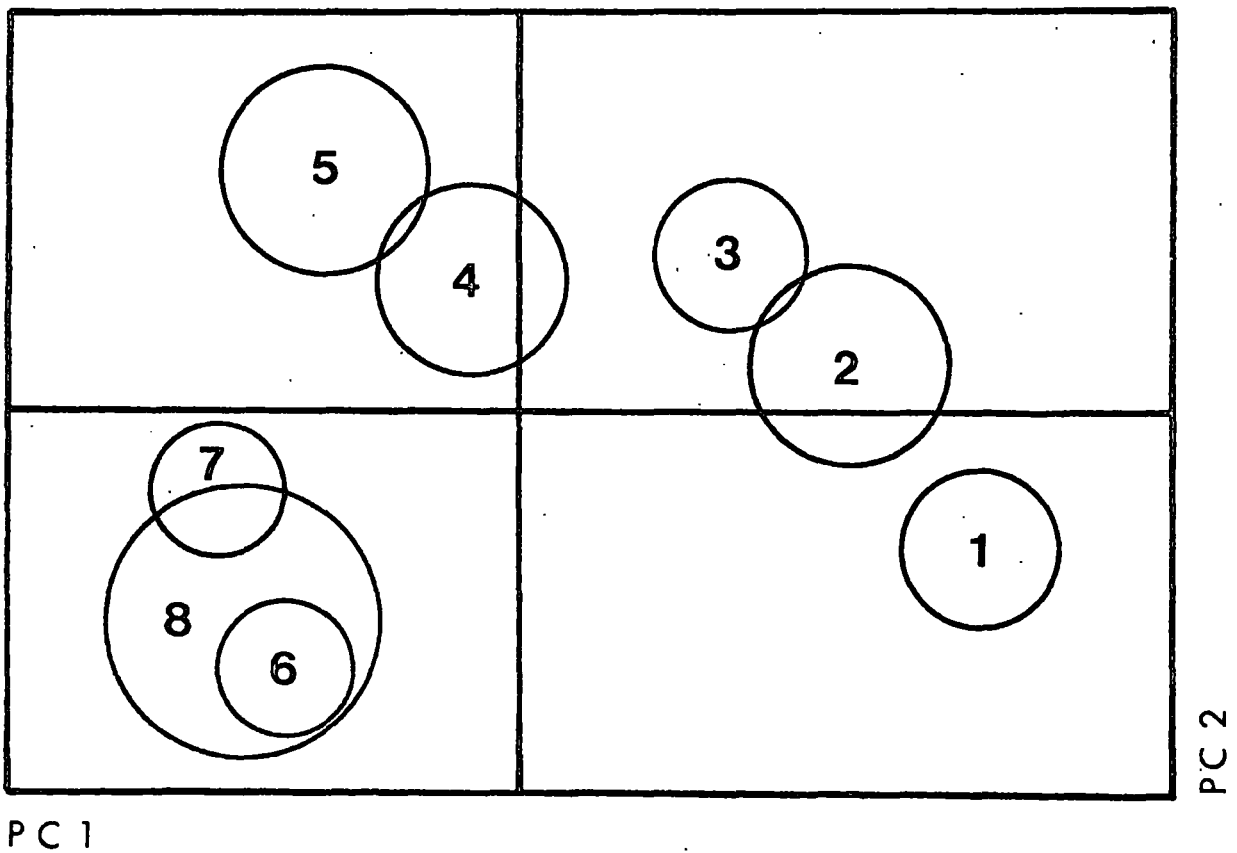
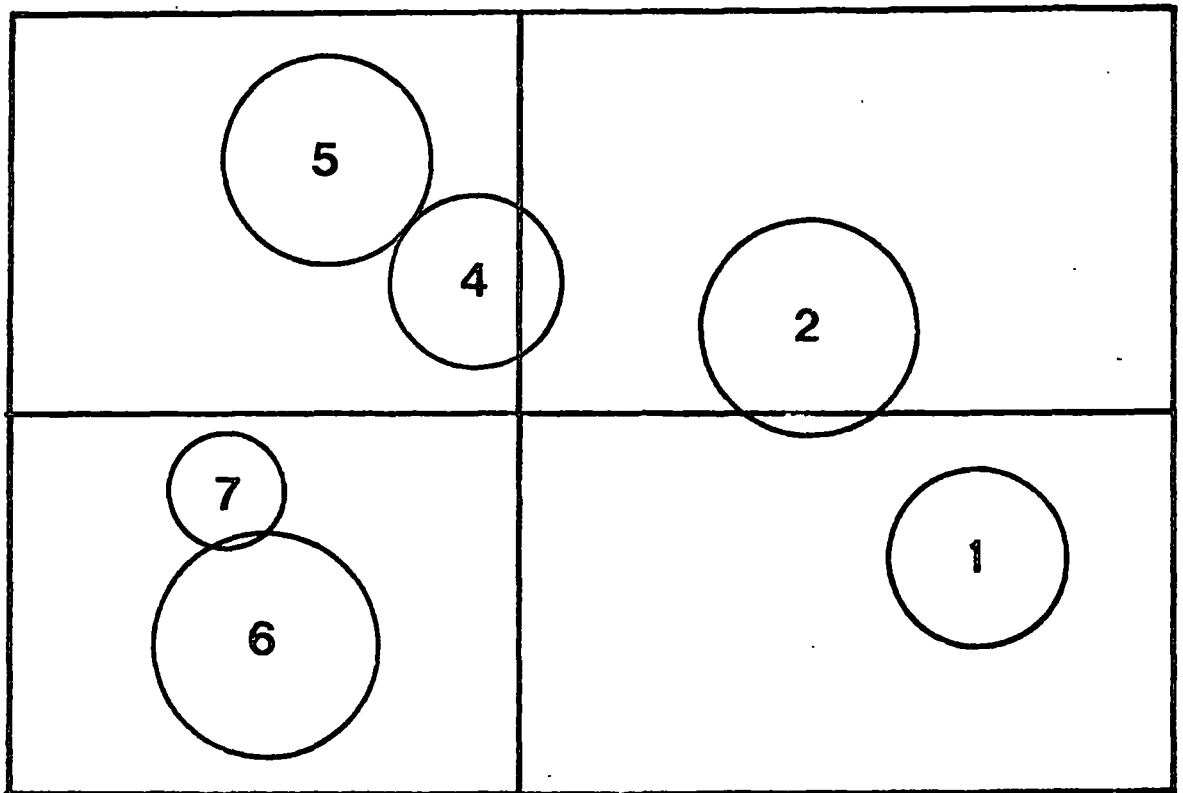

Fig. 34 Ordination of groups obtained by Relocation
(6 Cluster and 4 Cluster)

RELOC 6



PC 1

PC 2

RELOC 4

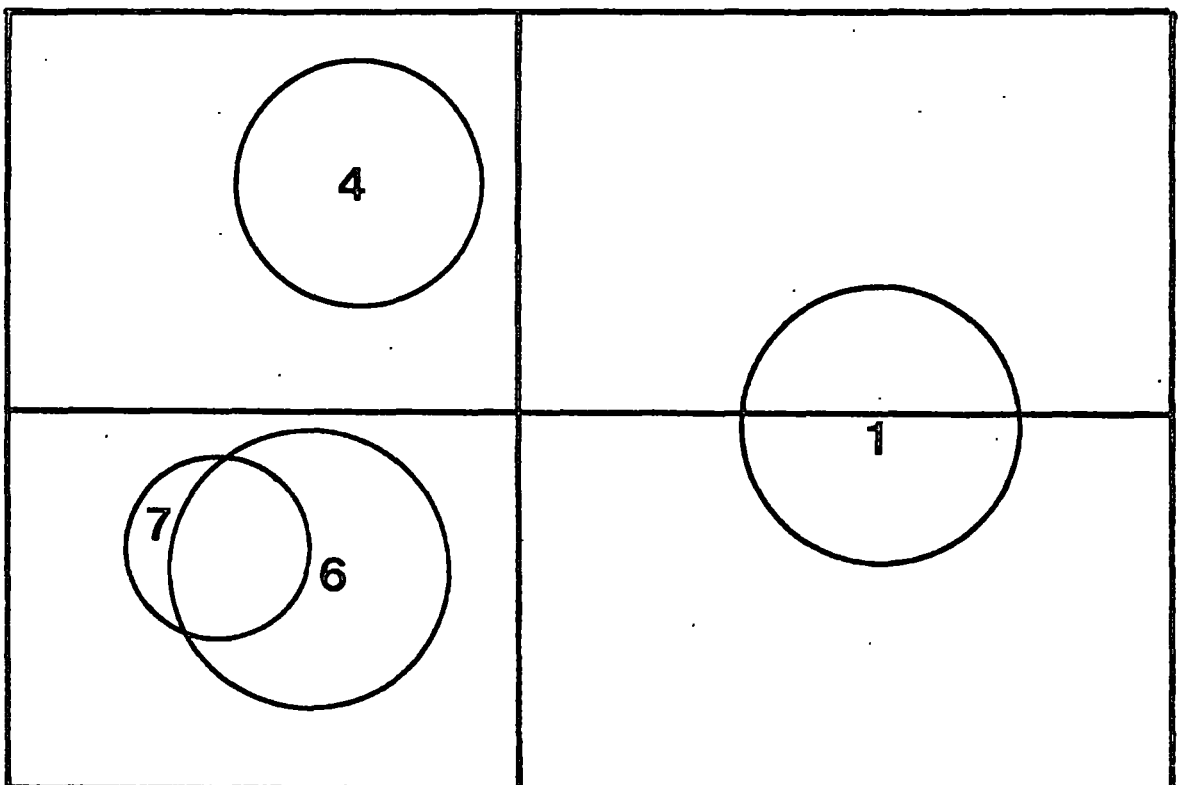

PC 1

PC 2

On the above criteria alone it would appear that the six cluster relocation phase is the optimal solution to the classification of the grid in terms of discrete homogeneous groups of quadrats. However the normal association analysis eight cluster stage did not present an incoherent picture and the two-way table derived from both the normal and inverse analysis provides an equally powerful classification with the added advantage that each of its units is distinguished by a characteristic species and quadrat.

The 6 Clusters derived by Iterative Relocation

Each quadrat was identified by a cluster code and the resultant locations of the clusters of quadrats on the first two principal component axes is shown (Fig. 35).

The three different symbols in Fig. 35 represent the groups at the three cluster stage. The differential shading within each group of symbols serves to separate the pairs of clusters that subsequently fused at the three cluster stage.

Each cluster of the six clusters (Table 6) in turn will be considered in terms of its biotic and abiotic characteristics. Short notes are added indicating the general synsystematic affinities of these groups. The comparisons with the continental phytosociological groups are tentative only as (a) the methods used were not those standard continental phytosociological practice (Braun Blanquet 1964) and (b) the phytosociological nomenclature is generally derived from the description of associations from the European mainland and phytogeographical differences on particular communities no doubt occur across its range.

Cluster 1

The eleven quadrats of this group were characterised by a wetland flora, having high percentage occurrences of Eriophorum angustifolium, Juncus articulatus, Eleocharis quinqueflora and Pinguicula vulgaris.

Fig. 35 Ordination and map of the component quadrats of
the 6 Clusters derived by Relocation

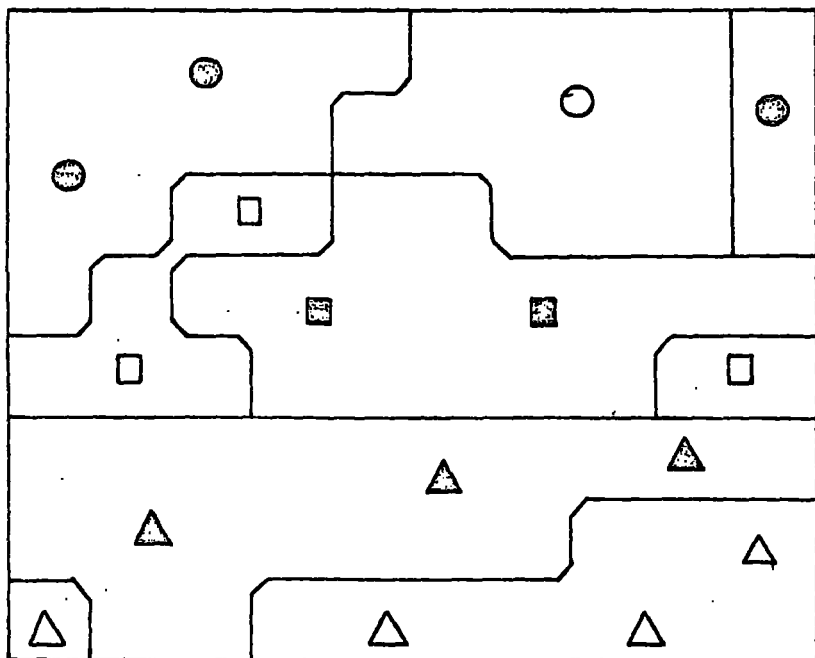
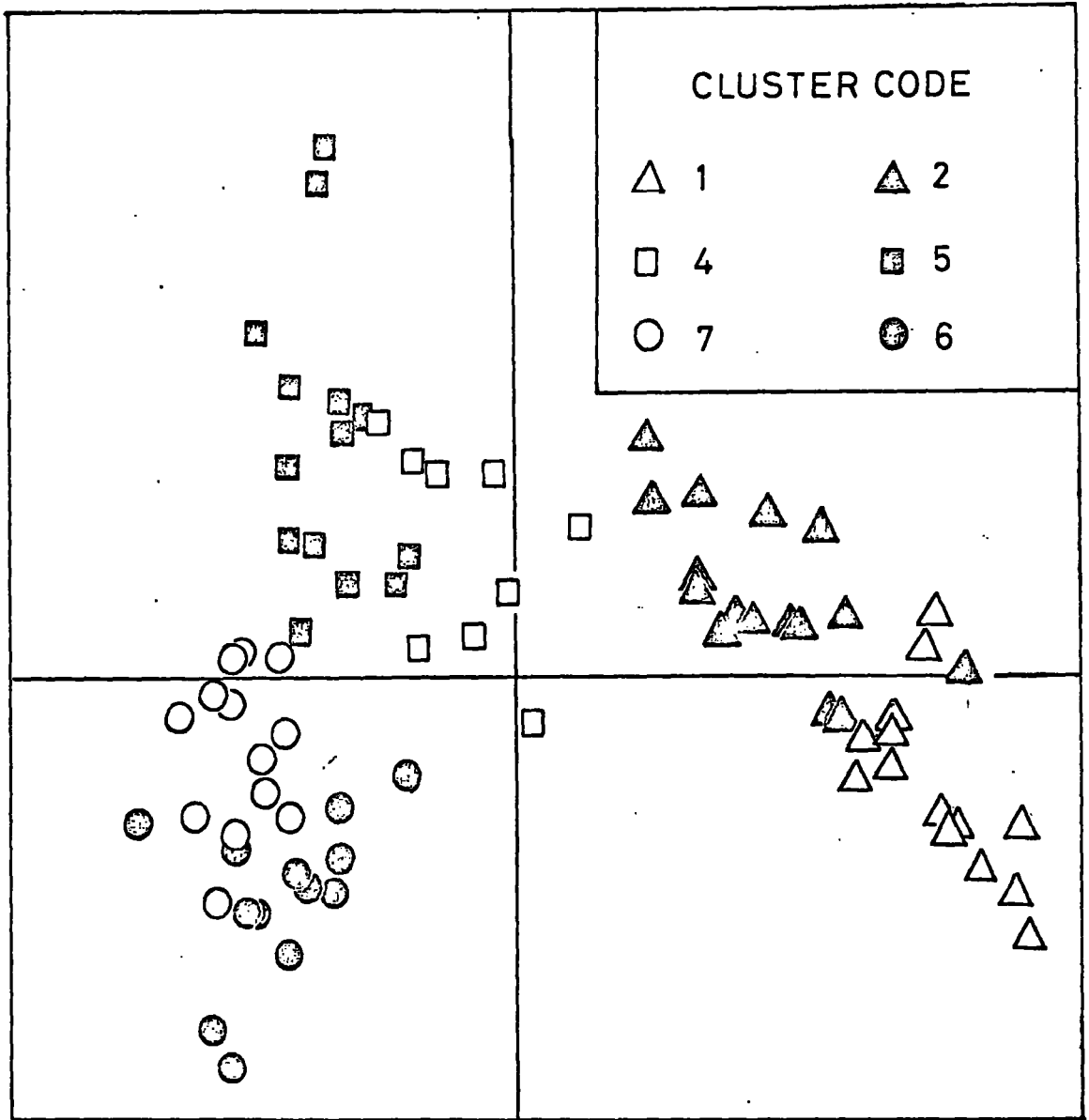

TABLE 6

The floristic composition of clusters at the six cluster stage as segregated by the Iterative Relocation Procedure

<u>CLUSTER 1</u>	<u>% occurrence</u>		<u>% occurrence</u>
Carex lepidocarpa	100	Anthoxanthum odoratum	50
Prunella vulgaris	100	Brium pseudotriquetrum	42
Ctenidium molluscum	100	Pellia epiphylla	42
Carex panicea	100	Philonotis fontana	33
Potentilla erecta	100	Leontodon hispidus	25
Eriophorum angustifolium	100	Juncus triglumis	25
Euphrasia micrantha	100	Carex capillaris	25
Festuca rubra	100	Deschampsia caespitosa	17
Equisetum variegatum	100	Plantago lanceolata	17
Juncus articulatus	100	Linum catharticum	17
Pinguicula vulgaris	100	Rumex acetosella	17
Eleocharis quinqueflora	92	Thymus drucei	17
Sagina nodosa	83	Riccardia multifida	17
Selaginella selaginoides	75	Carex pulicaris	17
Kobresia simpliciuscula	67	Preissia quadrata	8
Plantago maritima	67	Lophocolea bidentata	8
Primula farinosa	67	Bellis perennis	8
Tofieldia pusilla	58	Juncus squarrosus	8
Cardamine pratensis	50	Carex echinata	8
Agrostis canina	50	Rhacomitrium lanuginosum	8
 <u>CLUSTER 2</u>			
Carex panicea	100	Sagina nodosa	50
Ctenidium molluscum	100	Bellis perennis	50
Selaginella selaginoides	100	Philonotis fontana	45
Euphrasia micrantha	100	Linum catharticum	45
Potentilla erecta	100	Galium sternerii	39
Eriophorum angustifolium	95	Carex echinata	33
Prunella vulgaris	89	Tofieldia pusilla	33
Thymus drucei	83	Pinguicula vulgaris	28
Carex lepidocarpa	83	Primula farinosa	28
Juncus articulatus	78	Plantago maritima	28
Carex capillaris	78	Peltigera aphosa	28
Carex pulicaris	72	Festuca ovina	22
Agrostis canina	61	Pleurozium schreberi	17
Equisetum variegatum	61	Juncus squarrosus	17
Cardamine pratensis	56	Carex dioica	17
Festuca rubra	56	Brium pseudotriquetrum	17
Riccardia pinguis	17	Leontodon hispidus	6
Juncus triglumis	17	Preissia quadrata	6
Anthoxanthum odoratum	17	Kobresia simpliciuscula	6
Riccardia multifida	11	Dicranum bonjeani	6
Ranunculus acris	11	Rhacomitrium lanuginosum	6
Deschampsia caespitosa	11	Lotus corniculatus	6
Carex nigra	11	Rhytidiadelphus loreus	6
Cladonia chlorophea	11	Eurhynchium prolongum	6
Calluna vulgaris	11	Hylacomium splendens	6
Nardus stricta	6	Fissidens adianthoides	6

CLUSTER 4% occurrence% occurrence

Thymus drucei	100	Hypnum cupressiforme	22
Festuca ovina	100	Gentiana verna	22
Euphrasia micrantha	100	Linum catharticum	22
Selaginella selaginoides	100	Carex dioica	22
Carex panicea	100	Viola canina <small>(syn. a. a. / 147 F)</small>	22
Potentilla erecta	100	Equisetum arvense	22
Carex lepidocarpa	89	Sesleria caerulea	22
Prunella vulgaris	89	Hylocomium splendens	22
Carex capillaris	78	Plantago lanceolata	11
Galium sternerii	67	Plantago maritima	11
Pleurozium schreberi	45	Lycopodium clavatum <small>(syn. a. a. / 147 F)</small>	11
Campanula rotundifolia	45	Agrostis canina	11
Carex pulicaris	33	Galium saxatile	11
Trifolium repens	33	Leontodon hispidus <small>(syn. a. a. / 147 F)</small>	11
Rhacomitrium lanuginosum	33	Tortella tortuosa	11
Rhytidiadelphus loreus	33	Philonotis fontana	11
Nardus stricta	33	Bryum pseudotriquetrum	11
Thuidium tamariscinum	33	Cirsium dissectum <small>? at v. v. a. / 147 F palustre</small>	11
Agrostis tenuis	33	Pseudoscleropodium purum	11
Calluna vulgaris	33	Eriophorum angustifolium	11
Bellis perennis	33	Juncus articulatus	11
Kobresia simpliciuscula	33	Cladonia chlorophea	11
Cardamine pratense	22	Polytrichum commune	11
Ctenidium molluscum	22	Primula farinosa	11
Ranunculus acris	22		

CLUSTER 5

Thymus drucei	100	Bellis perennis	22
Festuca ovina	100	Polytrichum commune	22
Selaginella selaginoides	100	Calluna vulgaris	22
Carex panicea	100	Prunella vulgaris	22
Potentilla erecta	100	Thuidium tamariscinum	14
Rhytidiadelphus loreus	86	Hypnum cupressiforme	14
Agrostis tenuis	79	Carex capillaris	14
Euphrasia micrantha	79	Botrychium lunaria	14
Pleurozium schreberi	72	Linum catharticum	14
Juncus squarrosus	64	Deschampsia caespitosa	14
Hylocomium splendens	64	Pseudoscleropodium purum	14
Galium saxatile	57	Carex pulicaris	14
Equisetum arvense	57	Plantago maritima	7
Viola canina <small>riviniana</small>	43	Nardus stricta	7
Campanula rotundifolia	36	Dicranum bonjeani	7
Galium sternerii	36	Carex dioica	7
Cladonia chlorophea	36	Certraria islandica	7
Trifolium repens	29		

CLUSTER 6

	<u>% occurrence</u>		<u>% occurrence</u>
<i>Festuca ovina</i>	100	<i>Hylocomium splendens</i>	27
<i>Sesleria caerulea</i>	100	<i>Galium saxatile</i>	27
<i>Linum catharticum</i>	100	<i>Trifolium repens</i>	20
<i>Selaginella selaginoides</i>	93	<i>Cornicularia aculeata</i>	20
<i>Thymus drucei</i>	80	<i>Agrostis tenuis</i>	13
<i>Cladonia arbuscula</i>	80	<i>Prunella vulgaris</i>	13
<i>Anthoxanthum odoratum</i>	73	<i>Polygala amara</i>	13
<i>Potentilla erecta</i>	73	<i>Hieracium pilosella</i>	13
<i>Campanula rotundifolia</i>	73	<i>Luzula sylvatica</i>	13
<i>Kobresia simpliciuscula</i>	73	<i>Rhytidiadelphus loreus</i>	13
<i>Carex panicea</i>	67	<i>Carex pulicaris</i>	13
<i>Galium sternerii</i>	60	<i>Pinguicula vulgaris</i>	7
<i>Carex caryophyllea</i>	60	<i>Carex capillaris</i>	7
<i>Gentiana verna</i>	53	<i>Ditrichum flexicaule</i>	7
<i>Calluna vulgaris</i>	53	<i>Plantago lanceolata</i>	7
<i>Pleurozium schreberi</i>	53	<i>Primula farinosa</i>	7
<i>Tortella tortuosa</i>	47	<i>Juncus articulatus</i>	7
<i>Racomitrium lanuginosum</i>	47	<i>Galium boreale</i>	77
<i>Plantago maritima</i>	40	<i>Preissia quadrata</i>	7
<i>Viola canina</i>	40	<i>Bellis perennis</i>	7
<i>Polytrichum commune</i>	33	<i>Gentianella amarella</i>	7
<i>Euphrasia micrantha</i>	33	<i>Helianthemum chamaecistus</i>	7
<i>Certraria islandica</i>	27	<i>Deschampsia caespitosa</i>	7

CLUSTER 7

<i>Festuca ovina</i>	100	<i>Viola lutea</i>	25
<i>Selaginella selaginoides</i>	100	<i>Thymus drucei</i>	25
<i>Pleurozium schreberi</i>	100	<i>Dicranum scoparium</i>	17
<i>Cladonia arbuscula</i>	100	<i>Hypnum cupressiforme</i>	17
<i>Calluna vulgaris</i>	100	<i>Galium sternerii</i>	17
<i>Potentilla erecta</i>	100	<i>Polygala serpyllifolia</i>	8
<i>Campanula rotundifolia</i>	84	<i>Empetrum nigrum</i>	8
<i>Galium saxatile</i>	75	<i>Luzula sylvatica</i>	8
<i>Agrostis tenuis</i>	58	<i>Carex caryophyllea</i>	8
<i>Rhytidiadelphus loreus</i>	50	<i>Helianthemum chamaecistus</i>	8
<i>Koeleria cristata</i>	42	<i>Gentiana verna</i>	8
<i>Anthoxanthum odoratum</i>	42	<i>Gentianella amarella</i>	8
<i>Hylocomium splendens</i>	33	<i>Thuidium tamariscinum</i>	8
<i>Sesleria caerulea</i>	25	<i>Trifolium repens</i>	8
<i>Polytrichum commune</i>	25		

The rarities were well represented in this cluster not only in terms of numbers of species but also their frequency of occurrence. These included Equisetum variegatum (occurring in 100% of quadrats), Kobresia simpliciuscula (67%), Plantago maritima (67%), Primula farinosa (67%), Tofieldia pusilla (58%), Juncus triglumis (25%) and Carex capillaris (25%).

These quadrats were located at the lowest end of the grid and, being nearest the sike, were subjected to periodic and intense flooding which removed much of the organic material from the "soil" and deposited calcareous gravels in its place. This effect is shown by referring to the grid map of Exchangeable Calcium (Fig. 36) and organic material (Fig. 37).

Synsystematically the vegetation of these quadrats appeared to be related to the Class Eriophorium Latifolii. Class characters present were Eriophorium angustifolium and in the immediate vicinity in the same community but not on the grid Triglochin palustre and Drepanocladus revolvens.

Within this Class the vegetation could be further related to the Order Tofieldietalia, Preisg. apud Oberd. 49. by the presence of Equisetum variegatum, Carex capillaris and nearby Juncus alpino-articulatus and Scorpidium scorpioides. The high presence of Carex lepidocarpa, Eleocharis quinqueflora, Primula farinosa and Selaginella selaginoides enabled this group to be referred to the Alliance Caricion Davallianae Klika 34.

This sedge marsh group also contains such species as Rumex acetosella, Deschampsia caespitosa, Cardamine pratensis, Festuca rubra, Leontodon hispidus and Prunella vulgaris. These species are indicative of the Class Molinio-Arrhenatheretea, Tx. 37, but many other character species of this grassland class are absent.

Fig. 36

Distribution of Exchangeable Calcium on grid

Scale
1:200

Exchangeable
CALCIUM

.5 meq.
per 100cc

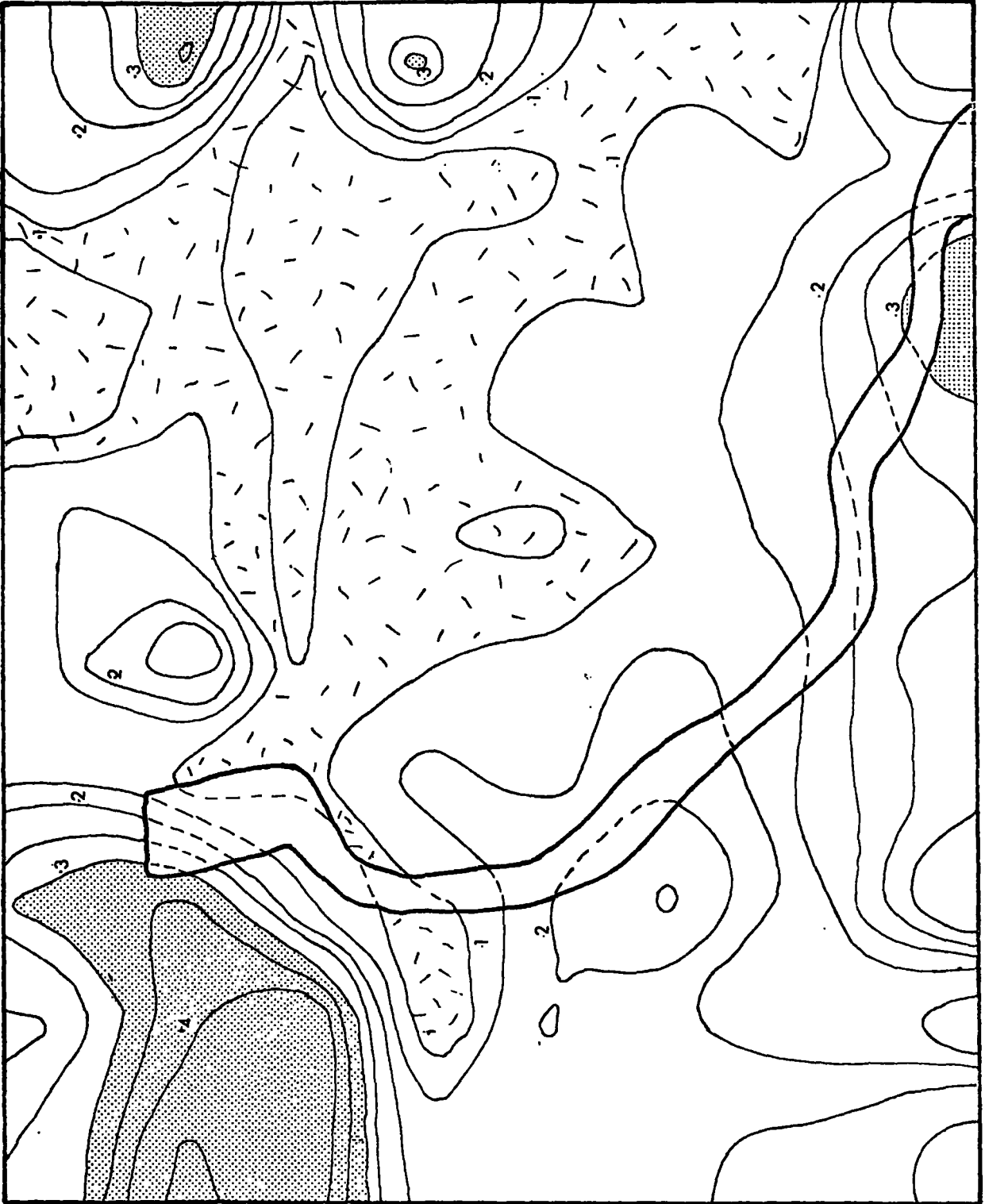
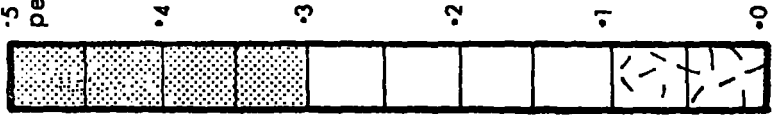
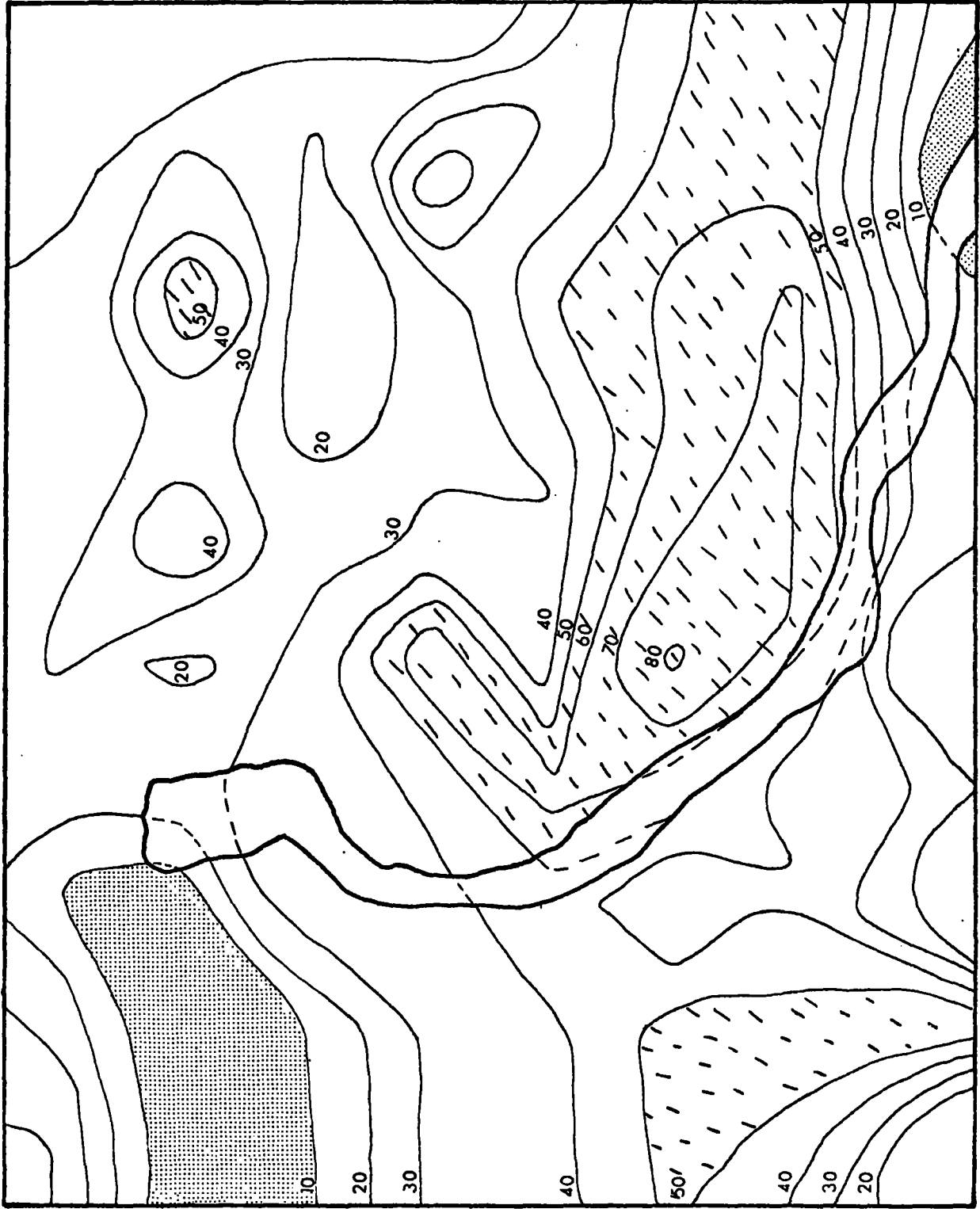
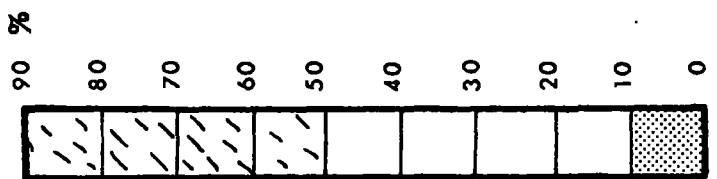

Fig. 37 Distribution of organic material in soil on grid

Scale
1:200

SOIL
ORGANIC
CONTENT



Cluster 2

The same wetland species as in the previous cluster occur in this group of 19 quadrats though the frequency of their occurrence is generally lower. More grassland species were found in this group, Festuca ovina and Rhytidiadelphus loreus.

The rarities present in Cluster 1 were all present in this cluster. All had lower frequencies of occurrence with the exception of Carex capillaris.

The synsystematics were as for cluster 1, but the affinity to the Class Molinio-Arrhenatheretea was developed further as witnessed by the introduction of the above Bryophyte.

This group was further from the scouring and flushing effects of the sike and organic material has accumulated in the soil (up to 80%) and exchangeable Calcium reduced to between 0.1 and 0.2 meq/100 cc soil. The higher organic content of the soil resulted in a high water retention as illustrated in Fig. 38.

Cluster 4

This cluster of eight quadrats shows a further reduction in the character species of the Tofieldietalia and an increase in the importance of species which typify group 5 below.

Rarities present include Carex capillaris, Kobresia simpliciuscula, Gentiana verna and Plantago maritima.

This group's soil samples indicated a lower calcium level (less than 0.1 meq Ca/100 cc soil) than the preceding group and also a reduction in organic content.

Cluster 5

This cluster of 15 quadrats contained few rarities, only Carex capillaris and Plantago maritima.

Fig. 38

Distribution of soil water "under normal conditions"

on grid

Scale
1:200

SOIL WATER
("NORMAL
CONDITIONS")

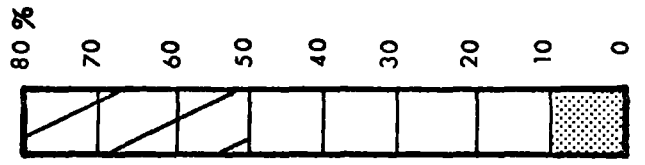

This vegetation was referable to the Nardo-Gallion Preisg. 49. This vegetation was typified by the Class characters of the Nardo-Gallunetum Preisg. 49 and the Order characters of the Nardetalia (Oberd 49) Preisg. 49, namely Potentilla erecta, Nardus stricta and Botrychium lunaria. The Alliance character species present were Polygala serpyllifolia, Viola canina, Galium saxatile, Juncus squarrosus and Thymus drucei.

Exchangeable calcium levels were relatively low in this group (less than 0.1 meq per 100 cc soil) with variable organic content.

This grades into the heath vegetation of cluster 7.

Cluster 7

The vegetation of this area appeared very heterogeneous but was referable to the Vaccinium myrtillus heath described by Bridgewater (1970), as typical of Northern Britain and Upland Wales.

The only rarity present was Gentiana verna and this with only low frequency.

This dwarf shrub heath graded away into Cluster type 6.

Cluster 6

This collection of quadrats was located on steep slopes of friable sugar limestone outcrops and was characterised by high exchangeable Calcium (greater than 0.30 meq/100 cc soil) and low organic content (less than 20%). Where the surface mat of vegetation was damaged due to trampling considerable wind erosion had occurred.

This sugar limestone grassland was rich in the rarities. These included Kobresia simpliciuscula, Gentiana verna, Plantago maritima, Carex capillaris and Primula farinosa.

This vegetation was typical of the association Seslerio-Caricetum Pulicarii Shimwell 1969.

The association was comparatively poor in character species of the

Seslerio Mesobromium due partly to the gregarity of Sesleria caerulea. Only Helianthemum chamaecystus was present on the grid and Poterium sanguisorba and Helictotrichon pratense were found in vegetation nearby.

Shimwell (1969) emphasised the intermediate nature of the Seslerio-Caricetum pulicarii lying between the southern lowland grasslands of the Festuco-Brometea Br. Bl. & R. Tx. 43 and the arctic-alpine grasslands of the Elyno-Seslerietea Br. Bl. 48. This association described for Upper Teesdale by Shimwell would appear to be a boundary or contact zone. This overall boundary nature of the vegetation of Upper Teesdale may explain the abundance of such species as Tofieldia pusilla and Kobresia simpliciuscula in pure associations (sensus Br. Bl.) including examples such as the Seslerio-Caricetum Pulicarii. That is a large scale example of a boundary complex of vegetation types fluctuating with changes in macro and micro climate - a constantly varying complex, unstable in detailed pattern but stable in overall makeup, and approximating to a large scale "limes divergens" situation in which many rare plants and rare combinations of plants may be expected (V. Leeuwan 1965).

Two-Way Table (Table 5) — where is it?
in pocket in back cover.

The two-way tables derived from the Association analysis produced groups broadly compatible with those obtained by the relocation procedure. The remarks made above regarding those groups of the latter procedure are pertinent when considering the groups derived from normal association analysis.

The main feature of interest in the two-way table is the Quadrat/Species nodum 3D which is found in a midway position between the two main end types of vegetation depicted in the table as nodes 1C, 5C and 6B, 8B, 4B, 6E, 8E, 4E.

This 3D node together with the other assembled species in Quadrat group 3 is synonymous with the sugar limestone grassland Cluster No. 6

depicted in the Relocation Procedure.

Not only does this community represent a phytosociological geographical boundary (see above) but it also represents a local boundary community in its own right.

This community must not be confused with the limes convergens boundary types previously described. This community was not a spatial transition zone but formed a homogeneous association type in its own right, the Seslerio-Caricetum Pulicarii Shimwell 1969.

Summary

An area was selected which covered much of the immediately visible range of variation of the vegetation in the Cow Green area of Upper Teesdale. This area included both types of boundary situations as determined in Section I.

The area was comprehensively gridded using 2 x 2 m quadrats, each of which was used as a basic vegetation unit.

Various agglomerative and divisive techniques of vegetation were applied. The most "convenient" classification was supplied by the six cluster stage of an iterative relocation procedure derived from the eight clusters obtained by Ward's agglomerative method.

These six clusters, however, formed a continuum of vegetation variation as witnessed by the principal components ordination, and appeared to be correlated with certain edaphic factors, notably exchangeable calcium.

This study was based on a restricted site but the analyses produced units which had affinities with certain synsystematic groups as described by the Zurich-Montpellier school of phytosociology.

However, as the two-way table from association analysis and the P.C.A. showed, there was a complete range of variation. It could be argued that the intermingling is simply a result from the coarse sampling technique, i.e. the size and regular shape of the samples.

The original boundary analysis, however, was taken from small 25 x 25 cm quadrats and nodal analysis produced relatively similar floristic units even though 64 of these small sampling units would nest in a single 2 x 2 metre quadrat, used in the main study.

It is therefore concluded that the area under investigation represented a complex admixture of vegetation types in an area where edaphic factors preclude the domination of any one type.

Two main extremes of floristic variation represented by Clusters 1 and 6 (Reloc.) were recognised that held large numbers of rare species. These were the communities of the friable sugar limestone skeletal soils; the one subjected to extensive wind erosion, whilst the other was vigorously flushed.

These two independent erosive phenomena precluded the complete development of plant cover over all of the quadrats in which these two communities were found.

The persistence of the rare species, which are considered to be intolerant of competition, within the base areas is easily understood. They represent habitats, albeit severe, which are open to colonisation by any organism which can gain and maintain a foothold under the prevailing ecological restraints.

The frequency of occurrence of the rarities in the closed areas within these two communities must be accounted for. To investigate this phenomenon more fully, those areas of quadrats in Clusters 1 and 6 with complete vegetation cover were selected to form the basis of the following production study. To afford a local comparison, the grassland of Cluster 5 was also analysed.

The sedge-marsh site represented by Cluster 1 was particularly rich in rare species. To investigate the role of interspecific competition and interference in the survival of these rarities, two further sites were selected. These represented a trend of increasing standing crop as

follows:-

- (i) Cluster 1 quadrats; with low standing crop and exposed tracts of ground.
- (ii) Lower Slapstone Sike; sedge-marsh providing complete ground cover.
- (iii) Nameless/Red Sike; sedge-marsh providing a very dense sward of sedge-marsh species.

PART IV

PRODUCTION STUDIES

THE SITES

The five sites selected for production studies were:-

1. Upper Slapestone Sike, Tofieldietalia.
2. Lower Slapestone Sike, Tofieldetalia-Molinio Arrhenatheratea.
3. Nameless/Red Sike, Tofieldetalia-Molinio Arrhenatheratea.
4. Upper Slapestone Sike, Nardo Gallion.
5. Upper Slapestone Sike, Seslerietalia.

Sites 1, 4 & 5 (Plate V) correspond closely to the groups 1, 5, 6 by the Relocation procedure at the 6 cluster stage, as described in the previous section of the thesis.

Sites 1, 2 & 3 represent stages in a sedge marsh continuum, progressing from Site 1, with very little organic soil material, through Site 2 to Site 3 (Plate VI), where the soil is composed almost entirely of organic material. These three wetland sites ultimately provided a good basis for comparison of the effects of differing productivity and differential performance of the Teesdale rarities.

Not only were the sites required to be large enough to contain all the key elements of the vegetation, but also they were required to be of a sufficient area to enable continual destructive cropping of plots within the sites throughout the period of the study.

In view of the relatively limited nature of certain of the study areas, the destructive cropping had to be restricted, and methods developed that enabled the maximum information to be gained from minimal disturbance.

The efficient usage of limited areas to be investigated was of importance. Newbold (1967) has suggested a scheme for woodland work, and a similar approach to site layout has been adopted.

PLATE V

Upper Slapestone Production Study Area



PLATE VI

Nameless/Red Sike Production Study Area

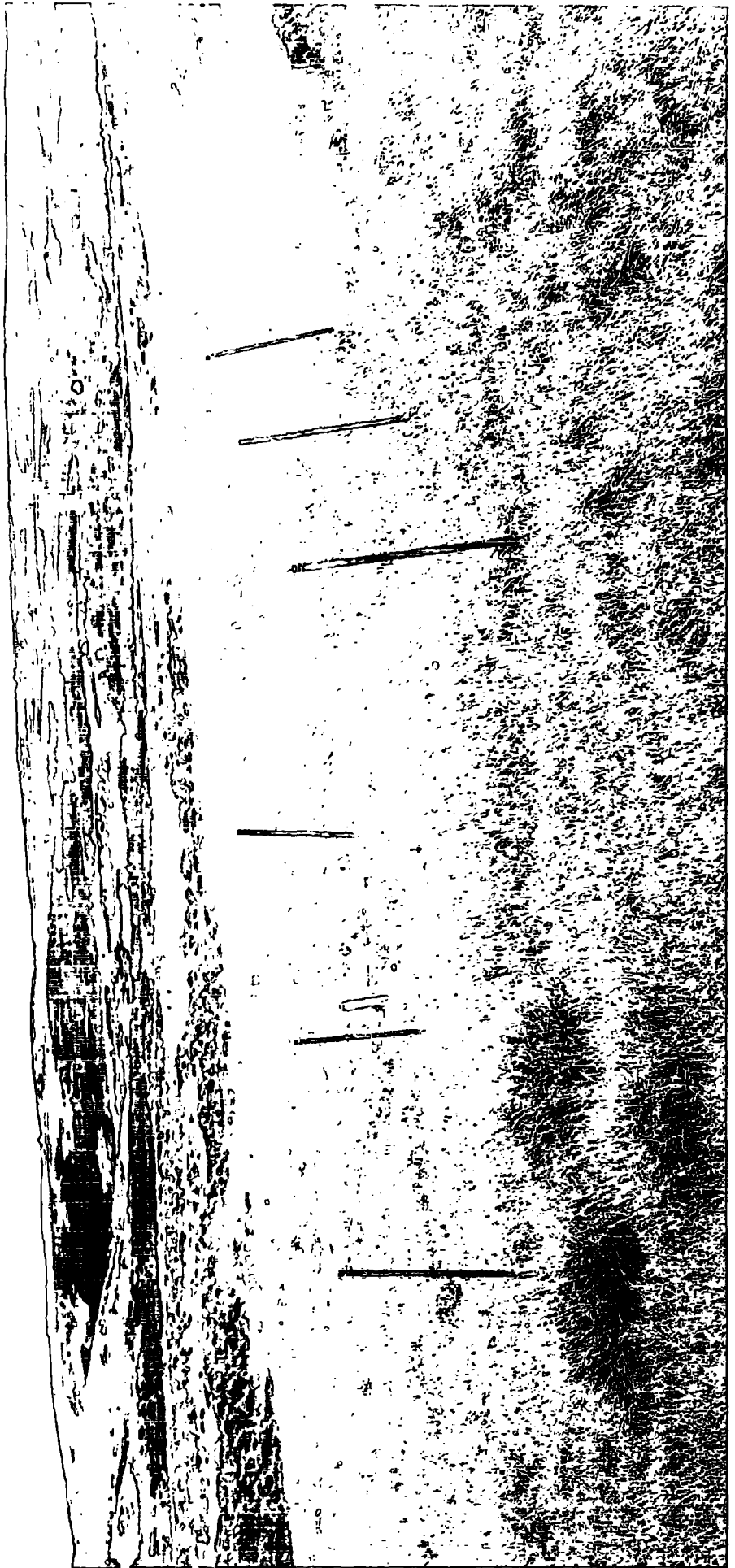

The measurement area was the area in which vegetation and roots were harvested. Each measurement area was surrounded by a buffer area which was subjected to as little disturbance as possible. Exclosures were erected to prevent the grazing and trampling of the vegetation of the measurement areas by large herbivores such as sheep.

THE HARVEST METHOD

The harvest method adopted required the measurement of standing crop at time intervals and in these grazed situations this involved the protection of the accumulated growth from sheep, to prevent an under-estimate of net primary production. However, the exclusion of these grazing animals imposes a different set of environmental conditions on the community which could affect the net primary production. Since it was obviously necessary to exclude large grazing animals, this effect had to be accepted.

The effect of cages has been reported as raising the dry matter production by more than 10% (Milne & Hughes 1968). Not only may this effect be attributed to reduction in wind velocity, increased humidity, and lowered transpiration rate, but also to the removal of the effect of soil compaction by grazing action.

The exclosures were constructed of galvanized wire netting supported at intervals by angle iron standards.

The netting was pegged to the ground to prevent sheep from forcing up the wire. These light exclosures proved adequate for the short duration of the study period, although at the beginning of each season damage caused by drifting snow had to be repaired.

Galvanized wire netting can give rise to zinc toxicity or contamination of the herbage (Milne & Hughes 1968). Consequently the exclosures were made larger than would have been necessary with a non galvanized superstructure so as to minimise possible edge effects due to this factor.

The net primary production was theoretically not difficult to determine. The weight of herbage produced within the exclosure was the difference between the biomass at the commencement of the season, and at the end of it. This figure did not include primary production channelled into invertebrate and small vertebrate herbivores, nor did it include dead material.

In practice the determination of the net primary production was complicated by several factors not necessarily limited to Teesdale.

The cropping area may be considered homogenous according to species abundance criteria, but in terms of biomass content the standing crop may vary greatly. To avoid complications caused by the small scale agglomeration of certain species the classical methods of cropping unit areas of vegetation, which require homogeneity, not only of species occurrence but also of biomass, were not considered applicable.

As previously stated, the net primary production per unit area provides a measure of the total primary production of each species within that area. The net primary production of each species is a function of the product of the number of individuals within the area and the mean increase of their individual weights.

The choice of sample size and shape to be harvested was subject to two main considerations. These were the necessity of obtaining an acceptable level of accuracy in determining the standing crop of the study area; and the practicability of harvesting the sample required.

In most studies, the time required in the field to clip the sample plots and for laboratory sorting, is the limiting factor which determines the number clipped and hence the accuracy of the estimate. Consequently a compromise was required between accuracy and the time available for field sampling and plant sorting.

This difficulty was overcome in part by the removal of turfs of the required size, with vegetation in situ, and transporting the complete turfs in large polythene bags to the laboratory. Here the vegetation could be removed in a more favourable environment. The turfs were stored in a dark room at 4°C, and the vegetation removed as soon as possible after cropping.

Traditionally large numbers of square sample plots are cropped, to keep variance at a minimum. However, a balance had to be struck between the possible lower variance of a large number of small plots, and the increased edge effects that will occur.

These difficulties were overcome by cropping on a unit plant individual basis as opposed to a unit area approach as is the normal procedure.

In general, variability between plots randomly distributed over an area of sedge marsh proved high, and emphasis was placed on finding apparently homogenous areas for study.

Single species individual increment cropping

This method depended on determining the standing crop of the "mean individual" of each species at each site, and simultaneously, determining the number of individuals of that species per unit area for each site.

The product of the mean individual standing crop and the density of individuals for that site gives a measure of the standing crop of that species per unit area.

Although this is theoretically a simple procedure, practical difficulties became apparent. The determination of what constitutes a plant "individual" proved difficult, particularly with those species of a gregarious nature. Tufted habits of Festuca ovina and Nardus stricta together with species of straggling habit such as Galium saxatile and Thymus drucei, were typical of species exhibiting these difficulties.

In general, most plants could be divided into recognisable discrete units. Also determination of the aerial portion of a plant often proved difficult, with no sharp demarcation between soil and Bryophyte layer. A relatively arbitrary yet constant level of demarcation was chosen for each species and adhered to where possible.

Cropping procedure

Turfs of 30x30 cms. dimensions were taken from limited areas of several square metres at each site, rendering the edaphic factors and floristic composition for the series of samples from the site relatively constant. Care was taken that the sample units were not closer than a half metre to minimise the trampling of future samples. The approach to the sample area, and movement within it, were restricted to well defined paths, to minimise trampling and soil compaction.

The samples were prepared by sliding a metre rule along at ground level and then lifting it to separate the vegetation, which was pushed aside by hand, thus providing a distinct furrow in the vegetation. The rule was then replaced in the furrow and a sharp knife used to incise vertically along the rule, cutting through soil, horizontal runners, rhizomes and roots. The remaining three sides of the sample were cut in the same way, and the 30 cm. square of vegetation could be separated from its surroundings. A small pit was dug alongside the turf to allow a spade to be slid under the turf.

The turfs were lifted and placed in large polythene bags, with the surface bearing the vegetation uppermost. Care was taken to minimise vertical or horizontal compression of the sample, which was immediately returned to the laboratory and placed in a dark cold room until required. No sample was stored for more than one week before being sorted. It was decided that under these conditions relatively little storage products would have been metabolised, and little dieback occurred.

Sorting

The sorting procedure was the same in all cases for aerial standing crop. The turfs were trimmed, in the laboratory, to a measured surface area. Cutting was always upwards from ground level to separate the vegetation and avoid severing leaves.

The purposes of standardising the sample area were

- (a) To facilitate subsequent calculations, and
- (b) To enable further density counts of individuals to supplement the counts made in the field.

Removal of plants from the sample turf was as follows:-

- (a) Bryophytes were removed en masse.
- (b) The higher plants with spreading habit were removed individually. These included Selaginella selaginoides, Potentilla erecta and Thymus drucei.
- (c) The remaining vegetation, mainly Monocotyledons with a few Dicotyledons, was removed species by species.
- (d) Fragile plants that were prone to leaf loss, e.g. Eriophorum angustifolium were packeted individually.
- (e) Robust plants with strongly adhering dead leaves were bulk packeted species by species.

To standardise the weight the packeted dried material was dried in an oven at 105°C for three days. The oven was fitted with an internal fan which kept a forced draught flowing over the samples whilst drying. The dried plants were kept in a dry atmosphere until they were weighed. Individual plants were then divided into dead and live leaves (dead and live at the time of cropping) and each category weighed separately.

For each cropping twenty to thirty plants of each species were individually weighed as above, and the mean individual weights of live and dead tissue, together with their standard deviations, were calculated. This sample size was found to be sufficient to reduce the error margin of the mean to within 5% of the mean in most species (Fig. 39).

Chemical analysis

After weighing, dead and live material from each species was wet-ashed separately, and determinations of the concentrations of certain

Fig. 39 Carex lepidocarpa

Graph illustrating the effect of increasing the sample size to decrease the error margin of the mean

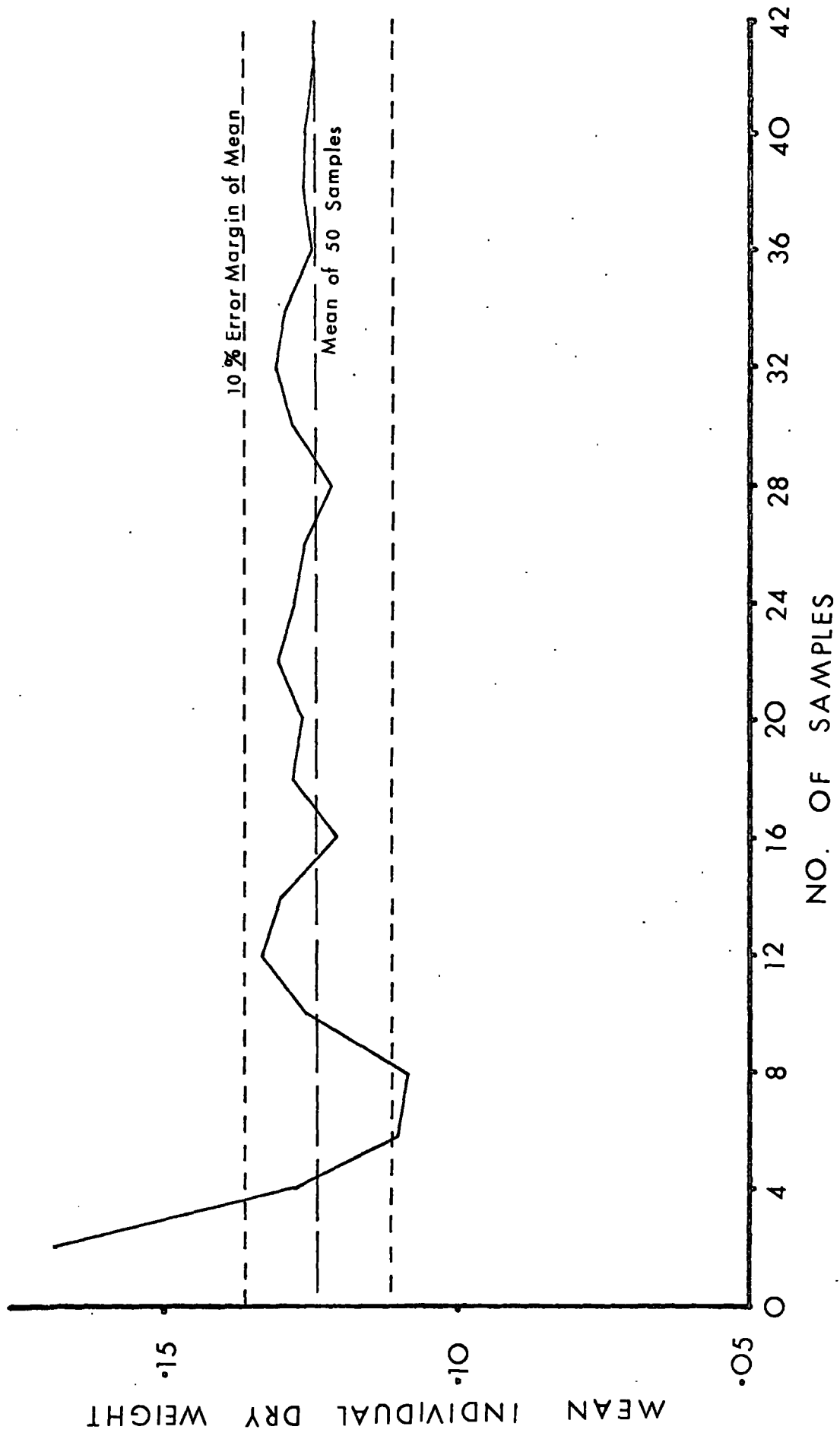

ations carried out. (See Appendix 1)

The method of calculation of net aerial production is best illustrated by a consideration of several species in detail.

ERIOPHORUM ANGUSTIFOLIUM

This plant was common on the wet uplands, and occurred in all three wetland sites, providing a possible basis for comparison between them.

Individual aerial shoots of the plant were readily distinguished and removed for sorting and drying. Dead leaves tended to detach themselves during handling, and therefore each individual aerial shoot was packeted separately to prevent loss of those parts.

The "mean" individual

The aerial biomass, with standard deviation, per mean individual at each site is shown in Tables 7, 8 and 9, and is shown graphically in Fig. 40.

The three sites show differential performance at the individual level. The Eriophorum of the Upper Slapstone site shows relatively little incremental change throughout the season, the growth rate maintaining a quasi equilibrium with the senescence and dying off of old leaves. However, towards the end of the growing season the standard deviation of the mean of the live leaves increases considerably as the spread of the sample includes young tillers and old mature individuals.

The Lower Slapstone Sike site exhibits slightly larger individuals, but shows no major differences from the previous site with regard to biomass accrual. The Eriophorum from the site between Nameless and Red Sike produced individuals of nearly twice the size of the other two sites.

From chemical analyses the content of the ions in the "mean individual" from each site are shown in Tables 7, 8 and 9.

Frequency of Occurrence

The frequency of occurrence of Eriophorum angustifolium was found to be:-

TABLE 7

Eriophorum angustifolium, aerial standing crop per "mean"
individual at Upper Slapestone Sike Site.

LL
DL
-1

ERIOPHORUM ANGUSTIFOLIUM

Upper Slapestone Sike Site

1969

Date		STANDING CROP PER "MEAN INDIVIDUAL"				
		Dry Wt. g.	K Mg/plant	Ca Mg/plant	Mg Mg/plant	Na Mg/plant
9 May	LL	0.022	0.127	0.045	0.019	0.003
	DL	0.012	0.019	0.040	0.007	0.022
	T	0.034	0.146	0.085	0.026	0.025
19 May	LL	0.026	0.150	0.053	0.023	0.003
	DL	0.017	0.028	0.057	0.010	0.031
	T	0.043	0.178	0.110	0.033	0.034
2 June	LL	0.047	0.272	0.096	0.041	0.006
	DL	0.052	0.084	0.176	0.031	0.096
	T	0.099	0.356	0.272	0.072	0.102
19 June	LL	0.049	0.272	0.100	0.043	0.006
	DL	0.039	0.063	0.131	0.023	0.072
	T	0.088	0.335	0.231	0.066	0.078
14 July	LL	0.033	0.190	0.068	0.029	0.004
	DL	0.018	0.029	0.061	0.011	0.033
	T	0.051	0.219	0.129	0.040	0.037
4 Aug	LL	0.039	0.225	0.078	0.034	0.005
	DL	0.036	0.058	0.122	0.022	0.067
	T	0.075	0.283	0.200	0.056	0.072
4 Sept	LL	0.086	0.497	0.178	0.076	0.011
	DL	0.035	0.057	0.118	0.021	0.065
	T	0.121	0.554	0.294	0.097	0.076
9 Oct	LL	0.028	0.162	0.057	0.025	0.004
	DL	0.037	0.060	0.125	0.022	0.068
	T	0.065	0.222	0.182	0.047	0.072

TABLE 8

Eriophorum angustifolium, aerial standing crop per "mean"
individual at Lower Slapestone Sike Site.

ERIOPHORUM ANGUSTIFOLIUM

Lower Slapestone Sike Site

1969

Date		STANDING CROP PER "MEAN INDIVIDUAL"				
		Dry Wt. g.	K Mg/plant	Ca Mg/plant	Mg Mg/plant	Na Mg/plant
19 May	LL	0.048	0.295	0.142	0.062	0.058
	DL	0.036	0.074	0.273	0.029	0.033
	T	0.084	0.369	0.415	0.091	0.091
24 May	LL	0.067	0.412	0.264	0.087	0.081
	DL	0.020	0.041	0.152	0.016	0.018
	T	0.087	0.453	0.416	0.103	0.099
2 June	LL	0.041	0.252	0.162	0.053	0.050
	DL	0.075	0.155	1.178	0.061	0.069
	T	0.116	0.407	1.340	0.116	0.119
19 June	LL	0.083	0.510	0.327	0.108	0.100
	DL	0.096	0.199	1.512	0.078	0.088
	T	0.179	0.709	1.839	0.186	0.188
25 June	LL	0.062	0.381	0.244	0.081	0.075
	DL	0.032	0.066	0.502	0.025	0.029
	T	0.094	0.447	0.746	0.106	0.104
14 July	LL	0.079	0.486	0.311	0.103	0.096
	DL	0.039	0.081	0.616	0.031	0.036
	T	0.118	0.567	0.927	0.134	0.132
4 Aug	LL	0.081	0.167	0.319	0.105	0.098
	DL	0.062	0.128	0.471	0.050	0.057
	T	0.143	0.295	0.790	0.155	0.155

TABLE 9

Eriophorum angustifolium, aerial standing crop per "mean"
individual at Red Sike Site.

ERIOPHORUM ANGUSTIFOLIUM

Red Sike Site

1969

Date		STANDING CROP PER "MEAN INDIVIDUAL"				
		Dry Wt. g.	K Mg/plant	Ca Mg/plant	Mg Mg/plant	Na Mg/plant
9 May	LL	0.034	0.233	0.122	0.049	0.052
	DL	0.053	0.087	0.341	0.046	0.044
	T	0.087	0.320	0.463	0.095	0.096
2 June	LL	0.063	0.431	0.227	0.090	0.096
	DL	0.111	0.183	0.716	0.096	0.092
	T	0.174	0.614	0.943	0.186	0.188
4 Aug	LL	0.199	1.361	0.716	0.284	0.302
	DL	0.111	0.183	1.180	0.096	0.092
	T	0.310	1.544	1.896	0.370	0.394
4 Sept	LL	0.163	1.115	0.587	0.233	0.247
	DL	0.115	0.185	0.741	0.100	0.095
	T	0.278	1.300	1.328	0.333	0.342
9 Oct	LL	0.160	1.094	0.576	0.229	0.043
	DL	0.114	0.188	0.735	0.099	0.095
	T	0.274	1.282	1.311	0.328	0.338

Fig. 40 Eriophorum angustifolium

"Mean" individual aerial standing crop for 1969 growing season at

Upper Slapestone Sike Site (upper)

Lower Slapestone Sike Site (middle)

Nameless/Red Sike Site (lower)

Vertical scale: gms dry wt. unshaded - live material
 shaded - dead material

spread of limits - 2 x Standard deviation of mean

Horizontal scale: months

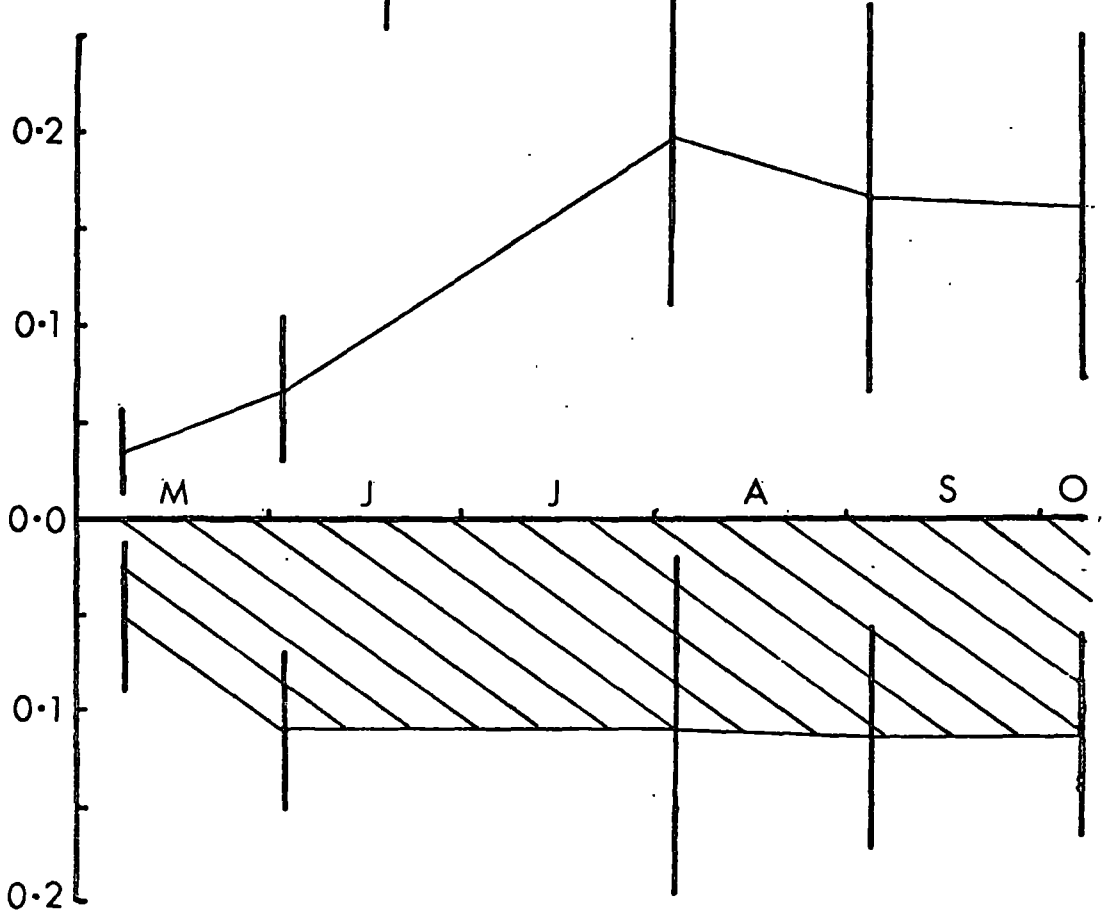
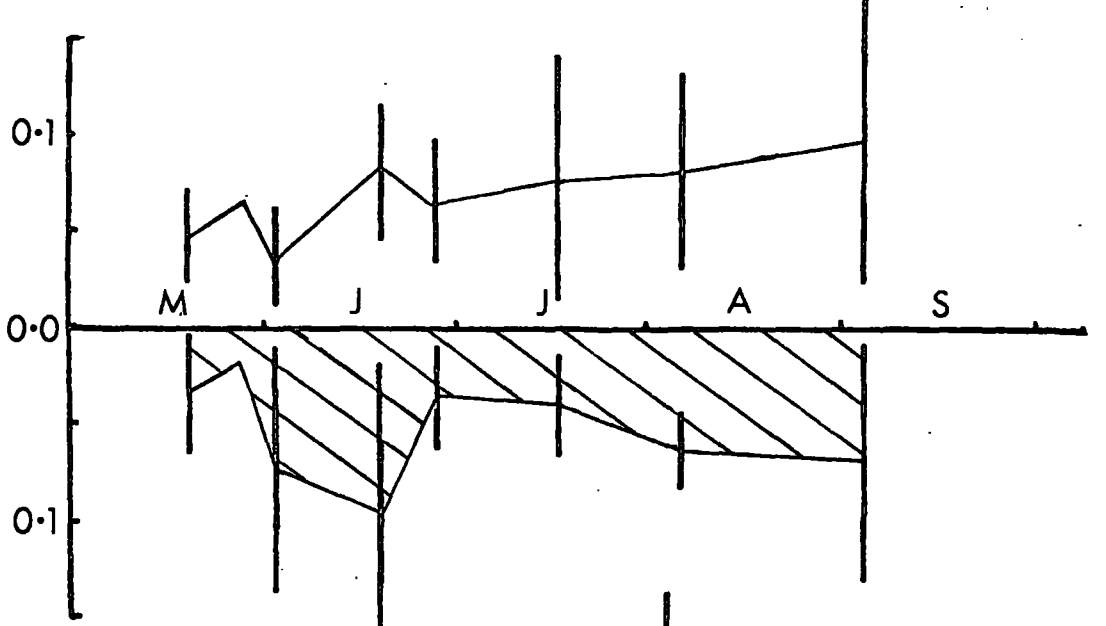
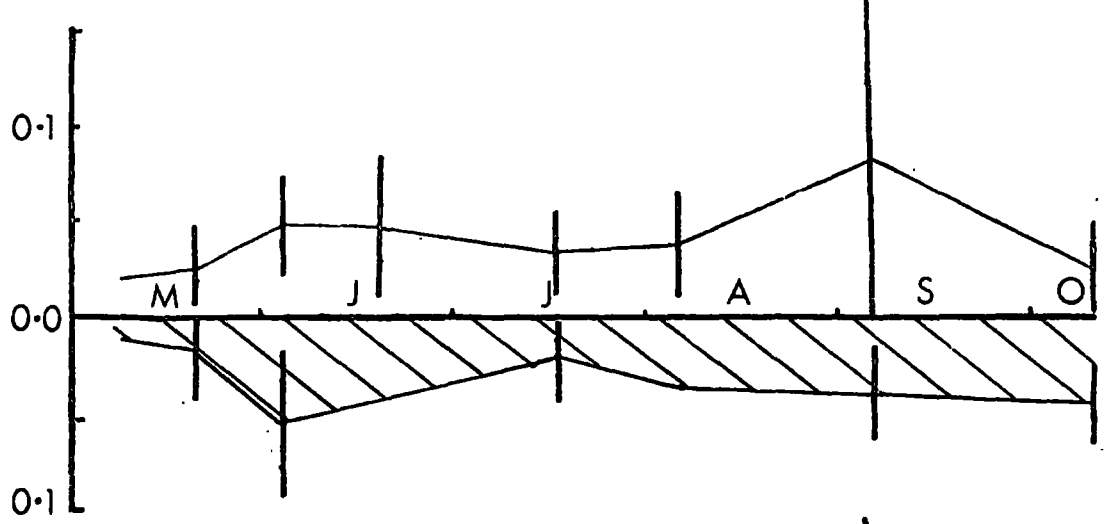

TABLE 10

Eriophorum angustifolium

Standing crop for Upper Slapestone Sike site
during 1969 growing season

Date	STANDING CROP g/m^2				
	Total Dry Wt.g.	Kg/m ²	Ca g/m ²	Mg g/m ²	Na g/m ²
9 May	8.67	0.037	0.021	0.006	0.006
19 May	10.96	0.045	0.028	0.008	0.009
2 June	25.25	0.090	0.069	0.018	0.026
19 June	22.44	0.085	0.059	0.017	0.020
14 July	13.00	0.055	0.033	0.010	0.009
4 Aug	19.13	0.072	0.051	0.014	0.018
4 Sept	30.85	0.140	0.075	0.025	0.019
9 Oct	16.6	0.056	0.047	0.012	0.018

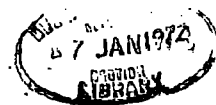

TABLE 11

Eriophorum angustifolium

Standing crop for Lower Slapstone Sike site
during 1969 growing season

Date	STANDING CROP G/m^2				
	Total Dry Wt.g.	Kg/m ²	Ca g/m ²	Mg g/m ²	Na g/m ²
19 May	26.71	0.118	0.132	0.029	0.029
24 May	27.66	0.144	0.132	0.033	0.031
2 June	36.89	0.129	0.426	0.037	0.038
19 June	56.92	0.225	0.585	0.059	0.059
25 June	29.90	0.142	0.238	0.034	0.033
14 July	37.52	0.181	0.294	0.043	0.042
4 Aug	45.48	0.0938	0.251	0.049	0.049

TABLE 12

Eriophorum angustifolium

Standing crop for Red Sike site
during 1969 growing season

Date	STANDING CROP G/m^2				
	Total Dry Wt.g.	Kg/m ²	Ca g/m ²	Mg g/m ²	Na g/m ²
9 May	41.32	0.052	0.220	0.045	0.046
2 June	82.65	0.292	0.448	0.088	0.089
4 Aug	147.25	0.733	0.900	0.176	0.187
4 Sept	132.06	0.618	0.631	0.158	0.162
9 Oct	130.15	0.609	0.623	0.156	0.161

TABLE 13

Eriophorum angustifolium

Growth increment for 1969 (gms/m²)

	Aerial Biomass	K ⁺	Ca ⁺⁺	Mg ⁺⁺	Na ⁺	Zn ⁺⁺
Upper Slapestone Sike	22.2	0.10	0.05	0.02	0.02	0.00
Lower Slapestone Sike	30.2	0.13	0.45	0.03	0.03	0.00
Nameless/Red Sike	106.0	0.58	0.68	0.13	0.14	0.01

Fig. 41 Eriophorum angustifolium

Graph of standing crop per m² for 1968, Upper Slapestone (lower) and Lower Slapestone (upper), and 1969, Upper Slapestone (lower), Lower Slapestone (middle) and Nameless/Red Sike (upper).

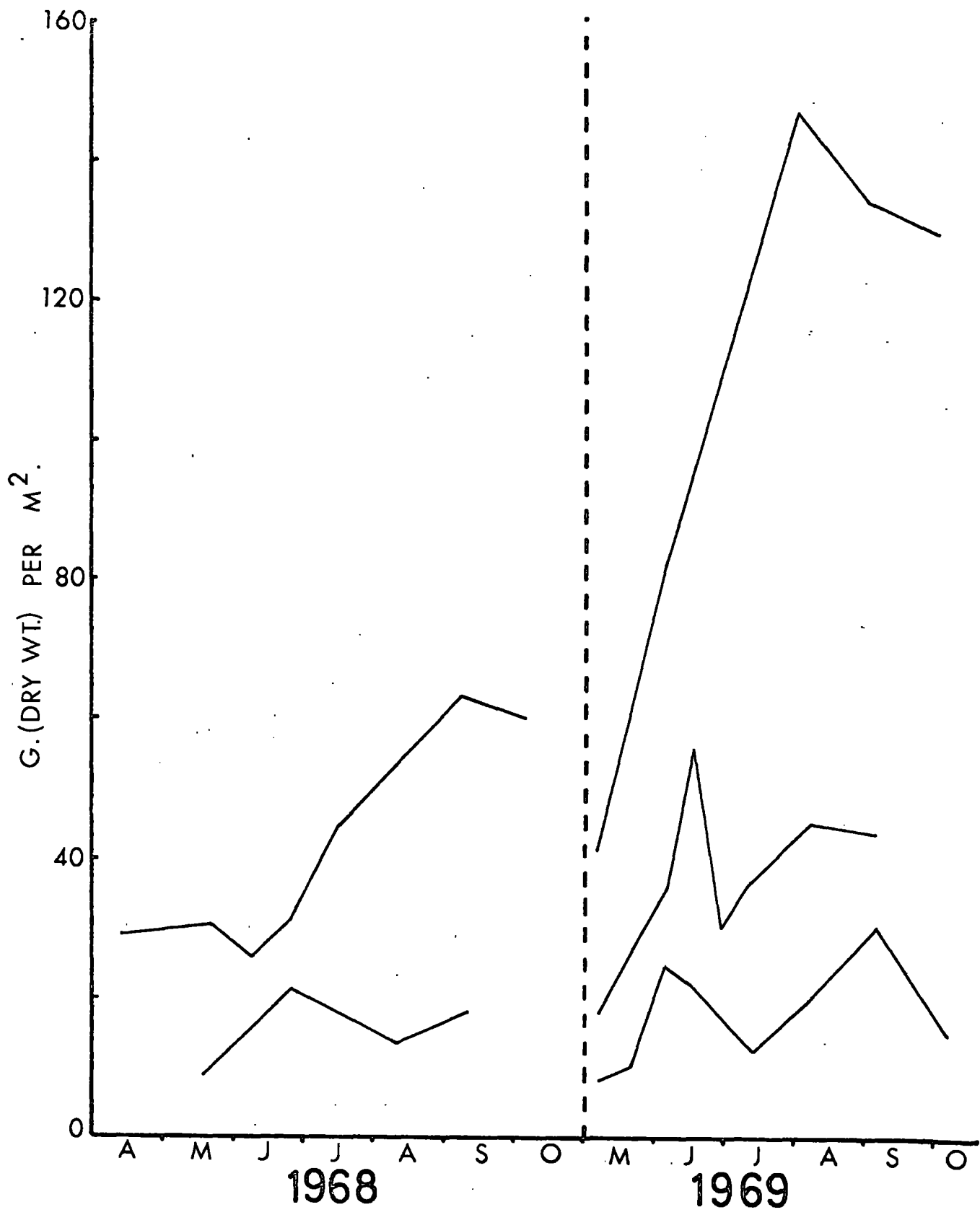

(a) Upper Slapestone	255 plants per m ² ± 36
(b) Lower Slapestone	318 " " " ± 45
(c) Nameless/Red Sike	475 " " " ± 39

Not only do the plants in these three sites show differences in weight per mean individual, but also in frequency. The area of highest density of E. angustifolium, Red Sike, is also the area containing the largest individuals of this species.

Since Eriophorum angustifolium at Red Sike showed not only the highest incremental increase in dry matter per mean individual in 1969 as well as the largest number of individuals, the net aerial production of this species was highest of all the three sites (Table 13).

The growth increments for each of the three sites is shown in Tables 10, 11 and 12.

The cotton grass of Upper Slapestone contributed 22 gms. of dry matter/m² to the community in 1969, whereas the contribution at the Lower Slapestone Sike was over 30 g./m² for the same period. At Red/Nameless Sike site this contribution was over 100 g. dry matter.

Fig. 41.

Carex panicea

The carnation sedge was abundant at each of the three wetland sites, together with Eriophorum angustifolium and Carex lepidocarpa. Carex panicea proved amenable to the same "mean individual increment cropping technique" as described for E. angustifolium.

The aerial biomass figures for the "mean individual" of the sample populations at the three sites at various time intervals throughout the growing season were determined. These results are tabulated in Table 14 and represented graphically in Fig. 42.

From the graph it may be seen that there was relatively little net increase in dry weight throughout the growing season of the "mean individual" from the Upper Slapestone population sample, compared to the increases at the other two sites. On average, the Upper Slapestone Sike population was composed of the smallest individuals, whereas the Red/Nameless Sike population contained the largest, with those individuals from the Lower Slapestone site occupying an intermediate position. This pattern of differential standing crop between sites was very similar to that shown by E. angustifolium, and indicative of possible major environmental difference between the sites.

Population density counts, as for E. angustifolium, gave variable results, spatial variation concealing any temporal fluctuations. Means and standard deviations of the number of individuals were calculated (Table 15). Here the population densities are not directly comparable to that of E. angustifolium and when standing crops per metre² are calculated the highest biomasses are shown by the Nameless/Red Sike sample and the Upper Slapestone Sike sample; the former having larger but sparsely distributed individuals whilst the latter site has smaller but more numerous plants.

Chemical analyses of the tissue from live and dead leaves were determined separately (Table 16) and the total standing crop per metre

Fig. 42 Carex panicea

"Mean individual aerial standing crop through 1969 growing season at Upper Slapestone (upper), Lower Slapestone (middle) and Nameless/Red Sike sites.

(Scale and Format as in Fig. 40)

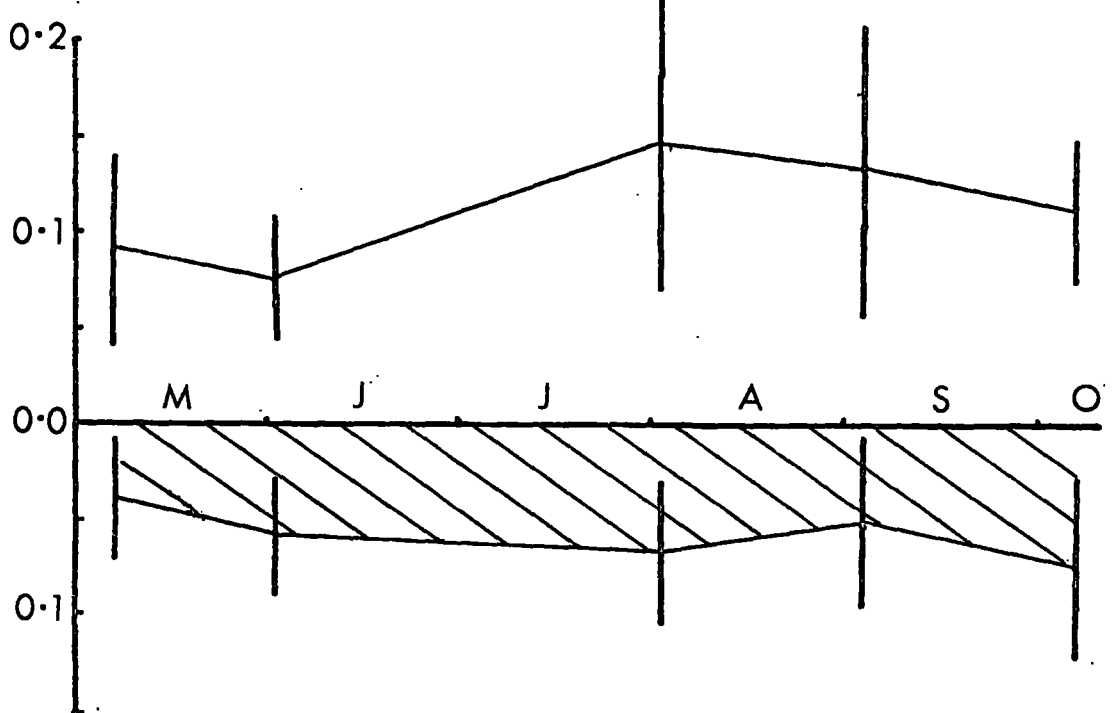
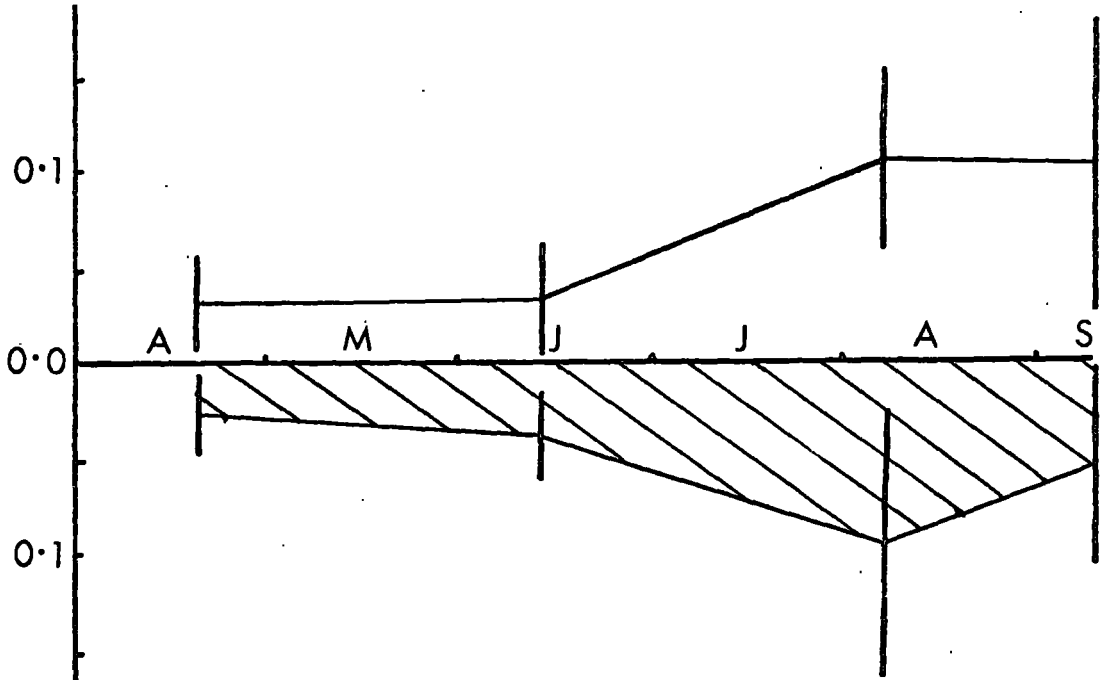
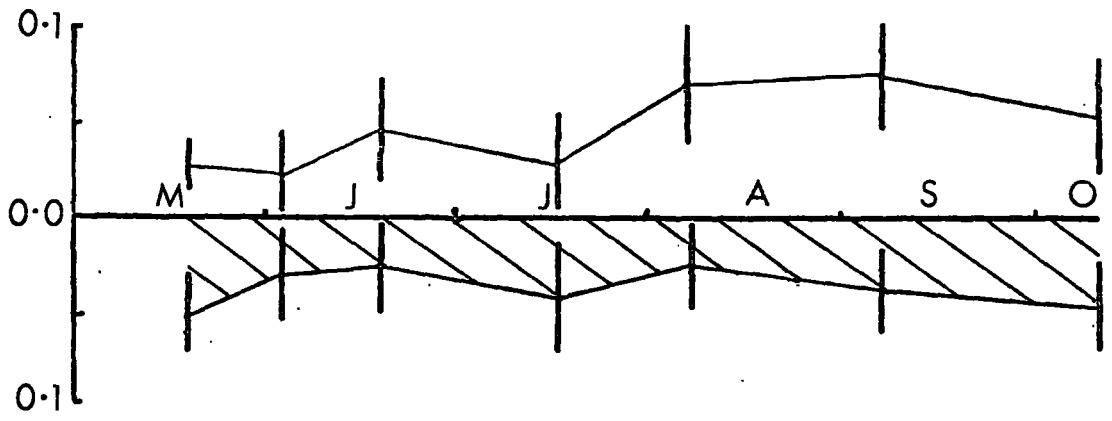

TABLE 14

Carex panicea

Mean aerial dry weights of individual plants
from sample populations of three wetland sites

<u>Site</u>	<u>Date</u>	<u>STANDING CROP (g dry wt.)</u>				<u>Total</u>
		<u>Live</u>		<u>Dead</u>		
		mean	S.D.	mean	S.D.	
Upper Slapestone Sike	19.5.69	0.027	0.018	0.050	0.018	0.077
	2.6.69	0.025	0.016	0.028	0.013	0.053
	19.6.69	0.050	0.020	0.023	0.019	0.073
	14.7.69	0.029	0.034	0.039	0.024	0.068
	4.8.69	0.068	0.029	0.022	0.017	0.090
	4.9.69	0.073	0.030	0.034	0.021	0.107
	9.10.69	0.052	0.032	0.042	0.014	0.094
Lower Slapestone Sike	17.4.69	0.033	0.013	0.025	0.008	0.058
	11.6.69	0.035	0.035	0.038	0.033	0.073
	4.8.69	0.108	0.048	0.093	0.068	0.201
	4.9.69	0.105	0.073	0.064	0.051	0.169
Red/ Nameless Sike	9.5.69	0.095	0.056	0.034	0.035	0.129
	2.6.69	0.070	0.028	0.055	0.028	0.125
	4.8.69	0.146	0.067	0.062	0.056	0.208
	4.9.69	0.132	0.074	0.049	0.029	0.181
	9.10.69	0.104	0.046	0.077	0.047	0.181

TABLE 15

Carex panicea

Mean number of individuals per metre² from sample
populations of three wetland sites (rounded to nearest 5)

	<u>No. of plants per metre²</u>	<u>Standard Deviation</u>
Upper Slapestone Sike	510	180
Lower Slapestone Sike	165	70
Nameless/Red Sike	295	90

TABLE 16

Carex panicea

Concentration of Potassium, Calcium, Magnesium,
Sodium and Zinc in dead and live material from
three sites in mg per g dry wt (with standard deviations)

<u>mg/g dry wt.</u>		<u>Upper Slapestone</u> <u>Sike</u>	<u>Lower Slapestone</u> <u>Sike</u>	<u>Red/Nameless</u> <u>Sike</u>
Potassium	Live	11.76 (4.63)	15.94 (1.91)	11.14 (1.61)
	Dead	3.43 (1.46)	6.47 (3.30)	3.37 (1.27)
Calcium	Live	24.86 (1.92)	19.69 (2.38)	17.15 (17.15)
	Dead	33.58 (12.40)	24.98 (3.01)	25.00 (-)
Magnesium	Live	1.72 (0.60)	2.25 (0.17)	1.60 (0.20)
	Dead	1.10 (0.46)	1.63 (0.06)	1.20 (0.25)
Sodium	Live	0.65 (0.03)	0.66 (0.35)	0.38 (0.03)
	Dead	0.85 (0.43)	0.92 (0.21)	0.86 (0.25)
Zinc	Live	0.19 (0.05)	0.11 (0.04)	0.13 (0.07)
	Dead	0.22 (0.06)	0.34 (0.07)	0.38 (0.11)

TABLE 17

Carex panicea

Standing crop (g per m²) for three sites
through 1969 growing season

Site	Date	STANDING CROP				
		<u>Biomass</u>	<u>Potassium</u>	<u>Calcium</u>	<u>Magnesium</u>	<u>Sodium</u>
Upper Slapestone Sike	19.5.69	39.4	0.25	1.20	0.05	0.03
	2.6.69	27.1	0.20	0.80	0.04	0.02
	19.6.69	37.3	0.34	1.03	0.06	0.02
	14.7.69	34.8	0.24	1.04	0.05	0.02
	4.8.69	46.0	0.44	2.15	0.07	0.03
	4.9.69	54.6	0.49	1.51	0.08	0.04
	9.10.69	48.0	0.38	1.38	0.07	0.04
Lower Slapestone Sike	17.4.69	9.5	0.11	0.21	0.02	0.01
	11.6.69	11.9	0.13	0.27	0.02	0.01
	4.8.69	33.0	0.38	0.38	0.06	0.03
	4.9.69	27.7	0.34	0.34	0.05	0.02
Nameless/ Red Sike	9.5.69	38.1	0.35	0.73	0.06	0.02
	2.6.69	36.9	0.29	0.41	0.05	0.02
	4.8.69	61.4	0.54	1.19	0.09	0.03
	4.9.69	53.4	0.48	1.03	0.08	0.03
	9.10.69	53.4	0.42	1.09	0.08	0.03

TABLE 18

Carex panicea

Net aerial production and net mineral flux
for 1969 growing season
g dry wt/metre²/annum

<u>Site</u>	<u>Biomass</u>	<u>Potassium</u>	<u>Calcium</u>	<u>Magnesium</u>	<u>Sodium</u>
Upper Slapestone Sike	27.5	0.39	1.35	0.04	0.02
Lower Slapestone Sike	23.5	0.27	0.17	0.04	0.02
Nameless/Red Sike	24.5	0.26	0.79	0.04	0.01

square of C. panicea in terms of biomass and certain chemical constituents is shown in Table 17.

No significant statistical variations in concentration per gram dry weight of any of the elements analysed were detectable throughout the growing season. The quantity of the elements that were analysed was not directly proportional to the standing crop at any one time, since the standing crop was composed of two variables, the live and the dead tissues both of which had their own characteristic concentration of chemical constituents. For example, potassium is of relatively low concentration in dead tissue since it is presumably exported from senescing tissues into the younger parts of the plant where higher concentrations are found. Therefore the final concentration of these elements in the total standing crop is dependent on the dead to live ratio, as well as the concentrations of the elements within those portions.

The net primary aerial production of this species was then calculated as the increment between the highest and lowest standing crops for each of the three sites (Table 18). The net accrual of certain elements is also tabulated but this does not necessarily indicate the gross movement of those elements as evidenced by the shunting of potassium from dying to the living leaves and the reverse passage of calcium.

The "performance", net primary production of aerial parts per unit area, of Carex panicea across the three wetland sites was very similar in that it ranged from 20 to 25 g per m² per annum even though there were marked inter-site differences in abundance and size of the individual plants.

Carex lepidocarpa

This sedge also occurred with the preceding two species at the three wetland sites. The cropping procedure adopted was as before.

The aerial biomass of the mean individual was again calculated (Table 19) for each site and these are shown graphically in Fig. 43.

A similar pattern emerged to that of Carex panicea and Eriophorum angustifolium; namely the Upper Slapestone Sike site supporting relatively small plants, Lower Slapestone individuals of intermediate size, and Red/Nameless Sike site large individuals.

From these "mean individual" standing crops and the respective frequencies of individuals at the three sites the standing crop per metre square of the aerial biomass was calculated in similar fashion to the preceding species. These results are tabulated together with "standing crop" of certain cations (Tables 20 and 21).

The net annual aerial production for Carex lepidocarpa was calculated to be 10, 28 and 38 g/m² for Upper Slapestone, Lower Slapestone and Nameless/Red Sike sites respectively. This differential performance is similar to that of the previous species.

TABLE 19

Carex lepidocarpa

Mean aerial dry weights of individual plants
from sample populations of three wetland sites (g)

<u>Site</u>	<u>Date</u>	<u>Live</u>		<u>Dead</u>		<u>Total</u>
		mean	S.D.	mean	S.D.	
Upper Slapestone Sike	1.5.69	0.041	0.020	0.017	0.008	0.058
	9.5.69	0.037	0.017	0.016	0.011	0.053
	19.5.69	0.029	0.020	0.019	0.017	0.048
	4.8.69	0.050	0.019	0.018	0.014	0.068
	3.9.69	0.045	0.018	0.033	0.025	0.078
	9.10.69	0.031	0.020	0.029	0.021	0.060
Lower Slapestone Sike	17.4.69	0.41	0.019	0.033	0.015	0.074
	9.5.69	0.050	-	0.029	-	0.079
	2.6.69	0.062	-	0.072	-	0.132
	11.6.69	0.107	0.024	0.033	0.017	0.140
	19.6.69	0.140	0.012	0.033	0.033	0.173
	14.7.69	0.086	0.037	0.053	0.037	0.139
Red/ Nameless Sike	4.8.69	0.075	0.052	0.064	0.005	0.139
	4.9.69	0.109	0.048	0.016	0.010	0.125
	9.5.69	0.108	0.038	0.022	0.011	0.130
	2.6.69	0.101	0.038	0.017	0.017	0.118
	4.8.69	0.189	0.189	0.074	0.079	0.264
27.8.69	0.093	-	0.060	-	0.153	
9.10.69	0.136	0.046	0.060	0.036	0.196	

Fig. 43 Carex lepidocarpa

"Mean" individual aerial standing crop through 1969 growing season at Upper Slapestone (upper), Lower Slapestone(middle) and Nameless/Red Sike sites.

(Scales and Format as in Fig. 40)

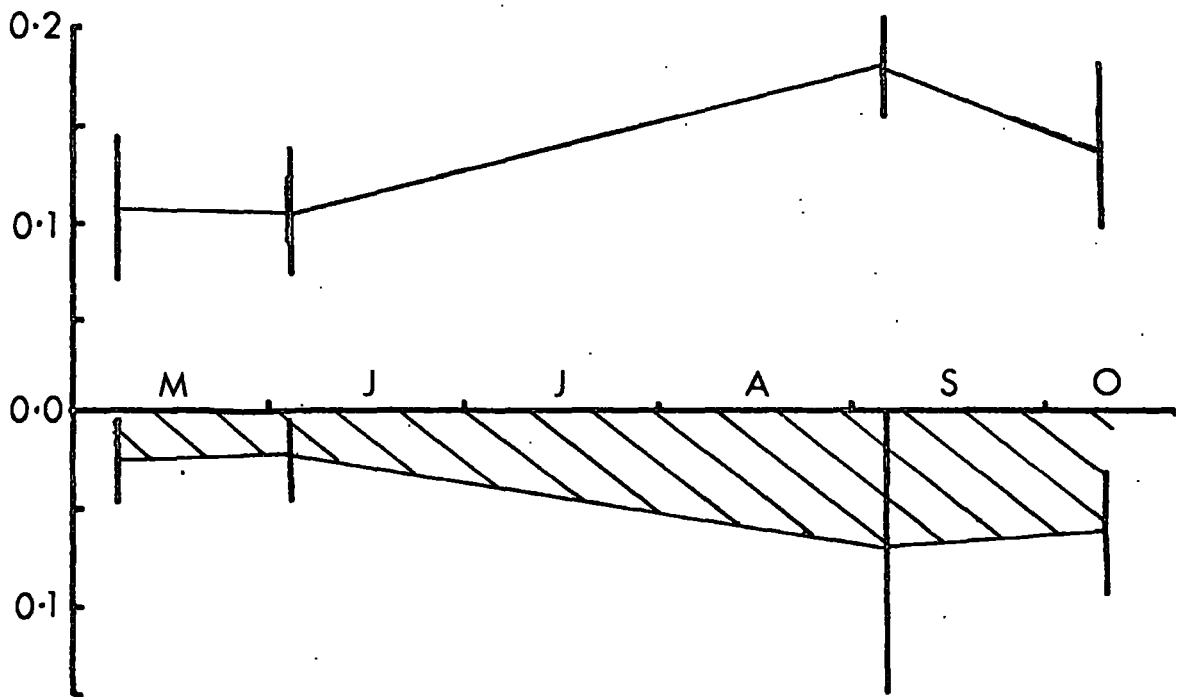
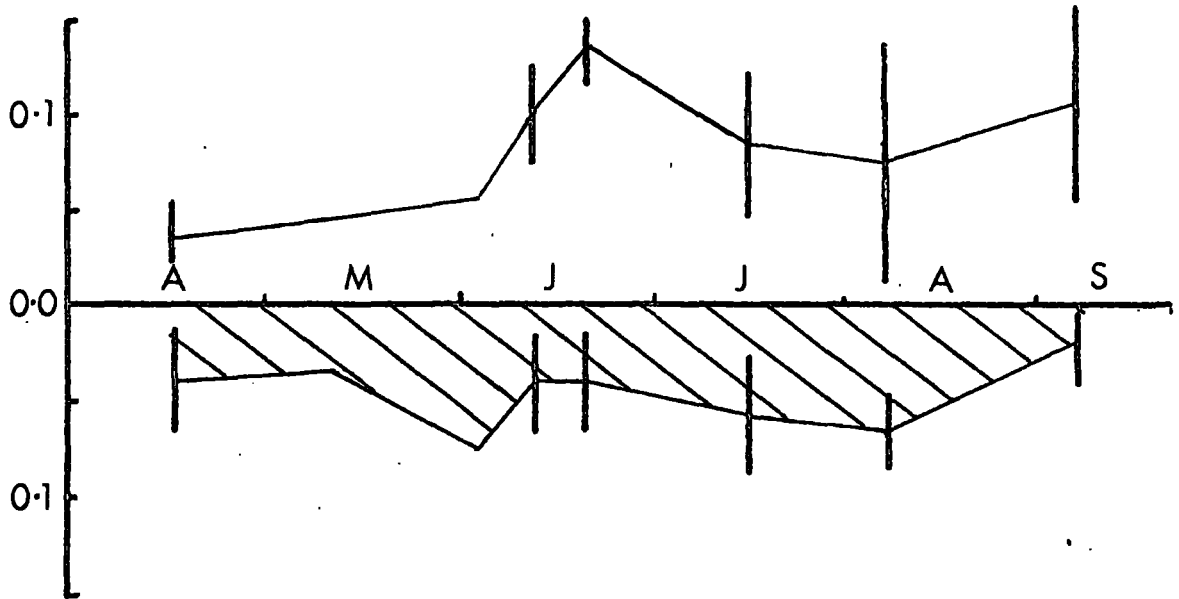
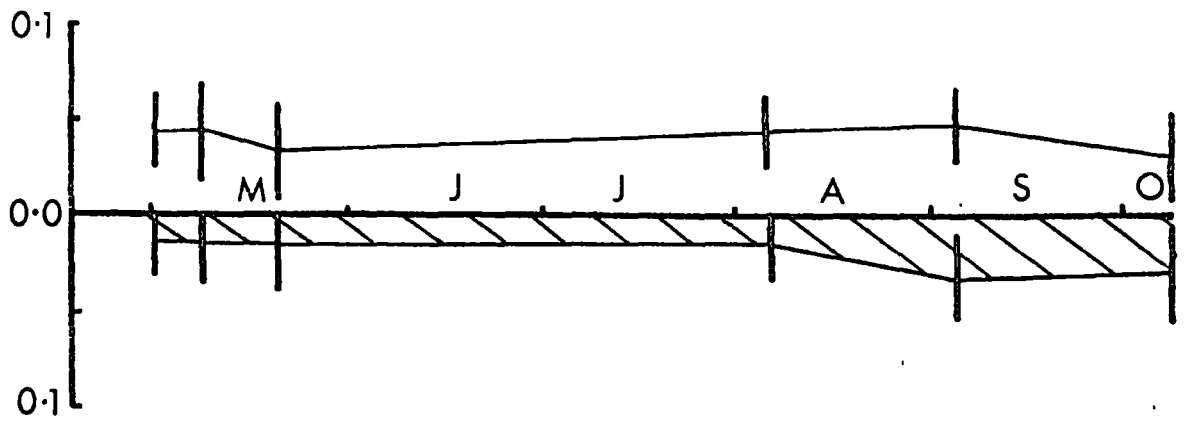

TABLE 20

Carex lepidocarpa

Mean concentration of Potassium, Calcium, Magnesium and Sodium
in dead and live material from three sites in mg per gm dry wt
plant material (with standard deviations)

<u>mg/g dry wt</u>		<u>Upper Slapestone</u> <u>Site</u>	<u>Lower Slapestone</u> <u>Site</u>	<u>Red/Nameless</u> <u>Site</u>
Potassium	Live	10.50 (1.27)	16.88 (5.41)	11.03 (0.92)
	Dead	9.40 (2.35)	12.70 (3.18)	14.42 (3.60)
Calcium	Live	19.60 (1.26)	17.08 (2.63)	14.75 (1.10)
	Dead	33.35 (3.31)	32.92 (17.06)	26.90 (2.24)
Magnesium	Live	1.38 (0.22)	1.22 (0.11)	1.18 (0.12)
	Dead	0.88 (0.16)	0.67 (0.32)	0.84 (0.43)
Sodium	Live	0.58 (0.13)	0.32 (0.13)	0.30 (0.08)
	Dead	0.86 (0.19)	0.57 (0.23)	0.81 (0.30)

TABLE 21

Carex lepidocarpa

Aerial standing crop for three wetland sites
through 1969 growing season (g/m²)

<u>Site</u>	<u>Date</u>	<u>Standing Crop</u>	<u>Potassium</u>	<u>Calcium</u>	<u>Magnesium</u>	<u>Sodium</u>
Upper Slapestone Sike	1.5.69	22.3	0.23	0.53	0.03	0.02
	9.5.69	20.4	0.21	0.50	0.01	0.01
	19.5.69	18.5	0.20	0.51	0.02	0.02
	4.8.69	26.2	0.29	0.67	0.03	0.02
	3.9.69	30.0	0.30	0.76	0.04	0.02
	9.10.69	23.0	0.23	0.61	0.03	0.02
Lower Slapestone Sike	17.4.69	19.1	0.30	0.49	0.02	0.01
	9.5.69	19.0	0.30	0.41	0.02	0.01
	2.6.69	36.4	0.53	0.93	0.03	0.02
	11.6.69	38.2	0.50	0.79	0.04	0.01
	19.6.69	47.0	0.76	0.95	0.05	0.02
	14.7.69	38.0	0.48	0.88	0.04	0.02
	4.8.69	38.0	0.56	0.92	0.04	0.02
4.9.69	34.0	0.55	0.65	0.04	0.01	
Red/ Nameless Sike	9.5.69	33.8	0.39	0.57	0.04	0.01
	2.6.69	30.7	0.29	0.41	0.04	0.01
	4.8.69	68.4	0.82	1.24	0.07	0.06
	27.8.69	39.8	0.49	0.77	0.04	0.02
	9.10.69	41.0	0.62	0.94	0.06	0.02

Narrow Leaved Grasses and Sedges

This category of plants consisted of those species having superficial morphological similarities in the vegetative condition, sufficient to make the sorting procedure of this group into their component species a tedious and laborious operation.

Difficulty in distinguishing between component species of this category is not necessarily encountered when considering good "type specimens" but, due to the range of fluctuations and variations exhibited by individuals selected at random in the field, it was not feasible to use a rapid sorting procedure to deal with the large bulk of material required for production and chemical analyses studies.

The species embraced within this category included Carex dioica, C. pulicaris, Festuca ovina, F. rubra, Deschampsia flexuosa as well as occasional small forms of atypical Nardus stricta.

This heterogeneous collection of species was encountered at two of the wetland sites, Lower Slapestone Sike and Nameless/Red Sike, as the narrow leaved species from other sites were readily sorted into their component species.

The standard procedure so far adopted for determining the biomass of a mean individual proved impractical due to the low dry weight of individual plants. Therefore plants were weighed in batches of ten and these were recorded as the basic unit (Table 22).

The fluctuations in frequency of these narrow leaved grasses and sedges were high, resulting in a high standard deviation of the mean frequency, but as before, the means from numerous counts were used to provide data for the model community.

Nameless/Red Sike had a mean of 4,380 individuals per metre square with a standard deviation of the mean of 1,808.

Lower Slapestone was typified by a mean of 3,445 narrow leaved individuals per metre square with a standard deviation of the mean of 2,108.

TABLE 22

Narrow Leaved Grasses & Sedges

Mean aerial dry weights per 10 individual plants
from sample populations of two wetland sites,
and concentrations of certain elements in the plant tissue

Standing Crop per 10 plants

<u>Site</u>	<u>Date</u>	<u>Dry wt.</u>	<u>S.D.</u>	<u>Phosphorus</u>	<u>Potassium</u>	<u>Calcium</u>	<u>Magnesium</u>	<u>Sodium</u>
	9.5.69	0.193	0.033	0.04	1.34	1.13	0.24	0.06
	19.5.69	0.193	0.013	0.04	1.34	1.13	0.24	0.06
Lower	2.6.69	0.393	0.026	0.09	2.72	2.31	0.48	0.11
Slapestone	14.7.69	0.410	0.037	0.09	2.84	2.41	0.50	0.12
Sike	4.8.69	0.460	0.096	0.10	3.18	2.70	0.57	0.13
	4.9.69	0.577	0.017	0.12	4.00	3.39	0.71	0.16
	9.5.69	0.318	0.001	0.07	1.85	2.27	0.40	0.14
Nameless/	2.6.69	0.463	0.006	0.10	2.69	3.30	0.59	0.20
Red	4.9.69	0.450	0.073	0.10	2.62	3.21	0.57	0.20
Sike	9.10.69	0.680	0.049	0.15	3.96	4.85	0.86	0.30

The standing crop per metre square was calculated as before (Table 23).

TABLE 23

Narrow Leaved Grasses & Sedges

Aerial Standing Crop for two wetland sites
through 1969 growing season (g/m²)

<u>Site</u>	<u>Date</u>	<u>Standing Crop per m²</u>					
		<u>Dry wt.</u>	<u>Phosphorus</u>	<u>Potassium</u>	<u>Calcium</u>	<u>Magnesium</u>	<u>Sodium</u>
Lower Slapstone Site	9.5.69	66.5	0.01	0.46	0.39	0.08	0.02
	19.5.69	66.5	0.01	0.46	0.39	0.08	0.02
	2.6.69	135.3	0.03	0.94	0.79	0.17	0.04
	14.7.69	141.2	0.03	0.98	0.83	0.17	0.04
	4.8.69	158.4	0.04	1.10	0.93	0.19	0.05
	4.9.69	198.7	0.04	1.37	1.17	0.24	0.06
Nameless/ Red Site	9.5.69	139.3	0.03	0.81	0.99	0.18	0.06
	2.6.69	202.8	0.05	1.18	1.45	0.26	0.09
	4.9.69	197.1	0.04	1.15	1.41	0.25	0.09
	9.10.69	297.8	0.06	1.73	2.12	0.38	0.13

Carex nigra

This common sedge was abundant on the Nameless/Red Sike site.

Mean individual weights were calculated as for the other sedges (Table 24) and the frequency of occurrence of individuals of this species was determined at each of the two sites.

Lower Slapstone Sike site	799 with S.D. of mean 245
Nameless/Red Sike site	278 with S.D. of mean 169

The standing crops per metre square were calculated and the net annual aerial production was calculated as for the previous species (Table 26).

The net aerial production for Carex nigra was calculated for the two sites and was found to be 46.3 gm per m² at Lower Slapstone and 23.1 gm per m² at Nameless/Red Sike respectively.

TABLE 24

Carex nigra

Mean aerial dry weight of individual plants from populations
sampled throughout growing season from two wetland sites

<u>Site</u>	<u>Date</u>	<u>Live Leaves</u>		<u>Dead Leaves</u>		<u>Total</u>
		Mean	S.D.	Mean	S.D.	Aerial Biomass
Lower Slapestone Sike	19.5.69	0.014	0.013	0.082	0.049	0.096
	2.6.69	0.039	0.021	0.031	0.026	0.070
	19.6.69	0.063	0.019	0.053	0.053	0.116
	25.6.69	0.049	0.024	0.042	0.015	0.091
	14.7.69	0.052	0.030	0.045	0.040	0.098
	4.8.69	0.076	0.035	0.052	0.046	0.128
	4.9.69	0.086	0.040	0.080	0.044	0.167
Red/ Nameless Sike	2.6.69	0.062	0.047	0.021	0.027	0.083
	4.8.69	0.104	0.043	0.025	0.021	0.129
	4.9.69	0.081	0.058	0.085	0.055	0.165
	9.10.69	0.027	0.030	0.052	0.014	0.079

TABLE 25

Carex nigra

Mean concentrations of Potassium, Calcium, Magnesium and Sodium in dead and live material from two sites in mg per gm dry weight of parent plant material (with standard deviations of mean)

<u>Mg/g dry wt</u>		<u>Lower Slapstone Site</u>	<u>Red/Nameless Site</u>
<u>Leaves</u>			
Potassium	Live	13.2 (4.4)	9.7 (1.4)
	Dead	4.6 (1.4)	4.4 (2.5)
Calcium	Live	14.4 (1.9)	21.9 (8.1)
	Dead	20.7 (8.5)	25.3 (3.8)
Magnesium	Live	1.4 (0.2)	2.1 (0.2)
	Dead	1.3 (0.2)	1.6 (0.3)
Sodium	Live	0.5 (0.1)	0.5 (0.1)
	Dead	0.7 (0.2)	0.8 (0.1)
<u>Flowering Shoots</u>			
Potassium		13.2 (1.0)	15.4 (*)
Calcium		21.0 (5.2)	17.3 (*)
Magnesium		1.5 (0.1)	2.4 (*)
Sodium		1.1 (0.3)	0.6 (*)

(*) Standard deviation not calculated on 3 or less samples.

TABLE 26

Carex nigra

Aerial Standing Crop for two wetland sites
through 1969 growing season (g/m²)

<u>Site</u>	<u>Date</u>	<u>Standing Crop</u>	<u>Potassium</u>	<u>Calcium</u>	<u>Magnesium</u>	<u>Sodium</u>
Lower Slapestone Sike	19.5.69	76.7	0.45	1.52	0.09	0.05
	2.6.69	55.9	0.52	0.96	0.07	0.03
	19.6.69	92.7	0.86	1.60	0.12	0.06
	25.6.69	72.7	0.67	1.26	0.10	0.04
	14.7.69	77.5	0.71	1.34	0.10	0.05
	4.8.69	102.3	0.99	1.73	0.14	0.06
	4.9.69	72.6	1.20	2.31	0.17	0.08
Nameless/ Red Sike	2.6.69	23.1	0.20	0.53	0.05	0.01
	4.8.69	35.9	0.31	0.81	0.07	0.02
	4.9.69	46.2	0.33	1.09	0.09	0.03
	9.10.69	22.0	0.14	0.43	0.04	0.02

Equisetum sp.

This species was the only Pteridophyte with a net production of more than 5 gm per m² and this level was, however, only attained at one site, Slapestone Sike.

The standard cropping procedure previously described was adopted, but great care was taken not to fragment the stems of these delicate plants during handling (Table 27).

Although perennial, most aerial shoots of this plant die back to ground level over winter, so there is no standing crop in the spring. Readily determinable amounts of Equisetum were consequently not available until June.

The highest aerial standing crop is the season's net annual aerial production, and in Lower Slapestone Sike this had a value of 13 gm per m² in 1969.

TABLE 27

Equisetum sp

Mean aerial standing crop per m² at Lower Slapestone Sike
through 1969 growing season

<u>Date</u>	<u>Standing Crop</u>	<u>Phosphorus</u>	<u>Potassium</u>	<u>Calcium</u>	<u>Magnesium</u>	<u>Sodium</u>
2. 6.69	4.4	0.001	0.08	0.09	0.01	0.003
14.7.69	9.8	0.003	0.17	0.19	0.03	0.008
4.8.69	8.8	0.003	0.15	0.17	0.03	0.007
4.9.69	12.7	0.004	0.22	0.25	0.04	0.010

Agrostis canina

This grass was only sufficiently abundant to be considered in the Lower Slapestone site.

Here frequency counts revealed a mean density of 266 plants per metre square, but because of its gregarious habit this plant's distribution tended to be irregular, as is shown by the high standard deviation of the mean, 200.

It is suggested that the dense stands of Carices in which this grass was found allowed considerable shading, resulting in the Agrostis remaining at a relatively constant level throughout the season (Table 28).

TABLE 28

Agrostis canina

Mean aerial standing crop per m² in Lower Slaughterstone Sike
through 1969 growing season (g/m²)

<u>Date</u>	<u>Dry wt.</u>	<u>Phosphorus</u>	<u>Potassium</u>	<u>Calcium</u>	<u>Magnesium</u>	<u>Sodium</u>
19.5.69	19.2	0.003	0.10	0.10	0.03	0.01
2.6.69	19.7	0.003	0.11	0.10	0.03	0.01
14.7.69	19.7	0.003	0.11	0.10	0.03	0.01
4.8.69	25.0	0.003	0.13	0.13	0.04	0.01

Eleocharis quinqueflora

This plant grew in quantity only in the Upper Slapestone sedge marsh site. This species was amenable to the standard cropping procedure.

The mean number of plants at this site was calculated to be 410 plants per metre square with the standard deviation of the mean 240.

The standing crop per mean individual plant was calculated as before and chemical analysis was carried out on the dried plant material.

From Table 29, which summarises the standing crop per metre square of the aerial biomass in terms of mass and certain chemical components, it can be seen that the standing crop decreased rapidly at the end of May due to senescence and death of shoots produced in the previous season. The effects of the 1969 growth become apparent and growth continues throughout the season.

The net annual aerial production was approximated to by determining the increment between highest and lowest standing crop as for the previous species. Eleocharis quinqueflora contributed 40 gm/m² aerial biomass to the 1969 production budget for the Upper Slapestone Sike sedge community.

TABLE 29

Eleocharis quinquefolia

Mean aerial standing crop per metre square in Upper Slapstone Sike
through 1969 growing season (g/m^2)

<u>Date</u>	<u>Dry wt.</u>	<u>Phosphorus</u>	<u>Potassium</u>	<u>Calcium</u>	<u>Magnesium</u>	<u>Sodium</u>
9.5.69	30.8	0.005	0.09	0.54	0.04	0.01
2.6.69	12.3	0.002	0.04	0.22	0.02	0.01
19.6.69	18.0	0.003	0.05	0.32	0.03	0.01
4.8.69	41.0	0.007	0.12	0.72	0.06	0.02
4.9.69	52.1	0.009	0.16	0.91	0.07	0.02

Juncus articulatus

As with the preceding species, Juncus articulatus was common in the Upper Slapestone sedge marsh site, but less frequent in the Nameless/Red Sike site. Their mean frequencies of occurrence in these sites were 960 with standard deviation of the mean 280, and 98 with standard deviation of the mean 42 respectively.

Standing crop determinations were calculated from bulked samples, each composed of 10 individuals, as for the narrow leaved grasses and sedges (Table 30).

The net aerial production for the growing season was determined as the increment at each site. The net production for the aerial biomass at Nameless/Red Sike and Upper Slapestone sedge sites were respectively 4 g/metre^2 and 18 g/metre^2 .

TABLE 30

Juncus articulatus

Mean aerial standing crop per metre² in Nameless/Red Sike
and Upper Slapestone Sedge sites through 1969 growing season (g/m²)

<u>Site</u>	<u>Date</u>	<u>Dry wt.</u>	<u>Phosphorus</u>	<u>Potassium</u>	<u>Calcium</u>	<u>Magnesium</u>	<u>Sodium</u>
Nameless/ Red Sike	9.5.69	1.30	-	0.002	0.003	-	-
	3.6.69	1.64	-	0.002	0.003	0.001	-
	4.9.69	4.24	0.001	0.006	0.008	0.002	0.001
	9.10.69	5.10	0.001	0.007	0.010	0.002	0.002
Upper Slapestone Sike	12.5.69	15.36	0.003	0.091	0.154	0.026	0.050
	2.6.69	14.11	0.003	0.084	0.141	0.024	0.046
	19.6.69	19.49	0.004	0.116	0.195	0.033	0.063
	14.7.69	19.47	0.004	0.116	0.195	0.033	0.063
	4.8.69	24.67	0.005	0.147	0.247	0.041	0.080
	4.10.69	31.97	0.006	0.190	0.320	0.054	0.057

Tofieldia pusilla

This Teesdale rarity was restricted to the calcareous gravel sedge marsh of Upper Slapstone Sike with the exception of a few isolated plants in the Lower Slapstone Sike.

At Upper Slapstone Sike there was a mean of 75 plants per metre square and since the mean standing crop for an individual plant was 0.05 gms in May, increasing to 0.078 gm in October, the net aerial productivity was not high. The increment between the May standing crop (3.80 g/m^2) and the October crop (5.70 g/m^2) was 1.9 g/m^2 .

The low productivity of this species as well as its general and local geographical restriction are indicative of the precarious existence of this species in Upper Teesdale. However since reproductive rates and capacities do not come within the scope of this study it is not appropriate to speculate further along these lines.

Kobresia simpliciuscula

This Teesdale rarity was confined to the two most highly calcareous sites, the wet sedge marsh and the drier sugar limestone grassland of the Upper Slapstone Sike sites.

This species was cropped by the standard procedure but difficulty in determining an individual plant was encountered. Many aerial shoots shared common underground organs; the aerial portion fusing at or just below ground level. In practice the plants were divided, albeit arbitrarily, where these bifurcations occurred and each was treated as a plant unit for frequency and weighing purposes.

The data was treated in the normal way (Table 31) and the Kobresia of the grassland was found to have had a net aerial production of 24 g whereas plants of the sedge marsh produced 12 g/m² during the 1969 growing season.

The Kobresia from the calcareous grassland was found to have a net aerial production of 24 g/m² whereas those of the Upper Slapstone sedge marsh site produced 12 g/m² per annum.

repetition

TABLE 31

Kobresia simpliciuscula

Mean aerial standing crop per metre² in Upper Slapstone Sedge site and Upper Slapstone calcareous grassland site through 1969 growing season (g/m²)

<u>Site</u>	<u>Date</u>	<u>Dry wt.</u>	<u>Phosphorus</u>	<u>Potassium</u>	<u>Calcium</u>	<u>Magnesium</u>	<u>Sodium</u>
Sedge Marsh	2.6.69	52.6	0.005	0.218	0.458	0.237	0.027
	14.8.69	53.8	0.005	0.223	0.468	0.242	0.028
	9.10.69	64.2	0.006	0.265	0.560	0.289	0.033
Calcareous Grassland	2.6.69	57.4	0.006	0.399	1.200	0.068	0.041
	4.7.69	78.8	0.008	0.550	1.645	0.093	0.056
	9.10.69	81.2	0.008	0.565	1.693	0.095	0.057

Sesleria caerulea

This plant was restricted to the calcareous grassland of Upper Slapestone where it was codominant with Kobresia simpliciuscula and Festuca ovina.

The standard procedure was adopted and it was found that there was a mean frequency of 1,820 individual plants per metre square with a standard deviation of the mean at 703.

In view of the significant contribution that this species provides to the community in which it is found the data for dead and live tissue is presented (Table 32).

The net annual aerial production for 1969 was determined as being 91 g/m².

TABLE 32

Sesleria caerulea

Mean aerial standing crop per m² in Upper Slapestone
Calcareous Grassland Site throughout 1969 growing season (g/m²)

<u>Date</u>	Live Leaves) Dead Leaves) Total)	Dry wt.	<u>Potassium</u>	<u>Calcium</u>	<u>Magnesium</u>	<u>Sodium</u>
9.5.69	25.8		0.34	0.34		
	<u>39.7</u>		<u>0.11</u>	<u>1.34</u>		
	65.5		0.45	1.68	0.05	0.02
19.5.69	26.5		0.35	0.35		
	<u>45.8</u>		<u>0.13</u>	<u>1.53</u>		
	72.3		0.48	1.89	0.06	0.02
2.6.69	31.6		0.41	0.42		
	<u>47.0</u>		<u>0.13</u>	<u>1.41</u>		
	78.6		0.54	1.83	0.06	0.02
4.7.69	85.7		1.12	1.15		
	<u>82.3</u>		<u>0.23</u>	<u>2.77</u>		
	168.0		1.35	3.92	0.14	0.05
4.10.69	91.9		1.18	1.24		
	<u>60.6</u>		<u>0.19</u>	<u>1.85</u>		
	152.5		1.37	3.09	0.13	0.04

Carex capillaris

Carex capillaris was confined to only one site in any quantity, the calcareous grassland of Upper Slapestone. Here the occurrences were only 175 per metre square and from the standard procedure the net annual aerial production was determined as being 27 g/m^2 for 1969 growing season (Table 33).

TABLE 33

Carex capillaris

Mean aerial standing crop in Upper Slapestone
Calcareous Grassland Site through 1969 growing season (g/m²)

<u>Date</u>	<u>Dry wt.</u>	<u>Phosphorus</u>	<u>Potassium</u>	<u>Calcium</u>	<u>Magnesium</u>	<u>Sodium</u>
9.5.69	26.1	0.006	0.10	0.66	0.033	0.003
19.5.69	52.2	0.012	0.20	1.33	0.065	0.007
4.8.69	40.5	0.010	0.15	1.04	0.051	0.005
4.10.69	34.8	0.008	0.13	0.89	0.044	0.005

Festuca ovina

This grass occurred predominantly at two sites, Upper Slapestone calcareous grassland and Upper Slapestone Agrostis-Fescue grassland sites.

The procedure adopted was that used to determine the standing crops of the narrow leaved grasses and sedges, i.e. batches of ten plants were used as a basic unit (Table 34).

The net aerial production for 1969 was determined as 8 g/m^2 for the calcareous grassland, and 1.3 g in the case of the Agrostis-Fescue grassland.

This apparently low figure for this grass, one of the apparent dominants, is not so surprising when it is considered that the dry weights of 2,125 plants from the Agrostis-Fescue grassland weighed 56 g at peak standing crop.

TABLE 34

Festuca ovina

Mean aerial standing crop for Upper Slapestone Calcareous grassland site and Upper Slapestone Agrostis-Fescue grassland site for 1969 growing season (g/m^2)

<u>Site</u>	<u>Date</u>	<u>Dry wt.</u>	<u>Potassium</u>	<u>Calcium</u>	<u>Magnesium</u>
Agrostis-Fescue Grassland	20.5.69	50.4	0.126	0.63	0.06
	4.8.69	63.3	0.158	0.79	0.08
	4.10.69	56.5	0.141	0.71	0.07
Calcareous Grassland	19.5.69	93.5	0.327	1.79	0.02
	27.9.69	101.9	0.357	1.94	0.02

Agrostis tenuis

This species, together with the preceding, gives the poorer, more acid grassland of the Pennines its common name, Bent-Fescue grassland.

Here again about two thousand plants are encountered per metre square (mean 1905, standard deviation of mean 818).

The standing crops were calculated by the standard procedure and are recorded in Table 35.

The net aerial production for the 1969 growing season was calculated to be 12 g/m^2 .

TABLE 35

Agrostis tenuis

Mean aerial standing crop for Bent-Fescue grassland site,
Upper Slapstone, for 1969 growing season (g/m^2)

<u>Date</u>	<u>Dry wt.</u>	<u>Phosphorus</u>	<u>Potassium</u>	<u>Calcium</u>	<u>Magnesium</u>	<u>Sodium</u>
9.5.69	99.1	0.027	0.69	0.40	0.13	0.07
19.5.69	111.1	0.030	0.77	0.45	0.14	0.08
4.8.69	100.4	0.027	0.70	0.41	0.13	0.08
4.10.69	111.1	0.030	0.77	0.45	0.14	0.08

Selaginella selaginoides

In the Upper Slapestone sedge marsh this species was found to contribute little over 1 gm/m^2 per annum but in the Upper Slapestone Agrostis-Fescue grassland 3.9 g/m^2 was the net aerial production for 1969. This species was cropped from three twenty-five centimetre square plots at each harvest as the difficulties of determining individuals and determining frequency of occurrence were not possible.

TABLE 36

Selaginella selaginoides

Mean aerial standing crop for Upper Slapestone Sedge Marsh
and Upper Slapestone Bent-Fescue Grassland

<u>Site</u>	<u>Date</u>	<u>Dry wt.</u>	<u>Phosphorus</u>	<u>Potassium</u>	<u>Calcium</u>	<u>Magnesium</u>	<u>Sodium</u>
Sedge Marsh	3.5.69	4.8	0.001	0.018	0.069	0.011	0.007
	4.8.69	6.1	0.001	0.023	0.086	0.014	0.008
	4.10.69	4.8	0.001	0.018	0.069	0.011	0.007
Bent Fescue Grassland	19.5.69	3.8	0.001	0.027	0.053	0.009	0.004
	2.6.69	7.7	0.002	0.053	0.106	0.017	0.007
	4.7.69	6.4	0.001	0.044	0.089	0.014	0.006
	4.10.69	5.1	0.001	0.036	0.071	0.012	0.005

Bryophytes

Bryophytes in general are not a convenient group for production studies. Relatively little work has been published on Bryophyte production in the community context. Detailed investigations have usually been confined to single species or to a group of species, e.g. Sphagnum sp. Clymo 1970.

The major difficulties encountered were:-

- (i) erratic distribution of the various species
- (ii) gregarity
- (iii) determination of growth increments
- (iv) separation of litter and humus
- (v) laborious sorting
- (vi) determination of an individual standard cropping unit

Fluctuations between standing crops from adjacent crops at any one time were sufficient to swamp any increment though growth should theoretically become apparent in temporal studies. Increase of sample size should decrease this spatial fluctuation but results in samples becoming uneconomic in terms of sorting and removal of litter, etc.

The mean standing crop throughout the season was calculated from monthly samples of several plots from each site.

These were:-

		Mean $\frac{g}{m^2}$	S.D.
Upper Slapestone	Sedge Marsh	400	205
	Agrostis-Fescue Grassland	590	145
	Calcareous Grassland	65	22
Lower Slapestone	Sedge Marsh	320	135
Nameless/Red Sike	Sedge Marsh	432	272

The material had been collected and dried in the normal way after removal of litter, though this presented difficulty in certain species, e.g. Cinclidium stygium.

The difficulty in detecting growth increments relative to spatial variation indicated that the net annual production was not high.

Live material represented in general approximately one third of total Bryophyte dry weight. The Bryophyte communities of all sites showed this trend irrespective of cropping time.

It was not practical to age the Bryophytes, with the exception of Fissidens adiantoides, Hylacomium splendens and Thuidium tamariscinum.

An estimate may therefore be obtained for new growth, but this does not take into account senescence or death of old tissue. Consequently the net annual primary production of these species are not readily obtainable.

It may be surmised that when the dieback is taken into account the figure for the net primary production would be in the 10-20% range of the maximum standing crop.

In the absence of an objective method of Bryophyte biomass determination it will be assumed that the level of net primary production is comparable to that attained by the higher plants. It must be emphasised that this is an approximation only but in the absence of accurate methods it must suffice though its limitations should be borne in mind.

Chemical analysis of the bulked Bryophytes indicated that the levels of calcium in the material were reflected in the calcium levels of the soils on which they grew (Tables 37 and 38). Hence the Bryophyte flora of the sugar limestone and wet calcareous gravel sites were higher than those elsewhere.

TABLE 37

Bryophytes

Mean concentrations (with standard deviations)
of certain ions (mg/g)

		P	K	Ca	Mg	Na
USS	M	0.119	0.878	32.020	2.213	0.873
	SD	0.001	0.059	0.769	0.130	0.029
LS	M	0.152	1.559	10.904	2.242	0.660
	SD	0.006	0.227	1.238	0.195	0.017
RS	M	0.100	1.800	18.647	2.496	0.675
	SD	0.036	0.422	10.982	1.730	0.529
USK	M	0.141	1.034	39.654	1.396	0.716
	SD	0.003	0.345	0.000	0.082	0.035
USG	M	0.126	1.250	9.500	1.428	0.325
	SD					

TABLE 38

Bryophytes

Estimated increment for 1969 growing season (g/m^2)

		P	K	Ca	Mg	Na
USS	398	0.047	0.349	12.74	0.881	0.347
LS	322	0.049	0.502	3.511	0.722	0.213
RS	432	0.043	0.776	8.06	1.078	0.292
USK	65	0.009	0.067	2.58	0.091	0.046
USG	588	0.074	0.735	5.58	0.840	0.191

Synthesis

The species by species biomass determinations described above provide information regarding the contribution of each species to each of the relevant sites. The summation of the differences between the maximum and minimum standing crops for each species at each site enables the community increment to be calculated, Table 39 and Table 40.

The sum of these individual species increments provides a measure of the net aerial production of the communities for the 1969 growing season.

The net above ground production in terms of g dry weight per m² (excluding all species with less than 2 g production) is tabulated together with a list of the rare species associated with the vegetation at each site (Table 41).

The net annual aerial production of higher plants of both the communities that contain appreciable numbers of rarities was below 150 g per m² per annum. The "absolute" exclusion limit for the rare species listed would appear to be less than 350 g per m² per annum, i.e. less than 2 g per m² per day based on a 175 day growing season.

The absence of rarities from Site 4 could be explained by the gregariousness of the two dominant species which form a dense tussocky mass. Although of low productivity this vegetation was rooted in a shallow but tough fibrous humic matrix which covered the bedrock completely and was devoid of any bare areas that would be open to colonisation by the rarities.

The problem of colonisation by arctic alpine species in these closed situations is further complicated by the effect of "competition" from root and underground organs.

The following investigation to determine vertical biomass distributions was carried out.

TABLE 39

Sedge SitesUpper Slapestone Sike Site 1

1969

Species	Maximum	Minimum	Increment
Eriophorum angustifolium	30.9	8.7	22.2
Carex panicea	54.6	27.1	27.5
Carex lepidocarpa	30.0	18.5	11.5
Eleocharis quinqueflora	52.1	12.3	39.8
Festuca rubra	1.6	1.0	0.6
Tofieldia pusilla	5.7	2.8	2.9
Juncus articulatus	32.0	15.4	16.6
Kobresia simpliciuscula	64.2	52.6	11.6
Selaginella selaginoides	5.1	3.8	1.3
Bryophytes	398.0	244.0	154.0
Total vascular plants	276.2	142.2	134.0
All plants	655.1	386.2	288.0

Lower Slapestone Sike Site 2

1969

Species	Maximum	Minimum	Increment
Eriophorum angustifolium	45.5	26.7	18.8
Carex panicea	33.0	9.5	23.5
Carex lepidocarpa	47.0	19.1	27.9
Carex nigra	102.3	55.9	46.4
Agrostis canina	25.0	19.2	5.8
Narrow leaved grasses & sedges	199.0	66.5	132.5
Equisetum arvense	12.7	4.4	8.3
Bryophytes	322.0	154.0	168.0
Total vascular plants	464.5	222.1	263.2
All plants	786.5	376.1	431.2

Nameless Red Sike Site 3

1969

Species	Maximum	Minimum	Increment
Carex panicea	61.4	36.9	24.5
Carex lepidocarpa	68.4	30.7	37.7
Carex nigra	46.2	23.1	23.1
Eriophorum angustifolium	147.3	41.3	106.0
Narrow leaved grasses & sedges	297.8	139.3	158.5
Juncus articulatus	5.1	1.3	3.8
Bryophytes	432.0	273.0	159.0
Total vascular plants	626.2	271.9	353.6
All plants	1,078.2	444.9	513.1

TABLE 40
Grassland Sites

Upper Slapestone Sike Site 4

1969

Species	Maximum	Minimum	Increment
<i>Festuca ovina</i>	63.3	50.4	12.9
<i>Agrostis tenuis</i>	111.1	99.1	12.0
<i>Selaginella selaginoides</i>	7.7	3.8	3.9
Bryophytes			132.0
Total higher plants			28.8
Total			170.8

Upper Slapestone Sike Site 5

1969

Species	Maximum	Minimum	Increment
<i>Kobresia simpliciuscula</i>	81.2	57.4	23.8
<i>Sesleria caerulea</i>	168.0	65.5	102.2
<i>Carex capillaris</i>	52.2	26.1	26.1
<i>Festuca ovina</i>	101.9	93.5	8.4
Bryophytes			43
Total higher plants			160.5
Total			203.5

TABLE 41

Net above ground production gms dry wt/m² (excluding all species with less than 2 gms/m² production)

	1	2	3	4	5
/ Eriophorum angustifolium	22	19	106	-	-
/ Carex panicea	28	24	25	-	-
/ Carex lepidocarpa	12	28	38	-	-
Narrow leaved grasses & sedges	-	132	159	-	-
/ Carex nigra	-	46	23	-	-
Equisetum sp.	-	8	-	-	-
Juncus articulatus	16	-	4	-	-
Tofieldia pusilla	2	-	-	-	-
Eleocharis quinqueflora	40	-	-	-	-
Agrostis canina	-	6	-	-	-
/ Kobresia simpliciuscula	12	-	-	-	24
Sesleria caerulea	-	-	-	-	102
/ Carex capillaris	-	-	-	-	27
Festuca ovina	-	-	-	13	8
Agrostis tenuis	-	-	-	12	-
Selaginella selaginoides	-	-	-	3	-
Bryophytes	154	168	159	123	43
Total higher plants	134	263	354	28	161
Total	286	431	510	151	204

Distribution of the rarities

Equisetum variegatum	+	+	-	-	-
Kobresia simpliciuscula	+	-	-	-	+
Tofieldia pusilla	+	+	-	-	-
Juncus triglumis	+	-	-	-	-
Primula farinosa	+	-	-	-	-
Plantago maritima	+	+	-	-	+
Armeria maritima	+ ? FEB	-	-	-	+ ? FEB
Carex ericetorum	+ ? FEB	-	-	-	+ ? FEB
Gentiana verna	-	-	-	-	+
Viola rupestris	-	-	-	-	+
Polygala amara	-	-	-	-	+ ? FEB
Carex capillaris	+	+	+	-	+
Juncus alpino-articulatus	+	-	-	-	-
Saxifraga aizoides	+	-	-	-	-
Cynclidium stygium	-	-	+	-	-
Total	10	4	2	-	7

Vertical Biomass Distribution

The method of obtaining root samples was similar to that adopted by Kotanska (1967) and the three sites investigated were:-

- a) Upper Slapestone Sedge Marsh
- b) Upper Slapestone Agrostis-Fescue Grassland
- c) Lower Slapestone Sedge Marsh

Monoliths, $\frac{1}{4} \text{ m}^2$, were cut out to a depth of 20 cms or to bedrock at each site.

These soil blocks together with their attendant vegetation were removed to the laboratory, care being taken that the blocks were not compacted in transit.

The aerial vegetation was removed and sorted into the following categories:-

- i) Pteridophytes
- ii) Bryophytes
- iii) Angiosperms, Monocots
- iv) Angiosperms, Dicots

Each category was individually packeted and dried in a forced draught oven.

The soil blocks were then cut into 1 cm thick horizontal slices with a sharp knife. Each section in turn was then vigorously washed under a running tap in a 1 mm sieve to remove fine sand and soil particles.

The roots and other underground organs were separated from the remaining inorganic fraction of gravel and larger stones by differential flotation.

The separation of live root material from the dead proved laborious and was effected by hand sorting using fine forceps. In general live roots were tough and springy, ranging from white to red-brown in colour, whereas the dead roots were flaccid or fragile and black in colour.

Fig. 44 Sorting categories for vertical biomass distribution

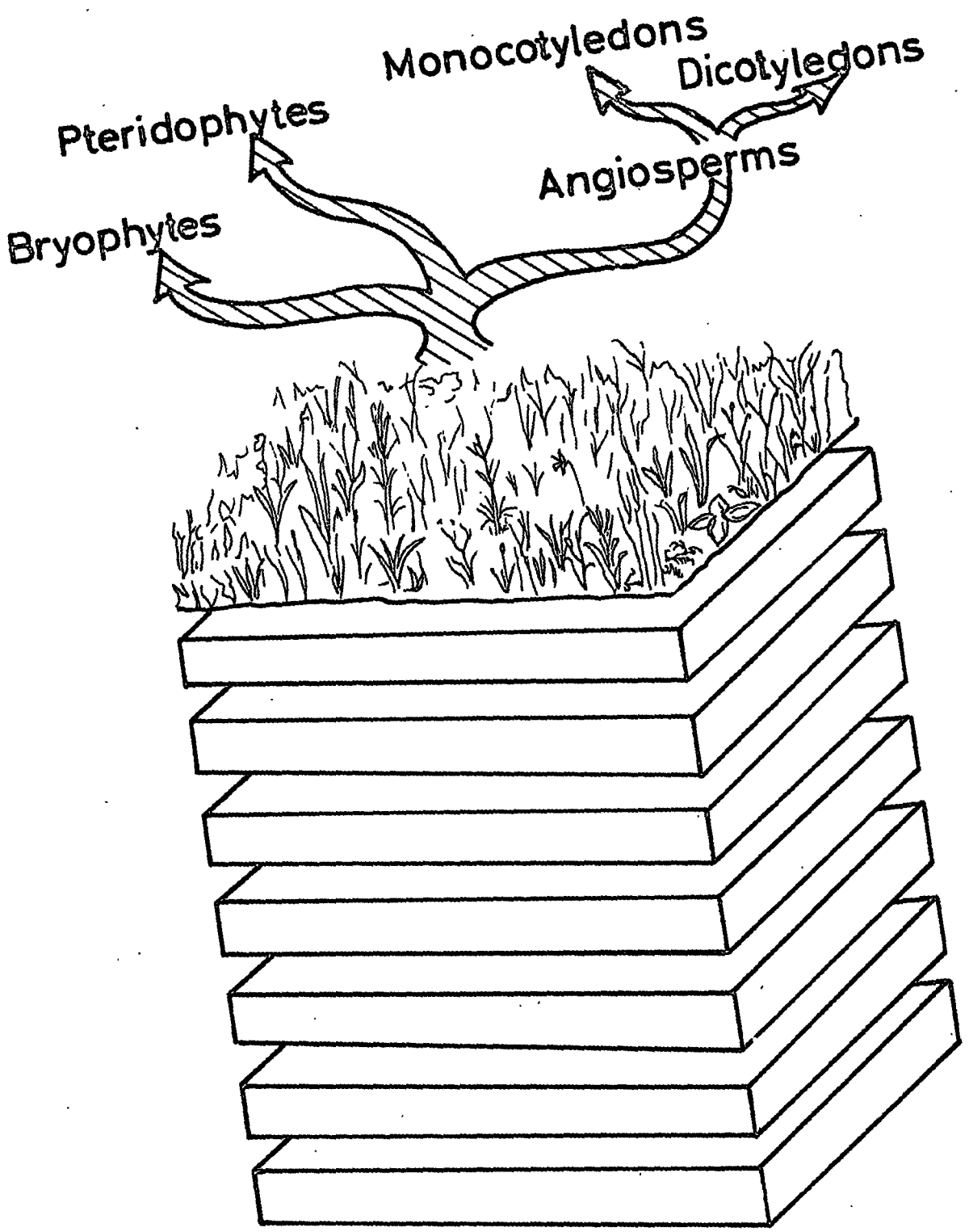

The live roots were packeted and dried in a forced draught oven for three days and the vertical distribution of biomass within and above the soil is illustrated in Fig. 45.

The bulk of the root material was concentrated in the upper few centimetres of the soil. In each example illustrated the above ground standing crop was far smaller than the below ground standing crop.

The Upper Slapestone sedge marsh site had a below ground standing crop of approximately 1200 g dry wt. per m^2 , whereas the Upper Slapestone had a standing crop of 1250 g per m^2 . These values were exceeded in the Lower Slapestone Sike site where a standing crop of 1400 g per m^2 was attained.

These simple determinations indicate that the aerial standing crop represents a small proportion of the biomass and the effect of rooting competition may be of significance in the establishment of the Teesdale rarities.

In view of the inherent inaccuracy of the method for the determination of root standing crop the values obtained should be regarded as approximations which nevertheless illustrate the general pattern of the vertical distribution of biomass.

The communities rich in the Teesdale rarities have been shown to be of low net annual aerial production with the bulk of their biomass underground.

Fig. 45

Vertical biomass distribution in August 1969 at Upper Slapestone Sedge Marsh, Upper Slapestone Agrostis-Fescue grasslands and Lower Slapestone Sike Sedge Marsh.

0 10 20 30 40 G.

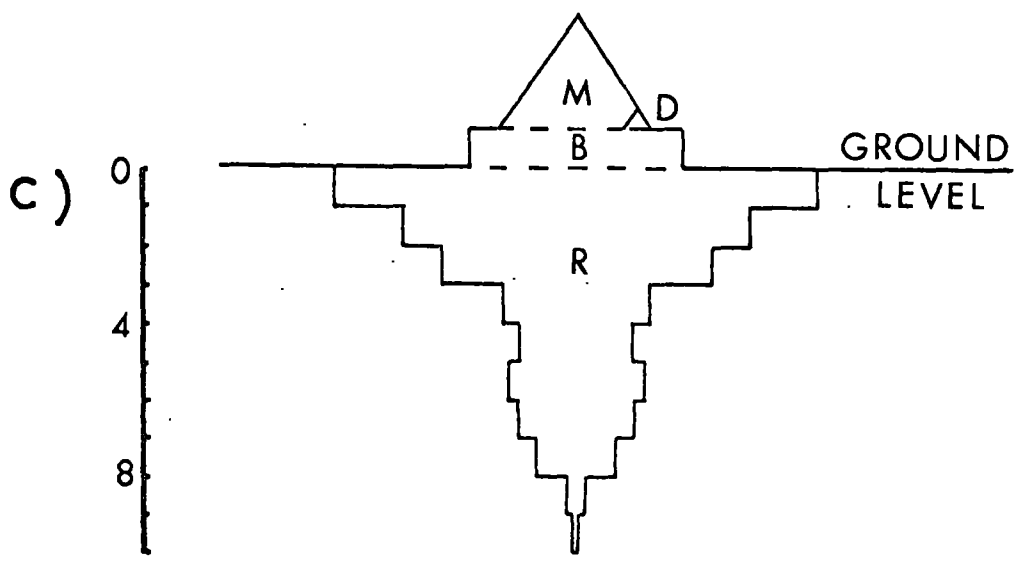
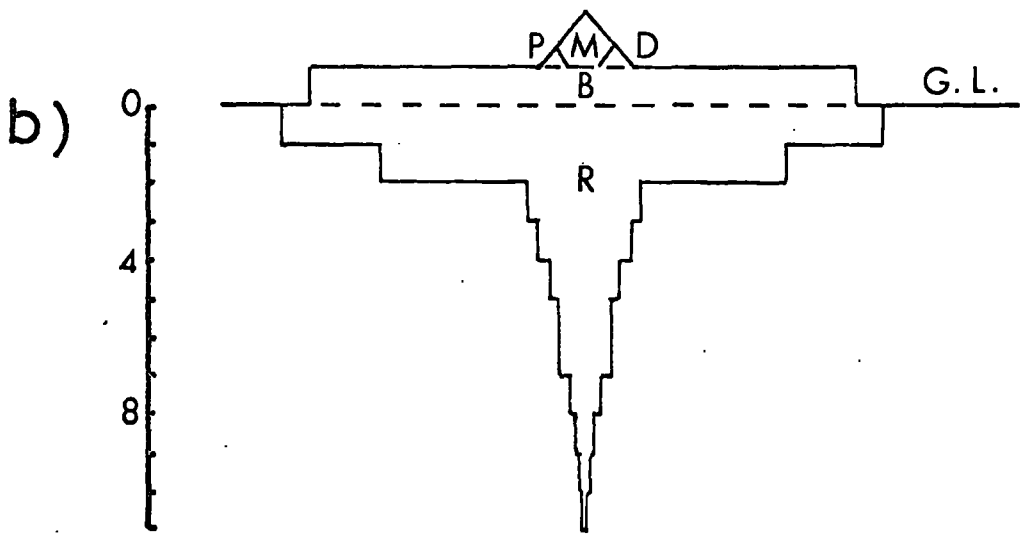
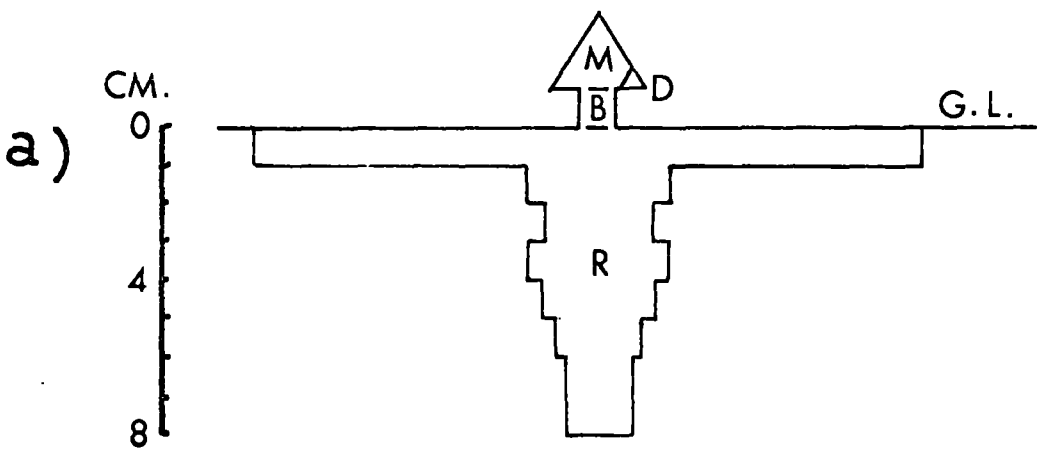

What limits the productivity of these communities?

Although it did not come within the scope of the work to study the possible factors in great detail, some experimental evidence is given below under the following headings:-

- i) The climate
- ii) The biotic
- iii) The Edaphic

(i) The Climate

As previously indicated the climate of the Fells of Upper Teesdale has long been known for its inhospitable and marginally sub-arctic nature (Manley 19~~58~~⁴²).

Regular climatological observations have only been taken on Widdybank Fell since January 1968 and so far these have indicated that the general climatic differences from the Moor House Station are slight. The growing season, if loosely defined as the number of days with the mean temperature above 6°C, is about 180 per annum, which is at least 60 days shorter than in the Eden Valley (Millar 1970).

Air frost can occur in any month of the year and lowest minimum air temperatures on Widdybank Fell (509 m) often prove to be lower than even those on Great Dun Fell (847 m).

These general observations indicate that the climate may contribute in part to the restriction of production.

However the presence of much more productive vegetation in close proximity to the low production communities indicated the need at least for detailed microclimatological studies in the area.

To test the effect of climatic restraint on the vegetation a simple experiment was devised to demonstrate the possible effects of short term amelioration of the microclimate.

Cold Frame Experiment

A cold frame similar to that used in horticultural practice was located on Bent-Fescue grassland on Widdybank Fell before the commencement of the 1969 growing season. A similar area was enclosed to prevent the grazing of herbage by sheep and other large animals.

At the conclusion of the experiment in October 1969 the vegetation from the experimental areas was harvested from both plots in three 400cm² cropping units and also from an adjacent grazed area.

PLATE VII

Cold Frame Experiment

Bent Fescue grassland sample

(i) from within cold frame, and

(ii) from ungrazed sward.

Scale - The vertical scale is graduated at 5 cm intervals.



These crops were transported back to the laboratory where the herbage was sorted, dried and weighed and the mean aerial standing crop calculated on a per metre square basis. The figures so obtained were only crude estimates but they do serve to illustrate the difference between treatments.

The only visual difference between the samples from the grazed and ungrazed swards not enclosed within the cold frame was a few "clipped" ends on the grazed sample. No obvious differences in standing crop were evident.

The difference between the grassland enclosed within the cold frame and that outside was visually striking (Plate ^{VIII} ~~III~~). The plot from within the cold frame had a high standing crop composed of tall sward of grasses interwoven with straggling stems of Thymus drucei and flowering shoots of Prunella vulgaris (Table 42). The grazed and ungrazed vegetation consisted of compact short swards. The Cirsium palustre rosettes measured 5-10 cms in diameter in the area around the cold frame as compared to 30 cms inside it (Plate ^{VIII} ~~V~~).

The internal climate of the cold frame was not monitored, but the main effects of the cold frame would have been to reduce wind speed and direct precipitation and increase internal temperatures especially by reducing the incidence and duration of frosts.

The general conclusion to be drawn from this crude qualitative experiment was that short term modification of the climate would be sufficient to produce dramatic changes in the growth rate and physiognomy of the vegetation. Short term removal of grazing and trampling pressure would have little effect.

TABLE 42

October standing crop of Bent Fescue Sward
(i) sample from within cold frame
(ii) ungrazed sample
expressed in gm dry wt per metre² and excluding Bryophytes

	(i)	(ii)
<i>Festuca ovina</i>	720	370
<i>Carex</i> sp.	140	12
<i>Agrostis tenuis</i>	205	75
<i>Achillea millefolium</i>	45	1
<i>Thymus drucei</i>	16	15
<i>Prunella vulgaris</i>	20	5
<i>Selaginella selaginoides</i>	-	9

PLATE VIII

Cold Frame Experiment

Cirsium palustre from

(i) within cold frame (above)

(ii) ungrazed sward (below).

Scale - Largest rosette 28 cms diameter.

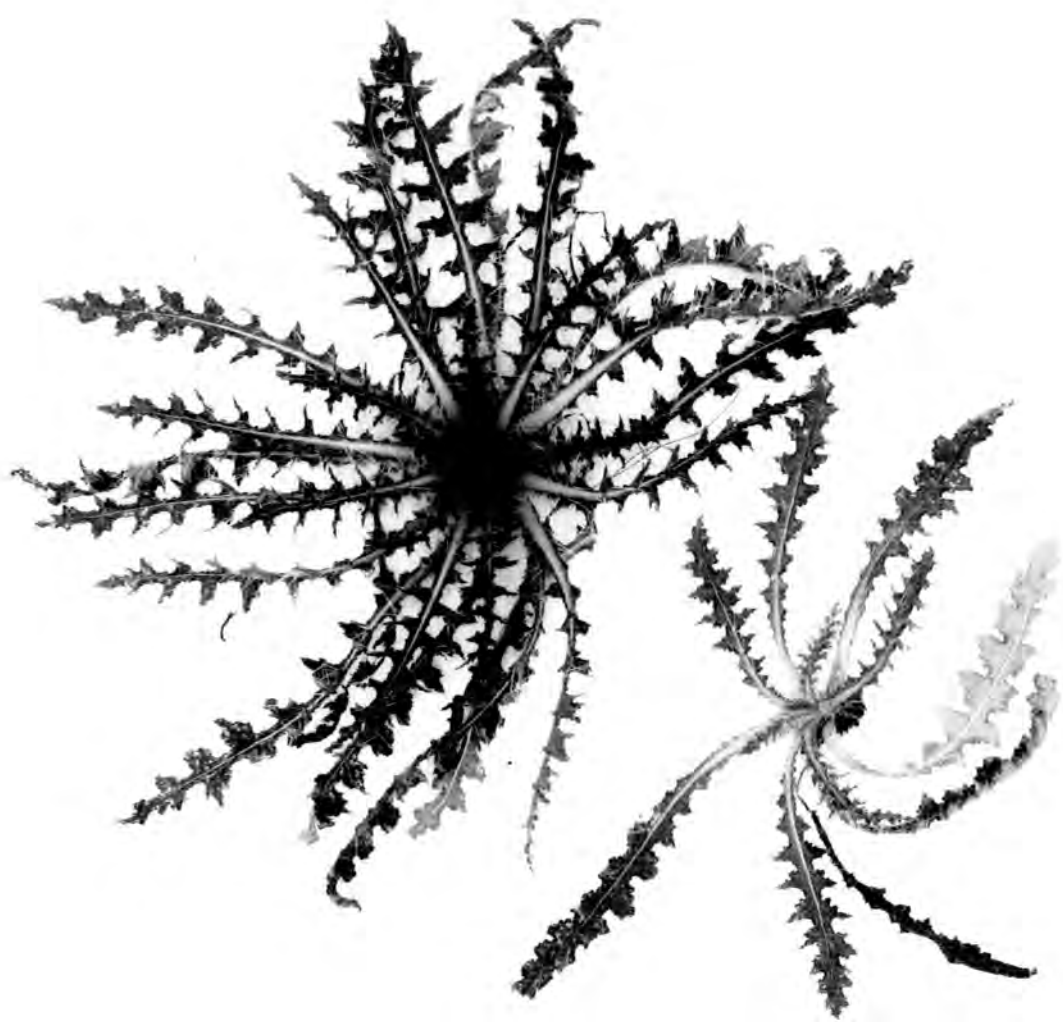

(ii) The Biotic

Exclusion of grazing for a single growing season showed little effect on the vegetation but exclusion for more than three seasons produced noticeable changes in the physiognomy of the vegetation. However no major change in the floristic content of the enclosed areas was recorded.

Exclosures had been erected in 1965 around spring head "brown moss" communities on Widdybank Fell during an earlier investigation.

These spring head communities consisted of hummocks ranging in diameter from 3 to 5 metres and in each case there was at least one similar, but unfenced, formation within 10 metres distance of the enclosure.

Aufnahmen were recorded of the fenced and the unfenced adjacent hummocks and these are listed in Tables 4.3a and 4.3b.

Assuming (i) that the hummocks were of similar floristic composition initially before fencing and (ii) that the present floristic composition is not due to chance, several general observations may be made.

The floristic diversity increases in terms of numbers of species due to the appearance of species such as:

Primula farinosa

Linum catharticum

Veronica beccabunga

Caltha palustris

Trifolium repens

Whilst Bryophytes decreased in cover-abundance the values for Festuca rubra and Carex nigra increased. This change in floristic composition was accompanied by an increase in height of the herbage.

Observation alone made it evident that the plants within the exclosures had the added advantage of abundant production of flower, fruits and seeds.

TABLE 4.3a

Floristic composition of two unfenced springhead hummocks
and an adjacent fenced hummock on Widdybank Fell
(Doing Cover Abundance Scale; see Appendix II)

	<u>Aufnahmen 1</u>	<u>Aufnahmen 2</u>	<u>Aufnahmen 3</u>
	Grazed	Grazed	Ungrazed
Area (m)	3x3	2x2	3x3
Aspect	S.E.	S.E.	S.E.
Slope	5°	5°	5°
No. of species	11	10	14
<u>Species</u>			
<i>Cratoneuron commutatum</i>	07	08	04
<i>Agrostis canina</i>	02	02	01
<i>Cardamine pratensis</i>	02	02	02
<i>Cratoneuron filicinum</i>	02		
<i>Philonotis calcarea</i>	+		
<i>Equisetum palustre</i>	+	+	+
<i>Juncus articulatis</i>	+	+	+
<i>Carex lepidocarpa</i>	+	+	+
<i>Bryum pseudotriquetrum</i>	+	01	01
<i>Carex panicea</i>	+		+
<i>Festuca rubra</i>	+	+	03
<i>Leontodon leysseri</i>		+	
<i>Carex dioica</i>		+	+
<i>Primula farinosa</i>			+
<i>Carex nigra</i>			03
<i>Linum catharticum</i>			+
<i>Deschampsia caespitosa</i>			+

TABLE 4Jb

Floristic composition of an unfenced springhead hummock
and an adjacent fenced hummock on Widdybank Fell
(Doing Cover Abundance Scale; see Appendix II)

	<u>Aufnahmen 4</u>	<u>Aufnahmen 5</u>
	Grazed	Ungrazed
Area (m)	3x3	3x3
Aspect	S.E.	S.E.
Slope	5°	5°
No. of species	13	31
<u>Species</u>		
<i>Philonotis calcarea</i>	05	02
<i>Cratoneuron filicinum</i>	04	02
<i>Agrostis canina</i>	02	01
<i>Carex lepidocarpa</i>	02	03
<i>Equisetum palustre</i>	01	01
<i>Carex panicea</i>	01	01
<i>Carex flacca</i>	01	01
<i>Briza pseudotriquetrum</i>	01	01
<i>Cratoneuron commutatum</i>	01	
<i>Festuca rubra</i>	01	04
<i>Prunella vulgaris</i>	+	+
<i>Cardamine pratensis</i>	+	02
<i>Juncus articulatus</i>	+	+
<i>Carex nigra</i>		02
<i>Veronica beccabunga</i>		02
<i>Acrocladium cuspidatum</i>		01
<i>Mnium affine</i>		+
<i>Carex echinata</i>		+
<i>Juncus conglomeratus</i>		+
<i>Juncus squarrosus</i>		+
<i>Eriophorum angustifolium</i>		+
<i>Festuca ovina</i>		+
<i>Briza media</i>		+
<i>Taraxacum officinale</i>		+
<i>Holcus lanatus</i>		+
<i>Caltha palustris</i>		+
<i>Deschampsia caespitosa</i>		+
<i>Anthoxanthum odoratum</i>		+
<i>Pellia epiphylla</i>		+
<i>Nardus stricta</i>		+
<i>Carex dioica</i>		+
<i>Trifolium pratense</i>		+

These observations indicate that it would be dubious to argue the persistence of arctic-alpines under present climatic conditions without the specific effects of heavy grazing and trampling.

However grazing itself cannot directly control the productivity of a community, it can only affect the final standing crop. Also grazing unless selective must also affect both the rarities and their competitors. Bradshaw (1970) has noted that approximately 10% of the individuals of Gentiana verna, Tofieldia pusilla and Carex ericetorum produced flowers, but almost none set fruit in the unfenced communities in 1969.

(iii) Edaphic Factors

The idea of an edaphic factor contributing in part to the survival of relict arctic-alpine species is in keeping with the continuous pollen record for such species. Of the seventeen Teesdale rarities which have recognisable pollen, eleven have been recorded from the time of maximum forest development (Turner and Hewetson, 1970). Jeffrey and Pigott (1970) argued that during the Atlantic period of climatic amelioration when competition from fast growing species would have been potentially high, an edaphic restriction on growth may have operated on particular sites.

Low phosphate availability has been indicated as a factor limiting the growth of possible competitors, thus permitting the growth of shade intolerant arctic-alpines. However the investigations of Jeffrey and Pigott of the soils on which Kobresia simpliciuscula grow in abundance did not reveal low levels of total phosphate but they maintained that there was a possibility of the interaction of high levels of lead or some other heavy metal in the soil affecting the availability of this nutrient.

From the analytical data obtained it is possible to make the following comments. The Kobresia-Sesleria grassland (as typified by Cluster 6 of the Relocation Procedure) was associated with the highest levels of exchangeable lead in the soil. Since this level was only 0.004 milli equivalents per 100 c.c. soil, and no traces of lead were detectable in any of the plant material analysed, the implication of lead acting directly as a growth inhibitor or indirectly by suppressing phosphate uptake remains to be proven.

Exchangeable zinc, while not specifically associated with any particular soil or vegetation type, showed high concentrations in soils of low organic content which were not subjected to periodic flushing.

The zinc content of the plant material differed markedly between live and dead tissue, in a similar manner to calcium (see below).

Comparisons of zinc levels were possible for some species which occurred across the range of wetland sedge communities. The zinc levels (ppm) for dead and live leaves of Eriophorum angustifolium and Carex lepidocarpa are shown together with the net aerial productivity of these species for the 1969 growing season in Table 44.

In these two species levels of zinc appear to be correlated with net aerial production; high concentrations of over 100 ppm zinc in the live tissue and 400 ppm in the dead are paralleled by low production both for the species concerned and the total community.

Although there appears to be an inverse correlation between zinc concentration and productivity in the wetland sites, there was no indication that zinc toxicity was the causal agent of these production levels. None of the classic symptoms were apparent.

Turning to elements of more direct nutritional value, namely calcium and potassium, it was found that significant differences are indicated between the concentration of these elements when comparing live and dead tissue as shown in Tables 48 + 49

It would appear that species in the table and all others analysed tended to retain potassium in the live tissue, presumably removing potassium from senescing tissue. Conversely calcium appeared to be shunted into the dying tissue.

The marked retention of potassium by Sesleria caerulea especially in the live leaves is noteworthy. Although not a Teesdale rarity, it is of restricted edaphic range in Britain, occurring only in areas of high soil calcium.

TABLE 44

Net aerial production for 1969 growing season and Zinc concentrations for dead and live leaves of Eriophorum angustifolium and Carex lepidocarpa for three wetland sites in Upper Teesdale

	<u>Zinc Concentration</u>		<u>Net aerial production</u> 1969 growth season g/m ²
	<u>Live leaves</u>	<u>Dead leaves</u>	
<u>Eriophorum angustifolium</u>			
Nameless Red Sike	81	183	106
Lower Slapestone	183	588	18
Upper Slapestone	115	434	22
<u>Carex lepidocarpa</u>			
Nameless Red Sike	78	101	38
Lower Slapestone	55	139	28
Upper Slapestone	160	460	12

TABLE 45

The rare species found in, and associated with, the six clusters derived by relocation with main abiotic trends

CLUSTER	1	2	5	4	7	6
<u>Data from Grid</u>						
<i>Equisetum variegatum</i>	100	61	-	-	-	-
<i>Primula farinosa</i>	67	28	-	-	-	-
<i>Juncus triglumis</i>	25	17	-	-	-	-
<i>Tofieldia pusilla</i>	58	33	-	-	-	-
<i>Plantago maritima</i>	67	28	7	11	-	-
<i>Carex capillaris</i>	25	78	14	78	-	7
<i>Kobresia simpliciuscula</i>	67	6	-	33	-	73
<i>Gentiana verna</i>	-	-	-	22	8	53
<i>Sesleria caerulea</i>	-	-	-	22	25	100
<i>Galium boreale</i>	-	-	-	-	-	7
<i>Polygala amara</i>	-	-	-	-	-	13

Comparative data of other species

	PRESENCE					
<i>Minuartia stricta</i>	*	-	-	-	-	-
<i>Thalictrum alpinum</i>	*	*	-	-	-	-
<i>Bartsia alpina</i>	*	*	*	-	-	-
<i>Juncus alpina-articulatus</i>	-	*	*	-	-	-
<i>Viola rupestris</i>	-	-	-	*	-	*
<i>Carex ericetorum</i>	-	-	-	*	-	*
<i>Helianthemum canum</i>	-	-	-	-	*	*
<i>Dryas octopetala</i>	-	-	-	-	-	*

	Wet		Dry
Abiotic trends	Low Organic	High Organic	Low Organic
	High Ca	Low Ca	High Ca
	Flushing		No Flushing
	Scouring		Wind Erosion

Two of the Teesdale rarities did in fact have low potassium levels in their live leaves. Kobresia simpliciuscula had a concentration of 6.9 mg per g of potassium (S.D. 5.0) in the Upper Slapestone calcareous grassland and 4.1 mg per g (S.D. 4.0) in Upper Slapestone sedge marsh. Tofieldia pusilla contained only 3.3 mg per g (S.D. 1.7) in its live leaves at the Upper Slapestone sedge marsh.

These observations indicate that further work on the role of potassium in these communities would be worth while.

This section of the work is summarised in Table 46 where the data for standing crop and uptake of nutrient by each community studied is given. Table 47 shows a crude estimate of production efficiency, production per unit uptake of Calcium, Magnesium and Potassium.

No outstanding differences between sites are indicated and the number of analyses which would be necessary to obtain statistically significant results indicate this to be a less profitable sphere for further work.

TABLE 46

Summary of Mineral standing crop and uptake area (g/m^2)

Site	Phytosociological Affinity	No. of Rare Species	Peak Standing Crops	Net Aerial Produc- tion	Standing Crop			Uptake		
					Ca	Mg	K	Ca	Mg	K
1 Upper Slapestone Sike	<u>Tofieldietalia</u>	10	276	134	4.5	0.5	1.4	1.5	0.2	0.8
2 Lower Slapestone Sike	<u>Tofieldietalia/Molinio- Arrhenatheretea</u>	4	464	263	5.2	0.7	4.3	2.8	0.4	2.5
3 Nameless/Red Sike	<u>Tofieldietalia/Molinio- Arrhenatheretea</u>	2	626	354	6.6	0.8	3.4	4.1	0.5	2.4
4 Upper Slapestone Sike	<u>Nardo Gallion</u>	-	123	29	1.3	0.2	1.0	0.2	0.0	0.1
5 Upper Slapestone Sike	<u>Seslerietalia</u>	7	403	161	7.3	0.3	2.0	2.4	0.1	1.1

TABLE 47

Biomass produced per gram of calcium,
magnesium and potassium at each site.

	1	2	3	4	5
Calcium	92	87	88	145	65
Magnesium	660	620	750	725	146
Potassium	173	98	148	224	150
No. of rarities	10	4	2	-	7

TABLE 48

Concentration of Calcium in dried material
from sedges and grasses at various sites

Species	Site	mg/g			
		Live	(standard déviation)	Dead	(S.D.)
<i>Carex nigra</i>	Lower Slapestone	14.4	(1.9)	20.7	(8.5)
	Upper Slapestone	21.9	(8.1)	25.3	(3.8)
<i>Carex panicea</i>	Upper Slapestone	24.9	(1.9)	33.6	(12.4)
	Lower Slapestone	19.7	(2.4)	25.0	(3.0)
	Nameless/Red Sike	17.2	(1.7)	25.0	(-)
<i>Eriophorum angustifolium</i>	Upper Slapestone	19.6	(1.3)	33.4	(3.3)
	Lower Slapestone	17.1	(2.6)	32.9	(17.0)
	Nameless/Red Sike	14.1	(1.1)	26.9	(2.3)
<i>Sesleria caerulea</i> (Sesl/Kob. grassland)	Upper Slapestone	13.5	(1.7)	33.6	(14.1)

TABLE 49

Concentration of Potassium in dried material of
Carex panicea and *Sesleria caerulea* at various sites

Species	Site	mg/g			
		Live	(S.D.)	Dead	(S.D.)
<i>Carex panicea</i>	Upper Slapestone	11.8	(4.6)	3.4	(1.5)
	Lower Slapestone	15.9	(1.9)	6.5	(3.3)
	Nameless/Red Sike	11.1	(1.6)	3.3	(1.3)
<i>Sesleria caerulea</i> (Sesl/Kob. grassland)	Upper Slapestone	13.0	(2.2)	2.9	(1.1)

PART V

CONCLUSION

Although the contemporary climate of the high western ridge of Upper Teesdale is marginally sub arctic, the climate of the main area in which the Teesdale Rarities are found appears to differ little from that of other large stretches of the Pennines.

Why then is the rich assemblage of relict species present only in Upper Teesdale?

Earlier work (Bellamy and Tickle 1965) had indicated that in Upper Teesdale there exists a complex of vegetation types characterised by low levels of production. These "low production" communities offer niches in which competitive effects are minimal and in which the Teesdale rarities are able to survive.

This study was designed to test this hypothesis by answering three questions:

- i) What are the communities?
- ii) What is their productivity?
- iii) What are the reasons for this level of production?

(i) The Communities

Detailed study of two transects, which appeared to include a wide range of the constituent vegetation of the area, indicated the importance of boundary situations to the presence of certain of the rarities. These were typified by sharp zones of both biotic and abiotic transition of the limes convergens type situation as defined by Van Leeuwen (1966). It is suggested that the status of the boundary complexes holds, at least in part, the key to the Teesdale problem.

The association of certain of the Teesdale rarities with limes convergens situations enabled the construction of the following hypothesis.

A vegetation boundary may be considered as a separator of adjacent but different vegetation systems. The area of interaction between them must be a zone of ecological transition where neither end-state community may find its full expression, that is its total species complement, nor their full viability. It is here in this zone of lowered potential that rare species and species from totally unrelated habitats may survive together in this "niche" which is characterised by low competition.

As previously stated, Upper Teesdale represents a large scale example of a boundary complex of vegetation types fluctuating with changes in macro and micro climate - a constantly varying complex, unstable in detailed pattern, but stable in overall make-up, approximating to the "limes convergens" situation, in which many rare plants and rare combinations of plants may be expected (Van Leeuwen 1966).

Typical of the "limes divergens" situation are the associations of the Trifolio-Geranietea. These appear to represent the seral stages between grassland and forest, but there are basic and integral differences. The true seral communities are classified in the order Prunetalia Spinosae, whose associations do not contain the character species of the Trifolio-Geranietea. The associations of this class are all restricted to the margins of cultivated land where succession is prevented by man's

influence; it must be made clear that they are distinct communities characterised by certain regionally restricted species.

Upper Teesdale bears abundant evidence of the effect of man as witnessed by numerous spoil heaps, trails and concentrated sheep grazing.

This effect could well account for the contemporary stabilisation of the boundary complex and thus for the existence of considerable tracts of unique vegetation in this area.

In Teesdale the communities may not represent the stabilisation of early seral stages held by grazing and climatic pressures, but specialised phytosociologically distinct communities analagous to the communities of the Trifolio-Geranietea.

It does, at first, seem somewhat dubious to argue the existence of relict species over long periods of time in such restricted and unstable habitats particularly times involving appreciable climatic change. However the very nature of the limes convergens situation, being a separator of highly dissimilar opposing systems, ensures a high degree of temporal stability (Van Leeuwen 1966). The breakdown of such transition zones would require relatively massive environmental or habitat changes.

The limes divergens situation, being a gradual transition between not necessarily markedly different, is more susceptible to modification through slight environmental change. This type of boundary system is therefore more prone to the ravages of time, especially if accompanied by climatic change.

The persistence of a limes convergens over a long period of time, theoretical considerations apart, is still a matter of conjecture. Only by detailed examination of fossil material in very local peat deposits will evidence be found supporting the above hypothesis.

Of the seventeen Teesdale rare species with recognisable pollen the following have left a more or less continuous record of their presence on Widdybank Fell since the time of forest maxima (Turner and Hewetson 1970).

Betula nana

Dryas octopetala

Gentiana verna

Helianthemum canum

Plantago maritima

Polemonium caeruleum

Rubus chamaemorus

Saxifraga stellaris

Saxifraga hirculus/hypnoides

Saxifraga aizoides type

Polygonum viviparum/bistorta

The fact that so many have been recorded indicates that the rarities may have been in the area since the late glacial period.

Sufficient evidence has accrued from the adjacent Cronkley Fell to indicate that a principal feature of the Flandrian history of the area was the marked instability since late glacial times both in terms of local mire dynamics and woodland (Squires 1970).

The following relevant picture is constructed from Squires' work. During the late glacial there is evidence of solifluction, where the upper part of the waste mantle of the retreating glaciers crept over the underlying frozen ground, even on areas of low gradient. Consequently solifluction deposits or creep soil would collect extensively in hollows and at the foot of slopes; such deposits are widespread in Upper Teesdale (Johnson 1965).

These unstable areas would have provided habitats for pioneer species, including possibly the present day rarities, in much the same way as plants encroach almost on to the ice sheet of Greenland today.

During the Late Glacial, the rare species were not confined to the Fell tops of Upper Teesdale. There is considerable evidence that they formed the components of widespread vegetation types and numerous records

of their remains have been found in lowland Britain (Allison, Godwin and ~~Walton~~^{Tren} 1952) (Mitchell 1953).

Later climatic amelioration evidently resulted in the withdrawal of the flora of the "park tundra" to high altitudes until finally restricted into the disjunct localities in which they are found today.

In Pollen Zone VI the edaphic instability of the Fell tops gave way to instability brought about by water level fluctuations which, as the study has shown, are a pertinent feature of certain boundary situations in the area even today.

The period of forest maximum would appear to have been the most critical for the survival of the relict species. The fact that many of the rarities are found only in a very short turf on limestone outcrops would indicate their intolerance to the shaded condition of woodland. However under the blanket bog which surrounds the outcrops there is abundant evidence of well developed forest which would have undoubtedly reduced wind erosion and soil wastage on such limited limestone outcrops.

Although the limestone may have been covered by open forest or scrub, the peculiar¹⁹⁷ flora need not necessarily have been exterminated under these conditions. Viola rupestris, Carex ericetorum and Dryas octopetala can survive under scrub on small outcrops, and Polygala amara and Gentiana verna have both been noted in fruit in small openings in the canopy of sub-alpine Picea abies forest in the Alps (Piggot 1956). Similarly the elements of the Tofieldietalia are found well developed under forests in calcareous flushes in sub-alpine river valleys (Siebert 1958).

Even at its maximum development the Upper Teesdale woodland was never closed (Turner and Hewetson 1970). Providing that local movements of rarities could occur to evacuate old habitats as they became untenable and exploit new and different niches as they became available, the relict species could have survived throughout the forest maximum.

Again survival through the main period of blanket bog development must be considered. Presumably restricted localities of limestone outcrops would have been available. It is interesting to note that limes convergens and limes divergens boundaries would have been a widespread feature of that time.

Although the boundary hypothesis may neatly explain the persistence of many of the rarities in certain situations it does not in others.

There is the abundance of species such as Tofieldia pusilla and Kobresia simpliciuscula which are not restricted to such zones of environmental instability. Species such as these may in fact be definitive plants of certain communities (see page 21).

The detailed phytosociological investigation of the grid on Slapstone Sike produced an optimum classification of 6 clusters all of which contained an admixture of rarities, though some more so than others.

Two main types of community, the sedge marsh (Clusters 1 and 2) and the sugar limestone grassland (Cluster 6) have a high proportion of arctic-alpine species occurring within them not only in terms of numbers of species but also in terms of frequency of occurrence. Table 45 lists these species under their appropriate cluster code with their frequency of occurrence as well as comparative data of distributions of other rare species from similar communities. Abiotic trends are also shown.

In general those communities with complete vegetation cover that are rich in the rarities appear to be admixtures of two or more phytosociologically recognisable vegetation taxa. These mixed communities are found where the soils are low in organic material and high in calcium.

Some of these areas have been classified into the association Seslerietum-Caricetum pulicariae Shimwell 1968. This association, together with its variants, forms a phytogeographical link between the lowland base rich grasslands of the class Festuco-Brometea Br. Bl. and R.Tx. and the arctic alpine grasslands of the class Elyno Seslerietea Br. Bl. and further emphasise the boundary nature of Upper Teesdale.

(ii) The Productivity of the Communities

The phytosociological study not only indicated the relevance of vegetational transitions to the survival of rarities, but also delineated the communities and sites for production studies.

The performance of each species at these sites was determined, by the single species increment cropping technique, and a composite picture was obtained of each community's dynamics in terms of biomass and mineral flux.

These investigations have indicated that those communities rich in rare species are typified by low levels of net aerial primary production (Table 41), though all areas of low productivity do not necessarily contain rarities, unless ecological, environmental and phytosociological factors are favourable.

Previous studies have indicated that Upper Teesdale plant communities containing arctic-alpine species have an annual dry weight shoot production of less than 150 gm per m^2 per annum (Bellamy and Tickle 1964). In the light of the present study this would appear an oversimplification. The rarities are certainly most abundant in the ⁴last productive areas, provided other environmental factors are suitable. They are common in communities with less than 150 g per m^2 per annum, but they do occur in communities whose productivity exceeds this level.

The relationship between net aerial primary production and the number of rare species was found to be an inverse relationship; the higher the productivity, the lower the number of rare species. Only two rarities were present in the Nameless/Red Sike site whose net annual aerial production for higher plants was 355 g per m^2 per 1969 growing season.

(iii) What maintains this low level of productivity?

The vulnerability of the presumed contemporary stabilised communities to modification by environmental modification was demonstrated.

The simple cold frame experiment illustrated the effect of short term amelioration of the climate. Lowland species in the Teesdale community studied showed a rapid response by doubling overall community standing crop in the length of a single growing season. The response of the Teesdale rarities under these experimental conditions remains to be investigated.

This response to climate would tend to depreciate an argument maintaining the inhibition of growth due to edaphic factor(s), assuming that such a factor(s) is not temperature sensitive.

This experiment also indicated the effect of climatic restraint in maintaining the production level below its maximum potential.

The importance of another environmental factor, heavy grazing, was emphasised by the observations of the fenced and unfenced spring head "brown moss" hummocks. The removal of grazing pressure on these particular communities resulted in changes in the physiognomy, reproductive modes and composition of the flora. This further demonstrated the delicate balance of the contemporary plant communities.

Chemical analysis of soil and plant extracts, apart from providing information of mineral flux within each species, were inconclusive, failing to produce evidence of the role of most of the heavy metals in inhibiting community productivity. Zinc levels were higher in plant material from the less productive sugar limestone communities. These are the communities which contain certain large numbers of rare species, and it is tentatively suggested that further investigations of this metal may be rewarding.

The Teesdale rarities are located in two basic types of situation:-

(a) various boundary and transition zones,

and (b) communities of low net annual aerial production, particularly those associated with sugar limestone soils.

What have these two basic situations in common?

They are both situations in which the vitality and viability of the lowland species are impaired by factors of ecology and climate. It is here in the face of lowered competition that the rare species, supposedly intolerant of competition, have been able to maintain a foothold.

The construction of the Cow Green Reservoir although flooding some of the present localities of the rarities, may provide new environments rich in boundary situations on the new shore line. Against this must be set any possible unfavourable changes in microclimate. It remains to be seen which influence will prove the stronger for the future of the Teesdale Rarities.

APPENDIX I

PLANT AND SOIL ANALYSIS

Gravimetric and chemical analysis were carried out on plant and soil material.

Preparation

The plant material was cropped according to the method previously outlined.

The soil samples were obtained by inverting aluminium canisters over the soil surface previously denuded of vegetation. The surface of the soil around the circumference of the can was cut with a sharp knife. This allowed the introduction of the can into the soil. Care was taken to avoid compaction and when the top 10 cm of soil filled the can the core was removed. Two samples were taken from each quadrat.

The soil samples were immediately returned to the laboratory with minimum soil water loss. The cans and soil were then weighed on a top loading balance.

The packeted plant material and the soil samples still in situ in their cans were loaded into hot air ovens set at 105°C. A constant flow of air was forced over the samples by an internal extractor fan integral to the oven. The samples were dried for three days.

In practice it was found not possible to dry samples to constant weight due to the loss of volatile organic compounds from the plant material and soil organic fraction. Three days at 105°C sufficed to drive off the aqueous content with minimum loss of volatile substances.

The dried packets of plant material were then stored in new polythene bags which were kept tightly sealed with a few crystals of silica gel inside. These crystals served to indicate if water vapour entered the bag, in which case the contents were transferred to a new bag with a larger quantity of gel to remove the vapour.

The soil samples were weighed again as soon as they were removed from the oven and the percentage of water loss from the soil was calculated.

The two soil samples from each quadrat were then bulked and gently ground in a clean pestle and mortar to break down the larger soil crumb structure and then sieved through a 2 mm gauge sieve. These samples were then packeted and stored in the same way as the plant material.

Soil Analysis and Preparation

Soil Organic content. Approximately 10 gms of each of the dried, lightly ground and sieved soil samples were accurately weighed into clean porcelain crucibles with lids. These crucibles were then placed in a muffle furnace and heated to 325°C for 24 hours. These were then removed and allowed to cool in a large dessicator. The ash was then weighed and the weight loss attributable to the organic fraction calculated.

Soil Extracts

(i) Exchangeable

The "exchangeable" ions in the soil were extracted with N. ammonium acetate at room temperature. The extraction procedure consisted of steeping 2.5 gms of the soil sample in 250 mls of the ammonium acetate solution for 24 hours. The soil particles were then filtered off and the filtrate evaporated almost to dryness to drive off the ammonia. The remaining solution was made up to 250 cc in a calibrated flask. Two exchangeable extracts of each soil sample were prepared and the analysis results were derived from the means of these samples.

(ii) Total

The "total" soil extracts were prepared by wet ashing (for method see Jeffries and Willis 1964). Again duplicates of each soil sample were prepared.

Plant Extracts

The dried plant material was cut into small pieces and wet ashed as above. Replicates and blank "controls" were prepared for analysis.

Cations

The monovalent cations, Sodium and Potassium, were determined by flame photometry using an EEL flame photometer.

Magnesium, Calcium, Zinc, Lead were determined by atomic absorption spectrophotometry (David 1960). Precautions were taken to suppress possible phosphate interference in the analysis of calcium (David 1959).

Anion

Phosphate was determined by a single solution method (Murphy and Riley).

APPENDIX II

THE "DOING" SCALE

This scale was developed to overcome the main weaknesses of the Braun-Blanquet system (Barkman, et al. 1964). These were considered to be:-

- (i) the use of a combined scale for estimation of abundance and cover.
- (ii) the lack of equivalence in the range of values of each class with most other existing scales.
- (iii) the inexact definition of degrees of abundance and sociability.

The "Doing" scale treats cover and abundance separately. It is perhaps an oversensitive method for general phytosociological usage but for detailed comparisons in either temporal or spatial contexts it is a more precise tool than the Braun-Blanquet method.

The cover scale only was used in this study.

vegetation cover %	<u>Doing Cover Scale</u>
2	-
2-5	00
5-15	01
15-25	02
25-35	03
35-45	04
45-55	05
55-65	06
65-75	07
75-85	08
85-95	09
> 95	10

BIBLIOGRAPHY

- ALLISON, J., GODWIN, H. and WARREN, S.H. (1952) Late-glacial deposits at Nazeing in the Lea Valley, North London. *Phil. Trans. B.* 236; 169.
- BARKMAN, J.J., DOING, H. and SEGAL, S. (1964) Kritische Bemerkungen und Vorschläge zur quantitative vegetationsanalyse. *Acta Botanica Neerlandica* 13; 394.
- BECKING, R.W. (1957) The Zurich-Montpellier school of phytosociology. *Bot. Rev.* 23; 411.
- BELLAMY, D.J., BRIDGEWATER, P., MARSHALL, C. and TICKLE, W.M. (1969)^a Status of the Teesdale Rarities. *Nature* 222, No. 5190; 238.
- BELLAMY, D.J., BRIDGEWATER, P., JONES, A. and MARSHALL, C. (1969)^b Teesdale Rarities. *Nature* 224, No. 5219; 619.
- BELLAMY, D.J. and TICKLE, W.M. (1965) A critical limit of primary production for the survival of arctic-alpine plants in the Northern Pennines of England. *Proc. Unesco Symp. on Subarctic Ecol.*, Uppsala.
- BRADSHAW, M.E., and CLARKE, W.A. (1965) Flora and vegetation, in the Natural History of Upper Teesdale. Ed. D.H. Valentine. Northumberland and Durham Naturalists Trust, Newcastle.
- BRAUN BLANQUET, J. (1964) *Pflanzensoziologie*. Wien, Springer Verlag, 865 pp.
- BRIDGEWATER, P. (1970) Phytosociology and community boundaries of the British heath formation. Ph.D. Thesis, Durham, 2 vols.
- CHAMBERLIN, T.C. (1965) The method of multiple working hypotheses. *Science* 148; 754.
- CLAPHAM, A.R., TUTIN, T.G. and WARBURG, E.F. (1962) *Flora of the British Isles*, 2nd Edn. Cambridge, 1268 pp.
- CLYMO, R.S. (1962) An experimental approach to part of the calcicole problem. *J. Ecol.* 50; 707.
- CLYMO, R.S. (1970) The growth of *Sphagnum*: methods of measurement. *J. Ecol.* 58; 51.

- ✓ COOMBE, D.E. and WHITE, F. (1951) Notes on calcicolous communities and peat formation in Norwegian Lapland. *J. Ecol.* 39; 33.
- ✓ CRAWFORD, R.M.M. and WISHART, D. (1967) A rapid multivariate method for the detection and classification of groups of ecologically related species. *J. Ecol.* 55; 505.
- CRAWFORD, R.M.M. and WISHART, D. (1968) A rapid classification and ordination method and its application to vegetation mapping. *J. Ecol.* 56; 385.
- ✓ DAHL, E. and HADAC, E. (1949) Homogeneity of plant communities. *Studia Botanica Cechoslovaca* 10; 159.
- DAUBENMIRE, R. (1966) Vegetation: identification of tygal communities. *Science* 151; 291.
- ✓ DAVID, D.J. (1959) The determination of calcium in plant material by atomic absorption spectrophotometry. *Analyst* 84; 536.
- ✓ DAVID, D.J. (1960) The determination of exchangeable sodium, potassium, calcium and magnesium in soil by atomic absorption spectrophotometry. *Analyst* 85; 495.
- ✓ GIMMINGHAM, C.H., PRITCHARD, N.M. and CORMACK, R.M. (1966) Interpretation of a vegetational mosaic on limestone in the Island of Gotland. *J. Ecol.* 54; 481.
- ✓ GITTINS, R.T. (1965) Multivariate approaches to a limestone grassland community. I, a stand ordination. *J. Ecol.* 53; 385.
- ✓ GLASSPOOLE, J. (1932) The rainfall of the Tees Valley. *Brit. Rainfall*; 289.
- ✓ GODWIN, H. and WALTERS, S.M. (1967) The scientific importance of Upper Teesdale. *Proc. Bot. Soc. Brit. Isles* 6; 348.
- GOODALL, D.W. (1963) The continuum and the individualistic association. *Vegetatio* 11; 297.
- ✓ GREIG-SMITH, P. (1964) *Quantitative Plant Ecology*. 2nd Edn. Butterworth and Co., London, 256 pp.

IVEMEY-COOK, R.B. and PROCTOR, M.C.F. (1966) The application of association analysis to phytosociology. *J. Ecol.* 54; 179.

JEFFREY, D.W. and PIGOTT, C.D. (1970) Some notes on the Kobresia problem. Teesdale Symposium, Durham.

JEFFRIES, R.L. and WILLIS, A.J. (1964) Studies on the Calcicole-Calcifuge habit. I Methods of analysis of soil and plant tissue and some results on investigations on four species. *J. Ecol.* 52; 121.

JENNY, H. (1958) Role of the Plant factor in the pedogenic functions. *Ecology* 39; 5.

JOHNSON, G.A.L. (1965) Geology in The Natural History of Upper Teesdale. Ed. D.H. Valentine. Northumberland and Durham Naturalists Trust, Newcastle.

KERSHAW, K.A. (1964) Quantitative and Dynamic ecology. Edward Arnold Ltd., London, 183 pp.

KOTANSKA, M. (1967) Biomass dynamics of underground plant organs in some grassland communities of the Ojeow National Park. *Bulletin de L'Academie Polonaise des Sciences*. Cl. II. 15; 625.

LAMBERT, J.M. and WILLIAMS, W.T. (1962) Multivariate methods in plant ecology. IV Nodal Analysis. *J. Ecol.* 50; 775.

LEEUWEN, C.G. VAN (1966) A relation theoretical approach to pattern and process in vegetation. *Wentia* 15; 25.

LOHMEYER, W. (1962) Contribution a l'unification du systeme phytosociologique pour l'Europe moyenne et nord-occidentale. *Melhoramento* 15.

LOOMAN, J. (1964) The distribution of some lichen communities in the Prairie Provinces and adjacent parts of the Great Plains. *The Bryologist* 67; 209.

VAN DER MAAREL, E. Vegetationsprenzen auf Kleinstem Raum; Über ihre Analyse und Typologie. Tatsachen und Probleme der Grenzen in ver vegetation. Rinteln, Weser. April, 1968. (in press).

MILNE, C. and HUGHES, R.E. (1968) Methods for the measurement of the Primary Production of Grassland. *Int. Biol. Prog. Handbook*. No. 6; 82 pp.

- MITCHELL, G.F. (1953) Further identifications of macroscopic plant fossils from Irish Quaternary deposits, especially a late-glacial deposit at Mapastown, Co. Louth. Proc. Roy. Irish Acad. B. 55; 221.
- MURPHY, J. and RILEY, J.P. (1962) A modified single solution method for the determination of phosphate in natural waters. Anal. Chim. Acta. 27; 31-36.
- NYHOLM, E. (1954-1965) Illustrated Moss Flora of Fennoscandinavia. Gleerups, Lund.
- PIGOTT, C.D. (1956) Vegetation of Upper Teesdale. J. Ecol. 44; 545-586.
- POORE, M.E.D. (1955) The use of phytosociological methods in ecological investigations. I The Braun-Blanquet System. J. Ecol. 43; 226-244.
- RADFORTH, N.W. (1962) Proceedings 1st Canadian Conference on permafrost. Tech. Memo 76. Res. Council Canada; 57-78.
- SHIMWELL, D. (1968) Phytosociology of calcareous grasslands in the British Isles. Ph.D. Thesis, Durham.
- SIEBERT, P. (1968) Die Pflanzengesellschaften im Naturschutzgebiet "Pupplinger Au". Landschaftspflege und Vegetationskunde Heft 1 78 pp.
- SQUIRES, R.H. (1970) A contribution to the vegetational history of Upper Teesdale. Ph.D. Thesis, Durham.
- TANSLEY, A.G. (1911) (editor). Types of British Vegetation. Cambridge Univ. Press, 416 pp.
- TURNER, J. and HEWETSON, V.P. (1970) Stratigraphical and Palynological evidence for the post-glacial environment and history of the Teesdale Flora. Teesdale Symp., Durham.
- WATSON, E.V. (1963) British Mosses and Liverworts. Cambridge Univ. Press, 419.
- WHITTAKER, R.H. (1952) A study of summer foliage insect communities in the Great Smoky Mountains. Ecol. Monogr. 22; 1-44.

- WHITTAKER, R.H. (1956) Vegetation of the Great Smoky Mountains. Ecol. Monogr. 26; 1-80.
- WILLIAMS, W.T. and LAMBERT, J.M. (1959) Multivariate methods in plant ecology. I Association-analysis in plant communities. J. Ecol. 47; 83-101.
- WILLIAMS, W.T. and LAMBERT, J.M. (1961) Multivariate methods in plant ecology. III Inverse association-analysis. J. Ecol. 49; 717-729.
- WILMOTT, A.J. (1935) Evidence of survival of British Flora in Glacial times. Proc. Roy. Soc. B. 118; 215-222.
- WISHART, D. (1969) An algorithm for hierarchical classification. Biometrics 22; 165-170.
- WISHART, D. (1969) CLUSTAN 1A User Manual. Computing Lab., St. Andrews; 118 pp.
- YARRANTON, G.A. (1966) A plotless method of sampling vegetation. J. Ecol. 54; 229-237.

ADDITIONS TO BIBLIOGRAPHY

- BLACKBURN, K.B. (1952) The dating of a deposit containing an elk skeleton found at Neasham near Darlington, Co. Durham. *New Phytol.* 51; 364.
- BRADSHAW, M.E. (1970) Population Dynamics of certain Teesdale Species. Teesdale Symposium Durham.
- McVEAN, D. and RATCLIFFE, D.A. (1962) Plant communities of the Scottish Highlands. H.M.S.O., London.
- MANLEY, G. (1942) Climate in Northern Britain. *Quart. Journ. Ross Meteorological Soc.* 68; 151.
- MILLAR, A. (1970) Climate. Teesdale Symposium Durham.
- NEWBOULD (1967) in Milne and Hughes (1968).



STATUS OF THE TEESDALE RARITIES

By

D. J. BELLAMY, P. BRIDGEWATER, C. MARSHALL

and

W. M. TICKLE

Status of the Teesdale Rarities

by

D. J. BELLAMY
P. BRIDGEWATER
C. MARSHALL
W. M. TICKLE

Department of Botany,
University of Durham

On the basis of field evidence, two hypotheses are advanced to account for the existence of "arctic alpine" plants in Upper Teesdale. They involve a critical limit of primary production and boundary instability.

UPPER Teesdale in the Northern Pennines of England has long been famous for its rich and peculiar flora^{1,2}, which includes prealpine, alpine, arctic alpine and sub-arctic plants³—"Teesdale rarities". Most of these are fairly abundant between the 300 and 600 m contours, which in an area at approximately latitude 54° 40' N. on the Atlantic coast of Europe is remarkable.

Manley⁴ has described the climate at 840 m on the western boundary of Upper Teesdale: "We therefore form

a conception of an excessively windy and pervasively wet autumn, a very variable and stormy winter with long spells of snow-cover, high humidity and extremely bitter wind, alternating with brief periods of rain and thaw. April has a mean temperature little above freezing point and sunny days in May are offset by cold polar air, while the short and cloudy summer is not quite warm enough to support the growth of trees. Throughout the year indeed the summits are frequently covered in cloud". He calls

the climate of the high western ridge sub-arctic, but emphasizes the marginal nature of this upland climate: "A relatively slight increase in the frequency of warm anticyclonic summer weather would allow a rise in mean temperature almost sufficient to permit the growth of trees".

Yet more than 300 m lower on both north and south facing slopes, ecosystems harbouring arctic alpine plants are widespread in conditions which might therefore be regarded as marginal for their survival.

The proportion of English gardens situated below the 300 m contour and the abundance of arctic alpiners in seed catalogues should be proof enough that these plants will grow at even low altitudes and in dryer situations, with much longer growing periods than the "arctic wastes" of Upper Teesdale.

We have two hypotheses to account for the restriction of the range of these plants in natural situations, and their relative abundance in Upper Teesdale. These involve, first, a critical limit of primary production, and, second, boundary instability.

Critical Limit of Primary Production

The importance of competition, or at least the lack of it, to the survival of arctic alpine plants has been discussed widely (refs. 3 and 5 are directly relevant). There are, however, few or no empirical data available concerning this important factor.

We have studied the floristic make-up and productivity of the "wetland ecosystems" of Upper Teesdale in relation to their mineral supply. Wetland ecosystems in the limited sense of this work are defined as ecosystems with a watertable, above, at or very near the substrate surface, the substrate remaining saturated throughout the year. These can be subdivided into two principal groups. (a) Blanket mires, which occupy watersheds which are covered with a blanket of peat (varying in thickness from a few centimetres to 4 m), with water and minerals supplied directly in rainfall. (b) Flushed ecosystems, which can be subdivided into those which (1) occupy the drainage axes of the blanket mire and are affected by run-off from peat covered catchments; (2) are supplied with run-off or spring water from the acid rocks of the area (mainly quartz dolerite) and from glacial drift formed from quartz dolerite; and (3) are supplied with spring water derived from the extensive deposits of Carboniferous Limestone in the area and from glacial drift and boulder clay formed from the limestone.

We mapped representative series of the "wetland ecosystems" and described their vegetation using standard phytosociological techniques⁸, combined with the use of point quadrats.

Differential analysis of the floristic data using Kulezynski's formula⁹ revealed a cline of wetland communities falling into seven groups, each with its own characteristic species. The direction of variation of this cline

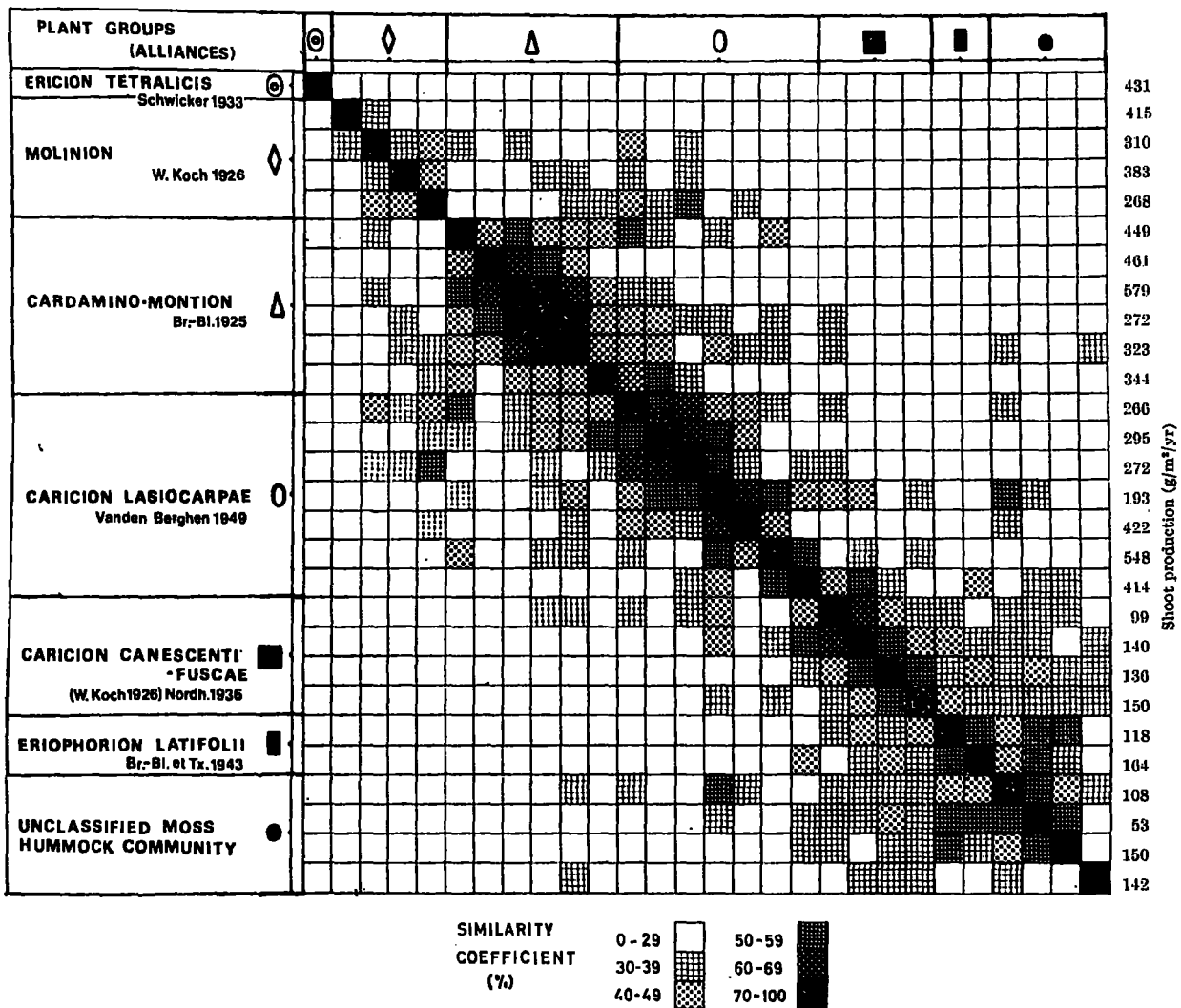

Fig. 1. Floristic groups of wetland ecosystems and their shoot production.

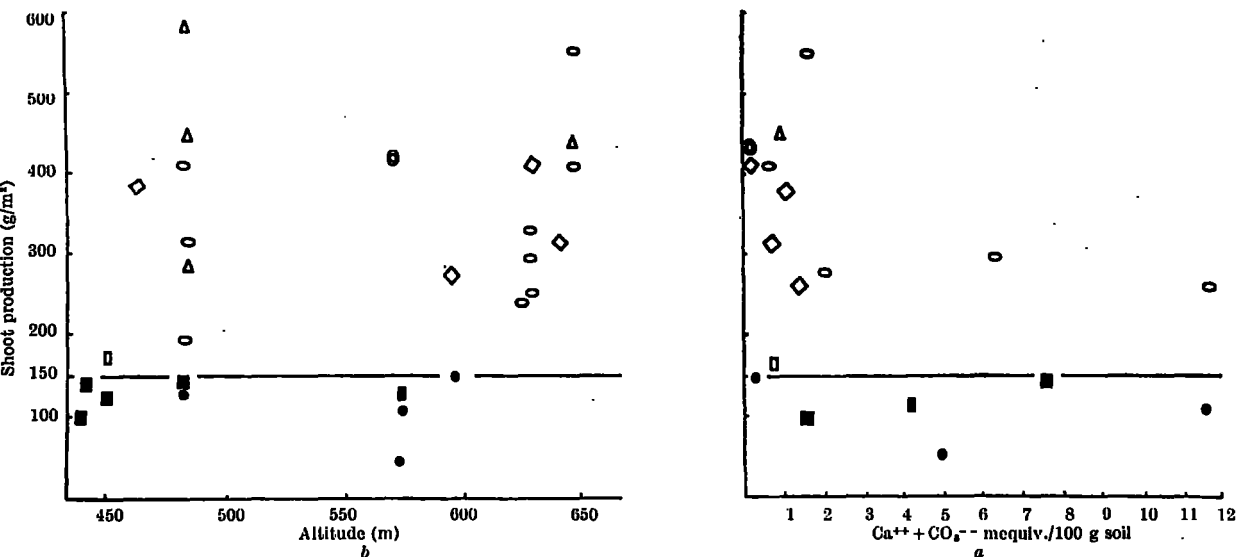

Fig. 2. Shoot production in relation to: (b) altitude, and (a) combined content of calcium and total carbonate of soil. Floristic groups denoted by symbols as in Fig. 1.

seems to be related to the increase in the effect of flowing bicarbonate-rich ground water¹⁰ passing from the blanket mire ecosystems to those developed in spring waters derived from the limestone.

The Kulczynski diagram in Fig. 1 shows the results of the differential analysis of the reduced matrix of sites used in the production studies.

Soil samples, collected from each community, were dried and aliquots were extracted with 2 N ammonium acetate¹¹, and analysed for calcium and magnesium (atomic absorption spectrophotometer) and sodium and potassium using a flame photometer. Total carbonates were determined by shaking dried soil with standard acid followed by back titration using bromothymol blue as indicator. The pH was determined on fresh soil samples made liquid with distilled water.

Sixteen wetland communities covering the seven floristic types were fenced in early 1965 against grazing by sheep and cattle. These ranged in altitude from 440 to 640 m Ordnance Datum. To minimize damage to rare communities, regular cropping was carried out on only two sites. For this the exclosures at either end of the altitudinal range were sited around communities which are widespread in the area, and which contain no rare plants. These were sampled monthly by paired, clipped quadrats, each 0.5 m² in size. As soon as the aerial standing crop became constant in the highest exclosure, cropping of the other enclosed communities began, gradually working downwards. All the crops were sorted into monocotyledons, dicotyledons and bryophytes, and then each component was sorted into current and previous year's growth. The components were dried to constant weight at 100° C. From the results a mean figure for the net annual aerial production per square metre was calculated. We shall refer to this simply as "shoot production".

The Hypothesis

Many Teesdale communities which contain arctic alpine species have a total vegetation cover of less than 30 per cent. Interspecific competition seems likely to be greatest in communities with maximum cover value, and so only results for communities with 100 per cent cover are discussed here.

Fig. 2 shows the values for shoot production plotted: (a) against the combined content of calcium and total carbonate /100 g dry weight of soil (as a rough edaphic scaler), and (b) against altitude (as a rough climatic scaler). Manley¹² states that for the Northern Pennines,

"a slight increase in elevation is accompanied by a remarkably large decrease in the length of the growing season (a shortening of 10 days for 80 m)".

Clearly there is no correlation between shoot production and either of these factors. But all communities containing arctic alpine species (shown on the figures in solid symbols) have an annual dry weight shoot production of less than 150 g/m².

Comparable figures for the shoot production of a whole range of true alpine tundra ecosystems are given in Table 1. The figures are all taken from Bliss¹³ and 75 per cent of

Table 1. SHOOT PRODUCTION

Bliss (1960)	Upper Teesdale
	579 Grass spring
	548 Brown moss spring
	461 Grass spring
	440
	431 <i>Polytrichum</i> heath
	422 Brown moss spring
	415 Tall rush mire
	414 Brown moss spring
	383 Tall rush mire
	344 Grass spring
	323
	310 Tall rush mire
	295 Brown moss spring
Heath 283	272 Heather moor
	272 Grass spring
	272 Brown moss spring
	208 Tall rush mire
	266 Brown moss spring
Snowbank	200
<i>Saxifraga-Antennaria</i>	193
<i>Artemisia</i> dry meadow	192
Calamagrostis wet meadow	180
Sedge meadow	176
	164 Sedge-rush sward
<i>Carex</i> dry meadow 150	150 Cushion community
	150 Sedge-rush sward
<i>Sibbaldia-Agrostis</i> 141	142 Cushion community
	140 <i>Carex</i> turf
	136 " "
Moist swales	24-125
Heath-rush meadow	124
	118 Sedge-rush sward
Sedge-rush heath	112
<i>Carex-Deschampsia</i> wet meadow	112
<i>Geum-sedge</i> , South slope	112
	108 Cushion community
<i>Carex-Deschampsia</i> , moist meadow	13-102
<i>Arenaria-Eriogonum</i> , dry meadow	78
Heath-rush fellfield	74
Turf sites	11-68
<i>Diapansia</i>	67
<i>Carex-Geum</i> turf	6-80
<i>Geum-Saxif</i> meadow	58
	53 Cushion community
<i>Geum-Sedge</i> , north slope	45
<i>Carex-Deschampsia</i>	40
Cushion plants	28
<i>Carex-Sibbaldia-Erigeron</i>	21

Shoot production is measured in g (dry wt/m²).

Table 2

	Calories/g ash free dry wt	
	Mt Washington	Upper Teesdale
Evergreen shrubs	5,098	5,239
Herbs	4,801	4,710
Mosses	4,410	4,410

them have a shoot production of less than 150 g/m²/annum. It is interesting that the highest shoot production given by Bliss is from a community dominated by woody perennials (tundra heath). This is certainly ecologically similar to the blanket mire ecosystems of Upper Teesdale, dominated by *Calluna vulgaris*, which have a shoot production of 272 g/m²/annum. Upper Teesdale ecosystems containing arctic alpine and true tundra ecosystems are also similar in the calorific value of the plant materials.

Table 2 gives comparative figures for Upper Teesdale and Mount Washington¹⁴. Bliss comments on the high calorific values of tundra plants, linking them to the storage of fats and surmising on the importance of energy-rich food stores in ecosystems with a short growing season.

Teesdale ecosystems seem to have much in common with true alpine tundra ecosystems, and it seems reasonable to speculate that the critical figure of 150 g dry weight shoot production/m² is of more than local significance in the survival of the type of plants in question.

In true arctic and alpine areas, harshness of climate and especially the short growing season must limit the production of the ecosystems. Also, instability of the substrate due to frost action and wind, rain and rime erosion could easily account for the maintenance of the ecosystem in an open "skeletal" form. In Upper Teesdale the action of herbivores, chiefly sheep, could well account for the latter effect⁵.

Boundary Instability

Against this background of low productivity we considered the floristic make-up of the region using phytosociology, *sensu* Braun-Blanquet⁵, and the descriptive ecological approach of Williams and Lambert¹⁵⁻¹⁷. Phytosociology considers the floristic structure of the communities, from which sociological units are abstracted. The basic unit is the "association" (analogous to the term "species"), numbers of which are combined into a hierarchy of alliances, orders and finally classes. Lohmeyer¹⁸

summarized the units described for north-west Europe and his nomenclature is used throughout.

Two typically Alpine orders, the *Seslerietalia* and the *Tofieldietalia*, although of restricted occurrence in the British Isles, meet in Upper Teesdale, particularly in the Cow Green area destined to be flooded. In Europe the "Teesdale rarities" occur in the associations of these two orders. The relationship between these two orders was explored by a study of the west-facing slope of Slapestone Syke on Widdybank Fell (grid ref. 35/812303, 480 m O.D.). The syke (small stream) drains a partially peat covered catchment and cuts down through the overlying glacial drift into the Melmerby Limestone beneath. The soils of the valley side form a catena from peat covered drift through various admixtures to limestone; they also become progressively wetter downslope due to seepage from limestone aquifers draining into the syke.

The upper part supports species-rich open heath and grassland communities dominated by *Sesleria caerulea* referable to the *Seslerietalia*, and the lower part sedge dominated communities referable to the *Tofieldietalia*.

The area was studied by means of a transect of contiguous 1/4 m² quadrats, the date being subjected to normal inverse and nodal analysis^{15,16}. Normal analysis compares homogeneity of quadrats based on their species content and divides them into related groups (Fig. 3), while inverse analysis in similar fashion divides the species into groups (Fig. 4). The combination and refining of the results of these two analyses produce a doubly defined set of units, or nodes, *sensu* Lambert and Williams¹⁷, of differing quantitative and qualitative definition. These have been rearranged to clarify their relationships in Fig. 5, from which two principal types of community have been defined.

Type 1, defined by the following nodes, 4/12, 4/1, 4/7, has the same floristic composition throughout, that is *Juncus articulatus*, *Kobresia simplicicaulis*, *Carex panicea* and *Carex lepidocarpa*. All these species are found in associations of the order *Tofieldietalia* and *C. lepidocarpa* is a "charakterarten" of the Alliance *Eriophorion latifolii* of that order.

Type 2, defined by the nodes 24/23, 24/31, 24/28, contains *Hylocomium splendens*, *Sesleria caerulea*, *Festuca ovina*, *Thymus drucei* and, except in node 24/31, *Gallium saxatile* and *Rhynchospora loreus*. This more difficult social

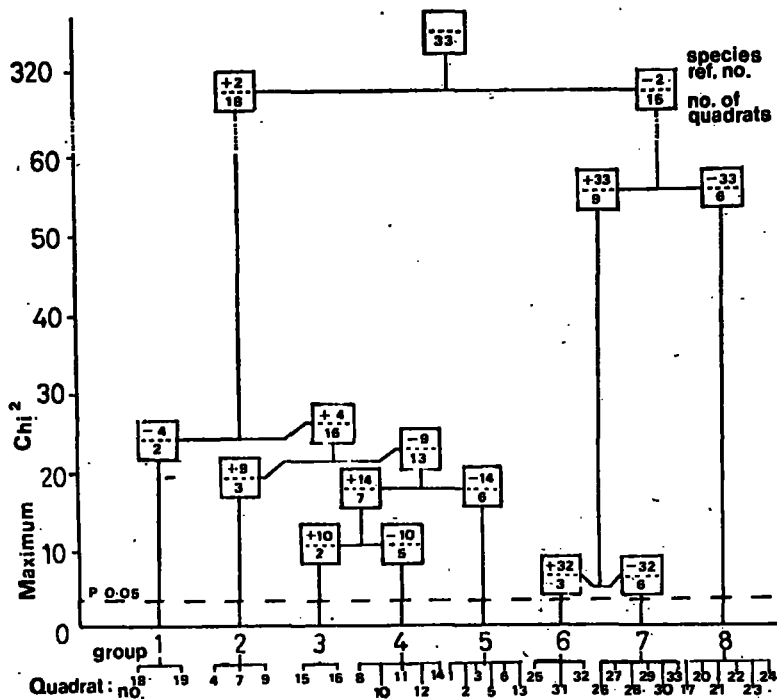

Fig. 8. Normal analysis.

grouping is referable to any of the orders Seslerietalia, Nardetalia or Brometalia.

A transition zone separates these two principal types and is characterized by many minor sub-noda and weak, poorly defined species groups. These constitute a distinct abrupt definable boundary zone much resembling the "limes convergens" situation, a zone of vegetational instability rather than a zone of continuous transition^{19,20}. Here occur three of the "Teesdale rarities" which are more widespread in the British Isles, being typical of open skeletal pioneer communities, *Plantago maritima* (Juncetalia maritimae of Saltmarsh), *Equisetum variegatum* (Scheuzerio-Caricetea fuscae of Montane flush and duneslack) and *Minuartia verna* (Violetalia calaminariae of heavy metal spoil heaps). In this zone of instability they exist, however, in a closed community with complete plant cover. One environmental variable which could account for this zone of instability by preventing the stabilization of either of the two principal vegetational types is the oscillation of the ground water in this wet to dry boundary zone.

This phenomenon is not restricted to Slapstone Syke. Pigott³ described the chief habitat of *Minuartia stricta* as a narrow zone around the bases of *Gymnostomium recurvirostrum* hummocks in open gravel flushes. *M. stricta* also occurs along Red Syke on Widdybank Fell in a closed bryophyte turf which forms a distinct boundary zone between the flushed vegetation of the syke and the bank above the normal level of flowing water. Table 3 gives the results of 100 point quadrats spaced at 0.5 cm intervals in a linear frame along the three chief zones at two sites. The communities of zone 3 at both sites belong to the Tofieldietalia, while those of zone 1 at site 1 belong to the Erico Sphagnetalia (blanket mire) and at site 2 to the Seslerietalia.

Perhaps the classic example of boundary zone species are the mosses *Paludella squarrosa*, *Oxycodidium stygium* and *Camptothecium nitens*. Although widespread in the arctic²¹ their relict localities are typical of a transition zone between associations of the Erico Sphagnetalia and Tofieldietalia, a zone of abrupt ecological transition²². The effect of changes in water regime brought about by drainage has been used to explain the disappearance of these species from numerous relict localities^{23,24}.

The importance of such boundaries to the existence of

certain species is thus indicated, and it is suggested that all such species are intolerant of competition. It does, however, seem somewhat dubious to argue the existence of relict species over long periods of time involving appreciable climatic changes in such restricted unstable habitats.

There is also the presence, and indeed abundance, of species such as *Tofieldia pusilla* and *Kobresia simpliciuscula*, which are not restricted to such zones and in fact are defining species for the type 1 community, yet to be explained. These points can be partly answered by considering the overall boundary nature of the vegetation of Upper Teesdale, representing as it does an area of contact between associations of two orders of vegetation developed in a climatically marginal situation. That is a large scale example of a boundary complex of vegetation types fluctuating with changes in macro and micro climate—a constantly varying complex, unstable in detailed pattern, but stable in overall make-up, approximating to the "limes divergens" situation, in which many rare plants and rare combinations of plants may be expected^{19,20}.

Typical of the "limes divergens" situation are the associations of the class Trifolio-Geranietea. These appear to represent the seral stages between grassland and forest, but there are basic and integral differences. The true seral communities are classified in the order Prunetalia spinosae, whose associations do not contain the character species of the Trifolio-Geranietea. The associations of this class are all restricted to the margins of cultivated land where succession is prevented by man's influence; it must be made clear they are distinct communities, characterized by certain regionally restricted species.

Upper Teesdale bears abundant evidence of the effect of man, for example, trails, spoil heaps and concentrated sheep grazing. This effect could well account for the contemporary stabilization of the boundary complex, and thus for the existence of considerable tracts of unique vegetation in this area.

We therefore suggest that in Teesdale we are not simply dealing with the stabilization of early seral stages, but with the production of specialized communities which are phytosociologically distinct. Only the complete phytosociological description of the area will clarify this. So far, however, results indicate the need to erect a new class of vegetation, analogous to the Trifolio-Geranietea. This

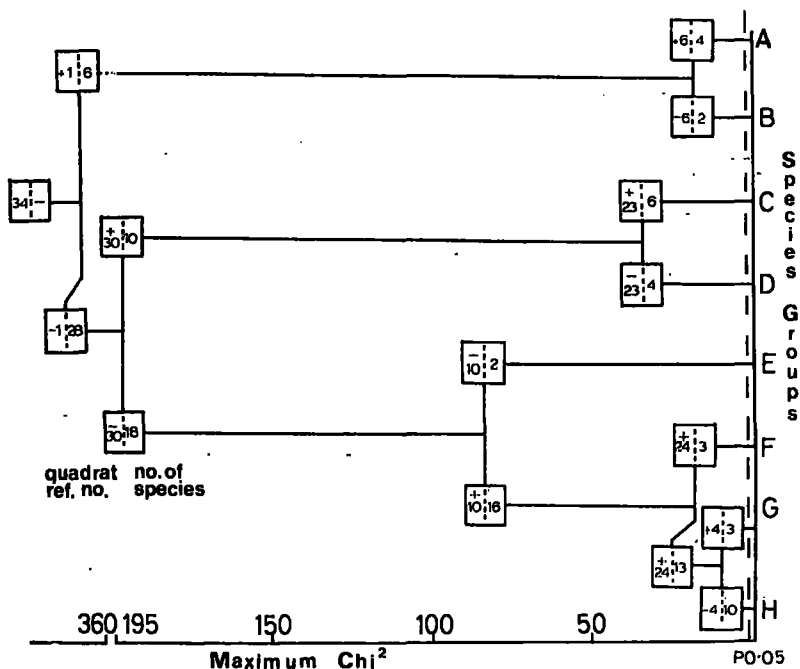

Fig. 4. Inverse analysis.

QUADRATS group ref. no.	SPECIES	4		5					2			3		1					8					6			7					
		12	8	10	11	14	1	2	3	5	6	13	7	8	4	15	16	18	19	23	24	20	27	22	17	31	32	25	26	27	28	29
A	4 KOBRESIA SIMPLICIUSCULA	4/12		4/1					4/7			4/15		/18																		
	1 CAREX PANICEA	4/12		4/1					4/7			4/15		/18																		
	2 C. LEPIDOCARPA	4/12		4/1					4/7			4/15		/18																		
E	13 PRUNELLA VULGARIS	13/12										13/15																				
	14 CAMPYLUM STELLATUM	13/12										13/15																				
B	5 CTENIDIUM MOLLUSCUM	5/12		5/1					5/7			5/15		5/18					6/23													
	6 POTENTILLA ERECTA	5/12		5/1					5/7			5/15		5/18					6/23													
GIOMINUARTIA VERNA												10/15																				
H	17 CLADONIA IMPEXA											/15																				
	18 RHACOMITRIUM LANUGINOSUM											/15																				
	19 EQUISETUM VARIAGATUM											/15																				
D	20 PLANTAGO MARITIMA											/16																				
	21 RICCARDIA PINGUIS											/16																				
	31 PLEUROZIUM SCHREBERI											/16																				
C	32 CALLUNA VULGARIS																							/31			31/28					
	28 RHYTIADDELPHUS SQUARROSUS																							/31			31/28					
	9 CAMPANULA ROTUNDFOLIA																							/31			31/28					
F	25 PSEUDOSCLEROPODIUM PURUM																															
	27 THUIDIUM TAMARISCINUM																															
	4 POLYTRICHUM JUNIPERINUM																															
C	29 GALLIUM SAXATILE																															
	23 RHYTIADDELPHUS LOREUS											/18																				
	15 THYMUS DRUCEI											/18																				
	22 FESTUCA OVINA											/18																				
C	12 SESLERIA CAERULEA																															
	24 HYLOCOMIUM SPLENDENS																															

Fig. 5. Extraction of vegetation units.

poses the following problem: Is the special vegetation of Upper Teesdale truly relict, or is it a product of recent land use? If the former, what stabilized the boundary

complex; if the latter, where did the "Teesdale rarities", now acting as adventives, exist before the advent of man on the catchment?

This work was carried out while two of us (W. T. and P. B.) held NERC research studentships, and while D. J. B. and C. M. were working under a grant from the ICI Teesdale Trust Fund. We thank the Raby and Strathmore Estates for permission to work on their lands, the Nature Conservancy for permission to work in the Upper Teesdale N.N.R., and John Peters, Hugh Proctor and Tom Buffey, for their assistance and hospitality.

Received January 9; revised February 24, 1966.

¹ Backhouse, J., and Backhouse J., *Phytologist*, 1, 892 (1843).

² Valentino, D. H., *The Natural History of Upper Teesdale*, 70 (Northumberland, Durham, Nat. Trust, Newcastle upon Tyne, 1965).

³ Pigott, C. D., *J. Ecol.*, 44, 545 (1956).

⁴ Manley, G., *Quart. J. Ross Meteorol. Soc.*, 68, 151 (1942).

⁵ Coombe, D. E., and White, F., *J. Ecol.*, 39, 33 (1951).

⁶ Bellamy, D. J., *Bericht 9 Intern. Kong. fur Univ. Moor und Torf* (1965).

⁷ Bellamy, D. J., and Holland, P., *Oikos*, 17, 272 (1966).

⁸ Braun-Blanquet, J., *Pflanzensoziologie*, 805 (Springer Verlag, Wien, 1964).

⁹ Kulczynski, S., *Mem. Acad. Sci. Cracoviae, Series B*, 1 (1949).

¹⁰ Bellamy, D. J., *Proc. Third Intern. Peat Cong. Quebec* (in the press).

¹¹ Jeffries, R. L., and Willis, A. J., *J. Ecol.*, 52, 121 (1964).

¹² Manley, G., *Geog. Rev.*, 35, 408 (1945).

¹³ Bliss, L. C., *Ecol. Monog.*, 28, 303 (1960).

¹⁴ Bliss, L. C., *Ecology*, 43, 753 (1962).

¹⁵ Williams, W. T., and Lambert, J. M., *J. Ecol.*, 47, 83 (1959).

¹⁶ Williams, W. T., and Lambert, J. M., *J. Ecol.*, 49, 717 (1961).

¹⁷ Lambert, J. M., and Williams, W. T., *J. Ecol.*, 50, 775 (1962).

¹⁸ Lohmeyer, W., *Contributions à l'unification du système phytosociologique pour l'Europe moyenne et nord-occidentale*, Melhoramento 25 (Élvas, 1962).

¹⁹ Leeuwen, C. G. Van, *Gortaria*, 2 (1965).

²⁰ Leeuwen, C. G. Van, *Wentia*, 15, 25 (1965).

²¹ Nyholm, E., *Illustrated Moss Flora of Fennoscandia* (Gleerups, Lund, 1954-1965).

²² Bellamy, D. J., and Rieley, J., *Oikos*, 18, 1 (1967).

²³ Bellamy, D. J., Bradshaw, M. E., Millington, G., and Simmons, I., *New Phytol.*, 65, 429 (1966).

²⁴ Janowski, M., *Zaklad. Ochron. Przyrody. Polsk. Akad.*, R.33, 70-124 (1968).

Table 3

Zone 1	Site 1	Site 2
Order	Erico Sphagnetalia	Seslerietalia
	<i>Calluna vulgaris</i> 2	<i>Agrostis stolonifera</i> 1
	<i>Erica tetralix</i> 14	<i>Carex panicea</i> 9
	<i>Primula farinosa</i> 1	<i>C. pulicaris</i> 24
	<i>Sphagnum capillaceum</i> 22	<i>Festuca ovina</i> 7
	<i>S. papillosum</i> 47	<i>Linum catharticum</i> 3
	<i>S. robustum</i> 3	<i>Minuartia verna</i> 9
	Bare ground 11	<i>Primula farinosa</i> 5
		<i>Sesleria caerulea</i> 21
		<i>Riccardia pinguis</i> 7
		Bare ground 14
Width of zone	More than 10 m	4-5 m
Zone 2		
<i>Armeria maritima</i>	1	0
<i>Minuartia stricta</i>	4	7
<i>Thalictrum alpinum</i>	0	3
<i>Selaginella selaginoides</i>	11	0
<i>Hepharostoma trichophyllum</i>	0	1
<i>Bryum pseudotriquetrum</i>	1	9
<i>Campyllum stellatum</i>	2	41
<i>Catascopium nigratum</i>	30	0
<i>Cratoneuron commutatum</i> var. <i>falcatum</i>	17	19
<i>Preissia quadrata</i>	21	4
<i>Riccardia pinguis</i>	2	10
Bare ground	5	0
Width of zone	8 cm	24 cm
Zone 3		
Order	Tofieldietalia	Tofieldietalia
<i>Carex dioica</i>	4	9
<i>C. lepidocarpa</i>	8	3
<i>Kobresia simpliciuscula</i>	21	11
<i>Primula farinosa</i>	3	11
<i>Thalictrum alpinum</i>	2	3
<i>Tofieldia pusilla</i>	4	3
<i>Equisetum variegatum</i>	0	0
<i>Cratoneuron commutatum</i>	8	9
<i>C. commutatum</i> var. <i>falcatum</i>	28	21
<i>Drepanocladus revolvens</i>	9	0
<i>D. revolvens</i> var. <i>intermedius</i>	0	1
<i>Scorpidium scorpioides</i>	0	4
Bare ground	13	25
Width of zone	4-7 m	2-2 m

Teesdale Rarities

SIMS¹ suggests that instability of substrate resulting from wind and water erosion could be a factor relevant to the existence of the Teesdale rarities, and asks the question, "Have the bare areas been the subject of critical study?"

In his classic paper on the vegetation of Upper Teesdale, Pigott² described the vegetation of the bare areas in detail and critically discussed the role of erosion by water and wind in the maintenance of their skeletal communities. He emphasized the important part played by herbivores, especially their trampling in the erosional process. Reference to his lists shows that the meagre flora of these areas includes both rare and common species, indicating that they simply represent habitats, albeit severe, which are open to colonization by any organism which can gain and maintain a foothold.

The vegetation of Widdybank Fell consists of the following. (1) The pure communities, all of which are of widespread occurrence in northern Britain³ and each of which is referable to one of several orders sensu Braun Blanquet⁴. The Teesdale rarities are poorly represented in these communities. (2) Skeletal, retrogressive and pioneer communities, subject to the erosion phenomena under discussion. (3) Areas of closed vegetation dominated by *Sesleria caerulea* (L.) Ard., which can be classified into the association Seslerietum-Caricetum pulicariae Shim⁵. This association, together with its variants, forms a phytogeographical link between the lowland base rich grasslands of the class Festuco-Brometea Br.-Bl. and R.Tx., and the arctic alpine grasslands of the class Elyno-Seslerietea Br.-Bl.⁶ The Teesdale rarities are well represented in these communities. (4) Tracts of closed vegetation, which consist of either patchworks of the pure communities, or admixtures of species from two, rarely more, of the pure communities. These boundary complexes, which include some of the variants of (3), are, however, not just admixtures, they are characterized by the presence, abundance and even dominance of the Teesdale rarities.

The existence of species, which are considered to be intolerant of competition, within the bare areas, is easily understood. The widespread occurrence of closed communities, which are rich in these species, must be accounted for. It is suggested that analysis of the status of the boundary complexes holds the key to that of the Teesdale rarities.

There seems little doubt that the active erosion taking place today is a retrogressive process and as such represents a threat to certain plant populations. But the

relationship, if any, between the stable boundary complexes and past erosion phenomena (for example, erosion surfaces and loess and outwash deposits) is an important facet of the study of the Teesdale problem. Detailed phytosociological, ecological and pedological studies, which include exclosure experiments, are under way within the area.

D. J. BELLAMY
P. BRIDGEWATER
A. JONES
C. MARSHALL

Department of Botany,
University of Durham.

Received August 28, 1960.

¹ Sims, C., *Nature*, 222, 980 (1960).

² Pigott, C. D., *J. Ecol.*, 44, 645 (1956).

³ MoVean, D. N., and Ratcliffe, D. A., *Plant Communities of the Scottish Highlands* (HMSO, London, 1962).

⁴ Braun-Blanquet, J., *Pflanzensoziologie*, 865 (Springer Verlag, Vienna, 1964).

⁵ Shilmwell, D., *Mitt fur-soz Arbeitsgem.*, 14, 309 (1969).

