

## Durham E-Theses

---

### *Studies on group ii metal alkyls particularly those of beryllium*

P.D. Robert

#### How to cite:

---

Robert, P.D. (1968) Studies on group ii metal alkyls particularly those of beryllium. Doctoral thesis, Durham University.

#### Use policy

---

The full-text may be used and/or reproduced, and given to third parties in any format or medium, without prior permission or charge, for personal research or study, educational, or not-for-profit purposes provided that:

- a full bibliographic reference is made to the original source
- a <https://etheses.durham.ac.uk/id/eprint/8717/> is made to the metadata record in Durham E-Theses
- the full-text is not changed in any way

The full-text must not be sold in any format or medium without the formal permission of the copyright holders.

Please consult the [full Durham E-Theses policy](#) for further details.

STUDIES ON GROUP II METAL ALKYL  
PARTICULARLY THOSE OF BERYLLIUM

by

P.D. ROBERTS, B.Sc.

A thesis submitted for the Degree of Doctor of Philosophy  
in the University of Durham

JULY 1968



P322

### Acknowledgements

The author wishes to thank Professor G.E. Coates, M.A., D.Sc., F.R.I.C., under whose supervision this research was carried out, for his constant encouragement and valuable advice.

Thanks are also given to Dr. A.J. Downs, formerly of the University of Newcastle upon Tyne, for his help with vibrational spectroscopy and to members of this department, especially Dr. N.A. Bell, who have taken part in many valuable discussions.

The author is indebted to the Scientific Research Council for a Research Studentship.

## Memorandum

The work described in this thesis was carried out in the University of Durham between September 1965 and June 1968. The work has not been submitted for any other degree and is the original work of the author except where acknowledged by reference.

Part of the work has been the subject of two publications in the Journal of the Chemical Society, [J.Chem.Soc.A, 1967, 1085; 1967, 1233].

## Summary

Analysis of the vibrational spectrum of di-t-butylberyllium in conjunction with the infrared spectrum of the fully deuterated derivative and of di-t-butylzinc suggests that the molecules are monomeric with linear C-M-C skeletons. Assignment of the vibrational frequencies of the heavy atom skeleton has been carried out. Di-t-butylberyllium is monomeric in benzene solution and in the vapour phase.

1:1 Complexes between di-t-butylberyllium and  $MMe_3$  ( $M = N, P$ ) are described. The p.m.r. spectrum of the N,N,N',N'-tetramethylethylenediamine (TMED) complex,  $Pr^i_2Be(TMED)$ , does not change with temperature, in contrast to that of  $Bu^t_2Be(TMED)$ .

The halides  $Bu^tBeX, OEt_2$  ( $X = Cl, Br$ ) are dimeric in benzene, and the chloride is monomeric in diethyl ether.

Di-t-butylberyllium reacts with N,N,N'-trimethylethylenediamine producing a monomeric compound,  $Bu^tBeNMeC_2H_4NMe_2$ . In contrast, di-n-propyl- and di-isopropyl-beryllium react with the same amine forming dimeric products. The p.m.r. spectrum of the latter is temperature dependent.

The complexes  $Bu^tBeOC_2H_4NMe_2$ ,  $Bu^tBeSC_2H_4NMe_2$ , and  $MeZnSC_2H_4NMe_2$  are dimeric in benzene solution.

Ether-free beryllium dialkyls ( $R_2Be$ ,  $R = Et, Pr^n, Bu^n, Bu^i$ ) can be obtained by a process of prolonged boiling of the ether complexes under reflux at low pressure. All the above ether-free beryllium dialkyls are dimeric in benzene. The proton magnetic resonance spectra (p.m.r.) of some of the beryllium dialkyls are described. In several cases there is a marked temperature and solvent dependence.

Pyrolysis of di-t-butylberyllium to the  $RBeH$  stage produced a mixture of t-butyl- and isobutyl-beryllium hydrides. Pyrolysis of di-isobutylberyllium resulted in the formation of isobutylberyllium hydride. Some co-ordination complexes of isobutylberyllium are described.

A co-ordination complex of beryllium hydride,  $(H_4Be_2)TMED$ , has been prepared.

## Table of Contents

	Page
<u>Introduction</u>	1-69
Group II Metal Alkyls and their Co-ordination Compounds	5-11
Beryllium	5
Magnesium	8
Zinc, Cadmium, and Mercury	10
Reactions of Metal Alkyls with Acidic Hydrogen	12-38
Beryllium	13
Zinc	22
Magnesium	30
Cadmium	37
Mercury	38
Anionic Complexes of the Group II Dialkyls	39
Organometal Halides of Group II	40-41
Hydride Chemistry of Beryllium	42-56
Hydride Chemistry of Magnesium	57-60
Hydride Chemistry of Zinc, Cadmium, and Mercury	61-64
Spectroscopic Studies on Organic and Hydride Derivatives	
of Group II	65-69

	Page
<u>Experimental</u>	
Apparatus and Techniques	70-72
Analyses	73-80
Preparation and Purification of Starting Materials	81-89
Reactions of dimethylzinc	90-92
Physical Properties and reactions of di-t-butylberyllium	92-104
Reactions of di-t-butylzinc	104-107
Reactions of di- <u>isopropyl</u> beryllium	107-109
Reactions of di-n-propylberyllium	109-112
Ether free diethylberyllium	112
P.m.r. spectra of beryllium dialkyls	113
Pyrolysis of [2-dimethylaminoethyl(methyl)amino t-butylberyllium]	114
Pyrolysis of di-t-butylberyllium	114-118
Preparation of di- <u>isobutyl</u> beryllium	119-122
Pyrolysis of di- <u>isobutyl</u> beryllium	122-125
Co-ordination compounds of <u>isobutyl</u> beryllium hydride	126-128
Decomposition of di-t-butylberyllium	128-130
Co-ordination compounds of beryllium hydride	130-133
Reactions of <u>isobutyl</u> beryllium hydride with olefins	133-134

	Page
<u>Discussion</u>	135-177
The vibrational spectra and molecular structures of di-t-butyl-beryllium and -zinc	135-146
Reactions of di-t-butylberyllium with bases and weak acids	147-152
Ether free beryllium di-alkyls	153-156
Reactions of zinc dialkyls with weak acids	157-159
P.m.r. spectra of beryllium dialkyls	160-164
Hydride chemistry	165-

Tables

Index

## INTRODUCTION

This thesis is concerned with preparative and structural studies on organic and hydride derivatives of beryllium and zinc.

The organic compounds of beryllium, calcium, strontium, and barium have been reviewed<sup>1</sup> (covering the literature to early 1961), and the co-ordination chemistry of beryllium, zinc and cadmium, and mercury was reviewed in 1966.<sup>2</sup> Organoberyllium compounds have been the subject of a very recent review by Fetter, covering the literature to early 1967.<sup>3</sup> This review includes a catalogue of all known organoberyllium compounds together with physical properties and preparative details. Organometallic compounds of the main group elements have been the subject of a recent book,<sup>4</sup> as have metal hydrogen compounds.<sup>5</sup>

This introduction will be concerned with organic and hydride derivatives of beryllium, magnesium, zinc, cadmium, and mercury together with relevant work on boron and aluminium. The structural problems of Grignard reagents will not be discussed in this thesis; they have been discussed in two reviews.<sup>6,7</sup> The organic derivatives of calcium, strontium, and barium will not be discussed as their organic chemistry, so far as it is known, is more akin to that of the heavier elements of Group I.

Preparative methods in organometallic chemistry of these elements are covered in detail in books, earlier theses, and review articles<sup>3,4,8,9,10</sup> and the relevant literature references can be obtained from them.



Preparative aspects are not, therefore, discussed in detail in this introduction.

Both beryllium and magnesium form 'electron-deficient' compounds, these are compounds in which an atom makes use of more orbitals than the number of available valence electrons, resulting in a structure in which the total number of valence electrons is less than twice the number of conventional electron pair bonds. This type of bonding is found in dimethylberyllium and dimethylmagnesium, both of which are polymeric solids.

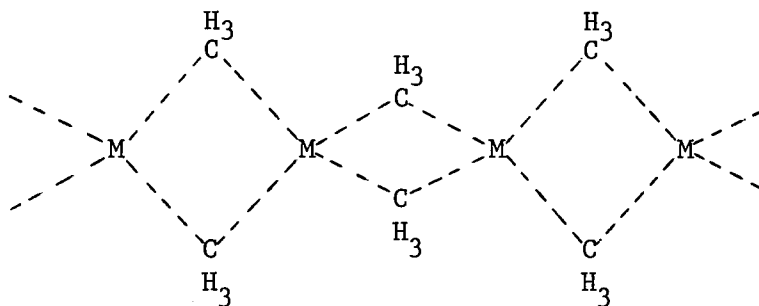

M = Be or Mg

The crystal structures have been determined by X-ray diffraction and the relevant data are tabulated:

	Me <sub>2</sub> Be <sup>11</sup>	Me <sub>2</sub> Mg <sup>12</sup>
M-M	2.09 ± 0.01 Å	2.73 ± 0.02 Å
M-C	1.93 ± 0.02 Å	2.24 ± 0.03 Å
∠ CMC	114 ± 1°	105 ± 2°
∠ MCM	66 ± 1°	75 ± 2°

The bonding can be explained in terms of 'three centre' molecular orbitals<sup>13</sup> formed from metal sp<sup>3</sup> hybrid orbitals and the remaining sp<sup>3</sup> orbital of carbon.

The organic compounds of zinc, cadmium, and mercury do not show the same tendency to form electron deficient compounds. The increased size of the metal atom resulting in the non-existence or poor overlap of the relevant orbitals. Hence dimethylzinc, -cadmium, and -mercury are monomeric liquids of normal covalent structure.<sup>14,15,16,17</sup>

Beryllium compounds are known in which the co-ordination number of the metal atom is two, three, or four. Two co-ordinate beryllium is relatively rare. It had been suggested that ether-free di-tert-butyl-beryllium is monomeric on vapour pressure grounds and hence would be the first example of two-co-ordinate beryllium at room temperature.<sup>4</sup> The only other example of a compound in which two-co-ordinate beryllium is present at room temperature is the silazane derivative, [(Me<sub>3</sub>Si)<sub>2</sub>N]<sub>2</sub>Be, which has been shown, by vibrational and p.m.r. spectroscopy, to have a linear N-Be-N skeleton and planar BeNSi<sub>2</sub> groups.<sup>18</sup>

Three-co-ordinate beryllium occurs in the dimeric metal alkyls,  $(R_2Be)_2$ , and in the aminoberyllium alkyls,  $(RBeNR'_2)_n$  where  $n = 2$  or  $3$  depending on steric considerations.<sup>19</sup> Four-co-ordinate beryllium is most common and is found, for example, in solid dimethylberyllium<sup>11</sup> and is likely to be present in the tetrameric alkylberyllium alkoxides.<sup>20</sup>

No organomagnesium compounds are known in which the co-ordination number of the metal is two: generally organomagnesium compounds contain four-co-ordinate magnesium in the  $sp^3$  hybridised state. This co-ordination number is attained either by polymerisation e.g.  $(Me_2Mg)_n$  or by the formation of a co-ordination compound, e.g.  $PhMgBr(OEt_2)_2$ .<sup>22</sup> Co-ordination numbers of three<sup>22</sup> and five<sup>23,24</sup> have also been suggested for some organomagnesium compounds.

Co-ordination numbers of two, three, and four are known for organo-zinc, -cadmium, and -mercury compounds.

## The Group II Metal Alkyls and their Co-ordination Compounds

### Beryllium

In contrast with dimethylberyllium which is a solid polymer as discussed earlier, the known higher alkyls are liquids at room temperature and are less associated. The degrees of association (cryoscopically) of diethylberyllium, in benzene and cyclohexane solutions respectively, are reported to be 2.09 and 2.39, these values increasing to 3.58 and 3.16 after 240 days.<sup>25</sup> Di-isopropylberyllium<sup>26</sup> and di-n-butylberyllium<sup>27</sup> are dimeric (cryoscopically) in benzene solution.

The co-ordination chemistry of the beryllium alkyls is well documented.<sup>2,28</sup> Complexes of the form  $R_2Be.L$  and  $R_2Be.L_2$  (L = ligand) are known with monodentate ligands and 1:1 complexes with bidentate ligands. In order to form complexes of dimethylberyllium the heat of formation of the complex must exceed the heat of depolymerisation of the dimethylberyllium. Studies on dimethylberyllium indicate that the order of heat of formation of co-ordinate links to beryllium is  $N > P > O \gg As, S$ , and no co-ordination compounds of dimethylberyllium with trimethylarsine or dimethylsulphide are known.<sup>29</sup> Similar results are obtained for trimethylaluminium<sup>30</sup> and trimethylgallium,<sup>31</sup> when there is no possibility of  $\pi$ -bonding complicating the system.

Trimethylamine forms 1:1<sup>29</sup> and 2:1<sup>32</sup> complexes with dimethylberyllium, the 2:1 complex is less stable than the 1:1 complex and has a

dissociation pressure of 22.7 mm. Hg of trimethylamine at 0°. The previously reported compound  $(\text{Me}_2\text{Be})_2(\text{NMe}_3)_3$ <sup>29</sup> has been shown to be a mixture of the two complexes.<sup>32</sup> With trimethylphosphine the situation is more complex since the heat of co-ordinates of trimethylphosphine with dimethylberyllium is of the same order of magnitude as the heat of depolymerisation of dimethylberyllium. Therefore a complex set of equilibria are set up and a range of compounds,  $(\text{Me}_3\text{P})_x(\text{Me}_2\text{Be})_y$  where  $x = 2, 3, 1, 2, 2, 2$  and  $y = 1, 2, 1, 3, 4, 5$  are formed. Each compound being stable over a range of temperature and pressure of trimethylphosphine.<sup>29</sup>

Diethylberyllium forms 1:1 and 1:2 complexes with trimethylamine<sup>33</sup> but only 1:1 complexes are known for di-isopropylberyllium<sup>26</sup> and di-tert-butylberyllium,<sup>34</sup> the latter not having been obtained in a pure state. Pyridine forms stable, coloured, crystalline 2:1 complexes with beryllium di-alkyls ( $\text{R} = \text{Me}, \text{Et},$ <sup>35</sup>  $\text{Pr}^i,$   $\text{Bu}^t$ <sup>36</sup>).

Dimethyl- and diethyl-ether also co-ordinate to dimethylberyllium but the complexes have high dissociation pressures at room temperature.<sup>29</sup> The higher beryllium alkyls all retain ether to a certain extent ( $\text{R}_2\text{Be}:\text{OEt}_2$  is  $\sim 1:1$ ) but the ether can be removed, by prolonged pumping under reflux, from di-isopropylberyllium.<sup>26</sup>

A series of 1:1 and 1:2 complexes of diphenylethynylberyllium with N and O donors have been prepared.<sup>37</sup> Those complexes which are sufficiently soluble in benzene have been found to be monomeric in that solvent (cryoscopically).

Crystalline 1:1 complexes are formed from beryllium di-alkyls and bidentate ligands, e.g. N,N,N',N'-tetramethylethylenediamine (TMED) forms the complexes  $R_2Be \cdot TMED$  where  $R = Me,$ <sup>35</sup>  $Et,$ <sup>36</sup>  $PhC \equiv C.$ <sup>37</sup> Dimethylberyllium<sup>32</sup> and diphenylberyllium<sup>38</sup> form similar complexes with N,N,N',N'-tetramethyl-o-phenylenediamine and 1,2-dimethoxyethane.

2,2'-Bipyridyl reacts with beryllium alkyls and halides to form a series of coloured compounds of the general formula  $bipyBeX_2$  where  $X = Cl, Br, I, Ph, Et, Me,$ <sup>35</sup> and  $PhC \equiv C.$ <sup>37</sup> Similar complexes from di-iso-propyl-, di-n-butylberyllium and isopropyl-beryllium hydride decomposed to brown tars.<sup>35</sup> Spectroscopic studies on these compounds have shown that the molar extinction coefficient of these compounds increases as the electronegativity of the group attached to beryllium decreases, the colours are explained by electron transfer from the Be-X bond to the lowest unoccupied molecular orbital of the bipyridyl  $\pi$  system.<sup>35</sup> The colours of the compounds are in agreement with this, with  $X = Cl, PhC \equiv C,$  the complexes are white;  $X = Br,$  pale cream;  $X = I, Ph, Me,$  yellow; and  $X = Et,$  red.

With tetramethylhydrazine the complex  $Me_2NNMe_2(BeEt_2)_2$  is formed<sup>39</sup> and in benzene solution both monomers and dimers are present in solution, association probably being through bridging ethyl groups as nitrogen already has maximum co-ordination. This result contrasts with the fission of O-O bonds in the reaction of  $Bu^tO-OBu^t$  with dimethylberyllium to produce  $[MeBeOBu^t]_4$ <sup>20</sup> and EtS-SEt with diethylberyllium to produce  $[EtBeSEt]_4$ .<sup>40</sup>

Tetramethyltetrazene (TMT) forms 1:1 and 1:2 complexes with diethyl- and di-isopropylberyllium, the 2:1 complex being formed by pyrolysis of the 1:1 complex at 70-90°. These complexes are formulated:

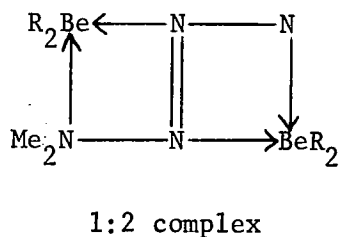
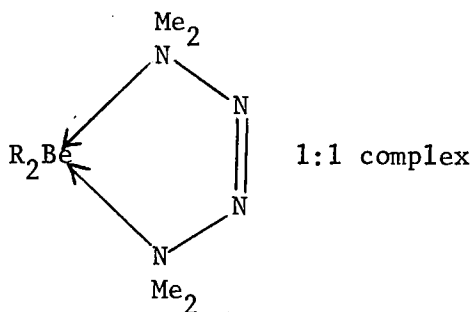

A corresponding 1:1 complex is formed with di-tert-butylberyllium but on pyrolysis the complex  $\text{Bu}_2^t\text{Be} \cdot \text{TMT} \cdot \text{Bu}^t\text{BeH}$  is formed, not the 1:2 complex as for the lower alkyls.<sup>41</sup>

### Magnesium

Dimethyl-<sup>12</sup> and diethylmagnesium<sup>42</sup> have been shown by X-ray powder diffraction methods to be polymeric solids containing magnesium-alkyl-magnesium bridges. They are insoluble in non-donor solvents and with one exception the higher alkyls, up to the butyls, have similar physical properties and are reasonably assumed to consist of long polymer chains. Di-sec-butylmagnesium has been prepared by the reaction between sec-butylmagnesium chloride and sec-butyl-lithium in ether and removing the ether by distillation after adding benzene. The product is dimeric in benzene solution.<sup>43</sup> The same authors have used this procedure to prepare mixed alkyls of magnesium.

Until recently very little work has been done on the co-ordination complexes of the magnesium dialkyls. X-ray structural studies have shown that the magnesium dialkyls form stronger polymers than beryllium dialkyls and therefore it is expected that the co-ordination compounds of magnesium dialkyls will not form so easily, and will lose the donor molecule more readily, than the corresponding beryllium compound. For example, dimethylmagnesium absorbs trimethylamine but no stoichiometric complex was isolated.<sup>44</sup> The dissociation pressure is given by the equation:

$$\log_{10} p(\text{mm.}) = 11.66 - 3316/T^{\circ}\text{K}$$

corresponding to a heat of dissociation of 15.2 kcal./mole of trimethylamine<sup>4</sup>, a marked contrast to the beryllium case where the dissociation pressure is unmeasurable at room temperature.<sup>29</sup>

Stable 1:1 complexes with N,N,N',N'-tetramethylethylenediamine (TMED) have been prepared where R = Et, Pr<sup>n</sup>, Pr<sup>i</sup>, Bu<sup>n</sup>,<sup>45</sup> Me, Ph, Bu<sup>t</sup>.<sup>46</sup> These are all solids, except for Bu<sub>2</sub><sup>n</sup>MgTMED which is a liquid, and can be sublimed unchanged in vacuo. In contrast the 1:1 complexes of dimethylmagnesium with N,N,N',N'-tetramethyl-o-phenylenediamine and 1,2 dimethoxyethane lose ligand on heating.<sup>46</sup> No stable complex of dimethylmagnesium with 2,2'-bipyridyl can be obtained, a yellow crystalline complex is initially formed but rapidly darkens, presumably due to addition of Mg-C across the C=N of the bipyridyl.<sup>46</sup>

Complexes with monodentate ligands are not well defined except in the case of  $\text{Ph}_2\text{Mg}(\text{THF})_2$  which does not dissociate in benzene solution in which it is monomeric.<sup>46</sup> Dimethylmagnesium can be crystallised, from solution in diethylether, free of ligand.<sup>47</sup>

### Zinc, cadmium, and mercury

The co-ordination chemistry of zinc and cadmium has been discussed at length in a review<sup>2</sup> and only the most recent work will be discussed here. Co-ordination compounds of mercury dialkyls are only known when the alkyl groups are halogenated.<sup>48</sup>

A dielectric titration procedure has been used to study the formation and stability constants of 1:1 complexes of zinc dialkyls with N,N,N',N'-tetramethylethylenediamine (TMED) and 2,2'-bipyridyl (bipy).<sup>49,50</sup> The results show that for the TMED complexes the order of stability is  $\text{Me} > \text{Et} > \text{Pr}^i > \text{Bu}^t$ . This is as expected because electron releasing substituents increase the electron density on the metal thereby weakening the co-ordinate bonds with TMED which is a pure  $\sigma$ -donor.<sup>50</sup> Steric effects will also affect complex stability and this order, shown above, follows the sequence for both polar and steric effects.<sup>50</sup> In the bipyridyl complexes the observed order of stability is reversed and cannot be explained simply in terms of  $\sigma$ -bonding.  $\pi$ -Bonding in transition metal complexes is favoured if the metal atom carries a formal negative charge or if the metal is substituted with electron donating groups.<sup>52,53</sup> Taking into account the relative electron donating properties of the

alkyl groups, synergic  $\sigma$ - $\pi$  bonding would be more effective in going from Me to Bu<sup>t</sup> in the series.<sup>50</sup> Zinc has a full d electron shell and the transference of one of these electrons to the heterocyclic  $\pi^*$  system could be responsible for the transition,<sup>54</sup> and not an  $\sigma$ - $\pi^*$  transition as in the beryllium case.<sup>35</sup> Recent work<sup>55,56</sup> on a series of R<sub>2</sub>Zn.bipy complexes (R = CH<sub>3</sub>-C<sub>9</sub>H<sub>19</sub>) has resulted in the following MO bonding scheme being proposed:

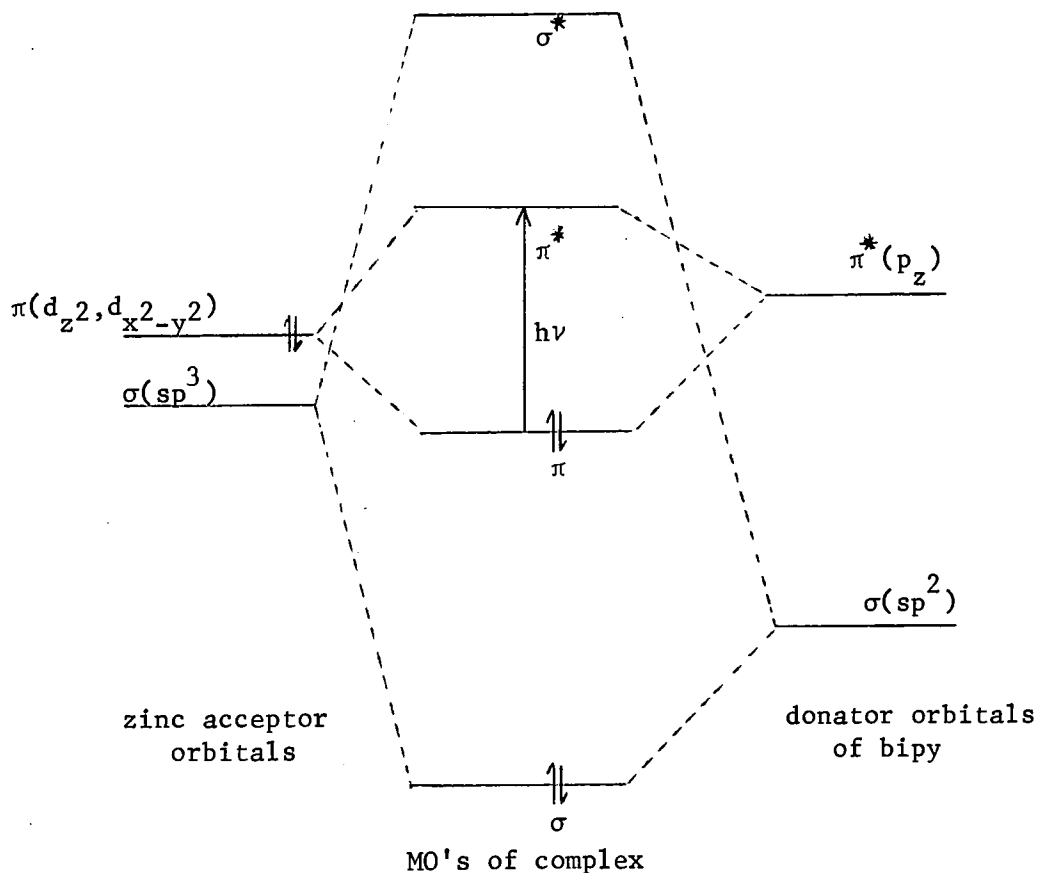

A  $\pi$ - $\pi^*$  transition being responsible for the light absorption.<sup>56</sup>

Reactions of Metal Alkyls with Acidic Hydrogen

Reaction of a Group II metal alkyl with a substance containing acidic hydrogen (HA) occurs in two stages:

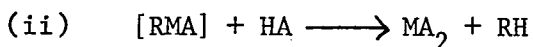
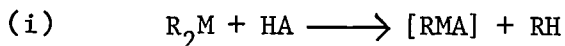

The compound RMA, if monomeric, would be co-ordinatively unsaturated at the metal atom, and the metal atom would have enhanced acceptor characteristics due to being attached to the more electronegative (than R in  $R_2M$ ) entity A. If the residue A possesses any lone-pair electrons on the atom attached to the metal atom then their donor properties will be enhanced due to the polarity of the M-A bond. Therefore the RMA species may be expected to undergo some associative process to remove the co-ordinative unsaturation of the metal atom.

The degree of association of this type of complex appears to be affected by four factors,<sup>57</sup> although the relative importance of them is not understood. The associative process may be written:

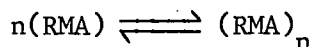

$$\Delta G = \Delta H - T\Delta S = -RT \ln K$$

1. Entropy factors. For association to take place  $\Delta G$  must be negative and this can be achieved if  $\Delta S$  is positive.  $\Delta S$  will be more positive the greater the number of particles per unit mass, and thus

entropy factors alone favour small values of n.

2. Steric interference. By the use of molecular models it can be shown that there is less interference between bulky substituents in dimers than in trimers, thus when bulky groups are present dimers are favoured relative to trimers.

3. Valency angle strain. The associated compound will tend to have the least possible strain. Valency angle strain is more readily tolerated by the heavier elements.<sup>58</sup>

4. Nature of the reaction intermediates. Polymeric intermediates formed by an inter-molecular condensation will favour polymers, tetramers and trimers as the isolated species. A monomeric intermediate will favour a dimer as the associated species.<sup>57</sup>

The majority of the work on the factors affecting the degree of association of such compounds has been carried out on the Group III metal alkyls. In recent years a considerable effort has been put into a study of the Group II metal alkyls, particularly those of beryllium, zinc and magnesium, with amines, alcohols and thiols.

#### Reactions of organoberyllium compounds with acidic hydrogen

In Table 1 are listed a number of aminoberyllium alkyls prepared by the reaction of a beryllium dialkyl (or diaryl) with one mol. of a secondary amine. From the Table it can be seen that the degree of association is three except when bulky groups are present, when the less sterically hindered dimer is formed. Entropy factors would favour the

formation of dimers (2,1) over trimers (2,2). However, the average ring angle in the dimer must be  $90^\circ$  and valence angle strain would be appreciable.

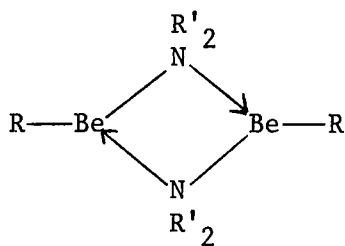

(2,1)

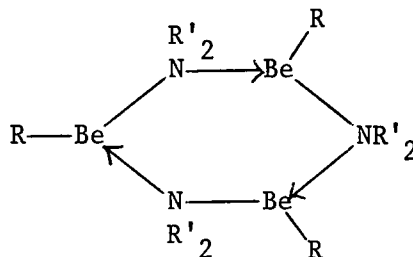

(2,2)

Rough calculations show that valency angle strain will be the most important factor except when bulky groups are present.<sup>19</sup> Both dimeric and trimeric products contain three-co-ordinate beryllium and therefore should react with bases. Table 2 lists some of the products formed from aminoberyllium alkyls with pyridine and 2,2'-bipyridyl. In some instances the reactions are complicated by disproportionation processes. The reaction of  $(\text{MeBeNMe}_2)_3$  with pyridine, however, takes place without complication:

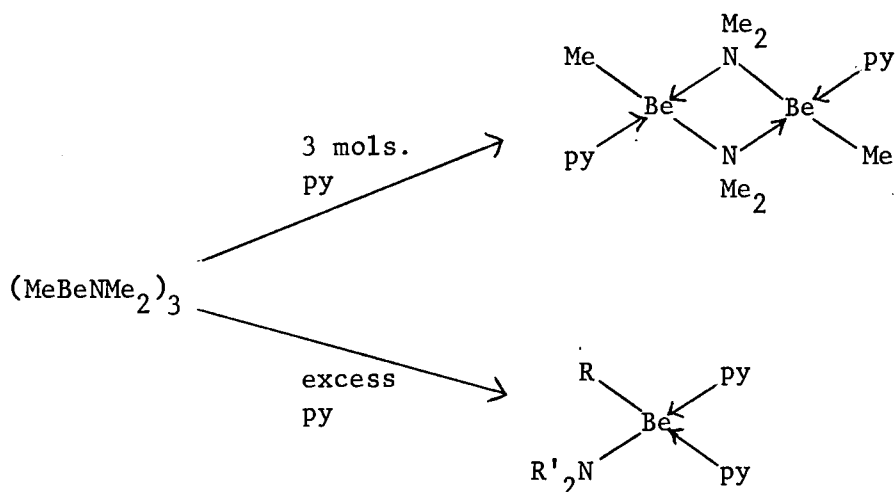

Reactions between organoberyllium compounds and secondary amines usually proceed rapidly to completion, and in some instances both alkyl groups can be replaced by secondary amino groups.<sup>26,61,62</sup> In contrast di-t-butylberyllium forms a 1:1 adduct with dimethylamine, and complete evolution of isobutane could not be achieved even on heating to  $70^\circ$ .<sup>19</sup> Construction of a model of the complex showed that the amino hydrogen is so shielded that it cannot come within reaction distance of a Be-C bond either in the same or a neighbouring molecule.

Dimethylberyllium forms a complex with N,N,N'-trimethylethylenediamine which evolves methane at room temperature forming a dimeric product (2,3):<sup>35</sup> Reaction of ethylenediamine, N,N- and N,N'-ethylenediamine with dimethylberyllium results in polymer formation.<sup>35</sup>

Di-isopropylberyllium reacts with excess dimethylamine to form bisdimethylaminoberyllium which is trimeric in benzene solution and in the vapour phase.<sup>26</sup> The structure (2,4) was originally proposed for the compound.

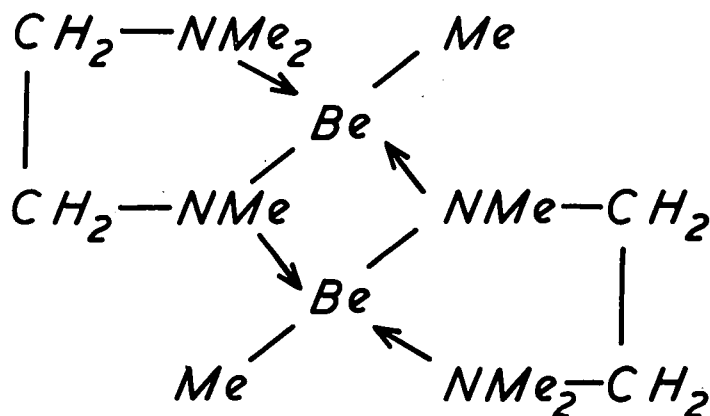

(2,3)

The p.m.r. spectrum, in benzene solution, of bisdimethylaminoberyllium shows two resonances at  $\tau$  4.28 and 4.90 in the ratio of 1:2, and the structure (2,5) has been proposed.<sup>61</sup> A recent X-ray structural analysis has confirmed structure (2,5).<sup>63</sup>

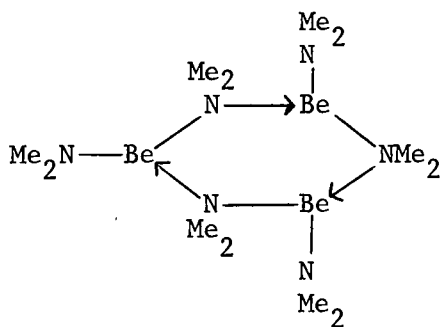

(2,4)

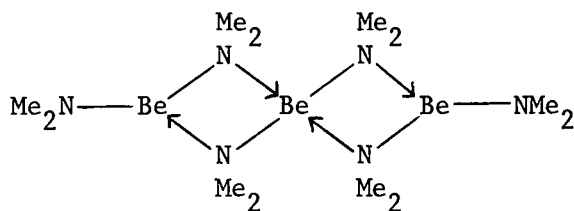

(2,5)

Extension of the p.m.r. work to the measurement of the  $^{13}\text{C}$ -H coupling constants has indicated the possibility of  $(\text{p} \leftarrow \text{p})\pi$  bonding between beryllium and the terminal dimethylamino groups in (2,5). This is further substantiated by the geometry of the molecule, since in the terminal dimethylamino-beryllium group  $\text{BeNC}_2$  are coplanar.<sup>63</sup>

Diethylberyllium reacts with diphenylamine (2 mols.) to form an insoluble, polymeric, material  $[\text{Be}(\text{NPh})_2]_x$ .<sup>62</sup>

Reactions between beryllium alkyls and primary amines are more complex. Dimethylberyllium reacts with methylamine evolving methane, but the product has not been fully characterised.<sup>59</sup> Similarly ammonia reacts with  $\text{R}_2\text{Be}$  ( $\text{R} = \text{Me}, \text{Et}$ ) but alkane evolution is not quantitative even at  $50^\circ$ , polymeric products of the form  $\text{R}-(\text{BeNHBe})-\text{NH}_2$  were obtained, but were not fully characterised.<sup>64</sup> The reaction between dimethylberyllium and t-butylamine has been carried out for a variety of stoichiometries:<sup>65</sup>

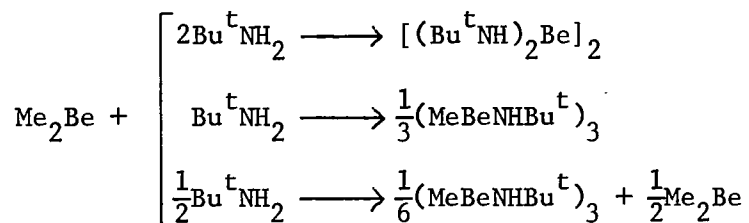

The dimer is assigned the structure (2,1) and the trimer (2,2) as discussed earlier. The failure of  $(\text{MeBeNHBu}^t)_3$  to react with dimethylberyllium is probably due to steric effects. The trimer,  $(\text{MeBeNHBu}^t)_3$ , eliminates methane on heating, but not quantitatively. After 72 hours at  $110^\circ$  only 66% of the expected methane was evolved.<sup>65</sup>

Table 3 lists a series of alkylberyllium alkoxides prepared mainly by alcoholysis of beryllium dialkyls. Most of the alkoxides are tetrameric in benzene solution, but lower degrees of association result when the organic groups are large, e.g.  $(\text{EtBeOCEt}_3)_3$ ,  $(\text{MeBeOCPh}_3)_2$ , and  $(\text{Bu}^t\text{BeOBu}^t)_2$ . The tetramers probably have the cubane structure as found in the methylzinc methoxide tetramer (to be discussed later). The size of both the alkoxy group and the alkyl group attached to beryllium affect the degree of association, an effect clearly shown by methylberyllium t-butoxide which is a tetramer whereas t-butylberyllium t-butoxide is a dimer.<sup>20</sup> The effect of size of the alkoxy group is shown by the series:  $(\text{MeBeOCH}_2\text{Ph})_4$ ,  $(\text{MeBeOCHPh}_2)_2$ ,  $(\text{MeBeOCPh}_3)_2$ . Organoberyllium alkoxides have been prepared by the addition of an alkylberyllium hydride to aldehydes or ketones,<sup>60</sup> and by the addition of beryllium dialkyls to aldehydes or ketones.<sup>20</sup> Methylberyllium t-butoxide has been prepared by four methods:

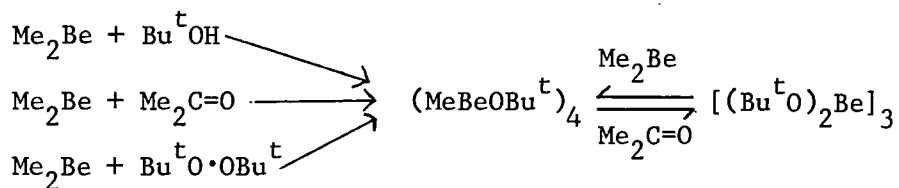

Ebullioscopic molecular weight determinations carried out in very dilute solutions (0.004-0.015M calculated as monomer) on the compounds  $(\text{MeBeOR})_n$  have shown them to be nearly dimeric (R = Me, n = 2.16; Et, 2.13; Pr<sup>n</sup>, 2.01; Pr<sup>i</sup>, 1.92; Bu<sup>t</sup>, 1.97). Alkoxy bridged dimers are

believed to exist in these solutions and some such complexes with ether and pyridine have been prepared.<sup>20</sup> Table 4 lists a series of such compounds. The monomeric complexes contain three co-ordinate beryllium; where association takes place, e.g. in  $\text{Me}(\text{Bu}^t\text{O})\text{Be}\cdot\text{py}$  it is probably due to an equilibrium between the dimer containing co-ordinated pyridine, the tetramer, and free pyridine:

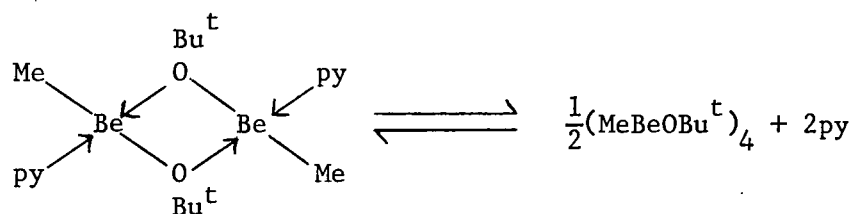

Pyridine could be evaporated from a solution of the complex in benzene.

The p.m.r. spectra of the alkylberyllium alkoxides are of some interest. In some cases they present evidence for some of the alkoxides possessing alkoxy groups in two different environments. For example, the  $\text{CH}_3$ -O resonance of  $(\text{MeBeOMe})_4$  is a doublet (in benzene solution) and is temperature and concentration independent. The spectrum of  $(\text{MeBeOBu}^t)_4$  is more peculiar; in benzene solution two singlets are observed as expected for a symmetrical structure like methylzinc methoxide. In perdeuteromethylcyclohexane, however, two doublets are observed. No change in either of the spectra was observed on variation of concentration and temperature.<sup>20</sup>

The bis(alkoxy)beryllium compounds are formed on reaction of a beryllium dialkyl with excess alcohol. Studies on various substituted

phenols have shown that the first alkyl (methyl, ethyl) group is eliminated below  $-80^{\circ}$  and the second starts to react between  $-55^{\circ}$  and  $-30^{\circ}$ .<sup>67</sup> Table 5 lists some beryllium alkoxides, the more sterically hindered alcohols have low degrees of association. P.m.r. data suggests a similar structure for  $[(\text{Bu}^{\text{t}}\text{O})_2\text{Be}]_3$ <sup>20</sup> to that confirmed by X-ray analysis for  $[(\text{Me}_2\text{N})_2\text{Be}]_3$ .<sup>63</sup>

Alkylthioberyllium alkyls have recently been described,<sup>69</sup> these generally have a higher tendency to disproportionate than their oxygen analogues as sulphur is a weaker donor to beryllium than is oxygen.<sup>29</sup> Four tetramers  $(\text{EtBeSR})_4$ ,  $\text{R} = \text{Et}$ ,  $\text{Pr}^{\text{i}}$ , or  $\text{Bu}^{\text{t}}$  and  $(\text{MeBeSBu}^{\text{t}})_4$  have been prepared and are believed to have structures based on a  $\text{Be}_4\text{S}_4$  cube. Whereas the ethylberyllium compounds could be crystallised solvent free, the isopropylberyllium compounds could only be obtained in the form of complexes  $(\text{Pr}^{\text{i}}\text{BeSEt.L})_2$  where  $\text{L} = \text{OEt}_2, \text{py}$ . Table 6 lists the compounds prepared. The sulphides  $\text{Be}(\text{SEt})_2$  and  $\text{Be}(\text{SBu}^{\text{t}})_2$  are insoluble in ether and hydrocarbons and are presumed to be polymeric.

Selenium derivatives  $(\text{MeBeSPh.OEt}_2)_2$  and  $\text{EtBeSEt.py}_2$  have also been described.<sup>69</sup>

Dimethylberyllium reacts with 2-dimethylaminoethanol and the product which crystallises solvent free is oligomeric ( $n \sim 7$ ) whereas methylberyllium 2-dimethylaminoethylsulphide is a trimer and is formulated with the cyclic structure (2,6).<sup>66</sup> The reason for the differences in the degrees of association is not clear. It is possible that both have cross linked polymeric structures (containing four co-ordinate beryllium in the

solid phase.

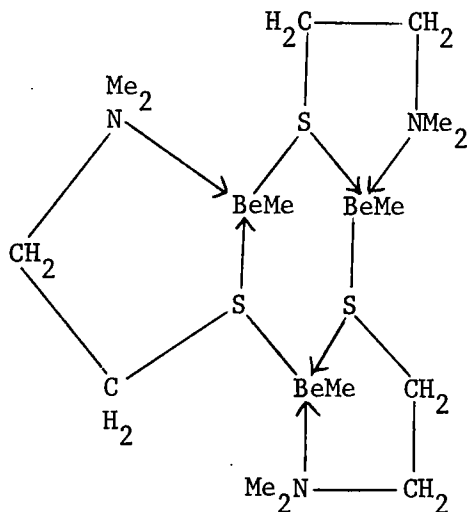

(2,6)

Dimethylberyllium reacts with acetoxime to form a tetramer,  $(\text{MeBeON}=\text{CMe}_2)_4$ . The p.m.r. spectrum of this compound is very interesting and will be discussed along with the analogous zinc compound. A tetrameric product is also formed when dimethylberyllium reacts with 8-hydroxyquinoline, it is believed to consist of two (non planar) dimeric units (2,7), parallel to each other, with co-ordination between each oxygen in one dimer and beryllium in another to give a tetramer containing three co-ordinate oxygen and four co-ordinate beryllium.<sup>66</sup>

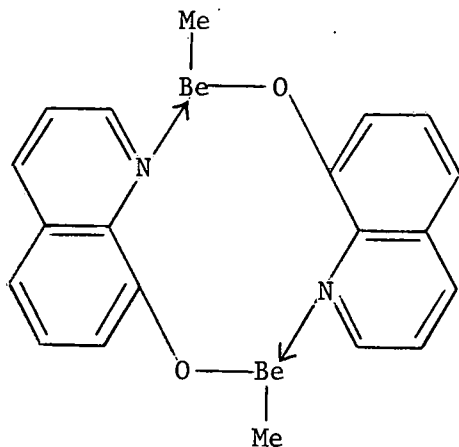

(2,7)

### Reactions of organozinc compounds with acidic hydrogen

Reactions involving zinc di-alkyls and compounds containing acidic hydrogen have been known for many years.<sup>70,71,72</sup>

Table 7 lists a series of aminozinc alkyls formed by reaction of a zinc dialkyl with a secondary amine.<sup>73,74</sup> The products are all dimeric in contrast to the analogous beryllium compounds where both dimers and trimers are formed. The crystal structure of  $(\text{MeZnNPh}_2)_2$  has been examined by X-ray diffraction<sup>75</sup> and is shown below (2,8). Dimethylzinc and an equimolar amount of dimethylamine gives only bis(dimethylamino)-zinc as an insoluble, involatile, presumably polymeric white solid. No evidence for  $(\text{MeZnNMe}_2)_n$  was obtained.<sup>73</sup> The acidolysis of various zinc

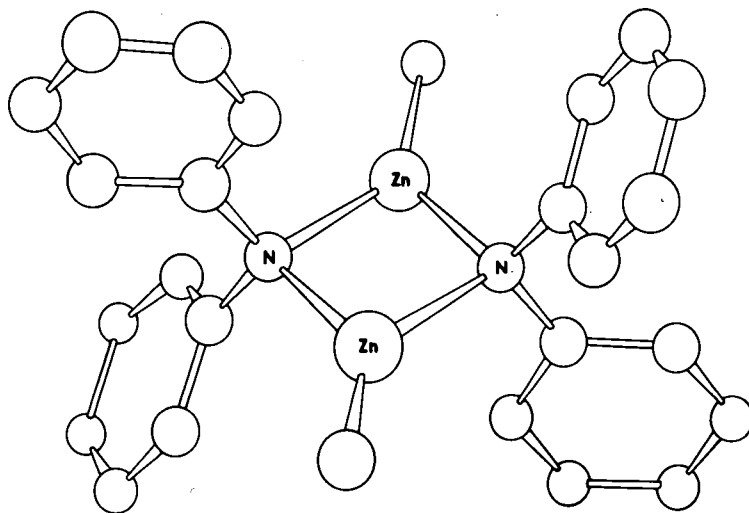

2,8

dialkyls in  $\text{Pr}_2^i\text{O}$  with several amines has been studied from a kinetic viewpoint, and the intermediates were not examined.<sup>76</sup>

With the exception of  $(\text{MeZnNMeC}_2\text{H}_4\text{NMe}_2)_2$ <sup>73</sup> whose structure is believed to be similar to the beryllium analogue (2,3) and would thus contain 4-co-ordinate zinc, the aminozinc alkyls listed in Table 7 contain 3-co-ordinate zinc. This explains the ease of formation of the yellow, crystalline complex,  $\text{Me}(\text{py})_2\text{ZnNPh}_2$ , which is monomeric. However, addition of one mol. of pyridine results in disproportionation and formation of  $\text{py}_2\text{Zn}(\text{NPh}_2)_2$ .<sup>73</sup> Aminozinc alkyls react with some unsaturated molecules:

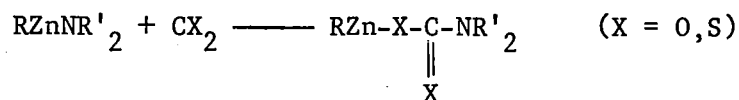
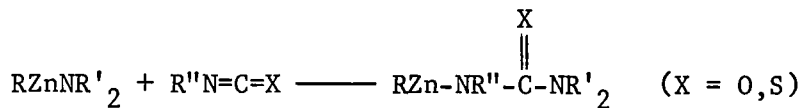

The products were not examined.<sup>74</sup>

Similar reactions take place between zinc dialkyls and secondary phosphines.<sup>78</sup> The products are more associated than the corresponding aminozinc compounds, (EtZnPPh<sub>2</sub>) being insoluble in benzene and (PhZnNPh<sub>2</sub>) having a degree of association of ca.7. Unlike the amino compounds, RZnPR'<sub>2</sub> reacts with a second mole of phosphine to produce Zn(PR'<sub>2</sub>)<sub>2</sub>.

Diethylzinc reacts with water at 0° and only one ethyl group is displaced,<sup>79</sup> the product has been formulated, (2,9):

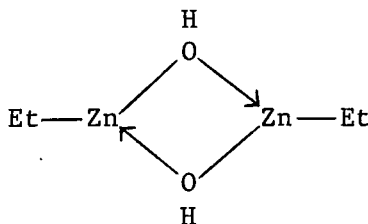

(2,9)

Crystalline products from zinc dialkyls and alcohols have been known for some time<sup>70</sup> and Table 8 lists a series of such products. The products are

generally tetramers except when very bulky groups are present. X-ray crystallographic examination of methylzinc methoxide has shown it to possess the highly symmetrical cubane structure shown in (2,10),<sup>80</sup>

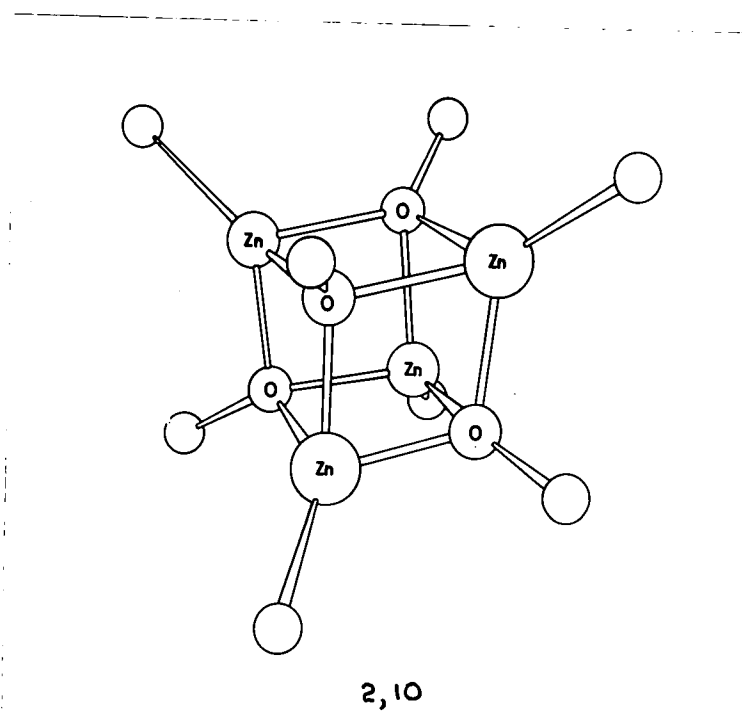

the structure consisting of two interpenetrating tetrahedra, one of zinc atoms, the other of oxygen atoms. The crystal structure of ethylzinc t-butoxide is reported to be similar.<sup>81</sup>

The tetrameric structure allows the alkoxides to become co-ordinately saturated and only the less basic phenoxide forms a pyridine adduct:

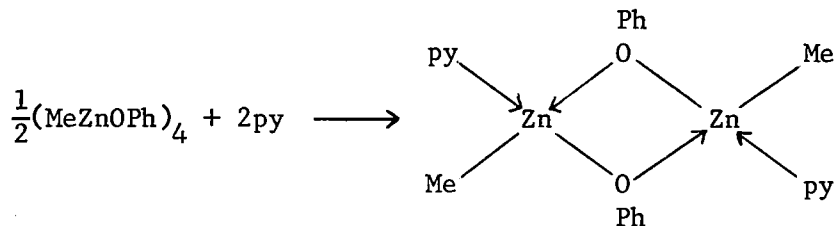

The infrared spectrum of methylzinc methoxide is virtually identical whether recorded as a Nujol mull of the crystalline solid, as a solution in cyclohexane, or as a solution in cyclohexane to which a mole of pyridine per gram-atom of zinc had been added.<sup>82</sup> The nearly cubic structure of the crystal persisting in solution. The stronger Lewis base, 4-dimethylaminopyridine causes  $(\text{MeZnOMe})_4$  to form a crystalline adduct  $[\text{Me}_2\text{NC}_5\text{H}_4\text{N} \cdot \text{Zn}(\text{OMe})\text{Me}]$  which is largely dissociated in benzene solution.<sup>82</sup>

The siloxy compound,  $\text{CH}_3\text{ZnOSiMe}_3$ , is also tetrameric in hydrocarbon solvents.<sup>83</sup> Trimers are produced in the reaction between zinc dialkyls and 2-dimethylaminoethanol, and the products do not react with excess methyl iodide; a structure analogous to methylberyllium 2-dimethylaminoethylsulphide (2,6) is therefore proposed.<sup>82</sup>

The p.m.r. spectra of the alkylzinc alkoxides have evoked considerable interest. The spectrum of methylzinc methoxide was reported to consist of two doublets at  $25^\circ$ , one due to  $\text{CH}_3\text{-Zn}$  and the other due to

$\text{CH}_3\text{O-Zn}$ . The methyl-zinc doublet collapses to a singlet on heating to  $40^\circ$  but the methoxy doublet remains even up to  $100^\circ$ . The spectrum of methylzinc-t-butoxide consists of the expected two singlets. This was explained in terms of isomeric forms of the methoxide not available to the t-butoxide on steric grounds.<sup>73</sup> A study of the methanolysis of dimethylzinc in several proportions, solvents and at various temperatures has led to the conclusion that methylzinc methoxide exists as an equilibrium mixture of dimethylzinc,  $(\text{MeZnOMe})_x$ , and a methylzinc methoxide,  $\text{Me}_6\text{Zn}_7(\text{OMe})_8$ . The p.m.r. spectrum of methylzinc methoxide being the expected two lines when freshly prepared, changing with time to the two doublets due to the above disproportionation.<sup>84,85</sup> Similar results were obtained with the systems diphenylzinc-methanol, dimethylzinc-ethanol, diphenylzinc-ethanol. Methylzinc isopropoxide and t-butoxide are considered to remain as tetramers in solution.<sup>84,85</sup> Similar explanations cannot be applied to the p.m.r. spectra of alkylberyllium alkoxides as dimethylberyllium is insoluble in hydrocarbons and no precipitates were observed.<sup>20</sup>

The reaction between acetoxime and diethylzinc was first reported more than thirty years ago,<sup>72</sup> insoluble  $(\text{Me}_2\text{C=NO})_2\text{Zn}$  and soluble  $(\text{Me}_2\text{C=NOZnEt})$  being produced. No molecular weight data were recorded for the latter. The methylzinc analogue is tetrameric in benzene solution,  $(\text{MeZnON=CMe}_2)_4$ .<sup>82</sup> The crystal structure has been determined by X-ray diffraction and is shown below (2,11).<sup>74</sup>

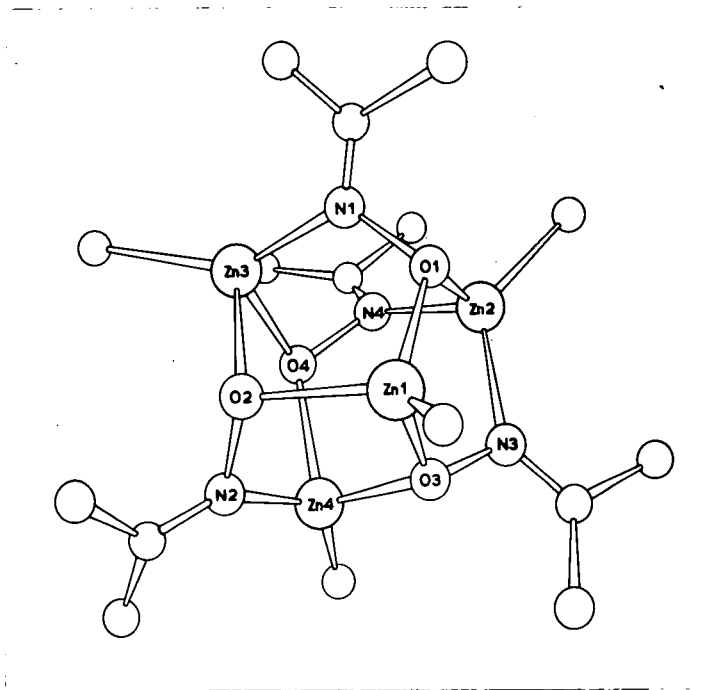

2, 11

Each zinc atom is four co-ordinate, and all nitrogen and oxygen atoms are three co-ordinate. The structure consists of four five-membered rings and two six-membered rings fused together. There are three different co-ordination environments for Zn in this structure, however, in benzene solution the p.m.r. spectrum showed only a single resonance due to Zn-CH<sub>3</sub>, possible due to exchange processes. The beryllium analogue<sup>66</sup> showed three Be-CH<sub>3</sub> resonances in the ratio 2:1:1 suggesting that the compounds have similar structures and exchange processes are slow in the case of beryllium.

The reaction between benzophenone and  $R_2Zn$  is interesting:<sup>83</sup>

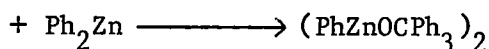
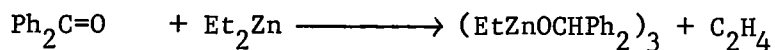
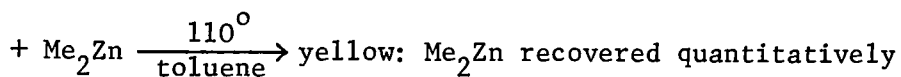

The two compounds produced clearly showing the effect of steric hindrance on degree of association.

Reaction between zinc dialkyls and thiols give compounds of the type  $(RZnSR')_x$ . The degrees of association of these compounds are peculiar. When  $R' = Ph, Pr^n, Me$ ;  $R=Me$  then the product is an insoluble polymer. When  $R' = Pr^i, Bu^t$ ;  $R=Me$  then the degrees of association are 6 and 5 respectively, ethylzinc t-butylsulphide is also pentameric.<sup>73</sup> All the above thio compounds dissolve in benzene to which pyridine has been added but only in one case was a crystalline complex isolated,  $[Me(py)ZnSBu^t]_2$ . The crystal structure of  $(MeZnSBu^t)_5$  has been studied by X-ray diffraction and is shown (2,12) below.<sup>86</sup>

Dimethylzinc reacts with acetic acid and with dimethylphosphinic acid to give insoluble polymeric solids.<sup>73</sup>

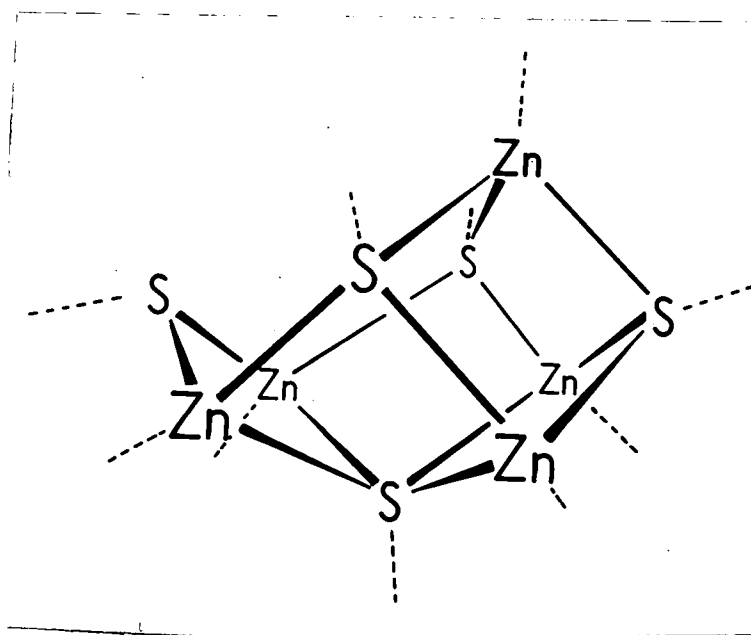

2, 12

Reactions of organomagnesium compounds with acidic hydrogen

The reactions of secondary amines with magnesium dialkyls have been studied by Coates and Ridley,<sup>22</sup> the nature of the products being complicated due to the fact that they can associate through both bridging amino and alkyl groups. Therefore compounds of the type  $\text{RMgNR}'_2$  are likely to be polymeric. Where the alkyl groups are large dimers have been prepared and these contain previously unknown 3-coordinate magnesium. Table 9 lists some of the aminomagnesium alkyls and some of their complexes.

Reaction between dimethylamine and one molar equivalent of diethylmagnesium gives the insoluble, polymeric, bisdimethylaminomagnesium.

It is likely that  $\text{EtMgNMe}_2$  is an intermediate and any disproportionation would proceed to completion due to the insolubility of the product. When amines with larger organic groups are used disproportionation does not occur but the products cannot be freed from ether. When THF is added to  $\text{EtMgNR}_2$  ( $\text{R} = \text{Et}, \text{Pr}^i$ ) in hexane solution, removal of solvent leaves syrups with the formulae  $(\text{EtMgNR}_2)_2 \cdot \text{THF}$ ; these are associated to some extent in benzene solution. Monomers would contain both three and four co-ordinate magnesium, dimers can readily be formulated (2,13) with four co-ordinate magnesium.

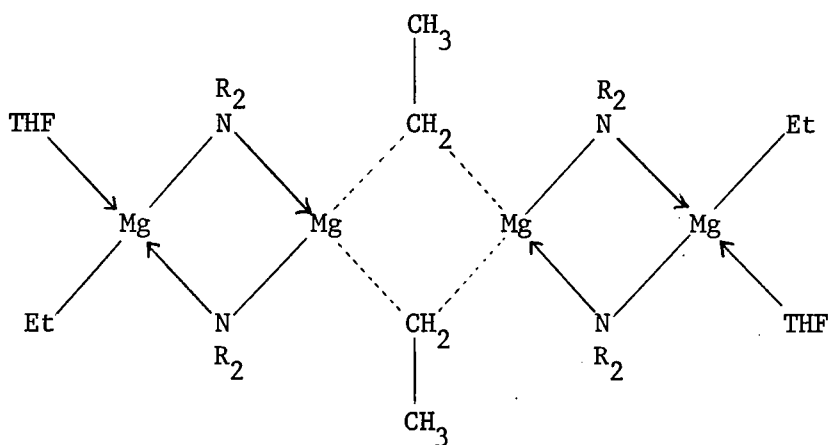

2,13

The p.m.r. spectra show only one quartet due to  $\text{Mg}-\text{CH}_2-\text{CH}_3$  due to rapid exchange taking place.

Reactions with diphenylamine are simpler, e.g.  $\text{EtMgNPh}_2$  is insoluble in hot toluene and is presumed polymeric. This dissolves in THF to give

the monomeric  $\text{EtMgNPh}_2(\text{THF})_2$ . With di-isopropylmagnesium a bis-ether complex is formed  $\text{Pr}^i(\text{Ph}_2\text{N})\text{Mg}(\text{OEt}_2)_2$  which dissociates in toluene solution depositing the polymer,  $(\text{Pr}^i\text{MgNPh}_2)_x$ , likely to contain both nitrogen and alkyl bridges.<sup>22</sup> Diphenylamine will also eliminate both ethyl groups from diethylmagnesium giving  $\text{Mg}(\text{NPh}_2)_2$  which is insoluble in ether but can be recrystallised from THF.<sup>87</sup>

Di-isopropylamine reacts with di-isopropylmagnesium to form  $\text{Pr}^i\text{MgNPr}^i_2$  which is dimeric in benzene solution and must be formulated with three co-ordinate magnesium.<sup>22</sup>

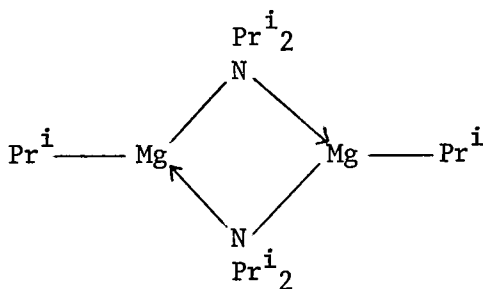

2,14

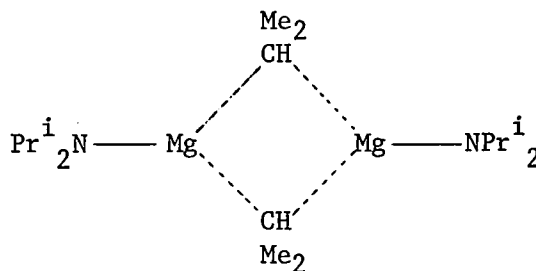

2,15

Structure (2,14) is preferred as nitrogen bound to electropositive magnesium will act as a strong electron donor and thus be a better bridging atom than carbon.

Three-co-ordinate magnesium, and two possible structures as above, are found in the dimeric aminomagnesium alkyls formed from (a) diethylmagnesium and 2,2,6,6-tetramethylpiperidine, and (b) diethylmagnesium and benzylideneaniline (2,15). The latter on hydrolysis yields the

expected amine  $\text{PhCHEt.NHPh}$ .<sup>22</sup>

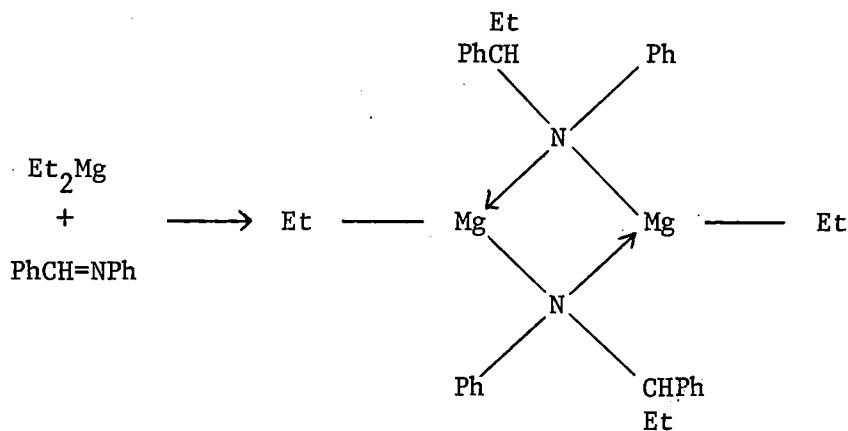

(2,16)

Reaction between diethylmagnesium and phenyl cyanide gives a product,  $\text{EtMgN:CPhEt}$ , which is extensively associated.

Issleib and Deylig<sup>87</sup> have studied the reactions of diethylmagnesium with various phenylphosphines. With an excess of diphenylphosphine the insoluble  $\text{Mg(PPh}_2)_2$  is formed which is presumably polymeric but can be recrystallised from THF as  $\text{Mg(PPh}_2)_2 \cdot 4\text{THF}$ . In 1:1 molar proportions this reaction gives crystalline  $\text{EtMgPPh}_2 \cdot \text{OEt}_2$  which may well be dimeric, but no molecular weight was reported. The ether can be removed on heating to  $100^\circ$ .

Diethylmagnesium reacts with an equal amount of phenylphosphine to give  $\text{EtMgPPh}_2$  from which the second ethyl group can be removed by heating:

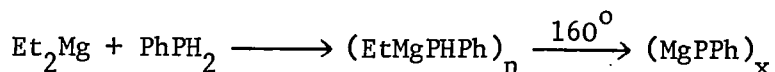

An excess of phenylphosphine produces bisphenylphosphinomagnesium at 25°. The chelating phosphine, P,P'diphenyl-1,3 diphosfinopropane, removes both ethyl groups from diethylmagnesium to form a chelate compound which is monomeric in THF. Higher homologues of the diphosphine produce polymers.

The first reported alkylmagnesium alkoxide was EtMgOEt prepared by the pyrolysis of diethylmagnesium containing some solvent ether, cleavage of solvent molecules forming EtMgOEt, which sublimes out of the reaction mixture,<sup>88</sup> not MgC<sub>2</sub>H<sub>4</sub> as first thought.<sup>89</sup> Alkylmagnesium alkoxides have been prepared by direct synthesis in hydrocarbon solvents:<sup>90</sup>

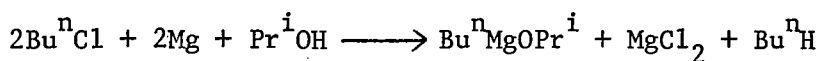

The product is trimeric in benzene solution.<sup>91</sup> The proposed structure, an Mg<sub>3</sub>O<sub>3</sub> ring contains three co-ordinate magnesium, and Mg-O π-bonding is proposed to account for the lack of acceptor properties for this molecule. The reaction between magnesium dialkyls and alcohols has been studied<sup>47</sup> and Table 10 lists some data on alkylmagnesium alkoxides prepared by this and the other methods discussed earlier.

The degree of association of alkylmagnesium alkoxides depends on the nature of the alkoxide group. If there is chain branching at the carbon α to oxygen then only tetramers (cryoscopically in benzene) are

formed. These compounds probably have a cubane structure similar to that of  $\text{MeZnOMe}^{80}$  and  $\text{EtZnOBu}^t$ .<sup>81</sup> When no branching occurs at the carbon atom  $\alpha$  to the oxygen atom then more associated species are formed,  $\text{EtMgOEt}$  is too insoluble in benzene for its molecular weight to be determined. These alkoxides are probably polymeric in the solid state. Some of these alkoxides have been prepared by the addition of magnesium dialkyls to carbonyl compounds.

Some alkylmagnesium alkoxides are tetramers in diethylether solution,  $(\text{EtMgOEt})_4$ ,  $(\text{MeMgOBu}^t)_4$  and  $(\text{EtMgOBu}^t)_4$ , but two are dimers,  $(\text{EtMgOCMeEt}_2)_2$  and  $(\text{EtMgOCt}_3)_2$ .<sup>47</sup> All the alkoxyberyllium alkyls studied are dimeric in diethylether solution.<sup>20</sup>

The p.m.r. spectra of some of the alkoxides are interesting in that in some cases the resonances are split into doublets, but no satisfactory explanation could be offered.<sup>47</sup>

Alkylthiomagnesium alkyls,<sup>93</sup> (Table 11), disproportionate more readily than their zinc analogues. Some complexes have been prepared and are believed to contain sulphur bridges. Tetrameric ethylmagnesium t-butylsulphide is produced when ether free reagents are used. It can be formulated as a  $\text{Mg}_4\text{S}_4$  cube as for methylzinc methoxide,<sup>80</sup> other structures require a formulation using three co-ordinate magnesium.<sup>93</sup>

Di-t-butylmagnesium reacts with 2-dimethylaminoethanethiol to produce a dimer whose structure (2,17) is shown below:

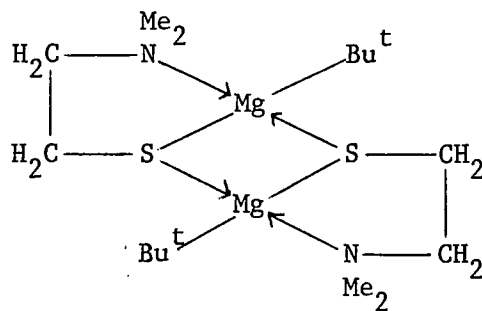

(2,17)

The corresponding methylmagnesium derivative is tetrameric and three structures are possible, an eight numbered  $Mg_4S_4$  ring with each dimethylamino group being co-ordinated to magnesium. More likely are cubane structures, two of which are possible, (2,18) and (2,19):<sup>93</sup>

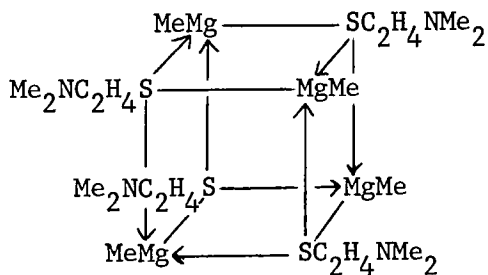

(2,18)

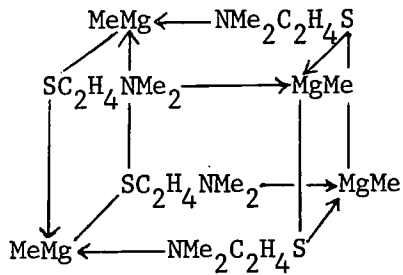

(2,19)

In structure (2,18) the dimethylamino-groups would very likely be near a neighbouring magnesium atom, which would be effectively five coordinate. (2,19) is an alternative structure.<sup>93</sup> An X-ray structural investigation of this compound is being undertaken.<sup>94</sup>

Reactions of organocadmium compounds with acidic hydrogen.<sup>95</sup>

Table 12 lists a series of compounds produced by reaction of dimethylcadmium with alcohols and thiols. The alkylcadmium alkoxides are similar to those of zinc with one striking difference, viz. methylcadmium t-butoxide is dimeric. The reason for this is somewhat obscure, entropy would favour dimers but in all other cases tetramers are formed so this cannot be the reason. Steric crowding would be more pronounced in  $(\text{MeZnOBU}^t)_4$  than in the corresponding cadmium tetramer.<sup>95</sup> The siloxy derivative,  $\text{MeCdOSiMe}_3$ , is tetrameric,<sup>83</sup> this compound is an analogue of the t-butoxide but there is less steric hindrance due to the greater size of the Si atom. The alkoxides do not form pyridine adducts but methylcadmium phenoxide forms a complex,  $[\text{Me}(\text{py})\text{CdOPh}]_2$ , which is partially dissociated in benzene solution.

Polymeric products are obtained from  $\text{Me}_2\text{Cd}$  and  $\text{RSH}$  unless R is a branched chain group. Thus  $\text{MeCdSPR}^i$  is hexameric, (2,20) and the more sterically hindered  $\text{MeCdSBu}^t$  is tetrameric. No stoichiometric pyridine adducts are formed.

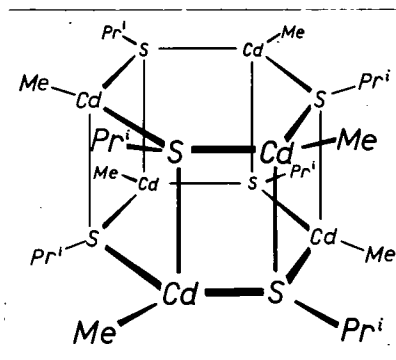

2,20

### Mercury

Mercury dialkyls do not react even with water or dilute mineral acids and, therefore, undergo no reactions as described for the other elements of Group II. Organomercury alkoxides can be prepared:

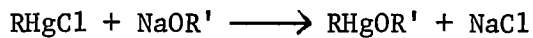

The products are trimeric.<sup>96</sup>

### Anionic Complexes of the Group II dialkyls

A series of ether-free complexes of diethylberyllium, with the general formula  $\text{MX}(\text{BeEt}_2)_n$ , [M = alkali metal; X = halide, CN; n = 1,2,4], have been prepared.<sup>97,98,99,100</sup> The tendency to complex formation is  $\text{Cs} > \text{Rb} > \text{K} > \text{Na}$  and  $\text{F} > \text{Cl}$ : complexes with  $\text{M} = \text{NR}_4^+$  have also been prepared. The crystalline salt  $\text{KF}(\text{BeEt}_2)_2$  decomposes at  $70^\circ$  in benzene and ether-free diethylberyllium can be distilled out. Heating  $\text{KF}(\text{BeEt}_2)_2$  to  $100\text{--}130^\circ$  also affords ether-free diethylberyllium. In both cases insoluble  $\text{KF} \cdot \text{BeEt}_2$  is produced.<sup>97</sup> This reaction appears to be fairly general for these complexes.<sup>100</sup>

Complexes of beryllium dialkyls with alkali-metal hydrides will be discussed in the section on hydrides of Group II. Diphenylberyllium reacts exothermically with phenyl-lithium and the complex  $\text{LiBePh}_3$  can be crystallised.<sup>101</sup> The complex  $\text{NaBeEt}_3$  has been described as a catalyst for the dimerisation of propene.<sup>102</sup>

Study of the  $^1\text{H}$  and  $^7\text{Li}$  magnetic resonance spectra of methyl-lithium and dimethylzinc has established complex formation. The equilibria involved are very labile and exchange of methyl groups takes place even at  $-107^\circ$ .<sup>103</sup>

Phenyl-lithium forms complexes with  $\text{Ph}_2\text{Zn}$ , Mg and Cd,  $\text{LiMPh}_3$ <sup>104,105</sup> and complexes containing a higher proportion of  $\text{PhLi}$  can also be isolated.

Organometal halides of Group II.

The Grignard reagents are the best known examples of this type of compound and a considerable amount of information on them is available.<sup>6,7</sup> In contrast the chemistry of the organoberyllium halides has scarcely been developed. Methylberyllium chloride, prepared from dimethylberyllium and dry hydrogen chloride, is a white solid less volatile than dimethylberyllium and evidently highly polymerised.<sup>59</sup> Other alkylberyllium halides have been prepared by heating an alkyl halide with beryllium in a tube.<sup>106,107,108</sup> The preparation of alkylberyllium hydride derivatives from  $R_2Be$ ,  $BeBr_2$  and  $2LiH$ <sup>60</sup> infers the presence of  $RBeBr$ . Tracer studies, using <sup>7</sup>Be, show that redistribution does not take place between diphenylberyllium and beryllium bromide in ether.<sup>109</sup> Redistribution does take place in the  $Me_2Be/BeBr_2$  system as shown by low temperature n.m.r. studies, ebullioscopic molecular weight data and precipitation of a 1:1  $MeBeBr$  complex with 1,4 dioxan.<sup>110</sup>

Organozinc halides have been known for a considerable time, and ethylzinc iodide was one of the earliest known organometallic compounds.<sup>111</sup> Organozinc halides can be prepared by both the methods described above for beryllium. The ethylzinc halides ( $EtZnX$ ) are interesting, when  $X = Cl, Br$  the products are tetrameric in benzene, and a cubane structure like that of methylzinc methoxide (2,10) has been proposed.<sup>112</sup> In contrast, ethylzinc iodide disproportionates in benzene solution. In the solid state it is a co-ordination polymer and its structure, as

determined by X-ray methods,<sup>113</sup> is shown below, (2,21).

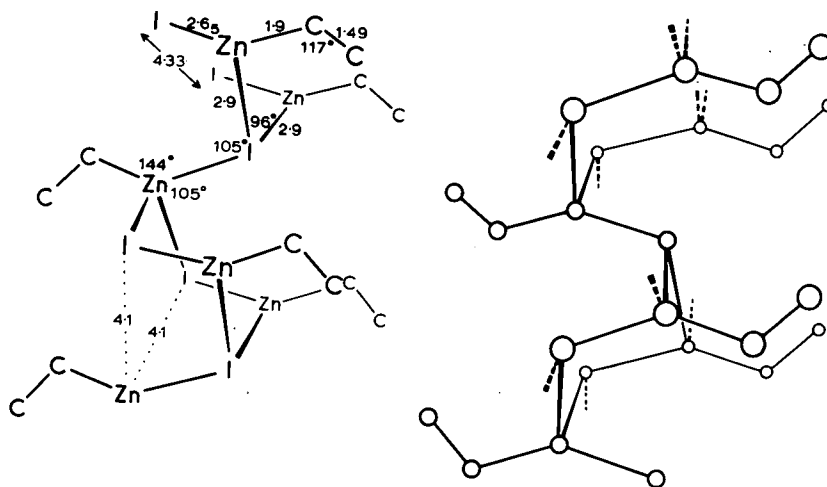

2,21

Organocadmium halides have been prepared by the redistribution reaction, no information is available as to their structure.

Organomercury halides are extensively discussed in the literature and are reviewed by Coates and Wade<sup>4</sup> (p.148-157).

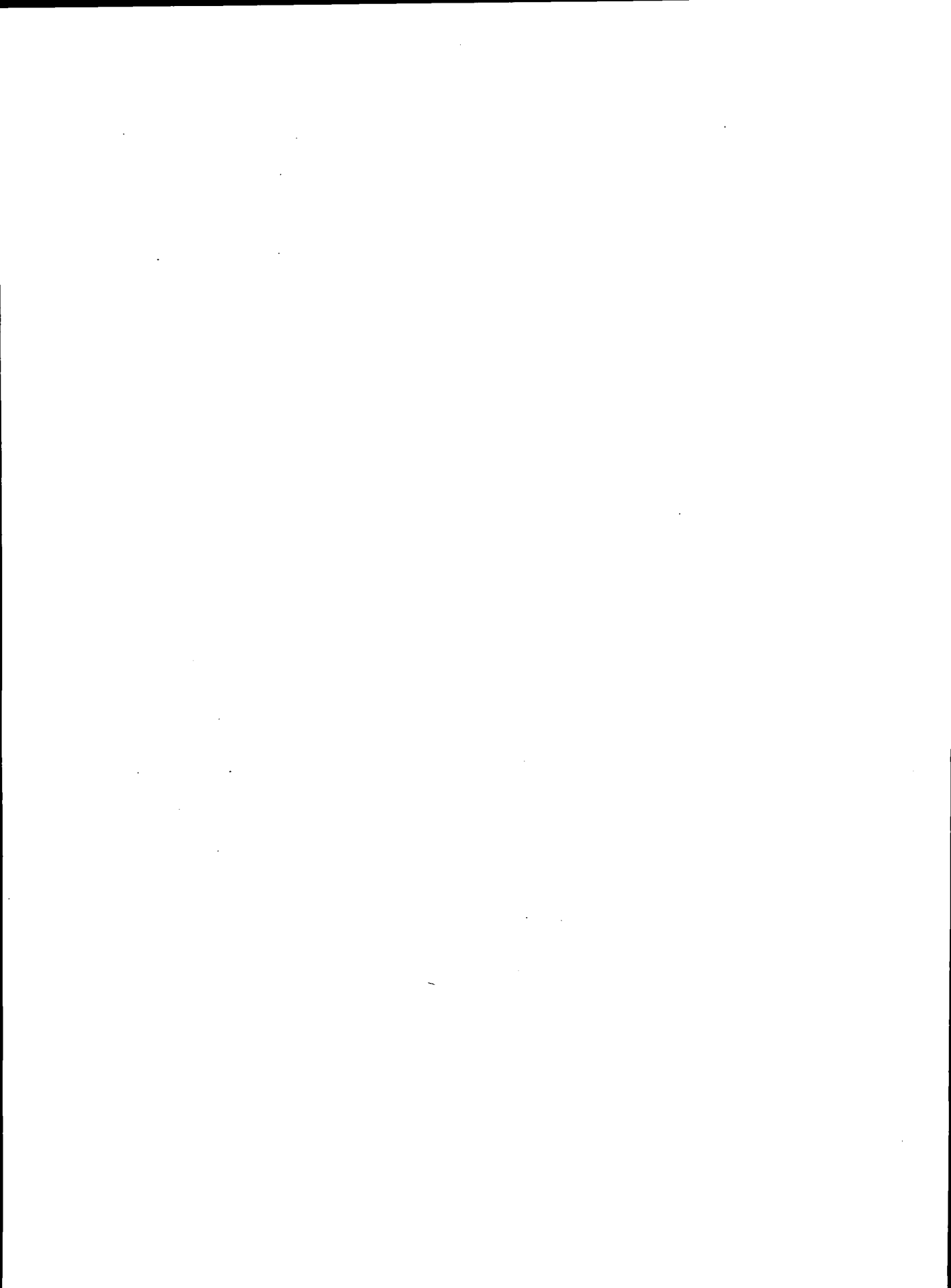

### Hydride Chemistry of Beryllium

Beryllium hydride has been prepared by a variety of methods and in varying degrees of purity.

Schlesinger and co-workers<sup>114</sup> first reported its preparation from lithium aluminium hydride and dimethylberyllium, both in diethylether solution. The product, a white, insoluble, involatile solid, contained 60 mole % of beryllium hydride; the remainder was assumed to be ether. Later work has shown the product to be contaminated with lithium and aluminium.<sup>115</sup> Pyrolysis of di-tert-butylberyllium etherate gave an improved product; after pyrolysis at 150° the product contained 89 mole % beryllium hydride and this increased to 96 mole % at 210°. <sup>34</sup> Pyrolysis of ether free di-tert-butylberyllium results in the formation of beryllium hydride which is 98 mole % pure.<sup>115</sup> The purest beryllium hydride reported so far has been made by abstracting BH<sub>3</sub> groups from beryllium borohydride with triphenylphosphine,<sup>116</sup>

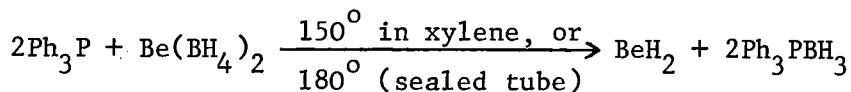

The product contains up to 99.5 mole % of beryllium hydride, the remainder being triphenylphosphineborane.

A surface reaction takes place between beryllium chloride and lithium hydride has been observed<sup>117</sup> but it was not possible to separate

the product from excess lithium hydride.<sup>115</sup> Various other methods of preparation have been attempted.<sup>118</sup>

The pyrolysis of di-tert-butylberyllium and its etherate have been re-examined, the evolved gases being subjected to gas chromatographic analysis. Small amounts of isobutane and ethane are produced as well as isobutene and ether. A reaction scheme is proposed to account for this.<sup>119</sup>

The properties of beryllium hydride depend on its mode of formation. The purest beryllium hydride prepared by pyrolysis<sup>115</sup> had a density of 0.57 g/cc at  $-110^{\circ}$ , and was only slowly attacked by water, the addition of acid being necessary to complete hydrolysis. It decomposes from  $200^{\circ}$  to hydrogen and beryllium. In contrast, beryllium hydride prepared by precipitation<sup>114</sup> decomposed quite rapidly at  $125^{\circ}$  and reacted vigorously with water vapour at  $-196^{\circ}$ .

The infrared-red spectra of beryllium hydride<sup>116</sup> and beryllium deuteride<sup>120</sup> are shown below (3,1):

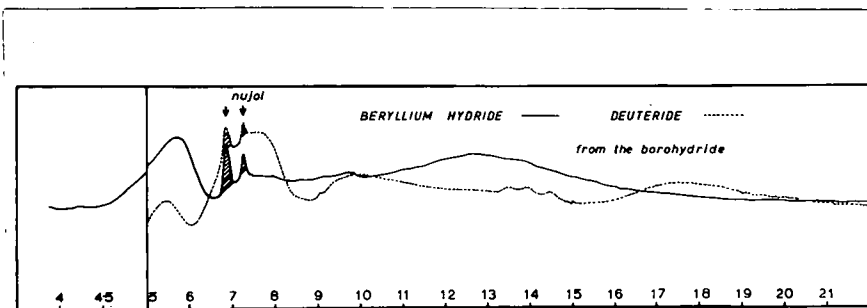

The main feature of the infrared spectrum of beryllium hydride is a rather broad (width at half-height  $\sim 310 \text{ cm}^{-1}$ ) peak centred on  $1758 \text{ cm}^{-1}$ . The deuteride has a broad absorption centred on  $1340 \text{ cm}^{-1}$  and with a peak width at half-height of  $280 \text{ cm}^{-1}$ , the ratio  $\nu_{\text{H}}/\nu_{\text{D}}$  is 1.31.<sup>116,120</sup> This compares with values of 1.31-1.35 obtained for the stretching modes of bridging hydrogen in diborane and the methyldiboranes.<sup>121</sup> The broad infrared absorptions of the hydride and deuteride, which are amorphous by X-ray diffraction, must involve a range of beryllium-hydrogen bond types. No absorptions were observed when the Raman spectrum of a sample of beryllium hydride was studied.<sup>122</sup>

Alkali metal hydrides react with beryllium dialkyls and diaryls<sup>123-126</sup> in ether solution to give complexes of the type  $\text{MBeR}_2\text{H}$  ( $\text{M} = \text{Na}$ ;  $\text{R} = \text{Me}$ ,  $\text{Et}$ ,  $\text{Pr}^{\text{n}}$ ,  $\text{Bu}^{\text{i}}$ ;  $\text{M} = \text{Li}$ ;  $\text{R} = \text{Et}$ ,  $\text{Ph}$ ). Di-tert-butylberyllium, however, reacts with sodium hydride to give the 1:2 compound  $\text{Na}(\text{Bu}^{\text{t}}_2\text{Be})_2\text{H}\cdot\text{OEt}_2$ .<sup>127</sup>

Sodium hydridodiethylberyllate crystallises from ether with one molecule of ether per sodium atom, although the ether is readily removed at low pressures (dissociation pressure 17 mm. at  $25^\circ$ ).<sup>124</sup> X-ray diffraction has shown the molecule to have the structure (3,2).<sup>128</sup>

The structure shows the existence of  $\text{Et}_4\text{Be}_2\text{H}_2$  units with the beryllium atoms linked by hydrogen bridges.

Ethereal lithium hydridodiethylberyllate reacts with a half-molar proportion of beryllium chloride, precipitating lithium chloride and giving a solution containing " $\text{Et}_4\text{Be}_3\text{H}_2$ ".<sup>123</sup> This type of reaction has

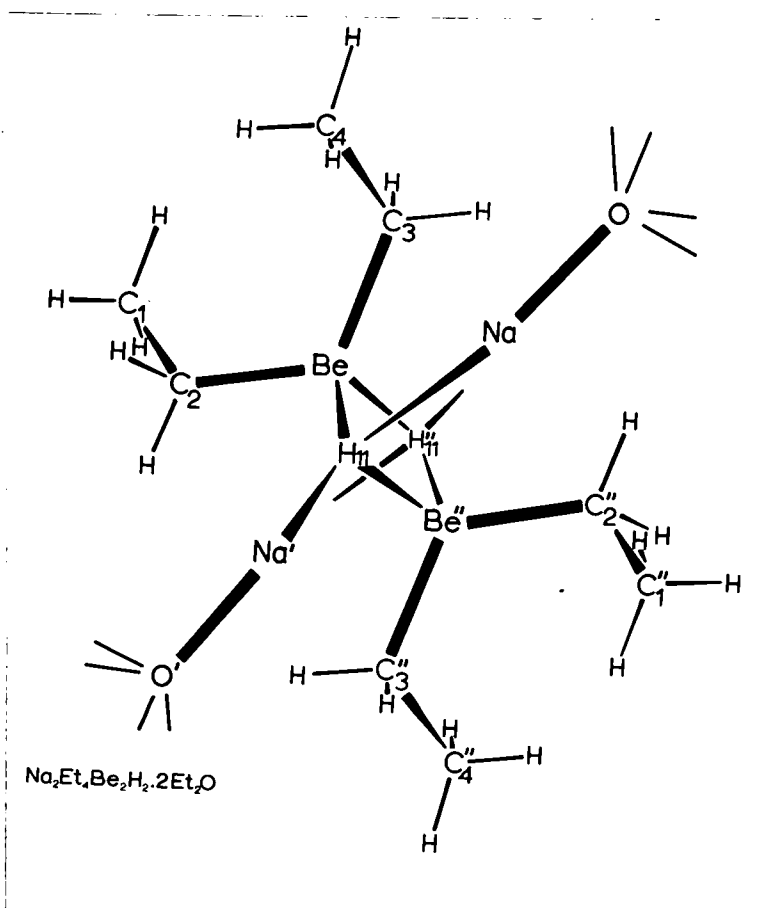

been fully investigated for other systems ( $M = \text{Na}; R = \text{Me, Et}$ ).<sup>124</sup>  
 Evaporation of solvent from ethereal " $\text{Me}_4\text{Be}_3\text{H}_2$ " results in the formation of an oily residue of approximate composition " $\text{Me}_4\text{Be}_3\text{H}_2 \cdot 0.0\text{Et}_2$ " which is considered to be some kind of electron deficient complex between dimethylberyllium and methylberyllium hydride such as (3,3). In this system many species are likely to be present in mobile equilibrium.

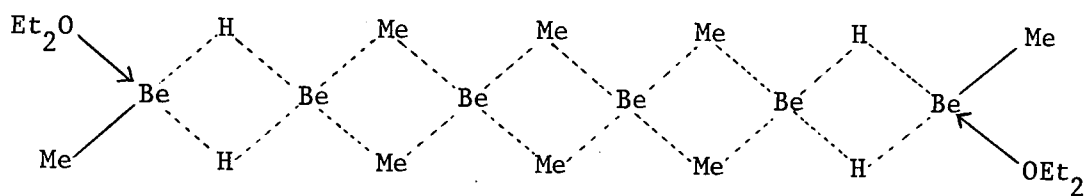

Addition of donor molecules to " $\text{Me}_4\text{Be}_3\text{H}_2$ " causes them to behave as mixtures of  $\text{R}_2\text{Be}$  and " $\text{RBeH}$ ", thus addition of trimethylamine gives  $\text{Me}_2\text{Be} \cdot \text{NMe}_3$  and the complex  $\text{RBeH} \cdot \text{NMe}_3$  which can be separated by fractional condensation.<sup>124</sup> The hydride complex is dimeric in benzene solution (cryoscopically) and has a normal Trouton constant (from vapour pressure data to  $110^\circ$ ). Thus the molecules are dimeric in the vapour phase also. The compound is formulated (3,4) with hydrogen rather than methyl bridges<sup>124</sup> as it is not decomposed by excess trimethylamine which readily depolymerises dimethylberyllium.<sup>29</sup>

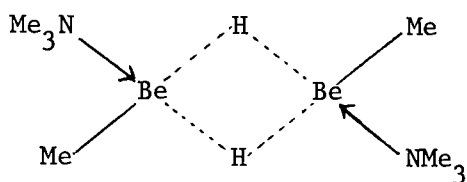

Coates and Glockling first reported the preparation of organoberyllium hydrides in 1954. Pyrolysis of di-isopropylberyllium at  $200^\circ$  results in the evolution of propene and the formation of a glass. This

was formulated as polymeric isopropylberyllium hydride. Pyrolysis of dimethylaminoisopropylberyllium results in the formation of glassy dimethylaminoberyllium hydride. These products were not studied further.<sup>34</sup>

Evidence for the formation of methylberyllium hydride was obtained by the dissolution of dimethylberyllium in a pentane solution of dimethylaluminium hydride:<sup>114</sup>

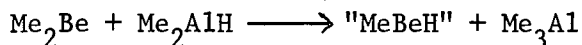

The product was not obtained free of aluminium and was not studied in detail.

Alkyl-hydrogen, but not alkyl-alkyl, exchange takes place when triethylstannane is heated with  $\text{R}_2\text{Be}$  ( $\text{R} = \text{Me}, \text{Et}$ ) even in the presence of ether.<sup>129</sup>

Organoberyllium hydrides, as their trimethylamine complexes, have been prepared by the following route ( $\text{R} = \text{Et}, \text{Ph}$ <sup>36, 129</sup>):

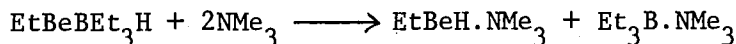
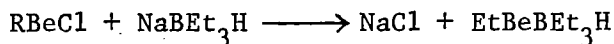

The simplest method of preparation of alkylberyllium hydrides is by refluxing an ethereal solution of alkylberyllium bromide ( $\text{R} = \text{Me}, \text{Et}, \text{Ph}$ ; from  $\text{R}_2\text{Be} + \text{BeBr}_2$ ) with lithium hydride:

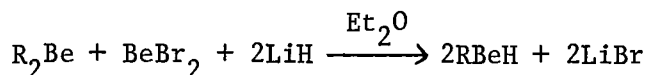

The ether is evaporated under reduced pressure after the addition of benzene, precipitating lithium bromide, and leaving a benzene solution of an ether complex of the alkylberyllium hydride.<sup>60</sup> The above methods (with the exception of the pyrolysis of di-isopropylberyllium) result in the formation of an alkylberyllium hydride in the presence of a donor solvent, that cannot be removed completely even on prolonged pumping. There are complications in pyrolysis procedures which will be discussed later.

Solutions of ether-solvated alkylberyllium hydrides have been used to prepare co-ordination compounds. Monodentate ligands result in the formation of dimeric complexes,  $(RBeH.L)_2$ , which are formulated as (3,4). Attempts to prepare monomeric complexes,  $L_2Be(Me)H$ , by the use of chelating ligands were not successful. Addition of N,N,N',N'-tetramethylethylenediamine to a solution of methylberyllium hydride results in the formation of a white precipitate of constitution,  $[(MeBeH)_2Me_2NC_2H_4NMe_2]_n$ , which is insoluble in hydrocarbons, ether, carbon tetrachloride, and carbon disulphide. It is presumed to be polymeric with structure (3,5):

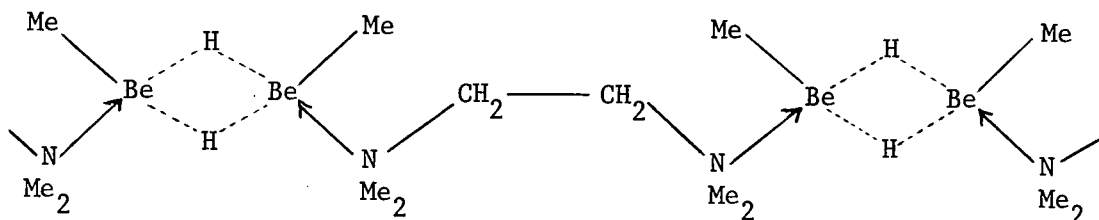

A similar product is obtained with 1,2-dimethoxyethane except that the product is a viscous oil.<sup>124</sup>

Attempts to prepare a complex with 2,2'-bipyridyl were not successful, evidently the Be-H groups added across the azomethine bond.<sup>124</sup> A pyridine complex,  $(\text{MepyBeH})_2$ , can be formed if the reaction is carried out at a low temperature and if only one mole of pyridine per gram-atom of beryllium is added. Addition of excess pyridine results in the formation of an orange dihydropyridine,  $(\text{C}_5\text{H}_6\text{N}(\text{Me})\text{Bepy}_2)$ , derivative containing no beryllium hydrogen bonds.<sup>60</sup> Co-ordination compounds of organoberyllium hydrides are listed in Table 13.

Some reactions of alkylberyllium hydrides with azomethine and carbonyl groups have been mentioned earlier in connection with amino- and alkoxy-derivatives of organoberyllium compounds.

Alkylberyllium hydrides react with alkenes under certain conditions. A process in which beryllium chloride reacts with triethylaluminium giving ethylberyllium chloride, which then reacts in diethyl ether with

sodium hydride and ethylene at 65° ( 6 hr., 8 atm.) giving diethylberyllium, has been described.<sup>130</sup> These reactions must have included a stage in which ethylene adds to ethylberyllium hydride. Bell and Coates have studied the reactions of a series of alkenes with organoberyllium hydrides.<sup>60</sup>

The hydroboration of alkenes is strongly catalysed by ethers,<sup>131,132</sup> but the addition of aluminium-hydrogen bonds across olefins is retarded by the use of ether as solvent.<sup>133</sup> The latter observation being based on observations that ethylene adds to lithium aluminium hydride in the absence of ether but not in the presence of ether. Studies on the reactions of dialkylaluminium hydrides with olefins have been reviewed at length.<sup>133,134</sup> Tri-isobutylaluminium reacts with propene or ethylene displacing isobutene, effectively a reaction of di-isobutylaluminium hydride. The affinities for the three types of alkenes are:

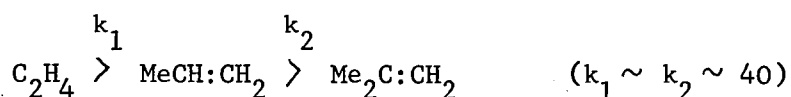

Where  $k_1$  and  $k_2$  are the equilibrium constants for the displacement of the other olefin. 1,2-di-substituted olefins add to alkenes about 100 times more slowly than  $\alpha$ -olefins. The effect of donor solvents on these reactions has not been reported.

Sodium diethylberyllium hydride reacts with ethylene readily in the presence of ether, but only sluggishly in its absence.<sup>60</sup> This is a

marked contrast to the case of lithium aluminium hydride mentioned earlier.<sup>133</sup> Bell and Coates studied the reactions of pentenes and higher olefins with ethylberyllium hydride in benzene solution containing some diethyl ether using p.m.r. spectroscopy. Progress of the reaction was studied by observing the decrease of the olefinic resonances. Table 14 lists the half lives of some reactions. The results show that the addition to pent-1-ene takes place over 200 times faster than to pent-2-ene. No reaction was observed with 2-methylbut-2-ene. Bromination of the products showed that the reaction resembles hydroboration both in the relative amount of product in which the beryllium (or boron) is in the 1- or the 2-position and in the migration of beryllium to the end of a carbon chain.

Beryllium hydride did not react with pent-1-ene after a week at 84°, but reaction was half complete after 40 hr. at 84° when a trace of ethylberyllium hydride had previously been added.<sup>60</sup>

Beryllium hydride reacts with two moles of dimethylamine, on heating to 160° for 10 hr., forming bisdimethylaminoberyllium.<sup>34</sup> Recently reactions have been carried out between beryllium hydride and one mol. of several secondary amines.<sup>135</sup> No aminoberyllium hydride was obtained from dimethylamine, di-isopropylamine, or 2,2,6,6-tetramethylpiperidine. With dimethylamine a material of approximate composition,  $\text{HBe}_2(\text{NMe}_2)_3$ , was obtained. Reaction of beryllium hydride with 2-dimethylaminoethanol and 2-dimethylaminoethanethiol<sup>135</sup> gave

$[\text{Be}(\text{OC}_2\text{H}_4\text{NMe}_2)_2]_x$  and  $[\text{Be}(\text{SC}_2\text{H}_4\text{NMe}_2)_2]_2$ , respectively, which have been described.<sup>68</sup>

In contrast, a well-defined crystalline product is obtained from beryllium hydride and N,N,N'-trimethylethylenediamine and is trimeric in benzene solution,  $[\text{HBeN}(\text{Me})\text{C}_2\text{H}_4\text{NMe}_2]_3$ . The structure (3,6) may exist in solution:

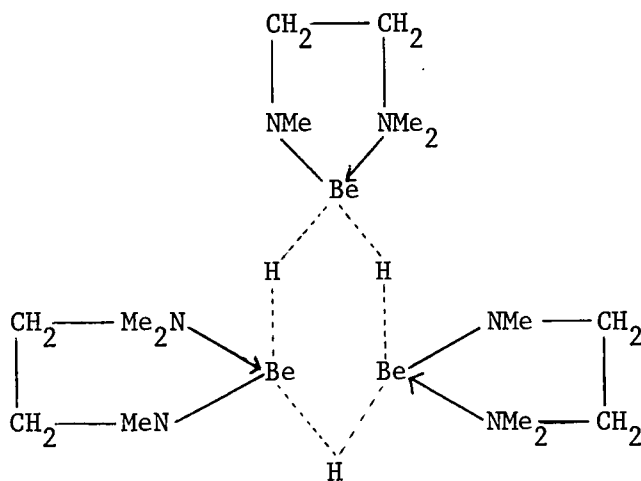

(3,6)

although more complex structures cannot be excluded. The compound sublimes unchanged and forms triclinic crystals. Crystallographic studies are in progress, and show that the compound has only two formula units,  $\text{HBeNMeC}_2\text{H}_4\text{NMe}_2$ , in the unit cell.<sup>94</sup> Hence the degree of association in the crystal must be different from that in benzene solution.

The amino-hydride (3,6) reduces benzophenone and benzylideneaniline

in toluene at room temperature, but the intermediates were not isolated. It (3,6) did not react with sodium or potassium hydride.<sup>135</sup>

Beryllium hydride reacts with benzophenone and benzylideneaniline in tetrahydrofuran to produce  $(\text{Ph}_2\text{CHOBeH})_{\sim 8}$  and  $(\text{HBeNPhCH}_2\text{Ph}\cdot\text{THF})$  respectively. The latter is somewhat dissociated in benzene solution.<sup>135</sup>

The reactions of bisdimethylaminoberyllium with some alkylaluminium hydrides, trimethylamine-alane and trimethylaluminium have been investigated. Mixed beryllium-aluminium complexes were formed but no methyl-dimethylamino exchange was observed.<sup>136</sup>

Attempts to prepare methylberyllium by the sublimation of dimethylberyllium from " $\text{Me}_4\text{Be}_3\text{H}_2$ " were not successful. Extensive disproportionation takes place in the range  $170\text{--}210^\circ$  which continued until the hydride:methyl ratio was  $10\cdot4:1$ . At higher temperatures decomposition took place.<sup>124</sup> Heating " $\text{Et}_4\text{Be}_3\text{H}_2$ " for 8 hours at  $70\text{--}80^\circ$  leaves a glassy residue of mainly ethylberyllium hydride. If a solution of sodium hydridodiethylberyllate is prepared from excess sodium hydride and a half molar proportion of beryllium chloride is added, then more sodium hydride dissolves and the solution contains a mixture of " $\text{Et}_4\text{Be}_3\text{H}_2$ " and  $\text{NaBeEt}_2\text{H}$ . Pyrolysis of this mixture at  $180^\circ$  leaves a residue of  $\text{BeH}_2$  (5 mol.) +  $\text{Na}_2\text{Be}_2\text{H}_6$  (3 mol.) or  $\text{BeH}_2$  (8 mol.) +  $\text{Na}_2\text{BeH}_4$  (3 mol.). Further evidence for an ether insoluble sodium beryllium hydride was obtained by boiling ethereal solutions of " $\text{Et}_4\text{Be}_3\text{H}_2$ " with excess sodium hydride. The Et:H ratio in solution is

always at least 2:1, but  $\text{NaEt}_2\text{BeH}$  can be isolated from solution showing that sodium hydride has dissolved and that hydride has left solution as beryllium hydride or as a complex sodium salt.<sup>124</sup>

The ether insoluble hydride  $\text{Na}_2\text{BeH}_4$  has been prepared:<sup>137</sup>

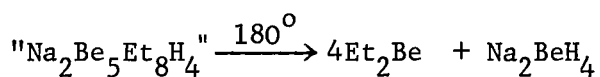
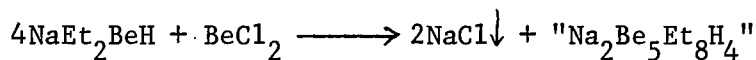

Ether-insoluble salts of the type  $\text{BeH}_2(\text{LiH})_n$  have been reported in a preliminary communication.<sup>117</sup>

Lithium beryllium hydride,  $\text{Li}_2\text{BeH}_4$ , has been prepared from lithium diethylberyllium hydride using the above reaction scheme.<sup>138</sup>

Unlike beryllium hydride, both  $\text{Na}_2\text{BeH}_4$  and  $\text{Li}_2\text{BeH}_4$  give X-ray diffraction patterns, none of the lines characteristic of sodium hydride being present. Attempts to prepare  $\text{MBeH}_3$  ( $\text{M} = \text{Li}, \text{Na}$ ) resulted in the formation of a mixture of  $\text{BeH}_2$  and  $\text{M}_2\text{BeH}_4$  since their X-ray powder patterns contain (with the exception of one weak line in each case) only the lines due to  $\text{M}_2\text{BeH}_4$ .<sup>138</sup>

$\text{M}_2\text{BeH}_4$  ( $\text{M} = \text{Li}, \text{Na}$ ) are regarded as electron-deficient polymers with strongly polarised metal-hydrogen bonds, rather than as salts analogous to  $\text{MBH}_4$ .<sup>137,138</sup> They are somewhat more reactive than beryllium hydride prepared by the pyrolysis of di-t-butylberyllium. Sodium beryllium hydride dissolves in methanol below room temperature

to form  $\text{NaBe}(\text{OMe})_3(\text{MeOH})$ . An identical product is obtained by dissolving beryllium in methanolic sodium methoxide.<sup>138</sup>

The pyrolysis of sodium di-isobutylberyllium hydride has been carried out, aimed at the preparation of  $\text{NaBeH}_3$ . Products of the type  $\text{Na}_1 + x \text{BeH}_3 + x$  have been obtained, and di-isobutylberyllium distils out of the pyrolysis vessel. X-Ray powder photographs of the product are independent of x and characteristic only of  $\text{Na}_2\text{BeH}_4$ . The reaction is believed to take the course:<sup>126</sup>

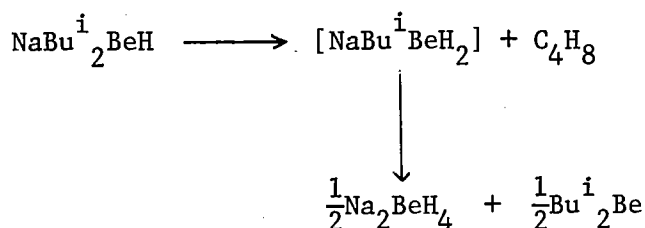

Evidence for exchange was obtained when di-isobutylaluminium hydride was heated with methylberyllium t-butoxide in toluene, but no simple product was isolable. The reaction between beryllium di-t-butoxide and two mols. of di-isobutylaluminium hydride was studied by p.m.r. spectroscopy. After 3 hours at 70-80° the deposition of some glassy material was observed and the p.m.r. spectrum showed that all the t-butoxyberyllium groups had disappeared from solution. The p.m.r. spectrum being identical with that of di-isobutylaluminium t-butoxide. A product approximating to a butoxyberyllium hydride was obtained.<sup>135</sup>

Bell and Coates<sup>138</sup> have studied exchange reactions between a series

of beryllium compounds and sodium triethylaluminium hydride,<sup>139</sup> with the precipitation of a series of alkali metal beryllium hydrides. The results are summarised in Table 15. X-Ray powder diffraction studies showed the presence of  $\text{Na}_2\text{BeH}_4$  in the precipitates and they appear to be mixtures with  $\text{BeH}_2$  together with some other material.<sup>138</sup>

Hydride Chemistry of Magnesium

Magnesium hydride has been prepared by various methods in varying degrees of purity. It was first prepared by the pyrolysis of diethylmagnesium,<sup>140</sup> which loses ethylene at 170° and by the pyrolysis of ethylmagnesium iodide at 175°. These reactions have been investigated in detail.<sup>89,141,142,143</sup> It was found that some other reaction was taking place during the pyrolysis and a white crystalline solid sublimed out of the reaction vessel.<sup>89</sup> This was given the formula  $MgC_2H_4$  and thought to be a polymer of the type  $(Mg-CH_2-CH_2-Mg-CH_2-CH_2-)_x$ . It was later shown to be ethylmagnesium ethoxide produced by cleavage of the ether present.<sup>88</sup>

The preparation of hydrohalides of magnesium ( $HMgX \cdot nEt_2O$ , n = 1) by the hydrogenation of ethylmagnesium halides at 100-150° has been reported.<sup>144</sup>

The preparation of  $HMgX(THF)_2$  has been reported<sup>145</sup> as a crystalline solid by bubbling diborane into a Grignard solution in THF or ether, in either case the dietherate was obtained. These have now been shown to be halomagnesium borohydrides:<sup>146</sup>

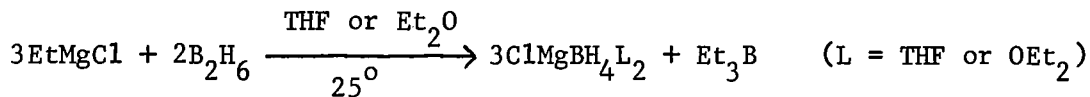

The products are dimeric in benzene solution.

Reaction between magnesium dialkyls and diborane can, under certain circumstances, produce magnesium hydride. The complex reaction scheme has been investigated by Bauer.<sup>147,148</sup>

Magnesium hydride, of about 75% purity, can be obtained by the addition of an ether solution of lithium aluminium hydride to a large excess of diethylmagnesium.<sup>114</sup> The reaction is complex if other ratios are used. Exchange occurs between diethylmagnesium and diethylaluminium hydride,<sup>149</sup> giving magnesium hydride and triethylaluminium. In absence of solvent, magnesium hydride 97% pure was obtained.

Magnesium reacts directly with hydrogen at high temperature and pressure. A variety of conditions and catalysts have been described.<sup>5,118</sup> Hydrogen also reacts directly, under pressure, with an ethereal solution of a Grignard reagent:<sup>150</sup>

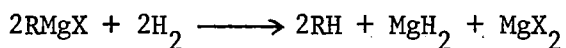

The structure of magnesium hydride has been shown by X-ray diffraction to be of the rutile ( $TiO_2$ ) type with an Mg-H distance of  $1.95 \text{ \AA}$ .<sup>143,151</sup> A neutron diffraction study has also been carried out.<sup>152</sup> The infrared spectrum contains a very broad band from  $900-1600 \text{ cm}^{-1}$  with a maximum at  $1160 \text{ cm}^{-1}$ .<sup>153</sup> The vibration is thought to be due to the valence vibrations of the Mg-H bond. Structure (3,7) is assigned to  $MgH_2$ :

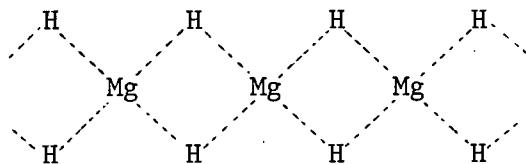

(3,7)

An ionic structure cannot be ruled out and the actual structure probably lies between the two structures.

The properties of magnesium hydride depend upon the method of preparation, due to a combination of purity and particle size. The reaction between magnesium hydride and ethylene<sup>154</sup> gave a product containing only 4% Mg-Et and traces of higher magnesium alkyl bonds. "EtMgH" was not observed. Ethoxymagnesium hydride has been prepared by bubbling silane into an ethereal solution of diethylmagnesium. The suggested reaction is:

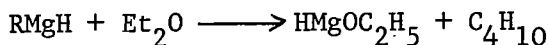
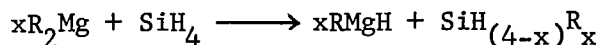

Ethoxymagnesium hydride is an insoluble solid.<sup>155,156</sup>

No alkali-metal dialkylmagnesium hydride analogous, for example, to  $NaEt_2BeH$  resulted from diethylmagnesium and lithium, sodium, or potassium hydride. Solvents used were diethyl ether, tetrahydrofuran,

and 1,2-dimethoxyethane.<sup>157</sup> Lithium hydride did not react with ethylmagnesium bromide on heating to 90°. Potassium hydride, in contrast, reacts slowly in diethyl ether and analysis is consistent with the reaction:<sup>157</sup>

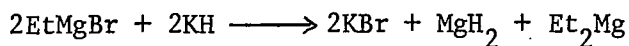

A complex,  $\text{LiBu}^n\text{Me}_2\text{Mg}\cdot\text{OEt}_2$ , is formed from n-butyl-lithium and dimethylmagnesium in diethyl ether. On pyrolysis of the complex (16 hr. at 160°) a mixture of LiH and  $\text{Me}_2\text{Mg}$  is obtained.

Exchange reactions between sodium trialkylborohydrides and some alkylmagnesium compounds result in the precipitation of magnesium hydride containing occluded alkyl groups.<sup>157</sup>

Hydride Chemistry of Zinc, Cadmium and Mercury

Zinc and cadmium hydrides can be prepared by the reaction of the respective dialkyls with lithium aluminium hydride at low temperature.<sup>114</sup> In the case of zinc, zinc iodide may be used. A later study<sup>158</sup> of the zinc iodide reaction with lithium aluminium hydride, by conductimetric titration, showed two discontinuities in the titration curve at  $ZnI_2:LiAlH_4$  ratios of 1:4 and 1:2. The conductivity rose towards the first point and fell towards the second, leading to the interpretation:

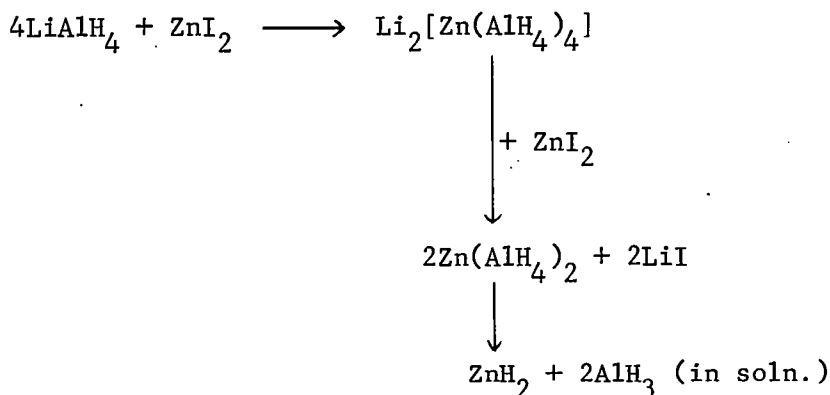

The conductivity curve showed the formation of other complexes.

Zinc and cadmium hydrides are white, involatile, insoluble materials which decompose at normal temperatures, zinc hydride slowly and cadmium hydride rapidly at  $0^\circ$ , giving hydrogen and the metals.<sup>159</sup>

Alkyl-hydrogen exchange takes place between diethylzinc and diethylcadmium with diethylaluminium hydride but no metal hydrides were isolated.<sup>149</sup>

Evidence for the existence of methylzinc hydride was reported in the observation that zinc hydride dissolves in ether containing a large excess of dimethylzinc.<sup>160</sup> Attempts to repeat this reaction and to prepare methylzinc hydride by reaction of dimethylzinc trimethylamine with lithium aluminium hydride, and of dimethylzinc with triethylstannane failed.<sup>9</sup>

Diborane reacts with dimethylzinc forming methylzinc borohydride and zinc hydride,<sup>9</sup> not  $(\text{HZnBH}_4)_x$  as previously reported.<sup>160</sup> Methylzinc borohydride is a volatile crystalline solid.<sup>9</sup>

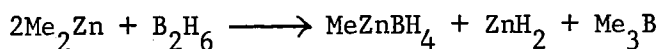

Zinc hydride reacts with N,N,N'-trimethylethylenediamine to form  $\text{HZnNMeC}_2\text{H}_4\text{NMe}_2$ , a crystalline complex which is dimeric in benzene solution.<sup>135</sup> The crystal structure (3,8) has been examined by X-ray diffraction:<sup>161</sup>

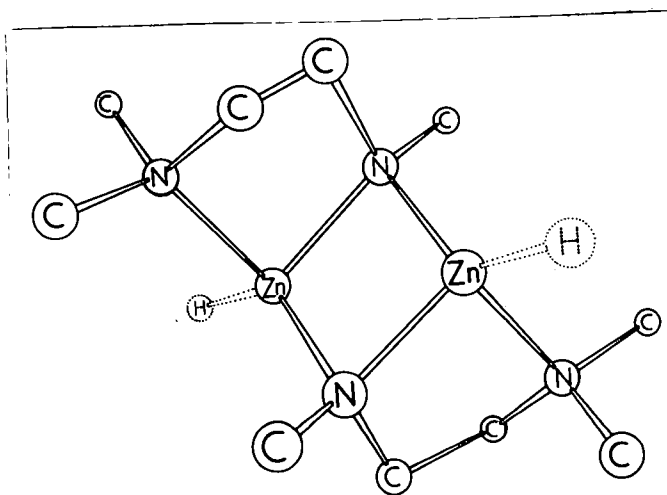

3,8

Anionic hydride complexes of zinc are known. Lithium hydride dissolves in an ethereal solution of diethylzinc and the complex  $\text{LiZnPh}_2\text{H}(\text{OEt}_2)$  can be crystallised.<sup>162</sup> Sodium hydride adds two mols. of diethylzinc in monoglyme or diglyme, giving  $\text{Na}(\text{Et}_2\text{Zn})_2\text{H}$  which decomposes when attempts are made to isolate it.<sup>163</sup>

Attempts to prepare mercury hydride by alkyl-hydride exchange failed even at  $-80^\circ$ , only mercury and hydrogen being produced.<sup>114</sup> The formation of  $\text{HgH}_2$  was reported by Wiberg and Henle<sup>164</sup> at  $-135^\circ$ , it decomposed above  $-90^\circ$ .<sup>159</sup>

Diethylaluminium hydride and diethylmercury react in the absence of solvent forming mercury, hydrogen and ethane. The presence of ethane is taken to indicate the transitory formation of ethylmercury hydride:<sup>149</sup>

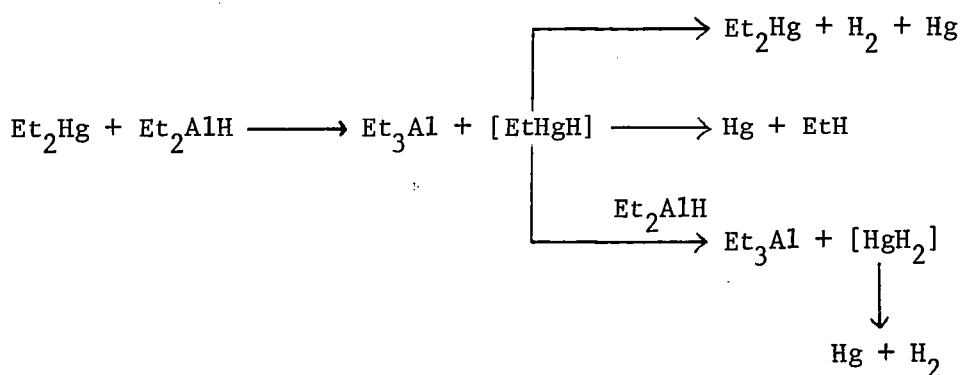

Trimethylamine-alane reacts with organomercury compounds:

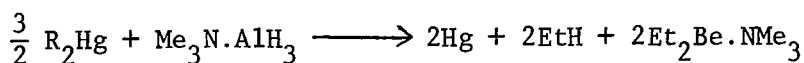

The formation of metallic mercury and hydrogen was believed to arise from the decomposition of the unstable mercury(II) hydride or from the disproportionation of "RHgH" giving  $R_2Hg$ , mercury and hydrogen.<sup>164</sup>

The reaction of ethylberyllium hydride trimethylamine complex with diethylmercury in the absence of solvent resulted in quantitative evolution of ethane:<sup>129</sup>

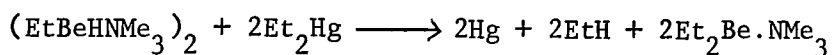

No hydrogen was formed in the reaction and there is no evidence for the formation of mercury hydride intermediates.

Spectroscopic Studies on Organic and Hydride Derivatives of Group II

The vibrational spectra of the dimethyl-derivatives of beryllium,<sup>165</sup> zinc,<sup>14</sup> cadmium,<sup>15,16</sup> and mercury<sup>14</sup> have been investigated in detail and the observed frequencies assigned.

Solid dimethylberyllium was shown to have  $D_{2h}$  symmetry with six infrared active and six Raman active fundamental vibrations. The assignments of the observed frequencies are listed in Table 16. A value of  $0.84 \times 10^5$  dynes  $cm^{-1}$  was obtained for the Be-C (bridging) force constant.<sup>165</sup>

Dimethylzinc, cadmium and mercury are monomeric liquids at room temperature. The vibrational assignments of these, in terms of  $D_{3h}$  symmetry are listed in Table 17. The force constants for the M-C bonds (M = Zn, Cd, Hg) are  $2.39$ ,  $2.05$ , and  $2.45 \times 10^5$  dynes  $cm^{-1}$  respectively. Infrared spectra of dimethylberyllium have been recorded in the vapour phase.<sup>8</sup> The unsaturated vapour of dimethylberyllium consists mainly of monomeric  $Me_2Be$ .<sup>166</sup> As expected a very simple infrared spectrum was observed consistent with a linear C-Be-C skeleton. The molecule may be reasonably assumed to have  $D_{3h}$  symmetry as for dimethylzinc, cadmium, and mercury. The saturated vapour contains dimeric and trimeric  $Me_2Be$  species,<sup>166</sup> and as expected the infrared spectrum is considerably more complex.<sup>8</sup>

The vibrational spectrum of dicyclopentadienylberyllium has been

examined.<sup>167</sup> The structure (in the vapour phase) found by an electron-diffraction study<sup>168</sup> is confirmed both in the solid phase and in solution. It has a sandwich type structure with an asymmetrically positioned beryllium atom.

Full vibrational analyses have not been reported for magnesium dialkyls. Absorptions due to  $\nu(\text{Mg-C})$  have been observed in the region 500-535  $\text{cm}^{-1}$  for  $\text{Me}_2\text{Mg}$ ,  $\text{Et}_2\text{Mg}$ , and some methyl and ethyl Grignard reagents in ether and tetrahydrofuran. The corresponding absorptions for phenylmagnesium compounds are between 365 and 383  $\text{cm}^{-1}$ .<sup>169</sup>

Coates and Ridley have assigned  $\nu(\text{Zn-C})$ ,  $\rho(\text{Zn-C})$ , and  $\delta_{\text{sym}}(\text{Zn-C})$  for a series of methyl- and ethyl-zinc derivatives.<sup>73</sup>

The presence of the  $\text{BeH}_2\text{Be}$  bridge in sodium hydridodiethylberyllate etherate was shown by X-ray diffraction.<sup>128</sup> Infrared absorptions due to this, and the deuterated analogue, have been studied in some detail.<sup>124,170</sup> The vibrational modes of the  $\text{BeH}_2\text{Be}$  bridge are analogous to the vibrational modes of the  $\text{BH}_2\text{B}$  bridge in diborane which are numbered<sup>171</sup>  $\nu_{13}$  (symmetric, out of phase) and  $\nu_{17}$  (asymmetric, in phase):

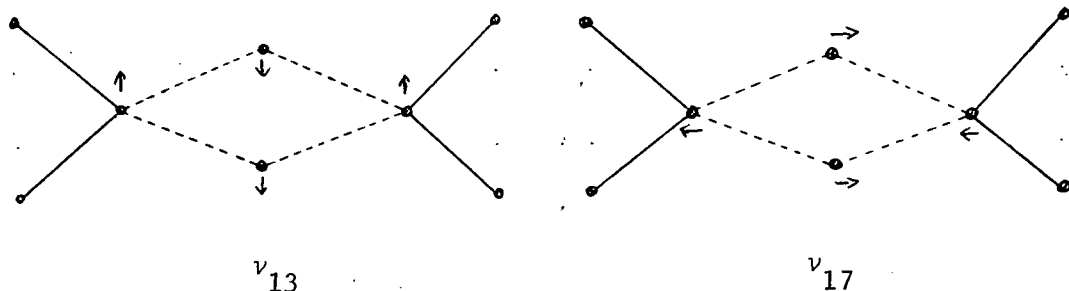

Table 18 lists the assignments of vibrational frequencies for the  $\text{BeH}_2\text{Be}$  bridge.

Comparison of the spectra of methylberyllium- and methyl[ $^2\text{H}_3$ ] beryllium-compounds has enabled absorptions due to  $\text{Be-CH}_3$  symmetric deformations to be identified in the region  $1186\text{-}1206\text{ cm}^{-1}$ . Beryllium methyl stretching vibrations are not clearly identified, but appear to be in the range  $700\text{-}900\text{ cm}^{-1}$ .<sup>170</sup>

The only reported example of terminal Be-H absorption is in the vapour phase infrared spectrum of  $\text{MeBeH.NMe}_3$  at  $80^\circ$ .<sup>124</sup> Vapour pressure measurements indicate the presence of monomer and a sharp absorption was observed at  $2141\text{ cm}^{-1}$ . Emission electronic spectra indicate that a terminal Be-H should absorb near  $2100\text{ cm}^{-1}$ .<sup>172</sup> A similar conclusion may be drawn from consideration of  $\nu(\text{X-H})$  for the derivatives of the first short period.

The p.m.r. spectra of some alkylberyllium hydride co-ordination complexes have been recorded. The absorption due to the  $\text{BeH}_2\text{Be}$  bridge have only been observed in three cases, data are given in Table 13.<sup>173</sup> The failure to observe this resonance in all cases may be attributed to an unfavourable relaxation time for the bridging protons on account of their proximity to the beryllium nuclei, which have a quadruple moment ( $I = 3/2$ ) and are in an unsymmetrical electric environment.

The trimethylamine resonance of  $(\text{MeBeH.NMe}_3)_2$  is partially split at  $25^\circ$  and this has been interpreted as arising from the presence of

cis- and trans-isomers (4,1):

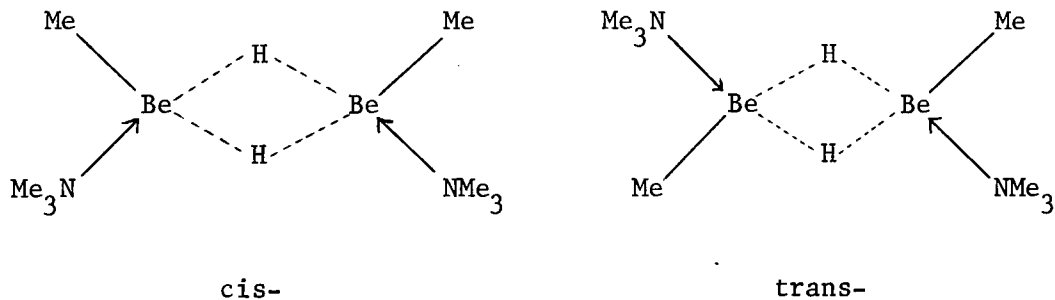

(4,1)

This was confirmed by recording the spectrum over a range of temperature. The observed spectra are shown in (4,2).

$(\text{Me}_3\text{N}\cdot\text{BeMeH})_2$  in  $\text{C}_7\text{D}_8$

Effect of temperature on  $\text{CH}_3\text{N}$  resonance

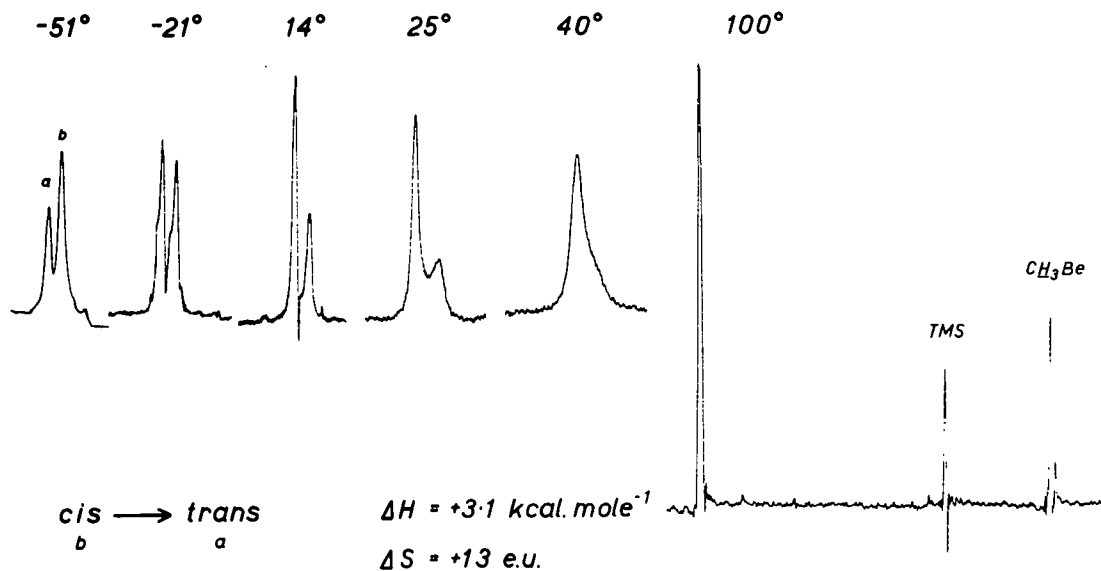

The changes in enthalpy and entropy for the cis-trans interconversion were found to be  $\Delta H = 3.1 \pm 0.2 \text{ kcal.mole}^{-1}$  and  $\Delta S = 13 \pm 2 \text{ cal.deg.}^{-1} \text{ mole}^{-1}$ . Interactions with solvent molecules would be less for the trans isomer (dipole moment zero) and therefore  $\Delta S$  for the process cis  $\longrightarrow$  trans should be positive. Therefore the cis isomer is the one more stable at low temperatures.

### Apparatus and Techniques

The majority of compounds studied were sensitive to both oxygen and moisture and therefore the work was carried out in an atmosphere of dry, oxygen-free nitrogen.

Nitrogen - B.O.C. 'White Spot' quality was purified by passing through copper needles at 400° to remove oxygen and through two traps cooled in liquid nitrogen to remove the final traces of water.

Manipulations that could not be carried out under nitrogen on the bench, e.g. making up of samples for infrared spectroscopy, were carried out in a nitrogen filled glove box. The glove box was fitted with a circulatory pump and when not in use the nitrogen was recycled through a purifying system as used for the bench supply. When necessary the oxidised copper was regenerated by passing a stream of hydrogen through the column at 120°. All connections were made using 5/16 inch copper tubing and flexible joints with butyl rubber tubing to minimise permeability to oxygen. The gloves (supplied by The Charleston Rubber Co.) were also of butyl rubber for the same reason.

A glove box using a room temperature purification system was used in later work. Oxygen was removed by passing through a column of manganous oxide supported on vermiculite and water and organic vapours by passing through molecular sieves (4A and 13X respectively). Regeneration of the oxygen scrubber was by passing hydrogen through at

350°. The molecular sieves were regenerated by pumping at 200°. These operations were carried out every three or four days and by having parallel columns the box was constantly in operation. Recirculation was carried out at the rate of 1.5 c.f.m. Oxygen contents of ~1 p.p.m. were easily obtainable compared with ~50 p.p.m. on the original system.

A conventional vacuum line was used in this work - a general view is shown in (5,1). The line consisted of three main sections (i) a fractionation train of three 'U' traps connected by mercury float valves and also connected individually to the main line. (ii) A gas measuring system consisting of a Töpler pump for measuring gases which could not be condensed by liquid nitrogen and a calibrated bulb system connected to a manometer. A gas infrared cell could be attached to the Töpler pump and if necessary a combustion bulb for analysing mixtures of methane and hydrogen. (iii) A storage system consisting of three tubes with a capacity of ca. 50 ml. and two 3 l. bulbs equipped with cold fingers and manometers for storing gases.

#### Calibration of the Measurement Systems

Small bulb of the Töpler pump	11.52 c.c.
Combined bulbs of the Töpler pump	151.8 c.c.
Volume of small standard bulb	505.6 c.c.
Volume of combined standard bulbs	4613 c.c.
Internal diameter of manometer tube	1.0 cm.
For 1 cm. drop in manometer level-level of reservoir increases by	0.0298 cm.

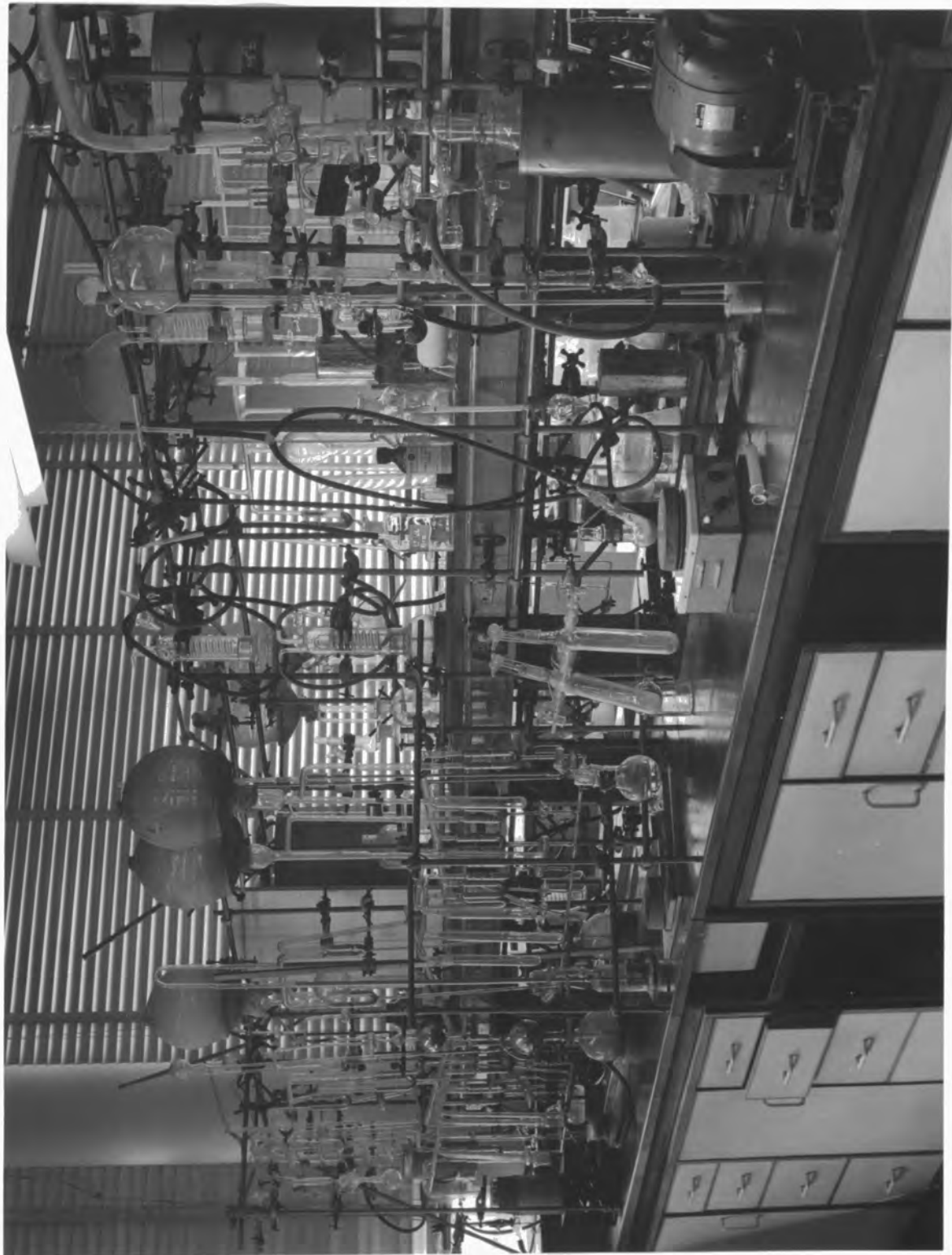

(5,1)

## Analyses

### Gas Analyses

A weighed amount of the sample (or a known volume in the case of a solution) was attached to the vacuum system. The sample was cooled to liquid nitrogen temperature and 'degassed' 2-methoxyethanol was run on to the sample. The mixture was allowed to warm up slowly and hydrolysis was completed by the addition of 2N sulphuric acid. Certain compounds were violently hydrolysed by 2-methoxyethanol and carbon formation was observed with a consequent reduction in the amount of hydrocarbon formed. In such cases the hydrolysis was repeated after the addition of a diluent to another sample. After fractionation and measurement, gases were identified by their i.r. spectra. All gas volumes are corrected to N.T.P. and are referred to as N.c.c.'s.

### Beryllium Analyses

The solution from hydrolysis was made up to a standard volume and aliquots taken to contain 3-5 mg. beryllium and titrated by the following procedure. To each aliquot was added 5 ml. of 0.5M potassium sodium tartrate and 2 drops of 1% bromothymol blue (in 50:50 ethanol and water) and the solution made alkaline by addition of 0.5N sodium hydroxide until a blue colour persisted. The solution was then made neutral by the addition of 0.1N sulphuric acid (green). The tartrate is added to complex the beryllium and avoid the precipitation of

$\text{Be(OH)}_2$ . The complex is then destroyed by adding 5 ml. of 1M potassium fluoride solution which liberates hydroxide ion:

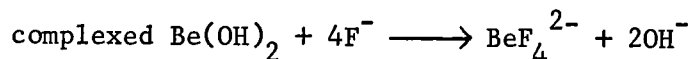

causing the solution to become alkaline (blue). After two minutes the solution is titrated with 0.1N sulphuric acid back to the green end-point previously obtained. The reaction is non-stoichiometric and requires calibration with standard beryllium solutions each time new solutions are prepared.

The presence of bases or a large concentration of ions is not desirable due to 'drifting' of the end-point. After hydrolysis with 2-methoxyethanol, solutions containing amines and ethers were pumped to remove base before completing the hydrolysis with 2N sulphuric acid. Consequently when both amine and beryllium analyses were required a separate sample had to be taken for the latter. Beryllium analyses could not be undertaken on solutions that had been used for amine analysis as drifting of the end point occurred. This is probably due to the large concentration of sodium sulphate in the solution.

### Zinc Analyses

The solution remaining on hydrolysis was evaporated almost to dryness and concentrated nitric acid added to destroy any organic matter. The solution was evaporated almost to dryness and the procedure repeated until no carbonaceous matter remained. The resulting white solid was dissolved in the minimum amount of dilute sulphuric acid and made up to

a known volume in a standard flask. An aliquot of this solution was titrated with 0.5N sodium hydroxide using B.D.H. '4.5' indicator to a grey end-point. A further aliquot was taken and the determined amount of 0.5N sodium hydroxide added. The solution was then buffered to pH 5-6 by adding hexamethylenetetramine, and then titrated with 0.005M 'EDTA' solution. The indicator used was xylenol orange (0.2% in water) and the end point is a sharp change from red to pale yellow.

#### Amine Analyses

The acid solution from hydrolysis was made alkaline with strong sodium hydroxide solution and the amine steam distilled into excess standard acid. The excess acid was titrated with standard alkali.

#### Carbon and Hydrogen Analyses

Analyses for these elements were carried out by members of the analytical staff of these laboratories. Very few compounds were stable enough for the combustion analysis procedure and repeatable results were only obtained when a metal-carbon bond was not present, e.g. bis t-butoxyzinc.

#### Analyses of Lithium Alkyls

Solutions of lithium alkyls in hexane (Pfizer Ltd.) were analysed by the method of Watson and Eastham<sup>174</sup> for alkyl content and for total alkali by syringing a sample into excess standard acid and titrating the excess with standard alkali. In this way the presence of alkoxide

in the lithium alkyl solution could be detected. The method of Watson and Eastham involves titrating the lithium alkyl with a 1M solution of sec-butanol in xylene using 1,10-phenanthroline as indicator - the colour change being from yellow green to colourless.

### Halogen Analyses

Chloride and bromide in acid solution were determined potentiometrically. The titration cell is shown in (5,2).

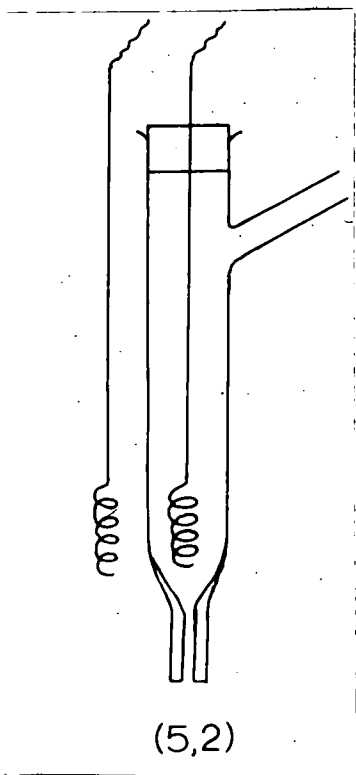

Samples containing between 0.05 and 0.1 mmoles were titrated against 0.01N silver nitrate solution. Chloride samples were diluted with 50 ml. of pure acetone and titrated using an Ag/AgCl electrode. Bromide samples

were titrated using an unplated electrode and in the minimum volume of solution. When the end-point had been determined approximately a further sample was taken and titrated under high sensitivity from 0.1 c.c. before the end-point and the end-point determined by plotting  $V + \frac{\delta V}{2}$  (where  $V$  = volume of silver nitrate added) against  $\Delta E$  (millivolts) observed on the E.I.L. pH meter used. The end-point is usually obvious without having to plot it out.

### Molecular Weights

Molecular weights were determined cryoscopically in benzene solution where solubility permitted. 'Analar' benzene was dried over sodium wire and the cryoscopic constant determined by calibration using freshly sublimed diphenyl as standard. All molecular weight determinations were carried out under a static nitrogen atmosphere.

Molecular weights of certain compounds were measured ebullioscopically in ether. Ensuring that the apparatus was dry was not easy and the following drying procedure was adopted. The apparatus, after cleaning, was washed with distilled water followed by acetone and dried. Then ca. 30 ml. dry ether (kept as a mixture with triethylaluminium) was distilled into the apparatus, which had previously been evacuated and let down to nitrogen, and ca. 3 ml. tri-isobutylaluminium added. The apparatus was then disconnected from the ether supply and the contents swirled around the whole of the apparatus. The solution was then poured out and the apparatus washed out with 3 x 30 ml. dry ether, all these and subsequent

operations being carried out under nitrogen. Finally the apparatus was pumped out and let down to nitrogen. A standard volume of ether was then run into the apparatus and the heating mantle switched on. The apparatus was totally shielded from draughts.

Temperature differences were measured using a 36-junction copper-constantan thermocouple. The ether was refluxed until equilibrium was reached. The compound was then added as a solution in ether - ca. 1 millimole (of monomer unit) X degree of association in ca. 1-5 ml. ether. The compound was added in 0.1 ml. units by gas tight syringe through a serum-cap - the e.m.f. being noted for each addition. Finally a standard solution of diphenyl in ether was added in 0.1 ml. until a further e.m.f. of  $100 \mu\text{V}$  had been obtained. Details of the calculation are shown in the relevant section of the experimental work.

### Infrared Spectra

Infrared spectra were recorded using Grubb-Parsons GS2A and Spectromaster instruments in the region  $4000-400 \text{ cm}^{-1}$  using KBr cells and a Grubb-Parsons DB3/DM2 spectrometer in the region  $400-200 \text{ cm}^{-1}$  using CsI cells. Specimens of air sensitive materials were prepared in the glove box. Solid materials were examined as Nujol mulls between KBr discs or as a solution in cyclohexane with solvent compensation in the reference beam. Spectra of liquids were usually recorded using sealed solution cells to minimise the risk of oxidation whilst being recorded. Gas samples were studied using a 10 cm. cell.

Instrument calibration was regularly checked in the region  $4000-400\text{ cm}^{-1}$  using a thin polystyrene film. When high resolution work was being undertaken the instrument (Spectromaster) was calibrated before each spectrum was recorded. In the region  $400 - 200\text{ cm}^{-1}$  the calibration was checked using water vapour absorptions whilst operating as a single beam instrument.<sup>175</sup> Frequencies above  $2000\text{ cm}^{-1}$  were measured to about  $\pm 5\text{ cm}^{-1}$  and to  $\pm 2\text{ cm}^{-1}$  below  $2000\text{ cm}^{-1}$  for reasonably intense and sharp bands.

### Raman Spectra

Raman spectra of di-t-butylberyllium and -zinc were recorded with a Cary 81 Raman spectrometer (University of Newcastle upon Tyne) with a 5 ml. sample and standard polaroid assemblies. Excitation was by the blue mercury line ( $4358\text{ \AA}$ ), an ethyl violet-nitrotoluene filter solution being used to reduce the intensity of primary lines that might otherwise interfere. The observed frequencies were calibrated from the positions of appropriate intense bands in the spectra of pure carbon tetrachloride, chloroform, and benzene, and are correct to within  $\pm 2\text{ cm}^{-1}$  for well defined lines; for diffuse or feeble features the limits of error may be wider.

Although a comparatively weak scatter, di-t-butylberyllium gave a Raman spectrum of good quality, and analysis of the material after the spectrum had been recorded (at ca.  $30^{\circ}$ ) showed negligible decomposition. In contrast, under similar conditions, di-t-butylzinc rapidly decomposed

with deposition of metallic zinc; accordingly, a detailed Raman spectrum could not be obtained, and in the short time available only three Raman lines could be identified with certainty but these were the closest to the exciting frequency and the most significant in connection with evidence relating to the molecular symmetry.

### N.M.R. Spectroscopy

Proton magnetic resonance spectra were recorded at 60 MHz on a Perkin-Elmer R10 spectrometer operating at 33.5°. Variable temperature studies were carried out using both the R10 and an AEI RS2 spectrometer at 60 MHz. Samples were recorded as neat liquids or as ca. 10 wt.% solutions in an appropriate solvent. Tetramethylsilane (TMS) was used as internal standard  $\tau = 10.00$  and values were calculated using the pre-calibrated charts for the Perkin-Elmer R10 and the side-band technique for the AEI RS2 spectrometer. Occasionally benzene ( $\tau = 2.73$ ) was used as internal standard.

### Gas Chromatography

Purity of starting materials was checked using a Pye 104 chromatograph and standard columns as appropriate. For quantitative work the instrument was calibrated with known samples as the detector - flame ionisation, was not linear. Alternatively a Panchromatograph with gas density balance detector was used - this gave a linear response i.e. standard peak area per molar unit. Areas were measured using a Kent integrator attached to the chromatograph.

Preparation and Purification of Starting Materials

Solvents

Pentane, hexane, benzene, toluene, xylene, methylcyclohexane were dried over sodium wire.

Diethyl ether was dried over sodium wire followed by distillation from lithium aluminium hydride just before use.

Tetrahydrofuran (THF) and 1,2-dimethoxyethane ('monoglyme') were purified by refluxing with potassium until a blue colouration (of the potassium ketyl) was obtained with benzophenone. The solvents were then distilled, under nitrogen, on to lithium aluminium hydride. Final purification was carried out just before use by refluxing with, and distillation from, lithium aluminium hydride.

Trimethylamine and triethylamine

Trimethylamine and triethylamine were distilled from phosphorus pentoxide and stored over this drying agent. Trimethylamine was distilled on to the vacuum line as required. Triethylamine was re-distilled just before use.

Trimethylphosphine

A pure sample was available in the laboratory.

N,N,N',N'-tetramethylethylenediamine, N,N,N',N'-tetraethylethylenediamine and N,N,N'-trimethylethylenediamine

These amines were purified by distillation from sodium.

### 2,2'-Bipyridyl

As supplied 2,2'-bipyridyl contains some terpyridyl and purification was effected by sublimation at 80<sup>o</sup>/0.05 mm.Hg. on to a solid carbon dioxide cooled finger.

### Benzoic acid

Thermochemical standard benzoic acid was used without further purification.

### Propionic acid

A small sample was collected from the middle fraction on distilling the commercially available material - b.p. 141<sup>o</sup>.

### Pyridine

Pyridine was distilled from sodium hydroxide pellets on to sodium hydroxide pellets under a nitrogen atmosphere.

### t-Butanol

t-Butanol was refluxed with aluminium turnings, activated with a trace of mercuric chloride, for 2-3 hours and the alcohol distilled from the alkoxide.

### N,N-dimethylaminoethanol

The alcohol was purified by distillation from calcium hydride just before use.

### N,N-dimethylaminoethanethiol

This was prepared from the corresponding hydrochloride by addition

of less than one molar equivalent of sodium hydroxide to an aqueous solution. The thiol was extracted with ether and purified by fractional distillation, and finally distillation from magnesium hydride, b.p. 126°.

### Alkyl halides for Grignard reactions

The purity of commercially available alkyl halides was checked by gas chromatography. It was necessary to purify n-propylbromide and iso-propylbromide by fractional distillation, iso-butylbromide was found to be > 97% pure and was used as such. Purification by distillation cannot be effected due to the equilibrium:

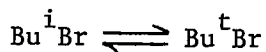

lying to the right at elevated temperatures.<sup>176</sup>

Purification of t-butylchloride was effected by the method of Norris and Olmstead, after washing with ice-cold distilled water the halide was dried with calcium chloride and distilled. The fraction boiling 51.0 - 52.0° was collected.<sup>177</sup>

### Grignard Reagents

These were prepared by the standard procedure from the alkyl bromide and magnesium turnings in sodium-dried diethyl ether. A slight excess (ca. 5-10%) of magnesium turnings was used. Yields varied according to the nature of the alkyl group and all solutions were analysed for hydrolysable alkyl before further reaction.

### Beryllium Chloride and Beryllium Bromide

Beryllium chloride was prepared in ca. 95% yield by burning beryllium powder in an atmosphere of chlorine. As the reaction is exothermic nitrogen was added to the chlorine as a diluent.

Beryllium bromide was similarly prepared using bromine vapour generated by passing nitrogen through warmed liquid bromine.

### Zinc Chloride

Sticks of anhydrous zinc chloride were powdered in a glove box and final traces of water were removed by refluxing with freshly distilled thionyl chloride until gas evolution was complete. The bulk of the thionyl chloride was removed by distillation and the remainder in vacuo. <sup>178</sup>

### Preparation of beryllium di-alkyls

Preparations were usually carried out on a 0.5 molar scale. The beryllium chloride was cooled to  $-78^{\circ}$  and ether slowly added, the temperature being kept low to avoid cleavage of the diethyl ether by the beryllium chloride. The solution was allowed to warm to room temperature and was stirred until all the beryllium chloride had dissolved, ca. 350 ml. of ether were used to dissolve 0.5 moles of beryllium chloride. On standing two liquid layers separated out - the lower layer is rich in  $\text{BeCl}_2(\text{OEt}_2)_2$  and the upper layer is a dilute solution of beryllium chloride in ether. The required amount of

Grignard was added over a period of half an hour with vigorous stirring of the mixture. Magnesium halides were precipitated at once and the reaction mixture became warm. After completion of the addition of Grignard solution the mixture was stirred until it had cooled to room temperature, after which time the precipitated halides settled out easily.

The ether solution of the dialkylberyllium was decanted off and the volume reduced to ca. 150-200 ml. by distillation. The solution was then transferred to a one piece distillation apparatus and the remaining ether removed in vacuo. The dialkyls were then distilled, as etherates, with variable ether content, at ca. 70° and ~ 1 mm.Hg.

Di-n-propylberyllium and di-iso-butylberyllium had not been described in the literature and their isolation is described in detail later.

Yields of 80-85%, based on amount of beryllium chloride used, were obtained. The loss can be accounted for in the numerous transference operations involved.

Di-t-butyl-d<sub>9</sub>-beryllium was prepared in the above way from 10 g. d<sub>9</sub>-t-butylchloride.

#### Preparation of ether-free beryllium di-alkyls

Ether-free di-t-butylberyllium and di-t-butyl-d<sub>9</sub>-beryllium were prepared by the method of Head, Holley and Rabideau.<sup>115</sup> This procedure uses anhydrous beryllium chloride as a Lewis acid and the resulting ether-

free material can be distilled from the mixture. The reported yield of this reaction is ca. 40% and it was noted that when the di-t-butylberyllium ether complex was added to beryllium chloride at room temperature there was considerable evolution of heat. The procedure was then modified and the reaction mixture kept cold during the addition, on warming to room temperature the mixture was stirred for one hour in vacuo during which time the ether-free material was produced as shown by the increase in pressure in the system. Ether-free di-t-butylberyllium was removed into the vacuum system and fractionated to remove any isobutene formed. Yields of 60-70% were obtained and the amounts of the white sublimate, reported by the original authors as an etherate of butylberyllium chloride, were considerably reduced. No analytical data were given for this compound when it was previously reported. Di-t-butylberyllium could be stored in clean glass apparatus at  $-78^{\circ}$  but significant decomposition took place if stored at room temperature or in glass apparatus containing a metallic deposit; this is discussed in detail later (see page 128).

The preparation of ether-free di-iso-propylberyllium had been described by Coates and Glockling<sup>26</sup> using a process of reflux distillation with continuous pumping. This process was used for the preparation of ether-free di-iso-propylberyllium and also adopted for the preparation of diethylberyllium, di-n-propylberyllium, and di-isobutylberyllium. The apparatus used is shown in (5,3).

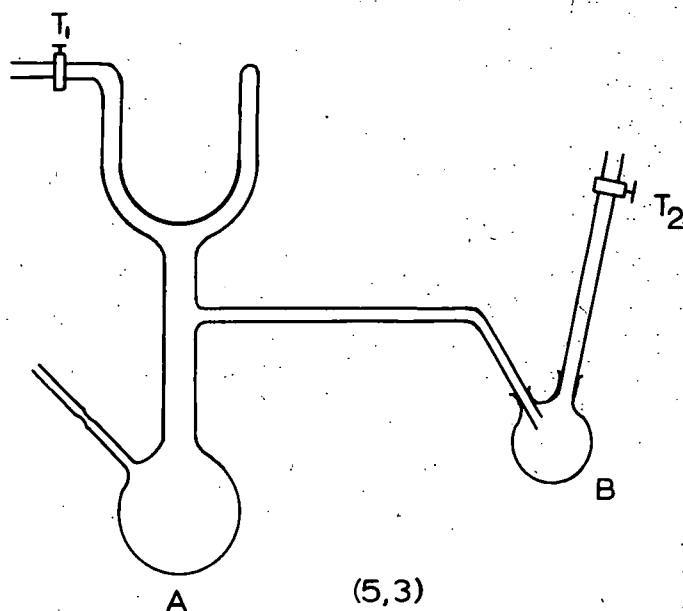

The etherate was syringed into the flask A and the constriction sealed, the etherate was then refluxed (oil bath temperature  $40-50^{\circ}$  and condenser  $-10$  to  $-20^{\circ}$ ) with continuous pumping through  $T_1$ , until ether evolution had ceased. This took ca. 24 hours. The ether-free material was then distilled into flask B with pumping (diffusion pumps) through  $T_2$ . The product was collected at liquid nitrogen temperature. In the case of di-isobutylberyllium some decomposition took place at the reflux stage and this is discussed later.

Samples of ether-free dimethylberyllium (prepared by Professor G.E. Coates) were available.

### Preparation of dimethylmercury

Dimethylmercury was prepared by reaction of mercuric chloride with two molar equivalents of methylmagnesium bromide. The product was separated from ether by fractional distillation and final purification effected by distillation, b.p.  $90^{\circ}$ /755 mm.Hg. Yield 55%.

### Preparation of dimethylzinc

Dimethylzinc was prepared by reaction of dimethylmercury with zinc dust using the apparatus described for the preparation of trimethylgallium.<sup>31</sup> Zinc dust (100% excess) and dimethylmercury were heated to boiling in a bulb sealed to a 20 cm. fractionating column packed with Fenske helices under dry nitrogen at atmospheric pressure. The reflux temperature was initially  $91^{\circ}$  ( $\text{Me}_2\text{Hg}$ ) but after 1 hour had dropped to  $44^{\circ}$  ( $\text{Me}_2\text{Zn}$ ) and fractions were taken off periodically over a period of five hours. It was stored on the vacuum line. Yield 87%.

### Diethylzinc

Diethylzinc (a gift from Ethyl Corporation) was available in the laboratory.

### Di-t-butylzinc

The preparation of this compound was reported by Abraham<sup>179</sup> but without analytical details. It was prepared by the reaction of anhydrous zinc chloride in ether with t-butylmagnesium chloride as for the beryllium analogue. It was significantly less stable to heat than

di-t-butylberyllium and the heat generated by the addition of the ether solution of zinc chloride to the Grignard reagent caused deposition of metallic zinc. The ether solution was decanted, and the dialkylzinc separated by fractionation on the vacuum line. The pure compound was a liquid when handled in a glove box - ca.30°. The m.p. has been reported as 28.8°. <sup>180</sup> [Found: Zn,36.4%; hydrolysable t-Bu-, 63.3%; M(by mass spectrometer for <sup>64</sup>Zn), 178.070. Calc. for C<sub>8</sub>H<sub>18</sub>Zn: Zn,36.5%; hydrolysable t-Bu-, 63.5%; M = 178.070 for <sup>64</sup>Zn]. The p.m.r. spectrum recorded as a neat liquid with TMS as internal standard consisted of a sharp singlet  $\tau$  8.93.

Measurement of vapour and dissociation pressures

Conventional apparatus was used in both cases. <sup>166</sup>

Experimental Results

Reactions of dimethylzinc

Reaction of dimethylzinc with N,N-dimethylaminoethanethiol - preparation of methyl-N,N-dimethylaminoethylsulphide dimer -  $(\text{MeZnSCH}_2\text{CH}_2\text{NMe}_2)_2$

A solution of 1.05 g. (10.0 millimoles) of N,N,-dimethylaminoethanethiol in 20 ml. hexane was added to 224 N c.c. (10.0 millimoles) of dimethylzinc dissolved in 10 ml. hexane and cooled to  $-80^\circ$ . On warming a white solid formed at ca.  $-30^\circ$  with gas evolution. This solid was recrystallised from 10 ml. 1:1 hexane-toluene mixture as small hexagonal plates. In a sealed capillary under nitrogen the crystals became opaque at  $90^\circ$ , turned brown at  $230^\circ$  and melted, with decomposition, at  $250^\circ$ . [Found: hydrolysable Me - 8.06%; Zn, 35.4%; M (cryoscopically in 0.83, 1.25 wt.% benzene solution) 360, 363.

$\text{C}_{10}\text{H}_{26}\text{N}_2\text{S}_2\text{Zn}_2$  requires hydrolysable Me - 8.15%; Zn, 35.4%; M, 369].

The infrared spectrum (as a Nujol mull) showed absorptions (below  $2000\text{ cm}^{-1}$ ) at: 510 s,br; 532 w,br; 649 s,br; 668 s; 767 s; 800 m,br; 862 w,br; 897 m; 945 s; 1000 s; 1029 s; 1042 m; 1101 m; 1124 m; 1147 m,sh; 1151 m; 1164 m; 1220 m; 1250 w; 1263 w; 1290 s; 1408w; 1439 s,sh; 1449 vs;  $\text{cm}^{-1}$ . s - strong, m - medium, w - weak, v - very, br - broad, sh - shoulder. These abbreviations are used throughout for i.r. spectra.

When the preparation was carried out in ether a product with an identical i.r. spectrum and m.p. was obtained.

Reaction between dimethylzinc and propionic acid - attempted preparation of methylzinc propionate -  $(\text{MeZnOOCeT})_n$ .

A solution of 1.0 g. (13.5 millimoles) of propionic acid in 20 ml. hexane was syringed on to 317 N c.c. (14.0 millimoles) of dimethylzinc in 20 ml. hexane cooled to  $-196^{\circ}$ . On melting vigorous gas evolution took place and a clear solution was obtained at room temperature. A white solid was obtained, from solution in 5 ml. hexane, on cooling to  $-30^{\circ}$ . [Found: hydrolysable Me - 5.9%, Zn, 40.7% and ratio Me:Zn = 0.63:1]. It was concluded that the product had disproportionated.

Reaction between dimethylzinc and benzoic acid - attempted preparation of methylzinc benzoate -  $(\text{MeZnOOCPh})_n$ .

A solution of 0.1833 g. (1.50 millimoles) of benzoic acid in 10 ml. toluene were syringed into one limb of a Schlenk tube. It was cooled to  $-196^{\circ}$  and 37.6 N c.c. (1.68 millimoles) dimethylzinc were condensed on. The reaction mixture was allowed to warm up and at ca.  $-30^{\circ}$  methane evolution occurred and 34.3 N c.c. methane (identified by i.r. spectrum) were collected. A clear solution resulted but after standing at room temperature for a few minutes a solid had deposited. After 1 hour the toluene solution was removed in vacuo and collected in a liquid nitrogen cooled trap. The solid residue was analysed. [Found: hydrolysable methyl, 2.36%; Zn, 22.7% and ratio hydrolysable Me - : Zn = 0.45:1]. The toluene solution was analysed by hydrolysis, 30.1 N c.c. of methane being collected. Allowing for the 3.3 N c.c. excess of

dimethylzinc used in the reaction, then 23.5 N c.c. of methane were formed by hydrolysis of the dimethylzinc present due to disproportionation of the product.

Analysis, molecular weight, and vapour pressure of di-t-butylberyllium

A sample of di-t-butylberyllium was fractionated as described<sup>115</sup> and transferred to a weighing 'V'<sup>181</sup> and then after weighing to a hydrolysis apparatus. [Found: hydrolysable Bu<sup>t</sup>, 92.0%; Be, 7.2%; C<sub>8</sub>H<sub>18</sub>Be requires hydrolysable Bu<sup>t</sup>, 92.7%; Be, 7.3%].

A sample of di-t-butylberyllium was weighed using a 'V'<sup>181</sup> to transfer it from the vacuum line. This was dissolved in benzene and the freezing points determined for three concentrations the results are tabulated below:

M	concentration*	degree of association
125.0	0.47	1.02
129.0	0.93	1.05
129.7	1.85	1.06

\* in wt.% benzene solution

The vapour pressure of di-t-butylberyllium was measured over the range -4 to +25<sup>o</sup>, above this temperature isobutene evolution was significant. The results are shown in the table. The vapour pressure can be represented by the equation:

$$\log_{10} p(\text{mm.}) = 7.40 - 1745/T$$

over this range of temperature. The results are shown graphically (5,4). From the graph the latent heat of evaporation is 7.98 kcal./mole and the extrapolated boiling point 115°. This results in a Trouton constant of 20.6 cal/mole/deg.

Vapour pressure of di-t-butylberyllium

T°C	T°K	10 <sup>3</sup> /°K	p(mm.)	log <sub>10</sub> p(mm.)	p(mm.) calc.
-4.4	268.8	3.720	7.8	0.892	8.1
+2.0	275.2	3.633	11.5	1.061	11.5
+8.9	282.1	3.545	16.8	1.225	16.2
+11.8	285.0	3.509	18.3	1.263	19.1
+15.0	288.2	3.474	21.8	1.339	22.4
+21.0	294.2	3.399	29.6	1.471	29.5
+23.5	296.7	3.370	32.0	1.506	33.1
+25.1	298.3	3.353	34.6	1.539	36.3

The pmr spectra of di-t-butylberyllium and di-t-butylberyllium etherate were recorded, as neat liquids, with TMS as internal standard. The t-butyl signal was in each case the expected single line resonance:

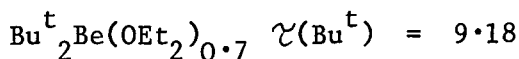
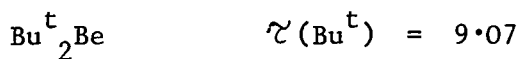

Infrared and Raman spectra of di-t-butyl-beryllium and -zinc

Samples of di-t-butylberyllium were fractionated before use to remove any isobutane and isobutene that may have been present.

(5,4)

Vapour pressure of di-t-butylberyllium

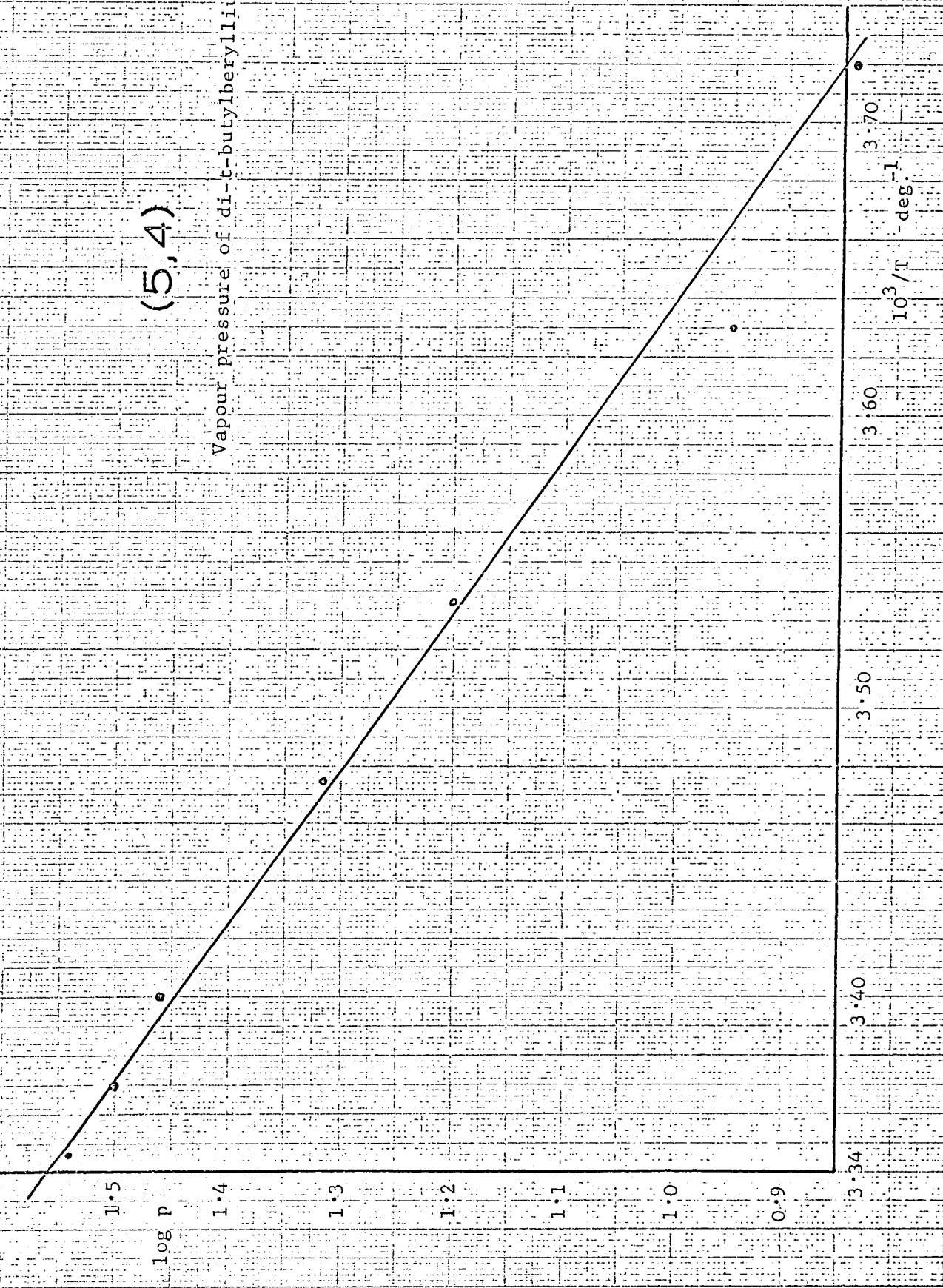

Recording gas phase i.r. spectra and the Raman spectrum presented no handling difficulties as the vacuum line could be used. Recording the i.r. spectra of the liquid posed handling problems due to the extreme air sensitivity and the volatility of this compound. It was found necessary to use a solution cell for this spectrum as oxidation around the edges of a capillary film affected the spectrum. A sealed solution cell was flushed out with pure dry nitrogen by evacuating in flanged flask and letting down with good nitrogen. This was then taken into the glove box in the flask and the sample made up after first ascertaining that the box was oxygen and water free by scavenging with triethylaluminium. In this way reproducible spectra could be obtained.

In the course of the spectroscopic work it became necessary to prepare di-t-butylzinc to clarify certain aspects of the spectra and this was handled in exactly the same way. It was a liquid at the temperature of operation of the glove box.

Only sufficient di-t-butyl- $d_9$ -beryllium was prepared for a gas phase i.r. spectrum.

The results are tabulated in the discussion section.

#### Co-ordination compounds of di-t-butylberyllium

##### N,N,N',N'-tetramethylethylenediamine di-t-butylberyllium

A solution of 1.16 g. (10.0 millimoles) of N,N,N',N'-tetramethylethylenediamine dissolved in 10 ml. methylcyclohexane was slowly added

to a solution of 1.74 g. (10.0 millimoles) of di-t-butylberyllium etherate in 15 ml. methylcyclohexane cooled to  $-30^{\circ}$ . On removal of solvent white needles were deposited and these could be re-crystallised from a small volume of methylcyclohexane. [Found: hydrolysable  $\text{Bu}^{\text{t}-}$ , 48.9%; Be, 3.73%; M (cryoscopically) in 1.07, 1.60 wt.% benzene solution 219, 227.  $\text{C}_{14}\text{H}_{34}\text{BeN}_2$  requires hydrolysable  $\text{Bu}^{\text{t}-}$ , 47.7%; Be, 3.76%; M, 239]. The complex decomposed at  $86^{\circ}$ .

The infrared spectrum was recorded (below  $2000\text{ cm}^{-1}$ ) as a Nujol mull: 463 vbr,m; 516 s,vbr; 606 vs; 690 vs; 775 m; 797 m; 807 s,br; 917 m; 939 s; 964 s; 1005 s; 1020 s; 1048 m; 1062 m; 1100 m; 1121 s; 1160 m-s; 1166 m-s; 1190 m-s; 1235 m,sh; 1242 s; 1282 s; 1285 s,sh; 1353 s; 1387 s,sh; 1410 m; 1449 vs,sh; 1481 s,sh; 1669 vw. When recorded as a solution in cyclohexane the spectrum was essentially the same but there was some sharpening up of detail. The p.m.r. spectrum was recorded as a solution in perdeuteromethylcyclohexane and in perdeuterotoluene at  $33^{\circ}$ :

	$\tau(\text{Bu}^{\text{t}})$	$\tau(\text{N}-\text{CH}_2)$	$\tau(\text{CH}_3-\text{N})$	concn.
$\text{C}_7\text{D}_{14}$	9.08	7.45	7.58	20 wt.%
$\text{C}_7\text{D}_8$	8.90	7.90	7.90	20 wt.%

low temperature spectra of the solution in  $\text{C}_7\text{D}_{14}$  could not be obtained as the solute crystallised out. Low temperature spectra of the solution in  $\text{C}_7\text{D}_8$  were recorded:

$T^{\circ}$	$\tau(\text{Bu}^t)$	$\tau(\text{N-CH}_2)$	$\tau(\text{CH}_3\text{-N})$
-10	8.81		7.84
-25	8.83	7.6	7.94 and 8.03
-50	8.73	7.72	7.94 and 8.06
-90	8.75	7.77	8.01 and 8.24

The observed spectra are shown in the discussion section.

Trimethylamine di-t-butylberyllium

130.0 N c.c. (5.8 millimoles) di-t-butylberyllium were condensed into a tube attached to the vacuum line, 342.5 N c.c. of trimethylamine were condensed on to it. The mixture was allowed to warm up to ca.  $-30^{\circ}$  and well stirred, this procedure was repeated after freezing down. Excess trimethylamine was removed and measured - 212.0 N c.c. Therefore 130.5 N c.c. of trimethylamine had reacted with 130.0 N c.c. of di-t-butylberyllium. Thus the product, a white solid, was a 1:1 adduct. The product sublimed at room temperature in a diffusion pump vacuum on to a cold finger at  $-78^{\circ}$ . When heated in a sealed tube under nitrogen the complex melted at  $45-46^{\circ}$  to a clear liquid. [Found: hydrolysable  $\text{Bu}^t$  - 62.1%; Be, 4.91%; M (cryoscopically) in 0.60, 0.89 wt.% benzene solution 182, 168;  $\text{C}_{11}\text{H}_{27}\text{BeN}$  requires hydrolysable  $\text{Bu}^t$  - 62.6%; Be, 4.95%; M, 182]. The infrared spectrum (as a Nujol mull): 545 s; 559 m,sh; 621 w,br,sh; 651 s; 666 m,sh; 694 vw; 723 vw; 738 m; 789 vw,sh; 807 vs; 821 vs; 844 vs; 926 vs; 936 s,sh; 971 vs; 995 vs; 1009 s; 1036 m; 1105 w; 1159 vw; 1190 s; 1202 m,sh; 1235 m,sh; 1242 m;

1256 m; 1282 w,sh; 1359 m,sh; 1370 s; 1393 m,sh; 1408 vw; 1488 s,sh.

The p.m.r. spectrum was recorded as a 15 wt.% solution in benzene with TMS as internal standard. The spectrum consisted of two singlets as expected  $\zeta(\text{Bu}^t\text{-Be}) = 8.82$  and  $\zeta(\text{Me}_3\text{N}) = 8.11$ .

The dissociation pressure of the complex was measured over the range 25-70°. Above 70° there was a considerable increase in pressure and on cooling a residual pressure remained. Infrared examination of the gas showed it to contain both trimethylamine and isobutene. Over the range 25-70° the vapour pressure observed are mean values of readings taken increasing and decreasing the temperature.

T°C	T°K	10 <sup>3</sup> /T°K	p(mm.)	log <sub>10</sub> p(mm.)	p(mm.)calc.
33.2	306.4	3.26	1.09	0.037	2.5
43.7	316.9	3.16	3.67	0.565	2.9
51.5	324.7	3.08	5.14	0.711	4.7
59.3	332.5	3.01	6.28	0.798	6.5
61.4	334.6	2.99	7.07	0.849	6.9
68.1	341.3	2.93	9.20	0.964	8.7
71.1	344.3	2.90	10.10	1.004	9.6
80.5	353.7	2.83	14.11	1.495	12.9

The vapour pressure can be represented by the equation:

$$\log_{10} p(\text{mm.}) = 5.77 - 1648/T$$

over this range of temperature.

Trimethylphosphine-di-t-butylberyllium

110.0 N c.c. (4.9 millimoles) di-t-butylberyllium were condensed into a small tube attached to the vacuum line and 261.3 N c.c. (10.65 millimoles) of trimethylphosphine were condensed on. After allowing to react 150.8 N c.c. of trimethylphosphine were removed, and therefore 110.0 N c.c. of di-t-butylberyllium had reacted with 110.5 N c.c. of trimethylphosphine, a 1:1 adduct being formed. The product sublimed on to a cold finger (-78°) in a diffusion pump vacuum at room temperature. When heated in a sealed tube under nitrogen the complex melted to a clear liquid at 44-46° [Found: hydrolysable Bu<sup>t</sup>-, 56.5%; Be, 4.56%; M (cryoscopically) in 0.29, 0.44 wt.% benzene solution 200, 191. C<sub>11</sub>H<sub>27</sub>BeP requires hydrolysable Bu<sup>t</sup>-, 57.3%; Be, 4.52%; M = 199]. The infrared spectrum (as a Nujol mull): 472 w,sh; 477 w,br; 496 m,br,sh; 518 vs,br; 529 s,sh; 592 vs,br; 671 vw,br; 709 s,sh; 721 s; 806 s; 821 vs; 841 w,br; 877 m,br; 924 s,sh; 935 vs; 951 vs; 957 vs,sh; 991 m; 1062 m,br; 1155 m-s; 1195 m; 1280 vs; 1300 vs; 1344 s; 1368 vs; 1414 vs; 1429 vs; 1445 vs,sh. The p.m.r. spectrum was recorded as a 15 wt.% solution in benzene with TMS as internal reference. The spectrum showed:

$\tau$	assignment	relative intensity
8.86	(CH <sub>3</sub> ) <sub>3</sub> CBe	2
9.16 9.20	(CH <sub>3</sub> ) <sub>3</sub> P	1 J = 3.5 c/sec.

The complex was less thermally stable than the trimethylamine complex and

attempts to measure the dissociation pressure led to isobutene evolution in each case.

Other t-butylberyllium compounds

t-Butylberyllium chloride diethyletherate dimer -  $(\text{Bu}^t\text{BeClOEt}_2)_2$

The residue from the preparation of ether-free di-t-butylberyllium was reported<sup>115</sup> to contain an etherate of butylberyllium chloride, but with no analytical data. The residue from a preparation of di-t-butylberyllium was heated to 60°/0.01 mm.Hg. and colourless needles sublimed up the walls of the tube. [Found: hydrolysable  $\text{Bu}^t$ -, 31.3%; Be, 5.07%; Cl, 20.27%; M(cryoscopically) in 0.55, 0.82 wt.% benzene solution 335, 330.  $\text{C}_{16}\text{H}_{38}\text{Be}_2\text{Cl}_2\text{O}_2$  requires hydrolysable  $\text{Bu}^t$ -, 31.9%; Be, 5.13%; Cl, 20.21%; M, 351]. When heated in a sealed capillary under nitrogen the compound melted at 79-80° with decomposition. The infrared spectrum was recorded (as a Nujol mull): ~479 m,vbr; ~493 m,vbr; ~575 m,vbr; 719 m; 772 m-s; 785 m; 797 m; 837 m; 870 m; 936 m; 1005 m; 1033 m,br; 1129 s; 1151 m; 1193 m; 1261 w; 1295 m; 1332 w; 1351 m; 1393 m,sh; 1449 s,sh; 1458 s,sh; 1481 m,sh. The p.m.r. spectrum was recorded as a 20 wt.% solution in benzene with TMS as internal standard:

$\tau$	assignment
6.07, 6.18, 6.32, 6.43	$\text{CH}_3\text{CH}_2\text{O}-$
8.75	$(\text{CH}_3)_3\text{C}-\text{Be}$
8.94, 9.06, 9.17	$\text{CH}_3\text{CH}_2\text{O}-$

The molecular weight of this compound was determined in ether solution by an ebullioscopic method as described earlier. A solution of 0.091 g. t-butylberyllium chloride in 1.00 ml. dry ether was made up. The apparatus was set up as described and the ether refluxed until a steady galvanometer reading was obtained. The solution was then added in 0.10 ml. samples from a gas-tight syringe and the potentiometer reading taken at the steady value reached after each addition. After the sample had been added a standard solution of diphenyl in ether (1 millimole/ml.) was added in a similar way.

volume of (Bu <sup>t</sup> BeCl) solution added (ml.)	0.0	0.1	0.2	0.3	0.4	0.5	0.6	0.7		
μV	78	88	99	107	115	123	131	140		
volume of standard solution added (ml.)	0.0	0.1	0.2	0.3	0.4	0.5	0.6	0.7	0.8	0.9
μV	142	152	162	172	180	191	200	210	218	228

The results are shown graphically in (5,5). From the graph 1 millimole of standard corresponds to an e.m.f. of 95 μV.

For a solution of 0.091 g. t-butylberyllium chloride in 1.00 ml. ether then 1 millimole  $\equiv$  1.115 ml. of this solution. From the graph this corresponds to an e.m.f. of 89 μV.

$$\begin{aligned} \therefore \text{degree of association, } n &= \frac{95}{89} \\ &= 1.07 \end{aligned}$$

(5,5)

220  
210  
200  
190  
180  
170  
160  
150  
140  
130  
120  
110  
100  
90  
80  
70

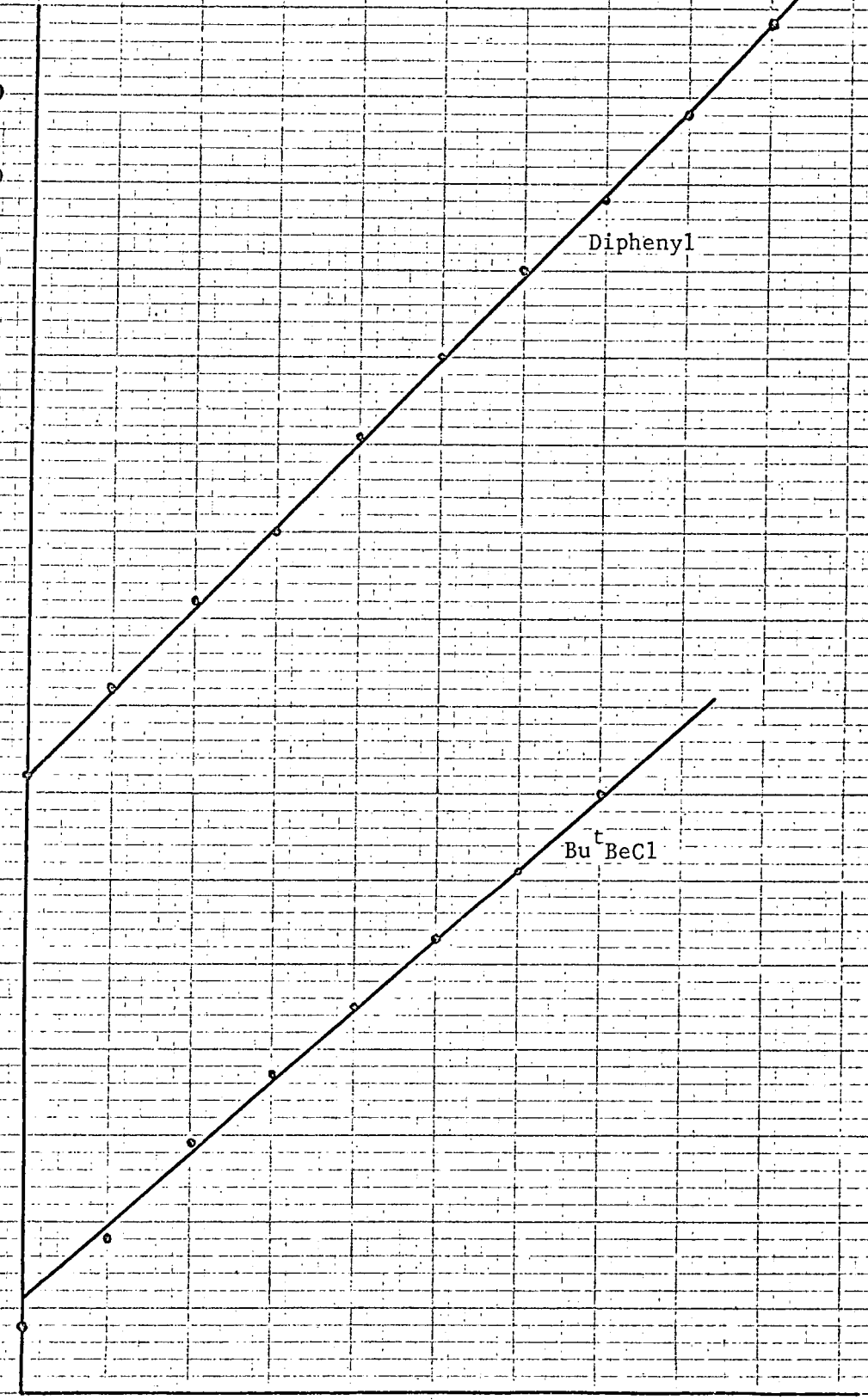

Diphenyl

Bu<sup>t</sup>BeCl

Volume Added (ml.)

0.0 0.1 0.2 0.3 0.4 0.5 0.6 0.7 0.8 0.9 1.0

t-Butylberyllium bromide diethyletherate dimer -  $(\text{Bu}^t\text{BeBrOEt}_2)_2$

Beryllium bromide was substituted for beryllium chloride in a preparation of ether free di-t-butylberyllium. After removal of the ether-free dialkyl the residue was heated in vacuum  $70^\circ/0.01$  mm. and colourless needles sublimed out. In a sealed tube under nitrogen they melted at  $55-56^\circ$  to a clear liquid. [Found: hydrolysable butyl, 25.83%; Be, 4.10%; Br, 36.40%; M (cryoscopically) in 0.70, 1.05 wt.% benzene solution 446, 458.  $\text{C}_{16}\text{H}_{38}\text{Be}_2\text{Br}_2\text{O}_2$  requires hydrolysable butyl 25.91%; Be, 4.10%; Br, 36.36%; M = 440].

The infrared spectrum (as a Nujol mull) showed absorptions:

$\sim$ 476 m,br; 532 s; 575 s; 718 s; 770 s; 781 s; 794 m; 832 s; 844 vs;  
916 s; 929 vw,sh; 935 w; 962 w,sh; 1000 vs; 1032 vs; 1094 s; 1152 s;  
1195 s; 1259 vw; 1294 m; 1333 m; 1351 m; 1425 vw,sh; 1453 vs; 1468 m,sh.

Reaction between di-t-butylberyllium etherate and N,N,N'-trimethylethyl-enediamine

A solution of 1.02 g. (10.0 millimoles) of N,N,N'-trimethylethyl-enediamine in 10 ml. of pentane was added to a solution of 1.74 g. (10.0 millimoles) of di-t-butylberyllium etherate in 20 ml. pentane at  $-100^\circ\text{C}$ . A white precipitate was formed which dissolved on warming to about  $-60^\circ$  and a clear solution was obtained at room temperature. Isobutane evolution occurred at room temperature and was complete after ca. six hours. On removal of solvent a slightly yellowish liquid was obtained. This was transferred to a distillation apparatus in pentane



solution and after removal of solvent the product was distilled at  $45^{\circ}/0.1$  mm. Hg into a receiver cooled to  $-40^{\circ}$ ; the compound melted at ca.  $-40$  to  $-45^{\circ}$ . [Found: hydrolysable  $\text{Bu}^t$ , 34.2%; Be, 5.31%; M (cryoscopically) in 0.97, 1.29, 1.93 wt.% benzene solution 187, 178, 173.  $\text{C}_9\text{H}_{22}\text{BeN}_2$  requires hydrolysable  $\text{Bu}^t$ , 34.1%; Be, 5.38%; M, 167].

The infrared spectrum (liquid film) contained absorptions at:

506 w,br,sh; 524 s; 595 w; 629 w,br; 707 s,br; 756 w,br; 787 s; 799 m; 837 w; 878 w; 899 w; 946 vs; 961 vs; 1012 m,sh; 1022 s; 1059 vs; 1065 s; 1103 m; 1120 m; 1161 m,sh; 1174 s,sh; 1188 vs; 1222 m; 1252 vs; 1290 s; 1348 s; 1370 m; 1379 m; 1408 w; 1449 m,sh; 1468 s; 2681 m; 2717 m,sh; 2770 vs,sh; 2778 vs,sh; 2809 vs; 2857 vs; 2907 vs; 2994 m,sh.

The p.m.r. spectrum when recorded as a 15 wt.% solution in perdeuteromethylcyclohexane with TMS as internal standard consisted of a singlet at  $\tau$  9.12 due to  $\text{Bu}^t\text{-Be}$ , a singlet at  $\tau$  7.61 due to  $-\text{NMe}_2 \rightarrow \text{Be}$ , a singlet at  $\tau$  7.29 due to  $-\text{NMe} - \text{Be}$  and a broad multiplet due to  $-\text{CH}_2 - \text{CH}_2 -$  centred on  $\tau$  7.2.

Reaction between di-*t*-butylberyllium and N,N-dimethylaminoethanol-formation of *t*-butylberyllium N,N-dimethylaminoethoxide dimer -  $(\text{Bu}^t\text{BeOC}_2\text{H}_4\text{NMe}_2)_2$ .

A solution of 1.35 g. (15.0 millimoles) of N,N-dimethylaminoethanol in 10 ml. of pentane was added to a solution of 3.22 ml. (15.0 millimoles) of di-*t*-butylberyllium/<sup>etherate</sup> in 10 ml. pentane cooled to  $-40^{\circ}$ . Immediately a yellow colouration developed in the solution but this

diminished as the solution warmed up. The solution became colourless after boiling the pentane for five minutes. On removal of solvent a white foam was obtained, 15 ml. hexane were added and the solution boiled for ten minutes, after removal of hexane the product was crystallised from 15 ml. pentane as small colourless needles. In a sealed capillary the product melts with decomposition 98-101°. [Found: hydrolysable butyl, 37.1%; Be, 5.94%; M (cryoscopically) in 0.78, 1.67 wt.% benzene solution 307, 309.  $C_{16}H_{38}Be_2N_2O_2$  requires hydrolysable butyl, 37.0%; Be, 5.85%; M, 308].

The infrared spectrum (as a Nujol mull) showed absorptions:

536 m; 568 m; 617 vw; 658 m; 690 w; 733 m; 755 s; 781 w; 789 w; 795 w; 821 vs; 826 s,sh; 849 m; 870 w; 887 s; 917 m; 936 s; 962 m; 1000 vw,sh; 1008 vw; 1012 vw; 1021 m,sh; 1031 s; 1046 s; 1075 s; 1089 vs; 1101 m; 1106 m,sh; 1167 m; 1170 m; 1190 m; 1192 w,sh; 1205 vw; 1250 vw,sh; 1266 m-w; 1280 m; 1285 w,sh; 1312 vw; 1342 vw; 1359 w; 1387 s; 1453 s,sh; 1471 vs; 1475 vs,sh.

Reaction between di-t-butylberyllium and N,N-dimethylaminoethanethiol - formation of t-butylberyllium N,N-dimethylaminoethylsulphide dimer,

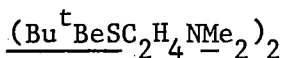

A solution of 1.05 g. (10.0 millimoles) of N,N-dimethylaminoethanethiol in 10 ml. hexane was added to 2.8 ml. of a 3.57M solution of di-t-butylberyllium in ether at -78°. The mixture warmed to room temperature and was heated to boiling to ensure completion of the reaction. As the

reaction took place ( $>0^{\circ}$ ) a white precipitate was formed. This was readily soluble in toluene but not in hexane. The product was recrystallised from 10 ml. of a 3:1 hexane/toluene mixture. When heated in a sealed capillary under nitrogen the compound melted to a clear liquid at  $99-101^{\circ}$ . [Found: hydrolysable butyl, 33.6%; beryllium, 5.31%; M (cryoscopically) in 0.08, 0.12 wt.% benzene solution 356, 332.  $C_{24}H_{38}Be_2N_2S_2$  requires hydrolysable butyl, 33.5%; beryllium, 5.29%; M, 340].

The infrared spectrum, recorded as a Nujol mull, contained absorptions at  $\nu(\text{max})$ : 446 s,sh; 461 vs; 488 m,sh; 546 vs; 573 m; 597 m; 698 m; 708 m; 773 m; 823 m,sh; 830 vs; 901 w; 930 w; 952 s; 1001 s; 1020 m; 1038 m; 1095 w; 1117 w; 1164 m; 1176 m,sh; 1209 w; 1241 w; 1299 m; 1351 w,sh; 1370 m; 1429  $m\text{ cm}^{-1}$ .

#### Reactions involving Di-t-butylzinc

Reaction between di-t-butylzinc and t-butanol - formation of t-butylzinc t-butoxide dimer -  $(Bu^tZnOBu^t)_2$

t-Butanol (1.0 g., 13.5 millimoles) in 10 ml. hexane was added to a stirred solution of di-t-butylzinc (2.42 g., 13.5 millimoles) in 20 ml. hexane at  $-78^{\circ}$ . There was slow evolution of gas during 3 hr. after the mixture had warmed to room temperature. Solvent was evaporated until about 8 ml. remained, and the t-butoxide crystallised at  $-78^{\circ}$ . [Found: Zn, 34.2%; hydrolysable butyl 29.2%; M (cryoscopically) in 0.60, 0.89

wt.% benzene solution, 413, 394.  $C_{16}H_{36}O_2Zn_2$  requires Zn, 33.4%; hydrolysable butyl, 29.1%; M, 391]. Hydrolysis of the t-butoxide is relatively slow at room temperature even with 2N sulphuric acid. When heated in a sealed capillary it decomposes, with charring, 179-184°. The p.m.r. spectrum as a 10% solution in benzene with TMS as internal standard consisted of two singlets of equal intensity at  $\tau$  8.66 ( $C_4H_9-O$ ) and  $\tau$  8.72 ( $C_4H_9-Zn$ ). The infrared spectrum (as a Nujol mull) contained absorptions at: 461 w,br; 515 m,sh; 526 s,sh; 535 s; 571 w,br; 599 m,br; 617 m,vbr; 722 w,br; 757 m; 766 w,sh; 815 m; 901 vs; 909 s,sh; 921 m,sh; 936 w,br; 964 w; 1010 m; 1027 w; 1178 s; 1202 w,sh; 1244 m; 1370 vs; 1379 s; 1389 s,sh; 1468 vs  $cm^{-1}$ .

t-butyl(pyridine)zinc t-butoxide

This was precipitated when pyridine in excess was added to the butoxide dissolved in hexane. It was re-crystallised from hexane as very pale yellow needles, melting at 132-134° to a pale yellow liquid which decomposed with charring at 150°. [Found: Zn, 23.9; hydrolysable butyl 20.5 and M (cryoscopically) in 0.91, 2.06, and 3.09 wt.% benzene solution 289, 294, 301 - corresponding to degrees of association of 1.06, 1.07 and 1.10 respectively.  $C_{13}H_{23}NOZn$  requires Zn, 23.8%; hydrolysable butyl, 20.8%]. The p.m.r. spectrum (ca. 10 wt.% solution in benzene) with TMS as internal standard consisted of two sharp singlets  $\tau$  8.34 ( $C_4H_9O$ ) and 8.70 ( $C_4H_9-Zn$ ).

Dissociation of the complex was believed to occur although the

observed degrees of association were only slightly greater than unity. A solution of the complex in toluene was evaporated into the vacuum line and infrared examination showed this to contain absorptions characteristic of both toluene and pyridine.

### Bis (pyridine)di-t-butylzinc

Pyridine (2 ml., an excess) in hexane (10 ml.) was added to a solution of 1.8<sub>9</sub> (9.2 millimoles) di-t-butylzinc in 20 ml. hexane. The mixture became yellow immediately, and was orange when all the pyridine had been added. The product was crystallised at ca. -30° from 5 ml. hexane as deep yellow needles melting at 40-41° to an orange liquid which decomposes at 100° forming a zinc mirror. [Found: Zn, 19.7%; hydrolysable butyl 34.7%; M (cryoscopically) in 0.78, 1.17 wt.% benzene solution 164, 189 - corresponding to degrees of association of 0.47 and 0.56. C<sub>18</sub>H<sub>28</sub>N<sub>2</sub>Zn requires Zn, 19.4%; hydrolysable butyl, 34.8%]. The p.m.r. spectrum in perdeuteromethylcyclohexane showed (Bu<sup>t</sup>-Zn) resonance as a sharp singlet at τ 9.01. The infrared spectrum (as a Nujol mull) showed absorptions at: 619 s; 704 vs; 752 s; 810 s; 935 w; 1008 s; 1039 s; 1064 w,sh; 1070 s; 1149 s; 1220 s; 1235 vw; 1266 vw; 1307 vw; 1366 m; 1385 s; 1418 w,sh; 1449 vs; 1493 m; 1587 w; 1600 m,sh; 1608 s; 1639 w cm<sup>-1</sup>.

### Zinc t-butoxide [(Bu<sup>t</sup>O)<sub>2</sub>Zn]<sub>x</sub>

t-Butanol (5.0 c.c. 10% excess for 2:1 reaction) was added to 2.95 g. (23.9 millimoles) of diethylzinc in 20 ml. toluene, and the mixture was

boiled under reflux for 90 hr. after which time samples withdrawn for analysis yielded no ethane on hydrolysis. A white precipitate formed after ca. 24 hr. and the amount increased with time. The product was separated, washed several times with hot toluene, and dried under reduced pressure. It was insoluble in toluene, diethyl ether, tetrahydrofuran, and pyridine. It did not melt below  $360^{\circ}$ . [Found: C, 45.9%; H, 8.5%; Zn, 30.8%.  $C_8H_{18}O_2Zn$  requires C, 45.4%; H, 8.5%; Zn, 30.9%].

The infrared spectrum (as a Nujol mull) contained absorptions at: 235 vs,br; 265 vs,br; 370 vs; 403 vs; 471 vs; 572 vs; 614 w,br,sh; 722 vw; 765 vs; 909 m,sh; 935 vs; 978 m,sh; 1028 m; 1070 vw; 1114 vw; 1188 vs; 1227 s; 1242 vs; 1361 vs; 1383 s; 1460 s; 1587 vw; 1887 vw  $cm^{-1}$

### Reactions of Di-isopropylberyllium

#### Reaction between di-isopropylberyllium and N,N,N'-trimethylethylenediamine

A solution of 1.02 g. (10.0 millimoles) of N,N,N'-trimethylethylenediamine in 10 ml. hexane was added to 2.86 ml. of a 3.49M solution (10.0 millimoles) of di-isopropylberyllium at  $-78^{\circ}$ . On warming there was a vigorous evolution of gas at ca.  $0^{\circ}$  and this resulted in the solution warming to ca.  $35^{\circ}$  and simultaneously a precipitate was formed. The product was re-crystallised from 5 ml. of a 3:1 hexane/toluene mixture. On heating in a sealed tube under nitrogen the crystals shrink at  $120-124^{\circ}$ , turn pale yellow at  $\sim 150^{\circ}$  and melt to a pale yellow liquid at  $165-167^{\circ}$ . [Found: hydrolysable Pr<sup>i</sup>, 28.5%; Be, 5.89% and M

(cryoscopically) in 0.54, 0.80 wt.% benzene solution, 293, 279.

$C_{16}H_{40}Be_2N_4$  requires: hydrolysable Pr<sup>i</sup>, 28.1%; Be, 5.88% and M, 306].

The infrared spectrum (as a Nujol mull) contained absorptions at:

495 m,br; 571 m; 636 s; 685 s; 772 s; 792 m; 848 s; 870 s; 941 m,sh;  
953 m; 971 m; 1000 w; 1028 s; 1044 w; 1062 w; 1105 m,sh; 1116 s; 1130 m,sh;  
1159 s; 1175 w; 1198 m; 1208 m; 1247 vw,sh; 1253 w; 1282 m; 1299 vw;  
1350 m; 1370 s; 1408 vw; 1420 vw,sh; 1456 vs,sh; 1471 vs,sh; 1490 m,sh  $cm^{-1}$ .

The p.m.r. spectrum recorded as a 10 wt.% solution in benzene with TMS as internal standard showed the following resonances:

	assignment
8.49, 8.54, 8.61, 8.68	quartet with a b a b structure $(CH_3)_2CH-Be$
7.97	broad singlet
7.90	singlet
7.55	singlet

The variation of the p.m.r. spectrum with temperature was investigated as a 10 wt.% solution in  $d_8$ -toluene with TMS as internal standard. The results will be discussed later.

#### Reaction between di-isopropylberyllium and N,N,N',N'-tetramethylethylenediamine

A solution of 1.16 g. (10.0 millimoles) of N,N,N',N'-tetramethylethylenediamine in 5 ml. ether was added to 2.94 ml. of a 3.4M solution (10.0 millimoles) of di-isopropylberyllium. The solution became warm and a white solid was left on removal of solvent. The product

crystallised as small white prisms from 20 ml. hexane [Found: hydrolysable Pr<sup>i</sup>, 41.3; Be, 4.26% and M (cryoscopically) in 1.04, 1.51 wt.% benzene solution, 230 227. C<sub>12</sub>H<sub>30</sub>BeN<sub>2</sub> requires hydrolysable Pr<sup>i</sup>, 40.8%; Be, 4.26%; M, 211]. The infrared spectrum (recorded as a Nujol mull) contained absorptions at: 466 w,br; 513 m,br; 595 m,br; 722 m; 775 s; 787 s,sh; 806 vs; 865 s; 876 s; 943 m,sh; 952 m; 965 m; 1010 s; 1020 m,sh; 1033 m; 1043 m; 1063 m; 1099 s; 1122 s; 1138 w; 1157 w; 1163 m; 1190 m; 1202 m,sh; 1241 w; 1262 w; 1283 s; 1340 w,sh; 1351 m; 1368 s cm<sup>-1</sup>. The p.m.r. spectrum recorded as a 5 wt.% solution in benzene with TMS as internal standard showed resonances:

$\tau$		assignment
8.02	singlet	CH <sub>3</sub> -N
8.25	singlet	-CH <sub>2</sub> -N
8.43, 8.54	doublet	(CH <sub>3</sub> ) <sub>2</sub> CH-Be

The p.m.r. spectrum of a sample in d<sub>8</sub>-toluene was recorded at various temperatures down to -80°. There was no splitting or broadening of the (N-CH<sub>3</sub>) resonance.

### Reactions of di-n-propylberyllium

#### Preparation of di-n-propylberyllium

The reflux distillation procedure described earlier (p.85) was carried out on a 0.19 molar scale. To a solution of 15.5 g. of beryllium chloride in 200 ml. ether was added 185 ml. of a 2.05M solution of n-propylmagnesium bromide at a rate to maintain a steady ether reflux -

ca. 15 minutes. The mixture was stirred for a further 15 minutes, after which the magnesium halides readily settled out. The ether layer was decanted off and, after removal of ether under reduced pressure, the product was distilled at  $85^{\circ}$  (oil bath)/ $0.1$  mm. Hg and collected in a vessel cooled in liquid nitrogen. [Found: hydrolysable n-propyl, 35.4%; Be, 3.71%.  $C_{14}H_{34}BeO_2$  requires hydrolysable n-propyl, 35.4%; Be, 3.70%. This analysis corresponds to a formula of  $Pr^{\text{n}}_2Be(OEt)_2$ . Molecular weight (cryoscopically) in 0.86, 1.28, 2.57 wt.% benzene solution, 126, 135, 148; corresponding to degrees of association of 0.52, 0.55 and 0.61]. The infrared spectrum was recorded as a liquid film: 649 m,br; 719 s; 781 vs; 796 s,sh; 840 s; 855 m,sh; 877 w; 901 m; 924 m; 975 m,sh; 1000 s; 1038 vs; 1053 s,sh; 1093 s; 1120 m; 1156 s; 1170 s; 1195 s; 1209 w,sh; 1263 w; 1284 w; 1315 m; 1324 m,sh; 1366 m,sh; 1379 m,sh; 1389 s; 1408 m,sh; 1453 s; 1471 s; 1481 m,sh  $cm^{-1}$ .

Ether-free di-n-propylberyllium was prepared by the method of reflux distillation with an oil bath temperature of  $60^{\circ}$  and  $10^{-3}$  mm.Hg with the condenser temperature  $-30^{\circ}$  for 24 hours. The product was distilled at  $40^{\circ}/10^{-3}$  mm. [Found: hydrolysable n propyl, 90.3%; Be, 9.43%; M (cryoscopically) in 0.52, 0.78 wt.% benzene solution 194, 203.  $C_{12}H_{28}Be_2$  requires hydrolysable n-propyl, 90.53%; Be, 9.47% M, 190]. The infrared spectrum as a liquid film:  $\sim$  556 m; 719 s; 777 m; 793 m,sh; 883 m; 893 m,sh; 980 m; 1007 m; 1053 vs; 1099 vw,sh; 1179 s; 1206 m,sh; 1218 m,sh; 1266 vw; 1307 w; 1326 m,sh; 1339 m; 1381 m; 1403 m; 1460 s; 1471 s; 2732 w,sh; 2786 m,sh; 2849 vs,sh; 2865 vs; 2924 s,sh; 2959 vs  $cm^{-1}$ .

Reaction between di-n-propylberyllium with N,N,N'-trimethylethylenediamine

A solution of 0.63 g. (6.2 millimoles) of N,N,N'-trimethylethylenediamine in 10 ml. hexane was added to 1.5 g. (6.2 millimoles) of bis(diethylether)di-n-propylberyllium in 10 ml. hexane cooled to  $-78^{\circ}$ . Reaction occurred below room temperature and the product was recrystallised from a small volume of methylcyclohexane. When heated in a sealed tube under nitrogen it decomposed at  $60^{\circ}$ . [Found: hydrolysable n-propyl, 28.0%; Be, 5.81%; M (cryoscopically) in 0.78, 1.17 wt.% benzene solution 284, 298.  $C_{16}H_{40}Be_2N_4$  requires hydrolysable n-propyl 28.1%; Be, 5.88% and M, 306]. The infrared spectrum (as a Nujol mull): 494 m,br;  $\sim 559$  m; 585 m;  $\sim 667$  m; 774 m; 779 s;  $\sim 800$  s; 882 m; 953 m; 979 w; 1001 m; 1017 s,sh; 1032 s; 1065 m; 1106 m,sh; 1125 s; 1161 s; 1175 m,sh; 1205 m,sh; 1205 m; 1214 w,sh; 1252 w,sh; 1258 m; 1282 m; 1318 m; 1353 m; 1376 s,sh; 1385 vs; 1420 m; 1460 vs; 1473 vs  $cm^{-1}$ .

Reaction between di-n-propylberyllium with pyridine and 2,2'-bipyridyl

Pyridine (2.5 ml., a large excess) was added to 1.0 g. (3.6 millimoles) of bis(diethylether)di-n-propylberyllium beryllium and an immediate yellow colour developed. On removal of solvent a yellow oil remained which solidified on further pumping. After removal of all the solvent the yellow solid melted at ca.  $10^{\circ}$ , as it warmed up, to a yellow oil. It was not investigated further.

Reaction between di-n-propylberyllium pyridine complex and 2,2'-bipyridyl

A solution of 0.56 g. (3.6 millimoles) of 2,2'-bipyridyl in 10 ml. of ether was added to the pyridine complex obtained above. The solution immediately turned red and when all the 2,2'-bipyridyl had been added the solution appeared black. Blood-red crystals were obtained from pentane solution, on heating in a sealed tube under nitrogen the complex decomposed above  $90^{\circ}$ . [Found: hydrolysable n-propyl, 34.4%; Be, 3.60%; M(cryoscopically) in 0.71, 1.06 wt.% benzene solution 271, 267.  $C_{16}H_{22}BeN_2$  requires hydrolysable n-propyl, 34.3%; Be, 3.58%; M, 251]. The infrared spectrum (recorded as a Nujol mull) contained absorptions: 690 s; 735 s; 763 vs; 797 m; 855 w,sh; 893 m; 962 w; 1000 w; 1041 s; 1047 m; 1124 w; 1159 w; 1169 w; 1252 w; 1277 w; 1311 m; 1323 w; 1366 w,sh; 1383 m; 1427 m; 1445 m; 1572 w;  $1605\text{ s cm}^{-1}$ .

Separation of ether from diethylberyllium

A mixture consisting of mainly diethylberyllium diethylether complex was boiled with reflux for 24 hours at ca.  $10^{-3}$  mm. (oil bath temperature  $50^{\circ}$ , condenser  $-15^{\circ}$ ). Evolution of ether was insignificant after 18 hours. The residue was distilled,  $65^{\circ}/10^{-3}$  mm. and no trace of ether nor any compound containing oxygen was detected in its mass spectrum [Found: M (cryoscopically, 0.73, 1.09 wt.% in benzene), 138, 136 and (cryoscopically, 0.36, 0.55, 0.72 wt.% in benzene), 131, 141, 137 after 6 months storage as a solution in benzene, 0.019 g. per c.c., in a sealed tube.  $C_8H_{20}Be_2$ , M = 134].

Proton magnetic resonance spectra of beryllium dialkyls

The p.m.r. spectra of the beryllium dialkyls,  $(R_2Be)_2$ ,  $R = Et, Pr^i, Bu^i, Bu^n$  have been examined over a range of temperatures. The results are discussed later.

Hydride Chemistry

Pyrolysis of [2-dimethylaminoethyl(methyl)amino]-t-butylberyllium - attempted preparation of  $[\text{HBe}(\text{NMe})\text{C}_2\text{H}_4\text{NMe}_2]_3$

A sample of the compound was heated in a sealed tube in vacuo. Gas evolution did not take place until 200°, and an infrared examination of the evolved gases then showed the presence of isobutane, isobutene, and ethylene. An orange residue containing no hydrolysable hydride remained. The reaction was not investigated further.

Pyrolysis of di-t-butylberyllium - attempted preparation of t-butylberyllium hydride

In all the reactions described, ether-free di-t-butylberyllium was fractionated through two traps at -78° immediately before use to remove any isobutene or isobutane that may have been present.

Initial experiments were carried out using the following technique. A measured volume of di-t-butylberyllium was condensed into the pyrolysis tube attached to the vacuum line. Nitrogen was admitted to a pressure of ca. 70 cm. to suppress distillation of the di-t-butylberyllium into a liquid nitrogen trap placed in the system to collect the evolved isobutene. The apparatus was sealed from the rest of the vacuum system and heating commenced. At intervals heating was discontinued and the nitrogen pumped out. The isobutene evolved was measured. Nitrogen was then re-admitted and the pyrolysis continued.

The data obtained for a series of experiments are listed below:

	Vol. Bu <sub>2</sub> <sup>t</sup> Be	T	time heated at temperature T	total heating time	<u>isobutene evolved</u>	<u>total isobutene evolved</u>
1	90.4 N c.c.	60°	17 hours	17 hours	15.8 N c.c.	15.8 N c.c.
		65°	5	22	8.1	23.9
		70°	9	31	12.1	36.0
		75°	3	34	4.8	40.8
		80°	4	38	11.9	52.7
2	141.6	90°	8	8	120.7	120.7
3	113.4	105°	3	3	112.9	112.9
		110°	12	15	0.2	113.1
4	204.8	110°	0.1	0.1	187.0	187.0
		110°	0.9	1	17.7	204.7
		110°	47	48	0.0	204.7

The first experiment was discontinued after 38 hours as the reaction time was far too long for convenient preparation of the half-hydride, without severe risk of oxidation. Excess di-t-butylberyllium was removed in vacuo and a very viscous oil remained. This was analysed by hydrolysis, in situ, and the ratio hydrolysable hydride:hydrolysable butyl was 1.06:1.

In Experiment 2, after pyrolysis 1 ml. of toluene was added and the mixture stirred for two hours before removing the toluene and excess

di-t-butylberyllium in vacuo. The product was a glass and it was hydrolysed in situ.

found: Bu : Be : H = 1.02 : 1.00 : 0.99

In the third pyrolysis the same procedure was adopted to remove excess di-t-butylberyllium and a glassy product obtained. A weighed sample was analysed. [Found: hydrolysable butyl, 83.3%; hydrolysable hydride, 1.49%; Be, 13.62% - ratio Bu : Be : H = 1.03 : 1.00 : 1.02.  $C_4H_{10}Be$  requires hydrolysable butyl, 85.1%; hydrolysable hydride, 1.50%; Be, 13.42%].

No evidence was obtained for the removal of the second mol. of isobutene as shown by the results of the fourth experiment.

Samples for p.m.r. and i.r. spectroscopy were prepared in the same way. The p.m.r. spectrum was recorded as a 10 wt.% solution in benzene at  $33.5^\circ$ . The spectrum was unexpectedly complex although some peaks were rather broad. Resolution was improved on recording the spectrum at  $100^\circ$ :

	$33.5^\circ$ ~	$100^\circ$ ~	assignment
broad peak	7.9 (centre)	7.9 (centre)	$(CH_3)_2CHCH_2^-$
doublet	8.86, 8.98	8.86, 8.96	$(CH_3)_2CHCH_2^-$
singlet	-	9.02	$(CH_3)_3C^-$
doublet	9.36 (centre)	9.31, 9.41	$(CH_3)_2CHCH_2^-$

The product appears to be a mixture of isobutyl- and t-butyl-beryllium hydrides.

The experimental procedure was then modified so that isobutene, once formed, was swept away from the t-butylberyllium hydride. Di-t-butylberyllium in toluene was syringed onto the top of a fractionating column in which toluene was refluxing (at such a rate that the toluene continued refluxing) and allowed to pyrolyse as it ran down the column. A current of nitrogen was flowing up the column in order to sweep away the isobutene as soon as it was formed. Analysis of the toluene solution showed:

isobutane : beryllium : hydrogen = 1.01 : 1.00 : 0.98

The p.m.r. spectrum of the material obtained on removal of the toluene was very similar to the one previously obtained. A chlorination procedure was used to establish the relative amounts of tert-butyl- and isobutylberyllium hydride.

A solution of chlorine in o-dichlorobenzene was prepared by bubbling dry chlorine into o-dichlorobenzene for approx. 15 minutes. This solution was then analysed by adding potassium iodide and titrating the liberated iodine with standard sodium thiosulphate solution.

A sample of the mixed hydrides dissolved in toluene was cooled to  $-78^{\circ}$  and chlorine in o-dichlorobenzene slowly added. The mixture was allowed to warm to room temperature. Reaction occurred at about  $10^{\circ}$  and was sufficiently exothermic to raise the temperature of the solution to approx.  $40^{\circ}$ . The reaction vessel was attached to the vacuum line and the more volatile constituents evaporated into the line. Hydrogen

chloride was removed by fractionation and the remaining gases condensed into a tube fitted with a serum cap and stopcock from which samples could be withdrawn. No hydrogen or isobutane was found in this procedure.

The mixture of t-butyl chloride and isobutyl chloride were analysed by gas chromatography using a 5 ft. neopentylglycol adipate column operating at 60°. A series of calibration mixtures were injected and peak areas measured. Base line separation of the peaks was obtained with liquid samples. Injection of gaseous samples caused some broadening of the peaks but base line separation of the peaks was still obtained.

Samples (gaseous 5.0 ml.) of the chlorination products were injected and peak areas integrated. Ten samples were injected and average values were:

<u>isobutyl</u> chloride	69 ± 3%
tert-butyl chloride	31 ± 3%

The chlorination procedure was applied to a sample that had been pyrolysed by the initial procedure, i.e. isobutene had not been swept away from the hydride. The product from Expt.4 (see page 115) was found to contain 82% isobutylberyllium hydride.

At this stage attempts to prepare t-butylberyllium hydride were abandoned in favour of the preparation of isobutylberyllium hydride in a similar manner. Di-isobutylberyllium had not been prepared previously.

Preparation of di-isobutylberyllium:

The preparation was carried out on a 0.45 molar scale using the general procedure discussed earlier.

To a solution of 35 g. beryllium chloride in 300 ml. ether was added 260 ml. of a 3.39M solution of isobutylmagnesium chloride in ether. When the precipitated magnesium chloride had settled, the ether layer was decanted off and after removal of most of the ether the product was distilled at 70° (oil bath)/0.001 mm.Hg into a flask cooled by liquid nitrogen. The product, a colourless liquid, analysed as  $\text{Bu}_2^i\text{Be}(\text{OEt}_2)_{0.5}$ . Its p.m.r. spectrum was recorded (as a neat liquid) with TMS as internal standard:

	$\tau$	<u>assignment</u>
quartet	5.71, 5.82, 5.96, 6.06	$\text{CH}_3\text{CH}_2\text{O}^-$
septet	7.69, 7.80, 7.91, 8.02, 8.13, 8.23, 8.33	$(\text{CH}_3)_2\text{CHCH}_2^-$
triplet	8.58, 8.69, 8.80	$\text{CH}_3\text{CH}_2\text{O}^-$
doublet	9.00, 9.11	$(\text{CH}_3)_2\text{CHCH}_2^-$
doublet	9.80, 9.11	$(\text{CH}_3)_2\text{CHCH}_2^-$

Removal of the remaining ether was attempted by the method of Head, Holley and Rabideau.<sup>115</sup> This was not successful since no material could be distilled from the reaction mixture. Ether removal by the reflux distillation method was then carried out as described earlier. The conditions used were identical with those used for di-isopropylberyllium and the product was distilled at 45°/0.001 mm. Hg into a flask cooled in

liquid nitrogen. [Found: hydrolysable isobutyl, 93.3%; beryllium, 7.37%; M (cryoscopically) in 0.52, 0.69, 1.04 wt.% benzene solution 264, 248, 248.  $C_{16}H_{36}Be_2$  requires hydrolysable isobutyl, 92.7%; beryllium, 7.31%; and M, 246].

The p.m.r. spectrum of di-isobutylberyllium was recorded both as a neat liquid and a 20 wt.% solution in benzene, with TMS as internal standard in both cases:

benzene solution	neat liquid	assignment
$\tau$	$\tau$	
9.43, 9.33	9.56, 9.45	$(CH_3)_2CHCH_2^-$
8.85, 8.75	8.94, 9.05	$(CH_3)_2CHCH_2^-$
7.80*	7.90*	$(CH_3)_2CHCH_2^-$

\* centre of resolved septet

The observed spectrum (in benzene solution) is shown in (5,5).

The infrared spectrum of the product was recorded as a liquid film,  $\nu(\max)$ : 719 m; 782 w; 833 m; 864 m; 945 w; 961 w; 976 w,br; 1018 m; 1031 w; 1073 m; 1081 m; 1163 m; 1189 s; 1205 m,sh; 1319 m; 1325 m,sh; 1333 m,sh; 1370 s; 1377 m; 1389 m; 1466 vs; 1538 w,br; 2591 vw; 2762 w; 2833 m,sh; 2857 vs; 2882 s; 2924 vs,sh; 2941 vs;  $cm^{-1}$ .

After distillation of ether free di-isobutylberyllium an involatile residue remained in the flask. This residue was very viscous and would take several hours to run down the sides of the flask. On hydrolysis a 0.2772 g. sample gave:

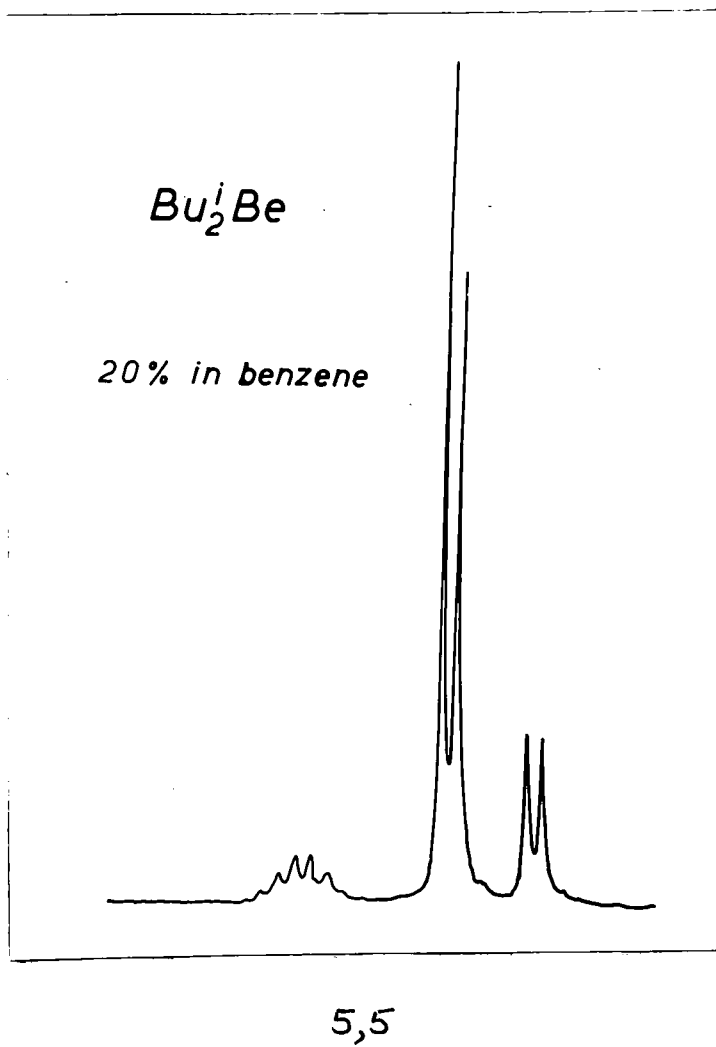

68.30 N c.c. hydrogen

63.12 N c.c. isobutane

28.16 mg. beryllium in solution

therefore ratio Bu : Be:H = 0.90 : 1.00 : 0.97

Chlorination of a sample as previously described showed that all the butyl content was in the isobutyl form. The residue was thus 68 wt.% isobutylberyllium hydride. The residue was not investigated further, but was used to prepare a co-ordination compound of isobutylberyllium hydride as will be described later.

Pyrolysis of di-isobutylberyllium - preparation of isobutylberyllium hydride

A variety of conditions were used in trial experiments for the preparation of isobutylberyllium hydride. These are summarised below.

1. 0.253 g. Di-isobutylberyllium was transferred to a pyrolysis apparatus and this was attached to the vacuum system. The pyrolysis was carried out under ca. 50 cm. nitrogen, measuring evolved isobutene at intervals. This being the same procedure as used for the pyrolysis of di-tert-butylberyllium. After 12 hours at 85°, 30.3 N c.c. of isobutene had been evolved, (46.1 N c.c. required for the preparation of the half-hydride) and after a further 4 hours at 110° the total isobutene evolution was 52.3 N c.c. The product was glassy and analysis confirmed that pyrolysis had continued beyond the half-hydride.

2. Further pyrolyses were carried out in a similar manner at a temperature of 85° measuring the evolved isobutene until the reaction had gone ca. 95% towards the half-hydride. At this stage the product was a very viscous liquid and 10 ml. pentane was added and the mixture stirred for about 5 minutes to remove excess di-isobutylberyllium. This washing

procedure was carried out three times. A double Schlenk tube fitted with a reflux condenser was used for these preparations. The product was dissolved in benzene and used in solution for reactions.

3. Pyrolysis of di-isobutylberyllium etherate - this involves the combination of two reactions: (a), removal of ether and (b), pyrolysis of the di-isobutylberyllium. The reaction was carried out both under vacuum and under 1 atm. nitrogen pressure at a temperature of 85<sup>o</sup> and using a similar washing procedure as for method (2). The evolved isobutene and ether were not measured as the extent of reaction could be visually estimated, the pyrolysis being stopped when the viscosity of the product stopped the magnetic stirrer.

The major objection to these methods is the time that a very air sensitive compound has to remain in apparatus with several greased joints and hence the risk of oxidation.

4. The most useful preparative route for large scale (ca. 5 g. samples of di-isobutylberyllium etherate) was to heat the di-isobutylberyllium etherate rapidly to 150<sup>o</sup> under 1 atm. nitrogen until the product became viscous (ca. 1 hour). The product was dissolved in benzene as described earlier. Samples for analysis and i.r. examination were obtained by removing the benzene under reduced pressure.

Samples produced by methods 2, 3, and 4 were found to give satisfactory analytical data. As samples for further work were prepared by method 4 analytical data are quoted for this mode of preparation.

[Found: hydrolysable butyl, 85.3%; hydrolysable hydride, 1.48%; beryllium, 13.34%;  $C_4H_{10}Be$  requires hydrolysable butyl, 85.1%; hydrolysable hydride, 1.50%; beryllium 13.42%]. Gas chromatographic analysis of the chlorination products showed that the product consisted of isobutylberyllium hydride only.

The p.m.r. spectrum was recorded in benzene solution with TMS as internal standard, resonances characteristic of isobutyl-groups were observed but not resonance due to  $-BeH$ :

$\tau$	assignment
9.49, 9.38	$(CH_3)_2CHCH_2^-$
8.96, 8.86	$(CH_3)_2CHCH_2^-$
7.9	$(CH_3)_2CHCH_2^-$ (septet)

The molecular weight was determined of two samples prepared by high temperature pyrolysis:

		<u>A</u>	<u>B</u>
Analysis:	Bu <sup>i</sup> , Be, H	83.9%, 13.44%, 1.52%	85.3%, 13.34%, 1.48%
	Calc.	85.1%, 13.42%, 1.50%	85.1%, 13.42%, 1.50%
M.Wt.	wt. compound	0.2601 g	0.2271 g
	wt. solvent	8.77, 13.15 g	8.77, 13.15 g
	$\Delta T$	0.089, 0.078 <sup>o</sup>	0.136, 0.086
	M	1770, 1550	1005, 1040
	degree of assocn.	27.2, 23.2	15.0, 15.5
	concn. (wt.%)	2.98, 1.99	2.59, 1.73

The infrared spectrum of isobutylberyllium hydride was recorded as a Nujol mull and as a solution in cyclohexane. The spectra recorded as Nujol mulls were of poor quality due to the difficulty involved in grinding up the glassy samples. Below  $1250\text{ cm}^{-1}$  the spectra are very similar, but in the region  $1250\text{-}2000\text{ cm}^{-1}$  there are considerable differences as illustrated in (5,6).

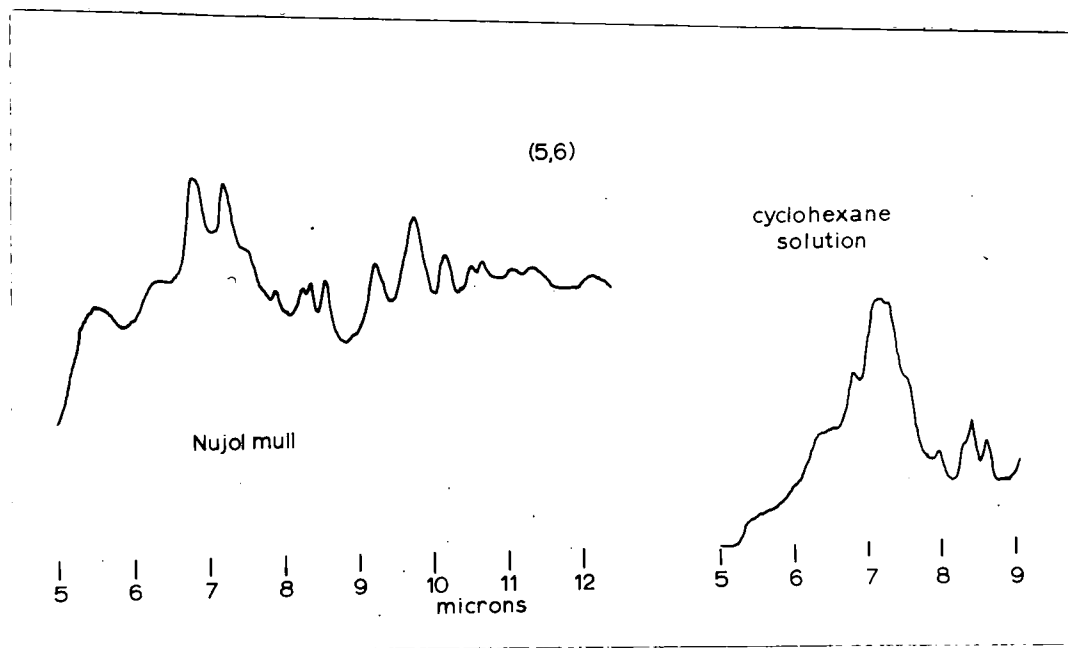

Co-ordination compounds of isobutylberyllium hydride

Reaction of isobutylberyllium hydride with N,N,N',N'-tetramethylethylenediamine

Excess N,N,N',N'-tetramethylethylenediamine (2.5 ml.) was added to 0.6 g. isobutylberyllium hydride dissolved in 10 ml. benzene. The solution became slightly warm. On removal of solvent (to 3 ml.) and addition of hexane (10 ml.) a white precipitate was formed. The complex was recrystallised from 1:2 benzene/hexane mixture (10 ml.) as colourless needles. The complex melted over the range 96-98° and sublimes readily at 80°/0.001 mm.Hg. The sublimed product had the same m.p. 96-98°. [Found: hydrolysable butyl, 44.8%; hydrolysable hydride, 0.81%; beryllium, 7.25%; M (cryoscopically) in 0.97, 1.46 wt.% benzene solution 241, 259.  $C_{14}H_{36}Be_2N_2$  requires hydrolysable butyl, 45.6%; hydrolysable hydride, 0.80%; beryllium, 7.20%; M, 250].

The p.m.r. spectrum was recorded as 10 wt.% solution in benzene. Resonances due to TMED coincided with that due to  $(CH_3)_2CHCH_2^-$  and the resonance due to  $BeH_2Be$  was not observed.

$\tau$	assignment
9.84, 9.75	$(CH_3)_2CHCH_2^-$
8.51, 8.41	$(CH_3)_2CHCH_2^-$
8.00	$Me_2NC_2H_4NMe_2$ (broad: width at half height 6 c.p.s.)
7.9	$(CH_3)_2CHCH_2^-$ (unresolved)

The infrared spectrum recorded as a cyclohexane solution contained absorptions,  $\nu(\text{max})$ : 595 m; 676 s; 763 m; 786 w; 814 vs; 828 w; 870 vw; 885 w; 942 vs; 964 vs; 998 s; 1007 m,sh; 1019 m,sh; 1064 s; 1087 m; 1101 w; 1134 m; 1159 m; 1183 s; 1203 w; 1225 m,sh; 1264 m,sh; 1333 vs; 1379 vs  $\text{cm}^{-1}$ . The spectrum recorded as a Nujol mull, was identical.

Reaction of isobutylberyllium hydride with N,N,N',N'-tetraethylethylenediamine

Excess N,N,N',N'-tetraethylethylenediamine (3.0 ml.) was added to a solution of 0.9 g. isobutylberyllium hydride in 15 ml. benzene. The complex was recrystallised as small needles from a small volume of pentane. When heated in a sealed tube under nitrogen the complex melted at 62-63°. [Found: hydrolysable butyl, 37.3%; hydrolysable hydride, 0.64%; beryllium, 5.90%; M (cryoscopically) in 1.63, 2.45 wt.% benzene solution 314, 309.  $\text{C}_{18}\text{H}_{44}\text{Be}_2\text{N}_2$  requires hydrolysable butyl, 37.2%; hydrolysable hydride, 0.63%; beryllium, 5.89%; M, 306].

The infrared spectra were identical when recorded as a Nujol mull and a solution in cyclohexane,  $\nu(\text{max})$ : 667 m; 671 m; 735 w; 760 m; 769 s; 784 m; 800 w; 827 w; 858 w; 891 m; 941 s; 963 s; 1015 m; 1050 m; 1064 m; 1093 m; 1127 m; 1159 m; 1176 m; 1258 w; 1325 s; 1342 s; 1370 vs; 1391 s; 1399 s; 1433 m; 1466 m  $\text{cm}^{-1}$ .

Reaction between isobutylberyllium hydride and tetrahydrofuran

Excess tetrahydrofuran (3.5 ml.) was added to a solution of 0.6 g. isobutylberyllium hydride in 10 ml. benzene. On removal of solvent a

viscous liquid remained which was redissolved in hexane (10 ml.) and filtered. Solvent was removed under reduced pressure after transferring the solution to a flask. [Found: hydrolysable butyl, 41.2%; beryllium, 6.49%; hydrolysable hydride, 0.70%; M (cryoscopically) in 1.37, 2.04 wt.% benzene solution 281, 284.  $C_{16}H_{36}Be_2O_2$  requires hydrolysable butyl, 41.0%; beryllium, 6.47%; hydrolysable hydride, 0.73%; M, 278].

The infrared spectrum was recorded as a liquid film,  $\nu(\max)$ :  
662 m; 800 w; 876; 896 w,sh; 921 w; 932 m; 947 m; 979 vs; 1020 vs; 1041 s,sh; 1064 s; 1158 w; 1188 s; 1203 m,sh; 1250 w; 1290 m,sh; 1315 s; 1359 s; 1371 s,sh; 1393 m,sh; 1466 s  $cm^{-1}$ .

#### Decomposition of di-t-butylberyllium on the vacuum line

Di-t-butylberyllium was stored in a trap, cooled to  $-78^{\circ}$ , on the vacuum line. The fractionation procedure used to purify it before use has been mentioned earlier. This procedure was found to be entirely satisfactory provided that the storage tube on the vacuum line was clean. One sample of di-t-butylberyllium was stored in a trap (at  $-78^{\circ}$ ) that contained a film of metallic zinc formed by the decomposition of di-t-butylzinc. After storage for ca. 3 weeks it was found that only a small proportion was distillable under vacuum. The residue, a highly viscous liquid was sealed-off from the vacuum line and transferred to a glove box. A sample was analysed:

0.2170 g on hydrolysis  $\longrightarrow$  7.48 N c.c. hydrogen  
22.11 N c.c. isobutane  
43.87 N c.c. beryllium

ratio Be : Be : H = 0.51 : 1 : 0.17

ratio Bu + H : Be = 0.68 : 1

The viscous liquid was chlorinated by the previously described procedure and, after fractionation, the products were analysed gas chromatographically:

iso-butyl chloride  $82 \pm 2\%$

t-butyl chloride  $19 \pm 2\%$

A benzene solution of the viscous solution was prepared and a sample of this was analysed by hydrolysis using water and 2N sulphuric acid. The hydrolysis solution was extracted with ether (3 x 20 ml.) and the combined ether extracts were dried with anhydrous magnesium sulphate. The bulk of the ether was removed by distillation and the residual solution analysed gas chromatographically using a 10 ft. Apiezon L column operating between  $50^{\circ}$  and  $150^{\circ}$ . Benzene and ether were the only two constituents that could be identified.

#### Decomposition of di-t-butylberyllium in a p.m.r. tube

A freshly fractionated sample of di-t-butylberyllium was condensed into a p.m.r. tube and its spectrum recorded immediately. The expected single line resonance, as observed previously, was obtained. The sample was kept at laboratory temperature and its p.m.r. spectrum recorded at intervals over the next 10 months. A representative selection of the observed spectra are reproduced (5,8). The spectral changes are consistent with the formation of iso-butylberyllium species. After 40 weeks resonance due to  $(\text{CH}_3)_3\text{C-Be}$  was not observable. The upfield shift

*t*-Butylberyllium: decomposition at room temperature  
 P.M.R. spectra, no solvent

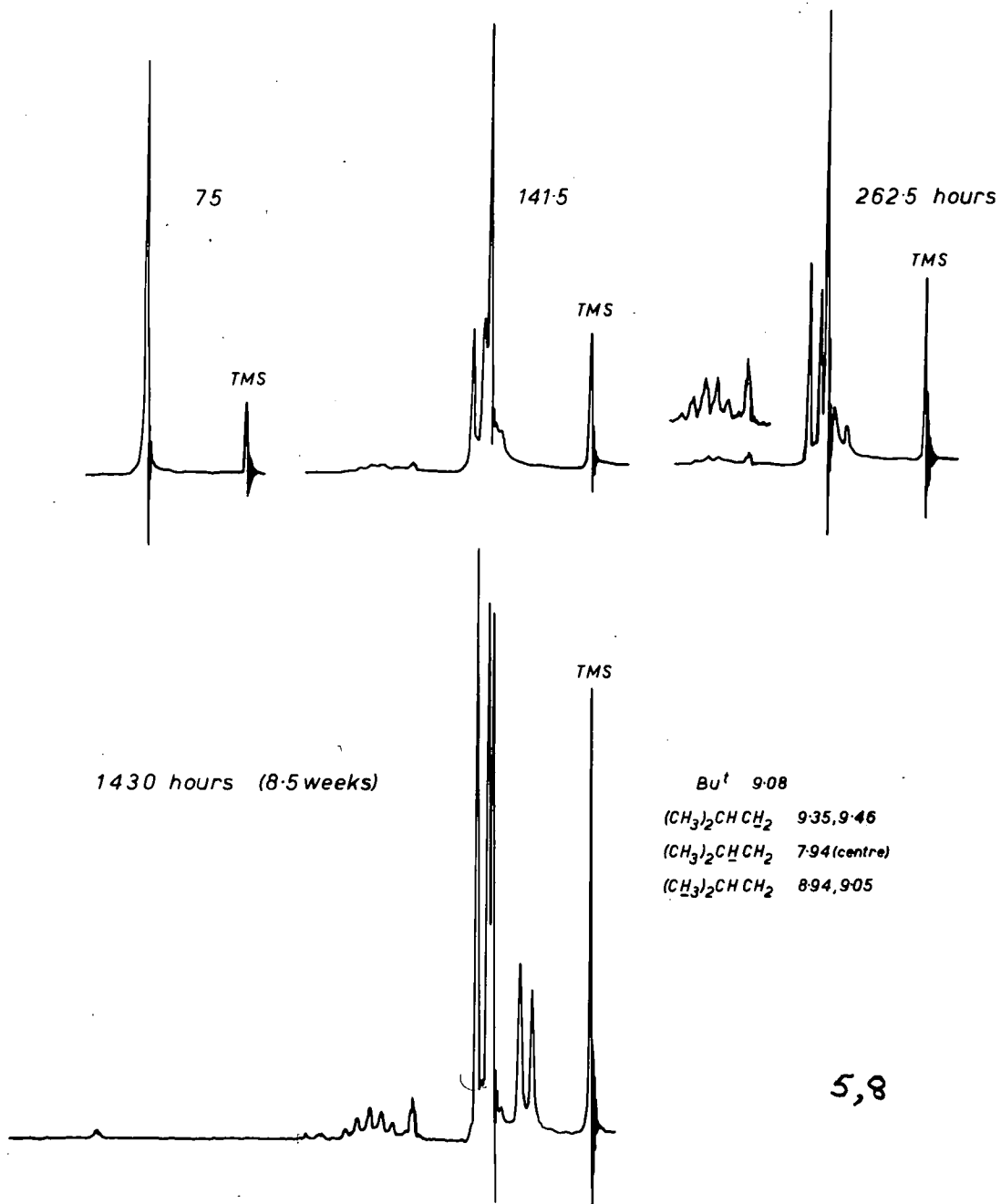

of the methylene protons with time is quite marked as can be seen from the table:

time	$\tau$ ( $\text{Me}_2\text{CH}.\underline{\text{CH}}_2$ )	ratio iso- : t-butyl
333 hr.	9.17, 9.28	
453	9.22, 9.33	
580	9.25, 9.36	4.2 : 1
645	9.26, 9.38	
9.5 wk.	9.35, 9.46	
13.5	9.38, 9.50	12 : 1
18.5	9.41, 9.52	
27	9.42, 9.54	
40	9.43, 9.54	

In contrast the resonances due to  $(\underline{\text{CH}}_3)_2\text{CHCH}_2\text{Be-}$  ( $\tau$  8.94, 9.05) were not observed to shift significantly throughout the experiment, once they had first appeared. The resonance due to  $(\underline{\text{CH}}_3)_3\text{CBe}$  was also constant at  $\tau$  9.07 throughout the experiment.

#### Co-ordination Compounds of Beryllium Hydride

In an experiment aimed at the formation of isobutylberyllium hydride 6 ml. di-isobutylberyllium etherate were heated to  $80^\circ$  overnight (15 hours) in vacuo. A hard foam formed which was insoluble in 40 c.c. refluxing benzene. To this mixture was added 4 ml. of N,N,N',N'-tetramethylethylenediamine (TMED), the glassy material immediately dissolved to form a clear, colourless solution. This solution was filtered and

on addition of hexane a white solid was obtained. On heating in a sealed capillary the substance shrank at  $128^{\circ}$  and  $190^{\circ}$ , finally melting over the range  $207-213^{\circ}$ . A sample was analysed, reaction with 2-methoxyethanol being violent at low temperature.

0.0440 g. on hydrolysis  $\longrightarrow$  21.15 N c.c. hydrogen  
3.86 N c.c. isobutane  
6.28 N c.c. TMED

0.0338 g. contains 3.56 mg. beryllium

$\therefore$  0.0440 g. would contain 4.63 mg. (11.55 N c.c.) beryllium

ratio Bu : Be : H : TMED = 1 : 2.99 : 5.48 : 1.63

ratio Bu + H : Be : TMED = 3.98 : 1.84 : 1

The infrared spectrum of the product showed the presence of the  $\text{BeH}_2\text{Be}$  bridge and also a strong sharp absorption at  $1767 \text{ cm}^{-1}$ .

It was concluded that the product was a mixture of  $(\text{Bu}^i\text{BeH})_2\text{TMED}$  and  $\text{H}_4\text{Be}_2\text{TMED}$ . Separation was attempted on the basis of the ready solubility of  $(\text{Bu}^i\text{BeH})_2\text{TMED}$  in pentane. The mixture was transferred to a Schlenk tube and 15 ml. pentane and 2.5 ml. TMED were added and the mixture stirred overnight. Very little solid appeared to have dissolved. On filtering and pumping dry some solid had dissolved - presumably  $(\text{Bu}^i\text{BeH})_2\text{TMED}$  but there was not sufficient to identify it. The white solid was removed and analysed. [Found: hydrolysable hydride, 2.91%; hydrolysable butyl, 0%; beryllium, 12.97%.  $\text{C}_6\text{H}_{20}\text{Be}_2\text{N}_2$  requires hydrolysable hydride, 2.91%; beryllium, 13.04%]. It was insoluble in

both aliphatic and aromatic hydrocarbons. When heated in a sealed capillary the compound melted at 210-211<sup>o</sup>, with decomposition. The infrared spectrum, recorded as a Nujol mull, contained absorptions at: 536 w; 571 w; 612 w; 725 m,sh; 741 vs; 780 m; 797 m,sh; 806 m; 823 s; 907 s; 948 vs; 960 s,sh; 995 vw; 1005 w; 1024 s; 1087 vw; 1105 w; 1135 w; 1181 w; 1205 vw; 1238 m; 1307 s; 1351 vs; 1366 vs; 1447 vs; 1481 m,sh; 1787 and 1807 vs doublet, cm<sup>-1</sup>.

The observed spectrum is shown in Fig. (5,9).

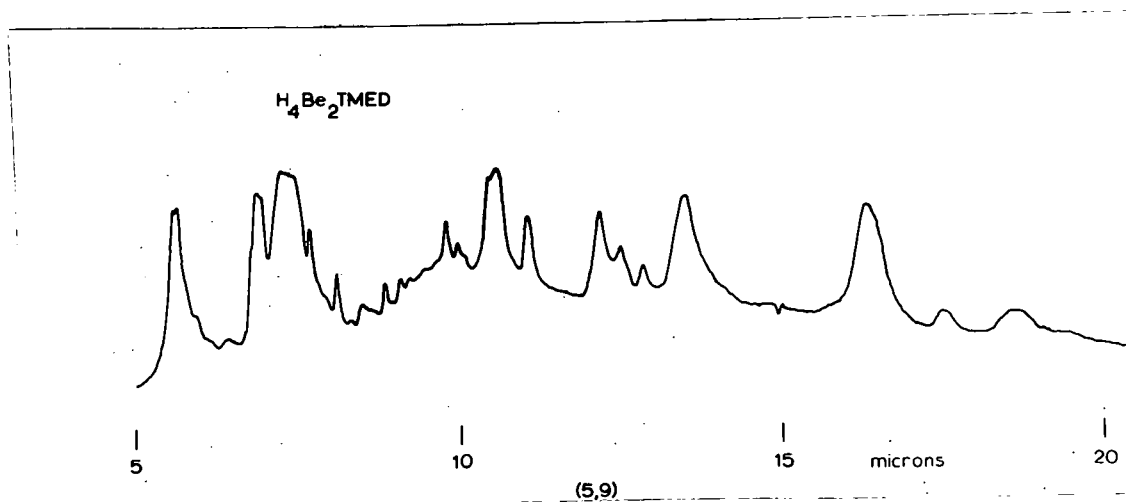

The hydride was insoluble in excess TMED.

In an attempt to prepare a soluble compound N,N,N',N''-tetraethylethylenediamine (TEED) was used. Di-isobutylberyllium etherate (6 ml.) was pyrolysed overnight (as before) and 4 ml. TEED was added to the foam in 20 ml. benzene. A clear solution was produced which was filtered and on removal of solvent a viscous oil remained. The oil redissolved in pentane and on prolonged pumping a waxy solid was obtained. Analysis showed it to be a mixture as before and as both compounds were soluble in pentane it could not be purified.

Work is now in progress studying the reactions of beryllium hydride prepared by precipitation in order to simplify purification problems.

#### Reactions between isobutylberyllium hydride and olefins

Reactions were carried out using the technique described by Bell and Coates.<sup>60</sup> The rate of disappearance of the olefinic peaks being measured by p.m.r. spectroscopy. As the reactions were carried out in benzene solution all areas of olefinic protons are measured relative to the area due to the aromatic protons.

#### Reaction of $\text{Bu}^i\text{BeH}$ with pent-1-ene at $33.5^\circ$

Benzene was evaporated under reduced pressure from a sample of 0.253 g. (3.8 millimoles) isobutylberyllium hydride in 3 ml. benzene, until the volume was  $\sim 0.5$  ml. Pent-1-ene, 0.41 ml. (84.4 N c.c.) was added and the sample transferred to a p.m.r. tube. The sample was maintained at  $33.5^\circ$  (spectrometer temperature) and spectra recorded at intervals.

time (min.)	area of -CH=CH <sub>2</sub>	time (min.)	area of -CH=CH <sub>2</sub>
17	12.9	37	3.9
20	10.0	48	2.7
24	8.3	64	1.8
28	6.9	78	1.0
31	5.3	130	-

From the graph the half-life is  $\sim 10$ -15 minutes.

Reaction of Bu<sup>i</sup>BeH with 2-methylbut-2-ene at 33.5°, 85° and 110°

The reaction was carried out as for the previous one.

(i) 33.5° : no reaction after 7 days

(ii) 85° : no reaction after 4 days

(iii) 110° :

time (hr.)	Me <sub>2</sub> C=CHMe
0	11.0
24	7.5
48	5.6
72	4.3
96	3.5

The solution then became too viscous to record its p.m.r. spectrum.

The half-life of the reaction is  $\sim 50$  hours.

The vibrational spectra and molecular structures  
of di-t-butyl-beryllium and -zinc

Di-t-butylberyllium is considerably more volatile than the other beryllium dialkyls. Its vapour pressure at 25° is comparable with that of a branched chain C<sub>9</sub> hydrocarbon and on these grounds it was presumed to be monomeric.<sup>4,115</sup>

The "normal" boiling point and Trouton constant indicate that on evaporation there is no marked change of molecular complexity, and any association in the liquid phase must involve relatively weak bonding. Cryoscopic measurements show that di-t-butylberyllium is monomeric in benzene solution. The mass spectrum of di-t-butylberyllium also shows it is monomeric in the vapour phase.<sup>182</sup>

The infrared spectrum of both gaseous and liquid samples of di-t-butylberyllium and the Raman spectrum of the liquid have been examined. To define the origin of certain features of the vibrational spectrum the infrared spectrum of the fully deuterated derivative was recorded in the vapour phase. While the vibrational spectra of numerous simple t-butyl compounds of the type (CH<sub>3</sub>)<sub>3</sub>CX (X = halogen, H, OH, SH)<sup>183-189</sup> have been analysed, there is little comparable information concerning di-t-butyl derivatives. For comparison therefore the vibrational spectrum of di-t-butylzinc was examined; in this case there is little doubt that the C-Zn-C skeleton is linear, and the spectrum provides a useful index to the spectroscopic properties of this type of system.

The observed vibrational frequencies of di-t-butylberyllium and [ $^2\text{H}_9$ ]di-t-butylberyllium, with relative intensities and states of polarisation are shown in Table 19. The corresponding data for di-t-butylzinc are given in Table 20. The overall symmetry of the  $\text{M}[\text{C}(\text{CH}_3)_3]_2$  molecules (M = Be or Zn) depends on the barrier to rotation of the  $\text{CH}_3$  groups about the C- $\text{CH}_3$  bonds; microwave evidence<sup>190</sup> indicates a comparatively high rotational barrier for  $(\text{CH}_3)_3\text{CF}$ , and if this were true for the  $\text{M}[\text{C}(\text{CH}_3)_3]_2$  molecules the exact symmetry will be determined by the exact conformation of the  $\text{CH}_3$  groups. However, on the reasonable assumption that the arrangement of the methyl groups will have little influence upon the vibrations of the  $\text{C}_3\text{C-M-CC}_3$  skeletons or their selection, it is possible to discuss the structures of the di-t-butyl compounds with reference to the precise point groups of either molecule as a whole. An electron diffraction study has recently shown that the minimum energy conformation is the eclipsed one, but the barrier to internal rotation is  $\leq 0.6$  kcal.<sup>191</sup>

For a molecule with 75 degrees of vibrational freedom di-t-butylberyllium has a remarkably uncomplicated vibrational spectrum. Particularly striking is the comparatively small number of bands attributable to the vibrations of the heavy atom skeleton of the  $\text{Be}[\text{C}(\text{CH}_3)_3]_2$  molecule. Of the 21 possible vibrational fundamentals of the  $\text{C}_3\text{C-Be-CC}_3$  unit, no more than 7 can be located in the Raman spectrum and 5 in the infrared spectrum (in the range explored). Moreover, apart

from certain ambiguities due to crowding of fundamentals (e.g. near  $1200\text{ cm}^{-1}$ ) there is a general absence of coincidences between Raman- and infrared -active skeletal fundamentals. These two generalisations strongly support a monomeric  $\text{Be}[\text{C}(\text{CH}_3)_3]_2$  molecule with a high degree of symmetry; the apparent operation of the "mutual exclusion" principle also suggests that the molecule is effectively centrosymmetric with a point group of  $D_{3d}$ , see Table 21.

A polymeric structure would require appreciably more complex spectra, whereas if the molecule were monomeric but possessed a bent skeleton (effective point group  $C_{2v}$ ) the selection rules would permit all 21 skeletal fundamentals (or 19 with free rotation) in the Raman and 17 (or 16) in the infrared spectrum. As in the cases of molecule like  $\text{Zn}(\text{CH}_3)_2$  and  $\text{Hg}(\text{CH}_3)_2$ ,<sup>14,192</sup> it is probable that the alkyl groups rotate more-or-less freely about the metal-carbon bonds, and in these circumstances, for a linear C-M-C skeleton, the appropriate effective point group is  $D_{3d}$ ,<sup>193</sup> although certain deviations from the strict  $D_{3d}$  selection rules may be expected.<sup>194</sup> Significantly, the Raman spectrum of di-t-butylberyllium contains a line at  $132\text{ cm}^{-1}$  which, contrary to the  $D_{3d}$  selection rules, can reasonably be attributed to the skeletal bending frequency ( $\nu_{14}$ ). This particular violation of the selection rules for a linear molecule has also been noted for  $\text{Me}_2\text{Zn}$ ,<sup>14</sup>  $\text{Me}_2\text{Cd}$ ,<sup>16</sup> and  $\text{Me}_2\text{Hg}$ <sup>14,195</sup> as well as for the  $\text{CS}_2$  molecule,<sup>196</sup> the weak appearance of whose forbidden bending mode has been shown to be due to molecular interactions.

The modes of vibration, their symmetry species and selection rules for the heavy atom skeleton of the  $M[C(CH_3)_3]_2$  molecule assumed to have effective point group  $D_{3d}$  are shown in Table 22. The rules permit 6 Raman and 7 infrared bands due to fundamentals; 3 of the Raman lines should be polarised. In fact the Raman spectrum of di-*t*-butylberyllium contains just 3 polarised lines at frequencies below  $1250\text{ cm}^{-1}$ , which are confidently assigned to  $\nu_1$ ,  $\nu_2$ , and  $\nu_3$  of species  $a_{1g}$ . As for related molecules, the essential linearity of the C-Be-C skeleton is confirmed conclusively by the observation that the intense, polarised Raman line at  $545\text{ cm}^{-1}$ , due to the symmetric C-Be-C stretching mode, is not active in the infrared region. Apart from the "extra" low frequency line already mentioned and a weak feature at  $450\text{ cm}^{-1}$ , there are then three other well defined (depolarised) Raman lines whose frequencies are in harmony with their assignments as  $\nu_8$ ,  $\nu_9$ , and  $\nu_{10}$  of species  $e_g$ .

Assignments of the infrared active fundamentals are less easily accomplished since there is no property of the spectra to aid the identification of vibrations of a particular class. The symmetric top  $Be[C(CH_3)_3]_2$  molecule has comparatively small moments of inertia (particularly along the top axis), and in principle the contours of the vapour phase infrared bands due to  $a_{2u}$  vibrations should differ appreciably from those due to  $e_u$  vibrations. In practice, the vapour phase infrared spectrum of di-*t*-butylberyllium showed only one band (at

ca.  $890\text{ cm}^{-1}$ ) with partially resolved rotational branches; otherwise the internal torsional motions of the  $\text{CH}_3$  groups and the  $(\text{CH}_3)_3\text{C-}$  groups are probably responsible for smearing out any fine structure arising from the rotation of the molecule as a whole.

In the absence of any information about band types in the vapour phase infrared spectrum, vibrational assignments have been based largely on the  $\text{D}_{3d}$  selection rules (particularly in conjunction with Raman polarisation data) and on analogies with the spectra of (i) molecules of the type  $(\text{CH}_3)_3\text{CX}$ ,<sup>183-189</sup> (ii) the structurally related paraffin 2,2,3,3-tetramethylbutane,  $(\text{CH}_3)_3\text{C.C}(\text{CH}_3)_3$ ,<sup>197,198</sup> and (iii) t-butyl-lithium.<sup>199</sup> The primary problem is to distinguish bands due to the  $\text{C}_3\text{C-Be-CC}_3$  skeleton from those due to the internal motions of the methyl groups (C-H stretching,  $\text{CH}_3$  deformation, and  $\text{CH}_3$  rocking). For the heavy atom framework of a simple t-butyl compound  $(\text{CH}_3)_3\text{CX}$  (point group  $\text{C}_{3v}$ ) there are 6 fundamental modes of vibration comprising, roughly, C-C stretching (symmetric and antisymmetric types),  $\text{CC}_3$  deformations (symmetric and antisymmetric),  $\text{CC}_3$  rock, and C-X stretching. Such modes have been identified for a range of X and the trends are useful as a guide in the analysis of the skeletal fundamentals of di-t-butyl-beryllium and -zinc. Bands due to the internal motions of the methyl groups have been ascribed to the appropriate general types of motions rather than to particular modes. The frequencies of the C-H stretching and  $\text{CH}_3$  deformation modes in t-butyl compounds have been

found to be within two fairly narrow and distinctive regions,<sup>183-185,200</sup> which have been adequately characterised, but there has been a long standing disagreement over the frequencies appropriate to the C-C stretching and CH<sub>3</sub> rocking modes, which appear in the range 800-1250 cm<sup>-1</sup>. Deuteration studies, and a normal co-ordinate analysis of (CH<sub>3</sub>)<sub>3</sub>CCl, have recently revealed<sup>187</sup> that there is pronounced mixing of the two types of motion so that simple pictures of group vibrations and frequencies are misleading. Nevertheless, the bands of (CH<sub>3</sub>)<sub>3</sub>CCl near 1200 cm<sup>-1</sup> are markedly less sensitive to deuteration than those in the region 800-1030 cm<sup>-1</sup>, and, with the qualification already made, it seems reasonable, to a first approximation, to attribute bands of the first type to (essentially) C-C stretching modes and those of the second type to (essentially) CH<sub>3</sub> rocking modes. To this extent the assignment originally favoured by Simpson, Shephard, and others<sup>200</sup> for t-butyl groups is still valid.

There is a second complication. For (CH<sub>3</sub>)<sub>3</sub>CX molecules the frequency of what approximates to the C-X stretching mode appears at ca. 900 cm<sup>-1</sup> when X is a "first row" element like F, O, or N.<sup>183-186</sup> Accordingly,  $\nu_6$ , the antisymmetric metal-carbon stretching mode in Be[C(CH<sub>3</sub>)<sub>3</sub>]<sub>2</sub> may well occur in a region already populated by bands due to CH<sub>3</sub> rocking or C-C stretching vibrations. To clarify these and other details reference is made to the infrared spectrum of the fully deuterated derivative Be[C(CD<sub>3</sub>)<sub>3</sub>]<sub>2</sub>. Deuteration causes a marked

decrease in frequency of all vibrations predominantly associated with movements of the hydrogen atoms of the methyl groups. Thus, the infrared features near  $2900\text{ cm}^{-1}$  for  $\text{Be}[\text{C}(\text{CH}_3)_3]_2$ , obviously due to symmetric and antisymmetric C-H stretching modes, show the expected large shift (to  $2025\text{-}2225\text{ cm}^{-1}$ ) on deuteration. Curiously, the absorptions of the deuterated compound have an intensity pattern quite different from that of the C-H absorptions, and also extend over a wider frequency range; this appears to be a characteristic of  $(\text{CD}_3)_3\text{C}$  groups,  $183\text{-}185, 187\text{-}189$  and presumably indicates the extensive interaction between the different C-H (or C-D) stretching vibrations. Frequencies between  $1360\text{-}1500\text{ cm}^{-1}$  in the spectrum of the  $(\text{CH}_3)_3\text{C}$  compound drop to  $1000\text{-}1080\text{ cm}^{-1}$  in the spectrum of the  $(\text{CD}_3)_3\text{C}$  compound, and are ascribed to methyl deformations (symmetric and antisymmetric types). Motions involving major contributions from methyl rocking, which appear in the region  $800\text{-}1000\text{ cm}^{-1}$  for di-*t*-butylberyllium, also appear at much lower frequencies ( $650\text{-}870\text{ cm}^{-1}$ ) for the deuterated compound. There is unavoidably some latitude in attributing the observed vibrational features to particular modes of this class ( $a_{1g} + a_{2u} + 2e_g + 2e_u$ ) though the assignments cannot be seriously in error. The infrared bands near  $1200\text{ cm}^{-1}$  in the spectrum of  $\text{Be}[\text{C}(\text{CH}_3)_3]_2$  suffer comparatively small frequency changes on deuteration, and are therefore associated mainly with C-C stretching modes of the skeleton of the molecule, although some interaction with  $\text{CH}_3$  rocking modes belonging to the same

symmetry class is inevitable (cf. t-butyl chloride<sup>187</sup>). The frequencies of the latter hybrid modes of di-t-butylberyllium are consistent with the identification of the polarised Raman scattering at  $1201\text{ cm}^{-1}$  with  $\nu_1$ ; the comparatively high depolarisation of this line (not much less than 6/7) probably reflects the influence of the vibrational coupling.

Comparison of the infrared spectrum of di-t-butylberyllium with that of its deuterio-analogue indicates, beyond doubt, that the anti-symmetric Be-C stretching vibration is to be attributed to the very intense infrared band at  $450\text{ cm}^{-1}$ , which is little influenced by deuteration. Thus contrary to the normal rule, the antisymmetric stretching mode appears at lower frequency than the corresponding symmetric mode ( $\nu_2 = 545\text{ cm}^{-1}$ ); this seems to be due to the unusually large interaction between the t-butyl groups. The remaining vibrations of the heavy atom skeleton of the  $\text{Be}[\text{C}(\text{CH}_3)_3]_2$  molecule should be relatively insensitive to the effect of deuteration, and the  $e_u$  deformation of the  $\text{C}(\text{CH}_3)_3$  groups ( $\nu_{12}$ ) has been identified with an infrared absorption at  $475$  and  $459\text{ cm}^{-1}$  in the spectra of the normal and deuterio-derivatives, respectively. The other deformation and rocking modes of the  $\text{C}(\text{CH}_3)_3$  group have frequencies below  $400\text{ cm}^{-1}$ , the limit of infrared measurements involving the deuterio compound; of necessity, assignments in this region depend upon comparisons with the spectra of other t-butyl compounds,<sup>183-189,197,198</sup> and upon the identification of the polarised Raman line at  $212\text{ cm}^{-1}$  with  $\nu_3$ , the totally symmetric

$(\text{CH}_3)_3\text{C}$  deformation mode. The situation is complicated by the coupling of  $\nu_2$  with  $\nu_3$  and  $\nu_6$  with  $\nu_7$  producing somewhat "uncharacteristic" frequencies for the skeletal deformation modes. Despite this, a virtually complete allocation of skeletal frequencies is suggested in Table 19; only  $\nu_{13}$ , the infrared active  $(\text{CH}_3)_3\text{C}$  rocking vibration (expected at ca.  $260\text{ cm}^{-1}$ ) has eluded detection. No feature clearly attributable to torsional motions of the methyl groups has been observed, but such modes are usually comparatively weak both in infrared absorption and Raman scattering, and it is doubtful whether this omission is significant.

Similar arguments are applicable to the analysis of the incomplete vibrational spectrum of di-t-butylzinc, with the results shown in Table 20. The conspicuous similarity between the infrared spectra of the zinc and beryllium derivatives in the region  $600\text{-}3500\text{ cm}^{-1}$  confirms that the bands here arise almost exclusively from internal vibrations of the  $(\text{CH}_3)_3\text{C}$  groups; consequently, the spectrum of di-t-butylzinc between  $600$  and  $3500\text{ cm}^{-1}$  is easily interpreted by reference to the corresponding features in that of di-t-butylberyllium. However, skeletal motions involving the metal atom or metal-carbon bond appear at lower frequencies when beryllium is replaced by the larger zinc atom; where observed, these can be identified for the zinc compound by the relative intensities and positions of the vibrational bands and by comparison with the spectra of molecules like  $(\text{CH}_3)_3\text{CBr}$ .<sup>183-185</sup>

The satisfactory analysis of the spectra of both  $\text{Be}[\text{C}(\text{CH}_3)_3]_2$  and  $\text{Zn}[\text{C}(\text{CH}_3)_3]_2$  in terms of a  $D_{3d}$  model leads to the fundamental frequencies for the skeletal vibrations listed in Table 23. The vibrational bands still unaccounted for, invariably of low intensity, can be interpreted as overtones or combinations of the fundamentals. The large number of fundamentals (some of which are inactive in both the Raman and infrared spectra) commonly allows several possible assignments, and detailed individual assignments taking account of the symmetry of the transition, were not practicable.

In general terms, therefore, the vibrational spectrum of di-*t*-butylberyllium in the vapour and the liquid phase leaves little doubt that the molecular unit is basically monomeric and linear with respect to the metal atom. The compound thus provides one of the rare instances of beryllium's exhibiting 2 co-ordination at room temperature, the only other comparable molecule is the recently prepared  $[(\text{Me}_3\text{Si})_2\text{N}]_2\text{Be}$ .<sup>18</sup> On the other hand, two features of the liquid-phase spectra of the *t*-butyl derivative could well signify that there is weak second-order molecular interaction in the condensed phases, viz: (1) Contrary to the  $D_{3d}$  selection rules, the antisymmetric Be-C stretching mode,  $\nu_6$ , appears weakly in the Raman scattering. This could mean that the C-Be-C skeleton is not strictly linear in the liquid or it could be due to the close approach of a second molecule leading to a reduction in the effective symmetry of the molecule (6,1):

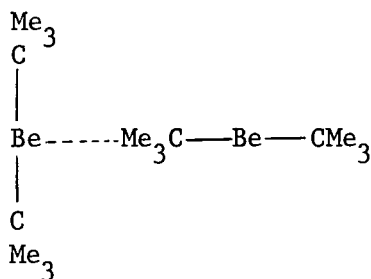

(6,1)

(2) Change of phase induces some unusually large frequency shifts (up to  $30 \text{ cm}^{-1}$ ) and changes in intensity of infrared absorptions (e.g., near  $2900$  and  $1000 \text{ cm}^{-1}$ ). This is indicative, though not necessarily proof, of some degree of molecular association in liquid di-*t*-butylberyllium.

The states of di-*t*-butylberyllium is possibly analogous to that of trimethylindium where the intermolecular interaction is so weak as to persist as a significant bonding influence only in the crystalline phase.<sup>201,202</sup>

The frequencies ( $450$  and  $545 \text{ cm}^{-1}$ ) attributable to the vibrations of the Be-C bonds are very low in comparison with the analogous frequencies of compounds of the type  $(\text{CH}_3)_3\text{CX}$   $891$ ,  $912$  and  $585 \text{ cm}^{-1}$  for  $\text{X} = \text{F}$ ,  $\text{OH}$  and  $\text{Cl}$  respectively<sup>183-187</sup> or with those of the zinc compound. Since beryllium is such a light atom, this can only mean that the Be-C bonds have an unusually small stretching force constant,  $k$ . Preliminary estimates<sup>122</sup> suggest that it is not very different from the value of  $0.8 \times 10^5 \text{ dynes cm}^{-1}$  estimated for bridging Be-C in polymeric

dimethylberyllium.<sup>165</sup> Though the comparison is limited by the variation of  $k$  with the alkyl substituent, the stretching force constants of the metal-alkyls of the Group II metals apparently form an irregular series. The trends shown in Table 24 are quite unlike the more regular variations observed in Groups III and IV.<sup>202</sup>

Reactions of di-t-butylberyllium with bases and weak acids

Trimethylamine does not displace ether quantitatively from di-t-butylberyllium etherate<sup>34</sup> but by using ether-free di-t-butylberyllium 1:1 complexes  $\text{Bu}^t_2\text{BeNMe}_3$  and  $\text{Bu}^t_2\text{BePMe}_3$  have been prepared. These complexes are of interest as they are iso-electronic with tri-t-butylborane, a compound whose preparation has caused some difficulty. Although tri-t-butylborane has been reported,<sup>207-209</sup> later work has shown that reaction between t-butylmagnesium chloride and boron trifluoride have resulted in  $\text{Bu}^i_3\text{B}$  or  $\text{Bu}^i_2\text{BBu}^t$ .<sup>210</sup> Both complexes have the same melting point within a degree and the relatively high value reflects the high degree of symmetry of these complexes. There was no evidence for the addition of a second mole of base. Since the bistrimethylamine complex of dimethylberyllium has a considerable dissociation pressure<sup>32</sup> (23 mm. at 0°), the greater volume of t-butyl relative to methyl groups would prevent the formation of  $\text{Bu}^t_2\text{Be}(\text{NMe}_3)_2$ . However the chelating base N,N,N',N'-tetramethylethylenediamine (TMED) displaces ether from di-t-butylberyllium etherate and gives a crystalline 1:1 complex,  $\text{Bu}^t_2\text{BeTMED}$ . Dimethylberyllium and<sup>35</sup> di-isopropylberyllium form similar 1:1 complexes. Construction of a model of  $\text{Bu}^t_2\text{BeTMED}$  shows that there is insufficient room around the beryllium atom for both t-butyl groups and both  $\text{Me}_2\text{NCH}_2$  groups. The p.m.r. spectrum of this complex is consistent with a constitution in which only one nitrogen is complexed at a time, but in which rapid exchange takes place between

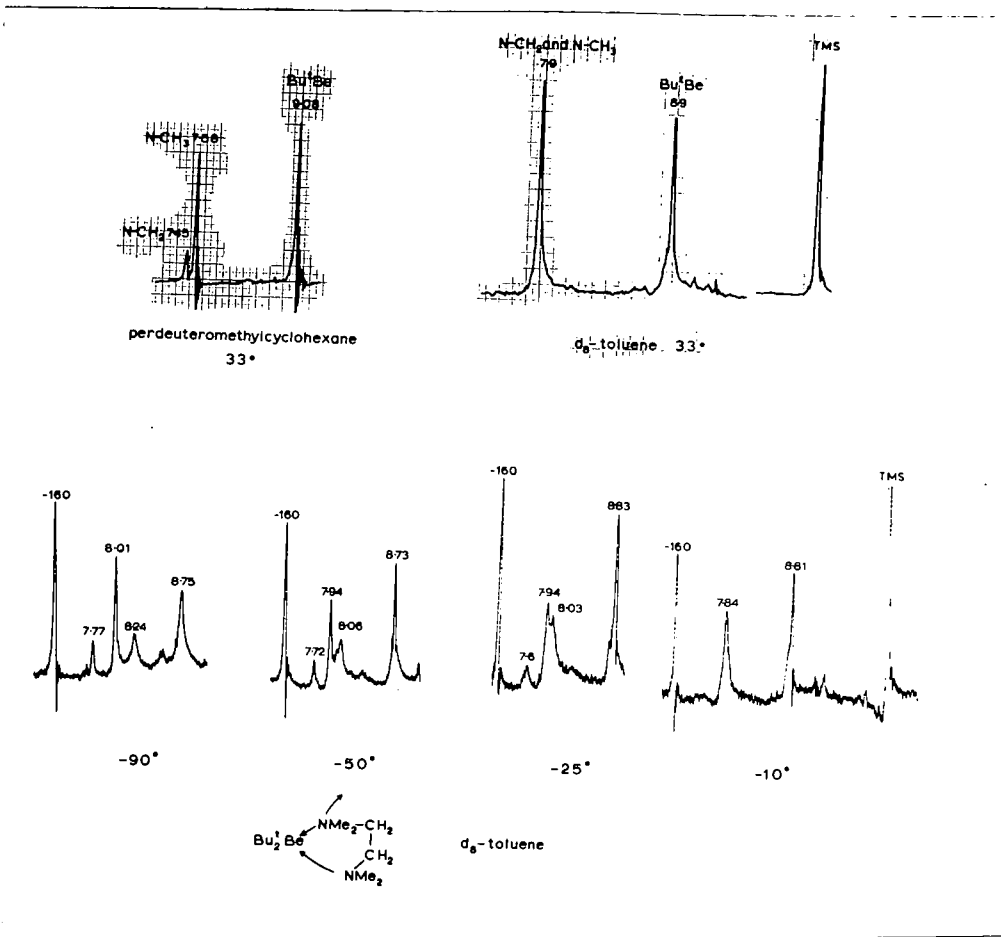

6,2

complexed and free nitrogen. The observed spectra are reproduced (6,2). The spectrum of the complex, in perdeuterotoluene, is unexpectedly simple due to the coincidence of the  $N-CH_2$  and  $N-CH_3$  resonances. In perdeuteromethylcyclohexane these resonances are observed separately. Due to the low solubility of the complex in perdeuteromethylcyclohexane low temperature p.m.r. spectra could not be recorded.

Low temperature p.m.r. spectra of the complex in perdeuterotoluene were recorded and splitting of the  $N-CH_3$  resonance is observed below

$-25^{\circ}$  as the exchange between complexed and uncomplexed dimethylamino groups becomes slow. This effect is not observed for the magnesium analogue,<sup>157</sup> the magnesium being bigger than the beryllium atom, nor for the di-isopropyl complex,  $\text{Pr}_2^i\text{BeTMED}$ , both of which are considered to have chelate structures. An alternative explanation is that exchange is still rapid at  $-80^{\circ}$  in those complexes.

Steric effects play an important part in reactions of di-t-butylberyllium with substances containing acidic hydrogen. Whereas  $\text{Me}_2\text{Be.NHMe}_2$  decomposes rapidly with methane evolution when it melts ( $44^{\circ}$ ),<sup>59</sup> and  $\text{Et}_2\text{Be.NHMe}_2$  evolves ethane below room temperature, the t-butyl complex does not evolve isobutane quantitatively even on prolonged heating. Inspection of a model of the complex,  $\text{Bu}_2^t\text{BeNHMe}_2$ , shows that the amino hydrogen is well shielded and would not be able to easily approach the tertiary carbon atom of the same or an adjacent molecule. Isobutene evolution is faster if trimethylamine is added, presumably by displacing some dimethylamine which is then able to react.<sup>19</sup> The effect of having a tertiary amine close at hand is very evident since the complex of di-t-butylberyllium with trimethylethylenediamine eliminates isobutane smoothly and quantitatively at room temperature: The product (6,3), a liquid is unique amongst the aminoberyllium alkyls prepared so far in being monomeric in benzene (cryoscopically).

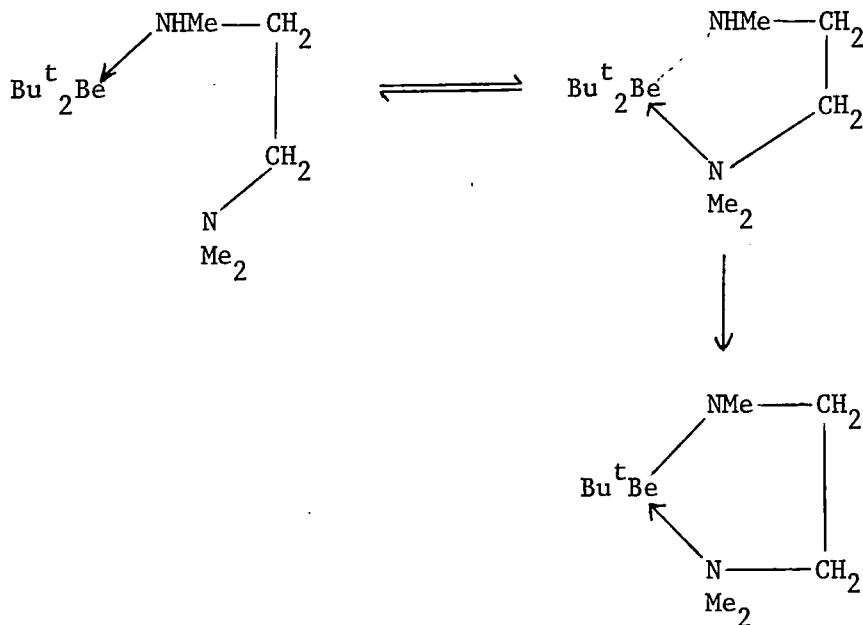

A series of complexes ( $\text{RMNMeC}_2\text{H}_4\text{NMe}_2$ ,  $\text{M} = \text{Be}, \text{Mg}, \text{Zn}$ ) has been described<sup>35,73,157</sup> and with the single exception described above are all dimeric in benzene solution, and are believed to have the structure (6,4):

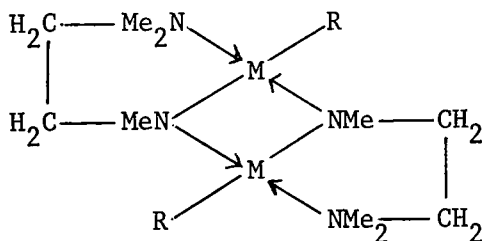

Small changes in the sizes of the alkyl groups attached to beryllium also result in dimeric structures (6,4: M = Be, R = Pr<sup>i</sup>, Pr<sup>n</sup>). Similarly the products formed when di-t-butylberyllium reacts with 2-dimethylaminoethanol and 2-dimethylaminoethanol are dimeric, (Bu<sup>t</sup>BeXC<sub>2</sub>H<sub>4</sub>NMe<sub>2</sub>)<sub>2</sub> X = O, S, because the oxygen or sulphur atom occupies less space than does the NMe group in Bu<sup>t</sup>BeNMeC<sub>2</sub>H<sub>4</sub>NMe<sub>2</sub>.

Since the change from monomeric Bu<sup>t</sup>BeNMeC<sub>2</sub>H<sub>4</sub>NMe<sub>2</sub> to dimeric (Pr<sup>i</sup>BeNMeC<sub>2</sub>H<sub>4</sub>NMe<sub>2</sub>)<sub>2</sub> must be due mainly to the volume of the t-butyl group being greater than that of the isopropyl group, to an extent which prevents dimer formation, one would expect the isopropyl groups in the dimer to be subject to considerable steric restraint. For example, rotation of the isopropyl groups about the Be-C bonds is likely to be restricted, and by construction of a model it is clear that the isopropyl group cannot rotate and that only two conformations are possible.

The resonances due to the (CH<sub>3</sub>)<sub>2</sub>CH- groups in the p.m.r. spectrum of (6,4: M = Be, R = Pr<sup>i</sup>) indicate such restriction since they consist of an overlapping pair of doublets, of equal intensity at  $\tau$  8.59 and  $\tau$  8.68 (both J = 7 c/sec.) at -40°,  $\tau$  8.66 and 8.72 (J = 7 c/sec.) at 20°, but which are collapsed to one doublet at  $\tau$  8.74 (J = 7 c/sec.) at 80°.

Degrees of association of two, three and four have been found for the 2-dimethylaminoethanol derivatives of di-t-butylmagnesium,<sup>93</sup> dimethylberyllium<sup>66</sup> and dimethylmagnesium.<sup>93</sup> All these can be readily formulated as containing four co-ordinate metal as discussed earlier.

In agreement with the general observation that larger substituents favour smaller degrees of association,<sup>20</sup> it is observed that  $\text{Bu}^t\text{BeSC}_2\text{H}_4\text{NMe}_2$  is dimeric in benzene. The analogous methylzinc derivative is also a dimer,  $(\text{MeZnSC}_2\text{H}_4\text{NMe}_2)_2$ , thus the beryllium, magnesium and zinc derivatives,  $\text{MeMSC}_2\text{H}_4\text{NMe}_2$  all have different degrees of association in benzene solution and form a very curious series. A crystal structure analysis of the magnesium derivative is in progress.<sup>94</sup>

Ether free beryllium dialkyls

The preparation of beryllium dialkyls by reaction of two moles of a Grignard reagent with one mole of beryllium halide is the most convenient reaction on a laboratory scale. The products, after separation from magnesium halides and distillation at low pressure, are normally ether adducts of indefinite composition. Coates and Glockling described a process of "reflux distillation" whereby ether could be removed from di-isopropylberyllium.<sup>26</sup> This method was not applied to the removal of ether from beryllium dialkyls and an idea has persisted that beryllium dialkyls are very difficult to separate from ether. Consequently processes<sup>99</sup> have been devised, related to those which allow aluminium alkyls to be separated from ether, such as the formation of complexes with potassium fluoride and their subsequent decomposition in the absence of ether, as discussed earlier. The use of organomagnesium halides, prepared and used in hydrocarbons, has been reported for the preparation of beryllium dialkyls, notably di-n-butylberyllium which is reported to be a viscous liquid.<sup>27</sup> In the present work its viscosity is found to be comparable with that of the other liquid beryllium dialkyls and is considerably less than that of concentrated sulphuric acid.

The reflux distillation procedure has been used for the preparation of several ether-free beryllium dialkyls,  $R_2Be$  ( $R = Et, Pr^n, Bu^n, Bu^i$ ), which were needed for a mass spectroscopic study of their fragmentation under electron impact.<sup>182</sup> Experimental details have been given earlier.

The temperatures at which the dialkyls distil are  $\sim 40-65^\circ$  at  $10^{-3}$  mm. with the exception of di-n-butylberyllium which surprisingly does not distil until  $95^\circ$ . The separation of ether from dimethylberyllium is more difficult, no doubt due to occlusion of ether within the crystalline material; repeated sublimations at low pressure are necessary. The diaryls of beryllium tenaciously retain ether, but this is likely to be due to their relatively strong acceptor strength, e.g. diphenylberyllium forms a bisdimethylsulphide complex<sup>38</sup> whereas dimethylberyllium and dimethylsulphide do not form a complex.<sup>29</sup> The use of organomagnesium halides in hydrocarbons is of considerable value in the preparation of beryllium di-aryls.<sup>27</sup>

Di-isopropyl-,<sup>26</sup> di-n-butyl-,<sup>27</sup> and di-sec-butyl-beryllium<sup>203</sup> are dimeric in benzene solution and structures (6,5) containing bridging and terminal alkyl groups have been proposed:

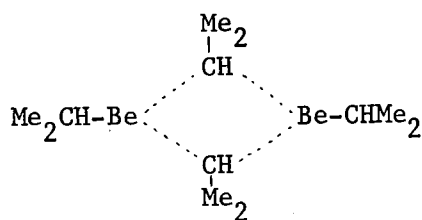

(6,5)

Di-t-butylberyllium is monomeric and steric factors must play a large part in this. There has been some uncertainty in connection with the molecular weight of diethylberyllium, the degree of association reported to be just over two shortly after solutions had been made but

rising to over three after eight months.<sup>25</sup> Oxidation could well have been the reason for this observation as ethylberyllium ethoxide may well have been formed and such compounds have been shown to be tetrameric in benzene except when there are steric abnormalities.<sup>20</sup> The molecular weight of diethylberyllium (in benzene) has been re-measured both as a freshly prepared solution and after storage, in benzene, for six months in a sealed tube under vacuum. It was found to be dimeric in both cases. Similarly di-n-propyl- and di-isobutyl-beryllium are dimeric in benzene and structures analogous to (6,5) are suggested.

The reflux distillation process cannot be applied to the separation of ether from its complex with di-t-butylberyllium, since ether-free di-t-butylberyllium is so volatile. Instead, ether may be separated by the addition of beryllium chloride, which is a stronger Lewis acid. Yields of up to 40% of di-t-butylberyllium were reported after stirring the mixture for 15 hours.<sup>115</sup> A white crystalline by-product, which sublimed in vacuum just below 50° was reported, and "from analysis it was apparently t-butylberyllium chloride etherate but it was not otherwise characterised". No analytical data were given.<sup>115</sup> Considerably increased yields were obtained when the period over which the mixture was stirred was reduced to 1 hour, with a consequent reduction in the amount of by-product formed.

In view of the possibility that this by-product was a beryllium analogue of a Grignard reagent, it was re-examined. Replacing beryllium

chloride by beryllium bromide the corresponding bromide was obtained. These products are t-butylberyllium halide diethyl ether complexes and both are dimeric in benzene solution. Since the bridging properties of halogen are undoubtedly better than those of t-butyl, the formulation (6,6) is proposed similar to that suggested for its t-butylmagnesium chloride diethyletherate which is also dimeric in benzene.

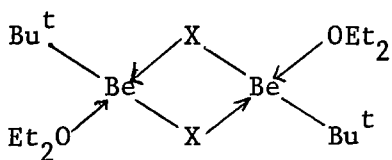

(6,6)

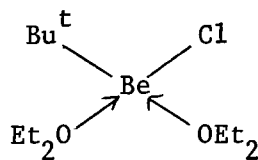

(6,7)

In refluxing diethylether, t-butylberyllium chloride had a mean degree of association of 1.07 over the concentration range 0.002-0.020M, so the chlorine bridge is presumably cleaved by ether giving monomeric (6,7)

Reactions of zinc dialkyls with weak acids

Dimethylzinc reacts with acetic acid and dimethylphosphinic acid to form products which are insoluble in benzene and which are believed to contain bridging acetate and dimethylphosphinate groups. Their insolubility is considered to be due to cross linking between the zinc atoms of one dimer unit and the oxygen atoms of another thereby raising the co-ordination number of zinc from 3 (in the dimer unit) to 4. These products dissociate above  $75^{\circ}$  and  $140^{\circ}$  respectively.<sup>73</sup> The reaction of dimethylzinc with propionic and benzoic acid were carried out in the hope of preparing soluble compounds containing three co-ordinate metal. This was not successful due to the disproportionation of the product at room temperature, quite a remarkable change from the cases mentioned above. Steric factors are unlikely to be the reason for this as the  $\text{Me}_2\text{P-}$  group is more bulky than the  $\text{CH}_3\text{-}$  group and yet the dimethylphosphinate does not disproportionate until a much higher temperature than the acetate.

Alkylzinc alkoxides are generally tetrameric in benzene solution,<sup>73</sup> but where bulky groups are involved lower degrees of association are observed, e.g, phenylzinc triphenylmethoxide is dimeric.<sup>82</sup> The degree of association of methylzinc-t-butoxide is concentration dependent, falling from 4 at about 0.5M to less than 3 at 0.12-0.2M.<sup>85</sup> In view of the steric hindrance it is reasonable to expect that t-butylzinc t-butoxide would have a degree of association of less than four. It is

dimeric in benzene solution and is formulated (6,8).

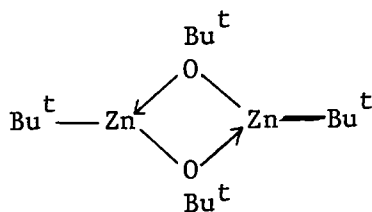

(6,8)

Very recently Noltes and Boersma have reported that (6,8) is trimeric in benzene.<sup>211</sup> As low concentrations were used, and therefore low depressions of freezing point obtained, this result is possibly in error. A pale yellow monopyridine adduct of (6,8) is readily prepared, whereas a pyridine adduct of  $(\text{PhZnOCPh}_3)_2$  could not be prepared.<sup>82</sup> The pyridine adduct dissociates in benzene solution, the observed degrees of association are only slightly greater than unity and the process:

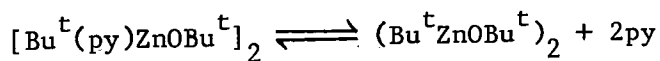

takes place in benzene solution. Pyridine has been identified in the solvent evaporated from solution.

The deep yellow pyridine adduct of di-t-butylzinc is extensively dissociated in benzene solution (cryoscopically).

The preparation of zinc di-t-butoxide from diphenylzinc and t-butanol gave a product whose analysis was not very good.<sup>85</sup> The preparation from diethylzinc and t-butanol is a more satisfactory

preparation. The product is insoluble and is believed to be polymeric (6,9):

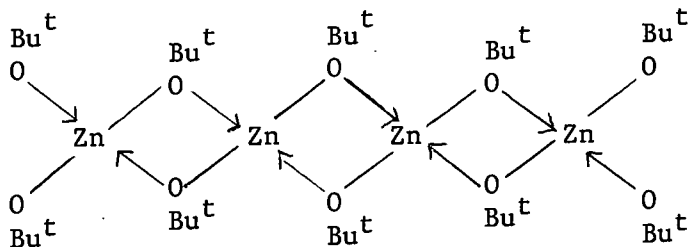

(6,9)

The possibility of a polymer containing cross linked units of (6,9), with zinc possibly six co-ordinate and oxygen four co-ordinate must be considered. The beryllium analogue of (6,9) is trimeric in benzene solution,<sup>20</sup> a result of the small size of the beryllium atom being unable to accommodate the steric requirements of the t-butoxy groups whereas the larger zinc atom can and is therefore polymeric.



P.m.r. spectra of beryllium dialkyls

The p.m.r. spectra of a number of beryllium dialkyls have been investigated in order to attempt to distinguish between bridging and terminal alkyl groups. Some of the spectra have turned out to be very complex and further work is necessary.

The p.m.r. spectrum of di-n-propylberyllium (TMS used as standard in all cases) at  $33.5^{\circ}$  consists of a doublet of unequal intensity at  $\tau$  8.82 and 8.92 and a broad unresolved peak centred on  $\tau$  9.4. A similar spectrum is obtained when di-isopropylberyllium is studied as a 40% solution in perdeuterotoluene. The spectrum of this sample has been examined over the temperature range  $-60$  to  $+80^{\circ}$ , spectra obtained below  $-45^{\circ}$  are considered unreliable due to the high viscosity of the solution. At temperatures of  $60^{\circ}$  and above the septet due to  $(\text{CH}_3)_2\text{CH-}$  is resolved, but there is no change in the positions of the observed resonances, though the resonances due to  $(\text{CH}_3)_2\text{CH-}$  are sharper. On lowering the temperature to  $20^{\circ}$  considerable broadening occurs and at  $-10^{\circ}$  very little detail is present. By  $-30^{\circ}$  more detail is present and at least five peaks are observed in the position of the  $(\text{CH}_3)_2\text{CH-}$  resonance. The spectrum is very similar at  $-45^{\circ}$  and the positions of the five peaks are  $\tau$  8.77, 8.90, 9.00, 9.10, 9.19. Some of the observed spectra are shown in the diagram (6,10).

The p.m.r. spectrum of di-isobutylberyllium has been described earlier both as a pure liquid and as a solution in benzene. There is a

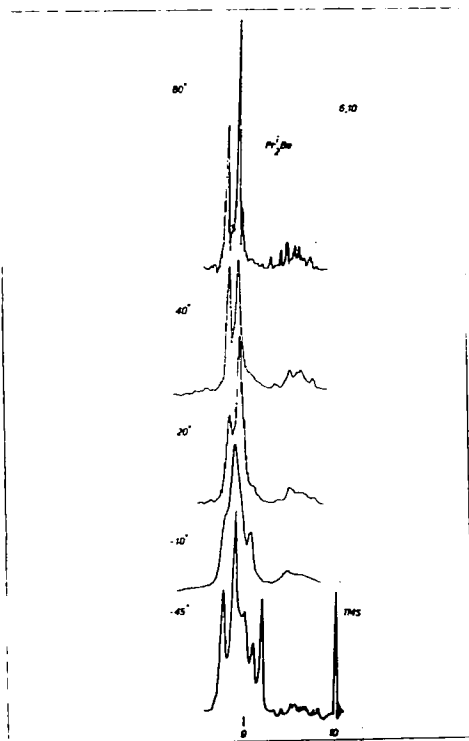

solvent effect. The spectrum has been investigated over the temperature range  $+100^{\circ}$  to  $-80^{\circ}$  as a solution in perdeuterotoluene. Broadening of all the peaks was observed as the temperature was lowered but no further effects were observed as the temperature was lowered still further.

Diethylberyllium has been studied as a solution in both perdeuterotoluene and perdeuteromethylcyclohexane (both concentrations 40% by weight). There are significant differences in the spectra in these two solvents and in their variation with temperature. In both solvents the spectra show second order effects as has been observed for triethylaluminium in cyclopentane. On lowering the temperature the methylene

resonance broadened and finally split into two quartets corresponding to terminal and bridging ethyl groups. The resonance due to the bridging methylene group coincided with that of the CH<sub>3</sub> groups.<sup>204</sup> Similar results were reported elsewhere.<sup>205</sup> The p.m.r. spectra of diethylberyllium in both toluene and methylcyclohexane are temperature invariant above 40°:

	d <sub>8</sub> -toluene		d <sub>14</sub> -methylcyclohexane	
	τ	J c/sec.	τ	J c/sec.
CH <sub>3</sub> CH <sub>2</sub> Be	8.94	8	8.45	7
CH <sub>3</sub> CH <sub>2</sub> Be	9.74	8	9.43	7

The resonances being at much higher field in toluene. Fetter<sup>3</sup>, has quoted values of τ 8.44 and τ 9.10 for the methyl and methylene protons respectively, but no data were given concerning the temperature or solvent, if any.

As the temperature is lowered the methylene resonance (of diethylberyllium in perdeuteromethylcyclohexane) broadens and at -10° no detail is present. As the temperature is lowered still further some detail re-appears in the methylene resonance. Some of the observed spectra are shown in (6,11). The spectrum of the sample in toluene behaves quite differently, at 0° considerable broadening has occurred and by -20° the methyl triplet has collapsed to a very broad peak. As the temperature is lowered still further this peak splits into two

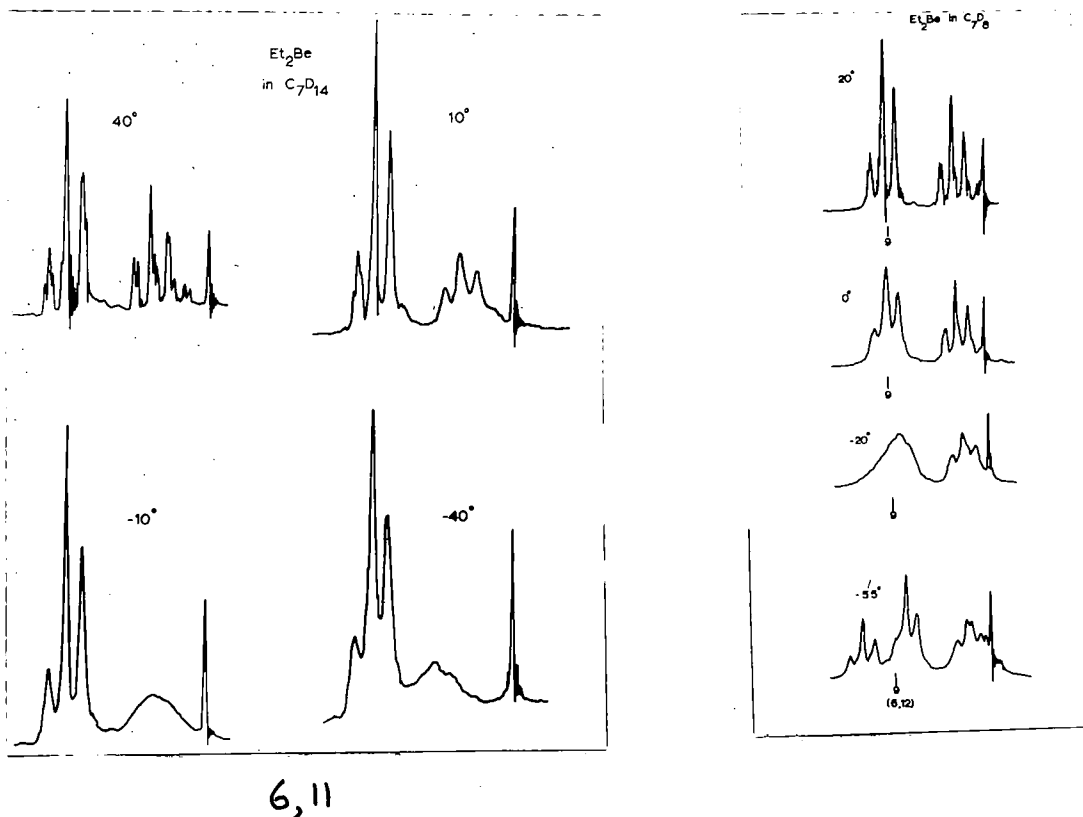

triplets centred on  $\approx 8.71$  and  $9.13$  with areas in the ratio 1:2 respectively at  $-60^\circ$ . By this temperature the methylene resonance is showing extra detail and at least five peaks are present. A selection of the observed spectra are shown in (6,12). Spectra could not be recorded below  $-60^\circ$  due to the high viscosity of the solution.

The p.m.r. spectrum of di-n-butylberyllium has been reported in a communication as "having a normal n-propyl pattern plus a multiplet containing at least eight lines".<sup>27</sup> The p.m.r. spectra of both di-n-butyl- and di-n-propyl-beryllium have been recorded. There are considerable differences in the spectra as can be seen from the

diagrams (6,13). The spectra are considerably more complex than a "normal" n-propyl pattern as found, for example, in 1-nitropropane and 1-bromopropane. The n-propyl pattern, in such molecules, consists of two triplets and a sextet.

Recent work has shown that dicyclopentadienylberyllium interacts with aromatic solvents to such an extent that paramagnetism is induced in the system. This caused large shifts in the aromatic resonance signals in the p.m.r. spectra and was directly observed by electron spin resonance (e.s.r.) spectroscopy. A complex of the form:

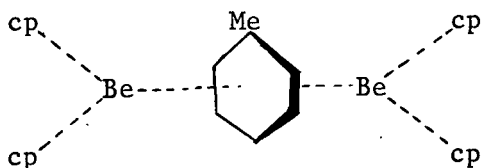

is postulated. A bonding scheme is proposed in which two beryllium  $sp^3$  hybrid orbitals are directed towards the complexed solvent molecule. Symmetry considerations permit a bond with the vacant  $E_2$  orbitals on the aromatic molecule into which electrons can be excited to form a bond.<sup>206</sup>

The possibility of this form of interaction must be considered in the cases of the beryllium dialkyls and more work must be done in aromatic hydrocarbons in order to observe any shifts in the aromatic resonances. The recording of spectra at 100 MHz and e.s.r. spectra of these would be of considerable value.

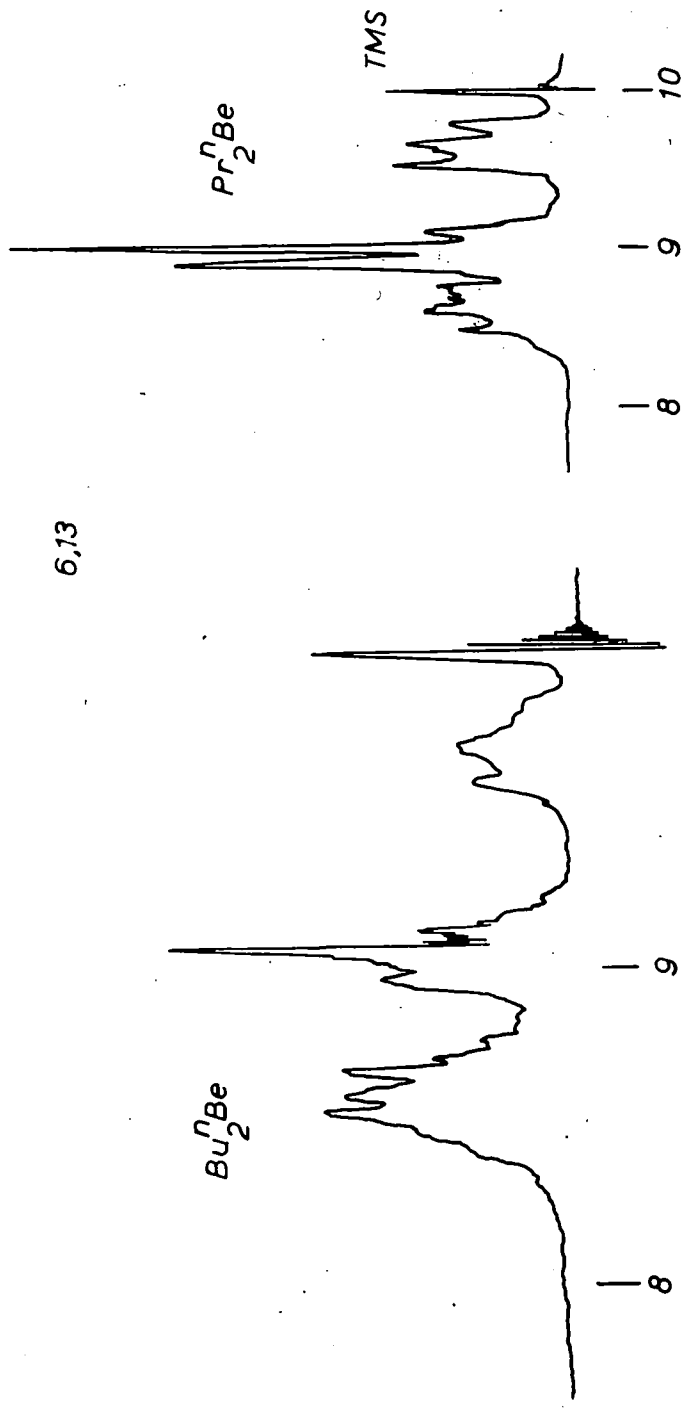

### Hydride Chemistry

Beryllium hydride reacts with N,N,N'-trimethylethylenediamine eliminating hydrogen and forming,  $(\text{HBeNMeC}_2\text{H}_4\text{NMe}_2)_3$ .<sup>135</sup> Pyrolysis of  $\text{Bu}^t\text{BeNMeC}_2\text{H}_4\text{NMe}_2$  was expected to lead to the same product as pyrolysis of  $(\text{Pr}^i\text{BeNMe}_2)_3$  resulted in the formation of  $(\text{Me}_2\text{NBeH})_x$ .<sup>26</sup> However, isobutene evolution from  $\text{Bu}^t\text{BeNMeC}_2\text{H}_4\text{NMe}_2$  did not take place below  $200^\circ$  and at this temperature the substance underwent general decomposition, ethylene being evolved and an orange residue remaining.

Coates and Glockling reported the formation of isopropylberyllium hydride by the pyrolysis of di-isopropylberyllium.<sup>26</sup> The glassy product was considered to be polymeric. The other routes to alkyl- (and aryl-)beryllium hydrides have been discussed in some detail earlier. All these methods result in a product that is not a pure alkylberyllium hydride, e.g., donor solvents are necessary in the early stages of some reactions and cannot be completely removed. Alkylberyllium hydrides prepared by such methods have been used to prepare co-ordination compounds and to study the reaction of  $-\text{BeH}$  with olefins in the presence of a trace of ether,  $(\text{RBeH}:\text{OEt}_2 \sim 6:1)$ . Solvent-free alkylberyllium hydrides are of considerable interest structurally and the pyrolysis reaction was studied with the aim of obtaining spectral and molecular weight data on the products. As the pyrolysis of di-isopropylberyllium results in the formation of a glass,<sup>26</sup> the pyrolysis of di-t-butylberyllium was carried out. Ether free di-t-

butylberyllium is readily prepared<sup>115</sup> and spectral characterisation is relatively simple.

Considerable effort has been directed towards the preparation of beryllium hydride by the complete pyrolysis of di-t-butylberyllium and its etherate,<sup>34,115,119</sup> but there have been no reports of the preparation of a half-hydride.

The conditions required for the pyrolysis have been described in the Experimental section. Pyrolysis at 105-110° was rapid and yet there was no evidence for the evolution of more than one mol. of iso-butene from di-t-butylberyllium. The product, a viscous liquid, was soluble in aromatic hydrocarbons and a p.m.r. spectrum of a sample in benzene was recorded. This showed quite conclusively that some isomerisation had taken place to isobutylberyllium hydride. Chlorination showed that isomerisation was not complete, a mixture of isobutyl- and t-butyl chlorides having been produced. The resonance due to t-butylberyllium was not observed in the p.m.r. spectrum at 33.5° but on raising the temperature it appeared as a shoulder on the high field side of the  $(\text{CH}_3)_2\text{CHCH}_2$  resonance and was quite distinct at 100°.

The isomerisation to isobutylberyllium is explainable by the addition of isobutene to beryllium hydride species. This can occur in two ways:

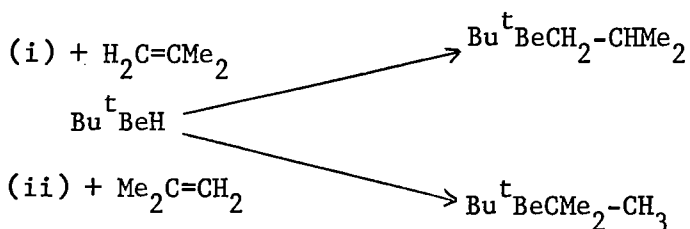

Reaction (i) is favoured both on steric and polar grounds. The products can then be re-pyrolysed.

If the isobutene can be removed from the reaction site as soon as it is formed then the proportion of t-butylberyllium hydride should increase. This was carried out, sweeping isobutene away with a current of nitrogen, the product was still  $\sim 70\%$  isobutylberyllium hydride. It seems likely that the product previously characterised as isopropylberyllium hydride<sup>26</sup> is, in fact, a mixture of n-propyl- and isopropyl-beryllium hydrides. On hydrolysis both form propane and therefore cannot be distinguished this way. Hydrolysis of both t-butyl- and isobutyl-beryllium results in the formation of isobutane.

As the products from the pyrolyses of di-t-butylberyllium were always mixtures, the pyrolysis of di-isobutylberyllium was next carried out. Both di-t-butyl- and di-isobutyl-beryllium are relatively easily pyrolysed. For example, when ether-free di-isobutylberyllium is prepared (24 hrs. reflux at  $50^\circ$ ) a residue remains when the di-isobutylberyllium is distilled and this accounts for a substantial proportion of the initial beryllium present (up to 25% in some instances). In contrast, di-isopropylberyllium requires heating to  $200^\circ$  in order to

form the half hydride.<sup>26</sup> This residue is substantially isobutyl-beryllium hydride, possibly contaminated with some ethoxy- and butoxy-beryllium derivatives. This residue was used to prepare some coordination complexes of isobutylberyllium hydride.

The conditions used to prepare isobutylberyllium hydride have been discussed in detail earlier. The p.m.r. spectrum of isobutyl-beryllium hydride does not show the resonance due to hydrogen directly attached to nitrogen. This is not unusual, it has only been detected in three cases so far (see Table 13). The quadrupole moment of beryllium is of the same order as that of <sup>14</sup>N and the resonance would be very broad. The beryllium-hydride resonance was not detected in any compound prepared in this work.

Infrared spectral studies and molecular weight measurements in benzene have been carried out in order to try and elucidate the structure of isobutylberyllium hydride. The solubility of isobutyl-beryllium hydride is somewhat anomalous and it takes some time for it to dissolve in benzene. Some samples have dissolved in aliphatic hydrocarbons to a certain extent, e.g. an infrared spectrum has been recorded in cyclohexane solution, but stirring with pentane was found to be a suitable way of removing any excess di-isobutylberyllium from the reaction vessel, without significantly reducing the yield of the hydride. Isobutylberyllium hydride was transferred as a solution in benzene and used as such when possible. Cryoscopic molecular weight

measurements indicate that the hydride is oligomeric, but that different molecular weight were observed for different preparations. In view of the small depressions of freezing point obtained, these values for the degree of association must be regarded as orders of magnitude (i.e. about 10-30).

Infrared spectra of several samples (recorded as Nujol mulls) were identical (2000-400  $\text{cm}^{-1}$ ) and the infrared spectrum of a solution in cyclohexane is the same as that of the mull (1250-400  $\text{cm}^{-1}$ ). The spectra do differ in the region 1250-2000  $\text{cm}^{-1}$ . It is probable that smaller units of isobutylberyllium hydride are present in cyclohexane solution and this would affect the light atom vibrations more than the skeletal modes in which fairly similar units would be present. The infrared spectra both indicate that  $\text{BeH}_2\text{Be}$  bridges are present. <sup>170</sup> The high frequency absorption in the spectrum of the Nujol mull (centre 1820  $\text{cm}^{-1}$ ) may be due to  $\text{BeHBe}$  vibrations but the possibility of it being due to a terminal  $\text{Be-H}$  bond may be considered. Its breadth could well be due to mulling difficulties. A structure of the type (6,14) must be considered.

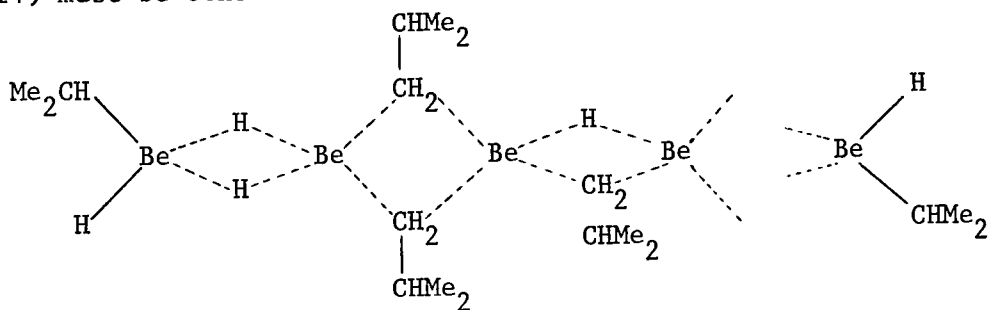

(6,14)

Alternatively, a structure based on (6,14) with just terminal iso-butyl-groups and therefore containing three co-ordinate beryllium at the chain ends is possible.

Similar structures to the above, with the ends joined, forming rings are also possible.

Structures containing the Be·H·Be bridge may occur, as in (6,15):

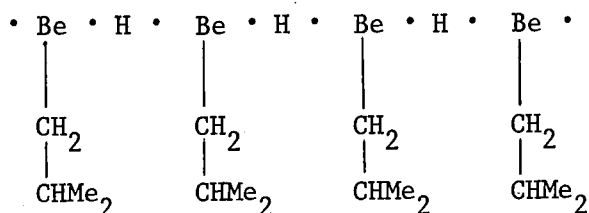

(6,15)

Structures containing combinations of (6,14) and (6,15) are also equally probable.

Co-ordination compounds of isobutylberyllium hydride.

Methylberyllium hydride forms insoluble, presumably polymeric, products with bidentate ligands. N,N,N',N'-tetramethylethylenediamine (TMED) forms a complex with isobutylberyllium hydride,  $(\text{Bu}^i\text{BeH})_2\text{TMED}$  which is monomeric in benzene. It sublimes readily in vacuo in contrast with its methyl analogue. The infrared spectrum shows the presence of the  $\text{BeH}_2\text{Be}$  bridge. Absorptions due to the  $\text{BeH}_2\text{Be}$  bridge have been characterised,<sup>170</sup> and this complex shows the expected strong absorption

at  $1333\text{ cm}^{-1}$ . On the basis of its molecular weight and its infrared spectrum it is assigned the structure (6,16).

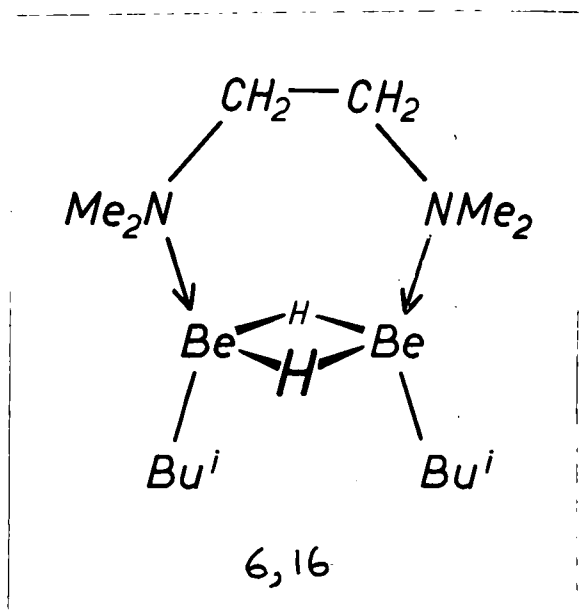

Construction of a model shows that the TMED molecule can fit in the required position with no strain involved in maintaining the conformation.

A similar structure is proposed for the complex with  $N,N,N',N'$ -tetraethylethylenediamine. A remarkable change takes place in moving from the methylberyllium- to the isobutylberyllium-hydride derivative. There is obviously scope for further work with other alkylberyllium hydrides.

The addition of monodentate ligands to alkylberyllium hydrides results in the formation of dimeric products such as (3,4)<sup>60,126</sup> and the tetrahydrofuran complex of isobutylberyllium hydride is formulated similarly.

### Decomposition of di-t-butylberyllium

The decomposition of di-t-butylberyllium appears to be catalysed by impurities. The ratio (Bu + H):Be would be expected to be 2:1 whereas it is 0.68:1. This suggests that some insertion of isobutene into Be-C bonds has taken place. However, gas chromatographic analysis of both the chlorination and hydrolysis products failed to reveal the presence of higher alkyl substituents.

The decomposition of di-t-butylberyllium at room temperature in a p.m.r. tube was then studied. Some of the observed spectra have been reproduced (5,8) and the spectra are consistent with the formation of di-isobutylberyllium over a period of 40 weeks. The positions of the methylene resonance have been tabulated, and after 40 weeks they are not quite in the positions expected for neat di-isobutylberyllium. In contrast the resonance due to  $(\text{CH}_3)_2\text{CHCH}_2-$  remains static. The environment of the methylene protons must undergo considerable change (upfield shift  $\sim 0.3$  p.p.m.) during the isomerisation, considerably more than the solvent effect on this resonance for di-isobutylberyllium (shift 0.12 p.p.m. downfield in benzene).

It is interesting to note that resonances due to isobutene were observed throughout the time that the reaction was studied. This suggests that a possible mechanism for the isomerisation is via the hydride as has been discussed earlier.

Preparation of  $H_4Be_2TMED$

Pyrolysis of di-isobutylberyllium etherate resulted in the formation of a hydride rich species which was insoluble in refluxing benzene, and was presumed to have a polymeric structure. This was evidently depolymerised by the addition of TMED. Analysis of the crude product showed that a hydride rich species had been obtained and the infrared spectrum showed a strong absorption at  $1767\text{ cm}^{-1}$ . The product was believed to be a mixture of  $(Bu^iBeH)_2TMED$  and  $(H_4Be_2TMED)$  and as the former is readily soluble in pentane this was used to separate the two components. This proved to be simpler than expected as the beryllium hydride derivative would not re-dissolve in aliphatic or aromatic hydrocarbons or in excess TMED. A structure analogous to that proposed for  $(MeBeH)_2TMED$  (3,5) with terminal Be-H groups is therefore suggested. Smaller units must be present initially:

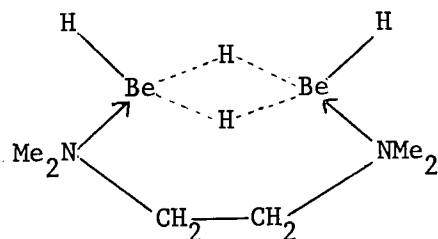

but on obtaining a solid this polymerises:

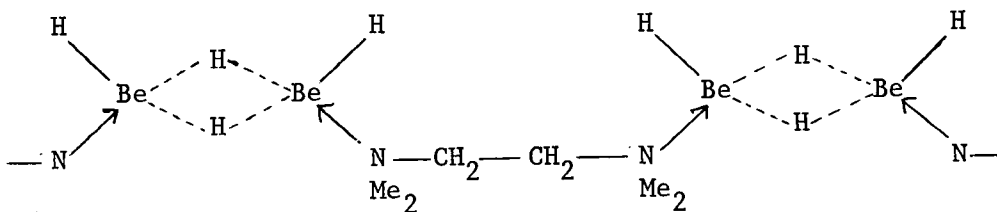

This compound shows two strong absorptions at 1787 and 1807  $\text{cm}^{-1}$ , as well as absorptions due to the  $\text{BeH}_2\text{Be}$  bridge, which are assigned to terminal Be-H modes,  $\nu(\text{BeH})$  in phase and out of phase. This, and beryllium borohydride<sup>216</sup> are the only compounds known to possess a terminal Be-H bond.

This type of complex has considerable interest and in an attempt to prepare a soluble complex, N,N,N',N'-tetraethylethylenediamine (TEED) was used. As separation was going to be a problem the TEED complex of isobutylberyllium hydride was first characterised. This has been discussed. Considerable effort went into the separation of  $(\text{Bu}^i\text{BeH})_2\text{TEED}$  and  $\text{H}_4\text{Be}_2\text{TEED}$  but was not successful. This is encouraging as  $\text{H}_4\text{Be}_2\text{TEED}$  is soluble in hydrocarbon solvents. In order to resolve the separation difficulty work on the reaction of TEED with beryllium hydride prepared by precipitation using di-isobutylberyllium and lithium aluminium hydride in ether is in progress. So far no beryllium hydride has dissolved in TEED.

Reactions with olefins

The reaction of isobutylberyllium hydride with pent-1-ene (1:1 molar ratio) had a half-life of 10-15 mins. at 33.5°. This contrasts with a value of 4.85 hr. for the reaction of ethylberyllium hydride (and some ether) with pent-1-ene under the same experimental conditions.<sup>60</sup> No reaction was detected between 2-methylbut-2-ene and ethylberyllium hydride (and some ether) was detected at 84°. <sup>60</sup> At the same temperature and under the same conditions (1:1 molar ratio, benzene solution) no reaction was observed between isobutylberyllium hydride and the same olefin. However, at 110° a slow reaction did take place ( $t_{\frac{1}{2}} \sim 50$  hours).

Ziegler and co-workers have studied the reactions of diethylaluminum hydride with olefins in the absence of ether.<sup>213</sup> It has been stated that ether has no significant effect on the reaction, and that this is not surprising as dialkylaluminum hydrides retain their trimeric structure in diethyl ether.<sup>214</sup> Similarly ether is reported to have no significant effect on the rate of hydroboration of  $\alpha$ -olefins by a tetra n-alkyldiborane.<sup>212</sup> However, the triethylamine complex of tetra n-propyl-diborane reacts much more slowly with olefins than does tetra n-propyl-diborane itself. The equilibrium:

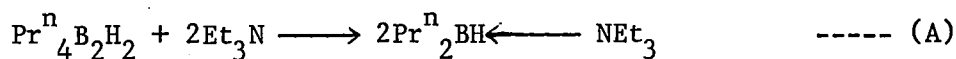

lies largely to the right at room temperature. Tetrahydrofuran (THF) incompletely breaks the  $\text{BH}_2\text{B}$  bridge and ether not at all. It is claimed

that THF takes part as follows:

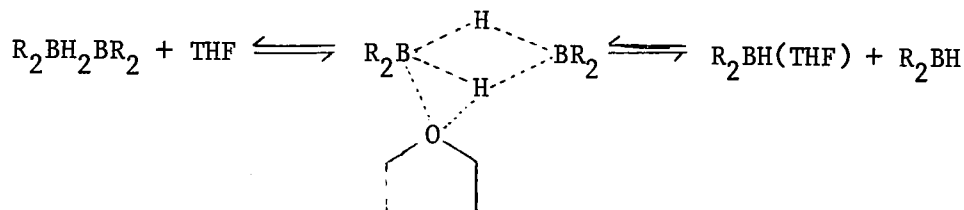

and if olefin is present this reacts with  $R_2BH$ . Hydroboration in the absence of donor solvents must take a different course, the equilibrium:

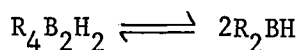

being set up spontaneously.<sup>212</sup>

Terminal BH bonds are therefore presumed to be the active species in hydroboration reactions. The retarding effect of a tertiary amine must depend on the equilibrium (A) lying well to the right whereas in ethereal solvents some uncomplexed BH must exist in close proximity to olefin molecules.

The presence of a tertiary amine affects the reactions of acetylenes with a dialkylaluminium hydride,<sup>215</sup> viz.,

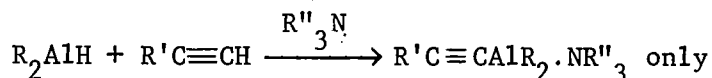
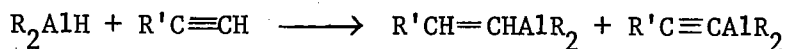

No information is available on the reactions of dialkylaluminium hydrides with olefins in the presence of tertiary amines. The crux of

the problem is whether or not the dialkylaluminum hydride retains its trimeric structure in the presence of the tertiary amine.

The rates of reactions of tertiary amine complexes of organoberyllium hydrides with olefins are then of some considerable importance as the  $\text{BeH}_2\text{Be}$  bridge remains intact in the presence of tertiary amines.<sup>124</sup> Trimethylamine ethylberyllium hydride reacts with ethylene quantitatively when heated to  $84^\circ$  for 8 hr. with excess ethylene.<sup>60</sup> No data is available concerning the rates of such reactions.

The increase in reactivity of isobutylberyllium hydride [over that of ethylberyllium hydride (and some ether)] with pent-1-ene is significant. The nature of the BeH bonding is the most likely factor causing this increase in rate, suggesting that some form of beryllium hydrogen bonding other than the  $\text{BeH}_2\text{Be}$  bridge is present in isobutylberyllium hydride. The other possible types of beryllium hydrogen bonding have been discussed earlier.

Further work on reactions of isobutylberyllium hydride, and ether and amine complexes of it, with olefins are in progress.

TABLES

In the following tables degrees of association refer to cryoscopic measurements in benzene solution except where stated otherwise. Concentrations are expressed as wt.% solutions, i.e. weight of compound per 100 g. of solvent.

TABLE 1

Aminoberyllium alkyls:  $R_2Be + R'_2NH \longrightarrow (RBeNR'_2)_n$

<u>Compound</u>	<u>State</u> <u>(at 25°)</u>	<u>n</u>	<u>Concentration</u>	<u>Ref.</u>
MeBeNMe <sub>2</sub>	glass	3	0.37, 0.75	59
EtBeNMe <sub>2</sub>	liquid	3	0.37, 0.75	19
Pr <sup>i</sup> BeNMe <sub>2</sub>	liquid	3	0.76, 1.07	19
PhBeNMe <sub>2</sub>	solid	3	0.74, 1.49	38
MeBeNEt <sub>2</sub>	liquid	3	0.51, 1.02	19
EtBeNEt <sub>2</sub>	liquid	2	0.49, 0.98	19
MeBeNPh <sub>2</sub>	solid	2	1.37, 2.06, 4.12	19
EtBeNPh <sub>2</sub>	solid	2	0.76, 1.53	19
MeBeNPr <sup>n</sup> <sub>2</sub>	liquid	2	0.97, 1.08	19
MeBeN(Ph)CH <sub>2</sub> Ph <sup>*</sup>	liquid	2	0.99, 1.48	60
PhBeNPh <sub>2</sub>	solid	2	0.85, 1.69	38

\* prepared from methylberyllium hydride and benzylideneanil.

TABLE 2Pyridine and 2,2'-bipyridyl adducts of aminoberyllium alkyls.<sup>19</sup>

<u>Compound</u>	<u>Colour</u>	<u>Degree of Association</u>	<u>Concentration</u>
Me(py)BeNMe <sub>2</sub>	colourless	2	0.30, 0.61
Me(py) <sub>2</sub> BeNMe <sub>2</sub>	cream	1	0.71, 0.76
Me(py)BeNPh <sub>2</sub>	yellow		
Me(py) <sub>2</sub> BeNPh <sub>2</sub>	deep yellow	1	0.58
Et(py) <sub>2</sub> BeNPh <sub>2</sub>	golden yellow	1	0.52, 1.04
Me(bipy)BeNPh <sub>2</sub>	brick red		
Et(bipy)BeNPh <sub>2</sub>	brick red	1	0.35, 0.69

TABLE 3

Organoberyllium alkoxides,  $(RBeOR')_n$

<u>Compound</u>	<u>m.p.</u>	<u>n</u>	<u>Concentration</u>	<u>Ref.</u>
MeBeOMe	24°	4	0.49, 0.99	20
MeBeOEt	29°	4	0.31, 0.47, 0.94	20
MeBeOPr <sup>n</sup>	39°	4	0.64, 1.28	20
MeBeOPr <sup>i</sup>	135°	4	0.30, 0.60	20
MeBeOBu <sup>t</sup>	93°	4	0.43, 0.86	20
MeBeOCH <sub>2</sub> Ph	liquid	4	0.78, 1.28	60
MeBeOCHPh <sub>2</sub>	97-108°	2	0.87, 1.73	20
MeBeOCPh <sub>3</sub>	183°	2	0.54, 1.08	20
EtBeOCe <sub>t</sub> <sub>3</sub>	< 10°	3	0.45, 0.90	20
Pr <sup>i</sup> BeOMe	134°	4	0.49, 0.97	20
Bu <sup>t</sup> BeOMe	199°	4	0.35, 0.70	20
Bu <sup>t</sup> BeOBu <sup>t</sup>	108° dec.	2	0.49, 0.98, 1.36	20
PhBeOMe	54°	4	0.93, 1.85	38
MeBeOC <sub>2</sub> H <sub>4</sub> OMe	103°	4	0.42, 0.85	66
EtBeOC <sub>2</sub> H <sub>4</sub> OMe	79°	4	1.25, 1.66	66
MeBeOC <sub>2</sub> H <sub>4</sub> NMe <sub>2</sub>	210° dec.	~ 7	1.33, 1.57, 2.00	66

TABLE 4

Co-ordination complexes of alkylberyllium alkoxides

<u>Compound</u>	<u>Degree of Association</u>	<u>Concentration</u>	<u>Ref.</u>
MeBeOCHPh <sub>2</sub> .OEt <sub>2</sub>	1	0.38, 0.86	60
MeBeOCHPh <sub>2</sub> .THF	1	0.40, 0.57	60
MeBeOCPh <sub>3</sub> .OEt <sub>2</sub>	1	1.15, 1.50	20
PhBeOMe.OEt <sub>2</sub>	1	1.27	20
MeBeOPh.OEt <sub>2</sub>	1.21, 1.41	0.59, 1.19	20
Me(MeO)Be.py <sub>2</sub>	1	0.61, 1.21	20
Me(Bu <sup>t</sup> O)Be.py	1.23, 1.41	0.35, 0.70	20

TABLE 5

Beryllium alkoxides, [Be(OR)<sub>2</sub>]<sub>n</sub>

<u>Compound</u>	<u>n</u>	<u>Concentration</u>	<u>Ref.</u>
Be(OC <sub>6</sub> H <sub>4</sub> X) <sub>2</sub> (X = H, OH, Cl, Me, NO <sub>2</sub> )	polymeric		67
Be(OBu <sup>t</sup> ) <sub>2</sub>	3	0.53, 1.06	20
Be(OMe) <sub>2</sub>	polymeric		20
Be(OCEt <sub>3</sub> ) <sub>2</sub>	2	0.36, 0.72	20
Be(OC <sub>2</sub> H <sub>4</sub> OMe) <sub>2</sub>	polymeric		68
Be(OC <sub>2</sub> H <sub>4</sub> NMe <sub>2</sub> ) <sub>2</sub>	8-11	0.99, 1.32, 1.97	68

TABLE 6

Alkylthioberyllium alkyls and some complexes<sup>69</sup>

<u>Compound</u>	<u>Colour</u>	<u>Degree of Association</u>	<u>Concn.</u>
MeBeSBu <sup>t</sup>		4	0.37, 0.74
MeBeSPh		2	0.43, 0.86
EtBeSEt		4	0.94, 1.42
EtBeSPr <sup>i</sup>		4	0.86, 1.30
EtBeSBu <sup>t</sup>		4	0.43, 0.86
(EtS) <sub>2</sub> Be		polymeric	
(Bu <sup>t</sup> S) <sub>2</sub> Be		polymeric	
Pr <sup>i</sup> BeSEt.OEt <sub>2</sub>		2	0.88, 1.76
Pr <sup>i</sup> BeSPr <sup>i</sup> .py <sub>2</sub>		1	0.97, 1.93
EtBeSBu <sup>t</sup> .THF		1	0.67, 1.00
EtBeSBu <sup>t</sup> .py	white	2	0.65, 1.30
EtBeSBu <sup>t</sup> .py <sub>2</sub>	lemon	1	0.64, 1.28
EtBeSBu <sup>t</sup> .bipy	orange-red		
Pr <sup>i</sup> BeSEt.py	yellow	2	0.86, 1.72
(Bu <sup>t</sup> S) <sub>2</sub> Be.py	cream	0.59, 0.64	0.24, 0.42
(Bu <sup>t</sup> S) <sub>2</sub> Be.bipy	ochre		

TABLE 7

Aminozinc alkyls,  $(RZnNR'_2)_n$

<u>Compound</u>	<u>State</u> <u>(at 25°)</u>	<u>n</u>	<u>concn.</u>	<u>Ref.</u>
MeZnNPh <sub>2</sub>	solid	2	0.74, 1.48	73
EtZnNPh <sub>2</sub>	solid	2	1.5, 1.79	73
Pr <sup>i</sup> ZnNPh <sub>2</sub>	solid	2	-	74
Bu <sup>n</sup> ZnNPh <sub>2</sub>	solid	2	-	74
PhZnNPh <sub>2</sub>	solid	2	-	74
EtZnNEt <sub>2</sub>	liquid	2	-	74
MeZn(NMe)C <sub>2</sub> H <sub>4</sub> NMe <sub>2</sub>	solid	2	1.26, 1.58, 1.66	73
MeZnNPh <sub>2</sub> ·py <sub>2</sub>	solid	1	1.22, 2.43	73

TABLE 8

Alkoxyzinc alkyls, (RZnOR')<sub>n</sub>

<u>Compound</u>	<u>State</u>	<u>n</u>	<u>Concn.</u>	<u>Ref.</u>
MeZnOMe	solid	4	1.12, 1.69	73
MeZnOBu <sup>t</sup>	solid	4	1.71, 2.43	73
EtZnOBu <sup>t</sup>	solid	4	1.43, 2.86	73
EtZnOPr <sup>i</sup>	solid	4	1.51, 2.26	79
MeZnOPh	solid	4	1.77, 3.05	73
EtZnOCHPh <sub>2</sub>	solid	3	2.15, 3.08	82
PhZnOCPh <sub>3</sub>	solid	2	2.98, 4.18	82
MeZnOC <sub>2</sub> H <sub>4</sub> NMe <sub>2</sub>	solid	3	1.14, 1.60	82
EtZnOC <sub>2</sub> H <sub>4</sub> NMe <sub>2</sub>	solid	3	1.98, 2.24	82
MeZnOC <sub>2</sub> H <sub>4</sub> OCH <sub>3</sub>	liquid	4	1.83, 2.29	82

TABLE 9

Aminomagnesium alkyls,  $(RMgNR'_2)_n$ .<sup>22</sup>

<u>Compound</u>	<u>State</u>	<u>n</u>	<u>Concn.</u>
$(EtMgNEt_2)_2 \cdot THF$	viscous liquid	1.09, 1.33	1.56, 1.71
$(EtMgNPr^i_2)_2 \cdot THF$	viscous liquid	1.11, 1.24	1.50, 2.00
$EtMgNPh_2$	solid	polymeric	-
$EtMgNPh_2(THF)_2$	solid	1	1.60, 1.83
$Pr^iMgNPh_2(OEt_2)_2$	solid	-	-
$Pr^iMgNPh_2$	solid	polymeric	-
$Pr^iMgNPr^i_2$	solid	2	1.02, 1.43
2,2,6,6, tetramethyl- piperidino(ethyl)magnesium	solid	2	0.98, 1.30
$EtMgN(Ph)PhCHEt$	solid	2	1.53, 2.17
$EtMgN:CPhEt$	solid	13, 21	1.1, 4.3

TABLE 10

Alkoxy­magnesium alkyls, (RMgOR')<sub>n</sub>

<u>Compound</u>	<u>n</u>	<u>Concn.</u>	<u>n</u> <sup>*</sup>	<u>Ref.</u>
MeMgOBu <sup>t</sup>	-	-	4	47
EtMgOEt	-	-	3,4 <sup>a</sup>	88, 92, 47 <sup>a</sup>
EtMgOPr <sup>n</sup>	7,7·2	2·80, 3·30	-	47
EtMgOPr <sup>i</sup>	4	1·73, 2·05	-	47
EtMgOBu <sup>t</sup>	4	1·84, 2·25	4	47
Pr <sup>i</sup> MgOMe	7·0, 7·4	1·25, 1·40	-	47
	8·5	4·06		
Pr <sup>i</sup> MgOEt	7·5, 8·1	1·31, 1·70	-	47
Pr <sup>i</sup> MgOPr <sup>i</sup>	4	2·0, 3·1	-	47
EtMgOCEt <sub>3</sub>	insoluble	-	2	47
EtMgOCEt <sub>3</sub> ·THF	2	1·0, 1·5	-	47
Bu <sup>n</sup> MgOPr <sup>i</sup>	3		-	90, 91
EtMgOCMeEt <sub>2</sub>	-	-	2	47
MeMgOC <sub>2</sub> H <sub>4</sub> NMe <sub>2</sub>	4	0·97	-	

\*  
n determined ebullioscopically in diethylether, concns. 0·008-0·05M  
(calc. as monomer).

TABLE 11

Thiomagnesium alkyls<sup>93</sup>

<u>Compound</u>	<u>Degree of Association</u>	<u>Concn.</u>
MeMgSBu <sup>t</sup> .THF	2	0.85, 1.13 1.69
EtMgSBu <sup>t</sup> .THF	2	0.68, 1.36
Bu <sup>t</sup> MgSPr <sup>i</sup> .OEt <sub>2</sub>	2	0.73, 1.12 1.67
EtMgSBu <sup>t</sup>	4	0.17, 0.25
MeMgSC <sub>2</sub> H <sub>4</sub> NMe <sub>2</sub>	4	1.12, 1.84
Bu <sup>t</sup> MgSC <sub>2</sub> H <sub>4</sub> NMe <sub>2</sub>	2	2.40, 2.59
Mg(SBu <sup>t</sup> ) <sub>2</sub>	polymeric	-

TABLE 12

Alkylcadmium alkoxides and alkylsulphides

<u>Compound</u>	<u>Degree of Association</u>	<u>Concn.</u>
MeCdOMe	4 <sup>*</sup>	-
MeCdOEt	4.3	1.67, 1.95 2.33
MeCdOPr <sup>i</sup>	4	1.27, 1.57 1.83
MeCdOBu <sup>t</sup>	2	0.74, 1.08 1.74, 1.95
MeCdOPh	3.6-4	1.66, 1.93 2.31
Me(py)CdOPh	1.40-1.52	2.15, 4.13
MeCdSMe	polymeric	-
MeCdSPr <sup>i</sup>	6	3.75, 4.33 5.11, 6.24
MeCdSBu <sup>t</sup>	4	2.23, 2.63 2.92
MeCdSPh	polymeric	-

\* insoluble in benzene, but isomorphous by X-ray diffraction with methylzinc methoxide.

TABLE 13

Complexes of organoberyllium hydrides,  $(RBeH.L)_2$

<u>R</u>	<u>L</u>	<u>State at</u> <u>25°</u>	<u>Prep.</u> <u>Method</u>	(BeH <sub>2</sub> Be)	<u>line width</u> <u>at half-</u> <u>height</u>
Me	OEt <sub>2</sub>	liquid	c	8.42	6 c/sec.
	NMe <sub>3</sub>	solid	a,d	-	
	py	solid	c	6.72	36 c/sec.
Et	NMe <sub>3</sub>	solid	a,b	8.41	6 c/sec.
Ph	NMe <sub>3</sub>	solid	b	-	
	PMe <sub>3</sub>	solid	b	-	

a addition of ligand to " $R_4Be_3H_2$ "<sup>124</sup>

b RBeCl and NaBEt<sub>3</sub>H.<sup>129</sup>

c  $R_2Be + BeBr_2 + 2LiH$ .<sup>60</sup>

d  $R_2Be + Et_3SnH$ .<sup>129</sup>

- not observed in spectrum.

TABLE 14

Addition of ethylberyllium hydrides to olefins <sup>a 60</sup>

<u>Olefin</u>	<u>Temp.</u>	<u>Half-life (hr.)</u>	<u>Time for completion of reaction (hr.)</u>
dec-1-ene	84 <sup>o</sup>	-	< 0.17
pent-1-ene	50 <sup>o</sup>	0.4	4.2 <sup>b</sup>
pent-2-ene <sup>c</sup>	50 <sup>o</sup>	90	- <sup>d</sup>
pent-1-ene	33.5 <sup>o</sup>	4.85	45-50
pent-1-ene <sup>e</sup>	33.5 <sup>o</sup>	1.4	15-20

a in the presence of ether and benzene

b bromination gave 95% 1-bromopentane and 5% 2-bromopentane.

c 95% cis isomer.

d after 250 hr. at 84<sup>o</sup> bromination gave 82% of 1-bromopentane, 12% of 2-bromopentane, and 6% of 3-bromopentane.

e BeH:olefin = 2:1, the others being 1:1

TABLE 15

Exchange reactions producing alkali metal beryllium hydrides 138

Reactants	Solvent	Ratio			Wt.% of ppt. accounted for
		Na	Be	H : Et	
(Bu <sup>t</sup> O) <sub>2</sub> Be + 2NaEt <sub>3</sub> AlH	C <sub>7</sub> H <sub>8</sub>	1.66	1	2.94 : 0.085	92
+ 3NaEt <sub>3</sub> AlH	C <sub>7</sub> H <sub>8</sub>	1.61	1	3.09 : 0.14	86
+ 4NaEt <sub>3</sub> AlH	C <sub>7</sub> H <sub>8</sub>	1.54	1	2.98 : 0.19	85 <sup>c</sup>
(EtBeH) + NaEt <sub>3</sub> AlH	C <sub>7</sub> H <sub>8</sub> /Et <sub>2</sub> O	1.39	1	3.13 : 0.17	63
+ NaEt <sub>3</sub> AlH	C <sub>7</sub> H <sub>8</sub> <sup>a</sup>	1.25	1	1.8 : 0.14	36
Et <sub>2</sub> Be + 4LiEt <sub>3</sub> AlH	Et <sub>2</sub> O	1.75 <sup>b</sup>	1	2.9 : 0.21	76 <sup>c</sup>
+ 4NaEt <sub>3</sub> AlH	C <sub>6</sub> H <sub>6</sub> /Et <sub>2</sub> O	1.55	1	3.64 : 0.066	85
+ 3NaEt <sub>3</sub> AlH	Et <sub>2</sub> O	1.37	1	2.86 : 0.08	61

a - trace of ether present

b - Li

c - low yield experiment

TABLE 16

The vibrational spectrum of dimethylberyllium.<sup>165</sup>

<u>Infrared</u>	<u>Raman</u>	<u>Assignment</u>
2912 cm <sup>-1</sup>	2912 cm <sup>-1</sup>	$\nu_s(\text{CH}_3)$
2885		$\nu_{as}(\text{CH}_3)$
1255 } 1243 }		$\delta(\text{CH}_3)$
835	923 }	$\rho(\text{CH}_3)$
567 535	510 455 }	$\nu(\text{Be}_2\text{C})$
403	412	$\delta(\text{Be}_2\text{C})$

TABLE 17

Vibrational assignments for  $\text{Me}_2\text{Zn}$ ,  $^{14}\text{Me}_2\text{Cd}$ ,  $^{16}\text{Me}_2\text{Hg}$ . <sup>14</sup>

<u>Assignment</u>		<u>Me<sub>2</sub>Zn</u>		<u>Me<sub>2</sub>Cd</u>		<u>Me<sub>2</sub>Hg</u>	
		<u>IR</u>	<u>R</u>	<u>IR</u>	<u>R</u>	<u>IR</u>	<u>R</u>
$\nu(\text{C-H})$	$\nu_1$		2898		2904		2910
$\text{CH}_3$ bend	$\nu_2$		1158		1129		1182
$\nu(\text{C-M-C})$	$\nu_3$		504		465		515
Torsion	$\nu_4$						
$\nu(\text{C-H})$	$\nu_5$	2870		2920		2880	
$\delta(\text{CH}_3)$	$\nu_6$	1185		1140		1205	
$\nu(\text{C-M-C})$	$\nu_7$	615		538		550	
$\nu(\text{C-H})$	$\nu_8$	2940		2895	2876	2966	
$\delta(\text{CH}_3)$	$\nu_9$	1444		1441	1448	1475	
$\rho(\text{C-M-C})$	$\nu_{10}$			705		787	
$(\text{C-M-C})$ bend	$\nu_{11}$		144		150		156
$\nu(\text{C-H})$	$\nu_{12}$		2833		2963		2869
$\delta(\text{CH}_3)$	$\nu_{13}$		1388		1384		1443
$\rho(\text{CH}_3)$	$\nu_{14}$		620		642		700

TABLE 18

Infrared absorptions due to the BeH<sub>2</sub>Be bridge.<sup>124,170</sup>

<u>Compound</u>	<u><math>\nu(\text{BeH}_2\text{Be})</math></u>	<u><math>\nu(\text{BeD}_2\text{Be})</math></u>	<u><math>\nu_{\text{H}}/\nu_{\text{D}}</math></u>
(MeBeH.NMe <sub>3</sub> ) <sub>2</sub> <sup>a</sup>	1344 cm <sup>-1</sup>	1016 cm <sup>-1</sup>	1.32
(EtBeH.NMe <sub>3</sub> ) <sub>2</sub> <sup>a</sup>	1333		
(MeBeH.NMe <sub>2</sub> CH <sub>2</sub> <sup>-</sup> ) <sub>n</sub> <sup>b</sup>	1331		
Na <sub>2</sub> (Me <sub>4</sub> Be <sub>2</sub> H <sub>2</sub> ) <sup>b</sup>	1325, 1165	920, 870	1.44, 1.33
Na <sub>2</sub> [(CD <sub>3</sub> ) <sub>4</sub> Be <sub>2</sub> H <sub>2</sub> ] <sup>b</sup>	1333, 1164		
Na <sub>2</sub> [Et <sub>4</sub> Be <sub>2</sub> H <sub>2</sub> ] <sup>b</sup>	1294, 1065	951, 835	1.36, 1.28

a - cyclohexane solution

b - Nujol mull

TABLE 19

(a) Observed vibrational spectrum of  $\text{Be}[\text{C}(\text{CH}_3)_3]_2$ 

I.r.

Raman liquid		Gas		Liquid		Assignment
$\text{cm}^{-1}$	I	$\text{cm}^{-1}$	I	$\text{cm}^{-1}$	I	
2936	sh	3160	w	3279	w	2916 + 367 ~2890 + 262
2914	s	2933	vs	3145	w	
2890	sh	2890	sh	2916	s	C-H stretching fundamentals
2872	sh	2849	s	2868	m	
2838	vs	2813	sh	2834	s	1444 + 1373
2765	m	2778	w, sh	2762	w	~1390 + ~1370
2703	m	2721	mw	2729	w	~1465 + ~1260
		2635	vw	2701	w	~1445 + ~1260
		1801	vw	2618	w	~1370 + ~1260
		1480	sh	1792	w	1445 + 354
		1474	s			CH <sub>3</sub> antisymmetric deformations
1464	m			1466	s	
1444	m			1445	m, sh	~1200 + 212 (A <sub>2u</sub> )
1393	vw	1396	sh	1422	vw, sh	
		1373	m	1387	w	CH <sub>3</sub> symmetric deformations
		1338	vw	1362	m	
		1305	w	1299	w, sh	~980 + 367 (A <sub>2u</sub> , E <sub>u</sub> ) or 1201 + 132 (E <sub>u</sub> )
		1266	s	1259	s	~940 + 367 (A <sub>2u</sub> , E <sub>u</sub> ) ν <sub>11</sub> (e <sub>u</sub> )

TABLE 19 (contd.)

I.R.

Raman Liquid		Gas		Liquid		Assignment
cm <sup>-1</sup>	I pol.	cm <sup>-1</sup>	I	cm <sup>-1</sup>	I	
1201	s p			~1200	w	$\nu_1(a_{1g})$
1169	m dp	1168	w	1168	w, sh	$\nu_5(a_{2u})$
996	mw dp	1003	w, sh	995	ms	$\nu_8(e_g)$
		980	s	973	s, sh	545 + 450 ( $A_{2u}$ )
		943	sh	961	s	CH <sub>3</sub> rock ( $e_g$ )
935	m dp			935	ms	CH <sub>3</sub> rock ( $e_u$ )
		891	mw, Q	907	w, sh	CH <sub>3</sub> rock ( $e_u$ )
810	m dp	873	mw, br, P	863	w	543 + 354 ( $A_{2u}$ )
545	s p	763	w	760	vw	CH <sub>3</sub> rock ( $a_{2u}$ )
448	vw	458	vs	475	m, br, sh	CH <sub>3</sub> rock ( $a_{1g}$ )
367	m dp			449	vs	OC or impurity?
262	w, br dp?			354	m	$\nu_2(a_{1g})$
212	m p					$\nu_{12}(e_u)$
132	mw dp					$\nu_6(a_{2u})$
						$\nu_9(e_g)$
						$\nu_7(a_{2u})$
						$\nu_{10}(e_u)$
						$\nu_3(a_{1g})$
						$\nu_{14}(e_u)$

TABLE 19 (contd.)

(b) Observed infrared spectrum of  $\text{Be}[\text{C}(\text{CD}_3)_3]_2$

I.r. (Gas-phase) cm <sup>-1</sup>	I	Assignment	Analogous frequency of $\text{Be}[\text{C}(\text{CH}_3)_3]_2$
2908	wR	$(\text{CD}_3)_3\text{CH}$ impurity	
2894	wQ		
2880	wP		
2225	m, sh	C-D stretching	2830-2940
2213	s, sh		
2202	vs		
2176	vs		
2102	m		
2057	vs		
2025	m, sh		
1398	vw, br	OC	
1319	w	OC	
1253	m	OC	
1219	s	$\nu_{11}(e_u)$	1266
1166	w	$\nu_5(a_{2u})$	~ 1180
1121	vw	OC	
1083	w, sh	OC	
1069	s, sh	$\text{CD}_3$ antisymm. deform.	1480
1064	s		1474
1018	m	$\text{CD}_3$ symm. deform.	1373
866	s	$\text{CD}_3$ rock ( $e_u$ )	980
806	m	$\text{CD}_3$ rock ( $e_u$ )	943
680	w, br	$\text{CD}_3$ rock ( $a_{2u}$ )	891
490	w, vbr	Impurity?	
459	s, sh	$\nu_{12}(e_u)$	475
450	vs	$\nu_6(a_{2u})$	458

TABLE 20

Observed vibrational spectrum of  $Zn[C(CH_3)_3]_2$

Raman liquid		I.r. liquid		Assignment	Analogous frequency of $Be[C(CH_3)_3]_2$
$cm^{-1}$	I	$cm^{-1}$	I		
		2929	sh	C-H stretching	2916
		2915	s		
		2857	m		
		2817	s		
		2755	mw	OC	2762
		2725	w	OC	2729
		2699	mw	OC	2701
		2629	w	OC	2618
		2339	w	OC	
		1464	s	$CH_3$ antisymm. deform	1466
		1455	sh		1445
		1385	w	$CH_3$ symm. deform.	1387
		1362	m		1362
		1263	mw	$\nu_{11}(e_u)$	1259
		1172	mw	$\nu_5(a_{2u})$	~ 1200
		1096	mw	OC	
		~ 1022	w, br, sh	OC	
		1010	m	$CH_3$ rock ( $e_u$ )	~ 970
		937	w	$CH_3$ rock ( $e_u$ )	935
		813	s	$CH_3$ rock ( $a_{2u}$ )	863
806	s			$CH_3$ rock ( $a_{1g}$ )	810
		~ 794	w, sh	OC	
		~ 552	w	OC	

contd.

TABLE 20 (contd.)

Raman liquid		I.r. liquid		Assignment	Analogous frequency of Be[C(CH <sub>3</sub> ) <sub>3</sub> ] <sub>2</sub>
cm <sup>-1</sup>	I	cm <sup>-1</sup>	I		
505	s			$\nu_2(a_{1g})$	545
		383	mw	$\nu_{12}(e_u)$	475
		308	s	$\nu_6(a_{2u})$	449
		241	s	$\nu_7(a_{2u}), \nu_{13}(e_u)$	354
212	s			$\nu_3(a_{1g})$	212

Abbreviations: w = weak, m = medium, s = strong, sh = shoulder, br = broad, v = very, p = polarised, dp = depolarised, OC = overtone or combination band.

TABLE 21

Activity of skeletal fundamentals for various

$\text{Be}[\text{C}(\text{CH}_3)_3]_2$  models

	Model			observed spectrum
	"Staggered" form	"Eclipsed" form	Bent skelton	
	$D_{3d}$	$D_{3h}$	$C_{2v}$	
Fundamentals	13*	13*	19*	12
Raman-active	6	10	19*	7
Polarised Raman lines	3	3	7	3
I.r.-active	7	7	16*	5
R.-I.r. coin- cidences	0	4	16*	1?

\*These numbers exclude torsional modes.

TABLE 22

Skeletal vibrations of  $M[CMe_3]_2$  (effective point group  $D_{3d}$ )

Type of vibration	Symmetry species					
	$a_{1g}$	$a_{1u}$	$a_{2g}$	$a_{2u}$	$e_g$	$e_u$
$CMe_3$ stretch (antisym.)					$\nu_8$	$\nu_{11}$
$CMe_3$ stretch (sym.)	$\nu_1$			$\nu_5$		
$MC_2$ stretch	$\nu_2$			$\nu_6$		
$CMe_3$ deform. (antisym.)					$\nu_9$	$\nu_{12}$
$CMe_3$ deform (sym.)	$\nu_3$			$\nu_7$		
$CMe_3$ rock					$\nu_{10}$	$\nu_{13}$
$MC_2$ bend						$\nu_{14}$
$(CMe_3$ torsion*)		$(\nu_4^*)$				
Activity	R, pol.				I.r. R, depol.	I.r.

\*Absent for free rotation of the  $CMe_3$  groups.

TABLE 23

Fundamental frequencies of  $M[CC_3]_2$  skeleton of  $Be[C(CH_3)_3]_2$   
and  $Zn[C(CH_3)_3]_2$  <sup>a, b</sup>

Species	Number	$Be[C(CH_3)_3]_2$	$Zn[C(CH_3)_3]_2$
		( $cm^{-1}$ )	( $cm^{-1}$ )
$a_{1g}$	$\nu_1$	1201	(~1200)
	$\nu_2$	545	505
	$\nu_3$	212	212
$a_{2u}$	$\nu_5$	1180	1172
	$\nu_6$	458	308
	$\nu_7$	354	241
$e_g$	$\nu_8$	1169	(~1200)
	$\nu_9$	367	(~350)
	$\nu_{10}$	262	(~250)
$e_u$	$\nu_{11}$	1266	1263
	$\nu_{12}$	475	383
	$\nu_{13}$	(~260)	241
	$\nu_{14}$	132	(~100)

<sup>a</sup> Frequencies in parentheses were not directly observed.

<sup>b</sup> Gas-phase infrared frequencies are used where available.

TABLE 24

M-C Stretching force constants for the dialkyls of  
Group II elements

Bond	Force constant		Ref.
	$k_{\text{M-C}}$ ( $10^5$ dynes $\text{cm}^{-1}$ )	Compound	
Be-C	$\sim 1.2$	$\text{Be}[\text{C}(\text{CH}_3)_3]_2$	122
Zn-C	2.39	$\text{Zn}(\text{CH}_3)_2$	14
Zn-C	$\sim 1.1$	$\text{Zn}[\text{C}(\text{CH}_3)_3]_2$	122
Cd-C	2.05	$\text{Cd}(\text{CH}_3)_2$	16
Hg-C	2.45	$\text{Hg}(\text{CH}_3)_2$	14

## REFERENCES

1. G.T. Balueva and S.T. Ioffe, Russ. Chem. Rev., 1962, 31, 439.
2. K.H. Thiele and P. Zdunneck, Organometal. Chem. Rev., 1966, 1, 331.
3. N.R. Fetter, Organometal. Chem. Rev., 1968, 3, 1.
4. G.E. Coates, M.L.H. Green, and K. Wade, "Organometallic Compounds",  
Vol. I "The Main Group Elements", Methuen, 1967.
5. K.M. Mackay, "Hydrogen Compounds of the Metallic Elements",  
Spon, 1966.
6. B.J. Wakefield, Organometal. Chem. Rev., 1966, 1, 131.
7. E.C. Ashby, Quart. Rev., 1967, 21, 259.
8. N.A. Bell, Ph.D. Thesis, Durham, 1964.
9. D. Ridley, Ph.D. Thesis, Durham, 1965.
10. M. Tranah, Ph.D. Thesis, Durham, 1966.
11. A.I. Snow and R.E. Rundle, Acta Cryst., 1951, 4, 348.
12. E. Weiss, J. Organometal. Chem., 1964, 2, 314.
13. R.P. Bell and H.C. Longuet-Higgins, J. Chem. Soc., 1943, 250.
14. H.S. Gutowsky, J. Chem. Phys., 1949, 17, 128.
15. F. Feher, W. Kolb, and L. Leverenz, Z. Naturforsch., 1947, 2a, 454.
16. H.S. Gutowsky, J. Amer. Chem. Soc., 1949, 71, 3194.
17. R.E. Rundle, "A Survey of Progress in Chemistry", Ed. A.I. Scott,  
Academic Press, 1963, 1, 96.
18. H. Burger, C. Forker, and J. Goubeau, Monatsheft., 1965, 96, 597.

19. G.E. Coates and A.H. Fishwick, J. Chem. Soc.A, 1967, 1199.
20. idem, *ibid.*, 1968, 477.
21. G.D. Stucky and R.E. Rundle, J. Amer. Chem. Soc., 1963, 85, 1002.
22. G.E. Coates and D. Ridley, J. Chem. Soc.A, 1967, 56.
23. G.D. Stucky and R.E. Rundle, J. Amer. Chem. Soc., 1964, 86, 4821.
24. G.E. Coates and J.A. Heslop, J. Chem. Soc.A, 1968, 631.
25. W. Strohmeier, K. Humpfner, K. Miltenberger, and F. Seifert,  
Z. Electrochem., 1959, 63, 537.
26. G.E. Coates and F. Glockling, J. Chem. Soc., 1954, 22.
27. W.H. Glaze, C.M. Selman, and C.H. Freeman, Chem. Comm., 1967, 474.
28. A.H. Fishwick, Ph.D. Thesis, Durham, 1967.
29. G.E. Coates and N.D. Huck, J. Chem. Soc., 1952, 4501.
30. H.C. Brown and N.R. Davidson, J. Amer. Chem. Soc., 1942, 64, 316.
31. G.E. Coates, J. Chem. Soc., 1951, 2003.
32. N.A. Bell and G.E. Coates, Canad. J. Chem., 1966, 44, 744.
33. F.M. Peters, J. Organometal. Chem., 1965, 3, 344.
34. G.E. Coates and F. Glockling, J. Chem. Soc., 1954, 2526.
35. G.E. Coates and S.I.E. Green, *ibid.*, 1962, 3340.
36. G.E. Coates and N.A. Bell, unpublished observations.
37. G.E. Coates and B.R. Francis, unpublished observations.
38. G.E. Coates and M. Tranah, J. Chem. Soc.A, 1967, 236.
39. N.R. Fetter, Canad. J. Chem., 1964, 42, 861.
40. G.E. Coates and A.H. Fishwick, J. Chem. Soc.A, 1968, 635.

41. N.R. Fetter, *ibid.*, 1966, 711.
42. E. Weiss, *J. Organometal. Chem.*, 1965, 4, 101.
43. C.W. Kamienski and J.F. Eastham, *ibid.*, 1967, 8, 542.
44. N.D. Huck, Ph.D. Thesis, Bristol, 1949.
45. L.I. Zakharkin, *J. Gen. Chem. (U.S.S.R.)*, 1964, 34, 3125.
46. G.E. Coates and J.A. Heslop, *J. Chem.Soc.A*, 1966, 26.
47. G.E. Coates, J.A. Heslop, M.E. Redwood, and D. Ridley, *ibid.*, 1968, 1118.
48. H.B. Powell, M.T. Maung, and J.J. Lagowski, *J. Chem. Soc.*, 1963, 2484.
49. E. Ch.Th. Gevers, *Rec. Trav. Chim.*, 1967, 86, 572.
50. J.G. Noltes and J. Boersma, *J. Organometal. Chem.*, 1967, 7, 1.
51. R.W. Taft Jr. in M.S. Newmann, "Steric Effects in Organic Chemistry",  
Wiley, New York, 1956, p.556.
52. R.S. Nyholm, *Proc. Chem. Soc.*, 1961, 273.
53. F.A. Cotton and G. Wilkinson, "Advanced Inorganic Chemistry",  
2nd. Edition, 1966, Ch.27.
54. J.G. Noltes and J.W.G. van den Hurk, *J. Organometal. Chem.*, 1965,  
3, 222.
55. H. Rau and K.H. Thiele, *Z. Anorg. Chem.*, 1967, 353, 127.
56. *idem*, *ibid.*, 1967, 355, 253.
57. O.T. Beachley and G.E. Coates, *J. Chem. Soc.*, 1965, 3241.
58. R.J. Gillespie, *J. Amer. Chem. Soc.*, 1960, 82, 5978.
59. G.E. Coates, F. Glockling, and N.D. Huck, *J. Chem. Soc.*, 1952, 4512.
60. N.A. Bell and G.E. Coates, *ibid. A*, 1966, 1069.

61. N.R. Fetter and F.M. Peters, *Canad. J. Chem.*, 1965, 43, 1844.
62. P. Longi, G. Mazzanti, and F. Bernadini, *Gazzetta*, 1960, 90, 180.
63. J.L. Atwood and G.D. Stucky, *Chem. Comm.*, 1967, 1169.
64. R. Masthoff and C. Vieroth, *Z. Chem.*, 1965, 5, 142.
65. G.E. Coates and R.G. Strafford, unpublished observations.
66. G.E. Coates and A.H. Fishwick, *J. Chem. Soc.A*, 1968, 640.
67. H. Funk and R. Masthoff, *J. Prakt. Chem.*, 1963, 22, 250.
68. N.A. Bell, *J. Chem. Soc.A*, 1966, 542.
69. G.E. Coates and A.H. Fishwick, *ibid.*, 1968, 635.
70. A. Butterow, *Jahresber.*, 1864, 467.
71. E. Frankland, *ibid.*, 1867, 419.
72. J.G. Aston and D.F. Menard, *J. Amer. Chem. Soc.*, 1935, 57, 1920.
73. G.E. Coates and D. Ridley, *J. Chem. Soc.*, 1965, 1870.
74. J.G. Noltes, *Rec. Trav. Chim.*, 1965, 84, 126.
75. H.M.M. Shearer and C.B. Spencer, unpublished observations.
76. M.H. Abraham and J.A. Hill, *Proc. Chem. Soc.*, 1964, 175.
77. *idem*, *J. Organometal. Chem.*, 1967, 7, 23.
78. J.G. Noltes, *Rec. Trav. Chim.*, 1965, 84, 782.
79. R.J. Herold, S.L. Aggarwal, and V. Neff, *Canad. J. Chem.*, 1963, 41,  
1368.
80. H.M.M. Shearer and C.B. Spencer, *Chem. Comm.*, 1966, 194.
81. Y. Matsui, K.Kamiya, M. Nishikawa, and Y. Tomie, *Bull. Chem. Soc.*  
Japan, 1966, 39, 1828.

82. G.E. Coates and D. Ridley, J. Chem. Soc.A, 1966, 1064.
83. F. Schendler, H. Schmidbauer, and U. Kruger, Ang. Chem. (Int. Ed.),  
1965, 4, 876.
84. G. Allen, J.M. Bruce, D.W. Farren, and F.G. Hutchinson, J. Chem. Soc.B,  
1966, 799.
85. J.M. Bruce, B.C. Cutsforth, D.W. Farren, F.G. Hutchinson,  
F.M. Rabagliati, and D.R. Reed, *ibid.*, 1966, 1020.
86. G.W. Adamson and H.M.M. Shearer, unpublished observations.
87. K. Issleib and H. Deylig, Ber., 1964, 97, 946.
88. W.H. Birnkraut, Inorg. Chem., 1963, 2, 1074.
89. E. Wiberg and R. Bauer, Ber., 1952, 85, 593.
90. D. Bryce-Smith and B.J. Wakefield, Proc. Chem. Soc., 1963, 376.
91. D. Bryce-Smith and I.F. <sup>ha</sup>Graham, Chem. Comm., 1966, 559.
92. A.D. Vreugdenhill and C. Blomberg, Rec. Trav. Chim., 1965, 84, 39.
93. G.E. Coates and J.A. Heslop, J. Chem. Soc.A, 1968, 631.
94. H.M.M. Shearer and M. Schneider, unpublished observations.
95. G.E. Coates and A. Lauder, J. Chem. Soc.A, 1966, 264.
96. G. Holam, Tetrahedron Letters, 1966, 1985.
97. W. Strohmeier and F. Gernert, Z. Naturforsch, 1961, 16b, 760.
98. *Idem*, *ibid.*, 1962, 17b, 128.
99. *Idem*, Chem. Ber., 1962, 95, 1420.
100. W. Strohmeier, W. Haecker, and G. Popp, Chem. Ber., 1967, 100, 405.
101. G. Wittig and P. Hornberger, Annalen, 1952, 577, 11.

102. K. Ziegler, Brit. Pat. 775,384; Chem. Abs., 1958, 52, 12893.
103. L.M. Seitz and T.L. Brown, J. Amer. Chem. Soc., 1966, 88, 4140.
104. G. Wittig, F.J. Meyer and G. Lange, Annalen, 1951, 571, 167.
105. R. Waack and M.A. Doran, J. Amer. Chem. Soc., 1963, 85, 2861.
106. H. Gilman and F. Schulze, *ibid.*, 1927, 49, 2904.
107. F. Schulze, Iowa State College J. Science, 1933, 8, 225.
108. L.I. Zakharkin, O.Yu. Okhlobystin, and B.N. Strunin, Izvest. Akad. Nauk., S.S.S.R., 1961, 2254; Chem. Abs., 1962, 57, 13785.
109. R.E. Dessy, J. Amer. Chem. Soc., 1960, 82, 1850.
110. E.C. Ashby, R. Sanders, and J. Carter, Chem. Comm., 1967, 997.
111. E. Frankland, Annalen, 1849, 71, 171.
112. J. Boersma and J.G. Noltes, Tetrahedron Letters, 1966, 1521.
113. P.T. Moseley and H.M.M. Shearer, Chem. Comm., 1966, 876.
114. G.D. Barbaras, C. Dillard, A.E. Finholt, T. Wartik, K.E. Wilzbach, and H.I. Schlesinger, J. Amer. Chem. Soc., 1951, 73, 4585.
115. E.C. Head, C.E. Holley and S.W. Rabideau, *ibid.*, 1957, 79, 3687.
116. L. Banford and G.E. Coates, J. Chem. Soc., 1964, 5591.
117. E. Wiberg and R. Bauer, Z. Naturforsch., 1951, 6b, 171.
118. C.E. Holley and J.F. Lemons, Los Alamos Scientific Laboratory Report LA-1660, 1954.
119. J. Mounier, Compt. Rend., 1967, 265C, 1261.
120. L. Banford and G.E. Coates, J. Chem. Soc.A, 1966, 274.
121. W. Lehmann, C.O. Wilson, and I. Shapiro, J. Chem. Phys., 1961, 34, 783.

122. A.J. Downs, personal communication.
123. G.E. Coates and G.F. Fox, Chem. and Ind., 1962, 269.
124. N.A. Bell and G.E. Coates, J. Chem. Soc., 1965, 692.
125. G. Wittig and P. Hornberger, Annalen, 1952, 577, 11.
126. G.E. Coates and R.E. Pendlebury, unpublished observations.
127. N.A. Bell and G.E. Coates, unpublished observations.
128. G.W. Adamson and H.M.M. Shearer, Chem. Comm., 1965, 240.
129. G.E. Coates and M. Tranah, J. Chem. Soc.A, 1967, 615.
130. Brit. Pat. 921,806, (Montecatini 1963).
131. H.C. Brown in "Organometallic Chemistry", Ed. H.H. Zeiss, Reinhold, New York, 1960, Ch.4.
132. Idem, "Hydroboration", Benjamin, New York, 1962.
133. K. Ziegler, in "Organometallic Chemistry", Ed. H.H. Zeiss, Reinhold, New York, 1960, Ch.5.
134. R. Koster and P. Binger, Adv. in Inorg. and Radiochem. 1965, 7, 263.
135. N.A. Bell and G.E. Coates, J. Chem. Soc.A, 1968, 823.
136. F.M. Peters and N.R. Fetter, J. Organometal. Chem., 1965, 4, 181.
137. N.A. Bell and G.E. Coates, Chem. Comm., 1965, 582.
138. Idem, J. Chem. Soc.A, 1968, 628.
139. L.I. Zakharkin and V.V. Gavrilenko, J. Gen. Chem. U.S.S.R., 1962, 32, 688.
140. P. Jolibois, Compt. Rend., 1912, 155, 353.
141. D.B. Clapp and R.B. Woodward, J. Amer. Chem. Soc., 1938, 60, 1019.

142. E. Wiberg and R. Bauer, Z. Naturforsch, 1950, 5b, 396.
143. W. Freundlich and R. Claudel, Bull. Soc. Chim. France, 1956, 967.
144. T.M. Dymova and N.G. Eliseeva, Russ. J. Inorg. Chem., 1963, 8, 1574.
145. E. Wiberg and R. Strebel, Annalen, 1957, 607, 9.
146. W.E. Becker and E.C. Ashby, Inorg. Chem., 1965, 4, 1816.
147. R. Bauer, Z. Naturforsch., 1961, 16b, 557, 839.
148. Idem, ibid., 1962, 17b, 277.
149. L.I. Zakharkin and I.M. Khorlina, J. Gen. Chem. U.S.S.R., 1962, 32, 2783.
150. W.E. Becker and E.C. Ashby, J. Org. Chem., 1964, 29, 954.
151. F.H. Ellinger, C.E. Holley, B.B. McInteer, D. Pavone, R.M. Potter, B. Stantzky, and W.H. Zachariasen, J. Amer. Chem. Soc., 1955, 77, 2647.
152. W.H. Zachariasen, C.E. Holley, and J.F. Stampfer, Acta Cryst., 1963, 16, 352.
153. N.N. Mal'tseeva and Y.Y. Kharitonov, Russ. J. Inorg. Chem., 1962, 7, 947.
154. H.E. Podall and W.E. Foster, J. Org. Chem., 1958, 23, 1848.
155. R. Bauer, Z. Naturforsch., 1962, 17b, 626.
156. Idem, ibid., 1962, 17b, 201.
157. G.E. Coates and J.A. Heslop, J. Chem. Soc.A, 1968, 514.
158. G. Jander and K.Kraffozyk, Z. Anorg. Chem., 1956, 283, 217.
159. E. Wiberg and W. Henle, Z. Naturforsch., 1951, 6b, 461.

160. H.I. Schlesinger and A.B. Burg, Chem. Rev., 1942, 31, 1.
161. P.T. Moseley and H.M.M. Shearer, unpublished observations.
162. G. Wittig and P. Hornberger, Annalen, 1952, 577, 11.
163. P. Kobetz and W.E. Becker, Inorg. Chem., 1963, 2, 589.
164. J.K. Ruff, J. Amer. Chem. Soc., 1961, 83, 1798.
165. J. Goubeau and K. Walter, Z. Anorg. Chem., 1963, 322, 58.
166. G.E. Coates and N.D. Huck, J. Chem. Soc., 1952, 4496.
167. H.P. Fritz and D. Sellmann, J. Organometal. Chem., 1966, 5, 501.
168. A. Almenningen, O. Bastiansen, and A. Haaland, J. Chem. Phys.,  
1964, 40, 3434.
169. R.M. Salinger and H.S. Mosher, J. Amer. Chem. Soc., 1964, 86, 1782.
170. N.A. Bell, G.E. Coates and J.W. Emsley, J. Chem. Soc.A, 1966, 49.
171. K. Nakamoto, "Infrared Spectra of Inorganic and Co-ordination  
Compounds", Wiley, New York, 1963, p.120.
172. G. Herzberg, "Molecular Spectra and Molecular Structure, Vol.I"  
Van Nostrand, Princeton, 1950, p.508.
173. N.A. Bell, G.E. Coates and J.W. Emsley, J. Chem. Soc.A, 1966, 1360.
174. S.C. Watson and J.F. Eastham, J. Organometal. Chem., 1967, 9, 165.
175. H.M. Randall, D.M. Dennison, N. Ginsberg, and L.R. Weber,  
Phys. Rev., 1937, 52, 160.
176. J.D. Roberts and M.C. Caserio, "Basic Principles of Organic  
Chemistry, Benjamin, New York, 1964, p.183.
177. J.F. Norris and A.W. Olmstead, Organic Syntheses, Coll. Vol.I, p.138.

178. A.R. Pray, *Inorg. Synth.*, 1954, 5, 153.
179. M.H. Abraham, *J. Chem. Soc.*, 1960, 4130.
180. J.G. Noltes and J. Boersma, *J. Organometal. Chem.*, 1967, 9, 1.
181. R.T. Sanderson, "Vacuum Manipulation of Volatile Compounds,"  
Wiley, New York, 1948, p.69.
182. D.B. Chambers, G.E. Coates, F. Glockling and P.D. Roberts,  
unpublished observations.
183. N. Sheppard, *Trans. Faraday Soc.*, 1950, 46, 527.
184. W. Zeil, H. Buchert, H. Heel, and H. Pfortner, *Z. Electrochem.*,  
1960, 64, 769.
185. W. Huttner and W. Zeil, *Spectrochim. Acta.*, 1966, 22, 1007.
186. D.E. Mann, N. Acquista and D.R. Lide, *J. Mol. Spectroscopy*,  
1958, 2, 575.
187. J.C. Evans and G.Y.-S. Lo, *J. Amer. Chem. Soc.*, 1966, 88, 2118.
188. J.C. Evans and H.J. Bernstein, *Canad. J. Chem.*, 1956, 34, 1037.
189. J.K. Wilmshurst and H.J. Bernstein, *ibid.*, 1957, 35, 969.
190. D.R. Lide and D.E. Mann, *J. Chem. Phys.*, 1958, 29, 914.
191. A. Haaland, personal communication.
192. D.R.J. Boyd, H.W. Thompson and R.L. Williams, *Discuss. Faraday Soc.*,  
1950, 9, 154.
193. R.P. Baumann, *J. Chem. Phys.*, 1956, 24, 13.
194. P.R. Bunker, *ibid.*, 1965, 42, 2991.
195. P.L. Goggin and L.A. Woodward, *Trans. Faraday Soc.*, 1960, 56, 1591.

196. J.C. Evans and H.J. Bernstein, *Canad. J. Chem.*, 1956, 34, 1127.
197. D.W. Scott, D.R. Douslin, M.E. Gross, G.D. Oliver and H.M. Huffmann, *J. Amer. Chem. Soc.*, 1952, 74, 883.
198. F.F. Cleveland, J.E. Lampton and R.W. Mitchell, *J. Chem. Phys.*, 1950, 18, 1320.
199. M. Weiner, G. Vogel and R. West, *Inorg. Chem.*, 1962, 1, 654.
200. N. Sheppard and D.M. Simpson, *Quart. Rev.*, 1953, 7, 33.
201. E.L. Amma and R.E. Rundle, *J. Amer. Chem. Soc.*, 1958, 80, 4141.
202. J.R. Hall, L.A. Woodward and E.A.V. Ebsworth, *Spectrochim. Acta*, 1964, 20, 1249.
203. L. Lardicci, L. Lucarini, P. Palagi, and P. Pino, *J. Organometal. Chem.*, 1965, 4, 341.
204. K.C. Ramey, J.F. O'Brien, I. Hasegawa, and A.E. Borchert, *J. Phys. Chem.*, 1965, 69, 3418.
205. O. Yamamoto, *Bull. Soc. Chim. Japan*, 1964, 37, 1125.
206. G.L. Morgan and G.B. McVicker, *J. Amer. Chem. Soc.*, in press.
207. E. Krause and P. Noble, *Ber.*, 1931, 64, 2112.
208. H.C. Brown, *J. Amer. Chem. Soc.*, 1945, 67, 374.
209. D.T. Hurd, *ibid.*, 1948, 70, 2053.
210. G.F. Hennion, P.A. McCusker, E.C. Ashby and A.J. Rutkowski, *ibid.*, 1957, 79, 5190.
211. J.G. Noltes and J. Boersma, *J. Organometal. Chem.*, 1968, 12, 425.
212. R. Koster, G. Griasnow, W. Larbig and P. Binger, *Annalen*, 1964, 672, 1.

213. K. Ziegler, H.G. Gellert, H. Martin, K. Nagel and J. Schneider,  
Annalen, 1954, 589, 91.
214. G. Bruno, personal communication to G.E. Coates.
215. P. Binger, Angew. Chem., 1963, 75, 918.
216. A. Almenningen, G. Gundersen, and A. Haaland, Chem. Comm.,  
1967, 557.

