

Durham E-Theses

Azomethine derivatives of some main group elements

B.K. Wyatt

How to cite:

Wyatt, B.K. (1968) Azomethine derivatives of some main group elements. Doctoral thesis, Durham University.

Use policy

The full-text may be used and/or reproduced, and given to third parties in any format or medium, without prior permission or charge, for personal research or study, educational, or not-for-profit purposes provided that:

- a full bibliographic reference is made to the original source
- a <https://etheses.durham.ac.uk/id/eprint/8710/> is made to the metadata record in Durham E-Theses
- the full-text is not changed in any way

The full-text must not be sold in any format or medium without the formal permission of the copyright holders.

Please consult the [full Durham E-Theses policy](#) for further details.

AZOMETHINE DERIVATIVES OF SOME
MAIN GROUP ELEMENTS.

by

B.K. WYATT, B.Sc.

A thesis submitted for the degree of Doctor of Philosophy

University of Durham

July 1968.



CONTENTS

Acknowledgements.	(i)
Memorandum.	(ii)
Summary.	(iii)

INTRODUCTION.

	Page
1. Introduction.	1
2. General Aspects.	1
3. Co-ordination Complexes.	4
4. Reactions of Aluminium Compounds with Protonic Acids.	15
5. Insertion of Unsaturated Compounds into Organoaluminium Compounds.	26

EXPERIMENTAL METHODS AND APPARATUS.

General Techniques.	37
Nitrogen Supply.	38
Glove Box.	38
Vacuum System.	39
Spectra.	41
Analytical Methods.	42
Molecular Weights	45

	Page
Solvents.	45
Preparation and Purification of Starting Materials.	45
 <u>EXPERIMENTAL RESULTS.</u>	
 <u>Reactions of Diphenylketimine with Organoderivatives of Aluminium and Gallium.</u>	
Reaction of diphenylketimine with:	
trimethylaluminium	52
triethylaluminium	53
triphenylaluminium	55
triphenylgallium	56
triphenylaluminium (3:1 molar proportions)	57
 <u>Reactions of Tetramethylguanidine with Trimethylaluminium.</u>	 58
 <u>Reactions of Dimethylcyanamide with Aluminium Alkyls.</u>	
Reaction of dimethylcyanamide with:	
trimethylaluminium	60
dimethylaluminium hydride	62
triethylaluminium	63
diethylaluminium hydride	65

	Page
<u>Reactions of Alkyl Cyanides with Organolithium Compounds.</u>	
Reaction of methyl cyanide with methyl-lithium	65
Reaction of ethyl cyanide with methyl-lithium	66
Reaction of methyl cyanide with ethyl-lithium	67
Reaction of ethyl cyanide with ethyl-lithium	67
<u>Reaction of Acetonitrile with Trimethylamine-dichloroalane.</u>	
	67
<u>Reactions of N-lithioketimines with metal halides.</u>	
Reaction of diphenylketiminolithium with:	
aluminium chloride	68
aluminium bromide	70
beryllium chloride	71
Reaction of di-p-tolyketiminolithium with	
beryllium chloride.	71
<u>Reactions of N-trimethylsilyldiphenylketimine with metal halides.</u>	
Reaction of N-trimethylsilyldiphenylketimine with:	
aluminium chloride	72
beryllium chloride	72

	Page
<u>Reaction of Dichloro-(α-phenylbenzylidenamino)aluminium dimer with Pyridine.</u>	73
 <u>DISCUSSION.</u>	
Introduction	74
Reactions of diphenylketimine with organoaluminium and -gallium compounds.	78
Reactions of diphenylketiminolithium with aluminium halides.	98
Reactions of azomethine derivatives of lithium with beryllium chloride.	105
Reactions of N-trimethylsilylketimines with aluminium and beryllium chlorides.	115
Reactions of organolithium compounds with nitriles.	116
Reactions of N,N-dimethylcyanamide and N,N,N',N'-tetramethylguanidine with organoaluminium compounds.	120
 <u>REFERENCES.</u>	 136

ACKNOWLEDGEMENTS.

The author wishes to express his gratitude to Dr. K. Wade, under whose direction this work was carried out, for his encouragement and helpful advice, and also to Mrs. D. Wyatt for assistance with proof-reading.

The author is indebted to the Research Corporation of New York for a maintenance grant.

MEMORANDUM

The work described in this thesis was carried out in the University of Durham between October 1965 and July 1968. It has not been submitted for any other degree and is the original work of the author except where acknowledged by reference.

Some of the work described in this thesis has been the subject of the following publications:

Azomethine Derivatives. Part II. Reactions between Diphenylketimine and Trimethylaluminium, Triethylaluminium and Triphenylaluminium. By K. Wade and B.K. Wyatt. J. Chem. Soc., (A), 1339, (1967).

Azomethine Derivatives. Part III. Reactions between Diphenylketimine and Trimethylgallium, Triethylgallium and Triphenylgallium. By J.R. Jennings, I. Pattison, K. Wade and B.K. Wyatt. J. Chem. Soc., (A), 1608, (1967).

Azomethine Derivatives. Part V. Reactions between Organolithium Compounds and Diphenylketimine, Some Cyanides, and N,N,N',N'-Tetramethylguanidine. By I. Pattison, K. Wade and B.K. Wyatt. J. Chem. Soc., (A), 838, (1968).

SUMMARY

This thesis describes the preparation of some azomethine derivatives of aluminium, gallium and beryllium, together with attempts to prepare related derivatives of lithium, and discusses the structural implications of their infrared, proton magnetic resonance and mass spectra. As a background to this work, some aspects of the co-ordination chemistry and reactions of organoaluminium compounds are outlined in an introductory chapter.

Diphenylketimine reacts with trimethyl-, triethyl- and triphenylaluminium, and triphenylgallium, forming 1:1 adducts, $\text{Ph}_2\text{C:NH.MR}_3$, which eliminate hydrocarbon RH, on heating, forming diphenylketimino derivatives $(\text{Ph}_2\text{C:NMR}_2)_2$. N,N,N',N'-tetramethylguanidine with trimethylaluminium gives a similar adduct $(\text{Me}_2\text{N})_2\text{C:NH.AlMe}_3$, which loses methane above 100° , producing $[(\text{Me}_2\text{N})_2\text{C:NAlMe}_2]_n$.

With nitriles of general formula RCH_2CN , organolithium compounds $\text{R}'\text{Li}$ evolve alkane $\text{R}'\text{H}$, leaving polymeric products which could not be fully characterised. N,N-dimethylcyanamide Me_2NCN reacted similarly at high temperatures with trimethylaluminium. Azomethine derivatives $(\text{Me}_2\text{NCH:NAlR}_2)_2$ were however obtained by reaction of Me_2NCN with triethylaluminium and dialkylaluminium hydrides.

Diphenylketiminoaluminium halides $(\text{Ph}_2\text{C:NAlX}_2)_2$ [$\text{X} = \text{Cl}, \text{Br}$] were prepared by reaction of equimolar proportions of aluminium halide and

diphenylketiminolithium. The compounds $(\text{Ph}_2\text{C:N})_3\text{Al}$ and $[(\text{R}_2\text{C:N})_2\text{Be}]_n$ [R = Ph, p-tolyl] were obtained by reaction of 1 mole of metal chloride with, respectively, 3 moles and 2 moles of N-lithioketimine. A similar reaction between the same metal chlorides and N-trimethylsilyldiphenylketimine, $\text{Ph}_2\text{C:N}\text{SiMe}_3$, resulted in the displacement of only one g. atom of chlorine per mole of chloride, and the formation of the halo-derivatives, $(\text{Ph}_2\text{C:NAlCl}_2)_2$, and $(\text{Ph}_2\text{C:NBeCl})_2$.

INTRODUCTION

1. Introduction

This thesis describes the reactions of organo-, hydrido-, and halo-derivatives of aluminium with certain unsaturated carbon-nitrogen systems, and the properties of the azomethine derivatives, $(R_2C:N)_n AlR'_{3-n}$, resulting from these reactions. Some similar derivatives of lithium and beryllium are also reported. A background to this work is provided by the following survey of the co-ordination chemistry of aluminium compounds $R_n AlX_{3-n}$, (R = alkyl, aryl; X = H, halogen; n = 0, 1, 2, 3). Their structures, interaction with Lewis bases and protonic acids, and their insertion reactions with unsaturated species are discussed, but anionic co-ordination complexes are not covered. Comprehensive reviews of organoaluminium chemistry were published in 1960,¹ 1963,² and 1965.³ Similar aspects of the chemistry of lithium and beryllium are covered later when the azomethine derivatives of these elements are discussed.

2. General Aspects

The electronic configuration of the ground state of aluminium is such that there are three electrons in the outer (m) shell, $(3s^2, 3p)$, leaving two atomic orbitals unoccupied. Compounds of trivalent aluminium, AlX_3 , are therefore co-ordinatively unsaturated, and only rarely exist as monomers. Aluminium normally achieves a co-ordination number of four by the formation of associated species



involving Al-X-Al bridges. When the bridge atom X has a lone pair of electrons available for interaction with the vacant atomic orbital, aluminium can adopt the inert gas electronic configuration, forming four sp^3 hybrid orbitals. The resultant approximately tetrahedral arrangement about the metal atom is typified in the dimeric halides.⁴ Most of the organoderivatives of aluminium are similarly dimeric,^{5,6}

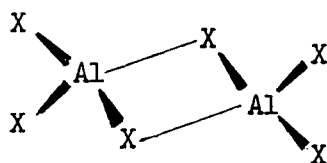

X = Cl, Br, I

affording a four co-ordinate environment for the metal atom. The crystal structures of trimethylaluminium^{7,8} and triphenylaluminium⁹ reveal that the structures of these dimers are geometrically similar to those of the aluminium halides. The nature of the bridge bonds, however, is radically different, since there are insufficient electrons available to form two covalent bonds to each bridging group. The monomer units are considered to be joined by two-electron, three-centre Al-C-Al bonds. Organoaluminium hydrides are normally trimeric rather than dimeric,^{10,11} but the bonding involves similar Al-H-Al three-centre bonds. When aluminium is bonded to both carbon or hydrogen, and to an element with lone pairs of electrons, bridging is invariably through the electron rich atoms. Where two such ligands

are present, the bridging moiety is that with the highest donor strength, although in some cases, such as ethyl-ethoxyaluminium chloride, dynamic equilibria between oligomers with different bridging groups can be detected.¹² It has recently been shown¹³ that electron deficient bridges in which π electrons may participate in the bonding are preferred to systems in which this is not possible. Thus phenyldimethylaluminium and p-tolyldimethylaluminium dimerise through aryl bridges, and phenylethynyl-dimethylaluminium dimerises through phenylethynyl bridges.

Monomeric derivatives of trivalent aluminium are restricted to compounds in which steric crowding by bulky substituents prevents association. Tri-isopropylaluminium is monomeric,⁶ as are all derivatives of the tri-isobutyl ($-\text{CH}_2\text{CHRR}'$) and tri-neopentyl ($-\text{CH}_2\text{CRR}'\text{R}''$) type.¹¹ This is in marked contrast with similar compounds of boron; the boron alkyls and halides, dialkoxyboranes,^{14,15,16} and all known aminoboranes $\text{R}_2\text{BNR}'_2$ ($\text{R}, \text{R}' \neq \text{H}$)¹⁷ are monomeric. These differences are explained by the ability of boron to participate in $\text{p}_\pi-\text{p}_\pi$ bonding with the first row elements of groups V, VI and VII. The monomeric nature of the trialkylboranes has been rationalised in terms of a hyperconjugation effect which releases electrons into the vacant p orbital of boron.^{18,19} The degree of association of a particular derivative is determined by other factors in addition to the relative orbital energies of metal and ligand, and the size of the substituents.

Four membered $(MX)_2$ rings which occur in dimers, result in considerable distortion of the \widehat{XMX} bond angle from the ideal tetrahedral angle, and this distortion can be better accommodated by larger atoms.²⁰ Systems in which the degree of association is low have a high entropy, and in the absence of other considerations, are favoured. Finally, the state of association of a compound may well reflect the nature of the reaction intermediate which led to its formation.

In addition to its vacant p orbital, aluminium has relatively accessible 3d orbitals, which may, by sp^3d or sp^3d^2 hybridisation, enable its co-ordination to be increased to five or six (see Section 3).

3. Co-ordination Complexes.

In addition to oligomerisation, the co-ordination shell of aluminium in compounds AlX_3 can be expanded to four, or even five or six by interaction with Lewis bases, forming donor-acceptor complexes. Four-co-ordinate complexes of aluminium are approximately tetrahedral (II), with bonding electrons in four sp^3 hybrid orbitals. Five-

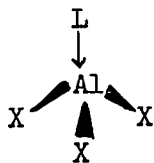

II

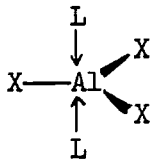

III

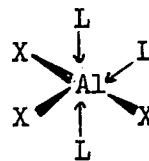

IV

co-ordinate complexes have trigonal bipyramidal structures (III),

with sp^3d hybridised aluminium, and six-co-ordinate adducts are octahedral (IV, sp^3d^2 hybridised aluminium).

The factors determining the stability of an adduct towards dissociation into its components are best represented by an energy cycle^{21,22} (Figure I). The gas phase energy of formation (ΔF_g)

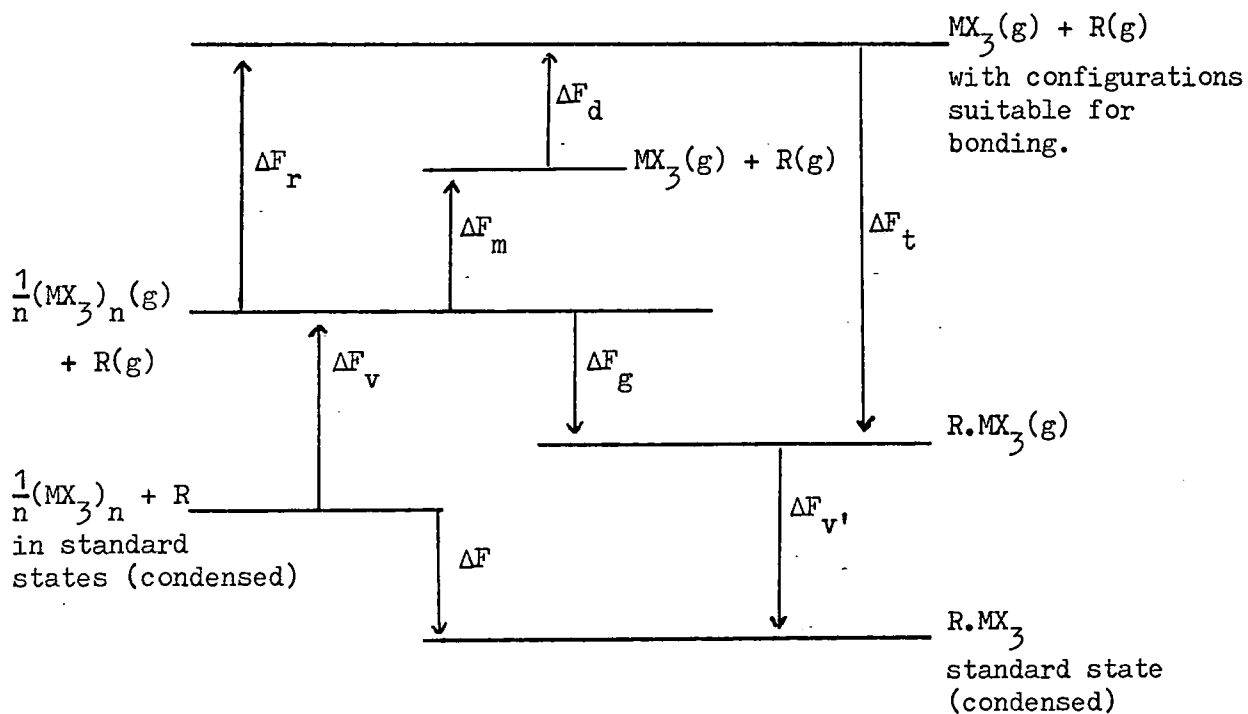

FIGURE I.

depends on the difference between the energy required to distort the free acceptor molecule into the form it takes in the complex (the reorganisation energy, ΔF_r), and the total energy released on formation

of a dative bond (ΔF_t)

$$\Delta F_g = \Delta F_t - \Delta F_r$$

The stability of the adduct over a mixture of its components in the condensed phase (ΔF) will differ from ΔF_g by the difference in energies of vapourisation of the adduct and its components.

$$\Delta F = \Delta F_g + (\Delta F_{v'} - \Delta F_v)$$

The reorganisation energies of the boron and aluminium halides have been calculated, and their relative acceptor powers correlated, using molecular orbital theory.^{23,24} These energies are the sum of the energy required to distort a planar sp^2 hybridised molecule to form a vacant sp^3 orbital (ΔF_d), and the energy required to break down oligomers into monomeric units, if the free Lewis acid is associated (ΔF_m). The boron halides are monomeric, and only ΔF_d contributes to the reorganisation energy. The considerable π character of the B-X bonds, which is lost on co-ordination, means that this term is particularly significant. ΔF_m makes the greater contribution to the reorganisation energy in the case of the dimeric aluminium halides. Despite these differences, calculations suggest that reorganisation energies in the two cases are of the same order.²⁴ Formation of a donor-acceptor complex results in a transfer of electronic charge from the donor atom, which is usually electronegative,

to the acceptor atom, usually electropositive. If the groups attached to the metal are electron withdrawing, this charge transfer is more readily accommodated, and the dative bond energy is high. Bulky groups attached to the acceptor atom result in a high value for the reorganisation energy, and prevent good overlap of donor and acceptor molecular orbitals, resulting in a weak co-ordinate link. Groups attached to the donor atom similarly affect adduct stability, except that electron releasing substituents result in strong interaction.

Aluminium alkyls, hydrides and halides are all very strong acceptors. Trimethylamine and trimethylphosphine adducts of trimethylaluminium are not measurably dissociated in the vapour phase at 150°, ²⁵ unlike the corresponding boron compounds for which vapour phase heats of dissociation have been measured. ^{26,27} The acceptor strengths of aluminium compounds and the donor strengths of Lewis bases towards them can often be related by performing displacement reactions. Dimethylaluminium chloride displaces trimethylaluminium from its trimethylamine and its dimethylether adducts, ²² and towards these bases, is the stronger acid. Since Me_6Al_2 is more readily dissociated than $\text{Me}_4\text{Al}_2\text{Cl}_2$, in this case the dominant influence on adduct stabilities is the inductive effect of the chlorine atom, rather than the reorganisation energy of the Lewis acid. An example of the influence of inductive effects of substituents on base strength is provided by the

dimethylphosphine adduct of trimethylaluminium which, in contrast with the trimethylphosphine adduct, is appreciably dissociated at 150°. ²⁵

Trimethylamine displaces trimethylphosphine from its adduct with trimethylaluminium; ²⁵ $\text{Me}_2\text{S} \cdot \text{AlMe}_3$ and $\text{Me}_2\text{Se} \cdot \text{AlMe}_3$ ²⁸ are sufficiently dissociated in the vapour phase to determine their heats of dissociation by gas pressure measurements, while $\text{Me}_2\text{Te} \cdot \text{AlMe}_3$ is too highly dissociated for measurements of this nature. ²⁸ These results can be summarised in the following order of donor strengths to trimethylaluminium:-

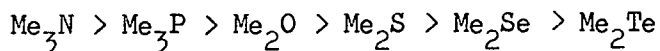

Investigations of the strengths of isostructural organometallic bases by measuring the extent of hydrogen bonding with chloroform, ^{29,30} show a similar order,

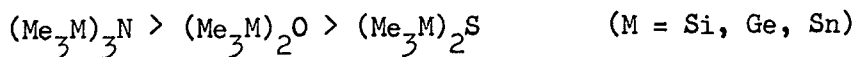

Nitriles are much stronger donors to aluminium than are alkyl halides. Acetonitrile forms an adduct with trimethylaluminium which, on heating, rearranges without evidence of dissociation, ³¹ while methyl chloride co-ordinates only with aluminium chloride, and not with trimethylaluminium, the weaker acceptor. ³² Both acetonitrile ³¹ and benzonitrile ³³ displace diethyl ether from its adduct with triphenyl-

aluminium in boiling benzene. Mole has shown that $\text{Ph}_3\text{Al.OEt}_2$ and $\text{Ph}_3\text{Al.NCPh}$ are in equilibrium in deuteriochloroform solution,³⁴ so these observations may reflect the relative volatilities of the donors, rather than their base strengths.

If an organoaluminium compound has bridge bonds of similar strength to the co-ordinate bond of its adduct with a particular donor, that adduct can co-exist in equilibrium with free Lewis base and associated aluminium compound. Examples of this are the etherates of alkylaluminium hydrides,^{35,36} and dialkylalkenyl and dialkylalkynyl derivatives of aluminium.³⁷ Alkoxy bridges are so strong that alkylalkoxy derivatives of aluminium do not form co-ordinate complexes with ethers or amines,³⁸ and diethylaluminium fluoride, which is tetrameric, has weaker acceptor properties than the other dimeric diethylaluminium halides.³⁹

Other criteria than the displacement of one species from an adduct by another have been used to correlate the relative strengths of Lewis acids. Kuhn and McIntyre compared the chemical shifts of the methyl protons of dimethylformamide on co-ordination to the halides of groups II, III and IV.⁴⁰ Their results agree very closely with similar data obtained from the shift in the carbonyl stretching frequency of xanthane,⁴¹ and ethyl acetate,⁴² on co-ordination. These results together give the following order of acceptor strengths for

group III halides:-

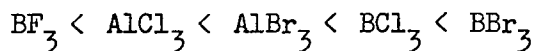

Coyle and Stone have used differences in chemical shift values between free and co-ordinated base as a measure of relative donor strengths.⁴³ Their results suggest that this criterion is not always successful in predicting the stabilities of addition compounds. A more recent spectroscopic study of addition compounds of aluminium halides with ethers and organic sulphides suggests that aluminium bromide is a stronger acceptor than aluminium chloride.^{44,45} Calorimetric measurement of the dissociation of these adducts in the condensed phase supports the spectroscopic results, but correction of the thermochemical data to the gas phase using a Born-Haber cycle suggests that there is little difference in the relative acceptor strengths in complexes with ethers, and that with organic sulphides aluminium chloride is the stronger acceptor. Similar calculations of gas phase heats of dissociation of pyridine and trimethylamine adducts of aluminium halides confirm that the acceptor powers of the trichloride and tribromide are comparable, and greater than that of the tri-iodide.^{21,46}

The shift to higher values of the nitrile stretching frequency on co-ordination has also been regarded as a measure of the acceptor power of the Lewis acid.^{31,33,47,48,49} An order of relative acceptor power of some organoaluminium compounds towards nitriles,

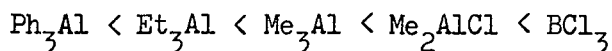

has been tentatively suggested.^{31,33} Beattie and Gilson, however, point out the hazards of using small shifts in stretching frequencies as a criterion of acceptor strength.⁵⁰

Many aluminium compounds form complexes in which the ratio of donor to acceptor is greater than 1:1. Although adducts of aluminium hydride in which aluminium is five-co-ordinate are well characterised, similar complexes of organoaluminium compounds or aluminium halides are comparatively rare. Diethylaluminium chloride forms a 1:2 addition compound with ammonia, which behaves in liquid ammonia as a cationic addition compound, $[\text{Et}_2\text{Al}(\text{NH}_3)_2]^+\text{Cl}^-$ involving four-co-ordinate aluminium.⁵¹ $\text{Et}_3\text{Al} \cdot 2\text{NH}_3$ was also detected in a pressure-composition study, and five-co-ordinate aluminium is possible in this compound. 2,2'-bipyridyl and 1,10-phenanthroline give 1:1 complexes with trimethylaluminium which do not react further with excess aluminium alkyl. A five-co-ordinate structure V has been proposed for these compounds.⁵² Similar structures VI have been proposed for

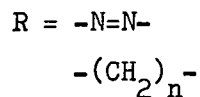
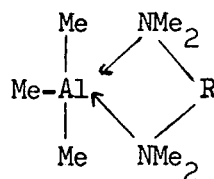
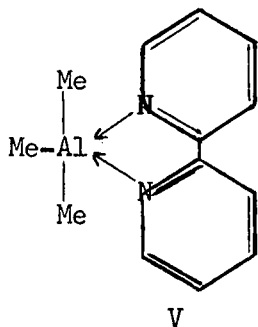

VI

the 1:1 complexes of trimethylaluminium with some diamino compounds, on the basis that only one peak assignable to the N-methyl protons was observed in the N.M.R. spectrum.^{53,54} More recent results suggest that a four-co-ordinate structure is probable, with rapid exchange of amino groups under the conditions that the spectra were recorded.⁵⁵

Phosphorus tri-iodide forms a 2:1 adduct with aluminium tri-iodide, for which a trigonal bipyramidal structure involving sp^3d hybridised five-co-ordinate aluminium has been proposed.⁵⁶ More recently, spectroscopic evidence has been published,⁵⁷ which suggests a similar structure for $AlCl_3 \cdot 2NMe_3$.

Examples of five-co-ordinate aluminium in adducts of aluminium hydride are much better characterised. $Me_3N \cdot AlH_3$ is partially associated in benzene solution^{58,59} and structure VII with sp^3d hybridised aluminium⁶⁰ is suggested. The 2:1 adduct of trimethylamine

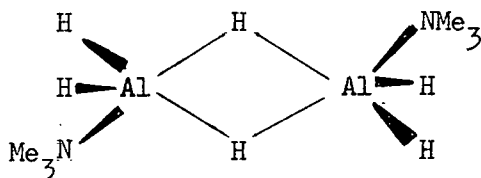

VII

with aluminium hydride has been shown to have a trigonal bipyramidal structure VIII,^{61,62} and aluminium is in a penta-co-ordinate environment in crystals of the adduct of N,N,N',N'-tetramethylenediamine with

aluminium hydride.⁶³ Young and Ehrlich isolated a similar adduct with N,N,N',N'-tetramethylpropanediamine in three forms;⁶⁴ a monomer, presumably with structure IX, a dimer, having probably structure X, and a polymer, which may well resemble the TMED adduct.

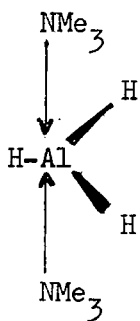

VIII

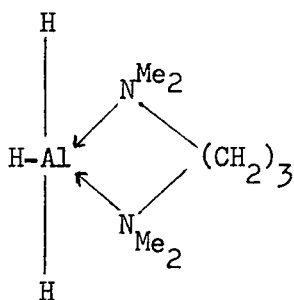

IX

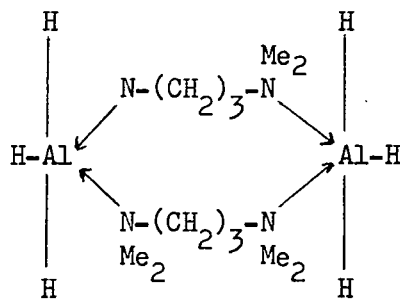

X

Aluminium compounds containing multiple bonds offer the possibility of interaction between the metal and the π electrons. The stability of aluminium-alkenyl and -alkynyl bridges has already been remarked upon (see page 3) but this is likely to be due to delocalisation effects rather than to direct interaction. Vapour pressure-composition phase studies^{65,66} and molecular weight determinations⁶⁷ on aluminium bromide-aromatic systems have confirmed the existence of 2:1 adducts between aluminium bromide and benzene, toluene, o-, m- and p-xylene, and mesitylene, and 1:1 adducts between aluminium bromide and m-xylene and mesitylene. These are presumed to have structures XI and XII,

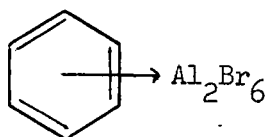

XI

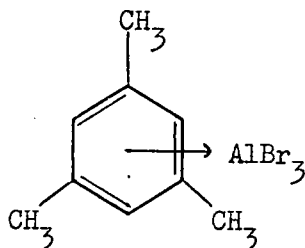

XII

held together by an electron donor-acceptor interaction between the aromatic π electrons and aluminium. Eley, as a result of an X-ray structure determination on a crystal of $C_6H_6 \cdot Al_2Br_6$ had previously suggested that the structure is an infinite lattice XIII, held together by van der Waal's forces.⁶⁸ Recently, spectroscopic evidence for an intramolecular aluminium-olefinic π electron interaction has been published.⁶⁹ A series of compounds $Bu^i_2Al(CH_2)_nCH:CHR$ ($n = 3,5,6$; $R = H, Me$) were synthesised from di-isobutylaluminium

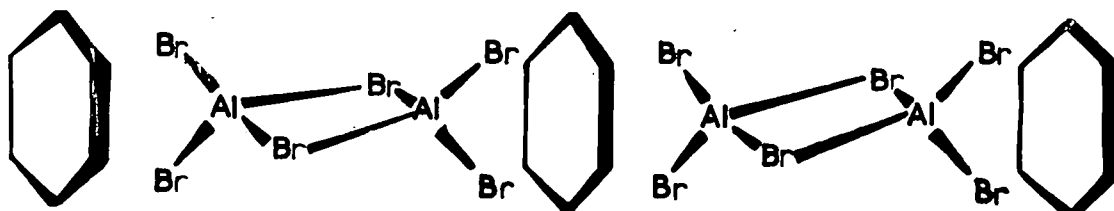

XIII

hydride and the appropriate diolefine. In the case of $\text{Bu}^i_2\text{Al}(\text{CH}_2)_3\text{CH:CHR}$, the CH:CH deformation moved to higher frequency, and the C:C stretch to lower frequency than in the parent olefine. In no other derivative was a significant frequency shift observed. These features of the infrared spectra of the alk-4-enyl derivatives are consistent with intramolecular complex formation as in XIV.

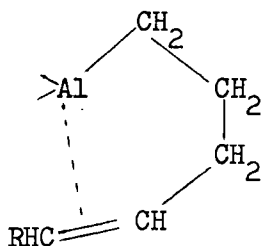

XIV

The N.M.R. spectra of the compounds confirms an increase in electron density at the aluminium atom, and a decrease in the vicinity of the olefinic bond.

4. Reactions of Aluminium Compounds with Protonic Acids.

Organoaluminium compounds and aluminium hydrides react quantitatively and very vigorously with protonic acids, eliminating hydrocarbon or hydrogen. In some cases a stable 1:1 co-ordination complex can be isolated, which, on heating undergoes the cleavage reaction. Secondary amines, phosphines and arsines form such adducts

with organoaluminium compounds which lose hydrogen, alkane, or aromatic hydrocarbon on heating.^{25,70,71,72,73,74,75}

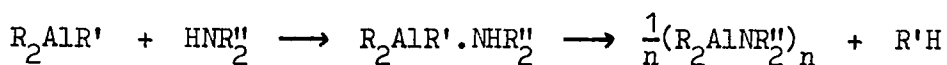

Ammonia and primary amines react similarly, and products $(R_2AlNHR')_n$ have been isolated,^{71,73,76} but unless steps are taken to prevent it, further condensation to polymeric imides, $(RAlNR')_n$, or with ammonia, to aluminium nitride, occurs. The aluminium-hydrogen bond is cleaved more readily than the aluminium-carbon bond. Dialkylaluminium hydrides, when treated in molar proportions with secondary amines, lose hydrogen rather than alkane to form aminodialkylaluminium derivatives $(R_2AlNR'_2)_n$,⁷⁰ and hydrogen is eliminated smoothly from mixtures of dialkylaluminium hydrides and piperidine at 40°, while the analogous reaction with aluminium trialkyls occurs only above 100°. ⁷⁷ When organoaluminium compounds react with alcohols and thiols, which contain protons more acidic than amino hydrogen, condensation occurs so readily that isolation of the intermediate adduct is not possible. Mixtures of trimethylaluminium with methanol and methane-thiol lose methane below room temperature to give, respectively, $(Me_2AlOMe)_3$ and $(Me_2AlSMe)_2$.³²

The factors affecting the degree of association of the product (viz. entropy, valence angle strain, steric interference and the nature of the precursor) have been discussed previously (p.3-4).

Organoaluminium derivatives are normally dimeric (XV), but higher oligomers, with larger, less strained cyclic structures are possible when steric interference is small (XVI).

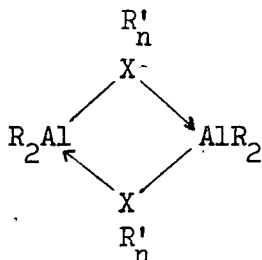

XV

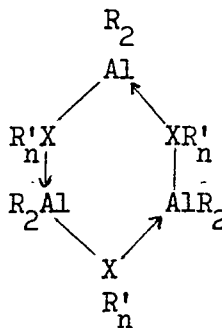

XVI

Hydrogen attached to aluminium, or to a group V element can relieve steric crowding sufficiently to permit the formation of trimers, and dimethylaminoalane, $(Me_2NAlH_2)_3$,⁷⁸ and aminodiethylaluminium $(Et_2AlNH_2)_3$ ⁷⁹ are both trimeric. Similarly, dimethylaminodimethylaluminium, $(Me_2AlNMe_2)_2$, is dimeric, while the corresponding dimethylphosphino compound, $(Me_2AlPMe_2)_3$ is trimeric.²⁵ The contrast between this system, and the related one involving group VI elements, where $(Me_2AlOMe)_3$ is trimeric, and $(Me_2AlSMe)_2$ is dimeric, (because oxygen is less ready than sulphur to tolerate the small bond angles of a four-membered ring) illustrates the complex balance between the factors determining the extent of association of these derivatives.

Adducts of organoaluminium compounds with primary amines, after cleavage of two moles of hydrocarbon, normally form polymeric products

as stated above (p. 16). Co-ordination complexes between triphenylaluminium and benzylamine, or primary aromatic amines with ortho substituents, cleave one mole of benzene only, giving dimeric products $(\text{ArNHAlPh}_2)_2$.³² Primary aromatic amines without an ortho substituent lose two moles of benzene, but the products are tetramers, rather than high polymers.⁸⁰ $(\text{PhAlNPh})_4$, typical of these compounds, has been shown to have the 'cubane' structure XVII.⁸¹ Similar

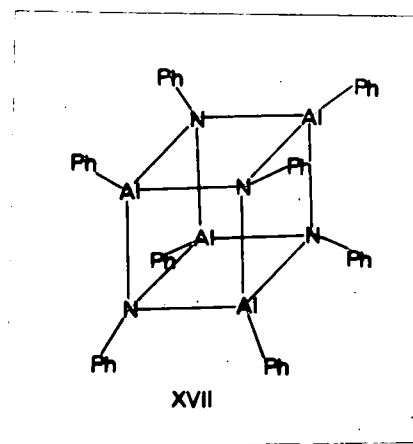

crystalline tetramers $(\text{EtAlNPh})_4$, $(\text{ClAlNMe})_4$ and $(\text{ClAlNPh})_4$ can be isolated when the appropriate organoaluminium compound and primary amine react in high boiling solvents such as tetralin.⁸²

Trialkyl derivatives of aluminium react with carboxylic acids, forming dialkylaluminium carboxylates,⁸³ and with phosphinic acids, forming dialkylaluminium phosphinates.⁸⁴ The structures of the aluminium carboxylates have not been elucidated, but diethylgallium acetate and the dialkylaluminium phosphinates are dimers. Their infrared spectra are consistent with eight-membered cyclic structures

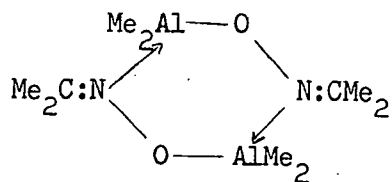

XXI

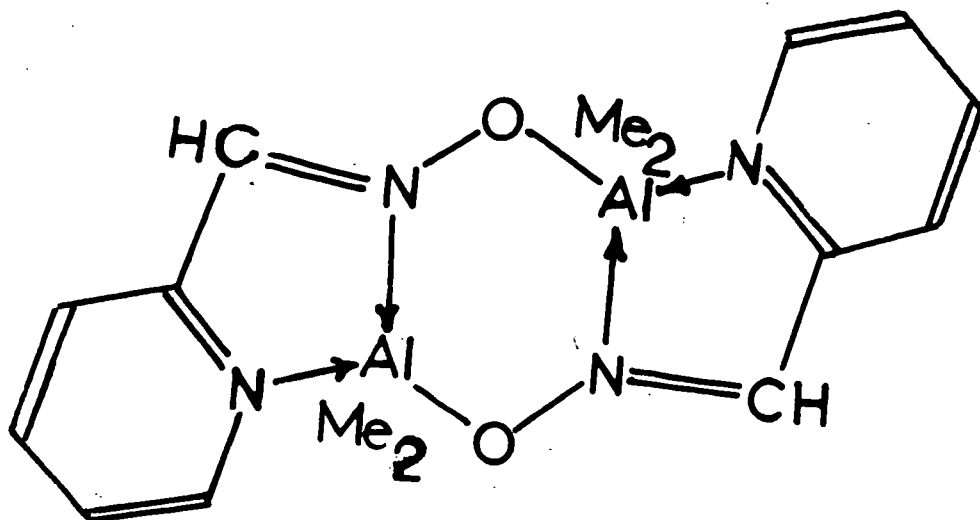

XXII

but in this case there is the added possibility of interaction with the pyridine nitrogen, increasing the co-ordination number of aluminium to five.

Triphenylaluminium reacts with 2(methylamino)biphenyl at 160° , eliminating one mole of benzene in the usual way.

XVIII and XIX. Monothiophosphinic acids give similar dimeric

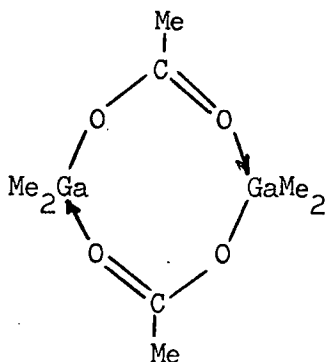

XVIII

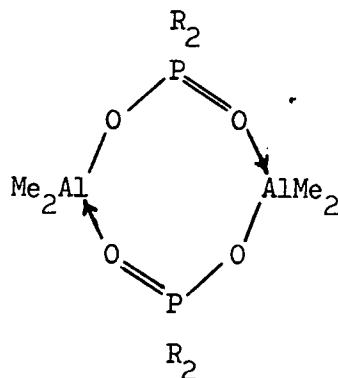

XIX

products, but dithiophosphinates are monomeric, apparently with the chelate structure XX, providing further evidence of the ability of

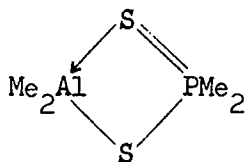

XX

sulphur to tolerate greater valence angle strain than oxygen (see p. 4).

Acetoxime reacts with trimethylaluminium, evolving methane, and giving a dimeric product believed to have the six-membered ring structure XXI.⁸⁵ Pyridine-2-aldoxime forms a similar dimer XXII,⁸⁶

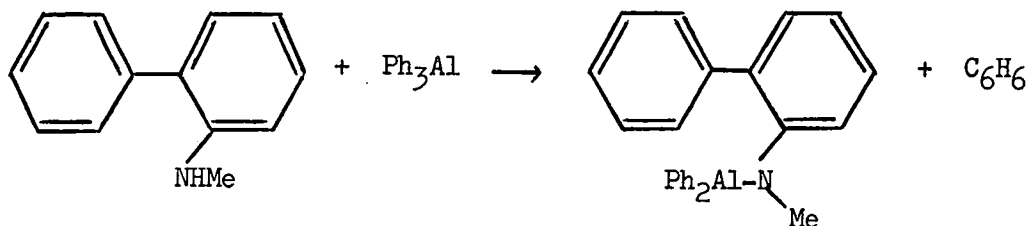

When the temperature is raised to 240° , more benzene is produced, and the derivative XXIII, which differs from its boron analogue in being polymeric, is formed.⁸⁷

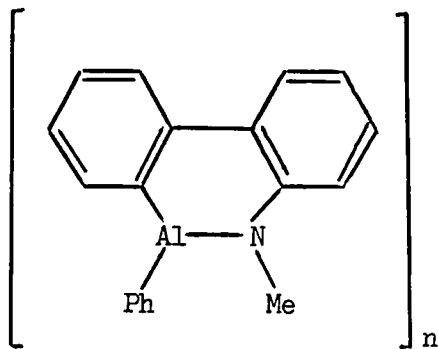

XXIII

Schmidbaur has isolated compounds with five-membered rings containing phosphorus, nitrogen, aluminium and carbon, by the action of heat on the co-ordination complex formed between triphenylaluminium and N-trimethylsilyl-triphenylphosphinimine.⁸⁸

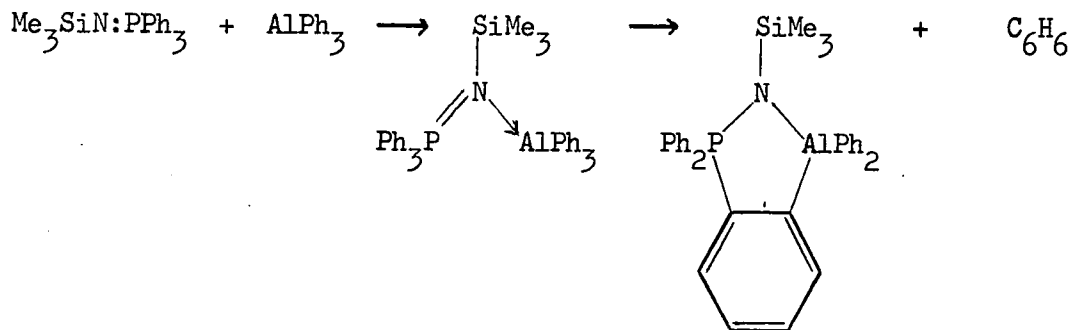

Organoaluminium compounds react with iminotrialkylphosphoranes in the same manner as with secondary amines, eliminating hydrocarbon, and giving a dimeric product with an aluminium-nitrogen four-membered ring.⁸⁹

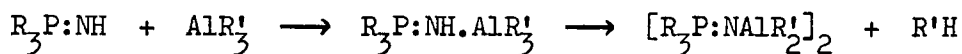

Trimethylhydrazine gives a similar product with trimethylaluminium, but mono- and dimethylhydrazine can eliminate more than one mole of methane, forming polymeric products.⁹⁰

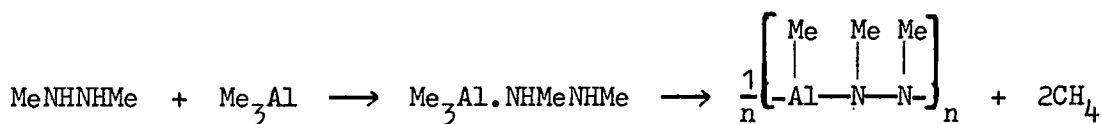

It has been suggested on infrared spectroscopic evidence,⁹¹ that $(\text{Et}_2\text{AlNHNMe}_2)_2$, prepared from triethylaluminium and 1,1-dimethylhydrazine has a six-membered ring structure XXIV rather than the

four-membered ring structure XXV.

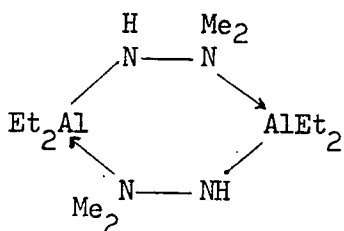

XXIV

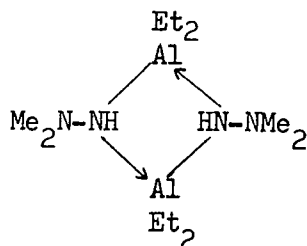

XXV

Aluminium alkyls react with hydrogen cyanide to give associated species $(R_2AlCN)_n$. $(Me_2AlCN)_4$ is tetrameric in benzene solution,⁹² although oligomers with a degree of association of 7-8 have been prepared from trimethyl- and triethylaluminium.⁹³ Aluminium can tolerate bond angles of less than 90° , so that the cyclic structure XXVI is reasonable for the tetramer, even if the $Al-C\equiv N-Al$ group is linear, as drawn.

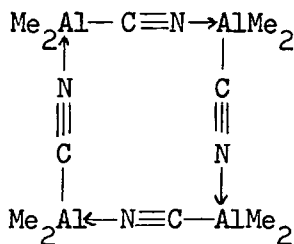

XXVI

Acetylenes react as protonic acids with organoaluminium compounds,^{94,95} despite earlier reports that only addition across the triple bond was observed.^{1,37} Up to 60% cleavage of hydrocarbon is reported in

reactions of phenylacetylene and monoalkylacetylenes with trimethyl-, triethyl-, tri-n-propyl-, tri-i-butyl- and triphenylaluminium.

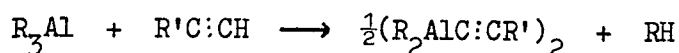

The products are dimeric, with alkynyl bridges. A similar reaction occurs between dimethyl- or diethylaluminium hydride and phenylacetylene, but diphenylaluminium hydride loses benzene rather than hydrogen.⁹⁶

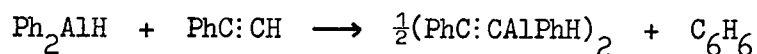
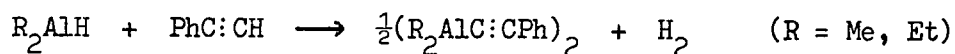

Trimethylamine adducts of organoaluminium compounds react smoothly above 20° with monosubstituted acetylenes, giving trimethylamine-dialkylalkynylaluminium adducts.⁹⁷

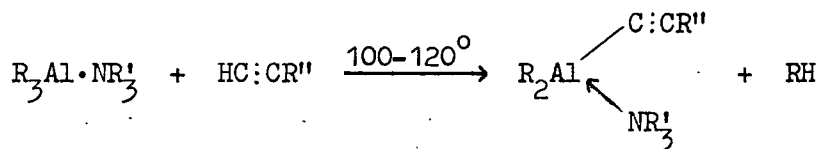
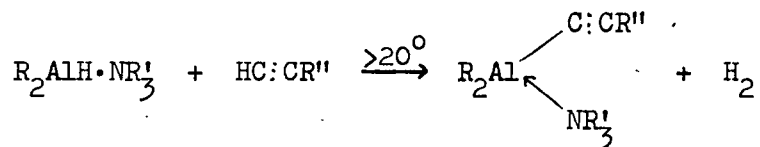

Both protons of acetylene itself react, to give the alkynyl bridged dimer XXVII.

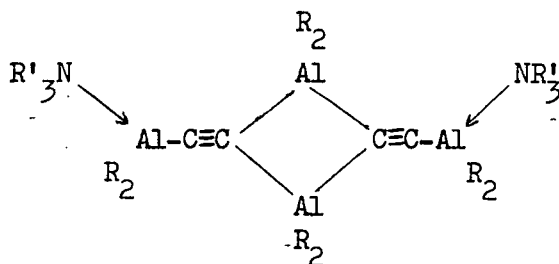

XXVII

Free dialkylalkynyl derivatives of aluminium can be isolated from exchange reactions with aluminium alkyls.

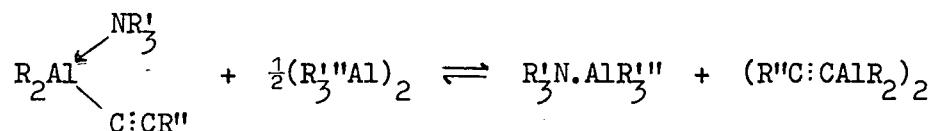

These cyclic oligomers are split by the displacement of bridging groups by a stronger donor species. Dimethylaluminium chloride dimer reacts with trimethylamine, and with dimethylether,²⁵ and the methylthio-²⁵ and diphenylphosphino-⁷⁴ derivatives of trimethylaluminium are similarly cleaved by trimethylamine, though not by ethers.

In contrast with the alkyls of the heavier metals of group III, all three aluminium-carbon bonds of aluminium tri-alkyls and -aryls are susceptible to hydrolysis, but the first is noticeably more reactive than the other two. It seems likely that this is because initial attack occurs at the bridging carbon atoms. The reaction intermediate would be an oxygen-bridged entity, and further attack must

be directed at terminal aluminium-carbon bonds, which are not electron-deficient. If the hydrolysing agent is particularly bulky (e.g. t-butanol), steric shielding can further inhibit hydrolysis and oxidation of a second and third aluminium-carbon bond.^{98,99}

Steric interference by the trimethylsilyl group renders $(\text{Me}_3\text{SiOAlMe}_2)_2$ ⁹⁹ and $(\text{Me}_3\text{SiNHAlMe}_2)_2$ ¹⁰⁰ similarly resistant to hydrolysis.

Aluminium-halogen bonds are much less susceptible to attack by protonic acids than aluminium-carbon or aluminium-hydrogen bonds. $\text{AlCl}_3 \cdot \text{NH}_3$ can be heated to its boiling point at 420° without losing HCl .¹⁰¹ However, nitrogen-bridged AlX_2 derivatives (where X = halogen) have been prepared by elimination of other species than HCl .

e.g.¹⁰²

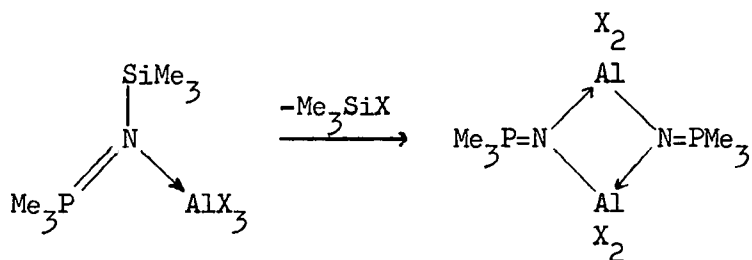

(X = Cl, Br, I)

5. Insertion of Unsaturated Compounds into Organoaluminium Compounds.

This heading covers the whole range of addition and reduction reactions of unsaturated hydrocarbons and organic oxygen containing

compounds, many of which are not of direct relevance to this discussion, and which have been exhaustively reviewed.^{1,3,103} Accordingly only brief mention will be made of these reactions, and the discussion will be concentrated on reactions of species containing unsaturated carbon-nitrogen bonds.

Dialkylaluminium hydrides react with terminal olefines to give

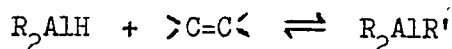

trialkylaluminium compounds.^{104,105} The reverse reaction, eliminating olefine from trialkylaluminium compounds also occurs, but below 100°, the equilibrium lies well to the right, except in the case of branched chain aluminium alkyls, such as tri-*i*-butylaluminium. 1-alkenes could in principle give rise to products with straight- or branched-chain alkyl substituents. In practice the major product

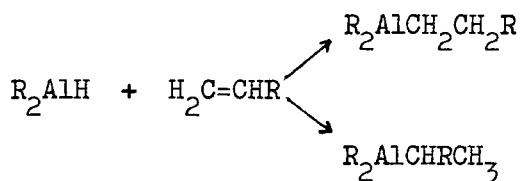

is always the straight chain derivative, because of the polarity of the aluminium-hydrogen and olefinic bonds.

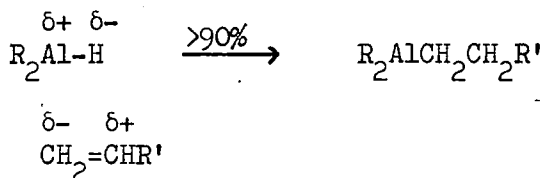

Substitution of alkenes with certain functional groups can reverse the direction of addition.³

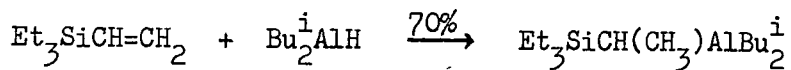

Trialkylaluminium compounds also give products of addition, with olefines. Ethylene successively inserts into aluminium-carbon bonds, forming unbranched long-chain aluminium alkyls.¹⁰⁵

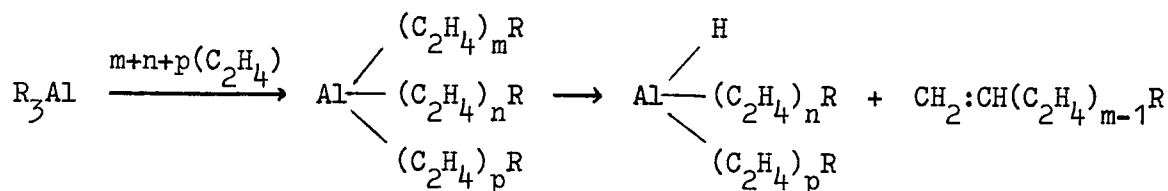

The dehydroalumination reaction, giving dialkylaluminium hydrides and long-chain olefines occurs simultaneously. Branched-chain aluminium alkyls, which eliminate olefine very readily, normally give products of displacement, with only partial insertion of olefine. Tri-*i*-butylaluminium, for example, reacts with ethylene giving triethylaluminium and isobutylene as well as products of insertion.³

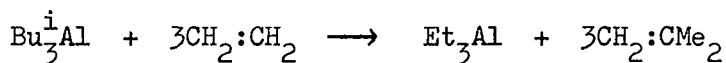

The ready dehydroalumination of branched aluminium alkyls explains why 1-alkenes react with trialkylaluminium compounds forming 2-alkyl-1-alkenes rather than longer chain olefines.

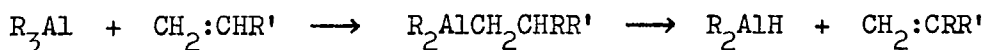

The rate of the growth reaction is pressure and temperature dependent, while the rate of dehydroalumination is not sensitive to pressure. High pressures therefore favour the formation of long chain alkenes.

Alkynes with terminal acetylenic groups react as protonic acids with organoaluminium compounds (see p. 23), but it is their addition reactions with aluminium-hydrogen and aluminium-carbon bonds which have been most extensively studied.^{1,3,37} Alkylaluminium hydrides add to alkynes giving products of cis addition.³⁷ The direction of addition is the same as that observed for insertion reactions of alkenes.

e.g.

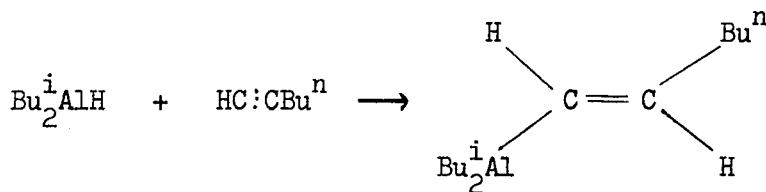

Excess alkylaluminium hydride adds across the olefinic bond of the product in the same direction as the first mole added to the alkyne, giving rise to a compound with two aluminium atoms attached to one carbon atom.

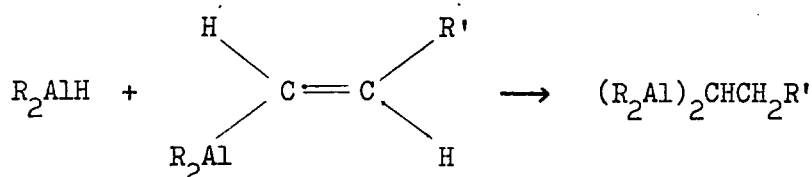

Addition of alkylaluminium hydrides to alkynylaluminium derivatives results in the formation of a similar product, with three aluminium atoms attached to a single carbon.

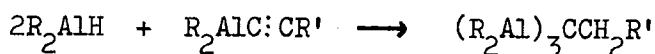

Triethylaluminium adds to alkynes, also giving products of cis addition.

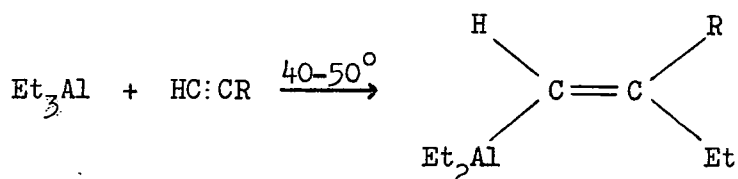

Tri-isobutylaluminium reacts with acetylene in a similar fashion at room temperature, forming the unstable vinyl compound $Bu_2^iAlCH:CHBu^i$. Trimethylaluminium, however, eliminates methane rather than adding to alkynes. These observations have given weight to the speculation that the addition reaction involves the monomeric aluminium alkyl as reaction intermediate.

If the product of addition of alkylaluminium hydrides to unsaturated hydrocarbons is hydrolysed, the original alkyne or alkene is reduced to alkene or alkane. The specific direction of the

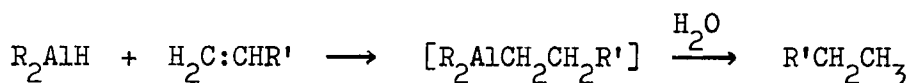
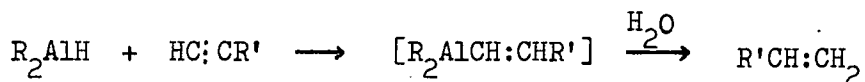

addition reaction makes this an attractive synthetic route to selected

hydrocarbons.¹⁰⁷ Aldehydes, ketones, carboxylic acid esters and epoxides are similarly reduced to the appropriate alcohol by treatment with alkylaluminium hydrides and subsequent hydrolysis.^{108,109} Trialkylaluminium compounds behave as reducing agents when it is possible for the aluminium-attached group to lose olefine.^{110,111}

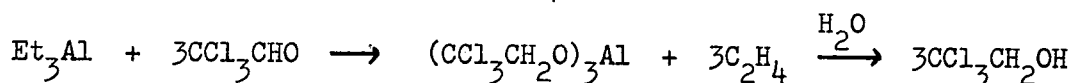

When olefine elimination is not possible, the carbonyl group can undergo an insertion reaction into the aluminium-carbon bond, giving products of addition.^{111,112}



Trimethylaluminium and triarylaluminium derivatives give the addition reaction exclusively,^{112,113} triethylaluminium gives products of addition and reduction,^{113,114} while use of tri-*i*-butylaluminium results in reduction.¹¹³ If the carbonyl compound can enolise, it behaves as a protonic acid, and the reaction products are contaminated by unsaturated alcohols.¹⁰⁸

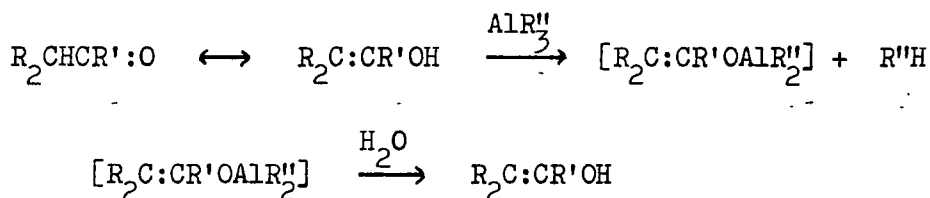

Unsaturated carbon-nitrogen systems with organoaluminium compounds, follow reaction courses essentially similar to those of carbonyl

compounds. Aluminium hydrides reduce nitriles^{108,109,115} and imines¹¹⁵ to aldehydes or amines.

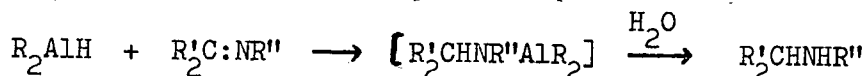
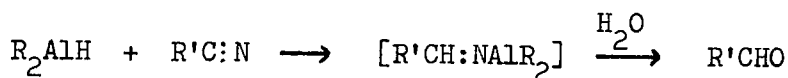

Organoaluminium compounds react with nitriles to give (after hydrolysis) ketones (products of addition),^{112,116,117}

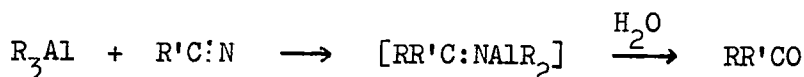

or, if the aluminium compound can eliminate olefine, aldehydes or amines (products of reduction).^{108,119}

e.g.

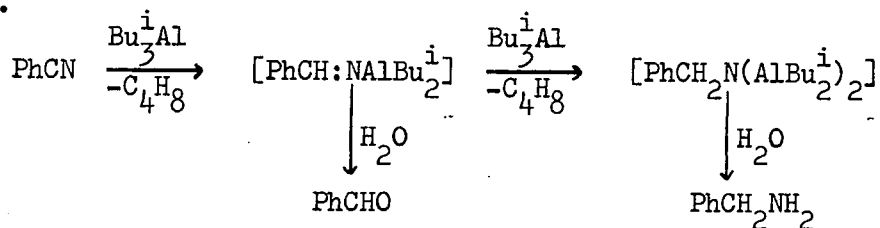

Amines are isolated only when excess aluminium alkyl is added, since only one alkyl group per aluminium can take part in addition or reduction reactions. This may be contrasted with the behaviour of aluminium hydride itself, in which two hydrogen atoms per aluminium are available for transfer reactions.¹¹⁸

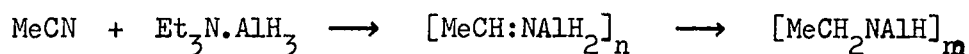

Nitriles with hydrogen attached to the α carbon atom can behave as protonic acids, and the major products of their reactions with organoaluminium compounds are polymers, $(R_2AlCH_2CN)_n$.³¹

Until recently the aluminium-containing reaction intermediates have been little studied, but Ehrlich and his co-workers have now investigated the polymeric products of reactions between aluminium hydrides and nitriles,^{118,119} and azomethine derivatives, $[RR'C:NALR''_2]_n$, products of the insertion reactions of nitriles with organoaluminium compounds, have been characterised.^{31,33,120,121} Nitriles form co-ordination complexes with organoaluminium compounds at or below room temperature (see p. 8), which rearrange at elevated temperatures (110-200°) by one of the above routes to give azomethine derivatives.^{31,33,119} Rearrangement occurs at a lower temperature if the adduct is treated

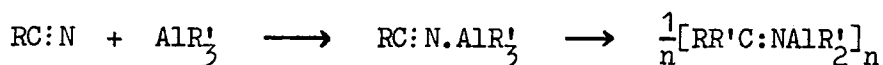

with equimolar quantities of organoaluminium compound.¹¹⁸ Aluminium-hydrogen bonds add so readily to nitriles that adducts of dimethylaluminium hydride cannot be isolated.^{31,33} In all cases where reliable molecular weight measurements have been made, azomethine derivatives have proved to be dimeric. $(Bu^tCMe:NALMe_2)_2$ has the four-membered aluminium-nitrogen ring structure XXVIII,¹²² apparently the configuration adopted by all known aluminium azomethine derivatives. Derivatives with unlike substituents on the azomethine carbon atom can

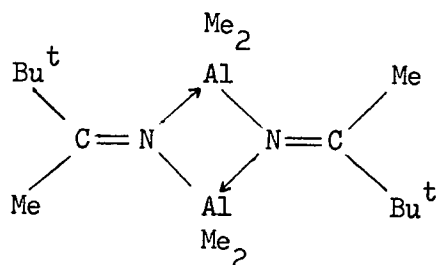

XXVIII

exist in two isomeric forms XXIXa, XXIXb. N.M.R. spectroscopic evidence for this isomerism has been published for $(\text{MeCH}:\text{NAlMe}_2)_2$ ³¹

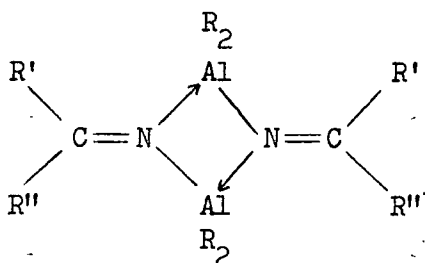

XXIXa

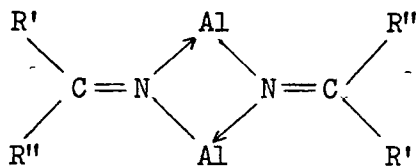

XXIXb

and $(\text{PhCMe}:\text{NAlMe}_2)_2$ ³³

Measurements of the rate of addition of methyl groups across aryl cyanides¹²³ have shown that at 120° the reaction follows first order kinetics, the rate determining step being the intramolecular rearrangement of the intermediate XXX.

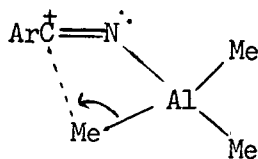

XXX

Organoaluminium compounds react with isocyanates giving products which on hydrolysis afford N-substituted acid amides.^{118, 124} The reaction could in principle involve insertion of either C:N or C:O into the aluminium-carbon bond, forming $[R_2AlNR'C:OR]$ (1) or $[R_2AlOCR:NR']$ (2) respectively, both of which would afford the same

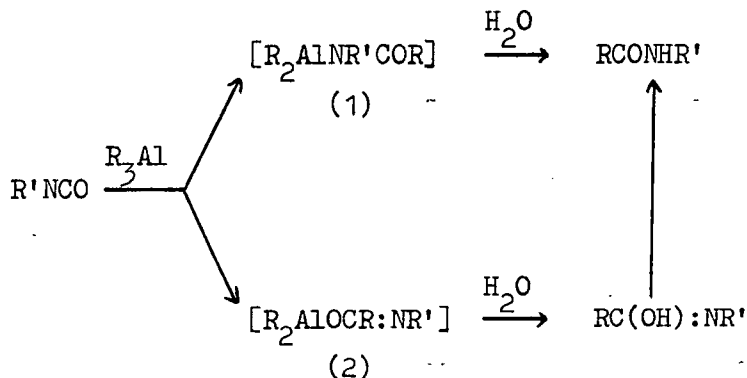

amide on hydrolysis. Largely on the basis of the infrared spectra of the products, Reinheckel and co-workers¹²⁴ concluded that addition to the C:N bond normally occurs, giving intermediates of type (1), which were believed to exist as chain polymers. More recently, the products of insertion of isocyanates into ethyl-aluminium bonds have been shown to be dimeric in solution.¹²⁵ Cyclic structures XXXI were proposed,

two canonical forms of which correspond to (1) (XXXIa) and (2) (XXXIb).

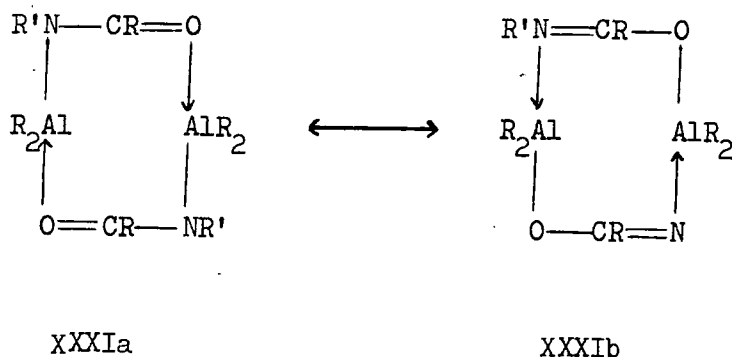

The product of the reaction between phenyl isocyanate and trimethylaluminium is also dimeric in benzene solution,¹²⁶ but a preliminary X-ray crystallographic investigation¹²⁷ suggests that there are twelve monomer units in the unit cell, arranged in the form of four trimers.

Acid amides react as protonic acids with aluminium alkyls affording an alternative route to the same compounds.¹²⁶ Where molecular weights could be determined, the products were also found to be dimeric. Isothiocyanates react in essentially similar fashion^{118,126} although $[\text{Me}_2\text{AlSCMe:NPh}]_n$, prepared from trimethylaluminium and phenyl isothiocyanate, is thermally unstable.

EXPERIMENTAL METHODS AND APPARATUS

General Techniques.

Most of the reactions described below involve handling compounds sensitive to atmospheric oxidation and hydrolysis.

Unless otherwise stated, reactions were carried out in an atmosphere of pure dry nitrogen in one limb of a double Schlenk tube. Purification of the product by fractional crystallisation was normally effected in the second limb of the Schlenk tube.

Where volatile materials were produced in a reaction, it was commonly carried out in an evacuated tube. The starting materials were introduced at -196° under an atmosphere of nitrogen, a flow of nitrogen across the mouth of the tube being provided by a T shaped adaptor (Fig.II). The tube was then evacuated, sealed, and warmed to the reaction temperature. On completion of the reaction, the tube was connected to the vacuum line by a second adaptor (Fig.III), and opened. The volatile reaction products were measured volumetrically in the vacuum line, and identified by vapour pressure measurements, and by recording their infrared spectra. The tube was then resealed under vacuum, and broken open inside the glove box. The involatile products were transferred to a two necked flask, and from there, against a flow of nitrogen, to a double Schlenk tube for purification by crystallisation.

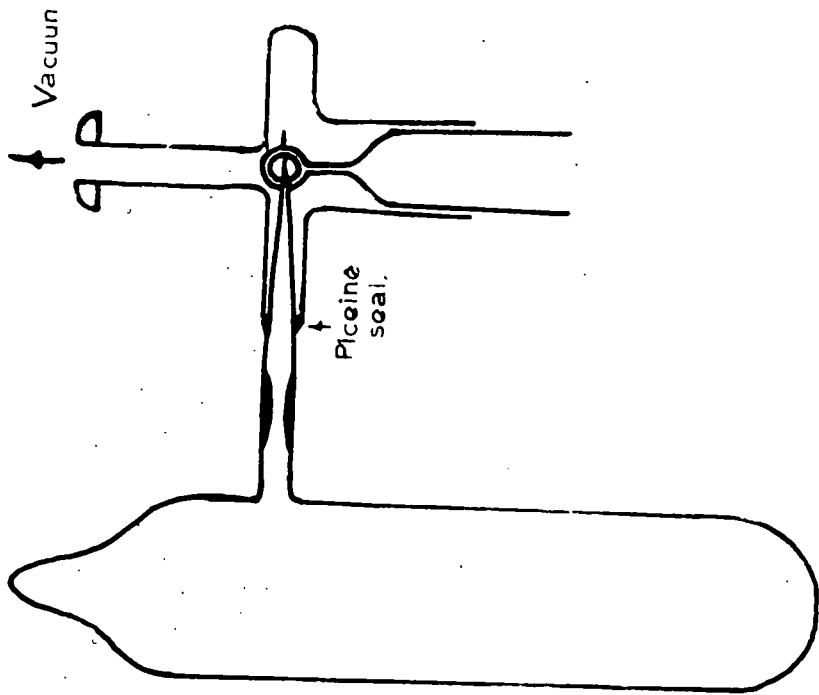

FIG. III

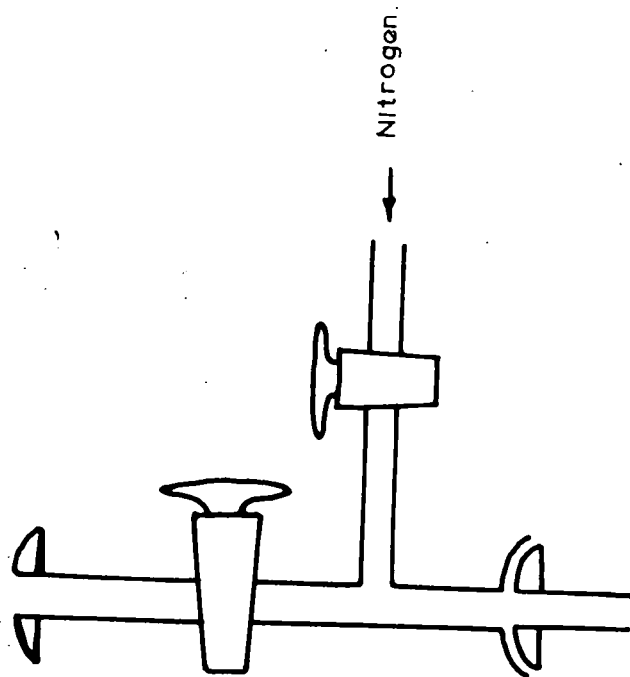

FIG. II

Nitrogen Supply.

'White Spot' nitrogen from the bench tap was passed through a furnace containing 'BTS' catalyst at 100-120°, to remove traces of oxygen. The gas was then dried by passing through two traps maintained at -196°, and delivered to a 'pig', providing multiple outlets. A constant pressure of nitrogen was maintained in the system by connecting one of the outlets to an oil bubbler. The catalyst was regenerated when necessary by passing hydrogen through the furnace.

Glove Box.

When it became necessary to remove samples of air sensitive material from closed vessels (e.g. to prepare samples for infrared spectroscopy, or to weigh exact quantities for analysis or for further reaction), a conventional glove box was used.

The nitrogen purification system is shown in Fig.IV. When the box was not in use, the atmosphere was continuously pumped through a trap at -196°, through two furnaces at 400° containing copper wire, and back to the box via a second trap at -196°. Bench nitrogen, passed through this purification system, was used to flush out the transfer tube. All external tubing was of copper or glass, to reduce diffusion of oxygen or moisture into the system. Gloves were of 'Butasol' rubber, and an oxygen level of less than 50 p.p.m.

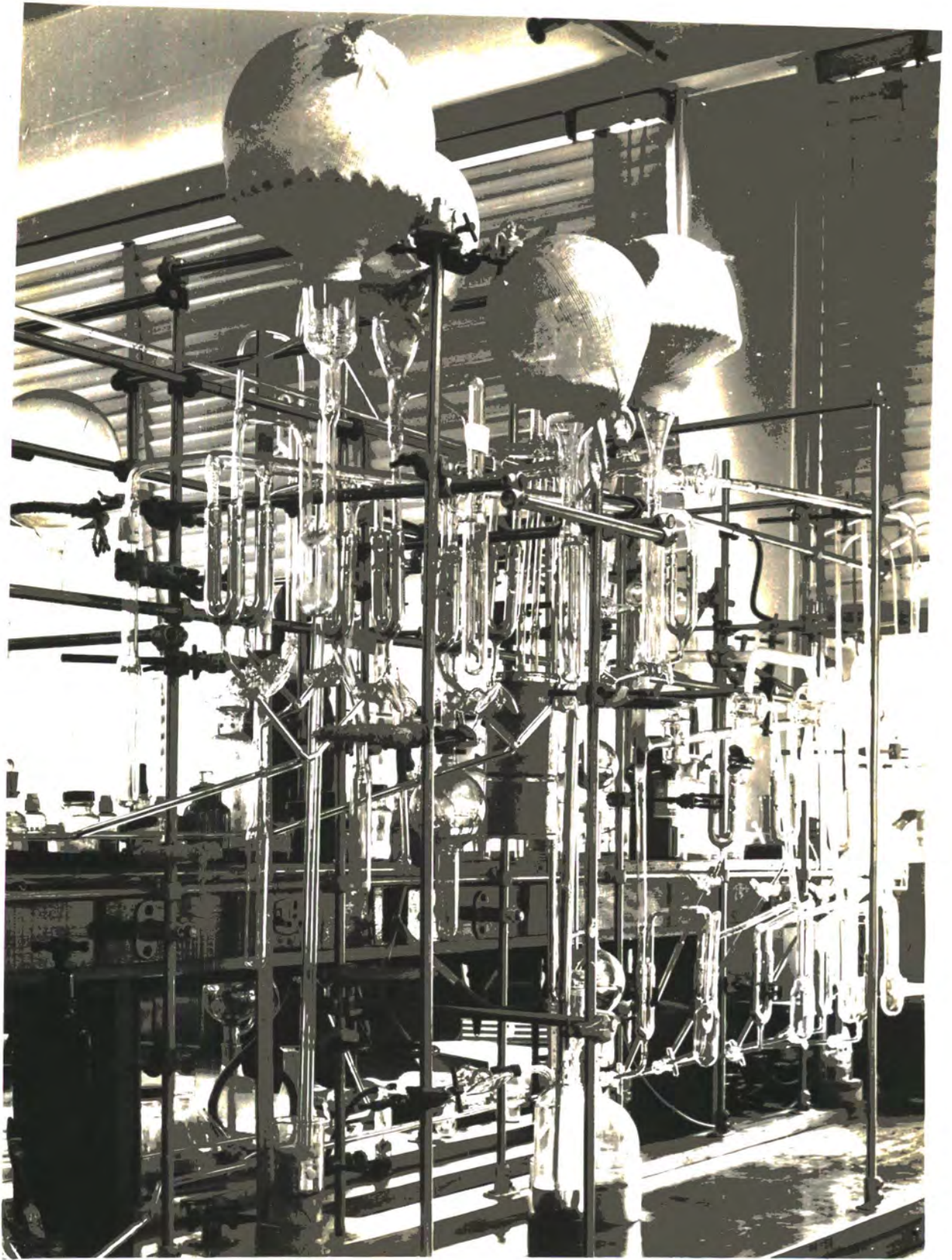

Photograph I.

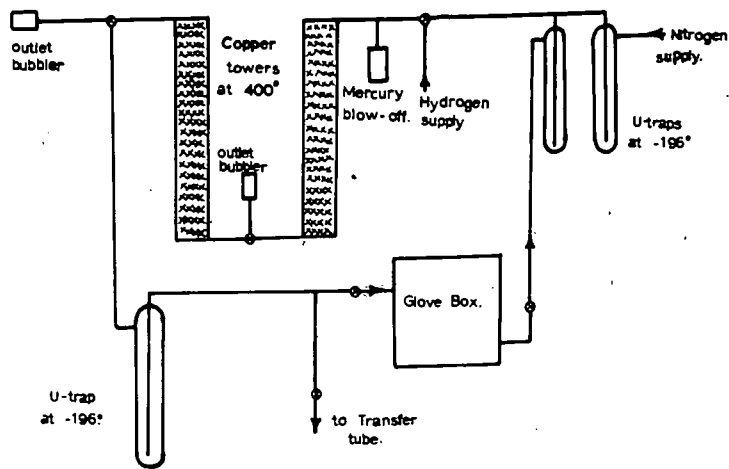

FIG. IV THE GLOVE BOX.

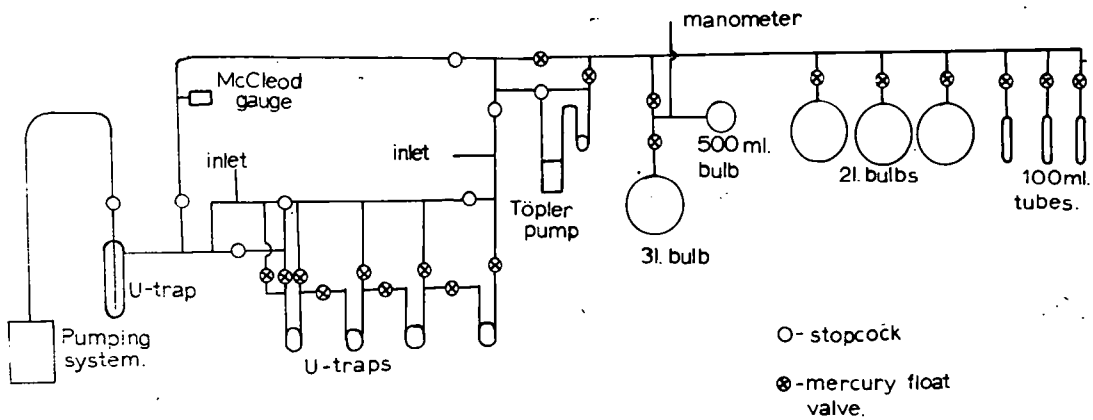

FIG. V The vacuum line.

was maintained. The furnaces were regenerated when necessary by passing hydrogen over the oxidised copper.

Vacuum System.¹²⁸

A vacuum system (Photograph I, Fig. V) was used for the separation, measurement and storage of volatile compounds.

Evacuation was effected using a rotary oil pump backing a mercury diffusion pump. Access to the system was possible at four points, utilising B14 and S19 sockets.

Compounds which were gases at room temperature were stored in 2 or 3 litre bulbs; volatile liquids were stored in 100ml. tubes. These storage vessels were separated from the main manifold by U shaped mercury float valves.

Volatile compounds with negligible vapour pressure at -196° could be measured in a system of standard bulbs.

A small (ca. 600ml.) bulb, connected to a manometer, and to the main manifold by a mercury float valve, could handle small volumes of gas; larger volumes were allowed to fill both the small bulb and a large (ca. 3l.) bulb, which were interconnected by a mercury float valve. The system was calibrated to a reference mark on the manometer using weighed samples of carbon dioxide.

Calibration of the Standard Bulbs.

Volume of two bulbs to reference mark	3028ml.
Volume of small bulb to reference mark	592ml.
Volume of 1cm. length of manometer	1.2ml.
Rise in mercury level of reservoir for a fall of 1cm. in the manometer level	0.038cm.

Permanent gases were measured using the Töpler pump, which delivered the gas into two standard bulbs. Large volumes of gas were measured using both bulbs; small volumes were compressed into the smaller bulb alone. The bulbs were standardised before erection of the line by filling them with mercury, and weighing the mercury.

Calibration of the Töpler Pump.

Volume of two bulbs	148.1ml.
Volume of small bulb	17.5ml.

When necessary, a gas combustion bulb or an infrared gas cell, could be attached to an inlet adjacent to the Töpler pump.

The fractionation section consisted of four U traps, each connected to adjacent traps and to the main manifold by mercury float valves.

Spectra.

Infrared Spectra.

Infrared Spectra in the range 2.5-25 microns were recorded on either a Grubb-Parsons GS2A prism-grating spectrophotometer or a Spectromaster. 'Fingerprint' spectra for identification purposes were recorded on a Perkin-Elmer Infracord.

Far Infrared Spectra in the range 20-50 microns were recorded on a Grubb-Parsons DB3/DM2 caesium iodide spectrometer.

Condensed phase spectra were recorded using samples in the form of nujol mulls or contact films between potassium bromide plates. These samples were made up in the glove box. Gas phase spectra were recorded using a 10cm. cell with potassium bromide windows.

Nuclear Magnetic Resonance Spectra.

Nuclear Magnetic Resonance Spectra were recorded on a Perkin-Elmer R10 spectrometer, operating at 60 Mc/sec.

Samples were made up as 20% solutions in benzene, or in perdeuteriobenzene or perdeuteriotoluene when the solvent peak masked peaks due to the specimen. The internal reference standard was either benzene itself, or tetramethylsilane. The sample tubes were filled by syringe against a counter-current of nitrogen, and were sealed under nitrogen.

Mass Spectra.

Mass spectra were recorded on an A.E.I. M.S.9 mass spectrometer at 70 eV and an accelerating potential of 8 kv, with a source temperature of 150-250° and electromagnetic scanning. Compounds were introduced by direct insertion into the ion source.

Analytical Methods.

Carbon and Hydrogen Analyses.

Carbon and Hydrogen determinations on the less air-sensitive materials were carried out by conventional microanalytical combustion techniques.

Hydrolyses.

Alkyl groups attached to aluminium and lithium were determined by hydrolysis, and volumetric measurement of the hydrocarbon evolved in the vacuum line.

A sample of material was weighed into a two necked flask, fitted with a dropping funnel. The flask was evacuated, and the sample hydrolysed with a few ml. 2-methoxyethanol followed by dilute sulphuric acid.

The gases evolved were fractionated, and collected and measured in the Töpler pump.

When a mixture of hydrogen and methane was produced, analysis was accomplished by compressing a measured sample of the mixture into

a 200ml. bulb with excess oxygen, and igniting it by passing an electric current through a platinum coil. The carbon dioxide produced could be measured directly, and the water condensed on to lithium aluminium hydride and the hydrogen produced measured in the Töpler pump.

Aluminium Analyses.

The aluminium content of the hydrolysate from the above analyses was determined by the E.D.T.A. method.¹²⁹

Organic matter was destroyed by repeatedly boiling the hydrolysate to dryness with c. nitric acid. The resulting white solid was dissolved in the minimal amount of dilute sulphuric acid, and made up to 500ml. with distilled water. 50ml. aliquots were taken, the pH was adjusted to 4.5 with 0.5N sodium hydroxide solution, buffered with hexamethylene-tetramine, and a known excess of 0.01M 'EDTA' solution was added, followed by several drops of xylenol orange indicator. The solution was warmed to 40° and back titrated with 0.01M zinc acetate solution.

Beryllium Analyses.

Beryllium was determined by titrating the alkaline solution formed by addition of excess potassium fluoride to beryllium hydroxide.

Aliquots of a standard beryllium solution, (0.01M BeSO₄) were made up to cover the range 0-6 mg. Be²⁺. To each was added 5ml.

0.5M potassium tartrate solution, and 2 drops of 0.1% alcoholic solution of bromothymol blue, and the solution was titrated with dilute sodium hydroxide to a green end-point. 5ml. M potassium fluoride solution was added, and the resulting blue solution was set aside for 2 minutes before titrating with 0.1N sulphuric acid to a green end-point. A linear calibration plot of beryllium concentration against volume of acid titrant was plotted.

The solutions resulting from hydrolysis of the compounds to be analysed were treated in the same way after boiling to dryness to destroy organic matter, as described previously.

Lithium Analyses.

Lithium was determined by flame photometry.

A weighed sample of the lithium containing material was hydrolysed with water, and organic matter was destroyed as described above. The resulting white solid was dissolved in distilled water and made up to a known volume. This solution was introduced into an EEL flame photometer, previously calibrated with standard lithium solutions, and the lithium concentration read directly from the calibration curve.

Nitrogen Analyses.

Nitrogen was determined by the normal Kjeldahl method.

A weighed sample was hydrolysed with a little water, and boiled with c. sulphuric acid until all the nitrogen was reduced to ammonia.

The solution was transferred to a small Kjeldahl flask, made alkaline with caustic soda, and boiled. The ammonia was steam distilled into a flask containing a known volume of standard acid. The excess acid was then titrated with standard alkali.

Molecular Weights.

Molecular weights were determined, where solubility limitations permitted, cryoscopically in 'Analar' grade benzene, dried over extruded sodium. The cryoscopic constant of the benzene was determined using freshly sublimed biphenyl. A conventional Beckmann apparatus was flushed out with nitrogen before each determination, and during the determination air was excluded by passing a current of nitrogen through the apparatus slowly enough to cause negligible loss of solvent by evaporation.

Solvents.

Solvents (pentane, hexane, benzene, toluene and diethyl ether) were dried and stored over extruded sodium.

Preparation and Purification of Starting Materials.

Organic Reagents.

Acetonitrile, propionitrile and benzonitrile were purified by distillation from phosphorus pentoxide.

Dimethylcyanamide was purified by distillation (b.p. 160°).

N,N,N',N'-Tetramethylguanidine and Pyridine were purified by distillation from sodium hydroxide pellets, and stored over sodium hydroxide.

Diphenylketimine.

Diphenylketimine was prepared by the method of Pickard and Tolbert,¹³⁰ from benzonitrile and phenylmagnesium bromide. Bromobenzene (78.5g., 0.5 mole) was added slowly to magnesium turnings (12.5g., 0.51g. atom) in diethyl ether (300ml.). When the reaction was complete, the solution was cooled to room temperature, and benzonitrile (46.5g., 0.45 mole) was added slowly. The resultant slurry was stirred at the reflux temperature for eight hours, and then allowed to cool to room temperature. Anhydrous methanol (96g., 3 moles) was added, and the solid was removed by filtration. Diethyl ether was distilled off, and the residual liquid distilled under vacuum, discarding the first 5ml. B.p. $92^{\circ}/10^{-3}$ m.m. Yield, 75%.

Di-p-tolylketimine.

Di-p-tolylketimine was prepared by an exactly analogous method from p-tolyl cyanide, and p-tolylmagnesium bromide.¹³¹

Trialkylaluminium Compounds.

Technical grade trimethylaluminium and triethylaluminium were purified by distillation, the former (b.p. 125°) under nitrogen, the latter under reduced pressure.

Triphenylaluminium.

Triphenylaluminium was prepared by reacting aluminium metal with diphenylmercury in refluxing toluene solution.⁷³

Diphenylmercury (20g., 56 m.moles) was heated with aluminium turnings (9g., 330 m.moles) in toluene (120ml.) for 36 hours. The hot solution was filtered, and colourless crystals of triphenylaluminium (m.p. 238-243°, decomp.) were obtained in 60% yield.

Dimethylaluminium Hydride.

Dimethylaluminium hydride was prepared from lithium aluminium hydride and trimethylaluminium.¹⁰

Lithium aluminium hydride (10g., 263 m.mole) in dry cyclohexane (50ml.) were reacted with trimethylaluminium (10g., 139 m.mole) for 24 hours at 70° in a thick walled Pyrex tube sealed under nitrogen.

The resultant dimethylaluminium hydride, together with the cyclohexane, was distilled under vacuum into a two-necked flask. The concentration of the solution was determined by hydrolysing a known volume and measuring the mixture of hydrogen and methane evolved. Yield = 7g. (85%).

Diethylaluminium Hydride.

Diethylaluminium hydride, a gift from Ethyl Corporation, was found to be sufficiently pure for use without further treatment.

Trimethylamine-dichloroalane.

Trimethylamine-dichloroalane was prepared by reaction of trimethylamine-alane with mercuric chloride.⁷⁸ Trimethylamine-alane was prepared by reaction of trimethylammonium chloride with lithium aluminium hydride in diethyl ether.⁵⁹

Trimethylamine (3.4g., 58 m.mole) was condensed on to diethyl ether (100ml.) at -196° . The mixture was warmed to -78° , and dry hydrogen chloride was bubbled through the stirred solution until no further precipitation occurred. Solvent was distilled off under vacuum, and the trimethylammonium chloride was pumped dry. Lithium aluminium hydride (2.2g., 58 m.mole) was dissolved in diethyl ether (100ml.) and the trimethylammonium chloride was added slowly against a countercurrent of nitrogen. When evolution of hydrogen ceased, solvent was pumped off, and the trimethylamine-alane was purified by vacuum sublimation. M.p. $75-6^{\circ}$, yield 85%.

Trimethylamine-alane (1.5g., 17 m.mole) was dissolved in diethyl ether (50ml.) and mercuric chloride (5.4g., 20 m.mole) was added slowly against a countercurrent of nitrogen. When hydrogen evolution ceased, the solvent was pumped off, and the trimethylamine-dichloroalane was purified by vacuum sublimation. M.p. $102-3^{\circ}$, yield 29%

Aluminium halides.

Aluminium chloride, a gift from Imperial Smelting, was sufficiently pure for use without further treatment. Aluminium bromide was purified

by vacuum sublimation.

Beryllium chloride.

A sample of beryllium chloride, provided by Mr. T. Caygill of these laboratories, was prepared by reaction of chlorine gas with beryllium metal.

Triphenylgallium.

Triphenylgallium was prepared from diphenylmercury and gallium metal.¹³² Diphenylmercury (20g., 56 m.mole) and gallium metal (3.94g., 56 m.mole) were heated in an atmosphere of nitrogen at 150° for 3 days. One crystal of mercuric chloride was added to catalyse the reaction. When the melt had set to a white solid, the reaction vessel was cooled, and triphenylgallium was recrystallised from toluene.

Methyl-lithium.

Methyl-lithium was prepared by the reaction of methyl chloride with lithium metal in diethyl ether. Methyl chloride was supplied under pressure in a cylinder, lithium metal as a suspension in a hydrocarbon wax, which could be washed off with ether before use.

Methyl chloride was bubbled through a suspension of lithium metal (14g., 2g. atom) in ether (500ml.) in a nitrogen filled, one litre, three necked flask, fitted with a stirrer, a condenser maintained at -78° and an inlet for the methyl chloride. The gas was passed at a rate (indicated by a flow meter) of 25g. (1 mole)

per hour, for two hours. The reaction started immediately, and on completion, the solution of methyl-lithium was filtered from lithium chloride and unreacted lithium metal, and stored at -30° as an ether solution. Analysis, by acid hydrolysis and measurement of the methane evolved, indicated a yield of 60%.

Ethyl-lithium.

Ethyl-lithium was prepared by a similar reaction between ethyl chloride and lithium metal in diethyl ether.

Ethyl chloride (45g., 0.7 moles) in diethyl ether (50ml.) was cooled to -78° and added slowly to a stirred suspension of lithium metal (10g., 1.4g. atom) in diethyl ether (600ml.) at 0° . The solution was stirred at 0° for 12 hours, solvent was removed under vacuum, and toluene (300ml.) was added. The resultant solution was filtered, and analysed by acid hydrolysis and measurement of the ethane produced. Yield, 50%.

Diphenylketiminolithium.

Diphenylketiminolithium was prepared by the action of alkyl-lithium compounds (normally methyl-lithium or n-butyl-lithium) on diphenylketimine in diethyl ether.¹³³ Since the product crystallised very readily, forming insoluble polymeric species, it was prepared in sufficient quantity for reaction in situ, and no attempt was made to store it.

Methyl-lithium (0.86g., 39 m.mole) in diethyl ether (35ml.) was added slowly to a solution of diphenylketimine (7.0g., 39 m.mole) in diethyl ether (80ml.) at -196° . The solution was allowed to warm slowly; at about -80° , a bright red colour developed, and methane was evolved. The clear red solution was stirred at 20° for 30 minutes, to ensure complete reaction, and used immediately.

Di-p-tolyketiminolithium.

Di-p-tolyketiminolithium was made by an exactly analogous method, from di-p-tolyketimine, and an alkyl-lithium compound.¹³⁴

N-trimethylsilyldiphenylketimine.

N-trimethylsilyldiphenylketimine was prepared by reaction of diphenylketiminolithium with trimethylchlorsilane in diethyl ether.¹³⁵

Diphenylketiminolithium (18.7g., 100 m.mole) in diethyl ether (200ml.) was cooled to -196° . Trimethylchlorsilane (10.9g., 100 m. mole) was added, and the solution was allowed to warm to room temperature. Below 0° the red colour faded, and a precipitate of lithium chloride was formed. The solution was stirred at 20° for one hour, and then filtered. Ether was distilled off and the residual yellow liquid was vacuum distilled (b.p. $138^{\circ}/3\text{m.m.}$).

Reactions of Diphenylketimine with Organo derivatives of Aluminium and Gallium.

Reaction of diphenylketimine with trimethylaluminium.

Trimethylaluminium (0.54g., 7.5 m.mole) was added slowly by syringe to a solution of diphenylketimine (1.35g., 7.5 m.mole) in 10ml. hexane at -78° . The solution was warmed to 20° , filtered, and then cooled to -78° , when white needles of the adduct diphenylketimine-trimethylaluminium, $\text{Ph}_2\text{C:NH,AlMe}_3$, m.p. $76-76.5^{\circ}$ crystallised and were collected and pumped dry. (Found: Al, 10.2; hydrolysable methyl, 19.0%; \underline{M} , 267. $\text{C}_{16}\text{H}_{20}\text{AlN}$ requires Al, 10.7; hydrolysable methyl, 19.0%; \underline{M} , 253). ν_{max} (nujol mull) 3290ms, 3068w, 2890s, 2809m, 1608sh, 1605s, 1572s, 1499w, 1491m, 1451s, 1414s, 1250ms, 1198sh, 1179s, 1172ms, 1160sh, 1083sh, 1079w, 1034w, 1002m, 998sh, 972vw, 936ms, 934ms, 912ms, 875s, 789s, 764s, 727sh, 694vs, 668sh, 649sh, 623ms, and 523m cm^{-1}

N.M.R. Data.*

τ values:- 1.2_0 s (1), 2.8 m (4), 3.0_5 m (6) and 10.4_5 s (9).
20% solution in perdeuteriobenzene; tetramethylsilane as internal reference standard.

* The following abbreviations are used throughout in describing N.M.R. spectra; s = singlet, d = doublet, t = triplet, q = quartet, m = multiplet, br = broad; relative intensities in parentheses.

Thermal Decomposition of $\text{Ph}_2\text{C:NH,AlMe}_3$.

Samples of the adduct $\text{Ph}_2\text{C:NH,AlMe}_3$ heated for 2 hours at 100° in evacuated tubes generated 1 mol. of methane per mol. of adduct leaving a colourless crystalline residue which after recrystallisation from toluene was identified as the azomethine derivative dimethyl-(α -phenylbenzylideneamino)aluminium dimer, $(\text{Ph}_2\text{C:NAlMe}_2)_2$, m.p. $172-173.5^\circ$. (Found: Al, 11.4; hydrolysable methyl, 13.1%; \underline{M} , 458. $\text{C}_{30}\text{H}_{32}\text{Al}_2\text{N}_2$ requires Al, 11.4; hydrolysable methyl, 13.5%; \underline{M} , 474). ν_{max} (nujol mull) 1616s, 1600sh, 1577m, 1264s, 1182w, 1083s, 1017vs, 951m, 910w, 795s, 787s, 713sh, 697vs, 678s, 667m, and 573vw cm^{-1}

N.M.R. Data.

τ values:- 2.5_3 m (2), 2.9_0 m (3) and 10.4_8 s (3). 20% solution in perdeuteriobenzene; tetramethylsilane as internal reference standard.

Reaction of diphenylketimine with triethylaluminium.

Triethylaluminium (1.74g., 9.6 m.mole) was added slowly by syringe to a stirred solution of diphenylketimine (1.10g., 9.6 m.mole) in 10ml. hexane at 20° . The solution became warm, but no gas evolution was observed. The hexane was pumped off, leaving an orange viscous liquid which could not be distilled without decomposition. This was identified as the adduct, $\text{Ph}_2\text{C:NH,AlEt}_3$. (Found: hydrolysable ethyl:aluminium ratio, 2.7:1.0. $\text{C}_{19}\text{H}_{26}\text{AlN}$ requires hydrolysable ethyl:

aluminium ratio, 3.0:1.0). ν_{\max} (liquid film) 3268w, 3058m, 3012w, 2924s, 2882s, 2849vs, 2786m, 2717vw, 1812vw, 1627sh, 1594s, 1575s, 1502sh, 1497w, 1466sh, 1458s, 1412s, 1368m, 1319w, 1292w, 1271sh, 1250m, 1196sh, 1185m, 1163m, 1107m, 1073ms, 1031m, 1001m, 987ms, 951ms, 936m, 913ms, 891sh, 872ms, 845w, 789s, 767s, 739w, 729w, 719sh, 699vs, 679s, 667sh, 642s, and 622s cm^{-1}

N.M.R. Data.

τ values:- 0.4₀ s (1), 2.7 br (4), 2.9₅ m (6), 8.8₇ t (9), and 10.1₂ q (6). 20% solution in perdeuteriobenzene; tetramethylsilane as internal reference standard.

Thermal Decomposition of $\text{Ph}_2\text{C:NH,AlEt}_3$.

Triethylaluminium (2.64g., 23.2 m.mole) was added slowly by syringe to a stirred solution of diphenylketimine (4.2g., 23.2 m.mole) in 10ml. hexane. The solution was boiled overnight, after which the hexane was removed by pumping at 20°. The residual moist yellow solid was dissolved in a mixture of hexane (15ml.) and toluene (5ml.), the solution was filtered, and the filtrate when cooled to -78° deposited colourless crystals of diethyl-(α -phenylbenzylideneamino)-aluminium dimer, $(\text{Ph}_2\text{C:NAEt}_2)_2$, m.p. 115-117° after a further recrystallisation from hexane/toluene. (Found: C, 78.1; H, 7.2; Al, 10.6%; \underline{M} , 538. $\text{C}_{34}\text{H}_{40}\text{Al}_2\text{N}_2$ requires C, 77.1; H, 7.6; Al, 10.2%; \underline{M} , 530). ν_{\max} (nujol mull) 3058w, 3021w, 2793w, 2725vw, 1609vs,

1580s, 1565sh, 1511vw, 1495w, 1451s, 1421m, 1326m, 1297ms, 1277ms, 1233w, 1190w, 1164w, 1104sh, 1080m, 1032w, 1023sh, 1006m, 993sh, 990m, 955s, 929s, 898vw, 849m, 793sh, 786vs, 735w, 709vs, 702vs, 682s, 668vw, 649vs, 618m, 602m, 577m, 511w, 474sh, and 471s cm^{-1}

N.M.R. Data.

τ values:- 2.4_5 m (2), 2.8_6 m (3), 8.7_9 t (3), and 9.8_9 q (2).
20% solution in perdeuteriobenzene; tetramethylsilane as internal reference standard.

Reaction of diphenylketimine with triphenylaluminium.

Diphenylketimine (0.06g., 0.3 m.mole) in 1ml. toluene was added to triphenylaluminium (0.08g., 0.3 m.mole) in 1ml. toluene at -196° . The mixture at 20° was a clear solution; removal of solvent by pumping gave the viscous yellow liquid adduct, $\text{Ph}_2\text{C:NH,AlPh}_3$ which was found to decompose slowly at 20° . ν_{max} (liquid film) 3257m, 3058s, 3003sh, 1957w, 1898w, 1818w, 1776w, 1661m, 1603s, 1570s, 1492m, 1449s, 1425m, 1364s, 1321w, 1302w, 1280w, 1261m, 1198s, 1178s, 1152m, 1086s, 1031s, 1002m, 971w, 933s, 887s, 788s, 761s, 730w, 720w, 696vs, 654w, 639w, 622s, 570m, 515m, and 481m cm^{-1}

N.M.R. Data.

τ values:- 0.4_5 s (1), 2.1 br, and 2.6-3.0 m (25). 20% solution in perdeuteriotoluene; tetramethylsilane as internal reference standard.

Thermal Decomposition of $\text{Ph}_2\text{C}:\text{NH}, \text{AlPh}_3$.

Diphenylketimine (0.35g., 1.9 m.mole) was added slowly to a stirred solution of triphenylaluminium (0.50g., 1.9 m.mole) in 10ml. toluene at 20° . After 2 days at 20° , the solution was concentrated by pumping off some solvent, filtered and cooled to -78° , when white crystals of diphenyl-(α -phenylbenzylideneamino)aluminium dimer, $(\text{Ph}_2\text{C}:\text{NAlPh}_2)_2$ m.p. 295° were deposited and identified by comparison of their infrared spectrum with that of an authentic sample of this compound prepared from Ph_3Al and PhCN .³³ ν_{max} (nujol mull) 3058m, 3030w, 3003m, 1620sh, 1604s, 1575m, 1490sh, 1479w, 1445ms, 1423m, 1366w, 1316w, 1290w, 1264m, 1248w, 1191vw, 1156vw, 1091ms, 1083ms, 1024w, 1001w, 997sh, 952m, 923w, 914m, 887vw, 863vw, 842vw, 789s, 762vw, 734sh, 730ms, 708vs, 703vs, 698vs, 686s, 676sh, 670sh, 661sh, 628m, 614vw, 564m, and 484s cm^{-1} .

Reaction of diphenylketimine with triphenylgallium.

Diphenylketimine (0.51g., 2.8 m.mole) was added slowly to a stirred solution of triphenylgallium (0.85g., 2.8 m.mole) in 5ml. toluene at 20° . The solution became warm and removal of solvent under vacuum left the viscous yellow adduct $\text{Ph}_2\text{C}:\text{NH}, \text{GaPh}_3$. ν_{max} (liquid film) 3268m, 3058s, 3003ms, 2916w, 1961w, 1887w, 1818w, 1595vs, 1563vs, 1493m, 1477m, 1447s, 1421s, 1395s, 1359ms, 1299w, 1253s, 1238sh, 1192m, 1177sh, 1159m, 1078vs, 1027s, 999ms, 973w, 934m, 909m,

879m, 788vs, 765s, 729vs, 698vs, 661s, 643s, 622s, 544m, and 447s cm^{-1}

N.M.R. Data.

τ values:- 0.5₈ s (1), 2.3 br and 2.7-3.1 m (25). 20% solution in perdeuteriobenzene; tetramethylsilane as internal reference standard.

Thermal Decomposition of $\text{Ph}_2\text{C:NH, GaPh}_3$.

Diphenylketimine (0.87ml., 5.2 m.mole) was added slowly to a stirred solution of triphenylgallium (1.56g., 5.2 m.mole) in 20ml. toluene at 20°. The solution was boiled for 2½ hours and then cooled to room temperature, when colourless crystals of diphenyl-(α -phenylbenzylideneamino)gallium dimer, $(\text{Ph}_2\text{C:N}\cdot\text{GaPh}_2)_2$ m.p. 302-3° were deposited. These were washed with hexane and pumped dry. (Found: C, 72.6; H, 4.8%; $\text{C}_{50}\text{H}_{40}\text{Ga}_2\text{N}_2$ requires C, 74.3; H, 5.0%). ν_{max} (nujol mull) 3058w, 1623w, 1612s, 1464ms, 1451ms, 1431m, 1381m, 1319w, 1290w, 1266s, 1092vs, 1025s, 1004sh, 954m, 923w, 912w, 863w, 842w, 801vs, 735sh, 730ms, 699vs, 674m, 668m, 535m, 465ms, and 450m cm^{-1}

Reaction of diphenylketimine with triphenylaluminium (3:1 molar proportions).

Diphenylketimine (0.58g., 3.21 m.moles) were added to triphenylaluminium (0.28g., 1.07 m.moles) at -196° in a tube under nitrogen. The vessel was evacuated, sealed, and heated to 100° for 24 hours.

On opening the tube to the vacuum line, benzene (0.074g., 0.94 m.moles) was recovered, and identified by its infrared spectrum. On reheating the tube to 170° for a further 24 hours, more benzene (0.047g., 0.60 m.moles) was recovered.

Reactions of Tetramethylguanidine with Trimethylaluminium.

Reaction of tetramethylguanidine with trimethylaluminium (1:1 molar proportions).

Trimethylaluminium (0.72g., 10 m.mole) was added slowly by syringe to a solution of tetramethylguanidine (1.15g., 10 m.mole) in hexane (15ml.) at -196°. A white solid was precipitated on warming the solution to room temperature; this was dissolved by the addition of the minimum amount of toluene. After filtration, the solution was cooled to -78°, and crystals of the adduct $(Me_2N)_2C:NH \cdot AlMe_3$, m.p. 44-5° were obtained. (Found: Al, 14.8; hydrolysable methyl, 23.6%; \underline{M} , 270. $C_8H_{22}AlN_3$ requires Al, 14.4; hydrolysable methyl, 24.1%; \underline{M} , 187). ν_{max} (nujol mull) 3356ms, 1612s, 1579s, 1553s, 1337m, 1263ms, 1232w, 1171m, 1135ms, 1066s, 1041ms, 1018s, 903mw, 797s, 751w, 720ms, 690ms, 667sh, 612w, 585w, and 515m cm^{-1}

N.M.R. Data.

τ values:- 5.5₈ s (1), 7.6₉ s (12) and 10.4₄ s (9). 20% solution in perdeuteriobenzene; tetramethylsilane as internal reference standard.

Reaction of tetramethylguanidine with trimethylaluminium (1:2 molar proportions).

Trimethylaluminium (1.44g., 20 m.moles) was added slowly by syringe to a solution of tetramethylguanidine (1.15g., 10 m.moles) in hexane (30ml.) at -196° . On warming to room temperature, a white solid was precipitated. Solvent was filtered off, and the solid was washed thoroughly at -78° with hexane. The combined washings were removed by syringe and pumped through a trap at -23° . Trimethylaluminium (0.7g., 10 m.mole) was recovered. The solid, m.p. $45-6^{\circ}$ was found to have an identical infrared spectrum to that of the 1:1 adduct. (Found: hydrolysable methyl, 23.9%. $C_8H_{22}AlN_3$ requires hydrolysable methyl, 24.1%).

Thermal Decomposition of $(Me_2N)_2C:NH \cdot AlMe_3$.

Trimethylaluminium (1.44g., 20 m.mole) was added slowly by syringe to tetramethylguanidine (2.30g., 20 m.mole) at -196° in a tube under nitrogen. The vessel was evacuated, sealed, and heated at 180° for 10 minutes. On opening the tube to the vacuum line, methane (0.315g., 19.7 m.mole) and dimethylamine (0.095g., 2.1 m.mole) were recovered, and identified from their infrared spectra and vapour pressure measurements. The solid residue was removed from the tube and dissolved in hot toluene. After filtration and cooling, the solution afforded crystals of the N-dimethylaluminium-N',N'',N''',N''''-

tetramethylguanidine derivative $[(\text{Me}_2\text{N})_2\text{C}=\text{NAlMe}_2]_n$. (Found: Al, 17.0; hydrolysable methyl, 17.4%. $\text{C}_7\text{H}_{18}\text{AlN}_3$ requires Al, 17.2; hydrolysable methyl, 17.5%). ν_{max} (nujol mull) 1618s, 1548vs, 1499s, 1318m, 1266m, 1232w, 1172s, 1144s, 1058sh, 1044s, 996m, 916m, 869ms, 795s, 752s, 734s, 693s, 663sh, 657s, 555m, and 515w cm^{-1}

Reactions of Dimethylcyanamide with Aluminium Alkyls.

Reaction of dimethylcyanamide with trimethylaluminium (1:1 molar proportions).

Trimethylaluminium (1.44g., 20 m.mole) was added slowly by syringe to a solution of dimethylcyanamide (1.4g., 20 m.mole) in hexane (10ml.) at -196° . The solution was warmed to room temperature with stirring, and the solvent was removed under vacuum. The residual white solid was dissolved in toluene (3ml.) and hexane (5ml.), and the resultant solution was filtered and cooled to -30° , when crystals of the adduct, $\text{Me}_2\text{NC}:\text{N}\cdot\text{AlMe}_3$, m.p. $40-41^\circ$ were deposited. These were washed at -78° with hexane, and pumped dry. (Found: Al, 19.3; hydrolysable methyl, 31.0%; $\underline{\text{M}}$, 148. $\text{C}_6\text{H}_{15}\text{AlN}_2$ requires Al, 19.0; hydrolysable methyl, 31.7%; $\underline{\text{M}}$, 142). ν_{max} (nujol mull) 2257s, 2208sh, 1263w, 1178s, 1095m, 1063s, 774s, 692vs, 667sh, 619s, and 522s cm^{-1}

N.M.R. Data.

τ values:- 7.9_2 s (2) and 10.3_0 s (3). 20% solution in benzene; solvent as internal reference standard.

Reaction of dimethylcyanamide with trimethylaluminium (1:2 molar proportions).

Trimethylaluminium (1.44g., 20 m.mole) was added slowly by syringe to a solution of dimethylcyanamide (0.70g., 10 m.mole) in hexane (30ml.) at -196° . A white solid was deposited on warming to room temperature. This was filtered off, and washed repeatedly with 10ml. aliquots of hexane. The combined washings were removed by syringe, and pumped through a trap at -23° . Trimethylaluminium (0.7g., 10 m.mole) was recovered. The solid was pumped dry, and its infrared spectrum was found to be identical with that of the 1:1 adduct. (Found: hydrolysable methyl, 30.5%. $C_6H_{15}AlN_2$ requires hydrolysable methyl 31.7%).

Thermal Decomposition of $Me_2NC:N \cdot AlMe_3$.

Trimethylaluminium (1.44g., 20 m.mole) was added to dimethylcyanamide (1.40g., 20 m.mole) at -196° in a tube under nitrogen. The vessel was evacuated, sealed, and heated at 115° for 30 minutes. On opening the tube to the vacuum line, methane (0.349g., 21.8 m.mole), hydrogen (0.004g., 2.2 m.mole), ethylene (0.017g., 0.6 m.mole) and dimethylamine (0.018g., 0.4 m.mole) were recovered and identified

either by their infrared spectra, or by their vapour pressures at standard temperatures.

Colourless volatile crystals sublimed from the solid residue at ca. 50° , and were identified as dimethylaminodimethylaluminium dimer $(\text{Me}_2\text{NAlMe}_2)_2$ by analysis, and by comparison of their infrared spectrum with the spectrum reported in the literature.¹³⁶ (Found: hydrolysable methyl, 29.0%. $\text{C}_8\text{H}_{24}\text{Al}_2\text{N}_2$ requires hydrolysable methyl, 29.7%). ν_{max} (nujol mull) 1595w, 1264w, 1236m, 1199s, 1167wm, 1120s, 1043s, 1025sh, 981w, 901s, 783wm, 690s, 584s, 509s cm^{-1}

N.M.R. Data.

τ values:- 7.8₀ s (1) and 10.4₈ s (1). 20% solution in benzene; solvent as internal reference standard.

The brown involatile solid residue reacted vigorously with alcohols and water, but was completely insoluble in inert organic solvents.

ν_{max} (nujol mull) 2172m, 1550s, 1266mw, 1192m, 1066w, 1023w, 792s, and 684s cm^{-1}

Reaction of dimethylcyanamide with dimethylaluminium hydride.

Dimethylaluminium hydride (0.91g., 15.6 m.mole) in hexane (25ml.) was slowly added by syringe to dimethylcyanamide (1.10g., 15.6 m.mole) in toluene (5ml.) at -196° . The solution was warmed to room temperature with stirring, when a white solid was deposited. Solvent

was removed under vacuum, and the solid was dissolved in hot toluene (15ml.). After filtration and cooling, colourless crystals of dimeric N-dimethylaluminium-N',N'-dimethylformamidine, $(\text{Me}_2\text{NCH:N}\cdot\text{AlMe}_2)_2$ m.p. $184-8^\circ$ (d) were obtained. (Found: Al, 20.9; hydrolysable methyl, 23.5%; \underline{M} , 258. $\text{C}_{10}\text{H}_{26}\text{Al}_2\text{N}_4$ requires Al, 21.1; hydrolysable methyl, 23.4%; \underline{M} , 256). ν_{max} (nujol mull) 1658sh, 1623vs, 1256mw, 1188m, 1100ms, 1060w, 1019w, 987w, 872mw, 753s, 686sh, 671vs, 668sh, and 596m cm^{-1}

N.M.R. Data

τ values:- 7.4-7.9 m (6), 8.1₂ s (1), and 10.3₅ s (6). 20% solution in benzene; solvent as internal reference standard.

Reaction of dimethylcyanamide with triethylaluminium.

Triethylaluminium (1.14g., 10 m.mole) was added slowly by syringe to dimethylcyanamide (1.20g., 10 m.mole) at -196° under nitrogen in a two necked flask. On warming to room temperature, the liquid adduct, $\text{Me}_2\text{NC:N}\cdot\text{AlEt}_3$ was obtained. (Found: Al, 14.8; hydrolysable ethyl, 47.2%. $\text{C}_9\text{H}_{21}\text{AlN}_2$ requires Al, 14.7; hydrolysable ethyl, 47.3%). ν_{max} (liquid film) 2924s, 2882s, 2849s, 2793sh, 2268s, 2212s, 1656m, 1623m, 1376m, 1339m, 1227sh, 1192m, 1099sh, 1058s, 987s, 947mw, 917w, 899w, 800m, 775s, 764sh, 690sh, 646vs, and 525m cm^{-1}

N.M.R. Data

τ values:- 7.6₂ s (2), 8.7₅ t (3) and 10.0₀ q (2). 20% solution in benzene; solvent as internal reference standard.

Thermal Decomposition of $\text{Me}_2\text{NC:N}\cdot\text{AlEt}_3$.

Triethylaluminium (2.28g., 20 m.mole) was slowly added by syringe to dimethylcyanamide (1.40g., 20 m.mole) in a tube under nitrogen. The vessel was evacuated, sealed, and heated at 115° for 1 hour. On opening the tube to the vacuum line, ethylene (0.35g., 12.5 m.mole), identified by its infrared spectrum, was recovered.

The residual liquid was distilled under vacuum (b.p. 115° at 10^{-3} m.m.), and the distillate was found to be a mixture of dimeric N-diethylaluminium-N',N'-dimethylformamidine ($\text{Me}_2\text{NCH:N}\cdot\text{AlEt}_2$)₂ and the adduct, $\text{Me}_2\text{NC:N}\cdot\text{AlEt}_3$. (Found: Al, 16.0; hydrolysable ethyl, 41.76%. $\text{C}_{14}\text{H}_{34}\text{Al}_2\text{N}_4$ requires Al, 17.3; hydrolysable ethyl, 37.18%. $\text{C}_9\text{H}_{21}\text{AlN}_2$ requires Al, 14.7; hydrolysable ethyl, 47.3%). ν_{max} (liquid film) 2169vw, 1631vs, 1580ms, 1462ms, 1410ms, 1261m, 1238m, 1192m, 1167vw, 1101s, 1073s, 1045s, 988ms, 951m, 913ms, 899ms, 876w, 794m, 753s, 655vs, 644vs, and 607vs cm^{-1}

N.M.R. Data

τ values:- 7.4₉ s, 7.7₀ s, 8.6₄ t, 8.7₁ t, 9.7₅ q, and 9.7₆ q.
20% solution in benzene; solvent as internal reference standard.

Reaction of dimethylcyanamide with diethylaluminium hydride.

Diethylaluminium hydride (0.86g., 10 m.mole) was added slowly by syringe to a solution of dimethylcyanamide (0.70g., 10 m.mole) in hexane (30ml.) at -196° . The solution was warmed to room temperature with stirring, filtered, and cooled to 0° , when colourless crystals of dimeric N-diethylaluminium-N',N'-dimethylformamidine, $(\text{Me}_2\text{NCH:N}\cdot\text{AlEt}_2)_2$ (m.p. $119-120^{\circ}$) separated, and were dried by pumping off solvent. (Found: Al, 17.1; hydrolysable ethyl, 36.4%; \bar{M} , 326. $\text{C}_{14}\text{H}_{34}\text{Al}_2\text{N}_2$ requires Al, 17.3; hydrolysable ethyl, 37.2%; \bar{M} , 312). ν_{max} (nujol mull) 1626vs, 1462ms, 1412m, 1263m, 1230vw, 1183w, 1098s, 1060m, 1022m, 991m, 945mw, 917mw, 876mw, 800ms, 747s, 639s, 623s, 606s, 436mw, and 417m cm^{-1}

N.M.R. Data

τ values:- 4.0_7 m (1), 7.6_1 s (6), 8.4_4 t (6) and 9.5_5 q (4).
20% solution in benzene; solvent as internal reference standard.

Reaction of Alkyl Cyanides with Organolithium Compounds.

Reaction of methyl cyanide with methyl-lithium.

A solution of methyl-lithium (5 m.moles) in diethyl ether (8.5ml.) was added by syringe to methyl cyanide at -196° in a tube. The tube was evacuated, sealed, and allowed to warm to room temperature. All material volatile at -196° was subsequently pumped into the vacuum

line, identified as methane (infrared spectrum) and measured (0.053g., 3.3 m.moles). Ether was then removed under vacuum, leaving a white insoluble powder. (Found: C, 50.7; H, 6.9; Li, 9.1; N, 21.7%). ν_{\max} (nujol mull) 2174sh, 2141s, 2083w, 1653w, 1592w, 1520s, 1342vw, 1316vw, 1266m, 1190w, 1099wm, 1020m, 980vw, 935vw, 903vw, 803m (br), and 723wm cm^{-1} . A substance with essentially the same infrared spectrum and percentage elemental composition was obtained in separate experiments in which the components were mixed at -78° in one limb of a double Schlenk tube, the precipitated product being collected on a filter and pumped dry. Qualitative tests for cyanide anion proved negative, and no alkane was evolved on hydrolysis with dilute acid. When heated with boiling tetrahydrofuran, the substance did not dissolve but changed to a yellow powder. ν_{\max} (nujol mull) 2190m, 1595s, 1550sh, 1302w, 1266w, 1081m, 1020m, 800m, and 722w cm^{-1} .

Reaction of ethyl cyanide with methyl-lithium.

Ethyl cyanide and methyl-lithium, mixed in equimolar proportions in ether, gave a pale yellow precipitate which was collected on a filter and pumped dry. ν_{\max} (nujol mull, region 2800-1500 cm^{-1}) 2128wm, 2045wm, 1639vw, 1580vs, and 1515m cm^{-1} . After a sample had been washed with toluene and hexane and again pumped dry, the spectrum was again recorded. ν_{\max} (nujol mull, region 2800-1500 cm^{-1}) 2183wm, 2045s, 1645w, and 1582vs cm^{-1} . No alkane was obtained when samples of the material were hydrolysed, and a qualitative test for anionic cyanide

was negative.

Reaction of methyl cyanide with ethyl-lithium.

Methyl cyanide (0.41g., 10 m.mole) in toluene (10ml.) was added to a frozen mixture of ethyl-lithium (10 m.moles) and toluene (10ml.) at -196° . The mixture was then heated slowly until the toluene boiled, when a pale yellow precipitate separated. This, after being washed with toluene, had ν_{\max} (nujol mull, $2800-1500\text{ cm}^{-1}$) 2130m(br), 2030ms, 1820vw, 1590sh, and 1524 m cm^{-1} .

Reaction of ethyl cyanide with ethyl-lithium.

Ethyl cyanide (0.55g., 10 m.moles) was added to ethyl-lithium (10 m.mole) in 10ml. ether at -196° . When the mixture was warmed to 20° , a white precipitate separated. (Found: Li, 6.1%). ν_{\max} (nujol mull, $2800-1500\text{ cm}^{-1}$) 2198sh, 2160sh, 2123s, 1639m, 1572s, and 1515 vs cm^{-1} . No ethane was evolved on hydrolysis of a sample, but addition of 2,4-dinitrophenylhydrazine to the hydrolysate gave a trace of precipitate, m.p. $104-108^{\circ}$. A sample of the 2,4-dinitrophenylhydrazone of diethyl ketone, prepared for comparison, had m.p. 156° .

Reaction of Acetonitrile with Trimethylamine-dichloroalane.

A solution of acetonitrile (0.47g., 11.4 m.mole) in hexane (10ml.) was added slowly to a stirred suspension of trimethylamine-dichloroalane (1.8g., 11.4 m.mole) in hexane (60ml.) at -78° in a three necked flask

under a nitrogen atmosphere, connected to a trap at -196° . The suspension was allowed to warm to room temperature, when trimethylamine was evolved, and identified by its infrared spectrum. The resultant clear solution was refluxed for $1\frac{1}{2}$ hours, and solvent was removed under vacuum, leaving a white solid, which, on acid hydrolysis produced hydrogen, and no acetaldehyde. Alkaline hydrolysis produced trimethylamine, together with a little ammonia (identified by their infrared spectra) as well as hydrogen. ν_{\max} (nujol mull) 1267s, 1097s, 1020s, 986m, 864w, 814sh, 802s, 722w, and 501m cm^{-1}

Reaction of N-lithioketimines with metal halides.

Reaction of diphenylketiminolithium with aluminium chloride (1:1 molar proportions).

A solution of diphenylketiminolithium (4.1g., 21.9 m.mole) in diethyl ether (60ml.) was filtered on to aluminium chloride (2.93g., 21.9 m.mole) at -196° . The solution was allowed to warm to room temperature with stirring, when the red colour disappeared, and a cream precipitate was formed. Ether was pumped off, and toluene (30ml.) was added. The solution was heated to boiling, and filtered. On cooling, colourless crystals of dichloro-(α -phenylbenzylideneamino)-aluminium dimer, $(\text{Ph}_2\text{C}=\text{NAlCl}_2)_2$, m.p. $199-200^{\circ}$, were deposited. (Found: C, 55.7; H, 3.75; Al, 9.6; Cl, 24.7; N, 5.0%.)

$C_{26}H_{20}Al_2Cl_4N_2$ requires, C, 56.2; H, 3.60; Al, 9.7; Cl, 25.5; N, 5.0%) ν_{max} (nujol mull) 1641sh, 1593vs, 1582vs, 1576vs, 1557vs, 1332s, 1321sh, 1295s, 1276s, 1193w, 1166w, 1109w, 1080w, 1032wm, 1003wm, 984vw, 978vw, 958s, 935w, 924m, 802s, 783sh, 725vs, 716vs, 707s, 699vs, 686m, 637s, 617w, 584m, 553vs, 492s, 452w, 426m, 398vw, 380m, 318s, 282m and 212m cm^{-1} .

N.M.R. Data.

τ values:- 2.6br (2) and 2.95m (3). Saturated (~10%) solution in perdeuteriotoluene; tetramethylsilane as internal reference standard.

Reaction of diphenylketiminolithium with aluminium chloride

(3:1 molar proportions).

Aluminium chloride (1.72g., 12.9 m.mole) was added to a solution of diphenylketiminolithium (7.23g., 38.7 m.mole) in diethyl ether (60ml.) at -196° . The solution was warmed to room temperature, when the red colour disappeared, and an orange precipitate formed, and was stirred at 20° overnight. Solvent was pumped off, toluene (50ml.) was added, the solution was heated to boiling, and filtered. On cooling to 0° , bright yellow crystals of tris-diphenylketimino-aluminium $(Ph_2C=N)_3Al$, m.p. $204-6^{\circ}$ were deposited. (Found: C, 81.6; H, 5.50; Al, 4.7%; M, 575. $C_{39}H_{30}AlN_3$ requires C, 82.5; H, 5.29; Al, 4.76%; M, 567). ν_{max} (nujol mull) 1714sh, 1686s, 1617s, 1600sh, 1580m, 1309w, 1289w, 1263sh, 1247ms, 1193vw, 1175w, 1155w, 1072w,

1029wm, 1001vw, 972vw, 952w, 931w, 904m, 887w, 832m, 822m, 789s, 759vw, 732w, 709s, 695vs, 679ms, 628ms, 567m, 529ms, 490s, and 430m cm^{-1}

N.M.R. Data.

τ values:- 2.6_5^m (3), 2.9_2^m (7), and 3.1_6^m (1). 20% solution in perdeuteriobenzene; tetramethylsilane as internal reference standard.

Reaction of diphenylketiminolithium with aluminium bromide.

A solution of diphenylketiminolithium (10.0g., 53.3 m.mole) in diethyl ether (50ml.) was filtered on to aluminium bromide (5.7g., 53.3 m.mole) at -196° . The solution was allowed to warm to room temperature with stirring, when the red colour disappeared, and a yellow precipitate was formed. Ether was pumped off, and toluene (30ml.) was added. The solution was heated to boiling, and filtered. On cooling, pale yellow crystals of dibromo-(α -phenylbenzylideneamino)-aluminium, $(\text{Ph}_2\text{C}=\text{NAlBr}_2)_n$, m.p. $246-9^\circ$ (decomp.) were deposited.

(Found: C, 42.5; H, 2.72; Al, 7.24; Br, 46.1; N, 4.02%.

$\text{C}_{13}\text{H}_{10}\text{AlBr}_2\text{N}$ requires C, 42.5; H, 2.72; Al, 7.36; Br, 43.6; N, 3.82%.

ν_{max} (nujol mull) 1587s, 1558vs, 1471s, 1335ms, 1319sh, 1297m, 1282m, 1191vw, 1167w, 1082wm, 1033wm, 1007w, 978w, 963m, 929wm, 841w, 792vs, 720vs, 709vs, 699s, 668vw, 638m, 617vw, 579m, 557vw, 526vw, 483vs, 450m, 400w, 330m, 304w, 284m, 267vw, 255w, 248w, and 209vs cm^{-1}

Reaction of diphenylketiminolithium with beryllium chloride.

Diethyl ether (20ml.) was slowly added to beryllium chloride (1.56g., 20 m.mole) at -78° . A solution of diphenylketiminolithium (7.5g., 40 m.mole) in diethyl ether (80ml.) was added to the resultant suspension, which was allowed to warm to room temperature with stirring. After stirring at 20° for one hour, when the red colour disappeared, leaving a yellow precipitate, solvent was pumped off, and the solid transferred to a Soxhlet extraction apparatus, and extracted over three days with toluene. A bright yellow solid resulted. ν_{\max} (nujol mull) 1732m, 1627s, 1600sh, 1547wm, 1306w, 1256ms, 1152w, 1075m, 1049m, 1027m, 999wm, 951m, 916w, 898vw, 830ms, 784ms, 716wm, 695vs, 629w, and 543m cm^{-1} .

Reaction of di-p-tolylketiminolithium with beryllium chloride.

To beryllium chloride (0.92g., 10.2 m.mole) in diethyl ether (10ml.) at -78° , was added a solution of di-p-tolylketiminolithium (4.39g., 20.4 m.mole) in diethyl ether (50ml.) and hexane (10ml.). The solution was warmed to 20° , with stirring, and held at that temperature for one hour. Solvent was removed from the resultant yellow solid under vacuum, and toluene (30ml.) was added. The solution was boiled, filtered and cooled to -10° (ice-salt) when crystals of bis(di-p-tolylketimino)beryllium $[(p\text{-tolyl}_2\text{C:N})_2\text{Be}]_n$, (m.p. $349\text{--}51^{\circ}\text{d}$) separated. (Found: C, 83.0; H, 6.8; Be, 2.30%. $\text{C}_{30}\text{H}_{28}\text{BeN}_2$ requires C, 84.7; H, 6.6; Be, 2.1%). ν_{\max} (nujol mull) 1908w, 1731s, 1626vs, 1607vs, 1567m, 1311m, 1290ms, 1259ms, 1208w, 1178ms, 1110m, 1064sh, 1054ms,

1019m, 955m, 935ms, 911m, 889m, 853vs, 827vs, 792m, 782m, 742s, 735s, 717ms, 683wm, 673w, 659w, 631m, 618ms, 569w, and 543ms cm^{-1}

N.M.R. Data

τ values:- 2.0₇d (1), 2.1₅d (1), 2.9₆d (3), 3.0₄d (3) and 7.9₁s (6).
Saturated solution in perdeuteriobenzene; tetramethylsilane as internal reference standard.

Reactions of N-trimethylsilylketimine with metal halides.

Reaction of N-trimethylsilylketimine with aluminium chloride.

N-trimethylsilylketimine (7.82g., 30.9 m.mole) was slowly added by syringe to a suspension of aluminium chloride (1.37g., 10.3 m.mole) in toluene (30ml.) at -196° . The solution was allowed to warm to room temperature, with stirring, and was then refluxed overnight. Solvent was removed until precipitation was observed, and the solution was boiled once more until the solid redissolved. On cooling, crystals of dichloro-(α -phenylbenzylideneamino)-aluminium dimer, identified by the m.p. ($199-200^{\circ}$) and the infrared spectrum, were deposited.

Reaction of N-trimethylsilylketimine with beryllium chloride.

Diethyl ether (40ml.) was slowly added to beryllium chloride (0.78g., 10 m.mole) at -78° . N-trimethylsilylketimine (5.06g., 20 m.mole) in diethyl ether (20ml.) was added slowly by syringe. The solution was warmed to room temperature with stirring, and then

refluxed for $1\frac{1}{2}$ hours. The solvent was pumped off, and the residual solid was dissolved in hot toluene. On cooling, colourless crystals of chloro-(α -phenylbenzylideneamino)-beryllium dimer, m.p. $120-1^\circ$ were obtained. (Found: C, 68.8; H, 4.79; Cl, 16.0%; M, 408.

$C_{26}H_{20}Be_2Cl_2N_2$ requires C, 69.5; H, 4.45; Cl, 15.8%; M, 449).

ν_{max} (nujol mull) 1608s, 1587s, 1572s, 1418m, 1328m, 1300ms, 1189vw, 1160w, 1075w, 1029w, 1002w, 973s, 937m, 920m, 887sh, 850vs, 813s, 803s, 781vs, 775vs, 756s, 732m, 719s, 704vs, 676s, 633wm, 609m, 577w, 545ms, 464w, and 448w cm^{-1}

Reaction of Dichloro-(α -phenylbenzylideneamino)-aluminium dimer with Pyridine.

Pyridine (0.79g., 10 m.moles) was added to a suspension of dichloro-(α -phenylbenzylideneamino)-aluminium dimer, $(Ph_2C=AlCl_2)_2$, (2.78g., 10 m.moles) in toluene (20ml.) at 20° . A yellow colouration resulted immediately; not all the solid dissolved, however. The suspension was heated to boiling, when a yellow solution was obtained. After filtration, yellow crystals of pyridine-aluminium trichloride (m.p. $146-7^\circ$) were obtained. (Found: Al, 12.6; Cl, 49.2%. $C_5H_5AlCl_3N$ requires Al, 12.7; Cl, 50.6%).

DISCUSSION

Azomethine derivatives have, until recently, received little attention, despite their importance as intermediates in the polymerisation¹³⁷ and in the reduction^{108,109,115} of nitriles (see p. 31-32). In the last six years, however, interest in these derivatives has quickened, and there are now seven established routes, some of more general utility than others.

1. Triorganosilyl imines, $(RR'C:NSiR''_3)_n$, can be prepared in 60% yield by reaction of sodium bis(triorganosilyl)amide with carbonyl compounds in refluxing benzene.¹³⁸ The reaction is not applicable to enolisable aldehydes and

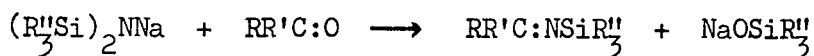

ketones because the hydroxy proton in the enol form is readily exchanged with the sodium ion of the silylamide.

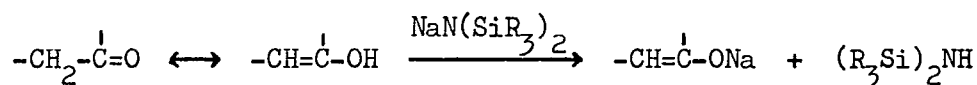

2. Addition reactions of nitriles with organometallic compounds affords a synthetic route to aldimine derivatives of boron,^{139,140} aluminium^{31,33} and gallium,¹⁴¹ and to ketimine derivatives of aluminium^{31,33} and lithium.¹³³ Grignard reagents, $RMgX$, also add to certain nitriles,¹³⁰ but the azomethine-magnesium halide intermediates have not

been isolated. The lower reactivities of organo-boron and -gallium compounds than of organoaluminium compounds towards insertion of an unsaturated functional group like nitrile prevents the preparation of ketimine derivatives of boron and gallium by this route. Another disadvantage is the contamination of azomethine derivatives prepared from nitriles with hydrogens attached to the α carbon atom by polymeric products of acidic reaction (p. 33).

Subsequent routes use starting materials in which the azomethine group is preformed.

3. Organometallic compounds react with the acidic proton of ketimines, eliminating hydrocarbon and giving azomethine derivatives.^{142, 143}



This reaction is exactly analogous to the method of attaching amino groups to metals by the use of secondary amines (p. 15-16).

4. Diphenylketiminolithium, $(\text{Ph}_2\text{C:NLi})_n$, is conveniently prepared from benzonitrile and phenyl-lithium¹³⁵ (method 2 above) or from diphenylketimine and organolithium compounds in diethyl ether¹³³ (method 3 above). Other azomethine derivatives of lithium are accessible by analogous methods,

with the limitations that certain ketimines are as yet unknown, and that organolithium derivatives, in common with organoaluminium derivatives, interact with hydrogens attached to the α carbon atom of nitriles, eliminating alkane. Azomethine derivatives of lithium conveniently undergo metathetical reactions with metal halides, producing lithium halide and an azomethine derivative of the metal.

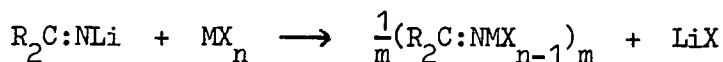

(X = F, Cl, Br, I).

This reaction has been used to prepare azomethine derivatives of silicon, germanium, tin,¹³⁵ boron,^{144,145,146} gallium¹⁴⁵ and titanium,¹⁴⁶ tris-azomethine derivatives of boron,¹³³ and bis-,¹³⁵ tris-¹³⁵ and tetrakisazomethine¹⁴⁵ derivatives of silicon.

5. N-trimethylsilyldiphenylketimine, $Ph_2C:NSiMe_3$, is obtained by reaction of diphenylketiminolithium with trimethylchlorosilane¹³⁵ (method 4 above). It also replaces the halide group by the azomethine group, eliminating trimethylchlorosilane,^{144,146} but at higher temperatures than those required for similar metatheses using the lithium azomethine. The high volatility of the silicon halide produced means that sparingly soluble derivatives, which can be separated from

lithium halide only with extreme difficulty are more readily obtained in a pure form by this route.

6. A relatively involatile secondary amine can displace a more volatile amine from an aminoborane under suitable conditions.^{147,148}

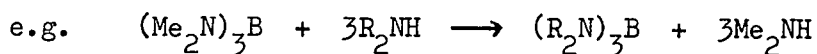

In the same way, trimethylamine has been displaced from trisdimethylaminoborane by heating with diphenylketimine.¹⁴⁹

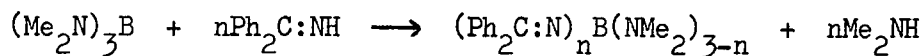

In an attempted preparation of tris-diphenylketiminoborane, however, displacement of amine was incomplete even with excess diphenylketimine at 150°, and separation of the product from starting materials proved impossible. In principle, provided these difficulties can be overcome, the reaction is applicable to the preparation of a wide range of azomethine derivatives.

7. Certain azomethine derivatives, together with the imine hydrohalide, are obtained by reaction of two moles of imine with one mole of a metal halide.

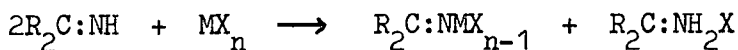

This method has been applied to the synthesis of azomethine derivatives of boron^{144,146,149} and silicon,¹⁴⁶ but its applications are limited to the preparation of relatively soluble azomethine derivatives, because of the difficulty of separating the products from the imine hydrohalide.

In the present work, some azomethine derivatives of aluminium, beryllium and lithium have been prepared, by routes 2, 3, 4 and 5, and are discussed in the following pages.

Reactions of diphenylketimine with organo-aluminium and -gallium compounds.

The preparation of azomethine derivatives of aluminium and gallium by reaction of the parent imine with organometallic compounds (route 3 above) was initially explored. Dialkylketimines with small alkyl groups appear to be highly susceptible to polymerisation or rearrangement with organometallic compounds, so much so that the dimethyl compound $\text{Me}_2\text{C}:\text{NH}$ has never been isolated during attempts at its preparation using acetonitrile and methylmagnesium bromide¹⁵⁰ or methyl-lithium (see below, p.117). Unsuccessful attempts were made during the present study to prepare diethylketimine, by methanolysis of the products of the reaction between propionitrile and ethylmagnesium bromide, as reported previously by Pickard and Tolbert,¹³⁰ or by acetylacetone cleavage at -78° of the product of the reaction between propionitrile and triethylaluminium.¹⁵¹ The difficulty of preparation

of dialkylketimines seems in part due to the presence of hydrogen attached to the carbons α to the azomethine group, resulting in cleavage of alkane (see p. 33). Evidence is presented below (p. 118) for the reaction of lithium alkyls with alkyl cyanides in the keteneimine form giving products $(\text{>C=C=NLi})_n$. Grignard reagents and aluminium alkyls may well react in a similar fashion, so that products of the above syntheses are probably mixtures of polymers. Diarylketimines cannot take part in similar side reactions, and diphenylketimine, as the simplest member of the series, was selected for the following investigation.

In contrast with the behaviour of the alkyls of zinc¹⁴³ and lithium¹³³ which, with diphenylketimine, eliminate alkane below room temperature, organoderivatives of the group III elements form adducts, $\text{Ph}_2\text{C:NH}\cdot\text{MR}_3$, which rearrange to give azomethine derivatives either slowly at room temperature, or only on heating.

The adduct $\text{Ph}_2\text{C:NH}\cdot\text{AlMe}_3$, m.p. $76-76.5^\circ$ was obtained at -78° from a hexane solution containing an equimolar mixture of its components. It was shown by cryoscopic measurements to be undissociated in cold (5°) benzene solution, and was also clearly stable to dissociation at 20° , at which temperature solvent could readily be removed under vacuum without affecting the stoichiometry of the crystals. Its stability contrasts with the appreciable dissociation of the boron analogue $\text{Ph}_2\text{C:NH}\cdot\text{BMe}_3$ for which the

dissociation pressure at 23.5° is 28 mm.,¹⁴² and is consistent with the generalisation that organoalanes R_3Al are stronger Lewis acids than are organoboranes R_3B .

In the systems $Ph_2C:NH/Et_3Al$, $Ph_2C:NH/Ph_3Al$ and $Ph_2C:NH/Ph_3Ga$, cooling solutions of equimolar mixtures of the components failed to afford crystals, and in all cases removal of solvent under vacuum left a viscous liquid residue. That the stoichiometry of the residue was unaffected by prolonged pumping was not unexpected in view of the low volatilities of the donor and acceptor moieties, and could not be interpreted as evidence of strong co-ordinate links in these systems. Indeed, the interaction between $Ph_2C:NH$ and Ph_3Al was sufficiently weak for triphenylaluminium alone to be precipitated from C_6D_6 solutions of a $Ph_2C:NH/Ph_3Al$ mixture when tetramethylsilane was added as a reference standard for proton magnetic resonance spectroscopic studies. Moreover, the high viscosity (itself an indication of interaction) of $Ph_2C:NH, AlEt_3$, $Ph_2C:NH, AlPh_3$ and $Ph_2C:NH, GaPh_3$ caused them to retain solvent tenaciously, so molecular weight studies were not attempted. A further complication was that these adducts decomposed slowly to azomethine derivatives $(Ph_2C:N \cdot MR_2)_2$ at room temperature, as revealed for example by the hydrolysable ethyl:aluminium ratio of 2.7:1.0 obtained during analysis of $Ph_2C:NH, AlEt_3$. However, some evidence of interaction was obtained by a study of the infrared and proton magnetic resonance spectra of freshly prepared samples.

The formation of an adduct between $\text{Ph}_2\text{C}:\text{NH}$ and R_3Al would be expected to be accompanied by the following changes in the infrared spectrum:-

(a) A new band associated with the stretching vibration of the Al-N bond should appear in the spectrum of the adduct, probably in the region $250\text{-}500\text{ cm}^{-1}$ by analogy with the suggested position of $\nu_{\text{Al-N}}$ in the spectra of $\text{Me}_3\text{N}, \text{AlH}_3$ (533 cm^{-1}),⁶² various amine adducts $\text{Me}_3\text{N}, \text{AlEt}_2\text{X}$ ($303\text{-}312\text{ cm}^{-1}$)¹⁵² and $\text{C}_5\text{H}_5\text{N}, \text{AlEt}_2\text{X}$ ($292\text{-}309\text{ cm}^{-1}$)¹⁵² and of various nitrile adducts $\text{RCN}, \text{AlR}'_3$ ($\sim 400\text{ cm}^{-1}$).^{31,33} No bands which could unambiguously be assigned to $\nu_{\text{Al-N}}$ could be observed in the spectra of these diphenylketimine adducts because of the presence of other skeletal absorptions in this region.

(b) The infrared spectra of the acceptor moieties in adducts $\text{Ph}_2\text{C}:\text{NH}, \text{AlR}_3$ should differ from those of free organoalanes in that the latter contain bridging groups R. Detailed interpretation of the spectra of the diphenylketimine adducts is complicated by the number of bands arising from vibrations of the donor molecule, and by uncertainties concerning assignments of bands to vibrations involving bridging groups in the free organoalanes.^{153,154} However, the strong shoulder at 1401 cm^{-1} in the spectrum of Et_6Al_2 assigned by Hoffmann¹⁵⁴ to a deformation vibration of the bridging methylene groups is absent from the spectrum of $\text{Ph}_2\text{C}:\text{NH}, \text{AlEt}_3$.

(c) The frequencies of both the N-H and C=N stretching vibrations of $\text{Ph}_2\text{C}:\text{NH}$ would be expected to decrease on co-ordination as electronic

charge was drained from the nitrogen. Assignments of bands to these vibrations were straightforward, and their frequencies, together with infrared spectroscopic data for related boron¹⁴² and gallium¹⁵⁵ adducts are listed in Table 1. Co-ordination at the imine nitrogen atom

TABLE 1.

Infrared spectroscopic results for adducts $\text{Ph}_2\text{C:NH,MR}_3$

Compound	Phase	$\nu_{\text{N-H}} \text{ cm}^{-1}$	$\nu_{\text{C=N}} \text{ cm}^{-1}$
$\text{Ph}_2\text{C:NH}$	CHCl_3 soln.	3256	1603
$\text{Ph}_2\text{C:NH, BMe}_3$ ¹⁴²	nujol mull	-	1604
$\text{Ph}_2\text{C:NH, AlMe}_3$	nujol mull	3290	1605
$\text{Ph}_2\text{C:NH, AlEt}_3$	liquid	3268	1594
$\text{Ph}_2\text{C:NH, AlPh}_3$	liquid	3257	1603
$\text{Ph}_2\text{C:NH, GaMe}_3$ ¹⁵⁵	nujol mull	3279	1604
$\text{Ph}_2\text{C:NH, GaEt}_3$ ¹⁵⁵	liquid	3268	1603
$\text{Ph}_2\text{C:NH, GaPh}_3$	liquid	3268	1595

might be expected to result in a decrease in electron density in the region of the C=N bond, and accordingly a reduction in $\nu_{\text{C=N}}$ analogous to the decrease in $\nu_{\text{C=O}}$ observed on adduct formation by carbonyl

compounds.¹⁵⁶ In this series of adducts, a perceptible decrease in $\nu_{\text{C=N}}$ was observed in only two cases, viz. $\text{Ph}_2\text{C:NH, AlEt}_3$ and $\text{Ph}_2\text{C:NH, GaPh}_3$, and this decrease may well be a result of differences in the physical states of samples. In all other cases, there is little change in the frequency of the band from one system to another. The two adducts $\text{Ph}_2\text{C:NH, BMe}_3$ and $\text{Ph}_2\text{C:NH, AlMe}_3$ have virtually identical values of $\nu_{\text{C=N}}$, in spite of their differing stabilities with respect to dissociation mentioned above. It must therefore be concluded that the strength of the co-ordinate bond in these systems has little effect on the strength of the C=N bond as reflected by their infrared spectra. A drift in electron density from donor to acceptor should result in a decrease in $\nu_{\text{N-H}}$. Co-ordination complexes of pyrrolidine, morpholine and piperazine with the hexacarbonyls of molybdenum and tungsten have bands in their infrared spectra assignable to $\nu_{\text{N-H}}$ at 50-100 cm^{-1} below the corresponding bands in the free bases.¹⁵⁷ Shifts of $\nu_{\text{N-H}}$ to low frequency have been noted in the spectra of diphenylketimine adducts of manganese tricarbonyl halides¹⁵⁸ and copper(I) chloride.¹⁵⁹ The same band in cobalt chloride complexes¹⁶⁰ and a 2:1 adduct of diphenylketimine with copper(II) chloride¹⁵⁹ moves to higher frequency, however, a phenomenon as yet unexplained. The adducts of organo-derivatives of group III with diphenylketimine also show a shift of $\nu_{\text{N-H}}$ to higher frequencies compared with the parent ketimine, by a maximum of 34 cm^{-1} (in the case of $\text{Ph}_2\text{C:NH, AlMe}_3$). This shift

(greater for $\text{Ph}_2\text{C:NH, AlMe}_3$ than for $\text{Ph}_2\text{C:NH, GaMe}_3$, $\text{Ph}_2\text{C:NH, AlEt}_3$ or $\text{Ph}_2\text{C:NH, AlPh}_3$) is consistent with the relative acceptor strengths $\text{Me}_3\text{Al} > \text{Et}_3\text{Al} > \text{Ph}_3\text{Al}$ and $\text{Me}_3\text{Al} > \text{Me}_3\text{Ga}$ suggested from infrared spectroscopic studies on their nitrile adducts,^{31,33,141} but differences in the physical states of samples means that correlations based on the small differences in frequency under consideration are at best unreliable.

The proton magnetic resonance spectra of the adducts were recorded and provide clearer evidence of interaction between the components. Chemical shift values and relative intensities are listed in Table 2, together with similar data for the related boron and gallium compounds. In the spectrum of diphenylketimine itself in C_6D_6 , the broad absorption centred on $\tau = 2.4$ p.p.m. (intensity 4) probably arose from the ortho protons of the phenyl groups, and the sharper multiplet centred on $\tau = 2.7_3$ p.p.m. (intensity 6) could be attributed to the meta and para protons, which would differ from the ortho protons as a result of the electron withdrawing properties of the azomethine group.^{161,162}

The figures in Table 2 show that all the peaks in the spectrum of $\text{Ph}_2\text{C:NH}$ including, surprisingly, the peaks due to the aromatic protons are shifted to higher fields on co-ordination. The shift is particularly marked in the case of the N-H peak, and is moreover in the direction opposite to that expected on electronic grounds, in that co-ordination through nitrogen should result in deshielding of the nitrogen-attached proton and to a lesser extent of the aromatic

TABLE 2.

Proton magnetic resonance spectroscopic results for adducts $\text{Ph}_2\text{C:NH,MR}_3$

Compound	τ values		
	= NH	= CPh_2	MR_3
$\text{Ph}_2\text{C:NH}^{a,b}$	0.0 ₄ s(1)	2.4br(4), 2.7 ₃ m(6)	-
$\text{Ph}_2\text{C:NH, BMe}_3^a$	0.0 ₀ s(1)	2.6 ₃ m(10)	9.8 ₀ s(9)
Me_3B	-	-	9.2 ₅ s
$\text{Ph}_2\text{C:NH, AlMe}_3^a$	1.2 ₀ s(1)	2.8m(4), 3.0 ₅ m(6)	10.4 ₅ s(9)
$(\text{Me}_3\text{Al})_2^c$	-	-	10.3 ₆ s
$\text{Ph}_2\text{C:NH, AlEt}_3^a$	0.4 ₀ s(1)	2.7br(4), 2.9 ₅ m(6)	8.8 ₇ t(9), 10.1 ₂ q(6)
$(\text{Et}_3\text{Al})_2^c$	-	-	8.8 ₉ t(3), 9.7 ₀ q(2)
$\text{Ph}_2\text{C:NH, AlPh}_3^b$	0.4 ₅ s(1)	2.1br, 2.6-3.0m(25)	-
$(\text{Ph}_3\text{Al})_2^b$	-	-	2.7 ₂ m(3), 2.8 ₇ br(2)
$\text{Ph}_2\text{C:NH, GaMe}_3^a$	0.8 ₈ s(1)	2.7 ₈ m(4), 3.0 ₂ m(6)	10.1 ₃ s(9)
Me_3Ga^a	-	-	9.8 ₉ s
$\text{Ph}_2\text{C:NH, GaEt}_3^a$	0.9 ₇ s(1)	2.7 ₀ m(4), 2.8 ₂ m(6)	8.7 ₁ t(9), 9.5 ₉ q(6)
Et_3Ga^a	-	-	8.8 ₆ t(3), 9.3 ₉ q(2)
$\text{Ph}_2\text{C:NH, GaPh}_3^a$	0.5 ₈ s(1)	2.3br, 2.7-3.1m(25)	-
Ph_3Ga^b	-	-	2.2 ₇ br(2), 2.7 ₂ m(3)

a, C_6D_6 solvent; b, $\text{C}_6\text{D}_5\text{CD}_3$ solvent; c, C_6H_6 solvent.

s = singlet, br = broad, m = multiplet, t = triplet, q = quartet.

relative intensities in parentheses; all concentrations ~30 wt.%.

protons.^{161,162} Values of τ_{N-H} for adducts $\text{Ph}_2\text{C:NH,MMe}_3$ (M = B, Al or Ga) are consistent with decreasing Lewis acidity in the sequence $\text{Me}_3\text{Al} > \text{Me}_3\text{Ga} > \text{Me}_3\text{B}$, a sequence established by thermodynamic data²² and supported by infrared spectroscopic studies on nitrile adducts.^{31,33}

However, by the same criterion, Et_3Ga is a stronger Lewis acid than Et_3Al , and Ph_3Ga is a stronger Lewis acid than Ph_3Al , conclusions inconsistent with those deduced from infrared spectroscopic studies on nitrile adducts. Changes in τ_{N-H} on complex formation by diphenylketimine are thus a poor criterion of co-ordinate bond strength. Similar poor correlations between changes in τ_{CH_3} and τ_{CH_2} values and adduct stabilities has been noticed for co-ordination complexes of boron halides with Et_3N , Et_2O and Et_2S ⁴³ and of gallium halides with Et_2O and Et_2S .¹⁶³ Changes in that part of the p.m.r. spectrum arising from the protons of R_3M are also caused by interaction with diphenylketimine. The peaks due to the metal-attached methyl groups of $\text{Ph}_2\text{C:NH,BMe}_3$, $\text{Ph}_2\text{C:NH,AlMe}_3$ and $\text{Ph}_2\text{C:NH,GaMe}_3$ are located at higher field than the corresponding peaks of the free metal alkyls, implying a higher electron density in the region of the acceptor molecule. The change on co-ordination is thus in the direction expected on electronic grounds. The magnitude of the change for both $\text{Ph}_2\text{C:NH,AlMe}_3$ (0.09 p.p.m.) and for $\text{Ph}_2\text{C:NH,GaMe}_3$ (0.24 p.p.m.) is appreciably less than that resulting from formation of $\text{Me}_3\text{N.MMe}_3$,

(M = Al, $\Delta\tau = 0.5_1$ p.p.m.; M = Ga, $\Delta\tau = 0.7_6$ p.p.m.¹⁶⁴) and may well reflect the weak donor strength of $\text{Ph}_2\text{C:NH}$ compared with Me_3N . The shift in the case of the diphenylketimine-trimethylaluminium adduct is smaller than for the corresponding gallium adduct. This trend is paralleled in the p.m.r. spectra of the trimethylamine adducts, and probably reflects the dimeric nature of the free aluminium alkyl, which prevents direct comparison with monomeric Me_3Ga . The quartets arising from the metal-attached methylene groups of $\text{Ph}_2\text{C:NH,Me}_3$ are also located at higher field than the corresponding peaks in the parent metal alkyls. The triplets arising from the methyl protons of the metal-attached ethyl groups are understandably little affected on co-ordination. Changes in the spectra of Ph_3M brought about by co-ordination to $\text{Ph}_2\text{C:NH}$ cannot be interpreted in any detail because of overlap of the signals from the two types of phenyl group in the adducts.

The thermal decomposition of the adducts $\text{Ph}_2\text{C:NH,AlR}_3$ in all cases led to dimeric azomethine derivatives $(\text{Ph}_2\text{C:NAlR}_2)_2$ by elimination of RH . The triphenylaluminium adduct $\text{Ph}_2\text{C:NH,AlPh}_3$ apparently decomposed the most readily, a good yield of $(\text{Ph}_2\text{C:NAlPh}_2)_2$ being recovered after two days at 20° in toluene. $\text{Ph}_2\text{C:NH,GaPh}_3$ also appears to rearrange under significantly milder conditions than do the adducts of gallium alkyls. The decomposition of $\text{Ph}_2\text{C:NH,AlEt}_3$

into $(\text{Ph}_2\text{C:NAlEt}_2)_2$ was effected overnight in boiling hexane, while two hours at 100° was ample for quantitative conversion of $\text{Ph}_2\text{C:NH,AlMe}_3$ into $(\text{Ph}_2\text{C:NAlMe}_2)_2$ and MeH. Elimination of methane from $\text{Ph}_2\text{C:NH,AlMe}_3$ occurs more readily than the corresponding rearrangement of $\text{Ph}_2\text{C:NH,GaMe}_3$,¹⁵⁵ and the trimethylborane adduct, $\text{Ph}_2\text{C:NH,BMe}_3$ requires still more forcing conditions for rearrangement.¹⁴² Increasingly forcing conditions are also needed for the comparable thermal decomposition of the dimethylamine adducts $\text{Me}_2\text{NH,AlMe}_3$,²⁵ $\text{Me}_2\text{NH,GaMe}_3$ ²⁸ and $\text{Me}_2\text{NH,BMe}_3$.¹⁶⁵ Ease of elimination of alkane is thus apparently related to the electronegativity of the metal (and hence the charge on the alkyl group).

The products of rearrangement were all crystalline solids. The aluminium derivatives reacted immediately with moist air; $(\text{Ph}_2\text{C:NGaPh}_2)_2$, in common with the derivatives of gallium alkyls, was more slowly hydrolysed. Acid hydrolysis of all four derivatives resulted in the formation of benzophenone, identified as its 2,4-dinitrophenylhydrazone.

Like related compounds $(\text{RR}'\text{C:N}\cdot\text{AlR}'_2)_2$ prepared from nitrile adducts $\text{RCN,AlR}'_3$, azomethine derivatives $(\text{Ph}_2\text{C:N}\cdot\text{AlR}'_2)_2$ were found to be dimeric in benzene solution (R = Me or Et; cryoscopy) and in the gas phase (R = Me or Ph; mass spectroscopy). It has been suggested that the dimeric (as opposed, for example, to trimeric) nature of such compounds prepared by the nitrile route might be a consequence of a bimolecular rearrangement of nitrile adducts $\text{RCN,AlR}'_3$.³¹ Trimers,

such as are known in related azide systems $(Et_2AlN_3)_3$ with six-membered $(AlN)_3$ rings,¹⁶⁶ would have allowed a greater bond angle \widehat{AlNAl} and accordingly less strain at the three-co-ordinate nitrogen. However, as the kinetic studies of Pasykiewicz and Kuran¹²³ show the rearrangement of $PhCN, AlMe_3$ to be a first order process, and the present results show the state of association of $(RR'C:N \cdot AlR''_2)_2$ to be independent of the method of preparation, it seems likely that the dimeric state is in fact thermodynamically the most stable. Azomethine derivatives of gallium are also dimeric,¹⁵⁵ but $Ph_2C:N \cdot BMe_2$ appears from mass spectroscopic studies to be monomeric in the vapour phase.¹⁴² In their states of association, therefore, azomethine derivatives of the group III elements closely resemble amino compounds $(Me_2NMR_2)_n$.

The mass spectroscopic results which reveal the presence (not necessarily exclusively) of dimers in gas phase samples of $(Ph_2C:N \cdot AlMe_2)_2$, $(Ph_2C:N \cdot AlPh_2)_2$ and $(Ph_2C:N \cdot GaPh_2)_2$ at 200° are summarised in Tables 3, 4 and 5 respectively. Peaks arising from fragments containing one or two gallium atoms were readily recognised by their characteristic isotope patterns resulting from the natural abundances of ^{69}Ga (60%) and ^{71}Ga (40%). In each case a weak peak corresponding to the molecular ion $(Ph_2CNMR_2)^+$ accounted for the fragment of highest mass detected, and in the spectra of the aluminium derivatives the peak at $m/e = 180$, attributable to Ph_2CN^+ , was the most intense in the spectrum. The most intense peak in the mass

TABLE 3

Mass spectroscopic results for $(\text{Ph}_2\text{C}:\text{N}\cdot\text{AlMe}_2)_2$

m/e	Relative intensity	Assignment
474	0.2	$\text{Ph}_4(\text{CN})_2\text{Al}_2\text{Me}_4$
459	14	$\text{Ph}_4(\text{CN})_2\text{Al}_2\text{Me}_3$
444	0.2	$\text{Ph}_4(\text{CN})_2\text{Al}_2\text{Me}_2$
237	4	$\text{Ph}_2\text{CNAlMe}_2$
222	4	Ph_2CNAlMe
181	47	Ph_2CNH
180	100	Ph_2CN
154	9	Ph_2
103	5	PhCN
78	22	PhH
77	46	Ph
16	9	MeH
15	9	Me

TABLE 4.

Mass spectroscopic results for $(\text{Ph}_2\text{C}:\text{N}\cdot\text{AlPh}_2)_2$

m/e	Relative intensity	Assignment
722	4	$\text{Ph}_4(\text{CN})_2\text{Al}_2\text{Ph}_4$
645	23	$\text{Ph}_4(\text{CN})_2\text{Al}_2\text{Ph}_3$
568	7	$\text{Ph}_4(\text{CN})_2\text{Al}_2\text{Ph}_2$
465	7	$\text{Ph}_2\text{CNAl}_2\text{Ph}_2$
387	7	$\text{Ph}_4(\text{CN})_2\text{Al}$
361	2	$\text{Ph}_2\text{CNAlPh}_2$
284	13	Ph_2CNAlPh
207	9	Ph_2CNAl
181	62	$\text{Ph}_2\text{Al} + \text{Ph}_2\text{CNH}$
180	100	Ph_2CN
154	27	Ph_2
104	47	PhAl
103	4	PhCN
78	96	PhH
77	62	Ph

TABLE 5.

Mass spectroscopic results for $(\text{Ph}_2\text{C:N}\cdot\text{GaPh}_2)_2$

m/e	Relative intensity	Assignment
810, 808, 806	very weak	$\text{Ph}_4(\text{CN})_2\text{Ga}_2\text{Ph}_4$
733, 731, 729	6, 18, 14	$\text{Ph}_4(\text{CN})_2\text{Ga}_2\text{Ph}_3$
656, 654, 652	very weak	$\text{Ph}_4(\text{CN})_2\text{Ga}_2\text{Ph}_2$
630, 628, 626	15, 45, 34	$\text{Ph}_2\text{CNGa}_2\text{Ph}_4$
585, 583	2, 3	$\text{Ph}_4(\text{CN})_2\text{GaPh}_2$
553, 551, 549	1, 3, 2	$\text{Ph}_2\text{CNGa}_2\text{Ph}_3$
476, 474, 472	1, 3, 2	$\text{Ph}_2\text{CNGa}_2\text{Ph}_2$
405, 403	2, 3	$\text{Ph}_2\text{CNGaPh}_2$
328, 326	7, 11	Ph_2CNGaPh
225, 223	67, 100	Ph_2Ga
181	11	Ph_2CNH
180	22	Ph_2CN
174, 172	2, 3	PhCNGa
148, 146	2, 3	PhGa
104	11	PhCNH
103	3	PhCN
78	39	PhH
77	15	Ph
71, 69	18, 27	Ga

spectrum of $(\text{Ph}_2\text{C}:\text{NGaMe}_2)_2$ can be assigned to the ion $\text{Ph}^{69}\text{GaMe}^+$, the presence of which must result from the transfer of a phenyl group from carbon to gallium.¹⁵⁵ Such rearrangements presumably also occur in the case of $(\text{Ph}_2\text{C}:\text{N}\cdot\text{GaPh}_2)_2$, but are not revealed by the identity of particular fragments as the groups originating on gallium and on the azomethine carbon are the same. However, the high intensity of the peaks due to Ph_2Ga^+ (Table 5), despite the fact that the separation of phenyl groups from gallium appears to be a major feature of the breakdown pattern, may well be a result of rearrangement or recombination reactions. All spectra contain peaks attributable to monomers $\text{Ph}_2\text{CNMR}_2^+$, and peaks of moderate intensity corresponding to fragments $\text{Ph}_4(\text{CN})_2\text{M}_2\text{R}_3^+$ resulting from loss of one group R from a metal atom in the dimer. The mass spectroscopic results on $(\text{Ph}_2\text{C}:\text{N}\cdot\text{AlPh}_2)_2$, in revealing an evidently high proportion of dimeric molecules in the gas phase at 200° , resolve the uncertainty concerning the state of association of this compound which arose from its low solubility in benzene.³³ Gibson and Hughes¹²¹ on the basis of ebulliometric studies on benzene solutions concluded that $(\text{Ph}_2\text{CNAlPh}_2)_n$ was only slightly associated ($n \sim 1.1$) in boiling benzene; a higher degree of association now seems probable.

The quality of the infrared spectrum obtained using the new sample of this compound was better than those of earlier samples, and it was possible to make unambiguous assignment of a band at 1604 cm^{-1}

to $\nu_{\text{C:N}}$. Gibson and Hughes¹²¹ had assigned a shoulder at 1660 cm^{-1} , absent from these spectra, to this mode. Corresponding absorptions in the spectra of $(\text{Ph}_2\text{C:N}\cdot\text{AlMe}_2)_2$ and of $(\text{Ph}_2\text{C:N}\cdot\text{AlEt}_2)_2$ were observed at 1616 and 1609 cm^{-1} respectively, (see Table 6). The sensitivity of this band to the nature of the groups R and R' in compounds $(\text{RR}'\text{C:N}\cdot\text{AlR}''_2)_2$ has already been noted,³¹ when it was found that if R and/or R' = Ph the frequency of this band was generally $< 1635 \text{ cm}^{-1}$. The data in Table 6 shows that $\nu_{\text{C:N}}$ in compounds $(\text{Ph}_2\text{C:NMR}_2)_n$ is also

TABLE 6.

Infrared spectroscopic results for azomethine derivatives $(\text{Ph}_2\text{C:N}\cdot\text{MR}_2)_n$

Compound	$\nu_{\text{C:N}} \text{ cm}^{-1}$	Compound	$\nu_{\text{C:N}} \text{ cm}^{-1}$
$\text{Ph}_2\text{C:N}\cdot\text{NBMe}_2$ ¹⁴²	1662	$(\text{Ph}_2\text{C:N}\cdot\text{NAlBr}_2)_2$ [*]	1587
$(\text{Ph}_2\text{C:N}\cdot\text{NAlMe}_2)_2$	1616	$(\text{Ph}_2\text{C:N}\cdot\text{NGaMe}_2)_2$ ¹⁵⁵	1626
$(\text{Ph}_2\text{C:N}\cdot\text{NAlEt}_2)_2$	1609	$(\text{Ph}_2\text{C:N}\cdot\text{NGaEt}_2)_2$ ¹⁵⁵	1613
$(\text{Ph}_2\text{C:N}\cdot\text{NAlPh}_2)_2$	1604	$(\text{Ph}_2\text{C:N}\cdot\text{NGaPh}_2)_2$	1612
$(\text{Ph}_2\text{C:N}\cdot\text{NAlCl}_2)_2$ [*]	1593	$(\text{Ph}_2\text{C:N}\cdot\text{NGaCl}_2)_2$ ¹⁴⁵	1591

All figures relate to Nujol mulls.

* See below, p. 98.

sensitive, both to the azomethine-attached metal, M, and to the substituents R. For most of the derivatives with alkyl or aryl substituents R, $\nu_{\text{C:N}}$ is higher than the corresponding band in diphenylketimine itself. Co-ordination through the azomethine group such as occurs in the association of the azomethine derivatives would be expected to reduce the electron density in the azomethine link, causing a corresponding reduction in $\nu_{\text{C:N}}$, but the mechanical constraint imposed on the vibration of the azomethine group by incorporation of the nitrogen in the $(\text{MN})_2$ ring is likely to be more than sufficient to offset this electronic effect when comparison is made between $\text{Ph}_2\text{C:NH}$ and $(\text{Ph}_2\text{C:N}\cdot\text{MR}_2)_2$. When substituents R are extremely electron-withdrawing (e.g. R = Cl, or Br) $\nu_{\text{C:N}}$ may fall below the frequency of the band in diphenylketimine. The C=N stretching frequency, as stated above, is also sensitive to the metal, M, rising to higher values with increasing electronegativity. Values of $\nu_{\text{C:N}}$ for azomethine derivatives of zinc lie between those of aluminium and gallium derivatives.¹⁴³ Relatively electronegative metals, M, in common with electron-withdrawing groups R, should result in a decrease in electron density in the azomethine link, and a reduction in $\nu_{\text{C:N}}$. The observed increase in $\nu_{\text{C:N}}$ with increasing electronegativity is as yet unexplained.

Where solubilities permitted, the p.m.r. spectra of the azomethine derivatives were recorded, and are summarised in Table 7.

As with related compounds $\text{Ph}_2\text{C:NH,MR}_3$ the signal arising from the phenyl groups attached to the azomethine carbon appeared as two multiplets of relative intensity 2:3. It is likely that the less intense multiplet can be assigned to the ortho protons and the more intense to the meta and para protons which would differ from the ortho protons as a result of the electron-withdrawing properties of the azomethine group.^{161,162}

TABLE 7.

Proton magnetic resonance spectroscopic results for $(\text{Ph}_2\text{C:N}\cdot\text{MR}_2)_2$

Compound	τ values	$(\tau_{\text{Me}_4\text{Si}} = 10.00)$
	= CPh ₂	MR ₂
$\text{Ph}_2\text{C:NBMe}_2$ ^a	2.7 ₇ m(2), 2.8 ₄ m(3)	9.7 ₀ s(3)
$(\text{Ph}_2\text{C:NAI Me}_2)_2$ ^a	2.5 ₃ m(2), 2.9 ₀ m(3)	10.4 ₈ s(3)
$(\text{Ph}_2\text{C:NAIEt}_2)_2$ ^a	2.4 ₅ m(2), 2.8 ₆ m(3)	8.7 ₉ t(3), 9.8 ₉ q(2)
$(\text{Ph}_2\text{C:NGaMe}_2)_2$ ^b	2.2 ₅ m(2), 2.7 ₅ m(3)	10.2 ₂ s(3)
$(\text{Ph}_2\text{C:NGaEt}_2)_2$ ^b	2.4 ₅ m(2), 2.8 ₇ m(3)	8.8 ₀ t(3), 9.5 ₁ q(2)

^a C₆D₆ solvent.

^b C₆D₅CD₃ solvent

m = multiplet, s = singlet, t = triplet, q = quartet;
relative intensities in parentheses.

Substitution of all three aluminium-attached organic groups by diphenylketimine would result in a product, $[(\text{Ph}_2\text{C:N})_3\text{Al}]_n$ which is of interest in that, if it were associated, the diphenylketimino-groups would be in more than one distinguishable environment, and if it were monomeric, it would afford another example of three-co-ordinate aluminium. It was noted above that elimination of benzene from the adduct $\text{Ph}_2\text{C:NH,AlPh}_3$ occurs more readily than elimination of alkane from $\text{Ph}_2\text{C:NH,AlMe}_3$ or $\text{Ph}_2\text{C:NH,AlEt}_3$. Accordingly, preparation of tris(diphenylketimino)aluminium was attempted by heating diphenylketimine and triphenylaluminium in 3:1 molar proportions in a sealed tube. Heating the mixture to 170° for two days resulted in elimination of only 1.5 m.moles of benzene from 1 m.mole of triphenylaluminium, and excess diphenylketimine could not be completely removed from the oil which was the involatile product of the reaction. In view of these difficulties, the reaction was abandoned in favour of the more successful metathetical reactions described below.

Reactions of diphenylketiminolithium with aluminium halides.

Although azomethine derivatives $(RMeC:NAlMeCl)_2$ have been prepared in yields of up to 60% from nitriles RCN and Me_2AlCl ,^{31,33} the related compounds $(RR'C:NAlX_2)_n$ (X = halogen) have not until now been investigated. Amino and imino derivatives of lithium react with the halides of less electropositive elements, transferring the amino- or imino- group to the other element,¹³⁵ and the reaction between diphenylketiminolithium and aluminium halides offers a convenient route to azomethine derivatives $(Ph_2C:NAlX_2)_n$.

When mixtures of aluminium chloride or aluminium bromide and an ethereal solution of diphenylketiminolithium in equimolar proportions at -78° were allowed to warm, reaction occurred below 0° , giving a colourless solution and a dense cream precipitate.

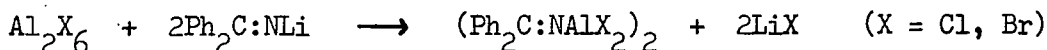

Ether was removed under vacuum, and the azomethine derivative was dissolved in boiling toluene and separated from lithium halide by filtration. When the solution cooled to 20° , the product separated as cubic crystals. Both $(Ph_2C:NAlCl_2)_2$ and $(Ph_2C:NAlBr_2)_2$ are crystalline solids which react slowly with moist air and afford benzophenone on vigorous hydrolysis. Neither compound was sufficiently soluble in benzene for cryoscopic molecular weight determinations, but the mass spectrum of the dichloride revealed the presence of dimers

at 200° in the gas phase, and it seems likely that it is also dimeric in the condensed phases, with the familiar aluminium-nitrogen four-membered ring structure. The related dimethylaminoaluminium dichloride, $(\text{Me}_2\text{NAlCl}_2)_2$, is a similar crystalline solid (m.p. 151°) which has been shown by cryoscopic measurements to be dimeric in benzene solution,⁷⁸ presumably with a similar structure. The close similarity in the physical properties (melting points and solubilities) and the infrared spectra of $(\text{Ph}_2\text{C:NAlCl}_2)_2$ and $(\text{Ph}_2\text{C:NAlBr}_2)_2$ suggests that they both have the same degree of association and similar structures.

The most important peaks in the mass spectrum of $(\text{Ph}_2\text{C:NAlCl}_2)_2$ are listed in Table 8. The main breakdown route, identified by the detection of peaks due to metastable ions, is through loss of Ph to $[\text{Ph}_3(\text{CN})_2\text{Al}_2\text{Cl}_4]^+$, loss of PhCN to $[\text{Ph}_2\text{CNAl}_2\text{Cl}_4]^+$ and then successive loss of Cl to $[\text{Ph}_2\text{CNAl}_2\text{Cl}_2]^+$. The spectrum differs from that of $(\text{Ph}_2\text{C:NAlMe}_2)_2$ in that the peak due to initial loss of Cl is relatively weak. In the spectrum of $(\text{Ph}_2\text{C:NAlMe}_2)_2$ the peak due to loss of Me from the parent is the most intense of any arising from aluminium-containing residues. The difference between the spectra presumably reflects the difference in the strengths of the aluminium-chlorine (ca. 118 kcal/mole¹⁶⁷) and aluminium-carbon (ca. 65 kcal/mole¹⁶⁸) bonds. An interesting feature of the spectrum of $(\text{Ph}_2\text{C:NAlCl}_2)_2$ is the absence of a peak due to the monomer $[\text{Ph}_2\text{C:NAlCl}_2]^+$. Weak peaks due to monomers $[\text{Ph}_2\text{C:NAlR}_2]^+$ were detected in the mass spectra of

TABLE 8.

Mass spectroscopic results for $(\text{Ph}_2\text{C}:\text{NAlCl}_2)_2$

m/e	Relative intensity	Assignment
554, 556, 558, 560, 562	47, 63, 31, 7, 0.6	$\text{Ph}_4(\text{CN})_2\text{Al}_2\text{Cl}_4$
519, 521, 523, 525	7, 7, 2, 0.2	$\text{Ph}_4(\text{CN})_2\text{Al}_2\text{Cl}_3$
477, 479, 481, 483, 485	75, 100, 50, 11, 1	$\text{Ph}_3(\text{CN})_2\text{Al}_2\text{Cl}_4$
374, 376, 378, 380, 382	70, 93, 47, 10, 0.9	$\text{Ph}_2\text{CNAl}_2\text{Cl}_4$
339, 341, 343, 345	35, 35, 12, 1	$\text{Ph}_2\text{CNAl}_2\text{Cl}_3$
304, 306, 308	14, 10, 1.5	$\text{Ph}_2\text{CNAl}_2\text{Cl}_2$
242, 244	56, 19	Ph_2CNAlCl
181	44	Ph_2CNH
180	100	Ph_2CN
139, 141	100, 33	PhAlCl
104	47	PhCNH
103	14	PhCN
97, 99, 101	33, 22, 3.5	AlCl_2
78	23	PhH
77	88	Ph
62, 64	8, 3	AlCl

Satellites observed beside all major peaks, and arising from the presence of ^{13}C isotopes are not listed.

both $(\text{Ph}_2\text{C}:\text{NAlMe}_2)_2$ and $(\text{Ph}_2\text{C}:\text{NAlPh}_2)_2$. The presence of a peak due to the ion PhGaMe^+ in the spectrum of $(\text{Ph}_2\text{C}:\text{NGaMe}_2)_2$, resulting from the transfer of a phenyl group from carbon to gallium has already been remarked upon. One of the most intense peaks in the spectrum of $(\text{Ph}_2\text{C}:\text{NAlCl}_2)_2$ is that due to PhAlCl^+ at $m/e = 139$ (together with ^{37}Cl satellite at 141), which must result from the transfer of phenyl groups from carbon to aluminium. The aluminium dibromide derivative decomposed so readily at the temperatures at which the spectra were recorded, that no ions with higher values of m/e than 181 (due to Ph_2CNH^+) were observed.

Features of the infrared spectra of both derivatives have already been remarked upon (p. 95). The frequency of the C=N stretching vibration is shifted to lower values compared with those observed in the organoaluminium derivatives $(\text{R}_2\text{C}:\text{NAlR}'_2)_2$ as a consequence of the relative electronegativity of the group attached to aluminium.

Of the two aluminium halide derivatives prepared only $(\text{Ph}_2\text{C}:\text{NAlCl}_2)_2$ was sufficiently soluble in inert solvents to record a p.m.r. spectrum. The pattern of peaks arising from the aromatic protons resembled that observed in the case of the organoaluminium derivatives, viz. a broad peak, of relative intensity 2 at $\tau = 2.6$ p.p.m., and a multiplet, of relative intensity 3, centred on $\tau = 2.9_5$ p.p.m. These chemical shift values did not differ significantly from the values for the corresponding organoaluminium compounds, the absorptions



occurring once more at higher fields than the corresponding peaks in the spectrum of diphenylketimine.

The resistance of aluminium nitrogen rings to cleavage by donor species has previously been noted. No evidence of interaction with trimethylamine has been observed in the case of $(\text{Me}_2\text{NAlMe}_2)_2$,²⁵ $(\text{Me}_2\text{NAlH}_2)_3$ ¹⁶⁹ or $(\text{Me}_2\text{NAlCl}_2)_2$,⁷⁸ although similar aminoboranes which can exist as an equilibrium mixture of monomer and associated species, do form adducts with trimethylamine. The azomethine derivatives described here are apparently equally resistant to attack by Lewis bases. There was no evidence of interaction between pyridine and $(\text{Ph}_2\text{C:NAlCl}_2)_2$ until, at 112° , disproportionation occurred. Pyridine-aluminium trichloride was obtained from the reaction, but the products

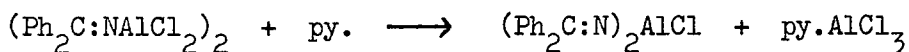

were worked up in such a manner that the other material believed to be present, bis-diphenylketiminoaluminium chloride, $(\text{Ph}_2\text{C:N})_2\text{AlCl}$, was not isolated.

Reaction of diphenylketiminolithium and aluminium chloride in the molar ratio. 3:1 in diethyl ether solution below room temperature resulted in the formation of a dense yellow precipitate. The product was separated from lithium chloride after removal of diethyl ether under vacuum, by dissolving in hot toluene and filtering the resultant solution. Tris-diphenylketiminoaluminium was obtained as

a yellow powder by cooling this clear yellow solution, and as yellow needles, (m.p. 204-6°) on recrystallisation from benzene. Cryoscopic molecular weight measurements confirmed that it is essentially monomeric in benzene solution. Sterically crowded tris-amino derivatives of aluminium, such as $(\text{Pr}^i_2\text{N})_3\text{Al}$ ⁷² and $[(\text{Me}_3\text{Si})_2\text{N}]_3\text{Al}$,¹⁷⁰ and even the analogous chromium compounds $(\text{Pr}^i_2\text{N})_3\text{Cr}$ and $[(\text{Me}_3\text{Si})_2\text{N}]_3\text{Cr}$ ¹⁷¹ are also monomeric. Molecular models of the $[(\text{Ph}_2\text{C:N})_3\text{Al}]_2$ system show that it is just possible to accommodate six ketimine groups about an $(\text{AlN})_2$ ring. The resultant configuration prevents Al-N $p_\pi-p_\pi$ stabilisation, however, and seriously restricts the freedom of rotation of the phenyl groups. Three ketimine groups are more readily arranged about a single aluminium atom in the monomer, but the bulky phenyl groups shield the central metal atom so effectively that the formation of a dimer $[(\text{Ph}_2\text{C:N})_3\text{Al}]_2$ by interaction between two monomer units is unlikely.

The infrared spectrum of the compound, recorded as a nujol mull, revealed two peaks in the region where C:N stretching vibrations occur. One, at 1686 cm^{-1} is at slightly higher wavelength than that (1667 cm^{-1}) observed in the infrared spectrum of $(\text{Ph}_2\text{C:N})_3\text{B}$,¹³³ in which the B-N bonds are assumed to have significant multiple bond character. The position of the band in the spectrum of tris-diphenylketiminoaluminium suggests that in this compound too there may be considerable metal-nitrogen $p_\pi-p_\pi$ overlap. The second band is at 1617 cm^{-1} , in the

region where bridging ketimine groups in dimeric azomethine derivatives absorb. Since both bands were also present in the infrared spectrum of a benzene solution of $(\text{Ph}_2\text{C:N})_3\text{Al}$, this lower frequency band is likely to be due to a second terminal C:N stretching mode (in so far as it is meaningful to discuss C:N rather than C:N·M modes in these compounds) rather than to a bridging C:N vibration. However, cryoscopic molecular weight measurements require the use of relatively dilute solutions, and it is possible that associated species are present, both in the crystal, and in the more concentrated solutions used for infrared spectroscopy.

The p.m.r. spectrum of $(\text{Ph}_2\text{C:N})_3\text{Al}$ consisted of a series of peaks, centred on τ values 2.6_5 , 2.9_2 and 3.1_6 p.p.m., in the same region as peaks due to the aromatic protons of other azomethine derivatives, but too complex for systematic assignments.

The mass spectrum was recorded, but at the temperature necessary to record the spectrum (200°), breakdown was so complete that no peaks with a greater value of m/e than 181 (corresponding to Ph_2CNH^+) were observed. This was a common difficulty with compounds of high molecular weight and low volatility.

Reactions of azomethine derivatives of lithium with beryllium chloride.

Diphenylketiminolithium and di-p-tolylketiminolithium react with beryllium chloride in 2:1 molar proportions, giving products containing beryllium, and no chlorine. The product from the reaction between (p-tolyl)₂C:NLi and BeCl₂ was characterised as bis(di-p-tolylketimino)beryllium, [(p-tolyl)₂C:N]₂Be. The similar compound isolated from the reaction between Ph₂C:NLi and BeCl₂ was so insoluble that it could be separated from lithium chloride only by prolonged Soxhlet extraction with toluene, a process which resulted in so much thermal decomposition that analytical data were inconclusive.

Bis-dimethylamino-beryllium [(Me₂N)₂Be]₃ was isolated and shown to be trimeric by Coates and Glockling.¹⁷² Recent p.m.r. studies¹⁷³ suggested that it was trimeric, but not cyclic, as postulated by Coates and Glockling. An X-ray crystallographic study¹⁷⁴ confirmed that the compound has structure XXXII, and measurements of the ¹³C-H

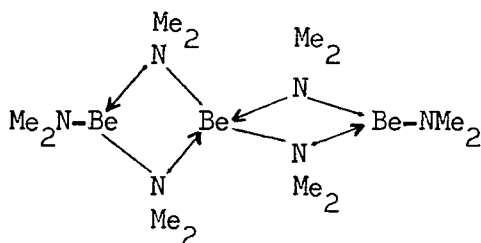

XXXII

spin-spin coupling constants suggest that there is a degree of π bonding between the terminal nitrogen and beryllium atoms. In view of these features of $[(\text{Me}_2\text{N})_2\text{Be}]_3$, there is considerable interest in the structure and degree of association of the bis-ketimino-beryllium compounds. $(\text{Ph}_2\text{C}:\text{N})_2\text{Be}$ is less soluble than $(\text{Ph}_2\text{C}:\text{N})_3\text{Al}$, which is monomeric, and considerably more soluble than $\text{Ph}_2\text{C}:\text{NLi}$, which is polymeric, so it seems likely that the beryllium compound exists as oligomers. A trimeric structure, XXXIII, analogous to that

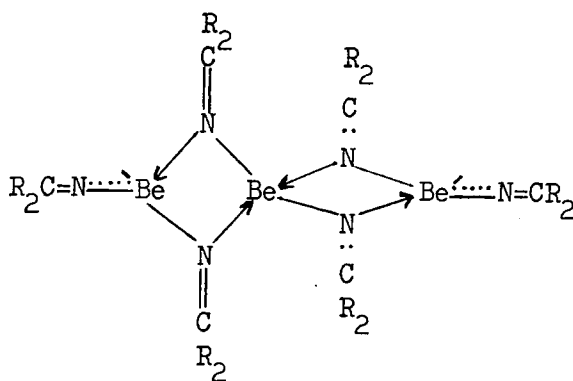

XXXIII

of $[\text{Be}(\text{NMe}_2)_2]_3$ is possible, although p.m.r. evidence suggests that the compound may be tetrameric in perdeuteriobenzene (see p.113). Unfortunately the relative insolubility of both $(\text{Ph}_2\text{C}:\text{N})_2\text{Be}$ and $[(p\text{-tolyl})_2\text{C}:\text{N}]_2\text{Be}$ has frustrated attempts at quantitative molecular weight determinations by cryoscopy on benzene solutions. It is intended to undertake ebullioscopic molecular weight measurements

in the near future.

The infrared spectra of both derivatives provide evidence of Be-N π bonding (see Table 9), in that both contain two strong bands,

TABLE 9.

Infrared spectroscopic results for some azomethine derivatives.

Compound	ν_{CX} cm ⁻¹ *	$\nu_{\text{C:N}}$ cm ⁻¹ †
(Ph ₂ C:N) ₃ B	1667	-
(Ph ₂ C:N) ₂ Be	1732	1627
Ph ₂ C:NLi	-	1620
[(p-tol) ₂ C:N] ₂ Be	1731	1626
[Ph ₂ C:NBCl ₂] ₂	-	1590
[Ph ₂ C:NBeCl] ₂	-	1608

All bands were strong absorptions, of approximately equal intensity.

* ν_{CX} refers to the frequency of the stretching vibrations of the terminal $>\text{C}=\text{N}-\text{M}$ groups.

† $\nu_{\text{C:N}}$ refers to the C:N stretching frequency of the bridging ketimine groups.

one in the region where bridging ketimine groups absorb, and one more than 100 cm^{-1} higher in frequency. The infrared spectra of monomeric azomethine derivatives $\text{R}_2\text{C}=\text{N}=\text{BR}'_2$ contain bands in the range 1786-1793 cm^{-1} , which have been assigned to the $\text{C}=\text{N}=\text{B}$ stretching vibration,¹⁴⁴ and the high frequency band in the spectra of the beryllium compounds is likely to be due to a similar $\text{C}=\text{N}=\text{Be}$ stretching vibration. The difference of 50 cm^{-1} in the frequency of the absorptions of the boron and beryllium compounds probably reflects the difference in the substituents on the metal, as well as a difference in the metal-nitrogen π bond orders due to orbital overlap considerations. The frequency of the $\text{C}=\text{N}=\text{B}$ vibration in the infrared spectrum of $(\text{Ph}_2\text{C}:\text{N})_3\text{B}$ is 1667 cm^{-1} , 60 cm^{-1} below the frequency of the corresponding band in $(\text{Ph}_2\text{C}:\text{N})_2\text{Be}$. Although detailed conclusions cannot be drawn from these values (since $(\text{Ph}_2\text{C}:\text{N})_3\text{B}$ is likely to be monomeric, and $(\text{Ph}_2\text{C}:\text{N})_2\text{Be}$ oligomeric) it seems probable that the metal-nitrogen π bond order is higher in the case of the beryllium compound (in which beryllium forms a π bond with only one nitrogen atom) than for the boron compound (in which three boron-nitrogen bonds probably have some π character). The frequency of the $\text{C}:\text{N}$ stretching vibration of bridging ketimine groups of $(\text{R}_2\text{C}:\text{N})_2\text{Be}$ lies in the same region as the $\text{C}:\text{N}$ stretch in polymeric $\text{Ph}_2\text{C}:\text{NLi}$ (in which all the ketimine groups must be involved in bridging). Differences in mass of the groups

attached to the azomethine carbon appear to have little effect on the stretching frequencies of either terminal or bridging ketimine groups. The values of $\nu(\text{C}=\text{N} \rightarrow \text{Be})$ and $\nu_{\text{C}:\text{N}}$ appear virtually identical in the spectra of both $(\text{Ph}_2\text{C}:\text{N})_2\text{Be}$ and $[(p\text{-tolyl})_2\text{C}:\text{N}]_2\text{Be}$.

The p.m.r. spectrum of $[(p\text{-tolyl})_2\text{C}:\text{N}]_2\text{Be}$ was recorded in perdeuteriobenzene solution, using tetramethylsilane as internal reference standard, and consisted (Figure VI) of four peaks (a, b, c, d) in the region associated with absorptions arising from aromatic protons, and a singlet (e) at $\tau = 7.9_1$ p.p.m., arising from the methyl protons.

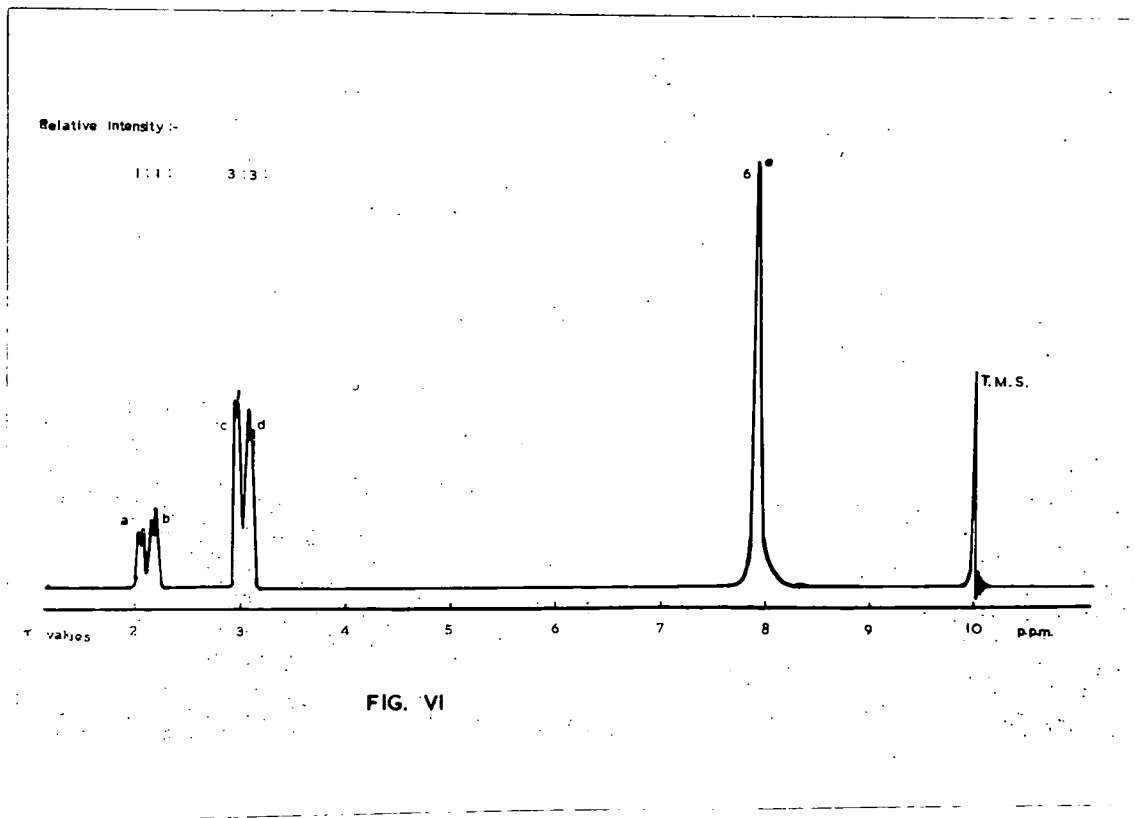

FIG. VI

The p.m.r. spectra of the aromatic protons of p-substituted tolyl derivatives $\text{CH}_3\text{C}_6\text{H}_4\text{X}$ have been analysed, and chemical shift values and spin-spin coupling constants reported.^{175,176} These spectra consist essentially of two absorptions of equal intensity, arising from the protons ortho- and meta- to the substituent X. The separation of these absorptions depends on the nature of the substituent, in a manner which is illustrated in Table 10.

TABLE 10.

P.M.R. data for p-tolyl derivatives $\text{CH}_3\text{C}_6\text{H}_4\text{X}$.¹⁷⁶

Substituent	values (p.p.m.)		$\Delta\tau$ p.p.m.	J c.p.s.
	Protons o- to CH_3 -	Protons m- to CH_3 -		
NH_2	3.15	3.55	-0.40	8.1
OMe	3.01	3.28	-0.27	8.3
Cl	2.98	2.84	0.14	8.4
Br	3.04	2.69	0.53	8.1
I	3.15	2.48	0.67	7.9
NO_2	2.77	1.91	0.86	8.5

Protons H_a and H_b couple strongly, as do H_a and H_b in p-disubstituted benzenes (see XXXIV), the spin-spin coupling constant J taking

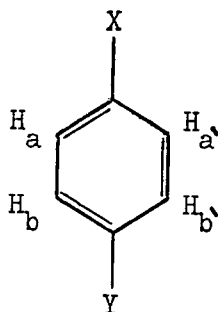

XXXIV

values of 7-10 c.p.s. If the difference in the chemical shift values of the ortho and meta proton peaks is small, splitting due to spin-spin coupling can result in considerable overlap of peaks. Further splitting due to the much weaker coupling of H_a with H_a and H_b with H_b (and even of H_a with H_b, and H_b with H_a) is measurable only at high resolution. In the spectrum of [(p-tolyl)₂C:N]₂Be, (Figure VI), peaks a and b are one third the intensity of peaks c and d. Since absorptions due to ortho and meta protons must necessarily be of equal intensity, peaks a and b are assigned to the aromatic protons of one type of ketimine group, and peaks c and d to the corresponding protons of ketimine groups in a different environment. This assignment is confirmed by the large separation of 0.9 p.p.m. between peaks a and c, and between peaks b and d, much greater than would be expected for simple ortho-meta differentiation.^{175,176} Each of the low-field peaks, a, b, c and d is further split, because of the spin-spin coupling mentioned above. The separation between the two components of each

peak is less than 2 c.p.s., in contrast with an expected value for the ortho-meta spin-spin coupling constant of 7-10 c.p.s.¹⁷⁶

Consequently straightforward assignment of peaks a and c to ortho protons, and peaks b and d to meta protons (Figure VII) is unlikely to be correct.

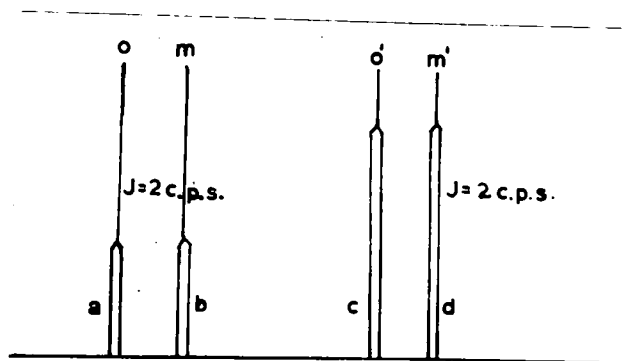

FIG. VII

A more probable explanation is represented in Figure VIII. Differences

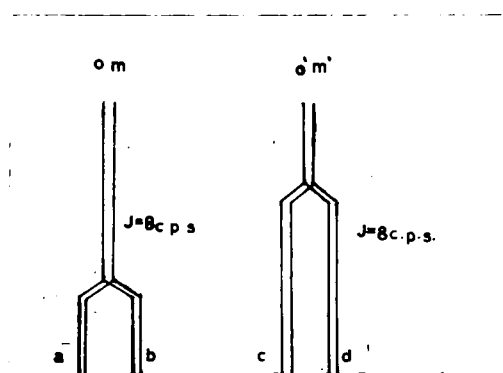
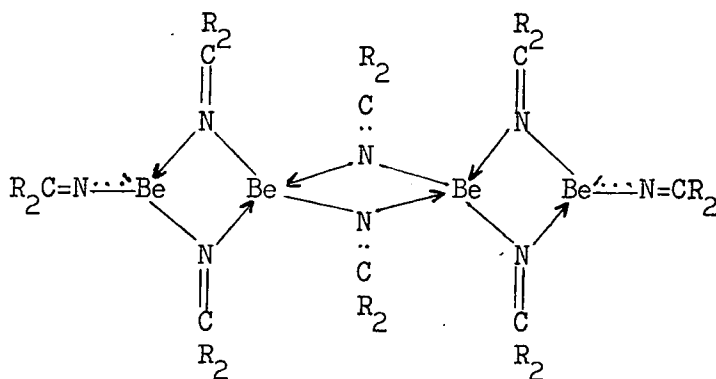

FIG. VIII

in the chemical shift values of protons on the same aromatic nucleus are postulated as small, and a spin-spin coupling constant of 7-10 c.p.s. results in overlap of the signals. Each absorption a, b, c and d

therefore consists of one peak due to ortho, and one peak due to meta protons. In view of the difference in the environments of the two types of ketimine groups as evidenced by the chemical shift differences between peaks a and c, and between peaks b and d, it is surprising that the two types of methyl groups are not differentiated.

The ratio of the intensities of the bands are $(a+b):(c+d):e = 1:3:3$, which is consistent with a tetrameric structure XXXV for these derivatives. This is likely to be as crowded as tris-diphenyl-ketiminoaluminium dimer, $[(Ph_2C:N)_3Al]_2$, discounted on steric grounds.



XXXV

Since the spectrum of the beryllium compound was recorded using a very dilute solution at such high field strength that the presence of benzene (an isotopic impurity in the C_6D_6 solvent) was revealed by a peak among those due to the aromatic protons of the sample, these relative intensity

measurements may not be reliable, and a less crowded dimeric or trimeric structure is also possible.

The mass spectra of both $(\text{Ph}_2\text{C:N})_2\text{Be}$ and $[(p\text{-tolyl})_2\text{C:N}]_2\text{Be}$ were recorded, but no peaks at higher values of m/e than those corresponding to the fragments R_2CNH^+ were observed.

Reactions of N-trimethylsilylketimines with aluminium and beryllium chlorides.

Trimethylsilylketimines react with metal halides in a similar fashion to ketiminolithium derivatives. The reactions differ in that the silicon compound produces volatile trimethylchlorosilane as the by-product, so that in principle this reaction offers a better synthetic route to the relatively insoluble azomethine derivatives. Accordingly the reaction of $\text{Ph}_2\text{C:NSiMe}_3$ with aluminium chloride in 3:1 molar proportions, and with beryllium chloride in 2:1 molar proportions was investigated. In both cases only one chlorine was displaced, even overnight in refluxing toluene, and $(\text{Ph}_2\text{C:NBAlCl}_2)_2$ and $(\text{Ph}_2\text{C:NBeCl})_2$ respectively were isolated. The aluminium compound has already been described (p. 98) and no further discussion is necessary. The beryllium compound is dimeric in benzene solution. The frequency of the C:N stretching vibration is included in Table 9, and is in the region typical of $\nu_{\text{C:N}}$ for bridging ketimine groups, although higher than the corresponding absorption in the spectrum of $[\text{Ph}_2\text{C:NBCl}_2]_2$.¹⁴⁴ This shift in frequencies is not unexpected in view of the increase in the number of electron-withdrawing substituents from beryllium to boron.

Reactions of Organolithium compounds with nitriles.

The difficulties encountered during attempts to make dialkylketimines by reaction of Grignard reagents or organoaluminium compounds with nitriles have been described previously (p. 78). The following pages describe attempts to prepare azomethine derivatives of lithium, $RR'C:NLi$ ($R,R' = \text{alkyl}$) which, by reaction with halides of less electropositive metals, would afford a route to dialkylketimino derivatives of a wide range of elements. Diphenylketiminolithium, $Ph_2C:NLi$ has been prepared both by the addition of phenyl-lithium across benzonitrile,¹³⁵ and by the reaction of diphenylketimine with organolithium compounds,¹³³ a route which is in principle applicable to all known ketimines, and has recently been used to prepare several aromatic azomethine derivatives of lithium.¹³⁴ $PhCMe:NLi$ has been obtained in low yield by addition of methyl-lithium across benzonitrile,¹³³ and by addition of phenyl-lithium across acetonitrile.¹³⁵ The low yields are probably due in part to the simultaneous formation of the phenyl cyanide trimer, 2,4,6-triphenyltriazine, which is known to be formed by the action of organolithium compounds on an excess of phenyl cyanide¹⁷⁷ in a reaction believed to proceed by successive insertions of phenyl cyanide into azomethine derivatives of lithium. Similar

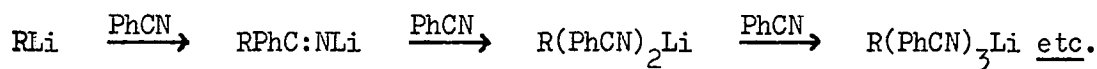

insertions of $PhC:N$ into alkyl derivatives of zinc are also believed to occur.¹⁴³ Chan and Rochow published p.m.r. evidence

which suggests that the trimethylsilyl derivative PhCMe:NSiMe_3 exists as an equilibrium mixture of the tautomers XXXVI,¹³⁵ and in principle

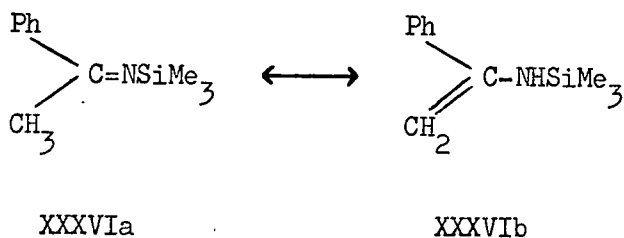

similar tautomerism is possible in alkyl substituted azomethine derivatives of lithium. *t*-Butyl cyanide, surprisingly, does not react with methyl- or ethyl-lithium at or below room temperature.¹³³ The reasons for this may lie in the bulk of the *t*-butyl group. Reaction did occur when methyl or ethyl cyanide was treated with methyl- or ethyl-lithium in ether (the reactants being taken in all four possible combinations in equimolar proportions), but the products were insoluble, involatile and seemingly polymeric materials resulting from elimination of alkane by acid reaction of the α -hydrogen atoms of the cyanides:

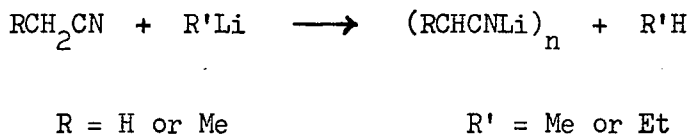

The composition of the products of these reactions was, however, more complex than is implied by the formula $(\text{RCHCNLi})_n$. The amount

of alkane evolved was less than required by this equation, although hydrolysis of the residue produced no further alkane. Rearrangement generating groups $\text{RCH}_2\text{CR}'\text{:N-}$ seemingly accounted for little of the remaining alkyl R', as only traces of 2,4-dinitrophenylhydrazones could be obtained from samples of hydrolysates of two of the polymers, and their infrared spectra had only weak absorptions (if any) in the region 1590-1680 in which $\nu(\text{C=N})$ would be expected. Elemental analysis of the product from methyl cyanide and methyl-lithium, however, showed the nitrogen:lithium ratio to be ca. 1.2:1.0, as if some insertion of nitrile into lithium-nitrogen links had also occurred, and the C, H, Li and N analytical figures totalled only 88.4%. The analytical figures varied slightly from one experiment to another, as if variable amounts of ether were incorporated in the polymers, a conclusion supported by the recovery of small quantities of ether when samples of the polymers were heated under vacuum. The most significant features of the infrared spectra of the polymers were the strong absorptions in the region $2000\text{-}2200\text{ cm}^{-1}$, at lower frequencies than $\nu(\text{C}\equiv\text{N})$ of the parent cyanides. Absorptions in this region are taken as indicative of the presence of groups >C=C=N- , formed by acid reaction of a nitrile in a ketenimine form. Accordingly, the polymers are probably best formulated empirically as $(\text{RCHCNLi})_x (\text{RCH}_2\text{CN})_y (\text{Et}_2\text{O})_z$. Dimethylcyanamide, $\text{Me}_2\text{NC:N}$, also reacted as a protonic acid towards

methyl-lithium, and indeed towards trimethylaluminium (see p.128), eliminating 0.89 mole methane per mole of methyl-lithium.¹³³

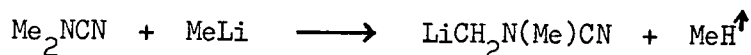

The product, a colourless insoluble amorphous solid which reacted violently with water, gave dimethylcyanamide when a fresh sample was treated cautiously with methanol. Like the products of the RCN/R'Li reactions, bands in its infrared spectrum occurred between 2000 and 2200 cm^{-1} , but not between 1580 and 1800 cm^{-1} , so that the presence of amidino groups $\text{MeC(NMe}_2\text{):NLi}$, which would have resulted from addition of the alkyl-lithium across the nitrile group, can be ruled out. The origin of the bands near 2100 cm^{-1} is not understood, as units N=C=N can be formed only by drastic rearrangement in this system. The continuous absorption below about 600 cm^{-1} in the infrared spectrum is consistent with a polymeric structure based on a complex skeleton.

Similar acidic behaviour of nitriles was observed when trimethylamine-dichloroalane reacted with acetonitrile during an attempt to isolate $\text{MeCH:NA}(\text{Cl})_2$. The infrared spectrum of the white, involatile and seemingly polymeric product was recorded, and gave no evidence of the presence of any imino species, nor was acetaldehyde produced on hydrolysis.

Reactions of N,N-dimethylcyanamide and N,N,N',N'-tetramethylguanidine with organoaluminium compounds.

Azomethine derivatives $\text{RCX:N.MR}'_n$, (where X is some functional group) containing donor sites in addition to the imino nitrogen atom which is bonded to the metal, provide further chemical and structural interest, in that interaction with acceptor species is possible if their structures resemble those of aldimine and ketimine derivatives, while it is also possible for these compounds to form structures totally different from the ketimine structures described above. Azomethine derivatives with a free donor site in the amino nitrogen, for example, might be formed by reaction of amidines, $\text{R}_2\text{NCR}'\text{:NH}$, and aluminium alkyls $\text{R}''\text{Al}$.

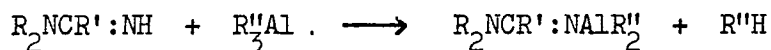

Similar derivatives are accessible by the insertion reactions of dimethylcyanamide, $\text{Me}_2\text{NC:N}$, with organoaluminium compounds, as described in the following pages.

N,N,N',N'-Tetramethylguanidine, $(\text{Me}_2\text{N})_2\text{C:NH}$, like diphenylketimine, reacts with organolithium compounds, with evolution of alkane, producing the azomethine derivative $[(\text{Me}_2\text{N})_2\text{C:NLi}]_2$.¹³³

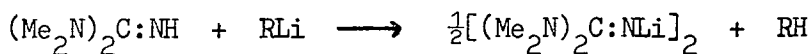

The analogous reaction with trimethylaluminium was investigated in order to isolate and examine an azomethine derivative of aluminium which has three potential donor sites.

Dimethylcyanamide reacts with trimethylaluminium below room temperature, forming a 1:1 solid adduct, $\text{Me}_2\text{NC}:\text{N},\text{AlMe}_3$, m.p. $40-41^\circ$, which is soluble in aromatic hydrocarbon solvents. A similar reaction with triethylaluminium produces the liquid adduct $\text{Me}_2\text{NC}:\text{N},\text{AlEt}_3$. The parent cyanamide has two potential donor sites, and co-ordination through either the amino or the cyanide nitrogen is possible. A chelated structure resulting from co-ordination through both nitrogen atoms cannot be formed because of the linearity of the $\text{>N-C}\equiv\text{N}$ skeleton. Interaction between neighbouring molecules in the crystal may occur, resulting in a five-co-ordinate environment for aluminium, XXXVII, but the adduct is unassociated in benzene at 0.1M, the concentration used for cryoscopic measurements.

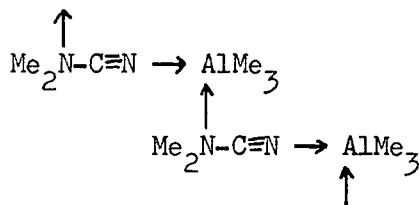

XXXVII

Trimethylaluminium also forms a solid 1:1 adduct, $(\text{Me}_2\text{N})_2\text{C}:\text{NH},\text{AlMe}_3$ with tetramethylguanidine below room temperature. No comparable

co-ordination complex was isolated in the methyl-lithium-tetramethylguanidine system. The adduct melts at 44° without decomposition, and loses methane only on heating above 100° . It is very sensitive to attack by oxygen and water, decomposing immediately on exposure to the atmosphere.

Any of the three potential donor sites of tetramethylguanidine could in principle be involved in co-ordination to aluminium in the adduct, giving rise to the monodentate structures XXXVIII or XXXIX.

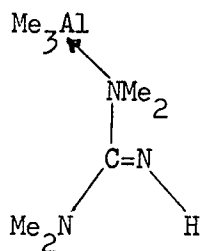

XXXVIII

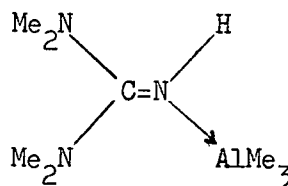

XXXIX

Unlike the corresponding dimethylcyanamide adducts $\text{Me}_2\text{NCN, AlR}_3$, chelated structures XL or XLI, involving five-co-ordinate aluminium, are also possible, though likely to be strained.

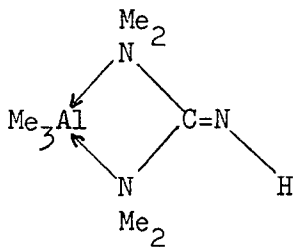

XL

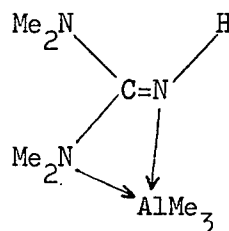

XLI

Related carbonyl donors, N,N,-dimethylformamide,⁴⁰ and N,N,N',N'-tetramethylurea,¹⁷⁸ both co-ordinate through oxygen rather than through nitrogen, so it is probable that tetramethylguanidine co-ordinates through the azomethine nitrogen.

The infrared spectrum of $(\text{Me}_2\text{N})_2\text{C}:\text{NH},\text{AlMe}_3$ was recorded to help resolve the problem of its structure. The frequency of the C:N stretching vibration (1612 cm^{-1}) was higher by 16 cm^{-1} for the adduct than for tetramethylguanidine itself, which suggests that the azomethine nitrogen rather than the amino nitrogen is the donor atom since co-ordination through the amino atom would have comparatively little influence on $\nu_{\text{C:N}}$. Co-ordination through the azomethine nitrogen of diphenylketimine raises the frequency of the corresponding band in its infrared spectrum by up to 25 cm^{-1} (in its adduct with BF_3 ¹⁴⁹), although co-ordination to weaker acceptors has much less effect upon this vibration (see p. 82).

Salient features of the infrared spectra of the dimethylcyanamide adducts are collected in Table 11, together with similar data for other nitrile adducts of trimethyl- and triethylaluminium.

In the spectra of both $\text{Me}_2\text{NC}:\text{N}.\text{AlMe}_3$ and $\text{Me}_2\text{NC}:\text{N}.\text{AlEt}_3$, $\nu_{\text{C:N}}$ is higher than the corresponding band for the parent nitrile. Similar frequency shifts are usual for co-ordination complexes of nitriles,^{31,33,47,48,49} and the observed data are thus consistent with co-ordination through the cyanide group, although the frequency shifts in the spectra of both

TABLE 11.

Infrared Spectra of Nitrile adducts.

Compound	$\nu_{\text{C:N}}$ cm^{-1}	$\Delta\nu$ cm^{-1}
PhCN	2230	-
PhCN·AlMe ₃ *	2273	43
PhCN·AlEt ₃	2270	40
MeCN	2253	-
MeCN·AlMe ₃ *	2296	43
MeCN·AlEt ₃	2290	37
Bu ^t CN	2235	-
Bu ^t CN·AlMe ₃ *	2282	47
Bu ^t CN·AlEt ₃	2282	47
Me ₂ NCN	2208	-
Me ₂ NCN·AlMe ₃ *	2257	49
Me ₂ NCN·AlEt ₃	2268	60

Data for PhCN, MeCN and Bu^tCN adducts from reference 31.

* Nujol mull. All other samples in the form of contact films.

$\text{Me}_2\text{NC:N}\cdot\text{AlMe}_3$, and especially $\text{Me}_2\text{NC:N}\cdot\text{AlEt}_3$ appear greater than for the alkylaluminium adducts of alkyl- or phenyl cyanides. P.m.r. spectroscopic results for the adducts are presented in Table 12.

TABLE 12

P.m.r. spectroscopic results for the adducts

$\text{Me}_2\text{NCN}\cdot\text{AlR}_3$ and $(\text{Me}_2\text{N})_2\text{C:NH}\cdot\text{AlMe}_3$.

Compound	τ values (p.p.m.)		
	=NH	-NMe ₂	-AlR ₃
Me_2NCN	-	7.4 ₂ s	-
$\text{Me}_2\text{NCN}\cdot\text{AlMe}_3$	-	7.9 ₂ s(2)	10.3 ₀ s(3)
$\text{Me}_2\text{NCN}\cdot\text{AlEt}_3$	-	7.6 ₂ s(2)	8.7 ₅ t(3), 10.0 ₀ q(2)
$(\text{Me}_2\text{N})_2\text{C:NH}$	4.7 ₃ s(1)	7.3 ₆ s(12)	-
$(\text{Me}_2\text{N})_2\text{C:NH}\cdot\text{AlMe}_3$	5.5 ₈ s(1)	7.6 ₉ s(12)	10.4 ₄ s(9)

s = singlet, t = triplet, q = quartet; relative intensities in parentheses.

Samples were in the form of 20% solutions in benzene.

$\tau_{\text{Me}_4\text{Si}} = 10.0_0$ p.p.m.

The peaks due to the N-attached methyl protons are all shifted to high field upon co-ordination. This may well reflect interaction between the amino nitrogens and aluminium atoms in dimeric species. Although the dimethylcyanamide adducts were both monomeric at the concentrations used for cryoscopic molecular weight measurements, association to give such structures as XLII may well occur in the more concentrated solutions used for recording p.m.r. spectra.

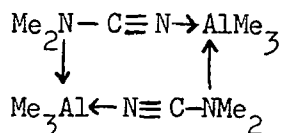

XLII

In the spectrum of $(\text{Me}_2\text{N})_2\text{C}:\text{NH}, \text{AlMe}_3$, the chemical shift of the proton is most markedly affected by adduct formation, suggesting that it is primarily the azomethine nitrogen that is bonded to aluminium.

However, the molecular weight of the adduct, measured by cryoscopy in benzene solution, corresponded to a degree of association of 1.3-1.5, the value increasing with the concentration of the solution used.

These results certainly suggest that the amino nitrogens can take part in the formation of dimers such as XLIII, involving five-co-ordinate aluminium, or even XLIV, involving six-co-ordinate aluminium.

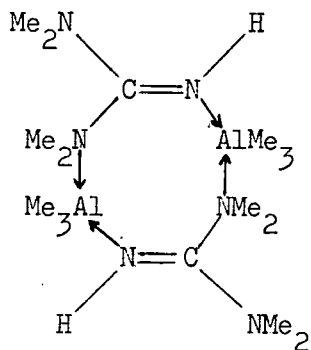

XLIII

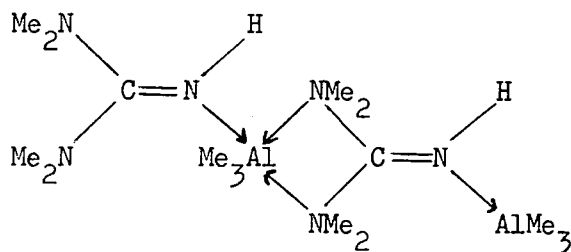

XLIV

Trimethylaluminium forms a 2:1 co-ordination complex, $\text{Me}_3\text{Al} \cdot \text{NMe}_2\text{C}_2\text{H}_4\text{NMe}_2 \cdot \text{AlMe}_3$, with tetramethylethylenediamine.¹⁷⁹ The above evidence for interaction between free donor sites of one molecule, and an acceptor atom of a neighbouring molecule suggested that dimethylcyanamide or tetramethylguanidine might also form a 1:2 adduct $\text{Me}_2\text{NCN} \cdot 2\text{AlMe}_3$, or $(\text{Me}_2\text{N})_2\text{C}:\text{NH} \cdot 2\text{AlMe}_3$, with trimethylaluminium. Accordingly, the components were mixed in the appropriate ratio at low temperature, and allowed to react. The products were collected on a filter, lest removal of solvent under vacuum caused dissociation of any weak adduct present, but no evidence for co-ordination of more than one mole of trimethylaluminium per mole of dimethylcyanamide or tetramethylguanidine was observed, and in each case, the excess of trimethylaluminium was recovered unchanged.

When the adduct $\text{Me}_2\text{NC:N,AlMe}_3$ was heated to 115° , very extensive thermal decomposition occurred, as evidenced by the isolation of ethylene and hydrogen from the gaseous products of the reaction. Rather more than one mole of methane per mole of adduct was produced, together with dimethylamine. Some of this reacted with trimethylaluminium, either freed by dissociation of the adduct, or possibly still co-ordinated, forming dimethylamino(dimethylaluminium)dimer, $(\text{Me}_2\text{NAlMe}_2)_2$, the only solid material which could be isolated from the reaction mixture and characterised. Methyl-lithium reacts with dimethylcyanamide (see p.118-119) under much milder conditions, eliminating methane in nearly the proportion required by the equation:-

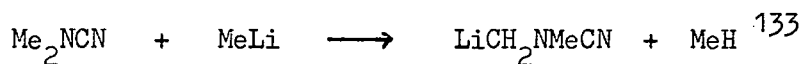

The products of both these reactions were insoluble amorphous solids which reacted violently with water and regenerated dimethylcyanamide on cautious hydrolysis with methanol. The infrared spectrum of the product of decomposition of $\text{Me}_2\text{NC:N,AlMe}_3$ differed from that of the lithio compound in having a strong band at 1550 cm^{-1} , characteristic of an amidino link. This suggests that dimethylcyanamide undergoes insertion reactions with organoaluminium compounds, as well as behaving as a protonic acid.

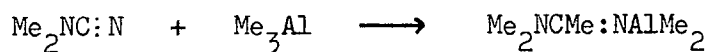

The adduct $\text{Me}_2\text{NCN,AlEt}_3$ underwent less drastic thermal decomposition on heating to 115° , leaving the dimeric N-diethylaluminium-N',N'-dimethylformamidine, $(\text{Me}_2\text{NCH:NAEt}_2)_2$, identified by comparison of its infrared spectrum with that of an authentic sample prepared by reaction of dimethylcyanamide with diethylaluminium hydride (see below).

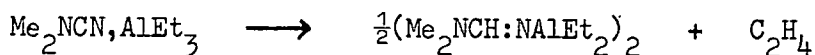

The product was a viscous liquid, because of contamination by unchanged adduct. Vacuum distillation yielded a similar liquid which, on spectroscopic examination proved still to contain some of the adduct, which was evidently capable of distilling unchanged.

Nitriles insert much more readily into Al-H bonds than into Al-C bonds. Adducts $\text{RCN,R}'_2\text{AlH}$ could not be isolated even below room temperatures when cyanides were mixed with alkylaluminium hydrides, while the trialkylaluminium adducts $\text{RCN,AlR}'_3$ rearranged only on heating above 110° .^{31,33} Dimethylcyanamide similarly reacted with dimethyl- and diethylaluminium hydrides below room temperature, giving crystalline products $(\text{Me}_2\text{NCH:NA}(\text{R}'_2))_2$ (R = Me, Et) which were soluble in hydrocarbon solvents, and proved by cryoscopy in benzene to be dimeric.

When $(\text{Me}_2\text{N})_2\text{C:NH,AlMe}_3$ in a sealed evacuated tube was immersed in an oil bath at 180° for ten minutes, one mole of methane per mole of adduct was produced, together with traces of dimethylamine, and

N-dimethylaluminium-N',N',N'',N''-tetramethylguanidine, $[(\text{Me}_2\text{N})_2\text{C:NAlMe}_2]_n$, could be recovered from the solid residue by recrystallisation from toluene. If the adduct was heated at lower temperatures than 180° , incomplete elimination of methane resulted. Heating at temperatures above 100° for prolonged periods resulted in the formation of much more dimethylamine, and the contamination of the product by uncharacterised resinous materials.

The tetramethylguanidine derivative $[(\text{Me}_2\text{N})_2\text{C:NAlMe}_2]_n$ was insufficiently soluble for cryoscopic molecular weight determinations, itself an indication that it is associated. N-lithio-tetramethylguanidine, $[(\text{Me}_2\text{N})_2\text{C:NLi}]_2$ is dimeric in benzene,¹³³ presumably with structure XLV or XLVI. It was not possible to distinguish between

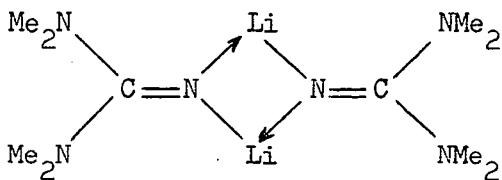

XLV

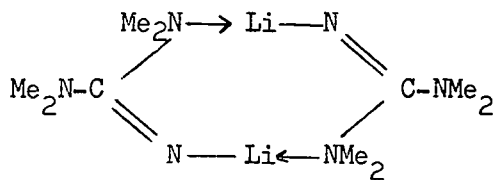

XLVI

the two possibilities with certainty; p.m.r. spectroscopic evidence favoured XLV, although structure XLVI permits linear co-ordination at lithium, presumably most likely in a two-co-ordinate situation.

The dialkylaluminium-dimethylformamidines, $(\text{Me}_2\text{NCH:NAlR}_2)_2$ are also dimeric. Corresponding structures XLVII or XLVIII are possible

for these compounds.

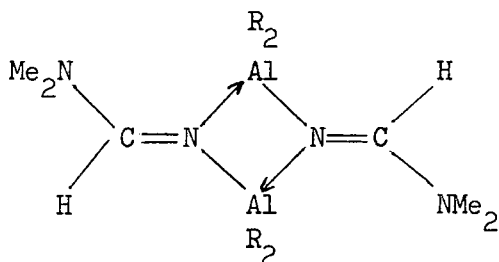

XLVII

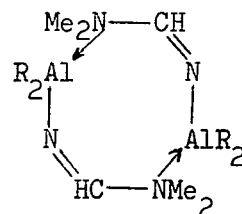

XLVIII

If the tetramethylguanidine derivative $[(\text{Me}_2\text{N})_2\text{C}:\text{NAlMe}_2]_n$ is also dimeric, it is likely to adopt the similar alternative four- or eight-membered ring systems XLIX or L.

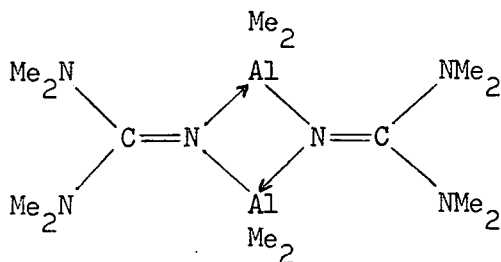

XLIX

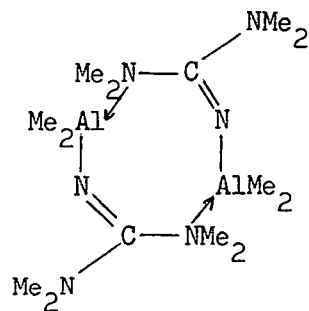

L

Spectroscopic evidence of structures analogous to XLVIII and L, in dialkylaluminium complexes with bidentate ligands having hydroxyl and amino functional groups has recently been published.¹⁸⁰

The infrared spectra of these azomethine derivatives were recorded, and their C:N stretching frequencies are compared in Table 13.

TABLE 13.

Infrared spectroscopic data for some tetramethylguanidine
and dimethylcyanamide derivatives.

Compound	$\nu_{\text{C:N}}$ cm^{-1}
$(\text{Me}_2\text{N})_2\text{C:NH}$ *	1596
$[(\text{Me}_2\text{N})_2\text{C:NA}(\text{Me}_2)]_n$	1618
$[(\text{Me}_2\text{N})_2\text{C:NLi}]_2$	1632
$(\text{Me}_2\text{NCH:NA}(\text{Me}_2))_2$	1623
$(\text{Me}_2\text{NCH:NA}(\text{Et}))_2$	1626

* liquid film. All other samples in the form of nujol mulls.

In all cases this band is at higher frequency than in tetramethylguanidine. Diphenylketimine derivatives, $(\text{Ph}_2\text{C:NMR}_2)_2$ also showed an increase in $\nu_{\text{C:N}}$ over the parent imine, so that these data are consistent with the four-membered ring configuration, but an eight-membered ring structure could equally well give rise to absorptions in the same region.

$[(\text{Me}_2\text{N})_2\text{C}:\text{NAlMe}_2]_n$ was not sufficiently soluble to record its p.m.r. spectrum. P.m.r. spectroscopic data for the dimethylcyanamide derivatives are summarised in Table 14. Neither of the alternative structures XLVII or XLVIII can be excluded on the basis of these results.

TABLE 14.

P.m.r. spectroscopic results for the dimethylcyanamide derivatives, $(\text{Me}_2\text{NCH}:\text{NAlR}_2)_2$.

Compound	τ values (p.p.m.)		
	NMe ₂	CH	AlR ₂
Me ₂ NCN	7.4 ₂ s	-	-
(Me ₂ NCH:NAlMe ₂) ₂	7.4-8.1m(6)	*	10.3 ₅ s(6)
(Me ₂ NCH:NALEt ₂) ₂	7.6 ₁ s(6)	4.0 ₇ m(1)	8.4 ₄ t(6), 9.5 ₅ q(4)

* Peak not observed.

s = singlet, t = triplet, q = quartet, m = multiplet;
relative intensities in parentheses.

Samples in the form of 20% solutions in benzene.

$\tau_{\text{Me}_4\text{Si}} = 10.0_0$ p.p.m.

P.m.r. spectra of dimethylaluminium derivatives of aldimines, $(RCH:NAI Me_2)_2$ show evidence of cis-trans isomerism, in that the peak arising from the aluminium-attached methyl groups is split, the cis compound giving rise to two peaks of equal intensity, and the trans compound to a third singlet.³¹ No evidence of such isomerism was given by the spectrum of $(Me_2NCH:NAI Me_2)_2$. The multiplicity of the absorption due to the N-attached methyl protons of the dimethylaluminium compound is surprising, as is the broadness of the same peak, and the complexity of the peak arising from the azomethine proton ($-CH:N$) in the spectrum of $(Me_2NCH:NAI Et_2)_2$. Long range spin-spin coupling between the N-attached methyl groups and the azomethine proton could in part explain this multiplicity and the absence (through broadening) of a band due to the azomethine proton in $(Me_2NCH:NAI Me_2)_2$, but no such coupling between methyl groups and the corresponding proton is observed in the p.m.r. spectrum of N,N-dimethylformamide.

The Dailey Schoolery rule¹⁸¹ relates the difference in chemical shifts of peaks due to methyl and methylene protons of ethyl derivatives EtZ to the electron withdrawing power (electronegativity) of the substituent Z. Applying this rule to the 1H n.m.r. spectra of the halides $(Et_2AlX)_2$, Wallbridge and Smith¹⁵² showed that the electronegativity of aluminium increases in the series $(Et_2AlI)_2 < (Et_2AlBr)_2 < (Et_2AlCl)_2 < (Et_2AlF)_4$. Comparison of Wallbridge's results with similar data for a series of azomethine

derivatives of aluminium (Table 15) suggests that the electron withdrawal power of aluminium in the azomethine derivatives is comparable with that of aluminium in $(Et_2AlF)_4$. The high degree of association of $(Et_2AlF)_4$ compared with $(Et_2AlCl)_2$ may have some influence on the

TABLE 15.

Compound	$\Delta_{CH_3} - \Delta_{CH_2}$ c.p.s.	Electronegativity x_{Al-X}
$(Et_2AlI)_2$	35.4	2.53
$(Et_2AlBr)_2$	45.0	2.75
$(Et_2AlCl)_2$	50.4	2.88
$(Et_2AlF)_4$	61.8	3.14
$(Et_2AlN:CHBu^t)_2$	61.8	3.14
$(Et_2AlN:CHPh)_2$	~60	~3.1
$(Et_2AlN:CPh_2)_2$	66.0	3.24
$(Et_2AlN:CHNMe_2)_2$	66.6	3.25

$$x_{Al-X} = 0.02315 (\Delta_{CH_3} - \Delta_{CH_2}) + 1.71$$

apparent electronegativity of the Al-F group, but the results obtained are in general agreement with the relative electronegativities of nitrogen and the halogens.

REFERENCES

1. K. Ziegler in "Organometallic Chemistry", A.C.S. Monograph No.147
(H. Zeiss ed.), p.194, Reinhold, New York, 1960.
2. J.R. Surtees, Rev. Pure and Appl. Chem., 13, 91, (1963).
3. R. Köster and P. Binger, Adv. Inorg. Chem. Radiochem., 7, 263, (1965).
4. K.J. Palmer and N. Elliot, J. Amer. Chem. Soc., 60, 1852, (1938).
5. A.W. Laubengayer and W.F. Gilliam, J. Amer. Chem. Soc., 63, 477,
(1941).
6. K.S. Pitzer and H.S. Gutowsky, J. Amer. Chem. Soc., 68, 2204, (1946).
7. P.H. Lewis and R.E. Rundle, J. Chem. Phys., 21, 986, (1953).
8. R.G. Vranka and E.L. Amma, J. Amer. Chem. Soc., 89, 3121, (1967).
9. J.F. Malone and W.S. McDonald, Chem. Comm., 444, (1967).
10. T. Wartik and H.I. Schlesinger, J. Amer. Chem. Soc., 75, 835, (1953).
11. E.G. Hoffmann, Annalen, 629, 104, (1960).
12. H. Scherer and G. Seydel, Angew. Chem., 75, 846, (1963).
13. E.A. Jeffery, T. Mole and J.K. Saunders, Austral. J. Chem., 21,
137, (1968).
14. A.B. Burg and H.I. Schlesinger, J. Amer. Chem. Soc., 55, 4020, (1933).
15. H.C. Brown, H.I. Schlesinger and A.B. Burg, J. Amer. Chem. Soc.,
61, 673, (1939).
16. F.G.A. Stone and H.J. Emeléus, J. Chem. Soc., 2755, (1950).
17. K. Niedenzu and J.W. Dawson, J. Amer. Chem. Soc., 81, 5553, (1959).
18. T.D. Coyle, S.L. Stafford and F.G.A. Stone, J. Chem. Soc., 3103,
(1961).

19. P. Love, J. Chem. Phys., 39, 3044, (1963).
20. R.J. Gillespie, J. Amer. Chem. Soc., 82, 5978, (1960).
21. D.D. Eley and H. Watts, J. Chem. Soc., 1319, (1954).
22. F.G.A. Stone, Chem. Rev., 58, 101, (1958)
23. F.A. Cotton and J.R. Leto, J. Chem. Phys., 30, 993, (1959).
24. D.R. Armstrong and P.G. Perkins, J. Chem. Soc. (A), 1218, (1967).
25. H.C. Brown and N.R. Davidson, J. Amer. Chem. Soc., 64, 316, (1942).
26. H.C. Brown, H. Bartholomay and M.D. Taylor, J. Amer. Chem. Soc.,
66, 435, (1944).
27. H.C. Brown, J. Chem. Soc., 1248, (1956).
28. G.E. Coates, J. Chem. Soc., 2003, (1951).
29. E.W. Abel, D.A. Armitage and D.B. Brady, Trans. Farad. Soc.,
62, 3459, (1966).
30. E.W. Abel, D.A. Armitage and S.P. Tyfield, J. Chem. Soc. (A),
554, (1967).
31. J.R. Jennings, J.E. Lloyd and K. Wade, J. Chem. Soc., 5083, (1965).
32. G.E. Coates, M.L.H. Green and K. Wade, "Organometallic Compounds",
(3rd ed., Vol. 1), Methuen, London, (1967).
33. J.E. Lloyd and K. Wade, J. Chem. Soc., 2662, (1965).
34. T. Mole, Austral. J. Chem., 16, 801, (1963).
35. E.G. Hoffmann and G. Schomburg, z. Electrochem, 61, 1101, (1957).
36. E.G. Hoffmann and G. Schomburg, z. Electrochem, 61, 1110, (1957).
37. G. Wilke and H. Müller, Annalen, 629, 222, (1960).

38. K. Ziegler and R. Köster, *Annalen*, 608, 1, (1957).
39. A.W. Laubengayer and G.F. Legnick, *Inorg. Chem.*, 5, 503, (1966).
40. S.J. Kuhn and J.S. McIntyre, *Canad. J. Chem.*, 43, 375, (1965).
41. D. Cook, *Canad. J. Chem.*, 41, 522, (1963).
42. M.F. Lappert, *J. Chem. Soc.*, 542, (1962).
43. T.D. Coyle and F.G.A. Stone, *J. Amer. Chem. Soc.*, 4138, (1961).
44. R.L. Richards and A. Thompson, *J. Chem. Soc. (A)*, 1244, (1967).
45. R.L. Richards and A. Thompson, *J. Chem. Soc. (A)*, 1248, (1967).
46. J.W. Wilson and I.J. Worrall, *J. Chem. Soc. (A)*, 316, (1968).
47. W. Gerrard, M.F. Lappert, H. Pyszora and J.W. Wallis, *J. Chem. Soc.*, 2182, (1960).
48. T.L. Brown and M. Kubota, *J. Amer. Chem. Soc.*, 83, 4175, (1961).
49. K. Starowieyski and S. Pasynkiewicz, *Roczniki Chem.*, 40, 47, (1966).
50. I.R. Beattie and T. Gilson, *J. Chem. Soc.*, 2292, (1964).
51. J.K. Gilbert and J.D. Smith, *J. Chem. Soc. (A)*, 233, (1968).
52. K.-H. Thiele and W. Brüser, *z. anorg. Chem.*, 348, 179, (1966).
53. N.R. Fetter, F.E. Brinckmann and D.W. Moore, *Canad. J. Chem.*, 40, 2184, (1962).
54. N.R. Fetter, B. Bartocha, F.E. Brinckmann and D.W. Moore, *Canad. J. Chem.*, 41, 1359, (1963).
55. T. Mole, *Chem. and Ind.*, 281, (1964).
56. M. Baudler and G. Wetter, *z. anorg. Chem.*, 329, 3, (1964).
57. I.R. Beattie, T. Gilson and G.A. Ozin, *J. Chem. Soc. (A)*, 1092, (1968).

58. E. Wiberg, H. Graf and R. Uson Lacal, *z. anorg. Chem.*, 272, 221, (1953).
59. J.K. Ruff and M.F. Hawthorne, *J. Amer. Chem. Soc.*, 82, 2141, (1960).
60. R.J. Gillespie, *J. Chem. Soc.*, 1002, (1952).
61. C.W. Heitsch, C.E. Nordman and R.W. Parry, *Inorg. Chem.*, 2, 508, (1963).
62. G.W. Frazer, N.N. Greenwood and B.P. Straughan, *J. Chem. Soc.*, 3742, (1963).
63. G.J. Palenik, *Acta. Cryst.*, 17, 1573, (1964).
64. A.R. Young and R. Ehrlich, *Inorg. Chem.*, 4, 1358, (1965).
65. H.C. Brown and W.J. Wallace, *J. Amer. Chem. Soc.*, 75, 6265, (1953).
66. S.U. Choi and H.C. Brown, *J. Amer. Chem. Soc.*, 88, 903, (1966).
67. S.U. Choi, W.C. Frith and H.C. Brown, *J. Amer. Chem. Soc.*, 88, 4128, (1966).
68. D.D. Eley, J.H. Taylor and S.C. Wallwork, *J. Chem. Soc.*, 3867, (1961)
69. Go Hata, *Chem. Comm.*, 7, (1968).
70. W.P. Neuman, *Annalen*, 667, 1, (1963).
71. A.W. Laubengayer, J.D. Smith and G.G. Ehrlich, *J. Amer. Chem. Soc.*, 83, 542, (1961).
72. J.K. Ruff, *J. Amer. Chem. Soc.*, 83, 2835, (1961).
73. A.W. Laubengayer, K. Wade and G. Legnick, *Inorg. Chem.*, 1, 632, (1962).

74. G.E. Coates and J. Graham, *J. Chem. Soc.*, 233, (1963).
75. O.T. Beachley and G.E. Coates, *J. Chem. Soc.*, 3241, (1965).
76. G. Bahr, F.I.A.T. review of German Science 1939-46, 24,
Inorganic Chemistry, 155.
77. W.P. Neuman, *Annalen*, 629, 23, (1960).
78. J.K. Ruff, *J. Amer. Chem. Soc.*, 83, 1798, (1961).
79. M. Cohen, J.K. Gilbert and J.D. Smith, *J. Chem. Soc.*, 1092, (1965).
80. J.I. Jones and W.S. McDonald, *Proc. Chem. Soc.*, 366, (1962).
81. T.R.R. McDonald and W.S. McDonald, *Proc. Chem. Soc.*, 382, (1963).
82. J.K. Gilbert and J.D. Smith, *Abstracts of the Chemical Society
Autumn Meeting at Nottingham*, pB3, (1965).
83. L.I. Zakharkin, G.S. Kolesnikov, S.L. Davydova, V.V. Gavrilenko
and A.A. Kamyslova, *Izv. Akad. Nauk. S.S.S.R.*, 364, (1961).
84. G.E. Coates and R.N. Mukherjee, *J. Chem. Soc.*, 1295, (1964).
85. J.R. Jennings and K. Wade, *J. Chem. Soc. (A)*, 1333, (1967).
86. I. Pattison and K. Wade, *J. Chem. Soc. (A)*, in press.
87. J.J. Eisch and M.E. Healy, *J. Amer. Chem. Soc.*, 86, 4221, (1964).
88. H. Schmidbaur and W. Wolfsberger, *Chem. Ber.*, 100, 1016, (1967).
89. H. Schmidbaur and G. Jonas, *Chem. Ber.*, 101, 1271, (1968).
90. N.R. Fetter and B. Bartocha, *Canada. J. Chem.* 39, 2001, (1961).
91. R.P. Nielsen and H.H. Sisler, *J. Chem. Soc.*, 3818, (1962).
92. G.E. Coates and R.N. Mukherjee, *J. Chem. Soc.*, 229, (1963).
93. R. Ehrlich and A.R. Young, *J. Inorg. Nucl. Chem.*, 28, 674, (1966).

94. T. Mole and J.R. Surtees, Chem. and Ind., 1727, (1963).
95. T. Mole and J.R. Surtees, Austral. J. Chem., 17, 1229, (1964).
96. J.R. Surtees, Austral. J. Chem., 18, 14, (1965).
97. P. Binger, Angew. Chem., Internat. Ed., 2, 686, (1963).
98. E.G. Hoffmann and W. Tornau, Angew. Chem., 73, 578, (1961).
99. H. Schmidbaur, Angew. Chem., Internat. Ed., 4, 152, (1965).
100. H. Schmidbaur and M. Schmidt, Angew. Chem., Internat. Ed., 1, 327, (1962).
101. T. Renner, z. anorg. Chem., 298, 22, (1959).
102. H. Schmidbaur, W. Wolfsberger and H. Kröner, Chem. Ber., 100, 1023, (1967).
103. M.F. Lappert and B. Prokai, Adv. Organometall. Chem., 5, 225, (1967).
104. K. Ziegler, H.G. Gellert, H. Martin, K. Nagel and J. Schneider, Annalen, 589, 91, (1954).
105. K. Ziegler, H.G. Gellert, H. Lehmkuhl, W. Pfohl and K. Zosel, Annalen, 629, 1, (1960).
106. K. Ziegler, Angew. Chem., 64, 323, (1952).
107. G. Wilke and H. Müller, Annalen, 618, 267, (1958).
108. K. Ziegler, K. Schneider and J. Schneider, Annalen, 623, 9, (1959).
109. A.E.G. Miller, J.W. Biss and L.H. Schwartzman, J. Org. Chem., 24, 627, (1959).

110. H. Meerwein, G. Hinz, H. Majert and H. Sönke, J. prakt. Chem., 147, 226, (1937).
111. S. Pasynkiewicz and E. Sliwa, J. Organometall. Chem., 3, 121, (1965).
112. H. Gilman and K.E. Marple, Rec. Trav. chim., 55, 133, (1936).
113. T. Mole and J.R. Surtees, Austral. J. Chem., 17, 961, (1964).
114. S. Pasynkiewicz, L. Kozerski and B. Grabowski, J. Organometall. Chem., 8, 233, (1967).
115. L.I. Zakharkin and I.M. Khorlina, Doklady Akad. Nauk. S.S.S.R., 116, 422, (1957).
116. H. Reinheckel and D. Jahnke, Chem. Ber., 97, 2661, (1964).
117. S. Pasynkiewicz and S.A. Maciaszek, Izv. Akad. Nauk. S.S.S.R., 1118, (1965).
118. R. Ehrlich, A.R. Young, B.M. Lichstein and D.D. Perry, Inorg. Chem., 3, 628, (1964).
119. R. Ehrlich and A.R. Young, J. Inorg. Nucl. Chem., 30, 53, (1968).
120. S. Pasynkiewicz, W. Dahlig and B. Tomaszewski, Roczniki Chem., 36, 1383, (1962).
121. G.K.J. Gibson and D.W. Hughes, Chem. and Ind., 544, (1964).
122. H.M.M. Shearer and J. Willis, unpublished observations.
123. S. Pasynkiewicz and W. Kuran, Roczniki Chem., 39, 979, (1965).
124. H. Reinheckel, D. Jahnke and G. Kretzschmar, Chem. Ber., 99, 11, (1966).
125. J.R. Horder and M.F. Lappert, J. Chem. Soc. (A), in press.

126. J.R. Jennings, K. Wade and B.K. Wyatt, J. Chem. Soc. (A), in press.
127. H.M.M. Shearer and J. Twiss, personal communication.
128. R.T. Sanderson, "Vacuum Manipulation of Volatile Compounds",
John Wiley and Sons Inc., New York, (1948).
129. J. Kinnunen and B. Wennerstrand, Chemist-Analyst, 48, 92, (1957).
130. P.L. Pickard and T.L. Tolbert, J. Org. Chem., 26, 4886, (1961).
131. E.J. Grubbs, J.D. McCullough, B.H. Weber and J.R. Maley,
J. Org. Chem., 31, 1098, (1966).
132. H. Gilman and R.G. Jones, J. Amer. Chem. Soc., 62, 980, (1940).
133. I. Pattison, K. Wade and B.K. Wyatt, J. Chem. Soc. (A), 837, (1968).
134. B. Samuel and K. Wade, unpublished observations.
135. L. Chan and E.G. Rochow, J. Organometall. Chem., 9, 231, (1967).
136. O.T. Beachley, G.E. Coates and G. Kohnstam, J. Chem. Soc., 3248,
(1965).
137. H.J. Emeléus and K. Wade, J. Chem. Soc., 2614, (1960).
138. C. Krüger, E.G. Rochow and U. Wannagat, Chem. Ber., 96, 2132, (1963).
139. M.F. Hawthorne, Tetrahedron, 17, 117, (1962).
140. J.E. Lloyd and K. Wade, J. Chem. Soc., 1649, (1964).
141. J.R. Jennings and K. Wade, J. Chem. Soc. (A), 1222, (1967).
142. I. Pattison and K. Wade, J. Chem. Soc. (A), 1098, (1967).
143. I. Pattison and K. Wade, J. Chem. Soc. (A), 57, (1968).
144. J.R. Jennings, I. Pattison, C. Summerford, K. Wade and B.K. Wyatt,
Chem. Comm., 250, (1968).

145. I. Pattison and K. Wade, unpublished observations.
146. C. Summerford and K. Wade, unpublished observations.
147. H. Nöth, z. Naturforsch., 16b, 470, (1961).
148. W.D. English, A.L. McCloskey and H. Steinberg, J. Amer. Chem. Soc.,
83, 2122, (1961).
149. I. Pattison and K. Wade, J. Chem. Soc. (A), 842, (1968).
150. R.W. Layer, Chem. Rev., 63, 489, (1963).
151. B. Bogdanovic, Angew. Chem. Internat. Edn., 4, 954, (1965).
152. C.A. Smith and M.G.H. Wallbridge, J. Chem. Soc. (A), 7, (1967).
153. A.P. Gray, Canad. J. Chem., 41, 1511, (1963).
154. E.G. Hoffmann, z. Electrochem., 64, 616, (1960).
155. J.R. Jennings, I. Pattison, K. Wade and B.K. Wyatt, J. Chem. Soc. (A),
1608, (1967).
156. D. Cook, "Friedel-Crafts and Related Reactions", ed. G. Olah,
Interscience, New York, 1963, vol.I, p.767.
157. G.W.A. Fowles and D.K. Jenkins, Inorg. Chem., 3, 257, (1964).
158. K. Farmery and M. Kilner, personal communication.
159. A. Misona, T. Osa and S. Koda, Bull. Chem. Soc. Japan, 41, 373, (1968).
160. M. Kilner and C.A. Payling, personal communication.
161. P.L. Corio and B.P. Dailey, J. Amer. Chem. Soc., 78, 3043, (1956).
162. H. Spiesecke and W.G. Schneider, J. Chem. Phys., 35, 731, (1961).
163. N.N. Greenwood and T.S. Srivastava, J. Chem. Soc. (A), 703, (1966).

164. A. Leib, M.T. Emerson and J.P. Oliver, *Inorg. Chem.*, 4, 1825, (1965).
165. J. Goubeau, F.I.A.T. review of German Science 1939-46, 1,
Inorganic Chemistry, 215.
166. K. Dehnicke, J. Strähle, D. Seybold and J. Müller, *J. Organometall.
Chem.*, 6, 298, (1966).
167. T.L. Cotterell, "The Strengths of Chemical Bonds", Butterworths,
London, (1954).
168. C.T. Mortimer and P.W. Sellars, *J. Chem. Soc.*, 1978, (1963).
169. J.K. Ruff and M.F. Hawthorne, *J. Amer. Chem. Soc.*, 83, 535, (1961).
170. J. Pump, E.G. Rochow and U. Wannagat, *Angew. Chem., Internat. Ed.*,
2, 264, (1963).
171. E.C. Alyea, J.S. Basi, D.C. Bradley and M.H. Chisholm, *Chem. Comm.*,
495, (1968).
172. G.E. Coates and F. Glockling, *J. Chem. Soc.*, 22, (1954).
173. N.R. Fetter and F.M. Peters, *Canad. J. Chem.*, 43, 1884, (1965).
174. J.L. Atwood and G.D. Stucky, *Chem. Comm.*, 1169, (1967).
175. P. Diehl, *Helvetica Chim. Acta.*, 44, 829, (1961).
176. J. Martin and B.P. Dailey, *J. Chem. Phys.*, 37, 2594, (1962).
177. R.M. Anker and A.H. Cook, *J. Chem. Soc.*, 323, (1941).
178. M. Schafer and C. Curran, *Inorg. Chem.*, 5, 265, (1966).
179. W. Brüser, K.H. Thiele and H.K. Müller, *z. Chem.*, 2, 342, (1962).
180. T.J. Hurley, M.A. Robinson, J.A. Scruggs and S.I. Trotz, *Inorg.
Chem.*, 6, 1310, (1967).
181. B.P. Dailey and J.N. Schoolery, *J. Amer. Chem. Soc.*, 77, 3977, (1955).

