

Durham E-Theses

Electron impact studies on organometallic compounds

D.B. Chambers

How to cite:

Chambers, D.B. (1968) Electron impact studies on organometallic compounds. Doctoral thesis, Durham University.

Use policy

The full-text may be used and/or reproduced, and given to third parties in any format or medium, without prior permission or charge, for personal research or study, educational, or not-for-profit purposes provided that:

- a full bibliographic reference is made to the original source
- a <https://etheses.durham.ac.uk/id/eprint/8646/> is made to the metadata record in Durham E-Theses
- the full-text is not changed in any way

The full-text must not be sold in any format or medium without the formal permission of the copyright holders.

Please consult the [full Durham E-Theses policy](#) for further details.

ELECTRON IMPACT STUDIES ON
ORGANOMETALLIC COMPOUNDS

by

D.B. Chambers, B.Sc.

(Grey)

A Thesis submitted for the degree of
Doctor of Philosophy in the University
of Durham.

July, 1968.



ACKNOWLEDGEMENTS.

It is a pleasure to thank Prof. G.E. Coates, Dr. F. Glockling and Dr. M. Weston for their help and encouragement throughout the work described in this Thesis.

I am indebted to the Science Research Council for a maintenance grant, and to those members of the Chemistry Department, University of Durham, who so readily gave advice and assistance.

NOTE

The work described in this Thesis was carried out in the University of Durham between October 1965 and July 1968. The work has not been submitted for any other degree and is the original work of the author except where acknowledged by reference.

PUBLICATIONS

The work described in this Thesis has been the subject of the following publications:

"Mass Spectra of Organo-germanes and -stannanes", Chem. Comm., 1966, 282.
(with F. Glockling, J.R.C. Light and M. Weston.)

"Mass Spectra of Organo-stannanes and -plumbanes", J. Chem. Soc., (A),
1967, 1759. (with F. Glockling and M. Weston.)

"Mass Spectra of Metal-Metal Bonded Compounds", J. Chem. Soc., (A),
1968, 735 (with F. Glockling.)

A review "Mass Spectra of Organometallic Compounds" has been accepted for publication by Quarterly Reviews. (with F. Glockling and J.R.C. Light.)

The author also gave a lecture "Electron Impact Behaviour and Bond Energies of Beryllium and Group IVb Organo- compounds" at the 3rd international Symposium on Organometallic Compounds, Munich, 1967. (with F. Glockling, J.R.C. Light and M. Weston.)

CONTENTS

SUMMARY

<u>Chapter 1.</u>	<u>INTRODUCTION</u>	1
1.1.	Mass Spectra of Organometallic Compounds of the Main Group.	5
1.2.	Ionization and Appearance Potentials.	15
1.3.	Derivation of Thermochemical Data from Appearance Potentials.	26
<u>Chapter 2.</u>	<u>EXPERIMENTAL</u>	35
2.1.	Preparation of Compounds.	
	Organostannanes.	35
	$\text{Ph}_3\text{C}\cdot\text{CMe}_3$	39
	Metal-Metal Bonded Compounds.	39
	Infra-Red Spectra of Metal-Metal Bonded Compounds.	43
	Organoberyllium Compounds.	43
	Organoaluminium Compounds.	44
2.2.	Recording Mass Spectra.	45
	2.2.1. Sample Handling Systems.	45
	2.2.2. Obtaining Spectra for Abundance Measurements.	49
	2.2.3. Detection of Metastable Peaks.	49
2.3.	Measurement of Appearance Potentials.	50

<u>Chapter 3. CALCULATION OF RESULTS.</u>	54
3.1. Evaluation of Appearance Potentials.	54
3.2. Identification of Ions.	57
3.3. Calculation of Abundances.	62
3.4. Assignment of Metastable Peaks.	67
<u>Chapter 4. RESULTS AND DISCUSSION.</u>	73
4.1. Appearance Potentials and Derivation of Bond Dissociation Energies and Heats of Formation.	73
4.1.1. Accuracy of Appearance Potential Measurements.	73
4.1.2. Appearance Potentials and Bond Dissociation Energies for Organotin Compounds.	73
i) Appearance Potentials.	73
ii) Bond Dissociation Energy Differences.	78
iii) Bond Dissociation Energies in Molecular Ions.	80
iv) Heats of Formation of Triphenyltin Compounds.	82
vi) $\text{Ph}_3\text{Sn-R}$ Bond Dissociation Energies.	83
4.1.3. Ionization Potentials and Bond Dissociation Energies of Dialkylberyllium Compounds.	89
i) Ionization Potentials of Dialkylberyllium Compounds.	89
ii) Appearance Potentials of Fragment Ions and Bond Dissociation Energies in Ions.	91
4.2. Mass Spectra of Organocompounds of Silicon, Germanium, Tin and Lead.	100

4.2.1.	Organostannanes.	100
	Decomposition Modes at 70eV.	100
	Major Rearrangement Decompositions.	106
	Minor Rearrangement Decompositions.	110
	Mass Spectra of $\text{Ph}_n\text{Sn}_{4-n}$, Et_6Sn_2 ,	
	Ph_6Sn_2 and $(\text{CH}_2)_4 > \text{Sn} < (\text{CH}_2)_4$	117
	Mass Spectra of Triphenyltin Halides.	120
4.2.2.	Metal-Metal Bonded Compounds.	121
	Modes of Decomposition at 70eV.	121
4.3.	Mass Spectra of Beryllium Dialkyls.	142
4.3.1.	Effect of Source Temperature.	142
4.3.2.	Mass Spectra and Modes of Decomposition.	150
	Modes of Decomposition of Associated Ions at 70eV.	151
	Modes of Decomposition of $\text{C}_x\text{H}_y\text{Be}^+$ ions.	
	Distinguishing Isomers.	158
4.4.	Mass Spectra of Organoaluminium Compounds.	160
4.4.1.	Effect of Source Temperature.	160
4.4.2.	Modes of Decomposition.	170
4.4.3.	Mass Spectra.	176

APPENDIX 1.

Tin and Lead Isotope Masses and Abundances.	178
Calculated Mass and Abundance Data for Sn ₂ , SnGe, Ge ₂ , SnCl and SnBr.	

APPENDIX 2.

Ion Abundances, as Percentage of Total Ion Current, for Beryllium Dialkyls at 70, 15 or 12eV, and High and Low Source Temperatures.	179
---	-----

APPENDIX 3.

Primary Experimental Data for Appearance Potential Measurements.	188
---	-----

REFERENCES.

SUMMARY

This thesis is concerned with electron impact studies on organoderivatives of beryllium, aluminium and Group IVb metals (mainly tin). The primary objectives of the research were:

- i) To obtain, from appearance potential measurements, comparative and if possible absolute bond dissociation energies in both molecules and ions, together with other thermodynamic data.
- ii) To examine the mass spectra of representative organometallic compounds with a view to determining the effect of the metal, changes in organic groups and spectrometer conditions.

From the appearance potentials of ions produced in the electron impact mass spectra of some organostannanes, bond dissociation energy differences, heats of formation of triphenyltin compounds and the dissociation energy of the bond $\text{Ph}_3\text{Sn} - \text{X}$ ($\text{X} = \text{Me}, \text{Et}, \text{Ph}, \text{I}, \text{GeMe}_3, \text{SnMe}_3, \text{SnPh}_3$) have been derived. The ionization potentials of beryllium dialkyls and the appearance potentials of the major beryllium - containing fragment ions have also been measured and bond dissociation energies in molecular and fragment ions evaluated.

In the mass spectra of organoderivatives of the Group IVb metals, the most abundant fragments are even-electron metal-containing ions in which the metal is three-co-ordinate. Parent ions are of low abundance and decompose mainly by radical elimination e.g.

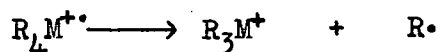

Bond energy measurements suggest that the bond most readily cleaved in this decomposition is the weakest in the neutral molecule. In further

fragmentation even-electron ions maintain their even-electron character by molecular elimination.

Certain trends are attributable to the increasing metal-carbon bond strength from lead to silicon. Molecular ions decrease in the order $\text{Si} > \text{Ge} > \text{Sn} > \text{Pb}$ while metal ions, M^{+} , are appreciable only for tin and lead. Ions formed by carbon-carbon or carbon-hydrogen cleavage, although always of low abundance, increase in importance from lead to silicon.

With beryllium dialkyls the abundance of all beryllium-containing ions but especially di- and tri-metallic ions falls with increasing source temperature due to dissociation of weak bridging bonds and thermal decomposition before ionization. The major di- and tri-metallic ions are even-electron and readily lose alkene. In contrast to Group IVb derivatives, odd-electron $\text{C}_a\text{H}_b\text{Be}^+$ ions are appreciable. Parent monomer ions, $(\text{C}_n\text{H}_{2n+1})_2\text{Be}^{+}$, decrease in abundance as the size of the alkyl group increases and major fragments are produced from the parent by elimination of the radical $\text{C}_n\text{H}_{2n+1}^{\cdot}$, and alkane, $\text{C}_n\text{H}_{2n+2}$.

Organoaluminium compounds give mass spectra which depend on source temperature. This is especially true for dimethyl- and diethyl-aluminium hydride which show thermal rearrangement above 100°C producing trimethyl- and triethyl-aluminium respectively. The decomposition modes of aluminium-containing ions are almost identical to those of Group IVb organoions.

1. INTRODUCTION.
- 1.1 Mass Spectra of Organometallic Compounds of the
Main Groups.
- 1.2 Ionization and Appearance Potentials.
- 1.3 Derivation of Thermochemical Data from
Appearance Potentials.

1. INTRODUCTION.

A mass spectrometer is an instrument which produces a beam of ions from a substance being investigated, sorts these ions into a spectrum according to their mass to charge ratios and records the relative abundance of each species of ions present. The theory and design of these instruments has been widely discussed ^{1,2} but a recent review sums up the salient points ³. Most early studies in mass spectrometry employed single focussing instruments using a magnetic field to separate ions by their mass to charge ratio. The resolution of such instruments never exceeded one part in three thousand and recent developments have been with the aim of extending their mass range, versatility and precision. With a careful choice of design parameters electric and magnetic fields may be combined to increase the resolution by elimination of the two main aberrations limiting the resolution of magnetic sector instruments; a) the angular divergence of the ion beam and b) variations in the velocity of the ions.

Such high resolution mass spectrometers have brought a new dimension to the subject. Not only are these instruments capable of measuring ion masses, in some cases up to 1000 mass units, with a precision of a few parts per million, but they can also give ion abundance values to a high degree of accuracy. These instruments are thus able to provide at least in theory, data which can lead to the exact elemental analysis of every ion in the spectrum. Such information is often vital in structural analysis. For example the loss of 28 mass



units from an ion observed in a low resolution spectrum could be identified as CO, N₂, C₂H₄ or NCH₂ loss by the high resolution measurements.

Although the majority of mass spectrometric investigations resolve ions by magnetic deflection, there exist other techniques of growing importance. For example the time of flight method has been developed into a versatile technique and several commercial instruments are available ².

Various methods are available for ion production ¹ but that most widely used is electron bombardment of gaseous molecules when the generally accepted interaction occurs ^{1,4,5,6}:

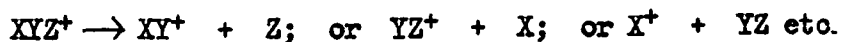
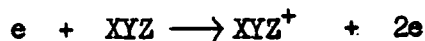

The electron beam energy normally employed (about 50 or 70eV) is in excess of the minimum energy required to cause ionization. (Generally the ionization potential rarely exceeds 10eV and the bond dissociation energy 5eV so that the incident electron beam has more than three times the minimum energy needed for the above reactions).

Ions may also be formed by pre-ionization or pre-dissociation⁷ when the interaction of an electron and a molecule does not lead directly to the formation of an ion but to a neutral excited molecule. The energy imparted to the molecule is postulated to be greater than, or at least as great as, the ionization potential so that the excited

molecule may subsequently decompose:-

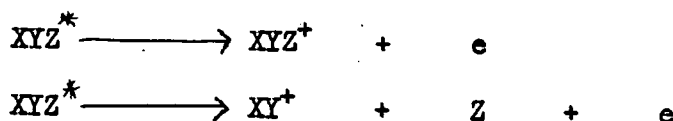

From the available evidence⁸ indirect ion formation may compete with direct ionization.

The mass spectrum produced under specified ionization conditions is sometimes known as the cracking pattern, and is characteristic of the compound. This pattern will contain all possible combinations of ions as shown above, but it will also include ions of the type XZ^+ which can only arise by a rearrangement process since in the original material the two constituents of this ion were separately attached to Y but not to each other.

One of the difficulties encountered in the analysis of spectra arises from the presence of these rearrangement ions. Although this interesting and difficult field has been the subject of extensive and detailed study for organic molecules with the aim of finding rules^{1,4,5,9} which are broadly applicable, when the work described in this thesis was begun, there were only few published reports on the spectra of organometallic compounds. For example for the particular metal-compounds examined herein there were only two papers for tin, both describing the mass spectrum of tetramethyltin, and none for beryllium, aluminium or metal-metal bonded compounds of main group metals.

Most of the reported studies on organometallic compounds have involved mono-isotopic elements or elements containing one dominant isotope. Furthermore only low resolution spectra have been

recorded and so have been without direct confirmation of the elemental composition of ions in the spectra obtained. The present study has made considerable use of high resolution mass measurement which for polyisotopic metals is based on data specifically calculated for each polyisotopic unit considered. This need for repeated mass measurement has arisen for a number of reasons which are discussed in chapter 3.,
Calculation of Results.

1.1. Mass Spectra of Organometallic Compounds of the Main Groups.

A number of papers on the mass spectra of organometallic compounds of the main groups have appeared either during or since the completion of the present work. Those papers of immediate relevance and comparability to this research, which in some cases have provided confirmation of the results reported in this thesis are dealt with in Chapter 4.2. of the Discussion.

In the following review the mass spectra were produced by electron impact using 50 to 70 volt electrons. Ions in which the number of bonding electrons is odd are represented as (ion)^{+•}, whereas even-electron ions are represented as (ion)⁺. This distinction has been found in the present study to have considerable significance for main group organometallic compounds, though for transition metal complexes, where ionization may involve removal of an electron from a non-bonding orbital such considerations often have no relevance.

Group I Li.

The mass spectra of lithium alkyls are of interest since they contain ions of associated species. For example ethyl lithium vapour ¹⁰ gives Et_5Li_6^+ , Et_4Li_5^+ , Et_3Li_4^+ , Et_2Li_3^+ , EtLi_2^+ and Li^+ . The appearance potentials of Et_5Li_6^+ and Et_3Li_4^+ are far lower than those of the other ions and from this it was tentatively deduced that the vapour of ethyllithium consisted of a mixture of hexamer and tetramer molecules (Et_6Li_6 and Et_4Li_4) which decomposed on ionization:

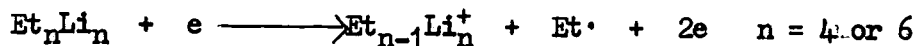

Further evidence for the composition of the vapour came from a shift in the ratios of ion intensities as a result of varying the temperature of the vapour prior to ionization.

All other ions produced were due to decomposition of the $\text{Et}_{n-1}\text{Li}_n^+$ species.

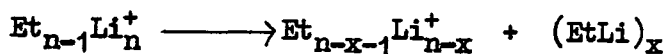

Lithiomethyltrimethylsilane ($\text{LiCH}_2\text{SiMe}_3$)¹¹ vapour produced a spectrum showing ions which could have been derived from tetramer molecules (R_4Li_4) via the ionization and decomposition processes shown above.

Group II Zn, Hg.

The compounds Me_2Zn ¹², $(t\text{-Bu})_2\text{Zn}$ ¹³, Me_2Hg , Et_2Hg and $(n\text{-Bu})_2\text{Hg}$ ¹⁴ have been examined. All give MR_2^{++} , MR^+ and M^{++} ions (M = metal, R = alkyl) in high abundance, indicating that the major decomposition processes are bond cleavages:



RMH^{++} and MH^+ ions are present in low abundance. Hydrocarbon ions are major species in the spectra of the mercury compounds but may arise from thermal decomposition before ionization.

The ionic cyclopentadienyls $(\text{C}_5\text{H}_5)_2\text{Mg}$ and $(\text{C}_5\text{H}_5)_2\text{Mn}$ give similar spectra producing fragment ions, $\text{C}_5\text{H}_5\text{M}^+$ and M^{++} , formed by

metal-ring bond cleavages ¹⁵. $\left[\begin{array}{l} (\text{C}_5\text{H}_5)_2\text{Mg}^{+\cdot} \text{ 21\%; } \text{C}_5\text{H}_5\text{Mg}^+ \text{ 38\%;} \\ \text{Mg}^{+\cdot} \text{ 31\% and } (\text{C}_5\text{H}_5)_2\text{Mn}^+ \text{ 19\%; } \text{C}_5\text{H}_5\text{Mn}^+ \text{ 29\%; } \text{Mn}^+ \text{ 25\%;} \end{array} \right]$ abundances expressed as percentage of total ion current.] The

bis-cyclopentadienyls of transition metals produce similar fragment ions although in different relative abundances and the molecular ion is generally the most intense ion ^{15,16}.

Group III Al

Trimethylaluminium gives Al^+ , $\text{AlCH}_3^{+\cdot}$; AlMe_2^+ and $\text{AlMe}_3^{+\cdot}$ as the most abundant metal containing species ¹². Rearrangement ions AlH_2^+ and $\text{HALMe}^{+\cdot}$ are of low abundance.

From clastograms (Plots of ion current VS. Electron energy) and appearance potentials of the major ions it may be deduced that simple bond cleavage decomposition of the parent ion occurs.

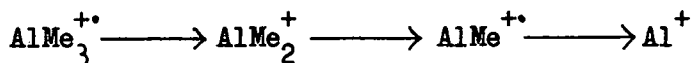

Although trimethylaluminium is known to be dimeric in the gas phase ¹⁷ Al_2Me_5^+ was the only bi-aluminium species detected in extremely low abundance. Work described in this thesis however shows that this is most probably due to a high source temperature ($\sim 200^\circ\text{C}$) an important instrument condition not specified by Winter and Kiser ¹² in their study.

In contrast $(\text{R}_2\text{AlNCPh}_2)_2$, R = Me, or, Ph, ¹⁸ produce a weak peak corresponding to the molecular ion and $\text{Ph}_4(\text{CN})_2\text{Al}_2\text{R}_3^+$ is the most abundant aluminium-containing ion. Weak ions

corresponding to monomer species were also observed but the major ion in the spectrum was Ph_2CN^+ .

Group IV Si, Ge, Sn, Pb.

Although all the work published prior to 1966 is described below, some later papers are more appropriately dealt with in the Discussion of this thesis.

The mass spectra of a variety of organosilanes, mainly methyl derivatives, have been described. All show low intensity molecular ions and major ions are produced by bond cleavage decompositions in the molecular ion. For example cyclic silicon organocompounds such as

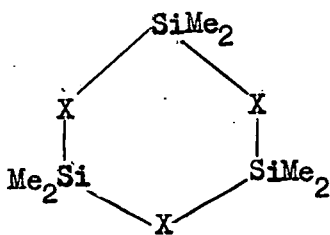

X = $-\text{CH}_2-$, $-\text{NH}-$, or $-\text{O}-$.

(I)

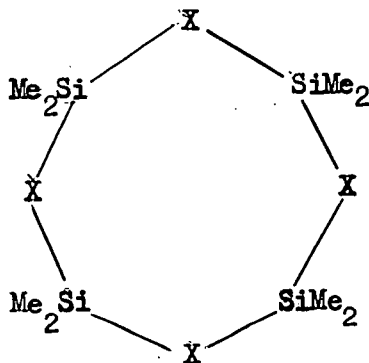

X = $-\text{CH}_2-$, or $-\text{NH}-$.

(II)

give similar spectra, loss of methyl from the molecular ion producing the most abundant ion 19,20,21,22,23. The eight-membered ring compound II (X = $-\text{CH}_2-$) in addition gives ions of high abundance

resulting from ring fragmentation.

In general the cyclic compounds are more stable to electron impact induced fragmentation than linear compounds containing the same number of silicon atoms. Thus for Me_4Si , $\text{Me}_3\text{Si}\cdot\text{CH}_2\cdot\text{SiMe}_3$, $\text{Me}_3\text{Si}\cdot\text{CH}_2\cdot\text{SiMe}_2\cdot\text{CH}_2\cdot\text{SiMe}_3$ and $\text{Me}_3\text{Si}\cdot\text{CH}_2\cdot\text{SiMe}_2\cdot\text{CH}_2\cdot\text{SiMe}_2\cdot\text{CH}_2\cdot\text{SiMe}_3$ silicon-carbon bond cleavage takes the form of methyl radical loss for the lighter compounds but for Si_3 and Si_4 compounds fragmentation of the silicon-carbon skeleton occurs by cleavage of Si - CH_2 bonds. ^{19,24}

Substitution of the methylene hydrogen atoms in $\text{Me}_3\text{Si}\cdot\text{CH}_2\cdot\text{SiMe}_3$ by methyl or benzyl groups, increases the probability of the molecular ion decomposing by cleavage of the central Si - CR_2 bonds. ¹⁹ Such behaviour is perhaps not surprising being paralleled by alkanes which also tend to fragment at highly branched carbon atoms. ^{1,9} The observation is useful, however, in that it allows a clear distinction to be made between isomers of the type $\text{H}_2\text{MeSi}\cdot\text{CH}(\text{Me})\cdot\text{SiMe}_2\text{H}$ and $\text{HMe}_2\text{Si}\cdot\text{CH}_2\cdot\text{SiMe}_2\text{H}$. The stability of the skeleton to electron impact induced fragmentation is also reduced by increasing the number of methylene groups between silicon atoms. Thus $\text{Me}_3\text{Si}\cdot\text{CH}_2\cdot\text{CH}_2\cdot\text{SiMe}_3$ gives Me_3Si^+ as the most abundant ion whereas for $\text{Me}_3\text{Si}\cdot\text{CH}_2\cdot\text{SiMe}_3$, $(\text{P-Me})^+$ i.e. (parent ion minus methyl) is the base peak. ¹⁹

Replacing any or all of the methyl groups of I ($\text{X} = \text{CH}_2$) and $\text{Me}_3\text{Si}\cdot\text{CH}_2\cdot\text{SiMe}_3$ does not affect the lability of the molecular skeleton to fragment after ionization ²¹. The loss of H· from fully methylated compounds is not generally observed but with $\text{H}_3\text{Si}\cdot\text{CH}_2\cdot\text{SiH}_3$ dissociation

of carbon-hydrogen bonds must occur at some stage since all the ions from CH_7Si_2^+ to CSi_2^+ are observed. When silicon-hydrogen bonds are present in a molecule (P-H)⁺ ions are always observed in addition to (P-Me)⁺ ions but methyl groups when present are lost preferentially. 24,21

With alkylchlorosilanes R_3SiCl , R_2SiCl_2 and RSiCl_3 where R is CH_3 or C_2H_5 , loss of both alkyl and chlorine from the molecular ion occurs but again cleavage of the silicon-carbon bond predominates. 25,26

Rearrangement ions are often observed in the spectra of organosilanes. For example Phenylchlorosilanes, Ph_2SiCl_2 and PhSiCl_3 produce Ph_2^+ and PhCl^+ . 25 and with $\text{Me}_n\text{SiH}_{4-n}$ ($n = 0, 1, 2, 3, 4$) compounds 24 rearrangement ions are of high abundance, the elimination of a stable molecule from an ion often being accompanied by a metastable peak:

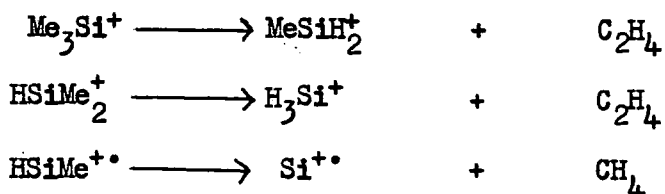

Although no metastable peaks were reported in the mass spectra of silicon-methylene compounds 19,20,21, ions of low abundance were often observed especially for the cyclic compounds which could have resulted by emission of methane from (P-Me)⁺ ions. Similarly silazanes 22 eliminate neutral molecules from (P-Me)⁺ ions and in some cases metastable peaks are present. Thus $(\text{Me}_2\text{SiNH})_3$ and $(\text{Me}_2\text{SiNH})_4$ show loss of both CH_4 and NH_3 from (P-Me)⁺ ions, the loss of NH_3 although requiring considerable rearrangement being confirmed 22 by a metastable peak. Similarly $\text{Me}_3\text{Si}\cdot\text{NH}\cdot\text{SiMe}_2\text{Cl}$ shows loss of HCl from (P-Me)⁺ while $(\text{MeO})\text{Me}_2\text{Si}\cdot\text{NH}\cdot\text{SiMe}_2(\text{OMe})$ eliminates formaldehyde after losing a methyl group.

Though the molecular weight of an alcohol is often found from the mass spectra of its trimethylsilyl derivative (Me_3SiOR) which show a large $(\text{P-Me.})^+$ ion 27, the origins of the rearrangement ions were not elucidated ²⁸ using deuterium labelling until 1967. The mechanisms involved are illustrated by the fragmentation of pentan-1-ol trimethylsilyl ether which exhibits peaks which appear in the spectra of practically all trimethylsilyl ethers

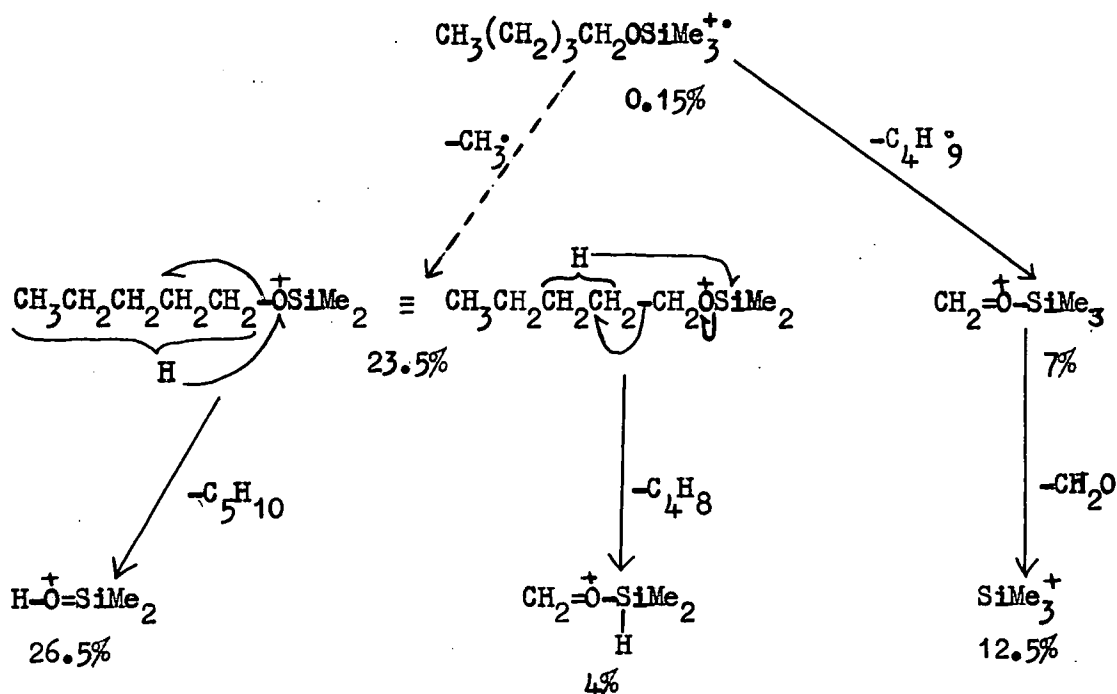

In the above solid straight arrows represent processes confirmed by metastable peaks and the numbers are the percentage of the total ion current carried by that ion. Curved fishhooks (\curvearrowright) represent movement of one electron and curved arrows (\curvearrowleft) movement of two.

The trimethyl derivatives of secondary alcohols $\text{Me}_3\text{Si}-\text{O}-\text{CH} \begin{matrix} \text{R}' \\ \text{R} \end{matrix}$; in addition give an intense peak corresponding to loss of the larger alkyl group R' or R .

An unusual feature of the methylsilalazanes, methylsiloxanes and methylsilicon methylene compounds is the production of multiply charged species often in quite high abundance. Thus

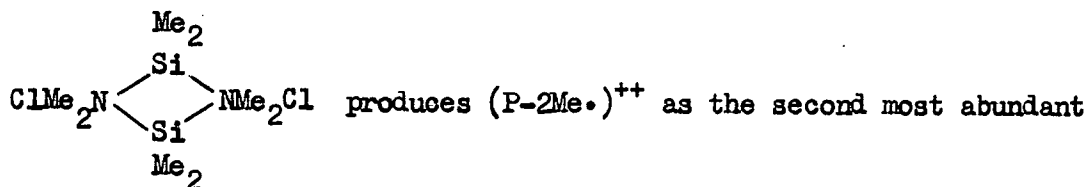

ion and the cyclic siloxane $(\text{Me}_2\text{SiO})_3$ shows $(\text{P-2Me}\cdot)^{++}$ and $(\text{P-3Me}\cdot)^{+++}$. Dibeler et. al. ²³ first observed this high abundance of doubly charged ions when there were two silicon atoms present and triply charged ions when there were three and proposed that the most probable ionization process involved the removal of one electron and methyl group from each silicon atom within the molecule.

As with organosilanes, molecular ions of lead alkyls are of low abundance as are all ions heavier than $\text{C}_6\text{H}_{15}\text{Pb}^+$. With the compounds Me_4Pb , Me_3PbR ($\text{R}=\text{Et}$, $n\text{-Bu}$, $s\text{-Bu}$, $t\text{-Bu}$), Me_2PbEt_2 , MePbEt_3 and Et_4Pb loss of the heaviest alkyl group from the molecular ion gives R_3Pb^+ as the most abundant ion in the spectrum.²⁹

Rearrangement ions were very common. For example with tetra- n -propyl- and tetra- iso -butyl-lead, CH_3Pb^+ was the most abundant ion in their spectra. No metastable peaks were reported, however, that could indicate the mode of formation of these rearrangement ions even though some, such as hydride ions, were quite abundant.

The mass spectra of the tetramethyl derivatives of carbon, silicon, germanium, tin and lead have been compared ^{30,111}. Again the

molecular ion is small and Me_3M^+ is the most abundant ion. This led to the suggestion that ionization occurred by loss of a bonding electron between the central atom and a methyl group. The abundances of M^+ , MR^+ , and MR_2^+ increase from carbon to lead while ions resulting from the dissociation of hydrogen atoms decrease from carbon to lead.

Hydride ions H_2MCH_3^+ and H_3M^+ also decrease in abundance from silicon to lead and it was postulated that extrapolation of the abundances could give information concerning the origin of some of the peaks in the spectrum of tetramethylmethane. Thus the height of the H_3M^+ peaks varies from zero for tin and lead to 5.1% for Si (base peak for all compounds is $\text{Me}_3\text{M}^+ = 100\%$) whereas the abundance of the methyl ion decreases from 12.4 in tetramethyllead to 5.07 in tetramethylsilicon. The abundance of the CH_3^+ peak has an intensity of 9.3% and it was argued that the trend observed with the other tetramethyl compounds showed that some of the CH_3^+ ions were in fact trihydrides of the central carbon. Measurements of $^{13}\text{CMe}_4$ showed ³¹ however, that no $^{13}\text{CH}_3^+$ ions occur in the spectrum illustrating the unsatisfactory nature of the use of one element as a homologue of another.

Group V As, Sb, Bi.

For triphenyl derivatives ³² molecular ion abundances diminish in the order $\text{As} > \text{Sb} > \text{Bi}$ whereas metal ion abundances M^+ follow the reverse order, as expected from the variation of metal-carbon bond strengths within a group. Similar observations concerning M^+ ions

may be made for the trimethyl-compounds. 12,33

Of these compounds trimethylantimony has been studied in most detail ¹² and elastograms and appearance potential measurements on the major ions $\text{Me}_3\text{Sb}^{+\bullet}$ (78%), Me_2Sb^+ (100%), $\text{MeSb}^{+\bullet}$ (36%) and Sb^+ (37%) indicate simple bond cleavage decompositions

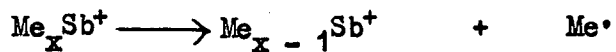

Loss of H_2 (or 2H^\bullet) from R_2M^+ ions is observed for all the arsenic and antimony compounds but not the bismuth.

1.2. Ionization and Appearance Potentials.

The first ionization potential of a molecule is defined as the energy difference between the ground state vibrational level of the lowest electronic state of the molecule and the molecular ion. This is sometimes referred to as the "adiabatic" ionization potential and is of importance in understanding the structure of molecules. Electrons of sufficient energy can ionize molecules by the process:-



The conditions under which ionization takes place are governed by the Franck-Condon principle since for electron bombardment ionization the time of interaction is so short (of the order of 10^{-15} sec.) compared to the time necessary for a vibration (10^{-12} to 10^{-13} sec.) that nuclei may be considered as fixed at their equilibrium distances during the ionization process. If the potential energy curves representing the molecule before the transition and the molecular ion after the transition are plotted, the points on these curves representing the conditions before and after ionization will correspond to the same nuclear separation and will thus lie on a line parallel to the energy axis. Such a transition is referred to as a vertical transition, and the ionization potential measured in this way as the vertical ionization potential. For the case of diatomic molecules various possibilities of electronic structures are shown in fig. 1.

It can be seen that ionization potentials of molecular ions which are obtained by electron impact measurements must be considered

Fig.1

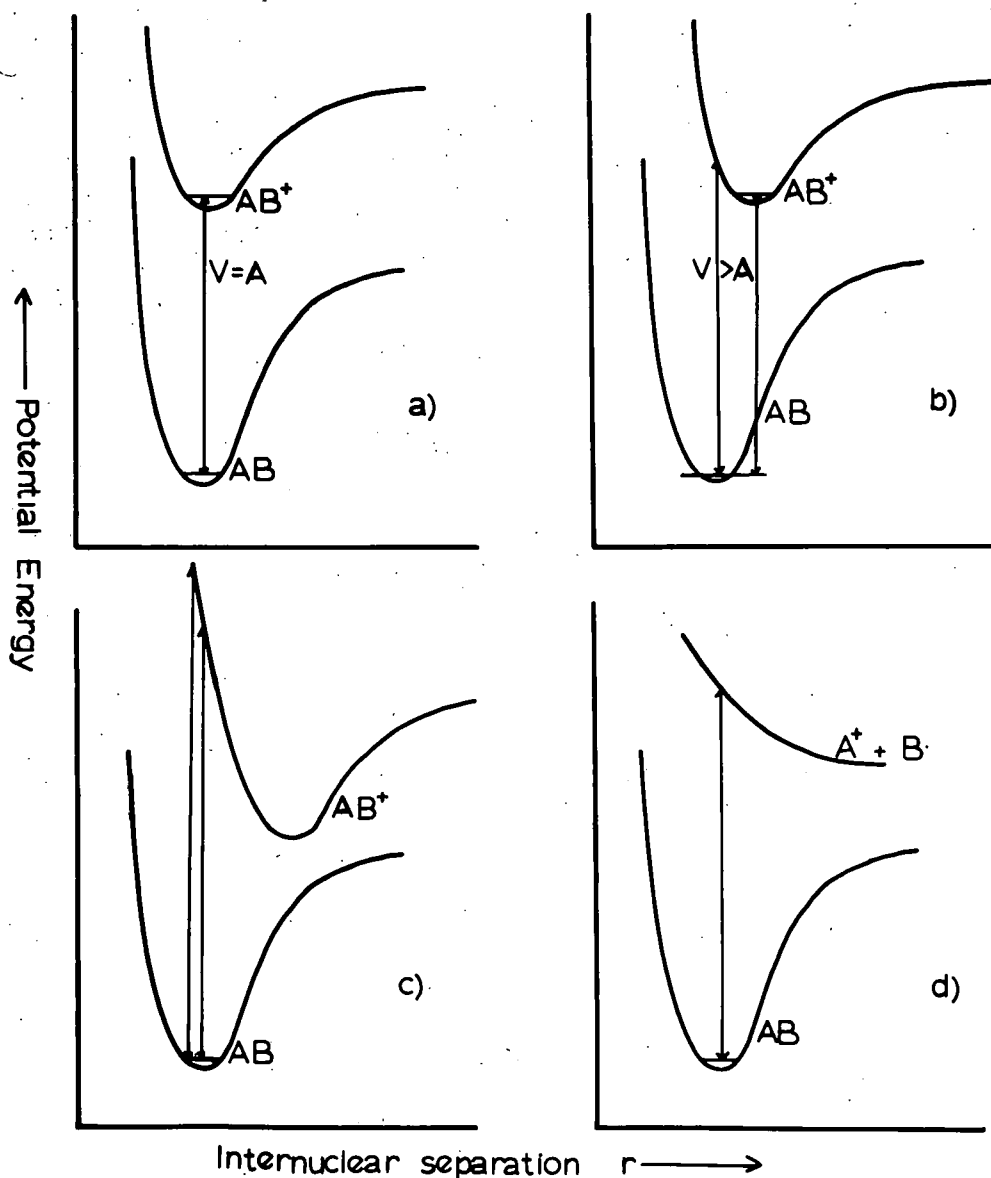

Potential energy curves showing:-

- a) Equal vertical and "adiabatic" ionization potential $V = A$
- b) $V \neq A$
- c) Vertical ionization potentials leading to dissociation of the parent into fragments
- d) Upper potential energy curve repulsive with ionization leading to dissociation.

as upper limits of the "adiabatic" value. However even when the interatomic distances of the two possible states differ appreciably as in fig 1.b),c). there is still a finite possibility that ionization to the lowest vibrational level of the ionic state will occur. This suggests that in some cases the measured value of the ionization potential may depend on the sensitivity of the detecting apparatus used. Increasing the sensitivity is, in fact, equivalent to "broadening" the Franck-Condon region.

Fig. 1(d) shows a transition to a repulsive upper state. Fragmentation accompanies all such transitions and the excess energy of the fragments formed is given by the height of the transition region above the dissociation asymptote. Thus the appearance potentials of fragments obtained by methods involving vertical transitions also give values which are upper limits of the "adiabatic" or "true" value.

The experimental problem in measuring appearance potentials is to determine accurately the intercept, on the voltage axis, of graphs of ion current versus accelerating voltage of the ionizing electrons (ionization efficiency curve). The general shape of these curves is well established. With decreasing voltage the curve increases to a maximum value followed by a region of linear decrease. The curve then approaches the energy axis almost exactly exponentially, there being two reasons why this should be so.

Firstly, this behavior is inherent in the ionization process as may be understood from consideration of fig. 2.

Fig. 2.

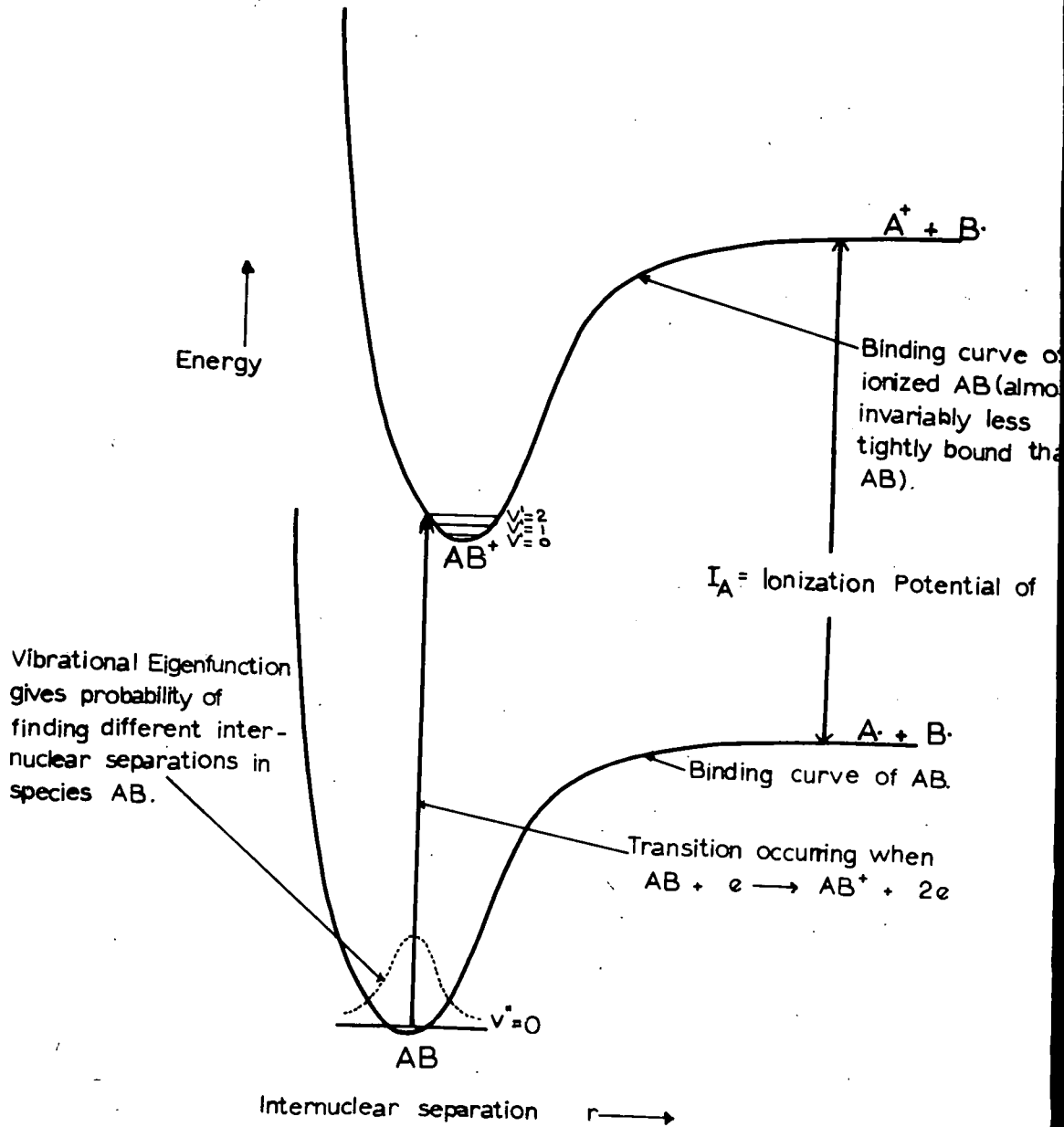

Suppose that precisely monoenergetic electrons are used of energy equal to the energy of the transition shown on the diagram. As the energy is reduced so that there is only sufficient energy for transitions first to the $v' = 1$ and then $v' = 0$ levels, the requirements that the transition must be shown as vertical line means that the transition must originate from further to the right in the lower state. However the probability of finding AB molecules with such internuclear separations is decreasing, consequently the number of ionized AB^+ formed (i.e. ion current of AB^+) decreases following the shape of the probability curve of the $v'' = 0$ level.

Secondly, a non-monoenergetic electron beam causes further curvature of these graphs. Normally a mass spectrometer source forms the electron beam by acceleration of electrons emitted from a hot filament. The energy distribution of the emitted electrons will be essentially Maxwellian^{34,35} and thus even when the minimum value of the electron energy is equal to the appearance potential of AB [$A(AB^+)$] appreciable ion current persists because appreciable numbers of electrons with higher energies remain. Further reduction of the electron energy is required before the ion current at mass AB^+ disappears and the approximately exponential curvature of the energy distribution of the emitted electrons must lead to the ionization efficiency curve approaching the energy axis asymptotically.

In addition to difficulties arising from the shape of the ionization efficiency curve, other sources of error can enter into the measurement of appearance potentials by mass spectrometry. These have

been discussed by Waldron and Wood and are briefly outlined below.

The occurrence of a potential gradient within the ionization chamber will lead to the electrons being given an additional increment of energy and for this reason the ion repeller voltage is kept to a minimum. Provided the voltage of the repeller is kept constant however, this effect should not lead to an error in measuring the difference between two ionization potentials. The field within the ionization chamber is partly due to penetration of the ion accelerating field through the slit via which the ions emerge. Thus if the field within the ion chamber is to be the same for the examination of two ions of different mass, magnetic scanning must be used. The slit leading from the ionization chamber to the electron trap is usually relatively wide and the voltage of the trap can produce a considerable field penetration extending to the ionizing region. It is therefore ideal to work with the trap at the same potential as the ionization chamber. There is also the effect of the magnetic field in which the ionizing region is immersed. This will give rise to discriminations in that ions of different mass which are observed will originate in different regions of the ionization chamber and might thus receive different accelerations as they travel along the weak fields within the ionization chamber. This effect will be negligible if all the ions are formed in a region in which the lines of equipotential are parallel to the electron beam.

If the temperature of the filament, producing the electron beam, increases so does the energy spread in electron energy. It is therefore desirable that the filament temperature should be held constant

during measurement of a pair of ionization efficiency curves. Contact potentials within the ionization chamber may vary when a sample is introduced and for this reason it is usual to use an "internal standard" when measuring appearance potentials i.e. to introduce a second substance of known ionization potential whose ionization efficiency curve can be compared with that of the substance under investigation while they are both in the system and thus identical potential conditions.

The problem of determining the true origin of the ionization efficiency curve and hence the appearance potential has been critically discussed by Nicholson ³⁷. The early means of determining the true value for the ionization potential was the "initial break" i.e. extrapolating the curve back to its intersection with the energy axis ^{38,39}. The method is not very satisfactory because of the effect of the electron energy spread in making the curve asymptotic to the energy axis so that the point detected in this way will depend on the sample pressure, the number of bombarding electrons and the sensitivity of the detector employed. When a rare gas is introduced at the same time as the sample, differences in the electron energy corresponding to the minimum detectable current in each case can be used to obtain the appearance potential. There still remains the objection that the shapes of the curves may not be the same very near to the potentials at which the two currents vanish.

A second method, now little used, was introduced by Vought ⁴⁰ who extrapolated the linear portion of the ionization efficiency curve to zero ion current using the extrapolated value as the ionization

potential. Its main disadvantage is due to using the current/voltage relationship comparatively far above the ionization potential where the ions may not be in their lowest energy states. The results obtained are generally higher than those from other methods especially when appearance potentials of fragment ions formed by complex reaction paths are being studied. It should be noted however that the method of Vought is practically the only one available for the determination of the potentials of second and higher breaks in the ionization efficiency curve.

An extension of the "initial break" method is due to Warren.⁴¹ In this method, which uses an internal standard of known ionization potential, the ion current scales for the two graphs are adjusted so as to make the straight line portions parallel. The difference in voltage between corresponding ion currents on the curves is plotted against ion current and from the voltage difference at zero ion current the appearance potential is found. The same objections apply to this method as to the "initial break" but the method has the advantage of rendering differences in the shapes of the two curves clearly visible.

Several other methods which also depend for their success on the shapes of the two curves being compared being closely similar are classified by Nicholson as the "logarithmic" methods. The first of these due to Honig and Wannier⁴² whilst not attempting to eliminate the electron energy spread accounts for it in an analytical expression which indicates that for about 1 eV below the ionization potential the curve will be approximately exponential. A semi-log plot of the ionization efficiency curve will give a slope of $\frac{2}{(3 kT)}$ at the ionization potential. Dibeler and Reese⁴³

measure the voltage difference between the particle being studied and a substance whose ionization potential is accurately known. The two graphs of ion current/electron voltage are plotted on the same scale so normalised that the two graphs are parallel. This normalisation is obtained by adjusting the partial pressure of the two components of the mixture until the ion current of each species is approximately equal with an electron beam of 50 - 70 eV energy. Another method similar to this is due to Lossing, Tickner and Bryce.⁴⁴ The pressure is again adjusted so as to get comparable intensities at 50eV, and a log. plot of peak heights, as percentages of the abundance at 50eV, against the electron energy yields parallel curves at the onset. Generally, voltage differences at 1% of the intensity at 50eV are taken as significant.

All the methods discussed give values which are usually reliable to 0.1eV for ions which give curves similar in form to those of the inert gas ions.

Morrison⁴⁵ has proposed an interesting analytical procedure for treating ionization efficiency curves, which enabled him to remove at least partly the blurring effect of energy spread and to obtain from a given curve more information (particularly about excited states of ions). It is the derivative method. The method shows that if $p(E)$, the probability of ionization to a given state, is a polynomial of the K th degree, the $(K + 1)$ th derivative represents the electron energy distribution, reversed with respect to the energy scale. An electronic device may be built to obtain automatically the derivative of the ionization

efficiency curve ⁴⁶. With this technique, Morrison was able to detect the appearance of excited states of ions and correlate them with known spectroscopic states. The technique is capable of giving interesting results, it has for instance allowed the estimation of relative probabilities for electronic transitions ⁴⁷. Ionization efficiency curves become easier to interpret if mono-energetic electrons are used since any fine structure which is smoothed out when there is a spread in electron energies is more easily observed. If, as is suggested by Nicholson ³⁷ all errors arise from the fact that ionization efficiency curves do not have the same shape and differences in shape are due to different contributions of upper energy levels of the positive ions to the ionization efficiency curve, accuracy will be increased by any method which can detect fine structure in the curves. Clarke ⁴⁸ using a beam of nearly mono-energetic electrons has shown that as the spread in electron energy is reduced the curves do, in most cases, become segmented straight lines with little curvature as the ionization potential is approached.

A quite different approach to the problem of obtaining the effect of mono-energetic electron beam has been made by Fox, Hickam, Kjeldaas and Grove ^{49,50} with their "retarding potential difference method". Ionization potentials determined by this method give results much closer to those calculated by spectroscopic methods than do the methods which do not employ "mono-energetic" electrons. This is especially so for molecules such as benzene ^{51,52,53,54} in which there are excited states of the ion close to the ground state ^{55,56}. Nevertheless there are some

difficulties in the results obtained by this method which have not been resolved ³⁷ .

In addition to the instrumental difficulties involved in reducing the electron energy spread, such reduction gives a correspondingly smaller electron current and therefore worse signal-to noise ratio in the final data. Morrison ⁵⁷ has recently proposed an analytical method for reducing the effect of energy spread. This "deconvolution" method is based essentially on the use of Fourier transform relationships and communication theory and obtains a marked reduction in the scatter in the experimental data and reduces the effective electron energy spread by a factor of four or five times. Although an exact knowledge of the form of electron energy spread is not required, the better this knowledge the better the ultimate result. Tests made on several artificial examples and on two actual cases show that the methods are of some promise. Eland, Shepherd and Danky ⁵⁸ used the same technique to obtain the ionization potentials of a series of aromatic amines. The method however does not mean that there is no advantage to be gained by using a beam of ionizing electrons with reduced energy spread. Morrison found it not possible to estimate an energy spread to a much greater accuracy than about $\frac{1}{4}$ to $\frac{1}{5}$ of its width, so that the smaller the width in the first place the better the ultimate result.

1.3. Derivation of Thermochemical Data from Appearance Potentials

Appearance potentials may be used in conjunction with ionization potentials, and/or calorimetric data allowing an estimation of certain thermodynamic quantities such as heats of formation and bond dissociation energies. Ionization by electron impact and subsequent fragmentation of the molecular ion by bond cleavage may be represented in a cycle of the form

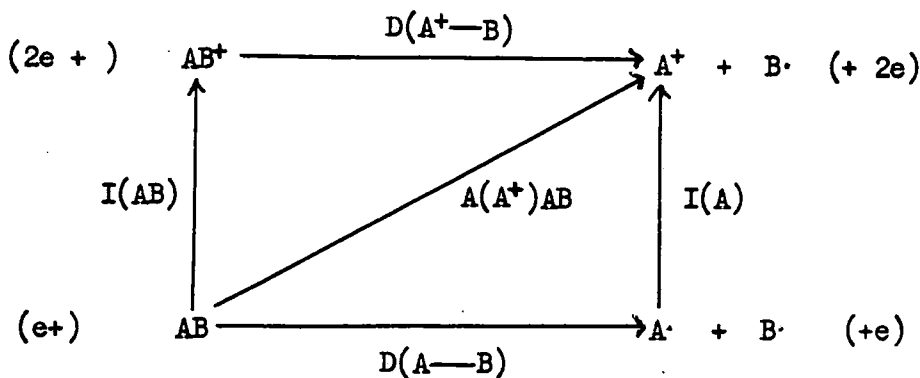

where $I(A\cdot)$ ionization potential of $A\cdot$

$A(A^+)AB$ appearance potential of A^+ from molecule AB

$D(A—B)$ dissociation energy of the bond $A—B$.

From this cycle the following relationships may be obtained.

$$A(A^+)AB = I(AB) + D(A^+—B) + E_1 \quad 1.1$$

$$A(A^+)AB = I(A\cdot) + D(A—B) + E_2 \quad 1.2$$

Here the terms E_1 and E_2 represent excess kinetic energy of the dissociation plus any excitation energy of the products A^+ and $B\cdot$.

The alternative products B^+ and $A\cdot$ may also be obtained leading to

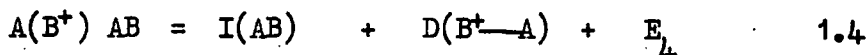
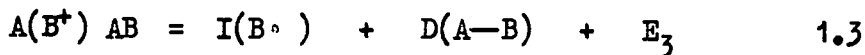

The values of E_1 , E_2 , E_3 and E_4 are not necessarily the same and in general will differ.

One simplifying assumption often made is that E_1 , E_2 ; E_3 , E_4 are zero i.e. that both the ion and the radical are produced in their ground state and that the kinetic energy term is zero. As $E_2 \neq E_3$ and $E_1 \neq E_4$, in general, this assumption will be true for only one of the two series of possible products. Stevenson⁵⁹, has pointed out that one might expect that ionization $e + XY \rightarrow X^+ + Y + 2e$ where $I(X\cdot) < I(Y\cdot)$ may lead to the formation of the ion and radical in their ground states. In many cases where the hypothesis that one of the excess energy terms is zero may be tested it has been found to hold^{4,6}. A fairly extensive series of measurements has been made for singly substituted methane derivatives CH_3X and these are shown in table 1.3.1 along with the bond-dissociation energies estimated by other methods. The agreement between the values from electron impact studies and other methods is good, supporting the view that the fragments are produced in their electronic ground states and that $E = 0$. The use of equation 1.2. to estimate accurate bond dissociation energies requires an estimate of the ionization potential of the free radical. Few direct measurements of such quantities have been made for organometallic radicals and accurate estimations of bond

Table 1.3.1

Bond-dissociation energies $D(\text{CH}_3\text{—X})$

X	Electron Impact (eV)	Other methods ^c (eV)
H	4.43 ^a	4.37
CH ₃	3.99 ^a	3.60
NO ₂	2.54 ^a	2.34
OH	3.95 ^b	3.90
Cl	3.40 ^b	3.47
Br	2.33 ^b	2.91
I	2.30 ^b	2.30

a) reference 6

b) R.I. Reed and W. Snedden, *Trans. Faraday Soc.*, 54, 301, (1958).

c) "The strengths of Chemical Bonds", T.L. Cottrell, 2nd Edition, 1958, Butterworths, London. (1st Edition 1954.)

dissociation energies by other methods from which ionization potentials could be calculated by a combination with the appropriate appearance potentials are often lacking. For example various workers 60,61,62 have measured appearance potentials of the Me_3Si^+ ions from various trimethylsilyl compounds obtaining good agreement. Accurate bond dissociation energies for $\text{Me}_3\text{Si}-\text{X}$ bonds remained in doubt, until recently 63 because of different estimations of $D(\text{Me}_3\text{Si}-\text{SiMe}_3)$ from which $I(\text{Me}_3\text{Si}^\bullet)$ is calculated.

Relative bond dissociation energy measurements may still be calculated however without knowledge of ionization potentials. If for the compounds $\text{L}_n\text{M}-\text{R}$ the appearance potential of L_nM^+ is measured then by a subtraction of the two equations.

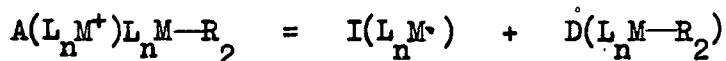
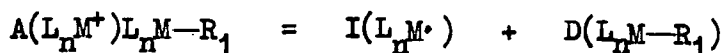

Bond dissociation energy differences are found.

$$D(\text{L}_n\text{M}-\text{R}_1) - D(\text{L}_n\text{M}-\text{R}_2) = A(\text{L}_n\text{M}^+)\text{L}_n\text{M}-\text{R}_1 - A(\text{L}_n\text{M}^+)\text{L}_n\text{M}-\text{R}_2 \quad 1.5$$

Hess, Lampe and Sommer⁶⁰ have introduced an indirect method of estimating ionization potentials which is applicable to the organo-compounds of metals which form homonuclear metal-metal bonds. To explain the method equation 1.2 must be modified to involve other thermodynamic data. The bond dissociation energy $D(\text{A}-\text{B})$ is the heat of reaction

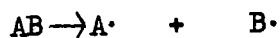

hence

$$D(A-B) = \Delta H_f^\circ(A\cdot) + \Delta H_f^\circ(B\cdot) - \Delta H_f^\circ(AB) \quad 1.6$$

where ΔH_f° represents the standard heat of formation.

Thus 1.2 becomes

$$A(A^+)AB = I(A\cdot) + \Delta H_f^\circ(A\cdot) + \Delta H_f^\circ(B\cdot) - \Delta H_f^\circ(AB) \quad 1.7$$

assuming

$$E_2 = 0$$

Also

$$I(A\cdot) = \Delta H_f^\circ(A^+) - \Delta H_f^\circ(A\cdot) \quad 1.8$$

and so

$$A(A^+)AB = \Delta H_f^\circ(A^+) + \Delta H_f^\circ(B\cdot) - \Delta H_f^\circ(AB) \quad 1.9$$

Suppose that for the compound AB, $\Delta H_f^\circ(AB)$ and $\Delta H_f^\circ(B\cdot)$ are known, then $\Delta H_f^\circ(A^+)$ can be found from the measurements of $A(A^+)AB$. With this value $A(A^+)$ can be measured from $A-A$. If $\Delta H_f^\circ(A-A)$ is known and it is assumed that any excess energy release associated with the formation of A^+ and $A\cdot$ is zero, the measurement permits a computation of $\Delta H_f^\circ(A\cdot)$. The ionization potential of $A\cdot$ can then be estimated using 1.8. Using this "indirect" method heats of formation and ionization potentials of the radicals $SiMe_3\cdot$ and $SnMe_3\cdot$ have been evaluated and bond dissociation energies $D(Me_3Si-R)$ ⁶⁰ and $D(Me_3Sn-R)$ ⁶⁴ found.

The high abundance of the metal ion (M^+) in the spectra of some organometallic compounds has prompted several workers^{65,66,67} to measure the appearance potential of this ion in order to determine the heat of formation of the parent compound or mean metal-carbon bond

dissociation energies. Aside from instrumental errors, it will be apparent from the preceding discussion that the validity of using appearance potentials in the derivation of thermodynamic quantities depends primarily on the correct designation of the process involved in the threshold measurement. Since this may be difficult for processes involving extensive fragmentation, more reliance may generally be placed on values derived from appearance potentials of ions formed by less extensive dissociative processes. Even so quite accurate estimations of thermodynamic quantities have resulted from the appearance potential of M^+ for various transition metal carbonyls and cyclopentadienyl complexes.

Mean metal-carbon bond dissociation energies for a ML_n compound (M is metal and L ligand) may be calculated if we assume that the appearance potential of M^+ is the energy required for the decomposition

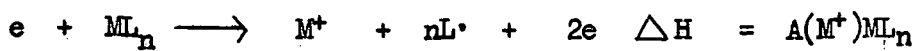

Assuming no excess energy release the cycle below may be written:-

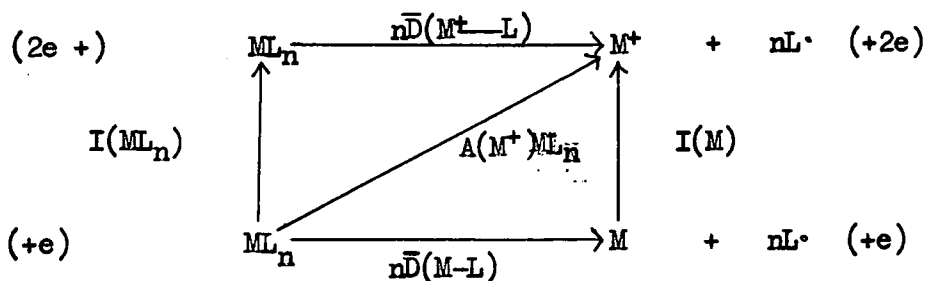

where $\bar{D}(M-L)$ = mean dissociation energy of M-L bond in ML_n

$\bar{D}(M^+L)$ = mean dissociation energy of M-L bond in ML_n^+

From this

$$\bar{D}(M-L) = \frac{1}{n} \left[A(M^+)_{ML_n} - I(M) \right] \quad 1.10$$

$$\bar{D}(M^+-L) = \frac{1}{n} \left[A(M^+)_{ML_n} - I(ML_n) \right] \quad 1.11$$

Providing the appearance potential measurements can be accurately carried out then mean bond dissociation energies can be calculated in both the neutral molecule and molecular ion.

Some measurements for transition metal carbonyls are shown in Table 1.3.2. The appearance potential measurements give larger values for $D(M-CO)$ than those calculated from heats of combustion. This discrepancy may be attributable to the failure of the negligible excess energy release assumption made in deriving equations 1.10 and 1.11.

Heats of formation may also be calculated. If M^+ is formed by the process below with no excess energy release:-

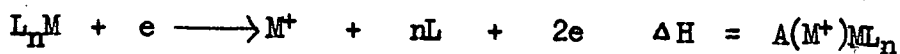

$$\text{then } A(M^+)_{ML_n} = \Delta H_f^\circ(M^+) + n\Delta H_f^\circ(L) - \Delta H_f^\circ(L_n M)$$

$$\text{from which } \Delta H_f^\circ(L_n M) = \Delta H_f^\circ(M^+) + n\Delta H_f^\circ(L) - A(M^+)_{ML_n} \quad 1.12$$

Since the heats of formation of metal ions in their ground states are known, then providing the heat of formation of the ligand L is known, measurement of the appearance potential allows an estimation of the heat of formation of the parent molecule.⁶⁷

Table 1.3.2

Mean metal-carbon bond dissociation energies in transition metal
carbonyl molecules and ions

	Kcal. mole. ⁻¹			
	Bidinosti et. al. ⁶⁵ D(M-CO)	Foffani et.al. ⁶⁶ D(M-CO)	Thermochemical ^a D(M-CO)	
Ni(CO) ₄	43	37		35.2
Fe(CO) ₅	33	32	30	27.7
Cr(CO) ₆	31	31	25	27.1
Mo(CO) ₆	42	39	38	35.9
W(CO) ₆	50	48	47	42.1
V(CO) ₆	34	31		

a) F.A. Cotton, A.K. Fischer and G. Wilkinson, J. Amer. Chem. Soc., 1959, 81, 800.

Sometimes appearance potential data can also throw light onto the decomposition process occurring just above the threshold measurement. Winters and Kiser⁶⁸ measured the appearance potential of the metal ion from compounds of the type $(C_5H_5)_M(CO)_x$ ($M = Co, Mn, V$). Heats of formation of the neutral molecules were calculated assuming in one instance metal ions to be formed by the decomposition

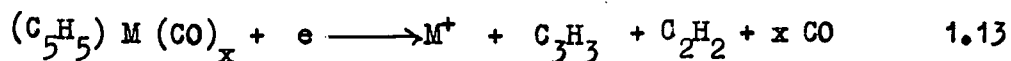

and in another by

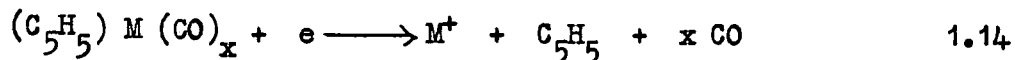

Decomposition 1.13 was considered to be the most probable since the heat of formation obtained for this process agreed with values estimated from bond strength data of similar compounds.

2. EXPERIMENTAL.

2.1 Preparation of Compounds.

2.2 Recording Mass Spectra.

2.3 Measurement of Appearance Potentials.

2. EXPERIMENTAL

2.1 Preparation of Compounds

Et₄Sn: Prepared from the reaction of stannic chloride and ethylmagnesium bromide in ether^{69,70}. The main impurity, triethyltin chloride was removed from an ether solution by agitating with aqueous/alcoholic potassium fluoride solution and filtering off the precipitated triethyltin fluoride⁷¹. Vapour phase chromatography [Pye 104 dual columns (5ft. 4 m.m. i.d.) dual flame ionization detectors. Stationary phase 10% Apiezon L on 100-200 mesh celite. Carrier gas N₂.] Temp. 200°C showed only one peak, b.pt = 174-176°C/760 m.m.

(CH₂:CH)₄Sn: The addition of anhydrous stannic chloride to vinylmagnesium bromide gave tetravinyltin in at least 60% yield⁷². b.pt. 160-163°C/760 m.m.

Ph₃SnCl: prepared from freshly distilled stannic chloride and tetraphenyltin by the redistribution reaction⁷³

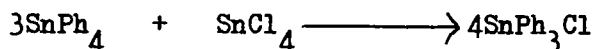

Pure triphenyltin chloride was obtained by sohxlet extraction of the powdered product using ether⁷⁴. m.pt. = 106-107°C

Ph₃SnBr: Prepared in the same way as triphenyltin chloride using anhydrous stannic bromide. m.pt. = 122°C.

Ph₃SnF: Triphenyltin chloride solution in hot ethanol was added to a hot aqueous/alcoholic solution of potassium fluoride. On cooling snow white fine crystals of triphenyltin fluoride formed ⁷⁵ m.pt. = At 341°C the solid turned brown and at 355°C liquified.

Ph₃SnI: Sodium iodide (45 g.) in acetone (300 cc.) was added to triphenyltin chloride (19.2 g.) in acetone (50 cc.). The mixture was refluxed for 6 hr., decanted from sodium chloride and more sodium iodide (30 g.) added with further refluxing (8hr.). The crude iodide was purified by soxhlet extraction with light petroleum (b.pt. 40-60°C) from which it crystallised, m.pt. = 121°C.

EtSnPh₃: The reaction of triphenyltin chloride with ethylmagnesium bromide in anhydrous ether as described by Lesbre et. al. ⁷⁶ gave ethyltriphenyltin in 63% yield.

The product was purified by alternatively recrystallising from ether and hexane until the mass spectrum showed no change after ten recrystallisations. m.pt. = 56°C.

MeSnPh₃: Prepared in an identical way to EtSnPh₃ using methylmagnesium bromide. Five alternate recrystallisations from hexane and ethanol were carried out. m.pt. = 58°C

Et₂SnPh₂: Diphenyltin dibromide first prepared in the following manner. Tetraphenyltin (109 g. 0.5 mole) was suspended in ethylenedibromide

and bromide (80 g. 1 mole) in the same solvent added drop wise over a period of three hours. Ethylenedibromide and bromobenzene were removed by distillation at reduced pressure leaving a brown liquid. The distillate boiling at 156-170°C/1 m.m. was collected yielding diphenyltin dibromide (100g. 60%) Diethyldiphenyltin was prepared from the reaction of this bromide with ethylmagnesium bromide in ether ⁷⁵. Unforeseen complications arose however because of the presence of chlorine even in analar bromine which resulted in the presence of some PhEt_2SnBr , PhEt_2SnCl and Ph_3SnEt in the diethyldiphenyltin obtained.

Purification was effected by chromatography using a column of silica gel (100/200 mesh, activated by heating for 3 days at 120°C) and eluting with petroleum (b.pt. 40-60°C). Retention on the column was in the order PhEt_2SnCl , PhEt_2SnBr > Ph_2SnEt_2 > Ph_3SnEt . Using such a column (dimensions: length 18in. diameter 1in.) and by taking a middle cut of the petroleum fractions, 0.1 g. of pure diethyldiphenyltin was obtained from 1.5 g. of crude material. This sample gave only one peak by vapour phase chromatography using two stationary phases at 200°C (10% apiezon L on 100-200 mesh celite and N.G.A. ; carrier gas N_2) and showed no peaks in the mass spectrum corresponding to PhEt_2SnCl , PhEt_2SnBr (i.e. PhEtSnCl^+ or PhEtSnBr^+) or Ph_3SnEt (i.e. Ph_3Sn^+).

Et_3SnPh : The preparation from tetraethyltin by the sequence $\text{Et}_4\text{Sn} \xrightarrow{\text{Br}_2}$

$\xrightarrow{\text{Br}_2} \text{Et}_3\text{SnBr} \xrightarrow{\text{PhMgBr}} \text{Et}_3\text{SnPh}$ has been described ⁷⁷. Again the presence of chlorine in the bromine used resulted in the product being contaminated with Et_3SnBr , Et_3SnCl and Et_2SnPh_2 . These were removed by silica gel column chromatography eluting with petroleum (b.pt. 40-60°C) (as for the diethyldiphenyltin purification described) followed by preparative scale vapour-phase chromatography using a 9ft. column of 10% apiezon L on celite and nitrogen as carrier gas.

It is interesting to note at this stage that an alumina column (Brockman No 1) and eluting with petroleum (b.pt. 40-60°C) would not separate either Et_2SnPh_2 or Et_3SnPh from their impurities.

Sn_2Et_6 : Sodium amalgam (225 g. Hg + 1.13 g. Na) triethyltin chloride (11.7 g.) and cyclohexane (10 cc.) were shaken in a nitrogen purged flask for 14 days. No colour change was observed, but the mercury became more mobile and sodium chloride separated. Normal work-up gave two fractions, b.pt. 85-110°C/10 m.m. (3.6 g.) and b.pt. 148-150°C/10 m.m. (4.2 g.), both of which contained some Et_3SnCl which was not completely removed by shaking with aqueous/alcoholic KF or by chromatography on silica gel. The higher fraction was refluxed with potassium (3 g.) in benzene (50. cc.) for 10 hr. giving pure hexaethyldistannane (0.5 g.) b.pt. 100-151°C/15 m.m.

5 - Stannaspiro (4,4.) nonane: The di-Grignard reagent from 1,4 - dibromobutane (92 g.), magnesium (22 g.) and ether (400 cc.) was added to stannic chloride (26 g.) in ether (500 cc.) and the mixtures refluxed

for 10 hr. After hydrolysing with saturated ammonium chloride solution the two layers were separated and the aqueous layer extracted with more ether. The combined ether solutions were dried and the ether removed by distillation. The residue was distilled yielding 2.1 g. of colourless liquid b.pt. $108-110^{\circ}\text{C}/30$ m.m.. Its infra red spectrum showed no Sn-H absorption. (Found C 58.9%; H 4.7%; $\text{C}_8\text{H}_{16}\text{Sn}$ requires C 58.8%; H 4.9%).

$\text{Ph}_3\text{Sn-S-Ph}$: Thiophenol (12 g.) in dry methanol (20 cc.) was added to sodium methoxide (5.4 g.) in dry methanol (20 cc.) Triphenyltinbromide (42 g.) in tetrahydrofuran (50 cc.) was then added slowly. The mixture was boiled with reflux for 30 min. and filtered; the product crystallized from the filtrate. Recrystallisation from ethanol gave a colourless product (37 g. 82%) m.pt. 103°C (Found C 62.8%; H 4.5%; requires C 62.7%; H 4.4%.)

$\text{Ph}_3\text{C}\cdot\text{CMe}_3$: Tertiarybutylmagnesium chloride in diethylether was prepared from purified ⁷⁸ tertiarybutylchloride. This was reacted with tritylbromide (1 mol.) (freshly prepared from triphenylcarbinol ⁷⁹) giving a 61% yield of tertiarybutyl-triphenylmethane m.pt. $175-177^{\circ}$.

Attempted preparation of tertiarybutyltriphenyltin: The reaction of tertiarybutylmagnesium bromide with triphenyltin chloride yielded only hexaphenylditin.

Metal-Metal bonded Compounds: These were prepared by the addition of the $\text{R}_3\text{M Li}$ derivative (M = Si, Ge, Sn; R = Me, Ph) to an equal number of

Table 2.1.1.

Products of reaction $R_3MLi + R_3M'X$ (M, M' = Si, Ge, Sn; X = Cl, Br).

Lithium Reagent	Halide	Solvent	Derivative and yield	M_2Ph_6 yield
Ph ₃ SnLi	Me ₃ SiCl	T.H.F.	-	62%
	Me ₃ SnBr	"	Ph ₃ Sn·SnMe ₃ 14%	21%
	Et ₃ SiCl	"	-	51%
Ph ₃ SiLi	Me ₃ SiCl	T.H.F.	Ph ₃ Si·SiMe ₃ 79%	-
	Et ₃ SnBr	"	-	66%
	Et ₃ SiCl	"	Ph ₃ Si·SiEt ₃ 53%	-
Ph ₃ GeLi	Me ₃ SnBr	Et ₂ O	Ph ₃ Ge·SnMe ₃ 67%	-
	Et ₃ SnBr	"	-	68%
	Et ₃ SiCl	"	Ph ₃ Ge·SiEt ₃ 58%	7%
Me ₃ GeLi	Ph ₃ SnCl		Ph ₃ Sn·GeMe ₃ 20%	present
Me ₃ SiLi	Ph ₃ SnCl		-	present

moles of $R'_3M'X$ ($M' = \text{Si, Ge, Sn}$; $R' = \text{Me or Et}$)

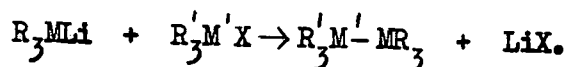

The results of these reactions are given in table 2.1.1. Because of halogen-metal exchange the symmetrical compounds R_6M_2 and $R'_6M'_2$ were often formed.

The preparations of a) Ph_3SnLi in tetrahydrofuran (T.H.F.) from Ph_3SnCl ⁸⁰ b) Ph_3SiLi in T.H.F. from Ph_3SiCl ⁸¹ and c) Ph_3GeLi in diethylether from Ph_3GeH ⁸² have been described. Me_3GeLi and Me_3SiLi were prepared from the mercury derivative $(\text{Me}_3M)_2\text{Hg}$ by reaction with lithium under an atmosphere of nitrogen.

$\text{Me}_3\text{GeSnPh}_3$: m.pt. $110^\circ - 111^\circ\text{C}$ recrystallised from benzene.

$\text{Me}_3\text{SnGePh}_3$: m.pt. 81° recrystallised from 1:1 (V:V) mixture of petroleum (b.pt. = $40 - 60^\circ\text{C}$) and diethylether.

$(\text{PhCH}_2)_3\text{GeSiMe}_3$: ⁸³ m.pt. 64°

$\text{Me}_3\text{SiSiPh}_3$: m.pt. 108°

$\text{Et}_3\text{SiSiPh}_3$: m.pt. $89 - 90^\circ$

$\text{Et}_3\text{SiGePh}_3$: m.pt. $91 - 91.5^\circ$ all recrystallised from methanol

$\text{Me}_3\text{SnSnPh}_3$: m.pt. 106° separated from Sn_2Ph_6 by successive recrystallisations from diethylether.

$\text{Ph}_3\text{SnSnPh}_3$: m.pt. 237° recrystallised from benzene

$\text{Ph}_3\text{SiSiPh}_3$: m.pt. 365° recrystallised from benzene

Table 2.1.2.

Infra-red data for $A_3M - M B_3$ compounds.

	Metal-Phenyl ^a Characteristic Vibration	Methyl ^b deformation	Methyl ^b Rock	CH ₃ - M ^b stretch asym. sym.	C ₂ H ₅ - M 84 characteristic symmetrical CH ₂ deformation
Ph ₃ Si·SiMe ₃	1102s	1253s	851s 835s	observed	
Ph ₃ Ge·GeMe ₃	1083s	1230w	826s	564m 594s	
Ph ₃ Ge·SnMe ₃	1083s	1193w	771sb	508m 523s	
Ph ₃ Sn·GeMe ₃	1068s	1230w	824s	561m 544s	
(PhCH ₂) ₃ Ge·SiMe ₃	-	1240m	84.7sh 837m	observed	
Ph ₃ Si·SiEt ₃	1101s				1232w 956w
Ph ₃ Ge·SiEt ₃	1084s				1233w 956w

a) refs. 84,85,86,87.

b) refs. 84,88,89,90.

The spectra are quoted in cm⁻¹. Methyl rock, Methyl-metal stretching frequencies were recorded in cyclohexane and the metal-phenyl characteristic vibration and methyl deformation were recorded in pressed discs in potassium bromide.

w weak, m medium, s strong, b broad, sh shoulder.

Infra-Red Spectra of Metal-Metal bonded Compounds.

In order to establish that the compounds prepared were in fact of structure $A_3M - MB_3$ and not $A_2BM - MB_2A$ etc, infra-red spectra were recorded using a Grubb-Parsons spectromaster. The characteristic bands observed are shown in Table 2.1.2. from which it is immediately obvious that the infra-red data is consistent with structures $Ph_3M-M R_3$ with all the phenyl groups attached to a single metal.

Organoberyllium Compounds.

These were all prepared by P.D. Roberts, to whom my thanks are due, using the general methods⁹¹ outlined below.

1. The dialkyls are obtained by the action of the Grignard reagent on beryllium chloride⁹²

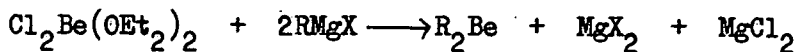

The separation of the product from the reaction mixture presents some difficulties. The dimethyl may be obtained by a process of "ether distillation" at atmospheric pressure whereby ether continuously circulates carrying dimethylberyllium from the reaction mixture to a receiver which is kept well above room temperature, excess ether evaporating from the latter and returning to the reaction vessel via a condenser⁹³. The higher alkyls should be distilled from the reaction mixture at reduced pressure at as low a temperature as possible (generally 50-80°) to minimise thermal decomposition. The use of non-ethereal Grignard reagents⁹⁴, or lithiumalkyls ~~alkyls~~ in

hydrocarbons, allows the preparation of ether free beryllium alkyls directly from beryllium chloride.

2. Dimethylberyllium ⁹⁵ has been prepared by the action of the corresponding organomercury compound on metallic beryllium.

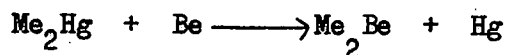

Organoaluminium Compounds.

These were available from Ethyl Corporation. After distillation the compounds were sealed in a tube containing a breakseal and attached to the direct evaporation line of the mass spectrometer.

2.2. Recording Mass Spectra

Spectra were recorded on an A.E.I. M.S.9 double focussing instrument. Routine measurements, such as high resolution mass measurements, were carried out as described in the instruction manual and unless otherwise stated ions were produced under the following conditions:

Ionizing electron beam voltage = 70eV
 Trap Current (i.e. electron beam current) = 100 μ Amps
 Ion repeller voltage = -2 to + 4 volts
 Source temperature = 190 to 210°C

Since some difficulties were encountered with the methods of sample introduction, the production of reproducible spectra for abundance measurements, the detection of metastable peaks and measurement of appearance potentials these topics are discussed in detail.

2.2.1. Sample Handling Systems

Since electron impact sources require sample vapour at a pressure of about 10^{-5} m.m., the usual approach is to maintain a pressure of about 10^{-2} m.m. in a large reservoir from which vapour passes to the source through a leak which reduces the pressure by the requisite factor $\sim 10^{-3}$. The sample reservoir is filled according to the nature of the compound.

a) Permanent gases and compounds with room temperature vapour pressures of a few cm. or more use a "cold inlet" where by an aliquot of the gas/vapour (i.e. a volume of ~ 10 cc. of pressure $\sim 7 - 8$ cm.) is

expanded into a 2 litre reservoir.

- b) With relatively involatile liquids a volume of about a drop (i.e. handleable in a micropipette) is introduced, via a gallium covered sinter, into a reservoir whose volume can be 100 cc. or ~ 1000 cc. The whole system can be heated to $\sim 200^{\circ}\text{C}$ to cause vapourisation.
- c) For very involatile liquids and solids the sample is introduced into a thimble where it may be frozen down in liquid nitrogen whilst the air in the thimble is evacuated. The sample is then given direct entry into the reservoir, and the thimble is heated in an oven until the vapour pressure reaches the required level. The oven and reservoir can be heated to $\sim 350^{\circ}\text{C}$.

Using this "heated inlet" system sometimes poses problems for solids because decomposition occurs: either the compound decomposes in the solid and it is the decomposition products that vapourise or else the vapour decomposes in the gas phase in the hot reservoir, possibly catalysed by the metal parts of the valves. A technique to minimise these troubles is the "direct insertion probe". A few micrograms of the solid are packed into a glass or ceramic probe. This is then introduced through a vacuum lock, directly into the source within a few m.m. of the electron beam. Sample vapourises from the probe under the influence of the source vacuum and source temperature ($\sim 200^{\circ}\text{C}$): If, under these conditions of vapourisation virtually directly into the electron beam, decomposition still occurs then it can probably never be eliminated.

To record mass spectra of solids the direct insertion probe

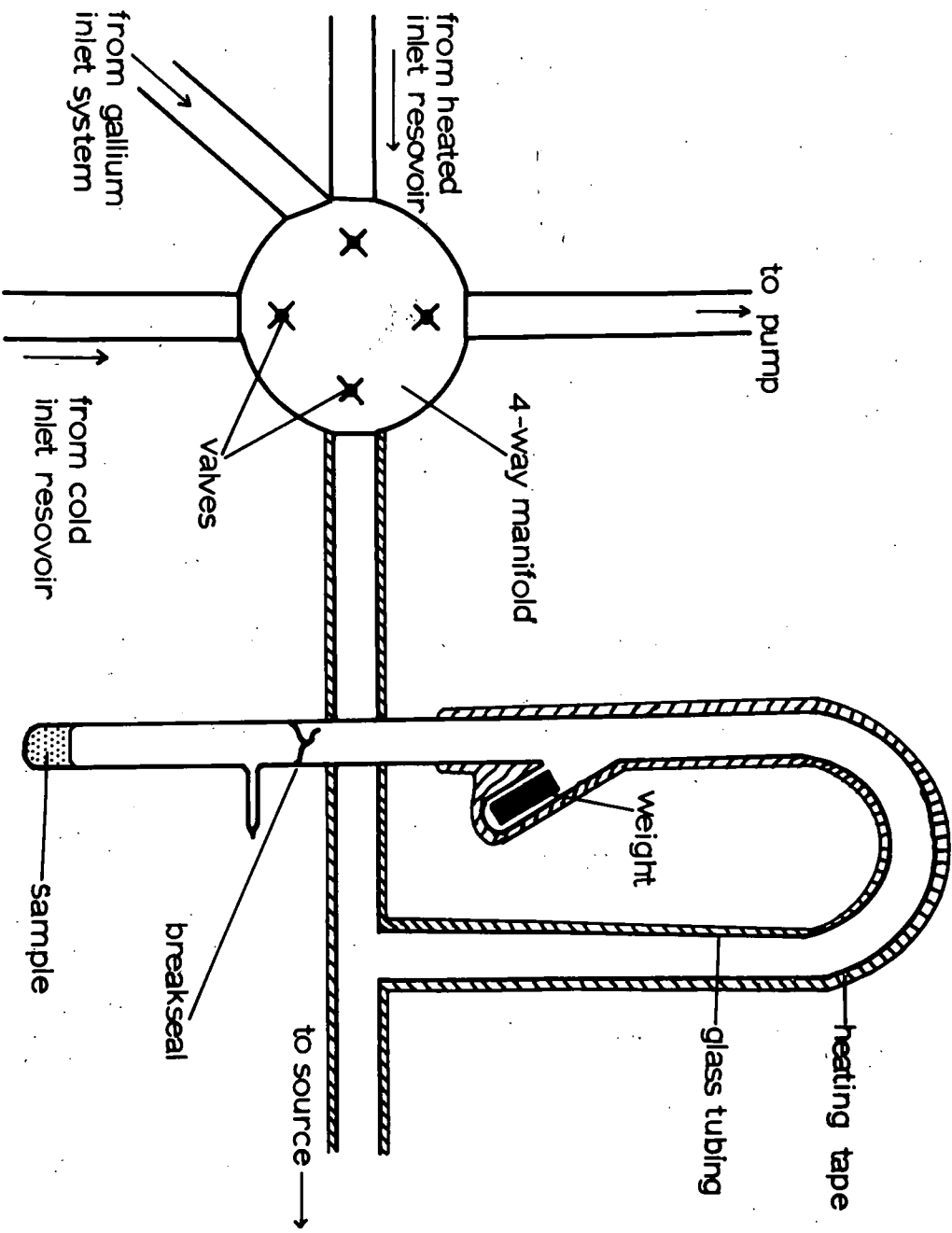

Fig. 3.

DIRECT EVAPORATION INLET SYSTEM.

was always used to introduce sample into the mass spectrometer.

With dialkylberyllium compounds in addition to difficulties encountered because of the highly reactive nature of these compounds to air and moisture, extensive decomposition of these compounds occurred whenever these inlet systems were used. Thus the volatile di-tertiary-butylberyllium decomposed giving mainly butene in the cold inlet system and dimethylberyllium, which does not thermally decompose until 200°C, produced a mass spectrum showing only peaks due to Me_3Sn^+ , Me_3Ge^+ and hydrocarbon ions when introduced via the heated inlet system at 100°C. Such decomposition occurred even after the heated inlet system had been "baked" for 6 hours at 350°C before cooling to 100°C in order to remove any volatile residues that would react with the organoberyllium compound.

In case this decomposition was catalysed by metallic surfaces, an all glass inlet system was constructed; a schematic diagram of which is shown in Fig. 3. The rate evaporation of material into the source was controlled by altering the temperature of the sample. To give a reading on the source ionization gauge of 2 to 8×10^{-6} m.m. the following sample temperatures (°C) were required for organo-beryllium and -aluminium compounds; Me_2Be 48°, Et_2Be 16.5°, $(i\text{-Pr})_2\text{Be}$ 25°, $(n\text{-Pr})_2\text{Be}$ 25°, $(i\text{-Bu})_2\text{Be}$ 29°, $(t\text{-Bu})_2\text{Be}$ - 60°, Me_3Al - 25°, Et_3Al - 15°, Me_2AlH - 22°, Et_2AlH 22°. (temperatures in degrees centigrade). A disadvantage of this inlet system is that the beryllium or aluminium sample has to be sealed in a tube with a breakseal and then glass-blown onto the inlet line. To remove the sample, the source and inlet line to the 4 - way manifold

has to be let down to pure dry nitrogen and the sample tube and inlet-line sealed using a blow torch.

It was not possible to introduce di-n-butylberyllium through any of the sample inlet systems described because of its low volatility. Using the direct evaporation inlet system elimination of butene occurred when the sample was heated above 85°C. Prolonged heating at this temperature caused further decomposition and the sample turned to a grey viscous liquid. At no stage was the mass spectrum of di-n-butylberyllium recorded.

2.2.2. Obtaining Spectra for Abundance Measurements

These were recorded using a resolution of 1 part in 5,000 and a source pressure not so high that "sparking" of the high voltage employed in the source occurred. It is also important that a constant monitor current (i.e. a quantity proportional to the total ion current issuing from the ionization chamber found by intercepting part of the ion beam before it enters the magnetic sector) prevails while the spectra is recorded if meaningful abundances are to be obtained. With the inlet systems which employ a leak to regulate the flow of material into the source (i.e. the cold, heated and gallium systems) this is relatively easy but using the direct insertion probe some manipulation is necessary, especially with solids m.pt. > 100°C, before constant evaporation into the source is obtained.

2.2.3. Detection of Metastable Peaks

For detection of such peaks an ion repeller voltage of + 20 to + 25 volts and a resolving power of one part in 500 to 1000 were used

since it has been shown ¹ that the height of these peaks increases relative to the others under these conditions.

2.3. Measurement of Appearance Potentials

While an appearance potential is being measured it is essential that a constant monitor current prevails (i.e. for about thirty minutes) Thus whenever possible the cold, gallium, heated or direct evaporation inlet systems were used. However for some solids of high molecular weight, such as Ph_6Sn_2 , decomposition ensued if the heated inlet system was used, and the direct insertion probe had to be employed. Even so it was found that by patient manipulation a constant monitor could be maintained for the duration of the measurements (Often, in fact, this constant monitor current occurred because material fell from the probe into the source, producing a background spectrum of the material and constant monitor current for several hours) The inlet systems used for the various elements and compounds for which appearance potentials of ions were measured were as follows:

Direct Evaporation: All dialkylberyllium compounds.

Heated Inlet: Ph_4Sn , Ph_3SnI , Ph_3SnEt , Ph_3SnMe , $\text{Ph}_3\text{Sn}\cdot\text{GeMe}_3$.

Gallium System: Et_4Sn , Et_3SnPh , Et_2SnPh_2 , Et_6Sn_2 .

Cold Inlet: All inert gases.

Direct Insertion Probe: Ph_6Sn_2 , $\text{Ph}_3\text{Sn}\cdot\text{SnMe}_3$, $\text{Ph}_3\text{Sn}\cdot\text{SMe}$.

After the sample which produced an ion whose appearance potential (A.P.) was to be measured had been introduced via the appropriate inlet system, a standard compound was introduced through one of the remaining systems. (The required A.P. is measured relative to the A.P. of an ion

produced in the spectrum of the standard material, which was generally tetraethyltin for organotin compounds when SnEt_4^+ was the standard ion or the inert gases, argon, krypton or xenon, for organoberyllium compounds.)

The precautions taken in measuring appearance potentials may be illustrated from a specific example. For the measurement of $\text{A}(\text{BeCH}_3^+)\text{BeMe}_2$ argon was used as the standard. The CH_3Be^+ peak was first tuned, by adjusting the magnetic field, onto the collector meter and the ion beam focussed to its maximum value with the ion repeller voltage set within the limits - 1.0 to +5 volts (i.e. readings on the ion repeller dial of 1.35 to 3.30), the electron beam voltage at 20V. and the trap current at $10 \mu\text{A}$ for organotin compounds and $20 \mu\text{A}$ for organoberyllium compounds. The electron beam voltage was then increased to 50V, and the ion currents given on the collector meter for the two ions, CH_3Be^+ and Ar^+ , adjusted to give equal values by altering either the pressure of argon in the cold inlet reservoir or the temperature of dimethylberyllium in the direct evaporation system. (One scanned from the CH_3Be^+ peak to the Ar^+ peak and vice-versa by altering the magnetic field).

Since the accuracy of A.P. measurements depends on the sensitivity of ion detection this was made as great as possible by using:

a) A high source pressure produced by sample and standard compound vapour. The pressure normally used was $\sim 8 \times 10^{-6}$ m.m. since it is important that this pressure is not so high that "sparking" occurs in the source. If "sparking" does occur while measurements are in progress then the A.P. determination must be restarted because potential gradients within

the source are altered.

b) Whenever possible the source slits were opened to give a resolution of only 1 part in 500. In practice this was not always possible. For example when measuring $A(C_2H_5Be^+)BeEt_2$ the ion $C_3H_3^+$ also occurred at the m/e value of 38. Since it is essential that the two ions were completely resolved a resolving power of 1 part in 1000 had to be used.

The electron beam was then reduced to 20 volts and the ion giving the largest ion current at this voltage tuned onto the collector meter. (In this case it was CH_3Be^+) The ion multiplier voltage was then increased so that the ion current was approximately 2 to 7 x 1000 units on the meter. In practice it was found that no advantage was gained by increasing this voltage above 2.8KV. (i.e. a reading on the ion multiplier dial of 6.00) Above this the collector meter reading was so unsteady for small ion currents that the advantage of increased sensitivity was annulled by a decreased accuracy of the readings.

Having made sure that the collector meter reads zero at an electron beam voltage of 5 volts (well below the appearance potential of ions under study) and the ion beam correctly focussed, the voltage was reduced in 0.2 volt steps and ion currents for CH_3Be^+ and Ar^{++} measured after each step. The meter was zeroed periodically when no peak was tuned onto the collector meter and readings of ion currents discontinued when they became less than 0.5×1 units. A graph could then be drawn of ion current against electron beam energy (in eV) and the linear portion of the ionization efficiency curve established.

In measuring the same appearance potential again ion currents

were read in 0.4 volt steps while in this linear region and reduced to 0.2 volt steps only when tailing of the ionization efficiency curve commenced. When the two ions were no longer being formed the voltage was increased to 20 volts and ion currents again read and checked with those found at the start of the appearance potential measurements. If there was any discrepancy between the values then that particular set of data was discarded.

Appearance potentials were determined from at least four sets of measurements using methods described in Chapter 3.1. Calculation of Results.

3. **CALCULATION OF RESULTS.**
- 3.1 **Evaluation of Appearance Potentials.**
- 3.2 **Identification of Ions.**
- 3.3 **Calculation of Abundances.**
- 3.4 **Assignment of Metastable Peaks.**

3. CALCULATION OF RESULTS

3.1. Evaluation of Appearance Potentials

Two methods were used in the evaluation of appearance potentials from the data obtained following the experimental procedure described earlier (p. 50). Both methods are illustrated by reference to specific examples.

a) Modified Warren Method

Ionization efficiency curves for Me_2Be^+ and Ar^+ are shown in fig. 4,a). In the Warren ⁴¹ method of evaluation the linear portions of these curves are made parallel by multiplying the curve of steeper slope by the ratio of the slopes of the linear regions. In this case ion currents for Ar^+ are multiplied by 0.87. These standardised ion currents when plotted as log. (ion current) vs. electron energy give the graph shown in fig. 4b). The curves so produced also have linear portions, AB and A'B'. Within this region voltage differences $\Delta V(\text{eV})$ are taken at corresponding ion currents and plotted to give graph 4c). From the voltage difference at zero ion current the ionization potential of Me_2Be is found.

b) Semi-logarithmic Method

Typical ionization efficiency curves for SnPh_3^+ (in this case from Ph_3SnI) and SnEt_3^+ (derived from SnEt_4) are shown in fig. 5a). In obtaining this experimental data ion currents of the two species at 50eV had been made equal and no further "standardisation" was carried out. In fig. 5b) log. (ion current) is plotted against electron energy producing the essentially straight line portions CD and C'D'. Voltage differences taken within this region at corresponding ion currents when

Fig. 4

Ionization Efficiency Curves for Me_2Be^+ and Ar^+ .

Illustration of Appearance Potential Determination by Modified Warren Method.

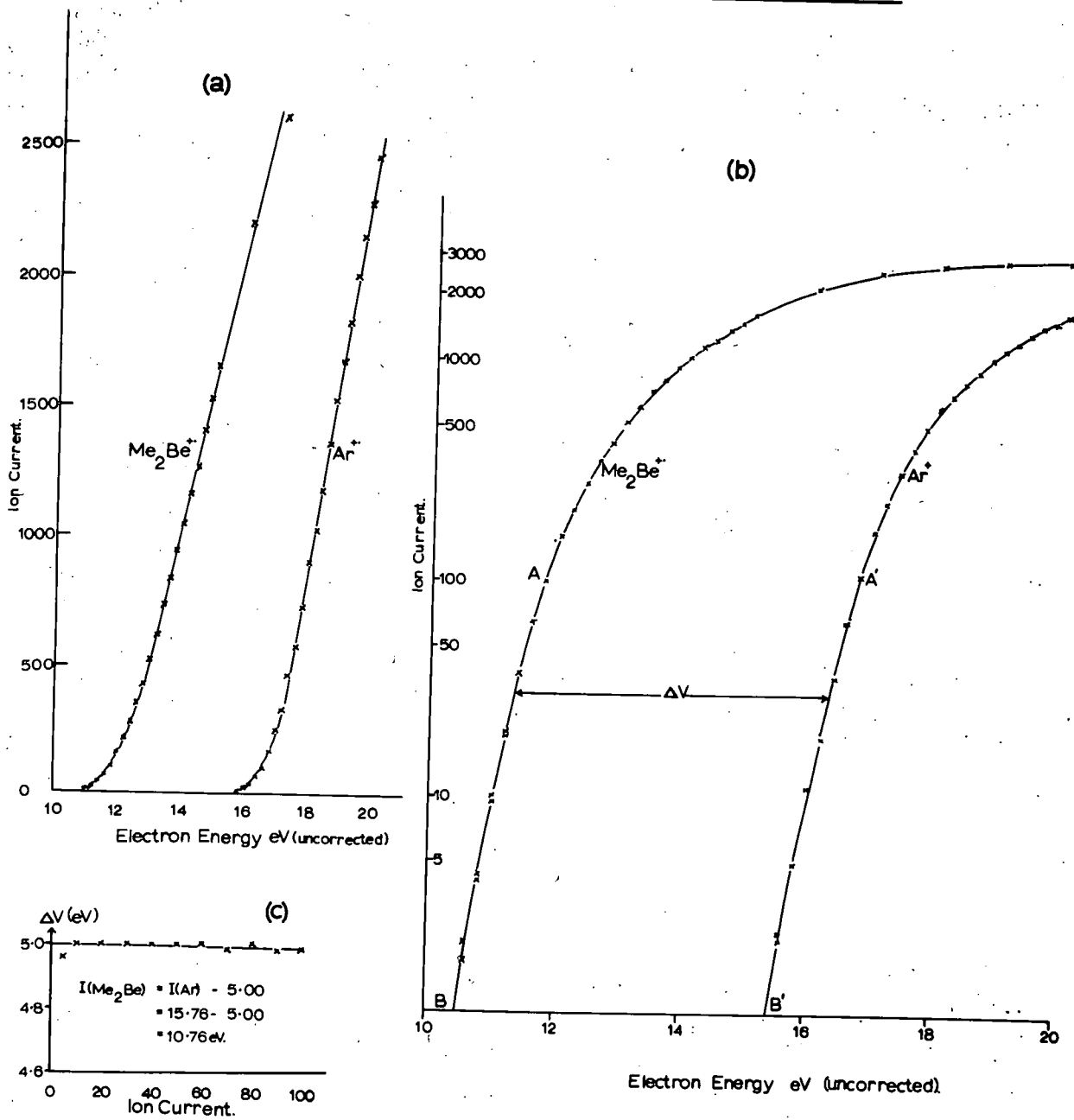

Ionization Efficiency Curves for Ph_3Sn^+ from Ph_3SnI and Et_3Sn^+ from Et_3SnI . Illustration of Appearance Potential Determination by Semi-logarithmic Method.

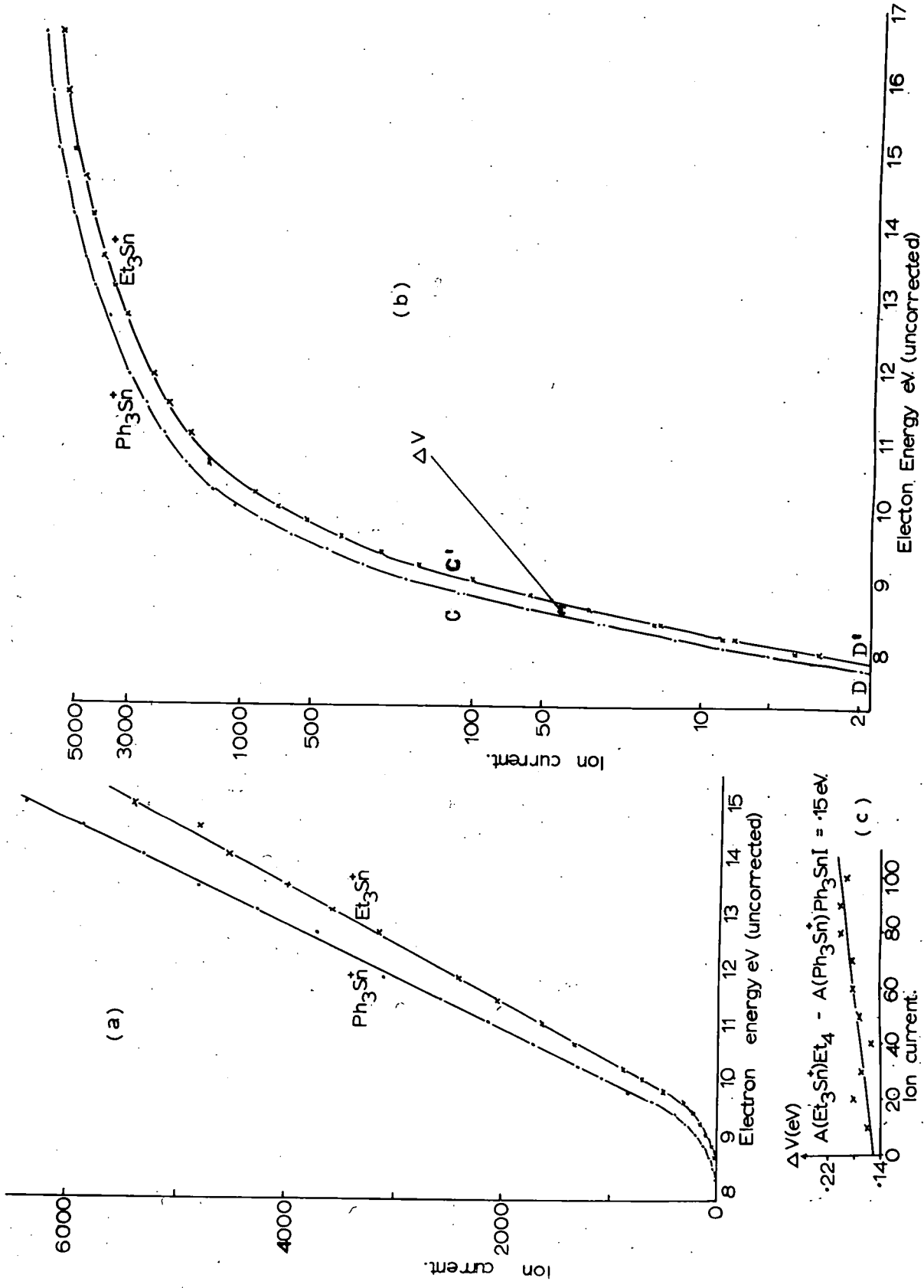

plotted to give graph 5c). The voltage difference at zero ion current allows $A(\text{SnPh}_3^+)\text{Ph}_3\text{SnI}$ to be found relative to $A(\text{SnEt}_3^+)\text{SnEt}_4$.

3.2. Identification of Ions

The mass spectra of Group IVb organometallic compounds, particularly germanium and tin, are complicated by the polyisotopic nature of these elements and characteristic patterns are produced for each metal containing ion which reflect the isotope abundances of the metal, as in the following illustration.

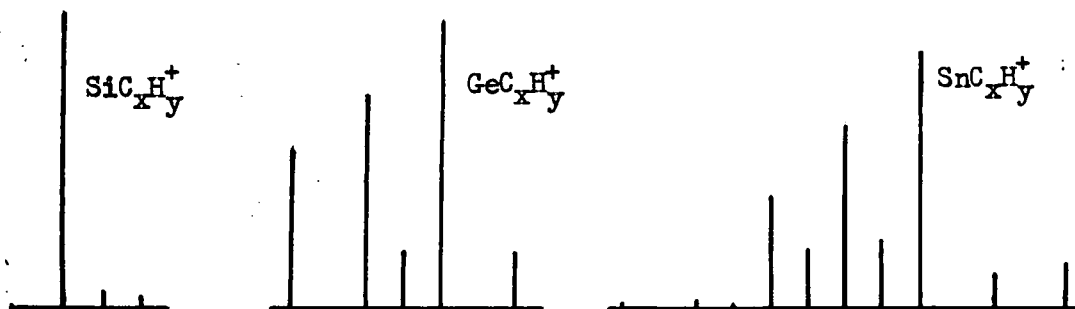

Even when x is as large as 18, the effects of ^{13}C are not sufficient to alter the visual appearance of these patterns.

Tin and lead isotope masses and abundances are given in Appendix 1. Since lead isotope abundances vary with sample origin these were calculated from the actual specimens of tetraethyl- and tetraphenyl-lead used.

Ions containing two or more polyisotopic elements produce a relatively high combined mass, extending over several mass units.

The combinations of isotopes for Ge_2 are shown below:-

Isotope Combination (mass numbers)		Mass	Abundance Product
70	70	139.848554	4.22714
72	70	141.846017	11.2751
73	70	142.847637	3.20325
74	70	143.845427	14.9965
76	70	145.845637-	3.19091
72	72	143.843480	7.51856
73	72	144.845099	4.27204
74	72	145.842890-	20.0001
76	72	147.842099	4.25558
73	73	145.846720-	.606841
74	73	146.844510	5.68203
76	73	148.844720	1.20901
74	74	147.842300	13.3006
76	74	149.842509	5.66014
76	76	151.842719	.602176

Number of combinations:- 15

The abundance product is the product of isotope abundances and factorial of total number of atoms, divided by the product of the factorial of numbers of each isotope present and is proportional to the probability of occurrence of the isotope combination.

Those combinations which have the same nominal mass (such as $^{76}\text{Ge} \text{ } ^{70}\text{Ge}$, $^{74}\text{Ge} \text{ } ^{72}\text{Ge}$ and $^{73}\text{Ge} \text{ } ^{73}\text{Ge}$) cover a mass spread of less than 50 p.p.m (parts per million) and even with a maximum spectrometer resolution of 1:20,000 appear as a single peak corresponding to the weighted arithmetic mean of the exact masses of the contributing combinations. For example the precise mass of the peak at mass 146 is given by

$$\begin{aligned}
 & \frac{145.84672 \times 0.606841 + 145.84289 \times 20.0001 + 145.845637 \times 3.19091}{0.606841 + 20.0001 + 3.19091} \\
 & = 145.843356.
 \end{aligned}$$

The peak height of this mass is proportional to the sum of the relative abundances of the individual combinations

(i.e. $0.606841 + 20.0001 + 3.19091$).

The isotope abundance pattern for Ge_2 and the precise masses of the peaks are given below:-

Nominal Mass	multiplicity	spread (ppm.)	Peak Mass (wtd mean)	Relative Abundance
140	singlet		139.848554	17.7626
141	no combination			
142	singlet		141.846017	47.3786
143	singlet		142.847637	13.4602
144	2	14	143.844777	94.6093
145	singlet		144.845099	17.9513
146	3	26	145.843357	100.0000
147	singlet		146.844510	23.8762
148	2	5.4	147.842494	73.7720
149	singlet		148.844720	5.0803
150	singlet		149.842509	23.7842
151	no combination			
152	singlet		151.842719	2.5304

It will be observed that the most abundant peak does not occur at the sum of the mass numbers of the predominant germanium isotopes i.e.

$74\text{Ge} + 74\text{Ge} = 148$. Often for combinations of elements which do not have one outstandingly predominant isotope, the integer mass of the most abundant peak does not correspond to the sum of the mass numbers of the predominant isotopes.

A computer programme has been written ⁹⁶ to determine the mass and relative abundances of combinations of up to three different polyisotopic elements. Abundances and masses for Sn_2 , SnGe , Ge_2 , GeSi , SnCl and SnBr combinations, calculated using this programme are given in Appendix 1.

18

Fig. 6

MASS SPECTRA OF Sn_2Et_6 AND Sn_2Ph_6

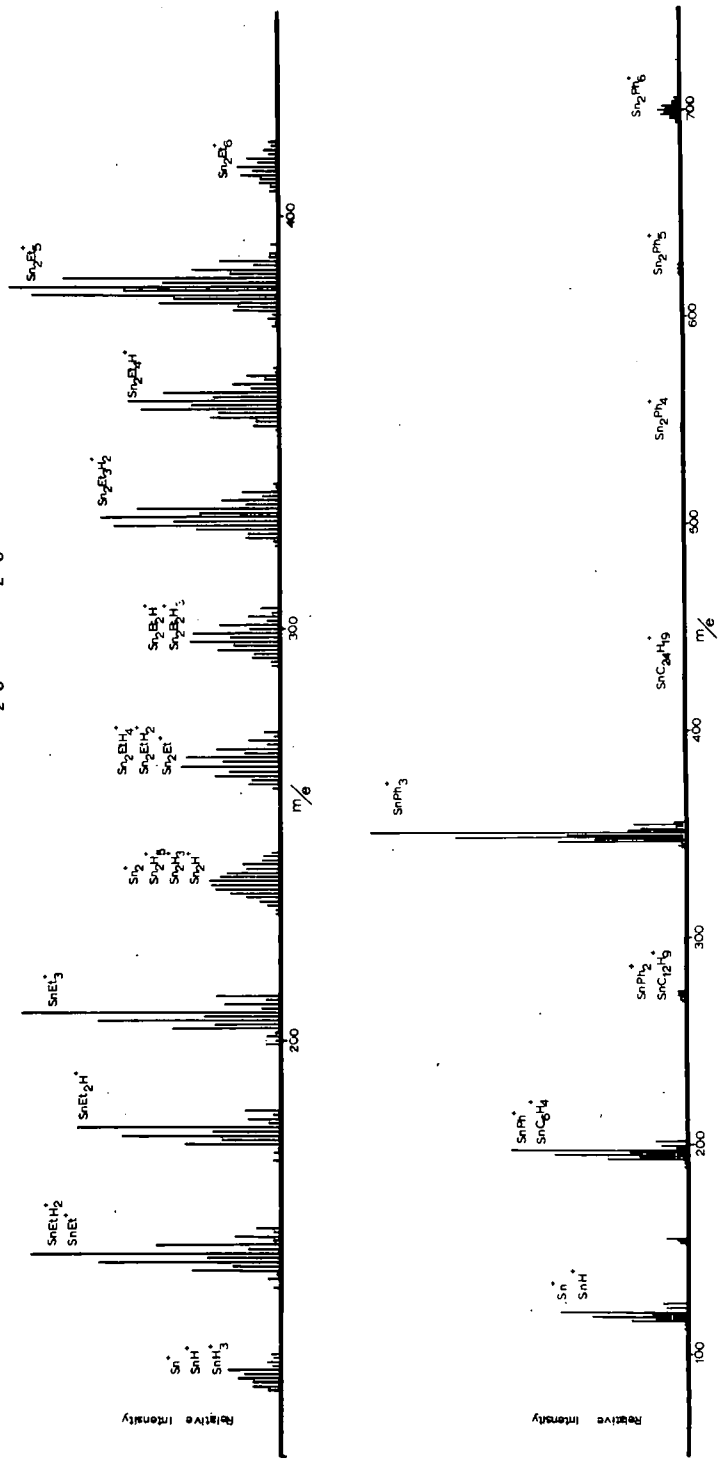

The characteristic patterns produced by ions containing a polyisotopic metal or metals are useful in allowing an immediate recognition of metal-containing ions and the determination of the number of metal atoms in an ion from the low resolution spectrum [see for example the spectrum of hexaethyldistannane and hexaphenyldistannane (Fig. 6)]. However the pattern produced by a major ion often masks the presence of a low abundance ion only a few mass units different. As an example of this consider the group of peaks at $m/e \sim 240$ in the spectrum of hexaethyldistannane where four ion patterns overlap: Sn_2^+ , Sn_2H^+ , Sn_2H_3^+ and Sn_2H_5^+ . Although it is possible to identify overlying ions from the low resolution pattern produced, the identification of ions present in a spectrum is more easily accomplished by measuring the precise masses of ions to 7 significant figures (using a resolving power of 1 part in 20,000).

This identification of overlying ^{ions} by precise mass measurement often poses problems especially in cases where mass differences between two peaks of the same high integer mass are small and barely resolved under high resolving conditions. With hexaethyldistannane the ions $^{240}\text{Sn}_2\text{Et}_2\text{H}_3^+$ and $^{242}\text{Sn}_2\text{Et}_2\text{H}^+$ are only just resolved having a mass difference of 45 p.p.m. For low abundance ions present under a group of peaks recourse must be made to the extremities of the peak pattern where peaks due to the more abundant ion may not be present. Thus Sn_2H_5^+ in the spectrum of Et_6Sn_2 was identified by a precise mass measurement of $^{244}\text{Sn}_2\text{H}_5^+$. With ions containing only one metal atom

similar difficulties sometimes occurred $^{120}\text{SnC}_{18}\text{H}_{19}^+$ and $^{119}\text{SnPh}_4^+$ are unresolved at high resolution differing in mass by only 23 p.p.m. and identification is achieved using the ^{112}Sn and ^{124}Sn isotopes respectively.

With organo-beryllium and - aluminium compounds it is essential to measure precisely the masses of each ion in the spectrum since the monoisotopicity of these metals means that metal-containing ions cannot be distinguished from hydrocarbon ions in the low resolution spectrum.

The empirical formulae of all ions described in this thesis were established by precise mass measurements. The agreement between measured and calculated mass was in all cases better than 6 p.p.m.

3.3. Calculation of Abundances

For ions containing monoisotopic elements abundances are found quite easily from peak heights produced by the ions in the low resolution spectra. Thus if A^+ is of peak height 4 arbitrary units (a.u.), B^+ 3a.u., C^+ 2a.u., and D^+ 1a.u., the abundance of A^+ as a percentage of total ion current is 40%. In comparing the abundances of ions containing polyisotopic elements with other types, contributions from each isotope combination must be summed. For example a spectrum showing three peaks of relative height 2:1:1 due to $^{127}\text{I}^+$, $^{81}\text{Br}^+$, and $^{79}\text{Br}^+$ corresponds to a 1:1 ratio of I^+ to Br^+ . ($^{81}\text{Br} = 49\%$; $^{79}\text{Br} = 51\%$) Similarly in the reported spectrum ⁹⁷ of $(\text{C}_6\text{F}_5)_4\text{Ge}$ although $(\text{C}_6\text{F}_4)_2^+$ is the largest peak, when allowance is made for the presence of germanium isotopes $(\text{C}_6\text{F}_5)_3\text{Ge}^+$ is found to be the most abundant ion.

In calculating the abundances of ions allowance has also been made

for the presence of ^{13}C . The natural abundance of ^{13}C is 1% and for ions containing n carbon atoms $n\%$ of the ions will contain a ^{13}C atom. Thus if the effects of ^{13}C are neglected the abundances of ions containing a large number of carbon atoms will be underestimated.

In the following illustrations of the method of calculation of abundances the following symbols are used:-

i_n	=	peak height due to ions at $m/e = n$
$i_n(\text{A}_w \text{C}_x \text{H}_y \text{M}_z^+)$	=	peak height at $m/e = n$ carried by ion $\text{A}_w \text{C}_x \text{H}_y \text{M}_z^+$
$I(\text{A}_w \text{C}_x \text{H}_y \text{M}_z^+)$	=	the sum of the peak heights of all A and M isotopic variants of the ion of composition $\text{A}_w \text{C}_x \text{H}_y \text{M}_z^+$
$It(\text{A}_w \text{C}_x \text{H}_y \text{M}_z^+)$	=	$I(\text{A}_w \text{C}_x \text{H}_y \text{M}_z^+) + I(\text{A}_w^{13}\text{C}_{x-1} \text{H}_y \text{M}_z^+)$
$i_n [^{13}\text{C}(n-1)]$	=	contribution to peak height at $m/e = n$ for one ^{13}C atom present in ion or ions at $m/e = (n-1)$.
$U(\text{A}_w \text{C}_x \text{H}_y \text{M}_z^+)$	=	abundance of ion $\text{A}_w \text{C}_x \text{H}_y \text{M}_z^+$

For ions including only monoisotopic elements and for hydrocarbon ions it is obvious that

$$i_n(\text{A}_w \text{C}_x \text{H}_y \text{M}_z^+) = I(\text{A}_w \text{C}_x \text{H}_y \text{M}_z^+)$$

For the aluminium and beryllium compounds, where hydrocarbon ions were important, abundances have been calculated using the formula

$$U(\text{A}_w \text{C}_x \text{H}_y \text{M}_z^+) = \frac{It(\text{A}_w \text{C}_x \text{H}_y \text{M}_z^+)}{\sum It(\text{A}_w \text{C}_x \text{H}_y \text{M}_z^+)} \quad - \quad 3.1$$

where the summation in the denominator is carried over all ions. For the metals silicon, germanium, tin and lead hydrocarbon ions generally comprised no more than 5% of the total ion current and abundances have

been found by restricting the summation in the denominator to metal-containing ions only.

Ion currents are measured in arbitrary units (a.u.) which depend on sample pressure in source and on instrument sensitivity of ion detection while the spectrum is being recorded. Abundances on the other hand are dimensionless quantities and are hence not dependant, at least to a first approximation on instrument sensitivity.

When a single peak in a low resolution spectrum was known to include currents of two or more ionic species, the current at this mass number was divided amongst the ion species present in the ratio of the ion currents measured for the species when separated under high resolution (1:20,000).

For example in the spectra of diethylberyllium (70eV, source temp. 196°C) the ions $C_2H_6Be^+$ and $C_3H_3^+$ are present at m/e 39. High resolution measurements show that

$$i_{39}(C_2H_6Be^+) = 8.625 \times i_{39}(C_3H_3^+) \quad 3.2$$

The current carried by ions at m/e = 39 is found from the low resolution spectra as 1.76 a.u.

$$1.76 \text{ a.u.} = i_{39}(^{13}C38) + i_{39}(C_2H_6Be^+) + i_{39}(C_3H_3^+) \quad 3.3$$

$i_{39}(^{13}C38)$ is found from the peak height of m/e 38 which is 8.51 units.

$$\begin{aligned} i_{39}(^{13}C38) &= i_{38} \times \left(\begin{array}{l} ^{13}C \text{ natural abundance} \\ \text{(no. of C atoms in } 38^+ \text{ ions)} \end{array} \right) \\ &= 8.51 \times 0.01 \times 2 = 0.170 \text{ a.u.} \end{aligned}$$

hence from 3.3

$$1.59 \text{ a.u.} = i_{39}(C_2H_6Be^+) + i_{39}(C_3H_3^+) \quad 3.4$$

from equations 3.2 and 3.4 it follows

$$\begin{aligned} i_{39}(\text{C}_3\text{H}_3^+) &= 0.165 \text{ a.u.} = I(\text{C}_3\text{H}_3^+) \\ i_{39}(\text{C}_2\text{H}_6\text{Be}^{++}) &= 1.425 \text{ a.u.} = I(\text{C}_2\text{H}_6\text{Be}^{++}) \end{aligned}$$

The contribution due to the presence of one ^{13}C atom is found as follows:

$$\begin{aligned} It(\text{C}_2\text{H}_6\text{Be}^{++}) &= I(\text{C}_2\text{H}_6\text{Be}^{++}) + I(\text{C}^{13}\text{CH}_6\text{Be}^{++}) \\ &= 1.425 + 1.425 \times 0.01 \times 2 \\ &= 1.454 \text{ a.u.} \end{aligned}$$

$$\begin{aligned} \text{Similarly } It(\text{C}_3\text{H}_3^+) &= I(\text{C}_3\text{H}_3^+) + I(\text{C}_2^{13}\text{CH}_3^+) \\ &= 0.168 \text{ a.u.} \end{aligned}$$

The total ion current for diethylberyllium is 52.681 a.u. from which using 3.1

$$U(\text{C}_2\text{H}_6\text{Be}^{++}) = \frac{1.454 \times 100}{52.681} = 2.76$$

$$U(\text{C}_3\text{H}_3^+) = \frac{0.168 \times 100}{52.681} = 0.32$$

With polyisotopic metals the calculation is similar. In the spectrum of tetraethyltin the peak pattern produced in the region of m/e 150 is due to the overlap of EtSn^+ and EtSnH_2^+ . High resolution mass measurements give

$$i_{151}({}^{122}\text{SnEt}^+) = 0.0995 i_{151}({}^{120}\text{SnEtH}_2^+) \quad 3.5$$

The current carried by ions at m/e 151 is found from the peak height of m/e 151 in the low resolution spectra.

$$3.105 \text{ a.u.} = i_{151}({}^{120}\text{SnEtH}_2^+) + i_{151}({}^{122}\text{SnEt}^+) + i_{151}({}^{13}\text{C}150) - 3.6$$

$i_{151}(^{13}\text{C}150)$ is found from the peak height of m/e 150 which is 0.77 a.u.

$$\begin{aligned} i_{151}(^{13}\text{C}150) &= 0.77 \times 0.01 \times 2 \\ &= 0.01 \text{ a.u.} \end{aligned}$$

hence from equations 3.5 and 3.6

$$i_{151}(^{122}\text{SnEt}^+) = (3.105 - 0.01) 0.0995 = 0.28 \text{ a.u.}$$

$$i_{151}(^{120}\text{SnEtH}_2^+) = (3.105 - 0.01) 0.9005 = 2.815 \text{ a.u.}$$

$I(\text{SnEt}^+)$ and $I(\text{SnEtH}_2^+)$ is then found

$$\begin{aligned} I(\text{SnEt}^+) &= i_{151}(^{122}\text{SnEt}^+) \times \frac{100}{\text{natural abundance of } ^{122}\text{Sn}} \\ &= 0.28 \times \frac{100}{4.91} = 5.945 \text{ a.u.} \end{aligned}$$

$$\text{Similarly } I(\text{SnEtH}_2^+) = 8.540 \text{ a.u.}$$

Adding the contributions for the presence of one ^{13}C atom in these ions gives

$$\begin{aligned} It(\text{SnEt}^+) &= 5.945 + 5.945 \times 0.01 \times 2 \\ &= 6.064 \text{ a.u.} \end{aligned}$$

$$\text{Similarly } It(\text{SnEtH}_2^+) = 8.711 \text{ a.u.}$$

Choosing another set of peaks the values of $It(\text{SnEt}^+)$ and $It(\text{SnEtH}_2^+)$ may be re-evaluated and mean taken. When ion currents of other metal containing ions have been found the abundances of the species are calculated using equation 3.1.

With ions containing 2 or more polyisotopic elements use is made of the calculated probabilities of occurrence of the various isotope combinations. (given in Appendix 1.) Thus if

$$\begin{aligned} i_{351} \left[^{197}(\text{SnBr})\text{Ph}_2^+ \right] &= 9.73 \text{ a.u.} \\ I \left[\text{SnBrPh}_2^+ \right] &= 9.73 \times \frac{100}{\text{probability of occurrence of } ^{197}(\text{SnBr}) \text{ combination}} \\ &= 9.73 \times \frac{100}{67.2} = 14.469 \text{ a.u.} \end{aligned}$$

$$\text{from which } It(\text{SnBrPh}_2^+) = 14.79 \times 1.12 = 16.216 \text{ a.u.}$$

for a complete analysis ⁹⁹.

The values m_1 and m_2 associated with any metastable peak m^* can usually be determined by a process of trial and error, remembering that the apparent mass is smaller than either of the masses of the ions giving rise to the peak and that the peaks at masses m_1 and m_2 will be much larger than the metastable peak. Of great help in this assignment are tables of m^* values that occur for various values of m_1 and m_2 ($m_1 \leq 500$ and $500 \geq m^* \geq 1$)¹⁰⁰.

With polyisotopic elements present in an ion, metastable peaks produced by the decomposition of such an ion eliminating a neutral species consisting of essentially monoisotopic elements (e.g. a hydrocarbon) must follow the peak pattern of the daughter and parent ions. For example 7a) and b) show metastable peaks for decomposition of $\text{Sn}_2\text{C}_x\text{H}_y^+$ and SnC_xH_y^+ ions respectively. When a polyisotopic element is lost as a neutral fragment, the ion formed will have a different peak pattern from its precursor. The resulting metastable peaks may merge because of their diffuse nature producing a single broad metastable peak. Examples of such are shown in fig.7c) and d). Fig.7e) shows the approximate metastable peak envelope for the decomposition

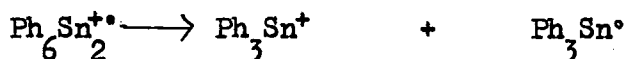

This has been calculated by considering all the possible decompositions for $\text{Ph}_6\text{Sn}_2^{+*}$ ions containing the abundant tin isotopes.

Fig. 7.

Metastable Peaks

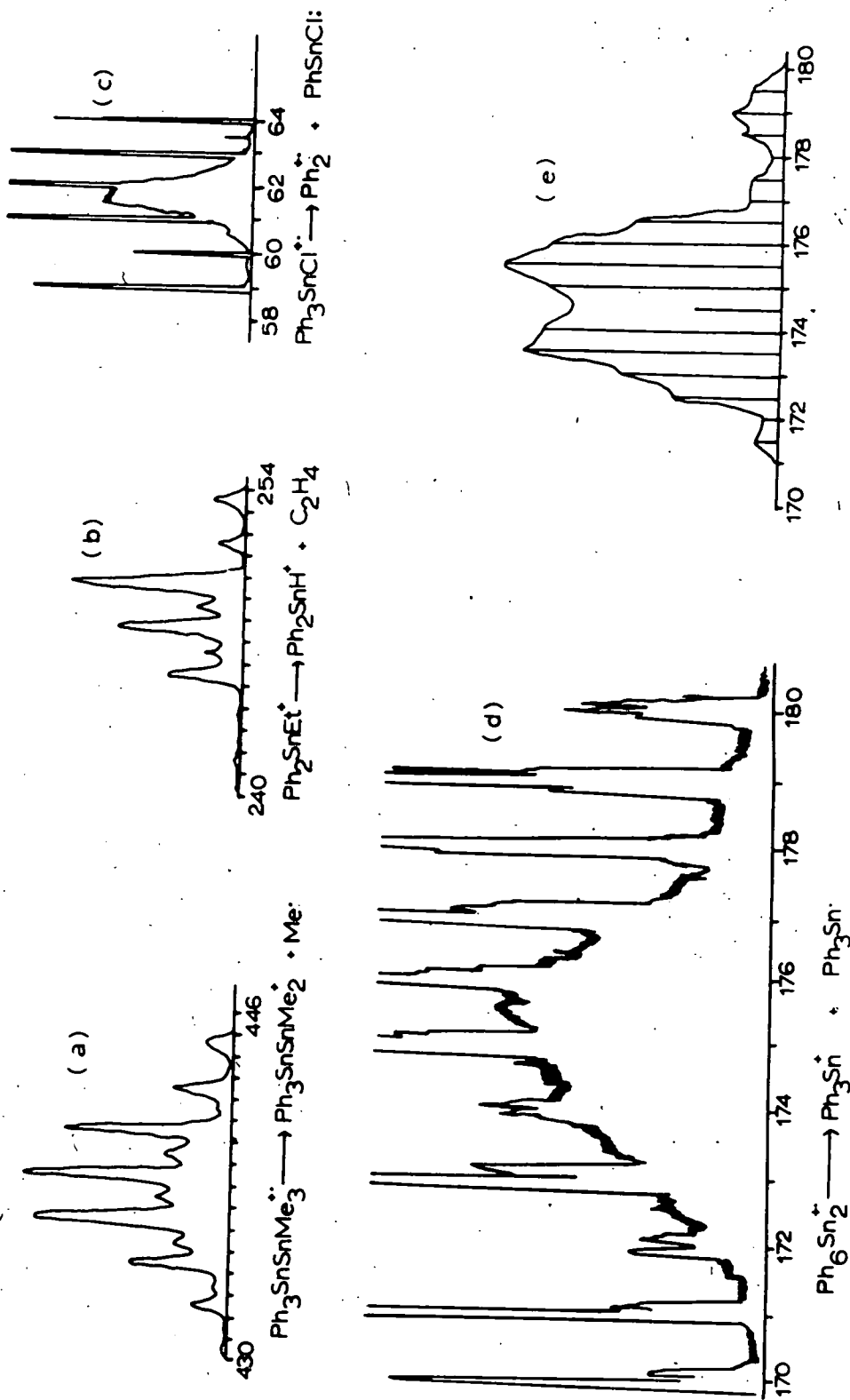

Metastable peaks for $\text{Ph}_3\text{Sn} \cdot \text{SnPh}_3^{m^*} \rightarrow \text{Ph}_3\text{Sn}^+ + \text{Ph}_3\text{Sn}^{\cdot}$

Tin isotopes in $\text{Ph}_3\text{Sn} \cdot \text{SnPh}_3^{m^*} (m_1^+)$	Tin isotope in $\text{Ph}_3\text{Sn}^+ (m_2^+)$	$\left(= \frac{m_2^*}{m_1} \right)$	abundance of m^*	
116	116	116	173.5	1
		116	173.5	1
116	117	116	173.25	1
		117	174.25	1
116	118	116	173.0	3.5
		118	175.0	3.5
117	118	117	173.7	2
		118	174.7	2
116	119	116	172.8	1
		119	175.8	1
118	118	118	173.5	3
		118	173.5	3
116	120	116	172.5	4.5
		120	176.5	4.5
117	119	117	173.5	0.5
		119	175.5	0.5
117	120	117	173.3	2.5
		120	176.3	2.5
118	119	118	174.3	2
		119	175.3	2
118	120	118	174	8
		120	176	8
116	122	116	172	0.5
		122	178	0.5
119	119	119	175	0.5
		119	175	0.5
119	120	119	174.8	3
		120	175.8	3
117	122	117	172.8	0.5
		122	178.8	0.5
120	120	120	175.5	5.5
		120	175.5	5.5
118	122	118	173.5	1
		122	177.5	1
116	124	116	171.5	1
		124	179.5	1
119	122	119	173.5	0.5
		122	177.3	0.5
117	124	117	172.3	0.5
		124	179.3	0.5
120	122	120	175	1.5
		122	177	1.5
118	124	118	173	1.5
		124	179	1.5

119	124	119	173.8	0.5
		124	178.8	0.5
120	124	120	174.5	2
		124	178.5	2

The relative abundance of the metastable peak produced is found from the relative abundance of the isotope combination of the "parent" m_1^+ ion. For example the relative abundance of the $^{116}\text{Sn}^{118}\text{Sn}$ combination is 7 and hence the relative abundance of the metastable peak formed by decomposition of $\text{Ph}_3^{116}\text{Sn}^{118}\text{SnPh}_3^+$ to $\text{Ph}_3^{118}\text{Sn}^+$ or $\text{Ph}_3^{116}\text{Sn}^+$ is 3.5. The m/e values at which the various metastable peaks occur were rounded off to the nearest 0.5 and plotted against relative abundance as shown in fig. 7e). The approximate metastable peak envelope was then drawn bearing in mind the gaussian shape of metastable peaks.

It will be apparent that the shape of the metastable peak for a decomposition

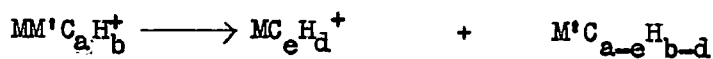

depends on the polyisotopic nature of M and M'.

4. RESULTS AND DISCUSSION.
- 4.1 Appearance Potentials and Derivation of Bond Dissociation Energies and Heats of Formation.
- 4.2 Mass Spectra of Organocompounds of Silicon, Germanium, Tin and Lead.
- 4.3 Mass Spectra of Beryllium Dialkyls.
- 4.4 Mass Spectra of Organoaluminium Compounds.

Table 4.1.1.

Comparison of measured ionization potentials (I.P.s) with literature values.

	Standard used	Individual determinations eV.		Measured I.P. eV.	Literature values for I.P. eV. ³
		Warren method	Semi-log method		
Argon	Krypton I.P. = 14.00eV	15.80	15.76	15.77 ±.01	15.755 spectroscopic
		15.80	15.74		
		15.76	15.78		
Benzene	Krypton	9.50	9.56	9.53 ±.01	9.52 ±.10 9.38 ±.10 electron-impact 9.247 spectroscopic 9.245 photo-ionization
		9.50	9.52		
		9.52			
Nitrogen	Argon I.P. = 15.76eV	15.60	15.60	15.60 ±.01	15.60 ±.01 electron impact 15.58 ±.02 spectroscopic
		15.58	15.60		
		15.64			

Source temperature 185 - 195°C

Ion repeller voltage 0.4 - 2.0 volts.

4. RESULTS AND DISCUSSION

4.1 Appearance Potentials and Derivation of Bond Dissociation Energies and Heats of Formation.

4.1.1. Accuracy of Appearance Potential Measurements.

To test the accuracy of the appearance potential measurements, ionization potentials of argon, nitrogen and benzene were measured using the logarithmic and Warren method. Different sets of experimental data were used for each method of calculation. The results of these measurements together with published values of the ionization potentials are presented in table 4.1.1.

The values obtained for argon and nitrogen agree well with the values obtained by other workers and it is apparent in this case that the adiabatic and vertical ionization potential are one and the same. With benzene the measured ionization potential agrees well with the values found by other workers using electron impact methods but is some 0.28eV higher than values obtained by photo ionization or spectroscopic methods.

Both methods of evaluation hence give good estimations of vertical ionization potentials.

4.1.2. Appearance Potentials and Bond Dissociation Energies for Organotin Compounds.

i) Appearance Potentials

Since R_3Sn^+ ions from mono-metallic compounds give similar ionization efficiency curves and under this condition the most accurate determinations of appearance potentials are obtained 101,

and Ph_3Sn^+ from $\text{Ph}_3\text{Sn}^+\text{GeMe}_3$

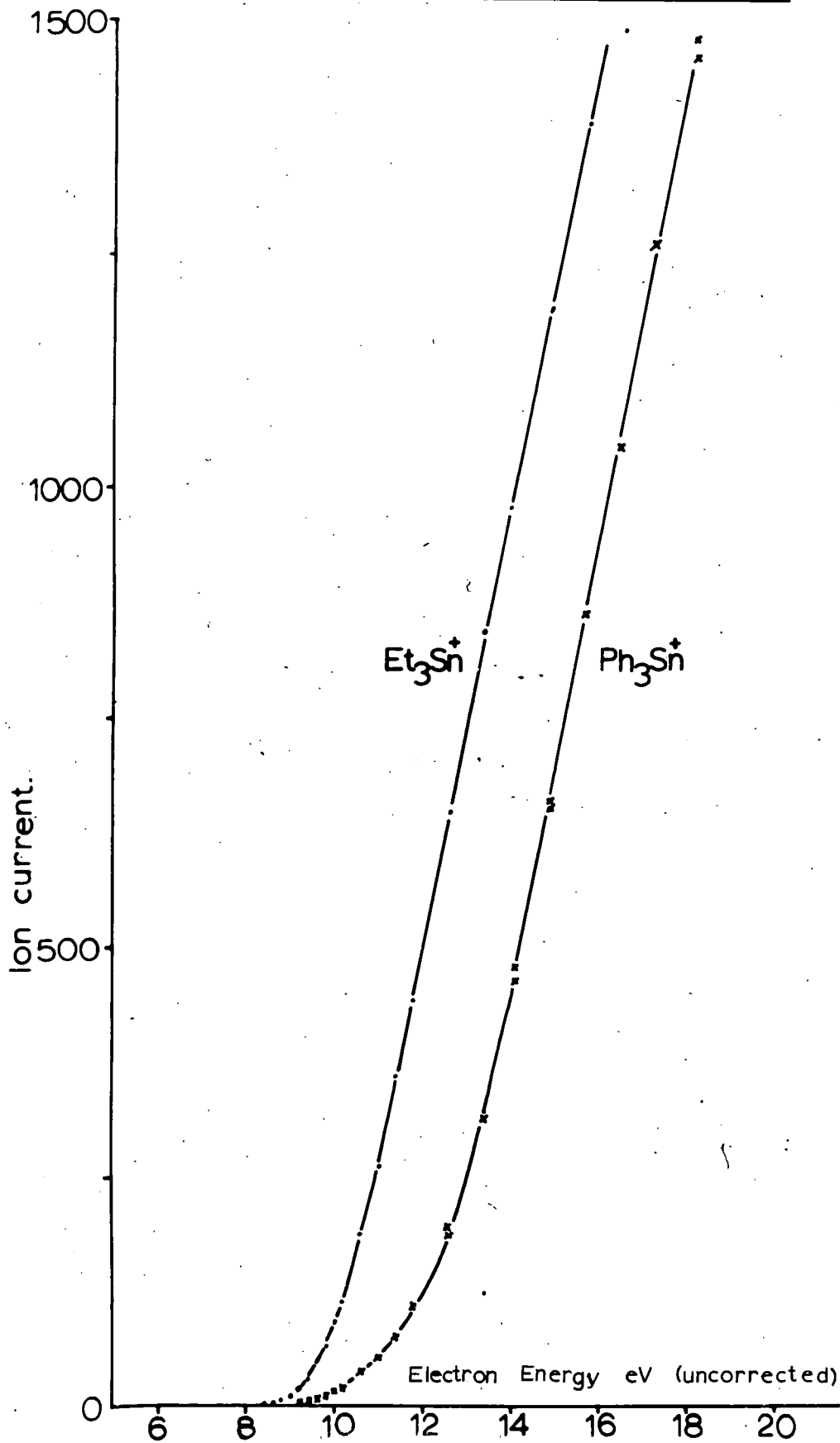

Et_3Sn^+ from Et_4Sn was used as standard except for PhSnEt_3 which produced this ion in its mass spectrum. For this compound Ph_3Sn^+ from triphenylethyl - or tetraphenyl-tin was used. The relationship between $A(\text{Ph}_3\text{Sn}^+)\text{Ph}_3\text{SnR} - A(\text{PhSnEt}_2^+)\text{PhSnEt}_3$ then enabled $A(\text{Et}_3\text{Sn}^+)\text{Et}_4\text{Sn} - A(\text{PhSnEt}_2^+)\text{PhSnEt}_3$ to be found.

The ionization efficiency curve for a typical R_3Sn^+ ion is shown in fig. 5 (p. 56) "Tailing" of the ionization efficiency curves often associated with excess energy was observed only for Ph_3Sn^+ ions derived from $\text{Ph}_3\text{Sn}\cdot\text{SnPh}_3$, $\text{Ph}_3\text{Sn}\cdot\text{SnMe}_3$ and $\text{Ph}_3\text{Sn}\cdot\text{GeMe}_3$. The extent of this tailing is shown in fig. 8. where the ionization efficiency curve for Ph_3Sn^+ derived from $\text{Ph}_3\text{Sn}\cdot\text{GeMe}_3$ is shown. A similar long tail has been observed with the ionization efficiency curve of Me_3Si^+ obtained from hexamethyldisilane. 62

The appearance potentials of R_3Sn^+ and $\text{R}_4\text{Sn}^{+\cdot}$ ions relative to that of Et_3Sn^+ from tetraethyltin are shown in tables 4.1.2. and 4.1.3. Separate sets of experimental data were used for each method of calculation.

$A(\text{Et}_3\text{Sn}^+)\text{Et}_3\text{SnPh}$ was not measured since this ion was of too low abundance.

The reproducibility of the measurements is good, the standard error of the mean being always less than $\pm 0.05\text{eV}$ and generally $< 0.03\text{eV}$. In calculating dissociation energy differences an error of twice the maximum observed standard error of the mean has been used (i.e. $\pm 0.10\text{eV}$)

Table 4.1.2.

Appearance potentials of R_3Sn^+ ions.

		A(Et_3Sn^+) Et_4Sn - A(R_3Sn^+) eV		
	R_3Sn^+	Warren method	Semi-log method	Mean
PhSnEt ₃	PhSnEt ₂ ⁺	0.17	0.14	0.19 ± .02
		0.21	0.22	
Ph ₂ SnEt ₂	PhSnEt ₂ ⁺	0.17	0.13	0.15 ± .01
		0.17	0.14	
	Ph ₂ SnEt ⁺	0.12	0.13	0.14 ± .01
		0.15	0.14	
Ph ₃ SnEt	Ph ₂ SnEt ⁺	-0.31	-0.30	-0.27 ± .02
		-0.21	-0.27	
	Ph ₃ Sn ⁺	0.15	0.17	0.13 ± .02
Ph ₄ Sn	Ph ₃ Sn ⁺	0.15	0.05	-0.90 ± .01
		-0.90	-0.90	
		-0.88	-0.92	
Ph ₃ SnI	Ph ₃ Sn ⁺	0.10	0.05	0.10 ± .02
		0.10	0.15	
Ph ₃ SnMe	Ph ₃ Sn ⁺	0.0	0.02	0.04 ± .01
		0.01	0.03	
		0.06	0.06	
		0.05	0.08	
Ph ₃ Sn•SPh	Ph ₃ Sn ⁺	-0.40	-0.30	- 0.31 ± .03
		-0.35	-0.23	
			-0.28	
Ph ₃ Sn•SnPh ₃	Ph ₃ Sn ⁺	-0.02	-0.07	- 0.03 ± .02
		-0.08	-0.10	
		-0.10	+0.04	
			+0.13	
Ph ₃ Sn•GeMe ₃	Ph ₃ Sn ⁺	-0.40	-0.29	- 0.38 ± .05
		-0.33	-0.48	
Ph ₃ Sn•SnMe ₃	Ph ₃ Sn ⁺	-0.36	-0.28	- 0.24 ± .03
		-0.27	-0.17	
			-0.17	
		-0.18	-0.20	

Source temperature 195 - 210°C

Ion repeller voltage 0.4 - 2.0 volts

Table 4.1.3.

Ionization Potential (I.P.) of Et_4Sn and Ph_2SnEt_2

$A(\text{Et}_3\text{Sn}^+)\text{Et}_4\text{Sn} - \text{I.P. eV}$

	Warren	Semi-log	Mean
Et_4Sn	0.58 0.60	0.63 0.59	$0.60 \pm .01$
Ph_2SnEt_2	0.57 0.49	0.62 0.54	$0.56 \pm .03$

Source temperature 200°C

Ion repeller voltage 0.4 - 2.0 volts.

ii) Bond Dissociation Energy Differences.

These have been derived using:

$$A(\text{R}_3\text{Sn}^+)\text{R}_3\text{SnR} = I(\text{R}_3\text{Sn}^\bullet) + D(\text{R}_3\text{Sn-R}) + E \quad 4.1$$

where $I(\text{R}_3\text{Sn}^\bullet) =$ Ionization potential of $\text{R}_3\text{Sn}^\bullet$

$D(\text{R}_3\text{Sn-R}) =$ dissociation energy of bond $\text{R}_3\text{Sn} - \text{R}$

$E =$ excess energy associated with R_3Sn^+ and R^\bullet

In all calculations E has been taken as zero. By Stevenson's rule ⁵⁹ this will probably be a correct assumption provided

$I(\text{R}_3\text{Sn}^\bullet) < I(\text{R}^\bullet)$. The low abundance of R^+ compared to R_3Sn^+ is consistent with this and as mentioned earlier tailing of the ionization efficiency curve was observed only with metal-metal bonded compounds. For $\text{Ph}_3\text{Sn}^\bullet$ it can be shown that $I(\text{Ph}_3\text{Sn}^\bullet) < I(\text{R}^\bullet)$ (p. 89). It must be emphasised however that possession of the lower ionization potential together with a simple appearance potential curve does not ensure the absence of excess energy so that calculated bond dissociation energies must be regarded as upper limits.

Bond dissociation energy differences are calculated directly from the differences in appearance potentials of the same ions produced from different compounds. Thus using eqn. 4.1 assuming $E = 0$

$$A(\text{Ph}_3\text{Sn}^+)\text{Ph}_4\text{Sn} = I(\text{Ph}_3\text{Sn}^\bullet) + D(\text{Ph}_3\text{Sn} - \text{Ph})$$

$$A(\text{Ph}_3\text{Sn}^+)\text{Ph}_3\text{SnR} = I(\text{Ph}_3\text{Sn}^\bullet) + D(\text{Ph}_3\text{Sn} - \text{R})$$

and by subtraction

$$A(\text{Ph}_3\text{Sn}^+)\text{Ph}_4\text{Sn} - A(\text{Ph}_3\text{Sn}^+)\text{Ph}_3\text{SnR} = D(\text{Ph}_3\text{Sn-Ph}) - D(\text{Ph}_3\text{Sn-R})$$

Even though appearance potentials are known only relative to

$A(\text{SnEt}_3^+)\text{Et}_4\text{Sn}$ appearance potential differences may still be found.

RESEARCH REPORT

1. Introduction
2. Methodology

3. Results
4. Discussion

5. Conclusion
6. References

7. Appendix
8. Acknowledgements

Table 4.1.4.

Bond energy data.

Bond dissociation energy differences (Kcal. mole⁻¹)

Tolerance = ± 3.2 Kcal. mole⁻¹.

$$D(\text{Ph}_3\text{Sn} - \text{Ph}) - D(\text{Ph}_3\text{Sn} - \text{Et}) = 23.8$$

$$D(\text{Ph}_2\text{EtSn} - \text{Ph}) - D(\text{Ph}_2\text{EtSn} - \text{Et}) = 10.4$$

$$D(\text{PhEt}_2\text{Sn} - \text{Ph}) - D(\text{PhEt}_2\text{Sn} - \text{Et}) = 1.2$$

Values of the difference (Δ) $D(\text{Ph}_3\text{Sn} - \text{Ph}) - D(\text{Ph}_3\text{Sn} - \text{R})$

where:-

R	Δ
GeMe ₃	12.0
SPh	13.6
SnMe ₃	15.2
SnPh ₃	20.1
Me	21.7
I	23.1
Et	23.8

Dissociation energies in molecular ions Kcal.mole⁻¹

$$D(\text{Et}_3\text{Sn}^+ - \text{Et}) = 13.9 \pm 2.3$$

$$D(\text{Ph}_2\text{EtSn}^+ - \text{Et}) = 9.7 \pm 3.2$$

$$D(\text{Ph}_2\text{EtSn}^+ - \text{Ph}) = 9.5 \pm 3.2$$

Thus

$$A(\text{Et}_3\text{Sn}^+)\text{Et}_4\text{Sn} - A(\text{Ph}_3\text{Sn}^+)\text{Ph}_3\text{SnEt} = 0.13\text{eV}$$

$$A(\text{Et}_3\text{Sn}^+)\text{Et}_4\text{Sn} - A(\text{Ph}_3\text{Sn}^+)\text{Ph}_4\text{Sn} = -.90\text{eV}$$

which by subtraction gives:

$$A(\text{Ph}_3\text{Sn}^+)\text{Ph}_4\text{Sn} - A(\text{Ph}_3\text{Sn}^+)\text{Ph}_3\text{SnEt} = 1.03\text{eV}$$

which is also $D(\text{Ph}_3\text{Sn} - \text{Ph}) - D(\text{Ph}_3\text{Sn} - \text{Et})$.

In this way the bond dissociation energies differences shown in table 4.1.4. were calculated.

The decrease in the difference in the energies of dissociation $D(\text{Et}_n\text{Ph}_{3-n}\text{Sn} - \text{Ph}) - D(\text{Et}_n\text{Ph}_{3-n}\text{Sn} - \text{Et})$ as n increases from 0 to 2 emphasises the well known unacceptability of the simple model of constant, transferable and additive bond energy terms. A similar variation occurs with methylphenyl tin compounds.

$$D(\text{Me}_3\text{Sn} - \text{Ph}) - D(\text{Me}_3\text{Sn} - \text{Me})^{64} = 8 \pm 6 \text{ Kcal. mole}^{-1}$$

$$\text{and } D(\text{Ph}_3\text{Sn} - \text{Ph}) - D(\text{Ph}_3\text{Sn} - \text{Me}) = 22 \pm 3 \text{ Kcal. mole}^{-1}$$

This may indicate a general rule that the energy difference in removing an alkyl or phenyl group from gaseous $(\text{alkyl})_n\text{SnPh}_{4-n}$ becomes less with increasing alkyl content.

The bond dissociation energies in table 4.1.4. have been extremely useful (see page 105) in interpreting the nature of the mass spectra of these organometallic compounds.

iii) Bond Dissociation Energies in Molecular Ions.

These were obtained using the relationship

$$A(\text{R}_3\text{Sn}^+)\text{R}_4\text{Sn} = I(\text{R}_4\text{Sn}) + D(\text{R}_3\text{Sn}^+ - \text{R})$$

assuming the excess energy associated with the formation of $\text{R}\cdot$ and R_3Sn^+

1. 2. 3. 4. 5.

6. 7. 8. 9. 10.

11. 12. 13. 14. 15. 16. 17. 18. 19. 20.

21. 22. 23. 24. 25. 26. 27. 28. 29. 30.

31. 32. 33. 34. 35. 36. 37. 38. 39. 40.

41. 42. 43. 44. 45. 46. 47. 48. 49. 50.

51. 52. 53. 54. 55. 56. 57. 58. 59. 60.

61. 62. 63. 64. 65. 66. 67. 68. 69. 70.

71. 72. 73. 74. 75. 76. 77. 78. 79. 80.

81. 82. 83. 84. 85. 86. 87. 88. 89. 90.

91. 92. 93. 94. 95. 96. 97. 98. 99. 100.

Table 4.1.5.

Appearance potential of Et_3Sn^+ derived from Et_4Sn (eV)

	Warren	Semi-log	Mean
$A(\text{Et}_3\text{Sn}^+)\text{Et}_4\text{Sn}$	8.66	8.48	8.70 ± 0.09
	8.93	8.73	

Source temperature 195°C Standard used Xe I.P. = 12.13eV.

Appearance potentials of Ph_3Sn^+ ions and heats of formation of triphenyltin compounds.

	$A(\text{SnPh}_3^+)$ eV ($\pm .2\text{eV}$)	$\Delta H_f^\circ (\text{SnPh}_3\text{R})_g$ Kcal. mole ⁻¹
Ph_4Sn	9.6	114 ± 1 103
Ph_3SnEt	8.6	91 ± 7
Ph_3SnI	8.6	91 ± 7
Ph_3SnMe	8.7	97 ± 7
$\text{Ph}_3\text{Sn}\cdot\text{SPh}$	9.0	103
$\text{Ph}_3\text{Sn}\cdot\text{GeMe}_3$	9.1	-
$\text{Ph}_3\text{Sn}\cdot\text{SnMe}_3$	8.9	92 ± 8
$\text{Ph}_3\text{Sn}\cdot\text{SnPh}_3$	8.7	-

to be negligible. Again appearance potentials measured relative to $A(\text{Et}_3\text{Sn}^+)\text{Et}_4\text{Sn}$ yield values for these energies viz:

$$A(\text{SnEt}_3^+)\text{Et}_4\text{Sn} = I(\text{Et}_4\text{Sn}) + D(\text{Et}_3\text{Sn}^+ - \text{Et})$$

Since $A(\text{SnEt}_3^+)\text{Et}_4\text{Sn} - I(\text{Et}_4\text{Sn}) = 0.6\text{eV}$ (table 4.1.3. p. 77)

It follows that

$$D(\text{Et}_3\text{Sn}^+ - \text{Et}) = 0.6\text{eV}$$

Similarly $D(\text{Ph}_2\text{EtSn}^+ - \text{Et})$ and $D(\text{PhEt}_2\text{Sn}^+ - \text{Ph})$ were evaluated the results being displayed in Table 4.1.4. Other dissociation energies in parent ions were not measured, because in these cases the parent ion was of such low abundance that the appearance potential could not be measured. The low Sn - C bond energies in $\text{R}_4\text{Sn}^{+\bullet}$ ions compared with those in the molecule (see Table 4.1.6.) are consistent with a bonding electron being removed from an Sn - C bond.

iv) Heats of Formation of Triphenyltin Compounds.

To determine heats of formation the absolute values of appearance potentials are required. Thus $A(\text{Et}_3\text{Sn}^+)\text{Et}_4\text{Sn}$ was measured using xenon as standard $I(\text{Xe}^\bullet) = 12.13\text{eV}$ ¹⁰² giving the result shown in Table 4.1.5.

In the determination of heats of formation an error of $\pm 0.2\text{eV}$ which is twice the standard error of the mean has been assumed. Using this value of $A(\text{Et}_3\text{Sn}^+)\text{Et}_4\text{Sn}$ ($8.7 \pm 0.2\text{eV}$) appearance potentials of Ph_3Sn^+ ions were derived using Table 4.1.2. and are shown in Table 4.1.5.

Heats of formation have been calculated assuming the occurrence of a simple dissociative process involving no excess energy:-

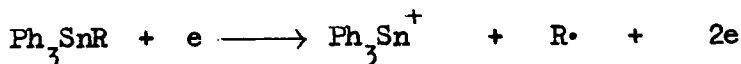

It follows that

$$A(\text{Ph}_3\text{Sn}^+)\text{Ph}_3\text{SnR} = \Delta H_f^\circ(\text{Ph}_3\text{Sn}^+) + \Delta H_f^\circ(\text{R}\cdot) - \Delta H_f^\circ(\text{Ph}_3\text{SnR})_g$$

from which

$$\Delta H_f^\circ(\text{Ph}_3\text{SnR})_g = \Delta H_f^\circ(\text{Ph}_3\text{Sn}^+) + \Delta H_f^\circ(\text{R}\cdot) - A(\text{Ph}_3\text{Sn}^+)\text{Ph}_3\text{SnR} - 4.2$$

First $\Delta H_f^\circ(\text{Ph}_3\text{Sn}^+)$ must be evaluated from a calorimetric estimation of $\Delta H_f^\circ(\text{Ph}_4\text{Sn})$ gaseous ($114.3 \pm 1 \text{ Kcal. mole.}^{-1}$)¹⁰³, $A(\text{Ph}_3\text{Sn}^+)$ and $\Delta H_f^\circ(\text{Ph}\cdot)$ gaseous ($72 \pm 2 \text{ Kcal. mole.}^{-1}$)¹⁰⁴. This quantity ($263 \pm 5 \text{ Kcal. mole.}^{-1}$) combined with the appropriate appearance potential and standard radical (gaseous) heats of formation ($\text{CH}_3\cdot$ 34 ± 1 ¹⁰⁴; $\text{C}_2\text{H}_5\cdot$ 26 ± 1 ¹⁰⁴; $\text{PhS}\cdot$ 50 ¹⁰⁴; $\text{Me}_3\text{Sn}\cdot$ 35 ± 4 ⁶⁴; $\text{I}\cdot$ 25.54 ± 0.01 ¹⁰² Kcal. mole.^{-1}) gives the standard heats of formation for triphenyltin compounds shown in table 4.1.5.

v) Ph₃Sn - R Bond Dissociation Energies.

For absolute evaluation of these dissociation energies the ionization potential of $\text{Ph}_3\text{Sn}\cdot$ is required. Since it is possible to evaluate this quantity from the appearance potential measurements provided $\Delta H_f^\circ(\text{Ph}_6\text{Sn}_2)$ (gaseous) is known⁶⁴ a calculation of this quantity using the Franklin group parameter method¹⁰⁵ was attempted.

It was shown for hydrocarbons that ΔH_f° was an additive function of the groups making up the molecule and ΔH_f° values for many characteristic hydrocarbon groups were calculated from known heats of formation for various hydrocarbons. Unmeasured heats of formation could then be estimated by the addition of these group values although for highly branched molecules correction factors had to be applied.

The ΔH_f° group value for tetravalent tin can be found from the standard heats of formation of gaseous organotin compounds using:

$$\Delta H_f^\circ (R_4Sn)_g = 4 \times G(R\cdot) + G(Sn\cdot)$$

where $G(R\cdot)$ is the ΔH_f° group value for R.

$G(Sn)$ is the ΔH_f° group value for tetravalent Sn.

Using ΔH_f° group values for R \cdot given by Franklin ¹⁰⁵ [In Kcal.mole⁻¹ at 298°K $G(CH_3\cdot) = -10.1$; $G(-CH_2-) = -4.9$; $G(-CH:CH_2) = 15.00$; $G(C_6H_5\cdot) = 22.1$] and the calorimetrically determined standard heats of formation for nine R₄Sn compounds ¹⁰⁶, $G(Sn)$ is evaluated at 298°K as 38 ± 3 Kcal. mole⁻¹.

Using this group value the following heats of formation were estimated at 298°K. $\Delta H_f^\circ (Ph_3SnEt)_g = 89 \pm 3$ Kcal. mole⁻¹ and $\Delta H_f^\circ (Ph_3SnMe)_g = 94 \pm 3$ Kcal. mole⁻¹. which agree with the experimentally determined values in table 4.1.5. [i.e. $\Delta H_f^\circ (Ph_3SnEt)_g = 91 \pm 7$; $\Delta H_f^\circ (Ph_3SnMe)_g = 97 \pm 7$ Kcal. mole⁻¹.]

Because a correction factor may apply to compounds containing a tin-tin bond calculated heats of formation of such compounds (obtained using the above ΔH_f° group values) were compared with experimentally determined values.

	Calculated Kcal. mole ⁻¹ .	Measured Kcal. mole ⁻¹ .	Difference Kcal. mole ⁻¹ .
$\Delta H_f^\circ (Me_6Sn_2)_g$	15 ± 6	-7.6 ± 2 ¹⁰⁶	22.6
$\Delta H_f^\circ (Et_6Sn_2)_g$	-13 ± 6	-37 ± 3 ¹⁰⁶	24
$\Delta H_f^\circ (Ph_3Sn\cdot SnMe_3)_g$	112 ± 6	92 ± 8	20

From these it follows that 22 Kcal. mole⁻¹. should be subtracted from the calculated heat of formation for a ditin compound. $\Delta H_f^\circ (Ph_6Sn_2)_g$ was thus estimated as 186 ± 6 Kcal. mole⁻¹.

From equation 4.2 it follows that:-

Table 4.1.6.

Bond dissociation energies.

R	Kcal. mole ⁻¹ .		
	D(Ph ₃ Sn - R) This work	D(Me ₃ Sn -R) Ref. 64.	D(Me ₃ Si - R) Ref. 63.
Ph	83 ± 10	81 ± 5	
Et	60 ± 10	68 ± 4	
T	60 ± 10	80 ± 4	69 ± 2
Me	62 ± 10	73 ± 4	76 ± 2
SPh	69 ± 10		
GeMe ₃	71 ± 10		
SnMe ₃	67 ± 10	76.0	
SnPh ₃	62 ± 10		
SiMe ₃			67 ± 2

$$\begin{aligned}\Delta H_f^\circ (\text{Ph}_3\text{Sn}^\bullet) &= \Delta H_f^\circ (\text{Ph}_6\text{Sn}_2) + A(\text{Ph}_3\text{Sn}^+)\text{Ph}_6\text{Sn}_2 - \Delta H_f^\circ (\text{Ph}_3\text{Sn}^+) \\ &= 124 \pm 9 \text{ Kcal. mole}^{-1}.\end{aligned}$$

The ionization potential of the triphenylstannyl radical is hence:-

$$\begin{aligned}I(\text{Ph}_3\text{Sn}^\bullet) &= \Delta H_f^\circ (\text{Ph}_3\text{Sn}^+) - \Delta H_f^\circ (\text{Ph}_3\text{Sn}^\bullet) \\ &= 139 \pm 10 \text{ Kcal. mole}^{-1}. \\ &= 6.0 \pm 0.4 \text{ eV.}\end{aligned}$$

Values for $D(\text{Ph}_3\text{Sn} - \text{R})$ determined from this ionization potential and $A(\text{Ph}_3\text{Sn}^+)\text{Ph}_3\text{SnR}$ (using eqn. 4.1) are given in table 4.1.6.

$\bar{D}(\text{Sn-Ph})$ has been calculated as $61.4 \pm 2 \text{ Kcal. mole}^{-1}$ from $\Delta H_f^\circ (\text{Ph}_4\text{Sn})\text{g.}$ ¹⁰³ using the relationship

$$\bar{D}(\text{Sn-Ph}) = \frac{1}{4}\Delta H_f^\circ (\text{Sn})\text{g.} + \Delta H_f^\circ (\text{Ph}) - \frac{1}{4}\Delta H_f^\circ (\text{Ph}_4\text{Sn})\text{g.}$$

giving $D(\text{Ph}_3\text{Sn-Ph}) = \bar{D}(\text{Sn-Ph}) + 22 \pm 10 \text{ Kcal. mole}^{-1}$. A similar

relationship has also been found with tetramethyltin where

$$D(\text{Me}_3\text{Sn-Me}) = \bar{D}(\text{Sn-Me}) + 21 \pm 4 \text{ Kcal. mole}^{-1}.$$
⁶⁴ Thus it appears that

one should not attempt to approximate a bond dissociation energy with a mean bond dissociation energy for organotin compounds. With silicon the picture is somewhat confusing. $D(\text{Me}_3\text{Si-Me})$ is about the same as the value $\sim 77 \text{ Kcal. mole}^{-1}$. for $\bar{D}(\text{Si-Me})$ calculated from $\Delta H_f^\circ = (\text{Me}_4\text{Si})\text{g.}$ ¹⁰⁷ and

$\Delta H_f^\circ (\text{Si})\text{g.}$ ¹⁰². But with alkylsilanes $D(\text{H}_3\text{Si-R})$ are higher than mean

$\bar{D}(\text{Si-R})$ values calculated assuming that the values for $\bar{D}(\text{C-H})$ and

$\bar{D}(\text{Si-H})$ determined for CH_4 and SiH_4 can be carried over to RSiH_3 compounds.¹⁰⁸

Even though $\bar{D}(\text{M-C})$ values for group IVb organometallic compounds increase steadily from lead to carbon,¹⁰⁶ $D(\text{Me}_3\text{Si} - \text{Me})$ is only slightly larger than $D(\text{Me}_3\text{Sn} - \text{Me})$ and $D(\text{Ph}_3\text{Sn} - \text{Me})$. Surprisingly the metal-metal bond strength in hexamethyldisilane is equal or even weaker than the

tin-tin bond in ditin compounds.

Comparison of $D(\text{Me}_3\text{Sn} - \text{R})$ and $D(\text{Ph}_3\text{Sn} - \text{R})$ shows that the strengths of tin-alkyl, tin-phenyl and tin-tin bonds are very similar for the two sets of compounds. The tin-iodine bond however is far weaker in the triphenyltin iodide and this is difficult to explain.

$p\pi - d\pi$ interaction between silicon and halogen atoms has been invoked to explain the variation of $D(\text{Me}_3\text{Si} - \text{X})$ from $\text{X} = \text{Cl}$ to $\text{X} = \text{I}$, this interaction being greatest for iodine¹⁰⁹. If such interaction occurs for tin it may be that with Ph_3SnI the π - electron cloud of the phenyl groups interact with d - orbitals of tin and prevent any $p\pi - d\pi$ interaction between tin and iodine so producing a weaker $\text{Sn} - \text{I}$ bond than found in $\text{Me}_3\text{Sn} - \text{I}$. Alternatively there may be steric interaction between iodine atoms and the bulky phenyl groups.

It is interesting to compare the ionization potentials of Group IVb $\text{R}_3\text{M}^\bullet$ radicals and Me_4M molecules.

	C	Si	Ge	Sn	Pb
Me_4M	10.29eV^{102}	$9.8 \pm .15\text{eV}^{111}$	$9.2 \pm .2\text{eV}^{111}$	$8.25 \pm .15\text{eV}^{111}$	$8.00 \pm .4\text{eV}^{111}$
$\text{Me}_3\text{M}^\bullet$	7.42eV^{102}	7.1eV^{63}	-	6.54eV^{64}	-
$\text{Ph}_3\text{M}^\bullet$	7.23eV^{110}	-	-	$6.00 \pm .4\text{eV}$	-

The ionization potentials decrease with both increase in atomic number of the central atom and with increasing phenyl content. This allows an approximate estimation of ionization potentials:- $I(\text{Me}_3\text{Ge}^\bullet) \sim 6.8\text{eV}$., $I(\text{Me}_3\text{Pb}^\bullet) \sim 6.2\text{eV}$., $I(\text{Ph}_3\text{Si}^\bullet) \sim 6.8\text{eV}$., $I(\text{Ph}_3\text{Ge}^\bullet) \sim 6.4\text{eV}$. and $I(\text{Ph}_3\text{Pb}^\bullet) \sim 5.6\text{eV}$.

1 2 3 4 5

6

7

8

9

10

11
12
13
14

15
16
17
18
19
20
21
22
23
24
25
26
27
28
29
30
31
32
33
34
35
36
37
38
39
40
41
42
43
44
45
46
47
48
49
50
51
52
53
54
55
56
57
58
59
60
61
62
63
64
65
66
67
68
69
70
71
72
73
74
75
76
77
78
79
80
81
82
83
84
85
86
87
88
89
90
91
92
93
94
95
96
97
98
99
100

101
102
103
104
105
106
107
108
109
110
111
112
113
114
115
116
117
118
119
120
121
122
123
124
125
126
127
128
129
130
131
132
133
134
135
136
137
138
139
140
141
142
143
144
145
146
147
148
149
150
151
152
153
154
155
156
157
158
159
160
161
162
163
164
165
166
167
168
169
170
171
172
173
174
175
176
177
178
179
180
181
182
183
184
185
186
187
188
189
190
191
192
193
194
195
196
197
198
199
200

201
202
203
204
205
206
207
208
209
210
211
212
213
214
215
216
217
218
219
220
221
222
223
224
225
226
227
228
229
230
231
232
233
234
235
236
237
238
239
240
241
242
243
244
245
246
247
248
249
250
251
252
253
254
255
256
257
258
259
260
261
262
263
264
265
266
267
268
269
270
271
272
273
274
275
276
277
278
279
280
281
282
283
284
285
286
287
288
289
290
291
292
293
294
295
296
297
298
299
300

301
302
303
304
305
306
307
308
309
310
311
312
313
314
315
316
317
318
319
320
321
322
323
324
325
326
327
328
329
330
331
332
333
334
335
336
337
338
339
340
341
342
343
344
345
346
347
348
349
350
351
352
353
354
355
356
357
358
359
360
361
362
363
364
365
366
367
368
369
370
371
372
373
374
375
376
377
378
379
380
381
382
383
384
385
386
387
388
389
390
391
392
393
394
395
396
397
398
399
400

401
402
403
404
405
406
407
408
409
410
411
412
413
414
415
416
417
418
419
420
421
422
423
424
425
426
427
428
429
430
431
432
433
434
435
436
437
438
439
440
441
442
443
444
445
446
447
448
449
450
451
452
453
454
455
456
457
458
459
460
461
462
463
464
465
466
467
468
469
470
471
472
473
474
475
476
477
478
479
480
481
482
483
484
485
486
487
488
489
490
491
492
493
494
495
496
497
498
499
500

501
502
503
504
505
506
507
508
509
510
511
512
513
514
515
516
517
518
519
520
521
522
523
524
525
526
527
528
529
530
531
532
533
534
535
536
537
538
539
540
541
542
543
544
545
546
547
548
549
550
551
552
553
554
555
556
557
558
559
560
561
562
563
564
565
566
567
568
569
570
571
572
573
574
575
576
577
578
579
580
581
582
583
584
585
586
587
588
589
590
591
592
593
594
595
596
597
598
599
600

601
602
603
604
605
606
607
608
609
610
611
612
613
614
615
616
617
618
619
620
621
622
623
624
625
626
627
628
629
630
631
632
633
634
635
636
637
638
639
640
641
642
643
644
645
646
647
648
649
650
651
652
653
654
655
656
657
658
659
660
661
662
663
664
665
666
667
668
669
670
671
672
673
674
675
676
677
678
679
680
681
682
683
684
685
686
687
688
689
690
691
692
693
694
695
696
697
698
699
700

701
702
703
704
705
706
707
708
709
710
711
712
713
714
715
716
717
718
719
720
721
722
723
724
725
726
727
728
729
730
731
732
733
734
735
736
737
738
739
740
741
742
743
744
745
746
747
748
749
750
751
752
753
754
755
756
757
758
759
760
761
762
763
764
765
766
767
768
769
770
771
772
773
774
775
776
777
778
779
780
781
782
783
784
785
786
787
788
789
790
791
792
793
794
795
796
797
798
799
800

801
802
803
804
805
806
807
808
809
810
811
812
813
814
815
816
817
818
819
820
821
822
823
824
825
826
827
828
829
830
831
832
833
834
835
836
837
838
839
840
841
842
843
844
845
846
847
848
849
850
851
852
853
854
855
856
857
858
859
860
861
862
863
864
865
866
867
868
869
870
871
872
873
874
875
876
877
878
879
880
881
882
883
884
885
886
887
888
889
890
891
892
893
894
895
896
897
898
899
900

Table 4.1.7.

Ionization potentials of dialkylberyllium compounds.

	Ionization Potential eV	Values of Individual Determinations eV	Standard Used	Ion Repeller Voltage	Source Temp. °C
Me ₂ Be	10.67 ± 0.07	10.64	Argon	0	217
		10.76	"	-0.2	193
		10.50	"	-0.2	187
		10.76	"	-0.2	183
		10.88	"	+0.2	183
		10.46	"	0	220
Et ₂ Be	9.46 ± 0.05	9.66	Krypton	-1	230
		9.50	"	0.4	213 - 230
		9.36	"	0.4	197 - 213
		9.48	"	-1	230
		9.38	"	0.4	197
		9.38	"	0.4	195
(n-Pr) ₂ Be	8.71 ± 0.06	8.52	Argon	5	180
		8.76	"	5	180
		8.60	"	5	180
		8.84	"	5	180
		8.84	"	5	180
(i-Pr) ₂ Be	8.80 ± 0.02	8.80	Krypton	-0.7	205
		8.88	"	-0.7	205
		8.80	"	-0.7	205
		8.80	"	-0.7	205
		8.72	Argon	-0.5	210
(i-Bu) ₂ Be	8.74 ± .05	8.69	Xenon	5.0	205
		8.71	"	5.0	205
		8.89	"	2.4	198 - 205
		8.89	"	5.0	205
		8.71	"	5.0	205
		8.57	"	5.0	205

These estimates and values for the ionization potentials of other radicals ¹⁰² ($I(\text{CH}_3^\bullet) = 9.86\text{eV}$, $I(\text{C}_2\text{H}_5^\bullet) = 8.80\text{eV}$., $I(\text{C}_6\text{H}_5^\bullet) = 9.4\text{eV}$. and $I(\text{I}^\bullet) = 10.45\text{eV}$.) verify the validity of the assumption made earlier that for the molecule Ph_3SnR , $I(\text{Ph}_3\text{Sn}^\bullet) < I(\text{R}^\bullet)$.

4.1.3. Ionization Potentials and Bond Dissociation Energies of Dialkylberyllium Compounds.

i) Ionization Potentials of Dialkylberyllium Compounds.

Appearance potentials of $\text{R}_2\text{Be}^{+\bullet}$ ions produced in the spectra of dialkylberyllium compounds have been measured. At the high source temperature used during these measurements (c.f 200°C) electron deficient associated species such as R_4Be_2 are almost totally decomposed to monomer R_2Be . Thus it is most likely that $\text{R}_2\text{Be}^{+\bullet}$ ions are formed by ionization of R_2Be molecules rather than decomposition of ions containing more than one beryllium atom. The appearance potential of this ion is hence most probably a measure of the vertical ionization potential of unassociated berylliumdialkyls.

The ionization efficiency curves for these ions were very similar to those produced for the inert gases and in fig. 4 (p. 55) typical curves obtained are illustrated. Values of the ionization potentials obtained by the Warren method are given in table 4.1.7. As with measurements on organotin compounds the reproducibility of the determination is good.

The determination of $I(\text{i-Bu}_2\text{Be})$ is probably high because the intensity of the ion $\text{i-Bu}_2\text{Be}^{+\bullet}$ was low so making the sensitivity of ion detection low.

.....

1. 2. 3. 4. 5. 6. 7. 8. 9. 10. 11. 12. 13. 14. 15. 16. 17. 18. 19. 20. 21. 22. 23. 24. 25. 26. 27. 28. 29. 30. 31. 32. 33. 34. 35. 36. 37. 38. 39. 40. 41. 42. 43. 44. 45. 46. 47. 48. 49. 50. 51. 52. 53. 54. 55. 56. 57. 58. 59. 60. 61. 62. 63. 64. 65. 66. 67. 68. 69. 70. 71. 72. 73. 74. 75. 76. 77. 78. 79. 80. 81. 82. 83. 84. 85. 86. 87. 88. 89. 90. 91. 92. 93. 94. 95. 96. 97. 98. 99. 100.

1. 2. 3. 4. 5. 6. 7. 8. 9. 10. 11. 12. 13. 14. 15. 16. 17. 18. 19. 20. 21. 22. 23. 24. 25. 26. 27. 28. 29. 30. 31. 32. 33. 34. 35. 36. 37. 38. 39. 40. 41. 42. 43. 44. 45. 46. 47. 48. 49. 50. 51. 52. 53. 54. 55. 56. 57. 58. 59. 60. 61. 62. 63. 64. 65. 66. 67. 68. 69. 70. 71. 72. 73. 74. 75. 76. 77. 78. 79. 80. 81. 82. 83. 84. 85. 86. 87. 88. 89. 90. 91. 92. 93. 94. 95. 96. 97. 98. 99. 100.

Table 4.1.8.

Vertical ionization potentials of main group organometallic compounds.

Group IIb

| | R | I.P.(eV.) | Ref | | R | I.P.(eV.) | Ref. |
|---------|------|-----------|-----|-----------|---------|-----------|------|
| R_2Zn | Me | 8.86±.15 | 12 | $RSiMe_3$ | OMe | 9.79±.04 | 60 |
| R_2Hg | Me | (8.90±.2 | 111 | | F | 10.55±.06 | 60 |
| | | (9.1 ±.1 | 112 | | Cl | 10.58±.04 | 60 |
| | Et | 8.5 ±.1 | 112 | | Br | 10.24±.02 | 60 |
| | i-Pr | 7.6 ±.1 | 112 | | NEt_2 | 8.06±.02 | 60 |

Group IIIb

| | | | | | | | |
|---------|----|---------|-----|--------------|----|----------|-----|
| R_3B | Me | 8.8 ±.2 | 113 | R_4Ge | Me | 9.2 ±.2 | 111 |
| | Et | 9.0 ±.2 | 113 | R_4Sn | Me | 8.25±.15 | 111 |
| R_3Al | Me | 9.09±.3 | 12 | | Et | 8.1 ±.2 | 115 |
| | | | | Et_2SnPh_2 | | 8.1 ±.2 | 115 |

Group IVb

| | | | |
|-----------|----------|------------|-----|
| $RSiH_3$ | Et | 10.18±.05 | 114 |
| | i-Pr | 9.85±.1 | 114 |
| | t-Bu | 9.5 ±.2 | 114 |
| $RSiCl_3$ | Me | 11.36±.03 | 114 |
| | Et | 10.74±.04 | 114 |
| | i-Pr | 10.28±.1 | 114 |
| $RSiMe_3$ | H | 9.8 ±.3 | 111 |
| | Me | (9.8 ±.15 | 111 |
| | | (9.98±.03 | 60 |
| | | (9.70±.01 | 60 |
| | Et | 9.70±.01 | 60 |
| | i-Pr | 9.50±.03 | 60 |
| | t-Bu | 9.34±.06 | 60 |
| $SiMe_3$ | 8.79±.08 | 60 | |
| $OSiMe_3$ | 9.59±.04 | 60 | |

R_4Pb

Me 8.0 ±.2 111

Group Vb

| | | | |
|---------------|--------|----------|-----|
| R_3As | Me | 8.3 ±.1 | 116 |
| | CF_3 | 11.0 ±.1 | 116 |
| | H | 10.6 ±.1 | 116 |
| $RAsH_2$ | Cl | 11.7 ±.1 | 116 |
| | Me | 9.7 ±.1 | 116 |
| | Me | 10.4 ±.1 | 116 |
| | Me | 10.5 ±.1 | 116 |
| | H | 10.9 ±.1 | 116 |
| $RAs(CF_3)_2$ | Cl | 11.0±.1 | 116 |
| | CF_3 | 9.2 ±.1 | 116 |
| | H | 9.0 ±.1 | 116 |
| $RAsMe_2$ | Cl | 9.9 ±.1 | 116 |
| | Me | 8.04±.16 | 12 |
| R_3Sb | | | |

The most apparent trend is the lowering of the ionization potential as the size of the attached group is increased, the largest drop being 1.21eV between $I(\text{Me}_2\text{Be})$ and $I(\text{Et}_2\text{Be})$. A similar variation occurs with the vertical ionization potentials of other organometallic compounds (see table 4.1.8.) of the main group.

The physical basis for such a result is the macroscopic view that in removing an electron from a molecule the resultant charged species can distribute the charge at least partially over its surface. Consequently the repulsive energy due to the net charge will be less as the surface increases. Another point of view is that any charged species will induce a dipole in any uncharged species and hence be attracted to it. Thus the work in removing an electron will be less if another species is in its neighbourhood.

The ionization potential of Me_2Be is higher than any other fully alkylated organometallic compound. If the dimethyl compounds of group IIa vary in the same way as those of IVb, this ionization potential will also be higher than those of Me_2Mg and Me_2Ca . Such a trend is however not apparent in group IIb where the ionization potentials of both Me_2Zn and Me_2Hg are about 8.9eV and in group IIIb the ionization potential of Me_3B is lower than that of Me_3Al .

ii) Appearance Potentials of Fragment Ions and Bond
Dissociation Energies in Ions.

The appearance potential curves for $\text{C}_4\text{H}_9\text{Be}^+$ and $\text{C}_4\text{H}_8\text{Be}^+$ produced from di-iso-butylberyllium are shown in fig. 9. The curves produced are typical of those given by ions $\text{C}_n\text{H}_{2n+1}\text{Be}^+$ and $\text{C}_n\text{H}_{2n}\text{Be}^+$ produced from $(\text{C}_n\text{H}_{2n+1})_2\text{Be}$. It is immediately apparent that some "tailing"

Fig. 9

Ionization Efficiency Curves for $C_4H_9Be^+$ and $C_4H_9Be^+$ produced from tBu_2Be .

Evaluation of Appearance Potential by Modified Warren Method.

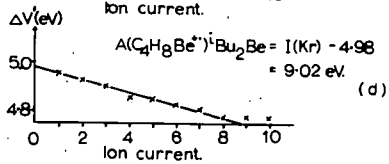
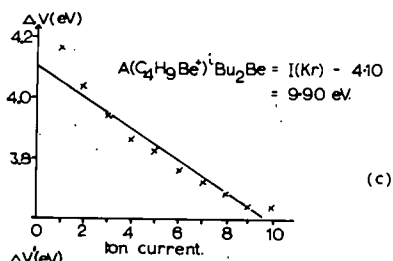
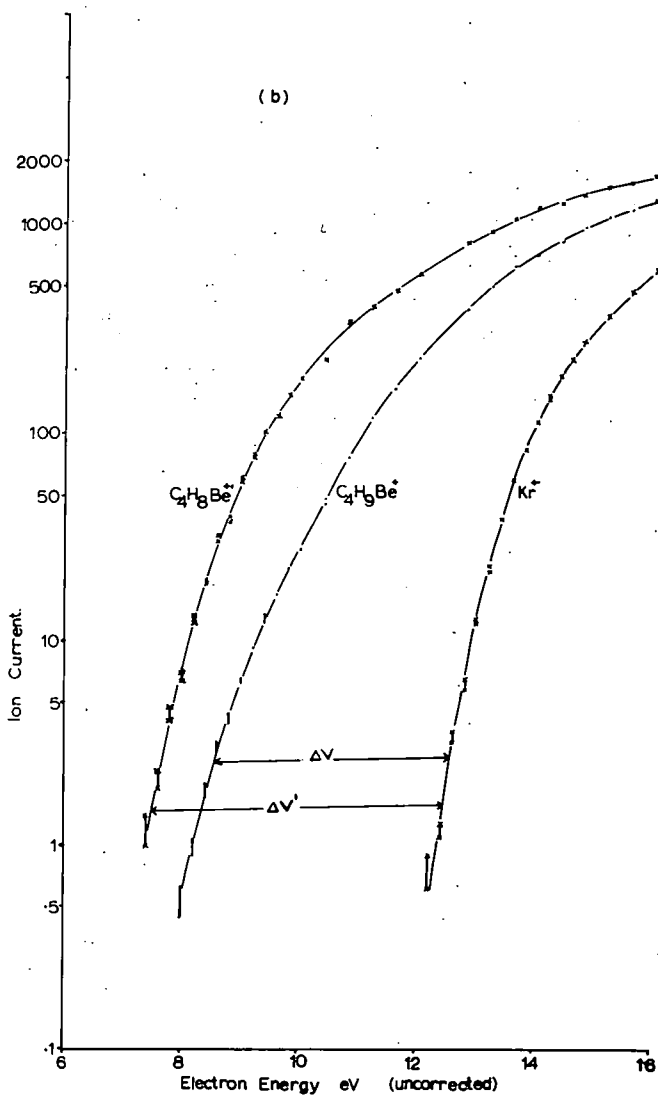
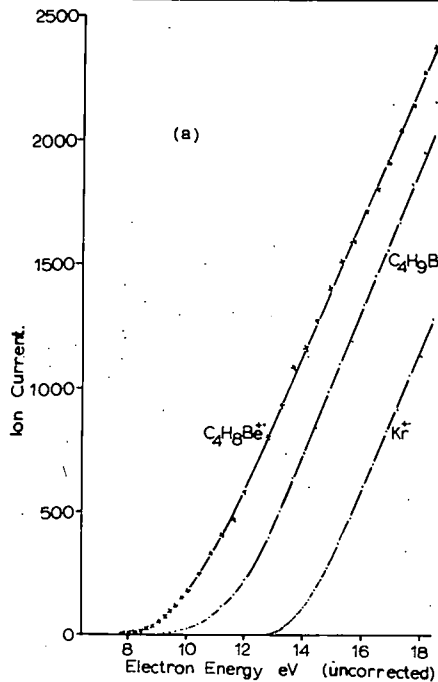

Table 4.1.9.

Appearance potentials of major ions in spectra of beryllium dialkyls.

| | Appearance
Potential
eV. | Values of
Individual
Determinations
eV. | Standard
Used | Ion
Repeller
Voltage | Source
Temp.
°C. |
|---|--------------------------------|---|--------------------------------------|----------------------------|--------------------------|
| <u>Me₂Be</u> | | | | | |
| CH ₂ Be ⁺ | 11.92 ± .05 | 11.92, 11.96, 12.02
12.01
11.70 | Argon
Me ₂ Be
Argon | -0.2
0
0.1 | 193
199
210 |
| CH ₃ Be ⁺ | 12.67 ± .02 | 12.70, 12.70, 12.68
12.71
12.58 | Argon
Me ₂ Be
Argon | -0.2
0
0.1 | 193
194
210 |
| <u>Et₂Be</u> | | | | | |
| C ₂ H ₄ Be ⁺ | 10.35 ± .03 | 10.42, 10.26, 10.26
10.44, 10.28, 10.38
10.42 | Argon
"
" | 1.4
0.2
0.5 | 220
200
225 |
| C ₂ H ₅ Be ⁺ | 11.51 ± .05 | 11.50, 11.76, 11.34
11.32, 11.52, 11.64
11.52 | Argon
"
" | 1.4
0.2
0.5 | 220
200
225 |
| <u>(i-Pr)₂Be</u> | | | | | |
| C ₃ H ₆ Be ⁺ | 9.60 ± .01 | 9.57, 9.56, 9.66
9.70, 9.51 | Argon
" | -0.5
1.0 | 205
190 |
| C ₃ H ₇ Be ⁺ | 10.65 ± .01 | 10.59, 10.68, 10.67
10.75, 10.54 | Argon
" | -0.5
1.0 | 205
190 |
| <u>(n-Pr)₂Be</u> | | | | | |
| C ₃ H ₆ Be ⁺ | 9.86 ± .05 | 9.92, 9.98, 9.76
9.72, 9.92 | Argon
" | + 4.6
+ 4.6 | 185
185 |
| C ₃ H ₇ Be ⁺ | 10.81 ± .05 | 10.92, 10.92, 10.72
10.72, 10.76 | Argon
" | + 4.6
+ 4.6 | 185
185 |
| <u>(i-Bu)₂Be</u> | | | | | |
| C ₄ H ₈ Be ⁺ | 9.14 ± .03 | 9.14, 9.02
9.20
9.16
9.16 | Krypton
"
"
" | 5.0
2.5
3.0
2.4 | 205
198
205
205 |
| C ₄ H ₉ Be ⁺ | 10.00 ± .05 | 10.18, 9.90
10.04
9.94
9.96 | Krypton
"
"
" | 5.0
2.5
3.0
2.5 | 205
198
205
205 |

occurs with these fragment ions especially for the $C_n H_{2n+1} Be^+$ ion (i.e. in fig. 9, $C_4 H_9 Be^+$).

In table 4.1.9. the values of the appearance potentials as determined by the Warren method are given. Again the reproducibility of measurement was good and the standard error of the mean of estimations never exceeded $\pm 0.05eV$. In calculating bond-dissociation energies an error of twice the maximum observed standard error of the mean has been used ($\pm 0.1eV$).

If the ion RBe^+ from R_2Be ($R = \text{alkyl}$) is formed by the simple dissociative process:-

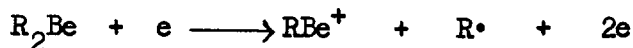

involving no excess energy then

$$D(RBe^+-R) = A(RBe^+)R_2Be - I(R_2Be) \quad 4.3$$

The excess energy term is most likely to be zero if $I(RBe\cdot) < I(R\cdot)$.

The low abundance of R^+ in comparison to RBe^+ at low source temperatures (when hydrocarbon ions are less likely to be formed by thermal decomposition of beryllium dialkyls prior to ionization) is consistent with this. The occurrence of "tailing" of the ionization efficiency curves is however not consistent with a negligible excess energy term and so all derived bond dissociation energies must be regarded as upper limits.

Using equation 4.3 bond dissociation energies shown in table 4.1.10 have been derived.

Table 4.1.10.

Bond dissociation energies in dialkylberyllium.

molecular ions.

| R | D(RBe ⁺ -R)
Kcal. mole. ⁻¹
*(error = ± 3.2 Kcal. mole. ⁻¹) |
|------|--|
| Me | 46.1 |
| Et | 47.3 |
| i-Pr | 48.7 |
| n-Pr | 42.7 |
| i-Bu | 29.1 |

* error calculated assuming a tolerance of ± 0.1eV in the appearance potential measurements.

The low value obtained for D(i-BuBe⁺-i-Bu) probably results from the estimation of I(i-Bu₂Be) being too high (see p. 89)

Beryllium-carbon bond strengths in molecular ions of the dialkyls are much stronger than the tin-carbon bond strengths in Et₄Sn⁺ or Ph₂SnEt₂⁺ which were of the order of 10 Kcal. mole.⁻¹. Other metal-carbon bond strengths in molecular ions may be evaluated from appearance potentials published in the literature assuming the decomposition

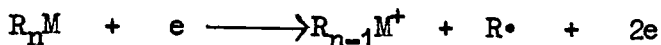

to occur with no excess energy release. Values are given in table 4.1.11.

The Be-C bond dissociation energy is most similar to that for zinc-methyl in Me₂Zn⁺. For dimethyl zinc the metal-carbon bond in the molecule is almost the same as in the ion indicating the removal of an essentially non-bonding electron upon ionization i.e. D(MeZn - Me)¹⁰⁶

Table 4.1.11.Bond dissociation energies in molecular ions (Kcal.mole.⁻¹)

| | | | |
|--|----------------------------|------------------------|--------------------------|
| $D(\text{MeZn}^+ - \text{Me})^{12}$ | 53 | | |
| $D(\text{RHg}^+ - \text{R})$ | 32 (Me) ^{111,112} | 27 (Et) ¹¹² | 35 (i-Pr) ¹¹² |
| $D(\text{R}_2\text{B}^+ - \text{R})^{117}$ | 35 (Me) | 14 (Et) | |
| $D(\text{Me}_2\text{Al}^+ - \text{Me})^{12}$ | 23 | | |
| $D(\text{Me}_2\text{Sb}^+ - \text{Me})^{12}$ | 58 | | |

= 47.2 ± 1 Kcal. mole.⁻¹ With dimethylmercury however the Hg-C bond strength in the ion is lower than in the molecule and in this case the electron comes from a bonding orbital i.e. $D(\text{MeHg} - \text{Me})^{106} = 51.5 \pm 2$ Kcal. mole.⁻¹; $D(\text{EtHg} - \text{Et})^{106} = 42.5 \pm 2$ Kcal. mole.⁻¹.

With beryllium dialkyls it is difficult to envisage removal of anything but a bonding-electron upon ionization in which case the beryllium carbon dissociation energy in the molecule $D(\text{RBe} - \text{R})$ will be greater than ~ 45 Kcal. mole.⁻¹. It would be interesting to compare this value with a mean beryllium-carbon bond dissociation energy to see whether the beryllium dialkyls resemble dimethylmercury in which $D(\text{MeHg} - \text{Me}) = 51.5 \pm 2$ Kcal. mole.⁻¹ and $D(\text{Hg} - \text{Me}) = 6.9 \pm 3$ Kcal. mole.⁻¹¹⁰⁶ or dimethylzinc where the difference between the two dissociation energies is much less $D(\text{MeZn} - \text{Me}) = 47.2 \pm 1$ Kcal. mole.⁻¹ and $D(\text{Zn} - \text{Me}) = 36.8 \pm 3$ Kcal. mole.⁻¹¹⁰⁶. Unfortunately however no calorimetric data is available for beryllium dialkyls.

A metastable peak present for berylliumdialkyls shows that the

$\text{C}_n\text{H}_{2n}\text{Be}^+$ ion is formed by the process

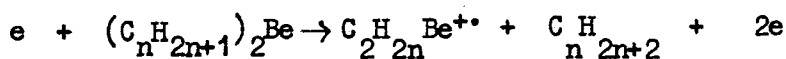

1952

1952

1952

1952

1952

1952

1952

1952

1952

1952

1952

1952

1952

1952

1952

1952

1952

1952

1952

1952

Table 4.1.12.

Enthalpy change (ΔH) for reaction:

$$C_n H_{2n+1} Be^+ + C_n H_{2n+1} \cdot \rightarrow C_n H_{2n} Be^{+\cdot} + C_n H_{2n+2}$$

| | | | | ΔH (Kcal. mole. ⁻¹) |
|---|---|-----------------------------------|---|---|
| | | | | error ± 3.2 Kcal. mole. ⁻¹ |
| CH ₃ Be ⁺ | + | CH ₃ · | → CH ₂ Be ^{+\cdot} + CH ₄ | -17.30 |
| C ₂ H ₅ Be ⁺ | + | C ₂ H ₅ · | → C ₂ H ₄ Be ^{+\cdot} + C ₂ H ₆ | -26.8 |
| n-C ₃ H ₇ Be ⁺ | + | n-C ₃ H ₇ · | → C ₃ H ₆ Be ^{+\cdot} + C ₃ H ₈ | -21.9 |
| i-C ₃ H ₇ Be ⁺ | + | i-C ₃ H ₇ · | → C ₃ H ₆ Be ^{+\cdot} + C ₃ H ₈ | -24.2 |
| i-C ₄ H ₉ Be ⁺ | + | C ₄ H ₉ · | → C ₄ H ₈ Be ^{+\cdot} + C ₄ H ₁₀ | -19.8 |

error calculated assumed a tolerance of $\pm .1eV$ for appearance potential measurements.

Table 4.1.13.

Bond dissociation energies $D(BeC_n H_{2n}^+ - H)$ (Kcal. mole.⁻¹)

| | |
|---|----------------|
| D(BeCH ₂ ⁺ —H) | 86.7 \pm 3.4 |
| D(BeC ₂ H ₄ ⁺ —H) | 71.5 \pm 3.4 |
| D(Be-i-C ₃ H ₆ ⁺ —H) | 76.0 \pm 3.8 |
| D(Be-n-C ₃ H ₆ ⁺ —H) | 70.7 \pm 3.4 |
| D(Be-i-C ₄ H ₈ ⁺ —H) | 77.7 \pm 3.8 |

Hence

$$A(C_nH_{2n}Be^+) = \Delta H_f^0(C_nH_{2n}Be^+) + \Delta H_f^0(C_nH_{2n+2}) - \Delta H_f^0(C_nH_{2n+1})_2Be$$

and
$$A(C_nH_{2n+1}Be^+) = \Delta H_f^0(C_nH_{2n+1}Be^+) + \Delta H_f^0(C_nH_{2n+1}\cdot) - \Delta H_f^0(C_nH_{2n+1})_2Be$$

by subtraction

$$\Delta H = A(C_nH_{2n}Be^+) - A(C_nH_{2n+1}Be^+) = \Delta H_f^0(C_nH_{2n}Be^+) - \Delta H_f^0(C_nH_{2n+1}Be^+) + \Delta H_f^0(C_nH_{2n+2}) - \Delta H_f^0(C_nH_{2n+1}\cdot)$$

Thus ΔH is the enthalpy change for the reaction

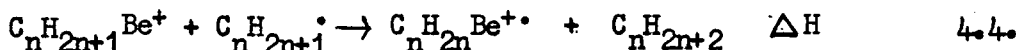

These values of ΔH are illustrated in table 4.1.12. The reaction 4.4... is exothermic in all cases to the extent of -22 Kcal. mole.⁻¹.

From eqn. 4.4. it also follows:

$$\Delta H_f^0(C_nH_{2n}Be^+) - \Delta H_f^0(C_nH_{2n+1}Be^+) = \Delta H - \Delta H_f^0(C_nH_{2n+2}) + \Delta H_f^0(C_nH_{2n+1}\cdot)$$

and so the dissociation energy

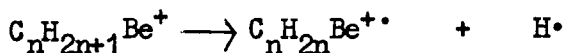

may be found

$$D(BeC_nH_{2n}^+ - H) = \Delta H - \Delta H_f^0(C_nH_{2n+2}) + \Delta H_f^0(C_nH_{2n+1}\cdot) + \Delta H_f^0(H\cdot)$$

These dissociation energies are given in table 4.1.13. In this calculation

the following heats of formation were used (expressed in Kcal. mole.⁻¹):

$$\begin{aligned} \Delta H_f^0(CH_3\cdot)^{104} &= 34 \pm 1; \Delta H_f^0(Et\cdot)^{104} = 26 \pm 1; \Delta H_f^0(n\text{-Pr}\cdot)^{104} = 21 \pm 2; \\ \Delta H_f^0(i\text{-Pr}\cdot)^{104} &= 17.6 \pm 1; \Delta H_f^0(i\text{-Bu}\cdot)^{104} = 14 \pm 2; \Delta H_f^0(CH_4)^{118} = 17.9; \\ \Delta H_f^0(C_2H_6)^{118} &= -20.2; \Delta H_f^0(C_3H_8)^{118} = 24.8; \Delta H_f^0(n\text{-butane})^{118} = -29.8; \\ \Delta H_f^0(2 \text{ methyl propane})^{118} &= -31.4. \end{aligned}$$

Excepting for $D(BeCH_2^+ - H)$ these ion dissociation energies are very similar at around 74 Kcal. mole.⁻¹. This exception for the CH_3Be^+ ion can be explained if some stabilising rearrangement is assumed for

$C_n H_{2n} Be^{+•}$ ions containing more than one carbon atom. Thus the structure of the ethyl compound may be $\left[\begin{array}{c} \text{CH}_2 \\ \vdots \\ \text{Be} \vdots \\ \text{CH}_2 \end{array} \right]^{+•}$ rather than $(\text{CH}_2^--\text{CH}_2^--\text{Be})^{+•}$

(where each dotted line represents a bond containing only one electron)

and similarly $C_3 H_6 Be^{+•}$ ions may be $\left[\begin{array}{c} \text{CH(Me)} \\ \vdots \\ \text{Be} \vdots \\ \text{CH}_2 \end{array} \right]^{+•}$. Alternatively

the structure $\left[\begin{array}{c} \text{CH}_2 \\ \diagup \quad \diagdown \\ \text{CH}_2 \text{---} \text{CH}_2 \\ \vdots \\ \text{Be} \vdots \end{array} \right]^{+•}$ may be proposed which bears

similarities to the cationated cyclopropane rings which have been postulated to explain the breakdown ¹¹⁹ of t-butyl-benzene - α - ¹³C and the structure ¹²⁰ of $C_3 H_7^+$ ions which are abundant in so many hydrocarbon spectra. Similar structures may be drawn for $C_4 H_8 Be^{+•}$ ions;

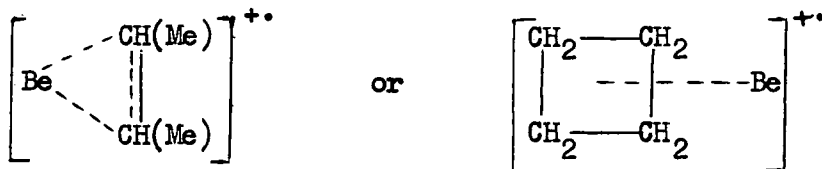

With the methyl compound it may not be possible for $\text{CH}_2 \text{Be}^{+•}$ to attain a ring structure and hence the hydrogen atom in $\text{CH}_3 \text{Be}^+$ is more tightly bound.

4.2. Mass Spectra of Organocompounds of Silicon, Germanium, Tin and Lead.

4.2.1. Organo-stannanes.

Since no data was initially available on the electron impact induced fragmentation of organo-tin compounds other than tetramethyltin^{30,111}, a mass spectroscopic study of the following tin-compounds was undertaken: $\text{Ph}_n\text{SnEt}_{4-n}$ ($n=0,1,2,3,4$), $\text{Ph}_3\text{Sn R}$ ($\text{R} = \text{SPh}, \text{CH}_2\text{CH}_2\text{Ph}$), spiro - $(\text{CH}_2)_4$ $\text{Sn} \langle (\text{CH}_2)_4$, Ph_3SnX ($\text{X} = \text{F}, \text{Cl}, \text{Br}, \text{I}$), R_6Sn_2 ($\text{R} = \text{Et}, \text{Ph}$). The abundances of ions (calculated as described in the calculation of results section) are given in tables 4.2.1., 4.2.2., and 4.2.3.

An electron energy of 70eV was mainly used to obtain spectra but for some compounds (given in table 4.2.1.) 20 volt electrons were also used. Other ionizing conditions are given in chapter 2.2 of the Experimental. (p.45).

The assignment of metastable peaks allows the decomposition modes of organotin compounds to be classified and these are outlined below. Throughout m^* refers to the observed mass of a metastable peak. The shapes of metastable peaks for processes in which a polyisotopic element is eliminated has already been commented upon. (chapter 3.3.). The experimental values quoted for such peaks are the mass spread of the metastable peaks and its mass at maximum intensity. In all other cases m^* refers to the most abundant isotope or combination of isotopes. The agreement between observed and calculated values of m^* was always better than $\pm .1$ a.m.u.

Decomposition Modes of Organostannanes at 70eV.

Metal-containing ions are generally the most abundant, accounting

DURHAM UNIVERSITY
SOE LC
11 OCT 1968
SECTION
LIBRARY

Table 4.2.1.

Ion abundance relative to total tin-containing ions

| SnPh ₄ | | | SnPh ₃ Et | | | SnPh ₂ Et ₂ | | | SnPhEt ₃ | | |
|----------------------------------|-------|-------|----------------------------------|-------|-------|-----------------------------------|-------|-------|---------------------------------|-------|-------|
| Ion ⁺ | 70 | 20 | Ion ⁺ | 70 | 20 | Ion ⁺ | 70 | 20 | Ion ⁺ | 70 | 20 |
| SnPh ₄ | 0.11 | 0.17 | SnPh ₃ Et | 0.05 | 0.05 | SnPh ₂ Et ₂ | 1.35 | 1.38 | SnPhEt ₃ | 0.26 | 0.50 |
| SnPh ₃ | 42.26 | 53.78 | SnPh ₂ Et | 62.27 | 89.90 | SnPh ₂ Et | 50.52 | 68.97 | SnPhEt ₂ | 30.37 | 53.17 |
| | | | SnPh ₂ Et | 0.47 | 1.02 | SnPhEt ₂ | 1.14 | 0.94 | SnEt ₃ | 0.82 | <0.1 |
| | | | SnPh ₂ H | 1.26 | 1.06 | SnPh ₂ H | 14.19 | 18.26 | SnPh(Et)H | 13.77 | 24.07 |
| | | | | | | SnPh(Et)H | 0.53 | 0.94 | SnPhH ₂ | 10.76 | 12.31 |
| | | | | | | SnPhH ₂ | 0.89 | 0.89 | SnEt ₂ H | 0.35 | <0.1 |
| | | | | | | | | | SnEtH ₂ | 0.20 | <0.1 |
| SnPh ₃ | 10.74 | 25.22 | SnPh ₃ | 0.18 | 0.32 | SnPh | 16.46 | 5.33 | SnPh | 19.50 | 9.80 |
| SnPh ₂ | 17.55 | 5.84 | SnPh | 17.67 | 4.20 | SnEt | 0.23 | 0.20 | SnEt | 3.15 | <0.1 |
| SnH | 0.56 | 0.1 | SnH | 0.74 | 0.04 | SnH | 1.07 | 0.15 | SnH | 5.20 | — |
| | | | | | | Sn | 9.61 | 2.21 | Sn | 9.83 | — |
| Sn | 18.61 | 13.04 | Sn | 13.35 | 2.66 | SnC ₁₁ H ₉ | 0.65 | 0.30 | SnC ₉ H ₇ | 1.26 | <0.1 |
| SnC ₁₁ H ₉ | 0.03 | 0.03 | SnC ₁₁ H ₉ | 0.09 | 0.08 | SnC ₁₁ H ₉ | 0.18 | — | SnC ₉ H ₇ | 0.11 | <0.1 |
| SnC ₁₁ H ₇ | 1.53 | 1.40 | SnC ₁₁ H ₇ | 0.61 | 0.27 | SnC ₁₁ H ₇ | 0.09 | — | SnC ₉ H ₅ | 0.89 | — |
| SnC ₁₁ H ₅ | 0.10 | — | SnC ₁₁ H ₅ | 0.10 | — | SnC ₁₁ H ₅ | 0.14 | — | SnC ₇ H ₃ | 0.33 | — |
| SnC ₉ H ₇ | 0.14 | — | SnC ₉ H ₅ | 0.16 | — | SnC ₉ H ₅ | 0.09 | 0.20 | SnC ₇ H ₃ | 3.31 | — |
| SnC ₉ H ₅ | 0.00 | 0.50 | SnC ₉ H ₃ | 0.73 | 0.40 | SnC ₉ H ₃ | 0.58 | 0.32 | | | |
| SnC ₇ H ₃ | 0.41 | — | SnC ₇ H ₃ | 0.60 | — | SnC ₇ H ₃ | 0.51 | — | | | |
| SnC ₇ H ₁ | 0.17 | — | SnC ₇ H ₁ | 0.24 | — | SnC ₇ H ₁ | 0.18 | — | | | |
| SnC ₅ H | 1.09 | — | SnC ₅ H | 1.48 | — | SnC ₅ H | 1.50 | — | | | |

| SnEt ₄ | | | SnPh ₂ (CH ₂ CH ₂ Ph) | | | Sn ₂ Ph ₂ | | | Sn ₂ Et ₂ | | | spiro(CH ₂) ₂ > Sn < (CH ₂) ₂ | | |
|----------------------------------|-------|-------|--|-------|----|----------------------------------|-------|----|--|-------|-------|---|-------|----|
| Ion ⁺ | 70 | 20 | Ion ⁺ | 70 | ev | Ion ⁺ | 70 | ev | Ion ⁺ | 70 | ev | Ion ⁺ | 70 | ev |
| SnEt ₄ | 0.97 | 2.76 | SnPh ₂ (CH ₂ CH ₂ Ph) | 0.01 | | Sn ₂ Ph ₂ | 6.51 | | Sn ₂ Et ₂ | 200* | 100* | SnC ₉ H ₇ | 10.19 | |
| | | | SnPh ₂ CH ₂ Ph | 0.74 | | Sn ₂ Ph ₂ | 1.48 | | Sn ₂ Et ₂ | 1.04 | 4.48 | SnC ₉ H ₅ | 8.94 | |
| | | | SnPh ₂ | 0.01 | | Sn ₂ Ph ₂ | 0.68 | | Sn ₂ Et ₂ H | 10.00 | 12.33 | SnC ₇ H ₃ | 20.80 | |
| SnEt ₃ ⁺ | 26.18 | 48.20 | SnPh ₂ (CH ₂ CH ₂ Ph) | 0.01 | | Sn ₂ Ph ₂ | 0.05 | | Sn ₂ Et ₂ H ₂ | 12.64 | 10.65 | SnC ₇ H ₁ | 35.29 | |
| SnEt ₂ H ⁺ | 24.16 | 32.68 | SnPh ₂ (CH ₂ Ph) | 0.23 | | SnPh ₂ | 43.26 | | Sn ₂ Et ₂ H ₂ | 3.66 | 3.50 | SnH ₂ | 0.73 | |
| SnEtH ₂ | 17.24 | 14.77 | SnPh ₂ H | 61.80 | | | | | Sn ₂ Et ₂ H ₂ | 2.78 | 3.13 | | | |
| SnH ₃ | 1.31 | 0.42 | SnPh ₂ H | 0.13 | | SnPh ₂ | 1.23 | | Sn ₂ Et ₂ H ₂ | 0.95 | 0.11 | SnH | 7.46 | |
| | | | | | | SnPh | 24.59 | | Sn ₂ Et ₂ H ₂ | 5.21 | 5.40 | Su | 16.50 | |
| | | | | | | SnH | 0.38 | | Sn ₂ Et ₂ H ₂ | 2.88 | 3.71 | | | |
| | | | | | | Sn | 18.42 | | Sn ₂ H ₂ | 0.38 | 0.30 | | | |
| | | | | | | | | | Sn ₂ H ₂ | 2.63 | 2.74 | | | |
| SnEt | 11.93 | — | SnPh ₂ | 0.18 | | SnC ₉ H ₉ | 0.42 | | Sn ₂ H ₂ | 2.31 | 2.41 | | | |
| SnH | 12.13 | 0.27 | SnPh | 18.85 | | SnC ₁₁ H ₉ | 0.88 | | Sn ₂ | 3.77 | 3.92 | | | |
| | | | SnH | 0.49 | | SnC ₁₁ H ₇ | 0.10 | | | | | | | |
| Sn | 4.89 | — | Sn | 15.35 | | SnC ₉ H ₇ | 0.14 | | SnEt ₂ | 9.36 | 8.01 | | | |
| SnEt ₂ Me | 0.12 | 0.04 | SnC ₁₁ H ₉ | 0.52 | | SnC ₉ H ₅ | 0.80 | | SnEt ₂ H | 8.01 | 7.23 | | | |
| SnC ₂ H ₂ | 0.16 | — | SnC ₁₁ H ₇ | 0.07 | | SnC ₇ H ₃ | 0.35 | | SnEt ₂ H | 3.94 | 4.87 | | | |
| SnCH ₂ | 0.47 | — | SnC ₉ H ₅ | 0.11 | | SnC ₇ H ₁ | 0.07 | | SnH ₂ | 0.18 | 0.25 | | | |
| SnCH ₃ | 0.46 | 0.27 | SnC ₇ H ₃ | 0.40 | | SnC ₅ H | 0.50 | | SnEt | 6.22 | 7.32 | | | |
| | | | SnC ₅ H | 0.18 | | | | | SnH | 1.82 | 2.38 | | | |
| | | | SnC ₃ H | 1.12 | | | | | Sn | 0.73 | 0.95 | | | |
| | | | | | | | | | SnEt ₂ Me | 0.24 | 0.21 | | | |
| | | | | | | | | | SnC ₂ H ₂ | 0.17 | 0.16 | | | |
| | | | | | | | | | SnCH ₂ | 0.20 | 0.25 | | | |
| | | | | | | | | | SnCH ₃ | 0.04 | 0.04 | | | |

* Temperature of ionisation chamber.

Table 4.2.2.

Abundances of ions in triphenyl tin halides at 70 ev relative to total tin-containing ions

| Ion ⁺ | I | Cl | Br | I |
|---|-------|-------|-------|-------|
| SnPh ₃ X | 0.81 | 1.22 | 1.40 | 0.05 |
| SnPh ₂ X | 44.44 | 46.98 | 46.28 | 3.70 |
| SnPh ₂ | 3.59 | 1.51 | 5.16 | 52.63 |
| SnPh ₂ | 0.50 | 0.19 | 0.13 | 0.20 |
| SnPhX | 1.48 | 2.10 | 3.90 | 0.08 |
| SnPh | 12.08 | 10.12 | 4.75 | 19.80 |
| SnX | 25.03 | 27.61 | 26.22 | 5.55 |
| SnH | 0.35 | 0.37 | 0.47 | 0.49 |
| Sn | 5.13 | 5.10 | 6.59 | 11.94 |
| SnPh ₂ C ₆ H ₄ X | 0.23 | 0.63 | 0.10 | — |
| SnPh ₂ C ₆ H ₄ | 2.12 | 0.77 | 1.09 | 1.61 |
| SnPhC ₆ H ₄ | 1.30 | 0.52 | 1.15 | 0.54 |
| SnC ₁₀ H ₇ | 0.11 | 0.05 | 0.15 | 0.05 |
| SnC ₈ H ₅ | 0.10 | 0.09 | 0.07 | 0.09 |
| SnC ₆ H ₃ | 0.57 | 0.60 | 0.26 | 0.97 |
| SnC ₄ H ₁ | 0.27 | 0.35 | 0.36 | 0.43 |
| SnC ₂ H | 0.25 | 0.15 | 0.34 | 0.28 |
| SnC ₂ H | 1.02 | 1.08 | 1.36 | 1.45 |

Table 4.2.3.

Ion abundances * in thiophenyltriphenyltin at 70eV.

| Ion ⁺ | |
|------------------------------------|-------|
| Ph ₃ SnSPh [•] | 3.56 |
| Ph ₂ SnSPh) | 1.21 |
| Ph ₃ SnS) | |
| Ph ₃ Sn | 47.24 |
| Ph ₂ Sn [•] | 0.62 |
| PhSnSPh [•]) | 1.99 |
| Ph ₂ SnS [•]) | |
| PhSSn) | 3.63 |
| PhSnS) | |
| PhSn | 22.16 |
| HSn | 0.54 |
| Sn [•] | 12.97 |
| C ₁₂ H ₉ Sn | 0.56 |
| C ₁₀ H ₇ Sn | 0.77 |
| C ₈ H ₅ Sn | 0.09 |
| C ₆ H ₄ Sn | 1.06 |
| C ₄ H ₃ Sn | 0.32 |
| C ₄ HSn | 0.36 |
| C ₂ HSn | 1.11 |

* Expressed as % of total tin-containing ions.

for about 95% of the total ion current. The electronegativity of carbon is greater than that of tin ¹²¹ and it is apparent that the charge is most likely to remain on the metal-containing fragment formed when an ion decomposes. The work confirms the influence of the odd bonding - or even bonding-electron character of an ion on its dissociation reactions ⁵ and in all cases the even-electron ions R_3M^+ and RM^+ are the most abundant. Parent ions, which are of low abundance decompose mainly by elimination of odd-electron fragments and even-electron ions tend to maintain themselves even-electron by eliminating an even-electron molecule.

i) Radical Elimination by Bond Cleavage.

This is a dominant process for odd-electron ions: Thus parent ions eliminate a group attached to the metal producing an even-electron ion in high abundance.

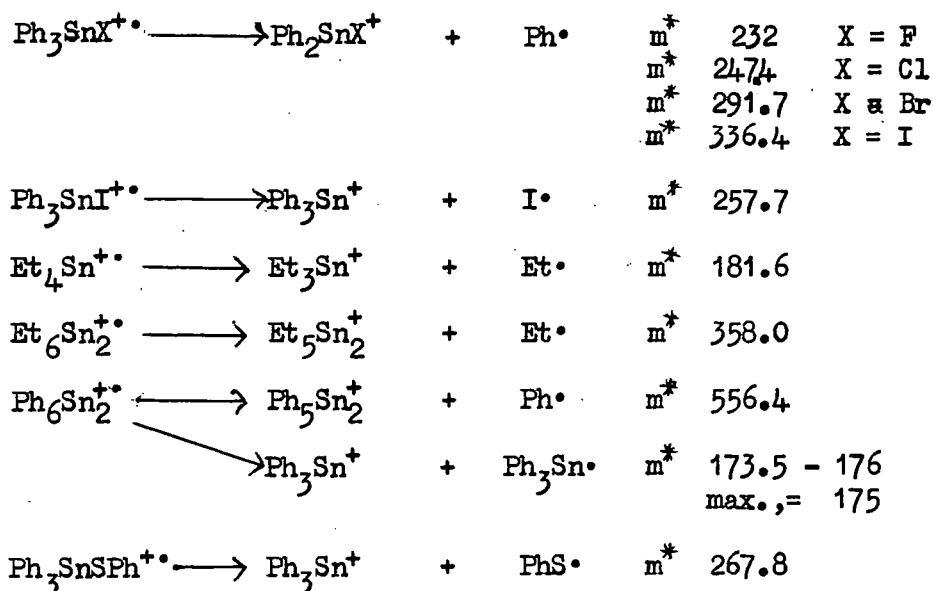

With unsymmetrical compounds different groups may be lost from the parent ion producing different three co-ordinate ions. The mixed ethylphenylstannanes produce two R_3Sn^+ ions the more abundant being

Table 4.2.4.

Abundances of SnR_4^{+} , SnR_3^+ and SnR_2^+ ions relative to total tin-containing ions for ethyl-phenyl tin compounds at 70 eV

| Compound | SnR_4^{+} | SnR_3^+ | SnR_2^+ | SnR_3^+ | SnR_2^+ | SnR_3^+ |
|---|--------------------|------------------|------------------|------------------|------------------|------------------|
| SnPh_4 | 0.11 | 42.26 | 0.47 | 1.14 | 0.62 | 0.01 |
| SnPh_3Et | 0.05 | 62.27 | 50.52 | 30.37 | 26.18 | 0.01 |
| SnPh_2Et_2 | 1.35 | | | | | |
| SnPhEt_3 | 0.26 | | | | | |
| SnEt_4 | 0.97 | | | | | |
| $\text{SnPh}_2(\text{CH}_2\text{-CH}_2\text{Ph})$ | 0.01 | 61.00 | | | | |

Table 4.2.5.

Abundances of SnR_3^+ ions making allowances for subsequent decompositions of the SnR_3^+ ions. Abundances relative to total tin-containing ions

| Compound | SnPh_3 | SnPh_2Et | SnPhEt_2 | SnEt_3 |
|----------------------------|--------------------|--------------------------|--------------------|-----------------|
| SnPh_4 | 83.15 ^a | | | |
| SnPh_3Et | 64.14 ^b | 1.73 | | |
| SnPh_2Et_2 | | 94.61 | 4.04 | |
| SnPhEt_3 | | | 90.22 ^c | 1.17 |
| SnEt_4 | | | | 90.03 |

^a Abundance of SnPh_3^{+} ignored since process $\text{SnPh}_4^{+} \rightarrow \text{SnPh}_3^{+} + \text{Ph}$ occurs. ^b Abundance of SnPh_3^{+} and all derivative ions ignored since the decompositions $\text{SnPh}_3\text{H}^+ \rightarrow \text{SnPh}_2^+ + \text{C}_6\text{H}_6$ and $\text{SnPh}_3^+ \rightarrow \text{SnPh}^+ + \text{Ph}_2$ occur. Thus both SnPh_2Et^+ and SnPh_3^+ are sources of SnPh_2^+ , SnEt^+ and SnH^+ ignored since SnPhEt_2^+ and SnEt_3^+ are both sources of these ions.

Table 4.2.6.

Dependence of hydride ion formation on the number of Sn-Et bonds present. Abundances (%) relative to total tin-containing ions

| Compound | Sn^+ | R_1SnH^+ | R_2SnH_2^+ | SnH_3^+ |
|----------------------------|---------------|--------------------------|----------------------------|------------------|
| SnPh_4 | 18.61 | 0.36 | | |
| SnPh_3Et | 13.35 | 2.00 | | |
| SnPh_2Et_2 | 9.61 | 16.79 | 0.89 | |
| SnPhEt_3 | 9.83 | 19.92 | 10.96 | |
| SnEt_4 | 4.89 | 36.29 | 17.24 | 1.31 |

* R_3SnH^+ and R_3SnH^+ absent.

that containing the greater proportion of phenyl groups. (table 4.2.4.) This could be due to the ease with which further decompositions of ions containing Sn - Et groups occurs, but in table 4.2.5. an attempt has been made to allow for the subsequent fragmentation of R_3Sn^+ ions, using the decomposition diagrams fig. 10. (p.118), thereby giving an estimate of the ratio of the two $Ph_nSnEt_{3-n}^+$ ions initially formed from the ethylphenyl stannanes.

Even when these allowances are made, the ion containing the greater proportion of phenyl groups is always the more abundant. The relative probabilities of the dissociative processes available depends on the relative bond strengths in the molecular ion and also on the relative stabilities of the radicals and ions produced. Appearance potential measurements discussed earlier were not sensitive enough to distinguish between $D(Ph_2EtSn^+ - Ph)$ and $D(PhEt_2Sn^+ - Ph)$ and the high abundance of the R_3Sn^+ ion containing the greater proportion of phenyl groups may not be due entirely to bond strengths but also to more effective delocalisation of positive charge in the R_3Sn^+ ion having the greater proportion of phenyl groups.

In the neutral molecules, however, the indications are that a tin-phenyl bond is stronger than a tin-ethyl although in some cases the difference is small.

$$D(Ph_3Sn - Ph) - D(Ph_3Sn - Et) = 23.1 \pm 3.2 \text{ Kcal. mole.}^{-1}$$

$$D(Ph_2EtSn - Ph) - D(Ph_2EtSn - Et) = 10.4 \pm 3.2 \quad "$$

$$D(PhEt_2Sn - Ph) - D(PhEt_2Sn - Et) = 1.2 \pm 3.2 \quad "$$

$$D(Me_3Sn - Ph) - D(Me_3Sn - Et)^{64} = 13 \pm 6 \quad "$$

Thus it appears that the radical most readily lost is that which would be

expected to be most weakly bonded totin in the neutral molecule. With hexaphenyldistannane less than 10% of the total ion current is carried by ions containing a tin-tin bond. Appearance potential measurements given earlier showed that the Sn - Sn bond in hexaphenyldistannane was some 20.1 Kcal. mole.⁻¹ weaker than the tin-phenyl bond in tetraphenyltin. Also in the spectra of ethylmethylstannanes¹²² the major ion is produced by ethyl loss and known bond dissociation energies give $D(\text{Me}_3\text{Sn} - \text{Me}) > D(\text{Me}_3\text{Sn} - \text{Et})$.⁶⁴

Loss of R· from an $\text{R}_2\text{Sn}^{+\bullet}$ ion has never been observed. PhSn^+ is the only even-electron ion which shows a bond-cleavage process.

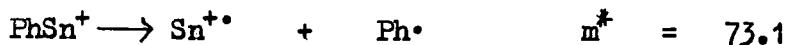

The odd electron metal ion, $\text{Sn}^{+\bullet}$, is of high abundance for all the tin compounds studied.

Ions formed by cleavage of C - C or C - H bonds are always of very low abundance. This probably reflects the weakness of tin-carbon bond strengths relative to C - C or C - H. Loss of a hydrogen atom is observed only for tetraphenyltin and the triphenyltin halides. In each case low abundance ions are produced, e.g.

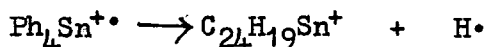

Major Rearrangement Decompositions.

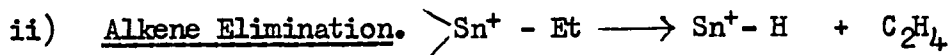

This process which is probably general for even-electron ions containing the grouping $\text{R}_2\text{CH}\cdot\text{CH}_2\text{M}$, has been observed with tetraethyl- and ethylphenyltin compounds. The percentage ion-current carried by hydride ions increases with the number of Sn - Et bonds (table 4.2.6. p. 104) and with the strength of the metal-hydrogen bond (table 4.2.7.)

Table 4.2.7.

Hydride ion abundances relative to total tin-containing ions in MEt_4 at 70eV.

| | M^+ | MH^+ and Et_2MH^+ | $EtMH_2^+$ | H_3M^+ | Total |
|----------------|-------|-----------------------|------------|----------|-------|
| Et_4Ge^{123} | 1.8 | 41.30 | 15.40 | 2.4 | 59.1 |
| Et_4Sn | 4.89 | 36.29 | 17.24 | 1.31 | 53.53 |
| Et_4Pb^* | 10.33 | 11.95 | 0.79 | - | 12.74 |

* See table 4.2.10. p. 123.

Metastable confirmed decompositions of this type are

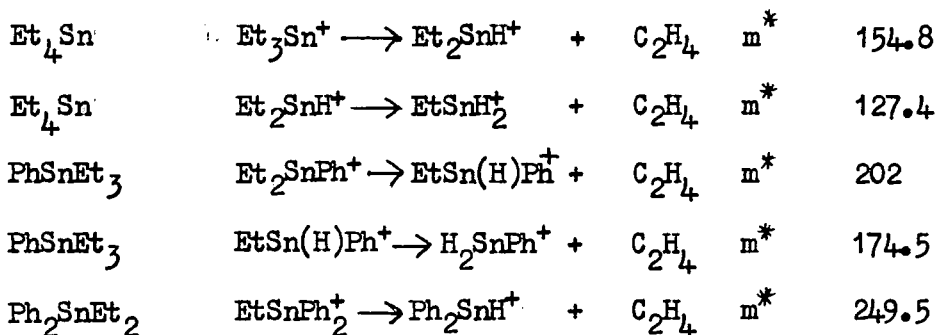

It seems probable that transfer of a hydrogen from a β - carbon atom is involved since ethylene elimination readily occurs from ions containing only one Sn - Et bond.

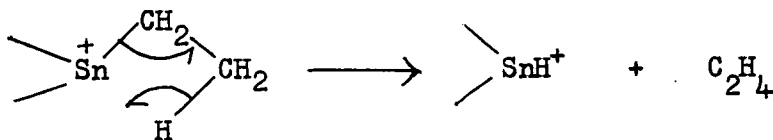

(here fishhooks \curvearrowright represent movement of one electron)

In the spectrum of tetraethyltin the presence of H_3Sn^+ can be explained by ethylene loss from H_2SnEt^+ which is of high abundance.

Elimination of ethylene from odd-electron molecular ions has never been observed and by the above mechanism would require a pentaco-ordinate transition intermediate which may be energetically

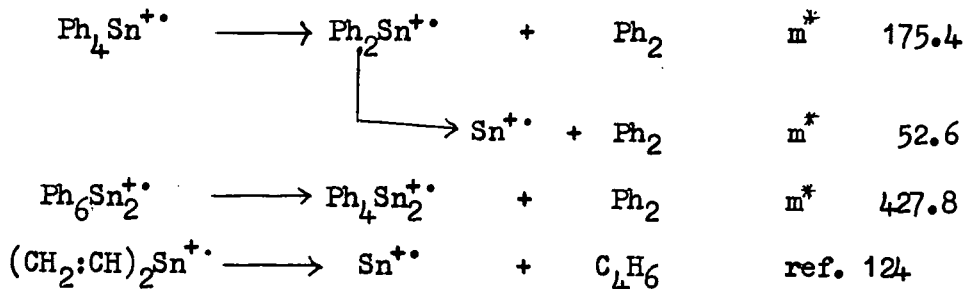

The elimination of biphenyl from $\text{Ph}_6\text{Sn}_2^{+\bullet}$ leads to a product ion which may be formulated as $\text{Ph}_3\text{SnSnPh}^{+\bullet}$ or $\text{Ph}_2\text{SnSnPh}_2^{+\bullet}$.

$\Delta H_f^\circ(\text{Sn}^{+\bullet})$ calculated from the appearance potential¹²⁴ of $\text{Sn}^{+\bullet}$ in the spectrum of tetraphenyltin agrees with biphenyl elimination.

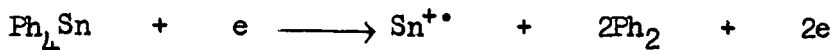

Since the abundance of $\text{Ph}_2\text{Sn}^{+\bullet}$ is only just detectable for a variety of triphenyltin compounds which show a strong Ph_3Sn^+ ion it may be inferred that biphenyl loss from $\text{Ph}_4\text{Sn}^{+\bullet}$ is the major process leading to $\text{Ph}_2\text{Sn}^{+\bullet}$, and that loss of a phenyl radical from Ph_3Sn^+ occurs to only a minor extent. It also follows that reactions such as

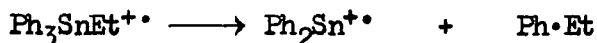

do not occur to any significant extent.

Elimination of RR' molecules from even-electron ions $\text{X-SnR}'\text{R}^+$ is a major process. Thus for all triphenyltin compounds examined the decomposition

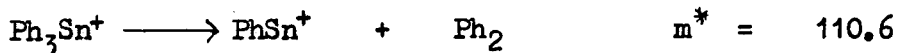

is observed. Diphenyltin halide ions eliminate both biphenyl and halogenobenzene

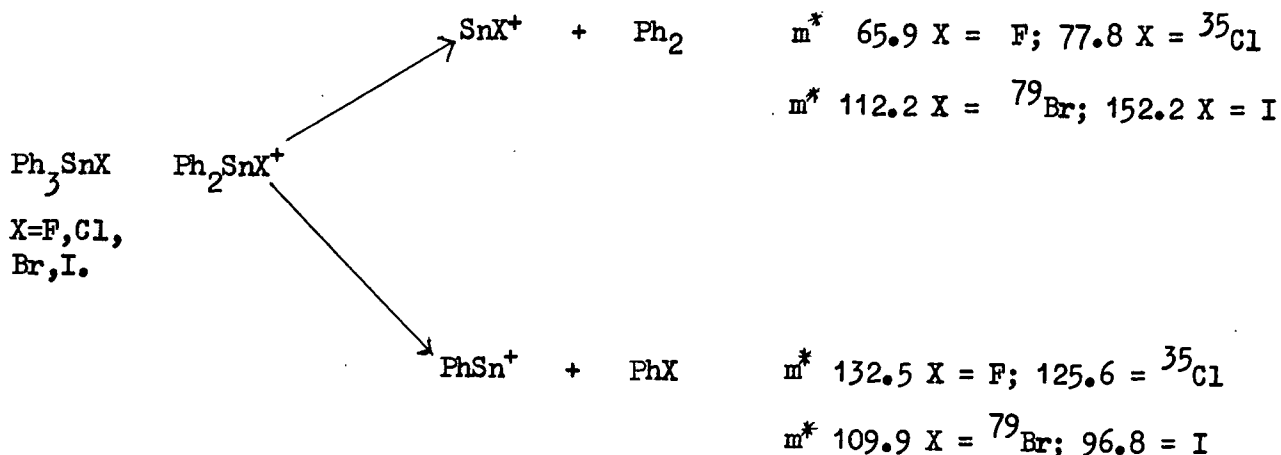

The diphenyltin hydride ion, from diethyldiphenyltin decomposes by elimination of benzene whilst loss of hydrogen is observed from $-\text{SnH}_2^+$ ions derived from tetraethyltin and hexaethyldistannane.

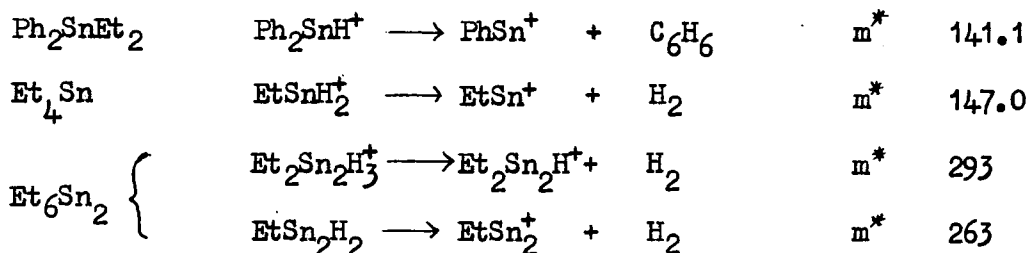

The elimination of ethane has been observed in the spectrum of triethyltin chloride¹²⁵.

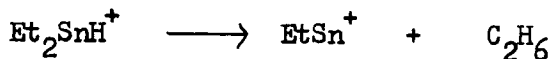

This elimination of RR' molecules could proceed via a 3 centre transition intermediate.

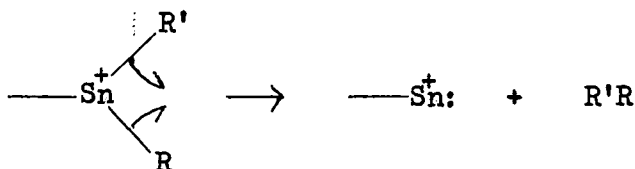

Here fishhooks(/) represent movement of one electron.

Minor Rearrangement Decompositions.

iv) Molecule Elimination by Cleavage of One Sn X Bond.

Such a process is observed in the spectra of $\text{Ph}_3\text{Sn}\cdot\text{SPh}$,

Ph_3SnEt , Ph_4Sn and triphenyltin halides producing ions of low abundance



It would be interesting to determine the hydrogen atom which is transferred in this process. This could be accomplished by deuterium labelling in specific positions in the phenyl group. It seems plausible that a σ -hydrogen may be involved with formation of a 5-centre transition intermediate.

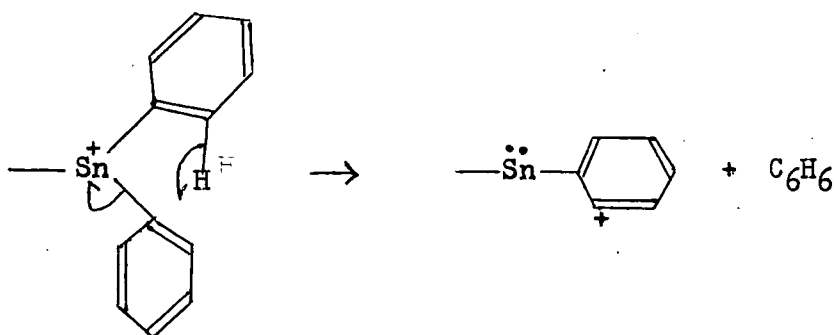

Here fishhooks (\curvearrowright) represent movement of one electron.

These product ions might involve a σ -bonded phenyl group from which a hydrogen atom has been removed, or they could be formulated as

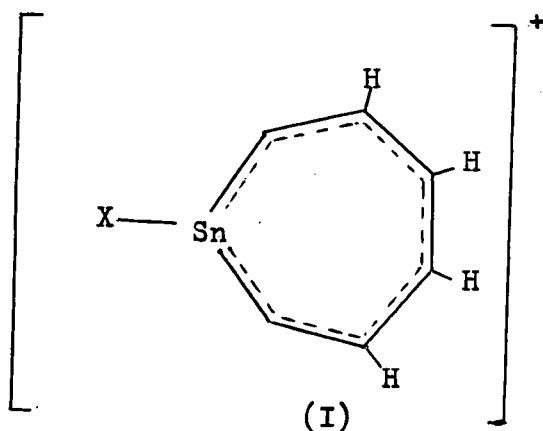

each dotted line represents
1 and 1/7 electrons.

Here the tin is trico-ordinate and extensive delocalisation of positive charge is possible. The high stability of trico-ordinate tin ions (tables 4.2.4. and 4.2.5. p. 104) is one of the dominant features revealed in this work.

The elimination of HX from Ph_3SnX^+ producing the ion $\text{Ph}_2\text{SnC}_6\text{H}_4^+$ in low abundance has been metastable confirmed for the fluorotin compound.



With 5 - stannaspiro (4,4) nonane elimination of ethylene from the parent ion and $\text{C}_4\text{H}_8\text{Sn}^+$ may involve cleavage of a tin-carbon bond.

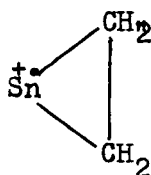
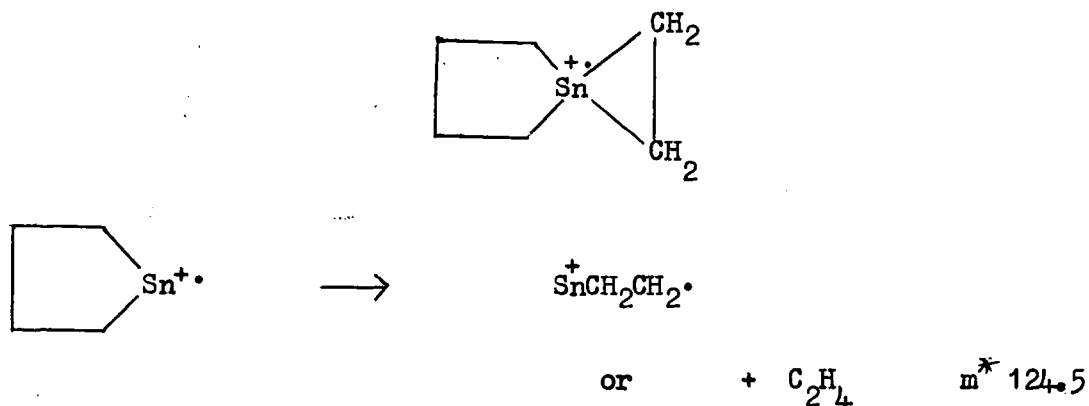
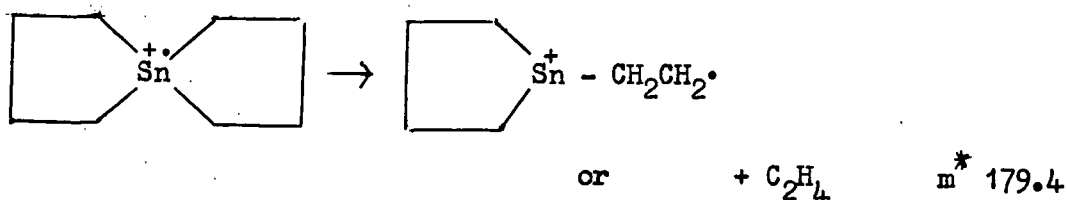

cydoalkanes. With the germanium compound deuterium labelling shows that Ge - C cleavage is involved.

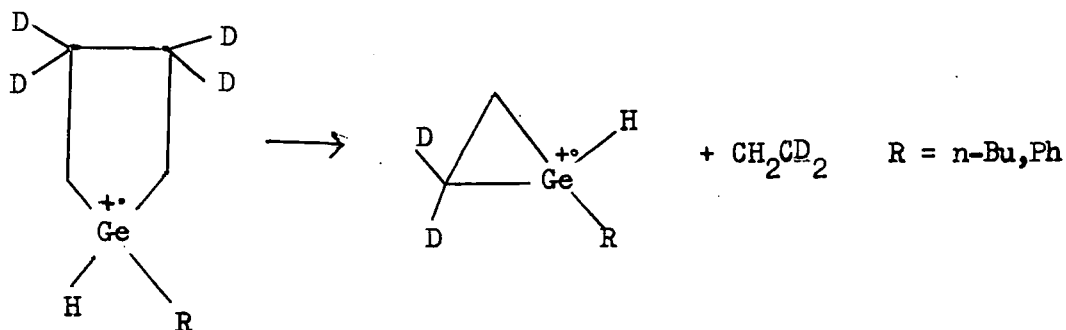

v) Fragmentation of Phenyl Groups Attached to Tin:

Such processes require considerable energy and disappear from the spectrum at 20eV. Phenyltin ions fragment by successive loss of acetylene and, although these transitions are not metastable supported for tin, they are for germanium and silicon (see p. 136.)

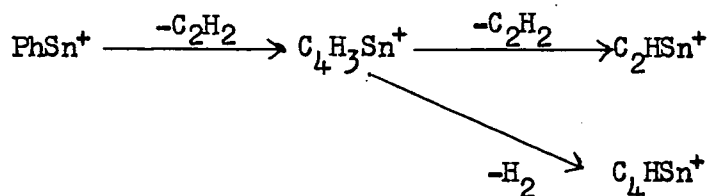

Tetraphenyltin and compounds of the type Ph_3SnX and Ph_2SnX_2 produce the ion $\text{C}_{12}\text{H}_9\text{Sn}^+$ which can be formulated as the trico-ordinate ion (I). Whenever $\text{C}_{12}\text{H}_9\text{Sn}^+$ is present so are ions which are probably derived from it by successive loss of acetylene.

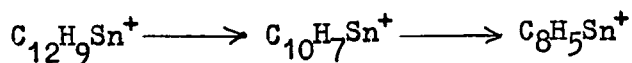

The analogous decomposition from silicon and germanium ions is confirmed by the presence of metastable peaks (see p. 136).

It is significant that ring fragmentation processes involving loss of acetylene from Ph_3Sn^+ are not observed. This may be because of other more favourable modes of decomposition available to Ph_3Sn^+

(i.e. such as biphenyl or benzene loss). Alternatively a certain minimum positive charge may be necessary on a phenyl group to cause C_2H_2 elimination. The triphenyltin halides, which produce $XSnC_6H_4^+$ ions in low abundance, also do not show ring fragmentation products $XSnC_4H_2^+$ or $XSnC_2^+$; this may be due to a mesomeric effect of the halogen atom reducing the positive charge on the organic group.

vi) Methylene Elimination from $SnCH_2CH_3^+$

All ethyltin compounds and triphenylethyltin show low abundance ions ascribable to a methylene elimination reaction

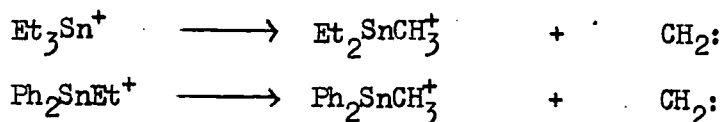

Since for tetraethyl - and ethyltriphenyl - tin the ion currents of the product ions vary linearly with those of Et_4Sn^{+} and Ph_3Sn^+ , respectively, the above unimolecular process is favoured, but this does not exclude the possibility of slow (rate determining) methyl loss followed by rapid hydrogen attachment. The ethylbromide used in the preparation of ethyltin compounds was free from methyl halides thus excluding the possibility that the ethyltin compounds contained traces of methyltin compounds. Moreover the mass spectrum of tetraethyltin showed no change in abundance of Et_2SnMe^+ over the temperature range 20 - 200°C, indicating that the ion is not produced by thermal rearrangement. Corresponding ions which could result from methylene elimination are observed with tetraethyl-germane¹²³ and - lead (table 4.2.10. p. 123) and ethyltriphenylgermane¹²³. With triphenylphenethyltin methylene elimination must occur. Ph_4Sn^{+} could be formed by ethylene elimination

Mass Spectra of $\text{Ph}_n\text{SnEt}_{4-n}$, Et_6Sn_2 , Ph_6Sn_2 and $(\text{CH}_2)_4 \text{Sn} < (\text{CH}_2)_4$

Using the observed decomposition modes for organostannanes, the probable decomposition processes for these compounds are shown in fig. 10.

For all the compounds the molecular ions are of very low abundance. At 20eV many of the fragment ions formed from ethylphenylstannanes virtually disappear; for example phenyl group fragmentation is no longer observed. With the exception of tetraphenyltin 90% of the ion current is carried by R_3Sn^+ ions (table 4.2.1. p. 101). For Et_4Sn and Et_3SnPh the ions Sn^{++} , SnH^+ and EtSn^+ fall to very low values. This is most readily ascribed to the non-occurrence of the process

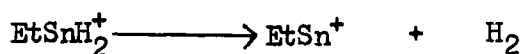

Hexaethyldistannane contrasts with hexaphenyldistannane in that almost 70% of the total ion current is carried by Sn_2 species. The earlier observation that the bond most likely to be cleaved on decomposition of the molecular ion was the one which would be expected to be the weakest in the neutral molecule can be used to explain this since $D(\text{Ph}_3\text{Sn} - \text{SnMe}_3)$ is about 8 Kcal. mole.⁻¹ weaker than $D(\text{Ph}_3\text{Sn} - \text{Et})$ and $D(\text{Me}_3\text{Sn} - \text{SnMe}_3)$ is about 8 Kcal. mole.⁻¹ weaker than $D(\text{Me}_3\text{Sn} - \text{Et})$.⁶⁴ The ion Et_5Sn_2^+ can then decompose further by successive eliminations of ethylene producing hydride ions.

There is some evidence that hexaethyldistannane undergoes partial thermal decomposition at an ionization chamber temperature of 200°C since at 100°C the abundance of the parent ion is doubled, with a decrease in the abundance of both Et_5Sn_2^+ and Et_3Sn^+ . (table 4.2.1.)

Tetraphenyltin, hexaphenyldistannane and the triphenyltin halides show the tin hydride ions SnH^+ which do not feature in fig. 10. and are not

Decomposition diagram for organostannanes.

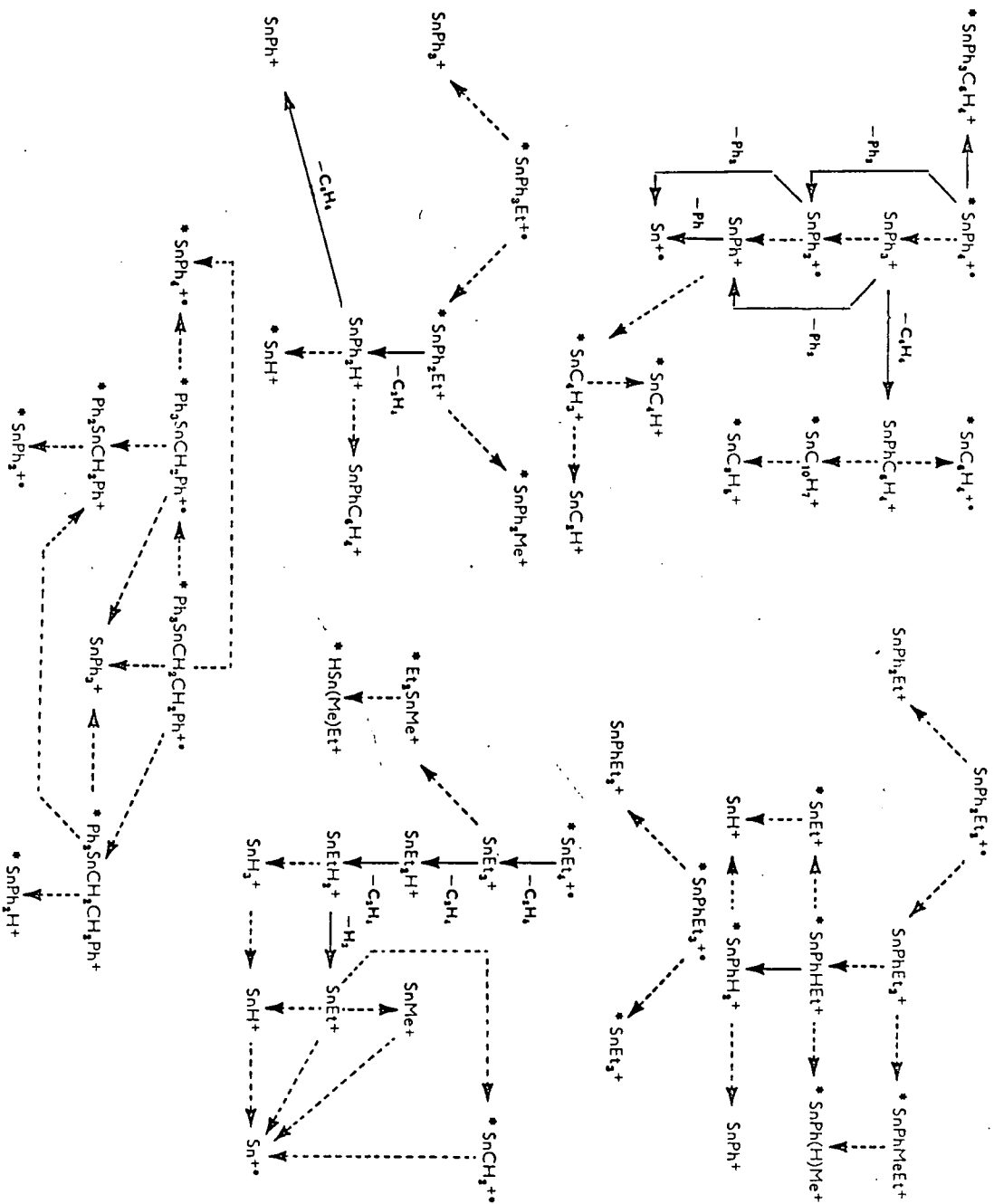
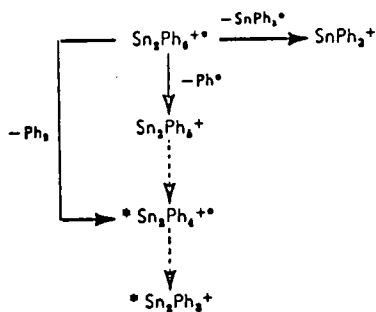
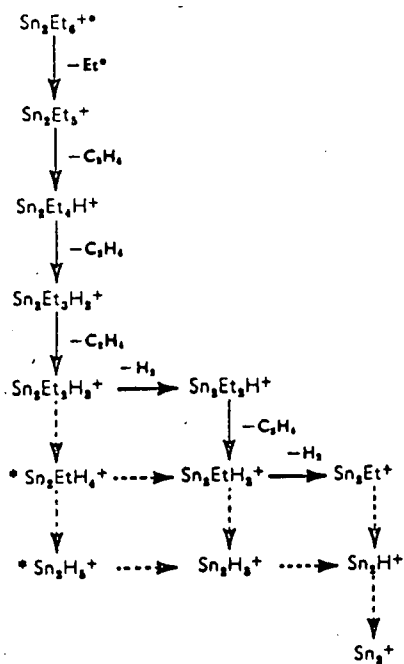
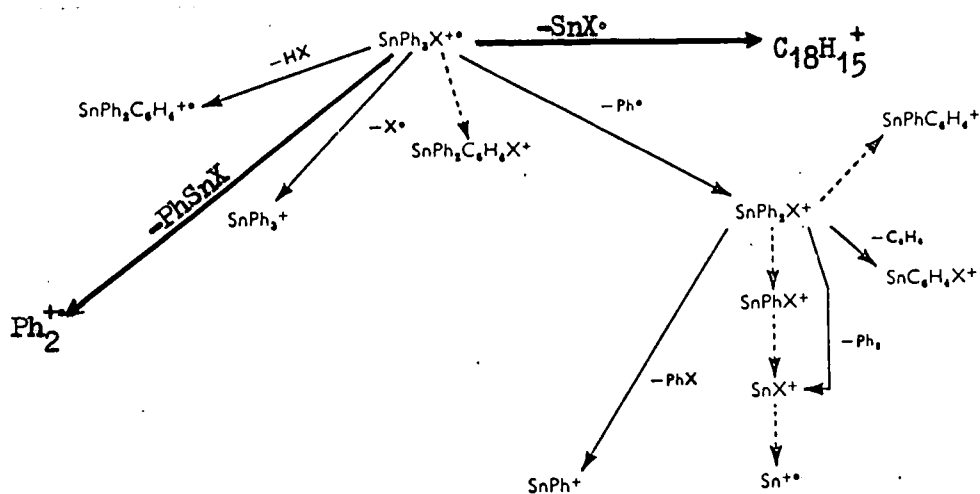

Fig. 10.

Fig. 10. continued



Fragmentation of ions common to two or more compounds are shown only once.

Solid arrows indicate metastable confirmed transitions.

* Abundance < 1% of total tin-containing ions.

explicable by any of the fragmentation modes discussed earlier. The abundance of SnH^+ varies linearly with that of $\text{Sn}^{+\bullet}$, hence it is probably not produced by hydrogen attachment but by processes such as

$$\text{C}_2\text{HSn}^+ \longrightarrow \text{SnH}^+ + \text{C}_2 \quad \text{and} \quad \text{PhSn}^+ \longrightarrow \text{SnH}^+ + \text{C}_6\text{H}_4.$$

An interesting feature of the spectra of Ph_6Sn_2 is the occurrence of $\text{C}_{24}\text{H}_{19}\text{Sn}^+$ (i.e. $\text{Ph}_3\text{SnC}_6\text{H}_4^+$). Since its abundance varied linearly with that of the parent ion it is best explained in terms of the transfer of an organic group from one tin atom to the other with cleavage of the tin-tin bond. Such transformations, which are clearly more readily studied when the two metals are dissimilar, are described in more detail in the following chapter 4.2.2.

In the mass spectrum of 5 - stannaspiro (4,4) nonane the molecular ion and first bond cleavage product have the same mass and cannot be distinguished. Similarly a number of reasonable structure can be assigned to the fragment $\text{C}_6\text{H}_{12}\text{Sn}^+$.

Mass Spectra of Triphenyltin Halides

The decomposition diagram for these compounds is given in fig.10. The cracking patterns are very similar except for the iodide, where cleavage of the Sn-I bond is the important process. This probably implies that $D(\text{Ph}_2\text{ISn-Ph}) > D(\text{Ph}_3\text{Sn-I})$ whereas for the other triphenyltin halides the order is reversed.

4.2.2. Metal-Metal Bonded Compounds $A_3M-M'B_3$

(M = Si, Ge and Sn) and Organoplumbanes.

The mass spectrum of hexaphenyldistannane showed the presence of an ion ($SnC_{24}H_{19}^+$) in which transfer of an organic group from one metal to the other had occurred. To investigate this rearrangement more fully the mass spectra of a variety of $A_3M-M'B_3$ compounds were recorded at 70eV. The specific compounds studied and the abundances of their decomposition products are shown in table 4.2.8.

Since it was apparent that the modes of decomposition found for the organo-tin ions applied equally well to organo-silicon and - germanium ions, the mass spectra of tetraethyl - and tetraphenyl - lead, tetraphenylmethane and t-butyltriphenylmethane were also recorded for comparison. The abundance of ions produced for these compounds are shown in tables 4.2.9., 4.2.10., and fig. 11. The spectrum of tetraethyllead shows minor differences from earlier observations¹⁴ which may be attributed to different source temperatures and spectrometers.

Modes of Decomposition at 70eV.

The major feature of the mass spectra of $A_3M-M'B_3$ compounds (M, M' = Si, Ge, Sn; A, B = phenyl, methyl, ethyl, benzyl) is the presence of ions, often in high abundance where transfer of organic groups between metal atoms has occurred (table 4.2.11.) Apart from this these compounds and the organoplumbanes studied decompose under electron impact in ways very similar to those observed for organostannanes (chapter 4.2.1.). Metal-containing ions are always the most abundant accounting for ~95% of the total ion current. Again this is not surprising since the electronegativity of carbon is greater than for the other group IV elements.

Table 4.2.8.

Ion abundances *

| (PhCH ₂) ₂ GeSiMe ₂ | Ph ₂ GeSiEt ₂ | Ph ₂ Sn ⁺ GeMe ₂ | Me ₂ Sn ⁺ GePh ₂ | Ph ₂ M ⁺ MMe ₂ | Sn | M | Si | Et ₃ Si ⁺ SiPh ₂ | Ph ₂ Si ⁺ SiPh ₂ | | | | | | |
|---|-------------------------------------|---|---|---|-------|---|-------|---|---|-------|-------|---|-------|--|-------|
| (PhCH ₂) ₂ Me ₂ GeSi ⁺ | 0-05 | Ph ₂ Et ₂ GeSi ⁺ | 3-99 | Ph ₂ Me ₂ SnGe ⁺ | 0-91 | Ph ₂ Me ₂ SnGe ⁺ | 1-68 | Ph ₂ M ₂ Me ₂ ⁺ | 1-83 | 4-00 | 9-14 | Et ₂ Ph ₂ Si ₂ ⁺ | 6-72 | Ph ₂ Si ₂ ⁺ | 14-87 |
| (PhCH ₂) ₂ Me ₂ GeSi | 0-73 | Ph ₂ Et ₂ GeSi | 3-98 | Ph ₂ Me ₂ SnGe | 1-29 | Ph ₂ Me ₂ SnGe | 15-56 | C ₁₂ H ₁₂ M ₂ ⁺ | 12-89 | 2-10 | 4-01 | Et ₂ Ph ₂ Si ₂ ⁺ | 0-63 | C ₁₁ H ₁₁ Si ₂ ⁺ | 0-07 |
| | | Ph ₂ Et(H)GeSi | 0-64 | C ₁₂ H ₁₂ SnGe ⁺ | 0-33 | C ₁₂ H ₁₂ M ₂ ⁺ | 0-33 | C ₁₂ H ₁₂ M ₂ ⁺ | 0-04 | 0-04 | 0-04 | Ph ₂ Et(H)Si ₂ ⁺ | 1-11 | Ph ₂ Si ₂ ⁺ | 2-61 |
| | | Ph ₂ H ₂ GeSi | 0-48 | Ph ₂ SnGe | 0-10 | C ₁₂ H ₁₂ M ₂ ⁺ | 0-10 | C ₁₂ H ₁₂ M ₂ ⁺ | 0-24 | 0-24 | 0-12 | Ph ₂ Si ₂ H ₂ ⁺ | 0-24 | C ₁₁ H ₁₁ Si ₂ ⁺ | 0-07 |
| | | Ph ₂ GeSi | 0-33 | | | Ph ₂ Me ₂ ⁺ | 0-14 | Ph ₂ Me ₂ ⁺ | 0-14 | 0-14 | 0-26 | Ph ₂ Et ₂ Si ₂ ⁺ | 0-07 | Ph ₂ Si ₂ ⁺ | 0-07 |
| (PhCH ₂) ₂ Me ₂ GeSi | 28-00 | Ph ₂ Et ₂ GeSi | 0-10 | Ph ₂ Me ₂ SnGe | 0-75 | Ph ₂ Me ₂ SnGe | 0-16 | Ph ₂ Me ₂ M ₂ ⁺ | 0-26 | 0-20 | 0-53 | Ph ₂ Et ₂ Si ₂ ⁺ | 0-07 | Ph ₂ Si ₂ ⁺ | 0-07 |
| C ₁₇ H ₁₇ GeSi ⁺ | 0-50 | Ph ₂ Et ₂ (H)GeSi | 0-12 | C ₁₁ H ₁₁ SnGe ⁺ | 0-17 | C ₁₁ H ₁₁ SnGe | 0-06 | C ₁₂ H ₁₂ M ₂ ⁺ | 0-06 | 0-06 | 0-34 | Ph ₂ Et ₂ H ₂ Si ₂ ⁺ | 0-05 | C ₁₁ H ₁₁ Si ₂ ⁺ | 0-04 |
| (PhCH ₂) ₂ Me ₂ GeSi ⁺ | 0-27 | Ph ₂ Et(H) ₂ GeSi | 0-28 | C ₁₃ H ₁₃ SnGe ⁺ | 0-10 | C ₁₃ H ₁₃ SnGe | 0-10 | C ₁₃ H ₁₃ M ₂ ⁺ | 0-10 | 0-10 | 0-34 | | | Ph ₂ Si ₂ ⁺ | 0-02 |
| C ₁₂ H ₁₂ GeSi | 3-72 | | | C ₁₂ H ₁₂ SnGe | 0-06 | C ₁₂ H ₁₂ SnGe | 0-06 | Ph ₂ Me ₂ M ₂ ⁺ | 0-04 | 0-04 | 0-04 | | | | |
| (PhCH ₂) ₂ Me ₂ GeSi ⁺ | 0-31 | | | | | | | C ₁₂ H ₁₂ M ₂ ⁺ | 0-07 | 0-07 | 0-04 | | | | |
| (PhCH ₂) ₂ Me ₂ GeSi | 0-67 | | | | | | | Ph ₂ Me ₂ ⁺ | 0-04 | 0-04 | 0-04 | | | | |
| | | | | | | | | C ₁₂ H ₁₂ M ₂ ⁺ | 0-04 | 0-04 | 0-14 | | | | |
| (PhCH ₂) ₂ Ge | 2-85 | Ph ₂ Ge | 9-83 | Ph ₂ Sn | 10-06 | Ph ₂ Ge | 26-81 | Ph ₂ M ₂ ⁺ | 11-97 | 40-50 | 40-60 | Ph ₂ Si | 24-77 | C ₁₁ H ₁₁ Si | 0-05 |
| C ₂₁ H ₁₁ Ge | 0-05 | C ₁₁ H ₁₁ Ge | 0-28 | | | C ₁₁ H ₁₁ Ge | 0-28 | Ph ₂ M ₂ ⁺ | 0-25 | 0-25 | 0-94 | C ₁₁ H ₁₁ Si | 0-87 | Ph ₂ Si | 69-45 |
| | | | | | | | | C ₁₁ H ₁₁ M ₂ ⁺ | 0-25 | 0-25 | 0-31 | C ₁₁ H ₁₁ Si | 0-37 | C ₁₁ H ₁₁ Si | 1-30 |
| | | | | | | | | C ₁₁ H ₁₁ M ₂ ⁺ | 0-27 | 5-04 | 6-52 | C ₁₁ H ₁₁ SiPh | 6-28 | C ₁₁ H ₁₁ Si | 0-04 |
| C ₁₁ H ₁₁ Ge | 0-30 | C ₄ H ₉ GePh | 3-84 | C ₄ H ₉ SnPh | 1-20 | C ₄ H ₉ GePh | 2-21 | C ₁₁ H ₁₁ M ₂ ⁺ | 0-27 | 1-02 | 2-32 | C ₁₁ H ₁₁ Si ⁺ | 2-00 | C ₁₁ H ₁₁ SiPh | 5-47 |
| C ₁₁ H ₁₁ Ge | 0-06 | C ₄ H ₉ GePh ⁺ | 1-71 | | | C ₄ H ₉ GePh ⁺ | 0-15 | C ₁₁ H ₁₁ M ₂ ⁺ | 0-55 | 0-55 | 0-11 | C ₁₁ H ₁₁ Si ⁺ | 0-61 | C ₁₁ H ₁₁ Si ⁺ | 1-75 |
| | | | | | | | | C ₁₁ H ₁₁ M ₂ ⁺ | 0-11 | 0-11 | 0-11 | C ₁₁ H ₁₁ Si ⁺ | 0-08 | C ₁₁ H ₁₁ Si ⁺ | 0-05 |
| | | PhGeC ₂ H ₅ | 0-25 | PhSnC ₂ H ₅ | 0-11 | PhGeC ₂ H ₅ | 0-54 | C ₁₁ H ₁₁ M ₂ ⁺ | 0-11 | 0-28 | 1-42 | PhSiC ₂ H ₅ | 1-49 | C ₁₁ H ₁₁ Si ⁺ | 0-01 |
| | | PhGeC ₃ | 0-16 | PhSnC ₃ | 0-10 | PhGeC ₃ | 0-22 | PhMC ₂ H ₅ | 0-05 | 0-19 | 0-62 | PhSiC ₂ H ₅ | 0-64 | PhSiC ₂ H ₅ | 1-31 |
| | | Ph ₂ Ge ⁺ | 28-92 | Ph ₂ Sn ⁺ | 17-46 | Ph ₂ Ge ⁺ | 0-89 | Ph ₂ M ₂ ⁺ | 0-05 | 0-19 | 0-62 | PhSiC ₃ | 1-72 | PhSiC ₃ | 0-05 |
| | | Ph ₂ GeH | 0-59 | Ph ₂ SnH | 0-15 | | | Ph ₂ M ₂ ⁺ | 1-81 | 3-65 | 3-41 | Ph ₂ Si ⁺ | 1-72 | Ph ₂ Si ⁺ | 1-29 |
| | | | | | | | | Ph ₂ MH | 0-14 | 0-76 | 0-39 | Ph ₂ SiH | 3-64 | Ph ₂ SiH | 0-43 |
| | | | | | | | | | | | | PhSiH ⁺ | 0-76 | | |
| (PhCH ₂) ₂ GeH ₂ | 0-85 | PhGeH ₂ | 0-46 | PhSn | 17-75 | PhGe | 11-28 | PhMH ₂ | 0-08 | 0-36 | 0-22 | PhSiH ₂ | 3-10 | | |
| (PhCH ₂) ₂ Ge | 15-03 | PhGe | 6-47 | PhSn | 17-75 | PhGe | 11-28 | PhM | 27-83 | 11-58 | 5-01 | PhSi | 8-21 | PhSi | 3-48 |
| C ₇ H ₇ Ge ⁺ | 0-04 | C ₄ H ₉ Ge ⁺ | 0-34 | C ₄ H ₉ Sn ⁺ | 0-45 | C ₄ H ₉ Ge ⁺ | 0-11 | C ₄ H ₉ M ⁺ | 0-61 | 2-00 | 1-92 | C ₄ H ₉ Si ⁺ | 0-13 | C ₄ H ₉ Si ⁺ | 0-02 |
| C ₇ H ₇ Ge | 0-08 | C ₄ H ₉ Ge | 0-59 | | | | | C ₄ H ₉ M ⁺ | 0-19 | 0-19 | 0-62 | C ₄ H ₉ Si | 0-77 | C ₄ H ₉ Si | 0-05 |
| C ₄ H ₉ Ge | 0-87 | | | | | | | | | | | | | | |
| C ₄ H ₉ Ge | 1-34 | C ₄ H ₉ Ge | 0-59 | C ₄ H ₉ Sn | 0-20 | C ₄ H ₉ Ge | 1-21 | C ₄ H ₉ M | 0-26 | 1-21 | 0-75 | C ₄ H ₉ Si | 0-10 | C ₄ H ₉ Si | 0-05 |
| C ₄ H ₉ Ge ⁺ | 0-35 | | | C ₄ H ₉ Sn | 0-12 | | | C ₄ H ₉ M ⁺ | 0-26 | 1-21 | 0-64 | C ₄ H ₉ Si ⁺ | 0-03 | C ₄ H ₉ Si ⁺ | 0-02 |
| | | | | | | | | C ₄ H ₉ M ⁺ | 0-14 | 0-21 | 0-21 | C ₄ H ₉ Si | 0-02 | C ₄ H ₉ Si | 0-01 |
| C ₄ H ₉ Ge | 0-42 | C ₂ H ₅ Ge | 0-43 | C ₂ H ₅ Sn | 0-68 | C ₂ H ₅ Ge | 0-04 | C ₄ H ₉ M | 0-56 | 1-04 | 1-21 | C ₄ H ₉ Si | 1-10 | C ₄ H ₉ Si | 0-07 |
| C ₄ H ₉ Ge ⁺ | 0-14 | | | | | | | | | | | | | | |
| C ₄ H ₉ Ge | 0-57 | | | | | | | | | | | | | | |
| HGe | 0-14 | HGe | 0-11 | H ₂ Sn | 0-17 | HGe | 0-09 | HM | 0-40 | 0-27 | 0-18 | H ₂ Si | 0-72 | | |
| Ge | 0-08 | Ge ⁺ | 0-15 | Sn ⁺ | 19-04 | Ge ⁺ | 0-28 | M ⁺ | 10-78 | 0-36 | 0-07 | HSi | 0-16 | HSi | 0-02 |
| Me ₂ Si | 11-24 | Et ₂ Si | 2-61 | Me ₂ Ge | 3-85 | Me ₂ Sn | 1-11 | Me ₂ M | 1-76 | 3-69 | 3-30 | Et ₂ Si | 3-30 | Si ⁺ | 0-01 |
| C ₄ H ₉ Si | 0-01 | | | C ₄ H ₉ Ge ⁺ | 0-17 | | | | | | | C ₄ H ₉ Si ⁺ | 0-58 | | |
| C ₄ H ₉ Si | 0-04 | | | | | | | | | | | | | | |
| Me ₂ SiH | 1-07 | Et ₂ SiH | 8-69 | Me ₂ GeH | 0-22 | | | | | | | | | | |
| Me ₂ Si ⁺ | 0-10 | Et ₂ Si ⁺ | 0-26 | Me ₂ Ge ⁺ | 0-76 | Me ₂ Sn ⁺ | 0-44 | Me ₂ M ⁺ | 0-53 | 0-63 | | Et ₂ SiH | 6-41 | | |
| C ₄ H ₉ Si | 0-10 | C ₄ H ₉ Si | 0-10 | | | C ₄ H ₉ Sn | 0-04 | C ₄ H ₉ M | 0-04 | 0-23 | | Et ₂ Si ⁺ | 0-67 | | |
| | | | | | | | | | | | | C ₄ H ₉ Si | 0-10 | | |
| MeSiH ₂ | 2-56 | EtSiH ₂ | 5-49 | McGeH ₂ | 0-54 | | | MeMH ₂ | | 1-27 | 0-87 | EtSiH ₂ | 5-09 | | |
| MeSi | 0-82 | EtSi | 1-11 | McGe | 0-33 | MeSn | 2-25 | MeM | 1-77 | 1-34 | 0-89 | EtSi | 0-72 | | |
| MeSiH | 0-12 | | | | | CH ₃ Sn ⁺ | 0-04 | CH ₃ M ⁺ | 0-13 | 0-37 | | EtSiH ⁺ | 1-21 | | |
| | | H ₂ Si | 0-40 | | | | | | | | | | | | |
| | | HSi | 0-06 | HGe | 0-45 | HSn | 0-06 | | | | | | | | |
| | | Si ⁺ | 0-02 | Ge ⁺ | 0-45 | Sn ⁺ | 1-48 | | | | | | | | |
| Rearrangement ions by group transfer | | | | | | | | | | | | | | | |
| (PhCH ₂) ₂ GeMe | 0-04 | Ph ₂ GeEt | 0-42 | Ph ₂ SnMe | 0-65 | Ph ₂ GeMe | 13-00 | Ph ₂ MMe | 17-36 | 12-03 | 7-33 | Ph ₂ SiEt | 1-01 | | |
| C ₁₁ H ₁₁ Ge | 0-13 | | | | | C ₁₁ H ₁₁ Ge ⁺ | 0-07 | C ₁₁ H ₁₁ M ⁺ | 0-07 | 0-03 | 0-60 | | | | |
| | | | | | | C ₁₁ H ₁₁ Ge | 0-30 | C ₁₁ H ₁₁ M | 0-27 | | | | | | |
| (PhCH ₂) ₂ GeMe ₂ | 0-19 | PhGeEt ₂ | 1-49 | PhSnMe ₂ | 0-65 | PhGeMe ₂ | 1-47 | PhMMe ₂ | 7-17 | 4-64 | 3-09 | PhSiEt ₂ | 0-52 | | |
| | | PhGeH(Et) | 0-74 | | | PhGeMe ₂ | 0-11 | PhMMe ₂ | 0-43 | 0-45 | 0-25 | PhSi(Et)H | 0-53 | | |
| | | EtGe | 0-09 | | | PhGeMe ₂ | 0-11 | PhM(Me)H | 0-08 | 0-12 | 0-62 | C ₄ H ₉ Si | 0-22 | | |
| Me ₂ Ge | 0-90 | | | Me ₂ Sn | 0-59 | Me ₂ Ge | 0-90 | C ₄ H ₉ M | | | | | | | |
| McGeH ₂ | 0-40 | | | McSn | 0-13 | McGe | 0-36 | | | | | | | | |
| McGe | 1-80 | Ph ₂ Si | 0-49 | Ph ₂ Ge | 0-97 | Ph ₂ Sn | 0-12 | | | | | | | | |
| (PhCH ₂) ₂ SiMe | 3-89 | Ph ₂ SiEt | 0-36 | Ph ₂ GeMc | 5-50 | Ph ₂ SnMe | 0-48 | | | | | | | | |
| | | | | C ₁₁ H ₁₁ Ge | 0-04 | | | | | | | | | | |
| | | | | C ₁₁ H ₁₁ Ge | 0-16 | | | | | | | | | | |
| | | PhSiC ₂ H ₅ | 0-29 | PhGeC ₂ H ₅ | 0-22 | PhSnC ₂ H ₅ | 0-12 | | | | | | | | |
| | | C ₁₁ H ₁₁ Si ⁺ | 0-16 | | | | | | | | | | | | |
| | | Ph ₂ Si ⁺ | 1-15 | Ph ₂ Ge ⁺ | 0-22 | Ph ₂ Sn | | | | | | | | | |

Table 4.2.9.

Ion abundances and metastable transitions in tetraphenylmethane at 70 ev relative to total carbon-containing ions

| Ion ⁺ | Abundance | Ion ⁺ | Abundance |
|---------------------------------------|-----------|--|-----------|
| C ₂₅ H ₂₀ | 12.60 | C ₁₂ H ₉ | 0.23 |
| C ₂₅ H ₁₉ | 2.53 | C ₁₂ H ₈ | 0.54 |
| C ₂₅ H ₁₈ | 0.23 | C ₁₂ H ₇ | 0.41 |
| C ₁₉ H ₁₆ | 32.98 | C ₂₅ H ₂₀ ⁺ | 1.07 |
| C ₁₉ H ₁₄ | 0.87 | C ₂₅ H ₁₉ ⁺ | 0.15 |
| C ₁₉ H ₁₃ | 2.61 | C ₁₁ H ₇ | 0.61 |
| C ₁₉ H ₁₂ | 0.46 | C ₁₁ H ₆ | 0.26 |
| C ₁₉ H ₁₁ | 2.40 | C ₁₁ H ₅ | 0.10 |
| C ₁₉ H ₁₀ | 0.20 | C ₁₉ H ₁₆ ⁺ | 0.18 |
| C ₁₉ H ₉ | 0.41 | C ₁₉ H ₁₄ ⁺ | 0.64 |
| C ₁₆ H ₁₂ | 1.84 | C ₉ H ₇ | 1.15 |
| C ₁₆ H ₁₁ | 0.46 | C ₉ H ₅ | 0.20 |
| C ₁₆ H ₁₀ | 0.84 | C ₁₃ H ₁₀ ⁺ | 0.08 |
| C ₁₇ H ₁₁ | 1.41 | C ₆ H ₆ | 3.30 |
| C ₁₇ H ₁₀ | 0.15 | C ₆ H ₅ | 0.95 |
| C ₁₇ H ₉ | 0.43 | C ₆ H ₄ | 0.28 |
| C ₁₆ H ₁₁ | 0.20 | C ₆ H ₃ | 1.74 |
| C ₁₆ H ₁₀ | 0.84 | C ₆ H ₂ | 0.26 |
| C ₁₆ H ₉ | 0.15 | C ₆ H ₅ | 0.28 |
| C ₁₆ H ₈ | 0.20 | C ₆ H ₃ | 0.28 |
| C ₁₆ H ₇ | 0.38 | C ₄ H ₄ | 0.56 |
| C ₁₅ H ₉ | 0.10 | C ₄ H ₃ | 0.89 |
| C ₁₅ H ₇ | 0.13 | C ₄ H ₂ | 0.54 |
| C ₁₄ H ₁₀ | 1.41 | C ₄ H | 0.10 |
| C ₁₄ H ₉ | 0.28 | C ₃ H ₃ | 0.84 |
| C ₁₃ H ₁₁ | 1.43 | C ₃ H ₂ | 0.18 |
| C ₁₃ H ₁₀ | 2.35 | C ₃ H | 0.13 |
| C ₁₃ H ₉ | 13.91 | C ₂ H ₄ | 0.10 |
| C ₁₃ H ₈ | 0.77 | C ₂ H ₃ | 0.10 |
| C ₁₃ H ₇ | 0.59 | C ₂ H ₂ | 0.10 |
| C ₁₃ H ₁₀ | 0.56 | CH ₄ | 0.03 |

| | | m * |
|--|---|-------|
| C ₂₅ H ₂₀ ⁺ → | C ₁₉ H ₁₅ ⁺ + C ₆ H ₅ [•] | 184.6 |
| C ₁₉ H ₁₆ ⁺ → | C ₁₃ H ₉ ⁺ + C ₆ H ₆ [•] | 112.0 |
| C ₁₉ H ₁₄ ⁺ → | C ₁₆ H ₁₂ ⁺ + CH ₃ [•] | 214.0 |
| C ₁₉ H ₁₃ ⁺ → | C ₁₉ H ₁₄ ⁺ + H [•] | 241.0 |
| C ₁₉ H ₁₂ ⁺ → | C ₁₉ H ₁₃ ⁺ + H [•] | 240.0 |
| C ₁₉ H ₁₁ ⁺ → | C ₁₉ H ₁₂ ⁺ + H ₂ | 239.0 |
| C ₁₉ H ₁₀ ⁺ → | C ₁₉ H ₁₁ ⁺ + H ₂ | 238.0 |
| C ₁₉ H ₉ ⁺ → | C ₁₉ H ₁₀ ⁺ + H ₂ | 237.0 |
| C ₁₃ H ₁₀ ⁺ → | C ₁₃ H ₉ ⁺ + H [•] | 164.0 |
| C ₁₃ H ₉ ⁺ → | C ₁₃ H ₈ ⁺ + H [•] | 163.0 |

Table 4.2. 10.

PbEt₄ and PbPh₄ ion abundances at 70 ev relative to total lead-containing ions

| PbEt ₄ | | PbPh ₄ | |
|--|-----------|---|-----------|
| Ion ⁺ | Abundance | Ion ⁺ | Abundance |
| PbEt ₄ | 0.42 | PbPh ₄ | 0.05 |
| PbC ₆ H ₁₉ | 0.27 | PbC ₂₄ H ₁₉ | 0.02 |
| PbEt ₃ | 35.00 | PbPh ₃ | 33.80 |
| PbC ₆ H ₁₃ | 0.02 | PbPh ₂ | 0.37 |
| PbEt ₂ H | 2.20 | PbC ₁₁ H ₉ | 0.60 |
| PbEt ₂ | 6.51 | PbPh | 33.30 |
| PbC ₃ H ₉ | 0.01 | PbC ₂ H | 0.14 |
| PbC ₃ H ₇ | 0.18 | PbH | 0.16 |
| PbEtH ₂ | 0.79 | Pb | 31.56 |
| PbEt | 33.17 | | |
| PbCH ₃ | 0.17 | | |
| PbCH ₂ | 1.16 | | |
| PbCH | 0.02 | | |
| PbH | 9.75 | | |
| Pb | 10.33 | | |

Fig. 12.

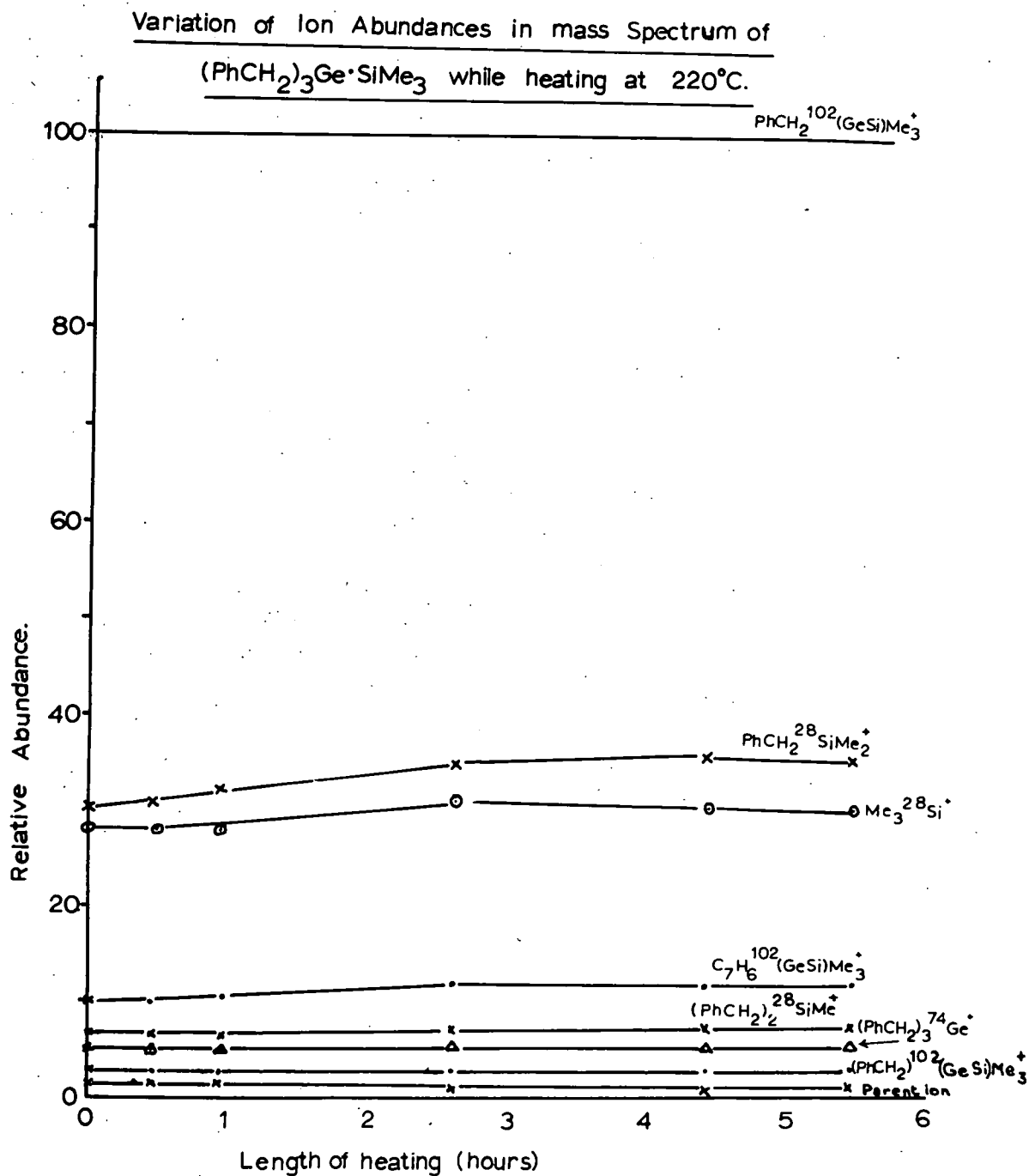

The first part of the document discusses the importance of maintaining accurate records of all transactions. It emphasizes that every entry should be supported by a valid receipt or invoice. This ensures transparency and allows for easy verification of the data.

In the second section, the author outlines the various methods used to collect and analyze the data. This includes both primary and secondary data collection techniques. The primary data was gathered through direct observation and interviews, while secondary data was obtained from existing reports and databases.

The third section provides a detailed description of the data analysis process. This involves identifying patterns, trends, and correlations within the data set. Statistical methods were employed to quantify the results and test the hypotheses. The findings indicate that there is a significant positive correlation between the variables studied.

Finally, the document concludes with a summary of the key findings and their implications. It suggests that the results have important implications for the field of study and provides recommendations for further research. The author notes that while the study has provided valuable insights, there are still some limitations and areas for future exploration.

Table 4.2.11.

Abundances of rearrangement ions formed by group transfer across the metal-metal bond.

| | Me_2MPh^+ | MeMPh_2^+ | | B_3M^+ | $\text{B}_2\text{M}^+\text{A}^+$ | EM^+A^+ | A_3M^+ | | Sum of abundances of all group transfer ions. |
|---|---------------------------|--------------------|--------------------|------------------------|----------------------------------|-------------------------|------------------------|--|---|
| $\text{Me}_3\text{M} \cdot \text{MPh}_3$ | | | MeMPh_2^+ | | | | | | 12.21 |
| $\text{Me}_3\text{Si} \cdot \text{SiPh}_3$ | 3.09 | 7.33 | | | | | | | 17.54 |
| $\text{Me}_3\text{Ge} \cdot \text{GePh}_3$ | 4.64 | 12.03 | | | | | | | 25.04 |
| $\text{Me}_3\text{Sn} \cdot \text{SnPh}_3$ | 7.17 | 17.36 | | | | | | | |
| $\text{A}_3\text{M} \cdot \text{M}^+\text{B}_3$ | | | AMB_2^+ | B_3M^+ | $\text{B}_2\text{M}^+\text{A}^+$ | EM^+A^+ | A_3M^+ | | |
| $\text{Ph}_3\text{Ge} \cdot \text{SnMe}_3$ | | | PhGeMe_2 | Me_3Ge | Me_2SnPh | MeSnPh_2 | Ph_3Sn | | |
| | | | 1.47 | 0.90 | 1.67 | 0.48 | 0.12 | | 31.56 |
| $\text{Me}_3\text{Ge} \cdot \text{GePh}_3$ | | | MeGePh_2 | Ph_3Ge | Ph_2SnMe | PhSnMe_2 | Me_3Sn | | |
| | | | 5.50 | 0.97 | 0.65 | 0.65 | 0.39 | | 22.45 |
| $\text{Me}_3\text{Si} \cdot \text{GeBz}_3$ | | | MeSiBz_2 | Bz_3Si | Bz_2GeMe | BzGeMe_2 | Me_3Ge | | |
| | | | 3.89 | - | 0.04 | 0.19 | 0.90 | | 17.10 |
| $\text{Et}_3\text{Si} \cdot \text{GePh}_3$ | | | EtSiPh_2 | Ph_3Si | Ph_2GeEt | PhGeEt_2 | Et_3Ge | | |
| | | | 0.35 | 0.49 | 0.42 | 1.49 | - | | |
| C_2H_4 | | | | | | | | | |
| corrected | 7.54 | 2.43 | | 0.49 | 0.42 | 1.62 | - | | 26.67 |

Loss of a radical from parent ions by cleavage of a M-C bond is a dominant process and in general even-electron ions are the major species and maintain themselves even-electron by eliminating a neutral molecule.

i) Migration of Organic Groups across a Metal-Metal Bond.

Ions formed by such migration are of high abundance for all $A_3M \cdot M' B_3$ compounds studied (table 4.2.11.). It is doubtful that rearrangement occurs prior to ionization. The infra-red spectra (p.43) give no indication that different groups are attached to the same metal. Thermal decomposition of $Me_3Sn \cdot SnEt_3$ has been studied ¹³⁰ and found to be free of dissociation when heated for several hours at 170°C. At 190°C general decomposition occurred with formation of Me_4Sn , Et_4Sn and traces of Me_6Sn_2 and Et_6Sn_2 . The mass spectra of $A_3MM'B_3$ compounds did not show ions corresponding to these symmetrical compounds. Furthermore only slight changes were observed in the mass spectrum of $(PhCH_2)_3GeSiMe_3$ when heated at 220°C for a period of 6 hours (fig. 12.)

These rearrangement processes make the identification of isomeric compounds of the type A_3B_3MM' (M = Si, Ge, Sn) by mass spectrometry somewhat ambiguous.

For $Me_3M \cdot MPh_3$ compounds the Ph_2MMe^+ ion is always the most abundant rearrangement ion of this type and the abundances of these ions decrease in the order $Si < Ge < Sn$. With $Me_3C \cdot CPh_3$ no ions resulting from the transfer of $Me \cdot$ or $Ph \cdot$ are present.

Each of the compounds $A_3M \cdot M' B_3$ show all six rearrangement ions.

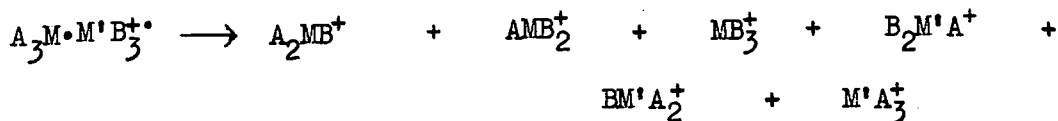

Concerning the relative abundances of these ions the observation may be made that if M is the lighter metal (i.e. forms stronger M-C bonds) in the compound $A_3M \cdot M'B_3$ then ions formed by migration of groups are most common for M, the most abundant being A_2MB^+ followed by AMB_2^+ (table 4.2.11 p.126). In this table since metal-ethyl groups in $Et_3Si \cdot GePh_3$ have a highly favourable mode not available in metal-phenyl or -methyl compounds ($Si^+-Et \rightarrow SiH^+ + C_2H_4$), allowance has been made to correct for ethylene elimination in obtaining the abundances of ions containing ethyl groups.

There is evidence that rearrangement occurs in the molecular ion either prior to elimination of a neutral species or as a synchronous process.

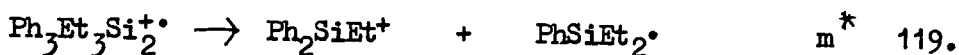

For this rearrangement to occur in the molecular ion would require a 5 - co-ordinate intermediate, probably with d - orbital participation, and this may explain why the hydrocarbon $Ph_3C \cdot CMe_3$ does not show these types of rearrangement ions. If exchange of groups occurs in the molecular ion it is difficult to see why this should not lead to all possible isomeric ions of the type $A_3B_3MM'^{++}$; the proportion of each would be strongly influenced by relative bond energy considerations.

The formation of these rearrangement ions from $A_2M \cdot MB_3^+$ ions has been confirmed in a few cases:

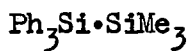

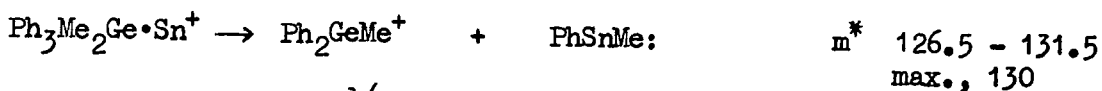
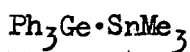
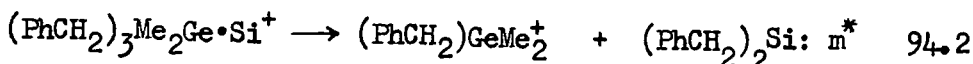
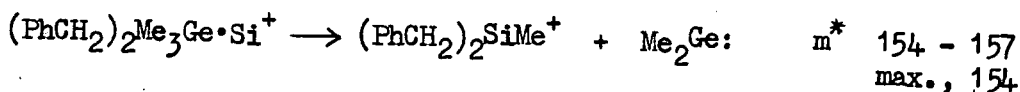
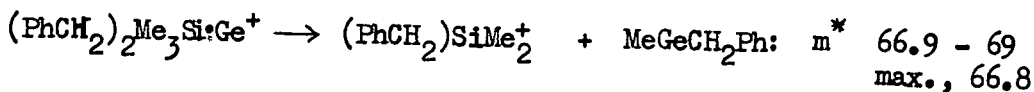
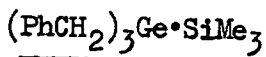
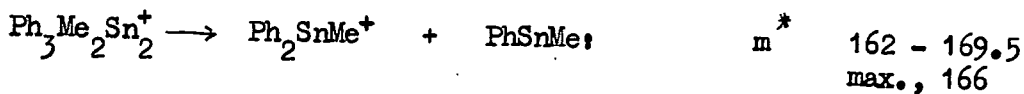
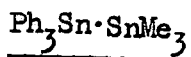

and/or



All these ions could have structures such that the products are simply the result of cleavage of the metal-metal bond; the necessary rearrangement having occurred in the parent ion. However there seems no reason why rearrangement should not also occur in fragment ions when d-orbital participation by the metal need not be invoked since at least one metal atom will be less than 4-co-ordinate. If rearrangement occurs in $\text{A}_2\text{M}\cdot\text{MB}_3^+$ ions then the abundance of A_2MB^+ , AMB_2^+ etc. ions will be influenced by the rate of formation of $\text{A}_2\text{M}\cdot\text{MB}_3^+$ from the parent ion, the lifetime of $\text{A}_2\text{M}\cdot\text{MB}_3^+$ which must be long enough to allow rearrangement to occur, the activation energy for the rearrangement and the stabilities of the resulting ion and fragment. With the carbon compound $\text{Ph}_3\text{C}\cdot\text{CMe}_3$ the major decomposition of the parent ion is formation of Ph_3C^+ and Me_3C^+ . Any rearrangement ions formed from $\text{Ph}_2\text{C}\cdot\text{CMe}_3^+$ or $\text{Ph}_3\text{C}\cdot\text{CMe}_2^+$ will thus also

be of low abundance.

In $\text{Et}_3\text{Si}\cdot\text{SiPh}_3$ the rearrangement ions Et_2SiPh^+ and EtSiPh_2^+ are present but of low abundance. The hydride ions Et(H)SiPh^+ , H_2SiPh^+ and HSiPh_2^+ may arise by hydrogen transfer from one silicon atom to the other or by ethylene elimination.

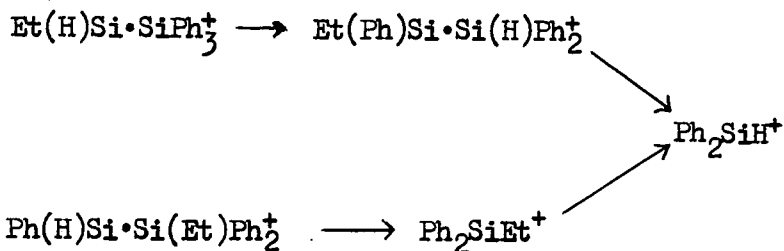

In $\text{Ph}_3\text{Ge}\cdot\text{SnMe}_3$ the PhSn^+ ion is of high abundance and a metastable peak shows that it is produced largely by the reaction.

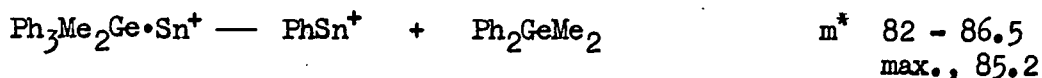

ii) Radical Elimination by Bond Cleavage.

This is the major mode of decomposition for molecular ions:

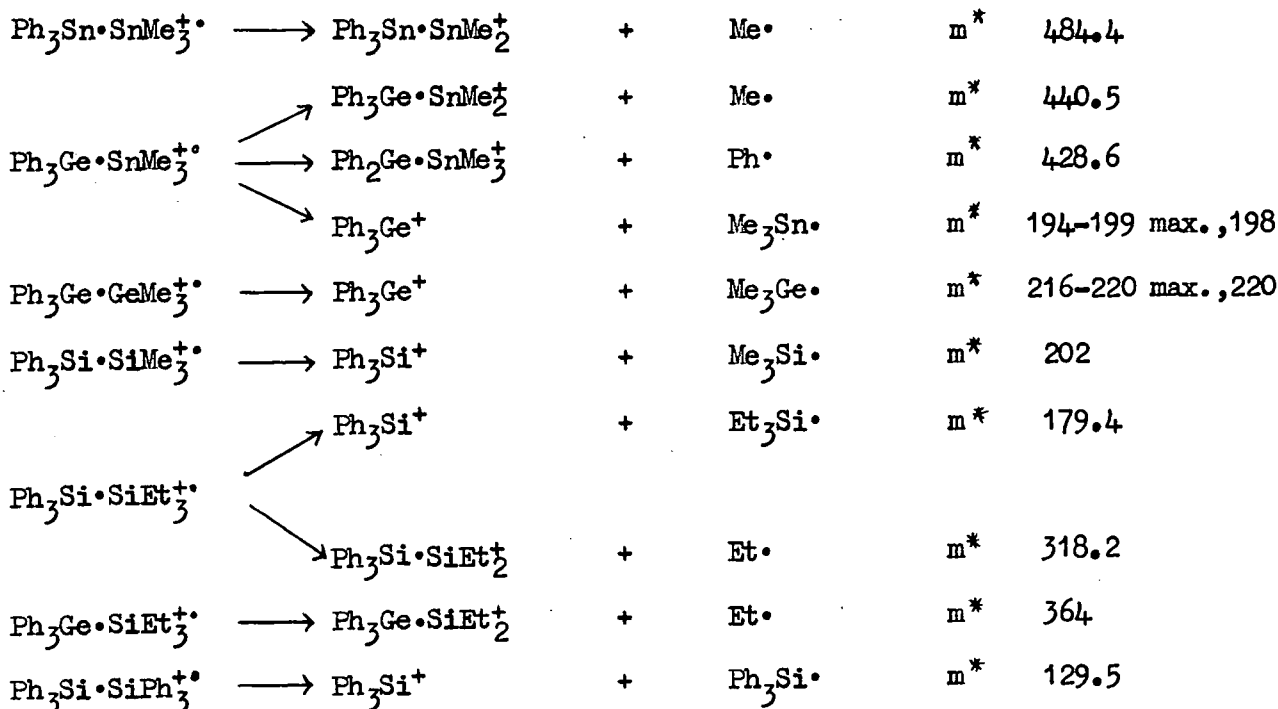

As with organostannanes discussed in chapter 4.2.1. it appears that bond cleavage of the molecular ion proceeds largely in the direction expected for the weakest bond in the molecule, although all four product ions are observed. Thus ions containing metal-metal bonds are abundant only for those compounds where the metal-metal bond is expected to be stronger than any metal-carbon bonds in the neutral molecule. For example with $\text{Ph}_3\text{Ge}\cdot\text{SnMe}_3$ and $\text{Ph}_3\text{Ge}\cdot\text{SnMe}_3$ cleavage of an Sn-Me bond in the parent ion gives ions of high abundance and the available bond dissociation energies suggest that this is the weakest bond in the molecule.

$$D(\text{Ph}_3\text{Sn-Ph}) - D(\text{Ph}_3\text{Sn-Me}) = 21.7 \pm 3.2 \text{ Kcal. mole.}^{-1}$$

$$D(\text{Ph}_3\text{Sn-SnMe}_3) - D(\text{Ph}_3\text{Sn-Me}) = 6.5 \pm 3.2 \quad "$$

$$D(\text{Ph}_3\text{Sn-GeMe}_3) - D(\text{Ph}_3\text{Sn-Me}) = 9.7 \pm 3.2 \quad "$$

$$D(\text{Me}_3\text{Sn-SnMe}_3)^{64} = 76 \text{ Kcal. mole.}^{-1} \quad D(\text{Me}_3\text{Sn-Me})^{64} = 73 \pm 4 \text{ Kcal. mole.}^{-1}$$

$$D(\text{Me}_3\text{Sn-Ph})^{64} = 81 \pm 5 \text{ Kcal. mole.}^{-1}$$

Also $\text{Me}_3\text{Si}\cdot\text{SiPh}_3$ and $\text{Ph}_3\text{Si}\cdot\text{SiEt}_3$ give $\text{C}_x\text{H}_y\text{Si}^+$ species as the major ions and the strength of the silicon-alkyl bond is stronger than the silicon-silicon bond in these compounds.^{62,131} Ions resulting from phenyl-metal bond cleavage from the parent are always of low abundance.

Parent ion decomposition by metal-metal bond cleavage can give two ions:

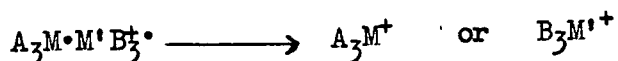

If A is phenyl and B methyl then Ph_3M^+ is always the more abundant. This may be due to several factors: the ionization potential of $\text{Ph}_3\text{M}\cdot$ radicals may be lower than $\text{R}_3\text{M}\cdot$ radicals; charge delocalisation in Ph_3M^+ will tend to stabilise the ion, and in individual cases there may be fewer low energy decomposition routes available for Ph_3M^+ than R_3M^+ ions.

Table. 4.2.12.

Molecule elimination by cleavage of two M-X bonds (M = Si, Ge, or Sn)

| | | | |
|--|---|--|-------|
| Ph ₃ Sn·GeMe ₃ | } | Ph ₃ Sn ⁺ → PhSn ⁺ + Ph ₂ | 110·6 |
| Ph ₃ Sn·SnMe ₃ | | | |
| Ph ₃ Ge·SnMe ₃ | } | Ph ₃ Ge ⁺ → PhGe ⁺ + Ph ₂ | 74·8 |
| Ph ₃ Ge·GeMe ₃ | | | |
| Ph ₃ Ge·SiEt ₃ | } | (PhCH ₂) ₂ Ge·SiMe ₃ ⁺ → PhCH ₂ Ge ⁺ + PhCH ₂ ·SiMe ₃ | 82·7 |
| (PhCH ₂) ₂ Ge·SiMe ₃ | | | |
| Ph ₃ Sn·SnMe ₃ | } | Ph ₂ Sn ⁺ → Sn ⁺ + Ph ₂ | 52·5 |
| Ph ₃ Sn·GeMe ₃ | | | |

Alkene elimination

| | | | |
|--|---|---|-------|
| (PhCH ₂) ₂ Ge·SiMe ₃ | } | (PhCH ₂) ₂ SiMe ₂ ⁺ → PhCH ₂ ·SiH ₂ ⁺ + C ₂ H ₄ | 98·4 |
| (PhCH ₂) ₂ Ge·SiMe ₃ | | Me ₃ Si ⁺ → MeSiH ₂ ⁺ + C ₂ H ₄ | 27·7 |
| Ph ₃ Si·SiMe ₃ | } | Me ₃ Ge ⁺ → MeGeH ₂ ⁺ + C ₂ H ₄ | 69·6 |
| Ph ₃ Sn·GeMe ₃ | | | |
| Ph ₃ Ge·GeMe ₃ | } | PhSiMe ₂ ⁺ → PhSiH ₂ ⁺ + C ₂ H ₄ | 84·8 |
| Ph ₃ Si·SiMe ₃ | | Et ₃ Si ⁺ → Et ₂ SiH ₂ ⁺ + C ₂ H ₄ | 65·8 |
| Ph ₃ ·SiSiEt ₂ | } | Et ₂ SiH ⁺ → EtSiH ₂ ⁺ + C ₂ H ₄ | 40·0 |
| | | PhSiEt ₂ ⁺ → PhSiEt(H) ⁺ + C ₂ H ₄ | 111·9 |
| | | PhSiEt(H) ⁺ → PhSiH ₂ ⁺ + C ₂ H ₄ | 84·8 |
| | | Ph ₂ SiEt ⁺ → Ph ₂ SiH ⁺ + C ₂ H ₄ | 158·7 |
| Ph ₃ ·SiSiEt ₂ | } | Ph ₂ Et ₂ Si ₂ ⁺ → Ph ₂ Et(H)Si ₂ ⁺ + C ₂ H ₄ | 291·3 |
| | | Ph ₃ Et(H)Si ₂ ⁺ → Ph ₃ H ₂ Si ₂ ⁺ + C ₂ H ₄ | 263·5 |
| | | Ph ₃ Et ₂ GeSi ⁺ → Ph ₃ Et(H)GeSi ⁺ + C ₂ H ₄ | 337 |
| Ph ₃ Ge·SiEt ₃ | } | Ph ₂ Et(H)GeSi ⁺ → Ph ₂ H ₂ GeSi ⁺ + C ₂ H ₄ | 309·3 |
| | | Ph ₂ GeEt ⁺ → Ph ₂ GeH ⁺ + C ₂ H ₄ | 204·1 |

Molecule elimination by cleavage of one M-X bond (M = Si, Ge, or Sn)

| | | | |
|--|---|---|-------|
| Ph ₆ Si ₂ | } | Ph ₃ Si ⁺ → C ₁₂ H ₉ Si ⁺ + C ₆ H ₆ | 126·5 |
| Ph ₃ Si·SiMe ₃ | | | |
| Ph ₃ Si·SiEt ₃ | } | Ph ₃ Ge ⁺ → C ₁₂ H ₉ Ge ⁺ + C ₆ H ₆ | 168·9 |
| Ph ₃ Ge·SnMe ₃ | | | |
| Ph ₃ Ge·GeMe ₃ | } | Ph ₃ Sn ⁺ → C ₁₂ H ₉ Sn ⁺ + C ₆ H ₆ | 212·4 |
| Ph ₃ Ge·SiEt ₃ | | | |
| Ph ₃ Sn·GeMe ₃ | } | (PhCH ₂) ₂ Me ₂ GeSi ⁺ → C ₁₀ H ₁₅ GeSi ⁺ + C ₇ H ₈ | 170·8 |
| Ph ₃ Sn·SnMe ₃ | | | |
| (PhCH ₂) ₂ Ge·SiMe ₃ | | | |

Molecule eliminations without M-X bond cleavage

| | | | |
|--|---|---|-------|
| (PhCH ₂) ₂ Ge·SiMe ₃ | } | (PhCH ₂) ₂ SiMe ⁺ → C ₆ H ₁₁ Si ⁺ + C ₆ H ₆ | 96·0 |
| | | (PhCH ₂) ₂ SiMe ⁺ → C ₁₅ H ₁₈ Si ⁺ + H ₂ | 221 |
| | | (PhCH ₂) ₂ Ge ⁺ → C ₂₁ H ₁₉ Ge ⁺ + H ₂ | 343 |
| | | C ₇ H ₇ Ge ⁺ → C ₆ H ₅ Ge ⁺ + C ₂ H ₂ | 117 |
| Ph ₃ Ge·SnMe ₃ | } | Ph ₂ GeMe ⁺ → C ₁₃ H ₁₁ Ge ⁺ + H ₂ | 239 |
| Ph ₃ Ge·GeMe ₃ | | Ph ₂ SiMe ⁺ → C ₁₃ H ₁₁ Si ⁺ + H ₂ | 193·1 |
| Ph ₃ Si·SiMe ₃ | } | PhSiMe(H) ⁺ → C ₇ H ₇ Si ⁺ + H ₂ | 117·0 |
| Ph ₃ Si·SiEt ₃ | | PhSi ⁺ → C ₆ H ₅ Si ⁺ + H ₂ | 101 |
| Ph ₃ Si·SiEt ₂ | } | Ph ₃ Si ⁺ → C ₁₈ H ₁₃ Si ⁺ + H ₂ | 255 |
| Ph ₄ Si ₂ | | C ₁₈ H ₁₃ Si ⁺ → C ₁₈ H ₁₁ Si ⁺ + H ₂ | 253 |
| Ph ₃ Ge·SiEt ₃ | } | Ph ₂ SiH ⁺ → C ₁₂ H ₉ Si ⁺ + H ₂ | 179·4 |
| Ph ₃ Si·SiEt ₂ | | PhSiH ₂ ⁺ → C ₆ H ₅ Si ⁺ + H ₂ | 103 |
| Ph ₃ Ge·SiEt ₂ | } | Ph ₂ H ₂ Ge·Si ⁺ → C ₁₈ H ₁₆ Ge·Si ⁺ + H ₂ | 331 |
| Ph ₃ Si·SiEt ₂ | | Ph ₂ H ₂ Si ₂ ⁺ → C ₁₈ H ₁₈ Si ₂ ⁺ + H ₂ | 285 |

Loss of H• or 2H• by cleavage of C-H bonds becomes increasingly important for Ph₃M•MMe₃ compounds in the order C > Si > Ge > Sn (table 4.2.8. and fig. 11 p. 122 and 124) which probably reflects the strength of the M-C bonds (C > Si > Ge > Sn). With the lead compounds (table 4.2.10. p. 123.) hydrogen loss does not give abundant ions.

Bond cleavage decompositions in even-electron ions also occur:

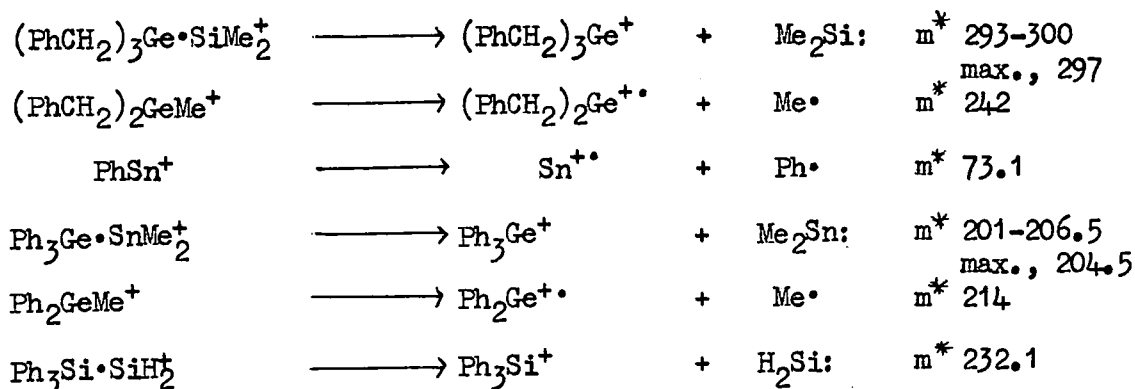

The metal ions M⁺ are of high abundance only for the tin and lead compounds. This is probably a reflection of the energy to remove all the groups from the metal decreasing in the order Si > Ge > Sn > Pb. ¹⁰⁶

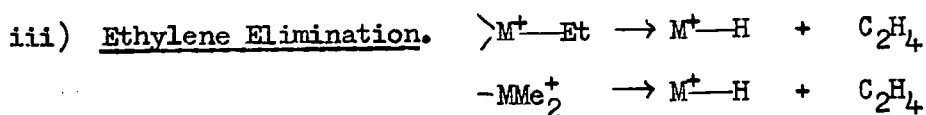

Metastable confirmed decompositions for this process are shown in table 4.2.12. Loss of ethylene occurs from even-electron ions containing an M⁺-Et bond and the mechanism is probably similar to that previously discussed for tin (p. 106). Other even-electron ethyl-germanium ¹²³ and - silicon ¹³² ions show ready loss of ethylene.

With the ions Me₃Ge⁺ and Me₃Si⁺ ethylene elimination also occurs. Although such a process may involve rearrangement to an ethylmetal hydride, loss of this molecule may also occur by concerted cleavage of two M-C bonds.

$\text{Ph}_3\text{M} \cdot \text{MMe}_3$ (M = Si, Ge, or Sn) also fail to show this elimination.

Elimination of RR' molecules from even-electron ions are very common and examples observed with metal-metal bonded compounds are given in table 4.2.12. Biphenyl elimination from Ph_3M^+ ions is observed for M = Ge, Sn, and Pb but not M = Si, or C.

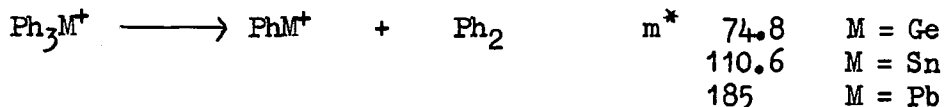

This is probably a reflection of the greater Si-Ph and C-Ph bond strengths in these ions. This type of decomposition may occur however from other silicon ions.

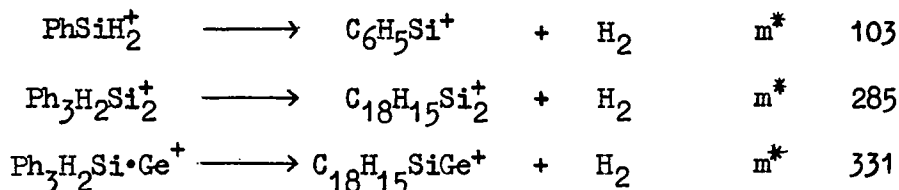

On the other hand these decompositions may not involve hydrogen atoms not attached to silicon.

In tetraethyllead the elimination of butane from Et_3Pb^+ ions occurs.



Such elimination is not observed with triethyl-silyl, -germyl or -stannyl ions. A similar decomposition occurring from the parent ion of tetraethyllead could also explain the high abundance of $\text{Et}_2\text{Pb}^{+\bullet}$ which contrasts with the low-abundance of $\text{Et}_2\text{M}^{+\bullet}$ ions for tetraethyl-tin and -germane. 123

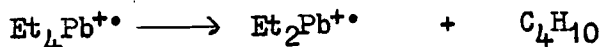

A metastable peak for this process was not observed however.

v) Molecule Elimination by Cleavage of one M-X Bond.

Benzene elimination from Ph_3M^+ ions gives a metastable peak for

all group IV elements C, Si, Ge, Sn, Pb;

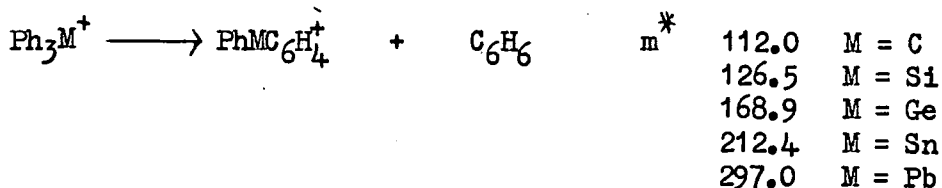

With $\text{Ph}_3\text{M}\cdot\text{MMe}_3$ compounds the abundance of the resulting ion decreases in the order $\text{C} > \text{Si} > \text{Ge} > \text{Sn}$ (table 4.2.8. and fig. 11. p.124). With Ph_4M compounds the ion $\text{PhMC}_6\text{H}_4^+$ is less abundant for Pb than Sn.

A somewhat similar elimination is loss of toluene from benzyl ions (table 4.2.12. p. 131).

In some trimethyl compounds, $\text{Me}_3\text{M}\cdot\text{M}^+\text{R}_3$, ions are produced in low abundance which can be explained as successive loss of methane, e.g.,

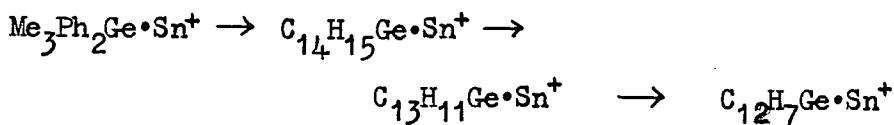

vi) Fragmentation of Phenyl Groups attached to Metal.

Ions which could result by successive elimination of acetylene by fragmentation of phenyl groups attached to metal are present in the triphenyl derivatives of silicon, germanium and tin.

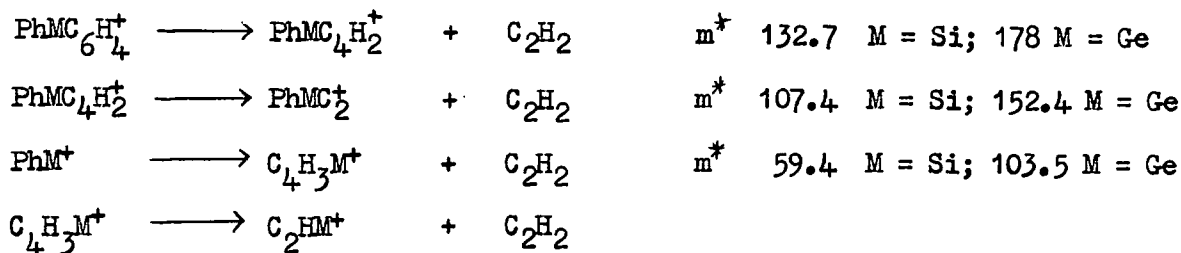

In phenyltin compounds these processes are not metastable confirmed. In tetraphenyllead only C_2HPb^+ was observed and then in very low abundance. (table 4.2.10.)

Table 4.2.13.Abundances of $\text{PhMC}_6\text{H}_4^+$, PhM^+ and ions produced by C_2H_2 elimination

| | $\text{PhMC}_6\text{H}_4^+$ | $\text{PhMC}_4\text{H}_2^+$ | PhMC_2^+ | PhM^+ | $\text{C}_4\text{H}_3\text{M}^+$ | C_2HM^+ |
|--|-----------------------------|-----------------------------|-------------------|----------------|----------------------------------|-------------------------|
| $\text{Ph}_3\text{Si}\cdot\text{SiEt}_3$ | 6.28 | 1.49 | 0.64 | 8.21 | 0.10 | 1.10 |
| $\text{Ph}_3\text{Si}\cdot\text{SiMe}_3$ | 6.52 | 1.42 | 0.62 | 5.01 | 0.75 | 1.21 |
| $\text{Ph}_3\text{Ge}\cdot\text{GeMe}_3$ | 5.04 | 0.28 | 0.19 | 11.56 | 1.21 | 1.04 |
| $\text{Ph}_3\text{Sn}\cdot\text{SnMe}_3$ | 0.27 | 0.11 | 0.05 | 27.83 | 0.26 | 0.56 |

From table 4.2.13. it will be observed that the fragment ions decrease in abundance in the order $\text{Si} > \text{Ge} > \text{Sn}$, which is probably a reflection of the change in metal-carbon bond strength.

vii) Loss of Hydrogen $\text{H}\cdot$ or H_2

Some of the H_2 eliminations e.g.

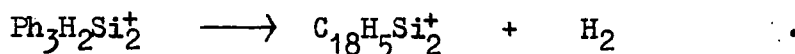

may well be decompositions of category iv) (p. 134) and have been discussed there. Others such as

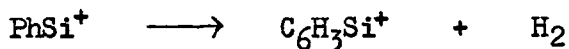

probably do not involve metal-hydrogen cleavage and are shown in table 4.2.12. (p. 132)

Decomposition modes of organo-silicon, - germanium, - tin and - lead compounds have been shown to be very similar for a variety of ions containing M-Me, M-Et and M-Ph bonds. From a detailed study of the mass spectra of organogermanes ¹²³ it is apparent that similarities to organostannanes extend over a wide variety of compounds.

The abundances of parent ions show some trends for group IV organometallic compounds. For example the abundances at 70eV of parent ions for the following compounds are:

| | Si | Ge | Sn | Pb |
|-------------------------------------|--------|-------|-------|-------|
| Ph_6M_2 | 14.87% | 8.9% | 6.51% | |
| $\text{Ph}_3\text{M}^+\text{MMe}_3$ | 9.14% | 4.00% | 1.83% | |
| Ph_4M | | 2.00% | 0.11% | 0.05% |
| Et_4M | | 2.00% | 0.97% | 0.42% |

Such a trend is probably due to the increase in M-C bond strength in the order $\text{Si} > \text{Ge} > \text{Sn} > \text{Pb}$. The increase in abundance of ions resulting from C-H or C-C cleavage in the order $\text{C} > \text{Si} > \text{Ge} > \text{Sn} > \text{Pb}$ is also probably because of the variation of M-C bond strength.

The decrease in abundance of RM^+ and M^{+} ions in going from analogous compounds of lead and silicon may also be related to the decreasing energy required to strip organic groups from the metal in going from silicon to lead.¹⁰⁶ Gielen, Nasielski and Boue¹³³ relate the intensity of RM^+ fragments primarily to the stability of the M^{II} oxidation state which increases in going from silicon to lead. These authors also regard parent ions as M^{V} species and R_2M^{+} as M^{III} species. The high abundance of the even-electron ions RM^+ and R_3M^+ is attributed not primarily to the even-electron character but to the stability of M^{II} and M^{IV} oxidation states relative to M^{III} and M^{IV} .

Rearrangement processes involving hydrogen migration are prevalent with these compounds especially when metal-alkyl bonds are present. Alkene elimination from even-electron ions containing alkyl groups with formation of metal hydride ions is particularly very favourable. Such hydrogen migrations are also well known in the mass spectra of organic compounds, for example the rearrangement of a ~~add~~ hydrogen to a polar functional group is often observed⁹. e.g.

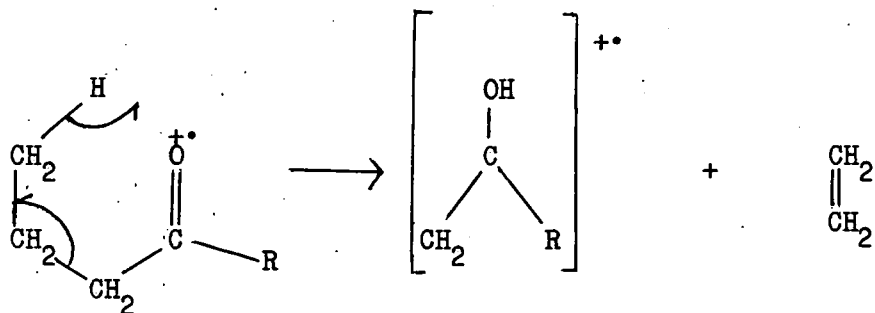

Rearrangements where migration of a functional group occurs, although common for the organometallic compounds discussed in this chapter, has only recently been shown to occur with organic compounds.¹²⁹

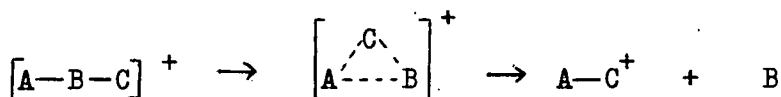

With transition metal complexes which have been widely investigated such rearrangement processes are well known.

Thus the iron-tin complex $\pi-C_5H_5(CO)_2Fe \cdot SnPh_3$ shows the metastable confirmed rearrangement.¹³⁴

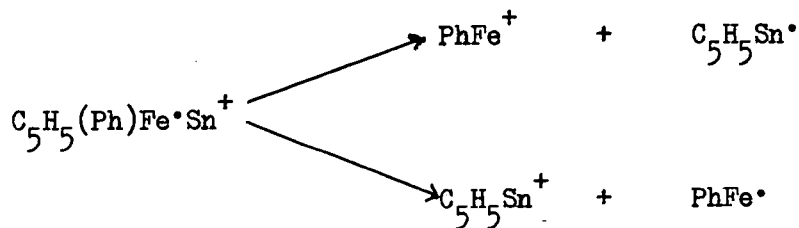

Similarly $PhMn^+$ is observed in low abundance in the spectrum of $Ph_3Sn \cdot Mn(CO)_5$.¹³⁴

Transfer of an initially π -bonded cyclopentadienyl group from a transition metal to a non-transition-metal is a common process and for

$[\pi-C_5H_5(CO)_2Fe]_2SnCl_2$ the ion $C_5H_5Sn^+$ is the most abundant ion in the spectrum. Trialkylgermyl-molybdenum and -tungsten complexes,

$\pi-C_5H_5(CO)_3M \cdot GeR_3$ behave similarly in forming $C_5H_5Ge^+$.¹³⁵ Similar migrations are observed with platinum-germanium phosphine complexes.¹³⁶

The μ -mercaptide, μ -alkoxo and μ -dialkylamido derivatives of chromium, iron and nickel produce rearrangement ions, a metastable peak for the

compound

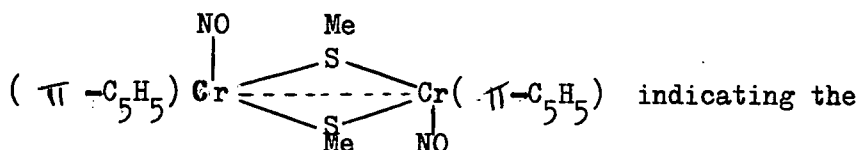

process:-

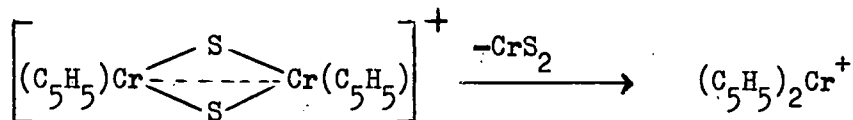

The migration of carbonyl groups across a metal-metal bond seems to be uncommon. However with $\text{Re}_2(\text{CO})_{10}$ ¹³⁸, $\text{ReMn}(\text{CO})_{10}$ ¹³⁹ and $\text{HRe}_3(\text{CO})_{14}$ ¹³⁸ it must occur since the ion $\text{M}(\text{CO})_6^+$ is produced in very low abundance. Sometimes however ions observed may result from thermal decomposition followed by ionization, as in $\text{Hg} \left[\text{Mn}(\text{CO})_5 \right]_2$ ¹⁴⁰ where 42% of the total in current is due to ions $\text{Mn}_2(\text{CO})_{10-7}^+$.

Such migration reactions are not confirmed to metal-metal bonded compounds. A variety of compounds involving two metals π -bonded to the same ligand (such as

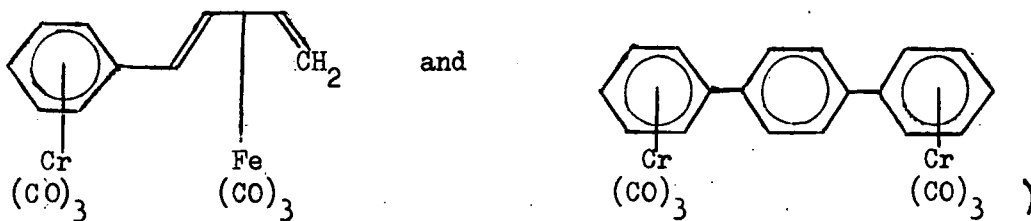

produce M-M^+ ions.

Migration of groups from carbon to metal has also been observed.

The spectra of some substituted π -bonded arene complexes

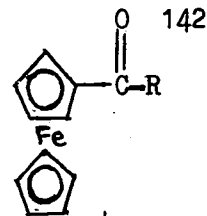

produce ions resulting from transfer of R to the metal i.e. $\text{C}_5\text{H}_5\text{FeR}^+$ and FeR^+ .

Trimethylsilyl derivatives of benzylalcohol and benzylamine

($\text{Me}_3\text{SiOCH}_2\text{Ph}$ and $\text{Me}_3\text{SiNHCH}_2\text{Ph}$) produce phenylsilyl ions although this rearrangement is only a minor feature of the corresponding sulphur compound.²⁸

Group migration reactions are common in fluorocarbon metal compounds, presumably because of the high strength of metal-fluorine bonds.

Tetrakis(pentafluorophenyl)germane⁹⁷ produces $(\text{C}_6\text{F}_5)_2\text{GeF}^+$ in high abundance contrasting with the low abundance of Ph_2GeH^+ derived from tetraphenylgermane.¹²³

Similar migrations of fluorine are observed with fluorocarbon derivatives of silicon⁹⁷, arsenic¹⁴³ iron^{97,144,145,146} manganese^{140,147} and rhenium¹⁴⁷, and elimination of neutral metal fluoride is often observed.

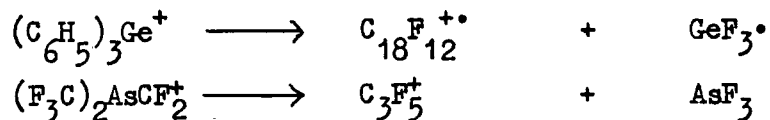

4.3. Mass Spectra of Beryllium Dialkyls.

Since most dialkyls of beryllium form electron deficient associated molecules in liquid and vapour phases ⁹¹ the mass spectra of these compounds are of considerable interest because of the possibility of forming ions from these associated molecules in high abundance. The following beryllium dialkyls were investigated using an ionizing electron beam of 70, 15 or 12 volts and various source temperatures:-

Me_2Be ; Et_2Be ; $(i\text{-Pr})_2\text{Be}$; $(n\text{-Pr})_2\text{Be}$; $(i\text{-Bu})_2\text{Be}$ and $(t\text{-Bu})_2\text{Be}$. Ion abundances for these compounds are given in Appendix 2.

The method of sample introduction for beryllium dialkyls has been discussed in chapter 2.2.1. p. 48. It is worth commenting here, however, that the temperature of the sample required for di-tert-butylberyllium reflects its monomeric structure ¹⁵³. Thus whereas di-iso-butylberyllium required a sample temperature of 0°C to give a source pressure reading of 5×10^{-6} m.m., a similar source pressure was obtained for the tertiary-butyl compound when the sample was solid at -60°C.

4.3.1. Effect of Source Temperature.

This was most apparent for diethylberyllium and fig. 13 shows the 70eV spectrum recorded at various source temperatures. As the temperature rises the abundance of monomeric ions, $\text{C}_x\text{H}_y\text{Be}^+$, increases whereas that of trimeric ions, $\text{C}_a\text{H}_e\text{Be}_3^+$, and the much more abundant dimeric ions, $\text{C}_a\text{H}_b\text{Be}_2^+$, decreases (fig. 14 and table 4.3.1.). Such behavior can be explained by increased dissociation of associated molecules to monomers at higher source temperatures prior to ionization.

Fig. 13.

Mass Spectra of Diethylberyllium (70 eV)

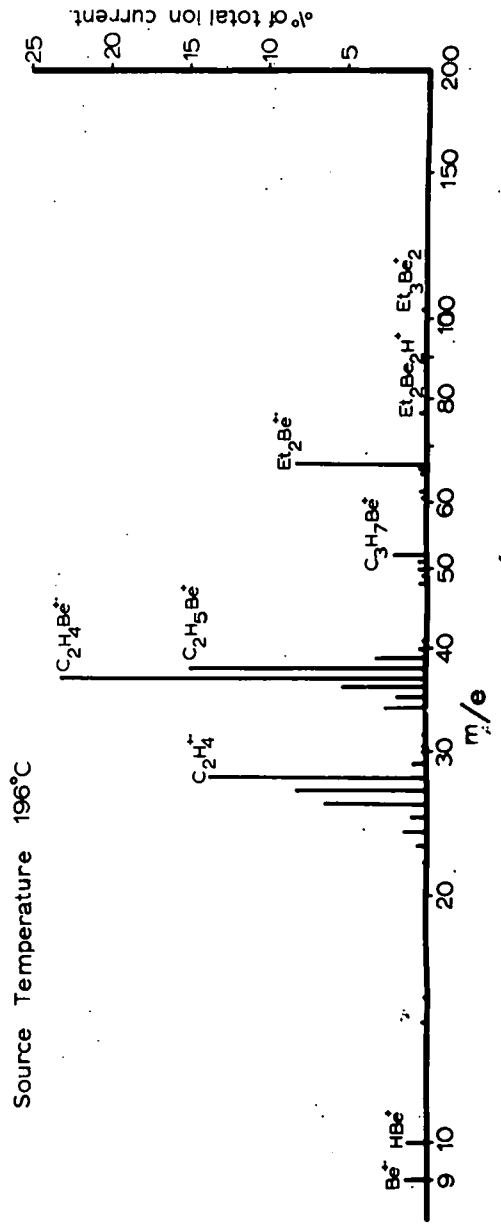
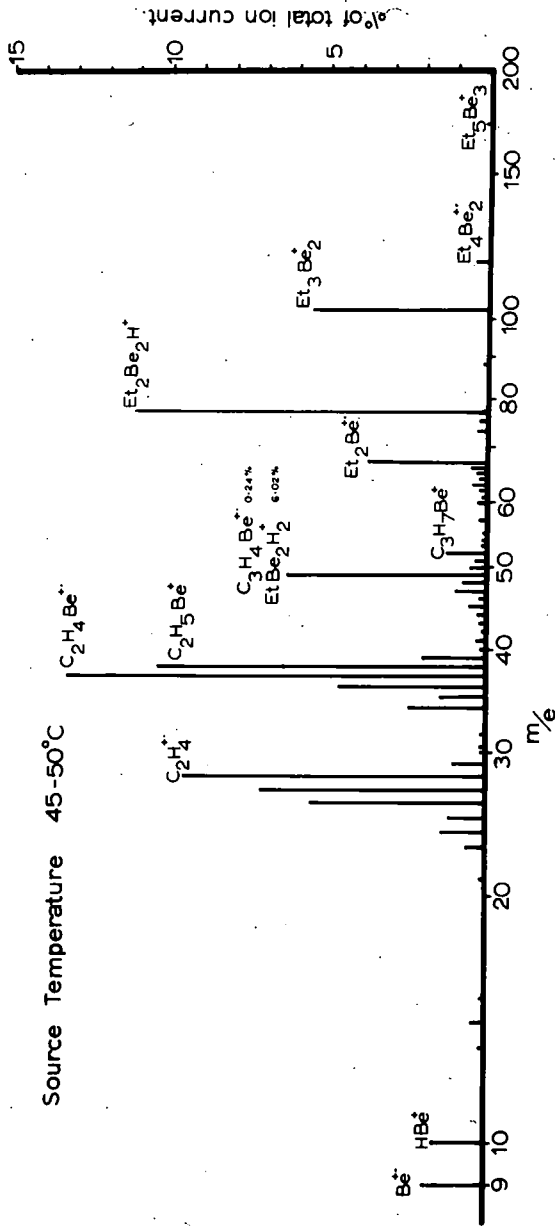

Fig. 14.

Variation of Ion Abundances with Source Temperature
for Diethylberyllium.

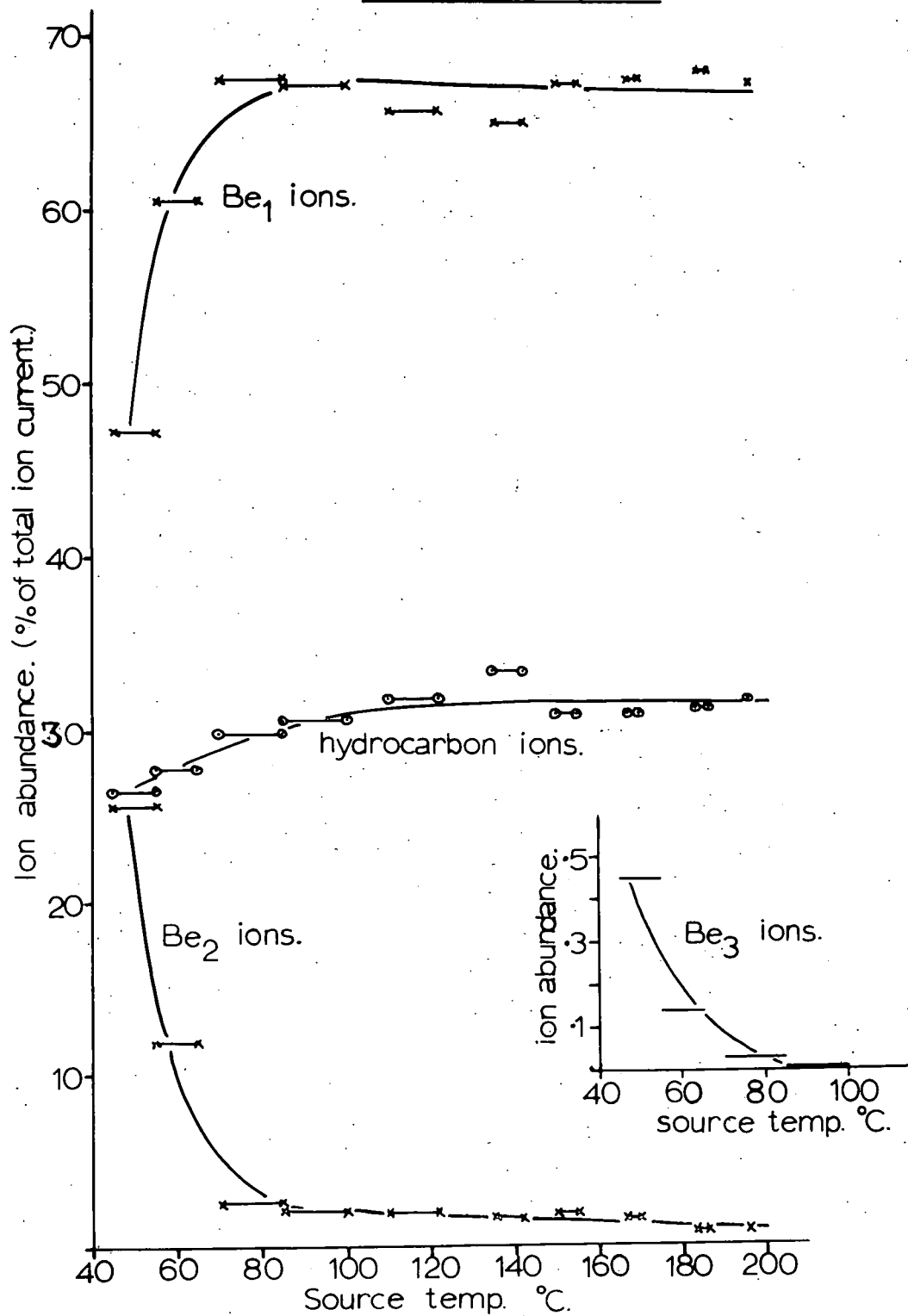

Fig. 15.

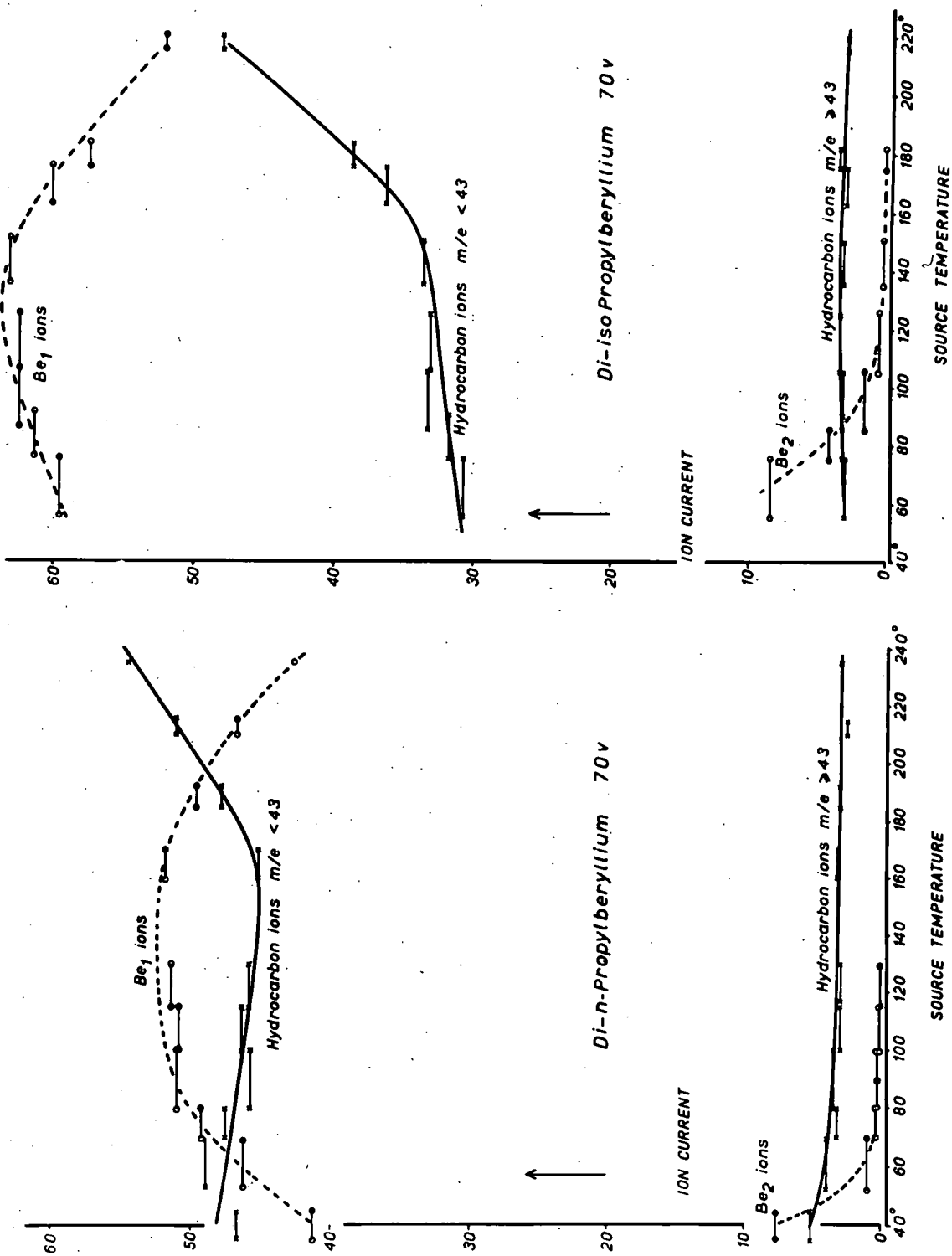

Table 4.3.1.

Variation of ion abundances with source temperature for diethylberyllium (70eV)

| Source temp. °C | % of total ion-current carried by:- | | | | |
|-----------------|-------------------------------------|------------------------|----------------------|-------------------------------------|-------|
| | $C_dH_eBe_3^+$
ions | $C_aH_bBe_2^+$
ions | $C_xH_yBe^+$
ions | Hydrocarbon
m/e > 30 m/e ≤ 30 | |
| 45-55 | 0.45 | 25.67 | 47.29 | 1.38 | 25.06 |
| 55-65 | 0.14 | 11.74 | 60.35 | 0.90 | 26.86 |
| 70-85 | 0.03 | 2.57 | 67.43 | 0.94 | 29.00 |
| 85-100 | 0.006 | 2.14 | 67.23 | 1.21 | 29.43 |
| 110-122 | 0.003 | 1.93 | 66.22 | 1.20 | 30.68 |
| 135-142 | 0 | 1.60 | 64.98 | 1.32 | 32.09 |
| 150-155 | 0 | 1.87 | 67.25 | 1.32 | 29.51 |
| 167-170 | 0 | 1.59 | 67.52 | 1.40 | 29.47 |
| 184-186 | 0 | 0.79 | 68.02 | 1.60 | 29.58 |
| 196 | 0 | 0.72 | 67.29 | 1.11 | 30.65 |

The greater importance of hydrocarbon ions at higher source temperatures is in agreement with the thermal decomposition of diethylberyllium which produces ethane, ethylene and butane from about 85°C.

The two propyl compounds also produce dimeric ions (table A23, p. and fig. 15).

At corresponding source temperatures such ions are of much lower abundance than with diethylberyllium and this reflects the decreasing degree of association of beryllium dialkyls as the size of the alkyl group increases.⁹¹ Like the ethyl compound the abundance of dimeric ions falls with increasing source temperature and there is a complementary increase in the intensity of monomeric ions. Again this is because associated molecules dissociate to monomer molecules prior to ionization at high source temperatures.

Dimeric ions, $C_aH_bBe_2^+$, are more abundant at corresponding source temperatures for $(i\text{-Pr})_2Be$ than for $(n\text{-Pr})_2Be$ from which it may be inferred that dimer molecules are more abundant in the vapour for the iso compound.

A tentative explanation of this observation is that the inductive effect of methyl groups attached to the bridging carbon atom in the dimer molecule

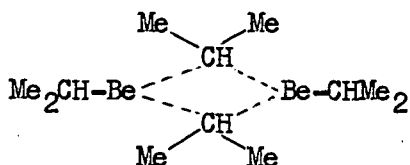

increase the electron density in the Be-C-Be bridging bonds. Inductive effects should be less pronounced with the n-propyl compound. Extending this argument to the butyl compounds one would expect di-tert-butylberyllium to be more associated than di-n-butylberyllium which is not the case; the tertiary compound being monomeric in benzene solution¹³ and the normal compound dimeric¹⁵⁴. Steric effects must also be considered to influence the degree of association and with di-tertiary-butylberyllium the size of the organic group probably inhibits association. Steric hindrance has been postulated to explain why diethylberyllium unlike dimethylberyllium does not form a polymer.¹⁵⁵

With di-iso-propylberyllium the abundance of hydrocarbon ions $m/e \leq 42$ increases from a source temperature of 55°C and rapidly above ~150°C. Since this compound is known to decompose thermally giving propene from about 50°C, the reaction becoming rapid at 200°C, these observations may be ascribed to thermal decomposition prior to ionization. Although hydrocarbon ions $m/e \leq 42$ are more abundant for di-n-propylberyllium they do not increase in abundance until about 165°C, source temperature, indicating that the n-propyl compound is somewhat more stable to thermal decomposition than the iso compound. The initial high abundance of hydrocarbon ions for the normal compound is probably because of a high

.....

.....

.....

.....

.....

.....

.....

.....

.....

.....

.....

.....

.....

.....

.....

.....

.....

.....

.....

.....

.....

.....

.....

.....

.....

.....

.....

Table 4.3.2.

Variation of ion abundances with source temperature (70eV).

di-iso-butylberyllium.

| Source temp.
°C | % of total ion current carried by:- | | |
|--------------------|-------------------------------------|--------------------------------|-----------------------------------|
| | $C_xH_yBe^+$
ions | hydrocarbon ions
$m/e > 56$ | hydrocarbon ions
$m/e \leq 56$ |
| 75-90 | 43.46 | 1.74 | 54.80 |
| 95-130 | 41.88 | 1.56 | 56.56 |
| 160-170 | 36.61 | 1.53 | 61.86 |
| 200-210 | 29.61 | 1.30 | 69.09 |
| 235 | 20.70 | 1.34 | 77.50 |

di-tert-butylberyllium.

| Source temp.
°C | % of total ion current carried by:- | | |
|--------------------|-------------------------------------|-----------------------------------|-----------------------------------|
| | $C_xH_yBe^+$
ions | hydrocarbon ions
$m/e \geq 57$ | hydrocarbon ions
$m/e \leq 56$ |
| 55-75 | 52.31 | 10.77 | 35.27 |
| 75-80 | 51.94 | 11.21 | 36.72 |
| 125-135 | 47.86 | 11.37 | 40.70 |
| 140.155 | 51.14 | 11.90 | 37.66 |
| 155-165 | 45.86 | 12.05 | 41.89 |
| 165-175 | 44.00 | 10.32 | 45.71 |
| 240 | 27.11 | 7.27 | 65.69 |

concentration of dissolved propene in the sample of di-n-propylberyllium when the spectra was recorded.

Even though di-iso-butylberyllium is dimeric in benzene¹³ only monomeric ions $C_xH_yBe^+$, are detected in the mass spectrum. As with di-tertiary-butyl beryllium, the abundance of these monomeric ions falls with increasing source temperature while hydrocarbon ions $m/e \leq 56$ increase in abundance. (table 4.3.2.). This reflects thermal decomposition to involatile hydride and butene prior to ionization.

Although solid dimethylberyllium is a long chain electron deficient polymer as revealed by X-ray analysis¹⁵⁶

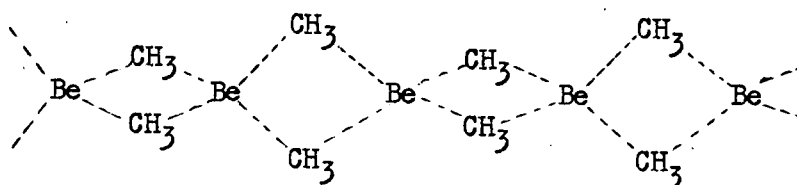

ions containing two or more beryllium atoms are of low abundance in the mass spectrum at 70eV and low source temperatures. This may be because only discrete monomer units can escape easily from the polymeric solid in contrast to liquid diethylberyllium which probably contains dimer and trimer molecules which can leave the surface of the liquid as complete entities. The infra-red spectrum of dimethylberyllium also indicates that the unsaturated vapour consists mainly of monomer while the saturated vapour gives a complex spectrum due to the presence of dimers and trimers.⁹¹

Since thermal decomposition of dimethylberyllium giving mainly methane does not occur until above $\sim 200^\circ C$ ⁹¹ it is not surprising that the abundance of hydrocarbon ions in the mass spectrum of this compound increase only slowly as the source temperature rises to $210^\circ C$ (table 4.3.3.)

Table 4.3.3.

Variation of ion abundances with source temperature for dimethylberyllium (70eV).

| Source temp.
°C | % of total ion current carried by | | | |
|--------------------|-----------------------------------|----------------------|------------------|---------------|
| | $C_xH_yBe^+$
ions | $C_aH_bBe^+$
ions | Hydrocarbon ions | |
| | | | $m/e > 16$ | $m/e \leq 16$ |
| 37-50 | 83.28 | 3.45 | 4.01 | 9.27 |
| 73-87 | 83.86 | 0.97 | 3.92 | 11.17 |
| 115-127 | 84.86 | 0.63 | 3.87 | 10.64 |
| 164-170 | 84.57 | 0.60 | 3.90 | 11.01 |
| 195-198 | 83.64 | 0.24 | 2.02 | 12.35 |
| 210 | 81.10 | 0.41 | 3.78 | 14.52 |

With dimethyl-, di-iso-butyl- and di-tert-butyl-beryllium which show essentially only $C_xH_yBe^+$ ions, the monomeric parent ions, R_2Be^+ , are most abundant at low source temperatures. In this respect they are like hydrocarbons^{1,157} which show a similar trend. As with hydrocarbons the effect is most pronounced in the highly branched molecules such as di-tert-butyl-beryllium. (table 4.3.2.).

4.3.2. Mass Spectra and Modes of Decomposition.

Unlike the organo derivatives of Group IVb elements, even-electron ions of the type, $C_xH_yBe^+$, are not outstandingly more abundant than odd-electron ions, as is illustrated in the following table calculated from the spectrum obtained at high source temperatures at 70eV.

The high abundance of odd-electron ions is mainly because of two factors:-

a) Monomer parent ions, $(C_nH_{2n+1})_2Be^+$, are abundant for all beryllium dialkyls except the butyl compounds. As the size of the alkyl

| $(C_n H_{2n+1})_2 Be$ | Abundance of odd-electron
$C_x H_y Be^+$ ions | | | Abundance of even-
electron $C_x H_y Be^+$
ions |
|-----------------------|--|----------------------------|-------|---|
| | $(C_n H_{2n+1})_2 Be^{+\bullet}$ | $C_n H_{2n} Be^{+\bullet}$ | Total | |
| $Me_2 Be$ | 17.91 | 15.14 | 39.63 | 41.47 |
| $Et_2 Be$ | 8.02 | 23.05 | 38.75 | 28.83 |
| $(i-Pr)_2 Be$ | 2.36 | 13.80 | 24.93 | 26.94 |
| $(n-Pr)_2 Be$ | 1.34 | 11.09 | 16.85 | 25.21 |
| $(i-Bu)_2 Be$ | 0.08 | 3.34 | 5.26 | 15.44 |
| $(t-Bu)_2 Be$ | 0.37 | 2.70 | 6.36 | 20.78 |

group increase so the abundance of the monomer parent ion decreases.

b) The odd-electron ion, $C_n H_{2n} Be^{+\bullet}$, is produced in high abundance by elimination of the alkane, $C_n H_{2n+2}$, from the parent monomer ion. This process is discussed in more detail when the decomposition modes of the monomeric ions, $C_x H_y Be^+$, are discussed.

In contrast abundant associated ions, $C_f H_g Be_n^+$, are even-electron and maintain themselves even-electron by eliminating a molecule such as hydrogen or a hydrocarbon. (Figs. 16 and 17).

Modes of Decomposition of Associated Ions at 70eV.

$C_f H_g Be_n^+$ ions are observed in the spectra of dimethyl-, diethyl- and di-propyl-beryllium compounds at low source temperatures. The observed metastable transitions for these ions are given in figures 16, 17 and 18.

The decomposition of these ions is very simple. The parent ion of the associated species, $R_{2n} Be_n^{+\bullet}$, first loses an alkyl group R, giving an even-electron ion which maintains its even-electron character by

Metastable confirmed decompositions for $C_aH_bBe_2^+$ and $C_dH_eBe_3^+$ ions in spectra of diethylberyllium.

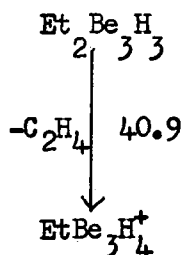
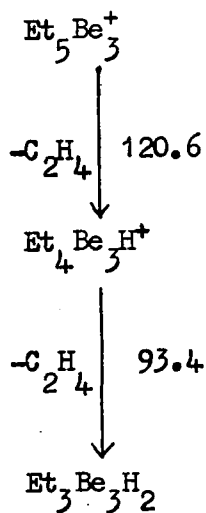
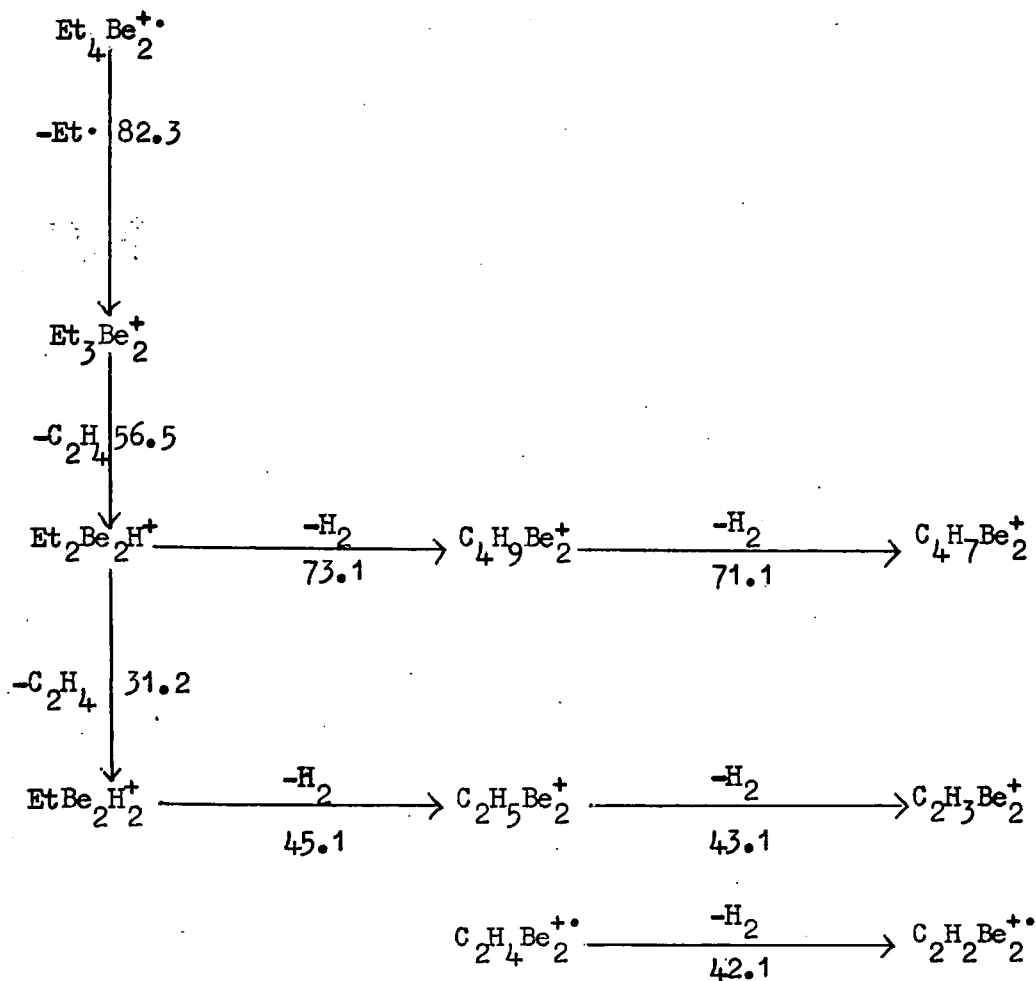

70eV; numbers are mass of observed metastable peak.

successive loss of neutral molecules.

With the ethyl compound successive elimination of ethylene from Et_3Be_2^+ and Et_5Be_3^+ yields hydride ions in high abundance at low source temperatures

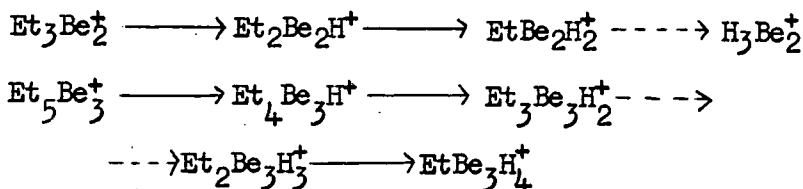

(metastable confirmed decompositions are given as solid arrows)

Such rearrangement may involve an intermediate similar to that postulated for ethylene elimination from even-electron ions of the Group IVb metals (p. 107)

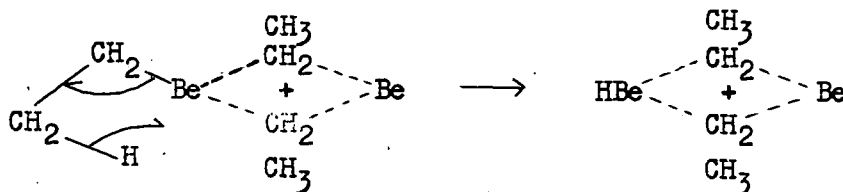

Alternatively or in addition a more complex mechanism involving a bridging ethyl group may apply.

The resulting ions can obviously be formulated in a variety of ways depending whether a hydrogen atom or ethyl group is involved in a bridge between two beryllium atoms. For example $\text{EtBe}_2\text{H}_2^+$ could be

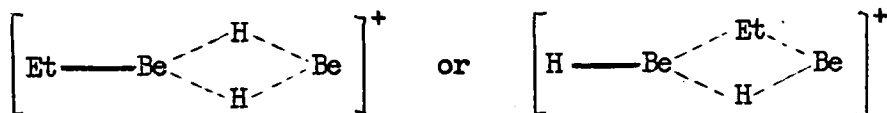

In addition trimer ions can be formulated as a 6-membered ring or a spiro structure:

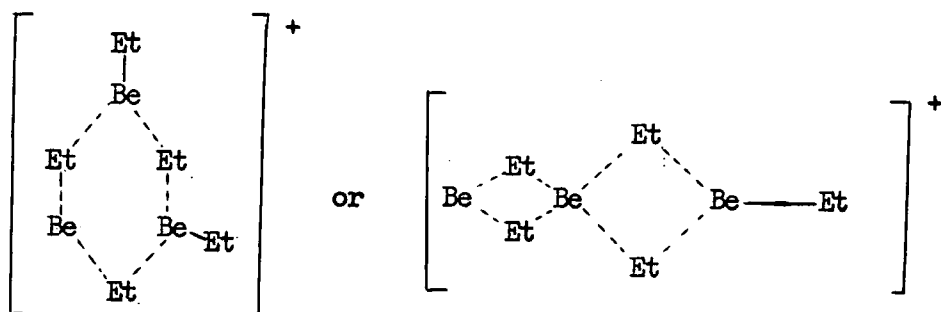

The hydride ions $\text{Et}_2\text{Be}_2\text{H}^+$ and $\text{EtBe}_2\text{H}_2^+$ also decompose by H_2 loss producing low abundance ions.

Pr_3Be_2^+ produced in the spectra of both propyl compounds shows successive elimination of propene giving $\text{Pr}_2\text{Be}_2\text{H}^+$ and $\text{PrBe}_2\text{H}_2^+$. In addition loss of ethylene is observed from $\text{Pr}_2\text{Be}_2\text{H}^+$ which may involve formation of a methyl group. e.g.

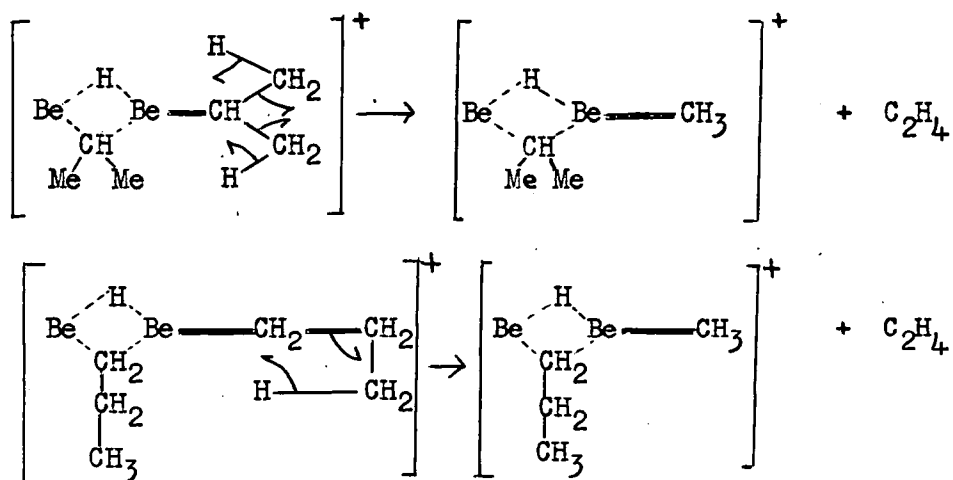

The bridging propyl group may also be involved.

Ions of very low abundance are observed at low source temperatures which could be produced by methane loss

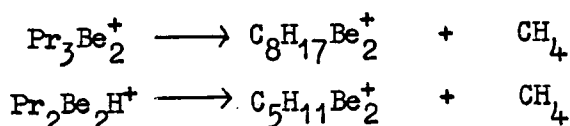

Although the mass spectrum of dimethylberyllium shows no ions of the type $\text{Me}_{2n}\text{Be}_n^+$, Me_3Be_2^+ carries 0.82% of the total ion current at low

FIG. 17.

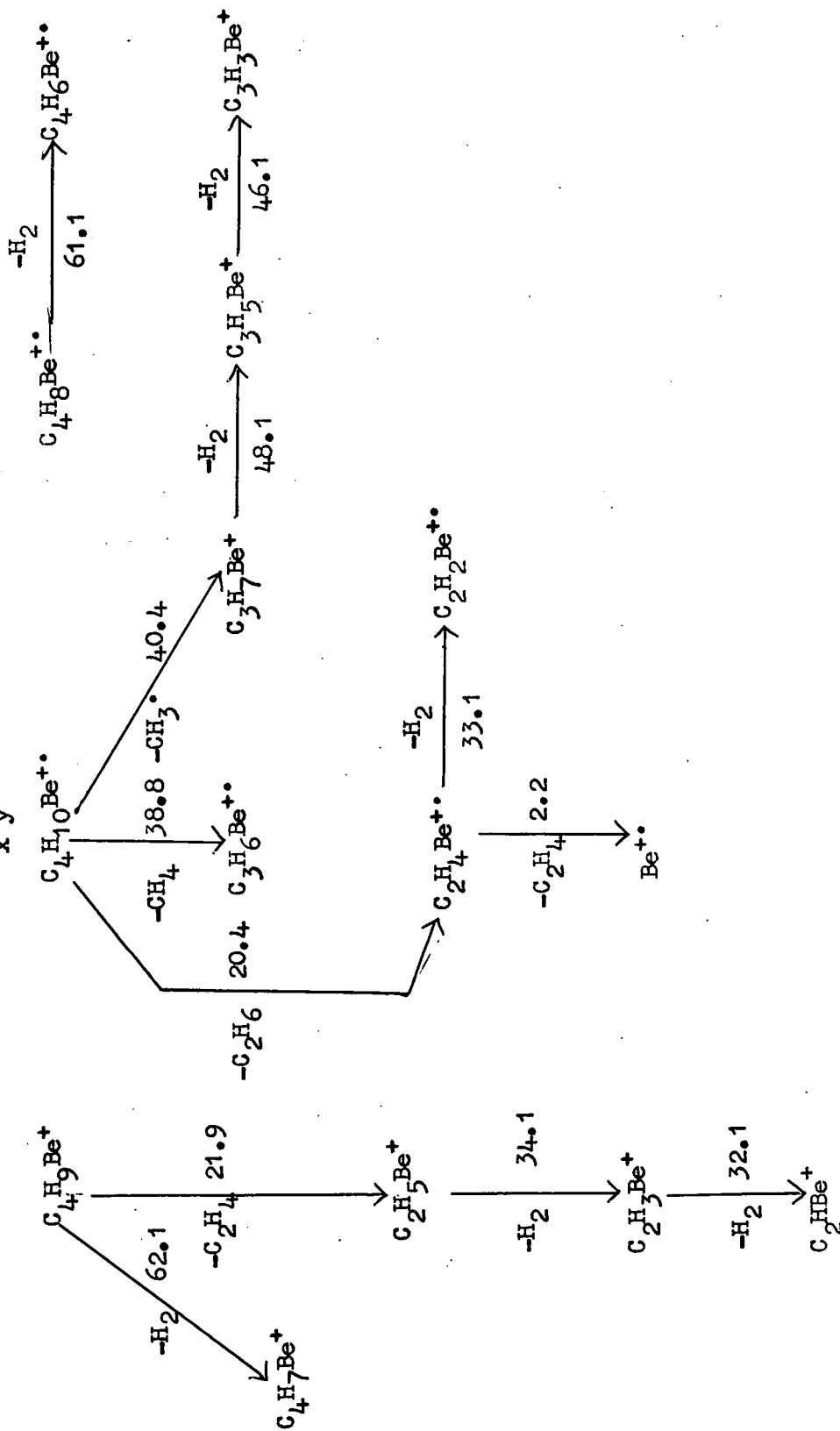
Metastable confirmed decompositions for $C_xH_yBe^+$ ions for diethylberyllium

70eV; numbers are observed mass of metastable peak.

Metastable confirmed decompositions for $C_xH_yBe^+$ ions for di-propylberyllium compounds.

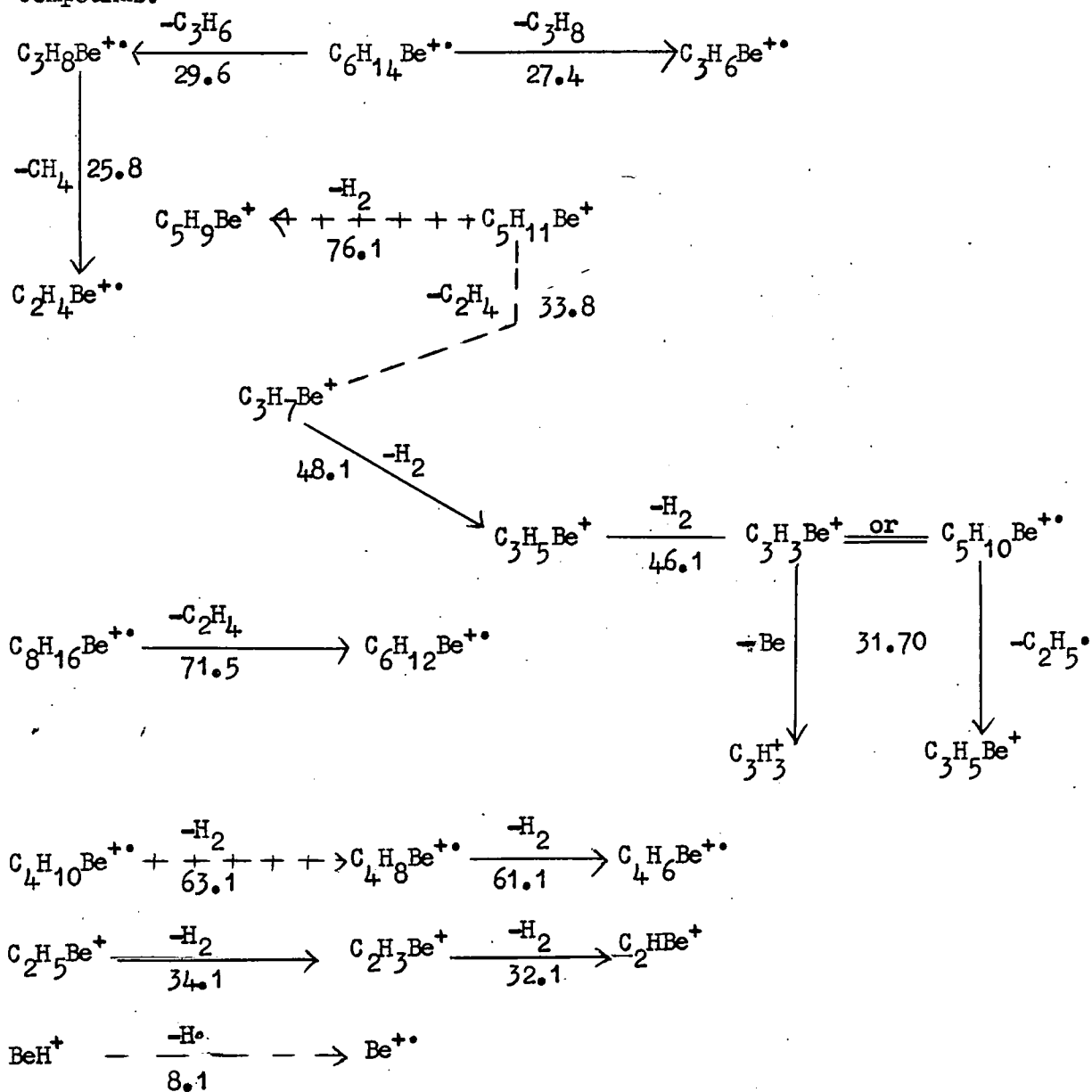

70eV; numbers are observed mass of the metastable peak. Solid arrows indicate metastable transitions common to both $(n-Pr)_2Be$ and $(i-Pr)_2Be$. Arrows $-->$ indicate transitions observed only for ${}^2(i-Pr)_2Be$. Arrows $++\rightarrow$ indicate transitions observed only for $(n-Pr)_2Be$.

Fig. 21.
Metastable confirmed decompositions for di-tertiary-butylberyllium

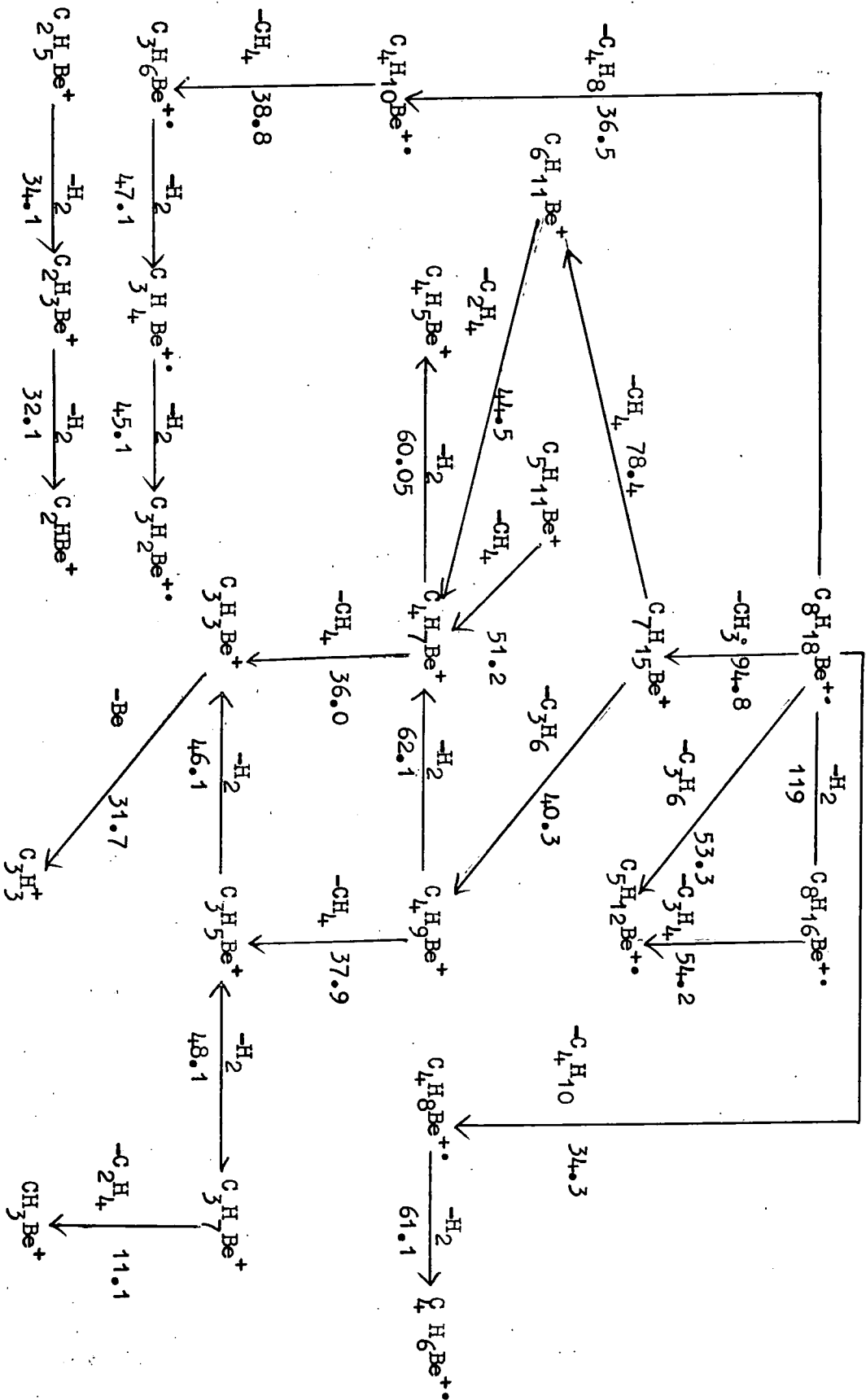

At 70eV; numbers are mass of observed metastable peak.

Fig. 22.

Metastable confirmed decompositions for di-iso-butylberyllium.

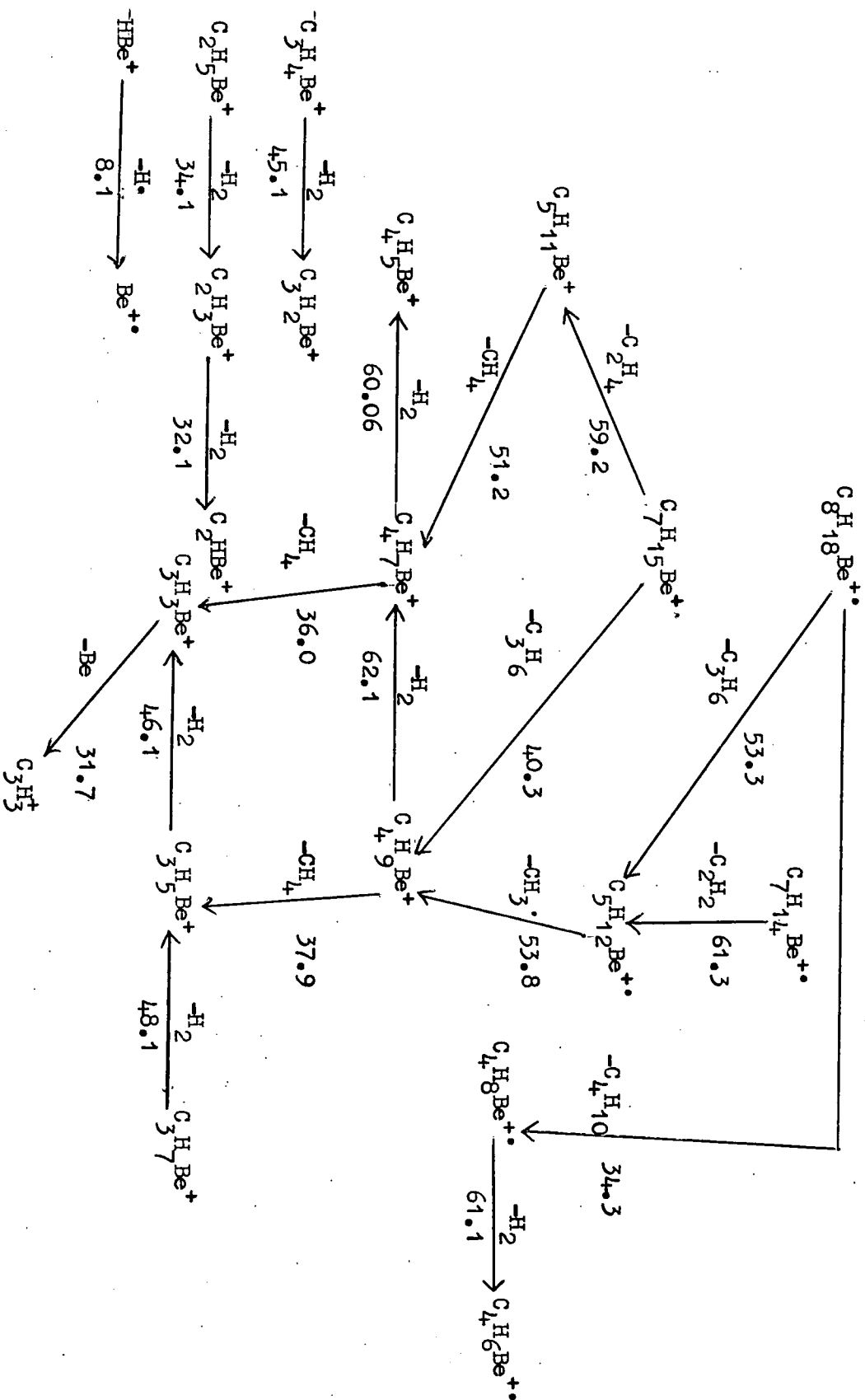

at 70eV; numbers are mass of observed metastable peak.

source temperatures. The ion $C_2H_5Be_2^+$ could be produced by methane loss from $Me_3Be_2^+$. With this compound the ions $C_{12}H_{33}Be_8^+$, $C_{10}H_{27}Be_7^+$, $C_8H_{21}Be_6^+$ and $C_6H_{15}Be_5^+$ are observed in low abundance together with metastable confirmed eliminations of C_2H_6Be ($Me_2Be?$)

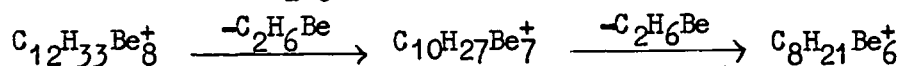

Since these are all even-electron they must be fragment ions of some unobserved parent ion. It seems unlikely that $(Me_2Be)_8^{+}$ is the parent ion since four carbon atoms and fifteen hydrogen atoms must then be lost either as radicals or molecules to give $C_{12}H_{33}Be_8^+$. It is possible that these ions are produced by ionization of a complex associated beryllium molecule formed during slight thermal decomposition of the dimethylberyllium polymer at 50°C (i.e. the sample temperature required) involving methane and hydrogen loss.

Obviously many structures can be postulated for these ions.

However it does reflect the polymeric nature of solid dimethylberyllium that ions containing up to eight beryllium atoms are observed.

Modes of Decomposition of $C_xH_yBe^+$ ions.

Metastable confirmed decompositions for these ions are given in figures 18,19,20,21 and 22. The modes of decomposition observed for parent monomeric ions, R_2Be^{+} are first discussed since these are similar for all compounds.

Parent Ion Decompositions.

The simple bond cleavage decomposition

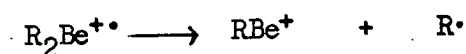

with formation of the abundant even-electron ion RBe^{+} , is not confirmed by a metastable peak for any compounds studied. With di-tert-butylberyllium

$C_4H_9^+$ is produced in much higher abundance than for di-iso-butylberyllium which suggests that for this compound the fragmentation:-



is important.

Carbon-carbon bond cleavage is also observed, the following decompositions being metastable confirmed:

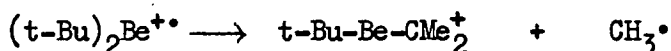
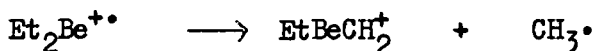

For di-tert-butylberyllium the resulting ion is of high abundance especially at 12eV. This is perhaps expected in view of the fact that hydrocarbons cleave readily at the carbon atom of greatest branching^{1,9}. With the iso-butyl compound the (p-Me)⁺ ion (i.e. parent ion minus methyl) is only of low abundance.

In contrast the (p-Me)⁺ ion for di-iso-propylberyllium is lower than for the normal compound. (i.e. (p-Me)⁺ constitutes 0.23% of the total beryllium-containing ions for di-iso-propylberyllium and 0.55% for di-n-propylberyllium). Surprisingly diethylberyllium gives an abundant (p-Me)⁺ ion especially at 12eV.

Parent ions also decompose by processes which involve rearrangement. All the dialkyls show a metastable peak for

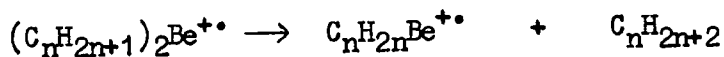

The ion $C_nH_{2n}Be^{+\bullet}$ is a major beryllium-containing ion. A simple hydrogen migration can be postulated; thus for the methyl compound a 4-centre intermediate can be invoked.

| | | | | | |
|-----|-----|-----|-----|-----|-----|
| 1 | 1 | 1 | 1 | 1 | 1 |
| 2 | 2 | 2 | 2 | 2 | 2 |
| 3 | 3 | 3 | 3 | 3 | 3 |
| 4 | 4 | 4 | 4 | 4 | 4 |
| 5 | 5 | 5 | 5 | 5 | 5 |
| 6 | 6 | 6 | 6 | 6 | 6 |
| 7 | 7 | 7 | 7 | 7 | 7 |
| 8 | 8 | 8 | 8 | 8 | 8 |
| 9 | 9 | 9 | 9 | 9 | 9 |
| 10 | 10 | 10 | 10 | 10 | 10 |
| 11 | 11 | 11 | 11 | 11 | 11 |
| 12 | 12 | 12 | 12 | 12 | 12 |
| 13 | 13 | 13 | 13 | 13 | 13 |
| 14 | 14 | 14 | 14 | 14 | 14 |
| 15 | 15 | 15 | 15 | 15 | 15 |
| 16 | 16 | 16 | 16 | 16 | 16 |
| 17 | 17 | 17 | 17 | 17 | 17 |
| 18 | 18 | 18 | 18 | 18 | 18 |
| 19 | 19 | 19 | 19 | 19 | 19 |
| 20 | 20 | 20 | 20 | 20 | 20 |
| 21 | 21 | 21 | 21 | 21 | 21 |
| 22 | 22 | 22 | 22 | 22 | 22 |
| 23 | 23 | 23 | 23 | 23 | 23 |
| 24 | 24 | 24 | 24 | 24 | 24 |
| 25 | 25 | 25 | 25 | 25 | 25 |
| 26 | 26 | 26 | 26 | 26 | 26 |
| 27 | 27 | 27 | 27 | 27 | 27 |
| 28 | 28 | 28 | 28 | 28 | 28 |
| 29 | 29 | 29 | 29 | 29 | 29 |
| 30 | 30 | 30 | 30 | 30 | 30 |
| 31 | 31 | 31 | 31 | 31 | 31 |
| 32 | 32 | 32 | 32 | 32 | 32 |
| 33 | 33 | 33 | 33 | 33 | 33 |
| 34 | 34 | 34 | 34 | 34 | 34 |
| 35 | 35 | 35 | 35 | 35 | 35 |
| 36 | 36 | 36 | 36 | 36 | 36 |
| 37 | 37 | 37 | 37 | 37 | 37 |
| 38 | 38 | 38 | 38 | 38 | 38 |
| 39 | 39 | 39 | 39 | 39 | 39 |
| 40 | 40 | 40 | 40 | 40 | 40 |
| 41 | 41 | 41 | 41 | 41 | 41 |
| 42 | 42 | 42 | 42 | 42 | 42 |
| 43 | 43 | 43 | 43 | 43 | 43 |
| 44 | 44 | 44 | 44 | 44 | 44 |
| 45 | 45 | 45 | 45 | 45 | 45 |
| 46 | 46 | 46 | 46 | 46 | 46 |
| 47 | 47 | 47 | 47 | 47 | 47 |
| 48 | 48 | 48 | 48 | 48 | 48 |
| 49 | 49 | 49 | 49 | 49 | 49 |
| 50 | 50 | 50 | 50 | 50 | 50 |
| 51 | 51 | 51 | 51 | 51 | 51 |
| 52 | 52 | 52 | 52 | 52 | 52 |
| 53 | 53 | 53 | 53 | 53 | 53 |
| 54 | 54 | 54 | 54 | 54 | 54 |
| 55 | 55 | 55 | 55 | 55 | 55 |
| 56 | 56 | 56 | 56 | 56 | 56 |
| 57 | 57 | 57 | 57 | 57 | 57 |
| 58 | 58 | 58 | 58 | 58 | 58 |
| 59 | 59 | 59 | 59 | 59 | 59 |
| 60 | 60 | 60 | 60 | 60 | 60 |
| 61 | 61 | 61 | 61 | 61 | 61 |
| 62 | 62 | 62 | 62 | 62 | 62 |
| 63 | 63 | 63 | 63 | 63 | 63 |
| 64 | 64 | 64 | 64 | 64 | 64 |
| 65 | 65 | 65 | 65 | 65 | 65 |
| 66 | 66 | 66 | 66 | 66 | 66 |
| 67 | 67 | 67 | 67 | 67 | 67 |
| 68 | 68 | 68 | 68 | 68 | 68 |
| 69 | 69 | 69 | 69 | 69 | 69 |
| 70 | 70 | 70 | 70 | 70 | 70 |
| 71 | 71 | 71 | 71 | 71 | 71 |
| 72 | 72 | 72 | 72 | 72 | 72 |
| 73 | 73 | 73 | 73 | 73 | 73 |
| 74 | 74 | 74 | 74 | 74 | 74 |
| 75 | 75 | 75 | 75 | 75 | 75 |
| 76 | 76 | 76 | 76 | 76 | 76 |
| 77 | 77 | 77 | 77 | 77 | 77 |
| 78 | 78 | 78 | 78 | 78 | 78 |
| 79 | 79 | 79 | 79 | 79 | 79 |
| 80 | 80 | 80 | 80 | 80 | 80 |
| 81 | 81 | 81 | 81 | 81 | 81 |
| 82 | 82 | 82 | 82 | 82 | 82 |
| 83 | 83 | 83 | 83 | 83 | 83 |
| 84 | 84 | 84 | 84 | 84 | 84 |
| 85 | 85 | 85 | 85 | 85 | 85 |
| 86 | 86 | 86 | 86 | 86 | 86 |
| 87 | 87 | 87 | 87 | 87 | 87 |
| 88 | 88 | 88 | 88 | 88 | 88 |
| 89 | 89 | 89 | 89 | 89 | 89 |
| 90 | 90 | 90 | 90 | 90 | 90 |
| 91 | 91 | 91 | 91 | 91 | 91 |
| 92 | 92 | 92 | 92 | 92 | 92 |
| 93 | 93 | 93 | 93 | 93 | 93 |
| 94 | 94 | 94 | 94 | 94 | 94 |
| 95 | 95 | 95 | 95 | 95 | 95 |
| 96 | 96 | 96 | 96 | 96 | 96 |
| 97 | 97 | 97 | 97 | 97 | 97 |
| 98 | 98 | 98 | 98 | 98 | 98 |
| 99 | 99 | 99 | 99 | 99 | 99 |
| 100 | 100 | 100 | 100 | 100 | 100 |

Table 4.3.4.

Abundances of parent monomeric ions and major Be-containing ions for beryllium dialkyls.

| parent ion
($C_n H_{2n+1}$) $_2 Be^{+}$ | Me $_2 Be$ | | Et $_2 Be$ | | (i-Pr) $_2 Be$ | | (n-Pr) $_2 Be$ | | (i-Bu) $_2 Be$ | | (t-Bu) $_2 Be$ | |
|--|-------------|------|------------|-------|----------------|-------|----------------|-------|----------------|------|----------------|-------|
| | 70eV | 15eV | 70eV | 12eV | 70eV | 12eV | 70eV | 12eV | 70eV | 12eV | 70eV | 12eV |
| (p-Me) $^+$ | (see below) | | 2.02 | 4.03 | 0.12 | 0.16 | 0.17 | 0.56 | 0.08 | 0.28 | 1.95 | 15.29 |
| (p-C $_n H_{2n}$) $^{+}$ | - | - | 2.76 | 0.43 | 0.61 | 1.34 | 0.69 | 0.89 | 0.44 | 0.55 | 0.47 | 2.28 |
| (p-C $_n H_{2n+1}$) $^+$ | 31.93 | 2.52 | 14.92 | 9.33 | 9.99 | 12.04 | 14.67 | 15.94 | 7.87 | 8.86 | 4.59 | 8.62 |
| (p-C $_n H_{2n+2}$) $^{+}$ | 15.14 | 6.89 | 23.04 | 30.67 | 13.70 | 30.76 | 11.09 | 24.53 | 3.34 | 7.34 | 2.70 | 9.54 |
| % of total ion current due to C $_x H_y Be^+$ ions carried by above ions | 80.1 | 96.8 | 75.1 | 93.5 | 51.6 | 83.2 | 66.5 | 84.4 | 54.0 | 87.4 | 37.2 | 82.5 |
| Source temp. °C | 210° | | 196° | | 215-220° | | 210-215° | | 235° | | 240° | |

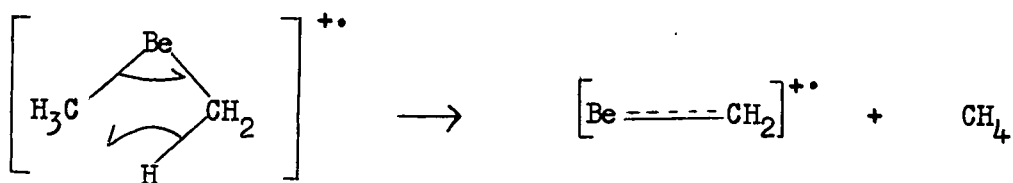

For the other dialkyls the position of hydrogen atoms involved can only be found by deuterium labelling in the alkyl group.

From the energy of dissociation

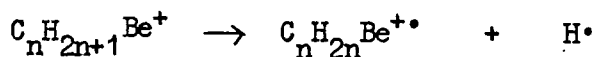

found from appearance potentials (p.98) it has been tentatively suggested that the ion $\text{C}_n\text{H}_{2n}\text{Be}^{+\bullet}$ ($n \geq 2$) formed by the above process may have a ring structure.

A metastable peak corresponding to loss of the alkene, C_nH_{2n} , is observed from parent ions, $(\text{C}_n\text{H}_{2n+1})_2\text{Be}$, of di-iso-propyl-, di-n-propyl- and di-tert-butylberyllium. Such rearrangement probably involves hydride formation. For example:

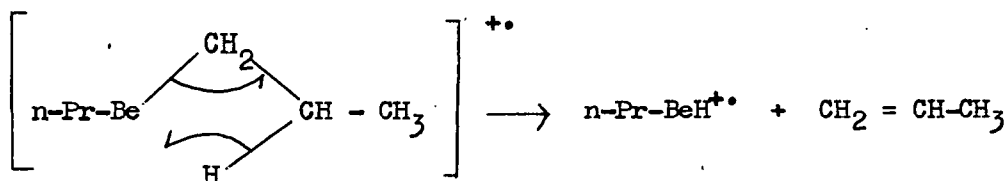

Although no metastable peak is present, the ions $\text{RBeH}^{+\bullet}$ ($\text{R} = \text{Et}$ or $i\text{-Bu}$) are probably produced in a similar way in the spectra of diethyl- and di-iso-butylberyllium. With dimethylberyllium the ion $\text{CH}_3\text{BeH}^{+\bullet}$ is not observed, probably because its formation from $\text{Me}_2\text{Be}^{+\bullet}$ would involve CH_2 : elimination.

In table 4.3.4. it will be seen that parent ions and fragment ions formed by the decompositions of parent ions discussed above account for most of the ion current due to $\text{C}_x\text{H}_y\text{Be}^+$ ions observed at high source

temperatures. This is especially true at low electron voltages when the number of types of ions formed is far less.

In addition to the decompositions discussed above, $(t\text{-Bu})_2\text{Be}^{+\bullet}$ and $(i\text{-Bu})_2\text{Be}^{+\bullet}$ show a metastable peak for propene elimination producing $\text{C}_5\text{H}_{12}\text{Be}^{+\bullet}$ in low abundance. A low abundance ion is also produced for methane elimination from $\text{Et}_2\text{Be}^{+\bullet}$

Fragment Ion Decompositions.

Elimination of H_2 from $\text{C}_x\text{H}_y\text{Be}^+$ ions is very favourable and many metastable peaks for such decompositions are observed. (Figs. 18-22) Whenever an abundant $\text{C}_x\text{H}_y\text{Be}^+$ ion occurs, then ions of much lower abundance are also observed 2,4,6 etc. mass units below formed by loss of hydrogen. Loss of a hydrogen atom gives a metastable peak in one case only:

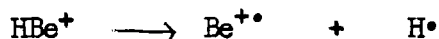

The propyl and butyl compounds produce ions which show metastable peaks for methane loss. Such decomposition is present for both odd- and even-electron ions. It is interesting to note that methane loss is the only alkane elimination from fragment ions that gives a metastable peak.

Both ethylene and propene on the other hand are eliminated from fragment ions (figs. 20,21,22) e.g.

| | | |
|----------------------------|---|--|
| $(t\text{-Bu})_2\text{Be}$ | } | $\text{C}_7\text{H}_{15}\text{Be}^+ \rightarrow \text{C}_4\text{H}_9\text{Be}^+ + \text{C}_3\text{H}_6;$ |
| $(i\text{-Bu})_2\text{Be}$ | } | $\text{C}_6\text{H}_{11}\text{Be}^+ \rightarrow \text{C}_4\text{H}_7\text{Be}^+ + \text{C}_2\text{H}_4$ |
| $(i\text{-Pr})_2\text{Be}$ | | $\text{C}_5\text{H}_{11}\text{Be}^+ \rightarrow \text{C}_3\text{H}_7\text{Be}^+ + \text{C}_2\text{H}_4$ |
| Et_2Be | | $\text{C}_2\text{H}_4\text{Be}^+ \rightarrow \text{Be}^{+\bullet} + \text{C}_2\text{H}_4$ |

The elimination of Be is observed only from $\text{C}_3\text{H}_3\text{Be}^+$ produced by the propyl and butyl compounds.

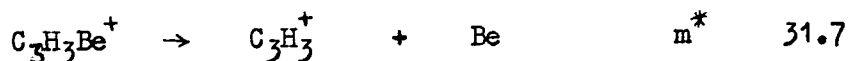

With the two butyl compounds the metastable peak at 31.7 can only be assigned to the above process but for the propyl compounds the transition

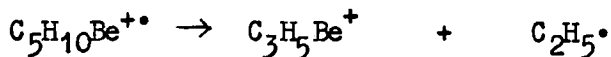

can also apply.

If C_3H_3^+ formed is identical to that produced by ionization of $\bullet\text{CH}_2-\text{C}\equiv\text{CH}$ then it is not surprising that the charge is retained by the hydrocarbon species since

$$\left. \begin{array}{l} I(\bullet\text{CH}_2 - \text{C}\equiv\text{CH}) = 8.25 \pm 0.08\text{eV} \\ I(\text{Be}) = 9.32\text{eV} \end{array} \right\} \text{ref. 102.}$$

and the charge would be expected to reside on the fragment of lowest ionization potential. ^{1,4}

Obviously the C_3H_3^+ ion could also have a ring structure especially if the ion $\text{C}_3\text{H}_3\text{Be}^+$ has the structure $\left[\begin{array}{c} \text{CH} \\ \diagup \quad \diagdown \\ \text{CH} \quad \text{CH} \end{array} \text{--- Be} \right]^+$. In the spectra of diethylberyllium the ion $\text{C}_3\text{H}_3\text{Be}^+$ is only of low abundance, which may account for the absence of a metastable peak corresponding to Be elimination. More probably this is because the ion, $\text{C}_3\text{H}_3\text{Be}^+$, has a different structure for this compound. It could for example be $(\text{CH}_2-\text{Be}-\text{C}\equiv\text{CH})^+$ rather than structures discussed earlier which involve all three carbon atoms bonded together.

Distinguishing Isomers.

The 70eV spectra of the two propyl compounds differ mainly in the relative intensities of the ions $\text{C}_3\text{H}_6\text{Be}^{+\bullet}$ and $\text{C}_3\text{H}_7\text{Be}^+$. At 12eV the spectra are almost identical. In contrast di-iso-butyl- and di-tert-butylberyllium are most easily identified from their mass spectra at 12eV. At this voltage the tertiary-butyl compound gives an intense ion formed by carbon-carbon

cleavage in the parent ion:

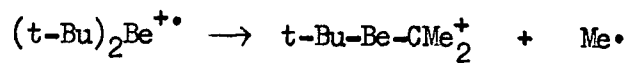

For the iso-butyl compound the ion $\text{C}_7\text{H}_{15}\text{Be}^+$ although observed is always of low abundance.

4.4. Mass Spectra of Organoaluminium Compounds.

In view of the considerable effect of source temperature in the mass spectrometry of organoberyllium compounds, it is desirable to determine the effect of this instrument parameter on the mass spectra of organoaluminium compounds which, like the beryllium compounds, form electron deficient molecules. It is also of interest to compare the decomposition modes of the organoderivatives of this metal with those observed for beryllium and group IV derivatives.

Ion abundances of the compounds studied are shown in tables 4.4.1, 4.4.2. and 4.4.3. Unfortunately the sample of triethylaluminium used was contaminated by diethylaluminium ethoxide and so it was not certain which of the peaks in the mass spectrum obtained are due to the ethoxide. Since the major peaks in the spectrum of mixture of diethylaluminium ethoxide and other oxides all contain oxygen, it was assumed that all ions not containing oxygen are due to triethylaluminium. The mass spectra given in table 4.4.3. are thus obtained. Abundances are expressed as a percentage of the base peak rather than as percentage of total ion current because hydrocarbon peaks can come from both triethylaluminium or the ethoxide.

4.4.1. Effect of Source Temperature.

a) Trimethylaluminium.

The mass spectrum of trimethylaluminium has been recorded at 70eV and dimeric ions Me_5Al_2^+ detected in extremely low abundance.¹² The effect of source temperature was not considered.

The present study shows that dimeric ions Me_5Al_2^+ and Me_3Al_2^+ are

Table 4.4.1.

Ion abundances * for Me_3Al and Me_2AlH .

| <u>Me_3Al</u> | | | | <u>Me_2AlH</u> | | | |
|--|--------------------------------------|--------------|---------|---|--------------------------------------|--------------|---------|
| m/e | Ion ⁺ | Source
°C | Temp. | m/e | Ion ⁺ | Source
°C | Temp. |
| | | 195 | 45 - 50 | | | 210 | 50 - 70 |
| 129 | Me_5Al_2 | .14 | 2.97 | 159 | $\text{Me}_5\text{Al}_3\text{H}_3$ | .01 | .45 |
| 99 | Me_3Al_2 | .04 | .55 | 115 | $\text{Me}_4\text{Al}_2\text{H}$ | .79 | 4.93 |
| 72 | $\text{Me}_3\text{Al}\cdot$ | 4.60 | 6.13 | 101 | $\text{Me}_3\text{Al}_2\text{H}_2$ | 4.18 | 24.72 |
| 57 | Me_2Al | 64.78 | 67.15 | 72 | $\text{Me}_3\text{Al}\cdot$ | 3.06 | 0.44 |
| 56 | $\text{C}_4\text{H}_8\cdot$ | .45 | 1.14 | 58 | $\text{Me}_2\text{AlH}\cdot$ | 1.51 | 0.99 |
| | $\text{C}_2\text{H}_5\text{Al}\cdot$ | .69 | .66 | 57 | C_4H_9 | 1.64 | 0.23 |
| 43 | C_3H_7 | .43 | .74 | | Me_2Al | 60.68 | 39.38 |
| | CH_4Al | 3.07 | 2.37 | 56 | $\text{C}_4\text{H}_8\cdot$ | 1.51 | 1.97 |
| 42 | $\text{C}_3\text{H}_6\cdot$ | .15 | .29 | | $\text{C}_2\text{H}_5\text{Al}\cdot$ | 0.54 | 0.67 |
| | $\text{CH}_3\text{Al}\cdot$ | 5.06 | 3.49 | 55 | C_4H_7 | .32 | .37 |
| 41 | CH_2Al | .75 | .60 | | $\text{C}_2\text{H}_4\text{Al}$ | .09 | .20 |
| 29 | C_2H_5 | .20 | .41 | 44 | $\text{C}_3\text{H}_8\cdot$ | .05 | .05 |
| | H_2Al | .88 | .83 | | $\text{CH}_5\text{Al}\cdot$ | .07 | .06 |
| 28 | $\text{C}_2\text{H}_4\cdot$ | .15 | .29 | 43 | C_3H_7 | 1.48 | 1.59 |
| | $\text{HAl}\cdot$ | .44 | .41 | | CH_4Al | 2.85 | 2.23 |
| 27 | $\text{C}_2\text{H}_3\cdot$ | .30 | .41 | 42 | $\text{C}_3\text{H}_6\cdot$ | .64 | .74 |
| | Al | 12.00 | 8.29 | | $\text{CH}_3\text{Al}\cdot$ | 3.86 | 3.14 |
| 26 | $\text{C}_2\text{H}_2\cdot$ | .12 | .19 | 41 | C_3H_5 | 1.19 | 1.50 |
| 16 | $\text{CH}_4\cdot$ | 2.58 | 1.17 | | CH_2Al | .50 | .18 |
| 15 | CH_3 | 2.54 | 1.46 | 29 | C_2H_5 | .67 | .65 |
| 14 | $\text{CH}_2\cdot$ | .31 | .33 | | H_2Al | .83 | .37 |
| 13 | CH | .11 | .10 | 28 | $\text{C}_2\text{H}_4\cdot$ | .19 | .20 |
| 12 | $\text{C}\cdot$ | .08 | .02 | | $\text{HAl}\cdot$ | .33 | .20 |
| | | | | 27 | C_2H_3 | .21 | .24 |
| | | | | | Al | 7.33 | 7.71 |
| | | | | 26 | $\text{C}_2\text{H}_2\cdot$ | .13 | .12 |
| | | | | 16 | $\text{CH}_4\cdot$ | 2.63 | 1.97 |
| | | | | 15 | CH_3 | 2.27 | 1.78 |
| | | | | 14 | $\text{CH}_2\cdot$ | .30 | .31 |
| | | | | 13 | CH | .09 | .12 |
| | | | | 12 | $\text{C}\cdot$ | .03 | .05 |

* expressed as % of total ion current at 70eV.

Ion abundances * for Et₂AlH

| m/e | Ion ⁺ | Source Temp. | | m/e | Ion ⁺ | Source Temp. | |
|-----|---|--------------|---------|-----|--|--------------|---------|
| | | 214°C | 32-45°C | | | 214°C | 32-45°C |
| 229 | Et ₅ Al ₃ H ₃ | .02 | .27 | 42 | CH ₃ Al ^o | .53 | .16 |
| 172 | Et ₄ Al ₂ H ₂ ^o | .05 | .90 | 30 | C ₂ H ₆ ^o | .99 | 4.37 |
| 171 | Et ₄ Al ₂ H | .18 | 1.54 | 29 | C ₂ H ₅ | 1.41 | 3.87 |
| 143 | Et ₃ Al ₂ H ₂ | 1.16 | 12.79 | | H ₂ Al | 4.72 | 2.50 |
| 115 | Et ₂ Al ₂ H ₃ | .91 | 5.83 | 28 | C ₂ H ₄ ^o | 11.84 | 14.71 |
| 114 | Et ₃ Al ^o | 3.54 | 1.21 | | HA1 ^o | 1.18 | .39 |
| 113 | C ₆ H ₁₄ Al | .05 | .32 | 27 | C ₂ H ₃ | 7.22 | 5.80 |
| 87 | EtAl ₂ H ₄ | .07 | .18 | | Al | 8.56 | 5.71 |
| 86 | Et ₂ AlH ^o | 1.13 | .78 | 26 | C ₂ H ₂ ^o | 5.89 | 3.33 |
| 85 | Et ₂ Al | 19.18 | 19.27 | 25 | C ₂ H | .64 | .86 |
| 71 | C ₃ H ₈ Al | .88 | .47 | 24 | C ₂ ^o | .24 | .20 |
| 70 | C ₃ H ₇ Al ^o | .07 | .08 | 16 | CH ₄ ^o | .11 | .40 |
| 69 | C ₃ H ₆ Al | .06 | .21 | 15 | CH ₃ | .23 | .71 |
| 57 | C ₂ H ₆ Al | 22.26 | 10.27 | 14 | CH ₂ ^o | .27 | .38 |
| 56 | C ₂ H ₅ Al ^o | 2.36 | .86 | 13 | CH | .11 | .13 |
| 55 | C ₂ H ₄ Al | 2.36 | .86 | 12 | C ^o | .05 | .06 |
| 43 | CH ₄ Al | 1.75 | .62 | | | | |

* expressed as % of total ion current at 70eV.

Table 4.4.3.

Ion abundances * for Et_3Al and $\text{Et}_2\text{Al}(\text{OEt})$

| m/e | Ion ⁺ | Abundance | m/e | Ion ⁺ | Abundance |
|---|---|-----------|-----|--|-----------|
| <u>Et_3Al</u> | | | | | |
| 114 | $\text{Et}_3\text{Al}^{\bullet}$ | 12.5 | 57 | HA1Et | 100 |
| 99 | Et_2AlCH_2 | 3.4 | 56 | EtAl^{\bullet} | 6.07 |
| 85 | Et_2Al | 69.7 | 55 | $\text{C}_2\text{H}_4\text{Al}$ | 7.18 |
| 84 | $\text{C}_4\text{H}_9\text{Al}^{\bullet}$ | .20 | 43 | CH_4Al | 4.29 |
| 83 | $\text{C}_4\text{H}_8\text{Al}$ | .74 | 42 | $\text{CH}_3\text{Al}^{\bullet}$ | 1.48 |
| 71 | $\text{C}_3\text{H}_8\text{Al}$ | 2.74 | 29 | H_2Al | 14.29 |
| 70 | $\text{C}_3\text{H}_7\text{Al}^{\bullet}$ | .93 | 28 | HA1^{\bullet} | 2.07 |
| 69 | $\text{C}_3\text{H}_6\text{Al}$ | .99 | 27 | Al | 23.83 |
| <u>Et_2AlOEt</u> | | | | | |
| 260 | $\text{Et}_4\text{Al}_2(\text{OEt})_2^{\bullet}$ | .45 | 131 | $\text{C}_4\text{H}_{13}\text{Al}_2$ | 2.62 |
| 259 | $\text{C}_{12}\text{H}_{29}\text{Al}_2\text{O}_2$ | 1.35 | 129 | $\text{C}_4\text{H}_{11}\text{Al}_2\text{O}$ | 3.49 |
| 231 | $\text{C}_{10}\text{H}_{25}\text{Al}_2\text{O}_2$ | 100. | 117 | $\text{C}_2\text{H}_7\text{Al}_2\text{O}_2$ | 9.28 |
| 215 | $\text{C}_9\text{H}_{21}\text{Al}_2\text{O}_2$ | 1.23 | 115 | $\text{C}_2\text{H}_5\text{Al}_2\text{O}_2$ | 5.47 |
| | $\text{C}_{10}\text{H}_{25}\text{Al}_2\text{O}$ | 3.67 | 101 | $\text{EtAl}(\text{OEt})$ | } 10.30 |
| | | | or | $[\text{EtAl}(\text{OEt})]_2^+$ | |
| 203 | $\text{C}_8\text{H}_{21}\text{Al}_2\text{O}_2$ | 74.1 | | $\text{C}_2\text{H}_7\text{Al}_2\text{O}$ | 4.23 |
| 187 | $\text{C}_7\text{H}_{17}\text{Al}_2\text{O}_2$ | 6.54 | 89 | $\text{H}_3\text{Al}_2\text{O}_2$ | 8.60 |
| | $\text{C}_8\text{H}_{21}\text{Al}_2\text{O}$ | 2.50 | 73 | $\text{HA1}(\text{OEt})$ | 11.20 |
| 175 | $\text{C}_6\text{H}_{17}\text{Al}_2\text{O}_2$ | 51.0 | | | |
| 173 | $\text{C}_6\text{H}_{15}\text{Al}_2\text{O}_2$ | 14.0 | | | |
| 159 | $\text{C}_6\text{H}_{17}\text{Al}_2\text{O}$ | 2.86 | | | |
| 147 | $\text{C}_4\text{H}_{13}\text{Al}_2\text{O}_2$ | 28.80 | | | |
| 145 | $\text{C}_4\text{H}_{11}\text{Al}_2\text{O}_2$ | 9.08 | | | |
| 143 | $\text{C}_4\text{H}_9\text{Al}_2\text{O}_2$ | 2.94 | | | |

* expressed as % of total ion current at 70eV.

Table 4.4.4.Variation of ion abundances * of Me_3Al with source temperature.

| Ion type | Source Temperature °C | | | | | | | | |
|---|-----------------------|-------|-------|-------|-------|---------|---------|---------|-------|
| | 44-50 | 50-57 | 60-75 | 75-85 | 85-98 | 120-128 | 155-160 | 175-178 | 195 |
| Me_3Al^+ | 6.13 | 7.06 | 6.93 | 6.72 | 6.07 | 5.82 | 5.31 | 4.88 | 4.60 |
| Monomer AlC_wH_x^+ | 89.93 | 91.82 | 92.02 | 91.17 | 91.91 | 90.50 | 90.91 | 90.37 | 92.27 |
| Dimer $\text{Al}_2\text{C}_y\text{H}_z^+$ | 3.52 | 2.16 | 0.99 | 0.62 | 0.40 | 0.29 | 0.22 | 0.16 | 0.18 |
| Hydrocarbon
m/e > 16 | 3.44 | 3.02 | 3.07 | 2.81 | 2.52 | 2.96 | 2.58 | 2.61 | 1.80 |
| m/e ≤ 16 | 3.08 | 3.00 | 3.92 | 5.40 | 5.16 | 6.24 | 6.29 | 5.41 | 5.62 |

* expressed as percentage of total ion current at 70eV.

Table 4.4.5.Variation of ion abundances * of Me_2AlH with source temperature.

| Ion type | Source Temperature °C | | | | | | | |
|---|-----------------------|-------|--------|---------|---------|---------|-------|-------|
| | 50-70 | 70-85 | 90-102 | 125-135 | 135-160 | 175-180 | 195 | 210 |
| Dimer $\text{Al}_2\text{C}_y\text{H}_z^+$ | 29.65 | 24.34 | 22.80 | 20.00 | 16.56 | 7.40 | 4.39 | 4.97 |
| Trimer $\text{Al}_3\text{C}_w\text{H}_x^+$ | 0.45 | 0.05 | 0.04 | 0.05 | 0.05 | 0.04 | 0.06 | 0.01 |
| Monomer AlC_aH_b^+
except Me_3Al^+ | 56.13 | 50.33 | 62.07 | 60.57 | 67.96 | 71.20 | 77.80 | 78.59 |
| Me_3Al^+ | 0.44 | 0.52 | 0.45 | 1.02 | 1.66 | 2.30 | 3.07 | 3.06 |
| Hydrocarbon
m/e > 16 | 7.66 | 9.43 | 9.53 | 12.62 | 9.28 | 10.47 | 10.33 | 8.03 |
| m/e ≤ 16 | 4.23 | 5.32 | 5.11 | 6.77 | 4.49 | 8.60 | 4.35 | 5.32 |

* expressed as percentage of total ion current at 70eV.

quite abundant at source temperatures of $\sim 40^\circ\text{C}$ but their abundance rapidly diminishes as the source temperature increases (table 4.4.4). Such variation is adequately explained by decomposition of dimer molecules to monomer molecules, prior to ionization, becoming increasingly important as the source temperature increases. The low heat of dimerisation of trimethylaluminium is in agreement with this.¹⁴⁸



The pyrolysis of trimethylaluminium at $200 - 250^\circ\text{C}$ has been studied¹⁴⁹ and proceeds by the elimination of methane and formation of aluminium carbide. The variation given in table 4.4.4. shows that as the source temperature increases so hydrocarbon ions $m/e \leq 16$ become more important. However even at 195°C all hydrocarbon ions constitute only 7.5% of the total ion current.

b) Dimethylaluminium Hydride.

The variation of the 70eV mass spectrum with source temperature is given in table 4.4.5. At low source temperatures dimeric ions constitute a large proportion of the ion current and the trimeric ion $\text{Me}_5\text{Al}_3\text{H}_3^+$ carries 0.45% of the total ion current. As the temperature increases so monomeric ions, $\text{C}_a\text{H}_b\text{Al}^+$, become more predominant, and this may be partly due to the thermal decomposition of associated molecules into monomer molecules prior to ionization. However from the marked increase in abundance of Me_3Al^+ with increase in source temperature, thermal rearrangement of $(\text{Me}_2\text{AlH})_n$ species to trimethylaluminium prior to ionization is mainly responsible for the high abundance of monomer ions, $\text{C}_a\text{H}_b\text{Al}^+$, at high source temperatures. The presence of Me_3Al^+ at low source temperatures

Abundances of monomer ions, $C_a H_b Al^+$, due to trimethylaluminium and dimethylaluminium hydride in the spectrum (70eV) of dimethylaluminium hydride at various source temperatures.

| | Source Temperature °C. | | | | | | 195 |
|--|------------------------|-------|-------|---------|---------|---------|-------|
| | 50-70 | 75-85 | 85-98 | 120-128 | 155-160 | 175-180 | |
| Me_3Al^+ plus
decomposition ions
$C_a H_b Al^+$ | 5.72 | 7.05 | 6.81 | 16.04 | 28.53 | 42.57 | 60.09 |
| Me_2AlH^+ plus
decomposition ions
$C_a H_b Al^+$ | 50.41 | 53.28 | 55.26 | 44.53 | 39.43 | 28.63 | 17.71 |

Table 4.4.7.

Variation of ion abundances * in 70eV spectrum of diethylaluminium hydride with source temperature.

| | 32-45 | 45-63 | 70-87 | 90-105 | 105-120 | 130-140 | 158-165 | 189-192 | 214 |
|--|-------|-------|-------|--------|---------|---------|---------|---------|-------|
| Dimer $Al_2 C_y H_z^+$ | 21.24 | 18.90 | 17.08 | 16.55 | 14.98 | 14.36 | 10.26 | 4.27 | 2.37 |
| Trimer $Al_3 C_w H_x^+$ | 0.27 | 0.19 | 0.08 | 0.06 | 0.05 | 0.06 | 0.04 | 0.03 | 0.02 |
| Monomer $AlC_a H_b^+$
except Et_3Al^+ | 42.50 | 44.79 | 47.19 | 48.57 | 50.12 | 53.94 | 58.43 | 63.74 | 64.09 |
| Et_3Al^+ | 1.21 | 1.57 | 1.55 | 2.12 | 2.27 | 2.55 | 2.66 | 3.18 | 3.54 |
| Hydrocarbon
$C_2 H_6^+$ | 4.37 | 4.22 | 3.46 | 3.31 | 2.80 | 2.11 | 1.55 | 0.98 | 0.99 |
| m/e ≤ 29 | 30.45 | 30.34 | 30.65 | 29.38 | 29.77 | 26.99 | 27.05 | 27.80 | 28.03 |

* expressed as percentage of total ion current.

Rearrangement of dimethylaluminium hydride with increasing

Source Temperature.

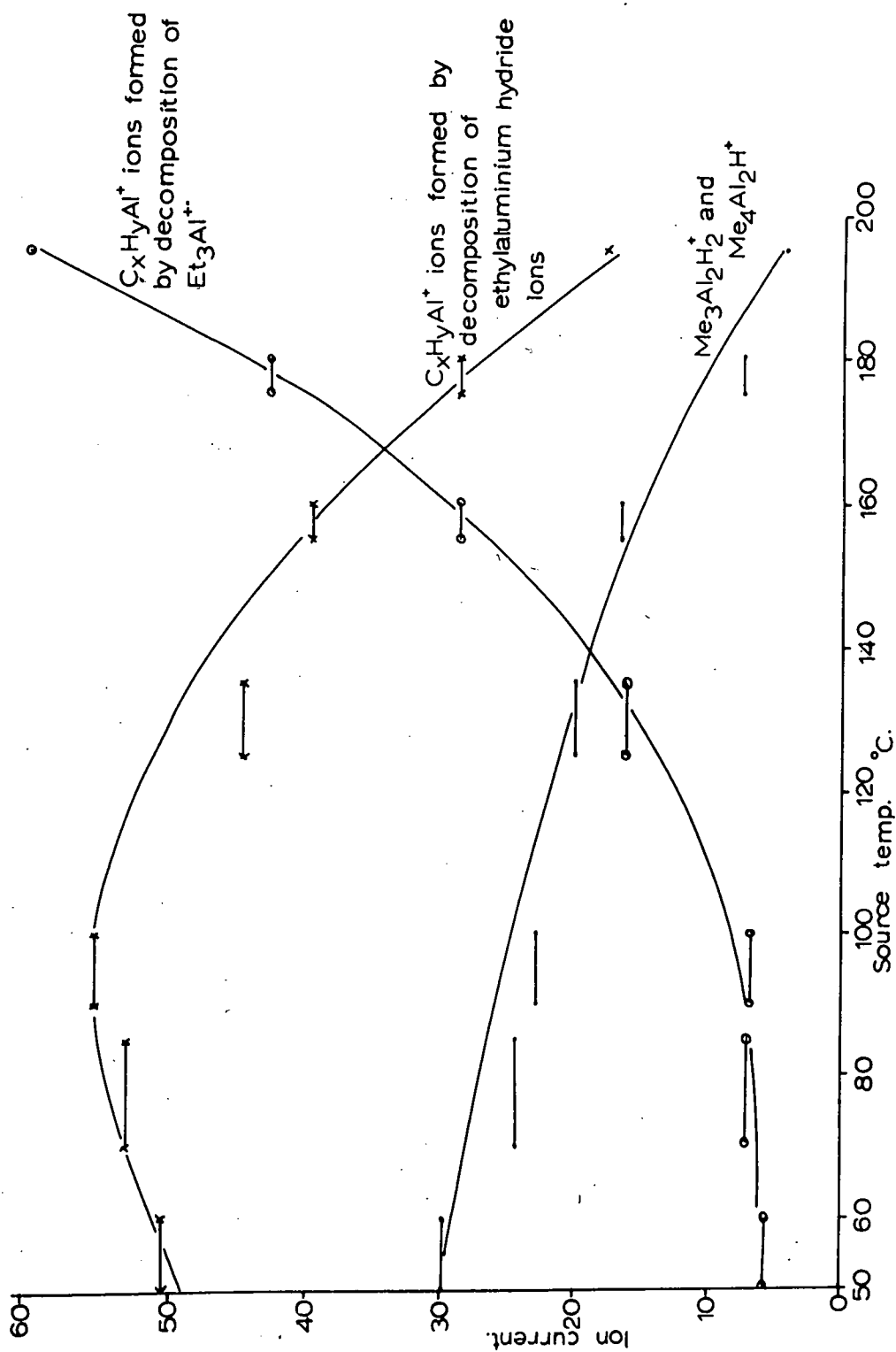

may indicate that the sample of dimethylaluminium hydride used was contaminated with trimethylaluminium or that the ion originates partly from dimer or trimer ions in which transfer of methyl groups from one aluminium atom to another occurs. Certainly in view of the ready transfer of organic groups occurring in the ionization and subsequent decomposition of $A_3M-M'B_3$ compounds ($M, M' = Si, Ge, \text{ or } Sn$) this possibility cannot be ignored entirely.

For trimethylaluminium the variation of the abundances of Me_3Al^+ and other $C_aH_bAl^+$ ions with source temperature is known (table 4.4.4.) Thus from the abundance of Me_3Al^+ in a spectrum of dimethylaluminium hydride the percentage of total ion current carried by $C_aH_bAl^+$ ions formed by ionization and subsequent decomposition of trimethylaluminium can be found. In table 4.4.6. the abundances of monomer ions, $C_aH_bAl^+$, due to trimethylaluminium and $C_aH_bAl^+$ ions due to dimethylaluminium hydride in the spectrum of dimethylaluminium ^{hydride} at various source temperatures are given.

The abundances of $C_yH_zAl_2^+$ and $C_aH_bAl^+$ ions from dimethylaluminium hydride and $C_eH_fAl^+$ ions from trimethylaluminium are plotted as a function of source temperature in fig 23.

Up to $100^\circ C$ as dimer ions decrease in abundance so monomer ions from dimethylaluminium hydride become more important. This is because dissociation of associated molecules to Me_2AlH becomes more important as the source temperature increases. At $100^\circ C$ the thermal rearrangement of $(Me_2AlH)_n$ species begins to increase in importance and ions formed by ionization and subsequent decomposition of trimethylaluminium become significant. At $200^\circ C$ the mass spectrum recorded is predominantly that

of trimethylaluminium.

Thermal rearrangement of dimethylaluminium hydride was not observed when the vapour density was measured ¹⁵⁰ within the temperature ranges 83 - 95°C and 160 - 167°C. The apparent molecular weights obtained were:

| | | | | | | | |
|----------------------------|-------|-------|-------|-------|-------|-------|-------|
| Temperature °C. | 82.9 | 88 | 89 | 90.8 | 95.05 | 160.1 | 167 |
| Measured molecular weight. | 141.6 | 141.6 | 139.5 | 143.3 | 142.6 | 118.8 | 118.5 |

The little variation of the apparent molecular weight in the temperature range 83 - 95°C was noted by the authors as disturbing. Their results would obviously be greatly influenced by any disproportionation of dimethylaluminium hydride to trimethylaluminium and involatile aluminium hydride.

c) Diethylaluminium Hydride.

Diethylaluminium hydride appears to behave similarly to dimethylaluminium hydride (table 4.4.7.) in that the abundances of dimeric and trimeric ions fall rapidly with increasing source temperature. The ion $\text{Et}_3\text{Al}^{++}$ becomes more abundant as the source temperature increases but it is also significant at lower temperatures. This may indicate that transfer of ethyl groups from one aluminium atom to another occurs in dimer or trimer ions or that the sample of hydride used contained some triethylaluminium.

The proportion of ion current carried by dimer and trimer ions falls off rapidly with increasing source temperature. Although the mass spectrum of triethylaluminium has been recorded the sample used was contaminated with ethoxide. Thus the proportion of monomer ions,

$\text{C}_a\text{H}_b\text{Al}^+$ due to triethylaluminium in the spectrum of diethylaluminium hydride

cannot be calculated. At 214°C the proportion of triethylaluminium is significant however since the mass spectrum obtained is very similar to that of triethylaluminium (table 4.4.3.). Whereas at a source temperature of 32 - 45°C the most abundant ion is Et_2Al^+ , at 214°C the base peak is the same as for triethylaluminium i.e. EtAlH^+ .

Disproportionation of diethylaluminium hydride giving triethylaluminium has been observed in the purification of this hydride by distillation¹⁵¹. The bath temperature should not exceed 80°C and the presence of solid phase in the still pot avoided since this appears to accelerate the disproportionation. In a study of the thermal decomposition of triethylaluminium in a glass vessel disproportionation reactions occurring in rapid succession were purported to lead to the deposition of aluminium as a mirror.¹⁵²

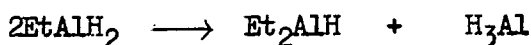
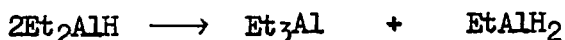

4.4.2. Modes of Decomposition.

With the limited number of compounds studied, major ions are predominately even-electron. The ratio of the abundances of even-electron aluminium-containing ions to odd-electron aluminium-containing ions for the following compounds is:

| | Abundance of
even-electron
Al - containing
ions | Abundance of
odd-electron
Al - containing
ions | Ratio
even-electron ions
odd-electron ions |
|-------------------------|--|---|--|
| Me_3Al | 82.76 | 10.69 | 7.74 |
| Me_2AlH | 60.84 | 4.38 | 13.89 |
| Et_2AlH | 81.17 | 5.50 | 14.20 |

(c.f. organoberyllium compounds p. 151)

Only for diethylaluminium hydride is a parent ion of an associated organoaluminium molecule detected. At low source temperatures this ion, $(\text{Et}_2\text{AlH})_2^{+\bullet}$, constitutes 0.90% of the total ion current. Although ions corresponding to the parent monomer ion may be fragment ions derived by decomposition of dimer and trimer ions, such ions are quite abundant at both low and high source temperatures.

The modes of decomposition for organoaluminium compounds are very similar to those of the group IV organo compounds and may be classified in a similar way.

a) Bond Cleavage by Radical Elimination.

With all compounds a major even-electron ion is produced by loss of a group bonded to aluminium in either parent monomeric, dimeric or trimeric ions.

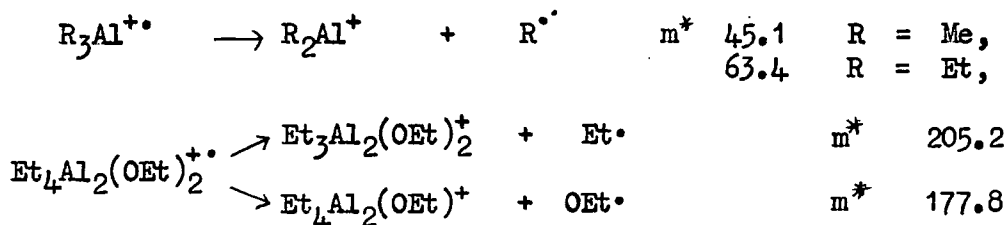

With dimethyl - and diethyl-aluminium hydride loss of both alkyl and hydrogen from the parent dimer ion occurs but loss of alkyl occurs to the greater extent. This H^\bullet loss probably results from cleavage of the aluminium-hydrogen bond since in the spectra of trimethyl - and triethyl-aluminium loss of H^\bullet from $\text{C}_a\text{H}_b\text{Al}^+$ ions by cleavage of a carbon-hydrogen bond is not significant.

With the methyl compounds a methyl group is lost from the even-electron ion Me_2Al^+ but the resulting odd-electron ion is not of high abundance.



The appearance potentials of the ions Me_2Al^+ , $\text{MeAl}^{+\cdot}$ and Al^+ in the spectrum of trimethylaluminium correspond to simple bond cleavage decompositions. ¹²

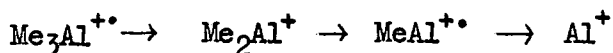

Rearrangement Processes.

b) Alkene Elimination.

With the ethyl compounds the elimination of ethylene from even-electron ions is a major process. For example with diethylaluminium ethoxide eleven metastable peaks are present corresponding to ethylene elimination from even-electron ions. (fig. 25). Also

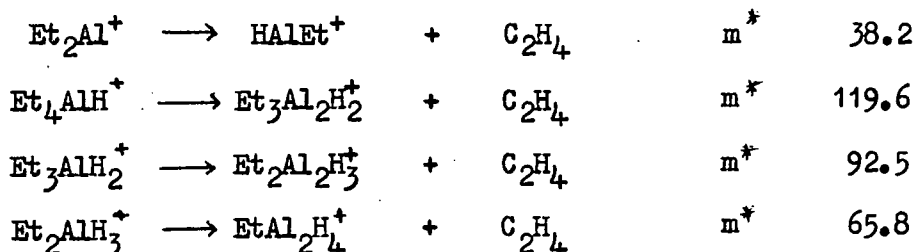

As with M^+-Et ions ($\text{M} = \text{Si}, \text{Ge}, \text{Sn}, \text{Pb}$) a mechanism involving transfer of a β -hydrogen may be envisaged for elimination of ethylene from $-\text{Al}^+-\text{Et}$ ions. With diethylaluminium ethoxide ethylene may be lost from both ethyl or ethoxy groups attached to aluminium. The formation of $\text{H}_3\text{Al}_2\text{O}_2^+$ must involve loss of ethylene from both. The high abundance of H_2Al^+ with the ethyl compounds is readily ascribed to

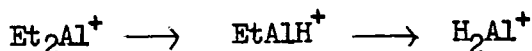

Me_2Al^+ also loses ethylene:

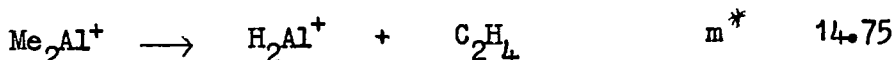

This elimination is probably very similar to the elimination of ethylene from Me_3Si^+ and Me_3Ge^+ . The ion H_2Al^+ is not as abundant for the methyl

compound as the ethyl.

c) Methane Elimination.

In addition to ethylene elimination Me_2Al^+ ions show a metastable peak for methane loss. The resultant ion although even-electron is of only low abundance.

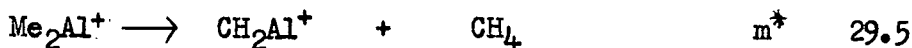

In the spectrum of diethylaluminium ethoxide an ion m/e 215 corresponds to methane loss from $\text{Et}_3\text{Al}_2(\text{OEt})_2^+$.

d) Molecule Elimination by Cleavage of two Al-X Bonds.

Two metastable peaks which may correspond to this process are given below:-



The first process is observed with trimethylaluminium and dimethylaluminium hydride, the second with triethylaluminium and diethylaluminium hydride. Since the presence of a metastable peak does not necessarily indicate an elimination in a single step ¹²⁸ the two processes above could involve elimination of $2\text{CH}_3\cdot$ and $(\text{H}\cdot \text{ and } \text{C}_2\text{H}_5\cdot)$ respectively. With trimethylaluminium the appearance potential of Al^+ corresponds to the process ¹²

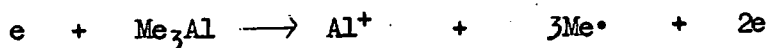

e) Hydrogen Loss (H_2)

This is observed with the ethyl compounds studied.

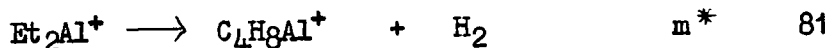

Similarly with diethylaluminium ethoxide ions are present which could result by H_2 loss. (fig. 25)

Fig. 24.

Decomposition diagrams for Me_3Al , Et_3Al , Me_2AlH , and Et_2AlH .

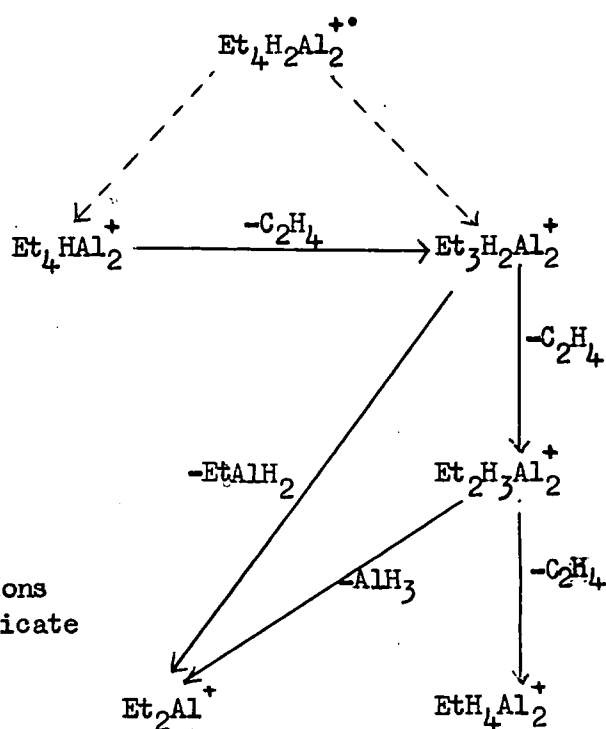
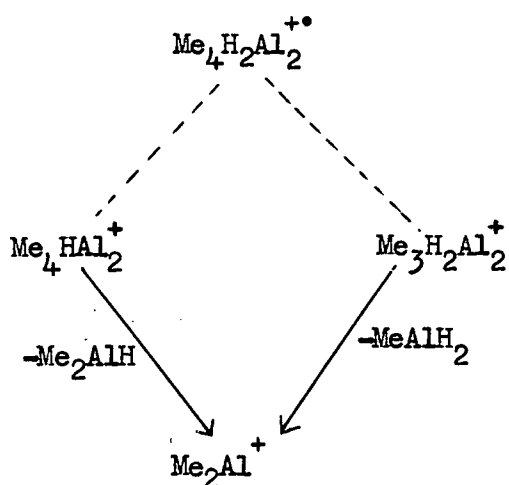
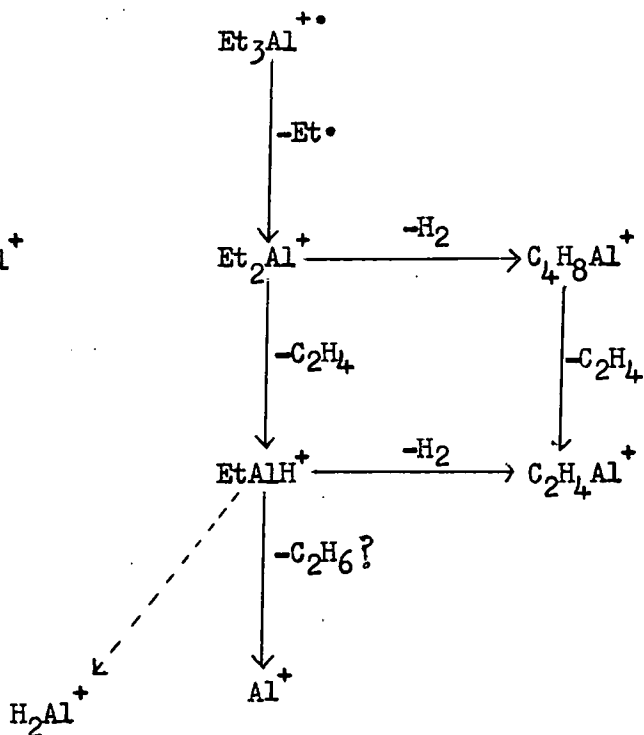
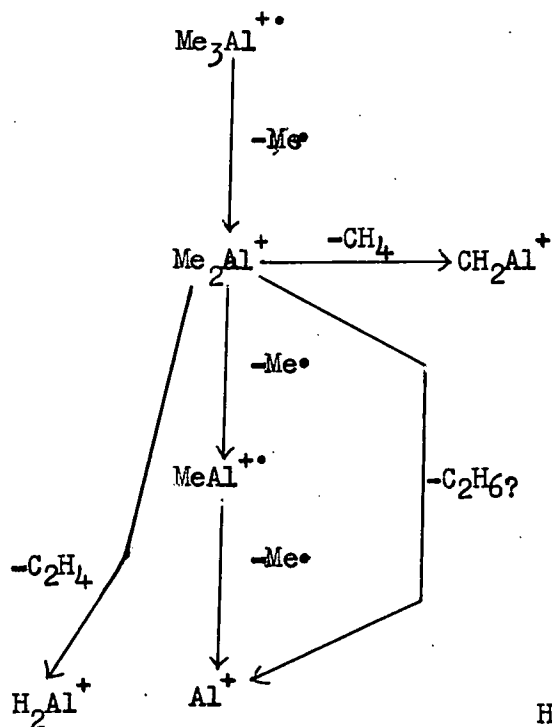

Fragmentations common to two or more ions are shown only once. Solid arrows indicate metastable confirmed decompositions.

f) Elimination of R_3Al ($R = Me, Et$ or H)

Unlike dimer ions of beryllium but like dimeric ions of group IV metals $Al_2C_xH_y^+$ ions decompose to $AlC_aH_b^+$ ions by loss of R_3Al molecules. The process is metastable confirmed only for dimethyl - and diethyl - aluminium hydride; a fact that may be accounted for by the high abundance of dimer ions with these compounds.

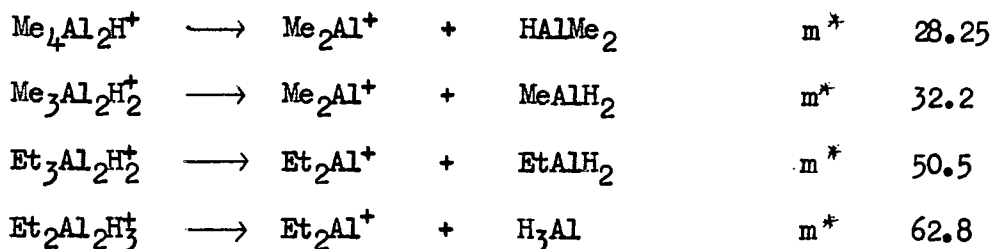

4.4.3. Mass Spectra.

The decomposition diagrams of the compounds studied are shown in figs. 24 & 25 and the abundances of ions in tables 4.4.1., 4.4.2. and 4.4.3.

The spectra recorded for trimethylaluminium at 70eV and source temperature of 195°C is virtually identical to that previously reported.¹²

Hydride ions are far more abundant for the ethyl compounds than the methyl which reflects the ease of ethylene elimination from ions containing Al - C_2H_5 bonds.

A variety of structures may be written for ions containing two aluminium atoms. For example $Et_3H_2Al_2^+$ may involve hydrogen or ethyl bridges or both:

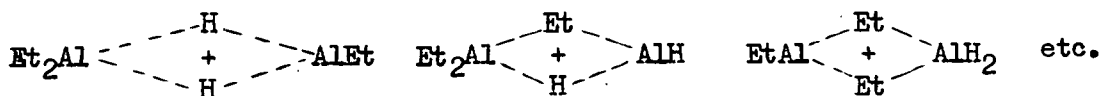

With oxygen containing ions structures involving oxygen bridges are probably more likely because of the ability of oxygen to donate a lone pair of electrons to the aluminium atom.

APPENDIX 1.

Tin and Lead Isotope Masses and Abundances.

Calculated Mass and Abundance Data for

Sn_2 , SnGe , Ge_2 , SnCl and SnBr .

Tin and lead isotope masses and abundances

| Mass * | | Abundances
(%) † | |
|-------------------------------------|-----------|---------------------|--------------|
| ¹¹² Sn | 111-90494 | | 0.95 |
| ¹¹⁴ Sn | 113-90296 | | 0.65 |
| ¹¹⁶ Sn | 114-90353 | | 0.34 |
| ¹¹⁸ Sn | 115-90211 | | 14.24 |
| ¹¹⁷ Sn | 116-90306 | | 7.57 |
| ¹¹⁸ Sn | 117-90179 | | 24.01 |
| ¹¹⁹ Sn | 118-90339 | | 8.58 |
| ¹²⁰ Sn | 119-90213 | | 32.97 |
| ¹²² Sn | 121-90341 | | 4.71 |
| ¹²⁴ Sn | 123-90524 | | 5.98 |
| PbPh ₄ PbEt ₄ | | | |
| ²⁰⁴ Pb | 203-97307 | 1.69 ± 0.08 | 1.42 ± 0.09 |
| ²⁰⁶ Pb | 205-97440 | 24.77 ± 0.08 | 25.17 ± 0.08 |
| ²⁰⁷ Pb | 206-97590 | 22.52 ± 0.06 | 21.90 ± 0.08 |
| ²⁰⁸ Pb | 207-97660 | 51.02 ± 0.07 | 51.51 ± 0.06 |

* L. A. König, J. H. E. Matthauch, and A. E. Wapstra, *Nuclear Phys.*, 1962, **31**, 18. † J. H. Beynon, 'Mass Spectrometry and its applications to Organic Chemistry,' Elsevier, Amsterdam, 1960.

| Nominal mass | Multiplicity | Spread p.p.m. | Peak mass (wtd. mean) | Relative abundance |
|-----------------|----------------|---------------|-----------------------|--------------------|
| GeSn | | | | |
| 182 | 1 | | 181-82922 | 0.95 |
| 184 | 2 | 3.0 | 183-82687 | 1.92 |
| 185 | 2 | 2.7 | 184-82806 | 0.70 |
| 186 | 3 | 9.1 | 185-82627 | 16.81 |
| 187 | 3 | 11 | 186-82719 | 8.28 |
| 188 | 5 | 16 | 187-82508 | 44.69 |
| 189 | 4 | 16 | 188-82594 | 24.70 |
| 190 | 5 | 17 | 189-82456 | 93.46 |
| 191 | 4 | 4.9 | 190-82477 | 34.13 |
| 192 | 5 | 25 | 191-82372 | 100.00 |
| 193 | 3 | 5.5 | 192-82492 | 30.60 |
| 194 | 4 | 33 | 193-82388 | 79.89 |
| 195 | 2 | 10 | 194-82547 | 5.03 |
| 196 | 3 | 18 | 195-82477 | 28.80 |
| 197 | 1 | | 196-82860 | 2.27 |
| 198 | 2 | 8.2 | 197-82616 | 12.40 |
| 200 | 1 | | 199-82660 | 2.26 |
| GeSi | | | | |
| 98 | 1 | | 97-90120 | 54.40 |
| 99 | 1 | | 98-90077 | 2.78 |
| 100 | 2 | 6.3 | 99-89865 | 74.39 |
| 101 | 2 | 20 | 100-89997 | 24.32 |
| 102 | 3 | 43 | 101-89803 | 100.00 |
| 103 | 2 | 5.1 | 102-89758 | 5.63 |
| 104 | 2 | 32 | 103-89782 | 23.80 |
| 105 | 1 | | 104-89785 | 1.05 |
| 106 | 1 | | 105-89512 | 0.69 |
| Ge ₃ | | | | |
| 140 | Singlet | | 139-848554 | 17.76 |
| 141 | No combination | | | |
| 142 | Singlet | | 141-846017 | 47.37 |
| 143 | Singlet | | 142-847637 | 13.46 |
| 144 | 2 | 14 | 143-844778 | 94.61 |
| 145 | Singlet | | 144-845099 | 17.95 |
| 146 | 3 | 26 | 145-843356 | 100.00 |
| 147 | Singlet | | 146-844510 | 23.88 |
| 148 | 2 | 5.4 | 147-842494 | 73.77 |
| 149 | Singlet | | 148-844720 | 5.08 |
| 150 | Singlet | | 149-842509 | 23.78 |
| 151 | No combination | | | |
| 152 | Singlet | | 151-842719 | 2.53 |

| Nominal mass | Multiplicity | Spread (p.p.m.) | Peak mass (wtd. mean) | Relative abundance |
|-----------------|----------------|-----------------|-----------------------|--------------------|
| Sn ₂ | | | | |
| 224 | singlet | | 223-80988 | 0.05 |
| 225 | no combination | | | |
| 226 | singlet | | 225-80790 | 0.07 |
| 227 | singlet | | 226-80847 | 0.04 |
| 228 | 2 | 5.0 | 227-80703 | 1.53 |
| 229 | 2 | 6.6 | 228-80796 | 0.82 |
| 230 | 3 | 8.7 | 229-80625 | 3.57 |
| 231 | 3 | 12 | 230-80697 | 1.99 |
| 232 | 4 | 12 | 231-80491 | 16.78 |
| 233 | 3 | 5.1 | 232-80523 | 13.51 |
| 234 | 5 | 19 | 233-80419 | 44.41 |
| 235 | 3 | 3.4 | 234-80513 | 35.04 |
| 236 | 5 | 28 | 235-80423 | 92.44 |
| 237 | 3 | 7.4 | 236-80519 | 50.83 |
| 238 | 4 | 18 | 237-80417 | 100.00 |
| 239 | 3 | 14 | 238-80565 | 35.64 |
| 240 | 3 | 13 | 239-80476 | 82.47 |
| 241 | 2 | 6.2 | 240-80759 | 9.53 |
| 242 | 2 | 6.2 | 241-80626 | 33.23 |
| 243 | singlet | | 242-80863 | 5.70 |
| 244 | 2 | 2.3 | 243-80734 | 23.16 |
| 245 | no combination | | | |
| 246 | singlet | | 245-80865 | 3.13 |
| 247 | no combination | | | |
| 248 | singlet | | 247-81048 | 1.99 |
| SnCl | | | | |
| 147 | singlet | | 146-87380 | 2.33 |
| 148 | no combination | | | |
| 149 | 2 | 6.6 | 148-87150 | 2.35 |
| 150 | singlet | | 149-87239 | 0.83 |
| 151 | 2 | 14 | 150-87093 | 35.46 |
| 152 | 2 | 16 | 151-87188 | 18.86 |
| 153 | 2 | 17 | 152-87022 | 70.24 |
| 154 | 2 | 21 | 153-87162 | 27.07 |
| 155 | 2 | 21 | 154-87036 | 100.00 |
| 156 | singlet | | 155-86929 | 6.82 |
| 157 | 2 | 27 | 156-86932 | 37.77 |
| 158 | no combination | | | |
| 159 | 2 | 30 | 158-87312 | 18.42 |
| 160 | no combination | | | |
| 161 | singlet | | 160-87114 | 4.75 |
| SnBr | | | | |
| 191 | singlet | | 190-82329 | 1.68 |
| 192 | no combination | | | |
| 193 | 2 | 0.13 | 192-82129 | 2.80 |
| 194 | singlet | | 193-82188 | 0.60 |
| 195 | 2 | 5.9 | 194-82041 | 26.34 |
| 196 | 2 | 7.8 | 195-82134 | 13.99 |
| 197 | 2 | 8.6 | 196-81952 | 67.20 |
| 198 | 2 | 12 | 197-82066 | 28.32 |
| 199 | 2 | 12 | 198-81950 | 100.00 |
| 200 | singlet | | 199-81973 | 14.88 |
| 201 | 2 | 16 | 200-81889 | 65.51 |
| 202 | no combination | | | |
| 203 | 2 | 19 | 202-82192 | 18.75 |
| 204 | no combination | | | |
| 205 | singlet | | 204-82158 | 10.37 |

APPENDIX 2.

Ion Abundances, as Percentage of Total Ion
Current, for Beryllium Dialkyls at 70, 15
or 12eV and High and Low Source Temperatures.

Ion abundances for Me₂Be.

| Ion ⁺ | 70eV
* 37-50° | 70eV
* 210° | 15eV
* 210° | Ion ⁺ | 70eV
* 37-50° | 70eV
* 210° | 15eV
* 210° |
|---|------------------|----------------|----------------|--|--------------------|----------------|----------------|
| C ₁₂ H ₃₃ Be ₈ | .48 | .09 | 2.50 | C ₂ H ₆ ^o | .11 | .07 | |
| C ₁₀ H ₂₇ Be ₇ | .67 | .23 | 1.21 | C ₂ H ₅ | .18 | .15 | |
| C ₈ H ₂₁ Be ₆ | .15 | .06 | | C ₂ H ₄ ^o | .78 | 1.00 | .31 |
| C ₆ H ₁₅ Be ₅ | .48 | .03 | | C ₂ H ₃ | 1.10 | 1.02 | |
| Me ₃ Be ₂ ^o | .82 | | | C ₂ H ₂ ^o | .40 | .37 | |
| C ₄ H ₉ | .13 | .12 | .16 | C ₂ H | .40 | .45 | |
| C ₄ H ₈ ^o | .11 | .15 | .24 | { C ₂ ^o | .20 | | |
| C ₄ H ₇ | .10 | .13 | | | CH ₃ Be | 30.13 | 31.93 |
| C ₂ H ₅ Be ₂ | .85 | | | CH ₂ Be ^o | 16.02 | 15.14 | 6.89 |
| C ₃ H ₇ | .13 | .12 | .15 | CHBe | 1.30 | 1.61 | |
| C ₃ H ₆ ^o | .09 | .12 | .29 | CBe ^o | .17 | .29 | |
| C ₃ H ₅ | .28 | .08 | | CH ₄ ^o | 3.29 | 5.95 | .13 |
| C ₂ H ₆ Be ^o | 22.19 | 17.91 | 78.37 | CH ₃ | 4.47 | 6.61 | 4.35 |
| C ₂ H ₅ Be | .54 | .40 | .09 | CH ₂ ^o | 1.22 | 1.45 | |
| C ₂ H ₄ Be ^o | 3.43 | 2.65 | 2.69 | CH | .24 | .40 | |
| C ₂ H ₃ Be | 1.66 | 1.45 | | { H ₃ Be | <.01 | <.01 | |
| C ₂ H ₂ Be ^o | .79 | .72 | | | C ^o | .05 | .11 |
| C ₂ HBe | 3.59 | 3.90 | | H ₂ Be ^o | <.01 | <.01 | |
| C ₂ Be ^o | .18 | .29 | | HBe | 1.68 | 2.18 | |
| | | | | Be ^o | 1.60 | 2.63 | .11 |

* Source temp. °C

Ions with same integer m/e ratio are linked by {

Table A.2.2.

Ion abundances for Et₂Be

| Ion ⁺ | 70eV
*45-55° | 70eV
*196° | 12eV
*196° | Ion ⁺ | 70eV
*45-55° | 70eV
*196° | 12eV
*196° |
|---|-----------------|---------------|---------------|--|-----------------|---------------|---------------|
| Et ₅ Be ₃ | .14 | | | C ₄ H ₉ | .23 | .05 | .03 |
| Et ₄ Be ₃ H | .06 | | | C ₄ H ₈ [•] | .04 | .04 | .09 |
| Et ₄ Be ₂ [•] | .38 | | | C ₄ H ₇ | .07 | .05 | .04 |
| Et ₃ Be ₃ H ₂ | .06 | | | C ₄ H ₆ [•] | .03 | .03 | |
| Et ₃ Be ₂ | 5.46 | .18 | .26 | { C ₃ H ₈ Be [•] | .05 | .07 | |
| C ₆ H ₁₄ Be ₂ [•] | .30 | | | { C ₄ H ₅ | .03 | .03 | .12 |
| Et ₂ Be ₃ H ₃ | .06 | | | C ₃ H ₇ Be | 1.19 | 2.02 | 4.03 |
| Et ₂ Be ₂ H | 11.11 | .42 | | C ₃ H ₆ Be [•] | .31 | .48 | .95 |
| C ₄ H ₉ Be ₂ | .22 | | .16 | C ₃ H ₅ Be | .46 | .48 | 1.57 |
| C ₄ H ₇ Be ₂ | .29 | | | { C ₂ H ₇ Be ₂ | 6.02 | .19 | |
| C ₅ H ₁₀ [•] | .02 | | .04 | { C ₃ H ₄ Be [•] | .24 | .14 | .40 |
| C ₅ H ₉ | .02 | | .04 | { C ₂ H ₆ Be ₂ [•] | .27 | .06 | |
| C ₄ H ₁₀ Be [•] | 3.72 | 8.02 | 21.28 | { C ₃ H ₃ Be | .50 | .41 | |
| C ₄ H ₉ Be | .48 | .34 | .41 | { C ₂ H ₅ Be ₂ | .72 | .02 | |
| C ₄ H ₈ Be [•] | .31 | .19 | .28 | { C ₃ H ₂ Be | .20 | .15 | |
| C ₄ H ₇ Be | .24 | .10 | .04 | { C ₂ H ₄ Be ₂ [•] | .08 | | |
| { C ₃ H ₉ Be ₂ | .12 | | | { C ₃ HBe | .05 | .06 | |
| { C ₄ H ₆ Be [•] | .31 | .28 | .16 | C ₂ H ₃ Be ₂ | .45 | .03 | |
| C ₄ H ₅ Be | .19 | .18 | | C ₂ H ₂ Be ₂ [•] | .24 | - | |
| C ₄ H ₄ Be [•] | .12 | .03 | | C ₃ H ₇ | .14 | .05 | .03 |
| EtBe ₃ H ₄ | .13 | | | C ₃ H ₆ [•] | .06 | .05 | .07 |
| C ₄ H ₃ Be | .13 | .11 | | C ₃ H ₅ | .26 | .15 | .06 |
| { C ₄ HBe | .07 | | | { C ₂ H ₇ Be | .06 | .10 | .10 |
| { C ₄ H ₁₀ [•] | .07 | .06 | .07 | { C ₃ H ₄ [•] | .04 | .28 | .44 |

Table A.2.2. continued.Ion abundances for Et₂Be

| Ion ⁺ | 70eV
* 45-55° | 70eV
* 196° | 12eV
* 196° | Ion ⁺ | 70eV
* 45-55° | 70eV
* 196° | 12eV
* 196° |
|---|------------------|----------------|----------------|----------------------------------|------------------|----------------|----------------|
| { C ₂ H ₆ Be• | 1.72 | 2.76 | .43 | { C ₂ • | 0.31 | .28 | |
| { C ₃ H ₃ | .37 | .32 | | { CH ₃ Be | 1.07 | 1.09 | .09 |
| C ₂ H ₅ Be | 10.25 | 14.92 | 9.33 | CH ₂ Be• | .54 | .56 | .04 |
| C ₂ H ₄ Be• | 13.13 | 23.05 | 30.67 | CHBe• | .07 | .08 | |
| C ₂ H ₃ Be | 4.54 | 5.15 | .37 | { H ₃ Be ₂ | .11 | <.01 | |
| C ₂ H ₂ Be• | 1.38 | 1.66 | .19 | { CBe• | .01 | <.01 | |
| C ₂ HBe | 2.39 | 2.50 | | CH ₄ • | .02 | .01 | |
| C ₄ H ₈ Be ⁺ | .01 | .02 | | CH ₃ | .14 | .11 | |
| C ₄ H ₆ Be ⁺ | .05 | .11 | | CH ₂ • | .33 | .21 | |
| C ₄ H ₄ Be ⁺ | .09 | .17 | | CH | .12 | .08 | |
| C ₂ H ₆ • | .10 | .10 | .23 | { H ₃ Be | <.01 | <.01 | |
| C ₂ H ₅ | 1.00 | .84 | .73 | { C• | .06 | .04 | |
| C ₂ H ₄ • | 9.47 | 13.58 | 25.32 | H ₂ Be• | <.01 | <.01 | |
| C ₂ H ₃ | 7.02 | 8.06 | .52 | HBe | 1.64 | 1.05 | |
| C ₂ H ₂ • | 5.44 | 6.42 | 1.21 | Be• | 1.82 | 1.30 | |
| C ₂ H | 1.05 | 0.92 | | | | | |

* Source temp. °C

Ions with same integer m/e ratio: are linked by {

Table A.2.3.

Ion abundances for (i-Pr)₂Be and (n-Pr)₂Be

| Ion ⁺ | (i-Pr) ₂ Be | | | (n-Pr) ₂ Be | | |
|--|------------------------|-----------|-----------|------------------------|-----------|-----------|
| | 70eV | 70eV | 12eV | 70eV | 70eV | 12eV |
| | *55-75° | *215-220° | *215-220° | *35-45° | *210-215° | *210-215° |
| Pr ₄ Be ₂ ° | .36 | | | | | |
| Pr ₃ Be ₂ | 1.61 | .02 | .06 | | | |
| C ₈ H ₁₇ Be ₂ | .04 | | | | | |
| Pr ₂ Be ₂ H | 2.43 | .04 | .06 | 3.12 | .04 | |
| C ₆ H ₁₄ Be° | 3.96 | 2.36 | 6.91 | 3.12 | 1.34 | 3.75 |
| C ₆ H ₁₃ Be | .09 | .23 | .18 | .07 | .10 | .56 |
| C ₆ H ₁₂ Be° | .16 | .08 | .59 | .17 | .05 | .13 |
| C ₅ H ₁₁ Be ₂ | .23 | | | | | |
| C ₅ H ₁₁ Be | .17 | .12 | .16 | .29 | .17 | .56 |
| C ₅ H ₁₀ Be° | .17 | .11 | .09 | .15 | .04 | .05 |
| C ₅ H ₉ Be | .31 | .25 | .18 | .12 | .06 | .09 |
| { C ₅ H ₈ Be° | .30 | .24 | .12 | .12 | .04 | .08 |
| { C ₄ H ₁₁ Be ₂ | 1.50 | | | 1.10 | .02 | |
| C ₄ H ₁₀ Be° | .78 | .82 | 2.36 | 1.36 | 1.22 | 4.10 |
| C ₄ H ₉ Be | .86 | .60 | .64 | 1.03 | .76 | 1.19 |
| C ₄ H ₈ Be° | .28 | .17 | .23 | .21 | .15 | .19 |
| C ₄ H ₇ Be | .66 | .63 | .42 | .16 | .14 | |
| { C ₄ H ₆ Be° | .37 | .26 | .17 | .15 | .06 | |
| { PrBe ₂ H ₂ | 2.27 | .12 | | .83 | .02 | |
| C ₄ H ₅ Be | .17 | .17 | | .06 | .06 | |
| C ₄ H ₃ Be | .04 | .08 | | .08 | .07 | |
| C ₄ H ₉ | | | | .82 | .33 | .31 |
| C ₄ H ₈ | | | | .54 | .25 | 1.11 |
| C ₄ H ₇ | .17 | .23 | .03 | .51 | .25 | .18 |
| { C ₃ H ₉ Be | .58 | .17 | .29 | .15 | .11 | |
| { C ₄ H ₆ ° | .17 | .06 | | .11 | .05 | .28 |
| C ₃ H ₈ Be | .96 | .61 | 1.34 | .69 | .69 | .89 |
| C ₃ H ₇ Be | 11.65 | 9.99 | 12.04 | 11.42 | 14.67 | 15.94 |
| C ₃ H ₆ Be° | 13.96 | 13.80 | 30.86 | 8.83 | 11.09 | 24.53 |
| C ₃ H ₅ Be | 8.15 | 7.23 | 2.13 | 3.57 | 5.09 | .88 |

Ion abundances for (i-Pr)₂Be and (n-Pr)₂Be

| Ion ⁺ | (i-Pr) ₂ Be | | | (n-Pr) ₂ Be | | |
|--|------------------------|-------------------|-------------------|------------------------|-------------------|-------------------|
| | 70eV
*55-75° | 70eV
*215-220° | 12eV
*215-220° | 70eV
*35-45° | 70eV
*210-215° | 12eV
*210-215° |
| C ₃ H ₄ Be• | .58 | .44 | .06 | .65 | .45 | |
| C ₃ H ₃ Be | 2.61 | 2.38 | .10 | 1.83 | 1.71 | |
| C ₃ H ₂ Be• | .37 | .40 | | .31 | .32 | |
| C ₃ HBe | .08 | .11 | | .10 | .09 | |
| C ₃ H ₈ • | .27 | .19 | .15 | .76 | .30 | .39 |
| C ₃ H ₇ | 2.33 | 2.43 | 2.14 | 2.34 | 1.30 | 2.02 |
| C ₃ H ₆ • | 6.92 | 8.80 | 30.30 | 9.01 | 10.49 | 33.12 |
| C ₃ H ₅ | 9.91 | 13.90 | 4.32 | 13.72 | 14.94 | 5.49 |
| C ₃ H ₄ • | 2.18 | 3.24 | .96 | 2.94 | 3.35 | 1.53 |
| C ₂ H ₆ Be• | .97 | .66 | | .09 | .11 | |
| C ₃ H ₃ | 4.31 | 6.40 | .03 | 7.33 | 8.78 | |
| C ₂ H ₅ Be | .97 | 1.03 | | .50 | .78 | .23 |
| C ₃ H ₂ • | 1.13 | 2.33 | .25 | 1.89 | 1.94 | |
| C ₂ H ₄ Be• | 2.74 | 2.78 | 2.15 | .70 | .93 | 1.00 |
| C ₃ H | .58 | 1.37 | | 1.70 | 1.33 | |
| C ₂ H ₃ Be | .95 | .82 | .03 | .66 | 1.02 | |
| C ₂ H ₂ Be• | 1.57 | 1.83 | .21 | .72 | .98 | .17 |
| C ₂ HBe | .80 | .77 | | .60 | .66 | |
| C ₅ H ₁₀ Be ⁺ | .05 | .02 | | .08 | .07 | |
| C ₅ H ₈ Be ⁺ | .08 | .04 | | .05 | .07 | |
| C ₅ H ₆ Be ⁺ | .05 | .02 | | .05 | .06 | |
| C ₅ H ₄ Be ⁺ | .02 | .01 | | | .04 | |
| C ₄ H ₆ Be ⁺ | .13 | .02 | | .21 | .18 | |
| C ₄ H ₄ Be ⁺ | .13 | .02 | | .09 | .15 | |
| C ₂ H ₅ | .73 | .79 | .10 | 1.79 | 1.74 | .43 |
| C ₂ H ₄ • | .60 | .85 | .18 | 2.45 | 1.17 | .72 |
| C ₂ H ₃ | 2.67 | 5.09 | .10 | 3.48 | 4.42 | .11 |
| C ₂ H ₂ | .45 | .96 | | 1.03 | .98 | |

Table A.2.3. continued

Ion abundances for (i-Pr)₂Be and (n-Pr)₂Be

| Ion ⁺ | (i-Pr) ₂ Be | | | (n-Pr) ₂ Be | | |
|--|------------------------|-------------------|-------------------|------------------------|-------------------|-------------------|
| | 70eV
*55-75° | 70eV
*215-220° | 12eV
*215-220° | 70eV
*35-45° | 70eV
*210-215° | 12eV
*210-215° |
| { C ₂ H | .06 | .13 | | .18 | .16 | |
| { CH ₄ Be• | .03 | .04 | | .02 | .03 | |
| CH ₃ Be | 1.98 | 1.94 | .03 | 1.28 | 2.00 | |
| CH ₂ Be• | .14 | .20 | | .18 | .29 | |
| CHBe | .10 | .01 | | .02 | .02 | |
| C ₃ H ₅ ⁺ | .05 | .06 | | .10 | .08 | |
| C ₃ H ₄ ⁺ | .14 | .24 | | .27 | .30 | |
| C ₃ H ₃ ⁺ | .10 | .12 | | .19 | .25 | |
| C ₃ H ₂ ⁺ | .15 | .25 | | .30 | .34 | |
| CH ₄ • | .06 | .04 | | .04 | .04 | |
| CH ₃ | .20 | .36 | | .49 | .43 | |
| CH ₂ • | .06 | .14 | | .19 | .16 | |
| CH | .02 | .04 | | .05 | .04 | |
| { C• | .01 | .02 | | .03 | .02 | |
| { H ₃ Be | .01 | .01 | | .01 | .01 | |
| HBe | .15 | .27 | | .19 | .29 | |
| Be• | .14 | .23 | | .19 | .28 | |

* Source temperature °C

Ions with the same integer m/e ratio are linked by {

Table A.2.4.

Ion abundances for (t-Bu)₂Be and (i-Bu)₂Be

| Ion ⁺ | (i-Bu) ₂ Be | | | (t-Bu) ₂ Be | | |
|-------------------------------------|------------------------|---------------|---------------|------------------------|---------------|---------------|
| | 70eV
*75-90° | 70eV
*235° | 12eV
*240° | 70eV
*55-75° | 70eV
*240° | 12eV
*240° |
| C ₈ H ₁₈ Be° | .89 | .08 | .23 | 5.01 | .37 | 3.36 |
| C ₈ H ₁₆ Be° | .05 | .02 | .06 | .12 | .03 | .22 |
| C ₇ H ₁₅ Be | .19 | .08 | .28 | 5.71 | 1.95 | 15.29 |
| C ₇ H ₁₄ Be° | .06 | .02 | | | | |
| C ₇ H ₁₃ Be | .04 | .02 | | | | |
| C ₆ H ₁₁ Be | .05 | .02 | | 1.48 | .65 | .15 |
| C ₆ H ₁₀ Be° | .08 | .03 | | | | |
| C ₆ H ₉ Be | | | | .36 | .17 | .11 |
| C ₆ H ₈ Be° | .01 | | | | | |
| C ₅ H ₁₂ Be° | .48 | .19 | .47 | .74 | .30 | 2.87 |
| C ₅ H ₁₁ Be | 2.02 | .76 | 1.11 | -1.70 | .62 | 2.44 |
| C ₅ H ₇ Be | | | | .05 | .03 | |
| C ₄ H ₁₀ Be° | .94 | .44 | .55 | 1.00 | .47 | 2.28 |
| C ₄ H ₉ Be | 16.54 | 7.87 | 8.86 | 8.43 | 4.59 | 8.62 |
| C ₄ H ₈ Be° | 8.17 | 3.34 | 7.34 | 4.59 | 2.70 | 9.54 |
| C ₄ H ₇ Be | 3.51 | 2.04 | .36 | 6.49 | 4.01 | 1.36 |
| C ₄ H ₆ Be° | .47 | .25 | | .82 | .51 | |
| C ₄ H ₅ Be | .26 | .08 | | .43 | .25 | |
| C ₄ H ₃ Be | .19 | .14 | | .17 | .09 | |
| C ₄ H ₁₀ ° | .20 | .09 | .18 | .79 | .49 | .54 |
| C ₄ H ₉ | 1.54 | 1.25 | 3.45 | 9.98 | 6.78 | 6.78 |
| C ₄ H ₈ ° | 9.13 | 12.30 | 58.76 | 4.58 | 8.55 | 32.48 |
| C ₄ H ₇ | 3.56 | 5.88 | 2.28 | 1.77 | 3.30 | 1.03 |
| C ₄ H ₆ ° | .41 | .52 | | .20 | .40 | .81 |
| C ₄ H ₅ | .89 | 1.28 | | .57 | 1.03 | |
| { C ₃ H ₇ Be | .34 | .21 | .13 | 1.21 | .79 | .54 |
| { C ₄ H ₄ ° | .19 | .28 | | .14 | .29 | |
| { C ₃ H ₆ Be° | .36 | .26 | .12 | 1.04 | .81 | .38 |
| { C ₄ H ₃ | .35 | .97 | | .40 | .79 | |

Table A.2.4. continued

Ion abundances for (t-Bu)₂Be and (i-Bu)₂Be

| Ion ⁺ | (i-Bu) ₂ Be | | | (t-Bu) ₂ Be | | |
|--|------------------------|---------------|---------------|------------------------|---------------|---------------|
| | 70eV
*75-90° | 70eV
*235° | 12eV
*240° | 70eV
*55-75° | 70eV
*240° | 12eV
*240° |
| { C ₃ H ₅ Be | 2.98 | 1.91 | .22 | 3.27 | 2.26 | .22 |
| { C ₄ H ₂ • | .69 | 1.27 | | .46 | 1.09 | |
| { C ₃ H ₄ Be• | .32 | .07 | | .61 | .39 | |
| { C ₄ H | .16 | .34 | | .13 | .25 | |
| C ₃ H ₃ Be | 2.29 | 1.28 | | 4.95 | 3.34 | |
| C ₃ H ₂ Be• | .19 | .12 | | .33 | .21 | |
| C ₆ H ₁₂ Be ⁺ | .52 | .24 | | .06 | .03 | |
| C ₃ H ₇ | 2.55 | 1.79 | 1.13 | 3.72 | 5.83 | 2.33 |
| C ₃ H• | 1.70 | 1.58 | 1.27 | 2.21 | 2.86 | 1.46 |
| C ₃ H ₅ | 15.97 | 23.91 | 10.75 | 8.78 | 18.87 | 4.56 |
| C ₃ H ₄ • | 1.31 | 1.91 | .84 | .92 | 1.82 | .54 |
| { C ₃ H ₃ | 5.00 | 8.04 | | 4.05 | 7.18 | |
| { C ₂ H ₆ Be• | .60 | .21 | | | | |
| C ₅ H ₈ Be ⁺ | .42 | .22 | | .16 | .09 | |
| C ₅ H ₆ Be ⁺ | | | | .10 | .06 | |
| { C ₂ H ₅ Be | .15 | .11 | | .21 | .26 | |
| { C ₃ H ₂ • | .66 | 1.07 | | .46 | .97 | |
| { C ₂ H ₄ Be• | | | | .28 | .19 | |
| { C ₃ H | .33 | .55 | | .23 | .53 | |
| C ₂ H ₃ Be | .37 | .22 | | .53 | .37 | |
| C ₂ H ₂ Be• | .18 | .11 | | .27 | .19 | |
| C ₂ HBe | .36 | .22 | | .68 | .43 | |
| C ₂ H ₆ • | .15 | .14 | | | | |
| C ₂ H ₅ | 3.77 | 4.59 | .18 | 2.35 | 3.37 | .05 |
| C ₂ H ₄ • | 2.84 | 4.60 | 1.45 | 1.12 | 3.10 | .70 |
| C ₂ H ₃ | 3.15 | 4.54 | | 2.35 | 3.81 | |
| C ₂ H ₂ • | .69 | .93 | | .32 | .67 | |
| C ₂ H | .08 | .14 | | .04 | .08 | |

Table A.2.4. continuedIon abundances for (t-Bu)₂Be and (i-Bu)₂Be

| Ion [†] | (i-Bu) ₂ Be | | | (t-Bu) ₂ Be | | |
|---------------------|------------------------|---------------|--------------|------------------------|--------------|--------------|
| | 70eV
*75-90° | 70eV
*235° | 12eV
240° | 70eV
55-75° | 70eV
240° | 12eV
240° |
| CH ₃ Be | .73 | .42 | | 1.06 | .85 | |
| CH ₂ Be• | .09 | .06 | | .11 | .07 | |
| CHBe | .01 | | | .01 | .01 | |
| CH ₄ • | .05 | .05 | | .05 | .06 | |
| CH ₃ | .42 | .62 | | .33 | .39 | |
| CH ₂ • | .12 | .15 | | .06 | .10 | |
| CH | .02 | .04 | | .02 | .03 | |
| C• | .01 | .02 | | .01 | .02 | |
| HBe | .09 | .06 | | .14 | .11 | |
| Be• | .09 | .06 | | .11 | .09 | |

* Source temperature °C

Ions with the same integer m/e ratio are linked by {

APPENDIX 3.

Primary Experimental Data for Appearance
Potential Measurements.

Throughout the following abbreviations are used:-

S.T. = Source temperature; I.R. = ion repeller voltage;

I(A) = Ionization potential of A.

A(X⁺)XY = Appearance potential of ion X⁺ from XY.

For beryllium dialkyls:-

i(Be) = Ion current of parent ion $(C_n H_{2n+1})_2 Be^+$

i(Be') = Ion current of fragment ion $C_n H_{2n+1} Be^+$

i(Be'') = Ion current of fragment ion $C_n H_{2n} Be^+$

For organotin compounds:-

i(Et) = Ion current of $Et_3 Sn^+$

i(Ph) = Ion current of $Ph_3 Sn^+$

i(Ph') = Ion current of $PhSnEt_2^+$

i(Ph'') = Ion current of $Ph_2 SnEt^+$

i(PhEt) = Ion current of $Ph_2 SnEt_2^+$

i(4Et) = Ion current of $Et_4 Sn^+$

I (Me₂Be)

| (eVx5) | i(Be) | i(Ar) | i(Be) | i(Ar) | i(Be) | i(Ar) | i(Be) | i(Ar) | i(Be) | i(Ar) | i(Be) | i(Ar) |
|--------|---------|---------|---------|-----------|-----------|-------|---------|-------|-------|-----------|-------|---------|
| 100 | 2800 | 1690 | 4400 | 1220 | 3150 | | | | 1058 | 510 | 349 | 187 |
| 99 | | 1580 | | 1080 | | | | | | 470 | | 163 |
| 98 | | 1500 | | 994 | | | 3050 | 1370 | | 430 | | 145 |
| 97 | | 1390 | | 910 | | | | 1215 | | 390 | | 133 |
| 96 | | 1270 | | 812 | | 1270 | | 1140 | | 350 | | 117 |
| 95 | 2950 | 1170 | 4150 | 714 | | 1130 | 3025 | 1030 | 1080 | 310 | 349 | 100 |
| 94 | | 1060 | | 616 | | 1000 | | 940 | | 275 | | 90 |
| 93 | | 940 | | 525 | | 920 | | 840 | | 230 | | 76 |
| 92 | | 820 | | 427 | | 800 | | 730 | | 195 | | 64 |
| 91 | | 713 | | 361 | | 700 | | 564 | | 160 | | 54 |
| 90 | 2850 | 630 | 3250 | 298 | 2825 | 600 | 2975 | 530 | 1070 | 130 | 334 | 44 |
| 89 | | 505 | | 221 | | 500 | | 434 | 1045 | 100 | | 32 |
| 88 | | 400 | | 171 | | 400 | | 374 | 1030 | 79 | | 24-5 |
| 87 | | 320 | | 129 | | 320 | | 271 | | 58 | | 18-2 |
| 86 | | 230 | | 91 | | 250 | | 195 | 983 | 37 | | 10.5 |
| 85 | 2600 | 170 | 2575 | 59.5 | 2600 | 178 | 2675 | 135 | | 25 | | 7.4-8 |
| 84 | | 108 | | 36 | | 122 | | 90 | | 13.5-14.5 | | 4.2-4.8 |
| 83 | | 66 | | 23 | | 80 | | 54 | | 6.8-7.4 | | 2.0-2.4 |
| 82 | | 36.5 | | 10.5-11.1 | | 45 | | 31 | | 3.3-3.7 | | .8-.1 |
| 81 | | 19.1 | | 4.4-4.6 | | 26 | | 16 | | 1.5-1.8 | | .3-.5 |
| 80 | 2200 | 11.1 | | 2.3 | 2250 | 11.4 | 2250 | 7.9 | 756 | .4-.6 | 230 | |
| 79 | | 4.9 | | .9-.1 | 2100 | 5.4 | | 3.8 | 718 | | 214 | |
| 78 | | 2.2-2.4 | | .5 | 2050 | 2.7 | | 1.7 | 668 | | 200 | |
| 77 | | 1.0-1.2 | | | 1960 | .9 | | .9 | 617 | | 184 | |
| 76 | | .6-.7 | 1860 | | | | | | 573 | | 169 | |
| 75 | 1650 | | 1720 | | 1700 | | 1560 | | 529 | | 158 | |
| 74 | 1520 | | 1620 | | 1640 | | 1430 | | 479 | | 143 | |
| 73 | 1400 | | 1480 | | 1540 | | 1350 | | 441 | | 131 | |
| 72 | 1260 | | 1340 | | 1400 | | 1250 | | 397 | | 118 | |
| 71 | 1160 | | 1220 | | 1260 | | 1120 | | 353 | | 105 | |
| 70 | 1040 | | 1110 | | 1140 | | 1010 | | 315 | | 94 | |
| 69 | 940 | | 920 | | 1040 | | 920 | | 272 | | 83 | |
| 68 | 830 | | 815 | | 940 | | 805 | | 232 | | 72 | |
| 67 | 730 | | 725 | | 830 | | 675 | | 197 | | 62 | |
| 66 | 610 | | 610 | | 720 | | 600 | | | | 53 | |
| 65 | 520 | | 510 | | 610 | | 480 | | 146 | | 43 | |
| 64 | 420 | | 415 | | 530 | | 390-450 | | 116 | | 35 | |
| 63 | 300 | | 337 | | 430 | | 342 | | 93.2 | | 29 | |
| 62 | 270 | | 252 | | 340 | | 257 | | 70.6 | | 21 | |
| 61 | 208 | | 183 | | 262 | | 192 | | 55 | | 17 | |
| 60 | 155 | | 132 | | 202 | | 132 | | 38 | | 11.8 | |
| 59 | 98 | | 89 | | 130 | | 90 | | 25 | | 8.1 | |
| 58 | 64 | | 55 | | 84 | | 48 | | 15 | | 4.4 | |
| 57 | 37 | | 31 | | 52 | | 36 | | 8.8 | | 2.5 | |
| 56 | 19 | | 14 | | 27.5 | | 18 | | 5.0 | | 1.37 | |
| 55 | 9.5 | | 6-6.7 | | 12.2-13.4 | | 8.5 | | 2.4 | | .7 | |
| 54 | 4-4.3 | | 2.8-3.2 | | 4.5-5.5 | | 3.3 | | .9 | | | |
| 53 | 1.7-2.1 | | 1.4-1.7 | | .5 | | 2.0 | | .4 | | | |
| 52 | .6-.9 | | .5-.9 | | | | .5-.9 | | | | | |
| 51 | .2-.4 | | | | | | | | | | | |
| S.T. | 193 | | 187 | | 215 | | 183 | | 217 | | 220 | |
| I.R. | -.2 | | -.2 | | 0.2 | | -.2 | | 0 | | 0 | |

| I (Et ₂ Be) | | | | | | | | | | | | | | |
|------------------------|---------|---------|---------|----------|-------|-----------|-------|-----------|-------|---------|-------|---------|-------|-------|
| eVx5 | i(Be) | i(Kr) | i(Be) | i(Kr) | i(Be) | i(Kr) | i(Be) | i(Kr) | i(Be) | i(Kr) | i(Be) | i(Kr) | i(Be) | i(Kr) |
| 98 | | 900 | | 570 | | 1270 | | 1580 | | 840 | | 1000 | | |
| 96 | | 780 | | 520 | | 1150 | | 1480 | | 760 | | 890 | | |
| 94 | | 670 | 2400 | 470 | | 1000 | | 1340 | | 680 | | 750 | | |
| 92 | | 580 | 2350 | 400 | | 840 | | 1150 | | 590 | | 640 | | |
| 90 | 3100 | 480 | | 360 | 1800 | 720 | | 980 | | 510 | | 540 | | |
| 88 | | 420 | 2350 | 310 | | 595 | | 810 | | 405 | | 450 | | |
| 86 | | 340 | | 255 | | 490 | | 665 | | 343 | | 380 | | |
| 84 | | 270 | | 200 | | 390 | | 530 | | 255 | | 300 | | |
| 82 | | 200 | | 146 | | 300 | | 415 | | 180 | | 220 | | |
| 80 | 2600 | 140 | 2275 | 98 | 1490 | 200 | 1695 | 288 | 1020 | 118 | 1170 | 155 | | |
| 79 | | 105 | | 75 | | 163 | | 233 | | 86 | | 120 | | |
| 78 | 2350 | 84 | 2250 | 55 | 1400 | 120 | 1580 | 172 | 950 | 62 | | 92 | | |
| 77 | | 61 | | 39 | | 89 | | 132 | | 40 | | 64 | | |
| 76 | | 39 | 2250 | 23 | 1300 | 62 | 1480 | 94 | 870 | 25.5 | 943 | 43 | | |
| 75 | 2100 | 24.5 | | 12.-13.4 | | 36 | | 62 | | 15-16.4 | | 28 | | |
| 74 | | 16.5 | | 6.5-7.2 | 1160 | 24 | 1330 | 375 | | 6.5-7.6 | | 16 | | |
| 73 | | 6.6-7.4 | | 2.6-3.1 | | 11.9 | | 22 | | 2.9-3.5 | | 8.2 | | |
| 72 | 1850 | 3.2-3.7 | | 1.1-1.4 | | 5.5-6.2 | 1200 | 11.1 | | 1.4-1.9 | 859 | 4-4.5 | | |
| 71 | | 1.2-1.6 | | .5-.7 | | 2.6-3.1 | | 5.4-5.7 | | .5-.8 | | 1.7-2 | | |
| 70 | 1700 | .5-.7 | 1900 | | | .9-1.1 | | 2-2.5 | 625 | | 775 | .6-.8 | | |
| 69 | | .1-.3 | 1780 | | | .3-.5 | 900 | .8-1 | 520 | | | .2 | | |
| 68 | 1500 | | 1670 | | | 816 | | 1000 | .2-.4 | | | 681 | | |
| 67 | 1380 | | 1550 | | | 760 | | 915 | | | | 616 | | |
| 66 | 1280 | | 1440 | | | 690 | | 853 | | 426 | | 561 | | |
| 65 | 1160 | | 1300 | | | 620 | | 770 | | | | 511 | | |
| 64 | 1070 | | 1160 | | | 570 | | 703 | | 358 | | 469 | | |
| 63 | 1000 | | 1010 | | | 530 | | 632 | | | | 440 | | |
| 62 | 900 | | 860 | | | 474 | | 570 | | 267 | | 402 | | |
| 61 | 840 | | 760 | | | 440 | | 512 | | | | 360 | | |
| 60 | 710 | | 585 | | | 382 | | 440 | | 193 | | 318 | | |
| 59 | 590 | | 460 | | | 320 | | 370 | | 156 | | 268 | | |
| 58 | 480 | | 380 | | | 268 | | 310 | | 123.5 | | 218 | | |
| 57 | 360 | | 250 | | | 211 | | 260 | | 99 | | 163 | | |
| 56 | 270 | | 167 | | | 154 | | 200 | | 70 | | 126 | | |
| 55 | 190 | | 108 | | | 111 | | 148 | | 47-48 | | 86 | | |
| 54 | 130 | | 59 | | | 80 | | 108 | | 28.5 | | 60 | | |
| 53 | 84 | | 34 | | | 53 | | 70 | | 18 | | 40.5 | | |
| 52 | 52 | | 16.5 | | | 33 | | 46 | | 10 | | 24.3 | | |
| 51 | 30 | | 9.2-10 | | | 20 | | 31-32 | | 5.5-6 | | 14-15 | | |
| 50 | 16 | | 4.5-5 | | | 12.7-13.2 | | 20 | | 2.4-2.8 | | 8.2-8.6 | | |
| 49 | 7.6-8.4 | | 1.9-2.2 | | | 6.6 | | 10.6-11.6 | | 1-1.3 | | 4-4.4 | | |
| 48 | 3.6-4.2 | | .6-1 | | | 3.3 | | 5.4-5.9 | | .5-6 | | 1.8-2.2 | | |
| 47 | 1.8-2.2 | | .2-.4 | | | 1.2-1.4 | | 2.5-3.0 | | | | .8-1 | | |
| 46 | .5-.8 | | | | | .4-.5 | | 1-1.2 | | | | .3 | | |
| S.T. | 195 | | 230 | | | 197-213 | | 213-230 | | 230 | | 215 | | |
| I.R. | .4 | | -1 | | | .4 | | .4 | | -1 | | -1 | | |

| I(i-Pr ₂ Be) | | | | | | | | |
|-------------------------|-----------|--------|-----------|---------|---------|-------|---------|---------|
| eVx5 | i(Be) | i(Kr) | i(Be) | i(Kr) | i(Be) | i(Kr) | i(Be) | i(Kr) |
| 100 | | 720 | 1215 | 655 | 3560 | 1609 | 1210 | 600 |
| 98 | | 645 | 1190 | 575 | | 1363 | 1200 | 540 |
| 96 | 1100 | 565 | | 510 | | 1210 | | 470 |
| 94 | 1050 | 485 | | 440 | 2600 | 1086 | | 400 |
| 92 | | 408 | | 380 | 2410 | 937 | | 350 |
| 90 | | 350 | 1000 | 330 | 2343 | 790 | 1040 | 295 |
| 88 | 910 | 287 | | 270 | 2215 | 680 | | 250 |
| 87 | 885 | 260 | | 242 | | 607 | | 215 |
| 86 | | 237 | | 220 | | 554 | | 205 |
| 85 | | 208 | | 193 | | 479 | 900 | 177 |
| 84 | 795 | 183 | 837 | 167 | 1960 | 437 | | 133 |
| 83 | | 157 | | 143 | | 350 | | 129 |
| 82 | | 132 | | 122 | | 315 | | 113 |
| 81 | | 112 | | 106 | | 260 | | 93 |
| 80 | 595 | 93 | 700 | 82 | 1683 | 217 | 730 | 75 |
| 79 | | 69 | | 66 | | 170 | | 61 |
| 78 | | 55 | | 47 | | 129 | | 46 |
| 77 | | 40 | | 35 | | 97 | | 31 |
| 76 | 585 | 28 | | 24 | 1470 | 68 | | 23.5 |
| 75 | | 16 | 550 | 16 | | 38 | 575 | 15-17 |
| 74 | | 9-11 | | 7.8-8.8 | | 20.5 | | 7.6-9 |
| 73 | | 5-6 | | 4.4-5.4 | 1220 | 12 | | 3.5-4.5 |
| 72 | | 2-2.6 | | 2.3-3 | | 4 | | 1.8-2.4 |
| 71 | | .9-1.4 | | .9-1.5 | | 2 | | .8-1.4 |
| 70 | | .4-.9 | | .4-1 | | | | .1-.5 |
| 69 | | | | | 965 | | | |
| 68 | 365 | | | | 897 | | 372 | |
| 66 | 310 | | 302 | | 784 | | 306 | |
| 64 | 262 | | 254 | | 684 | | 264 | |
| 62 | 223 | | 213 | | 570 | | 222 | |
| 60 | 181 | | 175 | | 460 | | 186 | |
| 58 | 143 | | 140 | | 354 | | 141 | |
| 56 | 102 | | 102 | | 277 | | 106 | |
| 54 | 71 | | 67 | | 177-187 | | 70 | |
| 52 | 41 | | 36.7-40 | | 104-109 | | 36-41 | |
| 50 | 19 | | 17.3-19 | | 51-53 | | 19 | |
| 51.5 | 34.5-35.5 | | 31-34 | | 91-96 | | 30-34 | |
| 50 | 20-21.5 | | 20-21.6 | | 59-61 | | 21-23 | |
| 49 | 11-12.25 | | 11.3-13.2 | | 34-36 | | 11-12.9 | |
| 48 | 6-7 | | 5.4-7 | | 18-19 | | 6-6.7 | |
| 46.5 | 2.5-3.25 | | 2.7-3.5 | | 6-9 | | 2.4-2.6 | |
| 46 | 1-1.75 | | 1.1-1.6 | | 3-4.7 | | 1.1-1.7 | |
| 45 | .3-.5 | | | | | | | |
| S.T. | 205 | | 205 | | 205 | | 205 | |
| I.R. | -.7 | | -.7 | | -.7 | | -.7 | |

| I(n-Pr ₂ Be) | | | | | | | | | | |
|-------------------------|---------|---------|-------|---------|-------|---------|---------|---------|---------|---------|
| eVx5 | i(Ar) | i(Be) | i(Ar) | i(Be) | i(Ar) | i(Be) | i(Ar) | i(Be) | i(Ar) | i(Be) |
| 98 | 1525 | | | | 3150 | | | | | |
| 96 | 1375 | | | | 2800 | | | | | |
| 94 | 1213 | | | | 2475 | | | | | |
| 92 | 1075 | | 1188 | | 2175 | | 3050 | | | |
| 90 | 925 | | 1038 | | 1850 | | 2550 | | 775 | |
| 88 | 780 | | 875 | | 1540 | | 2100 | | 670 | |
| 86 | 650 | | 725 | | 1280 | | 1700 | | 534 | |
| 84 | 520 | | 570 | | 1000 | | 1280 | | 410 | |
| 82 | 410 | | 440 | | 800 | | 940 | | 305 | |
| 81 | 350 | | 375 | | 680 | | 805 | | 259 | |
| 80 | 300 | | 305 | | 570 | | 645 | | 181 | |
| 79 | 245 | | 250 | | 460 | | 505 | | 173 | |
| 78 | 200 | | 195 | | 380 | | 375 | | 138 | |
| 77 | 153 | | 148 | | 280 | | 260 | | 103 | |
| 76 | 109 | | 104 | | 203 | | 190 | | 81 | |
| 75 | 76 | | 67 | | 130 | | 115 | | 57 | |
| 74 | 47.5 | | 46 | | 88 | | 70 | | 37 | |
| 73 | 28.3 | | 29 | | 54 | | 42 | | 26 | |
| 72 | 15.8 | | 15.5 | | 30 | | 23.5 | | 16 | |
| 71 | 8.2-9 | | 8.3 | | 16 | | 12 | | 10.3 | |
| 70 | 4.8-5.2 | | 4.1 | | 8.6 | | 5.7-6.2 | | 6.11 | |
| 69 | 2.4-2.7 | | 2-2.2 | | 4.2 | | 2.7-3 | | 3.8-4.1 | |
| 68 | 1.3-1.5 | | 1-1.2 | | 2.3 | | 1.4-1.7 | | 2.2-2.4 | |
| 67 | .6-.8 | | .6-.7 | | 1.2 | | .5-.8 | | 1.5-1.8 | |
| 64 | | 1540 | | 1560 | | 1480 | | 1720 | | |
| 62 | | 1400 | | 1430 | | 1360 | | 1580 | | |
| 60 | | 1290 | | 1300 | | 1250 | | 1440 | | 1040 |
| 58 | | 1130 | | 1130 | | 1100 | | 1250 | | 980 |
| 56 | | 960 | | 970 | | 930 | | 1070 | | 900 |
| 54 | | 830 | | 870 | | 780 | | 900 | | 800 |
| 52 | | 680 | | 670 | | 650 | | 730 | | 720 |
| 50 | | 540 | | 540 | | 520 | | 600 | | 585 |
| 48 | | 420 | | 415 | | 410 | | 450 | | 500 |
| 47 | | 355 | | 350 | | 340 | | 380 | | 440 |
| 46 | | 295 | | 300 | | 293 | | 320 | | 375 |
| 45 | | 250 | | 250 | | 240 | | 255 | | 320 |
| 44 | | 205 | | 195 | | 190 | | 205 | | 270 |
| 43 | | 158 | | 150 | | 136 | | 150 | | 220 |
| 42 | | 122 | | 108 | | 119 | | 114 | | 175 |
| 41 | | 85 | | 82 | | 82 | | 80 | | 130 |
| 40 | | 61 | | 56 | | 60 | | 52 | | 100 |
| 39 | | 41 | | 35 | | 31 | | 32 | | 74 |
| 38 | | 23 | | 22 | | 22 | | 18.5 | | 51 |
| 37 | | 12-13.6 | | 11.8 | | 10-12 | | 10.3 | | 32 |
| 36 | | 6.5 | | 6.4-6.9 | | 6.8-7.5 | | 5.3-5.7 | | 22 |
| 35 | | 3.5-3.9 | | 3.4-3.8 | | 3.5-3.9 | | 2.9-3.4 | | 13-13.6 |
| 34 | | 1.9-2.2 | | 1.5-1.8 | | 1.7 | | 1.3-1.7 | | 7-7.6 |
| 33 | | .8-1.2 | | .7-1.1 | | .5-.8 | | .5-.8 | | 4.4-4.9 |
| S.T. | | 185 | | 185 | | 185 | | 185 | | 185 |
| I.R. | | 5 | | 5 | | 5 | | 5 | | 5 |

| I(n-Pr ₂ Be) | | | I(i-Bu ₂ Be) | | | | |
|-------------------------|---------|---------|-------------------------|---------|-------|-----------|-------|
| eVx5 | i(Ar) | i(Be) | (eVx5) | i(Be) | i(Xe) | i(Be) | i(Xe) |
| 92 | 3000 | | 100 | 265 | 7600 | 32-34.5 | 675 |
| 90 | 2600 | | 98 | 260 | 7200 | | 620 |
| 88 | 2000 | | 96 | 260 | 6800 | 28-31 | 560 |
| 86 | 1750 | | 94 | 255 | 6500 | 27-28.5 | 490 |
| 84 | 1300 | | 92 | 250 | 6100 | 24.5-27 | 455 |
| 82 | 950 | | 90 | 235-240 | 5800 | 24-25 | 400 |
| 87 | 800 | | 88 | 225-235 | 5400 | 21-23 | 377 |
| 80 | 675 | | 86 | 220-230 | 5100 | 21-23 | 335 |
| 79 | 500 | | 84 | 215-220 | 4700 | 21-23 | 310 |
| 78 | 380 | | 82 | 205-215 | 4400 | 21-22.5 | 300 |
| 77 | 260 | | 80 | 195-205 | 4000 | 18.5-22 | 278 |
| 76 | 186 | | 78 | 190-200 | 3650 | 18.20.5 | 247 |
| 75 | 120 | | 76 | 185-195 | 3100 | 16-17.5 | 217 |
| 74 | 65 | | 74 | 175-185 | 2900 | 1 15-17 | 190 |
| 73 | 40 | | 72 | 165-175 | 2500 | 13.8-16 | 160 |
| 72 | 22 | | 70 | 160-165 | 2100 | 12-14.2 | 136 |
| 71 | 10 | | 68 | 145-155 | 1700 | 12-13.2 | 113 |
| 70 | 6 | | 66 | 135-145 | 1320 | 10.8-12.4 | 83 |
| 69 | 3 | | 64 | 124-130 | 920 | 10.4-12 | 61 |
| 68 | 1.4-1.7 | | 62 | 114-120 | 620 | 9.6-11 | 37.5 |
| 67 | .5-.8 | | 60 | 102-108 | 350 | 8.4-10.2 | 22 |
| 64 | | 1700 | 58 | 90-94 | 160 | 7.6-9.2 | 9-10 |
| 62 | | 1500 | 56 | 80-84 | 50-52 | 7.5-9 | 3-3.4 |
| 60 | | 1420 | 54 | 70-73 | 20-22 | 6-7.5 | .6-.8 |
| 58 | | 1200 | 52 | 58-61 | 1.5-2 | 4.4-5.6 | |
| 56 | | 1000 | 50 | 48-51 | .3-.5 | 3.5-4.5 | |
| 54 | | 950 | 48 | 37-41 | | 2.2-3.3 | |
| 52 | | 700 | 46 | 27-29 | | 1.5-2.4 | |
| 50 | | 550 | 44 | 18-19.5 | | .9-1.9 | |
| 48 | | 425 | 42 | 9.8-11 | | .3-7 | |
| 47 | | 370 | 40 | 4-4.7 | | | |
| 46 | | 310 | 38 | 1-1.6 | | | |
| 45 | | 250 | 36 | .1-.4 | | | |
| 44 | | 203 | 34 | 0-.2 | | | |
| 43 | | 145 | | | | | |
| 42 | | 110 | | | | | |
| 41 | | 75 | | | | | |
| 40 | | 50 | | | | | |
| 39 | | 30 | | | | | |
| 38 | | 19 | | | | | |
| 37 | | 9 | | | | | |
| 36 | | 5-5.5 | | | | | |
| 35 | | 3-3.2 | | | | | |
| 34 | | 1.3-1.7 | | | | | |
| 33 | | .5-.6 | | | | | |
| S.T. | | 210 | | 205 | | 205 | |
| I.R. | | -.5 | | 5 | | 5 | |

| I(i-Bu ₂ Be) | | | | | | | | | |
|-------------------------|-----------|---------|-----------|---------|--------------------|---------|-----------|---------|--|
| eVx5 | i(Be) | i(Xe) | i(Be) | i(Xe) | i(Be) | i(Xe) | i(Be) | i(Xe) | |
| 100 | 36-38.5 | 720 | 22.5-25 | 550 | 110-114 | 1000 | 25-27 | 116-122 | |
| 98 | 33.5-36 | 650 | 22.5-25 | 500 | 110-114 | 950 | 24-27 | 106-110 | |
| 96 | 31.5-34 | 580 | 22.5-25 | 460 | 108-112 | 910 | 22-25 | 98-100 | |
| 94 | 29-31.5 | 520 | 21-23 | 440 | 104-110 | 870 | 23-25 | 90-95 | |
| 92 | 26-30 | 470 | 19.5-22 | 380 | 104-106 | 850 | 17-18 | 79-82 | |
| 90 | 24-27 | 430 | 18.5-20.5 | 360 | 102-108 | 870 | 17-18.5 | 67-69 | |
| 88 | 22.5-26 | 400 | 17-18.5 | 330 | 98-102 | 790 | 17-19.5 | 60-64 | |
| 86 | 22.5-26 | 360 | 18-20.5 | 305 | 96 -102 | 740 | 15.5-18 | 64-66 | |
| 84 | 22-25 | 330 | 17.5-20 | 305 | 86-90 | 695 | 15.5-17 | 56-60 | |
| 82 | 21.5-24 | 310 | 17.5-20 | 270 | 86-90 | 620 | 14.5-16 | 50-52 | |
| 80 | 21.5-24 | 290 | 17.5-20 | 260 | 82-86 | 575 | 14.5-16 | 47-50 | |
| 78 | 21.5-24 | 270 | 16-18 | 240 | 80-84 | 505 | 13.5-16 | 42-44 | |
| 76 | 21-22.5 | 250 | 14.5-17 | 205 | 70-74 | 465 | 14.5-15.5 | 36-39 | |
| 74 | 19-21.5 | 215 | 13-14.6 | 185 | 69-72 | 387 | 14-16 | 35-38 | |
| 72 | 17-19 | 185 | 12.4-14 | 155 | 65-78 | 343 | 12.5-15 | 33-35 | |
| 70 | 16-17.5 | 154 | 12-14 | 136 | 60-64 | 282 | 12-14 | 27-30 | |
| 68 | 12-15.5 | 120 | 12-14 | 122 | 57.5-62 | 238 | 11-13 | 22-29 | |
| 66 | 11.4-13.4 | 90 | 11.4-12.8 | 100 | 52-56 | 178 | 10-12 | 15-17 | |
| 64 | 11-13 | 62 | 10.4-12 | 74 | 49-53 | 130 | 9-10 | 10-12 | |
| 62 | 9.8-11.4 | 41 | 9-10.8 | 52 | 45-48 | 87 | 8-10 | 6.2-7.2 | |
| 60 | 8.6-10 | 21.5 | 7.6-8.6 | 32 | 42-49 | 52.5 | 7.6-8.8 | 3.2-4 | |
| 58 | 7.8-9 | 8.5-10 | 7-8.4 | 16.5 | 38-40 | 23 | 6.2-8 | 1.6-2.1 | |
| 56 | 6.6-8.2 | 2.4-3.1 | | 6.8-7.2 | 33-35 | 12-13.6 | 4.5-6 | .5-.7 | |
| 54 | 7-8.4 | 7-1.1 | | 1.6-2.4 | 26.5-28 | 2.2-3.2 | 4-5 | | |
| 52 | 5.6-6.6 | | 4.8-5.8 | .3-.7 | 22.5-23.5 | .3-.4 | 3.5-4.5 | | |
| 50 | 4.2-5 | | 4-4.9 | | 17-19.2 | | 2.5-3.5 | | |
| 48 | 2.8-3.8 | | 3-4 | | 13-15 | | 1.9-2.9 | | |
| 46 | 2-2.8 | | 2.6-3.1 | | 9-11 | | 1-1.7 | | |
| 44 | .9-1.7 | | 1.5-1.9 | | 5.5-6.3 | | .5-1.3 | | |
| 42 | .4-.8 | | .8-1.2 | | 2.5-3.4 | | .3-.8 | | |
| 40 | .2-.5 | | .3-.7 | | 1-1.4 | | | | |
| 38 | | | .1-.3 | | .4-.5 | | | | |
| 36 | | | | | | | | | |

S.T. 205
I.R. 5

205
5

205
5

198 - 205
2.4

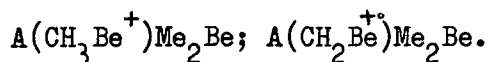

| eVx5 | i(Be')i(Be'')i(Ar) | | | i(Be')i(Be'')i(Ar) | | | i(Be')i(Be'')i(Ar) | | | i(Be')i(Be'')i(Ar) | | |
|------|--------------------|---------|-------|--------------------|---------|------|--------------------|---------|-------|--------------------|---------|-------|
| 100 | 2900 | 1350 | 600 | 3050 | 1450 | 870 | 2800 | 1350 | 780 | 2900 | 1800 | 760 |
| 99 | | | 562 | | | 800 | | | 730 | | | 715 |
| 98 | | | 530 | | | 750 | | | 680 | | | 670 |
| 97 | | | 500 | | | 700 | | | 630 | | | 620 |
| 96 | | | 460 | | | 640 | | | 580 | | | 572 |
| 95 | 2600 | 1300 | 417 | 2740 | 1350 | 590 | 2600 | 1230 | 540 | 2400 | 1200 | 539 |
| 94 | | | 370 | | | 520 | | | 490 | | | 470 |
| 93 | | | 335 | | | 480 | | | 440 | | | 420 |
| 92 | | | 300 | | | 430 | | | 390 | | | 380 |
| 91 | | | 257 | | | 361 | | | 330 | | | 310 |
| 90 | 2150 | 1120 | 215 | 2200 | 1175 | 300 | 2100 | 1080 | 286 | 2000 | 1070 | 279 |
| 89 | | | 172 | | | 260 | | | 230 | | | 215 |
| 88 | | | 137 | | | 206 | | | 182 | | | 180 |
| 87 | | | 109 | | | 155 | | | 140 | | | 120 |
| 86 | | | 80 | | | 118 | | | 104 | | | 102 |
| 85 | 1550 | 900 | 58.51 | 1580 | 930 | 85 | 1490 | 860 | 75 | 1400 | 840 | 72 |
| 84 | | | 37.4 | | | 58 | | | 48 | | | 45 |
| 83 | | | 22.6 | | | 35 | | | 31 | | | 29 |
| 82 | | | 12.1 | | | 18.5 | | | 16.17 | | | 15.17 |
| 81 | | | 6.9 | | | 11.1 | | | 8.9 | | | 8.1 |
| 80 | 880 | 620 | 3.0 | 920 | 640 | 5.2 | 860 | 600 | 4.1 | 830 | 550 | 4.0 |
| 79 | | | 1.5 | | | 2.3 | | | 2.0 | | | 2.0 |
| 78 | | | .7 | | | 1.2 | | | .95 | | | .8 |
| 77 | | | .4 | | | .5 | | | .45 | | | .4 |
| 75 | 370 | 355 | | 390 | 370 | | 338 | 330 | | 325 | 300 | |
| 74 | 300 | 300 | | 305 | 320 | | 275 | 285 | | 270 | 270 | |
| 73 | 220 | 260 | | 240 | 275 | | 210 | 250 | | 205 | 230 | |
| 72 | 160 | 215 | | 175 | 233 | | 146 | 203 | | 140 | 200 | |
| 71 | 120 | 180 | | 127.6 | 190 | | 114 | 168 | | 108 | 161 | |
| 70 | 80 | 135 | | 86 | 150 | | 78 | 136 | | 70 | 125 | |
| 69 | 56 | 112 | | 60 | 118 | | 53 | 109 | | 50 | 101 | |
| 68 | 37 | 88 | | 41 | 94 | | 35 | 86 | | 31 | 78 | |
| 67 | 23.5 | 67 | | 25 | 69 | | 22 | 62 | | 20 | 60 | |
| 66 | 14 | 46 | | 14.4 | 49 | | 12.4 | 44 | | 12 | 42 | |
| 65 | 7.6-8.2 | 31.5 | | 9 | | | 5.75 | 28-29 | | 4 | 27 | |
| 64 | 3.9-4.3 | 20.5 | | 5-5.6 | 23-24 | | 4.0 | 19-20 | | 3 | 18 | |
| 63 | 2.0-2.5 | 12-13 | | 2.4-2.7 | 13-14 | | 2.0 | 11-12 | | 2 | 10-11 | |
| 62 | .9-1.3 | 6.6-7.2 | | 1.0-1.3 | 7.2-8.0 | | .8-1.1 | 5.9-6.0 | | .9-1.0 | 5.7 | |
| 61 | | 3.-3.4 | | .5-.8 | 3.9-4.3 | | .4-.6 | 3-3.5 | | .5 | 3.2 | |
| 60 | | 1.5-1.8 | | | 1.8-2.1 | | | 1.4-1.7 | | | 1.2-1.6 | |
| 59 | | .6-.8 | | | .7-.9 | | | .5-.7 | | | .4-.6 | |
| 58 | | .1-.3 | | | .3-.4 | | | .1-.2 | | | .1 | |
| S.T. | | 193 | | | 193 | | | 193 | | | 199 | |
| I.R. | | -.2 | | | -.2 | | | -.2 | | | 0 | |

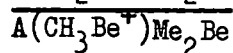
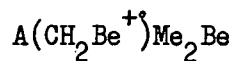
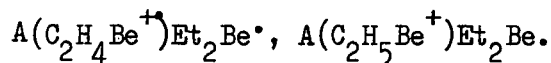

| eVx5 | A(C ₂ H ₄ Be ⁺)Et ₂ Be [·] | | | A(C ₂ H ₅ Be ⁺)Et ₂ Be | | | A(CH ₂ Be ⁺)Me ₂ Be | | | A(CH ₃ Be ⁺)Me ₂ Be | | |
|------|--|---------------------|---------|---|---------------------|---------|---|---------------------|---------|---|---------------------|-------|
| | i(Be ^{''}) | i(Be [']) | i(Ar) | i(Be ^{''}) | i(Be [']) | i(Ar) | i(Be ^{''}) | i(Be [']) | i(Ar) | i(Be ^{''}) | i(Be [']) | i(Be) |
| 100 | 4200 | 2150 | 500 | 5600 | 2400 | 800 | | | 1120 | 3850 | 6800 | 10000 |
| 98 | | | 450 | | | 710 | | | 990 | 3650 | 6250 | 9600 |
| 96 | | | 400 | | | 630 | | | 890 | 3400 | 5700 | 9350 |
| 94 | | | 350 | 5000 | 2450 | 560 | | | 730 | 3150 | 5200 | 8950 |
| 92 | | | 305 | 4800 | 2250 | 460 | | | 630 | 2900 | 4700 | 8600 |
| 90 | 3400 | 1600 | 260 | | | 390 | 4600 | 2100 | 540 | 2600 | 4050 | 8000 |
| 88 | | | 215 | 4250 | 1950 | 320 | | | 430 | 2350 | 3500 | 7600 |
| 86 | | | 170 | | | 235 | 4000 | 1740 | 335 | 2070 | 2950 | 6900 |
| 84 | | 1300 | 135 | 3850 | 1650 | 180 | 3750 | 1590 | 243 | 1800 | 2400 | 6400 |
| 83 | | 1220 | 118 | 3700 | 1575 | 150 | | | 200 | | | |
| 82 | | | 100 | | | 120 | 3500 | 1440 | 165 | 1550 | 1900 | 5800 |
| 81 | | | 84 | | | 94 | | | 132 | | | |
| 80 | 2600 | 1060 | 68 | 3300 | 1325 | 72 | 3300 | 1310 | 102 | 1300 | 1500 | 5300 |
| 79 | 2550 | 1010 | 55 | 3200 | 1250 | 57 | | | 71 | | | |
| 78 | | | 42 | | | 37.5 | 3050 | 1150 | 48 | 1000 | 1010 | 4550 |
| 77 | 2400 | 900 | 31 | | | 23 | | | 29 | | | |
| 76 | 2325 | 860 | 21 | 2800 | 1020 | 15.5 | | | 16.3 | 770 | 680 | 4000 |
| 75 | | | 13 | 2625 | 920 | 7.4 | | | 8.8-9.4 | 680 | 550 | |
| 74 | | | 6.4 | | | 3.2-3.5 | | | 3.4-3.9 | 570 | 420 | 3325 |
| 73 | | | 3.3 | | | 1.3-1.7 | | | 1.5-1.7 | 480 | 320 | 3050 |
| 72 | | | 1.2-1.5 | | | .3-.5 | | | .4-.7 | 400 | 225 | 2725 |
| 71 | | | .6-.7 | 2050 | 620 | | 2050 | 610 | | 325 | 165 | 2500 |
| 70 | 1600 | 500 | .2-.3 | 1900 | 550 | | 1870 | 540 | | 265 | 115 | 2200 |
| 68 | 1380 | 395 | | 1625 | 430 | | 1580 | 415 | | 160 | 51 | 1770 |
| 66 | 1200 | 315 | | 1320 | 320 | | 1290 | 295 | | 76 | 17.3 | 1280 |
| 65 | 1100 | 265 | | 1200 | 270 | | 1180 | 255 | | 54 | 11 | 1140 |
| 63 | 900 | 190 | | 960 | 185 | | 920 | 169 | | 18.5 | 2.5-2.8 | 740 |
| 62 | 800 | 155.5 | | 850 | 150 | | 800 | 128 | | 8.9 | .9-1.0 | 510 |
| 61 | 720 | 130 | | 740 | 117 | | 690 | 103 | | 4.4 | .3-.5 | 430 |
| 60 | 630 | 105 | | 640 | 89 | | 600 | 78 | | 1.7-2.0 | | 305 |
| 59 | 535 | 78 | | 530 | 64 | | 515 | 685 | | .6-.9 | | 195 |
| 58 | 450 | 58 | | 430 | 44 | | 407 | 39.5 | | | | 120 |
| 57 | 370 | 40 | | 360 | 31 | | 330 | 27 | | | | 68 |
| 56 | 308 | 29 | | 290 | 21 | | 260 | 16.8-17.8 | | | | 37 |
| 55 | 255 | 21 | | 225 | 14 | | 210 | 12.4 | | | | 18 |
| 54 | 195 | 13.5 | | 175 | 9-9.8 | | 152 | 7.4-7.9 | | | | 9.2 |
| 53 | 155 | 8.8 | | 128 | 5.4-5.6 | | 109 | 4.5-4.9 | | | | 3.4 |
| 52 | | 5.6 | | 94 | 1.8-1.9 | | 77 | 2.9-3.2 | | | | 1.2 |
| 51 | 90 | 3.8 | | | 1.1-1.2 | | 53 | 1.9-2.1 | | | | .3-.6 |
| 50 | 62 | 2.4-2.7 | | 41 | .7 | | 34.5 | .9-1.1 | | | | |
| 49 | 42 | 1.5-1.8 | | | | | 23 | .6-.8 | | | | |
| 48 | 29 | .9-1.1 | | 16.5 | | | | | | | | |
| 47 | 16.5 | .6-.8 | | | | | | | | | | |
| 46 | 9-9.4 | | | 4.4 | | | | | | | | |
| 45 | 4.8-5.0 | | | 2.1 | | | | | | | | |
| 44 | 3.0-3.3 | | | .8-1.0 | | | | | | | | |
| 43 | 1.4-1.5 | | | | | | | | | | | |
| S.T. | | 200 | | | 200 | | | 225 | | | 194 | |
| I.R. | | .2 | | | .2 | | | .5 | | | 0 | |

$A(C_2H_4Be^+)Et_2Be$; $A(C_2H_5Be^+)Et_2Be$

| eVx5 | i(Be ^{''}) | i(Be') | i(Ar) | i(Be ^{''}) | i(Be') | i(Ar) | i(Be ^{''}) | i(Be') | i(Ar) | i(Be ^{''}) | i(Be') | i(Ar) |
|------|----------------------|--------|---------|----------------------|---------|--------|----------------------|--------|----------|----------------------|---------|---------|
| 100 | | | 1580 | 3050 | 3100 | 1440 | 9400 | 4900 | 2350 | | | 1400 |
| 98 | | | 1430 | | | 1280 | | | 2175 | | | 1240 |
| 96 | | | 1280 | | | 1150 | | | 1920 | | | 1140 |
| 94 | | | 1100 | | | 1020 | | | 1710 | | | 1000 |
| 92 | | | 970 | | | 900 | | | 1480 | | | 865 |
| 90 | 6000 | 2750 | 795 | 5100 | 2400 | 760 | 8000 | 3700 | 1270 | 4300 | 2000 | 735 |
| 88 | | | 650 | | | 610 | | | 1080 | | | 610 |
| 86 | | | 510 | 4700 | 2100 | 510 | 7300 | 3225 | 845 | 3900 | 1730 | 500 |
| 84 | | 2300 | 385 | 4400 | 1900 | 380 | 6900 | 2960 | 640 | 3675 | 1600 | 363 |
| 83 | | 2200 | 330 | | | 330 | | | 550 | | | 315 |
| 82 | | 2150 | 270 | 4150 | 1750 | 270 | 6520 | 2700 | 455 | 3450 | 1450 | 260 |
| 81 | | 2050 | 210 | | | 225 | | | 368 | | | 218 |
| 80 | 5000 | 1740 | 156 | 3856 | 1560 | 183 | 6150 | 3450 | 300 | 3250 | 1320 | 173 |
| 79 | | | 122 | | | 132 | | | 220 | | | 129 |
| 78 | 4600 | 1740 | 81 | 3550 | 1380 | 98 | 5700 | 2175 | 163 | 3000 | 1170 | 99 |
| 77 | | | 55 | | | 68 | | | 110 | | | 67 |
| 76 | 4325 | 1540 | 28.5 | 3300 | 1240 | 46 | 5200 | 1840 | 67 | 2750 | 1010 | 39.5 |
| 75 | | | 15 | | | 26 | | | 41.5 | | | 23 |
| 74 | | | 7.1 | | | 14 | | | 22 | | | 13 |
| 73 | | | 3.2-3.6 | | | 5.6 | | | 9.4-10.8 | | | 4.8-5.2 |
| 72 | | | 1.4-1.7 | | | 2.4 | | | 4.5-5.0 | | | 1.9-2.1 |
| 71 | | | .5-.7 | | | .7-1.0 | | | 2-3 | | | .95 |
| 70 | 3150 | 900 | | 2300 | 700 | | 3850 | 1020 | 1.5-2 | | | .3-.4 |
| 68 | 2675 | 700 | | 2000 | 560 | | 3300 | 900 | | 1560 | 440 | |
| 66 | 2250 | 530 | | 1650 | 420 | | 2700 | 660 | | 1320 | 328 | |
| 65 | 2050 | 450 | | 1500 | 350 | | 2450 | 560 | | 1200 | 280 | |
| 63 | 1600 | 310 | | 1240 | 255 | | 2000 | 400 | | 970 | 195 | |
| 62 | 1440 | 250 | | 1100 | 210 | | 1730 | 302 | | 860 | 160 | |
| 61 | 1260 | 197 | | 970 | 165 | | 1560 | 252 | | 760 | 125 | |
| 60 | 1110 | 145 | | 840 | 128 | | 1320 | 193 | | 640 | 96 | |
| 59 | 930 | 108 | | 720 | 98 | | 1130 | 143 | | 550 | 72 | |
| 58 | 765 | 76 | | 600 | 70 | | 950 | 102 | | 460 | 52 | |
| 57 | 660 | 56 | | 500 | 56 | | 785 | 75 | | 380 | 37 | |
| 56 | 540 | 38 | | 400 | 34 | | 630 | 54 | | 305 | 25 | |
| 55 | 425 | 26 | | 320 | 22.5 | | 515 | 38 | | 245 | 17.5 | |
| 54 | 320 | 148-16 | | 250 | 15.3 | | 372 | 24 | | 190 | 11 | |
| 53 | 235 | 10.4 | | 195 | 10 | | 305 | 16 | | 138 | 6.4-7 | |
| 52 | 175 | 6-6.8 | | 1386.0-6.3 | | | 220 | 10.5 | | 106 | 4.5 | |
| 51 | 1173.5-3.9 | | | 4.5-5 | | | 160 | 8-9.5 | | 82 | 2.7-3 | |
| 50 | 84 | 2-2.5 | | 82 | 2.8-3.0 | | 106 | 4.5-6 | | 54 | 1.5-1.8 | |
| 49 | 51 | 1-1.4 | | 51 | 1.5-1.8 | | 68 | 3.5-5 | | 35 | .8 | |
| 48 | 26 | .3-.6 | | 29 | 1.0-1.1 | | 44 | | | 20 | | |
| 47 | 15.5 | | | 17.5 | .5 | | 31 | | | 12.4 | | |
| 46 | 5.7-6.7 | | | 10-10.4 | | | 17 | | | 6 | | |
| 45 | 2.9-3.4 | | | 5-5.4 | | | 10.5 | | | 3.4-3.7 | | |
| 44 | 1.3-1.6 | | | 2.6-2.9 | | | 6-8 | | | 1.3-1.5 | | |
| S.T. | 200 | | | 200 | | | 200 | | | 200 | | |
| I.R. | .5 | | | 1.4 | | | 1.4 | | | 1.4 | | |

$A(C_3H_6Be^+)i-Pr_2Be$; $A(C_3H_7Be^+)i-Pr_2Be$.

| eV | $i(Ar)$ | $i(Be^{II})$ | $i(Be^I)$ | $i(Ar)$ | $i(Be^{II})$ | $i(Be)$ | $i(Ar)$ | $i(Be^{II})$ | $i(Be^I)$ | $i(Ar)$ | $i(Be^{II})$ | $i(Be^I)$ |
|-------|---------|--------------|-----------|---------|--------------|---------|---------|--------------|-----------|---------|--------------|-----------|
| 19.43 | 900 | 5720 | 3700 | 820 | 5350 | 3410 | 8770 | | | 780 | | |
| 19.05 | 800 | | | 750 | | | 720 | | | 730 | | |
| 18.65 | 715 | | | 680 | | | 650 | | | 662 | | |
| 18.27 | 630 | | | 610 | | | 585 | | | 590 | | |
| 17.90 | 560 | | | 545 | | | 520 | | | 510 | | |
| 17.50 | 465 | 5300 | 3100 | 460 | 5100 | 3000 | 435 | | | 432 | | |
| 17.12 | 405 | | | 390 | | | 365 | | | 370 | | |
| 16.73 | 315 | | | 315 | | | 298 | | | 305 | | |
| 16.35 | 245 | | | 235 | | | 225 | | | 235 | | |
| 16.00 | 172.5 | | | 170 | | | 154 | | | 160 | | |
| 15.60 | 114 | 4650 | 2500 | 108 | 4325 | 2225 | 107 | 4330 | 2320 | 110 | | |
| 15.4 | 82 | | | 82 | | | 77 | | | 79 | | |
| 15.2 | 55 | | | 62 | | | 51 | | | 55 | | |
| 15.0 | 39.5 | | | 39.5 | | | 38 | | | 41 | | |
| 14.8 | 25 | | | 26 | | | 24 | | | 29 | | |
| 14.63 | 13 | | | 12.8 | | | 15.6 | | | 16 | | |
| 14.43 | 6.4-6.7 | | | 7.4 | | | 7.6 | | | 8 | | |
| 14.23 | 2.8-3.2 | | | 2.9-3.1 | | | 3.7-4 | | | 3.9 | | |
| 14.0 | 1.4-1.6 | | | 1.0-1.3 | | | 1-1.4 | | | 1.7 | | |
| 13.84 | .4-.5 | | | .3-.4 | | | .6-.7 | | | .6 | | |
| 13.64 | | 3200 | 1400 | | 3000 | 1320 | | 2750 | 1200 | 2760 | 1300 | |
| 13.25 | | | 1180 | | | 1120 | | | 1020 | | 1050 | |
| 12.87 | | 2500 | 960 | | 2365 | 910 | | 2150 | 820 | 2200 | 850 | |
| 12.48 | | 2135 | 770 | | 2000 | 700 | | 1800 | 625 | 1900 | 630 | |
| 12.10 | | | 575 | | | 530 | | | 480 | | 490 | |
| 11.7 | | 1480 | 415 | | 1380 | 390 | | 1240 | 350 | 1270 | 370 | |
| 11.32 | | 1180 | 263 | | 1080 | 250 | | 1000 | 233 | 1050 | 245 | |
| 10.93 | | 870 | 168 | | 870 | 150 | | 760 | 146 | 790 | 152 | |
| 10.53 | | 655 | 94 | | 630 | 94 | | 560 | 84 | 600 | 89 | |
| 10.14 | | 466 | 53 | | 443 | 52 | | 383 | 46 | 390 | 49 | |
| 10 | | 435 | 47 | | 410 | 47 | | | | | | |
| 9.8 | | 335 | 29 | | 325 | 30 | | 305 | 30 | 310 | 31 | |
| 9.6 | | 262 | 20.5 | | 248 | 19.5 | | 233 | 19.3 | 243 | 20 | |
| 9.4 | | 192 | 12.9 | | 188 | 12.2 | | 185 | 12.8 | 192 | 13 | |
| 9.2 | | 136 | 7.1 | | 133 | 6.8-7.6 | | 127 | 7.6 | 131 | 8.1 | |
| 9.0 | | 95 | 4.7 | | 96 | 2.8-3.1 | | 96 | 5-5.4 | 98 | 5.2 | |
| 8.8 | | 63 | 2.8-3.1 | | 67 | 1.3-1.4 | | 64 | 2.9-3.2 | 65 | 3.1 | |
| 8.6 | | 42.5 | 1.7-1.9 | | 43 | .7-.9 | | 43.5 | 1.8-2.1 | 44 | 1.9 | |
| 8.4 | | 275 | 1.0-1.2 | | 27.5 | .4-.6 | | 29 | 1.1-1.2 | 30 | 1.2 | |
| 8.2 | | 16.2 | .5-.7 | | 15 | .1-.2 | | 16 | .45 | 16 | .5 | |
| 8.0 | | 8.4-8.9 | | | 8.4-9.1 | | | 9.2 | .15 | 9.4 | .2 | |
| 7.8 | | 4.2-4.4 | | | 4.1-4.6 | | | 4.7 | | 5.0 | | |
| 7.6 | | 1.9-2.1 | | | 1.7-2.1 | | | 2.2 | | 2.2 | | |
| 7.4 | | .8-1.1 | | | .5-.8 | | | .9-1.1 | | 1.0 | | |
| 7.2 | | .4-.6 | | | .3-.4 | | | .3-.4 | | .4 | | |
| S.T. | | 205 | | | 205 | | | 205 | | 190 | | |
| I.R. | | -.5 | | | -.5 | | | -.5 | | 1.0 | | |

$(C_3H_6Be^+)_{n-Pr_2Be}; (C_3H_7Be^+)_{n-Pr_2Be}$

| eVx5 | i(Ar) | i(Be ^{''}) | i(Be') | i(Ar) | i(Be ^{''}) | i(Be') | i(Ar) | i(Be ^{''}) | i(Be') | i(Ar) | i(Be ^{''}) | i(Be') |
|------|---------|----------------------|---------|---------|----------------------|--------|---------|----------------------|--------|-------|----------------------|--------|
| 96 | 4950 | | | 3475 | | | | | | | 2450 | |
| 94 | 4400 | | | 3050 | | | 3200 | | | | 2150 | |
| 92 | 3800 | | | 2650 | | | 2800 | | | | 1850 | |
| 90 | 3200 | | | 2250 | | | 2425 | | | | 1600 | |
| 88 | 2700 | | | 1900 | | | 2075 | | | | 1325 | |
| 86 | 2100 | | | 1460 | | | 1700 | | | | 1050 | |
| 84 | 1600 | | | 1090 | | | 1328 | | | | 800 | |
| 82 | 1070 | | | 750 | | | 1000 | | | | 565 | |
| 80 | 680 | | | 475 | | | 690 | | | | 360 | |
| 79 | 490 | | | 360 | | | 435 | | | | 363 | |
| 78 | 340 | | | 256 | | | 330 | | | | 183 | |
| 77 | 230 | | | 166 | | | 220 | | | | 122 | |
| 76 | 128 | | | 109 | | | 110 | | | | 76 | |
| 75 | 74 | | | 62 | | | 86 | | | | 43 | |
| 74 | 43 | | | 33 | | | 49 | | | | 24 | |
| 73 | 20 | | | 16 | | | 25.8 | | | | 11.1 | |
| 72 | 11.1 | | | 10.2 | | | 12.9 | | | | 5.5 | |
| 71 | 6.3-6.5 | | | 5.1 | | | 6.8-6.9 | | | | 2.75 | |
| 70 | 3.5-3.7 | | | 2.5-2.7 | | | 3.7-3.8 | | | | 1.55 | |
| 69 | 2.2-2.3 | | | 1.7-1.8 | | | 1.9-2.1 | | | | .9-1 | |
| 68 | 1.6-1.8 | | | 1.1 | | | 1.2-1.3 | | | | .7 | |
| 67 | 1.3-1.5 | | | .9 | | | .8-.9 | | | | .5-.6 | |
| 66 | | 2175 | 1325 | | 2075 | 1325 | | 1940 | 1240 | | 2000 | 1280 |
| 65 | | 2025 | 1130 | | 1950 | 1175 | | 1780 | 1060 | | 1820 | 1120 |
| 64 | | 1850 | 970 | | 1800 | 1000 | | 1620 | 920 | | 1680 | 980 |
| 63 | | 1680 | 820 | | 1650 | 890 | | 1500 | 785 | | 1560 | 840 |
| 62 | | 1510 | 690 | | 1480 | 700 | | 1370 | 650 | | 1420 | 710 |
| 61 | | 1350 | 560 | | 1340 | 590 | | 1240 | 540 | | 1320 | 590 |
| 60 | | 1220 | 460 | | 1200 | 475 | | 1120 | 450 | | 1160 | 490 |
| 59 | | 1060 | 355 | | 1050 | 375 | | 935 | 325 | | 1040 | 390 |
| 58 | | 910 | 260 | | 890 | 275 | | 830 | 258 | | 890 | 300 |
| 57 | | 760 | 195 | | 760 | 208 | | 720 | 195 | | 770 | 228 |
| 56 | | 625 | 134 | | 630 | 143 | | 600 | 145 | | 660 | 160 |
| 55 | | 495 | 92 | | 515 | 107 | | 495 | 101 | | 550 | 120 |
| 54 | | 393 | 64 | | 410 | 71 | | 370 | 63.5 | | 445 | 82 |
| 53 | | 285 | 40 | | 302.5 | 49 | | 295 | 43.5 | | 355 | 59 |
| 52 | | 225 | 26 | | 230 | 30 | | 225 | 29 | | 260 | 37 |
| 51 | | 156 | 18 | | 165 | 20 | | 162 | 19.5 | | 210 | 27 |
| 50 | | 106 | 10.6 | | 119 | 12.6 | | 114 | 11.7 | | 148 | 16.6 |
| 49 | | 72 | 6.7 | | 81.5 | 8 | | 68 | 6.6 | | 103 | 10.4 |
| 48 | | 44 | 3.7 | | 56 | 5 | | 48 | 4.4 | | 63 | 5.7 |
| 47 | | 23 | 2.2-2.4 | | 39 | 3.5 | | 32.5 | 3 | | 42 | 3.5 |
| 46 | | 20 | 1.5-1.7 | | 27.5 | 2.2 | | 20.5 | 1.9 | | 25 | 2.2 |
| 45 | | 14.1 | 1.1-1.2 | | 19 | 1.6 | | 13.9 | 1.25 | | 14.4 | 1.3 |
| 44 | | 8.5 | .7-.8 | | 10.6 | .9 | | 10 | .95 | | 8.4 | .8-.9 |
| 43 | | 5.0 | .5 | | 5.8 | .6 | | 6.1-6.3 | .6 | | 5.15 | .6 |
| 42 | | 3 | | | 3.4 | | | 3.6-3.7 | | | 2.35 | |
| 41 | | 1.95 | | | 1.95 | | | 2.3 | | | 1.7-1.8 | |
| 40 | | 1.15 | | | 1.1-1.2 | | | 1.25 | | | 1.1-1.2 | |
| S.T. | | 185 | | | 185 | | | 185 | | | 185 | |
| I.R. | | 4.6 | | | 4.6 | | | 4.6 | | | 4.6 | |

| $A(C_3H_6Be^+)_{n-Pr_2}Be; A(C_3H_7Be^+)_{n-Pr_2}Be.$ | | | | $A(C_4H_8Be^+)_{i-Bu_2}Be; A(C_4H_9Be^+)_{i-Bu_2}Be$ | | | |
|---|-----|-------|---------|--|---------|---------|---------|
| eV | x 5 | i(Ar) | i(Be'') | i(Be') | i(Be'') | i(Be') | i(Ar) |
| 96 | | 2075 | | | | | 2120 |
| 94 | | 1825 | | | | | 1925 |
| 92 | | 1600 | | | | | 1720 |
| 90 | | 1375 | | | | | 1450 |
| 88 | | 1100 | | | | | 1320 |
| 86 | | 880 | | | | | 1140 |
| 84 | | 660 | | | 2500 | 4200 | 950 |
| 82 | | 470 | | | 2375 | 3675 | 775 |
| 80 | | 305 | | | 2350 | 3725 | 620 |
| 79 | | 220 | | | | | |
| 78 | | 165 | | | 2200 | 3000 | 420 |
| 77 | | 106 | | | | | 340 |
| 76 | | 66.5 | | | 1630 | 2425 | 268 |
| 75 | | 36.5 | | | | | 215 |
| 74 | | 19.5 | | | 1560 | 2075 | 161 |
| 73 | | 9.4 | | | | | 127 |
| 72 | | 5.2 | | | 1440 | 1870 | 84 |
| 71 | | 2.6 | | | | | 55 |
| 70 | | 1.4 | | | 1330 | 1470 | 30 |
| 69 | | .8 | | | | | 17-17.5 |
| 68 | | .6-.7 | | | 1080 | 1180 | 8-8.2 |
| 67 | | - | | | | | 3.5-3.9 |
| 66 | | | 1860 | 1220 | 870 | 860 | 1.3-2.5 |
| 65 | | | 1720 | 1060 | | | 0.4-0.5 |
| 64 | | | 1600 | 930 | 750 | 660 | .1-.2 |
| 63 | | | 1450 | 790 | | | |
| 62 | | | 1340 | 670 | 590 | 470 | |
| 61 | | | 1210 | 560 | | | |
| 60 | | | 1110 | 460 | 452 | 297 | |
| 59 | | | 970 | 365 | 403 | 225 | |
| 58 | | | 840 | 280 | 333 | 175 | |
| 57 | | | 720 | 210 | 292 | 132 | |
| 56 | | | 615 | 165 | 270 | 104 | |
| 55 | | | 515 | 113 | 223 | 84 | |
| 54 | | | 420 | 77 | 182 | 60.5 | |
| 53 | | | 323 | 53 | 147 | 42.5 | |
| 52 | | | 260 | 36.5 | 128 | 34 | |
| 51 | | | 205 | 26.5 | 101 | 25-26 | |
| 50 | | | 140 | 15.6 | 71 | 16-17 | |
| 49 | | | 98 | 9.6 | 54 | 12-12.5 | |
| 48 | | | 67 | 5.9-6.1 | 42 | 7.8-8.2 | |
| 47 | | | 42 | 3.4-3.6 | 30 | 5.5-5.8 | |
| 46 | | | 26.5 | 2.2-2.3 | 20.5 | 3.1-3.5 | |
| 45 | | | 15.4 | 1.3 | 10.4-11 | 1.7-2.0 | |
| 44 | | | 8.8 | .8 | 5.7-6.1 | .8-1.1 | |
| 43 | | | 5 | .5-.6 | 2.9-3.2 | .4-.6 | |
| 42 | | | 2.9 | | 1.3-1.6 | | |
| 41 | | | 1.5-1.6 | | .5-.7 | | |
| 40 | | | .9-.95 | | | | |
| 39 | | | 1.85 | | | | |
| S.T. | | | 4.6 | | | | |
| I.R. | | | | | | | |

205

+5

$A(C_4H_8Be^+)i-Bu_2Be$; $A(C_4H_9Be^+)i-Bu_2Be$.

| eVx5 | $i(Be'')i(Be')i(Kr)$ | | | $i(Be'')i(Be')i(Kr)$ | | | $i(Be'')i(Be')i(Kr)$ | | | $i(Be'')i(Be')i(Kr)$ | | |
|------|----------------------|---------|---------|----------------------|---------|---------|----------------------|---------|---------|----------------------|---------|---------|
| 90 | | | 1290 | | | 1040 | 2250 | 4500 | 1550 | 2250 | 4450 | 1400 |
| 88 | | | 1180 | | | 920 | 2150 | 4125 | 1230 | 2150 | 4150 | 1310 |
| 86 | | | 1060 | | | 840 | 1975 | 3775 | 1140 | 2050 | 3800 | 1130 |
| 84 | 2600 | 4300 | 900 | 3900 | 6600 | 740 | 1900 | 3500 | 920 | 1920 | 3550 | 1030 |
| 82 | 2478 | 3950 | 730 | 3800 | 6300 | 620 | 1780 | 3200 | 840 | 1810 | 3325 | 825 |
| 80 | 2425 | 3850 | 620 | 3750 | 5900 | 520 | 1720 | 2950 | 700 | 1720 | 3050 | 755 |
| 79 | | | 580 | 3650 | 5400 | 410 | | | 650 | | | |
| 78 | 2150 | 3375 | 510 | 3000 | 4700 | 370 | 1620 | 2750 | 590 | 1600 | 2700 | 590 |
| 77 | | | 345 | 2950 | 4400 | 290 | | | 510 | | | |
| 76 | 1500 | 2250 | 273 | 3100 | 4450 | 265 | 1500 | 2450 | 430 | 1520 | 2500 | 460 |
| 75 | | | 215 | 3000 | 4200 | 230 | | | 350 | | | |
| 74 | 1250 | 1820 | 162 | 2950 | 4100 | 190 | 1380 | 2100 | 300 | 1400 | 2250 | 345 |
| 73 | | | 128 | 2650 | 3700 | 140 | | | 255 | | | 290 |
| 72 | 1150 | 1610 | 90 | 2300 | 3150 | 104 | 1310 | 1920 | 205 | 1280 | 1910 | 233 |
| 71 | | | 66 | 2150 | 2750 | 64 | | | 159 | | | 187 |
| 70 | 1130 | 1360 | 47 | 2050 | 2500 | 44 | 1190 | 1630 | 117 | 1170 | 1680 | 143 |
| 69 | | | 28.5 | 1950 | 2450 | 30 | | | 88 | | | 107 |
| 68 | 780 | 930 | 12.4 | 1900 | 2150 | 14.5 | 1090 | 1370 | 53.5 | 1090 | 1460 | 75 |
| 67 | | | 5.6-6.1 | 1800 | 1950 | 7.2-7.8 | | | 32 | | | 48.5 |
| 66 | 660 | 705 | 1.9-2.1 | | | 3.4-3.8 | 890 | 1070 | 17 | 935 | 1150 | 27.5 |
| 65 | | | 1-1.3 | | | .9-1.3 | | | 9.8-11 | | | 15.5 |
| 64 | 510 | 530 | .4-.5 | | | .3-.6 | | | 4.9-5.6 | 810 | 900 | 7-8 |
| 62 | 410 | 345 | | 1200 | 1000 | | | | 2.3-3.1 | | | 1.4-1.8 |
| 60 | 332 | 245 | | 940 | 640 | | 630 | 555 | 1.3-1.6 | 585 | 525 | |
| 59 | 295 | 205 | | 840 | 550 | | | | .7-1 | | | |
| 58 | 255 | 165 | | 720 | 420 | | 535 | 390 | | 480 | 375 | |
| 57 | 225 | 127 | | 630 | 340 | | | | | | | |
| 56 | 208 | 99 | | 550 | 270 | | 440 | 272 | | 410 | 270 | |
| 55 | 176 | 77 | | 500 | 215 | | 410 | 235 | | | | |
| 54 | 148 | 575 | | 430 | 160 | | 355 | 195 | | 342 | 176 | |
| 53 | 131 | 47 | | 340 | 122 | | 308 | 153 | | | | |
| 52 | 108 | 34 | | 290 | 91 | | 263 | 116 | | 250 | 108 | |
| 51 | 94 | 28 | | 235 | 68 | | 228 | 88 | | | | |
| 50 | 71 | 9.3 | | 180 | 42 | | 186 | 63 | | 186 | 63-64 | |
| 49 | 52 | 15.2 | | 142 | 32.5 | | 148 | 52.5 | | 154 | 51 | |
| 48 | 44 | 9.3 | | 102 | 21 | | 128 | 40 | | 122 | 38 | |
| 47 | 33 | 6.5-7 | | 75 | 14.5-16 | | 97 | 27 | | 103 | 29 | |
| 46 | 25.5 | 4.1-4.6 | | 48 | 8.8-9 | | 70 | 17 | | 79 | 21 | |
| 45 | 17.5 | 3-3.6 | | 33 | 5-5.4 | | 56 | 13.5 | | 61.5 | 14.5 | |
| 44 | 10.6 | 1.5-1.8 | | 19 | 2.6-3.1 | | 41 | 8.4-9.4 | | 39 | 8.8-10 | |
| 43 | 6-6.5 | .9-1.1 | | 9.6 | 1.2-1.6 | | 26 | 5.5-6.5 | | 31.5 | 6.5-7.3 | |
| 42 | 2.8-3.1 | .4-.6 | | 4.8-5.4 | .6-.9 | | 15 | 3.3-3.9 | | 19.5 | 3.8-4.5 | |
| 41 | 1.4-1.7 | | | 2.2-2.6 | .2-.4 | | 9.6 | 2.2-2.5 | | 12.4-13.2 | 2.0-2.4 | |
| 40 | .6-.8 | | | .9-1.2 | | | 4.1-4.7 | 1.4-1.3 | | 6.4-7.1 | 1-1.4 | |
| 39 | | | | | | | 2.3-3.0 | | | 4-4.8 | .6-1.0 | |
| S.T. | | 205 | | | 198 | | | 205 | | | 205 | |
| I.R. | | 3 | | | 2.5 | | | 5 | | | 3 | |

$A(\text{Ph}_3\text{Sn}^+)\text{Ph}_3\text{SnI}$ vs. $A(\text{Et}_3\text{Sn}^+)\text{Et}_4\text{Sn}$

| eV | i(Et) | i(Ph) | i(Et) | i(Ph) | i(Et) | i(Ph) | i(Et) | i(Ph) |
|------|---------|----------|---------|---------|---------|-------|-------|-------|
| 70 | 840 | 860 | 850 | 960 | 1060 | 1080 | 900 | 1520 |
| 19.6 | 730 | 918 | 818 | 1160 | 720 | 613 | 619 | 880 |
| 18.9 | 720 | 804 | 806 | 1020 | 550 | 523 | 473 | 750 |
| 18.1 | 700 | 772 | 784 | 980 | 530 | 488 | 456 | 700 |
| 17.3 | 680 | 725 | 760 | 920 | 520 | 474 | 447 | 680 |
| 16.5 | 630 | 677 | 706 | 860 | 490 | 432 | 421 | 620 |
| 15.7 | 590 | 615 | 660 | 780 | 460 | 411 | 396 | 590 |
| 14.9 | 540 | 575 | 605 | 730 | 430 | 397 | 370 | 570 |
| 14.1 | 480 | 527 | 538 | 670 | 410 | 383 | 353 | 550 |
| 13.4 | 400 | 433 | 448 | 550 | 330 | 293 | 284 | 420 |
| 12.6 | 315 | 335 | 353 | 425 | 270 | 247 | 232 | 355 |
| 11.8 | 240 | 200 | 269 | 355 | 185 | 184 | 159 | 265 |
| 11.4 | 205 | 232 | 230 | 295 | | | | |
| 11.0 | 165 | 193 | 185 | 245 | 126 | 118 | 108 | 170 |
| 10.6 | 134 | 155 | 150 | 196 | 106 | 109 | 91.2 | 156 |
| 10.2 | 88 | 118 | 98.6 | 150 | 64 | 66.9 | 55 | 96 |
| 10 | 70 | 98.1 | 76.1 | 125 | 52 | 58.5 | 44.7 | 84 |
| 9.8 | 52 | 75.6 | 59.4 | 96 | 40 | 44.6 | 34.4 | 64 |
| 9.6 | 37 | 55.9 | 41 | 71 | 26 | 31.4 | 22.4 | 45 |
| 9.4 | 25 | 38.6 | 28 | 49 | 16.5 | 20.2 | 14.2 | 29 |
| 9.2 | 17 | 27.2 | 19 | 34.5 | 10 | 12.5 | 8.6 | 18 |
| 9.0 | 10-10.2 | 17.7 | 11-11.4 | 22.5 | 5.6-5.8 | 74 | 4.8-5 | 10.6 |
| 8.8 | 5.6 | 9.9-10.1 | 6.3 | 12.7 | 3.6 | 4.5 | 3.1 | 6.4 |
| 8.6 | 3.1-3.2 | 5.2-5.3 | 3.5-3.6 | 6.6-6.7 | 1.5 | .2 | 1.3 | 3 |
| 8.4 | 1.5-1.6 | 2.4-2.5 | 1.7-1.8 | 3.1-3.2 | .7 | .1 | .6 | 1.5 |
| 8.2 | .7-.8 | 1.2 | .8-.9 | 1.5-2.6 | .3 | .4 | .3 | .6 |
| 8.0 | .1-.4 | .45 | .1-.4 | .6 | .2 | .2 | | .3 |
| 7.8 | | .15 | | .2 | | | | |
| S.T. | 195 | | 205 | | 197 | | 210 | |
| I.R. | 0.4 | | 0.4 | | 0.5 | | 0.6 | |

 $A(\text{Ph}_3\text{Sn}^+)\text{Ph}_4\text{Sn}$ vs. $A(\text{Et}_3\text{Sn}^+)\text{Et}_4\text{Sn}$

| eV | i(Et) | i(Ph) | i(Et) | i(Ph) | i(Et) | i(Ph) | i(Et) | i(Ph) |
|------|---------|-------|-------|-------|-------|--------|-------|-------|
| 67.3 | 191 | 191 | 157 | 270 | 650 | 660 | 1480 | 1490 |
| 19.6 | 370-375 | 368 | 305 | 520 | 475 | 410 | 1080 | 930 |
| 18.9 | 362 | 361 | 297 | 510 | | | | |
| 18.5 | | | | | 444 | 350 | 1015 | 800 |
| 18.1 | 355 | 336 | 291 | 474 | | | | |
| 17.7 | | | | | 418 | 315 | 950 | 712 |
| 17.3 | 347 | 311 | 285 | 440 | | | | |
| 16.9 | | | | | 396 | 270 | 900 | 610 |
| 16.5 | 334 | 272 | 274 | 385 | | | | |
| 16.1 | | | | | 374 | 235 | 855 | 530 |
| 15.7 | 320 | 244 | 262 | 345 | | | | |
| 15.3 | 305 | 205 | 250 | 290 | 354 | 190 | 805 | 430 |
| 14.5 | 290 | 177 | 238 | 250 | 328 | 154 | 745 | 350 |
| 13.7 | 262 | 136 | 214 | 192 | 292 | 118 | 665 | 270 |
| 13.0 | 227 | 97.6 | 187 | 138 | 244 | 82-100 | 555 | 190 |

| eV | i(Et) i(Ph) | | i(Et) i(Ph) | | i(Et) i(Ph) | | i(Et) i(Ph) | |
|------|-------------|---------|-------------|---------|-------------|-----------|-------------|---------|
| | i(Et) | i(Ph) | i(Et) | i(Ph) | i(Et) | i(Ph) | i(Et) | i(Ph) |
| 12.6 | 205 | 79.2 | 168 | 112 | | | | |
| 12.2 | 179 | 61.5 | 147 | 87 | 195 | 53 | 442 | 120 |
| 11.8 | 156 | 48 | 128 | 68 | | | | |
| 11.4 | 133 | 37 | 109 | 52 | 143 | 31-33 | 325 | 71 |
| 11.0 | 105 | 24 | 86 | 34 | 121 | 24 | 275 | 54 |
| 10.6 | 80.3 | 16.5 | 65.8 | 23.5 | 95-97 | 16.4 | 217 | 37 |
| 10.2 | 63 | 11.3 | 51.7 | 15.4-16 | 73.9 | 11.4-12.2 | 168 | 25.8 |
| 9.8 | 45 | 7 | 36-37 | 9.8-10 | 58.1 | 8.2 | 132 | 18 |
| 9.6 | 39.5 | 64-65 | 32.4 | 9-9.2 | 47.5 | 5.9 | 108 | 13.3 |
| 9.4 | 31.5-32 | 4.6-4.7 | 26 | 6.5-6.7 | 40.5 | 4.9 | 92 | 11 |
| 9.2 | 23.5-24 | 3.1-3.3 | 19-19.7 | 4.4-4.6 | 28.2 | 3.7 | 64 | 8.4 |
| 9.0 | 17-17.4 | 2.0-2.1 | 14-14.3 | 2.8-2.9 | 26 | 2.85 | 58.5 | 6.4 |
| 8.8 | 12-12.4 | 1.3 | 9.8-10.2 | 1.8-1.9 | 19 | 1.9-2.2 | 43 | 4.3-5 |
| 8.6 | 8.2-8.4 | .9 | 6.7-7 | 1.2-1.3 | 15.2 | 1.4-1.6 | 35 | 3.2-3.6 |
| 8.4 | 5.1-5.4 | .4 | 4.2-4.4 | .6 | 10.8-11 | .9-1.1 | 24.7 | 2-2.5 |
| 8.2 | 3.1-3.3 | .2-.3 | 2.5-2.7 | .3-.4 | 7-7.4 | .7 | 16-16.8 | 1.6 |
| 8.0 | 1.9-2.0 | | 1.6 | .2-.3 | 4.6-4.8 | .3 | 10.4-10.8 | .7 |
| 7.8 | .9-1 | | .7-.8 | .1 | 2.9-3.1 | .1-.2 | 6.5-7 | |
| 7.6 | .4 | | .3 | | 1.6-1.8 | | 3.6-4 | |
| 7.4 | .2 | | .2 | | | | 1.8 | |
| 7.2 | .1 | | .1 | | | | .8 | |
| 7.0 | | | | | .2 | | .4-.5 | |
| S.T. | 195 | | 210 | | 195 | | 203 | |
| I.R. | .4 | | .4 | | .4 | | 1.5 | |

$A(\text{Ph}_3\text{Sn}^+)\text{Ph}_3\text{SnEt}$ vs. $A(\text{Et}_3\text{Sn}^+)\text{Et}_4\text{Sn}$

| eV | i(Et) i(Ph) | | i(Et) i(Ph) | | i(Et) i(Ph) | | i(Et) i(Ph) | |
|------|-------------|-------|-------------|-------|-------------|-------|-------------|-------|
| | i(Et) | i(Ph) | i(Et) | i(Ph) | i(Et) | i(Ph) | i(Et) | i(Ph) |
| 67.3 | 170 | 170 | 180 | 140 | 670 | 670 | 870 | 900 |
| 18.9 | 705 | 640 | | | 580 | 618 | 700 | 830 |
| 18.5 | | | | | | | | |
| 18.1 | 709 | 680 | | | | | | |
| 17.3 | 721 | 720 | | | 540 | 551 | 660 | 740 |
| 16.5 | 705 | 760 | | | | | | |
| 16.1 | | | | | 480 | 469 | 580 | 630 |
| 15.7 | 689 | 800 | 700 | 630 | | | | |
| 14.9 | 640 | 790 | 670 | 620 | | | | |
| 14.5 | | | | | 365 | 327 | 440 | 440 |
| 14.1 | 583 | 760 | 590 | 600 | | | | |
| 13.7 | 559 | 730 | 540 | 580 | | | | |
| 13.4 | 518 | 690 | 510 | 540 | | | | |
| 12.9 | 478 | 640 | 460 | 500 | 270 | 234 | 330 | 315 |
| 12.6 | 437 | 580 | 435 | 460 | 205 | 175 | 250 | 235 |
| 12.2 | 387 | 515 | 382 | 400 | | | | |
| 11.8 | 332 | 455 | 310 | 360 | 132 | 115 | 160 | 154 |
| 11.4 | 279 | 385 | 280 | 304 | 102 | 95.2 | 120 | 128 |
| 11.0 | 233 | 325 | 240 | 256 | 74 | 71.4 | 90 | 96 |
| 10.6 | 186 | 265 | 171 | 209 | 44 | 46.1 | 53 | 62 |
| 10.2 | 143 | 198 | 135 | 156 | 25 | 27.9 | 30 | 37.5 |
| 10 | 112.5 | 156 | 110 | 123 | 16.5 | 23.8 | 20 | 32 |
| 9.8 | 93.5 | 133 | 92 | 105 | 10.4-11.2 | 16.4 | 12.6-13.6 | 22 |

| eV | i(Et) i(Ph) | | i(Et) i(Ph) | | i(Et) i(Ph) | | i(Et) i(Ph) | |
|------|-------------|-----------|-------------|---------|-------------|-------|-------------|-------|
| 9.6 | 78.5 | 108 | 75 | 85 | 5.6 | 9.1 | 6.8 | 12.2 |
| 9.4 | 62 | 85-86 | 60 | 67.5 | 3 | 5.6 | 3.6 | 7.5 |
| 9.2 | 48.5 | 65-67 | 49 | 52 | 1.4-1.5 | 3.1 | 1.7 | 4.1 |
| 9.0 | 36.5 | 51-52 | 39 | 40.5 | .6 | 1.6 | .7 | 2.2 |
| 8.8 | 27 | 37 | 25 | 29 | .1-.2 | .6-.7 | .1-.2 | .8-.9 |
| 8.6 | 18.5-18 | 26 | 18 | 20.3 | | .4 | | .5 |
| 8.4 | 11.5-12 | 16.6-17 | 11.5 | 13.2 | | .15 | | .2 |
| 8.2 | 7.3-7.6 | 10.2-10.4 | 7-8 | 8-8.2 | | | | |
| 8.0 | 4.1-4.6 | 3.2-3.4 | 4-5 | 4.7-5 | | | | |
| 7.8 | 1.9-2.3 | 1.4-1.5 | 2-2.2 | 2.5-2.7 | | | | |
| 7.6 | .7-.8 | .6-.7 | .6-.9 | 1.1-1.2 | | | | |
| 7.4 | .2-.3 | .2-.3 | .2-.3 | .5-.6 | | | | |
| S.T. | 200 | 195 | | 195 | | 195 | | |
| I.R. | 2.0 | 2.0 | | 2.0 | | 2.0 | | |

A(Ph₃Sn⁺)Ph₃SnSPh vs. A(Et₃Sn⁺)Et₄Sn

| eV | i(Et) i(Ph) | | i(Et) i(Ph) | | i(Et) i(Ph) | | i(Et) i(Ph) | |
|------|-------------|---------|-------------|---------|-------------|---------|-------------|-----------|
| 70 | 1000 | 1360 | 930 | 2400 | 980 | 1240 | 920 | 1860 |
| 19.6 | 1000 | 1180 | | | 980 | 1060 | 900 | 1580 |
| 17.7 | 1000 | 1140 | 1080 | 1950 | 900 | 900 | 840 | 1360 |
| 15.7 | 740 | 760 | 800 | 1400 | 780 | 680 | 740 | 1040 |
| 13.7 | 500 | 460 | 540 | 860 | 590 | 420 | 520 | 610 |
| 11.8 | 250 | 200 | 270 | 380 | 295 | 175 | 260 | 260 |
| 11.4 | 205 | 150 | 225 | 305 | 230 | 127 | 210 | 200 |
| 11.0 | 154 | 111 | 180 | 240 | 186 | 100 | 165 | 148 |
| 10.6 | 119 | 80 | 130 | 166 | 135 | 72 | 120 | 100 |
| 10.2 | 80 | 51-52 | 89 | 108 | 102 | 48.5 | 84 | 66 |
| 10 | 65 | 39-40 | 74.5 | 86.5 | 81 | 36.5 | 70 | 53-55 |
| 9.8 | 53 | 30-32 | 59 | 65.5 | 65 | 28 | 53-55 | 38 |
| 9.6 | 37.5 | 21 | 43 | 47 | 47 | 19.5 | 39-41 | 26 |
| 9.4 | 28 | 14-14.6 | 31 | 32.5 | 33 | 12-12.8 | 27.5 | 16.8-17.2 |
| 9.2 | 17.8-18.6 | 8.8-9.2 | 21-22 | 21 | 23.5 | 7.6-8.1 | 16.5 | 8-8.8 |
| 9.0 | 11.4-12.2 | 4.5-4.8 | 13-13.4 | 12.6-13 | 13.2-14 | 4.2-4.6 | 11.3 | 3-3.3 |
| 8.8 | 6.8-7.5 | 2.6-2.9 | 8-8.5 | 7.5-8 | 8-8.7 | 2.4-2.8 | 6-.65 | 1.7 |
| 8.6 | 4.4-4.6 | 1.4-1.7 | 4.8-5.2 | 4.4-4.7 | 4.5-4.9 | 1.4-1.6 | 3.9-4.1 | .9-1.1 |
| 8.4 | 1.9-2.2 | .6-.8 | 2.6-2.9 | 2.4-2.5 | 2.5 | .8 | 2-2.4 | .4-.5 |
| 8.2 | .9-1.1 | .3 | 1.2-1.5 | 1-1.3 | 1.2-1.4 | .4 | .9-1 | .2 |
| 8.0 | .3-.5 | | | | .6 | | | |
| S.T. | 197 | 202 | | 203 | | 203 | | |
| I.R. | .9 | .8 | | .8 | | .8 | | .8 |

| eV | i(Et) i(Ph) | | eV i(Et) i(Ph) | | eV i(Et) i(Ph) | | | |
|------|-------------|------|----------------|------|----------------|-----|---------|-----|
| 70 | 1400 | 2400 | 10.6 | 127 | 133 | 8.8 | 7.8-8.4 | 5.2 |
| 19.6 | 1380 | 1980 | 10.2 | 87 | 85 | 8.6 | 4-4.4 | 2.7 |
| 17.7 | 1250 | 1720 | 10 | 66 | 63.5 | 8.4 | 2.2-2.5 | 1.4 |
| 15.7 | 800 | 1300 | 9.8 | 56 | 49 | 8.2 | .9-1.1 | .55 |
| 13.7 | 540 | 770 | 9.6 | 40 | 33 | 8.0 | .4-.6 | .1 |
| 11.8 | 270 | 330 | 9.4 | 29.5 | 23 | | | |
| 11.4 | 212 | 247 | 9.2 | 20 | 14-15 | | | |
| 11.0 | 163 | 181 | 9.0 | 12.6 | 9 | | | |
| S.T. | 203 | 200 | | 200 | | 200 | | |
| I.R. | .8 | 1 | | 1 | | 1 | | |

$A(\text{Ph}_3\text{Sn}^+)\text{Ph}_3\text{SnMe}$ vs. $A(\text{Et}_3\text{Sn}^+)\text{Et}_4\text{Sn}$

| eV | i(Et) | i(Ph) | i(Et) | i(Ph) | i(Et) | i(Ph) | i(Et) | i(Ph) |
|------|---------|---------|---------|---------|--------|--------|---------|---------|
| 70 | 2450 | 1200 | 858 | 1120 | 3050 | 1580 | 1250 | 2100 |
| 19.6 | 3050 | 1360 | 1067 | 1400 | 3500 | 1680 | 1430 | 2240 |
| 18.8 | 3100 | 1400 | 1067 | 1360 | 3450 | 1660 | 1420 | 2210 |
| 17.6 | 3000 | 1250 | 1090 | 1300 | 3300 | 1580 | 1350 | 2100 |
| 16.9 | 2950 | 1200 | 1050 | 1220 | 3200 | 1480 | 1310 | 1970 |
| 15.7 | 2600 | 1040 | 1030 | 1020 | 2800 | 1280 | 1150 | 1705 |
| 14.9 | 2300 | 885 | 910 | 880 | 2450 | 1100 | 1000 | 1460 |
| 13.7 | 1700 | 620 | 805 | 620 | 1950 | 830 | 800 | 1090 |
| 12.9 | 1340 | 500 | 595 | 490 | 1540 | 655 | 631 | 875 |
| 11.8 | 800 | 300 | 469 | 310 | 1000 | 450 | 410 | 600 |
| 11.4 | 620 | 250 | 280 | 245 | 800 | 365 | 328 | 478 |
| 11.0 | 450 | 185 | 214 | 180 | 620 | 293 | 254 | 390 |
| 10.6 | 305 | 126 | 158 | 124-128 | 430 | 207 | 176 | 273 |
| 10.2 | 210 | 83 | 107 | 81-86 | 265 | 133 | 109 | 177 |
| 10 | 154 | 67 | 73.5 | 65-69 | 210 | 106 | 84-88 | 139 |
| 9.8 | 110 | 50 | 38-39 | 46-49 | 141 | 73 | 57-59 | 93-100 |
| 9.6 | 74 | 30 | 25-27 | 29-31 | 92-100 | 50-54 | 38-41 | 67-72 |
| 9.4 | 47.5 | 19 | 16-17 | 18-21 | 57-62 | 32-35 | 21-25 | 43-47 |
| 9.2 | 39 | 12-14 | 14 | 12-14 | 34-37 | 21-23 | 14-15 | 27-31 |
| 9.0 | 16 | 6-8 | 5.3-6 | 6.5-7.5 | 17-20 | 11-13 | 8-8.2 | 15-17 |
| 8.8 | 9.6 | 3-4.5 | 3-3.7 | 3.5-4.4 | 8-11 | 5-6.5 | 3.3-4.5 | 6-8 |
| 8.6 | 4-6 | 1.9-2.5 | 1.4-2.1 | 1.8-2.7 | 3-4.5 | 2-3.5 | 1.2-1.9 | 2.7-4.7 |
| 8.4 | 2.2-3.6 | .5-1.3 | .8-1.3 | .5-1.4 | 1-2.3 | .9-1.7 | .4-.9 | 1.2-1.3 |
| 8.2 | .9-1.9 | .2-.7 | .3-.7 | .2-.7 | .2-.5 | .1-.9 | .2-.5 | .1-1.2 |
| 8.0 | .2-1.1 | | | | | | | |

| | | | | |
|------|-----|-----|-----|-----|
| S.T. | 195 | 200 | 195 | 200 |
| I.R. | .4 | 1.6 | .4 | 1.6 |

| | | | | | | | | |
|------|--------|-------|----------|---------|-------|-------|-------|-------|
| 70 | 2100 | 2650 | 2600 | 2700 | 780 | 800 | 1560 | 850 |
| 19.6 | 2380 | 2900 | 3000 | 3000 | 960 | 860 | 1920 | 780 |
| 18.4 | 2330 | 2800 | 2950 | 2900 | 860 | 850 | 1720 | 800 |
| 17.6 | 2050 | 2400 | 2580 | 2450 | 850 | 820 | 1700 | 810 |
| 16.5 | 1850 | 2050 | 2330 | 2000 | 780 | 730 | 1560 | 715 |
| 15.7 | 1700 | 1800 | 2142 | 1820 | 720 | 670 | 1440 | 660 |
| 14.5 | 1520 | 1620 | 1920 | 1600 | 580 | 520 | 1160 | 500 |
| 13.7 | 1300 | 1320 | 1640 | 1290 | 490 | 420 | 980 | 400 |
| 12.5 | 875 | 910 | 1100 | 890 | 335 | 295 | 670 | 300 |
| 11.8 | 620 | 650 | 781 | 640 | 238 | 220 | 480 | 210 |
| 11.4 | 500 | 530 | 630 | 510 | 193 | 180 | 390 | 190 |
| 11 | 370 | 405 | 466 | 400 | 140 | 134 | 280 | 130 |
| 10.6 | 255 | 275 | 320 | 275 | | 99 | 200 | 95 |
| 10.2 | 149 | 172 | 185 | 168 | 60-63 | 64 | 123 | 60 |
| 10 | 114 | 135 | 144 | 130-140 | 49.5 | 52.5 | 99 | 51 |
| 9.8 | 79-82 | 94 | 101 | 90-98 | 31.5 | 36.5 | 65 | 37 |
| 9.6 | 49-54 | 62-66 | 64.7 | 63 | 21 | 24 | 42 | 23 |
| 9.4 | 32-33 | 40-45 | 40-42 | 42 | 12-13 | 14-16 | 25-27 | 13-17 |
| 9.2 | 17-19 | 23-27 | 22-24 | 20-25 | 6-7 | 8-9.4 | 13.5 | 8-9 |
| 9.0 | 7.5-10 | 13-15 | 9.5-12.6 | 12-14 | 3-4 | 5-5.5 | 6-8 | 4-6 |

| | 206 | | 205 | | 206 | | | |
|------|---------|---------|---------|-------|-------|-------|---------|-------|
| | i(Et) | i(Ph) | i(Et) | i(Ph) | i(Et) | i(Ph) | | |
| 8.8 | 4.5-5 | 6-8 | 5.7-6.3 | 5-9 | 1-2.2 | 2.6-3 | 3.2-4.4 | 2-2.5 |
| 8.6 | 1.3-2.3 | 1.5-2.5 | 1.6-2.8 | 1-3 | .7-1 | 1-1.4 | .5-.9 | 1-1.2 |
| 8.4 | .3-.8 | | .3-.1 | | .2-.5 | .3-.7 | .3-.5 | .3-.6 |
| 8.2 | | | | | | | | |
| S.T. | 200 | | 200 | | 205 | | 206 | |
| I.R. | .7 | | .8 | | 1.2 | | 1.5 | |

$A(\text{Ph}_3\text{Sn}^+)\text{Ph}_3\text{Sn}\cdot\text{GeMe}_3$ vs. $A(\text{Et}_3\text{Sn}^+)\text{Et}_4\text{Sn}$

| eV | 205 | | 210 | | 195 | | 205 | |
|------|---------|-----------|----------|---------|---------|----------|-----------|---------|
| | i(Et) | i(Ph) | i(Et) | i(Ph) | i(Et) | i(Ph) | i(Et) | i(Ph) |
| 70 | 3700 | 3000 | 2800 | 2750 | 3200 | 2600 | 2900 | 2900 |
| 19.6 | 3250 | 2150 | 2720 | 2200 | 2700 | 1850 | 2630 | 2120 |
| 18.9 | 3150 | 1950 | 2560 | 2080 | 2650 | 1640 | 2550 | 1900 |
| 18.1 | 3050 | 1720 | 2510 | 1700 | 2600 | 1470 | 2470 | 1700 |
| 17.3 | 2750 | 1460 | 2460 | 1550 | 2450 | 1260 | 2230 | 1400 |
| 16.5 | 2600 | 1240 | 2320 | 1350 | 2300 | 1040 | 2110 | 1200 |
| 15.7 | 2425 | 980 | 2160 | 1075 | 2150 | 860 | 1970 | 950 |
| 14.9 | 2125 | 740 | 1960 | 800 | 1840 | 670 | 1720 | 720 |
| 14.1 | 1780 | 520 | 1680 | 610 | 1480 | 470 | 1440 | 510 |
| 13.4 | 1460 | 350 | 1344 | 380 | 1300 | 310 | 1180 | 340 |
| 12.6 | 1120 | 225 | 1064 | 243 | 1000 | 193 | 907 | 240 |
| 11.8 | 820 | 120 | 768 | 140 | 680 | 110 | 664 | 130 |
| 11.4 | 630 | 81 | 608 | 110 | 550 | 76 | 510 | 85 |
| 11.0 | 460 | 54 | 452 | 68 | 400 | 53.5 | 373 | 56 |
| 10.6 | 335 | 36 | 320 | 45 | 290 | 33 | 271 | 39 |
| 10.2 | 207 | 21 | 208 | 27 | 178 | 18-20 | 168 | 20 |
| 10.0 | 174 | 16.6-17.2 | 166 | 20.5-19 | 148 | 15-17 | 141 | 16-17 |
| 9.8 | 120 | 11.6-12.8 | 110 | 12-13.5 | 102 | 9.8-10.8 | 96-97 | 12 |
| 9.6 | 82-84 | 8.4-9.2 | 82 | 8.6-9.6 | 74 | 6.5-7.2 | 67 | 8.8 |
| 9.4 | 51-54 | 5.1-5.5 | 51 | 5.4-6.4 | 44 | 4-4.7 | 41-44 | 5-5.7 |
| 9.2 | 30-33 | 3.3-3.5 | 31-32.8 | 3.2-4.1 | 28.5 | 2.5-3.1 | 25-26 | 3-3.5 |
| 9.0 | 17-17.8 | 1.6-2.1 | 16.8-18 | 1.9-2.5 | 14-16 | 1.4-1.9 | 13.6-14.3 | 1.6-2.1 |
| 8.8 | 9-10.2 | 1-1.3 | 9.6-10.4 | 1.2-1.5 | 7-8 | .6-.9 | 7.3-8.3 | 1-1.4 |
| 8.6 | 4.4-5.1 | .5-.7 | 4.4-4.9 | .5-.9 | 3.5-4.5 | .4-.5 | 3.6-4.1 | .5-.6 |
| 8.4 | 2.5-2.8 | .2-.4 | 1.8-2.5 | .3 | 1.8-2.1 | .2-.4 | 2-2.3 | .2-.4 |
| 8.2 | .9-1.3 | | .8-1.2 | | .8-1.4 | .1-.2 | .7-1.1 | |
| 8.0 | .4-.7 | | .4 | | .4-.6 | | .3-.6 | |
| S.T. | 205 | | 210 | | 195 | | 205 | |
| I.R. | 1.2 | | 1.6 | | 2.0 | | 1.7 | |

$A(\text{Ph}_3\text{Sn}^+)\text{Ph}_6\text{Sn}_2$ vs. $A(\text{Et}_3\text{Sn}^+)\text{Et}_4\text{Sn}$

| eV | i(Et) | i(Ph) | i(Et) | i(Ph) | i(Et) | i(Ph) | i(Et) | i(Ph) |
|------|-----------|---------|-----------|---------|---------|---------|---------|---------|
| 70 | 2380 | 4100 | 5000 | 5600 | 8600 | 8300 | 7000 | 4000 |
| 19.6 | 1770 | 3750 | 4050 | 6500 | 7000 | 9600 | 5200 | 3700 |
| 17.6 | 1460 | 2750 | 3200 | 4100 | 5600 | 6050 | 4300 | 2700 |
| 15.6 | 1160 | 1500 | 2204 | 2600 | 3850 | 3850 | 2140 | 1450 |
| 13.7 | 748 | 900 | 1570 | 1480 | 2700 | 2190 | 1390 | 850 |
| 11.7 | 415 | 450 | 870 | 800 | 1500 | 1180 | 769 | 420 |
| 11.3 | 354 | 390 | 789 | 660 | 1360 | 977 | 655 | 380 |
| 10.9 | 282 | 315 | 673 | 550 | 1160 | 814 | 523 | 310 |
| 10.5 | 228 | 250 | 545 | 440 | 940 | 651 | 422 | 245 |
| 10.1 | 173 | 190 | 418 | 330 | 720 | 489 | 321 | 180 |
| 10 | 170 | 166 | 412 | 290 | 710 | 429 | 315 | 167 |
| 9.8 | 124 | 122 | 336 | 235 | 580 | 348 | 230 | 123 |
| 9.6 | 109 | 108 | 270 | 190 | 465 | 281 | 202 | 109 |
| 9.4 | 90.1 | 86 | 218 | 146 | 375 | 216 | 167 | 85 |
| 9.2 | 64.6 | 65 | 168 | 112 | 290 | 166 | 120 | 65 |
| 9 | 47.6 | 47-51 | 131 | 84 | 225 | 124 | 88.2 | 50 |
| 8.8 | 34-35 | 34-36 | 90 | 59-63 | 155 | 87-93 | 63-65 | 35 |
| 8.6 | 22.8-24.8 | 23-25 | 62.6 | 42-44 | 108 | 63.6 | 43-46 | 24.5 |
| 8.4 | 14.6 | 15 | 39.7 | 27 | 67-70 | 40 | 27.1 | 15-16 |
| 8.2 | 9.4 | 9-10.2 | 24.4 | 17-18 | 42 | 25.2 | 17.3 | 9-10 |
| 8.0 | 4.9-5.4 | 5-6 | 13.1-14.5 | 9-11 | 22.5-25 | 13.3 | 9.2-10 | 5-6 |
| 7.8 | 2.2-2.5 | 2.4-3.2 | 5.2-7 | 4.5-5.5 | 9-12 | 6.7-8.1 | 4-4.7 | 2.3-3.1 |
| 7.6 | 1-1.4 | 1-2 | 2-2.9 | 2-3 | 3.5-5 | 3-4.4 | 1.9-2.5 | 1-2.2 |
| 7.4 | .3-.5 | .5-.7 | .9-1.7 | .5-1.5 | 1.5-3 | 7-2.2 | .6-1 | .5-.7 |
| 7.2 | | | .3-.9 | | .5-1.5 | | | .1-.4 |

| | | | | |
|------|-----|-----|-----|-----|
| S.T. | 205 | 205 | 205 | 205 |
| I.R. | .4 | .4 | .4 | .4 |

| | | | | | | | | |
|------|---------|---------|-----------|---------|----------|---------|------|---------|
| 70 | 6900 | 2300 | 2620 | 4700 | 3300 | 3000 | 2150 | 3450 |
| 19.6 | 5700 | 1800 | 1940 | 3600 | 1600 | 1800 | 800 | 1640 |
| 17.6 | 4500 | 1340 | 1710 | 1680 | 1280 | 1140 | 620 | 980 |
| 15.6 | 3650 | 860 | 1390 | 1650 | 1060 | 610 | 520 | 600 |
| 13.7 | 2450 | 460 | 931 | 920 | 860 | 225 | 430 | 340 |
| 11.7 | 1300 | 220 | 494 | 450 | 440 | 155 | 235 | 134 |
| 11.3 | 1100 | 185 | 418 | 370 | 340 | 106 | | |
| 10.9 | 880 | 148 | 334 | 300 | 250 | 66 | 140 | 70 |
| 10.5 | 690 | 118 | 262 | 235 | 160 | 34 | 96 | 43 |
| 10.1 | 510 | 88 | 194 | 175 | 94 | 35 | 58 | 22.5 |
| 10.0 | 510 | 80 | 194 | 160 | 78 | 23 | 50 | 25 |
| 9.8 | 410 | 64 | 156 | 125 | 57 | 13.4 | 34 | 15-16.5 |
| 9.6 | 315 | 49.5 | 120 | 100 | 31.5 | 7.2 | 22 | 10.4 |
| 9.4 | 245 | 38-40 | 93 | 80 | 17-19 | 3.7 | 12 | 5.4 |
| 9.2 | 190 | 29-31 | 72 | 60 | 9.6-10.2 | 1.9-2.4 | 5.8 | 2.6 |
| 9.0 | 137 | 22.5 | 52 | 45 | 5-5.5 | .9-1.1 | 3.7 | 1.7 |
| 8.8 | 92 | 15-16 | 35 | 30-32 | 2.2-2.6 | .5 | 1.7 | .8 |
| 8.6 | 62 | 10-10.8 | 23.6 | 20-21 | 1-1.3 | | .8-1 | .4-.5 |
| 8.4 | 35-38 | 5.5-6.5 | 13.3-14.3 | 11-13 | .3-.5 | | | |
| 8.2 | 20.5 | 3.5 | 7.6-8 | 7 | | | | |
| 8.0 | 10-12 | 1.5-2 | 3.8-4.6 | 3-4 | | | | |
| 7.8 | 5-6.4 | .7-1.3 | 1.9-2.4 | 1.5-2.5 | | | | |
| 7.6 | 2.2-2.7 | .4-.8 | .8-.1 | .8-1.5 | | | | |
| 7.4 | .7-.1 | | .3-.4 | .4-.7 | | | | |

| | | | | |
|------|-----|-----|-----|-----|
| S.T. | 200 | 210 | 195 | 200 |
| I.R. | 1.7 | 1.7 | 1.7 | 1.7 |

$A(\text{Ph}_3\text{Sn}^+)\text{Ph}_3\text{Sn}\cdot\text{SnMe}_3$ vs. $A(\text{Et}_3\text{Sn}^+)\text{Et}_4\text{Sn}$

| eV | i(Et) | i(Ph) | i(Et) | i(Ph) | i(Et) | i(Ph) | i(Et) | i(Ph) |
|------|-----------|---------|---------|---------|-------|---------|---------|-----------|
| 70 | 274 | 274 | 1160 | 319 | 620 | 620 | 2200 | 691 |
| 19.2 | 352 | 275 | 1180 | 330 | 400 | 380 | 1420 | 430 |
| 17.3 | 287 | 220 | 960 | 264 | 321 | 285 | 1140 | 325 |
| 15.4 | 212 | 162 | 710 | 194 | 248 | 225 | 880 | 255 |
| 13.4 | 150 | 110 | 500 | 132 | 161 | 140 | 570 | 158 |
| 11.5 | 65.8 | 40-43 | 220 | 50 | 87.4 | 60 | 310 | 68 |
| 11.1 | 59.8 | 34-38 | 200 | 43 | 74.7 | 47 | 265 | 53 |
| 10.8 | 40.1 | 24-27 | 140 | 30 | 60.6 | 40 | 215 | 44.7 |
| 10.4 | 34.5-37 | 18-21 | 120 | 22 | 49.4 | 30-33 | 170 | 35.1 |
| 10 | 29.9 | 14-16 | 95 | 17-19 | 39.2 | 22.5-25 | 145 | 25.5-28.3 |
| 9.8 | 23.9-24.5 | 11-13 | 82 | 16-17 | 32.4 | 16-19 | 115 | 18.1-21.5 |
| 9.6 | 19.4-22.4 | 10-12.4 | 70 | 13 | 26.8 | 13-15 | 90-100 | 14.7-17 |
| 9.4 | 17.9-20.9 | 8-10 | 65 | 12-15 | 20.4 | 9-12 | 70-75 | 10.2-13.6 |
| 9.2 | 15-16.4 | 7-8 | 53 | 9.6-12 | 16.1 | 6.5-8 | 54-60 | 7.4-9 |
| 9.0 | 11-12.7 | 5-5.5 | 40 | 8.4-9.6 | 13 | 5-6 | 45-48 | 5.7-6.8 |
| 8.8 | 9-9.7 | 3.5-4.7 | 30-32.5 | 6-6.6 | 8.5 | 3.4 | 28-32 | 3.8-5.2 |
| 8.6 | 6.7-7.5 | 2.5-4 | 23-25 | 4.2-5.6 | 5.1 | 2-3 | 17-19 | 2.3-3.4 |
| 8.4 | 3.3-3.5 | 1-2.5 | 14-15 | 3-4.8 | 3.4 | .5-1.6 | 10-14 | .6-.8 |
| 8.2 | 2.7-3.6 | .5-1.5 | 9-12 | 1.2-3 | 2.1 | | 7-8 | |
| 8.0 | 1.6-2.1 | .1-1.5 | 5.5-7 | .6-1.8 | 1.13 | | 3.4-4.6 | |
| 7.8 | .9-1.3 | | 3-4.5 | .1-1.8 | .42 | | 1.5-3 | |
| 7.6 | .5-.9 | | 1.5-3 | | | | .5-1.5 | |
| 7.4 | .3-.5 | | .9-1.5 | | | | | |
| 7.2 | | | .1-1 | | | | | |
| S.T. | 205 | | 205 | | 210 | | 210 | |
| I.R. | .4 | | .7 | | .4 | | .7 | |

| eV | i(Et) | i(Ph) | eV | i(Et) | i(Ph) | eV | i(Et) | i(Ph) |
|------|-------|-------|------|-------|---------|-----|-----------|---------|
| 70 | 310 | 430 | 10.4 | 94-98 | 45 | 8.8 | 19-21.2 | 8-9 |
| 19.2 | 308 | 580 | 10 | 77 | 38 | 8.6 | 12.5-13.5 | 5.5-6.5 |
| 17.3 | 273 | 450 | 9.8 | 69 | 28.5-33 | 8.4 | 9.6-10.2 | 3.5-4.5 |
| 15.4 | 235 | 320 | 9.6 | 57 | 25-26 | 8.2 | 5.4-6.2 | 2.0-3.5 |
| 13.4 | 173 | 190 | 9.4 | 46 | 19-21 | 8.0 | 3.1-3.9 | 1-2 |
| 11.5 | 135 | | 9.2 | 35-36 | 13-15 | 7.8 | 1.9-2.5 | .5-1 |
| 11.1 | 119 | 78 | 9.0 | 27-29 | 11-13 | 7.6 | .8-1.2 | |
| 10.8 | 114 | 58 | | | | 7.4 | .4-.7 | |
| S.T. | 205 | | | | | | | |
| I.R. | .4 | | | | | | | |

$A(\text{PhSnEt}_2^+) \text{Ph}_2\text{SnEt}_2^+ \text{ vs. } A(\text{SnEt}_3^+) \text{Et}_4\text{Sn}$

| eV | i(Ph') | i(Et) | i(Ph') | i(Et) | i(Ph') | i(Et) | i(Ph') | i(Et) |
|------|--------|---------|---------|-----------|-----------|-----------|---------|----------|
| 67.3 | 475 | 479 | 3070 | 3055 | 630 | 630 | 1970 | 9700 |
| 19.6 | 395 | 518 | 2560 | 3355 | 560 | 590 | 1750 | 9200 |
| 18.9 | 380 | 502 | 2460 | 3250 | 540 | 578 | 1680 | 8900 |
| 18.1 | 360 | 480 | 2330 | 3130 | 530 | 558 | 1650 | 8600 |
| 17.3 | 340 | 560 | 2260 | 2950 | 495 | 526 | 1540 | 8100 |
| 16.5 | 290 | 433 | 1880 | 2800 | 455 | 493 | 1420 | 7600 |
| 15.7 | 255 | 399 | 1650 | 2560 | 417 | 454 | 1300 | 7000 |
| 14.9 | 220 | 363 | 1420 | 2350 | 378 | 409 | 1170 | 6300 |
| 14.1 | 182 | 317 | 1180 | 2050 | 320 | 350 | 1000 | 5400 |
| 13.4 | 146 | 260 | 940 | 1660 | 265 | 292 | 827 | 4500 |
| 12.6 | 106 | 201 | 685 | 1300 | 210 | 227 | 655 | 3500 |
| 11.8 | 65 | 150 | 420 | 940 | 156 | 169 | 477 | 2600 |
| 11.0 | 50 | 87 | 325 | 500 | 105 | 109 | 328 | 1680 |
| 10.6 | 33 | 66 | 215 | 420 | 80 | 82 | 250 | 1280 |
| 10.2 | 26 | 43 | 170 | 275 | 56 | 56.5 | 175 | 870 |
| 10 | 20 | 34 | 130 | 220 | 44 | 45.4 | 137 | 700 |
| 9.8 | 13.8 | 25 | 89.3 | 161 | 33-35 | 33-34 | 100-109 | 515 |
| 9.6 | 9.3 | 17-17.6 | 60.2 | 112 | 25-27 | 25 | 78-84 | 383 |
| 9.4 | 5.9 | 11-11.7 | 38.2 | 75 | 17.2-17.8 | 17-17.2 | 54-56 | 263 |
| 9.2 | 4.2 | 6.7-7.0 | 27.1 | 43.5-45.5 | 12.6-13.2 | 11.7-11.9 | 39-41 | 182 |
| 9.0 | 2.45 | 4.4-4.6 | 15.9 | 28.5-30 | 7.7-8.3 | 7.1-7.4 | 24-26 | 112 |
| 8.8 | 1.3 | 2.3-2.4 | 8.4 | 14.6-15.8 | 5.3-5.9 | 4.7-4.9 | 17-18.5 | 74 |
| 8.6 | .8 | 1.2-1.4 | 3.9-5.2 | 8-9 | 3-3.5 | 2.4-2.5 | 9-11 | 38 |
| 8.4 | .35 | .5-.6 | 1.2-3.2 | 3.5-4.1 | 1.6-2 | 1.3-1.4 | 5-6.2 | 20-21 |
| 8.2 | | .2-.3 | | 1.5-1.7 | .9-1.1 | .6-6.7 | 2.8-3.4 | 9.6-10.4 |
| 8.0 | | .1-.12 | | .6-.8 | .4-.6 | .3 | 1.2-1.8 | 4-4.5 |
| 7.8 | | | | .3-.4 | .2-.4 | | .6-1.2 | 2 |
| 7.6 | | | | | | | | .9-1.1 |
| 7.4 | | | | | | | | .5-.8 |
| S.T. | 200 | | 200 | | 200 | | 200 | |
| I.R. | 1.4 | | 1.4 | | 1.4 | | 1.4 | |

 $A(\text{Ph}_2\text{SnEt}^+) \text{Ph}_2\text{SnEt}_2 \text{ vs. } A(\text{Et}_3\text{Sn}^+) \text{Et}_4\text{Sn}$

| eV | i(Ph'') | i(Et) | i(Ph'') | i(Et) | i(Ph'') | i(Et) | i(Ph'') | i(Et) |
|------|---------|-------|---------|-------|---------|-------|---------|-------|
| 70 | 5100 | 5100 | 625 | 625 | 4300 | 4300 | 880 | 640 |
| 19.6 | 5030 | 4900 | 781 | 710 | 4230 | 4140 | 1100 | 700 |
| 18.9 | 4900 | 4700 | 760 | 690 | 4140 | 3950 | 1070 | 680 |
| 18.1 | 4770 | 4550 | 739 | 667 | 4050 | 3840 | 1040 | 660 |
| 17.3 | 4500 | 4300 | 689 | 635 | 3800 | 3630 | 970 | 640 |
| 16.5 | 4240 | 4050 | 646 | 610 | 3580 | 3450 | 910 | 620 |
| 15.7 | 3910 | 3700 | 597 | 570 | 3300 | 3120 | 840 | 590 |
| 14.9 | 3570 | 3350 | 540 | 525 | 3000 | 2820 | 760 | 515 |
| 14.1 | 3050 | 2900 | 479 | 470 | 2570 | 2450 | 675 | 465 |
| 13.4 | 2520 | 2450 | 419 | 410 | 2130 | 2060 | 590 | 405 |
| 12.6 | 2050 | 1910 | 348 | 340 | 1650 | 1610 | 490 | 330 |
| 11.8 | 1590 | 1440 | 270 | 260 | 1290 | 1250 | 380 | 255 |
| 11.4 | 1360 | 1200 | 234 | 223 | 1100 | 1010 | 330 | 221 |
| 11.0 | 1050 | 920 | 199 | 185 | 850 | 745 | 280 | 180 |

| eV | i(Ph ^{II}) | | i(Et) | | i(Ph ^{II}) | | i(Et) | | i(Ph ^{IV}) | | i(Et) | |
|------|----------------------|-----------|-----------|---------|----------------------|-----------|---------|---------|----------------------|--|-------|--|
| 10.6 | 834 | 720 | 165 | 150 | 675 | 585 | 233 | 140 | | | | |
| 10.2 | 596 | 505 | | | 480 | 410 | | | | | | |
| 10 | 503 | 410 | 112 | 100 | 407 | 335 | 158 | 98 | | | | |
| 9.8 | 404 | 330 | 95.1 | 84 | 326 | 267 | 134 | 82 | | | | |
| 9.6 | 295 | 245 | 78.1 | 68 | 240 | 198 | 110 | 69 | | | | |
| 9.4 | 222 | 178 | 62.5 | 54 | 180 | 144 | 88 | 52 | | | | |
| 9.2 | 156 | 122 | 48.3 | 41 | 126 | 98 | 68 | 40 | | | | |
| 9.0 | 109.5 | 83 | 39.1 | 33 | 87.5 | 67 | 55 | 31 | | | | |
| 8.8 | 72.9 | 54 | 28.8 | 23.5 | 59 | 43.5 | 40.5 | 21.5 | | | | |
| 8.6 | 46-47 | 32.5 | 19.5 | 15.2-16 | 37.3 | 26.4 | 27.5 | 15-16 | | | | |
| 8.4 | 27.2-27.8 | 17.8-18.6 | 13.9-14.1 | 11 | 22.4 | 14.4-15.1 | 19.7 | 11.5 | | | | |
| 8.2 | 14.9-15.2 | 8.8-9.2 | 9.5 | 6.8-7.2 | 12.15 | 7.1-7.5 | 13.4 | 6.7-7.1 | | | | |
| 8.0 | 7-7.3 | 3.9-4.1 | 5.6 | 3.95 | 5.8 | 3.2-3.3 | 7.9 | 4 | | | | |
| 7.8 | 3.3-3.6 | 1.8-2 | 3.1-3.2 | 2.1-2.2 | 2.7-2.9 | 1.5-1.6 | 4.45 | 2-2.1 | | | | |
| 7.6 | 1.5-1.6 | .9-1.1 | 1.6 | 1 | 1.2-1.3 | .7-.9 | 2.2-2.3 | 1 | | | | |
| 7.4 | .7-.8 | .5-.6 | .8 | .5 | .6-.7 | .4-.5 | 1.1 | .4-.5 | | | | |
| 7.2 | .7 | .4-.5 | .4 | .2-.3 | | | .5-.6 | .1 | | | | |
| S.T. | 205 | | 210 | | 205 | | 198 | | | | | |
| I.R. | 1.4 | | 1.2 | | 1.3 | | .7 | | | | | |

A(Ph₂SnEt⁺)Ph₃SnEt vs. A(Et₃Sn⁺)Et₄Sn

| eV | i(Ph ^{II}) | | i(Et) | | i(Ph ^{II}) | | i(Et) | | i(Ph ^{II}) | | i(Et) | |
|------|----------------------|---------|---------|-----------|----------------------|----------|-------|---------|----------------------|--|-------|--|
| 67.3 | 254 | 1400 | 260 | 253-268 | 506 | 700 | 260 | 1500 | | | | |
| 19.6 | 490 | 3150 | 495 | 600 | 957 | 1600 | 480 | 3200 | | | | |
| 18.9 | 520 | 3200 | 525 | 590-620 | 1000 | 1600 | 510 | 3150 | | | | |
| 18.1 | 530 | 3200 | 535 | 595 | 1040 | 1600 | 515 | 3150 | | | | |
| 17.3 | 510 | 3100 | 540 | 577 | 1010 | 1590 | 505 | 3160 | | | | |
| 16.5 | 470 | 2900 | 468 | 539 | 950 | 1450 | 465 | 2850 | | | | |
| 15.7 | 435 | 2780 | 442 | 512 | 890 | 1400 | 405 | 2800 | | | | |
| 14.9 | 387 | 2600 | 387 | 484 | 765 | 1305 | 390 | 2700 | | | | |
| 14.1 | 279 | 2050 | 282 | 386 | 550 | 1025 | 281 | 1950 | | | | |
| 13.4 | 165 | 1400 | 180 | 255 | 340 | 700 | 170 | 1390 | | | | |
| 12.6 | 130 | 1080 | 128-126 | 202 | 255 | 540 | 125 | 1070 | | | | |
| 11.8 | 74-79 | 710 | 74-80 | 132 | 149 | 355 | 76 | 710 | | | | |
| 11.0 | 30-35 | 330 | 33-35 | 60-63 | 65 | 175 | 31-36 | 310 | | | | |
| 10.6 | 22-23 | 210 | 21-22.5 | 39 | 50-52 | 105 | 21-23 | 210 | | | | |
| 10.2 | 11-15 | 129 | 11.4-13 | 23-25 | 21-28 | 64.5 | 10-14 | 130 | | | | |
| 10 | 10.5 | 111 | 10-11 | 20-21 | 21-24 | 55 | 11 | 110 | | | | |
| 9.8 | 4-6 | 70 | 5-6 | 12.6-13.4 | 11 | 34.3 | 4-6 | 65 | | | | |
| 9.6 | 3.2-4.1 | 43 | 3.5-4.3 | 7.8-8.4 | 7-8.6 | 21.2 | 3.3-4 | 40 | | | | |
| 9.4 | 2.5-3.1 | 28 | 2.5-3 | 5.1-5.5 | 5-6 | 14.5 | 2.6-3 | 25 | | | | |
| 9.2 | 1-1.7 | 19.5-21 | 1.4-1.6 | 3.6-3.9 | 2.8-3.6 | 8.9-10.1 | 1-1.8 | 19-22 | | | | |
| 9.0 | .7-.9 | 8.8-10 | .75 | 1.6-1.9 | 1.4-1.9 | 4.5-5 | .8 | 8-9.5 | | | | |
| 8.8 | .4-.6 | 6-7 | .5 | 1.1-1.3 | .8-1.2 | 3-3.9 | .5-.6 | 6.3-7.1 | | | | |

| eV | $\text{i(Ph}^{\text{II}})$ i(Et) | | $\text{i(Ph}^{\text{II}})$ i(Et) | | $\text{i(Ph}^{\text{II}})$ i(Et) | | $\text{i(Ph}^{\text{II}})$ i(Et) | |
|------|---|---------|---|----|---|---------|---|---------|
| | .1-.3 | 3-5 | .1 | .7 | .2-.6 | 1.4-2.4 | .1 | 3.1-5.1 |
| 8.6 | | | | | | | | |
| 8.4 | | 1.4-1.8 | | .3 | | .7-.9 | | 1.4-1.8 |
| 8.2 | | .4-.6 | | | | .15 | | .42 |
| S.T. | 205 | | 197 | | 205 | | 205 | |
| I.R. | .4 | | .6 | | .4 | | .4 | |

$\text{A(PhSnEt}_2^+) \text{PhSnEt}_3$ vs. $\text{A(Ph}_3\text{Sn}^+) \text{Ph}_4\text{Sn}$

| eV | i(Ph) $\text{i(Ph}'')$ | | $\text{i(Ph}'')$ i(Ph) | | eV | i(Ph) $\text{i(Ph}'')$ | | $\text{i(Ph}'')$ i(Ph) | |
|------|---------------------------------|-----|---------------------------------|------|------|---------------------------------|------|---------------------------------|-------|
| | 520 | 520 | 1950 | 1950 | | 12.6 | 27 | 170 | 682 |
| 70 | | | | | 12.2 | | | | |
| 19.6 | 350 | 462 | 1690 | 1300 | 11.8 | | | 501 | 71 |
| 18.9 | | | 1640 | 1160 | 11.4 | 14.1 | 116 | 385 | 46 |
| 18.5 | 300 | 440 | | | 11.0 | | | 296 | 31.5 |
| 18.1 | | | 1620 | 1040 | 10.6 | 6.0 | 65 | 218 | 20.5 |
| 17.7 | 265 | 433 | | | 10.2 | 3.5 | 45 | 139 | 10.9 |
| 17.3 | | | 1530 | 885 | 10 | | | 117 | 8.9 |
| 16.9 | 225 | 411 | | | 9.8 | 1.9 | 26.7 | 88 | 6.2 |
| 16.5 | | | 1460 | 740 | 9.6 | 1.2-1.4 | 18.2 | 61 | 4.3 |
| 16.1 | 184 | 383 | | | 9.4 | .7 | 12.3 | 38.5 | 2.6 |
| 15.7 | | | 1320 | 590 | 9.2 | .3-.4 | 7.9 | 22.6 | 1.45 |
| 15.3 | 144 | 361 | | | 9.0 | | 4.8 | | |
| 14.9 | | | 1200 | 445 | 8.8 | | 2.6 | 6.75 | .4-.5 |
| 14.5 | 110 | 314 | | | 8.6 | | 1.4 | 4.8 | |
| 14.1 | | | 1040 | 320 | 8.4 | | .6 | 2.1 | |
| 13.7 | 74 | 267 | | | 8.2 | | .4 | 1.05 | |
| 13.4 | | | 877 | 215 | 8.0 | | | .4-.6 | |
| 12.9 | 47 | 220 | | | | | | | |
| S.T. | 210 | | 205 | | | | | | |
| I.R. | 1.3 | | 1.4 | | | | | | |

$\text{A(PhSnEt}_2^+) \text{PhSnEt}_3$ vs. $\text{A(Ph}_3\text{Sn}^+) \text{Ph}_3\text{SnEt}$

| eV | $\text{i(Ph}'')$ i(Ph) | | $\text{i(Ph}'')$ i(Ph) | | eV | $\text{i(Ph}'')$ i(Ph) | | $\text{i(Ph}'')$ i(Ph) | |
|-------|---------------------------------|-------|---------------------------------|------|------|---------------------------------|--------|---------------------------------|------|
| | 5000 | 5000 | 4950 | 4500 | | 10.6 | 1000 | 750 | 980 |
| 67.27 | | | | | 10.2 | 764 | 588 | 700 | 590 |
| 19.6 | 5000 | 5100 | 5200 | 5210 | 10 | 596 | 455 | 600 | 460 |
| 18.9 | 5318 | 4950 | 5300 | 5110 | 9.8 | 509 | 400 | 500 | 400 |
| 18.1 | 5181 | 4800 | 5200 | 4910 | 9.6 | 388 | 308 | 400 | 307 |
| 17.3 | 5045 | 4550 | 5000 | 4600 | 9.4 | 297 | 242 | 300 | 241 |
| 16.5 | 4910 | 4300 | 4900 | 4300 | 9.2 | 220 | 183 | 210 | 180 |
| 15.7 | 4480 | 4000 | 4500 | 4000 | 9.0 | 159 | 128 | 165 | 130 |
| 14.9 | 4091 | 3500 | 4100 | 3600 | 8.8 | 100 | 80 | 105 | 80 |
| 14.1 | 3640 | 2900 | 3700 | 2850 | 8.6 | 64.5 | 51 | 65 | 50 |
| 13.4 | 3050 | 2350 | 3100 | 2400 | 8.4 | 37 | 29.2 | 40 | 30 |
| 12.6 | 2450 | 1850 | 2500 | 1900 | 8.2 | 22.5 | 16.8 | 21 | 17.5 |
| 11.8 | 1890 | 1350 | 1900 | 1400 | | | | | |
| 11.0 | 1380 | 914 | 1400 | 920 | | | | | |
| 8.0 | 12.0 | 8.6-9 | 11.9 | 9.0 | 7.4 | 1.15 | .9-1.1 | 1.1 | .95 |

| eV | i(Ph) | i(Ph') | i(Ph) | i(Ph') | eV | i(Ph) | i(Ph') | i(Ph) | i(Ph') |
|------|-------|--------|-------|--------|-----|-------|--------|-------|--------|
| 7.8 | 5.45 | 3.8 | 6.0 | 4.1 | 7.2 | .4-.6 | .3-.5 | .5 | .40 |
| 7.6 | 2.5 | 1.45 | 2.3 | 1.3 | 7.0 | | | | |
| S.T. | 205 | | 205 | | | | | | |
| I.R. | 1.3 | | 1.3 | | | | | | |

 $I(\text{Ph}_2\text{SnEt}_2) \text{ vs. } A(\text{Et}_3\text{Sn}^+)\text{Et}_4\text{Sn}$

| eV | i(Et) | i(PhEt) | i(Et) | i(PhEt) | i(Et) | i(PhEt) | i(Et) | i(PhEt) |
|------|-------|-----------|-------|---------|-------|-----------|-------|-----------|
| 70 | 10000 | 46-48 | 10000 | 46-49 | 9500 | 49-50 | 5100 | 50-51 |
| 19.6 | 9800 | 70-72 | 9600 | 71-72 | 9100 | 71-75 | 5000 | 70-72 |
| 18.9 | 9500 | 70-72 | 9300 | 71-72 | 8900 | 71-75 | 4900 | 71-72 |
| 18.1 | 9200 | 73-75 | 9020 | 72-73 | 8700 | 71-74 | 4700 | 71-72 |
| 17.3 | 8800 | 72-74 | 8600 | 72-73 | 8300 | 72-75 | 4500 | 72-73 |
| 16.1 | 8400 | 75-77 | 8240 | 72.-73 | 7900 | 72-75 | 4300 | 72-73 |
| 15.7 | 7800 | 72-74 | 7650 | 72-73 | 7300 | 72-75 | 4000 | 72-73 |
| 14.9 | 7100 | 69-71 | 7000 | 70-72 | 6700 | 69-72 | 3650 | 69-71 |
| 14.1 | 6300 | 67-69 | 6200 | 68-70 | 5900 | 67-69 | 3200 | 68 |
| 13.4 | 5400 | 62-65 | 5300 | 61-64 | 5090 | 62-65 | 28— | 63 |
| 12.6 | 4300 | 55-57 | 4200 | 54-56 | 4050 | 56-58 | 2200 | 55-58 |
| 11.8 | 3250 | 47-49 | 3200 | 48-50 | 3050 | 48-49 | 1650 | 47-49 |
| 11.4 | 2900 | 42-44 | 2850 | 43-45 | 2700 | 43-44 | 1500 | 42-45 |
| 11.0 | 2200 | 36-38 | 2150 | 35-39 | 2070 | 36-38 | 1150 | 37-38 |
| 10.6 | 1680 | 30-31.5 | 1650 | 31-32 | 1580 | 30-32 | 860 | 30-32 |
| 10.2 | 1280 | 25-26 | 1250 | 25-27 | 1200 | 25-26.5 | 660 | 25-27 |
| 10 | 1070 | 22.5-24 | 1050 | 23-26 | 1000 | 23-24 | 550 | 21-24 |
| 9.8 | 820 | 18.4-19.6 | 800 | 18-19 | 770 | 19 | 420 | 17-18.5 |
| 9.6 | 650 | 15.4-16.4 | 640 | 15-16.5 | 610 | 15-16 | 330 | 14.5-16.3 |
| 9.4 | 475 | 12.8-13.4 | 465 | 13-13.5 | 450 | 12.8-13.3 | 243 | 12.7-13.2 |
| 9.2 | 345 | 10.2-11 | 340 | 10-11 | 330 | 10.3-11.1 | 178 | 10-11 |
| 9.0 | 245 | 8-8.8 | 240 | 8-9 | 230 | 8-9 | 125 | 8-8.9 |
| 8.8 | 158 | 5.6-6.4 | 155 | 5-6.5 | 150 | 5.5-6.5 | 81 | 5.4-6.2 |
| 8.6 | 95 | 3.9-4.5 | 93 | 4-4.6 | 90 | 3.8-4.4 | 49 | 3.9-4.4 |
| 8.4 | 61 | 2.9-3.3 | 60 | 3-3.2 | 57 | 3.0-3.4 | 31 | 2.9-3.1 |
| 8.2 | 29.5 | 1.5-1.9 | 29 | 1.5-1.8 | 28 | 1.6-1.9 | 15.1 | 1.5-1.8 |
| 8.0 | 15 | .9-1.1 | 14.5 | .9-1 | 14 | .9-1.1 | 7.6 | .9-1.2 |
| 7.8 | 7.5 | .4-.6 | 7.5 | .5 | 7 | .5 | 3.8 | .4-.6 |
| 7.6 | 3.2 | .2-.3 | 3.1 | .25 | 3 | .2-.4 | 1.7 | .2-.3 |
| 7.4 | 1.7 | | 1.5 | | 1.5 | | .9 | |
| 7.2 | .9 | | .8 | | .8 | | .4 | |
| S.T. | 205 | | 205 | | 205 | | 200 | |
| I.R. | 1.4 | | 1.4 | | 1.4 | | 1.7 | |

 $I(\text{Et}_4\text{Sn}) \text{ vs. } A(\text{Et}_3\text{Sn}^+)\text{Et}_4\text{Sn}$

| eV | i(Et) | i(4Et) | i(Et) | i(4Et) | i(Et) | i(4Et) | i(Et) | i(4Et) |
|------|-------|---------|-------|---------|-------|---------|-------|--------|
| 70 | 3900 | 106-108 | 4400 | 107 | 3900 | 107 | 2000 | 55-56 |
| 19.6 | 5100 | 152-156 | 5700 | 158-159 | 5100 | 158-159 | 2625 | 78-79 |
| 18.9 | 5000 | 152-156 | 5600 | 156-157 | 5000 | 156-157 | 2575 | 78-79 |
| 18.1 | 4850 | 156-160 | 5400 | 154-158 | 4850 | 151-157 | 2500 | 78-79 |
| 17.3 | 4700 | 152-154 | 5260 | 152-154 | 4700 | 151-154 | 2425 | 80-81 |
| 16.5 | 4500 | 150-154 | 5000 | 152-154 | 4500 | 151-152 | 2300 | 78-81 |
| 15.7 | 4350 | 150-152 | 4900 | 152-154 | 4350 | 152 | 2250 | 77-80 |

| eV | i(Et) i(4Et) | | i(Et) i(4Et) | | i(Et) i(4Et) | | i(Et) | i(4Et) |
|------|--------------|-----------|--------------|---------|--------------|---------|-------|---------|
| 14.9 | 4050 | 154-156 | 4500 | 150-153 | 4000 | 150-153 | 2010 | 78-80 |
| 14.1 | 3625 | 136-140 | 4050 | 139-140 | 3600 | 139 | 1900 | 70-72 |
| 13.4 | 3150 | 128-130 | 3500 | 130-129 | 3100 | 131 | 1625 | 66-68 |
| 12.6 | 2550 | 112-114 | 2860 | 110-113 | 2500 | 112 | 1310 | 58-59 |
| 11.8 | 2150 | 104 | 2400 | 105 | 2100 | 105 | 1100 | 54 |
| 11.0 | 1460 | 79-81 | 1640 | 80 | 1500 | 81 | 750 | 41-42 |
| 10.2 | 840 | 55-56 | 950 | 57 | 850 | 56 | 440 | 28 |
| 10 | 760 | 53 | 850 | 51 | 750 | 50 | 390 | 27- |
| 9.8 | 615 | 46 | 700 | 45 | 600 | 44 | 315 | 24-25 |
| 9.6 | 505 | 38.5-40.5 | 560 | 39 | 500 | 38.5 | 260 | 19.8-20 |
| 9.4 | 395 | 33-35 | 440 | 34 | 400 | 33 | 200 | 17-18 |
| 9.2 | 292 | 27.5-28.5 | 325 | 28-29 | 300 | 28 | 150 | 14-15 |
| 9.0 | 225 | 23-25 | 250 | 22-24 | 215 | 24 | 115 | 12-13 |
| 8.8 | 159 | 18-19 | 175 | 18-19 | 160 | 18.5 | 82 | 9-9.5 |
| 8.6 | 111 | 14.2-15 | 125 | 14-15 | 110 | 14.7 | 57 | 7.3-8 |
| 8.4 | 73 | 10.4-11 | 82 | 10-12 | 75 | 10-11 | 38 | 5.4-5.7 |
| 8.2 | 41 | 6.8-7.2 | 45 | 6.7-7.5 | 40 | 7-7.1 | 21 | 3.5-3.7 |
| 8.0 | 25 | 4.6-5 | 28 | 4.7-5.1 | 20 | 4-6 | 13 | 2.4-2.6 |
| 7.8 | 12.6-13.8 | 3.1-3.5 | 14-15.4 | 3.2-3.6 | 13.6 | 3-4 | 6.7 | 1.6-1.8 |
| 7.6 | 5.5 | 1.5-1.8 | 6.2 | 1.4-1.9 | 6.0 | 2.0 | 2.8 | .8-.9 |
| 7.4 | 2.5 | .7-.8 | 2.8 | .7-.8 | 3 | .8 | 1.3 | .4-.5 |
| 7.2 | .9 | .3-.4 | 1.0 | .3 | .8 | .4 | .5 | |
| 7.0 | .5 | .1-.2 | .6 | | .3 | .1 | | |
| ST | 205 | | 205 | | 205 | | 200 | |
| I.R. | 1.2 | | 1.2 | | 1.4 | | 1.2 | |

A(Et₃Sn⁺)Et₄Sn

| eV | i(Xe) i(Et) | | i(Xe) i(Et) | | i(Xe) i(Et) | | i(Xe) i(Et) | |
|------|-------------|-----|-------------|-----|-------------|-----|-------------|-----|
| 70 | 365 | 250 | 435 | 285 | 420 | 415 | 365 | 370 |
| 19.6 | 217 | 275 | 227 | 290 | 216 | 440 | 215 | 384 |
| 19.2 | 207 | 271 | 213 | 282 | 202 | 428 | 205 | 379 |
| 18.9 | 202 | 268 | 204 | 274 | 195 | 415 | 200 | 374 |
| 18.5 | 189 | 258 | 193 | 269 | 183 | 408 | 190 | 360 |
| 18.1 | 183 | 268 | 184 | 264 | 176 | 400 | 180 | 374 |
| 17.7 | 180 | 271 | 176 | 261 | 168 | 395 | 180 | 379 |
| 17.3 | 183 | 268 | 168 | 257 | 160 | 390 | 182 | 374 |
| 16.9 | 173 | 248 | 158 | 254 | 151 | 385 | 172 | 370 |
| 16.5 | 165 | 241 | 149 | 248 | 141 | 375 | 164 | 360 |
| 16.1 | 155 | 235 | 140.5 | 244 | 135 | 370 | 154 | 351 |
| 15.7 | 141 | 220 | 131 | 238 | 125 | 360 | 140 | 328 |
| 15.3 | 131 | 216 | 119 | 231 | 113 | 380 | 130 | 323 |
| 14.9 | 122 | 210 | 105 | 221 | 101 | 335 | 121 | 314 |
| 14.5 | 111 | 204 | 100 | 224 | 95 | 340 | 111 | 304 |
| 14.1 | 99 | 191 | 85 | 213 | 81 | 323 | 99 | 285 |
| 13.7 | 85 | 179 | 69.5 | 200 | 66 | 303 | 82 | 267 |
| 13.4 | 72 | 166 | 57.5 | 188 | 54.5 | 285 | 72 | 248 |
| 13.0 | 59.5 | 153 | 42 | 168 | 40.5 | 255 | 60 | 229 |
| 12.6 | 46.5 | 141 | 29 | 155 | 27.7 | 235 | 47 | 211 |
| 12.2 | 36 | 129 | 17.5 | 139 | 17.1 | 210 | 36 | 192 |
| 11.8 | 27 | 114 | 9.1 | 119 | 8.7 | 180 | 27 | 170 |

| eV | i(Xe) | | i(Et) | | i(Xe) | | i(Et) | |
|------|-------|---------------------|------------------|---------------------|-------------------|---------------------|--------------------|---------|
| | i(Xe) | i(Et) | i(Xe) | i(Et) | i(Xe) | i(Et) | i(Xe) | i(Et) |
| 11.4 | 16.5 | 99.2 | 3.0 | 100 | 3.0 | 152 | 16.5 | 148 |
| 11.0 | 9.5 | 86.4 | 5 -.7 | 85.8 | .5 -.7 | 130 | 9.5 | 129 |
| 10.6 | 4.2 | 73.7 | .2 | 72.6 | .2 | 110 | 4.1 | 110 |
| 10.2 | 1.4 | 62.7 | | 55.4 | | 84 | 1.3 | 93.6 |
| 9.8 | .3 | 50.2 | | 43.6 | | 66 | .3 | 74.9 |
| 10 | 1.0 | 55 | | 49.5 | | 75 | .9 -1.1 | 79-89 |
| 9.8 | .4 | 52 | | 41.6 | | 63 | .3 | 81 |
| 9.6 | | 48.3 | | 34.3 | | 52 | | 72 |
| 9.4 | | 41.4 | | 28.4 | | 43 | | 62 |
| 9.2 | | 35.8 | | 22.4 | | 34 | | 53 |
| 9.0 | | 30.8 | | 17.2 | | 26 | | 45 |
| 8.8 | | 24.1 | | 12.9 | | 19.5 | | 36 |
| 8.6 | | 20.4 | | 8.6 -8.8 | | 13-13.4 | | 30.4 |
| 8.4 | | 17 | | 5.8 -6.1 | | 8.8 -9.2 | | 25.5 |
| 8.2 | | 13.5 | | 3.6 -3.7 | | 5.5 -5.6 | | 20 |
| 8.0 | | 10.3 | | 2.2 -2.4 | | 3.4 -3.6 | | 15.5 |
| 7.8 | | 7.6 -8 | | 1.3 -1.4 | | 1.9-2 | | 11.5-12 |
| 7.6 | | 5.5-5.7 | | .7 | | 1-1.1 | | 8.2-8.5 |
| 7.4 | | 3.8 -4.0 | | | | .5 | | 5.6-5.9 |
| 7.2 | | 2.6 -2.8 | | | | .25 | | 3.9-4.2 |
| 7.0 | | 1.6-1.7 | | | | | | 2.3-2.5 |
| 6.8 | | .9-1 | | | | | | 1.3-1.5 |
| 6.6 | | .4-.5 | | | | | | .7-.8 |
| 6.4 | | .2-.3 | | | | | | .3 |
| 6.2 | | | | | | | | .1-.2 |
| S.T. | 195 | | 195 | | 195 | | 195 | |
| I.R. | 0.4 | | 0.4 | | 0.4 | | 0.4 | |

REFERENCES.

1. J.H. Beynon, "Mass Spectrometry and its Applications to Organic Chemistry", Elsevier, 1960.
2. "Mass Spectrometry", A N.A.T.O. Advanced Study Institute. ed. R.I. Reed, Academic Press, London 1965.
3. R.I. Reed, Quarterly Reviews, 1966, 4, 527.
4. R.I. Reed, "Ion Production by Electron Impact", Academic Press, London 1962.
5. ~~F.W. McLafferty~~, "Mass Spectrometry of Organic Ions", ed. F.W. McLafferty, Academic Press, New York 1963.
6. F.H. Field and J.L. Franklin, "Electron Impact Phenomena and the Properties of Gaseous Ions", Academic Press, New York 1957.
7. R.L. Platzman, Vortex, 1962, 23, 372.
8. A.J.C. Nicholson, J. Chem. Phys., 1963, 39, 954.
9. H. Budzikiewicz, C. Djerassi and D.H. Williams, "Mass Spectrometry of Organic Compounds", Holden Day Inc., 1967.
10. J. Berkowitz, D.A. Bafus and T.L. Brown, J. Phys. Chem., 1961, 65, 1380.
11. G.E. Hartwell and T.L. Brown, Inorg. Chem., 1966, 5, 1257.
12. R.E. Winters and R.W. Kiser, J. Organomet. Chem., 1967, 10, 7.
13. P.D. Roberts, Ph.D Thesis, Durham 1968.
14. V.H. Dibeler and F.L. Mohler, J. Res. Nat. Bur. Stand., 1951, 47, 337.
15. L. Friedman, A.P. Irsa and G. Wilkinson, J. Amer. Chem. Soc., 1955, 77, 3689.
16. J. Müller and L. D'Or, J. Organomet. Chem., 1967, 10, 313.
17. A.W. Laubengayer and W.F. Gilliam, J. Amer. Chem. Soc., 1941, 63, 477.
18. K. Wade and B.K. Wyatt, J. Chem. Soc. (A), 1967, 1339.
19. G. Fritz, H. Buhl, J. Grobe, F. Aulinger and W. Reerink, Z. anorg. Chem., 1961, 312, 201.

20. F. Aulinger, Colloq. Spectros. Intern. 8th Lucern, Switzerland, 1960, 1959, 267.
21. F. Aulinger and W. Reerink, Z. anal. Chem., 1963, 197, 24.
22. J. Silbiger, C. Lifshitz, J. Fuchs and A. Mandelbaum, J. Amer. Chem. Soc., 1967, 89, 4308.
23. V.H. Dibeler, F.L. Mohler and R.M. Reese, J. Chem. Phys., 1953, 21, 180.
24. G.P. van der Kelen, O. Volders, H. van Onckelen and Z. Eeckhaut, Z. anorg. Chem., 1965, 338, 106.
25. C.A. Hirt, Anal. Chem., 1961, 33, 1786.
26. N.K. Sokolov, K.A. Andrianov and S.M. Akimova, J. Gen. Chem. U.S.S.R., 1955, 25, 647.
27. A.G. Sharkey, R.A. Friedel and S.H. Langer, Anal. Chem., 1957, 29, 770.
28. J. Diekman, J.B. Thomson and C. Djerassi, J. Org. Chem., 1967, 32, 3904.
29. E.I. Quinn, V.H. Dibeler and F.L. Mohler, J. Res. Nat. Bur. Stand., 1956, 57, 41.
30. V.H. Dibeler, J. Res. Nat. Bur. Stand., 1952, 49, 235.
31. C.P. Johnson and A. Langer, J. Phys. Chem., 1957, 61, 1010.
32. D.E. Bublitz and A.W. Baker, J. Organometal. Chem., 1967, 9, 383.
33. R.G. Kostyanousky and V.V. Yakshin, Izv. Akad. Nauk. S.S.S.R. Ser. Khim., 1967, 2363.
34. R.E. Honig, J. Chem. Phys. 1948, 16, 105.
35. W.B. Nottingham, Phys. Rev., 1939, 55, 203.
36. J.D. Waldron and K. Wood, "Mass Spectrometry." The Institute of Petroleum, London, 1952, p. 16.
37. A.J.C. Nicholson, J. Chem. Phys., 1958, 29, 1312.
38. A.O. Nier and E.E. Hanson, Phys. Rev., 1936, 50, 722.
39. H.D. Hagstrum, J. Chem. Phys., 1948, 16, 848.
40. R.H. Vought, Phys. Rev., 1947, 71, 93.

41. J.W. Warren, *Nature*, 1950, 165, 810.
42. See. 34.
43. V.H. Dibeler and R.M. Reese, *J. Res. Nat. Bur. Stand.*, 1955, 54, 127.
44. F.P. Lossing, A.W. Tickner and W.A. Bryce, *J. Chem. Phys.*, 1951, 19, 1254.
45. J.D. Morrison, *J. Chem. Phys.*, 1954, 21, 1767.
46. J.D. Morrison, *J. Chem. Phys.*, 1953, 21, 2090.
47. F.H. Dorman and J.D. Morrison, *J. Chem. Phys.*, 1961, 34, 578.
48. E.M. Clarke, *Can. J. Phys.*, 1954, 32, 764.
49. R.E. Fox, W.M. Hickam, T. Kjeldaas and D.J. Grove, *Phys. Rev.*, 1951, 84, 859.
50. R.E. Fox, W.M. Hickam, T. Kjeldaas and D.J. Grove, *Rev. Sci. Instr.*, 1955, 26, 1101.
51. F.H. Field and J.L. Franklin, *J. Chem. Phys.*, 1954, 22, 1895.
52. See. 34.
53. J.D. Morrison, *J. Chem. Phys.*, 1951, 19, 1305.
54. J.D. Morrison and A.J.C. Nicholson, *J. Chem. Phys.*, 1952, 20, 1021.
55. R.E. Fox and W.M. Hickam, *J. Chem. Phys.*, 1954, 22, 2059.
56. J.D. Morrison, *J. Chem. Phys.*, 1954, 22, 1219.
57. J.D. Morrison, *J. Chem. Phys.*, 1963, 39, 200.
58. J.H.D. Elard, P.J. Shepherd and C.J. Danby, *Z. Naturforschung*, 1966, 21a, 1580.
59. D.P. Stevenson, *Disc. Faraday Soc.*, 1951, 10, 35.
60. G.G. Hess, F.W. Lampe and L.H. Sommer, *J. Amer. Chem. Soc.*, 1965, 87, 5327; 1964, 86, 3174.
61. J.A. Connor, R.N. Haszeldine, G.J. Leigh and R.D. Sedgewick, *J. Chem. Soc. (A)*, 1967, 768.

62. J.A. Connor, G. Finney, G.J. Leigh, R.N. Haszeldine, P.J. Robinson, R.D. Sedgewick and R.F. Simmons, *Chem. Comm.*, 1966, 178.
63. S.J. Band, I.L. Stephenson, I.M.T. Davidson and C.A. Lambert, *Chem. Comm.*, 1967, 723.
64. A.L. Yergey and F.W. Lampe, *J. Amer. Chem. Soc.*, 1965, 87, 4204.
65. D.R. Bidinosti and N.S. McIntyre, *Can. J. Chem.*, 1967, 45, 641.
66. A. Foffani, S. Pignataro, B. Cantone and F. Grasso, *Z. physik. Chem.*, 1965, 45, 79.
67. J. Müller and L. D'Or, *J. Organometal. Chem.*, 1967, 10, 313.
68. R.E. Winters and R.W. Kiser, *J. Organometal. Chem.*, 1965, 4, 190.
69. W.J. Jones, D.P. Evans, T. Gulwell and D.C. Griffiths, *J. Chem. Soc.*, 1935, 39.
70. R. Sasin and G.S. Sasin, *J. Org. Chem.*, 1955, 20, 770.
71. L.A.K. Staveley, H.P. Paget, B.B. Goalby and J.B. Warren, *J. Chem. Soc.*, 1950, 2290.
72. D. Seyforth and F.G.A. Stone, *J. Amer. Chem. Soc.*, 1957, 79, 515.
73. K.A. Kozeschkow, M.M. Nadj and A.P. Alexandrov, *Ber.*, 1934, 1348.
74. G.J.M. Van der Kerk, J.G. Noltes and J.G.A. Luijten, *J. Appl. Chem.*, 1957, 7, 366.
75. E. Krause and R. Becker, *Ber.*, 1920, 173.
76. M. Lesbre, Mrs. R. Buisson, J.G.A. Luijten and G.J.M. Van der Kerk, *Rec. Trav. Chim.*, 1955, 74, 1056.
77. K. Bowden and E.A. Braude, *J. Chem. Soc.*, 1952, 1068.
78. J.F. Norris and A.W. Olmstead, *Org. Synthesis Coll. Vol.*, 1, 138.
79. W.E. Bachmann, *Org. Synthesis Coll. Vol.*, 3, 841.
80. H. Gilman, O.L. Marrs and See-Yuen Sim, *J. Org. Chem.*, 1962, 27, 4232.
G. Tamborski, F.E. Ford and E.J. Soloski, *J. Org. Chem.*, 1963, 28, 181.
81. M.V. George, D.J. Peterson and H. Gilman, *J. Amer. Chem. Soc.*, 1960, 82, 403.
82. H. Gilman and C.W. Gerow, *J. Amer. Chem. Soc.*, 1956, 78, 5435.

83. R.J. Cross and F. Glockling, *J. Chem. Soc.*, 1964, 4125.
84. A.L. Smith, *Spect. Chim. Acta.*, 1960, 16, 87.
85. R.D. Kross and V.A. Fassel, *J. Amer. Chem. Soc.*, 1955, 77, 5858.
86. R.C. Poller, *J. Inorg. Nuclear Chem.*, 1962, 24, 593.
87. M.C. Henry and J.G. Noltes, *J. Amer. Chem. Soc.*, 1960, 82, 555.
88. J.S. Thayer and R. West, *Inorg. Chem.*, 1964, 3, 889.
89. M.P. Brown, R. Okawara and E.G. Rochow, *Spect. Chim. Acta.*, 1960, 16, 595.
90. R. Okawara, D.E. Webster and E.G. Rochow, *J. Amer. Chem. Soc.*, 1960, 82, 3287.
91. G.E. Coates, K. Wade and M.L.H. Green, "Organometallic Compounds" vol. 1. 3rd ed., Methuen and Co. Ltd., 1967.
92. H. Gilman and F. Schulze, *J. Chem. Soc.*, 1927, 2663.
93. H. Gilman and R.E. Brown, *J. Amer. Chem. Soc.*, 1930, 52, 4480.
94. W.H. Glaze, C.M. Selman and C.H. Freeman, *Chem. Comm.*, 1966, 474.
95. A.B. Burg and H.I. Schlesinger, *J. Amer. Chem. Soc.*, 1940, 62, 3425.
96. A. Carrick, PhD. Thesis, Durham, 1967.
A. Carrick and F. Glockling, *J. Chem. Soc.*, (A) 1967, 40.
97. J.M. Miller, *J. Chem. Soc.*, (A) 1967, 828.
98. A.E. Williams, Proceedings of the 3rd Annual M.S.9. Users Meeting 1965.
99. J.H. Beynon and A.E. Fontaine, *Z. Naturforschung*, 1967, 22a, 334.
100. J.H. Beynon, R.A. Saunders and A.E. Williams, "Tables of Meta-Stable Transitions for Use in Mass Spectrometry", Elsevier, 1965.
101. A.J.C. Stevenson, *J. Chem. Phys.*, 1958, 29, 1312.
102. V.I. Vedeneyev, L.V. Gurvich, V.N. Kondrat'yev, V.A. Medvedev, Ye. L. Frankovich, "Bond Energies, Ionization Potentials and Electrom Affinities", Arnold, 1965.
103. A.E. Pope and H.A. Skinner, *Trans. Faraday Soc.*, 1964, 60, 1402.

104. J.A. Kerr, Chem. Rev., 1966, 66, 465.
105. J.L. Franklin, Ind. Eng. Chem., 1949, 41, 1070.
106. H.A. Skinner, Adv. Organometal. Chem., 1964, 2, 49.
107. H.E. O'Neal and M.A. Ring, Inorg. Chem., 1966, 5, 435.
108. G.G. Hess, F.W. Lampe and A.L. Yergey, Annals New York Academy of Sciences, 1966, 136, 106.
109. S.J. Band, I.M.T. Davidson and C.A. Lambert, J. Organometal. Chem., 1968, 12, 3P.
110. R. Ettinger, Tetrahedron, 1964, 20, 1579.
111. B.G. Hobrock and R.W. Kiser, J. Phys. Chem., 1961, 65, 2186; 1962, 66, 155.
112. B.G. Gowenlock, R.M. Haynes and J.R. Majer, Trans. Faraday Soc., 1962, 58, 1905.
113. R.W. Law and J.L. Margrave, J. Chem. Phys., 1956, 25, 1086.
114. W.C. Steele, L.D. Nichols and F.G.A. Stone, J. Amer. Chem. Soc., 1962, 84, 4441.
115. D.B. Chambers, F. Glockling and M. Weston, J. Chem. Soc., (A) 1967, 1759.
116. W.R. Cullen and D.C. Frost, Can. J. Chem., 1962, 40, 390.
117. R.W. Law and J.L. Margrave, J. Chem. Phys., 1956, 25, 1086.
118. "Handbook of Chemistry and Physics", 46th Edition 1965-1966, The Chemical Rubber Co., Cleveland, Ohio, U.S.A.
119. P.N. Rylander and S. Meyerson, J. Amer. Chem. Soc., 1956, 78, 5799.
120. M.B. Wallenstein, A.L. Wahrhaftig and H. Eyring, "The Mass Spectra of large Molecules I. Saturated Hydrocarbons", University of Utah, Utah, U.S.A. 1951.
121. "Advanced Inorganic Chemistry", F.A. Cotton and G. Wilkinson, 2nd. Ed., Interscience, 1966.
122. E. Heldt, K. Höppner and K.H. Krebs, Z. anorg. Chem., 1966, 347, 95.
123. F. Glockling and J.R.C. Light, J. Chem. Soc., (A) 1968, 717.
124. J.L. Occolowitz, Tetrahedron Letters, 1966, 5291.

125. M. Gielen and G. Mayence, *J. Organometal. Chem.*, 1968, 12, 363.
126. N. Ya. Chernyak, R.A. Khmel'nitskii, T.V. D'yakova, V.M. Vdovin and T.N. Arkhipova, *J. Gen. Chem.*, 1966, 36, 99.
127. A.M. Duffield, C. Djerassi, J. Dubac, G. Manwell and P. Mazerolles, *J. Organometal Chem.*, 1968, 12, 123.
128. K.R. Jennings, *Chem. Comm.*, 1966, 283.
129. P. Brown and C. Djerassi, *Angew. Chem. Int. Ed.*, 1967, 6, 477.
130. W.P. Newman, E. Peterson and R. Sommer, *Angew. Chem. Int. Ed.*, 1965, 4, 599.
131. I.M.T. Davidson and I.L. Stephenson, *Chem. Comm.*, 1966, 746.
132. N. Ya. Chernyak, R.A. Khmel'nitskii, T.V. D'yakova and V.M. Vdovin, *J. Gen. Chem.*, 1966, 36, 93.
133. M. Gielen and J. Nasielski, *Bull. Soc. Chim. Belges.*, 1968, 77, 5.
S. Boue, M. Gielen and J. Nasielski, *Bull. Soc. Chim. Belges.*, 1968, 77, 43.
134. J. Lewis, A.R. Manning, J.R. Miller and J.M. Wilson, *J. Chem. Soc.*, (A) 1966, 1663.
135. A. Carrick and F. Glockling, *J. Chem. Soc.*, (A) 1968, 913.
136. E.H. Brooks, R. Cross and F. Glockling, *Inorg. Chim. Acta.*, 1968, 2, 17.
137. F.J. Preston and R.I. Reed, *Chem. Comm.*, 1966, 51.
138. J.M. Smith, K. Mehner and H.D. Kaesz, *J. Amer. Chem. Soc.*, 1967, 89, 1759
139. H. Svec and G.A. Junk, *J. Amer. Chem. Soc.*, 1967, 89, 2836.
140. M.J. Mays and R.N.F. Simpson, *J. Chem. Soc.*, (A) 1967, 1936.
141. N. Moaz, A. Mandelbaum and M. Cais, *Tetrahedron Letters*, 1965, 2087.
142. A. Mandelbaum and M. Cais, *Tetrahedron Letters*, 1964, 3847.
143. R.C. Dobbie and R.G. Cavell, *Inorg. Chem.*, 1967, 6, 1450.
144. R.B. King, *J. Amer. Chem. Soc.*, 1967, 89, 6368.
145. M.I. Bruce, *J. Organometal Chem.*, 1967, 10, 495.

146. H.H. Hoehn, L. Pratt, K.F. Watterson and G. Wilkinson, J. Chem. Soc., 1961, 2738.
147. M.I. Bruce, J. Organometal. Chem., 1967, 10, 95.
148. A.W. Laubengayer and W.F. Gilliam, J. Amer. Chem. Soc., 1941, 63, 477.
D.P. Eyman, Inorg. Chem., 1967, 6, 1461.
149. K. Ziegler, K. Nagel and W. Pfohl, Annal. 1960, 629, 210.
150. T.H. Wartik and H.I. Schlesinger, J. Amer. Chem. Soc., 1953, 75, 835.
151. K. Ziegler, H.G. Gellert, H. Martin, K. Nagel and J. Schneider, Annal. 1954, 589, 91.
152. W.L. Smith and T. Wartik, J. Inorg. Nuclear Chem., 1967, 29, 629.
153. G.E. Coates, A.J. Downs and P.D. Roberts, J. Chem. Soc., (A), 1967, 1085.
154. W.H. Glaze, C.M. Selman and C.H. Freeman, Chem. Comm., 1966, 474.
155. E. Weiss, J. Organometal. Chem., 1965, 4, 101.
156. A.I. Snow and R.E. Rundle, Acta. Cryst., 1951, 4, 348.
157. F. Nakao, Natl. Tech. Rept., 1963, 9, 499. Chem. Abs., 1964, 60, 13985b.

