

Durham E-Theses

Psychological ownership: a study of autonomy and the nature of its association with task commitment

P. Michael Raynolds

How to cite:

Raynolds, P. Michael (1973) Psychological ownership: a study of autonomy and the nature of its association with task commitment. Doctoral thesis, Durham University.

Use policy

The full-text may be used and/or reproduced, and given to third parties in any format or medium, without prior permission or charge, for personal research or study, educational, or not-for-profit purposes provided that:

- a full bibliographic reference is made to the original source
- a <https://etheses.durham.ac.uk/id/eprint/8595/> is made to the metadata record in Durham E-Theses
- the full-text is not changed in any way

The full-text must not be sold in any format or medium without the formal permission of the copyright holders.

Please consult the [full Durham E-Theses policy](#) for further details.

PSYCHOLOGICAL OWNERSHIP

A Study of Autonomy and the Nature of its Association
with Task Commitment

P. Michael Reynolds

A Thesis submitted for the Degree of
Doctor of Philosophy in the University
of Durham.

DURHAM. JULY 1973.

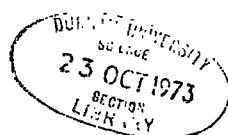

C O N T E N T S

Acknowledgements	i
Abstract	ii
Introduction	iv

PART I An Application of Herzberg's Theory of Motivation

Chapter

I	The Herzberg Studies	1
II	The Application of the Motivator-Hygiene Framework	13
III	The Results of the Oil Terminal Study	19
IV	The Motivator-Hygiene Theory - A Review	33

PART II The 2-Factor Phenomenon - A Basis for Further Research

Chapter

V	The Part Played by Perceptual Defence in Herzberg's Studies	40
VI	The Development of the Research Construct - Psychological Ownership	52
VII	The Phenomenological Approach to the Explanation of Human Behaviour	63

PART III The Investigation of Psychological Ownership

Chapter

VIII	The Pilot Study and Final Research Design	74
IX	Predictions and Statistics	95
X	Research Findings from Open-Ended Questions	110
XI	Research Findings from Scaled Questionnaires	128
XII	Psychological Ownership in Work - Summary and Discussion	150

APPENDICES

A.	Questionnaire Used in the Oil Terminal Survey	167
B.	Herzberg's Categories and Frequency of Occurrence in Questions on Likes and Dislikes	169
C.	Personal Influence and Motivator-Hygeine Factors - Questionnaire and Results	170
D.	Pilot Survey Instruments	172
E.	Main Survey Instruments	188
F.	Results of Opportunity Questionnaire (Pilot)	206
G.	Expressions of Psychological Ownership	207
H.	Details of Categories and Results from Open-Ended Questions	210
I.	Additional Tables of Scaled Questionnaire Data	217
J.	Correlation of G.J.A.Q. Factors	219
	Bibliography	220

ACKNOWLEDGEMENTS

I should like to express my appreciation to my colleagues and teachers for their support throughout this study. In particular I am deeply grateful to my supervisor, Professor Charles Baker for his guidance and criticism throughout the research and its subsequent documentation.

I am also indebted to Professors Don Marquis and David Sirota of M.I.T. for their encouragement of my initial ideas, and to the managers who took part in the surveys.

A special mention of thanks goes to my wife Liz, for her enthusiastic help in preparing and typing the final manuscript.

P.M.R.

ABSTRACT

The study begins with an investigation designed to test the 2-factor theory developed by Herzberg and his co-workers. (Herzberg, Mausner and Snyderman 1959) In this exploratory survey it was possible to measure both the motivational content of the work and people's attitudes towards it. The 2-factor theory (Motivator and Hygeine factors) is supported by the results, but only when certain opinions known to exist are suppressed.

This finding is interpreted using the concept of perceptual defence. When people identify with the work they are doing, they are able to talk openly about their successes but report failure experiences defensively. It is postulated that Herzberg's results are a manifestation of this. The process of identifying with work, of seeing a task as a part of oneself, is called in this study Psychological Ownership and becomes the focus of the main investigation.

The concept of Psychological Ownership is illustrated from managers' descriptions of tasks to which they feel committed. These tasks are compared with others for which they feel less enthusiasm. The data was collected using an interview with open-ended questions and scaled questionnaires. An association is demonstrated between Psychological Ownership and the Autonomy which the individual had in the task. These factors in turn, are shown to be related to feelings of Task Involvement.

Autonomy is compared with a 'Sense of Achievement' as a source of Task Commitment and found to be a more important factor in determining

positive attitudes to a task than is reflected in managers' beliefs about what motivates their subordinates. The study concludes with a discussion of Psychological Ownership as a concept, its relation to the other concepts, Achievement and Job Involvement, and its implications for management theory and practice.

INTRODUCTION

The aim of this study is to further an understanding of the factors which influence people's behaviour at work. It investigates the conditions necessary for people to experience enthusiasm and commitment.

The thesis is written in three parts.

Part I - An exploratory investigation.

Part II - A theoretical section linking the findings of the exploratory investigation and the main study.

Part III - The main study.

Part I (Chapters I-IV) introduces the study with a summary of Herzberg's research and an application of his 2-factor theory of motivation to the analysis of an organisational problem. In this exploratory survey it was possible to measure both the motivational content of work within a company and the attitudes of employees towards it. Herzberg's 2-factor phenomenon was found to be replicated but only when some opinions were suppressed.

In Part II (Chapters V-VII) this finding is interpreted in terms of perceptual defence. While previously observed as a flaw in Herzberg's methodology, in this study it becomes the foundation for developing the concept of Psychological Ownership. Because this involves the notion of self-referral, the third chapter of Part II contains a discussion of the phenomenological nature of the study and the implications of employing the concept of self.

Part III (Chapters VIII-XII) investigates the relationships hypothesised between Psychological Ownership, Autonomy and Task Commitment. The methodology and findings are presented. A discussion of the concept of Psychological Ownership and its implications for management practice concludes the study.

P A R T I

AN APPLICATION OF HERZBERG'S
THEORY OF MOTIVATION

CHAPTERS I-IV

- I The Herzberg Studies
- II The Application of the Motivator-Hygiene Framework
- III The Results of the Oil Terminal Study
- IV The Motivator-Hygiene Theory - A Review

CHAPTER I

THE HERZBERG STUDIES

1. Existing Problems of Measurement
2. Herzberg's Methodology
3. Herzberg's Findings and Conclusions
4. The Value of Herzberg's Theory

1. EXISTING PROBLEMS OF MEASUREMENT

In the last twenty years there has been a great deal of research into people's attitudes to their jobs, in order to learn more of the connection between those attitudes and motivation in the work context.

The energy which has resulted in this work has come, not only from the scientists' curiosity, but also from the felt need of employers and managers to understand the way in which motivation affects productivity, turnover, absenteeism and employee relations. As this understanding has increased, so our assumptions about man and his work behaviour have changed.

There has also been an increasing concern on the part of some to better the lives of people in organisations for its own sake. As Herzberg (1959) writes in his preface to Motivation to Work:

"To discover and then reinforce the kind of things which make people happier - to discover and diminish the kinds of things that make people unhappy - is indeed a worthy end."

But in the face of all the data which has been collected, what can we say with certainty about the source of man's motivation to work? How much nearer are we to understanding what it is he seeks and what the association is between job satisfaction, choice of job and performance?

Vroom (1964), in his book Work and Motivation cites more than 500 investigations in an attempt to draw out some consistent findings.

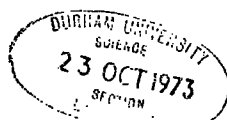

Research workers had studied morale, job satisfaction - both generally and specifically related to defined aspects of the job, occupational choice, the reasons for remaining in the job and performance. The main conclusions he drew were these:

- People's stated preferences among occupations, were consistent with the values or motives they expressed.
- The choice of occupation a person actually makes can be predicted from the strength of their values or motives.
- The general job satisfaction which people express is related to the extent to which their jobs provide those aspects which could be assumed to be attractive to them. (pay, promotion, social acceptance, influence etc.)
- That performance will increase if it is seen to result directly in an increase in some factor (eg. pay) which is desirable to the person concerned.

(a) Problems with Measures of Job Satisfaction

Although there is an inverse relationship between job satisfaction on the one hand and absenteeism and turnover on the other, there is certainly no simple relationship between job satisfaction and performance, which is considered by some to be the outward manifestation in behaviour of the presence of a motive or motives. If anything this latter relationship is weakly negative.

Vroom quotes Brayfield and Crockett (1955) as concluding:

"In summary, it appears that there is little evidence in the available literature that employee attitudes of the type usually measured in morale surveys bear any simple - or, for that matter appreciable - relationship to performance on the job."

In view of the wide use of job satisfaction as a measure, it is disappointing to find that the subsequent results are not very stable (Herzberg 1959). There are a number of general problems with this approach, studies of occupational choice and job satisfaction have usually been carried out separately; attitudes have been studied independently of the effects they produce and the possible effects of the environment have often been ignored.

There are also specific problems encountered when considering the validity of job attitude measures. For example:

- Satisfaction with one aspect of the job may mean the person is indifferent to its absence.
- Most methods involve the respondent choosing from or reacting to, categories defined by an interviewer.
- People differ in what they find satisfying and the degree to which they are satisfied with any given aspect of their work depends on previous experiences, the current situation, and their value system, affected in turn by what is accepted in the culture as a whole. If attraction to financial gain is frowned upon, an individual's expression of satisfaction or dissatisfaction with

that gain may be inhibited.

- In the same way, a person is influenced by the group to which he or she belongs and by other groups with which their own can be compared.
- Respondents are not necessarily aware of the specific factors in a situation which are responsible for the satisfaction - or lack of it - which they feel.
- Finally there is the halo effect. Satisfaction or dissatisfaction with one factor may colour the respondent's perception of others.

All these factors will affect what people feel or express to be their preferences in the work situation.

(b) Job Satisfaction and Motivation

But why are investigators interested in measuring job satisfaction as a way of learning about motivation? The rationale can be assumed to be that job satisfaction will be an index of the strength of relevant motivational characteristics (needs). Yet Vroom (1964) points out that most investigators begin by making over-simplified assumptions about the nature of respondents needs and therefore about those factors which will be experienced as reward or punishment. The assumption most commonly found is that job satisfaction is related to the difference between the strength of a need and the degree to which that same need is met in the job environment - the 'subtractive' model.

The fact that different people respond differently to the same environment means that needs cannot be looked at so simply. The relationship is probably a more complex interaction between the job and the personality of the individual than the 'subtractive' model suggests. But personality variables have played little part in research. It has been assumed that differences in job satisfaction must have been caused by differences in the work environment. This does not allow for variance in values, motives and levels of competence between different people.

(c) Summary of the Situation Pre-Herzberg

Looking at the main methods available to the researcher we have:

- Subjective reports, with the difficulties summarised above.
- Inferences from behaviour, with the problem that any single act of behaviour may be the result of different motives and often more than one motive.
- Projective techniques with the dangers of experimenter bias in interpretation.

It is perhaps no surprise therefore, that there are numerous studies showing little correlation between expressed attitudes and actual behaviour, or between behaviour and expressed desires. It is difficult to control for variables in the individual on the one hand and his environment on the other, without making either seem disconnected.

As Vroom (1964) observes:

"Traditionally, industrial and occupational psychologists have focussed on the accumulation of empirical observations and neglected the contribution of theory ... Instead of contributing to the construction of permanent edifice of knowledge, most additions to the morass of existing data only seem to increase our respect for the complexity of human behaviour and to emphasise our inability to achieve any lasting understanding of it."

It is against this background that some investigators have searched for new methods in order to build up a more reliable picture of the sources of motivation in work. Probably the most influential study of the 1960's was that of Frederick Herzberg at Western Reserve University, Ohio.

2. HERZBERG'S METHODOLOGY

Herzberg wished to study what he described as the Factors-Attitudes-Effects (F-A-E) complex, in contrast to the many previous studies which had looked at these aspects in a disconnected, fragmentary way. He determined to study this at an individual level, rather than on the basis of groups in the population having some aspect of the F-A-E complex in common.

"That is, an attempt should be made to note, individual by individual, how given kinds of factors lead to high or low morale and the consequences of the morale state as indicated by various criterion measures." (Herzberg 1959)

The method he used was the critical incident approach, in which he requested the respondent, in an interview, to recall incidents in his working life which he remembered as giving rise to good or bad feelings. The questions he asked were:

'Think of a time when you felt exceptionally good or exceptionally bad about your job, either your present job or any other job you have had. This can be either the 'long-range' or the 'short-range' kind of situation, as I have just described it. Tell me what happened.'

Whether the respondent chose the 'good' or 'bad' time first, he was then asked to describe the situation giving rise to the opposite feeling. Respondents were also questioned about the duration of the feeling, how long ago the event had occurred, why they felt the way they did, and the effects it had had on their job performance.

Three aims were accomplished by this method:

- Instead of obtaining satisfaction measures for the job in general, the respondent was able to cite his own events as causes of job satisfaction and job dissatisfaction, as different types of occurrence.
- Rather than obtain a static measure of satisfaction for any aspect of the job at a given time, Herzberg looked particularly for events which had resulted in a change of attitude or feeling about the job.
- A list of job categories was built up from coding the responses to the open-ended questions, rather than defining them before the study was carried out.

3. HERZBERG'S FINDINGS AND CONCLUSIONS

(a) Satisfaction is Two-Dimensional

It had usually been assumed that a given factor in a person's work

could be the cause of satisfaction or dissatisfaction. So for example, the degree of security a person felt he had could produce a range of feelings from extreme dissatisfaction by its absence to extreme satisfaction by its being guaranteed.

Herzberg's findings did not indicate such a continuum but rather a dichotomy. Certain factors appeared to cause satisfaction by their presence but not necessarily to cause dissatisfaction by their absence. Conversely, a second group of factors were a cause of dissatisfaction when they were absent but their presence merely removed this dissatisfaction, it did not create any positive feelings. So it seemed as though job feelings were not opposites, but could be grouped as positive factors and negative ones. Herzberg (1968) makes this summary:

"Two essential findings were derived from this study. First, the factors involved in producing job satisfaction were separate and distinct from the factors that led to job dissatisfaction. Since separate factors needed to be considered, depending on whether job satisfaction or job dissatisfaction was involved, it followed that these two feelings were not the obverse of each other. Thus the opposite of job satisfaction would not be job dissatisfaction, but rather no job satisfaction; similarly, the opposite of job dissatisfaction is no job dissatisfaction, not satisfaction with one's job. The fact that job satisfaction is made up of two unipolar traits is not unique, but it remains a difficult concept to grasp."

(b) The Two Sets of Factors Represented Extrinsic and Intrinsic Categories of the Work Situation

Herzberg found that:

Satisfiers were all things inherent in the job itself (Intrinsic), they were part of the job content. He called these MOTIVATORS to denote that they were a source of increased performance and favourable attitudes to work.

Dissatisfiers were all facets of the environment in which the work was carried out (Extrinsic). These Herzberg called HYGEINE factors. Figure 1. illustrates the job factors identified by Herzberg and the way in which they were related to satisfaction and dissatisfaction.

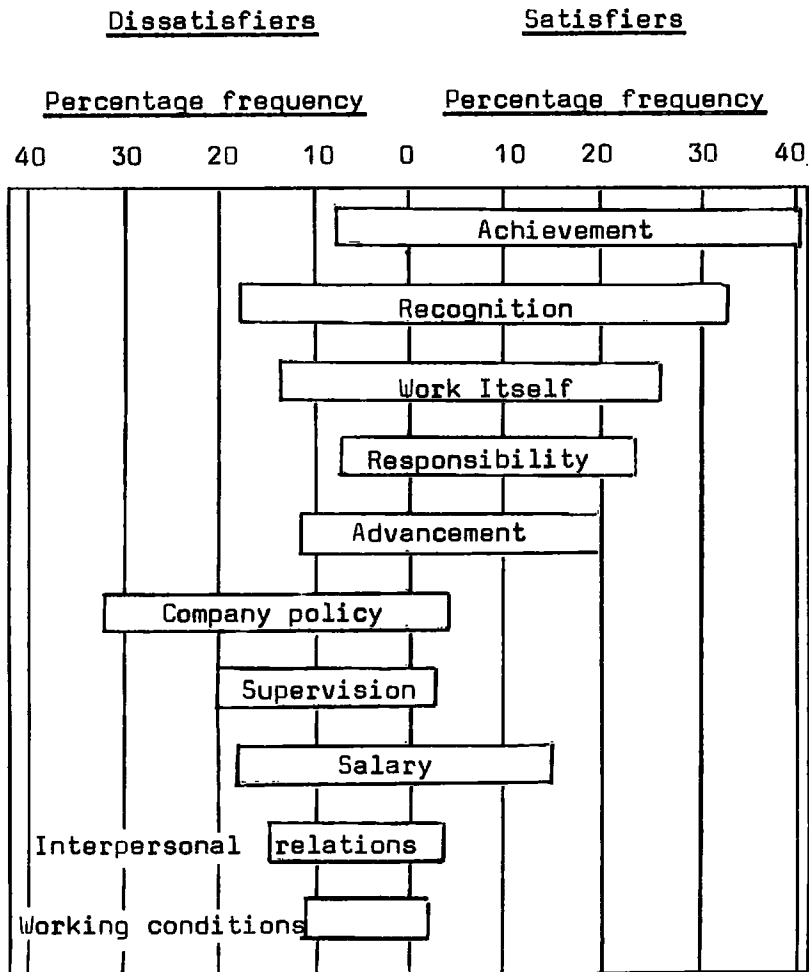

Figure 1. Comparison of satisfiers and dissatisfiers. (Adapted from Herzberg 1959)

(c) The Duration of the Effect

In general Motivators seem to affect the individual for a longer period of time. Herzberg hypothesised that one implication of this was that attention would have to be paid frequently to the level of Hygiene factors. Industrial relations history would, as Paul (1970) points out, bear witness to this need.

(d) The Relationship between Motivator and Hygiene Factors

Motivators have maximum effect in the absence of any dissatisfaction caused by inadequacies in Hygiene factors. If however causes of dissatisfaction are present, their effect tends to be overridden by the presence of Motivators. Myers' work (1964), suggests that if the job is low in Motivators the worker becomes preoccupied with Hygiene factors and this may show itself in the form of industrial strife and general disgruntlement. Alternatively, if Motivators are present, Hygiene factors have little effect on levels of satisfaction.

(e) Support from Other Research

Since Herzberg's original study (1959) with accountants and engineers, remarkably similar findings have been drawn from research work using his method with both sexes, at all levels of work, in different professions, in different industrial environments and on both sides of the Iron Curtain. With some minor differences, it appears that when his methods are used, and the setting is business or industry, the same results are obtained.* In fact Herzberg's method produces this pattern

*For a summary of supportive studies see Southgate 1969.

of results with such constancy that in teaching seminars, the two questions can be used as a technique for demonstrating the theory.

4. THE VALUE OF HERZBERG'S THEORY

Herzberg's claim to have produced a theory of motivation applicable to all situation may be questioned, as the research was conducted in a specific setting.:

"My task is to offer a definition of man's total needs - one that I have found within the world of work." (Herzberg 1959)

His research has however played an important part in encouraging both managers and management theorists to examine the role of the intrinsic factors, whereas previously such factors had not received as much attention as had salary or social needs for example. This shift in emphasis has also led to increased efforts in improving the amount of interest and challenge which people have in their work. (Paul and Robertson 1970)

A further contribution of Herzberg's study is that in using the critical incident technique, researcher-bias is reduced in that the categories emerge from descriptions of the actual situations, rather than from previous theories or opinions.

Job satisfaction measures may, after all, be a reliable way of investigating motivation, and perhaps the previous difficulties encountered, were because job factors had been regarded as having the same nature, rather than as forming the dichotomy which Herzberg illustrated.

If, as Herzberg claims, his results are valid, Motivators are those factors to which a man responds in a positive sense and are a reliable indicator of his needs. The implications of this are that for the good of the individual and for the ultimate benefit of the organisation of which he is a member, these are the factors which should, as much as possible, be made a significant feature of the task on which he works.

CHAPTER II

THE APPLICATION OF THE MOTIVATOR-HYGEINE FRAMEWORK

1. Background to the Study
2. The Reason for the Survey
3. Methodology

1. BACKGROUND TO THE STUDY

In December 1967 work began on an attitude survey carried out on behalf of the Durham University Business School in a local oil terminal. The study was completed in March 1968.

The function of the terminal was to store refined oils brought in from the company's refineries by sea tanker for later distribution to industries and petrol stations in the North East of England by road and rail. There were 109 employees:

Staff - managerial and clerical	25
Plant operatives	27
Tanker drivers	57

The types of work carried out at the terminal were as follows:

Supervisors

First line supervisors had traditionally been promoted from the ranks, a practice which seemed to be disappearing as the role of supervisor was increasingly being used as a training ground for graduates with higher management positions in view. The supervisors, whether of the drivers or of the plant operatives, worked shifts with their men and were the formal link between them and higher management.

Plant operatives

The plant, which covered unloading, storage and filling facilities, was manned 24 hours a day in two twelve-hour shifts. Apart from the shift gangs, the work force was supplemented by day workers. The duties of the plant operatives included maintenance of the vehicles and the

plant facilities and the process of unloading and storage from sea-tankers. The plant was mainly in the open and uncovered. More technical skills were required of plant operatives initially than of drivers, who could be a "milk float driver today and a tanker driver tomorrow".

Drivers

Each driver began work by collecting his instructions for which customers he should visit and by what route. After checking his vehicle he was then on his own for the day unless something went wrong, in which case he could 'phone in for help or advice. Drivers worked two shifts, from 6.0 a.m. till 2.0 p.m. or 2.0 p.m. till 10.0 p.m., or were classed as day-drivers.

2. THE REASON FOR THE SURVEY

(a) On the Company's Part

The company had, two years previously, entered into a productivity agreement affecting drivers and plant operatives. It was of a usual form, in that some restrictive practices were relinquished in exchange for increased pay. There had been some important changes in the drivers' job since the Agreement was introduced. Their routes were planned with to-the-minute schedules. This cut down the time they used to be able to spend in conversation with their supervisors and with other transport drivers in road cafes.

More specifically drivers no longer had mates, they did the same amount of work but in less time, cutting overtime down to a minimum, and were paid more. In the event of finishing early, they had agreed to be

given alternative work around the plant, though this measure rarely seemed to be put into effect.

In more general terms, it had been hoped that relationships with management would improve and it was intended that the men would be more flexible, in being prepared to do work outside their main job description if the situation required it.

Since the Agreement however, it was felt by management that only the clearly defined changes, such as pay and hours worked, had in fact occurred, but that areas left to trust and exhortation had not materialised. In fact the general mood of the hourly paid people was not as good as it was before the Agreement had been signed. As the terminal manager put it:

"Even though they are getting more money and the system is more efficient it has become more obvious that there isn't the same goodwill and feeling that there used to be between the company and the drivers. Rows occur over little things - they're just not behind us like they used to be. It's happened gradually but it's there all right."

And at the company headquarters we were told that the men were dissatisfied with the Unions because they felt that the Agreement had not represented their own needs. Overall, it was felt that there had been no real philosophy underlying the Agreement and therefore no forward planning. There was to be a new agreement and there was concern this time that it should be designed with the employee's needs and opinions more in mind.

Some other pressing factors were revealed. The company's profits had declined sharply over the last three years, yet the employees viewed the company as a 'bottomless well' financially. At least, that was management's perception of the employees' attitude. Also the company was 'strike-shy' and the men knew it, as in the past, management had given away considerable concessions without gaining much in return. The hourly paid workers were realising, some of them perhaps for the first time, that restrictive practices had a market value.

With this recent history the company was anxious to be more in touch with the attitudes of its employees to the new agreement, to management and to their jobs. More specifically, these were some of the questions to which answers would be sought:

- What was the men's interpretation of the Agreement?
- What was their attitude to flexibility?
- How could they be given (and would they welcome) more responsibility?
- Did they want promotion?
- What were their sources of satisfaction and how did the Agreement contribute, or fail to contribute to this?

It was this last area of questioning which provided an opportunity to test out Herzberg's framework.

(b) The Opportunities Presented by the Study - The Research Interests

The situation at the oil terminal provided an opportunity to study both the working environment and people's responses to it, particularly in the light of the changes that had recently occurred as a result of the

productivity agreement.

Using both a directive and non-directive approach, it was proposed to obtain opinions about specific aspects of the job and the company and to see what emerged from such open-ended questions as 'What do you like most about your job?' Using Herzberg's categories and his motivational theory as a frame of reference, it was of interest to see whether his views would be confirmed by the replies given in the light of the environment in which these people worked; or whether there would be alternative explanations for the results, even if they were apparently consistent with Herzberg's assumptions. It would also be possible to look for differences between the two occupational groups working on the site, drivers and plant operatives.

These then, were the questions of interest:

- How complete were Herzberg's categories as a frame of reference?
- Was the productivity agreement Hygiene or Motivator oriented?
- What were the levels of Hygiene or Motivator factors in various jobs as indicated by the satisfaction of the people with them?
- Given these levels, would people's reaction to their environment confirm or disconfirm Herzberg's theory of motivation?
- Even if the responses apparently confirmed the theory, would the nature of the men's jobs offer alternative explanations for their responses?

3. METHODOLOGY

After the preliminary discussions with higher management it was decided to conduct the survey by interview. The questions were open-ended

and care was taken to be non-directive in probing further or, where specific and directed probes were made, they were standardised. The three areas of enquiry were:

- (i) The Productivity Agreement: An analysis of what it had added to or subtracted from the job in Motivator and Hygeine factors.
- (ii) The Work Itself: Using the same framework for analysis, to build up a picture of the quality of the work and working environment for the drivers and plant operatives.
- (iii) Sources of Job Satisfaction: To examine Herzberg's theory and methodology by using open-ended questions and analysing the results in the light of (ii) above.

The questions asked were first pre-tested on a small group of employees. Those relevant to this preliminary study are contained in Appendix A. Some were specifically related to various aspects of the Agreement or the work and people's associated feelings. The questions used to investigate 'sources of satisfaction' were open-ended and two were of the critical incident type. (see questions 14-19, Appendix A)

The critical incident questions were of especial interest. In asking, for example, 'What is it makes you feel you have had a really good day?', the level of various factors in the job at present was controlled. As with Herzberg's questions, a person could cite 'achievement' even if it occurred but rarely, and would not therefore appear as a general source of satisfaction in answer to other questions such as 'What do you like about your job?'. The sources of satisfaction could thereby be investigated independently of the current quality of each individual's working environment.

CHAPTER III

THE RESULTS OF THE OIL TERMINAL STUDY

1. An Analysis of the Agreement in
Motivator-Hygeine Terms
2. The Work Itself
3. Sources of Job Satisfaction

1. AN ANALYSIS OF THE AGREEMENT IN MOTIVATOR-HYGEINE TERMS

In general, it appeared that the productivity deal focussed on the Hygeine aspects of the work. In this respect it was not dissimilar from other productivity deals. The main benefits to the employees were to be better pay and shorter hours. The aim was to tidy up a situation where previously overtime, though non-productive, was maintained by the employees as a boost to their incomes and was used by management in attracting new recruits.

But some valued aspects of the job were diminished. Because of the tighter scheduling of routes, it was no longer possible for the drivers to meet in transport cafes, which had been one of the few times in the day when they could talk to each other. Nor was there enough time for them to talk to colleagues and supervisors back in the depot. It meant too, that whereas a driver had been able to use his own initiative in planning his routes and dealing with unforeseen difficulties that occurred, his planning was now done for him and he was required to ring in to the planners in the event of some unprecedented occurrence (a garage being closed, for example).

So the Agreement, while it raised the level of some Hygeine factors, took away others (social) and reduced the Motivator content (responsibility). There was subsequently little evidence that it had done anything to increase the intrinsic satisfaction of the job itself. What the Agreement gave or failed to give is summarised in Tables 3.1 and 3.2.

Table 3.1. What People Liked about the Agreement: Percentages of Respondent Groups Who Cited Each Factor

	Drivers	Plant
Money	79	82
Better hours	49	22
More leisure time	28	15
Can get on with the work	14	15
Flexibility	0	15
Shifts	0	19

Table 3.2. What People Disliked about the Agreement: Percentages of Respondent Groups Who Cited Each Factor

	Drivers	Plant
Nothing	32	56
Schedules	39	0
Trivial jobs	11	7
Lack of promotion	0	11

These results confirmed the general impression described above. No one mentioned Motivators as benefits because they were not a feature of the Agreement, the emphasis being on Hygiene factors. It is also interesting that the lack of Motivators was not reflected in the 'dislikes' expressed by the drivers.

2. THE WORK ITSELF

Using Herzberg's categories, the replies of both drivers and plant personnel to specific questions about the various aspects of their jobs, were analysed for Motivator and Hygeine content. The results are presented in Table 3.3.

Table 3.3. Analysis of the Work Itself

<u>Hygeine Factors</u>	<u>Percentage of favourable responses</u>	
	<u>Drivers</u>	<u>Plant</u>
Attitude to the company and its policy	90	67*
Pay	79	82
Degree of supervision	91	86
Confidence in supervision	63	85*
Working relationships	63	67
Status	91	74*
Security	65	85*
Working conditions	89	74
 <u>Motivators</u>		
Responsibility	35	52
Recognition	18	56*
The work itself	30	46
Opportunity for advancement	30	11

*Difference between occupational groups significant at the .05 level.

(a) Hygeine Factors

Both groups seemed content with the Hygeine aspects of their jobs. They enjoyed working for the company, felt secure and were pleased with both the physical conditions and the amount of supervision they received. There were some differences however. The plant people had more confidence in their supervisors than the drivers did and this seemed to be due to the amount of time supervisors were able to spend with their men. The new Agreement had not helped the transport supervisors in this respect.

On the other hand, the plant personnel felt left out of things and lacking in status. This was because in the past the drivers had been the more demanding of the two groups and consequently most attention had been paid to them: the new Agreement was aimed primarily at the drivers and they had more direct access to higher management.

Even allowing for these differences there was general satisfaction with Hygeine factors, especially when compared with how people felt about the Motivator content of their jobs.

(b) Motivators

Opinions about these factors highlighted the deficiencies of the job. The percentage of people giving favourable replies was uniformly lower than it had been for Hygeine aspects.

The drivers were dissatisfied with the type of work they had to do, their opportunities for promotion and the amount of responsibility

they held.

"When problems crop up, I'd like a free hand to sort it out myself ... but it has to be taken to the supervisors."

They were particularly unhappy with the recognition they received.

(Only 18% favourable responses)

"You don't know when you've done a good job, you only know you've done a bad one when you get jumped on."

The plant personnel were also less content with Motivators than they had been with the Hygeine factors. Only 46% seemed to enjoy the work they had to do and as few as 11% were satisfied with promotion prospects.

"There's no opportunity for progress, I can only see a blank wall ahead of me."

It seemed then that the jobs met the requirements for Hygeine factors well but did little to provide the level of Motivators which, as Herzberg maintains, are the source of productive energy. The Agreement had been partly responsible for this picture. It was possible to see some indication of the general level of satisfaction in that 45% of plant personnel had considered moving in the previous six months, compared with only 9% of drivers. Also, significantly more plant personnel than drivers felt they had suffered through the Agreement.

These findings had provided a motivational profile of the work and working environment. The next section summarises the way in which answers to less specific questions reflected this high-Hygeine, low-Motivator situation, and the degree to which Herzberg's 2-factor phenomenon was demonstrated.

3. SOURCES OF JOB SATISFACTION

The non-specific questions, six in all, occurred in the middle of the questionnaire but in this section have been numbered 1-6 for convenience. The incidence of the various job categories was expressed as the frequency with which the item occurred in responses to a given question. An individual could be scored for any number of distinct categories but with a maximum score of 1 for any given category. So, for example, a person could only score 1 for achievement, but could also score 1 for recognition. The frequency counts were not converted into percentages. This was unnecessary as scores which were compared came from an equal size of sample, and moreover percentages were felt to be misleading if the sample size was small.

The statistic computed was the binomial test because the data comprises a nominal scale and because it is implicit in Herzberg's interpretation of his results that a significant finding in Hygiene-Motivator distribution, is one which diverges from a 1:1 ratio between satisfaction and dissatisfaction. For questions 1-4 a two-tailed test is used as it was uncertain what the direction of the results would be. In questions 5 and 6 however, the critical incident questions, direction was predicted and so a one-tailed test was applied.

(a) Likes and Dislikes

Question 1. What do you like most about your job?

Question 2. What do you dislike most about your job?

It is possible to anticipate what people would find satisfying or dissatisfying about their work from the tables constructed earlier from

their replies to the more direct questions. So for example, in the case of the drivers, while Hygeine factors seemed to be well represented, Motivators were not, especially Recognition, Advancement and Responsibility. In the same way predictions could be made for the plant personnel. But do the responses to these less specific questions reflect the strengths and weaknesses of the job, or do they reveal more about the degree to which a person is aware of different factors as sources of satisfaction or dissatisfaction, as demonstrated by the 2-factor phenomenon? In fact for the drivers, the Motivators, Work Itself and Responsibility, behave as would be expected from Herzberg's theory, as do the Hygeine factors, Working Conditions and Company Policy. However, Security and Social Relationships do not. (See Appendix B) Table 3.4 summarises these results for the two groups of factors.

Table 3.4. Frequency of Occurrence of Motivators and Hygeine Factors in Responses to the Questions on Likes and Dislikes

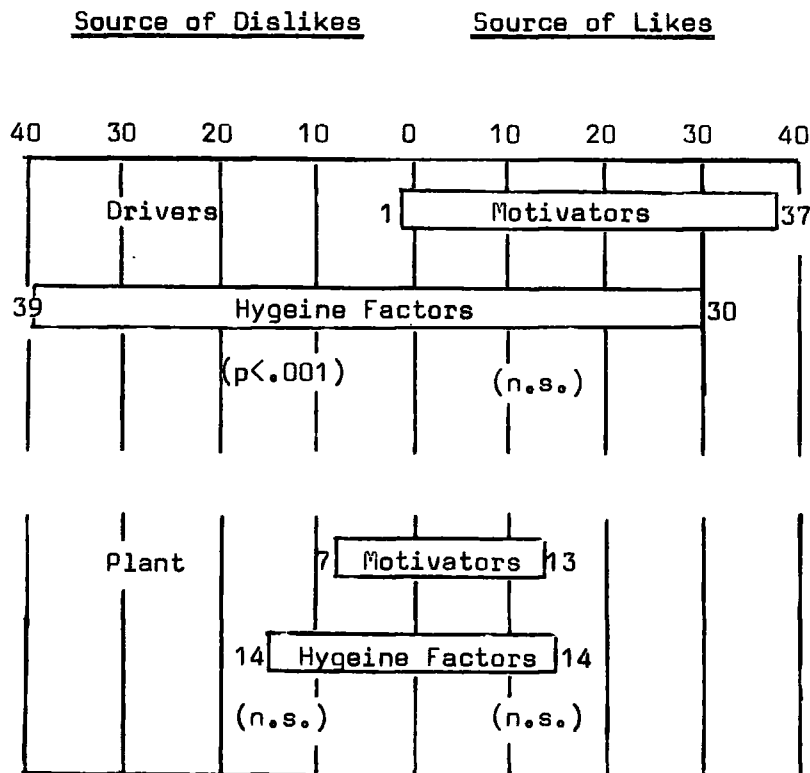

The most significant finding is that Motivators do not stand out as 'dislikes', even though, especially in the case of the drivers, there was considerable dissatisfaction expressed when they were asked specifically about Recognition, Responsibility and Advancement. Also, the Hygiene factors Pay, Status and Company Policy were not cited any more as 'likes' than 'dislikes' even though previous direct questions had shown that people were pleased with these aspects of their jobs.

The results of these questions thus provide partial support for Herzberg's theory, but there is some doubt, especially in the light of the picture of the work already built up, whether his explanation of the dichotomy is the only one.

It could be said that Motivators were absent as expressed sources of dissatisfaction in these open-ended questions because the need for them had not been aroused. For example, Responsibility as a motive could remain as a potential for an individual, unless it had been aroused by his being given it or by his seeing others being given it. Patchen (1958) showed that a person's satisfaction will depend on how he compares his lot with relevant others. This could explain why the drivers did not volunteer dissatisfaction with promotion prospects - their peers were just as badly off.

Similarly a worker may not expect promotion because it has formed no part of his previous experience, so he does not see it as a realistic possibility. Patchen refers to this as the 'objective standard', as opposed to the 'normative standard' in relation to comparisons with other groups. Kelley (1951) showed that people were less concerned about the

low status of their job if they did not see mobility as a realistic expectation.

Whichever of these explanations is the true one, these results do suggest that this non-specific type of question may be of doubtful validity. Because intrinsic factors are absent in responses to questions about 'dislikes', it does not necessarily mean that they are present in the person's job.

(b) Sources of Satisfaction and Desires for Change

Question 3. Is your job a major source of satisfaction in your life?

Question 4. Is there one thing you would like to change to make your job more satisfying?

These two questions were an alternative form of the satisfaction-dissatisfaction dichotomy, in that in thinking of objects for change, a person is likely to refer to those aspects of his job with which he feels dissatisfied. The first of these questions identifies what the job contains or would have to contain, for it to be a major source of satisfaction. Asking the question in this way, focussing on satisfaction whether currently present or absent, is qualitatively different from asking about sources of dissatisfaction. When the results of questions 3 and 4 are analysed for Motivators and Hygiene factors (see Table 3.5), the 2-factor phenomenon is seen more clearly than it was in the first two questions. Three out of the four comparisons are statistically significant.

A final comment about the frequency of extrinsic factors in the responses to the question on 'change'. Here too there is an alternative explanation for the findings, in the natural inclination to identify 'the company' as a target for change rather than one's self. This possibility becomes the main point of departure for Part II of this thesis.

(c) Good Days and Bad Days

Question 5. What is it which makes you feel you have had a really good day?

Question 6. What is the sort of thing which makes you glad when the day is over?

Both questions used the critical incident technique to test whether they could replicate the 2-factor phenomenon in the context of the working day. It was predicted that there would be a preference for Motivators in answers about 'good days', and for Hygiene factors in answers about 'bad days'.

The results in Table 3.6 parallel Herzberg's findings in the case of the plant personnel but not in the case of the drivers. With the drivers, although the description of bad days reflected the predicted emphasis on Hygiene factors, the answers about good days also contain more references to Hygiene factors than to Motivators. This is exactly the pattern which had emerged from the two previous sets of questions. Some qualifications could be made in that Weather, Scenery and Social Relationships, all coded as Hygiene factors, are a much greater part of the actual job the driver has to do, than is the case for the plant worker.

Table 3.6. Frequency of Occurrence of Motivators and Hygiene Factors in Responses to Questions on 'Good' and 'Bad' Days.

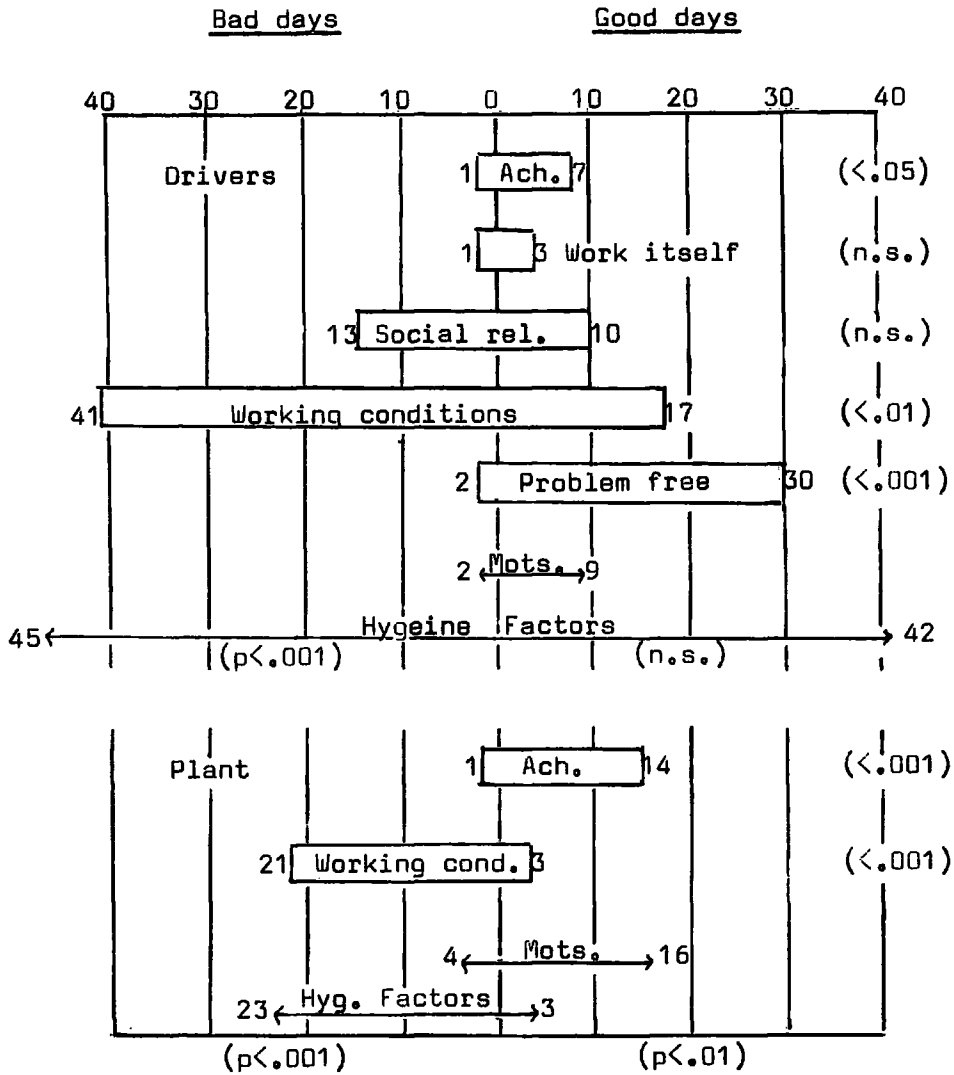

Another finding of interest is that Achievement figures much more prominently in all groups than it did in responses to other questions. This illustrates the way in which a critical incident type of question controls for the level of a factor in the present work situation, and identifies more clearly the effect of that factor on an individual. So that even if a driver has little opportunity for Achievement, if he has any opportunity at all, he can recall this as a source of good feelings.

This demonstrates how Herzberg's method reveals more about the respondent, than it does about his work or working environment.

The 'Trouble-free' Phenomenon

This was a factor which was hard to code with Herzberg's categories. It is illustrated by the descriptions drivers gave for what makes a 'good day'.

"When the day runs smoothly, no difficulties in drops.
When everything's gone right."

"No stoppages and I get through a fair day's work with a minimum of effort."

Sixty-two per cent of the drivers gave similar responses. This illustrates the effect of an environment scarce in Motivator opportunities, on the people who work in it. There is a clear distinction between the problem-averse attitude which these quotations illustrate and the more achievement-oriented attitude where problems are a source of challenge and therefore potentially, of satisfaction and fulfilment. One attitude expresses an avoidance of anything which threatens the uneventful, routine, mechanically performed task. The other implies an attraction to using initiative and experiencing success. This is illustrated by a plant operator's answer to the same question.

"When you've been very busy, ... one or two problems and you've sorted them out. You go away contented, you feel you've achieved something."

There are obvious implications here for the employer or manager. If it is desirable for the effectiveness of the company, that the individual seeks achievement and responsibility, then by denying him the opportunities for this, the man may ultimately avoid situations which challenge him or

call for the development and use of his skills or initiative. If this is what the working conditions produce, then human potential is wasted. With the drivers, problems were not a challenge, they were 'trouble' and the social norm was to avoid them.

To summarise, the responses to the six non-specific questions have demonstrated three main points:

- (i) That the 2-factor phenomenon is replicable by other than Herzberg's questions.
- (ii) It occurs when some negative feelings known to exist, are not expressed.
- (iii) In this company, Hygeine factors play a major part in the working lives of the drivers.

These points will be discussed in the next and final chapter of Part I.

CHAPTER IV

THE MOTIVATOR-HYGEINE THEORY - A REVIEW

1. Support for Herzberg's Theory
2. Herzberg's Contribution
3. Limitations of the Theory
4. The Significance of the Suppressed Data

1. SUPPORT FOR HERZBERG'S THEORY

The study in the oil terminal provided an opportunity to ask different questions of the same groups of people and compare the patterns of responses. This type of comparison, as Vroom (1964) points out, is not common in the literature.

(a) The 2-Factor Phenomenon

The results of the non-specific questions do provide some support for Herzberg's view that job satisfaction should not be considered as a unidimensional scale but as a dichotomy. Some factors are associated primarily with positive feelings towards the job and others with negative feelings. Factors which are sources of satisfaction are more likely to be Motivators (eg. Achievement, Recognition) and those which prove to be sources of dissatisfaction are more likely to be Hygiene factors (eg. Company Policy, Working Conditions).

(b) Hygiene-Seekers

Perhaps the clearest illustration of Herzberg's theory is seen in the different responses of drivers and plant workers in demonstrating the effect of the total working environment on people's attitudes. When the drivers' responses were analysed it was seen that:

- Hygiene factors were cited as frequently as Motivators as sources of satisfaction.
- Hygiene factors were predominant as sources of good or bad feelings in answers to the critical incident questions.
- Good days were 'trouble-free' days.

The drivers appear to illustrate the attitude which Herzberg describes as 'Hygiene-seeking', the result of working in an environment which emphasises extrinsic rather than intrinsic factors. In this situation people learn to respond positively to Hygiene factors and are described by Herzberg as having the following characteristics:*

- (i) They are motivated by the nature of the environment.
- (ii) They show chronic and heightened dissatisfaction with aspects of the job context (eg. Salary, Security, Physical Working Conditions).
- (iii) They over-react with satisfaction to improvement in Hygiene factors, but only for a short time.
- (iv) They over-react with dissatisfaction when Hygiene factors are not improved.
- (v) They show little interest in the kind and quality of work they do.

The attitudes of these men, in the light of the analysis made of the work and productivity agreement, supports this distinction Herzberg makes concerning the effect which extrinsic factors have on work behaviour, in contrast to that of intrinsic factors. In the long term it is likely that the individual becomes a victim of the stereotype which he is helping to perpetuate, in that this behaviour may cause his manager to create for him a Hygiene-dominated job and ultimately he may even come to believe himself incapable of accepting challenge or responsibility.

*Adapted from a table by Herzberg (1959).

2. HERZBERG'S CONTRIBUTION

There have been earlier theorists who have shown equivalent, if not precursory, views to that of the 2-factor concept of motivation. In particular, humanistic psychologists such as Fromm, Allport and Maslow found it difficult to accept motivation as a universal process of tension reduction.

Fromm (1942) drew the distinction between powerful drives which are the 'creative function of society' and other, basic needs 'to satisfy the physiologically conditioned drives and the necessity to avoid isolation and moral aloneness'. Allport (1955) also postulated two types of motive:

"Deficit motives do, in fact, call for the reduction of tension and restoration of equilibrium. Growth motives, on the other hand, maintain tension in the interest of distant and often unattainable goals."

These views are similar to the dichotomy of motives which Herzberg postulates. In particular, Maslow's description of 'deficiency-need-gratification-bent' individuals, in contrast to those who are 'growth-dominated', is a close parallel to the Hygiene-Motivator concept. Herzberg's contribution is that he demonstrated this 2-factor distinction in studying behaviour at work, which seemed to answer some of the difficulties encountered in using unidimensional models of job satisfaction.

3. LIMITATIONS OF THE THEORY

(a) The Categories

The categories which resulted from Herzberg's content analysis provide a useful framework which is near complete in the industrial context,

although there are some needs, such as power, which are not explicitly represented. But the distinction between Motivator and Hygeine factors depends on a delineation between categories which is not realistic. Reference has already been made to the difference in importance of a factor like Social Relationships, depending on the type of occupation (p. 29). Another factor classed by Herzberg as Hygeine is Salary, which he maintains can only satisfy avoidance needs. This neglects the importance of the individual's life outside his work. Money is not a goal but a means by which a number of goals may be attained, and some of these goals may represent self-fulfilment for the individual. Moreover, as French (1955) has demonstrated, extrinsic rewards differ in their incentive power for different people. For low achievers they are an incentive, but less so for high achievers. On the other hand McClelland (1962), stresses the importance of financial gain to the high achiever in the industrial setting, as concrete evidence to him of the degree of his accomplishment. Money can therefore be an important sign of recognition to the individual and as such could be classed as a Motivator.

Advancement or Promotion are also more complex than Herzberg allows. It is unrealistic to think of them only as 'needs', as something to be attained for their own sake. Promotion represents a transfer from one organisational state to another and this transfer may represent an increase in salary, self-esteem, status, recognition or a move to more interesting work.

(b) Allowance for Individual Differences

Herzberg sees the category 'Achievement' as including all 'growth potential' and quotes Jung in support of this view.

"The supreme goal of man is to fulfil himself as a creative unique individual according to his own innate potentialities and within the limits of reality." (In Herzberg 1968)

But Herzberg's categories and theory do not reflect a view of fulfilment as broad as this quotation would allow. His theory is developed from data collected in the industrial setting and is strongly achievement oriented. Yet Achievement, as McClelland (1961) has amply demonstrated, is only one way in which an individual can fulfil himself, others being Affiliation and Power. As already mentioned, the Power motive is scarcely represented in Herzberg's coding and Affiliation is relegated to the status of a Hygeine factor. In fact Herzberg's view is that people who are concerned about interpersonal relationships are motivationally 'sick'. This all seems to assume that the optimum state is one in which people are motivated to achieve, and that to be preoccupied with interpersonal relationships is to be overly concerned with Hygeine.

If it is assumed that individuals have different motives and respond differently to the same job factor (Graen 1968), then a person who is seeking affiliation can be regarded as being as creative or as expressive as a person who strives for achievement. Their motivational 'energy' is being channelled in a different way. Southgate's study (1969) is of particular importance in this respect. He predicted that responses to Herzberg's questions would vary according to the social context in which the incidents occurred. For example, Affiliation only behaved as a Hygeine factor in hierarchical situations, but as a Motivator if the context was 'democratic', as in the family or a 'T-group'.

The implication of this work is that the social context cannot be ignored in generalisations about the importance of various factors. It is reasonable to suppose that people are attracted to a work context of say, a democratic type because their motivational disposition is different from someone who prefers a hierarchical situation. Affiliation in one context may have an equivalent motive power of achievement in the other, and so both factors may behave as Motivators.

4. THE SIGNIFICANCE OF THE SUPPRESSED DATA

The findings of this study support the view that Herzberg's 2-factor theory, while it may have some coding defects, has been valuable in increasing our understanding about which factors are experienced by people as sources of good feelings about their work.

It suggests that levels of performance and sources of motivation can be more reliably predicted from job satisfaction measures when they are assumed to reflect an underlying dichotomy and when the effect on responses of the immediate environment is controlled by using a critical incident technique.

But perhaps the most intriguing aspect of the results, has been that the emergence of the 2-factor phenomenon in the analysis of responses to open-ended, non-specific questions, seems dependent on certain information being suppressed.

A particular advantage of the oil terminal study was that it enabled an examination of these responses, having identified in some detail what the strengths and weaknesses of the working environment were.

It was seen that some factors, though poorly represented in the jobs of the people interviewed, were not volunteered as sources of dissatisfaction, when from specific questions it was clear that people were unhappy with them.

The question which this leaves, and from which the research continues is this:

What is the source of the Motivator-Hygiene pattern in responses? Is this in fact a reflection of some motivational characteristic, or does it say more about the problems of the method used than of the behaviour it is designed to investigate?

P A R T I I

THE 2-FACTOR PHENOMENON - A BASIS FOR
FURTHER RESEARCH

CHAPTERS V-VII

- V The Part Played by Perceptual Defence
 in Herzberg's Studies

- VI The Perception of Ownership in Events
 and its Influence on Behaviour

- VII The Phenomenological Approach to the
 Explanation of Human Behaviour

CHAPTER V

THE PART PLAYED BY PERCEPTUAL DEFENCE

IN HERZBERG'S STUDIES

1. Investigations to Confirm Herzberg's Findings
2. Evidence from Studies of Ego-Involvement and Task Recall
3. Implications
4. Summary

1. INVESTIGATIONS TO CONFIRM HERZBERG'S FINDINGS

The results of the studies by Herzberg and his co-workers led to their conclusion that, contrary to traditional theory, satisfaction with job factors did not constitute a bipolar continuum. An investigation of this concept, which became known as the 2-factor theory of motivation, was reviewed in Part I. Since the original studies there have been many follow-ups, some supportive, some not.

(a) Supportive Studies

Most of the studies which confirmed the 2-factor phenomenon, also used the critical incident technique (Myers 1964, Herzberg 1968). But there have also been some which were not based exclusively on Herzberg's methods. Friedlander (1964) asked respondents to assess the importance of 18 factors as likely sources of satisfaction or dissatisfaction with reference to events recalled by the critical incident method. His results supported the 2-factor theory. Similarly Halpern (1966) found that when respondents considered their best-liked job, Motivators correlated more strongly with overall satisfaction than Hygiene factors did. This provided some support for the Herzberg theory but would have been more complete had the subjects also been asked to consider their least-liked job.

Partial support was provided by Hinrichs and Mischkind (1967) who asked people to think of two things which would be most likely to influence their feelings, positive and negative, about the company they worked for. They demonstrated that the 2-factor distribution depended on the person being satisfied overall with his job. For people who were less content, Motivators were an equal source of positive and negative feelings and

Hygeine factors were a more frequent source of good feelings than was the case for people who were more satisfied.

Lahiri and Srivastra (1967) confirmed that satisfaction and dissatisfaction did not constitute a bipolar continuum if Hygeines and Motivators were treated as factor groups, but also showed that individual Motivators and Hygeine factors could be a source of both satisfaction and dissatisfaction. More recently, Saleh and Grygier (1969) correlated individual preference for Motivators and Hygeine factors with certain personality variables and, in support of Herzberg, observed that overall,

"Concern with intrinsic factors signifies approach tendencies while the regard for extrinsic factors is characterised by avoidance tendencies."

(b) Non-Supportive Studies

Ewen (1964), using an attitude scale, showed that some factors were as likely to be a source of satisfaction as of dissatisfaction, and that others actually behaved in the opposite way to that presented in the 2-factor theory. Levine and Weitz (1968), in a factor analysis of responses to a 78 item questionnaire measuring the satisfaction of graduate students at two universities, also produced results which failed to confirm Herzberg's concept.

In fact a number of studies appear to confirm the traditional view of job satisfaction as being a single bipolar continuum. Hulin and Smith (1967) for example, used three measures, the Job Description Index, a measure of overall satisfaction, and a scale they developed to assess the importance of specific factors in determining satisfaction or dissatisfaction,

all other factors being held constant. Motivators and Hygeine factors seemed equally likely to be a cause of both satisfaction and dissatisfaction.

They comment:

"It would be reasonable to point out that Herzberg's results appear to be method bound and the conclusions appear to pivot on method variance rather than true content or scale variance."

A similar conclusion was reached by Graen (1966) and Graen and Hulin (1968) re-examining data from previous research.

Most of the studies cited in this chapter so far, have appeared to confirm either the 2-factor theory or the traditional view of satisfaction as a bipolar continuum. But there has also been considerable evidence since Herzberg's original studies to suggest that intrinsic factors are more important than extrinsic, in determining either satisfaction or dissatisfaction. Ewen, Smith, Hulin and Locke (1966) concentrated on the factors Work Itself, Promotion and Pay. They found that neither the 2-factor nor the traditional theories were completely supported. Similar results were obtained by Graen (1968) and Dunnette, Campbell and Hakel (1967), using the critical incident technique with a Q-sort factor analysis, showed that Achievement, Responsibility and Recognition figured more than any other factors in both good and bad events.

This emphasis on intrinsic factors was also illustrated by Wernimont (1966), in a study involving engineers and accountants and using free and forced choice methods. He found that while the results of the free choice method replicated Herzberg's findings, the forced choice method resulted in intrinsic factors playing the greatest part in both

satisfaction and dissatisfaction. Similarly Burke (1966), found that when college students were asked to choose from a list of ten job characteristics (five intrinsic and five extrinsic), the three which would be most likely to cause satisfaction and the three most likely to cause dissatisfaction, intrinsic factors were seen as more likely to be a cause of either feeling.

(c) An Alternative Explanation of Herzberg's Results

It appears that if the critical incident technique is used, Herzberg's results are replicated. It also seems that if other methods are used or even if recalled events are analysed by other methods than Herzberg's, intrinsic or content factors emerge as more important to either satisfaction or dissatisfaction than extrinsic or context factors. To be fair, this finding has been a consequence of the research stimulated by Herzberg's work.

"Herzberg must be given credit for highlighting the essential multi-dimensionality of satisfaction. The weight of recent evidence, however, is against his two-factor oversimplification." (Smith and Cranny 1968)

More recently there have been attempts to reconcile the conflicting findings by emphasising the content-context difference (Wolf 1970). The purpose of this chapter is to focus on an aspect of the critical incident method which has so far only been regarded as a source of error. It is possible that it may also prove to be a useful starting point in the search for factors which influence behaviour at work.

It has been observed that the critical incident method gives rise to bias in responses. Dunnette et al. (1967) described this bias as one of social desirability. They attempted to limit it by using methods based on recognition, to specify the nature of events which their subjects had recalled. In the same way, Wernimont (1966) reduced the bias effect by the use of forced choice methods. In these studies and in Burke's (1966), where recall was not used at all, the 2-factor phenomenon did not appear.

What is the nature of this bias, and why should it affect some methods (using recall) and not others (using recognition)? Vroom and Maier (1961) comment on this.

"It seems possible that the obtained differences between events may reflect defensive processes at work within the individual. Individuals may be more likely to perceive the causes of satisfaction within the self and hence describe experiences involving their own achievement, recognition or advancement in their job."

They go on to say that on the other hand it is equally natural for individuals to attribute dissatisfaction to environmental factors rather than to the self. The same point is made by Lahiri and Srivastra (1967) and Kahn (1961), who contrasts two job factors as an illustration of the way in which this bias is manifested in the 2-factor phenomenon. Kahn points out that it is likely that an individual needs to feel he is competent. 'Recognition' then means that his competence is appreciated and 'Unfairness', which appears at the opposite end of the scale to Recognition, is by way of focussing attention on the lapse of others in appreciation of his worth. In both cases the person's sense of competence has been preserved. But in the good event he draws attention to himself, in the bad event to someone else.

The explanation of the 2-factor pattern which this suggests, is that if the method involves recall and the incident concerned has negative associations, then the response may have been filtered or distorted as the subject avoids having to see himself, or be seen, in an unfavourable light. On the other hand, if he is asked to select reasons from a check-list, he is spared from having to volunteer such information and is therefore more ready to elaborate on aspects of the situation he may have otherwise preferred to conceal, if not forget.

This argument is consistent with the finding from the oil terminal study (p.26) that positive and negative opinions known to exist are filtered out when non-specific or critical incident questions are employed. This implies that the 2-factor phenomenon is, in part at least, the manifestation of some defensive process. The question remains as to what light this phenomenon throws on the nature of job satisfaction.

2. EVIDENCE FROM STUDIES OF EGO-INVOLVEMENT AND TASK RECALL

(a) Introduction - Repression in Recall

The last section contained a discussion of two points that had emerged from follow-up studies of Herzberg's original work. These were that:

- (i) Intrinsic factors play a more important role than extrinsic in job satisfaction or dissatisfaction.
- (ii) When the critical incident method is used, protective mechanisms may influence the results.

"Perhaps the most telling and persistent criticisms of the research supportive of the two-factor concept is concerned with possible biases in the data because of the ... critical incident method. This suggests that there is a tendency for people to associate things remote from them (job context) with failure (dissatisfaction) and things close to them (content) with success (satisfaction), a tendency which could certainly have an impact on the data collected by critical incident methodology." (Hinrichs 1970)

There is considerable evidence which suggests that we do not recall all material with equal readiness but tend to suppress memories which are in any way unpleasant or damaging to our self-esteem. Rapaport (1950), in his summary of research on recall, concludes that pleasant material is recalled more readily than unpleasant, and especially if the material is meaningful in personal terms to the individual. Hilgard and Atkinson (1967) express a similar view:

"The theory of repression holds that memories are not recalled because their recall would in some way be unacceptable to the person."

This defence is part of the 'struggle to keep one's self-picture good'. (Murphy 1947)

The possibility that Herzberg's results are a manifestation of some defensive attitude is supported by a series of studies into the effect of ego-involvement on repression of recall. These investigations go some way towards an explanation of the reason why such defences are invoked and ultimately help to define the nature of intrinsic aspects of work.

(b) Studies on Ego-Involvement and Repression of Recall

These studies were modifications of the work by Zeigarnik (1927) in which experiments involving simple tasks, arithmetical problems and puzzles, were devised to identify any differences in the ease of recall of completed and uncompleted tasks. Zeigarnik found that when subjects were asked to recall what they had worked on, they remembered more of the tasks they had been prevented from completing than of those they had been allowed to finish. The explanation for this was that the memory of the task had been strengthened by the unresolved motive to complete it.

In modified experiments where the motive to complete the task was more personal than merely completion for its own sake, the opposite result occurred. In these experiments, when the subjects were 'ego-involved', that is, when the perception they had of themselves was affected in some way by whether they completed the task or not, then recall of incompleting tasks was not as good as of those completed. (Lewis and Franklin 1944, Zeller 1950) Ego-involvement was generated in various ways. In some experiments subjects were told that the exercises represented 'a test', but given no other explanation. Because they felt they were being tested, incompleting meant failure. These subjects recalled fewer incompleting tasks than completed tasks. Control subjects, who had different instructions, were described as 'task-involved' and recalled more incomplete tasks - as in Zeigarnik's original experiments.

This reversal of the Zeigarnik effect was also seen if task completion was associated with ability (Rosenweig 1943), intelligence (Eriksen 1952), or by appealing to the subjects' willingness to help

the experimenter (Hays 1952). Also, the more threatened the subject was made to feel by the situation, the greater the tendency for recall of incompleting tasks to be repressed (Gilmore 1954). Green (1963) has demonstrated that in this type of experiment, ego-involvement was indeed increased by the different instructions. The subjects' need to protect their self-esteem outweighed the tendency to recall tasks that had not been completed. Miller and Swanson (1960) summarise this experimentally produced repression as:

"The tendency to remember more successes, or completed tasks, than failures, or incompleting tasks, on a test in which subjects were highly motivated to succeed."

The earlier comments of Lewis and Franklin (1944) suggest why this occurs.

"Whenever the person is using tasks as a means of ego-enhancement ... then interruption of the tasks is more likely to be regarded as a blow at ego-status. Since the goal is enhanced ego-status and interruption prevents fulfilment of that goal, interruption is likely to give rise to feelings of failure."

Thus when an individual perceives himself as having failed, he tends to repress the memory of the situation which demonstrated his failure. These findings support Horney's view that neurotic disturbances in work increase to the extent that the work requires 'personal initiative, vision, responsibility, self-reliance, ingenuity' (Horney 1951). A person is unlikely to become defensive about the bad conditions under which he works, if they can in no way be attributed to either his personal involvement or lack of it.

The term 'Repression' presents a difficulty of definition. It is used differently in the studies on ego-involvement, where it is an experimental phenomenon, than it is in psychoanalytic literature. In this

chapter, the language has been adopted from the investigations under review. What emerges as a working definition of a defence mechanism for this study is a process of dissociation from certain aspects of an unpleasant memory, or of difficulty and reluctance in recalling it.

3. IMPLICATIONS

(a) Implications for the Interpretation of Herzberg's Results

The 2-factor concept maintains that intrinsic factors are unlikely to be a cause of bad feelings towards the job. An alternative explanation is that events are recalled in such a way as to preserve the individual's self-image.

Motivators, which imply a degree of personal involvement in the situation (Achievement, Responsibility etc.), are the key features of events recalled as sources of good feelings. There is less reason to describe a situation in which a successful outcome was due to other people or contextual factors (Hygiene).

More especially, when a person is asked to recall an incident which gave rise to bad feelings, he is unlikely to do so in a way which implies personal failure, hence Motivators are absent in his account. Such information will be withheld or even forgotten and he will describe the situation in a way which implicates other people or outside factors as responsible for the failure or frustration which gave rise to the bad feelings.

To explain the 2-factor phenomenon in terms of repression of recall points to the essential difference in the nature of intrinsic and extrinsic

factors and the degree of personal involvement they imply. Of the two types of factor it is those which are intrinsic which give rise to feelings associated with both success and failure.

"When success or failure of goal-achievement are perceived by the person as signifying basic accomplishments or defects of the self, deeper and more central emotions of pride or shame may be engendered." (Krech and Crutchfield 1958)

Both of Herzberg's questions illustrated this, the first directly through expressions of achievement and the like, the second by invoking mechanisms of defence as was illustrated in the oil terminal data.

(b) Implications for the Critical Incident Method

It would appear that the recall of critical incidents is, on its own, an unreliable source of data about attitudes to work. This is further complicated in that people vary in their tendency to repress memories under the same conditions. The preference for pleasant over unpleasant memories for example, differs with individuals (Meltzer and Ludwig 1968). Repression also varies with the strength of achievement motivation (Rietman 1961) and with a perceptual measurement called by Fisher and Cleveland (1956) the 'Body-Image-Barrier', defined as the firmness with which an individual sees the boundary between himself and his environment.

It is not the purpose of this chapter to expand on these variables, but the fact that they and the mechanism of repression exist, means that recall data should always be supplemented by other methods, or the findings will be incomplete. Methods which rely on recognition rather than recall

may not elicit the 2-factor phenomenon but the data is more complete. Recognition not only provides more data (Collins and Drever 1936) but is less susceptible to the phenomenon of repression.

"Probably the most significant difference between recall and recognition lies in the fact that associative interference plays a major role in recall but not in recognition." (Kintsch 1970)

4. SUMMARY

This chapter has proposed an alternative explanation for the 2-factor phenomenon. It is based on earlier studies which demonstrated repression of recall in subjects who were unable to complete tasks in which they had some sense of involvement.

It was suggested that a similar process is involved when the critical incident technique is used. Good events are expressed in terms of Motivators (intrinsic) and bad events in terms of Hygeine factors (extrinsic). In both of these cases the self-image of the individual is preserved and further feelings of failure avoided.

The next chapter explores how the nature of intrinsic and extrinsic factors can be inferred from the different way these two types of factor are linked with perceptual defence. This argument forms the foundation of a theory of motivation to work, which will be investigated in the research which follows.

CHAPTER VI

THE DEVELOPMENT OF THE RESEARCH CONSTRUCT

- PSYCHOLOGICAL OWNERSHIP

1. The Nature of Intrinsic Factors - A Guide
to the Research Construct
2. Psychological Ownership - The Perception
of Closeness to Self
3. Psychological Ownership and the Concept of
Autonomy
4. The Aim of the Study

Between what a man calls me
and what he simply calls mine
the line is difficult to draw.

William James

1. THE NATURE OF INTRINSIC FACTORS - A GUIDE TO THE RESEARCH
CONSTRUCT

(a) Intrinsic Factors and Personal Involvement

The review of Herzberg's research methodology and subsequent findings has provided a basis for further enquiry. The role of perceptual defence which has been previously noted as merely a source of error becomes the keystone of the theoretical framework to be developed. Not only do intrinsic aspects of the job provide the main source of both positive and negative feelings, but the 2-factor phenomenon demonstrates that they are masked by defensive processes if the outcome is potentially damaging to the person's self-esteem.

The dichotomy of intrinsic and extrinsic, or content and context, might at face value appear to need no further definition. One set of factors is in some way directly associated with the person, the other set with the environment in which he works. But the association of intrinsic factors with perceptual defence gives the division added significance. It implies that when an individual uses intrinsic factors in speaking of a task, he is indicating a sense of personal involvement. He identifies with the task, he perceives it as something close to him, and that is why he may show a tendency to defend himself from any unhappy memories associated with it.

In order to obtain a sharper definition of what 'intrinsic' means, and in particular to explore the way in which it indicates personal involvement or 'closeness to self', a questionnaire was designed to test

the hypothesis that as a group, intrinsic factors would be seen by an individual as being more open to his personal influence than extrinsic factors. The rationale was that influence would be a source of involvement, in that the more a person puts into a task, the more involved he feels. The division into the two factor groups was the same as that developed by Herzberg. Respondents* were asked to indicate how much influence they felt they were likely to have over each factor. The questionnaire used and the results obtained, form Appendix C. The hypothesis was confirmed. Intrinsic factors were seen as being more open to influence than extrinsic by the people taking part in the study. (Result significant at $<.05$)

This finding supports a redefinition of 'intrinsic' in terms of closeness to self, providing that the assumed connection between influence and involvement can be verified. It suggests that the construct so far described as 'closeness to self' should be further investigated, in order to identify its origins and its nature in terms of the way in which it is experienced by the individual. If this factor underlies the need for perceptual defence demonstrated by the Herzberg studies, it is also reasonable to assume that it will be associated with personal commitment. In the light of the discussion and the review of research so far, what will be the characteristics of the construct to be examined?

(b) Characteristics of the Factor to be Investigated

Firstly, the factor will take the form of a continuum rather than a dichotomy. As already pointed out, there are deficiencies in the dichotomy into two groups, content and context. For example, Pay or

*Managers in an American manufacturing company.

Status cannot be as rigidly dissociated from Achievement, Recognition or Promotion as such a dichotomy would demand. Also, Personal Influence, assumed in the previous section to be related to the factor to be investigated, is itself a continuum. The factor will therefore also be assumed to form a continuous variable, which underlies and is related to the Herzberg categories. It can be considered as a scale on which the categories have been broadly divided into the two classes, Motivators and Hygiene factors, as about a median value.

Secondly, the factor to be investigated may be seen as playing a part in any decision, task or activity and the feelings associated with it. The research will focus on the nature of the relationship between the individual and the job, rather than on some fixed or absolute property of the job alone. Just as Recognition and Interpersonal Relationships are by nature a process of interaction between self and other (Lewin 1935), so other job factors cannot be thought of as discreet entities somehow separate from the individual. This approach of looking for the dynamics of the person-job relationship, may help to explain why for example, a potentially challenging task may prove less attractive to some than to others. To have labelled the task as 'challenging' is not a sufficient basis for predicting different people's attitudes towards it.

2. PSYCHOLOGICAL OWNERSHIP - THE PERCEPTION OF CLOSENESS TO SELF

(a) The Nature of Ownership

Psychological Ownership can be defined as the perception a person has of the relationship which exists between himself and some idea or

activity. In the previous section it was postulated that the more influence a person has had in a task the more central to him it becomes. So for example, it is impossible for an author to be dissociated from the thoughts and ideas which are contained in a research project on which he is working. The more it has been developed by him, the more closely associated with it he feels. Allport (1955), calls this 'ego-extension' which he defines as the way in which an object or ideal becomes seen by the person as 'his'.

The concept of Ownership involves the notion of psychological distance. An individual uses himself as a central reference point in his perception of other objects or situations. Sherif and Cantril (1947) describe this as a process in which:

"any stimulus or situation is consciously or unconsciously related to them by the individual."

In the same way interests or needs are differentiated into areas central or peripheral to the person (Lewin 1935). This is a dynamic phenomenon, as Lewin (1948) illustrates by pointing to the way in which the different groups to which a person belongs may vary in the importance they hold for him at different times. For example, the family can become more or less central to an individual, depending on whether he is at home or at his place of work.

(b) The Manifestation of Ownership

That which an individual owns, is a source of positive feelings to him, not only because of the features which initially attracted him to it, but also because he is interested in and committed to that which he identifies with his 'self'.

"We delight in that which we sense and that which we do.
It is good in itself, but it is all the better because
it is our own." (Murphy 1957)

Lewis and Franklin (1944), offer a similar explanation in the context of solving a problem.

"A person who has just solved a difficult problem will feel pride in his success, although he did not solve the problem to win this 'pride'. What is important in this case is that so much of the person was involved in his struggle with the difficult problem - his intelligence, his emotions, his energy - the problem, in other words, was so central to the person, that its solution results in satisfaction with the competent self."

It is because an activity is seen by a person in this way, that he feels emotionally involved, and wishes to appear to himself and others, as useful, worthwhile or successful. While therefore, he may be indifferent to criticism of a task which is not 'his own', he is likely to be defensive towards criticism of one that is. It then becomes criticism of himself.

If however, a task in which a person has some sense of ownership becomes a source of negative feelings, through failure or frustration, he may attempt to dissociate himself from the source of his discomfort. A discussion overheard between a lecturer and his students illustrates this. The discussion centred on whether a view the lecturer had put forward was plausible. At first he 'owned' the theory by talking of it in terms of 'what I meant' or 'what I am trying to convey'. But after a while, it was clear that he was losing ground and for the rest of the discussion his account was characterised by such expressions as 'what I think they are getting at' or 'the reason they hold this view is ...', and so on. He had 'disowned' the views which had become a source of embarrassment to him.

If then, a person has a sense of ownership in a task or idea, the feelings he experiences will depend on its outcome and on the attitude of others towards it. When it is threatened so is he, when it is derided he may feel foolish, angry or ashamed, but if it is successful it becomes for him a source of pride.

3. PSYCHOLOGICAL OWNERSHIP AND THE CONCEPT OF AUTONOMY

(a) The Meaning of Autonomy

Another aspect of Ownership is implicit in the definition proposed in the previous section. 'Doing what I want to do' is close to the idea of 'doing what I see as mine'. This raises the question of whether Autonomy is related to Ownership, or whether the two terms are merely synonymous.

The importance of Autonomy has been stressed particularly by those writers whose theories of personality are based on the concept of self-fulfilment: Jung (1940), Fromm (1942), Murphy (1947), Horney (1951), Anygal (1952), Maslow (1954) and Allport (1955). The view of personal autonomy which they share, is of the individual who emerges from the constraints of family and society and becomes free from the pressures to conform. This process is variously described as one of individuation (Jung, Fromm, Allport), self-realisation (Horney), or self-determination (Anygal), and results in the person having the freedom to choose, decide and live as he wishes, guided by his own law (Jung 1940). Jung described personality as 'the highest realisation of the inborn distinctiveness of the particular human being' and stressed the importance of the 'greatest possible freedom of personal decision'. Allport (1955) describes the

state of autonomy which is the manifestation of freedom in these terms:

"The emerging figure of man appears endowed with a sufficient margin of reason, autonomy and choice to profit from living in a free society."

Autonomy therefore, can be seen as the realisation of all that the person is capable of becoming. Above all, it implies wanting to and being able to, live and act as a person sees he must. Further, Horney and Allport emphasise the need for the person to accept that it is he who must decide and act, it is his responsibility.

"For me the real self is the spring of emotive forces, of constructive energies, of directive and judiciary powers."

(Horney 1951)

(b) Redefining Autonomy in Relation to Psychological Ownership

A distinction can be made between these two concepts in defining the different relationships to which they refer. So, in the context of a task, Autonomy refers to the relationship between the person and others connected with the task, whereas Psychological Ownership refers to the relationship between the person and the task itself. The definition of the two concepts and the connection between them can then be described.

AUTONOMY - The Relationship with Others. The degree of freedom the individual has from the control or constraints of other persons in making his choice of action. He only experiences himself as being in control of a situation if the influence he has had is seen by him as greater than the influence of relevant others. (cf. Lewin's concept of a 'field of power' 1935) At most he may have initiated the activity, and at least he may have had some choice when taking part. In this sense Autonomy is defined as the freedom which allows the individual to influence the situation in which he is involved.

PSYCHOLOGICAL OWNERSHIP - The Relationship with the Object or Activity. This is the degree to which the person, as a result of the freedom and therefore of the influence he has, experiences the object or activity as a part of himself.

In this model, then, the two concepts Autonomy and Psychological Ownership, are related but distinct. The greater the sense of autonomy, of freedom of choice, of the feeling that one is the cause, origin or source of an activity, the more one experiences Ownership in it. And because the activity has been adopted as part of the 'self', the person is committed to it and his feelings are affected by its outcome. The picture we have of ourselves is enhanced if we see the work we are doing as ours, more than if it 'belongs' to someone else. Ultimately a man wishes to feel that he is a free agent, acting out his choice rather than someone else's.

"When a man perceives his behaviour as stemming from his own choice, he will cherish that behaviour and its results."

(DeCharms 1968)

4. THE AIM OF THE STUDY

The overall aim of this study is to demonstrate an association between a person's perception of Ownership in an activity, with the commitment he feels towards it, to verify the claim which Sherif and Cantril (1947) make that:

"It is clear beyond any shadow of doubt that the satisfaction an individual has in his job can never be complete unless he feels that the work he is doing is his job."

It is also intended to investigate the factors which contribute to a sense of ownership. There is considerable evidence that the influence or control which a person has over a situation, disposes him to increased effort and involvement (French, Israel and Aas 1960), and that participation in goal setting is a major factor in determining the outcome, whether the goals are of personal change (Kolb and Boyatzis 1970) or of performance set in an appraisal scheme (French, Kay and Meyer 1966). Involvement in decisions has also been shown to contribute to change in behaviour, whether in an organisation (Coch and French 1948), or in the food-buying habits of housewives (Lewin 1947).

The basis of this study, is that an investigation of Psychological Ownership will identify the process by which an association such as that between influence and performance, comes about.

At this stage it is possible to summarise the relationships to be investigated and which form the basis for the pilot study which follows in Chapter VIII. The account which follows is also represented by the construct diagram. (See Figure 6.1)

(i) The degree of Psychological Ownership in a task will be a function of the Autonomy (freedom of choice, influence) the person has had in that task.

(ii) The degree of Psychological Ownership in a task will be manifested in the extent of the individual's commitment to it, his willingness to spend effort on it and the feelings, positive or negative, with which the task is associated.

(iii) The strength of these relationships - Psychological Ownership, Autonomy and the behavioural manifestations - will in turn be a function of three personality factors selected as relevant to this study. (The rationale for these choices and their precise definitions will be explored in Chapter VIII) They are:

- The tendency of the individual to conform to norms or constraints external to himself.
- His perception of himself as the origin or the object of circumstances with which he is involved (locus of control).
- His attraction to situations providing Ownership.

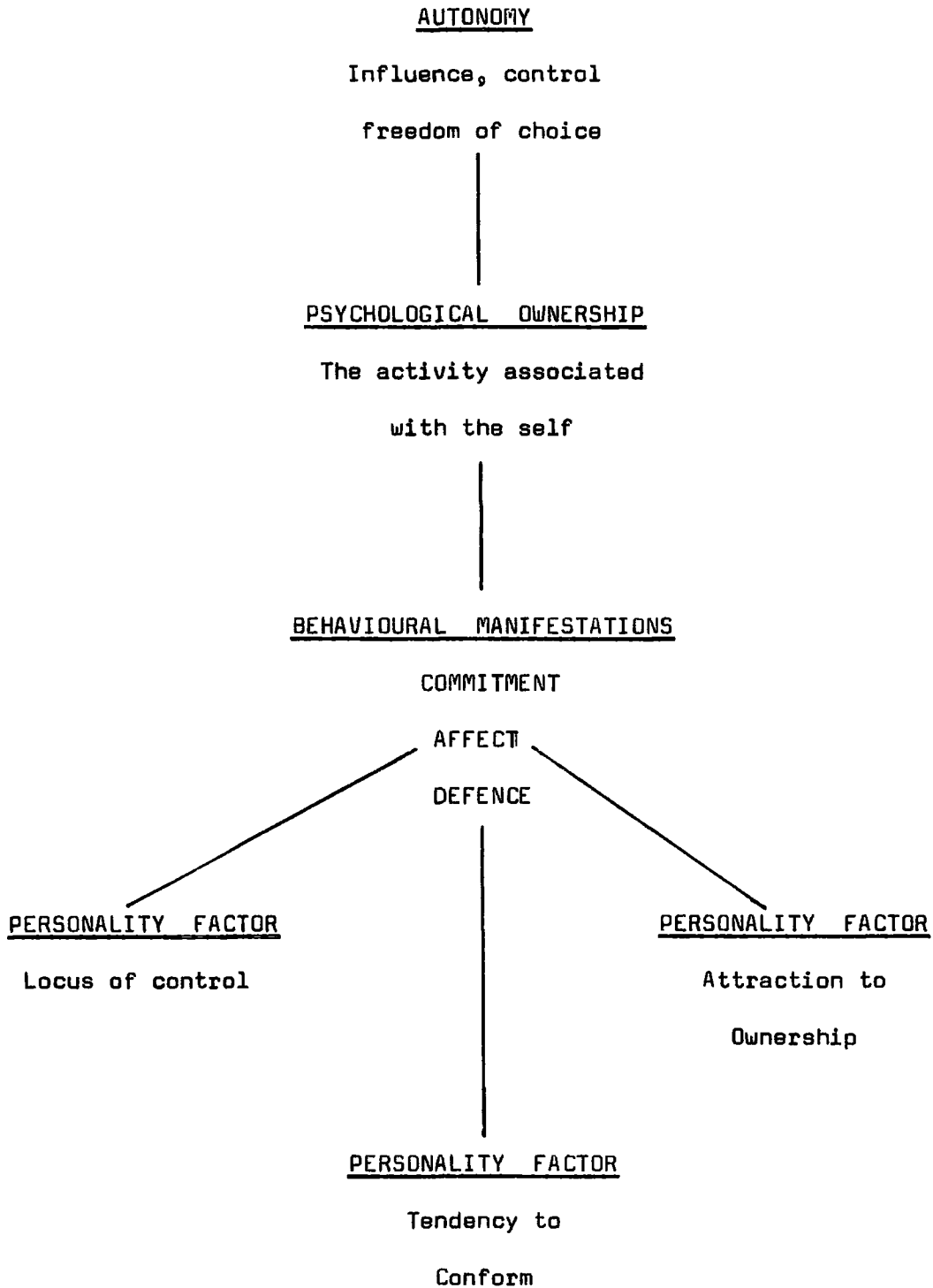

Figure 6.1. Construct Diagram

CHAPTER VII

THE PHENOMENOLOGICAL APPROACH TO THE EXPLANATION OF HUMAN BEHAVIOUR

1. Introduction
2. The Nature of Mediating Mechanisms
3. The Concept of Self
4. Implications for Understanding Motivation to Work

One group welcomed intuitive feelings and insights but scorned the trappings of science with its restriction upon the imagination and its narrow technical skills. The other applauded the rigour and precision of delimited investigation and shrank in distaste from the unrestrained use of clinical judgement and imaginative interpretation.

Hall and Lindzey 1957

1. INTRODUCTION

One of the problems in the study of motivation, is that it not only involves choosing between different concepts, but it also raises the more fundamental question of deciding whether a particular explanatory model is valid in terms of the assumptions on which it is based. So there have been and are, differing views, often mutually exclusive, as to what constitutes a legitimate approach to explaining human behaviour, and as to what constitutes a useful one.

The aim of this chapter is to make explicit the explanatory model of this study, and its underlying assumptions. It is intended to clarify what the model does and does not attempt to explain, by referring to some of the more influential theories. The construct of Psychological Ownership has been developed through a re-examination of Herzberg's data and an alternative analysis which centres on the phenomenon of perceptual defence. As Hilgard (1949) observes, it is difficult to understand defence mechanisms without adopting the concept of 'self'. He points out that experiences of which we are aware, such as self-criticism, self-evaluation, guilt or self-regard all imply some reference point, some process of self-referral. This constitutes a mediating mechanism, something within the person which influences the responses to external stimuli.

" ... between the physical properties of the S and the R stands a whole system of potential choices in the prepared and evaluating, not passive organism." (Shlien 1964)

J. B. Watson and B. F. Skinner defined their explanation of behaviour in terms of observable external entities based on the reflex or

S-R connection. They had therefore no need to elaborate any internal process. In fact, Skinner's view was that this model made the very concept of motivation unnecessary (DeCharms 1968). But later, this purely external approach was felt to be inadequate to explain all aspects of behaviour and models were developed which assumed the existence of some mediating mechanism (S-O-R). A brief summary of the more influential of these, provides a context in which to review the mediating process implicit in this present study and the fundamental questions of validity it poses.

2. THE NATURE OF MEDIATING MECHANISMS

C. L. Hull (1943) postulated states of tissue deficits which, by acting on the nervous system, caused a state of tension or 'drive' which was the origin of goal-seeking behaviour through reinforcement and instrumental learning. Later theorists were influenced by two developments: the increased knowledge of physiological processes acting on or within the central nervous system, and research which demonstrated that not all behaviour could be explained in terms of drive-reduction. Examples of this are: the finding that hungry rats learn to accept saccharine solution even though it has no nutritive value (Sheffield and Roby 1949), the exploratory behaviour of monkeys (Harlow 1953) and the discovery of 'pleasure' centres in the rat's brain (Olds 1956). Hebb's theory (1949) included a more centrally located mediating mechanism in the form of 'motive states' based on the organisation of brain cells in 'phase sequences'.

McClelland and his co-workers, like Hebb, believed that approach and avoidance behaviour was a function of the degree of discrepancy from accustomed physiological states (McClelland, Atkinson, Lowell and Clark 1953). They saw this mechanism as the basis of pleasure and

displeasure as experienced by an individual. This involved the inclusion of experienced phenomena in the explanation of behaviour, a development which is even more central to the theories put forward by the humanistic psychologists Rogers (1951), Maslow (1954) and White (1959). These theorists reacted against drive-reduction explanations of human behaviour, which they saw as too narrow and negative. They could not accept the passive view of man which such explanations seemed to infer.

"We may seek rest and minimal stimulation at the end of the day, but that is not what we are looking for the next morning. Even when its primary needs are satisfied and its homeostatic chores are done, an organism is alive, active and up to something." (White 1959)

In contrast to the more 'scientific' explanations, these all use the concept of self-referral as the process which mediates between the person and his immediate environment.

This summary of the mediating mechanisms proposed in some of the more influential theories, has illustrated a range of concepts from the purely physiological (Hull or Hebb), through an approach which attempts to explain experiential states in physiological terms (McClelland), to those which are purely experiential (Maslow or White). These differences in the type of mechanism proposed, raises a fundamental question for research into social behaviour. Should models of explanation in this field, involve the reduction of social phenomena to physical phenomena, or is it acceptable to explain social phenomena in terms of the reasons and meanings which people themselves, observers or agents, attach to them? This question is discussed prior to a more detailed account of the concept of self to which it is related.

2. THE PHYSICAL BASIS OF EXPLANATION

The study of Psychological Ownership will involve the use of first person data, the person's feelings, perceptions and attitudes as experienced by him. This is in contrast to the behaviourist's approach, which would be to explain behaviour only in terms of physical events. The materialist reductionism on which the behaviourist's approach is based, has been influenced by the Logical Positivist movement at the beginning of this century. Its proponents advocated the building of a science on factual and simple concepts gained from experiments, in order that complex theories could be developed from verifiable data. It was an attempt to build a scientific discipline modelled after the natural sciences such as physics or chemistry. Previous and more philosophical explanations of behaviour were shunned as being vague. The only legitimate mode of explanation was one which reduced observable phenomena to physiological or physical events. First person data was held to be of particularly low status.

The concept of reinforcement, one of the central themes in behaviourist theory, illustrates the reductionist approach in being based on a mechanical model of causality. But the application of this model to broader patterns of behaviour, has been questioned by social scientists and philosophers. Ryan (1970) for example, questions the validity of reducing social behaviour to mechanical causal processes. While accepting that regularities in social behaviour occur and can form the basis of prediction, and that a reductionist approach may be appropriate in explaining certain limited phenomena, he maintains that this model is too specific to be applied to the integrated and complex picture of social behaviour. His point is that it is illogical to apply a model derived

from the study of inanimate objects to human beings, who differ in their capacity to give meaning to events and to have thoughts and feelings, who are able to act on as well as to react to, their environment.

"Obviously the one claim that has to be resisted is that we should hope to develop a unified science of the whole natural order, both human and non-human." (Ryan 1970)

Ryan is sympathetic to the model of man as a reasoning, rule following being, arguing that this is more appropriate than a physical causal framework, which of necessity distorts or loses the 'social' aspect of social behaviour.

Earlier, Peters (1958) expressed a similar point of view in advocating an approach which was not limited by the assumption that a single explanatory model would explain behaviour in all situations, under any conditions. Peters observed that mechanical causal explanations may be relevant but insufficient in explaining human behaviour, because the generalisation from physiological to social phenomena is a speculative step and involves a denial of the fundamental differences involved.

"For apart from the fact that it is logically absurd to say that one could be driven to know anything, the use of the same term for all these very different types of action, is a case of unwarranted assimilation in the interest of an over-all theory." (Peters 1958)

Most recently, these views have been supported by Harre and Secord (1972) in their analysis of what they see as a growing and fundamental change in the theoretical approach within the social sciences. They argue

for:

" ... a view of man as an active, self-directing, self-monitoring agent whose acts occur in a social framework constructed out of meanings."

These authors, like Ryan, stress the need to adopt an explanatory model of behaviour which takes into account the meaning which people give to their own actions. The implication for research, is that, unlike studies based on a materialist reductionist framework, the investigation must involve data in the form of people's perceptions of themselves, of others and of events with which they are concerned. It should include the individual's experience and interpretation of those events in the way in which he represents them to himself. This can only be accomplished by starting from the descriptions he gives of them (Leeper and Madison 1959, Bannister and Fransella 1971). The importance of this mode of investigation is that, as Shlien (1964) asserts:

"The person is not an empty organism who reacts to stimuli he finds rewarding. He gives meaning to stimuli in his experience of them and it is this meaning which influences and directs his behaviour."

This use of the expressed content of immediate experience is in the phenomenological tradition (see Farber 1966) and is strongly supported by such authors as DeCharms (1968), Harré and Secord (1972) and Hudson (1968), who says of it:

"It offers the prospect ... of more accurate, more parsimonious prediction. We make better sense of an individual's responses to his environment from the moment we discover what that environment and those responses signify to him."

These arguments support the investigation of constructs such as Psychological Ownership and Autonomy, by way of the accounts which people give of their experience of them. In particular, these constructs infer the process of self-referral and the concept of self. It is therefore with this concept that the discussion continues.

3. THE CONCEPT OF SELF

The research is designed to investigate the concept of Psychological Ownership, in order to explain the observed relationship between the two factors, Autonomy and Task Commitment. The mediating process involved is one of self-referral in that it deals with the person's perception of outside events in relation to himself.

William James (1892) regarded the self as a viable concept. He considered it to be comprised of two components, the self as known ('me'), and more difficult to describe, the self as knower ('I'). Since that time and with the increasing weight of interest in behaviourism and experimental psychology, the concept of the self appeared to be little more than a word to fill the gap that empirical data had so far not been able to fill. At worst, it was considered by behaviourists as having 'a slight flavour of scientific obscenity' (Allport 1955). As such its value was in doubt and for a considerable time it all but disappeared from the domains of psychology (Sarbin 1952).

But more recently this concept has played an increasing part in the research and theory of personality (Wylie 1961) and is thought likely to continue to do so (Hilgard and Atkinson 1967). Hilgard, in his presidential address to the A.P.A. in 1949, called for more research into

the self and Hall and Lindzey (1957), in their review of personality theories, state that the self plays a role in most of them. The question remains as to whether the self is 'a fact of nature, or the arte-fact of men's minds' (Lowe 1961). Allport, in answering the same question as posed by Lowe, sees the self as a unifying concept which is dangerous if used as a 'factotum', a lazy way of binding together the fragments of more specific data produced by the labours of empiricism. However, he felt that it could be a valuable concept to aid thinking and further enquiry. His conclusion is worth quoting in full.

"But so far as psychology is concerned our position, in brief is this: all psychological functions commonly ascribed to a self or ego must be admitted as data in the scientific study of personality. These functions are not, however, coextensive with personality as a whole. They are rather the special aspects of personality that have to do with warmth, with unity, with a sense of personal importance. In this exposition I have called them 'propriate' functions. If the reader prefers, he may call them self-functions, and in this sense self may be said to be a necessary psychological concept. What is unnecessary and inadmissible is a self (or soul) that is said to perform acts, to solve problems, to steer conduct, in a transpsychological manner, inaccessible to psychological analysis." (Allport 1955)

The self then, may be defined as that part of the individual's personality of which he is aware, sometimes called the phenomenal self, and is made up of his thoughts, beliefs, perceptions, values and feelings. Murphy, in the index to his book on personality defines self as 'the individual as known to himself' (Murphy 1947), and this is close to the meaning adopted in this present study. It is the awareness of self which

is the key. It arises through growth and experience. The newborn infant cannot distinguish between himself and things outside himself. Gradually the idea of 'me' and 'mine' emerge and the perception of self is further refined through the process of social interaction. As Harvey (1963) suggests, it is the self as a totality of our concepts which makes the world meaningful to us.

The approach of this study is based on the fact that although a self cannot be observed, the process of referring to self can, in that individuals relate stimuli from their social or physical environment, consciously or unconsciously, to a picture they have of themselves. It is in this sense that the central theme of this study focusses, not on the internal physical mechanisms of the person, nor on some objective property of the task, but on the dynamics of the perceived relationship between the two. Within this framework the concept of self is used as Lowe describes it: '... an arte-fact which is invented to explain experience' (Lowe 1961).

4. IMPLICATIONS FOR UNDERSTANDING MOTIVATION TO WORK

The literature in Organisational Behaviour reflects the variety of philosophies which exist in the field of psychology. On the one hand there are the 'scientific' studies of job satisfaction to which Brayfield and Crockett refer. (See p.3) The theoretical models which are based on these studies are influenced by the work of experimental psychology and emphasise reward and reinforcement in propounding causal models of behaviour (McGregor 1960, Vroom 1964, Herzberg 1968).

"Without doubt, the law of effect or principle of reinforcement must be included among the most substantiated findings of experimental psychology and is at the same time among the most useful findings for an applied psychology concerned with the control of human behaviour." (Vroom 1964)

On the other hand there are those views based on the strongly humanistic theories of certain personologists, notably Maslow and Allport. These encourage a more lively and compassionate approach to the study of social behaviour yet frequently employ such global redescrptions as to leave in their wake more enthusiasm than real explanation.

It may prove fruitful in studying behaviour at work to combine empirical discipline with an acceptance of the kind of experienced phenomena investigated in the concept of Psychological Ownership. By this approach the frustrations of strict materialist reductionism or of global redefinitions may both be avoided.

"I am therefore going to commit a final and incorrigible lewdness. I am going to assess certain of the broad requirements for analyses of human motivation by examining human motivational phenomena. ... I will not be ashamed to consult the phenomena of human experience as well as human behaviour." (Koch 1956)

In as much as the arguments against a reductionist approach are valid, it must be a worthwhile exercise to explore this alternative. In this sense Psychological Ownership does not replace any of the motives which may be proposed by other authors, but may help to explain the complexities of social behaviour which seem inadequately explained in

single motive terms. It may prove to be as DeCharms (1968) wrote of his theory of Personal Causation:

" ... an overarching or guiding principle upon which specific motives are built."

P A R T I I I

THE INVESTIGATION OF PSYCHOLOGICAL OWNERSHIP

CHAPTERS VIII-XII

- VIII The Pilot Study and Final Research Design
- IX Predictions and Statistics
- X Research Findings from Open-Ended Questions
- XI Research Findings from Scaled Questionnaires
- XII Psychological Ownership in Work - Summary and Discussion

CHAPTER VIII

THE PILOT STUDY AND FINAL RESEARCH DESIGN

1. The Pilot Survey
2. Methodology
3. Procedures and Measuring Instruments
4. Results of the Pilot Survey and Design Modifications

1. THE PILOT STUDY

(a) Objectives

The aim of the research is to investigate the association between Autonomy and Task Commitment in terms of a person's perception of the task and of his relationship to it. This perception, called in the study, Psychological Ownership, is therefore a construct. It is an intervening variable, a term which, as Kerlinger (1969) points out:

" ... is invented to account for internal and directly unobservable psychological processes that in turn account for behaviour ... an 'in-the-head' variable. It cannot be seen, heard or felt. It is inferred from behaviour."

Specifically, the pilot study is based on the following areas of interest, as summarised in Chapter VI:

- The relationship of Psychological Ownership in a task and the Autonomy (Freedom of Choice and Influence) the person has in it.
- The manifestation of Psychological Ownership in the commitment and enthusiasm expressed by the individual and in other feelings, negative or positive, which the task generates.
- The part played by three personality factors:
 - (i) Perception of self as the locus of control,
 - (ii) Conformity,
 - (iii) Attraction to Ownership.

(b) Rationale for the Pilot Survey

The first step in the field research was to carry out a pilot survey.

This was necessary for the following reasons:

- To ensure that it was realistic to ask respondents to define the specific tasks which were to be the vehicle for subsequent enquiry.
- To test all instruments for clarity and each scaled item for balance and discriminating power.
- To ensure that open-ended questions were unambiguous, unthreatening and could be related by people to their own work situation.
- To review the order of questions and questionnaires, in order to minimise responses being biased by previous questions or replies.
- To provide data which would be a basis for improving the grouping of the items into 'clusters', for example Influence and Ownership.
- To find out how long the interview was likely to take.

(c) The Population

All the people interviewed were to be managers as it was necessary that their jobs should contain sufficient challenge and complexity that the relationship of Autonomy to Ownership could be explored. More specifically, it was decided that research scientists were to be the main respondent group because it could be expected that they would have considerable autonomy in their jobs (Marquis 1966).

Access was available, through previous contacts from consultancy and management courses, to a local manufacturing company with the numbers of research staff required. Eight research managers were invited to take part in the pilot survey, together with eight other managers from production

or engineering departments who would serve as a control group. All of the research scientists and most of the others were graduates. Both departments had been subject to reorganisation in the eighteen months previous to the survey, and there was no reason to believe that the two groups had had any different exposure to behavioural science teaching. The R & D department worked to a matrix model which meant that a manager could have a functional head and also at least one project leader.*

Because of the economic climate, the company had passed through a phase of redundancies which had resulted in some feelings of uncertainty in those who remained. But the worst of this was past. It was therefore decided to carry out the study in this company as it offered the greatest opportunity available for research, while being apparently free of any organisational problems likely to limit the value of the data collected.

2. METHODOLOGY

The research was to be conducted using an interview supplemented by scaled questionnaires. Before describing the procedure and instruments in detail, the reasons for choosing this approach in preference to alternative approaches, are discussed.

Firstly, an interview with open-ended questions was necessary because of the exploratory nature of the study. No scales existed which would measure the key variable - Psychological Ownership.

Observational methods or projective tests were not chosen because of the problems of reliability and validity associated with them. The data

*R & D department was used in the main survey. A more detailed description of the department follows in Chapter X.

generated by both these methods leaves more room for inference than would verbal reports (Selltiz, Jahoda, Deutsch and Cook 1959). Moreover observational methods alone would be incomplete, as the focus of the study was to be an intervening variable and therefore, by definition, unobservable. A projective test was considered but rejected because of the problems of validation. It would have involved presenting respondents with two pictures of people at work. One picture would be described as being associated with 'enthusiasm', the other not. Stories written about the pictures would then have been coded for Ownership themes. Using a Thematic Apperception Test is also difficult due to its sensitivity to factors in the situation during its actual administration (Shipley and Veroff 1952).

The advantage of using an interview was that it would be possible to draw on actual tasks in which the respondents were, or had been, involved. An account could be obtained in terms of people's perceptions of the tasks and of their attitudes and feelings towards them. The use of an interview with open-ended questions was particularly suitable at the pilot stage. Information might be lost if responses were restricted within a framework of predetermined categories.

"Open-ended questions are called for when the issue is complex, when the relevant dimensions are not known, or when the interest of research lies in the exploration of a process or of the individual's formulation of an issue."

(Selltiz et al. 1959)

At the same time however, supplementing the open-ended questions with scaled questionnaires, meant that the hypothesised constructs and their relationships could be examined without having to depend on those constructs being explicitly expressed in the respondents' 'open' answers.

The author's previous experience in teaching situations demonstrated that managers often recognised the concept of Psychological Ownership once it had been described to them. However, without such description, their analysis of the reasons for enthusiasm in work was more likely to be in terms of 'achievement'. It was as though the word achievement had come to have a non-specific meaning and was often used merely as a synonym for job satisfaction. Scaled items which were designed to measure the concept of ownership were therefore needed.

A further value of scaled questionnaires is that they introduce more uniformity, help to reduce any bias from respondent or interviewer sources, and make the total interview experience a more varied and interesting one for the people who take part.

A final feature of the method was that respondents were to be questioned about specific tasks. This was in order to obtain a more definite picture than that resulting from more general approaches. Descriptions of jobs as-a-whole embrace a number of tasks of varying attractiveness and associated with different feelings, so that the subsequent analysis is less specific and therefore less reliable.

3. PROCEDURES AND MEASURING INSTRUMENTS

Details of the interview schedule and the various scaled questionnaires used in the pilot survey are contained in Appendix D.

(a) The Choice and Description of the Two Tasks

Each respondent would be asked to describe what his job entailed, and then to identify specific tasks, managerial or technical, on which he

was currently working. These would then be ranked by him in order of his enthusiasm for them, regardless of the importance they might have for the company. Two of these tasks would be selected for further enquiry and called Tasks A and B.

Task A: The one he felt most enthusiastic about.

Task B: One towards which he felt indifferent.

A full account of both tasks would then be compiled from open-ended questions concerning the following aspects:

Their nature.

Their origin and rationale.

How the respondent became involved in them.

What part he had played and was playing.

How he felt about the tasks and why.

Each task was later to be the topic of a scaled questionnaire, a description of which now follows.

(b) The Job Activity Questionnaire (J.A.Q.)

The Job Activity Questionnaire contained items designed to measure the Autonomy and perception of Psychological Ownership associated with each task, as well as various behavioural manifestations of Ownership. Enthusiasm was the criterion on which the tasks were to be selected. The J.A.Q. also measured various aspects of involvement, commitment and related feelings for each individual (General Items). This questionnaire was to be completed twice (for Tasks A and B). In between, were open-ended questions and other scales so that conscious comparison of the two tasks would be minimised. The J.A.Q. contained 26 scaled items to investigate the history of the task and the respondent's attitude towards it. The three broad categories and 26 items are presented in Table 8.1.

Table 8.1. Categories and Items in the Job Activity Questionnaire (Pilot)

<u>CATEGORY</u>	<u>ITEM NO.</u>	<u>DESCRIPTION</u>
<u>AUTONOMY</u> The perception of influence and freedom of choice	3	Allocation of responsibilities
	*4	Task generated from his idea
	6	Able to choose or modify methods or procedures
	*9	Initial freedom to accept or reject the task
	*11	Target setting method
	13	Opportunity for his ideas
	16	Able to make changes
	21	Use of feedback
	*23	Amount of freedom
	25	Authority held
<u>PSYCHOLOGICAL OWNERSHIP</u>	1	Talking to others
	5	Identification with the task
	7	The task is his 'pigeon'
	10	Effects of task performance on feelings about self
	12	Rating in life
	*15	Sense of personal involvement
	19	Reaction to criticism
	*20	Tendency to think about task after work
	26	Perception of closeness of task to self
<u>GENERAL ITEMS</u>	2	Amount of challenge
	*8	Interest content
	*14	Importance to department management
	17	A source of self-fulfilment
	*18	Significance in departmental success
	22	Source of self respect
	24	Sense of accomplishment

*Reversed items

Each item was in the form of a graphic rating scale (Selltiz et al. 1959) with four scale points and a brief description in each. The respondent would be asked to check the box which best reflected the situation as he saw it. For example:

Allocation of tasks, responsibilities, duties etc. or the approval of subordinates undertaking of them in this task:

is at my sole discretion	is at my discretion for the most part	is outside my discretion at times	is almost never at my sole discretion
--------------------------------	--	--	--

This questionnaire is in Appendix D. Its form was chosen in preference to the Likert scale to encourage the respondents to relate each item to their work by having to read the descriptions and avoid ticking boxes without much thought. The items were arranged in random order to prevent inter-item influence and nine were reversed to minimise 'halo' effect. This reversal procedure was explained to the respondent to avoid the confusion and irritation it can sometimes cause. Each item was so constructed as to avoid the responses to some questions being pre-determined by responses to others.

The measures which were to be of particular interest in the analysis were those of the differences between Task A and Task B scores. The advantages of this were as follows:

- It controlled for individual differences in expressing feelings.
- It controlled for differences in opportunity, for the aspects of the task investigated.
- It provided more inter-respondent differentiation than using Task A questionnaire results alone. As the preferred task, Task A would have been more likely to produce consistently high scores on all items.

(c) The Opportunity Scale

A 'climate' questionnaire was adapted from the one used by Lawrence and Lorsch (1967). It was included to test the assumption that the structure and management philosophy of each department would be different because of the different functions involved. The aim of this questionnaire was therefore to provide an indication of any difference in the opportunities for personal influence and freedom in the two departments. By this means, it would be possible to assess the extent to which the part played by Psychological Ownership was dependent on the environment in which the person worked.

(d) Scales Measuring Personality Factors

(i) The Perceived Locus of Control - The I-E Scale

This scale was developed to measure a person's perception of the amount of control or influence which he feels he has in certain specific situations (Rotter 1966, Lefcourt 1966). Rotter defines the scale as follows:

"If the person perceives that the event is contingent upon his own behaviour or his own relatively permanent characteristics, we have termed this a belief in internal control."

In contrast to this, external control is the perception of events:

"... as the result of luck, chance, fate, as under the control of powerful others, or as unpredictable because of the great complexity of the forces surrounding him."

(Rotter 1966)

This concept is close to the influence component of Autonomy as defined in this study (p.58). The I-E scale was therefore chosen as one general characteristic which might determine the strength of association between Autonomy and Task Commitment in a specific situation.

The I-E scale was found by Rotter (1966) to have reasonably high internal consistency and test-retest reliability. The 10 items to be used were those selected by Thomas (1970) as those with the highest interscale correlation. The instructions and items are contained in Appendix D. Each item involved a forced choice between two statements, one reflecting internal and one reflecting external locus of control. For example:

- a) Becoming a success is a matter of hard work, luck has little or nothing to do with it. (internal)
- b) Getting a good job depends mainly on being in the right place at the right time. (external)

(ii) Independence versus Conformity - The I-C Scale

Conformity was selected as it is related to the second aspect of Autonomy: the Freedom of Choice the individual has to influence a situation. People with different tendencies to conform, could be expected to attach different values to the opportunity for freedom of choice in relation to a task. Conformity behaviour is also related to scores on the I-E scale. Externals are found to be more conformist than internals. Internals on the other hand are found to resist attempts to influence them unless they feel it is to their own advantage to be influenced (Rotter 1966).

The scale was constructed with 10 items which Crutchfield (1955) had found more frequently believed to be 'true' by independent subjects

than by conforming subjects. The independence of the individual was judged from behaviour in an Asch-type experimental situation. An example of an item to which respondents answered 'true' or 'false' follows.

"It is alright to get around the law if you don't actually break it." (See Appendix D)

(iii) Preference for Ownership - The O-P Scale

Fourteen further items were added to those measuring conformity. (See Appendix D) They were designed to distinguish between individuals on the basis of their attraction to situations likely to involve Ownership. Respondents were asked to answer 'true' or 'false' to such statements as:

"I usually find I'm reluctant to work to ideas or plans I have had little or no influence over."

"I find I often defend an author I am reading if someone else attacks him."

Agreement or disagreement with these items would indicate the importance to the individual of the Ownership he could have in a situation, either through personal influence (first example above), or by identification (second example). This was the third personality factor whose effect on the relationships of Autonomy, Psychological Ownership and Task Commitment, would be investigated.

(e) Further Open-Ended Questions

(i) Respondents' Views on Motivation to Work

The managers would be asked what their beliefs were as to what caused enthusiasm, pride or frustration at work, both from their own work experience and from their experience as managers. These questions were

designed to test the assumption posed earlier (p.78) that people might show their awareness of the link between Autonomy and Task Commitment but be as likely to express the nature of that link in terms of achievement as they would be to describe it in terms of Ownership.

(ii) Critical Incident Questions

Herzberg's original questions (p.7) and the ranked list of tasks generated at the beginning of the interview, allowed the following prediction to be investigated: that both situations recalled, whether associated with bad or good feelings would have been important to the individual at the time. The analysis of the answers to these questions would provide the link between Part I and Part II of this study. It would demonstrate that it is the commitment of the individual that causes him to remember the task at all, and that the associated feelings determine how it is remembered, with or without some involvement of perceptual defence.

4. RESULTS OF THE PILOT SURVEY AND DESIGN MODIFICATIONS

With this design the pilot survey was conducted. Before the interviews began, a meeting was held with the R & D group to provide them with an opportunity to ask questions about the survey. This was not possible for the production and engineering group so they were visited individually. A room was provided in each department in which to interview the 16 members of staff. One or two expressed doubts as to the motive behind the exercise but there was no evidence that this doubt remained when the interviews began. One respondent had to leave before completing all the questionnaires.

The interview, which had been pretested on colleagues, took three and a half hours at the first, but subsequently lasted about two hours. Before beginning with the questions, the following points were made.

- Respondents were told the purpose of the research and that it was at the instigation of the author.
- As it was a pilot study, comments would be welcomed.
- Answers would be treated confidentially.
- Only their own opinions were sought.

At the end of the interview each respondent was asked not to reveal the questions to his colleagues. The evidence suggested that they honoured this.

The results of the pilot survey and the subsequent modifications to the design are now covered in four subsections:

- (a) The choice and description of the two tasks (A and B).
- (b) The Job Activity Questionnaire.
- (c) Other scaled questionnaires.
- (d) Other open-ended questions.

(a) The Choice and Description of the Two Tasks (A and B)

In most cases, respondents were able to subdivide their work into specific tasks from which two of different preference could be chosen. Several modifications were required.

- Some engineering managers and some senior managers of both groups described their jobs in terms of broad areas of responsibility and

could not identify specific tasks that were of a significant size, or differed in associated feelings.

- The choice of Task B left too many variables uncontrolled. For example, the type of task, managerial or technical, and differences in importance to the company, made interpretation of the role of the key variable more difficult.
- The questions, designed to provide a detailed picture of the two tasks, were not comprehensive enough and the data was therefore incomplete. Additional questions were therefore added during the pilot stage.

The Final Design: As in the pilot, each respondent would be asked:

- To describe his work in terms of specific and current tasks.
- To rank them in order of his enthusiasm for them.
- To choose as Task A the one he felt most enthusiastic about.
- To choose for Task B one that met the following criteria:
 - . It would be seen as being at least as important to the company as Task A.
 - . It would be similar in type to Task A.
 - . It would be a task which the respondent felt less enthusiastic about.*

The revised questions, designed to provide data about the nature of the task, its origin, and the respondent's involvement in it and feelings about it, are contained in Appendix E.

*In cases where two tasks could not be identified, a 'back-up procedure' was used. (See Appendix E)

(b) The Job Activity Questionnaire

During the pilot, the divisions on the scale were increased from 4 to 8, as people found the smaller number too restricting. A number of items were modified because either or both extremes of the scale were not used. One item, concerning 'the effects of criticism', was significantly changed as respondents frequently commented on its ambiguity. Three items were deleted: item 23 (the amount of freedom) and item 25 (the amount of authority), were not specific enough, nor did they produce a sufficient spread of the A minus B score, which was to be the critical one for correlation. Item 22 (source of self respect), was deleted because many respondents found it too vague.

Category Formation from Psychological Ownership and General Items

Some of the Psychological Ownership items were, at face value, more specific than others. Compare for example the following items:

"All in all, I think of this as my pigeon." (specific Ownership)

"Depending on how well or how badly this goes, the effect on how I feel about myself is likely to be ..." (non-specific)

The items included under Psychological Ownership and some of those in the General category, were therefore regrouped as Psychological Ownership and Task Involvement. (See Tables 8.2 and 8.3) Psychological Ownership contained those items which were specific in describing feelings of identification. (Table 8.2) Task Involvement contained items which signified preoccupation or concern with the task. (Table 8.3) As such, the Task Involvement category was designed to measure a behavioural manifestation of Psychological Ownership.

Using data obtained with the J.A.Q. (Task A) and from both occupational groups, these two categories were tested for internal consistency by item-total correlation using Spearman's rho. The results are in Tables 8.2 and 8.3.

Table 8.2. Item-Total Correlations for Psychological Ownership*

<u>Item</u>	<u>rho</u>	<u>significance</u>
(5) Identification with the task	.94	.01
(7) 'His pigeon'	.72	.01
(12) Rating in life	.81	.01
(15) Personal involvement	.19	n.s.
(19) Reaction to criticism	.91	.01

n.s. = not significant at .05 level.

Table 8.3. Item-Total Correlations for Task Involvement

<u>Item</u>	<u>rho</u>	<u>significance</u>
(1) Talking to others	.56	.05
(10) Effect on feelings about self	.61	.05
(17) Source of self-fulfilment	.64	.05
(20) Thinking about task after work	.84	.01
(24) Personal accomplishment	.28	n.s.

As a result of these findings, item 15 was modified, and item 24 was included with two other items, Challenge and Interest, in an 'Achievement' group. The item-total correlations for this group follow in Table 8.4.

*Item 26 - 'Closeness to self', would have been in the Psychological Ownership group, but the scoring had been restricted to a four point scale and could not be used in this correlation.

Table 8.4. Item-Total Correlations for Achievement

<u>Item</u>	<u>rho</u>	<u>significance</u>
(2) Challenge	.90	.01
(8) Interest	.81	.01
(24) Personal accomplishment	.93	.01

The regrouping into these three categories was supported by the high item-total correlation in each and by the low intergroup correlation. (See Table 8.5)

Table 8.5. Intergroup Correlation of Psychological Ownership, Task Involvement and Achievement

<u>Correlation</u>	<u>rho</u>	<u>significance</u>
Psychological Ownership and Task Involvement	.38	n.s.
Psychological Ownership and Achievement	.38	n.s.
Task Involvement and Achievement	.01	n.s.

The Final Design: The three categories described above were included in the J.A.Q., as were three others which measured aspects of Autonomy. These were Influence, Freedom of Choice and Freedom to accept or reject the task. The items measuring these aspects of Autonomy were grouped on grounds of face validity rather than on the basis of inter-item correlations. It would not necessarily follow that because for example, a person is free to allocate responsibilities, he will also be able to make changes in procedure.

The scores for the items in each of the categories mentioned were to be summed in order to enhance discrimination between respondents. With two further items measuring the importance of the task to the company, the categories of the modified J.A.Q. were as below. (Table 8.6) The abbreviated titles used in this table are used throughout the remaining chapters. (See Appendix E for details)

Table 8.6. Factors Comprising the Redesigned Job Activity Questionnaire

Influence	-	The respondent's perception of the amount of influence he exerts on the task.
Freedom	-	The respondent's perception of the amount of freedom of choice which is his in relation to the task.
Autonomy	-	Influence and Freedom.
Psychological Ownership	-	Feelings of Ownership and identity in the task.
Achievement	-	A sense of achievement and related feelings.
Task Involvement	-	Concern and preoccupation with the task.
Initial Choice	-	Initial freedom to accept or reject the task.
Importance	-	Importance to the company.

(c) Other Scaled Questionnaires

(i) Opportunity Scale

The results are tabulated in Appendix F. It will be seen from a comparison of the 'total' columns that this scale failed to discriminate between the two occupational groups in the way predicted from the Lawrence and Lorsch study (1967). There was no evidence that the research scientist

worked in a less structured, less constraining organisation. Yet this is what would be expected, given the complexity of their technological environment. A probable cause of this finding was that the questions were answered by some managers with reference to their functional group and others with reference to their operational or project group. In any case it appeared that the scale did not provide the required information in an explicit enough form. It did not measure the opportunity people felt they had for those elements of their work which the J.A.Q. investigated. In view of this, a second 'opportunity scale' was designed and piloted. It was based on the J.A.Q. items, and is referred to as the General Job Attitude Questionnaire.

The Final Design - The General Job Attitude Questionnaire (G.J.A.Q.)

The purpose of this questionnaire was firstly to provide a comparison between the two occupational groups as to the opportunity they felt their job provided, for the factors examined in the J.A.Q. Secondly, and in conjunction with a measure of overall job satisfaction, it would provide an opportunity to compare this more standard job-as-a-whole procedure with that of comparing specific tasks.

For each of 19 items, respondents were required to check a seven point scale which lay between two opposite responses. For example:

I do not have enough freedom.	- versus -	I have about as much freedom as I could wish for.
----------------------------------	------------	---

A seven point scale was chosen in preference to the eight point scale used in the J.A.Q. for ease of siting the mid-point in the absence of any guiding statements. The questionnaire was piloted with a group of managers

attending a course at the Durham University Business School and corrected for clarity and bias. Six items were reversed. The factors, details of which are included in Appendix E, measured the opportunity the respondent felt his work provided, for:

Autonomy

Psychological Ownership

Achievement

Task Involvement

Two further items measured job satisfaction and job security.

(ii) Scales Measuring Personality Variables

The I-E Scale: The order of items needed changing to make better use of the fillers. Some wording was changed but otherwise no significant modifications were required.

The Independence-Conformity Scale: Three items (5, 7 and 10) were modified as they showed low discriminating power because of extreme wording. For example in item 10, the words 'a little' were deleted from the sentence 'A person needs to show off a little now and then'.

The Ownership-Preference Scale: Again on the basis of discriminating power, some items were modified (2, 8 and 9) and five were deleted (4, 11, 16, 19 and 24).

The final design for these questionnaires is contained in Appendix E.

(d) Other Open-Ended Questions

Several open-ended questions were modified or deleted during the pilot, as they proved redundant or difficult to answer. Some were ambiguous or difficult for the person to relate to his experience. A few, having the appearance of examination questions, obviously made a number of respondents anxious. A content analysis of these questions was not carried out at the pilot stage, as it had already been decided to leave them open to avoid restricting the language in which respondents would describe their tasks.

The Herzberg critical incident questions produced the usual 2-factor pattern of responses, with content factors being cited as causes of good feelings and contextual factors as causes of bad feelings.

The Final Design: Those general questions which proved clear, relevant and unthreatening were included in the final survey. The details of these are in Appendix E. The areas they covered were:

- Stated beliefs as to the sources of commitment.
- Stated beliefs as to the sources of frustration.
- Preference for the managerial or technical aspects of the job.
- The two Herzberg questions.
- Age and position.

CHAPTER IX

PREDICTIONS AND STATISTICS

1. The Purpose of Open-Ended Questions
2. Hypotheses from Scaled Questionnaires
3. Further Predictions
4. Statistical Notes
5. The Population

1. THE PURPOSE OF THE OPEN-ENDED QUESTIONS

(a) Questions Relating to the Two Tasks (A and B)

These questions (1-39 in Appendix E) would provide descriptions of the tasks and feelings associated with them, which would be examined for expressions of Psychological Ownership to illustrate the operational definition discussed in Chapter VI. Secondly, by comparing the ways in which respondents had come to be associated with each task and the part they had played in them, these questions would help define the forms in which Autonomy manifests itself at work. They would also enable the relationship to be explored, between Autonomy, Psychological Ownership and Enthusiasm for the task, which was the initial basis of distinguishing between the two tasks. Finally, descriptions would be analysed for evidence of ways in which people consciously sought to create the means of increasing their sense of Ownership, once a task was under way.

(b) Questions on Beliefs about Commitment

These general questions (41-43, 49 and 50 in Appendix E), would help construct a picture of what managers believed to be the sources of commitment and enthusiasm at work. More specifically, it would be possible to test out the view expressed earlier (p.78), that the part played by Autonomy and Ownership is not explicitly recognised because views are biased culturally in favour of the Achievement concept. It would be of particular interest therefore, to see how many people did not express beliefs as to the role of Autonomy or Psychological Ownership in some form, in spite of already having completed questionnaires containing items based on those same concepts.

(c) The Herzberg Critical Incident Questions

Two predictions were made on the basis of these questions. Firstly, that the 2-factor phenomenon would be demonstrated using the same categories as Herzberg developed. Secondly, that both incidents, whether cited as a source of good feelings or of bad, would prove to have been of similar importance to the individual at the time they took place. It is not that the incident recalled as being a source of bad feelings is trivial, but that to have identified contextual or Hygiene factors as the cause, is only to give half the picture. The task must have been important to the person for him to recall it at all. If however, it was associated with bad feelings, it can be more readily recalled if factors perceived as being external to the individual can be identified as the cause.

Specifically, it was predicted that where a task cited in either of the two Herzberg questions had been included at the outset of the interview, it would also have been ranked high in terms of enthusiasm. Where the task mentioned was in the past, it would have been important to the respondent at the time. These findings would therefore be consistent with the analysis of the 2-factor phenomenon which was developed in Part II. Incidents cited as giving rise to bad feelings would be those in which the person felt some Ownership, but the cause of bad feelings would be seen to have originated in others or in external factors.

2. HYPOTHESES FROM SCALED QUESTIONNAIRES

(a) The Significance of the Task A minus Task B Measures

At the interview, the basis of differentiating between Task A and Task B was the amount of enthusiasm the person felt for each one, and his willingness to put effort into them. Enthusiasm or commitment to a task is assumed to be related to how well a task is performed.

The significance of the A minus B measure therefore, is that a correlation of any two factors, say Autonomy and Task Involvement, not only indicates that a difference in one is related to a difference in the other. It also means that this association, in turn, will be related to enthusiasm, as this was the basis from which the data about the tasks had been generated.

By the same reasoning, it would be expected that A minus B values, especially Autonomy and Psychological Ownership, would be mainly positive. The exception to this would be values for Importance, the factor which was controlled in the criteria for selecting tasks.

(b) Summary of the Investigation

The relationships to be investigated through the scaled questionnaires, and their relevant hypotheses, can be summarised as follows:

- (i) To explore the relationship between Autonomy, Psychological Ownership and Task Involvement. (Hypotheses I, II and III)

(ii) To compare these factors with Achievement as a source of enthusiasm or commitment to a task. In particular:

- Can Achievement be distinguished from Psychological Ownership as a separate concept?
- If so, in what ways are the two related, and is one a greater source of Task Commitment than the other?

(Hypothesis IV)

(iii) To compare the strengths of the above relationships, as between researchers and engineers (Hypothesis V), and between people of either occupation on the basis of certain personality factors - locus of control, conformity and attraction to Ownership. (Hypothesis VI)

(iv) Finally, to explore the different opportunities for these factors as perceived by the two occupational groups - researchers and engineers. (Hypothesis VII)

A diagram of the theoretical construct developed, follows in Figure 9.1. It was developed after the pilot survey and forms the basis of the main hypotheses. The abbreviated titles for factors are defined in the previous chapter (p.91).

(c) Construct Diagram - Related to the J.A.Q. (post pilot)

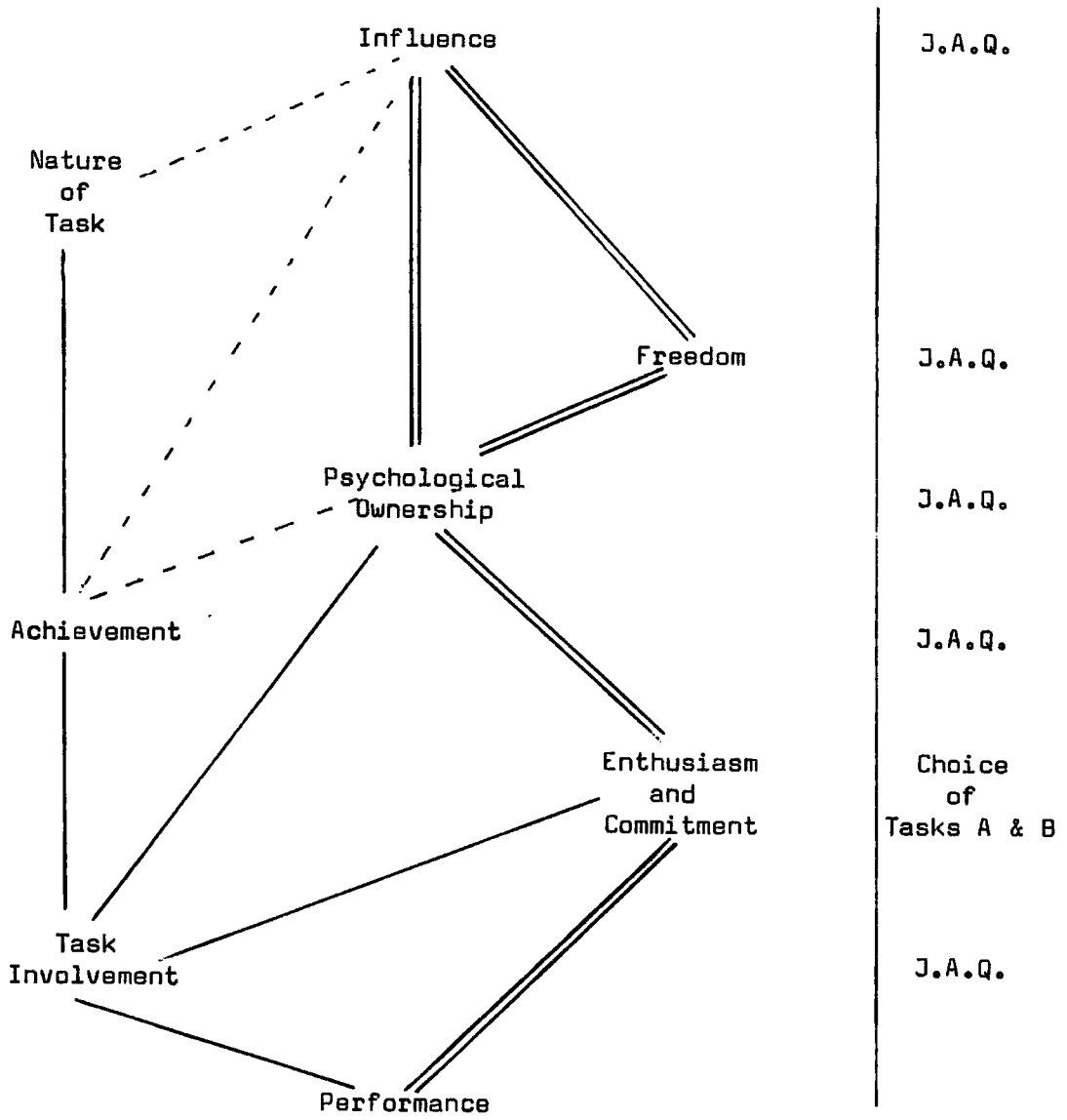

Figure 9.1. Construct Diagram

Note: The thickness of the lines depicts the predicted strength of relationships.

HYPOTHESIS I

The more Autonomy an individual sees himself as having in a task, the more Ownership he will feel towards it.

Autonomy is operationally defined as the individual's perception of the amount of Influence and Freedom of Choice he has in the task.

Prediction: There will be a positive correlation between the three factors:

Influence		Psychological
Freedom	and	Ownership
Autonomy		

These will be the strongest correlations observed, using J.A.Q. A-B measures, because of the specific role of Autonomy in the generation of feelings of Ownership.

Statistic: Kendall's Tau

HYPOTHESIS II

The more Ownership a person feels in a task, the more positive will be his attitude towards it.

The measure of attitude to the task is Task Involvement, the individual's concern for and preoccupation with, a task to which he is committed.

Prediction: There will be a positive correlation between:

Psychological		Task
Ownership	and	Involvement

Statistic: Kendall's Tau

HYPOTHESIS III

The amount of choice the individual sees himself as having had initially to accept or reject the task, will not be as obvious a source of enthusiasm as Autonomy, or Psychological Ownership.

The assumption to be tested concerns the nature of organised work, with its necessity for delegation and division of labour. What happens after the task has been apportioned, will be a stronger source of enthusiasm than the initial freedom to accept it. Psychological Ownership can be developed during the time the person is associated with a task.

Predictions:

(i) Using J.A.Q. (A) and J.A.Q. (B), there will not be a marked difference between Tasks A and B in the free choice available initially.

Statistic: Chi-Square.

(ii) Using J.A.Q. (A-B), the correlations of:

Initial		Psychological Ownership
	with	and
Choice		Task Involvement

will not be as strong as those of

Influence		Psychological Ownership
	with	or
Freedom and		Task Involvement
Autonomy		

Statistic: Kendall's Tau.

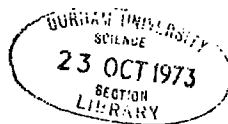

HYPOTHESIS IV

(i) The more Achievement a person associates with a task, the more positive are his feelings towards it.

(ii) This association will not be as strong as the one between Autonomy and Psychological Ownership.

(Hypotheses I and II)

(iii) Achievement will show a relationship with Psychological Ownership.

The concept to be investigated is that the two factors, Achievement and Psychological Ownership, are not one and the same, and that of the two, Psychological Ownership is the more potent source of task enthusiasm and related feelings. But neither factor is likely to occur without the other. The more challenge the task seems to offer, the more desirable Ownership becomes. Similarly the more Ownership is felt in a task, the greater the sense of Achievement possible from successes associated with it.

Predictions:

(i) There will be a positive correlation between Achievement and Task Involvement, but this will not be as strong as that between Psychological Ownership and Task Involvement.

(ii) There will be a positive correlation of Psychological Ownership with Achievement, though weaker than those described in (i), and the correlations of:

Influence		Psychological
Freedom and	with	Ownership
Autonomy		

will be weaker if the correlation is controlled for Achievement.

Statistics: Kendall's Tau and Partial Tau.

HYPOTHESIS V

Autonomy and Psychological Ownership will be more obvious sources of positive feelings towards tasks for the researchers than for the engineers.

An observed difference in the part played by Ownership in the work of these two groups of managers may be due to different opportunities, owing to the nature of the work involved. Alternatively, previous research has indicated that Autonomy in work is seen as more important by researchers than by engineers (Marquis 1966, Schultz 1964). Differences in opportunity will be examined later (Hypothesis VII). This Hypothesis (V) explores the possibility that if Autonomy is of greater value to the researchers, Psychological Ownership will be too, and these two factors will be more strongly associated with positive attitudes to a task in the case of the researchers than in the case of the engineers.

Predictions:

(i) Using J.A.Q. (A) and J.A.Q. (B) separately, there will be more evidence of high scores for the researchers than for the engineers in the following factors:

Influence

Freedom

Autonomy

Psychological Ownership

Achievement and Task Involvement will not reflect this difference.

Statistic: Mann-Whitney U.

(ii) The correlations described in Hypotheses I and II, involving Autonomy, Psychological Ownership and Task Involvement, will be stronger in the research than in the engineering group.

Statistic: Kendall's Tau.

HYPOTHESIS VI

The strength of the relationships between Autonomy, Psychological Ownership and Task Involvement, will depend on the strength of three personality factors.

These are: The Perceived Locus of Control - I-E Scale.

The Independence-Conformity Scale - I-C Scale.

The Ownership-Preference Scale - O-P Scale.

The first two are existing measures and the third was developed for this study. The I-E and I-C scales were chosen because of their relationship to Autonomy, a key variable in this research. This relationship was discussed more fully in Chapter VIII (p.83). The effects of all three personality factors on the part played by Autonomy and Psychological Ownership in generating positive attitudes are investigated. The procedure to be adopted is as follows. Each respondent group will be divided into two subgroups on the basis of each of the three personality factors in turn (using the median value). The correlations in Hypotheses I and II will then be repeated and a comparison made between each pair of subgroups so formed.

Prediction: The correlations carried out for Hypotheses I and II involving Autonomy, Psychological Ownership and Task Involvement, will be stronger in the case of the sub-group with the higher scores on each of the three personality factor scales.

Statistic: Kendall's Tau.

HYPOTHESIS VII

Researchers will see themselves as having more Opportunity for Autonomy and Psychological Ownership at work than engineers will. Achievement will not reflect this difference.

The questionnaire designed for this was the G.J.A.Q. The aim of this hypothesis is to see whether, in the perceptions of the managers themselves, there is a difference in opportunity for the various factors because of the nature of the work or organisational procedures.

Predictions: There will be higher scores from researchers than engineers, in:

Opportunity for Influence

Opportunity for Freedom

Opportunity for Autonomy

Opportunity for Psychological Ownership

but there will be no difference between the two groups in Opportunity for Achievement or Task Involvement.

Statistic: Mann-Whitney U.

3. FURTHER PREDICTIONS

These were more peripheral to the study and are therefore summarised in abbreviated form.

(a) Using J.A.Q. (A) and J.A.Q. (B), the same correlations would be examined as in Hypotheses I, II and III, using the same statistic: Kendall's Tau.

(b) The results of the G.J.A.Q. would be compared with those of the J.A.Q. to see whether:

- Correlations of items measuring Opportunity for the various factors will reflect the pattern of relationships shown by the factors themselves (Influence, Autonomy etc.).
- The correlation of Job Satisfaction with Opportunity for Psychological Ownership will be stronger than that of Job Satisfaction with Opportunity for Achievement.

Statistic: Kendall's Tau.

(c) The three personality factor scales will be intercorrelated. It is predicted that all the correlations will be positive. The scores of the three scales will also be examined for their distribution between the two occupational groups.

Statistic: Chi-Square.

4. STATISTICAL NOTES

(a) The Rationale for using Nonparametric Tests

The criteria for choosing the statistics, are that they will enable the data to be used appropriately and completely, in order to avoid adding to, or losing, information. With the data available from the questionnaires, neither a normal distribution nor equal-intervals can be assumed. Non-parametric tests are therefore more appropriate than parametric.

Some authors advocate using parametric tests in this situation, while being aware of possible inequalities of intervals and using caution in interpretation (Kerlinger 1969). Indeed this is common practice when Likert scales are used. In Oppenheim's terms (1966), the data is then assumed to be more quantitative than qualitative. The decision to employ nonparametric tests means that the approach is therefore more conservative than if parametric tests are used, but strictly speaking, the nature of the data being at most, ordinal, this was the more appropriate procedure.

(b) The Tests Used*

The Kendall Rank Correlation Coefficient (Tau): This test requires that both variables are measured in an ordinal scale and is more suitable than Spearman's rho, where large numbers of ties are likely to occur. It has a power-efficiency of 91%. Tau has the added advantage of having been adapted to provide a partial correlation coefficient which allows for one factor to be controlled. With this test the correlation of two variables (x and y) may be found while removing any effects from the third variable (z).

The Mann-Whitney U Test: This assumes ordinal measurement and two independent groups drawn from the same population. Correction for ties can be made and its power-efficiency is 95.5%.

The Chi-Square Test: This assumes at least nominal data and two independent groups.

For all these tests except Chi-square, the Scientific Subroutine Packages developed by I.B.M. were used.

*Reference: Siegel (1956).

(c) Testing for Significance

Where possible the actual p value will be given, otherwise the minimum level of statistical significance chosen, was .05. The tests used are one-tailed for the most part, as direction has been predicted. It is not possible to test for significance when using Kendall's partial correlation coefficient, as its sampling distribution is not known (Siegel 1956).

Frequently, it was necessary to compare different tau values in assessing the support they gave to the various hypotheses. Unfortunately, there does not seem to be a statistic for determining how significant the difference is, between the two tau values. Although values of Kendall's tau are assumed to form a normal distribution for large values of N (Hays 1963), a test equivalent to the one used for parametric data (Blalock 1960) could not be found.

The categories making up the J.A.Q. and the Ownership Preference scale would be retested for reliability, using data from the main survey. These two scales were to be retested as they had both been newly devised in order to investigate Psychological Ownership and its relation to other factors.

5. THE POPULATION

Although two other companies were considered, the main survey was carried out in the company in which the pilot had been conducted. The pilot stage had met with interest and the numbers of respondents available were adequate. This decision also had the advantage of the instruments having been piloted in the same environment.

A request was therefore made to interview people from the R & D department and from the Engineering works. Twenty managers from each department were chosen, from the same level, i.e. immediately senior to first line supervision. A request was also made to be able to interview 4 to 6 more senior managers from each department so that a wider view of the work situation would be possible.

The next chapter begins with a brief description of the departments involved.

CHAPTER X

RESEARCH FINDINGS FROM OPEN-ENDED QUESTIONS

1. The Population
2. The Language of Psychological Ownership
3. The Differences Between Tasks A and B
4. Managers' Beliefs about Motivation to Work
5. Herzberg's Critical Incident Questions

1. THE POPULATION

The research was conducted in the same company as the pilot survey had been. It was a division of a large company manufacturing chemicals and employing approximately 10,000 people.

Two departments, Research and Engineering, were invited to take part in the research with the same explanation and reassurances given in the pilot survey (See p.86). The invitations were sent out through the personnel officer in each department and all those who accepted the invitation were interviewed. Any obvious preselection of respondents on the basis of known attitudes to the company or their management was avoided. Nevertheless, there may be some difference due to the respondent group being more agreeable to the idea of taking part in the survey.

(a) The Research Managers

Amongst the management levels in research, there were few non-graduates. The work was of three kinds:

- Original research and development of substances or processes.
- The development of ongoing processes, usually for the company, but sometimes for customers, using the company's processes.
- An analytical service for other departments and production units.

Managers interviewed were often in the position of belonging to at least two working groups, the section in which they were organisationally based, and one or more project teams. A project team could also include people from non-research departments such as marketing.

(b) The Engineering Managers

Three types of engineering manager took part in the survey. Plant engineers, who were responsible for on-going plant maintenance and breakdowns. They reported to a senior engineer but received much of their work from the plant manager, hierarchically their equal. Some engineers were centrally based, and were responsible for the supervision of work of a service nature to plants where there was more work than the local plant team could deal with. Other projects, such as constructing, modifying or repairing plant machinery, were carried out in central workshops.

There were also those with a more general function such as planning or inspecting and those who were in-company consultant engineers, having a team of subordinates and being available to give advice to plant management.

About half these engineering managers were graduates.

(c) The Numbers Taking Part

A breakdown of the respondent population is in Table 10.1. One research manager was not included in the analysis because of foreign nationality. The replies of the senior managers were not included in the analysis either. They were interviewed only to provide further background information on the departments and the way they were organised. This helped to clarify the descriptions given in the other interviews.

Table 10.1. Numbers of Managers Interviewed

Research Managers	21	(1 excluded from analysis)
Research Senior Managers	5	
Engineering Managers	23	
Engineering Senior Managers	4	
Total	<u>53</u>	

(d) Age Distribution

Seventeen of the research managers were between 20 and 40 years old. In the engineers' group however, the age range was wider. (See Table 10.2) This raises the question as to what part age might play in the findings. For example ten out of twelve engineers aged 20 to 40 years, were able to refer to specific tasks, compared with only 5 out of the 11 older engineering managers.

Table 10.2. Age Distribution of Managers Included in the Analysis

<u>Age Group</u>	<u>Numbers of Managers</u>	
	<u>Research</u>	<u>Engineering</u>
20-30	8	5
31-40	9	7
41-50	3	5
51+	0	6
	<u>20</u>	<u>23</u>

This could represent a source of error in subsequent findings, but the numbers do not allow any meaningful analysis of the part played by age in Psychological Ownership and Task Commitment.

2. THE LANGUAGE OF PSYCHOLOGICAL OWNERSHIP

The purpose of this section is to use the actual expressions with which people described their tasks or attitudes to work, to amplify the operational definition of Psychological Ownership that has been developed.

This is an important part of the study for two reasons. First, because Psychological Ownership is not a concept about which respondents can be questioned directly. It has not been adopted into the vernacular as have the terms 'challenge' or 'achievement'. Second, because in presenting the expressions which people actually used, the concept is illustrated in a more recognisable form than that developed by the more rigorous process of constructing and analysing scaled items for a questionnaire.

The quotations which follow are samples which illustrate various aspects of Psychological Ownership; how it is experienced, the sources from which it is derived and what its relationship may be with the other, more familiar concept of Achievement. A fuller list of quotations forms Appendix G.

The Way Ownership is Experienced

"I'm interested because this is my baby ... it's mine ... and warts and all too. It's problematical but they're my problems and I like that - I like that very much."

The Way it is Sought

"I was looking for something that would grow out of what I was doing, something that would be 'mine', if you like."

Its Origins

"I'd be very annoyed if I was pulled off it, because I did a lot of thinking and work others didn't see. I went my way about it ... You carry a lot in your hands and head which others don't have."

Its Relation to Achievement

"It's the enjoyment of a visible result of my own actions. Either success or failure in terms of what I do."

These and other expressions were derived mainly from descriptions of the preferred task. They demonstrate the way Ownership is acquired, the way it can be threatened by being taken over by others and how it can conflict with organisational goals.

3. THE DIFFERENCES BETWEEN TASKS A AND B

The last section demonstrated the language of Psychological Ownership. In this section a comparison will be made between the descriptions of Tasks A and B, in order to investigate:

- The origins of Task Enthusiasm in the degree of Autonomy the person sees himself as having.
- The association of Autonomy and Enthusiasm with feelings of Ownership in the task.
- The part played by other factors, such as Achievement, in the generation of Enthusiasm.

A number of categories were developed through content analysis and used as the basis of distinguishing between tasks. The categories are not merely presented as the prerequisite to coding. Because the study is largely exploratory, one of its aims is to refine ways of studying the key variable - Psychological Ownership. For this, categories had to be developed. They have therefore been presented in some detail to illustrate and identify their origins.

Each set of categories is constructed to meet the following criteria:

- It will involve a single classifying principle.
- It will be exhaustive, i.e. all responses can be found a category.
- It will be mutually exclusive, i.e. there should be no overlap between the categories in each set.

(Selltiz et al. 1959)

When the responses to the questions on Origin, Involvement and Feelings for the Task were examined, it was found they could be organised into three category sets. These were:

- The timing of the person's involvement in the task.
- His degree of Autonomy in it.
- His reasons for the Enthusiasm he felt towards it.

The first two of these sets are combined in the analysis of the part played by Autonomy.

The two subsections which follow, describe the categories used in coding responses and the results of content analysis for:

- (a) The Part Played by Autonomy, and
- (b) The Reasons Given for Task Enthusiasm.

(a) The Part Played by Autonomy

(i) The Categories

The timing of the person's involvement with the project was represented by two categories:

- The respondent was involved from the beginning.
- The respondent was involved after the beginning.

The second set of categories concerned the degree of Autonomy the person had had in the task, the amount of Influence, Control and Freedom of Choice which was, or had been, his. Nine categories were identified to reflect the various degrees of Autonomy which the descriptions of the Tasks suggested. (Table 10.3) The categories, their definitions and the abbreviations used subsequently in the study, are grouped under three broad headings. They are:

- The task is self-generated.
- The task is not self-generated but provides significant scope for Autonomy.
- The task is not self-generated and provides little or no scope for Autonomy.

Table 10.3. The Different Degrees of Task Autonomy

<u>Categories</u>	<u>Abbreviations</u>
<u>Self-Generated</u>	
Initially develops idea <u>and</u> introduces it. It is outside his remit.	- <u>HIS IDEA</u>
Initially develops the idea. Within his remit.	- His idea
Responsible for introducing an idea which someone else developed outside his department or company.	- Imports
<u>Not Self-Generated but with Scope for Autonomy</u>	
The subsequent development of the task is due to his ideas. There is a creative process involved although he did not originate the task.	- Development
No creative element, but he is responsible for the development of the task through his organisation or procedure. Formal authority with minimal constraint.	- Management I
Subsequent development partly due to his ideas. A shared and central role, but without formal authority.	- Consultative I
<u>Not Self-Generated and Little or no Scope for Autonomy</u>	
Subsequent development only affected by him to a minor extent, i.e. formal authority within significant constraints.	- Management II
Subsequent development only affected by him to a minor extent. A shared but peripheral role and without formal authority.	- Consultative II
Subsequent development is in conflict with his ideas, beliefs or values.	- Conflict

(ii) The Findings

The content analysis of the accounts of Tasks A and B shows a clear association between Autonomy and Enthusiasm.

The Researchers: In Tasks A, over half the researchers had initiated the ideas from which the work had developed. The responses of the other researchers demonstrated significant involvement in the tasks through subsequent development of them. In contrast to this, in Tasks B, only one was self-generated and less than half seem to have afforded any significant scope for personal influence.

Respondents had also been involved from the beginning more often in the preferred than the less preferred tasks, but the significance of this finding is difficult to estimate as it is so often associated with self-generated tasks.

The Engineers: The difference in the amount of Autonomy in Tasks A as compared with Tasks B, was reflected in the engineers' descriptions too, but they cited less self-generated tasks than did the researchers. Only one third of the engineers' preferred tasks came in this category.

The results of both groups are summarised in Table 10.4. A more detailed analysis of the distribution of Autonomy in tasks of greater or lesser enthusiasm is included in Appendix H.

Table 10.4. Distribution of Tasks According to the Degree of Autonomy

	<u>Researchers</u>		<u>Engineers</u>	
	<u>Preferred Task</u>	<u>Less Preferred</u>	<u>Preferred Task</u>	<u>Less Preferred</u>
Self-Generated	11	1	5	1
Significant Autonomy	9	9	10	5
Neither	0	10	0	9

Comparing the two Roles - Researcher and Engineer: Of the two types of manager, it is the research scientist who has the greater opportunity to see his work grow from his own ideas and inventions. It is even possible for him to influence the extent of financial support his project receives because he alone may have the detailed knowledge on which such higher level decisions must be based.

The engineer, on the other hand, provides a service. Most of his work is on someone else's project or someone else's plant. His scope for creative solutions is limited by technology and procedure. He is rarely able to 'see a job through' and is prevented from seeing a task as 'his' because he works to detailed plans drawn up by another section in his department.

There is a particular paradox in the plant engineer's role, as some of them were aware. Their job is to prevent problems or breakdowns occurring. They must therefore work themselves out of the very situations which provide the opportunities for creativity and control which they enjoy. With Autonomy limited in this way, the psychological rewards open to engineers are gained from technical problem solving and management of the work force.

For the research scientist the problem is not how to gain Autonomy, but how to keep it. Collaboration, delegation or a senior's interest in his project, may be seen as a threat to the Autonomy from which he derives his energy and commitment.

"I've feelings of misgivings that my boss will want to get involved and I'll lose responsibility and have to take a less influencing part in it. It's difficult to carry it all but I'd like to maintain an identity and run the whole show right the way through."

(b) The Reasons Given for Task Enthusiasm

(i) The Categories

Six categories were defined on the basis of people's accounts of why they felt, or did not feel, enthusiastic about the tasks they had described. (See Table 10.5) Examples of the responses included in each category are contained in Appendix H.

Table 10.5. Reasons for Enthusiasm

Achievement	-	Success, challenge, solving problems.
Autonomy	-	A sense of control or influence over the task. Demonstrating talents or skills.
Importance	-	To the company.
Interest	-	The nature of the work.
Psychological Ownership	-	Identification, a sense of creativity.
Recognition	-	By superiors or peers.

(ii) The Findings

The aim of this analysis was to see whether the reasons people gave for feeling enthusiastic about the Tasks, would reflect the degree of Autonomy they held in each. Detailed tables for both groups of managers are contained in Appendix H.

Researchers: If all forty Tasks, both preferred and less preferred, are examined, the categories most frequently cited by researchers as reasons for their Enthusiasm are:

Achievement	-	18 times
Psychological Ownership	-	18 times
Autonomy	-	16 times

When the preferred Tasks are examined separately, both Psychological Ownership and Achievement are mentioned in approximately half of them. It is interesting that feelings of Ownership should not be mentioned any more frequently than this, when Autonomy had emerged in the previous analysis, as such an obvious feature of the preferred Tasks. However, three-quarters of the respondents mention either Autonomy or Psychological Ownership as reasons for their Enthusiasm for Task A.

It is in the self-generated tasks in particular, that expressions of Ownership occur (8 out of 11). It would seem therefore, as though the notion of Ownership is less readily recognised, in tasks which are not self-generated, even though subsequently they may present scope for influence or ideas. In these cases, Task Enthusiasm appears to be expressed in terms of Achievement. In the next chapter, the relationship of Psychological Ownership to Achievement, is discussed in the light of the results of the scaled questionnaires.

Engineers: Psychological Ownership plays less part in the engineers' reasons for Enthusiasm, than it does in the case of the researchers. (See Table 10.6) But the emphasis on Achievement is greater. Of the thirty Tasks (A and B), described by the engineers, Psychological Ownership is only mentioned in four of them compared with eighteen out of forty, in the researchers' Tasks. Furthermore, when the fifteen preferred Tasks are analysed separately, only two of them refer to feelings of Ownership compared with ten which mention Achievement. Even when those which cited either Psychological Ownership or Autonomy are added together, Achievement is still the most frequent category.

Table 10.6. Frequency of Factors Cited as Reasons for Enthusiasm

	<u>Researchers</u>	<u>Engineers</u>
	<u>N=20</u>	<u>N=15</u>
Achievement	10	10
Autonomy	9	5
Psychological Ownership	11	2

As fewer of the engineers were able to identify self-generated tasks, this finding also adds support to the explanation offered in the discussion of the researchers' replies, that Ownership is more likely to be recognised as an attitude, when the task concerned is self-generated, than when it is not.

It appears from these findings that Psychological Ownership plays a greater part in the life of the researcher than it does for the engineer.

Importance to the Company: Of particular interest from the researchers' replies is that in eight of the Task A accounts, Importance was cited as a reason for Enthusiasm. The task was seen as being useful, worthwhile, important or of value, to the company. This would seem to conflict with another finding, that when the tasks were chosen in the interview, eleven out of the twenty 'A' Tasks were described as being less important to the company than the 'B' Tasks with which they were compared.

This apparent preoccupation with Importance to the company as a reason for Enthusiasm, is probably indicative of researchers' perceptions of how projects are selected for company support. While much of the engineers' work is obviously necessary if existing plant is to run efficiently, the researcher is dependent on the value of his project to the company, if it is to continue. Their responses reflect this difference.

4. MANAGERS' BELIEFS ABOUT MOTIVATION TO WORK

The respondents were asked for their own opinions as to the source of people's commitment to work. It was of particular interest to see whether they would refer to Autonomy and Psychological Ownership, or whether their views would reflect the preoccupation with Achievement which characterises much of the management theory to which they are exposed. The findings demonstrate that Psychological Ownership did not emerge as a major aspect of managers' expressed beliefs on motivation, even though they had seen items in the J.A.Q. which described it. However, they did seem to be aware of the means by which feelings of Ownership could be generated.

The questions asked, were:

- What is your personal view, and from your experience as a manager, as to what causes people to be committed to their work?
- What implications does this (expressed view) have for managers?

The same categories for coding were used, that had been developed for the analysis of Enthusiasm for the Tasks, together with three others which had not occurred at that stage. Appendix H contains detailed definitions and illustrative quotations.

The two categories most frequently cited by both groups of managers were Autonomy, (giving people freedom, responsibility, a chance to use their ideas) and Boss-Subordinate Relationships (fair play, good listening, trust). Psychological Ownership was mentioned only eight times, and six of these were by research scientists, whereas Achievement was mentioned twice as often by both researchers and engineers. The results follow in Table 10.7.

Table 10.7. Frequency of Categories of Motivational Beliefs in the Total Group - Research and Engineering (N=44)

<u>Category</u>	<u>Frequency</u>
Autonomy	21
Boss-Subordinate Relationship	21
Achievement	15
Recognition	10
Importance	10
Psychological Ownership	8
Salary	6
Loyalty	4
Interest	3

Conclusion: These findings suggest that the concept of Psychological Ownership is not represented in the motivational vocabulary of the managers interviewed, as much as the examination of their preferred Tasks would have implied. This conclusion gains further support if the replies on Beliefs are compared with those on Reasons for Task Enthusiasm. (See Table 10.8) Nearly half the managers who had mentioned Achievement as a source of Enthusiasm for a preferred Task, also referred to it as a source of Commitment in other people. The equivalent proportion for Psychological Ownership was less than a third.

Table 10.8. Numbers of Respondents who Cite Achievement and Psychological Ownership in Both Task A and the Question on Beliefs

	<u>Cited in Task A</u>	<u>Cited in both Task A and the question on beliefs</u>
Achievement	20	8
Psychological Ownership	13	4

It is evident that managers are aware of the importance of Influence and Freedom of Choice in generating Commitment. But there is less transference of the notion of Ownership from their own experience of work, to acknowledging it as a source of Enthusiasm for others. It is as if it is easier to recognise that:

"I feel enthusiastic about this task because I see it as mine."

Than it is to allow that:

"He will be committed if he sees the job as his own."

This is illustrated by the reply of one research manager who said:

"I am a prime mover. I can start things going and see results from my ideas. It is very difficult for the junior staff, some are not able to contribute so they cannot see they are creating anything."

5. HERZBERG'S CRITICAL INCIDENT QUESTIONS

Each manager was asked to think of two incidents in his working life, one remembered as a cause of good feelings and one as a cause of bad feelings. The purpose of repeating Herzberg's questions was to gain additional support for the explanation developed in Chapter V, that the 2-factor phenomenon was due to perceptual defence. It was predicted that both types of incidents would be recalled because the task concerned had been important to the individual at the time. The way in which the incidents would be described, i.e. in terms of intrinsic or extrinsic factors, depends on whether or not the nature of the event is seen by the person to show him in a good light.

Procedure

(i) The responses were analysed by Herzberg's categories and grouped into Motivators and Hygeine factors. The 2-factor phenomenon was demonstrated by both researchers' and engineers' responses. (See Table 10.9. Details in Appendix H)

Table 10.9. Frequency of Motivators and Hygeine Factors in Responses to Herzberg's Questions

	<u>Researchers</u>		<u>Engineers</u>	
	<u>Good Events</u>	<u>Bad Events</u>	<u>Good Events</u>	<u>Bad Events</u>
Motivators	19	4	20	6
Hygeine Factors	0	13	0	14
Both	0	2	1	1

(ii) In order to compare the incidents in terms of their importance to the individuals, only those which related to specific tasks were retained

for the next step in the analysis. As was seen in the choice of specific tasks for the earlier part of the interview, the engineers referred mainly to general situations and this left insufficient cases to continue the analysis for this group of managers.

Thirteen researchers described an incident relating to a specific task for both Herzberg questions. In no case was there any evidence for the bad incident being associated with a task of lesser importance to the individual, than the task connected with the good incident. In fact, eight of the thirteen respondents referred to the same task in answer to both Herzberg questions. Furthermore, a Task A was mentioned ten times in descriptions of incidents giving rise to bad feelings but a Task B only twice.

This investigation supports the alternative analysis offered for the 2-factor phenomenon. The incidents cited in answer to both Herzberg's questions concern tasks which were important to the individual at the time the incident occurred. If the incident gave rise to bad feelings, it is recalled, or at least recounted, in a way which protects the individual from feelings of failure or lack of competence.

This finding provides the link between Herzberg's methodology, discussed earlier, and the theory of Psychological Ownership. The division into Motivator and Hygiene factors only distinguishes between the way incidents are recalled. The tasks with which they were connected may all have been associated with feelings of Ownership by the individual concerned.

CHAPTER XI

RESEARCH FINDINGS FROM SCALED QUESTIONNAIRES

1. Sources of Enthusiasm
2. Hypotheses
3. Further Predictions
4. Validity and Reliability

The previous chapter presented an analysis of the responses to the open-ended questions. In particular, it dealt with expressions of Psychological Ownership in people's descriptions of tasks they were working on and with the finding that Enthusiasm is related to Autonomy.

This chapter summarises the findings and correlations of the scaled questionnaires. Hypotheses based on these questionnaires cover a further investigation of the relationship between Autonomy and Psychological Ownership. A comparison is made between these two factors and Achievement as sources of Enthusiasm and related feelings towards a task.

The part played by Opportunity, type of occupation and certain personality factors is also investigated.

1. SOURCES OF ENTHUSIASM

Each respondent had been asked to identify two tasks, one more preferred than the other, and these tasks were each to be the subject of a Job Activity Questionnaire. It had been predicted that the preferred tasks would differ from the others in that respondents would score them higher in all J.A.Q. factors except Importance to the Company, which had been controlled by the method of selection. With few exceptions, this prediction was confirmed. Table 11.1 shows how the tasks differed from each other.

The researchers are likely to characterise the difference between a task they prefer and one they do not, in terms of Psychological Ownership and Task Involvement, and to a lesser extent, Influence and Achievement. But they would be unlikely to identify Freedom of Choice in this way. The engineers on the other hand, while they would also see Task Involvement as a difference between preferred and less preferred tasks, are more likely to emphasise Achievement than Psychological Ownership.

So with some important differences, which are explored further in the hypotheses, preferred tasks do differ from the others, particularly in the amount of Task Involvement, Psychological Ownership, Influence and Achievement which researchers and engineers associate with them.

Table 11.1. The Difference Between the Two Tasks (A and B) Reflected in the J.A.Q. Factors. Cases Where the A Score was Equal to the B Score are Omitted from the Table.

<u>Researchers (N=20)</u>			
	<u>Number scoring higher in A than in B</u>	<u>Number scoring lower in A than in B</u>	<u>Difference</u>
Influence	16	3	13
Freedom	12	8	4
Autonomy	15	4	11
Psychological Ownership	19	1	18
Achievement	15	2	13
Task Involvement	18	2	16
Initial Choice	14	2	12
Importance	12	6	6

<u>Engineers (N=15)</u>			
	<u>Number scoring higher in A than in B</u>	<u>Number scoring lower in A than in B</u>	<u>Difference</u>
Influence	11	3	8
Freedom	12	3	9
Autonomy	13	2	11
Psychological Ownership	13	1	12
Achievement	14	0	14
Task Involvement	15	0	15
Initial Choice	10	3	7
Importance	8	4	4

2. THE HYPOTHESES

The summaries of findings which follow, refer to the research group unless stated otherwise.

Hypothesis I

Autonomy and Psychological Ownership: It was predicted that there would be a strong correlation between Autonomy (with its component factors Influence and Freedom of Choice), and Psychological Ownership. This is the central construct of this study. The more Autonomy a person feels he has in a task, through the ideas he puts into it or through the choice of approach open to him, the more he will identify it as being 'his'. Psychological Ownership is related specifically to Autonomy because it is through Autonomy that feelings of Ownership are created. The correlations in Table 11.2 are significant and support this hypothesis.

Table 11.2. Correlation of Psychological Ownership and Autonomy

<u>Factors correlated with Psychological Ownership</u>	<u>tau</u>	<u>significance</u>
Influence	0.57	.001
Freedom	0.67	.0001
Autonomy	0.65	.0001

Hypothesis II

Psychological Ownership and Task Involvement: It was predicted that there would be an association between these two factors, but not as strong as those in the previous hypothesis between Psychological Ownership and Autonomy. Task Involvement is defined as the positive feelings a person has towards a task, his concern for it and the way its outcome affects him. It can reasonably be expected, that feelings of Task Involvement will be more pronounced, the more he identifies with tasks. But there are other sources of positive feelings besides Autonomy and Psychological Ownership, Achievement for example. In other words, the association between

Psychological Ownership and Task Involvement will not be as strong as the one between Autonomy and Psychological Ownership because it is not as specific. In fact, as Table 11.3 shows, the correlation of Psychological Ownership and Task Involvement is the highest discussed so far. Further, although a partial correlation shows that Achievement is also involved (tau value of 0.54 as opposed to uncontrolled value of 0.68), the association of these two factors is at least as strong as that between Psychological Ownership and Autonomy.

Table 11.3. Correlation of Ownership and Task Involvement

<u>Correlation</u>	<u>tau</u>	<u>significance</u>
Psychological Ownership and Task Involvement	0.68	.0001

These results indicate that the more Psychological Ownership a research manager experiences in a task, the stronger will be his feelings towards it and the more involved in it he will be. They also demonstrate that Achievement is not entirely distinct from the association between feelings of Ownership and Task Involvement. This relationship is more fully explored in the fourth hypothesis, which compares the two factors Psychological Ownership and Achievement, and investigates the connection between them.

Hypothesis III

The Part Played by Initial Choice: The third hypothesis stated that the opportunity a person had initially, to choose whether he would take on the task or not, would be a less important factor in determining

subsequent Enthusiasm than the other 'source' factors investigated (Influence, Freedom of Choice and Autonomy).

This prediction was made on the basis of assumptions about working in organisations and from discussions with senior managers in this company. It is not usual for individuals to be able to choose whether a task is carried out or not. The rule is that such decisions are made at a higher level in the light of wider considerations such as market forecasts or production needs. Specifically, it was predicted:

- That Initial Choice would be no more strongly represented in preferred tasks than in non-preferred.
- That Initial Choice would not prove to be as important a source of Psychological Ownership or Task Involvement as the Autonomy factors (source factors).

Table 11.4 contains chi-square values for the distribution of source factors between the two groups of tasks (A and B). Contrary to the above prediction, Initial Choice is more evident in preferred than less preferred Tasks, and at a level of significance as high as for the other source factors.

Table 11.4. Distribution of Source Factors Between Tasks A and B

<u>Factor</u>	<u>chi-square</u>	<u>significance</u>
Initial Choice	7.85	.01
Influence	10.00	.01
Freedom	1.60	.30
Autonomy	4.90	.05

On the other hand, Initial Choice did not play a significant part in determining feelings of Ownership or other positive attitudes towards the task. (See Table 11.5)

Table 11.5. Tau Values and Significance Levels for Correlations of Source Factors with Psychological Ownership and Task Involvement

	<u>Correlation with Psychological Ownership</u>		<u>Correlation with Task Involvement</u>	
	<u>tau</u>	<u>significance</u>	<u>tau</u>	<u>significance</u>
Initial Choice	0.10	n.s.	0.10	n.s.
Influence	0.57	.001	0.42	.005
Freedom	0.67	.0001	0.48	.005
Autonomy	0.65	.0001	0.49	.005

It may be concluded from these results that in preferred tasks, a person may have some initial choice to accept or reject the work. But this is partly because so many of these tasks, especially in research, often develop from people's own ideas. In this event, as was seen in the previous chapter, some initial choice is bound to be involved.

On the other hand, these results also support the view that what happens once a task is under way, is at least as important as the freedom to choose it at the start. The Autonomy a person is given in a task he has had to accept, can ultimately become a source of feelings of Ownership and other positive attitudes towards it.

Hypothesis IV

Comparing Achievement and Psychological Ownership: The purpose of this hypothesis is to compare the concept of Psychological Ownership with

that of Achievement. Achievement has received considerable attention in previous motivational studies. (See for example Herzberg 1968, and McClelland 1953) The results of the pilot study had supported these two factors being treated separately (p.90) and the open-ended questions had revealed that Achievement was at least as important as Psychological Ownership in the beliefs which people expressed about the sources of Enthusiasm and Commitment, whether related to their own preferred tasks, or to their experience of those who worked for them (pp.121 and 124).

The questions which remained were these:

- Is Achievement as important a source of positive feelings towards a task as Autonomy or Psychological Ownership?
- Is Achievement emphasised as much as it is, because the notion of Ownership is absent from people's motivational vocabulary? In which case, do feelings of both Achievement and Ownership come to be expressed in terms of Achievement?
- Is Achievement involved in the association between Autonomy and Psychological Ownership or are the two processes entirely distinct?

The results show, that contrary to the beliefs people expressed about sources of Task Commitment in others, as far as their own experience is concerned, Psychological Ownership is more strongly associated with positive feelings towards a task, than is Achievement. This is illustrated by the correlations of Psychological Ownership and Achievement with Task Involvement, which are significant at .0001 and .001 respectively. (This finding receives additional support from the partial correlations in Appendix I.)

In answer to the second question as to the relationship between Psychological Ownership and Achievement, they do appear to be associated in that their correlation is significant at the .001 level. However, if this correlation is controlled for Task Involvement, its tau value is reduced to 0.20. This reduction in the tau value certainly confirms that the two factors are distinct, but does not provide much support for assuming them to be related. More conclusive evidence is gained from the partial correlations of Psychological Ownership and the Autonomy factors. When Achievement is partialled out, these correlations are all reduced in strength. (See Table 11.6)

Table 11.6. Correlations Demonstrating the Involvement of Achievement in the Relationship Between Psychological Ownership and Autonomy

<u>Factors correlated with Psychological Ownership</u>	<u>tau value (uncontrolled)</u>	<u>tau value (controlled for Achievement)</u>
Influence	0.57	0.47
Freedom	0.67	0.56
Autonomy	0.65	0.53

These results and the relative strength of association between the factors, are summarised in Figure 11.1. It confirms the pre-survey construct depicted in Chapter IX (p.99).

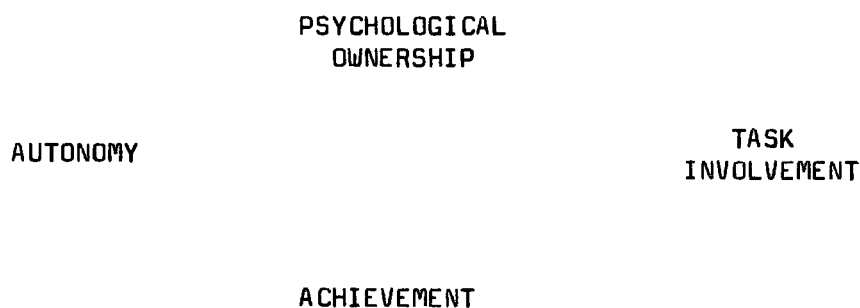

Figure 11.1. The Relationship of Autonomy, Achievement, Psychological Ownership and Task Involvement.

The explanation of the difference between the part played by Achievement on the one hand and by Autonomy and Psychological Ownership on the other, will be developed in the final chapter. It is reasonable to assume that these factors should be connected. The more Autonomy afforded the individual and the more the task is 'owned', the greater the sense of Achievement gained from its successful completion. Alternatively, the more challenge the task is seen to offer, the more interested the individual will be in 'owning' it.

However, this reciprocal relationship cannot be a complete explanation of the findings. As Autonomy and Psychological Ownership play the greater part in generating Enthusiasm, it would appear that, for the research managers at least, these are the most potent sources of Commitment.

Hypothesis V

Comparing the Two Occupational Groups: This hypothesis was designed to explore the possibility that, as Autonomy has been shown to play a more central part in the working lives of researchers (Marquis 1966), Psychological Ownership would be too. It was predicted that these two factors would be a more evident source of positive feelings for a task in the case of the researchers than of the engineers. Also, although differences in opportunity for these factors are covered in a later hypothesis (VII), this comparison was intended to help answer the question of whether differences between the two groups reflect differences of opportunity or of personal characteristics.

The results do not provide a simple answer to these questions. Firstly, when the J.A.Q. results were compared, there was no support for the prediction that Autonomy and Psychological Ownership would be given

higher scores by the researchers than by the engineers. On the contrary, one of these factors, Freedom of Choice, was scored higher by the engineers. (See Appendix I) Secondly, there was no difference in the strength of association between Psychological Ownership and Task Involvement when the findings for the two groups of managers were compared. (See Table 11.7)

Table 11.7. Levels of Significance Compared for Correlations of Autonomy, Psychological Ownership and Task Involvement - Researchers and Engineers

	<u>Researchers</u>	<u>Engineers</u>
<u>Factors correlated with Psychological Ownership</u>	<u>significance</u>	<u>significance</u>
Influence	.001	.04
Freedom	.0001	.03
Autonomy	.0001	.01
Task Involvement	.0001	.0001

However, Table 11.7 does show that the association between Autonomy and Psychological Ownership in the engineers' responses, while significant, is weaker than in the responses of the researchers.

These findings suggest that engineers may differ from researchers as to the sources of their feelings of Ownership but not in its importance to them. Psychological Ownership, where present, is a source of positive feelings towards a task for both groups. An explanation for the difference between them may be that the engineer is usually responsible for more employees than the research manager. He therefore gains his sense of Ownership, not only from influence over and freedom in a task, but also from his sense of control over the people who work for him. This explanation is consistent with the results of the open-ended questions

where control was more frequently cited by the engineers as a determinant of Task Enthusiasm. (See Appendix H) Autonomy appears to be as much a source of Enthusiasm for engineers as for researchers. But the way in which Autonomy is derived may depend on how much management is involved in the two roles.

Hypothesis VI

Autonomy, Psychological Ownership and the Involvement of Personality

Factors: So far in this chapter, an association has been demonstrated between Autonomy, Psychological Ownership and positive feelings towards a task (Enthusiasm and Task Involvement). Differences between occupational groups have also been explored. Hypothesis VI examines the role of certain personality characteristics, to see whether Autonomy or Psychological Ownership is equally important to different people as a source of Enthusiasm, or whether factors count more for some managers than they do for others.

To investigate this, three aspects of personality were chosen as relevant to the concept of Psychological Ownership.

- Perceiving the locus of control as 'internal'.
- The tendency to independence versus conformity.
- Having a preference for situations involving Ownership.

In each case it was expected that people in whom these attitudes were pronounced, would show the strongest association between Autonomy, Psychological Ownership and Task Involvement. So for example, the manager who sees himself as an autonomous person (locus of control internal), is more likely to find the source of his Enthusiasm in Autonomy and

Psychological Ownership. In the same way, Autonomy in a task is less likely to be a source of positive feelings for a manager who shows a strong tendency to conformity. The one factor limits the other.

The results are summarised in Table 11.8. They confirm the hypothesis for the first two personality factors but not for the third.

Table 11.8. Comparison of Significance Levels for Correlations of Autonomy, Psychological Ownership and Task Involvement for High and Low Scoring Subgroups on the Three Personality Scales - Total Group (N=35)

<u>Correlation</u>	<u>I-E Scale</u>		<u>I-C Scale</u>		<u>O-P Scale</u>	
	<u>High Scorers</u>	<u>Low Scorers</u>	<u>High Scorers</u>	<u>Low Scorers</u>	<u>High Scorers</u>	<u>Low Scorers</u>
Influence and Psychological Ownership	.001	.01*	.01	.05*	.05	.01
Freedom and Psychological Ownership	.005	.01*	.005	n.s.*	.01	.005
Autonomy and Psychological Ownership	.001	.005*	.0005	.10*	.01	.001
Psychological Ownership and Task Involvement	.0001	.005*	.001	.0005	.005	.0005

*The difference between p levels is in the predicted direction.

In each case the procedure was to use the scores on the personality scale to divide the total respondent group about the median value. The correlations carried out in Hypotheses I and II were repeated for the subgroups so formed. The total group of respondents had to be used for these calculations because of the large number of cases which shared the median values and so had to be discarded.

These results suggest that managers who see themselves as origins of their behaviour and who prefer to act independently of others or of social constraints, are more likely to derive their Enthusiasm at work from the Autonomy and sense of Ownership which they experience in it. But this finding provides no evidence for which comes first. There are two possibilities. Firstly, a person's attitude to conformity or his perception of himself as the locus of control, may determine the importance of Autonomy as a factor in his work. Secondly, these attitudes to conformity and locus of control, may result from his work experience if he has been given Autonomy. Both explanations seem reasonable but a further investigation would be needed to decide which of them was true.

Hypothesis VII

Differences in Opportunity: It was predicted on the basis of studies of different organisations and departments (Lawrence and Lorsch 1967) that the researchers would see themselves as having more opportunity for Autonomy and feelings of Ownership than the engineers would. Opportunities for Achievement and Task Involvement would be equally distributed.

The results of the G.J.A.Q. offer little support for this hypothesis. Achievement is the only factor which behaves as predicted. (Appendix I) This is surprising in view of the previous studies mentioned above and the findings from the open-ended questions on specific tasks. The descriptions of the Tasks had clearly shown that Autonomy was more evident in the experience of the researchers.

A possible explanation for this apparent contradiction is that the engineers do have less Autonomy, but they also expect less. Their responses are a realistic reflection of their past experience. Alternatively,

it may be that the engineers' general impression of their job had been biased by having had, earlier in the interview, the opportunity to reflect on one situation where they did have Autonomy and a sense of Ownership (Task A).

Whether these explanations are true or not, the results of this questionnaire do not confirm the distinction made between the two types of job. The support for using engineers as a control group comes from previous studies and the results of the open-ended questions.

This concludes the review of the hypotheses. The next section summarises the predictions relating to the J.A.Q. (A) and J.A.Q. (B) separately, and other investigations more peripheral to the study.

4. FURTHER PREDICTIONS

(a) Autonomy, Psychological Ownership, Achievement and Task Involvement

When these factors are correlated as for Hypotheses I, II and III, but using the two questionnaires J.A.Q. (A) and J.A.Q. (B) separately, the decision to use the difference between A and B scores in the main study is vindicated.

The J.A.Q. scores on the preferred Tasks (Tasks A) do not discriminate sufficiently between the factors, although there is a significant correlation between Psychological Ownership and Task Involvement. (See Table 11.9)

Table 11.9. Summary of Correlations for Both Occupational Groups Using J.A.Q. (A) Data

<u>Correlations</u>	<u>Researchers</u>		<u>Engineers</u>	
	<u>tau</u>	<u>significance</u>	<u>tau</u>	<u>significance</u>
Influence and Psychological Ownership	0.01	n.s.	0.34	.05
Freedom and Psychological Ownership	0.06	n.s.	-0.06	n.s.
Autonomy and Psychological Ownership	0.05	n.s.	0.24	n.s.
Psychological Ownership and Task Involvement	0.48	.005	0.48	.01
Achievement and Task Involvement	0.08	n.s.	0.12	n.s.

When the data is used from J.A.Q. (B) questionnaires, there is more spread between respondents' scores. Here, the engineers differ from the researchers in that Autonomy is less associated with positive feelings (Task Involvement) than is Achievement. (Table 11.10) This lends additional support to the findings from open-ended questions, that Achievement is more important to engineers. This is especially the case when the work is not particularly enjoyable (Tasks B).

Table 11.10. Summary of Correlations for Both Occupational Groups Using J.A.Q. (B) Data

<u>Correlations</u>	<u>Researchers</u>		<u>Engineers</u>	
	<u>tau</u>	<u>significance</u>	<u>tau</u>	<u>significance</u>
Influence and Psychological Ownership	0.55	.001	0.12	n.s.
Freedom and Psychological Ownership	0.54	.001	0.38	.03
Autonomy and Psychological Ownership	0.58	.001	0.26	n.s.
Psychological Ownership and Task Involvement	0.50	.005	0.58	.005
Achievement and Task Involvement	0.80	.0001	0.68	.001

(b) Correlations of G.J.A.Q. Factors

This questionnaire measured the perceived opportunity for the same factors studied with the J.A.Q. Its analysis reflects the results obtained from the specific tasks. (See Appendix J) Positive feelings are more strongly related to Psychological Ownership than to Achievement, although

neither of these associations is as strong as it is when J.A.Q. data is used. The opportunity for Autonomy is more strongly associated with the opportunity for Psychological Ownership in the researchers' answers than in those of the engineers.

(c) Correlations of G.J.A.Q. Factors with Job Satisfaction

These results are presented in Table 11.11. From the investigation of the hypotheses in the previous section, it might be expected that job satisfaction would be directly related to how much opportunity for Psychological Ownership managers felt their jobs provided. There is no evidence for this in the researchers' data from the G.J.A.Q., even though Psychological Ownership is strongly related to Enthusiasm in their specific Tasks (using the J.A.Q.).

In a previous chapter (VIII), the rationale for using specific tasks as the basis of the study, was explained. It was hoped to improve on the less precise measures of attitudes to the job-as-a-whole. The findings support this decision. Job satisfaction may reflect more attitudes than those held towards specific tasks. Status, financial reward and other aspects of the job can be expected to have more effect on job satisfaction measures, than attitudes to specific tasks. As job satisfaction has been shown not to have a simple relationship to task performance, Task Enthusiasm may well prove to be a more useful measure.

A second finding from this table (11.11) is that Autonomy appears more relevant to the researchers than to the engineers. This confirms the expected organisational difference between the two types of work, which failed to emerge in the previous section using a different procedure (Hypothesis VII).

Table 11.11. Correlations of Job Satisfaction with G.J.A.Q. Factors Measuring Opportunity - Both Occupational Groups

<u>Factors correlated with job satisfaction</u>	<u>Researchers</u>		<u>Engineers</u>	
	<u>tau</u>	<u>significance</u>	<u>tau</u>	<u>significance</u>
<u>Opportunity for:</u>				
Influence	0.31	.03	0.31	.03
Freedom	0.49	.005	0.20	n.s.
Autonomy	0.48	.005	0.24	n.s.
Psychological Ownership	0.14	n.s.	0.36	.01
Achievement	0.47	.01	0.45	.001
Task Involvement	0.24	n.s.	0.26	.05

Overall, it would seem that general scales such as the G.J.A.Q. are more helpful in measuring the opportunity for different factors than in investigating the strength of relationships between them.

(d) The Personality Factor Scale

Here, there were two questions of interest:

- Would the three scales show the direct association with each other that on face value they might be expected to?
- How would each of the three characteristics be distributed between the two occupational groups?

The only significant correlation was demonstrated by the engineers' responses, which showed an association between the Independence-Conformity scale (I-C) and the Preference for Ownership scale (O-P). (Significant at the .03 level*) The only significant difference in distribution

*Although this data is nominal, Kendall's tau was used, as the size of the groups after division about the median value was too small to permit chi-square. Chi-square is the initial step in calculating the Contingency Coefficient 'C', which would have been more appropriate with this data.

of the three factors was that researchers were more attracted to situations involving Ownership than were the engineers. (Difference significant at the .05 level)

4. VALIDITY AND RELIABILITY

(a) Aims of the Tests

Validity: The aim here is to assess the extent to which the measurements are actually of the criterion being studied, rather than any other. Mostly this involves an examination of construct validity and is therefore, not only concerned with the measuring instrument, but also with the theory on which it is based. This type of validity is based on the prediction of how the construct behaves in relation to other constructs, while being able to distinguish between them.

In some cases the assessment of validity was either pragmatic, i.e. by being able to make predictions from the results of an instrument, or was on face value, in that it was presumed that the validity of the measures was self-evident.

Reliability: Here, the interest is in the accuracy of the measurement, the extent to which variation in results is due to inconsistencies in the measuring instrument. Because the key variables were intervening variables, and because there is therefore no direct way of assessing validity, assessing reliability is especially important. The specific interest was in the equivalence or internal consistency of the scales, i.e. that all the items are measures of the same criterion.

(b) The Instruments Tested

It had been decided to test the Job Activity Questionnaire and the O-P scale. As these two instruments had been specially designed for this study, there were no previous estimates of their validity or reliability, although in the J.A.Q., the grouping of items had been based on data from a pilot survey (p.90).

The Job Activity Questionnaire: This scale was re-checked using main survey data and Kendall's W (Siegel 1956). The three factors suitable for testing for reliability were:

Psychological Ownership	-	6 items
Achievement	-	3 items
Task Involvement	-	4 items

The reliability of these scales is supported by the iter-item correlations using Kendall's W. (See Table 11.12)

Table 11.12. Internal Consistency of J.A.Q. Factors*

<u>Factor</u>	<u>W</u>	<u>significance</u>
Psychological Ownership	0.647	.001
Achievement	0.711	.02
Task Involvement	0.932	.001

The Ownership-Preference Scale: As the data collected from this scale was nominal, the test used is the Kuder-Richardson Formula 20 (Guilford 1954).

*Data was from J.A.Q. (B). Fifteen questionnaires were chosen, using random number tables.

The basis of validity of this scale is one of content, or 'face-validity'. The items were chosen because they could be presumed to give an indication of an individual's probable behaviour. The K.R. 20 result however, indicated low internal consistency (0.21). This is disappointing, although as Selltiz et al. (1959) point out, low reliability can be compatible with a valid scale where each item correlates with the criterion but not with the other items.

Some support can be drawn from the findings that a) researchers scored higher as a group, on this scale than the engineers did, and that b) Psychological Ownership was most strongly present in the researchers' Task descriptions. Further development of this scale would require a larger number of items.

CHAPTER XII

PSYCHOLOGICAL OWNERSHIP IN WORK - SUMMARY AND DISCUSSION

1. A Summary of the Research
2. Discussion of Theory
3. Discussion of Implications for Management Practice

1. A SUMMARY OF THE RESEARCH

(a) Its Origins in Herzberg's 2-Factor Theory of Motivation

In the initial research project, Herzberg's Motivator-Hygiene framework was used to analyse job attitudes in an organisation where the motivational content of the work and the environment in which it was performed was also measured. The 2-factor phenomenon was replicated by people's responses to non-directed questions about their jobs, but only when some sources of satisfaction and dissatisfaction known to exist were suppressed. So for example, although most respondents were unhappy with their promotion prospects, they did not volunteer this when asked what they disliked about their jobs.

Herzberg's conclusions were reviewed in the light of these findings and those of previous investigators, and the involvement of some mechanism of perceptual defence proposed as a basis of the 2-factor phenomenon. It was suggested that some such process was influencing the different ways in which people referred to the intrinsic (content) and extrinsic (context) aspects of their jobs. Support for this explanation was provided by earlier studies into the effect of ego-involvement on repression of recall in the presence of unfinished tasks.

The aim of further research was defined as the investigation of the differences between the intrinsic and extrinsic aspects of work, not as distinct job factors (promotion, pay, achievement) but in terms of the perception of a job or task as being close to or distant from the self. It is this closeness to self (Psychological Ownership) which determines that an incident is remembered as having been associated with strong feelings of any kind. The nature of the feelings will affect just how the incident is recalled.

(b) The Formulation of the Concept of Psychological Ownership

This concept was defined as the degree to which a person could perceive a task as his own, could identify it with himself, as part of him. The focus of the research was thus a relationship between a person and a task as he experienced it.

It was predicted that this perception would depend on the amount of Autonomy the person saw himself as having in the task - the influence he had and the freedom of choice he exercised in relation to it.

A Sense of Achievement would also be studied as distinct from but related to feelings of Ownership. It was expected that Autonomy and Psychological Ownership, because of their specific role in the generation of Commitment to a task, would be the most potent sources of Enthusiasm and feelings of involvement towards it.

(c) Methods and Findings

Two groups of managers were interviewed, research scientists and engineers. Each person was asked to describe two tasks in detail, including its origin, the role he played and his feelings about it. The two tasks were to differ in the enthusiasm the person concerned felt towards them. Open-ended questions and scaled questionnaires were used to investigate the tasks, people's general beliefs about motivation and certain personality characteristics.

The findings may be summarised as follows: (See Table 12.1)

Table 12.1. Summary of Factor Intercorrelations from Scaled Questionnaire Data - Researchers (tau values)

	2	3	4	5
1. Autonomy	0.65 ^{***}	0.48 [*]	0.49 [*]	0.23
2. Psychological Ownership		0.52 ^{**}	0.68 ^{***}	0.10
3. Achievement			0.59 ^{**}	0.07
4. Task Involvement				0.10
5. Initial Choice				

- * significant at the .005 level
 ** significant at the .001 level
 *** significant at the .0001 level

(i) Autonomy, Psychological Ownership and Enthusiasm for a task (Task Involvement), were strongly associated.

(ii) The Initial Choice open to the person to choose whether he would take on the task or not, was not as important as the way in which he could gain Autonomy once the task was under way.

(iii) Achievement did not emerge as such a potent source of Enthusiasm or related feelings as did Autonomy and Psychological Ownership when the responses to scaled questionnaires were analysed. This finding conflicted with the emphasis given to Achievement in the earlier replies to open-ended questions. Achievement and Psychological Ownership showed a relatively weak association with each other.

(iv) The association of Autonomy, Psychological Ownership and Task Involvement was stronger in the case of the research group but significant for the engineers also.

(v) Evidence for differences in opportunity for the various factors as between the two occupational groups was inconclusive.

(vi) The strength of association of the key factors was related to the respondents' scores on two personality scales, measuring the perception of locus of control and independence.

(vii) Both Herzberg's critical incident questions appeared to elicit accounts of tasks which were important to the individual at the time the events occurred. The way in which the events were perceived depended on the feelings associated with them.

2. DISCUSSION OF THEORY

The theoretical discussion will cover these four aspects:

- (a) The phenomenon of Psychological Ownership
- (b) Its roots in Autonomy
- (c) Its relation to Achievement
- (d) The related concept of Job Involvement

(a) The Phenomenon of Psychological Ownership

Psychological Ownership is experienced as an extension of self. This is illustrated in the way people talked about the tasks they enjoyed most. For example they used such expressions as:

"It's my baby."

"There's a bit of my blood in there."

"A bit of you is really involved."

"It has my name on it."

These expressions imply that the individual projects himself into the task and so subsequently identifies with it, it becomes 'his'.

The processes of projection and identification occupy a central place in psychoanalytic literature, but it is beyond the scope of this study to determine whether Psychological Ownership is analogous to these processes or whether it has its roots in their influence on infant development. In any case, the perceived relationship between person and task so formed is clear, and is as Murphy (1947) describes it in his discussion of Allport's theory of Functional Autonomy:

"All this is of special weight of course, when the activity is deeply coloured with the character of selfhood; it is not simply an activity, it is my own activity."

The person 'puts himself' into the task, he 'invests' something of himself in it and so perceives it as part of him, as an extension of himself.

From this point of view, the concept of Psychological Ownership does not imply possession, as of an object, but a more creative relationship. As one research manager described it:

"Men in particular feel they have to create something permanent ... something that remains behind when they are dead."

The quality of Ownership is thus more parental, more procreative. However it is still open to debate as to whether such expressions of procreation represent a transference of imagery from the experience of parenthood, or whether they are a manifestation of some such process as an 'anima'.

" ... a man brings forth his work as a complete creation out of his inner feminine nature ..." (Jung 1953)

There is a similar theme to Fromm's writings in his description of 'Productive Orientation' as one of the ways in which a man can relate to his world. Fromm (1949) talks of 'giving birth to one's own potentialities' and of caring for and responding to the outcome. In an earlier work (1942) he wrote:

"Ours is only that to which we are genuinely related by our creative activity."

Whatever the explanation for this projective imagery, at a phenomenological level, the basis of the person-task relationship is one of psychological distance. As the individual increases his sense of Ownership in an activity, so he closes the distance between it and himself as reference point. (cf. Sherif and Cantril's definition of Ego-Involvement, 1947) Allport (1955) describes this as 're-centering'.

"What once seemed to him cold, 'out there', 'not mine' may change places and become hot and vital, 'in here', 'mine' ..."

But he goes on to say that 'just why or how such shifts occur we cannot say'.

The outcome of this is that the more the activity becomes 'his', the more he likes it. It 'energises' him (Koch 1956), it is a source of pleasure, of excitement, and also of disappointment. The managers who took part in this investigation illustrated all of these attitudes. It is also likely that attempts to adopt the 'offspring' will be resisted, as illustrated by a plant manager's blunt description of his reaction to a senior's interference:

"It looked as if he was going to bundle it up and put it in his pocket. The rotten ***** was going to pinch my baby!"

How does this bond become forged?

(b) The Role of Autonomy

The interviews confirmed that Influence and Freedom of Choice, the two aspects of Autonomy defined, were strongly associated with the perception of Ownership.

In a previous section, the definition of Influence in a task has been defined as the active process by which a person invests something of himself in it, his skills, ideas and energy. Because he is aware of this and in as much as he can see evidence of it in the way the task takes shape, his perception of the task itself changes and so therefore do his effective attitudes towards it (Newcombe 1952). The managers' descriptions of their tasks illustrated the different ways and degrees in which a sense of Ownership was generated, through invention or organisation, and that this process is one of which people can be aware and which they may seek to promote.

"I was looking for something that would grow out of what I was doing, something that would be 'mine' if you like."

The results also indicated that Freedom of Choice is implicated in the creation of Ownership. This second facet of Autonomy, the relationship of the person to relevant others, has both an indirect and a direct effect on how 'owned' the task is felt to be.

Firstly, the more free choice the individual has, the more his scope to apply his ideas or skills in exercising his discretion in the task. But secondly, freedom of choice means that the person is able to locate the source of his actions within himself, rather than to external forces as when he is more constrained. He is therefore aware of his self-involvement. Because he is free to act, the actions are born of him and the outcome is his. He acts as an 'origin' rather than a 'pawn'

(DeCharms 1968). He is able to:

"exercise his freedom and to organise the relevant items of his world out of the autonomous centre of government which is his self." (Anygal 1952)

This state contrasts with the powerlessness of a person who, having little freedom, 'can act; but the sense of independence, significance, has gone' (Fromm 1942).

(c) Psychological Ownership and Achievement

Because of the emphasis it receives in current management theory, a Sense of Achievement was chosen as one factor whose role could be compared with those of Autonomy and Psychological Ownership. It seemed from this study to have a disproportionate place in people's beliefs about motivation to work.

The most intensive study of Achievement has been that conducted by McClelland and his co-workers over the last twenty years. (See McClelland et al. 1953 and McClelland 1961). Using thematic apperception tests (TAT's) under different arousal conditions, McClelland defined the need for achievement (nAch) as a motive. People with a high n Achievement were those whose TAT's:

"contained more references to 'standards of excellence' and to doing well, or wanting to do well, with respect to the standards." (McClelland 1961)

McClelland's view was that people with a strong need to achieve, would seek out situations which would provide satisfaction of this motive. He identified the characteristics of such people as, for example, moderate risk-taking, seeking personal responsibility and using concrete feedback on their performance (McClelland 1962). This description of the

Achievement motive is strongly represented in the motivational assumptions made by Herzberg (1968) and McGregor (1960).

There are difficulties with McClelland's theory, both in the reliability of the method and the validity of the thought-action paradigm underlying it. These and other points are covered in detail in the review of the Achievement motive made by DeCharms (1968), who states:

"The only kind of achievement involved in n Achievement is achievement through competition."

Moreover, while a 'Sense of Achievement' is an expression of feelings rather than a motive, and while it may not necessarily be reached through competition, it has in common with n Achievement, the element of success or accomplishment. This is different from the process of identification implied in Psychological Ownership, in that it refers to the nature of the outcome of the task rather than to the person's perception of his relationship with it.

A 'Sense of Achievement' will reflect both elements, Psychological Ownership and success, in that the greater the sense of Ownership, the greater will be the sense of accomplishment if the task is successful. The results of the study support this conclusion. The two factors were shown to be distinct (p.90) and related (p.136). One manager expressed the connection in this way during the interview.

"It's the enjoyment of a visible result of my own actions.
Either success or failure in terms of what I do."

These conclusions do not contradict the view that the actual degree of success will be a function of such elements of behaviour as individual risk-taking, use of feedback and target-setting. What they do suggest is

that providing opportunity for challenge and success without Autonomy may still result in a low level of Commitment or Enthusiasm for the task. These attitudes will depend on whether the person identifies with the targets, the element of risk taken and the eventual outcome because of the Influence he has had and the Freedom of Choice he has been given.

Perhaps the most significant finding to emerge from this comparison is that a 'Sense of Achievement' is compound in nature and as such, is too global to use for making specific predictions about work behaviour. It is also probable that while 'achievement' predominates in the motivational vocabulary of managers and management theorists, the comparative significance of Autonomy and Psychological Ownership may be masked, and the feeling of success gained from tasks in which there has been little personal involvement may, in Fromm's words, 'be illusory' (Fromm 1942).

At worst, the achiever may strive relentlessly to improve against organisational standards and in pursuit of tasks to which he has subordinated himself, as Charles Reich (1970) describes the state of mind he calls consciousness II:

"It has been persuaded that the richness, the satisfactions, the joy of life are to be found in power, success, status, acceptance, popularity, achievements, rewards, excellence and the rational competent mind."

(d) Psychological Ownership and Job Involvement

These concepts appear similar enough to merit the difference between them being made explicit. In this study two concepts have been employed:

- (i) Psychological Ownership - identifying the task with self.
- (ii) Task Involvement - being preoccupied with the task, concerned about it and affected by its outcome.

Lohdahl and Kejner (1965) define Job Involvement as 'the degree to which a person's work affects his self-esteem'. This is a close parallel to Task Involvement as defined above, but some of the items Lohdahl and Kejner used to measure Job Involvement were concerned with identification and some with preoccupation, viz.

- I live, eat and breathe my job. (Identification)
- Sometimes I lie awake at night thinking ahead to the next day's work. (Preoccupation)

Later, Lawler and Hall (1970) set out to investigate whether Job Involvement, Intrinsic Motivation and Satisfaction could be regarded as distinct factors and commented that the theoretical definitions of these concepts were unclear. But in using Lohdahl and Kejner's earliest definition of Job Involvement, Lawler and Hall again include both psychological processes of identification and preoccupation.

"Job Involvement is the degree to which a person is identified psychologically with his work, or the importance of work in his total self-image."

These measures of Job Involvement may provide some indication of the stage of Ownership which the person has reached, but they measure its effects rather than the phenomenon itself. A contribution of this present investigation has been to distinguish between two related processes of identification (Psychological Ownership) and preoccupation (Task Involvement), and, as Vroom (1964) urged, to determine the conditions under which they occur.

3. DISCUSSION OF IMPLICATIONS FOR MANAGEMENT PRACTICE

These conclusions have been derived from a study which has been primarily of research scientists, who as a profession, are known to differ from others in a number of ways (McClelland 1964). In particular, Autonomy has been shown to play more part in their jobs than in engineers', and the longer they remain in the job, the more this difference becomes apparent (Marquis 1966, Schultz 1964). How generally can the concept of Psychological Ownership be applied?

The evidence from this investigation is that Autonomy and Psychological Ownership are significant sources of enthusiasm for engineers as well as for research managers. Similarly, although Autonomy is a greater source of enthusiasm for people who have high scores on the I-E scale, and it can be assumed that this factor varies from individual to individual (Rotter 1966), these differences are only of degree and so do not materially reduce the significance of the part played by Autonomy in shaping people's attitudes to work.

Autonomy has been recorded as a source of job commitment before, (Vroom 1964, Tannenbaum 1966) and particularly by the proponents of participative management (Argyris 1964, McGregor 1967). The question is whether this study elaborates the way in which Autonomy affects individuals at work, or whether it also adds to or changes in any way the implication of these views for management practice.

(a) Theories of Participative Management

As Bennis (1966) points out, participative management theorists were influenced by Lewin's work on leadership styles, Mayo's illustration

of the social factors affecting task performance and by Maslow's concept of self-actualisation.

Argyris and McGregor have been the most influential authors, and Autonomy in some form is cited by them both as one factor which can act as a reward for the individual and which accordingly energises and directs his behaviour. Argyris (1962) postulates self-esteem as the 'reward which drives the individual to greater heights', and defines its source as the ability to define goals which are related to one's central needs. He also emphasises the notion of psychological success:

"the basic drive of human beings to experience success in living and experiencing their human condition."

With this somewhat global view of a rewarding end state similar to White's (1959) concept of competence, Argyris advocates the need for the organisation to provide an opportunity for individuals to meet their own needs in the pursuit of organisational goals rather than be thwarted by them.

McGregor (1967) questions simple cause and effect models which emphasise external rewards and punishments as determinants of behaviour. His (Lewinian) view is of an interactive process between environmental variables and the internal characteristics of the person. Adopting Maslow's theory of self-actualisation, McGregor asserts that once basic needs are satisfied, the individual will act in a way which incurs 'internal' rewards.

"These include needs for a degree of control over his own fate, for self-respect, for using and increasing his talents, for responsibility, for achievement both in the sense of status and recognition and in the sense of personal development and effective problem solving."

In this sense McGregor views man as 'being motivated' (a state), rather than needing 'to be motivated' (by external rewards or punishments).

The managerial strategy which McGregor advocates is one which achieves 'goal congruence'. Organisational goals are linked with opportunities for self-actualisation, for obtaining intrinsic rewards. This state of goal congruence, described by McGregor as identification, is a source of commitment. It is created by the individual being involved in a joint or transactional process of setting objectives and standards and identifying the contribution he can make to achieving them.

At this point it is worth noting that:

- Achievement and Autonomy are cited as two intrinsic rewards.
- The self-actualisation towards which managerial strategy aims, is similar enough to the concept of Psychological Ownership for the difference to need further discussion.
- Achievement and Autonomy are linked in McGregor's view in that he sees individuals as wanting to be identified with tasks that are 'exciting and challenging'.

(b) Participative Management and the Concept of Psychological Ownership

(i) The Emphasis on Achievement

Autonomy and Achievement are at most, alternative sources of motivation in the participative approach. In fact McGregor's view, emphasising goal attainment, standards and feedback, echoes the characteristics which McClelland identified in high achievers.

In contrast to this, the implication of the concept of Psychological Ownership, is that Autonomy is not merely one of a number of possible sources of psychological rewards. It is specifically and inextricably a part of the process by which Task Commitment is generated.

Achievement, recognition and other factors, where present, will contribute to a person's enjoyment of a task, but cannot be a substitute for personal autonomy. Individuals may be given challenging tasks which remain, in their perception, the organisation's and not their own. This situation would fall short of that described by Holmes (1967).

"Where we make a decision, there do we put ourselves into that which we do and so feel an identification and a sense of ownership. Here a sense of ownership springs straight from a sense of control."

(ii) Collaboration and Consensus

Participative theorists, especially Argyris, stress the importance of arriving at decisions and solutions by team work and consensus. But in as much as collaboration of this type begins with a process of group sharing, with the attendant possibility of compliant membership governed by group constraints, there may be little that any individual can see as 'his own', as having his personal 'stamp' on it. If there is thus no real independence, then there can be little possibility of true interdependence.

On the other hand, in a situation which first provides for the development of Ownership, independence is ensured in that each person has some task or responsibility with which he can identify. Then, directly or indirectly, his efforts can be integrated with those of others, and in this way interdependence is achieved without loss of Ownership in the final task, decision or solution.

This view of collaboration is consistent with that described by Lawrence and Lorsch (1967) as the 'achievement of unity of effort'. It accepts the desirability of independent activity where people can, wherever possible, see clearly the work for which they are responsible. As a result two people may be 'differentiated' because of their preoccupation with their own tasks, in the same way that two departments may be differentiated in function, time or goal orientation. Lawrence and Lorsch observe that:

" ... given the need for differentiated ways of working and points of view in various units of large organisations, recurring conflict is inevitable. The important question which we have tried to answer is ... how can integration be facilitated without sacrificing the needed differentiation?"

This statement may also be applicable at the level of individuals. If differentiation between them is inevitable, there is subsequently a need for integration of their efforts to those of others. This may be either through direct collaboration, or it may be indirectly through the management integrator function. Lawrence and Lorsch's view (1967a) would support such a role if individual orientations are too dissimilar for direct transaction to be a realistic goal, or if each person's preoccupation with his own task colours his perception of information relevant to it. Attitudes affect the selection of information as well as the output of behaviour (Newcomb 1952).

This Ownership and Integration approach contrasts with a team-centred philosophy which begins with the group rather than with the individual. It therefore enhances the commitment which is derived from a sense of Ownership rather than limiting it in a premature attempt to reach consensus.

In conclusion, we return to the question which began this section as to the implications of this study. Firstly, at the conceptual level, it has amplified the Autonomy-Commitment relationship by investigating the intervening variable in the experience of people who express Enthusiasm for their tasks. Secondly, the concept of Psychological Ownership implies that whatever attractions a task holds for an individual, however interesting or challenging it may be, his commitment will ultimately depend on the opportunity he has to generate the ideas from which the task evolves and to be involved with it from the beginning.

If the original idea was not his own, a person's commitment to a task will accompany the sense of Ownership which can still grow after the task has been delegated to him. This will depend on the extent to which he is able:

- To put in his own ideas.
- To choose methods or procedures.
- To decide on targets, timing or allocation.
- To make any changes he feels are necessary.
- To see the job through.

These are the conditions through which the process of Psychological Ownership is developed, from which in turn, Enthusiasm and Commitment to a task are derived.

APPENDICES

APPENDIX AQuestionnaire Used in the Oil Terminal Survey

1. What do you think of shift work?
2. Do you enjoy working overtime?
3. How do you like working for (the company)?
4. Would you like to know more about the reasons behind the policies and decisions the company makes?
5. Since the New Deal, has management been more approachable or less?
6. What do you like about the New Deal?
7. What do you dislike about the New Deal?
8. Who do you go to for help or advice?
9. Has your supervisor the time to listen when you want to sort out a problem?
10. Is the supervisor given enough backing by management?
11. Do you feel free to take complaints above your supervisor to your superintendent?
12. Which group of workers got most out of the New Deal?
13. How does your job compare with others at the terminal?
14. What do you like most about your job?
15. What do you dislike most about your job?
16. Is your job a major source of satisfaction in your life?
17. What is it makes you feel you have had a really good day?
18. What is the sort of thing which makes you glad when the day is over?
19. Is there one thing you would change to make your job more satisfying?
20. Is there an opportunity for you to make progress in your company?
21. Would you like your work to be made more interesting?
22. How often does your job entail cooperating with other people in the terminal? Does this ever cause any difficulty?
23. Has the New Deal made your work more satisfying?
24. How closely are you supervised?

25. Do people at the terminal work as a team?
26. Are you given freedom to use your own judgement?
27. Are there any Company rules or regulations which you think are unnecessary?
28. Do you feel you have to hide any mistakes you might make from your supervisor?
29. Does your supervisor discuss your job performance with you?
30. Do you think your individual efforts are appreciated?
31. How do you know when you have done a good job?

APPENDIX B(i) Frequency of Occurrence of Job Factors in Responses to the Questions on Likes and Dislikes - Drivers*

	<u>Source of Dislike</u>	<u>Source of Like</u>	<u>Significance</u>
Work Itself	0	27	.001
Social Relationships	5	18	.01
Responsibility	0	8	.01
Economic	0	5	n.s.
Security	0	7	.05
Physical Working Conditions	26	9	.01
Company Policy	7	0	.05
Supervision	5	0	n.s.

(ii) Coding Categories for Investigation of 2-Factor Phenomenon

Achievement: Successful completion of task. Work going well. Successful idea.

Advancement: Promotion. Opportunity to increase skills.

Responsibility: Freedom to work without close supervision. Opportunity to solve problems for oneself. Being trusted.

Recognition: Praise from supervisor. Achievement appreciated.

Work Itself: Interest, variety.

Company Policy: Procedure, policy. Decisions from senior management.

Supervision: Fairness and competence of supervisor. Relationship with supervisor.

Interpersonal Relationships: Team feeling. Cooperation from colleagues.

Job Security: Confidence in keeping job.

Pay: Salary, bonus, overtime.

Working Conditions: Workload, physical conditions, facilities.

*Data for plant personnel insufficient for detailed factor breakdown.

APPENDIX CThe Association Between Personal Influence and Motivator-Hygiene Factors(i) The Questionnaire

To what extent do you see the following aspects of your job as being subject to your own influence?

	my own influence			half and half	others' influence		
The amount of recognition or praise you receive	1	2	3	4	5	6	7
Your job security	1	2	3	4	5	6	7
The salary you receive	1	2	3	4	5	6	7
The extent to which you get a sense of challenge or achievement from your job	1	2	3	4	5	6	7
Your future advancement opportunities	1	2	3	4	5	6	7
The relationships with the people with whom you work	1	2	3	4	5	6	7
Your past advancement	1	2	3	4	5	6	7
The way your work is supervised	1	2	3	4	5	6	7
The amount of responsibility you have	1	2	3	4	5	6	7
The reputation of your organisation	1	2	3	4	5	6	7
The level of creativity in your work	1	2	3	4	5	6	7
Your physical working conditions or facilities	1	2	3	4	5	6	7
Your status (prestige) within the organisation	1	2	3	4	5	6	7

(ii) The Results - Correspondence of Order of Factors in the Influence Scale and in Herzberg's Original Results

<u>Factor</u>	<u>Herzberg's Ranking</u>	<u>Ranking on Influence Scale</u>
Achievement	1	1=
Recognition	2	1=
Responsibility	3	6
Advancement	4	4
Work Itself	5	5
Salary	6	8
Supervision	7	7
Interpersonal Relationships	8	3
Working Conditions	9	9

Spearman's rho 0.674

Significance level .05

APPENDIX DPilot Survey Instruments

- (i) Interview Schedule
- (ii) Opportunity Questionnaire
- (iii) Job Activity Questionnaire
- (iv) Opinion Questionnaire I (The I-C and O-P Scales)
- (v) Opinion Questionnaire II (The I-E Scale)

(i) Pilot Survey - Interview ScheduleBackground

1. What is the function of your department?
2. What is your official job description?
3. What are your chief responsibilities?
4. To whom are you responsible?

Listing Specific Tasks

5. List activities.
6. Rank them in terms of your enthusiasm for them, the feeling you have that you want to spend time and effort on them.

Task A and Task B

7. Describe how you feel about it.
8. How did you come to be doing it?
9. What part do you play in the task? Has it always been the same?

General Questions on Views about Work

10. In general, what decides whether you get enthusiastic or committed about a particular job or not?
11. Most of us get frustrated or disappointed in our jobs at some time. What would make you feel like that?
12. What are the five things you would say mattered most in life? (Rank)
13. "At work, I seem to spend most of my time"
14. "Five years from now I would like to think I was spending my time"
15. Let's say your boss asks you what you would advise him, in order to get your full commitment and effort. What would you advise?
16. What is it you think attracts some people to taking responsibility?
17. In your view, what makes one activity more interesting than another?
18. "For a successful task to give me a sense of achievement, it has to be one"

19. (a) How often do you get pulled off a job?
(b) If you do, how do you feel?
(c) Why?
20. In your experience, what is it that makes people want to do a job?
21. Think of a time when you felt exceptionally good about your job.
Describe what happened and how you felt.
22. Now think of a time when you felt exceptionally bad about your job.
Describe what happened and how you felt.

(ii) DEPARTMENT QUESTIONNAIRE
 (Oppportunity Questionnaire)

Read the following statements which you should refer to your present department.

Please indicate next to each statement your degree of agreement or disagreement by writing 1, 2, 3 or 4.

- 1 means strong agreement
- 2 means mild agreement
- 3 means mild disagreement
- 4 means strong disagreement

1 = Strong agreement

3 = Mild disagreement

2 = Mild agreement

4 = Strong disagreement

- ___ 1. The jobs in this Department are clearly defined and logically structured.
- ___ 2. We don't rely too heavily on individual judgement in this Department; almost everything is double-checked.
- ___ 3. You won't get ahead in this Department unless you stick your neck out and try things on your own sometimes.
- ___ 4. The policies and structure of the Department have been clearly defined.
- ___ 5. The importance of taking calculated risks at the right time is clearly recognised here.
- ___ 6. Red tape is kept to a minimum in this Department.
- ___ 7. In this Department it is sometimes unclear who has the formal authority to make a decision.
- ___ 8. Our management is willing to take a chance on a good idea.
- ___ 9. Our philosophy emphasises that people should solve their problems by themselves.
- ___ 10. I think our productivity must sometimes suffer from lack of organisation and planning.
- ___ 11. Decision making in this Department is too cautious for maximum effectiveness.
- ___ 12. Our management isn't so concerned about formal organisation and authority, but concentrates instead on getting the right people to do the job.
- ___ 13. Excessive rules, administrative details, and red tape make it difficult for new and original ideas to receive consideration.

(iii) Job Activity Questionnaire

Instructions

For each of the questions or statements in this booklet, check the one response which most closely reflects your opinion or feelings.

- Important
- (1) Relate this to the specific activity in question, not to your job as a whole.
 - (2) Read each of the 4 responses before choosing one of them.

How likely would you be to enjoy an opportunity you were given to talk to people you know socially about this part of your work ?

Very likely

Quite likely

Not very likely

Most unlikely

This activity-----

is definitely
challenging

can sometimes
be challenging

offers little
challenge

is plain
sailing

Allocation of tasks, responsibilities, duties etc or the approval of subordinates undertaking of them in this task.....

is at my sole
discretion.

is at my
discretion for the
most part

is outside my
discretion at
times

is almost never
at my sole
discretion.

The ideas or suggestions which generated this activity in the first place.....

Were not really
mine at all.
Someone else
thought of it.

were not much
mine, but I was
consulted about
them.

Were mine in part.
I had quite a lot of
say early on.

Were mainly mine,
I thought of it.

If people were to talk about this aspect of the job, would you feel they were virtually talking about you - the person?

Yes, I think I
would.

To some extent,
Yes.

Possibly, but it
wouldn't be a
strong feeling.

Most unlikely.

In choosing or modifying methods or procedures for this activity.

I certainly do
not have to do
the job a certain way if I
don't want to.
I am left free
to choose.

I have a fair
amount of free-
dom but within
some constraints.

I have some
freedom but
with significant
constraints.

I am virtually
constrained to
do this job a
certain way.

(By what or whom)

All in all, I think of this as my pigeon.

Yes - very true	To some extent	Not quite that strongly	Not at all.
-----------------	----------------	-------------------------	-------------

This aspect of my work is.....

Dull as ditchwater.	Not very interesting	Quite interesting	Fascinating, absorbing.
---------------------	----------------------	-------------------	-------------------------

When you undertook this activity.....

Were you instructed by your superior?	Were you asked by your superior but it was difficult to say no?	Was it suggested as a possibility by your superior?	Was it on your own responsibility?
---------------------------------------	---	---	------------------------------------

Depending on how well or how badly this goes, the effect on how I feel about myself is likely to be

Considerable	Quite significant	Not very marked	Little - if any
--------------	-------------------	-----------------	-----------------

The targets I work to in connection with this activity are set

Largely by others. I am allowed little say over what targets are set.	Largely by others but I have some say.	By me in conjunction with my superior (s)	Entirely by me, while taking into consideration the expectations and needs of other relevant parts of the organisation.
---	--	---	---

Of all I am doing in life at present, this rates

Extremely highly with me.	Quite highly with me.	Some, but not a lot.	Really not very much at all.
---------------------------	-----------------------	----------------------	------------------------------

Opportunity for my own ideas to be used in this activity is

Plentiful	Present a fair amount	Not present as much as I would like.	Pretty rare.
-----------	-----------------------	--------------------------------------	--------------

Top management regard this as

Insignificant	Not very important	Fairly important	Definitely important.
---------------	--------------------	------------------	-----------------------

The personal involvement I feel in this part of my work is

Little - if any.	Some, but not much	A fair amount	Quite strong
------------------	--------------------	---------------	--------------

The changes I can make in this activity are

Major, and off my own bat, though I may have to keep my superior posted	Major, but usually only after consultation with my superior.	Not often major, but minor ones at my own discretion	Not even minor unless first cleared with my superior.
---	--	--	---

This activity is a source of self-fulfilment.

Definitely	Quite a bit	Marginally	Hardly at all.
------------	-------------	------------	----------------

In determining the success of the department, this particular task

Doesn't affect things much	Is marginal	Is fairly important	is Critical.
----------------------------	-------------	---------------------	--------------

If I was to overhear criticism of this activity I would be likely to be

Annoyed or hurt	A bit irritated	perhaps mildly affected	pretty much indifferent.
-----------------	-----------------	-------------------------	--------------------------

This is something I would tend to go on thinking about when I left work in the evening.

Unlikely.	Perhaps - from time to time.	Possibly true	Probably true
-----------	------------------------------	---------------	---------------

Are the results of what you decide or do in connection with this activity fed back

To you for your own benefit	To you, before being passed to your superior.	To your superior, who then communicates them to you.	To your superior and not to you in time for it to be useful.
-----------------------------	---	--	--

Potentially, as a source of self respect to me, this part of my work counts:

Considerably	Moderately	Not greatly	Hardly at all
--------------	------------	-------------	---------------

The amount of freedom I have in this part of the job is

Almost non-existent	Not a great deal	A fair amount, but I would like more	About as much as I would like.
---------------------	------------------	--------------------------------------	--------------------------------

How likely is it that this will give you a feeling of personal accomplishment if it turns out as it should?

Very likely	Quite likely	Not very likely	Unlikely
-------------	--------------	-----------------	----------

5.

The authority I have over this activity.

Is virtually
absolute

is not absolute but
significant

Is not as much as
I would wish

is not much
at all.

Of the circles below, imagine that the centre one represents your 'self' and all that is close to you, and the outer circle represents the more remote aspects, things you are not so close to.

Where would you place this activity?

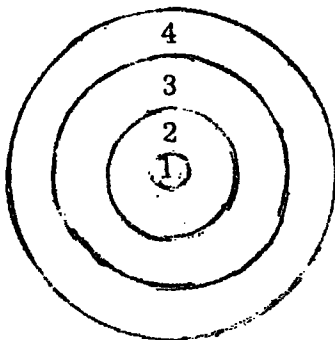

(iv) Opinion Questionnaire I

Instructions

This questionnaire contains 24 statements relating to situations not just at work but in everyday life and about which opinion seems pretty evenly divided.

Any one statement would be true for some people but not for others. The purpose of this questionnaire is to find out what your personal reaction is to the statements.

Read each one and decide whether it is true or false as far as you are concerned.

If a statement is TRUE or MOSTLY TRUE for you, put T in the right hand column. If a statement is FALSE or NOT USUALLY TRUE as far as you are concerned, put an F.

Work Rapidly

-2-

	T or F
1. The excitement for me in studying, would be in becoming familiar and competent with existing theories rather than having to develop my own.	
2. It is preferable that a professional clergy take the leading role in church worship.	
3. Sometimes I rather enjoy going against the rules and doing things I'm not supposed to.	
4. It is only natural and right for a person to think his family is better than any other.	
5. I am in favour of very strict enforcement of all laws no matter what the consequences.	
6. I find I often defend an author I am reading if someone else attacks him.	
7. I like to fool around with new ideas, even if they turn out later to be a total waste of time.	
8. 'Doing your own thing' is an overrated value.	
9. I am very likely to get annoyed if someone criticises a car, record or book which would be my choice.	
10. A person needs to "show off" a little now and then.	
11. Even if a piece of work was of interest to me, I would have no reluctance in delegating it.	
12. I would find it difficult to discard an idea which I had developed, even if the weight of opinion was against it.	

-3-

T or F

If I was in a music role, I would rather be a performer than a composer.

At times, I have been so entertained by the cleverness of a criminal, I have hoped he would get away with it.

Fools learn by experiences, wise men by the experience of others.

It is a good rule to accept nothing as certain or proved till you have proved it for yourself.

It is alright to get around the law if you don't actually break it.

It is unusual for me to express strong approval or disapproval of the actions of others.

Other people's problems are never likely to be as of much interest to you as your own.

Most people are honest chiefly through fear of being caught.

I usually find I'm reluctant to work to ideas or plans I have had little or no influence over.

I am so annoyed when someone tries to get ahead of me in a queue that I speak to him about it.

Compared to your own self respect, the respect of others means very little.

Being self-centred is almost always an undesirable trait.

(v) Opinion Questionnaire II

Instructions

This is a questionnaire to find out the way in which certain important events in our society affect different people. Each item consists of a pair of alternatives lettered a or b. Please select the one statement of each pair (and only one) which you more strongly believe to be the case as far as you're concerned. Be sure to select the one you actually believe to be more true rather than the one you think you should choose or the one you would like to be true. This is a measure of personal belief; obviously there are no right or wrong answers.

Please answer these items carefully but do not spend too much time on any one item. Be sure to find an answer for every choice.

In some ~~instances~~ you may discover that you believe both statements or neither one. In such cases, be sure to select the one you more strongly believe to be the case as far as you're concerned. Also try to respond to each item independently when making your choice; do not be influenced by your previous choices.

Circle the letter a or b according to your belief.

- a Children get into trouble because their parents punish them too much.
- b The trouble with most children nowadays is that their parents are too easy with them.
- a In the long run people get the respect they deserve in this world.
- b Unfortunately, an individual's worth often passes un-recognised no matter how hard he tries.
- a Without the right breaks one cannot be an effective leader.
- b Capable people who fail to become leaders have not taken advantage of their opportunities.
- a Becoming a success is a matter of hard work, luck has little or nothing to do with it.
- b Getting a good job depends mainly on being in the right place at the right time.
- a The average citizen can have an influence in government decisions.
- b This world is run by the few people in power, and there is not much the little guy can do about it.
- a Who gets to be the boss often depends on who was lucky enough to be in the right place first.
- b Getting people to do the right thing depends upon ability, luck has little or nothing to do with it.
- a In my case getting what I want has little or nothing to do with luck.
- b Many times we might just as well decide what to do by flipping a coin.
- a As far as world affairs are concerned, most of us are the victims of forces we can neither understand, nor control.
- b By taking an active part in political and social affairs the people can control world events.
- a Most people don't realise the extent to which their lives are controlled by accidental happenings.
- b There really is no such thing as "luck"
- a One should always be willing to admit mistakes.
- b It is usually best to cover up one's mistakes.
- a Many times I feel that I have little influence over the things that happen to me.
- b It is impossible for me to believe that chance or luck plays an important role in my life.
- a What happens to me is my own doing.
- b Sometimes I feel that I don't have enough control over the direction my life is taking.

APPENDIX EMain Survey Instruments

- (i) Interview Schedule
- (ii) Key to Job Activity Questionnaire
- (iii) Job Activity Questionnaire
- (iv) Opinion Questionnaire I (The I-E Scale)
- (v) Opinion Questionnaire II (The I-C and O-P Scales)
- (vi) General Job Attitude Questionnaire
- (vii) Back Up Procedure for Identifying Tasks

(i) Interview Schedule - Main Survey

1. Can you give me an idea of what your job is and where it fits in?
2. Filling out cards with specific tasks.
 - (a) What are you doing at present that you feel most enthusiastic about? (effort regardless of importance)
 - (b) List others - rank - pick pair.
3. Why is Task A highest in enthusiasm?
4. Why is Task B less so?

Task A - Specific Questions

5. First, briefly describe the nature of Task A (how problematical).

Origin

6. When did it come into being?
7. How? How was the decision made?
8. Whose idea was it?
9. What were the reasons for it?

Involvement

10. How did you come to be associated with it?
11. When was that?
12. Why you?
13. What stage is it at now?

Part Played

14. What part did you play at the beginning?
15. Can you remember the first step?
16. What part do you play now?
17. Who else is involved?

Subordinates:
 Superiors:
 Peers:
 Others:

18. How central is your part?
19. Who makes the final decisions and how? How free a hand?

Feelings

20. Could you describe how you feel overall about this task? What does it mean to you? Why? How would you feel if it was criticised?
21. How would you feel (have felt) if you had been pulled off it half way through to do something else? (of corresponding interest)
22. Are there any changes you would like to see?

Task B

23. Describe its nature (how problematical).

Origin

24. When did it come into being?
25. How? How was the decision made?
26. Whose idea was it?
27. What were the reasons for it?

Involvement

28. How did you come to be associated with it?
29. When was that?
30. Why you?
31. What stage is it at now?

Part Played

32. What part did you play at the beginning?
33. Can you remember the first step?
34. What part do you play now?

35. Who else is involved?

Subordinates:
 Superiors:
 Peers:
 Others:

36. How central is your part?

37. Who makes the final decisions and how? How free a hand?

38. Could you describe how you feel overall about this task? What does it mean to you? Why? How would you feel if it was criticised?

Feelings

39. How would you feel (have felt) if you had been pulled off it half way through to do something else? (of corresponding interest)

JAQ A.
 I-E

General Questions on views towards work and people's attitudes to it.

41. What is your personal view, and from your experience as a manager as to what causes people to be committed to their work?

42. What implications does this have for managers?

43. Most of us are frustrated or disappointed from time to time in our work, what would make you feel like that?

P.F. and J.A.Q. B

44. How long have you been with the company?

45. Think of a time when you felt exceptionally good about your job. Describe what happened and how you felt.

46. How important was it at the time?

47. Now think of another time, one when you felt especially bad about your job. Describe what happened and how you felt.

- 48. How important was it at the time?
- 49. How do you feel if you're pulled off a job half way through?
- 50. Which do you prefer, the managerial or the technical part of your job?

G.J.A.Q.

- 51. Age 20-30 _____
31-40 _____
41-50 _____
51 or _____
over _____
- 52. Number of subordinates.

(ii) Key to Items in Job Activity QuestionnaireCategory

Influence	4*, 6, 13.
Freedom of Choice	3, 11*, 16, 21.
Psychological Ownership	5, 7, 12, 15*, 19, 23*.
Achievement	2, 8*, 22.
Task Involvement	1, 10, 17, 20*.
Initial Choice	9*.
Importance to the Company	14*, 18*.

*Reversed Items

(iii) Job Activity Questionnaire

Instructions

For each of the questions or statements in this booklet, check the one response which most closely reflects your opinion or feelings.

- Important
- (1) Relate this to the specific activity in question, not to your job as a whole.
 - (2) Read each of the 4 responses before choosing one of them. But they are only guides.
 - (3) Work steadily without hurrying.

Activity:-

How likely would you be to enjoy an opportunity you were given to talk to people you know socially about this part of your work?

Very likely	Quite likely	Not very likely	Most unlikely

This activity at present,

is definitely challenging	is quite challenging	offers some challenge	offers little challenge

Allocation of tasks, responsibilities, duties etc or the approval of subordinates undertaking of them in this task.

is within my sole discretion	is within my discretion for the most part	is outside my discretion for the most part	is not often within my sole discretion.

The ideas or suggestions which generated this activity in the first place.

Were not really mine at all. Someone else thought of it.	Were not much mine, but I was consulted about them.	Were mine in part. I had quite a lot of say early on.	Were mainly mine, I thought of it.

If people were to talk about this aspect of the job, would you feel they were virtually talking about you - the person?

Yes, I think I would.	To some extent, Yes.	Possibly, but it wouldn't be a strong feeling.	unlikely.

In choosing or modifying methods or procedures for this activity.

I have considerable freedom of choice.	I have a fair amount of freedom but within some constraints.	I have some freedom but with significant constraints.	Methods and procedures are predetermined for the most part.

All in all, I think of this as my pigeon.

Very true	To some extent	Not quite that strongly	Not at all.
-----------	----------------	-------------------------	-------------

At present, this aspect of my work

Does not have a very high interest content	Has some interest content	Has quite a high interest content.	Has a very high interest content.
--	---------------------------	------------------------------------	-----------------------------------

When you undertook this activity

Were you instructed by your superior?	Were you asked by your superior but it was difficult to say no?	Was it suggested as a possibility by your superior?	Was it on your own responsibility?
---------------------------------------	---	---	------------------------------------

Depending on how well or how badly this goes, the effect on how I feel about myself is likely to be

Considerable	Fairly considerable	Moderate	Not very marked.
--------------	---------------------	----------	------------------

The targets I work to in connection with this activity are set

Largely by others. I am allowed little say over what targets are set.	Largely by others but I have some say.	By me in conjunction with my superior (s)	Largely by me while taking into consideration the expectations and needs of others.
---	--	---	---

Of all I am doing in life at present, this rates

Very highly with me.	Quite highly with me.	Moderately	fairly low.
----------------------	-----------------------	------------	-------------

Opportunity for my own ideas to be used in this activity is

Plentiful	Present a fair amount	present to some extent	fairly low
-----------	-----------------------	------------------------	------------

Department top management regard this as

Insignificant	Not very important	Fairly important	Definitely important.
---------------	--------------------	------------------	-----------------------

The sense of personal involvement I feel in this part of my work is

Not very great	moderate	quite strong	considerable.
----------------	----------	--------------	---------------

The changes I can make in this activity (or can see are made), are

Major, and off my own bat, though I may have to keep my superior posted	Major, but sometimes only after consultation with my superior.	Major ones usually only after consultation, but minor ones at my own discretion.	Even some minor ones may have to be cleared with my superior first.
---	--	--	---

This activity is a source of self-fulfilment.

Definitely	Quite a bit	to some extent	Not much really
------------	-------------	----------------	-----------------

In determining the success of the department, this particular task

Doesn't affect things much	Is marginal	Is fairly important	is critical.
----------------------------	-------------	---------------------	--------------

If someone whose opinion you respected was to make some derogatory remark to you about the value of this activity, would you feel hurt or annoyed.

Probably	Possibly	Perhaps a little	Unlikely

This is something I might still go on thinking about when I left work in the evening.

Unlikely	Perhaps - from time to time.	Possibly true	Probably true

Are the results of what you decide or do in connection with this activity fed back.

To you for your own benefit	To you, prior to discussion with your superior.	To your superior, who then communicates them to you with his views.	To your superior who then communicates his views to you.

How likely is it that this will give you a feeling of personal accomplishment if it turns out as it should?

Very likely	Quite likely	Possibly	Not very likely

The Right Hand End of this scale represents your 'Self' and all that you feel is close to you. The Left Hand End represents the remoter aspects, things you are not so close to.

Where would you place this activity. Think in terms of your life as a whole.

Remote from self'			Close to 'Self'

(iv) Opinion Questionnaire I

Below are 19 statements relating to situations in every day life and about which opinion seems evenly divided.

The purpose of this questionnaire is to find your personal reaction to each statement.

If a statement is TRUE or MOSTLY TRUE for you, put T in the right hand column, If a statement is FALSE or NOT USUALLY TRUE as far as you are concerned, put an F.

Work Rapidly

T or F

1. The excitement for me in studying, would be in becoming familiar and competent with existing theories rather than having to develop my own.

2. It makes sense to me that a professional clergy takes the leading role in church worship.

3. Sometimes I rather enjoy going against the rules and doing things I'm not supposed to.

4. I am in favour of strict enforcement of all laws no matter what the consequences.

5. I find I often defend an author I am reading if someone else attacks him.

6. I like to fool around with new ideas, even if they turn out later to be a total waste of time.

7. 'Doing your own thing' is perhaps an overrated value.

8. I am likely to get annoyed if someone criticises a car, record or book which would be my choice.

9. At times, I have been so entertained by the cleverness of a criminal, I have hoped he would get away with it.

10. A person needs to "show off" now and then.	T or F
11. I sometimes find it difficult to discard an idea which I have developed, even if the weight of opinion is against it.	
12. Fools learn by experience, wise men by the experience of others.	
13. It is alright to get around the law if you don't actually break it.	
14. It is unusual for me to express strong approval or disapproval of the actions of others.	
15. If I was a musician, I would rather be a performer than a composer.	
16. Most people are honest chiefly through fear of being caught.	
17. I usually find I'm reluctant to work to ideas or plans I have had little or no influence over.	
18. I am so annoyed when someone tries to get ahead of me in a queue that I speak to him about it.	
19. Compared to your own self respect, the respect of others means very little.	

(v) Opinion Questionnaire II

Instructions

This is a questionnaire to find out the way in which certain important events in our society affect different people. Each item consists of a pair of alternatives lettered a or b. Please select the one statement of each pair (and only one) which you more strongly believe to be the case as far as you're concerned. Be sure to select the one you actually believe to be more true rather than the one you think you should choose or the one you would like to be true. This is a measure of personal belief: obviously there are no right or wrong answers.

Please answer these items carefully but do not spend too much time on any one item. Be sure to find an answer for every choice.

In some ~~instances~~ you may discover that you believe both statements or neither one. In such cases, be sure to select the one you more strongly believe to be the case as far as you're concerned. Also try to respond to each item independently when making your choice; do not be influenced by your previous choices.

Circle the letter a or b according to your belief

1. a Who gets promoted often depends on who was lucky enough to be in the right place first.
b Getting people to do the right thing depends upon ability, luck has little or nothing to do with it.
2. a In the long run people get the respect they deserve in this world.
b Unfortunately, an individual's worth often passes un-recognised no matter how hard he tries.
3. a Children get into trouble because their parents punish them too much.
b The trouble with most children nowadays is that their parents are too easy with them.
4. a Many times I feel that I have little influence over the things that happen to me.
b It is impossible for me to believe that chance plays an important role in my life.
5. a As far as world affairs are concerned, most of us are the victims of forces we can neither understand, nor control.
b By taking an active part in political and social affairs the people can control world events.
6. a Without the right breaks one cannot be an effective leader.
b Capable people who fail to become leaders have not taken advantage of their opportunities.
7. a In my case getting what I want has little or nothing to do with luck.
b Many times we might just as well decide what to do by flipping a coin.
8. a The average citizen can have an influence in government decisions.
b This world is run by the few people in power, and there is not much the man in the street can do about it.
9. a Most people don't realise the extent to which their lives are controlled by accidental happenings.
b There really is no such thing as "luck"
10. a One should always be willing to admit mistakes.
b It is usually best to cover up one's mistakes.
11. a Becoming a success is a matter of hard work, luck has little or nothing to do with it.
b Getting a good job depends mainly on being in the right place at the right time.
12. a What happens to me is my own doing.
b Sometimes I feel that I don't have enough control over the direction my life is taking.

(vi) Job Questionnaire (G.J.A.Q.)

THIS QUESTIONNAIRE REFERS TO YOUR PRESENT JOB AS A WHOLE. For each statement, read BOTH statements and check (✓) Whichever space on the 7-point scale most closely reflects the situation as you see it.

I would be very likely to enjoy any opportunity I was given to talk to people about my job.

I would not be particularly likely to enjoy an opportunity I was given to talk to people about my job.

There is a great deal of challenge in this job.

There is not a great deal of challenge in this job.

I do not have enough freedom

I have about as much freedom as I could wish for.

Most of what I work on comes from my own ideas and suggestions

Most of what I work on comes from other people's ideas, requests, or suggestions.

For the most part, I find it easy to think of what I do at work as "my own".

For the most part I don't think I find it easy to think of what I do at work as "my own".

There are usually constraints as to what methods and procedures are used.

I am able to choose what methods and procedures are used.

The interest content of the job is very high.

The interest content of the job is not very high.

How the job goes, has a considerable effect on how I feel about myself

How the job goes, does not have much effect on how I feel about myself.

The targets I work to are set largely by others.

The targets I work to are set largely by me.

Of all I am doing in life, my job rates extremely highly with me.

Of all I am doing in life, my job doesn't rate very highly with me.

There is plenty of opportunity for my own ideas to be used in this job.

There is not much opportunity for my own ideas to be used in this job.

I do not get much sense of personal involvement in this job.



I get a considerable sense of personal involvement in this job.

I can make most major changes off my own bat.



Even some minor changes I am expected to clear with my boss first.

My job is not a major source of self fulfilment.



My job is a major source of self fulfilment.

If the job is made a subject of criticism, I would be very likely to feel it personally.



If the job is made a subject of criticism I would be unlikely to feel it personally.

I often go on thinking about the job when I have left work.



I do not often go on thinking about the job when I have left work.

In this job, there is considerable opportunity to feel I have accomplished something.



In this job, there is not much opportunity to feel I have accomplished anything.

All in all, I do not feel very happy with my present job.



All in all, I feel very happy with my present job.

I feel very secure in my job.



I do not feel very secure in my job.

(vii) Back Up Procedure for Identifying Tasks

- (a) If Task A but no similar Task B, a dissimilar Task would be chosen.
- (b) If Task A was not specific (eg. 'I like managing people best'), two specific Tasks would be picked, C and B where the enthusiasm for C was greater than B.
- (c) If no Tasks, A or B, only general questions would be asked:
 - How do tasks arise? How do they come to you?
 - What part do you play in them?
 - How do decisions get made in your department?
 - What determines how you feel about a task?

APPENDIX FResults of the Opportunity Questionnaire - Scores for Researchers and
Works Managers N=14

<u>Researchers</u>	<u>Production and Engineering Managers</u>
21	23
23	17
19	19
22	22
27	31
23	19
22	18

Scores represent items for Structure, Climate and Risk.

No significant difference between the two occupational groups

APPENDIX GExpressions of Psychological Ownership1. The way it is experienced

"I'm interested because this is my baby ... It's mine ... and warts and all too. Its problematical but they're my problems and I like that - I like that very much."*

"You're committed if you or a bit of you is really involved, if there's a bit of you tied up in what you're doing."

"There's a bit of my blood in there."

"I like to think that when they talk about the (job), they are talking about me."

"It's my hobby ... it's my life ... all my thoughts are built around it."

"One likes to carve a little niche for oneself."

"I have a long association with (a technique), its deeper inside me ... I have a feel for it, I grew up with it, it's still alive both in me and outside me."*

2. The way it is sought

"I was looking for something that would grow out of what I was doing, something that would be 'mine' - if you like."

"I wanted to do my own work - do my own thing."

"I want something which is my own."*

3. Its Origins

"You get frustrated when you can't see it through. (Why?) It's a personal thing. You like to take a thing from its origin to full development. It's your baby."*

"It's a process I have developed ... myself. The idea that it should be done wasn't mine ... I've seen the development of it right through."

"I get committed as soon as I've put my name on it, as soon as It's taken a different direction - no matter how slight, I've altered something, then I'm much more keen."

"I'd be very annoyed if I was pulled off it, because I did a lot of thinking and work others didn't see. I went my way about it ... you carry a lot in your hands and head which others don't have."*

"They become committed if they are creating something. If they can say something they have produced is theirs, if their stamp is on it."

"Men in particular feel they have to create something permanent ... something that remains behind when they're dead ... to do something they are proud of."

"In a job he knows thoroughly, he looks on it as his job."

4. Actively acquiring Ownership

"I take it over, I make it into something, I change it till it doesn't look like it did when I got it - it belongs to me, so I don't want to give it up."

"People above me take the high level decisions, but on the basis of what I tell them, so I can ensure it goes the way I want it to."

"I'm sure they (seniors) wouldn't have done it if I hadn't pushed it ... I showed them the way through."

5. What is owned being threatened

"I've feelings of misgivings that my boss will want to get involved and I'll lose responsibility and have to take a less influencing part in it. It's difficult to carry it all but I'd like to maintain an identity and run the whole show right the way through."

"It looked as if (his manager) was going to bundle it (a project) off and put it in his pocket. The rotten ***** was going to pinch my baby."*

6. The owned task in conflict with organisation goals

"It wasn't the boss's idea, so he didn't follow it up."

"(Task A) gives me a sense of achievement, but some people would laugh because it's only a small thing, there's not much opportunity for work like this." (i.e. initiated by him)

"This was my baby but it's complicated by politics, I can do myself harm if I spend too much time on this because they don't like it - it doesn't fit in."

7. Psychological Ownership and collaboration

"The finished product is not my baby because there are others involved."

"We have rows, but once having decided it you abide by it because you identify with it even if you've disagreed."

8. Its relation to the concept of Achievement

"You have original thoughts and see them come to fruition, it feeds your personal sense of power if they are successful."

"There's a lot of satisfaction ... from seeing something you've been in from planning coming off."*

"I'm enthusiastic because I have sole control of a problem solving experience."

"It's the enjoyment of a visible result of my own actions. Either success or failure in terms of what I do."

APPENDIX HDetails of Categories and Results from Open-Ended Questions

- (i) Distribution of Tasks According to the Degree of Autonomy.
- (ii) Reasons for Task Enthusiasm - Categories and illustrative Quotations.
- (iii) Frequency of Categories Cited as Reasons for Enthusiasm.
- (iv) Managers' beliefs about Motivation to Work - Categories Definitions and illustrative Quotations.
- (v) Frequency of Categories in Responses to Herzberg's Questions.

(i) Distribution of Tasks According to the Degree of Autonomy

<u>Degree of Autonomy*</u>	<u>Researchers (N=20)</u>		<u>Engineers (N=15)</u>	
	<u>Preferred Task</u>	<u>Less Preferred</u>	<u>Preferred Task</u>	<u>Less Preferred</u>
HIS IDÉA	1	-	1	-
His idea	7	-	4	1
Imports	3	1	-	-
Development	8	4	2	1
Management I	1	2	4	-
Consultative I	-	3	4	4
Management II	-	4	-	4
Consultative II	-	5	-	4
Conflict	-	1	-	1

*For definition of categories, see Table 10.3.

(ii) Reasons for Task Enthusiasm - Categories and Illustrative Quotations

Achievement:	A sense of challenge. Feelings of success.
Autonomy: (Control)	Being a cog in a wheel. Having a personal sense of power. Having control.
(Influence)	I can demonstrate my talents. There's no scope for my skills.
Importance:	It's good cash value. It's a worthwhile project.
Interest:	It's an interesting project.
Psychological Ownership	Having a project of your own. It's my baby. Doing someone else's work.
Recognition:	Increasing my credibility. My seniors are interested.

(iii) Frequency of Categories Cited as Reasons for Enthusiasm

<u>Category</u>	<u>Researchers (N=20)</u>		<u>Engineers (N=15)</u>	
	<u>Task A</u>	<u>Task B</u>	<u>Task A</u>	<u>Task B</u>
Achievement	10	8	10	3
*Autonomy	9	7	5	8
Importance	8	2	0	0
Interest	5	3	2	1
Psychological Ownership	11	7	2	2
Recognition	2	1	3	0
Others.	2	3	1	1

*'Control' was mentioned by engineers in 10 out of 13 cases and by researchers in 6 out of 16 cases.

(iv) Managers' Beliefs about Motivation to Work - Categories, Definitions and Illustrative Quotations

<u>Category</u>	<u>Definitions</u>	<u>Illustrations</u>
Achievement	Challenge Seeing results	- Having something to strive for. - Whatever it is that makes you want to win, testing yourself.
Autonomy	Control Freedom of Choice Influence	- If they know the plant runs solely due to them. - Most people, given freedom, responsibility, information and reasons, are willing to do it.
Boss-Subordinate Relationship	Trust Fair play Giving support Commanding respect	- The respect they have for the boss. - If they know they have someone they can talk to.
Importance	Believing in the work. Useful, Worthwhile	- You can't be committed to anything you don't believe in. - Most people need to feel it's of some use.
Interest	Interest of the Work Itself	- If you have a job which interests you, you're half way there.
Loyalty	Sense of Responsibility to the company Understanding the company's point of view	- Having a sense of responsibility to do the best for the company. - Being willing to understand the company's side.
Psychological Ownership	Self expression Creativity Identification	- If he is able to express himself in the job. - A bit of you is involved.
Recognition	Praise Respect from peers Promotion	- Giving praise lavishly and avoiding being excessively critical. Recognition by someone who is in a position to know.

Salary

Pay
Fringe benefits

- If you pay them enough they'll
feel obliged to do the job
they're supposed to be doing.

Others

Authority
Interpersonal
Relationships

(v) Frequency of Categories in Responses to Herzberg's Questions

	<u>Good Events</u>		
	<u>Researchers</u>	<u>Engineers</u>	<u>Both Groups</u>
Achievement	10	17	27
Work Itself	3	0	3
Recognition	7	3	10
Responsibility	3	2	5
Interpersonal Relationships	0	1	1
Company Policy	0	0	0
Supervision	0	0	0
Security	0	0	0
	<u>Bad Events</u>		
Achievement	3	4	7
Work Itself	0	1	1
Recognition	1	1	2
Responsibility	1	1	2
Interpersonal Relationships	3	5	8
Company Policy	4	3	7
Supervision	7	4	11
Security	1	2	3

Note: It is possible for a respondent to cite more than one category in answer to each question.

APPENDIX IAdditional Tables of Scaled Questionnaire Data(i) Partial Correlations of Autonomy, Psychological Ownership, Task Involvement and Achievement (Re. Hypothesis II)

<u>Factors correlated with Psychological Ownership</u>	<u>tau</u>	<u>Partialled for:</u>	<u>tau</u>
Influence	0.57	Task Involvement	0.43
Freedom	0.67	" "	0.53
Autonomy	0.65	" "	0.50
Task Involvement	0.68	Achievement	0.54

Note: The correlation of Psychological Ownership and Task Involvement is the strongest even after Achievement has been partialled out.

(ii) Distribution of J.A.Q. Factors between Researchers and Engineers - Significance levels of Mann-Whitney U (Re. Hypothesis V)

<u>Factor</u>	<u>J.A.Q. (A)</u>	<u>J.A.Q. (B)</u>
Influence	n.s.	n.s.
Freedom	.05*	n.s.
Autonomy	n.s.	n.s.
Psychological Ownership	n.s.	n.s.
Achievement	n.s.	n.s.
Task Involvement	n.s.	.07**

* In favour of engineers.

** In favour of researchers.

(iii) Differences in Opportunity for Factors (G.J.A.Q.) Between Researchers and Engineers (Re. Hypothesis VII)

Factor

<u>Opportunity for:</u>	<u>significance</u>
Influence	n.s.
Freedom	n.s.
Autonomy	n.s.
Psychological Ownership	n.s.
Achievement	n.s.
Task Involvement	.02*

*Significance of Mann-Whitney U. In favour of researchers.

APPENDIX JCorrelation of G.J.A.Q. Factors Using Kendall's Tau

Factors correlated with
opportunity for
Psychological Ownership

significance

<u>Opportunity for:</u>	<u>Researchers</u>	<u>Engineers</u>
Influence	.01	.03
Freedom	.01	n.s.
Autonomy	.005	n.s.
Achievement	.001	.0001
Task Involvement	.001	.0001
Correlation of opportunity for Achievement and opportunity for Task Involvement	.01	.001

BIBLIOGRAPHY

1. Allport, G.W. (1955). Becoming, New Haven: Yale University Press.
2. Allport, G.W. (1961). Pattern and Growth in Personality, London: Holt, Rinehart & Winston.
3. Anygal, A. (1952). "A Theoretical Model for Personality Studies" in Theoretical Models and Personality Theory, Krech, D., Klein, G.S. (Eds.), Duke University Press.
4. Argyris, C. (1962). Interpersonal Competence and Organisational Effectiveness, Homewood, Ill.: Irwin.
5. Argyris, C. (1964). Integrating the Individual and the Organisation, New York: Wiley.
6. Bannister, D. & Fransella, F. (1971). Inquiring Man. The Theory of Personal Constructs, Allen Lane the Penguin Press.
7. Bennis, W.G. (1966). Changing Organisations, New York: McGraw-Hill.
8. Blalock, H.M. (1960). Social Statistics, New York: McGraw-Hill.
9. Brayfield, A.H. & Crockett, W.H. (1955). Employee attitudes and employee performance. Psychol. Bull. 52, 396. Cited by Vroom (1964).
10. Burke, R.J. (1966). Are Herzberg's motivators and hygiene unidimensional? J. appl. Psychol. 50, 317.
11. Coch, L. & French, J.R.P. (1948). Overcoming resistance to change. Hum. Relat. 1, 512.
12. Collins, M. & Drever, J. (1936). Psychology and Practical Life, University of London Press.
13. Crutchfield, R.S. (1955). Conformity and character. Amer. Psychol. 10, 191.
14. DeCharms, R. (1968). Personal Causation, New York: Academic Press.
15. Dunnette, M.D., Campbell, J.P. & Hakel, M.D. (1967). Factors contributing to job satisfaction and job dissatisfaction in six occupational groups. Org. Behav. and Hum. Performance. 2, 143.
16. Eriksen, C.W. (1952). Individual differences in defensive forgetting. J. exp. Psychol. 44, 442.
17. Ewen, R.B. (1964). Some determinants of job satisfaction: A study of the generality of Herzberg's theory. J. appl. Psychol. 48, 161.
18. Ewen, R.B., Smith, P.C., Hulin, C.L. & Locke, E.A. (1966). An empirical test of the Herzberg two-factor theory. J. appl. Psychol. 50, 544.
19. Farber, M. (1966). The Aims of Phenomenology, New York: Harper & Row.

20. Fisher, S. & Cleveland, S.E. (1956). Body-image boundaries and style of life. J. abnorm. soc. Psychol. 52, 373.
21. French, E.G. (1955). Some characteristics of achievement motivation. J. exp. Psychol. 50, 232.
22. French, J.R.P., Israel, J. & Aas, D. (1960). An experiment on participation in a Norwegian factory. Hum. Relat. 13, 3.
23. French, J.R.P., Kay, E. & Meyer, H.H. (1966). Participation and the appraisal system. Hum. Relat. 19, 3.
24. Friedlander, F. (1964). Job characteristics as satisfiers and dissatisfiers. J. appl. Psychol. 48, 388.
25. Fromm, E. (1942). The Fear of Freedom, London: Routledge and Kegan Paul.
26. Fromm, E. (1949). Man For Himself, London: Routledge and Kegan Paul.
27. Gilmore, J.L. (1954). Recall of success and failure as a function of subjects' threat interpretations. J. Psychol. 38, 359.
28. Graen, G.B. (1966). Addendum to "an empirical test of the Herzberg two-factor theory". J. appl. Psychol. 50, 55.
29. Graen, G.B. (1968). Testing traditional and two-factor hypotheses concerning job satisfaction. J. appl. Psychol. 52, 366.
30. Graen, G.B. & Hulin, C.L. (1968). Addendum to "an empirical investigation of two implications of the two-factor theory of job-satisfaction". J. appl. Psychol. 52, 341.
31. Green, D.R. (1963). Volunteering and the recall of interrupted tasks. J. abnorm. soc. Psychol. 66, 397.
32. Guilford, J.P. (1954). Psychometric Methods, London: McGraw-Hill.
33. Hall, C.S. & Lindzey, G. (1957). Theories of Personality, New York: Wiley.
34. Halpern, G. (1966). Relative contributions of motivator and hygiene factors to overall job satisfaction. J. appl. Psychol. 50, 198.
35. Harlow, H.F. (1953). Monkeys, men and motives. Psychol. Rev. 60, 23.
36. Harré, R. & Secord, P.F. (1972). The Explanation of Social Behaviour, Oxford: Blackwell.
37. Harvey, O.J. (1963). Motivation and Social Interaction, New York: Ronald Press.
38. Hays, G.T. (1952). Situational instructions and task order in recall for completed and interrupted tasks. J. exp. Psychol. 44, 434.
39. Hays, W.L. (1963). Statistics, London: Holt, Rinehart & Winston.
40. Hebb, D.O. (1949). The Organisation of Behaviour, New York: Wiley.

41. Herzberg, F. (1968). Work and the Nature of Man, New York: World Publishing.
42. Herzberg, F., Mausner, B. & Snyderman, B. (1959). The Motivation to Work, New York: Wiley.
43. Hilgard, E.R. (1949). Human motives and the concept of self. Amer. Psychol. 4, 374.
44. Hilgard, E.R. & Atkinson, R.C. (1967). Introduction to Psychology, 4th ed. New York: Harcourt, Brace & World.
45. Hinrichs, J.R. (1970). Psychology of men at work. Annual Rev. Psychol. 21, 519.
46. Hinrichs, J.R. & Mischkind, L.A. (1967). Empirical and theoretical limitations of the two-factor hypothesis of job satisfaction. J. appl. Psychol. 51, 191.
47. Hoffman, M.L. (1956). Conformity as a defence mechanism and a form of resistance to genuine group influence. J. Pers. 25, 412.
48. Holmes, R. (1967). The ownership of work: a psychological approach. Brit. J. indust. Relat. 5, 19.
49. Horney, K. (1951). Neurosis and Human Growth, London: Routledge & Kegan Paul.
50. Hudson, L. (1968). Frames of Mind, Allen Lane the Penguin Press.
51. Hulin, C.L. & Smith, P.A. (1967). An empirical investigation of two implications of the two-factor theory of job-satisfaction. J. appl. Psychol. 51, 396.
52. Hull, C.L. (1943). Principles of Behaviour, New York: Appleton-Century.
53. James, W. (1892). Textbook of Psychology, London: MacMillan.
54. Jung, C.G. (1940). The Integration of the Personality, London: Kegan, Paul, Trench & Trubner.
55. Jung, C.G. (1953). Two Essays on Analytical Psychology, London: Routledge & Kegan Paul.
56. Kahn, R.L. (1961). In review of job factors, attitudes and effects. Contemporary Psychol. 6, 9.
57. Kelley, H.H. (1951). Communication in experimentally created hierarchies. Hum. Relat. 4, 39.
58. Kerlinger, F.N. (1969). Foundations of Behavioural Research, London: Holt, Rinehart & Winston.
59. Kintsch, W. (1970). Learning Memory and Conceptual Processes, London: Wiley.
60. Koch, S. (1956). Behaviour as "intrinsically" regulated: work notes towards a pre-theory of phenomena called "motivational", in Nebraska Symposium on Motivation. Jones, M.R. (Ed.), Univ. of Nebraska Press.

61. Kolb, D.A. & Boyatzis, R.E. (1970). Goal setting and self-directed behaviour change. Hum. Relat. 23, 439.
62. Krech, D & Crutchfield, R.S. (1958). Elements of Psychology, New York: Knopf.
63. Lahiri, D.K. & Srivastara, S. (1967). Determinants of satisfaction in middle-management personnel. J. appl. Psychol. 51, 254.
64. Lawler, E.E. & Hall, D.T. (1970). Relationship of job characteristics to job involvement, satisfaction and intrinsic motivation. J. appl. Psychol. 54, 305.
65. Lawrence, P.R. & Lorsch, J.W. (1967). Organisation and Environment: Managing Differentiation and Integration, Boston: Div. of Research, Harv. Bus. School.
66. Lawrence, P.R. & Lorsch, J.W. (1967a). New management job: the integrator. Harv. Bus. Rev. Nov.-Dec.
67. Leeper, R.W. & Madison, P. (1959). Toward Understanding Human Personalities, New York: Appleton Century Crofts.
68. Lefcourt, H.M. (1966). Internal versus external control of reinforcement. Psychol. Bull. 65, 206.
69. Levine, E.L. & Weitz, J. (1968). Job satisfaction among graduate students: intrinsic versus extrinsic variables. J. appl. Psychol. 52, 263.
70. Lewin, K. (1935). A Dynamic Theory of Personality, New York: McGraw-Hill.
71. Lewin, K. (1947). "Group decision and social change", Abridged by Proshansky, H. & Seidenberg, B. (1965). Basic Studies in Social Psychology, New York: Holt, Rinehart & Winston.
72. Lewin, K. (1948). Resolving Social Conflicts; Selected Papers on Group Dynamics, New York: Harper.
73. Lewis, H.B. & Franklin, M. (1944). An experimental study of the role of the ego in work. II The significance of task orientation in work. J. exp. Psychol. 34, 195.
74. Lohdahl, J.M. & Kejner, M. (1965). The definition and measurement of job involvement. J. appl. Psychol. 49, 24.
75. Lowe, C.M. (1961). The self-concept: fact or artefact? Psychol. Bull. 58, 325.
76. McClelland, D.C. (1961). The Achieving Society, New York: Free Press.
77. McClelland, D.C. (1962). Business drive and national achievement. Harv. Bus. Rev. July-August.
78. McClelland, D.C. (1964). The Roots of Consciousness, Princeton: Van Nostrand.

79. McClelland, D.C., Atkinson, J.W., Lowell, E.L. & Clark, R.A. (1953). The Achievement Motive, New York: Appleton-Century-Crofts.
80. McGregor, D. (1960). The Human Side of Enterprise, New York: McGraw-Hill.
81. McGregor, D. (1967). The Professional Manager, New York: McGraw-Hill.
82. Marquis, D.G. (1966). Scientists in a technology-oriented organisation. M.I.T. working paper 191, 66.
83. Maslow, A.H. (1954). Motivation and Personality, New York: Harper.
84. Meltzer, H. & Ludwig, D. (1968). Memory dynamics and work motivation. J. appl. Psychol. 52, 184.
85. Miller, D.R. & Swanson, G.E. (1960). Inner Conflict and Defence, New York: Holt.
86. Murphy, G. (1947). Personality, New York: Harper.
87. Myers, M.S. (1964). Who are your motivated workers? Harv. Bus. Rev. 42, 73.
88. Newcomb, T.M. (1952). Social Psychology. The Study of Human Interaction, London: Tavistock.
89. Olds, J. (1956). A preliminary mapping of electrical reinforcing effects in the rat brain. J. Comp. Physiol. Psychol. 49, 281.
90. Oppenheim, A.N. (1966). Questionnaire Design and Attitude Measurement, London: Heinemann.
91. Patchen, M. (1958). The effect of reference group standards on job satisfactions. Hum. Relat. 11, 303.
92. Paul, W.J. (1970). "The mechanics of motivation", in annual review of management techniques. Managt. Today. London: Management Publications.
93. Paul, W.J. & Robertson, K.B. (1970). Job Enrichment and Employee Motivation, London: Gower Press.
94. Peters, R.S. (1958). The Concept of Motivation, London: Routledge & Kegan Paul.
95. Rapaport, D. (1950). Emotions and Memory, New York: International Universities Press.
96. Reich, C.A. (1970). The Greening of America, Allen Lane the Penguin Press.
97. Rietman, W.R. (1961). Need achievement, fear of failure and selective recall. J. abnorm. soc. Psychol. 62, 142.
98. Rogers, C.R. (1951). Client-Centred Therapy, Boston: Houghton-Mifflin.

99. Rosenweig, S. (1943). An experimental study of repression with special reference to need-persistent and ego-defensive reactions to frustration. J. exp. Psychol. 32, 64.
100. Rotter, J.B. (1966). Generalised expectancies for internal versus external control of reinforcement. Psychol. Monogr. 80, 1.
101. Ryan, A. (1970). The Philosophy of the Social Sciences, London: MacMillan.
102. Saleh, S.D. & Grygier, T.G. (1969). Psychodynamics of intrinsic and extrinsic job orientation. J. appl. Psychol. 53, 446.
103. Sarbin, T.R. (1952). A preface to a psychological analysis of the self. Psychol. Rev. 59, 11.
104. Schultz, D.P. (1964). "R & D personnel: two basic types", Personnel, March, 62. In Schultz, D.P. (1970). (Ed.) Psychology and Industry, London: MacMillan.
105. Selltitz, C., Jahoda, M., Deutsch, M & Cook, S. (1959). Research Methods in Social Relations, New York: Holt, Rinehart & Winston.
106. Sheffield, F.D. & Roby, T.B. (1950). Reward value of a non-nutritive sweet taste. J. comp. physiol. Psychol. 43, 471.
107. Sherif, M. & Cantril, H. (1947). The Psychology of Ego-Involvement, New York: Wiley.
108. Shipley, T.E. & Veroff, J. (1952). A projective measure of need for affiliation. J. exp. Psychol. 43, 349.
109. Shlien, J.M. (1964). "Phenomenology and Personality". In Wepman, J.M. & Heine, R.W. Concepts of Personality, London: Methuen.
110. Siegel, S. (1956). Nonparametric Statistics, New York: McGraw-Hill.
111. Smith, P.C. & Cranny, C.J. (1968). Psychology of men at work. Ann. rev. Psychol. 19, 467.
112. Southgate, J. (1969). Research paper No. 1. Northwestern Polytechnic.
113. Strickland, B.R. (1965). The prediction of social action from a dimension of internal-external control. J. soc. Psychol. 66, 353.
114. Tannenbaum, A.S. (1966). Social Psychology of the Work Organisation, London: Tavistock.
115. Thibaut, J.W. & Strickland, L.H. (1956). Psychological set and social conformity. J. Pers. 25, 115.
116. Vroom, V.H. (1964). Work and Motivation, New York: Wiley.
117. Vroom, V.H. & Maier, N.R.F. (1961). Industrial Social Psychology. Ann. rev. Psychol. 12, 413.
118. Wernimont, P.F. (1966). Intrinsic and extrinsic factors in job satisfaction. J. appl. Psychol. 50, 41.

119. White, R.W. (1959). Motivation reconsidered: the concept of competence. Psychol. Rev. 66, 297.
120. Wolf, M.G. (1970). Need gratification theory: a theoretical reformulation of job satisfaction/dissatisfaction and job motivation. J. appl. Psychol. 54, 87.
121. Wylie, R.C. (1961). The Self Concept, Lincoln: Univ. of Nebraska Press.
122. Zeigarnik, B. (1927). On finished and unfinished tasks. Reprinted by Bobbs-Merrill, from Ellis, W.D. (1955). A Source Book of Gestalt Psychology.
123. Zeller, A.F. (1950). An experimental analogue of repression II. The effect of individual failure and success on memory measured by relearning. J. exp. Psychol. 40, 411.

