

Durham E-Theses

Internal symmetries and bootstrap models

P. K. Hutt

How to cite:

Hutt, P. K. (1972) Internal symmetries and bootstrap models. Doctoral thesis, Durham University.

Use policy

The full-text may be used and/or reproduced, and given to third parties in any format or medium, without prior permission or charge, for personal research or study, educational, or not-for-profit purposes provided that:

- a full bibliographic reference is made to the original source
- a <https://etheses.durham.ac.uk/id/eprint/8546/> is made to the metadata record in Durham E-Theses
- the full-text is not changed in any way

The full-text must not be sold in any format or medium without the formal permission of the copyright holders.

Please consult the [full Durham E-Theses policy](#) for further details.

INTERNAL SYMMETRIES AND BOOTSTRAP MODELS

INTERNAL SYMMETRIES AND BOOTSTRAP MODELS.

THESIS SUBMITTED TO THE

UNIVERSITY OF DURHAM

BY

PAUL K. HUTT, B.A. (CANTAB.)

FOR THE DEGREE OF DOCTOR OF PHILOSOPHY

DEPARTMENT OF PHYSICS

DURHAM UNIVERSITY

SEPTEMBER, 1972



Contents

	Page
Acknowledgements	4
Abstract	5
Chapter 1 Introduction	7
Chapter 2 Bootstrap Predictions for Symmetries	12
2.1 Mesons	12
2.2 Baryons	32
2.3 Broken Symmetry	35
Chapter 3 Duality Predictions for Symmetries	41
3.1 FESR and Duality	41
3.2 Meson Processes	47
3.4 Phenomenological Duality	57
Chapter 4 Comparison of Bootstrap and Duality Predictions	70
4.1 Meson Trajectories	70
4.2 Baryon Trajectories	78
4.3 Conclusions	79
Chapter 5 Quark Model Calculations	82
5.1 Introduction	82
5.2 N/D Model for Meson Exchanges	84
5.3 Conclusions	105
Appendices	
A Commutation Relations and Traces for SU(3) matrices	107
B Computation of Integrals	110
C Summary of N/D equations	113
References	117

Acknowledgements

My special thanks are due to Dr. P.D.B. Collins for patient and friendly guidance throughout the period in which this research was done.

I am grateful to friends in the Physics and Mathematics Departments of the University of Durham for many useful discussions and in particular to R.A. Swetman for help with computing.

I wish to thank Mrs. E. Lincoln for patient and accurate typing of the manuscript and my wife, Anne, for many hours spent stencilling the equations.

Finally my thanks are due to the Science Research Council for the award of a grant.

Abstract

Chapter 1 serves as a brief introduction to the ideas which form the subject of this thesis, internal symmetry, bootstraps, duality and the quark model.

In Chapters 2 and 3 we survey predictions for internal symmetries made from N/D bootstraps and the duality hypothesis respectively. Both approaches predict a Lie group structure and predict the meson representations. In addition the duality equations imply that the baryons transform as two-quark composites. A phenomenological choice of a subset of the duality constraints can be made which has a physical three-quark solution. Symmetry breaking is discussed in both cases.

In Chapter 4 we contrast the predictions surveyed in the previous two chapters. Duality requires exchange degeneracies among trajectories of different multiplets but these do not result from N/D models. In the dual case the even-signature, isosinglet trajectories are identified with mixed f, f' states, degenerate with the ω, ϕ respectively, whereas bootstrap models always produce a high-lying singlet trajectory which is most naturally identified with the Pomeron. It is argued that these differences make it unlikely that dual models can be deduced in any simple way from the bootstrap hypothesis.

An N/D quark model with meson exchanges is examined in Chapter 5. With the assumption that the quark mass is much larger than the meson mass, a singlet meson trajectory is obtained which lies an order of magnitude above the octet trajectories. This result is unaltered if symmetry breaking of any order is allowed. These difficulties are not removed by treating the particle exchange forces as perturbations to a background term. It is concluded that these results together with the known difficulties of obtaining physical slopes and intercepts imply that this type of quark model should probably be discarded.

CHAPTER 1

Introduction.

Since the advent of high energy accelerators physicists have been faced with a great proliferation of elementary particles. It is widely thought that at the present time the best way to describe this teeming population and their strong interactions lies within the framework of the S - matrix, with no reference to any underlying Lagrangian formalism. (see eg. Chew⁽¹⁾). This viewpoint will be adopted here. The S - matrix is taken to satisfy the following, generally accepted, principles: (a) Lorentz covariance, (b) connectedness decomposition, (c) unitarity, (d) crossing symmetry.

Phenomenologically the attempt to understand the particle spectrum began with the search for conserved quantum numbers, such as strangeness, which, together with the already known properties such as charge and parity, label the particles. The idea that strong interaction forces are invariant under neutron - proton exchange led to symmetry under the SU(2) group of transformations and the classifying of particles into representations of this Lie group. To incorporate the strangeness or hypercharge quantum number into an extended symmetry scheme, Gell-Mann and Ne'eman² chose SU(3) from amongst the second rank Lie groups and conjectured that the lowest mass mesons and baryons



correspond to octet representations of this group. This scheme has met with great success in that the particle spectrum clearly reflects a multiplet structure corresponding to representations of SU(3) despite the fact that the symmetry is badly broken. However allowing the broken symmetry part of the mass matrix to transform in a certain way under SU(3) led to the Gell-Mann - Okubo ⁽³⁾ sum rule for particle masses within a multiplet. The most dramatic success of this rule was the prediction of the mass of a strangeness - 3 particle, the Ω^- , to complete the spin $3/2$ baryon decuplet. This particle was subsequently found and with the predicted mass.

At about the same time as the introduction of SU(3), ideas were proposed, notably by Chew and Frautschi ^(4,5) to give a theoretical understanding of the dynamical basis of the particle spectrum. The crux of these ideas, alternatively called "nuclear democracy" or "the bootstrap" is that all the strongly interacting particles are composite or bound states of each other, owing their existence entirely to forces of the Yukawa type, i.e. forces expressible in terms of particle exchange. The particles are democratic in that none has a more elementary status than any other. To implement these ideas two further S-matrix principles are hypothesized. (a) The principle of maximal analyticity of the first kind: the connected parts of the S - matrix are analytic functions of the momenta on which they depend apart from poles corresponding to particles and the consequent singularities

implied by unitarity. This principle establishes that the S - matrix singularities are determined once the poles have been specified. However with no additional principles these poles may be arbitrary.

(b) Maximal analyticity of the second kind: there are only isolated singularities in the continued angular momentum plane. This implies that all the poles of the S - matrix are Regge poles ^(6,7) and, loosely speaking, that a knowledge of the cut discontinuities of the S - matrix determines these poles. These two principles give a set of non-linear self-consistency constraints from which it is hoped that the physical particle masses and coupling constants will emerge uniquely. It is conjectured that the only free parameter will be a dimensional parameter needed to set the scale of the masses and there will be no dimensionless free parameters. In particular the particle symmetries, together with the pattern of representations and of symmetry breaking, should not be arbitrarily imposed but should emerge as the unique solution to the bootstrap.

However, the idea of nuclear democracy suffers from severe practical limitations, when one tries to test it. Since a self-consistent closed subworld should not be a solution, the whole strong interaction problem must be considered simultaneously. To complete a practical calculation it is usually assumed, without much justification, that low mass states are most important and the higher mass particles are omitted.

Secondly one has to make mathematical approximations and these will almost certainly introduce extra free parameters into the calculation, against the spirit of bootstrapsism.⁽⁸⁾ Of course it must be said that the possibility that the bootstrap equations will turn out to be identities cannot be ruled out.

Historically the first bootstrap calculation was that of Zachariasen⁽⁹⁾ who treated the ρ - meson as a $\pi\pi$ composite, using the determinantal approximation to the N/D equations of Chew and Mandelstam.⁽¹⁰⁾ (A brief review of these equations is given in Appendix C.) In this calculation the π - meson has an elementary status. All the early bootstrap calculations were based on multichannel coupled integral equations which attempt at some incorporation of unitarity. The results have the general feature in common that the coupling constants come out too large.

More recently consistency equations for each two particle process have been written down using the rather vague principle of duality. This principle may be stated as the equivalence, in some average sense, of the resonance and Regge descriptions of an amplitude for some region of the dynamical variables s and t . (see e.g. ref.⁽¹¹⁾). These equations are much simpler than the partial wave, coupled N/D equations but since they are linear do not give a complete bootstrap. In particular the absolute values of the coupling constants are not determined.

An alternative understanding of the particle spectrum is the so-called quark model of Gell-Mann⁽¹²⁾ and Zweig⁽¹³⁾. In this model the known particles are thought to be composites of elementary spin $1/2$ objects, "quarks" and their antiparticles, which transform as the fundamental triplet representation of $SU(3)$. The correct $SU(3)$ spectrum is obtained if the mesons are quark- antiquark composites and the baryons are three quark states. This identification gives in addition the correct parity and charge conjugation properties of the mesons, but difficulty is found for the baryon states if the usual Fermi statistics are assumed for the quarks. (See eg. refs. ^(14,15)). One might also ask why three quark states should be more strongly bound than for instance two or four quark states. The quarks would be fractionally charged particles, and if they exist they have so far evaded detection. One possible explanation for this is that the quarks have an unusually large mass.

In the following chapters we survey and investigate aspects of these alternative approaches to an understanding of the particle spectrum and in particular to the prediction of particle symmetries. We make a careful comparison of predictions based on N/D bootstrap models, dual models and the quark model.

CHAPTER 2

Bootstrap predictions for Symmetries

In this chapter we survey the various arguments leading to the prediction of Lie group symmetry based on bootstrap models. These arguments originated with Cuklosky's⁽¹⁶⁾ work based on the Bethe - Salpeter equation. However identical relations are obtained in an N/D calculation and we adopt this latter approach, following essentially the arguments of Chan, de Celles and Paton⁽¹⁷⁾ and Hwa and Patil⁽¹⁸⁾. (See also Capps⁽¹⁹⁾).

2.1 Mesons

One considers the elastic scattering of a set of pseudoscalar mesons (P), $P_a + P_b \rightarrow P_c + P_d$ in the s - channel, where the labels denote internal quantum numbers.

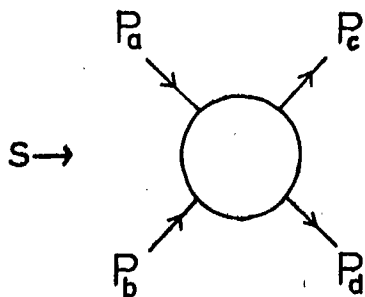

- i s-channel $a + b \rightarrow c + d$
- ii t-channel $a + \bar{c} \rightarrow \bar{b} + d$
- iii u-channel $a + \bar{d} \rightarrow c + \bar{b}$

Fig.2.1

The N/D equations can be written (see appendix C)

$$N_{ab,cd}^{\lambda} = B_{ab,cd}^{L,\ell} + \frac{1}{\pi} \int_{4m^2}^{\infty} \frac{ds'}{s'-s} \sum_{ef} \left(B_{ab,ef}^{L,\ell}(s') - \frac{s-s_0}{s'-s_0} B_{ab,ef}^{L,\ell}(s) \right) \times \rho_{\ell}(s') N_{ef,cd}^{\lambda}(s') \quad (2.1)$$

$$D_{ab,cd}^{\ell} = \delta_{ab,cd} - \frac{(s-s_0)}{\pi} \int_{4m^2}^{\infty} \frac{ds' \rho_{\ell}(s') N_{ab,cd}^{\ell}(s')}{(s'-s)(s'-s_0)} \quad (2.2)$$

where $\rho_{\ell}(s) = 2q_s^{2\ell+1} / \sqrt{s}$, m is the pseudoscalar meson mass and S_0 the subtraction point. $B_{ab,cd}^{L,\ell}$ is the 'potential' term specifying the left hand cut discontinuity, and calculated in this model from the exchange of a set of M degenerate vector mesons (V) in the t and u channels. If f_{ab}^r denotes the PPV coupling constant, which with Bose statistics must be antisymmetric under the interchange of a and b , then

$$B_{ab,cd}^{L,\ell} = F_{\ell}(s) \sum_r (f_{ac}^r f_{bd}^r + (-1)^{\ell} f_{ad}^r f_{bc}^r)$$

where $F_{\ell}(s) = \frac{Q_{\ell}(z_s) R_{\ell}(z_t)}{32 \pi q_s^{2\ell+2}}$ (see equation 10 Appendix C).

$$\text{Putting } V_{ab,cd}^{\ell}(s) = \sum_r (f_{ac}^r f_{bd}^r + (-1)^{\ell} f_{ad}^r f_{bc}^r)$$

this is a real symmetric matrix which may be diagonalized by the energy independent, orthogonal matrix U , whose columns are the eigenvectors of V

$$U_{ij} = \psi^i; \quad \text{where } V \psi^i = \lambda^i \psi^i, \quad (2.4)$$

$$U^{-1} V_{\ell} U = V_{\ell}^d \quad \text{where } V_{\ell}^d{}_{ij} = \lambda_{\ell}^i \delta_{ij} \quad (2.5)$$

it can easily be shown from equations (1) and (2) that this transformation simultaneously diagonalizes N and D and hence the partial wave amplitude B.

$$U^{-1}N_{\ell}U = N_{\ell}^d(s) \quad (2.6)$$

$$U^{-1}D_{\ell}U = 1 - \frac{s-s_0}{\pi} \int_{4m^2}^{\infty} \frac{ds' \rho_{\ell}(s') N_{\ell}^d(s')}{(s'-s)(s'-s_0)} \quad (2.7)$$

$$= 1 - \alpha_{\ell}(s)$$

$$U^{-1}B_{\ell}U = B_{\ell}^d(s) = N_{\ell}^d(s)(1 - \alpha_{\ell}(s))^{-1} \quad (2.8)$$

The following bootstrap conditions are imposed

a) Require that $B_1^d(s)$ has M degenerate poles at $S = (\text{vector meson mass})^2 = m_v^2$. This will be so if

$$\alpha_{1,i}(m_v^2) = 1 \quad \text{for } 1 \leq i \leq M$$

b) Assume that $N_{1,i}^d(s) = N_{1,i}^d(m_v^2) n(s)$,

$1 \leq i \leq M$ This is the assumption that the M eigenfunctions corresponding to the vector meson poles have the same s dependence, and includes the results of certain special approximations, eg. the determinantal or linear D approximations. The residues of the vector meson poles are:

$$\lim_{s \rightarrow m_v^2} (m_v^2 - s) B_{1,i}^d(s) = \frac{N_{1,i}^d(m_v^2)}{\left[\frac{d(\alpha_{1,i}(s))}{ds} \right]_{m_v^2}} \quad (2.9)$$

$$= \gamma \quad \text{for } 1 \leq i \leq M$$

$$= 0 \quad \text{for } i > M,$$

The assumption (b) ensures that γ is independent of i .

This implies

$$(2.10) \quad f_{ab}^r = \gamma^{1/2} \psi_{ab}^r \quad \text{or that}$$

$$(2.11) \quad V_{ab,cd}^1 f_{cd}^r = \lambda_r^1 f_{ab}^r \quad \text{The PPV coupling coefficients form the first } M \text{ eigenvectors of } V^1.$$

This result follows, provided analogous assumptions to (b) are made, for the coupling coefficients $g_{\ell,ab}^r$ of any ~~poles~~ ^{zeros} of D^ℓ . One obtains

$$V_{ab,cd}^\ell g_{\ell,cd}^r = \lambda_\ell^r g_{\ell,ab}^r \quad (2.12)$$

By orthogonality of the eigenvectors of a real symmetric matrix, we obtain with suitable normalization.

$$\sum_{ab} g_{\ell,ab}^i g_{\ell,ab}^j = \delta_{ij} \quad (2.13)$$

To be consistent the other poles of D_ℓ must occur at higher mass values than the vector mesons.

$$N_{\ell,j}^d(s) < N_{1,i}^d(s), \quad 1 \leq i \leq M$$

c) The above conditions constitute the weak bootstrap conditions. If we add the condition $N_{1,i}^d(s) = 0$ for $i > M$ we obtain a stronger form of the bootstrap condition⁽²⁰⁾. This implies

$$\begin{aligned} V_{ab,cd}^1 &= \frac{1}{\gamma} \sum_{r=1}^M f_{ab}^r \lambda^r f_{cd}^r \\ &= \sum_{r=1}^M (f_{ac}^r f_{bd}^r - f_{ad}^r f_{bc}^r) \end{aligned} \quad (2.14)$$

We see by the antisymmetry of the f's that $\lambda^r = \gamma$ with the result that

$$f_{ab}^r f_{cd}^r = f_{ac}^r f_{bd}^r - f_{ad}^r f_{bc}^r \quad (2.15)$$

The strong bootstrap condition ensures that the vector mesons (and their Regge recurrences) are the only poles which occur in the odd- ℓ partial waves. In addition there is the possibility of extra poles in the even- ℓ partial waves. Cutkosky⁽¹⁶⁾ in a VVV model was able to show (by assuming a gauge invariance for the couplings e.g. charge conservation) that the weak bootstrap conditions imply the strong ones. In the VVV

model the kinematics are much more complicated and additional assumptions (the neglect of certain couplings) have to be made. The advantage gained in a model with only one type of particle is that if we assume that the f_{ab}^r are totally antisymmetric in all three indices, then equation (15) becomes the Jacobi relation, satisfied by the structure constants of a Lie group. With this assumption of antisymmetry, the metric $f_{ab}^c f_{cd}^a$ must be non-positive and negative definite if indices corresponding to particles with zero f - interactions are ignored. The Lie group must therefore be semi-simple and compact and its structure constants are proportional to the VVV coupling coefficients. Since semi-simple groups can be expressed as the direct product of simple groups we can restrict our attention to simple groups without loss of generality. The vector mesons must form a basis for the adjoint representation space of this group. The model as it stands cannot distinguish between various simple Lie groups or their dimensions.

For illustration we solve our original PPV model assuming that the symmetry is $SU(3)$ and that the f 's become the structure constants of this group. The eigenvalue of V^l for l odd is just one and the associated eigenvectors form the adjoint, in this case the octet, representation. For the even partial waves, V^l has the eigenvalues, 2 for the singlet representation, 1 for the octet and $-2/3$ for the 27 representation. The model thus predicts that there will be singlet and

octet poles occurring in the even partial waves. The singlet, with eigenvalue 2, is predicted to lie above the octet trajectory, which in this simple model turns out to be exchange degenerate. It can be shown (see Cutkosky⁽²¹⁾) that the eigenvalues of the singlet and adjoint representations, obtained from adjoint - adjoint scattering, are independent of the particular simple Lie group chosen. The above feature with a singlet lying above the adjoint trajectory is therefore general. These bootstrap predictions for the trajectories will be contrasted with those obtained from duality in chapter 4. The second general feature shown by this model is the existence of additional particles in other partial waves. To be consistent these particles should be included both as exchange forces and as external scattering channels. The problem rapidly becomes more difficult.

As a first generalization, one can attempt to include even parity meson exchanges in our simple PP model with odd parity adjoint exchange. (See eg. Chan et al,⁽¹⁷⁾ Capps⁽²⁰⁾). The potentials in the antisymmetric and symmetric states are

$$V_r = 2 \left(\sum_r U_{oo} C_{rr'} g_r'^2 + \sum_s U_{oe} C_{rs'} g_s'^2 \right) \quad (2.16)$$

$$V_s = 2 \left(\sum_r U_{eo} C_{sr'} g_r'^2 + \sum_s U_{ee} C_{rr'} g_r'^2 \right) \quad (2.17)$$

where r, s label antisymmetric and symmetric states respectively. C_{ij} denotes the (s, t) crossing matrix and g_i^2 the coupling coefficients. The assumption has been made that states of a given parity are degenerate and U_{eo} denotes the potential in the even parity state arising from odd parity exchange, etc. Capps⁽²⁰⁾ shows that all the U are attractive potentials and assumes that $U_{oe} = K_o U_{oo}$ and $U_{ee} = K_e U_{eo}$

where K_o, K_e are positive constants. He argues that in the low energy region the shape of the potential is not expected to be important. The strong bootstrap conditions for the odd and even parity states and the determinantal approximation (see appendix C) give

$$\sum_r \delta_{rr'} g_r^2 = \lambda_o (\sum_r C_{rr'} g_r^2 + K_o \sum_s C_{rs'} g_s^2) \quad (2.18)$$

$$\sum_s \delta_{ss'} g_s^2 = \lambda_e (\sum_r C_{sr'} g_r^2 + K_e \sum_s C_{ss'} g_s^2) \quad (2.19)$$

where λ_o, λ_e are positive constants. Following Hwa and Patil⁽²²⁾ the crossing matrix can be written as

$$C_{st} = \begin{matrix} & s & r \\ \begin{matrix} s \\ \sim \\ N \end{matrix} & \begin{pmatrix} s & r \\ \sim & M \\ \sim & A \end{pmatrix} \end{matrix}$$

Since the square of the crossing matrix is 1, it follows that

$$\begin{aligned} 2.20) \quad \begin{matrix} \underline{S}^2 + \underline{MN} & = \underline{1}, & \underline{S} \underline{M} + \underline{M} \underline{A} & = 0, \\ \underline{A}^2 + \underline{MN} & = \underline{1}, & \underline{A} \underline{N} + \underline{N} \underline{S} & = 0, \\ \underline{S}^2 - \underline{MN} & = \underline{S}, & \underline{A}^2 - \underline{NM} & = -\underline{A} \end{matrix} \end{aligned}$$

These relations show that the matrix \underline{A} has eigenvalues -1 , $1/2$ and \underline{S} has eigenvalues 1 , $-1/2$. Our equations (1.16) and (1.17) are now written

$$(1 - \lambda_1 \underline{A}) \underline{a} - \lambda_2 \underline{N} \underline{s} = 0 \tag{2.21a}$$

$$(1 - \lambda_3 \underline{S}) \underline{s} - \lambda_4 \underline{M} \underline{a} = 0 \tag{2.21b}$$

where $\begin{pmatrix} \underline{a} \\ \underline{s} \end{pmatrix} = \begin{pmatrix} \underline{g}_r^2 \\ \underline{g}_s^2 \end{pmatrix}$ and λ_i are positive constants

Using relations (1.20) above we obtain

$$\left(1 - \frac{\lambda_1 \lambda_3 + \lambda_2 \lambda_4}{2} + \left(\lambda_3 - \lambda_1 + \frac{\lambda_1 \lambda_3 - \lambda_2 \lambda_4}{2} \right) \underline{A} \right) \underline{a} = 0 \tag{2.22c}$$

$$\left(1 - \frac{\lambda_1 \lambda_3 + \lambda_2 \lambda_4}{2} - \left(\lambda_3 - \lambda_1 + \frac{\lambda_1 \lambda_3 - \lambda_2 \lambda_4}{2} \right) \underline{s} \right) \underline{s} = 0 \quad (2.22b)$$

Hence \underline{a} , \underline{s} must be eigenvectors of \underline{A} , \underline{S} respectively with eigenvalues differing in sign. The eigenvalues of \underline{A} are -1 or $1/2$ and so we require

$$\frac{1 - \frac{\lambda_1 \lambda_3 + \lambda_2 \lambda_4}{2}}{\lambda_1 - \lambda_3 + \frac{\lambda_2 \lambda_4 - \lambda_1 \lambda_3}{2}} = -1 \text{ or } \frac{1}{2} \quad (2.23)$$

This has solutions

$$\lambda_3 = 1 \quad \text{for eigenvalue } -1 \quad (2.24c)$$

or

$$3\lambda_2 \lambda_4 = (2 + \lambda_1)(2 + \lambda_3) \quad \text{for eigenvalue } \frac{1}{2} \quad (2.24d)$$

The total crossing matrix has eigenvalues ± 1 .

Let $\begin{pmatrix} \underline{k} \\ \underline{l} \end{pmatrix}$ be an eigenvector with eigenvalue $+1$

and try to solve $\begin{pmatrix} \underline{k} \\ \underline{l} \end{pmatrix} = \begin{pmatrix} \mu \underline{s} \\ \nu \underline{a} \end{pmatrix}$. In the two cases

(2.24) above we can find μ, ν which satisfy

$$\text{or } \frac{1+v}{\mu} = \frac{1+\lambda_1}{\lambda_2} \quad (2.25a)$$

$$\frac{\mu}{v} = \frac{2+\lambda_3}{3\lambda_4} \quad (2.25b)$$

Since $\lambda_1 > 0$ in either case we must have $\frac{\mu}{v} > 0$

So we have proved that equations (2.18) and (2.19)

have solutions which correspond to eigenvectors of

the crossing matrix with eigenvalue one. Since

$a_r = g_r^2$, $s_s = g_s^2$ and $\frac{\mu}{v} > 0$ the

eigenvectors must have components with one sign. This

eigenvector condition was first found by Chew⁽²³⁾ in a

static N/D meson - baryon model with a linear D approx-

imation. The same condition will be found in the

exchange degenerate dual models surveyed in the next

chapter.

Specializing the above model to the case of SU(n),

the reduction of the product of adjoints representations

contains the representation I, D, M, P_S^A , P_A^S , P_A^A , P_S^S .

(The notation is that of Neville⁽²⁴⁾). P_A^A occurs only

for $n > 3$, and P_A^S , P_S^A occur only for $n > 2$.

For $n > 2$ the eigenvector solutions contain at least

three multiplets. Retaining only solutions involving

the adjoint, M, representation, the three multiplet

solutions are

$$\begin{aligned} I, D, M \text{ with } \frac{\mu}{v} g_I^2 : \frac{\mu}{v} g_D^2 : g_M^2 \\ = 2(n^2 - 1) : n^2 : (n^2 - 4) \end{aligned} \quad (2.26a)$$

$$I, M, P_A^A \text{ with } \frac{\mu}{V} g_I^2 : g_M^2 : g_{PA}^{2A} \\ = 2(n+1) : 1 : \frac{4(n-1)}{n(n-3)} \quad (2.26b)$$

The second solution exists only for $n > 3$ and involves many more states than the first, eg. for $SU(6)$, P_A^A has dimension 189. The simpler solution (a) seems to represent the physical situation. For $n = 2$ there are solutions involving only two multiplets

$$I, M \text{ with } \frac{\mu}{V} g_I^2 = \frac{3}{2} g_M^2 \quad (2.26c)$$

We have talked about PPV and VVV models and we now try to generalize these to include all external P and V channels. The first attempt along these lines was made by Hwa and Patil⁽¹⁸⁾ but they got the wrong answer because they tried to oversimplify the treatment of the particle spins. We follow essentially the arguments of Leung⁽²⁴⁾ but dispense with one of his assumptions. There are three types of coupling allowed by angular momentum and parity conservation, and we consider only those partial waves in which the V, P particles can resonate, the 1^- and 0^- states. The following assumptions are made: i) All interactions proceed via the p - wave. In the 1^- state the VP, PP channels must have orbital angular momentum $l = 1$ but the VV channel can also have $l = 3$. In the 0^-

state the V P, VV channels must have $\ell = 1$, while the PP channel doesn't have such a state. The $\ell = 3$, VV channel will be neglected. This coupling is expected to be suppressed relative to the $\ell = 1$ partial wave at resonance energies anyway.

In addition we make the following rather less plausible assumptions.

ii) Complete P V mass degeneracy. This is obviously a rather bad assumption.

iii) The internal V - mesons couple to the p - wave orbital angular momentum as a spin 0 object. This assumption was first discussed in the context of the static model for baryons by Capps⁽²⁵⁾ and Belinfante et al.⁽²⁶⁾. Thus in this model there will be no VVP coupling with a V meson internal state.

iv) Proportionality of all Born potential terms. Leung⁽²⁴⁾ has demonstrated that this is valid in the non-relativistic limit. The extent to which this assumption and assumption (i) are broken gives a measure of the increasing symmetry breaking that we can expect for higher energies.

With these assumptions the vertices can be written (δ_{ij} is the Kronecker delta and $\epsilon_{\alpha\beta\gamma}$ the completely antisymmetric SU(2) tensor).

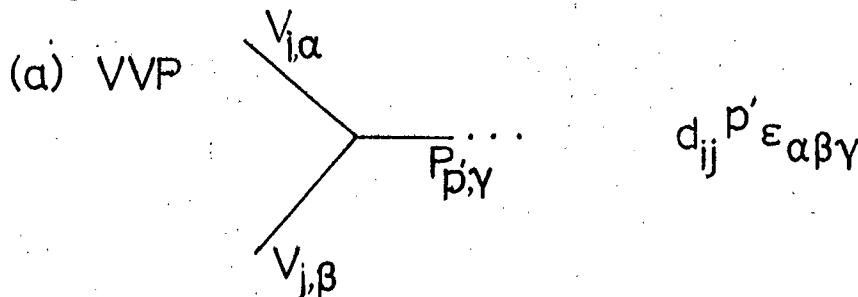

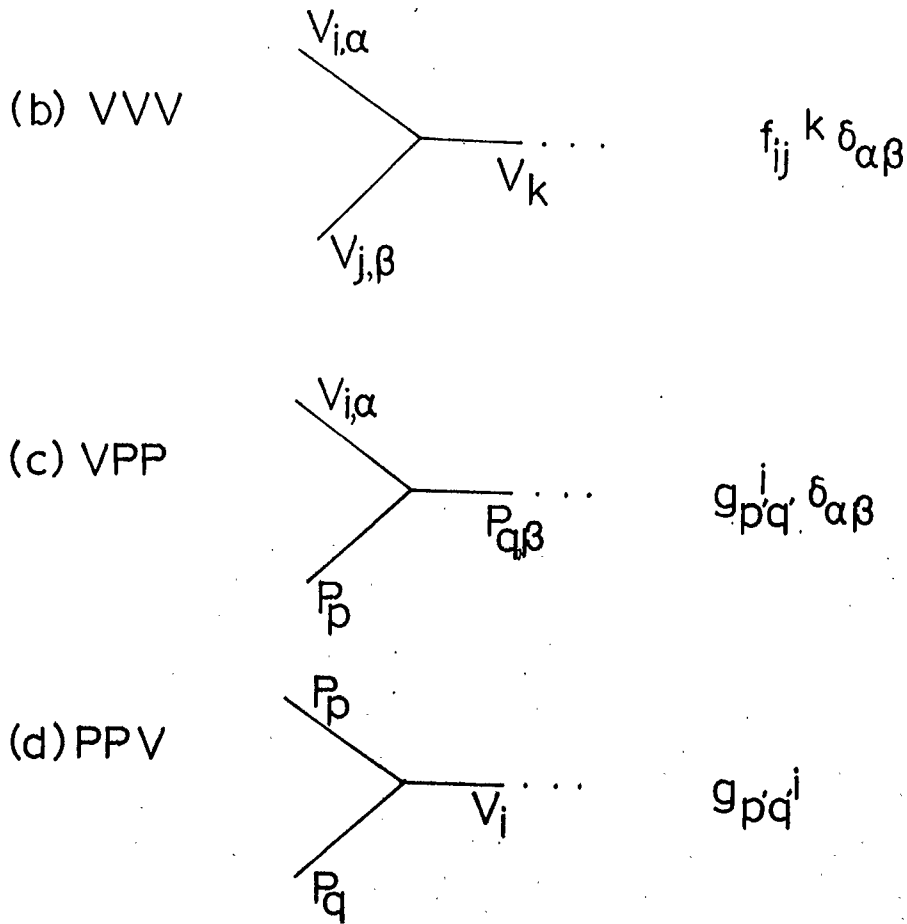

Figures 2.2(a) to (d).

(i j k) label the internal quantum numbers of the V - mesons and (p q) those of the P - mesons.

The Greek indices are spin labels and following assumption (iii) above, internal P - mesons have spin labels whereas internal V - mesons do not.

We now write down strong bootstrap conditions for all channels.

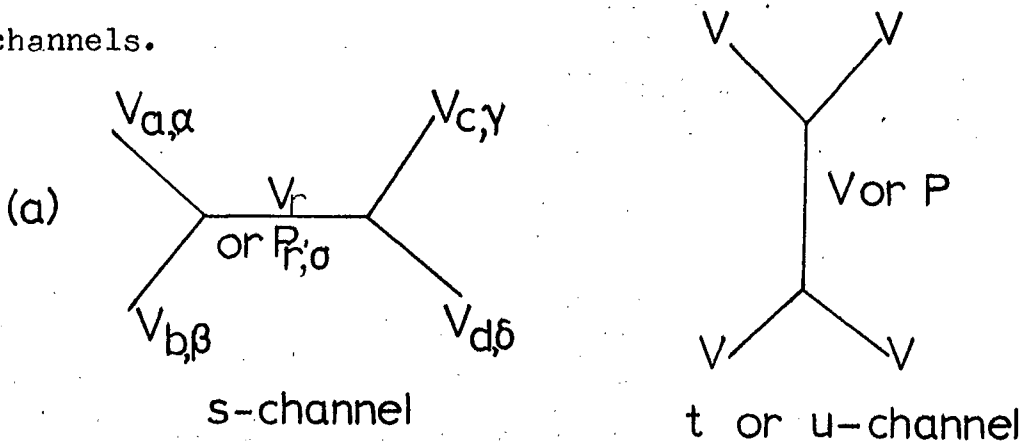

2.27 (The summation convention for repeated indices is used)

$$\begin{aligned}
 & f_{ab}{}^r f_{cd}{}^r \delta_{\alpha\beta} \delta_{\gamma\delta} + d_{ab}{}^{r'} d_{cd}{}^{r'} (\delta_{\alpha\gamma} \delta_{\beta\delta} - \delta_{\alpha\delta} \delta_{\beta\gamma}) \\
 &= \lambda \left\{ f_{ac}{}^r f_{bd}{}^r \delta_{\alpha\gamma} \delta_{\beta\delta} + d_{ac}{}^{r'} d_{bd}{}^{r'} (\delta_{\alpha\beta} \delta_{\gamma\delta} - \delta_{\alpha\delta} \delta_{\beta\gamma}) \right. \\
 &\quad \left. - f_{ad}{}^r f_{bc}{}^r \delta_{\alpha\delta} \delta_{\beta\gamma} - d_{ad}{}^{r'} d_{bc}{}^{r'} (\delta_{\alpha\beta} \delta_{\gamma\delta} - \delta_{\alpha\gamma} \delta_{\beta\delta}) \right\}
 \end{aligned}$$

(b)

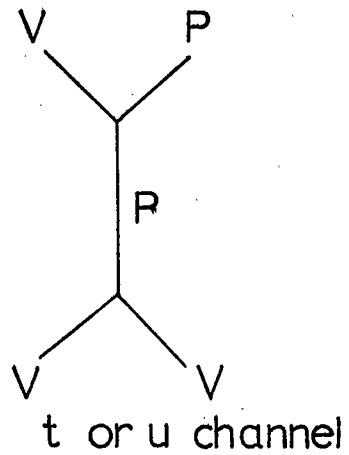
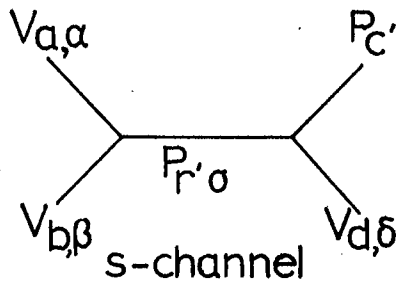

(2.28) $d_{ab}{}^{r'} g_{r'c}{}^a \epsilon_{\alpha\beta\delta} = \lambda \{ g_{c'r'}{}^a d_{bd}{}^{r'} - d_{ad}{}^{r'} g_{r'c}{}^b \} \epsilon_{\alpha\beta\gamma}$

(c)

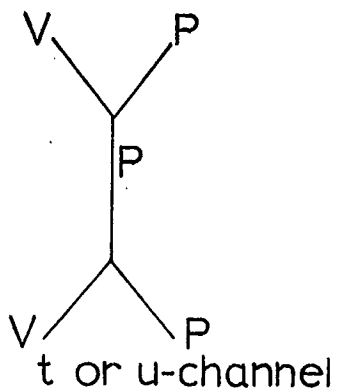
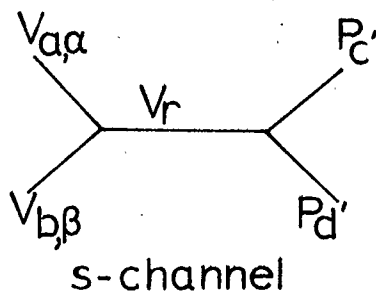

(2.29) $f_{ab}{}^r g_{cd}{}^r \delta_{\alpha\beta} = \lambda \{ g_{c'r'}{}^a g_{r'd'}{}^b - g_{d'r'}{}^a g_{r'c'}{}^b \} \delta_{\alpha\beta}$

(d)

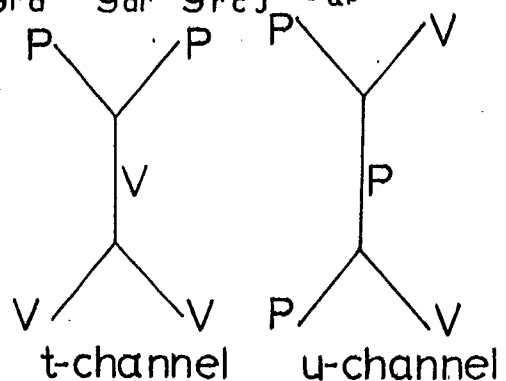
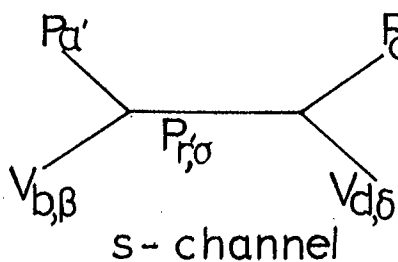

$$g_{a'r'b} g_{r'c'd} \delta_{pb} = \lambda \{ g_{a'c'r} f_{bd}^r - g_{a'r'd} g_{r'c'b} \} \delta_{pb} \quad (2.30)$$

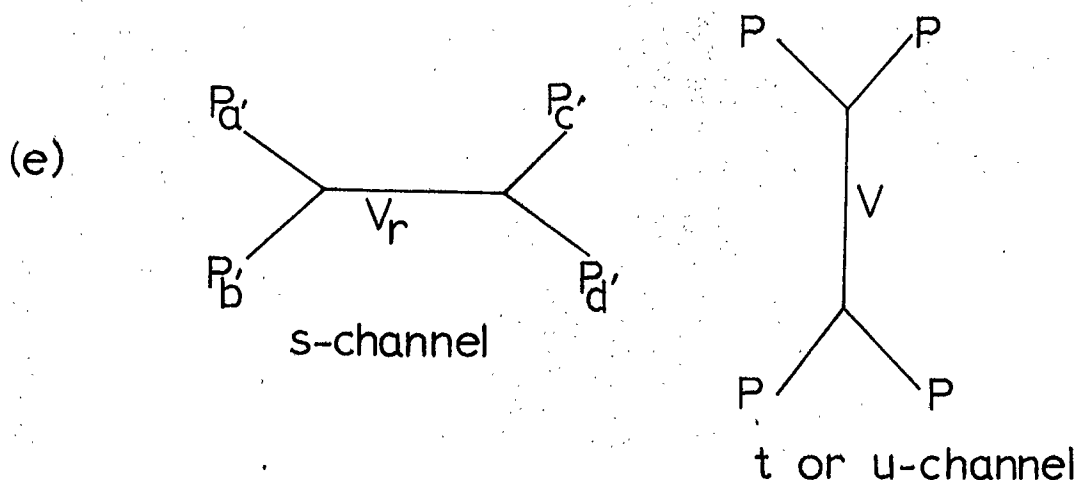

Figures 2.3(a) to (e)

$$g_{a'b'r} g_{c'd'r} = \lambda \{ g_{a'c'r} g_{b'd'r} - g_{a'd'r} g_{c'b'r} \} \quad (2.31)$$

We solve equations (2.27) to (2.31). Bose statistics implies that f_{ij}^k, g_{pq}^i are antisymmetric in their lower indices and d_{ij}^p symmetric in its lower indices. We assume that f_{ij}^k is totally antisymmetric in its indices, as above. Then putting $\alpha = \beta = \gamma = \delta$ in (2.27) the antisymmetry of the f 's implies $\lambda = 1$ and we recover the Jacobi relation (2.15).

$$f_{ab}^r f_{cd}^r = f_{ac}^r f_{bd}^r - f_{ad}^r f_{bc}^r$$

The f 's are thus the structure constants of a semi-simple Lie group. Putting $\alpha = \beta \neq \gamma = \delta$ we obtain

$$2.32 \quad f_{ab}^r f_{cd}^r = d_{ac}^{r'} d_{bd}^{r'} - d_{ad}^{r'} d_{bc}^{r'}$$

This equation fixes the normalization of the d's relative to the f's. (This fact was not realized by Leung). Equations (2.29) and (2.30) are identical and can be written in matrix form

$$[g^a, g^b] = f_{ab}^r g^r$$

(Square brackets denote the commutator).

This equation was first obtained by Polkinghorne⁽²⁷⁾ in the context of Regge poles generated by iterations of ladder - like Feynmann diagrams, and applied to the couplings of particles with spin 1 to the V - mesons. Here it shows that the PPV couplings form a representation of the group. Equation (2.31) is the same as (2.15) which was first written down by Chan et. al.⁽¹⁷⁾ If we assume that the P and V mesons both transform as the same representation of the group then (2.31) becomes the Jacobi relation and $f = g$. This will be assumed hereafter.

It remains only to solve (2.28) and (2.32).

Assuming d_{ij}^k is completely symmetric in its indices (2.28) can be written

$$[d^a, f^b] = f_{ab}^r d^r$$

The d's must transform as the adjoint or identity representations of the group. By equation (2.32) the d's cannot all vanish. The d's transforming as the adjoint representation exist only for the unitary groups SU(n) for $n > 2$ ⁽²⁸⁾. Assuming SU(n) symmetry, equation (2.32) has a unique solution with

the d couplings corresponding to adjoint plus singlet representations. The singlet and adjoint symmetric couplings can be included in a single notation if the indices are extended to include a singlet index, denoted by zero. The d 's remain completely symmetric in all their indices and equation (2.32) gives their normalization relative to the structure constants f . With the normalization for the f 's given by Appendix A $d_{ij0} = \sqrt{\frac{8}{n}} \delta_{ij}$ whenever one or three of its indices are zero. When two of its indices are zero $d_{i00} = 0$. The other equations remain unaltered by this inclusion of a singlet particle since the singlet cannot have antisymmetric couplings. Our equations can now be written as a single equation - the Jacobi relation for the structure constants of $SU(2n)$

$$[E^{a,\alpha} E^{b,\beta}] = E^{c,\gamma} E_{abc, \alpha\beta\gamma} \quad (2.33)$$

where the $E^{a,\alpha}$ can be written in their $SU(n) \otimes SU(2)$ decomposition as

$$E_{abc, \alpha\beta\gamma} = d_{abc} \epsilon_{\alpha\beta\gamma} + f_{abc} \zeta_{\alpha\beta\gamma}$$

where $d_{\alpha\beta\gamma}$ is defined to be totally symmetric in its indices with $\zeta_{\alpha\beta\gamma} = 0$ when either none or two of its indices are zero, and $\zeta_{\alpha\beta 0} = \delta_{\alpha\beta}$ otherwise. The P and V mesons now span the adjoint representation space of $SU(2n)$.

In this model there is some ambiguity concerning the internal spin couplings and assumption (iii)

appears to be rather arbitrary. (This ambiguity is discussed in the context of meson baryon couplings by Belinfante and Renninger⁽²⁹⁾.) Invariance of the vertices under W - spin gives the most successful predictions. (For definition and discussion of W - spin see ref.⁽³⁰⁾). In this prescription the singlet and triplet W spin states are identified as follows

$$W_{11} = V_1, \quad W_{10} = P, \quad W_{1-1} = -V_{-1}, \quad W_{00} = V_0$$

where the V mesons are labelled by their spin component in the interaction direction. Specializing to the case of $SU(6)_W$, the adjoint representation contains P and V octets, the P singlet and two components of the V singlet. Since the W - spin singlet, the third component of the V singlet, is not bootstrapped in the above model the V singlet is not required to be degenerate with the other P, V states. (See Capps⁽³¹⁾). In general a W - spin state w is a superposition of physical spin states w - 1, w, w + 1 and so the physical states will actually correspond to representations of $SU(6) \otimes O(3)$.

We see that trying to extend the original PPV model by including external particles with spin is simple when the symmetry group is $SU(n)$, which extends naturally to $SU(2n)$. It seems probable that a consistent extension for the other classes of simple Lie groups is not possible.

If we assume that the spin components behave as internal symmetry quantum numbers under crossing, which

will be true in the forward and backward directions, the following argument of Capps⁽³²⁾ may be used to obtain the permutation symmetries of the meson vertices. These have been assumed above. Let g_{ijk} denote a general three meson vertex $k \rightarrow i + j$, where the meson labels include both spin and internal symmetry quantum numbers and the mesons may be of either parity.

Reversing the directions of the emitted particles gives

$$g_{ijk} = \eta^{ijk} g_{jik} \quad (2.34)$$

where η^{ijk} is the orbital parity of the vertex and is the product of the intrinsic parities of the mesons. The g 's are defined to have the following crossing property

$$g_{ijk} = g_{\bar{i}kj}^* \quad (2.35)$$

where \bar{i} denotes the conjugate i meson state.

If all the meson states are taken to be self-conjugate then these two properties ensure that the g are completely symmetric and real or antisymmetric and imaginary according as η^{ijk} is positive or negative.

Again it is possible to include the effect of even parity meson exchanges in the $SU(2n)_W$ model as we did above in the PPV model and obtain the results given by (2.26). The model can now claim some completeness in that it includes all the low-lying mesons both as external states and as exchanged states. The even parity mesons form the $(35 \otimes 1, 3)$ representations of $SU(6) \otimes O(3)$ which gives octets of $J^C = 0^+, 1^+, 2^+, 1^-$ and singlets of $J^C = 0^+, 2^+, 1^-$.⁽³³⁾ These states differ from those obtained by the quark model only in the absence of an even parity 1^+ singlet.

We should now go on to include the even parity mesons as external states as well as exchanged states but the kinematical difficulties involved become much greater.

2.2 Baryons

So far no account has been taken of baryons with the assumption that they will not effect the meson bootstrap. However a model of mesons as $B_8 \bar{B}_8$ bound states has been considered by Hara⁽³⁴⁾. (B_8 will henceforth denote the $1/2^+$ baryon octet and D the $3/2^+$ decuplet). We assume that the meson results above stand and attempt to bootstrap the baryons. The baryons differ from mesons in that they carry a unit of conserved quantum number.

Models of this sort originate with the static model of Chew⁽²³⁾ in which the Δ particle is treated primarily as a P - wave meson - nucleon resonance. In the static approximation in which the nucleon recoil is neglected, the orbital angular momentum can be treated as forming an l - spin state with the P - meson. This early model lead to the reciprocal bootstrap model in which a u - channel nucleon is the primary force for producing an s - channel Δ resonance and vice versa. The SU(3) generalization was given by Capps⁽³⁵⁾ and Gerstein & Mahanthappa⁽³⁶⁾. Now the B_8 octet and D decuplet reciprocally bootstrap

each other. The $P B_8 \bar{B}_8$ F/D ratio in this approach can take a range of values depending on which exchange forces are included (37). Capps (25) and Belinfante & Cutkosky (26) generalized again to $SU(6)$ by including the V - mesons, coupling to the orbital angular momentum as we assumed above. The resulting simplicity is that the baryons can be included in one $SU(6)$ multiplet, the 56, with the mesons M in the 35. The $P B_8 \bar{B}_8$ F/D ratio is now fixed by $SU(6)$ to be $2/3$. By including the exchange of t - channel mesons Capps (20) obtained the equation

$$G_{ab} G_{bc} = \Lambda^2 (G_{ab} G_{bc} + K G_{ac} f_{ij}^k) \quad (2.36)$$

where G denotes the $M\bar{B}\bar{B}$ coupling and f the MMM couplings, which are the structure constants obtained above.

Symbolically (figure 2.4)

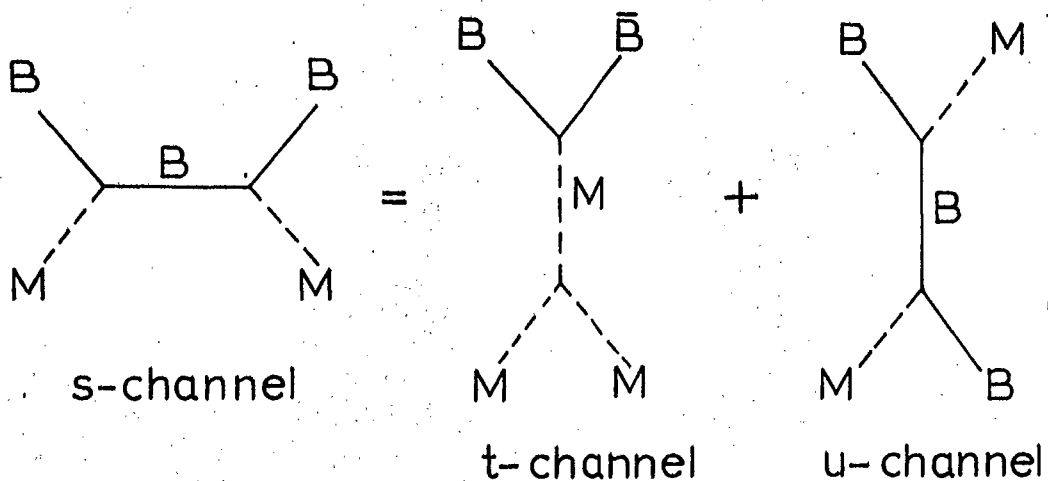

If one makes the effective range approximation as well as the static approximation $\Lambda^2 = 1$ and the equation (2.34) becomes the same as that first derived by Polkinghorne⁽²⁷⁾. It implies that the baryons correspond to a representation of the group. In the static approximation even - parity baryon exchanges in the u - channel effect only even parity s - channel states, and similarly for odd parity exchanges. So the even and odd parity baryons separately satisfy an equation like (2.34). Only the value of K may be different in the two cases. Putting $\Lambda^2 = 1$ (1.34) may be written in terms of irreducible representations i, and the crossing matrices C. For even parity baryons B.

$$\delta_{IB} G_B^2 = C_{IB}^{su} G_B^2 + K_{\text{even}} C_{IM}^{st} G_B f \quad (2.37)$$

For odd parity baryons, R

$$\delta_{IR} G_R^2 = C_{IR}^{su} G_R^2 + K_{\text{odd}} C_{IM}^{st} G_B f \quad (2.38)$$

Using general formulae of Belinfante and Cutkosky,⁽²⁶⁾ for M belonging to the adjoint representation

$$C_{IM}^{st} = \frac{1}{2} (X_M + X_B - X_I) / X_B$$

$$C_{IB}^{su} = \delta_{IB} + \frac{1}{2} (X_I - X_B - X_M) / X_B$$

where X_i is the quadratic Casimir operator for representation i . With these substitutions it can be seen that (2.35) will be satisfied for any choice of baryon representation B provided $K_{\text{even}} = G_B/f$. Similarly (2.36) will be satisfied for any choice of the R representation provided the B and R columns of $1 - C^{\text{su}}$ are proportional. Capps⁽³⁸⁾ has proved this will always be so when the $M\bar{B}\bar{B}$ coupling is unique. The number of possible solutions for the B and R representations is thus very large. We take the physically relevant case to be the 56 and 70 representations of $SU(6)_w$ for B and R respectively. As above the physical states correspond actually to representations of $SU(6) \otimes O(3)$. B will correspond to (56, 1) and R to (70, 3) representations.

2.3 Broken Symmetry

Cutkosky⁽²¹⁾ has pointed out that the bootstrap equations for N mutually interacting V - mesons have $O(N)$ symmetry. The derived particle symmetry is $SU(n)$ where $N = n^2 - 1$ and so the problem is really not one of obtaining symmetry but of breaking it. Here we shall study the breaking of $SU(n)$ symmetry and in particular $SU(3)$.

In the simple PPV model we can include some symmetry breaking by allowing the P meson masses to vary by a small amount from degeneracy. If the effects

of the mass changes of the exchanged mesons and changes in the coupling coefficients are neglected one obtains^(39,40) to first order in the perturbation

$$\delta m_{ij}^V = \frac{K_V}{3} \text{Tr}(f^i \delta m^P f^j) \quad (2.39)$$

for the V - mesons, and

$$\delta m_{ij}^T = \frac{3K_T}{5} \text{Tr}(d^i \delta m^P d^j) \quad (2.40)$$

for the even - parity octet, spin 2, T mesons. Here d^i, f^i denote the symmetric and antisymmetric adjoint representation matrices of SU(3). For simplicity the mass perturbations δm^P etc. are written as matrices

$$K_V = -4 \frac{d/ds \alpha_1(m_V^2)}{\alpha_1(m_V^2)}$$

$$K_T = -4 \frac{d/ds \alpha_2(m_T^2)}{\alpha_2(m_T^2)}$$

where $\alpha_\ell(s)$ is the trajectory function. Since

$d/ds \alpha_\ell(m^2)$ and $\alpha_\ell(m^2)$ are both positive

$$K_V, K_T < 0.$$

Putting $\delta m_{ij}^P = A d_{ij}^8$ gives (see Appendix A)

$$\delta m_{ij}^V = -\frac{A}{2} d_{ij}^8 K_V \quad (2.41)$$

$$\delta m_{ij}^T = -\frac{3A}{10} d_{ij}^8 K_T \quad (2.42)$$

These relations imply that if the P mesons satisfy the Gell-Mann - Okubo mass formula then so will the V and T mesons. Since $K < 0$ we have $m_\pi < m_K \Rightarrow m_\rho < m_{K^*}$ etc. Alternatively one might put $\delta m_{ij}^P = A D_{ij}^{27,0}$ (the matrix transforming as the $T = 0$, $Y = 0$ member of the 27 representation) which gives

$$\delta m_{ij}^V = \frac{K_V}{3} D_{ij}^{27} \quad (2.43)$$

$$\delta m_{ij}^T = \frac{K_T}{5} D_{ij}^{27} \quad (2.44)$$

For this dissymmetry mode we have $m_\pi < m_K \Rightarrow m_\rho > m_{K^*}$ etc. In this simple model, in which the P - meson dissymmetry is put in by hand, there is no bootstrap argument to distinguish between the two dissymmetry modes. The model however illustrated the general feature that the dissymmetry modes do not mix in a linear theory. This feature is unaltered if account is taken of the changes in mass of the exchanged particles and changes in the coupling constants. Physically the symmetry breaking is not small and although the P mesons satisfy the Gell-Mann - Okubo formula, the V, T mesons do not due to mixing between singlets and octets. The singlet V - meson is however not coupled in this model. A similar first order

calculation can be performed for the baryon mass differences with similar results.

To achieve a self - consistent dissymmetry, not one put in by hand, the above model has to be extended, for instance by bootstrapping the P meson as a PV bound state, and making the above argument circular. Capps⁽³⁹⁾ found by extending his equations to non-linear ones that the octet type of symmetry breaking was favoured. The model now has a so called "spontaneously broken" symmetry. The idea that asymmetric states in field theory could arise from a symmetric Hamiltonian was originated by Goldstone⁽⁴¹⁾ and first applied to the SU(3) case by Baker and Glashow.^(42,23) It requires the existence of massless bosons. However in a purely S - matrix theory they do not seem to be necessary. It is shown by Cutkosky and Tarjanne⁽⁴⁴⁾ that retaining mass perturbations up to second order one obtains equations of the form

$$\delta m_i = K_i \delta m_i + \sum_{jk} L_{ijk} \delta m_j \delta m_k \quad (2.45)$$

where i labels the dissymmetry and is 8 or 27 in the SU(3) case. For a solution in which $\delta m_8 \gg \delta m_{27}$ one derives

$$\frac{\delta m_{27}}{\delta m_8} = \frac{1 - K_8}{1 - K_{27}} \times \frac{L_{2788}}{L_{888}} \quad (2.46)$$

Provided $L_{27} \simeq L_8$ then this is consistent if

$$1 - K_8 \ll 1 - K_{27} \quad (2.47)$$

Dashen and Frautschi⁴⁵ generalised (1.41) by adding a driving force d_i

$$\delta m_i = K_i \delta m_i + d_i \quad (2.48)$$

where d_i might include higher order terms or maybe a small external perturbation (eg. Ne'eman's⁴⁶ fifth interaction or possibly the weak or electromagnetic interactions). Here octet enhancement is obtained if

$$\frac{1 - K_8}{d_8} \ll \frac{1 - K_{27}}{d_{27}} \quad (2.49)$$

The above authors calculate K_8 and K_{27} in certain models and conclude that (1.43) is not unreasonable. They also find that an $SU(2)$ subgroup remains unbroken, but the direction of this sub group, in one of three directions in weight space at 120° to each other is undetermined.

It is conjectured by some authors^(47,48) that although the electromagnetic and weak interactions are a much smaller effect than the medium strong $SU(3)$ breaking, they may provide sufficient driving force. Their function being possibly to point a broken symmetry solution in a certain direction.

Of interest here are two results by Brout⁽⁴⁹⁾.

(a) A rank two Lie group is much more unstable to spontaneous breakdown than one of rank one.

(b) A driving force of octet type may lead to breakdown at 120° to itself in weight space. A force along the Q - axis (eg. electromagnetism) might lead to broken symmetry in the Y - direction.

All these considerations of broken symmetry have two fundamental failings. In all practical cases where a broken symmetry solution is looked for a symmetry solution is also possible. How do we distinguish between the two solutions? Simplicity would favour the symmetry solution. Some rather unconvincing ideas have been put forward about stability of solutions. (See eg. Tarjanne⁽⁵⁰⁾.) Secondly from practical necessity we have to assume the symmetry breaking is small. This is experimentally untrue and as we have seen the discussion of spontaneous breakdown goes beyond the consideration of first order terms, as we would expect of any bootstrap argument.

CHAPTER 3

Duality Predictions for Symmetries

This chapter like the preceding one will be a survey of predictions for internal symmetry, but now arising from the duality hypothesis. We give a brief introduction to FESR and duality and outline a model of Capps^(32,51) which embodies a complete set of duality constraints for all meson and baryon two - particle reactions. This model uniquely predicts the symmetry and representations to which all particles belong. However the predicted baryon spectrum is not the physical spectrum, and the second part of this chapter will be devoted to a phenomenological discussion of how the physical spectrum satisfies a subset of the constraints. Broken symmetry within this scheme will also be discussed.

3.1 FESR and Duality.

The idea of duality developed from FESR⁽⁵²⁾. These equations can be derived merely from the assumptions of analyticity and Regge behaviour. One considers the amplitude $A(V,t)$, say for PP scattering, where V is the antisymmetric variable $V = \frac{s - u}{2}$. (The derivation for amplitudes of processes with spin is essentially the same). $A(V, t)$ is assumed to have the Regge

asymptotic form

$$A(v,t) \xrightarrow{|v| \rightarrow \infty} \sum_i -\beta_i(t) \frac{s_i + e^{-\pi\alpha_i(t)}}{2\sin\pi\alpha_i(t)} v^{\alpha_i(t)} \quad (3.1)$$

where the sum extends over Regge poles with signature S_i . The FESR is obtained by writing down the Cauchy theorem for the contour C in the complex v plane, (shown in fig. (3.1)).

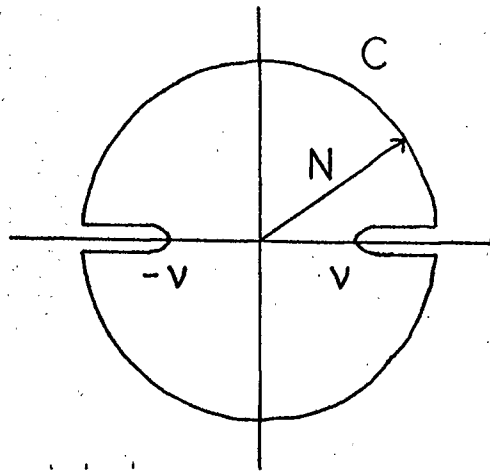

Fig. 3.1 The contour C consists of the circle C' at $|v| = N$ together with parts along the right and left real axis enclosing the branch cuts.

$$\oint_C v'^n A(v',t) dv' = 0 \quad \text{gives}$$

$$\int_{v_0}^N v'^n D_s(v',t) dv' + \int_{-v_0}^{-N} v'^n D_u(v',t) dv' = - \int_{C'} v'^n A_{\text{Regge}}(v',t) dv' \quad (3.2)$$

N is chosen so that $A(N, t)$ attains its Regge form (3.1)

on the circle at $|v| = N$. D_s, D_u stand for the right and left hand discontinuities of the amplitude across the real axis. Making the replacement $v \rightarrow -v$

in the second integral on L.H.S. and performing the integration round the circle by putting $v = Ne^{i\varphi}$

(3.2) becomes

$$\int_{\nu_0}^N v'^n (D_s(v',t) + (-1)^{n+1} D_u(-v',t)) dv' = i \sum_i \beta_i \frac{N^{\alpha_i+n+1}}{\alpha_i+n+1} (1 + (-1)^{n+1} s_i) \quad (3.3)$$

This relation is called the n'th moment sum rule.

The assumption has been made in deriving (3.3) that both $\alpha_i(t)$ and $\beta_i(t)$ are real, for real t . It can be shown that if two trajectories do not cross $\alpha_i(t)$ and $\beta_i(t)$ must be real for t below the t -channel threshold. (See eg. ref. (7)). The presence of the factor $(1 + (-1)^{n+1} s_i)$ ensures that only poles with signature $s_i = (-1)^{n+1}$ contribute to the R.H.S. Defining the signed amplitudes $A^\pm(v, t)$ by

$$A^\pm(v, t) = \frac{1}{2} \int_{\nu_0}^{\infty} \frac{(D_s(v',t) \pm D_u(-v',t)) dv'}{v - v'} \quad (3.4)$$

The even and odd moment FESR can then be written

$$\int_{\nu_0}^N v'^{2n} \text{Im} A^-(v', t) = \sum_i \beta_i \frac{N^{\alpha_i+2n+1}}{2(\alpha_i+2n+1)} (1 - s) \quad (3.5a)$$

$$\int_{\nu_0}^N \nu'^{2n+1} \text{Im} A^+(\nu', t) = \sum_i \beta_i \frac{N^{\alpha_i+2n+2}}{2(\alpha_i+2n+2)} (1+s_i) \quad (3.5b)$$

The idea of average duality is that L.H.S. of the FESR can be written entirely as a sum of s and u channel narrow resonance terms, so the Regge poles are 'dual' to the resonances.

There is a difficulty for elastic processes like $\pi^+ \pi^+ \rightarrow \pi^+ \pi^+$ whose high energy behaviour is dominated near the forward direction by a t - channel Pomeron trajectory, but which have no direct s - channel resonances. The additional hypothesis is made that the FESR breaks down into two parts. (53,54).

$$\int \text{Im} (s \text{ and } u \text{ channel resonances}) d\nu \approx \sum (t \text{ channel trajectories without the Pomeron})$$

$$\int (\text{background}) d\nu \approx \text{Pomeron}$$

Subtracting two such FESR's (3.5) for different end points N_1, N_2 one obtains for the zeroth and first moment sum rules

$$\int_{N_1}^{N_2} \text{Im} A_{\text{res}}^- d\nu' = - \frac{\beta^- (N_2^{\alpha^-+1} - N_1^{\alpha^-+1})}{\alpha^- + 1} \quad (3.7a)$$

$$\int_{N_1}^{N_2} \nu' \text{Im} A_{\text{res}}^+ d\nu' = \frac{\beta^+ (N_2^{\alpha^++2} - N_1^{\alpha^++2})}{\alpha^+ + 2} \quad (3.7b)$$

where only the leading positive and negative signature Regge trajectories have been retained on R.H.S. It is assumed that for some N_1 , N_2 and t the second equation can be approximated by

$$\int_{N_1}^{N_2} \text{Im } A_{\text{res}}^+ dv' \cong \beta^+ \frac{(N_2^{\alpha^+ + 1} - N_1^{\alpha^+ + 1})}{\alpha^+ + 1} \quad (3.8)$$

This is the wrong signature zeroth moment sum rule in which possible nonsense fixed poles contributing to the R.H.S. have been ignored. The leading such pole at $l = -1$ would cancel anyway. Adding (3.7a) and (3.8)

$$\int_{N_1}^{N_2} \text{Im } A_{\text{res}} dv' = \frac{\beta^+ (N_2^{\alpha^+ + 1} - N_1^{\alpha^+ + 1})}{(\alpha^+ + 1)} - \frac{\beta^- (N_2^{\alpha^- + 1} - N_1^{\alpha^- + 1})}{(\alpha^- + 1)} \quad (3.9)$$

Equation (3.9) expresses the idea of local duality: the idea that the s - channel resonance and t - channel Regge trajectory descriptions for the imaginary part of the amplitude are equivalent in some average sense and for some range of s and t .

It is evident from (3.9) that there must be exchange degeneracy of opposite signed trajectories if the quantum numbers are such that no resonances can be formed in the s - channel. In this case the L.H.S. of (3.9) is zero, and to satisfy the equation for a range of t this requires

$$\alpha^+(t) = \alpha^-(t) \quad (3.10)$$

$$\beta^+(t) = \beta^-(t) \quad (3.11)$$

If non-leading trajectories are retained in (3.9) such a matching is also required for them.

Alternatively the exchange degeneracy relations (3.10, 3.11) may be derived without the approximation of (3.8) if resonance saturation is assumed for all s and not just for low and intermediate energies as above. With this assumption $A^+(\nu, t) = -A^-(\nu, t)$ when no resonances can be formed in the s -channel and (3.9) now follows from (3.7a).

The duality equations can be expressed graphically by the quark scattering diagrams of Harari⁽⁵⁵⁾ and Rosner⁽⁵⁶⁾. "Exotic" resonances are defined to be those not predicted in the quark model and it is assumed there are no exotic resonances i.e. all mesons are quark - antiquark states, and all baryons are three quark states.

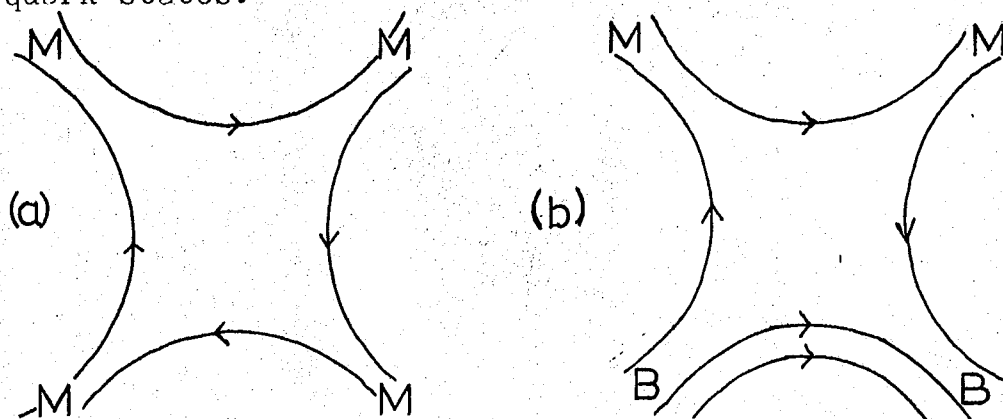

Fig. 3.2 Allowed duality diagrams (a) meson-meson scattering (b) meson-baryon scattering.

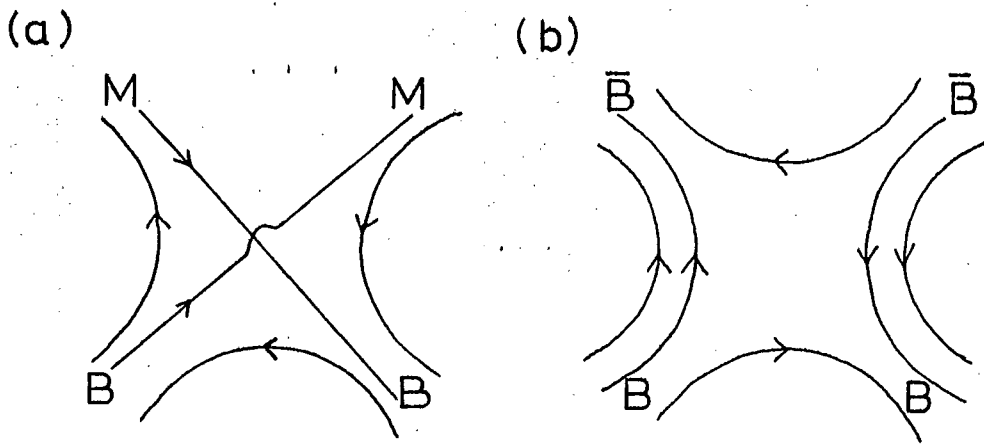
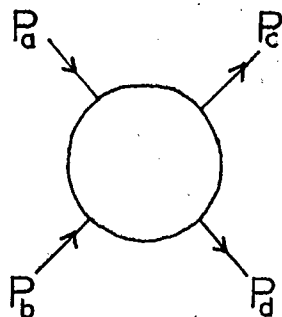

Fig.3.3 Illegal duality diagrams (a) meson-baryon non-planar diagram (b) baryon-antibaryon diagram with exotic $qq\bar{q}$ intermediate states.

Allowed diagrams fig (3.2) are planar with no exotic intermediate states. Processes for which no allowed diagrams can be drawn are predicted to have vanishing imaginary parts at high energy. However this scheme meets difficulties for baryon antibaryon scattering as can be seen in fig (3.3b). No diagram can be drawn for this process which does not involve exotic intermediate states and yet these processes do not have vanishing imaginary parts at high energy.

3.2 - Meson Processes



- i s - channel $a + b \rightarrow c + d$
- ii t - channel $a + \bar{c} \rightarrow \bar{b} + d$
- iii u - channel $a + \bar{d} \rightarrow c + \bar{b}$

Fig. 3.4 PP scattering.

We write consistency conditions corresponding to (3.9) for the elastic scattering of a set of degenerate

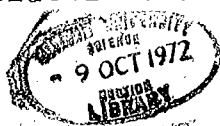

P mesons (see fig.3.4) with the exchange of V and T meson trajectories, following Schmid and Yellin⁽⁵⁷⁾, and Capps^(32,51). In accordance with (3.10) and (3.11) the V and T trajectories must be exchange degenerate. As above we denote the PPV and PPT coupling constants by f_{abr} and d_{abr} respectively. Following the arguments of Chapter 2, equations (2.34,235) and the assumptions made there about spin, f_{abr} is imaginary and completely antisymmetric and d_{abr} real and completely symmetric.

The Breit - Wigner form for the s - channel resonances R of spin J is

$$A_{res}(v,t) = \frac{g_{abr} g_{cdr}^* P_J(z_s) q_s^{2J} (2J+1)}{(v_R - v - i\Gamma_R)} \quad (3.12)$$

where g_{abr} stands for either f_{abr} or d_{abr} . The narrow width approximation for the imaginary part gives

$$\text{Im} A_{res}(v,t) = g_{abr} g_{cdr}^* \pi \delta(v - v_R) P_J(z_R) q_R^{2J} (2J+1) \quad (3.13)$$

where

$$z_R = \frac{1 + 2t}{(m_J^2 - 4m^2)}$$

m_J = resonance mass

$$v_R = m_J^2 - 2m^2 + \frac{t}{2}$$

m = P meson mass.

$$q_R = \frac{m_J^2 - 4m^2}{4}$$

The t - channel Regge pole contribution is given by (3.1). Near the t - channel resonance mass m_J^2 it has the form

$$A_{\text{Regge}}(v,t) \underset{t \sim m_J^2}{\approx} \frac{-s_J \beta_{ac,bd}(m_J^2) v^{\alpha(m_J^2)}}{\pi \alpha'(t - m_J^2)} \quad (3.14)$$

where α' is the trajectory slope, assumed constant. This is compared with the Breit - Wigner form for a t - channel resonance as $|v| \rightarrow \infty$

$$\begin{aligned} \lim_{|v| \rightarrow \infty} \frac{g_{acr} g_{bdr}^* P_J(z_t) q_t^{2J} (2J+1)}{(m_J^2 - t)} \\ = \frac{g_{acr} g_{bdr}^* v^J c_J (2J+1)}{2^J (m_J^2 - t)} \end{aligned} \quad (3.15)$$

since
$$P_J(z_t) \underset{|v| \rightarrow \infty}{\rightarrow} c_J z_t^J$$

and
$$z_t = \frac{v}{2q_t^2}$$

Comparing (3.14) and (3.15) gives

$$\beta_{ac,bd}(m_J^2) = \frac{s_J g_{acr} g_{bdr}^* \pi \alpha' c_J (2J+1)}{2^{2J}} \quad (3.16)$$

Substituting (3.13) and (3.16) into either side of (3.9), taken at $t = 0$ say, and assuming that

$$\gamma_J = \frac{\beta_{ab,cd}(0)}{\beta_{ab,cd}(m_J^2)}$$

is independent of (ab, cd) ,

gives

$$\sum_J \zeta_J g_{abr} g_{cdr}^* = \sum_{J'} \lambda_{J'} g_{acr} g_{bdr}^* \quad (3.17)$$

where

$$\lambda_J = \gamma_J \frac{(N_2^{\alpha(0)+1} - N_1^{\alpha(0)+1})}{(\alpha(0)+1) 2^{2J}} \pi \alpha' c_J (2J+1)$$

and

$$\zeta_J = f_J \pi q_R^{2J} (2J+1)$$

f_J is a positive fraction depending on N_1 and N_2 . The sign of λ_J depends on the sign of γ_J and that of ζ_J on the sign of q_R^{2J} . It will be assumed that the sign of $\beta(t)$ doesn't change between $t = 0$ and $t = m_J^2$ and that all the resonance poles occur above threshold. With these assumptions ζ_J and λ_J are all positive. Writing out (3.17) in terms of the coupling coefficients $g_{ijk} = f_{ijk}$ when J is odd and $g_{ijk} = d_{ijk}$ when J is even where f_{ijk}, d_{ijk} are imaginary and real respectively, gives

$$\zeta_1 f_{abr} f_{cdr} - \zeta_2 d_{abr} d_{cdr} = \lambda_1 f_{acr} f_{bdr} - \lambda_2 d_{acr} d_{bdr} \quad (3.18)$$

Renormalizing the d's relative to the f's this can be written

$$f_{abr} f_{cdr} - d_{abr} d_{cdr} = K_1 f_{acr} f_{abr} - K_2 d_{acr} d_{bdr}$$

where $K_1 = \frac{\lambda_1}{\xi_1}$, $K_2 = \frac{\lambda_2}{\xi_2}$ are positive constants.

Summing over permutations of (abcd) one obtains

$$(d_{abr} d_{cdr} + d_{acr} d_{bdr} + d_{adr} d_{bcr})(1 - K_2) = 0 \quad (3.19)$$

So $K_2 = 1$ if the d's are not all zero. Putting $b = c$ in (3.18) yields $K_1 = 1$. Finally the consistency equation may be written in terms of the commutators of matrices $(f_i)_{jk}$, $(d_i)_{jk}$

$$[f_c, f_a] = [d_c, d_a] \quad (3.20)$$

Since PP scattering is the same in all channels identical equations are obtained for the (s,u) and (u,t) pairs of channels. Equation (3.20) states that the coupling constants form an eigenvector of the (s,t) crossing matrix with eigenvalue one. This condition was also found in Chapter 2. The duality equations, however, always appear linear in the coupling constants unlike the bootstrap equations. (see eg. equation (2.12)). The duality equations thus do not determine the overall magnitude of the coupling constants.

The advantage of the duality formulation is that it allows particles of both parities to be included

on the same footing. Taking external mesons of both parities, and treating their spins as internal quantum numbers under crossing, equation (3.17) becomes generalized (see Capps⁽³²⁾) to

$$\sum_{r(J)} \zeta_J g_{abr} g_{cdr}^* = \eta_{abcd} \sum_{r(J')} \lambda_{J'} g_{acr} g_{bdr}^*$$

where η_{abcd} is the product of the intrinsic parities of the mesons a,b,c,d. Putting $g_{abr} = f_{abr}$ when η_{abr} is odd and $g_{abr} = d_{abr}$ when η_{abr} is even, yields (3.20) when η_{abcd} is even. When η_{abcd} is odd one obtains

$$[d_c, f_a] = [f_c, d_a] \quad (3.21)$$

Whereas equation (3.20) can be derived from those of Chapter 2, equation (3.21) is completely new, since bootstrap equations for the case when the parity factor η is odd were not written down.

The following results can be obtained from these two equations:

- a) There are trivial single state solutions with only one d non-zero and these are the only solutions involving zero f's.
- b) Summing (3.20) over permutations of (abcd), and including the minus sign for odd permutations, the Jacobi condition (2.15) can be derived for the f's. The f's are thus the structure constants of a compact semi-simple Lie group.

c) Summing (3.21) over permutations of (abc) one obtains

$$[\underline{d}_a, \underline{f}_d] = -f_{adr} \underline{d}_r \quad (3.22a)$$

This implies that \underline{d}_a transforms as the adjoint representation when $f_{adr} \neq 0$ for some r, d , and as the singlet if $f_{adr} = 0$ for all r, d .

d) Putting $\underline{p}_i = \underline{f}_i + \underline{d}_i$ and $\underline{m}_i = \underline{f}_i - \underline{d}_i$, and applying permutation operators to the sum and difference of (3.20) and (3.21), one obtains

$$[\underline{p}_c, \underline{p}_a] = 2 f_{acr} \underline{p}_r \quad (3.22)$$

$$\{\underline{p}_c, \underline{p}_a\} = 2 d_{acr} \underline{p}_r \quad (3.23)$$

$$[\underline{m}_c, \underline{m}_a] = 2 f_{acr} \underline{m}_r \quad (3.24)$$

$$\{\underline{m}_c, \underline{m}_a\} = -2 d_{acr} \underline{m}_r \quad (3.25)$$

Equations (3.22) and (3.23) show that all products of the \underline{p}_i are linear combinations of themselves, the combination matrices transforming like adjoint and singlet representations. This is sufficient to fix the symmetry group uniquely to be $SU(n)$ and the \underline{p}_i to transform as the fundamental 'quark' representation. (For proof see Capps⁽⁵⁸⁾).

Similarily the \underline{m}_i transform as the fundamental anti-quark representation. (The \underline{m}_i transform as the

conjugate representation to that of the \underline{p}_1 because of the relative minus sign occurring between (3.23) and (3.25)). For $n > 2$, the unique solution, ignoring the trivial one state solutions, has exchange degeneracy between trajectories of opposite parity, the mesons on both trajectories transforming as quark-antiquark combinations ie. adjoint \oplus singlet. For $n = 2$ a solution without parity doubling is possible in which an isosinglet trajectory is exchange degenerate with an isotriplet trajectory of opposite parity. Choosing the physical symmetry to be $SU(6)$ the unique solution has mesons of either parity belonging to the $35 \oplus 1$ representations, and lying on a single exchange degenerate trajectory.

3.3 Meson Baryon Processes.

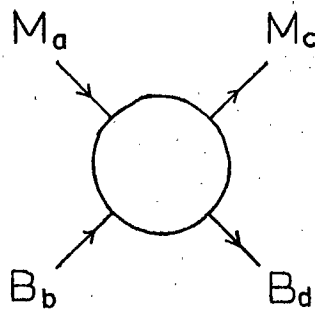

Fig.3.5 MB scattering. The channels are defined as in fig. (3.4).

We write down conditions analogous to (3.17) for meson-baryon scattering as in fig.(3.5). Let G_{ijk} denote a general meson-baryon-baryon coupling constant. Then the (s,u) condition becomes

$$\sum_r G_{cdr}^* G_{abr} = \eta_{abcd} \sum_r G_{adr} G_{cbr}^* \quad (3.26)$$

The (s,t) and (u,t) conditions involve t - channel meson couplings g_{ijk} ,

$$\sum_r G_{abr} G_{cdr}^* = K \eta_{abcd} \sum_r g_{acr} G_{rbd} \quad (3.27)$$

The couplings of odd parity mesons to baryons of the same and opposite parity are written as the matrices \underline{F}_a , \underline{D}_a , where the index a always refers to a meson. Then assuming that the even parity meson couplings to baryons are the same as the odd parity meson couplings, (Capps⁽³²⁾ shows that this follows from the consideration of constraints from B \bar{B} scattering) (3.26) and (3.27) become

$$[\underline{D}_a, \underline{D}_c] = [\underline{F}_a, \underline{F}_c] \quad (3.28)$$

$$\underline{D}_c \underline{D}_a + \underline{F}_c \underline{F}_a = K (f_{acr} \underline{F}_r + d_{acr} \underline{D}_r) \quad (3.29)$$

$$\underline{D}_c \underline{F}_a + \underline{F}_c \underline{D}_a = K (f_{acr} \underline{D}_r + d_{acr} \underline{F}_r) \quad (3.30)$$

The (s,t) condition is (3.29) or (3.30) according as the external baryons have the same or opposite parity.

Writing $\underline{P}_i = \underline{F}_i + \underline{D}_i$, $\underline{M}_i = \underline{F}_i - \underline{D}_i$, as above, one obtains

$$[\underline{P}_c, \underline{P}_a] = 2K f_{acr} \underline{P}_r \quad (3.31)$$

$$\{\underline{P}_c, \underline{P}_a\} = 2K d_{acr} \underline{P}_r \quad (3.32)$$

$$[\underline{M}_c, \underline{M}_a] = -2K f_{acr} \underline{M}_r \quad (3.33)$$

$$\{\underline{M}_c, \underline{M}_a\} = -2K d_{acr} \underline{M}_r \quad (3.34)$$

$$[\underline{P}_c, \underline{M}_a] = 0 \quad (3.35)$$

Equations (3.31) to (3.34) imply that both $\underline{P}_i, \underline{M}_i$ transform as fundamental quark representations.

Note that now \underline{M}_i doesn't transform as the antiquark representation since (3.33) and (3.34) have the same sign on the right hand side, while (3.24), (3.25) have opposite signs. Thus in the simplest solution the baryons correspond to quark-quark composites and not the expected three quark combinations. If baryons of opposite parity correspond to states of opposite symmetry under the exchange of the two quarks, the need for parity doubling in the solution is avoided.

The above solution can be generalized by allowing the baryons to have a set of "passive" quantum numbers. A baryon state is then labelled $|\alpha\beta\gamma\rangle$ where α, β are the two quark indices and γ is a third index corresponding to some representation (s). Then the $\underline{P}_a, \underline{M}_a$ matrices become

$$\langle \alpha' \beta' \gamma' | \underline{P}_a | \alpha \beta \gamma \rangle = K \lambda_{\alpha\alpha'}^a \delta_{\beta\beta'} \delta_{\gamma\gamma'}$$

$$\langle \alpha' \beta' \gamma' | \underline{M}_a | \alpha \beta \gamma \rangle = K \lambda_{\beta\beta'}^a \delta_{\alpha\alpha'} \delta_{\gamma\gamma'}$$

The extra factors $\delta_{\gamma\gamma'}$ just cancel on either side of equations (3.31 - 3.35). Choosing the extra quantum number to be a third quark gives the usual quark model, and if the symmetry is assumed to be SU(6) one obtains, with the parity rule above, baryon states $56 \oplus 70$ of one parity and $70 \oplus 20$ of opposite parity, in agreement with observation. However if equations for baryon - antibaryon scattering are written down the extra $\delta_{\gamma\gamma'}$ factors do not cancel and only the unphysical two quark solution is allowed. This situation can readily be seen in duality diagrams. In meson - baryon scattering, fig. (3.2a) a spectator quark for the baryons can be added at will, but in the baryon - antibaryon case, fig (3.3b), only the two quark baryon is allowed.

3.4 Phenomenological Duality

In the light of the above solution for baryons it is difficult to treat the duality hypothesis as a fundamental principle. Rosner⁽⁵⁹⁾ suggested that the existence of high mass exotic mesons which do not couple to low mass mesons, and are not ruled out by experiment could save the situation in baryon - anti-baryon scattering. However we would certainly not wish to admit the non-zero triality baryons which follow from the complete equations above.

Alternatively as suggested by Mandula, Weyers and Zweig⁽⁶⁰⁾, duality may be regarded as giving only an

approximate set of constraints, whose validity decreases the higher the threshold of the channel considered. In particular the constraints coming from decuplet - antidecuplet scattering should not be expected to be valid at all. Their explanation for this breakdown of duality is that the duality hypothesis (3.9) is satisfied in proportion to the size of the overlap region in which the two approximations - resonance saturation and Regge behaviour - are valid. Thus suppose that resonance saturation is a good approximation for $s < s_{\max}$, and Regge behaviour for $s > s_{\min}$. Provided $s_{\max} - s_{\min}$ is sufficiently positive the duality hypothesis is well satisfied. If $s_{\max} < s_{\min}$ duality is not expected to hold at all. s_{\max} is expected to be independent of the particular channel involved, and to depend merely on the particular resonances which can be formed, whereas s_{\min} is strongly dependent on the threshold of channel considered. Thus if we compared the equations for meson poles in MM and $B\bar{B}$ scattering, s_{\max} would be the same for both channels but s_{\min} would be much larger in $B\bar{B}$ scattering. The constraints coming from MM scattering are therefore expected to be better satisfied.

In this section we look at the phenomenological question of the pattern of trajectories predicted by various subsets of the duality equations. The symmetry

is assumed to be SU(3) with mesons belonging to representations contained in $3 \oplus 3^* = 1 \oplus 8$ and baryons in $3 \oplus 3 \oplus 3 = 1 \oplus 8 \oplus 8 \oplus 10$. One looks for so called minimal solutions, ie. those involving the smallest number of trajectories. This question has been investigated by a number of authors, (61-65) and their conclusions differ depending on how complete is the set of constraints they have taken. For a fairly complete discussion see Rimpault and Salin (66) and also Mandula, Weyers and Zweig. (67) A common relaxation of the constraints is to employ (3.9) only when one of the channels is exotic, ie. when both sides of the equation must be zero.

(a) Mesons

For meson - meson scattering the above relaxed constraints are equivalent to the complete set. Requiring no exotic contributions ensures that the amplitude must be an eigenvector of the crossing matrix. The following exchange degeneracies are predicted, (67) with the coupling pattern $g_1^2 : g_S^2 : g_A^2 = 16:5:9$ as given by equation (2.26) (g_S^2 stands for the coupling of the symmetric octet etc.)

Process considered	Trajectories (J^{PC}) related
PP \rightarrow PP	$8 \oplus 1(2^{++}) \Leftrightarrow 8(1^{--})$

$$PV \rightarrow PV \quad \left\{ \begin{array}{l} 8 \oplus 1(1^{--}) \Leftrightarrow 8(2^{++}) \\ 8 \oplus 1(1^{+-}) \Leftrightarrow 8(0^{-+}) \\ 8 \oplus 1(2^{--}) \Leftrightarrow 8(1^{++}) \end{array} \right.$$

$$VV \rightarrow VV \quad \begin{array}{l} 8 \oplus 1(0^{-+}) \Leftrightarrow 8(1^{+-}) \\ 8 \oplus 1(1^{++}) \Leftrightarrow 8(2^{--}) \end{array}$$

Following the arguments above these degeneracies are expected to be less well satisfied the further down the list they appear. For instance the 0^{-+} and 1^{++} singlets first appearing at the bottom of the list are not expected to be even nearly degenerate with their respective octets.

Chui and Finkelstein⁽⁶⁸⁾ showed that the no exotic condition can be maintained even when the octet masses are allowed to depart from SU(3) degeneracy but keeping exact symmetry for the couplings, provided there is singlet - octet mixing. A precise pattern for the symmetry breaking emerges in which there are three separate trajectories. One trajectory ($p\omega A_2 f$) has exchange degenerate $I = 0$ and $I = 1$ states, the second ($K^* K^{* *}$) has only strange $I = 1/2$ states and the third vacuum trajectory ($\Phi f'$) couples only to . A definite mixing angle $\tan \theta = 1/\sqrt{2}$ the ideal quark mixing, is predicted for both the V and

T nonets. This pattern fits the experimental picture impressively well (see fig. 3.6). The same pattern of symmetry breaking with strong mixing is predicted for the other nonets $9(1^{++}) \leftrightarrow 9(2^{--})$ and $9(0^{-+}) \leftrightarrow 9(1^{+-})$. However the 1^{++} , 0^{-+} octets satisfy the Gell-Mann - Okubo relation with little mixing. As we remarked above the predictions for the 1^{++} , 0^{-+} nonets come from the highest threshold channel $VV \rightarrow VV$ and are not expected to be well satisfied. The pattern of mixing which one might thus expect is the 1^{--} , 2^{++} nonets to show strong mixing, the 1^{+-} , 2^{--} nonets to show moderate mixing and the 0^{-+} , 1^{++} nonets to show little mixing.

(b) Baryon Trajectories

One looks for minimal sets of baryon multiplets which satisfy the following conditions:

- i) No exotics in any channel of the reaction $PB \rightarrow PB$ where B denotes either the baryon $1/2^+$ octet or the $3/2^+$ decuplet.
- ii) Positivity of residues.
- iii) Factorization of residues.

With this set of constraints Rempault and Salin⁽⁶⁶⁾ obtained the following results:

- i) There are no two multiplet solutions.
- ii) There are three linearly independent three multiplet solutions when only octet B constraints are considered.

iii) When decuplet channels are added, only two of these solutions can be extended. These solutions are

$$S_1 : 8^+(1) + 10^+ \leftrightarrow 8^-(1) + 1^-,$$

with the 10^+ not coupling to PB_8 , and

$$S_2 : 8^+(-\frac{1}{3}) \leftrightarrow 8^-(-\frac{1}{3}) + 10^-$$

The superscript denotes the signature, and the figure in brackets the F/D value for the octets coupling to PB_8 . The ratios of the couplings to PB_8 for these solutions are:

$$S_1 \quad g_1^2 : g_{s^+}^2 : g_s^2 = 64 : 15 : 5$$

$$S_2 \quad g_{10}^2 : g_{s^+}^2 : g_s^2 = 32 : 15 : 5$$

where g_s^2 denotes the symmetric coupling of the + octet to PB_8 etc. The solutions can be identified with baryon trajectories of opposite normality as follows

$$S_1 : N_\alpha^+ (\frac{1}{2}^+, 8) \leftrightarrow N_\gamma^- (\frac{3}{2}^-, 8) + \Lambda^- (\frac{3}{2}^-, 1)$$

$$S_2 : N_\beta^+ (\frac{5}{2}^-, 8) \leftrightarrow N_\delta^- (\frac{3}{2}^+, 8) + \Delta_\delta^- (\frac{3}{2}^+, 10)$$

except that a $3/2^+$ octet approximately degenerate with the $3/2^+$ decuplet is not known. It is argued that since the predicted coupling ratio of this octet to the decuplet is small this discrepancy is not too

serious. All the other multiplets can be identified with known particles and the predicted F/D ratios are found to be not unreasonable.

One may further require the amplitude to be an eigenvector of the (s,u) crossing matrix. An unique combination of S_1 and S_2 corresponds to such an eigenvector with eigenvalue one, and one obtains essentially an unique solution for the A and B amplitudes in PB_8 . Such amplitudes have been explicitly constructed by White⁽⁶⁹⁾, using the Veneziano model. When crossed into the t - channel both the A and B solutions predict $F/D = 1/3$ for the V and T couplings to $B_8 \bar{B}_8$. However the two trajectories S_1, S_2 of opposite normality, are now required to be completely degenerate. For an alternative in which the S_1, S_2 are not required to be degenerate see Auvil et al.⁽⁷⁰⁾ It is worth noting that Ademollo et al.⁽⁷¹⁾ find from current algebra considerations that the trajectories should be split by $\Delta\alpha = 0.5$.

The S_1 and S_2 degeneracies are quite badly broken although some particles show very accurate degeneracies (see fig. 3.7, 3.8). Barger and Michael,⁽⁶²⁾ and Capps⁽⁷²⁾ have tried, (as Chui and Finkelstein did for mesons) to satisfy the MB constraints when the B masses are allowed to depart from $SU(3)$ degeneracy, keeping exact symmetry for the couplings but including possible mixing. Trajectories of different strangeness are not required to be degenerate

and so immediately one can incorporate splitting according to the strangeness quantum number. Barger and Michael also show that for the S_1 solution N_α, N_γ and Ξ_α, Ξ_γ are required to be degenerate only through exact $SU(3)$, and if this constraint is relaxed the exchange degeneracy is no longer necessary. This is rather attractive as these degeneracies are very badly satisfied (fig. 3.7a,c). There remains the question of the degeneracies of the strangeness minus one trajectories. Capps shows that for the S_1 solution, by considering only (s,u) constraints, it is possible to incorporate $\Sigma - \Lambda$ splitting providing also that mixing between the $3/2^-$ isosinglets is included. There are then two strangeness = -1 exchange degeneracies:

- i) $\Lambda(1116) \rightarrow \Lambda(1520) \rightarrow \Lambda(1815)$
- ii) $\Sigma(1189) \rightarrow \Sigma(1670), \Lambda(1690) \rightarrow \Sigma(1910)$

The first of these is extremely well satisfied and the second less well satisfied (fig. 3.7b). However the branching ratios $\bar{K}N/\pi\Sigma$ for the mixed singlets $\Lambda(1520), \Lambda(1690)$ seem to contradict experiment. Similar considerations have not been applied to the S_2 solution. It seems completely arbitrary to introduce mixing with an unknown multiplet. The strangeness zero degeneracy (fig. 3.8a) of $\Delta(1236) \rightarrow N(1670)$ $\Delta(1950)$ seems well satisfied but there is again the

problem of $\bar{\Sigma} - \Lambda$ mixing for the $S = -1$ case.

Logan and Roy⁽⁷³⁾ have shown by considering the processes $\pi^+ p \rightarrow \pi^+ p$, $\pi^+ p \rightarrow k^+ \Sigma^+ k^+ \Sigma^+ \rightarrow k^+ \Sigma^+$ for which only Δ 's can be exchanged in the s - channel, that the t - channel meson nonet trajectories are required to be completely degenerate. This argument is symptomatic of the problems treated in this section. If all the constraints, including those from high mass channels are considered an over restricted, non physical solution emerges. It seems that the constraints coming from $B\bar{B} \rightarrow B\bar{B}$, and probably also $MM \rightarrow B\bar{B}$, should be discarded. When this is done the physical spectrum satisfies the relaxed constraints fairly well. However many other solutions are now possible.

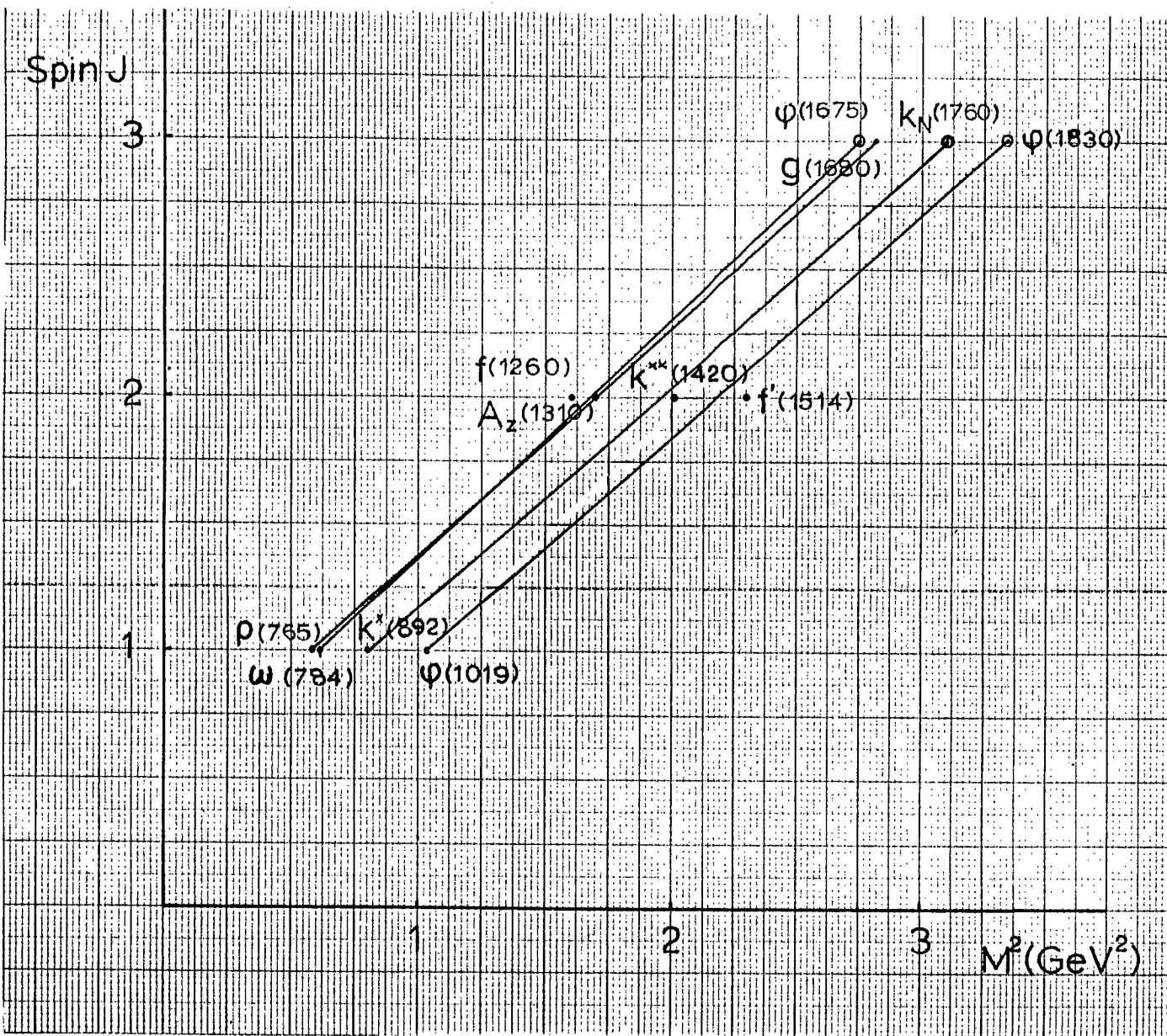

Fig.3.6 Speculative plot of leading natural parity meson trajectories. \odot denotes resonances whose spins are unknown. For $K_N(1760)$ the J^P assignment 3^- is favoured. The parity, spin and isospin are all unknown for $\psi(1830)$.

Fig. (3.7a)

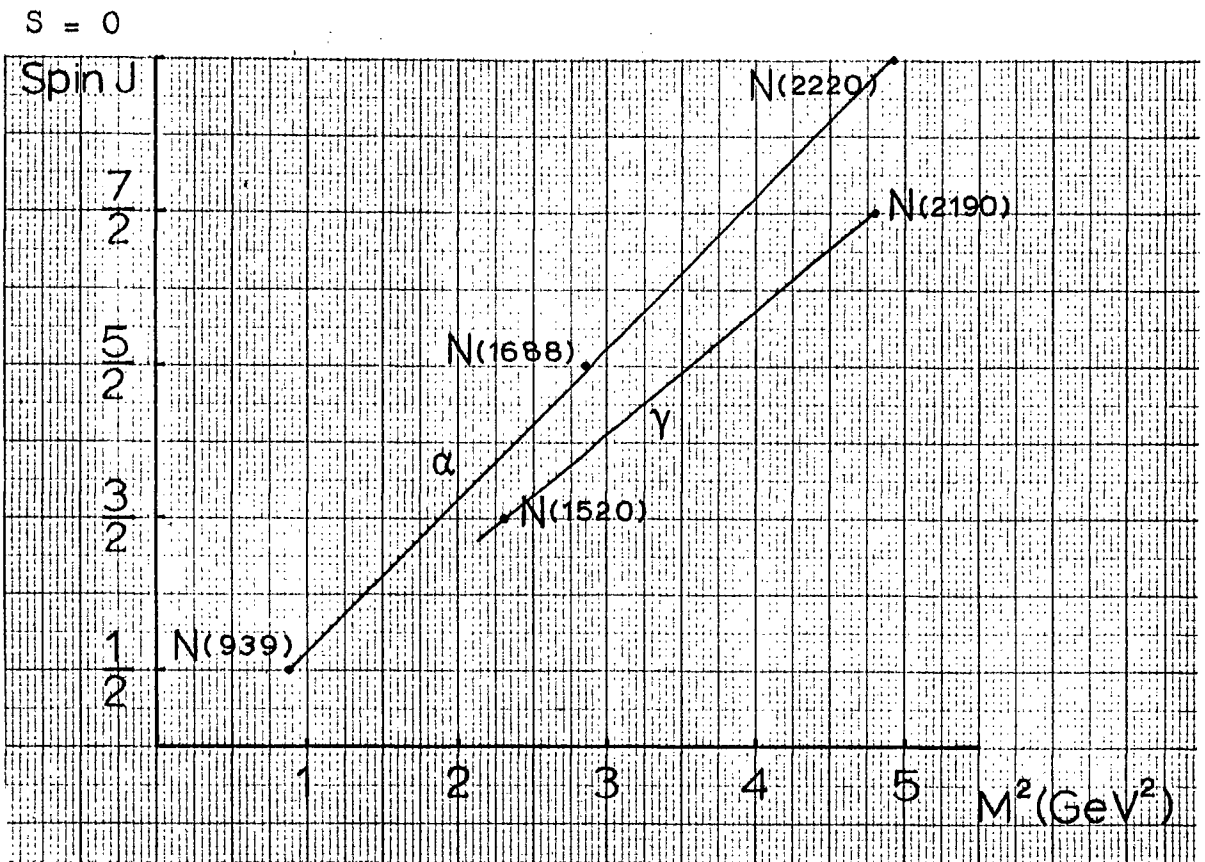
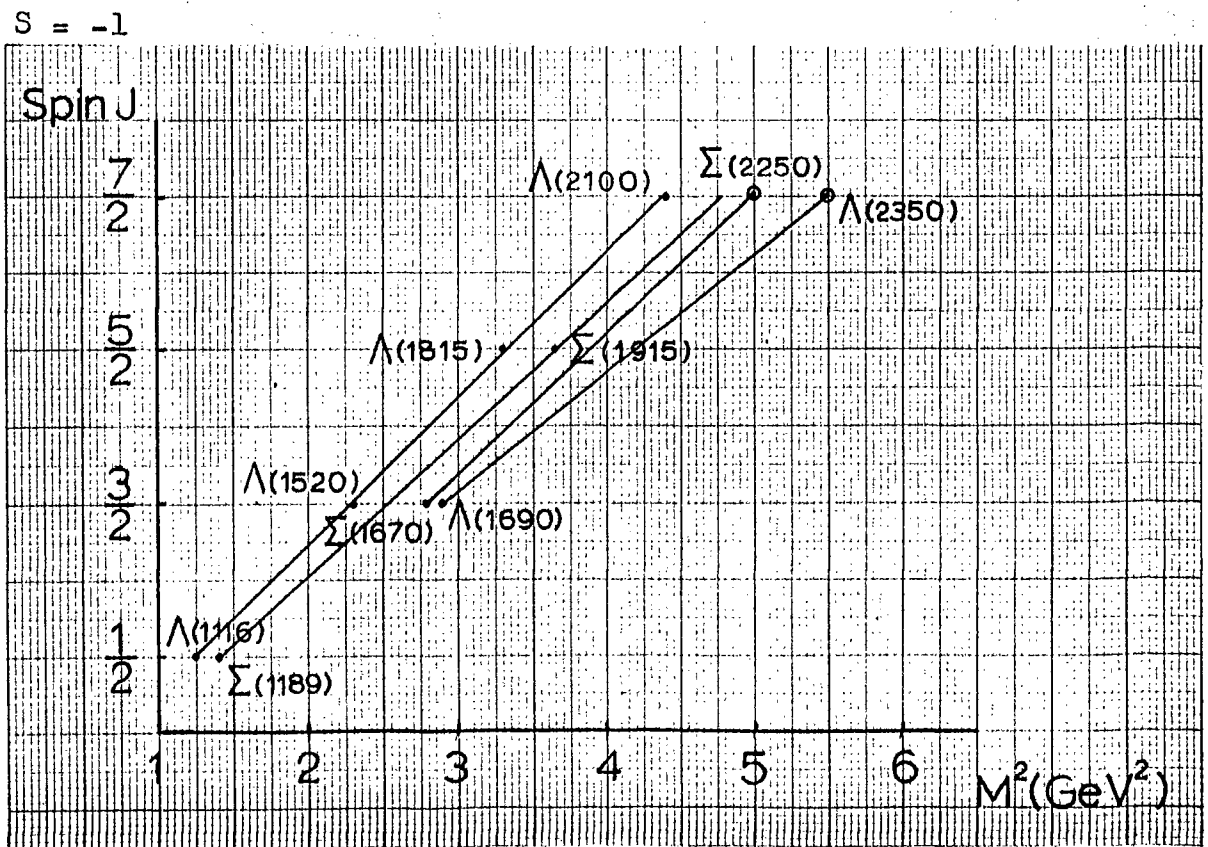
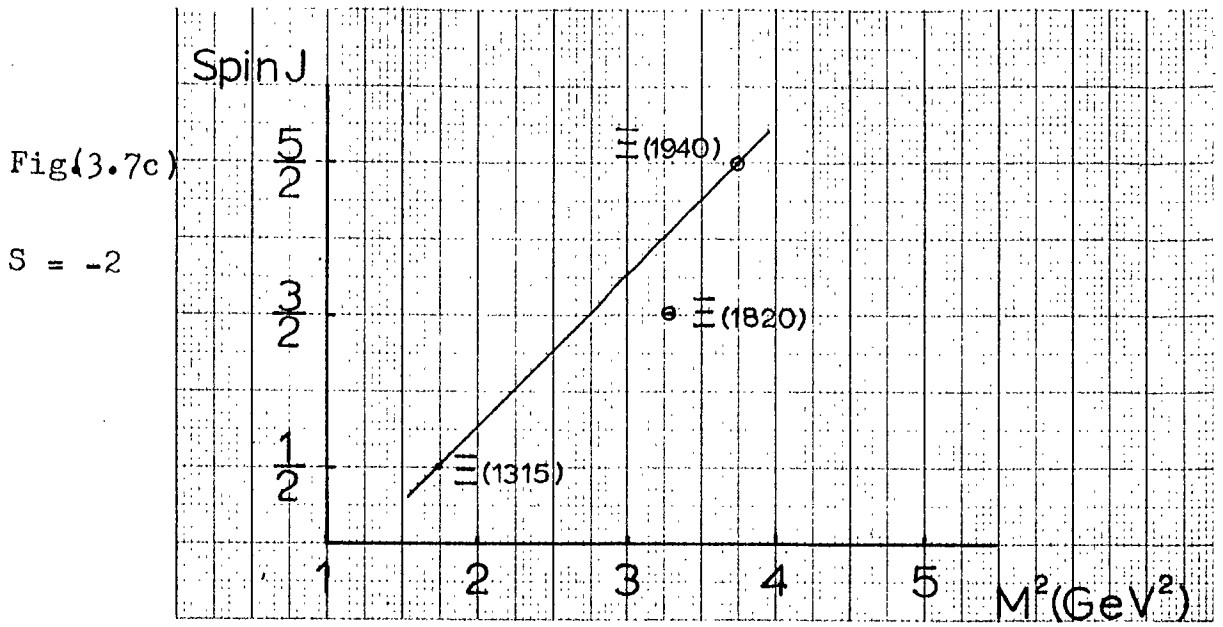

Fig. (3.7b)





Figs. 3.7 (a,b,c). Baryon trajectories of the scheme S_1 ; $8_\alpha^+ (\frac{1}{2}^+) \rightarrow 8_\gamma^- (\frac{3}{2}^-) + 1^- (\frac{3}{2}^-)$.

⊗ denotes resonances with unconfirmed spin assignments.

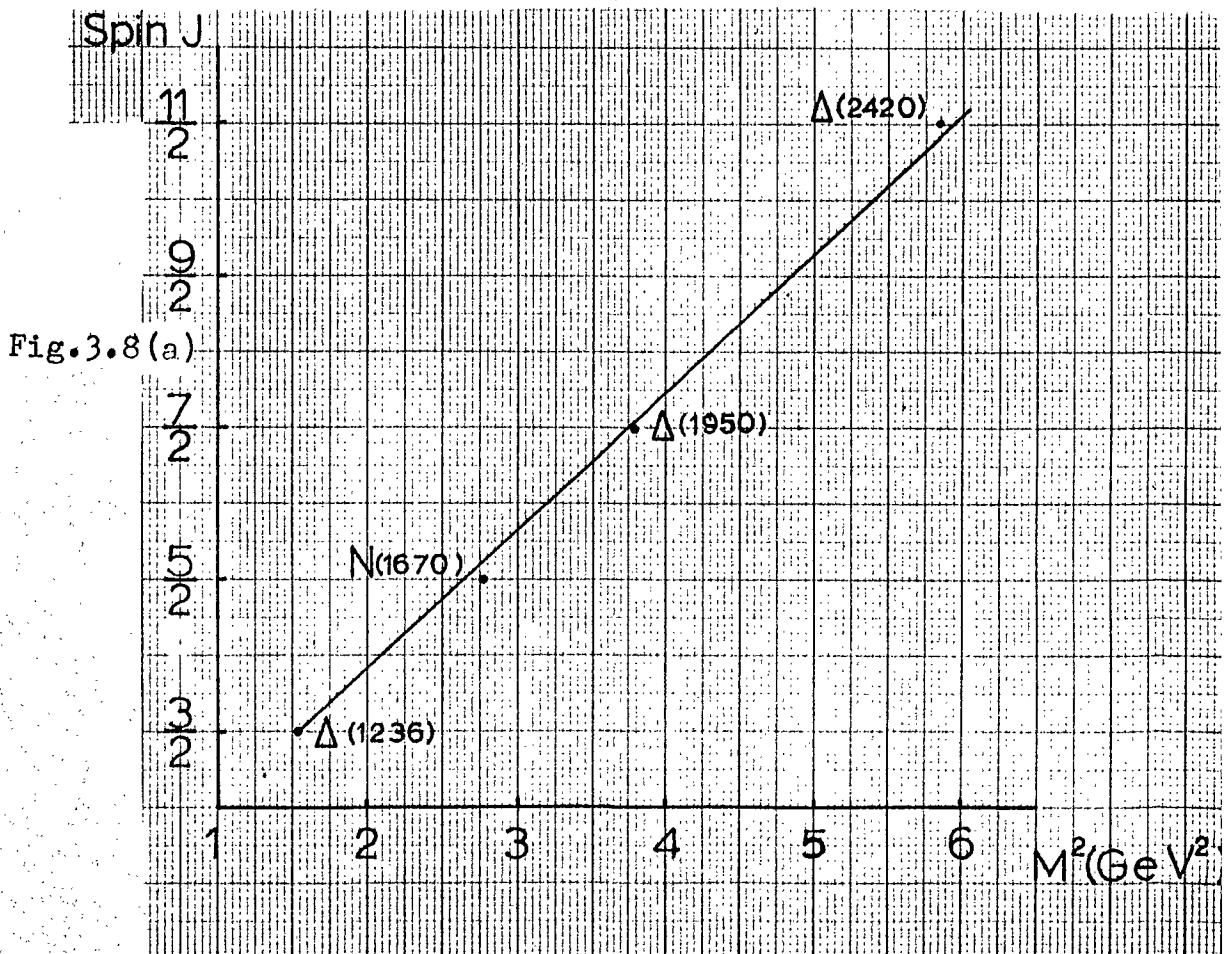
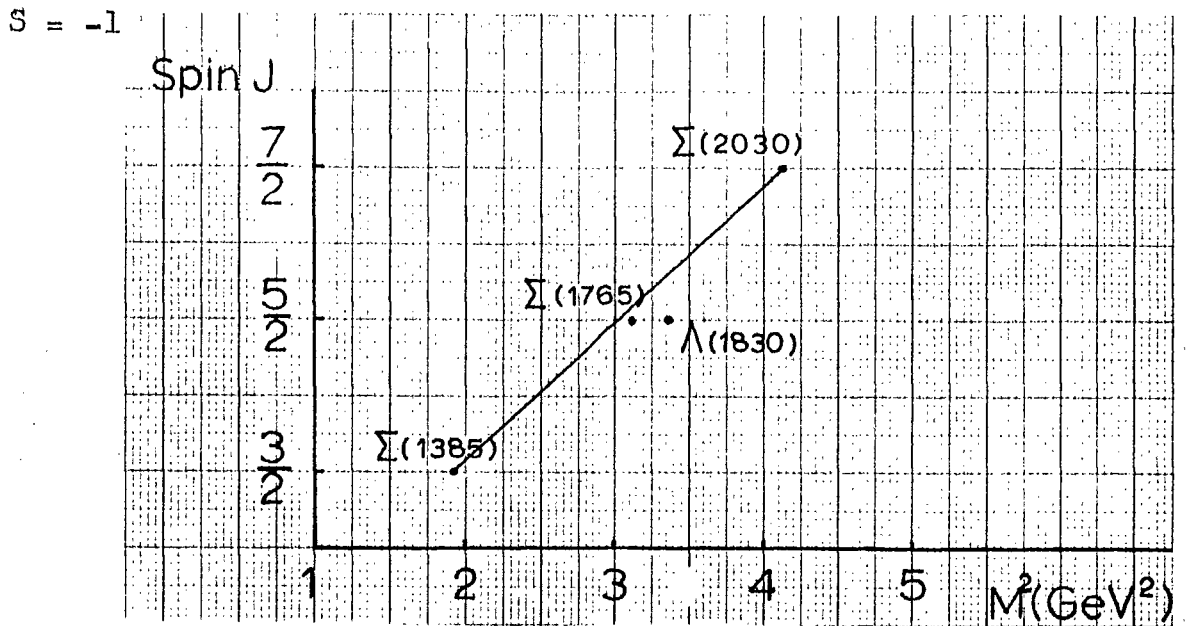

Fig. (3.8b)



Figs. 3.8(a,b) Baryon trajectories of the scheme $s_2 : 8\beta^+ (\frac{5}{2}^-) \longrightarrow 8 (\frac{3}{2}^+) + 10 (\frac{3}{2}^+)$. The $8 (\frac{3}{2}^+)$ resonances are unobserved.

CHAPTER 4

Comparison of Bootstrap and Duality Predictions

We summarise and compare the symmetry predictions of the bootstrap and duality equations surveyed in the previous two chapters. In particular we contrast the predicted relationships between multiplets and the consequent identification of the even signature singlet trajectories, following Collins & Hutt.⁽⁷⁴⁾ We examine whether the exchange degeneracies essential to the duality scheme can arise in a bootstrap calculation.

4.1 Meson Trajectories.

With similar assumptions about symmetry of the couplings the duality and bootstrap equations both lead to the Jacobi relation (2.15) for the antisymmetric trilinear couplings of three odd parity mesons. Hence a compact, semi-simple Lie group structure is predicted with the odd parity mesons belonging to the adjoint representation. The even parity mesons are also required to transform as some representation of the group. In the duality approach a complete set of equations corresponding to all possible odd and even parity external mesons can be written down. Apart from trivial one meson solutions, the equations have a unique solution with $SU(n)$ symmetry, with the mesons of either parity transforming as quark - antiquark composites. Hence the mesons belong to adjoint

singlet representations. The greater kinematical difficulties of the partial wave N/D equations allow only a subset of the complete set of bootstrap equations to be written down with any certainty. However $SU(n)$ seems to give a favoured solution and probably the only solution, with the simplest pattern for the mesons being that of adjoint singlet representations as above. Neither approach gives any constraint on the dimension n of the algebra, but as we have suggested this may be part of the problem of broken symmetry.

The predicted relationships between the multiplets are however quite different. Both sets of equations require the couplings, with suitable renormalization of the symmetric to the antisymmetric couplings, to be an eigenvector of the crossing matrix with eigenvalue one. The prescriptions for the renormalization are totally different in the two cases. The $SU(n)$ eigenvectors are given by (2.26). The physical eigenvector is taken to be

$$I: M: D = 2(n^2 - 1): n^2; (n^2 - 4)$$

In the duality solution the singlet and adjoint mesons are degenerate and lie on an exchange degenerate trajectory. We have seen in the case of $SU(3)$ how symmetry breaking for the masses may be incorporated, in good agreement with the physical spectrum (fig.3.6). There are now three separate exchange degenerate trajectories and the even signatored isosinglet trajectories are identified with the f, f' particles. For

the bootstrap equations with the determinantal approximation the predicted multiplet masses are proportional to the inverse elements of the eigenvector. Thus the predicted pattern of trajectories has the even signature singlet lying highest above the odd signature adjoint representation, which in turn lies above the even signature adjoint representation. As we remarked in Chapter 1 this pattern of a high - lying singlet is likely to persist even when the Lie group is not $SU(n)$. The singlet is naturally identified with the Pomeron. (75)

We investigate whether trajectory degeneracy as obtained from duality can be obtained in an N/D calculation, without making the strong assumption of proportionality of Born terms made in Chapter 2. We specialize hereafter to the case of $SU(3)$ symmetry. Two types of exchange degeneracies are involved.

a) Degeneracy between particles of the same $SU(3)$ quantum numbers eg. ρ , A_2 . (b) Degeneracy between particles of the same signature but different $SU(3)$ quantum numbers. Type (a) degeneracy requires no u - channel force which is suggestive of high mass thresholds controlling the dynamics. (76) Type (b) seems incompatible with the internal symmetry crossing matrices, which give the eigenvalues of the potential matrix and the corresponding multiplet masses as explained above.

	1	8_{ss}	8_{sa}	8_{as}	8_{aa}	10	$\bar{10}$	27
1	$\frac{1}{8}$	1	0	0	± 1	$\pm \frac{5}{4}$	$\pm \frac{5}{4}$	$\frac{27}{8}$
8_{ss}	$\frac{1}{8}$	$-\frac{3}{10}$	0	0	$\pm \frac{1}{2}$	$\pm \frac{1}{2}$	$\pm \frac{1}{2}$	$\frac{27}{40}$
8_{sa}	0	0	$\pm \frac{1}{2}$	$\frac{1}{2}$	0	$\frac{\sqrt{5}}{4}$	$-\frac{\sqrt{5}}{4}$	0
8_{as}	0	0	$\frac{1}{2}$	$\pm \frac{1}{2}$	0	$-\frac{\sqrt{5}}{4}$	$\pm \frac{\sqrt{5}}{4}$	0
8_{aa}	$\pm \frac{1}{8}$	$\pm \frac{1}{2}$	0	0	$\frac{1}{2}$	0	0	$\pm \frac{9}{8}$
10	$\pm \frac{1}{8}$	$\pm \frac{2}{5}$	$\frac{1}{\sqrt{5}}$	$\pm \frac{1}{\sqrt{5}}$	0	$\frac{1}{4}$	$\frac{1}{4}$	$\pm \frac{9}{40}$
10	$\pm \frac{1}{8}$	$\pm \frac{2}{5}$	$-\frac{1}{\sqrt{5}}$	$\pm \frac{1}{\sqrt{5}}$	0	$\frac{1}{4}$	$\frac{1}{4}$	$\pm \frac{9}{40}$
27	$\frac{1}{8}$	$\frac{1}{5}$	0	0	$\pm \frac{1}{3}$	$\pm \frac{1}{2}$	$\pm \frac{1}{2}$	$\frac{7}{40}$

Table: SU(3) $8 \otimes 8 \longrightarrow 8 \otimes 8$ crossing matrix from ref. (77) The upper and lower signs refer to the (s,t) and (s,u) crossing matrices, respectively. We have changed the signs of the sa and as elements in the (s,t) crossing matrix to conform to the usual convention for the F - type coupling to baryon - antibaryon (see ref. (78)).

We consider PP scattering with the exchange of T,V (octets) and S(singlet) mesons. We do not give a specific form to the potential Born term due to Regge pole exchange, but make use of the argument of Chew (79) that it is a fairly good approximation to represent the

exchange of a trajectory by the exchange of the lowest mass particles on it. Thus for the V meson trajectory the Born term resulting from the exchange of a spin one particle will probably be satisfactory, and we denote it by $g_V^2 F^V(s)$ where g_V^2 is the coupling of the V - mesons. The S and T exchanges are probably more complicated due to the presence of both an S - wave part (which may be repulsive⁽⁷⁶⁾) and a D - wave attractive part. From the arguments of ref. (76) we can expect the resultant to be a weak attraction and we denote the singlet force by $g_S^2 F^l(s)$ and the octet force by $g_T^2 F^l(s)$ assuming the singlet and octet tensor mesons are degenerate. From the (s,t) crossing matrix of the table the potentials in the various s - channel multiplets are:

$$\left. \begin{aligned}
 V_1(s) &= \frac{1}{8} g_S^2 F^l(s) + g_T^2 F^l(s) + g_V^2 F^V(s) \\
 V_{ss}(s) &= \frac{1}{8} g_S^2 F^l(s) - \frac{3}{10} g_T^2 F^l(s) + \frac{1}{2} g_V^2 F^V(s) \\
 V_{aa}(s) &= \frac{1}{8} g_S^2 F^l(s) + \frac{1}{2} g_T^2 F^l(s) + \frac{1}{2} g_V^2 F^V(s) \\
 V_{10}(s) &= V_{\bar{10}}(s) = \frac{1}{8} g_S^2 F^l(s) - \frac{2}{5} g_S^2 F^l(s) \\
 V_{27}(s) &= \frac{1}{8} g_S^2 F^l(s) + \frac{1}{5} g_T^2 F^l(s) - \frac{1}{3} g_V^2 F^V(s)
 \end{aligned} \right\} (4.1)$$

Note that V_{ss} is the force in the tensor channel and that V_{aa} is that in the vector channel, because of the symmetry of the couplings.

For no attraction in the 10, $\bar{10}$, 27 representations we need

$$g_T^2 \geq \frac{5}{16} g_s^2, \quad g_v^2 F^v(s) \geq \left(\frac{1}{8} g_s^2 + \frac{1}{5} g_T^2 \right) F^l(s) \quad (4.2)$$

Note that in the strong bootstrap conditions used in Chapter 2 we required the potentials in exotic states to be zero. Here we take the weaker form of the conditions that they be non-positive. It is immediately apparent that $V_1 > V_{aa}$ unless $g_T^2 = g_v^2 = 0$, when the above inequalities will be violated unless also $g_s^2 = 0$. Also $V_{aa} \geq V_{ss}$ with equality only if $g_T^2 = 0$, i.e. the tensor octet decouples, which is inconsistent since $V_{ss} > 0$. Hence we are forced to have the S trajectory lying highest above the V trajectory, with the T trajectory lowest. These conclusions are unaltered if we allow breaking of the input degeneracy i.e. $F^S \neq F^T$. The high lying S trajectory is identified with the Pomeron and it is interesting to note that the singlet trajectory function will have a similar l -dependence and hence slope as the octet trajectories.

It could be that the degeneracies arise from a multichannel calculation. The channel with the next lowest threshold which we might introduce is the PV channel. In this channel the roles of vector and

tensor mesons are reversed from the PP case in that they couple with opposite symmetry. The addition of this channel might therefore help to produce the exchange degeneracies. However the SU(6) model of Chapter 2 which includes all P, V external states produces the same pattern of trajectories as the simple PP model. For completeness one should attempt to investigate this multichannel problem without the gross assumptions of SU(6) symmetry. An attempt along these lines has been attempted by Chan & Wilkin⁽⁸⁰⁾ but these authors introduce the equally drastic assumption of parity doubling for the mesons. They do find however a meson spectrum with essentially the same pattern as that in the PP model. In summary we conclude that a multichannel N/D calculation will not produce the exchange degeneracies of duality.

Alternatively it has sometimes been argued⁽⁸¹⁾ that the $B_g\bar{B}_g$ channel could be more important in producing meson bound states. In this channel exchange degeneracy of opposite signated trajectories with the same SU(3) quantum numbers is guaranteed by the absence of an exchange force coming from the exotic BB channel. The situation is complicated by the fact that V and T mesons now have both symmetric and antisymmetric couplings to $B\bar{B}$. We denote the couplings by G_i^2 where $i = (1, 8_{SS}, 8_{SA}, 8_{AS}, 8_{AA}, 10, \bar{10}, 27)$. In the duality solution for this case, which we have previously eschewed,

the pattern of exchange degeneracies is the same as for the PP case. The couplings G_i^2 must form an eigenvector of the (s,t) crossing matrix with no 10, $\bar{10}$ or 27 states. The two such eigenvectors are (16, 5, 0, 0, 9, 0, 0, 0) and (0, 0, 1, 1, 0, 0, 0, 0). Factorization requires $G_{aa} G_{ss} = G_{as}^2$ and so the unique solution is $G_i^2 = (16, 5, 3\sqrt{5}, 3\sqrt{5}, 9, 0, 0, 0)$. This gives $F/D = \sqrt{5}/3$ $G_{aa}/G_{sa} = 1$ for both V, T couplings to $B_8\bar{B}_8$.

The left hand cut potentials for the N/D calculation of the $B_8\bar{B}_8$ channel are from the table:

$$\left. \begin{aligned}
 V_1(s) &= \frac{1}{8} G_1^2 F^1(s) + (G_{ss}^2 + G_{aa}^2) F^8(s) \\
 V_{ss}(s) &= \frac{1}{8} G_1^2 F^1(s) + \left(-\frac{3}{10} G_{ss}^2 + \frac{1}{2} G_{aa}^2\right) F^8(s) \\
 V_{sa}(s) &= V_{as}(s) = G_{ss} G_{aa} F^8(s) \\
 V_{aa}(s) &= \frac{1}{8} G_1^2 F^1(s) + \left| \frac{G_{aa}^2}{2} + \frac{G_{ss}^2}{2} \right| F^8(s) \\
 V_{10}(s) &= V_{\bar{10}}(s) = \frac{1}{8} G_1^2 F^1(s) - \frac{2}{5} G_{ss}^2 F^8(s) \\
 V_{27}(s) &= \frac{1}{8} G_1^2 F^1(s) + \left(\frac{1}{5} G_{ss}^2 - \frac{1}{3} G_{aa}^2\right) F^8(s)
 \end{aligned} \right\} (4.3)$$

where the V 's are identical for both signatures and $F^8(s) \equiv F^V(s) + F^q(s)$. Diagonalizing the octet potential matrix, we find an attraction in one diagonal element and repulsion in the other. Identifying the attractive element with the input pole gives $F/D = 1$ for consistency of input and output couplings, for both the V and T octets, in agreement with what was found from duality above. Substituting this value in (4.3) we again find repulsion in exotic states $10, \bar{10}, 27$, provided $G_{SS}^2 F^8(s) > 5/16 G^2 F(s)$, and we find that $V_1 > V_8$. Identifying the singlet with the Pomeron, the exchange degeneracy of the forces means that there has to be a trajectory of odd signature degenerate with the P . The absence of such a channel presumably means that the $B\bar{B}$ channel cannot in fact be dominant.

4.2 Baryon Trajectories.

For baryons the duality principle leads to a completely wrong spectrum, with baryons being two quark composites. Ignoring the constraints coming from the high threshold $B\bar{B} \rightarrow B\bar{B}$ channel allows a three quark solution but now there are many possible solutions. Specializing to the case of $SU(3)$ there are two minimal solutions with the three multiplet degeneracy patterns

$$S_1 : 8_\alpha \left(\frac{1}{2}^+\right) \rightarrow 8_\gamma \left(\frac{3}{2}^-\right) + 1 \left(\frac{3}{2}^-\right)$$

$$S_2 : 8_\beta \left(\frac{5}{2}^-\right) \rightarrow 8_\delta \left(\frac{3}{2}^+\right) + 10 \left(\frac{3}{2}^+\right)$$

which are identified with baryon trajectories of opposite nomality, except for the $8_\delta(\frac{3}{2}^+)$ which is not observed. Broken symmetry can be incorporated into the S_1 solution with some success except for the strangeness -1 trajectories (figs. 3.7, 3.8).

The N/D bootstrap equations merely predict that the baryons belong to some representation of the group, not necessarily irreducible and we have seen that many representations will satisfy the equations. In the static limit the even and odd parity baryon equations become independent and there is no requirement for exchange degeneracy between them. A detailed analysis of the meson and baryon exchange forces was given by Golowich⁽⁸¹⁾ who found there are strong attractive forces in $\Delta_\delta, N_\alpha, \Lambda_\gamma$ but very much weaker forces in N_β, N_γ and N_δ .

4.3 Conclusions.

The main conclusion we wish to draw in this chapter is that although both the bootstrap and duality hypotheses may be used to derive the fact that the strongly interacting particles will occur in multiplets which form a representation of a Lie group, their predictions are by no means identical as regards the relationships between different multiplets. In general the N/D method does not result in degenerate trajectories; neither exchange degeneracy (unless channels with exotic u - channel quantum numbers are chosen) nor degeneracy between different multiplets of the same signature is

predicted. On the other hand, degeneracies are essential to the duality scheme. Of course the N/D scheme which we have used is only an exceedingly crude first approximation to the dynamics and it might be argued that a more exact bootstrap treatment could restore agreement with the duality predictions.

Against this it should be noted that in both schemes the arguments for the occurrence of an internal symmetry rely on the poles dominating the amplitudes. If the bootstrap equations are such that poles are not a good first approximation to the dynamics then the fact that these couplings appear to obey $SU(3)$ symmetry would be just a dynamical accident.

For baryons there are so many multiplets involved that neither model gives predictions which compare critically with experiment, but for mesons the situation is much more transparent. The observed exchange degeneracy between the vector and tensor mesons is not found in N/D models unless we regard the mesons as bound states of a high-mass channel with exotic u - channels such as $B\bar{B}$. Even then the $SU(3)$ crossing matrix does not permit the tensor singlet to be degenerate with the octet. The singlet always lies higher and so should seem to be identifiable as the Pomeron rather than the f, f' mixed state.

Essentially the same problem has been noted in the multiperipheral bootstrap (which is essentially

the same as the N/D method with an iterated potential and no cut-off) by Chew & Snider⁽⁸²⁾. The input Pomeron is given the special status suggested by duality, and it is then found that the output may take the form of a split P, P' doublet (the 'schizophrenic Pomeron'). The authors admit that this seems hard to reconcile with the duality requirement that the P' occur as a normal trajectory degenerate with the ρ etc.

These results taken together with the difficulties of generating straight trajectories must cast considerable doubt on the possibility of deducing duality from any simple bootstrap theory. It has been noted⁽⁸³⁾ that straight trajectories suggest a dynamics controlled by very high mass channels rather than the decay channels, and the argument of this chapter is that the observed internal symmetries are unlikely to be obtained from coupling to low mass hadrons either.

CHAPTER 5

Quark Model Calculations

In accordance with the conclusions to Chapter 4 we investigate the consistency of regarding the vector mesons as bound states of quarks and antiquarks, using the determinantal approximation to the N/D equations. Since it is generally supposed that the quarks have a large mass, $M_q \gtrsim 5$ GeV, the quark model is an expression of the opposite point of view from the bootstrap hypothesis, in which the lowest threshold channels are assumed to dominate. Duality has its simplest expression in terms of quark scattering diagrams and we hope to shed light on the differences between duality and bootstrap predictions found above, and in particular on the appearance of the Pomeranchuk trajectory.

5.1 Introduction to the Quark Model.

The immediate attractiveness of the quark model is that it predicts the correct quantum numbers for the mesons. (See eg. ref. (14,15)). If a 'dynamic' quark model is considered, that is one with orbital excitations, one obtains meson bound states which are $SU(3)$ singlets and octets with parity $(-1)^L$ and charge - parity $(-1)^{L+S}$. For the ground state $L = 0$, one gets pseudoscalar and vector mesons. The higher mass mesons can be accommodated in excited, $L \neq 0$, states. There are four types of

states $J = L - 1, L, L + 1$ with $S = 1$ and $J = 1$ with $S = 0$. It is conjectured that there is a Regge trajectory corresponding to each type. The trajectory $J = L + 1$ can have no $J = 0$ state and so its intercept must be positive while the other three intercepts must be negative.

The baryons are supposed to be three quark composites, which correctly give $SU(3)$ singlets, octets and decuplets. The lowest mass baryons can be incorporated into a single representation of $SU(6)$, the 56. This representation, as well as the spin $3/2$ $SU(3)$ decuplet, is completely symmetric in its spin and unitary spin quark indices. If these states are ground states with $L = 0$, then the usual Fermi statistics demands that the space part of the ground state wave function be antisymmetric under interchange of the quarks. This is peculiar but not impossible. The second difficulty with baryon states is the question of why a $3q$ state is more strongly bound than a $4q$ state, for instance.

It has been shown⁽⁸⁶⁾ that in certain circumstances the internal dynamics of quark - antiquark meson bound states can be treated non-relativistically, even though the quark mass might be very much larger than the meson mass. In such a non-relativistic model it is easy to account for the splitting of the four meson trajectories by having a simple spin orbit term in the potential. If we also suppose that the strange quark

has a mass Δ greater than the non-strange quarks the mass splitting amongst the meson nonets can be accounted for. Writing the meson mass $m_A = \langle A | \sum Mq_i - U_\alpha | A \rangle$,

where U_α is an SU(3) invariant potential,

gives for example $m_\rho = m_\theta$, $m_{K^*} = m_\theta + \Delta$

$$m_{\omega_8} = m_\theta + \frac{4}{3} \Delta \quad \text{and} \quad m_{\phi_0} = m_\theta + \frac{2}{3} \Delta$$

For the vector mesons if we put $m_\theta = m_0$ and we have the canonical mixing, then $m_\omega = m + 2\Delta$,

$$m_\phi = m_\rho = m \quad . \quad \text{These predictions which}$$

are reasonably well satisfied agree with the qualitative pattern of trajectories obtained from duality. The value of Δ obtained from the vector meson masses is only consistent with that obtained from the pseudoscalar masses if squared masses are used in the relations.

The same considerations for the decuplet baryons gives the equal spacing rule and a fairly consistent value of Δ , but breaks down for the octet baryons where it implies $m_\Sigma = m_\Lambda$. To account for this difference

$m_\Sigma \neq m_\Lambda$ symmetry breaking effects must be included in the potential.

5.2 N/D Model for Meson Exchanges.

We consider an N/D model for quark - antiquark scattering amplitudes, with the exchange of vector meson poles, and make the assumption that $\frac{m^2}{M_q^2} \ll 1$, where m is the vector meson mass. It has been shown⁽⁸³⁾ that in such a model it is easy to obtain an approximately straight meson trajectory for $|s| \ll 4M^2$. However, the observed slopes and intercepts cannot be

obtained without imposing curious constraints on the input forces (84,85). We will ignore spin in our calculations for the sake of simplicity, expecting this to make no qualitative difference to our results. We could attempt to incorporate spin into the calculation by assuming SU(6) symmetry and at the same time include the pseudoscalar mesons.

a) We assume exact SU(3) symmetry for masses and couplings. We consider the quark-antiquark scattering amplitude for $q_a + \bar{q}_b \rightarrow q_c + \bar{q}_d$ as shown in fig. 5.1, with exchange of vector mesons.

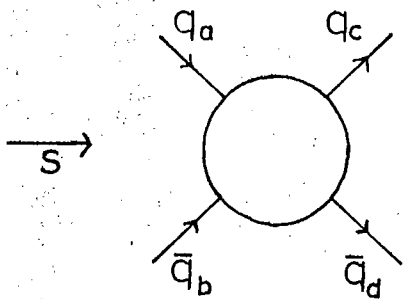

Fig. 5.1
 $q\bar{q}$ scattering.

The channels are defined as in fig.2.1.

Let m_8 = octet meson mass
 m_0 = singlet meson mass.

The $Mq\bar{q}$ coupling coefficients are

$$\langle q_a \bar{q}_b | m_8^i \rangle = g_8^2 \frac{\lambda_{ab}^i}{\sqrt{2}}$$

$$\langle q_a \bar{q}_b | m_0 \rangle = g_0^2 \frac{\delta_{ab}}{\sqrt{3}}$$

where λ_{ab}^i are the fundamental matrix, representations of SU(3). (See Appendix A for commutation relations).

The factors $\sqrt{2}$, $\sqrt{3}$ are included for normalization.

Using the determinantal approximation to the N/D equations (See Appendix C) with singlet and octet

t - channel vector meson exchanges, one obtains for the
 S - wave N and D amplitudes

$$N_{ab,cd}(s) = \frac{\delta_{ac} \delta_{bd}}{3} f_0(s) + \sum_{i=1}^8 \frac{\lambda_{ac}^i \lambda_{bd}^{*i}}{2} f_8(s) \quad (5.1)$$

$$D_{ab,cd}(s) = \delta_{ab} \delta_{cd} - \frac{s - s_0}{\pi} \int_{4M^2}^{\infty} \frac{N_{ab,cd}(s') 2q_{s'} ds'}{\sqrt{s'} (s'-s)(s'-s_0)} \quad (5.2)$$

where $f_i(s) = g_i^2 \frac{Q_0(z_t^i) P_0(z_s^i)}{q_s^2}$

$$z_t^i = 1 + \frac{2m_i^2}{s - 4M^2}, \quad z_s^i = 1 + \frac{2s}{m_i^2 - 4M^2}$$

So $f_i(s) = 2g_i^2 \ln \left| \frac{4M^2 - s - m_i^2}{m_i^2} \right|$

Put $F_i(s) = \frac{s - s_0}{\pi} \int_{4M^2}^{\infty} \frac{f_i(s') 2q_{s'} ds'}{\sqrt{s'} (s'-s)(s'-s_0)}$

So is the subtraction point which is not strictly necessary.

Replacing the variables by non-dimensional ones

$$s \rightarrow \frac{s}{4M^2} \quad m^2 \rightarrow \frac{m^2}{4M^2} \quad g^2 \rightarrow \frac{g^2}{4M^2}$$

we obtain

$$f^i(s) = \frac{2g_i^2 \ln((1-s-m_i^2) m_i^2)}{s-1}$$

$$F^i(s) = 2g_i^2 \frac{(s-s_0)}{\pi} \int_1^\infty \frac{\ln((1-s-m_i^2) m_i^2) ds'}{\sqrt{s'(s'-1)(s'-s)(s'-s_0)}}$$

We quote the results of Appendix B that for small s and m^2 these two functions may be expanded in powers of s, m^2 .

$$f^i(s) = \log m_i^2 (a_1 + a_2 s + \dots) + b_1 + b_2 s + \dots + O(m_i^2) \quad (5.3)$$

$$F^i(s) = \log m_i (A_1(s_0) + A_2 s + \dots) + B_1(s_0) + B_2 s + O(m_i^2) \quad (5.4)$$

The coefficients a_i, b_i, A_i, B_i are given in Appendix B.

Below we will take our equations always to lowest order

in s and m_i^2 .

$$\frac{1}{3}F_o(m_o^2) + \frac{1}{3}F_B(m_o^2) = 1 \quad (5.9)$$

$$\frac{1}{3}F_o(m_B^2) - \frac{8}{3}F_B(m_B^2) = 1 \quad (5.10)$$

The coupling constant equations

$$g_B^2 = \frac{-N_B(m_B^2)}{\left[\frac{d}{ds} D_B(s) \right]_{m_B^2}}$$

$$g_o^2 = \frac{-N_o(m_o^2)}{\left[\frac{d}{ds} D_o(s) \right]_{m_o^2}}$$

give

$$g_B^2 = \frac{f_o(m_B^2) - f_B(m_B^2)}{F_o'(m_B^2) - F_B'(m_B^2)} \quad (5.11)$$

$$g_o^2 = \frac{f_o(m_o^2) + 8f_B(m_o^2)}{F_o'(m_o^2) + 8F_B'(m_o^2)} \quad (5.12)$$

Using the results (5.3) and (5.4), taken to lowest order in s, m_1^2 we obtain from (5.9, 5.10)

$$\begin{aligned} F_o &= g_o^2(A_1 + B_1 \log m_o^2) = 3 \\ \implies \log m_o^2 &= \frac{3}{B_1 g_o^2} - \frac{A_1}{B_1} \end{aligned} \quad (5.13)$$

$$F_8 = g_8^2(A_1 + B_1 \log m_8^2) = 0$$

$$\implies \log m_8^2 = \frac{-A_1}{B_1} \quad (5.14)$$

and in principle (5.11) and (5.12) are now solvable for g_0^2 , g_8^2 .

We get the rather absurd result that for consistency we require to octet exchange force to be zero. This will be so if $\log m_8^2 = -A_1/B_1$. From the table of Appendix B this ratio ranges from about 1.4 to +2 as varies along the L.H. cut, and does not give a sufficiently small value of m_8^2 to make the approximation $m_8^2/4M^2 \ll 1$ valid. However $\log m_0^2 = \frac{3/g_0^2 - A_1}{B_1}$ does give a

small value for m_0^2 if $g_0^2 \sim 1$. We see that consistency requires not merely that the singlet trajectory lies above the octet trajectory as do bootstrap models, but that the octet mass is an order of $m^2/4M^2$ greater than the singlet mass.

b) We now look for a broken symmetry solution in the hope that by introducing singlet octet mixing the above results might be modified and in particular eliminate the need to have $F_8 = 0$. We keep the assumption $m^2/4M^2 \ll 1$ but allow symmetry breaking of the masses and couplings to all orders of $\frac{\Delta m}{m}$, $\frac{\Delta g^2}{g^2}$. We assume exact SU(2) and equality of the quark masses is preserved. Let m_i = mass of the vector mesons $i = 0, \dots, 8$ where $m_1 = m_2 = m_3$ and $m_4 = m_5 = m_6 = m_7$

to satisfy the requirements of isospin and charge conjugation invariance. The coupling coefficients are now written

$$\begin{aligned}
 \langle g_a \bar{g}_b | m_i \rangle &= g_i \frac{\lambda_{ab}^i}{\sqrt{2}} \quad i = 1, \dots, 7 \\
 &= g_8 \left(\cos \theta \frac{\lambda_{ab}^8}{\sqrt{2}} - \sin \theta \frac{\delta_{ab}}{\sqrt{3}} \right), i = 8 \\
 &= g_0 \left(\sin \theta \frac{\lambda_{ab}^8}{\sqrt{2}} + \cos \theta \frac{\delta_{ab}}{\sqrt{3}} \right), i = 0
 \end{aligned}$$

where $g_1 = g_2 = g_3$ and $g_4 = g_5 = g_6 = g_7$.

θ is the singlet - octet mixing angle and the couplings are written to preserve SU(2) and charge conjugation invariance, and to keep the m_8, m_0 states orthogonal. Put $t = \tan \theta$ and replace

$$g_8 \rightarrow g_8 \sqrt{1+t^2} \quad g_0 \rightarrow g_0 \sqrt{1+t^2}$$

and the m_8, m_0 couplings then become

$$\langle g_a \bar{g}_b | m_8 \rangle = g_8 \left(\frac{\lambda_{ab}^8}{\sqrt{2}} - t \frac{\delta_{ab}}{\sqrt{3}} \right)$$

$$\langle g_a \bar{g}_b | m_0 \rangle = g_0 \left(t \frac{\lambda_{ab}^8}{\sqrt{2}} + \frac{\delta_{ab}}{\sqrt{3}} \right)$$

Using the determinantal approximation as above, the N and D functions may now be written

$$\begin{aligned}
 N_{ab,cd}(s) &= \sum_{i=1}^8 \frac{1}{2} \lambda_{ac}^i f^i(s) \lambda_{bd}^{i*} + \frac{1}{2} t^2 \lambda_{ac}^8 f^8(s) \lambda_{bd}^{8*} \\
 &+ \frac{t}{\sqrt{6}} (f^0(s) - f^8(s)) (\lambda_{ac}^8 \delta_{bd} + \delta_{ac} \lambda_{bd}^{8*}) \\
 &+ \frac{1}{3} (f^0(s) + t^2 f^8(s)) \delta_{ac} \delta_{bd}
 \end{aligned} \tag{5.15}$$

$$D_{ab,cd}(s) = \delta_{ab} \delta_{cd} - \frac{s-s_0}{\pi} \int_1^{\infty} \frac{N_{ab,cd}(s') ds'}{\sqrt{s'(s'-1)}(s'-s)(s'-s)} \tag{5.16}$$

where as before

$$f^i(s) = 2g_i^2 \frac{\ln((1-s-m_i^2)/m_i^2)}{s-1}$$

We make the same unitary transformations to the N and D functions as we did in the symmetry case above, but now the N and D matrices are not diagonalized, and we are left with off-diagonal terms N^{80} , N^{08} terms, etc., due to singlet - octet mixing. We obtain (see Appendix A)

$$\begin{aligned}
 N^{ij} &= \frac{1}{2} \lambda_{ab}^{i*} N_{ab,cd} \lambda_{cd}^j \\
 &= \frac{1}{6} \left\{ (-3f_1 + f_8(1 - \frac{4t}{\sqrt{2}} + 2t^2) + f_0(2 + \frac{4t}{\sqrt{2}} + t^2)) I_3, \right. \\
 &\quad (f_8(-2 + \frac{2t}{\sqrt{2}} + 2t^2) + f_0(2 - \frac{2t}{\sqrt{2}} - 2t^2)) I_4, \\
 &\quad \left. (3f_1 - 8f_4 + f_8(3 + \frac{4t}{\sqrt{2}} + 2t^2) + f_0(2 - \frac{4t}{\sqrt{2}} + 3t^2)) I_1 \right\}
 \end{aligned} \tag{5.17}$$

for $i, j = 1, \dots, 8$, where I_n is the n -dimensional unit matrix.

$$\begin{aligned}
 D^{ij}(s) &= \frac{1}{2} \lambda_{ab}^{i*} N_{ab,cd}(s) \lambda^j_{cd} \\
 &= \delta_{ij} - \frac{1}{6} \left\{ (-3F_1 + F_8(1 - \frac{4t}{\sqrt{2}} + 2t^2) + 2F_0(1 + \sqrt{2}t + t^2)) I_3 \right. \\
 &\quad (2F_8(-1 + \frac{t}{\sqrt{2}} + t^2) + 2F_0(1 - \frac{t}{\sqrt{2}} - t^2)) I_4 \\
 &\quad (3F_1 - 8F_4 + F_8(3 + \frac{4t}{\sqrt{2}} + 2t^2) \\
 &\quad \left. + F_0(2 - \frac{4t}{\sqrt{2}} + 3t^2)) I_1 \right\} \quad (5.18)
 \end{aligned}$$

$$\begin{aligned}
 N^{oo}(s) &= \frac{1}{3} \delta_{ab} N_{ab,cd} \delta_{cd} \\
 &= \frac{1}{3} (3f_1 + 4f_4 + (1+t^2)f_8 + (1+t^2)f_0) \quad (5.19)
 \end{aligned}$$

$$\begin{aligned}
 D^{oo}(s) &= \frac{1}{3} \delta_{ab} D_{ab,cd} \delta_{cd} \\
 &= 1 - \frac{1}{3} (3F_1 + 4F_4 + (1+t^2)F_8 + (1+t^2)F_0) \quad (5.20)
 \end{aligned}$$

$$\begin{aligned}
 N^{o8}(s) &= N^{8o}(s) = \frac{1}{\sqrt{6}} \lambda_{ab}^8 N_{ab,cd} \delta_{cd} \\
 &= \frac{\sqrt{2}}{6} (3f_1 - 2f_4 - f_8 + \frac{4t}{\sqrt{2}}(f_0 - f_3) - t^2 f_0) \quad (5.21)
 \end{aligned}$$

$$\begin{aligned}
 D^{o8}(s) &= D^{8o}(s) = -\frac{\sqrt{2}}{6} (3F_1 - 2F_4 - F_8 + \frac{4t}{\sqrt{2}}(F_0 - F_3) - t^2 F_0) \\
 &\quad (5.22)
 \end{aligned}$$

$$B^{ij} = N^{ik} (D^{-1})^{kj}$$

$$= \begin{pmatrix} \frac{N_1}{D_1} \mathbb{I}_3, & & & \\ & \frac{N_4}{D_4} \mathbb{I}_4, & & \\ & & \frac{N^{88} D^{00}}{\Delta}, & \frac{-N^{88} D^{80} + D^{88} N^{80}}{\Delta} \\ & & \frac{-N^{00} D^{80} + D^{00} N^{80}}{\Delta}, & \frac{N^{00} D^{88}}{\Delta} \end{pmatrix}$$

where $\Delta = D^{88} D^{00} - (D^{08})^2$

We see that B^{ij} is not symmetric, in violation of time reversal invariance. This is the usual trouble encountered in the determinantal approximation to the N/D equations, and we will symmetrise by hand, and thereafter ignore the problem. (For discussion of this problem see Zachariassen & Zemach⁽⁸⁷⁾).

Under the same transformation the output residue matrix becomes

$$B_{RES}^{ij} = \begin{pmatrix} g_1^2 \mathbb{I}_3, & & & \\ & g_4^2 \mathbb{I}_4, & & \\ & & g_8^2 + t^2 g_0^2, & (g_0^2 - g_8^2) t \\ & & (g_0^2 - g_8^2) t, & g_8^2 t^2 + g_0^2 \end{pmatrix}$$

This matrix can be diagonalized by the further transformation $U^{-1} B_{RES} U$ where

$$U = \begin{pmatrix} \underline{I}_3, & & & & \\ & \underline{I}_4, & & & \\ & & \cos \theta, & \sin \theta & \\ & & -\sin \theta, & \cos \theta & \end{pmatrix}$$

$$B_{RES} \text{ becomes } \begin{pmatrix} g_1^2 \underline{I}_3, & & & & \\ & g_4^2 \underline{I}_4, & & & \\ & & g_8^2(1+t^2), & & \\ & & & g_0^2(1+t^2) & \\ & & & & \end{pmatrix} \quad (5.23)$$

a

(If $g_0^2 = g_8^2$ this further transformation is unnecessary as B_{RES} is already diagonal). Hence this further transformation must also diagonalize the amplitude B at the resonance position, which with our approximation is taken to be $s = 0$. It will not in general diagonalize both N and D . This requires

$$t = - \left[\frac{(N_{88} + N_{00}) D_{08} + (D_{88} + D_{00}) N_{08}}{N_{00} D_{88} - N_{88} D_{00}} \right] \text{ at } s = 0 \quad (5.24)$$

a

and B then becomes

$$\left(\begin{array}{c} N_1/D_1 \underline{I}_3, \\ N_4/D_4 \underline{I}_4, \tilde{N}_8/\Delta, \tilde{N}_0/\Delta \end{array} \right) \quad (5.25)$$

where

$$\begin{aligned} \tilde{N}_8 = & N_{88} D_{00} \cos^2 \theta + N_{00} D_{88} \sin^2 \theta \\ & + (-D_{08} (N_{00} + N_{88}) + N_{08} (D_{88} + D_{00})) \sin \theta \cos \theta \end{aligned}$$

$$\begin{aligned} \tilde{N}_0 = & N_{88} D_{00} \sin^2 \theta + N_{00} D_{88} \cos^2 \theta \\ & - (-D_{08} (N_{00} + N_{88}) + N_{08} (D_{88} + D_{00})) \sin \theta \cos \theta \end{aligned}$$

As in the symmetry case we take our pole and residue equations to lowest order in s . However, for Δ to be zero at both $s = m_g^2$ and $s = m_0^2$ we need it to be zero to order s^2 . To avoid double poles in the amplitude we need $\tilde{N}_8 = O(s)$, $\tilde{N}_0 = O(s)$. The pole and residue conditions become

$$D_1 = O(s) \quad (5.23)$$

$$D_4 = O(s) \quad (5.24)$$

$$D_{88} D_{00} - D_{08}^2 = O(s^2) \quad (5.25)$$

$$\tilde{N}_8 = O(s) \quad (5.26)$$

$$\tilde{N}_o = O(s) \quad (5.27)$$

$$g_1^2 = \frac{-N_1}{\frac{dD_1}{ds}} \quad \text{at } s=0 \quad (5.28)$$

$$g_4^2 = \frac{-N_4}{\frac{dD_4}{ds}} \quad \text{at } s=0 \quad (5.29)$$

$$g_8^2(1+t^2) = \frac{-\frac{d\tilde{N}_8}{ds}}{\frac{d^2\Delta}{ds^2}} \quad \text{at } s=0 \quad (5.30)$$

$$g_o^2(1+t^2) = \frac{-\frac{d\tilde{N}_o}{ds}}{\frac{d^2\Delta}{ds^2}} \quad \text{at } s=0 \quad (5.31)$$

Equations (5.26) (5.27) imply

$$N_{88} D_{oo} + N_{oo} D_{88} = O(s) \quad (5.32)$$

$$N_{o8}(D_{88} + D_{oo}) - D_{o8}(N_{oo} + N_{88}) = O(s) \quad (5.33)$$

The simplest solution to these equations and (5.25) is

$$D_{00} = 0(s) \quad (5.32)$$

$$D_{88} = 0(s) \quad (5.33)$$

$$D_{08} = 0(s) \quad (5.34)$$

These equations obviously have the correct limit as $t \rightarrow 0$, and we will ignore alternative solutions involving complicated products of the N and D functions.

In the exceptional case $g_0^2 = g_8^2$ we also arrive at (5.32) to (5.34). The pole equations (5.23, 5.24, 5.32 - 5.34) can be written in matrix form

$$\begin{pmatrix} -3 & 0 & 1-2\sqrt{2}t+2t^2 & 2+2\sqrt{2}t+t^2 & -6 \\ 0 & 0 & -2+\sqrt{2}t+2t^2 & 2-\sqrt{2}t-2t^2 & -6 \\ 3 & -8 & 3+2\sqrt{2}t+2t^2 & 2-2\sqrt{2}t+3t^2 & -6 \\ 6 & 8 & 2+2t^2 & 2+2t^2 & -6 \\ 3 & 2 & -(1+2\sqrt{2}t) & 2\sqrt{2}t-t^2 & 0 \end{pmatrix} \begin{pmatrix} F_1 \\ F_4 \\ F_8 \\ F_0 \\ 1 \end{pmatrix} = 0$$

These equations only have a solution when the determinant of the matrix vanishes. Unfortunately this happens for real t only when $t = 0$. It can then be shown that the equations above have only the symmetry solution $F_1 = F_4 = F_8 = 0$ and $F_0 = 3$. So we have proved that the only solution to our equations is the symmetry one.

c) Alternatively we could give the strange quark a different mass from the non-strange quarks and look for a driven type of broken symmetry. However it is difficult to treat this problem generally except as a

perturbation series in $\frac{\Delta M^2}{M^2}$. With the assumption $\frac{m^2}{M^2} \ll 1$ maintained as above, this perturbation cannot effect the results above unless $\frac{\Delta M^2}{M^2} \gg \frac{m^2}{M^2}$.

With canonical quark mixing the ρ, ω vector mesons couple only to the non-strange quarks p, n and ϕ couples only to the strange quarks λ . The problem then decouples into three parts.

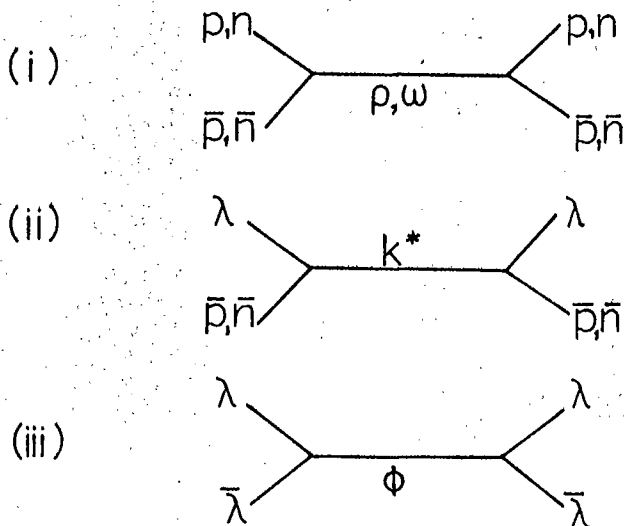

Allowing the strange quark to have a different mass to any order in $\frac{\Delta M}{M}$ allows different masses for the three types of particle (ρ, ω), k^* and ϕ , but doesn't affect the problem of obtaining singlets whose mass is an order lower than the other particles. This feature is now seen in (i) which involves SU(2) symmetry only. The SU(2) crossing matrix for this process is

$$0 \quad 1 \\ 0 \quad \left(\begin{array}{cc} \frac{1}{2} & \frac{3}{2} \\ \frac{1}{2} & -\frac{1}{2} \end{array} \right) \\ 1$$

d) An alternative solution to $m_0^2 \ll m_8^2$ of equations (5.13, 5.14) above is $g_0^2 \gg g_8^2$.

However this is not a consistent solution of the residue equations (5.11) and (5.12), but it does suggest the existence of a background singlet force, denoted P , not corresponding to a particle pole and an order of magnitude greater than the particle exchange forces. We modify our equations to include such a term. The particle forces will now appear as small perturbations to P and we hope in this way to produce singlets and octets with masses of the same order.

With exact $SU(3)$ symmetry the modified pole and residue equations are

$$P(m_0^2) + \frac{F_0}{3} + \frac{8F_8}{3} = 1 \quad (5.36)$$

$$P(m_8^2) + \frac{F_0}{3} - \frac{F_8}{3} = 1 \quad (5.37)$$

$$g_0^2 = \frac{P(m_0^2)}{\left[\frac{dP}{ds} \right]_{m_0^2}} \quad (5.38)$$

$$g_8^2 = \frac{P(m_8^2)}{\left[\frac{dP}{ds} \right]_{m_8^2}} \quad (5.39)$$

We assume $P(s) = P(0) + P'(0)s \dots$ for $s \ll 1$,
and then the zeroth order solutions to (5.36, 5.37) is
 $P = 1$

The first order solution is

$$P'(0)m_0^2 + \frac{F_0(0)}{3} + \frac{8}{3}F_8(0) = 0 \quad (5.40)$$

$$P'(0)m_8^2 + \frac{F_0(0)}{3} - \frac{F_8(0)}{3} = 0 \quad (5.41)$$

$$g_0^2 = g_8^2 = -\frac{p(0)}{P'(0)} \quad (5.42)$$

Putting $\lambda = \frac{m_0^2}{m_8^2}$ and again using the forms
 $F_i = g_i^2(A_i + B_i \log m_i^2)$ we derive

$$(\lambda - 1)\log \lambda = \frac{9(A_1 + B_1 \log m_8^2)}{B_1} \quad (5.43)$$

The L.H.S. of this equation is never negative and equals zero for $\lambda = 1$. The R.H.S. is ≥ 0 only if $\log m_8^2 \geq -A_1/B_1$. We see that although now we can have $m_0^2 \geq m_8^2$ with equality when $\lambda = 1$, and $g_0^2 = g_8^2$, both masses are now not small relative to the quark mass.

We next relax the condition of exact SU(3) symmetry but retain SU(2). The masses and couplings are given as in section (5.2b). The modified equations (5.35) are



$$-3P'(0)m_1^2 = F_0(1 + \sqrt{2}t + \frac{t^2}{2}) - \frac{3F_1}{2} + F_8(\frac{1}{2} - \sqrt{2}t + t^2) \quad (5.44)$$

$$-3P'(0)m_4^2 = (F_0 - F_8)(1 - \frac{t}{\sqrt{2}} - t^2) \quad (5.45)$$

$$-3P'(0)m_8^2 = F_0(1 - \sqrt{2}t + \frac{3t^2}{2}) + \frac{3F_1}{2} - 4F_4 + F_8(\frac{3}{2} + \sqrt{2}t + t^2) \quad (5.46)$$

$$-3P'(0)m_0^2 = F_0(1 + t^2) + 3F_1 + 4F_4 + F_8(1 + t^2) \quad (5.47)$$

$$0 = F_0(2\sqrt{2}t - t^2) + 3F_1 - 2F_4 - F_8(2\sqrt{2}t + 1) \quad (5.48)$$

The residue equations become

$$\begin{aligned} g_1^2 = g_4^2 = g_8^2(1+t^2) = g_0^2(1+t^2) \\ = \frac{-P(0)}{P'(0)} \end{aligned} \quad (5.49)$$

These equations are invariant under the transformations under $t \rightarrow -1/t$, $F_0 \leftrightarrow F_8$ as they should be.

Putting $F_i = g_i^2 (A_0 + B_0 \log m_i^2)$, substituting (5.48) into (5.44 - 5.47) and then dividing (5.44 - 5.47) by (5.45), provided $F_0 \neq F_8$, $(1 - \frac{t}{\sqrt{2}} - t^2) \neq 0$ and $t \neq \frac{1}{\sqrt{2}}$ or $-\sqrt{2}$ we obtain

$$\mu_1 = \frac{3 \log \mu_1(1+t^2)(1+2\sqrt{2}t) + \log \mu_8(t^4 - 4\sqrt{2}t^2 - 4\sqrt{2}t - 1)}{(1+t^2)(t^2 + \frac{t}{\sqrt{2}} - 1)(\log \mu_8 - 3 \log \mu_1)} \quad (5.50)$$

$$\mu_8 = \frac{3 \log \mu_1 (1+t^2)(\sqrt{2t}-1)^2 + \log \mu_8 (t^4 - 2\sqrt{2}t^3 - 7t^2 - 7\sqrt{2}t - 1)}{(1+t^2)(t^2 + \frac{t}{\sqrt{2}} - 1)(\log \mu_8 - 3 \log \mu_1)}$$

$$0 = \log \mu_0 (2\sqrt{2t} - t^2) + 3(1+t^2) \log \mu_1 - (2\sqrt{2t} + 1) \log \mu_8$$

$$\log m_4^2 = \frac{-A_1}{B_1} + \frac{1}{9(t^2 - 2\sqrt{2}t)} \left\{ \begin{array}{l} \mu_0 (\log \mu_8 - 3 \log \mu_1) \\ \times (t^2 + \frac{t}{\sqrt{2}} - 1) \\ - 3(\sqrt{2t} - 1)^2 \log \mu_1 - (t^2 - 4\sqrt{2}t - 1) \log \mu_8 \end{array} \right.$$

$$\text{where } \mu_1 = \frac{m_i^2}{m_0^2}$$

Equations (5.50, 5.51) can be solved by direct elimination and then μ_0 and m_4^2 can be found by substitution into (5.52, 5.53). It might be hoped that (5.53) would give a reasonably small value for m_4^2 . In principle substitution of the solution into (5.44) would then determine t in terms of P^+ .

A computer search was made for solutions in the range $-\sqrt{2} < t < \frac{1}{\sqrt{2}}$ (which is sufficient because the equations are invariant under $t \rightarrow -\frac{1}{t}$ and $F_0 \leftrightarrow F_8$) and in the range $-10 \log \mu < +10$. Solutions were

found (see the table) for $\frac{1}{\sqrt{2}} > t \geq -0.3$
 but not for $-0.3 \geq t > 1$. For some t there are
 two solutions. The solutions fluctuate wildly

$t = \tan \theta$	$\log \frac{m_1^2}{m_4^2}$	$\log \frac{m_8^2}{m_4^2}$	$\log \frac{m_0^2}{m_4^2}$	$\log m_4^2 + A_1/B_1$
0.63	2.1	0.0	-6.3	0.0
0.49	1.3	0.1	-4.1	0.0
0.35	-0.3	0.8	2.1	2.0
0.35	1.2	0.2	-4.4	0.1
0.21	-0.4	0.4	3.4	7.8
0.09	-0.6	0.4	11.5	1000
-0.9	-1.0	0.4	-16.3	2.1
-0.21	-1.9	0.7	-9.6	1.6

but have in common that $\log m_4^2 + A_1/B_1$ is always non-negative, and hence the corresponding value of m_4^2 is not sufficiently small.

The case $t = \frac{1}{\sqrt{2}}$ (or equivalently $t = -\sqrt{2}$), which is the canonical mixing angle, is investigated separately as this corresponds to a singular case of our equations. The R.H.S. of (5.45) is now zero and so we require $P'(0) = 0$. The remaining equations are then

$$0 = \frac{9}{4} F_0 - 3 F_{1/2}$$

$$0 = \frac{3}{4} F_0 + 3 F_{1/2} - F_4 + 3 F_8$$

$$0 = \frac{3}{2} F_0 + 3 F_1 + 4 F_4 + \frac{3}{2} F_8$$

$$0 = \frac{3}{2} F_0 + 3 F_1 - 2 F_4 - 3 F_8$$

These equations have only the nonet degeneracy solution $F_0 = F_1 = F_4 = F_8 = 0$ which we rejected above, and for which the mixing angle is meaningless.

5.3 Conclusions.

We conclude from the results of this chapter that it seems impossible to obtain the physical meson spectrum as a self-consistent set of quark - antiquark bound states with the forces responsible for binding the quarks being the mesons themselves, and with the assumption that $m^2/M^2 \ll 1$. This assumption seems to make our equations over - determined. The conclusion remains unaltered if we try to add some indeterminacy by introducing a background singlet term with the particle forces now as perturbations.

There seem to be two alternative courses either to discard the assumption $m^2/M^2 \ll 1$ or reject such a model of the quark - antiquark binding forces. The former raises the question of why such low mass quarks have not been seen and the latter, taken with the difficulty

of generating trajectories with the right slopes and intercepts seems to be the more appropriate conclusion.

Summing up the conclusions of Chapters 4 and 5 we see that both the bootstrap and the quark models considered do not reproduce the physical particle spectrum. Thus both models support the idea that high energy scattering is not dominated simply by the exchange of a Regge pole and account must be taken of production processes. However too little is known about these processes to include them in a dynamical calculation at present.

APPENDIX A

Commutation Relations and Traces for SU(3) matrices
(See eg. Tarjanne) (88)

The following formulae have been used extensively.

$$[\underline{\lambda}_i, \underline{\lambda}_j] = 2if_{ijk} \underline{\lambda}_k \quad (\text{A.1})$$

$$\{\underline{\lambda}_i, \underline{\lambda}_j\} = \frac{4}{3} \delta_{ij} + 2d_{ijk} \underline{\lambda}_k \quad (\text{A.2})$$

Square brackets stand for the commutator and curly brackets the anticommutator.

$$\text{tr}(\underline{\lambda}_i \underline{\lambda}_j) = 2 \delta_{ij} \quad (\text{A.3})$$

$$\text{tr}(\underline{\lambda}_i \underline{\lambda}_j \underline{\lambda}_k) = 2(d_{ijk} + if_{ijk}) \quad (\text{A.4})$$

$$\underline{f}_i \underline{f}_j = -\frac{f_{ijk} \underline{f}_k}{2} - \frac{3d_{ijk} \underline{d}_k}{2} + \frac{\{ij\}}{2} - \frac{\delta_{ij}}{2} \quad (\text{A.5})$$

$$\underline{d}_i \underline{d}_j = \frac{f_{ijk} \underline{f}_k}{2} - \frac{d_{ijk} \underline{d}_k}{2} + \frac{\{ij\}}{6} - \frac{[ij]}{3} + \frac{\delta_{ij}}{6} \quad (\text{A.6})$$

where

$$\{ij\}_{ab} = \delta_{ia} \delta_{jb} + \delta_{ja} \delta_{ib}$$

$$[ij]_{ab} = \delta_{ia} \delta_{jb} - \delta_{ib} \delta_{ja}$$

$$\text{tr}(\underline{f}_i \underline{f}_j) = -3\delta_{ij} \quad (\text{A.7})$$

$$\text{tr}(\underline{d}_i \underline{d}_j) = \frac{1}{3} \delta_{ij} \quad (\text{A.8})$$

$$\text{tr}(\underline{d}_i \underline{d}_j \underline{d}_k) = -\frac{1}{2} d_{ijk} \quad (\text{A.9})$$

$$\text{tr}(\underline{f}_i \underline{f}_j \underline{f}_k) = -\frac{3}{2} d_{ijk} \quad (\text{A.10})$$

$$\text{tr}(\underline{d}_i \underline{D}_{27} \underline{d}_k) = \frac{1}{3} D_{27ik} \quad (\text{A.11})$$

$$\text{tr}(\underline{f}_i \underline{D}_{27} \underline{f}_k) = D_{27ik} \quad (\text{A.12})$$

where D^{27} is the matrix transforming as the singlet member of the 27 representation.

$$D_{27} = \begin{pmatrix} \underline{I}_3, & & \\ & -3\underline{I}_4, & \\ & & 9\underline{I}_1 \end{pmatrix}$$

In Chapter 5 we calculate $g^{*i}_{ab} N_{ab,cd} g^j_{cd}$ where

$$\begin{aligned} g^{i}_{ab} &= \frac{\lambda_{ab}^i}{\sqrt{2}} \quad \text{or} \quad \frac{\delta_{ab}}{\sqrt{3}} \\ \lambda_{ab}^{i*} \lambda_{ac}^a f^a(s) \lambda_{bd}^{k*} \lambda_{cd}^j & \\ &= \left(\frac{2}{3} \delta_{ik} \delta_{cb} + (d_{ik} + if_{ik}) \lambda_{bc}^k \right) f^a(s) \left(\frac{2}{3} \delta_{jl} \delta_{bc} \right. \\ &\quad \left. + (d_{jlm} + if_{jlm}) \lambda_{cb}^m \right) \\ &= \frac{4}{3} \delta_{ij} f^i(s) + 2(d_{ik} f^k(s) d_{jkl} + f_{ik} f^k(s) f_{jkl}) \end{aligned} \quad (\text{A.13})$$

Similarly we may show

$$\lambda_{ab}^{*i} \lambda_{ac}^{\theta} \lambda_{bd}^{\theta*} \lambda_{cd}^j = 4 \delta_{j\theta} \delta_{j\theta} + \frac{4}{\sqrt{3}} d_{\theta ij} - \frac{2}{3} \delta_{ij} \quad (A.14)$$

$$\lambda_{ab}^{*i} \delta_{ac} \delta_{bd} \lambda_{cd}^j = 2 \delta_{ij} \quad (A.15)$$

$$\lambda_{ab}^{*i} (\lambda_{ac}^{\theta} \delta_{bd} + \delta_{ac} \lambda_{bd}^{\theta}) \lambda_{cd}^j = 4 d_{\theta ij} \quad (A.16)$$

$$\delta_{ab} \lambda_{ac}^l f^l(s) \lambda_{bd}^{l*} \delta_{cd} = 2 \sum_k f^k(s) \quad (A.17)$$

$$\delta_{ab} \lambda_{ac}^{\theta} \lambda_{bd}^{\theta*} \delta_{cd} = 2 \quad (A.18)$$

$$\delta_{ab} (\lambda_{ac}^{\theta} \delta_{bd} + \delta_{ac} \lambda_{bd}^{\theta}) \delta_{cd} = 0 \quad (A.19)$$

$$\delta_{ab} \delta_{ac} \delta_{bd} \delta_{cd} = 3 \quad (A.20)$$

$$\delta_{ab} \lambda_{ac}^l f^l(s) \lambda_{bd}^{l*} \lambda_{cd}^j = 2 \delta_{j\theta} d_{\theta ll}^{\theta} f^l(s) \quad (A.21)$$

$$\delta_{ab} \lambda_{ac}^{\theta} \lambda_{bd}^{\theta*} \lambda_{cd}^j = 2 d_{\theta \theta \theta}^{\theta} \delta_{j\theta} \quad (A.22)$$

$$\delta_{ab} (\lambda_{ac}^{\theta} \delta_{bd} + \delta_{ac} \lambda_{bd}^{\theta*}) \lambda_{cd}^j = 4 \delta_{j\theta} \quad (A.23)$$

$$\delta_{ab} \delta_{ac} \delta_{bd} \lambda_{cd}^j = 0 \quad (A.24)$$

With these results equations 2.1 to 2.6 of Chapter 5 can be written down after some simplification.

APPENDIX B

B. In Chapter 5 we calculate the following integrals:

$$\begin{aligned}
 F_i(s) &= \frac{2g_i^2(s-s_0)}{\pi} \int_1^{\infty} \frac{\ln((1-s'-m_i^2)/m_i^2) ds'}{\sqrt{s'(s'-1)(s'-s)}} \\
 &= \frac{2g_i^2(I_i(s) - I_i(s_0))}{\pi}
 \end{aligned}
 \tag{B.1}$$

where

$$I_i(s) = \int_1^{\infty} \frac{(\ln(1-s'-m_i^2) - \ln m_i^2) ds'}{\sqrt{s'(s'-1)(s'-s)}}$$

Make the following substitution,

$$t' = \sqrt{\frac{s'-1}{s'}} , \quad \frac{ds'}{\sqrt{s'(s'-1)}} = \frac{2dt'}{(1-t'^2)}$$

The integral becomes

$$\begin{aligned}
 I_i(s) &= 2 \int_0^1 \frac{(\ln(1-m_i^2 - 1/(1-t'^2)) - \ln m_i^2) dt'}{(1-s(1-t'^2))} \\
 &= J_{1,i}(s) + \ln m_i^2 J_2(s) + J_3(s)
 \end{aligned}
 \tag{B.2}$$

where

$$\begin{aligned}
 J_2(s) &= -2 \int_0^1 \frac{dt}{(st^2+1-s)} \\
 &= \frac{-2 \tan^{-1}(s/1-s)^{1/2}}{\sqrt{s(1-s)}} \\
 &= 2(1 + \frac{2}{3}s + \frac{8}{15}s^2 + \dots) \text{ for } s \ll 1
 \end{aligned}$$

$$\begin{aligned}
 J_3(s) &= -2 \int_0^1 \frac{\ln(1-t^2) dt}{(st^2+1-s)} \\
 &= -\sum_{s=0}^{\infty} s^r \int_0^1 \ln(1-t^2)(1-t^2) dt \quad s \ll 1
 \end{aligned}$$

These integrals may be computed by integration by parts

$$J_{1,i}(s) = \int_0^1 \frac{\ln(t^2(1-m_i^2) + m_i^2)}{(st^2+1-s)} dt$$

Differentiating with respect to m_i^2

$$\begin{aligned}
 \frac{\partial J_{1,i}}{\partial m_i^2} &= \int_0^1 \frac{(1-t^2) dt}{t^2(1-m_i^2) + m_i^2)(st^2+1-s)} \quad (B.3) \\
 &= \int_0^1 \left| \frac{1}{(1-s-m_i^2)(t^2(1-m_i^2)+m_i^2)} - \frac{1}{(1-s-m_i^2)(st^2+1-s)} \right| dt \\
 &= \frac{1}{(1-s-m_i^2)} \left(\frac{1}{\sqrt{m_i^2(1-m_i^2)}} \tan^{-1} \left| \frac{1-m_i^2}{m_i^2} \right|^{\frac{1}{2}} - \frac{1}{\sqrt{s(1-s)}} \tan^{-1} \left| \frac{s}{1-s} \right|^{\frac{1}{2}} \right)
 \end{aligned}$$

We expand this in powers of m_i^2 , which is supposed small and we can then integrate with respect to m_i^2 term by term.

We obtain

$$J_1 = [J_1]_{m_i^2=0} + \frac{\pi m_i}{1-s} + O(m_i^2) \quad (B.4)$$

$$\text{where } [J_1]_{m_i^2=0} = \int_0^1 \frac{\log t^2 dt}{(st^2+1-s)}$$

$$= 2 \sum_{r=0}^{\infty} s^r \int_0^1 \log t(1-t^2) dt \quad \text{for } s \ll 1$$

These integrals may again be computed by parts. Adding the results, we finally obtain for $m_i^2, S \ll 1$

$$I_i(s) = -\log m_i^2(2 + \frac{4}{3}s) - 2.78 - 3.18s + O(m_i, s^2) \tag{B.5}$$

The integrals $I_i(S_0)$ where S_0 is not small cannot be computed as a series in powers of S_0 , but the expansion for small m_i is still valid.

$$I_i(S_0) = C_1 \log m_i^2 + C_2 + O(m_i)$$

The coefficients $C_1(S_0), C_2(S_0)$ were evaluated numerically for a range of values of S_0 . As

$S_0 \longrightarrow -\infty$ (corresponding to no subtraction)

$C_1, C_2 \longrightarrow 0$.

We write the original integral

$$F_i(s) = A + B \log m_i^2 + O(s_1 m_i^2) \tag{B.6}$$

where the coefficients A, B are functions of the subtraction point S_0 and tend to the values given by equation (8) as $S_0 \longrightarrow -\infty$

Table 1.

$S_0/4M^2$	$-\infty$	-2.0	-1.5	-1.0	-0.5	+0.5	+0.9
A/B	1.39	1.9	2.0	2.1	2.2	2.7	3.5
$e^{+} A/B$	4.0	6.7	7.4	8.2	9.0	14.9	33.1

The ratio A/B alone appears in our calculations. If S_0 is placed on the left hand cut, that is $S_0 < -1$, we have $A/B < 2.1$, and it will only decrease significantly if it is placed near the right hand cut at +1. The usual arguments place it on the left hand cut.

APPENDIX C

Brief summary of the N/D equations and the determinantal approximation (See eg. ref. 7,8,10)
 The s - channel reduced partial wave amplitude $B_\ell (s)$ is normalized so that the elastic unitarity equation is

$$\text{Im} B_\ell (s) = B_\ell^*(s) \rho_\ell (s) B_\ell (s) \quad (\text{C.1})$$

where
$$\rho_\ell (s) = \frac{2q_s^{2\ell+1}}{\sqrt{s}}$$

This partial wave is written in the form

$$B_\ell (s) = \frac{N_\ell (s)}{D_\ell (s)} \quad (\text{C.2})$$

where the $N_\ell (s)$ function has only left hand cut singularities (originating from Yukawa type forces in the crossed channels) and $D_\ell (s)$ has only the right hand elastic unitarity cut. (Inelastic unitarity is ignored).

$$\text{Im} D_\ell (s) = -\rho_\ell (s) N_\ell (s) \quad \text{on the R.H. cut} \quad (\text{C.3})$$

$$\text{Im} N_\ell (s) = D_\ell (s) \text{Im} B_\ell (s) \quad \text{on the L.H. cut} \quad (\text{C.4})$$

Now $D_\ell (s)$ can be normalized to one at $s = s_0$ (usually taken as some point on the L.H. cut),
 $N_\ell (s) = 0$ at $s = s_0$, when once subtracted dispersion relations can be written for N and D .

$$D_{\ell}(s) = 1 - \frac{(s-s_0)}{\pi} \int_{\text{R.H. cut}}^{\infty} \frac{\rho_{\ell}(s') N_{\ell}(s') ds'}{(s'-s_0)(s'-s)} \quad (\text{C.5})$$

$$N_{\ell}(s) = - \frac{(s-s_0)}{\pi} \int_{\text{L.H. cut}}^{-\infty} \frac{B_{\ell}(s') D_{\ell}(s') ds'}{(s'-s_0)(s'-s)} \quad (\text{C.6})$$

Now define

$$B_{\ell}^L(s) = \int_{-\infty}^{\text{L.H. cut}} \frac{B_{\ell}(s') ds'}{s'-s},$$

Then by writing a dispersion relation for the function

$$C_{\ell}(s) \equiv N_{\ell}(s) - B_{\ell}^L(s) D_{\ell}(s),$$

one obtains

$$N_{\ell}(s) = B_{\ell}^L(s) + \frac{1}{\pi} \int_{\text{R.H. cut}}^{\infty} \frac{1}{s'-s} \left(B_{\ell}^L(s') - \frac{s-s_0}{s'-s_0} B_{\ell}^L(s) \right) \times \rho_{\ell}(s') N_{\ell}(s') ds'$$

(C.7)

Equations 5) and 7) generally provide a more convenient basis for calculations than 5) and 6). Equation 7) is a integral equation of the Fredholm type generally solved by iteration. The determinantal approximation consists in putting $N_\ell(s) = B_\ell^L(s)$, calculated from the lowest order Born approximation, and using this to calculate $D_\ell(s)$ from equation (5). It can be seen that this approximation is equivalent to putting $D_\ell(s)$ to be unity on the L.H. cut in equation (6).

The Born approximation for the exchange of a spin ℓ' particle in the t - channel.

$$V(s,t) = \frac{g^2(2\ell'+1)q_t^{2\ell'}P_{\ell'}(z_t)}{m^2-t-i\Gamma}, \quad (C.8)$$

has a t - discontinuity in the narrow width approximation given by

$$D_t(s,t) = \pi g^2 \delta(t-m^2) P_{\ell'}(z_t) q_t^{2\ell'} (2\ell'+1) \quad (C.9)$$

which gives

$$\begin{aligned}
 B_{\ell}^L(s) &= \frac{1}{16\pi^2} \int_{t_0}^{\infty} \frac{Q_{\ell}(z_s) D_t(s,t) dt}{2q_s^{2\ell+2}} \\
 &= \frac{g^2(2\ell'+1)q_t^{2\ell'}}{32\pi q_s^{2\ell+2}} Q_{\ell}(z_s) P_{\ell'}(z_t)
 \end{aligned}$$

(C.10)

The generalization of these equations to include coupled two body channels was first written down by Bjorken.⁽⁸⁹⁾ The above equations now become matrix equations. The only difficulty encountered is that the determinantal approximation violates time reversal in that the approximate matrix amplitude calculated in this way is not symmetric. The attempts to remedy this fault suffers from other ugly features and we have used throughout the simple unsymmetrized form. The departure from symmetry found will measure the goodness of the approximation. (For discussion see Zachariasen and Zemach).⁽⁸⁷⁾

References

1. G.F. Chew 'S - Matrix Theory of Strong Interactions', Benjamin, New York (1961).
2. M. Gell-Mann & Y. Ne'eman 'The Eightfold Way' Benjamin, New York (1964).
3. S. Okubo Progr. Theoret. Phys. 27 (1962) 949.
4. G.F. Chew & S.C. Frautschi Phys. Rev. Letters 7 (1961) 394.
5. G.F. Chew in Jacob & Chew, 'Strong Interaction Physics', Benjamin, New York (1964).
6. T. Regge Nuovo Cim. 14 (1959) 951,
Nuovo Cim. 18 (1960) 947.
7. P.D.B. Collins & E.J. Squires 'Regge Poles in Particle Physics', Springer, Berlin (1968).
8. F. Zachariasen 'Lectures on Bootstraps', Pacific Summer School, Hawii (1965).
9. F. Zachariasen Phys. Rev. Letters 7 (1961) 112 & 268E.
10. G.F. Chew & S. Mandelstam Phys. Rev. 119 (1960) 467
Nuovo Cim. 19 (1961) 752.
11. M. Jacob 'Duality in Strong Interactions' Cern Th.1010 (1969) (unpublished).
12. M. Gell-Mann Phys. Letters 8 (1964) 214.
13. G. Zweig Cern Th. 401, 412 (1964) (unpublished).
14. J.J.J. Kokkedee 'The Quark Model', Benjamin, New York (1969).
15. R.H. Dalitz in 'High Energy Physics', Lectures at Les Houches (1965).
16. R.E. Cutkosky Phys. Rev. 131 (1963) B1888.
17. Chan H.M., P.C. de Celles & J.E. Paton Nuovo Cim. 33 (1964) 70.
18. R.C. Hwa & S.H. Patil Phys. Rev. 140 (1965) B.1586.
19. R.H. Capps Phys. Rev. Letters 10(1963) 312.
20. R.H. Capps Phys. Rev. 161 (1967) 1538.
21. R.E. Cutkosky 'Self consistent dynamical models' in Particle Symmetries, Brandeis University Lectures (1965).

22. R.C. Hwa & S.H. Patil Phys. Rev. 139 (1965)B969.
23. G.F. Chew Phys. Rev. Letters 9 (1962) 233.
24. Y.C. Leung Phys. Rev. 157 (1967) 1351.
25. R.H. Capps Phys. Rev. Letters 14 (1965) 31.
26. J.G. Belinfante & R.E. Cutkosky Phys. Rev. Letters
14 (1965) 33.
27. J.C. Polkinghorne Ann. of Phys. 34 (1965) 153.
28. C.M. Andersen & J. Yellin Phys. Rev. D3 (1971)846.
29. J.G. Belinfante & G.H. Renninger Phys. Rev.148 (1966)
1573.
30. H.J. Lipkin, S. Meshkov Phys. Rev. 143 (1966) 143.
31. R.H. Capps Phys. Rev. 158 (1967) 1433.
32. R.H. Capps Phys. Rev. D3 (1971) 3059 .
33. R.H. Capps Phys. Rev. 165 (1968) 1899.
34. Y. Hara Phys. Rev. 133 (1964) B1565.
35. R.H. Capps Nuovo Cim. 34 (1964) 932.
36. I.S. Gerstein & K.T. Mahanthappa Nuovo Cim. 32
(1964) 239.
37. R.E. Cutkosky Ann. Phys. 23 (1963) 415.
38. R.H. Capps Ann. Phys. 43 (1967) 428 .
39. R.H. Capps Phys. Rev. 137 (1965) B125
Phys. Rev. 137 (1965) B1545.
40. A.M. Buoncristiani, P.C. de Celles Nuovo Cim. 5A
(1971) 631.
41. J. Goldstone Nuovo Cim. 19 (1961) 154 .
42. P. Tarjanne & R.E. Cutkosky Phys. Rev. 132 (1963)B1354
Phys. Rev. 133 (1964)B1292 .
43. M. Baker & S.L. Glashow Phys. Rev. 128 (1962) 2462 .
44. S.L. Glashow Phys. Rev. 130 (1963) 2132 .
45. R.F. Dashen & S.C. Frautschi Phys. Rev. 140 (1965) B698 .
46. Y. Ne'eman Phys. Rev. 134 (1964) B1355 .

47. A. Pais 8th Nobel Symposium, Wiley, New York (1968) 215.
48. N. Cabibbo 8th Nobel Symposium, Wiley, New York (1968) 227.
49. R. Brout Nuovo Cim. 47 (1967) 932.
50. P. Tarjanne Fortschritte der Physik, 13 (1965) 533.
51. R.H. Capps Phys. Rev. D2 (1970) 780,
Phys. Rev. D2 (1970) 2640.
52. R. Dolen, D. Horn & C. Samid Phys. Rev. 166 (1968) 1768.
53. H. Harari Phys. Rev. Letters 20 (1968) 1395.
54. P.G.O. Freund Phys. Rev. Letters 20 (1968) 235.
55. H. Harari Phys. Rev. Letters 22 (1969) 562.
56. J. Rosner Phys. Rev. Letters 22 (1969) 689.
57. C. Schmid & J. Yellen Phys. Rev. 182 (1969) 1449 &
D2 (1970) 1354 E.
58. R.H. Capps Phys. Rev. D5 (1972) 1018.
59. J. Rosner Phys. Rev. Letters 21 (1968) 950 & 1468(E).
60. J. Mandula, J. Weyers & G. Zweig Phys. Rev. Letters
23 (1969) 266.
61. R.H. Capps Phys. Rev. Letters 22 (1969) 215,
Phys. Rev. 185 (1969) 2008.
62. V. Barger & C. Michael Phys. Rev. 186 (1969) 1592.
63. H. Lipkin Nucl. Phys. B9 (1969) 349
64. J. Rosner, C. Rebbi & R. Slansky Phys. Rev. 188
(1969) 2367.
65. J. Mandula, C. Rebbi, R. Slansky, C. Weyers & G. Zweig
Phys. Rev. Letters 22 (1969) 1147.
66. M. Rimpault & Ph. Salin Nucl. Phys. B22 (1970) 235.
67. J. Mandula, J. Weyers & G. Zweig Ann. Rev. Nucl. Sci.
20 (1970) 289.
68. C. Chiu & J. Finkelstein Phys. Letters 27B (1968) 510.
69. J.N.J. White Nuovo Cim. Letters 1 (1971) 20.
70. P. Auvil, F. Halzen & C. Michael Nucl. Phys. B25
(1970) 317.

71. M. Ademollo, G. Veneziano & S. Weinberg
Phys. Rev. Letters 22 (1969) 83.
72. R.H. Capps Phys. Rev. D1 (1970) 254.
73. R.K. Logan & D.P. Roy Nuovo Cim. 3 (1970) 517.
74. P.D.B. Collins & P.K. Hutt Nuovo Cim. 8A (1972) 50.
75. G.F. Chew in 'High Energy Physics', Lectures at
Les Houches (1965).
76. P.D.B. Collins & R.C. Johnson Phys. Rev. 177 (1969)
2472,
Phys. Rev. 182 (1969)
1755,
Phys. Rev. 185 (1969)
2020.
77. J.J. de Swart Nuovo Cim. 31 (1964) 420.
78. R.H. Capps Phys. Rev. D1 (1970) 2395.
79. G.F. Chew Progress in Theoretical Phys. (Supplement
1965).
80. H.M. Chan & C. Wilkin Annals. Phys. 39 (1966) 300.
81. E. Golowich Phys. Rev. 139 (1965) B 1297.
83. P.D.B. Collins, R.C. Johnson & E.J. Squires
Phys. Letters 26B (1968) 223.
84. E.J. Squires & P.J.S. Watson Annals. Phys. 41 (1967)
409.
85. E. J. Squires Nuovo Cim. 58A (1968) 7.
86. G. Morpurgo Physics 2, (1965) 95.
87. F. Zachariassen & C. Zennach Phys. Rev. 138 (1962)
849.
88. P. Tarjanne Ph.D. Thesis, Ann. Acad. Sci. Fennicae
(1962).
89. J.D. Bjorken Phys. Rev. Letters 4 (1960) 473.

