

Durham E-Theses

The polymerisation of fluorinated Olefins

G. Douglass Dixon

How to cite:

Dixon, G. Douglass (1967) The polymerisation of fluorinated Olefins. Doctoral thesis, Durham University.

Use policy

The full-text may be used and/or reproduced, and given to third parties in any format or medium, without prior permission or charge, for personal research or study, educational, or not-for-profit purposes provided that:

- a full bibliographic reference is made to the original source
- a <https://etheses.durham.ac.uk/id/eprint/8532/> is made to the metadata record in Durham E-Theses
- the full-text is not changed in any way

The full-text must not be sold in any format or medium without the formal permission of the copyright holders.

Please consult the [full Durham E-Theses policy](#) for further details.

TO GILLIAN

UNIVERSITY OF DURHAM

A THESIS

entitled

"The Polymerisation of Fluorinated Olefins"

Submitted by

G. DOUGLASS DIXON, B.Sc., A.R.I.C.

(St. Cuthbert's Society)

A candidate for the degree of Doctor of Philosophy.

1967



Contents

	<u>Page No.</u>
Acknowledgments	i
Summary	ii
Memorandum	iii
List of Abbreviations	iv
<u>Section 1. The Polymerisation of Fluorinated Olefins</u>	
Introduction	1
Discussion	5
Experimental	20
<u>Section 2. The Evaluation of Fluorinated Polymers</u>	
Introduction	34
Discussion	42
Experimental	51
<u>Section 3. The Preparation of Polyfluoridoalkanes <u>and Polyfluoroalkenes</u></u>	
Introduction	71
Discussion	76
Experimental	96
<u>Appendices</u> (a) Pressure dependencies of ion currents	118
(b) Nuclear magnetic resonance data	124
(c) Infra red spectra	129
<u>Bibliography</u>	140

ACKNOWLEDGMENTS

I would like to thank Professor W. K. R. Musgrave for his help and encouragement during his supervision of this work.

I am especially indebted to Dr. W. J. Feast, of Durham University, and Dr. W. W. Wright, of the Royal Aircraft Establishment, Farnborough, for their extensive help and advice at all times.

I would also like to thank the many laboratory technicians, especially Mr. L. Chadwick who assisted in many of the preparations.

I would like to express my gratitude to the Ministry of Aviation for a maintenance grant and for the facilities made available for analyses.

SUMMARY

Tetrafluoroethylene was copolymerised with perfluorinated olefins of general formula $R_f \cdot CF = CF_2$, where R_f is CF_3 , C_2F_5 , C_3F_7 , C_7F_{14} , and C_9F_{18} . Thermogravimetric analyses of these polymers showed that there was a significant reduction in their thermal stability, relative to that of polytetrafluoroethylene, when the co-monomer had a branch-chain length of more than one carbon atom. This reduction appears to be independent of both the concentration and branch-chain length of the co-monomer for the olefins perfluorobutene to perfluorononene.

The telomerisation of trifluoroethylene with perfluoroalkyl iodides, $R_f I$, gave a series of polyfluoro-1-iodoalkanes, $R_f \cdot (C_2HF_3)_n I$, where $n = 1, 2, 3 \dots \dots \dots$. Dehydrohalogenation of the compounds, where $n = 1$, gave the terminal olefins $R_f \cdot CF = CF_2$. Dehydrohalogenation of the compounds $C_2F_5 (C_2HF_3)_2 I$ gave a series of perfluoro-hexadienes, from the adduct $C_2F_5 \cdot CHF \cdot CF_2 \cdot CHF \cdot CF_2 I$, and also a series of 1-iodoperfluorohexadienes from the adduct $C_2F_5 \cdot CF_2 \cdot CHF \cdot CF_2 \cdot CHF I$.

MEMORANDUM

The work described in this thesis was carried out in the University of Durham between September 1964 and July 1967.

This work has not been submitted for any other degree and is the original work of the author, except where acknowledged by reference.

Abbreviations

This is a list of abbreviations used in the text.

T.F.E.	Tetrafluoroethylene.
P.T.F.E.	Polytetrafluoroethylene.
H.F.P.	Hexafluoropropene.
P.H.F.P.	Polyhexafluoropropene.
V.F ₂	Vinylidene fluoride.
A.A.	Acetonyl acetone.
T.C.P.	Tricresyl phosphate.
N.m.r.	Nuclear magnetic resonance.
G.l.c.	Gas-liquid chromatography.
T.g.a.	Thermogravimetric analysis.
T.v.a.	Thermovolatilisation analysis
D.t.a.	Differential thermal analysis.
Ats.	Atmospheres.

SECTION I

THE POLYMERISATION OF FLUORINATED OLEFINS

INTRODUCTION

FLUORINATED ORGANIC POLYMERS

Thermally- and chemically-stable polymers have long been sought to provide such things as thermally-stable lubricants and hydraulic fluids for high speed machinery. Resistant metals or ceramics can be used as alternatives for corrosion-resistant construction materials required for chemical plant, but, it has been difficult to find resilient materials suitable for gaskets, etc. This has led to the investigation of fluorinated organic polymers because highly fluorinated aliphatic compounds show high thermal stability and extreme resistance to attack by many common reagents.

The most important, commercially, of the fluorinated polymers is polytetrafluoroethylene (P.T.F.E), which shows remarkable resistance to acids, alkalis, and all common solvents. It melts at 327° and no significant decomposition occurs up to 250° . Because of its high melt viscosity, P.T.F.E. is difficult to fabricate. Many methods have been used to polymerise T.F.E, emulsion,^{2,3} solution,^{4,5} and gamma-irradiation.^{9,10,11} Ziegler-Natta catalysis of T.F.E. was reported in 1958,⁶ and Sianesi and Capariccio^{7,13} have reported the stereospecific homopolymerisations of T.F.E. and hexafluoropropene (H.F.P.). The polymer obtained from H.F.P, by this method, is thought to be a 1:1 copolymer of H.F.P. and isobutene (from the catalyst).⁸ An unusual method of preparing P.T.F.E. and P.H.F.P. has been to subject dichlorodifluoromethane and H.F.P, respectively, to a glow discharge.¹²

The homopolymerisation, to high molecular weight, of perfluoro-olefins, other than T.F.E, is difficult to accomplish. H.F.P. has been polymerised,

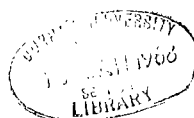

under very high pressures, in solvent,¹⁴ by emulsion technique,¹⁵ and by gamma-irradiation.¹⁶ The polymer melts in the range 210-250°. It has a low melt viscosity and is swelled by, or soluble in, perfluorinated aliphatic compounds, these properties being a result of its amorphous character.¹ Heating perfluoro-cyclobutene¹⁷ and gamma-irradiation of perfluoroheptene-1,¹⁸ both under pressure, produces solid polymers. Using conventional bulk and solution methods, Darby and Ellingboe¹⁹ reported the successful homopolymerisations of perfluoropropene, perfluoroheptene-1, and perfluorononene-1, whereas Adams and Bovey²⁰ failed to polymerise perfluorobutene-1, perfluorobutene-2, perfluoroisobutene, perfluoroheptene-1, and perfluorononene-1, using bulk and emulsion techniques at autogenous pressures.

Using gamma-irradiation and high pressures, Wall and his co-workers have polymerised the dienes; perfluoro-1,4-pentadiene,²¹ -1,5-hexadiene,²² -1,6-heptadiene,²² and -1,7-octadiene.²² The polymers are often brittle and insoluble, probably due to crosslinking. Wall found that the 1,4-diene was partly converted to the 1,3-diene, the two dienes then copolymerising. Khramchenkov and Zimin²³ have also subjected perfluoro-1,7-octadiene to gamma-irradiation, at autogenous pressure, but only obtained trimers and tetramers. Miller²⁴ obtained a solid polymer by heating the dimer of perfluorobutadiene. The polymer was insoluble in acetone and ethanol.

Tetrafluoroallene homopolymerises to give a highly crystalline, linear polymer, having =CF₂ groups on alternate carbon atoms.²⁵ Gamma-irradiation of hexafluorobut-2-yne gives a polymer said to have the repeating structure -(CF₃)C=C(CF₃)-.²⁶

The copolymer of T.F.E. and H.F.P. resembles P.T.F.E. Although its thermal stability is less than that of P.T.F.E, softening at 285°, and having an upper useful temperature limit of 200°, the reduction in crystallinity, due to pendant trifluoromethyl groups, allows fabrication by conventional melt techniques. H.F.P. has been copolymerised with vinylidene fluoride (V.F₂),²⁷ producing elastomers resistant to most solvents, except esters and ketones. Vulcanising the H.F.P.-V.F₂ copolymers with diamines allows them to be used at temperatures up to 200°. Although the copolymers of T.F.E. and V.F₂ only show elastomeric properties at elevated temperatures,²⁸ terpolymers of T.F.E, V.F₂, and H.F.P,²⁹ are elastomeric. The terpolymers are said to show greater resistance to heat, solvents, and acids, than the H.F.P-V.F₂ copolymers.³⁰

In a patent,³¹ Bro claims to have copolymerised T.F.E. with long chain perfluorinated olefins, giving rise to polymers having physical properties substantially the same as P.T.F.E, but with melt viscosities suitable for conventional melt fabrication. Using perfluorodimethyl cyclohexane as solvent and perfluorobutyryl peroxide as initiator, Bro claims to have copolymerised T.F.E. with perfluoropentene-1 (1.7% inclusion), perfluoroheptene-1 (0.8% inclusion), and perfluorononene-1 (5.5% inclusion). The analyses were carried out using infra red spectrometry and substantiated by pyrolysis of the polymers, and analysis of the pyrolysis gases. It is doubtful whether either of these methods of analysis is capable of the accuracy needed to quote the values that Bro claims. Bro⁵ and Krespan⁴ also claim other solution methods capable of producing these copolymers,

but they report only the copolymerisation of T.F.E. and H.F.P. as examples.

THE AIM OF THIS THESIS

The aim of the work reported in this thesis was to prepare copolymers, of accurately known composition, containing substantial concentrations of each comonomer, and to measure their thermal stabilities, in order to show how this property is affected by change in chain length, and concentration, of comonomer. The polymers were made by copolymerising tetrafluoroethylene with perfluorinated olefins, of general formula $R_f \cdot CF = CF_2$, where R_f is CF_3 , C_2F_5 , C_3F_7 , C_5F_{11} , C_7F_{15} .

DISCUSSION

The only claims for the preparation of copolymers of T.F.E. and perfluoroalkenes have been made by Krespan⁴ and Bro,^{5,31} using solution methods and novel initiators. Bro,⁵ in 1961, summarised the situation with respect to the preparation of these copolymers as follows:

"Although suitable for the conversion of T.F.E. to high molecular weight polymer, the aqueous system is not as effective with other fluorinated olefins, since both the rate of polymerisation and the molecular weight of the polymer obtained decrease significantly as the fluorinated olefin employed is increased in molecular weight. The homopolymerisation of hexafluoropropene, in an aqueous medium, has not been successful and, even in the copolymerisation of T.F.E. with fluorinated olefins of higher molecular weight, the rate of polymerisation is substantially effected." However, in 1963, Lo¹⁵ reported an emulsion polymerisation of H.F.P.

Although the preparations of copolymers of T.F.E. and perfluoroalkenes have been claimed, no information is available concerning the physical properties, especially thermal stabilities, of these polymers. Bro commented that his method of making these copolymers gave polymers having properties similar to P.T.F.E. but with lower melt viscosities. To obtain a satisfactory melt viscosity, he claimed that there need only be 1 to 5% incorporation of comonomer in the polymer.

The incorporation of comonomers in the copolymers claimed by Bro³¹ are; perfluoro-pentene (1.7%), - heptene (0.8%), and -nonene (5.5%). No indication was given as to whether these figures were weight- or mole-%. The difference between the two is quite significant. For example,

5 weight-% C_9F_{18} corresponds to only 1 mole-% C_9F_{18} and 0.8 weight-% C_7F_{14} corresponds to 0.2 mole-% C_7F_{14} . Bro's method of analysis was infra red spectroscopic examination of thin polymer films substantiated by pyrolysis of the polymers and analysis of the pyrolysis gases. It seems unlikely from the information given, that either of these methods is capable of the accuracy that Bro implies in his claim.

It was decided to try to find a method which would allow the preparation of these copolymers, with variable amounts of comonomer incorporation, in order to measure their thermal stabilities and, hence, determine the dependence of this property on concentration and branch-chain length of comonomer. Bro³¹ simply stated that increasing the concentration of comonomer beyond a certain low limit (5%) reduced the melt viscosity of the copolymers below the useful limit and caused a "lowering of the high temperature properties" of the copolymers.

Emulsion polymerisation was the first method chosen to attempt to prepare these copolymers. This technique was chosen in order to produce polymer of high molecular weight suitable for thermal stability analysis. This method was successful in producing copolymers of T.F.E. and H.F.P. at autogenous pressure, but only with a low incorporation of H.F.P. Attempts to copolymerise T.F.E. with octafluorobutene and decafluoropentene gave polymers with comonomer incorporation less than the limits of accuracy of the method of analysis, i.e. less than 2 mole-% incorporation. Thus, this method was not suitable for preparing the desired copolymers.

It was necessary to choose a more energetic system of polymerisation

since the rates of copolymerisation of the comonomers of molecular weight greater than that of H.F.P. appeared to decrease significantly. A ^{60}Co gamma-ray source was available and it was felt that this should be capable of initiating the copolymerisation of perfluoroalkenes of high molecular weight, even under autogenous pressures.

Bulk copolymerisation, initiated by gamma-irradiation, has the advantage that there is no added chemical initiator. The reaction tube only ever contains the comonomers and products of reaction. A disadvantage is that high-energy radiation produces high concentrations of radicals which can rapidly combine to give short-chain polymers. In fact the polymers obtained tended to be tacky solids, except for those from the reaction of T.F.E. with H.F.P., and thermal analyses indicated that in most cases, there were large amounts (>50%) of low-molecular weight material produced.

By this method, it was possible to produce polymers which contained varying amounts of the comonomers, perfluoro-propene, -butene, and -pentene. Polymers were also obtained which included the comonomers, perfluoro-heptene and -nonene.

The method of analysis was that of material balance and the amount of inclusion of comonomer into a polymer was determined by measuring the difference in composition and quantity between the initial and recovered olefin mixtures. This gave the maximum possible value for the comonomer concentration in the non-volatile material, being an apparent polymer composition. A minimum comonomer concentration was obtained from the weight of recovered polymer. The disparity between the upper and lower

limits of apparent comonomer inclusion was determined by how close the overall weight recovery was to 100%.

From the reactions of T.F.E. with perfluoro-heptene and -nonene, the recovery of material was very low and, consequently, the compositions of these polymers were not satisfactorily determined.

The methods available for determining polymer composition fall into two categories, those which are absolute methods and those which must be calibrated by an absolute method. Absolute methods include elemental analysis; material balance; radioactive labelling (e.g. ^{14}C) of one monomer in a copolymer; and nuclear magnetic resonance (n.m.r.) of polymer solutions. N.m.r. examination of a solid H.F.P.-T.F.E. copolymer has been reported but this required facilities for examining the sample at 200° .³⁴ An excellent spectrum was obtained at 310° , 20° above its crystalline melting point.

Methods which require prior calibration include mass spectroscopy which gives qualitative information and crystalline melting points, which provide a guide to fabrication possibilities rather than being a source of detailed structural information. The pyrolysis of the polymer and examination of the pyrolysis gases by infra red spectroscopy, mass spectroscopy, or gas-liquid chromatography (g.l.c.), and infra red spectroscopic examination of thin polymer films are also extensively used.

A method of preparation and examination of films prepared from the copolymers of T.F.E. and perfluoro-olefins has been reported.³⁵ The film preparation involves pressing the polymer, at 340° and 40,000 p.s.i., onto

an aluminium disc then removing the metal by heating in 10% sodium hydroxide, at 90-100°. The ratio of absorptions at 10.18 μ and 4.25 μ , multiplied by 4.5, gives the net weight % of H.F.P. in a T.F.E.-H.F.P. copolymer. The absorption at 4.25 μ (probably an overtone of the carbon-fluorine stretch at 8.5 μ) is used as an internal thickness standard. The absorption at 10.18 μ was chosen because it does not occur in the P.T.F.E. spectrum. This absorption may be due to a tertiary fluorine atom or to the system $\begin{array}{c} \text{C}-\text{C}-\text{C} \\ | \\ \text{C} \end{array}$. Imperial Chemical Industries Ltd. used an external standard of commercial T.F.E.-H.F.P. copolymer, containing 15% (w/w) H.F.P.

The copolymers produced in this work were insoluble in most reagents at room temperature, although acetone caused some swelling and did dissolve some material (< 1%), possibly low molecular weight material. However, these polymers were not soluble enough to allow spectroscopic methods of analysis. Elemental analysis could not be used because all the polymers have the empirical formula $(\text{CF}_2)_n$. ^{14}C labelling of olefins would have been too expensive in view of the large quantities used.

A method based on infra red spectroscopic examination of the polymer was initially sought. Samples of the T.F.E.-H.F.P. copolymer, prepared by the emulsion method, were pressed at room temperature at 5000 p.s.i. pressure, however, the films were too thick or too particulate, i.e. the polymer particles did not flow sufficiently, causing a high proportion of light-scatter. One spectrum obtained was analysed by the method described and gave an analysis corresponding to a 1:1 copolymer of T.F.E. and H.F.P. This result contradicted that obtained by mass spectroscopic analysis.

Using the acetone solutions, attempts were made to cast thin films onto a highly reflecting surface. By bouncing the infra red beam off this surface, some absorption occurs giving rise to a spectrum. An attempt was also made to cast a film onto one side of a silver chloride prism, made from a single crystal. Internal total reflection of the infra red beam through the other two faces of the prism can give rise to a spectrum. This is the method of attenuated total reflection and relies upon the beam penetrating slightly through into the polymer coating before being internally reflected.

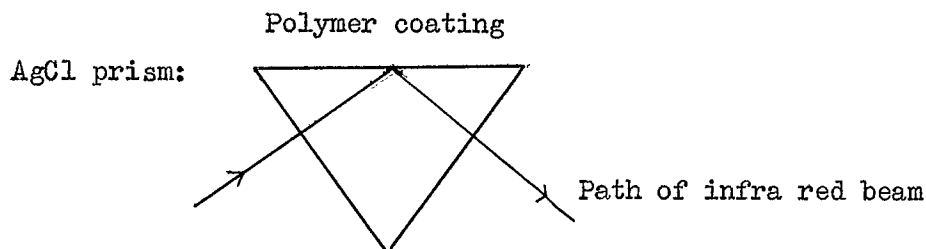

No useful spectrum was obtained from either of these reflectance methods due to the high proportion of light-scatter.

The only feasible method of analysing these polymers was material balance. This method requires accurate measurement of the comonomers into the reaction vessel, total reclamation, and separation, of the solid and gaseous products, and volume and compositional analysis of binary mixtures of the recovered gases in which one component often constitutes ca. 1%.

Since the boiling points of most of the olefins used are low, ranging from -76° (C_2F_4) to $+25^{\circ}$ (C_5F_{10}), a method of measuring gases accurately was required. The method used was a standard high-vacuum technique. With the apparatus originally chosen, reproducible gas measurements could not be obtained. By replacing the high-vacuum tap, connecting the standard bulb to

the manifold, with a mercury-float valve, satisfactory results were obtained. This system eliminated the possibility of the gases dissolving in Apiezone tap grease.

A series of emulsion homopolymerisations of T.F.E. were carried out to test the accuracy of the techniques involved. From this series recovery of material was $100 \pm 1.9\%$. Errors of this magnitude were acceptable. The greatest errors in this method were introduced in two ways, (a) incomplete drying of recovered gases, effected by vacuum transferring the gases three times from P_2O_5 , and (b) failure to recover all the solid products which were generally produced as fine powders. Attempts to handle the dry powder resulted in generation of static electricity causing the powder to fly in all directions. This was partly overcome by wetting the polymer with aqueous acetone, collecting it in the vessel for weighing, then drying the sample in a vacuum desiccator, over P_2O_5 , for about two weeks.

Towards the end of the work, it was found that the effect of static electricity on the polymer could be used to advantage. The normal procedure for removing a dry polymer sample from the filter, for weighing, involved the use of a clean spatula and sample tube, with the result that a great deal of fine polymer stuck to the length of the spatula and the outside of the sample tube. By polishing the inside of the tube and leaving a thin smear of grease around the outside neck, it was found that almost complete transfer of the fine polymer powder into the tube resulted. The tube could then be sealed, cleaned outside, and weighed.

Reclamation of volatile gases from bulk polymerisations was readily achieved, but it was much more difficult from emulsion polymerisations. In order to obtain complete recovery of the gases it was necessary to remove them from the reaction mixture under vacuum. However, under vacuum, the aqueous emulsion foamed excessively and this resulted in the volatile product and a great deal of foam plus solid product being trapped in the vacuum system. By allowing the entire contents of the reaction vessel to escape, under dynamic vacuum, into a flask cooled in acetone/carbon dioxide, the foam and solid products were trapped out. The volatile gases passed through this trap and were collected in a glass coil, cooled in liquid air, transferred to a flask containing P_2O_5 , and then into the standard bulb. The solid product was recovered by washing the apparatus with aqueous acetone, and filtering.

After measuring the volume of recovered gases, they were stored, under vacuum, in sealed glass tubes. A sample of this material was obtained for compositional analysis by vacuum transferring the gases from the tube into a large bulb and taking a small sample of the equilibrated gases. On opening one such sample, which had been stored in the dark for several weeks, it was noticed that the tube contained a colourless gum. On heating the tube, to about 100° , there was a violent explosion. This was probably caused by the decomposition of a peroxy-polymer, accidentally formed when a mixture of T.F.E. and H.F.P. was sealed in a tube in the presence of oxygen. Apparently the mixture in this tube was stored under ideal conditions for the formation of a peroxy-polymer, such as that formed from

T.F.E. and oxygen, having the repeating structure $(CF_2 \cdot CF_2 \cdot O \cdot O)_n$.³⁷ These peroxy-polymers can be handled safely only in solution, on heating they decompose violently. Thus, it is essential that when storing these, and many other, olefins in glass tubes, the presence of oxygen must be rigorously excluded.

The determination of the composition of the gaseous mixtures proved difficult. G.l.c. examination was not effective. The stationary phases used to separate T.F.E. and H.F.P. were silicone elastomer (2 m. column), didecyl phthalate (2 m.), silver nitrate in polyethylene glycol (up to 6 m.), acetonyl acetone (A.A.) (4 m.), and tricresyl phosphate (T.C.P.) (2 m.). Only on columns containing A.A. and T.C.P. could T.F.E. and H.F.P. be resolved, into individual peaks. However, after repeated attempts, it was found impossible to obtain reproducible analyses of mixtures of known composition and this method was abandoned. It would appear that with the apparatus available, this method was not capable of accurately determining the composition of gaseous mixtures in which the concentration of one component was about 1%. This method could be improved if it was possible to reproduce, and hold constant, effluent gas pressures and flow rates and by using a detector giving a better response.

Also using gaseous mixtures of known composition, infra red spectroscopic analysis produced random results. It is unlikely that quantitative analysis of gaseous mixtures, in which the concentration of one component is less than 5%, is feasible by this method, except in especially favourable circumstances.

Mass spectrometric analysis of gaseous mixtures is used extensively in the petroleum industry. The method described in the experimental section, was quite able to detect 1% of a component in a binary mixture. The use of mass spectroscopy for quantitative analysis of mixtures requires that the cracking pattern of a given compound, and the sensitivity of the instrument, should remain constant and be independent of other compounds present. This usually holds over fairly short operating times. Also, in a mixture, the intensities of the fragment ions should be in a constant relation to each other and be directly proportional to the quantity of compound present, in other words, the contributions of various components to a given fragment should be additive.³⁸

The methods of analysis described were not suitable for use with the olefins perfluoroheptene and perfluorononene because they condensed in the standard bulb. A solution to this problem was not discovered. Quantities of these pure olefins were weighed then transferred by pipette into the reaction vessel. After reaction, the liquid was removed by pouring into a Gooch filter, under vacuum. This will have removed most of the T.F.E. dissolved in the mixture, hence, weighing the recovered liquid gave the weight of unreacted comonomer. This method gave very poor material balance.

For the emulsion polymerisations, a simple aqueous solution was chosen, consisting of 0.2% (w/w) ammonium persulphate as initiator and 2% (w/w) sodium perfluoro-octanoate as emulsifier, in order to reduce contamination of any polymer produced. A hydrocarbon soap, sodium lauryl sulphate, was initially used but very little reaction occurred, probably due to the low solubility

of fluorocarbons in hydrocarbons.

The T.F.E.-homopolymerisations were carried out, under vacuum, in sealed Pyrex tubes. Initial copolymerisations were attempted using T.F.E. and H.F.P. in the same type of tube. These tubes always contained liquid H.F.P. (critical pressure 31.2 ats.)³² and frequent explosions occurred. Thus, a stainless steel vessel, designed to be capable of withstanding pressures up to 100 ats. was used.

The emulsion copolymerisation of T.F.E. with H.F.P. at autogenous pressure, was successful, giving a copolymer in which there was between 7 and 16 mole-% H.F.P. incorporation. Attempts to copolymerise T.F.E. with octafluorobutene (critical pressure ca.21 ats.)³² and decafluoropentene (critical pressure ca.18 ats.)³² gave polymers which contained less than 2 mole-% comonomer. The conversion of T.F.E. to polymer in these latter cases were 53% and 35%, whereas, in the reaction with H.F.P., 100% conversion occurred. This suggests that the comonomers, other than H.F.P., might behave as chain terminators producing lower molecular weight P.T.F.E. The polymers produced in these latter cases had softening points of 270° and 300°, respectively (P.T.F.E. melts at 327°).

Bro claimed that his method of polymerisation gave copolymers having properties similar to P.T.F.E. but with lower melt viscosities. In view of the errors inherent in the methods of analysis he used and the very low degrees of incorporation of comonomers, it is possible that he was simply producing low-molecular weight P.T.F.E.

The mode of formation of the polymers obtained, using gamma-ray

initiation, was difficult to define, other than it must have been a free radical mechanism. The actual composition of the polymers was also in doubt. It was found that irradiating mixtures of T.F.E. and H.F.P. gave polymers in which the incorporation of H.F.P., was time-dependent. Three mixtures were made up having similar H.F.P.-T.F.E. ratios and were irradiated for different time intervals. The results are expressed in the table:

H.F.P.-T.F.E. mole ratio	Irradiation time hrs.	Apparent H.F.P. incorporation in polymer max. mole %
7:1	54	2
6:1	73	9
8:1	378	53

There are several possibilities to account for this phenomenon. The assumption was made that most of the T.F.E. was homopolymerised very quickly. This was based on the fact that the mixture irradiated for 54 hrs. gave a polymer containing 98 mole-% T.F.E. and a volatile fraction with < 2 mole-% T.F.E. (originally 12.5 mole-%).

If carbon-fluorine bond scission in the P.T.F.E. then occurred, the radical formed may have attacked a molecule of comonomer to produce a graft copolymer:

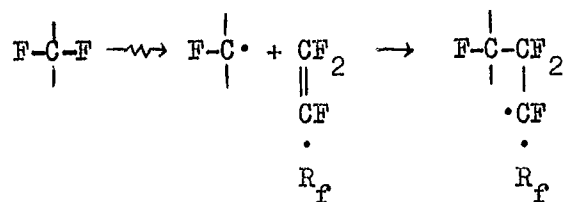

One imagines that this system could possibly lead to crosslinking. However, fluorocarbon polymers under the influence of gamma-rays, tend to undergo carbon-carbon bond scission, in fact P.T.F.E. depolymerises on irradiating for long periods of time.³⁹ Also, the products of pyrolysis, from these polymers, were mainly the original monomers. From a graft copolymer, one would expect regeneration of T.F.E. but not significant amounts of the comonomer.

The radicals formed from carbon-carbon bond scission could have reacted with comonomer molecules. This is represented schematically for T.F.E.(T) and H.F.P.(H):

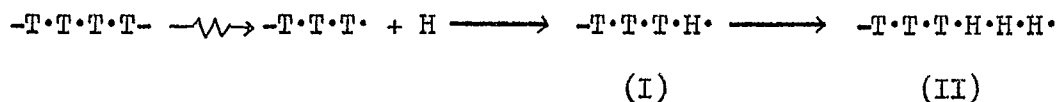

Addition of one molecule of H.F.P. could have caused chain termination by forming an unreactive radical-end to the chain (I), giving a polymer of relatively low molecular weight P.T.F.E. The radical (I) may have been reactive enough to add on more molecules of H.F.P. (II). This could have led to the formation of block copolymers:

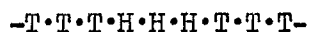

This depended upon the radicals formed from the comonomers, $P \cdot \overset{\circ}{C}F \cdot R_f$, being reactive enough to add on to another comonomer molecule.

Irradiation of pure H.F.P. gave a high boiling liquid with molecular weight up to 750 i.e. a pentamer of H.F.P. This liquid showed C=C absorptions in its infra red spectrum at 1770 cm.^{-1} (5.64μ) and 1710 cm.^{-1} (5.80μ). This confirms the work of Ballantine³³ who, after irradiating

H.F.P. (208.7 M.rads), obtained a viscous liquid that boiled at 175-180° and appeared to be a trimer or tetramer of H.F.P. The infra red spectrum indicated the presence of both terminal and internal double bonds. Charlesby⁴⁰ considered that, owing to the amount of radiation used, the H.F.P. was ionised and reacted stepwise rather than by a free-radical chain mechanism.

Irradiation of pure octafluorobutene gave material with molecular weight up to 800 i.e. a tetramer. The infra red spectrum of this material indicated that some unsaturation remained. Irradiation of pure decafluoropentene gave material with molecular weight up to 750 i.e. a trimer, which had two unsaturation absorptions in its infra red spectrum at 1760 cm.⁻¹ (5.67μ) and 1700 cm.⁻¹ (5.90μ). Hence, the possibility that block copolymers were formed does exist.

Alternatively, the initial P.T.F.E. radicals added on to one molecule of comonomer. This radical may have been reactive enough to attack another P.T.F.E. chain or it may have added on to another P.T.F.E. radical. In both cases, it can be seen that this would have given rise to a random copolymer having a comonomer concentration which was time (or dose) dependent.

It is possible that this method of polymerisation resulted in an equilibrium being set up between bond making and bond breaking producing material with a large spread of molecular weights.

It was hoped to provide some evidence for this mode of polymer formation by irradiating P.T.F.E. in the presence of H.F.P. There was a gain of 0.01 g. in the weight of polymer and a reduction of 5 mole-% (initially

1.699×10^{-2} in the H.F.P. This suggested an incorporation between 2 and 23 mole-% H.F.P. (recovery of material was 95.7%). The thermogravimetric analysis of this polymer gave a thermogram consistent with the degradation of a copolymer. Thus, it appears that breakdown of the initial P.T.F.E. may have taken place and most certainly there has been some H.F.P. incorporated into the polymer, not simply absorbed into it.

EXPERIMENTAL

APPARATUS

POLYMERISATION VESSELS

Polymerisations were carried out in Pyrex tubes (8 cm. x 1 cm. diameter; 2 mm. wall thickness), necked for sealing, or in stainless steel tubes (21.5 cm. x 1 cm. diameter; 4 mm. wall thickness), sealed with a stainless steel cap. (see diagram I). The steel tubes could be fitted with a cap having a metal ball joint suitable for attaching to a vacuum line, and a Teflon diaphragm valve (see diagram II).

VACUUM LINE (see diagram III).

The high-vacuum system consisted of a manifold evacuated by rotary and mercury-diffusion pumps. Attached to the manifold were two inlet points, and two 3 l. storage bulbs. Also attached to the manifold, via a mercury float valve, was a 1 l. bulb used to measure accurate quantities of the olefins, tetrafluoroethylene, hexafluoropropene, octafluorobutene, and decafluoropentene. The volume of this bulb, up to a reference mark in the manometer of known bore, was accurately known. The volume of free space in the manometer, below the reference mark, was calculated for each measurement. Hence, knowing the pressure, volume, and temperature, the quantity of gas could be calculated. As the mercury in the manometer falls, there was an increase in height in the reservoir, the gas pressure was compensated for this rise.

The bulb was calibrated by successive additions of carbon dioxide gas, vacuum transferred from a 300 c.c. bulb of accurately known volume, including

DIAGRAM I

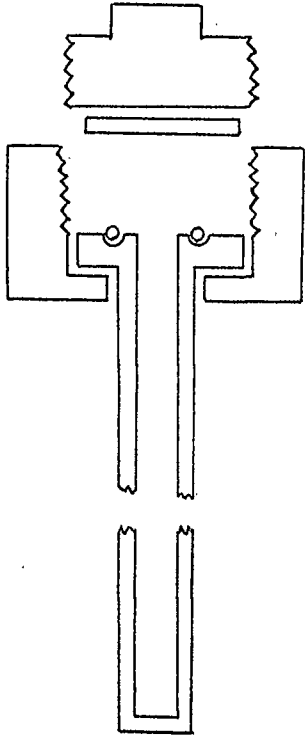

DIAGRAM II

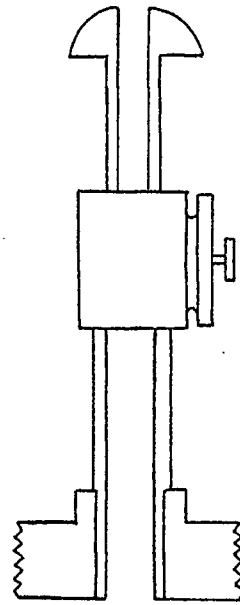
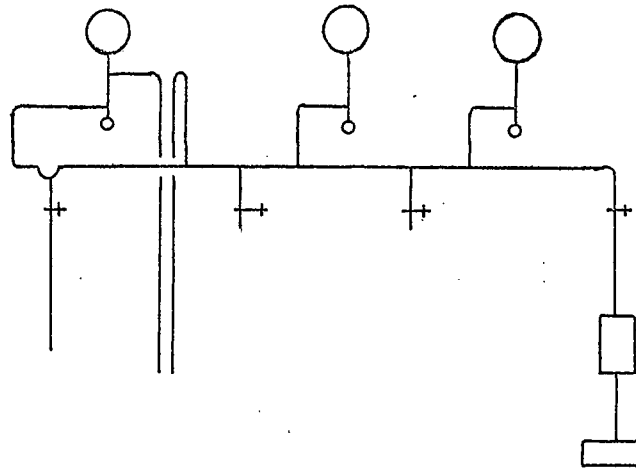

DIAGRAM III



the bore of the tap. The volume of the standard bulb, up to the reference mark, was 1.168 ± 0.004 l.

The manometer bore was measured by filling a known length of manometer tubing with mercury then weighing the mercury. Knowing the weight of mercury, the volume of the glass tube was determined, and from this, the radius of the tube was calculated:

$$\frac{\text{mass}}{\text{density}} = \text{Volume} = \text{height} \times \text{radius}^2 \times \pi$$

GAMMA-SOURCE

Irradiations were carried out using a nominal 500 curie ^{60}Co source. The source was calibrated according to the method used by Plimmer.⁵⁰ This uses a ferric-ferrous system which, under the influence of gamma-irradiation, undergoes the overall reaction:

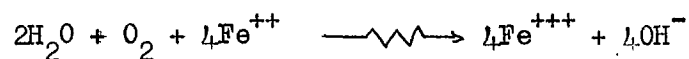

The solution irradiated consisted of ferrous ammonium sulphate (0.378 g.) and potassium chloride (0.060 g.), dissolved in deionised water, and made up to 1 l. with 1N sulphuric acid. The potassium chloride apparently nullifies the effect of slight impurities in the deionised water, for some unknown reason.

Optical densities were measured with a UNICAM SP 800 spectrophotometer ($\lambda = 305 \text{ m}\mu$, slit width 1.715 mm.) which was calibrated with solutions of ferric alum.

Calibration of spectrophotometer.

Ferric alum		Optical density
g.	micromoles/l	
0.0101	104.7	0.377
0.0221	229.2	0.762
0.0313	324.5	0.995
0.0472	489.3	1.31

Plotting micromoles/litre of ferric alum against optical density gave a graph of slope 0.00304. This is the extinction coefficient (see appendix (a)).

The G value (the number of molecules which have been changed for 100 eV. of energy absorbed) for this reaction was taken as 15.5 moles/litre/kilo rep. The dose was calculated from the formula given by Plimmer:

$$\text{Dose (rads)} = \frac{\text{optical density}}{\text{extinction coefficient}} \times \frac{10^3 \times 0.97}{15.5}$$

Irradiation of ferrous ammonium sulphate solutions.

Pyrex tubes (5 cm. x 1 cm. diameter) were filled with the prepared aerated ferrous solution. The tubes were placed at various distances from the source and irradiated for time intervals which ensured incomplete conversion of ferrous ion to ferric ion. The optical densities of these solutions were then measured. A control tube was placed next to the source-guide tube, the source lowered, then immediately raised. The optical density of this solution was subtracted from the optical densities of all other irradiated

solutions. The graph of dose rate against distance from the source falls off exponentially to a steady value.

Distance from source. cm.	Optical density	Time of irradiation mins.	Dose rads. x 10 ⁻⁴	Dose rate rads. x 10 ⁻⁴ /hr
Control, touching	0.06	0	0	0
Touching	0.846	5	1.74	20.88
5	1.038	30	2.14	4.28
10	0.336	30	0.69	1.38
20	0.101	30	0.21	0.42
30	0.104	30	0.21	0.42

MASS SPECTROSCOPIC ANALYSIS OF MIXTURES OF FLUORINATED OLEFINS

A vacuum line, incorporating a Bourdon spoon gauge, was attached to the inlet system of an A.E.I.-M.S.9 mass spectrometer. The method involved separately measuring known pressures of each pure component, and of the mixture, into the source reservoir, and measuring the ion current for 3 or 4 fragments in each spectrum. Solution of a set of simultaneous equations gave an analysis of the mixture. This can be illustrated by reference to a mixture of T.F.E. and H.F.P.

The ion currents for fragments with ^m/e 131, 100, 81 from a sample of pure H.F.P., and from a sample of the mixture, and for fragments with ^m/e 100, 81 from a sample of pure T.F.E., were measured.

m/e	131	100	81
Ion current in H.F.P.-T.F.E. mixture	x	y	z
" " " pure H.F.P.	a	b	c

The ion current due to H.F.P. in the mixture at m/e 100 was $\frac{xb}{a}$, and at m/e 81 was $\frac{xc}{a}$. The ion currents due to T.F.E. in the mixture at m/e 100 was $y - \frac{xb}{a}$, and at m/e 81 was $z - \frac{xc}{a}$. Sensitivity factors (S) for each fragment in the pure olefins were calculated from the relationship $S_f = \frac{P}{i_f}$; P is the pressure of pure olefin in units of cm. deflection of Bourdon gauge, and i_f is the ion current of a chosen fragment. The percentage of T.F.E. in the mixture is given by:

$$\frac{i_2 S_2}{i_2 S_2 + i_3 S_3} \times 100 = \frac{1}{1 + \frac{i_3 S_3}{i_2 S_2}} \times 100$$

where i_2, i_3 are the ion currents of T.F.E. and H.F.P., respectively, in the mixture at m/e 100 or 81, and S_2, S_3 are the sensitivity factors of T.F.E. and H.F.P. for the same fragment.

For these calculations to be valid, it is necessary for ion currents to be linearly related to reservoir pressure of pure olefin. This was established for the pressure range used for each olefin (see appendix (a)).

It was necessary to determine sensitivity factors for each olefin for each analysis carried out. Although the sensitivity was found to be constant for the duration of one set of measurements, it varied from day to day. The reason for this variation is that the exact value of the ion current, for a given pressure, depends on several factors:- the ultimate

vacuum attainable in the reservoir and the mass spectrometer slit widths, accelerating voltage, focussing of the ion beam, setting of the photo-multiplier, and the state of the source. All these factors vary daily.

POLYMERISATIONS

A typical emulsion polymerisation

The aqueous solution contained 0.2% (w/w) ammonium persulphate as initiator, and 2% (w/w) sodium pentadecafluoro-octanoate as emulsifying agent.

Into a stainless steel tube (18 c.c.), fitted with filling cap, was placed aqueous emulsion (13 c.c.), degassed twice, then tetrafluoroethylene (0.348 g., 0.348×10^{-2} moles) and hexafluoropropene (5.240 g., 3.493×10^{-2} moles) (both oxygen-free) were added by vacuum transfer. The remaining space was filled with nitrogen (1 at.), then the tube was removed from the vacuum line and sealed. On warming, the pressure in the tube exceeded the critical pressure of hexafluoropropene. The tube was rotated for 40 hrs. in an oil bath at 55-65°. After removing from the oil bath, the tube was frozen in liquid air, the filling cap replaced, the tube evacuated, then the valve in the cap closed. The tube was warmed to room temperature, and, on opening the valve, the contents of the tube were completely removed, effected by foaming. The aqueous solution and solid material were collected in an intermediate glass trap at -76°, and the volatile olefins were trapped in a glass coil, cooled in liquid air. The solid material (0.387 g.) was removed from the glass-ware with aqueous acetone, filtered (Gooch crucible No.3), washed (H₂O), and dried (P₂O₅; vacuum desiccator). The volatile gases were vacuum transferred from P₂O₅ and their total volume (3.423×10^{-2} moles)

was then measured in the standard bulb. The volatile product was sealed in a glass tube, under vacuum, until mass spectrometric analysis could be carried out.

A typical gamma-irradiation polymerisation

Tetrafluoroethylene (0.463 g., 0.463×10^{-2} moles) and hexafluoropropene (5.535 g., 3.690×10^{-2} moles) were sealed, under vacuum, in a Pyrex tube. On warming, the pressure in the tube exceeded the critical pressure of hexafluoropropene. The tube was placed 5 cm. from a ^{60}Co source for 54 hrs. at room temperature, then the volatile products were removed under vacuum and their total volume (3.747×10^{-2} moles) was measured in the standard bulb. The volatile products were then sealed in glass tubes to await analysis. The solid material (0.396 g.) was removed with aqueous acetone, filtered, washed (H_2O), and dried (P_2O_5 ; vacuum desiccator).

MATERIAL BALANCES

In order to determine the accuracy of using materials balance as a method of analysis, a series of homopolymerisations of T.F.E. were carried out. The reactions were carried out in Pyrex tubes (5 cm. x 1.9 cm. diameter; 3 mm. wall thickness) containing oxygen-free aqueous emulsion and tetrafluoroethylene. The tubes were rotated in a heated oil bath, then the unreacted tetrafluoroethylene was removed under vacuum. The solid material was filtered, washed, and dried. The results are summarised in table I.

TABLE I

C ₂ F ₄ moles x 10 ²	Time hrs.	Temp.range °C	Recovered material		Recovery of material % (N _i)	r (N _i -N̄)	r ²
			Solid g.	Volatile moles x 10 ²			
0.857	11	60-105	0.778	0.086	100.8	+0.8	0.64
0.832	15	53-63	0.817	0.041	103.1	+3.1	9.61
0.761	15	53-63	0.713	0.057	101.1	+1.1	1.21
0.857	1	78-85	0.775	0.073	99.0	-1.0	1.00
1.017	11	60-105	0.880	0.265	101.2	+1.2	1.44

In this table, $\bar{N} = 100$

$$\text{and } r = N_i - \bar{N}$$

$$\sum r^2 = 13.90$$

$$\text{The variance} = \frac{\sum r^2}{n-1} = \frac{13.90}{4} = 3.48$$

$$\text{The standard deviation, } \sigma = (\text{variance})^{\frac{1}{2}} = 1.9$$

Hence, the accuracy of these material balances was $100 \pm 1.9\%$.

The results of the copolymerisations of hexafluoropropene, octafluorobutene, and decafluoropentene are summarised in tables II and III.

The olefins tetradecafluoroheptene-1, and octadecafluorononene-1, are not very volatile, b.p.'s 81° and 123° respectively. Hence, they could not be handled conveniently using high-vacuum techniques. In the bulk copolymerisations involving these olefins, the quantity of olefin required was obtained by weighing, the olefin was pipetted into the glass tube, and tetrafluoroethylene was added by vacuum transfer. After the reaction,

the liquid product was filtered off through a Gooch No.3 filter, and stored in a stoppered tube. The solid product was always a tacky gum and was recovered from the tube with a spatula. The analysis of the polymer was based on the polymer recovered, and assumed complete conversion of tetrafluoroethylene to polymer. The results are recorded in tables IV and V.

Irradiation of pure olefins:

A sample of each pure comonomer was irradiated in a Pyrex tube, under vacuum. The results are recorded in table VI.

TABLE II

Polymer No.	Comonomer	Comonomer moles $\times 10^2$	C_{2F_4} moles $\times 10^2$	Technique Emulsion or Gamma	Time hrs.	Temp. range, or dose, $^{\circ}C$ or rads $\times 10^{-6}$	Recovered material	
							solid g.	Volatile moles $\times 10^2$
1	C_3F_6	3.493	0.348	E	40	55-65 $^{\circ}$	0.387	3.423
2	C_3F_6	3.690	0.463	G	54	2.3	0.396	3.747
3	C_3F_6	4.403	0.760	G	73	3.1	0.823	4.332
4	C_3F_6	3.651	0.520	G	378	16.2	0.730	3.328
5	C_4F_8	2.768	0.298	E	40	70-85 $^{\circ}$	0.158	2.839
6	C_4F_8	2.433	0.364	G	212	9.1	0.487	2.190
7	C_4F_8	1.306	0.311	G	285	12.2	0.278	1.131
8	C_5F_{10}	2.630	0.356	E	63	65-75 $^{\circ}$	0.124	2.680
9	C_5F_{10}	3.429	0.427	G	163	7.0	0.862	3.001
10	C_5F_{10}	1.967	0.368	G	265	11.3	0.522	1.941
11	C_5F_{10}	ca. 2.417	1.208	G	73	3.1	1.029	2.758
12	C_3F_6	1.699	0.390	G	329		0.400	1.609

* The C_{2F_4} was present as P.T.F.E.

TABLE III

Polymer No.	Recovered volatiles		Material used, based on mass spec. analysis.		Incorporation of comonomer into the polymer		Recovery of material %
	C_2F_4 moles $\times 10^2$	Comonomer moles $\times 10^2$	C_2F_4 moles $\times 10^2$	Comonomer moles $\times 10^2$	maximum mole %	minimum (based on polymer recovery) mole %	
1	0	3.423	0.348	0.070	16	7	98.8
2	0.064	3.683	0.399	0.007	2		99.8
3	0	4.332	0.760	0.071	9	5	99.4
4	0.127	3.200	0.393	0.450	53	21	94.4
5	0.034	2.805	0.264	0	2	0	99.5
6	0.035	2.155	0.329	0.278	46	32	92.4
7	0.022	1.109	0.289	0.197	41		86.2
8	0.021	2.660	0.335	0	2	0	98.0
9	0.038	3.555	0.389	0.466	55	29	92.3
10	0.013	1.927	0.355	0.098	14	10	101.3
11							
12	0	1.609	0.390	0.090	23	2	95.7

⊘ No analysis was possible because the C_5F_{10} initially contained C_2F_4 .

⊚ The C_2F_4 was present initially as P.T.F.E.

TABLE IV

Polymer No.	Co-monomer	Comonomer		C ₂ F ₄		Irradiation time hrs.	Dose rads x 10 ⁻⁶	Recovered material	
		g.	moles x 10 ²	g	moles x 10 ²			solid g.	liquid g.
13	C ₇ F ₁₄	4.4	1.3	0.2	0.2	234	10.0	0.3	3.9
14	C ₇ F ₁₄	3.8	1.1	0.2	0.2	306	13.1	0.3) not re-corded
15	C ₉ F ₁₈	2.8	0.6	0.1	0.1	259	11.1	0.3	

TABLE V

Polymer No.	Comonomer used based on polymer recovery		Incorporation of comonomer		Recovery of materials %
	g.	moles x 10 ²	Based on polymer recovered mole %	Based on Comonomer used mole %	
13	0.1	0.03	13	41	91
14	0.1	0.03	13		<u>ca.</u> 50
15	0.2	0.04	29		<u>ca.</u> 20

TABLE VI

Comonomer moles x 10 ²	Irradiation time hrs.	Dose rads x 10 ⁻⁶	Volatile material recovered moles x 10 ²	Loss of volatile material %	Non-volatile material: highest fragment in mass spectrum m/e
C ₃ F ₆ 0.759	378	16.2	0.729	4%	750
C ₄ F ₈ 0.731	569	24.4	0.710	3%	800
C ₅ F ₁₀ 0.792	265	11.4	0.772	2.5%	750

C₇F₁₄⁻¹ and C₉F₁₈⁻¹ gave no solid material after 250 hrs. irradiation.

SECTION 2

THE POLYMERISATION OF FLUORINATED OLEFINS

I N T R O D U C T I O N

The evaluation of the thermal stability, or resistance to thermal breakdown or pyrolysis, of materials used for high temperature applications has become an important problem in polymer research. Owing to the lack of information on correlations between the chemical structure of polymers and their thermal and oxidative stabilities, the stabilities of model compounds have often been used as guides. Although their study may assist in elucidating mechanisms of degradation, this approach is limited because very often the reactions which model compounds undergo are converted into chain reactions in the polymer and hence, the polymer often does not have as high a thermal stability as expected. Also polymers often incorporate some abnormal structures, not found in the model compounds, at which some other reaction may occur.

Bond dissociation energies set an upper limit to the thermal stability which is rarely attained in practice. Extrapolation of structural relationships of known polymers to others, even of a similar type, cannot be done with confidence.

The most common method of determining the thermal stabilities of polymers is measurement of weight loss with time either at constant temperature or at a constant rate of temperature rise, thermogravimetric analysis (t.g.a.). It is desirable that thermal stability measurements should give information on the chemical mechanism of thermal breakdown as well as the temperature of its onset. Ideally measurements such as weight loss should be accompanied by the simultaneous examination and

analysis of the volatile decomposition products. However, thermogravimetry can only measure weight loss, data obtained from these measurements will not resolve consecutive and overlapping reactions.⁴²

Thermogravimetric methods of analysis for determination of rates of degradation, at constant or programmed temperatures, are satisfactory only for polymers with insignificant non-volatile residues. For char-forming polymers, measurements must be confined to the first few per cent of weight loss. This is still not satisfactory for polymers such as phenolic resins because, with these polymers, there is a large initial weight loss due to post curing rather than to general degradation.⁴³

Thermogravimetry can be applied to the study of any conceivable polymer process in which change of weight is involved e.g. polymerisation, pyrolysis, oxidative degradation, volatilisation, absorption, or adsorption. Up to the present time, isothermal and non-isothermal thermogravimetry has been used to study the pyrolysis and oxidative degradation of polymers.^{44d}

In thermal analysis of polymers, there are often two types of products present, a volatile and a non-volatile material. Any non-volatile material, usually highly crosslinked degradation products, can be examined by infra red spectroscopy, X-ray diffraction, and chemical analysis. The volatile material, which may be produced by depolymerisation, secondary thermal reactions, or free-radical

splitting into low-molecular weight products, may be examined by gas-liquid chromatography (g.l.c.), mass spectrometry, or infra red spectroscopy. ^{44f}

Much work has been done recently on the qualitative analysis of polymers by pyrolysis and analysis of the volatile products by all three of these methods. Brauer ⁴⁵ has reviewed many of the techniques used to pyrolyse polymers to give volatile products suitable for meaningful analysis by g.l.c. and emphasises that gas chromatography offers a rapid means of analysis of volatile products. As with other pyrolytic techniques, the results are dependant upon the experimental conditions employed. Schooten and Evenhuist ⁴⁶ have analysed polymers by pyrolysis - g.l.c. while Scholz and his co-workers ⁴⁷ used g.l.c. to examine the volatile products of oxidative degradations.

McNeill ⁴⁸ has also analysed polymers by pyrolysis but, instead of identifying the compositions of volatile products, he measured rates of volatilisation from the vapour pressure produced.

The thermal stabilities of liquid model compounds have been determined by a vapour pressure method using an isoteniscope. ⁴¹ An allied method is thermoparticulate analysis whereby decomposition is sensed in terms of the concentration of gas-borne colloidal particles. ^{44c}

Shulman ⁴³ passed the pyrolysis products of polymers directly into a mass spectrometer and obtained ion currents for each pyrolysis product as functions of time and temperature.

Non-pyrolytic methods include examination of the changes which occur in the infra red spectra of polymer films on heating ⁴⁹ and differential thermal analysis (d.t.a.). D.t.a. examination of polymers

allows one to detect melting, sublimation, decomposition, and phase changes, glass transitions, crosslinking reactions, crystallisation, and chemical reactions.^{44b} In fact any physical or chemical change which involves absorption or release of heat can be measured by this method. Jen Chui⁴¹ has measured changes in the heat content (d.t.a.) of polymers and simultaneously measured changes in their electrical conductivity. Behun and his co-workers^{44d} have even used d.t.a. procedures to determine the thermal stabilities of polymers.

To obtain meaningful results from thermogravimetry, it is necessary to consider the effects of the following factors on the weight lost as a function of temperature; the amount, film thickness, or particle size of the sample and its thermal conductivity; the geometry and composition of the sample holder - some fluorinated polymers can attack silica crucibles under certain conditions to give volatile silicon compounds; the rate of heating; the sensitivity of the recording mechanism and the speed at which weight loss is recorded; and the changing density of the surrounding atmosphere and the solubility of evolved gases.^{44c, 42}

Errors can be introduced by condensation of volatile material on the sample holder and by buoyancy of the sample holder. Friedman and Hall⁴² have shown how buoyancy errors can lead to apparent weight losses by heating the sample outside the crucible. It is not immediately apparent what is the relevance of this work.

Measurements of thermal stability are usually expressed in terms of indices derived from the experimental data on the basis of features on a graph. Some indices which have been chosen, commonly expressed as decomposition temperatures, are the temperature at which a certain rate of breakdown is attained or the temperature for a certain percentage decomposition in a given time. Doyle^{44c} comments that such empirically determined decomposition temperatures are highly trivial because their measured values depend on the choice of analytical procedure, settings of procedural variables, and superficial choice of decomposition. Doyle takes care to call these indices "procedural decomposition temperatures".

Brauer,⁴⁵ in his review, discussed the merits or otherwise, of using a boat - or a filament - type of pyrolysis unit. Using the method of pyrolysis in which the sample, in a boat, is heated by a filament, the boat represents a relatively high mass and only reaches the final filament temperature after a finite time. This means that the composition of the breakdown products do not reflect the pyrolysis at a known temperature but the pyrolysis up to a known temperature. This can be overcome by using a heating chamber instead of a filament. The chamber represents a very high mass relative to the boat and heating-up can be considered instantaneous.

Brauer considers that, although the filament type pyrolyser does

not allow optimum control of degradation conditions, the pyrograms are entirely satisfactory for identification purposes when polymers of known composition are available for comparison. He gives examples of the quantitative determination of copolymer composition, estimated from g.l.c. peak heights, using polymers in which one component is present in about 1% concentration, but he also states that polymer decomposition is highly sensitive to minor changes in the pyrolysis conditions.

Since the degradative reactions do not proceed to equilibrium in flash pyrolysis, the extent of these reactions depends not only on the pyrolysis temperature but is influenced by such factors as rate of carrier gas flow, rate of cooling of products, and the geometry of the reaction chamber. ⁴⁵

McNeill ⁴⁸ heated polymer samples in a tube connected to a vacuum pump via a cold trap. In such a continuously evacuated system, in which volatile products passed from a heated sample to the cold surface of a trap some distance away, a small pressure developed which varied with rate of volatilisation of the sample. Measurements of this pressure, with a Pirani gauge, as the sample temperature was increased in linear manner, gave a thermovolatilisation analysis (t.v.a.) thermogram.

Each polymer gave a characteristic thermogram which consisted of one or more peaks. T.g.a. thermograms consist of traces with points of inflection which have to be differentiated to obtain rate plots. Hence, McNeill considers that t.v. analysis of polymers has the advantage of providing a more convenient trace as well as being experimentally much more simple.

The apparatus most commonly used for the study of model compounds has been the isoteniscope and a decomposition temperature has been defined as that at which the rate of pressure increase due to decomposition is 0.84 m.m. Hg/min.⁹³ Johns and his co-workers⁴¹ have designed an isoteniscope for determining thermal stabilities at high pressure. The sample was heated in a sealed metal tube, connected to a pressure gauge, for 30 minutes for equilibration. After this time, the change in pressure with time was recorded to obtain the rate of decomposition at the given temperature.

Thermoparticulate analysis depends upon the ability of nuclei to cause condensation of a vapour. The condensed vapour droplets quickly grow to a size which will cause light scattering and this scattering can be detected by photoelectric counters. The amount of light is proportional to the number of droplets (each containing one nucleus) and to their scattering area.⁹⁴

Shulman⁴³ passed the products of polymer pyrolysis directly into a mass spectrometer. By continuously recording a characteristic peak on an individual channel, or by intermittently and repeatedly scanning the whole spectrum, then plotting peak height as a function of temperature, he obtained separate determinations of each pyrolysis product as a function of time and temperature. However, he strongly recommends that, unless other confirmatory methods for identification

of products are employed, definitive assignments of products from degradation of condensation polymers should not be made by mass spectrometry.

The thermal properties of polymers can depend upon their thermal histories. For example, Clampitt⁸⁸ found d.t.a. curves with little character using unannealed samples of linear high pressure polyethylene, except for one major peak at 134°. After annealing at 120° for 30 minutes, he obtained extra peaks at 115° and 124°. It is important, therefore, to establish a uniform treatment for studies of thermal properties, especially those to be interpreted in terms of crystallinity.

Behun and his co-workers^{44a} have compared three temperatures in determining thermal stabilities from d.t.a. data. These temperatures were T_i , the point of initial development of the exotherm or endotherm, T_d , the intercept point of the extrapolated base line and the slope of the endotherm, and T_p , the temperature at which the endotherm or exotherm reaches a maximum with thermal stability data obtained by an isoteniscope method. The two methods could be correlated by a linear equation.

DISCUSSION

Examination of the thermogravimetric analyses of the conditioned polymer samples suggests that copolymers of T.F.E. with H.F.P. (chain structure - $\text{CF}_2 \cdot \underset{\text{CF}_3}{\text{CF}} \cdot \text{CF}_2$ -) and perfluoroisobutene (chain structure - $\text{CF}_2 \cdot \underset{\text{CF}_3}{\text{C}} \cdot \underset{\text{CF}_3}{\text{CF}_2}$ -) have thermal stabilities very similar to that of P.T.F.E. (figure I, samples 3, 16, 18). Copolymers of T.F.E. with perfluoro-butene - 1, -pentene- 1, - heptene - 1, and - nonene - 1, have much reduced thermal stabilities (figure I, samples 7, 10, 15 and figure VI, samples 14, 15).

The thermograms of the copolymers 7, 10, 15 (co-monomers C_4F_8 , C_5F_{10} , C_9F_{18}) are very similar to each other. These copolymers consist of chains of CF_2 units with straight - chain branch lengths of 2, 3, and 7 carbon atoms, respectively.

These results suggest that for a branch length of more than one carbon atom, up to at least seven carbon atoms, there is a significant decrease in the thermal stability of the copolymer relative to P.T.F.E. Also this decrease appears to be independent of the branch chain length.

Figure III consists of the thermograms of the T.F.E. - H.F.P. copolymers. Samples 3, 4, 17 have similar thermal stabilities to P.T.F.E. and samples 1, 2 have stabilities intermediate between P.T.F.E. and the copolymers of T.F.E. with the olefins perfluorobutene to perfluorononene. Sample 3 has an apparent H.F.P. concentration

of 5 to 9 mole - % and sample 17 (produced by E.I. Dupont Limited) has an unknown H.F.P. concentration. However, a n.m.r. investigation³⁴ showed that there is about 9 mole - % H.F.P. present in Teflon 100. Sample 4 has an apparent H.F.P. incorporation of 21 - 53 mole - %. These results would indicate a small dependence of thermal stability upon concentration of co-monomer. However, samples 1 and 2 have significantly lower thermal stabilities, sample 1 having 7 to 17 mole - % H.F.P. and sample 2 an apparent incorporation of 2 mole - % H.F.P.

The thermograms in figure III indicate that thermal stability is independent of the concentration of branching. The maximum branching concentration occurs in homopolymers of these co-monomers. Both, poly-H.F.P. and polyperfluoroheptene (figure VIa.) have thermal stabilities much lower than P.T.F.E. In fact poly-H.F.P. decomposes almost completely after 30 minutes around 300° whereas sample 4 (21 - 53 apparent mole - % H.F.P.) was conditioned for many hours at 400°. Both poly- H.F.P. and polyperfluoroheptene give almost 100% yields of the monomers and it is possible that steric strain increases the efficiency of the initial scissions.⁹⁶

Figure IV consists of the thermograms of the copolymers of T.F.E. with perfluoro-olefins containing four carbon atoms. Sample 18 (co-monomer perfluoroisobutene) has a thermal stability similar to that of P.T.F.E. All the other samples (the co-monomer in samples 5, 6, 7

is perfluorobutene - 1 and in sample 19 is perfluorocyclobutene) have almost identical thermal stabilities (significantly lower than that of P.T.F.E.) even though the apparent concentration of perfluorobutene ranges from 2 mole - % (sample 5) to 19 - 45 mole - % (sample 7). Again there appears to be no dependency upon comonomer concentration. Perfluorocyclobutene does not appear to confer any greater thermal stability than the straight - chain olefins.

Figure V consists of the thermograms of the copolymers of T.F.E. with olefins containing five carbon atoms. Samples 10 (perfluoropentene - 1) and 20 (perfluoroisopentene - 1) have identical thermal stabilities, both significantly lower than that of P.T.F.E. Sample 9 (perfluoropentene - 1) gave rise to a curious thermogram in that it has a relatively low stability but after about 40% weight loss the thermogram is identical to that obtained from P.T.F.E. after 40% weight loss.

Figure VI consists of the thermograms of the copolymers of T.F.E. and perfluoro - heptene - 1 and - nonene - 1. These show identical and poor thermal stabilities relative to P.T.F.E.

In figure II a comparison is made between the thermograms obtained from P.T.F.E. (sample 16) and a sample of P.T.F.E. which had been irradiated in the presence of H.F.P. (sample 12). Their thermal stabilities are identical but the thermogram of sample 12 has the shape associated with the degradation of a copolymer.

All the thermograms have the same basic profile, similar to that obtained from P.T.F.E. The mode of degradation of P.T.F.E. is a free-radical mechanism thought to be the reverse of the polymerisation of T.F.E.⁹⁵ This involves "unzipping" of the polymer chain from the ends, followed by some rearrangement of the pyrolysis products:

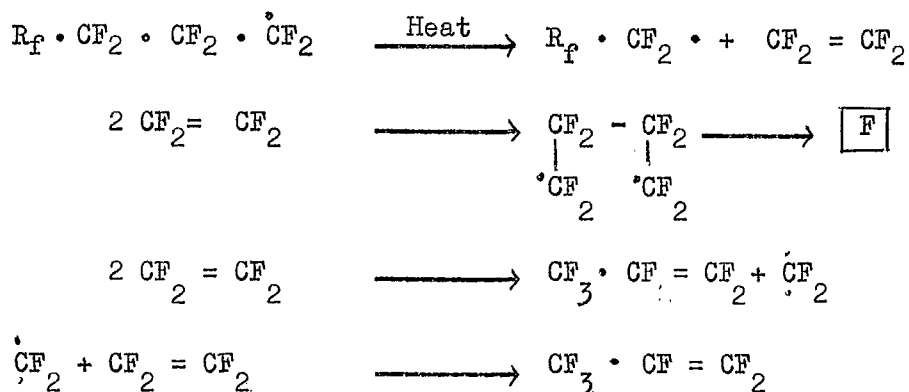

Analyses of the products obtained by pyrolysis - g.l.c. show that a large percentage of the original monomers are recovered. Thus, it seems reasonable to assume that in all the polymers analysed thermal degradation occurs by a free-radical "unzipping" process.

Many of the thermograms exhibit a step in the region of 20 to 40% weight loss. One construction that can be placed upon this is that random chain scission occurs at the site of a tertiary fluorine atom, i.e. where branching occurs, and that unzipping proceeds from these positions. This would give rise to initial volatile pyrolysis products rich in the co-monomer and the final volatile products would be

deficient in the comonomer. In fact Wall ⁹⁷ on pyrolysing a T.F.E. - H.F.P. copolymer, found that this did occur. At 10% decomposition, he found that the volatile product contained 85% H.F.P. and 9% T.F.E. whereas at 92% decomposition, the volatile material contained only 19% H.F.P. and 68% T.F.E.

Pyrolyses, with g.l.c. analysis of the volatile products, were carried out mainly using the filament pyrolyser. This method appeared to give the minimum number of rearrangement products, but it was still not possible to obtain a correlation between analyses obtained from material balance and those from pyrolysis - g.l.c.

Filament pyrolysis of a sample of P.T.F.E. gave a volatile product containing an average of 4% H.F.P. (table IX) at 800°. Using the boat pyrolyser at 700°, the same sample gave a volatile product containing an average of 11% H.F.P. and also an average of 8% perfluorocyclobutane.

Products obtained from boat pyrolysis of P.T.F.E. :

% C F 2 4	% C F 3 6	% C - C F 4 8
87	9	4
78	11	11
78	13	9

Under the pyrolysis conditions chosen P.T.F.E. gave 4% H.F.P. and 96% T.F.E. and copolymers of T.F.E. and H.F.P. gave varying amounts of the two co-monomers but no other product. Copolymers of T.F.E. with fluoro-olefins other than H.F.P. decomposed to give both co-monomers and other volatile products, including H.F.P. By considering that the T.F.E. and a small proportion of the H.F.P. (equal to $\frac{4}{96}$ ths. of the T.F.E.) were produced from long sequences of CF_2 units and that the remaining H.F.P. and all other products were produced by decomposition of the co-monomer, it is possible to obtain an analysis for each copolymer. Applying this method to samples 5 (2 mole - % perfluorobutene by material balance) and 8 (2 mole - % perfluoropentene by material balance) gave co-monomer incorporations of 29% C_4F_8 and 34% C_5F_{10} , respectively.

If one considers that all the H.F.P. produced came from degradation of long sequences of CF_2 units, and that all other volatile products, except T.F.E, were due to the co-monomer present, sample 5 would have an incorporation of 24% C_4F_8 and sample 8 would have an incorporation of 30% C_5F_{10} .

The errors arising from pyrolysis - g.l.c. analysis are quite large, for example, a series of analyses on sample 4 (T.F.E. - H.F.P. copolymer) gave the following results:

% C F 2 4	29	38	45	54	63
% C F 3 6	71	62	55	46	37

A major source of error is incomplete pyrolysis of the polymer. This is a consequence of the temperature gradient along the filament or may even be due to the sample falling off the filament. In the results quoted above for sample 4, the first three analyses (71, 62, and 55% C_3F_6) were obtained from samples which were thought to have fallen off the filament during pyrolysis. The volatile products would then be expected to contain a higher proportion of H.F.P. if one assumes that initial chain scission occurs at a branch in the chain. This appears to be the case in sample 4. It would appear that considerable refinement of this technique is required before meaningful results can be obtained.

The polymer samples produced by emulsion polymerisation in stainless steel tubes were all discoloured (yellow-brown). Analysis showed that this discolouration was due to the presence of inorganic impurities, including iron. These impurities must have been derived from the reaction vessel which did show signs of corrosion. One of these samples (1, figure III) has a thermal stability lower than anticipated. This may be due to the presence of these inorganic impurities in the polymer.

It was not possible to determine molecular weights or to fractionate any of the polymers produced because they were all insoluble in the reagents used. Thus, it was necessary to thermally condition the crude polymer samples before attempting thermogravimetric analyses. The conditioning procedure was to heat the crude polymer, isothermally in vacuo, at a temperature chosen from the thermogram of

the crude polymer, to constant weight. The temperature chosen was low enough to reduce decomposition to a minimum but high enough to remove all readily - volatile low molecular weight material. It was hoped that the polymer remaining would have a molecular weight high enough to be useful for t.g. analysis. This method appears to have been successful because the copolymers containing H.F.P. (samples 3 and 4; figure III) and perfluoroisobutene (sample 18; figure I) gave thermograms which suggested that their thermal stabilities were very similar to those of P.T.F.E. (sample 16; figure I) and a commercial sample of a T.F.E. - H.F.P. copolymer (sample 17, figure III). It is possible that the conditioned polymers had molecular weights similar to those of P.T.F.E. and the commercial T.F.E. - H.F.P. copolymer.

Madorsky and his co-workers⁹⁸ pyrolysed high molecular weight (2×10^6) polystyrene and found that after about 10% weight loss the molecular weight stabilised at about 40,000 to 60,000. This level of stabilisation was independent of the initial molecular weight and arose from thermal scissions of the polymer chain. These smaller chains then depolymerised by unzipping. On pyrolysing polystyrene samples which varied in molecular weight from 2×10^4 to 2×10^6 , these workers found that there was very little change in the rates of decomposition. Hence, in terms of thermal stability measurements the molecular weight of the polymer is not critical.

In the copolymers prepared by emulsion techniques, containing very small amounts of incorporation of one monomer (1%), it is possible that molecular weights may be calculated if one assumes that this monomer behaves as a chain terminating agent. For instance, Bro ⁵ claims to have made a copolymer of T.F.E. containing 0.8% perfluoroheptene. If this is 0.8 weight - % C_7F_{14} , this corresponds to 0.2 mole-% C_7F_{14} . On this basis, the polymer chains will consist of, on average, 499 molecules of C_2F_4 and 1 molecule of C_7F_{14} , i.e. the polymer will have an average molecular weight about 50,000.

EXPERIMENTAL

APPARATUS

Thermogravimetric analyses (t.g.a.) were carried out, in vacuo, using a Stanton Massflow thermobalance.

Pyrolysis - g.l.c. analyses were carried out on a Perkin Elmer 800 gas chromatograph.

Operating procedures

Thermogravimetric analyses were carried out as follows:

The polymer sample (ca. 20 mg.) was placed in a silica crucible which stood on a silica platform (1; diagram IV). This platform was mounted on a rod rising from the top of the rear balance - suspension piece of the thermobalance. The sample was covered by an alumina refractory sheath (2) and the whole enclosed in a gas tight furnace (3). The space inside the furnace was evacuated (ca. 10^{-4} torr) and then the temperature of the furnace was raised at a constant rate (3.5° /minute) until all the sample had disappeared. The furnace temperature and changes in sample weight were recorded simultaneously on a twin-pen electronic recorder (4). The pens were power-driven by servo motors and received their information from a platinum/rhodium - platinum thermocouple (5) and from a capacity follower plate, located over the balance beam. The follower plate follows every movement of the beam yet has no direct or mechanical contact with it.

Pyrolysis - g.l.c. analyses were carried out by one of two methods, in each case the pyrolysis unit was attached directly to the g.l.c. unit. One method was a boat pyrolysis. The apparatus was composed

DIAGRAM IV

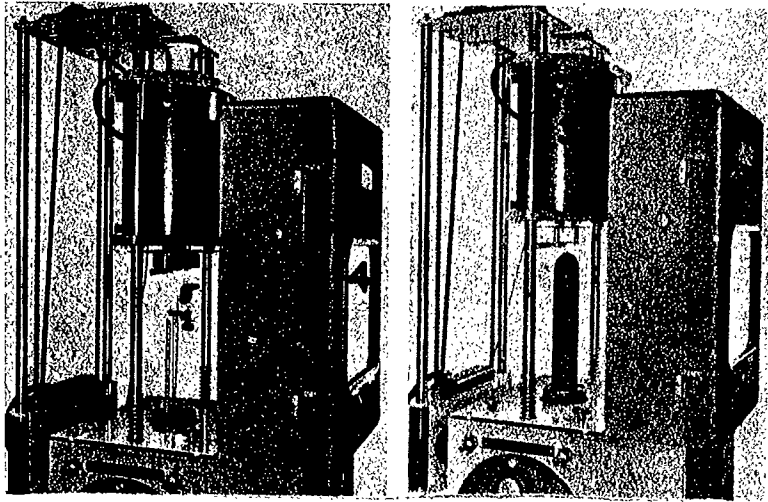
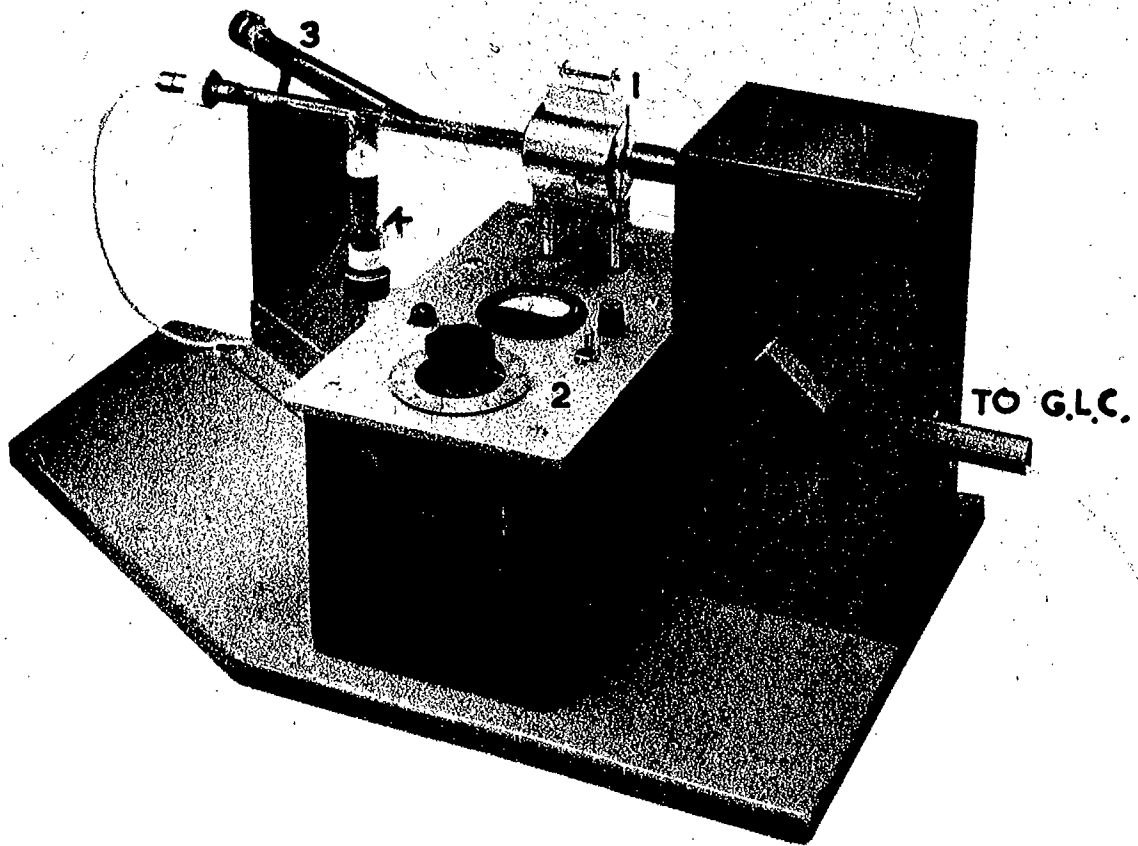

DIAGRAM V



of a quartz pyrolysis chamber with a furnace (1; diagram V) and an electrical control unit (2). The pyrolysis chamber had two attached tubes which served as storage places for the sample boats before (3) and after (4) pyrolysis, respectively. The weighed sample, in a silica boat, was moved inside the chamber with the help of an outside magnet which moved a short length of steel rod placed behind the boat. The chamber was pre-heated to the desired temperature and the pyrolysis products were purged, as a "plug", onto the chromatographic column by the carrier gas. The chromatograph was fitted with a silicone elastomer column (2m.) and a flame-ionisation detector, with nitrogen as a carrier gas (30 c.c./minute). The polymer was pyrolysed at 800° for 15 seconds then the pyrolysis products were passed onto the column at ca. 20° . The column was held at this temperature for 2 minutes then programmed, at 10° /minute, to 200° . Peak areas were measured by a Kent chromalog electronic integrator.

The other method was a filament pyrolyser (diagram VI). The pyrolysis unit was plugged into a septum cap attached to the end of the chromatographic column (at 1). Carrier gas entered one end of the unit and passed through onto the column. The polymer was held in a platinum-wire spiral (3) in the gas flow. The spiral filament was heated to the desired temperature for 10 seconds in a constant flow of carrier gas.

DIAGRAM VI

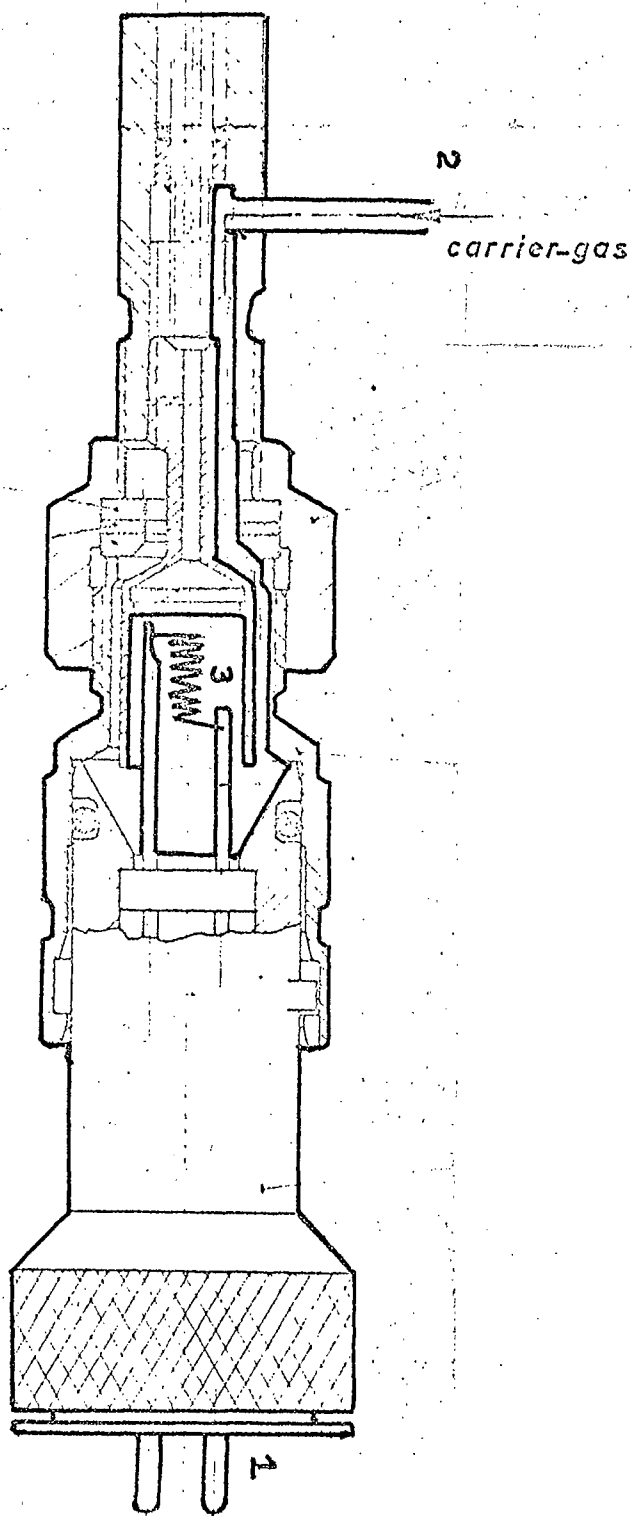

Polymer conditioning

A stepped-isothermal analysis was initially carried out on each crude polymer. The method used was to place a sample (ca. 20 mg.) of the crude polymer in the thermobalance, heat the sample to 200° and keep it at this temperature, in vacuo, until the polymer ceased to lose weight. The temperature was then raised 50° and the sample was heated until no further weight loss occurred. This procedure was repeated until all the sample had disappeared. From these analyses, a suitable temperature was chosen for conditioning each polymer such that all readily-volatile material could be removed. A larger quantity (ca. 0.5g.) of each crude polymer was then heated, at the temperature chosen for that polymer, in vacuo, until constant weight and further analyses were carried out on these conditioned polymers.

For the sake of completeness, the analyses of some polymers prepared in these laboratories by Dr. R. H. Mobbs have been included.

The polymer samples analysed, with apparent comonomer concentrations obtained by material balance or sources, are listed in table VII.

The thermogravimetric analyses of conditioned polymers are listed in table VIII.

The pyrolysis - g.l.c. analyses are listed in tables IX (unconditioned samples) and X (conditioned samples).

Figures I to VI are the thermogravimetric curves obtained from these copolymers.

TABLE VII.

Polymer number	Apparent % Comonomer incorporation by material balance or source.	Conditioning	
		°C.	hrs.
1	7-17 C ₃ F ₆	400	1.5
2	2 C ₃ F ₆	360	3
3	5-9 C ₃ F ₆	400	1
4	21-53 C ₃ F ₆	400	
5	0-2 C ₄ F ₈	220	15
6	40 C ₄ F ₈	300	1.5
7	19-46 C ₄ F ₈	300	
8	0-2 C ₅ F ₁₀		
9*	C ₅ F ₁₀	315	16
10	10-14 C ₅ F ₁₀	310	3
11	32-54 C ₅ F ₁₀		
12	2-23 C ₃ F ₆	390	1
13	13-41 C ₇ F ₁₄		
14	13 C ₇ F ₁₄	320	4
15	29 C ₉ F ₁₈	250	3.5
16	I.C.I. Fluon		
17	Dupont. Teflon 100		
18	R.H.Mobbs.iso.C ₄ F ₈	400	15
19	R.H.Mobbs.c-C ₄ F ₆	320	2
20	R.H.Mobbs.iso-C ₅ F ₁₀	300	15

* No analysis was available for this sample

TABLE VIII

Temp. °C.	% Weight Loss	Temp. °C.	% Weight Loss	Temp. °C.	% Weight Loss	Temp. °C.	% Weight Loss	Temp. °C.	% Weight Loss	Temp. °C.	% Weight Loss
Polymer	No. 1.	Polymer	No. 2.	Polymer	No. 3.	Polymer	No. 4.	Polymer	No. 5.	Polymer	No. 6.
200	2.4	400	2.9	480	1.5	270	2.5	300	3.9	340	3.1
300	4.0	410	5.4	490	3.8	315	3.7	320	4.4	360	6.1
400	4.8	430	12.9	500	11.5	360	4.9	340	7.4	380	14.9
420	6.4	450	25.3	510	23.8	405	6.1	360	12.8	400	24.9
440	9.7	470	42.8	520	27.7	445	7.8	380	23.7	430	55.9
460	22.6	490	63.2	530	30.8	465	10.2	400	41.9	440	69.5
480	60.9	500	71.4	570	30.8	490	14.3	420	67.5	460	82.1
500	84.2	510	76.4	585	96.9	515	31.6	440	89.2	480	90.0
520	91.1	520	78.5	590	100	530	31.6	460	96.1	500	93.1
540	92.3	530	79.6			540	44.7	480	100	520	94.4
560	93.9	540	80.3			555	55.7			540	94.4
580	96.7	560	82.8			580	91.4			560	94.8
600	97.9	570	96.4			600	100			580	95.3
		580	99.2							600	97.0
		590	100							620	97.9
										640	99.2

TABLE VIII (Continued)

Temp. °C.	% Weight loss	Temp. °C.	% Weight loss	Temp. °C.	% Weight loss	Temp. °C.	% Weight loss	Temp. °C.	% Weight loss
Polymer	No. 16	Polymer	No. 17	Polymer	No. 18	Polymer	No. 19	Polymer	No. 20
250	5.6	325	3.1	230	4.5	260	4.1	270	5.8
300	7.4	370	4.2	320	6.0	320	6.1	320	6.7
350	9.3	415	4.7	400	7.5	360	7.1	350	7.4
420	11.2	455	4.7	450	9.1	380	9.6	370	15.2
490	13.0	505	7.3	485	11.3	400	14.7	390	28.4
520	14.0	530	26.0	510	17.0	420	26.9	415	41.6
555	33.5	550	26.0	530	21.9	440	43.1	435	58.8
575	80.9	570	49.5	545	21.9	460	65.5	450	70.8
595	100	590	100	555	28.7	475	88.8	480	77.4
				575	54.7	495	96.7	500	84.0
				595	100	510	100	525	90.1
								545	98.4
								570	100

TABLE IX

These analyses were obtained, using the filament pyrolyser, from unconditioned polymer samples.

Polymer Number	Co-monomer	Peak Areas			
		% C ₂ F ₄	% C ₃ F ₆	% Co-monomer	% Remainder
P.T.F.E.		95	5		
		95	5		
		95	5		
		99	1		
		97	3		
1	C ₃ F ₆	54	46		
		58	42		
		53	47		
2	C ₃ F ₆	63	37		
		62	38		
		61	39		
3	C ₃ F ₆	78	22		
		77	23		
		80	20		
4	C ₃ F ₆	70	30		
		68	32		
		64	36		
12	C ₃ F ₆	91	9		
		91	9		

TABLE IX (Continued)

Polymer Number	Co-monomer	Peak Areas			
		% C ₂ F ₄	% C ₃ F ₆	% Co-monomer	% Remainder
5	C ₄ F ₈	60	12	15	13
		68	9	18	5
		49	15	14	22
		63	10	16	11
6	C ₄ F ₈	56	13	17	14
		75	10	10	5
		63	12	17	8
7	C ₄ F ₈	48	4	48	
		45	6	49	
		46	8	46	
8	C ₅ F ₁₀	76	10	3	11
		51	2	6	41
9	C ₅ F ₁₀	97	2	1	
		76	8	9	7
		85	6	6	3
10	C ₅ F ₁₀	56	11	25	8
		59	11	21	9
		57	14	18	11
		49	14	14	23
11	C ₅ F ₁₀	40	28	10	22
		34	24	15	27

TABLE X

After conditioning, there remained sufficient material to carry out pyrolyses on the following samples:

Polymer Number	Co-monomer	Peak Areas			
		% C ₂ F ₄	% C ₃ F ₆	% Co-monomer	% Remainder
1	C ₃ F ₆	40	60		
		46	54		
		51	49		
		45	55		
2	C ₃ F ₆	58	42		
		70	30		
		50	50		
		62	38		
4	C ₃ F ₆	63	37		
		54	46		
12	C ₃ F ₆	86	14		
		85	15		
		86	14		
		89	11		
5	C ₄ F ₈	79	9	9	3
		55	15	26	4
		67	10	23	
		60	12	24	4

TABLE X (Continued)

Polymer Numbers	Co-monomer	Peak Areas			
		% C ₂ F ₄	% C ₃ F ₆	% Co-monomer	% Remainder
6	C ₄ F ₈	57	6	21	16
		50	10	22	18
		65	9	10	16
9	C ₅ F ₁₀	93	6	1	2
		87	8	3	
		94	5	1	
		88	10	1	
10	C ₅ F ₁₀	84	9	7	8
		82	9	1	
		84	9	1	
18	i-C ₄ F ₈	78		22	
		83		17	
		74		26	
19	o-C ₄ F ₆	73	18	4	5
		77	18	2	3
20	i-C ₅ F ₁₀	67	17	6	10
		68	16	7	9

FIGURE I

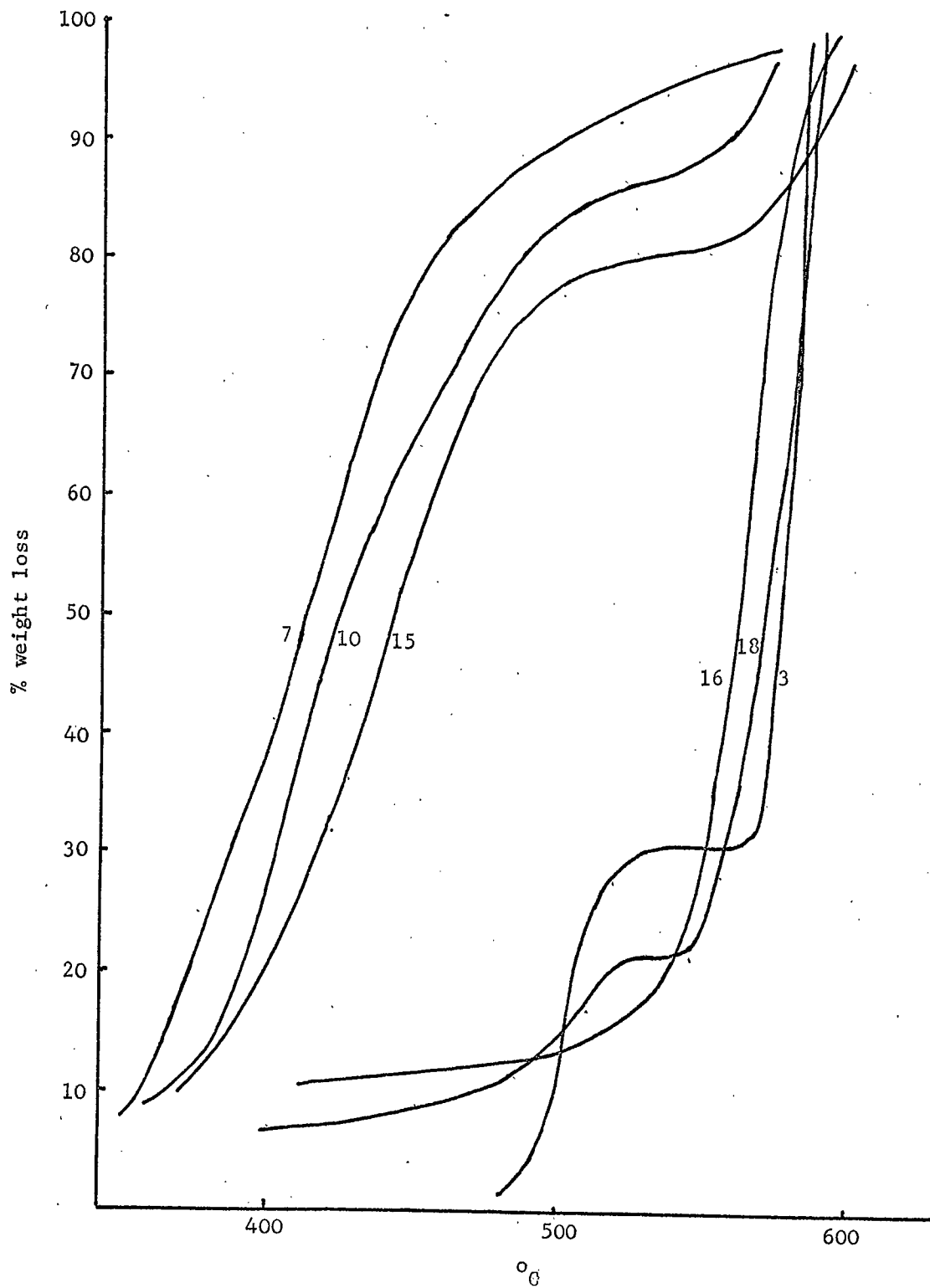
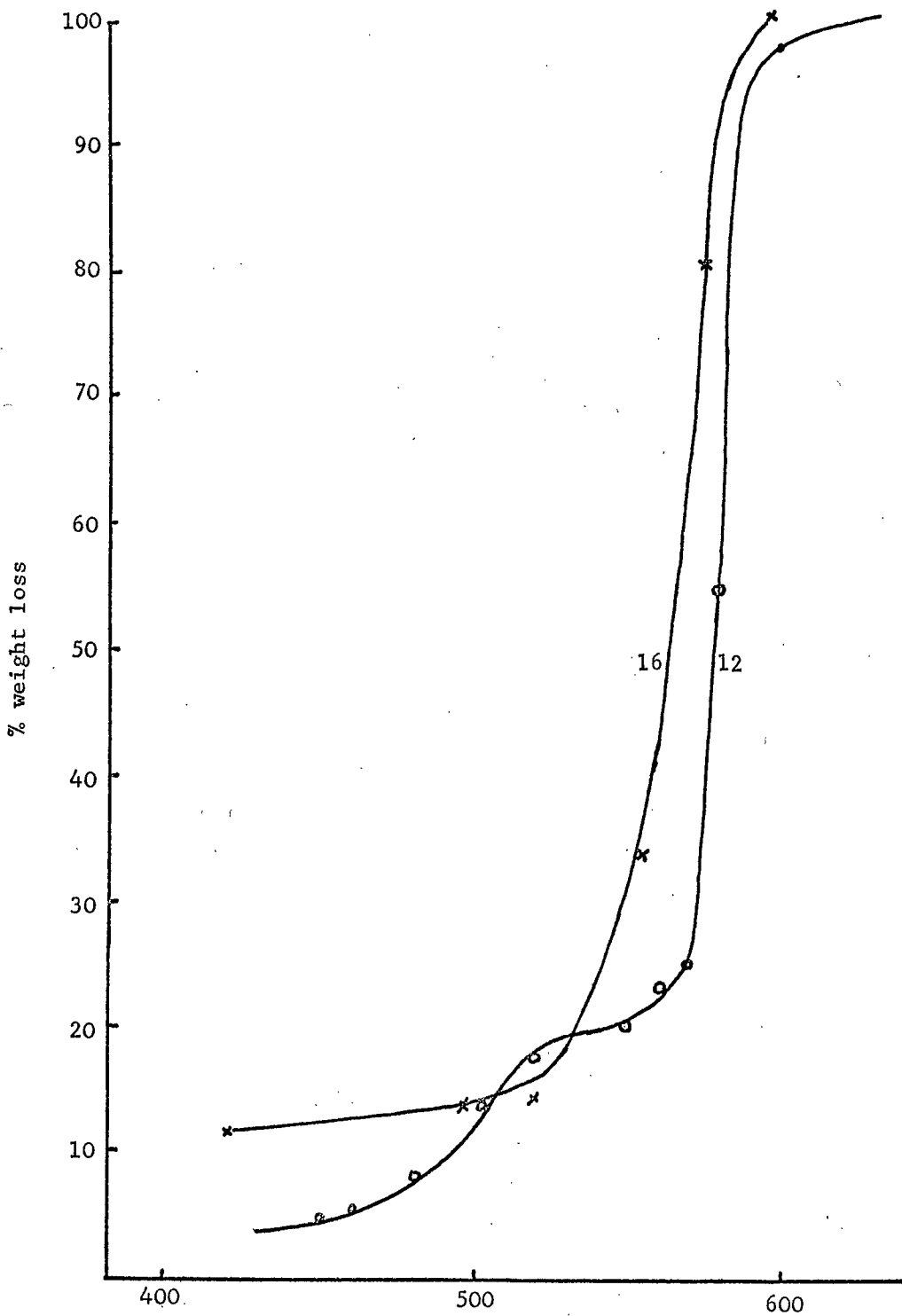

FIGURE II



0.5

FIGURE III

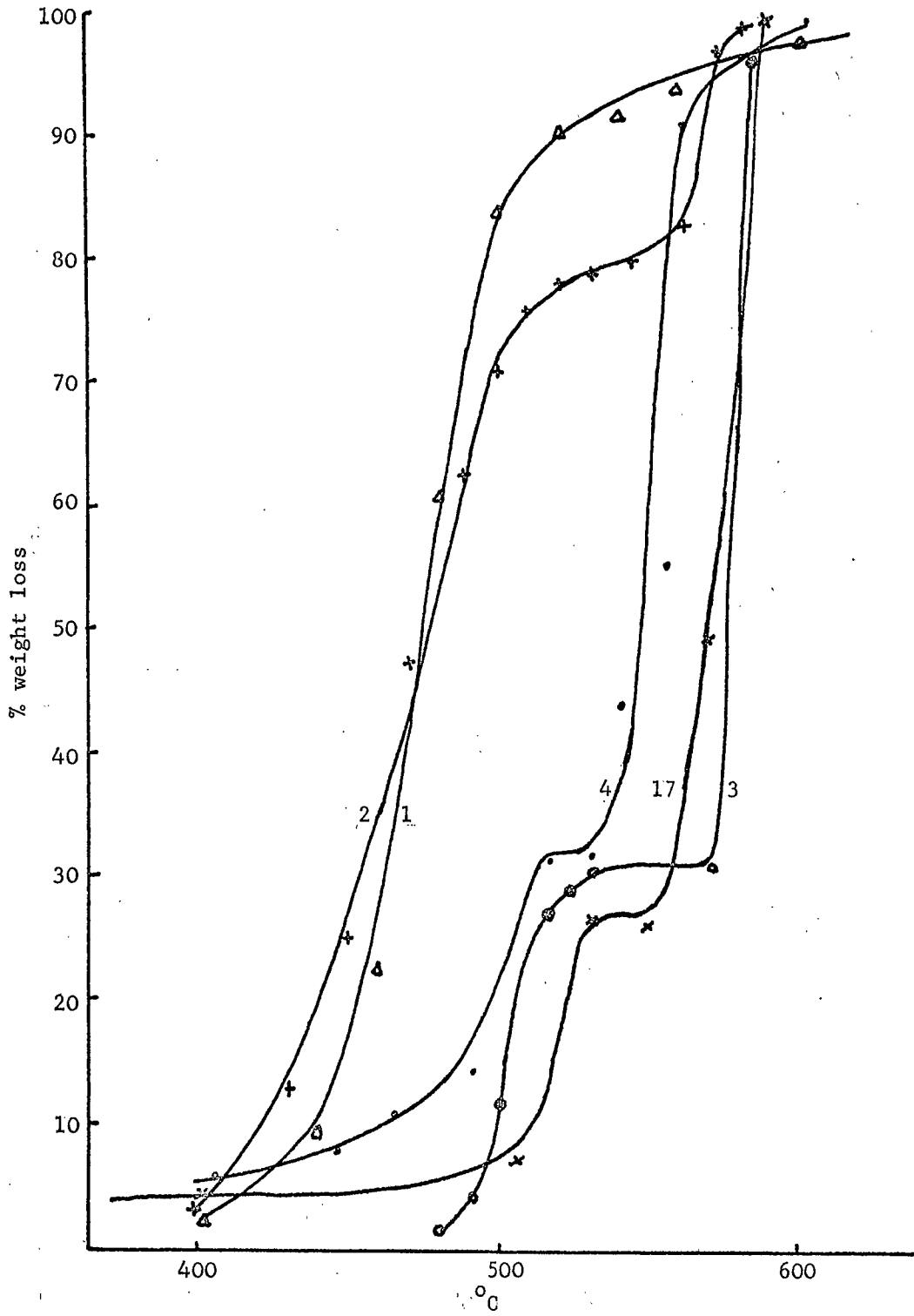

FIGURE IV

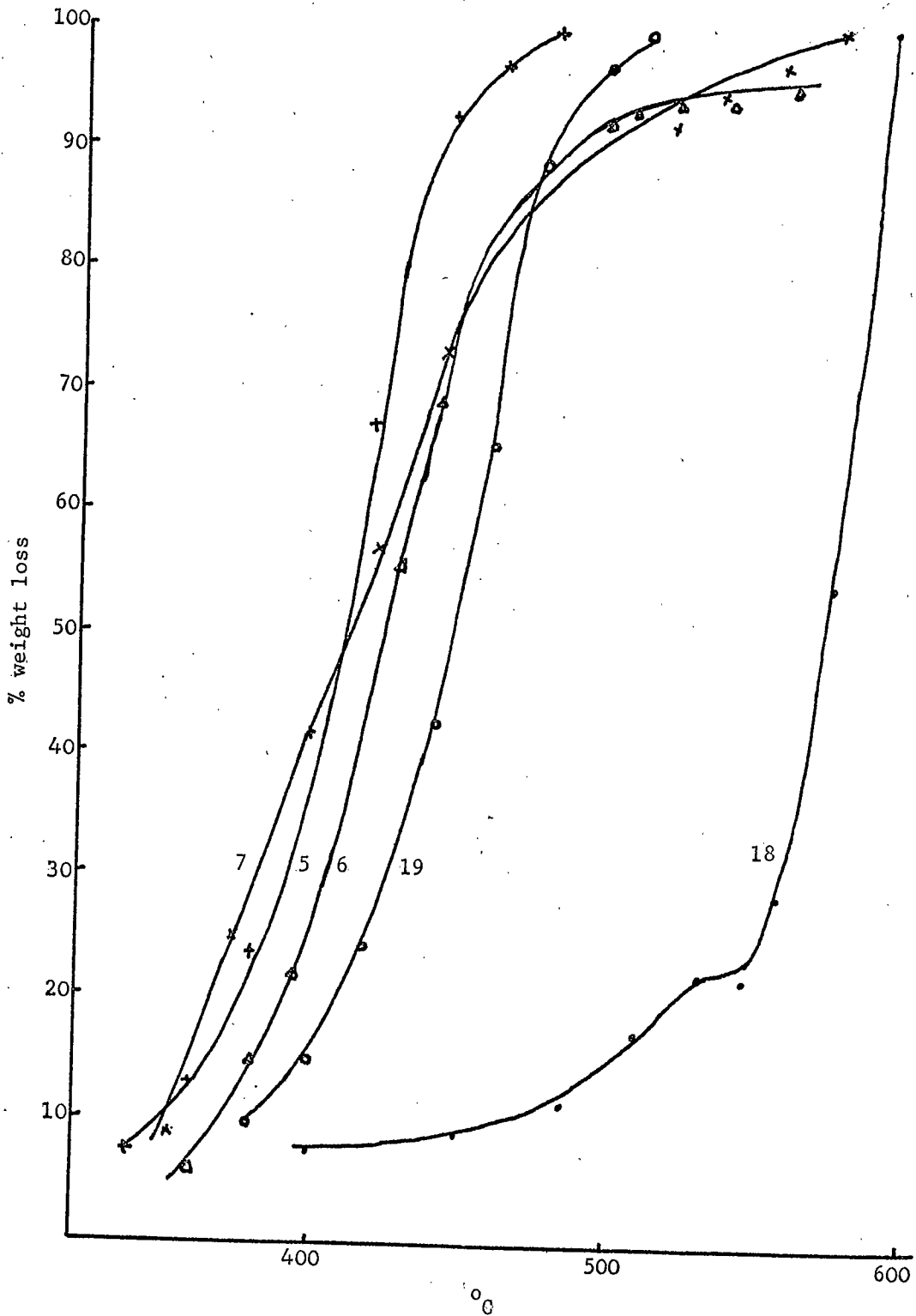

FIGURE V

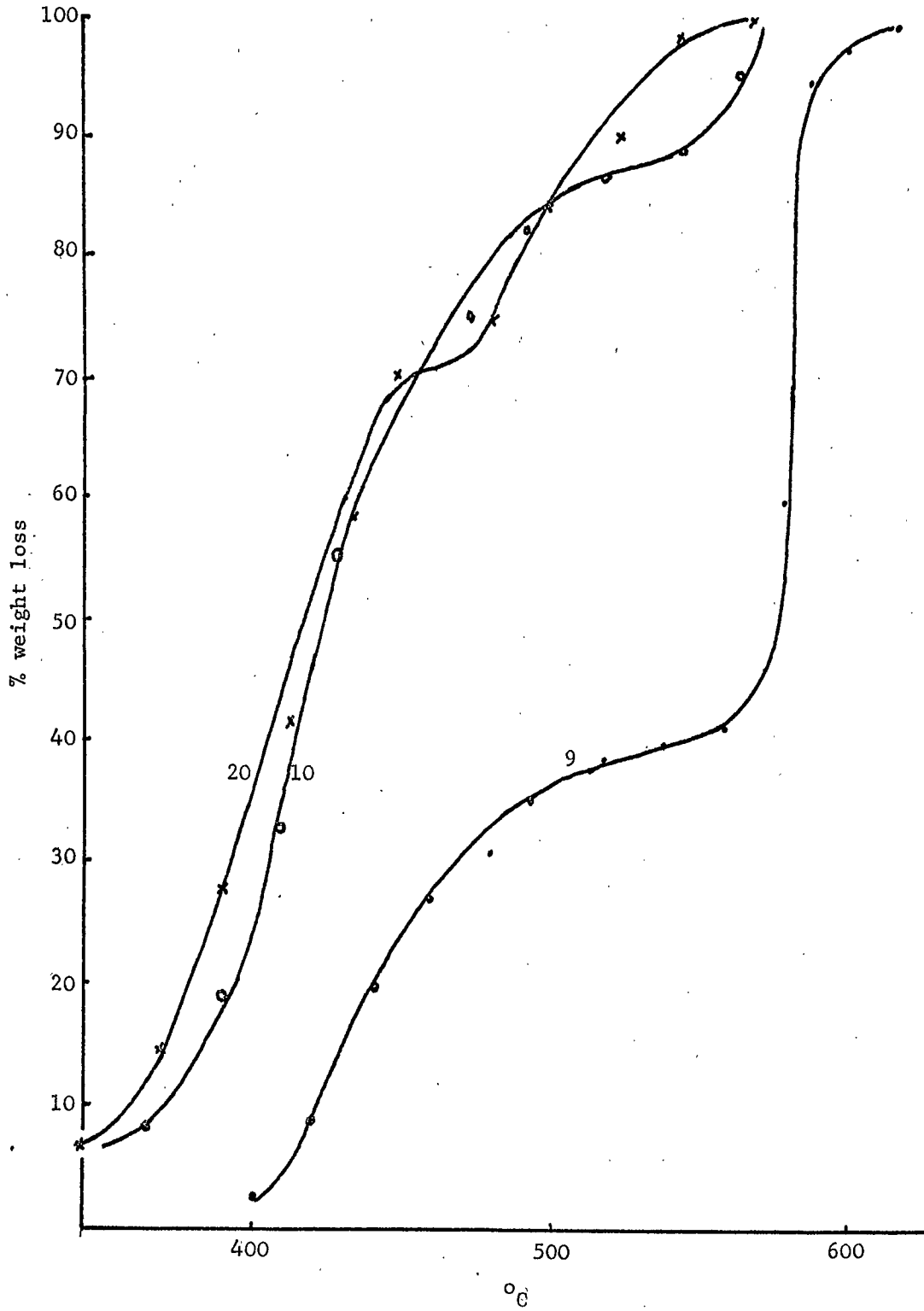

FIGURE VI

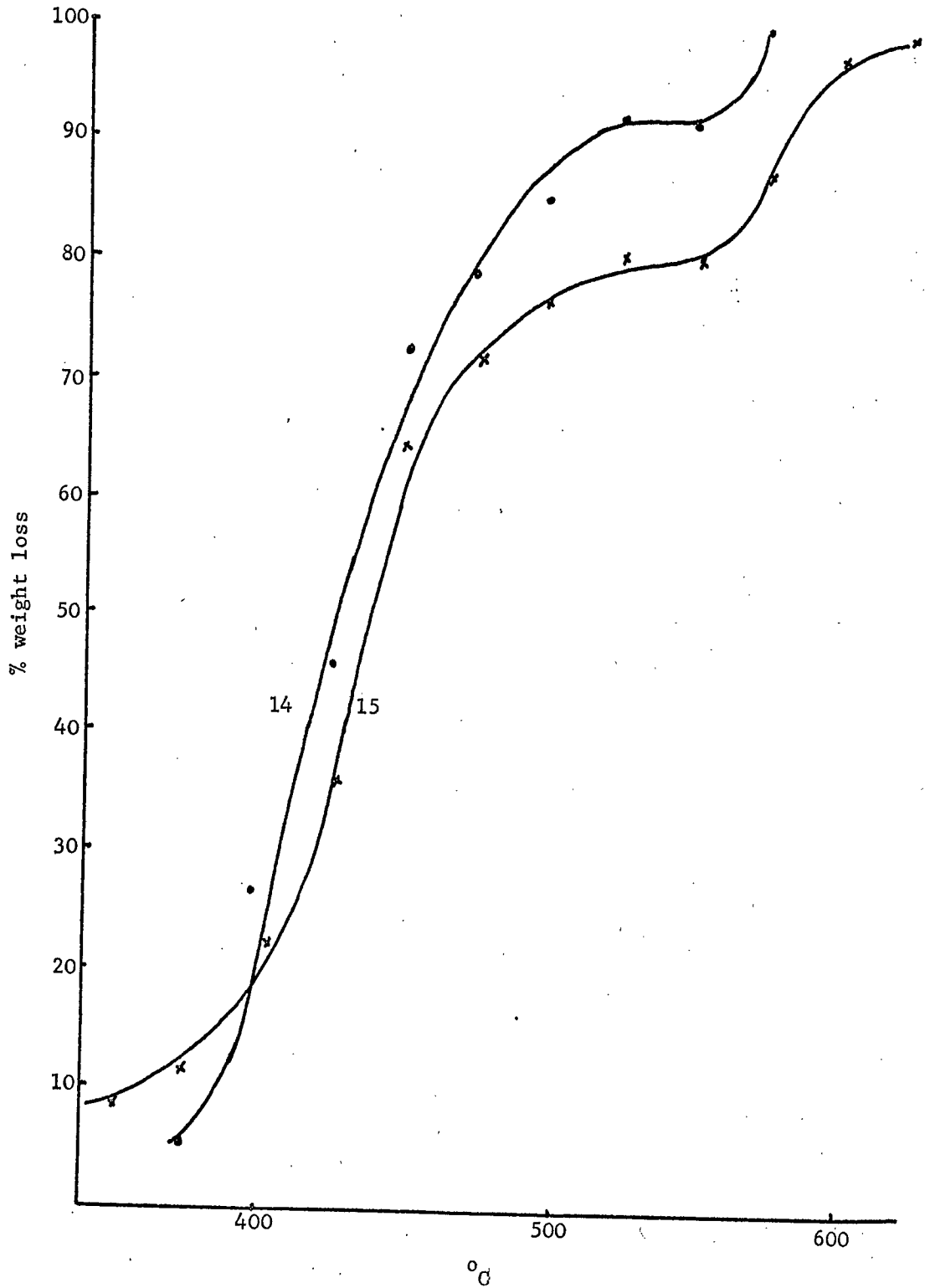
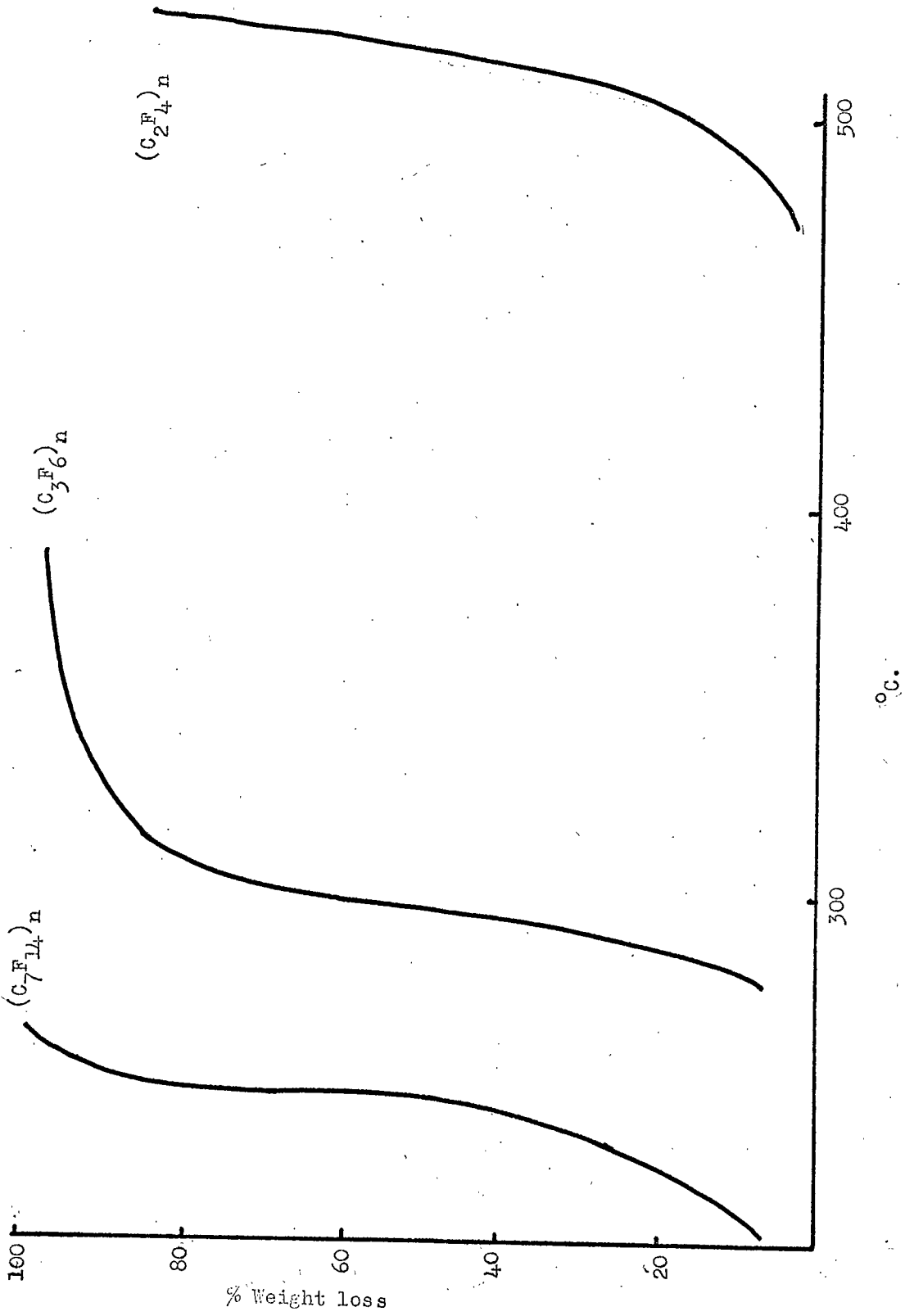

Figure VIa



SECTION 3

THE PREPARATION OF POLYFLUORIODOALKANES AND POLYFLUOROALKENES

I N T R O D U C T I O N

THE PREPARATION OF POLYFLUOROiodoALKANES

The reported preparations of polyfluoroiodoalkanes consist essentially of two methods. One method is the Hunsdiecker reaction. This involves heating the silver salts of perfluorinated carboxylic acids with iodine, in a sealed tube, for example, heating silver heptafluorobutyrate with iodine gives heptafluoropropyl iodide.⁵¹ The other method involves adding iodine or iodo-compounds to olefins. Thus, iodine will add to tetrafluoroethylene to give 1,2-di-iodotetrafluoroethane⁵² which, on further heating, gives compounds of general formula $I(C_2F_4)_nI$, where $n=1,2,3$.⁵³ Interhalogens, such as iodine mono-chloride and "iodine monofluoride" will also add to fluorinated olefins. All these reactions are carried out in autoclaves and great care must be taken since the reactions are highly exothermic and many explosions have occurred. An extension of this latter method is the telomerisation of fluorinated olefins, using perfluoroalkyl iodides as chain-transfer agents, for example, heptafluoropropyl iodide adds to vinylidene fluoride to give a series of compounds of formula $C_3F_7(CH_2CF_2)_nI$, where $n=1-5$.⁵⁵

THE PREPARATION OF POLYFLUOROALKENES

Polyfluoroalkenes can be prepared by the dehydrohalogenation of polyfluoroalkanes, having hydrogen and halogen on adjacent carbon atoms. This reaction is often base-catalysed⁵⁶ but examples of pyrolytic dehydrohalogenation have been reported.⁵⁷ Elimination of hydrogen iodide occurs preferentially when there is more than one halogen in the compound,

but dehydro-chlorination, -bromination, and -fluorination can also be carried out. Thus, treating 1-hydro-1,1,3-trichlorotetrafluoropropane with alcoholic sodium hydroxide gives 1,1,3-trichloro-2,3,3-trifluoropropene,⁵⁶ in 55% yield.

Under appropriate conditions, any combination of halogens, except F_2 and ClF , can be removed from vicinal dihalogeno-compounds, by treating with a metal, such as zinc or magnesium, in a polar solvent. The choice of solvent is important, for example, treating 1,2,3,4-tetrachlorohexafluorobutane with zinc in dioxan gives 40% of 3,4-dichlorobutene-1 and 15% of the diene, whereas treating with zinc in ethanol gives 98% diene.⁵⁸

Polyfluoro-olefins can also be prepared by pyrolysis of a variety of fluorinated compounds. Thus, the most important fluoro-olefin produced in industry, tetrafluoroethylene, is prepared by pyrolysing chlorodifluoromethane at 700° . The reaction proceeds through the formation, and then dimerisation, of difluorocarbene.⁵⁹ Tetrafluoroethylene (b.p. -76°) is conveniently stored as its homopolymer which can be depolymerised, at 600° and 5 mm.Hg, in good yield ($>90\%$). Pyrolytic elimination of hydrogen halide from fluorinated alkanes can occur, for example, heating 1-chloro-1,1-difluoroethane, at 870° in a silica tube, gives vinylidene fluoride (loss of HCl ; 67%) and 1-chloro-1-fluoroethene (loss of HF ; 31.5%).⁵⁷

Decarboxylation of the sodium salts of carboxylic acids, to give olefins, is a reaction unique to fluorinated acids. Terminally unsaturated olefins from tetrafluoroethylene to perfluorononene⁶⁰ have been prepared by this method. Recently the pyrolysis of an acid has been reported,⁶¹

2,2,4,4,4-pentafluorobutyric acid, at 620° and 120 mm.Hg, gave 1,1,3,3,3-pentafluoropropene, in 93% yield.

Dehydration of fluorinated alcohols, by concentrated sulphuric acid or phosphorous pentoxide, gives fluorinated olefins in good yields.⁶² However, this method sometimes fails, as in the case of 1,1,1-trifluoro-2-hydroxyoctane,⁶³ where the carbon-oxygen bond is said to be strengthened by the inductive effect of the adjacent trifluoromethyl group. In such cases, the olefin may be obtained by pyrolysis of the ester.

The carbonyl-oxygen of non-fluorinated ketones can be replaced by difluoromethylene:⁶⁴

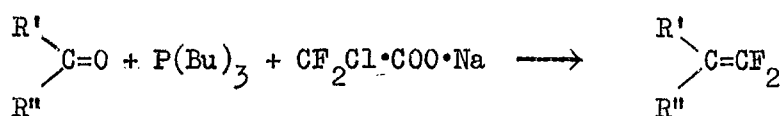

Alternatively, using fluorinated ketones:⁶⁵

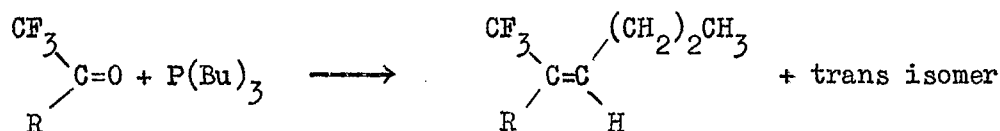

Another method, not generally applicable to hydrocarbon compounds, is the reaction of a fluorinated olefin with an organo-metallic compound. Methyl lithium⁶⁶ reacts with tetrafluoroethylene and chlorotrifluoroethylene, in ether at -80°, to give 1,1,2-trifluoropropene and 1-chloro-1,2-difluoropropene.

By heating tetrafluoroethylene with caesium fluoride, in an autoclave, Graham⁶⁷ has obtained a wide range of straight-chain and branched olefins,

and some dienes. The reaction product is usually extremely complex, for instance, on heating tetrafluoroethylene at 100° with caesium fluoride in diglyme, Graham obtained a reaction mixture containing the olefins perfluoro-octene (2 isomers), perfluorodecene (3 isomers), perfluorododecene (4 isomers), perfluorotetradecene (2 isomers), and a residue. The two isomers of the octene were the cis- and trans- forms of $C_2F_5(CF_3)C=C(CF_3)C_2F_5$.

Free-radical addition of halogenated alkanes to alkynes occurs readily, for example, pentafluoroethyl iodide reacts with acetylene, in an autoclave at 220-260°, giving 1-iodo-3,3,4,4,4-pentafluorobutene-1, in 72% yield.⁶⁸

THE PREPARATION OF POLYFLUORODIENES AND POLYFLUOROALLENES

Fluorinated dienes are prepared by the reactions already described, for example, α,ω -dienes have been prepared by the decarboxylation of fluorinated dicarboxylic acids⁶⁹, and by the Knunyant's method.⁵³ Haszeldine⁶⁹ obtained perfluorobutadiene, in 30% yield, by heating disodium perfluoroadipate.

Knunyant's method is described by the reaction scheme:

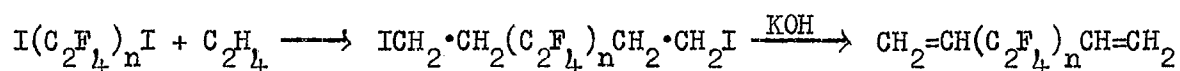

Yields of 48-75% are quoted for the dehydrohalogenation step. Ring opening of fluorinated cyclobutenes has also been carried out successfully,^{70,71} giving conjugated dienes, which can also be prepared by coupling vinyl iodides in the presence of copper-bronze.⁷² Thus, $C_2ClF=C_2FI$ couples to give a 14% yield of the three isomers of $C_2ClF=CF \cdot CF=C_2ClF$.

Unsaturation may be introduced, in specific positions, by dehalogenation or dehydrohalogenation of appropriate precursors, to give fluoro-dienes and

-allenes. Thus, 1,1-difluoroallene was prepared by debrominating 2,3-dibromo-3,3-difluoropropene,⁷³ and tetrafluoroallene was prepared by dehydrobrominating 1,1,3,3,tetrafluoro-3-bromopropene.⁷⁴ Allenes have also been prepared by isomerising fluoro-dienes, in the presence of caesium fluoride at 80°, for example, perfluoro-1,4-pentadiene gave a mixture of perfluoropent-2-yne and octafluoropenta-2,3-diene:⁷⁵

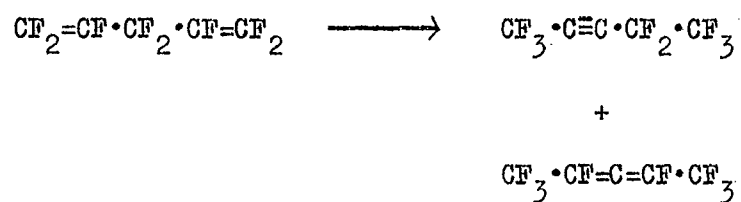

DISCUSSION

The preparation and properties of the perfluoroalk-1-enes, represented by the general formula $R_f \cdot CF=CF_2$ ($R_f = C_n F_{2n+1}$, $n=1-7$), have been reported.^{60,76,77} The olefins were prepared by pyrolysis of the sodium salt of the appropriate carboxylic acid.

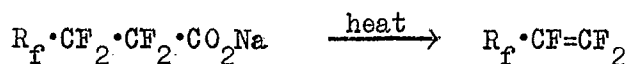

An alternative route to these olefins is represented by the following reaction scheme:

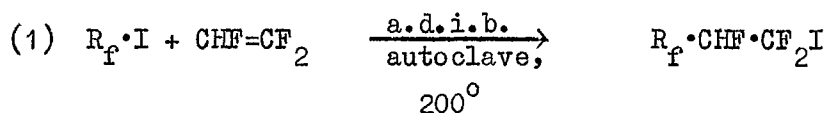

The second route to the perfluoroalk-1-enes appeared most attractive for this work, because the starting materials were readily obtainable and the reactions were suitable for relatively large scale work. Thus, trifluoroethylene was obtained (ca. 80% yield) by dechlorobromination of 1-chloro-1,2,2-trifluoro-2-bromoethane, $CHClF \cdot CF_2 Br$, using zinc in refluxing ethanol.

Haszeldine⁸⁰, in 1953, reported the additions of perfluoro-methyl and -ethyl iodides to tetrafluoroethylene, using ultra violet irradiation, giving respectively propyl iodide (81%) and perfluorobutyl iodide (91%). On carrying out the same reactions in an autoclave at 220° , he obtained perfluoropropyl iodide (51%) and implied a similar yield of perfluorobutyl iodide. Earlier, in 1949, Haszeldine⁹⁰ had reported that the addition of perfluoromethyl iodide to tetrafluoroethylene, using u.v. initiation, gave

mainly polytetrafluoroethylene and only traces of $\text{CF}_3(\text{C}_2\text{F}_4)_n\text{I}$, where $n = 1$ or 2 .

Perfluoroethyl iodide can be prepared in very high yield (ca. 80%) by the addition of "iodine monofluoride" to tetrafluoroethylene.⁵⁴ A similar method, but including antimony trifluoride in the reaction mixture, has been reported⁷⁹ which was said to produce perfluoroethyl iodide (48.8%), as well as perfluoro-butyl iodide (15.8%) and -hexyl iodide (12.3%). The preparation of perfluoropentyl iodide, in 76% yield, by the addition of perfluoropropyl iodide to tetrafluoroethylene, has also been reported.⁵⁵

Haszeldine⁸⁴ has also added perfluoromethyl iodide to trifluoroethylene and obtained a mixture of the isomers of the 1:1 adduct, in 85% yield. Park and his co-workers⁸⁹ reported the addition of iodine monochloride to trifluoroethylene and obtained 1-chloro-1,1,2-trifluoro-2-iodoethane, $\text{CF}_2\text{Cl}\cdot\text{CHF}_2\text{I}$, in 72% yield. Dehydrochlorination of this compound gave the olefin, $\text{CF}_2=\text{CFI}$, in 76% yield. Mobbs⁸¹ reported yields of up to 90% for the addition of perfluoro-isopropyl iodide to trifluoroethylene.

In view of the high yields reported in these reactions, it was considered that the second route to the preparation of the perfluoroalk-1-enes was suitable for preparing large quantities of the required materials.

Perfluoro-ethyl, -propyl, -butyl, -pentyl, -hexyl, and -heptyl iodides were prepared by one of the following reactions:

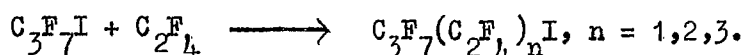
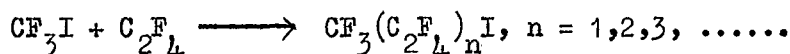

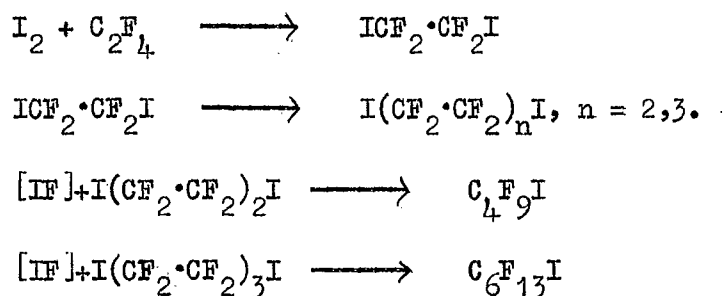

Perfluoro-ethyl, -propyl, and -heptyl iodides were bought from Peninsular Chemical Co. The properties of all these iodides have been reported,^{57,58} they were originally prepared by the Hunsdiecker reaction.

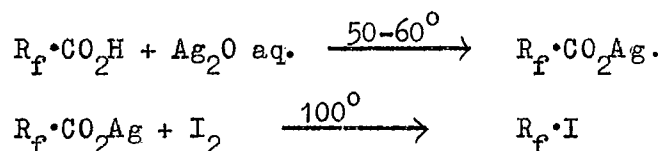

The addition of "iodine monofluoride" to tetrafluoroethylene, thought to proceed via an ionic mechanism,⁵⁴ was carried out by sealing tetrafluoroethylene, iodine, and iodine pentafluoride, in an autoclave in correct molar proportions, and reaction occurred while the autoclave warmed to room temperature from liquid air temperature. Occasionally no reaction occurred, even on heating to 100° and, on one such occasion, excessive heating resulted in corrosion of the autoclave top, liberating iodine and iodine pentafluoride vapours into the atmosphere.

Failure of reaction to occur was considered to be due to the formation of iodine oxyfluorides formed on storing iodine pentafluoride. However, using a commercial sample of iodine pentafluoride gave no better results. It was then considered that a catalyst was necessary and addition of iodine monochloride, also produced in the preparation of iodine pentafluoride,

resulted in high yields of perfluoroethyl iodide.

The method reported to produce perfluoro-ethyl, -butyl, and -hexyl iodides with an antimony trifluoride catalyst was attempted, following the literature report as carefully and accurately as possible, but perfluoroethyl iodide was the only detectable reaction product.

Iodine pentafluoride was prepared by directing a stream of chlorine trifluoride, diluted with nitrogen, onto a layer of iodine crystals in a brass pot. Difficulty was often experienced in starting the reaction but this could be overcome by priming the iodine with liquid iodine pentafluoride. The material for priming was often obtained by carrying out the reaction on a small scale in a scrupulously dry, glass flask, giving greater control of this violent reaction.

The additions of the iodoalkanes, R_fI , to tetrafluoroethylene and trifluoroethylene occur by telomerisation reactions. These involve free-radical chain mechanisms requiring the steps initiation, propagation, and chain termination. With tetrafluoroethylene, thermal initiation was satisfactory but with trifluoroethylene, it was found necessary to use a chemical initiator.⁸¹ Termination in both cases was due to coupling of an iodine radical with the growing telomer radical. For tetrafluoroethylene, these steps are represented by the following:

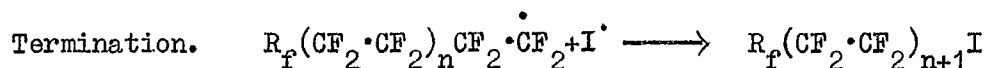
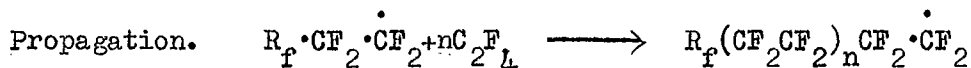
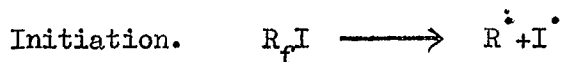

In practice, it was found that the best way to obtain the desired product in a series of compounds of general formula, $R_f(C_2F_4)_nI$, was to proceed stepwise i.e.



This was brought about by using a large excess (> 5:1 molar ratio) of iodoalkane over tetrafluoroethylene. This results in the 1:1 adduct being the major product.

However, the major product obtained on heating perfluoromethyl iodide and tetrafluoroethylene (molar ratio 5:1), in an autoclave at 200°, was a white solid and only 21% of perfluoropropyl iodide was obtained. This confirms Haszeldines earlier publication⁹⁰ in which he reported the production of polytetrafluoroethylene as the major product.

U.V. irradiation of a mixture of perfluoroethyl iodide and tetrafluoroethylene (molar ratio 8:1), in a Pyrex tube, was unsuccessful but, using a thin-walled glass tube (1 mm. wall thickness), perfluorobutyl iodide was obtained in 16% yield, compared with 91% reported by Haszeldine.⁸⁰ He also implied that this reaction could be carried out in an autoclave at 220°. However, on heating mixtures of perfluoroethyl iodide in molar ratios from 2:1 up to 8:1, and at temperatures of 220° to 300°, in an autoclave, negligible reaction occurred even in the presence of a chemical initiator.

The addition of perfluoropropyl iodide to tetrafluoroethylene (molar ratio 4:1), in an autoclave, gave perfluoropentyl iodide in 33% yield. A yield of 76% has been reported.⁵⁵

Additions to trifluoroethylene reported in the literature,^{88,89} were

initiated with u.v. irradiation. Mobbs⁸¹ found that thermal initiation was not sufficient and that a chemical initiator (α, α' -azobisisobutyronitrile) was required.

Perfluoro-ethyl, -propyl, -pentyl and -heptyl iodides readily add to trifluoroethylene in an autoclave with a chemical initiator, to give both isomers of the 1:1 adducts. The ratio of $R_f \cdot \text{CHF} \cdot \text{CF}_2\text{I}$ to $R_f \cdot \text{CF}_2 \cdot \text{CHF}\text{I}$ (measured by ^1H n.m.r. spectroscopy) varied from 3.7 to 5.6:1 and Haszeldine⁸⁸ found that addition of perfluoromethyl iodide gave both adducts in the ratio 4:1. Thus, free-radical addition occurs more readily at the =CHF end of the molecule than at the =CF₂ end.

In the theory of Walling and Mayo,⁸⁷ the orientation of addition is determined by the relative stability of the two possible intermediate radicals, and this in turn by the extent to which the odd electron is resonance-stabilised. By this theory, $R_f \cdot \text{CHF} \cdot \overset{\cdot}{\text{C}}\text{F}_2$, which is a tertiary radical with respect to hydrogen substitution, is more stable than $R_f \cdot \overset{\cdot}{\text{C}}\text{F}_2 \cdot \text{CHF}$, a secondary radical. Tedder and Walton,⁸⁶ on the other hand, propose that attention should be focussed on the strength of the bond formed, not on the site of the odd electron. However, the only way this can be done qualitatively is to examine the possible sites for the odd electron and then assume that the new bond is formed at the carbon atom which forms the least stabilised radical. This inevitably leads to the same predictions. Tedder and Walton argue that this is more logical because it draws attention to the substituents attached to the carbon atom and enables rate of attack at sites in different molecules to be compared

directly.

The structures of the two isomers, obtained from each of these reactions, were established by dehydrohalogenating the mixtures of isomers with potassium hydroxide at 90° . The only reaction product obtained under these conditions was the olefin, $R_f \cdot CF=CF_2$, which must have been produced by elimination of HI from $R_f \cdot CHF \cdot CF_2 I$. The unreactive isomer must have the only alternative structure, $R_f \cdot CF_2 \cdot CHF I$.

The 1H n.m.r. spectra of the series of compounds, $R_f \cdot CHF \cdot CF_2 I$ always consisted of a doublet of broad bands with a coupling constant of ca.4.2 c.p.s. This doublet arises from geminal H-F coupling since JH-F gem. is usually of the order of 40-80 c.p.s.⁸² Each member of the series contains an asymmetrically substituted carbon atom, C, and consequently is a racemic mixture. The analytical techniques available were unable to separate enantiomers.

The 1H n.m.r. spectrum of the series of compounds, $R_f \cdot CF_2 \cdot CHF I$, which also contains an asymmetrically substituted carbon atom, always consisted of a doublet (J=ca.4.8 c.p.s.) of doublets (J=ca.19 c.p.s.). The large coupling constant again arises from geminal H-F coupling. The smaller coupling constant possibly arises from vicinal H-F coupling with one of the fluorine atoms on the adjacent carbon atom. Since C is asymmetrically substituted, the two vicinal fluorine atoms will be in different environments:

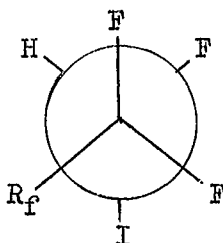

Detailed n.m.r. spectra were obtained from the products $C_2F_5(C_2HF_3)_nI$, where $n = 1$ and 2 .

The 1H spectrum of $C_2F_5 \cdot CHF \cdot CF_2I$, compound (a), consisted of a doublet of broad bands ($J = \text{ca. } 14.2$ c.p.s.) at -5.37 p.p.m. and the spectrum of $C_2F_5 \cdot CF_2 \cdot CHFI$, compound (b), consisted of a doublet ($J = 4.8$ c.p.s.) of doublets ($J = 19$ c.p.s.) at -7.50 p.p.m. with respect to T.M.S.

The ^{19}F spectrum of (a) consisted of a CF_3 group at -80.8 p.p.m., a CF_2 group at -40.0 p.p.m. and a second CF_2 group, shifted a long way downfield, at -111.5 p.p.m. There was also a CF group at $+28.8$ p.p.m. with respect to C_6F_6 . The downfield shift of the CF_2 group to -111.5 p.p.m. resulted from the fluorine atom being bonded to a carbon atom which was also bonded to iodine.

The ^{19}F spectrum of (b) consisted of a CF_3 group at -84 p.p.m., two CF_2 groups at -50.0 and -44.8 p.p.m., and a CF group at $+2.8$ p.p.m. The CF group is shifted downfield from that in (a), again this is due to the effect of an iodine atom bonded to the same carbon atom.

The mixture of isomers $C_2F_5(C_2HF_3)_2I$ could be resolved by g.l.c. into four components. Three of these components, denoted as (c), (d), and (e), were separated for analyses. Accurate mass measurements of the top mass peak in the mass spectrum showed that the three fractions had the same molecular formula, $C_6H_2F_{11}I$. These were initially considered to be three of the four possible structural isomers, $C_2F_5 \cdot CHF \cdot CF_2 \cdot CHF \cdot CF_2I$, $C_2F_5 \cdot CHF \cdot CF_2 \cdot CF_2 \cdot CHFI$, $C_2F_5 \cdot CF_2 \cdot CHF \cdot CHF \cdot CF_2I$, and $C_2F_5 \cdot CF_2 \cdot CHF \cdot CF_2 \cdot CHFI$. However, each of these structures has two asymmetrically substituted carbon

atoms and there are four possible optical isomers from each structural isomer.

The ^1H n.m.r. spectrum of fractions (c) and (d) were very similar to that of (a). Both consisted of a doublet of broad lines at -5.45 p.p.m., with coupling constants $J_c = 44$ c.p.s. and $J_d = 48$ c.p.s. This means that both fractions contain the structural unit $-\text{CF}_2 \cdot \text{CHF} \cdot \text{CF}_2-$. The two hydrogen atoms in each fraction must be in similar environments, resulting in overlap of their absorption bands. The structures of both these fractions now can be partly described as $\text{C}_2\text{F}_5(\text{C}_2\text{HF}_3)\text{CHF} \cdot \text{CF}_2\text{I}$.

The ^1H n.m.r. spectrum of fraction (e) consisted of a doublet ($J = \text{ca. } 42$ c.p.s.) of broad bands at -5.70 p.p.m. and a doublet ($J = 47$ c.p.s.) of doublets ($J = 18$ c.p.s.) at -7.65 p.p.m. By similar reasoning to that applied above, the hydrogen atom giving rise to the doublet of broad bands will be in the structural unit $-\text{CF}_2 \cdot \text{CHF} \cdot \text{CF}_2-$. The hydrogen atom giving rise to the doublet of doublets (the same system that occurs in the spectrum of fraction (b)) will be in the structural unit $-\text{CF}_2 \cdot \text{CHF} \cdot \text{I}$. Thus, the partial structure for fraction (e) is $\text{C}_2\text{F}_5(\text{C}_2\text{HF}_3)\text{CF}_2 \cdot \text{CHF} \cdot \text{I}$.

Further information on the structures of these compounds was obtained from their ^{19}F n.m.r. spectra. The low resolution ^{19}F spectrum of fractions (c) and (d) were very similar. Both consisted of a CF_3 group at -80 p.p.m., a CF_2 group at -110 p.p.m. and two other CF_2 groups in the region -50 to -36 p.p.m., and two CF groups in the region $+30$ to $+50$ p.p.m. The CF_2 groups at -110 p.p.m. confirm the presence of the unit CF_2I .

The ^{19}F spectrum of fraction (e) consisted of a CF_3 group at -80 p.p.m.,

a series of peaks, arising from three CF_2 groups, in the region -50 to -36 p.p.m., and two CF groups at +2 p.p.m. and +4.8 p.p.m. The CF group at +2 p.p.m. confirms the presence of the unit CHF .

The high resolution ^{19}F n.m.r. spectra of these fractions were extremely complex. The complete structures were deduced by comparing the fine structures of the CF_3 groups. In the fractions (a), (c), and (d), the CF_3 bands were split, basically, into doublets, with coupling constants ca. 11 c.p.s. This suggests that the CF_3 group is in a similar environment in all three compounds and therefore that they all contained the structural unit $\text{CF}_3 \cdot \text{CF}_2 \cdot \text{CHF}$ -. Thus, the same structural formula can be written for fractions (c) and (d):

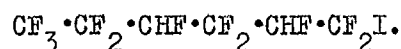

In fractions (b) and (e), the CF_3 bands were split, basically, into ill-defined triplets ($J=10.5$ c.p.s.). Following the same reasoning as above, this suggests that they both contained the structural unit, $\text{CF}_3 \cdot \text{CF}_2 \cdot \text{CF}_2$ -. Thus, the structural formula for (e) can be written as:

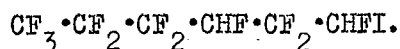

The doublet splitting of the CF_3 peak in compounds containing the structural unit $\text{CF}_3 \cdot \text{CF}_2 \cdot \text{CHF}$ -, and the triplet splitting of the CF_3 peak in compounds containing the unit $\text{CF}_3 \cdot \text{CF}_2 \cdot \text{CF}_2$ -, is consistent with previous reports that 1:3 F:F coupling is greater than 1:2 coupling in highly fluorinated molecules.⁸³

Although fractions (c) and (d) have the same structural formula, there is a very strong possibility that each fraction consists of a racemic mixture and that the two fractions are diastereo-isomeric. The four possible optical

isomers of (c) and (d) are represented in Fischer projections as:

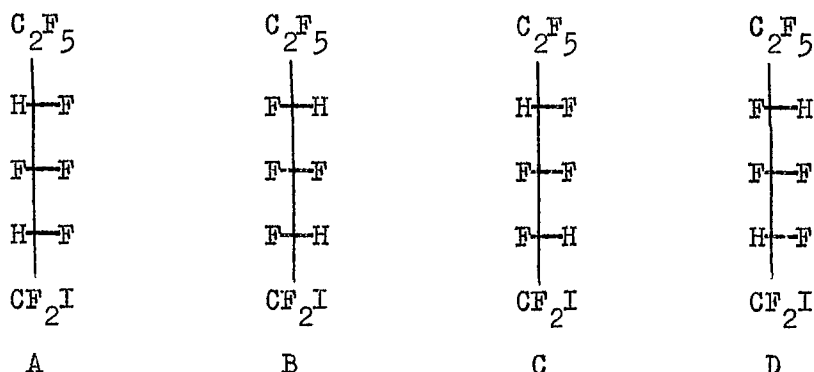

A and B, and C and D are enantiomers and A and B are each diastereo-isomeric with C and D. Fraction (e) can consist of either of the two possible racemic mixtures or it may consist of all four possible optical isomers.

Fractions (c) and (d) are the most expected products i.e. addition at the CHF end of both trifluoroethylene molecules, and (e) is the least expected product i.e. addition at the CF_2 end of both trifluoroethylene molecules.

Although it was considered that dehydrohalogenation did not readily occur when the hydrogen or the halogen atoms were attached to carbon also bonded to fluorine,⁵⁸ solid potassium hydroxide at 90° was found to dehydro-iodinate compounds of the general formula, $\text{R}_f \cdot \text{CHF} \cdot \text{CF}_2\text{I}$, quite readily. Under these conditions there was no elimination of HF from these compounds or from compounds of general formula, $\text{R}_f \cdot \text{CF}_2 \cdot \text{CHFI}$, but using more forcing conditions, molten potassium hydroxide at 200° , resulted in elimination of both HI and HF from highly fluorinated iodoalkanes. For example, dehydrohalogenating the mixed isomers of $\text{C}_2\text{F}_5(\text{C}_2\text{HF}_3)\text{I}$ at 90° gave octafluorobutene-1 as the only reaction product, but at 200° four products were isolated, two of which were characterised as octafluorobutene-1 (from compound (a)) and trans-1-iodoheptafluorobutene-2 (from compound (b)). The other two products were also

obtained by elimination of HF from compound (b).

Specific elimination of HI occurs on dehydrohalogenating with lithium chloride in N,N'-dimethyl formamide. A 53% yield of perfluorodecene-1, C_5F_{10} ,^{pentene} was obtained by dehydrohalogenating 2H-1-iododecafluoropentane, $C_5F_7 \cdot CHF \cdot CF_2I$, with this reagent whereas, using potassium hydroxide at 90° gave a 43% yield and at 200° gave a 73% yield of olefin.

Dehydrohalogenating the fractions (c) and (d), of $C_2F_5(C_2HF_3)_2I$, with potassium hydroxide at 200°, gave a series of compounds of molecular formula, C_6F_{10} . These included four isomeric hexadienes i.e. they had two absorptions in their infra red spectra in the region 5.5μ to 6.0μ, and a fifth compound with an absorption at 4.95μ. The fifth compound was considered to be an allene. An olefin was also produced with the formula C_6HF_{11} , which most probably had the structure $C_2F_5 \cdot CHF \cdot CF_2 \cdot CF=CF_2$. Further dehydrohalogenation of this olefin gave one of the hexadienes already isolated and the product considered to be an allene.

Many perfluorodienes have been reported, the majority being α,ω-dienes prepared by decarboxylating the sodium salts of perfluorodicarboxylic acids. However, there are very few routes to conjugated dienes, the method of coupling vinyl iodides⁷² has not been shown to be generally applicable and yields are low (ca. 14%). The preparations of dienes by ring-opening of cyclobutenes^{70,71} required many steps. A method has now been established which will readily give perfluorodienes of any desired chain length. Although there are a number of products obtained, one hexadiene occurred greatly in excess of the other products. It was thought that this was

possibly the perfluoro-1,3-hexadiene.

In an attempt to determine the scope of this reaction, a detailed examination was undertaken of the products obtained on dehydrohalogenating the isomers of $C_2F_5(C_2HF_3)_2I$.

The dehydrohalogenations carried out, using potassium hydroxide at 90° , generally gave an olefin yield in the range 30-40%. The reaction was carried out by forming a slurry of the iodo-alkane and powdered potassium hydroxide (in a molar excess of ca.4:1) which could be stirred while the mixture was heated at 90° . This was a most difficult technique and the reaction frequently failed due to inability to form the slurry. At 90° , potassium hydroxide forms a paste which is difficult to stir and, on several occasions, the glass flask was attacked to such an extent that all the product was lost through the small holes produced.

In an attempt to improve the olefin yield, the dehydroiodination was carried out with lithium chloride in N,N'-dimethyl formamide. The advantages were that lithium chloride is a better dehydrohalogenating agent and the reaction was carried out in a homogeneous phase which could be easily agitated. However, in the one reaction attempted, the increased yield of perfluorodecene (from 43% to 53% by this method) did not seem sufficient to justify the labour involved. A great deal of effort was required to dry, and keep dry, the hygroscopic lithium chloride. This was dried by refluxing with thionyl chloride, which was removed by boiling, the last traces being removed under vacuum. The anhydrous lithium chloride was stored in an atmosphere of nitrogen.

In both of these methods of dehydrohalogenating, the volatile olefin

fraction was removed from the site of reaction by blowing a stream of nitrogen through the apparatus. The olefin was trapped out of the nitrogen stream in a flask cooled in liquid air.

Both of these methods resulted in a great deal of contamination of the olefin by unreacted starting materials. This contamination is serious because the iodoalkanes are excellent chain transfer agents and would prevent polymerisation. It was found that these iodoalkanes co-distill with the olefins during fractional distillation even though the boiling points are far apart ($C_4F_8, 0^\circ$; C_4HF_8I (mixed isomers), 94°). The only way that 100%-pure olefins could be obtained was by preparative-g.l.c. of large quantities (ca. 10 g.) and taking a very small middle cut from the olefin fraction.

A method which gave high yields of olefin (e.g. 95% for the preparation of perfluoroheptene), and very little contamination by starting material, was dehydrohalogenating with molten potassium hydroxide at 200° . The iodoalkane was vaporised in a tube, heated to about 150° , through which a stream of nitrogen was flowing. This stream of vapour was then bubbled through a tube containing molten potassium hydroxide and the reaction products were collected in a tube cooled in liquid air. This provided a continuous method and so, when accidents did occur, there was very little loss of material.

Care must be taken when using this method to ensure that there is sufficient potassium hydroxide to keep the reaction mixture liquid. Solid potassium iodide and fluoride are precipitated during the reaction and can quickly block the tubes through which the nitrogen flows. The build-up of pressure can be dangerous because it is likely to result in spraying molten potassium

hydroxide about.

On dehydrohalogenating the mixture of isomers of $C_2F_5(C_2HF_3)I$ at 200° , four products were obtained. It was apparent that the isomer $C_2F_5 \cdot CF_2 \cdot CHF_2I$ had reacted, hence, it was necessary to obtain samples of each structural isomer to determine the products of reaction of each isomer. Separation of these isomers proved extremely difficult and small samples (ca. 3 g.) of each structural isomer were obtained by repeatedly enriching samples of each isomer, using preparative-g.l.c.

The isomer $C_2F_5 \cdot CHF \cdot CF_2I$, with potassium hydroxide at 200° , gave only octafluorobutene-1. However, $C_2F_5 \cdot CF_2 \cdot CHF_2I$ gave three products which were separated by preparative-g.l.c., sufficient quantities of each pure product were isolated to be analysed by g.l.c., infra red and mass spectroscopy. Accurate mass measurements of the parent peaks of the three compounds showed that they all had the molecular formula, C_4F_7I . Product 1 had a characteristic C=C absorption in its infra red spectrum at 5.74μ , product 2 had a weak, broad absorption at 5.77μ , and product 3 did not absorb in the region $5-6\mu$.

Sufficient material of product 3 was accumulated to carry out a ^{19}F n.m.r. analysis. The spectrum consisted of a CF_3 group at -77.2 p.p.m., a CF_2 group at -42.2 p.p.m., and vinylic fluorines (split into doublets) at -51.5 and -16.2 p.p.m. with respect to C_6F_6 . The coupling constant (J_{2-3}) for the vinylic fluorine peaks is 152.2 c.p.s. Emsley⁸⁵ and his co-authors quote the following coupling constant ranges for vinylic fluorine atoms; trans olefins $115-131$ c.p.s. and cis olefins $35-58$ c.p.s.

The only possible configuration for this molecule is trans-1-iodoheptafluorobutene-2.

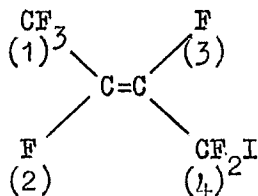

The high resolution spectrum of the CF_2 peak consists of a doublet ($J=28.2$ c.p.s.) of doublets ($J=15.5$ c.p.s.) of quartets ($J_{1-4}=2.8$ c.p.s.). The coupling constant 2.8 c.p.s. undoubtedly arises from 1:4 coupling and the two sets of doublets arise from 2:4 and 3:4 F:F coupling. It is not possible to say which fluorine causes which coupling.

The CF_3 peak in high resolution is quite complex however, it can be shown to fit the scheme caused by overlapping of a doublet ($J=5$ c.p.s.) of doublets ($J=5$ c.p.s.) of triplets ($J_{1-4}=2.8$ c.p.s.). The two doublet splittings (J_{1-2} and J_{1-3}) both have coupling constants of 5 c.p.s. However, these couplings may well have opposite signs (and hence differ by 10 c.p.s.) thus, being comparable in size with the difference (12.7 c.p.s.) in their values found on examining the CF_2 peak.

Product 1 from this reaction was taken to be 1-iodoheptafluorobutene-1, from the intensity of its C=C absorption in the infra red spectrum. Product 2 is another olefin and is likely to be a geometric isomer of either product 1 or 3.

Product 1 arises from direct loss of the elements of hydrogen fluoride from $\text{C}_2\text{F}_5 \cdot \text{CF}_2 \cdot \text{CHF}_2$. The reaction mixture then contained F^- which could

attack the terminal carbon atom giving the anion $\text{CF}_3 \cdot \text{CF}_2 \cdot \overset{-}{\text{CF}} \cdot \text{CF}_2 \text{I}$.

4 3 2 1

Loss of F^- from carbon atom 3 results in isomerisation to 1-iodoheptafluorobutene-2.

Dehydrohalogenation at 200° of $\text{C}_2\text{F}_5 \cdot \text{CHF} \cdot \text{CF}_2 \text{I}$, $\text{C}_3\text{F}_5 \cdot \text{CHF} \cdot \text{CF}_2 \text{I}$, $\text{C}_5\text{F}_{11} \cdot \text{CHF} \cdot \text{CF}_2 \text{I}$, and $\text{C}_7\text{F}_{15} \cdot \text{CHF} \cdot \text{CF}_2 \text{I}$, gave the olefins perfluorobutene-1 (52%), -pentene-1 (73%), -heptene-1 (95%), and -nonene-1 (55%). Reduction of losses, inherent in handling volatile materials, resulted in higher olefin yields as the olefins increased in molecular weight. This reached a maximum for perfluoroheptene. The higher boiling olefins (C_9F_{18} , 123°) tended to condense around the top of the reaction vessel and were not easily removed. High material loss occurred on separating low boiling materials (b.p. $< \text{ca. } 70^\circ$) by g.l.c. because these compounds tended to form aerosols. This allowed them to blow through the traps on the carrier gas. This effect could be reduced by filling the traps with glass wool and vacuum transferring the material out of the trap.

On working-up the products obtained by dehydrohalogenating material from the reaction of perfluoropropyl iodide with trifluoroethylene, an unknown compound was isolated. Mass spectroscopy showed that this had the molecular formula C_7F_{12} and its infra red spectrum showed two C=C absorptions at 5.63μ and 5.88μ . This compound was possibly the 1,3-heptadiene, $\text{C}_3\text{F}_7 \cdot \text{CF}=\text{CF} \cdot \text{CF}=\text{CF}_2$, arising from dehydrohalogenation of the 1:2 adduct, $\text{C}_3\text{F}_7(\text{C}_2\text{HF}_3)_2\text{I}$, present as impurity.

In an attempt to show that this could provide a general route to perfluorodienes, a detailed examination was made of the products of

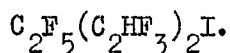

On dehydrohalogenating the total mixture of $\text{C}_2\text{F}_5(\text{C}_2\text{HF}_3)_2\text{I}$, with potassium hydroxide at 200° , the major product (ca. 90% of the total reaction mixture) was a compound with the molecular formula C_6F_{10} (from accurate mass spectrometric measurements), and its infra red spectrum showed two absorptions, of almost equal intensity, at 5.55μ and 5.80μ . It was considered that this was most likely to be perfluoro-1,3-hexadiene but an assignment could not be made solely from the infra red spectrum.

The second product isolated (ca. 5% of the total reaction mixture) had the molecular formula C_6HF_{11} (from accurate mass spectrometric measurements) and had a strong infra red absorption at 5.56μ . This must be 4H-undecafluoro-hexene-1, $\text{C}_2\text{F}_5 \cdot \text{CHF} \cdot \text{CF}_2 \cdot \text{CF} = \text{CF}_2$, formed by elimination of HI from $\text{C}_2\text{F}_5 \cdot \text{CHF} \cdot \text{CF}_2 \cdot \text{CHF} \cdot \text{CF}_2\text{I}$. Further loss of HF from this molecule will give the 1,3- or the 1,4-diene. There were also a number of unidentified compounds produced in very small yields.

A sample of the undecafluorohexene was dehydrohalogenated to give the same diene as above, suggesting that this was an intermediate in the reaction sequence leading to the diene. It also gave another product with the formula C_6F_{10} . This did not absorb in the region $5.5-6.0\mu$ but had a very strong absorption at 4.95μ . Allene, C_3H_4 , absorbs at 4.87μ , 1,1-difluoroallene⁷³ at 4.95μ , tetrafluoroallene⁷⁴ at 4.87μ , and perfluoro-2,3-pentadiene⁷⁵ at 4.94μ . It seems reasonable to assume that this product is an allene, but it was not possible to distinguish between the 1,2- and the 2,3-diene.

The extremely tedious task of separating the four resolvable fractions

of $C_2F_5(C_2HF_3)_2I$ was accomplished by repeatedly enriching samples of each fraction by preparative-g.l.c. Eventually samples of three of the fractions, consisting of single components on g.l.c., were obtained in sufficient quantities to carry out the n.m.r. analyses which have been discussed in detail.

Dehydrohalogenating product (c), at 200° gave four products, all with the same molecular formula C_6F_{10} . The first product was identical with the first hexadiene obtained. Two other products were also hexadienes, with infra red absorptions at 5.59μ (strong) and 5.80μ (weak), and 5.55μ (strong) and 5.76μ (weak), respectively. The fourth product was identical with the compound postulated to be an allene.

Dehydrohalogenating product (d), $C_2F_5CHF \cdot CF_2 \cdot CHF \cdot CF_2I$, gave three products, the hexadiene first isolated, 1,4H-undecafluorohexene $C_2F_5 \cdot CHF \cdot CF_2 \cdot CF = CF_2$, and a fourth perfluorohexadiene.

Dehydrohalogenation, with potassium hydroxide, of 2H,4H-1-iodoundecafluorohexane results in initial loss of HI. Loss of HF can then give the 1,3- and/or the 1,4-hexadiene. At this stage the reaction mixture contains fluoride ion, F^- . This can catalyse the conversion of these hexadienes into other isomeric forms, including the allene. Miller and his co-workers⁷⁵ have used F^- catalysis to carry out similar isomerisations.

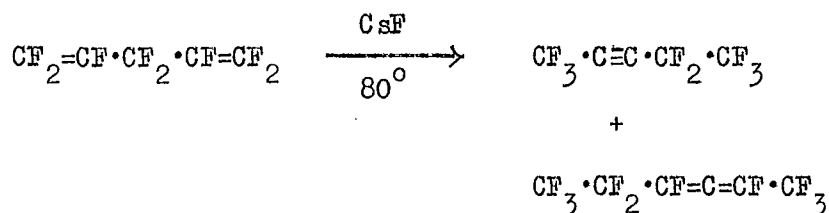

Dehydrohalogenating the product (e) gave ten products in similar yields. The g.l.c. trace showed that these consisted of five compounds with similar low retention times and five with similar high retention times. It was possible to affect a partial separation of these two sets of products by allowing the low boiling products to evaporate at room temperature, and 1 at., and recondensing them in a flask cooled in solid carbon dioxide. Five samples of these products were isolated by preparative-g.l.c. High resolution mass spectroscopy showed that they all had the molecular formula C_6F_9I , corresponding to the elimination of two molecules of HF. The infra red spectrum of four of these compounds showed that each contained two peaks in the region associated with C=C. It seems probable that the ten products form a series of isomers of the possible 1-iodononafluorohexadienes.

EXPERIMENTAL

APPARATUS

GAS LIQUID CHROMATOGRAPHY

This technique has been used extensively on both analytical and preparative scale. The analytical columns available were:

Column A: 2.2 m. x 6 mm. diameter stainless steel tube, packed with didecylphthalate on firebrick (20% w/w), temperature range - 10° to 165°.

Column O: 2.2 m. x 6 mm. diameter stainless steel tube, packed with silicone grease on firebrick (20% w/w), temperature range - 50° to 250°.

Column L: 4 m. x 6 mm. diameter stainless steel tube, packed with acetylacetone on firebrick (20% w/w), 0°.

Using hydrogen as carrier gas, the flow rates were 50 c.c./min. for columns A and L, and 160 c.c./min. for column O.

The preparative columns available were:

Column O: 6.5 m. x 12 mm. diameter copper tube, packed with silicone elastomer on Celite (20% w/w), temperature range 50° to 250°.

Column D: 6.5 m. x 12 mm. diameter copper tube, packed with dinonylphthalate on Celite (30% w/w), temperature range 20° to 100°.

Column E: 5 m. x 75 mm. diameter copper tube, packed with dinonylphthalate on Celite (30% w/w), temperature range 20° to 100°.

Using nitrogen as carrier gas, the flow rates were 200 c.c./min. for columns O and D, and 800 c.c./min. for column E. In all cases a katharometer detector was used, and products were trapped from the gas stream in glass traps cooled in liquid air. It was sometimes necessary to pack the traps with glass wool to facilitate trapping. The products were recovered by vacuum transfer.

SPECTRA

Mass spectra were measured on an A.E.I. MS9, double focussing mass spectrometer. Nuclear magnetic resonance spectra of ^1H and ^{19}F nuclei were measured on an A.E.I. RS2 and/or a Perkin Elmer R10 n.m.r. spectrometer. Chemical shifts are recorded in parts per million as being -, downfield, or +, upfield of the reference peak.

Infra red spectra were recorded on a Grubb Parsons spectrumaster and/or a Perkin Elmer 137 sodium chloride (infracord) spectrophotometer.

AUTOCLAVES

High pressure reactions were carried out in cylindrical, stainless steel autoclaves of 500 c.c. or 700 c.c. capacity. Volatile materials were introduced into the autoclaves by vacuum transfer. Mixing was achieved by rotating the autoclaves at 45° to the vertical inside an electrical heater, and was aided by including a short length of stainless steel rod inside the autoclave.

PREPARATION OF PERFLUOROALKYL IODIDES

IODINE PENTAFLUORIDE

Chlorine trifluoride, diluted with N_2 (ca. 1:1 v/v) was passed through iodine (50 g.), primed with iodine pentafluoride (ca. 20 g.), until a water-white liquid was formed (ca. 8 hrs.). The product was transferred to a dry flask (100 c.c.) and crystalline iodine (ca. 0.5 g.) added until the solution was brown. Distillation gave iodine pentafluoride (102 g; b.p. 98-101°; 1 at.).

TETRAFLUOROETHYLENE

Polytetrafluoroethylene chips (145 g.) were pyrolysed in a stainless steel tube (580-650°; 5 mm.Hg.). The volatile products (140 g.) were condensed in a glass trap cooled in liquid air, and fractionally distilled (Column 1; vacuum jacketed; 50 cm. x 2 cm. diameter; glass helices; 1 at.) to give:

1. Tetrafluoromethane (1 g; b.p. -128°).
2. Tetrafluoroethylene (130 g; b.p. -76°), with correct infra red spectrum.
3. A residual mixture (5 g.) of tetrafluoroethylene, hexafluoropropene, and octafluorocyclobutane, examined by g.l.c. (Column L).

PENTAFLUOROETHYL IODIDE

Iodine (102 g.) iodine pentafluoride (14 g.), and tetrafluoroethylene (100 g.) were sealed in an autoclave (500 c.c.). The autoclave, after warming slowly to room temperature, was heated to 100° for 14 hours. After cooling, the gaseous products (194 g.) were condensed and fractionally distilled (Column 1; 1 at.) to give:

1. Tetrafluoroethylene (25 g.).
2. Pentafluoroethyl iodide (166 g; b.p. 13°), both with correct infra red spectra.

1,2-DI-IODOTETRAFLUOROETHANE

Iodine (270 g.) and tetrafluoroethylene (100 g.) were sealed in an autoclave (500 c.c.) which was then heated for 14 hours at 200° . The volatile product (10 g; b.p. $< 20^{\circ}$) had the same g.l.c. retention time (Column L) as tetrafluoroethylene. G.l.c. analysis (Column O; 75°) of the liquid residue (24.0 g.) indicated a mixture of 1,2-di-iodotetrafluoroethane (ca. 95%) and 1,4-di-iodo-octafluorobutane (ca. 5%). Iodine (105 g.) was recovered. Preparative g.l.c. (Column O; 120°) gave pure samples of 1,2-di-iodotetrafluoroethane and 1,4-di-iodo-octafluorobutane, both with correct infra red spectra.

1,4-DI-iodo-octafluorobutane

Experiment 1.

1,2-Di-iodotetrafluoroethane (300 g.) was sealed in an autoclave (500 c.c.) and heated for 14 hrs. at 240° . The volatile product (12 g; b.p. $< 20^{\circ}$) was shown by g.l.c. (Column L) to consist of tetrafluoroethylene and pentafluoroethyl iodide. The liquid residue (160 g.) was fractionally distilled (30 cm. x 2 cm. diameter; Dixon gauzes; 1 at.) to give:

1. 1,2-di-iodotetrafluoroethane (101 g.)
2. 1,4-di-iodo-octafluorobutane (53 g.)
3. A residue consisting mainly of 1,6-di-iodododecafluorohexane (6 g.)

Iodine (80 g.) was recovered from the autoclave.

Experiment 2.

1,2-di-iodotetrafluoroethane (160 g.) was heated in a sealed autoclave (500 c.c.) for 1 hr. at $> 300^{\circ}$. The products consisted of: (a) A volatile fraction (5 g; b.p. $< 20^{\circ}$) shown by g.l.c. (Column L) to contain two components having the same retention times as tetrafluoroethylene and pentafluoroethyl iodide (trace), (b) a liquid residue (88 g.) which was fractionally distilled (vigreux column; 30 cm. x 2 cm. diameter; 1 at.) to give:

1. Pentafluoroethyl iodide (53 g.).
2. 1-iodononafluorobutane (16 g.).
3. 1-iodotridecafluorohexane (3 g.).
4. 1,2-di-iodotetrafluoroethane (7 g.).
5. A residue (7 g.) consisting mainly of 1,4-di-iodo-octafluorobutane.

All products had correct infra red spectra, (c) A large amount of iodine and carbonization products.

1-IODOHEPTAFLUOROPROPANE

Trifluoromethyl iodide (280 g.) and tetrafluoroethylene (140 g. added in 35 g. quantities) were sealed in an autoclave (700 c.c.). After each addition of tetrafluoroethylene, the autoclave was heated to 220° for 8 hours. The volatile product (331 g.) was condensed in a glass trap cooled in liquid air, and fractionally distilled (30 cm. x 2 cm. diameter column; glass helices; 1 at.) giving fractions consisting mainly of:

1. Trifluoromethyl iodide (265 g.).
2. 1-Iodoheptafluoropropane (19 g.).
3. 1-Iodoundecafluoropentane (13 g.).
4. A residue of 1-iodopentadecafluoroheptane (4 g.).

Each fraction was purified by g.l.c. (Column E; 50°) and the purified products identified by their infra red and/or mass spectra.

The autoclave contained a solid, white residue (55 g.) which turned pink in sunlight.

The large discrepancy in the material balance was due to loss of tetrafluoroethylene in the working-up procedure.

1-iodononafluorobutane

Experiment 1.

Pentafluoroethyl iodide (21.6 g.) and tetrafluoroethylene (1.2 g.) were sealed in a thin walled (1 mm.) Pyrex tube (50 c.c.). The gas phase was shielded by aluminium foil and the liquid phase was irradiated by ultra-violet light (Hanovia lamp at 15 cm.) for 3 hours with the tube rotating in a vertical position.

The volatile material (22.2 g.) was removed by vacuum transfer leaving some solid and high-boiling material (0.6 g.).

The volatile material was fractionally distilled (vigreux column 30 cm. x 2 cm. diameter; 1 at.) to give pentafluoroethyl iodide (20.1 g.) and a residue (2.1 g.). This residue was separated by preparative g.l.c. (Column O, 50°) to give:

1. Pentafluoroethyl iodide (1.1 g.).
2. 1-Iodononafluorobutane (0.8 g.).
3. 1-Iodotridecafluorohexane (0.2 g.).

The products were identified by their infra red and mass spectra.

Experiment 2.

Pentafluoroethyl iodide (115 g.) and tetrafluoroethylene (19 g.) were sealed in an autoclave (500 c.c.) which was then heated for 40 hours at

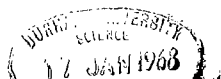

260°. Venting the autoclave gave volatile material (130 g.) leaving no residue in the autoclave. Fractional distillation (vigreux column; 30 cm. x 2 cm. diameter; 1 at.) of the condensed product gave a mixture (120 g.) of two components, having g.l.c. (Column L) retention times identical to tetrafluoroethylene and pentafluoroethyl iodide (major component), leaving a residue of 1-iodononafluorobutane (7.5 g.).

Experiment 3.

Iodine (84 g.), iodine pentafluoride (40 g.), antimony pentafluoride (0.6 g.) and tetrafluoroethylene (120 g.) were sealed in an autoclave (500 c.c.) which was then heated for 39 hours at 150°. The volatile products (96 g.) were shown by g.l.c. (Column L) to have the same retention times as pentafluoroethyl iodide and tetrafluoroethylene (trace). The liquid residue (38 g.), after washing (i. H₂O, ii. Na₂S₂O₅ aq.), and drying (MgSO₄), was fractionally distilled (20 cm. x 1 cm. column; Dixon gauzes) to give:

1. Pentafluoroethyl iodide (10 g.).
2. 1-Iodononafluorobutane (28 g.).

Experiment 4.

1,4-Di-iodo-octafluorobutane (210 g.) and iodine pentafluoride (55 g.) were sealed in an autoclave (500 c.c.) for 5 hours at 240°. The volatile products (4 g; b.p. < 20°) were shown by g.l.c. (Column L) to have the same retention times as tetrafluoroethylene, pentafluoroethyl iodide and 1-iodononafluorobutane. The liquid residue (127 g.), after washing (i. H₂O, ii. Na₂S₂O₅ aq.), and drying (MgSO₄), was fractionally distilled (30 cm. x 2 cm. diameter vigreux column; 1 at.) to give:

1. Pentafluoroethyl iodide (2 g.).
2. 1-iodononafluorobutane (33 g.).
3. 1-iodotridecafluorohexane (3 g.).
4. A residual mixture (98 g.) containing mainly
1,4-di-iodo-octafluorobutane.

The pentafluoroethyl iodide and 1-iodotridecafluorohexane were obtained from 1,2-di-iodotetrafluoroethane and 1,6-di-iodododecahexane impurities in the starting material.

1-IODOUNDECAFLUOROPENTANE

1-iodoheptafluoropropane (159 g.) and tetrafluoroethylene (9 g.) were sealed in an autoclave (500 c.c.) for 16 hrs. at 220°. Venting the autoclave gave tetrafluoroethylene (1 g.). The liquid residue (152 g.) was fractionally distilled (vigreux column; 30 cm. x 2 cm. diameter; 1 at.) to give:

1. 1-Iodoheptafluoropropane (118 g.).
2. 1-Iodoundecafluoropentane (24 g.).
3. A residue (10 g.) containing 1-iodopentadecafluoroheptane and 1-iodononadecafluorononane.

ADDITIONS OF PERFLUOROALKYL IODIDES TO TRIFLUOROETHYLENE

PENTAFLUOROETHYL IODIDE

Pentafluoroethyl iodide (310 g.), trifluoroethylene (15 g.), and α, α' -azobisisobutyronitrile (a.d.i.b.) (0.5 g.), were sealed in an autoclave (500 c.c.) which was then heated to 200° for 16 hours. The volatile product (311 g.; b.p. 20°) was condensed in a glass trap cooled

in liquid air, then fractionally distilled (Column 1; 1 at.) to give:

1. Pentafluoroethyl iodide (300 g.).
2. A mixture (10 g.) shown by g.l.c. (Column 0; 50°) to contain two components.

The liquid residue (14 g.) from the autoclave was fractionally distilled (30 cm. x 2 cm. diameter; Dixon gauzes; 1 at.) to give:

3. A mixture (11 g.) of two components with identical g.l.c. retention times as the components in fraction 2.
4. A residue (3 g.) shown by g.l.c. (Column 0; 75°) to be a complex mixture.

Fractions 2 and 3 were combined and the resulting mixture separated by g.l.c. (Column 0; 50°) to give pure samples of:

- (a) 2H-1-Iodo-octafluorobutane (mass spec. parent ion m/e 327.9006; calculated for C_4HF_8I 327.8997). The major fragments in the mass spectrum were 328, C_4HF_8I ; 239, C_3F_4I ; 201, C_4HF_8 ; 120, C_2HF_5 ; 113, C_3HF_4 ; 69, CF_3 . The 1H n.m.r. spectrum showed a doublet ($J=ca.4.2$ c.p.s.) of broad lines at -5.3 p.p.m. The ^{19}F spectrum showed 6 peaks at -112; -111; -80.8 (doublet, $J=ca.11$ c.p.s.); -4.0; -37.2; +28.8 p.p.m., with relative intensity ratios of 1:1:3:1:1:1 respectively.
- (b) 1H-1-Iodo-octafluorobutane (mass spec. parent ion m/e 327.9003). The major fragments were 328, C_4HF_8I ; 201, C_4HF_8 ; 119, C_2F_5 ; 113, C_3HF_4 ; 69, CF_3 . The 1H n.m.r. spectrum showed a doublet ($J=ca.4.8$ c.p.s.) of doublets ($J=ca.19$ c.p.s.) at -7.50 p.p.m.

The ^{19}F spectrum showed 5 peaks at -84 (doublet, $J=\text{ca.}11$ c.p.s.); -50 ; -44.8 ; -36 ; $+2.4$ p.p.m. with relative intensity ratios of 3:1:1:2:1 respectively.

The ^1H spectrum of the mixture in fraction 2 showed that the two isomers were produced in the ratio a:b = 4.5:1.

Fraction 4 was separated by g.l.c. (Column D; 90°) to give four components, each with the same molecular weight 410, $\text{C}_6\text{H}_2\text{F}_{11}\text{I}$ (mass spectroscopy). Three of these components were identified as:

- (c) 2H,4H-1-Iodoundecafluorohexane. The major fragments from the mass spectrum were 410, $\text{C}_6\text{H}_2\text{F}_{11}\text{I}_2$; 283, $\text{C}_6\text{H}_2\text{F}_{11}$; 177, CF_2I ; 113, C_3HF_4 ; 69, CF_3 . The ^1H n.m.r. spectrum showed a doublet ($J=\text{ca.}44$ c.p.s.) of broad lines, at -5.45 p.p.m. The ^{19}F spectrum showed 7 peaks at -110 ; -79.6 (doublet, $J=\text{ca.}11$ c.p.s.); -41.6 ; -38 ; -36 ; $+28$; $+48$ p.p.m. with relative intensity ratios of 2:3:2:1:1:1:1 respectively.
- (d) 2H,4H-1-Iodoundecafluorohexane. The mass spectrum fragmentation pattern was almost identical to that of (c). The ^1H n.m.r. spectrum showed a doublet ($J=\text{ca.}48$ c.p.s.) of broad lines, at -5.45 p.p.m. The ^{19}F spectrum showed 7 peaks at -110.8 ; -80 (doublet, $J=\text{ca.}11$ c.p.s.); -47.4 ; -38.6 ; -36 ; $+30$; $+50$ p.p.m. with relative intensity ratios of 2:3:1:2:1:1:1 respectively.
- (e) 1H,3H-1-Iodoundecafluorohexane. The major fragments from the mass spectrum were 410, $\text{C}_6\text{H}_2\text{F}_{11}\text{I}$; 245, $\text{C}_6\text{H}_2\text{F}_9$; 159, CHF_2I ; 151, C_3HF_6 ; 113, C_3HF_4 ; 69, CF_3 . The ^1H n.m.r. spectrum showed a doublet ($J=\text{ca.}44$ c.p.s.) at -5.70 p.p.m. and a doublet

($J = \text{ca. } 17$ c.p.s.) of doublets ($J = \text{ca. } 18$ c.p.s.) at -7.65 p.p.m. The ^{19}F spectrum showed 8 peaks at -80.8 (triplet, $J = \text{ca. } 11$ c.p.s.); -50.8 ; -44.8 ; -42.4 ; -40.8 ; -36.4 ; $+2$; $+4.8$ p.p.m. with relative intensity ratios of 3:1:1:1:2:1:1:1 respectively.

All chemical shifts were measured with respect to C_6F_6 and T.M.S. as external references. The relative proportions of the compounds (c), (d), and (e) were obtained by g.l.c. (Griffin and George gas density balance; Column A; 100°) to give the following ratios:

$$c:d:e = 1:4:4.5$$

1-IODOHEPTAFLUOROPROPANE

1-Iodoheptafluoropropane (296 g.), trifluoroethylene (20 g.), and a.d.i.b. (2 g.), were sealed in an autoclave (500 c.c.) which was then heated for 24 hours at 200° . The volatile product (3 g.; b.p. $< 20^\circ$) was shown by g.l.c. (Column L) to have the same retention time as trifluoroethylene. The liquid residue (311 g.) was fractionally distilled (30 cm. x 2 cm. diameter, vigreux column; 1 at.) to give:

1. 1-Iodoheptafluoropropane (246 g.).
2. A fraction (57 g.) which was shown by g.l.c. (Column O, 50°) to contain two components.
3. A residue (7 g.) which was shown by g.l.c. to be a complex mixture.

The two components in fraction 2 were separated by g.l.c. (Column O; 100°) to give pure samples of:

- (a) 2H-1-Iododecafluoropentane (mass spec. parent ion m/e 377.8989; calculated for $C_5HF_{10}I$ 377.8965). The major fragments in the mass spectrum were 378, $C_5HF_{10}I$; 127, I; 119, C_2F_5 ; 113, C_3HF_4 ; 69, CF_3 . The 1H n.m.r. spectrum showed a doublet ($J=ca.4.2$ c.p.s.) centred at -5.46 p.p.m.
- (b) 1H-1-Iododecafluoropentane (mass spectrum as for (a)). The 1H n.m.r. spectrum showed a doublet ($J=ca.4.8$ c.p.s.) of doublets ($J=ca.1.9$ c.p.s.) at -7.64 p.p.m.

The 1H spectrum of fraction 2 showed that the ratio of a:b = 5.5:1.

Chemical shifts were measured with respect to a T.M.S. external reference.

Fraction 3 was separated by g.l.c. (Column 0; 120^0) to give four components, each having the same molecular weight, 460, $C_7H_2F_{13}I$ (mass spectroscopy).

1-iodoundecafluoropentane

1-Iodoundecafluoropentane (242 g.), trifluoroethylene (15 g.), and a.d.i.b. (1.5 g.), were sealed in an autoclave (500 c.c.) which was then heated for 67 hours at 215^0 . The volatile product (0.5 g.; b.p. $<20^0$) had the same g.l.c. retention time (Column I) as trifluoroethylene. The liquid residue (248 g.) was fractionally distilled (vigreux column, 30 cm. x 2 cm. diameter; 1 at.) to give:

1. 1-Iodoundecafluoropentane (154 g.).
2. A mixture (53 g.) shown by g.l.c. (Column 0; 75^0) to contain two components.
3. A small amount (ca.10 g.) of tarry residue.

The autoclave also contained a small amount of tarry material. Fraction 2

was separated by g.l.c. (Column 0; 125°) to give:

- (a) 2H-1-Iodotetradecafluoroheptane (mass spec. parent ion m/e 477.8901; calculated for $C_7HF_{14}I$ 477.8905). The major fragments in the spectrum were 478, $C_7HF_{14}I$; 351, C_7HF_{14} ; 177, CF_2I ; 119, C_2F_5 ; 69, CF_3 . The 1H n.m.r. spectrum showed a doublet ($J=ca.42$ c.p.s.) at -5.40 p.p.m.
- (b) 1H-1-Iodotetradecafluoroheptane (mass spectrum as for (a)). The 1H n.m.r. spectrum showed a doublet ($J=ca.48$ c.p.s.) of doublets ($J=ca.19$ c.p.s.) at -7.70 p.p.m.

The 1H spectrum of fraction 2 showed that the ratio of a:b = 5.6:1. All chemical shifts were measured with respect to T.M.S.

1-iodopentadecafluoroheptane

1-Iodopentadecafluoroheptane (139 g.), trifluoroethylene (9 g.), and a.d.i.b. (1 g.), were sealed in an autoclave (500 c.c.) which was then heated for 11 hours at 185°. Venting the autoclave gave a volatile product (2 g.) having the same retention time (Column L) as trifluoroethylene. The liquid residue (133 g.) was fractionally distilled (vigreux column, 30 cm. x 2 cm. diameter; 1 at.) to give:

1. 1-Iodopentadecafluoroheptane (110 g.).
2. A residue (23 g.) consisting mainly (> 90%) of two components which were separated by g.l.c. (Column 0; 150°) to give:
 - (a) 2H-1-Iodo-octadecafluorononane. The major fragments in the mass spectrum were 578, $C_9HF_{18}I$; 451, C_9HF_{18} ; 177, CF_2I ; 131, C_3F_5 ; 113, C_3HF_4 ; 69, CF_3 . The 1H n.m.r. spectrum

showed a doublet ($J = \text{ca.} 42$ c.p.s.) at -5.45 p.p.m.

- (b) 1H-1-Iodo-octadecafluorononane. The major fragments in the mass spectrum were 578, $C_9^{HF}_{18}I$; 269, $C_5^{F}_{11}$; 219, $C_4^{F}_9$; 131, $C_3^{F}_5$; 120, $C_2^{HF}_5$; 69, CF_3 . The 1H n.m.r. spectrum showed a doublet ($J = \text{ca.} 48$ c.p.s.) of doublets ($J = \text{ca.} 19$ c.p.s.) at -7.62 p.p.m.

The 1H spectrum of fraction 2 showed that the ratio of a:b = 3:7:1. All chemical shifts were measured with respect to T.M.S.

DEHYDROHALOGENATIONS

2H-1-iodo-octafluorobutane

Experiment 1, method A.

2H-1-Iodo-octafluorobutane (60 g.), containing 1H-1-iodo-octafluorobutane (15 g.), was added dropwise onto sodium hydroxide (40 g.), in a 3 necked flask (250 c.c.) fitted with a mercury seal stirrer, reflux condenser, and dropping funnel and then heated to 90° . After refluxing for 1 hour, the reaction product was removed by blowing a stream of nitrogen through the flask, the volatile material being collected in a glass trap cooled in liquid air. The condensed material was fractionally distilled (30 cm. x 2 cm. diameter column; glass helices; 1 at.) to give:

1. Octafluorobutene-1 (24 g.), identified by its infra red spectrum.
2. A residue (30 g.) containing unreacted 1H- and 2H-1-iodo-octafluorobutane.

Experiment 2, method B.

2H-1-iodo-octafluorobutane (0.6 g.), containing 1H-1-iodo-octafluorobutane (0.06 g.), was added dropwise into a stream of nitrogen, heated to

150°, which was then bubbled through a flask (20 c.c.) half-filled with molten potassium hydroxide, at 190-195°. The volatile products (0.2 g.) were condensed in a glass trap cooled in liquid air. The condensed products were dried by vacuum transferring from P₂O₅, then dissolved in carbon tetrachloride (0.2 c.c.), and separated by g.l.c. (Column D; 20°) to give:

1. Octafluorobutane-1 (mass spec. parent ion ^m/_e 199.9876, calculated for C₄F₈ 199.9888). The product also had the correct infra red spectrum. G.l.c. (Column A; 20°) showed that this constituted ca. 95% of the total reaction product.

Minute quantities of three other products were isolated but infra red and mass spectrometric analysis showed that they must have come from impurities.

1H-1-iodo-octafluorobutane

Method B.

1H-1-Iodo-octafluorobutane (3.7 g.), in a stream of nitrogen at 150°, was bubbled through molten potassium hydroxide (10 c.c.) at 195°. The volatile products (2.5 g.) were collected in a trap cooled in liquid air, dried over P₂O₅, then separated by g.l.c. (Column D; 20°) to give:

1. 1-Iodobutene-1. (mass spec. parent ion ^m/_e 307.8944, calculated for C₄F₇I 307.8935). The major fragments from the mass spectrum were 308, C₄F₇I; 182, C₄HF₇; 113, C₃HF₄; 75, C₃HF₂; 69, CF₃. The infra red spectrum showed a strong, sharp absorption at 5.74μ, characteristic of C=C.
2. A second product having the same molecular formula as 1 (mass spec. parent ion ^m/_e 307.8944) and producing similar fragments in

the mass spectrum. The infra red spectrum showed a weak, broad absorption at 5.77μ .

3. trans 1-Iodobutene-2 (mass spec. parent ion m/e 307.8938). The major fragments in the mass spectrum were 308, C_4F_7I ; 239, C_3F_4I ; 162, C_4F_6 ; 112, C_3F_4 ; 69, CF_3 . The infra red spectrum showed no absorption in the region 5- 6μ . The ^{19}F n.m.r. spectrum showed 4 peaks: i. -77.2 p.p.m. (intensity 3); ii. a doublet ($J=ca.150$ c.p.s.) at -51.5 p.p.m. (intensity 1); iii. -42.2 p.p.m. (intensity 2); iv. a doublet ($J=ca.150$ c.p.s.) at -16.2 p.p.m. (intensity 1). Chemical shifts were measured with respect to C_6F_6 as internal reference.

2H-1-iododecafluoropentane

Experiment 1, method A.

2H-1-Iododecafluoropentane (17 g.), containing 1H-1-iododecafluoropentane (3 g.), was added dropwise onto sodium hydroxide at 90° , refluxed for 1 hr., then the volatile material collected in a trap cooled in liquid air. The condensed material was fractionally distilled (30 cm. x 2 cm. diameter vigreux column; 1 at.) to give:

1. Decafluoropentene-1 (8 g.), identified by its infra red spectrum.
2. A residue (5 g.) containing 1H- and 2H-1-iododecafluoropentane.

Experiment 2, method C.

2H-1-Iododecafluoropentane (17 g.), containing 1H-1-iododecafluoropentane (3 g.), was mixed with a solution of anhydrous lithium chloride (5 g.),

in N,N'-dimethyl formamide (20 g.), in a flask (250 c.c; 3-necked) fitted with a mercury seal stirrer, and a reflux condenser. The flask was heated to 150° for 1 hour then the volatile product was removed at this temperature. The product was condensed in a glass trap cooled in an acetone-carbon dioxide slush bath. Fractional distillation (20 cm. x 2 cm.) diameter; Dixon gauzes; 1 at.) gave:

1. Decafluoropentene-1 (6 g.).
2. A residue (10 g.) containing 1H- and 2H-1-iododecafluoropentane and N,N'-dimethyl formamide (trace).

2H-1-IODOTETRADECAFLUROHEPTANE

Method B.

2H-1-Iodotetradecafluoroheptane (20 g.), containing 1H-1-iodotetradecafluoroheptane (3 g.), in a stream of nitrogen at 150°, was bubbled through molten potassium hydroxide (100 c.c.) at 200°. The volatile product was condensed in a trap cooled in liquid air. The condensed material was fractionally distilled (30 cm. x 2 cm. diameter; Dixon gauzes; 1 at.) to give:

1. A fraction (1 g.) containing unidentified material.
2. Tetradecafluoroheptene-1 (14 g.), identified by its infra red spectrum
3. A residue (3 g.) containing 1H- and 2H-1-iodotetradecafluoroheptane and tetradecafluoroheptene (trace).

2H-1-IODO-OCTADEC AFLUORONONANE

Method B.

2H-1-iodo-octadecafluorononane (35 g.), containing 1H-1-iodo-octadecafluorononane (10 g.), in a stream of nitrogen at 200°, was bubbled through molten potassium hydroxide (100 c.c.) at 200°. The volatile product (25 g.) was condensed in a trap cooled in liquid air, then fractionally distilled (30 cm. x 2 cm. diameter; Dixon gauzes; 1 at.) to give:

1. An unidentified fraction (4 g.).
2. Octadecafluorononene-1 (10 g.).
3. A mixture (8 g.) containing octadecafluorononene and 1H- and 2H-1-iodo-octadecafluorononane.
4. A solid residue (3 g.).

Dehydrohalogenation of the products $C_{25}F_5(C_{23}F_3H)_2I$ using method B.

TOTAL PRODUCT $C_{25}F_5(C_{23}F_3H)_2I$

Dihydro-1-iodoundecafluorohexane (1 g.) was injected into a stream of nitrogen, at ca. 150°, and then bubbled through molten potassium hydroxide (20 c.c.) at 200°. The volatile products (0.5 g.) were collected in a trap cooled in liquid air, dried over P_2O_5 , then separated by g.l.c. (Column D; 20°) to give pure samples of:

1. A decafluorohexadiene (mass spec. parent ion m/e 261.9794; calculated for C_6F_{10} 261.9840). The major fragments in the mass spectrum were 193, C_5F_7 ; 143, C_4F_5 ; 131, C_3F_5 ; 93, C_3F_3 ; 69, CF_3 . The infra red spectrum showed two strong absorptions of

almost equal intensity, at 5.55μ and 5.80μ . G.l.c. (Column A; 20°) analysis showed that this constituted ca.90% of the total products.

2. 1H-Undecafluorohexene (mass spec. parent ion m/e 281.9890; calculated for C_6HF_{11} 281.9902). The major fragments in the mass spectrum were 181, C_4F_7 ; 143, C_4F_5 ; 131, C_3F_5 ; 125, C_4HF_4 ; 106, C_4HF_3 ; 93, C_3F_3 ; 69, CF_3 . The infra red spectrum showed a strong absorption at 5.56μ . G.l.c. analysis (Column A; 20°) showed that this constituted ca.5% of the total products.

2H,4H-1-iodoundecafluorohexane (product C).

2H,4H-Iodoundecafluorohexane (1.2 g.) was injected into a stream of nitrogen, heated to ca. 150° , then bubbled through molten potassium hydroxide (20 c.c.), at 210° . The volatile products (0.35 g.) were condensed in a trap cooled in liquid air, dried over P_2O_5 , dissolved in carbon tetrachloride (0.4 c.c.) then separated by g.l.c. (Column D; 20°) to give:

1. A decafluorohexadiene with an identical infra red spectrum to that already isolated.
2. A second decafluorohexadiene (mass spec. parent ion m/e 261.9835), giving the same major fragments in the mass spectrum. The infra red spectrum showed absorptions at 5.59μ (strong) and 5.80μ (weak).
3. A third decafluorohexadiene (mass spec. parent ion m/e 261.9794), giving the same major fragments in the mass spectrum. The infra red spectrum showed absorptions at 5.55μ (strong) and 5.76μ (weak).
4. A product having the same molecular weight, 262; C_6F_{10} , and giving the same major fragments in the mass spectrum. There was no

infra red absorption in the region $5.5 - 6.0\mu$, but there was an absorption at 4.95μ (v. strong).

2H,4H-1-iodoundecafluorohexane (product d).

2H,4H-1-Iodoundecafluorohexane (2.4 g.) was injected into a stream of nitrogen, at ca. 150° , then bubbled through molten potassium hydroxide (20 c.c.), at 190° . The volatile products (0.8 g.) were collected in a trap cooled in liquid air, dried over P_2O_5 , dissolved in carbon tetrachloride, then separated by g.l.c. (Column D; 20°) to give:

1. A decafluorohexadiene with an identical infra red spectrum to the first diene isolated.
2. A fourth decafluorohexadiene, giving the same major fragments, in the mass spectrum, as the other dienes isolated. The infra red spectrum showed absorptions at 5.55μ (strong) and 5.80μ (weak).
3. 4H-Undecafluorohexene, identified by its infra red spectrum.

1H,3H-1-iodoundecafluorohexane

1H,3H-1-Iodoundecafluorohexane (1.1 g.) was injected into a stream of nitrogen, at ca. 150° , then bubbled through molten potassium hydroxide (10 c.c.), at 190° . The volatile products (0.4 g.) were collected in a trap cooled in liquid air, then dried over P_2O_5 . The more volatile of the condensed products were allowed to evaporate at room temperature, and 1 at., and re-condensed in a trap cooled in solid carbon dioxide. This fraction was dissolved in carbon tetrachloride (0.2 c.c.). G.l.c. analysis (Column A, 100°) showed that each fraction consisted mainly of 5 compounds. The products

in the carbon tetrachloride fraction were separated by g.l.c. (Column D, 20°) as were those in the less volatile fraction (Column D, 100°). Fairly pure (>90%) samples of five of the products were isolated. They all had the same molecular formula, C₆F₉I (mass spectroscopy). The major fragments in the mass spectra of these compounds were:

1. 186, C₆F₆; 131, C₃F₅; 100, C₂F₄, 69, CF₃. Infra red absorptions occurred at 5.58μ (strong) and 6.13μ (strong).
2. 244, C₆HF₉; 175, C₅HF₆; 131, C₃F₅; 113, C₃HF₄; 69, CF₃.
Infra red absorptions occurred at 5.58μ (weak) and 5.76μ (strong).
3. 244, C₆HF₉; 175, C₅HF₆; 113, C₃HF₄, 69, CF₃. Infra red absorptions occurred at 5.55μ (weak) and 5.73μ (strong).
4. 370, C₆F₉I; 212, C₅F₈; 162, C₄F₆; 93, C₃F₃; 69, CF₃.
There was no absorption in the infra red spectrum in the region 5-6μ.
5. 370, C₆F₉I; 224, C₆F₈; 174, C₅F₆; 124, C₄F₄; 69, CF₃. The infra red spectrum showed several weak absorptions in the range 5.80-6.00μ.

1H-UNDECAFLUOROHEXENE

1H-Undecafluorohexene (0.5 g.) was added to a stream of nitrogen, at ca. 150° then bubbled through molten potassium hydroxide (10 c.c.) at 210°. The volatile products (0.1 g.) were collected in a trap cooled in liquid air, dried over P₂O₅, then separated by g.l.c. (Column D, 20°) to give pure samples of:

1. The decafluorohexadiene first isolated.
2. A compound having an identical infra red spectrum to the 4th product obtain on dehydrohalogenating 2H,4H-1-iodoundecafluorohexane (product c).

APPENDICES

Appendix (a)

Calibration of spectrophotometer (section 1):

Figure VII. Micromoles/litre Ferric ion vs. Optical density.

Calibration of mass spectrometer vacuum system (section 1):

Figure VIII. Ion current of $C F_{24}$ vs. pressure.

Figure IX. Ion current of $C F_{36}$ vs. pressure.

Figure X. Ion current of $C F_{48}$ vs. pressure.

Figure XI. Ion current of $C F_{510}$ vs. pressure

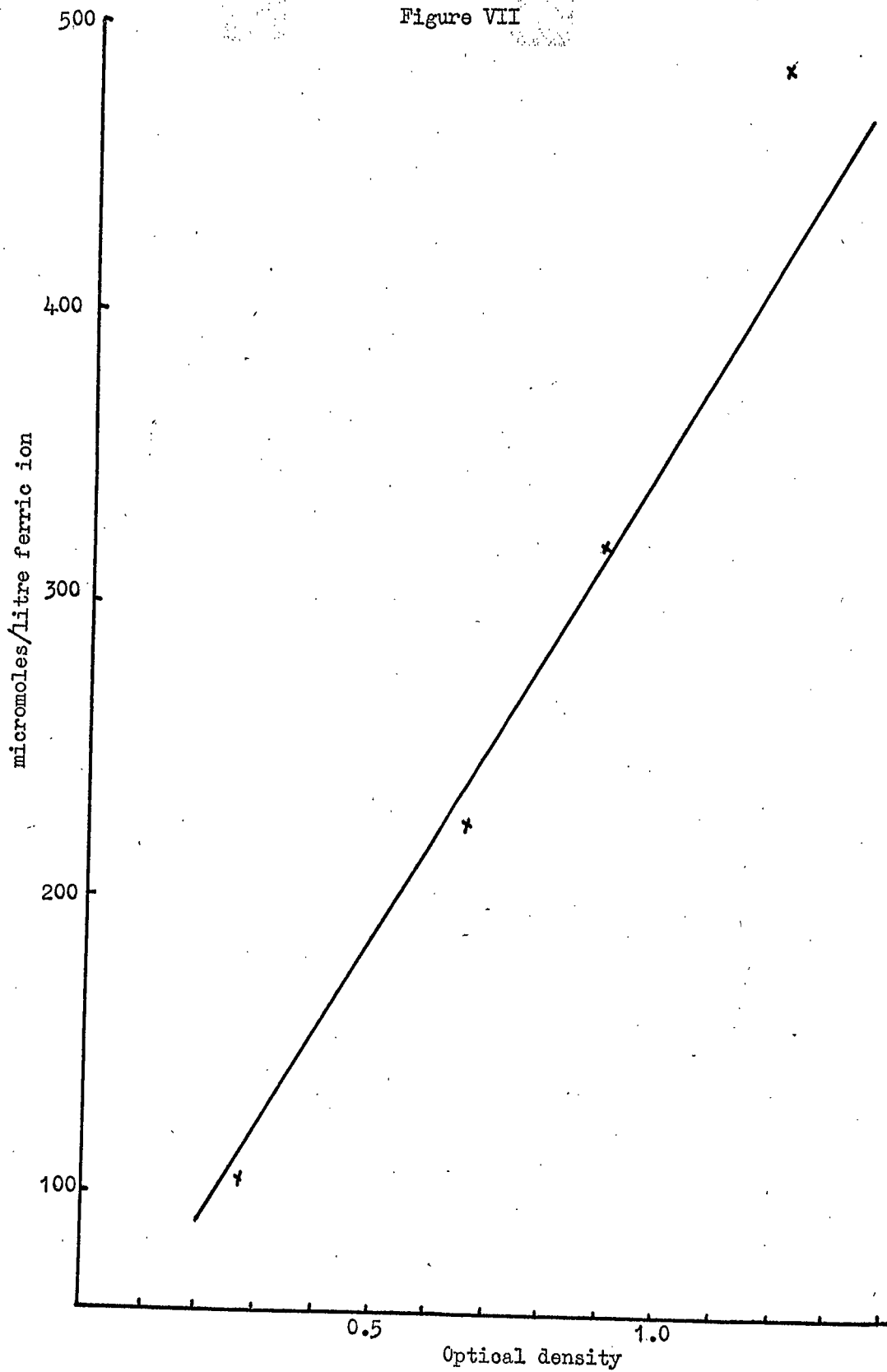

-120-
Figure VIII

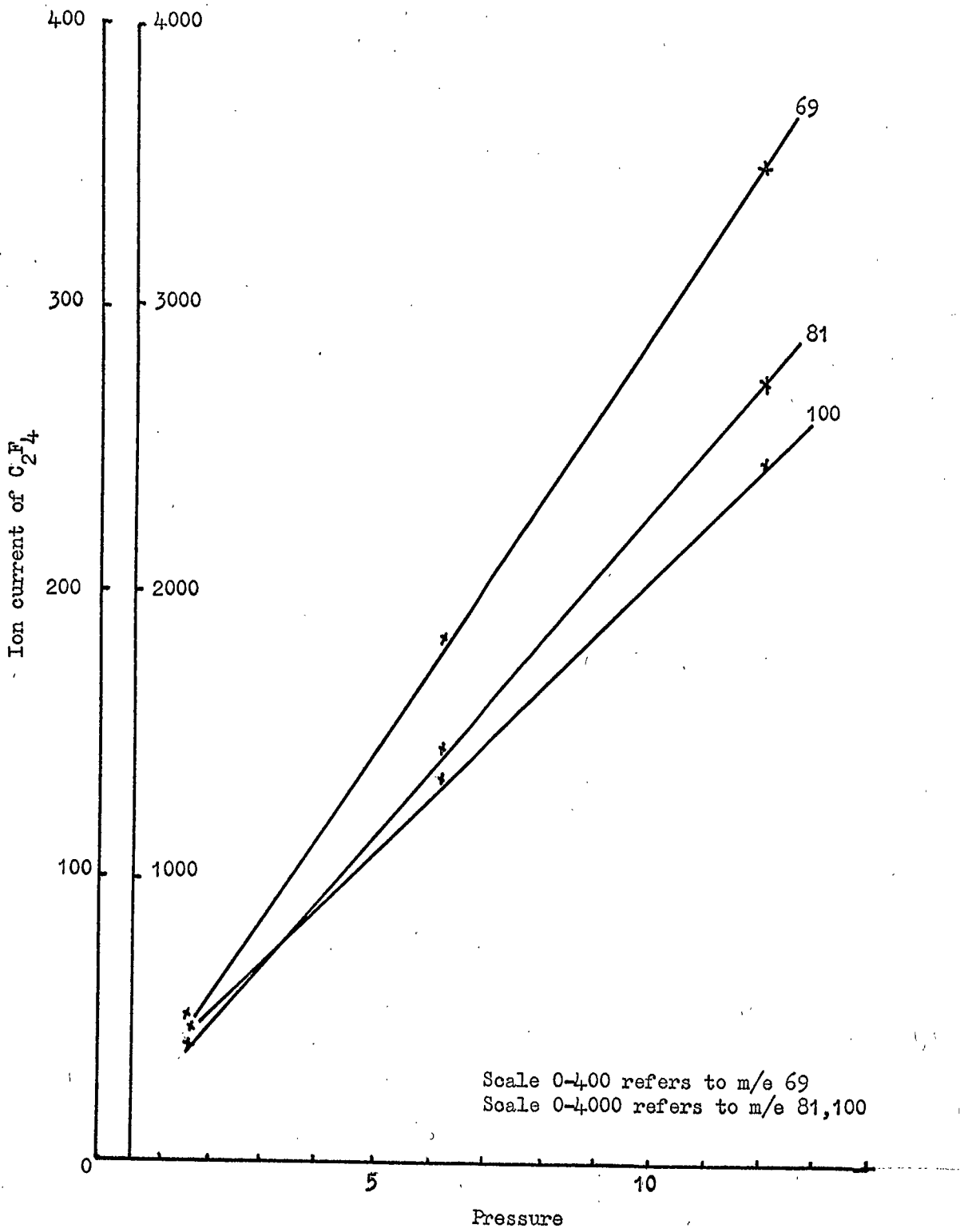

Figure IX

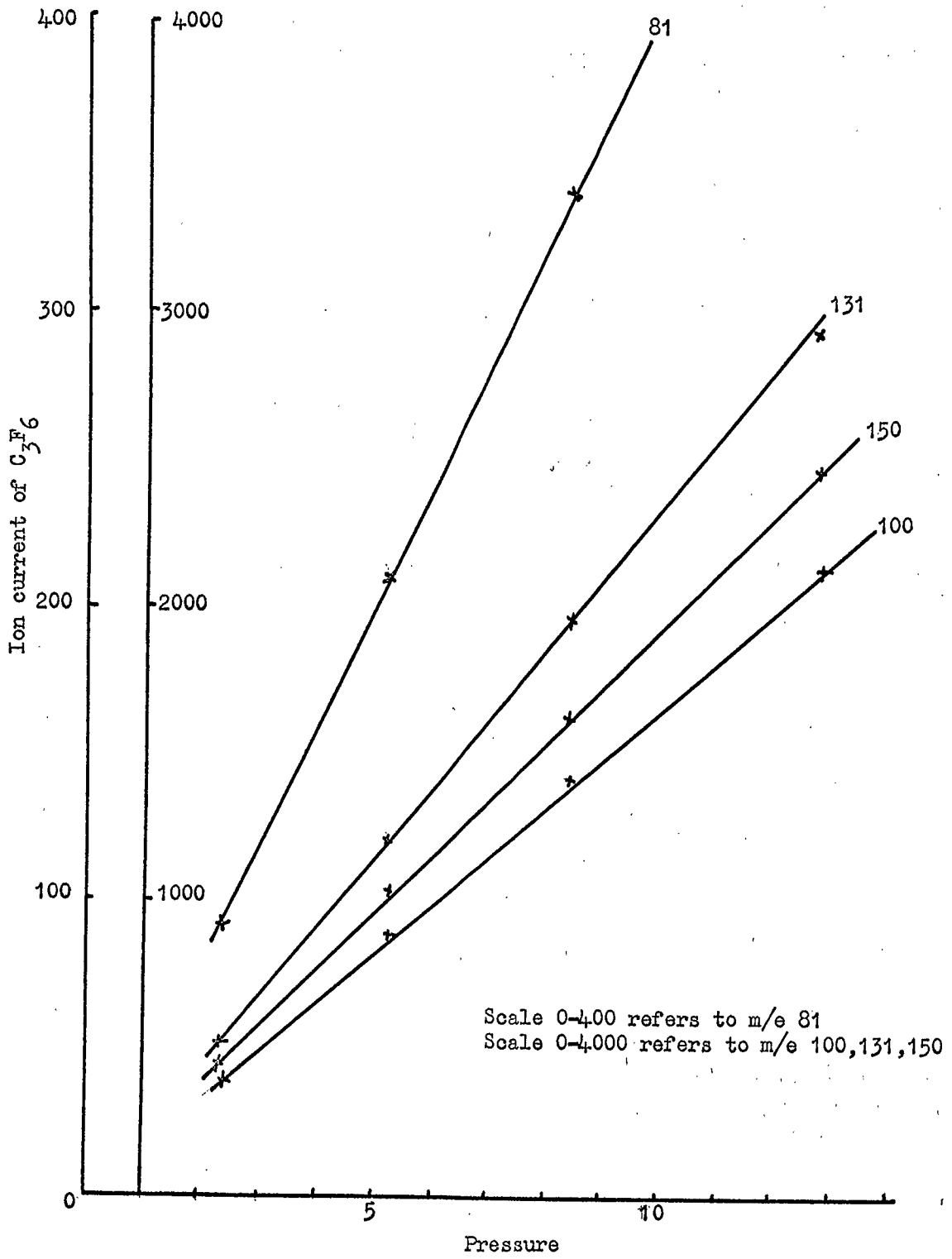

Figure X

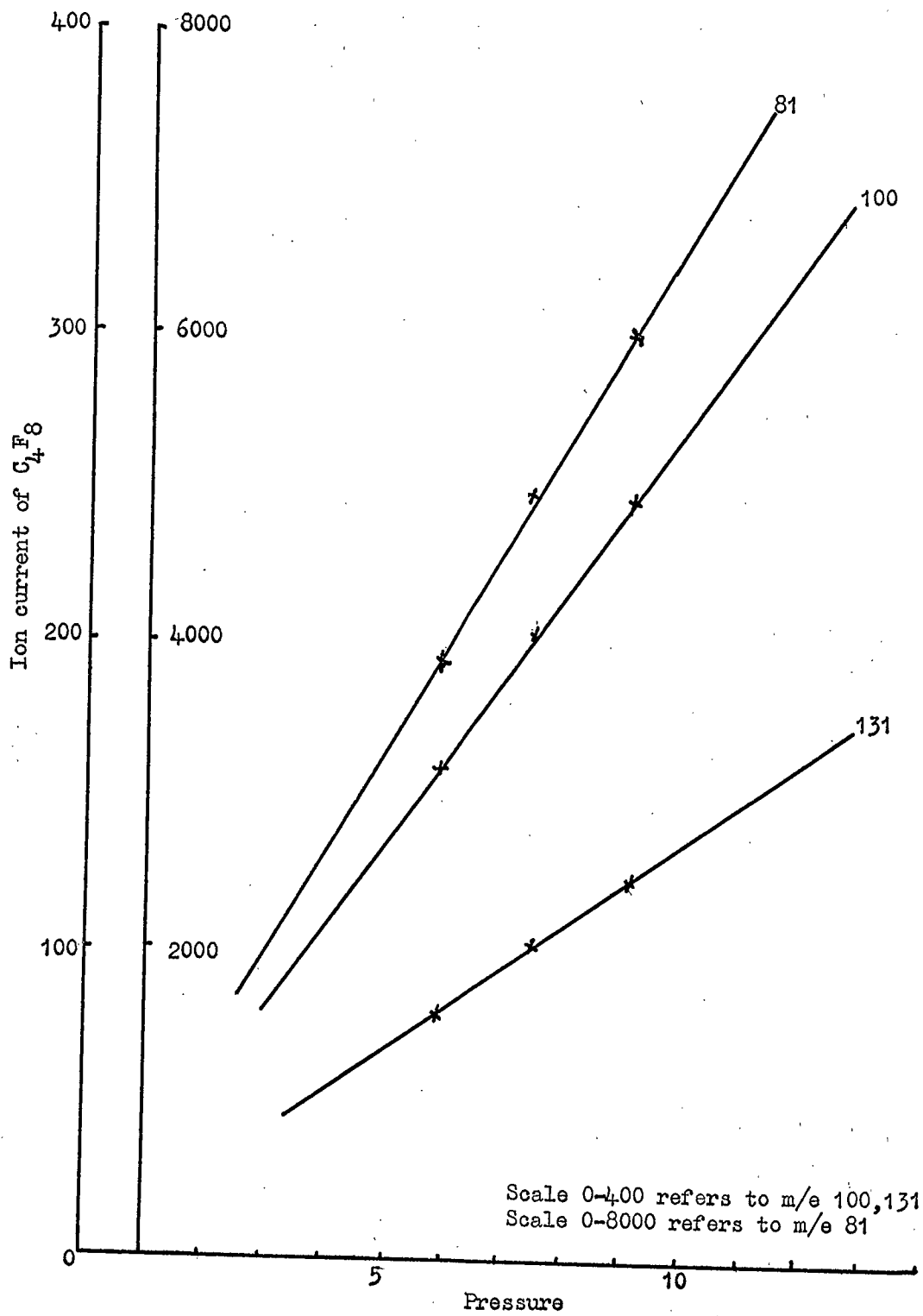
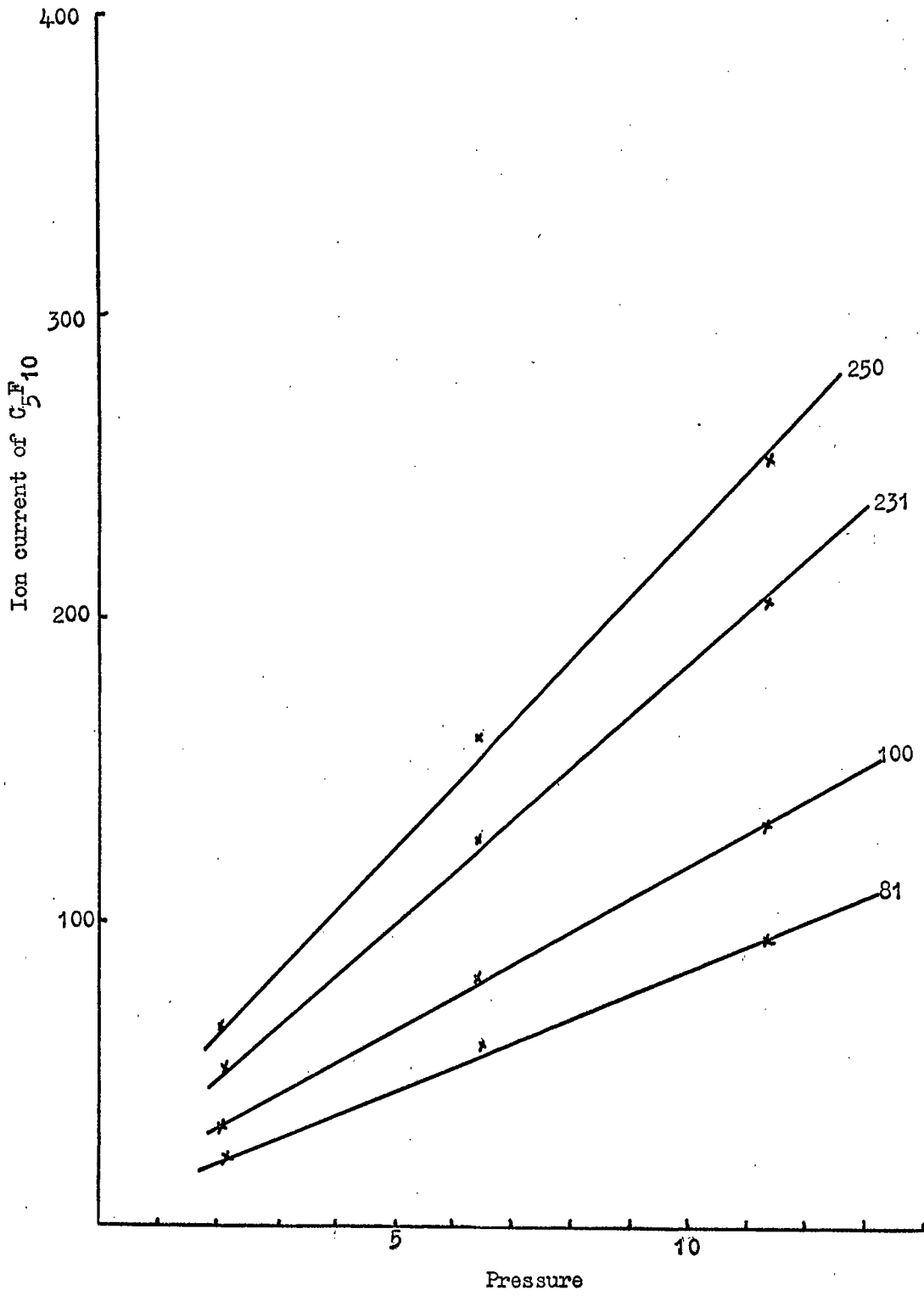

Figure XI



Appendix (b)

Figure XII. ^1H n.m.r. spectra of the compounds
 $\text{C}_2\text{F}_5(\text{C}_2\text{HF}_5)_n \cdot \text{I}$, where $n = 1$ and 2 .

- Product (a). 2H-1-Iodo-octafluorobutane.
(b). 1H-1-Iodo-octafluorobutane.
(c). 2H,4H-1-Iodoundecafluorohexane.
(d). 2H,4H-1-Iodoundecafluorohexane.
(e). 1H,3H-1-Iodoundecafluorohexane.

Figure XIII. ^{19}F n.m.r. spectra of the compounds
 $\text{C}_2\text{F}_5(\text{C}_2\text{HF}_3)_n \cdot \text{I}$, where $n = 1$ and 2 .

- Figure XIV (a) ^{19}F n.m.r. spectrum of trans-1-iodoheptafluorobutene-2.
(b) The theoretical spectrum of the CF_3 band in (a)
(c) The simplified high resolution spectrum of
of the CF_3 band in (a).

Figure XIII

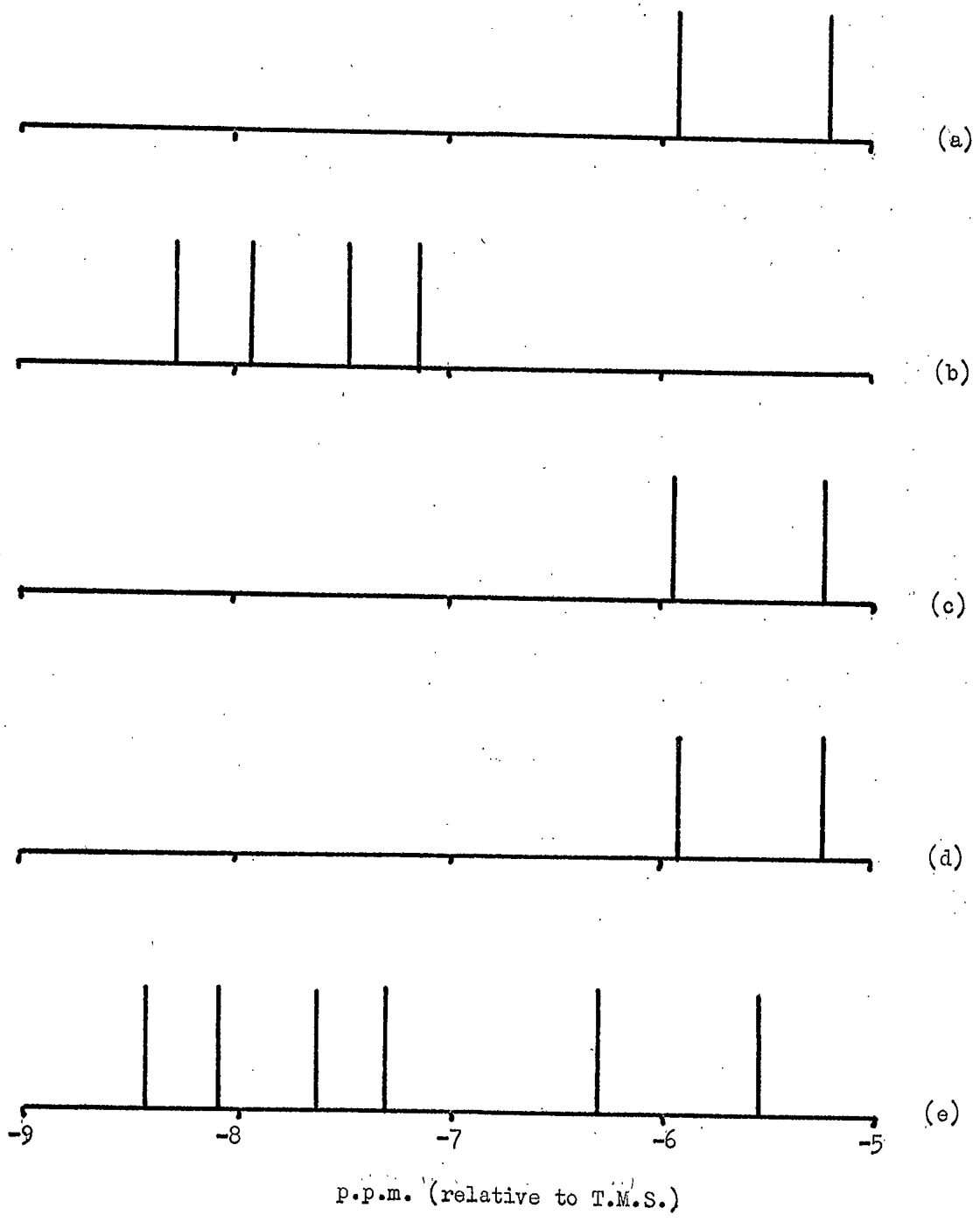

Figure XIII

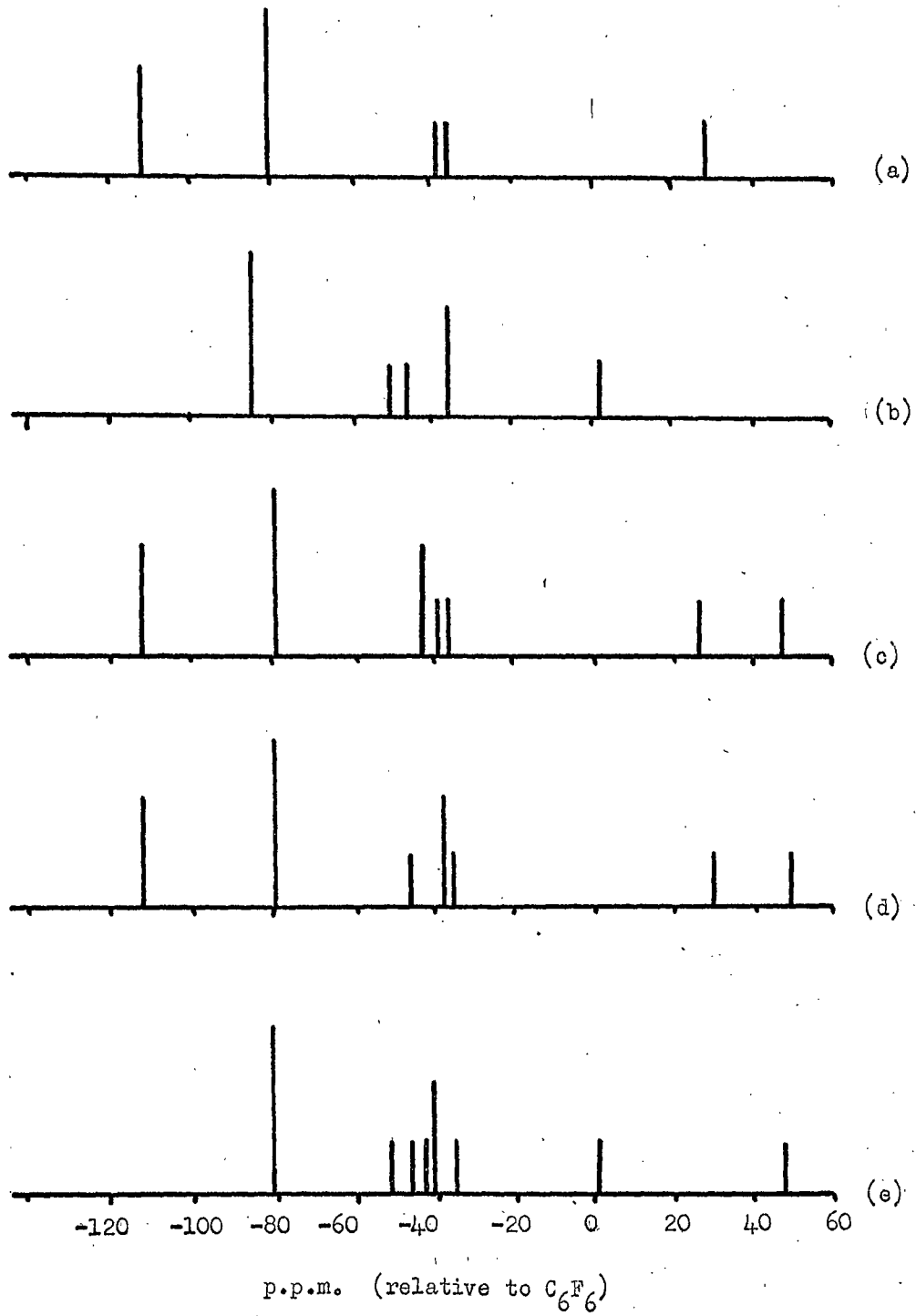
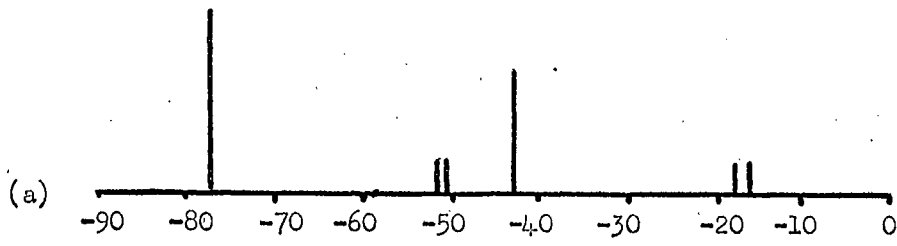
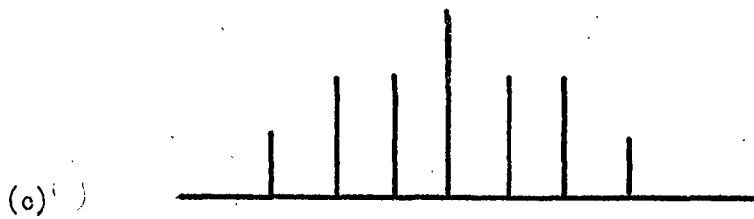
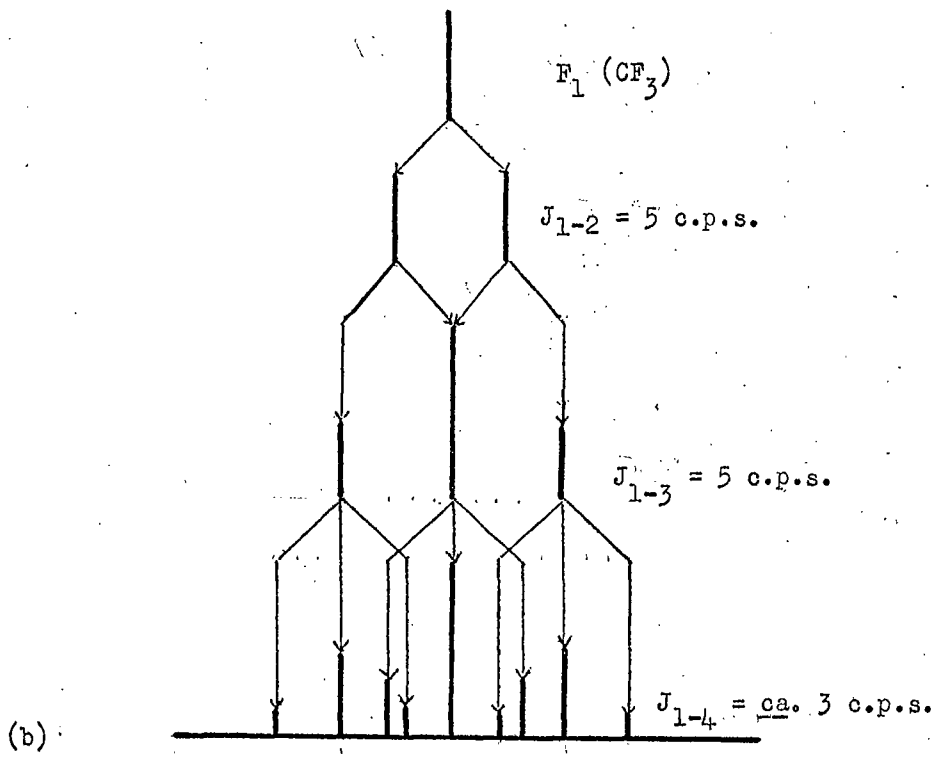

Figure XIV



p.p.m. relative to C_6F_6



Appendix (c)

Infra red spectra:

1. 2H-1-Iodo-octafluorobutane.
 2. 1H-1-Iodo-octafluorobutane.
 3. 1H-1-Iododecafluoropentane.
 4. 2H-1-Iodotetradecafluoroheptane.
 5. 1H-1-Iodotetradecafluoroheptane.
 6. 2H-1-Iodo-octadecafluorononane.
 7. 1H-1-Iodo-octadecafluorononane.
 8. 2H,4H-1-Iodoundecafluorohexane (product 6).
 9. 2H,4H-1-Iodoundecafluorohexane (product d).
 10. 1H,3H-1-Iodoundecafluorohexane (product e).
 11. 1-Iodoheptafluorobutene -1
 12. trans-1-Iodoheptafluorobutene -2
 13. The geometric isomer of 12 or 13.
 14. Decafluorohexadiene (suspected 1,3-diene).
 15. The second decafluorohexadiene.
 16. The third decafluorohexadiene.
 17. The fourth decafluorohexadiene.
 18. Decafluorohexadiene (suspected allene).
 19. 4H-Undecafluorohexene-1.
- 20, 21, 22,) The series of 1-iodononafluorohexadienes, in order
23, 24.) of g.l.c. retention times.

Appendix (c)

25. Hexafluoropropene (after irradiation).
26. Octafluorobutene (after irradiation).
27. Decafluoropentene (after irradiation).
28. Dodecafluoroheptadiene.
29. 1, 4-Di-iodo-octafluorobutane.
30. 1, 6-Di-iodododecafluorohexane.

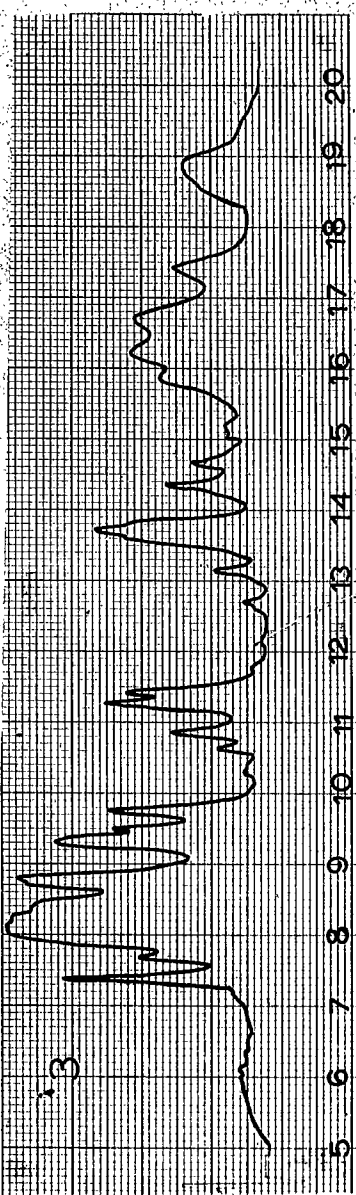
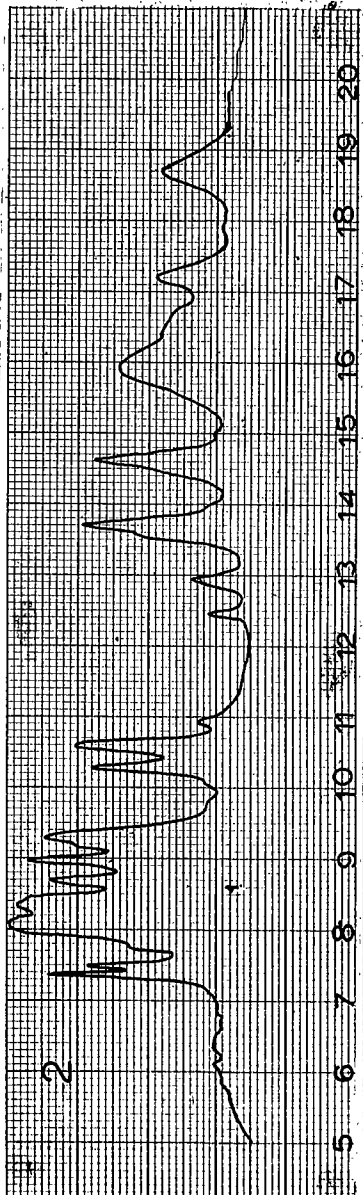
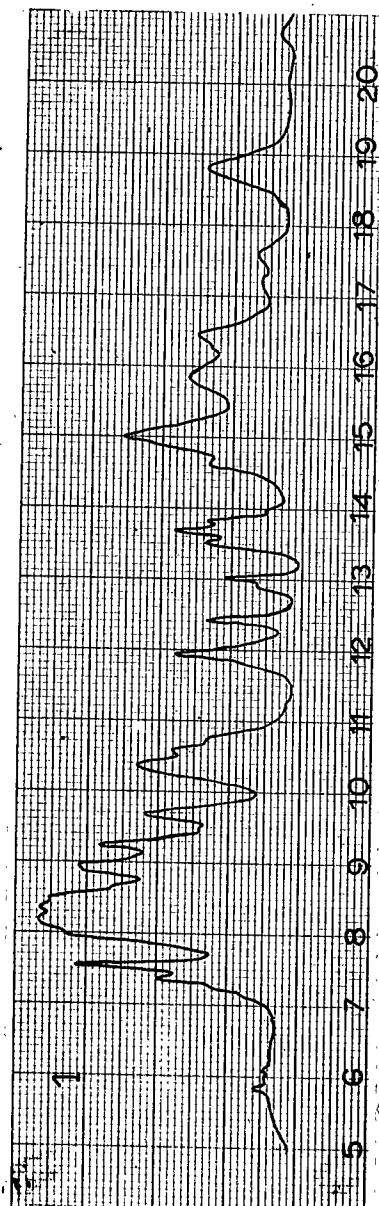

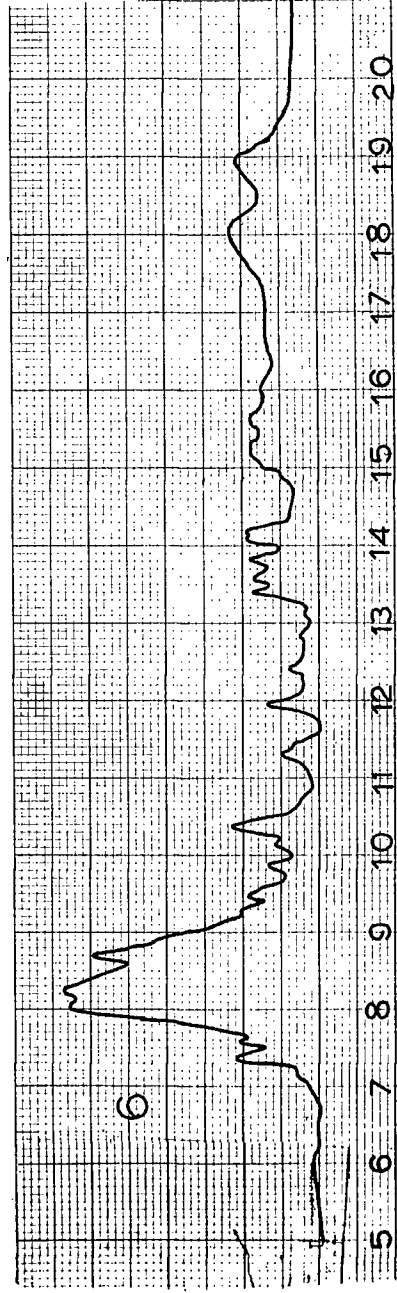
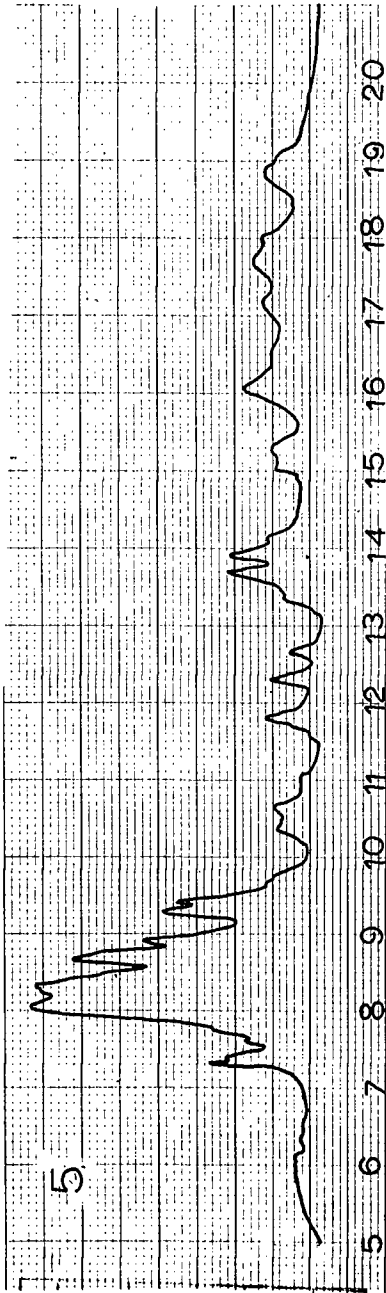
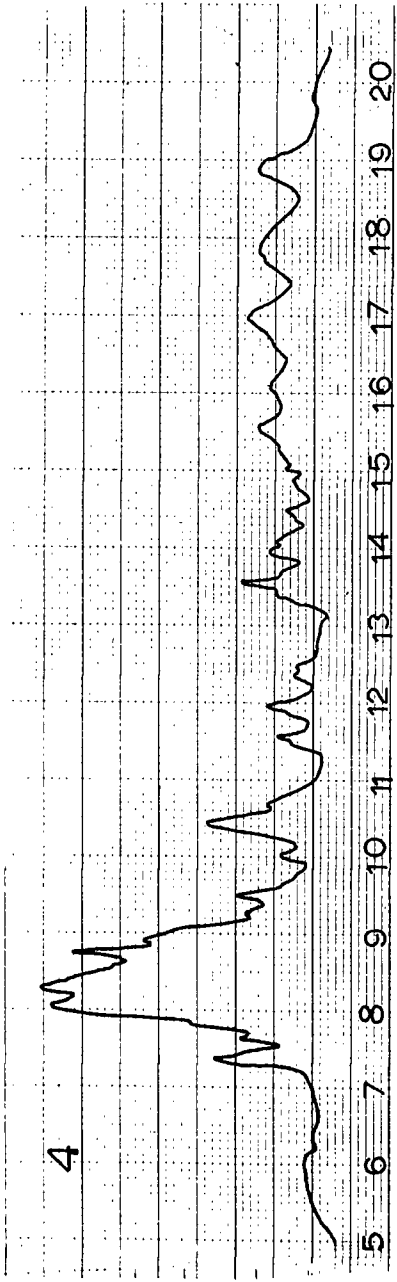

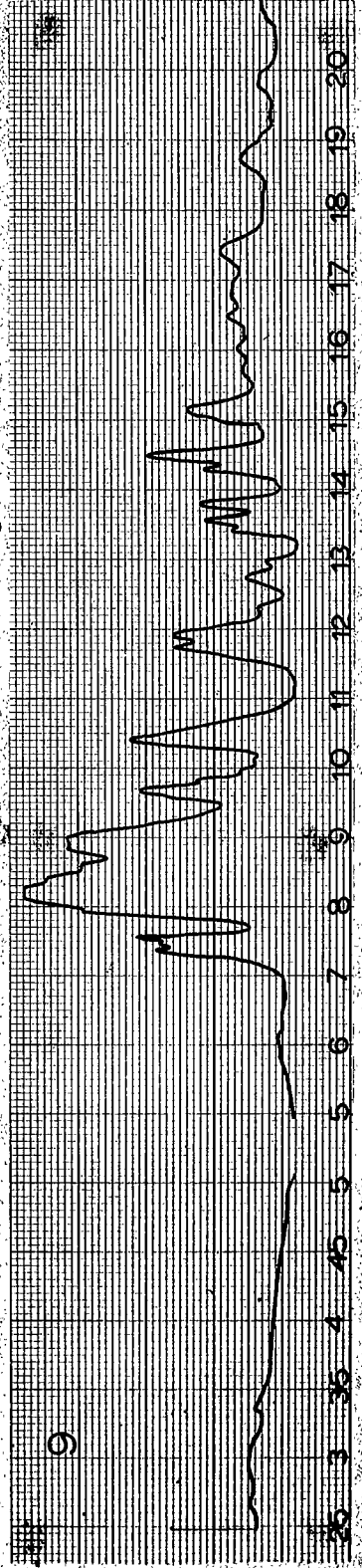
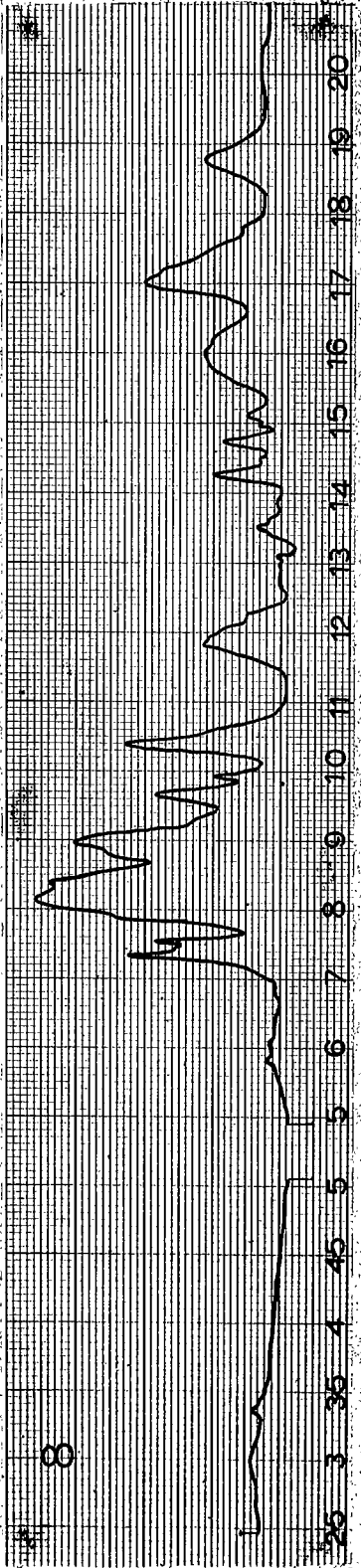
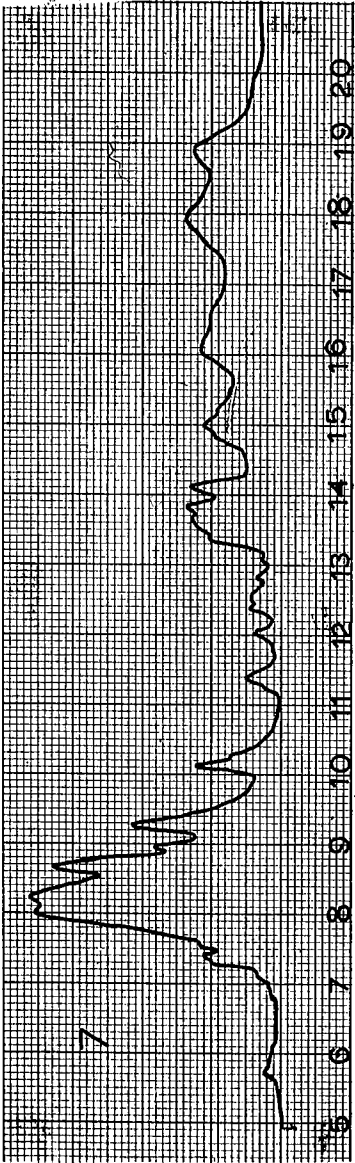

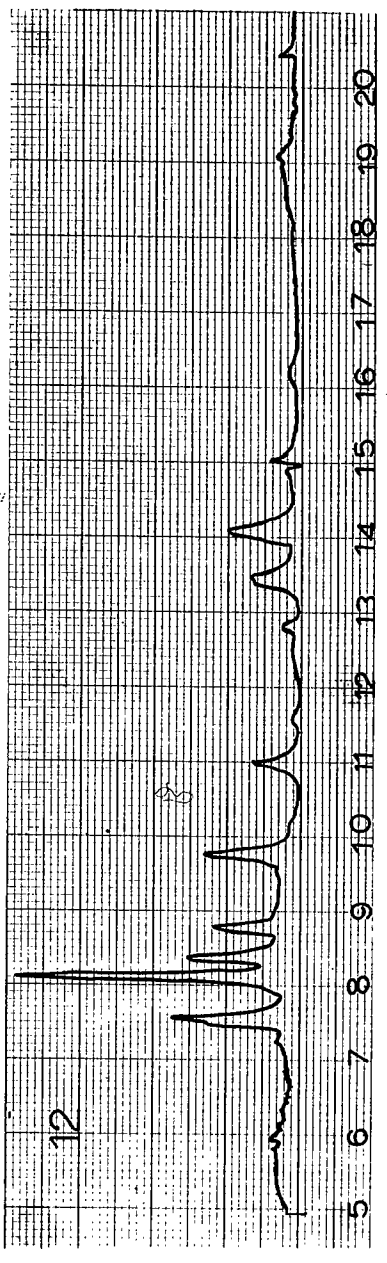
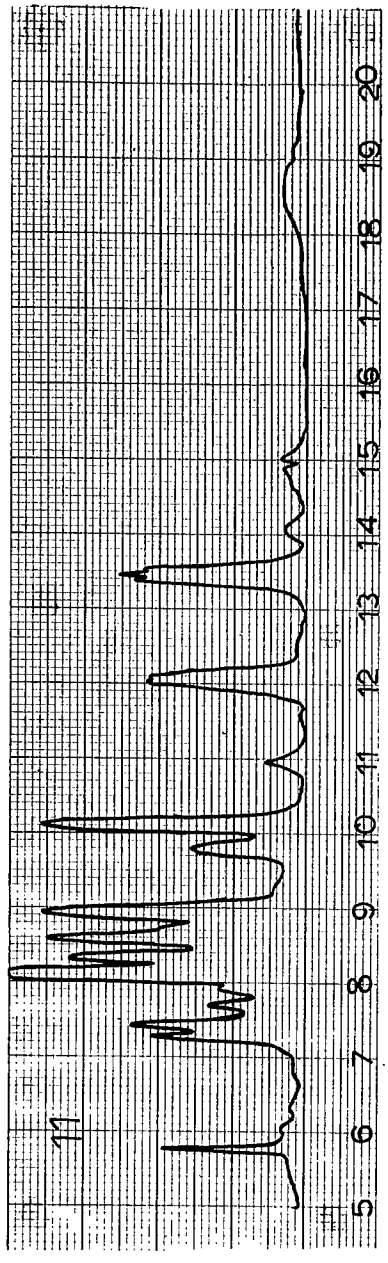
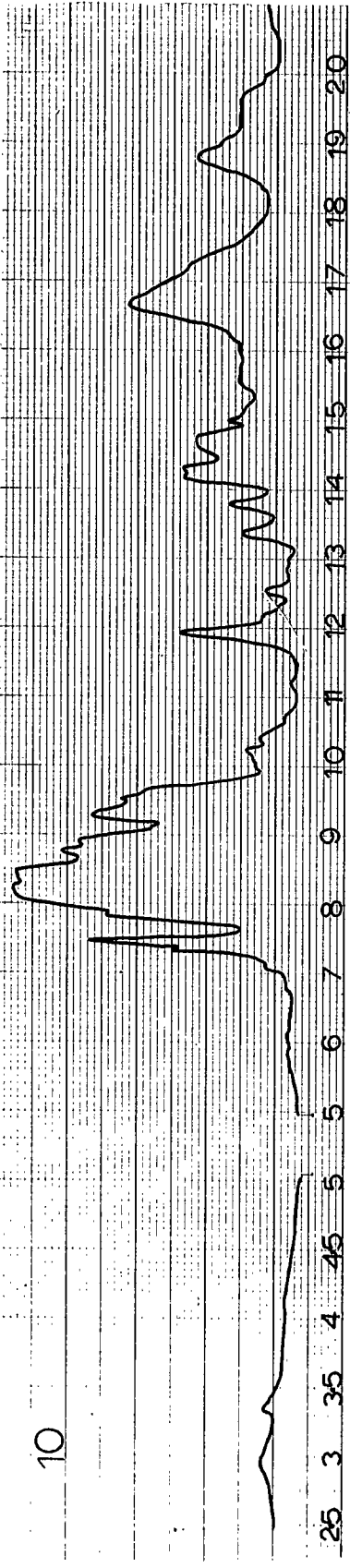

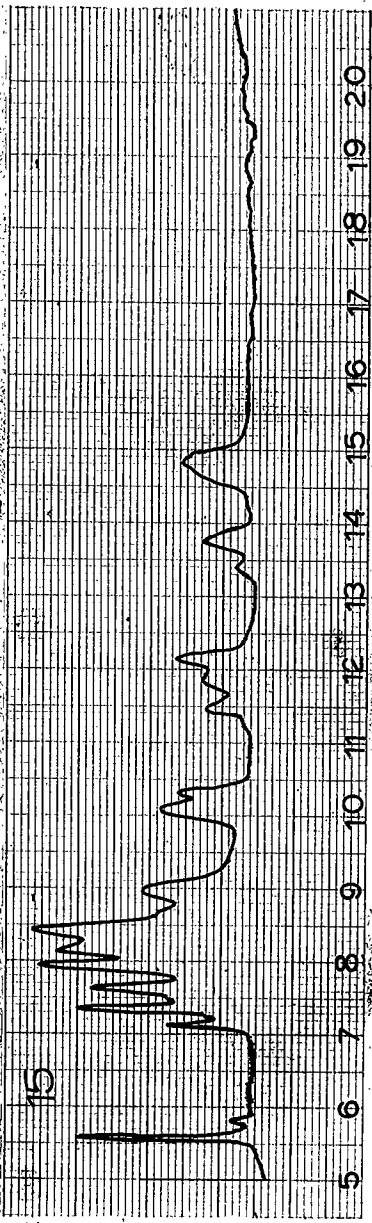
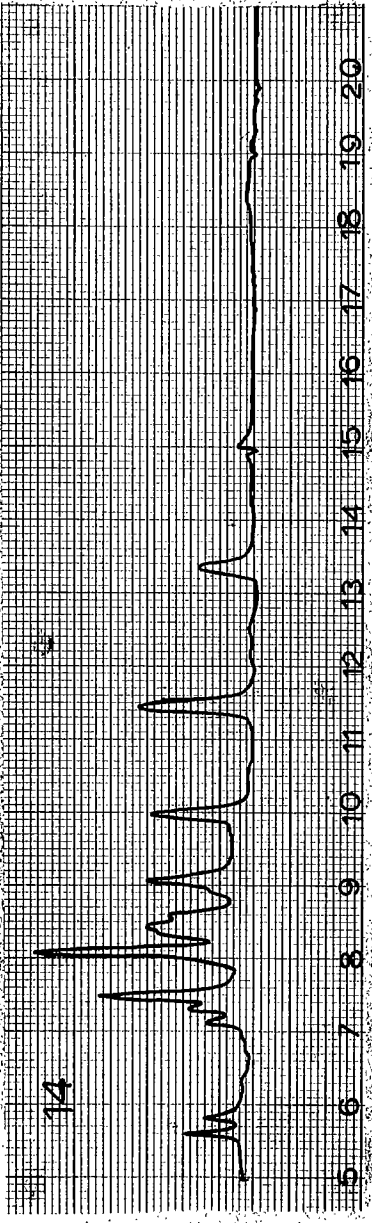
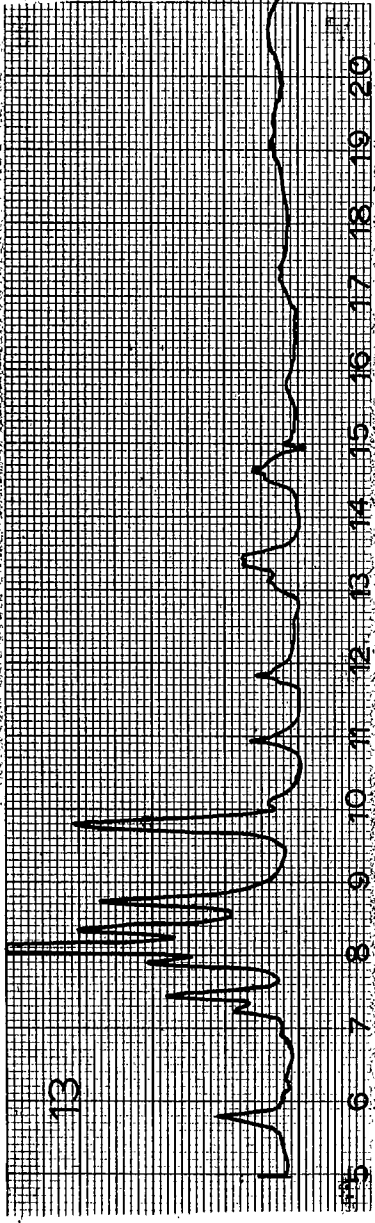

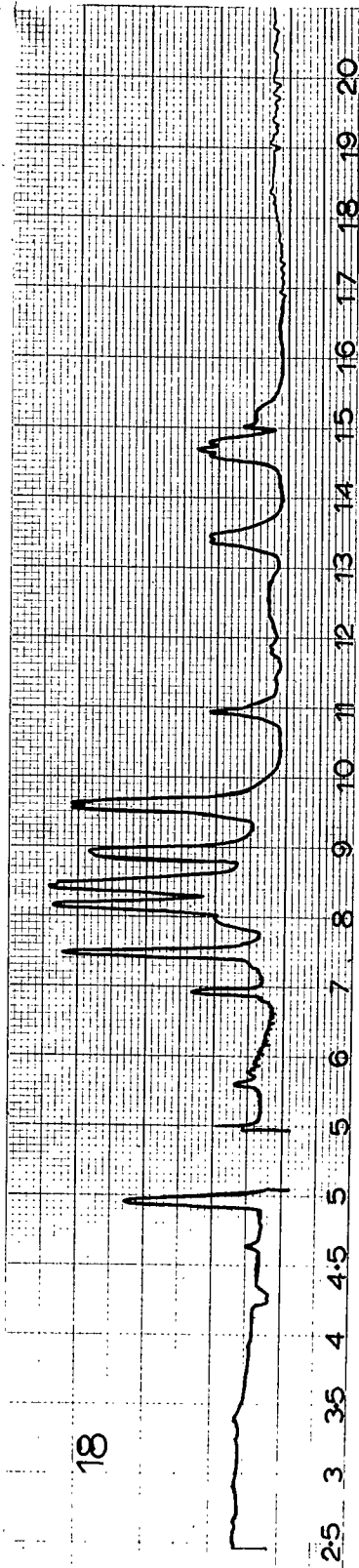
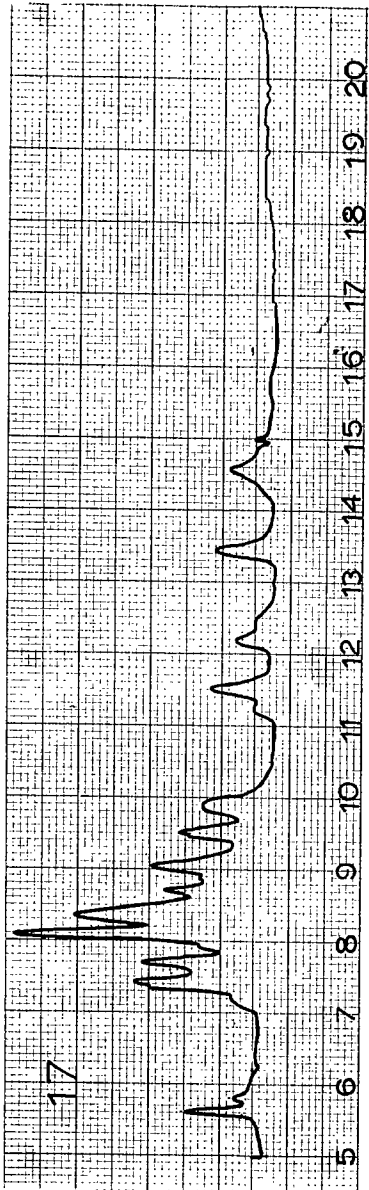
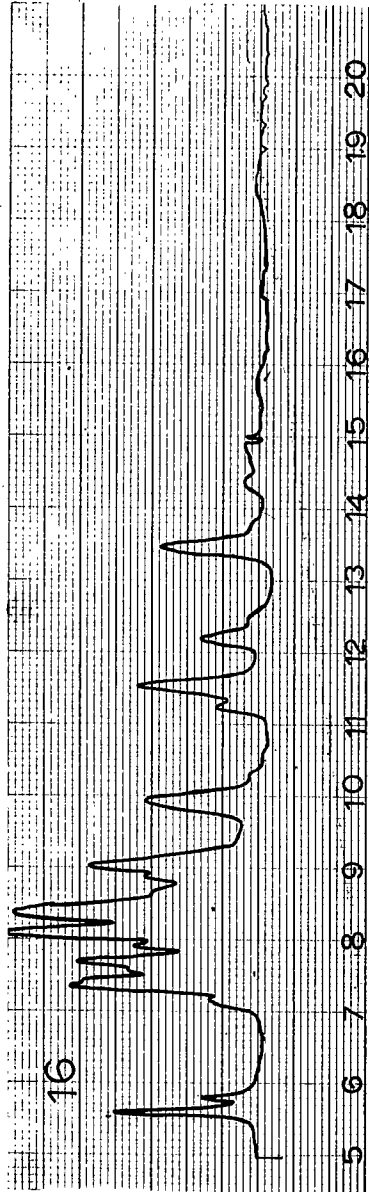

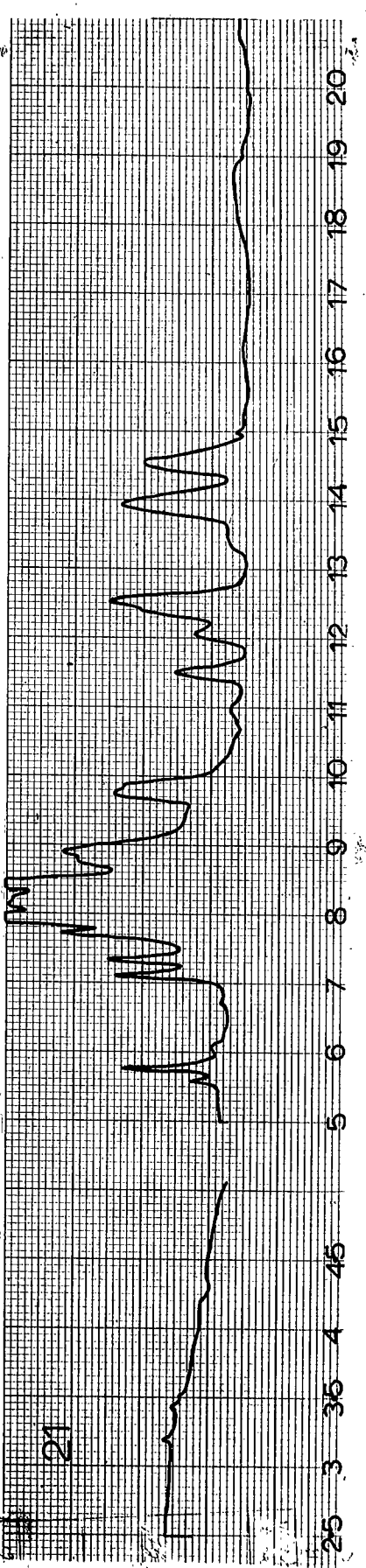
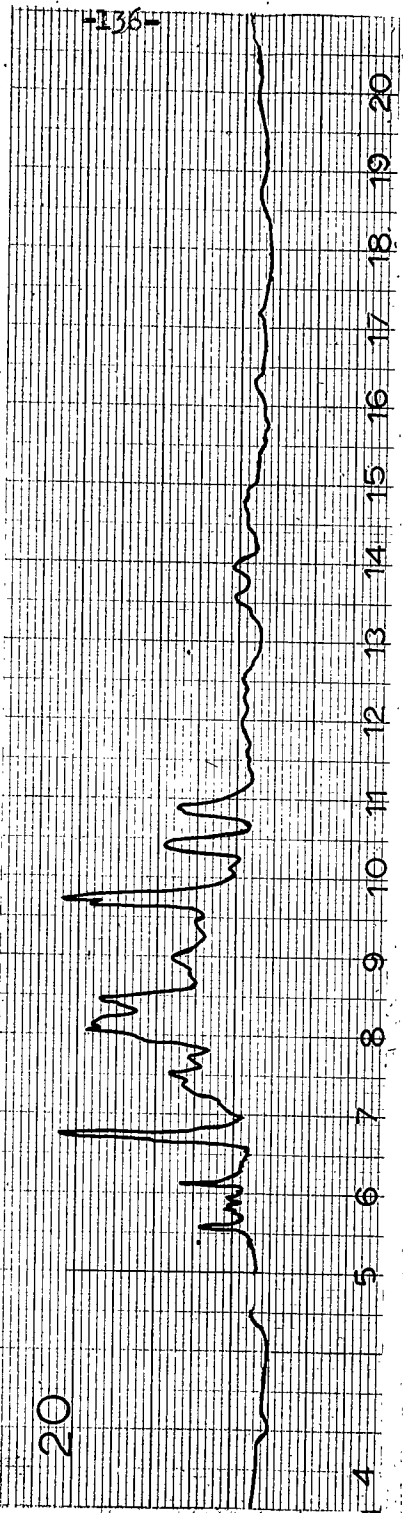
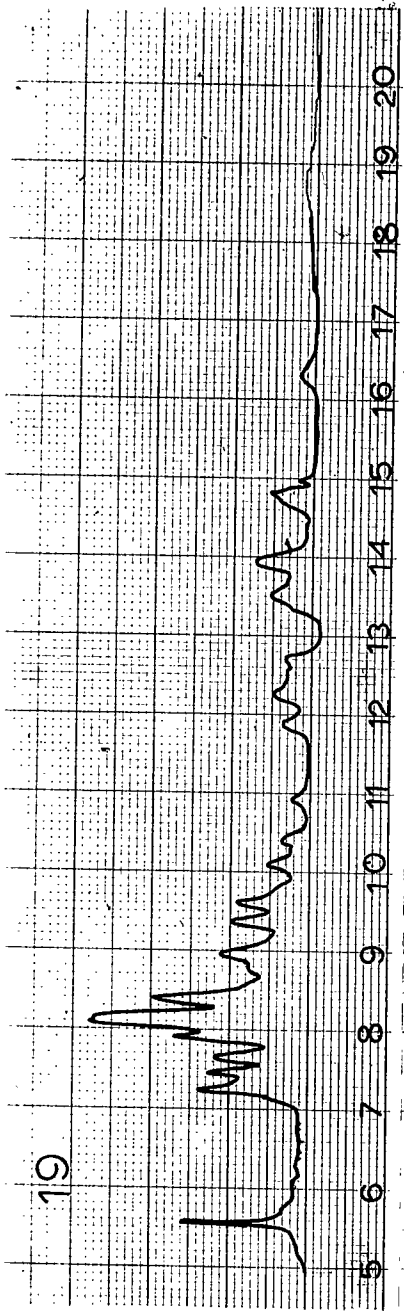

22

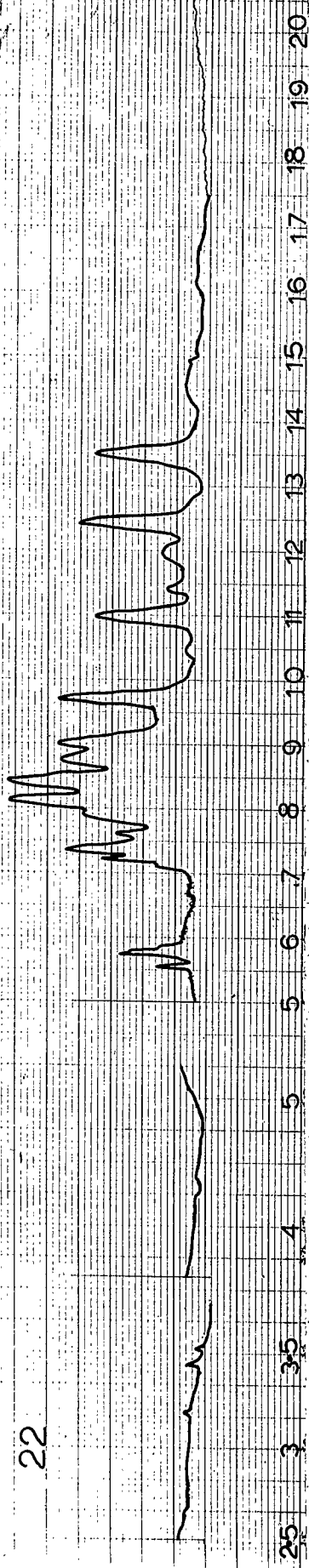

23

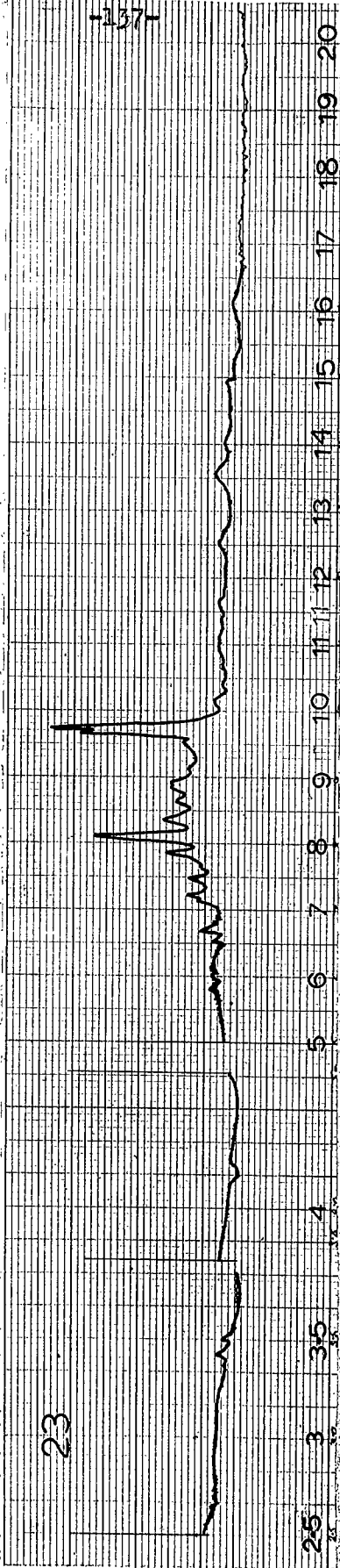

137

25

3 3.5 4

5 5 6 7 8 9 10 11 12 13 14 15 16 17 18 19 20

24

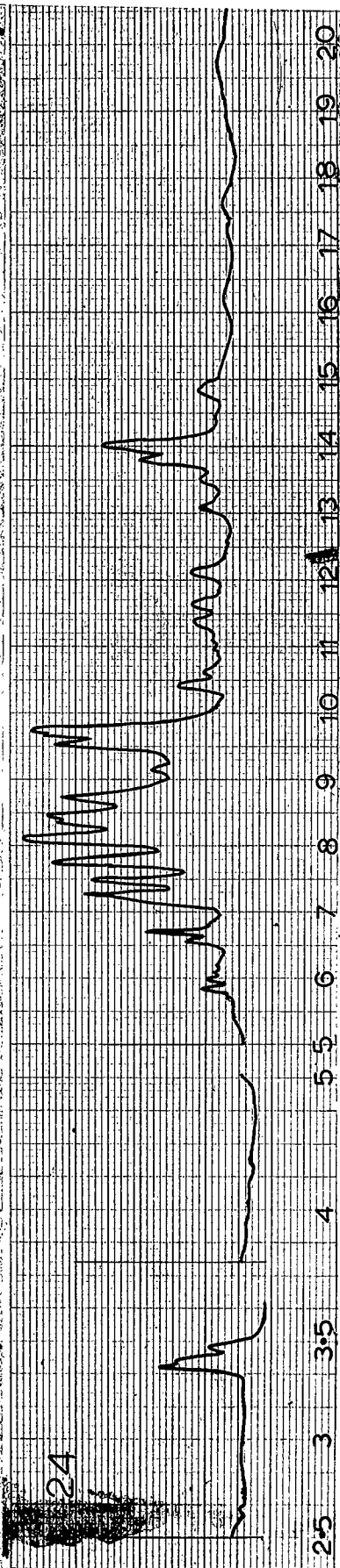

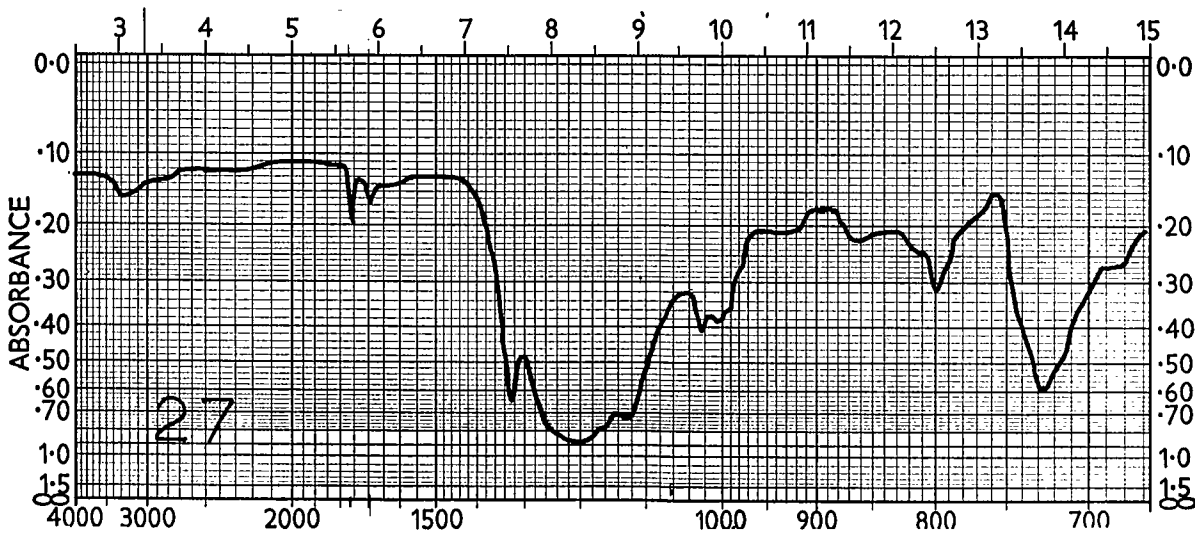
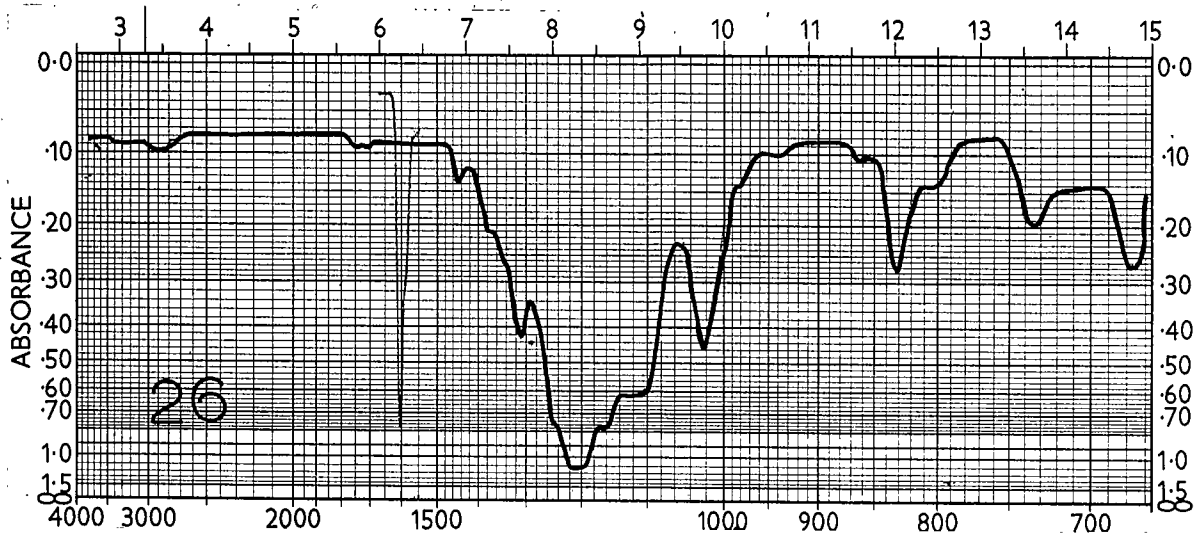
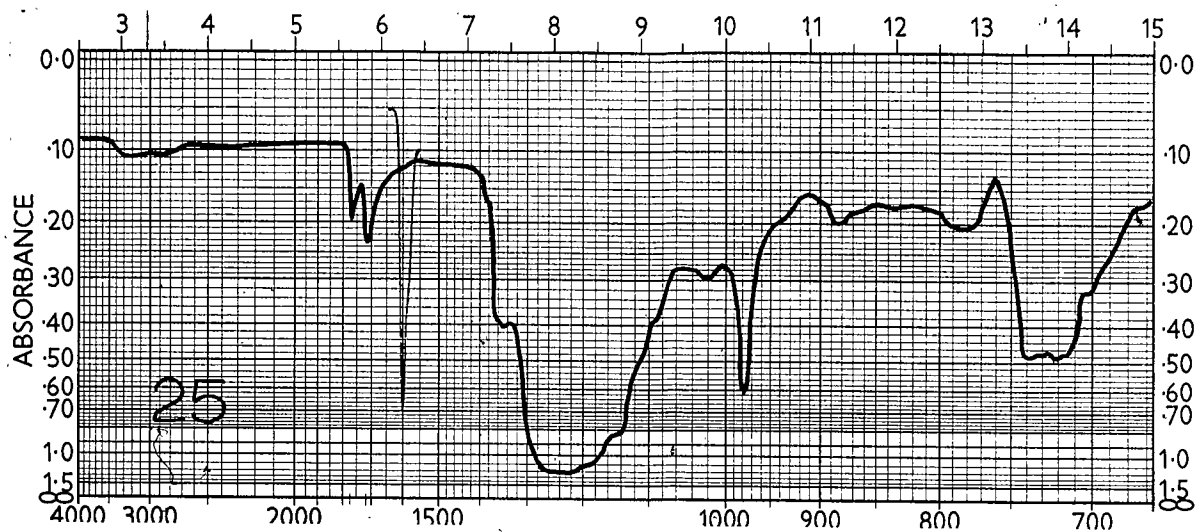

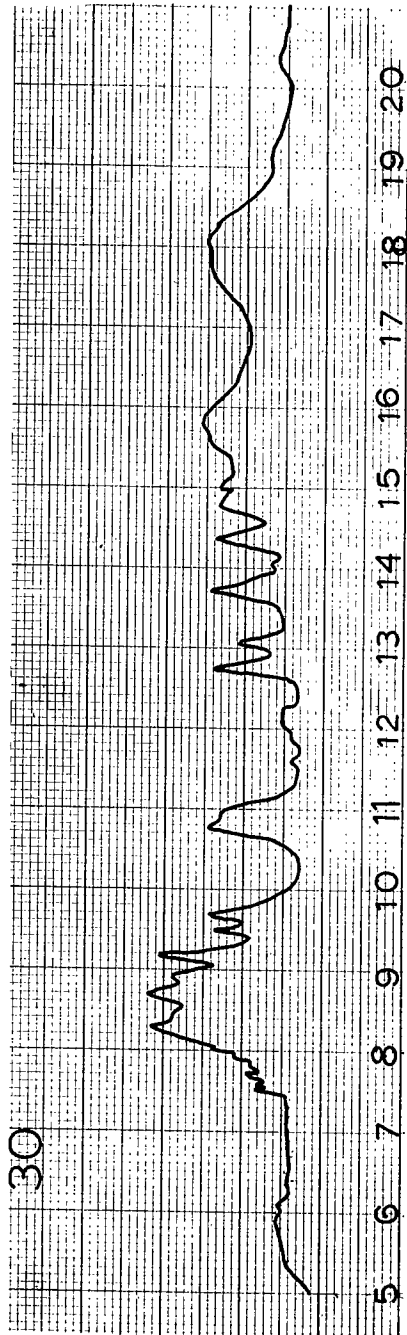
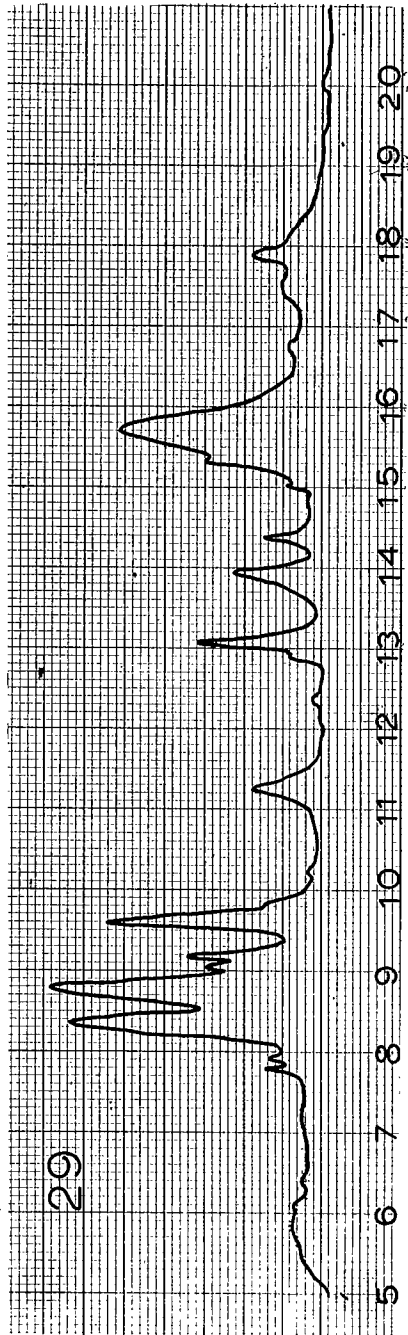
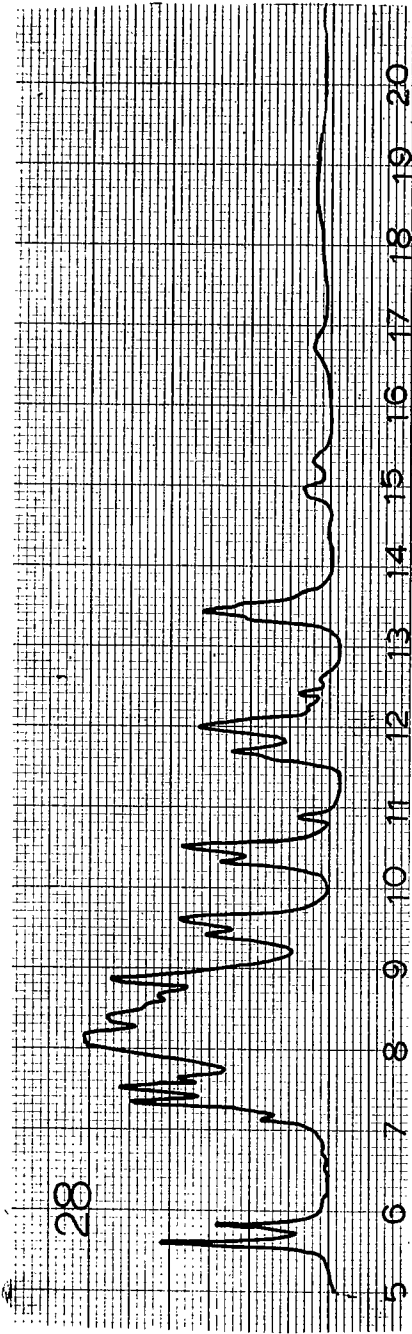

BIBLIOGRAPHY

1. C. A. Barson, C. R. Patrick, Brit. Plastics, 70 (1963).
2. M.M. Brubaker, U.S.P. 2,239,967.
3. T.A. Kudryautseva, N.M. Chirkov, Vysok. Soed. Vol.6, 1717 (1964).
4. C. G. Krespan, U.S.P. 2,938,889.
5. M.I. Bro, R.J. Convery, R.C. Schreyer, U.S.P. 2,988,542.
6. E.W.Duck, B.P. 853,355.
7. D. Sianesi, G. Caporiccio, Makromol. Chem. Band 60, 213 (1963).
8. W.K.R. Musgrave, Private communication.
9. E.V. Volkova, R.V. Zimakov, A.V. Fokin, Dokl. Akad. Nauk. SSSR. 167 (5) 1057 (1966).
10. M.A. Bruk, Dokl. Akad. Nauk. SSSR. 149 (6) 1322 (1963).
11. V. M. Belikov, Tezisy Dokl. Vsev. Konf. po Khim. Ftororgan Soedin Novosibirsk Sb.23 (1964).
12. Daikin Kogyo Co. Ltd., Chem. Abs. 64, 12838b (1966).
13. D. Sianesi, G. Caporiccio, Belg. P. 618,320.
14. H.S.E. Leuterio, U.S.P. 2,958,685.
15. E.S.Lo, U.S.P. 3,085,996.
16. R.E. Lowry, D.W. Brown, L.A. Wall, J. Pol. Sci. 4, A-1, 2229 (1966).
17. E.S. Jones, W.H. Mears, Chem. Abs. 65, 3992g (1966).
18. L.A. Wall, D.W. Brown, Chem. Abs. 58, 6933e (1963).
19. R.A. Darby, E.K. Ellingboe, U.S.P. 3,069,404.
20. R.M. Adams, F.A. Bovey, J. Pol. Sci. 9, A-1, 481 (1952).

21. J. E. Fearn, D.W. Brown, L.A. Wall, J. Pol. Sci, 4, A-1, 131 (1966).
22. J. E. Fearn, L.A. Wall, Chem. Abs. 64, 8321b (1966).
23. V.A. Khramchenkov, A.V. Zimin, Chem. Abs. 56, 299i (1962).
24. W.T. Miller, U.S.P. 2,729,613.
25. T.L.Jacobs, R.S.Bauer, J.Amer. Chem. Soc. 81, 606 (1959).
26. H.C.Brown, H.L. Gerwanter, J. Org. Chem. 25, 2071 (1961).
27. "Montecatini", Belg. P. 626,289 (1964).
28. Minnesota Mining and Manufacturing Co. B.P. 827,308.
29. "Montecatini", Chem. Abs. 65, 903b (1966).
30. J.Res. Nat. Bur. Stds. 58, 137 (1957).
31. M.I.Bro, U.S.P. 2,943,080.
32. D. C-H. Cheng, J.C. McCoubrey, J. Chem. Soc. 4993 (1963).
33. D.S. Ballantine, B.N.L. 294 (1954).
34. C.W.Wilson, J. Pol. Sci. 56, 163, S16 (1962).
35. M.I.Bro, B.W. Sandt, U.S.P. 2,946,763.
36. M.I.Bro, B.W. Sandt, R.S. Mallouk, B.P. 829,600.
37. F.Gozzo, G. Carraro, Nature, 206 (4983) 507 (1965).
38. R.I. Reed, "Advances in Organic Chemistry" Vol. 3, Interscience.
39. R.E.Florin, M.S.Parker, L.A.Wall, J.Nat. Res. Bur. Stds. 70A, 115 (1966).
40. A.Charlesby, "Atomic Radiation and Polymers", Pergamon (1960), p.389.
41. I.B.Johns, E.N.McElhill, J.O.Smith, Ind. Eng. Chem. Prod. Res. Develop. 1, 2 (1962).
42. H.L. Friedman, G.A. Griffith, 1st International Thermal Analysis Conference (1965).
43. G.P.Shulman, H.W.Lochte, J.Ap.Pol. Sci, 10, 619 (1966).

44. P.E.Slade, L.T.Jenkins, "Techniques and Methods of Polymer
"Evaluation", Vol. 1, Thermal Analysis, Arnold, 1966.
(a) p.39, (b) p.44, (c) p.91, (d) p.110, (e) p.120, (f) p.217.
45. G.M. Brauer, J. Pol. Sci. C, No.8, 1 (1964).
46. J. van Schooten, J.K. Evenhuist, Polymer 343 (1965).
47. R.G. Scholz, J. Bednarczyk, J. Yamauchi, Anal. Chem. 38, 331 (1966).
48. I.C. McNeill, J. Pol. Sci. 4, A-1, 2479 (1966).
49. J.P.Sibilia, A.R.Paterson, J. Pol. Sci. C, No.8, 41 (1964).
50. P.N. Plimmer, Ph.D. Thesis, Durham University, (1962).
51. M.Hauptschein, A.V.Grosse, J.Amer. Chem. Soc. 73, 2461 (1951).
52. M.S. Raache, U.S.P. 2,424,667.
53. I.L.Knunyants, S.P.Khrlakyan, Yu.V.Zeifmann, U.V.Shokina, Izvest.
Akad. Nauk.SSSR. Seriya Khimicheskaya No.2, 384 (1964).
54. R.D.Chambers, W.K.R.Musgrave, J.Savory, J. Chem. Soc. 3779 (1961).
55. R.D.Chambers, J.Hutchinson, R.H.Mobbs, W.K.R.Musgrave,
Tetrahedron, 20, 497 (1964).
56. A.L.Henne, C.J.Fox, J.Amer. Chem. Soc. 76, 479 (1954).
57. C.F.Feasley, W.A.Stover, U.S.P. 2,627,529.
58. A.M.Lovelace, W.Poltelnek, D.A.Rausch, "Aliphatic Fluorine
Compounds", Reinhold (1958), p.102, p.105.
59. C. Patrick, F.Gozzo, Tetrahedron 22, 3329 (1966).
60. L.J.Hals, T.S.reid, G.H.Smith, J.Amer. Chem. Soc. 73, 4054 (1951).
61. D.Sianesi, G.Nelli, Chem. Abs. 61, 2970b (1964).
62. E.T.McBee, O.R.Pierce, M.C.Chen, J.Amer. Chem. Soc. 75, 2324 (1953).
63. K.N.Campbell, J.A.Knoblock, B.K.Campbell, J.Amer Chem.Soc. 72,
4380 (1950).

64. S.A.Fuqua, W.G.Duncan, R.M.Silverstein, J.Org. Chem. 2543 (1965).
65. D.J.Burton, F.E.Merkes, K.J.Klabunde, J.Amer.Chem.Soc. 88, 5042 (1966).
66. S. Dixon, J.Org.Chem. 21, 400 (1956).
67. D.P.Grahm, J.Org.Chem. 955 (1966).
68. R.N.Haszeldine, K.Leedham, J. Chem. Soc. 3483 (1952).
69. R.N.Haszeldine, J. Chem. Soc. 4026 (1954)
70. A.T.Blomquist, P.P.Nicholas, J.Org.Chem. 863 (1967).
71. J.L.Anderson, R.E.Putnam, W.H.Sharkey, J.Amer.Chem.Soc. 83, 382 (1961).
72. G. Cammagi, S.F.Campbell, D.R.A.Perry, R.Stephens, J.C.Tatlow,
Tetrahedron 22, 1755 (1966).
73. A.T.Blomquist, D.T.Longone, J.Amer.Chem.Soc. 79, 4981 (1957).
74. T.L.Jacobs, R.S.Bauer, J.Amer.Chem.Soc. 78, 4815 (1956),
75. W.T.Miller, W.Frass, P.R.Resnick, J.Amer.Chem.Soc. 83, 1767 (1961).
76. T.J.Brice, J.D.Lazerte, W.H.Pearlson, J.Amer.Chem.Soc. 75, 2698 (1953).
77. R.N.Haszledine, J. Chem. Soc. 4259 (1952).
78. M.Hauptschein, A.V.Grosse, E.A.Nodiff, J.Org.Chem. 18, 235 (1953).
79. R.E.Parsons, U.S.P. 3,132,185.
80. R.N.Haszledine, J. Chem. Soc. 3761 (1953).
81. R.H.Mobbs, Unpublished work.
- 82,83, } J.W.Emsley, J.Feeney, L.H.Sutcliffe, "High Resolution Nuclear
85.) Magnetic Resonance Spectroscopy", Vol.2. p.886, p.876, p.908,
Pergamon (1966).
84. R.N.Haszledine, J. Chem. Soc. 2800 (1957).
86. J.M. Tedder, J.C.Walton, Trans. Farad. Soc. 1859 (1966).
87. C.Walling, F.R.Mayo, Chem. Rev. 27, 351 (1940).

88. B.H.Clampitt, R.H.Hughes, Division of Polymer Chemistry Meeting, New York, September 1963.
89. J. D. Park, R.H.Sefel, J.R.Lacher, J.Amer.Chem.Soc. 78, 59 (1956).
90. R.N.Haszledine, J. Chem. Soc. 2856 (1949).
91. Jen Chui, J.Pol.Sci., C, No. 8, 27 (1964).
92. W.W.Wendlandt, "Thermal Methods of Analysis", Interscience, (1964).
93. E.S.Blake, W.C.Hammann, J.W.Edwards, T.E.Richards, M.R.Ort, J.Chem. and Eng. Data, 6, 87 (1961).
94. G. F. Skala, Anal. Chem. 35, 702 (1963).
95. E.E.Lewis, M.A.Naylor, J.Amer.Chem.Soc. 69, 1968 (1947).
96. S.Straus, L.A.Wall, Amer.Chem.Soc. 142nd. meeting, Polymer Chemistry Division, New Jersey, 1962.
97. S. Straus, L.A.Wall, J. Res. Nat. Bur. Stds. 65A, 227 (1961).

