

## Durham E-Theses

---

### *Reactions of perfluoro-3,4-dimethyl-3-hexene and some related systems*

Andrew Arthur Lindley

#### How to cite:

---

Lindley, Andrew Arthur (1978) Reactions of perfluoro-3,4-dimethyl-3-hexene and some related systems. Doctoral thesis, Durham University.

#### Use policy

---

The full-text may be used and/or reproduced, and given to third parties in any format or medium, without prior permission or charge, for personal research or study, educational, or not-for-profit purposes provided that:

- a full bibliographic reference is made to the original source
- a <https://etheses.durham.ac.uk/id/eprint/8426/> is made to the metadata record in Durham E-Theses
- the full-text is not changed in any way

The full-text must not be sold in any format or medium without the formal permission of the copyright holders.

Please consult the [full Durham E-Theses policy](#) for further details.

UNIVERSITY OF DURHAM

A THESIS

entitled

REACTIONS OF PERFLUORO-3,4-DIMETHYL-3-HEXENE  
AND SOME RELATED SYSTEMS

Submitted by

ANDREW ARTHUR LINDLEY, B.Sc. (Dunelm)

(University College)

The copyright of this thesis rests with the author.  
No quotation from it should be published without  
his prior written consent and information derived  
from it should be acknowledged.

A candidate for the degree of Doctor of Philosophy

1978

To my Mother and Father,

and Debbie

### ACKNOWLEDGEMENTS

I would like to express my thanks to Professor R.D. Chambers for his considerable help, encouragement, and rewarding discussions.

I would also like to thank Dr. H.C. Fielding and his colleagues from I.C.I. Ltd., Mond Division, for their interest and useful discussions, and also for the supply of starting materials.

Thanks are also due to the many technical and laboratory staff for their assistance and to Mrs. C. Dowson for typing this thesis.

Finally, thanks are due to I.C.I. Ltd., Mond Division, for providing a maintenance grant.

MEMORANDUM

The work described in this thesis was carried out in the University of Durham between October 1975 and September 1978.

This work has not been submitted for any other degree and is the original work of the author except where acknowledged by reference.

Part of this work has been the subject of a paper presented at the 6th European Symposium on Fluorine Chemistry at Dortmund, W. Germany, March 1977, and also the following publications:

R.D. Chambers, A.A. Lindley, P.D. Philpot, H.C. Fielding,  
and J. Hutchinson, Israel J. Chem., 1978, 17, 150.

R.D. Chambers, A.A. Lindley, P.D. Philpot, H.C. Fielding,  
J. Hutchinson, and G. Whittaker, J. Chem. Soc. Perkin 1,  
in the press.

R.D. Chambers, A.A. Lindley, P.D. Philpot, H.C. Fielding,  
J. Hutchinson, and G. Whittaker, J. Chem. Soc. Chem. Comm.,  
1978, 431.

R.D. Chambers, A.A. Lindley, H.C. Fielding, J. Moilliet, and  
G. Whittaker, J. Chem. Soc. Chem. Comm., 1978, 475.

R.D. Chambers, A.A. Lindley, and H.C. Fielding, J. Fluor.  
Chem., in the press.

## SUMMARY

The work described in this thesis is concerned with reactions of a perfluorotetraalkylated ethylene, namely perfluoro-3,4-dimethyl-3-hexene, and some related systems, which include a perfluorinated diene and perfluoro tri- and tetra-methyl furans. Also described are fluoride ion induced oligomerisations and co-oligomerisations of some simple fluoro-olefins.

Perfluoro-3,4-dimethyl-3-hexene and other oligomers (see examples) are produced from chlorotrifluoroethylene and perfluoro-2-butene by

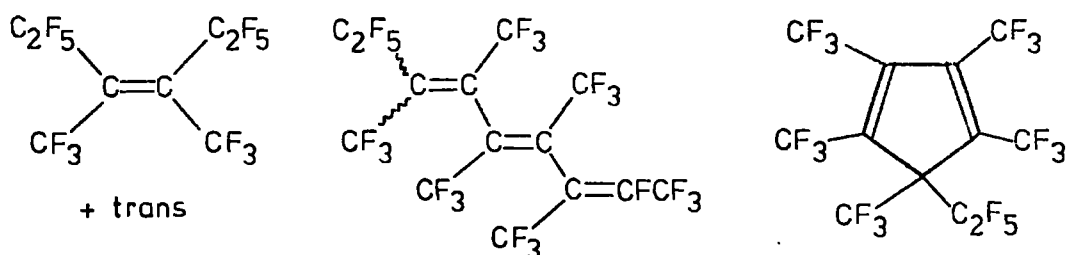

fluoride ion induced reactions. Two interesting dehalogenation processes occur during oligomerisation, one of which is suggested to be induced by caesium fluoride.

The reactions of perfluoro-3,4-dimethyl-3-hexene with a variety of O- and N-nucleophiles gave a diverse range of products formed by various substitution mechanisms. These reactions are rationalised by a general overall scheme when several factors are taken into consideration. For example the products from reactions with amines are dependent upon the steric requirements of the amine, its basicity, and the presence or absence of active fluoride ion.

Two unusual internal nucleophilic substitutions from a saturated difluoromethylene group are reported. One of these produces a furan derived from perfluoro-3,4-dimethyl-3-hexene.

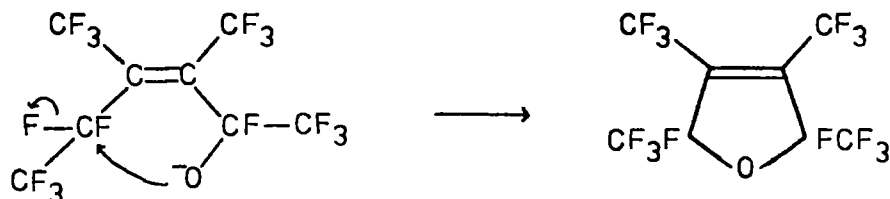

Pyrolysis of perfluoro-3,4-dimethyl-3-hexene over hot platinum gave a good yield of F-2,3-dimethylbutadiene, whereas hot iron or caesium fluoride gave defluorination products. Passage of perfluoro-3,4-dimethyl-3-hexene over hot surfaces also gave a mixture of the starting olefin and its two isomers resulting from 1,3-fluorine shifts. The reaction of a mixture of these isomers with neutral methanol clearly demonstrates the relative reactivities of isomeric terminal and internal perfluoro-olefins.

Similar pyrolyses of some related systems are also described. In particular two interesting furan derivatives were produced.

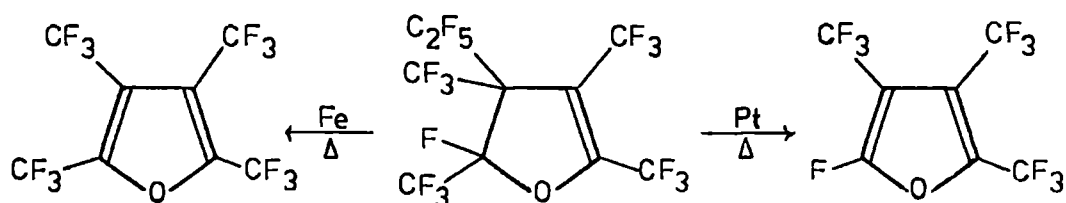

The reported reactions of these furans include photolyses giving cyclopropenyl derivatives, and the fluoride ion induced dimerisation of perfluoro-2,3,4-trimethylfuran.

Some reactions of F-2,3-dimethylbutadiene are also described, including an interesting fluoride ion induced dimerisation when there is a competition between either end of an allylic anion for the starting material.

## CONTENTS

Page

### INTRODUCTION

<u>CHAPTER I</u>	<u>Ionic Oligomerisation of Fluoro-olefins</u>	
	Introduction .. .. .	1
I.A	<u>Oligomerisation in General</u> .. .. .	1
I.B	<u>Effects of Fluorine on Reactive Centres</u> .. .. .	2
	1. Fluorocarocations .. .. .	2
	2. Fluorocarbanions .. .. .	6
	3. Fluoro-olefins .. .. .	8
	a. Fluoride Ion Induced Isomerisation .. .. .	9
	b. Antimony Pentafluoride Induced Isomerisation .. .. .	12
I.C	<u>Electrophilic Oligomerisation</u> .. .. .	12
	1. Fluoropropene Dimerisations .. .. .	13
	2. Co-oligomerisations using Fluoro-propenes .. .. .	16
	3. Co-oligomers from Cyclic Olefins .. .. .	17
I.D	<u>Nucleophilic Oligomerisation</u> .. .. .	21
	1. General Considerations .. .. .	21
	a. Mechanism .. .. .	21
	b. Fluoride Ion Reactivity .. .. .	22
	c. Crown Ethers and Phase Transfer Catalysis .. .. .	23
	d. Other Catalysts .. .. .	24
	e. Side Reactions .. .. .	25
	2. Oligomerisation of F-propene and Related Olefins .. .. .	25
	a. Dimer Formation .. .. .	26
	b. Trimer Formation .. .. .	26

	<u>Page</u>
c. Tetramer and Higher Oligomers .. ..	28
d. Related Olefins .. ..	32
3. Oligomerisation of F-ethylene and F-2-butene ..	33
a. Solvent-Catalyst Systems .. ..	33
b. Side Reactions .. ..	34
c. Reaction Mechanism and Structure of Products	34
i) F-2-butene Dimerisation .. ..	34
ii) Hexamer Formation .. ..	36
iii) Degradation of Oligomers .. ..	36
4. Oligomers from Cyclic Olefins .. ..	38
a. Effect of Ring Size .. ..	38
b. Mechanism .. ..	38
c. Reaction of F-cyclobutene with Pyridine ..	40
5. Formation of Co-oligomers .. ..	40
a. Requirements .. ..	40
b. Without Solvent .. ..	41
c. In the Presence of Solvent .. ..	42
 <u>CHAPTER II</u> <u>Reactions of Oligomers and Related Fluoro-olefins</u> ..	 45
Introduction .. ..	45
II.A <u>Reaction with Fluoride; Carbanion Trapping</u> .. ..	46
1. Requirements .. ..	46
2. With Alkyl Halides .. ..	48
3. With Perchloryl Fluoride .. ..	48
a. Possible Nucleophilic Attack on Fluorine ..	49
b. Alternative Radical Mechanism .. ..	50
II.B <u>Reactions with Nucleophiles</u> .. ..	52
1. Formation of Products .. ..	52

	<u>Page</u>
a. Kinetic and Thermodynamic Control .. ..	52
b. Relative Reactivities of Fluoro-olefins ..	53
i) Initial State Effects .. ..	55
ii) Transition State Effects .. ..	55
iii) Other Effects .. ..	56
c. Effect of Substituents on Further Reaction	57
2. O-Nucleophiles .. ..	58
a. Alcohols and Phenols .. ..	58
b. Hydroxide .. ..	58
c. Carboxylate .. ..	65
i) Facile Synthesis of Acid Fluorides ..	65
ii) Derivatives from F-olefins .. ..	66
3. S-Nucleophiles .. ..	67
4. N-Nucleophiles .. ..	70
a. Secondary Amines .. ..	70
b. Primary Amines .. ..	73
c. Ammonia and Hydrazine .. ..	74
5. C-Nucleophiles and Sodium Borohydride .. ..	76
6. Chloride .. ..	77
II.C <u>Reactions with Electrophiles</u> .. ..	78
1. At the Double Bond .. ..	78
2. Replacement of Allylic Fluorines .. ..	78
II.D <u>Additions Across the Double Bond</u> .. ..	80
1. Permanganate Oxidation .. ..	80
2. Fluorination .. ..	83
II.E <u>Photochemically Induced Isomerisation</u> .. ..	85
II.F <u>Thermolysis</u> .. ..	87

## DISCUSSION

	<u>Page</u>
<u>CHAPTER III</u> <u>Oligomers from Chlorotrifluoroethylene and F-2-butene</u> .. .. .	89
III.A <u>Oligomers from Chlorotrifluoroethylene</u> .. .. .	89
1. Formation of F-3,4-dimethyl-3-hexene .. .. .	92
2. Formation of Higher Oligomers .. .. .	94
3. Structural Assignments .. .. .	97
III.B <u>Oligomers from F-2-butene</u> .. .. .	101
1. Defluorination Mechanism .. .. .	101
2. Formation of Oligomers .. .. .	102
3. Reaction of F-propene with F-3,4-dimethyl-3-hexene .. .. .	105
III.C <u>Co-oligomers from F-propene</u> .. .. .	106
1. Using F-2-butene .. .. .	106
2. Using F-ethylene .. .. .	107
 <u>CHAPTER IV</u> <u>Reactions of F-3,4-dimethyl-3-hexene with Nucleophiles</u> .. .. .	 108
Introduction .. .. .	108
IV.A <u>O-Nucleophiles</u> .. .. .	109
1. Alcohols .. .. .	109
a. Mechanism .. .. .	110
2. Reaction of C <sub>8</sub> F <sub>16</sub> Isomers with Methanol .. .. .	110
3. With Phenol .. .. .	111
4. Bifunctional Nucleophiles .. .. .	112
5. Structural Assignments .. .. .	113
6. Further Reaction Involving Alkoxy Groups .. .. .	115
7. Formation of Furans .. .. .	117
a. Defluorination by Triethylamine .. .. .	119

	<u>Page</u>
7. b. An Analagous Cyclisation .. .. .	120
c. Structural Assignments .. .. .	120
8. Reaction of F-propene Trimers with O-Nucleophiles	121
IV.B. <u>N-Nucleophiles</u> .. .. .	122
1. Ammonia and Methylamine .. .. .	123
a. Anhydrous Conditions .. .. .	123
b. Aqueous Conditions .. .. .	124
c. Structural Assignments .. .. .	126
2. Ethylamine and t-Butylamine, Anhydrous Conditions	127
a. Structural Assignments .. .. .	129
3. Diethylamine .. .. .	130
IV.C <u>Summary of Reactions with O- and N-Nucleophiles</u> ..	131
IV.D <u>Phenylmagnesium Bromide</u> .. .. .	132
1. Structural Assignments .. .. .	133
IV.E <u>Potassium Permanganate</u> .. .. .	134
1. Reaction of Diol with Potassium Hydroxide ..	135
2. Structural Assignments .. .. .	136
<u>CHAPTER V</u> <u>Pyrolysis of F-olefins</u> ... .. .	137
V.A <u>F-3,4-dimethyl-3-hexene</u> .. .. .	137
1. Mechanism .. .. .	139
2. Structural Assignments .. .. .	140
V.B <u>F-2,3-dimethyl-2-pentene</u> .. .. .	141
V.C <u>F-propene Trimers</u> .. .. .	143
V.D <u>Furan Derivatives</u> .. .. .	143

	<u>Page</u>
CHAPTER VI <u>Some Reactions of F-2,3-dimethylbutadiene and F-tri- and F-tetra-methylfurans</u> .. .. .	146
VI.A <u>F-2,3-dimethylbutadiene</u> .. .. .	146
1. Reactions with Methanol and Phenol .. .. .	146
a. Structural Assignments .. .. .	147
2. Hydrolysis .. .. .	148
3. Reaction with Fluoride, Dimerisation .. .. .	148
a. Structural Assignments .. .. .	151
b. Formation of a Stable Anion .. .. .	152
c. Fluorination of Dimers .. .. .	153
d. Attempted Dimerisation using Other Catalysts .. .. .	154
4. Photolysis with F-acetone .. .. .	155
5. Radical Reactions .. .. .	156
VI.B <u>F-tri- and F-tetra-methyl furans</u> .. .. .	156
1. Reactions with Nucleophiles .. .. .	156
2. Dimerisation .. .. .	157
3. Photolysis .. .. .	159
4. Attempted Diels-Alder Reactions .. .. .	160
<u>EXPERIMENTAL</u>	
EXPERIMENTAL .. .. .	161
CHAPTER VII <u>Experimental to Chapter III</u> .. .. .	164
VII.A <u>Oligomerisation of Chlorotrifluoroethylene</u> .. .. .	164
1. At 25° .. .. .	164
2. At 120° .. .. .	165
VII.B <u>Co-oligomerisation of Chlorotrifluoroethylene</u> .. .. .	165
1. With F-2-butene .. .. .	165
2. With F-3,4-dimethyl-3-hexene .. .. .	166

							<u>Page</u>
VII.B	3. With C <sub>10</sub> F <sub>18</sub> Isomers	..	..	..	..	..	166
VII.C	<u>Oligomerisation of F-2-butene</u>	..	..	..	..	..	167
VII.D	<u>Co-oligomerisation of F-2-butene</u>	..	..	..	..	..	168
	1. With C <sub>8</sub> F <sub>14</sub> Isomers	..	..	..	..	..	168
	2. With F-2-butyne	..	..	..	..	..	168
VII.E	<u>Reactions of F-propene</u>	..	..	..	..	..	169
	1. With F-2-butene	..	..	..	..	..	169
	2. With F-3,4-dimethyl-3-hexene	..	..	..	..	..	169
	3. With F-4-ethyl-3,4-dimethyl-2-hexene	..	..	..	..	..	170
	4. With F-ethylene	..	..	..	..	..	170
VII.F	<u>Defluorination of F-3,4-dimethyl-3-hexene; the Effect of Fluoride Ion</u>	..	..	..	..	..	171
	1. Without Caesium Fluoride	..	..	..	..	..	171
	2. With Caesium Fluoride	..	..	..	..	..	171
VII.G	<u>Attempted Defluorination of F-2-butene</u>	..	..	..	..	..	171
<u>CHAPTER VIII Experimental to Chapter IV</u>		..	..	..	..	..	172
	Introduction	..	..	..	..	..	172
VIII.A	<u>Reactions of F-3,4-dimethyl-3-hexene with O-Nucleophiles</u>	..	..	..	..	..	172
	1. Alcohols, using Caesium Fluoride as Base	..	..	..	..	..	172
	2. Methanol, using Sodium Methoxide as Base	..	..	..	..	..	175
	3. Methoxide	..	..	..	..	..	175
	4. Reaction of C <sub>8</sub> F <sub>16</sub> Isomers with Neutral Methanol	..	..	..	..	..	175
	5. Alcohols and Water, using Pyridine as a Base	..	..	..	..	..	176
	6. Reaction of F-2,5-dihydro-tetramethylfuran with Ethanol	..	..	..	..	..	178
	7. Conversion of Alkyl Ethers to F-2,5-dihydro- tetramethylfuran	..	..	..	..	..	179

	<u>Page</u>
VIII.A 8. Reactions of F-2,5-dihydropyridomethylfuran ..	179
a. With Triethylamine .. .. .	179
b. With Pyridine .. .. .	179
c. With Caesium Fluoride or Chloride .. ..	180
9. Effect of Alcohol and Amine .. .. .	180
a. Ethanol, using Trimethylamine .. ..	180
b. Ethanol, using Triethylamine .. ..	180
c. Methanol, using Trimethylamine .. ..	180
d. Methanol, using Triethylamine .. ..	181
10. Ethylene Glycol .. .. .	181
11. Ethanolamine .. .. .	182
12. Sorbitol .. .. .	182
13. Phenol .. .. .	182
VIII.B <u>Reactions with N-Nucleophiles</u> .. .. .	183
1. Ammonia .. .. .	183
2. Aqueous Methylamine .. .. .	184
3. Anhydrous Methylamine .. .. .	184
4. Anhydrous Ethylamine .. .. .	185
5. t-Butylamine .. .. .	185
a. In the Presence of Pyridine .. .. .	185
b. Without Pyridine .. .. .	186
6. Ethylenediamine .. .. .	186
7. Urea .. .. .	187
8. Diethylamine .. .. .	187
a. Without Solvent .. .. .	187
b. With Ether Present .. .. .	187
9. Triethylamine .. .. .	188

								<u>Page</u>
VIII.C	<u>Phenylmagnesium Bromide</u>	..	..	..	..	..	..	188
VIII.D	<u>Halide</u>	..	..	..	..	..	..	189
VIII.E	<u>Potassium Permanganate</u>	..	..	..	..	..	..	189
	1. Reaction of Diol with Potassium Hydroxide						..	190
VIII.F	<u>Difluorocarbene</u>	..	..	..	..	..	..	190
<u>CHAPTER IX</u>	<u>Experimental to Chapter V</u>	..	..	..	..	..	..	191
IX.A	<u>Pyrolysis of F-olefins, General Method</u>					..	..	191
	1. Workup	..	..	..	..	..	..	192
IX.B	<u>F-3,4-dimethyl-3-hexene</u>	..	..	..	..	..	..	192
	1. Over Iron	..	..	..	..	..	..	192
	2. Caesium Fluoride	..	..	..	..	..	..	193
	3. Platinum	..	..	..	..	..	..	193
	a. Isomerisation	..	..	..	..	..	..	193
	b. Fragmentation	..	..	..	..	..	..	193
	4. Quartz Wool	..	..	..	..	..	..	195
IX.C	<u>F-2,3-dimethyl-2-pentene</u>	..	..	..	..	..	..	195
	1. Iron	..	..	..	..	..	..	195
	2. Platinum	..	..	..	..	..	..	195
IX.D	<u>F-propene Trimers</u>	..	..	..	..	..	..	196
	1. Iron	..	..	..	..	..	..	196
	2. Platinum	..	..	..	..	..	..	197
IX.E	<u>F-2,5-dihydrotetramethylfuran</u>	..	..	..	..	..	..	197
	1. Iron	..	..	..	..	..	..	197
	2. Platinum	..	..	..	..	..	..	197
IX.F	<u>F-4-ethyl-2,3,4,5-tetramethyl-2-oxolene</u>	..	..	..	..	..	..	197
	1. Platinum	..	..	..	..	..	..	197
	2. Iron	..	..	..	..	..	..	198

		<u>Page</u>
IX.G	<u>Others</u> .. .. .	199
CHAPTER X	Experimental to Chapter VI .. .. .	200
X.A	<u>Reactions of F-2,3-dimethylbutadiene</u> .. .. .	200
	1. Neutral Methanol .. .. .	200
	2. Phenol .. .. .	200
	3. Caesium Fluoride and Bromine .. .. .	201
	4. Caesium Fluoride, Dimerisation .. .. .	201
	a. At Room Temperature .. .. .	201
	b. At 90° .. .. .	202
	c. Pyridine .. .. .	202
	d. Reaction of Dimers with Fluoride Ion .. .. .	202
	5. Formation of Carbanions from the Dimers .. .. .	203
	a. From Other Fluoro-olefins .. .. .	203
	6. Fluorination of Dimers using Cobalt Trifluoride .. .. .	203
	a. At 100° .. .. .	204
	b. At 200° .. .. .	204
	7. With Antimony Pentafluoride .. .. .	204
	8. Photolysis with F-acetone .. .. .	205
	9. Radical Reactions .. .. .	205
	a. Bromine .. .. .	205
	b. Attempted Copolymerisations .. .. .	206
X.B	<u>Reactions of F-2,3,4-trimethylfuran</u> .. .. .	206
	1. Methanol .. .. .	206
	2. Phenylmagnesium Bromide .. .. .	207
	3. Potassium Sulphide .. .. .	207
	4. Caesium Fluoride, Dimerisation .. .. .	208

									<u>Page</u>
X.B	5.	Reaction with its Methoxy Derivative	..	..	..	..	..	..	209
	6.	Photolysis	..	..	..	..	..	..	209
X.C		<u>Reactions of F-tetramethylfuran</u>	..	..	..	..	..	..	210
	1.	Photolysis	..	..	..	..	..	..	210
	2.	Attempted Diels-Alder Reactions	..	..	..	..	..	..	211
<u>REFERENCES</u>	..	..	..	..	..	..	..	..	212
<u>APPENDIX 1</u>	<sup>19</sup> F and <sup>1</sup> H	n.m.r. Spectra	..	..	..	..	..	..	226
<u>APPENDIX 2</u>		Infra-red Spectra	..	..	..	..	..	..	252
<u>APPENDIX 3</u>		Research Seminars and Lectures, Conferences and Papers	..	..	..	..	..	..	261

INTRODUCTION

## CHAPTER I

### Ionic Oligomerisation of Fluoro-olefins

#### Introduction

Low molecular weight fluoro-olefins, such as F-ethylene\*, F-propene, and F-cyclobutene, are either available commercially or, in some cases, may be readily prepared on a laboratory scale. These fluoro-olefins are, in themselves, chemically interesting, but it is possible to convert them to a range of higher molecular weight fluorocarbons by a number of routes, some of which are outlined below.

The formation of higher fluoro-olefins, which are oligomers of the starting materials, is particularly relevant to the work described in this thesis. These oligomers are interesting because their chemistry is relatively unexplored. They are also proving to be useful, industrially, as intermediates in the production of various surface active agents and, when fluorinated, as solvents, inert fluids, etc.

In this chapter the formation of these higher fluoro-olefins, by ionic oligomerisation processes, is reviewed, and in Chapter II their chemistry is discussed.

#### I.A Oligomerisation in General

Oligomerisation involves taking a monomer, M, and reacting it in some way, such that a product consisting of a number of monomer units,  $(M)_n$ , is obtained (eq.I.1). This is essentially different from telomerisation and many polymerisation processes (eq.I.2) where a radical initiator, AB, is used and this is normally incorporated into the product as end groups.

---

\* F- is an accepted abbreviation for a fully fluorinated system.

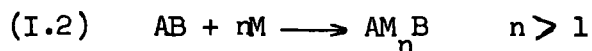

There are a number of other important differences between the two types of process and, to illustrate these, some examples of radical processes (eq.I.2) are listed in Table 1. The products formed, from radical processes, contain repeating units and so for F-ethylene (1) straight chain saturated fluorocarbons are obtained. This is in contrast to, for example, an anionic oligomerisation process, which produces highly branched, unsaturated fluoro-olefins, and which cannot be induced to give significant amounts of products containing greater than about eight monomer units.

Oligomers may be produced from thermal and photochemical reactions and more extensively from ionic processes. Some examples of thermal and photochemical oligomerisations are given in Table 2. Before reviewing cationic and anionic oligomerisation it is worthwhile to outline the various effects of fluorine on reactivity and stability of carbocations, carbanions, and fluoro-olefins. Only a summary of these effects is given here but further reviews are available.<sup>12-15</sup>

## I.B Effects of Fluorine on Reactive Centres

### I.B.1 Fluorocarocations

Two situations arise for fluorocarocations:- 1) when fluorine is attached to carbon having some formal positive charge, that is directly bonded to a positive centre (eq.I.3) or to carbon conjugated to a positive centre (eq.I.4); and 2) when fluorine is not directly attached to carbon having some formal positive charge (eq.I.5 and I.6).

Table 1

Reactions of Fluoro-olefins Giving Telomers and, or Polymers.

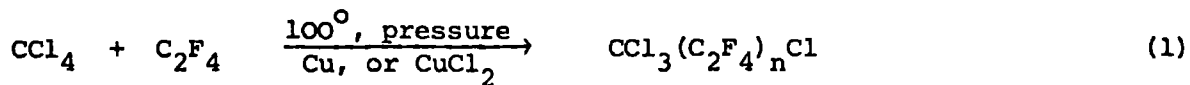

ratio  $n = 1-5 : n > 5, = 4 : 3.$

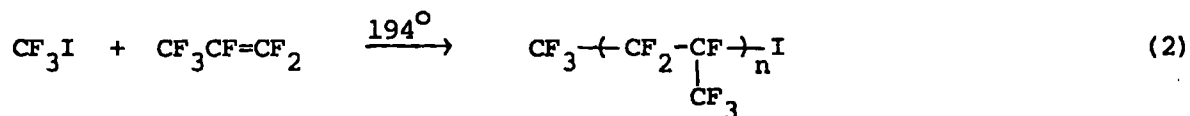

$n = 1 (47\%), n = 2-4 (50\%)$

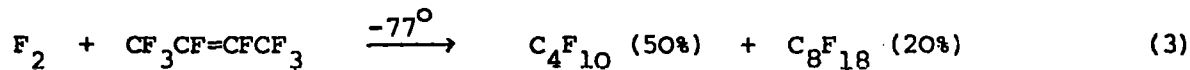

$n = 400,000-9,000,000$

Table 2

Thermal and Photochemical Oligomerisation

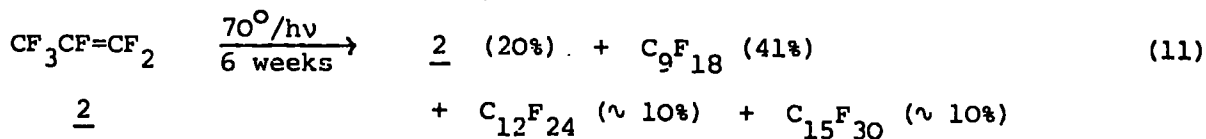
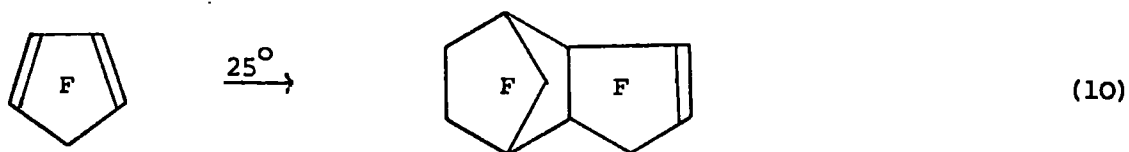
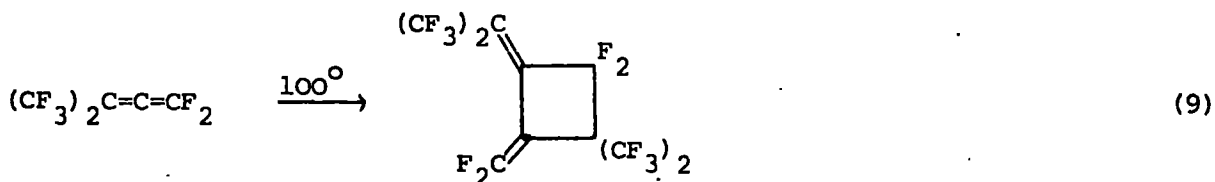
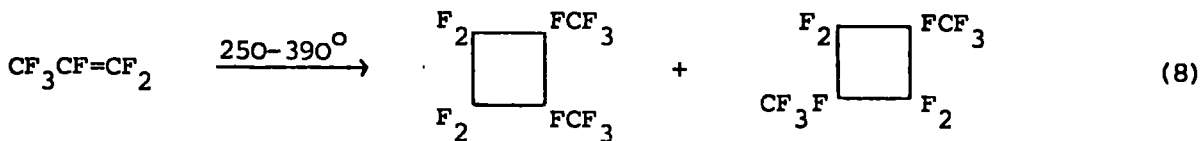
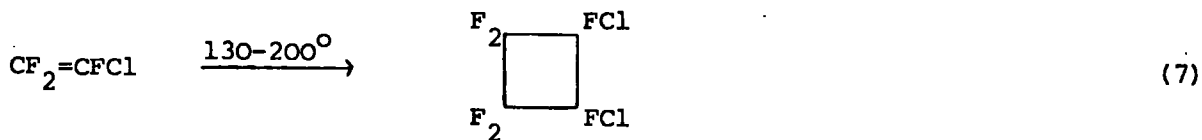
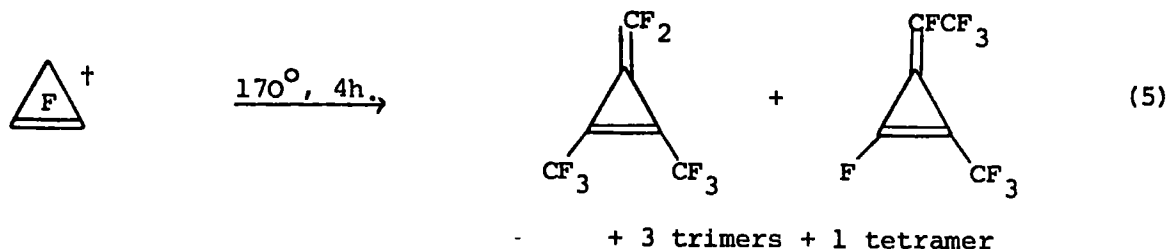

† Fluorinated ring systems will be represented in this way throughout this thesis.

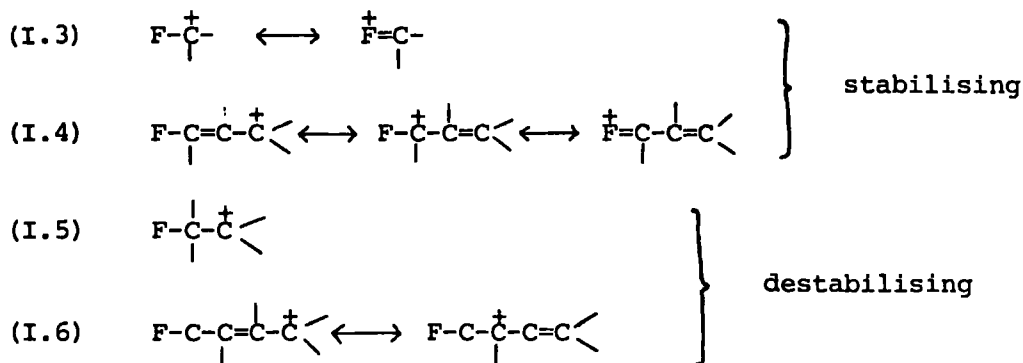

In the first case fluorine has a stabilising influence, relative to hydrogen, because destabilising electron withdrawal,  $\overset{\oplus}{\text{C}} \rightarrow \text{F}$ , is offset by mesomeric electron release,  $\overset{\oplus}{\text{F}} \leftarrow \overset{\oplus}{\text{C}}$  (equivalent to  $\text{C}=\overset{\oplus}{\text{F}}$ ), whereas in the second case fluorine is destabilising, relative to hydrogen, because electron withdrawal cannot be offset by mesomeric electron release,  $\text{F} \leftarrow \overset{\oplus}{\text{C}}$ . Mesomeric electron release, by fluorine, has been demonstrated experimentally for stable carbocations, by the large deshielding observed using nmr spectroscopy.<sup>17</sup> For example, the dimethyl fluorocation is deshielded by 260 ppm from the starting material<sup>18</sup> (eq.I.7). Similarly the F-cyclopropenium ion shows one signal, 57.8 ppm downfield from the average shift of F-cyclopropane<sup>19</sup> (eq.I.8). Like fluorine, chlorine and bromine are found to stabilise carbocations, again by mesomeric electron release. Thus the trichlorocyclopropenium ion, which is readily formed from tetrachlorocyclopropane and aluminium trichloride (eq.I.9), has been shown, by spectroscopic techniques, to have about half the positive charge delocalised through the  $\pi$  system onto the chlorines.<sup>20</sup>

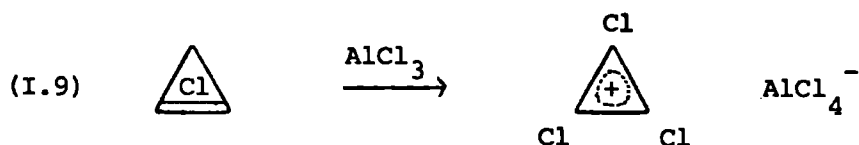
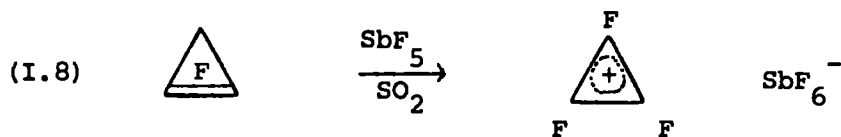
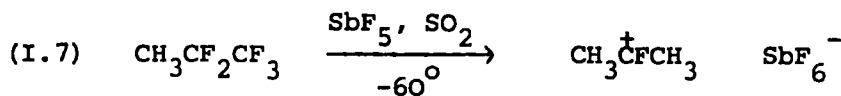

### I.B.2 Fluorocarbanions

For fluorocarbanions one might expect that fluorine directly bonded to the negative centre,  $\text{C}^-$ , would be strongly stabilising as a result of inductive electron withdrawal,  $I_G$  (eq.I.11), but in practice it is found that fluorine has a much greater stabilising effect when bonded to carbon adjacent to the negative centre (eq.I.10). Obviously, for fluorine directly bonded to  $\text{C}^-$  a destabilising effect must also operate. One explanation for this effect is that there is considerable  $I\pi$  repulsion between lone pairs on fluorine and carbon<sup>16</sup> (eq.I.12).

The other halogens, in order  $\text{Cl} < \text{Br} < \text{I}$ , become progressively more stabilising relative to fluorine when directly bonded to  $\text{C}^-$ , probably as a result of a combination of factors:

- 1) reduced  $I\pi$  repulsion<sup>21</sup>
- 2) relief of steric crowding on formation of the anion; and
- 3) increasing polarisability and availability of d-orbitals, especially for bromine and iodine<sup>22</sup> (eq.I.13).

Table 3  
Stable Carbanions

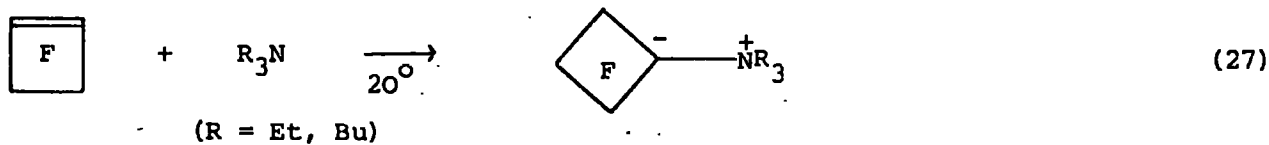
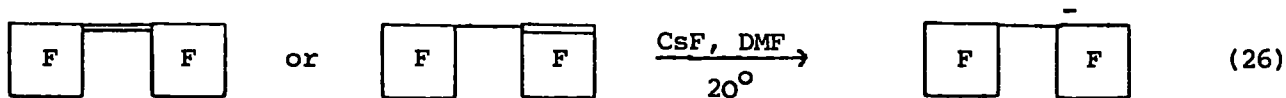
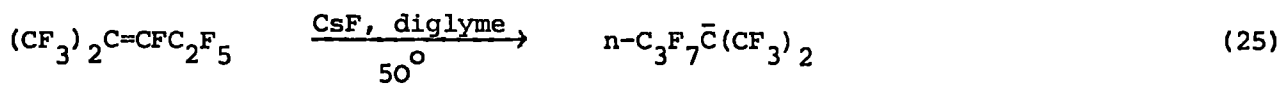
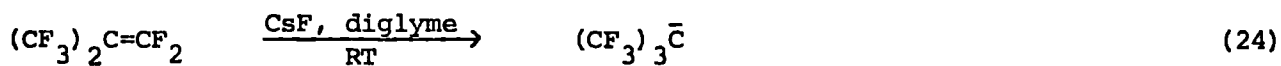

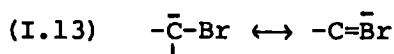
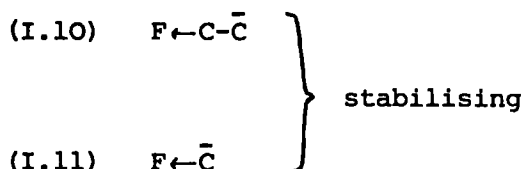

These observations allow one to predict the relative stabilities of a series of fluorocarbanions (which is, of course, the reverse order of reactivity).

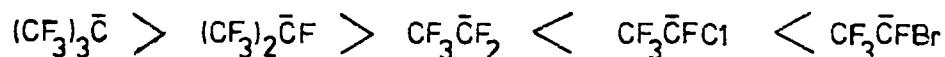

Normally fluoro-olefins react with fluoride ion to form the most stable carbanion and so, for example, chlorotrifluoroethylene (3) gives  $\text{CF}_3\text{CFCl}^-$ , rather than  $\text{CF}_2\text{ClCF}_2^-$ , as intermediate, shown by the formation of  $\text{CF}_3\text{CHFCl}$  from (3) using potassium fluoride in formamide.<sup>23</sup>

A number of fluorocarbanions are stable under certain conditions and some may be observed, in solution, using nmr spectroscopy. Examples are given in Table 3.

### I.B.3 Fluoro-olefins

It is well established that fluorine prefers not to be bonded to unsaturated carbon. This may be a result of a destabilising interaction between lone pairs on fluorine and the  $\pi$  system of the carbon-carbon double bond, in an analagous manner to that described for fluorocarbanions (Section I.B.2). Alternatively the C-F bond strength may be decreased for

fluorine attached to  $sp^2$  carbon compared to  $sp^3$  carbon because of an increase in the electronegativity of carbon in going from  $sp^3$  to  $sp^2$  hybridisation.<sup>28</sup>

The effect of fluorine on stability is clearly demonstrated by comparison of the total bond energies<sup>29</sup> for the carbon skeletons of butadiene and 2-butyne.



374.2

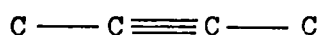

364.8 kcal/mole

On this basis, one would expect butadiene to be the more stable, as is found, in practice, for the hydrocarbon compounds, but F-butadiene is readily isomerised to F-2-butyne by fluoride ion<sup>30</sup> (see below).

#### I.B.3.a Fluoride Ion Induced Isomerisation

Fluoride ion induced isomerisations of fluoro-olefins may be  $SN_2'$  (concerted) processes (scheme 1) or may proceed via intermediate carbanions (4), giving (5) (scheme 2). For convenience the term  $SN_2'$  will be used, although the reactions described may not be concerted. Some examples are given in Table 4.

These isomerisations are reversible and it will be seen later that various nucleophilic reactions involve initial isomerisation to less stable fluoro-olefins. Another reaction pathway for carbanion (4) (scheme 2) is the elimination of fluoride giving a non-rearranged product (6). Although this will be described as vinylic substitution it is not generally a concerted process. The preference for either pathway, in scheme 2, depends on the relative stabilities of the various possible products.

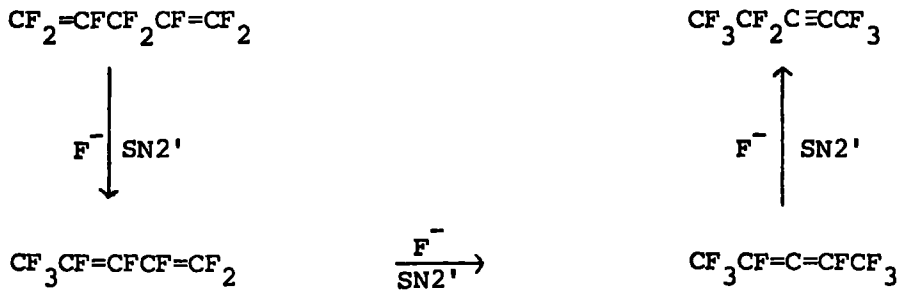

Scheme 1 (see eq. I.16)

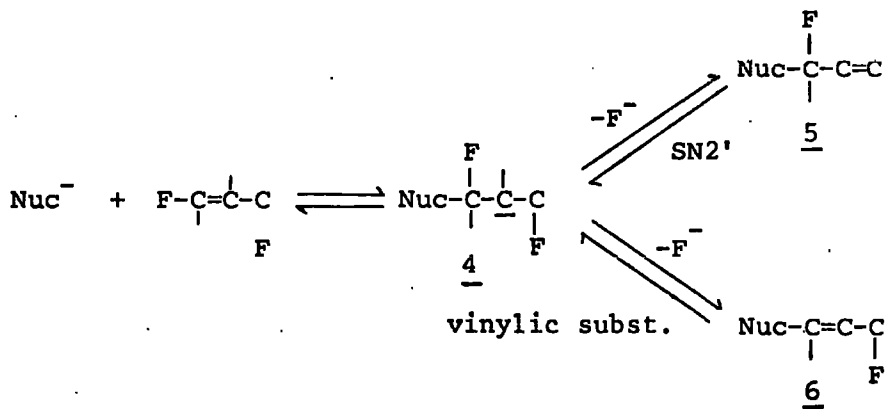

Scheme 2

Table 4

Fluoride Ion Induced Isomerisations

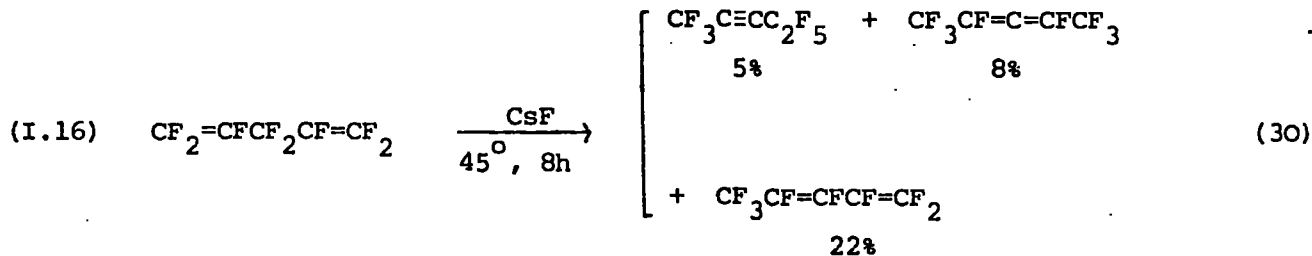
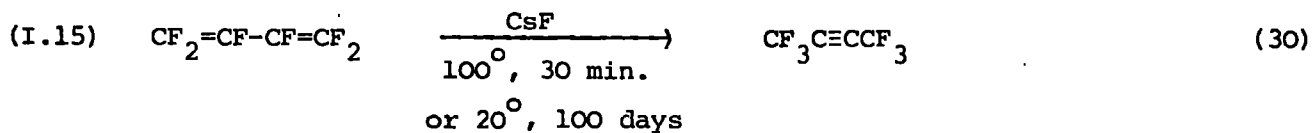
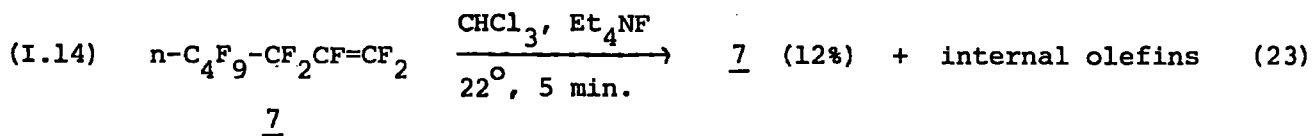

For a more detailed discussion of nucleophilic reactions of some fluoro-olefins see Chapter II.

I.B.3.b Antimony Pentafluoride Induced Isomerisations

Antimony pentafluoride induced isomerisations (eq.I.17 and I.18) appear to involve allyl cations as intermediates. The conversion of F - 1, 7-octadiene to, specifically, F-trans, trans-2, 6-octadiene<sup>31</sup> (eq.I.17) is readily explained by considering the stereochemistry of the intermediate allyl cation (8) (eq.I.19). The most stable configuration

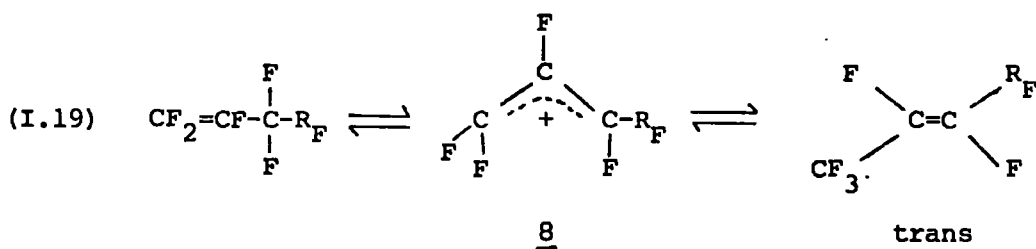
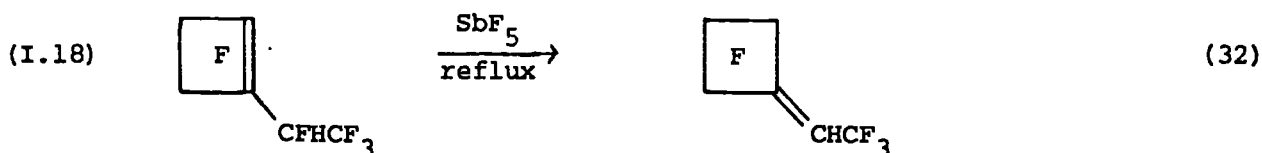
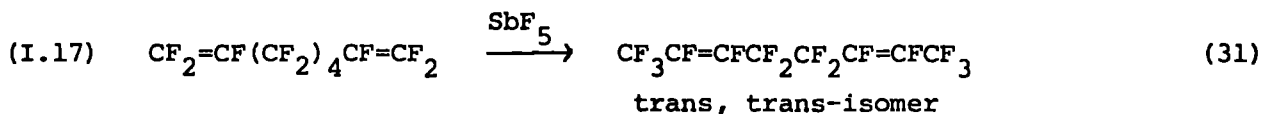

for planar cation (8) has a cis arrangement for the C-1 and C-3 fluorines. It has been shown, by nmr spectroscopy, for a similar allyl cation (p-MeOC<sub>6</sub>H<sub>4</sub> replaces R<sub>F</sub> in 8) that there is considerable interaction between the cis C-1 and C-3 fluorines.<sup>33</sup> A trans arrangement for these fluorines would therefore produce a significant destabilising interaction between F and R<sub>F</sub> in (8).

I.C Electrophilic Oligomerisation

It has been reported that F-ethylene is polymerised, at room

temperature, by antimony pentafluoride and fluorosulphonic acid, in the presence of a radical inhibitor ( $\alpha$ -pinene)<sup>34</sup>. This suggests a cationic polymerisation process, although the stability of  $\alpha$ -pinene under these conditions is somewhat uncertain.

In general, though, only dimers and, in one instance a trimer, have been produced from fluoro-olefins using either fluorosulphonic acid or antimony pentafluoride. These are strong Lewis acids and, in particular,  $\text{SbF}_5$  very readily accepts fluoride ion. A comprehensive list of these oligomerisations is given in Table 5.

#### I.C.1 Fluoropropene Dimerisations

Myhre<sup>35</sup> published the first example of electrophilic dimerisation of a fluoro-olefin, for 3,3,3-trifluoropropene (9a), which in  $\text{HSO}_3\text{F}$  or  $\text{DSO}_3\text{F}$  gave only one dimer (10a) (scheme 3). Furthermore, the same olefin labelled at C-2 with deuterium ( $\text{CF}_3\text{CD}=\text{CF}_2$ , 9b) in  $\text{HSO}_3\text{F}$  gave dimer (10b) labelled with deuterium at C-2 and C-4 only. (See also Table 5). The absence of H,D exchange with solvent and specific formation of dimer (10b) from the deuterium labelled fluoropropene (9b) indicated an electrophilic mechanism for this dimerisation (scheme 3). Intermediate cation (11) is suggested to rearrange, via a 1,3-hydride shift to give allyl cation (12).

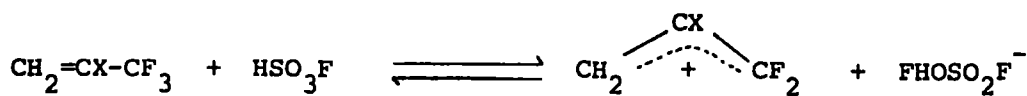

9a, X = H

9b, X = D

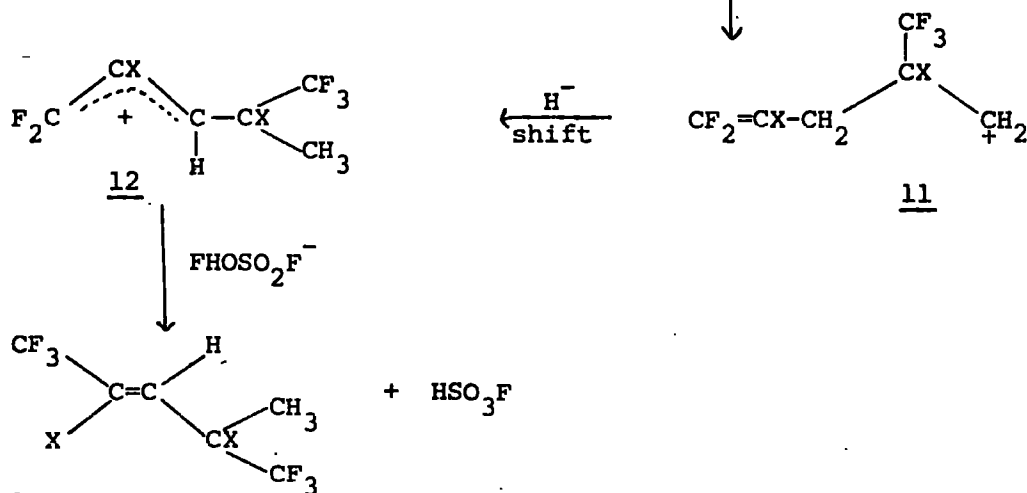

10a, X = H

10b, X = D

Scheme 3<sup>35</sup>

An analogous mechanism has been described for the dimerisation of F-propene (2), giving F-trans-4-methyl-2-pentene (13) (see Table 5), but now a 1,3 fluoride shift is proposed.<sup>33</sup> A slightly different mechanism is given in scheme 4, where intermediate cation (14) is suggested to abstract fluoride from  $\text{SbF}_6^-$ , giving a terminal olefin (15), although this was not isolated.<sup>36</sup> The terminal olefin will then isomerise, in the presence of  $\text{SbF}_5$ , to give dimer (13) (see also Section I.B.3.b). Further isomerisation to the thermodynamically more stable dimer, F-2-methyl-2-pentene (16) does not occur, with  $\text{SbF}_5$ , although this is a well known process with fluoride ion.<sup>37</sup>



The absence of isomerisation to (16), with  $\text{SbF}_5$ , is suggested to be a result of the instability of the required intermediate cation (17) (eq.I.20). The  $\text{CF}_3$  groups in (17) are strongly destabilising, and so (17) will not be readily formed from F-4-methyl-2-pentene (13); thus the fluorine in (13) is not sufficiently labile.<sup>36</sup>

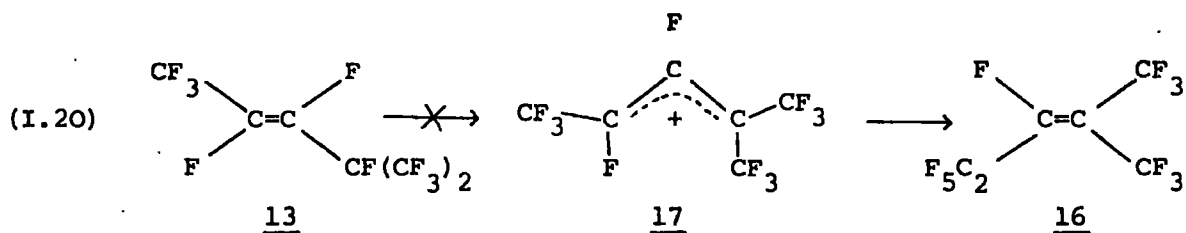

#### I.C.2 Co-oligomerisations using Fluoro-propenes

F-ethylene (1) reacts readily with F-propene (2), using  $\text{SbF}_5$  as catalyst, to give F-trans-2-pentene (18), derived from attack of the F-allyl cation (19) on F-ethylene<sup>36</sup> (scheme 5). A similar dimerisation occurs with trifluoroethylene (20) and F-propene (2), giving specifically 2-H-nonafluoro-2-pentene (21) via attack of the F-allylcation (19) on the CFH end of (20) (see Table 5).<sup>36</sup> In contrast, F-propene and chlorotrifluoroethylene (3) give products arising from attack of the F-allyl cation on both ends of (3) (scheme 6), suggesting that the intermediate carbocations have similar stabilities,<sup>36</sup> as would be expected (see Section I.B.1).

Interestingly 2H-pentafluoropropene and F-ethylene gave the expected dimer, 2H-nonafluoro-2-pentene (21) (also formed from F-propene and trifluoroethylene, see above) and a trimer, which was also produced directly from (21) and F-ethylene (Table 5). Using similar conditions, F-2-pentene (18) and F-ethylene (1) did not react. The difference in

reactivity of 2H-nonafluoro-2-pentene and F-2-pentene, towards (1) is again reflected in the stability of the intermediate allyl cations<sup>36</sup> (eq.I.21 and I.22).

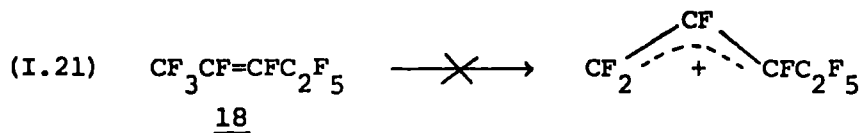

### I.C.3 Co-oligomers from Cyclic Olefins

F-cyclobutene (22) failed to dimerise, using  $\text{SbF}_5$ .<sup>33</sup> This is possibly because reaction of (22) with the F-cyclobutenium ion (23), would produce a relatively unstable cation (24) (eq.I.23).

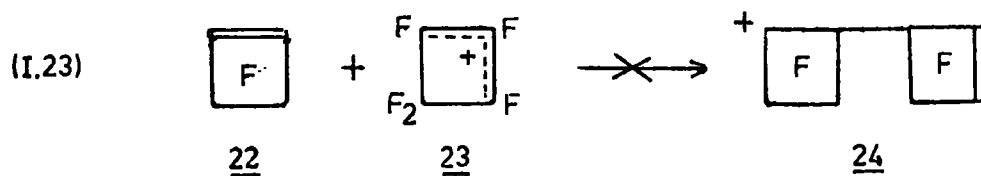

However, F-cyclobutene will react with F-ethylene (1), F-propene (2), and trifluoroethylene, to give dimers<sup>32</sup> (Table 5). In each case the products are explained by attack of the F-cyclobutenium ion on the fluoro-olefin (scheme 7). With (1) and (2) only cyclobutene derivatives, (25, X = F, CF<sub>3</sub>) are obtained, whereas with trifluoroethylene, although the expected cyclobutene derivative, (25, X = H), is formed, the major product, (26, X = H), arises from isomerisation of (25, X = H) (see Section I.B.3.b).

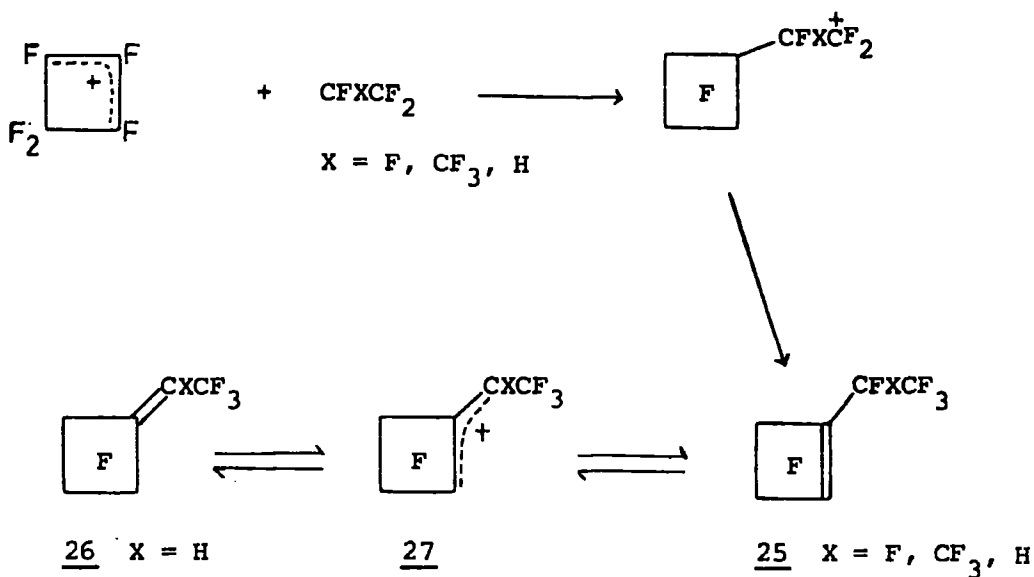

Scheme 7<sup>32</sup>

Again the relative stabilities of the postulated intermediate cations (27) explains why cyclobutene derivative (25, X = H) isomerises and (25, X = CF<sub>3</sub>) does not. Clearly cation (27, X = H) will be much more stable. One would expect that cation (27, X = F) would be even more readily formed than (27, X = H) (see Section I.B.1) and, presumably, the reason that cyclobutene derivative (25, X = F) does not isomerise is because it is the more stable isomer.

In contrast, F-cyclopentene failed to react with F-ethylene, using conditions where F-cyclobutene gave products. It has been suggested that the difference in reactivity could possibly be explained by additional homoaromatic stabilisation for the F-cyclobutenium ion.<sup>32</sup> The cyclobutenium ion (28) is thought to be stabilised in this way, but the cyclopentenium ion (29) probably has no additional stabilisation.<sup>38</sup> However long lived fluorocyclobutenium ions have been observed, using nmr spectroscopy, and the evidence suggests that additional homoaromatic stabilisation is not significant.<sup>33</sup>



Table 5

Electrophilic Oligomerisation of Fluoro-olefins<sup>†</sup>

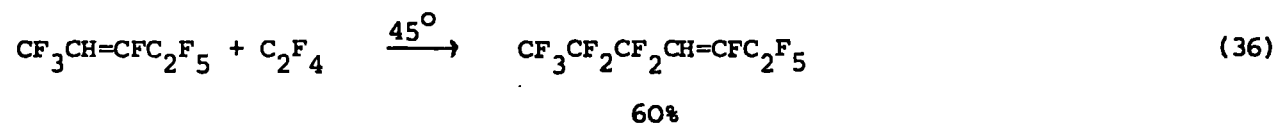
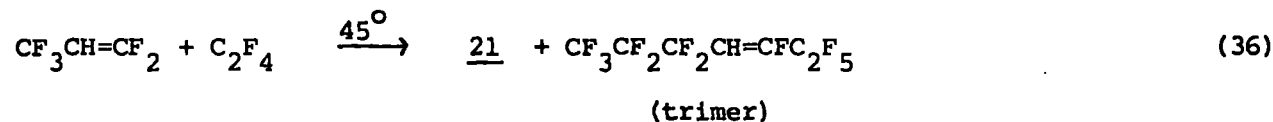
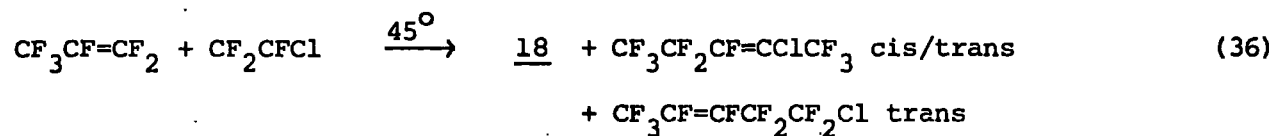
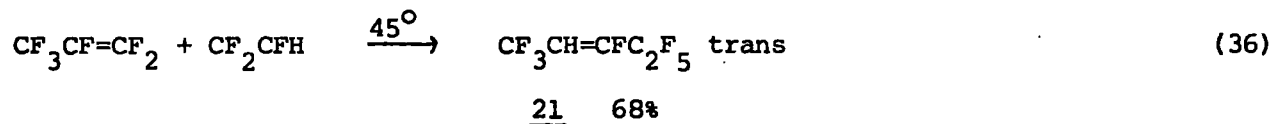
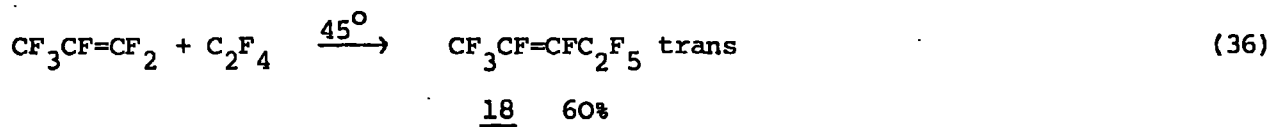
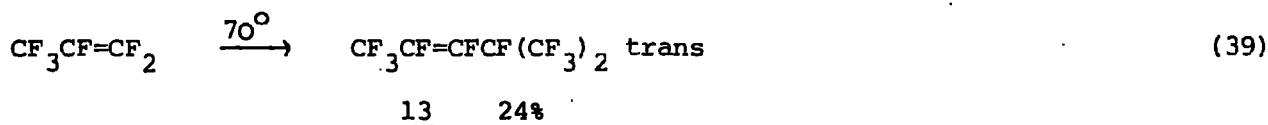
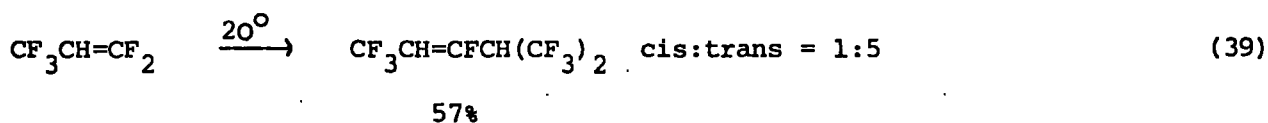
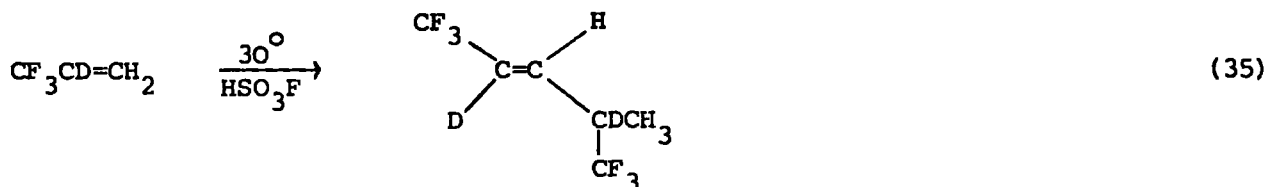
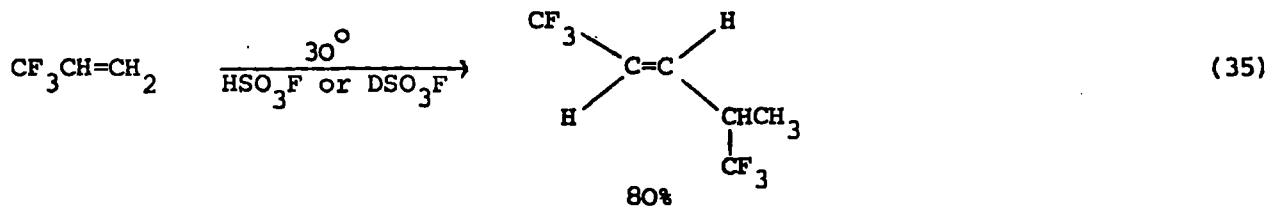
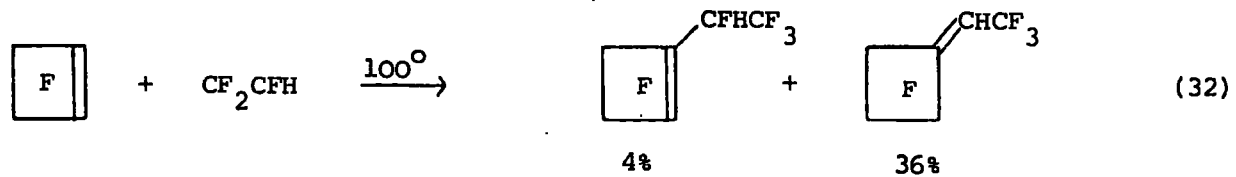
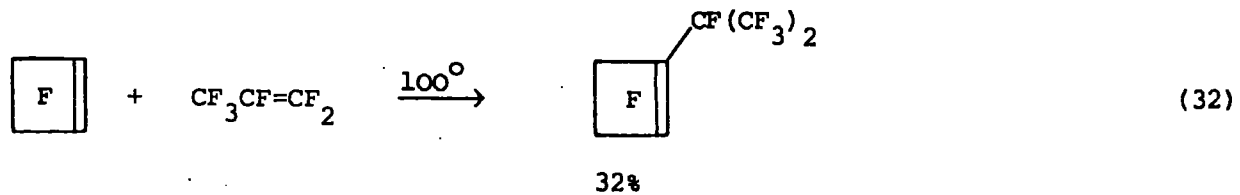
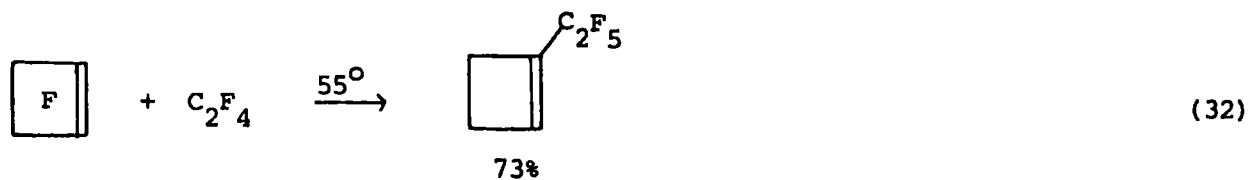

Table 5 continued



† using antimony pentafluoride, unless otherwise stated.

I.D Nucleophilic Oligomerisation

I.D.1 General Considerations

I.D.1.a Mechanism

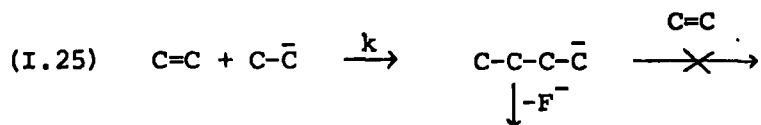
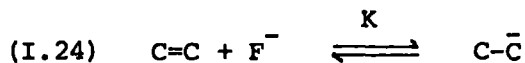

These oligomerisations are, in general, catalysed by fluoride ion. The first stage of reaction, an equilibrium, is the formation of a carbanion, from the fluoro-olefin and fluoride ion (eq.I.24). Subsequent reaction between this carbanion and fluoro-olefin produces a larger carbanion (eq.I.25). This readily loses fluoride and, if possible, isomerises to a more stable internal olefin (see Section I.B.3.a), rather than reacting directly with another molecule of fluoro-olefin. Thus the products tend to be highly branched rather than straight chain materials.

For this mechanism:-

$$r \propto kK[C=C]^2[F^-]$$

where  $r$  is reaction rate;  $k$ , the rate constant for eq.I.25;  $K$ , the equilibrium constant for eq.I.24; and  $[C=C]$ ,  $[F^-]$ , the concentrations of olefin and fluoride. The constant,  $kK$ , is a measure of fluoro-olefin reactivity towards oligomerisation. For a series of olefins, though, a comparison of reactivities is complicated by the wide range of experimental conditions used, because of rate dependence on olefin concentration. This, in turn, is affected by olefin solubility, temperature, and pressure.

However, the ease of oligomerisation appears to reflect the reactivity towards nucleophilic attack for the series:-

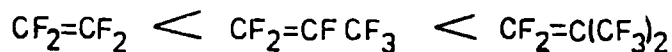

F-isobutene readily forms an anion and it is very susceptible to nucleophilic attack by this anion,  $k_k$  is therefore large. In contrast F-ethylene does not readily form an anion and it is not very susceptible to attack by this anion, which is however, very reactive. Although  $k_k$  is probably smaller than for F-isobutene, the insolubility of F-ethylene, in the solvents used, will markedly reduce reaction rate, making comparisons difficult.

The ease of oligomerisation is affected by the cation counter to fluoride and by the particular solvent used, if one is present. The solvent effect is not just a result of fluoro-olefin solubility.

#### I.D.1.b. Fluoride Ion Reactivity

The reactivity of fluoride increases for the series  $\text{KF}$ ,  $\text{CsF}$ ,  $\text{Et}_4\text{NF}$  (anhydrous materials) as a result of decreased lattice energy for fluorides with large cations. In the absence of solvent only lattice energy and, of course, the surface area of catalyst will affect reactivity. More generally, though, a solvent is employed. With suitable solvents fluorides are more active than in the absence of solvent.

Fluoride ion is a weak nucleophile in polar protic solvents, such as water and methanol, because it is highly solvated. In polar, aprotic solvents, however, for example DMF, acetonitrile, and the glymes, there is much less solvation and fluoride is a strong nucleophile, as is required for these oligomerisations. Anhydrous conditions are advantageous because water, obviously, will solvate fluoride and therefore decrease reactivity. The solubility of fluorides, in these preferred solvents, increases in order  $\text{KF}$ ,  $\text{CsF}$ ,  $\text{Et}_4\text{NF}$  as lattice energy decreases;  $\text{KF}$  is only sparingly

in these solvents. As the cation size increases, it is probable that reactivity increases because ion pairing, in solution, is reduced for the cation with fluoride ion, and with carbanions. It will be seen later that fluoride ion reactivity can markedly affect product distribution.

#### I.D.1.c. Crown Ethers and Phase Transfer Catalysis

Crown ethers are very useful macrocyclic multidentate ligands for metal ions, especially when the crown-ether hole and ion are of similar size. For example 18-crown-6 ethers, which have eighteen ring carbon and oxygen atoms and six equally spaced oxygens, form particularly stable complexes with  $K^+$ .<sup>41</sup>

Two important effects result from the use of crown ethers for oligomerisation reactions:-

- 1) The solubility of alkali metal fluorides is increased in polar aprotic solvents and they may become soluble, to a limited extent, in hydrocarbon solvents; and
- 2) Ion pairing is decreased because the metal ion is shielded by the crown ether and therefore fluoride ion is more active,<sup>42</sup> particularly in hydrocarbon solvents, such as methylene chloride, when fluoride ion solvation is probably absent.

Thus, KF, 18-crown-6 ether is as active as CsF alone for F-propene oligomerisation in acetonitrile<sup>37</sup> and KF, 18-crown-6 ether in methylene chloride, at  $-78^{\circ}C$ , readily oligomerises F-propene.<sup>43</sup>

Crown ether may be described as a solid-liquid phase transfer catalyst for the KF, methylene chloride system because KF is otherwise

insoluble. As yet there have been no reports of liquid-liquid phase transfer catalysis for oligomerisation, although this is well known for other ionic organic reactions. An aqueous-hydrocarbon system is normally used, with either an alkali metal ion-crown ether complex or quaternary-ammonium or phosphonium salts acting as the phase transfer catalyst for fluoride. There is probably no great advantage to be derived from this system for oligomerisations.

#### I.D.1.d. Other Catalysts

Other catalysts can either produce fluoride ion in solution, by reaction with the fluoro-olefin, or directly catalyse oligomerisation. Normally these catalysts give the same products as fluoride ion catalysed reactions. Even so both types of catalysis may still occur. However, F-cyclobutene, with pyridine as catalyst, gives a different trimer to the one formed using fluoride ion and an entirely different mechanism is thought to operate (see section I.D.4.c.). For F-propene, the formation of a tetramer and higher oligomers was reported only for amine catalysed reactions (see section I.D.2.c.).

In principle any compound which reacts with the fluoro-olefin to produce fluoride ion could be used as catalyst and NaOH, NaBr, NaCl, KBr, Me<sub>4</sub>NCl, and MeOH have, in fact, been used for the oligomerisation of F-propene.<sup>44</sup>

More generally, though tertiary amines are used and these have the advantage of solubility in polar aprotic solvents. Tertiary amines can react, reversibly, with fluoro-olefin giving a quaternary ammonium ion and fluoride ion (eq.I.26). If a fluoride ion mechanism operates, then

simple amines, such as  $\text{Me}_3\text{N}$ , will probably have the same order of reactivity as simple quaternary ammonium fluorides, like  $\text{Me}_4\text{NF}$ , because

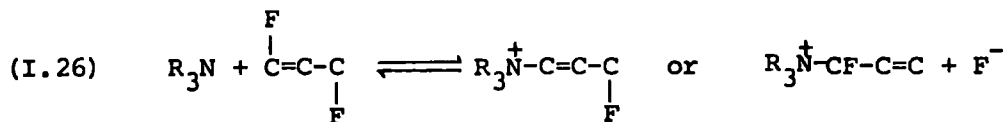

the cations are not very different. More complex amines, particularly fluorinated amines, will give cations having very shielded positive centres, and this probably reduces ion pairing. An example is given in scheme 8, when the fluorinated amine is formed in situ.<sup>45</sup>

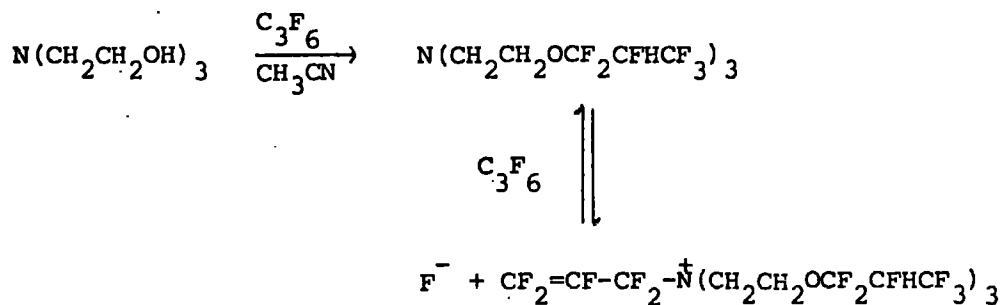

Scheme 8

#### I.D.1.e Side Reactions

Although solvents produce many advantages for oligomerisations, side reactions with the solvent can occur. These are most extensive for very reactive carbanions, such as the F-ethyl anion. For example, using CsF and diglyme at  $100^\circ\text{C}$ , 40% of the F-ethylene reacted with the solvent.<sup>46</sup> However it has been observed that the presence of crown ethers reduces reaction of F-ethylene with solvent,<sup>47</sup> (see section I.D.3.b.) although this is not easily explained.

#### I.D.2 Oligomerisation of F-propene and Related Olefins

Oligomerisation of F-propene has been achieved in the absence of solvent, using CsF as catalyst.<sup>48-50</sup> More generally, a polar aprotic solvent is employed, although benzene and cyclohexane<sup>44</sup> (with a

tetraalkylammonium chloride) and methylene chloride<sup>43</sup> (with KF, crown ether) have also been used. For very nucleophilic solvents, like DMSO, oligomers can be produced without any additional catalyst present.<sup>44</sup> The choice of solvent-catalyst system can strongly influence product distribution and a list of the more specific oligomerisations is given in Table 6. Other, less selective oligomerisations have used alkali metal fluorides.<sup>51-53</sup> Some interconversion of the F-propene oligomers is also possible, and the various reaction conditions used are given in Table 7.

The probable mechanism for formation of oligomers is given in scheme 9.

#### I.D.2.a Dimer Formation

The kinetic dimer, F-4-methyl-2-pentene (13), is most probably formed from F-propene (2) by nucleophilic attack of the F-isopropyl anion (30) on (2) and loss of fluoride, either as a concerted process, or by intermediate formation of a carbanion (31) (scheme 9). Dimer (13) is produced in good yields using less active catalysts, such as KF or  $(CF_3CHF_2OCH_2CH_2)_3N$ , presumably because these less readily isomerise (13) to the thermodynamic dimer, F-2-methyl-2-pentene (16). The isolation of kinetic dimer (13) is aided by use of acetonitrile, in which the dimers are sparingly soluble.<sup>37</sup>

With more active catalysts, for example CsF or KF-crown ether in acetonitrile,<sup>37</sup> good yields of thermodynamic dimer (16) are obtained (Table 6). Alternatively dimer (13) may be isomerised to (16) by various solvent-catalyst systems (Table 7).

#### I.D.2.b Trimer Formation

Two of the three trimers produced have the same carbon framework and are derived from F-2-methyl-2-pentene (16) by vinylic substitution of

Probable Mechanism for Oligomerisation of F-Propene

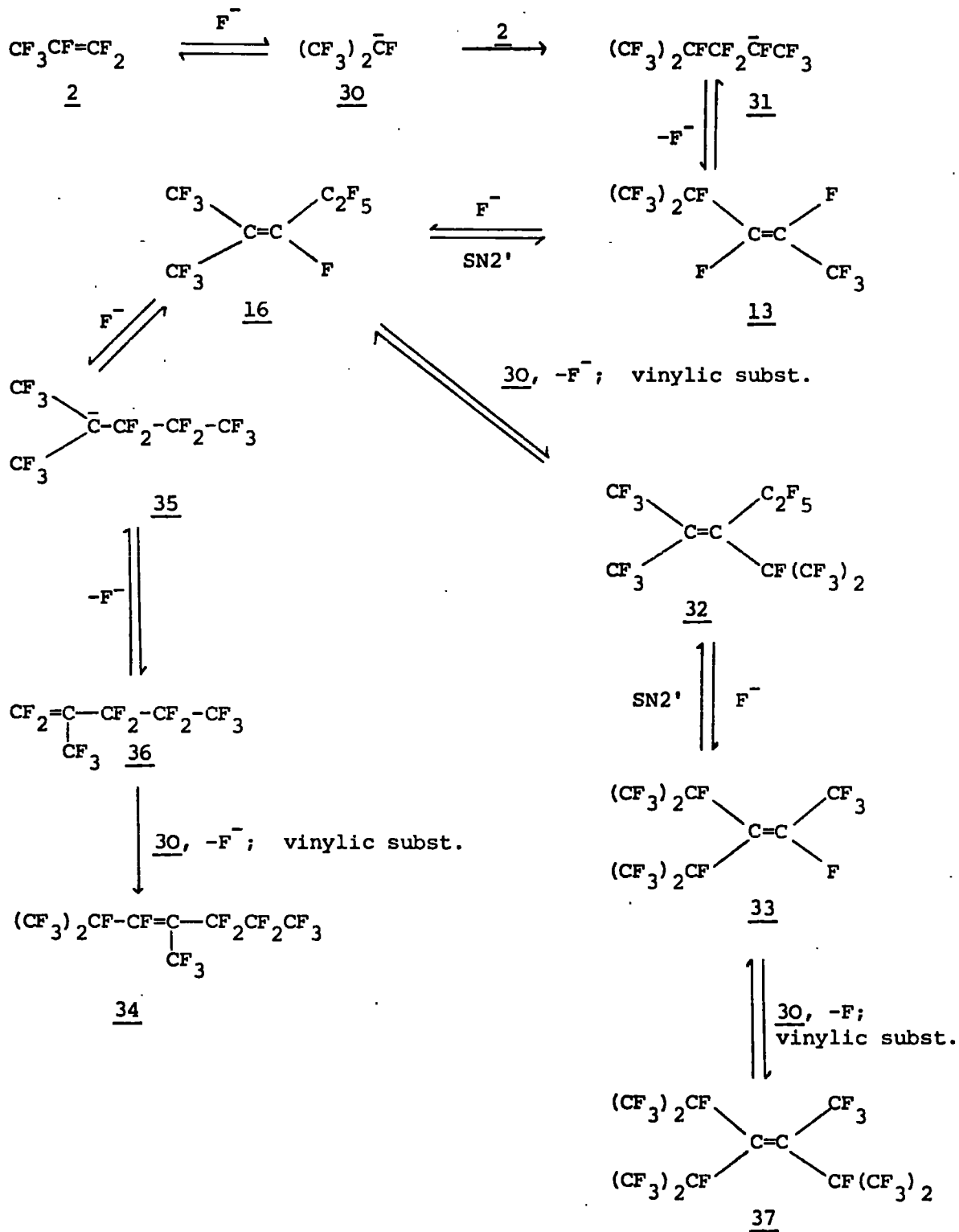

Scheme 9<sup>54</sup>

fluoride giving initially trimer (32), which is readily isomerised to (33) (scheme 9). Trimers (32) and (33) are products of kinetic control, their formation being favoured by low temperatures.

At higher temperatures, thermodynamic trimer (34) is the major trimer produced from F-propene (see Table 6) and under similar conditions kinetic trimers (32) and (33) are isomerised to (34) (Table 7). This, presumably, occurs via the intermediate formation of F-2-methyl-2-pentene (16). Dimer (16) very readily forms an anion (35)<sup>25</sup>, which will be in equilibrium with a low concentration of terminal olefin (36). Vinyllic substitution of fluoride from (36) by the F-isopropyl anion (30) leads to trimer (34)<sup>54</sup> (scheme 9).

#### I.D.2.c Tetramer and Higher Oligomers

Tetramer (37) is produced from F-propene using  $(\text{CF}_3\text{CFHCF}_2\text{OCH}_2\text{CH}_2)_3\text{N}$  (38) and triethylamine in acetonitrile.<sup>45,55</sup> The tetramer (37) is most probably derived from kinetic trimer (33) by vinyllic substitution of fluoride (scheme 9). Lesser amounts of higher oligomers, particularly three  $\text{C}_{14}\text{F}_{26}$  isomers of unknown structure, are also formed. The yield of  $\text{C}_{14}\text{F}_{26}$  isomers may be increased by using fluorinated ether (38) with 1,4-diazobicyclo (2.2.2) octane (39) in DMSO, or other very polar, aprotic solvents<sup>45</sup> (Table 6). Increasing the ratio of (39) in the reaction system increases the yield of tetramer and  $\text{C}_{14}\text{F}_{26}$ .<sup>56</sup>

The  $\text{C}_{14}\text{F}_{26}$  isomers may possibly be formed by loss of the elements  $\text{CF}_4$  from pentamer(s),<sup>45</sup> which, in turn, could be derived from either tetramer (37) or the thermodynamic trimer (34). One possible route to  $\text{C}_{14}\text{F}_{26}$  from pentamer, a very crowded molecule, would be loss of an F-methyl radical,

Table 6

Formation of Particular Oligomers from Hexafluoropropene (2)

<u>Solvent</u>	<u>Catalyst</u>	<u>Temp (°C)</u>	<u>Time (h)</u>	<u>Yield (%)</u>	<u>Other Products</u>	
<div style="display: flex; align-items: center; justify-content: center;"> <div style="text-align: center;"> <math display="block">  \begin{array}{c}  \text{CF}_3 \quad \quad \text{F} \\  \diagdown \quad \diagup \\  \text{C}=\text{C} \\  \diagup \quad \diagdown \\  \text{F} \quad \quad \text{CF}(\text{CF}_3)_2  \end{array}  </math> <p>(13)</p> </div> </div>						
CH <sub>3</sub> CN	KF	20	20	86	(16) 6%	(37)
THF or Diglyme	Me <sub>3</sub> N	25	35	61	(16) 3% + trimers	(54)
CH <sub>3</sub> CN	KF	90	2.5	88	(16) 6%	(57)
CH <sub>3</sub> CN	KF or KHF <sub>2</sub>	RT	-	a		(58)
DMSO	KHF <sub>2</sub>	RT	-	b		(59)
CH <sub>2</sub> Cl <sub>2</sub>	KF/CE <sup>c</sup>	-76	0.5	83	(16) + (13 cis) 4%	(43)
CH <sub>3</sub> CN	R <sub>3</sub> N <sup>d</sup>	RT	-	81	(13 cis) 5%	(55,60)
<div style="display: flex; align-items: center; justify-content: center;"> <div style="text-align: center;"> <math display="block">  \begin{array}{c}  \text{CF}_3 \quad \quad \text{C}_2\text{F}_5 \\  \diagdown \quad \diagup \\  \text{C}=\text{C} \\  \diagup \quad \diagdown \\  \text{CF}_3 \quad \quad \text{F}  \end{array}  </math> <p>(16)</p> </div> </div>						
CH <sub>3</sub> CN	CsF	20	20	92	none	(37)
CH <sub>3</sub> CN	KF/CE <sup>c</sup>	20	18	89	trimers 7%	(37)
CH <sub>3</sub> CN	CsF	150-160	24	86		(61)
THF or Diglyme	Me <sub>3</sub> N	25 then 115	65 24	67	trimers 12%	(54)
-	CsF	215	87	65 <sup>e</sup>		(50)
<div style="display: flex; align-items: center; justify-content: center;"> <div style="text-align: center;"> <math display="block">  \begin{array}{c}  \text{CF}_3 \quad \quad \text{C}_2\text{F}_5 \\  \diagdown \quad \diagup \\  \text{C}=\text{C} \\  \diagup \quad \diagdown \\  \text{CF}_3 \quad \quad \text{CF}(\text{CF}_3)_2  \end{array}  </math> <p>(32)</p> </div> <div style="margin: 0 20px;">+</div> <div style="text-align: center;"> <math display="block">  \begin{array}{c}  (\text{CF}_3)_2\text{CF} \quad \quad \text{F} \\  \diagdown \quad \diagup \\  \text{C}=\text{C} \\  \diagup \quad \diagdown \\  (\text{CF}_3)_2\text{CF} \quad \quad \text{CF}_3  \end{array}  </math> <p>(33)</p> </div> </div>						
THF	CsF/CE <sup>c</sup>	20	2	92		(37)
CH <sub>3</sub> CN	R <sub>3</sub> N/Et <sub>3</sub> N	< 50		92 <sup>f</sup>		(45,55,60)

Table 6 continued

<u>Solvent</u>	<u>Catalyst</u>	<u>Temp (°C)</u>	<u>Time (h)</u>	<u>Yield (%)</u>	<u>Other products</u>
$(CF_3)_2CF.CF=C(CF_3)CF_2CF_2CF_3$ (34)					
THF	CsF/CE <sup>c</sup>	130-200	5	60	Dimers 34% (37) No other Trimers
THF or Diglyme	Me <sub>3</sub> N	100		10	No other Trimers (54)
DMSO	<sup>d</sup> R <sub>3</sub> N/DABCO <sup>g</sup>	< 70		h	(32) and (33) (45,55)
$  \begin{array}{c}  (CF_3)_2CF \quad \quad CF_3 \\  \quad \quad \quad \diagdown \quad / \\  \quad \quad \quad C=C \\  \quad \quad \quad / \quad \quad \diagdown \\  (CF_3)_2CF \quad \quad CF(CF_3)_2  \end{array}  $ (37) + C <sub>14</sub> F <sub>26</sub> <sup>i</sup>					
CH <sub>3</sub> CN	<sup>d</sup> R <sub>3</sub> N/Et <sub>3</sub> N	60-70	18	~ 20	trimers + > C <sub>14</sub> (45,55)
DMSO	<sup>d</sup> R <sub>3</sub> N/DABCO	60		j	trimers + > C <sub>14</sub> (45)

a, exclusive formation of 13; b, no yield given; c, CE = 18-crown-6 ether;

d, R = CF<sub>3</sub>CFHCF<sub>2</sub>OCH<sub>2</sub>CH<sub>2</sub>; e, 70% conversion of (2); f, 32:33 = 2.2:1;

g, DABCO = Diazabicyclo(2.2.2)octane; h, (34) is 76% of trimer fraction,

(34 trans):(34 cis) = 3.1:1; i, consists of 3 isomers; j, C<sub>14</sub>F<sub>26</sub> is approx

50% of recovered oligomers.

Table 7

Interconversion of Hexafluoropropene Oligomers

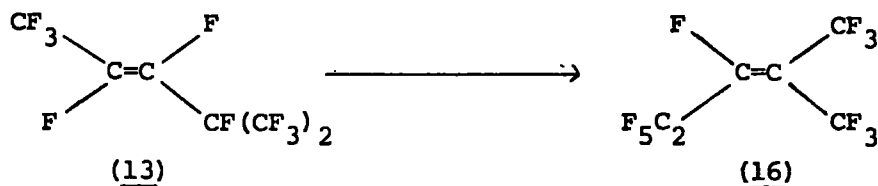

- using:-
- a) DMSO, R<sub>3</sub>N and DABCO<sup>a</sup> at 20° (55)
  - b) Sulpholane and KF with heating (59)
  - c) CH<sub>3</sub>CN, KF and CE at 40° for 3h. (62)
  - d) DMF and KHF<sub>2</sub> at 100° for 2h. (44)

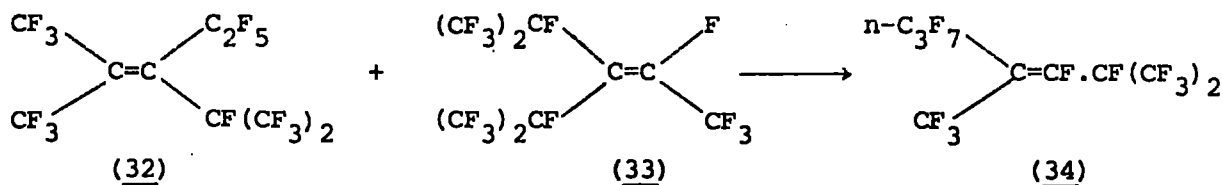

- using:-
- a) DMF and KHF<sub>2</sub> at 100° for 100h. (34, 50%) (54)
  - b) Diglyme and CsF at 100° (55)
  - c) CH<sub>3</sub>CN, KF and CE at 70° for 20h. (34, 22%) (62)

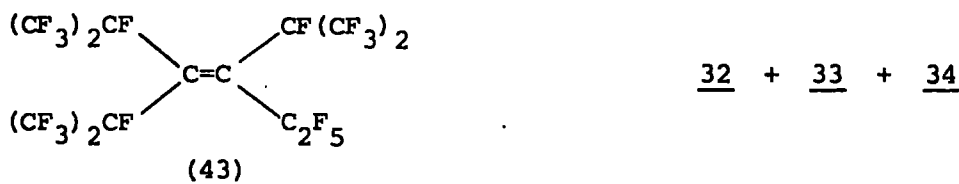

- using:- Diglyme and CsF at 100° (55)

a, R = CF<sub>3</sub>CFHCF<sub>2</sub>OCH<sub>2</sub>CH<sub>2</sub>; DABCO = Diazabicyclo(2.2.2)octane.

followed by electron transfer and loss of fluoride (scheme 10).

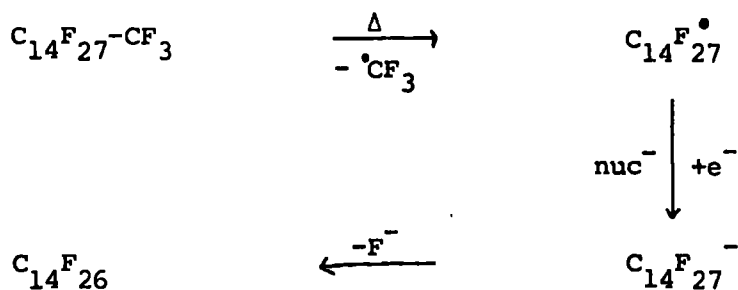

Scheme 10

I.D.2.d Related Olefins

Fluoro-olefins of the type  $\text{R}_\text{F}\text{-CF=CF}_2$  or  $(\text{R}_\text{F})_2\text{C=CF}_2$  will only oligomerise in a manner similar to that of F-propene if they cannot preferentially undergo isomerisation to internal olefins.

Such a situation arises for F-4-vinylpyridine, which gives a dimer analogous to the kinetic dimer of F-propene<sup>63</sup> (eq.I.26). Similarly F-isobutene readily gives a dimer, using  $\text{CsF}$  with ether<sup>64</sup> (eq.I.27) or diglyme<sup>24</sup>, but dimerisation does not occur in the absence of solvent.<sup>65</sup> F-vinylethers are claimed to dimerise in the presence of fluoride<sup>66</sup> (eq.I.28) but these results have recently been disputed, when it was suggested that reactions are more complex and dimers are not formed.<sup>67</sup> Some aza-analogues of F-propene also give dimers (eq.I.29 and I.30).

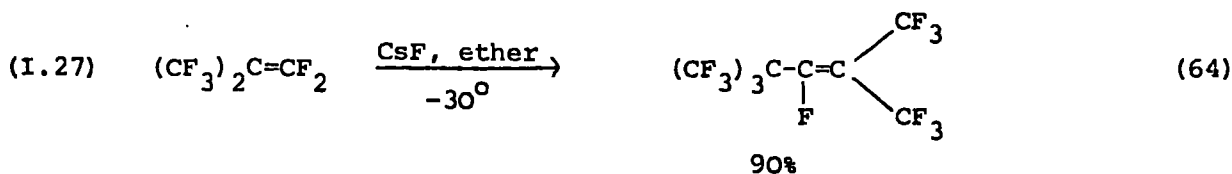
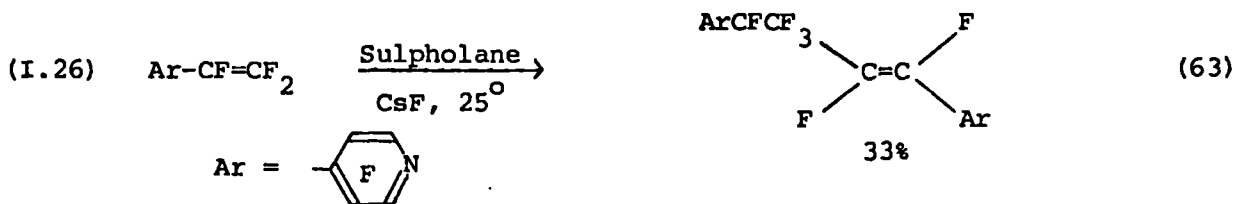

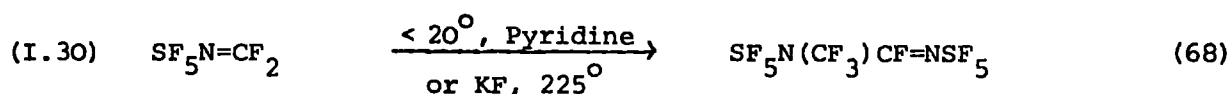
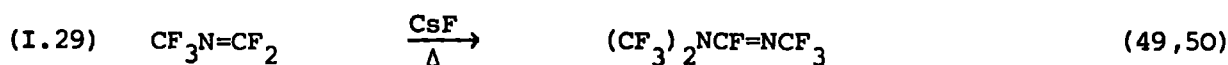
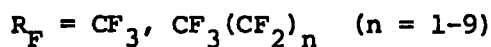
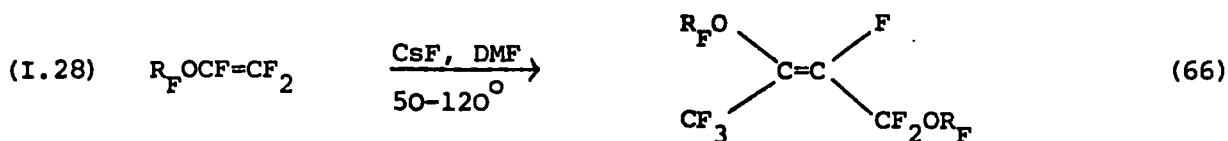

### I.D.3 Oligomerisation of F-ethylene and F-2-butene

#### I.D.3.a Solvent-Catalyst Systems

Like F-propene, F-ethylene will oligomerise, using a fluoride catalyst in the absence of solvent, but much less readily. Using CsF at 100° only high polymer and unreacted F-ethylene were recovered,<sup>69</sup> whereas with Et<sub>4</sub>NF at 150°, a 10% yield of oligomers was obtained.<sup>70</sup> Normally polar aprotic solvents are used with a fluoride ion catalyst, such as alkali metal fluorides,<sup>37, 46, 47</sup> or tetraalkylammonium fluorides,<sup>70, 71</sup> although CsSO<sub>2</sub>F, KSO<sub>2</sub>F and KHF<sub>2</sub> are also effective.<sup>70</sup>

The particular solvent-catalyst system used does have an effect on the product distribution, but not to the extent found for F-propene (see Section I.D.2). The product distributions for three similar solvents, using the same experimental conditions, are given in Table 8a. It should be noticed that pentamer (40) is the major component in each case, as is generally found for other solvent-catalyst systems (see Table 8b). For example, C<sub>8</sub>F<sub>16</sub> (15%), C<sub>10</sub>F<sub>20</sub> (65%), and C<sub>12</sub>F<sub>24</sub> (10%) was described as the composition of a typical reaction product, using DMF and fluoride ion.<sup>72</sup>

Pressure, however, can have a marked effect on product composition leading to heptamers as the main component<sup>46</sup> (see Table 8a).

### I.D.3.b Side Reactions

It was stated previously that side reactions of the F-ethyl anion with solvent can occur (see Section I.D.1.e) and normally the yield of oligomers is less than 70%. For example KF, DMF, and F-ethylene (approx. 200 psi), at 130° for 2.5h, gave 65% oligomers.<sup>70</sup> This problem can be overcome, to some extent, by using crown ethers (see Table 8b); thus with KF and dibenzo-18-crown-6 ether in DMF at 75°, oligomers (43%) and F-ethylene (57%) accounts for all the starting material.<sup>47</sup> Crown ether does not have a marked effect on the product distribution<sup>37</sup> and pentamer remains the major component<sup>47</sup> (see Table 8b).

### I.D.3.c Reaction Mechanism and Structures of Products

A possible mechanism<sup>73</sup> for formation of the identified products is given in scheme 11. Tetramer (41), a cis-trans mixture are the only isomers formed,<sup>71</sup> (40) is the main isomer<sup>71</sup> of three pentamers,<sup>46</sup> and two hexamers are formed,<sup>71</sup> of which (42) is approx. 90%.<sup>74</sup>

The formation of trimer (44) is unambiguous, and successive reactions of (44), with the F-ethyl anion, would lead to tetramer (41), pentamer (40) and, finally, the main hexamer (42) (Scheme 11). Pentamer would also result from attack of trimer anion (45), which is likely to be present in solution (see I.D.2.b), on the dimer, F-2-butene (46).

#### (1) F-2-Butene Dimerisation

Tetramer (41) could also be formed by dimerisation of F-2-butene; a known process using similar conditions<sup>51,75,76</sup> (eq.I.31 and I.32).



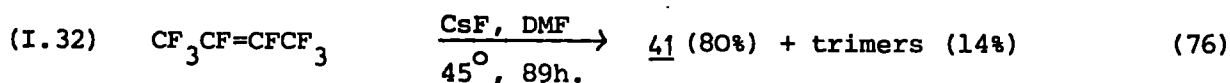
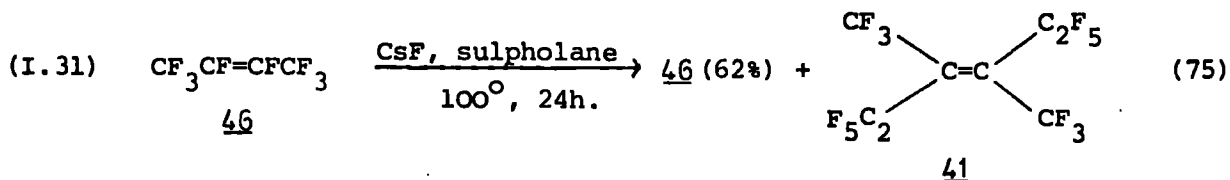

(ii) Hexamer Formation

The main hexamer (42), formed from pentamer, is a terminal olefin, which is somewhat surprising because the alternative isomer (47) is an internal olefin (scheme 11). Both are derived from the same carbanion (48). Isomer (42) may be formed because loss of fluoride from  $\text{CF}_3$ , in carbanion (48), is kinetically preferred due to steric effects. Alternatively steric crowding in hexamer (47) may preclude its formation.

The minor hexamer (43) is probably produced from tetramer (41) and the n-F-butyl anion. Although (43) is only 10% of the hexamers and therefore approx. 1% of the total product, its formation, if it is produced in the suggested manner, indicates that tetramer must be very susceptible to nucleophilic attack, under these conditions, in order to trap the n-F-butyl anion before it loses fluoride.

(iii) Degradation of Oligomers

The oligomerisation of F-ethylene is reversible; thus pentamer and hexamers are degraded to mainly tetramer by refluxing with an alkali metal fluoride in polar aprotic solvents. In particular refluxing pentamer with DMF and CsF, for 24h, gave tetramer (68%).<sup>77</sup>

Table 8

Product Distribution from Tetrafluoroethylene Oligomerisationa) Effects of solvent and pressure.<sup>46</sup>

<u>Solvent</u>	<u>Product Composition (%)</u> <sup>a</sup>				
	$C_8F_{16}$	$C_{10}F_{20}$	$C_{12}F_{24}$	$C_{14}F_{28}$	Residue
Diglyme <sup>b,c</sup>	11	58	12	14	5
Triglyme <sup>c</sup>	3	65	21	2	9
Tetraglyme <sup>c</sup>	6	80	12	0.5	1.5
Triglyme <sup>d</sup>	6	21	25	42	6

a, All reactions  $C_2F_4$  catalysed at 100°C; b, yield of oligomers ~ 60%;

c, 10-20 psi of  $C_2F_4$ ; d, 150-200 psi of  $C_2F_4$ .

b) Use of crown ethers.<sup>47</sup>

All experiments used DMF as solvent, KF, < 25 atmos.  $C_2F_4$  and  $\alpha$ -pinene.

<u>Crown Ether</u>	<u>Temp</u> (°C)	<u>Time</u> (h.)	<u>Conversion to</u> <u>products (%)</u>	<u>Selectivity for</u> <u>Oligomers (%)</u>	<u><math>C_{10}F_{20}</math> in</u> <u>Oligomers (%)</u>
18-crown-6 <sup>a</sup>	75	5	60.4	64.9	58.6
Dibenzo-18-C-6 <sup>a</sup>	83	4	69.1	69.8	59.6
Dibenzo-18-C-6 <sup>b</sup>	75	4	42.6	100	58.7
Benzo-15-C-5 <sup>a</sup>	100	4	79.7	45.5	59.7
None <sup>c</sup>	100	3.5	65.9	43.5	57.3
None <sup>c</sup>	125	2.5	82.7	37.3	51.8

Approx molar ratio  $C_2F_4$ :KF:CE a, 30:2:1; b, 15:2:1; c, 15:2:0.

#### I.D.4 Oligomers from Cyclic Olefins

F-cyclobutene readily oligomerises, using a fluoride ion catalyst in solvent, to give two dimers, and one major trimer (50),<sup>51,78</sup> but F-cyclopentene and F-cyclohexene each give only one dimer using forcing conditions. At still higher temperatures, for F-cyclopentene, a diene becomes the major product<sup>78</sup> (See Table 9).

##### I.D.4.a Effect of Ring Size

The difference in reactivity of these fluoro-olefins is probably a result of ring strain. The double bond in an F-cyclobutene ring is very strained and formation of a less strained cyclic anion therefore means that F-cyclobutene is very susceptible to nucleophilic attack.

It should be noticed that although F-cyclobutene gives two dimers, with an exocyclic or ring double bond, the preferred F-cyclopentene dimer has an exocyclic double bond, whereas the preferred F-cyclohexene dimer has a ring double bond. As yet it is not clear why a reversal of stabilities, for the two types of dimer, should occur as ring size increases from 5 to 6.

##### I.D.4.b Mechanism

A mechanism<sup>78</sup> for the formation of oligomers from F-cyclobutene, using fluoride ion, is given in scheme 12, and, of course, this also explains the production of dimers from the other cyclic olefins.

Table 9

Oligomers from Cyclic Olefins

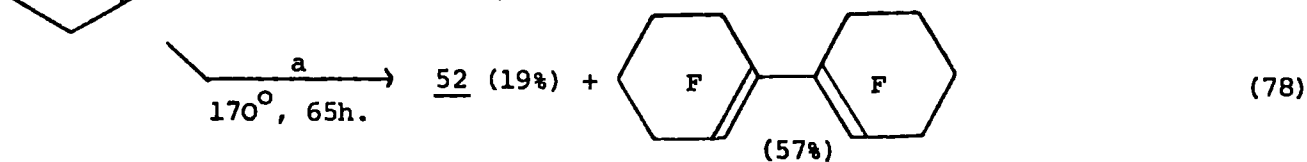
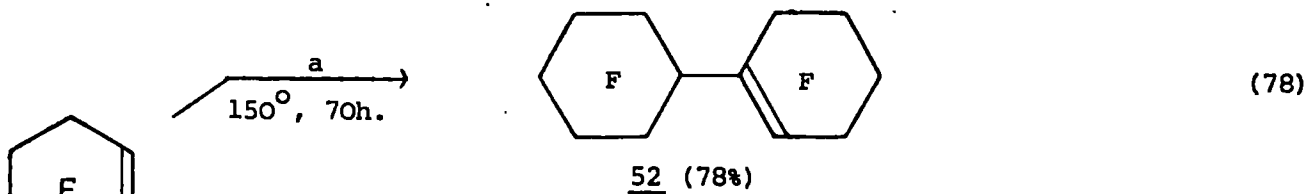
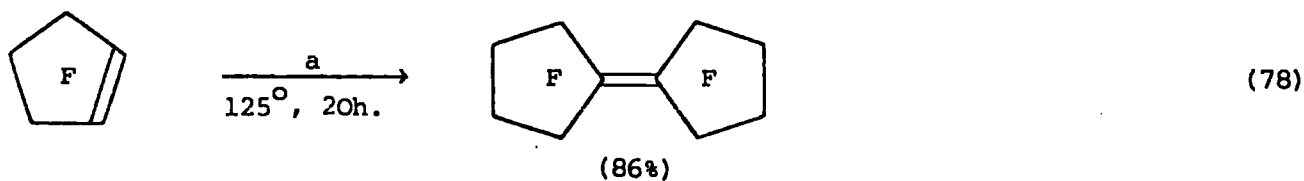
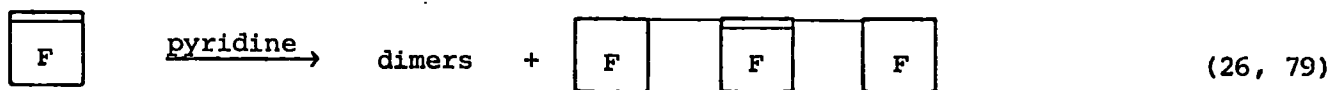
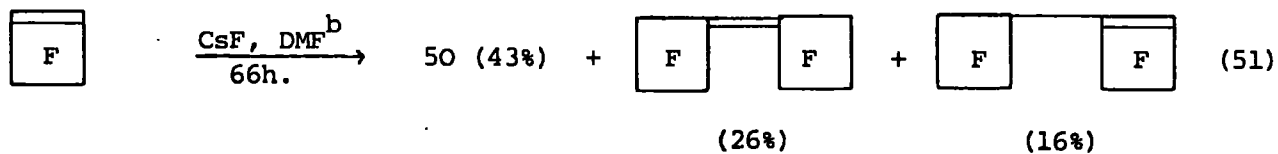
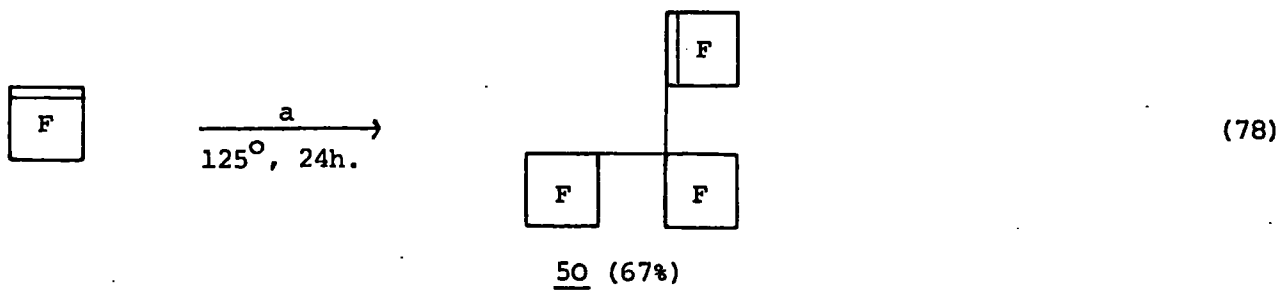

a, CsF, sulfolane; b, large excess of solvent.

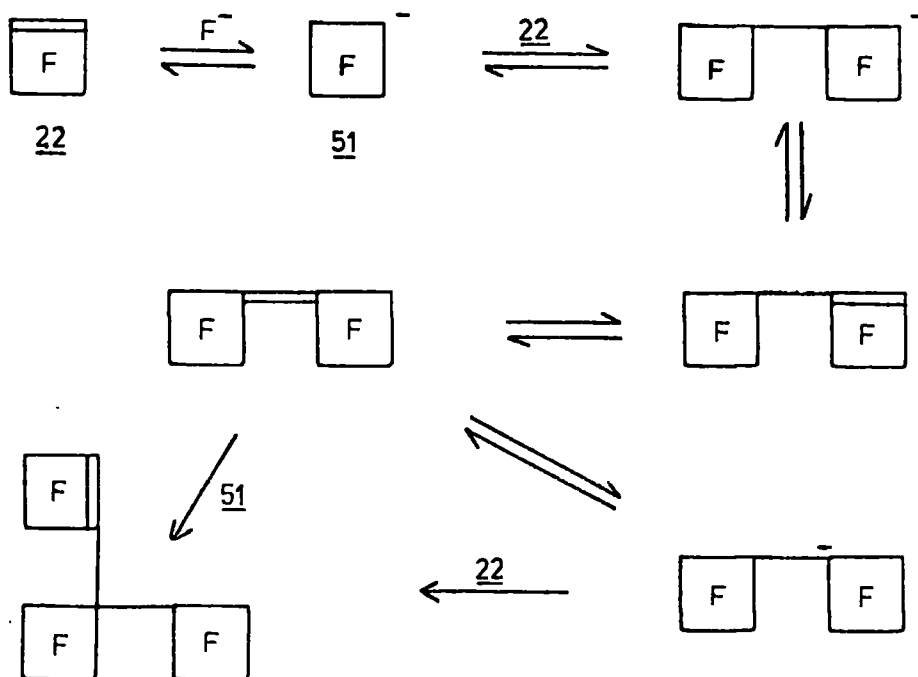

Scheme 12<sup>78</sup>

#### I.D.4.c Reaction of F-cyclobutene with Pyridine

When pyridine is used instead of fluoride ion, with F-cyclobutene, then the same dimers are formed, but a different trimer to (50) is produced. Equivalent amounts of F-cyclobutene and pyridine favour the trimer, whereas a catalytic amount of pyridine gives more dimers.<sup>79</sup>

The trimer is a linear trimer,<sup>26</sup> presumably arising by a completely different mechanism to the one given in Scheme 12. It is probably produced by the initial formation of an ylide from F-cyclobutene and pyridine, followed by subsequent reaction of the ylide with more F-cyclobutene.<sup>79</sup> A similar ylide is formed with triethylamine<sup>27</sup> (see Table 3).

#### I.D.5 Formation of Co-oligomers

##### I.D.5.a Requirements

To achieve good yields of co-oligomers it is probably necessary that the fluoro-olefins used have similar reactivities and concentrations,

in order to suppress independent reaction. For example, reaction between F-ethylene and F-isobutene would be expected to be inefficient due to their very different reactivities, and this was found, even when using preformed  $\text{Cs}^+ \bar{\text{C}}(\text{CF}_3)_3$  in solution.<sup>65</sup> A concentration effect is demonstrated by the reaction of  $\text{CF}_2\text{CCL}_2$  with F-2-butene, using CsF. A poor yield of F-3-methyl-2-pentene (44) was obtained using DMF, but a DMF - THF mixture gave a higher yield of (44) (see Table 10). The suggested explanation is that both olefins are soluble in the mixed solvent, and only  $\text{CF}_2\text{CCL}_2$  is soluble in DMF alone.<sup>51</sup>

Co-oligomers have been produced in the absence of solvent, but more frequently from reactions in solution. Table 10 contains a list of the various co-oligomer forming reactions.

#### I.D.5.b. Without Solvent

Good yields of co-dimers were obtained by heating pairs of fluoro-olefins with CsF, and in each case the thermodynamic product is formed<sup>80</sup> (Table 10a). For example reaction between F-propene and F-isobutene gives a dimer arising from attack of the F-isopropyl anion on F-isobutene, and not the kinetic product, formed from anion attack on F-propene (Scheme 13). For F-isobutene with F-azapropene kinetic or thermodynamic control will give the same product (Table 10a).

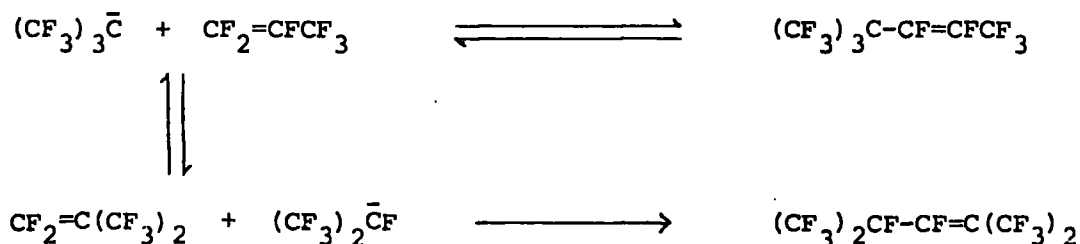

Scheme 13

I.D.5.c In the Presence of Solvent

In contrast to reactions in the absence of solvent, in solution at low temperatures it appears that the co-oligomers formed are products of kinetic control. They therefore result from attack of the more stable anion. Thus the reaction between preformed  $(\text{CF}_3)_2 \text{N}^- \text{Cs}^+$  (53) and F-isobutene gives a dimer, which is also produced from F-2-azapropene and F-isobutene without solvent. The dimer arises by initial fluoride exchange and then attack of  $(\text{CF}_3)_3 \text{C}^-$  on F-2-azapropene. However, F-cyclobutene and (53) give cyclobutene derivatives,<sup>81</sup> although a dimer formed by initial fluoride exchange would probably be thermodynamically more stable (scheme 15).

The same considerations hold for reactions of F-cyclopentene with F-propene,<sup>82</sup> and F-cyclobutene with F-propene, although, in this case, reaction is complex<sup>51</sup> (Table 10b).

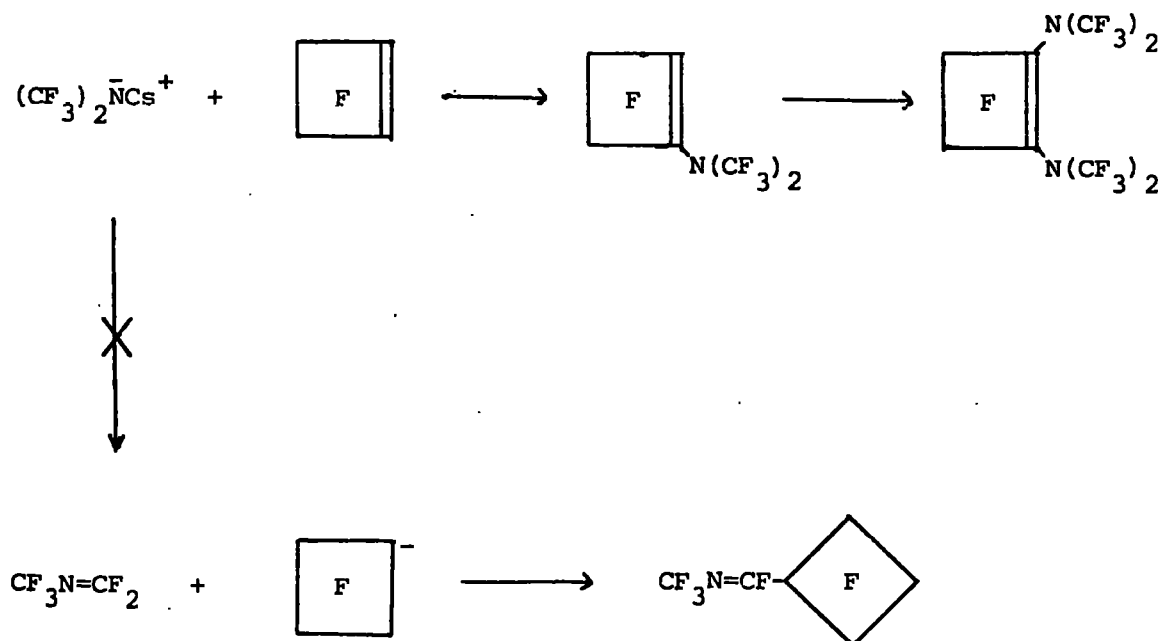

Scheme 15

Table 10

Co-oligomers from Fluoro-olefinsa) Without solvent.<sup>80</sup>a, CsF,  $\Delta$ .b) With solvent present

Table 10 continued



† all compounds are fully fluorinated.

CHAPTER II

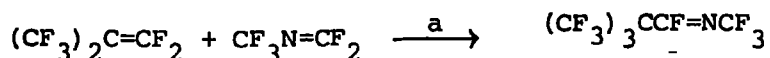
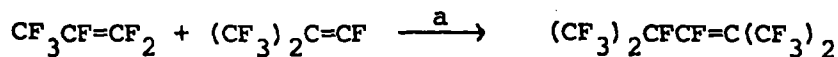
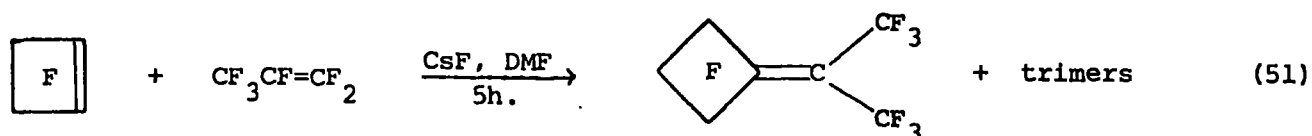
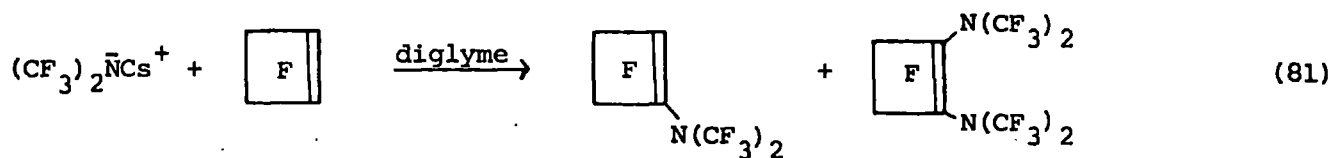
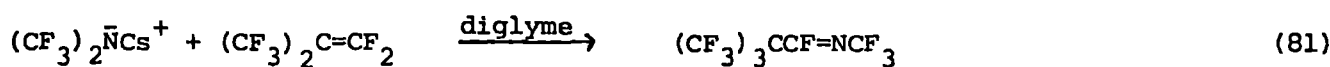
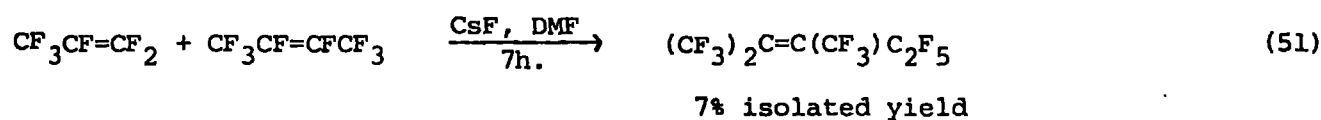
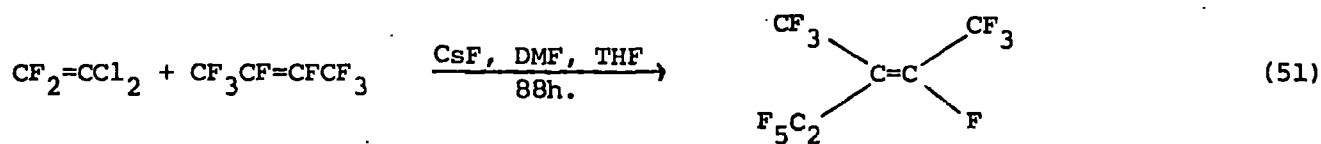
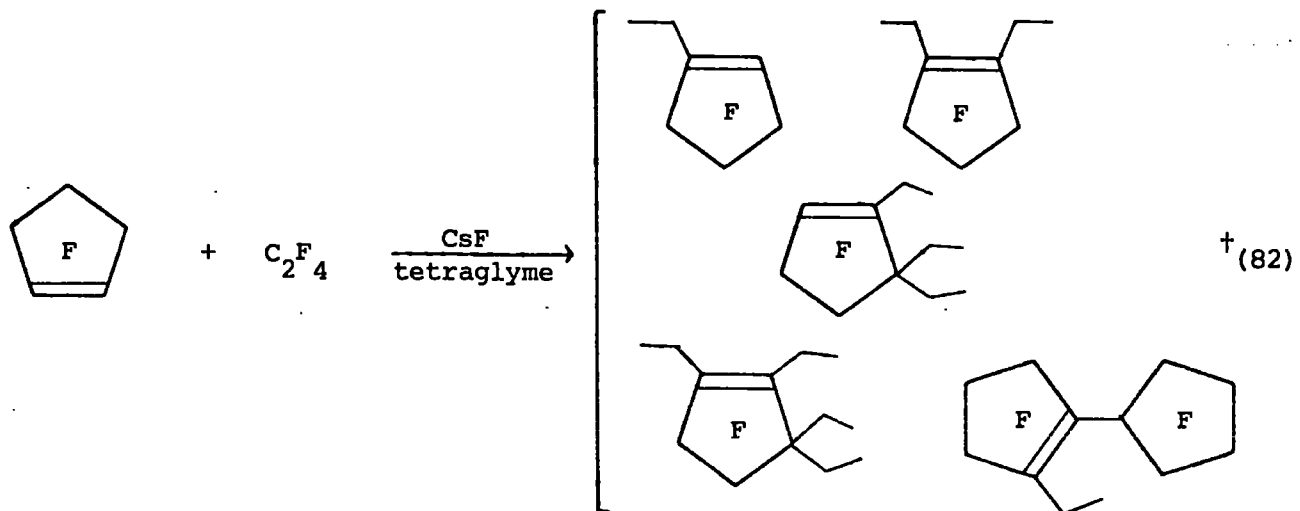
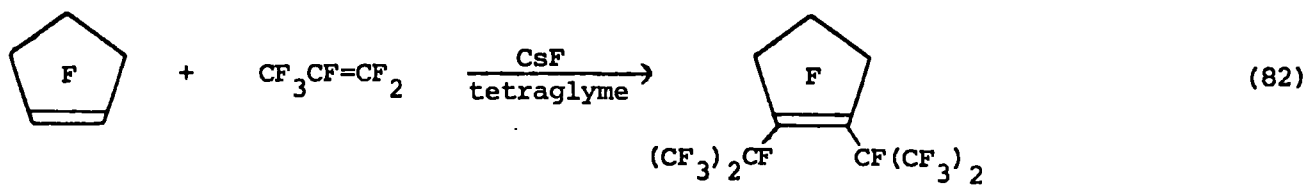
Reactions of Oligomers and Related Fluoro-olefins

Introduction

The chemistry of fluoro-olefins is extensive, particularly for fluoro-ethylenes and -propenes, and has been widely reviewed.<sup>13,14,28,83-86.</sup>

In this chapter discussion will be limited mainly to reactions of tri- and tetra-substituted fluoro-olefins, although some comparable reactions of less substituted olefins are also mentioned. The highly substituted olefins include the various oligomers (see Chapter I) and other fluoro-olefins, such as:-

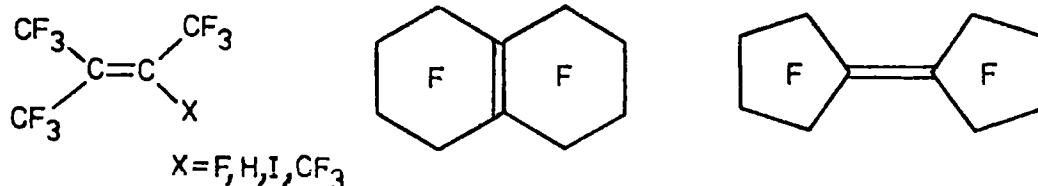

Their chemistry may be divided into three broad areas:-

- 1) Ionic reactions involving carbanionic and, to a much lesser extent, carbocationic intermediates;
- 2) The various types of addition reactions across carbon-carbon double bonds; and
- 3) Thermal and photochemical isomerisations and fragmentations.

The formation of polymers and co-polymers from these olefins would not be expected to readily occur. The required intermediate radicals would be relatively stable and sterically hindered. Thus F-2,3-dimethyl-2-butene was found not to polymerise with F-ethylene, using conditions which gave poly-F-ethylene.<sup>87</sup>

## II.A Reaction with Fluoride; Carbanion Trapping

Oligomerisation of fluoro-olefins (Chapter I) and polyfluoro-alkylation of aromatics<sup>88</sup> are two examples of reactions involving initial formation of a carbanion with fluoride ion, and subsequent trapping of the carbanion with electrophiles. In the simplest case the electrophile is H<sup>+</sup> (eq.II.1).

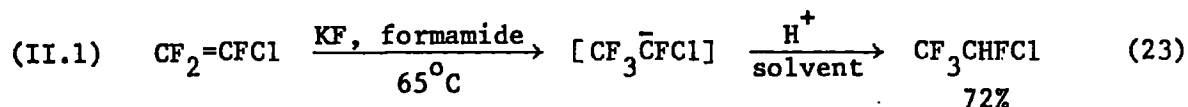

There are numerous examples of carbanion trapping reactions for lower olefins like F-ethylene, F-propene, and F-isobutene,<sup>28,89</sup> but relatively few for higher fluoro-olefins. Some examples are given in Table 11.

### II.A.1 Requirements

Obviously, for these reactions to occur the fluoro-olefin has to form a carbanion. The rate of reaction will be influenced by the concentration of carbanion in solution and its reactivity (I.B.2):

All the F-olefins discussed in this section give tertiary carbanions and the reactivities of these carbanions are probably influenced by steric effects, but the overall reaction rate will be very dependent on the position of equilibrium between olefin and carbanion. For example F-2-methyl-2-pentene (16), like F-isobutene, gives a stable carbanion (eq.II.2), which is readily trapped by electrophiles.<sup>25</sup> For F-3,4-dimethyl-3-hexene (41), however, there is very little carbanion present at equilibrium and trapping reactions are much slower.<sup>76</sup>

Clearly F-olefins, having vinylic fluorines, are more susceptible to nucleophilic attack than F-tetraalkylolefins (see later).

Table 11

Carbanion Trapping Reactions

<u>Olefin</u>	<u>Electrophile</u>	<u>Conditions</u>	<u>Product</u>	
$(CF_3)_2C=CF_2$	$ClC\equiv CCF_3$	diglyme, CsF 1 h., 40°	$(CF_3)_3CC\equiv CCF_3$ 90%	(91)
"	$N\equiv NPh^+$	DMF, CsF	$(CF_3)_3CN=NPh$	(92)
"	$AgO_2CCF_3$	DMF, KF -78°	$(CF_3)_3CAG$	(93)
$CF_3CF=CFCF_3$	$I_2$	$CH_3CN$ , KF	$CF_3CFIC_2F_5$ 17%	(94)
"	$FCIO_3$	DMF, CsF 90 h., 30°	$C_4F_{10}$ + st. mat. 64% 31%	(76)
$(CF_3)_2C=CFC_2F_5$	$PhCH_2Br$	diglyme, CsF 60°	$n-C_3F_7(CF_3)_2CCH_2Ph$ 90%	(25)
"	$Br_2$	$CH_3CN$ , AgF 0°	$n-C_3F_7(CF_3)_2CBr$ 62%	(95)
"	HCl	$CH_3CN$ , AgF 0°	$n-C_3F_7(CF_3)_2CH$ 95%	(95)
"	$FCIO_3$	$CH_3CN$ , CsF 3 h., 30°	$n-C_3F_7CF(CF_3)_2$ 97%	(76)
$  \begin{array}{c}  F_5C_2 \quad \quad CF_3 \\  \quad \quad \diagdown \quad / \\  \quad \quad C=C \\  \quad \quad / \quad \quad \diagdown \\  CF_3 \quad \quad \quad C_2F_5  \end{array}  $ <p>+ cis</p>	$FCIO_3$	$CH_3CN$ , CsF 24 h., 30°	$C_8F_{18}$ + st. mat. 49% 49%	(76)

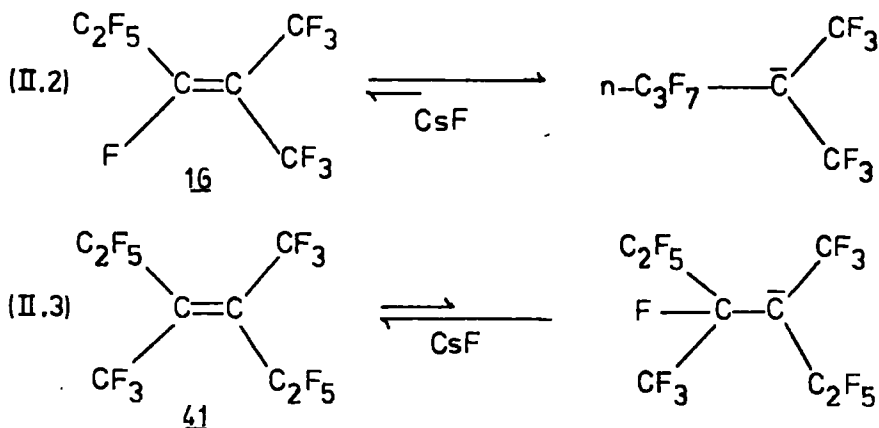

### II.A.2 With Alkyl Halides

Substitution products are formed from F-2-methyl-2-pentene using primary alkyl halides. None were obtained from secondary or tertiary alkyl halides. These results are consistent with an SN2 mechanism (eq.II.4). Analogous products were not obtained from F-3,4-dimethyl-3-hexene or F-2-methyl-3-isopropyl-2-pentene (32) even when using

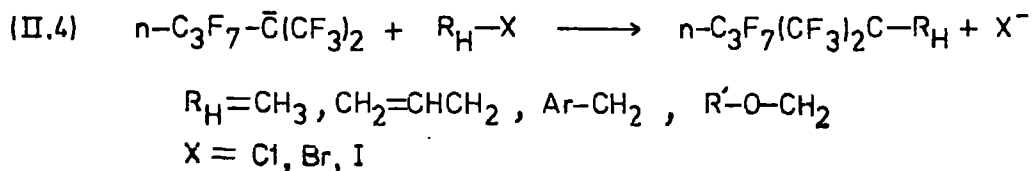

primary alkyl halides. With (32) only products derived from F-2-methyl-2-pentene (16) were formed.<sup>76</sup>

### II.A.3 With Perchloryl Fluoride

The reactions of some fluoro-olefins with CsF and perchloryl fluoride in acetonitrile gave good yields of F-alkanes (see Table 11).<sup>76</sup>

The initial formation of a carbanion seems most probable because F-propene did not react with FClO<sub>3</sub> in the absence of CsF. Two mechanisms (scheme 16) were therefore suggested; 1) Nucleophilic attack

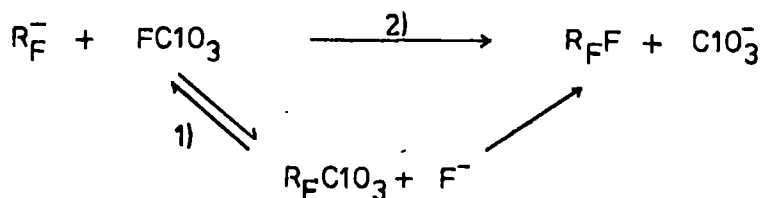
Scheme 16

by a carbanion on chlorine, generating fluoride, followed by SN2 displacement of  $\text{ClO}_3^-$  by fluoride;<sup>90</sup> and 2) direct nucleophilic attack on fluorine displacing  $\text{ClO}_3^-$ .

For primary and secondary F-carbanions the first mechanism is thought to operate because 2-perchloryl-F-propane was isolated from the reaction of F-propene with  $\text{FClO}_3$  (eq.II.5). Although there are no other examples of nucleophilic attack on fluorine, even with  $\text{FClO}_3$ ,<sup>90</sup> it was argued, as follows, that this could explain the reaction of tertiary F-carbanions with  $\text{FClO}_3$ .

#### II.A.3.a Possible Nucleophilic Attack on Fluorine

2-perchloryl-F-propane, isolated from F-propene and  $\text{FClO}_3$ , produces F-propane with  $\text{CsF}$  in acetonitrile (eq.II.5). This is probably an SN2 displacement of  $\text{ClO}_3^-$  because no F-propene dimers were formed, but intermediate formation of  $\text{C}_3\text{F}_7^-$  and  $\text{FClO}_3$  in a solvent cage is also possible.<sup>76</sup> It was argued that the non-isolation of perchloryl-F-ethane, from F-ethylene and  $\text{FClO}_3$  (eq.II.6) could be a result of reduced steric hindrance in  $\text{CF}_3\text{CF}_2\text{ClO}_3$  aiding the SN2 displacement of  $\text{ClO}_3^-$ . However,

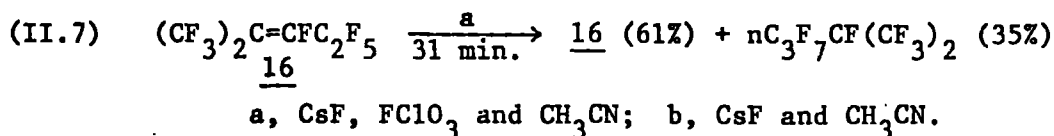
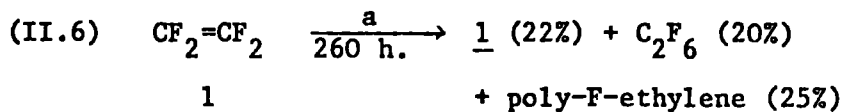
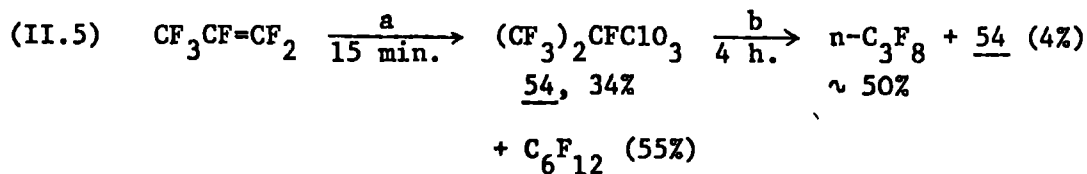

F-2-methyl-2-pentene, using comparable conditions to those used for the formation of 2-perchloryl-F-propane, gave no perchloryl derivatives (eq.II.7). If a tertiary perchloryl derivative had been formed, then it would be resistant to SN2 displacement of  $\text{ClO}_3^-$  because of steric hindrance.<sup>76</sup> Obviously, an SN1 reaction is very unlikely. Thus direct attack on fluorine, by a tertiary carbanion, could explain the formation of F-alkanes.<sup>76</sup>

#### II.A.3.b Alternative Radical Mechanism

There is an alternative mechanism to the proposed attack on fluorine, which does, in fact, seem more plausible. Again, there are two competing mechanisms (scheme 17). The first, as before, is displacement of fluoride

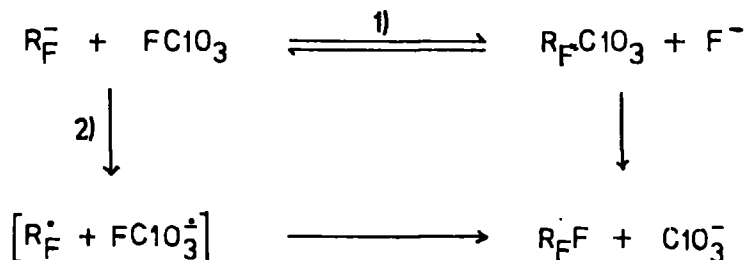

Scheme 17

from  $\text{FClO}_3$  which may be followed by  $\text{SN}_2$  displacement of  $\text{ClO}_3^-$ . Competing with this is a one electron transfer from  $\text{R}_\text{F}^-$  to  $\text{FClO}_3$ , giving a radical pair, which collapses to give products. It should be noticed (eq.II.6) that poly-F-ethylene is produced from F-ethylene and  $\text{FClO}_3$ . In this case, once the radical pair has been formed  $\text{C}_2\text{F}_5^\bullet$  can escape the solvent cage and initiate polymerisation. Of course route 1) can also operate. With F-propene, a much less efficient electron donor,<sup>96</sup> route 1) probably predominates. For tertiary carbanions, the radical pathway 2) is probably the only mechanism operating. As stated earlier polymerisation does not occur with these crowded F-olefins.

A similar radical mechanism was proposed to account for the reaction of F-isobutene with 2-nitroso-F-propane, using  $\text{KF}$  and DMF, when the product resulted from attack on oxygen and not, as expected, on nitrogen<sup>97</sup> (scheme 18). A radical mechanism has been shown to operate for the reaction of the F-t-butyl anion with triarylmethyl halides.<sup>98</sup>

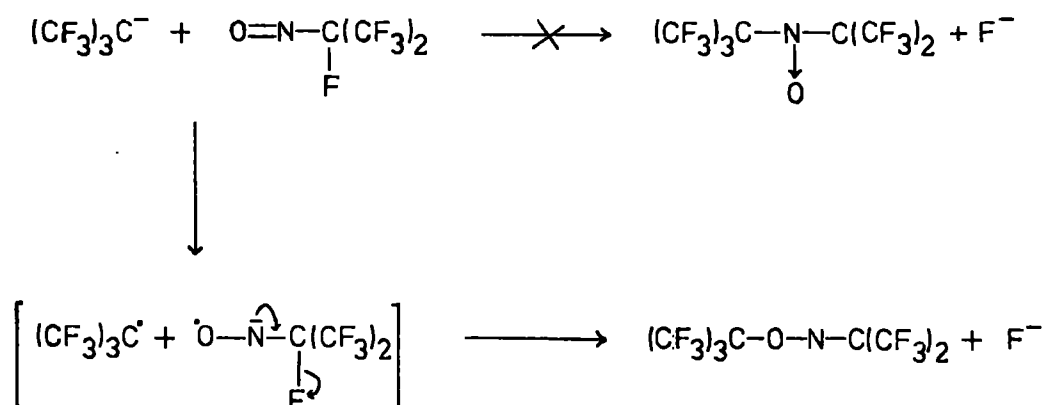

Scheme 18<sup>97</sup>

## II.B Reactions with Nucleophiles

### II.B.1 Formation of Products

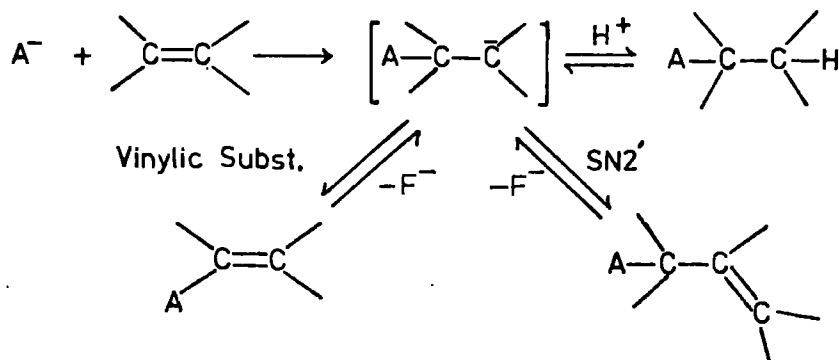

Scheme 19

The initial step for the reaction of fluoro-olefins with nucleophiles is the formation of a carbanion (see also Section I.B.3.a). This is shown in scheme 19 for charged nucleophiles,<sup>28</sup>  $A^-$ , but a similar mechanism will apply for neutral species. The carbanion may have a transient lifetime or be long lived and therefore more stable. Subsequent reactions, as shown, will give products or reactive intermediates. In some cases reactions of the carbanion can be reversible (scheme 19) and carbanion stability will greatly influence this reversability.

#### II.B.1.a Kinetic and Thermodynamic Control

Obviously, vinylic substitution requires the presence of a vinylic fluorine atom and an  $SN2'$  process requires an allylic fluorine atom in the fluoro-olefin. The preference for either vinylic or  $SN2'$  substitution, when both are possible does not always depend on the relative stabilities of the two products. For example the reaction of F-2-methyl-2-pentene with sodium phenoxide in ether at low temperatures gives products arising from both vinylic substitution, (55), and  $SN2'$  substitution, (56)<sup>99</sup>

(eq.II.8). However subsequent reaction of a mixture of (55), and (56),

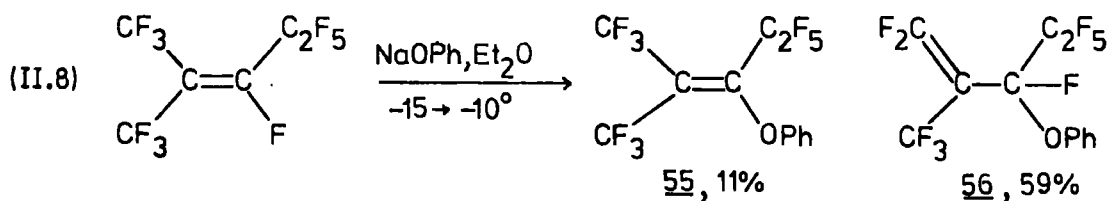

with Et N in ether at room temperature gave only the more stable isomer (55).

Using NaOPh in ether, it is likely that fluoride ion induced isomerisation is much reduced because NaF is not a good catalyst for isomerisation. A concerted SN2' process will therefore explain the formation of terminal olefin (56).

It will be seen later that even some mono-substituted products are derived from isomeric terminal olefins. In these cases reaction of the nucleophile with the more stable isomer is sufficiently slow, such that any fluoride generated promotes isomerisation to a terminal olefin, which can then react much faster.

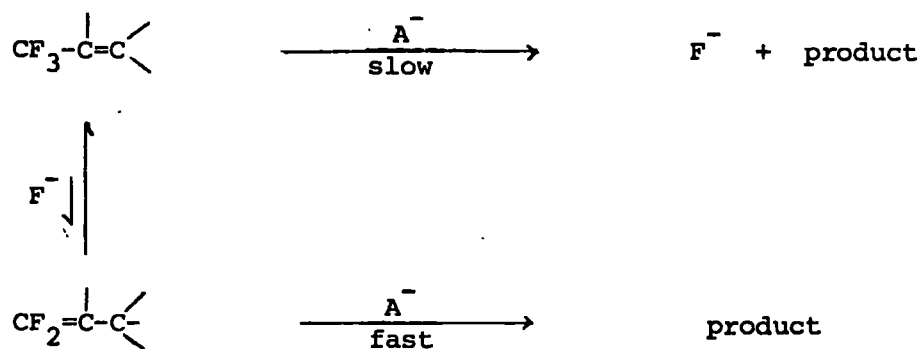

#### II.B.1.b Relative Reactivities of Fluoro-olefins

The relative reactivities of terminal and internal olefins are demonstrated by the reactions of F-isobutene, F-2-methyl-2-butene, and F-2,3-dimethyl-2-butene with methanol (see below). F-isobutene readily

reacts with neutral methanol at room temperature but F-2-methyl-2-butene will only react, at a comparable rate, using elevated temperatures.

F-2,3-dimethyl-2-butene, however, does not react with neutral methanol.

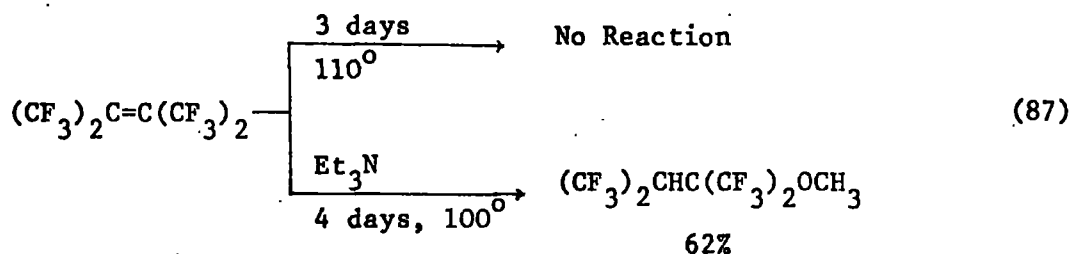
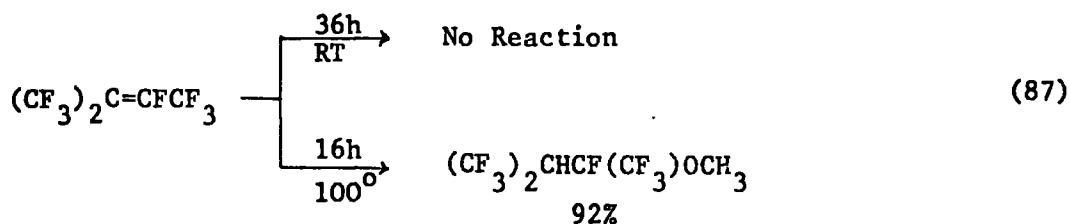
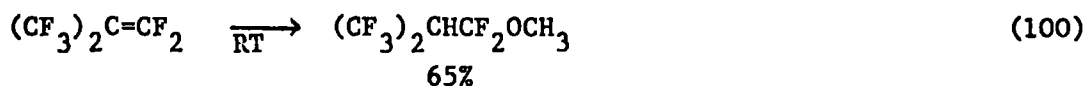

From the relative reactivities of these three olefins and the order of reactivity  $\text{CF}_2=\text{CF}_2 < \text{CF}_3\text{CF}=\text{CF}_2 < (\text{CF}_3)_2\text{C}=\text{CF}_2$  it is clear that fluorine and F-alkyl groups influence reactivity as follows.

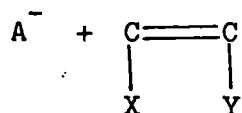

X = F, activating

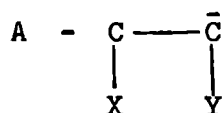

Y = F, deactivating

Y = R<sub>F</sub>, activating

The rate determining step of these reactions will be the formation of an intermediate carbanion. The transition state lies somewhere between initial state (olefin) and intermediate carbanion and therefore there will be some negative charge developed on carbon in the transition state.

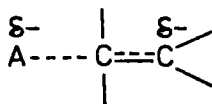

Factors which raise the energy of the initial state and lower the energy of the transition state will increase reactivity.

(i) Initial State Effects

Vinylic fluorines have a destabilising influence on F-olefins probably as a result of  $I_{\pi}$  repulsion (see Section I.B.3). Thus going from an F-olefin, having one or two vinylic fluorines at the site of attack, to a carbanion, having no vinylic fluorines, removes this destabilising effect.

For crowded olefins the initial state may be destabilised by steric effects, which will probably be reduced on forming a carbanion.

(ii) Transition State Effects

The transition state energy will be lowered by stabilisation of negative charge. Indeed the relative reactivities of the series  $\text{CF}_2=\text{CF}_2$ ,  $\text{CF}_3\text{CF}=\text{CF}_2$ , and  $(\text{CF}_3)_2\text{C}=\text{CF}_2$ <sup>101</sup> reflect the stabilities of their intermediate carbanions (Section I.B.2). This effect is demonstrated, for more complex olefins, by F-2-methyl-2-pentene (16) and F-4-methyl-2-pentene (13) (F-propene dimers). F-olefin (16) is the more reactive,<sup>99</sup> even though it is, thermodynamically, the more stable isomer.

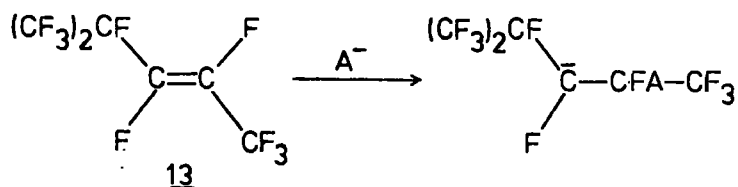
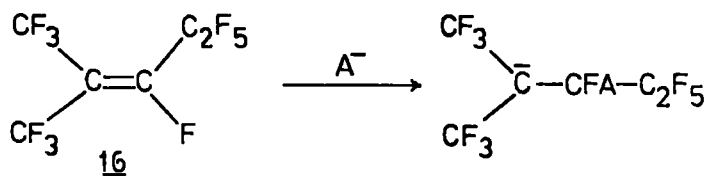

(iii) Other Effects

The effects described above will adequately explain the reactivities of most F-olefins and are easily understandable because they alter the energies of initial and transition states.

It is probable that other effects, outlined below, may also be important. These are more difficult to assign the terms initial and transition state effects because although they modify the initial state they do not necessarily raise its energy.

Polarisation of the C—F bond may increase susceptibility to nucleophilic attack. This effect has been suggested to contribute to the greater reactivity of  $\text{CF}_2=\text{CF}_2$  compared to  $\text{CCl}_2=\text{CCl}_2$  because F-ethylene would give a less stable intermediate carbanion<sup>101</sup>. Bond polarity would probably be reduced for C—Cl (and also C—R<sub>F</sub>) thereby decreasing reactivity.

However the lower reactivity of  $\text{CCl}_2=\text{CCl}_2$  can be explained by the destabilising effect of vinylic fluorine on  $\text{CF}_2=\text{CF}_2$  and the steric shielding of the double bond by chlorine. In fact  $\text{CCl}_2=\text{CCl}_2$  is probably not very different from  $(\text{CF}_3)_2\text{C}=\text{C}(\text{CF}_3)_2$ .

A less accessible double bond in (58) was suggested to account for the lower reactivity of (58), when compared to (59).<sup>102</sup>

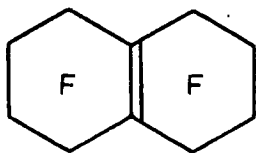

58

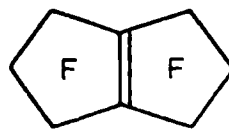

59

II.B.1.c Effect of Substituents on Further Reaction

Once a mono-substituted fluoro-olefin has been formed then any further reaction may be influenced by the nature of the substituent, especially when it is attached to the double bond. For example, further reaction of fluoro-olefins (60) occurs at the <sup>\*</sup>CF<sub>3</sub> group.<sup>72</sup> It has been found that alkyl ethers (60, A = OR) are more susceptible to nucleophilic attack than phenyl ethers (60, A = OPh). This suggests that the initial step is the formation of terminal olefin (61) by donation of a lone pair

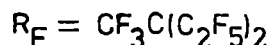
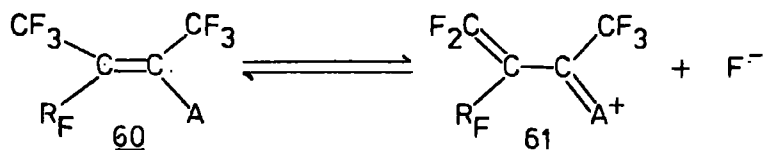

of electrons from oxygen. The lone pair will be more available for alkyl ethers.<sup>72</sup>

Further examples of this effect are given later.

The following sections describe reactions of fluoro-olefins with various types of nucleophile. Reactions with each nucleophilic type are grouped together so that differences between the olefins can easily be seen. Most of the reactions proceed by mechanisms already described and attention will be drawn only to important features and differences. Further interesting reactions of some products are also given. Some of the work contained in this thesis describes reactions of F-3,4-dimethyl-3-hexene. Therefore literature reports of its reactions with nucleophiles are reserved for the discussion as are the reported reactions of F-propene trimers with O-nucleophiles<sup>103-106</sup> because these are also particularly relevant.

## II.B.2 O-Nucleophiles

### II.B.2.a Alcohols and Phenols

See Table 12 for a list of these reactions. The reactions can all be accommodated by previously described mechanisms except for F-hexamethyl-bicyclopropenyl, when an intermediate internal nucleophilic substitution probably occurs.<sup>107</sup>

There are two significant differences between alcohols and phenols;

- 1) Alcohols are, generally, the stronger bases and alkoxy substituents can promote further reaction (see Section II.B.1.c), and
- 2) The increased steric requirements of phenols can be important.

Thus phenols may fail to react, using conditions where alcohols give products, and when products are formed these may be structurally different to those obtained using alcohols.

Using similar experimental conditions the steric requirements of the OR group are suggested to account for F-2-methyl-2-pentene giving an addition product with methanol, but substitution products with ethanol and phenol.<sup>99</sup>

### II.B.2.b Hydroxide

Hydroxide, like alkoxides, is a strong nucleophile and reactions with more than one equivalent of hydroxide can readily occur. Thus F-ethylene pentamer can give any one of three products depending on the choice of conditions. These and reactions of related olefins are contained in Table 13. A mechanism accounting for the various products from F-ethylene pentamer is given in scheme 20.

Table 12  
Reactions with Alcohols<sup>†</sup> and Phenols

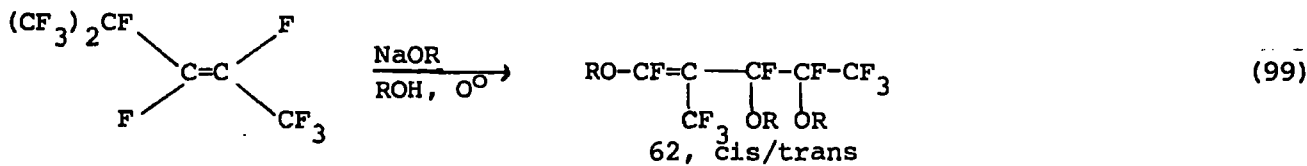
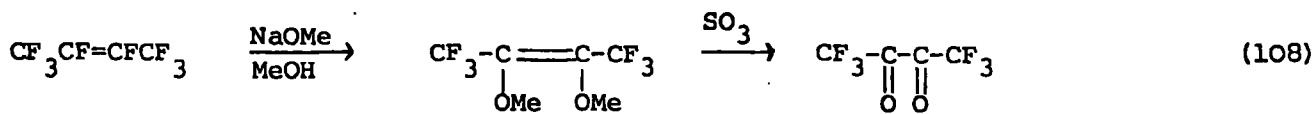

R = Et, Me; 1:1 or excess NaOR gives 62; R = Ph, no reaction.

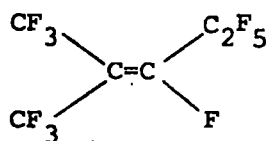

<u>Conditions</u>	<u>Product(s)</u>	<u>Further Reactions</u>
MeOH, cat. Et <sub>3</sub> N (97) -10-0° or MeOH, cat. NaOCH <sub>3</sub> (109)	$\begin{array}{c} \text{CF}_3 \\ \diagdown \\ \text{H}-\text{C}-\text{C}-\text{OMe} \\ \diagup \\ \text{CF}_3 \end{array} \begin{array}{c} \text{C}_2\text{F}_5 \\ \diagdown \\ \text{C}=\text{C} \\ \diagup \\ \text{F} \end{array}$	$\xrightarrow{\text{SO}_3} \begin{array}{c} \text{CF}_3 \\ \diagdown \\ \text{C}-\text{C}=\text{O} \\ \diagup \\ \text{F}_2\text{C} \end{array} \begin{array}{c} \text{C}_2\text{F}_5 \\ \diagdown \\ \text{C}=\text{C} \\ \diagup \\ \text{C}_2\text{F}_5 \end{array} \quad (99)$
EtOH, cat. Et <sub>3</sub> N RT.	$\begin{array}{c} \text{CF}_3 \\ \diagdown \\ \text{C}=\text{C} \\ \diagup \\ \text{CF}_3 \end{array} \begin{array}{c} \text{C}_2\text{F}_5 \\ \diagdown \\ \text{C}=\text{C} \\ \diagup \\ \text{OEt} \end{array}$	(99)
MeOH, NaOH 0-10°	$\begin{array}{c} \text{MeOCF}_2 \\ \diagdown \\ \text{C}=\text{C} \\ \diagup \\ \text{CF}_3 \end{array} \begin{array}{c} \text{OCH}_3 \\ \diagdown \\ \text{C}=\text{C} \\ \diagup \\ \text{C}_2\text{F}_5 \end{array}$ cis/trans	$\xrightarrow{\text{SO}_3} \begin{array}{c} \text{O}=\text{C} \\ \diagdown \\ \text{C}=\text{C} \\ \diagup \\ \text{F}_5\text{C}_2 \end{array} \begin{array}{c} \text{CF}_3 \\ \diagdown \\ \text{C}=\text{C} \\ \diagup \\ \text{C}=\text{O} \end{array} \quad (109)$
ROH, NaOH -10-0° R = Et, Me;	$\text{RO}-\text{CF}=\underset{\text{CF}_3}{\text{C}}-\underset{\text{OR}}{\text{CF}}-\text{C}_2\text{F}_5 \quad (\sim 50\%)$	(99)
	<u>63</u> cis/trans	
EtO <sup>-</sup> , -80°	$\text{F}_2\text{C}=\underset{\text{CF}_3}{\text{C}}-\underset{\text{OEt}}{\text{CF}}-\text{C}_2\text{F}_5 \quad (10\%) + \text{63} \quad (58\%)$	(54)

Table 12 continued

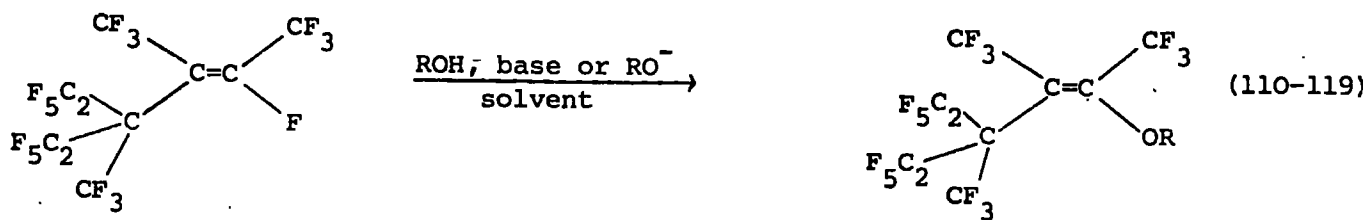
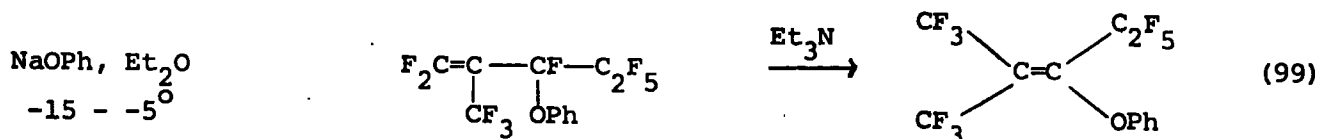

R = aryl or alkyl and includes bifunctional compounds.

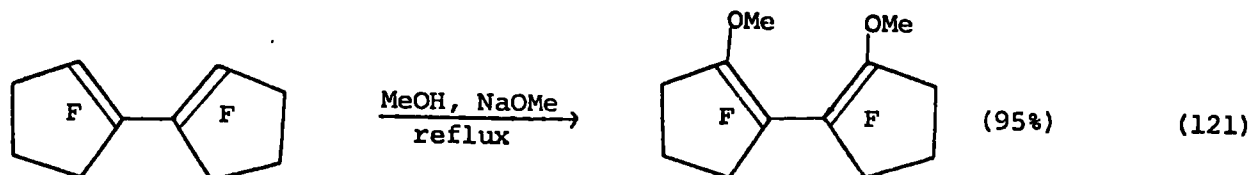
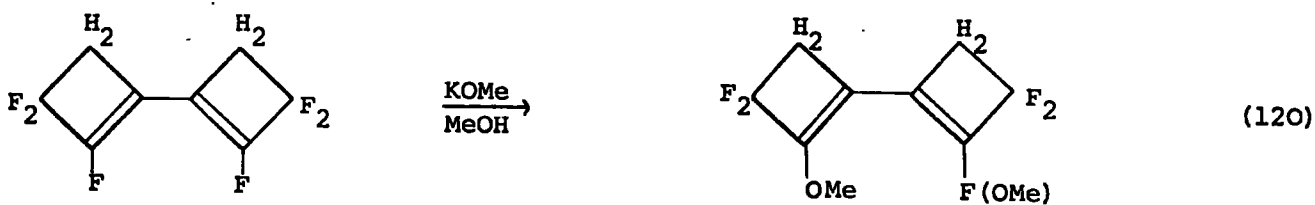
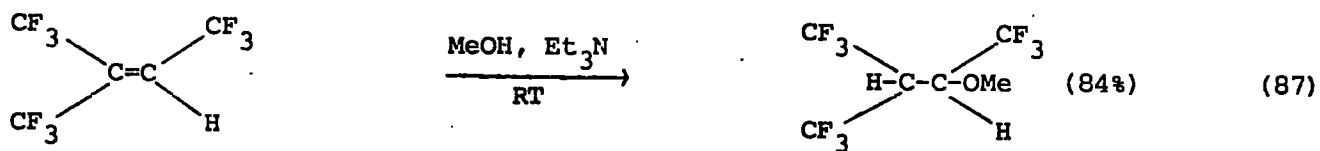
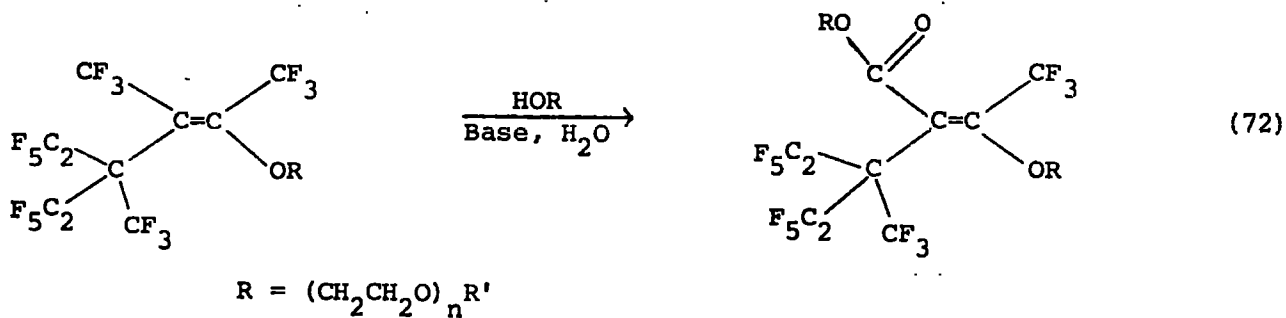
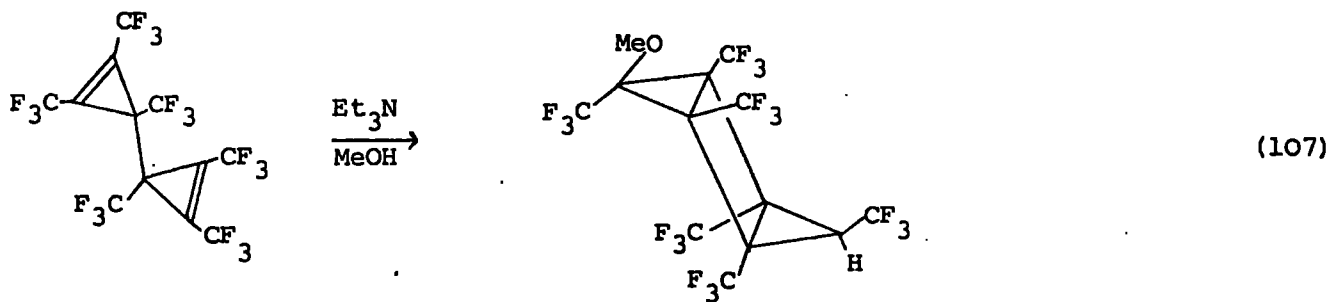
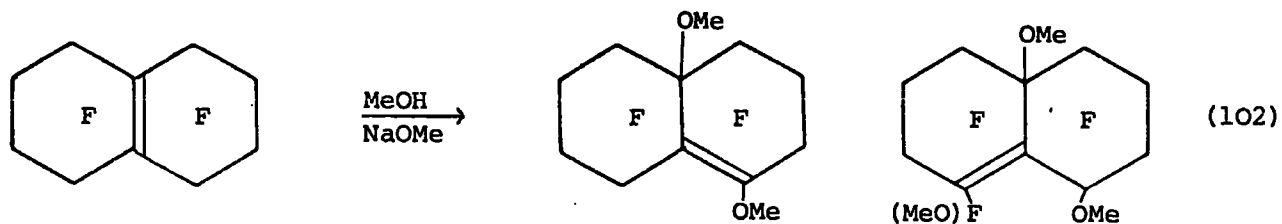
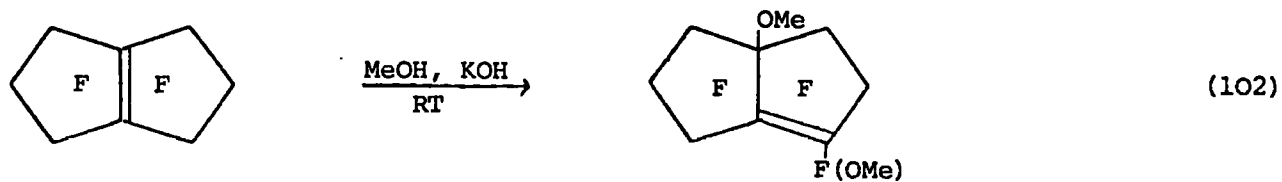
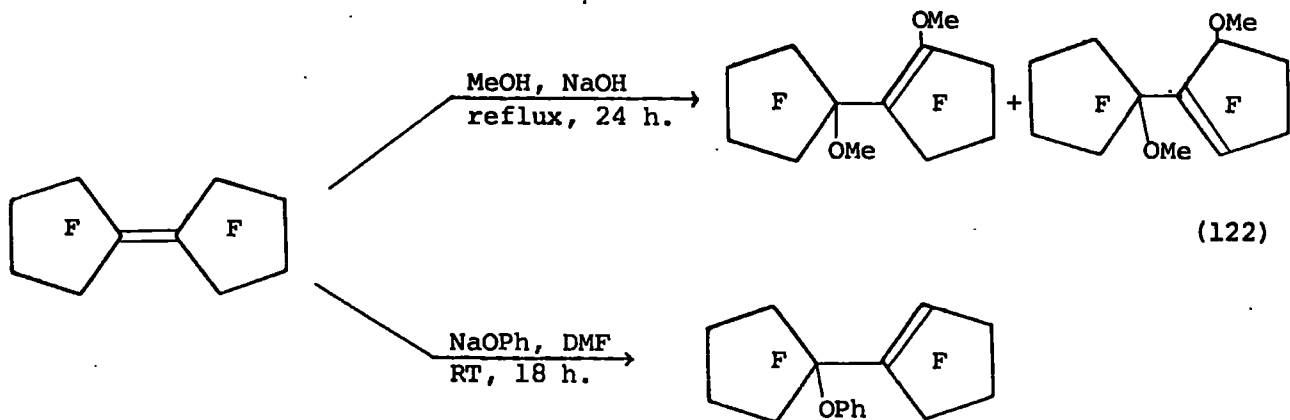
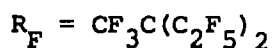
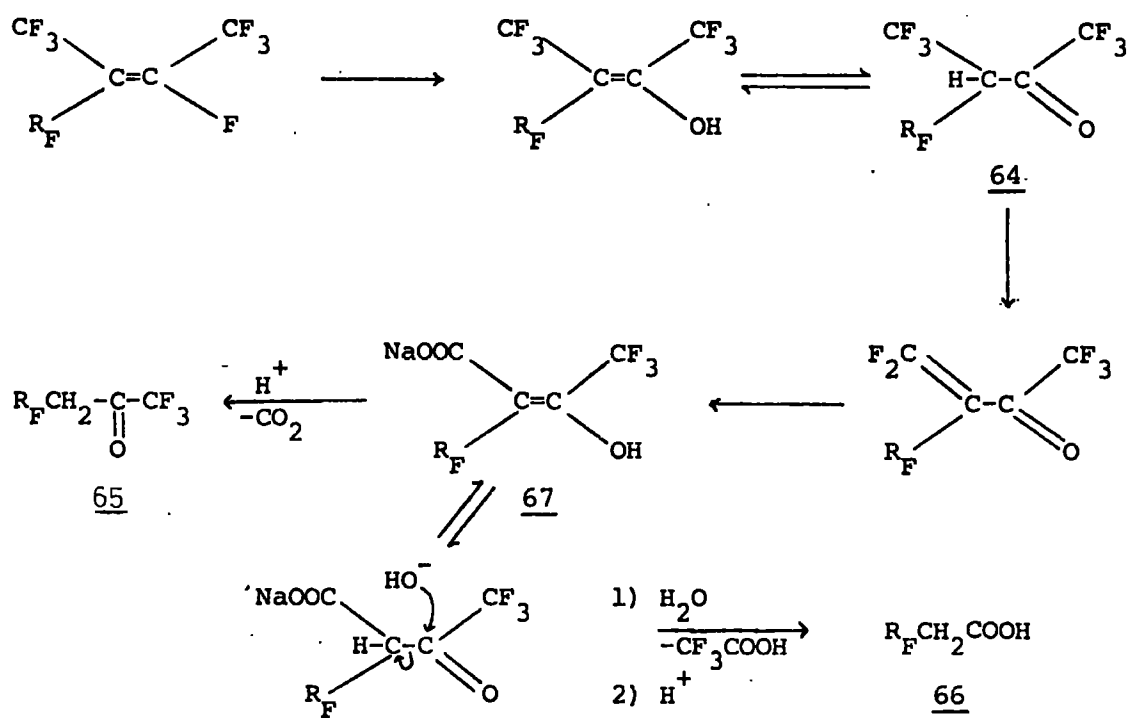

Table 12 continued



† see also section II.B.1.b.



Scheme 20

Using the mildest conditions, replacement of the vinylic fluorine occurs giving ketone (64) rather than its tautomeric alcohol. At elevated temperatures, using dilute alkali, ketone (65) is obtained, whereas concentrated alkali gives carboxylic acid (66), after acidification.<sup>72</sup> Decarboxylation to ketone (65) only occurs on acidification,<sup>72</sup> but the intermediate sodium salt (67) can react further to give the acid (66), presumably by displacement of trifluoroacetic acid. The acid (66) is formed from either the pentamer or the initial ketone (64) using strong aqueous alkali.<sup>72</sup>

Decarboxylation, on acidification, is found also for the enolate anion derived from F-2-methyl-2-pentene, but in this case acid catalysed hydrolysis of the  $\text{CF}_3$  group occurs (Table 13).<sup>124</sup>

Table 13

Reactions of F-Olefins, having one Vinylic Fluorine, with Hydroxide

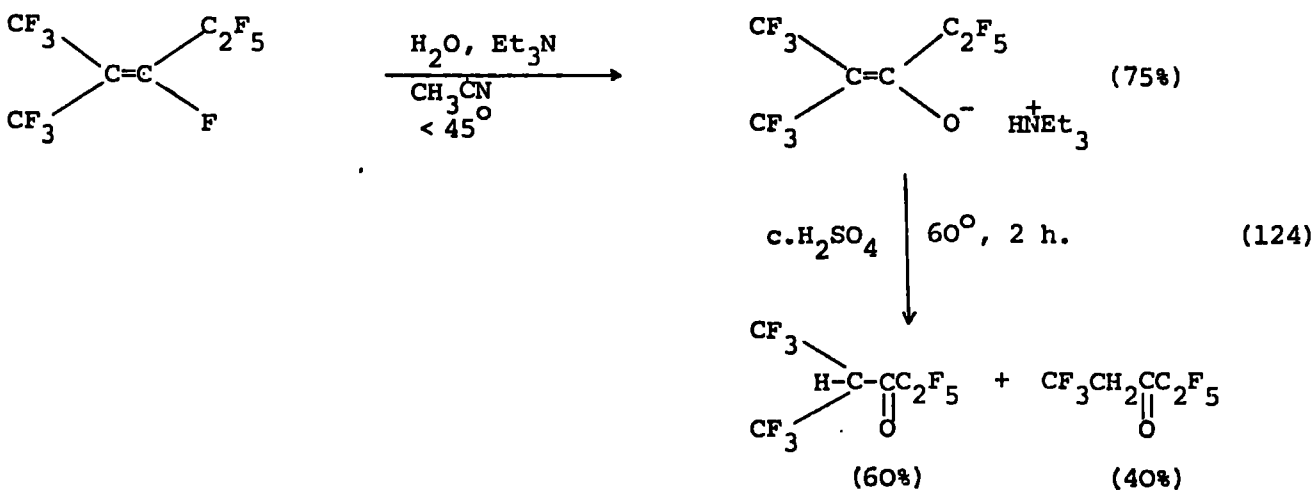
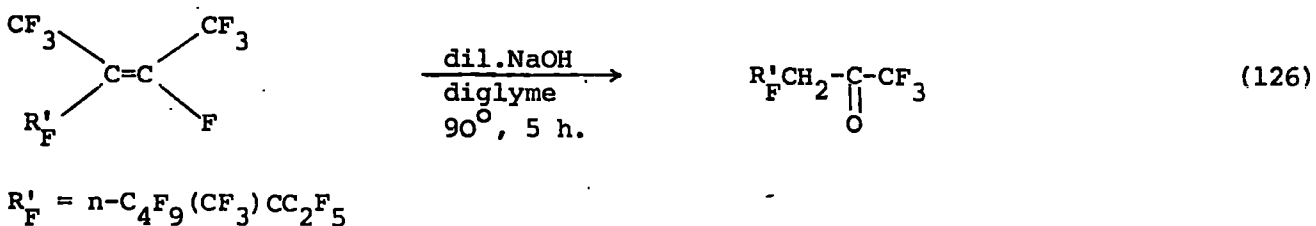
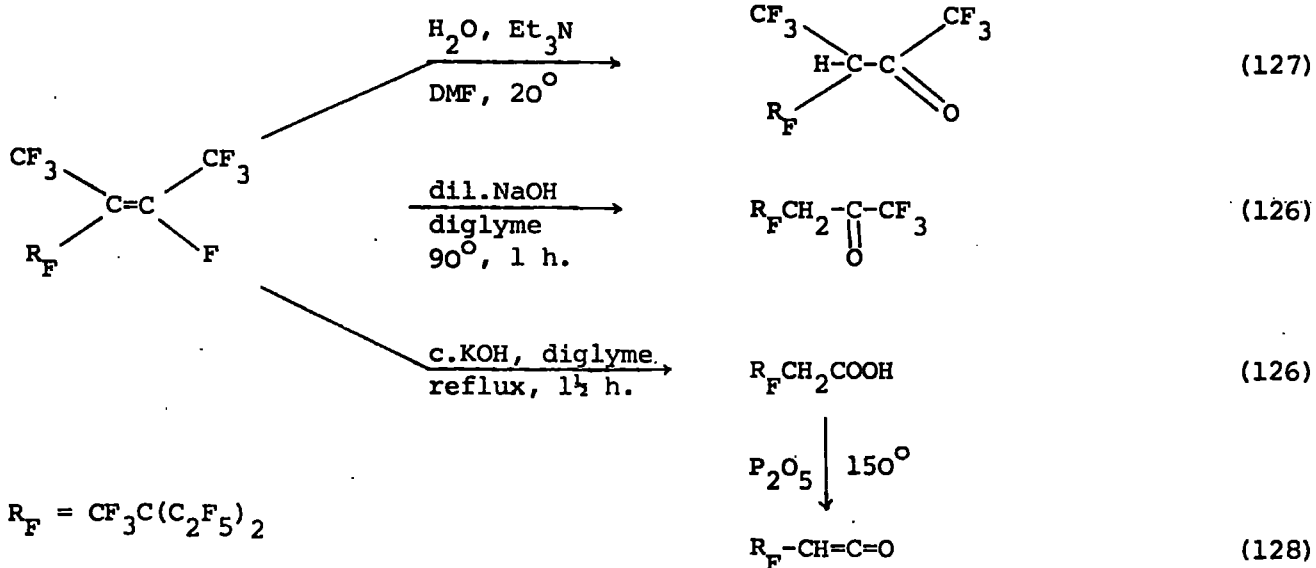



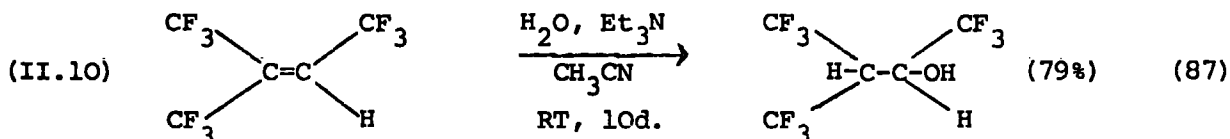
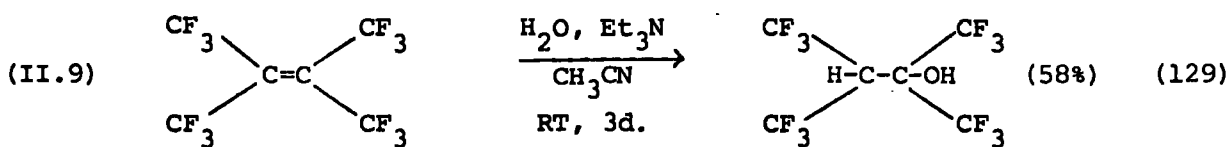

### II.B.2.c Carboxylate

The reaction of carboxylates with internal F-olefins has been found to be useful in two ways:- 1) as a facile synthesis of acid fluorides using the F-olefin as a fluorinating agent; and 2) as a route to derivatives of the F-olefin.

#### 1) Facile Synthesis of Acid Fluorides

The reaction of F-2-methyl-2-pentene with carboxylate anions, using polar aprotic solvents, produces poor to good yields of aromatic and aliphatic acid fluorides but rather poor yields of F-olefin derivatives<sup>130</sup> (eq.II.11). As an alternative to polar

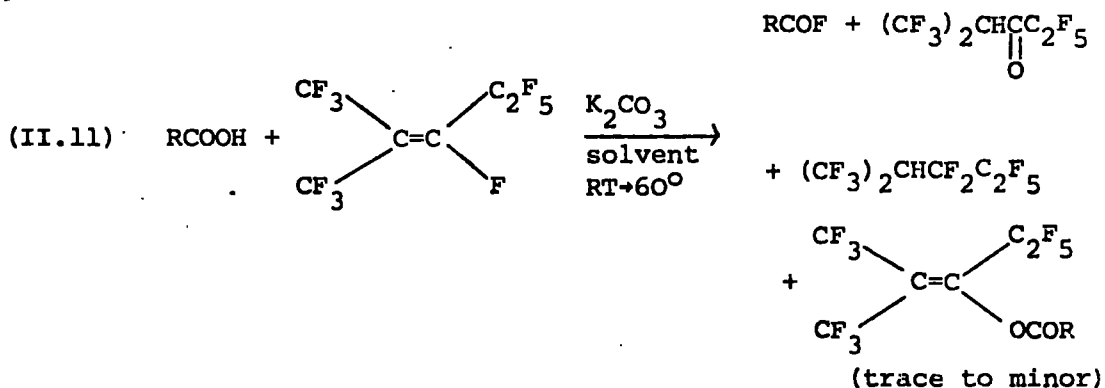

R = aryl, alkyl but not F-alkyl

aprotic solvents, benzene and methylene chloride can be used in conjunction with a phase transfer catalyst (18-crown-6-ether or

trioctylmethylammonium chloride). The preferred mechanism for formation of the acid fluorides is given in scheme 22. The enolate anion, thus formed, and its derived ketone are also produced from F-2-methyl-2-pentene by hydrolysis<sup>124</sup> (see Section II.B.2.b).

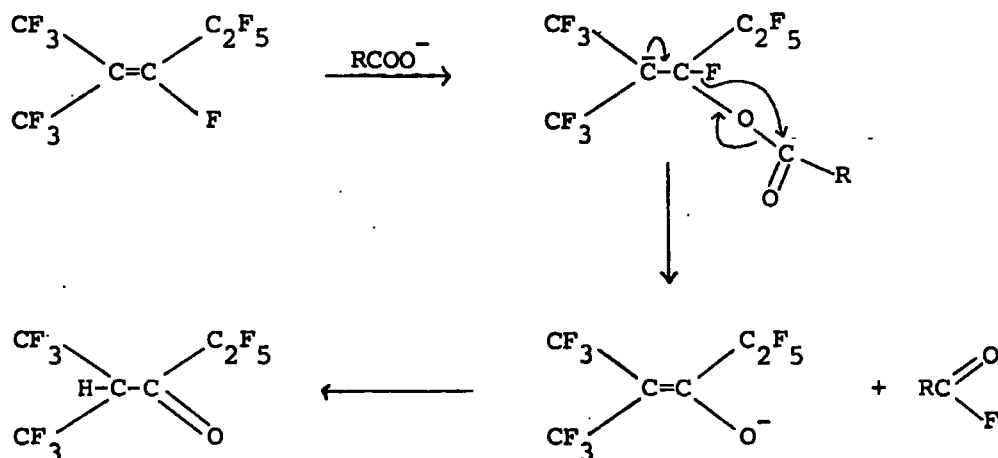

Scheme 22<sup>130</sup>

2) Derivatives from F-olefins

F-ethylene pentamer, when heated with a lower aliphatic acid and/or its salt in anhydrous DMF or diglyme, gives an F-acetylene.<sup>131</sup>

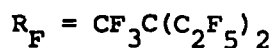
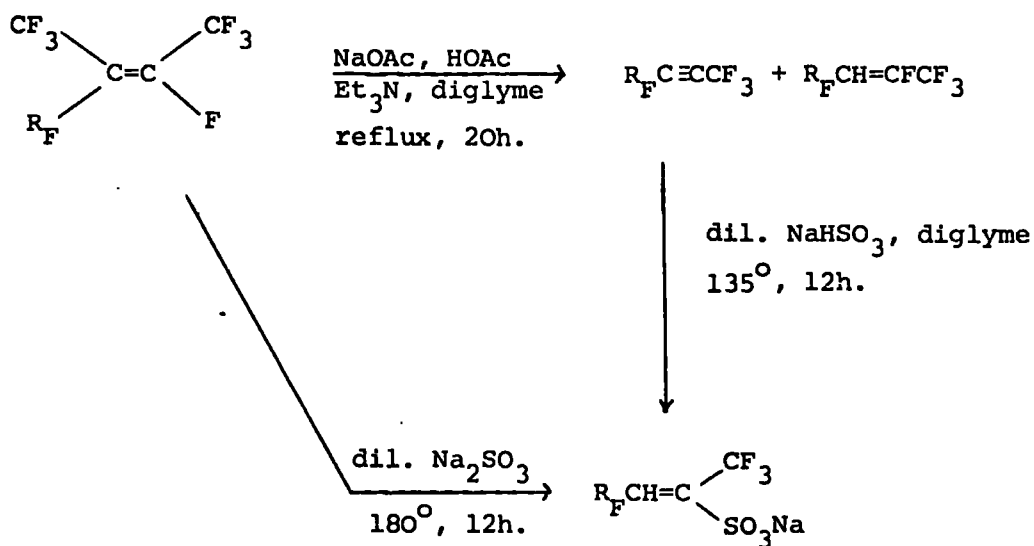

Scheme 23

The acetylene<sup>131</sup> or F-ethylene pentamer itself,<sup>131,132</sup> on heating with sodium bisulphite or sulphite, give the sodium salt of a sulphonic acid (scheme 23).

The F-acetylene could be produced from pentamer and carboxylate as shown in scheme 24 and it seems likely that the reaction of pentamer with sulphite involves the F-acetylene as intermediate. A similar mechanism is therefore probable for this reaction.

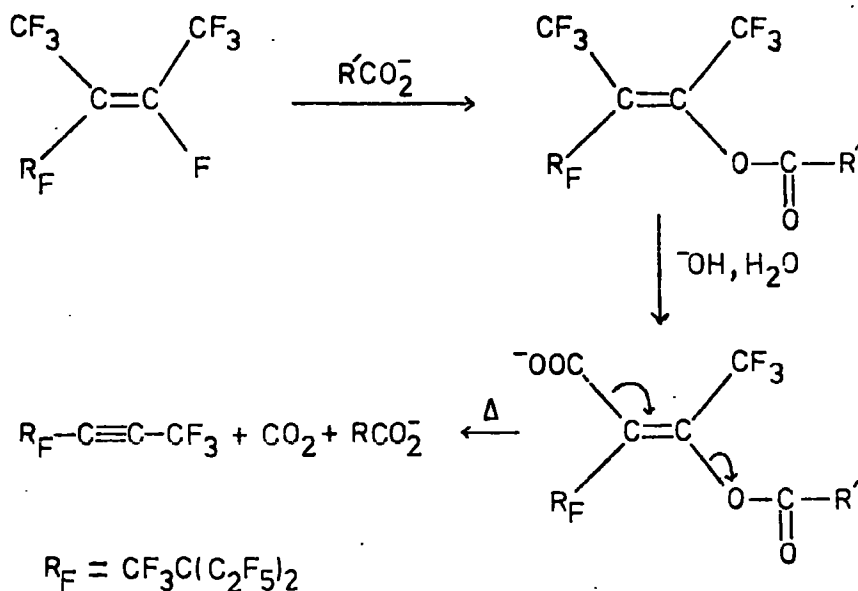

Scheme 24

### II.B.3 S-Nucleophiles

The reactions of F-propene dimers with thiophenol and phenylmethanethiol have recently been reported.<sup>133</sup> The results are summarised in Table 14.

The various products can be explained by the usual nucleophilic mechanisms if a novel 1,4-elimination of RSF is also assumed (eq.II.12). Sulphenyl fluoride, RSF, would then immediately react with thiol (eq.II.13). Air oxidation to give RSSR was shown not to occur.

Table 14

Reactions of F-Propene Dimers with Thiols 133

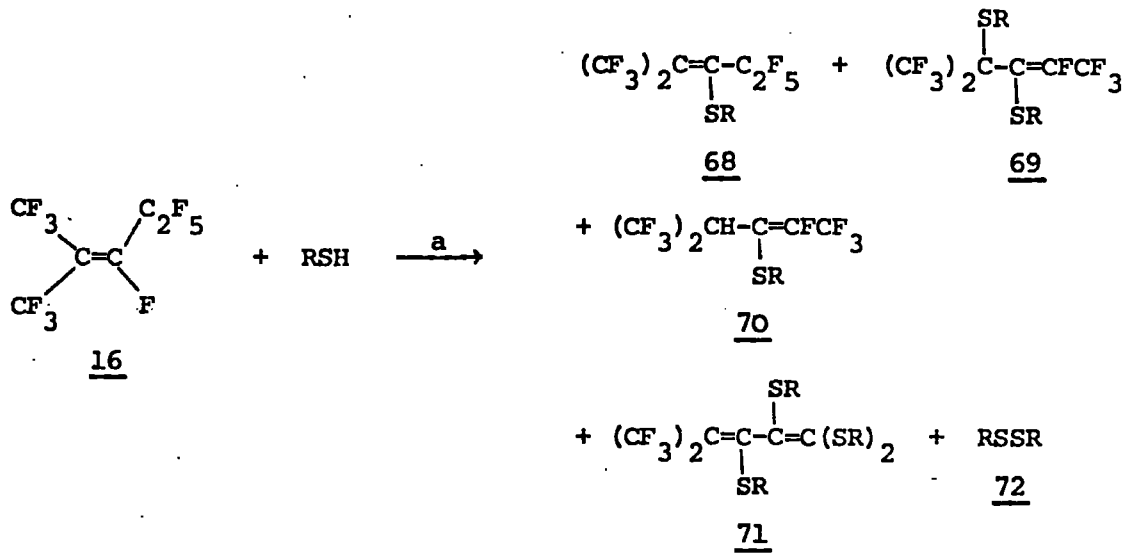

RSH	Mol. ratio RSH: 16	Yields (%)				
		68	trans 69	70	71	72
PhCH <sub>2</sub> SH	1	59	32	3	-	6
PhCH <sub>2</sub> SH	10	-	-	-	26	15
PhSH	10	-	-	-	30	32

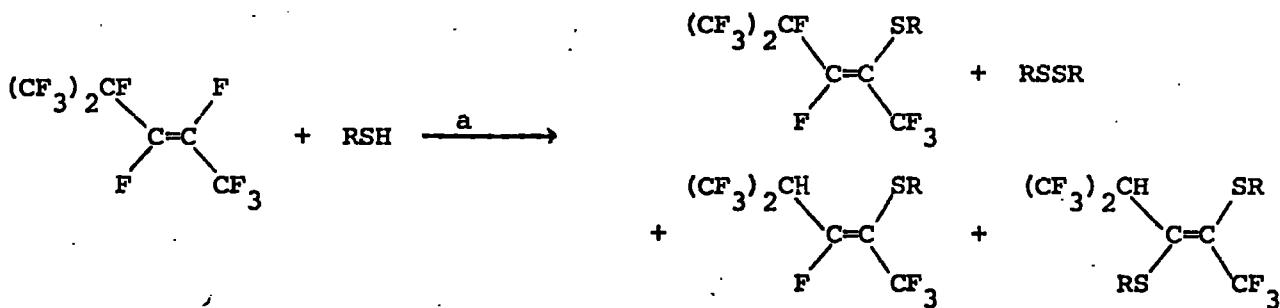

RSH = PhCH<sub>2</sub>SH;

a, Et<sub>3</sub>N, CH<sub>3</sub>CN, 0°-5°.



Only the trans isomer of disubstituted product (69) was detected in the reaction mixture, although the cis isomer should also have been formed. Elimination of RSF from the cis isomer of (69) would account for its non-isolation. Molecular models have indicated that the

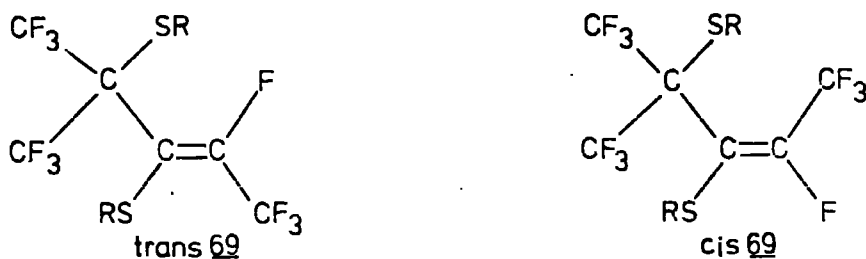

interatomic distance between S and F in (cis 69) is approx. 1.6Å, an average S—F bond length. Although elimination of RSF appears to be unfavourable from a consideration of bond energies<sup>134</sup> ( $\Delta H = +189 \text{ kJ mol}^{-1}$ ) steric and entropy effects will be important. A similar elimination of ROF seems very unlikely ( $\Delta H = +389 \text{ kJ mol}^{-1}$ ).

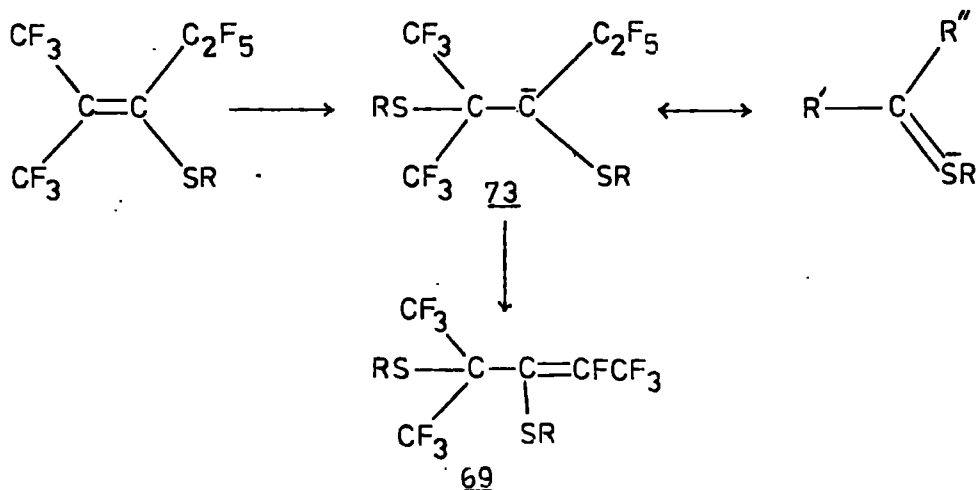

Scheme 25

Interestingly the disubstituted product (69) is formed more readily than a similar product from the reaction of F-2-methyl-2-pentene with phenol.<sup>99</sup> This difference can be attributed to stabilisation of intermediate carbanion (73) by sulphur, through its available 3d orbitals<sup>133</sup> (scheme 25).

#### II.B.4 N-Nucleophiles

Sodium nitrite reacts, as an N-nucleophile, with F-propene and other simple terminal fluoro-olefins.<sup>135</sup>

After the initial reaction of a fluoro-olefin with an amine (including ammonia and hydrazine), if there is hydrogen attached to nitrogen, then loss of HF will occur if at all possible because this is, thermodynamically, very favourable. Tertiary amines normally do not give stable compounds with internal olefins (but see Table 3) because the amine group is readily displaced by fluoride or other nucleophiles, hence their use either as bases or as catalysts for oligomerisation (Section I.D).

##### II.B.4.a Secondary Amines

The reactions of F-propene dimers with diethylamine and piperidine (Table 15) are an excellent example of the effect of competition between fluoride ion induced isomerisation and direct reaction with nucleophile.

F-2-methyl-2-pentene (16) and piperidine gives mainly the product derived from vinylic substitution, whereas (16) and diethylamine give an enamine produced from isomeric terminal olefin (36).<sup>136</sup> The reaction of diethylamine with (16), an internal olefin, must be sufficiently slow so that once fluoride ion has been generated a much faster reaction with terminal olefin (36) can occur. Piperidine is, in fact, a stronger

Table 15

Reactions of F-Propene Dimers with Secondary Amines

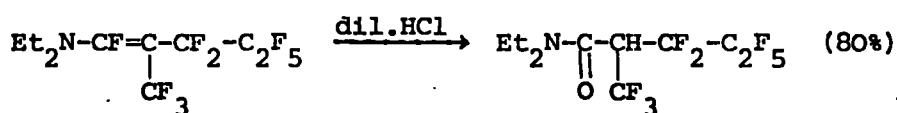
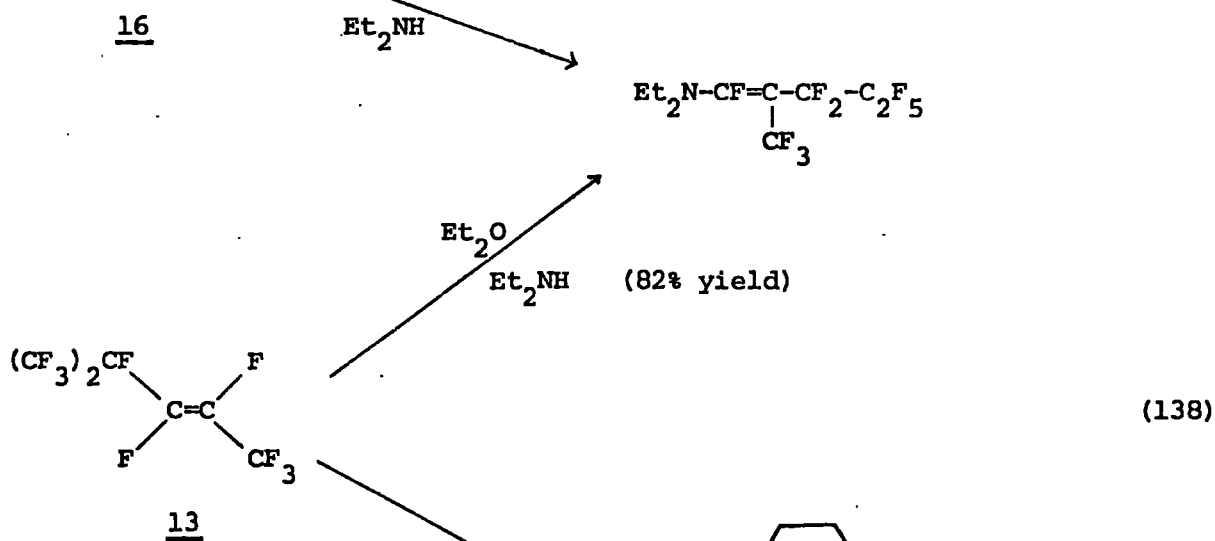
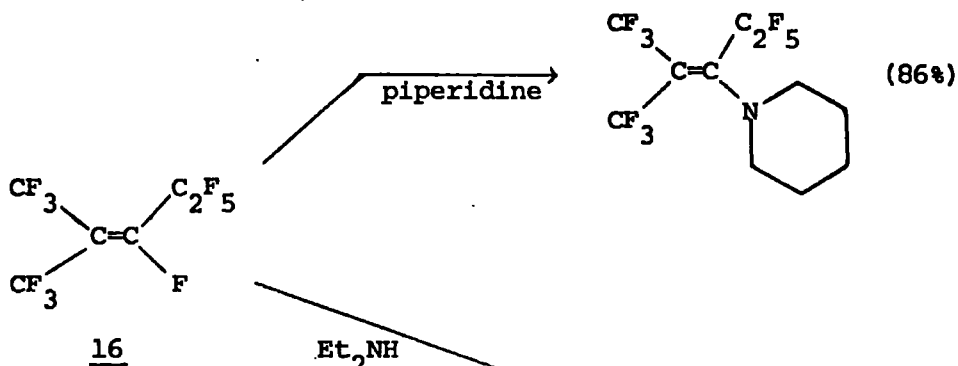
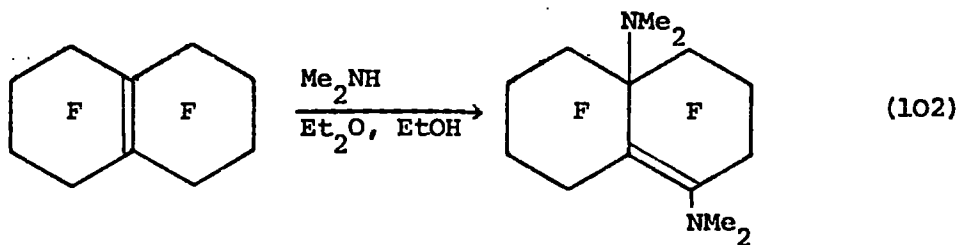
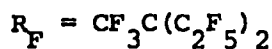
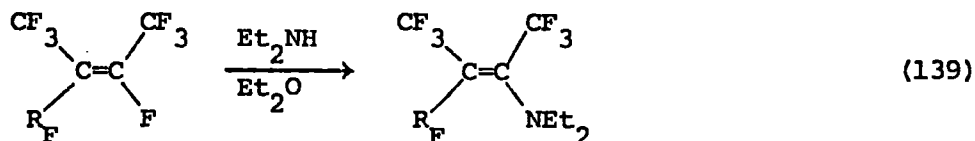
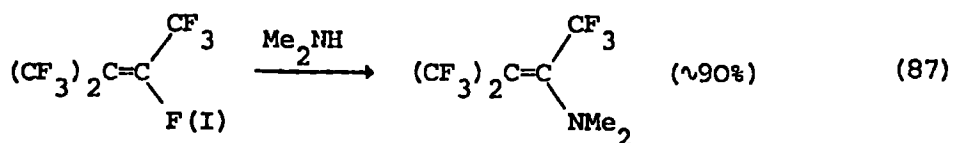
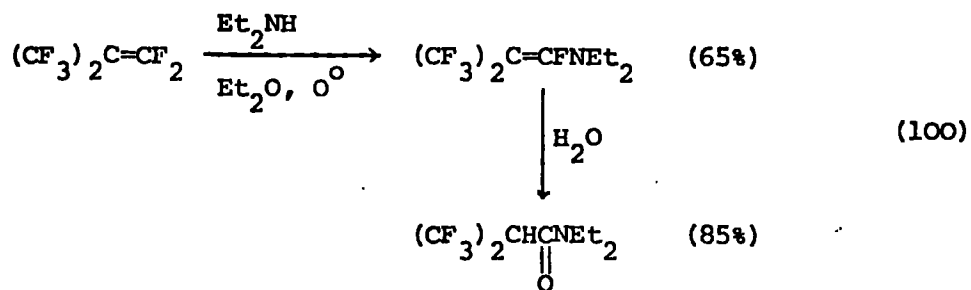
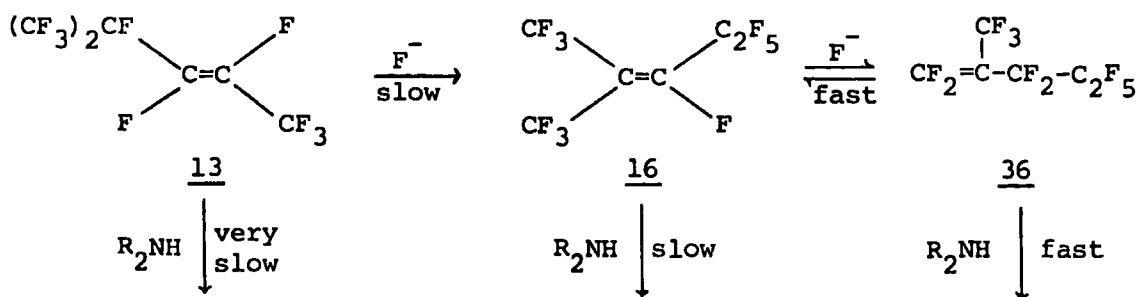

Table 16

Reactions of Fluoro-olefins with Secondary Amines



base than diethylamine (1.7 : 1).<sup>137</sup>



This explanation is reinforced by similar reactions of F-4-methyl-2-pentene (13). For both diethylamine and piperidine the major product is derived from terminal olefin (36).<sup>138</sup> Isomer (13) is less reactive than F-2-methyl-2-pentene (16)<sup>99</sup> (see Section II.B.1.b.ii) and so reactions with both amines will be slow. Once fluoride is produced a slow isomerisation to (16) will occur. Subsequent isomerisation of (16) to terminal olefin (36) is fast and reactions of (36) are fast. Thus there will be only a low concentration of F-2-methyl-2-pentene (16).

Other reactions of secondary amines with fluoro-olefins are given in Table 16.

#### II.B.4.b Primary Amines

Reactions with primary amines can be quite complex. Two simple examples are shown in eq.II.14 and II.15.

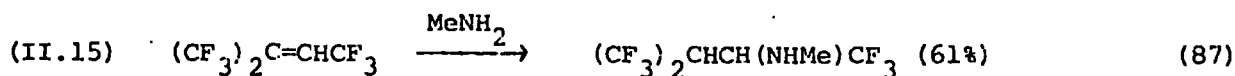
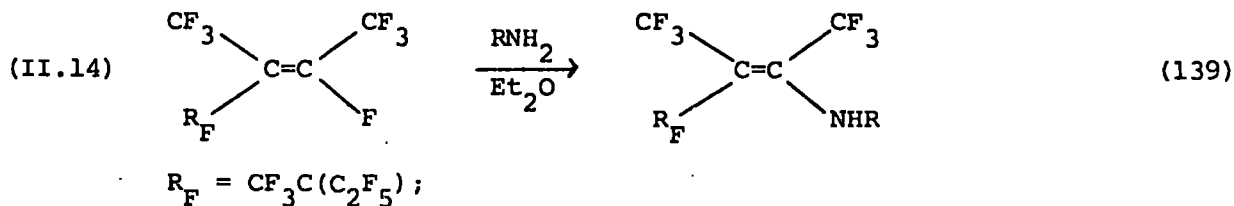

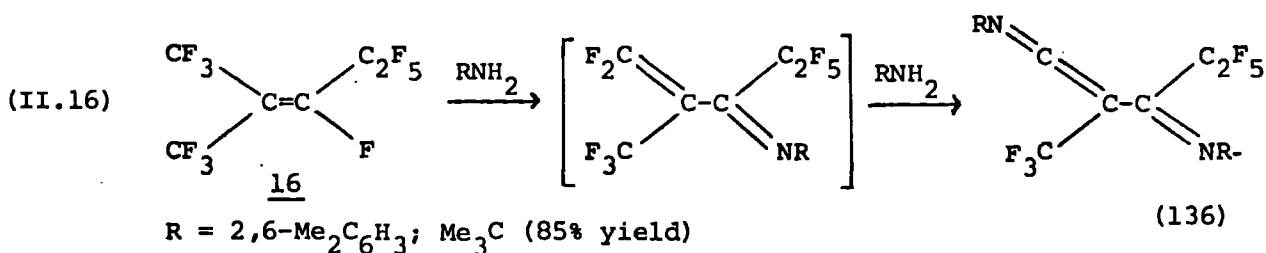

F-2-methyl-2-pentene (16) gives isolable ketenimines (eq.II.16) with aromatic primary amines, having no ortho-hydrogen, and with t-butylamine.<sup>136</sup> If the aromatic primary amine has an available ortho-hydrogen then 4-arylaminoquinolines are obtained via cyclisation of the ketenimine<sup>136,140,141</sup> (scheme 26). The ketenimines (eq.II.16) are formed by reaction with two moles of aromatic primary amines but if four moles of amine are used then the ketenimines can react further with amine prior to cyclisation to produce azetidines and quinolines<sup>141</sup> (scheme 26).

#### II.B.4.c Ammonia and Hydrazine

Hydrazine is approx. 20 times less basic than ammonia.<sup>142</sup> This may explain the difference between the reactions of F-ethylene pentamer with ammonia and hydrazine.<sup>143</sup> Hydrazine derivative (74) will less readily

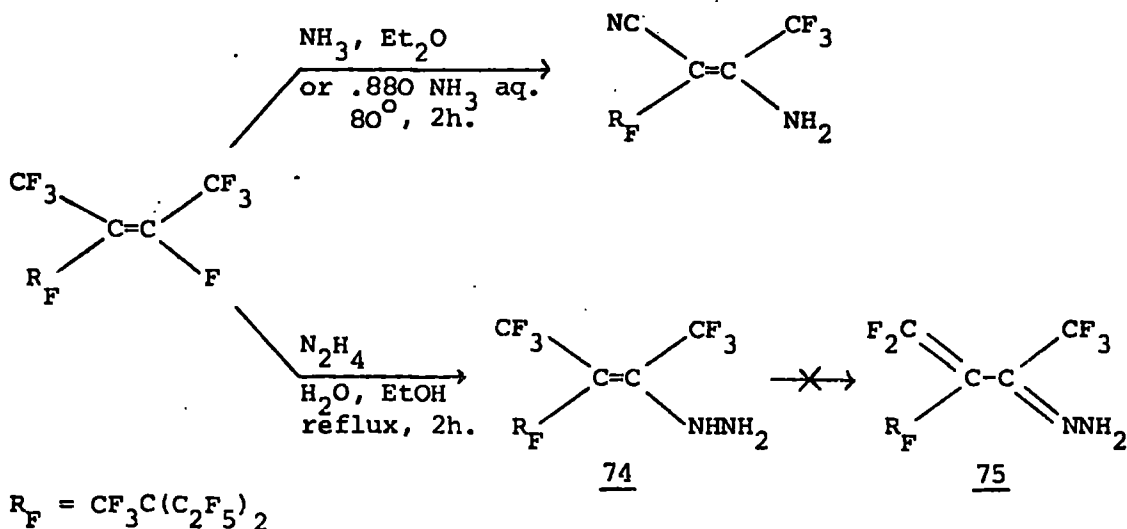

Reaction of Aromatic Primary Amines with F-2-methyl-2-pentene

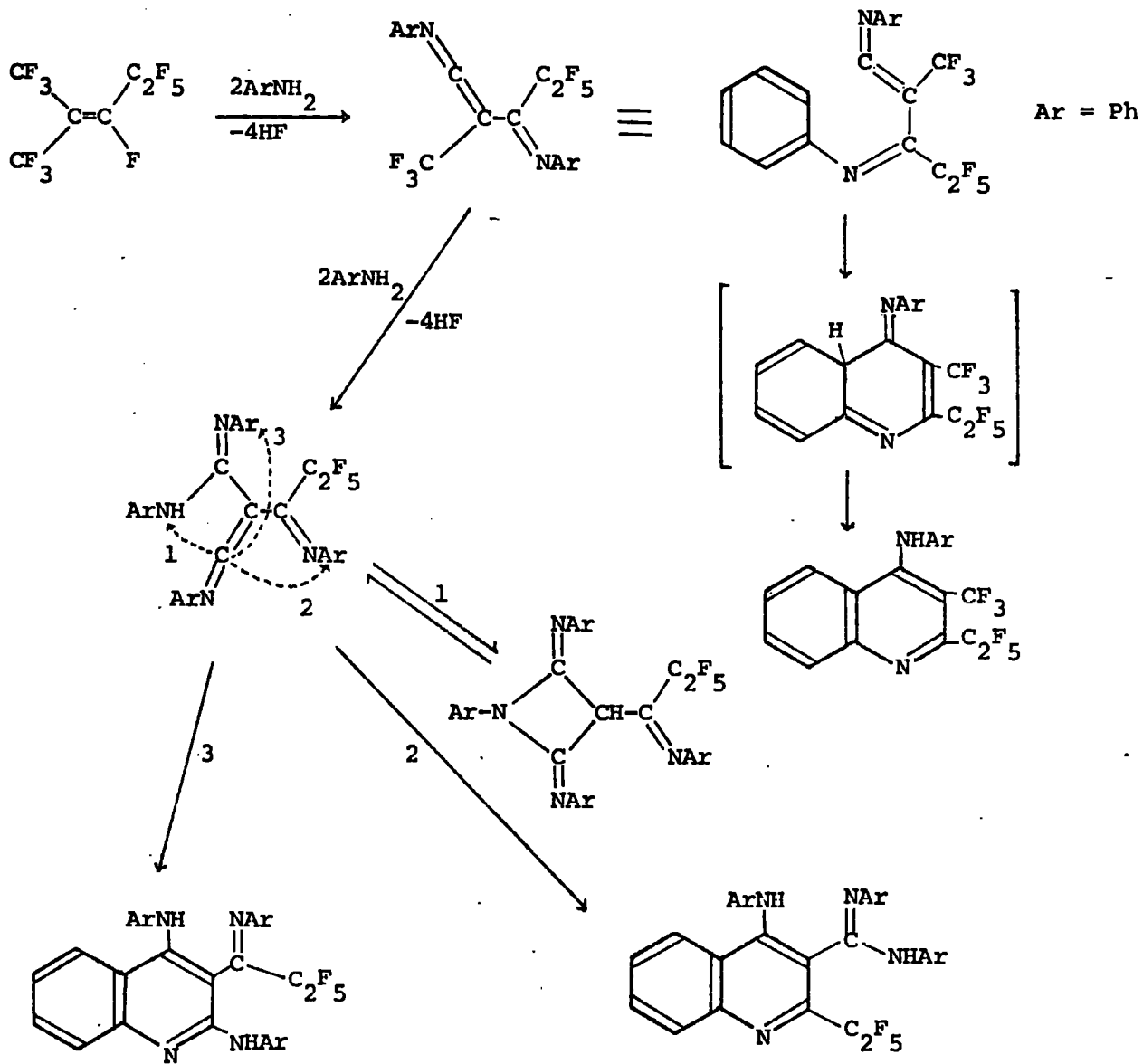

Scheme 26<sup>141</sup>

lose fluoride to give terminal olefin (75), whereas this step obviously occurs for the corresponding ammonia derivative. Other reactions with ammonia are given below.

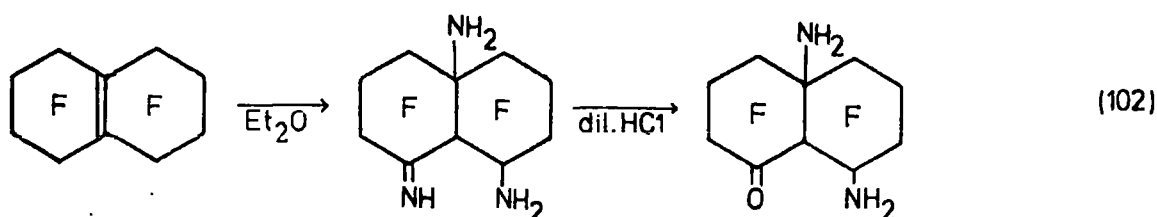
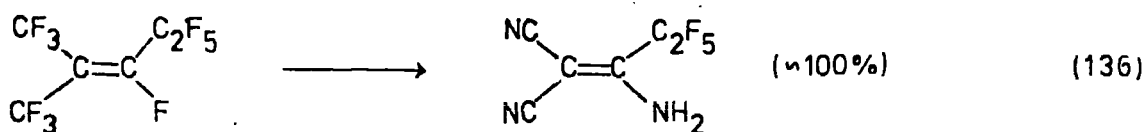
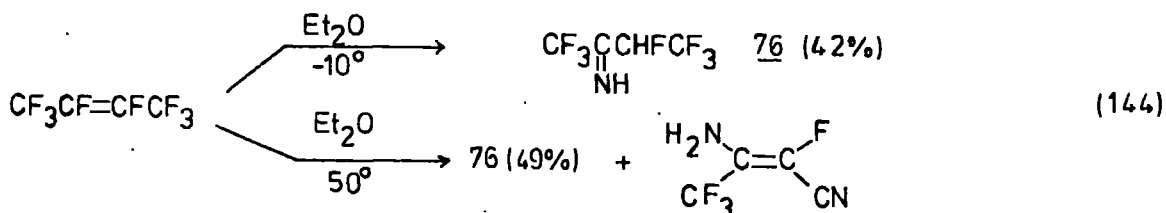
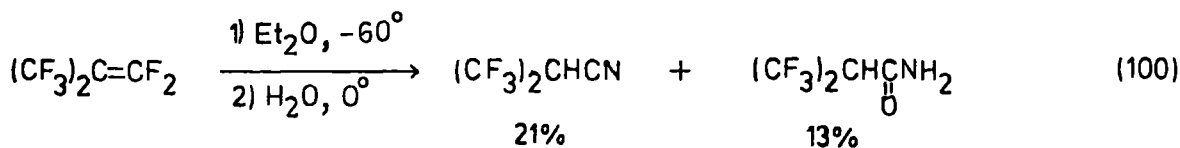

### II.B.5 C-Nucleophiles and Sodium Borohydride

Examples of reactions with these nucleophiles are as follows.

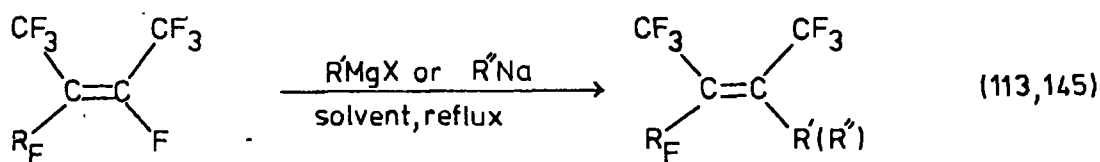

$\text{R}_\text{F} = \text{CF}_3\text{C}(\text{C}_2\text{F}_5)_2$ ;  $\text{R}''\text{Na} = \text{NaCH}(\text{COOC}_2\text{H}_5)_2$ , solvent = DMF, Dioxan;

$\text{R}'\text{MgX} = \text{CH}_2\text{CHCH}_2\text{MgBr}, \text{C}_6\text{F}_5\text{MgCl}, \text{MeMgI}, \text{EtMgBr}$ , solvent =  $\text{Et}_2\text{O}, \text{THF}$ ;

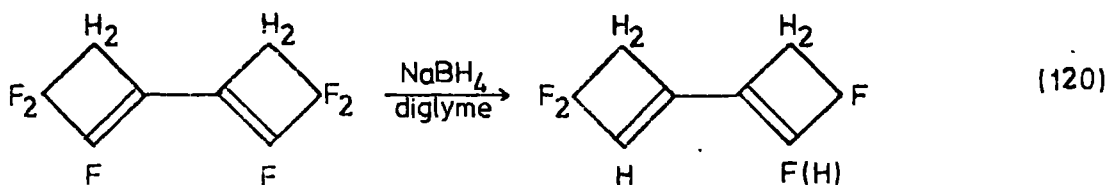
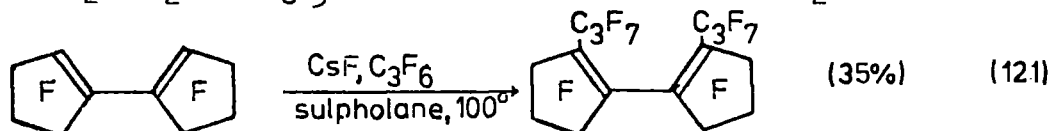

## II.B.6 Chloride

So far there appear to be no examples of nucleophilic reaction of chloride with F-trialkyl- and F-tetraalkyl-olefins. However, the replacement of fluoride by chloride or indeed other halides seems quite possible for these olefins. It is therefore worthwhile to describe the reaction of F-isobutene with chloride<sup>146</sup> because the results are probably applicable to more substituted F-olefins.

The reaction of F-isobutene with an excess of a tetraalkylammonium chloride forms only traces of a mono-substituted product. This is thought

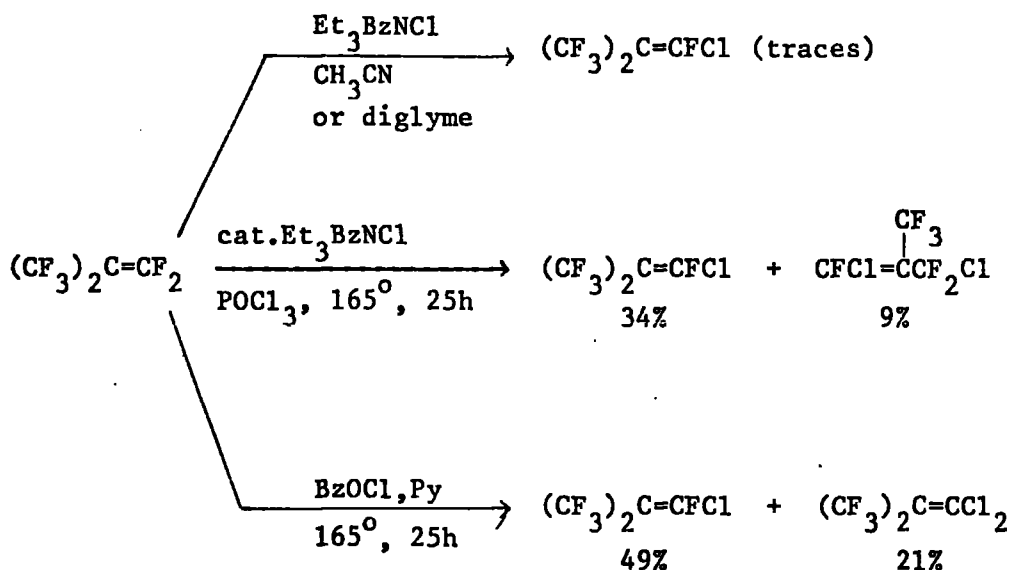

to be a result of an equilibrium favouring F-isobutene, possibly because of the stronger C—F bond.<sup>147</sup> Replacement of fluoride can, in fact, be achieved in the presence of POCl<sub>3</sub> or benzoyl chloride, compounds which trap out fluoride generating chloride. That these reactions are nucleophilic in nature is confirmed by no reaction occurring with POCl<sub>3</sub> in the absence of ionic chloride.

## II.C Reactions with Electrophiles

### II.C.1 At the Double Bond

Although electrophilic attack on less substituted fluoro-olefins is known<sup>28</sup>, the order of reactivity being  $\text{CF}_2=\text{CF}_2 > \text{CF}_3\text{CF}=\text{CF}_2 \sim \text{CF}_3\text{CF}=\text{CFCF}_3$  for addition of anhydrous HF,<sup>148</sup> there are no examples of electrophilic attack on the double bonds of F-trialkyl- and F-tetraalkyl-olefins. This is not surprising because:- 1) Generation of positive charge on carbon attached to F-alkyl groups is unfavourable; and 2) Strong electrophiles preferentially abstract an allylic fluorine.

Reactions with electrophiles after initial formation of carbanions are described in Section II.A.

### II.C.2 Replacement of Allylic Fluorines

Some examples of the replacement of allylic and, in some instances, vinylic fluorines are given in table 17. All these reactions can be explained by an electrophilic mechanism involving initial loss of fluoride, forming an intermediate allylic cation (see Sections I.B.1 and I.C.1), which then reacts further to give products. The driving force for these reactions is likely to be formation of very stable fluorides such as  $\text{AlF}_3$  from  $\text{AlCl}_3$ <sup>149</sup> and HF from  $\text{H}_2\text{SO}_4$ . The ease of reaction, however, will be influenced by the stability of the intermediate allyl cation. This is apparent from a comparison of the reactions, with  $\text{AlCl}_3$ , of F-cyclobutene (at 0°)<sup>150</sup> and F-isobutene (155° for 28h leaves 37% unreacted F-isobutene)<sup>146</sup> (see Table 17).

Most of the F-trialkyl- and F-tetraalkyl-olefins discussed in this chapter would produce allylic carbocations less stable than that derived from F-isobutene and therefore this type of reaction would need very vigorous conditions.

Table 17

Electrophilic Replacement of Allylic Fluorines

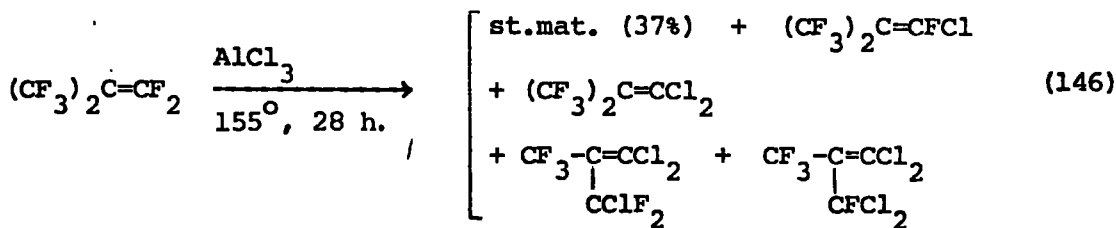
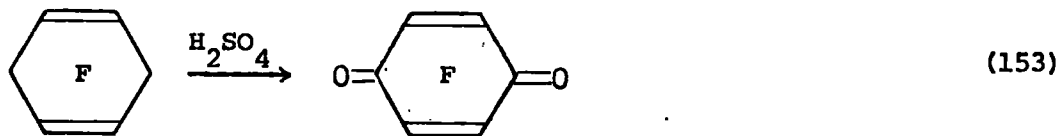
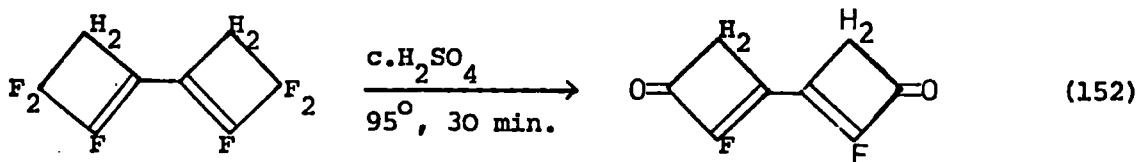
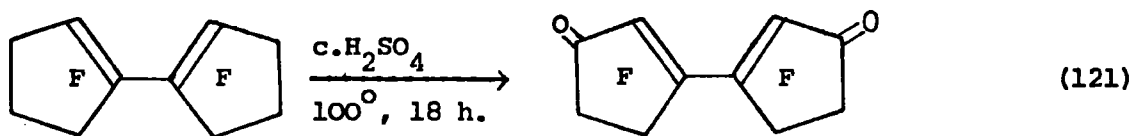
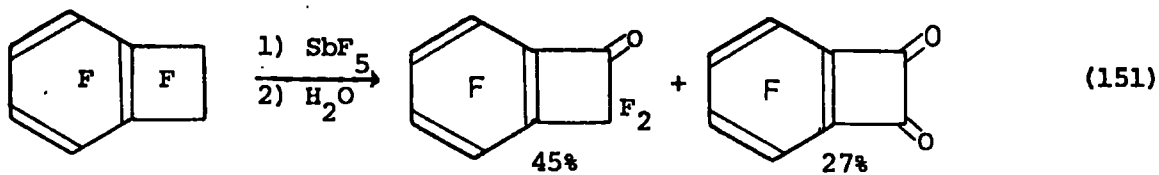

The replacement of vinylic fluorine probably occurs by double bond migration. An example is given below.

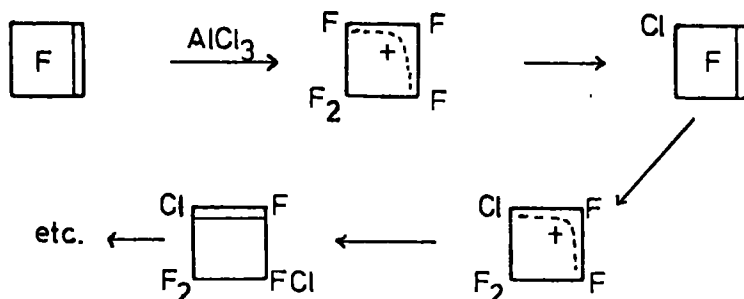

## II.D Additions across the Double Bond

Although some of the reactions described earlier in this chapter are additions to carbon-carbon double bonds, they proceed via intermediate carbanions. This section deals with other additions. These are either concerted, have radicals as intermediates or, for cobalt trifluoride fluorination, may proceed via intermediate radical cations.<sup>154</sup>

Examples of these reactions are given in Table 18 and Table 19 (fluorinations). Permanganate oxidation and fluorination are discussed briefly below.

Diels-Alder reactions of F-trialkyl- and F-tetraalkyl-olefins and particularly their reactions with ozone occur most readily for olefins such as F-hexamethylbenzvalene (see Table 18) and F-hexamethyl-Dewar-benzene.<sup>155</sup>

### II.D.1 Permanganate Oxidation

The reaction of  $\text{KMnO}_4$  with fluoro-olefins is suggested to involve initial nucleophilic attack by  $\text{MnO}_4^-$  giving a cyclic manganese complex.<sup>159</sup> This step is probably concerted. Subsequent addition of water will give

Table 18

Additions Across the Double Bond

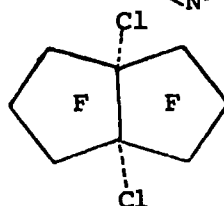
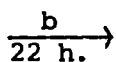
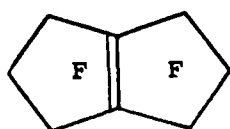
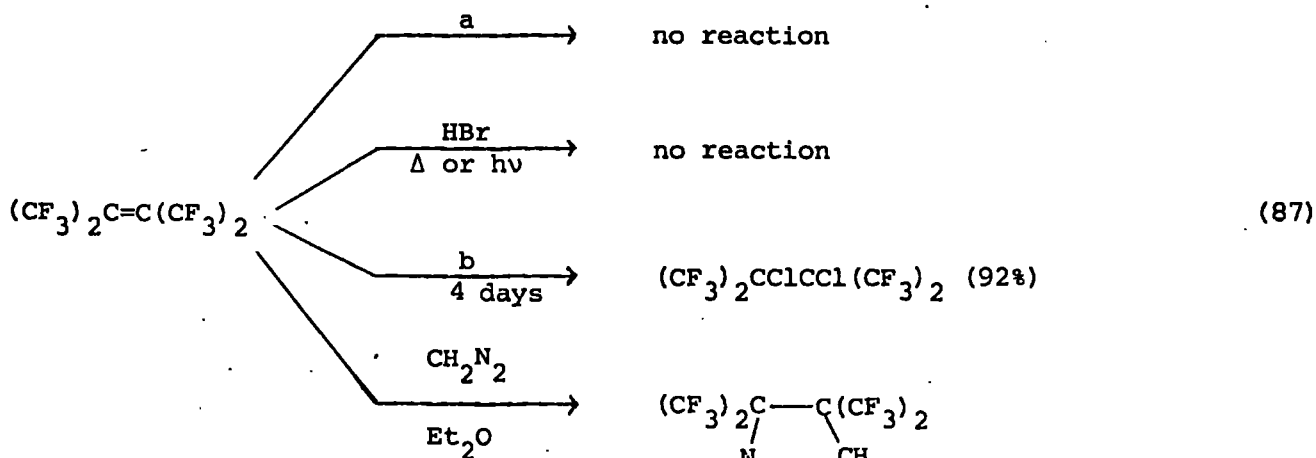
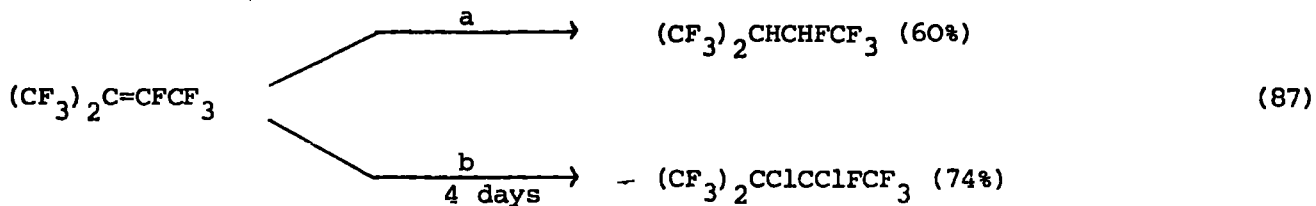
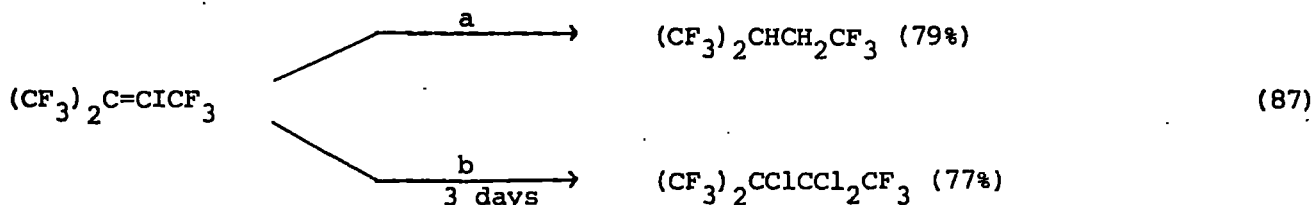
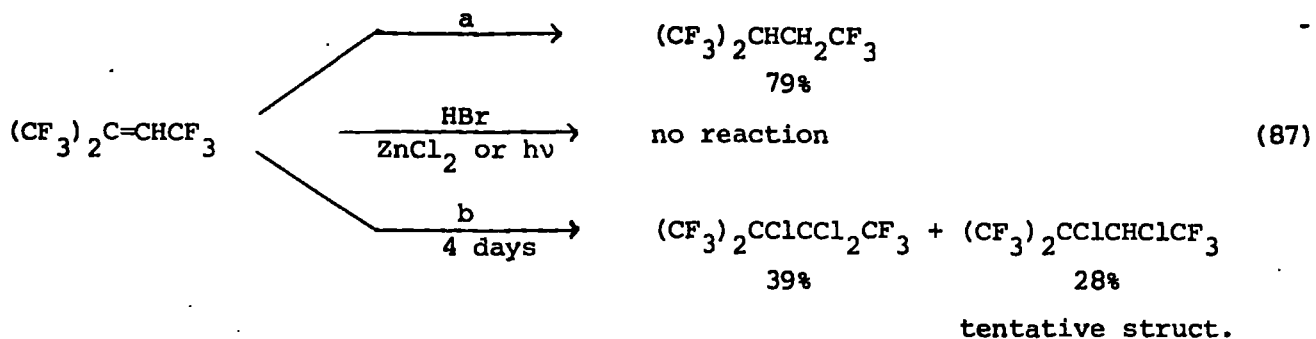

(102)

Table 18 continued

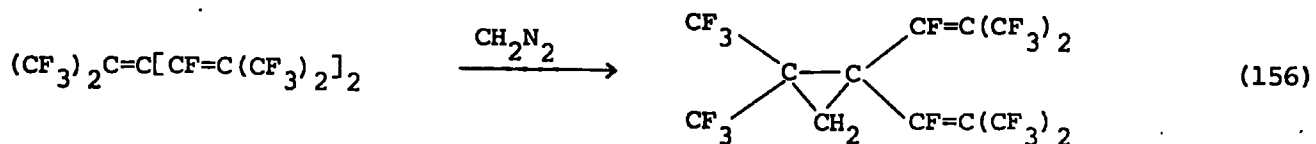
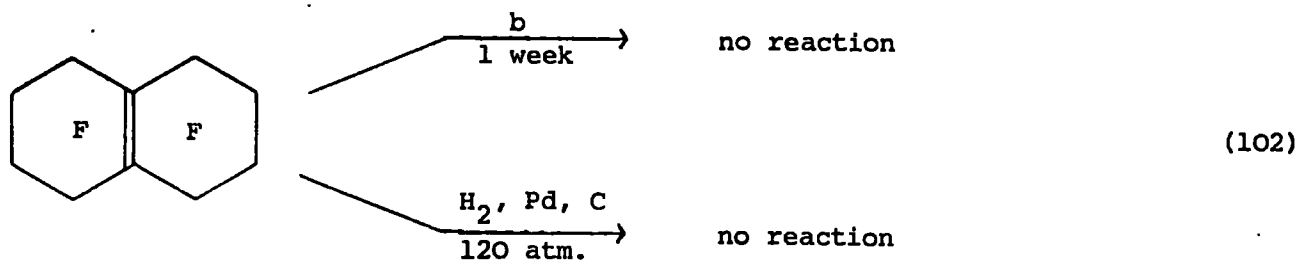

Addition Reactions of F-hexamethylbenzvalene

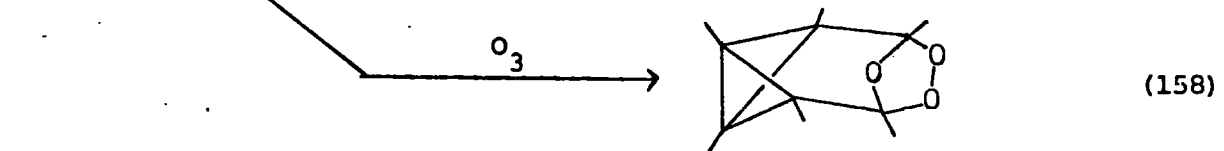
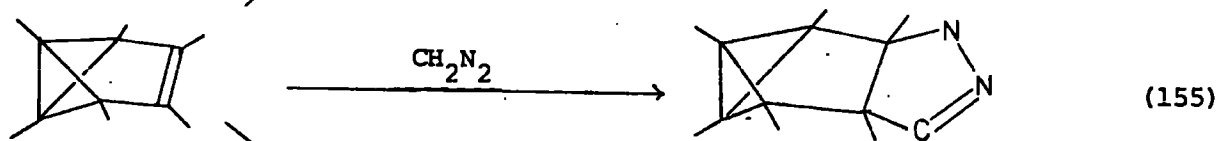
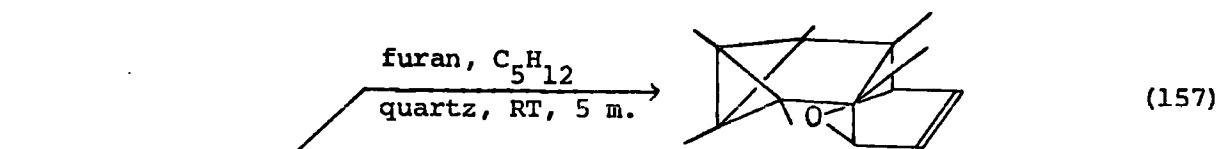

a = H<sub>2</sub>, Pd, Al<sub>2</sub>O<sub>3</sub>; b = Cl<sub>2</sub>, hv

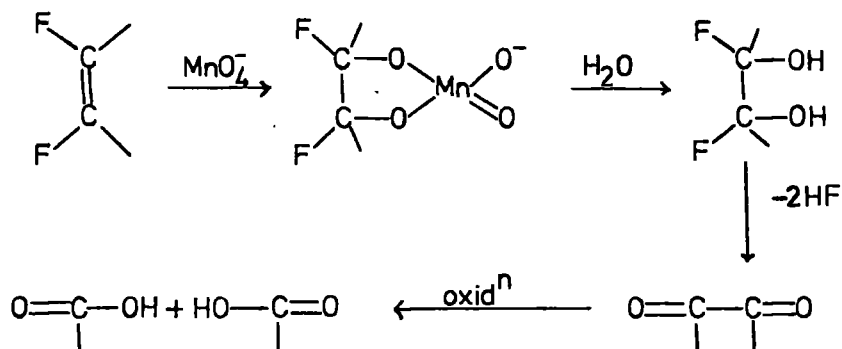

diols for F-tetraalkyl-olefins, whereas loss of HF and further oxidation will occur for olefins having vinylic fluorines. An example of each type is given below.

Acetone is normally used as solvent because the reactions are much faster than in water. Olefin solubility and permanganate solvation are the probable reasons for this.<sup>159</sup>

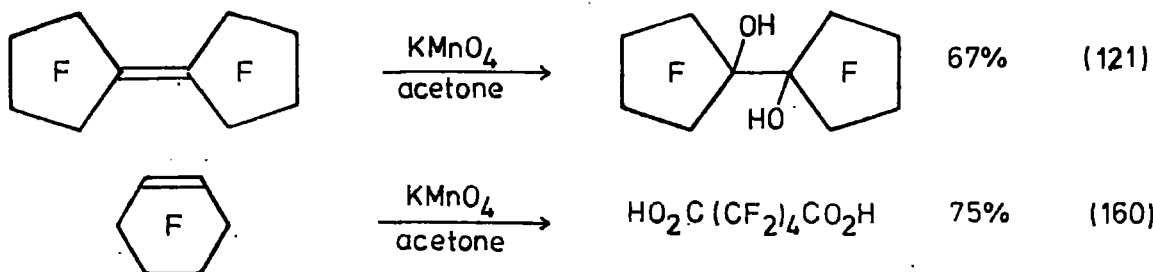

### II.D.2 Fluorination

The effect of increased substitution on the fluorination of F-olefins is demonstrated by the conditions required for direct fluorination of F-propene and its oligomers (Table 19). The order of reactivity is F-propene  $\gg$  dimers  $>$  trimers  $>$  tetramer.<sup>161</sup> The initial reaction is addition of F $\cdot$  giving a radical, which can then react further by a

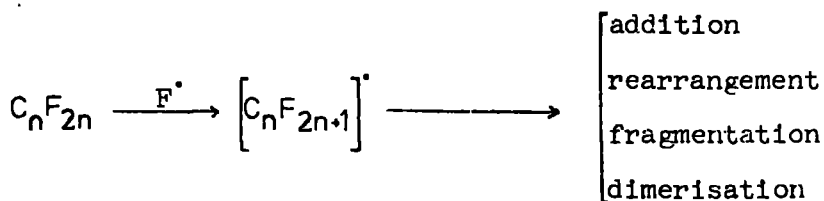
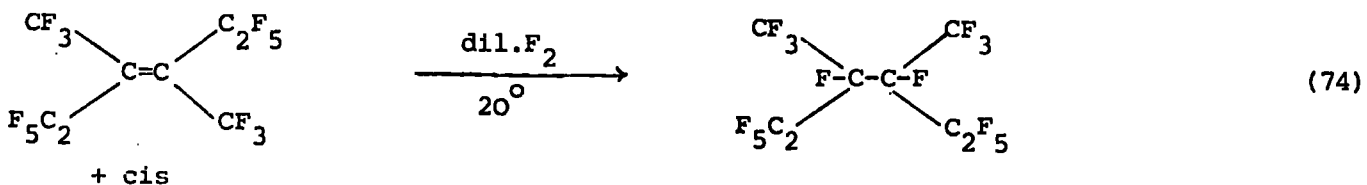
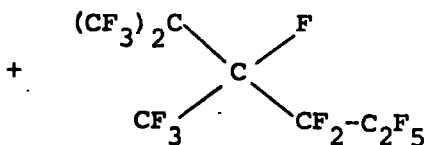
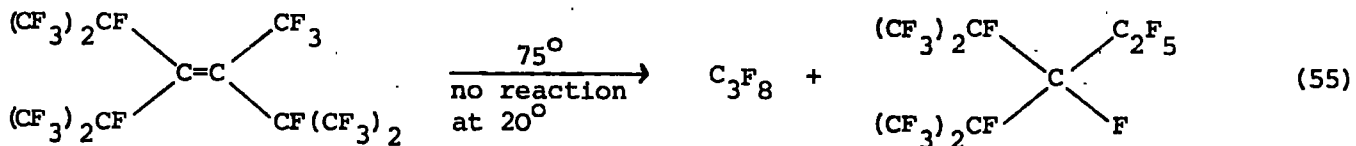
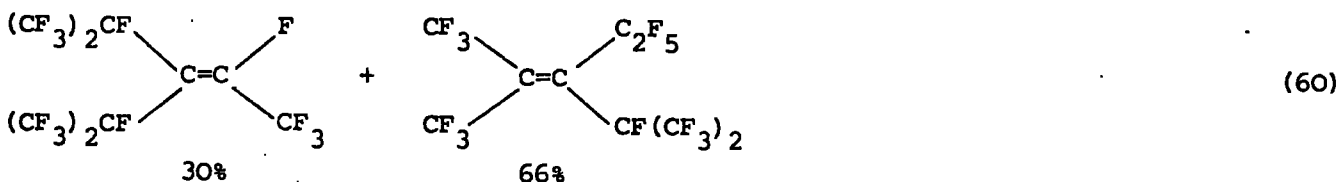
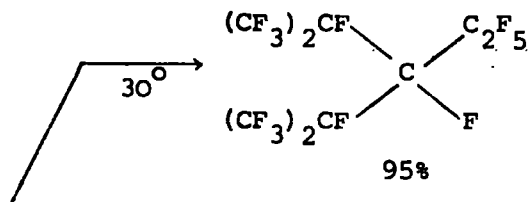
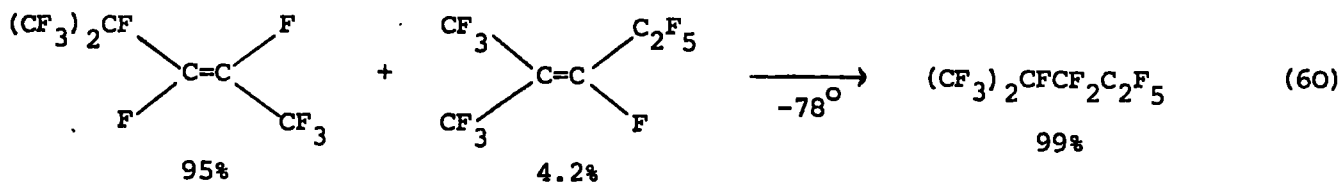

Table 19

Fluorination of F-Olefins<sup>a</sup>



a, using undiluted F<sub>2</sub> unless stated; b, no conditions given.

number of routes depending on the conditions used.<sup>161</sup> Simple addition is favoured by high concentrations of F<sub>2</sub> at low temperatures, fragmentation and rearrangement by higher temperatures than required for fluorination to occur, and dimerisation by low temperatures and a low F<sub>2</sub> concentration.

For example F-propene trimers undergo addition without rearrangement at 30° (Table 19), but at 100° a rearrangement of the intermediate radical occurs (eq.II.17) accompanied by some fragmentation.<sup>60</sup> F-propene tetramer

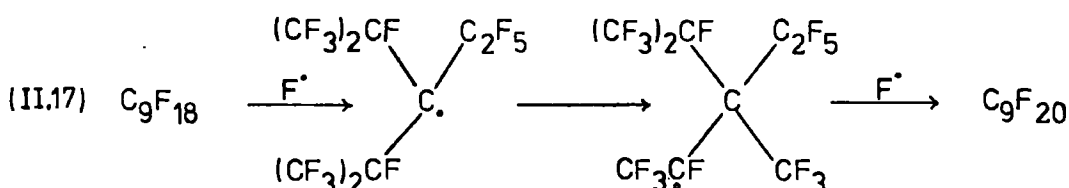

is only fluorinated above room temperature and gives low yields of C<sub>9</sub>F<sub>20</sub> alkanes via fragmentation reactions<sup>55</sup> (Table 19).

Dimerisation (eq.II.18) can occur very readily when the intermediate radical and olefin are not too sterically hindered. Thus F-propene dimers, using diluted F<sub>2</sub> at -50°, give decanes formula C<sub>12</sub>F<sub>26</sub>.<sup>161</sup> Similarly F-2-butene produces C<sub>8</sub>F<sub>18</sub> (Table 1) and F-cyclobutene is also found to dimerise<sup>162</sup> (eq.II.19).

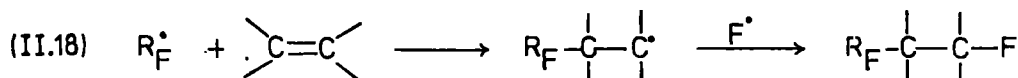

### II.E Photochemically Induced Isomerisation

Examples of photochemically induced isomerisations of F-olefins are given in Table 20. In all cases the products arise from 1,3-allylic shifts of fluorine or F-alkyl groups.<sup>82</sup> For substituted ethylenes the

Table 20<sup>a</sup>

Photochemically<sup>b</sup> Induced Isomerisations of F-Olefins 82,163

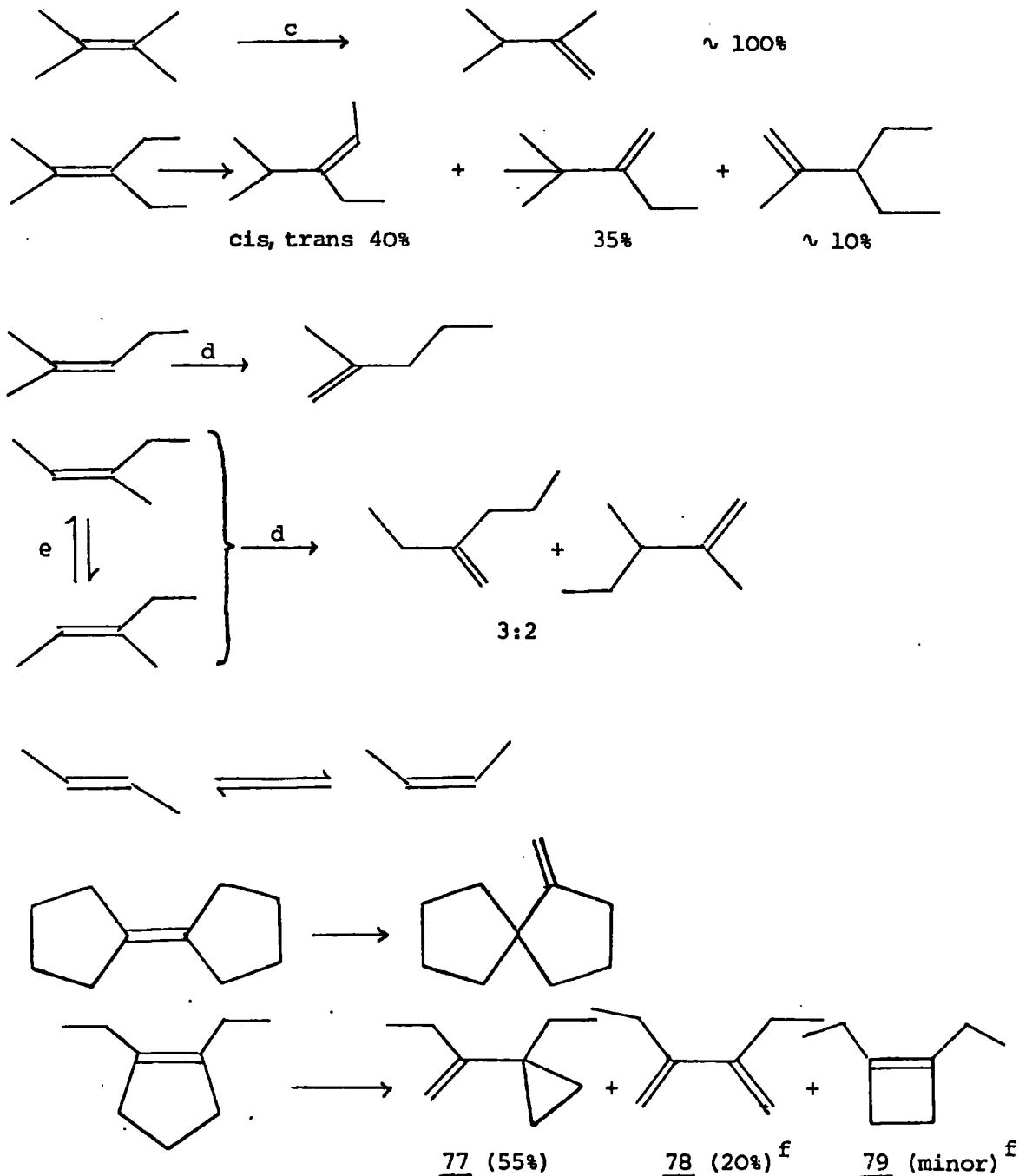

a, for clarity compounds are represented schematically, all are fully fluorinated.

b, liquid phase, medium pressure lamp, no filter, silica tubes.

c, 7 days.

d, prolonged irradiation.

e, mild conditions.

f, ambient temp.  $\sim 100^\circ$ , 78 and 79 probably result from thermolysis of 77 because 77  $\xrightarrow{320^\circ}$  78 (54%) + 79 (44%).

ease of rearrangement is in the order F-tetraalkyl > F-trialkyl > F-dialkyl.<sup>163</sup>

In fact, F-2-butene only undergoes cis-trans isomerisation using conditions which induce rearrangements in the more substituted olefins. F-trialkylethylenes also undergo cis-trans interconversion using milder conditions.<sup>163</sup>

### II.F Thermolysis

There are numerous reports of thermolytic reactions of fluorocarbons, but relatively few concern unsaturated compounds. Some examples are shown below, illustrating three processes. These are:- 1) Loss of fragments containing carbon, using an inert surface (e.g. Pt or SiO<sub>2</sub>); 2) Double bond migration, or 3) Defluorination using a reactive metal surface, such as iron or zinc, metals which readily form fluorides.

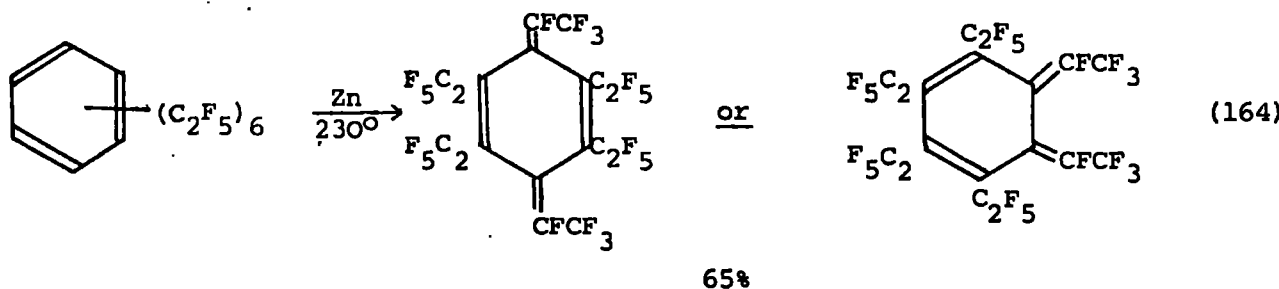
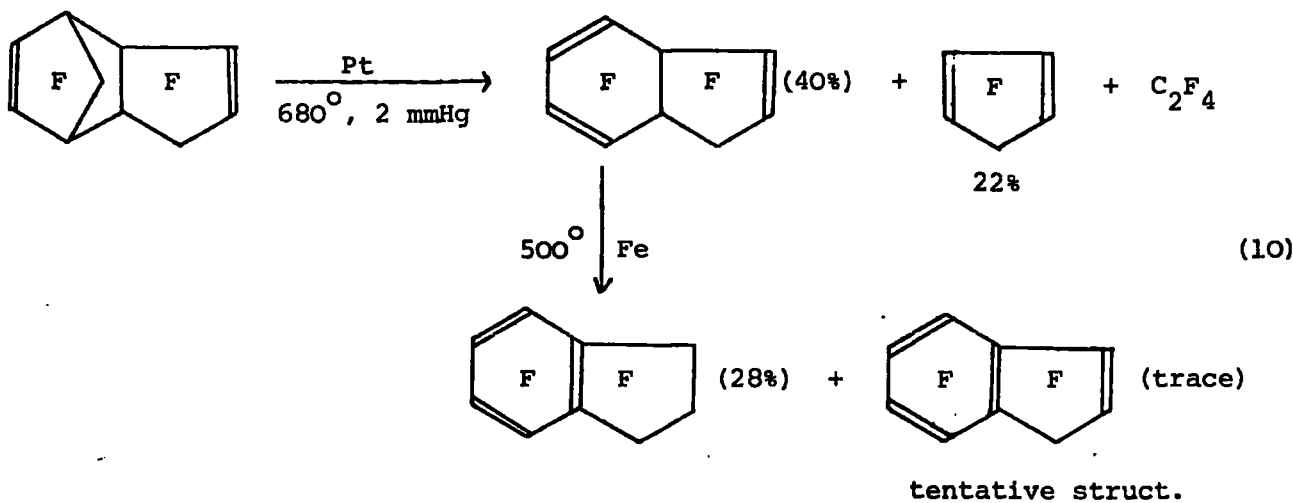

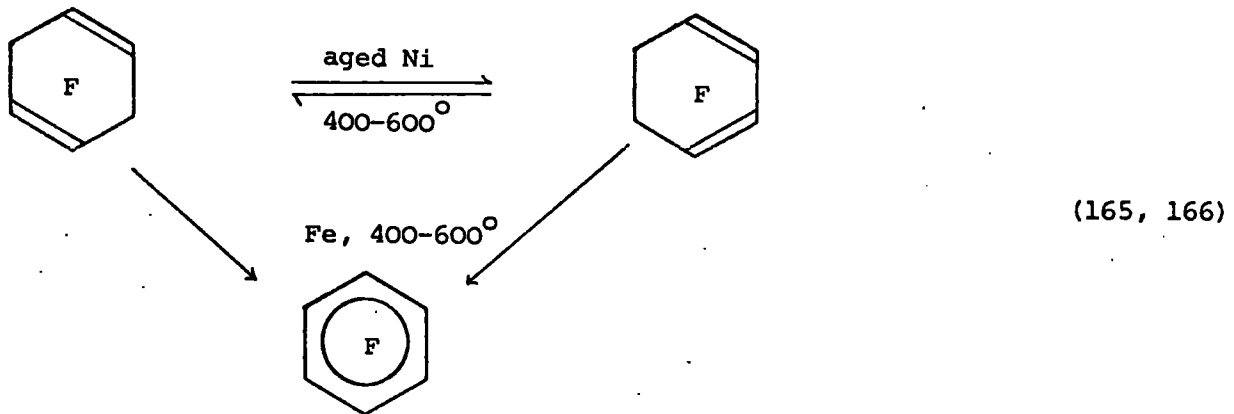
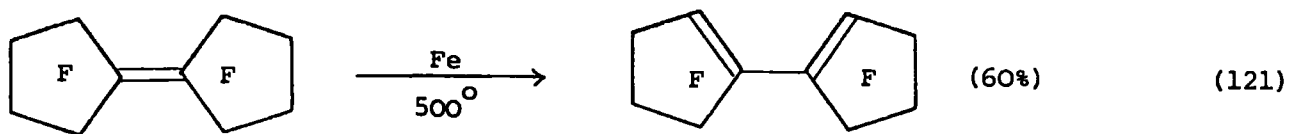
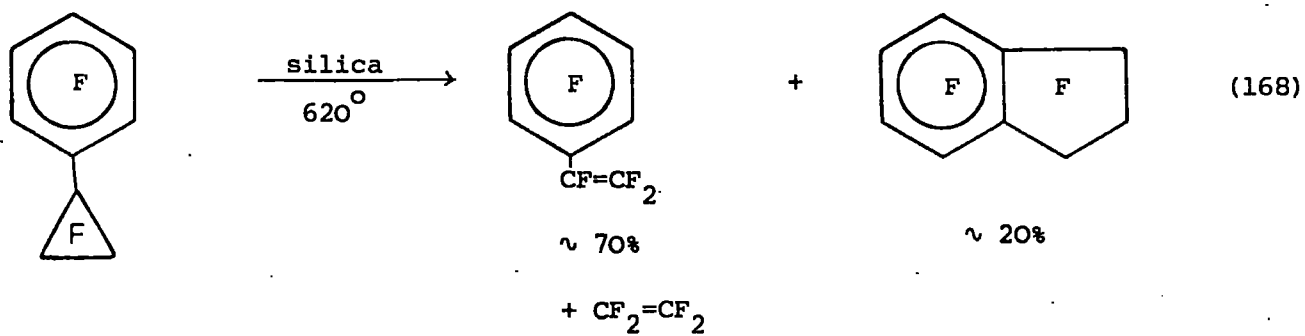
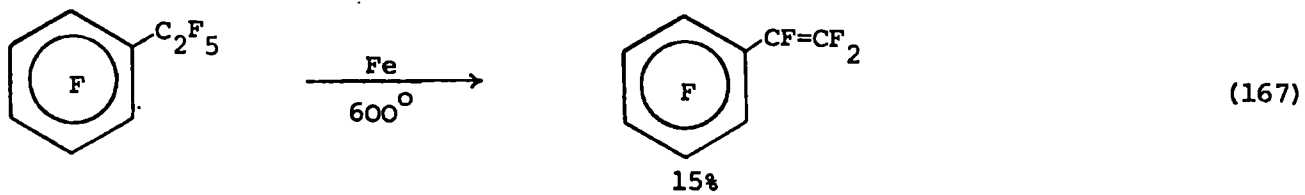

DISCUSSION

CHAPTER III

Oligomers from Chlorotrifluoroethylene and F-2-butene

The major part of this chapter describes the formation of oligomers from chlorotrifluoroethylene and F-2-butene. This work is a continuation of a previous investigation carried out in this laboratory.<sup>75,169</sup> These processes have also been studied elsewhere<sup>51,76</sup> (see chapter I). Some similar reactions of F-propene are also described.

III.A Oligomers from Chlorotrifluoroethylene

It is well established that  $CF_3\bar{C}FCl$  can be generated from chlorotrifluoroethylene and fluoride ion. This is demonstrated by the fluoride ion induced reactions of chlorotrifluoroethylene with cyanuric fluoride<sup>170</sup> (eq.III.1) and with F-pyridine<sup>171</sup> (eq.III.2).

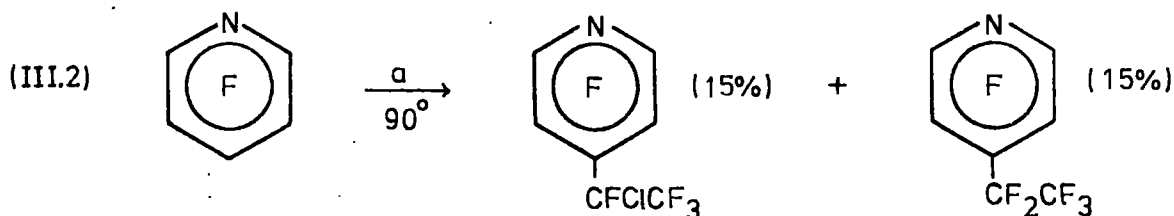
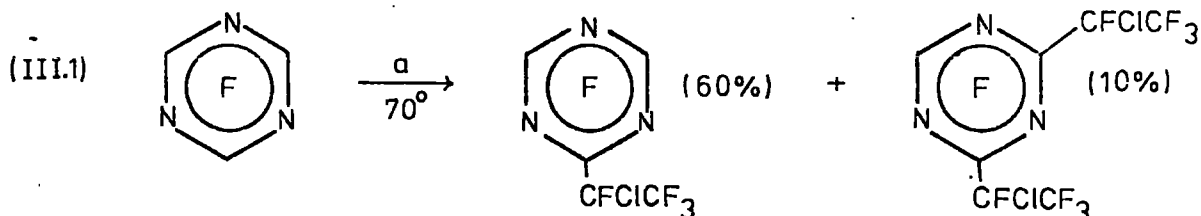

a =  $CF_2CFCl$ , CsF, and sulpholane

Since  $CF_3\bar{C}FCl$  (80) is formed it is to be expected that reaction of (80) with  $CF_2CFCl$  should also occur. Previously in this laboratory it has been found that oligomers of  $CF_2CFCl$  are, in fact, formed by heating with CsF and tetraglyme in a Ni tube<sup>169</sup> (see Table 22). The oligomers

were not separated and were identified by g.l.c.-ms. None contain chlorine and extra degrees of unsaturation are introduced. These features could have been a result of dehalogenation at the Ni surface. Further investigation was therefore necessary to try to establish the structures and mechanism of formation of the various oligomers, and also the dehalogenation mechanism.

Table 22

Yields (%) of Oligomers from Chlorotrifluoroethylene<sup>a</sup>

<u>Temp. °C</u>	<u>C<sub>8</sub>F<sub>16</sub></u>	<u>C<sub>10</sub>F<sub>18</sub></u>	<u>C<sub>12</sub>F<sub>20</sub></u>	<u>C<sub>12</sub>F<sub>22</sub></u>	<u>&gt;C<sub>12</sub>F<sub>22</sub></u>
25 <sup>b</sup>	3	16	-	19	ca.30
56 <sup>c</sup>	10	16	2	4	15
140 <sup>c</sup>	18	11	2	3	5

a, all using CsF and tetraglyme

b, in glass at <1 atmos. press. (VIII.A.1.a)

c, Using Ni tube under autogenous pressure.<sup>169</sup>

Chlorotrifluoroethylene will oligomerise at room temperature and <1 atmos. pressure forming CF<sub>3</sub>CFCl<sub>2</sub>, as well as the same oligomers produced by the Ni tube reactions. The results are summarised in Table 22.

The important features of these reactions are:

- (i) the oligomers contain no chlorine,
- (ii) above C<sub>8</sub> extra degrees of unsaturation are introduced,
- (iii) CF<sub>3</sub>CFCl<sub>2</sub> is formed, and
- (iv) the yield of C<sub>8</sub>F<sub>16</sub> (41) increases at higher reaction temperatures.

Although the oligomers given in Table 22 contain no chlorine, when CF<sub>2</sub>CFCl was allowed to react at room temperature for a much shorter time

(16h instead of 88h) then, after removal of  $\text{CF}_3\text{CFCl}_2$ , elemental analysis of the remaining volatile material showed the presence of chlorine. This volatile material contained the expected oligomers, together with a complex mixture of products less volatile than  $\text{C}_{12}\text{F}_{22}$ . As expected, after heating with fluoride the proportion of less volatile products was reduced and chlorine was absent.

Samples of  $\text{CF}_3\text{CFCl}_2$ ,  $\text{C}_{10}\text{F}_{18}$  (81), and  $\text{C}_{12}\text{F}_{22}$  (82) were separated by preparative scale g.l.c.,  $\text{CF}_3\text{CFCl}_2$  being identified by its  $^{19}\text{F}$  n.m.r. spectrum.<sup>172</sup> Compound  $\text{C}_8\text{F}_{16}$  (41), an approx. 50:50 mixture of cis, trans isomers, was identified in the product obtained from oligomerisation of  $\text{CF}_2\text{CFCl}$  at  $120^\circ$  by comparison of the  $^{19}\text{F}$  n.m.r. spectrum with that of an authentic sample of (41). The structures of  $\text{C}_{10}\text{F}_{18}$  (81), and  $\text{C}_{12}\text{F}_{22}$  (82), both mixtures of geometric isomers unresolvable by g.l.c., follow mainly from their  $^{19}\text{F}$  n.m.r. spectra. A full discussion of their structural derivations is given later.

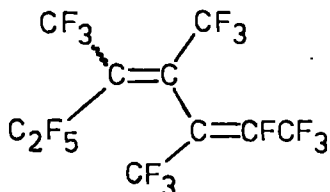
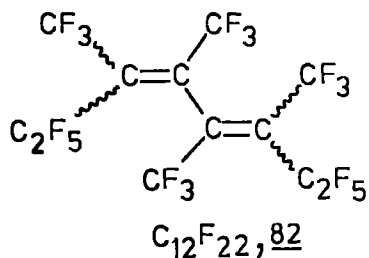
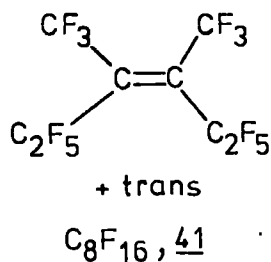

+

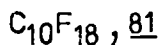
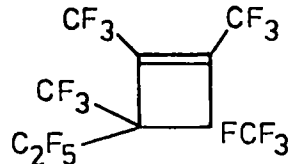

III.A.1 Formation of F-3,4-dimethyl-3-hexene

A mechanism, accounting for the formation of  $C_8F_{16}$  (41), is given in Scheme 27 and it is very similar to the mechanism (Scheme 11) suggested for oligomerisation of F-ethylene.

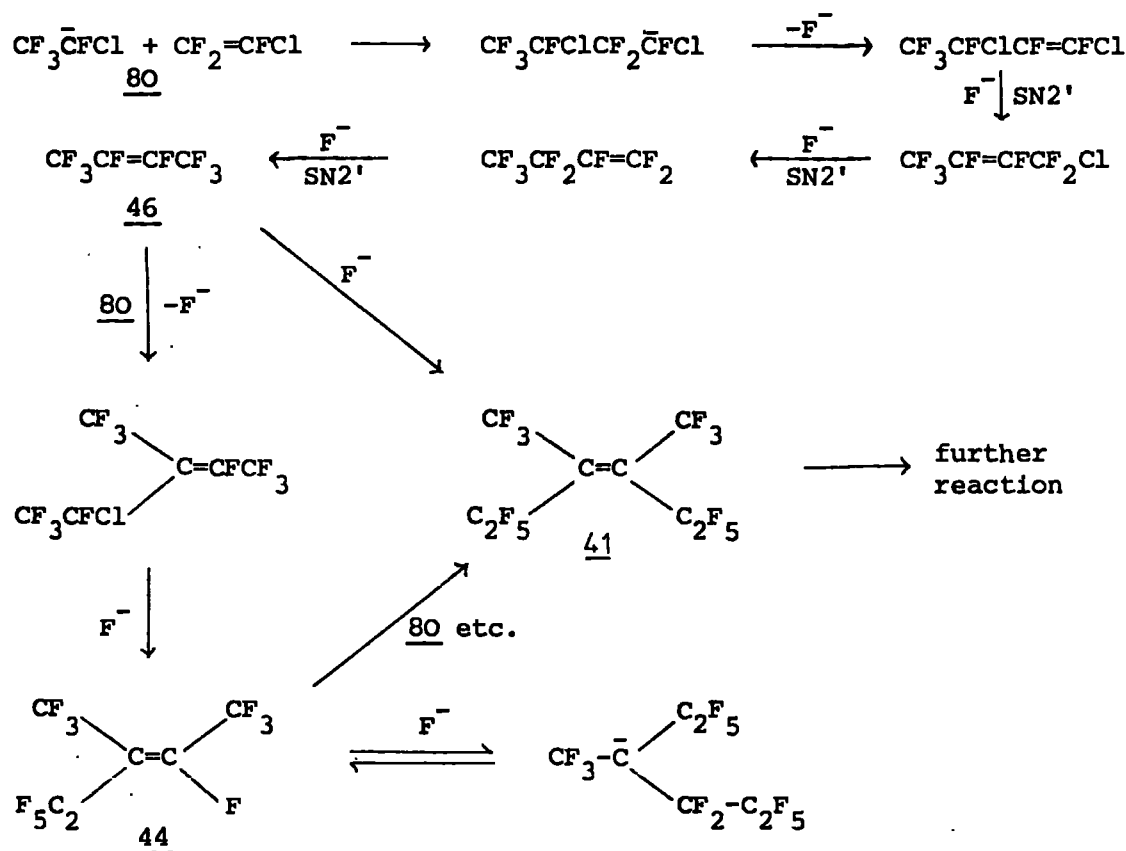

Scheme 27

For  $\text{CF}_2\text{CFCl}$ , however, replacement of chlorine by fluorine is required and this almost certainly occurs via  $\text{SN2}'$  processes, since these are known to occur very readily<sup>23,28</sup> (eq.III.3).

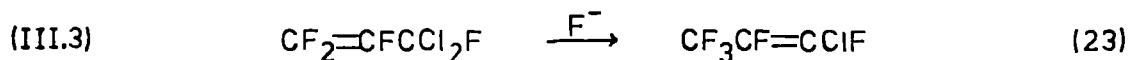

Once F-2-butene has been formed, further reaction can occur via two routes:- 1) fluoride ion induced dimerisation of F-2-butene giving  $C_8F_{16}$  (41) (eq.III.4) (to be discussed later); and 2) reaction of F-2-butene with  $\text{CF}_2\text{CFCl}$ , leading to  $C_6F_{12}$  (44) and  $C_8F_{16}$  (41).

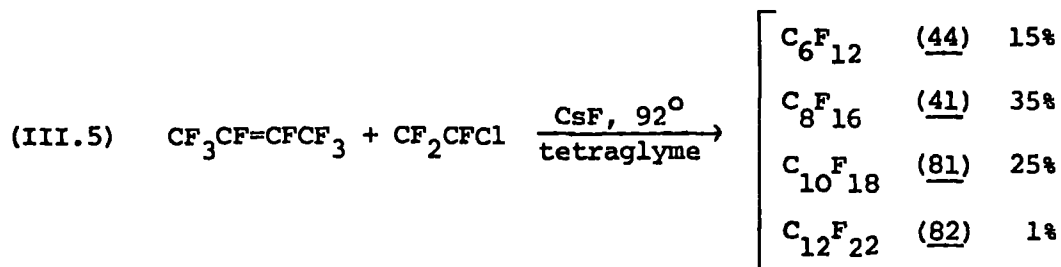
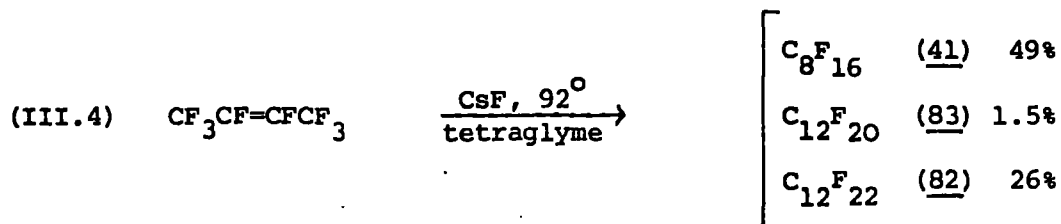

In fact, the reaction between F-2-butene and  $CF_2CFCl$  (eq.III.5) gives the same products as  $CF_2CFCl$  alone except that a significant amount of  $C_6F_{12}$  (44) is formed (also produced from F-2-butene and  $CF_2CCl_2$  - see section I.D.5).

Compound  $C_6F_{12}$  (44) readily forms an anion with fluoride and this may react with F-2-butene producing  $C_{10}F_{20}$  (40) during the oligomerisation of F-ethylene (see Scheme 11 and Section I.D.3.c). However, no  $C_{10}F_{20}$  (40) was detected in the product from F-2-butene and  $CF_2CFCl$  (eq.III.5).

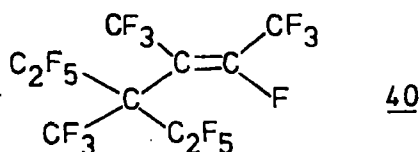

The increased yield of  $C_8F_{16}$  (41) at higher reaction temperatures can now be explained. Dimerisation of F-2-butene (46) is a slow process at room temperature, and most of the  $C_8F_{16}$  formed reacts further. At higher temperatures  $C_8F_{16}$  is produced more quickly than it reacts, as a result of the much faster dimerisation of (46), and it therefore accumulates.

III.A.2 Formation of Higher Oligomers

The reaction of  $\text{CF}_2\text{CFCl}$  with  $\text{C}_8\text{F}_{16}$  (41) occurs very readily and good yields of higher oligomers are obtained (eq.III.6). In addition the reaction gives a high yield of  $\text{CF}_3\text{CFCl}_2$ , which roughly corresponds to the extra degrees of unsaturation introduced into the higher oligomers.

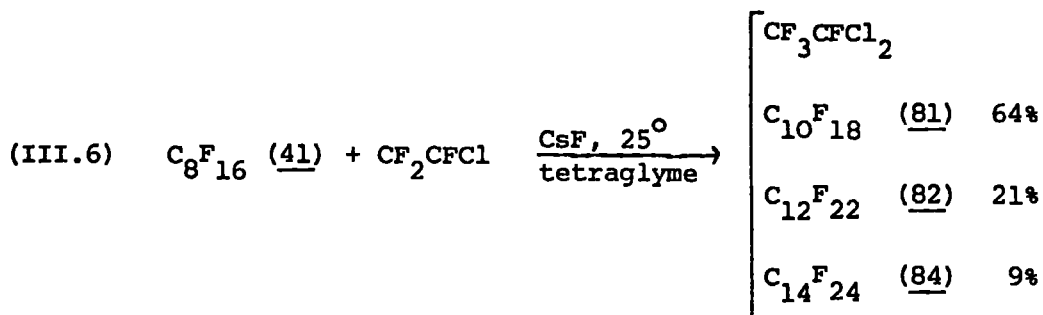

A mechanism accounting for the production of  $\text{CF}_3\text{CFCl}_2$  and the introduction of an extra degree of unsaturation is shown in Scheme 28 for the formation of  $\text{C}_{10}\text{F}_{18}$  (81). Nucleophilic attack on chlorine

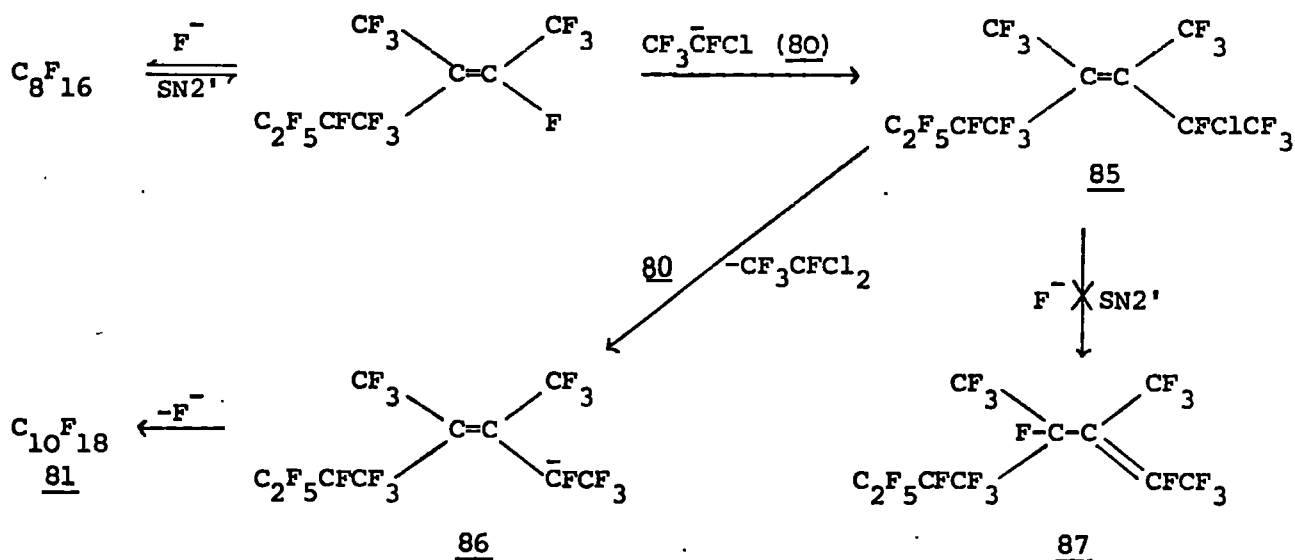

Scheme 28

in (85) will produce  $\text{CF}_3\text{CFCl}_2$  and carbanion (86), which is an allylic system. The  $\text{SN2}'$  displacement of chloride by fluoride in (85) is probably slow as a result of steric crowding, but the alternative nucleophilic attack on chlorine must occur very readily in order to inhibit

the formation of (87). This is not unreasonable because there are other examples of similar attacks on halogen.<sup>173</sup>

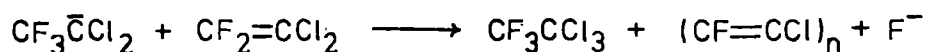
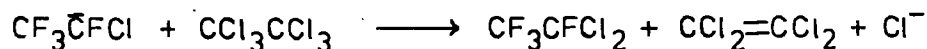

A sample of  $\text{C}_{14}\text{F}_{24}$  (84) was isolated, as a mixture of isomers, from the reaction of  $\text{C}_8\text{F}_{16}$  (41) with  $\text{CF}_2\text{CFCl}$ . The assignment of structure (84) to  $\text{C}_{14}\text{F}_{24}$  is discussed later.

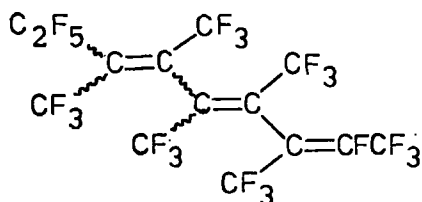

$\text{C}_{14}\text{F}_{24}$ , 84

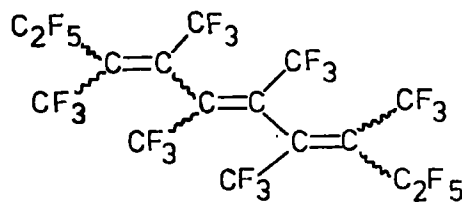

$\text{C}_{16}\text{F}_{28}$ , 88

The reaction between  $\text{C}_{10}\text{F}_{18}$  (81) and  $\text{CF}_2\text{CFCl}$  gives mainly  $\text{C}_{12}\text{F}_{22}$  (82) and  $\text{C}_{16}\text{F}_{28}$  (88) (eq.III.7). A sample of  $\text{C}_{16}\text{F}_{28}$  (88) was separated, again as a mixture of isomers (see later), but  $\text{C}_{18}\text{F}_{30}$  was only identified by g.l.c.-ms.

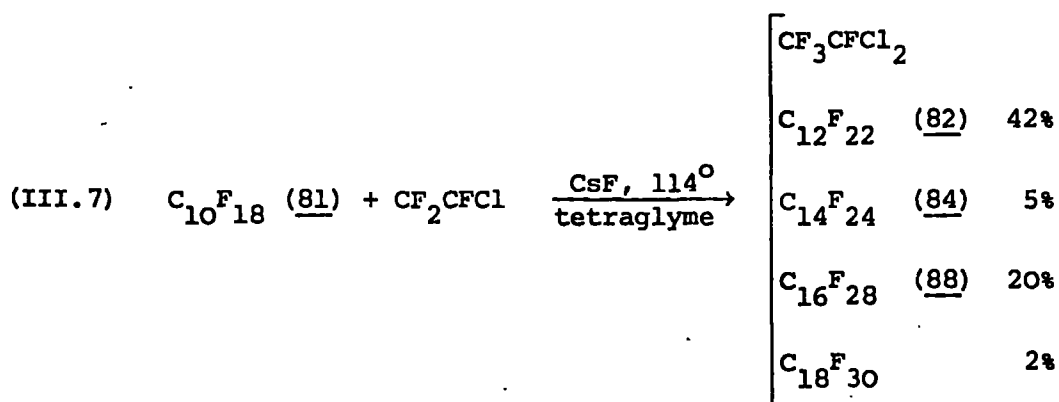

A mechanism, explaining the formation of oligomers above  $\text{C}_{10}\text{F}_{18}$ , is given in Scheme 29 and it uses the same processes proposed in Scheme 28 to account for the formation of  $\text{C}_{10}\text{F}_{18}$  (81).

Formation of Higher Oligomers

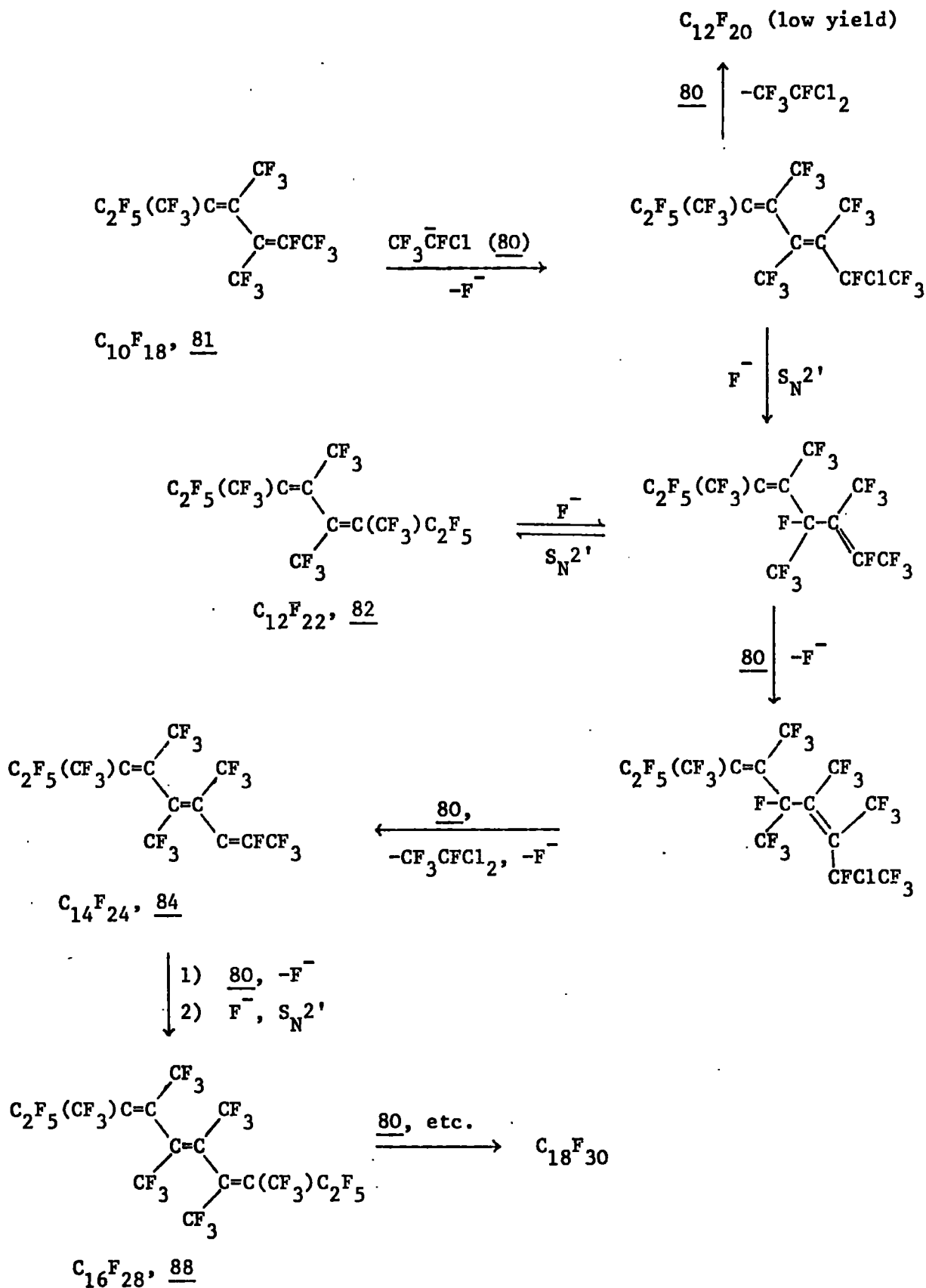

Scheme 29

### III.A.3 Structural Assignments

Structures were assigned to the oligomers by comparison of their  $^{19}\text{F}$  chemical shifts and  $\text{C}=\text{C}$  stretching frequencies and intensities with the data for some similar model compounds. The data for these two groups of compounds is contained in Table 23.

For the model compounds, it is clear that various types of  $\text{CF}_3$  groups can be distinguished by their  $^{19}\text{F}$  n.m.r. shifts:- (unmarked bonds to carbon)  $\text{CF}_3\text{C}=\text{}$  and  $\text{CF}_3\text{C}$  ( $^{19}\text{F}$  S 65 p.p.m. rel. to  $\text{CFCl}_3$ ),  $\text{CF}_3\text{CF}=\text{}$  ( $\sim 67 - 71$ ), and  $\text{CF}_3\text{CF}_2$  ( $\sim 74 - 85$ ). Similarly  $\text{CF}_3\text{CF}_2\text{C}=\text{}$  or  $\text{CF}_3\text{CF}_2\text{C}$  ( $\sim 100 - 110$ ) and  $\text{CF}_3\text{CF}_2\text{CF}=\text{}$  ( $\sim 115$ ) may be distinguished from each other and from  $\text{CF}_3$  groups. The shifts of  $\text{CF}_3\text{CF}=\text{}$  are all in the range 98 - 105 p.p.m. except for  $\text{C}_{10}\text{F}_{20}$  (40) ( $\text{CF}_3\text{CF}=\text{}$ , 76), which is a crowded molecule. The  $\text{C}=\text{C}$  stretches are also a useful aid for distinguishing between  $\text{CF}_3\text{CF}=\text{}$  (normally  $1670 - 1710 \text{ cm}^{-1}$ , mw) and  $\text{CF}_3\text{C}=\text{}$  ( $1670 - 1650$ , w) for the model compounds.

The structures of  $\text{C}_{12}\text{F}_{22}$  (82),  $\text{C}_{14}\text{F}_{24}$  (84), and  $\text{C}_{16}\text{F}_{28}$  (88) then follow from a comparison of their  $^{19}\text{F}$  chemical shifts and  $\text{C}=\text{C}$  stretches with those of the model compounds, if each oligomer is produced in turn, i.e.  $\text{C}_8\text{F}_{16} \rightarrow \text{C}_{10}\text{F}_{18} \rightarrow \text{C}_{12}\text{F}_{22} \rightarrow \text{C}_{14}\text{F}_{24} \rightarrow \text{C}_{16}\text{F}_{28}$ . Although the  $^{19}\text{F}$  chemical shifts for  $\text{C}_{12}\text{F}_{22}$  (82) do not distinguish between acyclic diene (82a) and cyclobutene (82b), the  $\text{C}=\text{C}$  stretch indicates that only diene (82a) is present. Thus the weak  $\text{C}=\text{C}$  str. at  $1630 \text{ cm}^{-1}$  in the i.r. spectrum is consistent with diene (82a) and the Raman spectrum does not show a  $\text{C}=\text{C}$  str. between  $1700$  and  $1720 \text{ cm}^{-1}$  as would be expected for (82b) from the  $\text{C}=\text{C}$  str. of a comparable cyclobutene ( $1720 \text{ cm}^{-1}$ ) (see Table 23).

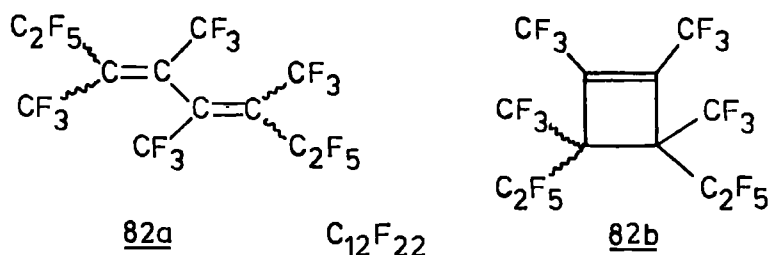

$\text{C}_{10}\text{F}_{18}$  (81) is more complex because its  $^{19}\text{F}$  n.m.r. spectrum can only be explained adequately if another structural isomer, besides acyclic diene (81a), is present. Thus the spectrum contains additional signals at 75.8 ( $\text{CF}_3\text{CF}$ ) and ca. 163 p.p.m. ( $\text{FC}$ ). These signals could arise from cyclobutene (81b) since similar chemical shifts were found for a comparable system (see Table 23). It is not unreasonable that the other fluorines of (81b) give rise to absorptions in the same regions as the acyclic diene (81a). If this interpretation of the n.m.r. spectrum is correct then from the integration the ratio of cyclobutene (81b) to acyclic diene (81a) is ca. 30 : 70.

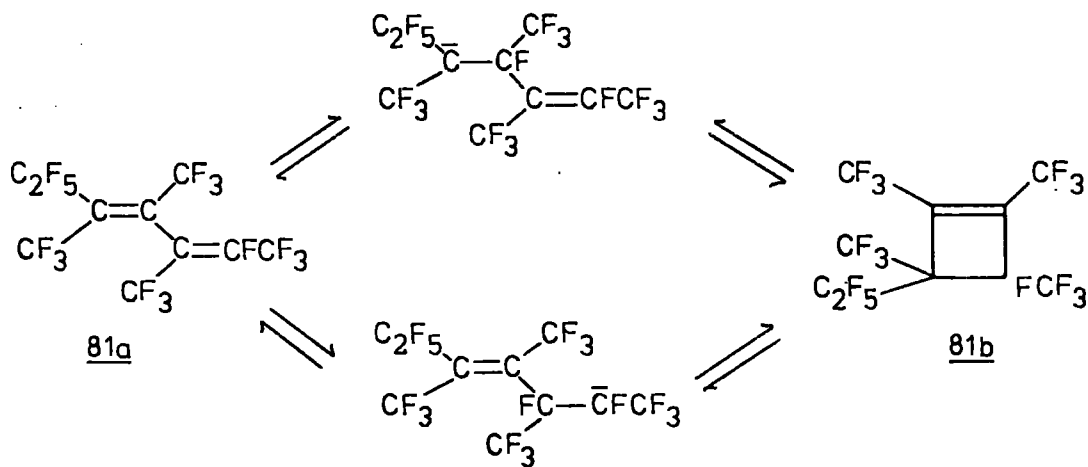

Scheme 30

Cyclobutene (81b) could be formed by a fluoride ion induced cyclisation of diene (81a), via two intermediate carbanions (Scheme 30). An analogous cyclisation for  $\text{C}_{12}\text{F}_{22}$  (82) is less likely.

Table 23

 $^{19}\text{F}$  Chemical Shifts (rel. to  $\text{CFCl}_3$ ) and C-C str. Frequencies

Model Compounds	$^{19}\text{F}$ $\delta$	Assignment <sup>†</sup>	C-C str. ( $\text{cm}^{-1}$ )
$\text{C}(\text{CF}_3)_4$	63.7	$\text{CF}_3\text{C}$	(174)
$(\text{CF}_3)_2\text{C}=\text{C}(\text{CF}_3)_2$	61	$\text{CF}_3\text{C}=\text{C}$	1670 (Raman) (87)
	58.8a 60.3b,c	$\text{CF}_3\text{C}=\text{C}$	1653 (87)
	59.7	$\text{CF}_3\text{C}=\text{C}$	1653 (175)
	58.0a 74.5b 99.8c	$\text{CF}_3\text{C}=\text{C}$ $\text{CF}_3\text{CF}_2$ $\text{CF}_3\text{CF}_2\text{C}=\text{C}$	1650v
41			
	57.7a 74.5b 99.8c	$\text{CF}_3\text{C}=\text{C}$ $\text{CF}_3\text{CF}_2$ $\text{CF}_3\text{CF}_2\text{C}=\text{C}$	
$\text{C}_8\text{F}_{16}$ , 41			
	59.9a 61.3c 68.8b 98.8d	$\text{CF}_3\text{C}=\text{C}$ $\text{CF}_3\text{CF}=\text{C}$ $\text{CF}_3\text{CF}=\text{C}$	1704 (87)
	57.2a 67.0b 84.6c 112.0d	$\text{CF}_3\text{C}=\text{C}$ $\text{CF}_3\text{CF}=\text{C}$ $\text{CF}_3\text{CF}_2$ $\text{CF}_3\text{CF}_2\text{C}=\text{C}$	1680ms
$\text{C}_6\text{F}_{12}$ , 44			
	58.5a 61.1b 84.2c 98.2e 116.9d	$\text{CF}_3\text{C}=\text{C}$ $\text{CF}_3\text{CF}_2$ $\text{CF}=\text{C}$ $\text{CF}_3\text{CF}_2\text{CF}=\text{C}$	(51)
	51.9b 56.9c 67.4a 75.9f 79.2d 105.8e	$\text{CF}_3\text{C}=\text{C}$ $\text{CF}_3\text{C}$ $\text{CF}_3\text{CF}=\text{C}$ $\text{CF}_3\text{CF}=\text{C}$ $\text{CF}_3\text{CF}_2$ $\text{CF}_3\text{CF}_2\text{C}$	1640m
$\text{C}_{10}\text{F}_{20}$ , 40			
	62.8a 70.9b 104.4c	$\text{CF}_3\text{C}=\text{C}$ $\text{CF}_3\text{CF}=\text{C}$ $\text{CF}_3\text{CF}=\text{C}$	1706w 1687m (176)
	66.5a 78.6b 171.4c		1720 (177)

Table 23 continued

CF<sub>2</sub>CFC1 Oligomers

Compound	<sup>19</sup> F δ	Assignment	C=C str. (cm. <sup>-1</sup> )
 <p>C<sub>12</sub>F<sub>22</sub>, <u>82</u></p>	57.6 ] 58.4 ] a, b 59.0 ] 81.0 ] 81.5 ] c 106.1 ] 108.3 ] d	CF <sub>3</sub> = CF <sub>3</sub> CF <sub>2</sub> CF <sub>3</sub> CF <sub>2</sub> C=	1630w
 <p>C<sub>16</sub>F<sub>28</sub>, <u>88</u></p>	57.8 ] 59.0 ] a, b, c 60.0 ] 61.3 ] 79.9 ] d 106.8 ] e	CF <sub>3</sub> C= CF <sub>3</sub> CF <sub>2</sub> CF <sub>3</sub> CF <sub>2</sub> C=	1640w
 <p>C<sub>14</sub>F<sub>24</sub>, <u>84</u></p>	59.0 ] a, b, c, d 61.2 ] 64.7 ] e 71.5 ] f 73.0 ] 80.6 ] h 81.7 ] 103.5 ] g, i 106.9 ]	CF <sub>3</sub> C= CF <sub>3</sub> CF= CF <sub>3</sub> CF <sub>2</sub> CF <sub>3</sub> CF= CF <sub>3</sub> CF <sub>2</sub> C=	1705mw 1635w
 <p>C<sub>10</sub>F<sub>18</sub>, <u>81a</u></p>	58.8 ] 59.9 ] a, b 61.3 ] 62.2 ] 65.5 ] c 72.1 ] d 80.9 ] f 82.6 ] 100.2 ] 104.8 ] e, g 107.7 ]	CF <sub>3</sub> C= CF <sub>3</sub> CF= CF <sub>3</sub> CF <sub>2</sub> CF <sub>3</sub> CF= CF <sub>3</sub> CF <sub>2</sub> C=	1710mw 1645w
<p>ratio 81a:81b ~ 70:30</p>			
 <p>C<sub>10</sub>F<sub>18</sub>, <u>81b</u></p>	75.8 ] h ~163 ] i	CF <sub>3</sub> CF FC	

III.B Oligomers from F-2-butene

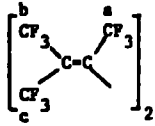
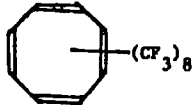
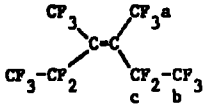
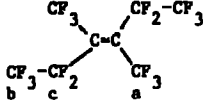
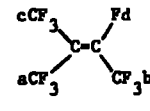
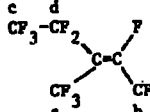
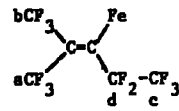
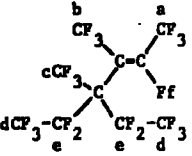
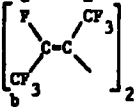
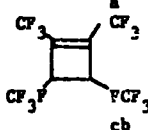
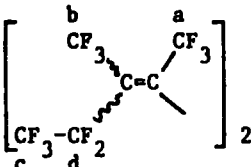
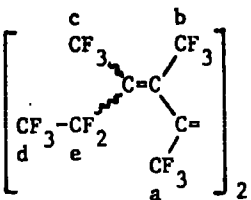
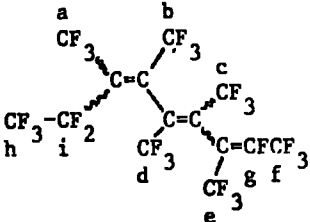
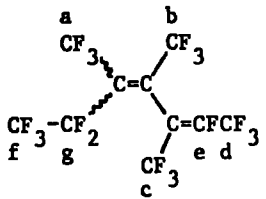
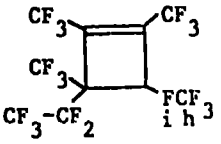
Previously in this laboratory, fluoride ion induced oligomerisations of F-2-butene have been carried out in Ni tubes, giving rise to defluorinated products<sup>169</sup> as well as the expected  $C_8F_{16}$  (41)<sup>51,75</sup> (eq.III.8). Defluorination also occurs using glass apparatus (eq.III.4), again forming  $C_{12}F_{22}$  (82). Compound  $C_{12}F_{22}$  (82) has also been isolated from a similar reaction, using DMF as solvent, but it was incorrectly identified as  $C_{12}F_{24}$ .<sup>76</sup>

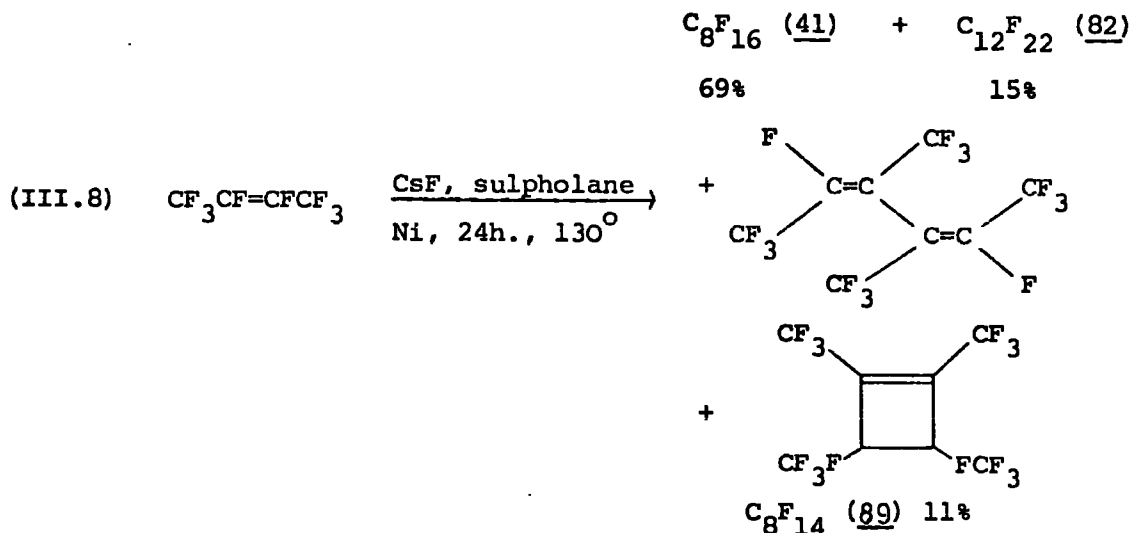

III.B.1 Defluorination Mechanism

A defluorination (eq.III.9) analogous to the dehalogenation (giving  $CF_3CFCl_2$ ) described earlier can be ruled out because no F-n-butane was detected in the products. The reaction of F-2-butene with  $CF_2CFCl$

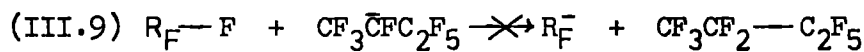

(eq.III.5) did not produce any  $CF_3CFCl_2$ , even though extra degrees of unsaturation are introduced into the oligomers, again indicating that another defluorination mechanism must operate.

There are two possibilities: 1) defluorination by CsF forming complex salts like  $CsF_3$ ; and 2) an electron transfer process (eq.III.10).

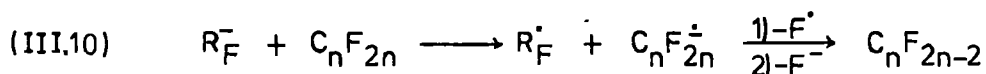

Defluorinations, in the presence of alkali metal fluorides (eq.III.11), have been observed by other workers<sup>178,179</sup> but no explanation was advanced. Caesium fluoride does, in fact, appear to enhance defluorination

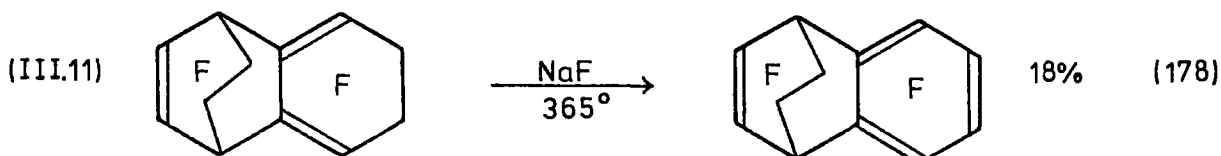

of  $C_8F_{16}$  (41) over iron, in the presence of tetraglyme.\* However, electron transfer processes cannot be ruled out as these are known to occur for F-carbanions (see Section II.A.3.b).

### III.B.2 Formation of Oligomers

Defluorination could occur for one or more of the following: F-2-butene,  $C_8F_{16}$  (41),  $C_{12}F_{24}$  (not isolated), and  $C_{12}F_{22}$  (82), but defluorination of F-2-butene seems the most likely.

Although F-2-butene, when heated with iron and tetraglyme, does not lose fluorine to give F-2-butyne, defluorination over CsF may well occur. The reaction of F-2-butene or its dimer  $C_8F_{16}$  (41) with any F-2-butyne thus formed would give the various oligomers with extra degrees of unsaturation (Scheme 31). This mechanism is supported by the results of the reactions between F-2-butene and F-2-butyne and between F-2-butene and  $C_8F_{14}$  (89) (a mixture of F-3,4-dimethyl-2,4-hexadiene and F-1,2,3,4-tetramethylcyclobutene). Both reactions give the same products as F-2-butene alone, but with increased proportions of  $C_{12}F_{22}$  (82) and  $C_{12}F_{20}$  (83), as would be expected (see Table 24).

---

\* (41) is also defluorinated over CsF at  $540^\circ$  (Chapter V).

TABLE 24

<u>Reaction</u> <sup>a</sup>	<u>Molar Ratios of Oligomers</u>		
	<u>C<sub>8</sub>F<sub>16</sub>(41)</u>	<u>C<sub>12</sub>F<sub>20</sub>(83)</u>	<u>C<sub>12</sub>F<sub>22</sub>(82)</u>
F-2-butene <sup>b</sup>	87	1	12
F-2-butene + C <sub>8</sub> F <sub>14</sub> (89) <sup>c</sup>	62	7	31
F-2-butene + F-2-butyne <sup>c</sup>	39	15	46

a, using CsF and tetraglyme.

b, at 92° and autogenous pressure (see III.4).

c, at room temperature and atmospheric pressure.

A sample of C<sub>12</sub>F<sub>20</sub> was isolated, from the reaction between F-2-butene and F-2-butyne, and assigned structure (83). This follows from a symmetrical <sup>19</sup>F n.m.r. spectrum, a weak C=C str. at 1650 cm<sup>-1</sup> (i.r.), and a u.v. absorption at 252 nm, which indicates a conjugated double bond system. Absorption is below 220 nm for the other dienes and trienes mentioned in this chapter.

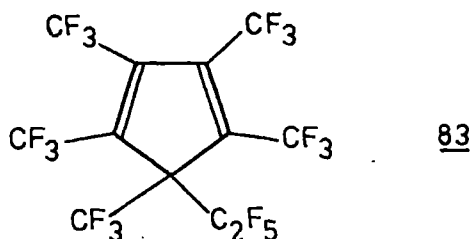

The reaction of the growing carbanion  $F(CF_3C=CCF_3)_n^-$ , produced from F-2-butyne and fluoride ion, also occurs with some polyfluoroaromatic compounds.<sup>180</sup> Further evidence for the participation of F-2-butyne in the F-butene oligomerisation is given below.

Oligomers from F-2-Butene

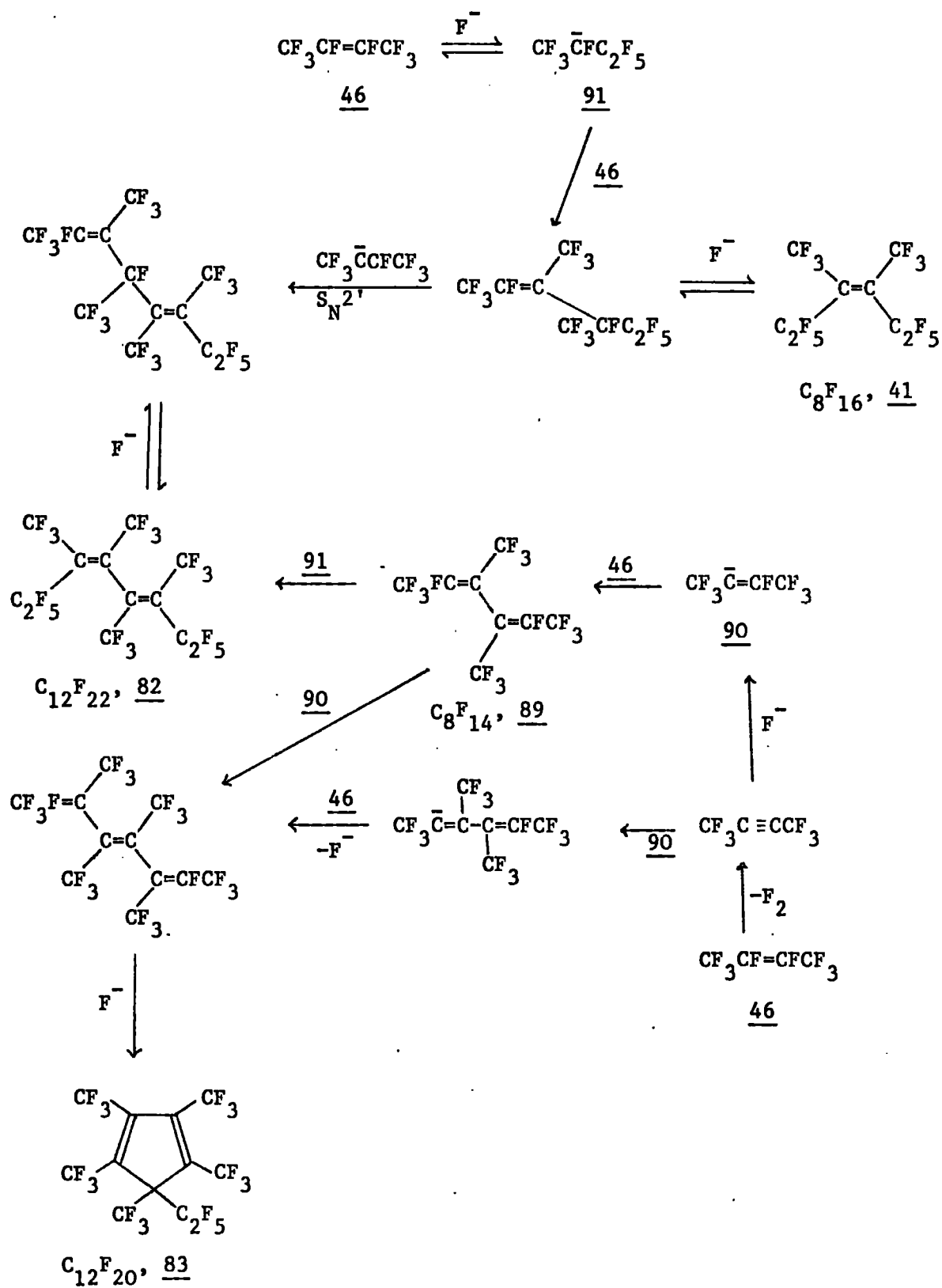

Scheme 31

III.B.3 Reaction of F-propene with F-3,4-dimethyl-3-hexene

It was hoped that the reaction of F-3,4-dimethyl-3-hexene (41) with F-propene would help to explain the oligomerisation of F-2-butene. Namely, is it reasonable that the F-2-butyl anion and C<sub>8</sub>F<sub>16</sub> (41b) could react to give C<sub>12</sub>F<sub>24</sub> which could then lose fluorine giving C<sub>12</sub>F<sub>22</sub> (82).

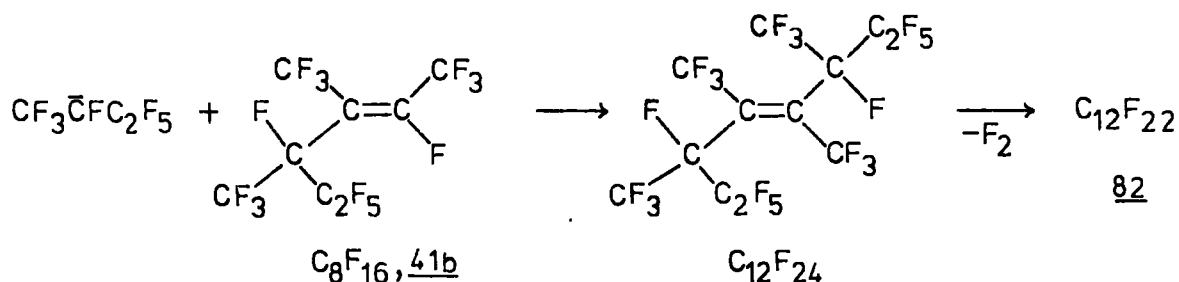

In fact, the only products obtained from an analogous reaction using F-propene were recovered starting material (C<sub>8</sub>F<sub>16</sub>), F-propene oligomers, and a low yield of F-2,3-dimethyl-2-pentene (92). This result therefore supports the proposed mechanism for F-2-butene oligomerisation involving F-2-butyne as intermediate.

Similarly a higher molecular weight product was not formed from C<sub>10</sub>F<sub>20</sub> (40) and F-propene. In this case, F-propene oligomers, C<sub>10</sub>F<sub>20</sub> (40), and C<sub>8</sub>F<sub>16</sub> (41) were obtained. The C<sub>8</sub>F<sub>16</sub> (41) is formed from C<sub>10</sub>F<sub>20</sub> (40) by loss of C<sub>2</sub>F<sub>5</sub><sup>-</sup> (see I.D.3.c.iii).

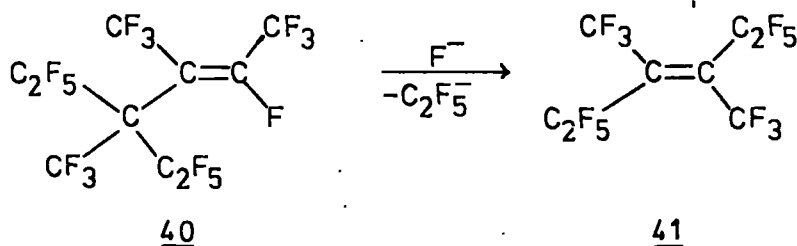

III.C Co-oligomers from F-propene

III.C.1 Using F-2-butene

The fluoride ion induced reaction of F-propene with F-2-butene occurs very readily giving F-2,3-dimethyl-2-pentene ( $C_7F_{14}$ , 92) (92% yield based on F-2-butene) and only low yields of F-propene oligomers. The structure of  $C_7F_{14}$  (92) was deduced from a comparison of its  $^{19}F$  n.m.r. spectrum and  $C=C$  stretch with those of  $C_8F_{16}$  (41). Compound  $C_7F_{14}$  (92) has previously been prepared in low yields from the same F-olefins<sup>51</sup> (see Table 10, Chapter 1).

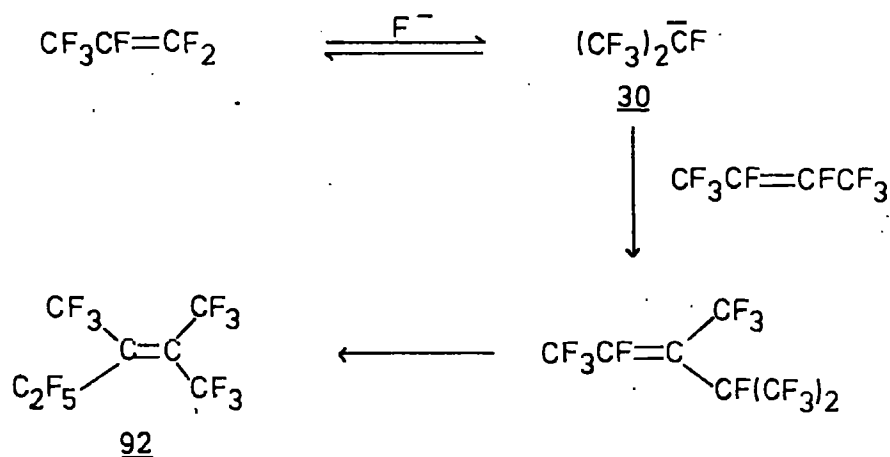

Scheme 32

The most likely mechanism for the formation of  $C_7F_{14}$  (92) (Scheme 32) involves the reaction of F-2-butene with the F-isopropyl anion (30). The preferential reaction of (30) with F-2-butene rather than F-propene (2) is probably a result of a low concentration of (2) and higher concentrations of anion (30) and F-2-butene in solution, since F-propene will more readily form an anion with fluoride ion.

III.C.2 Using F-ethylene

In contrast to the reaction described above, F-propene and F-ethylene gave only a low yield of a co-oligomer,  $C_{11}F_{22}$ , as well as F-propene oligomers. A sample of  $C_{11}F_{22}$  was separated by preparative scale g.l.c. and its spectral data is consistent with structure (93). Compound (93) and F-propene tetramer (37) (see I.D.2.c.) could both be formed from F-propene trimer (33). The  $^{19}F$  chemical shifts of  $C_{11}F_{22}$ (93) and  $C_{12}F_{24}$ (37) are compared below. The more complex spectrum of  $C_{11}F_{22}$ (93) could arise from rotational isomers even though the spectrum is unchanged between  $40^\circ$  and  $190^\circ$ .

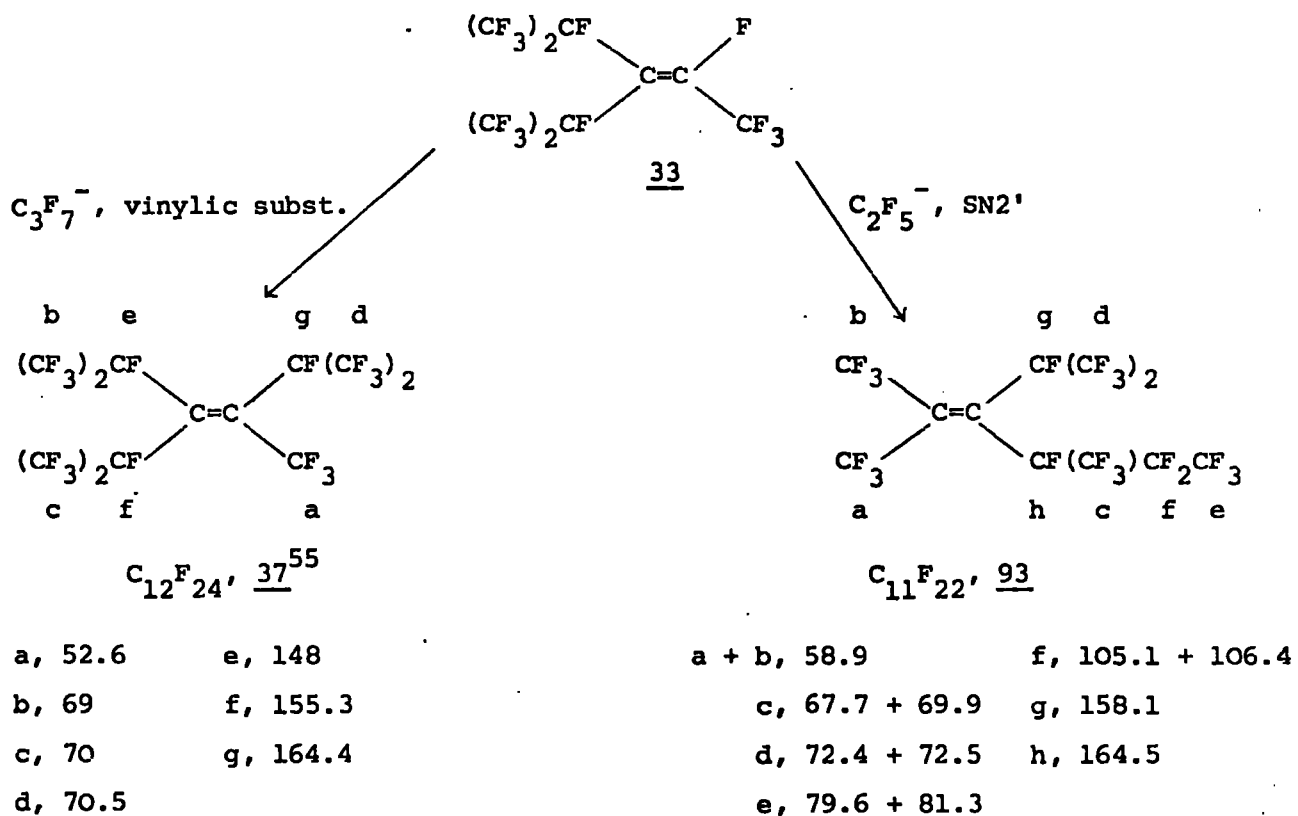

CHAPTER IV

Reactions of F-3,4-dimethyl-3-hexene with Nucleophiles

Introduction

Some reactions of olefin (41) with O- and N-nucleophiles, phenylmagnesium bromide, and potassium permanganate are described in this chapter. The reactions with some O- and N-nucleophiles had been briefly studied in this laboratory<sup>169</sup> and the present work continues the investigation. Reactions of (41) with lithium chloride and sodium iodide using solvent proved unsuccessful, as did a reaction with difluorocarbene (see experimental, Chapter VIII). Other workers in this laboratory have reacted (41) with hydride<sup>181</sup>, diazomethane<sup>181</sup>, and, by a radical mechanism, with methanol, acetaldehyde<sup>182</sup>, etc. Similar additions of methanol and acetaldehyde have been observed for F-propene dimers.<sup>183</sup>

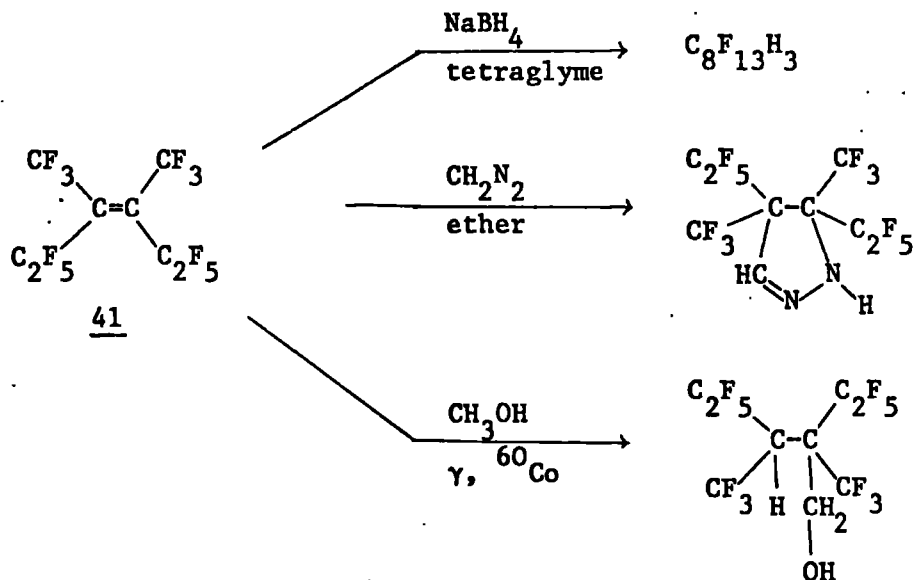

IV.A O-Nucleophiles

IV.A.1 Alcohols

Like F-2,3-dimethyl-2-butene (94), (41) is unreactive towards refluxing neutral methanol, but in the presence of base the two olefins react with methanol giving different types of product. Thus (94) undergoes addition<sup>87</sup> whereas (41) gives

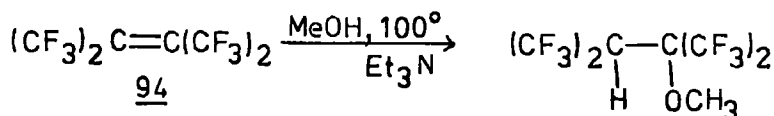

products arising from substitution reactions (Scheme 33). This is because (41) has allylic fluorines which are more easily displaced (CF<sub>2</sub>-CF<sub>3</sub> as opposed to CF<sub>3</sub>).

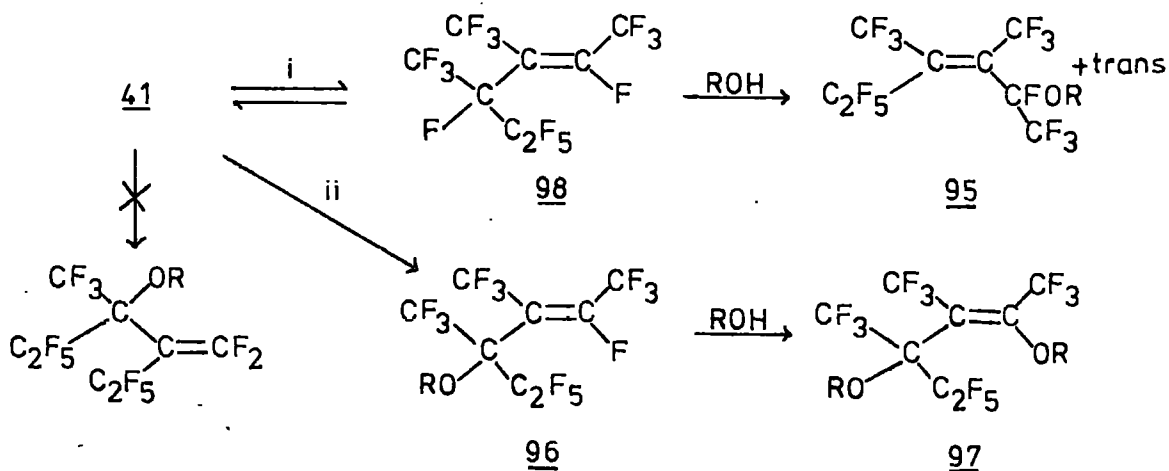

R = CH<sub>3</sub>, C<sub>2</sub>H<sub>5</sub>, CH(CH<sub>3</sub>)<sub>2</sub> but not C(CH<sub>3</sub>)<sub>3</sub>

Preferred pathway: i, using tetraglyme and CsF, at 22°

ii, using tetraglyme and Na<sub>2</sub>CO<sub>3</sub>, at 22°

Scheme 33

Olefin (41) and methanol, using sodium carbonate as base and tetraglyme as solvent, give either a monomethoxy derivative (96, R = CH<sub>3</sub>)<sup>169</sup>

or a dimethoxy derivative (97, R = CH<sub>3</sub>) as the main product depending on the conditions used (efficiency of stirring, rate of addition of methanol, etc.). An additional minor product from this reaction is monomethoxy derivative (95, R = CH<sub>3</sub>) which is, in fact, the major product from a similar reaction, but using CsF as base. Isomers (95, R = CH<sub>3</sub>) and (96, R = CH<sub>3</sub>) are not interconverted under the conditions of these reactions. A similar range of products was obtained from ethanol and isopropanol using CsF as base.

#### IV.A.1.a Mechanism

Clearly, (96) is formed by direct SN2' displacement of fluoride from (41) whereas (95) is derived from (98), an isomer of (41) produced in the presence of fluoride. The equilibrium constant between (98) and (41) will greatly favour (41) but (98) has a vinylic fluorine and will therefore be the more reactive (see below). The monoalkyl ethers (96) also have a vinylic fluorine and would be expected to have the same order of reactivity as (98). However ethers (96) will probably be more soluble than (98) in tetraglyme (see experimental) and this will obviously influence the reaction.

#### IV.A.2 Reaction of C<sub>8</sub>F<sub>16</sub> Isomers with Methanol

A mixture of isomers (41), (98), and (99) is produced from (41) by passage over hot iron (see Chapter V). The reaction of this mixture

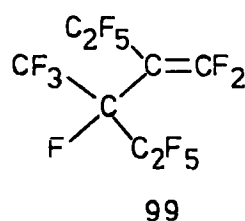
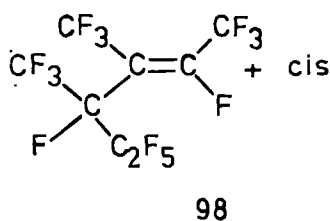
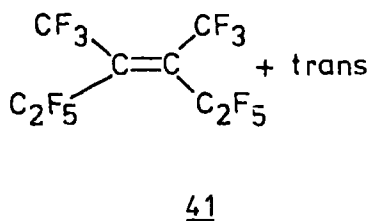

with neutral methanol proceeds as expected (see II.B.1.b). Thus at room temperature only terminal olefin (99) reacts, giving a mixture of  $C_8F_{15}OMe$  isomers (from elemental analysis).

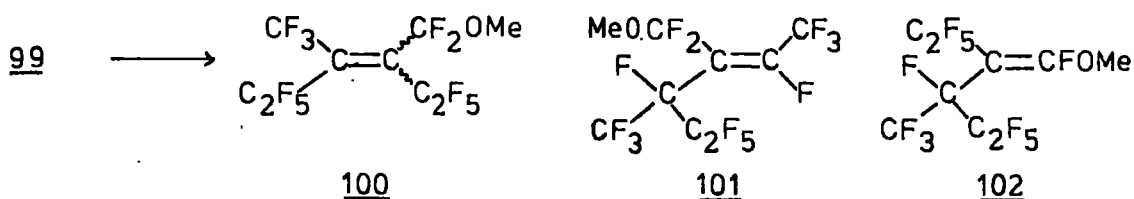

The  $^{19}\text{F}$  n.m.r. spectrum is obviously complex, but isomer (100) is indicated by a  $\text{CF}_3\text{CF}_2\text{C}=\text{C}$  absorption at 100 p.p.m. as is found for (41). The presence of the other isomers is inferred from the i.r. spectrum which shows stretches at 1635  $\text{cm}^{-1}$  ( $\text{C}=\text{CFCF}_3$ , 101; cf. 96, 1660  $\text{cm}^{-1}$ ) and 1715  $\text{cm}^{-1}$  ( $\text{C}=\text{CFOMe}$ , 102; cf.  $\text{CF}_2=\text{C}(\text{CF}_3)$ ,  $\text{C}(\text{CF}_3)=\text{CFOMe}$ , 1700  $\text{cm}^{-1}$ ).

The remaining mixture of (41) and (98) was refluxed with neutral methanol and only (98) reacted.

#### IV.A.3 With Phenol

Reactions of (41) with phenol were investigated by a previous worker.<sup>169</sup> At that time two of the phenoxy derivatives were incorrectly assigned but, now that more n.m.r. data is available, it has been possible to reassign the structures, from a comparison of data with that of the alkoxy derivatives. All the structural assignments will be discussed later.

The monophenoxy derivatives from these reactions are a mixture containing isomers (95, R = Ph) (cis, trans isomers resolvable by g.l.c.) but instead of (96), a different isomer (103, R = Ph) is present.

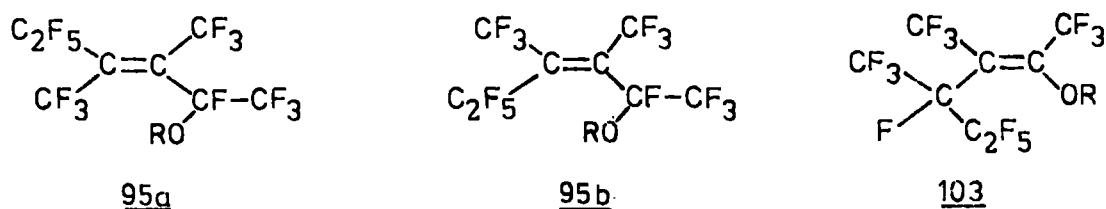

It was demonstrated that compounds (95, R = Ph) and (103, R = Ph) are in equilibrium in the presence of fluoride ion.<sup>169</sup> Therefore, it seems likely that the isolation of (103, R = Ph) from reaction with phenol, but not from the analogous reactions with alcohols, occurs because of the lower nucleophilic character of the oxygen atom in the enol ether (103, R = Ph) than in (103, R = alkyl). The alkyl derivatives are probably sufficiently nucleophilic to promote the conversion of (103) to (95).

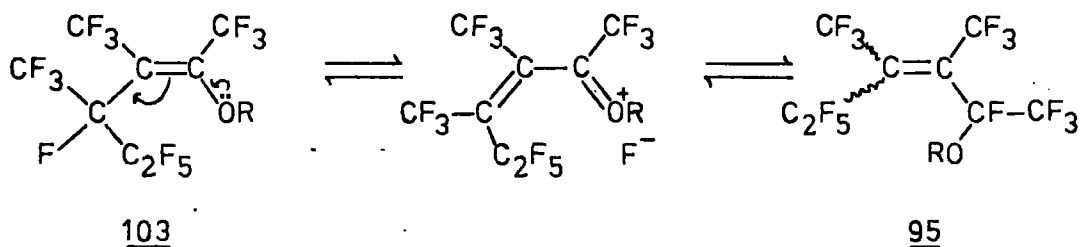

The absence of significant amounts of isomer (96, R = Ph) is probably a result of the lower reactivity of phenoxide when compared to alkoxide ions. Consequently, as soon as fluoride ion is formed and C<sub>8</sub>F<sub>16</sub> isomer (98) is generated, then preferential reaction with (98) will occur.

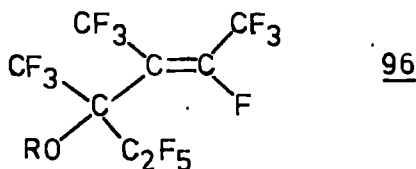

#### IV.A.4 Bifunctional Nucleophiles

The reaction of (41) with ethylene glycol in tetraglyme using sodium carbonate as base gave cyclic product (104), corresponding to the dialkoxy products (97). In contrast, intermolecular reaction is apparently more important for ethanolamine since only an 8% yield of

cyclic product (105) was obtained, together with water soluble products.

Although (41) reacted with ethylene diamine, urea, and sorbitol (a multifunctional nucleophile) it was not possible to identify any products (see experimental).

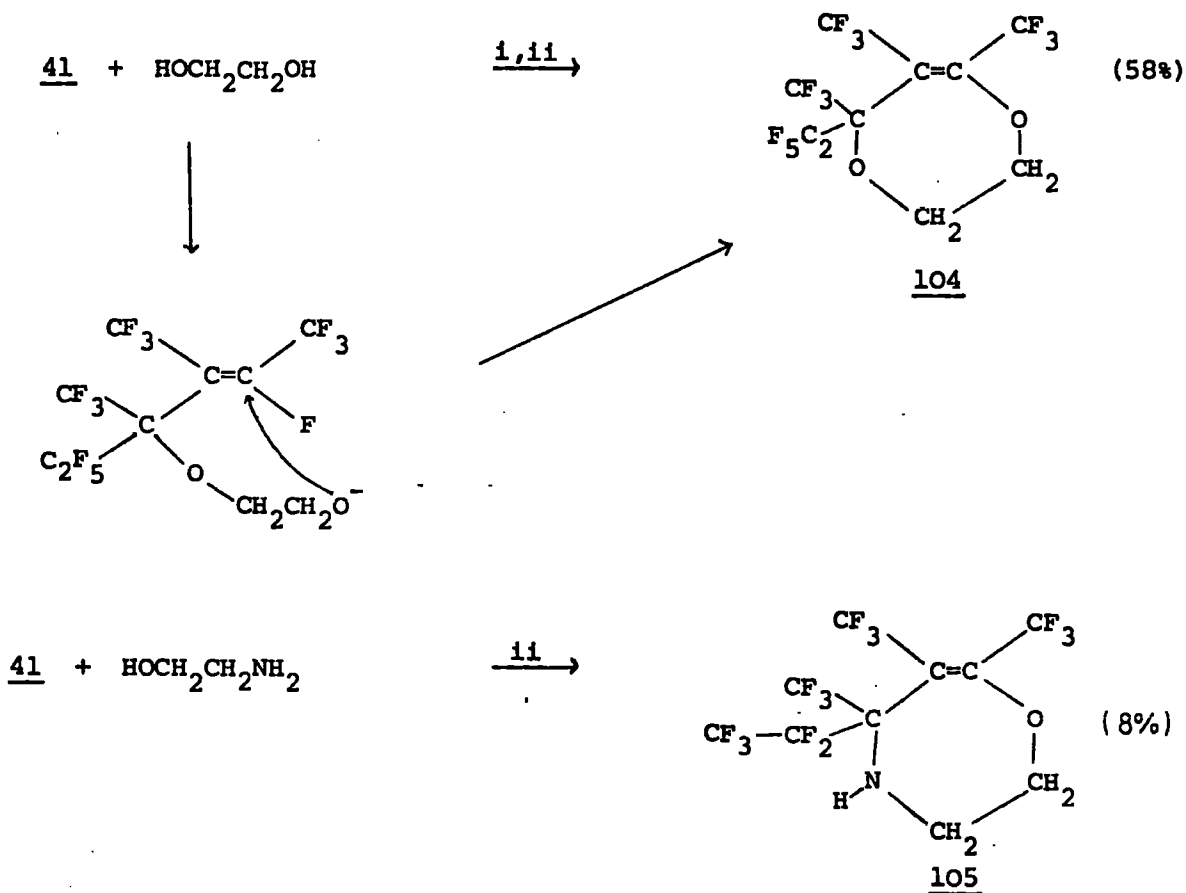

i, Na<sub>2</sub>CO<sub>3</sub>; ii, tetraglyme.

#### IV.A.5 Structural Assignments

The usefully diagnostic features for the assignment of these structures have been discussed in section III.A.3.

The basic structures of (95) follow simply from a comparison of <sup>19</sup>F chemical shifts and i.r. C=C stretching vibrations with those of (41). The cis and trans isomers of (95, R = Ph) were separated<sup>169</sup> and the cis isomer (95b, R = Ph) could be assigned on the basis of the CF<sub>3</sub>CF<sub>2</sub> signal at 75 p.p.m. (D, J = 21 Hz). Assignments to the cis,

trans mixtures (95, R = alkyl) were then possible.

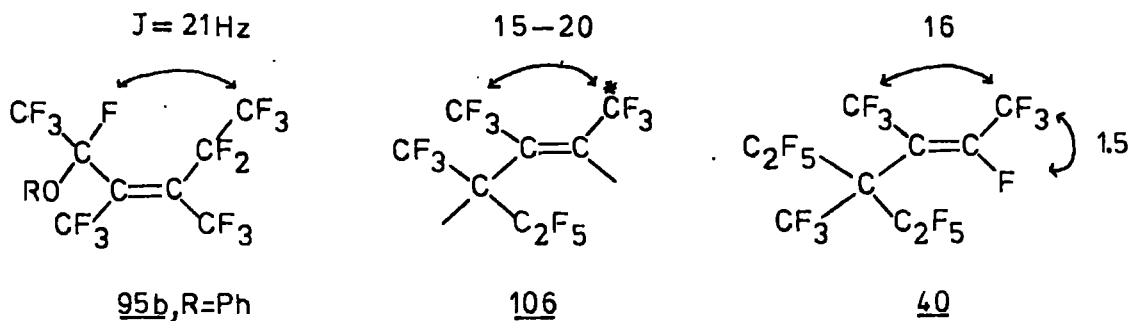

The other mono- and bi-functional derivatives have the same basic carbon-fluorine framework (106), which was easily assigned by comparison of  $^{19}\text{F}$  n.m.r. data with that for (40) (see Table 23, Chapter III for chemical shifts). The n.m.r. signal of the  $^*\text{CF}_3$  group of (106) is very useful because it is only coupled to the adjacent  $\text{CF}_3$  (Q,  $J = 15\text{-}20$  Hz) and the vinylic fluorine ( $J = 1.5 - 2$  Hz) if one is present. Obviously the presence or absence of a vinylic fluorine (ca. 90 p.p.m.) and a tertiary fluorine (181 p.p.m. for 103, R = Ph) is diagnostic. The compounds having basic structure (106) show consistent i.r.  $\text{C}=\text{C}$  stretches:- ca. 1660  $\text{cm}^{-1}$  (96;  $\text{C}=\text{CFCF}_3$ ) and ca. 1620  $\text{cm}^{-1}$  (97, 104, 105;  $\text{C}=\text{CCF}_3\text{OR}$ ).

The spectral data for the cyclic derivative from ethanolamine does not distinguish between the assigned structure (105) and an isomer (107), but (107) would almost certainly exist as its tautomer.

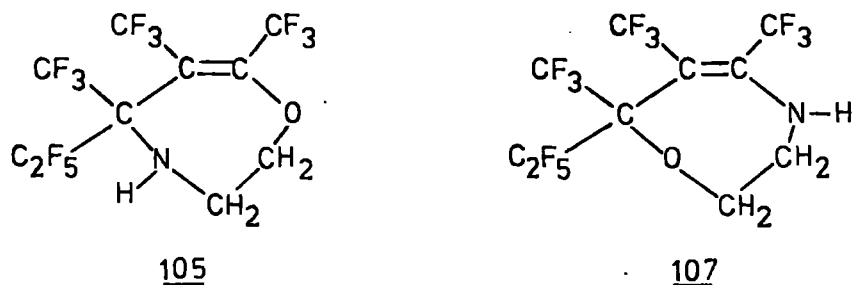

IV.A.6 Further Reaction Involving Alkoxy Groups

Although the reactions of (41) with a large excess of ethanol (no other solvent) using either Et<sub>3</sub>N or Me<sub>3</sub>N as base (two fold excess) produced mainly mono- and di-ethoxy derivatives (95, R = C<sub>2</sub>H<sub>5</sub>) and (97, R = C<sub>2</sub>H<sub>5</sub>). similar reactions using methanol were more complex.

With Me<sub>3</sub>N as base the two major products formed are dimethoxy derivative (97, R = CH<sub>3</sub>) and an ester (108). The analagous reaction using Et<sub>3</sub>N as base also gave (108) but much less (97, R = CH<sub>3</sub>).

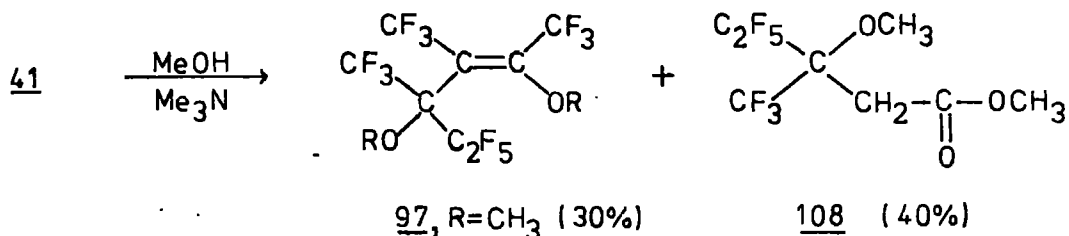

Similarly the reactions of (41), (95, R = CH<sub>3</sub>), and (96, R = CH<sub>3</sub>) with sodium methoxide in methanol are also complex. Thus (41) with a four fold excess of methoxide gave a product mixture showing carbonyl stretches and containing no (95, R = CH<sub>3</sub>) or (97, R = CH<sub>3</sub>). Clearly nucleophilic attack on methyl must occur. This has also been found for pentafluoroanisole with methoxide.<sup>184</sup>

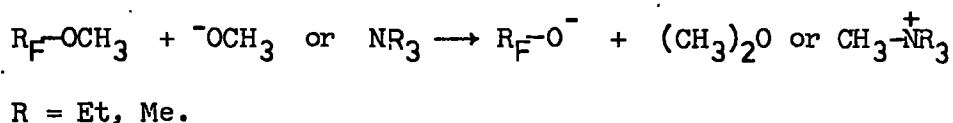

A possible mechanism for the formation of ester (108) is given in scheme 34, together with similar mechanisms accounting for the products obtained from the reaction of (41) with dilute NaOH (eq.IV.1)<sup>126</sup>. These reactions are very similar to those described earlier for olefin (40) with hydroxide, and olefin (42) with hydroxide, when a ketene was isolated (Section II.B.2.b).

Reactions of (41) with Water<sup>a</sup> and Methanol<sup>b</sup>

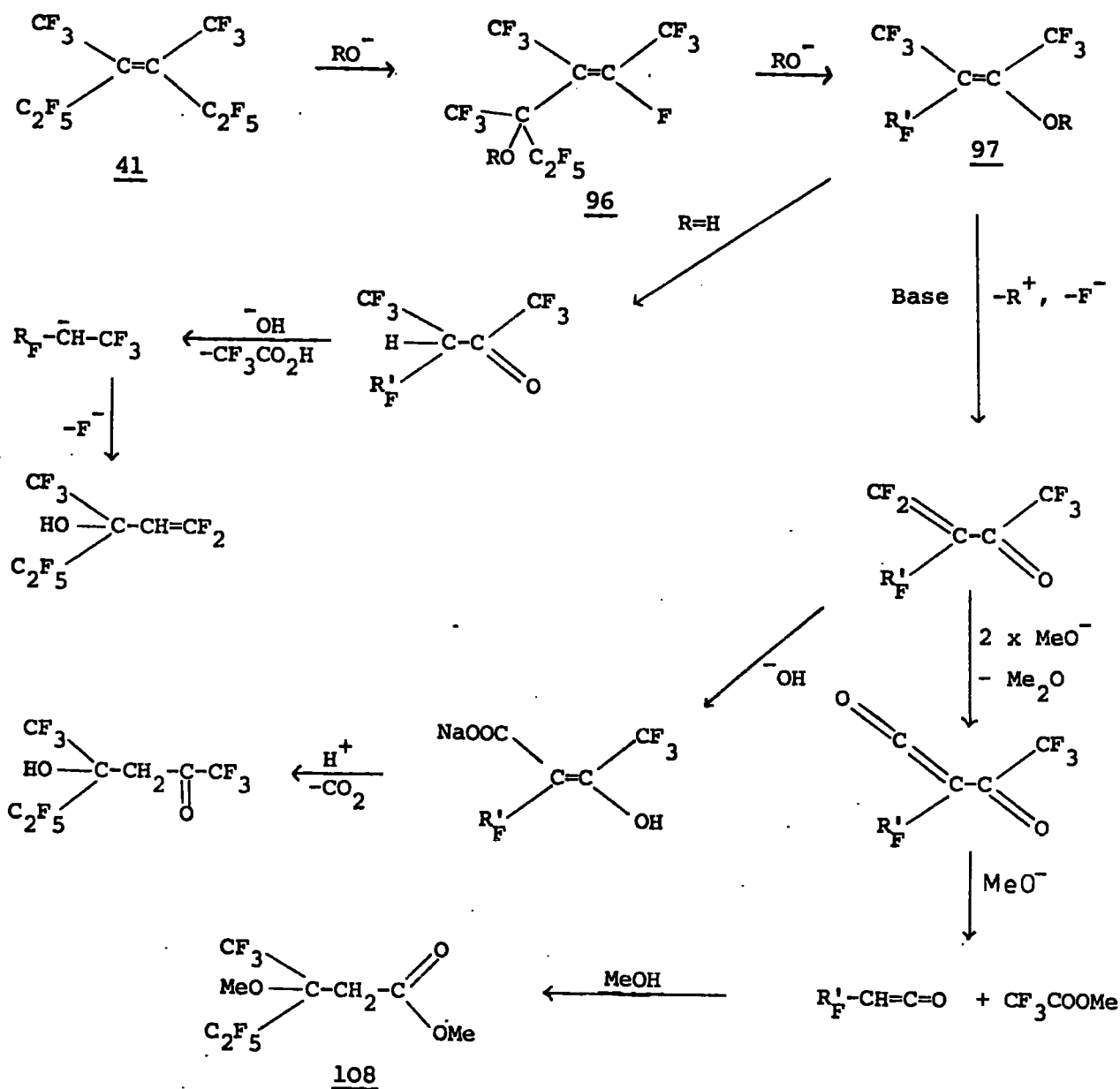

R = Me, H.

$\text{R}'_F = \text{RO}(\text{CF}_3)\text{CC}_2\text{F}_5$ .

a, using dil. NaOH at ca. 35° 126.

b, using MeOH and  $\text{Me}_3\text{N}$  (or  $\text{Et}_3\text{N}$ ) at room temperature.

Scheme 34

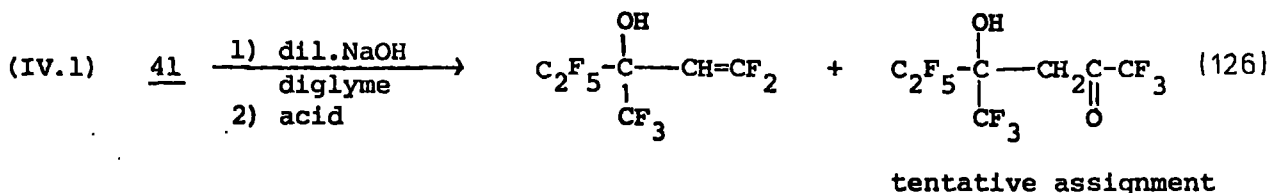

The ester (108) was separated by preparative scale g.l.c. and gave a satisfactory analysis. The mass spectrum did not show a parent peak but showed peaks at M-31 (loss of OCH<sub>3</sub>) and M-73 (loss of CH<sub>2</sub>CO<sub>2</sub>CH<sub>3</sub>). The i.r. spectrum shows a carbonyl stretch (at 1755 cm<sup>-1</sup>) and the <sup>1</sup>H spectrum has two signals, ratio 3:1. The <sup>19</sup>F n.m.r. spectrum shows a CF<sub>3</sub> group and a CF<sub>3</sub>CF<sub>2</sub> group having similar chemical shifts to those found for an analogous compound (see later).

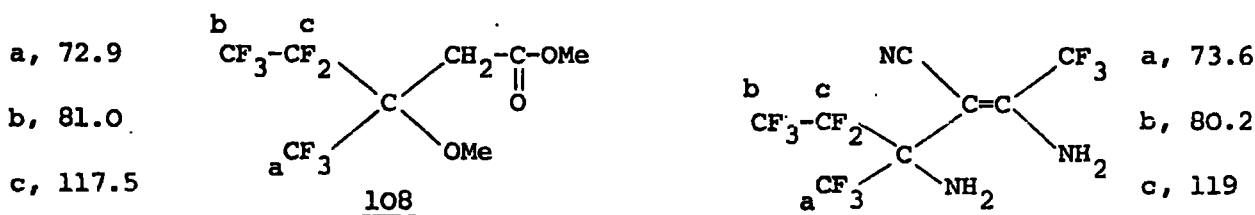

#### IV.A.7 Formation of Furans

Interestingly if the reaction of (41) with methanol (ca 1:1 molar ratio), using Et<sub>3</sub>N<sup>169</sup> or Me<sub>3</sub>N as base is carried out with tetraglyme present as solvent, then besides the expected monomethoxy derivatives (95) and (96), F-2,5-dihydro-tetramethylfuran (109) is formed (10 - 20% yield at room temperature). However, much better yields of (109) (ca. 50%) were obtained from reactions under reflux using pyridine as base (scheme 35). In this case the formation of (109) is not limited to methanol, occurring also for ethanol and isopropanol but not for t-butanol or water.

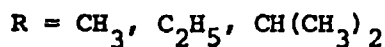
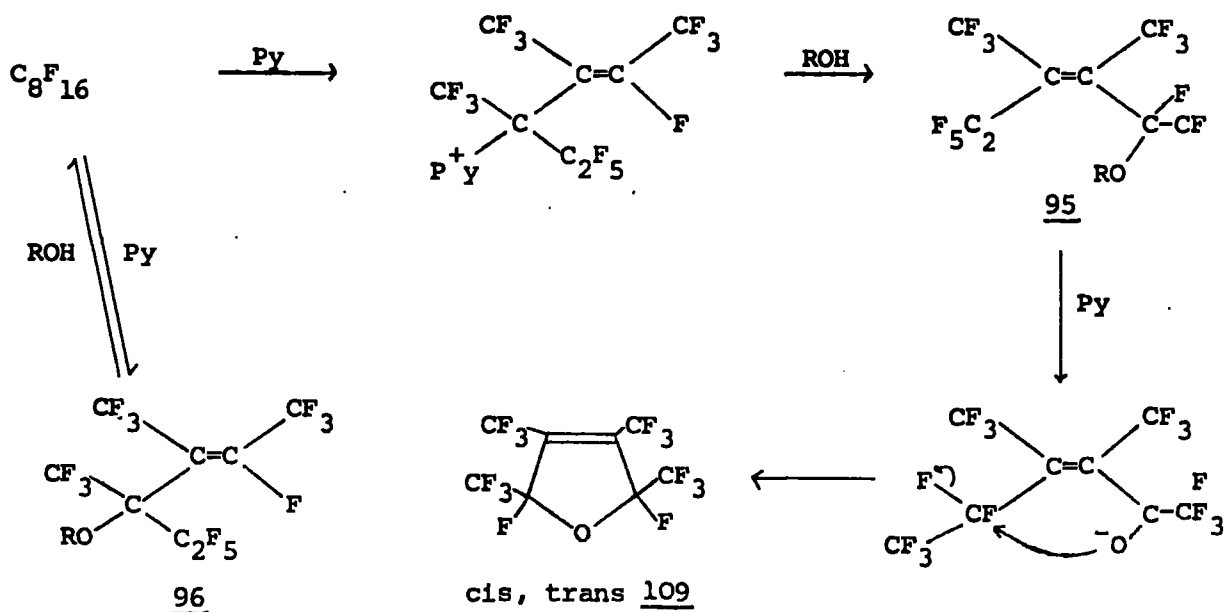

Scheme 35

Also in separate experiments it was shown that ether (95) is converted to furan (109) by pyridine or caesium fluoride using tetraglyme as solvent.

Obviously, the process involves the generation of an oxygen anion by nucleophilic cleavage of ether (95), followed by cyclisation. The cyclisation can be accounted for by a mechanism involving intramolecular  $SN_2'$  displacement of fluoride, for which there is ample precedent. However, cyclisation via an internal nucleophilic attack on saturated carbon seems more likely (Scheme 35) by analogy with an example given later.

Only a low yield of ether (96) was obtained from the reactions of (41) with methanol and ethanol using pyridine as base and, in fact, (96) and pyridine under similar conditions gave (41) (Scheme 35).

Furan (111,  $R = C_2H_5$ ) (61% yield) was formed from (109) and ethanol, at room temperature, in the presence of pyridine and tetraglyme. Also compounds (111,  $R = CH_3, C_2H_5$ ) were produced in low yields from the

reactions of (41) with ethanol and methanol described above.

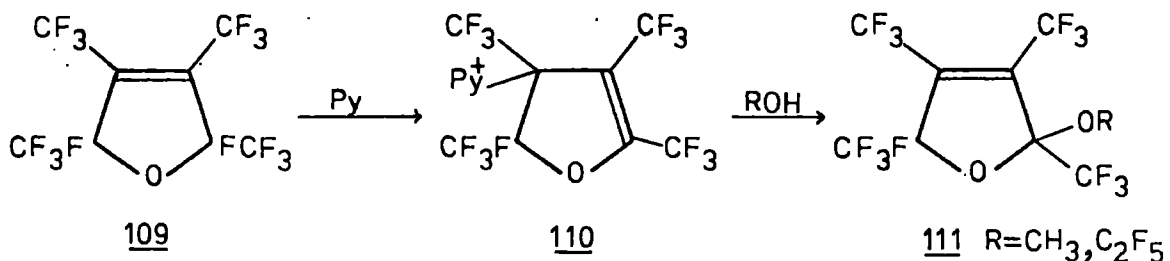

#### IV.A.7.a Defluorination by Triethylamine

The cyclisation induced by triethylamine is even more intriguing because F-tetramethylfuran (112) is obtained from reaction under reflux. Also (109) when heated with Et<sub>3</sub>N and tetraglyme, gave (112) in 41% yield. Defluorination induced by fluoride ion (see III.B.1) can be ruled out because (109), when heated with tetraglyme and CsF (or CsCl), does not produce any (112). An electron transfer process also seems unlikely because of the contrasting results obtained with pyridine and triethylamine. A mechanism, which accounts for these observations involves the intermediate formation of an ylid (Scheme 36).

Furan (112) was produced more efficiently (79% yield) by defluorination over iron at 580° (see Chapter V).

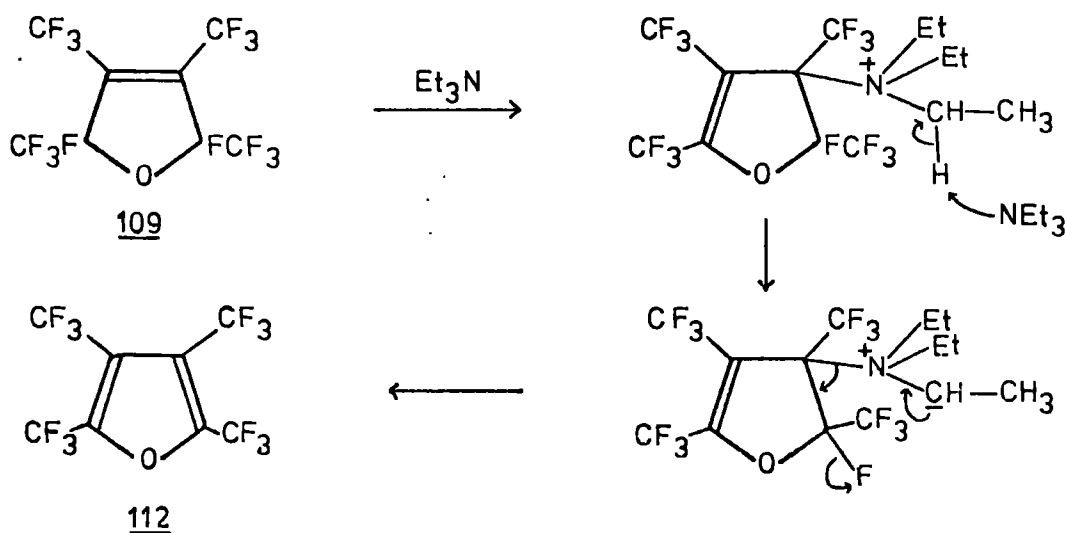

Scheme 36

IV.A.7.b An Analogous Cyclisation

The reactions of olefin (40) with aqueous base have been described earlier (II.B.2.b). The use of mild conditions (aq. Et<sub>3</sub>N, DMF, 20°) leads to ketone (64) after acidification.<sup>127</sup> However, it is also possible to obtain cyclic product (113) (78% yield) using slightly different conditions (Et<sub>3</sub>N, diglyme, H<sub>2</sub>O).<sup>185</sup>

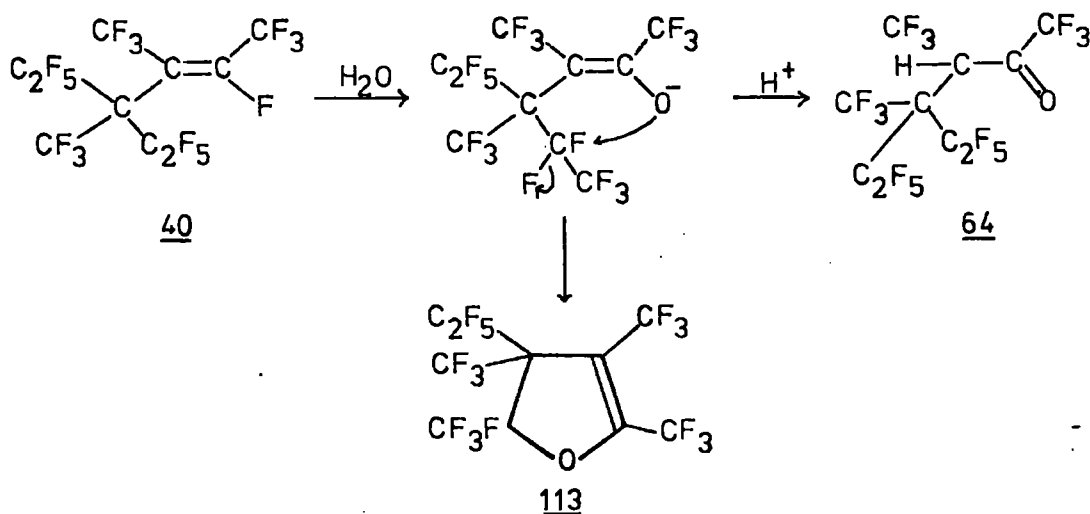

Cyclic product (113) must arise via an intramolecular nucleophilic displacement from a difluoromethylene group. This suggests that the cyclisation described earlier also occurs in this manner.

IV.A.7.c Structural Assignments

Compounds (109) and (112) have been isolated previously<sup>169</sup> and (112) is a known compound.<sup>155</sup> A satisfactory analysis has now been obtained for (109). Compound (111, R = C<sub>2</sub>H<sub>5</sub>) gave a satisfactory analysis and M-1 peak in its mass spectrum. Its structure follows from a comparison of the <sup>19</sup>F n.m.r. spectrum with that of (109). Both compounds are mixtures of cis and trans isomers (by <sup>19</sup>F n.m.r.).

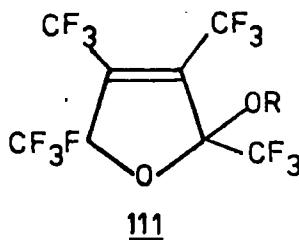
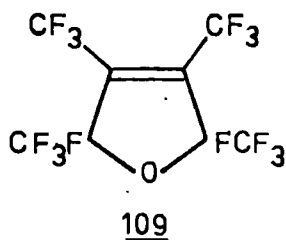

#### IV.A.8 Reaction of F-Propene Trimers with O-Nucleophiles

The reactions of F-propene trimers with O-nucleophiles are very similar to some of the reactions of (41) described above, with the notable exception that the formation of cyclic derivatives was not reported.<sup>103</sup>

The F-propene trimer used was a mixture of two main isomers, (32) (65%) and (33) (30%), which are in equilibrium in the presence of Et<sub>3</sub>N.

Isomer (33), having a vinylic fluorine, is the more reactive towards alcohols and phenols using Et<sub>3</sub>N as base and, in fact, the products are derived solely from (33). Alcohols favour the formation of allylic ethers (114). For example, using ethanol the ratio of (114):(115) is 13:1. In contrast vinylic ethers are the main products from phenols. Thus phenol itself gives (114) and (115), ratio 1:12. Both F-propene trimers will react with alkoxides but (32) is unreactive towards phenoxide.

Nucleophilic cleavage of ethers (114), by fluoride ion or other nucleophiles, gives F-tetramethyl-2-fluoropropenyl caesium.

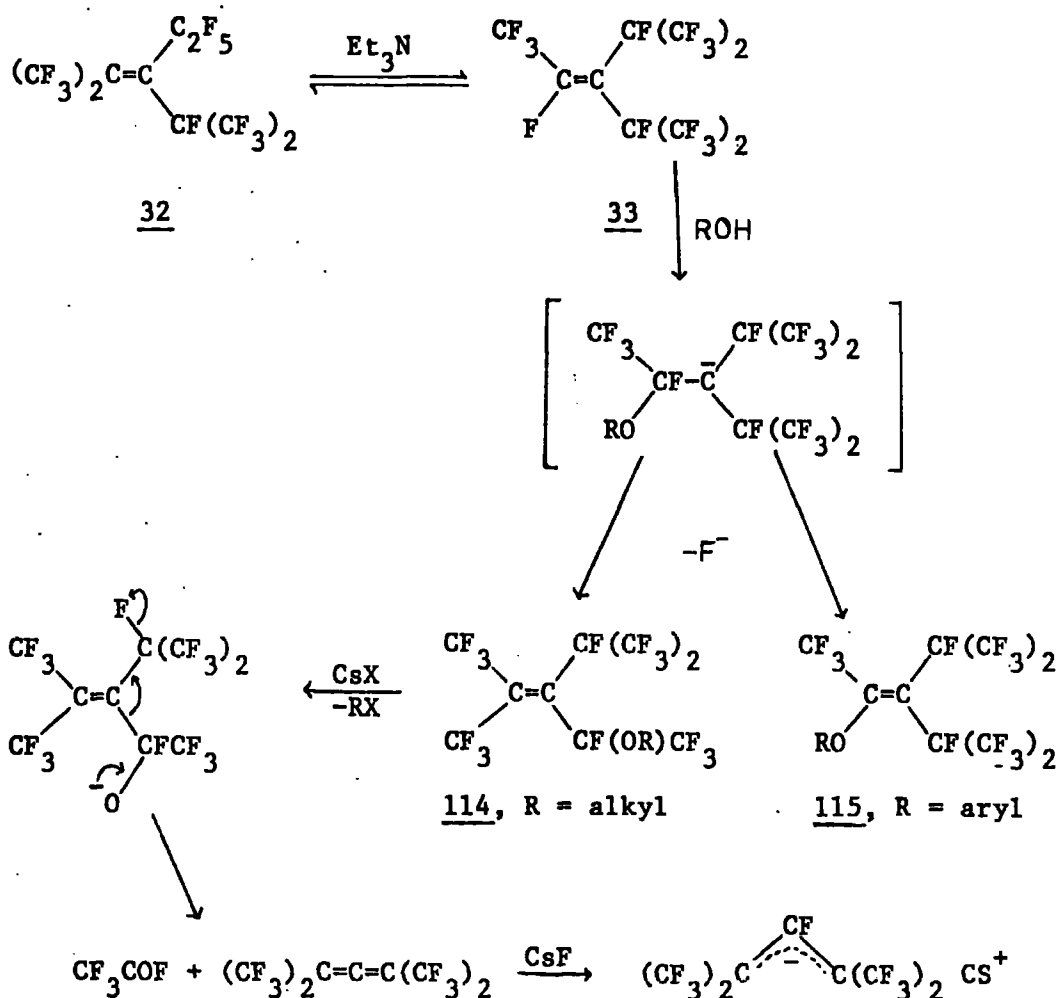

R = CH<sub>3</sub>, C<sub>2</sub>H<sub>5</sub>, CH<sub>2</sub>CH=CH<sub>2</sub>, CH<sub>2</sub>CHCH<sub>2</sub>O

X = F, (CF<sub>3</sub>)<sub>3</sub>C, (CF<sub>3</sub>)<sub>2</sub>CFO

#### IV.B N-Nucleophiles

The reactions of (41) with N-nucleophiles are influenced by the base strength and steric requirements of the nucleophile. The reactions are not markedly influenced by the presence or absence of an anhydrous aprotic solvent but when aqueous systems are employed, and fluoride is

a weak nucleophile, different products can be formed.

Interestingly some amines give products arising from (99), the terminal olefin isomer of  $C_8F_{16}$  (41). Analogous products were not observed with O-nucleophiles. Table 25 lists the base strengths of the N-nucleophiles used in this study.

Table 25

Base Strengths of N-Nucleophiles<sup>137</sup>

<u>Nucleophile</u>	<u><math>K_b</math></u>	<u>Relative Base Strength</u>
NH <sub>3</sub>	$1.79 \times 10^{-5}$	1.0
t-BuNH <sub>2</sub>	$2.80 \times 10^{-4}$	15.6
MeNH <sub>2</sub>	$4.38 \times 10^{-4}$	24.5
EtNH <sub>2</sub>	$5.60 \times 10^{-4}$	31.3
Et <sub>2</sub> NH	$9.60 \times 10^{-4}$	53.6

IV.B.1 Ammonia and Methylamine

IV.B.1.a Anhydrous Conditions

It has been reported that two main products are formed by bubbling anhydrous ammonia through a solution of (41) in ether.<sup>143</sup> These are mono-imino and di-imino derivatives (116 and 117). In contrast, only one main product, an amino derivative (118, R = CH<sub>3</sub>), was formed by bubbling anhydrous methylamine through excess (41) in the presence or absence of ether (see Scheme 37).

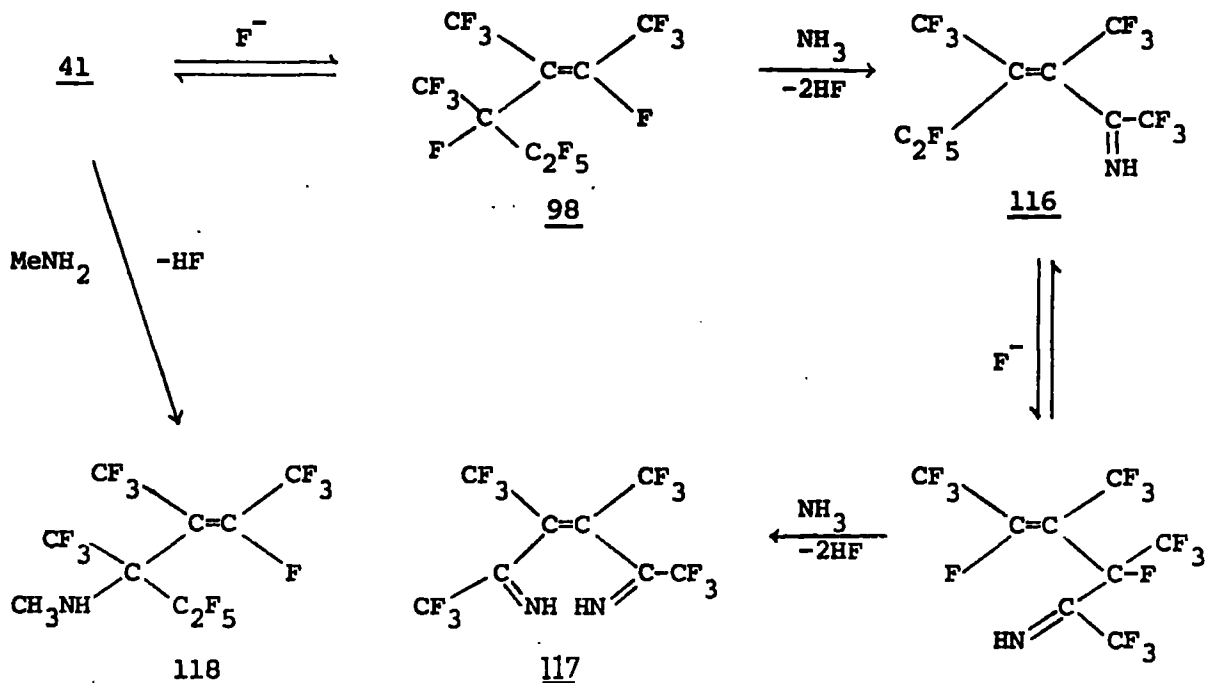

Scheme 37

Clearly, the product from methylamine is formed by direct attack on (41), whereas the products from ammonia result from attack on (98), an isomer of  $C_8F_{16}$ . From Table 25 it can be seen that methylamine is ca. 24 times more basic than ammonia and it will therefore react much faster with (41). Ammonia will react slowly with (41) and any fluoride ion produced will set up an equilibrium forming isomer (98), with which ammonia can then react much faster. The di-imino derivative (117) will be formed in a similar manner.

Compound (118,  $R = CH_3$ ) was not isolated but was identified by comparison of the  $^{19}F$  n.m.r. spectrum with that of (118,  $R = C_2H_5$ ) (see later). The  $^{19}F$  chemical shifts and coupling constants of these two compounds are virtually the same.

#### IV.B.1.b Aqueous Conditions

The reaction of (41) with aqueous ammonia gave one main product (119) (72% crude yield), a solid, which was purified by sublimation. A

mechanism accounting for the formation of (119) is given in Scheme 38. After the initial attack by  $\text{NH}_3$  the reaction is the same as that found for olefin (40) with ammonia (see II.B.4.c).

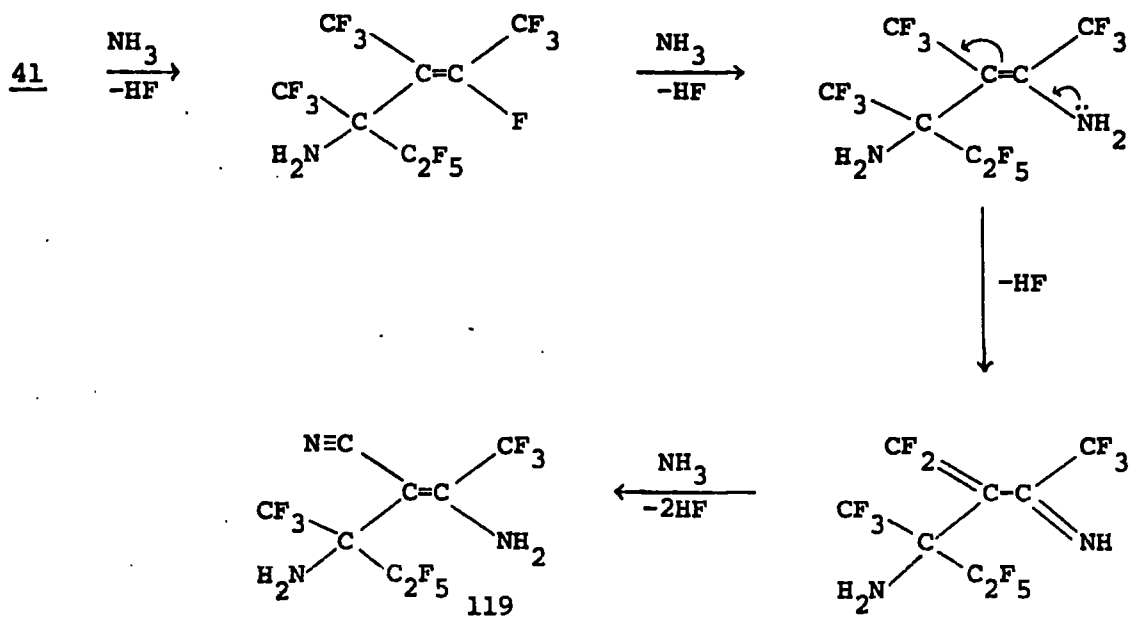

Scheme 38

The reaction with methylamine gave a product mixture containing two main components which were separated by distillation and preparative scale g.l.c. The less volatile component was identified as azetine (120) but the more volatile component had a very complex  $^{19}\text{F}$  n.m.r. spectrum and was not identified. The formation of (120) can be explained by a similar mechanism to that suggested for (119). Again the maximum

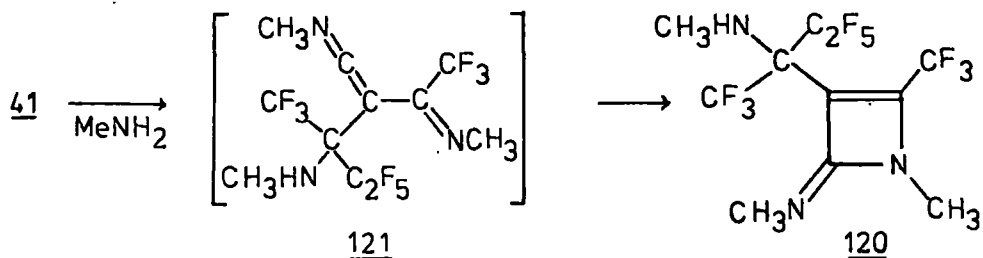

amount of HF is lost giving ketenimine (121) which must cyclise spontaneously to the isolated product (120).

Similar ketenimines have been isolated (see II.B.4.b) but these have bulky t-butyl or aryl groups on nitrogen, which will hinder cyclisation. Spontaneous cyclisations of related fluorobutadienes have been observed.<sup>186</sup>

#### IV.B.1.c Structural Assignments

Compound (119) gave a satisfactory analysis and a parent peak in the mass spectrum. The i.r. spectrum shows NH<sub>2</sub> stretches, a very strong C=C stretch at 1625 cm<sup>-1</sup>, and a strong C≡N stretch at 2220 cm<sup>-1</sup> (cf. 112, C≡N at 2220 cm<sup>-1</sup><sup>144</sup>) and the u.v. spectrum indicates conjugation (ε = 15,400). The <sup>1</sup>H n.m.r. spectrum (in acetone) shows two types of NH<sub>2</sub> group, one undergoing slow exchange (δ 7.9, broad) and one fast exchange (δ 3.3). The <sup>19</sup>F n.m.r. spectrum (see also IV.A.6) shows two CF<sub>3</sub> groups and one CF<sub>3</sub>CF<sub>2</sub> group and in particular one of the CF<sub>3</sub> groups is a sharp singlet at 68.7 p.p.m. (cf. 112, CF<sub>3</sub> at 67 p.p.m.<sup>144</sup>).



Compound (120) gave a satisfactory analysis for N and H only, but showed a parent peak in the mass spectrum. The i.r. spectrum shows very strong C=C and C=N stretches at 1710 and 1685 cm<sup>-1</sup> (cf. 89b, C=C at 1720 cm<sup>-1</sup><sup>177</sup>) and no C=C=N stretch as expected for ketenimine (121) (ca. 2100 cm<sup>-1</sup><sup>136</sup>). The double bonds are conjugated (ε = 13,600). Like (119), the <sup>19</sup>F n.m.r. spectrum shows two CF<sub>3</sub> groups and a CF<sub>3</sub>CF<sub>2</sub> group, having similar chemical shifts to those found for (119) but, in

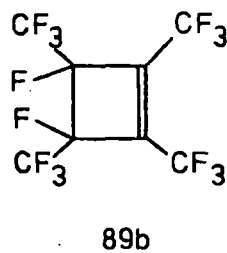
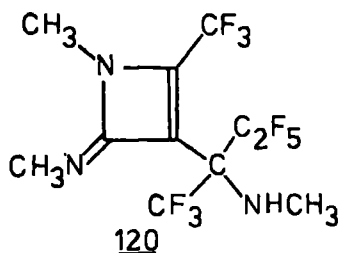

this case, the vinylic  $\text{CF}_3$  group gives a broad signal (at 67 p.p.m., cf. 89b, vinylic  $\text{CF}_3$  at 66.5 p.p.m.). The  $^1\text{H}$  n.m.r. spectrum is also consistent with structure (120).

#### IV.B.2 Ethylamine and t-Butylamine, Anhydrous Conditions

The reaction of (41) with ethylamine gave a product mixture containing at least seven components. Two of the more volatile components were separated by distillation and preparative scale g.l.c. and were identified as (118,  $\text{R} = \text{C}_2\text{H}_5$ ), and a mixture of (123,  $\text{R} = \text{C}_2\text{H}_5$ ) and (124,  $\text{R} = \text{C}_2\text{H}_5$ ) (Unresolvable by g.l.c., ratio 123:124 = 2:1 by  $^{19}\text{F}$  n.m.r.).

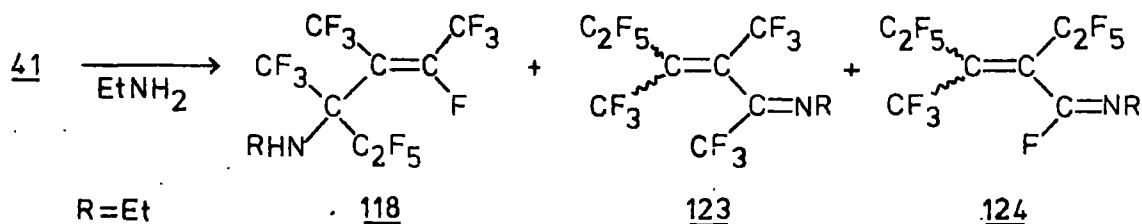

Clearly each of the products arises from a different isomer of  $\text{C}_8\text{F}_{16}$ . Although  $\text{EtNH}_2$  is a slightly stronger base than  $\text{MeNH}_2$  it is more bulky and this must retard direct reaction with (41). Again an equilibrium will be set up between (41) and its isomers, as was found for F-propene dimers (see II.B.4.a).

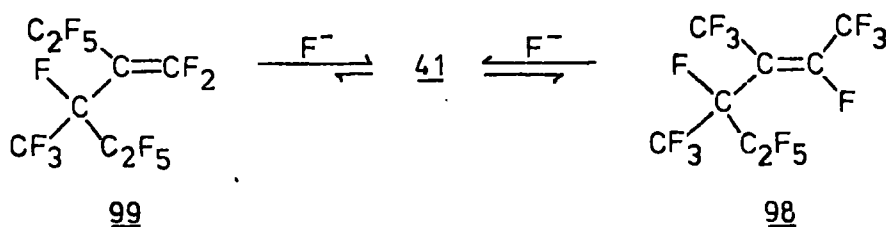

No products arising from terminal olefin (99) were obtained using ammonia or methylamine. It seems likely that this difference is a result of the greater steric requirements of EtNH<sub>2</sub> which must also hinder reaction with isomer (98).

An approximately 1:1 molar ratio of (41) and t-butylamine in pyridine gave recovered (41), and (124, R = C<sub>4</sub>H<sub>9</sub>) as the main product (ca. 60% yield based on 41 consumed). Compound (124, R = C<sub>4</sub>H<sub>9</sub>) was identified in the product by comparison of the <sup>19</sup>F n.m.r. spectrum with that of (124, R = C<sub>2</sub>H<sub>5</sub>). Similarly (123, R = C<sub>4</sub>H<sub>9</sub>) is a minor component or is absent (Scheme 39).

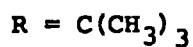
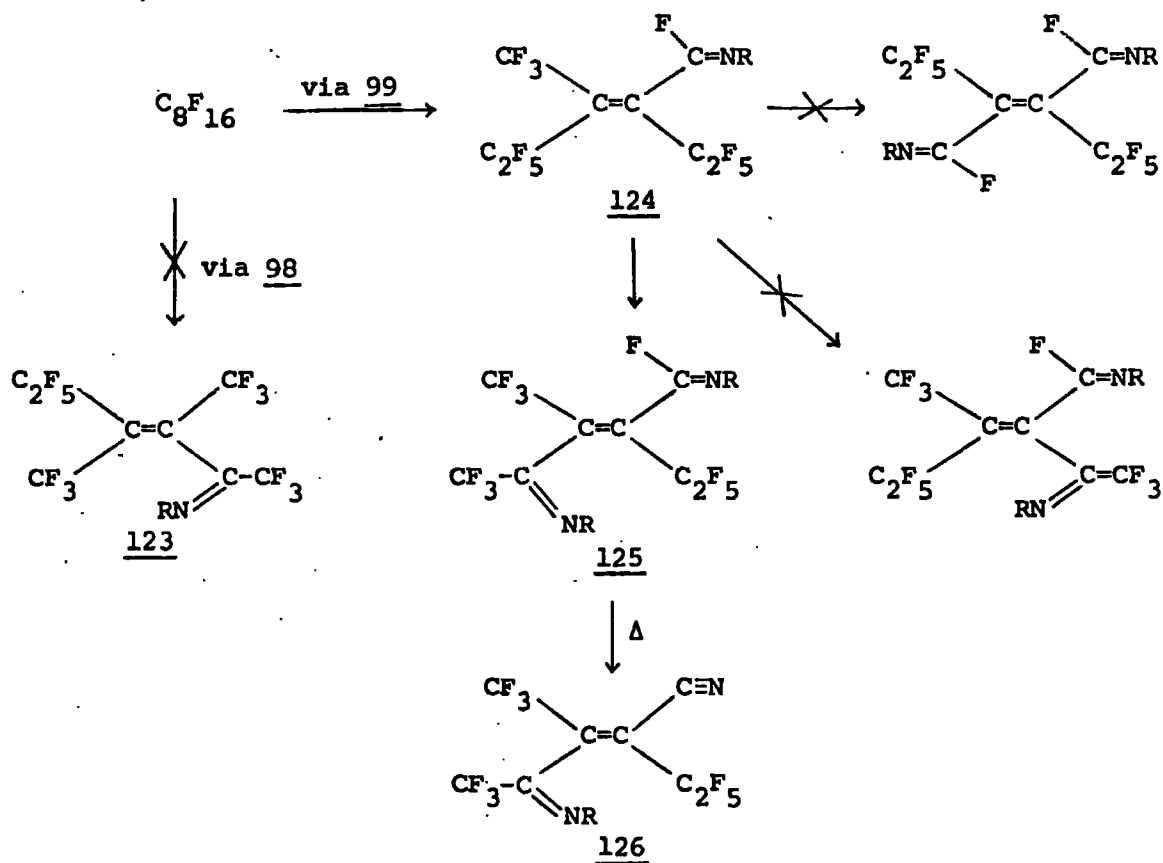

Scheme 39

An excess of t-butylamine in pyridine gives a disubstituted product (125) as the main component. However, when separation of (125) was attempted using preparative scale g.l.c. t-butyl fluoride was lost giving nitrile (126). This did not go to completion and unfortunately there was not enough time available to repeat these reactions in order to isolate and fully characterise the products.

The initial reaction giving (124, R = C<sub>4</sub>H<sub>9</sub>) is understandable in terms of the bulky t-butyl group. Subsequent reaction giving (125) is more difficult to explain. It could be argued that this is the least crowded of the three possible products from (124, R = C<sub>4</sub>H<sub>9</sub>) (Scheme 39).

#### IV.B.2.a. Structural Assignments

Compound (118, R = C<sub>2</sub>H<sub>5</sub>) gave a satisfactory analysis and a parent peak in the mass spectrum. The i.r. and n.m.r. spectra are consistent with structure (118) by comparison with the data for ethers (96) (see IV.A.5).

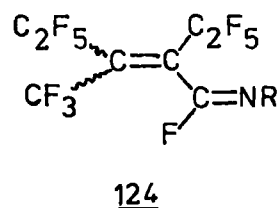
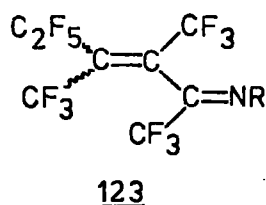
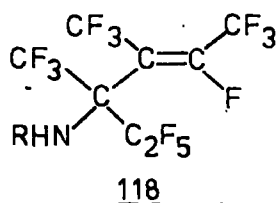

The mixture (123, R = C<sub>2</sub>H<sub>5</sub>) and (124, R = C<sub>2</sub>H<sub>5</sub>) gave a satisfactory analysis and a parent peak in the mass spectrum. The i.r. spectrum shows three double bond stretches at 1640 (C=C), 1670 (CF<sub>3</sub>C=N), and 1750 cm<sup>-1</sup> (CF=N). Besides the signals expected for vinylic CF<sub>3</sub> and vinylic C<sub>2</sub>F<sub>5</sub>, the <sup>19</sup>F n.m.r. spectrum shows a broad signal at 70.5 (123, CF<sub>3</sub>C=N), and two signals at 17.6 and 20.2 p.p.m. (124, CF=N), which probably arise from cis and trans isomers.

Compound (124, R = C<sub>4</sub>H<sub>9</sub>) was identified by comparison of the <sup>19</sup>F n.m.r. spectrum with that of (124, R = C<sub>2</sub>H<sub>5</sub>). In particular the spectrum shows the characteristic CF=N signals at 6.5 and 9.7 p.p.m.

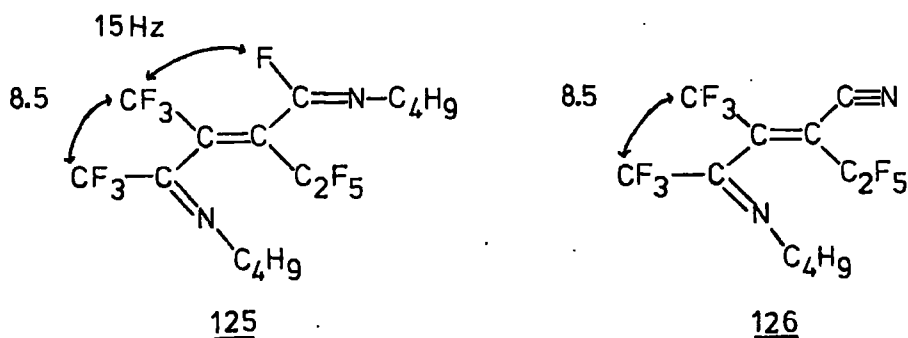

Compound (125) shows a M-19 peak in the mass spectrum, two singlets at δ 1.4 in the <sup>1</sup>H n.m.r. spectrum, and signals in the <sup>19</sup>F n.m.r. spectrum corresponding to a vinylic CF<sub>3</sub>, a vinylic C<sub>2</sub>F<sub>5</sub>, a CF<sub>3</sub>C=N group (at 69.3 p.p.m.), and a CF=N group (at 11.8 p.p.m.). The fine structure indicates structure (125) because the vinylic CF<sub>3</sub> is a doublet of quartets and is not coupled to the C<sub>2</sub>F<sub>5</sub> group. Compound (126) shows a M-15 peak in the mass spectrum, and multiple bond stretches in the i.r. spectrum at 1625 (C=C), 1685 (C=N), and 2225 cm<sup>-1</sup> (C≡N). The <sup>1</sup>H n.m.r. spectrum shows a singlet (δ 1.4) and the <sup>19</sup>F n.m.r. spectrum is similar to that of (125), except that the CF=N group is absent and the vinylic CF<sub>3</sub> is a simple quartet.

#### IV.B.3 Diethylamine

The reaction of (41) with diethylamine, using sulpholane as solvent, gave one product (127). The structure of (127) was confirmed by subsequent hydrolysis.<sup>169</sup> Compound (127) is also formed using ether as solvent or with no solvent present. Again the product is almost

certainly a result of steric effects as there does not appear to be any other simple explanation.

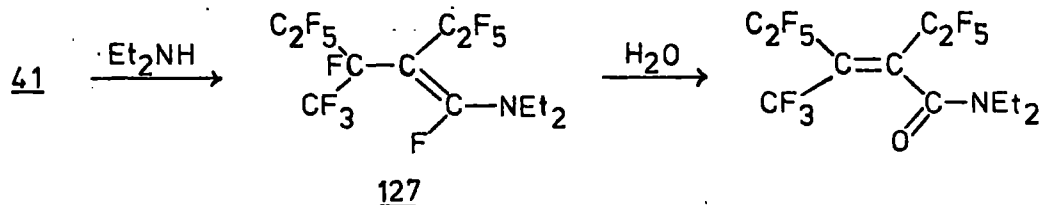

#### IV.C Summary of Reactions with O- and N-Nucleophiles

It is now possible to explain the reactions of (41) with O- and N-nucleophiles by the following general points and the scheme given below.

- 1) Equilibria must be set up between the various  $\text{C}_8\text{F}_{16}$  isomers (41, 98, and 99) if there is active fluoride present.
- 2) There is a competition between fluoride ion and the nucleophile for (41).
- 3) As the reaction proceeds there is a competition between the isomers of  $\text{C}_8\text{F}_{16}$  for the nucleophile.
- 4) There must be some specific difference between O- and N-nucleophiles to explain why the O-nucleophiles give no products arising from (99). This may be a result of markedly different relative reactivities of the  $\text{C}_8\text{F}_{16}$  isomers towards the two types of nucleophile.
- 5) Steric effects are important for N-nucleophiles.
- 6) The presence of water inhibits equilibria by deactivating fluoride.

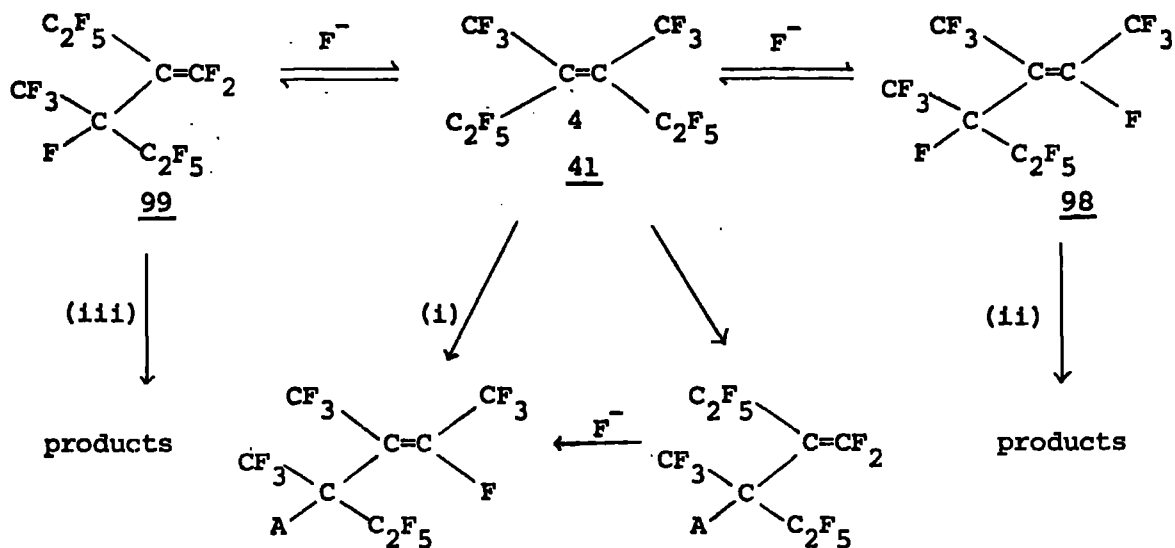

- (a) O-nucleophiles routes (i) and (ii).
- (b)  $Et_2NH$  - exclusively route (iii), steric inhibition of (i) and (ii).
- (c)  $t-BuNH_2$  - as for  $Et_2NH$ .
- (d)  $EtNH_2$  - routes (i), (ii) and (iii) all occur.
- (e)  $MeNH_2$  - route (i), steric requirements less than for  $EtNH_2$
- (f)  $NH_3$  - anhydrous - route (ii), base strength of  $NH_3$  inhibits route (i).
- (g)  $NH_3$  - aqueous - route (i) only.

#### IV.D Phenylmagnesium Bromide

Interestingly (41) does not undergo direct nucleophilic attack by phenylmagnesium bromide. A reaction does occur but the products result from an initial defluorination giving  $C_8F_{14}$  isomers (128), biphenyl, and presumably magnesium fluoride.

Compound (128) also reacts further with  $PhMgBr$  giving a mixture of  $C_8F_{13}Ph$  isomers which are mainly (129). Subsequent stirring of this

mixture with CsF and tetraglyme produces isomers (129) only (from the  $^{19}\text{F}$  n.m.r. spectrum) (see Scheme 40).

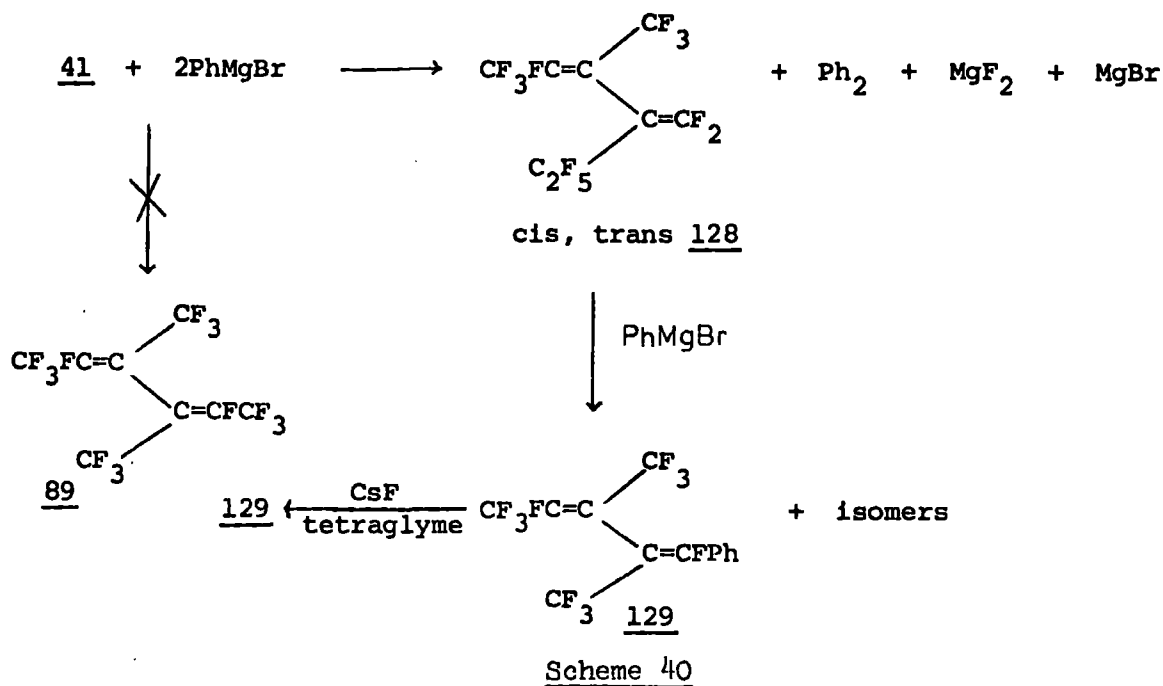

The initial reaction almost certainly proceeds via an electron transfer process but there is no obvious explanation as to why (128) should be formed in preference to (89). The isolation of (128) is readily explained by the fact that there will be no active fluoride in solution since  $\text{MgF}_2$  has a high lattice energy.

The overall reaction is not very efficient since 63% of the fluorine in (41), consumed, was recovered as inorganic fluoride. This feature has also been observed for the reaction of  $\text{PhMgBr}$  with F-biphenyl ketone which produced more than 70% of fluoride.<sup>187</sup>

#### IV.D.1 Structural Assignments

Compound (129) gave a satisfactory analysis and a parent peak in the mass spectrum. The i.r. spectrum shows  $\text{C}=\text{C}$  stretches between 1650 and  $1710\text{ cm}^{-1}$ , and the  $^{19}\text{F}$  n.m.r. spectrum shows a  $\text{CF}_3\text{CF}_2$  group as well

as indicating that a mixture of isomers are present. Assignments were made by a comparison of the spectrum with those of isomers (89)<sup>169,176</sup>

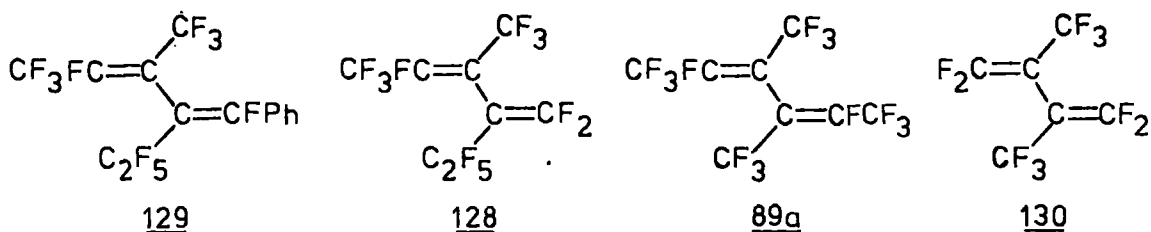

and compounds given in Table 23 (Chapter III). Compound (128) was not isolated but was identified in a mixture containing (41). The n.m.r. spectrum is similar to that of (129), except that it shows a C=CF<sub>2</sub> group at ca. 69 p.p.m. (cf. 130, C=CF<sub>2</sub> at 72 p.p.m.), and the i.r. spectrum shows C=C stretches at 1690 and 1715 (CF<sub>3</sub>CF=C, cf. 89, see Table 23 Chapter III), and 1740 cm<sup>-1</sup> (CF<sub>2</sub>=C, cf. 130, 1740 and 1760 cm<sup>-1</sup>).

#### IV.E Potassium Permanganate

Potassium permanganate is generally regarded as nucleophilic in character and, like other F-tetraalkylethylenes (see Section II.D.1), olefin (41) gives diol (131) from reaction in anhydrous acetone.

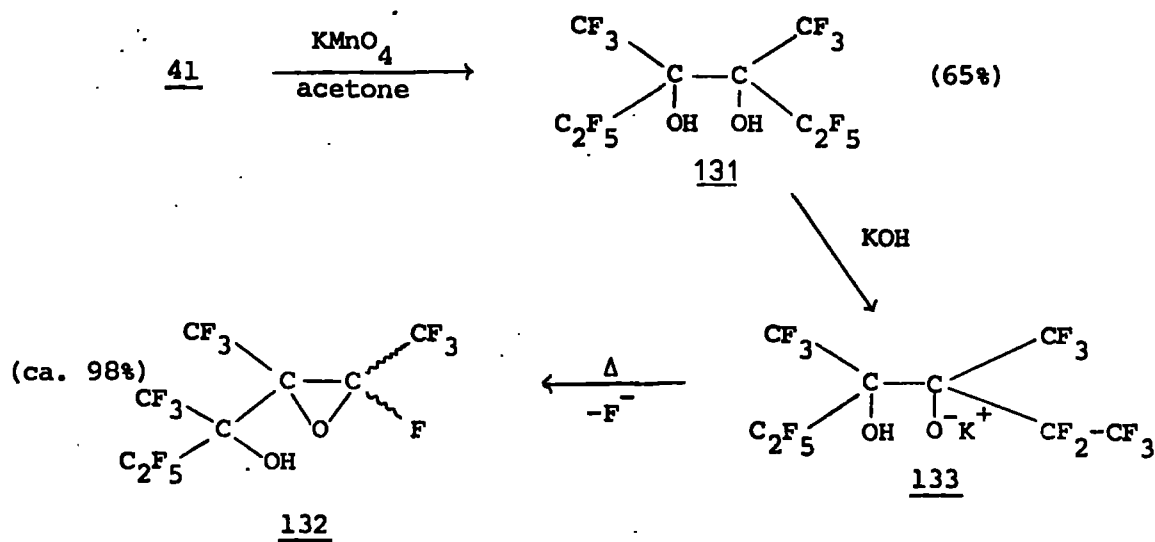

Scheme 41

IV.E.1 Reaction of Diol with Potassium Hydroxide

Interestingly, if diol (131) is allowed to stand over dry KOH and the products recovered by heating under vacuum, then a more volatile component is formed. This was isolated, by preparative scale g.l.c., as a mixture of two isomers (ratio 4:1) and the spectral data indicated that loss of HF had occurred giving epoxide (132) (Scheme 41). It is important that dry KOH is used because a violent reaction occurred with wet KOH.

Epoxide (132) is probably formed from the monopotassium salt (133), via intramolecular nucleophilic displacement of fluoride. Two similar examples of this type of reaction were described earlier.

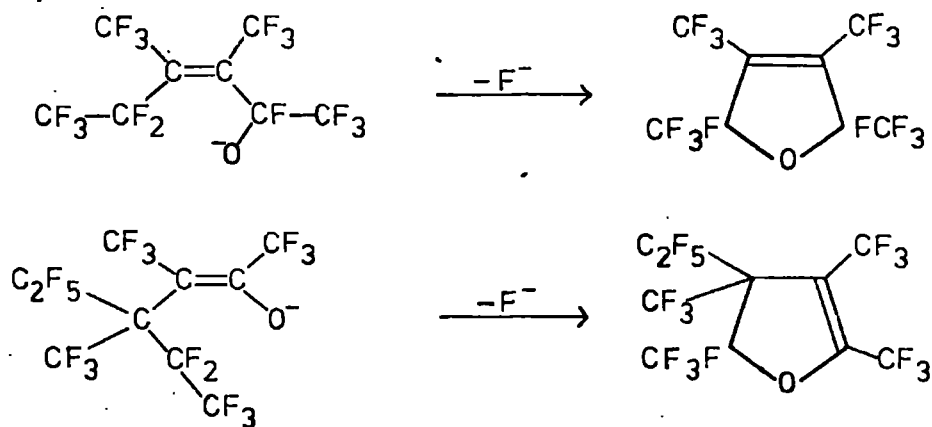

The disodium salt of F-pinacol has, in fact, been isolated as a stable solid hydrate.<sup>188</sup>

IV.E. Structural Assignments

Diol (131) gave a satisfactory analysis and shows OH stretches in the i.r. spectrum. The <sup>19</sup>F n.m.r. spectrum shows the presence of CF<sub>3</sub> and C<sub>2</sub>F<sub>5</sub> groups, which are broadened because (131) has two asymmetric centres giving rise to dl and meso forms.

Epoxide (132) gave an M-19 peak in its mass spectrum but a

satisfactory analysis could not be obtained. The i.r. spectrum shows OH stretches.

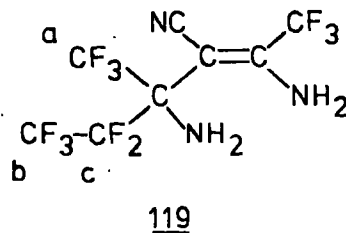
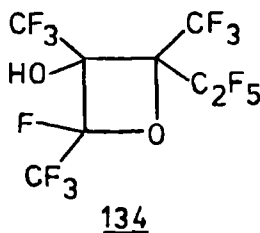
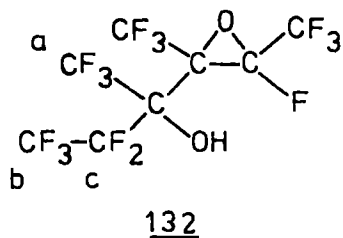

a, 74.7;  $J_{a,b} = 4$

b, 81.4;  $J_{a,c} = 10$

c, 126.9.

a, 73.6,  $J_{a,b} = 4$

b, 80.2,  $J_{a,c} = 12.5$

c, 119

Structure (132) is preferred to (134) because the  $^{19}\text{F}$  n.m.r. spectrum shows a tertiary fluorine signal at 211 p.p.m. Oxetane (134) would be expected to give a signal at a much lower shift (ca. 130 p.p.m.)<sup>189</sup>. Also the shifts and coupling constants of the relevant groups compare favourably with those of (119).

CHAPTER V

Pyrolysis of F-olefins

Although there are many reports<sup>190</sup> (see also II.F) of the pyrolysis of fluorinated organic compounds very few concern acyclic systems. As stated earlier three processes have been found to occur. These are: 1) isomerisation, 2) defluorination over a reactive surface such as iron or caesium fluoride, and 3) loss of fragments containing carbon. The reactions described in this chapter illustrate these processes for acyclic F-olefins and some related cyclic systems. Some of these reactions are very useful since they give good yields of dienes and furan derivatives from readily available starting materials using a very simple technique. All the reactions involve passing a compound in a stream of nitrogen over a hot surface.

Some reactions of the dienes and furans are reported in Chapter VI.

V.A. F-3,4-dimethyl-3-hexene (41)

All three processes, mentioned above, can occur for F-3,4-dimethyl-3-hexene (41) by using various surfaces and temperatures:-

Isomerisation: Fe, CsF, Pt, 540°.

Defluorination: Fe, 430-540°; CsF, 540°.

Fragmentation: Pt, Quartz, or any inert surface, 550-700°.

It has been found previously that (41) defluorinated over iron filings between 430 and 500° giving diene (89a), as a mixture of two isomers, and cyclobutene (89b).<sup>169</sup>

Isomerisation of (41) also occurs over iron filings and reaction at 540° gave a mixture of C<sub>8</sub>F<sub>16</sub> isomers (41), (98), and (99), as well as

the expected (89) (ca. 50% of the recovered product).

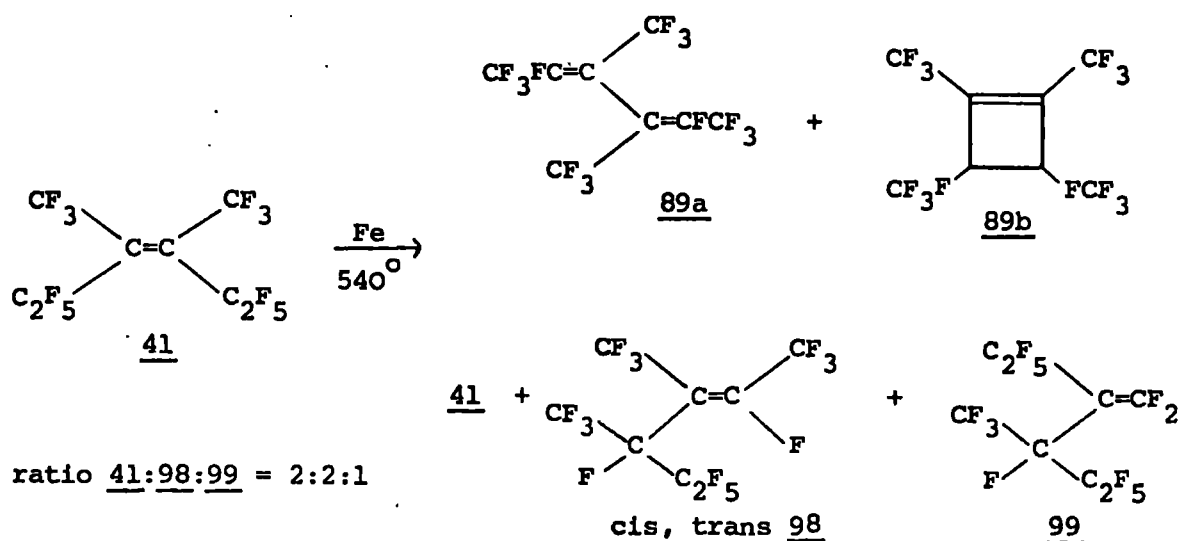

These reactions are very difficult to reproduce, which is probably a result of variations in the activity of the iron filings (see experimental, IX.A).

Caesium fluoride at 540° gave a similar product mixture to that obtained using iron filings at the same temperature, but in this case the terminal olefin (99) was not formed. The conversion to defluorinated products (89) was about 28%. A similar defluorination over CsF was mentioned earlier (III.B.1).<sup>178</sup> The absence of terminal olefin (99) in the product obtained from passage over CsF is not surprising since alkali metal fluorides are known to isomerise terminal olefins to internal olefins (see Table 4, Chapter I).

Isomerisation also occurs over platinum and reaction at 540° gave a mixture containing (41) (ca. 70%), (98) (25%) and (99) (5%). At higher temperatures fragmentation gives diene (130) and cyclobutene (135) (ratio ca. 4.4:1).

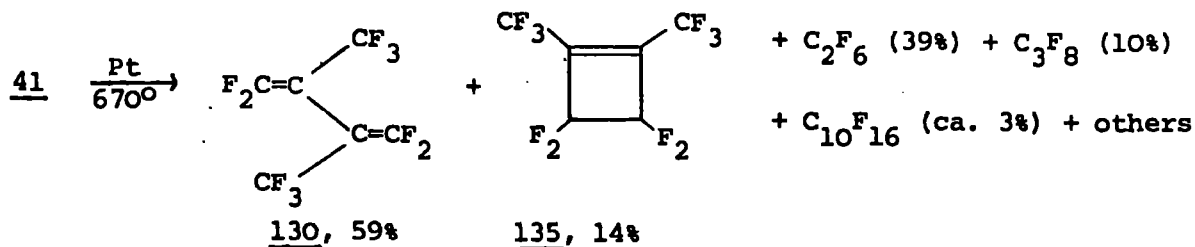

Compounds (130) and (135) are  $\text{C}_6\text{F}_{10}$  isomers, formed from (41) by loss of  $\text{C}_2\text{F}_6$ . Although this is the major reaction pathway others must occur since F-propane,  $\text{C}_{10}\text{F}_{16}$  isomers, and other unidentified products are also produced.

#### V.A.1 Mechanism

The isomerisations of (41) to (98) and (99) are most probably thermal 1,3-shifts of a fluorine atom, since they occur over inert surfaces. The absence of (99), a terminal olefin, from the product obtained using CsF will be a result of fluoride ion induced isomerisation of (99) to (41) and/or (98).

The fragmentation and defluorination reactions can be explained by the formation of intermediate allylic radicals. Thus loss of  $\cdot\text{CF}_3$  occurs over platinum whereas loss of  $\cdot\text{F}$  is obviously preferred over iron. Subsequent cyclisation of the dienes to cyclobutenes is a

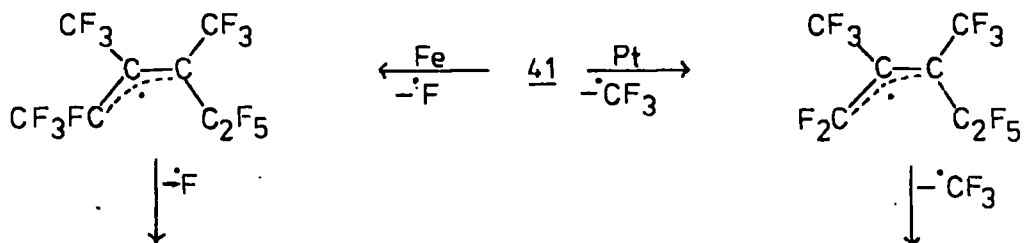

well known thermal process. 186,191

Loss of  $\cdot\text{C}_2\text{F}_5$  from (41) must also occur over platinum since F-propane (10% yield) was produced. The formation of F-propane and also the  $\text{C}_{10}\text{F}_{16}$  isomers (ca. 3% yield) (g.l.c.-ms only) can be accommodated by the following mechanism.

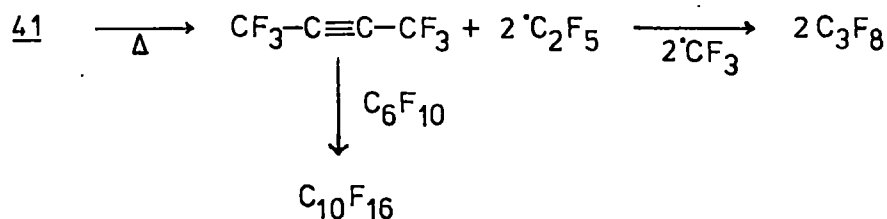

However there was no reaction between diene (130) and F-2-butyne after heating at  $300^\circ$  for 24 h in a Carius tube.

#### V.A.2 Structural Assignments

F-olefins (89a) and (89b) are known compounds.<sup>176,177</sup>

A mixture of  $\text{C}_8\text{F}_{16}$  isomers (41), (98) and (99) (ratio ca. 2:2:1) was isolated by distillation and preparative scale g.l.c. from the product obtained using iron at  $540^\circ$ . The mixture gave a satisfactory analysis. The structures of (98) and (99) follow largely from the  $^{19}\text{F}$  n.m.r. spectra of enriched samples (the isomers were not fully resolved by g.l.c.) by comparison with data given in Table 23 (Chapter III), data for alkoxy derivatives of (41) related to (98) (Chapter IV), and the data for diene (130). The cis isomer (98b) shows a diagnostic

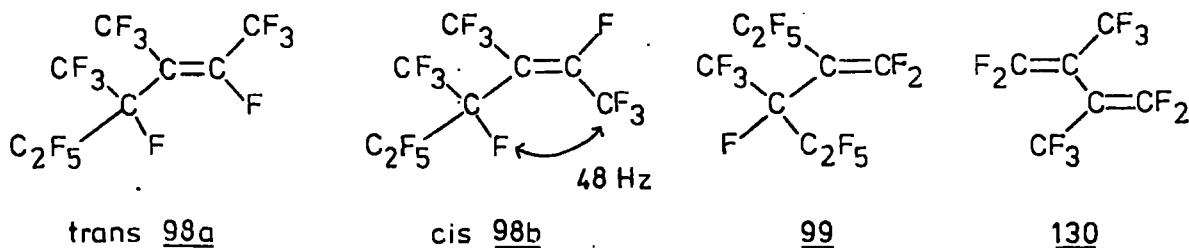

ratio 98a:98b = 4:1

doublet ( $J = 48$  Hz) for the  $\text{CF}_3\text{CF}=\text{C}$  group. Further evidence of structure was obtained by the reaction of a mixture of these isomers with methanol (see IV.A.2).

Diene (130),<sup>192,193</sup> cyclobutene (135),<sup>193</sup> F-ethane<sup>194</sup> and F-propane are known compounds.

V.B F-2,3-dimethyl-2-pentene (92)

Like (41), F-olefin (92) is defluorinated over iron and gives a similar range of products.

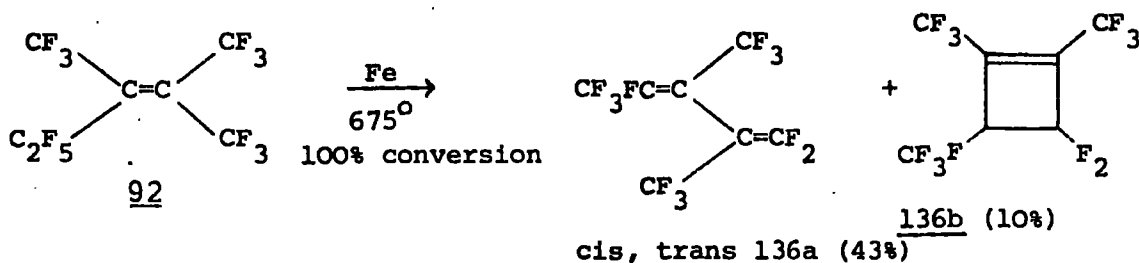

Fragmentation of (92) over platinum requires higher temperatures ( $620^\circ - 715^\circ$ ) than the corresponding reaction of (41) and gives low yields of products.

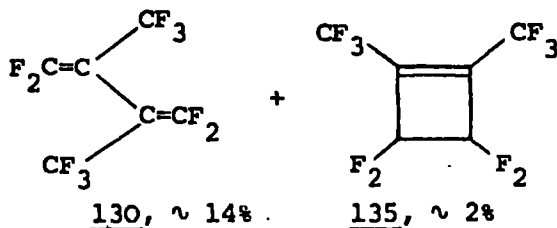
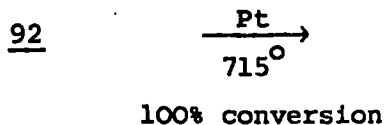
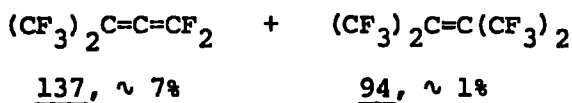

Again, the products can be explained by intermediate allylic radicals. In this case the allylic radical produced over platinum reacts further by three routes: 1) loss of  $\cdot\text{CF}_3$  giving allene (137), 2) loss of F giving (130) and (135), and 3) addition of F giving (94).

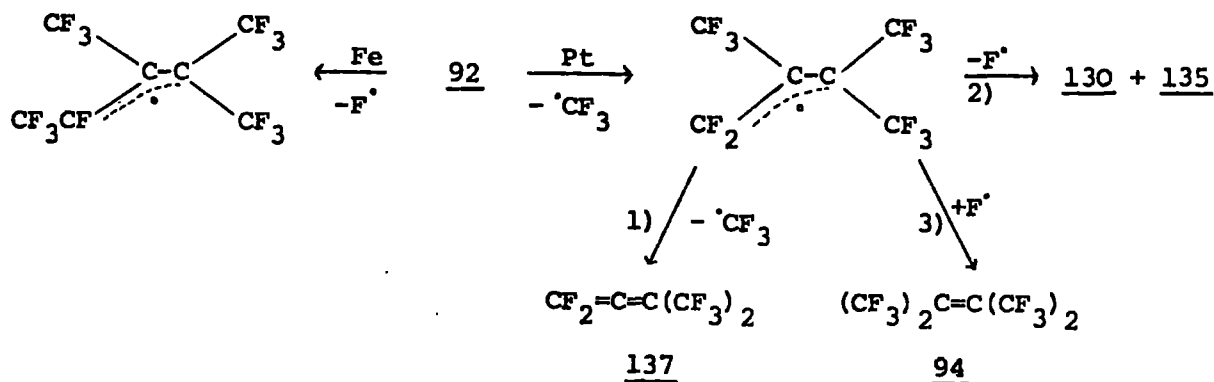

Process 2) will not be as favourable as loss of  $\cdot\text{CF}_3$  from the corresponding allylic radical produced from (41) and process 3) is possible because the allylic radical will have a longer lifetime than that from (41) and also because F atoms are produced by process 2). Clearly all three processes must be energetically similar whereas for (41) there is one very favourable process.

Compounds (94)<sup>87</sup>, (130)<sup>192</sup>, (135)<sup>192</sup>, and (137)<sup>195</sup> are known compounds. These were not separated but were identified by g.l.c.-ms and by comparison of the  $^{19}\text{F}$  n.m.r. and i.r. spectra of the product mixture with the literature data and data for samples of (130) and (135) obtained from (41) (see earlier).

Isomers (136), from defluorination of (92), were separated, as a mixture, by preparative scale g.l.c., giving a satisfactory analysis and a parent peak in the mass spectrum. Their structures were assigned by a comparison of  $^{19}\text{F}$  n.m.r. spectral data with that of the related



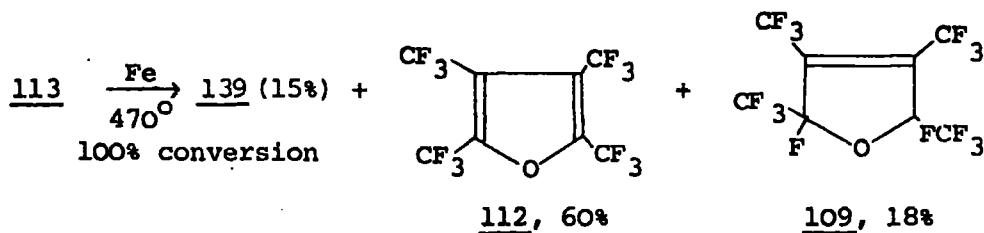
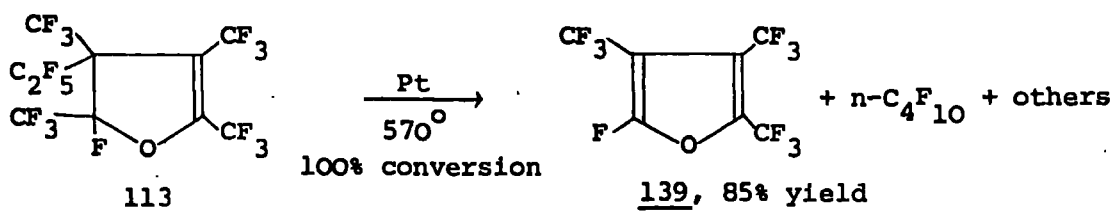

Pyrolysis of (113) over iron at 470° produced furans (112) and (109) as well as (139).

The first step of both reactions is the loss of <sup>•</sup>C<sub>2</sub>F<sub>5</sub> giving an allylic radical. The alternative loss of <sup>•</sup>CF<sub>3</sub> from (113) does not occur because <sup>•</sup>CF<sub>3</sub> is less stable. Subsequent reactions are then determined by the metal.

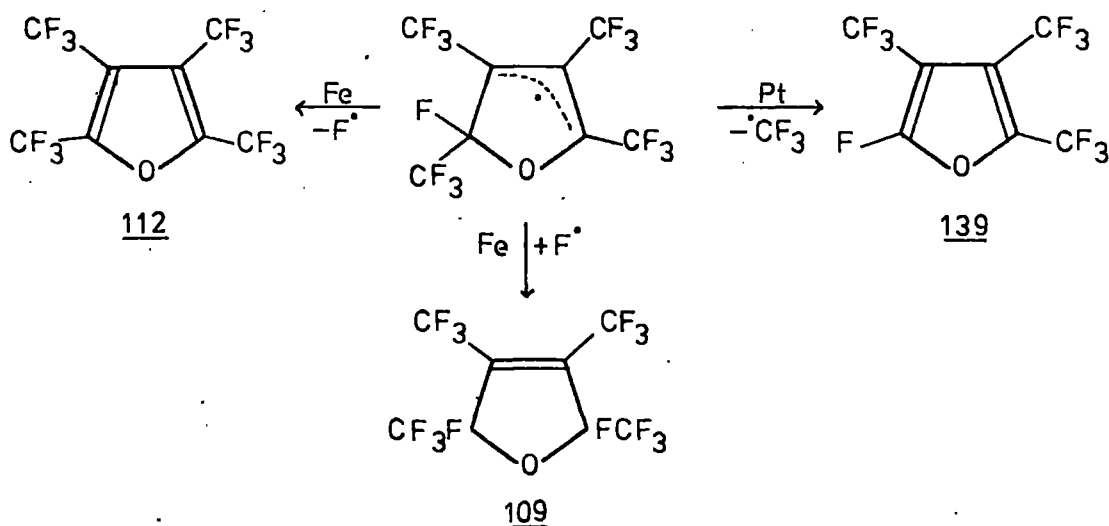

It is quite interesting that furan (109), from the addition of F<sup>•</sup>, is formed since (109) was defluorinated over iron at a higher temperature (580°) giving (112). Furan (109) does not pyrolyse readily over

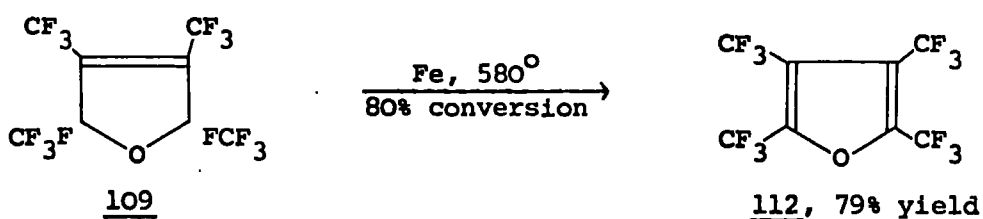

platinum at  $715^\circ$  and only a low conversion to two unidentified products was obtained.

Furan (112) is a known compound<sup>155</sup> and (109) has been characterised<sup>169</sup> (see also IV.A.7.c). The structure of (139) follows simply from a comparison of its  $^{19}\text{F}$  n.m.r. spectrum with that of (112). The coupling constants are usefully diagnostic. Furan (139) also gave a satisfactory analysis and a parent peak in the mass spectrum.

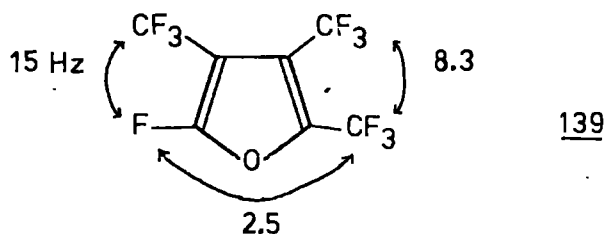

CHAPTER VI

Some Reactions of F-2,3-dimethylbutadiene and F-tri- and F-tetra-methylfurans

The work described in this chapter is a brief survey of some reactions of the products obtained from the pyrolyses described in Chapter V.

VI.A F-2,3-dimethylbutadiene (130)

VI.A.1 Reactions with Methanol and Phenol

Like F-isobutene (II.B.1.b), diene (130) reacts with neutral methanol at room temperature giving an addition product (140) and a substitution product (141). The addition product (140) is formed by a 1,2-addition of methanol and not by a 1,4-addition. This is to be

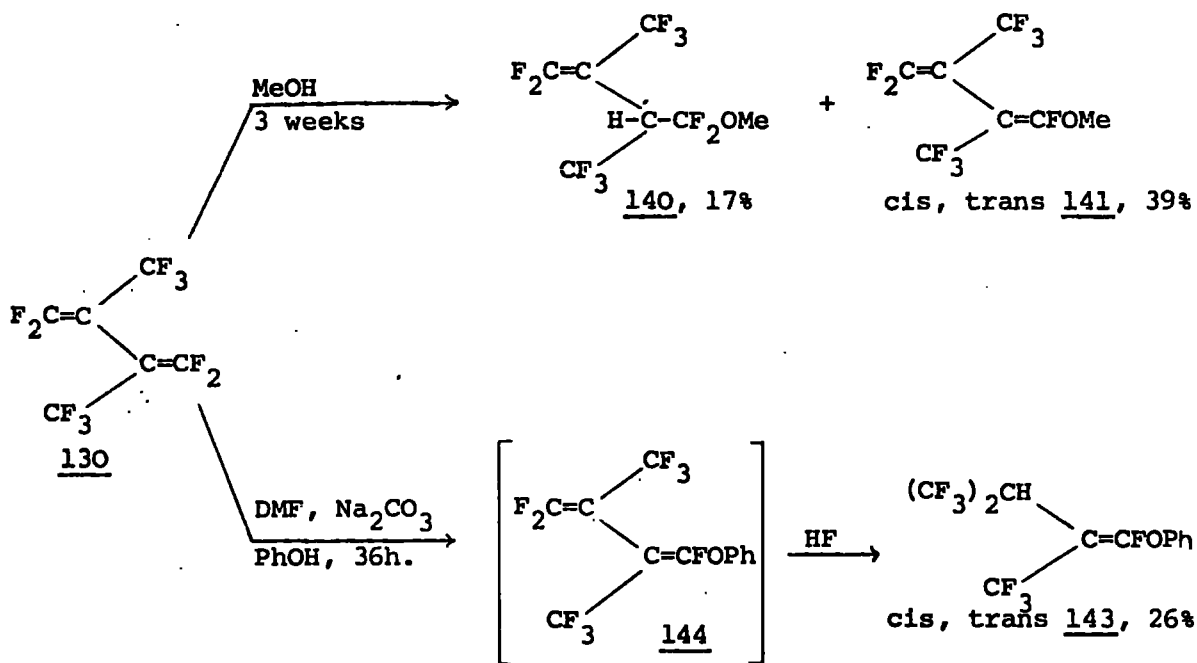

expected since diene (130) will be non planar and have largely unconjugated double bonds like F-1,3-butadiene (142). Spectroscopic techniques have shown that (142) is non planar<sup>196</sup> and it also undergoes 1,2-addition of methanol.<sup>197</sup>

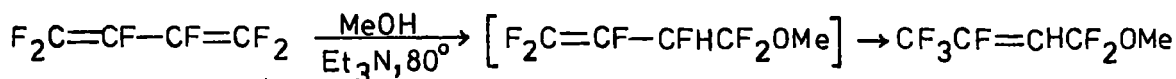

The reaction of (130) with phenol, using sodium carbonate as base and DMF as solvent, is more complex than that with neutral methanol. The only identified product (143) (ca. 26% yield) must arise via initial substitution giving (144) followed by 1,2-addition of HF to the other double bond. It is probable that the addition of HF occurred because the reaction was carried out in an aprotic solvent, in which fluoride ion is a strong nucleophile. In contrast, fluoride ion would only be a weak nucleophile in neutral methanol.

#### VI.A.1.a Structural Assignments

The methoxy derivatives (140) and (141) both gave satisfactory analyses and parent peaks in their mass spectra. Their structures follow simply from a comparison of  $^{19}\text{F}$  n.m.r. data and  $\text{C}=\text{C}$  stretching frequencies with those of the starting material (130). The phenoxy derivative (143) was not obtained pure after using preparative scale g.l.c. but was identified by a parent peak in the mass spectrum and by a comparison of its  $^{19}\text{F}$  n.m.r. spectrum with those of (141) and (145).<sup>76</sup>

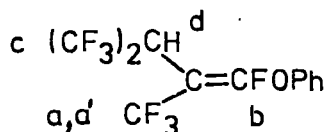

cis, trans 143

a, 60.7 D( $J_{\text{a,b}} = 22$ )

a', 61.3 D( $J_{\text{a',b}} = 10$ )

c, 65.7 D( $J_{\text{c,d}} = 7.5$ )

d,  $\delta$  4.1

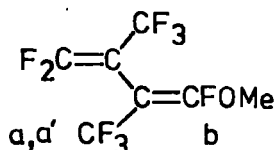

cis, trans 141

a, 60.4 D( $J_{\text{a,b}} = 19$ )

a', 61.1 D( $J_{\text{a',b}} = 12$ )

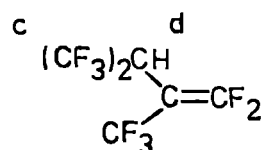

145

c, 69.6 ( $J_{\text{c,d}} = 7.6$ )

d,  $\delta$  3.8

VI.A.2 Hydrolysis

The hydrolysis of diene (130) has been reported in the literature. <sup>198</sup>

All the products may be explained by mechanisms described in Section II.B.2.b.

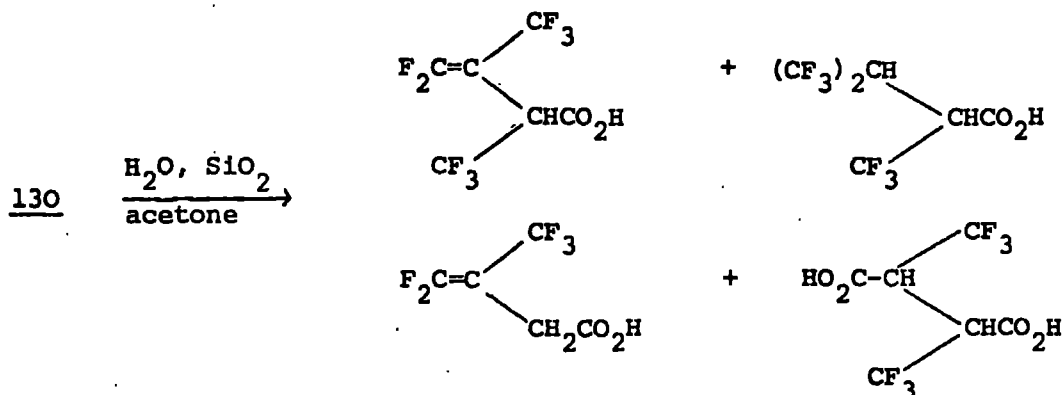

Like the carboxylic acids mentioned in that section these products are dehydrated over  $\text{P}_2\text{O}_5$  to form stable ketenes or anhydrides.

VI.A.3 Reaction with Fluoride, Dimerisation

Diene (130) dimerises very readily in the presence of  $\text{CsF}$  and tetraglyme. Two dimers are formed as the main products and their ratio is temperature dependent. However they are not interconverted by  $\text{CsF}$  and tetraglyme at room temperature or at  $80^\circ$ .

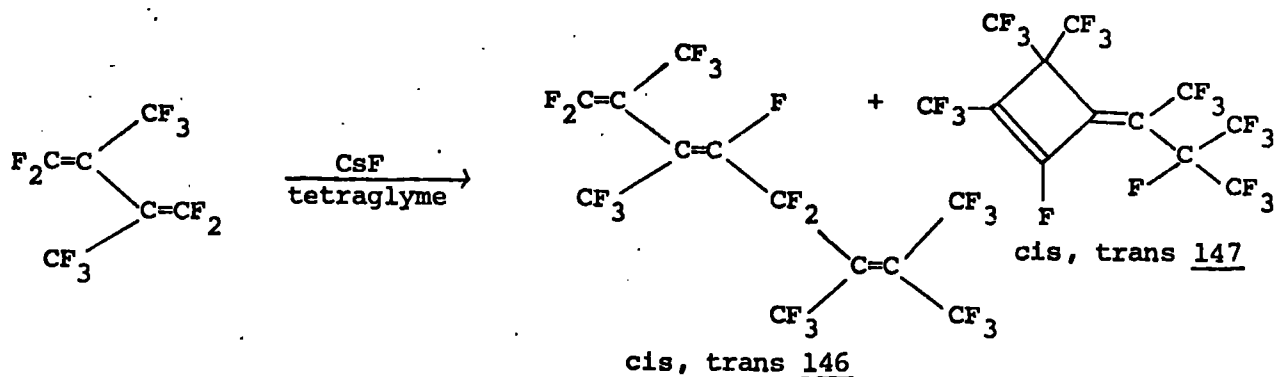

Room temperature: (146) (57% yield), (147) (30%)

$90^\circ$ : (146) (28%), (147) (44%)

Fluoride Ion Induced Dimerisation of F-2,3-dimethylbutadiene

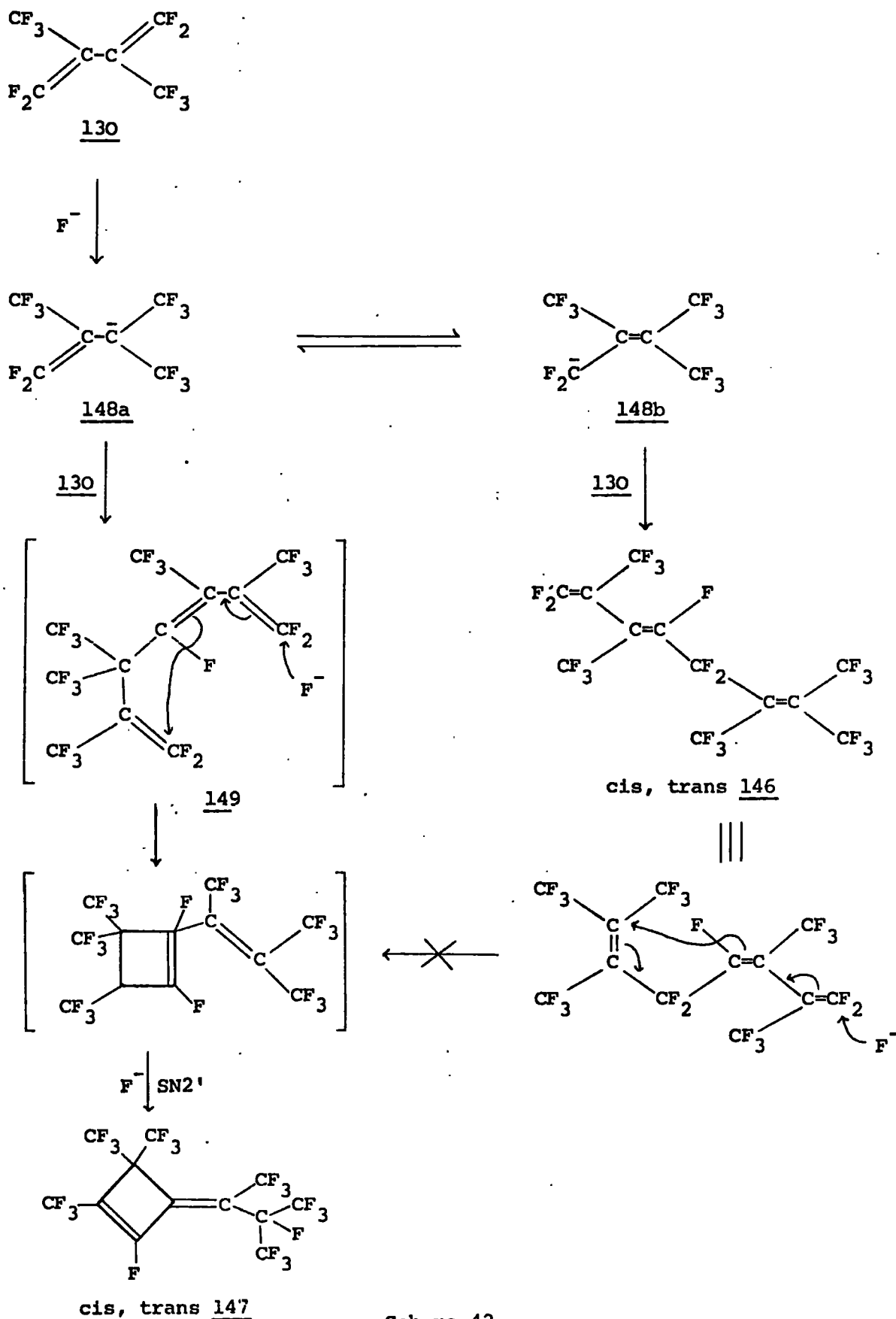

Scheme 42

A mechanism accounting for these observations is given in Scheme 42. Addition of fluoride ion to diene (130) will give an allylic anion (148). It is probable that (148a) and (148b) are

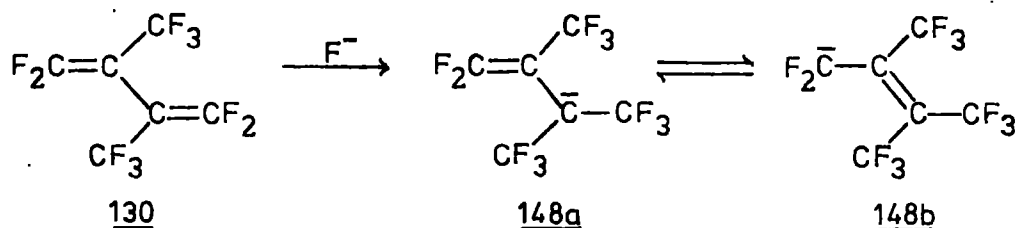

discrete species rather than resonance canonicals because the products are derived from both. Isomer (148a) will be more stable but less reactive. Thus at room temperature dimer (146), derived from (148b), predominates. However, at 90° the increased reactivity of the more stable isomer (148a) leads to increased yields of (147) at the expense of (146).

The cyclisation step leading to (147) is an internal vinylic substitution of fluoride from a reactive C=CF<sub>2</sub> group in (149). The analagous cyclisation of dimer (146) does not occur because it would require an internal nucleophilic attack on a much less reactive C=C(CF<sub>3</sub>)<sub>2</sub> group.

The allylic anion (148) is trapped by bromine, but no bromine containing products were isolated because further reaction with fluoride readily occurs. The main product is the known F-2,3-dimethyl-2-butene (94).<sup>87</sup>

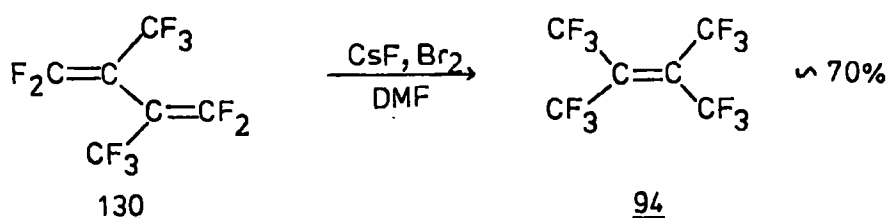

VI.A.3.a Structural Assignments

Dimers (146) and (147) were separated by preparative scale g.l.c. and both gave satisfactory analyses and parent peaks in their mass spectra.

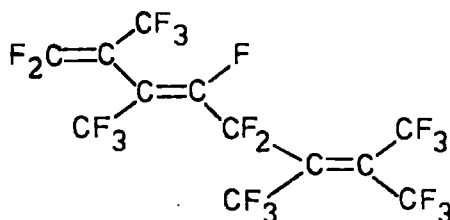

cis, trans 146

The structure of (146) follows from a comparison of i.r. data with that of diene (130) (from which it is derived), and from its  $^{19}\text{F}$  n.m.r. spectrum. Thus the i.r. spectrum shows two strong  $\text{C}=\text{C}$  stretches at 1720 and 1730  $\text{cm}^{-1}$  (cf. 130, 1735 and 1760  $\text{cm}^{-1}$ ) and the  $^{19}\text{F}$  n.m.r. spectrum shows five vinylic  $\text{CF}_3$  groups, a terminal  $\text{CF}_2$  group, one other vinylic fluorine, and a vinylic  $\text{CF}_2$  group. The  $^{19}\text{F}$  n.m.r. spectrum also indicates that cis and trans isomers are present in the ratio 2:1 but it is uncertain which isomer predominates.

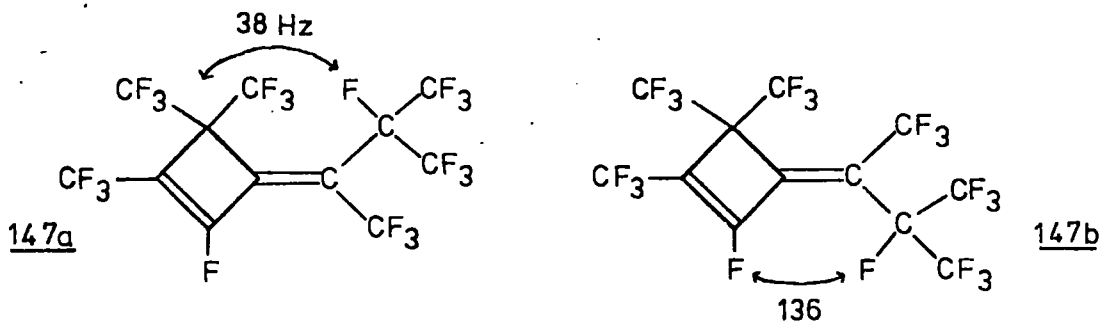

ratio 147a:147b = 2.2:1

The most important features indicating structure (147) for the other dimer are: 1) the tertiary fluorine gives rise to two signals

(ratio 2.2:1) at 174.5 (septet,  $J = 38$ ) and 167.7 p.p.m. (doublet,  $J = 136$ ) and 2) the double bonds are conjugated from the u.v. spectrum ( $\epsilon = 17,700$ ). The other spectral data is also consistent with these structures. Thus the i.r. spectrum shows  $C=C$  stretches at 1730 and 1640  $\text{mw cm}^{-1}$ , and the  $^{19}\text{F}$  n.m.r. spectrum shows two vinylic  $\text{CF}_3$  groups, two sets of two equivalent  $\text{CF}_3$  groups, and one vinylic fluorine giving rise to signals at 77.1 (147a) and ca. 58 (147b).

#### VI.A.3.b Formation of a Stable Anion

Acyclic dimer (146), when stirred with  $\text{CsF}$  and tetraglyme gave a 1 phase system although (146) is not soluble in tetraglyme alone. The  $^{19}\text{F}$  n.m.r. spectrum was different to that of the starting material (146) in that it showed  $\text{CF}_3$  groups at low field (2 x  $\text{CF}_3$  at 39.8 p.p.m.), but the remainder of the spectrum was similar to that of (146). The

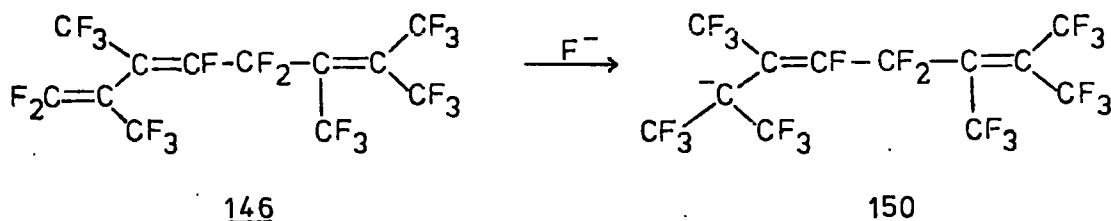

spectrum is consistent with anion (150) although the integration is uncertain. Addition of  $\text{BF}_3$ -etherate resulted in regeneration of (146) as a lower layer and formation of a precipitate (presumably  $\text{CsBF}_4$ ). The other dimer (147) did not give a one phase system with  $\text{CsF}$  and tetraglyme using the same conditions as for (146). The  $^{19}\text{F}$  n.m.r. spectrum of the tetraglyme layer was very weak and different to that of (150). Several other fluorodienes were studied, but like (147) these did not give observable anions (see experimental).

Some other stable carbanions have been reported (see Table 3, Chapter I) and low field signals appear to be characteristic of these and related systems. An example of each is given below.<sup>199,200</sup>

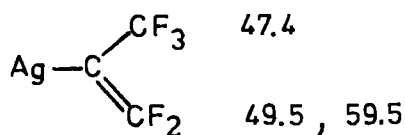
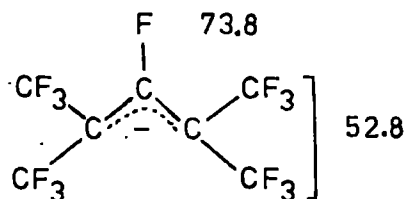

VI.A.3.c Fluorination of Dimers

A mixture of the two dimers (146) and (147) (ratio ~ 65:35) was fluorinated by passing over cobalt trifluoride heated at 100° and 200°. At 100° each dimer adds one mole of fluorine and at 200° further fluorination and some fragmentation occurs. It is not obvious

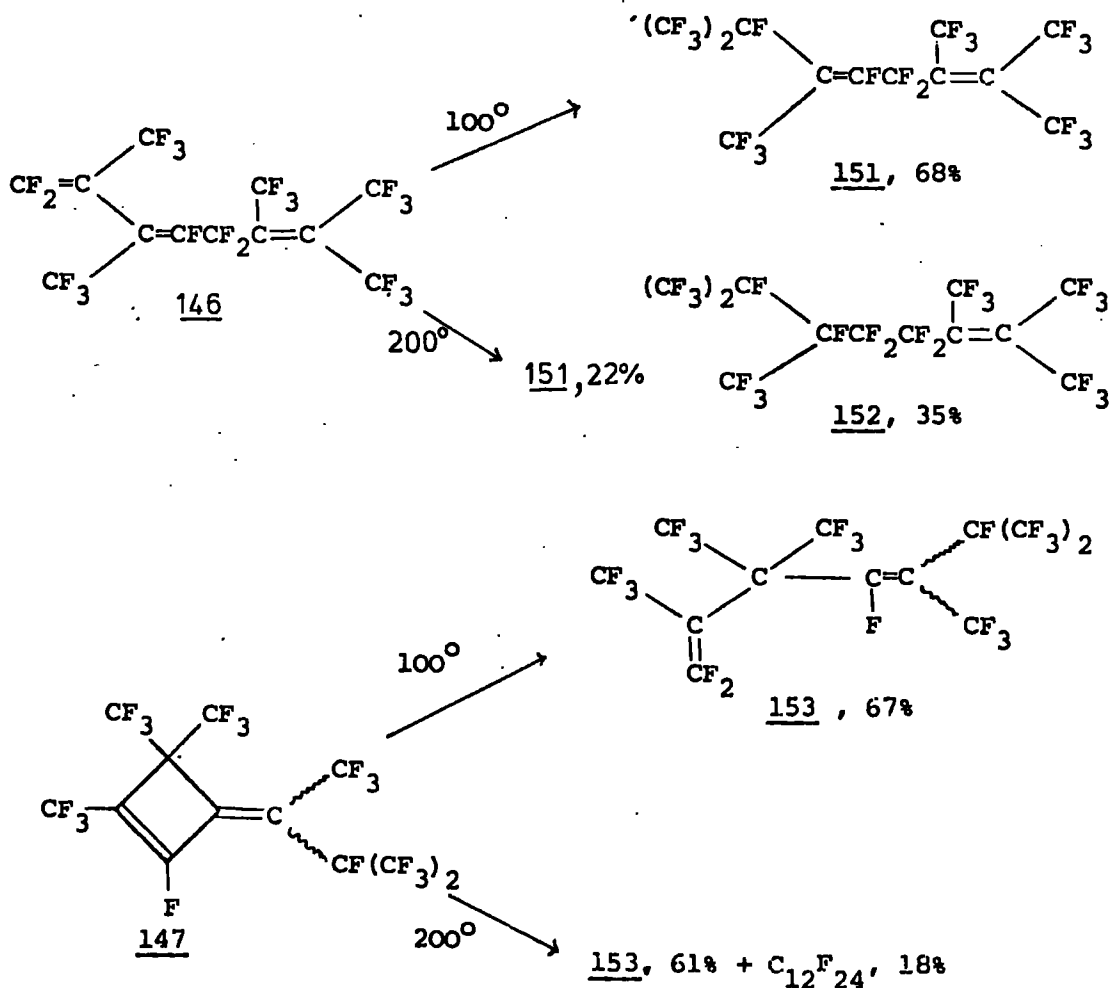

why terminal olefin (153) does not readily undergo further fluorination.

Both products from acyclic dimer (146) were isolated and gave satisfactory analyses and  $M^+F$  peaks in their mass spectra. Their structures follow simply from a comparison of their  $^{19}F$  n.m.r. spectra and  $C=C$  stretches with the data for (146). Thus (151) shows a strong  $C=C$  stretch at  $1705\text{ cm}^{-1}$  (cf. 146,  $1720$  and  $1730\text{ cm}^{-1}$ ) and one tertiary fluorine whereas (152) shows a very weak  $C=C$  stretch at  $1700\text{ cm}^{-1}$  and two tertiary fluorines.

The  $C_{12}F_{22}$  isomer (153), formed from cyclic dimer (147), was separated and gave a satisfactory analysis and a parent peak in its mass spectrum. The i.r. spectrum shows two  $C=C$  stretches at  $1740$  and  $1650\text{ cm}^{-1}$  (cf. 147,  $1730$  and  $1640\text{ cm}^{-1}$ ) but both are weaker than those of (147). The structure (153) would give the required  $C=C$  stretches and the  $^{19}F$  n.m.r. spectrum is also consistent with (153) since it shows a  $CF(CF_3)_2$  group and four other  $CF_3$  groups, as well as signals for the vinylic fluorines.

#### VI.A.3.d Attempted Dimerisations using Other Catalysts

It was thought that dimerisation of (130) could possibly occur using antimony pentafluoride as catalyst (see Section I.C). Although a precipitate formed at room temperature using a deficiency or excess of antimony pentafluoride subsequent transference, under vacuum, resulted in a disappearance of the precipitate and gave only (130) (89%, using excess 130). The precipitate may have been an  $SbF_6^-$  salt of an F-carbocation (see I.B.1).

Only (130) (85%) was recovered after stirring with pyridine and tetraglyme at room temperature.

VI.A.4 Photolysis with F-acetone

Photolysis of fluorocarbonyl compounds with fluoro-olefins can produce polyfluorooxetanes.<sup>189</sup> When a mixture of diene (130) and F-acetone was photolysed three main products were formed.

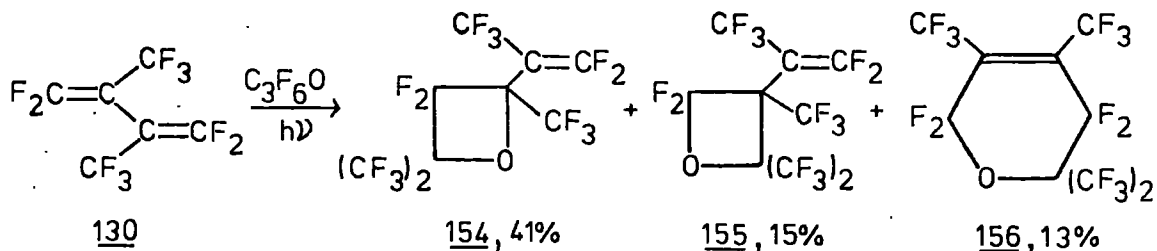

Two oxetanes (154) and (155) and also a pyran (156) were produced.

An analogous pyran has been isolated from a thermal reaction of H-2, 3-dimethylbutadiene with F-diethyl ketone.<sup>201</sup>

The three main products were isolated by preparative scale g.l.c. and (155) and (156) gave satisfactory analyses. The mass spectra showed a parent peak for (155), an M-F peak for (154), and an M-COF peak for (156). The structures of (154) and (155) follow from their strong C=C stretches (154 at 1700 and 155 at 1730  $cm^{-1}$ ) and their  $^{19}F$  n.m.r. spectra. Thus (155) shows a low field  $-CF_2-$  signal at ca. 65 p.p.m. characteristic of  $CF_2$  adjacent to O in a four membered ring,<sup>189</sup> whereas (154) shows a 'normal'  $CF_2$  signal at 109.4 p.p.m. The other chemical shifts are also consistent with the proposed structures.

Pyran (156) does not show a C=C stretch in the i.r. spectrum but it appears at 1660  $cm^{-1}$  in the Raman spectrum. The  $^{19}F$  n.m.r. spectrum shows two vinylic  $CF_3$  groups (at ca. 59 p.p.m.), two  $CF_3$  groups at 76.5 p.p.m. and two equivalent  $CF_2$  groups at 101 p.p.m.

VI.A.5 Radical Reactions

Diene (130) did not react with bromine and this feature has also been reported in the literature.<sup>198</sup> Similarly, copolymers with butadiene and methylmethacrylate were not formed. Styrene and (130) gave a polymer containing some fluorine (3.9%) but this was removed after reprecipitation from toluene.

These features most probably result from the stability of the allylic radical derived from (130).

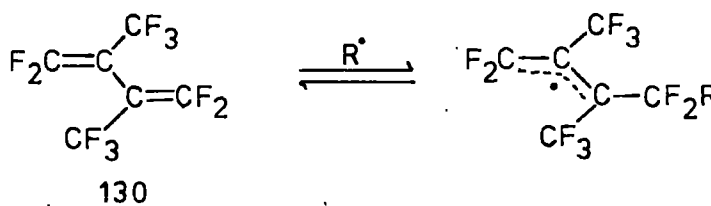

VI.B F-tri- and F-tetra-methyl furans

VI.B.1 Reactions with Nucleophiles

Nucleophiles will readily replace the vinylic fluorine of F-2,3,4-trimethylfuran (139):-

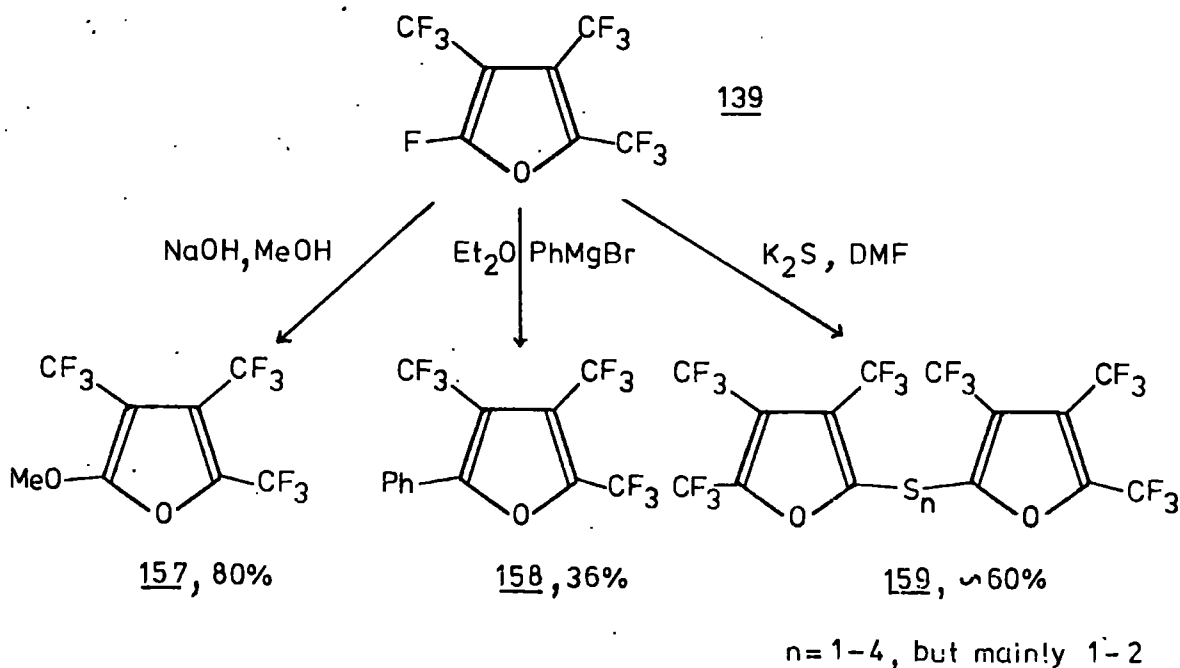

Methoxy derivative (157) and phenyl derivative (158) both gave satisfactory analyses and parent peaks in their mass spectra. Their structures follow simply from a comparison of spectral data with that of the starting material (139). Two fractions of (159) were isolated by molecular distillation, one contained mainly (159,  $n = 1$ ) from the elemental analysis and the less volatile fraction mainly (159,  $n = 2$ ). The mass spectrum of the less volatile fraction showed parent peaks for (159,  $n = 1-4$ ). Again the  $^{19}\text{F}$  n.m.r. spectrum shows that the furan ring is intact.

Similar polysulphide compounds have been obtained from F-isobutene.<sup>202</sup>

#### VI.B.2 Dimerisation

Dimer (160) (95% yield) is formed from (139) in the presence of CsF and tetraglyme at room temperature. Of the two possible dimers (160) and (161) only (160) was observed.

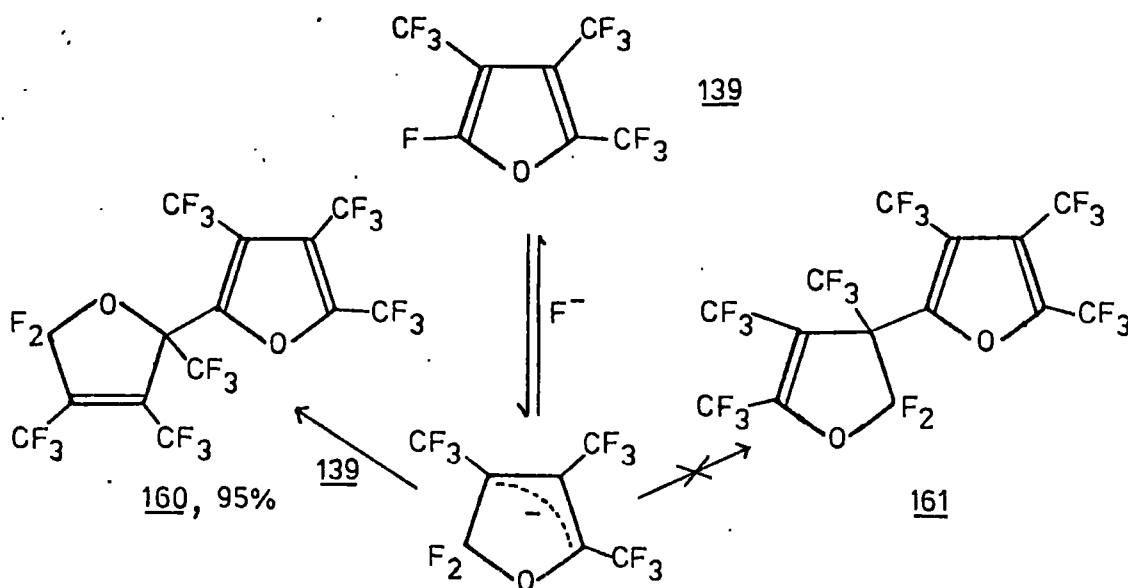

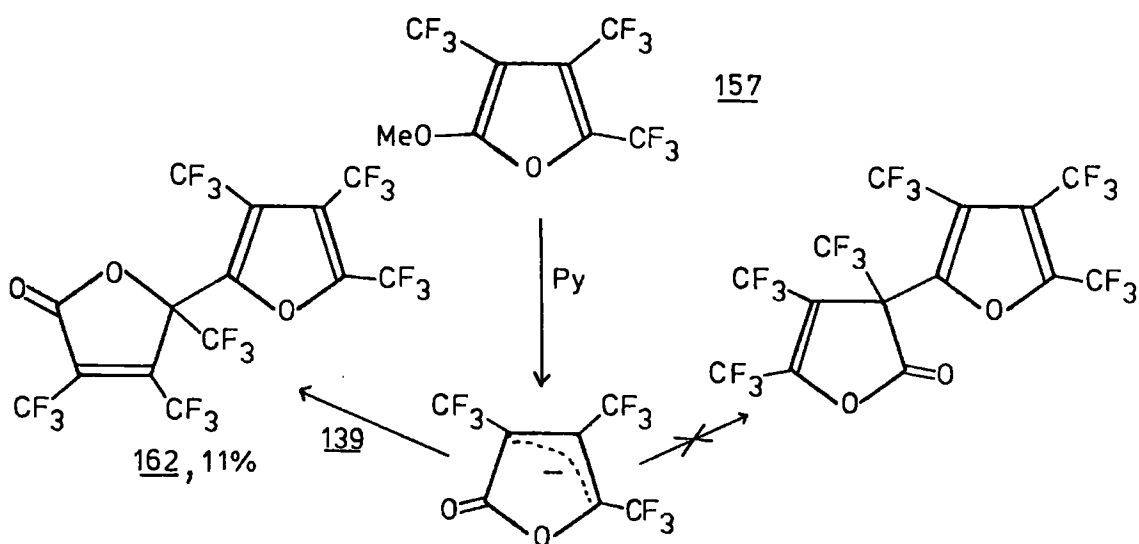

An analogous product (162) (11% yield based on 157) was obtained from (139) and its methoxy derivative (157) by refluxing with tetraglyme and pyridine. Dimer (160) is also formed in this reaction.

Both (160) and (162) gave satisfactory analyses and (160) gave a parent peak while (162) gave an  $M-F$  peak in their mass spectra. The mass spectrum of (160) showed a metastable peak for loss of  $C_5F_8$ , which is not possible for the alternative dimer (161). Although (162) did not give a strong metastable for analogous loss of  $C_5F_6O$  the peaks which would produce this metastable are very strong ( $489 \rightarrow 299$ ) and

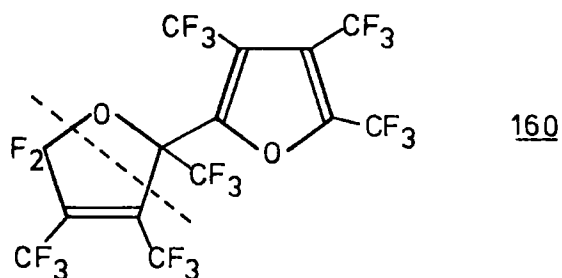

again this is only consistent with (162). The i.r. spectra of (160) and (162) are very similar except that (162) shows a strong  $C=O$  stretch at  $1840\text{ cm}^{-1}$ . Likewise the  $^{19}\text{F}$  n.m.r. spectra are similar except that (160) shows an AB signal at ca. 63 p.p.m. which is consistent with a  $\text{CF}_2$  group adjacent to oxygen. The other assignments were possible by

comparison with the similar furan derivatives (109) and (157).

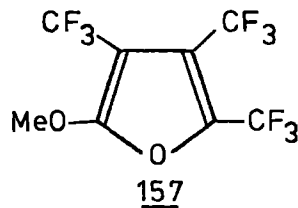
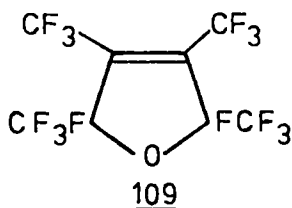

### VI.B.3 Photolysis

The photochemistry of fluorinated furans is of interest because of the possibility of obtaining valence isomers since a Dewar thiophene is formed from F-tetramethylthiophene on irradiation.<sup>203,204</sup>

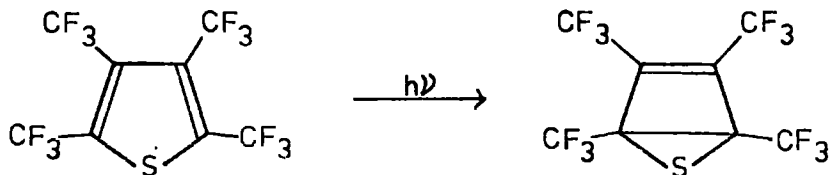

In fact low conversions (ca. 20%) to cyclopropenyl derivatives were obtained from both (139) and (112), by using transfer conditions<sup>205</sup> and a high pressure Hg lamp.

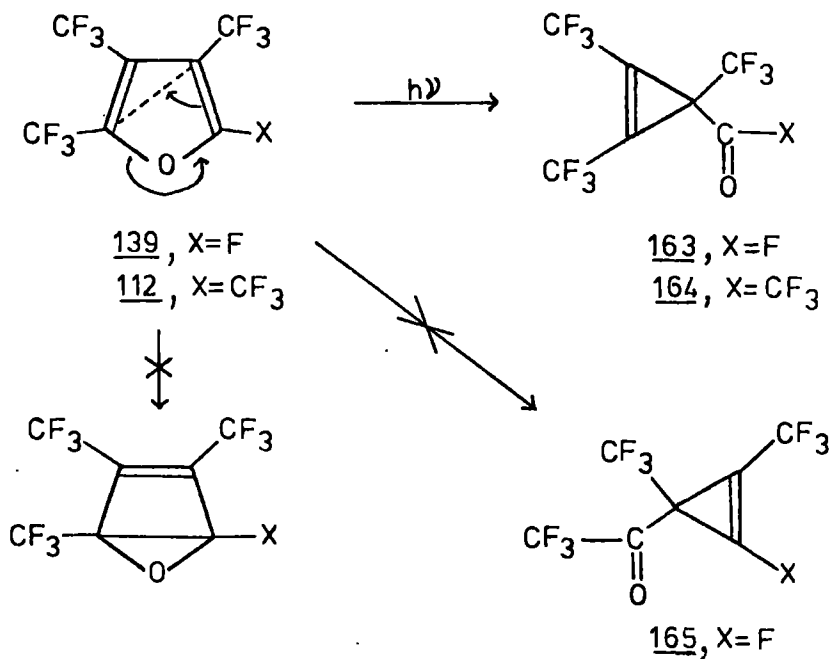

A static system is unsuitable for these reactions because complex mixtures of less volatile products are formed. Similarly repeated transference decreases the yields of cyclopropenyl derivatives although a number of other volatile components are also produced. These may be other isomers of the furans but they were not isolated or identified.

It is interesting that ring opening of furan (139) gave only the acid fluoride (163), rather than ketone (165). This may be a result of the destabilising influence of a fluorine atom directly attached to a carbon-carbon double bond (see I.B.3), as in (165) and/or a stabilising influence of F-methyl groups on small rings,<sup>206,207</sup> as in (163).

Cyclopropene derivative (164) is a known compound and forms furan (112) when heated with bromine.<sup>207</sup>

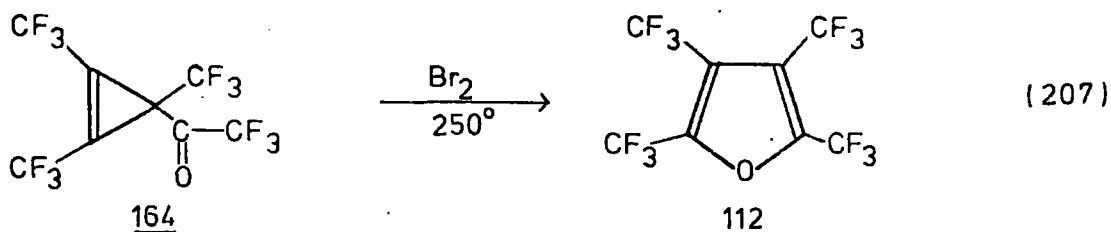

Acid fluoride (163) gave a satisfactory analysis and a  $M^{+}19$  peak in its mass spectrum. The structure follows simply from a comparison of spectral data with that of (164) and it also shows the characteristic acid fluoride signal at -29.7 p.p.m.

#### VI.B.4 Attempted Diels-Alder Reactions

It has been reported that no Diels-Alder Adducts were obtained from F-tetramethylfuran (112).<sup>155</sup> In fact no adducts were obtained from (112) using furan and diphenylacetylene.

EXPERIMENTAL

### Chemicals

F-3,4-dimethyl-3-hexene (41) was supplied by I.C.I. (Mond) Ltd. As supplied it contained amines and other impurities and was purified by washing with dil. HCl and water, drying over  $\text{MgSO}_4$ , and finally by distillation. The (41) thus obtained contained <5% of 3-methyl-3-trifluoromethyldecafluoropentane, which azeotroped with (41). The weights and yields of products quoted in this experimental do not allow for this impurity.

F-4-ethyl-2,3,4,5-tetramethyl-2-oxolene was also supplied by I.C.I. (Mond) Ltd.

Chlorotrifluoroethylene had been prepared by dechlorination of Arcton 113,  $\text{CF}_2\text{ClCFCl}_2$ , with zinc dust suspended in ethanol.

The caesium fluoride was reagent grade, and was dried by heating ( $150^\circ$ ) under high vacuum for 24 h, ground to a powder under dry nitrogen in a glove bag, and then heated under vacuum for a further 24 h and was stored under dry nitrogen.

### Solvents

Tetraglyme was purified by stirring with sodium at  $95^\circ$  for 24 h, followed by a fractional distillation under vacuum, the middle fraction being collected over dry molecular sieve (Type IVA), and then stored under dry nitrogen.

Sulpholane was purified by fractional vacuum distillation and the middle fraction collected over dry molecular sieve (Type IVA), and then stored at room temperature under dry nitrogen.

Any other solvents used were also dry.

### Instrumentation

Infra-red spectra were recorded using Perkin-Elmer 457 and 577 Grating Infra-red Spectrophotometers using the normal techniques.

Raman spectra were recorded for neat liquid samples using a Cary 82 Laser Raman Spectrophotometer with a Spectra-Physics Model 164 Ar/Kr Laser at  $19436.3 \text{ cm}^{-1}$  (green).

Ultra-violet spectra were recorded using a Unicam S.P.8000 Spectrophotometer and using Spectrosol grade solvents.

Mass spectra were recorded on an A.E.I. M.S9 spectrometer, or on a V.G. Micromass 12B spectrometer fitted with a Pye 10<sup>4</sup> gas chromatograph.

Proton (<sup>1</sup>H) and fluorine (<sup>19</sup>F) nuclear magnetic resonance spectra were recorded on a Varian A56/60D spectrometer, operating at 60 and 56.4 MHz respectively, for neat large samples and chemical shifts are quoted relative to external T.M.S. and CFC1<sub>3</sub>. Variable temperature facilities permitted spectra to be recorded at temperatures other than the standard probe temperature of 40°. The spectra of small liquid samples ( ≤ 0.1g), which were contained in capillaries inside the n.m.r. tube, were recorded using the Varian or, more frequently, a Bruker HX90E spectrometer operating at 84.67 MHz (for fluorine).

Quantitative gas line chromatographic analysis was carried out using a Griffin and George D6 Gas Density Balance or a Varian Aerograph Model 920, using columns packed with 30% silicone gum rubber SE-30 on chromosorb P (Column 'O') and 20% di-isodecyl phthalate on chromosorb P (Column 'A'). Preparative scale gas line chromatography was carried out using a Varian Aerograph or Varian Aerograph Model 920 using columns 'O' and 'A'.

Fractional distillations of product mixtures were carried out using a small or large concentric tube, Fischer-Spaltrohr Systems MMS 200 and HMS 500.

Carbon, nitrogen, and hydrogen analyses were obtained using a Perkin-Elmer 240 Elemental Analyser. Analysis for halogens were carried out as described in the literature.<sup>208</sup>

Boiling points were determined by Siwoloboff's Method, and are not corrected for changes in atmospheric pressure.

## CHAPTER VII

Experimental to Chapter IIIVII.A Oligomerisation of ChlorotrifluoroethyleneVII.A.1 At 25°

VII.A.1.a A mixture of caesium fluoride (12g, 79 mmol) and tetraglyme (15 ml.), contained in a dry flask (500 ml.), which was connected to a glass bulb (1 l.), was stirred in an atmosphere of chlorotrifluoroethylene (ca. 0.6 atmosphere pressure). The chlorotrifluoroethylene (9g, 77.3 mmol) was added at intervals (ca. 12h) as the pressure decreased. After 88 h the volatile products (6.3 g), containing unreacted chlorotrifluoroethylene (3) (2.9 g), were transferred under vacuum to a cold trap and (3) was removed at atmospheric pressure. The components in the residue (3.4 g) were identified using g.l.c.-ms and the estimated proportions (% weight) (GDB, col. '0', 50°) are as follows:  $\text{CF}_3\text{CFCl}_2$  (24%),  $\text{C}_8\text{F}_{16}$  (41) (4%),  $\text{C}_{10}\text{F}_{18}$  (81) (22%),  $\text{C}_{12}\text{F}_{22}$  (82) (27%), and  $>\text{C}_{12}\text{F}_{22}$  (23%). Involatile material (1 g) was recovered by ether extraction from tetraglyme and water. The yields of the oligomers, based on  $\text{CF}_2\text{CFCl}$  consumed, were estimated as:  $\text{C}_8\text{F}_{16}$  (41) (3%),  $\text{C}_{10}\text{F}_{18}$  (81) (16%),  $\text{C}_{12}\text{F}_{22}$  (82) (19%), and  $>\text{C}_{12}\text{F}_{22}$  (ca. 30%).  $\text{C}_8\text{F}_{16}$  (41) was identified by comparison of g.l.c. retention times and g.l.c.-ms with an authentic sample. Samples of  $\text{CF}_3\text{CFCl}_2$ ,  $\text{C}_{10}\text{F}_{18}$  (81), and  $\text{C}_{12}\text{F}_{22}$  (82) were separated by preparative scale g.l.c.;  $\text{CF}_3\text{CFCl}_2$  was identified by its  $^{19}\text{F}$  n.m.r. spectrum;  $^{172}\text{C}_{10}\text{F}_{18}$  (81, a mixture of isomers from  $^{19}\text{F}$  n.m.r.), b.p. 116°, (Found F, 73.6%;  $\text{M}^+$  462.  $\text{C}_{10}\text{F}_{18}$  requires F, 74.0%; M, 462), i.r. spectrum No.1,  $^{19}\text{F}$  n.m.r. spectrum No.1; F-3,4,5,6-tetramethyl-3,5-octadiene (82) (a mixture of isomers by  $^{19}\text{F}$  n.m.r.), b.p. 147.5°, (Found C, 25.5; F, 74.8%;  $\text{M}^+$ -19, 543.  $\text{C}_{12}\text{F}_{22}$  requires C, 25.6; F, 74.4%;

M, 562), i.r. spectrum No.2,  $^{19}\text{F}$  n.m.r. spectrum No.2.

VII.A.1.b A similar reaction for a shorter time (16 h) gave a complex mixture of volatile products. After removal of  $\text{CF}_3\text{CFCl}_2$ , elemental analysis of the remaining mixture showed chlorine. After heating this mixture with caesium fluoride and tetraglyme, chlorine was absent and the amount of material less volatile than  $\text{C}_{12}\text{F}_{22}$  had been reduced.

#### VII.A.2 At 120°

A mixture of chlorotrifluoroethylene (8.5 g, 73 mmol), caesium fluoride (8.3 g, 54.6 mmol), and tetraglyme (10 ml.) was heated and stirred in a Carius tube (100 ml.) for 18 h at 120°. After cooling the volatile material (4.3 g) was recovered by transferring under vacuum to a cold trap. Any gases present were allowed to escape and the  $^{19}\text{F}$  n.m.r. spectrum of the residue showed, besides  $\text{CF}_3\text{CFCl}_2$  and  $\text{C}_{10}\text{F}_{18}$  (81), the presence of  $\text{C}_8\text{F}_{16}$  (41) by comparison of the  $^{19}\text{F}$  n.m.r. spectrum with that of an authentic sample of (41).

An earlier worker in this laboratory has reported similar oligomerisations of  $\text{CF}_2\text{CFCl}$ , using Ni tubes at 56° and 140°. <sup>169</sup> These results, together with those obtained at 25° (VII.A.1 above) are given in Table 22 in the discussion (Chapter III).

#### VII.B Co-oligomerisation of Chlorotrifluoroethylene

##### VII.B.1 With F-2-butene

A mixture of caesium fluoride (1.5 g, 9.9 mmol), chlorotrifluoroethylene (1.25 g, 10.7 mmol), F-2-butene (46) (2.5 g, 12.5 mmol), and tetraglyme (10 ml.) was heated and stirred in a Carius tube (100 ml.) for 36 h at 80°. After allowing any gases to escape the recovered volatile material (2.1 g) was analysed (g.l.c.-ms and GDB, col. '0', 50°) and

contained  $C_4F_8$  (46) (16%),  $C_6F_{12}$  (44) (24%),  $C_8F_{16}$  (41) (36%),  $C_{10}F_{18}$  (81) (19%),  $C_{12}F_{20}$  (4%), and  $C_{12}F_{22}$  (82) (1%). Involatile material (0.1 g) was recovered as before (VII.A.1). A sample of F-3-methyl-2-pentene (44) was separated by preparative scale g.l.c. and it has an identical  $^{19}F$  n.m.r. spectrum to that of an authentic sample of (46) isolated from fluoride ion induced oligomerisation of F-ethylene. Compound (46) has also been prepared, using a different route (see Section I.D.5), by Fraticelli.<sup>51</sup>

#### VII.B.2 With F-3,4-dimethyl-3-hexene (41)

Caesium fluoride (9 g, 59.2 mmol),  $C_8F_{16}$  (41) (11.7 g, 29.3 mmol), and tetraglyme was stirred for 16 h at 25° in an atmosphere of  $CF_2CFCl$ . The volatile material (15.4 g) was recovered as before (VII.A.1) and contained (g.l.c.-ms and GDB, col. '0', 50°)  $C_6F_{12}$  (46) (3%),  $CF_3CFCl_2$  (16%)  $C_8F_{16}$  (41) (47.5%),  $C_{10}F_{18}$  (81) (21%),  $C_{12}F_{22}$  (82) (8.5%), and  $C_{14}F_{24}$  (84) (4%). The yields of the higher oligomers, based on (41) consumed, were estimated as  $C_{10}F_{18}$  (81) (64%),  $C_{12}F_{22}$  (82) (21%), and  $C_{14}F_{24}$  (84) (9%). A sample of  $C_{14}F_{24}$  (84) was separated by preparative scale g.l.c. as a mixture of isomers and identified as F-3,4,5,6,7-pentamethyl-2,4,6-nona-triene (84), (Found F, 72.6%;  $M^+$ , 624.  $C_{14}F_{24}$  requires F, 73.1%;  $M$ , 624), i.r. spectrum No.3,  $^{19}F$  n.m.r. spectrum No.4.

#### VII.B.3 With $C_{10}F_{18}$ (81)

As for VII.B.2 above, using caesium fluoride (4 g, 26.3 mmol),  $C_{10}F_{18}$  (81) (1.2 g, 2.6 mmol), and tetraglyme (8 ml.) for 18 h at 114°. The recovered volatile material (1.4 g) has the following composition  $CF_3CFCl_2$  (1%),  $C_8F_{16}$  (41) (13%),  $C_{10}F_{18}$  (81) (16%),  $C_{12}F_{20}$  (5%),  $C_{12}F_{22}$  (82) (36%),  $C_{14}F_{24}$  (84) (5%),  $C_{16}F_{28}$  (88) (22%), and  $C_{18}F_{30}$  (2%). The

yields of the higher oligomers, based on  $C_{10}F_{18}$  (81) consumed, were estimated as  $C_{12}F_{20}$  (6%),  $C_{12}F_{22}$  (82) (42%),  $C_{14}F_{24}$  (84) (5%),  $C_{16}F_{28}$  (88) (20%), and  $C_{18}F_{30}$  (2%). A sample of  $C_{16}F_{28}$  (88) was separated by preparative scale g.l.c. giving F-3,4,5,6,7,8-hexamethyl-3,5,7-decatriene (88) (mixture of isomers, unresolved by g.l.c.) (Found F, 73.9%;  $M^+$ -19, 705.  $C_{16}F_{28}$  requires F, 73.5%; M, 724), i.r. spectrum No.4,  $^{19}F$  n.m.r. spectrum No.3.

### VII.C Oligomerisation of F-2-butene

VII.C.1 A mixture of caesium fluoride (3 g, 19.7 mmol), F-2-butene (46) (4.5 g, 22.5 mmol), and tetraglyme (10 ml.) was heated and stirred in a Carius tube (100 ml.) for 87 h at  $92^{\circ}$ . Volatile material (3.6 g) was recovered by transferring under vacuum to a cold trap. F-2-butene (.8 g) was removed at atmospheric pressure to leave liquid product (2.8 g).

Based on F-2-butene consumed the yields of products were estimated as  $C_8F_{16}$  (41) (49%),  $C_{12}F_{20}$  (83) (1.5%), and  $C_{12}F_{22}$  (82) (26%). Samples of  $C_8F_{16}$  (41) and  $C_{12}F_{22}$  (82) were separated by preparative scale g.l.c. and identified by their  $^{19}F$  n.m.r. spectra. Involatile material (0.8 g) was recovered by pouring the remaining tetraglyme layer, after removal of the volatile products, into water and extracting with ether.

VII.C.2 An identical mixture to that used in VII.C.1 above was heated and stirred for 92 h at  $100^{\circ}$ . The volatile material was fractionally transferred, under reduced pressure, into three n.m.r. tubes, which were then sealed under vacuum. No F-n-butane was detected by comparison of the  $^{19}F$  n.m.r. spectra with the reported spectrum of F-n-butane.<sup>209</sup> Similarly F-2-butyne was absent.<sup>174</sup>

Previously in this laboratory a Ni tube has been used for oligomerisation of F-2-butene. Using shorter reaction times at  $58^{\circ}$ ,  $100^{\circ}$ , and  $130^{\circ}$

$C_8F_{16}$  (41) and  $C_{12}F_{22}$  (82) were obtained, together with isomers of  $C_8F_{14}$  (89), identified as F-3,4-dimethyl-2,4-hexadiene and F-1,2,3,4-tetramethyl-cyclobutene.<sup>169</sup>

#### VII.D Co-oligomerisation of F-2-butene

##### VII.D.1 With $C_8F_{14}$ isomers

The mixture of  $C_8F_{14}$  isomers (89), obtained by defluorination of  $C_8F_{16}$  (41), contains F-3,4-dimethyl-2,4-hexadiene as the main component.<sup>169</sup> Caesium fluoride (5 g, 33 mmol),  $C_8F_{14}$  (3.7 g, 10.2 mmol), and tetraglyme (20 ml.) were stirred for 40 h at 25° in an atmosphere of F-2-butene (11 g, 55 mmol). After allowing any F-2-butene to escape the volatile liquid products (10 g) have the following estimated composition  $C_4F_8$  (46) (18%),  $C_8F_{14}$  (5%),  $C_8F_{16}$  (41) (37%),  $C_{12}F_{20}$  (83) (6%),  $C_{12}F_{22}$  (82) (26%), and unidentified material (∞ 8%). (3.2 g) of  $C_8F_{14}$  are consumed.

##### VII.D.2 With F-2-butyne

A mixture of caesium fluoride (8.3 g, 54 mmol) and tetraglyme (25 ml.) was vigorously stirred in an atmosphere of F-2-butene (16.8 g, 84 mmol), which, as before, was contained in a bladder. F-2-butyne (9.4 g, 58 mmol) was allowed to diffuse into the system from a second bladder. After 119 h any remaining gas was allowed to escape and water (100 ml) was added. The lower fluorocarbon layer was separated, washed with water, and finally transferred, under vacuum, from  $P_2O_5$  to give a colourless liquid product (11.2 g). Less volatile material (6.2 g) was also recovered but not investigated further. Analysis of the liquid product (GDB and g.l.c.-ms, col '0', 50°) showed three major components (% weight)  $C_8F_{16}$  (41) (30%),  $C_{12}F_{20}$  (83) (15%), and  $C_{12}F_{22}$  (82) (50%). These were separated by

distillation and preparative scale g.l.c. (Autoprep, col 'A', 50°).

Compounds C<sub>8</sub>F<sub>16</sub> (41) and C<sub>12</sub>F<sub>22</sub> (82) were identified by comparison of their <sup>19</sup>F n.m.r. spectra with those of authentic samples. Compound

C<sub>12</sub>F<sub>20</sub> (83) was characterised as F-ethyl-1,2,3,4,5-pentamethylcyclopentadiene (83), b.p. 142°, (Found C, 27.2; F, 72.1%; M<sup>+</sup>, 524. C<sub>12</sub>F<sub>20</sub> requires C, 27.5; F, 72.5%; M, 524), λ<sub>max</sub> (methanol) 252 nm (ε=2900), i.r. spectrum No.5, <sup>19</sup>F n.m.r. spectrum No.5.

## VII.E Reactions of F-propene

### VII.E.1 With F-2-butene

F-propene (10.5 g, 70 mmol) and F-2-butene (12 g, 60 mmol) were contained in separate bladders attached to a flask containing a stirred mixture of caesium fluoride (7 g, 46.1 mmol) and tetraglyme (20 ml.). Some F-propene was allowed into the flask, and after stirring for 15 min. at 22° the bladder containing F-2-butene was opened to the flask. Within 1 h this bladder was almost flat. The remaining F-propene was then allowed into the flask and the mixture was stirred for 14 h, when both bladders were deflated. The volatile liquid products (19.6 g) contained (% wt.) F-2-butene (18%), C<sub>7</sub>F<sub>14</sub> (92) (70%) and C<sub>9</sub>F<sub>18</sub> (12%). F-2-butene and C<sub>9</sub>F<sub>18</sub> (F-propene trimers) were identified by g.l.c.-ms and comparison of g.l.c. retention times with those of authentic samples. The products were distilled (Fischer-Spaltrohr) giving F-2,3-dimethyl-2-pentene (92) (7.7 g, 52% isolated yield based on F-2-butene consumed), b.p. 76°, (Found F, 75.8%; M<sup>+</sup>-19, 331. C<sub>7</sub>F<sub>14</sub> requires F, 76.0%; M, 350), i.r. spectrum No.6, <sup>19</sup>F n.m.r. spectrum No.6. F-2,3-dimethyl-2-pentene has been previously prepared using the same starting materials (7% isolated yield).<sup>51</sup>

### VII.E.2 With F-3,4-dimethyl-3-hexene

A mixture of C<sub>8</sub>F<sub>16</sub> (41) (7.2 g, 18 mmol), caesium fluoride (7 g, 46.1 mmol) and tetraglyme (20 ml.) was stirred for 72 h at 46° in an atmosphere

containing a partial pressure of F-propene (8.5 g, 56.7 mmol, 26 cm Hg pressure at start) and nitrogen (40 cm Hg pressure). A sample of the fluorocarbon lower layer was withdrawn and contained (GDB, col '0', 50°) mainly C<sub>8</sub>F<sub>16</sub> along with a small amount of F-propene trimers and F-2,3-dimethyl-2-pentene (C<sub>7</sub>F<sub>14</sub>, 92).

VII.E.3 With F-4-ethyl-3,4-dimethyl-2-hexene

VII.E.3.a A mixture of C<sub>10</sub>F<sub>20</sub>(40) (8.6 g, 17.2 mmol), caesium fluoride (5.9 g, 38.8 mmol), and tetraglyme (20 ml) was stirred at 70° under F-propene (8.9 g, 59.3 mmol, 33 cm Hg pressure at start). After 21 h the pressure had fallen to 10 cm Hg and the products (16 g) were recovered as before. After removal of gases at atmospheric pressure the remaining products (13 g) had the following estimated composition C<sub>3</sub>F<sub>6</sub> (4%), F-propene dimers (9%), C<sub>7</sub>F<sub>14</sub> (92) (trace), C<sub>8</sub>F<sub>16</sub> (41) (10%), F-propene trimers (26%), and C<sub>10</sub>F<sub>20</sub> (40) (51%).

VII.E.3.b In a similar experiment at 22° only F-propene, F-propene oligomers, and C<sub>10</sub>F<sub>20</sub> (40) were recovered.

VII.E.4 With F-ethylene

A mixture of caesium fluoride (4.7 g, 31 mmol) and tetraglyme (20 ml) was stirred in an atmosphere of F-propene (7.6 g, 50.7 mmol) and F-ethylene (3.3 g, 33 mmol), which were contained in bladders. After 66 h the bladders were completely deflated. The recovered volatile products gave, after warming to room temperature, F-ethylene (2.8 g), identified by its i.r. spectrum, and liquid product (7.3 g). The liquid product contained (GDB, col '0', 80°) F-propene dimers (24%) and trimers (59%) and C<sub>11</sub>F<sub>22</sub>(93) (17%). A sample of C<sub>11</sub>F<sub>22</sub> (93) was separated by preparative scale g.l.c. (GDB, col '0', 130°) giving F-3-isopropyl-2,4-dimethyl-2-hexene (93) (two isomers, ratio 3:2 by <sup>19</sup>F n.m.r., unresolved by g.l.c.), b.p. 149.5°.

(Found C, 23.8; F, 75.5%;  $M^+$ , 550.  $C_{11}F_{22}$  requires C, 24.0; F, 76.0%; M, 550), i.r. spectrum No.7,  $^{19}F$  n.m.r. spectrum No.7. The  $^{19}F$  n.m.r. spectrum remained unchanged over the range  $40^\circ - 190^\circ$ .

VII.F Defluorination of F-3,4-dimethyl-3-hexene;  
the Effect of Fluoride Ion

VII.F.1 Without Caesium Fluoride

A mixture of  $C_8F_{16}$  (41) (4 g), iron powder (5 g), and tetraglyme (15 ml.) was heated in a Carius tube for 45 h at  $118^\circ$ . The product (3.6 g) was recovered by transferring, under vacuum, to a cold trap and analysis (GDB, col '0',  $50^\circ$ ) showed  $C_8F_{14}$  isomers (14% conversion).

VII.F.2 With Caesium Fluoride

The same for VII.F.1 above, but in the presence of caesium fluoride (2 g), gave product (3.6 g) containing  $C_8F_{14}$  isomers (22% conversion).

VII.G Attempted Defluorination of F-2-butene

A mixture of F-2-butene (5 g), iron powder (6 g), and tetraglyme (15 ml.) was heated for 40 h at  $94^\circ$  in a Carius tube. All the F-2-butene was recovered, and no F-2-butyne was detected in its i.r. spectrum.

CHAPTER VIII

Experimental to Chapter IV

Introduction

The solubilities of reactants and products in the solvents used will be discussed at this stage so that they need not be mentioned for each individual experiment.

Olefin (41) is soluble in ether, much less soluble in methanol, and virtually insoluble in tetraglyme. The products from reaction of (41) with alcohols are more soluble in these and similar solvents, and the solubility of the dialkoxy derivatives is greater than that of the monoalkoxy derivatives. For example, the reaction of (41) with excess methanol using amine as base (see VIII.A.9) is a two phase system at the start and a one phase system at the end. Similar considerations apply to the amino derivatives of (41). Differences in solubility can be useful for separating products. For example, although (41) and similar F-olefins are soluble in ether at room temperature, they separate as a lower layer on cooling. Also (41) may be separated from its monoalkoxy derivative by dissolving the latter in warm alcohol while (41) remains as a lower layer.

VIII.A Reactions of F-3,4-dimethyl-3-hexene with O-Nucleophiles

VIII.A.1 Alcohols, using Caesium Fluoride as Base

A slight excess of alcohol (methanol, ethanol, or isopropanol) was added, dropwise over 2-4 h, to a stirred mixture containing (41), caesium fluoride, and tetraglyme at room temperature. The mixture was stirred for a further period of 18-20 h and then water ( $\sim$  150 ml) was added. The product, which separated as a lower layer, was washed and then dried over sodium sulphate. The yields of the main products (given below) were estimated from analytical scale g.l.c. (GDB, col '0',  $\sim$  110<sup>o</sup>).

Experimental Details

<u>Reactants</u>	<u>Methanol</u>	<u>Ethanol</u>	<u>Isopropanol</u>
Alcohol (g, mmol)	1,31.3	2.6,56.5	3.3,55
(41) (g, mmol)	10,25	20,50	20,50
CSF (g, mmol)	3,17.7	7.7,50.7	9,59.2
Tetraglyme (ml)	20	35	35
Alcohol addition (h)	4	2	3
Further stirring (h)	20	18	18
Crude product (g)	9.1	19	18.4

Product Yields (%)

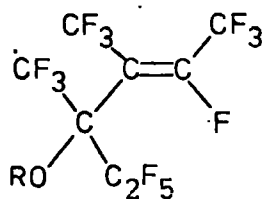

96

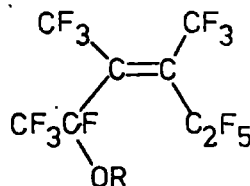

95

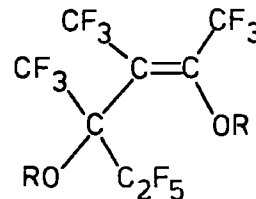

97

R = CH<sub>3</sub>

8

53

17

R = C<sub>2</sub>H<sub>5</sub>

23

40

7

R = (CH<sub>3</sub>)<sub>2</sub>CH

51<sup>a</sup>

a, unresolved by g.l.c.

Samples of the three main products from each reaction were separated by distillation (Fischer-Spaltrohr), and preparative scale g.l.c. of the volatile fractions, for the mono-alkoxy derivatives (Autoprep: col '0', 60°:- methoxy, ethoxy; col '0', 180°:- isopropoxy), and residues, for the di-alkoxy derivatives (col 'A', 140°:- methoxy; col '0', 180°:- ethoxy, isopropoxy).

Methoxy derivatives: (96), R = CH<sub>3</sub>) identified by comparison of spectral data with that of an authentic sample<sup>169</sup> (n.m.r. spectrum No.14); cis-, trans-2-methoxy-3,4-bistrifluoromethylnonafluoro-3-hexene (95, R = CH<sub>3</sub>), b.p. 126.5°, (Found C, 26.5; F, 68.6%; M<sup>+</sup>, 412. C<sub>9</sub>H<sub>3</sub>F<sub>15</sub>O requires C, 26.2; F, 69.1%; M, 412 ), i.r. spectrum No.8, n.m.r. spectrum No.11; trans-2,4-dimethoxy-3,4-bistrifluoromethyloctafluoro-2-hexene (97, R = CH<sub>3</sub>), b.p. 161°, (Found C, 28.1; F, 62.9%; M<sup>+</sup>-F, 405. C<sub>10</sub>H<sub>6</sub>F<sub>14</sub>O<sub>2</sub> requires C, 28.3; F, 62.7%; M, 424), i.r. spectrum No.11, n.m.r. spectrum No.17.

Ethoxy derivatives: trans-4-ethoxy-3,4-bistrifluoromethylnonafluoro-2-hexene (96, R = C<sub>2</sub>H<sub>5</sub>), b.p. 128.5°, (Found C, 28.2; F, 66.6%; M<sup>+</sup>-H, 425. C<sub>10</sub>H<sub>5</sub>F<sub>15</sub>O requires C, 28.2; F, 66.9%; M, 426), i.r. spectrum No. 10, n.m.r. spectrum No. 15; cis, trans-2-ethoxy-3,4-bistrifluoromethylnonafluoro-3-hexene (95, R = C<sub>2</sub>H<sub>5</sub>), b.p. 132° (Found C, 28.2; F, 66.5%; M<sup>+</sup>, 426), i.r. spectrum No.9, n.m.r. spectrum No.12; trans-2,4-diethoxy-3,4-bistrifluoromethyloctafluoro-2-hexene (97, R = C<sub>2</sub>H<sub>5</sub>), b.p. 180°, (Found C, 32.0; F, 58.3%; M<sup>+</sup>, 452. C<sub>12</sub>H<sub>10</sub>F<sub>14</sub>O requires C, 31.9; F, 58.8%; M, 452), i.r. spectrum No.12, n.m.r. spectrum No.18.

Isopropoxy derivatives: (96, R = C<sub>3</sub>H<sub>7</sub>) and (95, R = C<sub>3</sub>H<sub>7</sub>) (unresolved by g.l.c., ratio 96:95 is 1.2:1 by <sup>19</sup>F n.m.r.), b.p. 145°, (Found C, 30.2; F, 64.3%. C<sub>11</sub>H<sub>7</sub>F<sub>15</sub>O requires C, 30.0; F, 64.7%; M, 440), n.m.r. spectra Nos. 13 and 16; trans-2,4-di-isopropoxy-3,4-bistrifluoromethyloctafluoro-2-hexene (97, R = C<sub>3</sub>H<sub>7</sub>), unsatisfactory analysis, (Found M<sup>+</sup>-C<sub>3</sub>H<sub>7</sub>, 437. C<sub>14</sub>H<sub>14</sub>F<sub>14</sub>O<sub>2</sub> requires M, 480), i.r. spectrum No.13, n.m.r. spectrum No.19.

Dialkoxy products are still formed from similar reactions when a slight deficiency of methanol or ethanol is used. A very similar product

mixture, to that from reaction at room temperature, is obtained from the reaction of (41) with isopropanol at 85°. The composition of a mixture of monomethyl ethers (95) and (96) was unchanged after stirring with caesium fluoride and tetraglyme at room temperature for 20 h.

#### VIII.A.2 Methanol, using Sodium Carbonate as Base

Using the same method as above, a slight deficiency of methanol and sodium carbonate as base gave recovered starting material, (41), and disubstituted product (97, R = CH<sub>3</sub>) as the main components of the product and (95, R = CH<sub>3</sub>) and (96, R = CH<sub>3</sub>) as minor components.

A similar experiment conducted in this laboratory gave (96, R = CH<sub>3</sub>) as the main product (61% yield).<sup>169</sup> The rate of addition of methanol and efficiency of stirring appear to greatly affect product distribution.

#### VIII.A.3 Methoxide

A mixture of (41) (8.5g, 21.2 mmol), sodium methoxide (87 mmol), and methanol (25 ml) was stirred at room temperature for 18 h. After addition of water the recovered product (6.5 g) contained no (41, 95, 96, or 97). The i.r. spectrum shows carbonyl groups.

#### VIII.A.4 Reaction of C<sub>8</sub>F<sub>16</sub> Isomers with Neutral Methanol

After passing (41) over iron filings at 540° C<sub>8</sub>F<sub>14</sub> isomers (89) and a mixture of C<sub>8</sub>F<sub>16</sub> isomers are obtained (see Chapter V):

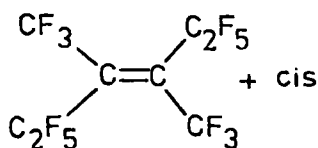

41

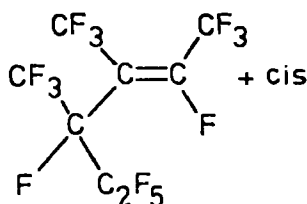

98

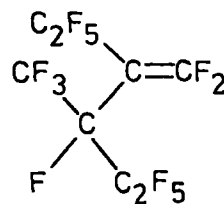

99

A mixture of  $C_8F_{16}$  isomers (41:98:99 2:2:1; 2.15g, 5.4 mmol) and methanol (1.6g, 50 mmol) was stirred at room temperature for 5 days. After adding water the recovered fluorocarbons (2.05g) contained (estimated using GDB, col '0', 100°)  $C_8F_{16}$  (81%) and  $C_8F_{15}OMe$  (19%). Preparative scale g.l.c. (col '0', 125°) gave (41) and (98) (1.05g) and a mixture of  $C_8F_{15}OMe$  isomers (100, 101, 102) (by  $^{19}F$  n.m.r. and i.r. spectroscopy) (Found C, 26.0; F, 68.9%;  $M^+ - F$ , 393.  $C_9H_3F_{15}O$  requires C, 26.2; F, 69.1%;  $M$ , 412),  $\nu_{max}$  1635 w, 1715 m  $cm^{-1}$  (C=C str.). The recovered (41) and (98) were heated with methanol in a sealed glass tube at 100° for 16 h. Only (98) reacted.

VIII.A.5 Alcohols and Water, using Pyridine as Base

Experimental Details

<u>Reactant</u>	<u>CH<sub>3</sub>OH</u>	<u>C<sub>2</sub>H<sub>5</sub>OH</u>	<u>C<sub>3</sub>H<sub>7</sub>OH</u>	<u>C<sub>4</sub>H<sub>9</sub>OH</u>	<u>H<sub>2</sub>O</u>
ROH (g,mmol)	2,62.5	2.5,54	3.1,52	1.9,26	1.2,67
( <u>41</u> ) (g,mmol)	20,50	20,50	20,50	10,25	10,25
Pyridine (g,mmol)	9.3,118	9.3,118	9.3,118	4.7,59	4,51
Tetraglyme (ml)	35	35	35	20	20
Reflux (°, h)	100,5.5	105,5.5	105,6	105,6	100,17
Volatiles (g)	13.9	14.8	16.6	7.6	] 6.8
Black Oil (g)	2	1.5	.5	0	

A slight excess of an alcohol (methanol, ethanol, isopropanol, or t-butanol) or water was added to a stirred mixture containing (41), pyridine, and tetraglyme at ca. 80°. After refluxing at ca. 100° the mixture was allowed to cool and the product recovered as for VIII.A.1 above. The volatile component of the product was transferred under vacuum to a cold trap leaving, in some cases, an involatile black oil.

The yields of the major volatile products were estimated by g.l.c. and  $^{19}\text{F}$  n.m.r. spectroscopy.

Product Yields (%)

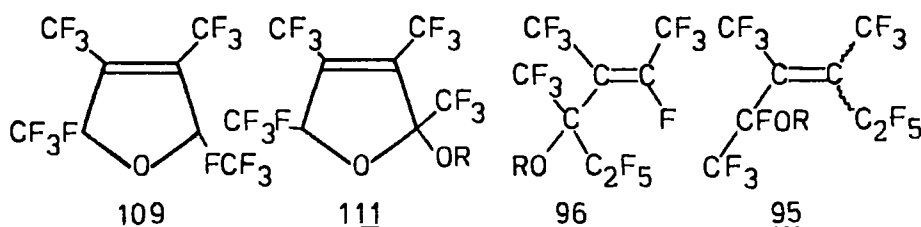

	<u>109</u>	<u>111</u>	<u>96</u>	<u>95</u>
Methanol (R = CH <sub>3</sub> ) <sup>a</sup>	42	12	3	0
Ethanol (R = C <sub>2</sub> H <sub>5</sub> ) <sup>a</sup>	48	8	9	0
Isopropanol (R = C <sub>3</sub> H <sub>7</sub> ) <sup>b</sup>	18	0	18	37

a, ca. 100% conversion;      b, ca. 70% conversion.

Products from methanol: The volatile products were distilled (Fischer-Spaltrohr) giving an unidentified component (0.3g), b.p. 71°;

cis, trans-F-2,5-dihydro-tetramethylfuran (109) (5.1g, 27% isolated yield),

b.p. 83°, (Found C, 25.3; F, 70.0%; M<sup>+</sup>-F, 359. C<sub>8</sub>F<sub>14</sub>O requires C, 25.4;

F, 70.4%, M, 378),  $\nu_{\text{max}}$  1705 cm<sup>-1</sup> (C=C str. Raman), i.r. spectrum No.16,

$^{19}\text{F}$  n.m.r. spectrum No.22; and a mixture of (96, R = CH<sub>3</sub>) and (111, R = CH<sub>3</sub>)

(identified by  $^{19}\text{F}$  n.m.r. spectroscopy). These two compounds could not be

separated by distillation and preparative scale g.l.c. (col. 'O' and 'A')

but a sample containing the furan (111, R = CH<sub>3</sub>) as the major component

(94%) was obtained. Compound (111, R = C<sub>2</sub>H<sub>5</sub>) was prepared pure (see below).

Products from ethanol: Distillation gave (109) (6g, 32% isolated yield),

a mixture of (96, R = C<sub>2</sub>H<sub>5</sub>) and (111, R = C<sub>2</sub>H<sub>5</sub>) and a minor unidentified

component (from preparative scale g.l.c.).

Products from Isopropanol: (109) (1.5g, 11% isolated yield), unreacted (41), and a mixture of (95, R = C<sub>3</sub>H<sub>7</sub>) and (96, R = C<sub>3</sub>H<sub>7</sub>) (ratio 1:2 by <sup>19</sup>F n.m.r.).

Products from t-butanol: Only recovered starting material, (41) (7.6g, 76% recovery).

Products from water: Complex mixture, but no (109) is formed (by <sup>19</sup>F n.m.r. spectroscopy).

#### VIII.A.6 Reaction of F-2,5-dihydro-tetramethylfuran with Ethanol

A mixture containing ethanol (0.26g, 5.7 mmol), (109) (2.2g, 5.8 mmol), pyridine (0.46g, 5.8 mmol), and tetraglyme (5 ml) was stirred for 11 days. The lower layer (1.6g) was separated, transferred under vacuum from phosphorus pentoxide, and contained (111, R = C<sub>2</sub>H<sub>5</sub>) (90%, 61% yield) and five minor components. A sample was separated by preparative scale g.l.c. (Autoprep, col '0', 100°) giving cis-, trans-2-ethoxy-5-fluoro-tetrakis(trifluoromethyl)furan (111, R = C<sub>2</sub>H<sub>5</sub>) (isomer ratio = 83:17 by <sup>19</sup>F n.m.r. spectroscopy), b.p. 126.5° (Found C, 30.0; F, 60.6%; M<sup>+</sup>-H, 403. C<sub>10</sub>H<sub>5</sub>F<sub>13</sub>O<sub>2</sub> requires C, 29.7; F, 61.1%; M, 404), i.r spectrum No.17, n.m.r. spectrum No.23.

Furan (109) (22% yield) was obtained from reaction, at room temperature, of (41) with methanol using Et<sub>3</sub>N as base and tetraglyme as solvent.<sup>169</sup> Compounds (95, R = CH<sub>3</sub>) and (96, R = CH<sub>3</sub>) were also formed. The same reaction, but under reflux, produced (109), (96, R = CH<sub>3</sub>), and furan (112) (8%).<sup>169</sup> No (95, R = CH<sub>3</sub>) was obtained. Furan (112) is a known compound.<sup>155</sup>

VIII.A.7 Conversion of Alkyl Ethers to F-2,5-dihydrotetramethylfuran (109)

VIII.A.7.a A stirred mixture containing (95, R = C<sub>2</sub>H<sub>5</sub>) (1g, 2.3 mmol), pyridine (0.21g, 2.7 mmol), and tetraglyme (5 ml) was heated in a sealed glass tube at 120° for 2 h. After cooling volatile material was transferred under vacuum from the tube, washed with dilute HCl and the product (0.4g) contained ca. 95% of (109) (43% yield) by <sup>19</sup>F n.m.r. spectroscopy.

VIII.A.7.b A similar mixture but containing CsF instead of pyridine was heated at 110° for 21 h and (109) (34% yield) was transferred from the tube.

VIII.A.7.c A similar mixture to that in a) but containing (95, R = CH<sub>3</sub>) and (96, R = CH<sub>3</sub>) was heated at 110° for 2 h. The recovered product contained (41) and (109) from its <sup>19</sup>F n.m.r. spectrum.

VIII.A.8 Reactions of F-2,5-dihydrotetramethylfuran (109)

VIII.A.8.a With Triethylamine

A mixture containing (109) (2g, 5.3 mmol), triethylamine (1g, 9.9 mmol), and tetraglyme (5 ml) was heated in a sealed glass tube at 95° for 20 h. The recovered volatile material (1g) contained (GDB, col '0', 80°) (109) (61%) and furan (112) (39%, 41% yield based on 109 consumed). Involatile material (0.5g) was recovered from the tetraglyme layer on addition of water.

VIII.A.8.b With Pyridine

A reaction analogous to that described for (a) but using pyridine, gave recovered (109).<sup>169</sup>

VIII.A.8.c With Caesium Fluoride or Chloride

Similar mixtures to that in (a) above but containing CsF or CsCl were heated at 130° for 40 h. Only (109) was recovered (64% using CsF, 86% using CsCl). No (112) was detected.

VIII.A.9 Effect of Alcohol and Amine

The particular amine used as base can affect the product distribution obtained from an alcohol (i.e. ethanol or methanol) and (41). This was shown by pyridine and Et<sub>3</sub>N (see earlier). For a given amine, using similar conditions, methanol and ethanol can give very different product mixtures.

VIII.A.9.a Ethanol, using Trimethylamine

A mixture of (41) (10g, 25 mmol), Me<sub>3</sub>N (3.5g, 59.3 mmol), and ethanol (20 ml) was stirred at 0° for 2 h and then at room temperature for 20 h. Water (150 ml) was added and the lower layer was separated, washed, and dried (NO<sub>2</sub>SO<sub>4</sub>) giving product (9.4g) containing (estimated % yields based on 41) (95, R = C<sub>2</sub>H<sub>5</sub>) (20%), (97, R=C<sub>2</sub>H<sub>5</sub>) (35%), two unidentified components (10 and 15%), and three minor components. Compounds (95) and (97) were separated and identified by comparison of spectra with those of authentic samples.

VIII.A.9.b Ethanol, using Triethylamine

A similar mixture but containing Et<sub>3</sub>N (5.4g, 53.5 mmol) was stirred for 18 h giving product (9.7g) containing (95) (45% yield), (97) (26%), and the same two unidentified components (5 and 10% yields).

VIII.A.9.c Methanol, using Trimethylamine

(i) A mixture, similar to that for (a) above but containing methanol (20 ml) was stirred at 0° for 3 h and then at room temperature for 18 h.

The product (8.2g) contained (97, R = CH<sub>3</sub>) (30% yield), (108) (40%) and eight minor components. Furan (109) was not formed. Preparative scale g.l.c. (col 'A', 110°) gave (97) (identified by comparison with an authentic sample) and methyl 3-methoxy-3-trifluoromethyl-4,4,5,5,5-pentafluoropentanoate (108) (Found F, 50.4%; M<sup>+</sup>-OCH<sub>3</sub>, 273. C<sub>8</sub>H<sub>8</sub>F<sub>8</sub>O<sub>3</sub> requires F, 50.0%; M, 304), i.r. spectrum No.18, n.m.r. spectrum No.24.

- (11) Methanol (.8g, 25 mmol) was added over 1.5 h to a stirred mixture of (41) (10g, 25 mmol), Me<sub>3</sub>N (3g, 50.8 mmol), and tetraglyme (20 ml) at 0°. The mixture was then stirred at room temperature for 4 - 6 h. A solid was filtered from the mixture, washed with ether and its analysis and spectral data are consistent with (CH<sub>3</sub>)<sub>4</sub> N HF<sub>2</sub>. The lower layer (3.8g) of the remaining mixture contained (109) (12% yield), (41) (9%), (96, R = CH<sub>3</sub>) (12%), (95, R = CH<sub>3</sub>) (2%) and two other components. Addition of water to the tetraglyme gave further product (1.2g).

#### VIII.A.9.d Methanol, using Triethylamine

Similar mixtures to that for (b) above but containing methanol (10 ml) were stirred at room temperature for 30 h, or at 70° for 18 h. The recovered products (ca. 8g) were of similar composition and contained two major and eight minor components. The two major products were separated by preparative scale g.l.c. (col 'A', 110°). One was identified as (108) (see c above) but the other was uncharacterised.

#### VIII.A.10 Ethylene Glycol

A mixture containing (41) (10.1g, 25.3 mmol), ethylene glycol (1.75g, 28.2 mmol), sodium carbonate (5g, 47.2 mmol), and tetraglyme (20 ml)

was stirred for 42 h. The product (6.9g) separated as a lower layer on addition of water (50 ml). Analysis by g.l.c. (col '0', 160°) showed one major product (58% yield) and separation of a sample by preparative scale g.l.c. (col 'A', 145°) gave 5-pentafluoroethyl-5,6,7-tristrifluoromethyl-1,4-dioxo-6-cycloheptene (104), b.p. 183.5°, (Found C, 28.7; F, 62.5%; M<sup>+</sup>, 422. C<sub>10</sub>H<sub>4</sub>F<sub>14</sub>O<sub>2</sub> requires C, 28.5; F, 63.0%; M, 422), i.r. spectrum No.14, n.m.r. spectrum No.20.

#### VIII.A.11 Ethanolamine

Ethanolamine (4.5g, 73.6 mmol) was added slowly to a stirred mixture of (41) (10g, 25 mmol) and tetraglyme (20 ml). After 1 h water (50 ml) was added and the product (3g), which separated as a lower layer, contained (GDB, Col '0', 170°) four components. Preparative scale g.l.c. gave 5-pentafluoroethyl-5,6,7-tristrifluoromethyl-1-oxa-4-aza-6-cycloheptene (105) (8% yield) (Found N, 3.3%; M<sup>+</sup>, 421. C<sub>10</sub>H<sub>5</sub>F<sub>14</sub>NO requires N, 3.3%; M, 421), i.r. spectrum No.15, n.m.r. spectrum No.21. The other analysis figures were not satisfactory.

#### VIII.A.12 Sorbitol

Using a 3:1 ratio of (41) to sorbitol, with sodium carbonate as base and DMSO as solvent, at room temperature, (41) (20%) was recovered together with a small amount (0.2g) of a solid which showed OH and CF stretches in its i.r. spectrum.

#### VIII.A.13 Phenol

The reactions with phenol were carried out by a previous worker.<sup>169</sup> Now that related n.m.r. data is available for similar alkoxy products it has been possible to reassign structures to two of the products,

(95a, R = Ph) and (95b, R = Ph). The n.m.r. data for all three monophenoxy derivatives is given in the appendices; n.m.r. spectra Nos. 19-21.

### VIII.B Reactions with N-Nucleophiles

#### VIII.B.1 Ammonia

A mixture of (41) (7.7g, 19.3 mmol), 880 aqueous ammonia (10 ml) and ether (8 ml) was stirred at room temperature for 71 h. There was no apparent reaction after 30 minutes in the absence of ether, but a rapid colouration occurred when ether was added. Water (50 ml) and ether (50 ml) were added and the ether layer was separated, washed, and dried over  $MgSO_4$ . Analysis by g.l.c. (GDB, col '0',  $200^\circ$ ) showed one major component. The ether was removed under reduced pressure leaving a pale yellow solid (4.9g, 72% crude yield) which was fractionally sublimed at  $100^\circ$  and .005 mm Hg pressure giving trans-2,4-diamino-3-cyano-4-trifluoromethyl-octafluoro-2-hexene (119) (2.9g, 43% isolated yield), m.p.  $73-4^\circ$ , (Found C, 27.5; F, 59.3; N, 12.2%;  $M^+$ , 351.  $C_8H_4F_{11}N_3$  requires C, 27.4; F, 59.5; N, 12.0%; M, 351),  $\lambda_{max}$  (chloroform) 260 nm ( $\epsilon = 15,400$ ), i.r. spectrum No.19, n.m.r. spectrum No.25.

Compound (119) was recovered unchanged after stirring with ether, dil. HCl and aqueous sodium nitrite at  $0-5^\circ$  for 1 h and then at room temperature overnight.

Anhydrous ammonia, when bubbled through a solution of (41) in ether gives entirely different products<sup>143</sup> (see discussion).

### VIII.B.2 Aqueous Methylamine

A mixture of (41) (8.5g, 21.3 mmol), 25/30% w/v aqueous methylamine (20 ml), and ether (10 ml) was stirred for 74 h. The liquid product (7.5g) was recovered as in VIII.B.1 above and contained two major and several minor components (GDB, col 'O', 200°). The two main components were separated by reduced pressure distillation (Fischer-Spaltrohr) and preparative scale g.l.c. The more volatile component contained several isomers or compounds from its  $^{19}\text{F}$  n.m.r. spectrum and was not investigated further. The spectral and analytical data of the less volatile component is consistent with 2-trifluoromethyl-3-(2'-methylamino-octafluoro-2'-butyl)-4-methylimino-N-methyl-2-azetine (120) (Found H, 2.6; N, 10.9%;  $\text{M}^+$ , 393;  $\text{M}^+ - \text{CF}_3$ , 324;  $\text{C}_{11}\text{H}_{10}\text{F}_{11}\text{N}_3$  requires H, 2.6; N, 10.7%; M, 393),  $\lambda_{\text{max}}$  (cyclohexane) 290 nm ( $\epsilon = 13,600$ ), i.r. spectrum No.20, n.m.r. spectrum No.26. The other analysis figures were not satisfactory.

### VIII.B.3 Anhydrous Methylamine

Anhydrous methylamine (1.3g, 42 mmol) was bubbled into (41) (7.2g, 18 mmol) and a white solid formed. Addition of water (30 ml) gave a liquid product (6.6g) containing (GDB, col 'A', 140°) (41) (ca. 75% wt composition), (118, R =  $\text{CH}_3$ ) (20%), and two minor components. Trans-4-methylamino-3,4-bistrifluoromethylnonafluoro-2-hexene (118, R =  $\text{CH}_3$ ) was not isolated but its structure follows from a comparison of the  $^{19}\text{F}$  n.m.r. spectrum with that of (118, R =  $\text{C}_2\text{H}_5$ ) (see below) and similar alkoxy derivatives described earlier.

A similar reaction but with ether present also gave (118, R =  $\text{CH}_3$ ).

VIII.B.4 Anhydrous Ethylamine

Ethylamine (2.4g, 53.3 mmol) was added to (41) (10g, 25 mmol) and tetraglyme (20 ml) at 0°. After stirring at room temperature for 18 h water (100 ml) was added and the product (6.9g) was recovered. Transference under vacuum gave a less volatile fraction (3.4g) and a volatile fraction (3.5g). The volatile fraction contained two main components which were separated by preparative scale g.l.c. (GDB, col 'A', 145°) giving trans-4-ethylamino-3,4-bistrifluoromethylnonafluoro-2-hexene (118, R = C<sub>2</sub>H<sub>5</sub>), b.p. 127°, (Found F, 66.5%; M<sup>+</sup>, 425. C<sub>10</sub>H<sub>6</sub>F<sub>15</sub>N requires F, 67.0%; M, 425), i.r. spectrum No.21, n.m.r. spectrum No. 27. and a mixture of cis-, trans-2-ethylimino-3,4-bistrifluoromethyloctafluoro-3-hexene (123, R = C<sub>2</sub>H<sub>5</sub>) and cis-, trans-3-(N-ethyliminofluoromethyl)-4-trifluoromethyldecafluoro-3-hexene (124, R = C<sub>2</sub>H<sub>5</sub>) (unresolved by g.l.c., ratio 123:124 is 2:1 by <sup>19</sup>F n.m.r. spectroscopy) (Found C, 29.3; F, 65.1; N, 3.5%; M<sup>+</sup>, 405. C<sub>10</sub>H<sub>5</sub>F<sub>14</sub>N requires C, 29.6; F, 65.7; N, 3.5%; M, 405), λ<sub>max</sub>(cyclohexane) < 235 nm, ν<sub>max</sub> 1640 w (C=C), 1670 mw (CF<sub>3</sub>C=N, 123), 1750 m cm<sup>-1</sup> (CF=N, 124), n.m.r. spectrum No. 28.

VIII.B.5 t-ButylamineVIII.B.5.a In the presence of Pyridine

(1) Excess Amine: t-Butylamine (1.75g, 24 mmol) was added to (41) (1.1g, 2.8 mmol) and a white solid immediately formed. The reaction was exothermic. Pyridine (10 ml) was added and the mixture was stirred for 7 days after which water was added. The recovered lower layer (0.8g) contained one main component (ca. 80%) (GDB, col 'A', 140°). The <sup>19</sup>F n.m.r. spectrum suggests the main component is cis-2-t-butylimino-3-trifluoromethyl-4-(N-t-butyliminofluoromethyl)-octafluoro-3-hexene (125)

(Found  $M^+ - F$ , 447.  $C_{16}H_{18}F_{12}N_2$  requires  $M$ , 466), n.m.r. spectrum No.29. Attempted separation of (125), using preparative scale g.l.c. (col 'A',  $150^\circ$ ), gave a mixture containing (by  $^{19}F$  n.m.r.) (125) (15 mole %) and a compound identified as cis-2-t-butylimino-3-trifluoromethyl-4-cyano-octafluoro-3-hexene (126) (85 mole %) (Found,  $M^+ - CH_3$ , 375.  $C_{12}H_9F_{11}N_2$  requires  $M$ , 390),  $\lambda_{max}$  (cyclohexane)  $< 235$  nm ( $\epsilon < 2000$ ),  $\nu_{max}$  ( $cm^{-1}$ ) 1625 m (C=C), 1685 m (C=N), 2225 w (C $\equiv$ N), n.m.r. spectrum No.30.

(11) Equimolar Amounts of Amine and  $C_8F_{16}$ : A mixture of (41) (1g, 2.5 mmol), t-butyl-amine (0.18g, 2.5 mmol), and pyridine (3 ml) produced a white solid, which after stirring for 7 days had disappeared leaving a lower layer (0.95g) containing (GDB, col 'A',  $145^\circ$ ) (41) (ca. 45%), (124, R =  $C_4H_9$ ) (33%), an unidentified component (17%), and (125) (5%). Compound (125) was identified by comparison of g.l.c. retention times and (124, R =  $C_4H_9$ ) (ca. 60% yield based on 41 consumed) was identified by a comparison of the  $^{19}F$  n.m.r. spectrum with that of 124, R =  $C_2H_5$ ).

#### VIII.B.5.b Without Pyridine

The reactions of t-butylamine with (41), in the absence of pyridine, using molar ratios of 2:1 and 1:1 (amine: 41), produce white solids. Subsequent addition of water or  $BF_3$  etherate gives product mixtures containing (41) (main component) and (125).

#### VIII.B.6 Ethylenediamine

Ethylenediamine (31g, 51.6 mmol) was added dropwise, with stirring, to (41) (10.9g, 27.3 mmol) at  $0^\circ$ . Any volatiles were transferred under vacuum, and after addition of water (41) (7.9g) was recovered. The remaining involatile material appeared to be heat sensitive and no products could be sublimed.

VIII.B.7 Urea

A mixture of (41) (10.4g, 26 mmol), urea (3g, 50 mmol), Et<sub>3</sub>N(2g, 19.8 mmol), and DMF (20 ml) was refluxed for 6 h. After cooling, water (100 ml) was added and the recovered lower layer was washed and pumped under vacuum leaving a very viscous black tar (8g), which did not sublime.

No reaction occurred in the absence of Et<sub>3</sub>N.

VIII.B.8 Diethylamine

Previously in this laboratory it has been found that the reaction of (41) with Et<sub>2</sub>NH in sulfolane at room temperature gives a single product (127). Subsequent hydrolysis (dil. NaOH) gives the expected amide.<sup>169</sup>

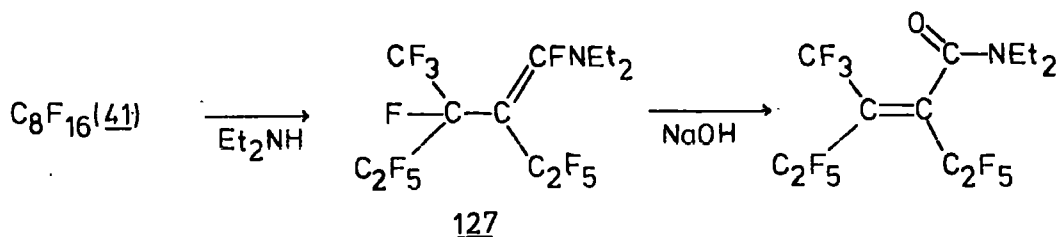

VIII.B.8.a Without Solvent

Et<sub>2</sub>NH (0.6g, 8.2 mmol) was added dropwise to (41) (7.7g, 19.2 mmol) and a solid forms immediately. After 30 min. (41) and Et<sub>2</sub>NH<sub>2</sub>F were transferred under vacuum leaving pure (127) (1.7g, ca. 90% yield).

VIII.B.8.b With Ether Present

A similar reaction, but with (41) in solution in dry ether, gave the same product.

### VIII.B.9 Triethylamine

Refluxing (41) with an excess of Et<sub>3</sub>N for 24 h gave mainly (41) and some F-3,4-dimethyl-2,4-hexadiene (89, 5%).<sup>169</sup>

A low yield of (89) was also obtained from a similar reaction, but in the presence of DMF as solvent. With tetraglyme as solvent C<sub>8</sub>F<sub>13</sub>NH<sub>2</sub> (g.l.c. -ms only) was formed in low yield but no (89) was detected. Both reactions, in the presence of solvent, gave complex mixtures.

### VIII.C Phenylmagnesium Bromide

Phenylmagnesium bromide was prepared under nitrogen in dry ether (60 ml) from magnesium (1.3g, 53 mmol) and bromobenzene (8.1g, 51.6 mmol). A solution of deoxygenated (41) (10g, 25 mmol) in dry ether (50 ml) was then added over 15 min. The mixture was refluxed for 1 h and then water (100 ml) and 4M HCl (40 ml) were added. The ether layer was separated, washed, and dried (Na<sub>2</sub>SO<sub>4</sub>), and then ether and unreacted (41) (ca. 2g) were removed by distillation leaving a residue (6.7g) containing fluorine (19.6%, 68.9 mmol) by elemental analysis. The aqueous layer and washings were combined, neutralised and all water removed leaving inorganic salts which, by elemental analysis, contain 202 mmol of fluoride. Thus the recovered fluorine accounts for 84% of C<sub>8</sub>F<sub>16</sub> consumed (8g).

The organic residue was fractionated under vacuum giving involatile material, biphenyl (3.25g, 81% yield, based on bromobenzene), and a colourless liquid (1.5g) which consisted mainly (ca. 95%) of a mixture of C<sub>8</sub>F<sub>13</sub>Ph isomers (from ms and <sup>19</sup>F n.m.r.). Stirring the mixture of C<sub>8</sub>F<sub>13</sub>Ph isomers with CsF and tetraglyme gave a less complex <sup>19</sup>F n.m.r.

spectrum and loss of a C=C str. at  $1730\text{ cm}^{-1}$  in i.r. spectrum. The data is consistent with 3-trifluoromethyl-4-(phenylfluoromethene)-nonafluoro-2-hexene (129) (Found C, 40.3; F, 58.3%;  $M^+$ , 420.  $C_{14}H_5F_{13}$  requires C, 40.0; F, 58.8%; M, 420), i.r. spectrum No.22, n.m.r. spectrum No.31.

The same reaction, as above, when worked up without addition of water or dil. acid, by transferring under vacuum, gave the same products but in this case the recovered (41) (3g) was shown by  $^{19}\text{F}$  n.m.r. spectroscopy, to contain ca. 35% of F-3-methyl-4-methene-2-hexene (128),  $\nu_{\text{max}}$  1690  $\text{cm}^{-1}$  and 1715  $\text{cm}^{-1}$  ( $\text{CF}_3\text{CF}=\text{C}$ ), and 1740  $\text{cm}^{-1}$  ( $\text{F}_2\text{C}=\text{C}$ ),  $^{19}\text{F}$  n.m.r. spectrum No.32. Compound (128) could not easily be separated from (41) using preparative scale g.l.c.

#### VIII.D Halide

Chloride: No reaction of (41) with LiCl using tetraglyme at room temperature.

Iodide: Only (41) recovered using NaI and acetone at  $60^\circ$ .

#### VIII.E Potassium Permanganate

To a solution of potassium permanganate (4.7g, 29.7 mmol) in dry acetone (100 ml), (41) (9.7g, 24.3 mmol) was added slowly. After stirring for 3 h, water (100 ml) was added and sulphur dioxide was bubbled into the mixture to decolourise. On cooling to  $0^\circ$  a lower layer formed, which was separated, and after addition of water (100 ml) was extracted into carbon tetrachloride. After washing and drying ( $\text{MgSO}_4$  then  $\text{P}_2\text{O}_5$ ) the solvent was removed by distillation, and the last traces by bubbling nitrogen through the product at  $100^\circ$  to give 3,4-bistrifluoromethyldecafluoro-3,4-hexadiol (131) (65%), m.p.  $49-51^\circ$ ,

(Found C, 22.0; F, 69.5%;  $C_8H_2F_{16}O$  requires C, 22.1; F, 70.0%; M, 434),  
i.r. spectrum No.23, n.m.r. spectrum No.33.

#### VIII.E.1 Reaction of Diol with Potassium Hydroxide

Crushed dry KOH (10g, 178 mmol) was added to diol (131) (8.4g, 19.3 mmol) and the mixture was left for 7 days. Strong heating under vacuum gave a colourless liquid (8g) containing (GDB, col '0', 150°) diol (131) (25% by wt) and a more volatile component (132) (75%). The yield of (132) based on diol (131) consumed is 98%. A sample of (132) was separated, by preparative scale g.l.c., as a mixture of two isomers (ratio 80:20). The spectral data is consistent with 2,3-bistrifluoromethyl-2-(2'-hydroxyoctafluoro-2'-butyl)-fluoro-oxirane (132) (Found  $M^+ - F$ , 395.  $C_8HF_{15}O$  requires M, 414), i.r. spectrum No.24, n.m.r. spectrum No.34. The volatility of the sample prevented a satisfactory analysis from being obtained.

When wet KOH was used a very vigorous exothermic reaction occurred and little material was recovered.

#### VIII.F Difluorocarbene

Only (41) recovered using sodium chlorodifluoroacetate at 130°.

CHAPTER IX

Experimental to Chapter V

IX.A Pyrolysis of F-olefins, General Method

All the reactions described in this chapter involved passing the reactant, in a stream of nitrogen, over a packing material contained in a hot silica tube. The products were collected in a trap cooled with liquid air or solid CO<sub>2</sub>. The silica tube was heated by a cylindrical furnace (ca. 30 cm long), the temperature being measured by a thermocouple along the outside of the tube. Nitrogen was bubbled through the reactant, which was warmed for less volatile compounds, and a flow rate of about 50 cc/min gave a contact time of about 25 seconds. Flow rates much above 50 cc/min decreased the efficiency of trapping but this could be enhanced by packing the receiver with glass wool and/or using two traps.

The concentration of the reactant, in the heated tube, and the contact time did not markedly affect product distribution, although very short contact times will obviously reduce conversion. However, conversion to products will increase at higher tube temperatures, but this may be offset by increasing degradation.

The silica tube contained one of the following: platinum foil, quartz wool, CsF, or coarse iron filings. Iron filings, which are used as a defluorinating agent, were renewed regularly. It is important that lower temperatures are used for defluorination than those required to give high conversions to purely thermal fragmentation products. For example,  $\leq 540^\circ$  was used for defluorination of C<sub>8</sub>F<sub>16</sub> (41) because fragmentation is only significant above 540<sup>o</sup> for the contact times used.

IX.A.1 Workup

The products are generally mixtures of volatile liquids and sometimes gases, although less volatile oils may also be formed to a limited extent. The products were treated either by 1) separating the gases from the volatile liquids, at room temperature and under reduced pressure, followed by further analysis of both fractions or 2) allowing any gases to escape at room temperature leaving the more interesting liquid products. It should be noted that F-ethane (b.p.  $-78^{\circ}$ ) which can be one of the products, is not trapped using solid  $\text{CO}_2$ . The liquid products, which may still contain dissolved gases such as F-propane and F-butane, were then analysed further.

The percentage conversions and yields quoted should be treated as approximations because of the nature of the products and the number of variables in these experiments, especially when using iron filings since their activity is very variable.

IX.B F-3,4-dimethyl-3-hexene (41)

IX.B.1 Over Iron

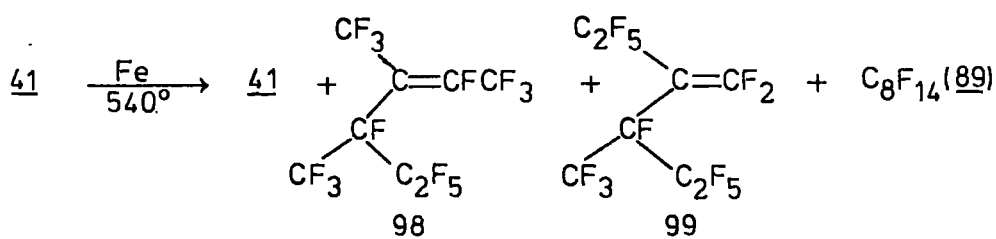

A freshly packed tube at  $540^{\circ}$  using about 30 g of (41) gave a product mixture containing (89) (ca. 50%) and a mixture of  $\text{C}_8\text{F}_{16}$  isomers, (41), (98), and (99) (ratio 2:2:1 by  $^{19}\text{F}$  n.m.r. spectroscopy). A mixture of the  $\text{C}_8\text{F}_{16}$  isomers was separated by distillation and preparative

scale g.l.c. (col '0', 80°) (Found C, 23.9; F, 75.9%. C<sub>8</sub>F<sub>16</sub> requires C, 24.0; F, 76.0%). Some further separation of the isomers was possible, again using preparative scale g.l.c., enabling <sup>19</sup>F n.m.r. assignments to be made, <sup>19</sup>F n.m.r. spectra Nos. 35 (98) and 36 (99). Further structural evidence is given in Section VIII.A.4. Isomers (89) have been prepared previously by the same method<sup>169</sup> and are known compounds.<sup>176,177</sup>

### IX.B.2 Caesium Fluoride

Fresh dry CsF at 540° gave a similar product mixture (2.1g from 2.5g of 41) to that obtained using iron at 540°. Thus it contains C<sub>8</sub>F<sub>16</sub> isomers (41) and (98) (ca. 70%) and C<sub>8</sub>F<sub>14</sub> isomers (89a) and (89b) (30%, ca. 28% conversion to defluorinated products) from a comparison of the <sup>19</sup>F n.m.r. spectrum with those of authentic samples. Similarly (99) is not present.

### IX.B.3 Platinum

#### IX.B.3.a Isomerisation

Platinum at 540° gave a product mixture (1.8g from 2g of 41) containing (41) (ca. 70%), (98) (25%) and (99) (5%).

#### IX.B.3.b Fragmentation

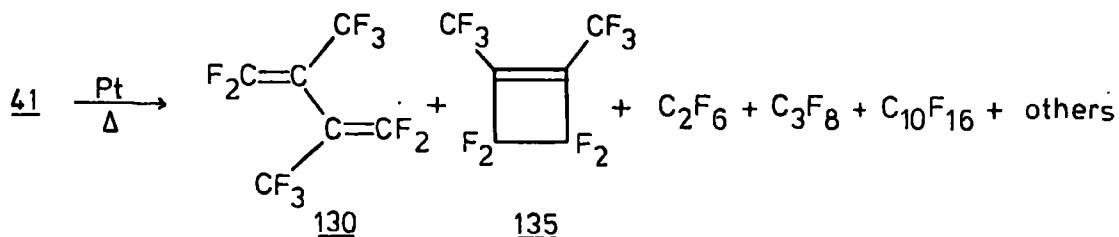

Ratio 130:135 ~ 4.4:1

For convenience  $C_8F_{16}$  isomers (98) and (99) are not considered as products.

Effect of Temperature

<u>Tube temp.</u>	<u>41 (g)</u>	<u>Liquid products (g)</u>	<u>% Conversion to products</u>	<u>% Recovery</u>
550	5.1	4.5	15	93
580	5.1	4.0	35	89
620	5.0	3.2	60	80
670	5.0	2.6	100	79

Passage of (41) (100g) through the tube ( $670^{\circ}$ ) gave a fraction (13.5g) consisting mainly of F-ethane (ca. 39% yield), and a liquid mixture (55.5g) after fractionating the products at  $-78^{\circ}$  under reduced pressure. The liquid mixture contained three main components (GDB, col 'O' and 'A',  $25^{\circ}$ ) which are F-propane (10%), (135) (16%), and (130) (70%), giving a ratio of (130) to (135) of 4.4:1. The yields, based on (41), are F-propane (12%), (135) (14%), and (130) (59%), a total yield of  $C_6F_{10}$  isomers of 73%. The liquid mixture was distilled (Fischer-Spaltrohr) with the distillation fractions being collected in tubes cooled in  $CO_2$ /acetone because the boiling points are F-propane ( $-39^{\circ}$ ), (135) ( $36^{\circ}$ ),<sup>192</sup> and (130) ( $49-51^{\circ}$ ).<sup>193</sup> The distillation gave a high recovery of material (49.8g) and the fractions (28.7g) containing mainly (130) (>90%) is an approx. yield of 40%.

F-ethane was identified by its i.r.<sup>194</sup> and mass spectra ( $M^+-F$ , 119), F-propane by its mass spectrum ( $M^+-F$ , 169), and (130) and (135) ( $M^+$ , 262) by comparison of their i.r. and Raman (for 135)



Effect of Temperature

<u>Tube temp.</u>	<u>92 (g)</u>	<u>Liquid products (g)</u>	<u>% Conversion to products</u>
620°	0.7	0.6	5
675°	0.7	0.35	75
715°	0.7	0.2	100

The weights of product, quoted above, were determined after allowing any gases present to escape at room temperature. The g.l.c.-ms (col '0', 35°) showed C<sub>5</sub>F<sub>8</sub> (137) (M<sup>+</sup>-F, 193), C<sub>6</sub>F<sub>10</sub> (135) (M<sup>+</sup>, 262), C<sub>6</sub>F<sub>12</sub> (94) (M<sup>+</sup>-F, 281), and C<sub>6</sub>F<sub>10</sub> (130) (M<sup>+</sup>, 262).

At 700°, (92) (0.8g) gave 100% conversion to a mixture of products (0.4g, including any gases) which was transferred under vacuum and sealed in an n.m.r. tube. The <sup>19</sup>F n.m.r. spectrum showed the presence of allene (137)<sup>195</sup>, cyclobutene (135), diene (130), and (94)<sup>87</sup>. F-2-butyne may also be present. The i.r. spectrum confirms the presence of diene (130) and allene (137) (C=C=C, 2045 cm<sup>-1</sup>)<sup>195</sup>. The yields of the products are roughly the same between 675 and 715° and are estimated as follows: (137) (7%) (135) (2%), (130) (14%), (94) (1%).

IX.D F-propene Trimers

IX.D.1 Iron

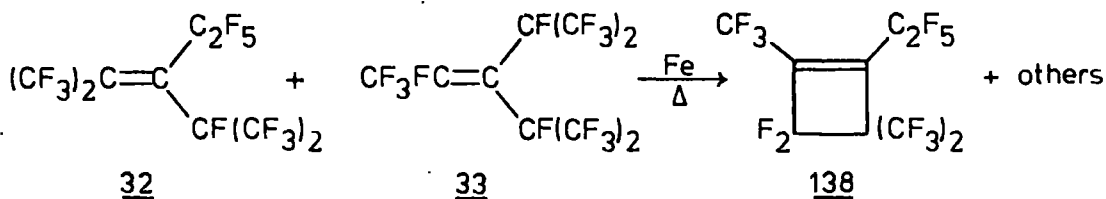

A mixture of (32) and (33) (ratio 3:1) (2.3g), at 605°, gave a product (1.45g) containing (GDB, col '0', 70°) one main component (ca. 70%, 48% yield). This was separated by preparative scale g.l.c. giving F-2-ethyl-1,3,3-trimethylcyclobutene (138) (0.6g, 28% isolated yield based on total st. mat.), b.p. 89°, (Found C, 25.9; F, 74.1%; M<sup>+</sup>, 412. C<sub>9</sub>F<sub>16</sub> requires C, 26.2; F, 73.8%; M, 412),  $\nu_{\max}$  (Raman) 1708 cm<sup>-1</sup> (C=C str.), i.r. spectrum No.25, <sup>19</sup>F n.m.r. spectrum No.41.

#### IX.D.2 Platinum

Isomer (32) fragments more readily than (33). At 560° most of (32) has reacted, (33) is still present at 620°, but all (33) has reacted at 670°. Most of the products are very volatile, none were identified.

#### IX.E F-2,5-dihydrotetramethylfuran (109)

##### IX.E.1 Iron

At 580°, (109) (9.95g) gave liquid product (7.55g) containing, by <sup>19</sup>F n.m.r., (109) (23% by wt.) and F-tetramethylfuran (112) (77%, 79% yield based on 109 consumed). The product was distilled (Fischer-Spaltrohr) giving, as the residue, (112) (3.65g, 49% isolated yield).

##### IX.E.2 Platinum

At 715°, (109) (2.1g) gave a product liquid (1.5g) containing mainly (109) (>90%) and two unidentified minor components from g.l.c. (GDB, col '0', 50°).

#### IX.F F-4-ethyl-2,3,4,5-tetramethyl-2-oxolene (113)

##### IX.F.1 Platinum

At 430° there is a 45% conversion of (113) to products. From 500° to 700° the conversion to products is 100% and the yield

of the main product (139) remains between 80 and 85%.

Passage of (113) (47.9g) through the tube (570°) gave, after allowing any gases to escape, liquid products (28.2g) containing (GDB, col 'A', 60°) (139) (ca. 88% by wt. 85% yield), n-F-butane (4%), and unidentified material (8%). A white crystalline solid (ca. 0.5g) formed in the product on standing, but this was not identified. Preparative scale g.l.c. (col 'A', 50°) of a sample of the product (5g) gave n-F-butane and F-2,3,4-trimethylfuran (139) (3.2g, equivalent to 62% isolated yield), b.p. 90.5°, (Found C, 29.3; F, 65.2%; M<sup>+</sup>, 290. C<sub>7</sub>F<sub>10</sub>O requires C, 29.0; F, 65.5%; M, 290), λ<sub>max</sub> (methanol) 220 nm (ε = 3900), i.r spectrum No.26, <sup>19</sup>F n.m.r. spectrum No.42. n-F-butane was identified by its <sup>19</sup>F n.m.r. spectrum.<sup>174</sup> Distillation of the product mixture (19.2g) obtained from (113) (35g) (tube temp. 590°) gave (139) (14.7g, 69% isolated yield).

#### IX.F.2 Iron

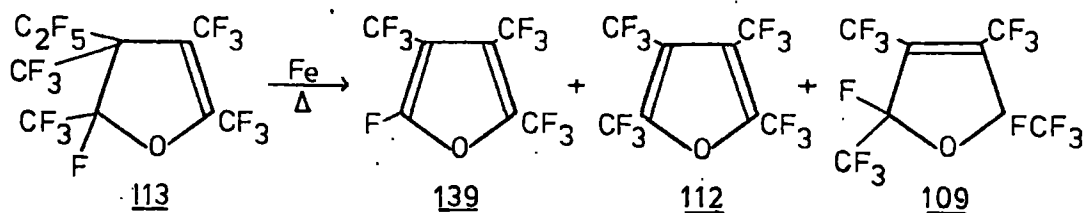

Passage of (113) (27.0g) through the tube (470°) gave, after allowing any gases to escape, a product mixture (19.1g) containing (GDB, col 'A', 65°) (109) (20% by wt), (139) (13%), and (112) (60%), and minor components. The yields are (109) (18%), (139) (15%), and (112) (60%). Distillation gave (112) (8.5g, 44% isolated yield) and a fraction

containing (109), which was separated (1.1g, 5% isolated yield) by preparative scale g.l.c. (col 'A', 50°) and identified by comparison of <sup>19</sup>F n.m.r. data with that of an authentic sample.

IX.G Others

Olefin (82) at 670° over platinum did not give any liquid products although gases may have been formed. Over iron at 520°, (82) gave recovered starting material (ca. 6%) and two C<sub>12</sub>F<sub>20</sub> isomers (ca. 2%), which are not (83) from their g.l.c. retention times.

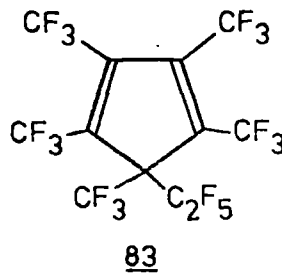
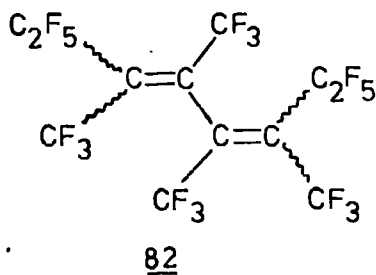

Olefin (83) at 550° over platinum gave ca. 50% recovery of material containing at least six products, including isomers of C<sub>10</sub>F<sub>16</sub>, C<sub>11</sub>F<sub>18</sub>, and C<sub>12</sub>F<sub>20</sub>.

CHAPTER X

Experimental to Chapter VI

X.A Reactions of F-2,3-dimethylbutadiene (130)

X.A.1 Neutral Methanol

A mixture of (130) (7.8g, 29.8 mmol) and neutral methanol (4.0g, 125 mmol) was allowed to stand for 3 weeks. Water was added and the recovered product was washed, and dried over magnesium sulphate giving a colourless liquid (5.1g) containing (GDB, col '0', 100°) two main components identified as (140) (28% by wt, 17% yield) and (141) (62%, 39% yield). Preparative scale g.l.c. (GDB col '0', 130°) gave 3-hydro-4-methoxy-2,3-bistrifluoromethyltetrafluoro-1-butene (140), b.p. 95.5°, (Found C, 28.7; F, 64.0%; M<sup>+</sup>, 294. C<sub>7</sub>H<sub>4</sub>F<sub>10</sub>O requires C, 28.6; F, 64.6%; M, 294), i.r. spectrum No.28, n.m.r. spectrum No.43 and cis-, trans-1-methoxy-2,3-bistrifluoromethyltrifluorobutadiene (141) (ratio cis:trans = 1.6:1), b.p. 114°, (Found C, 30.9; F, 61.9%; M<sup>+</sup>, 274. C<sub>7</sub>H<sub>3</sub>F<sub>9</sub>O requires C, 30.7; F, 62.4%; M, 274), i.r. spectrum No.29, n.m.r. spectrum No.44.

X.A.2 Phenol

A mixture containing (130) (4.1g, 15.6 mmol), phenol (1.5g, 15.9 mmol), sodium carbonate (1.75g, 16.5 mmol) and DMF (25 ml) was stirred for 36 h at 22°. The reaction mixture was poured into water (300 ml) and the products extracted into ether. The ether layer was washed with dil. NaOH, dil. HCl, and water and then dried over sodium sulphate. Ether was removed by distillation leaving a liquid (3.6g) showing one main component (g.l.c. -ms and GDB, col '0', 200°) which is a mixture

by  $^{19}\text{F}$  n.m.r. containing (143) (ca. 40%, 26% yield). Compound (143) could not be obtained pure using preparative scale g.l.c. but was identified as cis-, trans-3-hydro-1-phenoxy-2,3-bistrifluoromethyl-tetrafluoro-1-butene (143) (ratio cis:trans = 1:2 by  $^{19}\text{F}$  n.m.r.) (Found  $\text{M}^+$ , 356.  $\text{C}_{12}\text{H}_6\text{F}_{10}\text{O}$  requires  $\text{M}$ , 356),  $\nu_{\text{max}}$  1700  $\text{cm}^{-1}$  (C=C str.), n.m.r. spectrum No.45.

#### X.A.3 Caesium Fluoride and Bromine

Caesium fluoride (3g, 19.7 mmol) was added severally to a stirred mixture containing (130) (2g, 7.6 mmol), bromine (9.4 mmol), and DMF (8 ml). After 3 days the recovered lower layer (1.8g) contains mainly F-2,3-dimethyl-2-butene (94) (90%, ca. 70% yield). Preparative scale g.l.c. (GDB, col '0', 110 $^{\circ}$ ) gave (94) (1.1g, 48% isolated yield) which was identified by its mass spectrum and by comparison of its  $^{19}\text{F}$  n.m.r. spectrum with that reported in the literature.<sup>87</sup>

#### X.A.4 Caesium Fluoride, Dimerisation

##### X.A.4.a At room temperature

A mixture of (130) (7.1g, 27.1 mmol), caesium fluoride (2.5g, 16.5 mmol), and tetraglyme (20 ml) was stirred for 18 h, when a one phase system remained and most of the CsF had dissolved. This orange solution is ca. 0.8 M in CsF, almost certainly in the form of carbanions (see below). The products (6.7g) were recovered by transferring under vacuum to a cold trap and contained (% wt, GDB, col '0', 50 $^{\circ}$ ) (130) (2%), (147) (32%, 30% yield), (146) (60%, 57% yield), and an unidentified less volatile component (6%). The CsF was precipitated from the tetraglyme layer after removal of products.

Samples of the two main products were separated by preparative scale g.l.c. (GDB, col '0', 60°) giving cis-, trans-F-3-(3'-methyl-2'-butylidene)-1,4,4-trimethylcyclobutene (147) (ratio = 2.2:1 by <sup>19</sup>F n.m.r.), b.p. 137°, (Found F, 72.9%; M<sup>+</sup>, 524. C<sub>12</sub>F<sub>20</sub> requires F, 72.5%; M, 524), λ<sub>max</sub> (cyclohexane) 232 nm (ε = 17,700), i.r. spectrum No. 30, <sup>19</sup>F n.m.r. spectrum No.46, and cis-,trans-F-2,3,6,7-tetramethyl-1,3,6-octatriene (146) (isomer ratio = 2:1 by <sup>19</sup>F n.m.r.), b.p. 148° (Found F, 72.3%; M<sup>+</sup>, 524), i.r. spectrum No.31, <sup>19</sup>F n.m.r. spectrum No. 47.

X.A.4.b At 90°

A mixture of (130) (2.1g, 8 mmol), caesium fluoride (1g, 6.6 mmol), and tetraglyme (5 ml) was stirred at 90° for 15 h in Carius tube. The recovered product (1.6g) contained (147) (58%, 44% yield) and (146) (37%, 28% yield).

X.A.4.c Pyridine

A mixture of (130) (1.3g, 5 mmol), pyridine (0.15g, 1.9 mmol), and tetraglyme (5 ml) was stirred for 19 days. Only (130) (1.1g) was recovered.

X.A.4.d Reaction of Dimers with Fluoride Ion

A mixture of (146) and (147) (146:147 = 95:5) (0.25g, 0.5 mmol), caesium fluoride (0.2g, 1.3 mmol), and tetraglyme (2 ml) was stirred for 31 days. The recovered product (0.13g) contained (146) (90%) and (147) (10%).

A similar mixture at 80° for 68 h gave a product containing mainly (146) (ca. 90%).

A similar mixture but containing (146) (5%) and (147) (95%) at room temperature gave a product containing (147) (98%).

#### X.A.5 Formation of Carbanions from the Dimers

A mixture containing (146) (0.38g, 0.7 mmol), CsF (0.14g, 0.9 mmol), and tetraglyme (2 ml) was stirred for 40 h. After filtering under nitrogen a sample of the tetraglyme layer was removed. The  $^{19}\text{F}$  n.m.r. spectrum (run using the Brüker spectrometer) is different to that from (146) and is consistent with the F-2,3,6,7-tetramethyl-3,6-octenyl anion (150),  $^{19}\text{F}$  n.m.r. spectrum No.51. Addition of  $\text{BF}_3$  etherate (60  $\mu\text{l}$ ) regenerated (146) and produced  $\text{BF}_4^-$  (154 p.p.m.).

A similar experiment, but using (147) gave a two phase system and the tetraglyme layer produced only a very weak  $^{19}\text{F}$  n.m.r. spectrum which was different to that of (150). After addition of  $\text{BF}_3$  etherate the spectrum was still very weak.

A similar experiment, but starting with (130) instead of the dimers, gave a  $^{19}\text{F}$  n.m.r. spectrum showing all the signals arising from anion (150) and in addition peaks at 51.9 (Int.6), 60.4, 61.8 (ca. 8.5), 72.8 (3), and 177 (1).

#### X.A.5.a From Other Fluoro-olefins

The dienes (89), (81), (82), and (129) all gave yellow or orange solutions with CsF and tetraglyme or sulpholane, but two phase systems remained and the solvent layers showed very weak  $^{19}\text{F}$  n.m.r. spectra.

#### X.A.6 Fluorination of Dimers using Cobalt Trifluoride

This is a standard technique previously used in this laboratory and involves passing material in a stream of nitrogen over a mixture of cobalt trifluoride and calcium fluoride.

X.A.6.a At 100°

A mixture of (146) and (147) (ratio 65:35) (3g) gave a product (2.3g) containing (g.l.c.—ms, GDB, col 'A', 50°) 3 isomers of  $C_{12}F_{22}$  (% wt, 62, 33, and 5). The yield of (151), based on (146), is 68% and the yield of (153), based on (147), is 67%. Samples of the two main isomers were separated by preparative scale g.l.c. (Autoprep, col 'O', 30°) giving F-2,3,6,7-tetramethyl-2,5-octadiene (151) (Found F, 75.0%;  $M^+$ -F, 543.  $C_{12}F_{22}$  requires F, 74.4%; M, 562), i.r. spectrum No.32,  $^{19}F$  n.m.r. spectrum No.48, and F-2,3,3,5,6-pentamethyl-1,4-heptadiene (153) (Found F, 75.0%;  $M^+$ , 562) i.r. spectrum No.34,  $^{19}F$  n.m.r. spectrum No.50.

X.A.6.b At 200°

A mixture of (146) and (147) (ratio 63:37 respectively) (1.2g) gave a product (1g) containing (% wt., g.l.c.—ms and GDB, col 'O', 50°)  $C_3F_8$  (1%),  $C_9F_{16}$  (3%),  $C_9F_{18}$  (9%),  $C_{12}F_{22}$  (153) (29%),  $C_{12}F_{22}$  (151) (19%),  $C_{12}F_{24}$  (9%), and  $C_{12}F_{24}$  (152) (30%). Yields, based on (146), are  $C_{12}F_{22}$  (151) (22%) and  $C_{12}F_{24}$  (152) (35%), and yields, based on (147), are  $C_{12}F_{22}$  (153) (61%) and  $C_{12}F_{24}$  (18%). Preparative scale g.l.c. (Autoprep, col 'O', 70°) gave F-2,3,6,7-tetramethyl-2-octene (152) (Found F, 75.7%;  $M^+$ -F, 581.  $C_{12}F_{24}$  requires F, 76%; M, 600), i.r. spectrum No.33,  $^{19}F$  n.m.r. spectrum No.49.

The  $C_{12}F_{22}$  isomer (151) is unchanged after heating with caesium fluoride and tetraglyme for 64 h at 145°.

X.A.7 With Antimony Pentafluoride

Antimony pentafluoride (0.82g, 3.8 mmol) and (130) (3.1g, 11.8 mmol) were stirred for 42 h, when a yellow precipitate had formed. The material

(2.9g) recovered by transferring under vacuum was mainly (130) ( $\geq 95\%$ , 89% recovery). The precipitate had also disappeared.

A similar reaction, but using excess  $\text{SbF}_5$  gave a white solid, which after vacuum transference gave (130) (66% recovery). Again the solid disappeared.

#### X.A.8 Photolysis with F-acetone

F-acetone (2.7g, 16.3 mmol) and (130) (2g, 7.6 mmol) were sealed in a silica tube and irradiated with ultra-violet light (300 nm) for 550 h. The recovered volatile liquid products (2.2g) contained starting material (130) and three main products, which are isomers of  $\text{C}_9\text{F}_{16}\text{O}$ . The yields, based on (130) consumed (1.2g) are (156) (13%), (154) (41%) and (155) (15%). Preparative scale g.l.c. (GDB, col '0',  $80^\circ$ ) gave F-3-(2'-propenyl)-2,2,3-trimethyloxetane (155) (0.12g, 6.1% isolated yield) (Found C, 25.0; F, 70.7%;  $\text{M}^+$ , 428.  $\text{C}_9\text{F}_{16}\text{O}$  requires C, 25.3; F, 71.0%; M, 428), i.r. spectrum No.35,  $^{19}\text{F}$  n.m.r. spectrum No.52, F-4-(2'-propenyl)-2,2,4-trimethyloxetane (154) (0.44g, 22.4%) (Found  $\text{M}^+$ -F, 409) i.r. spectrum No.36,  $^{19}\text{F}$  n.m.r. spectrum No.53, and F-3,4,6,6-tetramethyl-5,6-dihydro-2H-pyran (156) (0.11g, 5.6%) (Found F, 70.7%;  $\text{M}^+$ -COF, 381),  $\nu_{\text{max}}$  (Raman)  $1660\text{ cm}^{-1}$  ( $\text{C}=\text{C}$ ), i.r. spectrum No.37,  $^{19}\text{F}$  n.m.r. spectrum No.54.

#### X.A.9 Radical Reactions

##### X.A.9.a Bromine

No reaction after standing in bright sunlight, irradiating with ultra-violet light, or after 334 h on the  $^{60}\text{Co}$  source. The absence of reaction with bromine has also been reported in the literature.<sup>198</sup>

X.A.9.b Attempted Copolymerisations using <sup>60</sup>Co Source

A one phase system consisting of (130) (2.3g, 8.8 mmol), butadiene (0.7g, 13 mmol), and Arcton 113 (20 ml) was irradiated for 336 h. There was no incorporation of fluorine, by <sup>19</sup>F n.m.r., in the liquid butadiene polymer and (130) was recovered. A similar reaction, but in the absence of solvent, using methylmethacrylate gave a polymer containing no fluorine from the elemental analysis. Styrene, again without a solvent, gave a polymer containing 3.9% of fluorine after reprecipitation from toluene. After a further reprecipitation the polymer did not contain fluorine.

X.B Reactions of F-2,3,4-trimethylfuran (139)

X.B.1 Methanol

A solution of sodium methoxide was prepared from sodium (0.3g, 13 mmol) and dry methanol (10 ml). An impure sample containing (139) (2.5g, 8.8 mmol) was added and the mixture was stirred for 15 h. All the volatiles were transferred under vacuum and methanol, containing (139) (0.4g) was removed by distillation leaving a product (2.15g) containing (157) (83%, 80% yield based on 139 consumed). Preparative scale g.l.c. (Autoprep, col '0', 90°) gave 2-methoxy-3,4,5-tristrifluoromethylfuran (157) (1g, 46% yield based on 139 consumed), b.p. 139.5°, (Found C, 32.0; F, 56.2%; M<sup>+</sup>, 302. C<sub>8</sub>H<sub>3</sub>F<sub>9</sub>O<sub>2</sub> requires C, 31.8; F, 56.6%; M, 302), λ<sub>max</sub> (methanol) 237 nm (ε = 6300), i.r. spectrum No.38, n.m.r. spectrum No.55.

A similar reaction using sodium carbonate as base and tetraglyme as solvent gave (157) (76% yield).

### X.B.2 Phenylmagnesium Bromide

Phenylmagnesium bromide was prepared, in dry ether (15 ml), from magnesium (0.25g, 10.3 mmol) and bromobenzene (1.4g, 8.9 mmol). Furan (139) (2g, 6.9 mmol) was added and the mixture was refluxed for 1 h and stirred at room temperature for a further 3 h. After transferring the volatiles under vacuum, ether was removed by distillation to leave a liquid residue (1.1g) containing some starting materials and a main component identified as (158) (80%, 36% yield). Preparative scale g.l.c. (GDB, col '0', 240°) gave 2-phenyl-3,4,5-tristrifluoromethylfuran (158) (0.6g, 23% yield) (Found C, 44.6; F, 49.0%; M<sup>+</sup>, 348. C<sub>13</sub>H<sub>5</sub>F<sub>9</sub>O requires C, 44.8; F, 49.1%; M, 348)  $\lambda_{\text{max}}$  (cyclohexane) 253 nm ( $\epsilon = 13,900$ ), i.r. spectrum No.39, n.m.r. spectrum No.56.

### X.B.3 Potassium Sulphide

A mixture of (139) (2.8g, 9.7 mmol), powdered poly potassium sulphide (2.1g, 19 mmol), and DMF (20 ml) was stirred for 8 days. Water was added and the products were extracted into 40 - 60° petroleum ether which was washed with dil. HCl and water, and then dried over MgSO<sub>4</sub>. Most of the solvent was removed under reduced pressure and then sulphur was removed by filtration. The remaining solvent was removed and molecular distillation (0.01 mm Hg and ca. 100°) gave a pale yellow liquid (1.2g) and an orange residue (0.5g). Both liquids are mixtures of compounds (159). The more volatile fraction consists mainly of

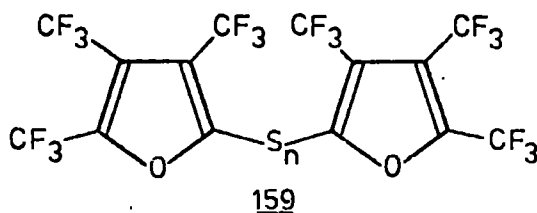

(159,  $n = 1$ ) (Found C, 28.2; S, 6.6%;  $M^+$ , 574.  $C_{14}F_{18}O_2S$  requires C, 29.3; S, 5.6%; M, 574) but the mass spectrum also shows (159,  $n = 2$ ) ( $M^+$ , 606). The less volatile component contains mainly (159,  $n = 2$ ) (Found S, 10.8%;  $M^+$ , 606.  $C_{14}F_{18}O_2S_2$  requires S, 10.6%; M, 606) but the mass spectrum also shows (159,  $n = 1$ ) ( $M^+$ , 574), (159,  $n = 3$ ) ( $M^+$ , 638), and (159,  $n = 4$ ) ( $M^+$ , 670). The total yield of (159) is ca. 60%. The  $^{19}F$  n.m.r. spectra of the two fractions are virtually the same, n.m.r. spectrum No.57. The workup procedure used has been described in the literature.<sup>202</sup>

#### X.B.4 Caesium Fluoride, Dimerisation

An impure sample (0.47g) containing (139) (0.41 g) was stirred with caesium fluoride (0.5g) and tetraglyme (3 ml) for 30 minutes. The product (0.43g), recovered by transferring under vacuum, contained (GDB, col 'A',  $60^\circ$ ) (139) (11%), (160) (81%) and unidentified material. The yield of (160) based on (139) consumed (0.36g) is 95%. Preparative scale g.l.c. (Autoprep, col 'A',  $90^\circ$ ) of the product of this and similar reactions gave F-2-(2',3',4'-trimethyl-2',5'-dihydrofuryl)-3,4,5-trimethylfuran (160), b.p.  $165^\circ$ , (Found C, 29.2; F, 65.1%;  $M^+$ , 580.  $C_{14}F_{20}O_2$  requires C, 29.0; F, 65.5%; M, 580), i.r. spectrum No.40,  $^{19}F$  n.m.r. spectrum No.58. The mass spectrum shows a metastable peak at 175 which is a result of loss of  $C_5F_8$  ( $511 \rightarrow 299$ , calculated value 174.95).

A similar reaction, but at  $110^\circ$  for 1 h, gave a much lower yield of (160) (8%) and involatile material which was not investigated further. During the reaction the mixture became bright red.

Furan (139) is not dimerised by CsF in the absence of solvent at room temperature or at 110°.

#### X.B.5 Reaction with Methoxy Derivative (157)

A mixture of (139) (2.1g, 7.2 mmol) and (157) (1.9g, 6.3 mmol) was added dropwise over 20 minutes to a stirred mixture of pyridine (1g, 12.7 mmol) and tetraglyme (8 ml) heated at 90°. After refluxing for a further 3 h at 100° The mixture was allowed to cool and was then poured into water. The lower layer was washed with dil. HCl and water and then transferred under vacuum from P<sub>2</sub>O<sub>5</sub> giving a pale orange liquid (1.2g) containing (GDB, col '0', 150°) (139) (22% wt), (160) (37%), (162) (31%, 11% yield based on 157). Preparative scale g.l.c. (GDB, col '0', 150°) gave (160) (0.25g), identified by comparison of <sup>19</sup>F n.m.r. data with that of an authentic sample (see above), and F-2-(2',3',4'-trimethyl-2',5'-dihydro-4'-furanonyl)-3,4,5-trimethylfuran (162) (0.16g, 4.6% isolated yield based on 157) (Found C, 29.9; F, 61.0%; M<sup>+</sup>-F, 539. C<sub>14</sub>F<sub>18</sub>O<sub>3</sub> requires C, 30.1; F, 61.3%; M, 558), i.r spectrum No.41, <sup>19</sup>F n.m.r. spectrum No.59. The mass spectrum shows strong peaks at 489 and 299 (489 → 299 = loss of C<sub>5</sub>F<sub>6</sub>O).

#### X.B.6 Photolysis

Furan (139) was recovered unchanged, by <sup>19</sup>F n.m.r., after irradiation, in the gas phase, with ultra-violet light (253.7 nm) for 140 h in a sealed silica tube.

#### Under Transference

Irradiation under transfer conditions is a well established technique.<sup>205</sup>

The furan (139) (5.3g) was irradiated in a silica vessel in the gas phase using a high pressure Hg lamp. A partial pressure of nitrogen (ca. 2 cm Hg) allowed the material to transfer at ambient temperature over about 24 h to a trap cooled at  $-78^{\circ}$ . This procedure was carried out twice for the same material giving a volatile product mixture (4.1g) containing (GDB, col '0',  $70^{\circ}$ ) (163) (ca. 25%, 42% yield based on 139 consumed), (139) (ca. 70%) and four minor components. Preparative scale g.l.c. (GDB, col '0',  $105^{\circ}$ ) gave (139) (2.3g) and the more volatile F-1,2,3-trimethylcyclopropenyl acyl fluoride (163) (0.5g, 21% isolated yield based on 139 consumed) (Found C, 28.7; F, 65.9%;  $M^+$ -F, 271.  $C_7F_{10}O$  requires C, 29.0; F, 65.5%; M, 290), i.r. spectrum No.42,  $^{19}F$  n.m.r. spectrum No.60.

#### X.C Reactions of F-tetramethylfuran (112)

##### X.C.1 Photolysis

Like (139), (112) was recovered unchanged after irradiation with ultra-violet light (253.7 nm).

A static irradiation of (112) in a silica vessel using a high pressure Hg lamp gave a complex mixture of less volatile products.

##### Under Transference

Using the same experimental conditions described in X.B.6 above, except that the material was transferred only once, (112) (2.4g) gave recovered volatiles (2.2g) containing (112) (77%), (164) (20%, 62% yield based on 112 consumed) and two minor components. Preparative scale g.l.c. (GDB, col '0',  $100^{\circ}$ ) gave (112) (1.5g) and F-1,2,3-trimethylcyclopropenyl F-methyl ketone (164), (0.25g, 35% isolated yield based on 112 consumed),

identified by comparison of spectral data with data reported in the literature,<sup>207</sup> i.r. spectrum No.43, <sup>19</sup>F n.m.r. spectrum No.61.

The yield of (164) decreased with repeated irradiation and the number of minor components, and less volatile material increased.

#### X.C.2 Attempted Diels-Alder Reactions

A mixture of (112) (0.63g, 1.9 mmol) and furan(0.13g, 1.9 mmol) was sealed in a pyrex n.m.r. tube and heated for 3 days at 130-150°. There was no significant reaction.

A similar experiment using diphenylacetylene again gave no reaction.

REFERENCES

REFERENCES

1. B. Tittle and A.E. Platt, B.P., 1,007,542/1965; Chem. Abs.; 1966, 64, 1956.
2. H. Hauptschein, M. Braid, and F.E. Lawlor, J. Amer. Chem. Soc., 1957, 79, 2549.
3. W.T. Miller, J.O. Stoffer, G. Fuller, and A.C. Currie, J. Amer. Chem. Soc., 1964, 86, 51.
4. H.G. Bryce, Fluorine Chemistry, 1964, 5, 295.
5. G. Camaggi and F. Gozzo, J. Chem. Soc. (C), 1970, 178.
6. J. Harmon, U.S.P. 2,404,376/1946; Chem. Abs., 1946, 40, 7234.
7. J.D. Park, K.V. Holler, and J.R. Lacher, J. Org. Chem., 1960, 25, 990.
8. M. Hauptschein, A.H. Fainberg, and M. Braid, J. Amer. Chem. Soc., 1958, 80, 842.
9. P.W.L. Bosbury, R. Fields, R.N. Haszeldine, and D. Moran, J. Chem. Soc., Perkin Trans. 1, 1976, 1173.
10. R.E. Banks, A.C. Harrison, and R.N. Haszeldine, J. Chem. Soc. (C), 1966, 2102.
11. R.N. Haszeldine, J. Chem. Soc., 1953, 3559.
12. R.D. Chambers, "Fluorine in Organic Chemistry", Wiley Interscience, New York, 1973.
13. R.D. Chambers and R.H. Mobbs, Adv. Fluor. Chem., 1965, 4, 50.
14. J.A. Young, Fluor. Chem. Rev., 1967, 1, 359.
15. G.A. Olah and Y.K. Mo, "Carbonium Ions", Vol.5, Wiley, New York, 1976, 2135.

16. Reference 12, Chapter 4.
17. G.A. Olah and Y.K. Mo, Adv. Fluor. Chem., 1973, 7, 69.
18. G.A. Olah, R.D. Chambers, and M.B. Comisarow,  
J. Amer. Chem. Soc., 1967, 89, 1268.
19. P.B. Sargeant and C.G. Krespan, J. Amer. Chem. Soc., 1969,  
91, 415.
20. (i) R. West, Acc. Chem. Res., 1970, 3, 130.  
(ii) S. Patai, "The Chemistry of the Carbon Halogen Bond",  
Part 2, Wiley Interscience 1973, see T. Chivers, Chapt. 14.
21. D.T. Clark, N.J. Murrel, and J.M. Tedder, J. Chem. Soc.,  
1963, 1250.
22. J. Hine, "Physical Organic Chemistry", McGraw-Hill,  
New York, 1962, 487.
23. W.T. Miller, J.H. Fried, and H. Goldwhite, J. Amer. Chem. Soc.,  
1960, 82, 3091.
24. D.P. Graham and W.B. McCormack, J. Org. Chem., 1966, 31, 958.
25. K.N. Makarov, L.L. Gervits, and I.L. Knunyants, J. Fluor. Chem.,  
1977; 10, 157.
26. R. D. Chambers, G. Taylor and R.L. Powell, J. Chem. Soc. Chem. Comm.,  
1978, 431.
27. D.J. Burton and R.D. Howells, J. Amer. Chem. Soc., 1977, 99, 4830.
28. Reference 12, Chapter 7.
29. J.D. Roberts and M.C. Caserio, "Basic Principles of Organic Chemistry,"  
Benjamin, 1965.
30. W.T. Miller, W. Frass, and P.R. Resnick, J. Amer. Chem. Soc.,  
1961, 83, 1767.

31. L.S. German and G.G. Belen'kii, Abstracts of Papers, 6th European Symp. on Fluorine Chemistry, Dortmund, 1977.
32. G.G. Belen'kii, E.P. Lure, and L.S. German, Bull. Acad. Sci. U.S.S.R. (Engl. Transl.), 1976, 2208.
33. R.D. Chambers, A. Parkin, and R.S. Matthews, J. Chem. Soc., Perkin Trans.1, 1976, 2107.
34. French Patent, 1,576,012/1969; Chem. Abs., 1970, 72, 79617.
35. P.C. Myhre and G.D. Andrews, J. Amer. Chem. Soc., 1970, 92, 7595.
36. G.G. Belen'kii, E.P. Lure, and L.S. German, Bull. Acad. Sci. U.S.S.R. (Engl. Transl.), 1975, 2614.
37. W. Dmowski, W.T. Flowers, and R.N. Haszeldine, J. Fluor. Chem., 1977, 9, 94.
38. G.A. Olah, J.S. Staral, R.J. Spear and G. Liang, J. Amer. Chem. Soc., 1975, 97, 5489.
39. Yu.L. Kopaevich, G.G. Belen'kii, E.T. Mysov, L.S. German and I.L. Knunyants, Zh. Vses. Shim. Obshchest., 1972, 17, 236; Chem. Abs., 1972, 77, 33864.
40. Reference 13, p.52.
41. A.C. Knipe, J. Chem. Ed., 1976, 53, 619.
42. C.L. Liotta and E.E. Grisdale, Tetr. Letts., 1975, 4205.
43. M. Ozawa, T. Komatsu, and K. Matsuoka, Japan Kokai, 76, 125, 307/1975; Chem. Abs., 1977, 86, 189174.
44. W. J. Brehm, K.G. Bremer, H.S. Eleuterio, and R.W. Meschke, U.S.P., 2,918,501/1959.
45. (i) B.P., 1,407,391/1975.  
(ii) B.P., 1,407,392/1975.

46. (i) D.P. Graham, J. Org. Chem., 1966, 31, 955.  
(ii) D.P. Graham, U.S.P., 3,403,191/1968.
47. M. Ozawa, F. Inove, T. Komatsu, and K. Matsuoka, Ger. Offen.,  
2,627,115/1976.
48. J.A. Young and R.D. Dresdner, U.S. Dept. Com. Office Tech. Serv. AD.,  
264,676/1961; Chem. Abs., 1963, 58, 4408.
49. W.H. Christie, F.N. Tlumac, R.D. Dresdner, and J.A. Young,  
Abstracts of Papers, 138th Meeting, Amer. Chem. Soc., New York, 1960.
50. R.D. Dresdner, F.N. Tlumac, and J.A. Young, J. Org. Chem., 1965,  
30, 3524.
51. K.J.R. Fraticelli, Ph.D. Thesis, Cornell University, Ithica, N.Y.,  
1965.
52. R.D. Chambers, J.A. Jackson, W.K.R. Musgrave, and R.A. Storey  
J. Chem. Soc. (C), 1968, 2221.
53. T. Mizuno, N. Ishikawa, and S. Nakamura, Japan Kokai, 75,1177,05/1975;  
Chem. Abs., 1976, 84, 58599.
54. W. Brunskill, W.T. Flowers, R. Gregory, and R.N. Haszeldine,  
Chem. Comm., 1970, 1444.
55. T. Martini and S.P. Von Halasz, Tetr. Letts., 1974, 2129.
56. T. Martini, Ger. Offen., 2,306,439/1974; Chem. Abs., 1975, 83,  
205747.
57. N. Ishikawa and T. Mizuno, Japan Kokai, 74,134,614/1974;  
Chem. Abs., 1975, 82, 139294.
58. N. Ishikawa and A. Sekiya, Nippon Kagaku Kaishi, 1972, 2214;  
Chem. Abs., 1973, 78, 57656.
59. N. Ishikawa and A. Nagashima, Nippon Kagaku Kaishi, 1975, 1439;  
Chem. Abs., 1975, 83, 163550.

60. S.P. Von Halasz, F. Kluge, and T. Martini, Chem. Ber., 1973, 106, 2950.
61. Reference 14, p.367.
62. M. Ozawa, T. Komatsu, and K. Matsuoka, Ger. Offen., 2,706,603/1977; Chem. Abs., 1977, 87, 183969.
63. R.D. Chambers, J. Hutchinson, and P.D. Philpot, J. Fluor. Chem., 1977, 9, 15.
64. D.L. Miller, U.S.P., 3,389,187/1968.
65. Reference 14, p.377.
66. T.A. Mashburn, U.S.P., 3,257,466/1966; Chem. Abs., 1966, 65, 13544.
67. A.A. Glazkov, A.V. Ignatenko, S.P. Krukovskii, and V.A. Ponomarenko, Bull. Acad. Sci. U.S.S.R. (Eng. Transl.), 1976, 896.
68. C.W. Tullock, D.D. Coffman, and E.L. Muetterties, J. Amer. Chem. Soc., 1964, 86, 357.
69. Reference 14, p.364.
70. H.C. Fielding and A.J. Rudge, B.P., 1,082,127/1967.
71. W.R. Deem, B.P., 1,302,350/1973; Ger. Offen., 2,009,967/1970; Chem. Abs., 1971, 75, 21446.
72. J. Hutchinson, Fette Seifen Anstrichm., 1974, 76, 158.
73. See also Reference 12, p.169.
74. H. Fielding, Abstracts of Papers, 5th European Symp. on Fluorine Chemistry, Menton, 1976.
75. R. D. Chambers, J.A. Jackson, S. Partington, P.D. Philpot, and A.C. Young, J. Fluor. Chem., 1975, 6, 5.
76. T. Opie, Ph.D. Thesis, Cornell University, Ithica N.Y., 1976.
77. W. R. Deem, Ger. Offen., 1,901,006/1969.

78. R.D. Chambers, M.Y. Gribble, and E. Marper, J. Chem. Soc.,  
Perkin Trans.1, 1973, 1710.
79. R.L. Pruett, C.T. Bakner, and H.A. Smith, J. Amer. Chem. Soc.,  
1952, 74, 1638.
80. Reference 14, p.378.
81. A.F. Gontar, E.G. Bykhovskaga, and I.L. Knunyants,  
Bull. Acad. Sci. U.S.S.R. (Eng. Transl.), 1975, 2161.
82. J. V. Drayton, W.T. Flowers, R.N. Haszeldine, and T.A. Parry,  
J. Chem. Soc. Chem. Comm., 1976, 490.
83. D.R.A. Perry, Fluor. Chem. Rev., 1967, 1, 253.
84. B.L. Dyatkin, E.P. Mochalina, and I.L. Knunyants,  
Fluor. Chem. Rev., 1969, 3, 45.
85. W.H. Sharkey, Fluor. Chem. Rev., 1968, 2, 1.
86. J.D. Park, R.J. McMurtry, and J.H. Adams, Fluor. Chem. Revs.,  
1968, 2, 55.
87. H.H. Evans, R. Fields, R.N. Haszeldine, and M. Illingworth,  
J. Chem. Soc., Perkin Trans. 1, 1973, 649.
88. Reference 12, p.296.
89. B.L. Dyatkin, N.I. Delyagina, and S.R. Sterlin, Usp. Khim., 1976,  
45, 1205; Chem. Abs., 1976, 85, 142102.
90. Reference 12, p.44.
91. N.I. Delyagina, B.L. Dyatkin, and I.L. Knunyants, Bull. Acad.  
Sci. U.S.S.R. (Engl. Transl.), 1974, 1594.
92. B.L. Dyatkin, L.G. Zhuravkova, B.I. Martynov, S.R. Sterlin, and  
I.L. Knunyants, J. Chem. Soc. Chem. Comm., 1972, 618.
93. B.L. Dyatkin, B.I. Martynov, L.G. Martynova, N.G. Kizim,  
S.R. Sterlin, Z.A. Stumbrevichute, and L.A. Fedorov,  
J. Org. Metallic Chem., 1973, 57, 423.

94. C.G. Krespan, J. Org. Chem., 1962, 27, 1813.
95. W. T. Miller and R.J. Burnard, J. Amer. Chem. Soc., 1968, 90, 7367.
96. R.D. Chambers and M.Y. Gribble, J. Chem. Soc., Perkin Trans. 1, 1973, 1405.
97. B.L. Dyatkin, L.G. Martynova, B.I. Martynov, and S.R. Sterlin, Tetr. Letts., 1974, 273.
98. N.I. Delyagina, B.L. Dyatkin, I.L. Knunyants, N.N. Bubnov, and B.Y. Medvedev, J. Chem. Soc. Chem. Comm., 1973, 456.
99. N. Ishikawa and A. Nagashima, Bull. Chem. Soc. Jpn., 1976, 49, 502.
100. I.L. Knunyants, L.S. German, and B.L. Dyatkin, Jzv. Akad. Nauk SSSR, Otdel. Shim. Nauk, 1956, 1353; Chem. Abs., 1957, 51, 8037.
101. Reference 12, p.151.
102. J.A. Oliver, R. Stephens, J.C. Tatlow, and J.R. Taylor, J. Fluor. Chem., 1976, 7, 555.
103. K.N. Makarov, L.L. Gervits, Yu. A. Cheburkov, and I.L. Knunyants, J. Fluor. Chem., 1977, 10, 323.
104. T. Kawaguchi, U. Yonemura, and S. Negishi, Japan Kokai, 74,132,020/1974; Chem. Abs., 1975, 83, 9480.
105. T. Mizuno, N. Ishikawa, and S. Nakamura, Japan Kokai, 75,117,727/1975; Chem. Abs., 1976, 84, 73878.
106. B. Tittle, B.P., 1,143,927/1969.
107. M.W. Grayston and D.M. Lemal, J. Amer. Chem. Soc., 1976, 98, 1278.
108. C.G. Krespan, U.S.P., 4,005,104/1977; Chem. Abs., 1977, 86, 171461.
109. (i) D.C. England, Angew. Chem. Int. Ed. Engl. 1973, 12, 1023.  
(ii) D.C. England, U.S.P., 3,825,599/1974; Chem. Abs., 1974, 81, 104757.

110. J.H. Atherton, Ger. Offen., 2,311,879/1973; Chem. Abs., 1974, 80, 121681.
111. W.R. Deem, Ger. Offen., 2,230,911/1973; Chem. Abs., 1973, 79, 32856.
112. H.C. Fielding, W.R. Deem, L.E. Houghton, and J. Hutchinson, Ger. Offen., 2,215,385/1973.
113. H.C. Fielding, B.P., 1,130,822/1966.
114. H.C. Fielding and R. Jones, Chem. Phys. Chem. Anwendungtech Grenzflaechenaktwen Stoffe Ber. Int. Kongr. 6th, 1972, Band 1, 273; Chem. Abs., 1975, 82, 126903.
115. L.E. Houghton, Ger. Offen., 2,215,388/1972; Chem. Abs., 1973, 78, 31818.
116. L.E. Houghton and J. Hutchinson, Ger. Offen., 2,301,551/1973; Chem. Abs., 1973, 79, 115452.
117. J. Hutchinson, Ger. Offen., 2,244,028/1973; Chem. Abs., 1973, 79, 20650.
118. J. Hutchinson, B.P., 1370024/1974.
119. Hua Hsueh Hsueh Pao, 1975, 33, 79; Chem. Abs., 1976, 85, 123245.
120. J.D. Park and W.C. Frank, J. Org. Chem., 1967, 32, 1333.
121. E. Marper, Ph.D. Thesis, Durham, 1971.
122. D. Pearce, Ph.D. Thesis, Durham, 1977.
123. L.M. Yagupol'skii, V.G. Lukmanov, and L.A. Alekseeva, Zh. Org. Khim., 1976, 12, 470; Chem. Abs., 1976, 84, 150295.
124. T. Martini and C. Schumann, J. Fluor. Chem., 1976, 8, 535.
125. D.C. England and C.G. Krespan, J. Amer. Chem. Soc., 1965, 88, 5582.

126. H.C. Fielding, B.P., 1,176,492/1970.
127. P. Robinson, B.P., 1,182,645/1970.
128. H.C. Fielding, B.P., 1,176,493/1970.
129. W. J. Middleton and R.V. Lindsey, J. Amer. Chem. Soc.,  
1964, 86, 4948.
130. S. Yanagida, Y. Noji, and M. Okahara, Tetr. Letts., 1977, 2337.
131. H.C. Fielding and G.J. Moore, B.P., 1,206,596/1970.
132. H.C. Fielding, B.P., 1,155,607.
133. N. Ishikawa and M. Maruta, Chem. Lett., 1977, 967.
134. F.A. Cotton and G. Wilkinson, "Advanced Inorganic Chemistry",  
Wiley Interscience, 1972, 113.
135. A.M. Krzhizhevskii, Yu. A. Cheburkov, and I.L. Knunyants,  
Bull. Acad. Sci. U.S.S.R. (Eng. Transl.), 1974, 2065.
136. W.T. Flowers, R.N. Haszeldine, C.R. Owen, and A. Thomas,  
J. Chem. Soc. Chem. Comm., 1974, 134.
137. R.C. Weast, "Handbook of Chemistry and Physics, 46th Edn.",  
C.R.C. Press, Cleveland, 1965, p.D-77.
138. G. Tsukamoto and N. Ishikawa, Chem. Letts., 1972, 577.
139. H.C. Fielding, B.P., 1,148,486/1969.
140. N. Ishikawa, A. Nagashima, and A. Sekiya, Chem. Letts., 1974, 1225.
141. N. Ishikawa and A. Nagashima, Bull. Chem. Soc. Jpn., 1976,  
49, 1085.
142. F.A. Cotton and G. Wilkinson, "Advanced Inorganic Chemistry",  
Wiley Interscience, 1972, 350.
143. H.C. Fielding, B.P., 1,151,601/1969.
144. C.G. Krespan, J. Org. Chem., 1969, 34, 42.

145. H.C. Fielding, B.P., 1,143,599/1969.
146. V.V. Tyuleneva, L.A. Rozov, Yu. V. Zeifman, and I.L. Knunyants, Bull. Acad. Sci. U.S.S.R. (Eng. Transl.), 1975, 1042.
147. Reference 12, p.106.
148. Reference 13, p.78.
149. Reference 12, p.102.
150. W.C. Solomon, L.A. Dee, and D.W. Schultz, J. Org. Chem., 1966, 31, 1551.
151. V.E. Platonov, T.V. Senchenko, and G.G. Yakobson, Zh. Org. Khim., 1976, 12, 816; Chem. Abs., 1976, 85, 20910.
152. J.D. Park and W.C. Frank, J. Org. Chem., 1967, 32, 1336.
153. E. Nield and J.C. Tatlow, Tetrahedron, 1960, 8, 38.
154. (i) J. Burdon, I.W. Parsons, and J.C. Tatlow, Tetrahedron, 1972, 43.
- (ii) J. Battersby, R. Stephens, and J.C. Tatlow, Tetr. Letts., 1970, 5041.
155. Y. Kobayashi, Y. Hanzawa, Y. Nakanishi, and T. Kashiwagi, Tetr. Letts., 1978, 1019.
156. I.L. Knunyants and E.G. Ter-Gabrielyan, Dokl. Akad. Nauk. S.S.S.R., 1976, 228, 1344; Chem. Abs., 1976, 85, 142515.
157. Y. Kobayashi, K. Itsumaro, A. Ohsawa, Y. Hanzawa, and I. Masomitsu, Tetr. Letts., 1976, 2545.
158. Y. Kobayashi, I. Kumadaki, A. Ohsawa, Y. Hanzawa, and M. Honda, Tetr. Letts., 1975, 3001.
159. Reference 13, p.93.
160. J. Burdon and J.C. Tatlow, J. Appl. Chem., 1958, 8, 293.

161. S.P. Von Halasz, Abstracts of Papers, 6th European Symp. on Fluorine Chemistry, Dortmund, 1977.
162. W.T. Miller, U.S.P., 2,716,141/1955.
163. A.N. Bell, R. Fields, R.N. Haszeldine and I. Kumadaki, J. Chem. Soc. Chem. Comm., 1975, 866.
164. W.T. Flowers, R.N. Haszeldine, and J.E.G. Kemp, Chem. Comm., 1969, 203.
165. B. Gething, C.R. Patrick, J.C. Tatlow, R.E. Banks, A.K. Barbour, and A.E. Tipping, Nature, 1959, 183, 586.
166. P.L. Coe, C.R. Patrick, and J.C. Tatlow, Tetrahedron, 1960, 240.
167. B.R. Letchford, C.R. Patrick, M. Stacey, and J.C. Tatlow, Chemistry and Industry, 1962, 1472.
168. K.V. Dvornikova, V.E. Platonov, and G.G. Yakobson, J. Fluor. Chem., 1978, 11, 1.
169. P.D. Philpot, Ph.D. Thesis, Durham, 1975.
170. R.D. Chambers, J. Hutchinson, and P.D. Philpot, J. Fluor. Chem., 1977, 9, 15.
171. R.D. Chambers and M.Y. Gribble, J. Chem. Soc., Perkin Trans.1, 1973, 1411.
172. J. Lee and L.H. Sutcliffe, Trans. Farad. Soc., 1959, 55, 880.
173. W.T. Miller and R. Becker, Abstracts of Papers, Amer. Chem. Soc., 1963, 14M.
174. J.W. Emsley, J. Feeney, and L.H. Sutcliffe, "High Resolution Nuclear Magnetic Resonance Spectroscopy", Vol.2, Pergamon Press, 1966, Chapt.11.

175. L.F. Pelosi and W.T. Miller, J. Amer. Chem. Soc., 1976, 98, 4311.
176. W.T. Miller, R.J. Hummel, and L.F. Pelosi, J. Amer. Chem. Soc., 1973, 95, 6850.
177. L. Pelosi, Ph.D. Thesis, Cornell University, Ithica N.Y., 1973.
178. W.J. Feast, R.H. Hughes, and W.K.R. Musgrave, J. Chem. Soc. Perkin I, 1977, 152.
179. A.B. Clayton, W.J. Feast, D.R. Sayers, R. Stephens, and J.C. Tatlow, J. Chem. Soc. (C), 1971, 1183.
180. R.D. Chambers, S. Partington, and D.B. Speight, J. Chem. Soc. Perkin I, 1974, 2673.
181. G. Taylor, Personal Communication.
182. N. Kelly, G. Whittaker, Personal Communications.
183. N. Ishikawa and A. Nagashima, Nippon Kagaku Kaishi, 1974, 7, 1240; Chem. Abs., 1974, 81, 119432.
184. J. Burdon, W.B. Hollyhead, and J.C. Tatlow, J. Chem. Soc., 1965, 5152.
185. R.D. Chambers, A.A. Lindley, P.D. Philpot, H.C. Fielding, J. Hutchinson, and G. Whittaker, J. Chem. Soc. Perkin I, in the press.
186. P.W.L. Bosbury, R. Fields, and R.N. Haszeldine, J. Chem. Soc. Perkin I, 1978, 422.
187. T.N. Gerasimova, T.V. Fomenko, and E.P. Fokin, Zh. Org. Khim., 1977, 13, 1562; Chem. Abs., 1977, 87, 151799.
188. M. Allan, A.F. Janzen, and C.J. Willis, Can. J. Chem., 1968, 46, 3671.
189. J.F. Harris and D.D. Coffman, J. Amer. Chem. Soc., 1962, 84, 1553.
190. V.E. Platonov and G.G. Yakobson, Synthesis, 1976, 374, and references cited therein.
191. J.P. Chesick, J. Amer. Chem. Soc., 1966, 88, 4800.

192. W. Mahler, J. Amer. Chem. Soc., 1962, 84, 4600.
193. G.S. Krasnikova, L.S. German, and I.L. Knunyants, Bull. Acad. Sci. U.S.S.R. (Eng. Transl.), 1973, 444.
194. J. Rud Nielsen, C.M. Richards, and H.L. McMurray, J. Chem. Phys., 1948, 67, 16.
195. R.E. Banks, A. Braithwaite, R.N. Haszeldine, and D.R. Taylor, J. Chem. Soc. (C), 1969, 996.
196. (i) C.J. Wurrey, W.E. Bucy, and J.R. Durig, J. Chem. Phys., 1977, 67, 2765.
- (ii) C.R. Brundle and M.B. Robin, J. Amer. Chem. Soc., 1970, 92, 5550.
197. I.L. Knunyants, B.L. Dyatkin, and E.P. Mochalina, Bull. Acad. Sci. U.S.S.R. (Eng. Transl.), 1962, 1398.
198. N.B. Kaz'mina, G.S. Krasnikova, E.P. Lure, E.I. Mysov, and I.L. Knunyants, Bull. Acad. Sci. U.S.S.R. (Eng. Transl.), 1975, 2410.
199. L.L. Gervits, L.A. Rozov, N.S. Mirzabekyants, K.N. Makarov, Yu. V. Zeifman, Yu. A. Cheburkov, and I.L. Knunyants, Bull. Acad. Sci. U.S.S.R. (Eng. Transl.), 1976, 1592.
200. R.E. Banks, R.N. Haszeldine, D.R. Taylor, and G. Webb, Tetr. Lett., 1970, 5215.
201. W.J. Linn, J. Org. Chem. 1964, 29, 3111.
202. C.G. Krespan and D.C. England, J. Org. Chem., 1968, 33, 1850.
203. H.A. Wiebe, S. Braslavsky, and J. Heicklen, Can. J. Chem., 1972, 50, 2721.
204. Y. Kobayashi, I. Kumadaki, A. Ohsewa, and Y. Sekine, Tetr. Lett., 1974, 2841.

205. R.D. Chambers, J.R. Maslakiewicz, and K.C. Srivastava,  
J. Chem. Soc. Perkin I, 1975, 1130.
206. D.M. Lemal and L.H. Dunlap, J. Amer. Chem. Soc., 1972, 94, 6562.
207. C.J. Boriack, E.D. Laganis, and D.M. Lemal, Tetr. Lett., 1978,  
1015.
208. R. E. Banks, F. Cuthbertson, and W.K.R. Musgrave,  
Anal. Chim. Acta., 1955, 13, 442.
209. R. C. Hopkins, J. Mol. Spec., 1966, 20, 321.

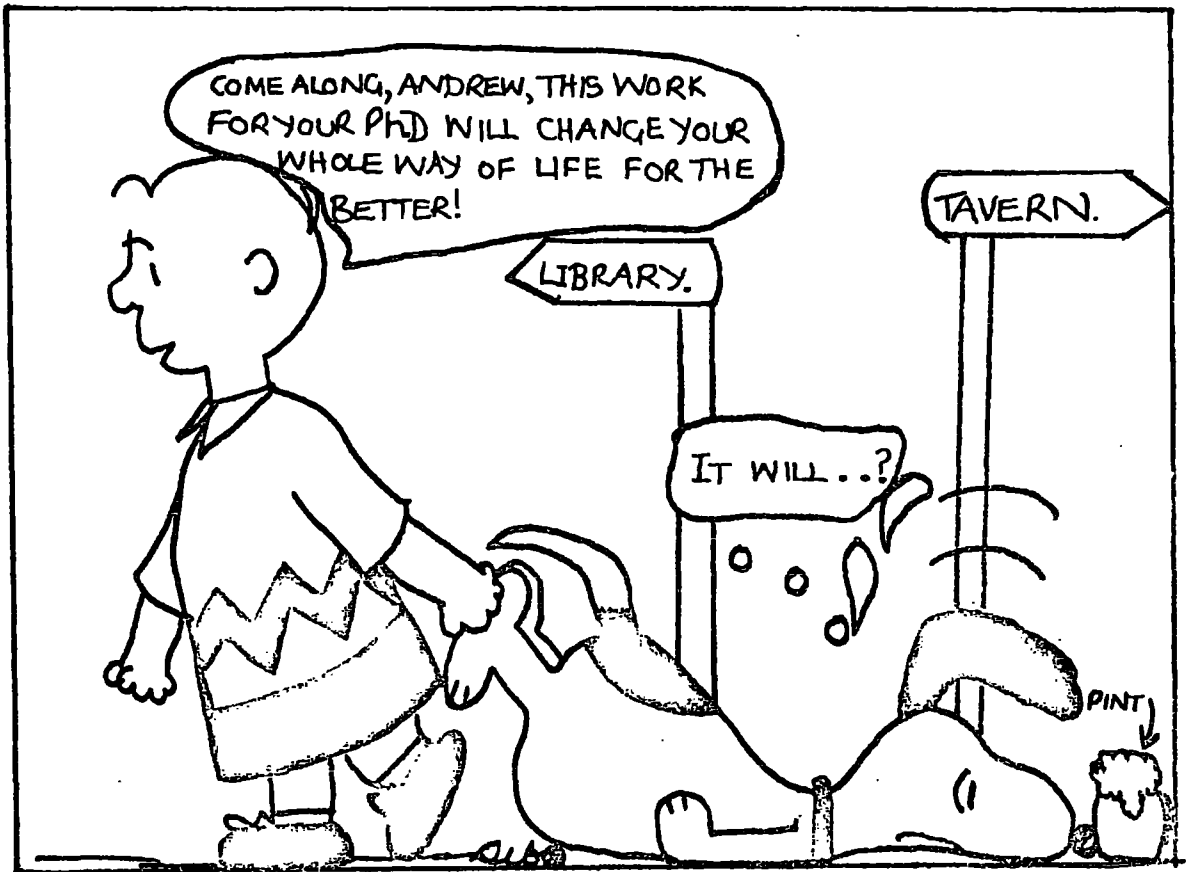

APPENDIX 1

$^{19}\text{F}$  and  $^1\text{H}$  n.m.r. Spectra

The following abbreviations have been used in describing spectra:- M - multiplet; S - singlet; D - doublet; T - triplet; Q - quartet.

Shift p.p.m.	Fine Structure J values in Hz	Relative Intensity	Assignment
58.8 ]	Broad overlapping resonances	12	3a, 4a, 5a 1a', 2a', 3a'
59.9			
61.3			
62.2 ]			
65.5			
72.1	Broad S	1	
75.8	Broad	4a'	
80.9 ]	Overlapping multiplets	3	7, 3c'
82.6 ]			
100.2	Broad	]	2
104.8	Broad		
107.7	M	3	6, 3b'
163.0	Broad		

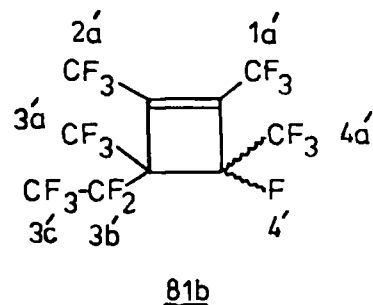
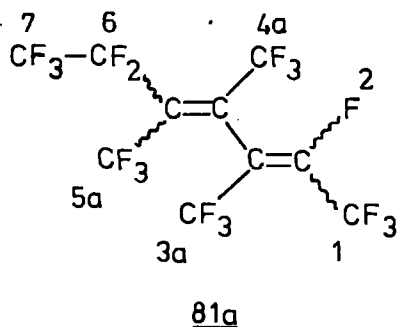

Ratio 81a:81b  $\approx$  70:30

Shift p.p.m.	Fine Structure J values in Hz	Relative Intensity	Assignment
2. <u>F-3,4,5,6-tetramethyl-3,5-octadiene (82)</u>			
57.6 ]	Broad overlapping resonances	12	3a, 4a, 5a, 6a
58.4 ]			
59.0 ]			
81.0 ]	Broad overlapping resonances	6	1, 8
81.5 ]			
106.1 ]	Broad multiplets	4	2, 7
108.3 ]			

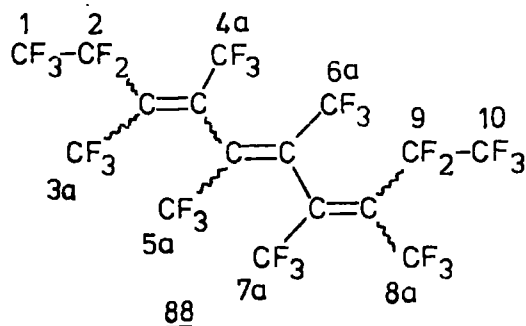
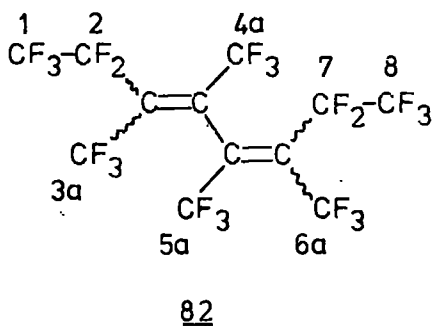

3. F-3,4,5,6,7,8-hexamethyl-3,5,7-decatriene (88)

57.8 ]	Broad overlapping resonances	18	3a, 4a, 5a 6a, 7a, 8a
59.0 ]			
60.0 ]			
61.3 ]			
79.9	Broad M	6	1, 10
106.8	Broad M	4	2, 9

Shift p.p.m.	Fine Structure J values in Hz	Relative Intensity	Assignment
4. <u>F-3,4,5,6,7-pentamethyl-2,4,6-nonatriene (84)</u>			
59.0	}	15	3a, 4a, 5a 6a, 7a
61.2			
64.7			
71.5	}	3	1
73.0			
80.6			
81.7	}	3	9
100.0			
103.5	}	3	8, 2
106.9			

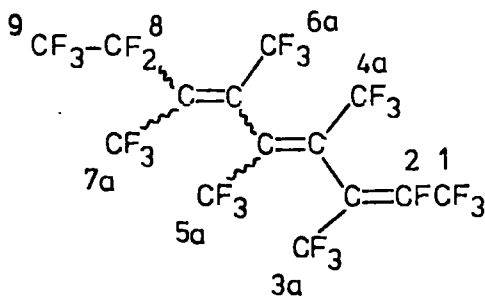

84

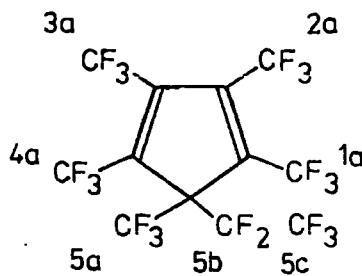

83

5. F-ethyl-1,2,3,4,5-pentamethylcyclopentadiene (83)

57.6	Broad	6	1a, 4a
60.1	Septet ( $J_{1a,5a}, J_{4a,5a} = 10.5$ )	3	5a
61.8	M	6	2a, 3a
82.7	S	3	5c
106.3	M ( $J_{1a,5b}, J_{4a,5b} = 10$ )	2	5b

Shift p.p.m.	Fine Structure J values in Hz	Relative Intensity	Assignment
6. <u>F-2,3-dimethyl-2-pentene (92)</u>			
60.1	M	9	1a, 2a, 3a
60.9	M		
61.4	M		
76.9	M	3	5
101.3	M	2	4

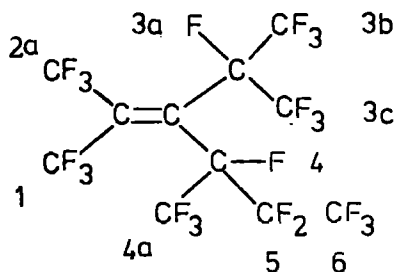
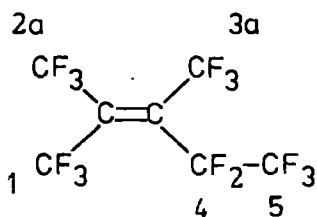

7. F-3-isopropyl-2,4-dimethyl-2-hexene (93)

58.9	Broad	6	1a, 2a
67.7	Broad M	3	4a
69.9			
72.4	S	6	3b, 3c
72.5	D(J = 70)		
79.6	Br.S	3	6
81.3			
105.1	Br.M	2	5
106.4			
158.1	Broad	1	3a
164.5	Broad	1	4

Shift p.p.m.	Fine Structure J values in Hz	Relative Intensity	Assignment
-----------------	----------------------------------	-----------------------	------------

8. Trans-2-phenoxy-3,4-bistrifluoromethylnonafluoro-2-hexene (103, R = Ph)

58.6	M	3	3a
60.4	Q( $J_{1,3a} = 15$ )	3	1
73.5	Broad	3	4a
82.6	Br.D( $J_{4,6} = 18$ )	3	6
117.9	Complex AB Q	2	5
181.0	M	1	4

<sup>1</sup>H δ 7.8 p.p.m.

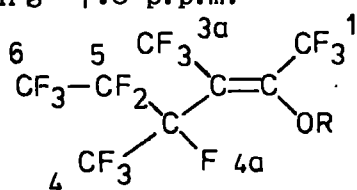

103

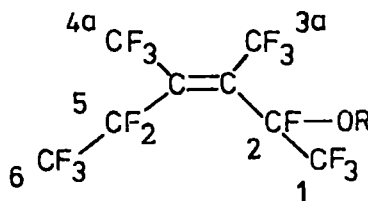

95a

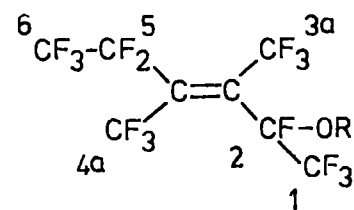

95b

9. Cis-2-phenoxy-3,4-bistrifluoromethylnonafluoro-3-hexene (95a, R = Ph)

58.8 ]	Overlapping M	6	3a, 4a
59.4 ]			
71.3	M	3	1
75.5	D( $J_{2,6} = 21$ ) of Q( $J_{4a,6} = 5$ )	3	6
99.5	Broad	2	5
106.2	Broad	1	2

<sup>1</sup>H δ 7.8 p.p.m.

10. Trans-2-phenoxy-3,4-bistrifluoromethylnonafluoro-3-hexene (95b, R = Ph)

58.3	Broad	6	3a, 4a
70.8	M	3	1
76.1	M	3	6
100.4	Broad	2	5
105.6	M	1	2

<sup>1</sup>H δ 7.8 p.p.m.

Shift p.p.m.	Fine Structure J values in Hz	Relative Intensity	Assignment
-----------------	----------------------------------	-----------------------	------------

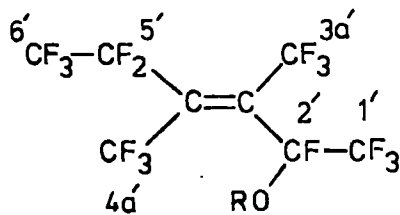
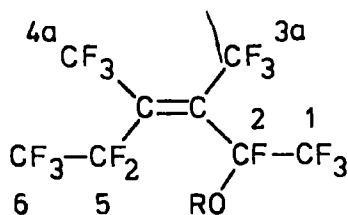

95

11. Cis-,trans-2-methoxy-3,4-bistrifluoromethylnonafluoro-3-hexene (95, R = CH<sub>3</sub>)

58.4 ]	Overlapping M	6	3a, 4a, 3a', 4a'
59.2 ]			
72.9	M	3	1, 1'
75.3	D(J <sub>2,6</sub> = 18)	3	6
75.6			
99.7	Broad	2	5, 5'
115.8	Br. M	1	2, 2'

<sup>1</sup>H δ 3.7 p.p.m. (singlet).

12. Cis-,trans-2-ethoxy-3,4-bistrifluoromethylnonafluoro-3-hexene (95, R = C<sub>2</sub>H<sub>5</sub>)

58.0 ]	Overlapping M	6	3a, 4a, 3a', 4a'
59.0 ]			
72.6	M	3	1, 1'
75.0	D(J <sub>2,6</sub> = 20)	3	6
75.7			
100.0	Broad	2	5, 5'
112.9	Br. M	1	2, 2'

<sup>1</sup>H δ 1.4 (CH<sub>3</sub>), 4.0 (CH<sub>2</sub>) p.p.m.

13. Cis-,trans-2-isopropoxy-3,4-bistrifluoromethylnonafluoro-3-hexene (95, R = C<sub>3</sub>H<sub>7</sub>)

58.3	Broad	6	3a, 4a, 3a', 4a'
71.7	Broad	3	1, 1'
74.9	Br. D (J <sub>2,6</sub> = 20)	3	6
75.6			
99.7	Broad	2	5, 5'
110.4	Broad	1	2, 2'

<sup>1</sup>H δ 1.1 (2 x CH<sub>3</sub>), 4.5 (CH) p.p.m.

Shift p.p.m.	Fine Structure J values in Hz	Relative Intensity	Assignment
-----------------	----------------------------------	-----------------------	------------

96

14. Trans-4-methoxy-3,4-bistrifluoromethylnonafluoro-2-hexene (96, R = CH<sub>3</sub>)

54.3	M	3	3a
65.7	Broad	3	4a
68.8	D(J <sub>1,2</sub> = 2) of Q(J <sub>1,3a</sub> = 15)	3	1
81.0	M	3	6
92.1	Broad	1	2
119.0	M	2	5

<sup>1</sup>H δ 3.7 (singlet) p.p.m.

15. Trans-4-ethoxy-3,4-bistrifluoromethylnonafluoro-2-hexene (96, R = C<sub>2</sub>H<sub>5</sub>)

54.7	M	3	3a
66.1	Broad	3	4a
68.7	D(J <sub>1,2</sub> = 2) of Q(J <sub>1,3a</sub> = 15)	3	1
81.1	T(J <sub>5,6</sub> = 5)	3	6
92.1	Broad	1	2
118.7	M	2	5

<sup>1</sup>H δ 1.3 (CH<sub>3</sub>), 3.8 (CH<sub>2</sub>) p.p.m.

16. Trans-4-isopropoxy-3,4-bistrifluoromethylnonafluoro-2-hexene (96, R = C<sub>3</sub>H<sub>7</sub>)

55.7	M	3	3a
67.3	Q(J <sub>1,3a</sub> = 16)	3	1
67.7	Broad	3	4a
80.9	D(J = 9)	3	6
87.0	Broad	1	2
115.0	M (AB)	2	5

<sup>1</sup>H δ 1.4 (2 x CH<sub>3</sub>), 4.7 (CH) p.p.m.

Shift p.p.m.	Fine Structure J values in Hz	Relative Intensity	Assignment
-----------------	----------------------------------	-----------------------	------------

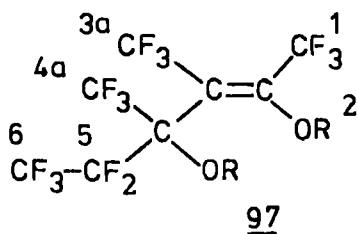

17. Trans-2,4-dimethoxy-3,4-bistrifluoromethyloctafluoro-2-hexene (97, R = CH<sub>3</sub>)

53.0	Broad	3	3a
63.1	Q(J <sub>1,3a</sub> = 17)	3	1
64.4	Broad	3	4a
80.6	M	3	6
118.5	M (AB)	2	5

<sup>1</sup>H δ 3.7 (4 - OCH<sub>3</sub>), 4.0 (2 - OCH<sub>3</sub>).

18. Trans-2,4-diethoxy-3,4-bistrifluoromethyloctafluoro-2-hexene (97, R = C<sub>2</sub>H<sub>5</sub>)

53.1	Broad	3	3a
62.8	Q(J <sub>1,3a</sub> = 17)	3	1
63.9	Broad	3	4a
80.1	M	3	6
117.3	M (AB)	2	5

<sup>1</sup>H δ 1.4 (2 x CH<sub>3</sub>), 4.0 (2 x CH<sub>2</sub>) p.p.m.

19. Trans-2,4-diisopropoxy-3,4-bistrifluoromethyloctafluoro-2-hexene (97, R = C<sub>3</sub>H<sub>7</sub>)

52.3	Broad	3	3a
61.8	Q(J <sub>1,3a</sub> = 16)	3	1
65.1	Broad	3	4a
79.3	S	3	6
106.4 ]	Br.AB (J = 275)	2	5
112.3 ]			

<sup>1</sup>H δ 1.1 (4 x CH<sub>3</sub>), 4.5 (2 x H) p.p.m.

Shift p.p.m.	Fine Structure J values in Hz	Relative Intensity	Assignment
-----------------	----------------------------------	-----------------------	------------

20. 5-pentafluoroethyl-5,6,7-tristrifluoromethyl-1,4-dioxa-6-cycloheptene (104)

52.8	M	3	6a
66.6	M(J = 13) of T(J <sub>5a,5b</sub> = 3)	3	5a
69.8	Q(J <sub>6a,7a</sub> = 15.5)	3	7a
79.7	S	3	5c
117.0	M	2	5b
118.3	M		

<sup>1</sup>H δ 4.5 p.p.m.

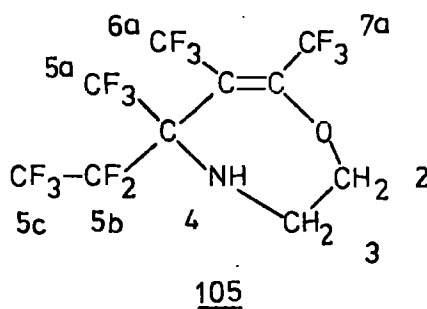
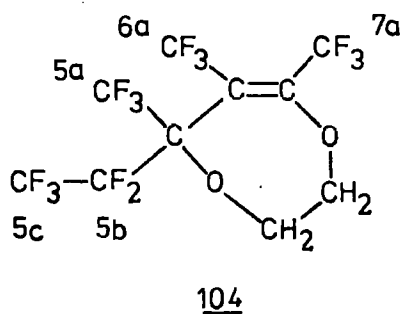

21. 5-pentafluoroethyl-5,6,7-tristrifluoromethyl-1-oxa-4-aza-6-cycloheptene (105)

53.0	M	3	6a
65.0	M	3	5a
70.2	Q(J <sub>6a,7a</sub> = 16)	3	7a
78.6	S	3	5c
114.9	AB(J = 290) of M	2	5b
118.7			

<sup>1</sup>H δ 3.0 (Int.1, 4-H), 3.8 (Int.2, 3-H), 5.0 (Int.2, 2-H) p.p.m.

Shift p.p.m.	Fine Structure J values in Hz	Relative Intensity	Assignment
-----------------	----------------------------------	-----------------------	------------

22. Cis-, trans-F-2,5-dihydro-tetramethylfuran (109)

Isomer A

63.3	M	3	3a
85.0	M	3	2a
122.6	Br. M	1	2

Isomer B

62.9	M	3	3a
83.4	M	3	2a
112.2	Br. M	1	2

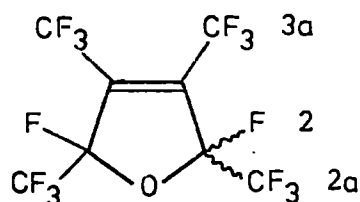

109

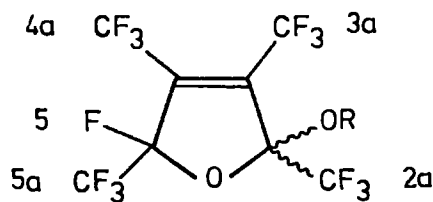

111

23. Cis-, trans-2-ethoxy-5-fluorotetrakis(trifluoromethyl)furan (111, R = C<sub>2</sub>H<sub>5</sub>)

Isomer A

61.6	M	6	3a, 4a
80.7	M	6	2a, 5a
81.5	M		
105.9	Broad	1	5

Isomer B

62.1	M	6	3a, 4a
82.1	Q(J= 6)	6	2a, 5a
113.6	Broad	1	5

<sup>1</sup>H δ 1.4 (CH<sub>3</sub>), 3.7 (CH<sub>2</sub>) p.p.m.

The <sup>19</sup>F n.m.r. data for (111, R = CH<sub>3</sub>) is very similar.

Shift p.p.m.	Fine Structure J values in Hz	Relative Intensity	Assignment
-----------------	----------------------------------	-----------------------	------------

24. Methyl 3-methoxy-3-trifluoromethyl-4,4,5,5,5-pentafluoropentanoate (108)

72.9	Hextet	3	3a
81.0	Q(J <sub>5,3a</sub> = 8)	3	5
117.5	Q(J <sub>4,3a</sub> = 11)	2	4

<sup>1</sup>H δ 3.8 (singlet, 2 x CH<sub>3</sub>), 3.1 (singlet, CH<sub>2</sub>) p.p.m.

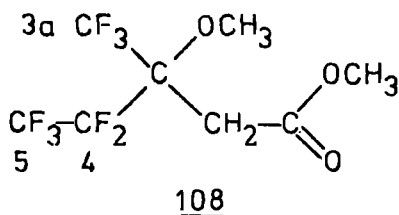

25. Trans-2,4-diamino-3-cyano-4-trifluoromethyloctafluoro-2-hexene (119)

68.7	Sharp S	3	1
73.6	T(J <sub>4a,5</sub> = 12.5) of Q	3	4a
80.2	Q(J <sub>4a,6</sub> = 4)	3	6
118.9	Q	2	5
119.1	Q		

<sup>1</sup>H δ (Acetone) 3.3 (Singlet, 2-NH<sub>2</sub>), 7.9 (Broad, 4-NH<sub>2</sub>) p.p.m.

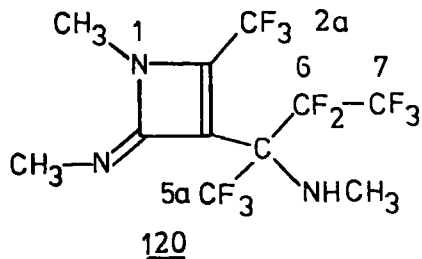
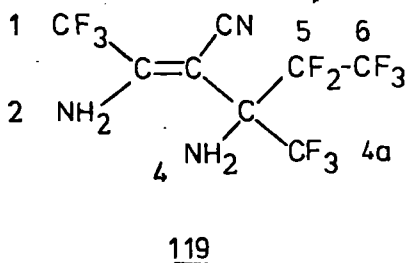

26. 2-Trifluoromethyl-3-(2'-methylamino-octafluoro-2'-butyl)-4-methylimino-N-methyl-2-azetine (120)

67.0	Broad	3	2a
70.4	Q (J <sub>5a,7</sub> = 10)	3	5a
82.3	S	3	7
118.3	M	2	6

<sup>1</sup>H δ 1.5 (CH<sub>3</sub>), 1.8 (2 x CH<sub>3</sub>), 7.8 (NH) p.p.m.

Shift p.p.m.	Finè Structure J values in Hz	Relative Intensity	Assignment
27. <u>Trans-4-ethylamino-3,4-bistrifluoromethylnonafluoro-2-hexene</u> ( <u>118</u> , R = C <sub>2</sub> H <sub>5</sub> )			
53.7	M	3	3a
63.8	M	3	4a
68.8	Q(J <sub>1,3a</sub> = 15) of D(J <sub>1,2</sub> = 2)	3	1
80.3	Br. S	3	6
96.4	Broad	1	2
117.6	M	2	5

<sup>1</sup>H δ 1.2 (CH<sub>3</sub>), 1.9 (NH), 2.7 (CH<sub>2</sub>) p.p.m.

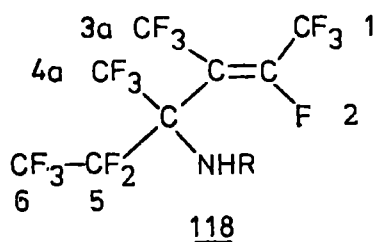

The <sup>19</sup>F n.m.r. data for the methylamine derivative (118, R = CH<sub>3</sub>) is virtually the same.

28. Cis-,trans-2-ethylimino-3,4-bistrifluoromethyloctafluoro-3-hexene (123, R=C<sub>2</sub>H<sub>5</sub>)  
and Cis-,trans-3-(N-ethyliminofluoromethyl)-4-trifluoromethyldecafluoro-3-hexene (124, R = C<sub>2</sub>H<sub>5</sub>)

17.6	Broad	] 3a'
20.2	Broad	
57-61	Br. overlapping M's	3a, 4a, 4a'
70.5	Br. S	1
80-81.7	Overlapping M's	1', 6', 6
105.7-109.2	Overlapping M's	2', 5', 5

<sup>1</sup>H δ 1.3 (CH<sub>3</sub>), 3.6 (CH<sub>2</sub>) p.p.m.

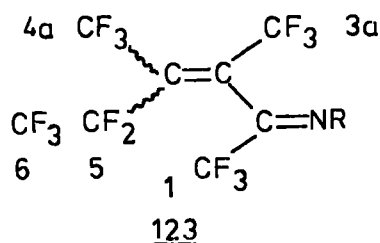
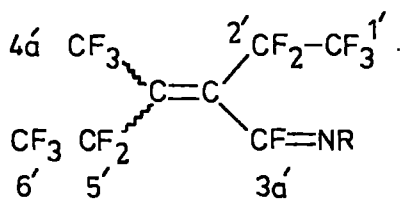

Shift p.p.m.	Fine Structure J values in Hz	Relative Intensity	Assignment
29. <u>Cis-2-t-butylimino-3-trifluoromethyl-4-(N-t-butyliminofluoromethyl) octafluoro-3-hexene (125)</u>			
11.8	$Q(J_{3a,4a} = 15)$	1	4a
59.5	D of $Q(J_{3a,1} = 8.5)$	3	3a
69.3	Broad	3	1
81.9	Broad	3	6
107.7	Broad	2	5

$^1\text{H } \delta$  1.4, 1.45 (singlets) p.p.m.

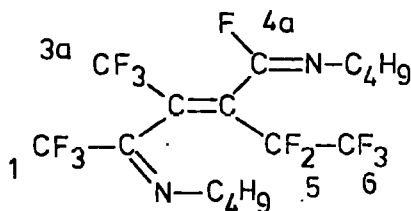
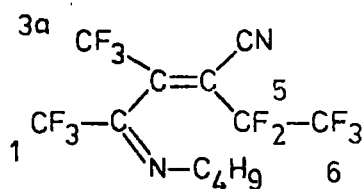
125126

30. Cis-2-t-butylimino-3-trifluoromethyl-4-cyano-octafluoro-2-hexene (126)

61.1	$Q(J_{1,3a} = 8.5)$	3	3a
70.0	Broad	3	1
80.9	$M(J = 4)$	3	6
108.4	Broad	2	5

$^1\text{H } \delta$  1.4 (singlet) p.p.m.

Shift p.p.m.	Fine Structure J values in Hz	Relative Intensity	Assignment
57.9	Broad	3 ]	3a
61.8	D(J <sub>3d',2'</sub> = 17)		3a'
62.5	D(J <sub>3d',2'</sub> = 18)		
70.0	Q(J = 19)	4 ]	4a, 4a'
70.9	M		1
71.7	Br. S		1'
85.1	D(J = 21)	3 ]	6, 6'
85.7	D(J = 18)		
102.7	Broad	1 ]	2
105.9	Br. M		2'
107.0	Broad		
110.2	Br. D(J = 19)	2 ]	5, 5'
111.3	Br. D(J = 22)		

<sup>1</sup>H δ 7.4 p.p.m.

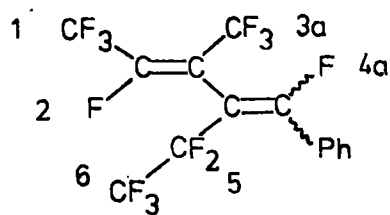

129a

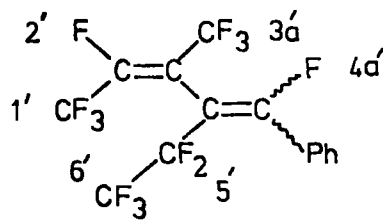

129b

Ratio 129a:129b ∼ 25:75

Shift p.p.m.	Fine Structure J values in Hz	Relative Intensity	Assignment
32. <u>F-3-methyl-4-methene-2-hexene (128)</u> *			
ca.59*			3a
63.8	$D(J_{3a,2'} = 18)$		3a'
68.3	Broad	2	4,4'
69.2	$Q(J = 16)$		
71.2	M	3	1
72.3	Broad		1'
87.2	Br. M	3	6,6'
113.0	Broad	2	5,5'

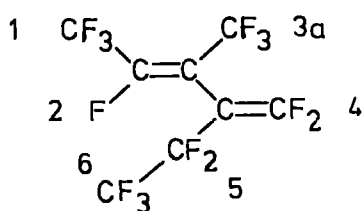

128a

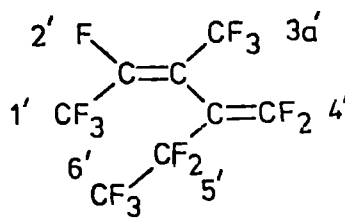

128b

Ratio 128a:128b  $\sim$  30:70

\* Run on a mixture containing (41),  
signal at ca.59 is masked.

Shift p.p.m.	Fine Structure J values in Hz	Relative Intensity	Assignment
-----------------	----------------------------------	-----------------------	------------

33. 3,4-bistrifluoromethyldecafluoro-3,4-hexadiol (131)

69.8 ]	Br. overlapping M's	3	3a
70.4 ]			
80.4 ]	Br. overlapping S's	3	1
80.6 ]			
111.0	Broad	2	2
<sup>1</sup> H δ (ether) 6.1 (Broad)			

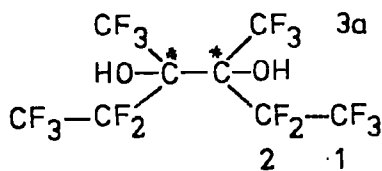

131

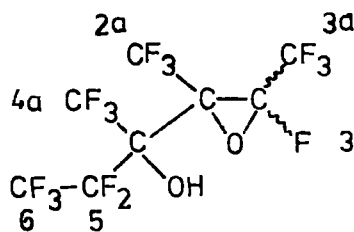

132

34. 2,3-bistrifluoromethyl-2-(2'-hydroxyoctafluoro-2'-butyl)-fluorooxirane (132)

Main Isomer

74.7	M	3	4a
81.4	Q( $J_{6,4a} = 4$ )	3	6
83.2	M	3 ]	2a, 3a
86.0	D( $J = 10$ ) of Q( $J_{2a,3a} = 2$ )		
126.9	Q( $J_{5,4a} = 10$ )	2	5
211.0	D( $J = 44$ ) of Septets ( $J_{3,3a}, J_{3,2a} = 10$ )	1	3

<sup>1</sup>H δ 4.8 (Broad)

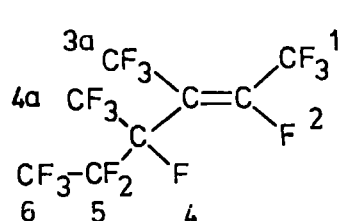
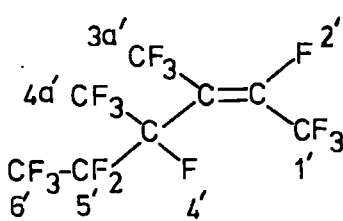
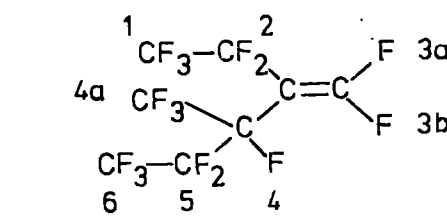
Shift p.p.m.	Fine Structure J values in Hz	Relative Intensity	Assignment
<b>35. <u>Cis-,trans-F-3,4-dimethyl-2-hexene (98)</u>*</b>			
ca.60.0*		3	3a,3a'
66.0	D(J <sub>1',4'</sub> = 48)	3	1'
67.4	Q(J <sub>1,3a</sub> = 15)		1
75.6	Broad	3	4a,4a'
82.7	Br. D(J <sub>4,6</sub> = 16)	3	6,6'
87.8	Br. Q(J <sub>2',3d'</sub> = 20)	1	2'
90.0	Broad		2
119.7	Br. M	2	5,5'
183.1	Broad	1	4,4'
<div style="display: flex; justify-content: space-around; align-items: flex-end;"> <div style="text-align: center;">  <p><u>98a</u></p> </div> <div style="text-align: center;">  <p><u>98b</u></p> </div> <div style="text-align: center;">  <p><u>99</u></p> </div> </div>			
ratio <u>98a:98b</u> = 4:1			
<b>36. <u>F-3-methene-4-methylhexane (99)</u>*</b>			
62.3	Br. M	1	3b
68.1	Br. M	1	3a
75.6	Broad	3	4a
83.0	Br. D	3	6
88.3	Broad	3	1
109.1	Br. M	2	2
119.7	Br. M	2	5
183.0	Broad	1	4

\* From spectra of enriched samples containing (98), (99) and (41).

Shift p.p.m.	Fine Structure J values in Hz	Relative Intensity	Assignment
-----------------	----------------------------------	-----------------------	------------

37. F-2,3-dimethylbutadiene (130)

63.8	M	3	2a
71.4	Q( $J_{1a,2a} = 20$ ) of M	1	1a
73.1	M	1	1b

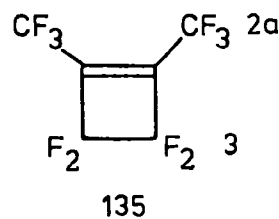
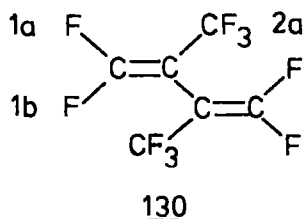

38. F-1,2-dimethylcyclobutene (135)

66.0	M ( $J = 2$ )	3	2a
117.5	M	2	3

39. Cis-, trans-F-2,3-dimethyl-1,3-pentadiene (136a)

60.8	M	6	3a'
62.5	M		2a, 2a'
64.5	D( $J_{3a,4} = 21$ )		
70.8	M	5	1,1',5,5'
71.8	M		
73.1	Br. M		
102.4	Br. M	1	4'
105.0	Q( $J = 21$ ) of Q( $J_{4,5} = 6$ )		4

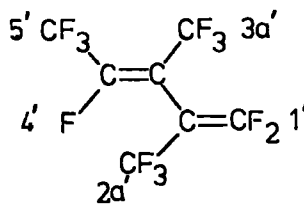
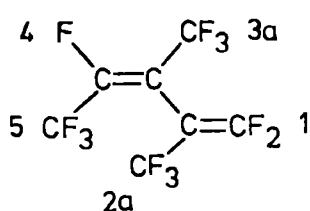

136a

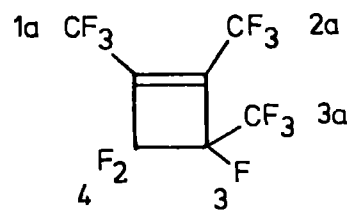

136b

ratio trans:cis is  $\sim 1.4:1$

40. F-1,2,3-trimethylcyclobutene (136b)

66.1	Br. S	6	1a,2a
78.1	M	3	3a
115.3	M	2	4
173.8	Broad	1	3

Shift p.p.m.	Fine Structure J values in Hz	Relative Intensity	Assignment
-----------------	----------------------------------	-----------------------	------------

41. F-2-ethyl-1,3,3-trimethylcyclobutene (138)

65.7	Q( $J_{1a,2b} = 5$ ) of T( $J_{1a,4} = 2$ )	3	1a
67.8	M	6	3a
85.6	Br. S.	3	2b
111.2	Septet ( $J_{4,3a} = 10$ )	2	4
114.5	M	2	2a

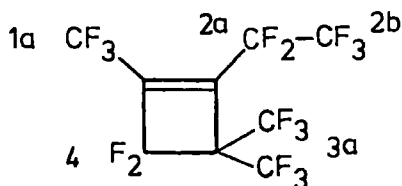

138

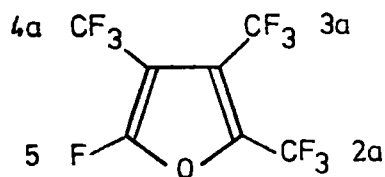

139

42. F-2,3,4-trimethylfuran (139)

60.2 ]	Overlapping M's	6	3a, 4a
60.5 ]			
64.5	D( $J_{2a,5} = 2.5$ ) of Q( $J_{2a,3a} = 8.3$ )	3	2a
103.7	Q( $J_{5,4a} = 15$ ) of Q	1	5

43. 3-hydro-4-methoxy-2,3-bistrifluoromethyltetrafluoro-1-butene (140)

59.4	Broad	1	1b
63.2	Br. D( $J_{1a,2a} = 19$ )	3	2a
67.2	Broad	3	3a
69.0	Q	1	1a
77.3	Broad	2	4

<sup>1</sup>H δ 3.5 (singlet, CH<sub>3</sub>), 3.6 (Broad, H) p.p.m.

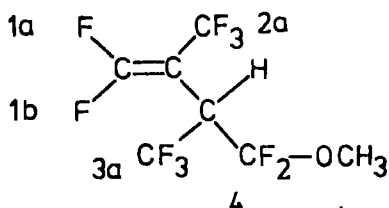

140

Shift p.p.m.	Fine Structure J values in Hz	Relative Intensity	Assignment
-----------------	----------------------------------	-----------------------	------------

44. Cis-, trans-1-methoxy-2,3-bistrifluoromethyltrifluorobutadiene (141)

Ratio cis:trans = 1.6:1

Cis Isomer (141a)

61.1	$D(J_{1,2a} = 12)$	3	2a
63.1	M	3	3a
73.6	$Q(J_{3a,4a} = 19)$	1	4a
74.5	M	2	1, 4b

$^1\text{H } \delta$  4.03 (Singlet) p.p.m.

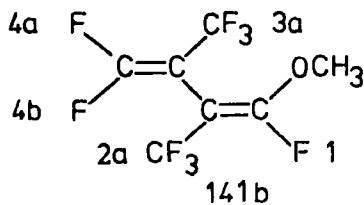
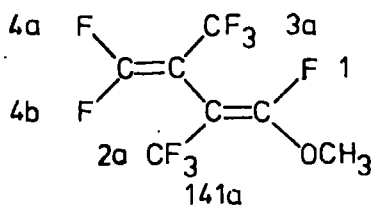

Trans Isomer (141b)

60.4	$D(J_{1,2a} = 19)$	3	2a
63.1	M	3	3a
73.7	$Q(J_{3a,4a} = 19)$	1	4a
74.5	M	1	4b
76.1	Q	1	1

$^1\text{H } \delta$  3.98 (Singlet) p.p.m.

45. Cis-, trans-3-hydro-1-phenoxy-2,3-bistrifluoromethyltetrafluoro-1-butene (143)

60.7	$D(J_{1,2a} = 22)$	3	2a
61.3	$D(J_{1,2a} = 10)$		2a'
65.7	$D(J_{3,3a}, J_{3,4} = 7.5)$	7	3a, 4a, 3a', 4a'
66.0	Broad		1, 1'

$^1\text{H } \delta$  4.1 (Broad, H), 7.0 (M,  $\text{C}_6\text{H}_5$ ) p.p.m.

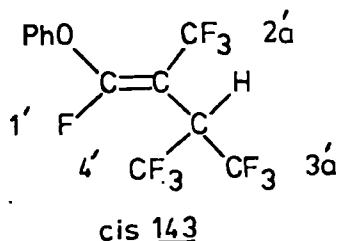
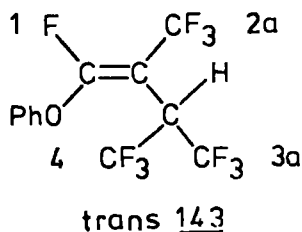

ratio cis:trans = 1:2

\* not fully characterised

Shift p.p.m.	Fine Structure J values in Hz	Relative Intensity	Assignment
46. <u>Cis-, trans-F-3-(3'-methyl-2'-butylidene)-1,4,4-trimethylcyclobutene (147)</u>			
56.8	M	3.3	5a,5a',2'
58.6	Br. M		
62.7	M	3	1a,1a'
68.1	D( $J_{4a,6} = 38$ )	6	4a,4a'
74.6	Br. D( $J_{6a,6} = 8$ )	6.7	6a
75.4	M		6a'
77.1	M		2
167.7	D( $J_{2',6'} = 136$ )		6'
174.5	Septet ( $J_{4a,6} = 38$ ) of M	1	6

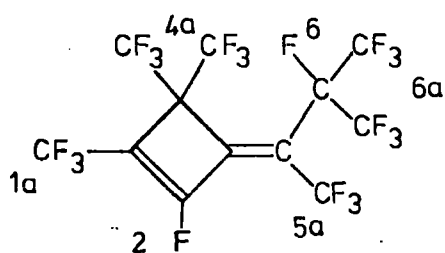

147a

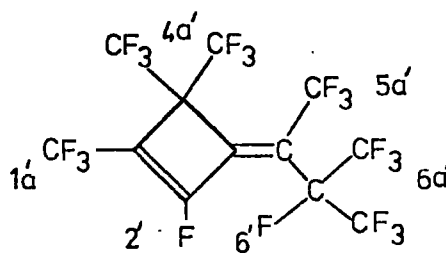

147b

ratio 147a:147b = 2.2:1

47. Cis-, trans-F-2,3,6,7-tetramethyl-1,3,6-octatriene (146)

58.2	M	3	6a,7a or 7a,8
60.5	M		
62.0	Q or T ( $J = 19$ )	3	3a
62.8	M		
64.9	M	5	2a
67.8	M	3	6a or 8a
88.2	Broad	1	4
90.0	Broad		
103.1	Broad	2	5

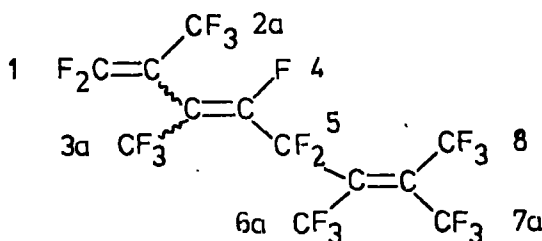

146

two isomers ratio 2:1

Shift p.p.m.	Fine Structure J values in Hz	Relative Intensity	Assignment
-----------------	----------------------------------	-----------------------	------------

48. F-2,3,6,7-tetramethyl-2,5-octadiene (151)

60.7	Br. M	6	1a,2a
64.7	Br. M	6	3a,6a
72.1	Br. M	6	7a,8
87.4	Broad	1	5
93.0	Very broad	2	4
171.4	Broad	1	7

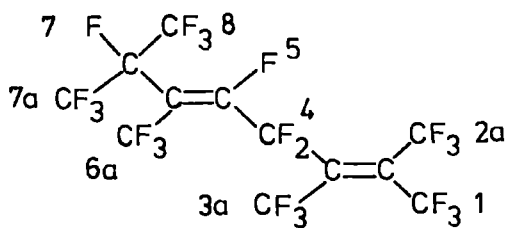

151

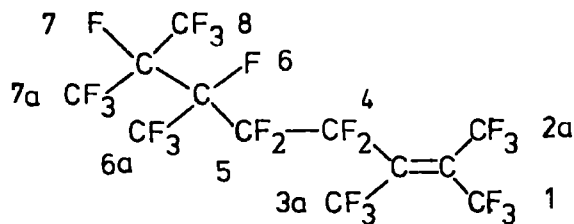

152

49. F-2,3,6,7-tetramethyl-2-octene (152)

58.2	Broad	3	3a
59.7	Broad	6	1a,2a
68.8	Octet ( $J_{7a,6a}, J_{8,6a} = 13.5$ ) ( $J_{6a,6}$ or $J_{6a,7} = 13.5$ )	3	6a
71.5	M	3	7a,8
72.5	M	3	
89.0	Broad	2	4
106.8	Broad	2	5
166.2	Broad	1	6,7
174.1	Broad	1	

50. F-2,3,3,5,6-pentamethyl-1,4-heptadiene (153)

60-66	Broad signals	14	1,2a,3a,3b,5a
76.0	Broad	7	4,6a,7
180.0	Broad	1	6

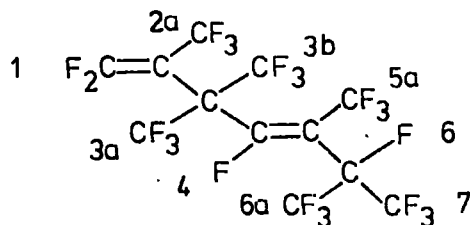

153

Shift p.p.m.	Fine Structure J values in Hz	Relative Intensity	Assignment
51. <u>F-2,3,6,7-tetramethyl-3,6-octenyl Anion (150)*</u>			
39.8		2	1,2a
57.8		1	3a
63.0	No fine structure	] Uncertain Integration	6a,7a,8
64.2			
65.3			
81.9			
101.9			

\* run in tetraglyme, from (150) and CsF.

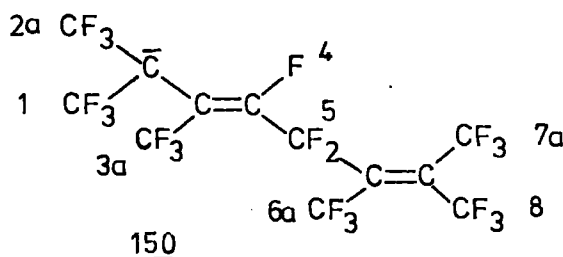

52. F-3-(2'-propenyl)-2,2,3-trimethyloxetane (155)

59.1		3	3'
64.2	No fine structure	2 ]	4,1'
66.2		2 ]	
68.2		3 ]	2a,2b
69.8	3 ]		
72.0		3	3a

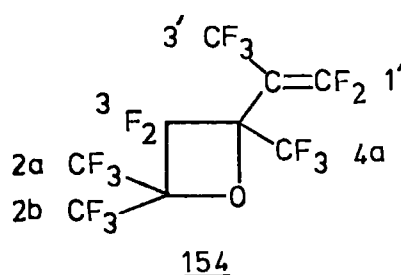
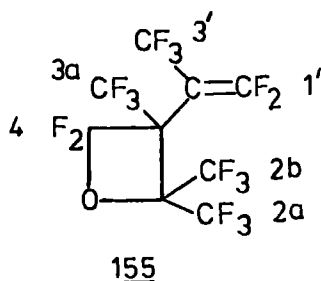

53. F-4-(2'-propenyl)-2,2,4-trimethyloxetane (154)

53.4	Br. M ]	5	3',1'
55.6	Broad ]		
61.5	M	6	2a,2b
81.0	Br. Singlet	3	4a
109.4	M	2	3

Shift p.p.m.	Fine Structure J values in Hz	Relative Intensity	Assignment
-----------------	----------------------------------	-----------------------	------------

54. F-3,4,6,6-tetramethyl-5,6-dihydro-2H-pyran (156)

59.3	Broad ] Br. S ]	6	3a, 4a
59.9			
76.5	Br. M	6	6a, 6b
101.0	Broad	4	2, 5

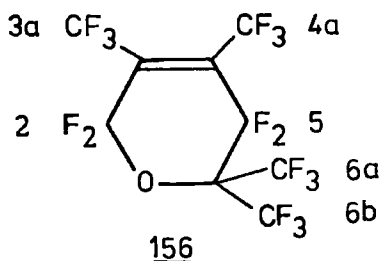

55. 2-Methoxy-3,4,5-tristrifluoromethylfuran (157)

58.7	Q( $J_{4a,3a} = 7$ )	1	3a
59.6	Septet	1	4a
63.3	Q( $J_{4a,5a} = 8.5$ )	1	5a

<sup>1</sup>H δ 4.4 p.p.m. (singlet)

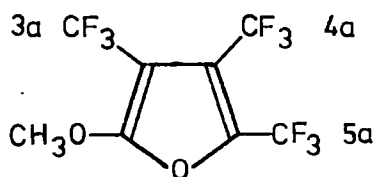

157

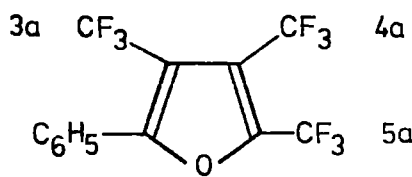

158

56. 2-Phenyl-3,4,5-tristrifluoromethylfuran (158)

57.2	Q( $J_{4a,3a} = 8$ )	1	3a
58.5	Septet	1	4a
63.3	Q( $J_{4a,5a} = 8.5$ )	1	5a

<sup>1</sup>H δ 7.4 p.p.m.

57. Bis-F-3,4,5-trimethylfuryl Sulphide and Disulphide (159)\*

59.0	Br. S	2	3a, 4a
64.0	Br. Q (J = 7)	1	5a

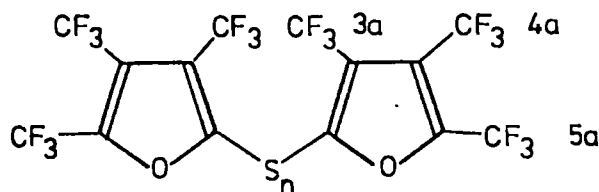

159

\* n = 1-4 but mainly 1,2.

Shift p.p.m.	Fine Structure J values in Hz	Relative Intensity	Assignment
-----------------	----------------------------------	-----------------------	------------

58. F-2-(2',3',4'-trimethyl-2',5'-dihydrofuryl)-3,4,5-trimethylfuran (160)

57.3	M	3	3a
59.3	Septet (J = 9)	14	4a
60.8	Br. M		3a'
63.3	M		4a'
64.5	Q (J <sub>4a,5a</sub> = 8.5)		5a
61.5 ]	AB (J = 150)*		5'
66.3 ]			
74.3	Br. M	3	2a'

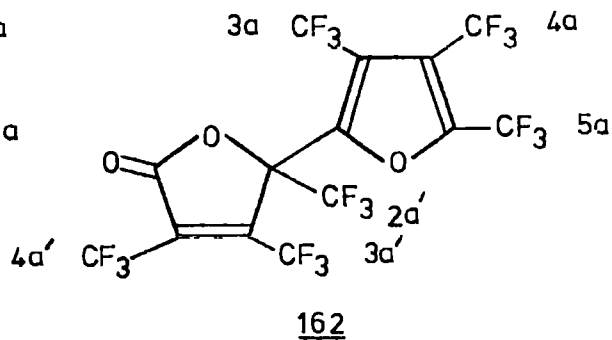
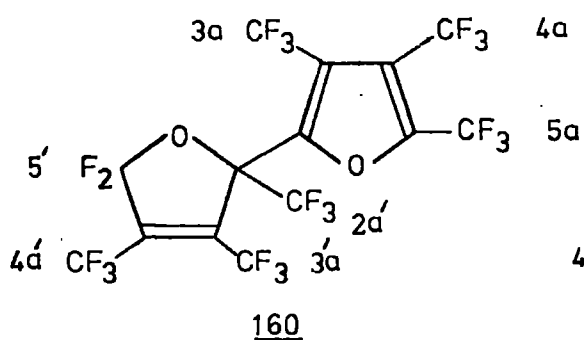

\* AB system is resolved only by the Brücker spectrometer.

59. F-2-(2',3',4'-trimethyl-2',5'-dihydro-4'-furanonyl)-3,4,5-trimethylfuran (162)

58.0	M	3	3a
59.8	M		4a
61.0	Broad		3a'
65.2	Br. M	2	4a', 5a
74.6	M	1	2a'

Shift p.p.m.	Fine Structure J values in Hz	Relative Intensity	Assignment
-----------------	----------------------------------	-----------------------	------------

60. F-1,2,3-trimethylcyclopropenyl acyl fluoride (163)

-29.7	$Q(J_{1a,4} = 10)$ of $M(J \leq 1)$	1	4
63.6	S	6	2a,3a
70.4	D	3	1a

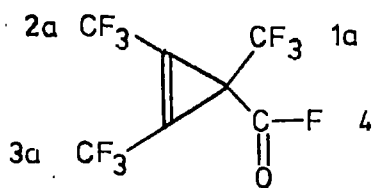

163

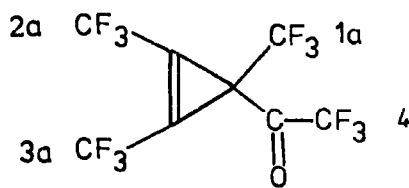

164

61. F-1,2,3-trimethylcyclopropenyl F-methyl ketone (164)

63.1	S	2	2a,3a
69.3	S	1	1a
76.9	S	1	4

APPENDIX 2

Infra-red Spectra



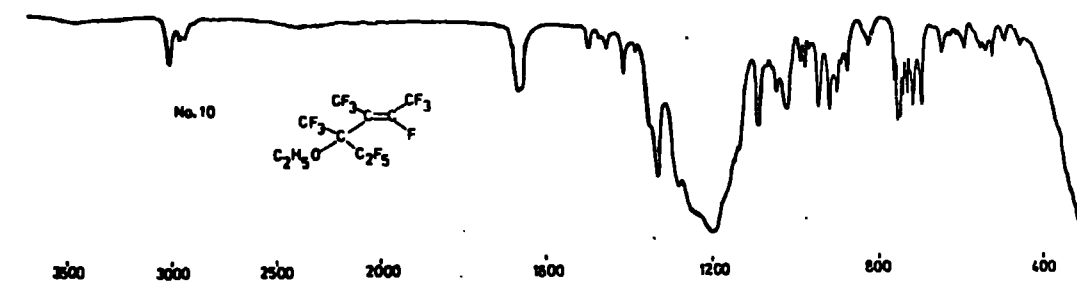
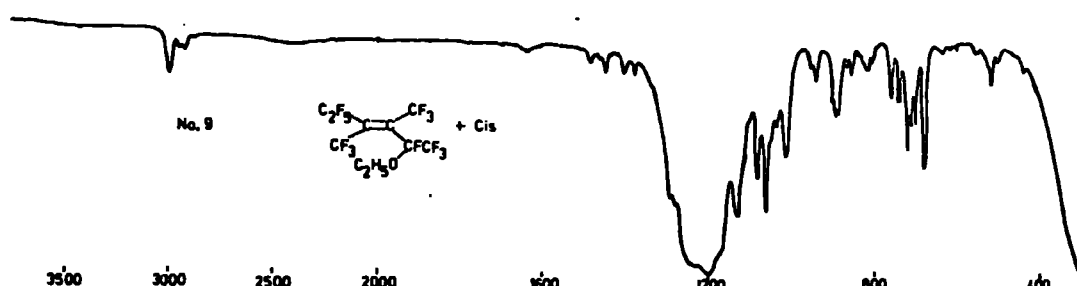
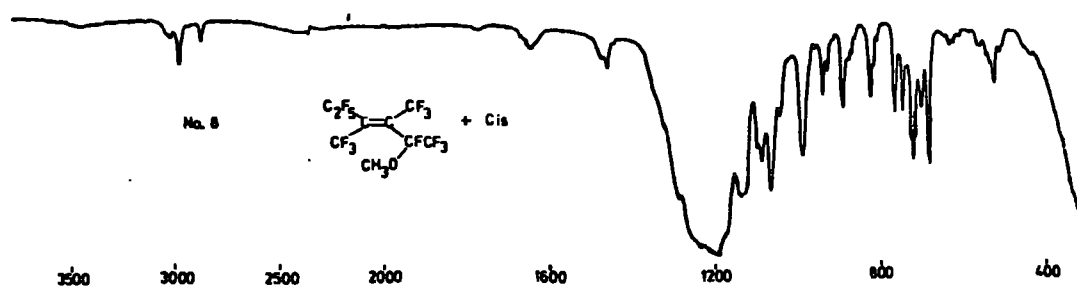
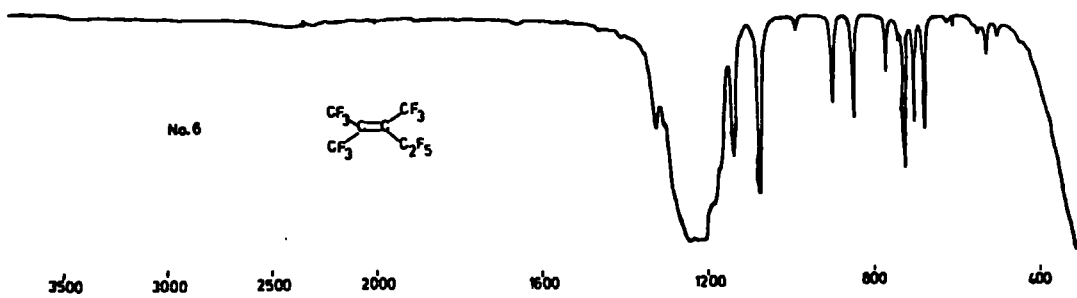

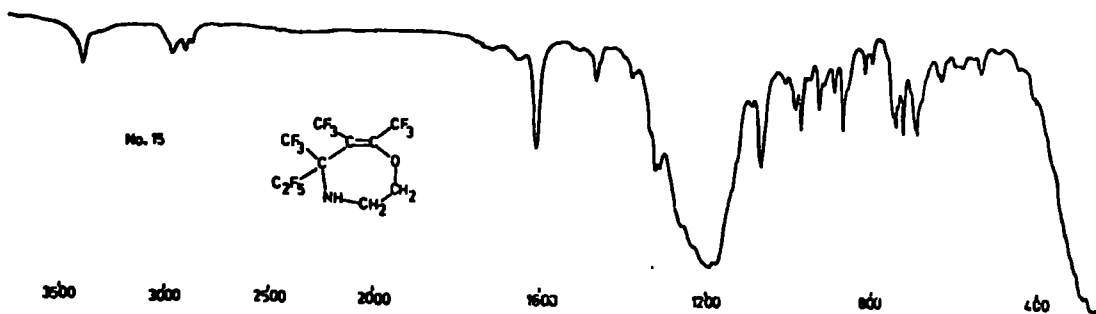
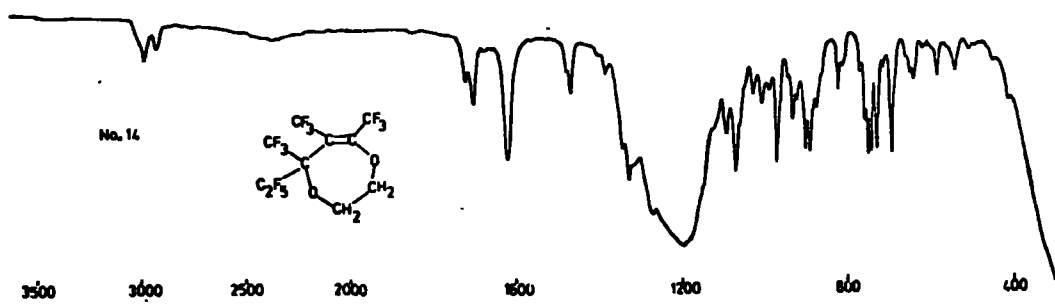
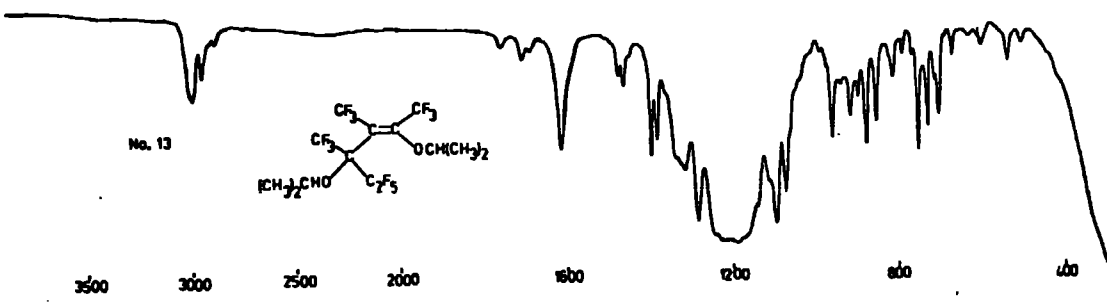
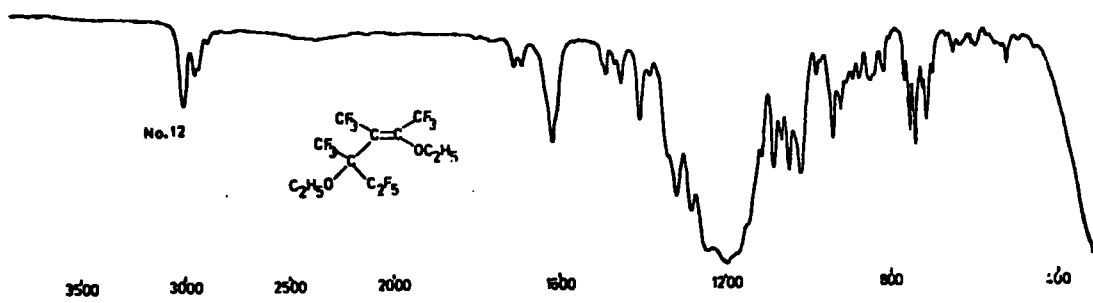
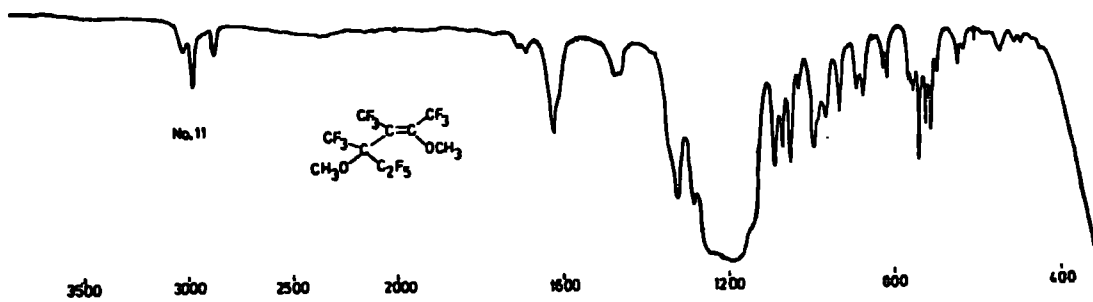

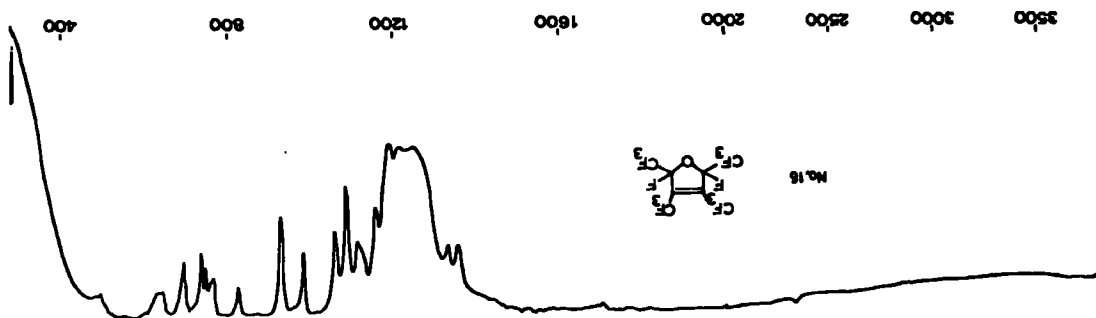
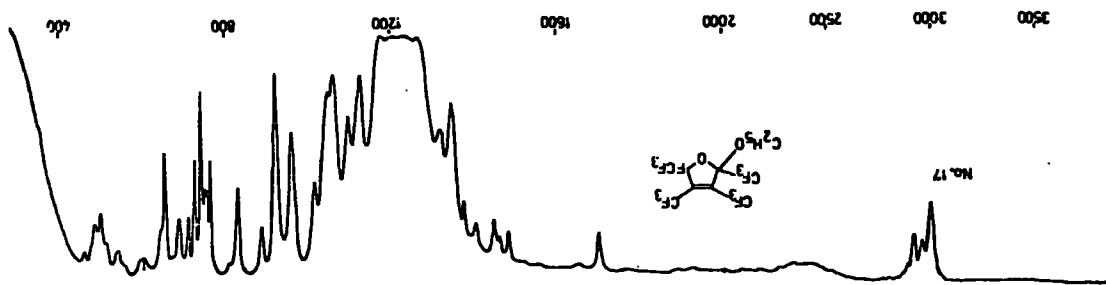
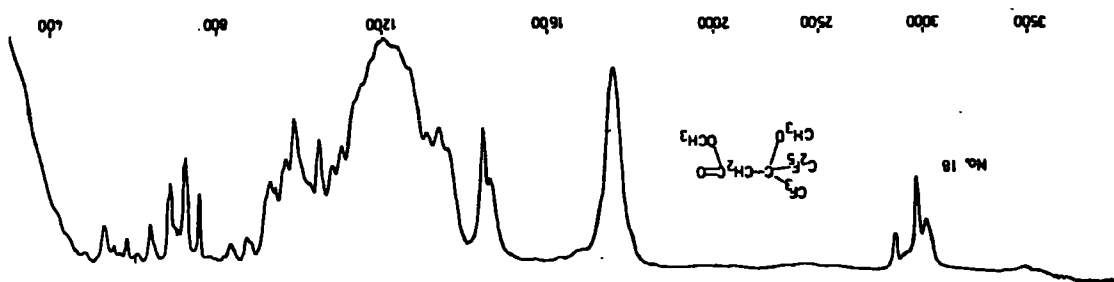
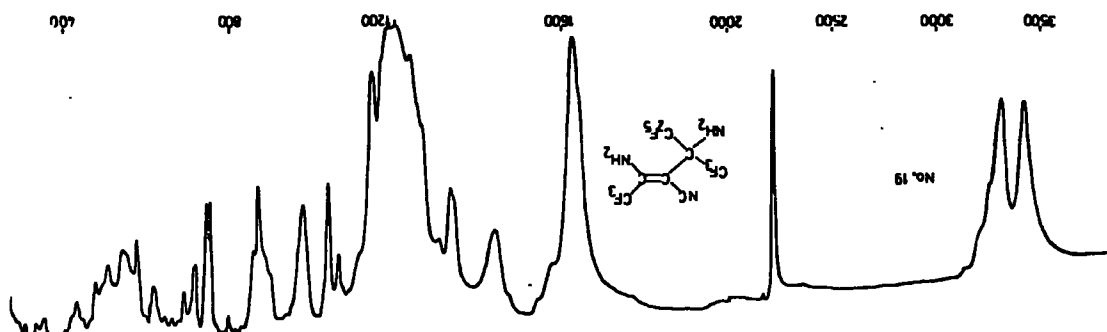
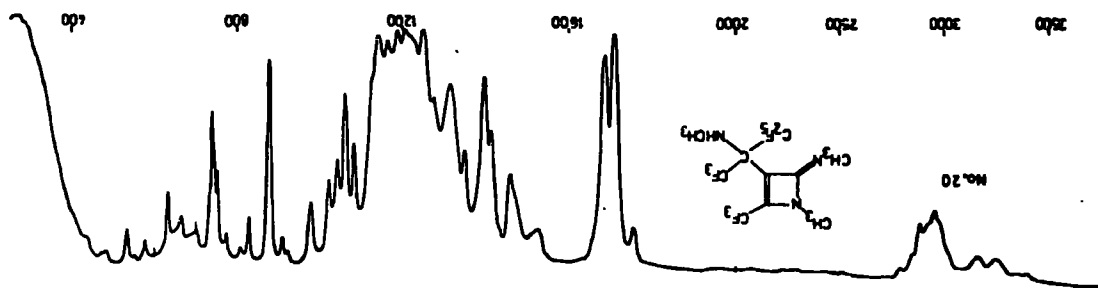

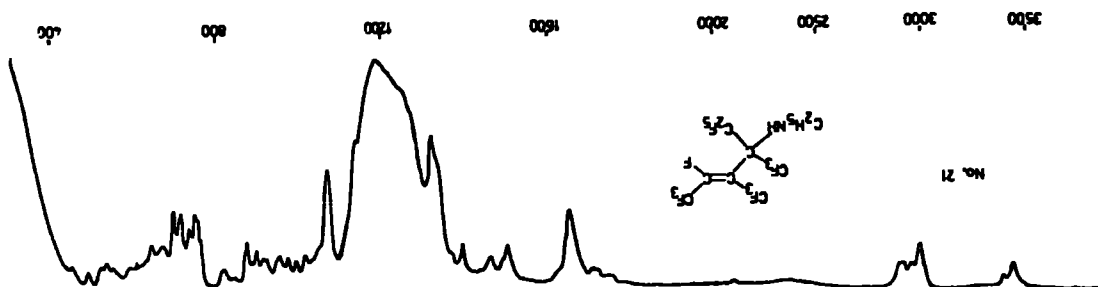
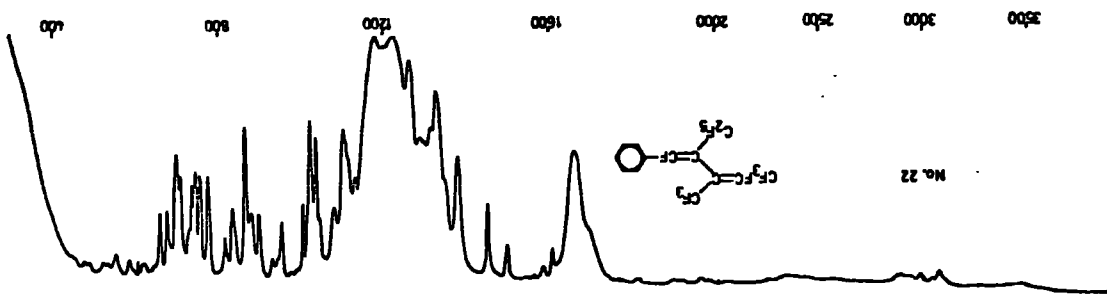
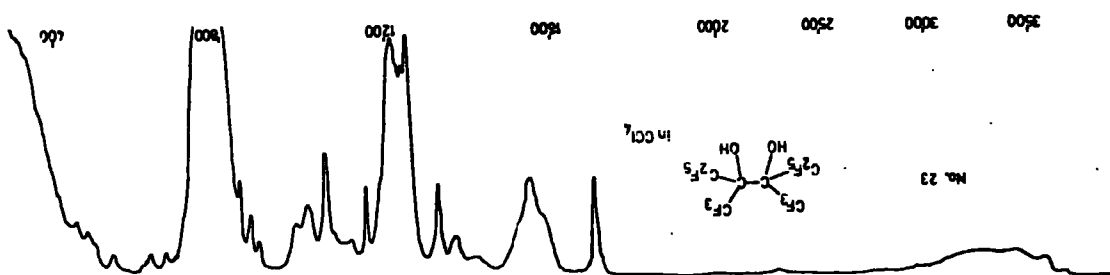
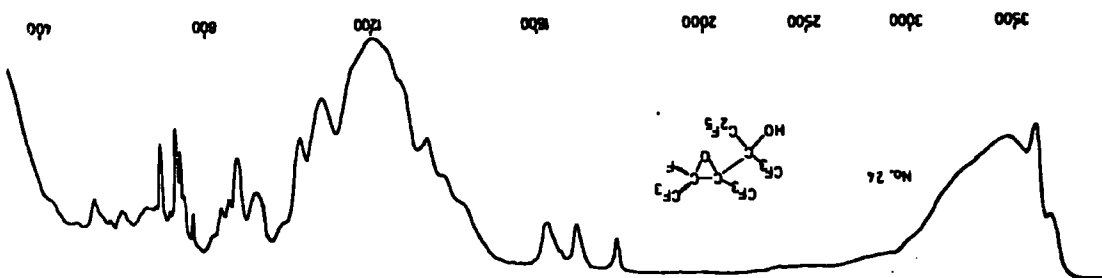
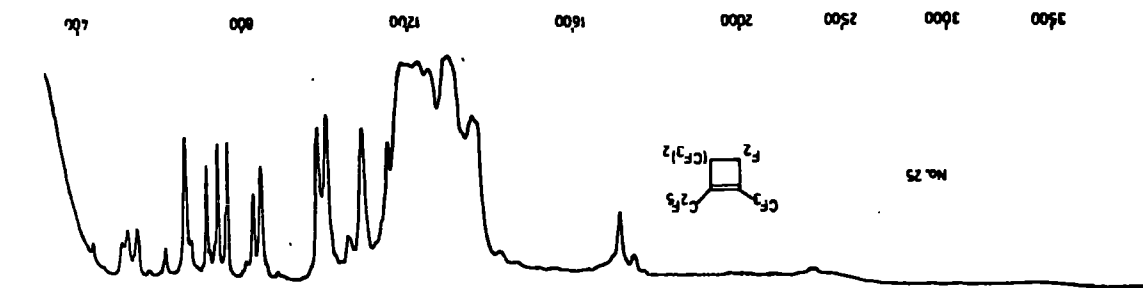

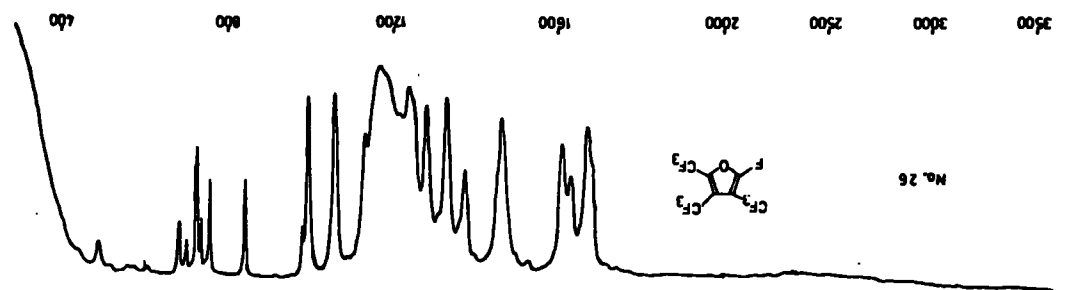
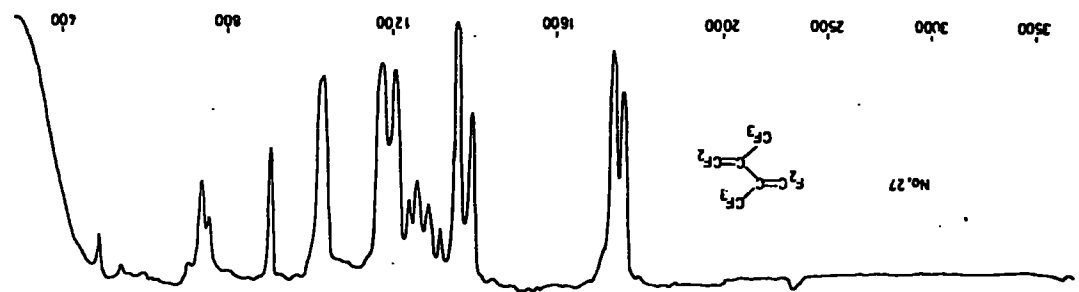
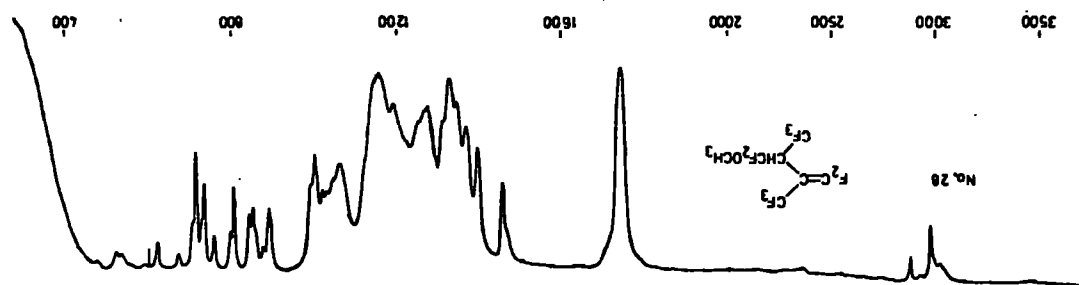
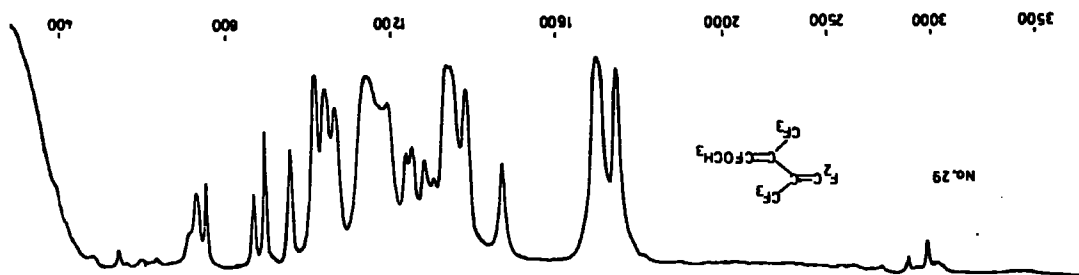
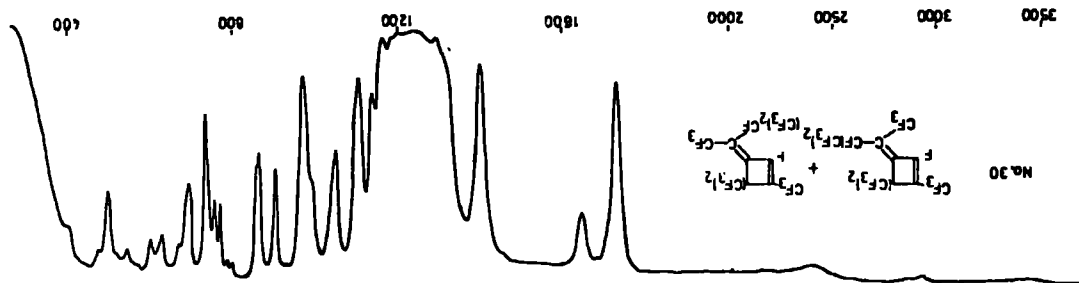

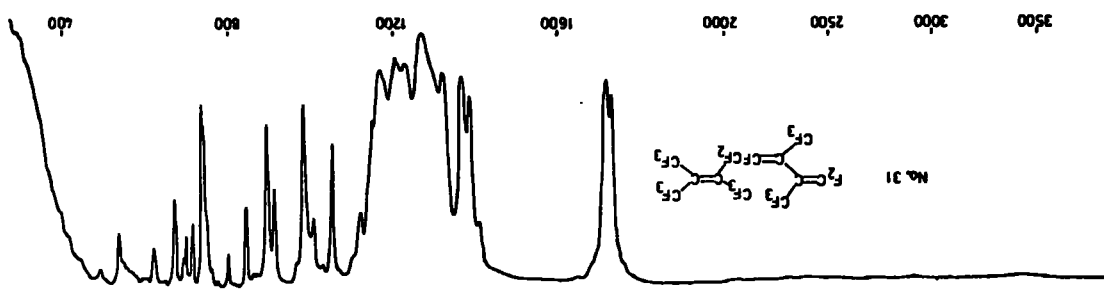
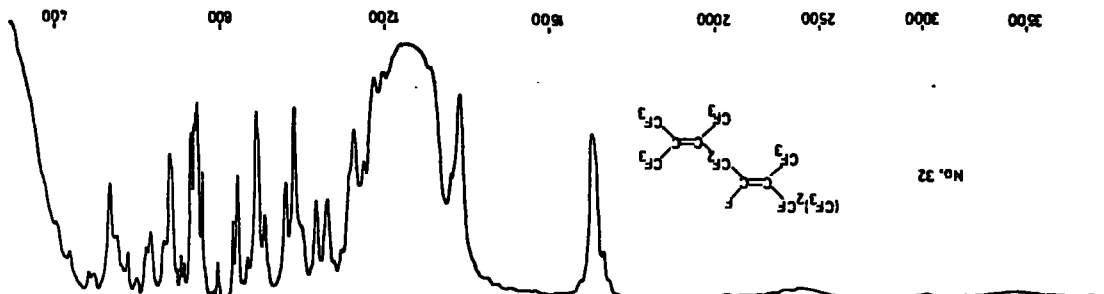
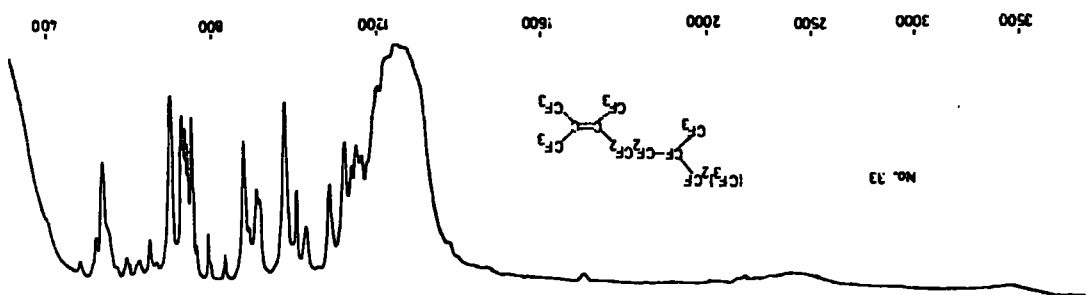
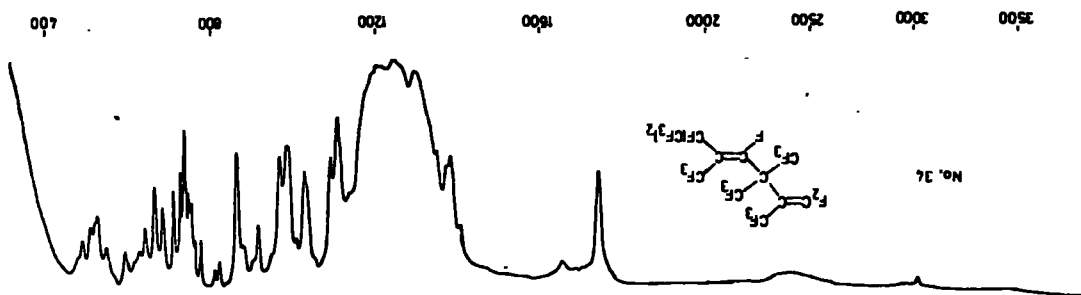
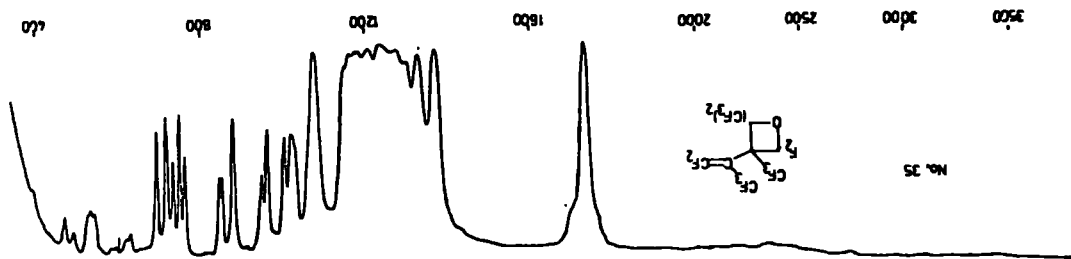

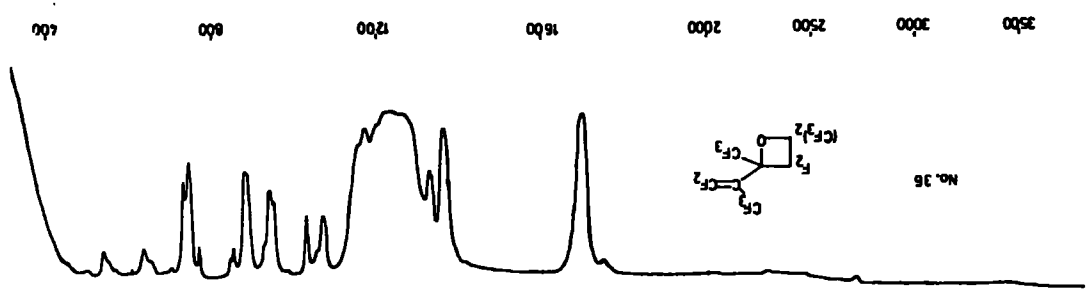
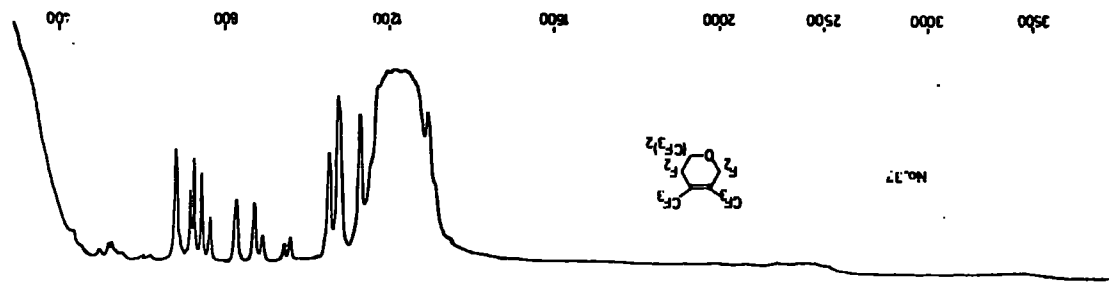
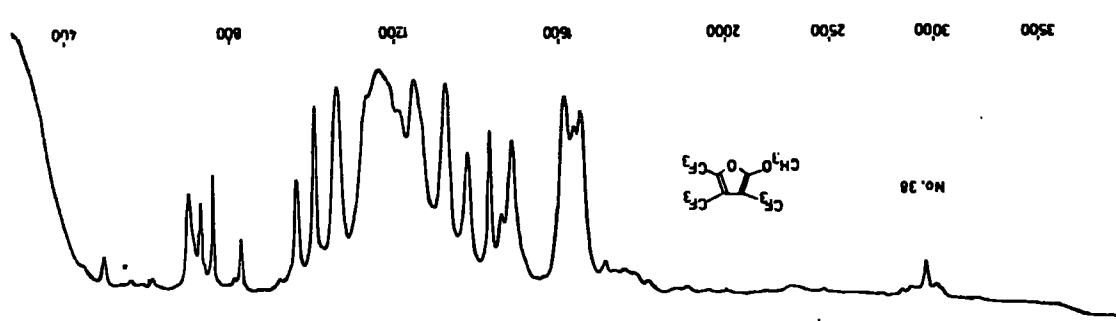
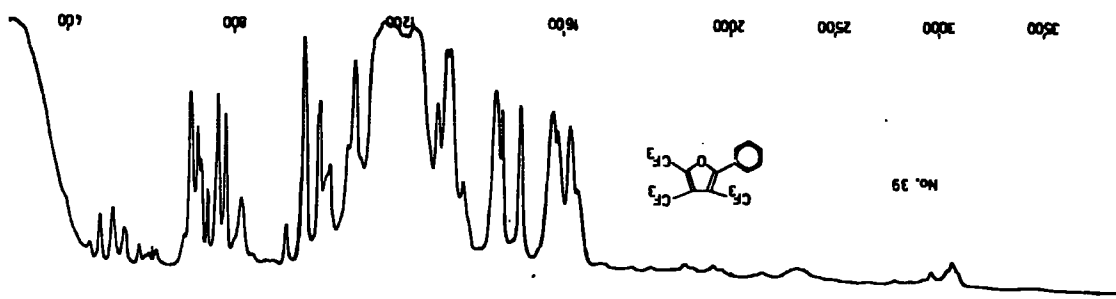
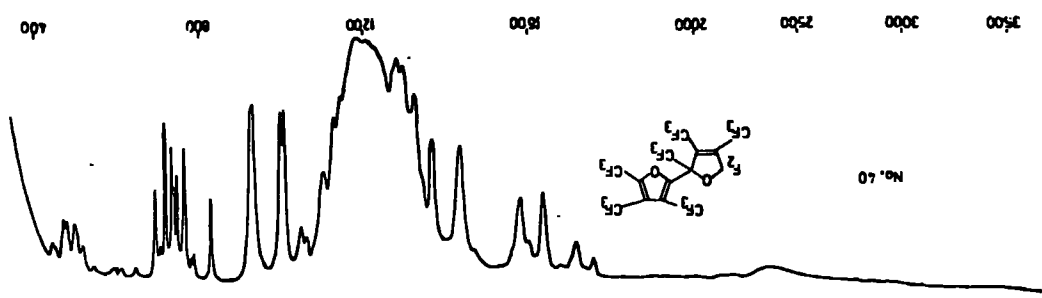

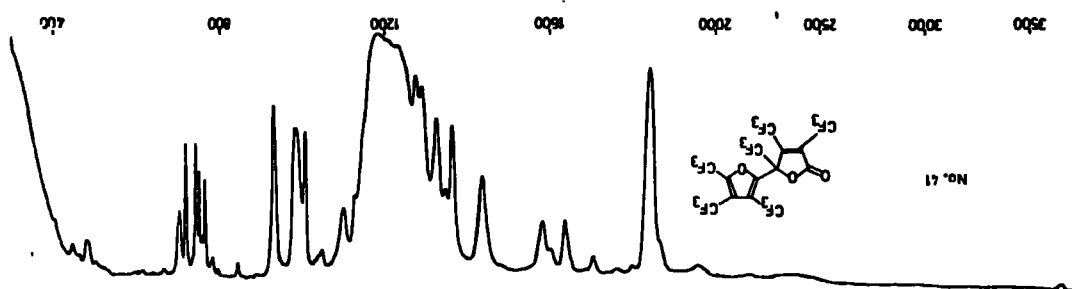
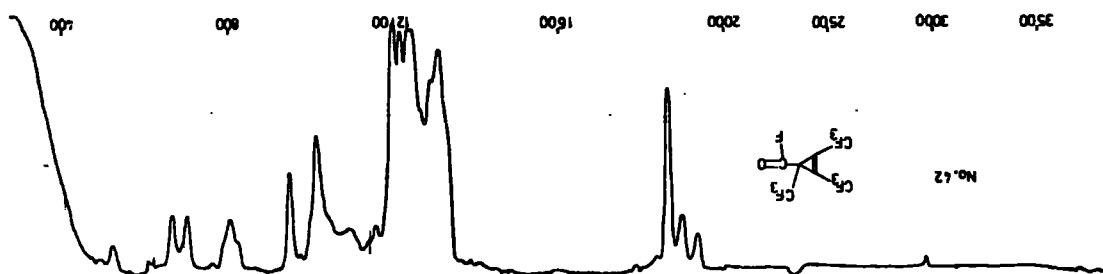
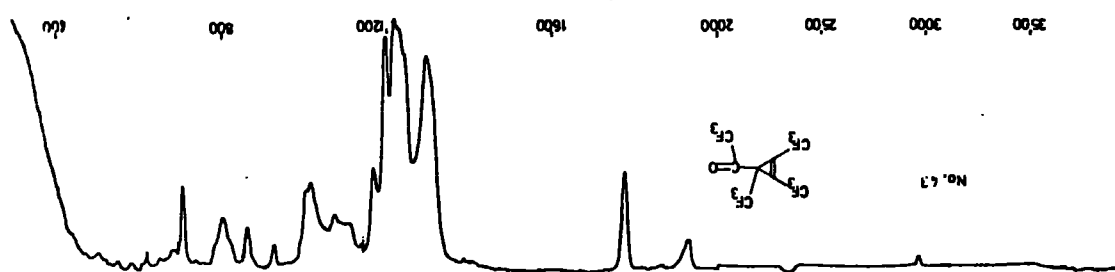

Conferences and Papers

Research Seminars and Lectures

APPENDIX 3

APPENDIX III

The Board of Studies in Chemistry requires that each postgraduate research

thesis contain an appendix listing

(a) all research colloquia, research seminars and lectures (by external

speakers) arranged by the Department of Chemistry since 1 October 1976;

and (b) all research conferences attended and papers read out by the writer

of the thesis, during the period when the research for the thesis was

carried out.

1. Research Colloquia, Seminars and Lectures

1.1 1976-77

a) University of Durham Chemistry Colloquia

\* Wednesday, 20th October

Professor J.B. Hynes (University of Calgary), "New Research on an

Old Element - Sulphur".

Wednesday, 10th November

Dr. J.S. Ogden (Southampton University), "The Characterization of

High Temperature Species by Matrix Isolation".

\* Wednesday, 17th November

Dr. B.E.F. Fender (University of Oxford), "Familiar but Remarkable

Inorganic Solids".

\* Wednesday, 24th November

Dr. M.I. Page (Huddersfield Polytechnic), "Large and Small Rate

Enhancements of Intramolecular Catalysed Reactions".

\* Wednesday, 8th December

Professor A.C. Leadbetter (University of Exeter), "Liquid

Crystals".

\* indicates events attended

- \* Wednesday, 26th January  
 Dr. A. Davis (ERDR), "The Weathering of Polymeric Materials".
- Wednesday, 2nd February  
 Dr. M. Falk, (NRC Canada), "Structural Deductions from the Vibrational Spectrum of Water in Condensed Phases".
- \* Wednesday, 9th February  
 Professor R.O.C. Norman (U. of York), "Radical Cations; Intermediates in Organic Reactions."
- Wednesday, 23rd February  
 Dr. G. Harris (U. of St. Andrews), "Halogen Adducts of Phosphines and Arsilnes".
- Friday, 25th February  
 Professor H.T. Dick (Frankfurt U.), "Diazadienes - New Powerful Low-Valent Metal Ligands".
- Wednesday, 2nd March  
 Dr. F. Hibbert (Birkbeck College, London), "Fast Reaction Studies of Slow Proton Transfers Involving Nitrogen and Oxygen Acids".
- Friday, 4th March  
 Dr. G. Brink (Rhodes U., R.S.A.), "Dielectric Studies of Hydrogen Bonding in Alcohols".
- \* Wednesday, 9th March  
 Dr. I.O. Sutherland (Sheffield U.), "The Stevens' Rearrangement: Orbital Symmetry and Radical Pairs".
- Friday, 18th March  
 Professor Hans Bock (Frankfurt U.), "Photoelectron Spectra and Molecular Properties: A Vademecum for the Chemist".

\* Wednesday, 30th March

Dr. J.R. MacCallum (U. of St. Andrews), "Photooxidation of Polymers".

\* Wednesday 20th April

Dr. D.M.J. Lilley (G.D. Searle, Research Div.), "Tails of Chromatin

Structure - Progress towards a Working Model".

\* Wednesday, 27th April

Dr. M.P. Stevens (Univ. of Hartford), "Photocycloaddition

Polymerisation".

Wednesday, 4th May

Dr. G.C. Tabisz (Univ. of Manitoba), "Collision Induced Light

Scattering by Compressed Molecular Gases".

\* Wednesday, 11th May

Dr. R.E. Banks (UMIST), "The Reaction of Hexafluoropropene with

Heterocyclic N-Oxides".

Wednesday, 18th May

Dr. J. Atwood (Univ. of Alabama), "Novel Solution Behaviour of

Anionic Organoaluminum Compounds: the Formation of Liquid Clathrates".

Wednesday, 25th May

Professor M.M. Krevey (Univ. of Minnesota), "The Dynamics of

Proton Transfer in Solution".

Wednesday, 1st June

Dr. J. McLeverly (Univ. of Sheffield), "Consequences of

Deprivation and Overcrowding on the Chemistry of Molybdenum and Tungsten".

Wednesday, 6th July

Professor J. Passmore (Univ. of Brunswick), "Adducts Between

Group V Pentahalides and a Postscript on  $S_7I^+$ ".

b) Durham University Chemical Society

\* Tuesday, 19th October

Dr. J.A. Salthouse (Univ. of Manchester), "Chemistry and Energy".

\* Tuesday, 26th October

Dr. R.E. Richards (Univ. of Oxford), "NMR Measurements on Intact Biological Tissue".

\* Tuesday, 2nd November

Dr. B. Sutcliffe (Univ. of York), "The Chemical Bond as a Figment of the Imagination".

\* Tuesday, 16th November

Mr. R. Ficken (Rohm & Haas), "The Graduate in Industry".

Tuesday, 30th November

Dr. R.J. Donovan (Univ. of Edinburgh), "The Chemistry of the Atmosphere".

\* Tuesday, 18th January

Professor I. Fells (Univ. of Newcastle), "Energy Storage: the Chemists' Contribution to the Problem".

\* Tuesday, 8th February

Dr. M.J. Cleare (Johnson Matthey Research Centre), "Platinum Group Metal Compounds as Anti-Cancer Agents".

Tuesday, 1st March

Professor J.A.S. Smith (Q.E. College, London), "Double Resonance".

\* Tuesday, 8th March

Professor C. Eaborn (Univ. of Sussex), "Structure and Reactivity".

1.2 1977-78

a) University of Durham Chemistry Colloquia

\* Tuesday, 27th September

Dr. T.J. Broxton (La Trobe Univ. Australia), "Interaction of Aryldiazonium Salts and Arylazoalkyl Ethers in Basic Alcoholic Solvents".

\* Wednesday, 19th October

Dr. B. Heyn (Univ. of Jena, D.D.R.), " $\sigma$ -Organo-Molybdenum Complexes as Alkene Polymerisation Catalysts".

\* Thursday, 27th October

Professor R.A. Filler (Illinois Inst. of Technology, U.S.A.), "Reactions of Organic Compounds with Xenon Fluorides".

Wednesday, 2nd November

Dr. N. Boden (Univ. of Leeds), "NMR Spin-Echo Experiments for Studying Structure and Dynamical Properties of Materials Containing Interacting Spin- $\frac{1}{2}$  Pairs".

\* Wednesday, 9th November

Dr. A.R. Butler (Univ. of St. Andrews), "Why I lost Faith in Linear Free Energy Relationships".

Wednesday, 7th December

Dr. P.A. Madden (Univ. of Cambridge), "Raman Studies of Molecular Motions in Liquids".

Wednesday, 14th December

Dr. R.O. Gould (Univ. of Edinburgh), "Crystallography to the Rescue in Ruthenium Chemistry".

\* Wednesday, 25th January

Dr. G. Richards, (Univ. of Oxford), "Quantum Pharmacology".

\* Wednesday 1st February, 2.30 p.m.

Professor K.J. Ivin (Queens University, Belfast), "The olefin metathesis reaction: mechanism of ring-opening polymerisation of cycloalkenes".

\* Friday 3rd February

Dr A. Hartog (Free University, Amsterdam, Holland), "Surprising recent Studies in Organo-magnesium Chemistry".

\* Wednesday 22 February

Professor J.D. Birchall (Mond Division, I.C.I. Ltd.), "Silicon in the Biosphere".

\* Wednesday 1st March

Dr A. Williams (University of Kent), "Acyl Group Transfer Reactions".

Friday 3rd March

Dr G. van Koten (University of Amsterdam, Holland), "Structure and Reactivity of Arylkopper Cluster Compounds".

Wednesday 15 March

Professor G. Scott (University of Aston), "Fashioning Plastics to match the Environment".

Wednesday 22 March

Professor H. Vahrenkamp (University of Freiburg, Germany), "Métal-Metal Bonds in Organometallic Complexes".

Wednesday 19 April

Dr M. Barber (UMIST), "Secondary Ion Mass Spectra of Surfaces and Adsorbed Species".

Tuesday 16th May

Dr P. Ferguson (C.N.R.S., Grenoble), "Surface Plasma Waves and Adsorbed Species on Metals".

Thursday 18th May

Professor M. Gordon (University of Essex), "Three Critical Points in Polymer Science".

Monday 22nd May

Professor D. Tuck (University of Windsor, Ontario), "Electrochemical Synthesis of Inorganic and Organometallic Compounds".

Wednesday - Thursday 24th, 25th May

Professor P. von R. Schleyer (University of Erlangen, Nürnberg),

I. "Planar Tetra-co-ordinate Methanes, Perpendicular Ethylenes, and Planar Allenes".

\* II. "Aromaticity in Three Dimensions".

III. "Non-classical Carbocations".

Wednesday 21st June

Dr S.K. Tyrlik (Academy of Science, Warsaw), "Dimethylglyoxime-cobalt Complexes - Catalytic Black Boxes".

Friday 23rd June

Professor W.B. Pearson (University of Florida), "Diode Laser Spectroscopy at 16  $\mu\text{m}$ ".

Friday 30th June

Professor G. Mateescu (Cape Western Reserve University),

"A Concerted Spectroscopy Approach to the Characterization of Ions and Ion Pairs : Facts, Plans, and Dreams".

(b) Durham University Chemical Society

\* Thursday 13th October

Dr J. C. Young, Mr A.J.S. Williams (University of Aberystwyth),  
"Experiments and Considerations Touching Colour".

\* Thursday 20th October

Dr R.L. Williams (Metropolitan Police Forensic Science Dept.),  
"Science and Crime".

\* Thursday 3rd November

Dr G.W. Gray (University of Hull), "Liquid Crystals - Their Origins and Applications".

Thursday 24th November

Mr G. Russell (Alcan), "Designing for Social Acceptability".

\* Thursday 1st December

Dr B.F.G. Johnson (University of Cambridge), "Chemistry of Binary Metal Carbonyls".

\* Thursday 2nd February

Professor R.A. Raphael (University of Cambridge), "Bizarre Reactions of Acetylenic Compounds".

Thursday 16th February

Professor G.W.A. Fowles (University of Reading), "Home Winemaking".

\* Thursday 2nd March

Professor M.W. Roberts (University of Bradford), "The Discovery of Molecular Events at Solid Surfaces".

\* Thursday 9th March

Professor H. Suschitzky (University of Salford), "Fruitful Fissions of Benzofuroxans".

\* Thursday 4th May

Professor J. Chatt (University of Sussex), "Reactions of Co-ordinated Dinitrogen".

\* Tuesday 9th May

Professor G.A. Olah (Case Western Reserve University, Cleveland, Ohio), "Electrophilic Reactions of Hydrocarbons".

2. Conferences Attended and Papers Read Out

5th European Symposium on Fluorine Chemistry, Menton, 1976.

6th European Symposium on Fluorine Chemistry, Dortmund, 1977, where a

paper entitled "Oligomers from Chlorotrifluoroethylene" was presented.