

Durham E-Theses

*An investigation of atmospheric electrical phenomena
within 22 m of the ground during disturbed weather*

H. L. Colin

How to cite:

Colin, H. L. (1968) An investigation of atmospheric electrical phenomena within 22 m of the ground during disturbed weather. Doctoral thesis, Durham University.

Use policy

The full-text may be used and/or reproduced, and given to third parties in any format or medium, without prior permission or charge, for personal research or study, educational, or not-for-profit purposes provided that:

- a full bibliographic reference is made to the original source
- a <https://etheses.durham.ac.uk/id/eprint/8408/> is made to the metadata record in Durham E-Theses
- the full-text is not changed in any way

The full-text must not be sold in any format or medium without the formal permission of the copyright holders.

Please consult the [full Durham E-Theses policy](#) for further details.

An Investigation of Atmospheric Electrical Phenomena
within 22 m of the Ground
during Disturbed Weather

by H. L. Collin

Submitted for the degree of Doctor of Philosophy
of the University of Durham, May 1968

The copyright of this thesis rests with the author.
No quotation from it should be published without
his prior written consent and information derived
from it should be acknowledged.

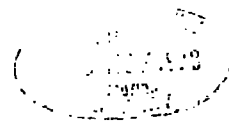

ABSTRACT

Measurements of potential gradient, precipitation current and rate of rainfall were made at ground level and simultaneously measurements of potential gradient and precipitation current were attempted at the top of a 22 m mast.

On the mast reliable measurements of precipitation current could not be obtained and the calibration of the field mill proved difficult. An attempt was made to calculate its exposure factor and response to low level space charge by numerical methods. Some success was achieved in this and the mill was found to be about half as sensitive to space charges below it as it was to those above, which halved the experimental arrangement's sensitivity as a space charge detector. Despite this space charges of several hundred picocoulombs per cubic metre were observed when the potential gradient exceeded about 800 Vm^{-1} . On one occasion it was possible to show that the space charge was produced by corona discharge from a group of trees.

The precipitation current at ground level could be adequately described by the equation $I = -2.6R(F - 112) \text{ pAm}^{-2}$ where R is in mm min^{-1} and F in Vm^{-1} . Although no direct measurements of variations of precipitation current with height could be made it was clear that the rain sometimes did gain charge close to the ground by collecting local space charge.

CONTENTS

1. Introduction

2. Equipment

- 2.1 The Site
- 2.2 Precipitation Collectors
- 2.3 Field Mills
- 2.4 Rate of Rainfall
- 2.5 Recording System
- 2.6 Automatic Control

3. Exposure Factors

- 3.1 Possible Methods of Evaluation
- 3.2 Calculation
- 3.3 Results

4. Data Analysis

- 4.1 Observation Length
- 4.2 Computing Procedures

5. Precipitation Current

- 5.1 General
- 5.2 Relation with Potential Gradient and Rate of Rainfall
- 5.3 Discussion

6. Space Charge

- 6.1 General
- 6.2 Corona Discharge
- 6.3 Dissipation of Space Charge
- 6.4 Kelvin-Chauveau Effect

7. Conclusions

CHAPTER I

Introduction

The earliest investigations of precipitation electricity were prompted by their possible importance in the maintenance of the earth's charge. It is also generally accepted that the origin of precipitation charges is closely related to the charge separation processes in clouds so that information gained about the charges on precipitation particles and the accompanying potential gradients would provide clues to the nature of these processes.

Elster and Geitel (1888) were the first to measure precipitation charges. They collected the rain in a vessel which was electrostatically shielded to avoid the displacement currents caused by changes in the bound charge accompanying changes in potential gradient. An electrometer was used to measure the charge which reached the vessel in a short interval. Their method was used by several later workers, notably Simpson (1909 and 1949). Scrase (1938) and a number of others found the charge on a known quantity of water by allowing the rain to run into a small cup which tipped up when full and simultaneously earthed the electrometer.

These methods have the disadvantage that the shielding might exclude some of the rain and much of this will probably be small drops, especially if there is a strong wind. Such a bias could be important if the small drops carry a significant proportion of the total charge as suggested by Smith (1955). In addition the conduction current and any charging due to splashing are excluded.

Wilson (1916) made some observations with an unshielded receiver which was fitted with a guard ring in order that charges lost from the receiver by water splashing off it would be balanced by splashes from the guard ring. Chalmers (1956) and Ramsay and Chalmers (1960) have made observations with exposed receivers and corrected for displacement currents.

Some earlier workers found that the precipitation current tended to be opposite in sign to the potential gradient, but not all investigators agreed. However, the observations of Simpson (1949) dispelled all doubt of the existence of this inverse relation between precipitation current and potential gradient. More recent work has confirmed that the current is usually proportional to the potential gradient and of opposite sign to it although Reiter (1965) found that in very light rain they were the same sign. Similar results have been found for single raindrops, but Smith (1955) found that the sign of a drop's charge was related to its mass. With single drops the divergence from average was found to be very great with drops of the same size which reached the ground at the same time having charges of different magnitude or even sign.

The inverse relation can be explained by a charge separation process in the cloud giving charge of one sign to the precipitation and leaving the opposite charge in the cloud to give rise to the potential gradient. Another explanation (Wilson 1929) is that the drops capture corona discharge ions which are opposite in sign to the potential gradient. Corona discharge only occurs

when the potential gradient is high, more than about 1000 Vm^{-1} , so this process is unlikely to be of primary importance in nimbostratus conditions. No satisfactory interpretation of the results for steady rain has been made although Chalmers(1959) assumed that rain originated as snow and was able to conclude that there must be a charge separation process when the precipitation was in the ice phase and another when it melted. This deduction is reinforced by the observations made by Reiter (1965) at stations at various altitudes. These showed that the region between 0°C and 3°C , where ice crystals just melt, acts as a boundary between the region of solid precipitation where the potential gradient is predominantly positive and one of rain with negative potential gradients predominating. MacCready and Proudfit (1965) measured the charges on precipitation particles below thunderclouds and found that they changed sign in the melting zone.

In addition to the inverse relation many observers have noticed that the potential gradient and precipitation current changed sign either simultaneously or with a short time lag. This has been named the mirror image effect and is an instantaneous association whereas the inverse relation is a statistical one although of course the two are connected. It is possible to consider the mirror image effect to be due to the movement overhead of the charges in the clouds as the clouds are blown past. If the wind is of uniform strength between the cloud and ground the precipitation is always directly below the part of the cloud where it originated. The time lags sometimes observed can be explained if the wind strength

varies (Chalmers 1965). Groom and Chalmers (1967) have pointed out that these time lags can account for the occasional apparent absence of the inverse relation. Alternatively the explanation may be that the rain gains its charge by some process which operates near the ground.

Most workers have made measurements at ground level only, although Gunn (1950) and MacCreedy and Proudfit (1965) made observations from aircraft. However, Kelvin (1860) and Chauveau (1900) measured potential gradients, but not precipitation currents, simultaneously at the top and foot of a tower. They both found that during steady rain the potential gradient was usually negative but occasionally that at the top became positive while at the bottom it remained negative. They also found that sometimes the changes in potential gradient at the top were less pronounced and did not last for so long as those at the bottom.

The difference in sign of the potential gradients at the top and bottom indicates the presence of a negative space charge between the levels of their instruments and if its density varied the potential gradient which it produced would also vary. If also most of it were below the top of the tower these changes of potential gradient would be more pronounced at the ground.

Several suggestions have been made to account for the production of this charge. Lenard (1892) found that when drops splashed a negative charge was given to the air which could lead to the accumulation of a negative charge near the ground. Recently, however, the reality of this process has been questioned (Gill and

Alfrey 1952). Aitkins (1959a) suggested that the precipitation could have been snow at the top of the tower and that this melted before reaching the ground and that the melting was accompanied by a charge separation process. However, Chauveau reported that the effect occurred quite frequently and it is unlikely that he would not have observed any snow. In Kelvin's case the separation of his instruments was only 15 m and it seems improbable that sufficient melting could take place in this distance to account for the results on the basis of the melting hypothesis.

The work of Kelvin and Chauveau was continued by Merry (1959) who made simultaneous measurements of the potential gradients and precipitation currents at the top and bottom of a mast, but was able to make recordings on only two occasions. He did not report differences in the sign of the potential gradients, but he did observe, at both places, the inverse relation and mirror image effect which are well known for observations at the ground. He also found that the current at the top of the mast was several times that at the bottom.

Later the author in collaboration with others (Collin, Raisbeck and Chalmers 1963) continued Merry's work on the same site. Although this was brought to a premature end by the collapse of the mast in a gale it was possible to make a few recordings. Like Merry's these did not show the Kelvin-Chauveau effect and it was not possible to measure the potential gradient at the top of the mast sufficiently accurately to show small concentrations of space charge. The relation between potential gradient and

precipitation current at the bottom of the mast agreed well with that found by other workers. At the top the precipitation current was several times larger but there was some evidence that this was caused by the raindrops splashing on the collector in the exaggerated potential gradient there (Collin and Raisbeck 1964). Thus it was not possible to draw any conclusions about variations in atmospheric electrification with height and it was obvious that before this could be done the difficulties in obtaining meaningful readings from instruments on a mast would have to be overcome. It was with this intention that the present work was undertaken.

CHAPTER II

Equipment2.1 The Site

The investigation was carried out at Durham University Observatory. The mast was situated in a field about 90 m west of the Observatory buildings in the same position as the one used by Merry. The mast had been blown down in June 1962 and repairs were not completed until the March of the following year, when it was fitted with guy-lines to enable it to withstand high winds. The mast was 22 m in height with a robust platform at the top which was reached by a ladder. This made it very convenient to work on and no difficulty was experienced with the installation of equipment.

Five main pieces of equipment were required to measure potential gradient and precipitation current at both top and on the ground near the foot of the mast and also to measure rate of rainfall. The latter was included because it had been found that the constant of proportionality between potential gradient and current depended on the rate of rainfall (Ramsay and Chalmers 1960). Most of the instruments that had been used earlier had been only slightly damaged by the collapse of the mast and could still be used. However, the potential gradient at the top had been measured with an agrimeter which gave an output of only a microampere which was adequate for the photographic recording that had been used before but was not enough for the chart recorder which it was intended to install. Accordingly it was replaced by a fieldmill similar to that used at ground level. A third fieldmill was also required

to give an absolute measure of the potential gradient in order to determine the exposure factors of the other fieldmills.

The signals from the instruments were carried along cables to the Observatory where they could be amplified and recorded although in some cases it was convenient to have the amplifiers and power supplies in the field. These were housed in weatherproof boxes at the foot of the mast.

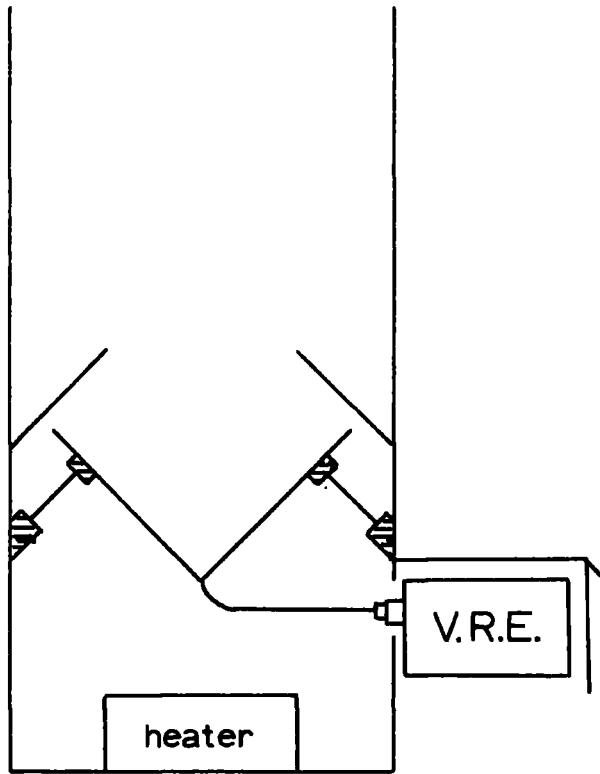

2.2a
shielded receiver

2.2 Collectors

The original collectors were of the design of Scrase (1938) with electrostatic shielding extending 30 cm above the receiving cone whose effective area was 0.031 m^2 (Fig. 2.2a) with Vibrating Reed Electrometers (V.R.E.) as the amplifiers. This design had proved satisfactory at the ground but the extremely high potential gradient at the top of the mast gave rise to large displacement currents and caused drops splashing on the shield to acquire very high charges which masked the true precipitation current (Collin and Raisbeck 1964). There seemed to be two methods by which these effects could be overcome. The first was to improve the collector design and the second to measure the charge on each drop with an induction ring. Such an instrument could easily be made insensitive to displacement currents and as the drops did not have to touch the ring splashing effects would have been small. Unfortunately such an instrument would not have been easy to make and it would have required special recording apparatus, either a recording oscilloscope in which case the record would have had to be analysed manually drop by drop, or if this labour was to be reduced by making it automatic far more elaborate recording equipment would have been required. In view of these difficulties it was decided to try the first alternative. It was estimated that if the potential gradient at the surface of the shield could be reduced by a factor of five the 'splashing current' would be reduced to an acceptable level. In order to find the most satisfactory way of doing this a series of experiments were carried out using an electrolytic tank.

The tank consisted of a large enameled photographic developing dish about 24" x 18" and containing an inch of water. Aluminium plates along the longer sides simulated the ground and electro-sphere in section. A sectional model of the collector was made and attached to one of the plates. It was found that the model had to be less than one quarter of the width of the tank in height as otherwise the "distant" potential gradient became distorted and ceased to be a good representation of natural conditions. A potential gradient was provided by a 25 v, 1 kHz oscillator. The A.C. supply was used in order to prevent polarisation. The potential at any point could be found by inserting a metal probe into the water and connecting it to an oscilloscope, or the mean potential gradient at a surface could be obtained if it was insulated and a resistor inserted between it and the "ground" electrode. The voltage generated across this resistor gave the current reaching the surface and thus the exposure factor would be found by comparing this with the current to a distant piece of "ground". This method had the disadvantage of raising the surface to a higher potential than it would be at normally and so giving a slightly lower value of potential gradient. In view of this, the exposure factor of the model collector was always found by measuring the potential at a fixed point inside it.

The first experiment that was carried out was to determine the effect of increasing the height of the cylindrical electrostatic shield round the collector. This of course decreased the potential gradient inside, and it was found to fall off exponentially with

an increase equivalent to 3.6 inches reducing the potential gradient to half its previous value.

It would thus have been possible to reduce the potential gradient to a sufficiently low value merely by increasing the height of the shielding, but this would have meant that only those raindrops which were falling at small angles to the vertical would have reached the conical receiver. If this had been done it would have meant that the collector would have measured the precipitation current only in very low windspeeds. It seemed possible that an earthed hoop round and above the collector would reduce the potential gradient to some extent while not preventing the rain from getting in.

A cross-sectional model of the hoop was made by two copper wires supported above the collector by "plasticine" on the base of the tank. Their separation and height could easily be altered by moving the "plasticine". The effect of height and diameter on the exposure factor of the receiver was rather complex, but in general the higher the hoop the greater the reduction and larger hoops have smaller reductions. In all cases the effect was much less than that of increasing the height of the shield with a maximum reduction to about half the original value. In view of these limitations a compromise was adopted. A reduction of exposure factor to one quarter would be tolerated. This was accomplished by increasing the shield height by 4" and setting up a hoop 30" in diameter 12" above the top of the shield. This allowed raindrops at angles of up to 37° to the vertical to be admitted.

The modified collector was installed at the uppermost point of the mast like the earlier model. The collector to be used at the ground did not have a hoop fitted but the shield was raised by 4" so that it would receive a similar sample of rain to the other.

Unfortunately the collectors did not live up to expectations. The upper instrument always showed a much larger current than the lower although it never seemed to collect as much water. On one occasion when there was a wind of about 10 ms^{-1} the lower collector was receiving no current while the upper one showed about half full scale. When the instruments were examined it was found that no raindrops were falling straight into the conical receivers but were all striking the shields and some of the droplets splashing off were falling in instead. The current was entirely produced by these splashing effects. The cylindrical shield was clearly not preventing splashing currents and was seriously reducing the amount of rain caught except when the windspeed was very low.

The only way to get over these drawbacks seemed to be to use exposed receivers, but of course these have the serious disadvantage that the rain current is often swamped by displacement currents. This would be especially pronounced on the mast where displacement currents of as much as 30 pA can be expected, if the rate of change of potential gradient is only $3 \text{ V.m}^{-1}.\text{s}^{-1}$ and the exposure factor of the receiver is about 30. When this figure was compared with the probable precipitation current, up to 10 pA, it was clear that to attempt to compensate by calculating the displacement

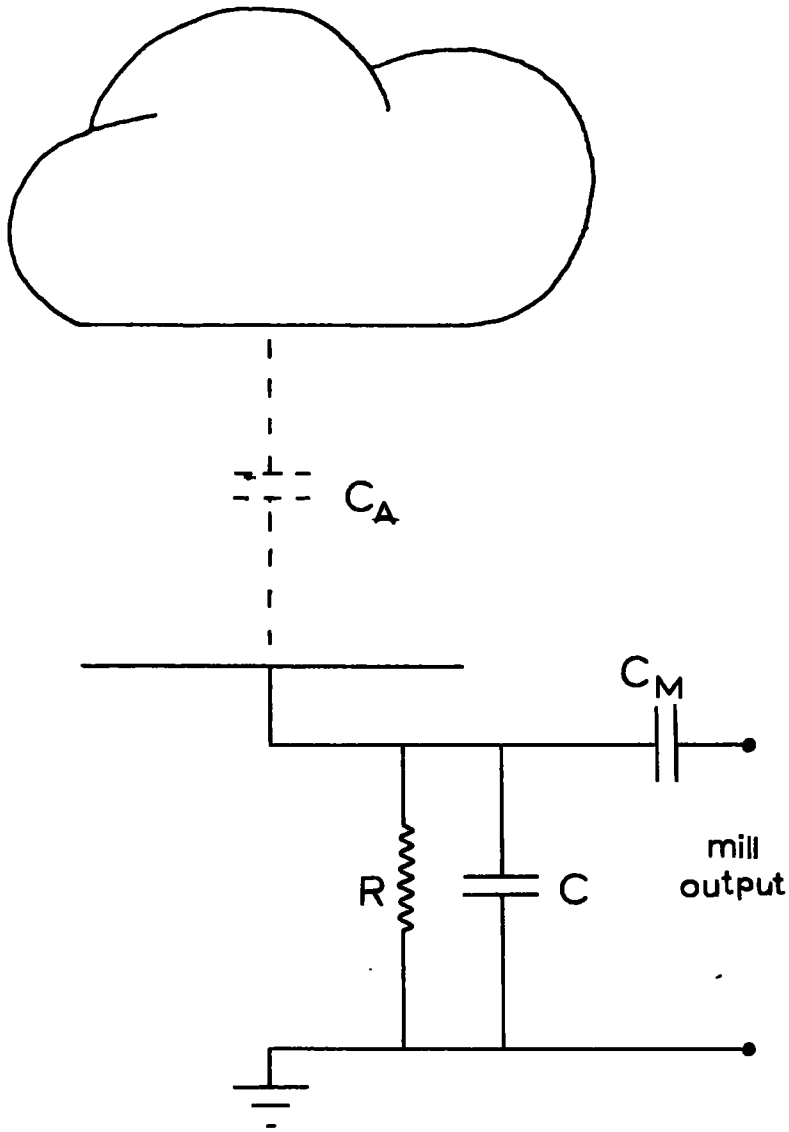

2.2b
compensating for displacement currents

current to be expected from the observed potential gradient during, say, a one minute period and then subtracting it from the average collector current would have been most unreliable. An attempt was made therefore to compensate electronically. It is possible to compensate for displacement currents (Adamson 1960) by differentiating the output of a fieldmill and subtracting this from the output of the collector amplifier. To do this it is necessary to match the relaxation times of the two instruments very accurately. This is not easy. Hutchinson (1966) attempted a method where the match should not be so critical. In this the output of a field mill with a fast response was arranged to be opposite in sign to the potential gradient and to be as large as possible. It could then be used to produce a displacement current, at the input to the collector, opposite in sign to the natural one. This could be done by differentiating the mill's output by means of a condenser and the input resistor of the collector-amplifier (Fig. 2.2b). The time constant of the collector with respect to the atmosphere is given by $R.(C + C_A)$ where C_A is the capacitance of the collector to the cloud, while with respect to the mill output it is $R(C + C_M)$. As C_A is negligible C_M must be as small as possible if the time constants are to match accurately. The value of C is 1000 pF so that only a few picofarads could be tolerated and since the compensating current is proportional to C_M a reduction in C_M must be accompanied by an increase in the gain of the mill amplifier.

This method was tried with an artificial potential gradient in the laboratory. A new mill amplifier had to be made to give

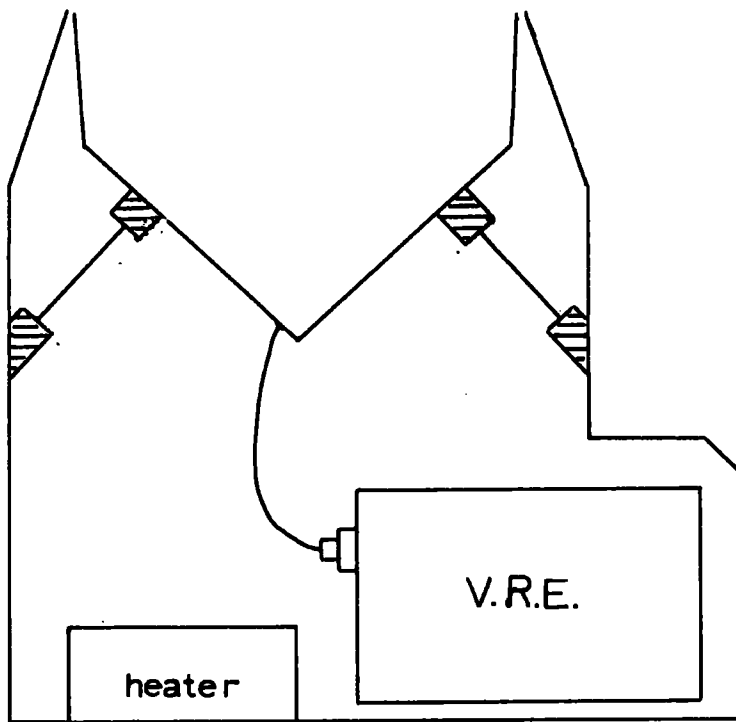

2.2c
exposed receiver

an output of up to 100 V.D.C.

Two points at once became obvious. The condenser C_M had to have a very high leakage resistance. This was because the maximum precipitation current expected was 10 pA so leakage from the mill output had to be less than 0.2 pA. This required a condenser with leakage resistance of at least $5 \times 10^{14} \Omega$, which was greater than the resistance of those available. To overcome this difficulty a condenser was made from a few centimetres of coaxial cable with polythene dielectric. The second cause of trouble was the ripple on the mill output which disturbed the V.R.E. The only way to prevent that was to improve the smoothing which increased the time constant of the mill to about 0.3 s. It was hoped that this would not matter as the time constant of the collector was about 10 s.

The arrangement was by no means perfect but it afforded a reduction of displacement currents to less than a tenth. This seemed to be reasonable for steady rain when the potential gradient did not usually change at a rate greater than $3 \text{ Vm}^{-1} \text{ s}^{-1}$ which would give less than 3 pA in the collector on the mast. A new collector was then constructed (Fig. 2.2c). It had no electrostatic shielding above the insulated receiver. The upper edges of the receiver and the outer shield were nearly vertical in order to reduce the amount of splashing and came to the same level in the hope that splashing in and out of the receiver would cancel.

The collector was installed at the bottom of the mast and an attempt was made to adjust the compensating device. This was not

so easy as in the laboratory since the natural potential gradient had to be used because no sufficiently large plate could be set up. The adjustment was carried out by varying the size of the compensating current and then recording the potential gradient and collector current for a time to show how effective the compensation was. It soon became apparent that the compensation was not at all satisfactory, probably on account of short term fluctuations which the field mill was not able to follow. As a result the reduction of displacement current was only by a half. In addition to this the condenser insulation repeatedly fell below the critical value although it had been installed inside the dedicated head unit of the V.R.E.

Since the compensating device was not satisfactory on the ground there was no chance of it working on the mast and so it had to be abandoned. By then there was no time to start the construction of equipment for single drop measurements, and the building of a more sophisticated compensating device seemed equally out of the question. In view of this it was decided to leave the collectors as they stood and only make use of them when the wind-speed was very low.

Apart from the points outlined above the instruments worked reliably and only required to have their insulation cleaned occasionally.

The V.R.E.'s were calibrated in two parts. Each input resistor was measured by removing it from its head unit and allowing a condenser to discharge through it so that the time constant of

the combination could be determined. Since the value of the condenser was known accurately the value of the resistor could be found. The values were $1.08 \times 10^{10} \Omega$ and $1.07 \times 10^{10} \Omega$ to within 2%.

The VRE's were calibrated for input voltage by inserting calibrating voltages into the feedback line through a special socket. No accurate voltage source was available so one had to be constructed. It was powered by a 12 V battery which provided 6.8 V roughly stabilised by a zener diode. This voltage was used to supply a second zener diode which gave 3.3 V with greater stability. Temperature changes as well as current changes affected the running voltage of this diode so in order to overcome the effects of temperature a thermistor was included in the dropper resistor from the 6.8 V supply. When the temperature changed it caused the current to the diode to change and give rise to a change in running voltage complementary to that caused by the temperature. The 3.3 V was connected across a "Muirhead" potential divider and a series resistor. This resistor was adjusted to give exactly 1 V across the potential divider as measured by a sensitive bridge. It was found that the voltage source varied by only ± 1.2 mV between -10 and $+20$ $^{\circ}\text{C}$ and showed no detectable change for battery voltages between 10 V and 14 V.

The calibration curves of the VRE's were linear and did not change with time. The lower collector was adjusted to give a full-scale deflection for $\pm 200 \text{ pAm}^{-2}$ and the upper where larger currents were expected for $\pm 420 \text{ pAm}^{-2}$.

2.3 Field Mills

The potential gradient had earlier been measured with an agrimeter (Chalmers 1952) at the top of the mast and a field mill at the ground. The field mill had used a marker system of sign discrimination (Collin 1962). It was intended to use a sixteen channel point recorder and this was not sensitive enough to use with an agrimeter which made it necessary to use two field mills. Also since the record was discontinuous the marker method of sign discrimination was unsuitable. A number of other methods of sign discrimination were possible. The simplest seemed to be to displace the zero by exposing the field mill to an auxiliary potential gradient which was produced by a stabilised voltage applied to a plate above the mill. The auxiliary potential gradient could be made very stable so that there would be no trouble from drift, but the range over which the instrument could be used was limited. This was because the output of the mill corresponded to the magnitude of the sum of the two potential gradients. No difficulties would arise when the potential gradients were the same sign, but if they were not and the natural potential gradient was greater than the auxiliary, its magnitude would be ambiguous. However, this was not a serious disadvantage since periods when the potential gradient was higher than about 800 V/m were unsuitable for analysis because corona discharge would occur at such potential gradients.

The original field mills were modified by fitting an insulated annular plate a few millimetres above the vanes. This arrangement allowed the auxiliary potential gradient to be applied to the

ends of the vanes, while the rest was exposed to the natural potential gradient. An additional field mill was constructed which like the others had four vanes 15 cm in diameter and housed a cathode follower unit. It was driven by a synchronous electric motor in order to avoid the pickup from the commutator which had plagued the earlier models.

The mills were installed in an inverted position to protect them from rain as far as possible. The upper mill was fixed to the outside of the handrail on the mast's platform. In this exposed position it was affected by rain despite being upside down and a cover had to be fitted to protect it. This also reduced its exposure factor somewhat. The lower mill was supported on a stand about 1 metre above the ground and two metres away from the foot of the mast. A third mill could be put in the calibration pit where it faced upwards through a hole in a plate 2 metres square which was supported level with the ground. In this position it could be used as a standard by comparison with which the exposure factors of the other mills could be found.

All the power supplies were housed in a box near the mast and were connected to the mills by sixcore cables. The output signals were taken along coaxial cables to the observatory where they were amplified and recorded. The amplifiers were similar to the ones previously used.

Little trouble was experienced with the instruments. Earth loops accentuated some noise but this was reduced to an acceptable level without much difficulty although some of the loops could not

be broken because of the earthed supports of the field mills.

The vanes had been chromium plated in an effort to reduce contact potentials and they were clean and polished when the mills were first put outside. As the surfaces became dirty the contact potentials changed rapidly and caused considerable zero drift. Eventually this settled down but by that time the chromium was completely covered with dirt. Subsequently whenever a mill needed repair care was taken not to clean it.

The calibration of the mills was carried out in two stages. First an absolute calibration was performed for which the mill was placed in the central hole in the lower of the 2 m square calibration plates with its vanes just level with the plate. The other plate was held above it on wooden supports. The lower plate was earthed and potential gradients produced by applying voltages to the upper plate. Contact potentials between the plates were accounted for by changing their separation. This caused the contact potentials to produce a different potential gradient which was recorded as a change of zero. When the errors arising from this and from zero drift are taken into account the accuracy of the calibration was ± 100 v/m.

When all the mills had been calibrated the upper and lower mills were replaced in their operating positions but the third mill was left in the calibration pit. This time however the upper plate and its supports were removed so that the natural potential gradient could be measured under the same conditions as those under which the mill had been calibrated. The three mills were all run together and their records compared in order to determine their

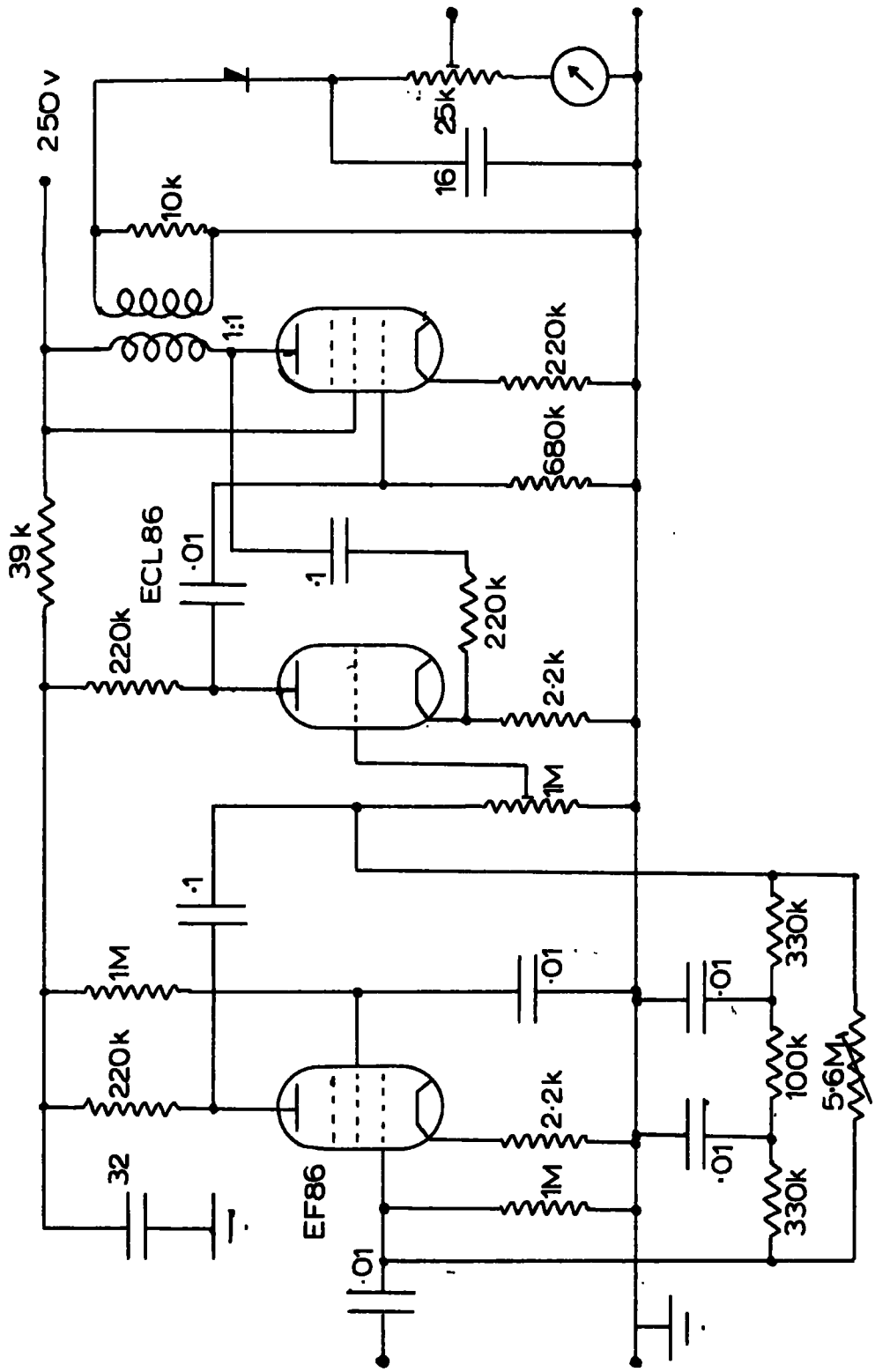

2.3a
field mill amplifier

exposure factors. When this was done it was particularly important that there should be no space charge present since that would influence the lower mills more than the upper one. The space charge was being measured directly at two levels on the mast by Dr. R. B. Bent who was able to recommend suitable times for the determination of the exposure factor. It turned out that on space charge free days the potential gradient was low which reduced the accuracy with which the exposure factors could be evaluated. In the case of the lower mill this was not very serious since it was affected by space charge in the same way as the standard mill. This meant that the exposure factor could be found quite accurately in conditions which were not ideal. The values found were, for the lower mill 1.08 ± 0.06 , and for the upper 6.5 ± 1.0 .

Later when the exposed rain collector was being tried it was necessary to have a high voltage output and a new amplifier was built (Fig. 2.3a). It consisted of a filter and power stage. The first pentode had a low pass filter in its negative feedback loop and this gave it a high pass characteristic with a cutoff at about 100 c/s. This was to reduce mains hum. The triode and the second pentode provided voltage amplification and the power output stage. Transformer output was used since the output could then be easily referred to earth. More power was available than from the cathode follower output used in the earlier amplifier. This made it possible for the rectifiers to pass larger currents in order that the amplifier would have a linear response down to low signals.

The amplifier performed satisfactorily. Its output was adequate for the compensating circuit. It was insensitive to supply voltage fluctuations and rejected 50 c/s sufficiently well to prevent it from being a source of trouble. The only drawback was that it consumed 8 watts and so needed a special power supply.

2.4 Rate of Rainfall Recorder

The original instrument had been built by Raisbeck from a design by Adkins (1959c) but had never been very satisfactory. It was therefore overhauled and after a few modifications was made operational.

The basic idea was quite simple. The rain was caught in a funnel and allowed to run out through a small hole in a stream of equal sized drops. These fell through a wire mesh and made electrical contact between adjacent wires. These caused a condenser to discharge and so produce voltage pulses, the frequency of which gave the rate of rainfall directly. This method was more satisfactory than the usual recorder which would have given the accumulating total rainfall of which the slope would have had to be found and provision made for returning to zero once full scale had been reached.

Mechanically the instrument was very simple, an inverted zinc cone 26 cm in diameter surrounded by an aluminium cylinder. The outlet was a tapered hole through a brass block and the mesh consisted of a few platinum wires fixed between 'tufnol' supports. In order to be able to use the instrument to measure snowfall, a heater cord was wrapped round the cone and used when snow was expected. The electronic part (Fig. 2.4a) consisted first of a monostable multi-vibrator which converted the small triggering pulses to 240 V ones which lasted for about 200 ms. The negative high tension supply was necessary to keep the base of the pulses slightly below the potential of the cathode of the miller integrator into which they were fed. This was arranged to give an output corresponding to the frequency of the pulses.

The obvious method of calibrating the instrument by running water into the receiver at a steady rate and recording the output proved not feasible since it was difficult to maintain a steady flow of water at an accurately known rate. Instead calibration was carried out in two parts. First the size of the drops was determined by allowing water from a burette to run into the receiver at a convenient rate and the number of drops counted by observing the needle of the monitor meter. This kicked upwards when the integrator received a pulse and then fell away until the next pulse arrived. About 500 drops were counted with the help of a key and electromechanical counter. The remainder of the calibration consisted of triggering the multivibrator by operating a key at a steady rate of between once a second to once in ten seconds, and recording the output for a few minutes. This could be done with a quite high degree of accuracy by using a watch to time the operation of the key. This gave the recorder reading corresponding to various rates at which water was entering the receiver. As the area of the receiver was known the rate of rainfall could be found immediately. The response was linear with full scale of 0.1 mm min^{-1} .

The device suffered from two faults. The most important was in the formation of the drops. As the metal of the orifice aged its surface changed somewhat which caused the angle of contact which water made with it to change too. This gave rise to a slow change in drop size. An attempt was made to overcome this by greasing the brass and after a few days this gave drops that did

not change much in size. What little variation was left was kept track of by recalibrating at intervals. The second fault was a short term zero drift, typically about 2% of full scale. This originated in the integrator and was suspected to be caused by temperature fluctuations, but the use of high stability components did not give any noticeable improvement and neither did stabilised supplies, so eventually it had to be left. Fortunately the drift was not large enough to be important. Apart from these the only troubles were caused by insects and dirt getting into the orifice or shorting out the wires below it.

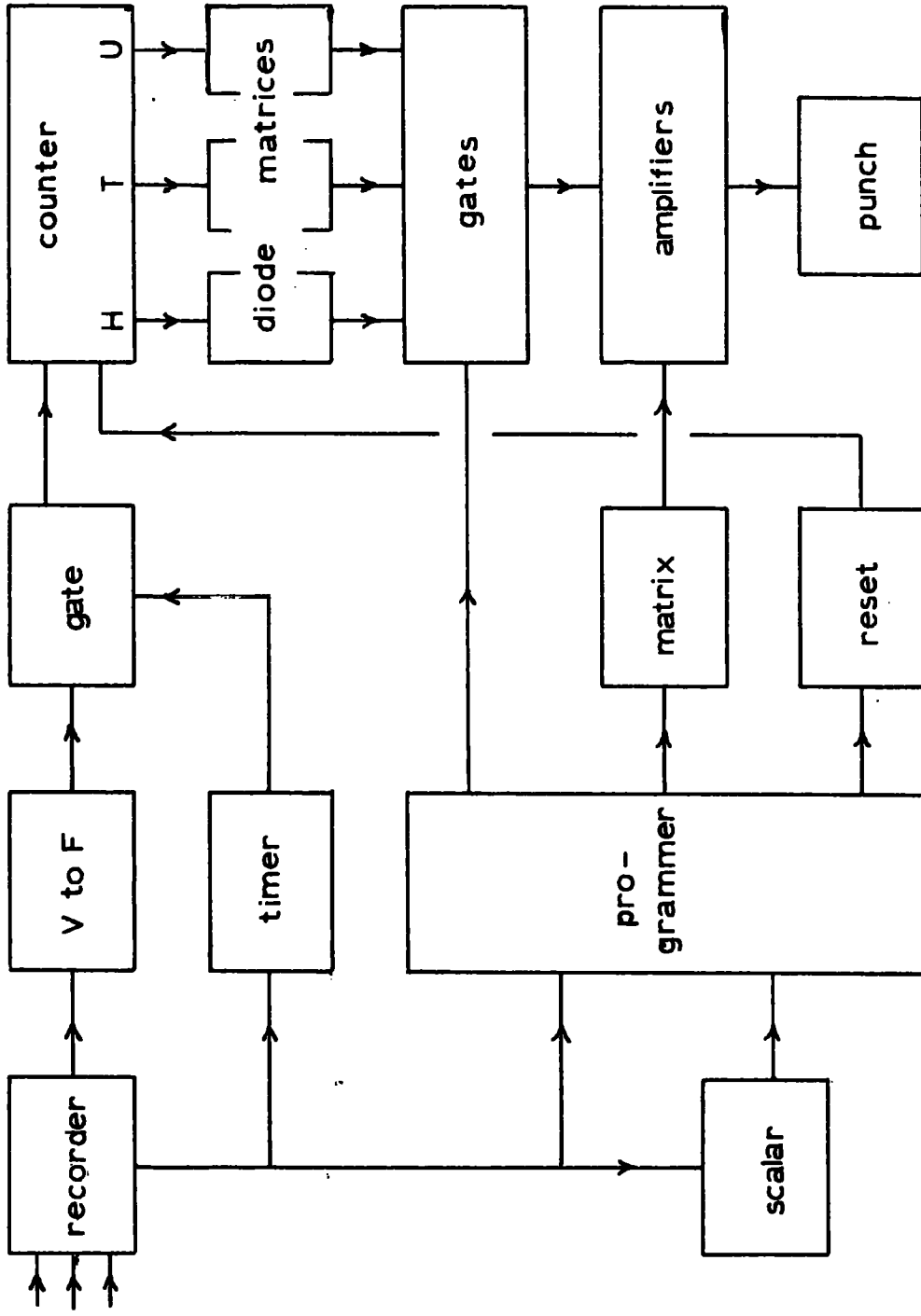

2.5a

digitiser, block diagram

2.5 Recorder

In order to make maximum use of computer facilities it was necessary to record directly onto punched tape. The alternative of taking measurements from a chart and punching by hand would have taken so long that it would have severely hampered any extensive analysis. A number of suitable systems were available commercially but all were prohibitively expensive. This meant that the construction of the recorder had to be undertaken. The task was engaged upon in cooperation with Dr. R. B. Bent who also wished to make use of the computer.

The method adopted was suggested by Dr. L. Molyneux of the University of Newcastle upon Tyne and he took a leading part in the design of the instrument. The recorder had to produce a punched tape suitable for the computer as well as an analogue chart which could be examined and would show up occurrences easily. To do this the signals from the various instruments were registered on a chart recorder which also acted as a D.C. amplifier. The output from the amplifier was measured by means of a digital voltmeter and its reading punched onto paper tape.

Since the recorder was quite complicated it seems appropriate to elaborate on this brief description but a detailed account of the operation of each stage will not be given as it appears to be unnecessary to this report and a complete description has already been given by Bent (1965).

A simplified block diagram is shown in Fig. 2.5a. The signals from all the instruments were fed into the sixteen channel 'Honeywell'

chart recorder and the reading of each of the sixteen inputs was recorded on the chart by the printing head which replaced the pen of a single channel recorder. The head was coupled to the slider of a potentiometer which gave up to 12 V corresponding to the position of the head and so to the value of the parameter which was being recorded. The voltage controlled the repetition rate of the pulses which were produced by the voltage to frequency converter. This device is fully described by D'Sa and Molyneux (1962) and nothing need be said about it except that it produced a train of pulses whose repetition rate was between 0 and 1000 s^{-1} . The relation between the input voltage and repetition rate was linear to within 0.7% over the range used.

When the printing head operated it was made to close a micro-switch to give a trigger pulse to the digitising equipment. Various actions were initiated by this pulse. The timing unit, a monostable multivibrator, was made to open a gate for about a tenth of a second to allow the pulses from the voltage to frequency converter to be counted by a three decade counter. The count would be proportional to the pulse repetition rate and so to the original input voltage.

The trigger also set the programmer unit into action. This part of the digitiser had the task of organising the punching of the number held on the counter together with the code for a 'space' or when necessary for starting a new line. To achieve this it used a decade counter tube as a commutator. The trigger stepped the commutator to its first position where a signal was passed through a diode matrix to form the 'space' code which in turn caused the

appropriate output amplifiers to activate electromagnets in the punch causing the correct pattern of holes to be formed. Punching the space took about the same time as counting the pulses so the digital version of the input voltage would then be ready to be punched. As soon as the punch had finished a character it sent a pulse back to the programmer unit which then caused the commutator to step on to its next position in which it caused the 'hundreds' character to be punched. This was done by opening a gate to allow the signal from the hundreds decade tube, which had already passed through a coding matrix and was so in binary code, to operate the appropriate output amplifiers and cause the character to be punched. The 'tens' and 'units' characters were punched in a similar manner.

The fifth position of the commutator controlled resetting to the standby state. A voltage was applied to the resetting unit which generated a large pulse to reset the counter tubes to zero and the commutator to an inactive position to await the selection of the next input.

When all the sixteen inputs had been recorded the process started again and it seemed suitable to indicate this by starting a new line when the tape was printed out on a teleprinter. The original trigger pulses from the recorder were counted on a binary scalar which consisted of five bistable units. At the sixteenth pulse the last scalar was switched over and in this state gave a signal that suppressed the resetting operation. Instead the programmer went on to punch out the 'carriage return' and 'line feed'

characters, which would cause a teleprinter reading the tape to start printing on a new line. This was done in exactly the same way as for the 'space' character. After that the resetting was done in the same manner as before except that the binary scalar was included.

The digitiser was constructed so that the decade counter tubes could be seen and its performance checked by watching them and also by simulating its operation in slow motion with the aid of manual switches that controlled various stages. The calibration could be adjusted by means of potentiometers to vary the pulse repetition rate and the length of time for which the pulses were counted. This was set to be 0 to 100 for the range of the Honeywell recorder. Since the Honeywell recorder was a centre zero instrument this made the zero reading to be 50. Larger numbers would have been possible but were unjustified by the linearity of the voltage to frequency converter and the general accuracy of the instruments.

As might have been expected with such a complex instrument, the recorder took a considerable time to put into operation and this was aggravated by the Honeywell recorder which had not been fitted with the correct amplifier. For some time after it was put into working order various faults occurred. These were usually caused by poor design and an appreciable time had to be spent eliminating them. After this had been done the equipment gave very little trouble and the only fault that recurred was that sometimes if a parameter was changing rapidly while printing took place the slider of the potentiometer made bad contact with its

track and the voltage fed to the voltage to frequency converter was discontinuous. This caused a very low number to be recorded.

It was decided to have only one sensitivity range for each instrument. Two considerations prompted this. One was that since automatic recording was to be used extensively any range changing would have had to have been done automatically. Circuitry to do this would not have been easy to devise. Also it was not intended to use the equipment when corona discharge occurred. This set an upper limit of about 1000 v m^{-1} for the potential gradient. The evaluation of the exposure factors of the field mills was subject to considerable errors, particularly in the case of the one on the tower so it was unlikely that the potential gradients could be compared to within 100 v m^{-1} . The recording system could discriminate to a hundredth of its scale so was able to register potential gradient sufficiently accurately in a single range. Similar remarks applied to the other instruments except that the limitations to the accuracy of the collectors was expected to be splashing and sampling errors while the sensitivity of the rate of rainfall meter was limited by the size of its receiver.

The Honeywell recorder had sixteen inputs and its sensitivity was $\pm 5 \text{ mV}$ full scale while there were only five instruments in normal use and they gave outputs of $\pm 100 \text{ mV}$ in the cases of the collectors and $0-3 \text{ V}$ from the fieldmills and rate of rainfall meter. The coupling circuits for the collectors were simple, just a potential divider, but those for the fieldmills were more complicated. The output of the fieldmill amplifiers which corresponded to zero potential gradient was about one volt. To make it suitable for

the centre zero recorder the output was compared with a steady voltage equal to the zero output and the amplitude of the difference reduced by a potential divider. This turned out to be a rather unsatisfactory arrangement. The recorder changed channels by means of a two pole selector switch and usually one pole would be changed before the other. This meant that the recorder was momentarily connected to two inputs, one at about zero potential and the other at one volt. The result was that the recorder went hard offscale and then had to return when the connections had been made correctly. The time taken to do this was sufficient to prevent the printing head from reaching the correct point before it acted. This was eliminated by reducing the amplitude of the output first and then comparing it with a much smaller reference voltage. The effect of this was to bring all the inputs to within a few millivolts of each other so that incorrect connections only gave rise to small signals.

In order to make the most use of the sixteen channels available each instrument was connected to several channels. Individual drop charges caused the collectors to have rather peaky outputs so each was allocated four channels in order to enable a good value for the mean current to be obtained. The fieldmills and rate of rainfall meter were each allocated two channels since they were not expected to change very rapidly. The two remaining channels were wired together and used occasionally as a spare channel.

2.6 Automatic Recording

Unfortunately rain does not keep normal office hours. Consequently if recordings are to be made under the experimenter's complete control he must be prepared either to keep a day and night watch or to lose a substantial proportion of possible records. As the present worker did not care for either of these alternatives it was resolved to make use of an automatic device for taking records.

The ideal device would switch on all equipment some minutes before rain commenced and switch off again after it had finished. It would also make zero and calibration checks at suitable intervals and make a note of the times of all its actions.

To forecast rain even for a few minutes ahead would not be at all easy. Consequently the observation periods were controlled by a rain detector. The instruments had sufficiently steady calibrations to make it unnecessary to check at each recording.

The detector was very simple. It consisted of two electrodes, the lower a stainless steel sheet, the upper a mesh of nichrome wires held in a brass frame, separated by a sheet of filter paper. When the paper was dry it was insulating but when rain fell on it it became conducting, (This short circuit was used to apply a signal to an amplifier that operated relays.) until the water evaporated. A heater under the lower electrode aided drying out and so prevented the equipment from remaining on long after the rain had stopped.

The device appeared to work very well at first, but a serious defect soon became apparent. When the rain was only light the

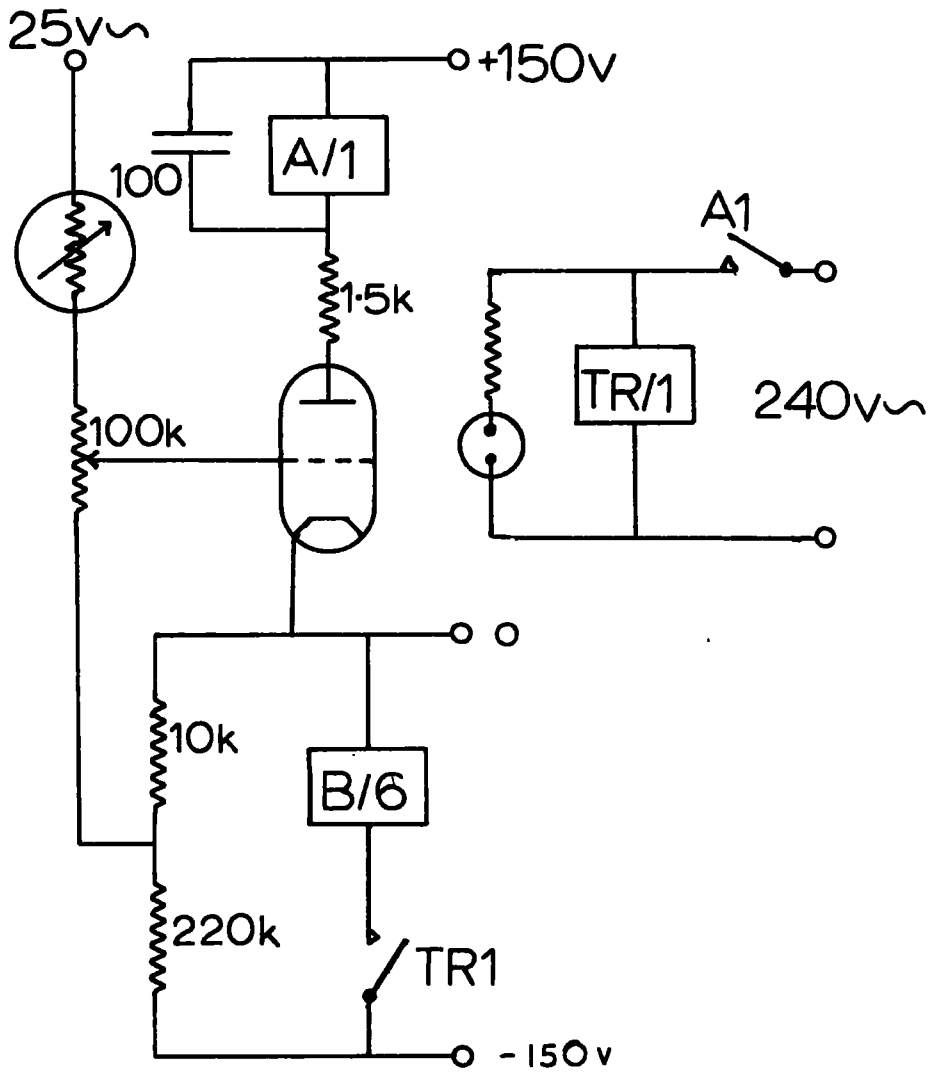

2.6a
rain detector

filter paper would frequently dry out for short intervals. This resulted in a very discontinuous recording. Also the equipment was switched on for every solitary drop of rain that fell. Such records were quite useless and to prevent them a time delay was incorporated to check the switching on until the filter paper had been wet for about two minutes, and also prevent switching off until it had been dry for as long.

The electronic side of this device gave some trouble at first. A number of relay circuits were tried using a thyrotron and a cold cathode tube but they all failed, probably due to bad design. The circuit that finally proved satisfactory is shown in Fig. 2.6a. Normally the triode was biased to cut off but when the detector was conducting it received about 15 VAC, the positive half cycles of which switched it hard on and it passed sufficient current to operate a reed relay in its anode load. This relay applied mains voltage to the heater of a thermal relay and after two minutes this connected a multicontact relay to its power supply. This last relay was used to control the instruments.

This circuit performed very well and together with the detector formed a most reliable device.

It was desirable to operate the equipment manually when required and to enable this to be done switches were arranged to control the recorder and fieldmill motors, while the amplifiers were left running continuously. These switches controlled relays, one inside the digitizer and the other, for the fieldmills, in the box in the field. These relays could also be operated by the last relay in

the automatic control unit.

The end of a record could be seen quite clearly on the chart but it was not always easy to tell if the break was between two automatic recordings made at greatly different times or if it was only a short gap in what was essentially the same period of rainfall.

In order to show which records were of separate occurrences an event marker was constructed. This consisted of an old spiral drum camera modified so that a trace could be drawn on it by a pen. A long arm connected the pen to the armature of a relay which could be operated at the same time as those controlling the instruments. The effect of this arrangement was that as the drum revolved the pen traced a spiral line on the paper that covered the drum. Normally the line was unbroken except by the joint of the paper, but when the relay was activated its armature and so the pen moved. This caused the line to be displaced somewhat and so give an indication of the time when recording was taking place to within about five minutes. The event marker could run for four days without attention, although this was not usually necessary since when records were made manually the times were marked on the Honeywell recorder chart, together with any comments on weather conditions that seemed relevant.

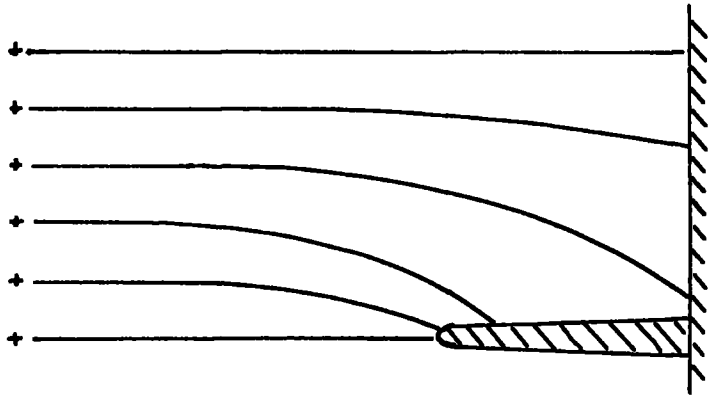

1

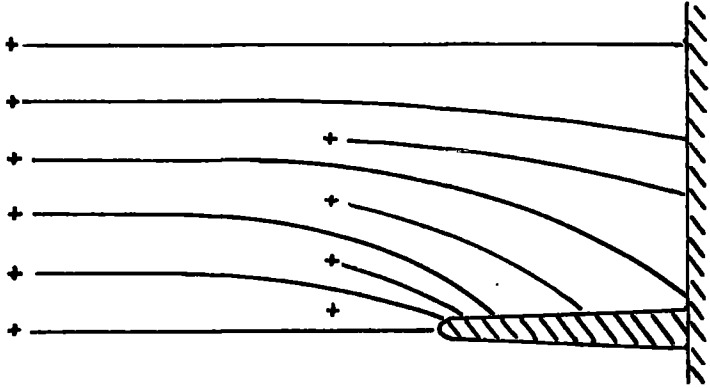

2

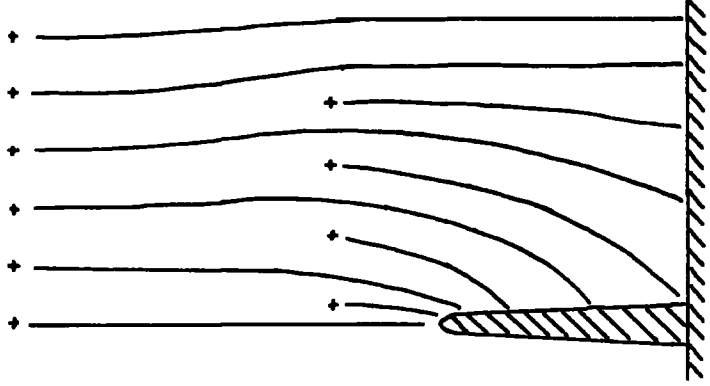

3

3.1a
field lines near the tower

CHAPTER III

The exposure factors

3.1 Possible Methods of evaluation

As mentioned earlier it is possible to find out how much the potential gradient is distorted by the mast by running a fieldmill at the top of the mast and comparing its output with that obtained from a fieldmill at some distance from the mast. Unfortunately if low level space charge is present it disturbs the potential gradient near the ground and the comparison is not valid. This introduces a serious problem since it is not easy to be sure that there is no space charge present. The exposure factor is of particular importance but it is also of interest to know how an instrument at the top of the mast reacts to local space charges. The exposure factor arises when the lines of force from distant charges converge onto the top of the earthed mast, Fig. 3.1a(1). If a volume of space charge is present a little way above the mast the lines of force from it will also converge. To a first approximation they will take up positions parallel to those from the distant charges, Fig. 3.1a(2). Clearly they will not converge more and will probably converge less than those from a greater distance, Fig. 3.1a(3). Since the exposure factor is the extent to which the lines of force are concentrated the 'space charge exposure factor' can be expected to be smaller than the normal exposure factor and the difference will depend on the position of the charges.

Another approach might give a more reliable value than direct

observations. The exposure factor could be found by measurements on a scale model in an electrolytic tank. This would get over the problem of stray space charges. On the other hand the mast is a three dimensional structure and a reasonably accurate model would require a large tank. Also the investigation of the effects of space charge would present difficulties. One way in which space charge could be simulated would be to consider that current density represents density of lines of force. A current passed into a point in the tank thus simulates a source of lines of force. This is easy to arrange unless a large or irregular volume of space charge is required, which would call for a number of variable current sources which might have to be at different potentials.

There remains the possibility of calculating the exposure factor, but this is not easy. The potential distribution around simple regular shapes can be found analytically (see for example Smythe 1950). However, even in such cases the mathematics is difficult and the presence of space charges would complicate it further. For an irregular body the only practical method of calculation would be to use numerical techniques and to carry out the calculation on a computer. It would be possible to arrange the computation in such a way that any surface configuration and arrangement of space charge could be dealt with. This would mean that once a satisfactory procedure had been developed a great many evaluations could be made with very little trouble.

3.2 Calculation

The numerical approach seemed to be the most promising one and the next step was to choose the way in which the calculation was to be carried out. Basically the procedure would have to be to assume some solution, then to calculate the error terms that would be produced by the shortcomings of the assumed distribution and use these to correct it. The process would be repeated as often as necessary to reduce the errors to an acceptable level.

The obvious way of doing this is to represent the space under investigation by an array of points and to assume their potentials, then find the potential gradients. Any discontinuities in the potential gradients can be used to correct the original potential distribution.

This method suffers from troubles similar to those associated with the electrolytic tank. The shape of the model is defined by some of the points of the array so for a three dimensional model a very large number of points would be needed to get any reasonable accuracy.

The potential gradient over a surface is mirrored by the density of the bound charge induced upon it and variations of potential gradient over an uneven surface can be considered to be caused by the charges arranging themselves under their mutual attractions and repulsions. When the arrangement is perfect the sum of all the forces on any element of charge will have no component tangential to the surface at that point. This allows the error term to be found as the difference between the direction of the total force

on an element of charge and the direction of the normal to the surface. Adjustment could take place by moving some of the charge in the direction indicated by the error term.

An immediate advantage of this procedure is that one only needs to consider points on the surface. Also space charge, can be introduced in exactly the same way as the bound charge, except of course that it need not be moved. A further reduction in the array of points to be considered is possible if the surface under investigation is symmetrical about a vertical axis since in this case it is only necessary to consider the distribution of charge along a radius. However it is still necessary to consider the forces exerted by charges all over the surface.

The system adopted was to split up the radius that represented the surface into a number of 'surface elements' and assume a charge density for each one, then specify the distant potential gradient and the densities and positions of any space charges. Each element was taken in turn and the force exerted on it by the bound charge over the whole of the surface calculated. This was done by dividing the surface into rings each of which corresponded to a surface element. The forces exerted by the rings could then be integrated to give the total and the forces exerted by space charges and potential gradient were added.

In practice it was convenient to do the calculation in two parts. The forces exerted by each ring on each surface element were found on the assumption of unit charge density. These values

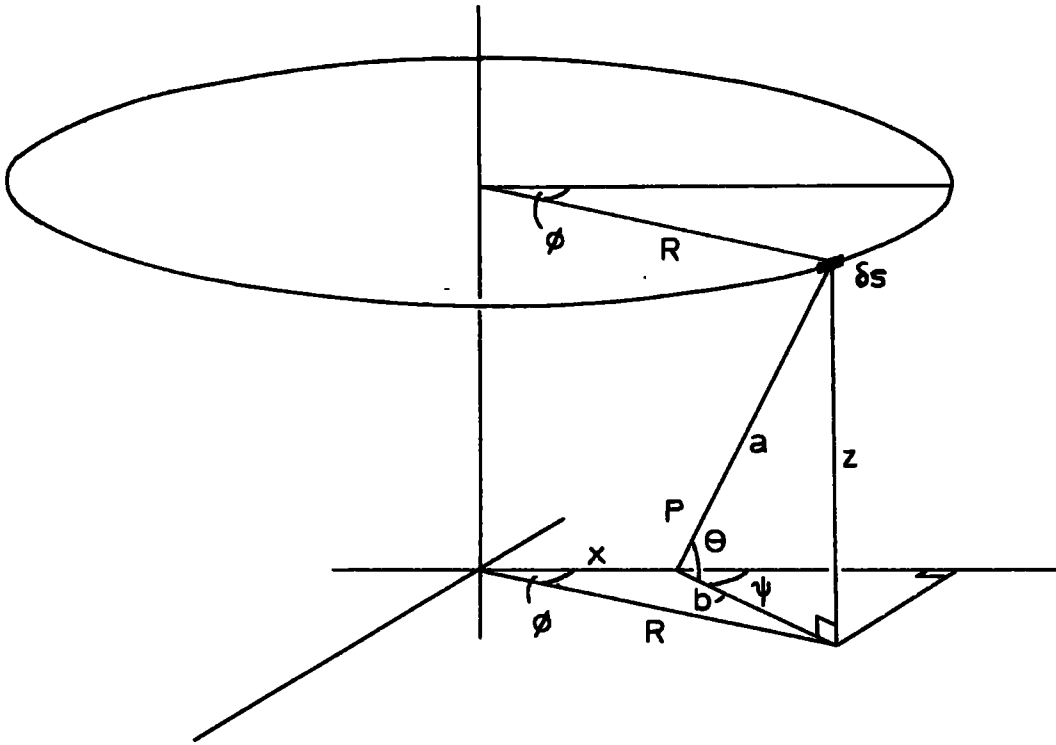

3.2a

were controlled entirely by geometrical considerations and so did not change. The integration made use of both these and the current values of charge density. This made it unnecessary to repeat the whole calculation each time the charge densities were modified.

After the integration had been carried out the direction of the force was compared with that of the normal to the surface. If the difference was unacceptably large part of the charge was moved in the indicated direction. The quantity that was moved was determined by the size of the discrepancy between the two directions. When no more adjustment was necessary the charge distribution was converted into the local potential gradient.

This calculation required the force exerted by a charged ring on a charge at an arbitrary point. It is convenient to take as axes the vertical and one horizontal component of this force. The other horizontal component can be made zero by defining one of the axes to be along the same line as that representing the surface. The formulae for the components can be derived as follows. See Fig. 3.2a.

If the line charge density on the ring is q then the force exerted on a unit charge of the opposite sign and situated at P by the element of the ring δs is $\frac{q\delta s}{4\pi\epsilon a^2}$. The vertical component, F_z , of this is $\frac{q\delta s}{4\pi\epsilon a^2} \sin\theta$ and the horizontal component is $\frac{q\delta s}{4\pi\epsilon a^2} \cos\theta$ so the component along the x axis, F_x , is $\frac{q\delta s}{4\pi\epsilon a^2} \cos\theta \cos\psi$. Since $\delta s = R d\theta$ the total components when integrated with respect

to θ are

$$F_z = \int_0^{2\pi} \frac{qR}{4\pi\epsilon a^2} \sin\theta \, d\theta \quad \text{and}$$

$$F_x = \int_0^{2\pi} \frac{qR}{4\pi\epsilon a^2} \cos\theta \cos\psi \, d\phi$$

Now: $b^2 = x^2 + R^2 - 2xR\cos\phi$

and $a^2 = b^2 + z^2$

$$= x^2 + z^2 + R^2 - 2xR\cos\phi$$

also $\cos\theta = b/a$, $\sin\theta = z/a$, $\cos\psi = (R\cos\phi - x)/b$

Thus $F_z = \int_0^{2\pi} \frac{qR}{4\pi\epsilon a^2} \frac{z}{a} \, d\phi = \int_0^{2\pi} \frac{qR_z}{4\pi\epsilon(x^2 + z^2 + R^2 - 2xR\cos\phi)^{3/2}} \, d\phi$

and $F_x = \int_0^{2\pi} \frac{qR}{4\pi\epsilon a^2} \frac{b}{a} \frac{R\cos\phi - x}{b} \, d\phi$

$$= \int_0^{2\pi} \frac{qR(R\cos\phi - x)}{4\pi\epsilon(x^2 + z^2 + R^2 - 2xR\cos\phi)^{3/2}} \, d\phi$$

So far as the author is aware these cannot be integrated analytically but since the calculation was to be done on the computer they could be dealt with by numerical methods.

The programme was written and tested in stages since it was long and became fairly complicated. Fortunately it was possible to split it into sections - much as in the above description of the principles of the calculation. For some of the sections it was possible to check the performance by carrying out the calculation on a desk calculating machine but as the programme took shape any reasonable check would have involved too much computation to be feasible. At this stage data was prepared which represented a flat surface and no space charge but with a nonuniform distribution

of bound charge. The programme attempted to redistribute the bound charge in a suitable manner and its performance gauged by the smoothness of the final distribution. When mistakes had been corrected and necessary modifications made a second test was made. This employed a number of single space charges at various heights above the centre. The potential gradient set up by such a charge distribution can be calculated quite simply so that it was possible to check the behaviour in the presence of space charge.

Unfortunately the programme did not live up to expectations. It overestimated potential gradients at the very centre and underestimated them just outside this region. Except for this inner part of the surface the approximations were within about 15% of the expected values. The principal cause of the inaccuracy appeared to be the method of integration. Simpson's Rule had been used which is not very satisfactory for rapidly varying functions unless a large number of point values are used. This is because it is assumed that between points the curve has the form of a parabola. If this is not a good approximation errors arise. In the case in question the force exerted on a surface element by a charged ring would be zero if the ring was at the origin. Then as the radius of the ring increased the force would increase too until the radius was about equal to the distance of the surface element from the origin. When this occurred the force became negative and then began to decrease to zero as the radius continued to increase. If the surface element was near the origin the first part of the change took place over a very short distance so very

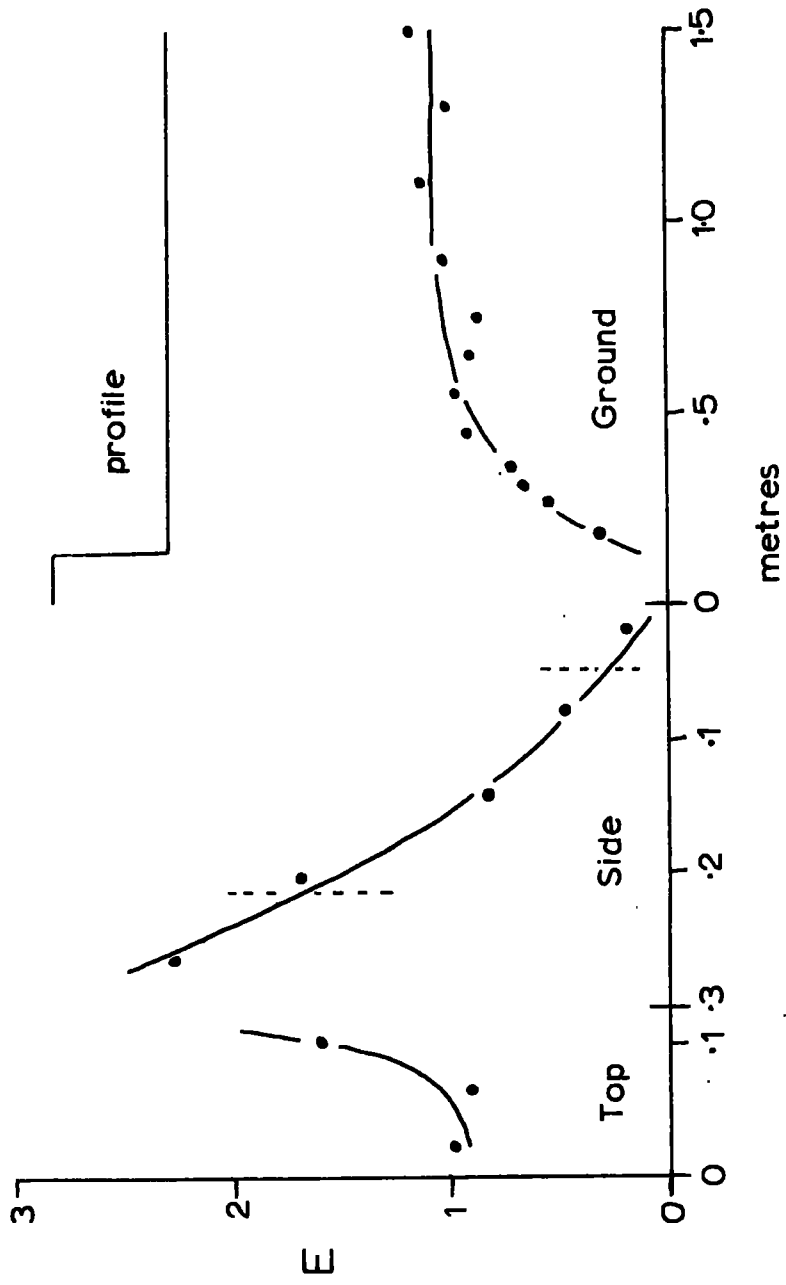

3.3a
exposure factor of field mill

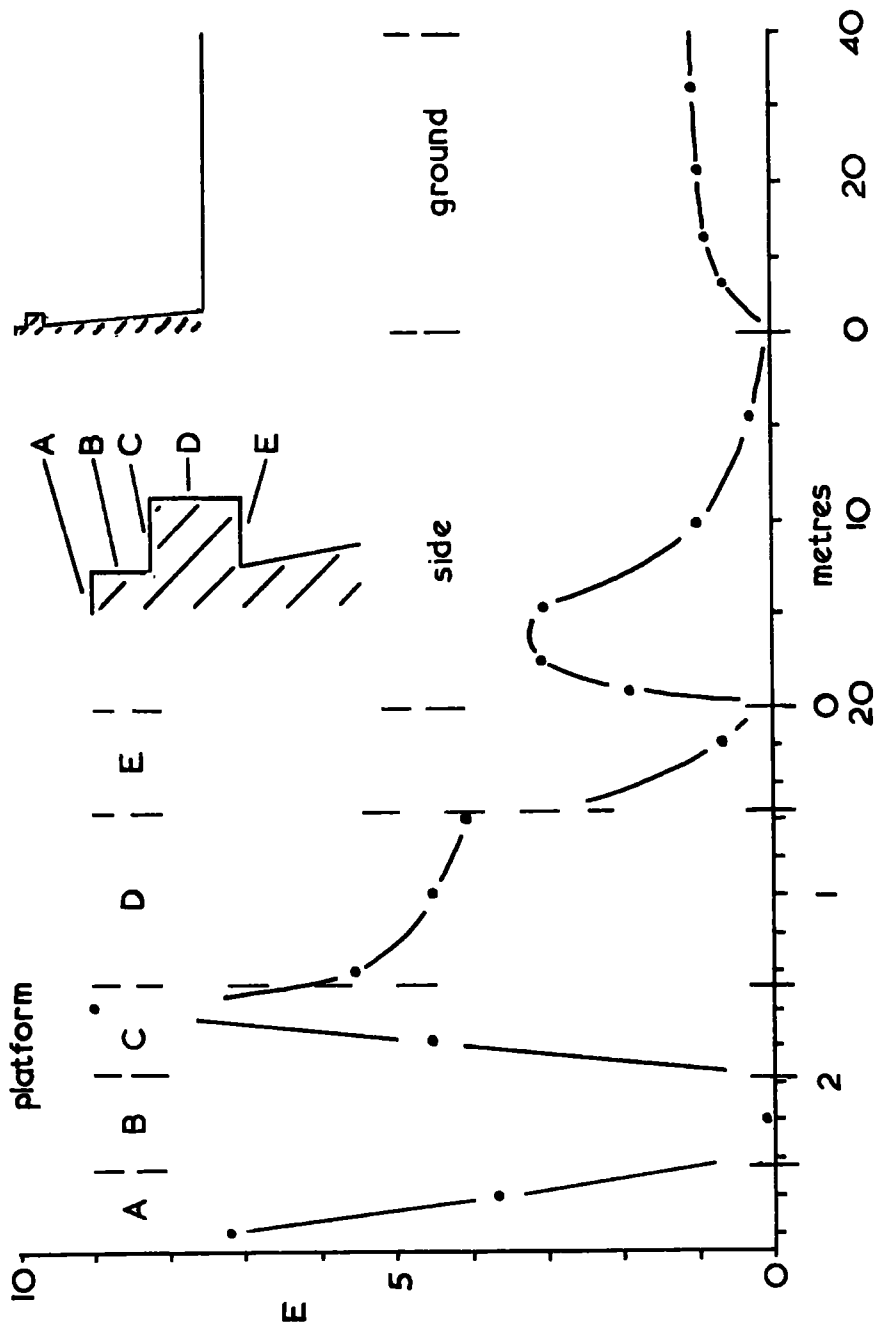

3.3b
exposure factor of the tower

few values were available for the integration of this part.

3.3 Results

The evaluation of the exposure factor of the upper mill was carried out in two stages. It will be recalled that the mill was mounted on the side of the platform's handrail and faced downwards. The mast would have the predominant effect but it was felt that the way that the mill was mounted would influence the exposure factor too. Because of the small size of the mill and the limited number of surface elements which it was possible to use the shapes of the mast, platform and mill could not all be included in the calculation at once. Instead it was necessary first to carry out the calculation to find the exposure factor of the mill on a flat surface, and then for the mast in order to find the exposure factor of the handrail. These two exposure factors could then be combined. The profiles used to represent these two cases together with the calculated values of the exposure factor E are shown in Figs. 3.3a and 3.3b. In these diagrams the surface of the profile and nearby ground is shown as the abscissa. To make this possible the surface has been unfolded and the scale of the more detailed parts has been increased. This accounts for the discontinuous and nonuniform scale of the abscissa. The limits of each section of surface are shown and a scale drawing of the profile indicates their relative positions.

The shapes of these curves are at least a good qualitative picture although as pointed out in 3.2, the accuracy is likely to be low.

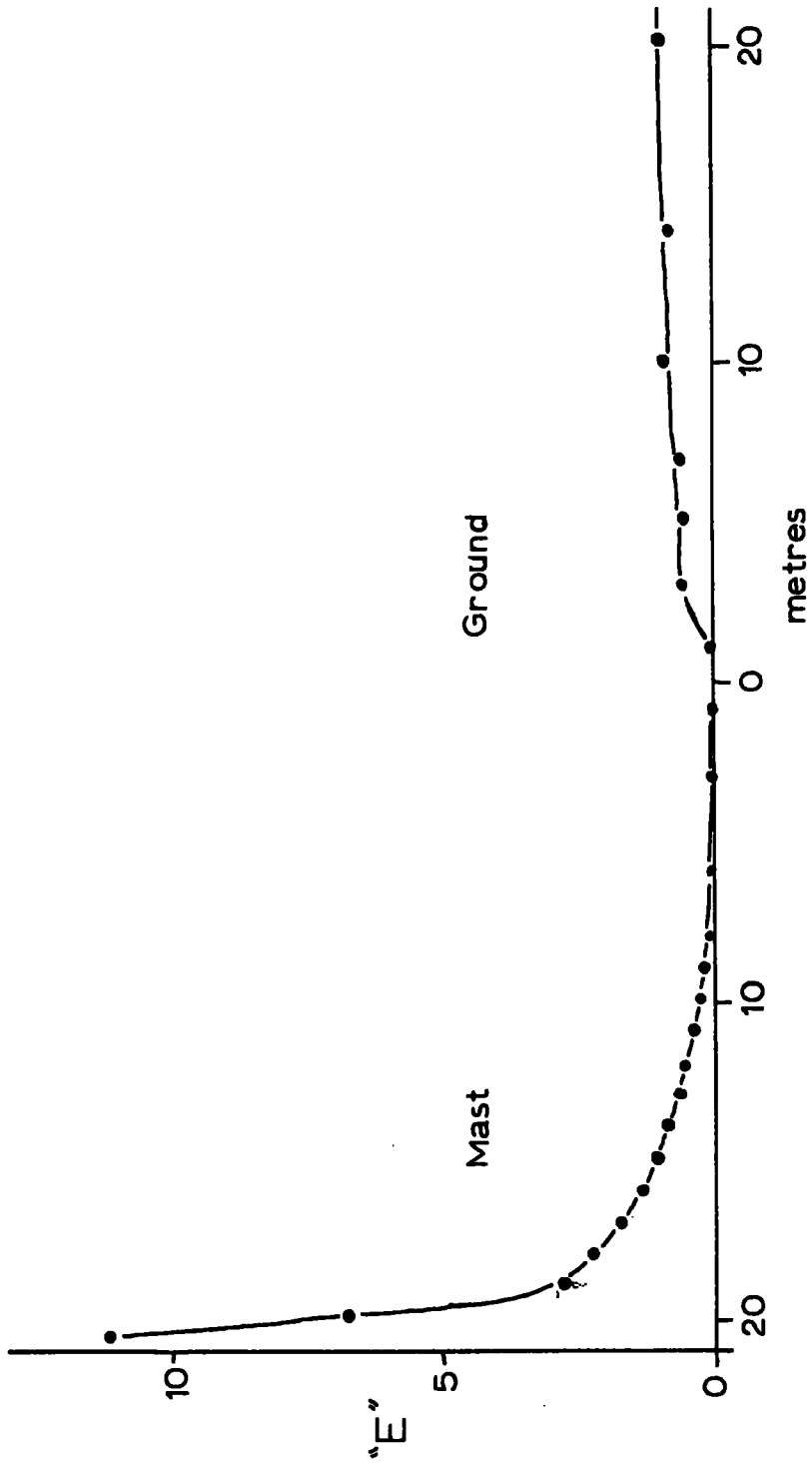

3.3C
exposure factor of a simple mast

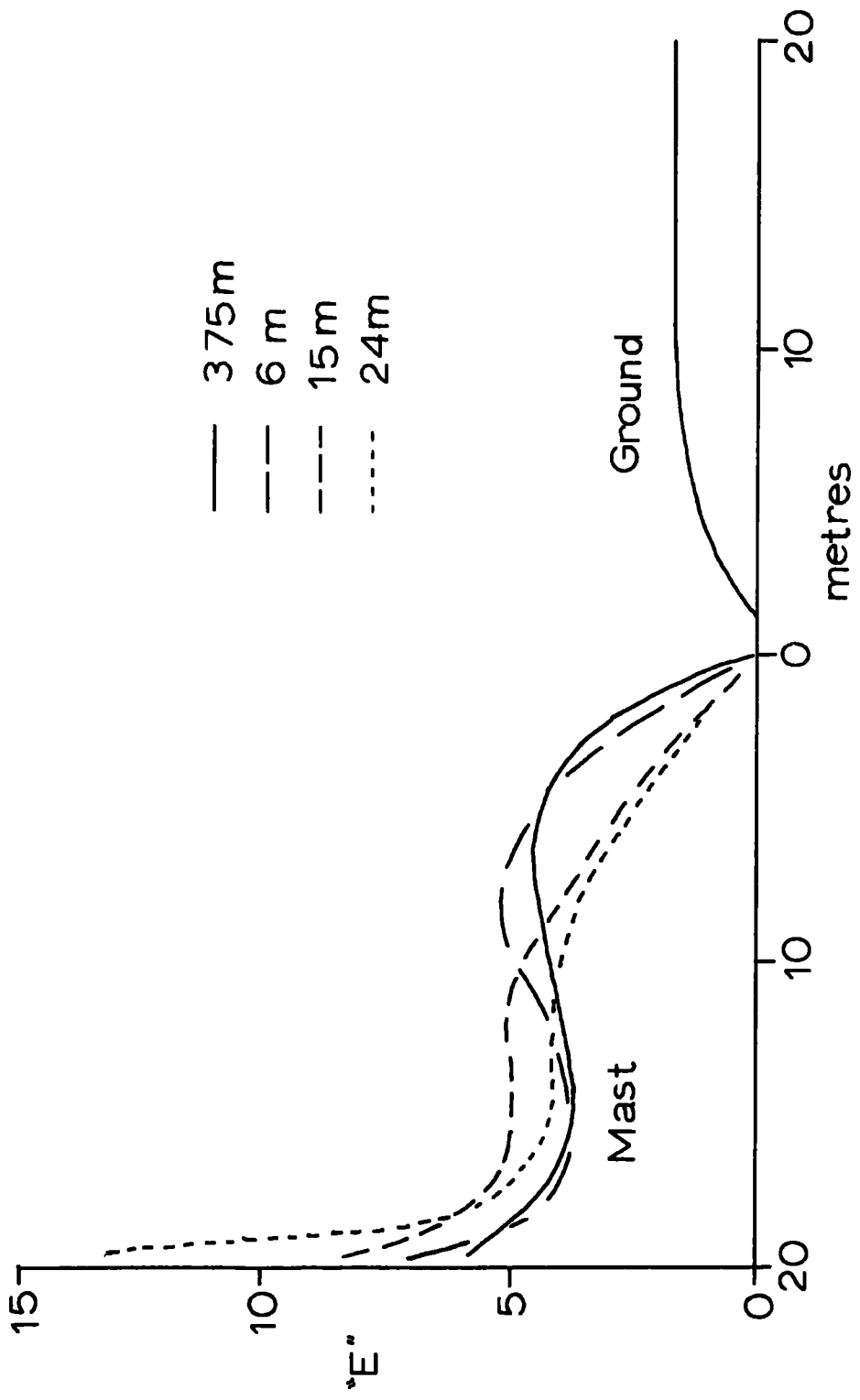

3.3d
exposure factor with space charge

The vanes of the mill occupied a position indicated on 3.3a by the pecked lines and the mean exposure factor over this section is 0.97. Over the section of 3.3b which represents the handrail the exposure factor is 4.9. When the large errors are taken into account this suggests that the exposure factor of the mill lies between 4 and 6, which agrees reasonably with the experimental value of 6.5 ± 1.0 .

The programme was also used to investigate the effects of low level space charges on the potential gradients on the mast. For this purpose a simplified model of the mast was used. It consisted of a uniform cylinder 2 m in diameter and 21 m high. The exposure factors for this are shown in Fig. 3.3c. A number of runs were made with different layers of space charge whose heights and thicknesses were such that together they made up a uniform layer from the ground to 28.5 m. The results are shown in Fig. 3.3d which gives the potential gradient distribution set up by each space charge layer on the surface of the mast. The potential gradients have been normalised to give unity on the ground at infinity. 'Infinity' appeared to start at about 15 m in this case.

The height of the layers had little effect on the potential gradient distribution on the ground and the distribution here has been shown as a single line in Fig. 3.3d.

On the mast too the changes caused by the height of the layer were smaller than had been expected. At the top of the mast in particular large potential gradients were indicated even for the lowest

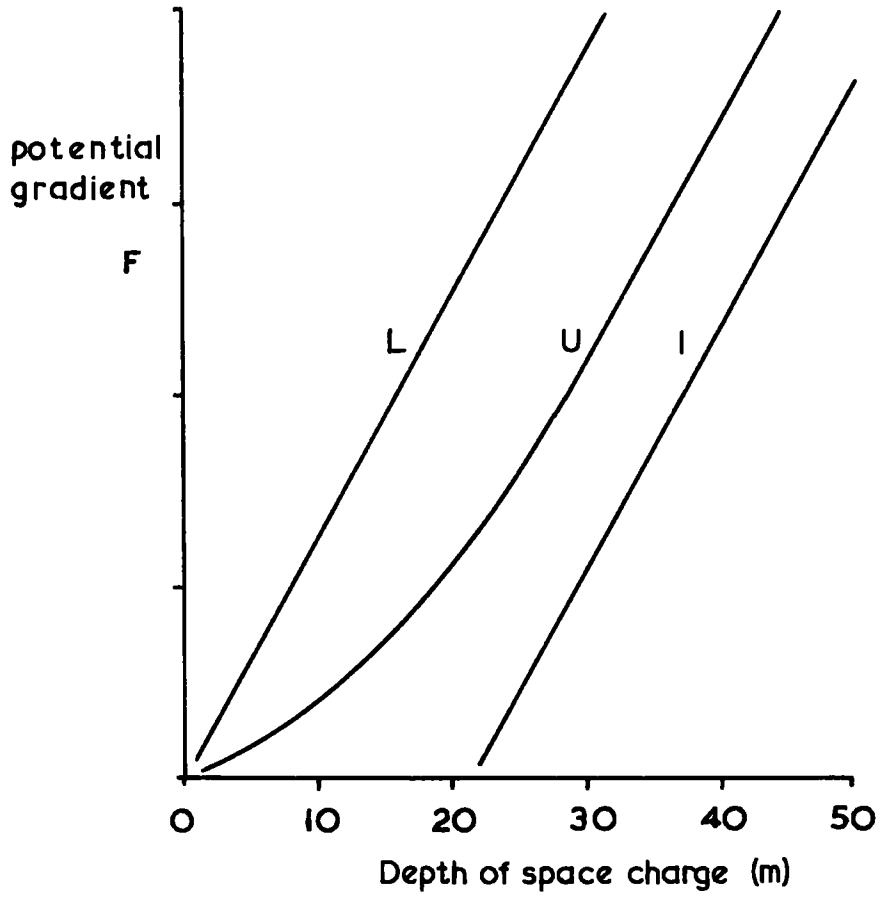

3.3e

layers. The exposure factor in these cases is nearly half of its value for uniform potential gradients. This means that the experimental arrangement used was inefficient as a detector of space charge. In Fig. 3.3e a uniform layer of space charge is supposed to be built up from ground level. The potential gradient recorded at the ground (L) rises steadily while at the height of the mast an ideal instrument would also show a steady rise (I) but only for space charge above it. The separation of the lines which represent these potential gradient changes is a measure of the space charge between the instruments. However, if the calculated responses are used the upper instrument, V, shows an increase of potential gradient at all times with the result that the separation of the lines is reduced to two thirds of the ideal.

Now the separation is the observed difference between the upper and lower potential gradients and corresponds to the space charge between them. Consequently all the observed space charges have only two thirds of the magnitude which they would have had if the ideal instrument had been used. This means that space charge measurements should be multiplied by a correction factor of 1.6.

The sensitivity of the system is also reduced. From the accuracy of the field mill calibrations and the errors on the exposure factors the smallest difference in potential gradient that could have been detected with certainty was between 100 Vm^{-1} and 250 Vm^{-1} for low and high potential gradients respectively. These are corrected to 160 Vm^{-1} and 400 Vm^{-1} which correspond to space charge densities of 75 pCm^{-3} and 180 pCm^{-3} .

CHAPTER IV

Calculations4.1 'Observation Length'

In an investigation of precipitation electricity an empirical equation can be found which relates any relevant parameters, but it is also desirable to find several different equations and compare them. Usually large quantities of data have to be used to produce a meaningful result and if the calculations have to be done manually much labour and time are required to find even one equation. The present investigation was carried out with the intention of doing as much of the analysis as possible on a computer so it was hoped that an extensive analysis could be undertaken.

One of the main tasks attempted was to compare different empirical equations. The method which was employed for this was to use multivariate linear regression, but to take as parameters not only the basic current, potential gradient and rate of rainfall, I , F and R , but also parameters derived from these such as products and roots, for example the equation $I = aR(F + b)$ would be found as $I = aX + (ab)R$ where X is $R.F.$ The reason for adopting this procedure was that an excellent programme for carrying out multivariate linear regression was available in the computer library. Had this not been used it would have been necessary to write a special programme for each equation and this would have been less efficient in its use of computer time. When several possible regression equations had been found they were compared by the standard 'analysis of variance' technique. In common with many other

statistical tests this makes use of an error term. To take a rather simplified illustration a regression equation $Y = aX + b$ may have been fitted to some observations and it is desired to decide whether or not 'a' is the same as the theoretical value 'A'. Since errors in the observations are certain to cause some difference they can be said to be the same if this difference is not large compared with the standard error of 'a'. The calculation of the standard error involves the term $1/\sqrt{N}$ where 'N' is the number of observations. Thus the more observations there are the smaller are the differences which can be shown to be significant. In view of the importance of 'N' it is as well to examine what is meant by 'one observation'. In cases where the parameters are changing with time the obvious definition of 'the value of a parameter at some instant' is not adequate. This is shown most easily by an example.

Suppose that a recording of precipitation current and potential gradient during steady rain has been made. Point values could be read off at minute intervals, a regression line fitted to these values and the standard error of the slope calculated. Alternatively measurements could be taken at half minute intervals. This set of values consists of the previous set and an equal number taken at intermediate times. As the parameters will have changed very little in half a minute the values in these sets will be almost identical. This means that the observations taken at half minute intervals will give a regression equation almost the same as the earlier one, but as N has been doubled the standard error will not be so large.

By extending this process it would be possible to 'prove' almost anything just by sampling the record at appropriate intervals.

When the half minute values were being considered it was pointed out that one value was not much different from the preceding one. In statistical terms they were not independent and this recalls the assumption of independent observations which is made when the theory of standard errors is derived.

Thus the times between observations must be sufficiently long for one to be independent of the preceding one. The degree of dependence of readings which have been taken with a time lag k separating them can be measured by means of the autocorrelation coefficient, $r(k)$. This takes the value 1 when the dependence is complete and falls to zero if the readings are independent. If there is dependence but the variations are in the opposite sense then $r(k)$ is negative. A series of values of autocorrelation coefficient with lags from 0 upwards can be found and when $r(k)$ has fallen to zero the 'observation length' L can be taken to be the corresponding value of k .

Of course $r(k)$ never becomes exactly zero. Chance fluctuations cause it to take values that vary erratically about zero. This means that a test has to be made to see if $r(k)$ is not significantly different from zero. Such a test requires the standard error of $r(k)$ which as before involves the, as yet, unknown number of observations. To get round this the standard error for each value of $r(k)$ can be found by using N as the number of readings divided by k . That is the number of observations if the observation length was in fact k .

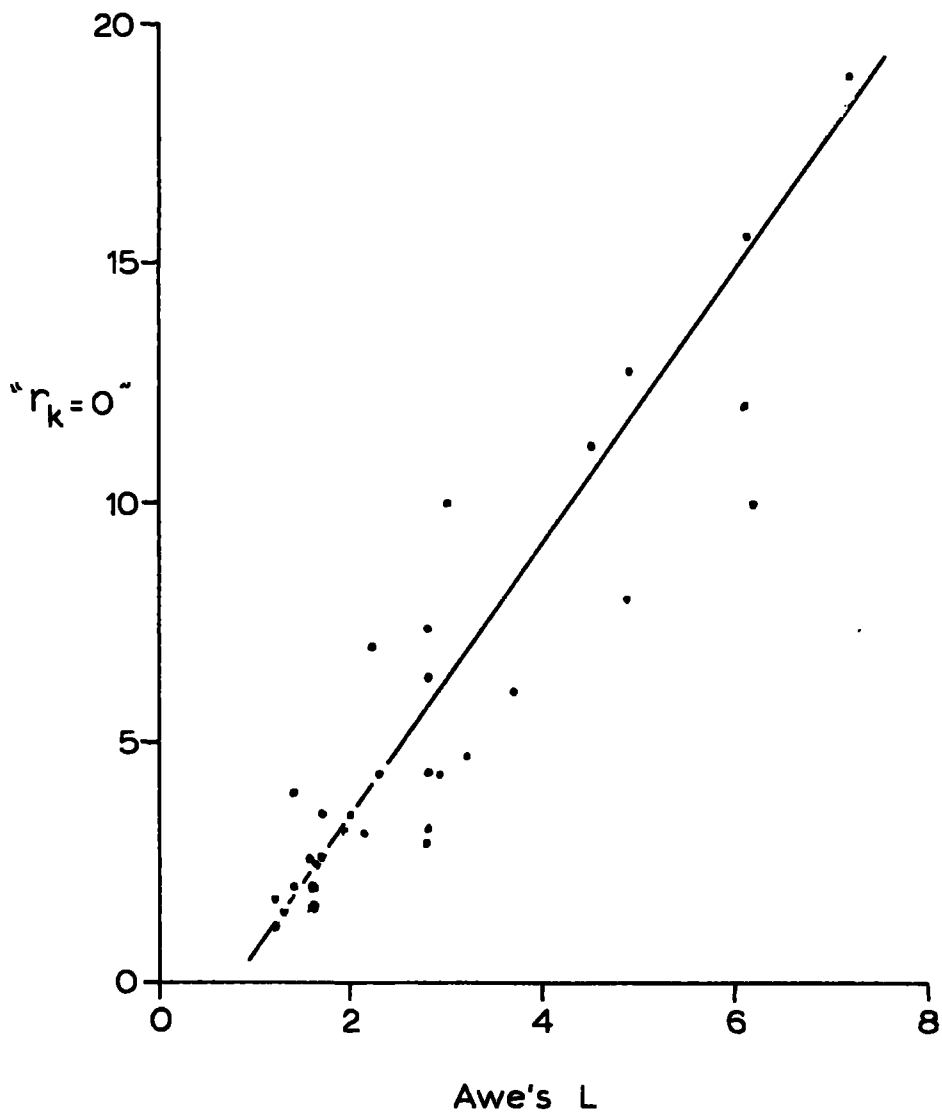

4.1a
observation lengths

The theoretical basis for this approach is weak and at the time when it was devised the literature did not appear to contain any treatment of observation length. However, a little later a paper was published (Awe 1964) which gave a theoretical derivation of the value of L. It was shown to be equal to $\sum(r(k))^2$, the sum of both positive and negative values of k over the central maximum. During the course of some other work (Collin, Groom and Higazi 1966) the observation lengths for some of Higazi's data were found by the method outlined above and also by Awe's method. Fig. 4.1a shows that Awe's method gives values of L less than half those obtained by the other method but otherwise they are consistent.

The 'r(k) = 0' method had been used on a large proportion of the records by the time Awe's work was published and as the old method was simpler and apparently not seriously misleading it was retained, although the values of N were in all cases adjusted to those that Awe's method would probably have given.

4.2 Computing Procedure

Before any computing could be done it was necessary to check the data tapes and select suitable portions. Only those records were used where all the instruments had been working satisfactorily and none of them had gone off scale for more than about a minute. In a number of cases conditions had been steady for a considerable time and had then become rather violent with large potential gradients and much corona discharge. In these cases only the steady part of the record was used. After this selection had been made the corresponding section of the data tape was cut out and checked

visually for punching errors. Such errors could have been located by printing the tape out but as they were infrequent and easy to distinguish from correct data the visual method was usually quicker. The most common error was when the bead contactor on the auxilliary potentiometer became badly worn and failed to make good contact. This resulted in the number 989 being punched. Another fault that occurred frequently was that one of the output amplifiers or relays would appear to jam and this gave rise to a line of holes on the tape. When the mistakes had been found they were corrected with the aid of the chart.

Next the prepared data was processed by a short programme whose output gave the mean values of the various parameters over one minute intervals. The original purpose of this programme was to smooth out 'noise' in particular on the precipitation currents where single drop charges caused large short term fluctuations. Since it was intended to ~~take~~ take means over the 'observation length' the smoothing was not necessary but the programme was retained for another reason. The recorded data was punched with a single space to separate the numbers and this form was only acceptable to a programme written in the programming language 'Algol'. On the other hand it was desirable to use the faster 'Autocode' language. The smoothing programme rewrote the data in a suitable form and contracted it.

The 'observation length' was found with the aid of a second programme which calculated a series of autocorrelation coefficients as described above. These were printed out together with the

corresponding standard errors in order that the best value of the observations length could be selected and then fed into the computer as additional data. This set the second part of the programme into action. Its function was to form means of all the parameters over the observation length and also roots, products and slopes. These were punched out and were later used with the library programme to find the regression equations.

The library programme was designed in such a way that the regression equation of any group of parameters could be found. This made it possible to compare a number of equations. As well as finding the coefficients of the equations the programme gave the sums of squares of the deviations from the fitted line which enabled a statistical comparison to be made.

CHAPTER V

Precipitation Current5.1 General

Recordings were made over a period of about eighteen months and a large number of records accumulated. Many of these were of storms or other periods when the potential gradient was high and conditions were disturbed. In a number of cases one or more of the instruments had developed faults or the digitising equipment had broken down. These were mostly among the earlier records. From all these a total of 24 records were selected for analysis. They covered 65 hours in all and were spread fairly evenly over the period from February 1964 to April 1965. This resulted in the majority being made in the winter months but despite this only three were of snow.

As explained in section 2.2 the records of the upper precipitation current were valueless which reduced the useful parameters to four; lower precipitation current, $I_p \text{Am}^{-2}$, lower potential gradient, $F_L \text{Vm}^{-1}$, upper potential gradient, $F_U \text{Vm}^{-1}$ and rate of rainfall, $R \text{mm min}^{-1}$. In some cases it was possible to make use of the space charge density, $S \text{pCm}^{-3}$, whose value was derived from the difference between the two potential gradient measurements. As indicated in section 3.3 the accuracy of this was low and it could only be used when the estimated density exceeded about 200pCm^{-3} . The air temperature and the direction and speed of the wind were sometimes of interest and these were obtained from the Observatory meteorological records.

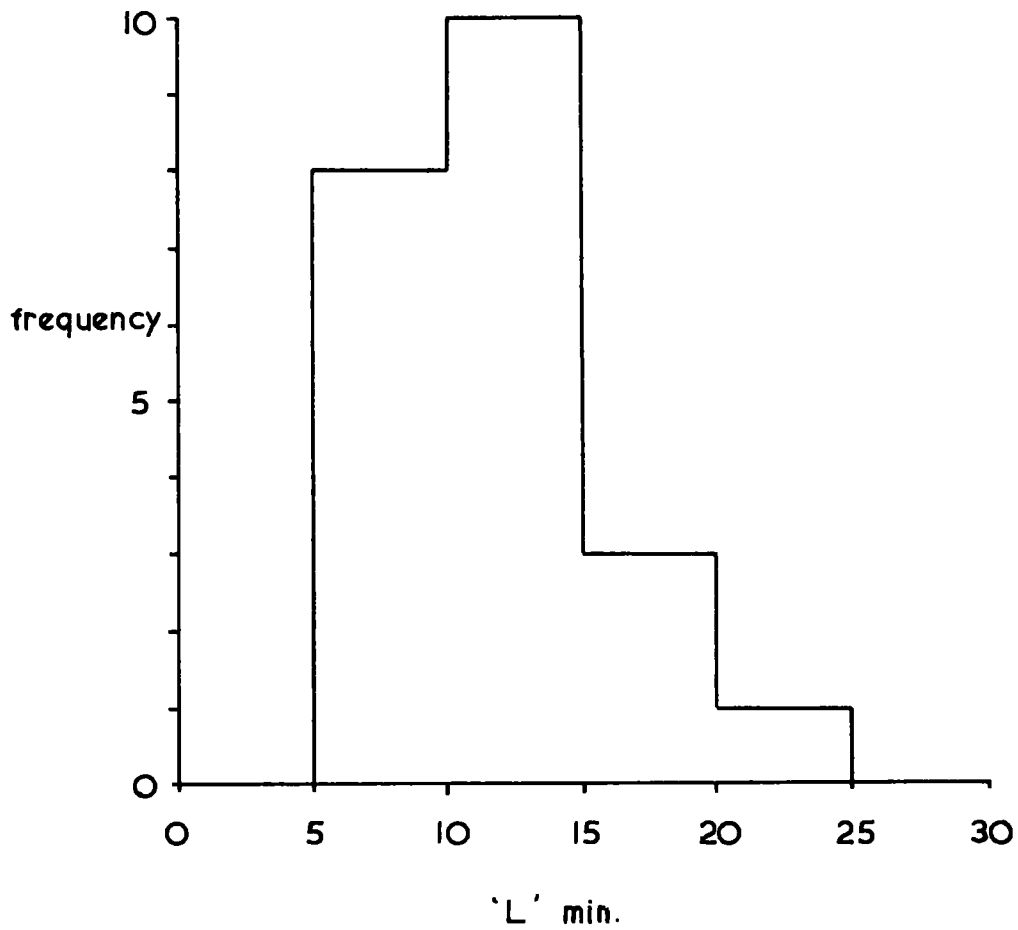

5.1a
distribution of observation length

The character of the records differed considerably. At one extreme the potential gradient would be as high as 1000 Vm^{-1} and vary from positive to negative while the rate of rainfall took values of perhaps 0.04 mm min^{-1} . On the other hand conditions could be quite steady for many hours and the potential gradient might not vary by more than 50 Vm^{-1} . In such cases the rate of rainfall would be low, typically $0.005 \text{ mm min}^{-1}$ and also steady. In almost all cases the two potential gradient measurements followed each other closely which indicated the absence of space charges. The mirror image effect was in evidence, sometimes with time lags, which were usually small and on no occasion exceeded three minutes.

The observation length 'L' was evaluated for each record and its value was found to vary from 6 minutes to 24 minutes with an average of 12.5 minutes (Fig. 5.1a). Now if a parameter changes slowly then its autocorrelation function also changes slowly which means that large values of L are associated with slowly changing electrical conditions at the Observatory. The changes arise as a combination of the effect of wind moving the cloud system and changes in the cloud itself. If the variations in conditions in the cloud take place only slowly then L should be primarily a function of windspeed. This was checked by plotting $1/L$ against the windspeed, but there was no significant correlation between them. It is tempting to conclude that this means that the electrical conditions in clouds change appreciably within times of the order of 15 minutes. However the lack of correlation can also be explained as the result of a large range of rates

of change of the electrical conditions in the cloud. This point might be resolved if a very much larger number of records could be used.

5.2 Relationships with Potential Gradient and Rate of Rainfall

One of the main objects of the investigation had been to compare the precipitation currents at the top and bottom of the mast in order to establish whether or not the precipitation gained its charge near the ground. Because of the poor performance of the upper collector this was impossible, but a second study could still be carried out. This was to examine the 'inverse relation' Y between precipitation current and potential gradient in an attempt to find out if the accepted form of the relation, $I = a(F - b)$ could be improved upon. Simpson (1949) found a relation of a similar form for the charge on a volume of water which implies that the precipitation current would be proportional to the rate of rainfall. Ramsey (1959) evaluated 'a' and 'b' for different rates of rainfall and the values he obtained led him to suggest that the current might be more closely related to the square root of the rate of rainfall rather than to the rate itself. Other possibilities were adding more parameters to the regression equation and trying power laws.

Initially a series of regression equations were evaluated between the precipitation current and a number of parameters one at a time. As described in section 4.2 the data were averaged over intervals equal to the observation length and the regression

equation's coefficients found by means of a computer library programme. The first parameters used were both the upper and lower potential gradients and the rate of rainfall. When the difference between the potential gradients was sufficiently large to be certain of space charge this was also used. Other derived parameters were the square root of the rate of rainfall and the rate of change of potential gradient which was intended to act as a check on the importance of displacement currents.

The computer programme gave tables of 'sums of squares' and 'degrees of freedom' which enabled the significance of the regression to be assessed. The analysis of variance techniques were used for this. The results of these analyses were as follows: as was expected I showed a very marked dependence on both potential gradients. This was significant at the 99% confidence level. The dependence of I upon F_U was slightly greater than upon F_L although the difference was not significant at the 95% level. However F_U was used in all subsequent equations. This point will be dealt with in more detail later, but the two potential gradients followed each other so closely that it made little difference which was used. The dependence on the rate of change of potential gradient was not significant even at the 95% level which indicated that as had been hoped displacement currents did not make an important contribution to the recorded current. The rate of rainfall, R, also showed a close association with I, significant at the 98% level, so too did $R^{\frac{1}{2}}$ which had a slightly lower significance level. This difference in significance

level was assessed and found to be insignificant at the 95% level but significant at the 90% level. Clearly there was not a great deal to choose between R and R^2 but on the strength of the difference it was decided to make use of R in other formulae.

A number of other derived parameters were also tried. Two, F_U^3 and F_U^2 with the same sign as F_U , proved to be closely related to I but were significantly worse than F_U . When a complete polynomial was formed a slightly closer dependence was of course suggested but it was not significantly closer than the dependence of I on F_U alone. Another important parameter was the product of F_U and R , with which I showed a greater dependence than it did with either F_U or R , and this improvement was significant at the 95% level. The equation given by this combination, $I = aF_U R + b$ is similar to that suggested by the results of Simpson (1949) which implied $I = aF_U R + bR$ and this was clearly the next equation to try. The addition of R did indeed give a closer relationship which was significant at the 95% level. F_U was also added to form the equation $I = aF_U R + bR + cF_U$, but this did not give a significant improvement. Two other combinations were possible, namely $I = aF_U + bR$ and $I = aF_U R + bF_U$. Both showed a good fit to the data, significant at 99% but the equation $I = aF_U R + bR$ was better than either at the 95% significance level.

5.3 Discussion

Clearly the most satisfactory equation to describe the available data was $I = aF_U R + bR$ which could be rearranged to $I = aR(F_U + b)$ and when the constant terms which had been evaluated by the computer

programme were modified to suit this it became:

$$I = - (2.6 \pm 0.1)R \left[F_U - (112 \pm 21) \right]$$

A number of other workers have found relationships between I and F which can sometimes be expressed in the same form. Simpson (1949) measured the charge on a volume of rain and Ramsey (1959) found a series of equations corresponding to a range of rates of rainfall. Collin, Raisbeck and Chalmers (1963) found equations for two events which had different average rates of rainfall. Chalmers (1956) and Reiter (1965) did not take the rate of rainfall into account. All these formulae are shown in table 5.3a.

Table 5.3a

Author	$I = aR(F + b) \text{ pAm}^{-2}$	Mean Rate of rainfall mm min^{-1}
Present Work	$I = -2.6R (F - 112)$	
Collin et al	$I = -0.31R (F - 92)$	0.015
	$I = -2.7R (F - 83)$	0.03
Ramsey	$I = -2.7R (F - 100)$	0.015
	$I = -1.7R (F - 86)$	0.03
Simpson	$I = -0.8R (F - 400)$	
Reiter	$I = -0.0093 (F - 40)$	
Chalmers	$I = -0.0118 (F - 150)$	

The first six values of 'a' are all in reasonable agreement while the last two values cannot be determined without a knowledge of the rate of rainfall. The values of 'b' are interesting, for all the values except those of Simpson and Reiter were obtained at Durham and are all similar. As Reiter has pointed out the values of 'b' are the same as the local fine weather potential gradient and

the closeness with which the present value fits the earlier Durham ones appears to strengthen this observation.

Earlier it was pointed out that the upper potential gradient had been used in preference to the lower one although the upper was only marginally more closely related to the precipitation current. As well as making a comparison for all the records together similar computations were performed for each record in turn. Of these four cases were found when F_U was preferred at the 98% confidence level another four where it was preferred at the 95% level, twelve where the difference was not significant at the 95% level, two showed a preference for F_L at the 95% level and two at the 98% level. At first sight it appeared that this was no more than a random distribution with no real preference either way, but then it was realised that in the majority of the records there had been no detectable space charge whereas the cases where F_L was most clearly preferred were two records where there had been extensive space charge. This showed up more strongly in F_L than in F_U and if the rain was gaining its charge from the space charge a closer relation with F_L would be expected. When these two records were removed the remainder showed rather greater preference for F_U but even then only at the 90% confidence level. On this rather dubious basis F_U was taken instead of F_L .

It is not easy to see just why F_U should apparently be more basically associated with the precipitation current than F_L is. The difference must be caused by differences between the two potential gradient records. One would expect these to indicate space charges

within the height of the mast, but then they should contribute to the precipitation current and so tend to give a closer association with F_L as in the two cases mentioned earlier. It is possible however that the space charge is very low lying, perhaps produced by splashing (Adkins 1959b) and that the rain which enters the collector is not influenced by it. Also since the inside of the collector is well shielded from the potential gradient there may not be any appreciable space charges inside it. An alternative explanation is that the lower mill suffered from a fault which gave rise to small fluctuations in its output. These could have escaped detection if they were not very rapid but would be shown up by a sensitive comparison test.

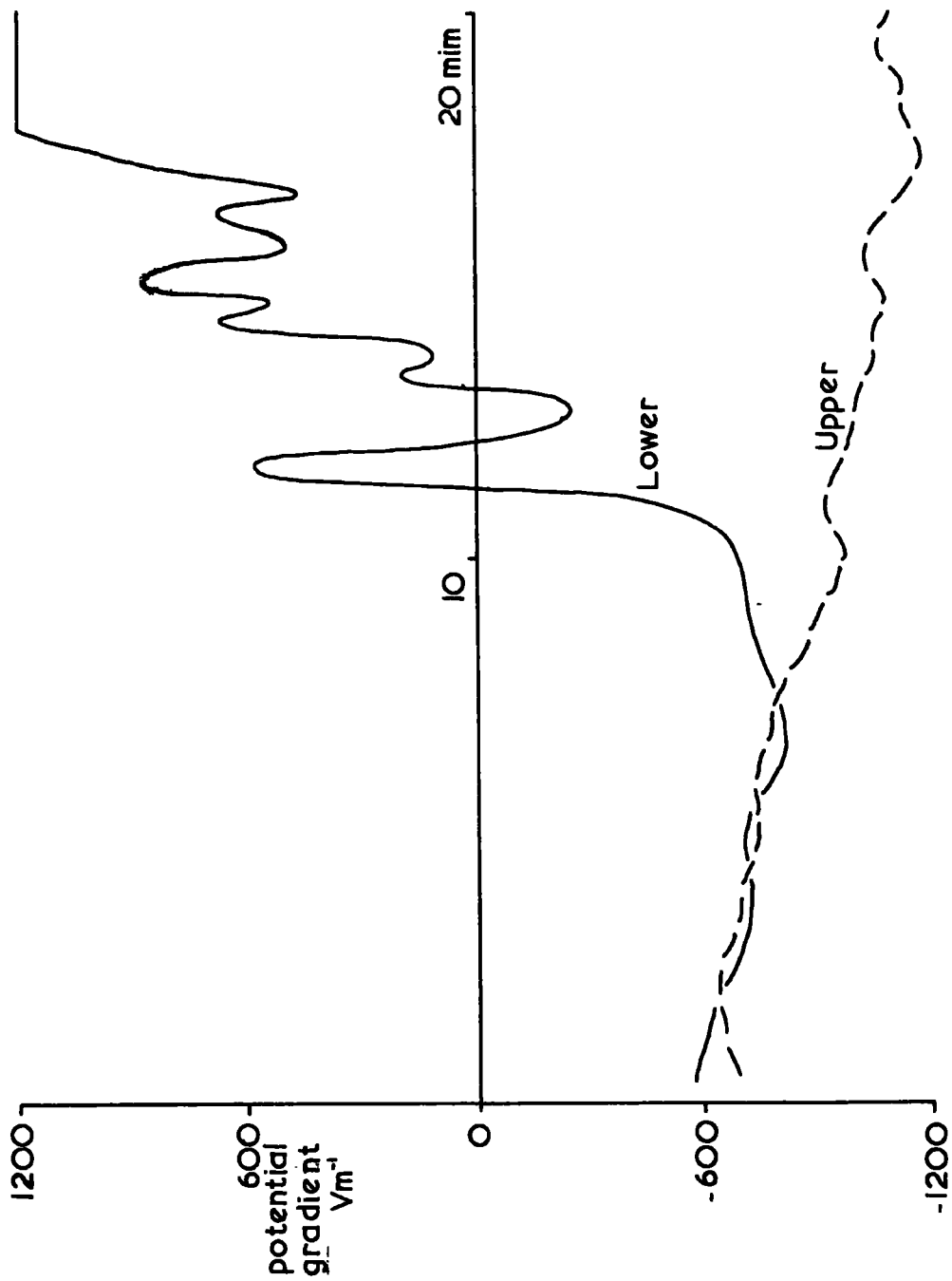

6.2a

CHAPTER VI

Space Charge6.1 General

As explained in section 3.3, the sensitivity of the experimental arrangement to space charge was rather low which meant that unless there was a great deal its density could not be estimated with any degree of accuracy. Despite this, fluctuations of space charge density could be seen easily since they showed as discrepancies between the readings of the two field mills. In the majority of records the two potential gradients followed each other very closely and the fluctuations in space charge rarely reached 20 p Cm^{-3} if it can be assumed that it was uniformly distributed.

In several instances, however, the space charge was very much in evidence and could be seen to exert a considerable influence on the potential gradient at the ground. These cases will now be discussed.

6.2 Corona Discharge

On a number of occasions the two potential gradient records would follow each other quite accurately while the potential gradient was comparatively low, but if the potential gradient at the top of the mast became large and perhaps went off scale the potential gradient at the ground followed rather slowly or erratically and sometimes returned to a low value or even reversed (Fig. 6.2a shows a particularly marked example). In extreme cases the records went off scale in opposite directions. These phenomena

were always associated with potential gradients on the mast which were outside the range -800 to $+800 \text{ Vm}^{-1}$. The difference between the two potential gradients always indicated a space charge opposite in sign to the upper potential gradient. These two observations suggested that the cause of the phenomena might be corona discharge from nearby objects, probably trees. However there was no direct evidence of the source of the space charge or that any corona discharge was taking place.

Direct evidence that corona discharge was occurring would have been interesting since there has been some doubt whether or not it normally occurred from trees. Schonland (1928) measured currents through a dead tree which was insulated from the ground and Milner and Chalmers (1961) were able to detect corona currents by inserting electrodes into a tree to short circuit part of the trunk. Maund and Chalmers (1960) found that the potential gradient downwind of a line of trees was sometimes less than that to windward, but this was not always observed when conditions were suitable for corona discharge. Also Chalmers (1962) found that the current in a tree did not always agree closely with that through a nearby metal point. Extensive corona discharge from trees would produce a space charge that would make the potential gradient increase with height and the failure of Simpson and Scrase (1937) and of Simpson and Robinson (1940) to detect such a variation has been an important argument that there is little corona discharge from trees. Simpson (1949) made measurements that showed a linear relationship between rain current and the corona current into

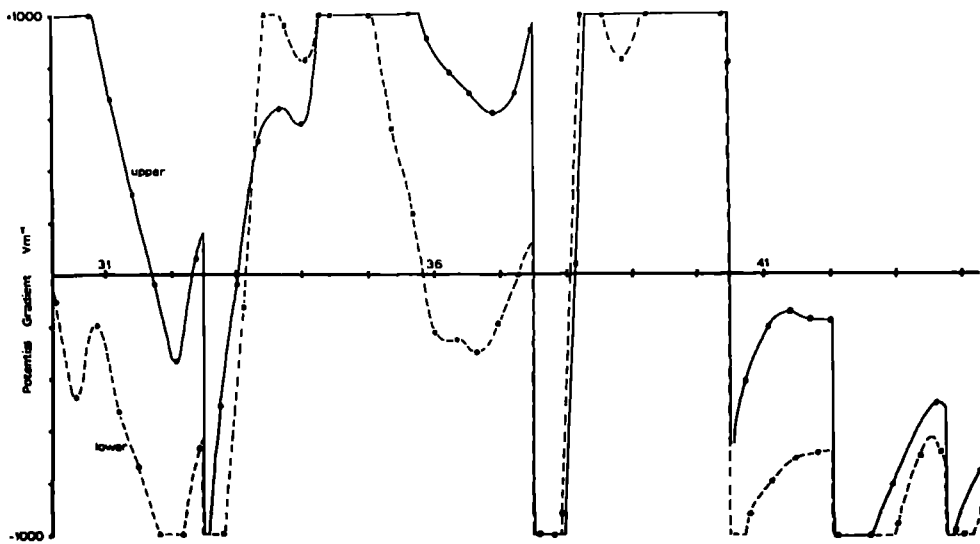
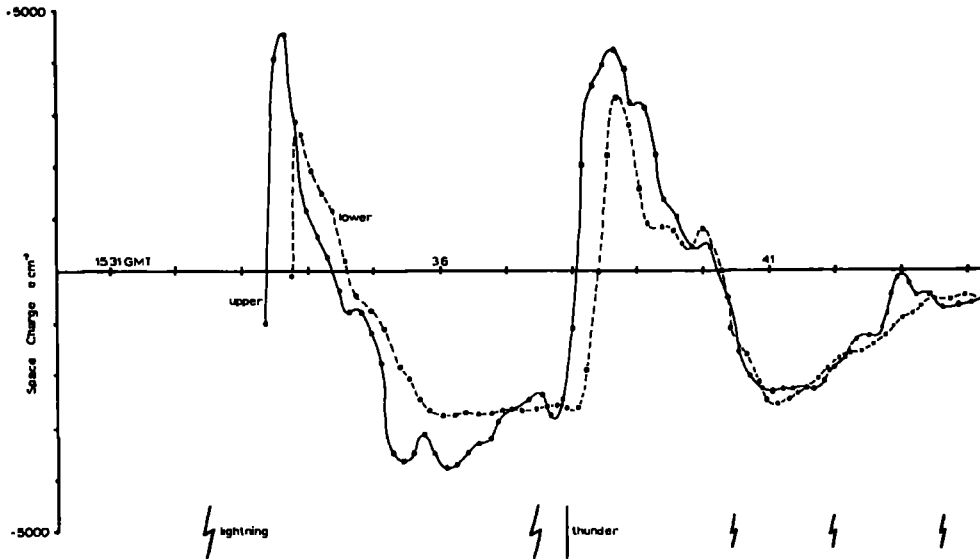

6.2 b

a single point and that the currents were opposite in sign. This can be explained by the presence of space charge.

The observations reported above indicated such a space charge but its origin was not certain. Some observations made under rather unusual conditions enabled more definite conclusions to be drawn.

On the afternoon of 21.4.64 there was heavy rain and large potential gradients, but by 15.30 GMT the rain had ceased although the clouds responsible were still nearby and the potential gradient remained high. At about this time there was a series of lightning flashes.

The potential gradient measurements had indicated that considerable space charge was present and when the rain stopped space charge measuring apparatus (Bent 1964) was switched on. This gave measurements at heights of 1 m and 18.5 m. All four parameters were recorded on the same chart although Fig. 6.2b shows them separately for clarity.

The times of lightning flashes were obtained from records supplied by Dr. I.E. Owolabi. In addition to the flashes shown there were a number of later ones, but by that time the cloud had moved away and the potential gradient was quite low.

The record can be conveniently divided into three sections: from immediately after the first lightning flash until 15.35; the comparatively steady conditions from 15.35 45 to 15.37 30; and from after the second lightning flash until 15.41.

During the steady section the mean potential gradients at the

top and foot of the mast were 750 Vm^{-1} and -160 Vm^{-1} while the mean space charge densities at the upper and lower collectors were -500 pCm^{-3} and -430 pCm^{-3} respectively which gives a mean density over the height of the mast of -465 pCm^{-3} .

The difference between the potential gradients of 910 Vm^{-1} corresponds to a space charge density of -385 pCm^{-3} . Because of the sensitivity of the upper field mill to space charge at low levels, as indicated in section 3.3, this figure should be increased perhaps by as much as 1.6 to -615 pCm^{-3} and will have an error of $\pm 180 \text{ pCm}^{-3}$ because of the zero and calibration errors of the field mills. This indicates reasonable agreement between the direct and indirect methods of measurement and might even be taken to suggest that an unduly pessimistic view has been taken of the indirect method of estimating space charge density.

When the second lightning flash occurred the potential gradients went rapidly negative and recovered with a time constant of about 25 s. The space charges did not change immediately and the maximum rate of change did not occur until 41 s after the flash. With the exception of this time delay the sign of the space charges was always opposite to those of the potential gradient which suggests that they were produced by corona discharge somewhere to windward of the mast. At the time of the observations the windspeed measured at the Observatory fluctuated between 2.4 ms^{-1} and 5.4 ms^{-1} with a mean value of 3.9 ms^{-1} , from directions between 135° and 175° . Thus the positive space charge would have been between 98 and 221 m downwind at the time of the flash. Fig. 6.2c shows a map of the

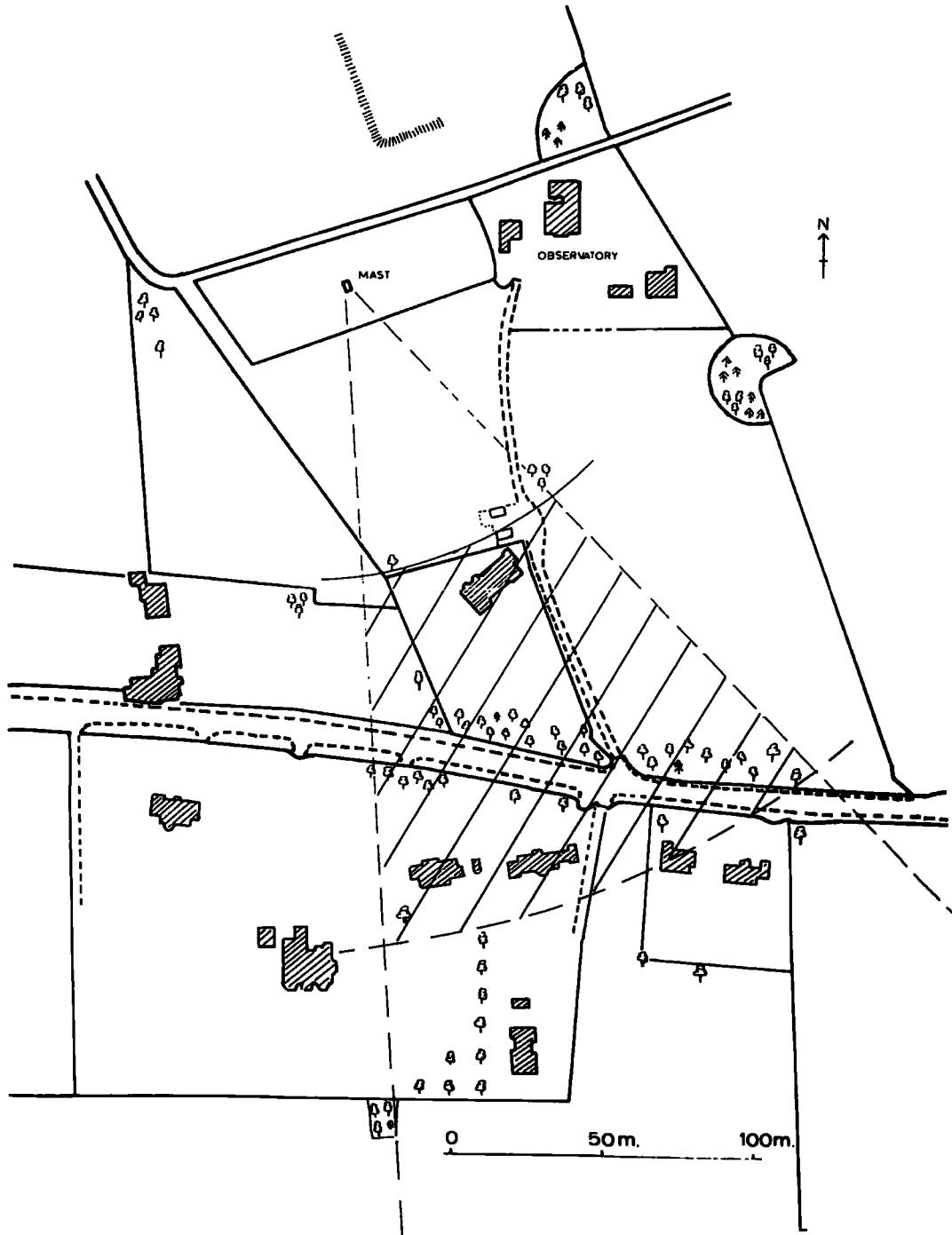

6.2 c

district to the south of the mast with the shaded area representing the position of the space charge at this time. It is clear that the space charge originated at the trees near the road or possibly at the more northerly house. The houses at the south of the road may have played some part but they were all small ones dominated by the much taller trees.

Before recordings of space charge density were started some visual observations had shown that it was negative before the first lightning flash. This means that both potential gradient and space charge behaved in the same way for both flashes but there is not sufficient data to allow an accurate measurement of the time delay to be made for the first flash. However it can be estimated as about 50 s. This suggest a distance of Origin of between 120 m and 270 m which is consistent with the space charge originating at the trees.

After the second flash the results indicate that the total charge given by the trees was $7.65 \mu\text{C}$ for each metre length perpendicular to the wind within the height of the mast. Because of turbulence the space charge would of course have extended to an unknown height which could well have been several times that of the mast. A visual count of the trees suggests a distribution of about one tree per 3.4 m and since the positive space charge would all be produced during the 25 s when the potential gradient was negative the mean current in each tree would be $1.0 \mu\text{A}$ or more depending on the vertical spread of space charge.

In the steady condition just before this flash the mean space

charge density was -465 pCm^{-3} and in a wind whose mean speed was 3.9 ms^{-1} this corresponds to a current of $0.036 \text{ } \mu\text{Am}^{-1}$ from a line source. In this case the current from each tree would have been $0.12 \text{ } \mu\text{A}$ which again would have to be multiplied by the unknown space charge spread factor. This value of current is certainly close to that which has been observed to flow in a tree in potential gradients of the order of -1000 Vm^{-1} (Milner and Chalmers 1961). The corona current which flowed after the flash was very much greater but this is not unreasonable since the potential gradient must have been considerably larger than -1000 Vm^{-1} for much of the time.

After the third and subsequent lightning flashes the potential gradient was insufficient to produce any considerable corona discharge. On a number of subsequent occasions when there were thunderstorms in the vicinity attempts were made to obtain additional data, but there was always too much rain to allow the space charge collectors to be used. Nevertheless the results which were obtained are sufficient to indicate without much doubt that corona discharge can take place from trees under conditions of high potential gradient and can give rise to considerable concentrations of space charge.

6.3 Dissipation of Space Charge

A number of the records were made on occasions when the windspeed was very low, less than 2 ms^{-1} , but on only two of these occasions did the potential gradient reach 800 Vm^{-1} . In both cases a great deal of space charge developed, presumably as the result of corona discharge from nearby objects. On the many other occasions when this happened the space charge disappeared within three or four

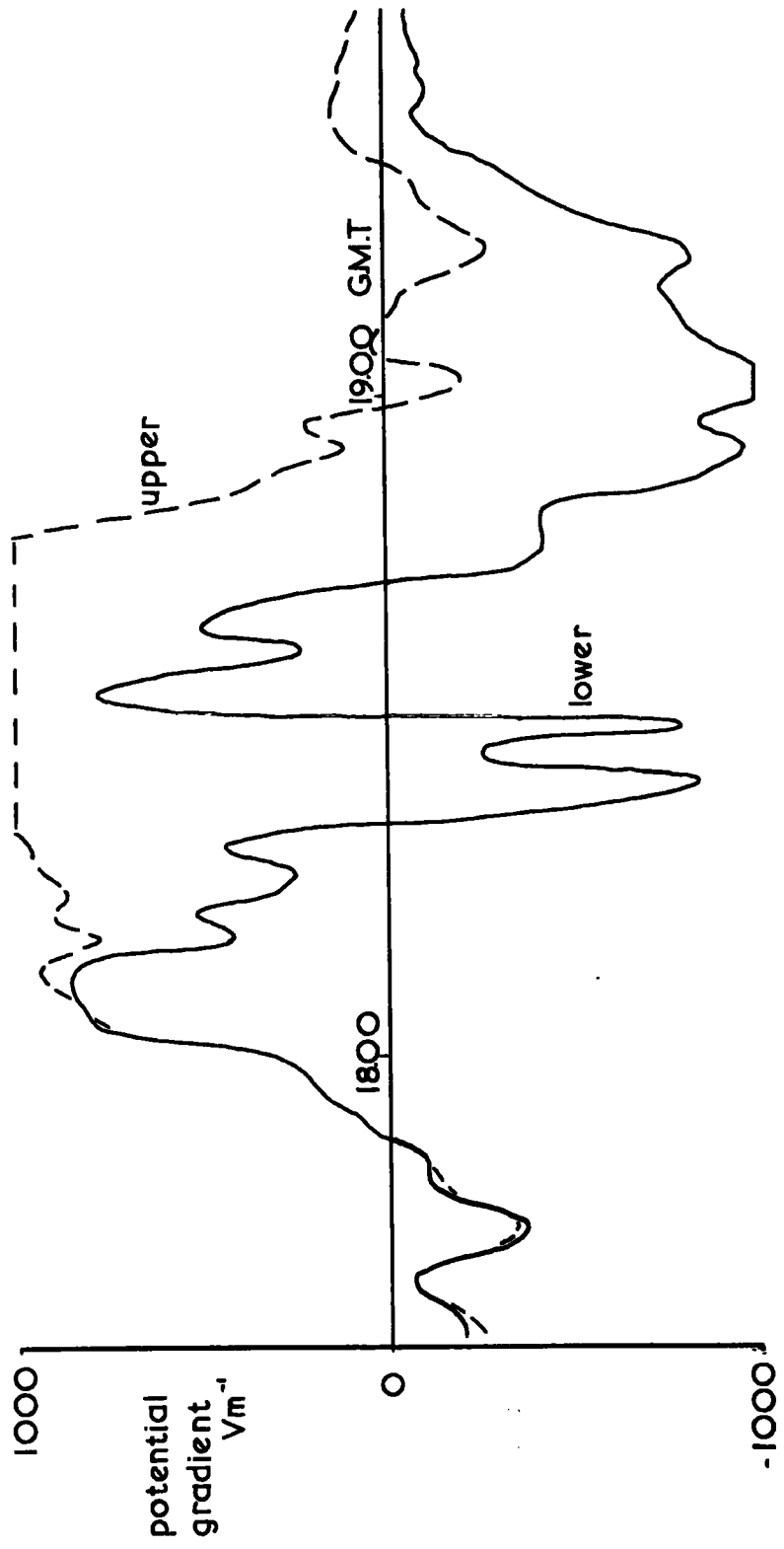

6.3a

minutes of the potential gradient returning to a low level. These two records show nothing of the kind. On the contrary space charge decayed very slowly and remained at high densities for as long as an hour after the potential gradient had fallen below 800 Vm^{-1} .

The meteorological conditions were rather unusual for both records. The first which lasted for nearly eight hours on the afternoon and evening of 23.2.64 was made in thick fog. On 7.11.64 there was some mist and a marked inversion with smoke accumulating at about 70 m. On this occasion the rain was light at first but became moderately heavy for about twenty minutes. During this time the upper potential gradient became strongly negative and much space charge was produced.

The behaviour of the space charge was the same on both occasions and in all the sequence of high potential gradient accompanied by the production of space charge and its slow dissipation was repeated five times. Four of these were on 23.2.63 and the other on 7.11.64. On no occasions did the space charge disappear rapidly. One of the more notable events from 23.2.64 is shown in Fig. 6.3a and 6.3c.

It would be possible to explain this phenomenon by postulating a source of space charge to windward of the observatory. Since this was apparently corona discharge the potential gradient at the source would have to rise to a suitably high value somewhat earlier than at the observatory and then remain high for considerably longer. This would have been possible if the mast can be considered to have become enveloped in the space charge layer to such an

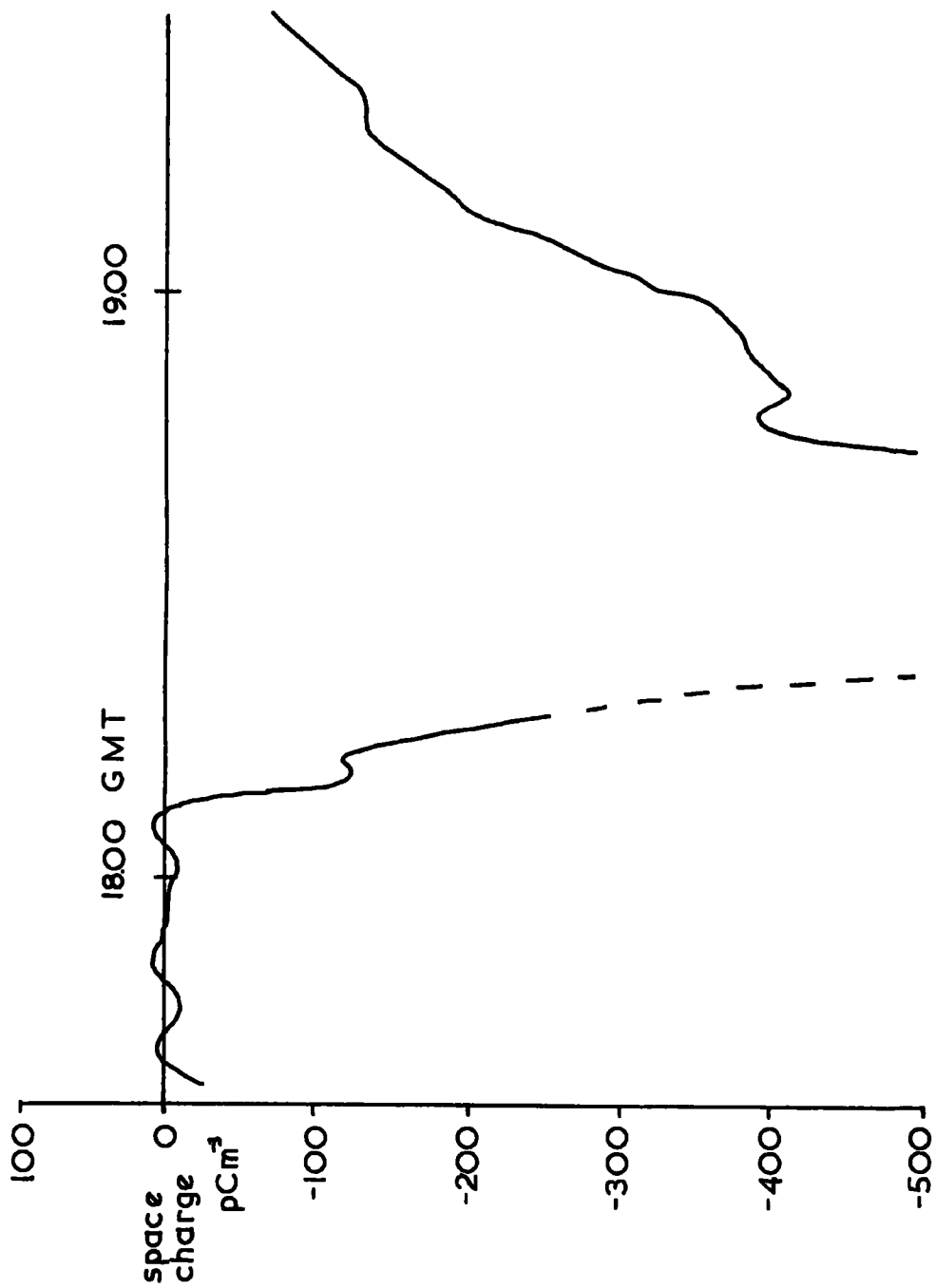

6.3c

extent that the potential gradient at its top was considerably reduced while the source was some particularly high object exposed to the unmodified potential gradient. If this were the case, however, it might be expected that after the upper potential gradient had been reduced below the 'threshold level' the unmodified potential gradient could still rise and so increase the output of space charge. This never happened. The space charge density always decreased steadily although, as can be seen in Fig. 6.3a, there were variations in potential gradient which were not accompanied by changes in the space charge density within the height of the mast.

Another explanation is that the space charge was produced locally and remained in more or less the same place because the windspeed was so low, 1.5 ms^{-1} on 23.2.64 and zero on 7.11.64. The small ions produced by corona discharge would have soon become attached to nuclei or fog droplets and would only have moved slowly under the influence of the potential gradient. On the other hand they could have been captured by rain drops and gradually washed out.

The records show that the space charge density decreased in a nearly linear manner while rain would be expected to cause an exponential decrease. However, this could be masked by errors in the space charge measurements and there is a limit to the charge a raindrop can collect (Whipple and Chalmers 1944). This would cause the maximum rate of removal of charge to be limited which would reduce the slope of the steeper part of the otherwise

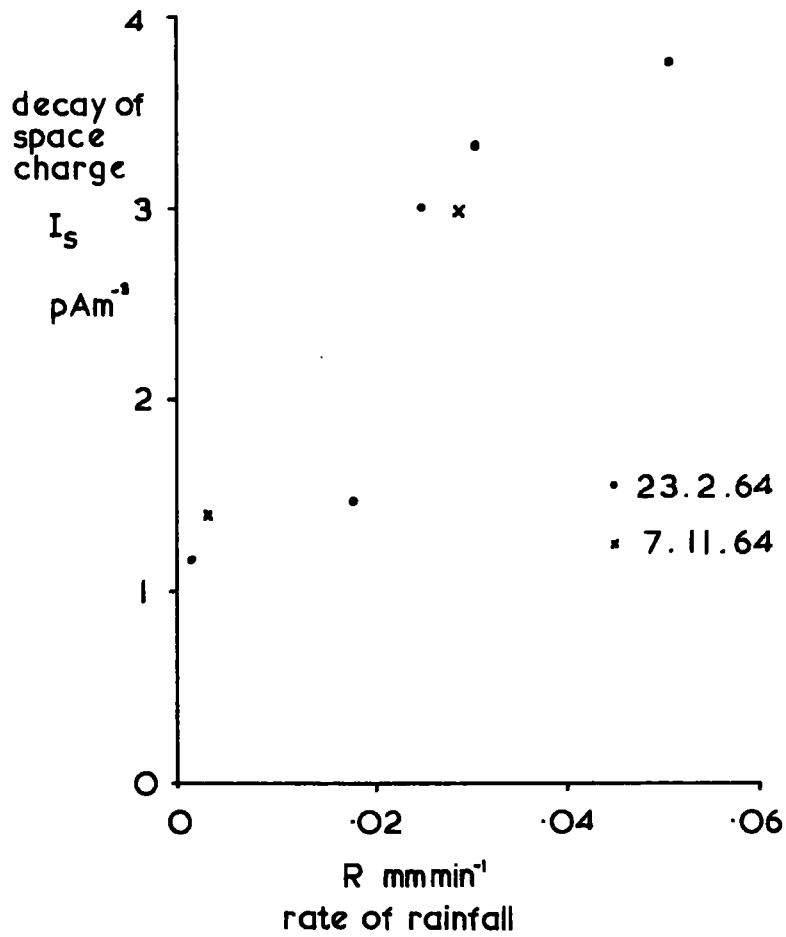

6.3 b

exponential decay.

The mean rate of loss of space charge, J_s , was plotted in Fig. 6.3b against the rate of rainfall for all the events. On 7.11.64 and one of the events on 23.2.64 the rate of rainfall changed considerably and these have each been plotted as two separate measurements. There is a very clear relationship between J_s and R despite the fact that since the averages were taken over periods of up to half an hour the whole cloud system would have moved about 2 km. This can be taken to suggest that the changes in the clouds' electrical structure took place in the same fashion over a large area.

The removal of space charge by the rain implies a relation between the space charge density and the precipitation current. Unfortunately the lower collector was out of action on 7.11.64 and broke down halfway through the record on 23.2.64 but it was possible to make use of the first part of this record. It was found that I was closely correlated with F_U , S and R, all of which were significant at the 95% confidence level. This meant that the potential gradient was still exerting some influence on the precipitation current which is to be expected since the drop charges would be related to F_U before entering the space charge region. In view of this a regression equation was found which was of the same form as the one computed for normal conditions but with the addition of a space charge term. The equation was:

$$I = (R \ 0.41S - 0.94 (F + 8))$$

Because only four hours of record could be used the errors on the constants are quite high, 0.41 ± 0.19 and 0.94 ± 0.31 .

In principle it is possible to calculate the quantity of charge which the rain could remove from the atmosphere (Whipple and Chalmers 1944) and so check the equation, but not sufficient information about the raindrops and the distribution of space charge is available to enable this to be done.

However, a crude check is possible since the contribution of the space charge to the precipitation current should be equal to the total rate of loss of space charge, $I = hJ_s$, is h is the vertical extent of the space charge. The contribution to I by the space charge is $0.415R$ and J_s can be found from Fig. 6.3b. If the intercept can be attributed to errors or to the thinning of the space charge by turbulence then $J_s = 6.2R$. Thus:

$$0.415R = h 6.2R$$

A typical value of S was 300 pCm^{-3} which suggests a value for h of 20 m. This is a little less than the mast, 22 m, but is clearly of the correct order since if the space charge extended to many times the height of the mast the potential gradient at the top would be expected to vary in the same way as the space charge instead of which it is usually of the opposite sign.

None of the forgoing figures can be regarded as very reliable in view of the small amount of data and the uncertainties in the measurement of space charge density but they do appear to be consistent with the washing out of space charge. Both these records were made in foggy conditions and it is unfortunate that no comparison can be made with clear weather since space charge and calm did not occur together on any other occasion.

6.4 The Kelvin-Chauveau Effect

Both Kelvin (1860) in Glasgow and Chauveau (1900) in Paris, made simultaneous observations of the potential gradient at the ground and on a tower. They found that during rain the potential gradient on the ground became negative while on the tower it was usually less so and sometimes even remained positive. Also the changes in potential gradient were smaller on the tower. This implied negative space charge near the ground.

In common with earlier work at the Durham University Observatory site the effect was never observed. The only space charge which could be detected could be attributed to corona discharge and this tended to give behaviour which was opposite to the Kelvin-Chauveau effect. This was because the space charge depressed the lower potential gradient so it usually was smaller in magnitude than the upper potential gradient. Moreover Kelvin reported the effect even when potential gradient was only about 150 Vm^{-1} . It is difficult to see why the effect was not observed at Durham. The records extended over 200 hours if those which lack one of the instruments are included. Kelvin's upper measurements were made on a tower at 22 m which is the same as the height of the mast used in the Durham work. The main difference in the experimental arrangement seems to be the site. The Observatory is in rural surroundings with only a few houses within about half a mile whereas the author understands that the areas in which Kelvin and Chauveau worked were rather more built up. Now Smith (1955) suggested

that the space charge is produced by splashing at the ground and Adkins (1959) found that the charges produced by a drop striking a surface increase with the hardness of the surface. This suggests that the effect could have been smaller at the Observatory where most of the surfaces are grass covered, but whether it can account for its apparent absence is difficult to say.

CHAPTER VII

Conclusions

The main object of the work was to investigate variations of precipitation electricity with height and this was not achieved because of the difficulties which were encountered in the operation of the precipitation collector on the mast. It is clear that if in future precipitation current is to be measured in such conditions some other method will have to be adopted.

With regard to the precipitation current at ground level the observations that were made can be adequately described by an equation which has often been used before but with the addition of a rate of rainfall term. This equation is $I = -2.6R(F - 112) \text{ pAm}^{-2}$ where F is in Vm^{-1} and R mm min^{-1} .

Although no measurements of precipitation current above ground level could be made it was apparent that precipitation did gain charge close to the ground by washing out local space charge.

Detectable space charges, densities greater than 180 pCm^{-3} were only present when the potential gradient exceeded 800 Vm^{-1} and were always opposite in sign to it. This suggested that it was produced by corona discharge which was confirmed on one occasion when under unusual circumstances it was possible to trace its source to a group of trees.

Although some conclusions about space charge could be drawn, it was not possible to make accurate measurements of either the space charge density or the potential gradient at 22 m. This was because of the difficulties encountered in calibrating the upper field mill. Since the natural variations of potential gradient

did not help it had to be carried out on a numerical model with only limited success.

The present shape of the mast is complicated, especially in the vicinity of the instruments which means that it is not easy to construct a satisfactory model. This difficulty could be overcome by shaping the mast suitably, perhaps by enveloping it in a cylinder of wirenetting and arranging for the instruments to be in the plane of the netting. In addition it should not be hard to develop a better computer programme in order to improve accuracy and possibly deal with more elaborate shapes. As an alternative to this other approaches such as the use of an electrolytic tank or a resistance network could be considered.

A rather more sensitive method of detecting space charge is suggested by Fig. 3.3d which shows the exposure factor, E , along a mast for thin layers of space charge at various heights in the atmosphere. It can be seen that for a point about halfway up the mast the exposure factor for layers of space charge below about 20 m is roughly constant at 2.5 while Fig. 3.3c indicates that the exposure factor for the potential gradient produced by distant charges is only 0.2. This means that a field mill in such a position would be twelve times more sensitive to space charge than to the distant potential gradient. Thus in a potential gradient of 1000 Vm^{-1} the limit of sensitivity would be 80 Vm^{-1} which is the equivalent of 35 pCm^{-3} which is a considerable improvement on the present system. However the accuracy of such a system

would be determined entirely by how well the calibration of the model could be carried out.

A point which has arisen several times was ignorance of conditions at some distance from the mast. In section 6.2 the source of the space charge pulse would have been defined with more certainty if there had been a field mill to windward of the trees. In 6.3 such an instrument would have made it possible to tell whether the decay of space charge was really a variation with time or whether any of it could be accounted for by different parts of the cloud system drifting past, each with rather different electrical characteristics.

A single mobile field mill which could be positioned to windward of the main observing station would go a long way to resolving such ambiguities but an even better system would be a central station surrounded by perhaps six minor ones. The distance between them would be determined by the anticipated windspeed and the resolving time of the recording system or the timescale of the phenomena to be investigated. For a windspeed of 10 ms^{-1} and a resolving time of 30 s a separation of at least 300 m would be required. If the siting of the stations was arranged to include buildings and groups of trees their behaviour as sources of space charge could be examined in some detail. Alternatively some information on the electrical structure and development of clouds could be obtained if the stations were sufficiently widely spaced.

ACKNOWLEDGMENTS

The author would like to express his thanks to all the many people without whose help, stimulation and bullying this thesis would never have been written.

In particular to the late Professor J.A. Chalmers for his invaluable help and encouragement.

To Professor G.D. Rochester for the research facilities of the Physics Department and to the United States Office of Naval Research who bore the financial burden of the work.

To the technical staff, especially Messrs J. Moralee, D. Jobling and E. Lincoln.

Also to Dr. W.C.A. Hutchinson and all the research students who were the author's contemporaries, in particular Dr. K.N. Groom for many helpful discussions and Dr. R.B. Bent for his cooperation with the recorder and the space charge measurements.

Finally to Miss V. Hall-Patch for undertaking the task of typing the thesis.

REFERENCES

- Adamson, J., 1960. Quart. J. Roy. Met. Soc., 86, 252
- Adkins C.J., 1959a. Quart. J. Roy. Met. Soc., 85, 60
- 1959b. Quart. J. Roy. Met. Soc., 85, 237
- 1959c. Quart. J. Roy. Met. Soc., 85, 419
- Awe, O., 1964. J. Atmos. Terr. Phys., 26, 1239
- Bent, R.B., 1964. J. Atmos. Terr. Phys., 26, 313
1965. Ph.D. Thesis, Durham
- Chalmers, J.A., 1952. J. Atmos. Terr. Phys., 1,
1956. J. Atmos. Terr. Phys., 9, 311
1959. Recent Advances in Atmospheric Electricity; Pergamon Press, p.309
1962. J. Atmos. Terr. Phys., 24, 1059
1965. J. Atmos. Terr. Phys., 27, 899
- Chauveau, 1900. Annales de B.C.M., 5, 1
- Collin, H.L., 1962. J. Atmos. Terr. Phys., 24, 281
- Collin, H.L., Groom, K.N. and Higazi, K.A., 1966. J. Atmos. Terr. Phys., 28, 695
- Collin. H.L., Raisbeck, I.A., 1963. J. Atmos. Terr. Phys., 25, 631 and Chalmers, J.A.
- Collin, H.L. and Raisbeck, I.A., 1964. J. Atmos. Terr. Phys., 26, 1107
- De'Sa, O. and Molyneux, L., 1962. Electronic Engineering, 34, 468
- Dinger, J.E. and Gunn, R., 1946. Terr. Mag. Atmos. Elect., 51, 477
- Elster, J. and Geitel, H., 1888. Met. Z., 5, 85
- Gill, E. W.B. and Alfrey, G.F., 1952. Proc. ~~Phil.~~ Soc., B65, 546
Phys.
- Groom, K.N. and Chalmers, J.A., 1967. J. Atmos. Terr. Phys., 29, 877

- Gunn, R., 1950. J. Geophys. Res., 55, 171
- Kelvin, Lord., 1860. Papers on Electrostatics and Magnetism, p.208
- Lenard, P., 1892. An. Phys. Lpz., 46, 584.
- MacCready, P.B. and Proudfit, A., 1965. Quart. J. Roy. Met. Soc.,
91, 44
- Maund, J.E. and Chalmers, J.A., 1960. Auart. J. Roy. Met. Soc.,
86, 85
- Merry, G.H., 1959. M.Sc. Thesis, Durham
- Milner, J.W. and Chalmers, J.A., 1961. Quart. J. Roy. Met. Soc.,
87, 592
- Ramsay, M.W., 1959. Ph.D. Thesis, Durham
- Ramsay, M.W. and Chalmers, J.A., 1960. Quart. J. Roy. Met. Soc.,
86, 530
- Reiter, R., 1965. Quart. J. Roy. Met. Soc., 91, 60
- Schonland, B.F.J., 1929. Proc. Roy. Soc., A118, 252
- Scrase, F.J., 1938. Geophys. Mem. Lond., 75, 1
- Simpson, G.C., 1909. Phil. Trans., A209, 379
1949. Geophys. Mem. Lond., 84, 1
- Simpson, G.C. and Robinson, G.D., 1940. Proc. Roy. Soc., A177, 281
- Simpson, G.C. and Scrase, F.J., 1937. Proc. Roy. Soc., A161, 309
- Smith, L.G., 1955. Quart. J. Roy. Met. Soc., 81, 23
- Smythe, W.R., 1950. Static and Dynamic Electricity, McGraw Hill
- Whipple, F.J.W. and Chalmers, J.A., 1944. Quart. J. Roy. Met. Soc.,
70, 103.

Wilson, C.T.R., 1916. Proc. Roy. Soc., A92, 555

1929. J. Frank. Inst., 208, 1

()