

# Durham E-Theses

---

## *Some studies in step-growth photopolymerization*

David John Andrews

### How to cite:

---

Andrews, David John (1973) Some studies in step-growth photopolymerization. Doctoral thesis, Durham University.

### Use policy

---

The full-text may be used and/or reproduced, and given to third parties in any format or medium, without prior permission or charge, for personal research or study, educational, or not-for-profit purposes provided that:

- a full bibliographic reference is made to the original source
- a <https://etheses.durham.ac.uk/id/eprint/8353/> is made to the metadata record in Durham E-Theses
- the full-text is not changed in any way

The full-text must not be sold in any format or medium without the formal permission of the copyright holders.

Please consult the [full Durham E-Theses policy](#) for further details.

SOME STUDIES IN STEP-GROWTH  
PHOTOPOLYMERIZATION

by

David John Andrews, B.Sc.  
(Van Mildert College)

A thesis submitted to the University of Durham for the  
Degree of Doctor of Philosophy

1973

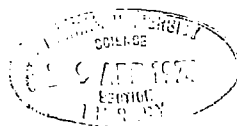

Errata.

Page 20. Equation 1.10. Repeat unit of polymer should be

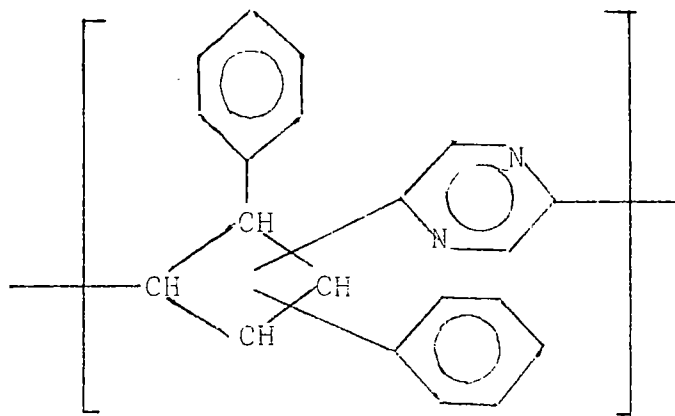

Page 81. 2nd. complete paragraph, line 5. For 'cyclohexane', read 'cyclohexene'.

Page 125. 2nd. complete paragraph, line 2. For 'ketones', read 'ketenes'.

Page 136. 2nd. complete paragraph, lines 6 and 7. Erase 'gave yields of diketone', replace with 'were'.

Page 177. 1st. complete paragraph, line 7. For 'lower', read 'higher'.

Page 182. Structure (72) should be

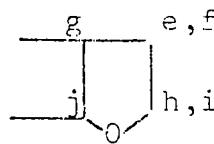

Page 220. 2nd. complete paragraph, line 5. For 'correspodning', read 'corresponding'.

Reference 189. Page number should read '333', not '233'.

To Isolde

ABSTRACTSome Studies in Step-Growth Photopolymerization

This work reviews some reported investigations and describes some further studies in step-growth photopolymerization.

Benzophenone-type aromatic diketones were prepared by Friedel-Crafts synthesis.

The diketones were photopolymerized directly with tetramethylallene and with 2,5-dimethylfuran in benzene solution, yielding low to medium molecular weight polymers containing oxetane rings in the main polymer chains. Irradiation of diketones in a large excess of furan resulted in cycloaddition of carbonyl groups to furan C=C double bonds and the formation of furan-diketone 2:1 adducts. The 2:1 adducts were photopolymerized with equimolar quantities of diketone to give polymers.

Spectroscopic evidence indicated that all polymers contained OH groups, arising presumably from hydrogen abstraction reactions. The physical properties of polymers from tetramethylallene and 2,5-dimethylfuran were consistent with the formation of linear polymers, hydrogen abstraction from methyl groups still allowing propagation of the polymer chain. The physical properties of polymers containing furan residues were indicative of crosslinks in the polymers, one possible source of such crosslinks being abstraction of hydrogens  $\alpha$  to furan residue oxygens.

Pyrolysis of polymers resulted in cleavage of oxetane rings, and polymers and 2:1 adducts from furan were unstable at room temperature.

Polybenzopinacols were prepared by irradiation of the diketones in benzene-isopropanol mixtures. Solvent mixtures containing greater than 50% by volume of benzene were found to be most satisfactory.

The photochemical oxidative-reductive dimerization of acetophenones, and the photoenolization of 2-alkylbenzophenones followed by Diels-Alder addition of the photoenols to dienophiles have been examined as possible model reactions extendable to photopolymerization. Preliminary results indicated that the production of high polymers from the diketones studied was unlikely.

### ACKNOWLEDGEMENTS

The author is indebted to Dr. W.J. Feast for his continued help and encouragement unfailingly given during the supervision of this work, and to Professor W.K.R. Musgrave for his interest. Thanks are due to Professor F.C. De Schryver, Universiteit te Leuven, Belgium, for making available preprints of several of his papers.

Assistance from members of the technical and laboratory staff is greatly appreciated; in particular, practical assistance from Mr. D. Hunter is gratefully acknowledged.

The author thanks the Science Research Council for the award of a maintenance grant.

MEMORANDUM

The work described in this thesis was carried out in the Chemistry Laboratories of the University of Durham between October 1970 and August 1973. This work has not been submitted for any other degree and is the original work of the author, except where acknowledged by reference.

NOTE TO READER

In this thesis compounds, intermediates, structures etc. are designated by arabic numerals only where discussion in the text is aided by such referencing. Compounds are mostly referred to by their full names.

In Chapter 4, the preparation and characterization of series of polymers from benzophenone-type aromatic diketones and dienes is described. The polymers are identified by abbreviated names, the abbreviation being a composite form of abbreviated monomers. Monomer abbreviations are as follows:

<u>Monomer</u>	<u>Abbreviation</u>	<u>Reference No.</u>
Tetramethylallene	TMA	
Furan	F	
2,5-Dimethylfuran	DiMeF	
m-Dibenzoylbenzene	M	(40)
p-Dibenzoylbenzene	P	(41)
4,4'-Dibenzoyldiphenyl ether	E	(42)
4,4'-Dibenzoyldiphenyl	O	(43)
4,4'-Dibenzoyldiphenylmethane	1	(44)
1,2-(4,4'-Dibenzoyldiphenyl)ethane	2	(45)
1,3-(4,4'-Dibenzoyldiphenyl)propane	3	(46)
1,4-(4,4'-Dibenzoyldiphenyl)butane	4	(47)
1,5-(4,4'-Dibenzoyldiphenyl)pentane	5	(48)
1,6-(4,4'-Dibenzoyldiphenyl)hexane	6	(49)
1,10-(4,4'-Dibenzoyldiphenyl)decane	10	(50)

Polymers from tetramethylallene and diketones are designated as polyTMAM, polyTMA2 etc. where polyTMA2, for example, is the polymer prepared from tetramethylallene and 1,2-(4,4'-dibenzoyldiphenyl)ethane.

Polymers from furan and diketone were generally obtained via intermediate furan-diketone 2:1 adducts which are designated as diFP, diF3 etc. where diFP, for example, is the furan-diketone 2:1 adduct of p-dibenzoylbenzene. Corresponding polymers are abbreviated to the form polyFP, polyF3 etc., where, as an example, polyF3 is the polymer containing furan and 1,3-(4,4'-dibenzoyldiphenyl)propane residues. Polymers prepared from 2,5-dimethylfuran and diketone are abbreviated to polyDiMeF4 etc.

Polybenzopinacols prepared from the various diketones are denoted by the term polypinacol followed by the abbreviation for the diketone from which the polymer has been prepared. Thus, for example, polypinacol 10 is the polybenzopinacol from 1,10-(4,4'-dibenzoyldiphenyl)decane.

Throughout this thesis the term molecular weight, with reference to polymers, refers to the number average molecular weight. Nuclear magnetic resonance (n.m.r.) spectra are all  $^1\text{H}$  n.m.r. spectra.

TABLE OF CONTENTS

	Page
Abstract	ii
Acknowledgements	iv
Memorandum	v
Note to Reader	vi
<u>CHAPTER 1 Step-Growth Photopolymerization</u>	
<u>Introduction</u>	
1.1 Classification of Polymer Forming Reactions	1
1.2 Photopolymerization	3
a) Photoinitiated Polymerization	6
b) Photochemical Crosslinking of Polymers	8
c) Step-Growth Photopolymerization	10
1.3 Photodegradation of Polymers	13
1.4 General Requirements for Step-Growth Photopolymerization	16
<u>A Review of Known Step-Growth Photopolymerizations</u>	
1.5 Four-Centre Type Photopolymerization in the Solid State	19
a) Preparation and Characterization of Polymers	25
b) Polymerization Mechanism	27
c) Stereochemistry of Polymers	30
d) Other Data Obtained on PolyDSP	31
e) Depolymerization	31
1.6 Photocycloaddition Polymerization of N,N'-Polymethylene-bismaleimides	32
a) Preparation and Characterization of Polymers	33
b) Mechanism and Kinetics of Photopolymerization	37
c) Solid-state Photopolymerization	40
1.7 Photopolymerization of Biscoumarins	40
1.8 Synthesis of Polyimides by Photoaddition of Bismaleimides to Benzene and Alkylbenzenes	43
a) Preparation and Characterization of Polymers	47
b) Mechanism and Factors Affecting Yield	49
1.9 Photopolymerization of Bisanthracenes	51

	Page
1.10 Reductive Coupling of Aromatic Diketones to Polybenzopinacols	54
a) Discussion	56
b) Effect of Solvent Mixtures	63
c) Pinacol-Pinacolone Rearrangement of Polymers	63
1.11 Photoreductive Coupling of Bisbenzal Imines	64
1.12 Synthesis of Poly(Perfluoroalkylene Oxides)	65
a) Polymers Obtained from Iodine Coupling Reactions	67
b) Polymers Obtained from Perfluoroacyl Compounds	68
1.13 Further Studies in Step-Growth Photopolymerization	71
<b><u>CHAPTER 2 Aspects of the Photochemistry of Carbonyl Compounds</u></b>	
2.1 Primary Photophysical Processes of Organic Molecules	72
2.2 Excitation of the Carbonyl Chromophore	77
2.3 Introduction to Organic Photochemistry of Carbonyl Compounds	80
2.4 Quenching and Photosensitization	81
2.5 Norrish Type I and Type II Processes	83
2.6 Photoreduction of Carbonyl Compounds	85
a) Introductory Survey	85
b) Solvents	87
c) Effect of Structure on Photoreduction of Aromatic Ketones	93
d) Photoaddition of Ketones to Methylene Groups	97
2.7 Photocycloaddition of Carbonyl Compounds to Unsaturated Systems	98
a) Scope of the Reaction	99
b) Mechanism	103
c) Limitations	111
d) Experimental Conditions	114
2.8 Miscellaneous Photochemical Reactions of Carbonyl Compounds	114
2.9 Effect of Oxygen in Photochemical Reactions	115
2.10 Selection of Starting Materials for Step-Growth Photopolymerization Involving the Paternò-Büchi Reaction	118

CHAPTER 3 Synthesis of Aromatic Diketones

<u>Introduction</u>	Page
3.1 Principal Routes to Aldehydes and Ketones	120
3.2 The Friedel-Crafts Reaction	120
3.3 Aromatic Ketone Synthesis by Friedel-Crafts Reaction	121
a) Mechanism	121
b) Catalysts	123
c) Acyl Components	124
d) Substrates	125
e) Experimental Conditions	125
f) Limitations	127
g) Synthesis of Aromatic Diketones	128
3.4 The Wurtz-Fittig Reaction	132
a) Mechanism	132
b) Synthesis of $\alpha$ , $\omega$ -Diphenylalkanes	134
<u>Discussion</u>	
3.5 Synthesis of $\alpha$ , $\omega$ -Diphenylalkanes	136
3.6 Friedel-Crafts Synthesis of Aromatic Diketones	137
a) Problems in the Friedel-Crafts Synthesis of Diketones (42)-(50)	138
b) Characterization of the Aromatic Diketones	140
<u>Experimental</u>	
3.7 Preparation of Diketones from Friedel-Crafts Reaction of Bis(acyl chlorides) and Benzene	146
a) Preparation of m-Dibenzoylbenzene	146
b) Preparation of p-Dibenzoylbenzene	146
3.8 Preparation of Diketones by Friedel-Crafts Reaction between Diphenyl Compounds and Benzoyl Chloride	147
a) Preparation of $\alpha$ , $\omega$ -Diphenylalkanes	147
b) Friedel-Crafts Benzoylation of Diphenyl Compounds	148

CHAPTER 4 Step-Growth Photopolymerization Via Triplet States of  
Benzophenone-Type Aromatic Diketones

	Page
4.1 General Introduction	153
<u>A. The Photopolymerization of Aromatic Diketones with Tetramethylallene</u>	
<u>Introduction</u>	
4.2 Photoaddition of Benzophenone to Tetramethylallene	154
a) Preparation of Photoadducts	154
b) Characterization of Products	156
c) Mechanism	157
d) Applicability of Tetramethylallene as a Diene in Step-Growth Photopolymerizations Involving Oxetane Formation	159
<u>Discussion</u>	
4.3 Preparation of Polymers from Aromatic Diketones and Tetramethylallene	161
4.4 Polymer Solubilities	162
4.5 Molecular Weights and Melting Characteristics of Polymers	162
4.6 Further Characterization of Polymers	164
a) Model Compound Study	166
b) Infrared Spectra of Polymers	166
c) N.M.R. Spectra of Polymers	167
4.7 Effect of HCl on PolyTMAM	168
4.8 Growth Characteristics of PolyTMA1	169
4.9 Effect of Concentration on Polymer Molecular Weight	172
4.10 Thermal Stability of Polymers	175
a) Pyrolysis of PolyTMA1	175
b) Thermogravimetric Analysis	177
<u>B. The Photopolymerization of Aromatic Diketones with Furans</u>	
<u>Introduction</u>	
4.11 Photocycloaddition of Benzophenone to Furan and Substituted Furans	179

a) Preparation of Photoadducts	180
b) Characterization of Adducts	181
c) Mechanism	187
d) Applicability of Furans as Dienes in Step-Growth Photopolymerizations Involving Oxetane Formation	189

#### Discussion

4.12 Direct Irradiation of Equimolar Quantities of Diketone and Furan in Benzene Solution	190
4.13 An Alternative Route to Furan-Diketone Polymers Containing Oxetane Units in the Main Chain	191
4.14 Preparation of Furan-Diketone 2:1 Adducts	191
4.15 Spectroscopic Characterization of Furan-Diketone 2:1 Adducts	193
a) Infrared Spectra	193
b) N.M.R. Spectra	194
c) Ultraviolet Spectra	196
d) Mass Spectra	196
4.16 General Discussion on Furan-Diketone 2:1 Adducts	197
4.17 Preparation of Polymers from Furan-Diketone 2:1 Adducts and Diketones	201
4.18 Solubility of Furan-Diketone Polymers	202
4.19 Molecular Weights and Melting Characteristics of Furan-Diketone Polymers	202
4.20 Further Characterization of Furan-Diketone Polymers	204
a) Model Compound Study	204
b) Infrared Spectra of Polymers	206
c) N.M.R. Spectra of Polymers	207
4.21 Growth Characteristics of PolyFM	210
4.22 Effect of Concentration on Polymer Molecular Weight	214
4.23 Thermal Stability of Furan-Diketone Polymers	214
a) Pyrolysis of Polymers	214
b) Thermogravimetric Analysis	216
4.24 Further Comment on the Stability of Furan-Diketone Polymers and Adducts	216
4.25 Preparation of Furan-Diketone Polymers Derived from Two Diketones	223

	Page
4.26 Studies with 2,5-Dimethylfuran as Diene	225
a) Irradiation of 4,4'-Dibenzoyldiphenylmethane in 2,5-Dimethylfuran	225
b) Polymerizations with 2,5-Dimethylfuran as Diene	226
4.27 Possible Competing Reactions in the Photopolymerization of Furan-Diketone 2:1 Adducts with Diketones	228
 <u>C. The Preparation of Polybenzopinacols</u>	
4.28 Introduction	233
 <u>Discussion</u>	
4.29 Reductive Coupling of Aromatic Diketones	233
a) In 50:50 Benzene-Isopropanol Mixtures	233
b) In Benzene-Isopropanol Mixtures Containing More than 50% Benzene	237
c) Some Comments on the Differing Results Obtained for Photopinacolizations in the Varying Benzene- Isopropanol Mixtures	239
d) Thermogravimetric Analysis of Polybenzopinacols	240
 <u>D. The Use of Dichloromethane as Solvent</u>	
4.30 Studies with Dichloromethane as Solvent	241
 <u>E. Conclusions</u>	
4.31 Conclusions	242
 <u>F. Experimental</u>	
4.32 Photopolymerization of Aromatic Diketones with Tetramethylallene, and Related Investigations	244
a) General Method of Polymerization	244
b) Irradiation of Benzophenone and Tetramethylallene in Benzene	245
c) Effect of HCl on PolyTMAM	245
d) Effect of Initial Monomer Concentration on Molecular Weight of PolyTMAM Attained after Irradiation for 22 Hours	247
e) Effect of the Period of Irradiation on Molecular Weight of PolyTMAM	247
f) Pyrolysis of PolyTMAM	248

	Page
4.33 Studies with Furan as Diene	249
a) Direct Irradiation of an Equimolar Solution of m-Dibenzoylbenzene and Furan in Benzene	249
b) Preparation of Furan-Aromatic Diketone 2:1 Adducts	249
c) Irradiation of More Concentrated Solutions of Aromatic Diketones in Furan	250
d) Irradiation of Benzophenone in Furan	252
e) Irradiation of Furan-Aromatic Diketone 2:1 Adducts with Aromatic Diketones	252
f) Irradiation of Benzophenone and Furan in Benzene	255
g) Effect of the Period of Irradiation on Molecular Weight of PolyFM	255
h) Pyrolysis of Furan-Diketone Polymers and 2:1 Adducts	257
i) Preparation of Furan-Aromatic Diketone Polymers Derived from Two Differing Diketone Monomers	258
4.34 Studies with 2,5-Dimethylfuran as Diene	260
a) Irradiation of 4,4'-Dibenzoyldiphenylmethane in 2,5- Dimethylfuran	260
b) Preparation of Polymers from Aromatic Diketones and 2,5-Dimethylfuran	260
4.35 Irradiation of Aromatic Diketones in Benzene	261
a) m-Dibenzoylbenzene	261
b) 4,4'-Dibenzoyldiphenylmethane	261
4.36 Preparation of Polybenzopinacols	263
a) By Irradiation of Aromatic Diketones in 50:50 v/v Mixtures of Benzene-Isopropanol	263
b) By Irradiation of Aromatic Diketones in Benzene- Isopropanol Solvent Mixtures Containing Greater than 50% Benzene	264
c) Irradiation of Polypinacol 1 in the Solid State	264
4.37 Experiments with Dichloromethane as Solvent	267
a) Irradiation of 1,2-(4,4'-Dibenzoyldiphenyl)ethane in a Furan-Dichloromethane Mixture	267
b) Irradiation of an Equimolar Solution of 1,2-(4,4'- Dibenzoyldiphenyl)ethane and Tetramethylallene in Dichloromethane	268
c) Irradiation of m-Dibenzoylbenzene in Dichloromethane	268

CHAPTER 5 Some Preliminary Studies on Photopolymerization Utilizing Photoenolization Reactions

5.1	General Introduction	269
<u>A. Intermolecular Photoenolization</u>		
<u>Introduction</u>		
5.2	The Photochemical Oxidative-Reductive Dimerization of Acetophenones	270
	a) Scope of the Reaction	270
	b) Mechanism	270
	c) Extension of the Reaction to Photopolymerization	274
<u>Discussion</u>		
5.3	Preparation and Characterization of 4,4'-Diacetyldiphenyl and 4,4'-Diacetyldiphenylmethane	275
5.4	Attempted Photopolymerizations of 4,4'-Diacetyldiphenyl and 4,4'-Diacetyldiphenylmethane in the Presence of Phenol Catalyst	275
<u>Experimental</u>		
5.5	Preparation of Diketones	278
	a) Preparation of 4,4'-Diacetyldiphenyl	278
	b) Preparation of 4,4'-Diacetyldiphenylmethane	279
5.6	Irradiations	279
	a) Irradiation of 4,4'-Diacetyldiphenyl and Phenol Catalyst in Dichloromethane	279
	b) Irradiation of 4,4'-Diacetyldiphenylmethane and Phenol Catalyst in Acetone	280
<u>B. Intramolecular Photoenolization</u>		
<u>Introduction</u>		
5.7	Photoenolization of 2-Alkylbenzophenones	281
	a) Scope of the Reaction	282
	b) Mechanistic Studies	284
	c) Extension of the Reaction to Photopolymerization	288
<u>Discussion</u>		
5.8	Preparation and Characterization of Diketones	290
5.9	Photoenolization Investigations	291

	Page
<u>Experimental</u>	
5.10 Preparation of Diketones	295
a) Preparation of m-Dimesitoylbenzene	295
b) Preparation of p-Dimesitoylbenzene	295
c) Preparation of 1,4-Di-o-toluoylbenzene	296
d) Attempted Preparation of 1,3-Di-o-toluoylbenzene	297
5.11 Irradiations	297
a) Irradiation of m-Dimesitoylbenzene and Dimethyl Acetylenedicarboxylate in Benzene	298
b) Irradiation of p-Dimesitoylbenzene and Dimethyl Acetylenedicarboxylate in Benzene	299
c) Irradiation of 1,4-Di-o-toluoylbenzene and Dimethyl Acetylenedicarboxylate in Benzene	300
d) Irradiation of 1,4-Di-o-toluoylbenzene and Phenylacetylene in Benzene	301
e) Irradiation of 2-Methylbenzophenone and 1-Heptyne in Benzene	301
f) Irradiation of 1,4-Di-o-toluoylbenzene and 1,6- Heptadiyne in Benzene	302

#### Appendices and References

Appendix A - Apparatus, Instruments and General Techniques

Appendix B - Mass Spectra

Appendix C - Infrared Spectra

Appendix D - Thermogravimetric Analyses

References

CHAPTER I

STEP-GROWTH PHOTOPOLYMERIZATION

INTRODUCTION

### 1.1 Classification of Polymer Forming Reactions

In 1929, with the increasing need for organization of the accumulating data of organic polymer chemistry, Carothers suggested a system of polymer classification in which polymers were divided into two groups based on a comparison of the structure of the repeating unit of the polymer with the structure(s) of the monomer(s) from which the polymer was derived.<sup>1</sup> The two classes of polymers were called addition polymers and condensation polymers.

Addition polymers were defined as those in which the molecular formula of the repeating unit is the same as that of the monomer, the polymer molecular weight being the sum of the molecular weights of the monomer units used to construct the polymer chain. A common example is that of polymers formed from the polymerization of vinyl monomers (1.1).

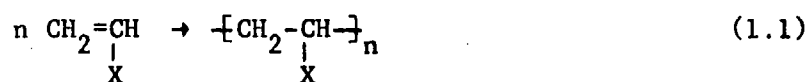

Condensation polymers, on the other hand, were defined as polymers in which the molecular formula of the repeating unit differs from that of the monomer, the repeating unit containing fewer atoms than the monomer and the polymer molecular weight being less than the sum of the molecular weights of the monomer units from which the polymer is derived. For example, linear polyesters formed by the reaction of a glycol with a dibasic acid are typical condensation polymers (1.2).

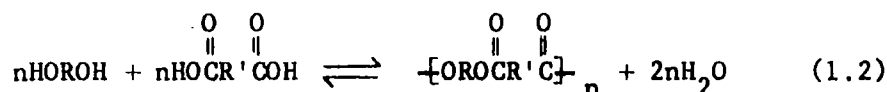

The corresponding classes of polymerization processes, by which addition polymers and condensation polymers are formed, are respectively

addition polymerizations and condensation polymerizations.

Although Carothers' classification has proved useful and acceptable for many polymers, it does have serious shortcomings in merely relating the molecular formulae of monomers to those of the repeating units. Flory<sup>2</sup> has pointed out that the reactions producing the polymers are the important factors in polymer classification rather than the comparison of monomer and repeating unit stoichiometries. He regarded a polymerization process proceeding by reaction between pairs of functional groups with the formation of a type of interunit functional group not present in monomers as a condensation polymerization. This definition allows, for example, the classification of the reaction between a glycol and diisocyanate (1.3) as a condensation process, although there is no difference between the molecular formula of the monomers and that of the repeating unit.

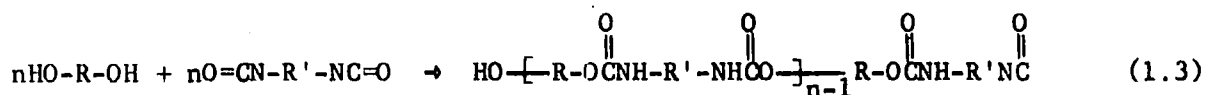

Polymers containing a particular repeating unit may be synthesized by addition polymerization or condensation polymerization. Lenz<sup>3</sup> has exemplified the case of polyethylene and related polymers containing the  $-\text{CH}_2-\text{CH}_2-$  repeating unit. High molecular weight material may be obtained by addition polymerization of ethylene, and by condensation polymerization of diazomethane (1.4).<sup>4</sup>

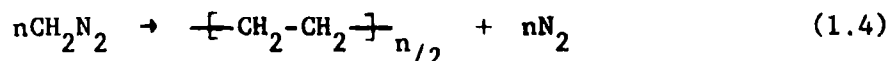

A low molecular weight polymer of the same empirical formula may be prepared by condensation polymerization of decamethylene dibromide and

sodium via the Wurtz reaction.<sup>5</sup> This polymer possesses very different physical properties from the higher molecular weight polymers, although the two polymers formally classified as condensation polymers might be expected to possess the more similar properties.

Consideration of the characteristics of the growth reactions producing the polymers allows a more meaningful system of polymer classification, especially in rationalization of resulting physical properties. Such considerations lead to chain-growth polymerization and step-growth polymerization as the polymerization classes based on polymer growth reactions. The characteristics of these limiting types of polymerization reactions are listed in Table 1.1.

Lenz<sup>3</sup> has advocated a more comprehensive polymer classification scheme incorporating three important variable parameters. Consideration of growth mechanism, relationship between monomer structure and repeating unit structure, and molecular weight of polymer thus leads to eight polymer classes.

## 1.2 Photopolymerization

The commonly accepted definition of photopolymerization has been the initiation by light of a chain polymerization process, although more generally it implies the increase in molecular weight caused by light and therefore includes the photocrosslinking of macromolecules.<sup>6,7</sup> The link between these two aspects of photopolymerization is the use of light as energy source and polymeric materials as the object of interest.

TABLE 1.1<sup>3</sup>Characteristics of the Limiting Types of Polymerization Reactions

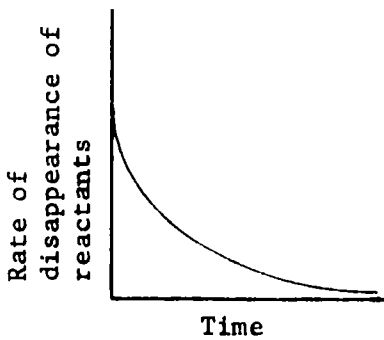
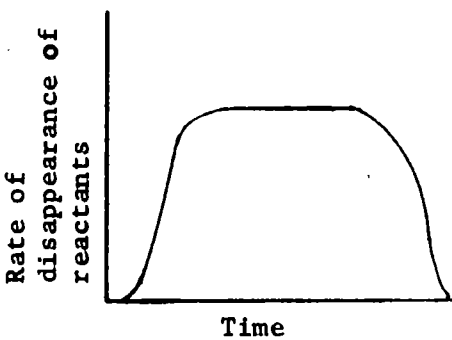
Characteristic	Step-growth polymerization	Chain-growth polymerization
Component reactions	Initiation, propagation & termination reactions are essentially identical in rate and mechanism.	Initiation, propagation & termination reactions significantly different in rate and mechanism.
Polymer growth	Slow, random growth of polymer. High reaction conversion is required for a high degree of polymerization.	Once initiated, a rapid, preferential growth of each polymer chain. High degrees of polymerization are attained at the start of the reaction.
Reactivity of monomer	Functional group in monomer unit is usually assumed to have the same reactivity as the functional group on the end of the growing polymer chain. Monomer is capable of combining with itself or with any other species present with equal ease. This results in rapid disappearance of monomer at early stages of the polymerization reaction.	External energy or addition of highly reactive compound is required to initiate monomer polymerization. In propagation reactions monomer is capable of reacting only with an active end-group on a polymer chain. This results in significant but steadily decreasing concentrations of monomer throughout the polymerization reaction.
	 <p style="text-align: center;">Time</p>	 <p style="text-align: center;">Time</p>

contd./

Table 1.1 contd.

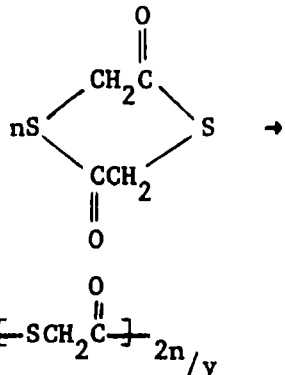
Characteristic	Step-growth polymerization	Chain-growth polymerization
<p>Typical example</p>	<p>Self-esterification of thioglycolic acid.</p> $n\text{HSCH}_2\overset{\text{O}}{\parallel}\text{COH} \rightarrow$ $x\left[\text{SCH}_2\overset{\text{O}}{\parallel}\text{C}\right]_{n/x} + n\text{H}_2\text{O}$ <p><math>x</math> = number of polymer molecules</p> <p><math>\frac{n}{x}</math> = average degree of polymerization</p>	<p>Ring-opening transesterification of dithioglycolide</p>  <p><math>y</math> = number of polymer molecules</p> <p><math>\frac{2n}{y}</math> = average degree of polymerization</p>
	<p><math>x &gt; y</math></p> <p><math>\frac{n}{x} &lt; \frac{n}{y}</math></p>	

(a) Photoinitiated Polymerization

A vast number of valuable polymers have been prepared using ultraviolet light. Over a century ago Blyth and Hofmann<sup>8</sup> obtained a polymer from styrene on exposure of the monomer to light. Berthelot and Gaudechon<sup>9</sup> successfully employed ultraviolet light in the first reported polymerization of ethylene to a solid.

The majority of photochemically initiated polymerizations are typical chain processes in which the elementary steps are the production of primary radicals, initiation of chain radicals from primary radicals, chain propagation and chain termination. The chain reaction nature of such processes was first shown by Ostromislenski<sup>10</sup> in 1912, who found that, for poly(vinyl bromide), the quantity of polymer produced by light was considerably greater than that expected from an ordinary photochemical reaction. Quantum yields (in terms of the number of monomer molecules polymerized per quantum absorbed), of the order  $10^3$  or more were known in the 1930's, examples being the photoactivated polymerization of vinyl acetate in the liquid phase,<sup>11</sup> and the photoactivated polymerization of methyl acrylate.<sup>12</sup>

Direct photolysis of the monomer may be sufficient to produce free radicals initiating polymerization, as in the case of pure styrene polymerization. Alternatively a wide range of substances may be employed as suitable free radical sources on photochemical irradiation. A few examples of compounds used in initiation are shown in Table 1.2. Further examples may be found in a review by Oster and Yang<sup>6</sup> and references cited therein.

TABLE 1.2  
Photochemical Initiating Systems in Free Radical Polymerization of Vinyl Monomers

Initiating System		Monomer	Reference
Class of Compound	Example		
Carbonyl compounds	Acetone	Acrylonitrile	13
Peroxides	Di-t-butyl peroxide	Acrylonitrile	14
Organic sulphur compounds	Tetramethylthiuram monosulphide $\left( \begin{array}{c} \text{S} \\ \parallel \\ (\text{CH}_3)_2\text{NC-S-S-C-N}(\text{CH}_3)_2 \end{array} \right)$ $\alpha, \alpha'$ -azobisisobutyronitrile	Methyl methacrylate	15
Azo compounds	Bromoform	Vinyl chloride	16
Halogen containing compounds	Rhenium carbonyl	Acrylonitrile	17
Metal carbonyls	Lead tetraethyl	Methyl methacrylate	18
Inorganic and organometallic substances	Riboflavine	Acrylonitrile	19
Dyes		Acrylamide	20

Amongst advantages of light-initiated free radical processes over thermally induced processes are the possibilities of studying nonsteady-state kinetics of polymerization simply by turning the light on and off,<sup>6</sup> the study of polymerizations at very low temperatures which reduces the frequency of chain-transfer processes leading to branched polymers and sometimes makes it possible to obtain stereoregular polymers,<sup>21</sup> and its uses in photography<sup>22</sup> (also see section 1.2(b)).

Not all photoinitiated polymerizations involve the production of free radicals. In solution, ionic mechanisms may operate. For example sodium tetrachloroaurate,  $\text{NaAuCl}_4 \cdot 2\text{H}_2\text{O}$ , has been used as a photosensitizer in the cationic polymerization of N-vinylcarbazole.<sup>23</sup>

#### (b) Photochemical Crosslinking of Polymers

Applications of photocrosslinkable polymers can be traced back as far as the time of the Babylonians who used exposure of a form of pitch to light in the preparation of decorations.<sup>24</sup> Niépce, "the world's first photographer", used the natural light sensitivity of an asphalt, bitumen of Judea, in the preparation of a heliographic copy of an engraving in 1822.<sup>22,25</sup>

The work of Minsk was of prime importance in the development of the field, with his preparation of poly(vinyl cinnamate) and the incorporation of dyes into the coating of the polymer, providing a means of photosensitization.<sup>26</sup> Some structures of light sensitive units incorporated into polymers are indicated in Fig.1.1.<sup>24</sup>

Crosslinking may involve photodimerization via cyclobutane formation, as is thought to be the case with poly (vinyl cinnamylideneacetate);<sup>27</sup> (cinnamylideneacetate =  $\text{PhCH}=\text{CH}-\text{CH}=\text{CH}-\text{COO}-$ ).

FIGURE 1.1

Light sensitive units incorporated into polymers.<sup>24</sup>

Olefin  $>C=C<$

$\alpha, \beta$ - Unsaturated ketone  $>C=C \leftarrow C=O$

Diazoketone

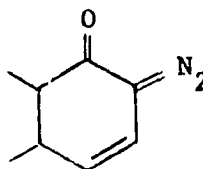

Azide  $-N_3$

Carboazide  $\begin{array}{c} O \\ || \\ -C-N_3 \end{array}$

Sulphone azide  $\begin{array}{c} O \\ || \\ -S-N_3 \\ || \\ O \end{array}$

Diazonium salt  $R-N_2X^+$

Crosslinking is commonly observed as a competing process with degradation in polymers exposed to light. In general terms such crosslinking is largely due to reactions of secondary polymer radicals resulting from cleavage of groups or atoms from the main polymer chain (cf. section 1.3). Actual crosslinking may occur by radical combinations or by addition to unsaturated sites in other chains. As an example of radical combination, irradiation of poly(ethyl acrylate) films at 253.7nm results in crosslinking, the degree of which is proportional to the amount of light absorbed.<sup>28</sup> Cleavage of the carbon-carbon bond adjacent to the carbonyl function produces a stable free radical capable of combination at a similar site on another chain (1.5).

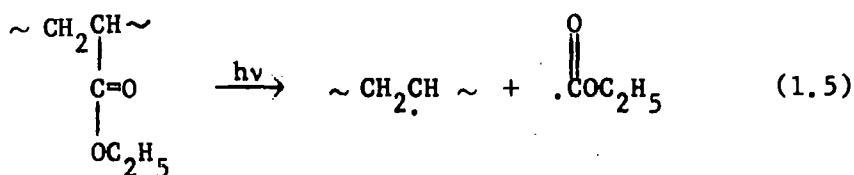

A plethora of examples of photochemical crosslinking of polymers and the related photochemical grafting of one monomer to a polymer may be found in the literature.

### (c) Step-growth Photopolymerization

The preceding sections 1.2(a), 1.2(b) briefly indicate the multitude of well established polymers that have been prepared by reactions long classified under the general heading of photopolymerization. Over the last few years, however, there has been an increasing number of reports of polymer reactions of the step-growth type, in which photochemical reactions are used in forming the bonds of a linear polymer chain in each propagation reaction. De Schryver and Smets have thus

pointed out the need to reexamine the concept of photopolymerization. Recently they have suggested that the term photopolymerization be reserved specifically for polymerization processes in which every chain propagation step involves a photochemical reaction.<sup>29</sup> In this sense photopolymerization is distinct from photoinitiated polymerization.

De Schryver and Smets have divided photopolymerizations into three classes according to the nature of the species intervening in the propagation step. The intervening species may be a singlet excited state, a triplet excited state or a reactive ground state resulting from a photochemical reaction. Examples of each class have been reported and a detailed review of polymerizations embraced by the redefined term photopolymerization may be found in sections 1.5-1.12 of this chapter.

Step-growth photopolymerizations generally involve the use of suitable non-conjugated bichromophoric systems. Possible processes occurring on excitation of one of the chromophores are illustrated in Figure 1.2.<sup>30</sup>

Deactivation of the excited state (path a) may yield ground state starting material. Delocalization of the excited state over the two chromophores (path b) may occur and the resulting complex may also deactivate to starting material (path c). Cyclomerization is possible (paths b, d, or path e), depending on the probability of reaching, within the lifetime of the excited state involved, a conformation favourable for reaction, and on the stability of this conformation.<sup>31,32</sup> With non-identical chromophores intramolecular energy transfer is possible (paths f and g) as is subsequent deactivation (path h). All these processes are alternatives to photopolymerization (path i) and for the latter reaction to be successful, due consideration must be given to the possible competing processes.

FIGURE 1.2

Possible reaction pathways in non-conjugated bichromophores<sup>30</sup>

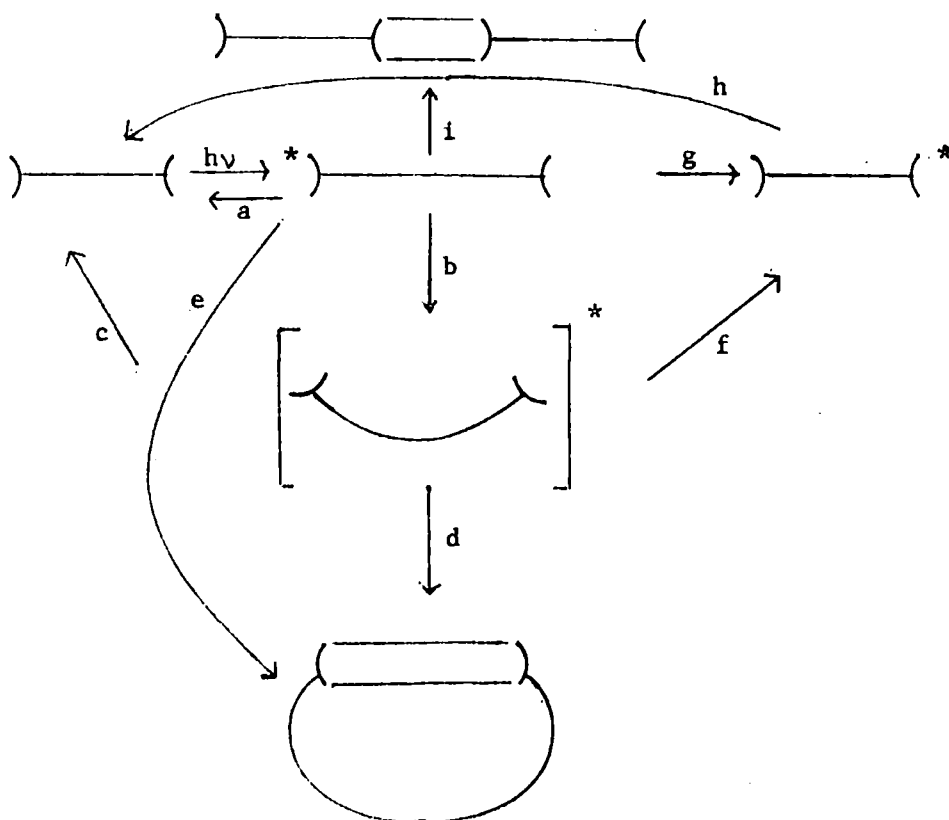

Key ) = chromophoric group; \* = photoexcited group.

### 1.3 Photodegradation of Polymers<sup>33</sup>

In any study on photopolymerization possible destructive effects of light on the polymers must be taken into account in the selection of suitable systems and reaction conditions. A considerable volume of research has been directed towards obtaining an understanding of the photodegradation and photooxidation of polymers. The destruction of man-made polymers and changes in polymer properties as a result of exposure to sunlight are problems of particular interest to industry and environmentalists alike.

In relation to polymer degradation, ultraviolet light is responsible for two major types of reaction; firstly chain scission involving rupture of bonds in the backbone of the polymer chain leading eventually to the formation of low molecular weight fragments of the polymer, and secondly crosslinking with the formation of an insoluble infusible network structure. Competition between these two reactions usually determines the net effect of such irradiation. Crosslinking has already been considered in section 1.2(b).

An understanding of processes involved in the interaction between ultraviolet or visible light and polymers is fundamental to studies of polymer photodegradation.<sup>33</sup> Primary processes involved on absorption of a photon by a molecule are discussed in Chapter 2. Effects of irradiation at suitable wavelengths on polymers containing chromophores, such as the carbonyl group, may be considered in terms of fundamental photochemical reactions of the chromophores. Two fundamental photochemical reactions of simple aliphatic ketones are  $\alpha$ -cleavage and  $\gamma$ -hydrogen transfer (Chapter 2, section 2.5). Products from the

photolytic degradation of poly(methyl vinyl ketone) may be explained by such reactions occurring in the polymer.<sup>34</sup>

Amongst many studies of the destructive effects of ultraviolet light on polymers are those of Stephenson<sup>35</sup>, who has studied the effectiveness of ultraviolet light in producing scission, crosslinking, and degradation of physical properties in polymers including nylon, poly(ethylene terephthalate), polyethylene, teflon and acrilan. Decomposition products have been identified and mechanisms discussed. Free radicals produced by rupture of a chain may recombine, giving no net result, or may combine with some other radical or reactant resulting in scission. Free radicals formed on adjacent sites of different molecular chains by C-H bond rupture may combine to form a crosslink or may combine with mobile species preventing crosslinking. A typical proposed<sup>35c</sup> mechanism is that for the photolysis of poly(ethylene terephthalate), shown below (1.6).

Kinetic expressions have been derived for chain scission and crosslinking associated with photodegradation, and applied to polymers such as poly( $\alpha$ -methylstyrene).<sup>36</sup> In general, polymers producing high monomer yields on pyrolysis also do so on photolysis at elevated temperature, an example being the photodegradation of poly(methyl methacrylate).<sup>37</sup>

Polymers may lose pendant groups on photolysis, poly(vinyl chloride) losing HCl on exposure to ultraviolet irradiation (or heat).<sup>33,38</sup>

Processes occurring on photolysis of polymers may also be a result of indirect reactions resulting from excitations and free radical formation involving materials 'foreign' to the polymer. Important examples are impurities incorporated during the synthesis of polymers, and the effect of atmospheric oxygen. Photooxidation mechanisms are

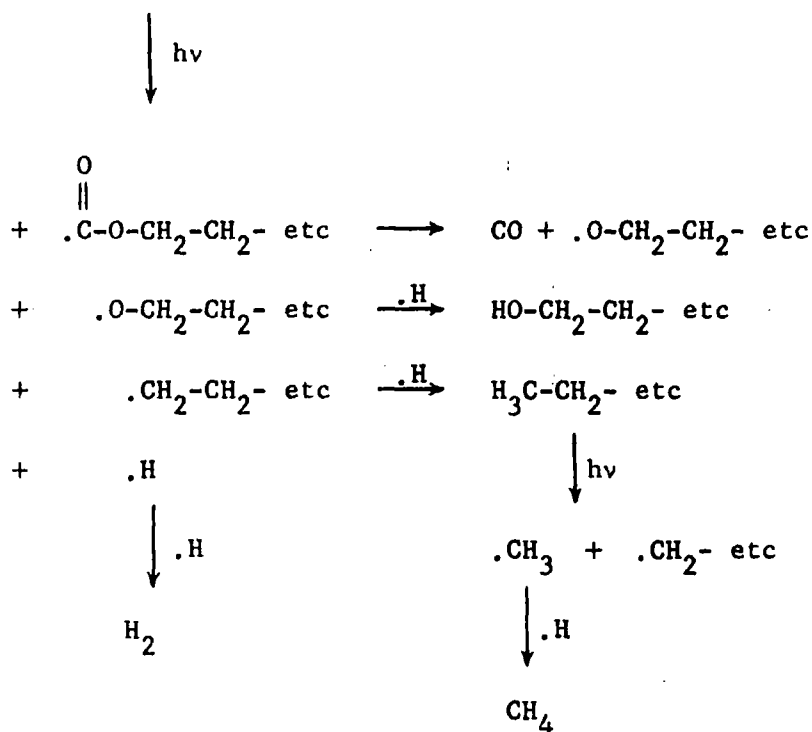
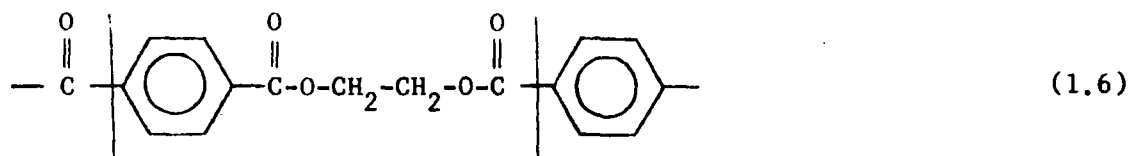

discussed in Chapter 2. Oxygen may act as an accelerator (polystyrene), or an inhibitor (poly(methyl methacrylate)) towards chain scission, or may be without influence.<sup>33</sup>

Vinyl polymers are thought to degrade in sunlight, owing to the presence of small amounts of impurities which absorb light and initiate oxidative chain reactions within the polymer.<sup>39</sup> In the oxidation process, compounds containing peroxy and keto groups are formed which absorb in the long wavelength region and accelerate breakdown of polymer chains.

In general terms, decomposition of hydroperoxide groups on polymer chain backbones is probably responsible for the greatest amount of polymer chain scission occurring in oxidative degradation reactions.<sup>3</sup>

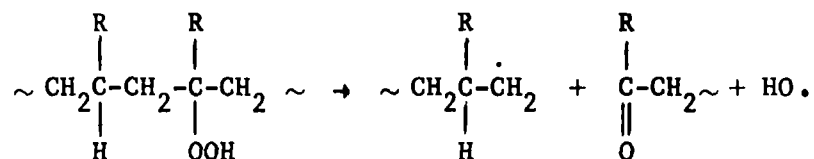

#### 1.4 General Requirements for Step-growth Polymerization<sup>3</sup>

The requirements for production of a high molecular weight polymer by a step-growth mechanism are comparable with those for obtaining a pure product, in almost quantitative yield, in synthetic organic chemistry. Maximum molecular weight can only be expected where conditions favour the most efficient reaction of the functional groups involved.

A simple equation derived by Carothers relates the degree of polymerization to the extent of reaction. For reaction of a pair of monomers each containing two functional groups of the same type (A-A and B-B), the polymerization may be represented by equation (1.7).

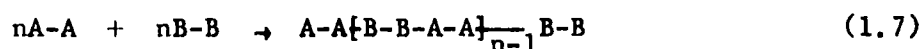

Carothers' equation states that the degree of polymerization ( $\overline{\text{D.P.}}$  = the average number of repeating units per chain) is related to the reaction conversion,  $p$ , of either functional group, by the expression:

$$\overline{\text{D.P.}} = \frac{1}{1-p}$$

Some corresponding  $\overline{D.P.}$ 's and reaction conversions are shown in Table 1.3.

TABLE 1.3  
D.P.'s as a function of reaction conversion  
(derived from Carothers' equation)

Reaction Conversion	$\overline{D.P.}$
50%	2
75%	4
80%	5
90%	10
95%	20
98%	50
99%	100

An equivalent expression applies to self-condensation of a single monomer of the type A-B containing two dissimilar reactive functional groups.

As can be seen from the table high reaction conversions are necessary to achieve even moderate  $\overline{D.P.}$ 's of around 20. In addition, to attain such  $\overline{D.P.}$ 's the condensation process must be free of side reactions preventing the attainment of theoretical yields by consumption of functional groups without producing intermolecular linkages. In polymerizations of the A-A+B-B type, an exact equivalence of functional groups is necessary to attain high molecular weights. For a reaction conversion of 98%, the presence of only 1% monofunctional impurity is sufficient to reduce the expected  $\overline{D.P.}$  from 50 to ca. 34.<sup>3</sup> Consequently

monomers must be available in states of high purity to aid attainment of functional group equivalence and avoidance of undesirable side-reactions. Essentially, therefore, to obtain high molecular weight polymers the step-growth polymerization reactions must occur in virtually quantitative conversions to a unique product.

In view of the rigorous requirements for successful step-growth polymerization, the resulting polymers, particularly from reactions of the A-A + B-B type, are products of finite molecular weight with at least a few unreacted functional groups at the ends of the linear molecules.

Where monomers containing more than two reactive functional groups are present, crosslinking may occur to give network polymers of much greater  $\overline{D.P.}$ 's.

A REVIEW OF KNOWN STEP-GROWTH PHOTOPOLYMERIZATIONS

### 1.5 Four-centre Type Photopolymerization in the Solid State

Over the past few years a number of polymers have been prepared involving a four-centre type solid-state photopolymerization. To date, the major contributions to this area of research have been due to Hasegawa and co-workers, and a brief review covering the earlier stages of the work has been published.<sup>40</sup>

The basic coupling reaction involved is the four-centre cycloaddition of C=C double bonds giving a cyclobutane type ring, (1.8).

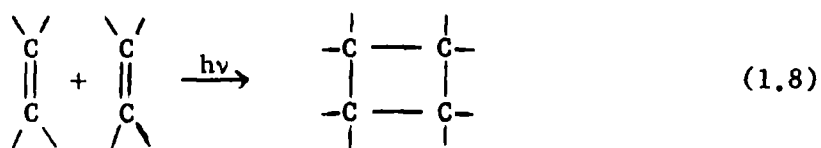

Investigations have been based on the extension of such photodimerizations to solid-state photopolymerizations of compounds having two dimerizable olefinic units per molecule. The resulting polymers have the common structural feature of recurring cyclobutane units in the main chain, most polymerizations being represented by the equation (1.9).

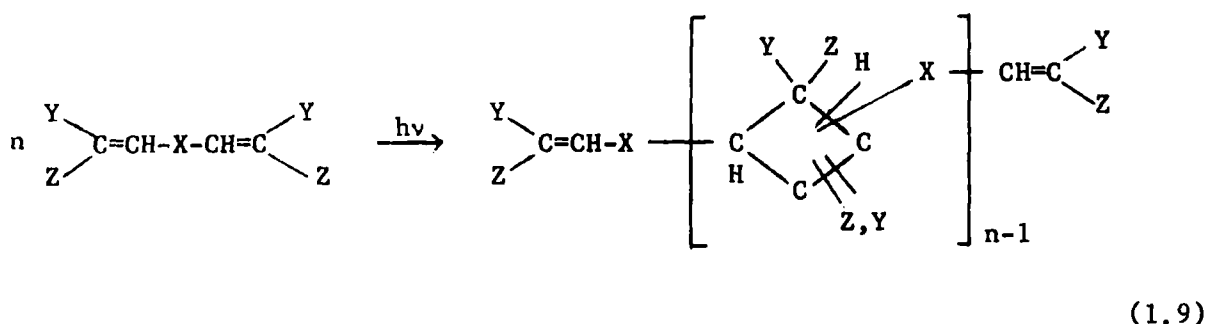

In 1958, Koelsch reported<sup>41</sup> that 2,5-distyrylpyrazine (DSP) was converted, in the solid state, into a colourless infusible polymer on exposure to ultraviolet irradiation for a few hours. This polymerization

was also observed by Hasegawa, and in a more detailed investigation a linear high molecular weight polymer with recurring cyclobutane units in the main chain was obtained (1.10).<sup>42</sup>

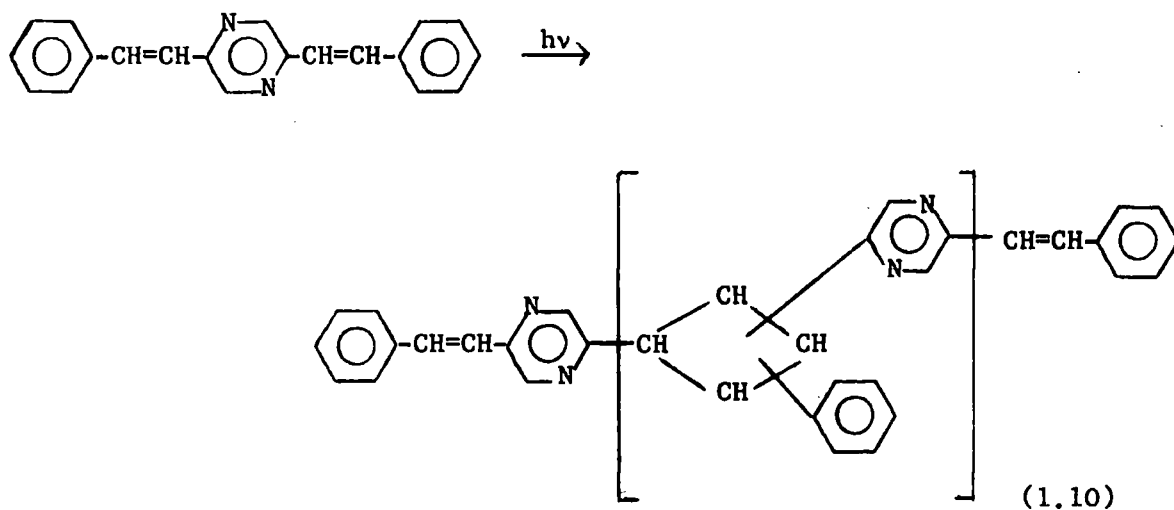

Investigation of the scope of this type of reaction has resulted in the production of a range of polymers. Monomers so far successfully photopolymerized are listed in Table 1.4, together with accompanying data on the resulting polymers. Photodimerizations on which photopolymerizations have been modelled include those of 2-styrylpyridine,<sup>43</sup> cinnamic acid derivatives<sup>44</sup> and ethyl 2-methoxybenzylidene cyanoacetate.<sup>45</sup> Monomers yielding oligomers only are listed in Table 1.5.

TABLE 1.4

## Four-Centre Type Photopolymerization in the Solid State Yielding High Polymers



Monomers	Polymers and Polymerizations							Reference
	Structural Formula of Polymer	Dispersion Medium	Yield (%)	Elemental Analysis (%) Calculated Found	Reduced Viscosity	M.Pt. (°C)		
2,5-Distyrylpyrazine  (DSP)		Cyclohexane	95	84.48 C 5.67 H 9.85 N	3.08 <sup>a</sup>	339-343	42,46	
1,4-bis[β-pyridyl-(2-vinyl)]benzene  PZVB		Water-ethanol 5 : 1	85-90%	84.48 C 5.67 H 9.85 N	1.19 <sup>b</sup>	340	46	
Phenylene diacrylic acid and derivatives 		Water or Water-ethanol	~ 100 ~ 100 ~ 100 42 65 85 ~ 100	66.65 C 4.62 H 68.28 C 5.73 H 70.05 C 6.61 H 71.50 C 7.34 H 71.50 C 7.34 H 77.82 C 4.90 H 66.66 C 5.59 H 14.80 N	0.12 <sup>c</sup> 25.0 <sup>c</sup> 1.41 <sup>c</sup> 0.26 <sup>c</sup> 0.45 <sup>c</sup> 0.90 <sup>d</sup> 1.50 <sup>c</sup>	290 415 347 360 320 420 405	47,48	

Table 1.4 contd.

Monomers	Polymers and Polymerizations							Reference
	Structural Formula of Polymer	Dispersion Medium	Yield (%)	Elemental Analysis (%) Calculated Found	Reduced Viscosity	M.Pt. (°C)		
<p><math>\alpha, \alpha'</math>-Dicyano-p-benzenediacrylic acid and derivatives</p>  <p> <math>\text{COOCH}_3</math>  <math>\text{COOC}_2\text{H}_5</math>  <math>\text{COO-nC}_3\text{H}_7</math>  <math>\text{COO-iC}_3\text{H}_7</math>  <math>\text{COO-nC}_4\text{H}_9</math>  <math>\text{COO-nC}_8\text{H}_{17}</math> </p>		Inert solvent e.g. water-ethanol	<p>~ 100</p> <p>66</p> <p>~ 100</p> <p>~ 100</p> <p>88</p> <p>~ 100</p>	<p>64.86 C 4.08 H 9.45 N</p> <p>66.65 C 4.94 H 8.65 N</p> <p>68.14 C 5.71 H 7.96 N</p> <p>68.14 C 5.17 H 7.96 N</p> <p>69.45 C 6.36 H 7.37 N</p> <p>73.13 C 8.14 H 5.68 N</p>	<p>0.3<sup>c</sup></p> <p>2.6<sup>c</sup></p> <p>3.0<sup>c</sup></p> <p>1.8<sup>c</sup></p> <p>0.6<sup>c</sup></p> <p>-</p>	<p>290</p> <p>340</p> <p>335</p> <p>320</p> <p>330</p> <p>-</p>	43	
<p>Polymethylene dicinnamates</p> <p>e.g.</p> 		40° - 60° petroleum ether	7		Inherent Viscosity 0.25 <sup>e</sup>	198-200 <sup>f</sup>	50	

Table 1.4 contd.

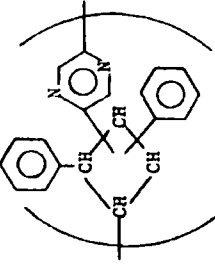
Monomers	Polymers and Polymerizations						Reference
	Structural Formula of Polymer	Dispersion Medium	Yield (%)	Elemental Analysis (%) Calculated Found	Intrinsic Viscosity	M. Pt. (°C)	
<p>Dibenzylidenebenzenediacetoneitriles e. g.</p>		methanol-water 1:1	—	70.85 C 4.76 H 5.51 N 70.95, 71.00 4.91, 4.73 5.48, 5.60	0.448	300-320	51

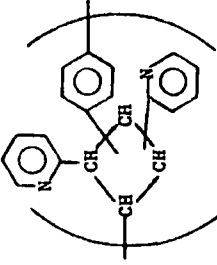
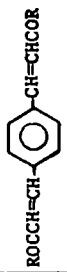
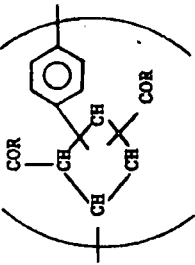
Notes

- 0.35 g. polymer/100 ml.  $\text{CF}_3\text{COOH}$  at  $30^\circ\text{C}$
- 0.36 g. polymer/100 ml.  $\text{CF}_3\text{COOH}$  at  $30^\circ\text{C}$
- 0.36 g. polymer/100 ml. conc.  $\text{H}_2\text{SO}_4$  at  $30^\circ\text{C}$
- Measured in aqueous NaOH
- Polymer 80% soluble. Reduced viscosity of soluble fraction recorded for 0.39 g. polymer/100 ml. dichloroacetic acid
- Soluble fraction - see note e.
- Measured in  $\text{H}_2\text{SO}_4$

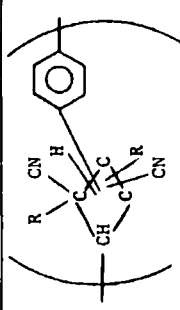
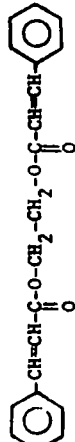
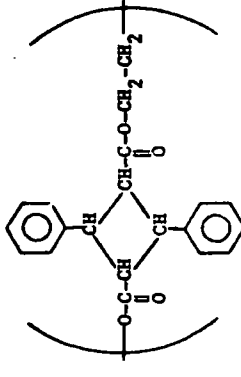
TABLE 1.5

Four-Centre Type Photopolymerization in the Solid State of Phenylene Diacrylic Acid Derivatives,  $\text{ROCCH}=\text{CH}-\text{Ar}-\text{CH}=\text{CHCOR}$ , yielding Oligomers. <sup>48</sup>

Monomer		Oligomer			
Ar	R	Yield %	Elemental Analysis %		Melting Point °C
			Calculated	Found	
p-C <sub>6</sub> H <sub>4</sub>	OC <sub>6</sub> H <sub>4</sub> NO <sub>2</sub>	89	62.61 C 3.51 H 6.09 N	62.46 3.32 5.97	310-320
m-C <sub>6</sub> H <sub>4</sub>	OH	~ 100	66.05 C 4.62 H	67.62 5.33	230-260
m-C <sub>6</sub> H <sub>4</sub>	OCH <sub>3</sub>	~ 100	68.28 C 5.73 H	67.40 5.68	85-95
p-C <sub>6</sub> H <sub>4</sub>	OCH <sub>2</sub> C <sub>6</sub> H <sub>5</sub> <sup>a</sup>	-	-	-	-
p-C <sub>6</sub> H <sub>4</sub>	OC <sub>6</sub> H <sub>4</sub> CH <sub>3</sub> <sup>a</sup>	-	-	-	-
p-C <sub>6</sub> H <sub>4</sub>	OC <sub>4</sub> H <sub>9</sub> <sup>a</sup>	-	-	-	-
p-C <sub>6</sub> H <sub>4</sub>	NHC <sub>4</sub> H <sub>9</sub> <sup>a</sup>	-	-	-	-
m-C <sub>6</sub> H <sub>4</sub>	OC <sub>6</sub> H <sub>5</sub> <sup>a</sup>	-	-	-	-

Note a. These monomers showed spectral change on irradiation (KBr pellet method).

(a) Preparation and Characterization of Polymers

Polymers were obtained by dispersion of the crystalline monomer in an inert medium such as cyclohexane, petroleum ether, or water-alcohol mixtures, and irradiation with, for example,<sup>46</sup> 100-W high pressure mercury lamps or 500-W xenon lamps. Attempts to photopolymerize the monomers in the molten state, e.g. p-phenylene diacrylic acid (p-PDA) ethyl ester, or in solution, e.g. dicyano-p-benzenediacrylic acid (p-CBA) ethyl ester, were largely unsuccessful with, respectively, virtually complete recovery of starting material<sup>48</sup> or for solution reactions, formation of monomer-solvent adducts or isomerization of starting material.<sup>49</sup> However, amorphous oligomer was obtained from irradiation ( $\lambda > 380$  nm) of DSP in chloroform.<sup>52</sup>

Suitable selection of the dispersion medium allowed some control over polymerization. DSP dissolves slightly in cyclohexane with resulting absorption of light by dissolved DSP, and a decrease in the rate of solid-state photopolymerization compared to use of a water-methanol dispersion medium in which DSP is entirely insoluble.<sup>53</sup>

Direct exposure of layers of crystals of dibenzylidenebenzenediacetonitriles was sufficient for their polymerization.<sup>51</sup>

Standard procedures were used in the characterization of the polymers. Elemental analyses (Table 1.4) of polymers were in the same region as monomer analyses. Changes in infrared spectra on photopolymerization were consistent with those expected for the postulated course of reaction. Thus the absorption peak in the  $1640\text{-}1600\text{ cm}^{-1}$  region (C=C stretch), prominent in monomer spectra, disappeared on irradiation. A weak peak at ca.  $930\text{ cm}^{-1}$  in poly DSP and poly(1,4-bis[ $\beta$ -pyridyl-(2)-vinyl]benzene),

(poly P2VB) has been assigned to a vibration of the cyclobutane units.<sup>54</sup> Other changes such as disappearance of an absorption peak at  $1000-970\text{ cm}^{-1}$ , indicative of trans CH=CH bonding in monomer, and shift of the carbonyl group absorption to higher frequency in p-PDA ester polymerization,<sup>48</sup> were also consistent with the proposed reaction. Infrared analysis of the polymerization was aided by direct irradiation of a few milligrams of monomer dispersed in a potassium bromide pellet.<sup>48</sup>

N.m.r. evidence for the presence of cyclobutane units in the main chains of polymers included a broad band at 5.0-5.16 in the n.m.r. spectra of poly DSP and poly P2VB, characteristic of protons bonded to 1,2,3,4-tetraarylated cyclobutane rings.<sup>55</sup> Satisfactory assignment of other proton absorptions and satisfactory integrations have been recorded.

Chemical evidence for polymer structures included the failure of poly DSP to be brominated under conditions appropriate for bromination of DSP.<sup>46</sup>

The high molecular weight polymers were high melting, crystalline solids although slight decomposition to monomers was observed below the melting point, attributable to pyrolytic degradation of the cyclobutane residues.<sup>46</sup> The highly crystalline polymers were only soluble in strong acid solvents such as concentrated sulphuric, trifluoroacetic or dichloroacetic acids, where the polymers exist in the salt form.<sup>46,49</sup> Lower molecular weight amorphous polymers were at least partially soluble in ordinary organic solvents.

(b) Polymerization Mechanism

Kinetic studies were consistent with a step-growth polymerization mechanism. A detailed study on DSP photopolymerization showed that the reduced viscosity at first increased gradually with increasing conversion. Above 80% conversion, reduced viscosity increased sharply and continued to rise on irradiation even after consumption of monomer was complete.<sup>53</sup> The molecular weight of the polymer at low conversion had a wide distribution. Polymerization proceeded only during irradiation, reaction rate increasing with light intensity, and crystalline DSP did not polymerize under the action of free radical initiators such as benzoyl peroxide.<sup>53</sup> The kinetic polymerization behaviour of other polymers under consideration was close enough to the DSP example to indicate a similar mechanism although polymerization rate and polymer yield varied from monomer to monomer.<sup>48,49</sup>

DSP, P2VB and p-PDA dimethyl ester could be converted quantitatively into highly crystalline oligomers (ca. pentamers) on irradiation at the long-wavelength edge of absorption of the monomer.<sup>52,56</sup> Oligomer formation rendered the molecules so produced transparent to the initial irradiation but reirradiation at a shorter wavelength resulted in quantitative conversion of oligomers into crystalline, high molecular weight polymers identical to those obtained on direct photopolymerization to high polymer. Quantum yields for oligomerization and polymerization of DSP and p-PDA dimethyl ester were between 1 and 2 (in terms of number of olefinic double bonds consumed to form the cyclobutane ring). These results indicate two kinds of separable, step-growth addition mechanisms represented by an overall reaction scheme (1.11).

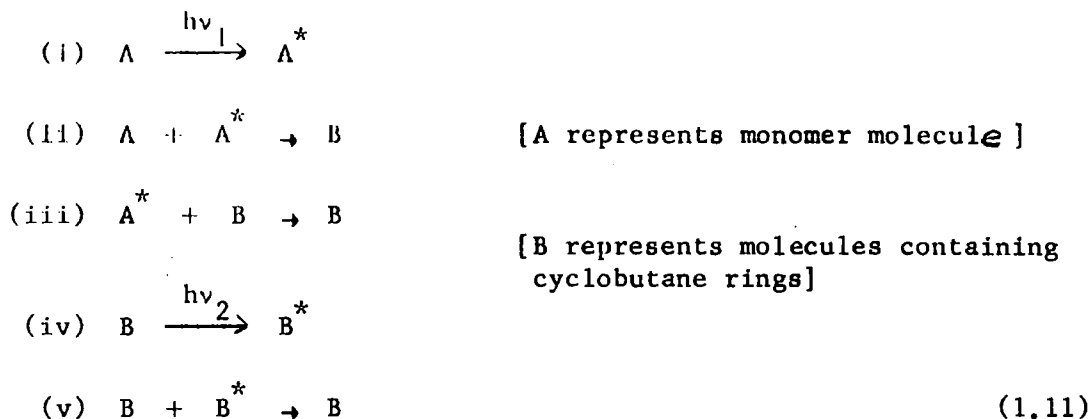

Irradiation at the long-wavelength edge of absorption of A ( $h\nu_1$ ) results only in excitation of A [interruption of  $\pi$ -electron conjugation leaves B transparent to such irradiation and therefore in the ground state]. Oligomer formation thus occurs converting A into B through steps (ii) and (iii). Excitation of B (iv) results in production of high polymer through a growth reaction of the terminal group in the growing chain (v).

Initial exposure to light exciting both A and B results in oligomerization and polymerization through steps (i) to (v) and also allows a  $A + B^* \rightarrow B$  reaction.

p-CBA n-propyl ester could be similarly photooligomerized and photopolymerized.<sup>57</sup>

Although scale-like or sword-like crystals of DSP readily photopolymerized, needle-like crystals of DSP did not polymerize.<sup>53,58</sup> X-ray crystallographic studies showed a simple relationship between the crystal units of photopolymerizable crystalline monomer and polymer crystals.<sup>59</sup> The monomer crystal in which DSP molecules are suitably arranged for polymerization changes into a three dimensionally orientated

polymer crystal, and both polymer and monomer possess the same space group. Crystal axes of the polymer agree in direction with those of monomer, crystal chains extending along the 'C' axis. The relative position and orientation of the reactive double bonds are favourable for cyclobutane formation.<sup>60</sup> It was concluded that the photopolymerization was a topochemical polymerization, three-dimensionally controlled by the crystal structure of the monomer.

Further evidence for a topochemical process lies in the change in density during polymerization of the p-CBA series monomers.<sup>49</sup> Where the density change was found to be smallest (p-CBA n-propyl ester, isopropyl ester and ethyl ester) polymers of highest molecular weight were formed, implying the molecules were favourably aligned in the monomer crystal to polymerize with least atomic or molecular movement.

The topochemical character of the reaction is an explanation of the failure of some monomers to polymerize. X-ray analysis of DSP and P2VB yielded nearly identical powder diagrams in terms of diffraction angles and intensities. In contrast 1,4-bis[ $\beta$ -pyridyl-(3)-vinyl]benzene (P3VB) and 1,4-bis[ $\beta$ -pyridyl-(4)-vinyl]benzene (P4VB) yielded different powder diagrams and did not photopolymerize<sup>58,60</sup> under conditions suitable for P2VB photopolymerization.

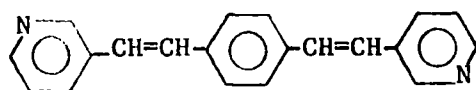

P3VB

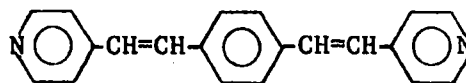

P4VB

It has been suggested that non-polymerizable monomers may polymerize in other crystal modifications.<sup>46</sup> Recrystallization of  $\alpha, \alpha'$ -dicyano-p-benzenediacrylic acid, n-propyl ester oligomer<sup>57</sup> or DSP oligomer<sup>52</sup> yielded non-polymerizable oligomers with crystal structures different from the oligomers as polymerized.

Also consistent with a lattice-controlled topochemical reaction is the fact that polymerization proceeded most readily and yielded the highest, most crystalline polymers at temperatures far below the melting point of the monomer.<sup>53,48,61</sup> For example, with DSP photopolymerization at temperatures greater than 0°C, there was a marked decrease in reduced viscosity as the polymerization temperature increased.<sup>53</sup>

### (c) Stereochemistry of Polymers

There is conflicting evidence over the stereochemistry of the polymers. Originally the absolute configuration, including the distinction between head-to-head and head-to-tail structures, of polymers such as poly DSP was not established.<sup>46</sup> However monomers possessed a trans-trans orientation and polymerization of the p-PDA series of monomers with minimum of atomic or molecular movements indicated the trans-trans orientation must be kept in the polymer. Formation of a five-membered cyclic anhydride from poly p-PDA indicated a probable head-to-head structure<sup>48</sup> (1) whilst the hydrolysed polymer from poly p-PDA phenyl ester appeared to give a six-membered cyclic anhydride indicative of a likely head-to-tail structure (2).

Crystallographic evidence suggested a 1,3-trans configuration (3) as most probable for poly DSP, and was supported by the polymer crystal space group  $P_{bca}$  requiring the centre of symmetry to be at the centre of the cyclobutane ring.<sup>61</sup>

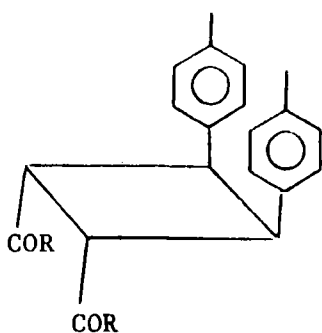

(1)

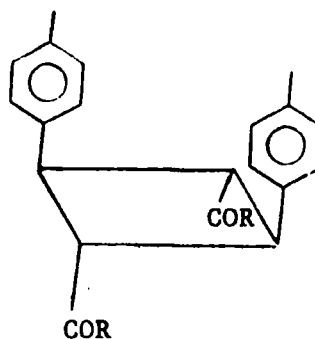

(2)

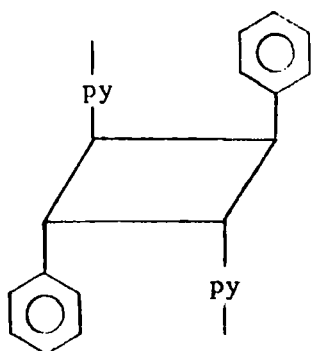

(3)

However this was inconsistent with earlier presumptions based on the hydrodynamic behaviour of solubilized polymer suggesting a randomly kinked polymer chain with 1,2- or 1,3-cis configuration.<sup>62</sup>

(d) Other Data Obtained on poly DSP

Thermal behaviour, dynamic viscoelastic behaviour and electrical properties of poly-DSP have been studied.<sup>63</sup>

(e) Depolymerization

DSP oligomer in chloroform depolymerized to monomer on irradiation at 340 nm,<sup>52</sup> and p-CBA n-propyl ester oligomer in 95% ethanol depolymerized to monomer on irradiation at 224 nm.<sup>57</sup>

### 1.6 Photocycloaddition Polymerization of N,N'-Polymethylenebismaleimides

Investigations on the photopolymerization of N,N'-polymethylenebismaleimides<sup>64,65</sup> are based on established photodimerizations of maleimides.<sup>66</sup> (1.12)

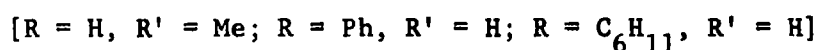
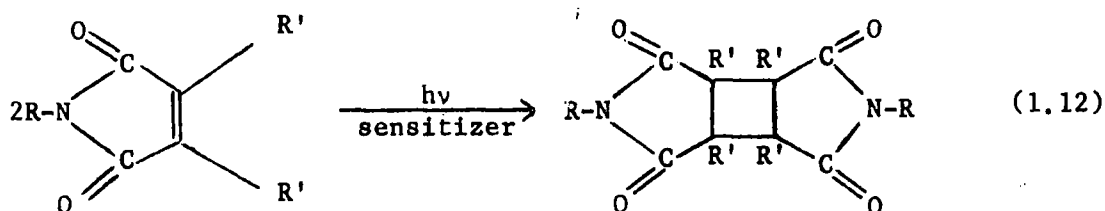

In considering the extension of the solution photochemistry of N-substituted maleimides to N,N'-polymethylenebismaleimides, 3 feasible reaction paths (1,13) were envisaged, namely photocyclomerization (path a), photopolymerization to linear polymer (path b) and production of insoluble cross-linked polymer involving vinyl type polymerization<sup>67</sup> (path c).

Prior<sup>68</sup> and subsequent<sup>31</sup> investigations on the photochemistry of a range of N,N'-polymethylenebismaleimides (R =H) indicates that photocyclomerization occurs when n = 3-7, but the amount of photocyclomerization reduces dramatically for n > 7 and is replaced by formation of largely insoluble material presumably due to crosslinking. Selection of suitably substituted polymethylenebismaleimides has resulted in the formation of some high linear polymers by repeated 2π + 2π photocycloaddition. Both sensitized<sup>64</sup> and unsensitized<sup>65</sup> polymerizations have been performed.

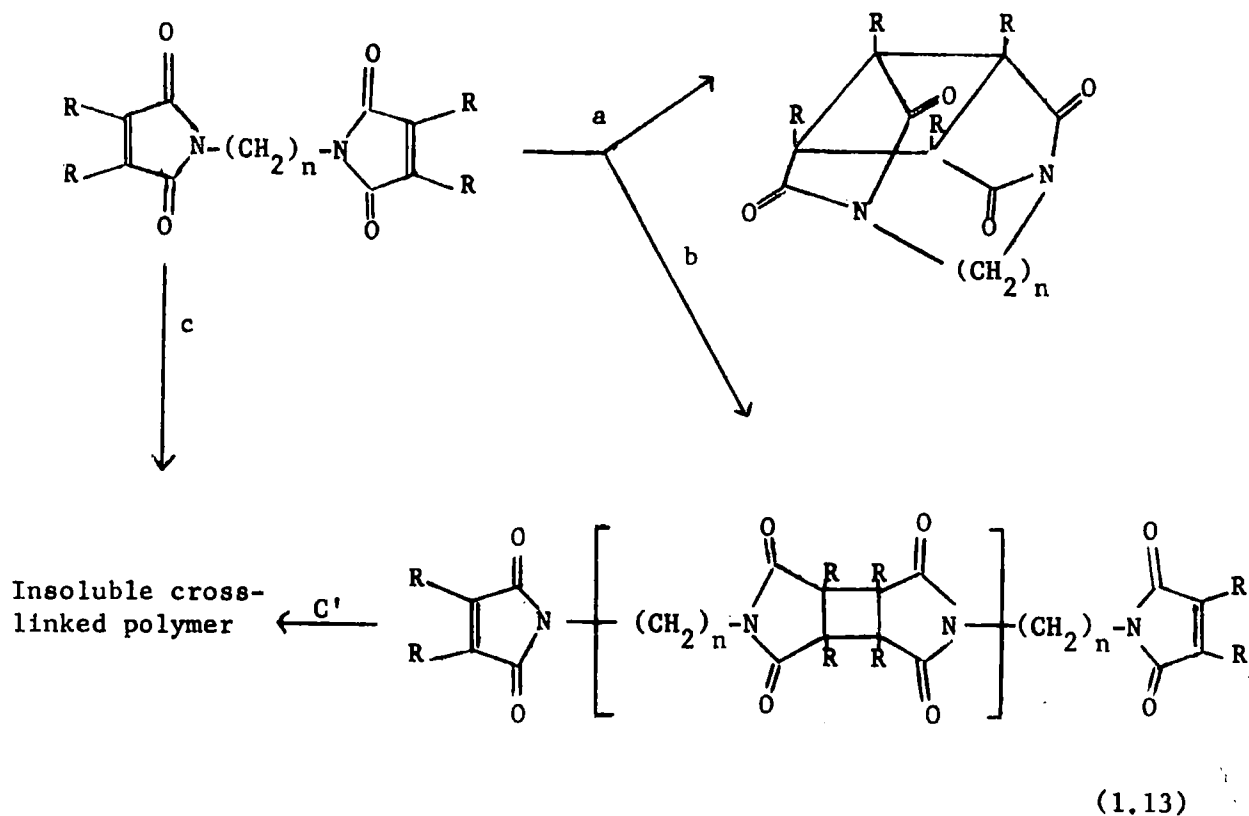

Benzophenone-sensitized solution phase photopolymerization of  $N,N'$ -polymethylenebis(dichloromaleimide)s has resulted in a range of polymers, some data for which is shown in Table 1.6. Selected data on unsensitized photopolymerization of substituted  $N,N'$ -polymethylenebis(maleimide)s is given in Table 1.7.

#### (a) Preparation and Characterization of Polymers

Dichloromethane solutions of monomer and benzophenone sensitizer, where appropriate, contained in stoppered Pyrex reaction vessels were irradiated in the 350 nm region. High monomer purity necessitated purification by column chromatography and solutions for irradiation were first streamed with nitrogen or argon. After irradiation, products were

TABLE 1.6

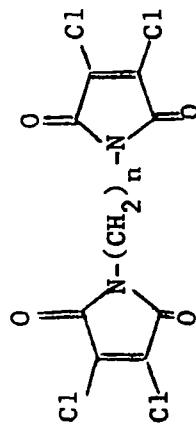
Photocycloaddition Polymerization of N,N'-Polymethylenebisdichloromaleimides,<sup>64</sup>

Monomer, M	Polymerization						Polymer Properties					
	[M] mole litre <sup>-1</sup>	[Benzophenone] mole litre <sup>-1</sup>	Irradiation time (hrs)	Recovered Materials			$\bar{M}_n$	DP	[ $\eta$ ] DMF	D.S.C. melting range °C	T.G.A. onset of decomposition °C	
				(a) %	(b) %	Total %						
n												
7	0.052 0.049 0.195	0.033 0.026 0.137	112 114 121	None None None	51 73 100	51 73 100	1600 4130 -	4 10 -	- - 0.25	130-155 198-220 222-280	- 334 332	
8	0.068	0.055	112	43	43	86	2000	5	-	201-247	-	
9	0.039 0.044 0.20	0.027 0.027 0.12	113 117 120	None None None	75 100 98	75 100 98	3800 6300 30000	8 14 66	- - 0.45	130-150 137-200 None	- - 330	
10	0.043 0.051 0.127	0.007 0.036 0.165	111 118 115	11 22 Most	37 60 90	48 82 90	2700 - -	6 - -	- - -	200-216 200-247 194-224	- 314 -	
11	0.16 0.12	0.11 0.10	118 74	None None	98 76	98 76	- 7000	- 15	0.65 0.11	None -	314 -	
12	0.183	0.183	115	Most		63	-	-	-	185-237	294	

Notes: (a) Precipitated during irradiation. (b) Recovered by solvent evaporation. (c) In N<sub>2</sub> atmosphere.

TABLE 1.7  
Unsensitized Photocycloaddition Polymerization of N,N'-Polymethylenebismaleimides 65

Monomer, M	Polymerization			Polymer Properties		
	[M] mole litre <sup>-1</sup>	Irradiation time (hr)	Yield <sup>a</sup> %	$\bar{M}_n$	$\bar{DP}_n$	$[\eta]$
N,N'-Nonamethylenebis- 3,4,5,6-tetrahydrophthalimide	0.15	72	28	2500	5.9	-
	0.15	166	50	5100	12	0.16
N,N'-Decamethylene- bisbromomaleimide	0.1	93	74	9500	19.4	-
	0.1	165	80	9700	19.8	0.50
N,N'-Undecamethylenebis- bromomaleimide	0.15	96	80	14,500	28.8	0.43
	0.15	41	78	8600	17.1	-
N,N'-Undecamethylene- bisdimethylmaleimide	0.15	48	90	17,900	44.6	-
	0.15	72	90	20,800	51.7	0.90
N,N'-Undecamethylene- biscitraconimide	0.15	17	84	10,000	26.8	-
	0.15	65	100	crosslinked	-	-
N,N'-Undecamethylene- bisdichloromaleimide	0.15	72	69	1960	4.05	-
	0.15	200	69	3880	8.02	0.09

Note: (a) On precipitation.

either recovered by precipitation into methanol, filtering and drying,<sup>65</sup> or by removal of precipitated polymer during irradiation (polymers with an even number of methylene units in the repeating unit tended to precipitate out during irradiation) and solvent evaporation together with Soxhlet extraction of benzophenone.<sup>64</sup>

Generally complete polymer solubility in one or several common organic solvents such as chloroform, dichloromethane or N,N-dimethylformamide was consistent with formation of linear polymers (reaction path 1.13b), polymers with an odd number of methylene units in the repeating unit being the more soluble.

Elemental analyses were in excellent agreement with calculated analyses and infrared spectra of the polymers exhibited characteristically broad bands with the C=C absorption of the monomer ( $\sim 1600 \text{ cm}^{-1}$ ) absent in the polymer spectra. N.m.r. spectra of polymers from the unsensitized photopolymerizations showed singlets characteristic of cyclobutane ring protons. Polymer from N,N'-undecamethylenebisbromomaleimide showed singlets at 4.36 (endo configuration) and 3.986 (exo configuration), integration revealing an endo/exo ratio of 0.22.

Molecular weight data (Table 1.6, 1.7) indicated particularly high polymers from N,N'-nonamethylenebisdichloromaleimide, N,N'-undecamethylenebisdichloromaleimide and N,N'-undecamethylenebisdimethylmaleimide. Thermal analysis data on poly-N,N'-polymethylenebisdichloromaleimides indicated thermal stability (thermo-gravimetric analysis under nitrogen) to be independent of  $\overline{D.P.}$ , whilst melting ranges varied with  $\overline{D.P.}$ 's.

(b) Mechanism and Kinetics of Photopolymerization

Both unsensitized and benzophenone sensitized photopolymerizations of the polymethylenebismaleimides proceed via the triplet manifold of excited maleimide unit. The step-growth nature of the polymerization has been verified by studies on the growth characteristics of the polymerization.

The following reaction scheme (1.14) has been proposed,<sup>30,65,69</sup> where A represents the chromophore of the bichromophoric system A-A

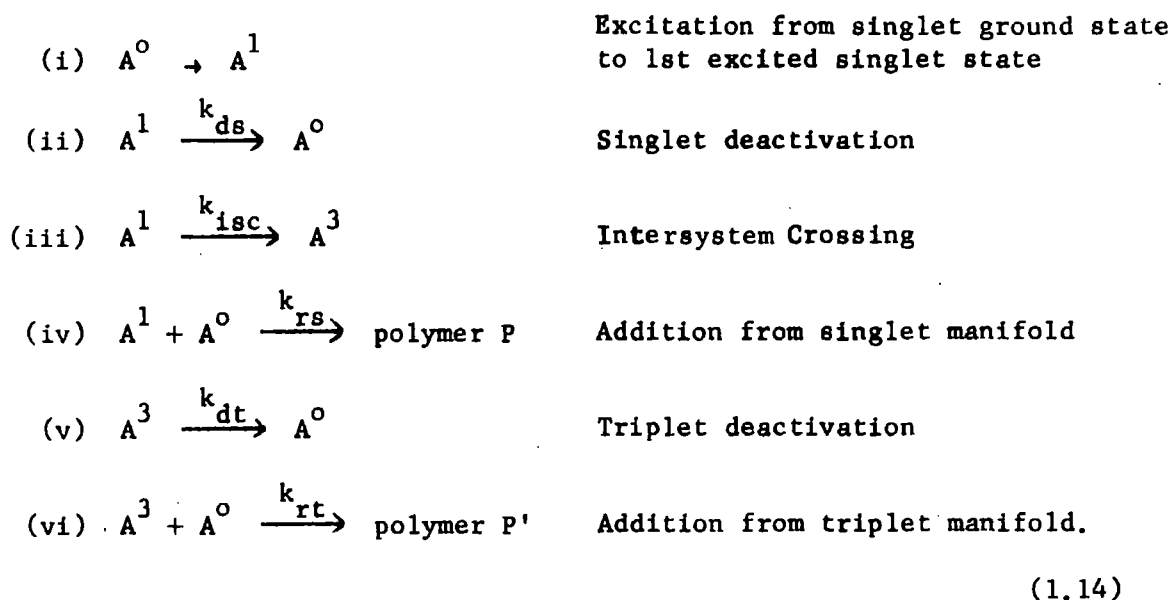

$k_{rs}$  is zero for triplet only polymerization.

Application of the steady state approximation then leads to a rate of polymerization (1.15):

$$-\frac{d[A]}{dt} = \frac{dP'}{dt} = \frac{k_{rt}[A^0]\phi_{isc}I_0}{k_{dt} + k_{rt}[A^0]} \quad (1.15)$$

where  $\phi_{isc}$  = quantum efficiency of intersystem crossing

$I_0$  = incident light intensity (assuming complete light absorption).

Integration leads to the expression (1.16) and (1.17),

$$\frac{k_{dt}}{k_{rt}} \ln \frac{1}{1-p} + p[A^0]_{\text{initial}} = I_0 \phi_{isc}(t-t_0) \quad (1.16)$$

$$\frac{k_{dt}}{k_{rt}} \ln \frac{x_n}{x_n - 1} + \frac{x_n - 1}{x_n} \cdot [A^0]_{\text{initial}} = I_0 \phi_{isc}(t-t_0) \quad (1.17)$$

where  $p$  = degree of conversion

$$x_n = (\equiv \overline{D.P.}) = \frac{1}{1-p}$$

Monitoring of the change in optical density (and hence monomer concentration) as a function of time, and also monitoring of the  $\overline{D.P.}$  as a function of time has shown the validity of the expressions (1.15, 1.16 and 1.17) for bismaleimide photopolymerization. If  $k_{rt} \gg k_{dt}$ , the photopolymerization should obey zero order kinetics as in the case of  $N,N'$ -polymethylenebisdimethylmaleimide. For  $k_{rt} \ll k_{dt}$ , the photopolymerization should be first order in monomer concentration as a function of time, as with  $N,N'$ -polymethylenebisbromomaleimides. Intermediate kinetics have been found for  $N,N'$ -polymethylenebisdichloromaleimides ( $k_{rt} \sim k_{dt}$ ).<sup>69</sup>

For photopolymerization of  $N,N'$ -undecamethylenebisdimethylmaleimide, plots of intrinsic viscosity and number average molecular weight against degree of conversion have been shown to be nearly identical hyperbolas (Figure 1.3) indicating a near linear relationship between intrinsic viscosity and number average molecular weight.<sup>65</sup>

FIGURE 1.3

Dependence of intrinsic viscosity and number average molecular weight  
on degree of conversion in photopolymerization of N,N'-undecamethyl-  
enebisdimethylmaleimide

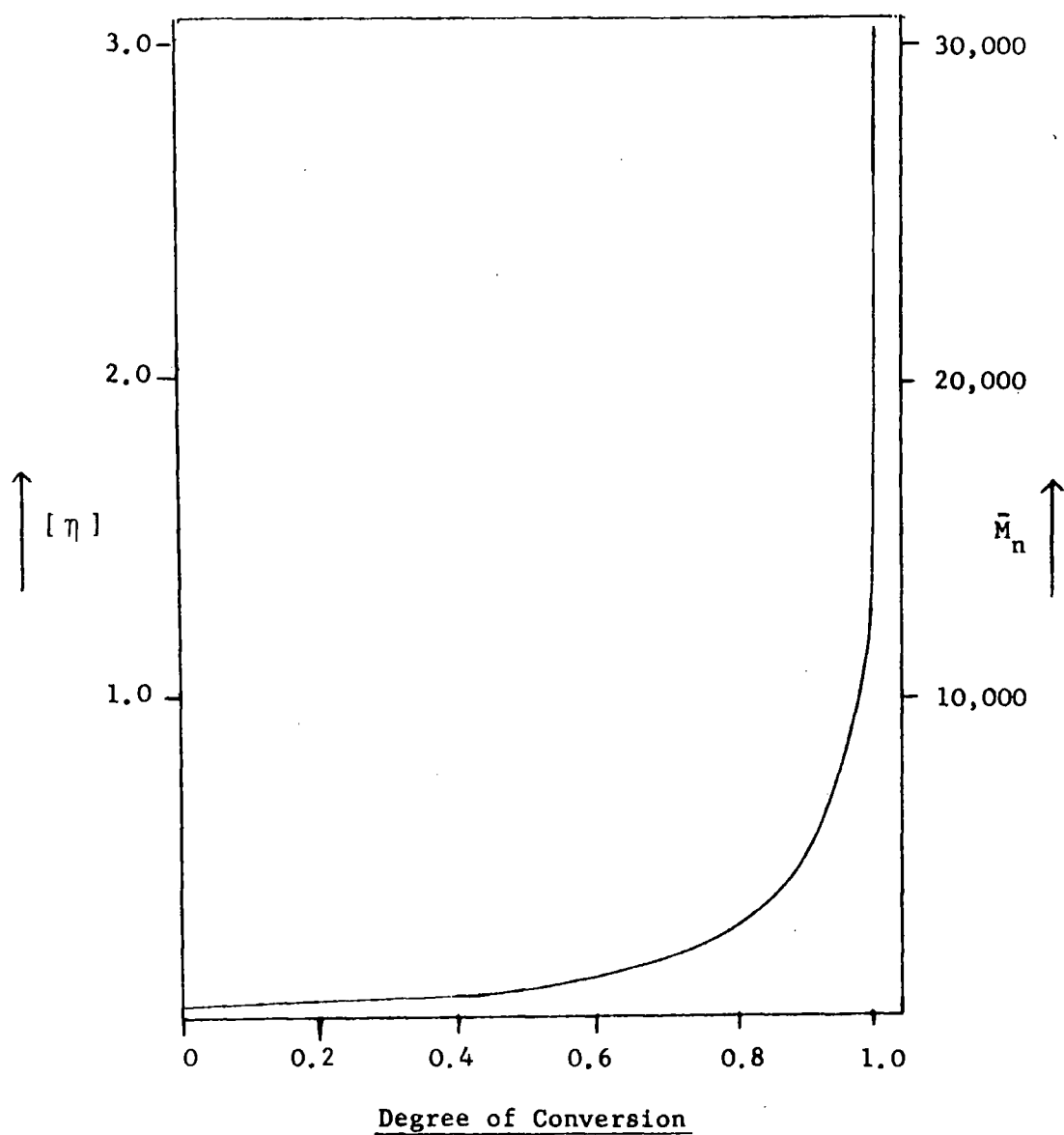

(c) Solid-state Photopolymerization

Some N,N'-polymethylenebismaleimides containing three methylene link units (including -bisdichloro- and -bisdimethyl- maleimides) are also photopolymerizable in the solid state, the reaction being lattice controlled.<sup>69</sup> More than three methylene link units have been shown to render polymethylenebisdichloromaleimides non-photopolymerizable owing to a change in molecular packing in the crystals.

1.7 Photopolymerization of Biscoumarins

Coumarins may be photodimerized in solution, an example being benzophenone sensitized triplet photodimerization of 7-acetoxycoumarin (1.18).<sup>70</sup>

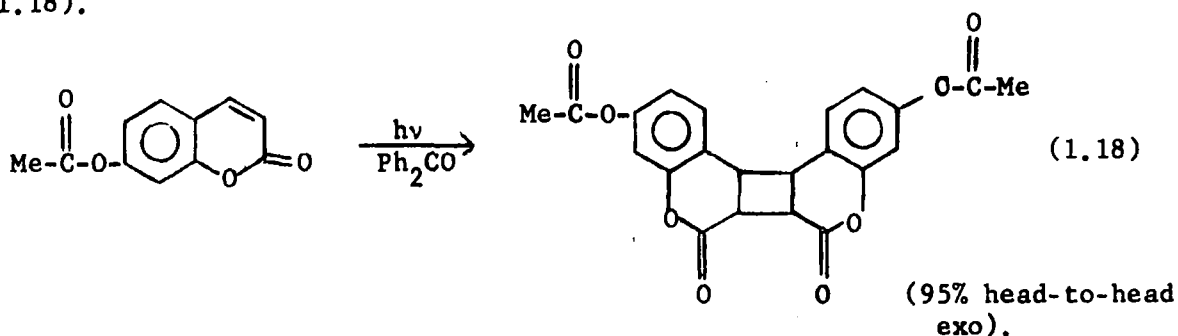

Extension of this reaction to biscoumarins<sup>69</sup> has yielded polymers according to the equation (1.19).

Some data for polymers obtained is given in Table 1.8.

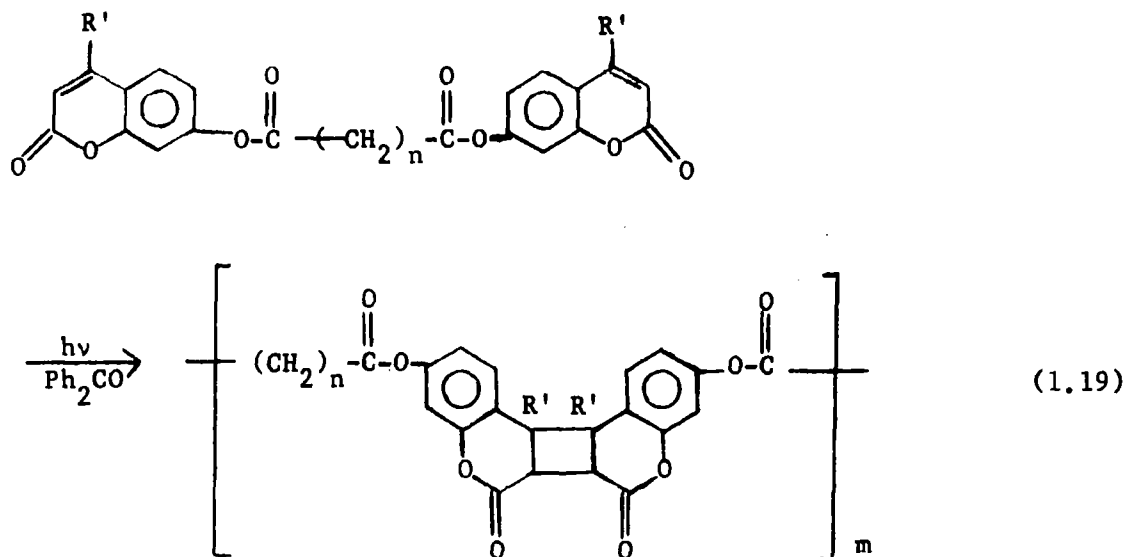

TABLE 1.8

Photopolymerization of Biscoumarins ( $R' = \text{Me}$ )

n	Intrinsic Viscosity in $\text{CHCl}_3$	$\bar{M}_n$
7	0.3	-
8	0.4	-
10	0.3	-
11	0.4	-
12	0.5	22,000

The linkage has been assumed to be head-to-head as with the 7-acetoxycoumarin photodimer.<sup>70</sup>

In contrast, direct irradiation of the polymethylenedicarboxylic acid (7-coumarinyl) diesters ( $R' = \text{H}$ ) where  $n = 4-7$  yielded cyclomers<sup>70</sup> (4) and (5).

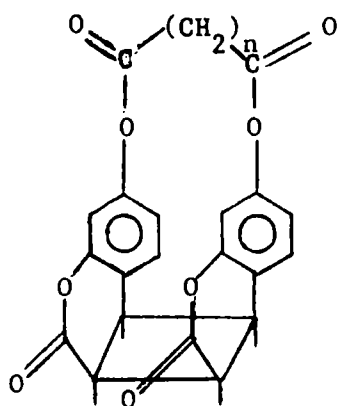

(4)

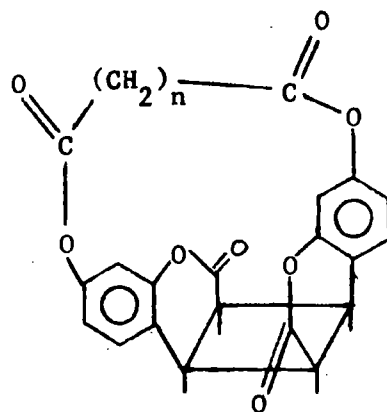

(5)

Direct irradiation of solutions of 7,7'-polymethylenedioxycoumarins, as below, also gave cyclomers (equation 1.20).<sup>70</sup>

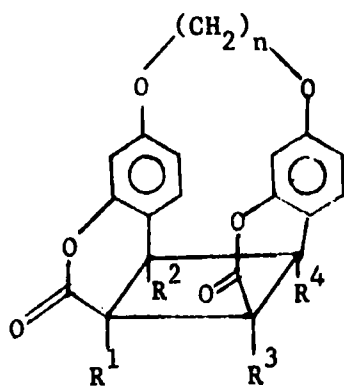
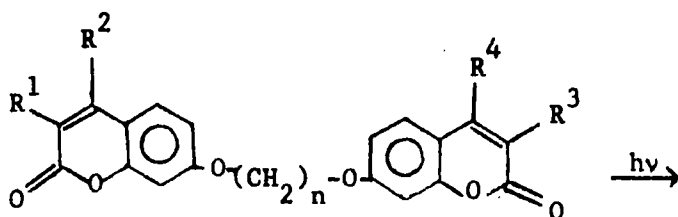

head-to-head

+ head-to-tail isomer.

(1.20)

$\underline{n}$	$\underline{R^1}$	$\underline{R^2}$	$\underline{R^3}$	$\underline{R^4}$
2-11	H	H	H	H
4	H	H	H	Me
5	H	Me	H	Me

A small amount of intermolecular reaction also occurred, the quantity of oligomeric material obtained increasing with increasing solution concentration.

However polymers could be obtained on benzophenone sensitized irradiation of higher ( $n = 10, 11$ ) 7,7'-polymethylenedioxy coumarins. Intrinsic viscosities of 0.25 ( $n = 10$ ) and 0.38 ( $n = 11$ ) in chloroform, at 25°C, are reported.<sup>70</sup> N.m.r. evidence indicated an anti configuration for the latter polymer.

#### 1.8 Synthesis of Polyimides by Photoaddition of Bismaleimides to Benzene and Alkylbenzenes

Maleimide and N-substituted maleimides readily form 2:1 photoadducts with benzene (1.21).<sup>71</sup>

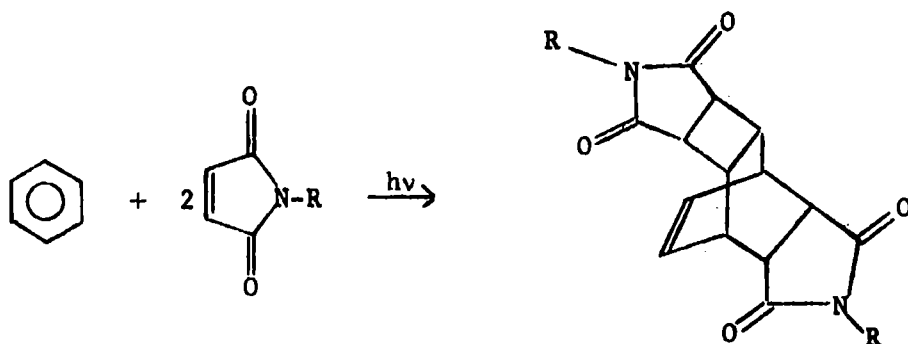

(1.21)

A similar reaction occurs with alkylbenzenes.<sup>72</sup> Reaction is thought to involve 2+2 cycloaddition of photoexcited maleimide to benzene (or alkylbenzene) giving an intermediate homoannular diene (6)

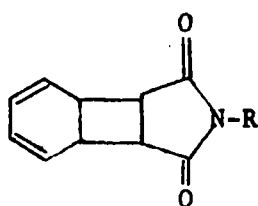

(6)

followed by Diels-Alder addition with a second maleimide molecule giving the 2:1 adduct.

This reaction has been extended to photopolymerization involving the synthesis of polyimides by photoaddition of bismaleimides to benzene<sup>73</sup> and alkylbenzenes<sup>74</sup> (1.22).

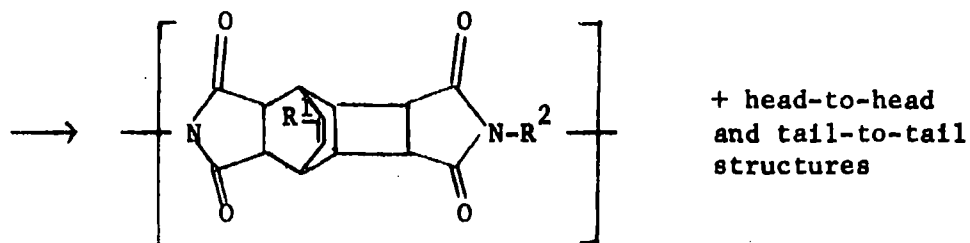
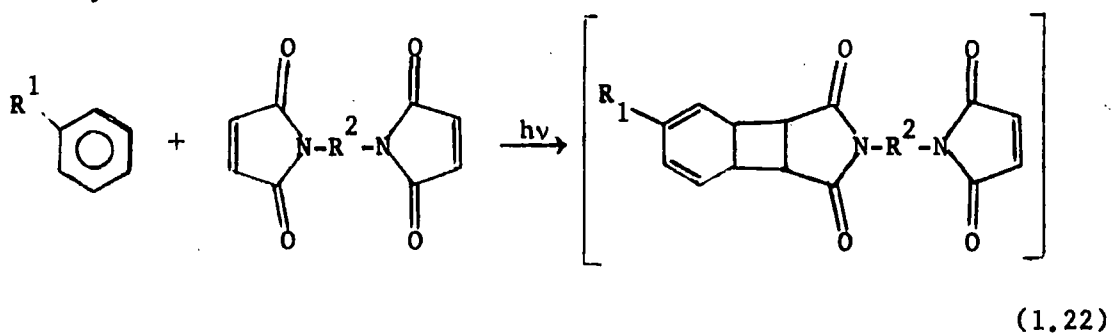

Photoreaction is acetophenone sensitized. Data on monomers used, irradiation times, yields and temperatures of onset of decomposition are recorded in Table 1.9.

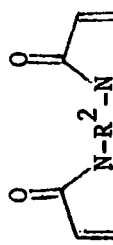
TABLE 1.9  
 Photoaddition of Bismaleimides, , to Benzene<sup>73</sup> and Alkylbenzenes<sup>74</sup>



Monomers		Polymerization		Polymer	
Bismaleimide (-R <sup>2</sup> -)	Benzenoid Compound	Irradiation time (hr)	Yield (%)	Initial Decomposition Temperature (°C)	Polymer Reference No.
-((CH <sub>2</sub> ) <sub>2</sub> ) <sub>2</sub> -	Benzene	18	95	420	(7)
	Benzene	18	80	420	(8)
	Benzene Toluene Ethylbenzene Cumene t-Butylbenzene	18 24 24 24 24	70 40 23 28 34	410 380 390 390 425	(9)
	Benzene	18	65	485	
	Toluene	40	45	390	
	Ethylbenzene	40	0	-	
	Cumene	40	0	-	
	t-Butylbenzene	40	44	370	

Table 1.9 contd.

Monomers		Polymerization		Polymer	
Bismaleimide (-R <sup>2</sup> -)	Benzenoid Compound	Irradiation time (hr)	Yield (%)	Initial Decomposition Temperature (°C)	Polymer Reference No.
	Benzene	18	80	440	
	Benzene	18	15	420	
	Benzene	18	30	420	(10)
	Benzene Toluene Ethylbenzene Cumene t-Butylbenzene	18 5 5 5 5	85 89 50 60 85	450 400 360 420 400	(11)

(a) Preparation and Characterization of Polymers

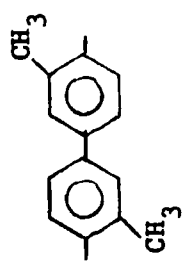
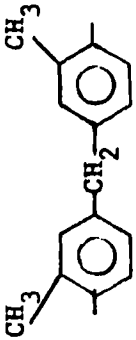
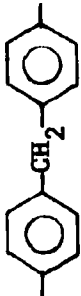
Mixtures of bismaleimide (0.02 mole), acetophenone (2.5 ml.), acetone (to effect solubility) and benzene or alkylbenzene were irradiated in Pyrex test tubes using a 450-W ultraviolet lamp. Polymers, which precipitated out or were deposited on sides of the tubes, were washed with acetone and dried.

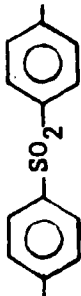
Elemental analysis on a typical polymer (9, Table 1.9) was satisfactory.

Polymers of the same basic structure could be prepared by an alternative route<sup>75</sup> involving the reaction of maleic anhydride-benzene 2:1 adducts<sup>76,77</sup> with diamines (1.23) or the reaction of the maleic anhydride-alkylbenzene 2:1 adduct<sup>78</sup> with diamines.

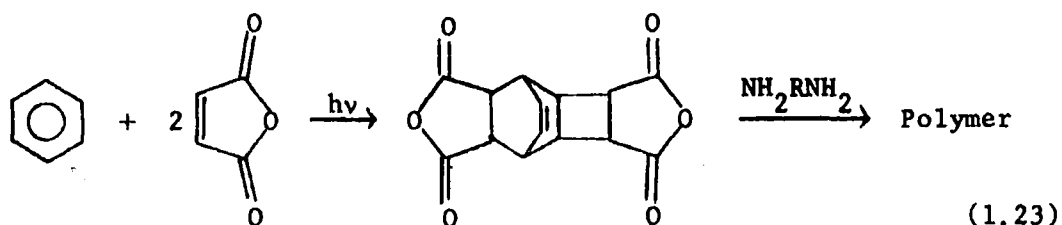

In general, agreement between the infrared spectra observed for polymers prepared by either route was good. The only major discrepancies were polymers (8 and 10, Table 1.9) where only gross structure of the infrared spectra of corresponding polymers was the same, and more generally the presence of peaks at ca.  $1850\text{ cm}^{-1}$ ,  $1085\text{ cm}^{-1}$  and  $925\text{ cm}^{-1}$  in polymers prepared by the anhydride-amine route, such absorptions being attributable to unreacted amine or anhydride. These peaks were absent from the spectra of polyimides prepared by the photoaddition polymerization.

The n.m.r. spectrum of polymer (11, Table 1.9) showed symmetrical doublets at 67.50-8.46 (aromatic protons), a broad singlet at 66.74 (vinyl protons) and multiplet structure at 62.90-4.00 (aliphatic protons).

Ultraviolet spectra in acetonitrile indicated both maleimide ( $\lambda$  max 221 nm) and homoannular diene ( $\lambda$  max 257 nm) endgroups.

Initial decomposition temperatures were generally around 400°C. Differential thermal analysis showed further decomposition around 500°C and thermograms were comparable with those of corresponding polymers obtained via the anhydride-amine route. Pyrolysis of polymer (7, Table 1.9) yielded benzene as a major decomposition product, attributable to decyclization as with benzene-maleic anhydride photoadducts.<sup>76</sup>

Low polymer solubility in such solvents as N,N-dimethylformamide, N,N-dimethylacetamide and trifluoroacetic acid suggested that cross-linking occurred during irradiation. Polymers from alkylbenzene were less soluble than polymers from benzene and crosslinking by copolymerization of bismaleimide with the alkene resulting from photoaddition could be enhanced by alkyl substitution. The high solubility of polymer (11, Table 1.9) may be due to the influence of the strongly electron-withdrawing sulphone group. Polyimides prepared by the anhydride-amine route were soluble in such solvents as trifluoroacetic acid.

The position of the alkyl substituent in the polyimides was uncertain but the most probable location is indicated in equation (1.22). Bryce-Smith<sup>79</sup> has shown that in the photosensitized addition of maleic anhydride to methylbenzenes, structural isomers may be produced in ratios dependent on the reaction temperature (1.24).

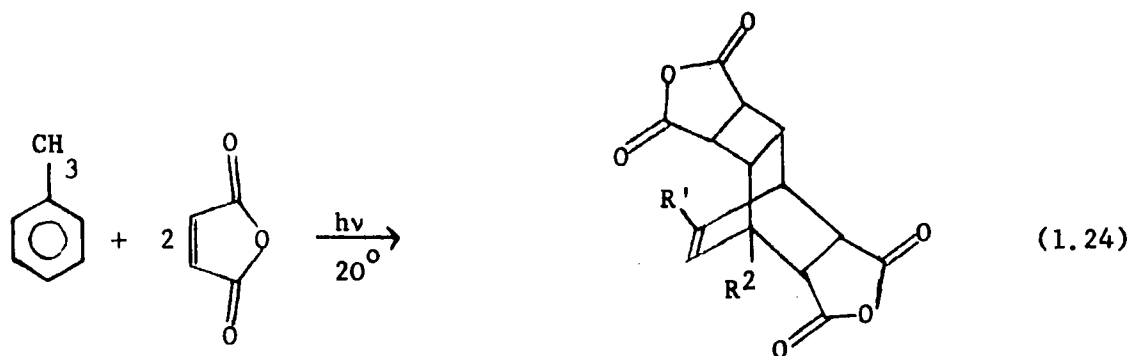

This could imply the presence of a thermal activation step in the reaction of a photochemically generated intermediate species, or a temperature effect on equilibria involving precursor complexes in solution.

(b) Mechanism and Factors Affecting Yield

As stated earlier, reaction is thought to proceed via formation of an intermediate homoannular diene. This intermediate may be trapped with tetracyanoethylene in maleimide-benzene photoaddition.<sup>80</sup> Photoadditions of N-substituted maleimides to benzene involve  $n \rightarrow \pi^*$  transitions of maleimide which is largely complexed with benzene.<sup>80</sup> Dipolar intermediates are not thought to be involved in N-substituted maleimide photoaddition, in contrast to maleic anhydride photoaddition to benzene where Zwitterionic intermediates (12) are postulated.<sup>80</sup>

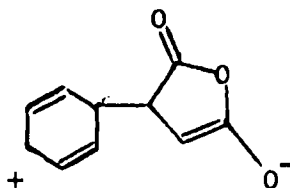

(12)

Trifluoroacetic acid is virtually without effect on the photoaddition of N-butylmaleimide to benzene, consistent with the conclusions that dipolar intermediates are not involved here.<sup>81</sup>

Yields in the alkylbenzene series were related to a balance between steric and inductive effects. Reactivity due to steric effects should be in the order

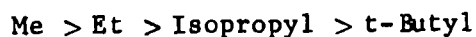

Inductive effects should operate in the reverse direction owing to the electrophilic nature of the maleimide double bond.

In the case of bismaleimides linked via benzene rings, substituents ortho to the nitrogen should promote adduct formation by preventing coplanarity of the benzene ring and maleimide. It is thought that coplanarity allows the existence of low-lying excited states with consequent quenching of the required reactive excited intermediate.

Unexpectedly high yields from the bismaleimide incorporating a sulphone group could have been due to the strong electron-attracting effect of the group and, in the case of its photoaddition to alkylbenzenes, it has been alternatively suggested<sup>74</sup> that reaction may proceed via an excited charge-transfer complex rather than through a homoannular diene intermediate.

Intramolecular cyclization of polymethylenebismaleimides may account for a decrease in polymer yield with the bismaleimides containing longer methylene chains. No intermolecular 2+2 cycloaddition has been detected (cf. section 1.6).

### 1.9 Photopolymerization of Bisanthracenes

Anthracene undergoes photodimerization at the 9,10 positions (1.25) via a singlet excited manifold of one of the anthracene molecules. The central anthracene rings lose their aromaticity and planarity whilst the outer rings are bent outwards from their original molecular planes by electrostatic repulsion.<sup>82</sup>

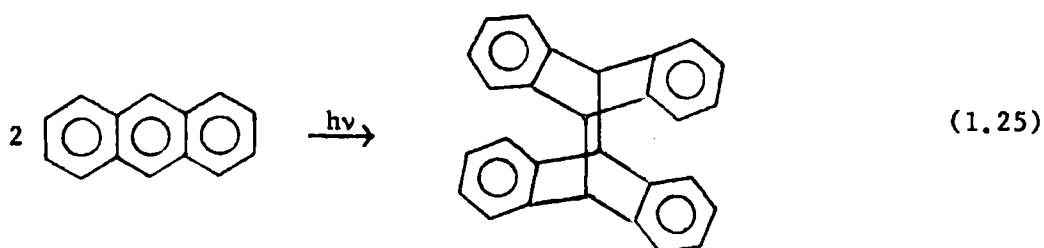

Extension of the reaction to bisanthracenes has resulted in the synthesis of several polymers (1.26).<sup>83</sup>

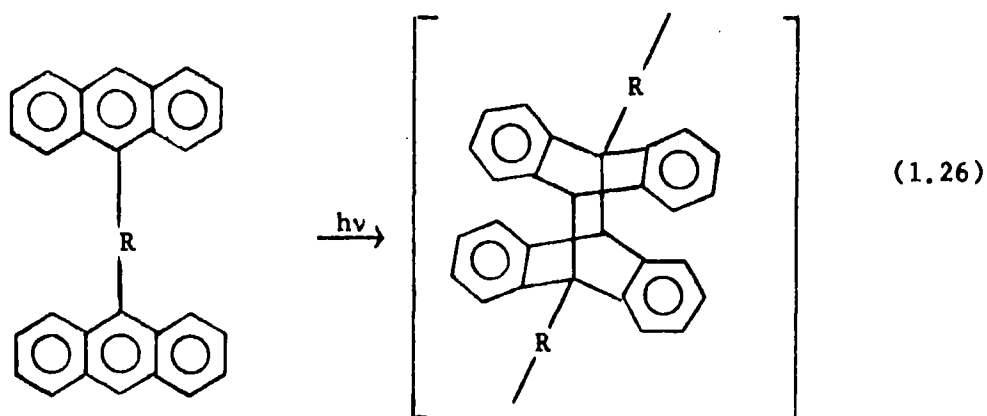

Two series of polymers have been prepared, diesters derived from  $\alpha, \omega$ -aliphatic diacid chlorides + 9-hydroxymethylantracenes (AMADE,  $R = -CH_2-O-\overset{\overset{O}{\parallel}}{C}-(CH_2)_n-\overset{\overset{O}{\parallel}}{C}-O-CH_2-$ ), and diesters derived from 9-anthroylchloride and an  $\alpha, \omega$ -aliphatic diol (AADE,  $R = -\overset{\overset{O}{\parallel}}{C}-O-(CH_2)_n-O-\overset{\overset{O}{\parallel}}{C}-$ ).

9,9'-Linked bisanthracenes may also intramolecularly photocyclize (1.27) if the number of bonds in the link does not exceed three.<sup>32</sup>

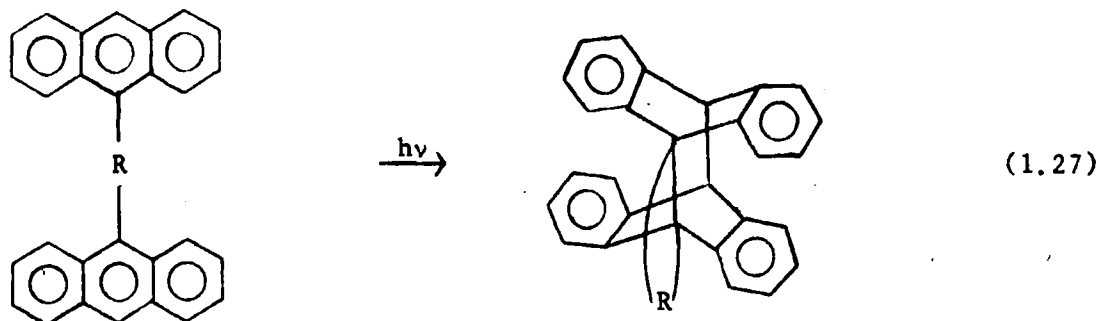

Examples include bisanthracenes with 9,9' links where  $R = \text{O}-\overset{\text{O}}{\underset{\text{O}}{\parallel}}{\text{C}}-\text{O}$ ,  $-\text{NH}-\overset{\text{O}}{\parallel}{\text{C}}$  and  $-\text{N}=\text{N}-$ .<sup>84</sup>

#### Preparation and Characterization of Polymers

Dichloromethane solutions of the monomers contained in Pyrex vessels were irradiated at 350 nm and the resulting polymers precipitated in acetone. Data on the polymerizations and polymers is given in Table 1.10. Only limited molecular weights have been obtained for polymers of the AMADE series. Any initial head-to-head addition leads to increased steric hindrance for addition of the next monomer.

In the AMADE series of photopolymerizations, the 1,5-sigmatropic shift of a methylene proton to the 10 position may occur as a reaction competing with polymerization. Such a shift has been observed with 6-methylpentacene (1.28).<sup>85</sup>

TABLE 1.10  
Photopolymerization of Bisanthracenes<sup>83</sup>

Monomer, M		Polymerization		Polymer Properties	
Series	n	[M] mole litre <sup>-1</sup>	Irradiation time (hrs)	$\overline{M}_n$	$[\eta]_{\text{CHCl}_3}^{25^\circ\text{C}}$
AMADE	4	0.1	69	6,800	-
AMADE	5	0.2	48	6,400	0.11
AMADE	6	0.2	48	4,500	0.11
AMADE	7	0.2	48	6,000	0.14
AMADE	7	0.2	48	12,000	0.37
AMADE	8	0.2	48	11,600	0.25
AADE	9	0.2	24	-	0.88
AADE	10	0.2	24	-	0.61
AADE	11	0.2	41	52,000	1.3
AADE	12	0.2	24	28,000	0.68

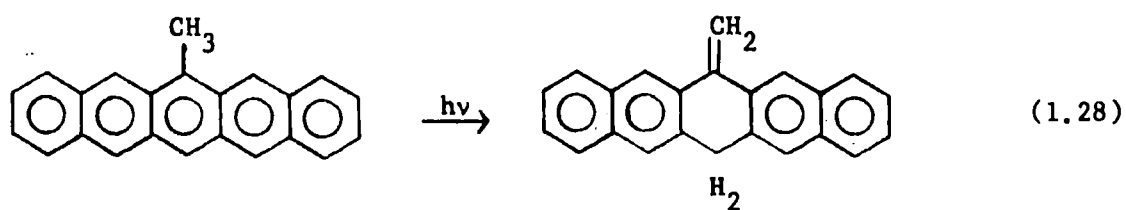

This reaction would obviously limit polymer molecular weights, if competitive with the polymerization. Higher molecular weights were obtained for polymers of the AADE series where such a shift was not possible.

It was necessary to exclude oxygen during polymerization, since endoperoxide formation by cycloaddition of oxygen at the 9, 10 anthracene positions could occur.

Polymers were generally soluble in halogenated solvents such as dichloromethane or chloroform.

Infrared and n.m.r. spectra of the polymers were consistent with the proposed structures, comparison being made with dimers of the model compounds 9-anthrylmethylacetate and 9-methylanthrolylate. The infrared spectra (AMADE series) showed splitting of the  $1450\text{ cm}^{-1}$  band (C-H bending at 10 position) into two bands at  $1450$  and  $1470\text{ cm}^{-1}$ . The C=C stretch ( $1650\text{ cm}^{-1}$ ) disappeared. Tertiary bridgehead protons in the n.m.r. spectra were observed at 3.76 and 4.26 for AMADE polymers, and at 5.86 for AADE polymers.

$\text{C}^{13}$  analysis of dimer bridgehead protons indicated that only a head-to-tail dimer was formed from 9-methylanthrolylate. N.m.r. study on the model dimer from 9-anthrylmethylacetate indicated that head-to-tail and head-to-head cycloadducts were formed in a ratio 4:1.

Polymers could be thermally or photochemically ( $\lambda < 300\text{ nm}$ ) degraded back to monomers in an analogous manner to cleavage of anthracene photodimer.

#### 1.10 Reductive Coupling of Aromatic Diketones to Polybenzopinacols

The photoreductive coupling of benzophenone in ethanol<sup>86</sup> or isopropanol<sup>87</sup> (1.29) is a well established reaction.

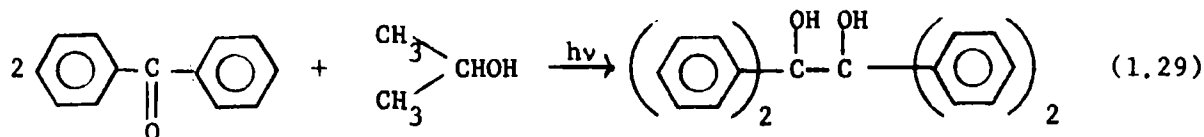

Benzopinacol

Reaction occurs by  $n \rightarrow \pi^*$  excitation of benzophenone carbonyl followed by reduction and coupling of the resultant ketyl radicals. With benzophenone and isopropanol, the yield is quantitative<sup>88</sup> and reaction processes may be represented by the reaction sequence (1.30).

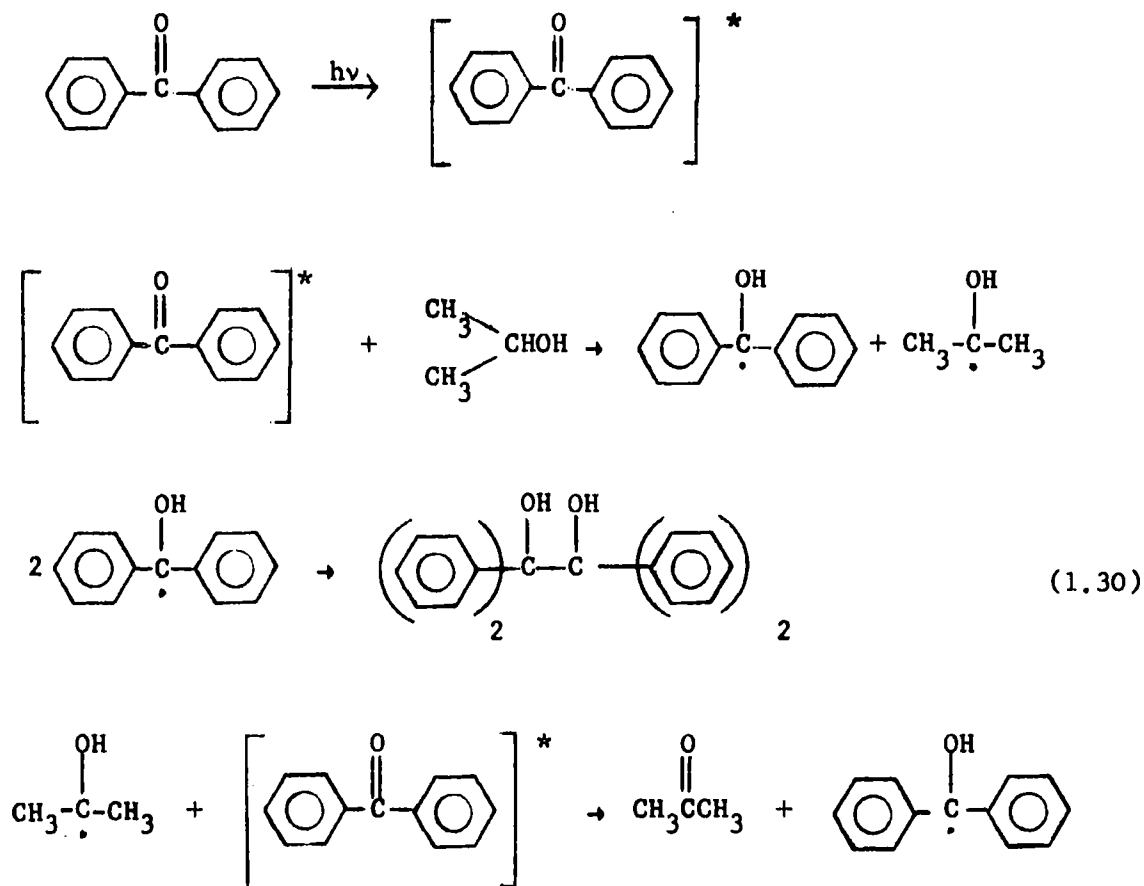

A detailed discussion of this photoreduction reaction may be found in Chapter 2.

Photoreductive coupling has been extended to the photopolymerization of benzophenone-type aromatic diketones into polybenzopinacrols (1.31).<sup>89-92</sup>

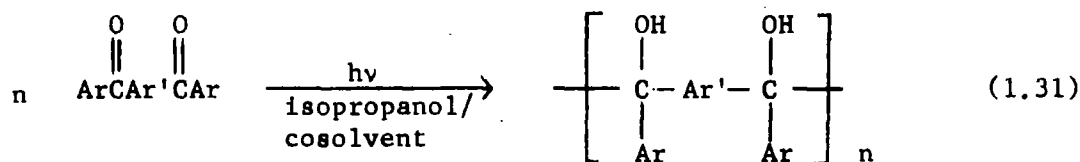

Polymers have been prepared from a variety of monomers and under various experimental conditions. Data on the monomers used, polymerization techniques and the resulting polymers may be found in Table 1.11.

(a) Discussion

De Schryver and co-workers<sup>92</sup> have obtained fairly high molecular weight polybenzopinacrols by irradiation of degassed isopropanol-dichloromethane solutions of bisbenzophenones at 350 nm (preparative method G, Table 1.11).  $\overline{D.P.}$ 's ranged from 23 to 70. Earlier work by Higgins and co-workers<sup>90</sup> on m- and p-dibenzoylbenzenes and 4,4'-dibenzoyldiphenyl ether (preparative method A), and by Pearson and Thiemann<sup>89</sup> on p-dibenzoylbenzene (preparative methods D-F) gave only low molecular weight oligomers. Modifications<sup>91</sup> (preparative methods B,C) of Higgins original procedure using an open system under a stream of nitrogen rather than a closed vessel under a nitrogen atmosphere, and shorter irradiation times gave a significantly higher polymer from 4,4'-dibenzoyldiphenyl ether. Polymers from 4,4'-dibenzoyldiphenyl sulphide, 4,4'-dibenzoyldiphenyl-methane and -ethane were also obtained by the modified procedures B,C, but m- and p-dibenzoylbenzenes and 4,4'-dibenzoyldiphenyl failed to give polymers.

TABLE 1.11

## Photochemical Coupling of Aromatic Diketones

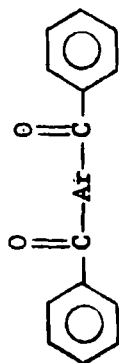

Monomer	Polymerization		Polymer Properties					Reference
	Preparative Method	Yield (%)	$\bar{M}_n$	$\bar{DP}$	Inherent viscosity $\eta$	Solvent	M.Pt. ( $^{\circ}\text{C}$ )	
	A	94	435	1.89	0.06 <sup>a</sup>	Benzene	135	90
	B,C	-						91
	D	-	1,570				162-4	89
	E	-	698				107-110	89
	F	-						89
CYCLIC PRODUCT								
	A	94	825	2.91	0.12 <sup>a</sup>	Benzene	140	90
	B,C	-						91
	B,C	-						91
	A	92	805	2.80	0.14 <sup>a</sup>	Benzene	160	90
	B	~100			0.30	Dioxane	165-180	91
	C	78			0.26	Dioxane	165-170	91
	B	~100			0.10	Dioxane	155-165	91
	C	60			0.04	Dioxane	130-145	91

contd./

Table 1.11 contd.

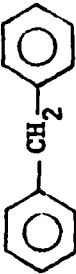
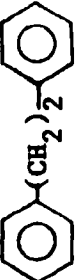
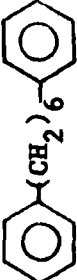
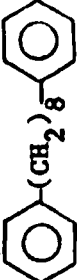
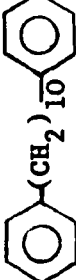
Monomer	Polymerization		Polymer Properties					Reference
	Preparative Method	Yield (%)	$\bar{M}_n$	$\bar{DP}$	$\eta$	Viscosity solvent	M. Pt. (°C)	
Ar								
	B C G	~ 100 76	26,000	70	0.25 <sup>b</sup> 0.21 <sup>b</sup>	Dioxane Dioxane	160-170 135-160	91 91 92
	B C	~ 100 68			0.45 <sup>b</sup> 0.37 <sup>b</sup>	Dioxane Dioxane	170-185 155-170	91 91
	G		13,000	32	0.26 <sup>c</sup>	DMF		92
	G		11,000	23				92
	G		16,000	35	0.32 <sup>c</sup>	DMF		92

Preparative Methods

A. 5 g. diketone dissolved in 125 ml. benzene + 125 ml. isopropanol and 1 drop acetic acid added. Solution deoxygenated (N<sub>2</sub> at reflux) and irradiated (Fisher Blak-Ray long wavelength UV lamp) for 1 week in stoppered flask. Solvent removed, polymer washed and then dried at 62°C under vacuum.

contd./

Table 1.11 contd.

- B. 6 g. diketone dissolved in 200 ml. 1:1 benzene/isopropanol and 2 drops glacial acetic acid added. Solution purged with N<sub>2</sub> at reflux and irradiated (100-W Blak-Ray B100-A long wavelength lamp) at reflux under slow stream of N<sub>2</sub> for 24 hours. Solvent removed, polymer washed and then dried in vacuo at 80°C.
- C. 5 g. diketone dissolved in 250 ml. 1:1 benzene/isopropanol and then treated essentially as in B except that irradiation was for only 1½-2 hours with Ace Glass No. 3515 450-W lamp fitted with Pyrex filter.
- D. 2.334 g. polymer dissolved in 150 ml. benzene + 50 ml. isopropanol and irradiated for 19 hours. Solution was contained in Pyrex apparatus, stirred by magnetic bar and protected from air by argon atmosphere. Irradiation was with mercury high-pressure lamp, Philips HPK 125W, suspended in an open well surrounded by water cooled jacket. After irradiation, solution was concentrated and product dissolved in acetone, filtered, acetone evaporated and resulting solid dried in vacuo at 80°C and then 120°C.
- E. Solutions were irradiated in series of 3 ml. ampoules. Ampoules were filled, flushed with argon, sealed and mounted against outer wall of water jacket of irradiation apparatus described in D. During irradiation (25 hours) water was allowed to boil gently from heat generated by lamp. After irradiation, contents of several ampoules were combined and evaporated to dryness.
- F. Ampoules were filled with solution to be irradiated, degassed, sealed and mounted on a plastic board and immersed in water bath at 25°C. Plastic board was 15" from an immersed Sylvania 400-W, H33-ICD medium pressure lamp.
- G. 0.06M solutions of monomer in 1:2 isopropanol/dichloromethane mixture were degassed and irradiated at 350 nm for ca. 7 hours. Solvent was then evaporated and the residual yellow powder dissolved in DMSO (~10% insoluble) and precipitated by addition of DMSO solution to methanol.

Notes

- a) 0.25 g. polymer/100 ml. benzene. b) Inherent viscosity. c) Intrinsic viscosity.

Higgins showed that use of a 450-W lamp with Pyrex filter instead of a 100-W long wavelength lamp allowed much shorter irradiation times but produced polymers of lower inherent viscosity.<sup>91</sup> The correspondingly lower molecular weight polymers may have been a result of cleavage of C-C bonds with the higher intensity irradiation.<sup>91</sup>

The reported failure of *m*- and *p*-dibenzoylbenzenes and 4,4'-dibenzoyldiphenyl to form good polymers has been attributed<sup>91</sup> to a bathochromic shift of the  $\pi \rightarrow \pi^*$  absorption in going from benzophenone to these diketones, resulting in overlap with the  $n \rightarrow \pi^*$  absorptions and lack of efficient hydrogen abstraction from the low-lying  $\pi$ ,  $\pi^*$  triplet.

High polymers showed no carbonyl absorptions ( $\sim 1650 \text{ cm}^{-1}$ ) in their infrared spectra but low molecular weight polypinacols showed considerable residual carbonyl stretch, which may be attributable<sup>90</sup> to unreacted monomer or to such structures as (13).

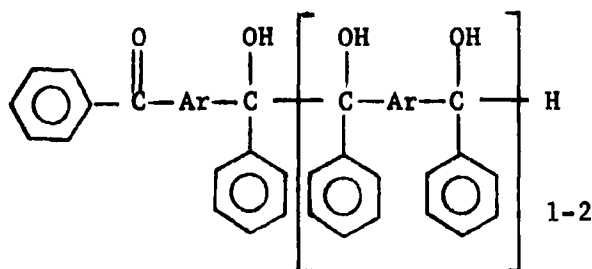

(13)

Strong broad bands centred around  $3500 \text{ cm}^{-1}$  were characteristic of the tertiary OH groups in the polypinacols. Higgins<sup>91</sup> prepared model pinacols by photocoupling of *p*-benzoyldiphenyl ether and *p*-benzoyldiphenylethane, and by coupling of *p*-benzoyldiphenylmethane with magnesium and iodine.<sup>93</sup> Infrared spectra of the resulting model pinacols and the

corresponding polypinacols indicated the latter to be consistent with the proposed structures. Infrared spectra of oligomers from m- and p-dibenzoylbenzenes compared with the infrared spectrum of benzopinacol.

N.m.r. spectra of the oligomers from m- and p-dibenzoylbenzenes and 4,4'-dibenzoyldiphenyl ether<sup>90</sup> showed a small peak at 5.36 corresponding to benzhydryl protons. Subsequent polymers obtained by Higgins<sup>91</sup> and De Schryver<sup>92</sup> showed no benzhydryl hydrogen in their n.m.r. spectra, coupling occurring more readily. Higgins<sup>91</sup> has suggested that in preparative methods B, C, this may be a result of increased monomer concentration compared to method A, and that weaker reducing solvents may also yield higher molecular weight polymers.<sup>90</sup>

Pearson and Thiemann have studied the irradiation of p-dibenzoylbenzene in isopropanol in some detail.<sup>89</sup> Under 'normal' irradiation conditions (preparative method D) a polymer comprising ca. 5 coupled monomer units was obtained. The n.m.r. spectrum of this polymer exhibited the following features: 61.3 (singlet CH<sub>3</sub>), 62.4 (broad singlet OH), 63.0 (broad singlet OH), 65.8 (v. weak, benzhydryl H), 67.8 (multiplet, aromatic H). The n.m.r. signal at 65.8 indicated at least half the polymer ends were capped with benzhydryl hydrogen (14).

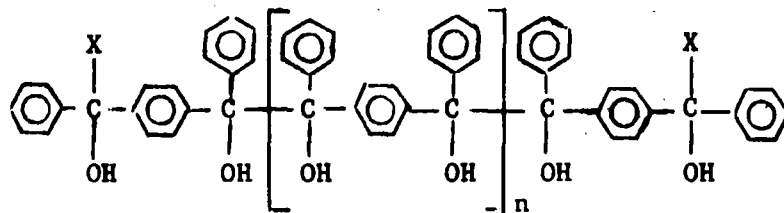

(14)

X = H

Integration indicated that a few polymer chains terminated with isopropyl alcohol groups ( $X = (\text{CH}_3)_2\text{COH}$ ) whilst the remainder of the polymer was designated to be in cyclic form. More severe irradiation conditions (preparative method E) yielded a polymer capped with almost exclusively hydrogen, the n.m.r. signal at  $\delta 5.8$  being much stronger. Milder irradiation conditions (preparative method F) yielded a cyclic product with only aromatic ( $\delta 7-7.5$ ) and OH ( $\delta 3.0$ ) proton n.m.r. signals.

Infrared spectra of these products from p-dibenzoylbenzene showed the absence of carbonyl groups.<sup>89</sup>

Elemental analyses of polypinacols, where reported,<sup>89-91</sup> were sometimes in only fair agreement with the required values.

During irradiations of m- and p-dibenzoylbenzenes<sup>89,94</sup> and 4,4'-dibenzoyldiphenylalkanes<sup>92</sup> a yellow colour has been observed. Pearson<sup>89</sup> has suggested this is due to the intermediate (15) in the case of

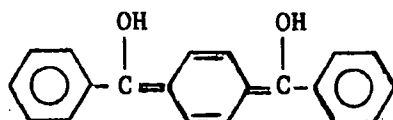

(15)

p-dibenzoylbenzene. Evidence is based on long wavelength absorption at 416.4 nm, the nonradical nature of the intermediate (which showed no E.S.R. signals) and its stability. However m-dibenzoylbenzene could not form a quinone-dimethide structure. Further discussion on intermediates may be found in Chapter 2.

(b) Effect of Solvent Mixtures

Data has been obtained for different solvent mixtures. Higgins found a 50:50 mixture to be most satisfactory for benzene-isopropanol irradiations. Increasing the proportion of isopropanol reduced monomer solubility whilst decreasing the proportion of isopropanol necessitated longer irradiation times.<sup>91</sup> For polypinacols prepared by method A, neat isopropanol, 50:50 THF-isopropanol and 50:50 benzene-ethanol were found to give similar results to 50:50 benzene-isopropanol.<sup>90</sup> De Schryver<sup>92</sup> has shown that reaction rate depends on the nature of the cosolvent. For 0.05M solutions of 4,4'-dibenzoyldiphenylmethane at 32°C, relative rates for a 1:5 molar ratio of isopropanol/cosolvent have been found to be, chloroform 1, toluene 2.5 and benzene 4.

(c) Pinacol-Pinacolone Rearrangement of Polymers

Polybenzopinacols from photocondensation of 4,4'-dibenzoyl-diphenyl-methane, -ethane and ether have been rearranged<sup>95</sup> in sulphuric acid-dioxane solution to polybenzopinacolones (1.32).<sup>95</sup>

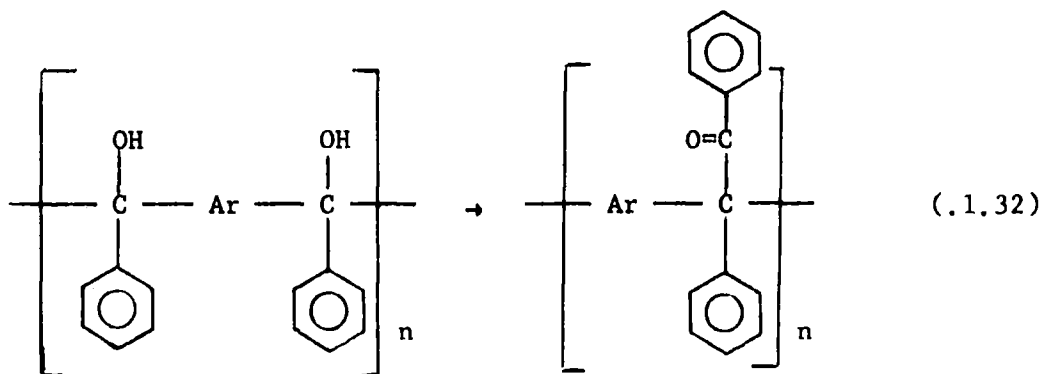

N.m.r. evidence suggested that polymer chain migration was favoured over phenyl migration.

Further syntheses of polybenzopinacols and relevant discussion may be found in Chapter 4.

### 1.11 Photoreductive Coupling of Bisbenzal Imines

Irradiation of a series of benzaldehyde N-alkylimines ( $\text{Ar-HC=NR}$ ) in 95% ethanol yields dihydro photodimers.<sup>96</sup>

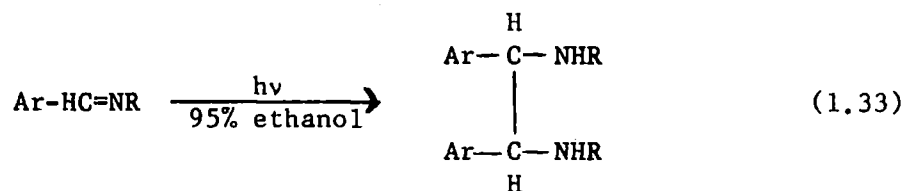

For Ar = phenyl, N-alkyl substituents include R =  $\text{C}_6\text{H}_{11}$ ,  $\text{CH}_2\text{Ph}$ , t-Bu and  $\text{CH}_3$ . Benzaldehyde imines with substituents in the aromatic ring have also been photodimerized.

Excited states of the imines are not reactive intermediates. Ketyl radicals appear to be the active reducing agents and may be derived from carbonyl compounds present in the reaction mixture as an impurity, an added sensitizer or as a photogenerated species.<sup>96</sup>

Thus with benzophenone sensitizer and alcohol solvents such as isopropanol, the photodimerization may be represented by the reaction sequence (1.34).

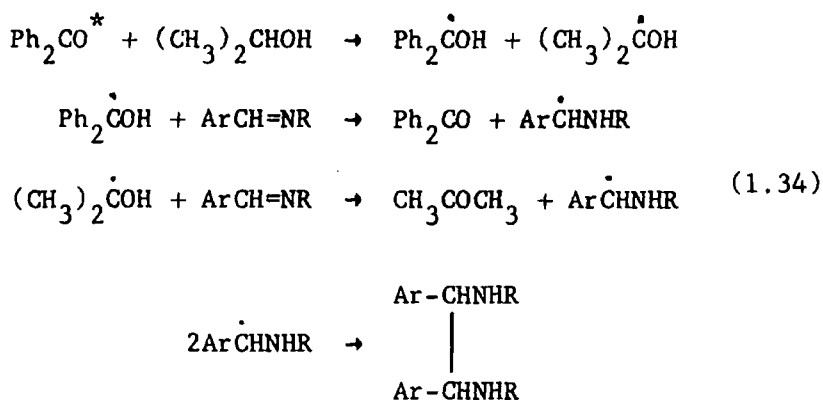

Irradiation of bisimines has resulted<sup>97,98</sup> in polymer formation by 'true' photopolymerization (1.35).

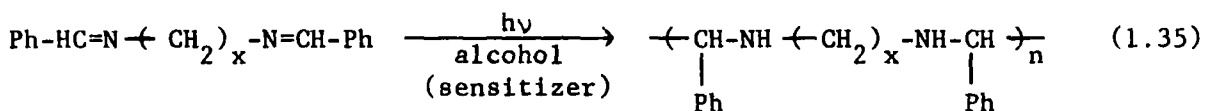

Thus irradiation of ethylenediamine-*N,N'*-dibenzylidene ( $x = 2$ ) and propylenediamine-*N,N'*-dibenzylidene ( $x = 3$ ) in ethanol solution has been reported to give polymeric products (although not characterized).<sup>97</sup>

Irradiation of such bisbenzal imines in isopropanol with benzophenone sensitizer has been reported to give polymers<sup>98</sup> according to equation (1.35).

### 1.12 Synthesis of Poly(perfluoroalkylene Oxides)

Poly(perfluoroalkylene oxides) have been prepared by two photopolymerization routes.

The first route<sup>99</sup> is based on an iodide coupling reaction under the influence of ultraviolet radiation and in the presence of mercury.

Using such a reaction both primary and secondary perfluoroalkyl iodides

have been coupled in high yield,<sup>100</sup> an example being coupling of perfluoropropyl iodide (1.36)

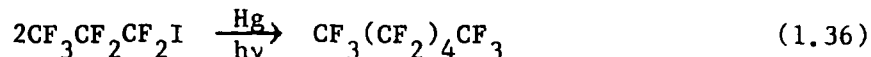

Extension of this coupling reaction to bis(2-iodotetrafluoroethyl) ether has resulted in formation of a polymer with a fluorinated alkylene oxide backbone (1.37).<sup>99</sup>

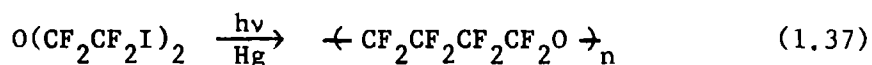

The second route<sup>101</sup> is an extension of the photolysis of perfluoroacyl fluorides such as  $n\text{-C}_3\text{F}_7\text{COF}$  leading primarily to the formation of polyfluoroalkanes (1.38).<sup>102</sup>

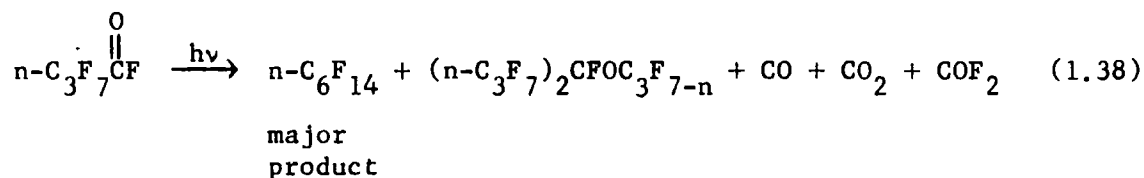

Irradiation of perfluoroglutaryl fluoride (PGF) had already been observed<sup>102</sup> to give a solid polymer (16), (1.39)

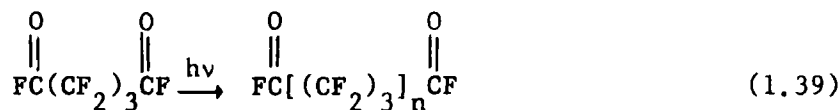

(16)

Subsequently, poly(perfluorotetramethyleneoxide) (17) was prepared from perfluorooxydipropionyl fluoride (1.40).<sup>103</sup>

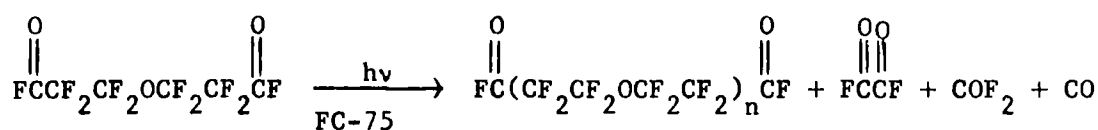

(17)

(1.40)

Other related perfluoroacyl fluoride monomers have since been photopolymerized.<sup>101</sup>

(a) Polymers Obtained from Iodine Coupling Reactions<sup>99</sup>

The polymers were prepared by sealing a mixture of  $O(CF_2CF_2I)_2$ , mercury and a perfluorinated solvent in a quartz ampoule and irradiating for 5-9 days with a 325-W medium pressure mercury lamp. A black precipitate indicated complete reaction. Separation of the fluorocarbon solution and removal of solvent gave the polymer  $\left[CF_2CF_2OCF_2CF_2\right]_n$ . Structure has been confirmed by means of elemental analysis, infrared and n.m.r. spectroscopy.

Typically, number average molecular weights of approximately 40,000 have been obtained, such polymers being weak elastomers soluble in partially or wholly fluorinated solvents but insoluble in common organic solvents. Thermal analysis (T.G.A. and D.T.A.) indicated that the material was stable in air and nitrogen up to ca. 400°C.

The feasibility of preparing copolymers was demonstrated by the successful polymerization of a mixture of  $O(CF_2CF_2I)_2$  and  $I(CF_2)_3I$ .

Low molecular weight polymers could be produced by addition of fluorocarbon monoiodide to  $O(CF_2CF_2I)_2$ , 15 mole% of monoiodide giving a polymer of number average molecular weight 4700 and containing  $C_{7.15}F_{15}$  end groups. Polymers with ester end groups were obtained using  $CH_3OOC(CF_2)_3I$  but use of  $NC(CF_2)_3I$  as monoiodide resulted in cross-linked material involving formation of a C=N- linkage.

The coupling reaction appears to proceed, at least to some extent, via the intermediate formation of some type of perfluoroalkyl mercury compound, probably  $RfHgI$ .<sup>100</sup>

(b) Polymers Obtained from Perfluoroacyl Compounds

Irradiation of perfluoroglutaryl fluoride, PGF, in a quartz tube with a low pressure mercury resonance lamp for 4 days yielded a solid reaction mixture, the nature of which was not extensively investigated.<sup>102</sup> The structure was taken to be essentially that of long chain dicarboxylic acid fluorides (16).

Irradiation of perfluorooxydipropionyl fluoride (POPF) in perfluorinated solvent gave acid fluoride terminated poly(perfluoro-tetramethylene oxide) (17) in quantitative yield. Other monomers successfully polymerized were perfluorooxydiacetyl fluoride (POAF), (1.41),

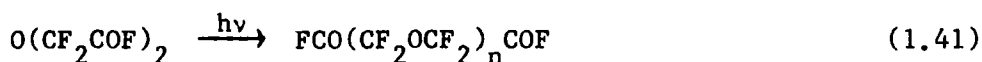

and the dimer of POPF (POPF-D), (1.42)

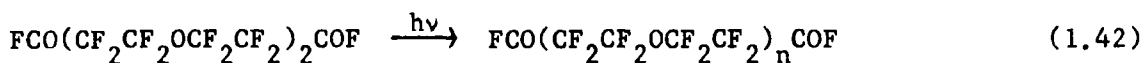

Copolymers have been obtained from various molar ratios of POAF and PGF, some details for which are shown in Table 1.12 below.

Mechanism<sup>101</sup>

Polymerization occurs by a photochemically induced cleavage of the  $\text{CF}_2$ -COF bond in the monomer or growing polymer chain (1.43). The  $-\dot{\text{C}}\text{F}_2$  radicals produced may either couple to give linear polymer (1.43 (ii)) or attack the oxygen atom of an acid fluoride group leading to a new radical capable of coupling and thus producing cross-links (1.43(iii)).

TABLE 1.12

Preparation of POAF/PGF Copolymers

Monomers		Polymers <sup>a</sup>		
Monomers used	Mole ratio POAF:PGF	No. average molecular weight	Functionality	Glass transition temperature, °C
POAF		750	2.6	-48
POAF/PGF	5:1	1100	3.4	-45
POAF/PGF	2:1	1000	2.5	-30
POAF/PGF	1:1	1060	2.7	-13

a. Obtained after irradiation for 5 hours at 5-35°C.

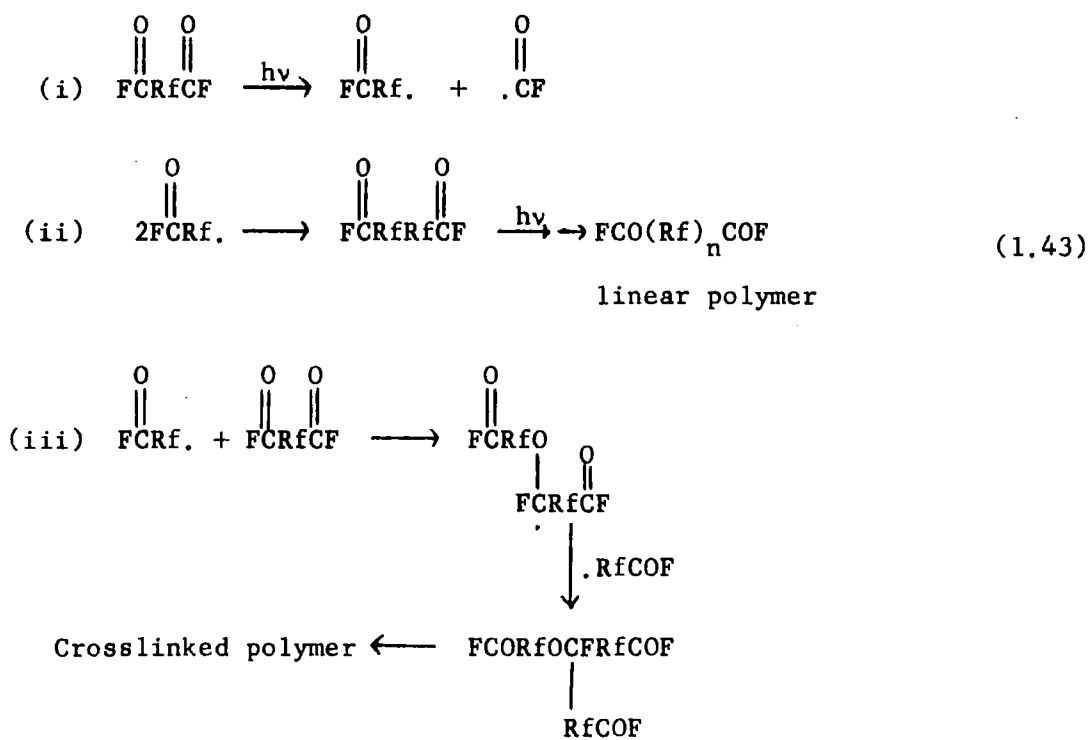

Consistent with this mechanism, longer irradiation times yielded higher polymers of greater functionality. For POPF, molecular weights (corresponding functionalities underlined in parentheses) ranged from 500(2) to 15,000 (8). The extent of branching appeared to be independent of reaction temperature in the range 0-100°C.

### 1.13 Further Studies in Step-Growth Photopolymerization

The following chapters of this thesis are concerned with further studies on carbonyl containing compounds as possible bichromophoric monomers for step-growth photopolymerization. Photochemical reactions of carbonyl containing compounds are reviewed in Chapter 2.

The greater proportion of the work has been concerned with studies on the photocycloaddition of a carbonyl group to a C=C double bond, with oxetane formation, as the polymer growth reaction. Results are described and discussed in Chapter 4, together with some further studies on related photopolymerizations producing polybenzopinacols. Preparation of the relevant monomers is described in Chapter 3.

Other photopolymerization studies involving biscarbonyl compounds are reported in Chapter 5.

CHAPTER 2

ASPECTS OF THE PHOTOCHEMISTRY OF CARBONYL COMPOUNDS

## 2.1 Primary Photophysical Processes of Organic Molecules

The initial stage of an organic photochemical reaction is the absorption of a photon of light producing an electronically excited state. Primary photochemical processes then occur involving the electronically excited state, followed chronologically by secondary or 'dark' (thermal) reactions of the various chemical species produced by the primary processes.

Only light absorbed in a system is effective in producing a chemical change (Grotthus-Draper law), and the amount of radiation absorbed is generally limited to one quantum per molecule taking part in a reaction (Stark-Einstein law). Subsequent primary photochemical processes are those starting with absorption of a photon by a molecule and ending either with the disappearance of that molecule or its conversion to a state such that its reactivity is statistically no greater than that of similar molecules in thermal equilibrium with their surroundings.<sup>104</sup>

Substances are selective in the absorption of radiation depending on the presence of chromophores usually containing p electrons or  $\pi$  bonds. Excitation occurs when the absorption of electronic energy results in the transition of an electron from a bonding or nonbonding orbital to an antibonding orbital. Several designations exist for transitions in polyatomic molecules, the more precise being spectroscopic notations involving symmetry. However for photochemical purposes electronic transitions are commonly discussed in terms of the initial and final orbitals of the electron involved in a transition and this notation is used here. Thus  $n \rightarrow \pi^*$  represents the transition of an electron from a non-bonding orbital to an antibonding  $\pi^*$  orbital.

In most electronic excitations initiating photochemical reactions one electron per molecule undergoes transition to a higher orbital and two half vacant orbitals are associated with the molecule in the excited state. The spin of the promoted electron is no longer defined by the Pauli exclusion principle and may be parallel or opposite to that of the electron remaining in the orbital vacated by the promoted electron. Two values of spin multiplicity are thus generally associated with the excited state:

- i) Singlet state, multiplicity 1 (spins preserved)
- ii) Triplet state, multiplicity 3 (spins parallel)

Singlet-triplet transitions are forbidden by selection rules but nevertheless observed, usually as a result of spin-orbit coupling between the electron spin and orbital angular momentum allowing relaxation of selection rules. The triplet state from a given electronic configuration is lower in energy than the corresponding singlet state, a consequence of Hund's rule.

Electronic transitions occur faster than changes in nuclear positions associated with vibration. Consequently, geometry obtained upon excitation should be the same as that existing before excitation (Franck-Condon principle), and since potential-energy curves in ground and excited states differ in shape, Franck-Condon excitation usually leads to the population of higher vibrational levels in the excited state (vertical transition A shown in Fig.2.1).

The excess energy of singlet and triplet states is usually in the range 40-200 Kcal mole<sup>-1</sup> and this energy is frequently sufficient to

FIG.2.1

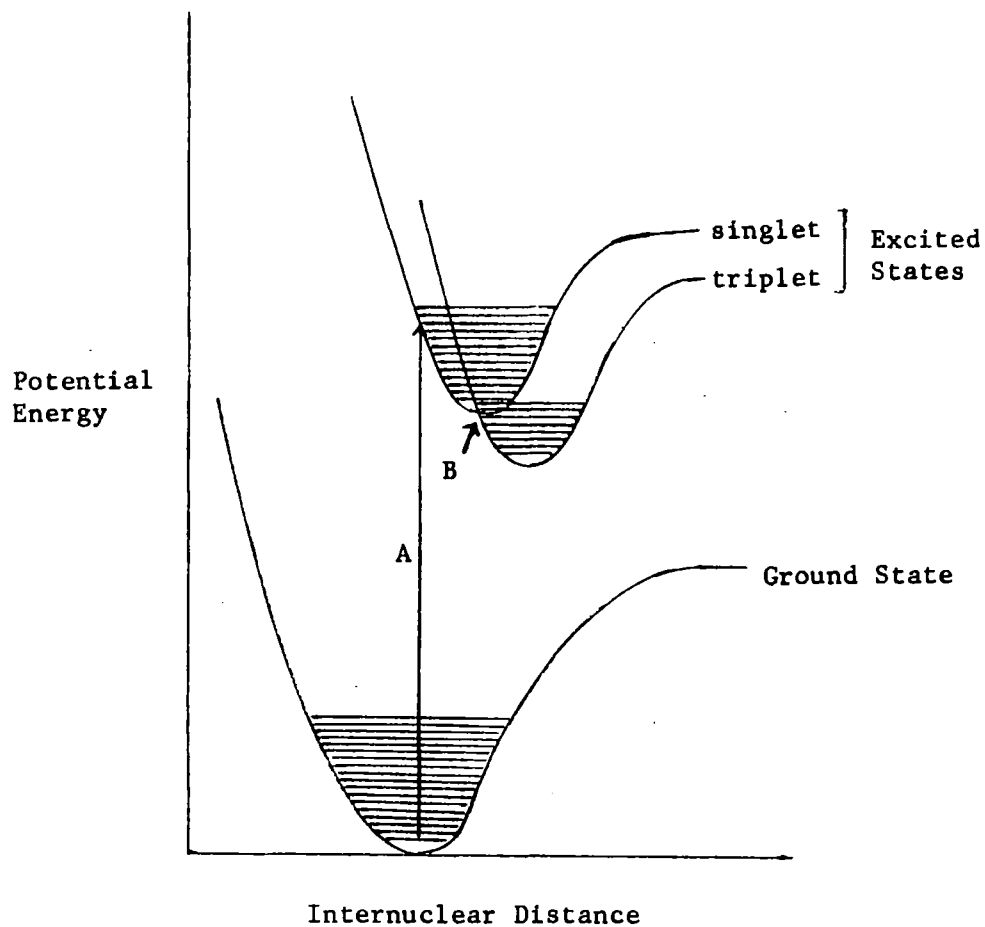
Potential Energy Surfaces for a Diatomic Molecule

allow chemical reaction to occur. Other processes by which this excess energy may be lost are:

- i) Radiative transition with emission of light .
- ii) Radiationless transitions between states without chemical reaction .
- iii) Electronic excitation energy transfer .

Emission of light may occur as fluorescence (emission between states of the same multiplicity) or phosphorescence (emission between states of different multiplicity). Excess vibrational energy in the excited state is generally lost very rapidly through collision (vibrational cascade) before emission of light which is consequently of lower energy than that absorbed (Stokes law). Thermal agitation may sometimes raise the excited state to a higher vibrational energy level with consequent emission of higher energy light.

If absorption occurs to excited states of higher energy than the first excited state, very rapid isoenergetic internal conversion may occur leading to higher vibrational levels of lower electronically excited states of the same multiplicity. Close proximity of potential energy surfaces and quantum mechanical mixing of similar energy states aids internal conversion. Further deactivation may occur by processes described above.

Interconversion between states of different multiplicity may occur by the process termed intersystem crossing. The process is associated with the crossing of potential energy curves (B, Fig.2.1) and aided by spin-orbit coupling effects. The population of triplet states via intersystem crossing depends largely on the lifetime of the excited state, relatively long lived singlets aiding heavy population of the appropriate triplet state. Following intersystem crossing, vibrational cascade to the lowest vibrational level of the triplet occurs making the reverse triplet-singlet conversion process endothermic and unlikely.

These radiative and non-radiative processes are shown diagrammatically in Fig.2.2. More detailed discussion of the general physical aspects of photochemistry may be found in standard works on the subject.<sup>105</sup>

FIGURE 2.2

Energy Levels of Molecular Excited States and  
Transitions Between Them.<sup>105c,d</sup>

The lowest vibrational energy levels of a state are indicated by thick horizontal lines, other horizontal lines represent associated vibrational levels. Vertical straight lines represent radiative transitions, zig-zag lines non-radiative transitions. The orders of magnitude of the first order rate constants for the various processes are indicated (in  $\text{sec}^{-1}$ ). S = singlet, T = triplet.

FIGURE 2.2

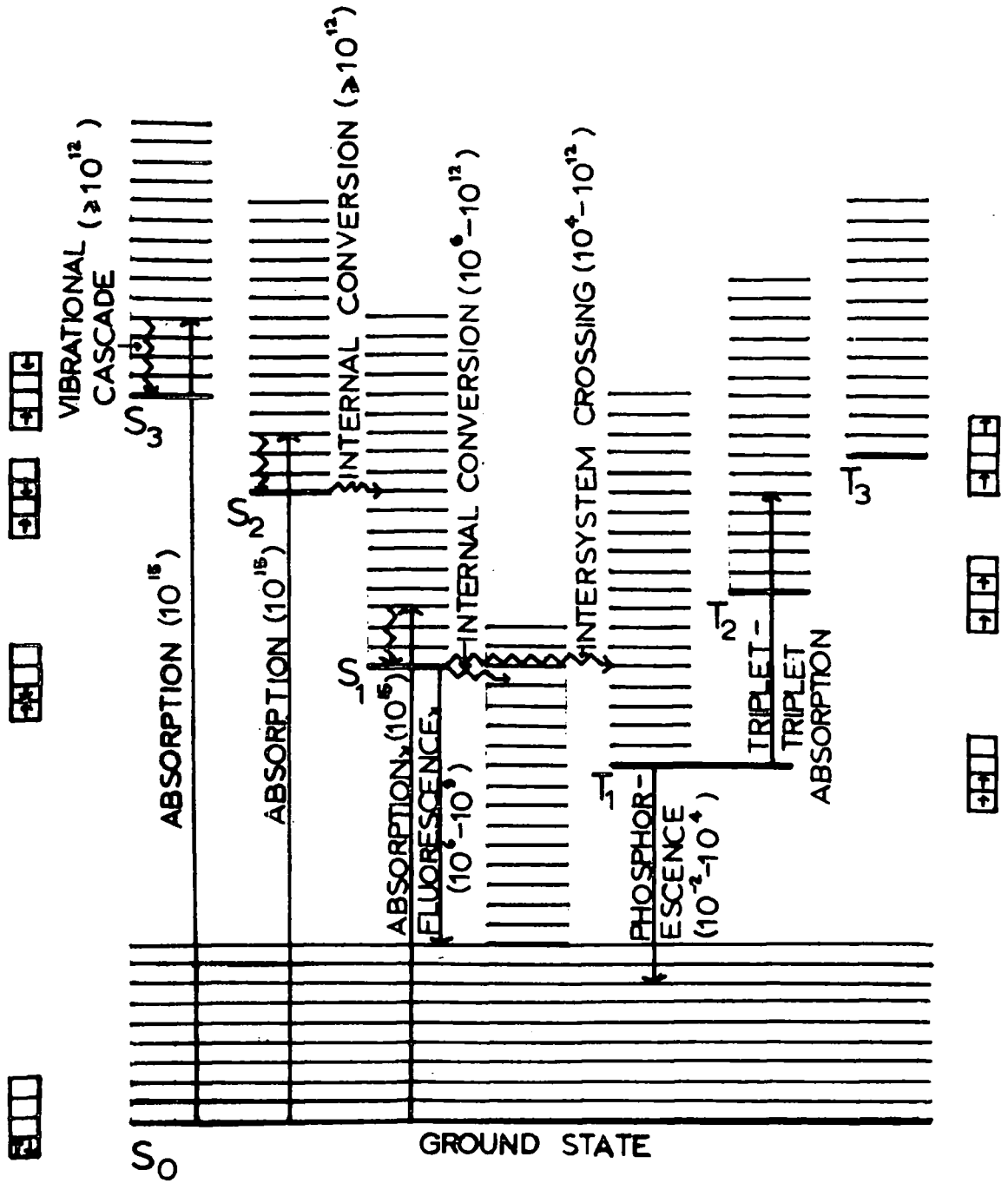

## 2.2 Excitation of the Carbonyl Chromophore

The absorption of light in non-conjugated organic molecules usually involves the promotion of a single electron from a  $\sigma$ ,  $\pi$  or  $n$  orbital in the ground state to a previously vacant  $\pi^*$  or  $\sigma^*$  antibonding orbital. The simplest example of a molecule containing the carbonyl chromophore is formaldehyde. Molecular orbitals, appropriate energy levels and electronic transitions for formaldehyde are shown diagrammatically in Fig.2.3.<sup>106</sup>

With simple ketones, the transition of lowest energy is the weak  $n \rightarrow \pi^*$  transition generally responsible for the longest wavelength (ca. 290 nm) absorption and fundamental in most photochemical processes involving saturated ketone photolysis. Moderately intense absorptions occurring in the 195 nm and 175 nm regions have been subject to some dispute over assignment.<sup>107</sup> A very intense absorption around 150 nm corresponds to a  $\pi \rightarrow \pi^*$  excitation. The  $n, \pi^*$  state of formaldehyde is a pyramidal species with a very long essentially single C-O bond and a substantially reduced dipole moment.<sup>108</sup>

The fact that energies of the longest wavelength absorptions of carbonyl compounds are grouped relatively closely together indicates conjugative effects are generally small and suggests that the concept of the upper orbital being a  $\pi^*$  molecular orbital is an oversimplification,<sup>105a</sup> with excitation appearing to stay largely localized on the heteroatom.

Conjugation shifts both the  $n \rightarrow \pi^*$  and  $\pi \rightarrow \pi^*$  absorption bands to longer wavelengths. The lone pair orbitals are relatively unaffected whilst the highest  $\pi$  orbital in the ground state is raised in energy, relative to a non-conjugated carbonyl  $\pi$  orbital, and the lowest  $\pi^*$

# FIGURE 2.3

Molecular Orbitals,<sup>a</sup> Approximate Energy Levels and Electronic  
Transitions in Formaldehyde.<sup>106</sup>

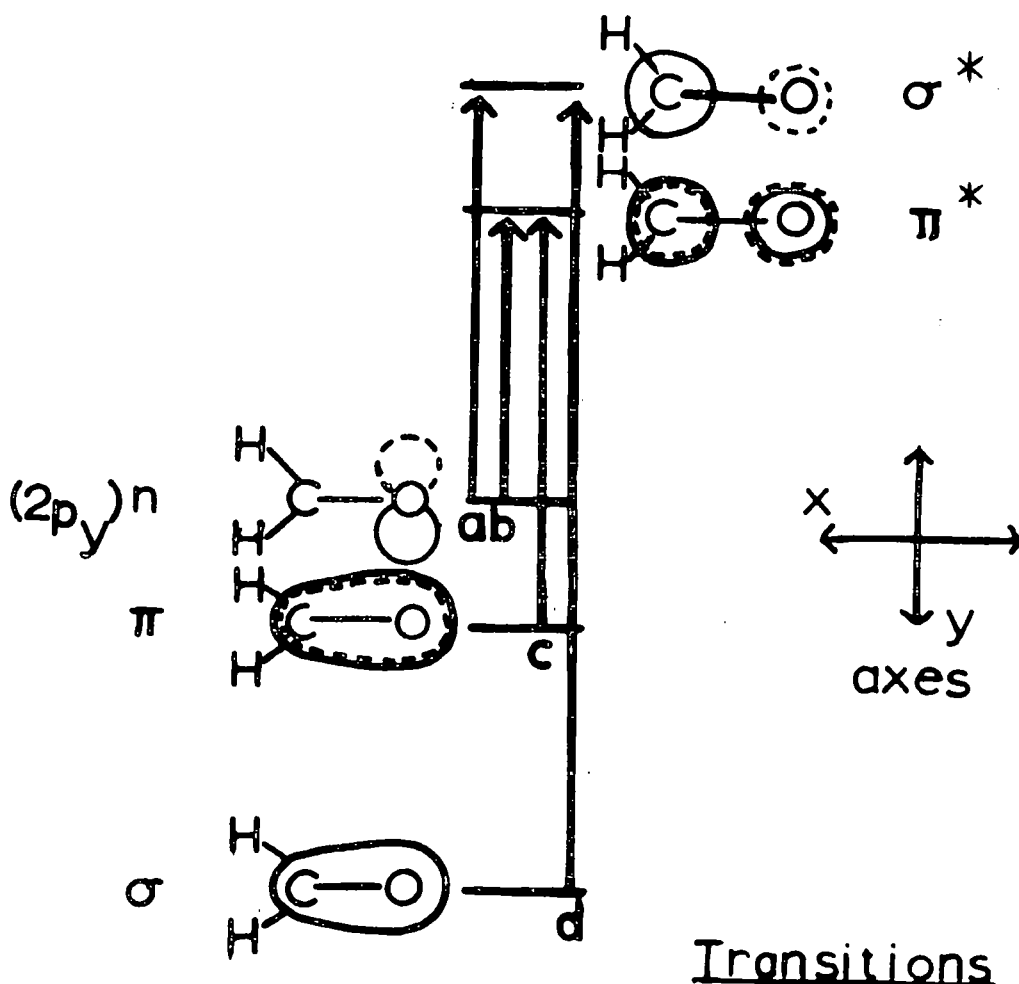

Note a) Solid contour lines represent (+) regions. Dashed contour lines represent (-) regions.

## Transitions

$$a = \sigma \rightarrow \sigma^*$$

$$b = \pi \rightarrow \pi^*$$

$$c = \pi \rightarrow \pi^*$$

$$d = \sigma \rightarrow \sigma^*$$

orbital lowered in energy. In appropriately substituted unsaturated ketones the  $\pi, \pi^*$  configuration may become the lowest triplet state, the  $\pi \rightarrow \pi^*$  shift being large compared to the  $n \rightarrow \pi^*$  shift.<sup>105a</sup>

The position and intensity of the  $n \rightarrow \pi^*$  absorption maximum for some carbonyl compounds is given in Table 2.1.<sup>109</sup>

TABLE 2.1  
 $n \rightarrow \pi^*$  Transition of Selected Carbonyl Compounds in  
Hydrocarbon Solvents<sup>109</sup>

Carbonyl Compound	Wavelength of absorption maximum ( $\lambda_{\max}$ )	$\log_{10}$ (extinction coefficient)
Acetaldehyde	290	1.22
Acetone	279	1.16
Crotonaldehyde	327	1.32
Mesityl oxide	321	1.58
Benzaldehyde	327	1.6
Acetophenone	326	1.7
Benzophenone	345	2.1

For most carbonyl compounds intersystem crossing from the excited singlet to the triplet state is a very efficient process.<sup>109</sup> The quantum yield for intersystem crossing of benzophenone is 1.00. With some carbonyl compounds, however, the relative energies of the excited states may be unfavourable for intersystem crossing. For example 3- and 4-pyrenealdehyde, 2-naphthaldehyde, 9-anthraldehyde, 3-acenaphthaldehyde and 9-tetracenealdehyde all fluoresce on irradiation in ethanol indicating

inefficient intersystem crossing.<sup>110</sup> In non polar solvents the  $n \rightarrow \pi^*$  transition is shifted to longer wavelengths and the  $\pi \rightarrow \pi^*$  transition to shorter wavelengths, and in heptane solvent, 3-pyrenealdehyde, 2-naphthaldehyde, 9-anthraldehyde and 3-acenaphthaldehyde become non fluorescent with efficient intersystem crossing.

The commonly accepted picture of the  $n, \pi^*$  excited states of carbonyl compounds, involving promotion of a 'n' electron to an antibonding  $\pi^*$  orbital, results in a lone electron localized on the oxygen.<sup>109</sup> The state is thus formally analogous to an ordinary alkoxy radical (2.1).

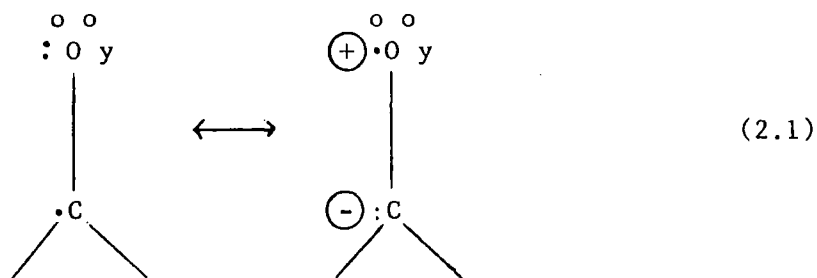

o = 2s unshared electrons

y = unshared electrons in the  $p_z$  orbital

Such analogy extends to observed reactions where ordinary alkoxy radicals are known to abstract hydrogen from and add to olefins, counterparts of photoreduction and photocycloaddition reactions to be described.<sup>109,111,112</sup>

### 2.3 Introduction to Organic Photochemistry of Carbonyl Compounds

The majority of known photochemical reactions of alkanones have been classified under one of three reaction types.<sup>113</sup>

i) Cleavage of the bond  $\alpha$  to the carbonyl group - Norrish type I cleavage (eq. 2.2)



ii) Intramolecular (Norrish type II) or intermolecular abstraction of a hydrogen atom by the carbonyl oxygen atom (eg. eq.2.3)

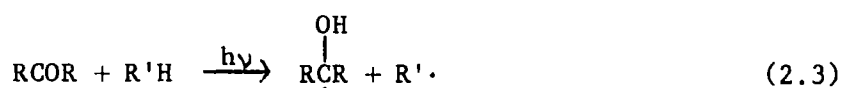

iii) Cycloaddition to an unsaturated carbon-carbon linkage (eq.2.4)

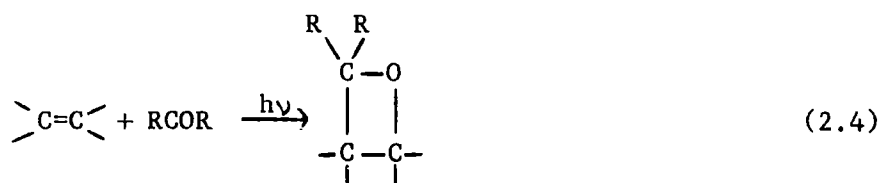

and related sensitized reactions of the olefinic type compound.

Aldehydes and aromatic ketones undergo related reactions and unsaturated carbonyl compounds (conjugated and non-conjugated) undergo a wide variety of cleavage, abstraction, rearrangement and cycloaddition reactions. The varying reactions are discussed in standard texts,<sup>105</sup> and discussions specifically relating to carbonyl compound photochemistry may be found in reviews such as those by Swenton<sup>114</sup> and Turro et al.<sup>113</sup>

The various types of reaction are discussed in following sections in varying detail dependent on their applicability and relevance to possible polymer forming reactions. Firstly, however, the phenomena of photosensitization and quenching will be briefly considered as they have

particular bearing on the chemical reactions of excited carbonyl containing compounds.

#### 2.4 Quenching and Photosensitization

Electronic energy transfer frequently occurs between organic molecules in solution. Singlet and triplet states may be deactivated or quenched by interaction with some other molecule, essentially by energy transfer from the excited state of one molecule to the ground state of the quencher.<sup>115</sup> Triplet energy transfer is of particular importance in rationalization of the course of photochemical reactions of carbonyl compounds, and may be represented by the scheme (2.5)

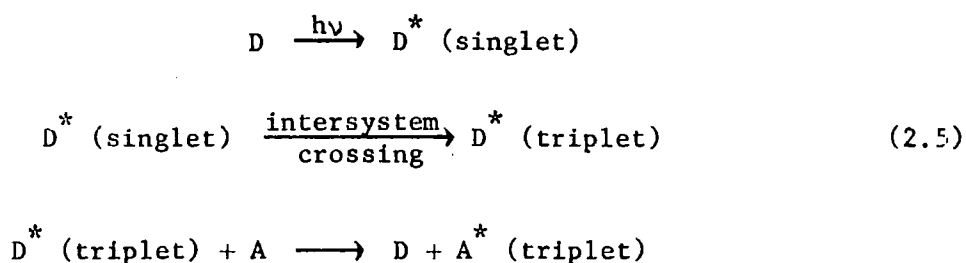

[D = donor; A = acceptor]

Triplet-triplet transfer may quench both the photoreduction<sup>116</sup> and phosphorescence<sup>117</sup> of benzophenone, and may be an important competing reaction in the photocycloaddition of carbonyl compounds to olefins and other unsaturated systems. Some examples of quenchers are naphthalene, cyclohexane and azulene. If the triplet energy of an unsaturated system is lower than that of the carbonyl compound, efficient triplet-triplet transfer may occur to the exclusion of cycloaddition. Triplet-triplet transfer frequently results in isomerization or dimerization of the



of olefins in quenching triplet states of ketones such as acetone have been determined.<sup>123</sup>

Sensitization is particularly useful in excitation to triplet states of species that have poor efficiency of intersystem crossing or high singlet excitation energies. The most effective sensitizers are those that have very efficient intersystem crossings, that absorb preferably at longer wavelength than the acceptor but have a higher triplet energy than the acceptor, and that are photochemically unreactive themselves.<sup>122</sup>

### 2.5 Norrish Type I and Type II Processes<sup>105,114</sup>

Many ketone and aldehyde photochemical reactions fall into these two categories. The Norrish type I cleavage may be formally represented by cleavage of a  $\text{-}\overset{\text{O}}{\parallel}{\text{C}}\text{-}\overset{\text{O}}{\parallel}{\text{C}}\text{<}$  bond, followed by decarbonylation. Combination of radicals, hydrogen abstraction or secondary fission reactions lead to various products (2.7).

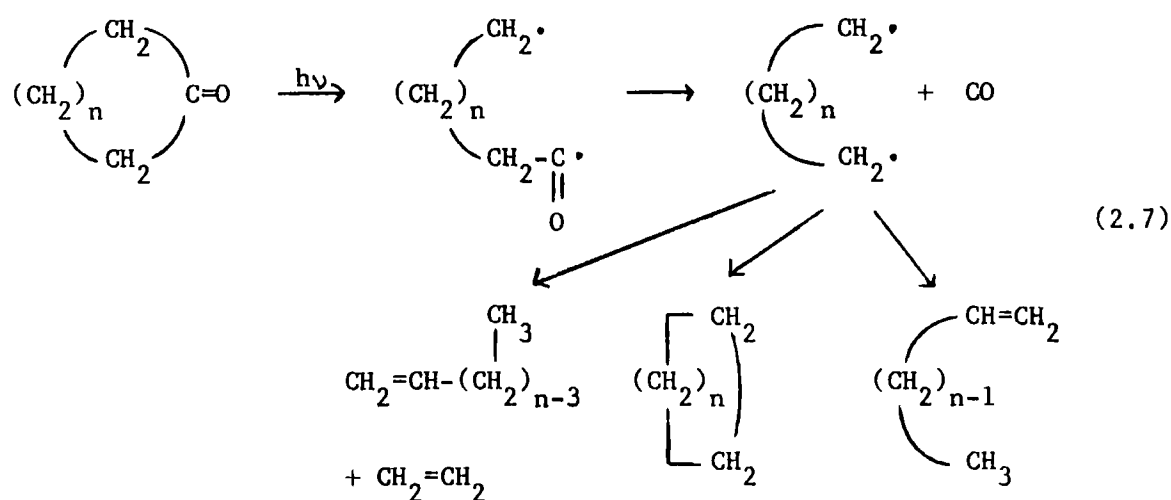

Norrish type II processes occur with carbonyl compounds possessing  $\gamma$ -hydrogens abstractable by the carbonyl group after  $n \rightarrow \pi^*$  excitation. Cleavage of the bond  $\alpha, \beta$  to the carbonyl group often occurs concurrently with the initial formation of enols and olefins (2.8)

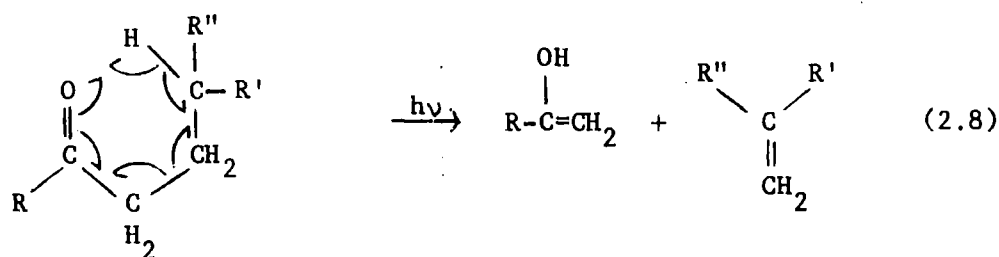

Type I cleavage may occur from either the excited triplet or singlet state, as with *t*-butyl alkyl ketones,<sup>124</sup> and its extent is dependent on the substitution at the  $\alpha$ -carbon. The process is consequently unimportant with diaryl ketones such as benzophenone where an unstable phenyl radical would be produced. Although the process is generally more efficient in the vapour phase, the process may also occur in solution.<sup>124</sup>

Type II processes may also occur from either singlet or triplet excited states, as with 2-pentanone and 2-hexanone,<sup>125</sup> and 2-octanone.<sup>126</sup>

Studies have been made on competing type I and type II processes, for example in a series of *n*-propyl alkyl ketones.<sup>127</sup> Type I cleavage was found to increase relative to type II processes as the alkyl group was changed from methyl through to *t*-butyl, probably related to the decreasing acyl-carbon bond strength across the series of ketones studied. With an unsymmetrically substituted ketone, cleavage occurs

preferentially across the weakest C-C bond, methyl ethyl ketone predominantly cleaving to yield an acetyl radical and ethyl radical at 313 nm.<sup>114</sup>

The different reactivity of excited states towards Norrish type II reaction is a function of electronic structure. For example, butyrophenones with a p-hydroxy or p-amino substituent do not undergo the reaction and have been shown to possess  $\pi, \pi^*$  rather than  $n, \pi^*$  lowest lying triplets.<sup>128</sup>

The diverse products obtained from aliphatic carbonyl compounds generally render them unsuitable for consideration as possible carbonyl compounds undergoing cycloaddition reactions to oxetanes in near quantitative yield.

## 2.6 Photoreduction of Carbonyl Compounds

### (a) Introductory Survey

The photoreduction of carbonyl compounds in suitable hydrogen donating solvents has been widely investigated for well over half a century,<sup>129</sup> since Ciamician and Silber began research in the field.<sup>86</sup> Photoreductive coupling has already been discussed briefly in Chapter 1 (section 1.10) with reference to the preparation of polybenzopinacols, and is now discussed in further detail.

The initial work of Ciamician and Silber indicated that benzophenone was reduced to benzopinacol on exposure of an alcoholic solution of the ketone to sunlight, (eq.2.9).

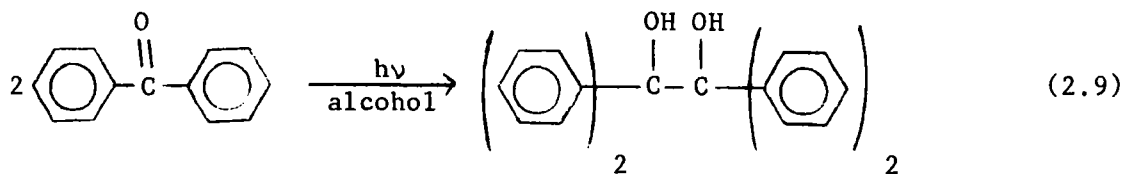

The mechanism of this reaction has already been briefly indicated (Chapter 1, section 1.10), reaction proceeding via the  $n, \pi^*$  carbonyl triplet.

In the presence of alkali, however, it was discovered that benzhydrol was formed,<sup>130</sup> and in a series of photoreductions of benzophenone and substituted benzophenones in isopropanol containing a small amount of sodium-2-propanolate, Bachmann<sup>130</sup> showed that benzhydrols could be obtained in high yield. He proposed that as fast as the pinacol was formed it decomposed to benzhydrol (in the case of benzopinacol) according to reaction scheme (2.10).

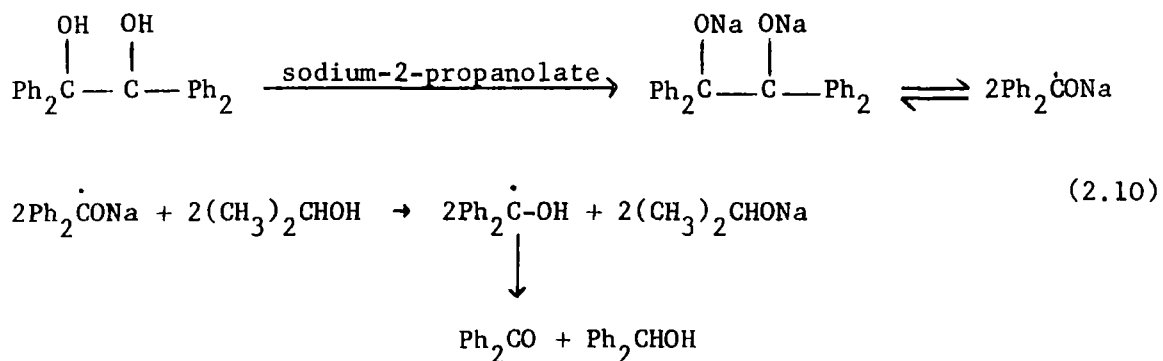

However, proposed mechanisms for the formation of benzhydrol from benzophenone<sup>130</sup> in the presence of alkali have recently been questioned.<sup>131</sup>

The most intensively studied reaction is the actual photoreductive coupling reaction to 1,2-ethanediols. Aldehydes and ketones undergo the reaction,<sup>129</sup> ketones having received by far the most attention. Some

examples of ketones that yield pinacols on a preparative scale are given in Table 2.2.

TABLE 2.2

Some examples of Ketones Undergoing Photopinacolization

Ketone	Hydrogen Donor Solvent	Reference
Benzophenone	isopropanol	132
4,4'-dimethoxybenzophenone	"	133
4,4'-dichlorobenzophenone	"	133
3-benzoylpyridine	"	134
Acetophenone	butanol	135
2-, 3-, and 4-acetylpyridines	isopropanol	136
$\alpha$ -tetralone	isopropanol	137

Benzophenone is the most thoroughly studied ketone, yielding benzopinacol in quantitative yield. The quantum yield for the formation of acetone in the photoreduction of benzophenone in isopropanol is nearly constant using irradiation at several different wavelengths between 366 and 254 nm,<sup>138</sup> suggesting that both  $n \rightarrow \pi^*$  excitation and  $\pi \rightarrow \pi^*$  excitation (of the benzene chromophore) may ultimately bring about reaction.<sup>109</sup>

(b) Solvents

Various solvents have been used as hydrogen donors, in particular alcohols and alkylbenzenes.<sup>139,140</sup> Many comparisons of solvents have been made with benzophenone as reacting ketone. Some quantum yields of

benzophenone disappearance in various solvents are shown in Table

2.3.<sup>141</sup>

TABLE 2.3

Quantum Yields of Benzophenone Disappearance in Hydrogen Donor Solvents

Solvent	Molar Concentration of Benzophenone	Quantum Yield of Disappearance
Water	$10^{-4}$	0.02
Benzene	$10^{-2}$	0.05
Toluene	$10^{-2}$	0.45
Hexane	$10^{-2} - 10^{-4}$	1.0
Ethanol	$10^{-4} - 10^{-1}$	1.0
Isopropanol	$10^{-5} - 10^{-1}$	0.80 to 2.0

Where the quantum yields of benzophenone disappearance are almost zero (water and benzene), bond energies with respect to hydrogen abstraction are high enough ( $> 100 \text{ kcal mole}^{-1}$ ) to prevent hydrogen atom abstraction by the triplet with anything other than very low collisional efficiency.<sup>140</sup>

In hexane, toluene and ethanol, quantum yields are less than or equal to unity and concentration independent.<sup>140</sup> It is suggested that all benzophenone triplets abstract a hydrogen atom, the appropriate C-H bond energies in hexane and toluene being approximately 85 and 80  $\text{kcal mole}^{-1}$  respectively. The overall quantum yields then depend on the thermal reactions of the radical  $R\cdot$  formed on abstraction from the solvent RH. Reversion of the primary hydrogen abstraction reaction (eq. 2.11) results in an overall quantum yield of less than unity.



In isopropanol where quantum yields tend to a limiting value of 2,  $\text{R}\cdot$  [=  $(\text{CH}_3)_2\dot{\text{C}}\text{OH}$ ] may undergo further hydrogen abstraction with the production of acetone and more  $\text{Ph}_2\dot{\text{C}}\text{OH}$  (2.12).

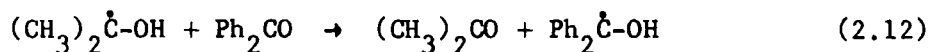

Such an abstraction is energetically improbable in the benzyl or hexyl radicals from toluene or hexane. Where ketones are not photoreduced in alcoholic solvents, a more powerful hydrogen donor such as tri-n-butylstannane may allow photoreduction, as is the case with 2-acetonaphthone.<sup>142</sup>

A recurring problem<sup>143</sup> in mechanistic studies of benzophenone photoreduction in isopropanol has been the failure to detect the mixed pinacol (18), whereas analogous cross-coupled products have been

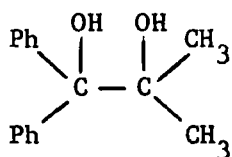

(18)

obtained for benzophenone photoreduction in toluene and cumene,<sup>139</sup> and alcohol solutions.<sup>144</sup> Weiner has now shown that this mixed pinacol is produced on benzophenone photoreduction in isopropanol, and under conditions where all acetone ketyl radicals,  $(\text{CH}_3)_2\dot{\text{C}}\text{OH}$ , are scavenged.<sup>143</sup> Weiner thus indicates that the mixed pinacol results from a cage reaction, reaction being best explained by the following modified sequence (2.13).

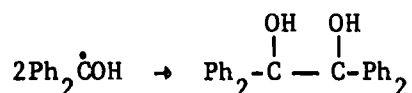
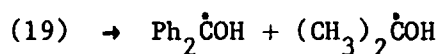
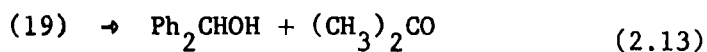
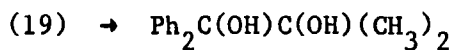
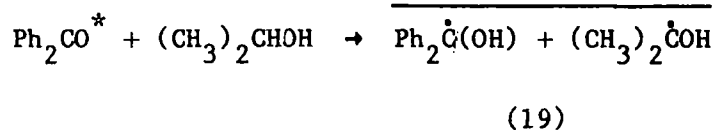

(overline represents a caged species)

The significant fraction of cage reaction (0.11) requires that, in the pair of radicals comprising (19) (where the electron spins are initially parallel), spin flipping must occur in some radical pairs prior to diffusion out of the solvent cage.

It must be noted that there has been much controversy over the nature of intermediates in the photoreduction of benzophenones in isopropanol.<sup>145</sup> Filipescu<sup>145,146</sup> has proposed a yellow intermediate of structure (20) in the cases of benzophenone and 4-alkyl substituted

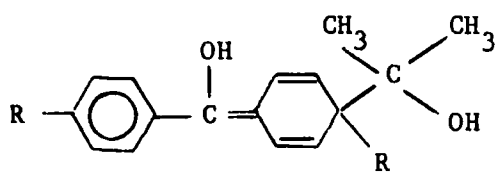

(20)

benzophenone photoreduction in isopropanol. For benzophenone, Filipescu<sup>145</sup> suggested a reaction scheme (2.14).

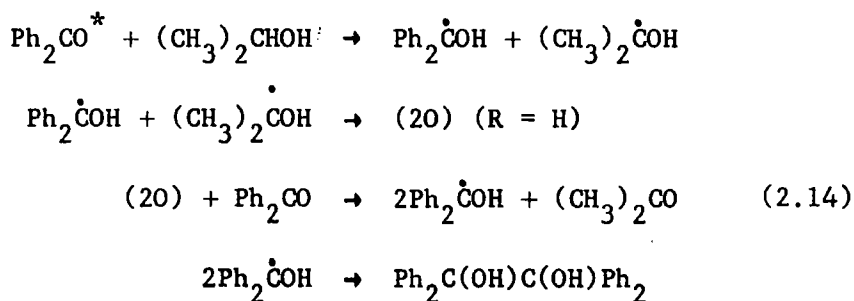

It was proposed that (20) yielded products via the dark reaction (2.15)

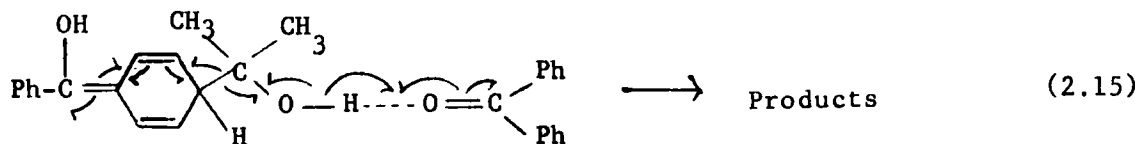

However Weiner<sup>143</sup> states that the quantitative formation of (20) from (19) is inconsistent with the detection of the mixed pinacol in the product mixture. Whilst observed yellow coloration in the reaction may be due to the presence of (20), Weiner<sup>143</sup> concludes that the yellow intermediate cannot be transformed into products at a rate consistent with his and earlier studies.

The low efficiency of photoreduction in benzene has resulted in the solvent being used in many sensitization experiments. However, there is a low quantum yield of reduction even with benzene solvent and observations concerning the actual behaviour of benzophenone triplets in benzene solvents are confusing.<sup>147</sup> The value given for the quantum yield of disappearance of benzophenone in Table 2.3 is 0.05 and is the

upper limit as determined by Beckett and Porter.<sup>140</sup> Dedinas<sup>148</sup> reports an initial quantum yield of benzophenone disappearance of  $5.1 (+0.8, -1.5) \times 10^{-3}$ , in agreement with earlier values of approximately  $10^{-3}$ ,<sup>149</sup> whilst Bell and Linschitz<sup>150</sup> estimate a quantum yield of 0.1 for formation of the primary ketyl radical  $\text{Ph}_2\dot{\text{C}}\text{OH}$  compared to  $0.022 \pm 0.006$  found by Buettner and Dedinas.<sup>151</sup> Deactivation of triplets in benzene has been suggested<sup>152,153</sup> to occur via formation of biradical intermediates of the type (21) (shown for benzophenone).

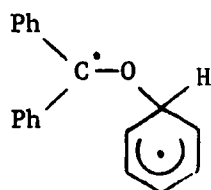

(21)

Schuster and Brizzolara<sup>153</sup> have pointed out that this provides a path for formation of biphenyl according to the scheme (2.16)

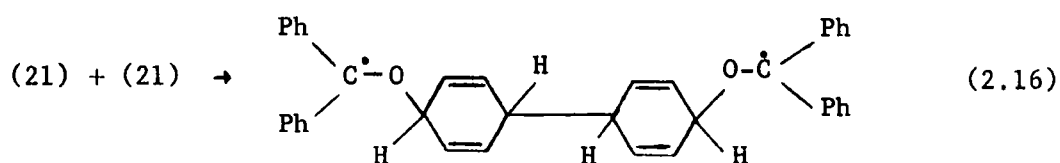

(22)

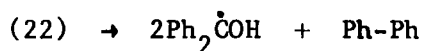

The major products from irradiation of benzophenone in benzene ( $6 \times 10^{-3} \text{ M}$  solution) at 290 nm are biphenyl and benzopinacol and  $^{14}\text{C}$  studies have recently shown that the biphenyl is essentially solvent derived.<sup>147</sup> A value of  $k_a = 19 \text{ M}^{-1} \text{ sec}^{-1}$  has been calculated for the rate of hydrogen abstraction from benzene.<sup>147</sup> Schuster<sup>149</sup> suggests that the quenching of benzophenone triplets in aromatic solvents involves an interaction incorporating at least partial charge transfer from ketone triplet as donor towards aromatic as acceptor.

(c) Effect of Structure on Photoreduction of Aromatic Ketones

Not all ketones are photoreduced to give pinacols. The reactivity of aromatic ketones has been rationalized in relation to the lowest lying triplet levels of the ketone.<sup>154</sup> When the lowest lying triplet level is  $n, \pi^*$ , ketones are generally readily photoreducible with quantum yields frequently approaching unity. Ketones which possess a  $\pi, \pi^*$  configuration for the lowest triplet state, however, are much less disposed towards photoreduction, an example being *p*-phenylbenzophenone. It is suggested that the higher efficiency in photoreduction processes by the  $n, \pi^*$  state may arise from the highly localized  $n$ -electron of the oxygen, whereas in the  $\pi, \pi^*$  triplet state the unpaired electrons are more delocalized and hydrogen abstraction is thus more endothermic.<sup>114,142</sup>

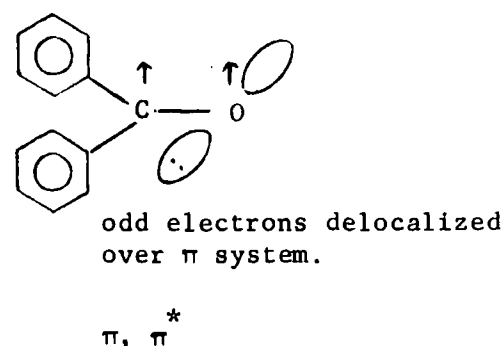
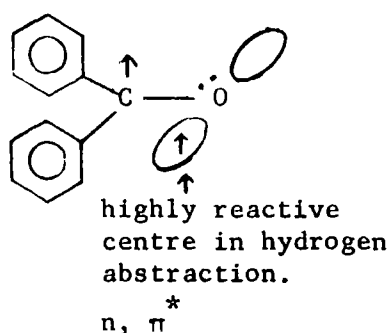

A third type of possible lowest lying triplet state is a charge-transfer state.<sup>154</sup> In p-aminobenzophenone represented by the formula  $DRA$ , where  $D$  is the electron-donating amino group,  $R$  is the aromatic ring, and  $A$  is the electron-accepting carbonyl group, three important charge-transfer states may be considered. These are  $DR^+A^-$  corresponding to the charge-transfer state of benzophenone,  $D^+R^-A$  corresponding to the charge-transfer state of aniline and  $D^+RA^-$ . The three states interact with one another to give a new low energy charge-transfer (C-T) state not present in benzophenone or aniline. The negative charge on the oxygen in this C-T state results in virtually zero reactivity towards hydrogen atom abstraction. Polar solvents such as isopropanol should enhance intramolecular charge-transfer from the electron donating group to the carbonyl group, thus helping to decrease the energy of such charge-transfer states below that of the  $n, \pi^*$  state.

Thus in isopropanol where the C-T state of p-aminobenzophenone is the lowest lying triplet state, the quantum yield of pinacolization is zero. In a less polar solvent such as cyclohexane, where the charge-transfer triplet is no longer the lowest lying triplet, photopinacolization of p-aminobenzophenone has been thought to occur quite readily with a quantum yield of 0.2.<sup>155</sup> p-Hydroxybenzophenone has been reported to behave in a similar manner, the molecule reacting in the basic form in the excited state where the  $pK$  of its protonation equilibrium is much lower than in the ground state.

In accord with this theory aminobenzophenones can be reduced in isopropanol when converted to their onium salts. Photoreduction of p-dimethylaminobenzophenone in isopropanol is reported to proceed very slowly, the ketone possessing a charge-transfer band at 352 nm,<sup>156</sup> arising

from excitation to structure (23). Addition of HCl causes a decrease in the intensity of this absorption and is reported to increase the quantum yield of photopinacolization.

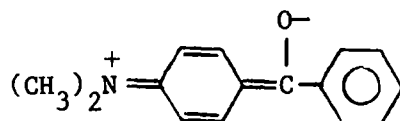

(23)

However, many of these results have recently been questioned and are now suspect.<sup>157</sup> Thus in relation to solvent effects on the substituted benzophenones, although the ketones are unreactive in isopropanol but react in cyclohexane, the process, in fact, does not appear to involve hydrogen atom abstraction leading to pinacols. Pitts<sup>157a</sup> states that no pinacol is formed on irradiation of p-aminobenzophenone in cyclohexane. He emphasizes that spectrophotometric methods of analysis have frequently been employed in studying benzophenones and that these methods involve disappearance of reactant rather than appearance of product. Thus alterations in reaction paths arising from uncontrolled environmental changes and leading to products other than pinacols may not be observed.

Studies by Cohen<sup>157c</sup> of solvent effects on the isomerization of trans-stilbene in the presence of benzophenone and aminobenzophenones have suggested that the failure of p-aminobenzophenone to photoreduce in polar solvents results from essentially the complete absence of triplets rather than the charge-transfer state itself being unreactive. Cohen suggests that in isopropanol the charge-transfer singlet and triplet levels may be below the  $n, \pi^*$  levels and that intersystem crossing between

the like charge-transfer states is slow. It is also conceivable<sup>157c</sup> that a triplet is formed, but is deactivated and thus, in effect, quenched by the alcohol.

Pinacols may only be isolated following photochemical reduction of aryl ketones in isopropanol, if the pinacols are themselves stable in irradiated acetone solutions.<sup>129</sup> Thus 9,9'-dihydroxy-9,9'-bixanthene is converted into xanthen-9-one in sunlight,<sup>133</sup> (eq.2.17), and correspondingly xanthen-9-one is not converted to the pinacol on irradiation in isopropanol.

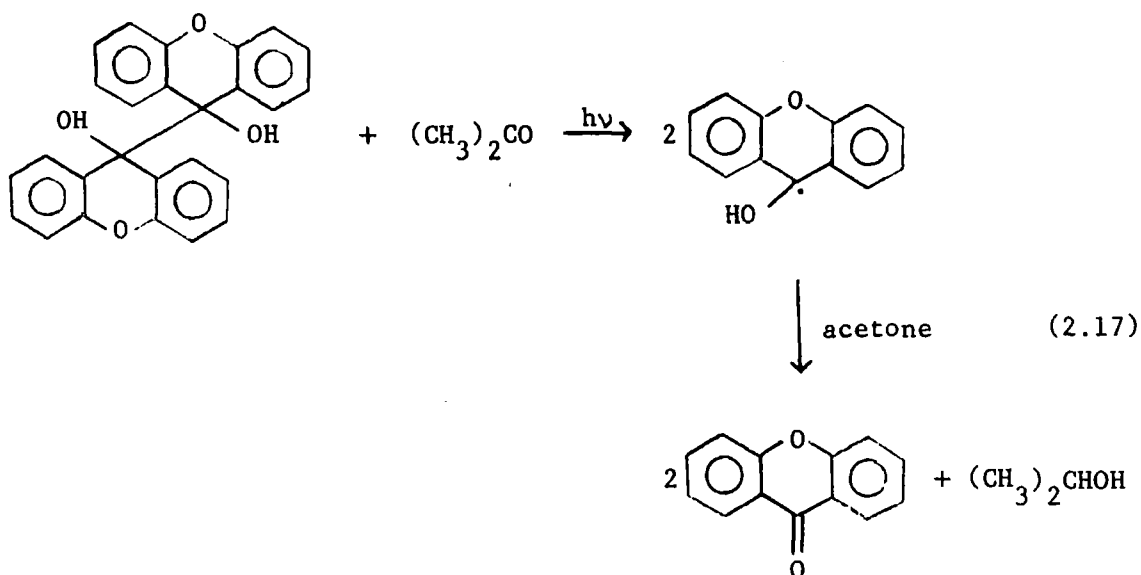

Ortho substituted aromatic ketones, or those with other substituents which can form a six-membered ring hydrogen bonded to the carbonyl oxygen, may tautomerize in an intramolecular hydrogen abstraction reaction. Thus 2-methylbenzophenone forms an enol under the influence of ultraviolet light, (eq.2.18), to the complete exclusion of photopinacolization.<sup>158</sup>

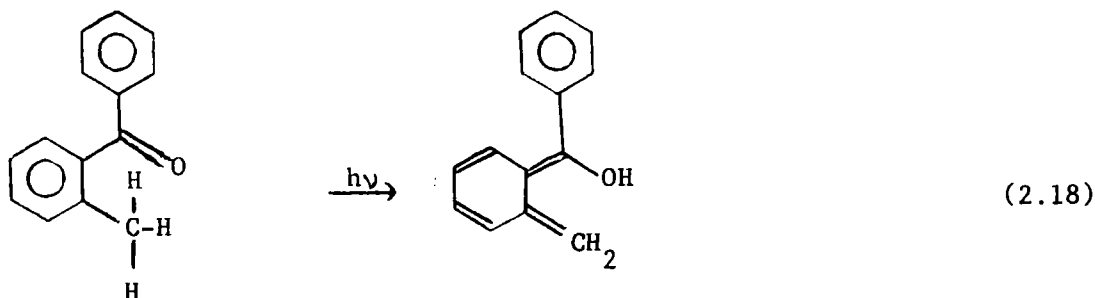

This reaction has been investigated in relation to other alkyl substituted ketones,<sup>159</sup> and is discussed further in Chapter 5.

(d) Photoaddition of Ketones to Methylene Groups

Carbonyl groups may undergo photoaddition to methylene groups adjacent to double bonds or aromatic systems.

Benzophenone reacts with diphenylmethane in sunlight to form 1,1,2,2-tetraphenylethanol (eq.2.19).<sup>160</sup>

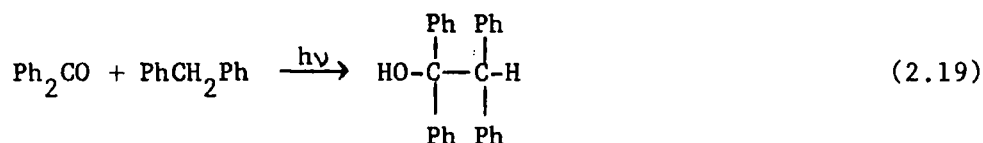

Irradiation of benzophenone with bis-(4-methoxyphenyl)methane gives the carbinol and symmetrical dimers of the radicals involved in the reaction (eq. 2.20).<sup>161</sup>

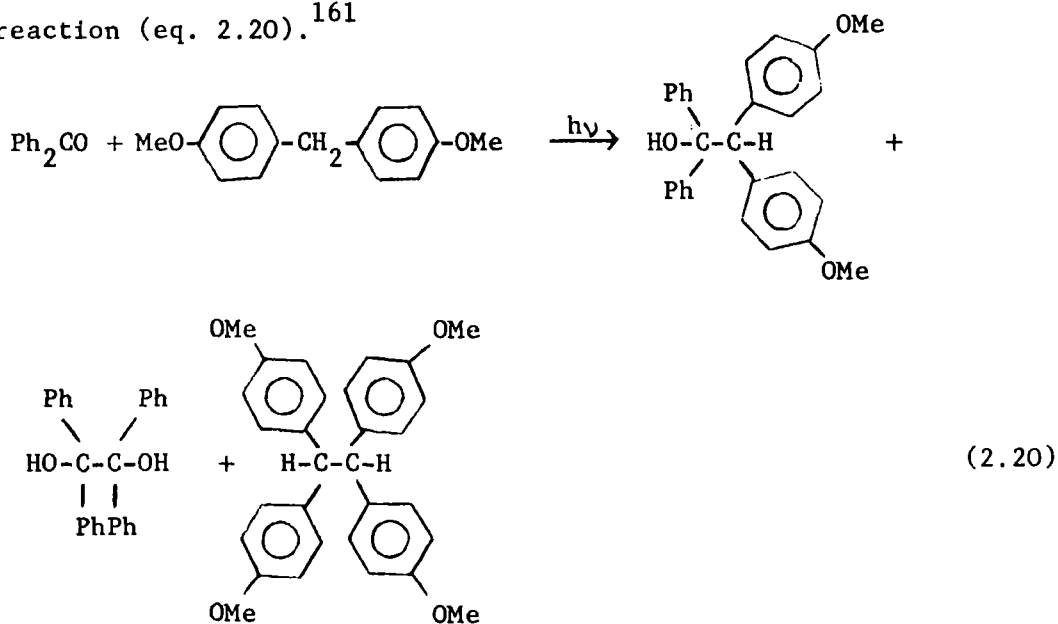

Transannular interaction between the excited carbonyl group of cyclododecanone and one of the nearest methylene groups, with intramolecular cyclization, yields a tertiary alcohol (eq. 2.21).<sup>162</sup>

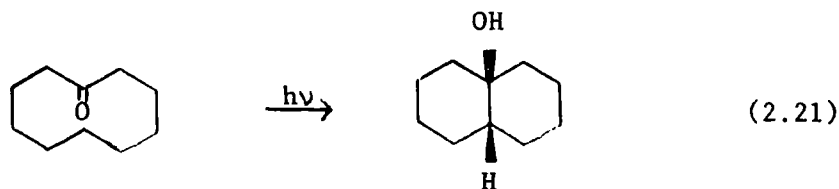

Many other examples of such photoadditions may be found in the literature.<sup>163</sup>

## 2.7 Photocycloaddition of Carbonyl Compounds to Unsaturated Systems

The photocycloaddition of carbonyl compounds to olefins with the formation of oxetanes (eq. 2.22) was first reported by Paternò and Chieffi in 1909.<sup>164</sup>

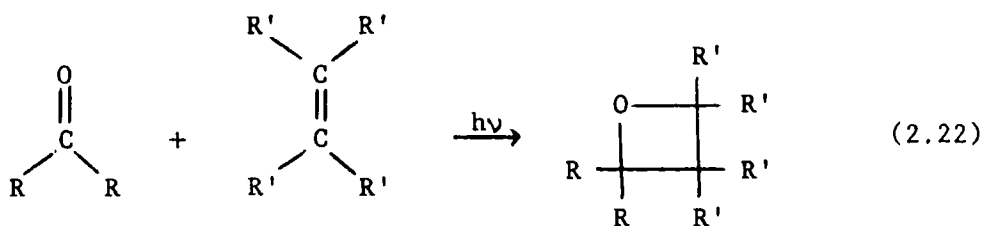

The reaction was not reinvestigated until 1954 when Büchi<sup>165</sup> verified the structure of the product, and it is only in the last decade that the scope and usefulness of the reaction has been demonstrated.<sup>109</sup> The reaction has been named the Paternò-Büchi reaction and is frequently the one chosen for oxetane synthesis. Starting materials are readily available and yields may be nearly quantitative, an essential requirement for application to step-growth polymerization. Two fairly

recent reviews of the Paternò-Büchi reaction are available.<sup>109,166</sup>

(a) Scope of the Reaction

Paternò and Chieffi reported that irradiation of benzophenone in a petroleum mixture rich in 2-methyl-2-butene gave an oxatane in good yield (eq.2.23).<sup>109</sup>

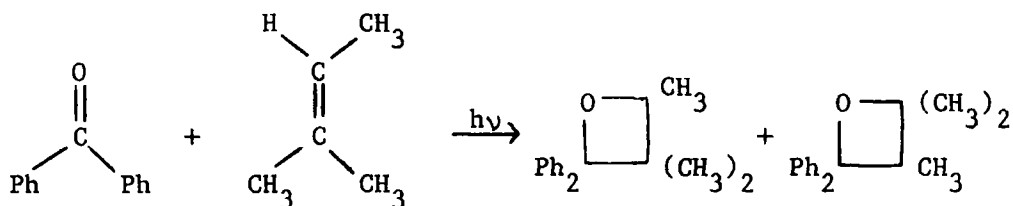

(2.23)

Büchi<sup>165</sup> photoreacted 2-methyl-2-butene with benzaldehyde, acetophenone and n-butyraldehyde and assigned oxetane structures to the products by identifying the carbonyl compounds formed from acid-catalysed cleavage. Numerous oxetanes have subsequently been synthesized by the Paternò-Büchi reaction.<sup>109</sup> Arnold has produced a comprehensive table<sup>109</sup> of oxetanes prepared by the reaction, and a few examples indicating the scope of the reaction are given in Table 2.4.

Examination of the examples in Table 2.4 indicates the variety of carbonyl compounds and unsaturated systems studied. Carbonyl compounds successfully undergoing photocycloaddition include aliphatic and aromatic aldehydes and ketones, p-quinones, fluoro-compounds and compounds containing functional groups in addition to the carbonyl group. Olefins used embrace linear and cyclic systems, including fluoro-olefins. In addition to olefins other unsaturated systems have been employed including allenes, acetylenes and ketenimines. The cycloaddition may be intramolecular as well as intermolecular.

TABLE 2.4

Some Photocycloadditions of Carbonyl Compounds to Unsaturated Systems, Yielding Oxetanes

Carbonyl Compound	Unsaturated System	Oxetane	Oxetane Yield (%)	Ref.
Perfluoroacetaldehyde	Chlorotrifluoroethylene		14	167
n-Butyraldehyde	2-Methyl-2-butene		7	165
Perfluoroacetone	Ethylene		ca. 80	168
Acetone	Cyclohexene		8	169
5-Methyl-5-hexen-2-one				170
Benzaldehyde	1-Hexene		30	169
Cinnamaldehyde	2-Methyl-2-butene			171
Acetophenone	Cyclohexene		15	169
2-Benzoylpyridine	Isobutylene		57	172
Benzophenone	Tetramethylethylene		70	173

Table 2.4 contd.

Carbonyl Compound	Unsaturated System	Oxetane	Oxetane Yield (%)	Ref.
Benzophenone	Norbornene		80	173 174
m-Dibenzoylbenzene	Isobutylene			172
Acetylcyanide	Norbornene	 + isomer	77	175
1,4-Benzoquinone	Cyclohexene		10	176
3-Octyne-2-one	Isobutylene	 + isomer	82	177
Benzaldehyde	5-Decyne		13	178
Benzophenone	Allene		38	179 180 181

Table 2.4 contd.

Carbonyl Compound	Unsaturated System	Oxetane	Oxetane Yield(%)	Ref.
Benzophenone	Tetramethylallene	SEE CHAPTER 4		
Crotonaldehyde	Furan		11	182
4-Methoxybenzaldehyde	Dimethyl-N-(2-cyano-2-propyl)ketenimine		34	183
Benzophenone	Furan	SEE CHAPTER 4		

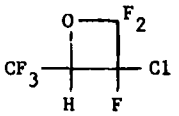
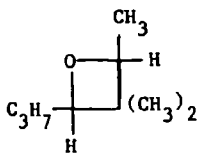
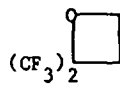
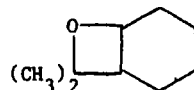
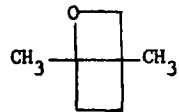
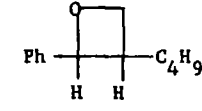
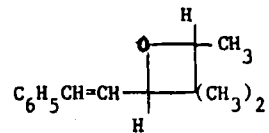
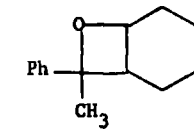
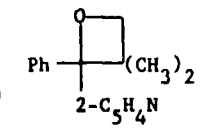
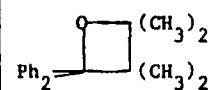
(b) Mechanism

As in the case of photoreduction, most photocycloaddition reactions of the carbonyl group are characteristic of the carbonyl  $n, \pi^*$  state,<sup>109</sup> and carbonyl compounds undergoing photocycloaddition generally undergo photoreduction in isopropanol.<sup>173</sup>

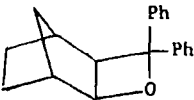
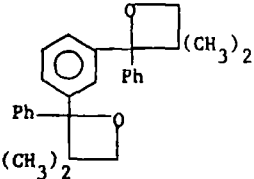
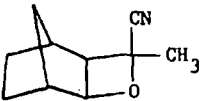
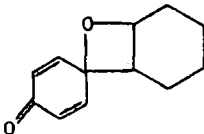
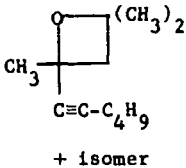
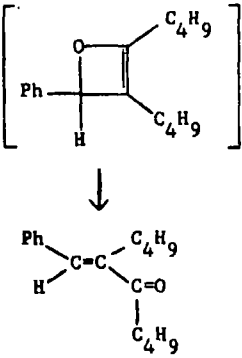
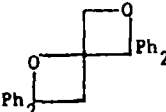
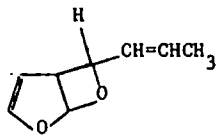
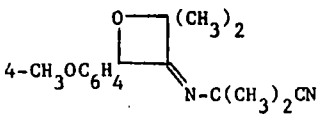
The important steps in the reaction for "electron rich" olefins may frequently be adequately represented by the reaction scheme (2.24).

- i) Excitation  $\text{RCOR} \xrightarrow{h\nu} \text{RCOR}^*$  (singlet)
- ii) Intersystem Crossing  $\text{RCOR}^*$  (singlet)  $\rightarrow$   $\text{RCOR}^*$  (triplet)
- iii) Deactivation  $\text{RCOR}^* \rightarrow \left[ \begin{array}{l} \text{(i) Radiative or nonradiative} \\ \text{(ii) With or without quenchers} \\ \text{(iii) With molecular rearrangement} \end{array} \right] \rightarrow \text{RCOR ground state}$
- iv) Reaction

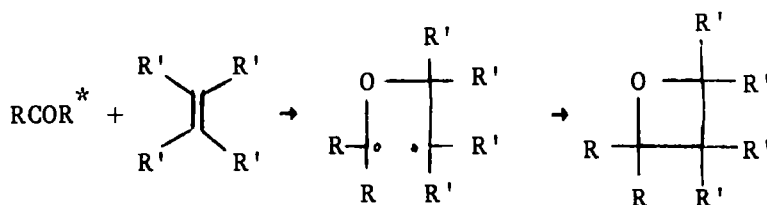

(2.24)

Excitation of the carbonyl chromophore has already been discussed. Initial excitation of the carbonyl chromophore is demonstrated by the fact that reaction may be brought about by irradiation in regions where only the carbonyl compound absorbs.

If the rate of intersystem crossing is faster than the rate of diffusion in solution, bimolecular reactions of the excited singlet state will not occur. The rate of intersystem crossing in aromatic carbonyl

compounds is fast compared to the rate in aliphatic carbonyl compounds, reaction from the excited singlet state being more likely in the latter case.

Deactivation of the excited state without oxetane formation may occur by a variety of competing processes, the  $n, \pi^*$  triplet existing in fluid solution for approximately  $10^{-5}$  sec.<sup>150</sup> The rate of cycloaddition must be rapid enough to occur before the excited carbonyl compound returns to the ground state by, for example, radiative deactivation. Singlet and triplet excited states may be quenched by interaction with some other molecule such as the unsaturated system, (section 2.4). An example of the unsaturated system acting as quencher of the singlet state is in the photocycloaddition of fluorenone to dimethyl-N-(cyclohexyl)ketenimine (eq.2.25).

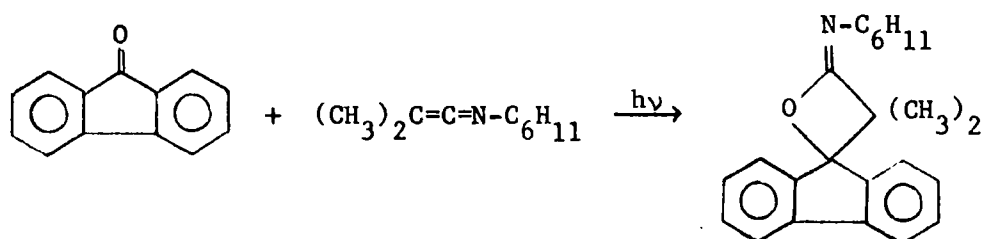

(2.25)

A striking decrease in quantum yield of adduct formation at high ketenimine concentrations is believed to be due to deactivation of the fluorenone singlet state via complex formation with the ground state of the ketenimine. Photoenolization is another deactivation pathway.

The actual photocycloaddition generally involves attack on the ground state olefin by the  $n, \pi^*$  triplet excited carbonyl compound.<sup>109</sup>

The reaction sequence

depicted above involves addition of the lone electron of the oxygen atom to an "electron rich" unsaturated system giving a biradical intermediate which subsequently closes, forming the oxetane.

With unsymmetrical "electron-rich" unsaturated olefins two isomers may be formed and the stereochemistry of the major adduct is predicted from Markovnikov addition or consideration of the most stable biradical intermediate. This is consistent with the simple model for the carbonyl  $n, \pi^*$  state predicting electrophilic attack on the  $\pi$  system of the  $C=C$  double bond by oxygen. This should occur preferentially in the plane of the carbonyl group and produce a biradical, the orbitals forming the  $C-C$  bond being orthogonal to each other immediately after the  $C-O$  bond is formed (2.26). If the  $n, \pi^*$  triplet is involved, spin inversion must occur before bonding.<sup>185</sup>

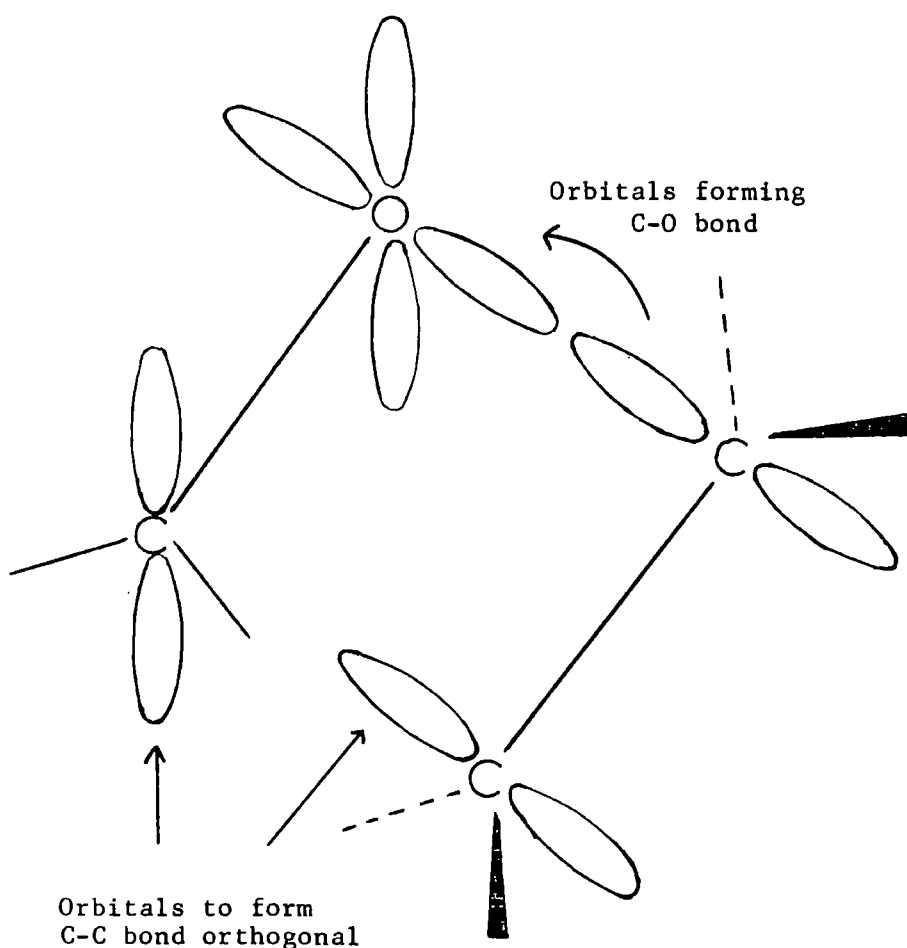

Evidence for the biradical intermediate is the degree of retention of cis- and trans-substitution in the product from a cis- or trans-olefin. Isomerization would not occur if both bonds were formed concurrently in a concerted process whilst bond rotation is possible in the biradical mechanism. Irradiation of benzophenone in 2-butene yields approximately the same mixture of both isomeric oxetanes starting with either the cis-olefin or the trans-olefin before significant isomerization of the olefin occurs, indicative of the biradical mechanism (eq.2.27).<sup>109</sup>

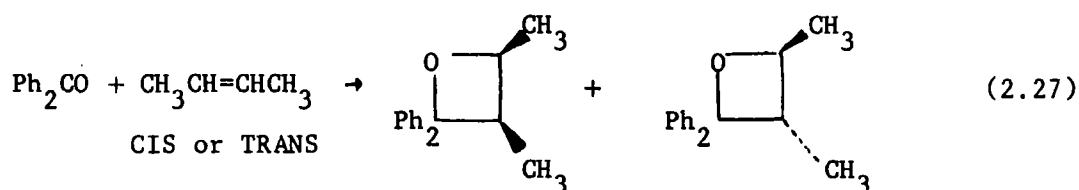

Photocycloaddition of benzophenone to isobutylene gives the oxetane (24) as the major product.<sup>173</sup>

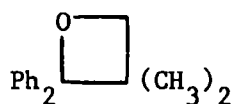

(24)

The intermediate biradical (25) is more stable than biradical (26), tertiary radicals being more stable, and leads to the major product (24).

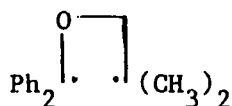

(25)

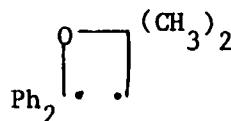

(26)

Product orientation may be influenced by steric factors. For example photoaddition of benzophenone to 2-methylnorbornene gives a preponderance of isomer (27) over isomer (28).<sup>109</sup>

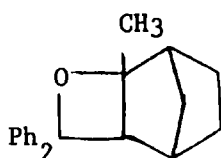

(27)

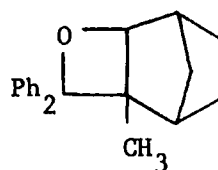

(28)

Isomer (28) is preferred from the point of view of radical stability and steric interference to the attacking oxygen. If intermediate formation is reversible, steric repulsion will influence closing of the biradical giving (27). Steric factors favour production of the exo oxetane (29) from benzophenone and norbornene, the exo position being more easily approached than the endo position.<sup>173,174</sup>

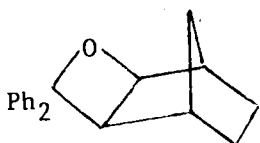

exo (29)



endo (30)

The previous discussion on the mechanism of the Paternò-Büchi reaction has been based essentially on a biradical mechanism involving initial attack of carbonyl  $n, \pi^*$  triplet. The biradical mechanism is adequate for the rationalization of many cycloaddition products, but over the past few years there has been particular interest in further studies on

mechanism and the nature of intermediates formed during reactions. It has been suggested that the biradical intermediates may undergo cleavage to generate isomerized olefin,<sup>175</sup> (eq.2.28), although there has been dispute as to whether fragmentation gives triplet state olefin<sup>175</sup> or ground state olefin.<sup>186</sup>

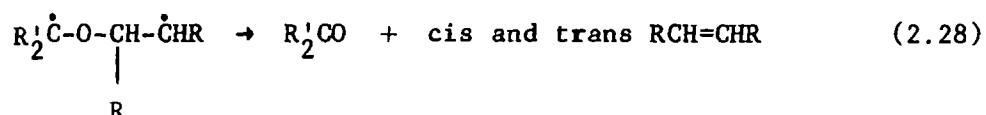

This is an alternative mechanism to photosensitized isomerization via energy transfer. The possibility of some intermediate prior to the biradical has been suggested,<sup>187</sup> inconsistencies in effects of olefin and ketone structure on quenching rate constants suggesting a charge-transfer complex or exciplex\* may precede the biradical.<sup>188</sup> A primary interaction between ketone triplet and olefin with charge-transfer complex formation has been postulated whenever energy transfer is so endothermic as to be negligibly slow.<sup>188</sup>

Very recently, largely on the basis of isotope effects, it has been reported that the primary interaction between benzophenone triplet and simple alkenes involves irreversible formation of a complex with substantial charge-transfer character, olefin being the donor and ketone the acceptor.<sup>190</sup> A possible structure for the complex has been suggested (Fig.2.4) which includes n-orbital participation, a geometry symmetric with respect to olefin double bond and which maintains the geometric integrity of the olefin.

---

\* Exciplexes (excimers) are molecular aggregates defined as being stable in an electronically excited state but not in their ground state.<sup>113,189</sup>

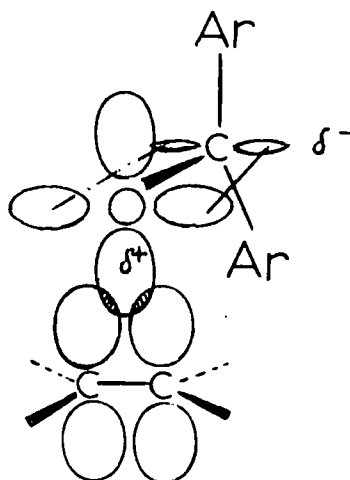
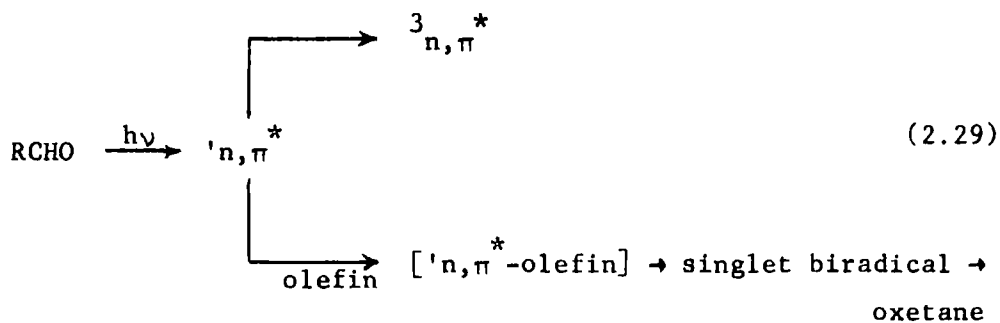

FIG. 2.4

A structural hypothesis for the complex between benzophenone triplet and simple alkenes.<sup>190</sup>

The direction of collapse of the complex is reported to be dependent on factors in addition to biradical stability. Charge distributions and polarizabilities in the complex may be involved.

Attack of carbonyl  $n, \pi^*$  singlet on an "electron rich" olefin is established<sup>191-193</sup> and proceeds through a singlet complex and then via a concerted or very short-lived 1,4-biradical pathway with insufficient time for bond rotation. For the Paternò-Büchi reaction of alkanals, Yang<sup>191</sup> has proposed the reaction sequence (2.29).



In the photocycloaddition of acetone to 1-methoxy-1-butene, both singlet and triplet biradical intermediates have been postulated,<sup>192</sup> the former being expected to cyclize and fragment more efficiently relative to rotation about C-C and C-O bonds. It has recently been pointed out,<sup>190</sup> however, that the value and validity of simple concepts, like slowness of spin inversion relative to bond rotation rates, in biradicals have been questioned.<sup>194</sup>

Intramolecular cycloaddition in 5-hepten-2-one is thought to proceed via singlet exciplex formation.<sup>195</sup>

Photocycloaddition to "electron-deficient" olefins such as  $\alpha$ ,  $\beta$  unsaturated nitriles involves attack of singlet excited carbonyl compound on the olefin to give a singlet complex<sup>196-199</sup> in which an electron appears to have been transferred from the carbonyl  $n, \pi^*$  state to the olefin.

Oxetanes may be formed by photocycloaddition to conjugated dienes via singlet excited ketone attack on ground state diene giving a singlet complex with charge-transfer character.<sup>200</sup> It has been suggested that oxetane formation from 2,3-dimethyl-1,3-butadiene and benzophenone proceeds by addition of diene triplet to ground state benzophenone,<sup>201</sup> but Barltrop later proposed a mechanism involving attack of excited triplet benzophenone on ground state diene.<sup>202</sup> Other reports of oxetane formation from excited olefin and ground state carbonyl compound have recently been made.<sup>203</sup>

An upper excited electronic state of 9-anthraldehyde may be reactive in its Paternò-Büchi reaction.<sup>204</sup>

Exciplex formation between the electron deficient aromatic ring of the  $\pi, \pi^*$  excited singlet state of the esters dimethylterephthalate and

dimethylisophthalate, and the olefin 2-methyl-2-butene has been proposed for the associated photocycloaddition reaction,<sup>205</sup> the reaction scheme being (2.30).

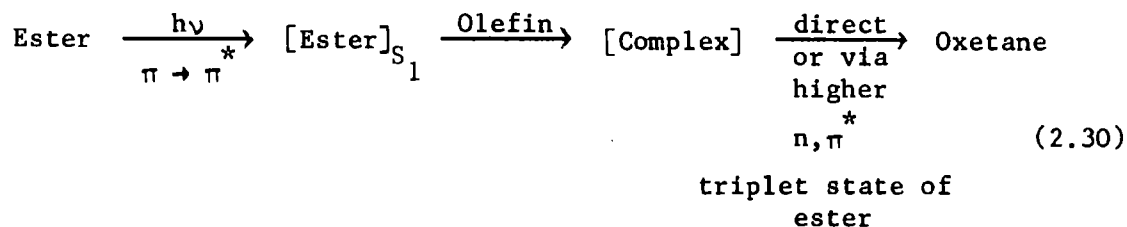

Excitation of charge-transfer complexes from anhydrides and "electron-rich" olefins is reported to lead to oxetanes.<sup>206</sup>

(c) Limitations

Many restrictions on successful photocycloadditions yielding oxetanes have already been considered in the preceding discussion.

A major competing reaction is hydrogen abstraction and intramolecular, intermolecular and solvent hydrogen abstractions have already been discussed. Olefins with easily abstractable hydrogens should be avoided. Benzaldehyde adds to cyclohexene and also abstracts hydrogen from it (eq. 2.31).<sup>109</sup>

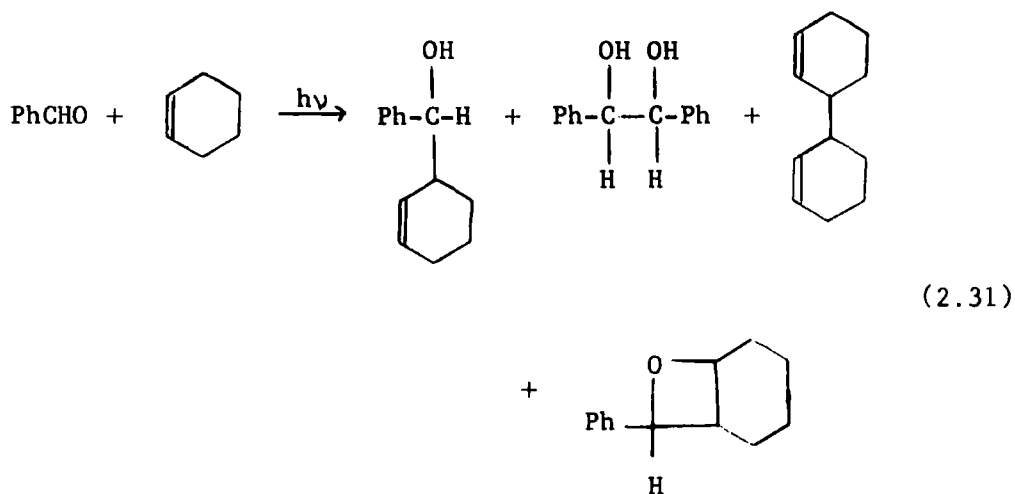

Hydrogen abstraction from the oxetane itself must also be considered, hydrogen  $\alpha$  to ether oxygen being susceptible to abstraction.<sup>109,207</sup>

Attainment and sufficient lifetime of the  $n, \pi^*$  state of the carbonyl compound is most often a prerequisite of reaction and some factors influencing the nature of the lowest lying excited state have already been discussed in section 2.6. Cyclobutane formation may be an alternative reaction to oxetane formation, as with 1,4-quinones such as chloranil (eq.2.32).<sup>208</sup>

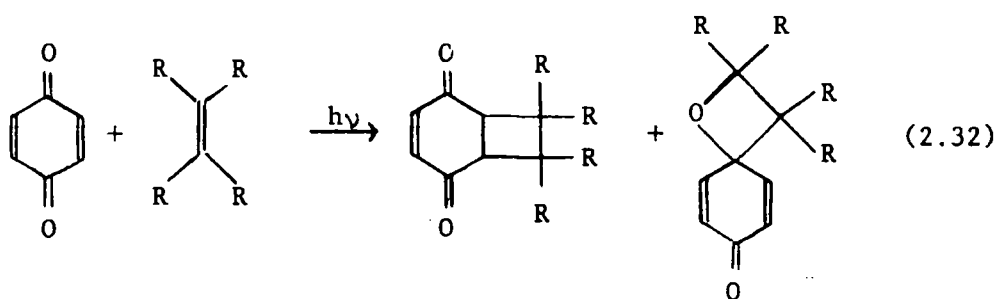

Energy transfer to the unsaturated system has again already been considered (section 2.4).

Stability of the biradical intermediate in most reactions restricts the possible isomers yielded by the reaction.

Norrish type I and type II processes may compete with oxetane formation. Norrish type I rupture of acyl-halide bonds of perfluoroacyl chlorides and bromides competes with oxetane formation from these carbonyl compounds.<sup>209</sup>

Some other reactions of carbonyl compounds, that could compete with oxetane formation are indicated briefly in section 2.8.

Products must be stable to the irradiation conditions used. Oxetanes are transparent in the long wavelength region but may ring open on irradiation at short wavelengths.<sup>210</sup>

Photochemically active chromophores present in addition to the carbonyl group of the carbonyl compound may lead to complications, for example in further reaction beyond oxetane formation as with irradiation of fluorenone and tetramethylallene (eq.2.33).<sup>109,181</sup>

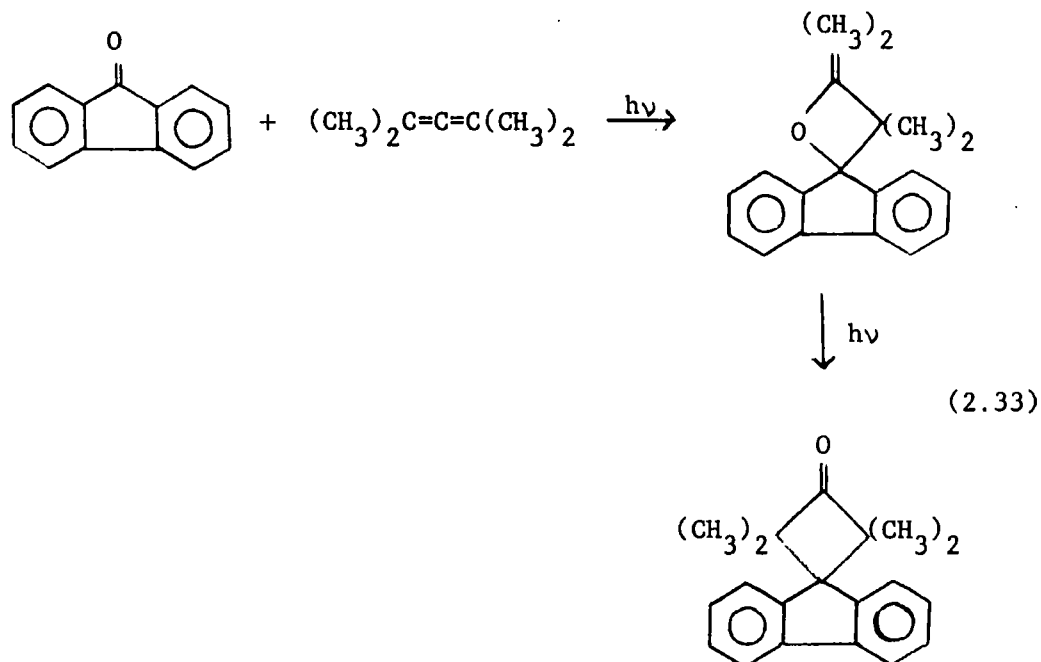

Oxetane products though detectable and characterizable by infrared and n.m.r. spectroscopy may be too unstable for purification, an example being the oxetane from 4,4'-dimethoxybenzophenone and isobutylene which fragments into formaldehyde and diarylethylene (eq. 2.34).<sup>109,173</sup>

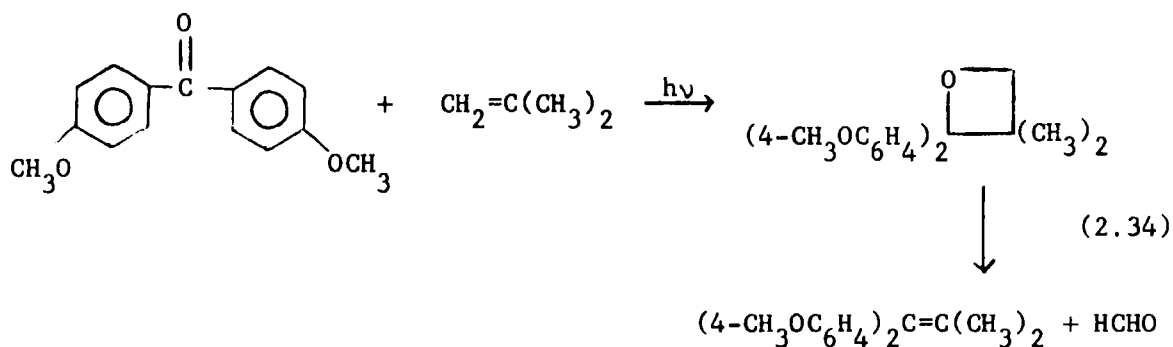

(d) Experimental Conditions

Standard photochemical procedures are employed in the photocycloaddition reactions.<sup>109</sup>

Solvents should be transparent to the wavelength of light used, inert with no easily abstractable hydrogen atoms and have no quenching properties. Amongst solvents successfully used are: benzene, pyridine, acetic acid, acetonitrile, excess olefin, excess carbonyl compound, saturated hydrocarbons and ethers.<sup>109</sup>

2.8 Miscellaneous Photochemical Reactions of Carbonyl Compounds

In this section some further photochemical reactions of carbonyl compounds are indicated, their relevance being that they may possibly interfere with oxetane formation.

Aliphatic aldehydes such as acetaldehyde, butyraldehyde and heptanal add to olefinic double bonds under the influence of light, forming ketones by a free radical mechanism (eq. 2.35).<sup>211</sup>

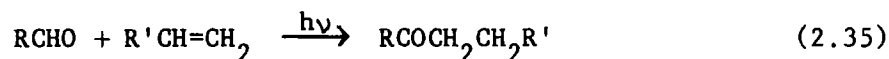

This reaction is obviously in contrast to oxetane formation. Free radical additions to olefins have been reviewed generally.<sup>212</sup>

Ultraviolet irradiation of aqueous solutions of cyclic ketones may result in hydrolysis to acids (eq. 2.36).<sup>213</sup>

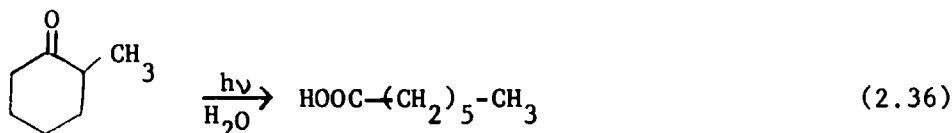

Photoisomerization with ring contraction has been reported, (eq.2.37).<sup>214</sup>

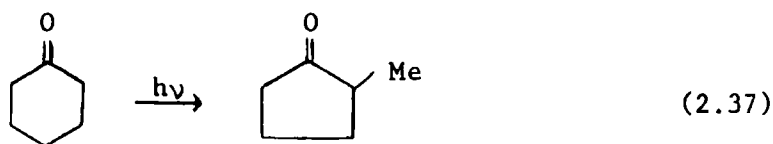

Expulsion of carbon monoxide may occur (eq.2.37).<sup>215</sup>

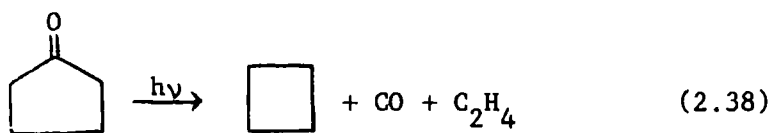

Other examples of photochemical reactions of carbonyl compounds may be found in the literature.<sup>105,114,141</sup>

## 2.9 Effect of Oxygen in Photochemical Reactions

The exclusion of oxygen from photochemical reactions is frequently of vital importance. The quenching of excited states by oxygen has been known for many years.<sup>216</sup> Explanations for this quenching by oxygen<sup>217</sup> include transfer of electronic energy to oxygen<sup>218</sup> resulting in excitation to a low-lying singlet state.

Since oxygen is paramagnetic, spin-orbit interactions in an excited molecule may be enhanced, allowing relaxation of restrictions relating to singlet-triplet transitions.<sup>219</sup> Oxygen may be involved in the formation of a charge-transfer complex with a molecule in its excited state. This could catalyze internal conversion processes.<sup>220</sup>

Oxygen may actually be incorporated in photochemical oxidation reactions, there being two possible reaction mechanisms.<sup>221</sup> The first

is a photosensitized oxidation mechanism involving hydrogen abstraction by excited sensitizer followed by indiscriminate addition of oxygen to the new radical (2.39).

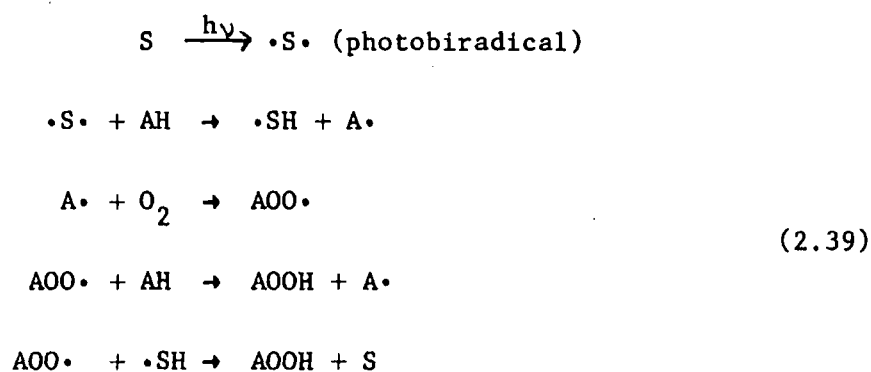

(S = sensitizer; AH = hydrogen donor).

This mechanism accounts for the formation of hydroperoxides from the photosensitized irradiation of secondary alcohols in an atmosphere of oxygen, an example being the benzophenone-sensitized oxidation of isopropanol with formation of (31).

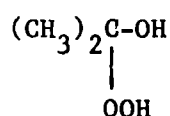

(31)

This reaction would interfere with photopinacolization. The hydroperoxide decomposes in aqueous solution to give acetone and hydrogen peroxide (eq.2.40)

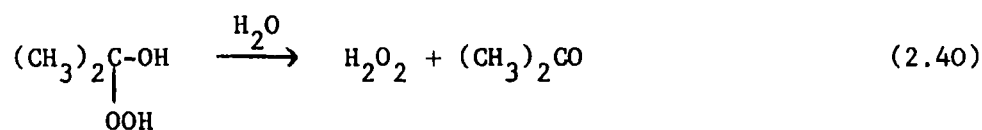

The second mechanism is a photosensitized oxygen transfer involving direct combination of the sensitizer with oxygen, only biradicals taking part in the reaction (2.41).

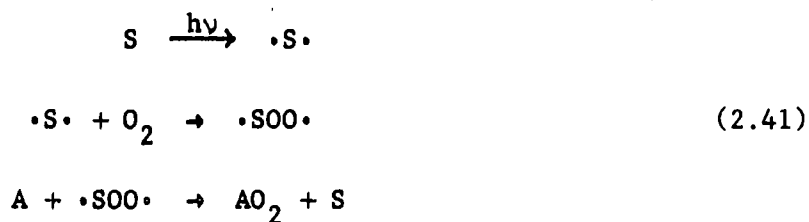

Footo has suggested that singlet oxygen is the sole agent in the transfer step (2.42).<sup>222</sup>

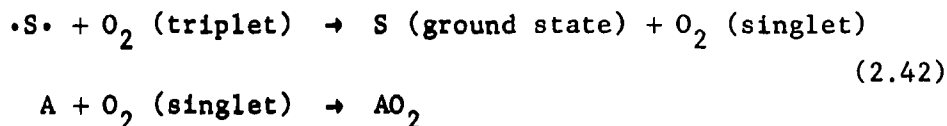

An example of photooxidation by the second general mechanism is the oxidation of furans (eq. 2.43).<sup>223</sup>

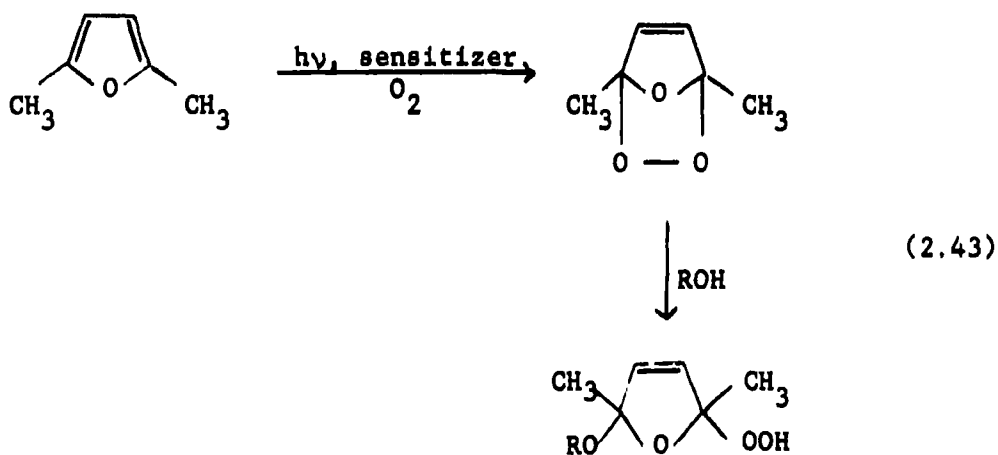

Oxygen may effect extremely complex reactions. For example, products from the photooxidation of acetone<sup>224</sup> include  $H_2CO$ ,  $H_2O$ ,  $CH_3OH$ ,  $CH_3OOH$ ,  $CH_3COOH$ ,  $HCOOH$ ,  $CH_3OOCH_3$  + higher molecular weight products. Possibly 140 reactions could be occurring!

Photooxidation of polymers has already been mentioned in Chapter 1.

### 2.10 Selection of Starting Materials for Step-Growth Photopolymerization Involving the Paternò-Büchi Reaction

In principle the Paternò-Büchi reaction may be used in either of two ways in attempts to prepare polymers containing oxetane rings in the main chain. Irradiation of monomers containing both carbonyl and olefinic functions (eq. 2.44), or irradiation of equimolar mixtures of dicarbonyl compounds and dienes (eq. 2.45) may give the desired products.

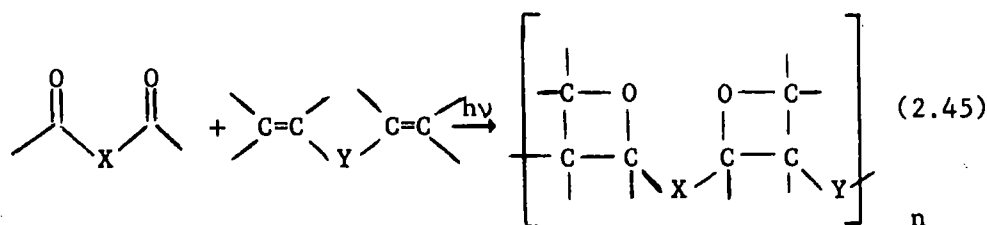
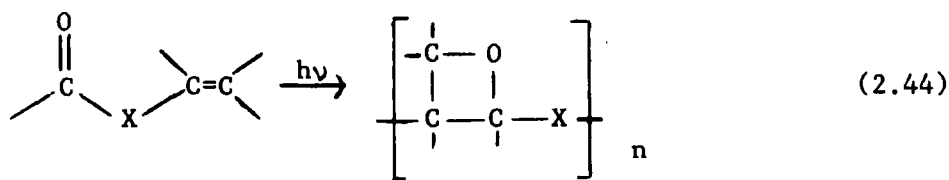

Bearing in mind the criteria for step-growth polymerization and the possible competing reactions, especially of aliphatic ketones and aldehydes, aromatic ketones were chosen for study as dicarbonyl compounds. The analogy between the Paternò-Büchi reaction and photopinacolization, together with initial preference for use of known monomers, obtainable in a high state of purity, led to the selection of benzophenone-type aromatic diketones which were known to form polypinacols by a step-growth mechanism (Chapter 1, section 1.10).

The necessity for near quantitative yields in coupling reactions , and the similarity in the environment of the carbonyl groups in selected diketones to that of the carbonyl group in benzophenone, indicated that an essential requirement was for benzophenone to undergo photocycloaddition to both double bonds of any selected diene in high yield with the formation of benzophenone-diene 2:1 adducts.

Examination of the available literature<sup>109,166</sup> revealed few such reactions, but tetramethylallene and furans seemed to be dienes worthy of investigation. Their photoreactions with benzophenone are discussed in Chapter 4.

CHAPTER 3

SYNTHESIS OF AROMATIC DIKETONES

INTRODUCTION

### 3.1 Principal Routes to Aldehydes and Ketones

Several general methods are available for the preparation of aldehydes and ketones.<sup>225</sup> They may be divided into three principal routes:

- 1) Oxidation of an organic compound to one containing a carbonyl group.
- 2) Modification of a compound already containing a carbonyl group, such as a carboxylic acid or derivative, into an aldehyde or ketone.
- 3) Introduction of carbonyl or potential carbonyl groups into an organic compound with formation of new C-C bonds.

Included in the third principal route is the Friedel-Crafts reaction, readily applicable to the synthesis of aromatic diketones.

### 3.2 The Friedel-Crafts Reaction

The first report by Friedel and Crafts of an alkylation reaction using anhydrous aluminium chloride as 'condensing agent' was made in 1877.<sup>226</sup> Subsequent investigations by Friedel and Crafts showed aluminium chloride to be a highly versatile catalyst effecting alkylations, dealkylations, acylations, polymerizations and many other reactions. The original scope of the reaction has been extended to cover many variations of reagent, acid catalyst system and related reactions such as those involving the formation of bonds from carbon to various other atoms including O, N, S, P, B and halogens. The reaction is of great value in organic syntheses and has been the subject of extensive documentation.<sup>227</sup> Its use may be conveniently divided into three categories:

- i) Alkylations and related reactions .
- ii) Acylations and related reactions .
- iii) Miscellaneous reactions .

The acylation reaction provides a major route to ketones and is discussed in the following section with particular reference to aromatic ketone synthesis.

### 3.3 Aromatic Ketone Synthesis by Friedel-Crafts Reactions

Friedel-Crafts ketone synthesis essentially involves reaction between an acyl component and an aromatic substrate in the presence of a catalyst. A common example is reaction between an acyl halide, a benzene derivative and aluminium chloride (eq.3.1).



#### (a) Mechanism

The mechanism of the acylation has been the subject of detailed investigation and thorough review.<sup>228</sup>

The reaction may be represented simply and generally by the scheme (3.2) for metal halide catalyst  $\text{MX}_n$ , acyl component  $\text{RCOY}$  and benzene substrate.

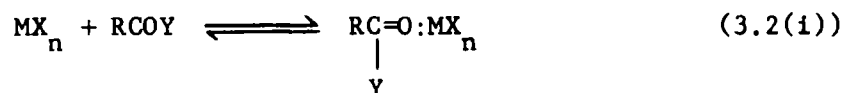

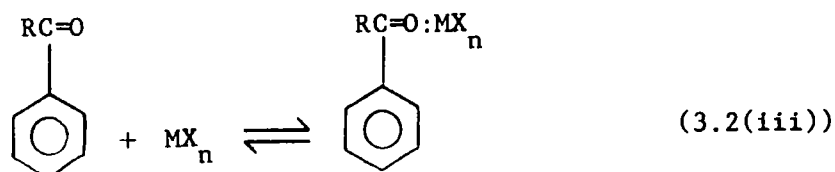
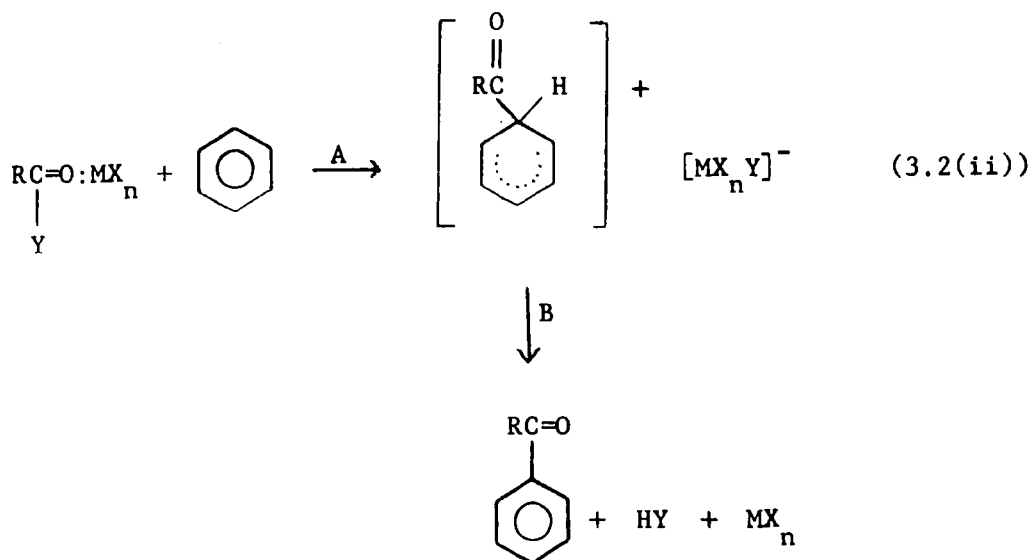

Step (3.2(i)) involves complexation between acyl component and catalyst. Structures proposed for addition compounds of  $\text{AlCl}_3$  with acid chloride include (32)-(36).<sup>228</sup>

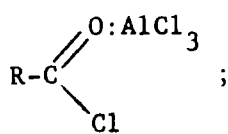

(32)

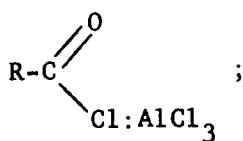

(33)

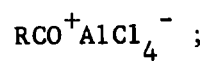

(34)

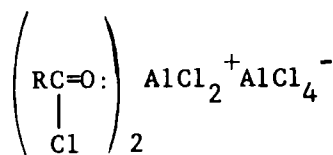

(35)

and

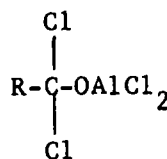

(36)

It has been shown that (32) and (34) are the major species serving as electrophiles.<sup>228,229</sup> For aluminium halide catalyzed benzoylations the favoured mechanistic postulates are:

- a) Reaction of aromatic with oxonium compound (3.3).

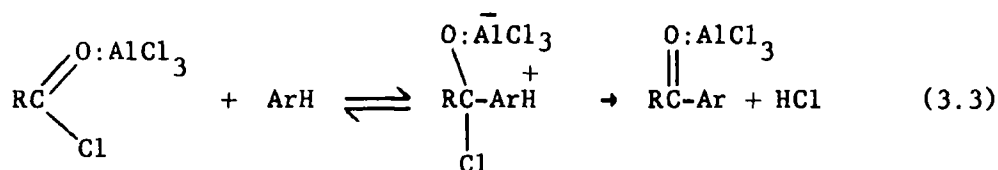

- b) Reaction of aromatic and acylium ion (3.4).

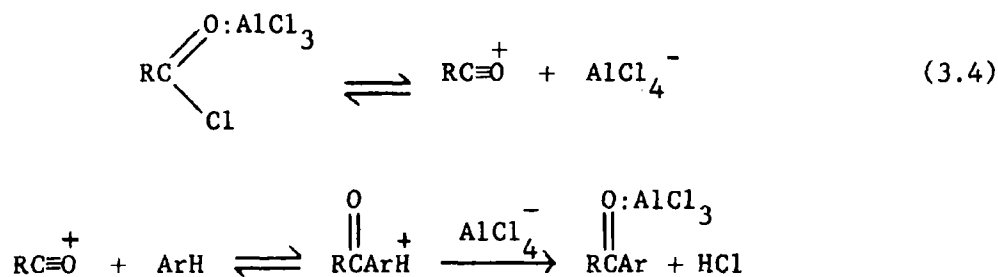

A third mechanism involves participation of complex (33).

Oxonium compounds (32) are probably the principal forms present in non polar solvents and benzoyl chloride, and Gore has stated that for most acylation reactions mechanism (3.3) is generally the most likely.<sup>230</sup> In contrast Jensen states that the second acylium ion mechanism (3.4) has received the most favour.<sup>228</sup>

### (b) Catalysts<sup>230</sup>

The most popular choice of catalyst has long been aluminium chloride, it being cheap and possessing high catalytic activity. For routine work commercially available aluminium chloride is sufficiently pure. Traces of water have been used both to moderate and accelerate reactions, the activating influence of water being explained by formation of hydrates of the type  $[\text{AlX}_3\text{OH}]^- \text{H}^+$  functioning like other strong proton

acids.<sup>231</sup> Other metal halides used with acyl halides include  $\text{AlBr}_3$ ,  $\text{FeCl}_3$ ,  $\text{FeBr}_3$ ,  $\text{SbCl}_5$ ,  $\text{SbBr}_3$ ,  $\text{TiCl}_4$ ,  $\text{NbCl}_5$ ,  $\text{GaCl}_3$ , and  $\text{ZrCl}_4$ . Rates of benzoylation have been found<sup>232</sup> to follow the sequence :

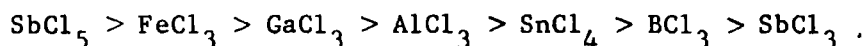

Metal powders (e.g. Zn, Cu, Al, Fe), mineral and other acids, salts, acid anhydrides,  $\text{BF}_3$  complexes and iodine are amongst many other catalysts employed.

(c) Acyl Components<sup>230</sup>

Any substance convertible to a potential acyl cation or other reactive entity under the influence of a catalyst or by heat alone may be suitable as the acyl component.

Commonly used reagents include acid halides, anhydrides, esters and carboxylic acids. Acyl chlorides are most commonly used with aromatic substrates; the other three classes of reagent are first converted into acyl halide by the catalyst and then into the reactive complex. Complex formation is represented stoichiometrically for  $\text{AlCl}_3$  catalyst by the equations (3.5)-(3.8).

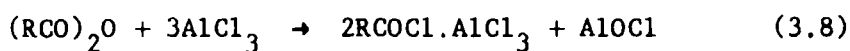
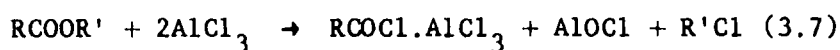
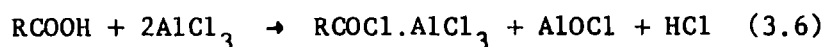
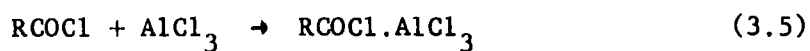

Reactivity of acetyl halides used with  $\text{AlCl}_3$  catalyst and benzene substrate decreases with increasing electronegativity of the halogen.<sup>233</sup>

In other cases the reactivity order may be changed and useful generalizations are not possible.

The use of aliphatic acid anhydrides is reported to offer several advantages over acid chlorides including more ready availability in a pure state, greater ease of handling, smaller yields of by-products and tars and easier ketone purification.<sup>234</sup> Inherent advantages in use of acetic anhydride over acetyl chloride have, however, been questioned.<sup>230</sup> The use of esters results in both alkylation and acylation, an example being reaction between benzene and ethyl acetate ( $\text{AlCl}_3$  catalyst) when both ethylbenzene and acetophenone occur amongst the known products.

Benzoyl halides and substituted derivatives react readily with aromatic substrates. Amongst other acylating agents are ketones, silanes, boranes and germanes.

(d) Substrates<sup>230</sup>

A vast number of substrates have been used including benzene and other benzenoid compounds, polycyclic compounds and heterocyclic compounds.

A comprehensive compilation of acylations used for aromatic ketone synthesis is available.<sup>230</sup>

(e) Experimental Conditions

The stoichiometric equations for formation of the reactive complexes with  $\text{AlCl}_3$  have already been given (eqs. 3.5-3.8). In practice the optimum number of moles of  $\text{AlCl}_3$  to acyl component has been found to be 1.1,  $\geq 2$ , 2.2,  $\geq 3$  for acid chlorides, carboxylic acids, esters and anhydrides respectively. A deficiency of catalyst tends to lower the

overall yield because of incomplete utilization of acyl component and may cause self-condensation of only partially complexed ketone, an example being dypnone formation during benzene acetylation via self-condensation of acetophenone (eq. 3.9).<sup>235</sup>

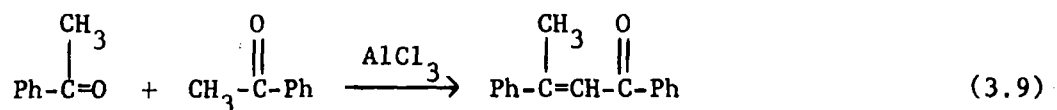

Excess catalyst generally gives appreciable amounts of tar, often making ketone purification extremely difficult.

Several variations are possible in the sequence of addition of reactants. The catalyst and acyl component may be mixed prior to addition of or to the substrate. Alternatively the acyl component or the catalyst may be added as the last reactant, this method resulting in a continuous variation in acyl component/catalyst ratio and having a marked effect on the reproducibility of results.

The reaction may be performed with neat reactants or in the presence of a suitable solvent, frequently nitrobenzene or carbon disulphide. In a polar solvent such as nitrobenzene reaction is essentially homogeneous,  $\text{AlCl}_3$ , the acyl halide- $\text{AlCl}_3$  complex and often the ketone- $\text{AlCl}_3$  complex being soluble. In non polar solvents, neither  $\text{AlCl}_3$  nor its acyl halide complex is appreciably soluble and reaction is largely heterogeneous. Solvents of intermediate polarity, such as dichloromethane, may be used.

Reaction in a homogeneous medium will provide greater catalytic surface area and solvent may prevent irreversible side reactions. Polycyclic aromatic hydrocarbons, for example, tend to undergo rearrangement, self-condensation or polymerization with  $\text{AlCl}_3$  in the

absence of a solvent.<sup>236</sup> Solvent may have a profound effect on the yield of ketone, and on position of substitution especially with polycyclic aromatic hydrocarbons as substrates. Naphthalene gives mixtures of  $\alpha$ - and  $\beta$ -ketones in most Friedel-Crafts acylations although 'normal' electrophilic substitution gives almost exclusively the  $\alpha$ -isomer. Explanations of this effect have included steric factors involving formation of a bulky complex from acyl chloride,  $\text{AlCl}_3$  and nitrobenzene solvent, and reversibility of acylation with rearrangement of any  $\alpha$ -isomer to the more stable  $\beta$ -isomer.

(f) Limitations<sup>230</sup>

Side reactions may limit the yield of the reaction and ease of purification of the required product. The use of  $\text{AlCl}_3$ , for example, gives rise to such side reactions as intra- or inter-molecular migration of alkyl groups, removal of alkyl groups preceding or accompanying acylation, replacement of halogen atoms and splitting of ortho-alkoxy groups. Thus cumene reacts with acetyl chloride and  $\text{AlCl}_3$  to give the products shown in (3.10).

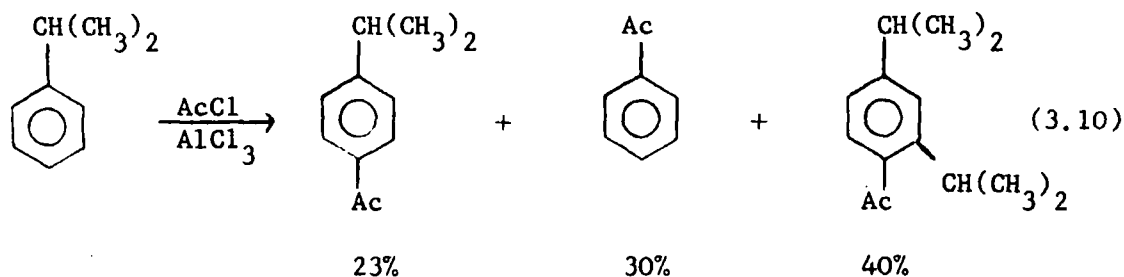

The usual limitations of electrophilic aromatic substitution as a synthetic route apply equally in this case. The deactivating effect of an acyl group introduced into a benzene nucleus generally limits the reaction

to monosubstitution. A second acyl group may, however, be introduced if this deactivation is offset by substitution of powerfully electron releasing OH or OR groups (e.g. 3.11), or if the deactivating effect

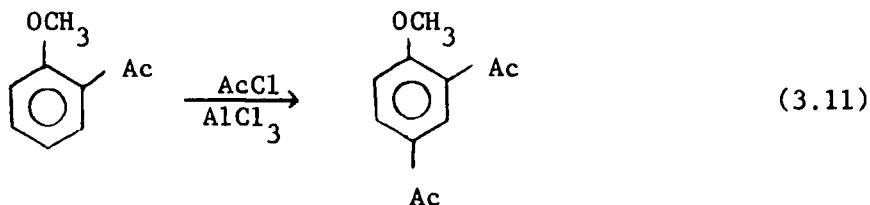

of an acyl group attached to the nucleus is reduced by the presence of two ortho-alkyl groups which prevent the acyl group attaining the conformation necessary for effective conjugation (e.g. 3.12).

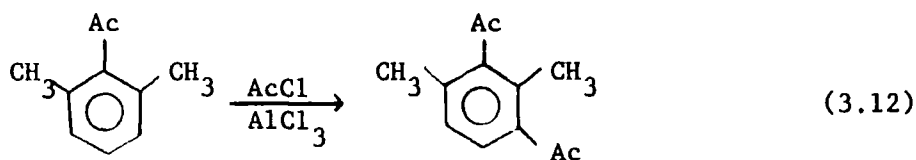

### (g) Synthesis of Aromatic Diketones

Two Friedel-Crafts routes may be envisaged to aromatic diketones of the type (37).

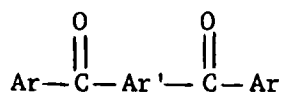

(37)

Using acyl chlorides and aluminium chloride they may be represented by equations (3.13) and (3.14).

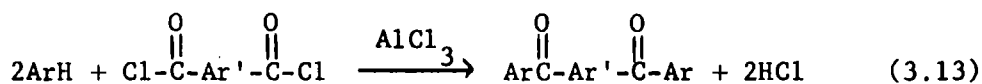

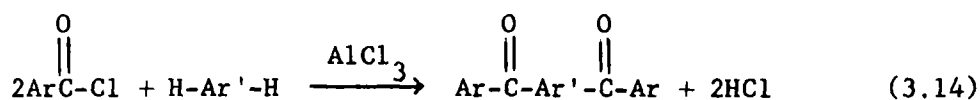

The first route stoichiometrically requires one mole of bis(acyl chloride) to two moles of aromatic substrate. The second route requires two moles of acyl chloride to one mole of aromatic substrate.

i) Reaction between a bis(acyl chloride) and aromatic substrate

This route is especially applicable to readily obtainable aromatic dicarboxylic acid chlorides and is illustrated by the synthesis of *m*-<sup>237</sup> and *p*-<sup>238</sup> dibenzoylbenzenes. These diketones have been prepared using excess benzene as substrate, isophthaloyl and terephthaloyl dichlorides as acyl components and  $\text{AlCl}_3$  catalyst (eq.3.15).

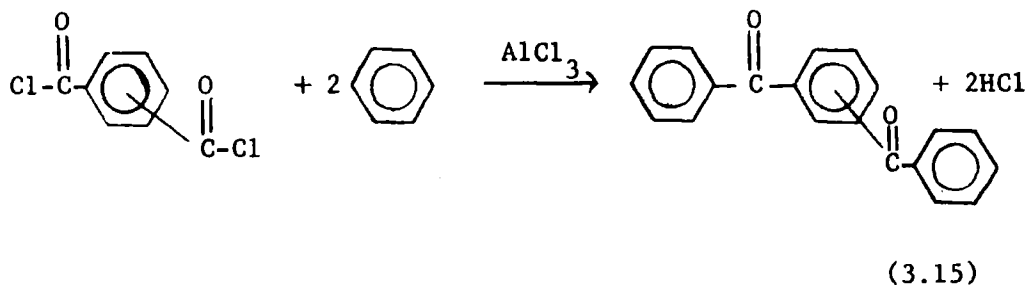

Their preparation has recently been described in connection with photopinacolization studies - see Table 3.1.<sup>90</sup>

TABLE 3.1

Preparation of *m*- and *p*-Dibenzoylbenzenes

Diketone	Yield of Diketone (%)	Solvent used in Preparation	M.p. of Diketone (°C)	Reference
<i>m</i> -dibenzoylbenzene	45	Excess benzene	109-110	90
<i>p</i> -dibenzoylbenzene	25	"	161-162	90

ii) Reaction between mono acyl chloride and aromatic substrate

Aromatic diketones of the type (38) have been prepared by reaction between benzoyl chloride and substrate of type (39). Data for such syntheses is given in Table 3.2 together with appropriate references.

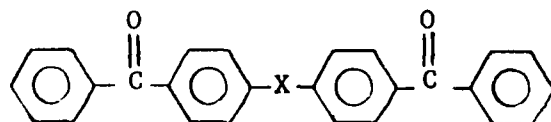

(38)

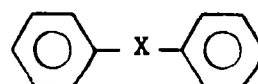

(39)

$\alpha,\omega$ -Diphenylalkane ( $X = (\text{CH}_2)_n$ ) substrates closely resemble alkylbenzenes in reactivity, the paraffin bridge effectively isolating one ring from the other and allowing disubstitution to occur in which each aromatic ring is monosubstituted. For diphenylalkanes where  $n = 1$  or  $2$ , diketones have been obtained by direct addition of the neat diphenylalkane to a mixture of benzoyl chloride and  $\text{AlCl}_3$ . For diphenylalkanes where  $n = 2, 4, 6$ , and  $10$ , various solvents have been employed, solvent choice sometimes considerably affecting yield. For example, with 1,6-diphenylhexane substrate and carbon disulphide solvent, no diketone was isolated, whereas with nitrobenzene as solvent, the yield of diketone was 43%.<sup>241</sup>

Diphenyl ( $X = (\text{CH}_2)_0$ ) can be benzoylated at one or both of its para positions,<sup>239</sup> 4,4'-dibenzoyldiphenyl being prepared by reaction between excess benzoyl chloride and diphenyl with  $\text{AlCl}_3$  catalyst.

Diphenyl ether ( $-X- = -O-$ ) may similarly be monobenzoylated<sup>242</sup> or dibenzoylated<sup>243</sup> in the para positions with carbon disulphide as solvent.

Preparation of several of these diketones has again been recently described in connection with photopinacolization studies.<sup>90, 91</sup>

TABLE 3.2

Aromatic Diketone Syntheses by Benzoylation of

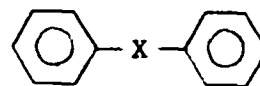
substrates

X	Yield of diketone (%)	Solvent used in preparation	M.p. of Diketone (°C)	Reference
-O-	90	CS <sub>2</sub>	163-4	243
	50	CS <sub>2</sub>	163-4	90
(CH <sub>2</sub> ) <sub>0</sub>	50	None	218	239
	41	None	219-220	91
(CH <sub>2</sub> ) <sub>1</sub>	50	None	147.5-148.5	240
	12	None	145-147	91
(CH <sub>2</sub> ) <sub>2</sub>	64	CS <sub>2</sub>	177	241
	45	None		241
	50	None	174.5-176	240
	52	None	175-6	91
(CH <sub>2</sub> ) <sub>4</sub>	75	CS <sub>2</sub>	152	241
(CH <sub>2</sub> ) <sub>6</sub>	-	CS <sub>2</sub>		241
	-	petroleum ether		241
	43	nitrobenzene	104	241
(CH <sub>2</sub> ) <sub>10</sub>	20	nitrobenzene	75	241

### 3.4 The Wurtz-Fittig Reaction

Coupling of two molecules of alkyl or aryl halides, with elimination of halogen, occurs on reaction with sodium (eq.3.16).

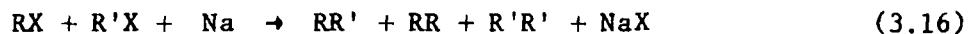

This reaction is named after the French chemist Wurtz. The original reaction between alkyl halides was modified by Fittig who found that unsymmetrical coupling between an alkyl halide and an aryl halide (Wurtz-Fittig reaction) was a more practicable process yielding more easily separated products.<sup>244</sup> For example, methyl bromide condensed with bromobenzene in the presence of sodium yields toluene (b.p. 111°C) which is readily separable from by-products ethane and diphenyl.

The reaction is frequently carried out in ether solvent.

#### (a) Mechanism

Two plausible mechanisms<sup>245</sup> have been suggested for the Wurtz reaction. The one mechanism involves the formation of free radicals which may couple to give product, reaction between bromobenzene and ethyl bromide being represented by equations (3.17).

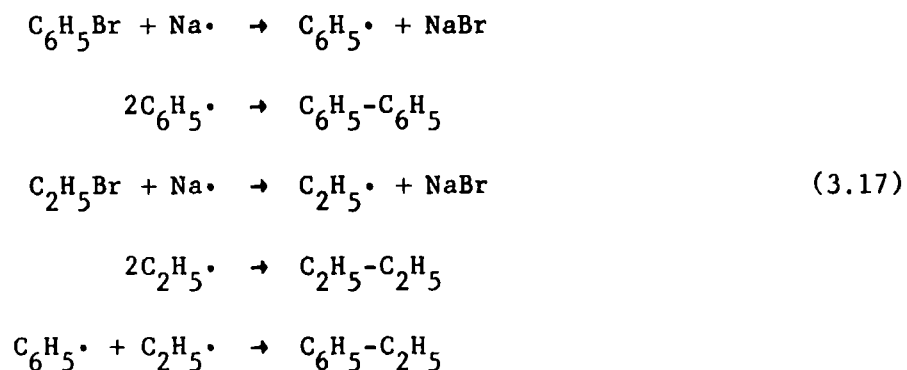

The alternative mechanism involves the formation of organo-sodium compounds (eqs. 3.18).

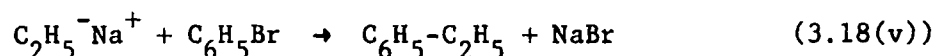
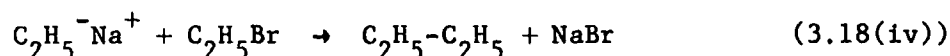
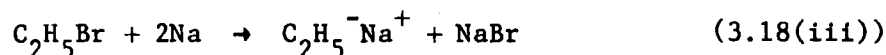
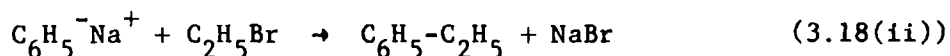
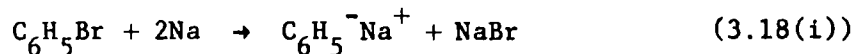

Since reaction (3.18(i)) is fast compared to reaction (3.18(iii)), a better yield of product will be expected from a Wurtz-Fittig reaction compared to a Wurtz reaction,<sup>245</sup> reaction (3.18(ii)) being the main reaction.

Experimental evidence has been cited in favour of both mechanisms. By-products have been explained on the basis of disproportionation between two free radicals, an example being formation of benzene and ethylene by-products from reaction of sodium phenyl and ethyl bromide (eq.3.19).<sup>246</sup>

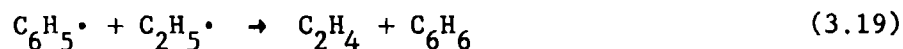

The formation of triphenylene and o-diphenylbenzene as by-products in the synthesis of diphenyl from chlorobenzene and sodium has been reconciled with formation and reaction of free phenyl radicals (3.20).<sup>247</sup>

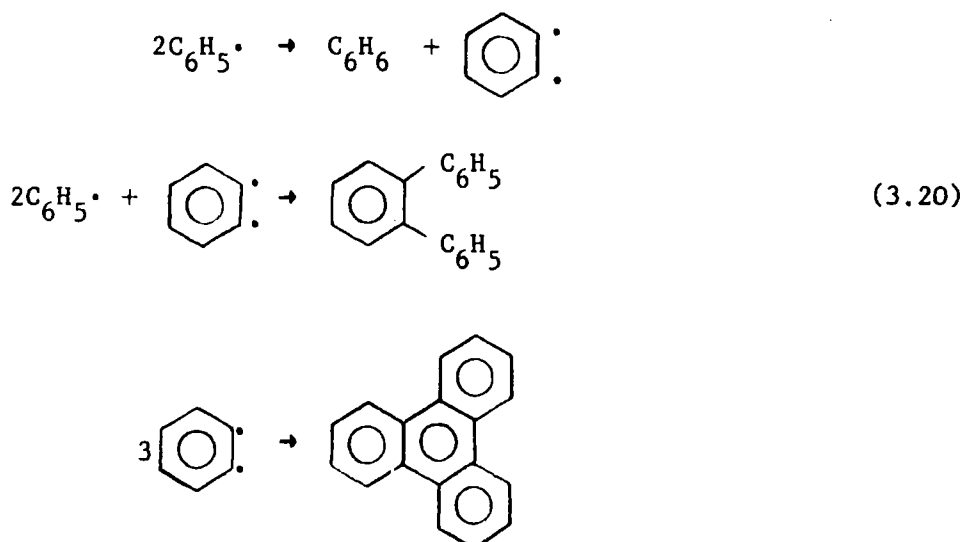

Sodium alkyls and sodium aryls have also been postulated as intermediates<sup>248</sup> and 'disproportionation' may be explained by simultaneous elimination and substitution in reactions of organo-sodium compounds with alkyl halide,<sup>249,250</sup> for example (3.21).

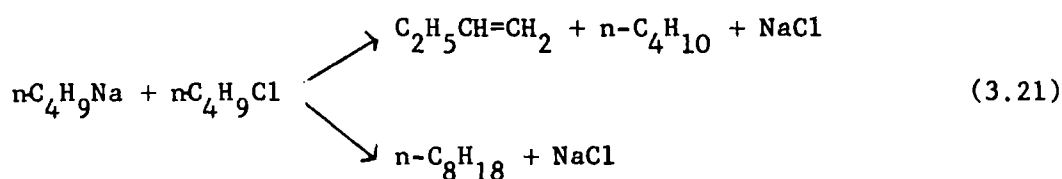

Several optically active halides give optically active products with predominant inversion of configuration consistent with an  $\text{S}_{\text{N}}2$  type reaction involving intermediate sodium alkyl.<sup>251</sup>

(b) Synthesis of  $\alpha,\omega$ -Diphenylalkanes

$\alpha,\omega$ -Diphenylalkanes may be prepared in good yield by a Wurtz-Fittig reaction between bromobenzene, sodium and  $\alpha,\omega$ -dibromoalkane.<sup>252</sup> Reaction proceeds according to the equation (3.22).

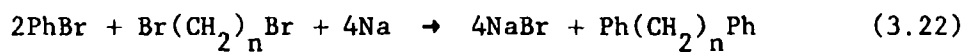

Van Alphen<sup>252</sup> reports yields of 40-75% where  $n = 3, 5, 6$  and 10. A yield of 54% is reported<sup>241</sup> for  $n = 4$ .

Cycloparaffins are thought to be side-products, and 1,20-diphenyl-eicosane is probably also formed with 1,10-dibromodecane starting material.<sup>252</sup> However no 1,6-diphenylhexane could be detected from 1,3-dibromopropane. 1,2-Dibromoethane gave only ethylene and diphenyl, explained by the 1,2-dibromoethane reacting more quickly with sodium, forming ethylene, than with the aromatic sodium derivative.

DISCUSSION

### 3.5 Synthesis of $\alpha,\omega$ -Diphenylalkanes

The  $\alpha,\omega$ -diphenylalkanes,  $\text{Ph}(\text{CH}_2)_n\text{Ph}$ , ( $n = 3, 4, 5, 6$  and  $10$ ) were prepared by a Wurtz-Fittig sodium coupling reaction between the corresponding  $\alpha,\omega$ -dibromoalkane and bromobenzene, following the procedure of Van Alphen.<sup>252</sup> All preparations were straightforward, giving the  $\alpha,\omega$ -diphenylalkanes in yields of between ca. 30% and 70%.

Fractional distillation of the reaction products under reduced pressure gave several fractions with boiling points in the vicinity of literature values.<sup>252</sup> Fractions of identical infrared spectra and with boiling points varying by a maximum of  $10^\circ$  from the published boiling point were combined and used in the subsequent benzylation reactions; yields from these apparently slightly impure  $\alpha,\omega$ -diphenylalkanes gave yields of diketone comparable with the yields obtained from the commercially available  $\alpha,\omega$ -diphenylalkanes such as 1,2-diphenylethane.

Infrared spectra of the  $\alpha,\omega$ -diphenylalkanes exhibited bands typical of aromatic and aliphatic systems. Combination and overtone bands from the phenyl groups were particularly prominent in the  $2000\text{--}1700\text{ cm}^{-1}$  region.

Mass spectra of typical  $\alpha,\omega$ -diphenylalkanes ( $n = 3, 6$ ) showed parent peaks at  $m/e$  196 and 238 respectively. Particularly prominent peaks were observed at  $m/e$  91 ( $\text{C}_7\text{H}_7^+$ , tropylium ion) and  $m/e$  77 ( $\text{C}_6\text{H}_5^+$ ).

A typical n.m.r. spectrum ( $n = 10$ ) bore a close resemblance to spectra of higher 4,4'-dibenzoyldiphenylalkanes (section 3.6, Table 3.4), showing the following features:  $\delta 7.2\text{--}7.0$  (10 protons),  $\delta 2.7\text{--}2.35$  (4 protons),  $\delta 1.7\text{--}1.1$  with strong absorption at  $\delta 1.25$  (16 protons).

### 3.6 Friedel-Crafts Synthesis of Aromatic Diketones

Aromatic diketones of the type PhCO-Ar'-COPh (37), as enumerated below, were prepared by Friedel-Crafts synthesis.

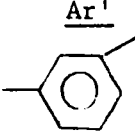
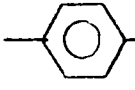
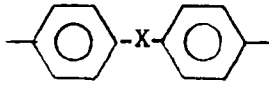
	<u>Reference No.</u>
	(40)
	(41)
	
X = O	(42)
X = (CH <sub>2</sub> ) <sub>0</sub>	(43)
X = (CH <sub>2</sub> ) <sub>1</sub>	(44)
X = (CH <sub>2</sub> ) <sub>2</sub>	(45)
X = (CH <sub>2</sub> ) <sub>3</sub>	(46)
X = (CH <sub>2</sub> ) <sub>4</sub>	(47)
X = (CH <sub>2</sub> ) <sub>5</sub>	(48)
X = (CH <sub>2</sub> ) <sub>6</sub>	(49)
X = (CH <sub>2</sub> ) <sub>10</sub>	(50)

The preparations of m-dibenzoylbenzene (40) and p-dibenzoylbenzene (41) followed published routes,<sup>90</sup> involving reaction between the appropriate phthaloyl dichloride and benzene (AlCl<sub>3</sub> catalyst). Recrystallization of crude products yielded the diketones as white crystals without difficulty. Purification of (42)-(50) from benzoylations of  $\alpha,\omega$ -diphenyl compounds often proved more difficult although published routes<sup>90,91,241</sup> to several of the diketones were followed.

(a) Problems in the Friedel-Crafts Synthesis of (42)-(50)

Reaction periods for actual benzoylations varied from 1 to 6 hr., typical reaction periods being shown in Table 3.6 (section 3.8). Calloway and Green<sup>235</sup> have pointed out the difficulties in determination of the point at which HCl evolution ceases and assessment of the completion of reaction, and the possibilities of extended reaction time decreasing the yield of ketone. Although reaction periods were varied as were proportions of benzoyl chloride and aluminium chloride, no particular correlation was found between these factors, tar formation and yield of diketone. A detailed study of one particular diketone preparation might be more informative with respect to optimization of yields. Diketones (43), (44), (45), (49) and (50) were successfully prepared by direct reaction between  $\alpha,\omega$ -diphenylalkane, benzoyl chloride and  $\text{AlCl}_3$ . Diketones (42), (46), (47) and (48) were prepared by benzoylation in the presence of carbon disulphide solvent.

No pure (46) and (48) could be obtained when benzoylations without solvent were attempted. The vast amount of tar produced could not be separated from the desired products. The use of carbon disulphide solvent gave a cleaner reaction although the resulting crude products could still not be purified directly by recrystallization.

Even after removal of any tar, crude diketones were generally deeply yellow in colour. Repeated recrystallization and/or refluxing with decolourising charcoal usually proved successful in producing white, pure product, but often ten or more such recrystallizations were necessary to obtain white material.

Column chromatography proved partially successful as a purification technique. Thus column chromatography of crude yellow (44) on silica gel (chloroform eluent) yielded a much less highly coloured sample of the diketone requiring fewer recrystallizations to give white product of constant melting point. However, the relative efficiency of column chromatography as a purification technique, taken together with its time-consuming nature, usually did not warrant its use in place of repeated recrystallization. Chromatography on other media such as alumina or florisil and the use of eluents other than chloroform proved no more successful. Filtration of solutions of crude diketone through columns of decolourising charcoal and attempted sublimation of crude diketone were also unsatisfactory.

Attempts to recrystallise crude (46) and (48) proved unsuccessful yielding oils apparently no purer than the initial crude materials. The crude diketones were therefore 'vacuum' distilled to yield a partially purified viscous yellow material, as a necessary step prior to recrystallization. For (48) preliminary column chromatography on silica gel also proved a necessary precursor to recrystallization which was eventually achieved only from alcohol solutions cooled to ca.  $-30^{\circ}\text{C}$ . The concentration of diketone in the recrystallization of (46) and (48) also proved to be a crucial factor, too concentrated a solution yielding an oil and slightly too dilute a solution failing to yield any solid product even on cooling to ca.  $-30^{\circ}\text{C}$ . These problems in recrystallization are consistent with the relatively low melting points of the two diketones. The syntheses of (46) and (48) by Friedel-Crafts benzylation have not apparently been previously achieved despite investigations of the applicability of this reaction.<sup>230</sup>

The required high standard of purity for each diketone was attained at the expense of higher yields.

(b) Characterization of the Aromatic Diketones

Satisfactory elemental analyses were obtained for the diketones. Diketones were not analysed until at least three successive recrystallizations gave material of constant melting point.

i) Infrared Spectra

The infrared spectra of diketones (40)-(50) are recorded in Appendix C.

The aromatic diketones showed a strong C=O stretch around 1660-1650  $\text{cm}^{-1}$ , characteristic of conjugation with two benzenoid units. Aromatic C-H stretch was observed in the 3100-3000  $\text{cm}^{-1}$  region and aliphatic C-H stretch (for 4,4'-dibenzoyldiphenylalkanes) between ca. 2940 and 2860  $\text{cm}^{-1}$ . Other typical aromatic and methylene chain absorptions were observed in the relevant regions. A particularly strong resemblance between the spectra of the 4,4'-dibenzoyldiphenylalkanes (44)-(50) could be noticed.

ii) Mass Spectra

Mass spectra of the diketones are tabulated in detail in Appendix B.

As is generally the case for aromatic ketones,<sup>253a</sup> molecular ions were clearly observed, the parent peak being the base peak for (43), (47) and (48) and prominent with most of the other diketones. The base peak for (40), (41), (44) and (49) was at  $m/e$  105 ( $\text{C}_6\text{H}_5\text{CO}^+$ ). Other base peaks included  $m/e$  91 ( $\text{C}_7\text{H}_7^+$  ion) for (50) and  $m/e$  77 ( $\text{C}_6\text{H}_5^+$ ) for (46).

Breakdown patterns were characteristic of aryl ketones with loss of  $C_6H_5+$  etc. from the parent, and metastable peaks commonly being observed with loss of CO, for example at m/e 56.5 corresponding to the fragmentation (3.23).



Peaks corresponding to fragmentation of the methylene chain were often abundant in the 4,4'-dibenzoyldiphenylalkane spectra. Thus, for example, the base peak in the spectrum of (45) was at m/e 195 corresponding to cleavage of the central C-C bond of the methylene chain, this fragmentation route being analogous to that observed for 1,2-diphenylethane.<sup>253b</sup> Other methylene chain fragmentation modes were likewise analogous to those of the appropriate  $\alpha,\omega$ -diphenylalkanes.

### iii) Ultraviolet Spectra

Details of absorption wavelength maxima ( $\lambda_{max}$ ) and corresponding extinction coefficients ( $\epsilon$ ) for the  $n \rightarrow \pi^*$  and  $\pi \rightarrow \pi^*$  absorptions (in 95% ethanol) of the diketones are given in Table 3.3.

The spectra of the 4,4'-dibenzoyldiphenylalkanes resembled one another closely. Introduction of a methylene group between two chromophores is generally considered capable of destroying conjugation<sup>254</sup> and the spectra compared favourably with spectra<sup>255</sup> of benzophenone [ $\lambda_{max}$  333 nm, ( $\epsilon$  160);  $\lambda_{max}$  253 nm ( $\epsilon$  18,000)] and particularly alkyl substituted benzophenones such as 4-methylbenzophenone [ $\lambda_{max}$  330 nm, ( $\epsilon$  230);  $\lambda_{max}$  260 nm ( $\epsilon$  17,500)] and 4-ethylbenzophenone [ $\lambda_{max}$  330nm, ( $\epsilon$  250);  $\lambda_{max}$  259 nm ( $\epsilon$  17,400)] determined in 95% ethanol. The two benzophenone type units in the 4,4'-dibenzoyldiphenylalkanes show an additive effect.

TABLE 3.3

Ultraviolet Spectra of Aromatic Diketones (40)-(50)<sup>a</sup>

Diketone	n → π* transition		π → π* transition	
	λ <sub>max</sub>	ε × 10 <sup>-2</sup>	λ <sub>max</sub>	ε × 10 <sup>-4</sup>
(40)	333	2.5	252	2.8
(41)	335	4.2	264	2.9
(42)	Strong absorption observed at λ <sub>max</sub> 289 nm (ε = 26,000)			
(43)	Submerged under π → π* transition		300	3.6
(44)	330	4.4	264	3.2
(45)	330	4.4	262	3.5
(46)	330	4.5	262	3.5
(47)	330	4.4	263	3.5
(48)	330	4.4	261	3.5
(49)	330	4.4	261	3.3
(50)	330	4.3	261	3.2

a. All spectra recorded in 95% ethanol.

The bathochromic shift of the  $\pi \rightarrow \pi^*$  transition with increasing conjugation in going from benzophenone to (40), (41) and (43) has already been reported,<sup>91</sup> the  $n \rightarrow \pi^*$  transition of (43) being completely submerged under the  $\pi \rightarrow \pi^*$  transition. This may be compared with the spectrum of 4-phenylbenzophenone, where the lowest triplet is  $\pi, \pi^*$ .<sup>154</sup>

From the present work, however, it was noted that the  $n \rightarrow \pi^*$  absorption of (40) was about as well resolved from the  $\pi \rightarrow \pi^*$  absorption as it was in the 4,4'-dibenzoyldiphenylalkanes. In (41), the  $n \rightarrow \pi^*$  transition was less well resolved and could be observed as a shoulder on the  $\pi \rightarrow \pi^*$  absorption.

In benzene and cyclohexane the  $\lambda_{\max}$  of the  $n \rightarrow \pi^*$  absorptions were in the 342-347 nm region whilst the  $\lambda_{\max}$  of the  $\pi \rightarrow \pi^*$  absorption remained relatively stationary in the various solvents. The hypsochromic shift of the  $n \rightarrow \pi^*$  transition with increasing solvent polarity is indicative of the increasing degree of hydrogen bonding lowering the energy of the 'n' orbital.

A spectrum of (42) in 95% ethanol showed an absorption in the 325-350 nm region merging into a strong absorption,  $\lambda_{\max}$  289 nm ( $\epsilon$  26,000) and it was not possible to obtain a meaningful value of  $\epsilon$  or  $\lambda_{\max}$  for the  $n \rightarrow \pi^*$  absorption. In cyclohexane the  $n \rightarrow \pi^*$  absorption was clearly distinct,  $\lambda_{\max}$  346 nm, and the intense absorption appeared at  $\lambda_{\max}$  282 nm. Very low solubility of (42) in cyclohexane precluded determination of  $\epsilon$  for the  $n \rightarrow \pi^*$  absorption.

#### (iv) N.m.r. Spectra

N.m.r. spectra of some typical 4,4'-dibenzoyldiphenylalkanes are recorded in Table 3.4.

TABLE 3.4

N.m.r. Spectra of 4,4'-Dibenzoyldiphenylalkanes<sup>a</sup>

Diketone	Aromatic Protons		Aliphatic Protons	
	Chemical Shift <sup>b</sup>	No. of protons	Chemical Shift <sup>b</sup>	No. of protons
(44)	7.9 -7.2	18	4.0 (singlet)	2
(45)	7.9 -7.2	18	3.05 (singlet)	4
(46)	7.95-7.2	18	2.9-2.55 (multiplet- broadened triplet)	4
			2.25-1.8 (unresolved multiplet)	2
(48)	7.8 -7.1	18	2.85-2.45 (multiplet- broadened triplet)	4
			1.9-1.4 (unresolved multiplet)	6

Notes a. Spectra recorded in  $\text{CDCl}_3$  solvent.

b. Chemical shifts are  $\delta$  values in ppm relative to internal T M S.

Satisfactory integrations were obtained in all cases. The methylene protons in the higher 4,4'-dibenzoyldiphenylalkanes appeared as multiplets in two general regions. Methylene protons  $\alpha$  to the aryl group appeared in the region  $\delta$ 2.9-2.45. Other methylene protons appeared as broad unresolved multiplets upfield relative to the  $\alpha$ -methylene protons.

EXPERIMENTAL

### 3.7 Preparation of Diketones from Friedel-Crafts Reaction of Bis(acyl chlorides) and Benzene

#### (a) Preparation of m-Dibenzoylbenzene

To a stirred solution of isophthaloyl dichloride (50 g., 0.246 mole) in dry benzene (400 ml), anhydrous aluminium chloride (80 g., 0.60 mole) was added in small portions. The solution was refluxed for 2 hr., cooled and hydrolysed by pouring into 10% HCl-ice water solution (2.5 l). After evaporation of the benzene, the resulting crude material was filtered off and washed successively with a 5% aqueous solution of sodium carbonate, a 5% aqueous solution of HCl, and water. The crude product was then recrystallized from cyclohexane to a constant melting point to give m-dibenzoylbenzene (21 g., 30%, m.p. 103-104°, (lit. 99.5-100°; <sup>237</sup> 109-110°<sup>90</sup>)). Found: C, 83.92; H, 4.64%. Calculated for C<sub>20</sub>H<sub>14</sub>O<sub>2</sub>: C, 83.90; H, 4.93%.

#### (b) Preparation of p-Dibenzoylbenzene

Following the same procedure as for m-dibenzoylbenzene but substituting terephthaloyl dichloride for isophthaloyl dichloride, the crude product was recrystallized from carbon tetrachloride to give p-dibenzoylbenzene (7.5 g., 11%, m.p. 159-160°, (lit. 160-161°, <sup>238</sup> 161-162°<sup>90</sup>)). Found: C, 84.25; H, 4.63%. Calculated for C<sub>20</sub>H<sub>14</sub>O<sub>2</sub>: C, 83.90; H, 4.93%.

3.8 Preparation of Diketones by Friedel Crafts Reaction Between Diphenyl Compounds and Benzoyl Chloride

Aromatic diketones of the type (38) were prepared by Friedel-Crafts

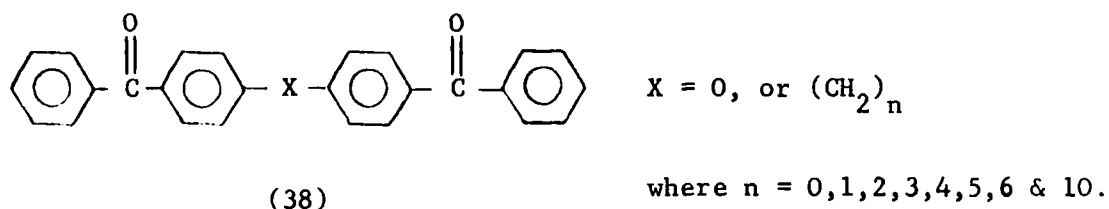

benzoylation of the appropriate diphenyl compound. Diphenyl, diphenyl ether, diphenylmethane and 1,2-diphenylethane were commercially available as laboratory reagent grade chemicals, and were used without further purification.

(a) Preparation of  $\alpha, \omega$ -Diphenylalkanes<sup>252</sup>

$\alpha, \omega$ -Diphenylalkanes [ $X = (\text{CH}_2)_n$ ,  $n = 3, 4, 5, 6$  and  $10$ ] were prepared by Wurtz-Fittig reaction of  $\alpha, \omega$ -dibromoalkanes with bromobenzene.

A mixture of  $\alpha, \omega$ -dibromoalkane (1 molecular proportion) and bromobenzene ( $\geq 2$  molecular proportions) was added dropwise with stirring to thinly sliced sodium ( $\geq 4$  molecular proportions) in dry ether. A deep blue colour formed fairly rapidly. After any initial violent reaction, controlled by cooling with ice, the mixture was stirred at room temperature for 24 hr. The ethereal solution was then filtered, the solid residue being washed with ether, and then residual sodium was carefully destroyed by addition of alcohol. The filtrate and ether washings were combined, the ether removed and the resulting residue fractionally distilled under reduced pressure to yield the  $\alpha, \omega$ -diphenylalkanes as colourless liquids. Although fractions of a fairly wide

boiling range were combined, spectral data (infrared, n.m.r. and mass spectra) proved satisfactory.

Data for typical preparations of individual  $\alpha,\omega$ -diphenylalkanes is summarized in Table 3.5.

(b) Friedel-Crafts Benzoylation of Diphenyl Compounds<sup>90,91,241</sup>

i) Benzoylations in the Absence of Solvent

The diphenyl compound was slowly added to a well stirred mixture of powdered anhydrous  $AlCl_3$  and benzoyl chloride, with rapid darkening of the reaction mixture. The mixture was stirred at 80-90°C to complete reaction, partially cooled and poured into a 10% HCl-ice-water solution. The crude product was filtered off, washed with alkali and then with water. The resulting material was then repeatedly recrystallized to a constant melting point.

On initial recrystallizations, tars tended to separate out from the cooling solutions before the appearance of any crystals. As soon as tar separation appeared complete, recrystallizing solutions were decanted off from the tars and allowed to stand for several hours whereupon yellow crystals of impure diketone generally formed. Repeated recrystallization of this material together with refluxing in the presence of decolourising charcoal was necessary to obtain pure product. In some cases it was found beneficial to change solvents during the recrystallization processes.

Preparative data on typical preparations of individual diketones is given in Table 3.6.

TABLE 3.5

Preparation of  $\alpha, \omega$ -Diphenylalkanes,  $\text{Ph}(\text{CH}_2)_n\text{Ph}$ 

n	Quantities of Reactants						Boiling Ranges of Products under Reduced Pressure				Yield	
	Bromobenzene		Dibromoalkane		Sodium		Experimental		Literature <sup>252</sup>			
	g.	moles	g.	moles	g.	moles	° C	mm.Hg <sup>a</sup>	° C	mm.Hg		
3	60.0	0.382	34.0	0.168	20.0	0.870	120	147-157	14	157	14	30%
4	30.0	0.191	20.7	0.0959	10.0	0.435	50	149-158	8			69%
5	90.0	0.573	52.5	0.228	30.0	1.305	150	171-178	14	196-200	25	39%
6	80.0	0.509	60.0	0.246	28.0	1.218	150	187-194	13	197	14	51%
10	64.0	0.408	60.0	0.200	20.0	0.870	200	160-164	< 1	240	14	38%

Note. a) Average pressure (uncorrected).

TABLE 3.6

## Preparation of Aromatic Diketones

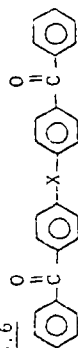

X	Quantities of Reactants						Solvent	Reaction Time hr.	Purification <sup>a</sup> Technique Sequence	Sequence of Solvents used in Recrystallization	Yield of pure material %
	Diphenyl Compound		Benzoyl Chloride		AlCl <sub>3</sub>						
	g	mole	g	mole	g	mole					
0	30.0	0.176	59.0	0.420	66.5	0.499	CS <sub>2</sub> (300 ml)	2	R	i) CCl <sub>4</sub> ii) C <sub>2</sub> H <sub>5</sub> OH	41
(CH <sub>2</sub> ) <sub>0</sub>	29.0	0.188	91.0	0.647	125.0	0.937	None	6	R, B, R	CHCl <sub>3</sub>	20
(CH <sub>2</sub> ) <sub>1</sub>	60.0	0.357	210.0	1.494	200.0	1.500	None	1	R, B, R	i) C <sub>2</sub> H <sub>5</sub> OH ii) CH <sub>3</sub> COOH	3
(CH <sub>2</sub> ) <sub>2</sub>	25.0	0.137	105.0	0.747	100.0	0.75	None	1.5	R, B, R	i) C <sub>6</sub> H <sub>6</sub> ii) C <sub>6</sub> H <sub>5</sub> CH <sub>3</sub> iii) CH <sub>3</sub> COOH	22
(CH <sub>2</sub> ) <sub>3</sub>	20.0	0.102	34.2	0.243	38.5	0.289	CS <sub>2</sub> (200 ml)	2	D, R	C <sub>2</sub> H <sub>5</sub> OH	5
(CH <sub>2</sub> ) <sub>4</sub>	14.0	0.0656	22.8	0.162	25.6	0.192	CS <sub>2</sub> (140 ml)	3	R, B, R	CH <sub>3</sub> COOH	18
(CH <sub>2</sub> ) <sub>5</sub>	23.0	0.102	34.2	0.243	38.5	0.289	CS <sub>2</sub> (200 ml)	2	D, C, R	C <sub>2</sub> H <sub>5</sub> OH	2
(CH <sub>2</sub> ) <sub>6</sub>	19.0	0.0797	52.5	0.373	50.0	0.375	None	5	R, B, R	i) C <sub>2</sub> H <sub>5</sub> OH ii) CH <sub>3</sub> COOH	10
(CH <sub>2</sub> ) <sub>10</sub>	12.0	0.0407	26.25	0.187	25.0	0.187	None	3	R	C <sub>2</sub> H <sub>5</sub> OH	20

a) Key to abbreviations: R = Recrystallization, B = Charcoal boiling, C = Column chromatography, D = Distillation (10<sup>-3</sup>-10<sup>-4</sup> mm.Hg)

(ii) Benzoylations with Carbon Disulphide as Solvent

Benzoyl chloride (ca. 2.4 molecular proportions) was slowly added to a vigorously stirred mixture of diphenyl compound (1 molecular proportion) and powdered anhydrous  $\text{AlCl}_3$  (ca. 2.8 molecular proportions) in carbon disulphide. After spontaneous refluxing had subsided, the solution was refluxed for a few hours, cooled and poured into 10% HCl ice-water solution. Following evaporation of the carbon disulphide, the resulting crude product was filtered off and purified by combinations of 'vacuum' distillation, column chromatography and recrystallization (together with boiling with decolourising charcoal) until repeated recrystallization gave products of constant melting point.

Crude products obtained in the preparation of 1,3-(4,4'-dibenzoyl-diphenyl)propane and 1,5-(4,4'-dibenzoyldiphenyl)pentane were subjected, before recrystallization, to distillation under reduced pressure ( $10^{-3}$  -  $10^{-4}$  mm Hg) to give

- 1) benzoic acid (identified by infrared spectrum),
- 2) impure diketones as highly viscous yellow oils.

The oil (1 g.) comprising mostly 1,5-(4,4'-dibenzoyldiphenyl)pentane was chromatographed on a column of silica gel (40 cm x 2.5 cm diameter), eluting with chloroform and collecting fractions of ca. 15 ml. volume. Removal of chloroform (rotary evaporator) from fractions containing essentially one product (as detected by thin layer chromatography on silica gel, developing with chloroform) yielded a less highly coloured viscous oil, from which crystals of diketone could be obtained.

Typical preparative data on individual diketones is recorded in Table 3.6. Elemental analyses and melting points are recorded in Table 3.7.

TABLE 3.7

## Characterization of Aromatic Diketones

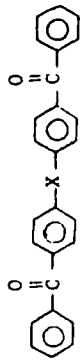

X	Melting Points (°C)		Elemental Analyses (%)						Molecular Formula
	Experimental	Literature Values m.p.	Found		Calculated for Molecular Formula				
			Reference	C	H	C	H		
0	161-2	163-4 163-4	243 90	82.26	4.91	82.52	4.79	C <sub>26</sub> H <sub>18</sub> O <sub>3</sub>	
(CH <sub>2</sub> ) <sub>0</sub>	214.5-215.5	218 219-220	239 91	85.90	4.79	86.16	5.01	C <sub>26</sub> H <sub>18</sub> O <sub>2</sub>	
(CH <sub>2</sub> ) <sub>1</sub>	147-8	147.5-148.5 145-147	240 91	85.80	5.26	86.14	5.35	C <sub>27</sub> H <sub>20</sub> O <sub>2</sub>	
(CH <sub>2</sub> ) <sub>2</sub>	175-6	177 174.5-176 175-6	241 240 91	85.81	6.08	86.13	5.68	C <sub>28</sub> H <sub>22</sub> O <sub>2</sub>	
(CH <sub>2</sub> ) <sub>3</sub>	68-69			86.44	6.32	86.11	5.98	C <sub>29</sub> H <sub>24</sub> O <sub>2</sub>	
(CH <sub>2</sub> ) <sub>4</sub>	148.5-150	152	241	86.12	6.62	86.09	6.26	C <sub>30</sub> H <sub>26</sub> O <sub>2</sub>	
(CH <sub>2</sub> ) <sub>5</sub>	56-58			85.75	6.28	86.08	6.52	C <sub>31</sub> H <sub>28</sub> O <sub>2</sub>	
(CH <sub>2</sub> ) <sub>6</sub>	108.5-109.5	104	241	85.78	7.04	86.06	6.77	C <sub>32</sub> H <sub>30</sub> O <sub>2</sub>	
(CH <sub>2</sub> ) <sub>10</sub>	81-2	75	241	85.82	7.28	86.01	7.62	C <sub>36</sub> H <sub>38</sub> O <sub>2</sub>	

CHAPTER 4

STEP-GROWTH PHOTOPOLYMERIZATION VIA TRIPLET STATES OF BENZOPHENONE-  
TYPE AROMATIC DIKETONES

GENERAL INTRODUCTION

#### 4.1 General Introduction

Step-growth photopolymerization of suitable diketones with dienes offers a route to novel polymers containing oxetane rings in the main polymer chain. Such photopolymerizations are of interest, not only from the standpoint of a contribution to this new concept in the field of polymer chemistry, but also because the polymers themselves may find interesting applications. The production of linear polymers from oxetanes is well established,<sup>256</sup> and extension of reactions producing such polymers to macromolecules containing a series of oxetane rings in a linear chain may lead to interesting and valuable network polymers.

In this chapter, the preparation and characterization of a series of polymers, produced by Paterno-Büchi reaction of benzophenone-type aromatic diketones (see Chapter 3) with tetramethylallene and furans (mainly furan itself) is described. Photopinacolization of the aromatic diketones, to give polybenzopinacols, has also been undertaken, and is described as a related investigation.

A.

THE PHOTOPOLYMERIZATION OF AROMATIC DIKETONES

WITH TETRAMETHYLALLENE

INTRODUCTION

## 4.2 Photoaddition of Benzophenone to Tetramethylallene

### (a) Preparation of Photoadducts

Carbonyl compounds may undergo photocycloaddition to allenes with the formation of 2-alkylideneoxetane and 1,5- and 1,6-dioxaspiro[3,3]heptane ring systems.<sup>109,172,179-181,257</sup> Allenes used include allene itself, 1,1-dimethylallene and tetramethylallene (TMA). Carbonyl compounds employed include benzophenone, acetophenone, benzaldehyde, fluorenone, xanthone and acetone.

Photoaddition of benzophenone to TMA occurs on irradiation of either a solution of benzophenone in TMA or solutions of the two reactants in benzene.<sup>257</sup> Products obtained in the latter case are listed in Table 4.1 together with yields and infrared spectral data. In a typical experiment, a solution of 0.10 moles of benzophenone and 0.12 moles of TMA was irradiated for 24 hours, the solution being purged with nitrogen throughout the irradiation period.<sup>109</sup> Resulting products could be separated by column chromatography on alumina, eluting with n-hexane-benzene mixtures. In addition to the cycloaddition reaction with oxetane formation, hydrogen abstraction from the methyl groups of TMA occurred with the formation of compounds (54), (55) and (56) (Table 4.1).

Direct irradiation of benzophenone in TMA appeared to give compound (53) as major product plus two unidentified compounds, neither of which were identical to compound (52), although (52) may have been initially present, undergoing rearrangement in the course of chromatographic separation of the crude product mixture.<sup>181,257</sup>

TABLE 4.1

The Photoaddition of Benzophenone to Tetramethylallene in Benzene Solvent<sup>109</sup>

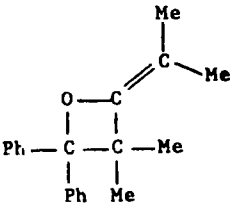
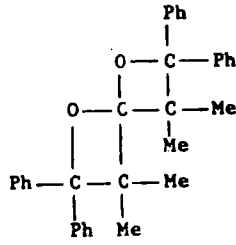
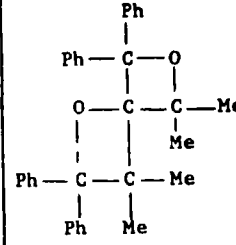
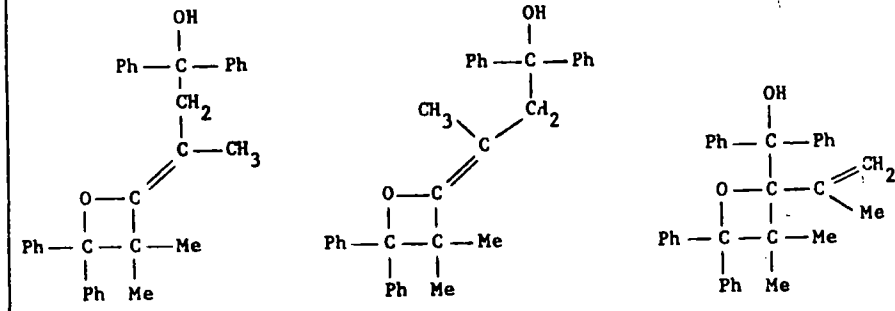
Product	Optimum Yield (%)	Infrared Spectral data
 <p>(51)</p>	17	1724 $\text{cm}^{-1}$ (m) 990 $\text{cm}^{-1}$ (s)
 <p>(52)</p>	22	961-935 $\text{cm}^{-1}$ (s)
 <p>(53)</p>	43	1010-980 $\text{cm}^{-1}$ (s)
 <p>(54)                      (55)                      (56)</p>	15	3570-3450 $\text{cm}^{-1}$ (w) 1724 $\text{cm}^{-1}$ (m) 990-980 $\text{cm}^{-1}$ (s)

(b) Characterization of Products

Products showed strong absorption in the  $1000\text{ cm}^{-1}$  region, characteristic of oxetane rings.<sup>109,256,258,259</sup> The products (51), (54), and (55) showed an absorption band at ca.  $1725\text{ cm}^{-1}$ . It has been proposed<sup>257</sup> that this band is analogous to the absorption of enol ethers between  $1633\text{--}1712\text{ cm}^{-1}$ , and the very high frequency is consistent with that usually observed for double bonds exocyclic to small strained rings. Compounds (54), (55) and (56) showed characteristic weak OH stretch absorptions at ca.  $3450\text{--}3570\text{ cm}^{-1}$ .

The n.m.r. spectrum of compound (53) showed four sharp resonances in the aliphatic region (ca.  $\delta 1$ ) which have been tentatively assigned as shown in the structure below.<sup>257</sup>

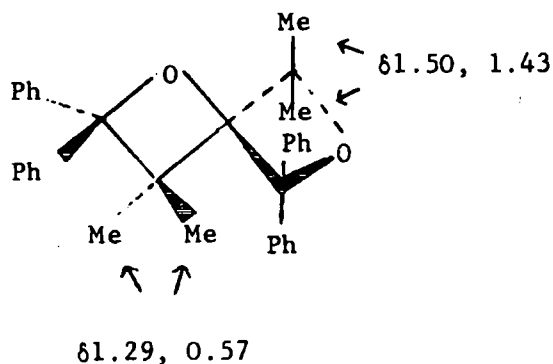

The n.m.r. spectrum of compound (52) showed sharp singlets at  $\delta 1.29$  and  $\delta 1.03$ .<sup>257</sup>

Arnold and Glick<sup>179</sup> have assigned the spiro ketal structure to compound (52), supported by the chemical evidence that treatment of (52) with ethanolic HCl gave 1,1-dimethyl-2,2-diphenylethylene as one of the products. Cleavage of the monoadduct (51) gave benzophenone and the

ketone formally derived from addition of the elements of water to TMA  
(eq.4.1).<sup>257</sup>

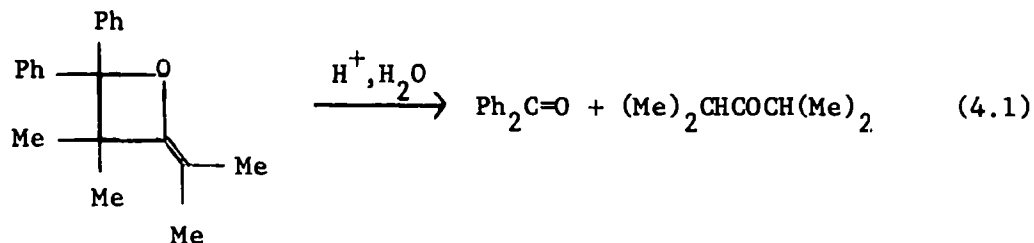

Compound (53) was not cleaved to ketones by aqueous acid at room temperature.<sup>257</sup>

(c) Mechanism

The first step of the reaction, which results almost exclusively in the bonding of carbonyl oxygen to the central allene carbon, may be readily explained by selective formation (eq.4.2) of an intermediate having a stabilized allylic part structure (as opposed to a vinylic radical structure for the alternative mode of addition).

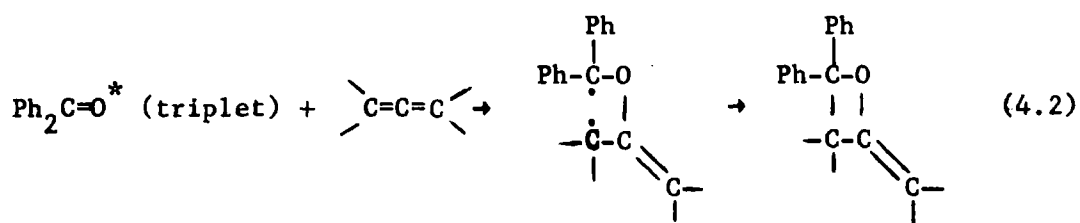

Factors controlling competition between the possible courses of the second addition step, however, are less well defined.<sup>257</sup> The conventional biradical mechanism involves the intermediates (57) and (58)

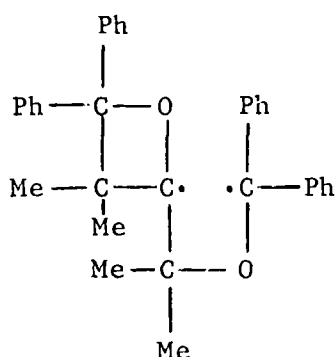

(57)

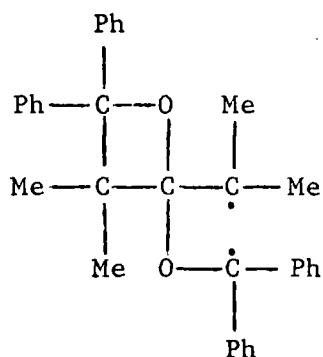

(58)

It has been pointed out that the high strain energy in the exocyclic double bonds of the enol ethers will make the double bonds highly reactive.<sup>257</sup> With the resulting rapid reaction normal selectivity may not be observed. Evidence for high reactivity includes the formation of diadducts by addition of carbonyl compound to monoadduct as a competition reaction to formation of monoadduct by addition of carbonyl compound to parent allene, even when the latter is in large excess as reaction medium.

Stabilization of biradical (57) with oxygens  $\alpha$  to both spin centres may be less than expected because of a decrease in the  $\pi$  interaction for the spin centre that is part of the oxetane ring, compared to interactive stabilization in acyclic  $\alpha$ -oxy radicals.<sup>257</sup>

Schroeter has suggested that the mode of addition of the second benzophenone molecule may be due primarily to the low directing effect of the alkoxy groups in general, rather than as a result of decrease in  $\pi$  interaction in the small ring systems.<sup>260</sup>

(d) Applicability of Tetramethylallene as a Diene in Step-Growth Photopolymerizations Involving Oxetane Formation

All the products listed in Table 4.1 result from reactions that should, if extended to reaction between a suitable benzophenone-type aromatic diketone and tetramethylallene, propagate the polymer chain in step-growth photopolymerization.

Approximately 90% of benzophenone molecules react by cycloaddition with oxetane formation, and extended to the photopolymerization this may be expected to produce a polymer containing predominantly oxetane units in the main polymer chain, as shown in the structure (59).

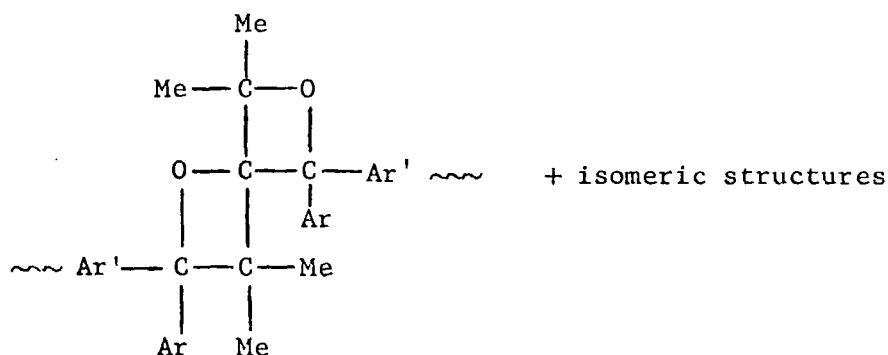

(59)

Approximately 10% of benzophenone molecules react by abstracting hydrogen from the methyl groups of tetramethylallene. Such a reaction occurring in the polymerization process will be expected to produce a proportion of tertiary OH groups in the polymer (cf. polypinacol formation) in place of oxetane link units, giving overall polymer structures of the type (60).

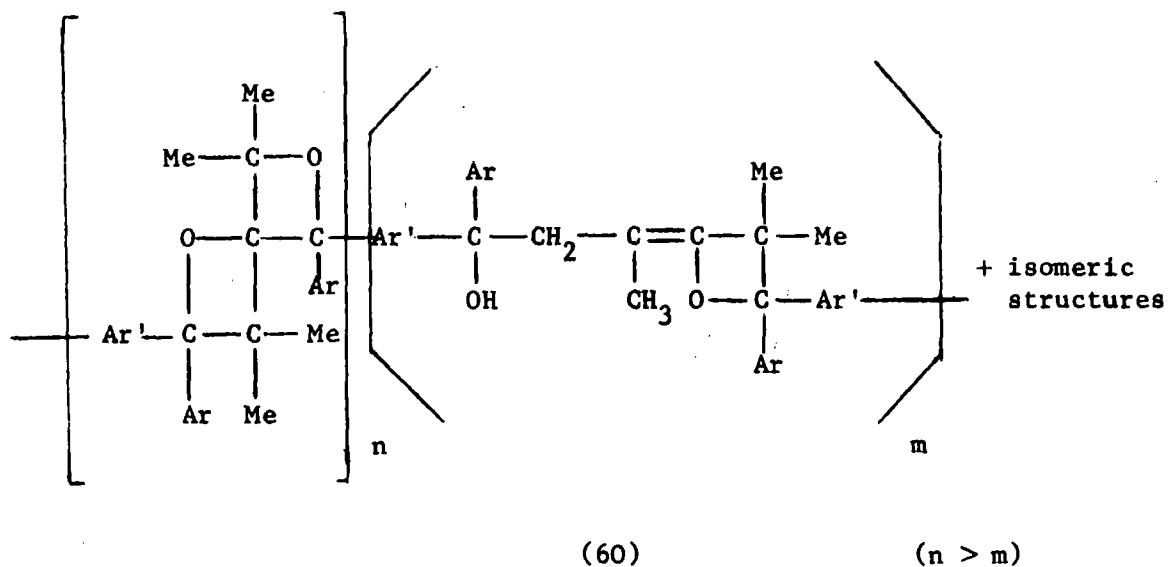

The overall high yield of the products from photoreaction of benzophenone and tetramethylallene (Table 4.1) suggests its suitability as a model system for extension to photopolymerization.

There is no report of addition of a third benzophenone molecule to residual C=C double bonds in structures of the type (54) and (55) (which could act as a crosslinking site in the polymerization process).

DISCUSSION

#### 4.3 Preparation of Polymers from Aromatic Diketones and Tetramethylallene

Irradiation at 350 nm of equimolar quantities of aromatic diketones [(40)-(42), (44)-(50) - see Chapter 3] and TMA in benzene solution, with the exclusion of oxygen, gave low to medium molecular weight polymers as enumerated below:

137

<u>Diketone</u>	<u>Polymer</u>	<u>Diketone</u>	<u>Polymer</u>
(40)	Poly TMAM	(46)	Poly TMA3
(41)	Poly TMAP	(47)	Poly TMA4
(42)	Poly TMAE	(48)	Poly TMA5
(44)	Poly TMA1	(49)	Poly TMA6
(45)	Poly TMA2	(50)	Poly TMA10

Factors governing the choice of monomer concentration for irradiation purposes included the solubility of the aromatic diketone in benzene and the availability of monomer. Virtually no reaction occurred between diketone (43) and TMA.

Total reaction products were isolated by freeze drying from dilute benzene solutions; this allowed efficient removal of solvent without recourse to heating. Most polymers were redissolved and then precipitated from benzene solutions using 40-60° petroleum ether as the non solvent. The precipitated polymers were again dissolved and recovered by freeze drying from benzene. Attempting to pump off residual solvents from the precipitated polymers after filtration was not effective as heating was required for complete removal of solvents, and molecular weight studies indicated that polymer degradation occurred during the heating. The freeze drying technique gave polymers as white or creamy white fine powders.

#### 4.4 Polymer Solubilities

All the polymers were extremely soluble and dissolved rapidly in benzene; they tended to be as or more soluble than the corresponding diketone monomer in benzene. For example, the solubility of polyTMAM in benzene was > 350 g./l. PolyTMA2 was more than six times as soluble in benzene as the 1,2-(4,4'-dibenzoyldiphenyl)ethane monomer (45). Precipitation of polymer during the photopolymerization process was never observed. The high solubilities are indicative of linear polymers with little or no crosslinking.

#### 4.5 Molecular Weights and Melting Characteristics of Polymers

Molecular weights of polymers (measured by the isopiestic method in benzene - see Appendix A) and corresponding  $\overline{D.P.}$ 's (based on an addition reaction between diketone and TMA, and a repeating unit combining the molecular formulae of diketone and TMA) for crude and precipitated polymers are shown in Table 4.2. Temperatures at which the first apparent change occurred on heating polymer samples in melting point capillaries are also recorded. Maximum observed  $\overline{D.P.}$ 's for each polymer ranged from ca. 10 to 27. The highest polymers, in terms of  $\overline{D.P.}$ , were polyTMA1, polyTMAM and polyTMA3.

Although, in the series of polymers containing methylene chains in the repeating unit, the highest polymers were obtained from diketones with the shorter methylene chains ( $n = 1-3$ ), general conclusions on the relative efficiency of 4,4'-dibenzoyldiphenylalkanes in the photopolymerization reaction may be modified when variations in conditions of preparation and precipitation are taken into account, and the observed

TABLE 4.2

Molecular Weights, Degrees of Polymerization and Melting Characteristics  
of Diketone -Tetramethylallene Polymers

Polymer <sup>a</sup>	Molecular Weight ( $\overline{D.P.}$ )		Temperature at which Polymers Visibly Changed State ( $^{\circ}\text{C}$ ) <sup>b</sup>	
	Crude	Precipitated	Crude	Precipitated
PolyTMAM	6610 (17.3)	- -	187 <sup>d</sup>	-
PolyTMAP	2200 (5.8)	3900 (10.2)	174 <sup>e</sup>	177 <sup>f</sup>
PolyTMAE	6200 (13.1)	- -	186 <sup>e</sup>	-
PolyTMA1	13000 (27.5)	- -	182 <sup>d</sup>	-
PolyTMA2}	2800 (5.8)	4200 (8.6)	-	-
	6400 <sup>c</sup> (13.2)	7300 <sup>c</sup> (15.0)	180 <sup>e</sup>	177 <sup>f</sup>
PolyTMA3	5300 (10.6)	8100 (16.2)	160 <sup>d</sup>	163 <sup>d</sup>
PolyTMA4	4100 (8.0)	6100 (11.9)	164 <sup>d</sup>	164 <sup>d</sup>
PolyTMA5	2800 (5.3)	6300 (11.9)	146 <sup>d</sup>	158 <sup>d</sup>
PolyTMA6	3100 (5.7)	6200 (11.4)	150 <sup>e</sup>	160 <sup>e</sup>
PolyTMA10	3700 (6.2)	7400 (12.4)	125 <sup>d</sup>	-

Notes

- a) Polymers prepared as recorded in Table 4.12.  
 b) Determined in melting point capillaries  
 c) After reirradiation  
 d) Sample became tacky  
 e) Shrinkage of sample  
 f) Sample darkened and became tacky.

differences in  $\overline{D.P.}$  are probably not significant except for the markedly higher  $\overline{D.P.}$  observed for polyTMA1.

Despite earlier reports on the inefficiency of *m*-dibenzoylbenzene in forming polybenzopinacols,<sup>90,91</sup> fairly high  $\overline{D.P.}$  (ca.17) photocyclo-addition polymers have been obtained although the mechanisms of the two

photopolymerizations bear common features (see Chapter 2 and section 4.2).

Heating of polymers in melting point capillaries caused observable change of physical state below  $190^{\circ}\text{C}$  in all cases. The general trend towards decreasing thermal stability with increasing methylene chain length, observed with the polymers derived from 4,4'-dibenzoyldiphenylalkanes, followed a similar trend in melting points of the parent diketones. The relationship between 'melting point' and molecular weight for polyTMA1 is demonstrated graphically in Figure 4.1.

The graph shows a classical physical property versus molecular weight relationship, the plateau value for the 'melting point' being reached at a molecular weight of ca.4000. Consequently, 'melting point' comparisons for polymers from different diketones may be valid despite variations in  $\overline{D.P.}$  between ca.10 and 27. Brittle fibres could be drawn from the melt for all polymers.

#### 4.6 Further Characterization of Polymers

Yields of crude polymers were quantitative for photoaddition between aromatic diketones and tetramethylallene. Elemental analyses for poly-TMAM, TMA1, TMA2, TMA3, TMA4, TMA6 and TMA10 were in good agreement with analyses required for such photoaddition. C,H analyses for poly-TMAP, TMAE and TMA5 were ca.1% out, although it may be noted that less satisfactory analyses have been accepted for polymers from step-growth photopolymerization by other workers (for example - see Table 1.4 or references 90,91).

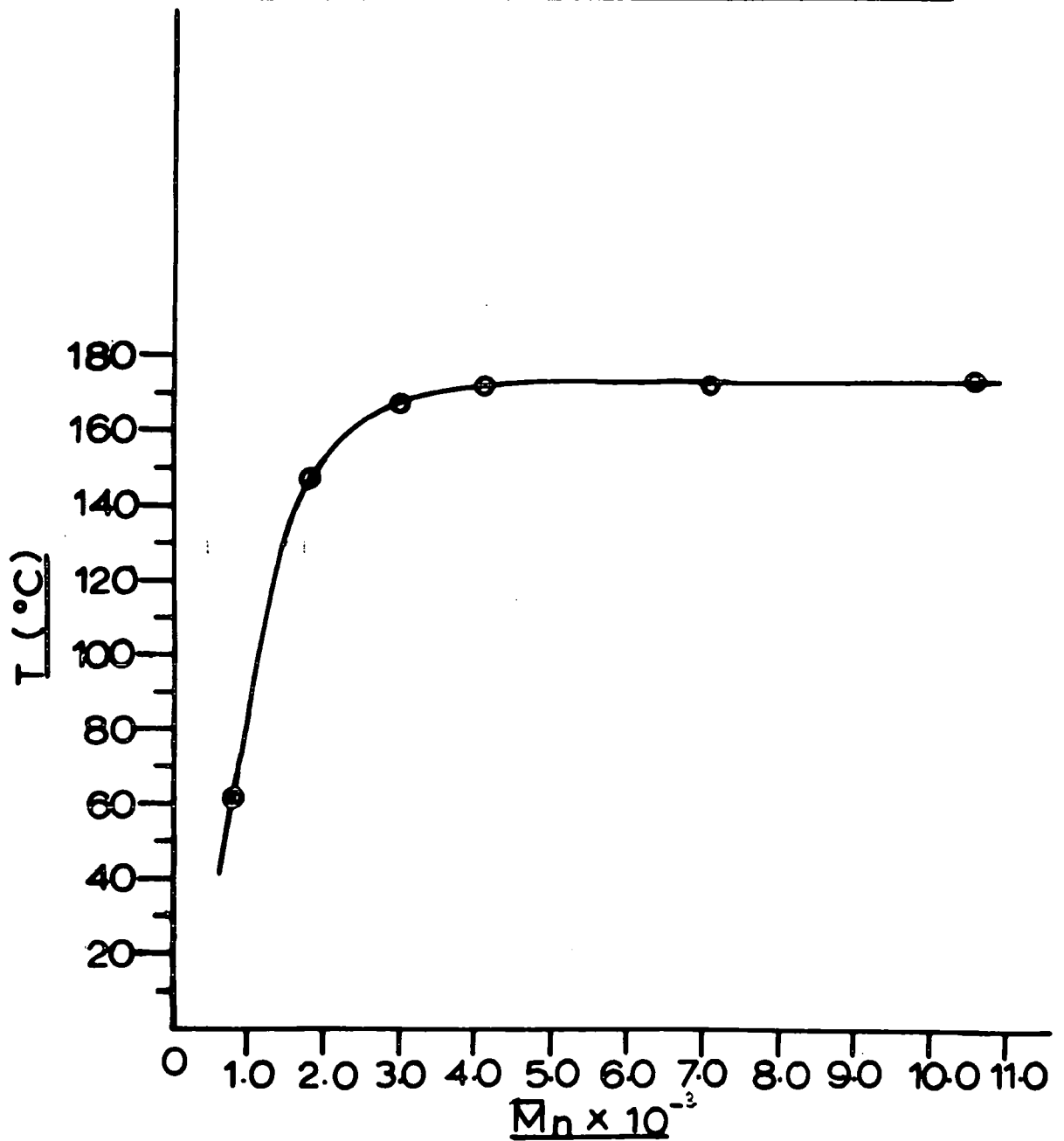
**FIGURE 4.1**Melting Point (T)<sup>a</sup> - Molecular Weight for PolyTMA1

Note a) Determined as temperature at which polymer samples first softened on heating in melting point capillaries.

(a) Model Compound Study

Characterization of polymers was aided by comparison with the model system benzophenone-tetramethylallene. Products and infrared spectral data for this system have already been discussed (section 4.2). A repetition of the irradiation of benzophenone and TMA in benzene, with a ratio of materials similar to that used by Arnold,<sup>109</sup> yielded a product mixture comprising at least four components (as detected by thin layer chromatography). Since individual products had been separated and characterized by Arnold, and all corresponding structural units were expected to be present in the polymers, separation of the components was not attempted. An infrared spectrum of the product mixture (appendix C) showed a broad absorption centred at  $3550\text{ cm}^{-1}$ , aromatic and aliphatic C-H stretch between  $3100\text{-}2850\text{ cm}^{-1}$ , a medium to weak absorption at  $1730\text{ cm}^{-1}$ , negligible residual carbonyl stretch (ca.  $1655\text{ cm}^{-1}$ ) and a strong broad absorption between ca.  $1010$  and  $930\text{ cm}^{-1}$  with peaks of intensity at  $990\text{ cm}^{-1}$ ,  $955\text{ cm}^{-1}$  and  $940\text{ cm}^{-1}$ , in good agreement with the combined absorptions from products obtained by Arnold (Table 4.1) and the relative ratios of products obtained by him.<sup>109</sup>

(b) Infrared Spectra of Polymers

The infrared spectra of typical samples of polymers from the individual diketones and tetramethylallene are recorded in appendix C. With the exception of polyTMAP the spectra show negligible residual C=O stretch ( $1665\text{-}1650\text{ cm}^{-1}$ ). Weak broad absorptions centred at  $3550\text{ cm}^{-1}$  are characteristic of the tertiary OH grouping. Absorptions varying from very weak to medium weak are observed around  $1720\text{ cm}^{-1}$ . Broad, strong absorptions in the  $1010\text{-}940\text{ cm}^{-1}$  region, centred generally at ca.

1000-980  $\text{cm}^{-1}$ , 960  $\text{cm}^{-1}$  and 945  $\text{cm}^{-1}$  are characteristic of oxetane rings. All these absorptions correspond closely to the absorptions quoted for the model system; the relative intensity ratios also suggest that the frequency with which the various structural units occur in the polymers is approximately the same as that observed in the model system.

The generally broadened bands in the spectra are characteristic of polymeric material and, as would be expected, there is a striking resemblance between spectra of polymers derived from the 4,4'-dibenzoyl-diphenylalkanes and TMA.

Absorption at 1710  $\text{cm}^{-1}$  in the spectrum of polyTMAP was very strong, and an anomalous absorption was also noted at 1770  $\text{cm}^{-1}$ .

(c) N.m.r. Spectra of Polymers

N.m.r. spectra of the polymers (in  $\text{CDCl}_3$ ) obtained at 60 MHz were poorly resolved, but generally showed broad aromatic absorption in the  $\delta 7.7-6.7$  region and broad aliphatic absorptions in the  $\delta 2.0-0.5$  region. Protons of methylene groups  $\alpha$  to benzene rings in polymers derived from 4,4'-dibenzoyldiphenylalkanes could be distinguished at chemical shifts analogous to those observed for the parent diketones (ca.  $\delta 4.0-2.5$ ), and the broad strong absorption between  $\delta 2.0-0.5$  corresponded largely to the methyl protons derived from TMA. Other methylene protons, tertiary OH protons etc. were either incorporated in the broad  $\delta 2.0-0.5$  absorption or not detected on account of the poor signal to noise ratio. However, overall aromatic to aliphatic proton integrations could be obtained and were consistent with the postulated polymer structures.

Good evidence for postulated polymer structures has been obtained from a 220 MHz spectrum of polyTMA1, which showed absorptions at  $\delta$ 7.9-6.6 (broad), 4.0-3.8, 2.95 (weak), 2.35 (weak), 2.1 (v.weak) and 1.9-0.55. The peaks were not integrated individually but overall integration indicated the ratio of aromatic to aliphatic protons ( $\delta$ 7.9-6.6: $\delta$ 4.0-0.5) was 9:7 as required for the postulated polymer structure. The signal to noise ratio for the  $\delta$ 1.9-0.5 region was improved by the CAT technique and from this improved spectrum individual bands could be resolved and their chemical shifts compared with those recorded for the methyl protons of the benzophenone-TMA 2:1 adducts (52) and (53). Thus bands were detected at  $\delta$ 1.65, 1.5-1.4, 1.28, 1.13, 1.03 and 0.58 and these should be compared with the values for model compounds (53) at  $\delta$ 1.50, 1.43, 1.29 and 0.57, and (52) at  $\delta$ 1.29 and 1.03. Together with the bands due to aromatic protons ( $\delta$ 7.9-6.6) and the benzylic methylene ( $\delta$  ca. 4.0) the above assignments account for the greater part (ca.95%) of the area under the n.m.r. spectrum of polyTMA1. The remaining weak absorptions at  $\delta$ 2.95, 2.35, 2.1, 1.65 and 1.13 have not been assigned but presumably arise from minor structural contributions.

#### 4.7 Effect of HCl on PolyTMAM

Passage of HCl gas through a solution of polyTMAM in benzene for 3 hours reduced the molecular weight from 6100 to 1100. An infrared spectrum of the product (Appendix C) showed, in particular, a strong absorption at  $1665\text{ cm}^{-1}$  and a greatly narrowed, though still strong, 'oxetane' absorption now centred at ca.  $1000\text{ cm}^{-1}$ , there being virtually no absorption between  $960$  and  $930\text{ cm}^{-1}$  compared to strong absorption in that

region for the initial polymer. This evidence is essentially consistent with cleavage of structural units of the type (61) leaving residual type (62) links in the polymer.

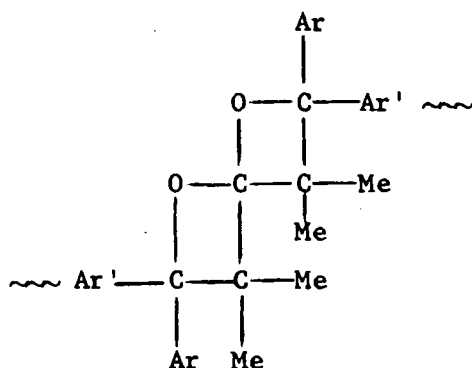

(61)

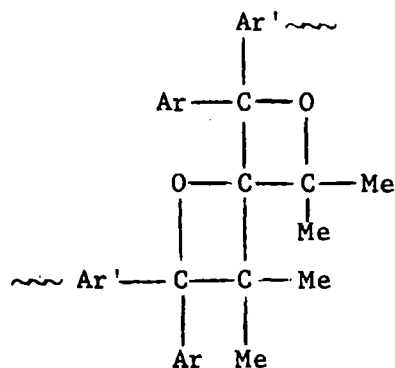

(62)

Oxetane absorptions at ca.  $960-930\text{ cm}^{-1}$  for Ar =  $\sim\sim\sim$  Ar' = Ph (compound (52))<sup>109</sup>

Oxetane absorptions at ca.  $1010-980\text{ cm}^{-1}$  for Ar =  $\sim\sim\sim$  Ar' = Ph (compound (53))<sup>109</sup>

It has been reported<sup>257</sup> that compound (53), unlike compound (52), does not undergo facile hydrolytic cleavage with aqueous  $\text{H}_2\text{SO}_4$ . Polysubstituted oxetanes generally undergo fragmentation to olefins and carbonyl compounds when treated with mineral acid.<sup>256</sup>

#### 4.8 Growth Characteristics of PolyTMAI

The growth of polyTMAI was studied by irradiation, under identical conditions, of benzene solutions of the monomers (0.0199M in each reactant) for varying periods of time and determination of the number average molecular weight (and hence  $\overline{\text{D.P.}}$ ) of the resulting recovered crude polymer.

A graph showing the dependence of molecular weight on irradiation time, under the conditions employed, is given in Figure 4.2.

During the initial stages of irradiation (0 - ca.0.7 hours), growth of the polymer was a little slower than during the main growth period (ca. 0.7-2 hours). The increase in rate of reaction after the initial stages is consistent with addition of excited carbonyl to the first tetramethylallene double bond being slower and selective compared to subsequent addition of carbonyl to highly reactive enol ether, as is the case with the benzophenone-tetramethylallene photoaddition reaction (section 4.2).

For a conventional bimolecular step-growth polymerization where reaction between functional groups is kinetically first order in each functional group, the disappearance of either functional group is given by the rate equation for an overall second order reaction (simplified by taking into account the equality in concentration of both types of functional groups). Application of Carothers' equation leads to the expression (4.3)

$$\overline{D.P.} = 1 + [M_0]kt \text{ where } [M_0] = \text{concentration of monomer at start of polymerization} \quad (4.3)$$

This expression predicts that  $\overline{D.P.}$  should increase linearly with time.

The situation is more complex for the step-growth photopolymerization where the maximum effective concentration of functional group is governed by the quantity of the relevant excited chromophore. Further complications include modes of deactivation of excited chromophore, reversible and irreversible formation of intermediate complexes, biradical

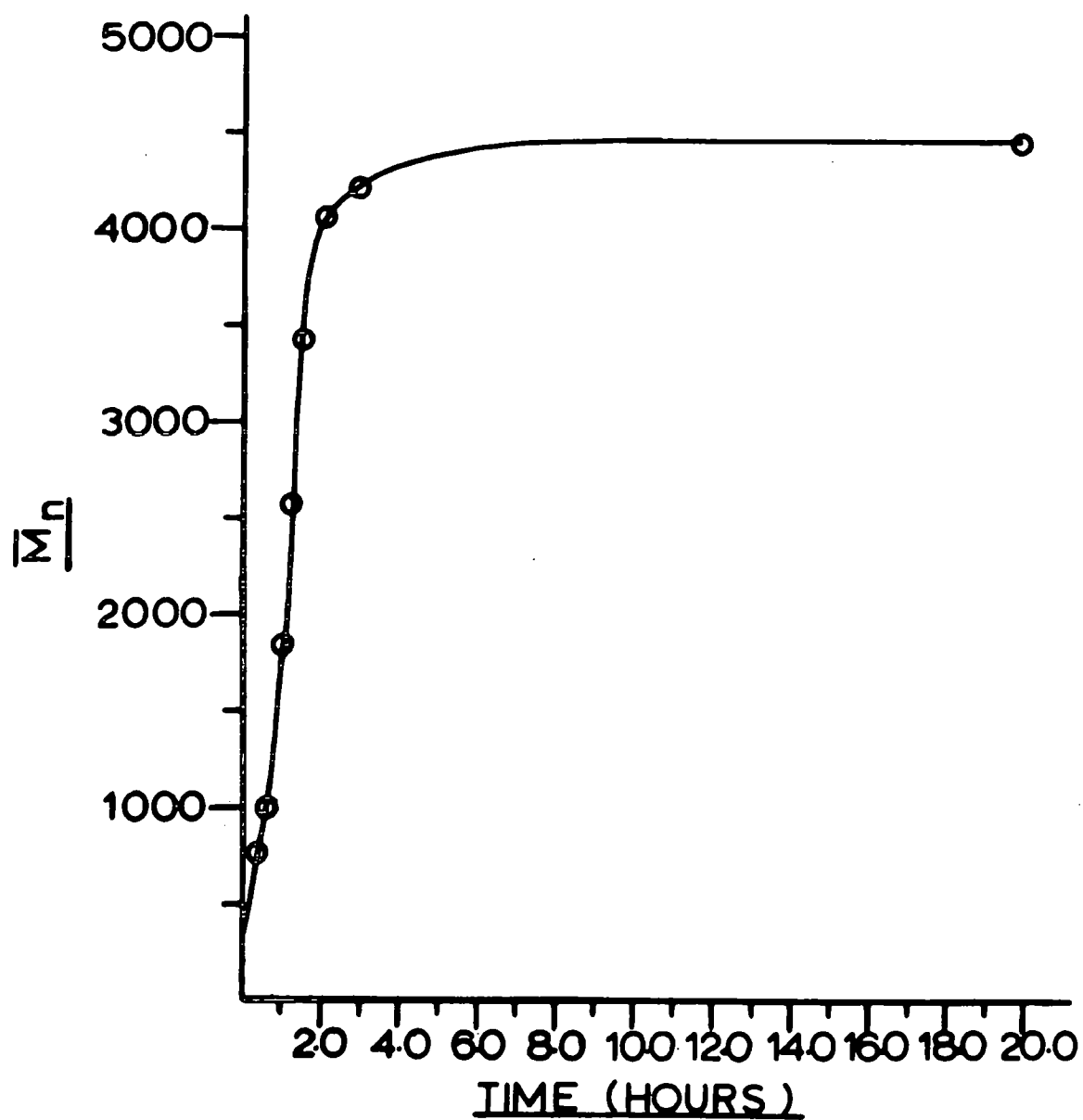
FIGURE 4.2Molecular Weight - Irradiation Time for PolyTMA<sup>a</sup>

Note a) 0.0199M Solutions of 4,4'-dibenzoyldiphenylmethane and TMA in benzene irradiated in Rayonet RPR-208 Reactor.

intermediates, differing rates of cycloaddition and competing hydrogen abstraction reactions.

With the few empirical results available here, together with the general complexity of the system, a kinetic treatment equivalent to that for the more straightforward bismaleimide photopolymerization (Chapter 1, section 1.6) is not warranted.

Growth of polymer has also been followed by disappearance and development of infrared absorption bands in the polymer samples (Figure 4.3). Disappearance of the C=O stretch (ca.  $1655\text{ cm}^{-1}$ ) and appearance of bands at ca.  $3500\text{ cm}^{-1}$ ,  $1720\text{ cm}^{-1}$  and in the 'oxetane' region with increasing molecular weight is clearly observed.

Once the plateau molecular weight was reached, extended irradiation caused no significant change in polymer molecular weight. In an initial attempt to study the growth of polyTMA1, six solutions of 4,4'-dibenzoyl-diphenylmethane and TMA in benzene were irradiated under identical conditions for periods of between 15 and 160 hours. The resulting crude polymers all possessed number average molecular weights of between 4400 and 4600.

#### 4.9 Effect of Concentration on Polymer Molecular Weight

The molecular weight attained in photopolymerization of 4,4'-dibenzoyl-diphenylmethane with TMA has been found to depend considerably on the initial concentration of monomers. Irradiation of benzene solutions of varying concentration in monomers (0.00335M to 0.1117M) for 22 hours at 350 nm under identical conditions, and determination of the number average molecular weights of the resulting crude polymers revealed a molecular weight-concentration dependence shown graphically in Figure 4.4.

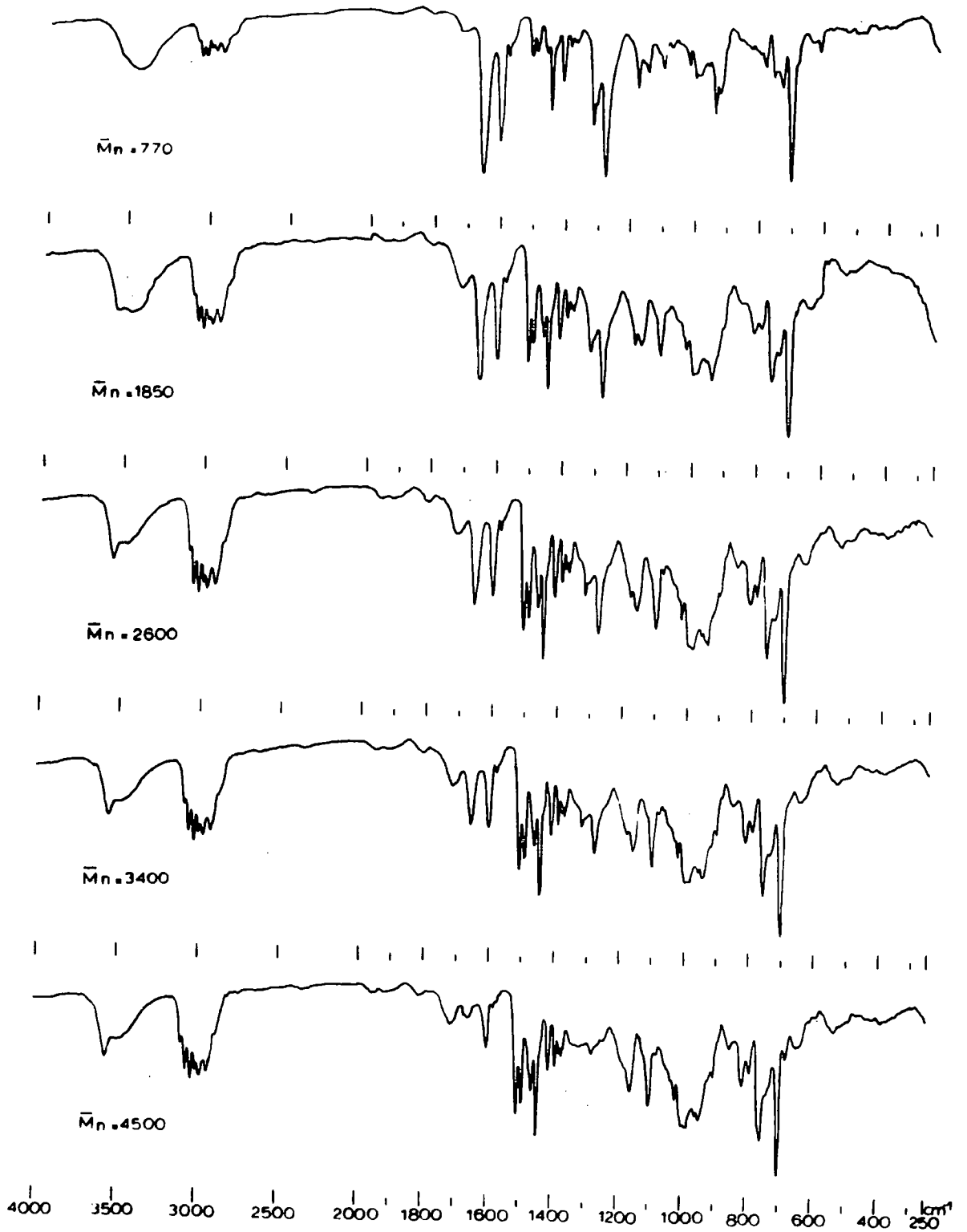
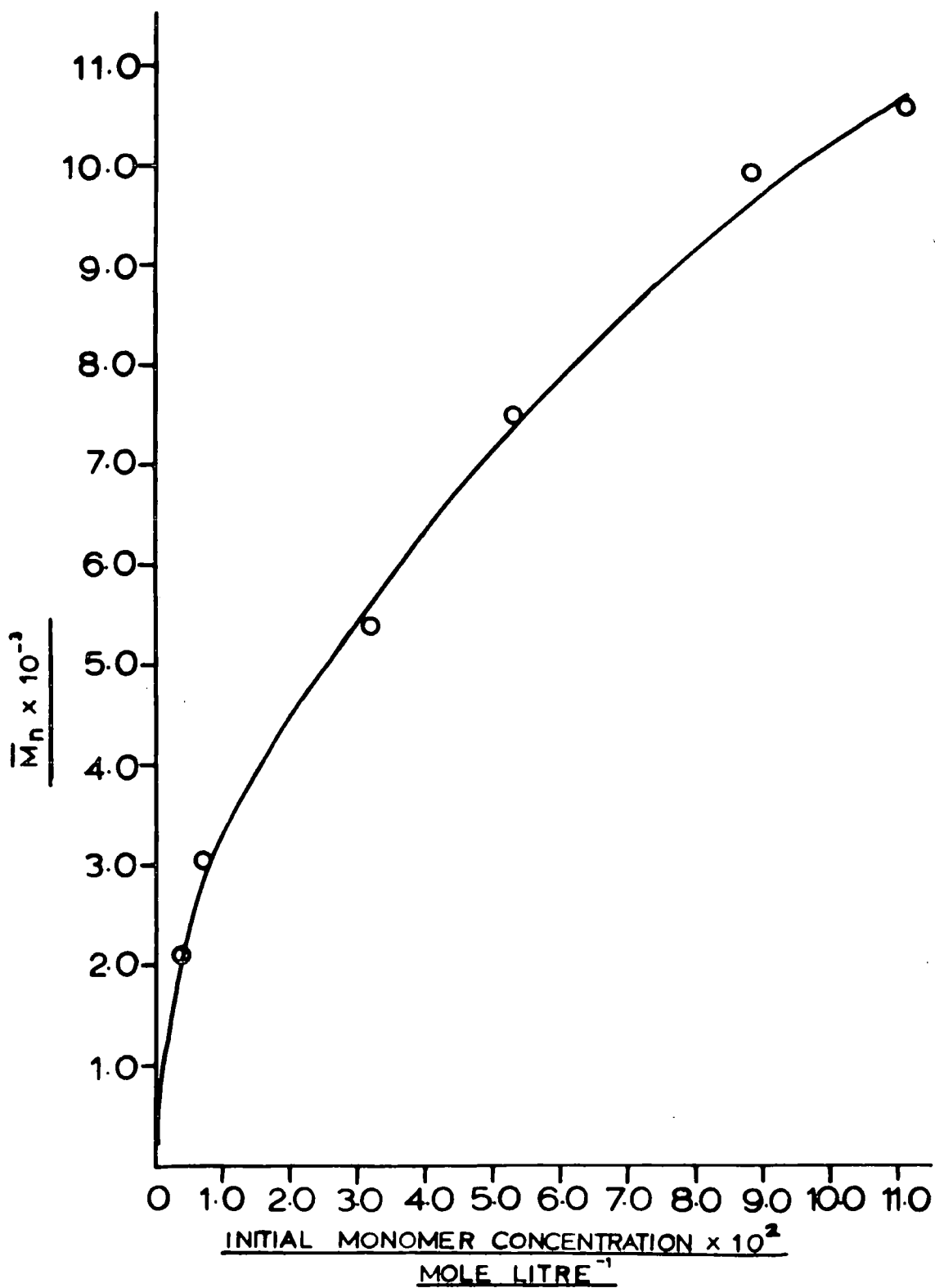

FIGURE 4.3

Infrared Spectra of Differing Molecular Weight Samples of PolyTMA1

**FIGURE 4.4**

Molecular Weight - Initial Monomer Concentration for PolyTMAI<sup>a</sup>



Note a) Solutions irradiated in Rayonet RPR-208 Reactor for 22 hr.

Results on the polymer growth characteristics indicated that for a 0.0199M solution in both reactants, the plateau molecular weight was effectively reached in ca. 4 hours. The significantly higher molecular weights attained with increased monomer concentration may be explained by the increased likelihood of encounter between an excited carbonyl chromophore and a C=C double bond (taking into account the lifetime of the carbonyl triplet) and the consequently increased likelihood of reaction leading to polymer formation.

As a consequence it was possible to reirradiate a polymer, initially prepared in dilute solution, at a higher concentration and to obtain a higher polymer. Thus reirradiation of polyTMA2, molecular weight 2800 (initially obtained at an overall polymer concentration of 4.49 g/l. owing to the low solubility of diketone in benzene), at an increased concentration of 24.0 g/l. for 390 hours yielded a crude polymer of molecular weight 6400.

#### 4.10 Thermal Stability of Polymers

Storage of polyTMAM for 9 months at room temperature caused no significant change as determined by infrared spectroscopy and molecular weight measurement. Heating of a sample of polyTMAM in vacuo for 24 hours at 61°C lowered the molecular weight of the sample from 3300 to 2700.

##### (a) Pyrolysis of PolyTMA1

Heating of a 0.42 g. sample of polyTMA1 (molecular weight 10,000) for 1.5 hours at a temperature of 280-290°C and pressure of ca.  $10^{-3}$  mm.Hg yielded ca. 0.015 g. of volatile material. A gas phase infrared spectrum of this material indicated that two of the components were benzene and

acetone, leaving unidentified absorptions particularly at  $3000\text{-}2860\text{ cm}^{-1}$  and  $2350\text{ cm}^{-1}$ . (The absorption at  $3000\text{-}2860\text{ cm}^{-1}$  was relatively too intense to be assigned solely to acetone and the lack of absorption at  $3716\text{ cm}^{-1}$  and  $3609\text{ cm}^{-1}$  precluded assignment of the  $2350\text{ cm}^{-1}$  absorption to carbon dioxide). Mass spectroscopy confirmed the presence of benzene and was consistent with acetone as another component.

Infrared spectroscopy on the residual material at the bottom of, and the 'distillate' around the neck of, the pyrolysis flask revealed, in both instances, gross structure corresponding to 4,4'-dibenzoyldiphenylmethane, with a strong absorption at  $1660\text{ cm}^{-1}$  and no oxetane absorption in the  $1000\text{ cm}^{-1}$  region.

Oxetanes in general decompose thermally to form olefins and carbonyl compounds, trimethylene oxide, for example, decomposing at  $450^\circ\text{C}$  (eq.4.4).<sup>256</sup>

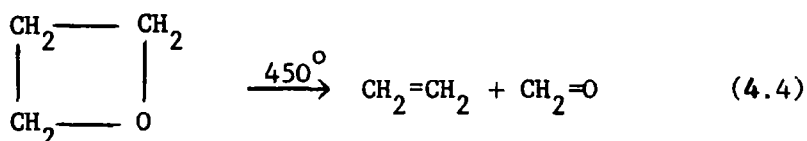

Trimethylene oxide decomposition occurs either by a concerted scission of both bonds simultaneously or via initial scission of the C-O bond only, forming an unstable 1,4-biradical.<sup>261</sup> Ease of pyrolysis of substituted oxetanes varies with the degree and type of substitution.<sup>256</sup>

The spectroscopic data obtained on the pyrolysis products of poly-TMAI was consistent with the oxetane rings cleaving in two directions to account for aromatic and aliphatic carbonyl stretch absorptions. Unidentified volatile material is probably a hydrocarbon (or hydrocarbons) arising from the TMA residue or its fragmentation products. Benzene

detected as one of the volatiles may possibly have been due to a trace of residual solvent benzene in the sample of polymer pyrolysed.

(b) Thermogravimetric Analysis

Typical thermogravimetric analyses (for polyTMAM and polyTMA6 in nitrogen and static air) are recorded in appendix D together with data on instrumentation and operating conditions. In air thermograms were two step curves, the first step corresponding to the major weight loss (mainly in the ca.300-400°C temperature range), whereas in nitrogen thermograms were single step curves. Temperature thresholds for major decomposition were generally slightly lower in a nitrogen atmosphere than in static air, and in nitrogen a small quantity of charred residue remained at the end of the analysis.

Curves for the polymers from 4,4'-dibenzoyldiphenylalkanes and TMA bore a close resemblance to one another, 50% weight loss occurring at temperatures of between ca.360-390°C in air and 390-410°C in nitrogen, but no specific relationship between stability and methylene chain length was apparent.

To obtain information on the dependence of thermal stability on molecular weight, four samples of polyTMA1 (molecular weights: 770, 1000, 2600 and 7100) were analysed in static air under the general conditions given in Appendix D, and the thermograms are shown in Figure 4.5. Little variation was observed in the threshold temperature of decomposition but at temperatures of the order of 450°C, the quantity of residual material increased significantly with increasing molecular weight of the polymer sample.

## FIGURE 4.5

Thermograms of Differing Molecular Weight Samples of PolyTMAI

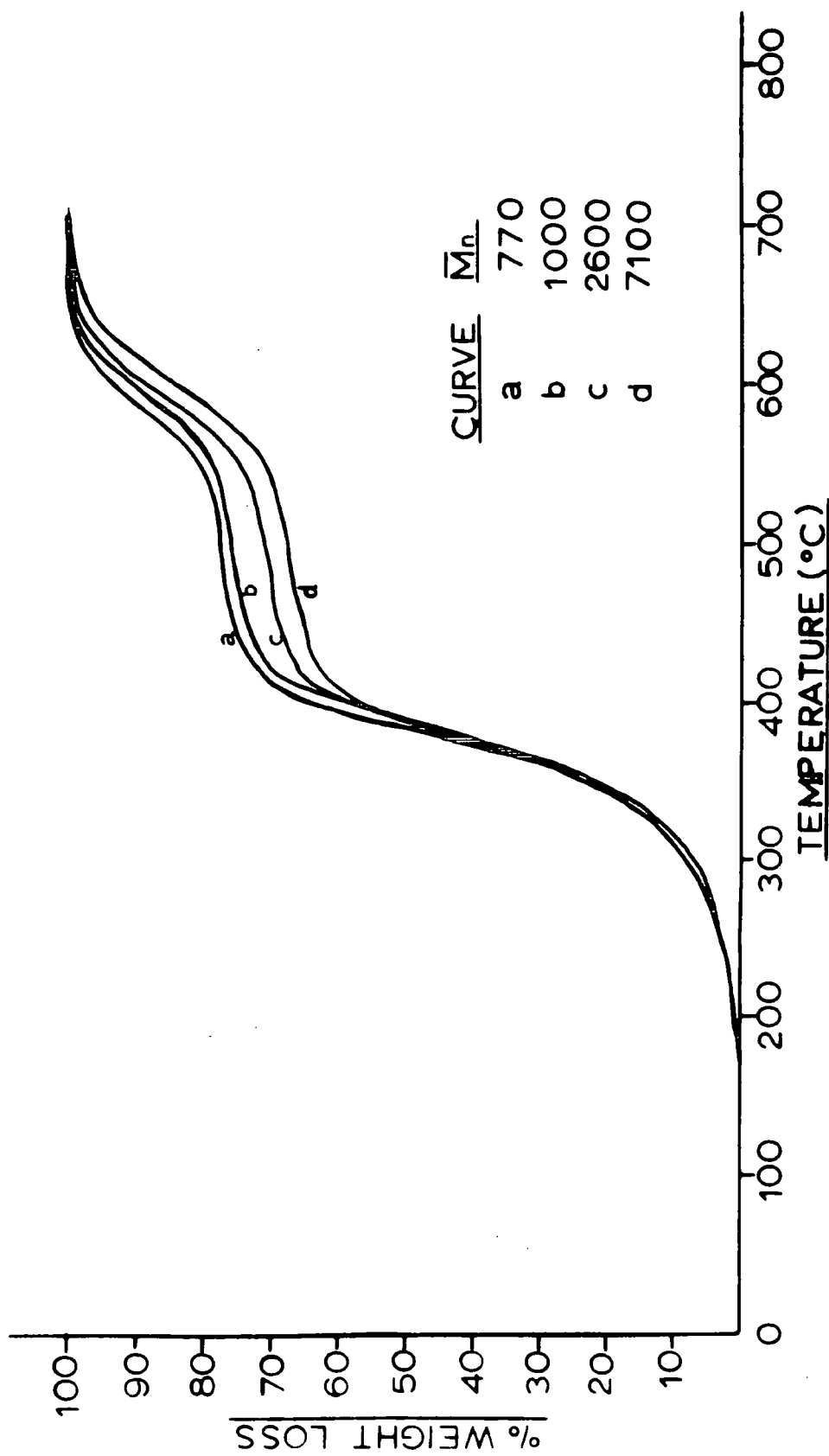

B.

THE PHOTOPOLYMERIZATION OF AROMATIC DIKETONES WITH FURANS

INTRODUCTION

#### 4.11 Photocycloaddition of Benzophenone to Furan and Substituted Furans

Benzophenone undergoes photocycloaddition to furan giving a 1:1 adduct and 2:1 adducts.

The formation of a 1:1 adduct in near quantitative yield was first reported in 1963.<sup>262,263</sup> Irradiation of benzophenone in excess furan (eq.4.5) gave a 1:1 adduct to which the structure 6,6-diphenyl-2,7-dioxabicyclo[3.2.0]hept-3-ene (63) was assigned. N.m.r. analysis

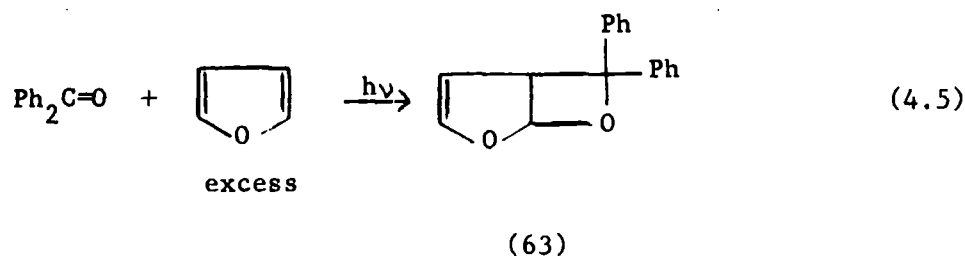

confirmed this structure.<sup>264</sup>

Formation of 2:1 adducts from photocycloaddition of 2 molecules of benzophenone to furan in benzene solvent was subsequently reported.<sup>265</sup> Two 2:1 adducts were obtained to which the structures (64) and (65) were initially assigned. A different structure (66) was subsequently assigned<sup>266-8</sup> to the more symmetrical 2:1 adduct originally designated as (64).

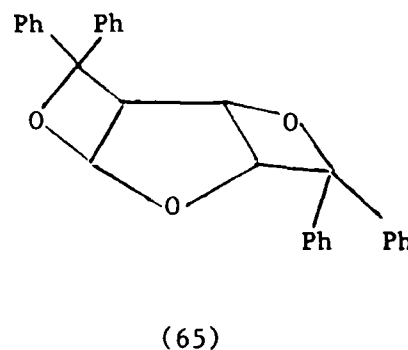
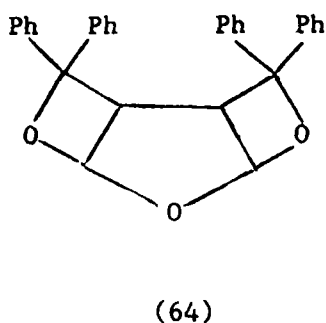

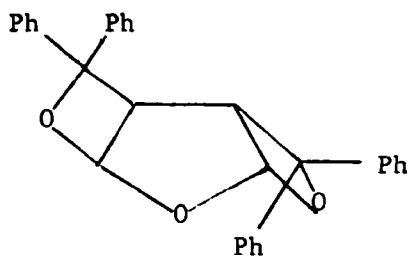

(66)

Adducts have also been obtained from benzophenone and the substituted furans 2-methylfuran,<sup>265,269</sup> 2,5-dimethylfuran,<sup>265,267</sup> 3-methylfuran,<sup>269</sup> 2-furfuryl alcohol<sup>269</sup> and 2,4-dimethylfuran.<sup>269</sup>

(a) Preparation of Photoadducts

1:1 Benzophenone-furan (or substituted furan) adducts have been obtained by direct irradiation of the ketone in an excess of the furan.<sup>262,269</sup>

Yields, where noted, were near quantitative and apart from oxetanes no other products were generally recorded.<sup>269</sup> Benzophenone added to the double bond of the furan having the methyl substituent in mono-methyl substituted furans. With 2,4-dimethylfuran a 50:50 mixture of 1:1 adducts was formed, addition occurring equally to either double bond.<sup>269</sup>

2:1 adducts have been prepared by irradiation of nearly equimolar benzene solutions of benzophenone and the furan,<sup>265,267</sup> and by irradiation of (63) and benzophenone in benzene.<sup>265</sup> Combined yields for 2:1 adducts are reported to be up to 50%,<sup>267</sup> but no experiments have been reported for irradiation of benzene solutions of benzophenone-furan where the molar ratio of benzophenone to furan was greater than 1.

Thus irradiation of a benzene solution of benzophenone and furan (molar ratio 2:3) gave, after purification, 2:1 adducts (65) and (66) in yields of 18% and 29% respectively.<sup>267</sup>

(b) Characterization of Adducts(i) 1:1 Adducts

The 1:1 adduct of benzophenone was initially assigned the structure (63) (as opposed to structure (67)) on account of the acid-sensitive character of its dihydro derivative.<sup>262</sup>

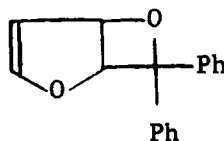

(67)

Gagnaire and Payo-Subiza confirmed the structure by n.m.r. analysis.<sup>264</sup> Neglecting the 10 aromatic protons, the n.m.r. spectrum of the 1:1 adduct showed the following chemical shifts and coupling constants for the furan protons a-d.

$\delta_a$	= 4.30 ppm	$J_{ab}$	= 3.1 Hz
$\delta_b$	= 4.79 ppm	$J_{ac}$	= 4.5 Hz
$\delta_c$	= 6.20 ppm	$J_{ad}$	= 1.3 Hz
$\delta_d$	= 6.31 ppm	$J_{bc}$	= 0
		$J_{bd}$	= 2.9 Hz
		$J_{cd}$	= 0.8 Hz

Partial analysis of the corresponding six protons (e-j) of the dihydro derivative revealed the following data.

$\delta_e$ and $\delta_f$	= 1.85 ppm	(multiplet, 2 protons)
$\delta_g, \delta_h, \delta_i$	= 3.85 ppm	(multiplet, 3 protons)
$\delta_j$	= 6.15 ppm	(doublet, $J = 4$ Hz)

The high values of the coupling constants  $J_{ac}$ ,  $J_{ab}$  and  $J_{bd}$  in the 1:1 adduct correspond to couplings between vicinal protons, possible assignments being (68) and (69).

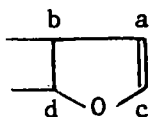

(68)

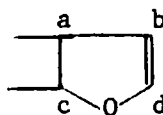

(69)

(68) was ruled out by the relatively low chemical shift of  $H_a$  (4.30 ppm) and comparison with chemical shifts in compound (70).

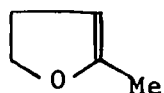

(70)

This resulted in the assignments (71) and (72).

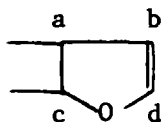

(71)

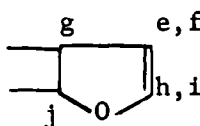

(72)

Reference to the spectrum of trimethylene oxide (73), and consideration of

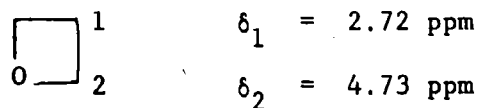

(73)

$$\delta_1 = 2.72 \text{ ppm}$$

$$\delta_2 = 4.73 \text{ ppm}$$

the effects of phenyl substitution and fusion to the furan ring system increasing the chemical shifts of the tertiary protons  $H_a$ ,  $H_c$  etc.,

confirmed that the structure was (74)≡(63).

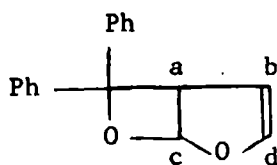

(74)

Equivalent n.m.r. assignments have been made for the 1:1 adducts of benzophenone and substituted furans.<sup>264,269</sup>

Structures of the type (75) were ruled out on n.m.r. evidence.<sup>270</sup>

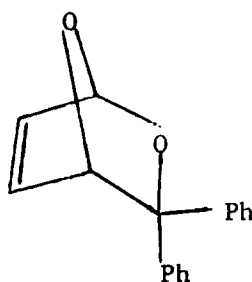

(75)

(ii) 2:1 Adducts

The n.m.r. spectra of benzophenone-furan 2:1 adduct (65) and the 'symmetrical' 2:1 adduct originally assigned the structure (64) showed the following 'furan proton' signals:

2:1 adduct (65)

$\delta$  = 5.92 ppm (1 proton, doublet,  $J$  = 4 Hz)

$\delta$  = 5.31 ppm (1 proton, doublet,  $J$  = 4 Hz)

$\delta$  = 4.98 ppm (1 proton, doublet,  $J$  = 4 Hz)

$\delta$  = 4.27 ppm (1 proton, doublet,  $J$  = 4 Hz)

Symmetrical 2:1 adduct

$\delta = 5.94$  ppm (2 protons, doublet,  $J = 4$  Hz)

$\delta = 3.70$  ppm (2 protons, doublet,  $J = 4$  Hz)

Comparison with n.m.r. spectra of compounds (76) and (77) led to the

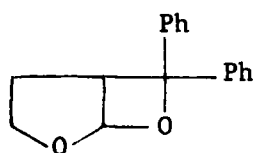

(76)

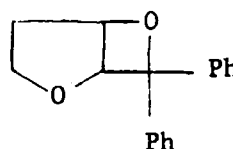

(77)

assignment of the structures (64) and (65).<sup>265</sup> Reduction of the 'symmetrical' 2:1 adduct with  $\text{LiAlH}_4$  in THF-dioxane gave a diol, designated to be of structure (78) and treatment of the diol with acetic

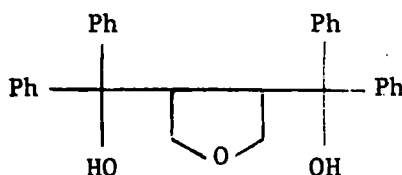

(78)

acid-HCl yielded 1,1,4,4-tetraphenylbutadiene.<sup>265</sup>

Two 2:1 adducts obtained from 2-methylfuran were formulated as 5-methyl derivatives of (64) and (65) on the basis of n.m.r. analysis and diol formation.<sup>265</sup> A single symmetrical 2:1 adduct (79) obtained from benzophenone and 2,5-dimethylfuran was found to be readily isomerizable to another isomer on treatment with methanolic acetic acid at room temperature. The isomerization was thought to be a syn to anti

isomerization. The rearrangement product was designated the anti isomer on account of its smaller dipole moment.<sup>265</sup> Additional evidence originally cited for the assignment of the 'symmetrical' 2:1 adduct as (64) was the good agreement between its observed dipole moment and group moment calculations based on THF and compound (76).

Subsequently on the basis of data given<sup>265</sup> by Ogata, Leitich<sup>266</sup> assigned the structure (66) to the 'symmetrical' 2:1 adduct. Leitich pointed out that the n.m.r. spectrum obtained for this adduct could only be expected if the coupling between the two equivalent protons at the 3 and 4' positions of the THF ring were very small. Consideration of the dependence of vicinal coupling constants on dihedral angle indicated that in (64) couplings of 7-8 Hz would be expected, whereas the structure (66), where the dihedral angle between the two protons is close to  $90^\circ$ , was consistent with the observed very small coupling. Dreiding models of (64) exhibited prohibitive non-bonding interactions even with distortion of the assembly, whereas (66) was free of any strain. Leitich also showed that dipole moment calculations on (66) equally well fitted the observed<sup>265</sup> dipole moment of the adduct. Leitich proposed a structure (80) for the compound produced on mild acidic treatment of the benzophenone-2,5-dimethylfuran 2:1 adduct (79).

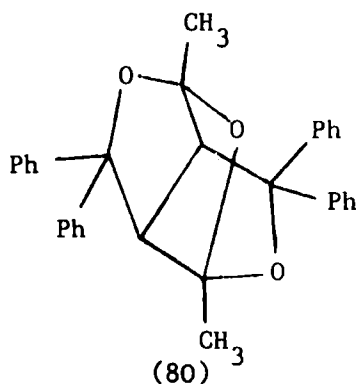

Evanega and Whipple,<sup>267</sup> on the basis of analysis of an AA'XX' spin system for the 'symmetrical' furan 2:1 adduct, also independently deduced that the structure was (66) and confirmed a trans-anti structure for the unsymmetrical adduct (65). They proposed<sup>267</sup> acid catalysed decomposition of adduct (79) to proceed via a dicarbonyl carbonium ion giving the tricyclic product of structure (80) (reaction scheme 4.6).

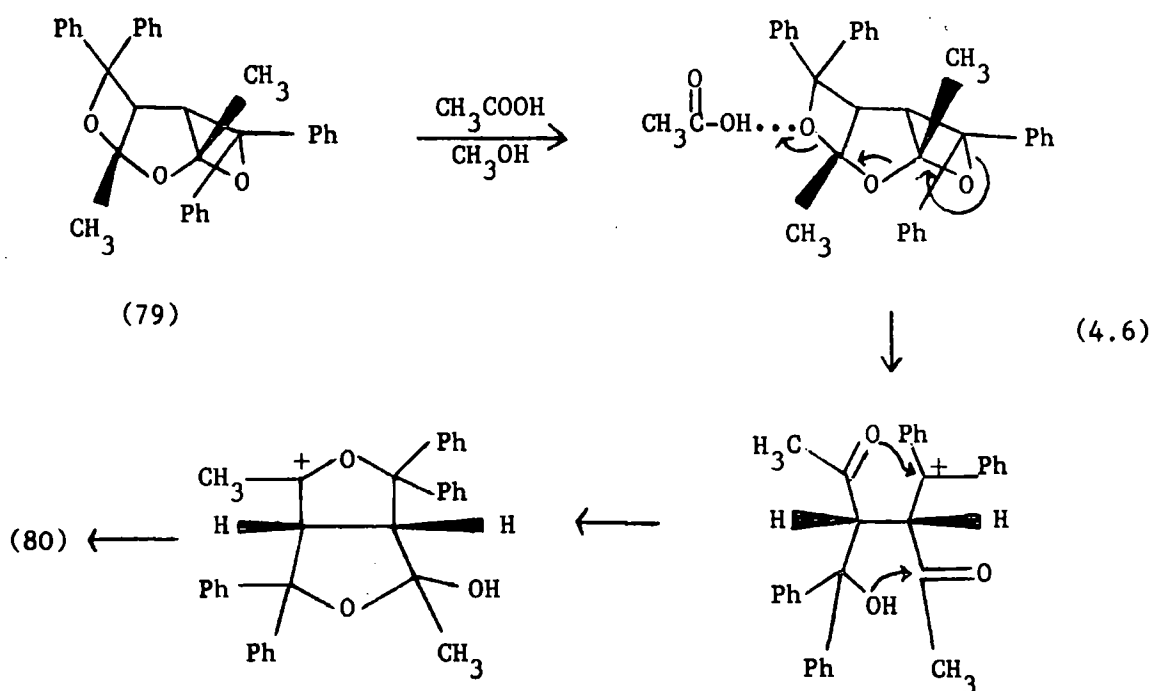

Such rearrangements for the corresponding furan or 2-methylfuran adducts would be less likely since intermediate aldehydes would be formed and hemiacetal formation might be favoured with solvents employed.

Evanega and Whipple also considered the good agreement between experimental and calculated dipole moments, cited by Ogata<sup>265</sup> as evidence for structure (64), to be fortuitous.

Toki and Sakurai<sup>268</sup> on the basis of X-ray analysis showed that, for crystals of 'symmetrical' benzophenone-furan 2:1 adduct, the molecule was of the anti-configuration (66). Ultraviolet absorption spectrum evidence pointed to no interaction between non-bonded phenyl groups. Such interaction should lead to bathochromic shifts of absorptions in the 260 nm region and higher extinction coefficients,<sup>271</sup> and was not observed, being taken as further evidence for the anti-configuration (66). The high field chemical shift of the 3 and 4' THF protons, which lie above a phenyl group in anti-configuration (66), were cited as further evidence for such a structure.

Evanega and Whipple<sup>267</sup> have observed that adduct (66) is thermally unstable; sublimation (or treatment with trifluoroacetic acid at room temperature for 10 minutes) gave 1,1,4,4-tetraphenylbuta-1,3-diene.

(c) Mechanism

Formation of the benzophenone-furan 1:1 adducts has been readily explained in terms of attack by benzophenone triplet on the most labile double bond of the furan system, giving the most stable biradical (81), which then closes giving the 1:1 adduct (63) as in eq.4.7.<sup>265,269</sup>

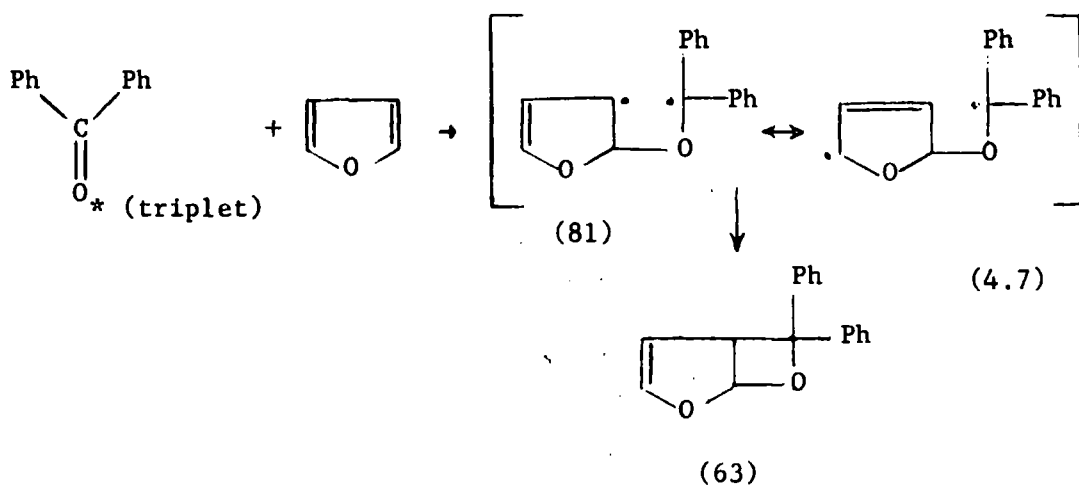

Attack of a second benzophenone triplet on the olefinic bond of (63), from the less hindered side, gives (65) and (66). However, formation of a preponderance of (66) is not predictable on the basis of stability of intermediate biradicals. It was originally thought<sup>265</sup> that (64) could arise via an orientated allylic biradical (82) produced via reaction of

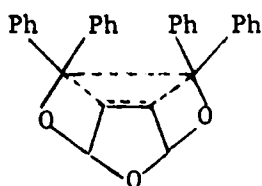

(82)

biradical (81) with ground state benzophenone or directly from 1:1 adduct (63). Bond breaking of (63) with triplet benzophenone partially yielding biradical (81) was expected from observations that irradiation of (63) in acetone or benzene solutions of acetophenone gave benzophenone-furan 2:1 adducts in low yield.<sup>265</sup>

Results of Schroeter on the photocycloaddition of carbonyl compounds to enol ethers have shown that the direction of cycloaddition cannot be predicted on the basis of intermediate biradical stability in these systems.<sup>260,272</sup> Schroeter suggests that a combination of factors such as radical stability, polarization of reactants and lack of selectivity due to enhanced reactivity of the olefin probably control the orientation of these latter additions, (cf. photocycloadditions with TMA as diene).

(d) Applicability of Furans as Dienes in Step-Growth Photopolymerizations Involving Oxetane Formation

The high yields, under the conditions used, and apparent lack of side-reactions make the benzophenone-furan photocycloaddition reaction a possible model system for extension to step-growth photopolymerization utilizing benzophenone-type aromatic diketones. Polymers containing isomeric structural units indicated by the structure (83) are to be

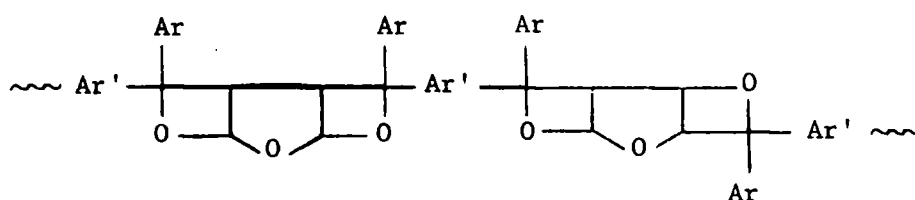

(83)

expected from such aromatic diketones and furan.

It may be noted that furan has been added photochemically to poly(vinylbenzophenone) (eq.4.8).<sup>273</sup>

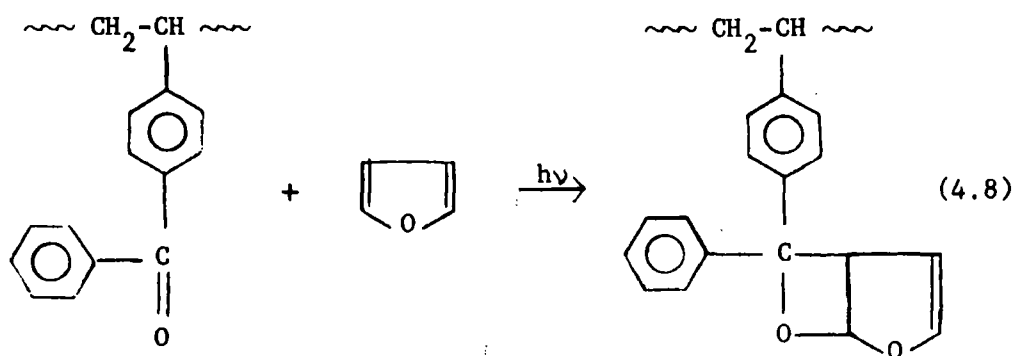

The photoaddition may involve the other double bond of furan, thereby effecting crosslinking of the polymer.

DISCUSSION

4.12 Direct Irradiation of Equimolar Quantities of Diketone and Furan  
in Benzene Solution

Irradiation of a degassed equimolar benzene solution of m-dibenzoylbenzene and furan (0.199 M in each monomer) in a sealed Pyrex tube at 350 nm gave, after removal of solvent, a pale yellow oligomeric material, molecular weight 1250.

An infrared spectrum of the oligomer, Appendix C, showed a strong residual C=O stretch at ca.  $1665\text{ cm}^{-1}$ . A broad absorption at ca.  $1050\text{--}900\text{ cm}^{-1}$  was consistent with possible cycloaddition giving oxetane rings in an oligomer chain, and the infrared spectrum generally corresponded closely to that of a characterized polymer, molecular weight 1390, prepared by the two stage route from m-dibenzoylbenzene and furan described below.

Amongst the rigorous requirements (Chapter 1, section 1.4) for a successful step-growth polymerization is the necessity for an exact equivalence of functional groups in reactions of the type (4.9).

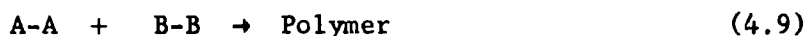

The extremely high volatility of furan (b.p.  $32^{\circ}$  @ 760 mm Hg) and consequent difficulties in handling and quantitative manipulation of the diene could readily be one factor accounting for the production of only oligomeric material on direct irradiation of the m-dibenzoylbenzene-furan mixture in benzene.

#### 4.13 An Alternative Route to Furan-Diketone Polymers Containing Oxetane Units in the Main Chain

A ready method for obtaining functional group equivalence in a polymerization of the A-A + B-B type is by the direct handling and weighing of solid and easily manipulated materials. Since benzophenone yielded a 1:1 adduct (63) on irradiation in furan (section 4.11) and the C=C double bond of this adduct was susceptible to further addition of benzophenone giving 2:1 adducts, an alternative route to furan-diketone polymers was investigated involving initial irradiation of diketone in a large excess of furan with the aim of producing a furan-diketone 2:1 adduct (equation 4.10) that could be readily manipulated.

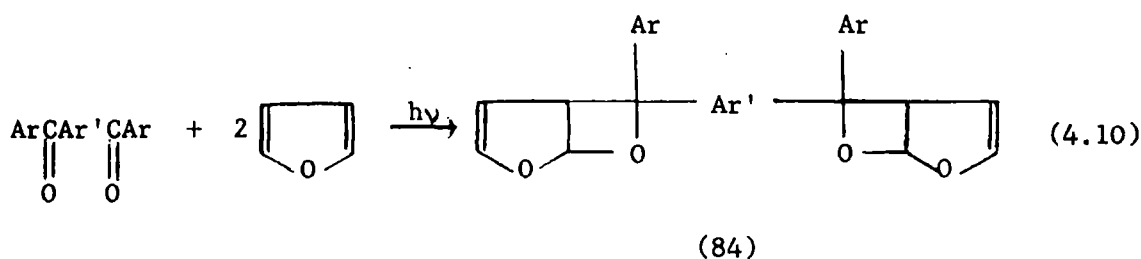

Irradiation of the 2:1 adduct (84) with an equimolar quantity of diketone would then be a possible polymer forming reaction.

#### 4.14 Preparation of Furan-Diketone 2:1 Adducts

Irradiation at 350 nm of the aromatic diketones (40), (41), (44)-(50), in a large excess of furan gave, after removal of excess furan, the photoadducts detailed in Table 4.3, where molecular weights of photoadducts together with required molecular weights for formation of furan-diketone 2:1 adducts (84) are also recorded.

TABLE 4.3

Irradiation of Aromatic Diketones in Excess Furan

Diketone	Furan adduct Abbreviation	Molecular Weight <sup>a</sup>	Molecular weight calculated for 2:1 adducts (84)
(40)	DiFM	421	422.5
(41)	DiFP	420	422.5
(44)	DiF1	502	512.6
(45)	'DiF2'	567	526.6
(46)	DiF3	530	540.7
(47)	DiF4	544	554.7
(48)	DiF5	557	568.7
(49)	DiF6	589	582.7
(50)	DiF10	623	638.8

Note a) Measured by the isopiestic method in benzene solution.

b) Prepared in mixed benzene-furan solvent owing to low solubility of diketone (45) in furan.

With the exception of 'diF2' (which was prepared in a mixed benzene-furan solvent), and within the limits of accuracy of the molecular weight determination (see Appendix A), measured molecular weights were in good agreement with those calculated for furan-diketone 2:1 adducts.

As a model the reported formation of the benzophenone-furan 1:1 adduct (63) was also repeated here, by irradiation of benzophenone in excess furan.

#### 4.15 Spectroscopic Characterization of Furan-Diketone 2:1 Adducts

##### (a) Infrared Spectra

Infrared spectra of the various adducts are recorded in Appendix C.

The infrared spectrum of benzophenone-furan 1:1 adduct (63) showed no residual C=O stretch at  $1665\text{ cm}^{-1}$ . A strong band in the  $980\text{ cm}^{-1}$  region has been reported as characteristic of oxetanes formed by photo-addition of various carbonyl compounds to furan.<sup>274</sup> Fusion of oxetane rings to other rings has also been reported to depress the characteristic absorption frequency of the oxetane ring to below  $900\text{ cm}^{-1}$ .<sup>259,275</sup> Furan itself shows a ring breathing vibration at  $995\text{ cm}^{-1}$  and various C-H vibrations between  $1268$  and  $660\text{ cm}^{-1}$ .<sup>259</sup> The ring frequency at ca.  $1075\text{ cm}^{-1}$  in tetrahydrofuran can shift down to ca.  $960\text{ cm}^{-1}$  when the ring is fused to a rigid system.<sup>259,275</sup> Thus individual assignments of bands observed in the  $1200\text{-}900\text{ cm}^{-1}$  region for the furan adducts carry little conviction when all the possible vibrations and complexities introduced by ring fusion are considered.

For the 1:1 adduct (63), within the region  $1200\text{-}900\text{ cm}^{-1}$ , strong bands were observed at 1130, 1045, 1020, 1004 (m), 990, 963, 930 and  $902\text{ cm}^{-1}$ . A band at ca.  $1492\text{ cm}^{-1}$  has been reported<sup>273</sup> and was observed here. However, generally there is a sparsity of reported infrared data for benzophenone-furan adducts.

The spectra of the furan-diketone adducts possessed similar features to those observed for (63). The spectra showed no residual C=O stretch ( $1665\text{-}1650\text{ cm}^{-1}$ ). Individual absorptions in the  $1200\text{-}900\text{ cm}^{-1}$  region were typically observed at ca. 1135, 1050, 1020, 990, 970 and  $930\text{ cm}^{-1}$ .

comparing favourably with absorptions in the spectrum of (63). Any v. weak broad absorptions centred on ca.  $3450\text{ cm}^{-1}$  were ascribable to water in the KBr used for preparing KBr discs (verified by running of KBr blanks). The peak at ca.  $1495\text{ cm}^{-1}$ , and the general aromatic and aliphatic features expected, especially for adducts from 4,4'-dibenzoyldiphenylalkanes, were present.

An absorption at  $1613\text{ cm}^{-1}$  has been recorded as characteristic of the 2,3-dihydrofuran structure of the benzophenone-furan adduct (63).<sup>262</sup> Such an absorption is also present in the spectra of the furan-diketone 2:1 adducts (84). However, its diagnostic value is complicated by the aromatic absorptions (as in the diketones) in the same region, and absorptions around  $1600\text{ cm}^{-1}$  were, in fact, observed with most substances examined by infrared spectroscopy. Spectra of poly(vinyl-benzophenone) and its furan photoadduct, recorded in the literature,<sup>273</sup> both showed an absorption around  $1600\text{ cm}^{-1}$ .

(b) N.m.r. Spectra

The n.m.r. spectrum of dIFM showed the absorptions listed in Table 4.4, where corresponding absorptions are also given for the benzophenone-furan 1:1 adduct (63).

TABLE 4.4  
N.m.r. data for dIFM<sup>a</sup> and (63)

dIFM			(63) <sup>264</sup>	
$\delta$ (ppm)	No. of protons	Proton	$\delta$	No. of protons
7.7-7	14	Aromatic	-	-
6.3	2	d	6.31	1
6.2	2	c	6.20	1
4.8	2	b	4.79	1
4.3	2	a	4.30	1

Note a) Recorded at 60 MHz in  $\text{CCl}_4$  solution, with TMS as internal reference.

The favourable comparison between chemical shifts of diFM and (63) is indicative of the assignment (85) for diFM.

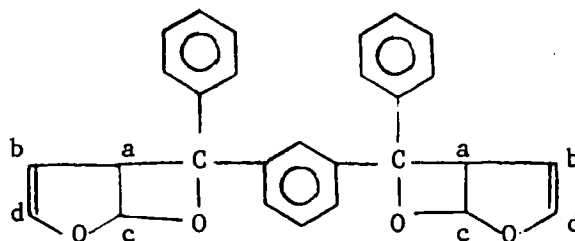

DiFP yielded an identical n.m.r. spectrum to diFM apart from a narrower ( $\delta$ 7.5-7.1) aromatic absorption. Recorded n.m.r. spectra of the 2:1 adducts from 4,4'-dibenzoyldiphenylalkanes were similar but with additional signals from the methylene chain protons. As examples, n.m.r. data for diF1 and diF6 is given in Table 4.5.

TABLE 4.5

N.m.r. data for DiF1 and DiF6<sup>a</sup>

DiF1		DiF6	
$\delta$	No. of Protons	$\delta$	No. of Protons
7.6-6.9	18	7.45-6.95	18
6.31	2	6.32	2
6.20	2	6.20	2
4.75	2	4.8	2
4.25	2	4.3	2
3.9	2 methylene protons	3.5 (broad)	4
		1.15-1.7	8

Note a) Recorded at 60 MHz in CCl<sub>4</sub> solution with TMS as internal reference

The 'furan' proton absorptions were best resolved in the spectra of diFM and diFl. The absorption at  $\delta 6.2$  ( $H_c$ ) appeared as a doublet,  $J =$  ca. 4Hz, with further slight splitting of each limb. This is consistent with the coupling constants  $J_{ac} = 4.5$  Hz,  $J_{cd} = 0.8$  Hz and  $J_{bc} = 0$ , recorded by Gagnaire<sup>264</sup> for (63). The absorption at  $\delta 4.8$  ( $H_b$ ) appeared essentially as a triplet ( $J$  ca. 3 Hz) consistent with Gagnaire's values<sup>264</sup> of  $J_{ab} = 3.1$  Hz,  $J_{bd} = 2.9$  Hz,  $J_{bc} = 0$  for (63). The  $\delta 6.31$  ( $H_d$ ) and  $\delta 4.25$  ( $H_a$ ) signals were complex and poorly resolved although the overall broadness of the absorptions was consistent with Gagnaire's coupling constants for (63).

#### (c) Ultraviolet Spectra

Oxetanes are reported to be generally transparent in the visible and ultraviolet regions, except where substituents with chromophoric groups are present.<sup>256</sup> The absorption spectrum of trimethylene oxide shows a maxima at 183 nm, with little absorption above 220 nm.<sup>276</sup>

An ultraviolet absorption spectrum of diFM in ethanol showed the adduct to be transparent above 280 nm. The lowest energy absorption was an absorption  $\lambda_{max}$  259 nm,  $\epsilon$  770 (in 95% ethanol).

#### (d) Mass spectra

Mass spectra of the 2:1 adducts proved extremely difficult to obtain. Many attempts were made with the various adducts but a combination of low volatility of the parent molecule and poor thermal stability necessitated very precise operating conditions to obtain a parent peak. Satisfactory mass spectra were eventually obtained on diFM, diFP and diFl by suitable adjustment of the source and inlet system temperatures. These three mass spectra are tabulated in Appendix B, and

showed parent peaks at m/e 422, 422 and 512 respectively. Parent peak intensities were ca. 20-30% those of the base peaks. Peaks were observed corresponding to loss of one and two furan molecules, the latter giving rise to fairly strong diketone molecular ions, the breakdown pattern of the diketones also being clearly apparent.

Strong peaks at m/e 68 corresponded to furan and the furan breakdown pattern was also apparent (m/e 39,  $^+ \triangleleft$ , m/e 29,  $\text{HC}\equiv\text{O}^+$ ). Base peaks varied from m/e 68 in diF1 and diFP to m/e 105 ( $\text{C}_6\text{H}_5\text{CO}^+$ ) in diFM.

Attempts to obtain mass spectra of other 2:1 adducts generally gave spectra clearly characteristic of breakdown to furan and partial breakdown patterns of diketones.

The mass spectral fragmentation pathway of these adducts resembles that of the simplest oxetane in that the major route involves cleavage to ketone and olefin. It is worth noting that trimethylene oxide's mass spectral fragmentation is basically similar to that observed in pyrolysis and photolysis,<sup>256</sup> with initial cleavage to ethylene and formaldehyde.<sup>277</sup>

#### 4.16 General Discussion on Furan-Diketone 2:1 Adducts

Adducts obtained directly by removal of furan from the irradiation mixture were generally white solids. Attempted determination of melting points in capillary tubes revealed that, on heating, the adducts tended to slowly change to viscous materials, sometimes over temperature ranges of thirty degrees or more, with or without melting. Temperatures at which adducts first showed signs of change were diFM, 57°C; diFP, 154°C; diF1, 66°C; 'diF2', 110°C; diF3, 45°C; diF4, 102°C; diF5, 19°C; diF6, 40°C and diF10, <15°C.

In contrast to adduct (63) where the compound was successfully recrystallized,<sup>262</sup> no satisfactory solvent or solvent mixture was found for recrystallization of the furan-diketone 2:1 adducts. Attempted recrystallization from common organic solvents often gave tacky materials setting to solids. Where white solids could be obtained on recrystallization (for example with diF1 in methanol/water) there was no improvement in the melting characteristics of the material. Attempted column chromatography on silica gel or alumina with various eluents again gave no apparent improvement in purity. Chromatography of diFM on silica gel, eluting with chloroform, appeared to cause decomposition of the adduct, oxetane absorptions not being detected in the infrared spectra of samples obtained from the column.

Thin layer chromatography of the adducts obtained directly from the irradiation mixture indicated a single clean component; this (together with the spectroscopic evidence and molecular weight measurements) indicates the efficiency of formation of the adducts. Yields were generally quantitative for formation of 2:1 adducts.

Adducts tended to decompose on standing at room temperature. Thin layer chromatography of adducts stored for several months showed a broad smear rather than a single sharp component. Infrared spectra of diFP and diF3 stored for several months showed a weak absorption at ca.  $1660\text{ cm}^{-1}$  suggesting regeneration of C=O, together with a weak absorption at  $1730\text{ cm}^{-1}$ . Unlike (63), samples of 2:1 adducts tended to smell strongly of furan after storage in closed vessels for a few hours, even after prior pumping of adduct samples for several days on a vacuum line. A sample of diFM held at  $80^{\circ}\text{C}$  overnight showed a weight loss of ca.5%, as determined

on thermogravimetric equipment. Thermogravimetric analysis at higher temperatures could not be performed since adducts tended to bubble out of the crucible suspended on the microbalance.

Further discussion on the thermal stability and pyrolysis of 2:1 adducts may be found in section 4.24, together with related discussion on furan-diketone polymers.

The molecular weight of 'diF2' (567) was significantly too high for it to be a simple furan-diketone 2:1 adduct. Since the infrared spectrum of the adduct showed no residual C=O stretch and was virtually identical to the spectra of adducts characterized as 2:1 adducts, it was assumed that 'diF2' was essentially a 2:1 adduct with the molecular weight raised slightly by a proportion of furan-diketone 3:2 adduct formed by attack by diketone C=O on the C=C double bond of 2:1 adduct, followed by further cycloaddition of the residual carbonyl group to another furan molecule (4.11).

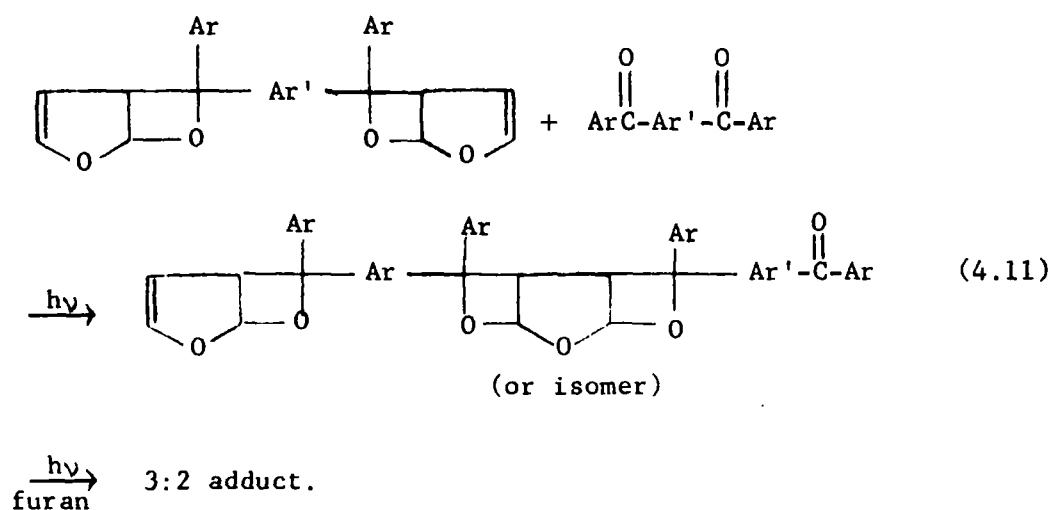

The small proportion of this material was not detectable by spectroscopic examination. Assuming a mixture of 2:1 and 3:2 adducts,

calculations based on the molecular weight of 567 indicated ca.15% by weight of 3:2 adduct.

'DiF2' preparation necessitated one of the lowest excesses of furan and a large quantity of benzene cosolvent. On account of the poor solubility of 1,2-(4,4'-dibenzoyldiphenyl)ethane in furan it was not possible to increase the relative excess of furan with the aim of producing purer 2:1 adduct.

Irradiation of a 0.0282M solution of 4,4'-dibenzoyldiphenylmethane in furan resulted in formation of 2:1 adduct, diF1, as determined by mass spectroscopy and molecular weight measurement. However irradiation of a 0.133M solution of the same diketone in furan resulted in the formation of material of molecular weight 617 (512 required for 2:1 adduct). The infrared spectrum of this higher molecular weight material showed no C=O stretch and appeared virtually identical to that of the characterized 2:1 adduct. This was taken as further evidence that decreasing the excess of furan allowed formation of adducts higher than 2:1 adducts, whilst the excess furan ensured complete consumption of carbonyl groups.

However, on irradiation of a highly concentrated (0.873M), saturated solution of m-dibenzoylbenzene in furan, a product precipitated which showed residual carbonyl groups (as determined by infrared spectroscopy). Removal of material from solution, as a solubility effect, presumably precluded complete consumption of carbonyl groups.

4,4'-Dibenzoyldiphenyl was too insoluble in furan or suitable furan-cosolvent mixtures to attempt preparation of a 2:1 adduct.

Irradiation of 4,4'-dibenzoyldiphenyl ether in furan resulted in precipitation of an orange-yellow solid, molecular weight 620 (514

required for 2:1 adduct). The infrared spectrum of this product (Appendix C) differed fundamentally from characterized 2:1 adducts, particularly with a strong absorption at ca.  $1735\text{ cm}^{-1}$ . The product was not investigated further.

#### 4.17 Preparation of Polymers from Furan-Diketone 2:1 Adducts and Diketones

Irradiation at 350 nm of equimolar quantities of aromatic diketone and furan-diketone 2:1 adduct in benzene solution gave low to medium molecular weight polymers. Since the 2:1 adducts were generally obtained in quantitative yield by a clean reaction, and attempts at purification, as described above, resulted in no apparent improvement in purity, they were used as prepared. As with preparation of polymers from diketones and tetramethylallene, factors governing the choice of monomer concentrations included the availability of monomers and their solubility in benzene (diketones generally being the least soluble). Compensation was made in quantities of reactants for the suspected presence of some 3:2 adduct in 'diF2'.

Polymers were obtained from diketones and 2:1 adducts as enumerated below.

<u>Diketone</u>	<u>2:1 Adduct</u>	<u>Polymer</u>	<u>Diketone</u>	<u>2:1 Adduct</u>	<u>Polymer</u>
(40)	DiFM	PolyFM	(47)	DiF4	PolyF4
(41)	DiFP	PolyFP	(48)	DiF5	PolyF5
(44)	DiF1	PolyF1	(49)	DiF6	PolyF6
(45)	'DiF2'	PolyF2	(50)	DiF10	PolyF10
(46)	DiF3	PolyF3			

Total reaction products were quantitatively recovered by freeze drying from benzene solution, and after examination they were dissolved and precipitated from benzene into 40-60° petroleum ether. Polymers were white or pale yellow solids.

#### 4.18 Solubility of Furan-Diketone Polymers

Solutions of polyFM, polyFP and polyF10 were completely clear at the end of the irradiation period, and the polymers were soluble in such solvents as chloroform, dichloromethane and benzene. Solutions of polyF2, polyF5 and polyF6 showed turbidity at the end of the irradiation period, whilst polyF3 and polyF4 solutions showed still greater cloudiness. PolyF1 was formed as a fairly heavy suspension on irradiation of a 0.0175M solution (in each monomer) for 200 hours. Irradiation of a more dilute (0.00975M) solution for a shorter irradiation period (90 hours) resulted in only a trace of turbidity.

#### 4.19 Molecular Weights and Melting Characteristics of Furan-Diketone Polymers

Molecular weights of polymers, as measured by the isopiestic method in benzene solution, and corresponding  $\overline{D.P.}$ 's (based on a repeating unit comprising the molecular formulae of one diketone molecule and one furan molecule) are recorded for crude and precipitated polymers in Table 4.6. Temperatures at which the first apparent change occurred on heating precipitated polymer samples in melting point capillaries are also recorded.

Consistent molecular weights could be obtained for polyF1, polyF2, polyF5 and polyF6 even though the benzene solutions of these polymers showed traces of turbidity after the irradiation period. However, molecular weights of polyF3 and polyF4 may only be treated as rough estimates owing to distinct cloudiness in solutions used for molecular weight determination. Various other solvents including ethanol,

TABLE 4.6  
Molecular Weights, Degrees of Polymerization and Melting  
Characteristics of Furan-Diketone Polymers

Polymer <sup>a</sup>	Molecular Weight ( $\overline{D.P.}$ )		Temperature at which Polymers Visibly Changed State ( $^{\circ}\text{C}$ ) <sup>b</sup>
	Crude	Precipitated	
PolyFM	4800 (13.5)	8000 (22.6)	209 <sup>e</sup>
PolyFP	1800 (5.1)	2200 (6.2)	188 <sup>e</sup>
PolyF1	5400 <sup>c</sup> (12.1)	4300 (9.7)	204 <sup>f</sup>
PolyF2	3400 (7.4)	6100 (13.3)	195 <sup>e</sup>
PolyF3	6000 (12.7)	6500 (13.8)	192 <sup>f</sup>
PolyF4	7600 (15.6)	9000 (18.5)	190 <sup>f</sup>
PolyF5	3700 (7.4)	3500 (7.0)	176 <sup>f</sup>
PolyF6	4100 (8.0)	7300 (14.2)	180 <sup>e</sup>
PolyF10	2500 (4.4)	-	
	2900 <sup>d</sup> (5.1)	8600 (15.1)	152 <sup>f</sup>

Notes a) Polymers prepared as recorded in Table 4.14

b) Determined for precipitated polymers in melting point capillaries

c) From 0.00975M solution - irradiation for 90 hours

d) After reirradiation

e) Sample darkened and became tacky

f) Sample became tacky.

dichloromethane, chloroform, carbon tetrachloride, acetone, ethyl acetate, N-methyl-2-pyrrolidone, trichloroethylene, tetrachloroethylene, DMF and dioxane proved no more satisfactory.

Maximum observed  $\overline{D.P.}$ 's of the individual polymers ranged between ca. 6 and 23, the highest polymer being polyFM. The molecular weight of 8000 (4800 for crude polymer) may be contrasted with the low molecular weight of 1250 obtained by direct irradiation of a benzene solution of

m-dibenzoylbenzene and furan, although the latter solution was the more concentrated in monomers, demonstrating the greater efficiency of the technique utilizing a two stage synthesis.

Unlike the polymers from tetramethylallene, the polymers from furan as diene usually became rubbery and foamy on heating in melting point capillaries. Only very short and broad fibres could be drawn from the melt. 'Melting points' of polymers derived from 4,4'-dibenzoyldiphenylalkane diketones tended to decrease with increasing methylene chain length.

The relationship between 'melting point' and molecular weight for crude polyFM is shown in Figure 4.6. Temperature of onset of melting initially increased rapidly with increasing molecular weight and reached a plateau value at a molecular weight of ca.4000 ( $\overline{D.P.}$  ca. 11.3), (cf. polyTMA1).

#### 4.20 Further Characterization of Furan-Diketone Polymers

With the possible exception of polyF4, elemental analyses were in satisfactory agreement with values required for photoaddition between 2:1 adduct and diketone.

##### (a) Model Compound Study

Characterization of polymers was aided by comparison with the model systems: benzophenone-furan 1:1 adduct (63), furan-diketone 2:1 adducts (84) and the 2:1 adducts (65) and (66) formed between benzophenone and furan. The photoreaction between benzophenone and furan in benzene solution<sup>267</sup> was repeated. Two adducts were isolated from the crude reaction mixture, of melting points 191-192.5°C and 208-210°C compared to reported<sup>267</sup> melting points of 192-193°C for (65) and 211-212°C for (66). An infrared spectrum of the higher melting adduct (appendix C)

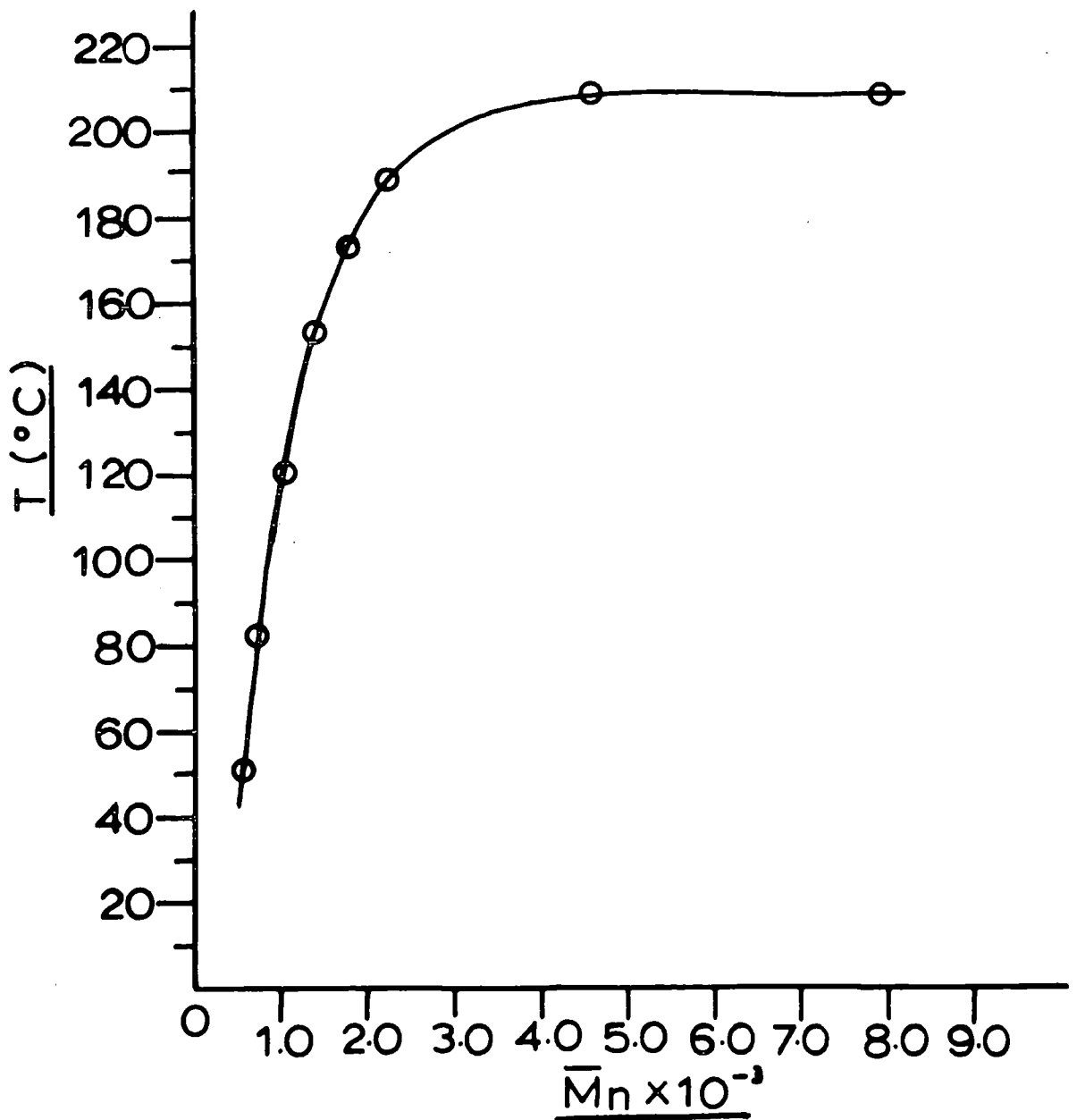
FIGURE 4.6Melting Point (T)<sup>a</sup> - Molecular Weight for PolyFM

Note a) Determined as temperature at which polymer samples first softened on heating in melting point capillaries.

showed no C=O stretch, and within the 1200-900  $\text{cm}^{-1}$  region, strong or medium strength absorptions at 1080, 1020, 990, 960, 940, 935 and 910  $\text{cm}^{-1}$ . There was a fairly close resemblance between this spectrum and those of the 1:1 adduct (63) and furan-diketone 2:1 adducts, with slight differences in frequencies of bands in the 1100-900  $\text{cm}^{-1}$  region. Bands at 730  $\text{cm}^{-1}$  and 1130  $\text{cm}^{-1}$  in the spectrum of the benzophenone-furan 1:1 adduct were noticeably absent in the spectrum of the higher melting 2:1 adduct.

An infrared spectrum of the crude mixture from the irradiation of benzophenone and furan in benzene (containing both (65) and (66)) was very similar to the spectrum of the 2:1 adduct described above, apart from a slight residual C=O stretch at ca. 1660  $\text{cm}^{-1}$ .

#### (b) Infrared Spectra of Polymers

Infrared spectra of typical samples of individual furan-diketone polymers are recorded in Appendix C.

With the exception of polyFP, the infrared spectra indicated little or no residual carbonyl group. Extremely broad absorptions in the 1050-900  $\text{cm}^{-1}$  region could be observed with particular peaks frequently visible at 1020, 1000, 975, 945, 925 and 900  $\text{cm}^{-1}$ . The overall merging of these absorptions, which are individually characteristic of the model compounds, to the extremely broad absorption observed is to be expected in polymers containing structural units of the type (83).

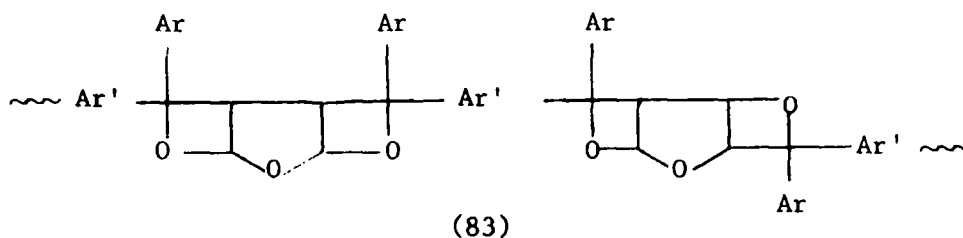

A strong absorption at  $1140\text{ cm}^{-1}$  in the spectra of the benzophenone-furan 1:1 adduct (63) and the furan-diketone 2:1 adducts was absent in the spectra of the polymers and benzophenone-furan 2:1 adducts.

The infrared spectra of the polymers, however, also showed a weak to medium strength, broad absorption centred at  $\text{ca. } 3550\text{ cm}^{-1}$  and suggestive of the presence of OH grouping in the polymer. Checks on KBr blanks showed that these absorptions were not ascribable to dampness in the KBr used for preparing discs.

A weak absorption at  $1730\text{ cm}^{-1}$  was also observed in the infrared spectra of some of the polymers, particularly after storage of polymer samples for a few months at room temperature (see section 4.24). The  $1730\text{ cm}^{-1}$  absorption was particularly noticeable with polyFP, even when its infrared spectrum was recorded immediately after its preparation.

### (c) N.m.r Spectra of Polymers

A 220 MHz spectrum of polyFM showed a complex series of resonances between  $\delta 6.15$  and  $\delta 3.1$  in addition to aromatic absorptions between  $\delta 7.8$  and  $\delta 6.8$ . Overall aromatic to aliphatic integration was satisfactory for photoaddition between *m*-dibenzoylbenzene and diFM.

The n.m.r. spectrum in the  $\delta 6.15$ - $3.1$  region was resolved, using a Dupont 310 Curve Resolver, into ten peaks, the resolved spectrum being shown in Figure 4.7.

Evanega and Whipple<sup>267</sup> reported yields of ca.29% and 18% for the benzophenone-furan 2:1 adducts (66) and (65) respectively. The n.m.r. spectra of these adducts have already been discussed, absorptions occurring at  $\delta 3.70$  and  $\delta 5.94$  for (66) and at  $\delta 4.27$ ,  $4.98$ ,  $5.31$  and  $5.92$

FIGURE 4.7

N.m.r. spectrum of PolyFM

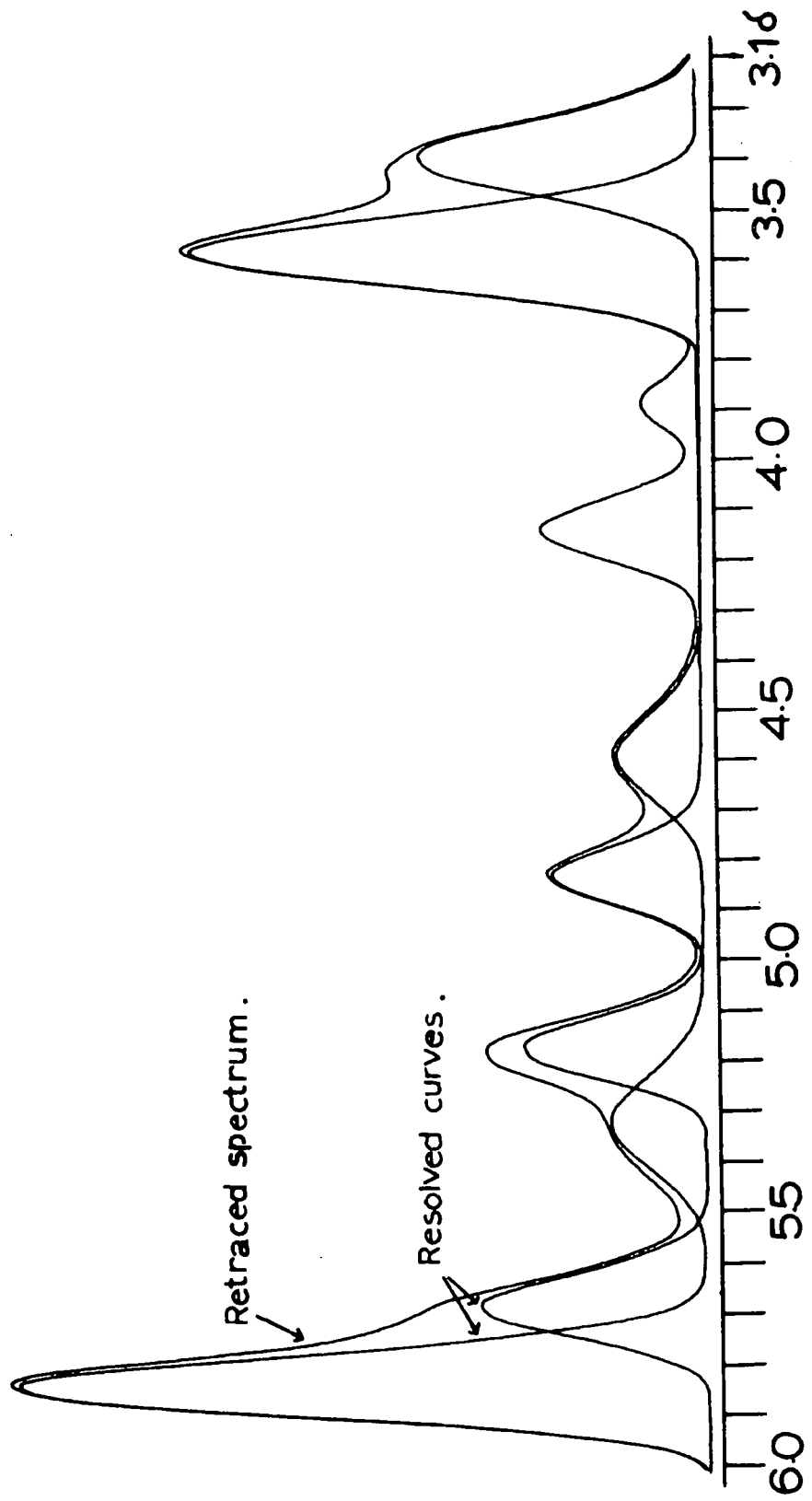

for (65). THF residue protons from corresponding structural units in polyFM should be expected to give rise to absorptions at approximately the same chemical shifts, as shown below.

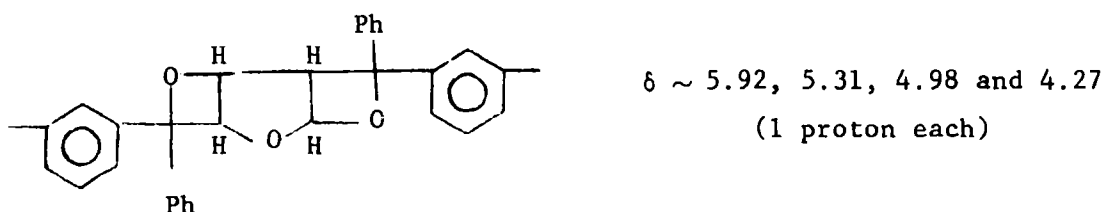
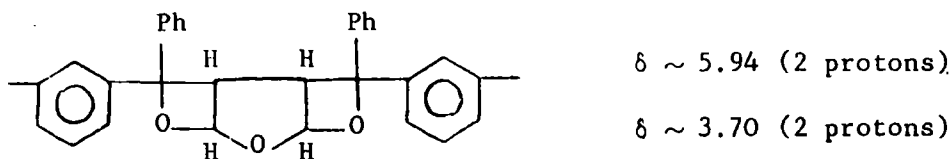

If these structural units were in the polymer in the approximate ratio (ca.3:2) in which adducts (66) and (65) were obtained, then areas under peaks at  $\sim 5.94, 5.92, 5.31, 4.98, 4.27,$  and  $3.70$  should be in the approximate ratio 3:1:1:1:1:3 respectively.

In the resolved n.m.r. spectrum, peaks are observed at ca.  $5.85, 5.65, 5.35, 5.15, 4.85, 4.6, 4.15, 3.9, 3.65,$  and  $3.25,$  corresponding relative areas under the curves being 28, 9, 5, 7, 5, 4, 5, 1, 21 and 12 respectively. The peaks at  $5.85, 5.35, 4.85$  (or  $5.15$ ),  $4.15$  and  $3.65$  compare favourably in chemical shift and intensity with the values deduced above for polyFM and based on analogy with the benzophenone-furan photoaddition reaction.

This approach involves obvious limitations in assumption of the same chemical shifts for the structural units in the polymer in the ratio 3:2

(yields for (65) and (66) were reported after recrystallization<sup>267</sup>), leaves unassigned resolved absorptions (corresponding to ca.30% of the total area under the resolved spectrum) particularly at  $\delta$ 5.65 and  $\delta$ 3.25, and the actual curve resolution process involves some approximation. However, it does provide an approach towards partial interpretation of such a complex n.m.r. pattern for the polymer and is good evidence for the presence of the postulated structural units. Additional structural units are to be expected with the significant indication, from infrared spectroscopy, of the presence of OH groups in the polymer.

A 90 MHz n.m.r. spectrum of polyF10 showed similar general features to that of polyFM, with additional absorptions from methylene chain protons, but was generally too poorly resolved for detailed analysis. Major absorptions could be observed at  $\delta$ 7.5-6.9,  $\delta$ 6.5-3.0 (with particularly prominent absorptions at ca.  $\delta$ 5.9 and 3.6) and  $\delta$ 1.8.

N.m.r. spectra of other polymers, obtained at 60 MHz were generally only sufficiently resolved to see aromatic protons clearly at the low polymer concentrations employed.

#### 4.21 Growth Characteristics of PolyFM

As with polymerization of polyTMA1, the growth of polyFM with time was studied by irradiation at 350 nm, under identical conditions, of benzene solutions of m-dibenzoylbenzene and diFM (0.01746M in each monomer) for varying lengths of time. The number average molecular weights of the resulting crude polymers are plotted as a function of time in Figure 4.8.

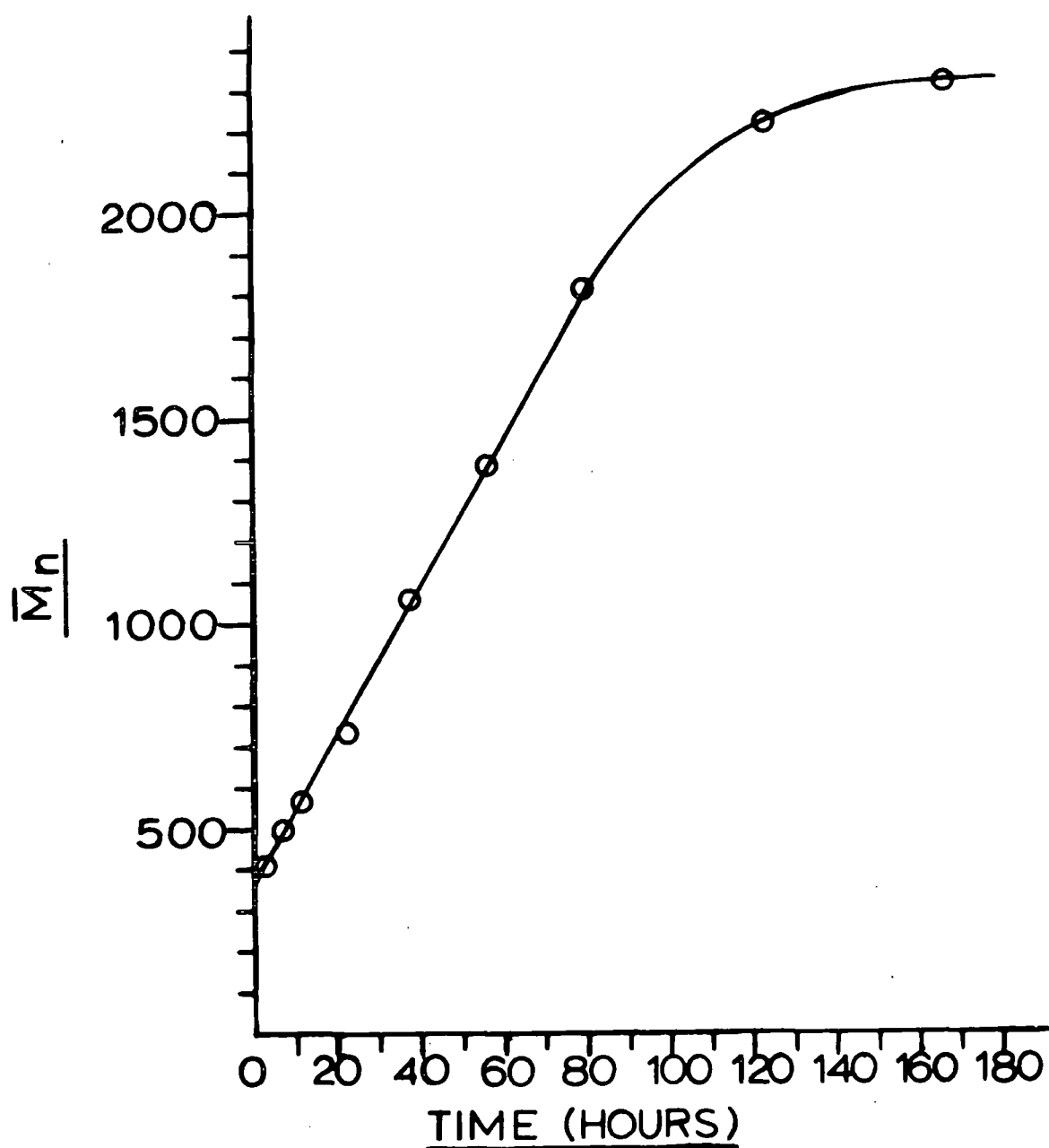
FIGURE 4.8Molecular Weight - Irradiation Time for PolyFM<sup>a</sup>

Note a) 0.0175M solutions of m-dibenzoylbenzene and diFM in benzene irradiated in RPR-208 Reactor.

Reaction occurred slowly, an irradiation time in excess of 100 hours being necessary to approach a plateau molecular weight of ca.2300 under the conditions employed. Prolonged irradiation for 500 hours under the same conditions produced a crude polymer of molecular weight ca.2600.

Reaction appeared to follow second order kinetics there being a linear increase in molecular weight (and hence  $\overline{D.P.}$ ) with time until the plateau molecular weight was approached.

The complications inherent in a full kinetic treatment of the reaction are generally analogous to those enumerated for the growth of polyTMA1. However, the initial addition of carbonyl group to the first C=C double bond of furan being accomplished in the preparation of diFM, only the non-stereospecific consumption of the second furan double bond would have to be considered in relation to the polymer growth mechanism.

Monitoring of the polymer growth by thin layer chromatography also indicated the slowness of the reaction, materials of  $R_f$  values corresponding to starting materials still being present in the reaction mixture after irradiation for 62 hours.

Polymer growth was also followed by infrared spectroscopy. Spectra of polymers obtained at the various stages of reaction are reproduced in Figure 4.9. Consumption of the carbonyl group ( $1665\text{ cm}^{-1}$ ) and development of the broad ca.1150-900  $\text{cm}^{-1}$  absorption is clearly demonstrated. At the plateau molecular weight of ca.2300, residual C=O group is detectable in the spectrum of the polymer.

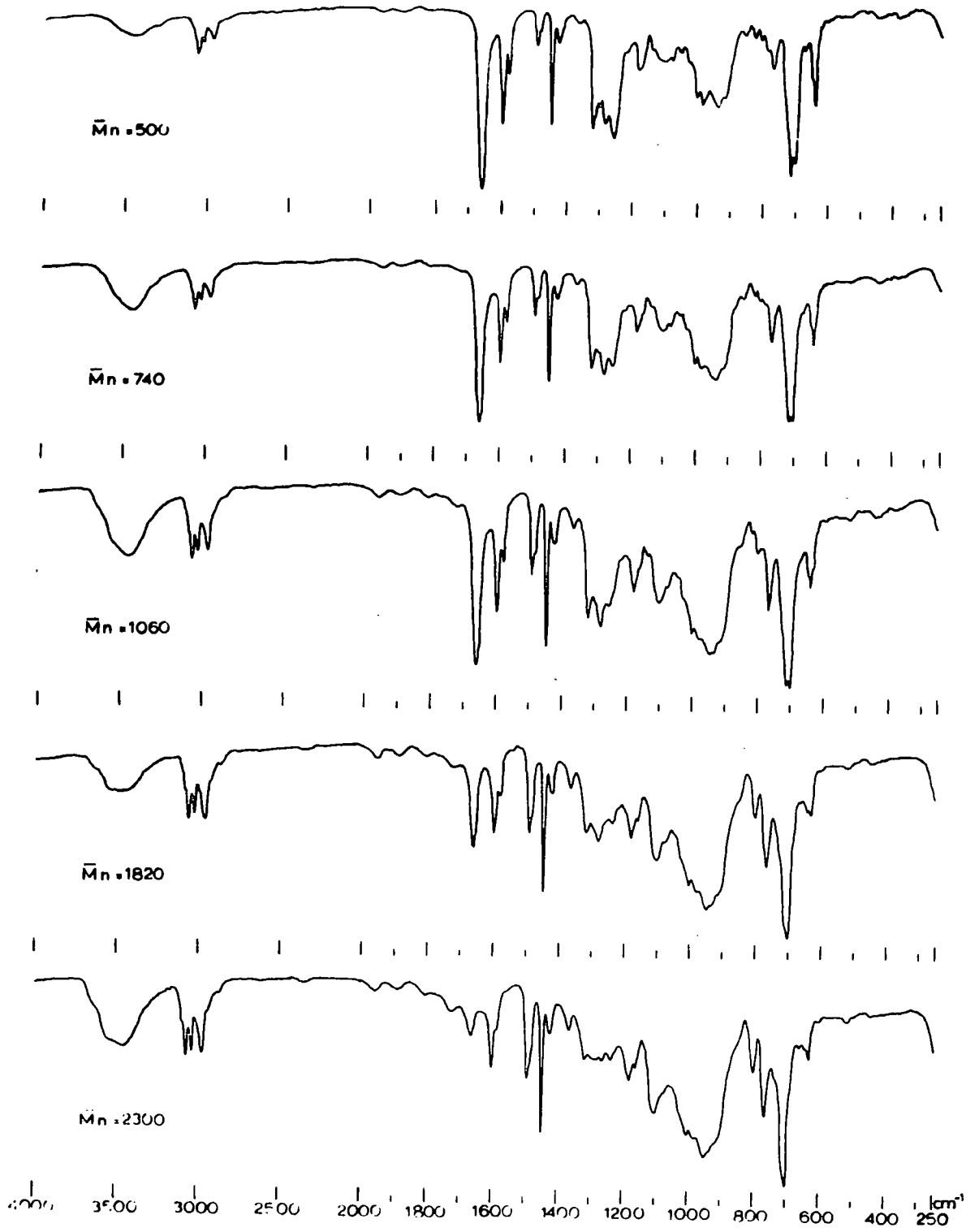

FIGURE 4.9

Infrared Spectra of Differing Molecular Weight Samples  
of PolyFM

#### 4.22 Effect of Concentration on Polymer Molecular Weight

Although a detailed study of the effect of concentration on plateau molecular weight of a furan-diketone polymer was not performed, the maximum molecular weight of ca.2600 for polyFM attained with an initial monomer concentration of 0.01746M may be compared with the molecular weight for crude polyFM of ca.4800 obtained with an initial monomer concentration of 0.08456M. Thus, as with the tetramethylallene-diketone polymerizations, increasing the initial monomer concentration appeared to increase the plateau molecular weight of the polymer.

Reirradiation of polyF10 (initially prepared at a concentration of 9.264 g/l) at an increased concentration of 15.33 g/l raised the molecular weight of crude polymer from 2500 to 2900.

#### 4.23 Thermal Stability of Furan-Diketone Polymers

A sample of polyF1 stored for 9 months at room temperature showed new medium-weak infrared absorption bands at  $1730\text{ cm}^{-1}$  and  $1660\text{ cm}^{-1}$ .

##### (a) Pyrolysis of Polymers

###### (i) PolyFM

Heating of a sample of polyFM (molecular weight 8000) for 2 hours at a temperature of  $245\text{-}250^{\circ}\text{C}$  and pressure of  $\text{ca.}10^{-3}\text{ mm.Hg}$  yielded furan as virtually the only volatile material. The furan collected was equivalent to ca.35% of possible furan residues in the polymer. The residual non volatile material consisted of orange-yellow viscous matter around the neck of the pyrolysis flask, identified by infrared spectroscopy as essentially m-dibenzoylbenzene, and a black residue. The latter showed a strong C=O stretch and largely weakened

absorptions in the 1100-900  $\text{cm}^{-1}$  region characteristic of the original polymer. This data was consistent with cleavage of oxetane rings in the main polymer chain and analogous to the aforementioned pyrolytic cleavage of oxetanes to olefins and carbonyl compounds.

(ii) PolyF1

Samples of polyF1 were heated for 2 hours at temperatures of 100-120 $^{\circ}$ , 200 $^{\circ}$  and 270 $^{\circ}$ C (and a pressure of ca.  $10^{-3}$  mm.Hg) Sample size was too small to yield characterizable amounts of volatile material.

Infrared spectra on residues from the polymer samples after heating showed, at selected wavelengths, the features given below in Table 4.7.

TABLE 4.7

Infrared Data on Residues from Pyrolysis of PolyF1

Temperature of Heating ( $^{\circ}$ C)	Intensity of Absorptions at Selected Wavelengths					
	$\sim 3500$ $\text{cm}^{-1}$	1730 $\text{cm}^{-1}$	1660 $\text{cm}^{-1}$	1280 $\text{cm}^{-1}$	1140 $\text{cm}^{-1}$	1100-900 $\text{cm}^{-1}$
100-120	w/m	w	w	w	w	s
200	w	s	s	s	m/s	little absorption
270	-	w	s	s	-	little absorption

The infrared spectrum of the residue obtained from heating polyF1 at 270 $^{\circ}$ C corresponded essentially to that of diketone, comparable with results from the pyrolysis of polyFM

#### (b) Thermogravimetric Analysis

Typical thermogravimetric analyses (for polyFM and polyF6 in nitrogen and static air) are recorded in Appendix D. As with polymers from TMA as diene, two step curves resulted from heating in air and single step curves from heating in nitrogen. Major weight loss occurred in the 250-450°C region. For polymers derived from 4,4'-dibenzoyldiphenylalkanes, 50% weight loss occurred at temperatures of between ca.320 and 450°C, but threshold temperatures of decomposition and temperatures corresponding to 50% weight loss were not always lower for analyses of corresponding polymers in atmospheres of air compared to atmospheres of nitrogen.

To obtain information on the dependence of thermal stability on molecular weight, five samples of polyFM (molecular weights: 500, 740, 1050, 1820 and 4600) were analysed in static air - for general conditions see Appendix D. The thermograms are shown in Figure 4.10. A general trend of increasing thermal stability with increasing molecular weight was apparent, being most noticeable in the 300-600°C temperature region. The polymer sample of molecular weight 500 was substantially less stable than the sample of molecular weight 740.

#### 4.24 Further Comment on the Stability of Furan-Diketone Polymers and Adducts

Particularly noticeable in the spectrum of the residue from pyrolysis of polyF1 at 200°C was a strong absorption at 1730 cm<sup>-1</sup>. Weak absorptions at this wavelength in the infrared spectra of samples of furan-diketone 2:1 adducts stored for several months have already been

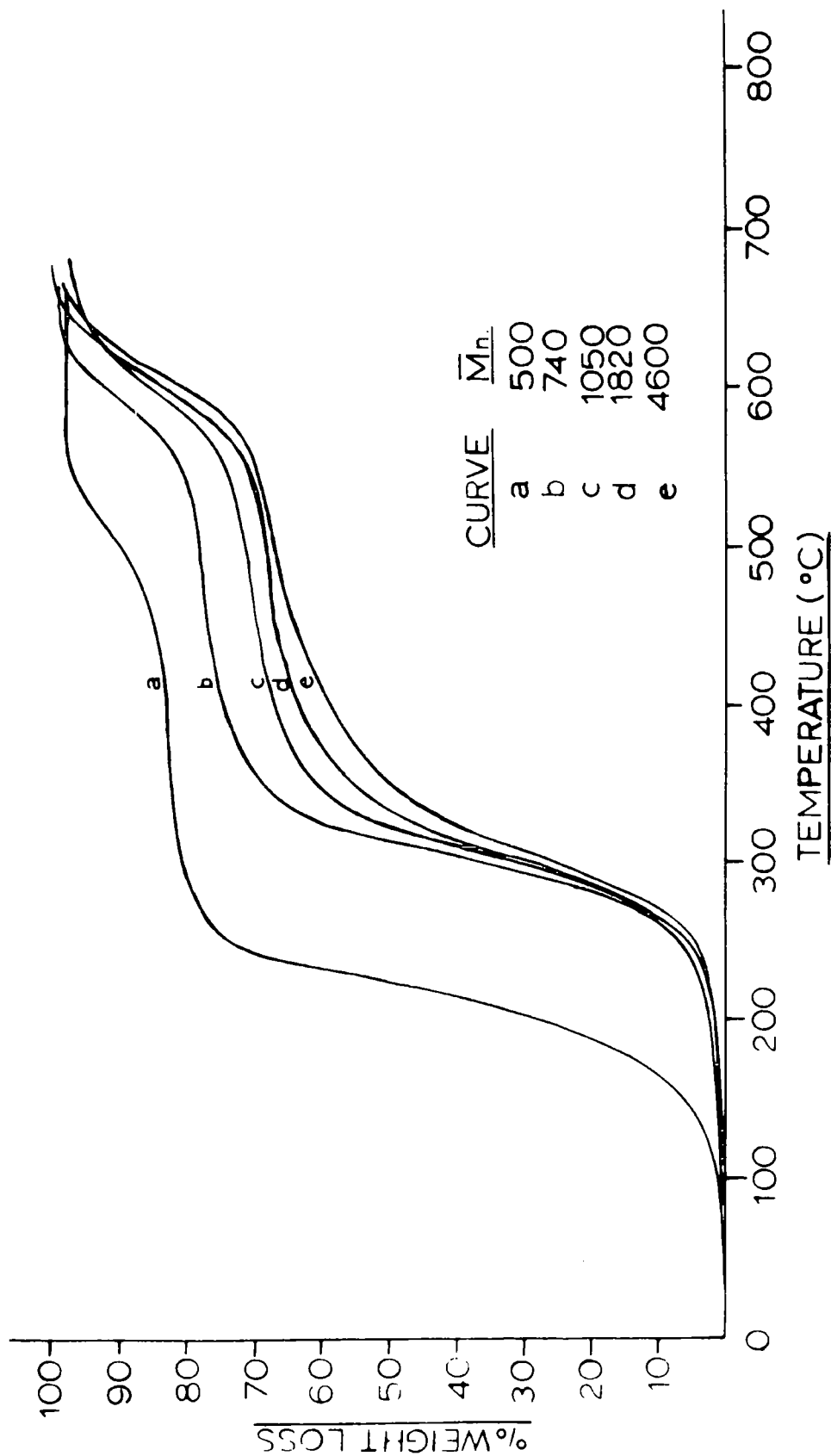
FIGURE 4.10Thermograms for Differing Molecular Weight Samples of PolyFM

remarked on, as have similar weak absorptions in some furan polymers, particularly after polymer storage. A strong absorption at ca.  $1730\text{ cm}^{-1}$  was also apparent in the infrared spectrum of the product from irradiation of 4,4'-dibenzoyldiphenyl ether in furan.

A sample of diFl heated at  $130\text{--}150^{\circ}\text{C}$  for 5 hours at a pressure of ca.  $10^{-3}$  mm.Hg also showed a strong absorption at  $1730\text{ cm}^{-1}$  together with strong absorption at  $1140\text{ cm}^{-1}$ .

A rationalization of the appearance of the absorptions at  $1730\text{ cm}^{-1}$  thus appeared to be a thermal effect causing some decomposition or rearrangement reaction, and greatly enhanced by heating at temperatures in the range ca.  $130\text{--}200^{\circ}\text{C}$ .

An absorption at  $1730\text{ cm}^{-1}$  is typically characteristic of an aliphatic carbonyl compound, although C=C double bond frequencies may be raised to this region as in the case of the exocyclic C=C double bond observed in tetramethylallene-diketone polymers.

Some possible decomposition paths are indicated below although the source of the  $1730\text{ cm}^{-1}$  absorption has not been positively identified.

2,3-Dihydrofurans are known to undergo thermal<sup>278,279</sup> and photochemical<sup>280</sup> rearrangement to cyclopropyl carbonyl compounds. Thus 2,3-dihydrofuran itself gives<sup>279</sup> some cyclopropane aldehyde at  $375^{\circ}\text{C}$  and 2-methyl-4,5-dihydrofuran is isomerizable<sup>278</sup> to methyl cyclopropyl ketone, ring fission occurring at the 1,5 bond (eq.4.12).

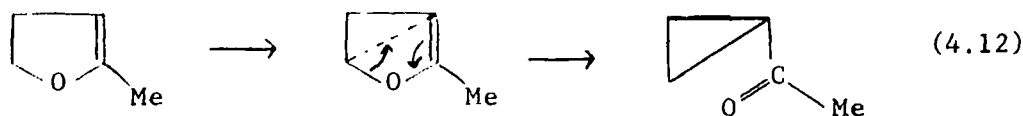



However the carbonyl group in lactones of the type (89) is reported to absorb in the  $1800\text{ cm}^{-1}$  region.<sup>281</sup>

In addition to cleavage of oxetane rings in the polymer chains or in 2:1 adducts, giving furan and aromatic carbonyl, the alternative oxetane cleavage could be postulated, as exemplified by equation 4.16.

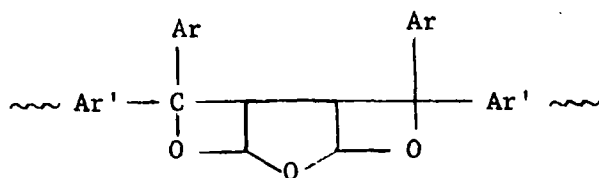

(4.16)

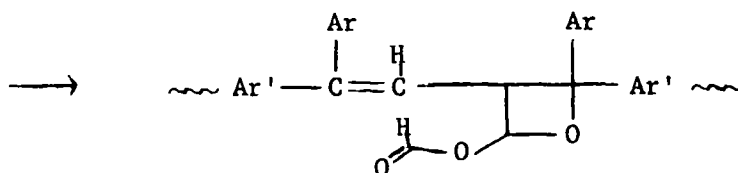

Evanega and Whipple<sup>267</sup> have reported the thermal instability of the 'symmetrical' benzophenone-furan 2:1 adduct (66), sublimation giving a 43% yield of 1,1,4,4-tetraphenylbutadiene. 1,1,4,4-Tetraphenylbutadiene shows no infrared absorption between  $1780$  and  $1620\text{ cm}^{-1}$ , and no evidence for the presence of a corresponding link unit in furan-diketone polymers has been obtained.

Cleavage in the 2:1 adducts, corresponding to that shown for the polymer in eq.4.16 would give a structure of the type (90).

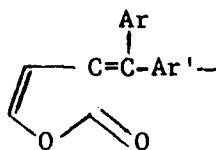

(90)

However, compounds of the type CO-O-C=C- show a marked increase in carbonyl frequency, regardless of whether the double bond is normal or part of an aromatic ring.<sup>282</sup> 'Autooxidation' reactions of oxetanes,<sup>256</sup> tetrahydrofurans, and furans are well known.

For example, 2-oxaspiro[3.2]hexane undergoes<sup>283</sup> autooxidation and polymerization according to the equation (4.17).

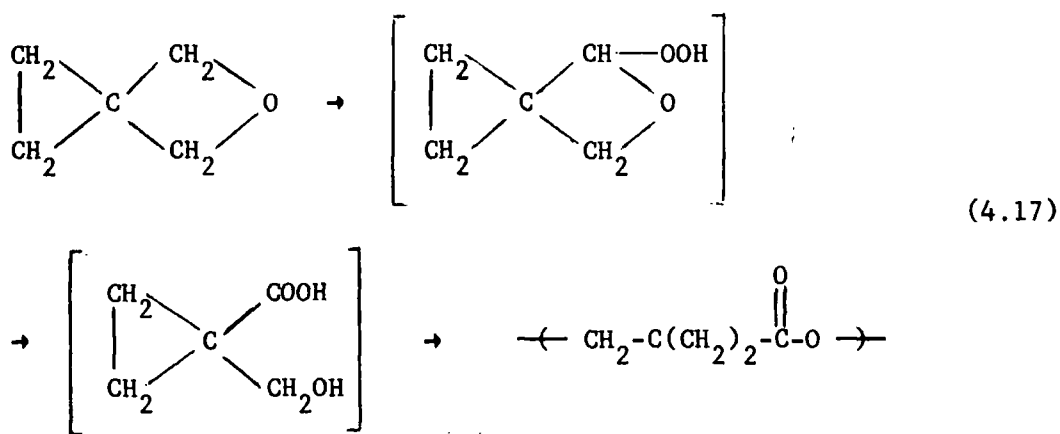

THF undergoes oxidation on prolonged exposure to air during storage, the hydroperoxide undergoing thermal decomposition to  $\gamma$ -butyrolactone (eq.4.18).<sup>284</sup>

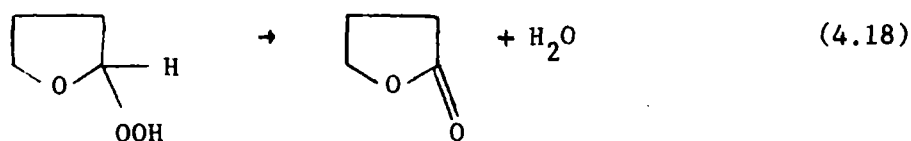

Autooxidation of 2-phenyloxetane is reported to give a product that is a low polymer with carbonyl absorptions characteristic of a phenyl ketone.<sup>256</sup> The most easily abstractable hydrogen here is tertiary hydrogen.

Similar autooxidation reactions may be postulated for the furan-diketone polymers and 2:1 adducts, for example as shown in reaction scheme (4.19).

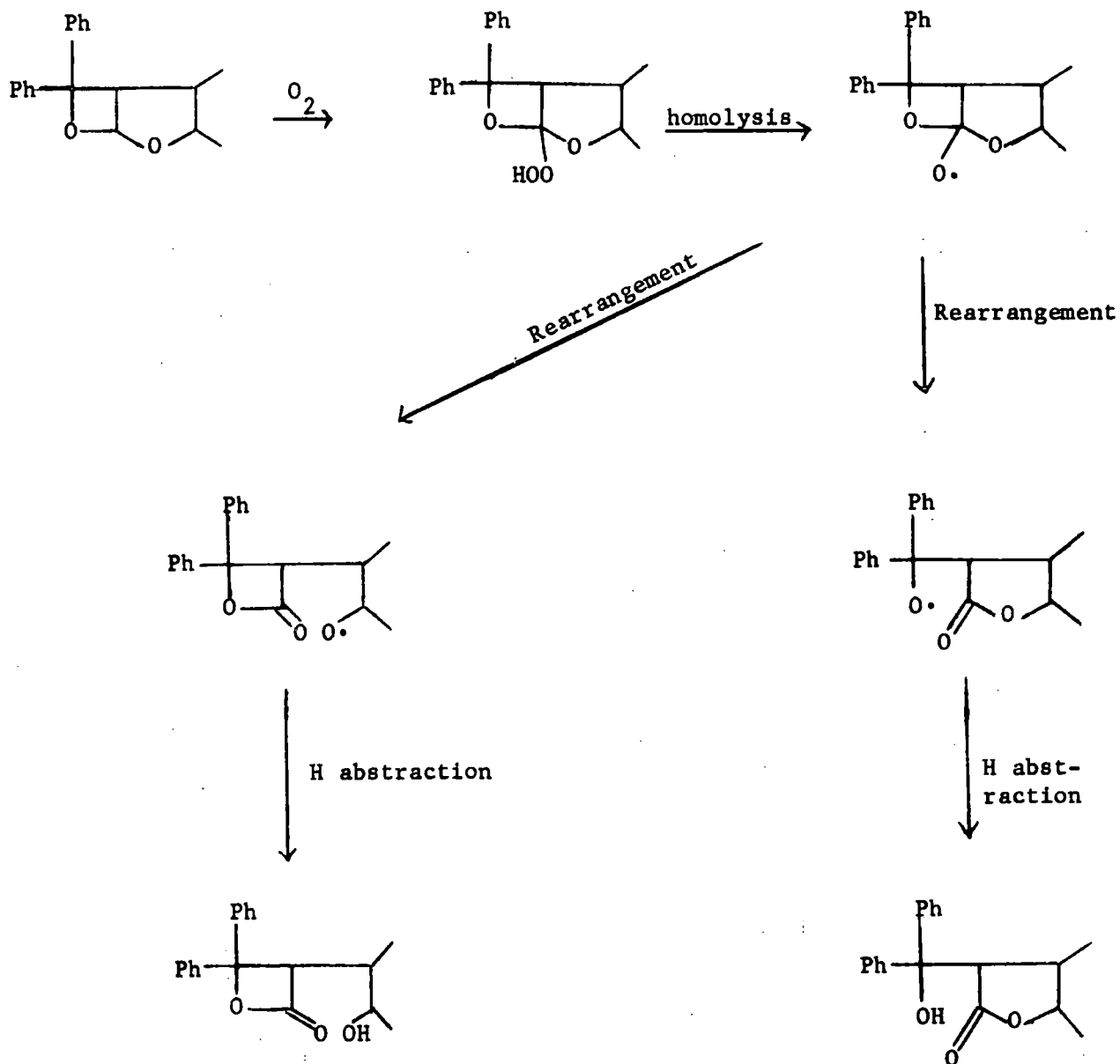

Reaction Scheme (4.19)

The substantial recovery of furan, and the strong aromatic carbonyl absorption in the residue, from pyrolysis of polyFM indicate a considerable amount of cleavage as a reversal of the cycloaddition reaction forming the oxetane ring.

#### 4.25 Preparation of Furan-Diketone Polymers Derived from Two Diketones

De Schryver has pointed out that step-growth photopolymerization can provide a good method of preparing alternating copolymers.<sup>69</sup> The proposed structures for the polymers from furan and diketones, so far described, contain alternate furan and diketone residues. The copolymerization technique should be further extendable to reaction between a diketone and a furan-diketone 2:1 adduct derived from a second diketone (eq.4.20).

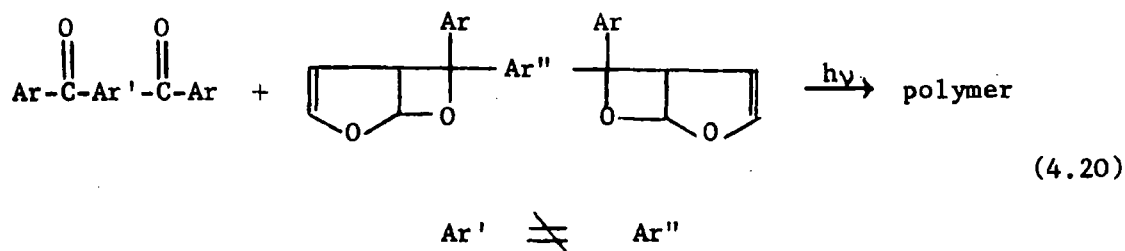

Such polymerizations are of interest since diketones, such as p-dibenzoylbenzene, that did not photopolymerize very efficiently with furan-diketone 2:1 adduct might photopolymerize efficiently when photo-reacted, in the form of furan-diketone 2:1 adduct, with another readily photopolymerizable diketone. Properties of polymers from such photopolymerizations could also be compared with the properties of the polymers containing the individual diketone and furan residues.

Thus photoreaction between 1,6-(4,4'-dibenzoyldiphenyl)hexane and diFM in benzene solvent yielded a pale yellow polymer in quantitative yield for photoaddition. The temperature of onset of melting of the precipitated polymer was 190°C, intermediate between that of polyFM (209°C) and polyF6 (180°C). The infrared spectrum of the polymer (Appendix C) showed a weak residual C=O stretch (1660 cm<sup>-1</sup>), and was in general agreement with those of other furan-diketone polymer spectra. Elemental analysis was satisfactory.

Irradiation at 350 nm of dilute benzene solutions of diFM with p-dibenzoylbenzene, and the corresponding irradiation of diFP with m-dibenzoylbenzene under identical conditions produced polymers of differing  $\overline{D.P.}$  Elemental analyses for both polymers were satisfactory. Molecular weight and 'melting point' data is shown for the two polymers in Table 4.8.

TABLE 4.8  
Photopolymerization of m-Dibenzoylbenzene with DiFP and  
of p-Dibenzoylbenzene with DiFM

Monomers		Polymers <sup>a</sup>			
2:1 Adduct	Diketone	Molecular Weight		'Melting point' <sup>b</sup>	
		Crude	Precipitated <sup>c</sup>	Crude	Precipitated <sup>c</sup>
DiFP	m-Dibenzoylbenzene	1410	2240	156	163
DiFM	p-Dibenzoylbenzene	990	1570	110	147

Notes a) Prepared as recorded in Table 4.15  
 b) Determined in melting point capillaries by development of tackiness  
 c) Under identical conditions.

Infrared spectra of the two polymers were almost identical, but the higher molecular weight polymer showed the stronger 'oxetane' absorptions in the 1100-900  $\text{cm}^{-1}$  region. Both polymers exhibited a band at 1730  $\text{cm}^{-1}$  in their spectra.

The higher molecular weight of the polymer from m-dibenzoylbenzene as diketone was consistent with the higher efficiency of m-dibenzoylbenzene compared to p-dibenzoylbenzene in all photopolymerizations discussed in this chapter.

#### 4.26 Studies with 2,5-Dimethylfuran as Diene

Photopolymerization of diketones with 2,5-dimethylfuran was undertaken partially with the aim of extending the scope of the photopolymerizations, and also to yield information on the source of OH grouping (as indicated by infrared spectroscopy) in, and the cause of reduced solubility of, polymers from furan (see section 4.27).

##### (a) Irradiation of 4,4'-Dibenzoyldiphenylmethane in 2,5-Dimethylfuran

Irradiation of 4,4'-dibenzoyldiphenylmethane in 2,5-dimethylfuran at 350 nm yielded, on removal of excess diene, a mixture of at least four components as determined by thin layer chromatography. An infrared spectrum of the crude irradiation products showed a strong residual carbonyl peak, a broad, weak absorption centred at ca. 3500  $\text{cm}^{-1}$ , a weak-medium strength peak at 1710  $\text{cm}^{-1}$  and several peaks in the 1100-900  $\text{cm}^{-1}$  region equivalent to corresponding peaks in furan adducts. No attempt was made to separate the crude product mixture. 2,5-Dimethylfuran was sufficiently involatile to attempt direct photopolymerization with diketone in a manner analogous to preparation of TMA-diketone polymers.

(b) Polymerizations with 2,5-Dimethylfuran as Diene

Irradiation at 350 nm of benzene solutions containing equimolar quantities of *m*-dibenzoylbenzene and 2,5-dimethylfuran and of 1,4-(4,4'-dibenzoyldiphenyl)butane and 2,5-dimethylfuran yielded clear solutions of polymers isolated by freeze drying and precipitated as for furan polymers. Elemental analyses were in good agreement with values required for photoaddition between diene and diketone yielding polymer, and yields were quantitative for such photoaddition. Molecular weight and 'melting point' data is given in Table 4.9.

TABLE 4.9Photopolymerization of Aromatic Diketones with 2,5-Dimethylfuran

Diketones	Polymers <sup>a</sup>		
	Molecular Weight ( $\bar{D.P.}$ )		'Melting Point' <sup>b</sup> (°C)
	Crude	Precipitated	
<i>m</i> -Dibenzoylbenzene	2400 (6.3)	3000 (7.8)	158
1,4-(4,4'-Dibenzoyldiphenyl)butane	4000 (7.8)	6700 (13.0)	155
Notes a) Prepared as recorded in Table 4.16			
b) Determined for precipitated polymers by development of tackiness			

In contrast to furan polymers, good brittle fibres could be drawn from the melt. Infrared spectra of the polymers (Appendix C) showed the general characteristics of the furan polymers, but both 2,5-dimethylfuran-diketone polymers showed strengthened absorptions at ca. 3550  $\text{cm}^{-1}$  and medium strength absorptions at 1700  $\text{cm}^{-1}$ . These features may be analogous to those in polymers from TMA with hydrogen abstraction from

methyl groups causing reactions of the type (4.21).

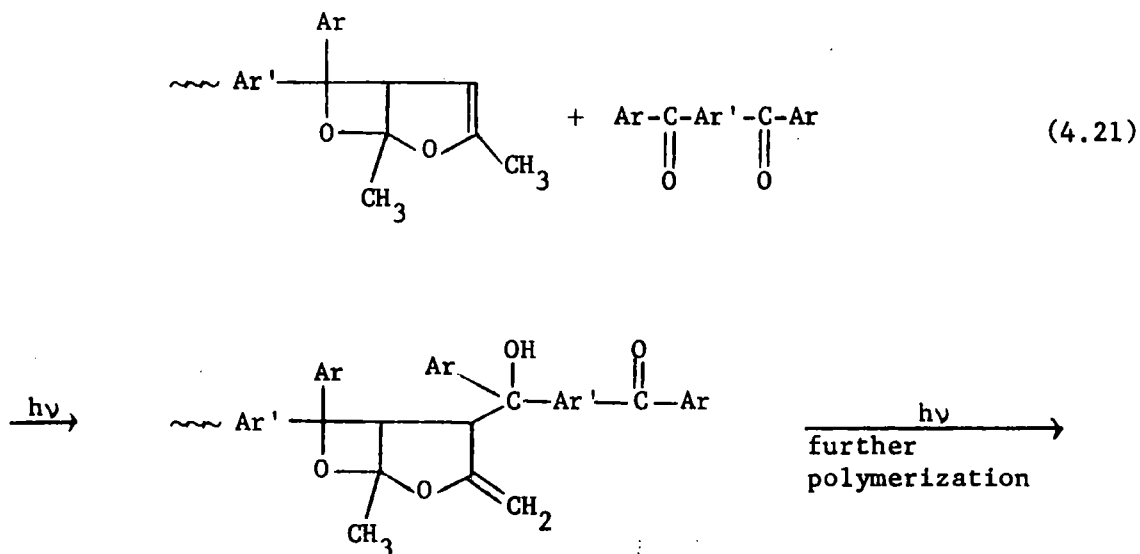

The  $1700 \text{ cm}^{-1}$  absorption could thus be assignable to a C=C double bond exocyclic to a five membered ring and at lower frequency than the analogous C=C double bonds exocyclic to four membered rings in TMA-diketone polymers.

The lower molecular weight *m*-dibenzoylbenzene-2,5-dimethylfuran polymer showed considerable residual C=O stretch in its infrared spectrum.

However, in view of the reasonable polymer obtained from 2,5-dimethylfuran and 1,4-(4,4'-dibenzoyldiphenyl)butane, with almost complete consumption of carbonyl group, it is surprising that more complete consumption of carbonyl group did not occur in the irradiation of 4,4'-dibenzoyldiphenylmethane in 2,5-dimethylfuran. The 2,5-dimethylfuran used was of 'practical grade' purified by distillation. Possibly some quenching effect due to the presence of unremoved or introduced impurities was operating during the latter irradiation. Overall yields of oxetanes

from benzophenone and 2,5-dimethylfuran are reported<sup>109</sup> to be only in the 70% region compared to the virtually quantitative yields with furan. Since polymers could be obtained directly in a one stage reaction between diketone and 2,5-dimethylfuran, and chromatographic evidence together with postulated hydrogen abstraction reactions rendered quantitative formation of 2,5-dimethylfuran-diketone 2:1 adducts unlikely, the irradiation in excess 2,5-dimethylfuran was not repeated.

Thermograms of the two polymers from 2,5-dimethylfuran as diene are recorded in Appendix D. Weight loss commenced at lower temperatures (ca. 100°C) than with polymers from furan as diene. Thermograms were two step curves with the exception of the one for the polymer from m-dibenzoylbenzene and 2,5-dimethylfuran in a nitrogen atmosphere, which was a single step curve, more than 10% by weight of sample remaining as a charred residue at the end of the analysis.

#### 4.27 Possible Competing Reactions in the Photopolymerization of Furan-Diketone 2:1 Adducts with Diketones

Although polymers were successfully obtained from 2:1 adducts and diketones the spectroscopic data on the polymers was inconsistent with the only reaction occurring during irradiation being cycloaddition with oxetane formation. Infrared spectra, particularly of polymers from 4,4'-dibenzoyldiphenylalkanes, were indicative of the presence of OH groups. Solubilities of the polymers, compared to generally high solubility of the 2:1 adducts used and the high solubility of tetramethylallene polymers, and also the melting characteristics of the furan polymers were suggestive of some occurrence of branching and/or cross-linking during the polymerization process.

Several possibilities exist for the rationalization of these phenomena including:

- 1) Reaction with benzene solvent
- 2) Hydrogen abstraction from reactive methylene groups during polymerizations involving relevant ketones.
- 3) Hydrogen abstraction from furan residues in 2:1 adducts or growing polymer.

Interaction of benzophenone triplets with benzene solvent has already been discussed in Chapter 2, diphenyl and benzopinacol being detectable as the major products. A similar reaction is equally likely between diketones studied here and the benzene solvent. Irradiation of *m*-dibenzoylbenzene in benzene at 350 nm and subsequent removal of benzene yielded a solid which, although substantially *m*-dibenzoylbenzene, and highly soluble in benzene, contained a second component (observed by thin layer chromatography) and gave a just detectable OH absorption around  $3500\text{ cm}^{-1}$  in its infrared spectrum.

The possibility of any hydrogen abstractions from benzene could be eliminated by use of a non-abstractable perfluorinated solvent such as perfluoromethylcyclohexane or perfluorodimethylcyclobutane. However the diketones were too insoluble in these solvents to allow such an investigation.

The photoaddition between benzophenone and diphenylmethane, involving hydrogen abstraction from the methylene group, has been discussed in Chapter 2. Such a reaction occurring in the polymerization process could provide one rationalization of the presence of OH groups

and the occurrence of branching in polymers incorporating methylene chains. Such reaction may be represented by equation (4.22).

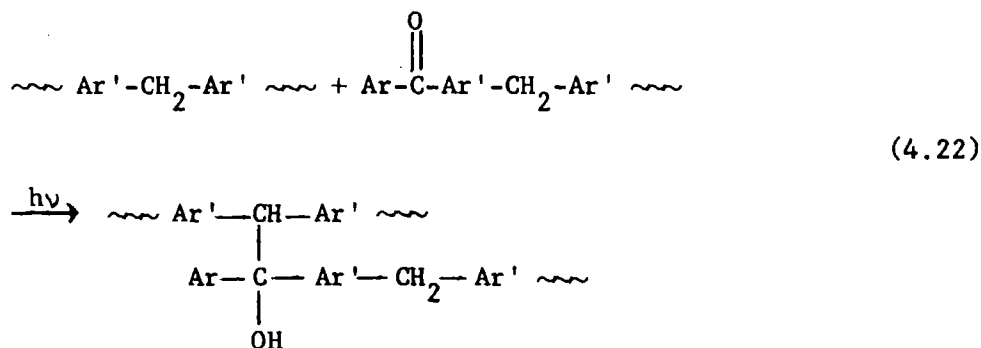

Irradiation of 4,4'-dibenzoyldiphenylmethane in benzene at 350 nm resulted in a small degree of photoreaction with the presence of OH groups indicated by a weak, broad absorption centred at ca. 3500  $\text{cm}^{-1}$  in the infrared spectrum. With an additional weak absorption at 1500  $\text{cm}^{-1}$ , new absorptions were comparable with corresponding absorptions in the polypinacol from the same diketone (section 4.29). The presence of a small quantity of material insoluble in benzene, after the irradiation, suggested that the material was not just linear polypinacol. Possible interaction with benzene solvent has already been indicated but the irradiations of *m*-dibenzoylbenzene and 4,4'-dibenzoyldiphenylmethane in benzene produced materials with fundamentally different solubilities.

Difficulties resulting from abstraction of oxetane hydrogens by the carbonyl  $n, \pi^*$  triplet have also been pointed out in Chapter 2. In general, free radical reactions of cyclic ethers are well known,  $\alpha$ -hydrogens undergoing reaction most readily and the ease of formation of free radicals from various cyclic ethers has been investigated.<sup>285</sup>

A specific example of a photoreduction involving hydrogen  $\alpha$  to ether oxygen is the photoreduction of benzophenone in methyl 2-octyl ether, which proceeds at a rate ca.0.17 times that of photoreduction in isopropanol.<sup>207</sup>

Thus another feasible reaction accounting for the experimental observations is abstraction of such  $\alpha$ -hydrogens in competition with the cycloaddition, an example of such abstraction being representable by equation (4.23).

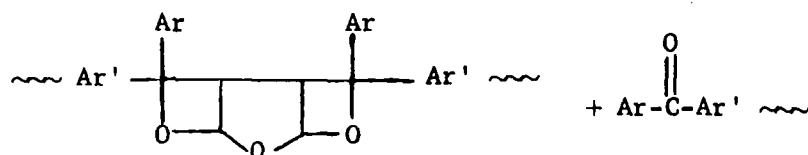

(4.23)

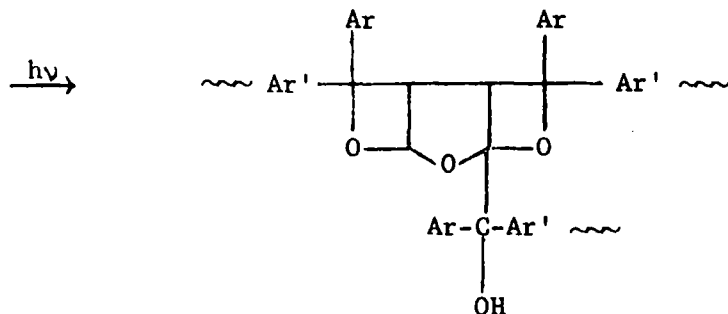

Equivalent branching reactions are not possible with TMA as diene.

As pointed out earlier, 2,5-dimethylfuran was studied as an alternative diene to furan partially to yield information on the source of OH grouping in diketone-furan polymers and the cause of reduced solubility of such polymers. Although the methyl hydrogens of 2,5-dimethylfuran appeared to be abstractable, such abstractions, as with TMA

as diene, could still lead to growth of linear polymers, whereas abstractions of hydrogen  $\alpha$  to furan oxygen (such hydrogens not being present in 2,5-dimethylfuran) could lead to the formation of non-linear polymers of lower solubility. The complete solubility in benzene of the polymer from 1,4-(4,4'-dibenzoyldiphenyl)butane and 2,5-dimethylfuran was in marked contrast to the incomplete solubility of polyF4 in benzene, and such observations, although not precluding other explanations, are consistent with the occurrence of reactions of the type (4.23).

Thus a combination of reactions may be occurring during the polymerization process, in competition with the cycloaddition reaction. The above examples are illustrative of possible processes occurring, although additional radical reactions, such as coupling of ketyl radicals produced in the above processes, are not excluded.

C.

THE PREPARATION OF POLYBENZOPINACOLS

#### 4.28 Introduction

In Chapter 1, preparations of polybenzopinacols from benzophenone type aromatic diketones were described, and the mechanism of the photo-reduction process was reviewed in Chapter 2.

Photoreductive coupling to polybenzopinacols has been repeated and extended with the aromatic diketones described in Chapter 3, largely as a check on the purity of the diketones and the effectiveness of the irradiation technique in producing the required excited species.

### DISCUSSION

#### 4.29 Reductive Coupling of Aromatic Diketones

##### (a) In 50:50 Benzene-Isopropanol Mixtures

Polybenzopinacols were prepared by irradiation at 350 nm of aromatic diketones in a benzene-isopropanol mixture. On the basis of the statement by Higgins<sup>91</sup> that a 50:50 mixture of the solvents was satisfactory, providing a suitable balance between monomer solubility and rate of reaction, a 50:50 (v/v) solvent mixture was initially employed in this study. (In Higgins initial studies,<sup>90</sup> mixtures of 125 ml. benzene and 125 ml. isopropanol were used as solvent. Subsequently<sup>91</sup> in further studies, Higgins did not categorically state whether the mixture was v/v, w/w or mole/mole. A 50:50 w/w mixture would have required more isopropanol than used here. A 50:50 mole/mole mixture would only have made a small difference to the solvent ratio - densities of benzene and isopropanol are 0.878 and 0.785 g/ml. respectively at 20°C).

The diketones enumerated below were photopolymerized to give the corresponding polybenzopinacols.

<u>Diketone</u>	<u>Polymer</u>	<u>Diketone</u>	<u>Polymer</u>
(40)	Polypinacol M	(46)	Polypinacol 3
(41)	Polypinacol P	(47)	Polypinacol 4
(42)	Polypinacol E	(48)	Polypinacol 5
(44)	Polypinacol 1	(49)	Polypinacol 6
(45)	Polypinacol 2	(50)	Polypinacol 10

During the irradiation periods light to heavy precipitates were formed from all but *m*-dibenzoylbenzene (v. light suspension), *p*-dibenzoylbenzene and 1,10-(4,4'-dibenzoyldiphenyl)decane.

Freeze drying of the polymers was complicated by the nature of the solvent mixture, the large proportion of isopropanol tending to cause melting of the solvent mixture during the drying process unless external cooling was employed. Following removal of the solvent, the polymeric material, which still appeared damp, was dissolved so far as possible in benzene and freeze dried. Where polymers precipitated out during the irradiation they tended to cling to the side of the reaction vessel, making quantitative recovery difficult. However, yields where a meaningful comparison with weight of starting material used was possible tended to be slightly higher than quantitative yields expected for polypinacol formation, especially with polymers precipitated during irradiation. This suggested occlusion of solvent by the polymer. Pearson, in his studies on *p*-dibenzoylbenzene photopolymerization, noted<sup>89</sup> that a slight amount of isopropanol was strongly absorbed by the oligomeric pinacol obtained under 'strenuous' irradiation conditions.

Infrared spectra of the crude polymers are recorded in Appendix C. They were generally in good agreement with published infrared spectra<sup>90-92</sup> of

polypinacols with a strong OH absorption at ca.  $3560\text{ cm}^{-1}$  although polypinacol 2 showed considerable C=O stretch ( $1655\text{ cm}^{-1}$ ) and slight residual C=O stretch was also observed for polypinacol 1, polypinacol 4 and polypinacol 6. A weak absorption at ca.  $1710\text{ cm}^{-1}$  was noted in the spectrum of polypinacol P.

Samples of polymers were dried under reduced pressure for 3 days @  $77^{\circ}\text{C}$  in attempts to remove any occluded solvent. This drying resulted in the appearance of a considerable C=O stretch absorption in the infrared spectrum of polypinacol 1.

Attempts to precipitate polypinacol 1 and polypinacol 4 by dissolution in dimethylsulphoxide and addition of this solution to methanol, following the method of De Schryver,<sup>92</sup> gave polymer samples containing occluded methanol which could not be removed by drying under reduced pressure.

Molecular weights of polymer samples were determined by the isopiestic method with benzene or DMF as solvent. Molecular weights are recorded in Table 4.10 together with the temperature at which polymers first became tacky on heating in a melting point capillary tube. Polypinacol M, polypinacol 5, polypinacol 6 and polypinacol 10 exhibited fairly high  $\overline{\text{D.P.}}$ 's, the high  $\overline{\text{D.P.}}$  (ca.16) of polypinacol M being in considerable contrast to earlier reports that the diketone formed only very low molecular weight material or did not react.<sup>90,91</sup> The molecular weights of some polymers must be treated with caution owing to the presence of insoluble material (e.g. ca.3% for a 'solution' of 0.0564 g. of polypinacol 4 in 5.20 g. DMF), and molecular weights of polymers may be gross underestimates as a result of occluded solvent. Pearson recorded that drying of polypinacol P at 0.001 mm.Hg and  $80^{\circ}\text{C}$  gave material of

**TABLE 4.10**  
Molecular Weights, Degrees of Polymerization and Melting  
Characteristics of Polybenzopinacols

Polymer <sup>a</sup>	Molecular Weight ( $\overline{D.P.}$ ) <sup>b</sup>		'Melting Point' <sup>b,c</sup> (°C)
	Before Drying	After Drying	
Polypinacol M	4800 <sup>d</sup> (16.6)	4700 <sup>e</sup> (16.3)	158
Polypinacol P	1300 <sup>d</sup> (4.5)	-	143
Polypinacol E	3400 <sup>e</sup> (8.9)	2500 <sup>e</sup> (6.6)	155
Polypinacol 1	950 <sup>e</sup> (2.5)	1400 <sup>e</sup> (3.7)	150
Polypinacol 2	2700 <sup>e</sup> (6.9)	2000 <sup>e</sup> (5.1)	134
Polypinacol 3	2300 <sup>e,g</sup> (5.7)	2700 <sup>e,g</sup> (6.6)	133
Polypinacol 4	3500 <sup>e</sup> (8.3)	4300 <sup>efg</sup> (10.2)	134
Polypinacol 5	9100 <sup>e,g</sup> (20.9)	-	116
Polypinacol 6	10300 <sup>e</sup> (23.0)	-	109
Polypinacol 10	12600 <sup>d</sup> (25.0)	-	92

Notes a) Prepared as recorded in Table 4.17.

b) For crude polymer.

c) Temperature at which undried polymer becomes tacky.

d) Determined in benzene.

e) Determined in DMF.

f) After precipitation.

g) Incomplete dissolution of sample used in molecular weight determination.

molecular weight 1335. Further drying with an increased temperature of 120°C was necessary to obtain a higher observed molecular weight of 1570.<sup>89</sup> For a polymer,  $\overline{M}_n = 10,000$ , the presence of 1% by weight of occluded solvent, molecular weight 60 (isopropanol), would lower the observed molecular weight (as determined by the isopiestic method in benzene or DMF) to ca.3800. Only a small error is introduced if the occluded solvent is that used for the molecular weight determination. General variations in molecular weight, due to occluded solvent, could at

least to some extent be related to methods of recovery of polymers.

The onset of melting of the polypinacols occurred at fairly low temperatures ( $< 160^{\circ}\text{C}$ ) and showed the usual trend with respect to length of methylene chains. The temperature of onset of melting of polypinacol M ( $158^{\circ}\text{C}$ ) was considerably higher than the 'melting point' recorded by Higgins ( $140^{\circ}\text{C}$ ).<sup>90</sup> Polypinacol P and polypinacol E showed melting points comparable to those obtained by Higgins ( $135^{\circ}\text{C}$ <sup>90</sup> and  $160^{\circ}\text{C}$ <sup>90</sup> or  $165^{\circ}\text{C}$  respectively). Polypinacol 1 and polypinacol 2 showed lower temperatures of onset of melting than the corresponding polypinacols of Higgins ( $160$ - $170$  or  $135$ - $160^{\circ}\text{C}$  and  $170$ - $185$  or  $165$ - $170^{\circ}\text{C}$  respectively - depending on the preparative method<sup>91</sup>). The polypinacols generally melted over a  $10$ - $20^{\circ}\text{C}$  range; brittle fibres could be drawn from the melt.

A satisfactory elemental analysis was obtained for polypinacol 10. Other polypinacols did not give satisfactory analyses.

(b) In Benzene-Isopropanol Mixtures Containing More than 50% Benzene

Owing to the generally unsatisfactory nature of the polypinacols, as obtained above, and especially in relation to complications caused by precipitation of products, some polypinacol preparations were repeated in benzene-isopropanol solvent mixtures containing a higher proportion of benzene. 4,4'-Dibenzoyldiphenylmethane, 1,2-(4,4'-dibenzoyldiphenyl)ethane, 1,3-(4,4'-dibenzoyldiphenyl)propane and 1,5-(4,4'-dibenzoyldiphenyl)pentane were photopolymerized using between 3:1 and 4:1 (v/v) ratios of benzene to isopropanol. No precipitates were formed during irradiation under these conditions, and polymers were readily isolated by freeze drying. Infrared spectra of polymers (Appendix C) showed no trace of residual

C=O stretch and molecular weights of all polymers could readily be determined in benzene with no solubility problems. Molecular weights and 'melting points' are recorded below in Table 4.11, for the crude polymers.

TABLE 4.11

Molecular Weights, Degrees of Polymerization and Melting Characteristics of Polybenzopinacols Prepared in 3:1-4:1 Benzene-Isopropanol Mixtures

Polymer <sup>a</sup>	Molecular Weight ( $\overline{D.P.}$ )	'Melting Point' <sup>b</sup> (°C)
Polypinacol 1	14700 (38.8)	160
Polypinacol 2	3700 (9.4)	147
Polypinacol 3	4400 (10.8)	138
Polypinacol 5	7900 (18.2)	120

Notes a) Prepared as recorded in Table 4.18

b) Recorded as temperature at which polymer samples became tacky

Particularly noticeable was the marked increase in  $\overline{D.P.}$  for polypinacol 1. The molecular weight of polypinacol 2 was probably limited by the low solubility of monomer, necessitating photopolymerization in very dilute solution (ca. 0.005M). Availability of 1,3-(4,4'-dibenzoyldiphenyl)propane and 1,5-(4,4'-dibenzoyldiphenyl)pentane also limited their photopolymerizations to fairly dilute solutions.

Suitable precipitation of the polymers would be expected to give improved molecular weights, but was not performed, partly in view of the small quantities of material being examined.

Elemental analyses of polypinacol 1, polypinacol 2 and polypinacol 3 were fairly satisfactory, particularly compared to analyses for the corresponding polymers prepared in the 50:50 solvent mixtures.

(c) Some Comments on the Differing Results Obtained for  
Photopinacolizations in the Varying Benzene-Isopropanol Mixtures

It appeared, from the results described above, that increasing the proportion of benzene in the solvent mixture gave an improved pinacol solvent, allowing complete consumption of carbonyl groups with formation of linear polypinacols during the irradiation period. However, the polypinacols that precipitated out in a 50:50 mixture of benzene-isopropanol during irradiation were not soluble in the 'improved' solvent nor in neat benzene. A possible explanation for this would be that irradiation of the polypinacol, once precipitated as a solubility effect, effected a change in this material causing its subsequent insolubility in any improved solvent.

To test this theory a thin solid layer of soluble polypinacol 1, obtained by irradiation in a 3:1 benzene-isopropanol solvent mixture, was cast around the surface of a round bottomed flask (residual pressure within flask was ca.  $10^{-3}$  mm.Hg) and irradiated at 350 nm for 3 days. The resulting material was virtually insoluble in benzene compared to the complete solubility of the polymer before this irradiation. An infrared spectrum of the insoluble material revealed that a carbonyl group had been regenerated (as indicated by a medium strength absorption at ca.  $1655\text{ cm}^{-1}$ ).

Benzopinacol is known to undergo alkaline cleavage to benzhydrol and benzophenone (eq.4.24).<sup>88</sup>

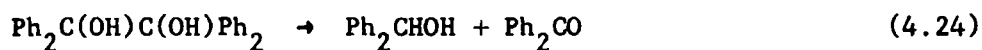

Such alkaline cleavage could result from contact of polymer with a glass surface, regenerating the carbonyl group either on heating or during an irradiation. Cleavage products from benzopinacol, however, are much more soluble in alcohol than benzopinacol itself.<sup>88</sup> Regenerated carbonyl grouping (or any residual carbonyl in the polymer) could abstract a hydrogen from the reactive methylene groups present (cf. photoreaction of benzophenone and diphenylmethane) causing a branching reaction (possibly as a solid phase reaction) as postulated for furan-diketone polymers, and causing decreased polymer solubility.

More complex radical reactions could also be effected, for example as a result of any residual oxygen during irradiations.

(d) Thermogravimetric Analysis of Polybenzopinacols

Typical thermograms (for polyopinacol M and polyopinacol 10 prepared in a 50:50 benzene-isopropanol mixture) are recorded in Appendix D. Two step curves were again observed for polyopinacols heated in air (> 80% weight loss being covered by the first step of the curve) and single step curves for polyopinacols heated in a nitrogen atmosphere. For polyopinacols derived from the 4,4'-dibenzoyldiphenylalkanes, 50% weight loss was observed at temperatures of between ca. 345 and 375°C in air, and 355 and 410°C in nitrogen, decomposition occurring more rapidly in air than in nitrogen.

D.

THE USE OF DICHLOROMETHANE AS SOLVENT

#### 4.30 Studies with Dichloromethane as Solvent

In view of the low solubility of 1,2-(4,4'-dibenzoyldiphenyl)ethane in benzene, the possibility of the use of dichloromethane as solvent, in which the diketone was fairly soluble, was investigated. Dichloromethane had been used as a cosolvent with isopropanol in the preparation of polybenzopinacols.<sup>92</sup>

However, both attempts to photopolymerize 1,2-(4,4'-dibenzoyldiphenyl)ethane with TMA in dichloromethane, and to prepare the furan 2:1 adduct of the diketone with dichloromethane as cosolvent to furan failed. In each case material of molecular weight of the order  $10^3$  was produced. Infrared spectra indicated the presence of OH groups, particularly in the product from attempts to prepare furan 2:1 adduct, and showed little absorption between  $1000-900\text{ cm}^{-1}$ .

Subsequent irradiation of m-dibenzoylbenzene in dichloromethane gave at least one product in addition to unreacted m-dibenzoylbenzene, and the crude material obtained from the reaction mixture was orange-brown in contrast to the white or pale yellow products obtained from successful irradiations. Again infrared spectroscopy indicated the presence of OH groups.

Irradiations in dichloromethane thus appeared to involve a not unreasonable abstraction reaction from the solvent. Hydrogen abstraction followed by polymerization processes (not involving oxetane ring formation) presumably yielded the materials isolated with molecular weights of  $\text{ca.}10^3$ .

E.

CONCLUSIONS

#### 4.31 Conclusions

Polymers have successfully been prepared by step-growth photopolymerizations utilizing the Paterno-Büchi reaction and yielding polymers with oxetane rings in the main chains. Hydrogen abstraction reactions appear to have been the major competing reactions, accounting for the presence of OH groups in polymers. Polymerizations with tetramethylallene as diene were more successful than polymerizations with furan, the physical properties of the tetramethylallene-diketone polymers being consistent with, essentially, the formation of linear polymers, and abstraction reactions, as expected, leading to propagation of the polymer chain. The physical properties of the polymers prepared from furan as diene, on the other hand, generally suggested that some reactions occurring during the photopolymerization resulted in branching and/or crosslinking. Some possible branching reactions have been considered, and one of the major branching reactions may well result from abstraction of hydrogen atoms  $\alpha$  to furan residue oxygens. Photopolymerizations have been performed in benzene solvent; dichloromethane is unsuitable.

Polybenzopinacols have also been prepared, by irradiation of diketones in 50:50 v/v benzene-isopropanol solvent mixtures, and also by irradiation in benzene-isopropanol mixtures containing more than 50% by volume of benzene. The latter solvent mixtures yielded the more soluble and generally higher molecular weight polymers.

Contrary to earlier reports,<sup>90,91</sup> m-dibenzoylbenzene was found to readily undergo photopolymerization reactions yielding polybenzopinacols and polyoxetanes. The  $\overline{D.P.}$ 's obtained with m-dibenzoylbenzene as diketone were comparable with those from 4,4'-dibenzoyldiphenylalkane diketones,

consistent with the similarities between the absorption spectra of these diketones, as discussed in Chapter 3. *p*-Dibenzoylbenzene, where the  $n \rightarrow \pi^*$  absorption of the carbonyl chromophore was less well resolved from the  $\pi \rightarrow \pi^*$  absorption, gave only oligomeric material. Pearson<sup>89</sup> has shown that the course of the reaction of *p*-dibenzoylbenzene irradiated in isopropanol is complex and variable. In the course of the present work, all polymers from *p*-dibenzoylbenzene have shown anomalous absorptions in the 1700-1800  $\text{cm}^{-1}$  region of their infrared spectra. Improved furan-diketone polymers containing *p*-dibenzoylbenzene residues could be prepared by irradiation of furan-*p*-dibenzoylbenzene 2:1 adduct with a more reactive diketone. 4,4'-Dibenzoyldiphenyl failed to photopolymerize with tetramethylallene, consistent with the submergence of its  $n \rightarrow \pi^*$  absorption under the  $\pi \rightarrow \pi^*$  absorption and its reported<sup>91</sup> failure to give a polybenzopinacol.

Whereas polymers from tetramethylallene as diene appeared to be stable at room temperature, furan adducts and polymers were unstable, storage for several months at room temperature causing noticeable change in their infrared spectra. Several hypotheses can be advanced to account for this observation, but firm conclusions have not been drawn. 4,4'-Dibenzoyldiphenyl ether failed to give a furan 2:1 adduct, a strong absorption at ca. 1730  $\text{cm}^{-1}$  in the infrared spectrum of the product from attempts to prepare the adduct being consistent with the hypothesis that a process comparable to the reactions which occur slowly on storage of other furan adducts and polymers is much more rapid, or is photochemically promoted, with this diketone.

F.

EXPERIMENTAL

#### 4.32 Photopolymerization of Aromatic Diketones with Tetramethylallene, and Related Investigations

Aromatic diketones were prepared as described in Chapter 3. Tetramethylallene was purchased from Aldrich Chemical Co. Inc. and used as obtained. Examination by n.m.r. and v.p.c. indicated no detectable impurities.

##### (a) General Method of Polymerization

Benzene solutions containing equimolar quantities of aromatic diketone and TMA were irradiated at 350 nm.

A solution of the diketone in benzene was placed in a cylindrical Pyrex reaction vessel and dry  $N_2$  was bubbled through the solution for at least 30 minutes. The TMA, a liquid b.p.  $70^\circ$ , was then injected from a calibrated micro syringe into the solution via the nitrogen streaming system. The use of a calibrated micro syringe provided an accurate means of measuring TMA quantities. Quantities of TMA were also checked by difference weighings, verifying that the micro syringe used gave highly reproducible results. After injection of the TMA, the benzene solution was streamed with nitrogen for a further few minutes. The reaction vessel was then quickly stoppered with a ground glass stopper and the solution irradiated in a Rayonet Type RPR-204 preparative photochemical reactor fitted with four RUL-3500 $\text{\AA}$  lamps. The reaction temperature was ca.  $30^\circ\text{C}$ .

After irradiation the solutions were clear and either colourless or pale yellow. Solutions were transferred to round-bottomed flasks, and benzene solvent was removed by freeze drying to yield white or pale yellow

polymers, quantitatively, as fine powders. Crude polymers were generally dissolved in a few ml. of dry solvent benzene and precipitated by dropwise addition of the benzene solution to dry, stirred A.R. 40-60° petroleum ether (3-4 times the volume of benzene solvent used). The precipitated polymer was filtered off and freeze dried from benzene solution. Quantities and concentrations of reactants, irradiation times and state of solutions after irradiation, for typical experiments, are recorded in Table 4.12 together with analytical data. Infrared spectra of polymers are recorded in Appendix C, and molecular weights and melting characteristics are given in Table 4.2.

(b) Irradiation of Benzophenone and Tetramethylallene in Benzene

The procedure was as for aromatic diketone-TMA photopolymerizations. Benzophenone (1.824 g., 0.0100 moles) and TMA (1.174 g., 0.0122 moles) dissolved in benzene (17 ml.) were irradiated for 113 hours at 350 nm. After irradiation the resulting colourless solution was transferred to a round-bottomed flask and freeze dried, yielding a white solid. Thin layer chromatography of the crude solid on silica gel, developing with benzene, showed at least four components. The infrared spectrum of the product mixture is recorded in Appendix C.

(c) Effect of HCl on PolyTMAM

PolyTMAM (0.27 g., molecular weight 6100) was dissolved in benzene (15 ml.), and HCl gas was bubbled slowly through the solution for 3 hr. The solution, initially a straw yellow colour, darkened to a medium yellow colour during passage of the HCl. The resulting solution was freeze dried to yield a pale yellow solid (molecular weight 1100). The infrared spectrum is recorded in Appendix C.

TABLE 4.12

Photopolymerization of Tetramethylallene with Aromatic Diketones in Benzene Solvent

Diketone	Polymer	Quantities of Reactants (g)		Volume of Benzene (ml)	Molarity of Solution (in Diketone & TMA)	Irradiation Time (hr x 10 <sup>-2</sup> )	Colour of Solution After Irradiation	Molecular Formula of Polymer	Elemental Analysis (%)			
		Diketone	TMA						Found		Required	
									C	H	C	H
(40)	PolyTMA1	3.000	1.007	25.0	0.419	5.5	Colourless	(C <sub>27</sub> H <sub>26</sub> O) <sub>n</sub>	84.59	6.64	84.78	6.85
(41)	PolyTMA2	0.8000	0.2680	25.0	0.112	7.9	Pale yellow	(C <sub>27</sub> H <sub>26</sub> O) <sub>n</sub>	83.82	5.85	84.78	6.85
(42)	PolyTMAE	3.000	0.7600	240	0.033	6.7	Pale yellow	(C <sub>33</sub> H <sub>30</sub> O) <sub>n</sub>	82.59	6.49	83.51	6.37
(43)	None	2.000	0.5307	500	0.0110	17.3	Pale yellow					
(44)	PolyTMA1	1.700	0.4342	35.0	0.129	3.6	Colourless	(C <sub>34</sub> H <sub>32</sub> O) <sub>n</sub>	86.57	7.07	86.41	6.82
(45)	PolyTMA2	0.9000	0.2215	250	0.00922	5.0	Colourless	(C <sub>35</sub> H <sub>34</sub> O) <sub>n</sub>	86.66	7.30	86.38	7.04
(46)	PolyTMA3	0.3040	0.0723	25.0	0.0301	4.4	Colourless	(C <sub>36</sub> H <sub>36</sub> O) <sub>n</sub>	86.55	7.64	86.36	7.25
(47)	PolyTMA4	0.8000	0.1838	60.0	0.0318	5.2	Colourless	(C <sub>37</sub> H <sub>38</sub> O) <sub>n</sub>	86.06	7.71	86.34	7.44
(48)	PolyTMA5	0.1457	0.0324	15.0	0.0225	5.1	Colourless	(C <sub>38</sub> H <sub>40</sub> O) <sub>n</sub>	85.08	8.94	86.32	7.63
(49)	PolyTMA6	0.8500	0.1830	100	0.0190	3.7	Colourless	(C <sub>34</sub> H <sub>42</sub> O) <sub>n</sub>	85.99	7.64	86.30	7.80
(50)	PolyTMA10	0.1824	0.0349	10.0	0.0363	4.3	Colourless	(C <sub>43</sub> H <sub>50</sub> O) <sub>n</sub>	85.95	8.80	86.24	8.42

(d) Effect of Initial Monomer Concentration on Molecular Weight of PolyTMAI Attained after Irradiation for 22 Hours

Seven solutions, each equimolecular in 4,4'-dibenzoyldiphenylmethane and tetramethylallene, containing the monomers at concentrations of 0.00335, 0.00693, 0.0136, 0.0319, 0.0531, 0.0885 and 0.1117M, in benzene solvent (20 ml.) were prepared in identical cylindrical Pyrex reaction vessels in the conventional manner.

The solutions were placed in a Rayonet MGR-100 Merry-Go-Round fitted within a Rayonet Type RPR-208 preparative photochemical reactor equipped with 8 RUL-3500 $\text{\AA}$  lamps. The solutions were irradiated for 22 hr. and after irradiation the resulting polymers were recovered by freeze drying and molecular weights of the individual polymers measured.

Molecular weights of crude polymers (in order of increasing initial monomer concentration) were 2100, 3000, 3800, 5400, 7500, 9900 and 10,600.

(e) Effect of the Period of Irradiation on Molecular Weight of PolyTMAI

Eight solutions containing 4,4'-dibenzoyldiphenylmethane (0.1500 g., 0.000398 moles) and tetramethylallene (0.0383 g., 0.000398 moles) in benzene (20 ml.), giving solutions 0.0199M in each reactant, were prepared in identical Pyrex reaction vessels in the conventional manner.

The Pyrex reaction vessels were placed in a Rayonet MGR-100 Merry-Go-Round fitted within a Rayonet Type RPR-208 preparative photochemical reactor equipped with 8 RUL-3500 $\text{\AA}$  lamps, and the solutions irradiated.

Solutions were removed after irradiation periods of 0.37, 0.6, 1.0, 1.2, 1.5, 2.05, 3.0 and 20 hr. and crude polymers recovered by freeze

drying and molecular weights determined. Molecular weights of the polymers (in order of increasing irradiation period) were 770, 1000, 1850, 2570, 3400, 4070, 4220 and 4450.

A further six identical solutions were irradiated in a similar manner for periods of 15.4, 24.1, 40.5, 63.7, 87.9 and 160 hr. Molecular weights of the crude polymers were determined, as above, to be 4640, 4560, 4590, 4600, 4470 and 4400 respectively.

(f) Pyrolysis of PolyTMAI

PolyTMAI (0.420 g., molecular weight 10,000) was placed in a round-bottomed flask and the latter fitted to conventional vacuum transfer apparatus, the other limb of the transfer apparatus leading to a trap cooled in liquid air.

The polymer, at a pressure of ca.  $10^{-3}$  mm.Hg, was heated fairly rapidly. At ca. 200°C darkening and softening occurred. Bubbles appeared in the softened material at 260°C. The polymer was maintained at a temperature of 280-290°C for 1.5 hr., during which period droplets of yellow viscous oil formed around the neck of the flask containing the polymer. A brown residue remained at the conclusion of the pyrolysis and a white solid (0.015 g.) vaporizing at room temperature, was observed in the cold trap.

An infrared spectrum of the trapped volatile material showed peaks at ca. 3120-3030  $\text{cm}^{-1}$ (m), 3000-2860  $\text{cm}^{-1}$ (m), 2350  $\text{cm}^{-1}$ (m-w), 1960  $\text{cm}^{-1}$ (w), 1800  $\text{cm}^{-1}$ (w), 1740  $\text{cm}^{-1}$ (m), 1480  $\text{cm}^{-1}$ (m), 1375  $\text{cm}^{-1}$ (m-w), 1220  $\text{cm}^{-1}$ (m-w), 1040  $\text{cm}^{-1}$ (m), 797  $\text{cm}^{-1}$ (w), 730  $\text{cm}^{-1}$ (w), 673  $\text{cm}^{-1}$ (s). Infrared spectra of the residues in the pyrolysis flask both corresponded, in terms of gross structure, to 4,4'-dibenzoyldiphenylmethane.

A mass spectrum of the volatile material showed prominent peaks at  $m/e$  92, 91, 78 (base peak), 77, 68, 58, 57, 56, 52, 51, 50, 44, 43, 42, 41, 39, 28.

#### 4.33 Studies with Furan as Diene

Laboratory reagent grade furan was fractionally distilled twice (column 15 cm x 2 cm diameter, glass helices), collecting the fraction b.p. 31.5-32.5°C, and used immediately. Aromatic diketones were prepared as described in Chapter 3.

##### (a) Direct Irradiation of an Equimolar Solution of m-Dibenzoylbenzene and Furan in Benzene

A solution of m-dibenzoylbenzene (4.000 g., 0.01397 moles) in benzene (70 ml.) was placed in a Pyrex ampoule and furan (0.951 g., 0.0139 moles) syringed directly into the solution. The resulting solution was degassed by two freeze-thaw cycles and the ampoule sealed under vacuum. The solution was irradiated for 670 hr. at 350 nm, using a Rayonet Type RPR-204 preparative photochemical reactor fitted with four RUL-3500<sup>9</sup> lamps. The reaction temperature was ca. 30°C. After irradiation the solution was clear and of medium yellow colour.

Product was recovered by freeze drying to yield a pale yellow solid, molecular weight 1250. The infrared spectrum of the solid is recorded in Appendix C.

##### (b) Preparation of Furan-Aromatic Diketone 2:1 Adducts

A solution of the aromatic diketone in a large excess of furan was placed in a cylindrical Pyrex ampoule, degassed by 2-3 freeze-thaw cycles and the ampoule sealed with the contents frozen and under vacuum.

After careful thawing the furan solution was irradiated in a Rayonet Type RP4-204 preparative photochemical reactor fitted with four RUL-3500Å lamps (reaction temperature ca. 30°C). After irradiation, solutions were generally clear and colourless or straw yellow. Furan was removed by vacuum transfer to give the products as white or creamy-white solids. Yields were quantitative for formation of 2:1 adducts.

Owing to the low solubility of 1,2-(4,4'-dibenzoyldiphenyl)ethane in furan, it was necessary to use a mixed solvent of furan and benzene to obtain furan adduct on a preparative scale.

Thin layer chromatography of the products obtained directly after irradiations and on removal of the furan showed only a single sharp component.

Data on typical preparations of individual furan adducts is recorded in Table 4.13. Infrared spectra of the adducts are recorded in Appendix C, and molecular weight and melting point data are recorded in Table 4.3 and section 4.16 respectively.

(c) Irradiation of More Concentrated Solutions of Aromatic Diketones in Furan

Experimental procedures were as described for other irradiations of aromatic diketones in furan.

(i) 4,4'-Dibenzoyldiphenylmethane

4,4'-Dibenzoyldiphenylmethane (0.500 g., 0.00133 mole) in furan (10 ml.) was irradiated at 350 nm for 290 hr. The solution was colourless and clear after irradiation. Furan was removed by vacuum transfer to yield a white solid, molecular weight 617. An infrared

TABLE 4.13

Preparation of Furan-Diketone 2:1 Adducts

Diketone	2:1 Adduct	Quantities of Reactants		Molarity of Solution Irradiated	Irradiation Period (hr x 10 <sup>-2</sup> )
		Diketone (g)	Furan (ml)		
(40)	DiFM	1.950	200	0.0340	3.1
(41)	DiFP	1.400	150	0.0326	5.8
(42)	-	1.400	150	0.0246	3.8
(44)	DiF1	1.700	160	0.0282	5.3
(45)	DiF2	0.402	55 <sup>a</sup>		1.7
(46)	DiF3	0.332	80	0.0103	5.6
(47)	DiF4	0.900	140	0.0154	3.3
(48)	DiF5	0.110	30	0.0085	3.5
(49)	DiF6	0.900	100	0.0201	4.4
(50)	DiF10	0.336	80	0.0084	4.7

Note a) 140 ml. benzene used as cosolvent.

spectrum of the product showed no residual C=O stretch at  $1655\text{ cm}^{-1}$ , several strong absorptions between  $1050$  and  $900\text{ cm}^{-1}$  and was virtually identical to the spectrum of diF1 recorded in Appendix C.

(ii) m-Dibenzoylbenzene

m-Dibenzoylbenzene (ca. 2.5 g., 0.0087 moles) in furan (10 ml.) was irradiated at 350 nm for 240 hr. At the end of the irradiation period there was a yellow deposit in the tube. Furan was removed by vacuum transfer to yield a dark yellow solid. An infrared spectrum of the solid showed a fairly strong residual C=O stretch at ca.

$1660\text{ cm}^{-1}$  and several absorptions between  $1050$  and  $900\text{ cm}^{-1}$  corresponding to those in the spectrum of diFM.

(d) Irradiation of Benzophenone in Furan

The usual procedure for irradiations in furan was followed.

A solution of benzophenone (0.3916 g., 0.00215 moles) in furan (70 ml.) was irradiated at 350 nm for 160 hr. After irradiation the solution was clear and colourless. Furan was removed by vacuum transfer to yield a white solid.

Thin layer chromatography on silica gel, developing with chloroform and with benzene, indicated a single component. The infrared spectrum of the product is recorded in Appendix C.

(e) Irradiation of Furan-Aromatic Diketone 2:1 Adducts with Aromatic Diketones

A solution containing equimolar quantities of aromatic diketone and corresponding furan-aromatic diketone 2:1 adduct in benzene was placed in a cylindrical Pyrex reaction vessel and dry nitrogen was bubbled

through the solution for at least 30 minutes. The reaction vessel was then quickly stoppered with a ground glass stopper and the solution irradiated in a Rayonet Type RPR-204 preparative photochemical reactor fitted with four RUL-3500Å lamps (reaction temperature ca. 30°C). During irradiation some solutions became slightly cloudy.

After irradiation, solutions were transferred to round-bottomed flasks and benzene was removed by freeze drying to yield polymers as white or very pale yellow fine powders. Yields of crude polymers corresponded virtually quantitatively to the combined initial weight of aromatic diketone and 2:1 adduct.

The quantity of diketone used with the furan adduct of 1,2-(4,4'-dibenzoyldiphenyl)ethane was calculated on the basis of the significantly higher molecular weight of the furan adduct, and the assumption that the latter was a mixture of furan-diketone 2:1 and 3:2 adducts.

Crude polymers were precipitated by dissolution, so far as possible, in a few ml. of dry benzene and dropwise addition of this solution to dry AR 40-60° petroleum ether. The precipitated polymer was filtered off and freeze dried from benzene solution.

Quantities and concentrations of reactants, irradiation times, state of solutions after irradiation and analytical data, for typical photopolymerizations and polymers, are recorded in Table 4.14. Infrared spectra of polymers are recorded in Appendix C and molecular weights and melting characteristics are given in Table 4.6.

TABLE 4.14  
Photopolymerization of Aromatic Diketones with Furan-Aromatic Diketone 2:1 Adducts

Diketone & Diketone residue in 2:1 adduct	Polymer	Quantities of Reactants (g)		Volume of Benzene Solvent (ml)	Molarity of Solution Irradiated (in Diketone & 2:1 adduct)	Irradiation Time (hr x 10 <sup>-2</sup> )	State of Solution After Irradiation	Molecular Formula of Polymer	Elemental Analysis (%)					
		Diketone	2:1 Adduct						Found			Required		
(40)	PolyFM	0.6780	1.000	28	0.0846	4.1	Clear Pale yellow	(C <sub>24</sub> H <sub>18</sub> O <sub>3</sub> ) <sub>n</sub>	81.07	5.43	81.34	5.12		
(41)	PolyFP	0.2100	0.3098	25	0.0293	6.4	Clear Pale yellow	(C <sub>24</sub> H <sub>18</sub> O <sub>3</sub> ) <sub>n</sub>	81.09	5.51	81.34	5.12		
(44)	PolyF1	0.3672	0.5000	100	0.00975	0.9	Almost clear colourless	(C <sub>31</sub> H <sub>24</sub> O <sub>3</sub> ) <sub>n</sub>	84.29	5.75	83.76	5.44		
		0.6609	0.9000	100	0.0176	2.0	Heavy suspension v. pale yellow	-	-	-	-	-	-	-
(45)	PolyF2	0.1810	0.2500 <sup>a</sup>	55	0.00843 <sup>b</sup>	1.1	Slight turbidity	(C <sub>32</sub> H <sub>26</sub> O <sub>3</sub> ) <sub>n</sub>	83.56	6.09	83.82	5.72		
(46)	PolyF3	0.1431	0.1913	25	0.0142	2.1	Cloudy v. pale yellow	(C <sub>33</sub> H <sub>28</sub> O <sub>3</sub> ) <sub>n</sub>	83.59	5.13	83.87	5.97		
(47)	PolyF4	0.2264	0.3000	25	0.0216	1.2	Cloudy	(C <sub>34</sub> H <sub>30</sub> O <sub>3</sub> ) <sub>n</sub>	83.12	6.77	83.92	6.21		
(48)	PolyF5	0.0374	0.0492	10	0.00864	1.4	Slight turbidity	(C <sub>35</sub> H <sub>32</sub> O <sub>3</sub> ) <sub>n</sub>	83.68	6.84	83.97	6.44		
(49)	PolyF6	0.3830	0.5000	50	0.0172	2.7	Slight turbidity	(C <sub>36</sub> H <sub>34</sub> O <sub>3</sub> ) <sub>n</sub>	83.51	6.51	84.01	6.66		
(50)	PolyF10	0.1020	0.1296	25	0.00812	3.4	Clear colourless	(C <sub>40</sub> H <sub>42</sub> O <sub>3</sub> ) <sub>n</sub>	83.81	7.95	84.17	7.42		

Notes a) Assumed to be a mixture of 0.212 g. 2:1 adduct and 0.038 g. 3:2 adduct

b) Molarity of solution in diketone.

(f) Irradiation of Benzophenone and Furan in Benzene

A solution of benzophenone (9.050 g., 0.04966 moles) in benzene (58 ml.) was placed in a Pyrex reaction vessel and streamed with nitrogen for 30 min. Furan (5.620 g., 0.0825 moles), after being nitrogen streamed for 15 min, was injected into the solution via the nitrogen streaming system. The solution was nitrogen streamed a further few minutes and the reaction vessel than quickly stoppered. The solution was irradiated at 350 nm for 330 hr. in a Rayonet Type RPR-204 preparative photochemical reactor fitted with four RUL-3500Å lamps. At the end of the irradiation period there was a pale yellow precipitate at the bottom of the tube and the solution was pale yellow.

Thin layer chromatography of the precipitated solid on silica gel (developing with dichloromethane) indicated three major components and one minor component. Infrared spectroscopy showed a very weak absorption at  $1660\text{ cm}^{-1}$ .

A portion of the precipitated solid was repeatedly recrystallized from benzene to give benzophenone-furan 2:1 adduct (66) as a white solid (0.3 g., m.p.  $208-210^{\circ}$  (lit.  $209-211^{\circ 267}$ ), infrared spectrum in Appendix C.).

A portion of combined crude reaction products was repeatedly recrystallized from THF to give benzophenone-furan 2:1 adduct (65) as a white solid (m.p.  $191-192.5^{\circ}$ , (lit.  $192-193^{\circ 267}$ )).

(g) Effect of the Period of Irradiation on Molecular Weight of PolyFM

A solution of m-dibenzoylbenzene (0.8000 g., 0.002794 moles) and diFM (1.1800 g., 0.002794 moles) in benzene (80 ml.) was prepared, and 10 ml. aliquots of this solution were placed in each of eight identical

Pyrex reaction vessels and prepared for irradiation in the conventional manner.

The Pyrex vessels were placed in a Rayonet MGR-100 Merry-Go-Round fitted within a Rayonet Type RPR-208 preparative photochemical reactor equipped with 8 type RUL-3500 $\text{\AA}$  lamps and the solutions were irradiated.

Seven of the tubes were removed after irradiation periods of 2.55, 6.5, 11.1, 22.1, 37.4, 56.2, and 78.9 hr. and crude polymers recovered by freeze drying and molecular weights determined. Molecular weights of the polymers (in order of increasing irradiation period) were 410, 500, 570, 740, 1060, 1390 and 1820.

Samples were withdrawn from the remaining reaction vessel after irradiation periods of 123.0, 166.9 and ca. 500 hours. Molecular weights of polymers isolated from these samples were, respectively, 2230, 2330 and 2600.

#### Monitoring of Reaction by Thin Layer Chromatography

A solution of m-dibenzoylbenzene (0.1000 g., 0.000349 moles) and diFM (0.1475 g., 0.000349 moles) in benzene (20 ml.) was prepared in the usual manner and irradiated at 350 nm in a Rayonet Type RPR-204 preparative photochemical reactor fitted with four RUL-3500 $\text{\AA}$  lamps. Samples of solution were withdrawn after irradiation periods of 23 hours, 62 hours and 119 hours and examined by thin layer chromatography on silica gel (developing with chloroform). The first two samples both showed components corresponding in  $R_f$  value to starting materials. The third sample showed only a single component ( $R_f$  value  $< 0.02$ ) and no evidence of starting materials.

(h) Pyrolysis of Furan-Diketone Polymers and 2:1 Adducts

(i) Pyrolysis of PolyFM

PolyFM (0.400 g., molecular weight 8000) was placed in a round-bottomed flask and the latter fitted to one limb of a conventional vacuum transfer system, the other limb leading to a trap cooled in liquid air.

The polymer was heated (at a pressure of ca.  $10^{-3}$  mm.Hg), and darkening and melting occurred at ca. 210-240°C. The polymer was maintained at a temperature of 245-250°C for a period of 2 hr., during the early stages of which bubbles formed in the polymer and a white solid began to collect in the trap. The polymer slowly shrank to a black residue and droplets of viscous orange-yellow material collected around the neck of the pyrolysis flask.

Trapped volatile material was identified by v.p.c., infrared spectroscopy and mass spectroscopy as furan (0.0265 g.). The orange-yellow viscous material was identified by infrared spectroscopy as essentially m-dibenzoylbenzene. The black residue showed a strong absorption at ca.  $1660\text{ cm}^{-1}$  in its infrared spectrum. Absorptions in the  $1100\text{-}900\text{ cm}^{-1}$  region were generally largely weakened compared to corresponding absorptions in polyFM.

(ii) Pyrolysis of PolyFl

PolyFl (ca. 0.04 g. samples, molecular weight 4300) contained in a round-bottomed flask and fitted to the vacuum transfer system as above, was heated (at a pressure of ca.  $10^{-3}$  mm.Hg) under the following conditions:

- i) 100-120°C for 2 hr.
- ii) 200-205°C for 2 hr.
- iii) 270°C for 2 hr.

Traces of trapped volatiles were obtained in each case, but in insufficient quantities to allow characterization. The infrared spectra of the residues have been discussed earlier - see Table 4.7.

(iii) Pyrolysis of DiFl

DiFl (0.183 g.) was placed in a round-bottomed flask and the flask fitted to the vacuum transfer system as above. The adduct was heated for 5 hr. at a temperature of 130-150°C and a pressure of ca.  $10^{-3}$  mm.Hg. At the end of the pyrolysis, a clear colourless residue remained in the flask, setting to a white solid on standing. Infrared spectroscopy of the solid showed strong absorptions at  $1730\text{ cm}^{-1}$  and  $1140\text{ cm}^{-1}$ , and a medium-weak absorption at  $1660\text{ cm}^{-1}$  in addition to basic absorptions of diFl. Insufficient volatiles were collected to allow characterization.

(i) Preparation of Furan-Aromatic Diketone Polymers Derived from Two Differing Diketone Monomers

Furan-diketone 2:1 adducts were photopolymerized with a diketone differing from the diketone residue of the 2:1 adduct. The experimental procedure was exactly as described for conventional 2:1 adduct-diketone polymerizations. Data for the photopolymerizations is given in Table 4.15, together with analytical data on the polymers. Infrared spectra of the polymers are recorded in Appendix C and molecular weights and melting characteristics are given in Table 4.8. Yields of crude polymers were quantitative for photoaddition between 2:1 adduct and diketone.

TABLE 4.15

Photopolymerization of Diketones with Furan-Diketone Adducts Containing a Different Diketone Residue

Diketone	2:1 Adduct	Quantities of Reactants (g)		Volume of Benzene Solvent (ml)	Molarity of Solution Irradiated	Irradiation Time (hr x 10 <sup>-2</sup> )	Molecular Formula of Polymer	Elemental Analysis (%)			
		Diketone	2:1 Adduct					Found		Required	
								C	H	C	H
(40)	DIFP	0.1000	0.1475	20	0.0175	2.6	(C <sub>24</sub> H <sub>18</sub> O <sub>3</sub> ) <sub>n</sub>	80.88	5.49	81.34	5.12
(41)	DIFM	0.1000	0.1475	20	0.0175	2.6	(C <sub>24</sub> H <sub>18</sub> O <sub>3</sub> ) <sub>n</sub>	80.97	4.77	81.34	5.12
(49)	DIFM	0.1695	0.1603	20	0.0190	1.6	(C <sub>60</sub> H <sub>52</sub> O <sub>6</sub> ) <sub>n</sub>	82.50	5.73	82.92	6.03

#### 4.34 Studies with 2,5-Dimethylfuran as Diene

'Practical' grade 2,5-dimethylfuran was fractionated as described for furan, collecting the fraction b.p. 93.0-93.5°.

Diketones were prepared as described in Chapter 3.

##### (a) Irradiation of 4,4'-Dibenzoyldiphenylmethane in 2,5-Dimethylfuran

A solution of 4,4'-dibenzoyldiphenylmethane (0.298 g., 0.000791 moles) in 2,5-dimethylfuran (45 ml.) was placed in a Pyrex ampoule, degassed by three freeze-thaw cycles and the ampoule sealed under vacuum. The resulting solution was irradiated at 350 nm for 240 hr. in a Rayonet Type RP4-204 preparative photochemical reactor fitted with four RUL-3500Å lamps. At the end of the irradiation period the solution was clear and a very pale yellow.

After irradiation, excess 2,5-dimethylfuran was removed by vacuum transfer to yield an almost white viscous material. This was dissolved in benzene and freeze dried to yield a white solid. Thin layer chromatography on silica gel (developing with chloroform) showed at least four components although none corresponded in  $R_f$  value to starting material.

An infrared spectrum included the following absorptions: ca. 3500  $\text{cm}^{-1}$  (w), 1710  $\text{cm}^{-1}$  (w/m), 1665  $\text{cm}^{-1}$  (s), 1200-900  $\text{cm}^{-1}$  (series of absorptions with peaks of intensity at 1200, 1130, 1020, 990, 975 and 920  $\text{cm}^{-1}$  (m to s)).

##### (b) Preparation of Polymers from Aromatic Diketones and 2,5-Dimethylfuran

Two diketones, m-dibenzoylbenzene and 1,4-(4,4'-dibenzoyldiphenyl)butane, were used. Experimental procedure was as described for photopolymerizations with TMA as diene, the 2,5-dimethylfuran being injected through the nitrogen streaming system.

After irradiation at 350 nm, solutions were completely clear, and polymer recovery and precipitation was as described for furan-diketone polymers. Data on the photopolymerizations is given in Table 4.16, together with elemental analyses. Infrared spectra of the polymers are recorded in Appendix C and molecular weights and melting characteristics are given in Table 4.9. Yields of crude polymers were quantitative for photoaddition between diketone and diene.

#### 4.35 Irradiation of Aromatic Diketones in Benzene

##### (a) m-Dibenzoylbenzene

A solution of m-dibenzoylbenzene (0.40 g., 0.00140 moles) in benzene (20 ml.) was placed in a Pyrex reaction vessel, streamed with nitrogen for 1 hr., the tube quickly stoppered and the solution irradiated for 63 hr. at 350 nm in a Rayonet Type RPR-204 preparative photochemical reactor fitted with four RUL-3500Å lamps.

After irradiation the solution was clear and pale yellow. Thin layer chromatography of the solution on silica gel (developing with chloroform) showed two components, a major one corresponding in  $R_f$  value to m-dibenzoylbenzene, and an extremely weak component of slightly lower  $R_f$  value. Benzene solvent was removed from the reaction mixture to yield a pale yellow solid, the infrared spectrum of which corresponded to that of m-dibenzoylbenzene with an additional weak, though definite, absorption at ca.  $3450\text{ cm}^{-1}$ .

##### (b) 4,4'-Dibenzoyldiphenylmethane

Two solutions containing 4,4'-dibenzoyldiphenylmethane (0.400g., 0.00106 moles) in benzene (10 ml.) were prepared and irradiated, as in

TABLE 4.16

Photopolymerization of Aromatic Diketones with 2,5-Dimethylfuran

Diketone	Quantities of Reactants (g)		Volume of Benzene Solvent (ml)	Molarity of Solution Irradiated	Irradiation Time (hr x 10 <sup>-2</sup> )	Molecular Formula of Polymer	Elemental Analysis (%)			
	Diketone	2,5-Dimethylfuran					Found		Required	
							C	H	C	H
(40)	0.4745	0.1593	23	0.072	1.6 <sup>a</sup>	(C <sub>26</sub> H <sub>22</sub> O <sub>3</sub> ) <sub>n</sub>	81.30	5.99	81.65	5.80
(47)	0.2945	0.0676	15	0.047	1.6	(C <sub>36</sub> H <sub>34</sub> O <sub>3</sub> ) <sub>n</sub>	83.85	6.50	84.01	6.66

Note a) 0.332 g. polymer were also reirradiated for 260 hr. in 10 ml. benzene solvent.

(a), for periods of 89 and 1130 hr. At the end of the irradiation periods, there were slight precipitates in both tubes and solutions were pale yellow. Thin layer chromatography of the solutions on silica gel (developing with chloroform) showed a large amount of tailing of the observed component, the head of which corresponded in  $R_f$  value to starting material.

Benzene solvent was removed by freeze drying to yield pale yellow solids. Infrared spectra were virtually identical showing weak absorptions at ca.  $3500\text{ cm}^{-1}$  and  $1500\text{ cm}^{-1}$  in addition to those corresponding to 4,4'-dibenzoyldiphenylmethane.

#### 4.36 Preparation of Polybenzopinacols

##### (a) By Irradiation of Aromatic Diketones in 50:50 v/v Mixtures of Benzene-Isopropanol

A solution of diketone in a 50:50 v/v mixture of benzene-isopropanol was placed in a cylindrical Pyrex reaction vessel and dry nitrogen was bubbled through the solution for at least 30 minutes. The reaction vessel was then quickly stoppered with a ground glass stopper and the solution irradiated in a Rayonet Type RPR-204 preparative photochemical reactor fitted with four RUL-3500Å lamps. In most cases a white or pale yellow solid precipitated out during the irradiation.

After irradiation the solution was transferred to a round-bottomed flask and solvent removed by freeze drying to yield white or pale yellow polymer. Freeze drying necessitated several refreezings of the polymer/benzene-isopropanol mixture. Recoveries by weight of product, in several cases, were slightly in excess of values calculated for quantitative photoreductive coupling. Drying of samples of polymers for 3 days under reduced pressure at  $77^{\circ}\text{C}$  made little difference to product weight.

Data for the photopolymerizations is given in Table 4.17. Weights of recovered material are given only where all precipitated material and solution were freeze dried. Infrared spectra of crude polymers are recorded in Appendix C, and molecular weights and melting characteristics are given in Table 4.10.

Precipitations of polypinacol 1 and polypinacol 4 were attempted by dissolution of polymer samples in a few ml. of dry DMSO and dropwise addition of the solution to an excess of AR methanol. The resulting precipitated material was filtered off and dried 'in vacuo'. Infrared spectra of precipitated polymers showed a new very broad absorption at  $3500-3300\text{ cm}^{-1}$ , indicative of absorbed methanol. Heating of these precipitated polymers for 3 days at  $77^{\circ}\text{C}$  under reduced pressure (ca.  $10^{-3}$  mm.Hg) failed to remove absorbed methanol.

(b) By Irradiation of Aromatic Diketones in Benzene-Isopropanol Solvent Mixtures Containing Greater than 50% Benzene

The procedure was as described for polymerizations in 50:50 v/v benzene-isopropanol. Polymers did not precipitate out during irradiation. Data for photopolymerizations is given in Table 4.18. Infrared spectra of polymers are recorded in Appendix C and molecular weights and melting characteristics are given in Table 4.11. Polymers were not precipitated.

(c) Irradiation of Polypinacol 1 in the Solid State

A thin layer of soluble polypinacol 1 was cast around the inside of a 250 ml. round-bottomed flask by placing a solution of polypinacol 1 (0.108 g.) in benzene (10 ml.) in the flask, and removing the benzene by freeze drying. The resulting solid was irradiated under a pressure of ca.  $10^{-3}$  mm.Hg at 350 nm for 94 hr. in a Rayonet Type RPR-204 preparative

TABLE 4.17

Preparation of Polybenzopinacols in a 50:50 Benzene-Isopropanol Solvent Mixture

Diketone	Weight of Diketone Used (g)	Solvent Volume (ml)	Molarity of Solution Irradiated	Irradiation Time (hr x 10 <sup>-2</sup> )	State of Solution After Irradiation	Yield (g)	Molecular Formula of Polypinacol	Elemental Analysis (%)			
								Found		Required	
								C	H	C	H
(40)	1.000	50	0.070	2.9	Slight turbidity		(C <sub>20</sub> H <sub>16</sub> O) <sub>2</sub> n	80.93	5.81	83.31	5.59
(41)	0.580	35	0.058	2.9	Clear	0.620	(C <sub>20</sub> H <sub>16</sub> O) <sub>2</sub> n	80.46	6.37	83.31	5.59
(42)	0.316	60	0.0139	2.9	Precipitate		(C <sub>26</sub> H <sub>20</sub> O) <sub>3</sub> n	80.84	6.53	82.08	5.30
(44)	0.320	30	0.0283	1.2	Precipitate	0.350	(C <sub>27</sub> H <sub>22</sub> O) <sub>2</sub> n	82.70	7.46	85.69	5.86
(45)	0.250	100	0.0064	1.9	Precipitate	0.261	(C <sub>28</sub> H <sub>24</sub> O) <sub>2</sub> n	82.16	7.39	85.68	6.16
(46)	0.200	25	0.0198	3.3	Precipitate		(C <sub>29</sub> H <sub>26</sub> O) <sub>2</sub> n	82.75	8.44	85.68	6.45
(47)	0.450	60	0.0179	3.1	Precipitate	0.470	(C <sub>30</sub> H <sub>28</sub> O) <sub>2</sub> n	86.58	8.90	85.68	6.71
(48)	0.111	12	0.0214	0.44	Precipitate		(C <sub>31</sub> H <sub>30</sub> O) <sub>2</sub> n	84.16	8.96	85.68	6.96
(49)	0.307	35	0.0196	0.95	Precipitate	0.315	(C <sub>32</sub> H <sub>32</sub> O) <sub>2</sub> n	84.42	9.04	85.68	7.19
(50)	0.278	20	0.0276	3.7	Clear	0.280	(C <sub>36</sub> H <sub>40</sub> O) <sub>2</sub> n	85.12	7.66	85.67	7.99

TABLE 4.18

Preparation of Polybenzopinacols in Benzene-Isopropanol Mixtures containing > 50% Benzene ( by volume)

Diketone	Weight of Diketone (g)	Solvent Mixture		Molarity of Solution Irradiated	Irradiation Time (hr x 10 <sup>-2</sup> )	Molecular Formula of Polymer	Elemental Analysis (%)			
		Benzene (ml)	Isopropanol (ml)				Found		Required	
							C	H	C	H
(44)	0.6430	18	6	0.0712	1.17	(C <sub>27</sub> H <sub>22</sub> O <sub>2</sub> ) <sub>n</sub>	85.33	5.75	85.69	5.86
(45)	0.0994	40	10	0.0051	1.79	(C <sub>29</sub> H <sub>24</sub> O <sub>2</sub> ) <sub>n</sub>	85.34	6.32	85.68	6.16
(46)	0.0991	15	5	0.0122	1.19	(C <sub>29</sub> H <sub>26</sub> O <sub>2</sub> ) <sub>n</sub>	85.07	6.81	85.68	6.45
(48)	0.0441	3.4	1.1	0.0232	0.94	(C <sub>31</sub> H <sub>30</sub> O <sub>2</sub> ) <sub>n</sub>	83.54	8.42	85.68	6.96

photochemical reactor fitted with four RUL-3500Å lamps. During irradiation, the initially white solid turned yellow.

An infrared spectrum on the irradiated solid showed a medium strength absorption at  $1655\text{ cm}^{-1}$  in addition to peaks present in the starting material.

Starting material and product (0.009 g. of each) were shaken separately with benzene (ca. 0.5 ml.). The starting material dissolved in the benzene but the irradiation product still remained largely undissolved even after shaking for 2 days.

#### 4.37 Experiments with Dichloromethane as Solvent

All irradiations were carried out with a Rayonet Type RPR-204 preparative photochemical reactor fitted with four RUL-3500Å lamps.

##### (a) Irradiation of 1,2-(4,4'-Dibenzoyldiphenyl)ethane in a Furan-Dichloromethane Mixture

The procedure was entirely analogous to that described for preparation of furan-diketone 2:1 adducts. 1,2-(4,4'-Dibenzoyldiphenyl)ethane (1.000 g., 0.00256 moles) was irradiated in a mixture of furan (100 ml.) and dichloromethane (80 ml.) for 340 hr. After irradiation the solution was yellow. Solvents were removed by vacuum transfer to yield an orange-yellow solid (1.518 g., molecular weight 1010). An infrared spectrum of the solid included a medium-strong absorption at  $\text{ca. } 3400\text{ cm}^{-1}$  and a weak-medium strength residual C=O stretch at  $\text{ca. } 1660\text{ cm}^{-1}$ . There was relatively little absorption between  $1000$  and  $900\text{ cm}^{-1}$ .

(b) Irradiation of an Equimolar Solution of 1,2-(4,4'-Dibenzoyldiphenyl)ethane and Tetramethylallene in Dichloromethane

The procedure was as described for equivalent irradiations in benzene solvent. A solution of 1,2-(4,4'-dibenzoyldiphenyl)ethane (1.500 g., 0.00384 moles) and TMA (0.3694 g., 0.00384 moles) in dichloromethane (60 ml.) was irradiated at 350 nm for 670 hr. After irradiation, the solution was yellow. Removal of dichloromethane solvent gave a yellow solid (2.00 g., molecular weight 1470). An infrared spectrum of the solid showed a weak-medium strength absorption at ca.  $3500\text{ cm}^{-1}$ , a residual C=O stretch at  $1660\text{ cm}^{-1}$  and no absorption between  $1040$  and  $960\text{ cm}^{-1}$ .

(c) Irradiation of m-Dibenzoylbenzene in Dichloromethane

A solution of m-dibenzoylbenzene (1.3 g., 0.00454 moles) in dichloromethane (20 ml.) was placed in a Pyrex reaction vessel, streamed with nitrogen for 45 min, the tube quickly stoppered and the solution irradiated at 350 nm for 1 month. At the end of the irradiation period the solution was an orange-yellow colour. Thin layer chromatography of the solution on silica gel (developing with chloroform) indicated at least two components, the major one corresponding in  $R_f$  value to m-dibenzoylbenzene. Removal of dichloromethane solvent yielded an orange-brown solid. An infrared spectrum of the solid showed, in addition to absorptions corresponding to m-dibenzoylbenzene, a weak, broad absorption centred at  $3450\text{ cm}^{-1}$  and a strong absorption at  $1100\text{ cm}^{-1}$ .

CHAPTER 5

SOME PRELIMINARY STUDIES ON PHOTOPOLYMERIZATION

UTILIZING PHOTOENOLIZATION REACTIONS

## 5.1 General Introduction

In this chapter some further, though preliminary, investigations on possible step-growth photopolymerizations involving diketones are described. The proposed polymer growth reactions have the common feature of requiring a photochemically induced inter- or intra-molecular enolization of diketone.

In part A, the photochemical oxidative-reductive dimerization of acetophenones is considered as a model reaction. Part B is devoted to a discussion of the photoenolization of 2-alkylbenzophenones and subsequent addition of the photoenols to dienophiles as possible model reactions extendable to photopolymerization.

A.

INTERMOLECULAR PHOTOENOLIZATION

INTRODUCTION

## 5.2 The Photochemical Oxidative-Reductive Dimerization of Acetophenones

### (a) Scope of the Reaction

Irradiation of acetophenone containing a catalytic quantity of phenol and using ultraviolet light filtered through Pyrex results in oxidative-reductive dimerization of acetophenone according to equation (5.1).<sup>286</sup>

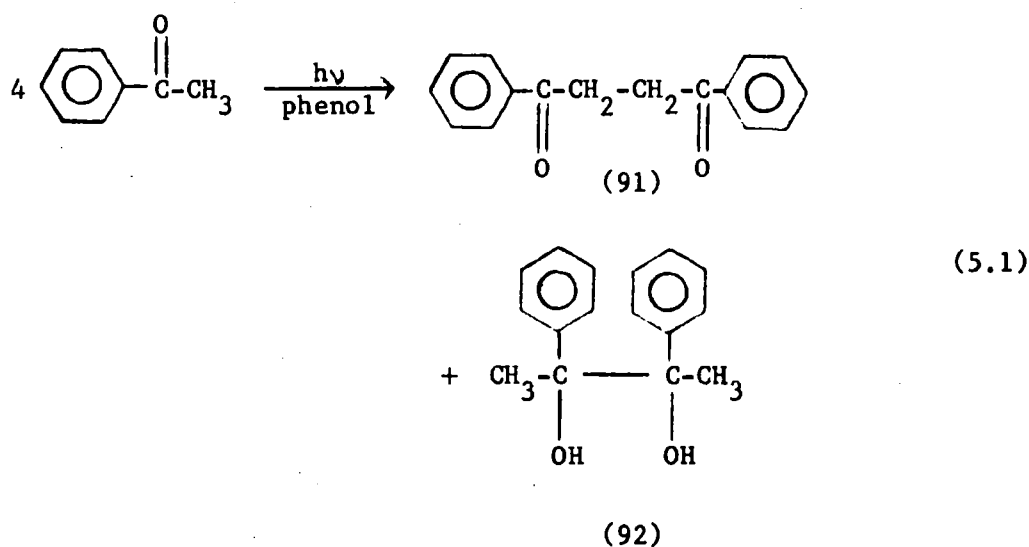

Products have been isolated in greater than 85% yield and no side-products detected by vapour phase chromatography. Reaction also proceeds in acetone solution but irradiation without solvent is reported to be preparatively advantageous.

4-Methylacetophenone and 3,4-dimethylacetophenone undergo a corresponding reaction in the presence of phenol.<sup>286</sup>

### (b) Mechanism

A mechanism for the reaction has been proposed, involving a phenol-catalyzed photoenolization of acetophenone according to the scheme (5.2).

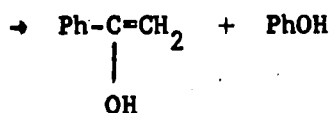
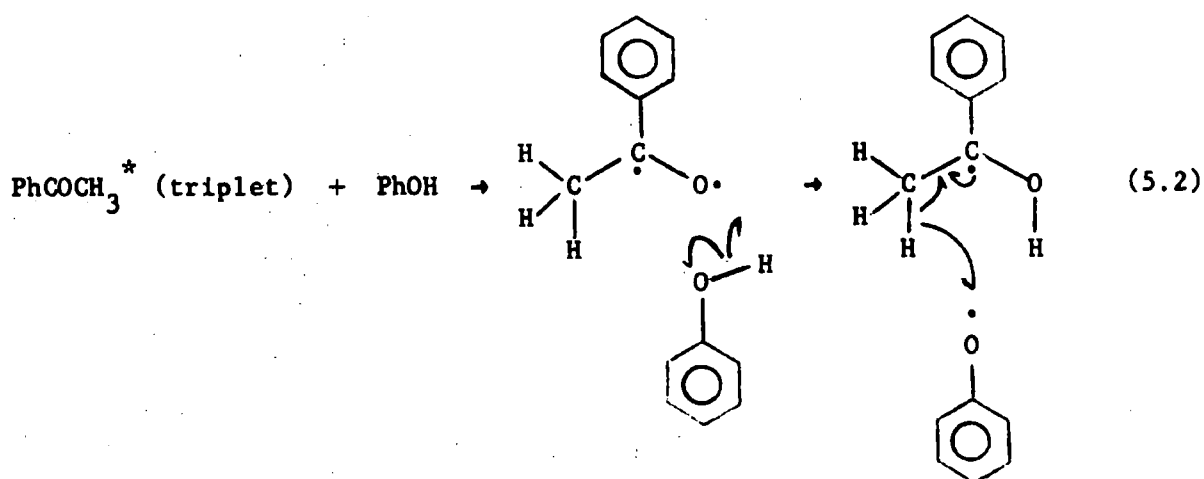
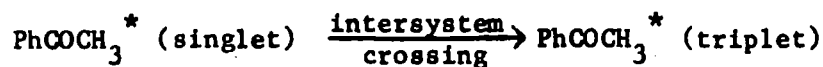
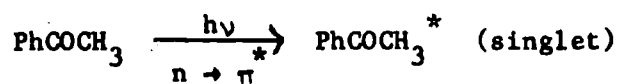

(93)

Oxidation of acetophenone enol (93) by acetophenone triplet produces a semipinacol radical (94) and an enoxy radical (95), both of which dimerize to give the products (92) and (91), according to the scheme (5.3).

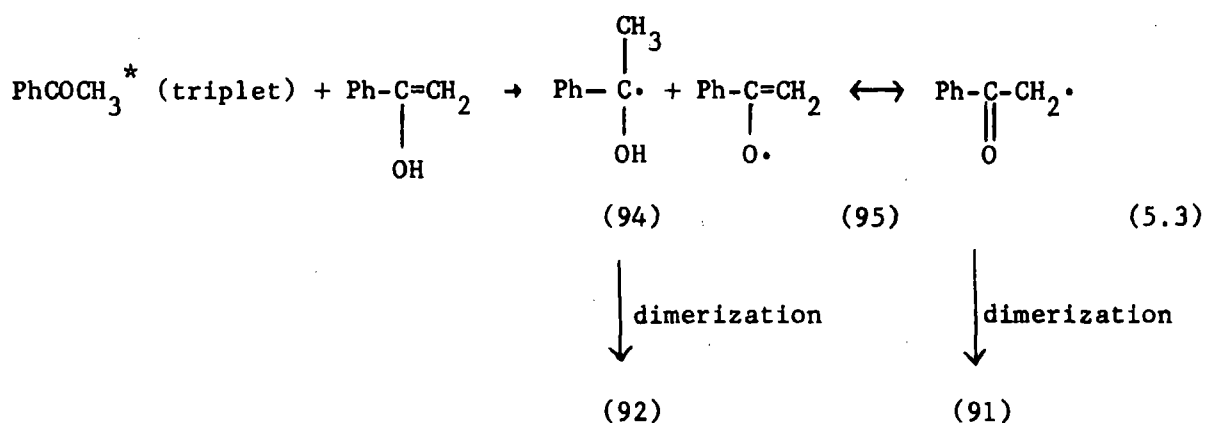

The presence of phenol, at a concentration of ca.1% and preferably adsorbed on silica gel, is essential. In the absence of phenol, acetophenone only yielded traces of the products (91) and (92). The advantageous effect of having the phenol adsorbed on silica gel is thought to result from restriction of the mobility of phenoxy radicals, thus inhibiting dissociation of the intermediate radical pair and suppressing the possible side-reaction of irreversible phenol oxidation. Other phenols, such as 2,6-di-*t*-butylphenol and 2,6-diphenylphenol can also act as catalysts, though with less efficiency than phenol itself.

A simple ground-state enolization of acetophenone due to the acidity of phenol was rejected on the grounds that addition of a trace of HCl did not show any effect on the photochemical reaction of acetophenone in the absence of phenol, and an attempt to exchange the hydrogen atoms of the acetophenone acetyl group for deuterium by shaking acetophenone with D<sub>2</sub>O in the presence of phenol was unsuccessful.

Unlike reaction between triplet-state benzophenone and 2,6-disubstituted phenols, where radical coupling between phenoxy radical and ketyl radical has been proposed,<sup>287</sup> a redox reaction occurs with acetophenone to the exclusion of radical coupling.

The proposed mechanism involves the participation of phenol in the formation of an intermolecular six-membered transition state with triplet-state acetophenone. 2,4-Dimethylacetophenone, in the absence of phenol, undergoes photochemical reaction giving (96a), (97a) and polymeric material (eq.5.4).<sup>286</sup>

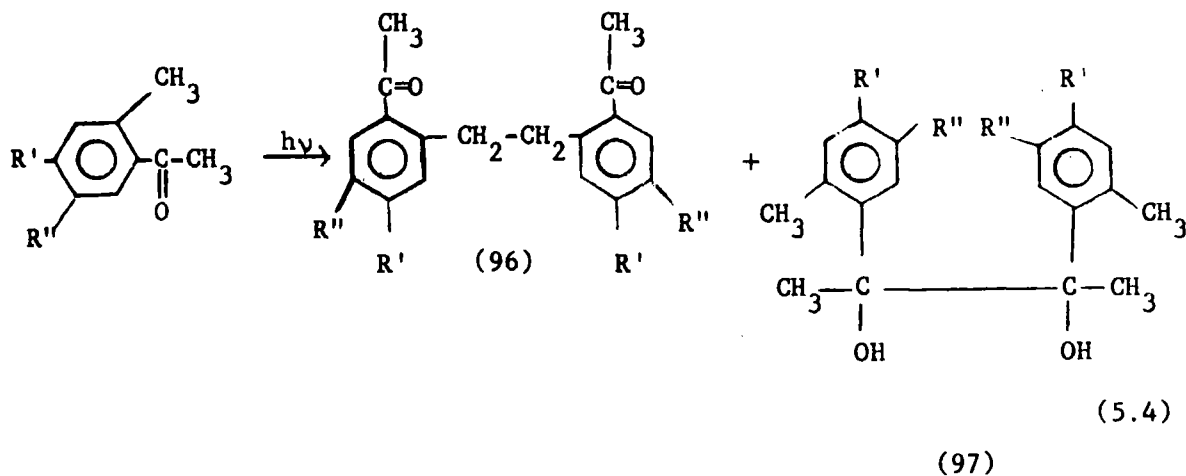

a)  $R' = \text{CH}_3$ ,  $R'' = \text{H}$

b)  $R' = \text{H}$ ,  $R'' = \text{CH}_3$

Similar reaction is reported for 2,5-dimethylacetophenone, 18% of (96b) being isolated from a large amount of nonvolatile reaction products. The addition of phenol was without effect on the course of the photo-reactions of o-methyl-substituted acetophenones. Intramolecular photo-enolization, yielding photoenols according to the equation (5.5) appeared to be favoured over intermolecular hydrogen abstraction from phenol.

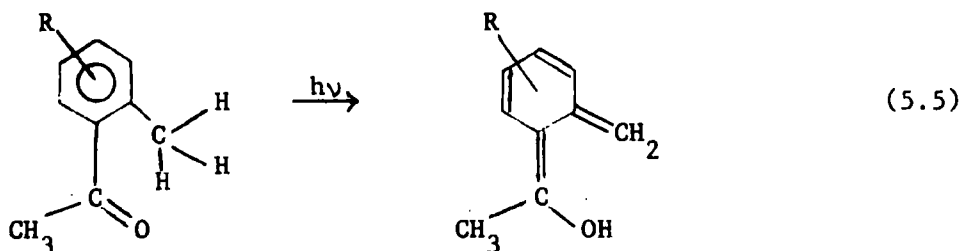

Spectroscopic evidence has been presented for reversible photoenolization of *o*-methyl-substituted acetophenones.<sup>288</sup> Oxidation of the photoenol would then lead to the products.

(c) Extension of the Reaction to Photopolymerization

Irradiation of bisacetophenones of the type (98), with phenol

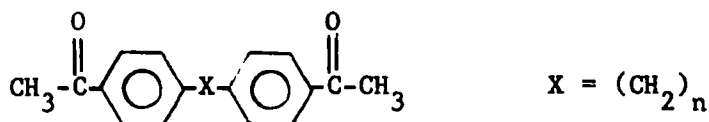

(98)

catalyst, might reasonably be expected to yield polymers containing structural units as depicted in (99) and corresponding to (91) and (92)

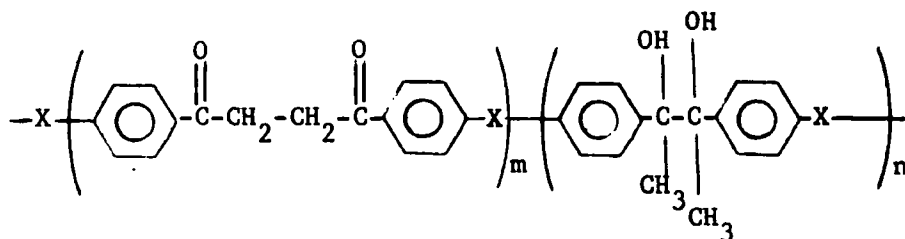

(99)

obtained from acetophenone. The reported high yields with the acetophenones, and the lack of side-reactions, should favour photopolymerization.

Polymeric material already obtained from *o*-methyl-substituted acetophenones has been attributed to successive coupling reactions of the primarily formed bifunctional, photoenolizable reaction products.

In the present work, 4,4'-diacetyldiphenyl and 4,4'-diacetyldiphenylmethane have been investigated.

## DISCUSSION

### 5.3 Preparation and Characterization of 4,4'-Diacetyldiphenyl and 4,4'-Diacetyldiphenylmethane

4,4'-Diacetyldiphenyl and 4,4'-diacetyldiphenylmethane were prepared by Friedel-Crafts acetylation of diphenyl and diphenylmethane respectively, and were characterized by combinations of melting points, elemental analyses, infrared and ultraviolet spectroscopy, and mass spectrometry.

The ultraviolet absorption spectrum of 4,4'-diacetyldiphenyl was analogous to that of 4,4'-dibenzoyldiphenyl (Chapter 3) in so far as the  $n \rightarrow \pi^*$  absorption was submerged under the  $\pi \rightarrow \pi^*$  absorption ( $\lambda_{\max}$  286 nm,  $\epsilon$  31,000 in cyclohexane). The  $n \rightarrow \pi^*$  absorption of 4,4'-diacetyldiphenylmethane was observed at  $\lambda_{\max}$  320 nm, ( $\epsilon$  170), and the  $\pi \rightarrow \pi^*$  absorption at 253 nm in cyclohexane solvent. In 95% ethanol the  $n \rightarrow \pi^*$  absorption was partially submerged under the  $\pi \rightarrow \pi^*$  absorption, the latter being at  $\lambda_{\max}$  258 nm ( $\epsilon$  28,000).

### 5.4 Attempted Photopolymerizations of 4,4'-Diacetyldiphenyl and 4,4'-Diacetyldiphenylmethane in the Presence of Phenol Catalyst

Solution phase irradiation at 300 nm of 4,4'-diacetyldiphenyl and of 4,4'-diacetyldiphenylmethane, in the presence of phenol catalyst, failed to produce any significant amount of product.

The failure of 4,4'-diacetyldiphenyl to react is not surprising, the  $n \rightarrow \pi^*$  absorption of the diketone apparently being submerged under the  $\pi \rightarrow \pi^*$  absorption and the corresponding lack of reactivity being analogous to that of 4,4'-dibenzoyldiphenyl discussed in Chapters 1 and 4, all reactions under consideration requiring a reactive  $n, \pi^*$  triplet. Dichloromethane was used as solvent, the limitations of which, for this

kind of reaction, have already been pointed out (Chapter 4). 4,4'-Diacetyldiphenyl was too insoluble in acetone to allow use of the latter as solvent.

The failure of 4,4'-diacetyldiphenylmethane to react to any significant extent must, in the first instance, be explained on practical grounds. In the absence of a stream of nitrogen passing through the reaction mixture during irradiation, as employed by Becker,<sup>286</sup> phenol catalyst adsorbed on silica gel tended to remain at the bottom of the reaction vessel, thus reducing its efficiency. Direct dissolution of phenol in the acetone solution of 4,4'-diacetyldiphenylmethane also failed to promote significant reaction. However Becker has pointed out the desirability of using phenol adsorbed on silica gel (see section 5.2) and yields with pure phenol as catalyst are only ca. one third those when phenol adsorbed on silica gel is used. The advantage of irradiation without a solvent has also been noted, but is obviously impracticable with fairly high melting solids. In addition, although yields of products from the acetophenones are high (> 85% with acetophenone itself), they are based on consumed starting material and the majority of starting material (up to ca.90% with acetophenone and phenol) remained unreacted after irradiation for 14 hours. Trace products from the attempted photopolymerization, detected only by thin layer chromatography, may thus be indicative of only very slight reaction under the experimental conditions employed. Modification of experimental technique allowing, for example, efficient use of phenol adsorbed on silica gel may increase the yield, but the production of high polymers appears unlikely.

It is worth noting, also, that methylated acetophenones, such as 4-methylacetophenone, exhibit a very low-lying  $\pi, \pi^*$  triplet state in addition to the low-lying  $n, \pi^*$  triplet state.<sup>289</sup> However this does not preclude photoreduction in isopropanol, photoreduction of acetophenone and 4-methylacetophenone occurring with comparable efficiency,<sup>289</sup> and since 4-methylacetophenone underwent oxidative-reductive dimerization in an analogous manner to acetophenone,<sup>286</sup> the possibility of similar low-lying  $\pi, \pi^*$  triplet states with 4,4'-diacetyldiphenylmethane does not appear to account for the observed lack of reactivity of the diketone.

## EXPERIMENTAL

## 5.5 Preparation of Diketones

### (a) Preparation of 4,4'-Diacetyldiphenyl

To a stirred solution of diphenyl (46.2 g., 0.299 moles) and powdered anhydrous  $\text{AlCl}_3$  (85 g., 0.637 moles) in carbon disulphide (300 ml), acetyl chloride (47.1 g., 0.600 moles) was added over a period of 15 min. After spontaneous refluxing had subsided, the mixture was refluxed for 4 hr., cooled and hydrolysed by pouring into 10% HCl-ice water (2.5 l.). After evaporation of the carbon disulphide, the resulting crude material was filtered off and washed successively with a 5% aqueous solution of sodium carbonate, a 5% aqueous solution of HCl, and water. The crude product was then recrystallized three times from alcohol, retaining the filtrates, refluxed with decolourising charcoal in alcohol, and again recrystallized from alcohol to a constant melting point to give 4,4'-diacetyldiphenyl (1.0 g., 1.4%, m.p. 187-189° [lit.191<sup>o290</sup>]).

The filtrates obtained during the recrystallization procedure were evaporated to dryness to yield a suspected mixture of 4-acetyldiphenyl and 4,4'-diacetyldiphenyl (43g.). The mixture was reacetylated as above using powdered anhydrous  $\text{AlCl}_3$  (120 g., 0.900 moles), acetyl chloride (35.0 g., 0.446 moles) and carbon disulphide solvent (300 ml.). Crystals obtained on recrystallization from alcohol were combined with the first batch of crystals (m.p. 187-189°) and the combined batches were recrystallized from carbon tetrachloride to a constant melting point to give 4,4'-diacetyldiphenyl (12 g., 17%; m.p. 189.5-191° [lit.191<sup>o290</sup>]). Found: M (mass spectrometry), 238. Calculated for  $\text{C}_{16}\text{H}_{14}\text{O}_2$ : M, 238.  $\nu_{\text{C=O}}$  1680  $\text{cm}^{-1}$ .  $\lambda_{\text{max}}$  ( $\pi \rightarrow \pi^*$ ) 286 nm,  $\epsilon$  31,000 (cyclohexane solvent).

(b) Preparation of 4,4'-Diacetyldiphenylmethane<sup>291</sup>

To a stirred suspension of anhydrous  $\text{AlCl}_3$  (87.5 g., 0.656 moles) in carbon disulphide (150 ml.) at  $0^\circ\text{C}$ , a mixture of acetyl chloride (40.0 g., 0.509 moles) and diphenylmethane (84.0 g., 0.499 moles) was slowly added. The mixture was allowed to warm up to room temperature and then poured into 10% HCl-ice water (2.5 l.). The aqueous and carbon disulphide layers were separated and carbon disulphide was removed from the latter and the residue fractionally distilled at a pressure of ca. 0.1 mm.Hg. Fractions collected within the range  $184\text{--}190^\circ\text{C}$  were combined and recrystallized from alcohol to a constant melting point giving 4,4'-diacetyldiphenylmethane (2.0 g., 3.1%; m.p.  $92.5\text{--}93.5^\circ$  [lit.  $92.5\text{--}93^\circ$ <sup>291</sup>]). Found: C, 80.94; H, 6.58%. M (mass spectrometry), 252. Calculated for  $\text{C}_{17}\text{H}_{16}\text{O}_2$ : C, 80.92; H, 6.39%. M, 252.  $\nu_{\text{C=O}}$ ,  $1675\text{ cm}^{-1}$ .  $\lambda_{\text{max}}$  ( $n \rightarrow \pi^*$ ) 320 nm,  $\epsilon$  170;  $\lambda_{\text{max}}$  ( $\pi \rightarrow \pi^*$ ) 253 nm (cyclohexane solvent).  $\lambda_{\text{max}}$  ( $\pi \rightarrow \pi^*$ ) 258 nm,  $\epsilon$  28,000 (95% ethanol solvent).

5.6 IrradiationsPhenol catalyst

Phenol catalyst was prepared by warming and shaking together a mixture of A.R. phenol (1.0 g.) and silica gel (5.0 g., 70-325 mesh).

(a) Irradiation of 4,4'-Diacetyldiphenyl and Phenol Catalyst in Dichloromethane

A solution of 4,4'-diacetyldiphenyl (1.057 g.) in dichloromethane (25 ml.) was placed in a Pyrex reaction vessel together with phenol catalyst (0.07 g.). The solution was streamed with  $\text{N}_2$  for 30 min, the reaction vessel quickly stoppered, and the solution irradiated at 300 nm

for 500 hr. in a Rayonet type RPR-204 preparative photochemical reactor fitted with four RUL-3000Å lamps. After irradiation, the resulting pale yellow solution was separated from the catalyst and dichloromethane solvent removed (rotary evaporator) to yield a pale yellow solid. An infrared spectrum of the solid was virtually identical to that of 4,4'-diacetyldiphenyl, and thin layer chromatography on silica gel (developing with chloroform) showed essentially only one component of  $R_f$  value corresponding to starting material.

(b) Irradiation of 4,4'-Diacetyldiphenylmethane and Phenol Catalyst in Acetone

A solution of 4,4'-diacetyldiphenylmethane (0.519 g.) in acetone (12 ml.) was placed in a Pyrex reaction vessel together with phenol catalyst (0.09 g.). The solution was streamed with  $N_2$  for 30 min., the reaction vessel quickly stoppered and the solution irradiated at 300 nm for 170 hr., as above. At the end of the irradiation period the solution was pale yellow. Thin layer chromatography of the solution on silica gel (developing with chloroform) indicated essentially only one component of  $R_f$  value corresponding to 4,4'-diacetyldiphenylmethane.

To the residual solution, phenol (0.045 g.) was added and the solution was reirradiated at 300 nm for 270 hr. After irradiation the acetone was removed from the resulting yellow solution to yield a yellow solid, the infrared spectrum of which was virtually identical to that of 4,4'-diacetyldiphenylmethane. Thin layer chromatography on silica gel (developing with chloroform) of the solid showed traces of three other components in addition to a major component of  $R_f$  value corresponding to that of 4,4'-diacetyldiphenylmethane.

B.

INTRAMOLECULAR PHOTOENOLIZATION

INTRODUCTION

### 5.7 Photoenolization of 2-Alkylbenzophenones

The photochemical enolization of 2-substituted benzophenones was first reported in 1961 by Yang and Rivas,<sup>158</sup> who observed that on irradiation of 2-benzylbenzophenone or 2-methylbenzophenone, intramolecular hydrogen transfer occurred, giving the corresponding enol (eq.5.6).

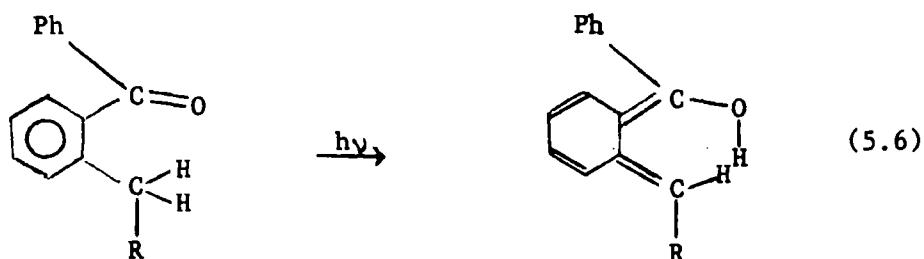

R = Ph or H

Both benzophenones were recovered unchanged after prolonged irradiation in alcohol solutions. Irradiation of a solution of 2-benzylbenzophenone in  $\text{CH}_3\text{OD}$  resulted in the incorporation of 1.04-1.09 atoms of deuterium per molecule, the deuterium atoms being located at the benzylic position. The photoenol of 2-methylbenzophenone underwent Diels-Alder addition with dimethyl acetylenedicarboxylate in high yield to give the adduct (100), which, on treatment with acid, was converted to 1-phenylnaphthalene-2,3-dicarboxylic acid (101) (eq.5.7).

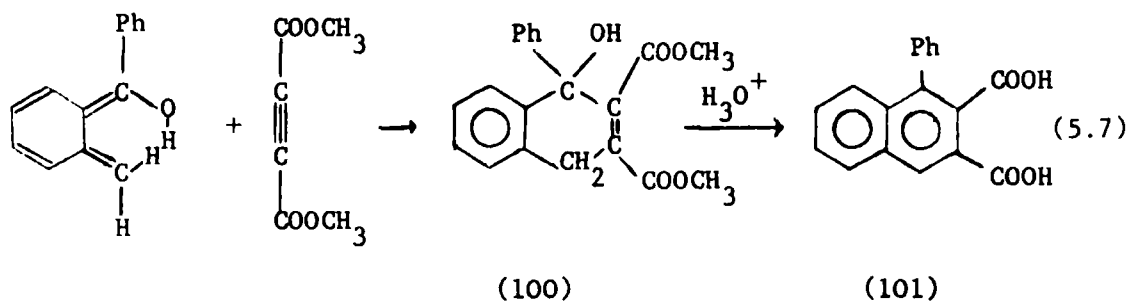

Subsequent flash photolysis and spectroscopy<sup>292</sup> of 2-benzylbenzophenone identified the  $n, \pi^*$  triplet of the ketone as the precursor of the enol. A transient species, with a lifetime of a few seconds, detected in the same investigation was tentatively identified as the enol.

(a) Scope of the Reaction

The utility of the photoenolization was extended by Pfau and co-workers<sup>159</sup> who showed that Diels-Alder adducts and related dehydration products could also be obtained in ca.80% yield from dimethyl acetylenedicarboxylate and the benzophenones: 2,4-dimethylbenzophenone, 2,5-dimethylbenzophenone, 2-methyl-4'-methoxybenzophenone and 2-methyl-4'-chlorobenzophenone. 2,6-Dimethylbenzophenone, 2-methylacetophenone and 2,5-dimethylacetophenone failed to give any adduct.

While testing other acetylenic and olefinic compounds (cyclohexene, dimethyl maleate, ethyl cinnamate, diphenylacetylene and phenylacetylene) as potential dienophiles for the photoenol of 2,4-dimethylbenzophenone, Pfau and co-workers subsequently obtained<sup>293</sup> low yields (5-10%) of the pinacol of the parent benzophenone. No enol-dienophile adducts were obtained. Irradiation of 2-methylbenzophenone, 2,4-dimethylbenzophenone, 2,5-dimethylbenzophenone, 2,3',4'-trimethylbenzophenone and 3-methyl-4-benzoylpyridine in isopropanol resulted in photopinacolization, yields varying between 28% and 50%. Irradiation of 2,4-dimethylbenzophenone and dimethyl acetylenedicarboxylate in isopropanol resulted in a 30% yield of the pinacol as the only photoproduct. In contrast, a competition experiment involving irradiation of equimolar (0.05M) quantities of 2,4-dimethylbenzophenone, dimethyl acetylenedicarboxylate and isopropanol in benzene solution resulted in a 78% yield of trapped enol, no pinacol apparently being formed.

Ullman and co-workers have prepared<sup>294,295</sup> ketones in which structural modifications of 2-methyl- and 2-benzylbenzophenone were made to increase the lifetime of the photoenols, investigations being directed towards reducing the loss of aromatic resonance energy on photoenolization, and providing stabilization of photoenols by positioning a carbonyl group so as to permit its involvement in hydrogen bonding with the enolic hydrogen. The chromone (102), which readily photoenolized at room temperature (eq.5.8), was prepared. The photoenol (103) persisted in non polar solvents for several hours in the absence of oxygen.

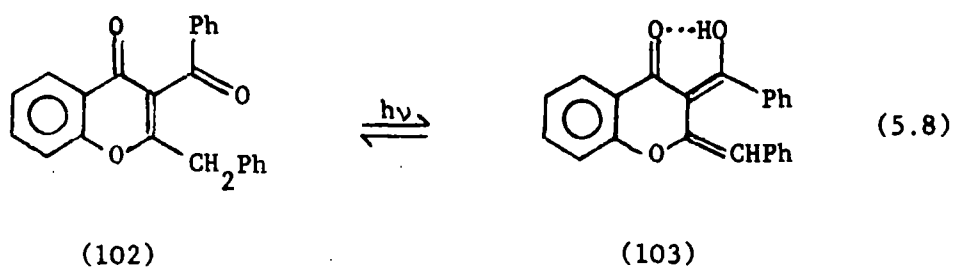

Several substituted derivatives of (102) displayed similar photochromic properties, as did quinolone analogues such as (104).

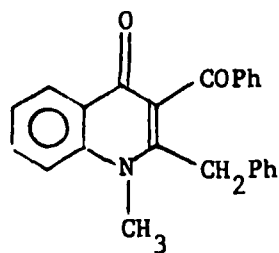

(104)

(b) Mechanistic Studies

Resulting from a study of primary photochemical processes in alkyl-substituted benzophenones and using 4-methyl-, 2-ethyl-, 2-methyl- and 2-t-butylbenzophenones as representative examples, Beckett and Porter<sup>296</sup> reported that alkyl-substituted benzophenones having a hydrogen directly attached to carbon substituted at the ortho position exhibited low quantum yields of photolysis, and ketyl radicals were not observed on flash photolysis. Metastable intermediates with no E.S.R. spectra and lifetimes of several hours were thought to be the photoenols. However, these results conflicted with those of Yang<sup>292</sup> who detected a transient species of lifetime ca. 10 sec. from 2-benzylbenzophenone (referred to above) and tentatively assigned this as the corresponding photoenol. Subsequently, the metastable intermediate from 2-methylbenzophenone, observed by Beckett and Porter, was reexamined<sup>297</sup> with respect to mode of formation and chemistry, and reassigned the structure (105), (105) being

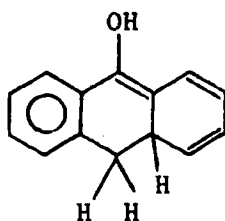

(105)

formed from the photoenol by a reversible photochemical reaction. A transient species,  $\lambda_{\max}$  400 nm, was assigned to the photoenol and a long-lived yellow species,  $\lambda_{\max}$  383 nm, was assigned to (105). Irradiation of 2-methylbenzophenone for 7 hours at  $-80^{\circ}$  followed by warming and exposure to oxygen gave ca.1% anthrone, which could be formed (in the dark) by

oxidation of (105), (eq.5.9).

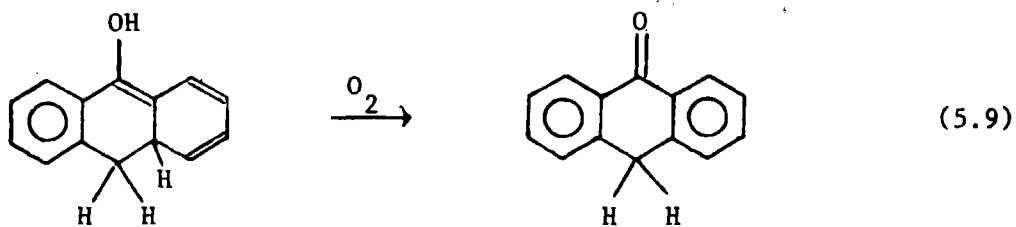

Anthraquinones, detected as photooxidation products of 2-methylbenzophenones, may be formed by further photooxidation of the anthrone.<sup>298</sup> Other products formed from irradiation of 2-methylbenzophenones, in a flowing air stream, in benzene solvent at 350 nm include 2-formylbenzophenones (106), 2-benzoylbenzoic acids (107) and 3-phenylphthalides (108).<sup>298,299</sup>

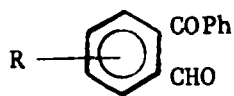

(106)

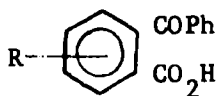

(107)

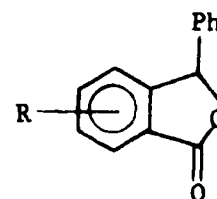

(108)

Following the detection of five transients in the flash photolysis of 2,4-dimethylbenzophenone, intermediates and a reaction pathway have been suggested<sup>300</sup> as shown below (5.10).

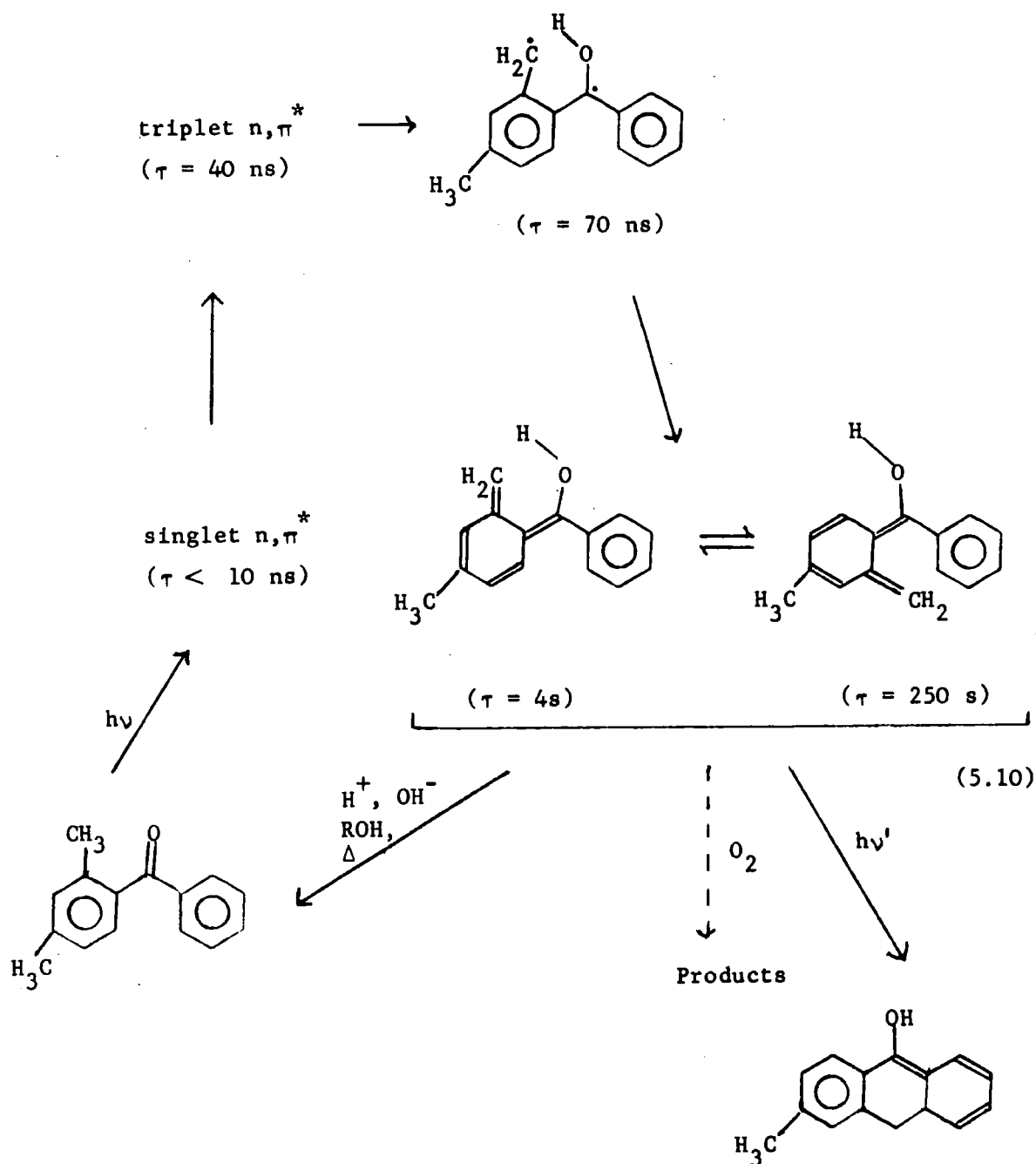

Mechanistic studies, particularly relating to chromones<sup>294</sup> were generally consistent with photoenolization only occurring efficiently when the lowest triplet was  $n, \pi^*$ . However, it was proposed that, for chromones at least, the mechanism should be modified to include an intermediate excited state of the enol, according to the equations (5.11).

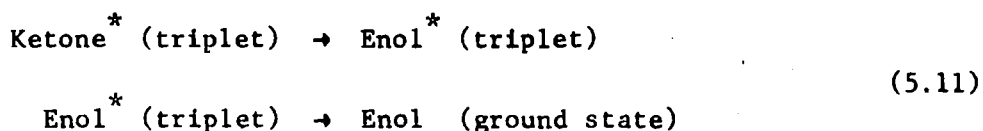

This modification was necessary to explain why 2-methyl-3-benzoylchromone (109) was unreactive whereas 2-benzyl-3-benzoylchromone (102) was photoenolizable. With virtually identical chromophores, the initial

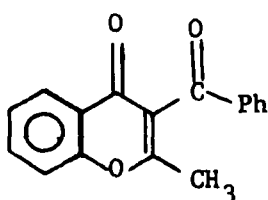

(109)

reactions of (102) and (109) would be expected to be very similar, so any differences in the outcome of the reaction had to be accounted for on the basis of differences between the various intermediate species. Ground state energies of the two enols would be very similar, whereas if excited states of the enols were formed as intermediates, the more conjugated excited photoenol of (102) would be substantially less energetic than that of (109).

The photoreactions of (102) and 2-benzhydryl-3-benzoylchromone (110) have been studied in detail.<sup>295</sup> In alcohol solvent, triplet reaction related to photopinacolization has been observed, the photoproduct from (102) being assigned the structure (111).

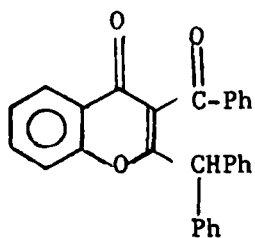

(110)

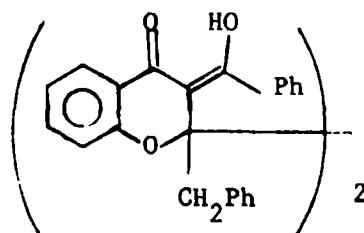

(111)

(c) Extension of the Reaction to Photopolymerization

The photoenolization reaction of 2-methylbenzophenone and subsequent Diels-Alder reaction of the photoenol may be extendable to photoenolization of appropriate diketones and subsequent Diels-Alder addition with a suitable bisdienophile, as illustrated by equation (5.12).

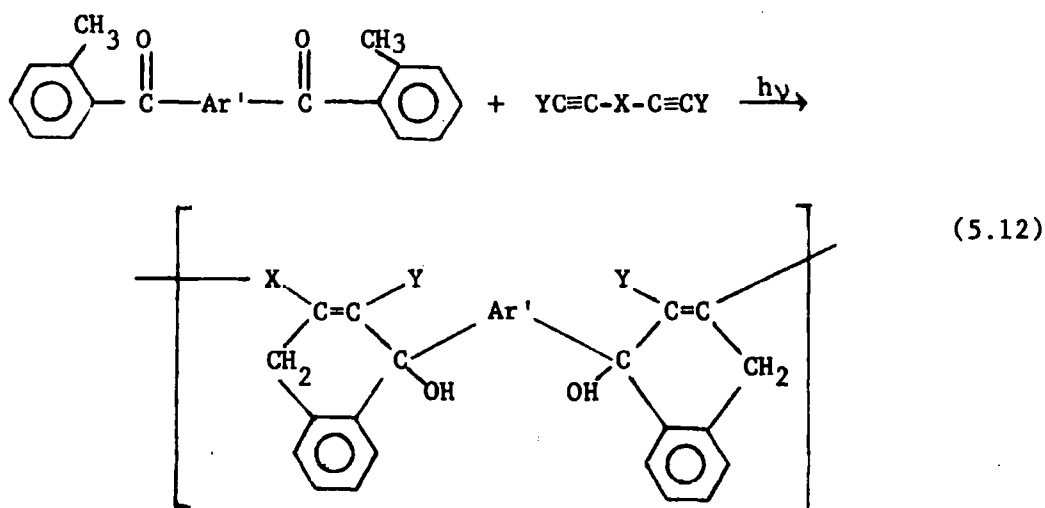

Reaction may also be possible with further substituents in the benzene ring, in analogy to the various 2-substituted benzophenone photoenolizations discussed earlier. Possible complications include photopinacolization, even in benzene solution, depending on the nature of the ketone and dienophile. It may also be noted that acetylenes such as dimethyl acetylenedicarboxylate and phenylacetylene are known to add to benzene under the influence of ultraviolet light.<sup>301</sup> Dimethyl acetylene-<sup>302</sup>dicarboxylate, for example, reacts according to the equation (5.13).

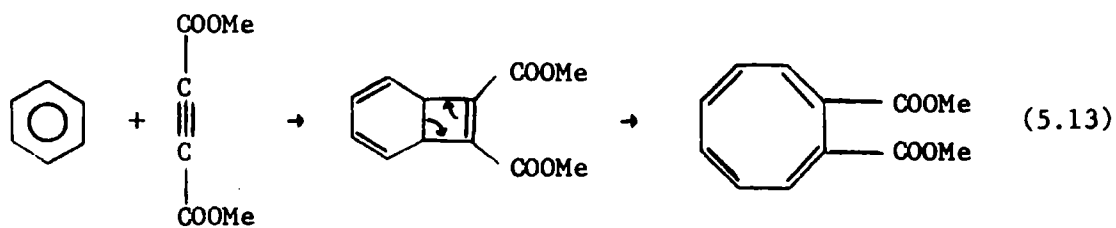

However, such reactions are not reported as interfering with Diels-Alder trapping of photoenols produced in benzene solution, under the conditions required for the photoenolization.

## DISCUSSION

m-Dimesitoylbenzene, p-dimesitoylbenzene and 1,4-di-o-toluoylbenzene have been investigated as possible photoenolizable diketones for photopolymerization with bisdienophiles. Dimethyl acetylenedicarboxylate has been used as a monofunctional dienophile in preliminary studies aimed at isolating model compounds. 1-Heptyne and 1,6-heptadiyne, as possible monofunctional and bifunctional dienophiles, have been examined, as has phenylacetylene which could be modified to a diethynylbenzene in attempted photopolymerizations.

#### 5.8 Preparation and Characterization of Diketones

m-Dimesitoylbenzene and p-dimesitoylbenzene were prepared by Friedel-Crafts reaction between the corresponding phthaloyl dichloride and mesitylene (in excess as solvent) with  $\text{AlCl}_3$  as catalyst. 1,4-Di-o-toluoylbenzene was prepared by reaction between o-tolyl magnesium bromide and terephthaloyl dichloride, following a published route.<sup>303</sup> Attempts to obtain a pure sample of 1,3-di-o-toluoylbenzene were unsuccessful.

Diketones were characterized satisfactorily by melting points, elemental analyses, infrared and ultraviolet spectroscopy, and mass spectrometry.

Ultraviolet spectra were largely analogous to those of m- and p-dibenzoylbenzenes described in Chapter 3. In cyclohexane solvent, the  $n \rightarrow \pi^*$  absorptions were fairly well resolved ( $\lambda_{\text{max}}$  ca. 350 nm) from the  $\pi \rightarrow \pi^*$  absorptions, the  $n \rightarrow \pi^*$  absorption of m-dimesitoylbenzene being the most clearly resolved. In going from p-dibenzoylbenzene to 1,4-di-o-toluoylbenzene to p-dimesitoylbenzene, a decrease in extinction coefficient for the  $n \rightarrow \pi^*$  absorption ( $\epsilon$ , 370, 310, 240 respectively in cyclohexane solvent) was observed, possibly due to increasing restriction of coplanar

conformations with 2-alkyl substitution. In 95% ethanol solvent,  $n \rightarrow \pi^*$  absorptions were partially submerged under the  $\pi \rightarrow \pi^*$  absorptions and  $\lambda_{\text{max}}$ 's were not observed for the former absorptions.

It is interesting to note that crystals of 1,4-di-o-toluoylbenzene in a Pyrex flask turned from white or a very pale yellow to medium yellow in colour, on exposure to sunlight. In the dark the yellow colouration slowly faded to give very pale yellow crystals. The cycle could be repeated several times and may be indicative of a reversible solid-state photoenolization.

### 5.9 Photoenolization Investigations

All the reactions attempted gave products which could not, in these initial stages of investigation, be isolated in a pure state. Conclusions may be only be drawn on the basis of mostly qualitative results relying heavily on infrared spectroscopy, thin layer chromatography and analogy with reactions in the literature and described in section 5.7.

Irradiation at 350 nm of benzene solutions of m- and p-dimesitoylbenzenes (1 molecular proportion) with dimethyl acetylenedicarboxylate (ca. 2 molecular proportions) apparently resulted only in partial reaction, as shown by thin layer chromatography which indicated a substantial proportion of materials with  $R_f$  values corresponding to those of the diketones, and by infrared spectroscopy, in the case of m-dimesitoylbenzene, which suggested that a large amount of carbonyl group remained unreacted. This evidence was largely consistent with reports<sup>159</sup> that 2,6-dimethylbenzophenone failed to give any adduct on irradiation in the presence of dimethyl acetylenedicarboxylate. Infrared spectroscopic evidence did, however, indicate the presence of OH groups in one product

from *m*-dimesitylbenzene irradiation, there being a medium strength broad absorption centred at ca.  $3500\text{ cm}^{-1}$ . Attempts to isolate and purify products by chromatography and recrystallization were, however, unsuccessful and it was not possible to determine whether the OH groups were derived from a photoenolization or a pinacolization type process. The apparently large proportion of unreacted carbonyl function pointed towards the diketones being unsuitable in polymerization incorporating a photoenolization process.

1,4-Di-*o*-toluoylbenzene appeared a more suitable diketone for study, there being little residual carbonyl function after irradiation at 350 nm of a benzene solution of the diketone with dimethyl acetylenedicarboxylate. However, although thin layer chromatography indicated no residual starting material, at least four products were detected. Complete separation of products was not achieved by column chromatography or recrystallization, although infrared spectra of two partially purified solid products indicated the presence of considerable OH grouping and were not inconsistent with adduct formation between photoenol and dienophile.

Photoenol-dienophile adducts should be dehydrated on treatment with HCl. To determine whether such reaction was effective in producing more easily purifiable material, crude material from an irradiation of 1,4-di-*o*-toluoylbenzene and dimethyl acetylenedicarboxylate was treated for 6 hours with HCl. However at least five components were subsequently detected by thin layer chromatography and the reaction was not investigated further.

By analogy with the photochemistry of *m*- and *p*-dibenzoylbenzenes, 1,3-di-*o*-toluoylbenzene might be expected to react more efficiently, but attempts to produce the latter diketone on a preparative scale have, so far, been unsuccessful.

Irradiation at 350 nm of benzene solutions of 1,4-di-o-toluoylbenzene and phenylacetylene, 2-methylbenzophenone and 1-heptyne, and 1,4-di-o-toluoylbenzene and 1,6-heptadiyne all gave solid products, but overall yields approximately corresponded only to the quantity of ketone starting material, suggesting removal of the unreacted acetylene during isolation of crude product. Medium to strong absorptions in the infrared spectra of crude products were indicative of a substantial proportion of OH groupings. Yields suggested that the OH groups were derived from pinacol type reactions, Pfau and co-workers<sup>293</sup> previously having detected pinacols in irradiations of 2-methylbenzophenones in 'such a poor hydrogen donating medium as benzene', an illustrative example being the irradiation of 2-methylbenzophenone and phenylacetylene. Oligomeric material ( $\bar{M}_n$  ca. 1600) was produced in the 1,4-di-o-toluoylbenzene/1,6-heptadiyne irradiation. Consumption of carbonyl group, as determined by infrared spectroscopy, was almost complete in the 2-methylbenzophenone/1-heptyne irradiation.

In conclusion, 1-heptyne and 1,6-heptadiyne, and also phenylacetylene (and presumably diethynylbenzenes) do not appear to be suitable dienophiles. 1,4-Di-o-toluoylbenzene appears to be the most reactive diketone studied in relation to the photoenolization process, but the number of products obtained with dimethyl acetylenedicarboxylate, although as yet unidentified, suggest severe limitations on any photopolymerizations with suitable bisdienophiles.

Complete separation and characterization of products from the reactions described would have required more extensive investigation of possible purification procedures. Such investigation was not undertaken

since the qualitative results obtained for the systems studied were inconsistent with their successful extension to the desired step-growth photopolymerizations.

**EXPERIMENTAL**

## 5.10 Preparation of Diketones

### (a) Preparation of m-Dimesitoylbenzene

To a stirred solution of isophthaloyl dichloride (15.0 g., 0.0739 moles) in mesitylene (100 ml.), powdered anhydrous  $\text{AlCl}_3$  (24.0 g., 0.180 moles) was added in 1 g. portions. The resulting mixture was heated on a steam bath for 3 hr., cooled and poured into 10% HCl-ice water (600 ml.). Solid material was filtered off from the water-mesitylene mixture and the mesitylene layer was then separated and evaporated to dryness to yield more solid. Solid material was then recrystallized from ethanol to a constant melting point, to give m-dimesitoylbenzene (3.5 g., 12.8%; m.p. 150.5-152° [lit. 149-151°]<sup>304</sup>). Found: C, 84.55; H, 7.02%. M (mass spectrometry), 370. Calculated for  $\text{C}_{26}\text{H}_{26}\text{O}_2$ : C, 84.29; H, 7.07%. M 370.  $\nu_{\text{C=O}}$  1680  $\text{cm}^{-1}$ .  $\lambda_{\text{max}}$  ( $n \rightarrow \pi^*$ ) 350 nm,  $\epsilon$  200;  $\lambda_{\text{max}}$  ( $\pi \rightarrow \pi^*$ ) 233 nm (cyclohexane solvent).  $\lambda_{\text{max}}$  ( $\pi \rightarrow \pi^*$ ) 233 nm,  $\epsilon$  37,000 (95% ethanol solvent).

### (b) Preparation of p-Dimesitoylbenzene

p-Dimesitoylbenzene was prepared in a manner analogous to that described for the preparation of m-dimesitoylbenzene, using terephthaloyl dichloride (30.0 g., 0.148 moles), mesitylene (200 ml.) and powdered anhydrous  $\text{AlCl}_3$  (48.0 g., 0.360 moles). Crude product was recrystallized from benzene to a constant melting point to give p-dimesitoylbenzene (13 g., 24%; m.p. 244.5-245.5° [lit. 244-246°]<sup>304</sup>). Found: C, 84.23; H, 7.11%. M (mass spectrometry), 370. Calculated for  $\text{C}_{26}\text{H}_{26}\text{O}_2$ : C, 84.29; H, 7.07%. M, 370.  $\nu_{\text{C=O}}$  1665  $\text{cm}^{-1}$ .  $\lambda_{\text{max}}$  ( $n \rightarrow \pi^*$ ) 348 nm,  $\epsilon$  240;  $\lambda_{\text{max}}$  ( $\pi \rightarrow \pi^*$ ) 265 nm (cyclohexane solvent).  $\lambda_{\text{max}}$  ( $\pi \rightarrow \pi^*$ ) 263 nm,  $\epsilon$  26,000 (95% ethanol solvent).

(c) Preparation of 1,4-Di-o-toluoylbenzene<sup>303</sup>

Preparations were carried out under an atmosphere of nitrogen.

i) Preparation of o-Tolyl Magnesium Bromide

To a stirred mixture of magnesium turnings (7.5 g., 0.308 moles) covered with dry ether (40 ml.), a solution of o-bromotoluene (53.5 g., 0.313 moles) in dry ether (60 ml.) was slowly added over a period of 2 hr. (The Grignard reaction was initiated by addition of a few drops of 1,2-dibromoethane). After addition of all the o-bromotoluene, the resulting mixture was refluxed for 1 hr. and then cooled and filtered.

ii) Reaction of o-Tolyl Magnesium Bromide with Terephthaloyl Dichloride

To a stirred mixture of terephthaloyl dichloride (25.0 g., 0.123 moles) in 50:50 v/v dry benzene-ether (125 ml.) cooled initially to ca.  $-10^{\circ}$ , the solution of o-tolyl magnesium bromide, prepared as in (i) above, was added at such a rate that the temperature of the reaction mixture remained within the range  $-13 - -7^{\circ}$ . After addition of the Grignard reagent was complete, the solution was refluxed for 30 min, cooled and 10% HCl-ice water (500 ml.) carefully added. The resulting mixture was steam distilled for 2 hr., cooled and the aqueous layer decanted off to leave a yellow-orange highly viscous material. 2N NaOH (500 ml.) was added to this viscous material and the mixture digested with steam for 1 hr. After cooling, the aqueous layer was decanted off and residual material distilled under reduced pressure (ca.  $10^{-2}$  mm.Hg) collecting the fraction b.p.  $165-192^{\circ}$  which solidified to a yellow solid on standing. The yellow solid was recrystallized from ethanol, (together with refluxing with decolourising charcoal), to a constant melting point

to give 1,4-di-o-toluoylbenzene (5.0 g., 13%; m.p. 84-85°, [lit. 82°<sup>303</sup>]). Found: C, 83.79; H, 5.49%. M (mass spectrometry), 314. Calculated for C<sub>22</sub>H<sub>18</sub>O<sub>2</sub>: C, 84.05; H, 5.77%. M, 314.  $\nu_{C=O}$  1655 cm<sup>-1</sup>.  $\lambda_{max}$  (n  $\rightarrow$   $\pi^*$ ) 348 nm,  $\epsilon$  310;  $\lambda_{max}$  ( $\pi \rightarrow \pi^*$ ) 263 nm (cyclohexane solvent).  $\lambda_{max}$  ( $\pi \rightarrow \pi^*$ ) 264 nm,  $\epsilon$  26,000 (95% ethanol solvent).

(d) Attempted Preparation of 1,3-Di-o-toluoylbenzene

Attempts were made to prepare 1,3-di-o-toluoylbenzene in a manner analogous to that described for 1,4-di-o-toluoylbenzene and on the same scale, replacing terephthaloyl dichloride by isophthaloyl dichloride. Vacuum distillation of crude product at ca. 10<sup>-3</sup> mm.Hg gave a highly viscous yellow oil which could not be successfully recrystallized.

5.11 Irradiations

All irradiations were performed with a Rayonet Type RPR-204 preparative photochemical reactor fitted with four RUL-3500Å lamps. Solutions for irradiation were prepared in Pyrex reaction vessels in the conventional manner, being streamed with N<sub>2</sub> for ca. 45 min. and reaction vessels then rapidly stoppered prior to irradiation. Dimethyl acetylenedicarboxylate, 1-heptyne, 1,6-heptadiyne and phenylacetylene were injected into the reaction vessels via the nitrogen streaming system in a manner analogous to that described for photopolymerizations utilizing tetramethylallene (see Chapter 4, section 4.32).

Dimethyl Acetylenedicarboxylate

Dimethyl acetylenedicarboxylate was purchased from Koch-Light Laboratories Ltd. and fractionally distilled (column 15 cm x 2 cm diameter filled with glass helices) under reduced pressure, the fraction b.p. 87-88° at 18 mm.Hg being used in the irradiations.

### Phenylacetylene

Phenylacetylene was purchased from Ralph N. Emmanuel Ltd. and fractionally distilled (column as for dimethyl acetylenedicarboxylate), the fraction b.p. 141-141.5° being used in irradiations.

### 1-Heptyne

1-Heptyne was purchased from Koch-Light Laboratories Ltd. and fractionally distilled (column 15 cm x 1 cm diameter filled with glass helices), the fraction b.p. 96.8-97.2° being used in irradiations.

### 1,6-Heptadiyne

1,6-Heptadiyne was purchased from K. and K. Laboratories, Inc. Examination by v.p.c. showed only one component and the diacetylene was used without further purification.

### 2-Methylbenzophenone

2-Methylbenzophenone was purchased from Eastman Organic Chemicals and distilled (Fischer Spaltrohr Concentric Tube Fractionating Column, FB-MMS 200), the fraction b.p. 109° @ ca. 0.25 mm.Hg being used in irradiations.

#### (a) Irradiation of m-Dimesitylbenzene and Dimethyl Acetylenedicarboxylate in Benzene

A solution of m-Dimesitylbenzene (0.6736 g., 0.001818 moles) and dimethyl acetylenedicarboxylate (0.5168 g., 0.003636 moles) in benzene (25 ml.) was irradiated for 280 hr. at 350 nm. After irradiation, thin layer chromatography of a sample of the resulting yellow solution on silica gel (developing with chloroform) indicated four components, the most intense corresponding in  $R_f$  value to m-dimesitylbenzene, a second much less intense component having a  $R_f$  value of ca. 0.3 and the other

two components being still less intense. Benzene solvent was removed by freeze drying to yield a yellow solid. The infrared spectrum of this solid showed a weak absorption at ca.  $3500\text{ cm}^{-1}$  and strong absorptions particularly at  $1730$ ,  $1665$  and  $1260\text{ cm}^{-1}$ . The solid was chromatographed on a column of silica gel (30 cm x 2.5 cm diameter), eluting with chloroform and collecting fractions of 10-15 ml. in volume. Fractions containing the component of  $R_f$  value corresponding to m-dimesitylbenzene were combined and solvent removed (rotary evaporator) to yield a yellow solid, the infrared spectrum of which corresponded closely to that of m-dimesitylbenzene with additional peaks (particularly at  $1730$  and  $1260\text{ cm}^{-1}$ ) corresponding to the acetylene. Fractions containing the second most intense component were combined, solvent removed and an infrared spectrum of the resulting yellow solid recorded (peaks particularly at  $3500$ ,  $1730$  and  $1675\text{ cm}^{-1}$  (m-s) and  $1280$ - $1200\text{ cm}^{-1}$  (s)). Thin layer chromatography of the two solids showed more than one component in each. All attempts to purify the solids by recrystallization were unsuccessful.

(b) Irradiation of p-Dimesitylbenzene and Dimethyl Acetylenedicarboxylate in Benzene

A solution of p-dimesitylbenzene (0.4733 g., 0.001277 moles) and dimethyl acetylenedicarboxylate (0.3631 g., 0.002554 moles) in benzene (100 ml.) was irradiated at 350 nm for 670 hr. After irradiation, thin layer chromatography of a sample of the resulting yellow solution on silica gel (developing with chloroform) indicated largely one component of  $R_f$  value corresponding to that of p-dimesitylbenzene, plus a further weak component of  $R_f$  value zero.

(c) Irradiation of 1,4-Di-o-Toluoylbenzene and Dimethyl Acetylene-dicarboxylate in Benzene

A solution of 1,4-di-o-toluoylbenzene (0.4813 g., 0.00153 moles) and dimethyl acetylenedicarboxylate (0.4351 g., 0.00306 moles) in benzene (25 ml.) was irradiated at 350 nm for 36 hr. After irradiation, thin layer chromatography of the resulting pale yellow solution on silica gel (developing with chloroform) indicated four components all of  $R_f$  value lower than that of 1,4-di-o-toluoylbenzene. Benzene solvent was removed by freeze drying to give a pale yellow solid (0.86 g.). An infrared spectrum of the solid showed particular absorptions at ca.  $3450\text{ cm}^{-1}(\text{m})$ ,  $1730\text{ cm}^{-1}(\text{s})$ ,  $1660\text{ cm}^{-1}(\text{m})$ ,  $1440\text{ cm}^{-1}(\text{m})$  and  $1260\text{ cm}^{-1}(\text{s})$ .

The solid was chromatographed on a column of silica gel (45 cm x 2.5 cm diameter), eluting with chloroform and collecting fractions of ca. 10 ml. in volume. Combination of fractions apparently containing the same component and removal of chloroform gave two samples of pale yellow viscous material and two samples of pale yellow solids. Infrared spectra of the samples all showed strong absorptions at  $1730\text{ cm}^{-1}$  and  $1260\text{ cm}^{-1}$ . The two samples (i) and (ii) of viscous material showed additional absorptions at (i)  $1665\text{ cm}^{-1}(\text{s})$ ,  $1440\text{ cm}^{-1}(\text{s})$ ,  $1320\text{-}1120\text{ cm}^{-1}(\text{s})$ ; (ii)  $3450\text{ cm}^{-1}(\text{m})$ ,  $1665\text{ cm}^{-1}(\text{s})$ ,  $1440\text{ cm}^{-1}(\text{s})$ ,  $1220\text{ cm}^{-1}(\text{s})$ .

The two solid samples (iii) and (iv) showed additional absorptions as follows:

(iii)  $3450\text{ cm}^{-1}(\text{m})$ ,  $1665\text{ cm}^{-1}(\text{w})$ ,  $1440\text{ cm}^{-1}(\text{m})$

(iv) As for (iii).

Thin layer chromatography on silica gel (developing with chloroform) showed that all samples contained traces of at least a second component.

Attempts to purify the products by recrystallization were unsuccessful.

The irradiation was repeated and HCl passed through a solution of crude product (0.5 g.) in benzene (30 ml.) for 6 hr. Thin layer chromatography of a sample of the resulting solution showed three major components, one component not corresponding in  $R_f$  value to any components in the crude material obtained directly from the irradiation mixture, plus traces of at least two other components.

(d) Irradiation of 1,4-Di-o-toluoylbenzene and Phenylacetylene in Benzene

A solution of 1,4-di-o-toluoylbenzene (0.3233 g., 0.001028 moles) and phenylacetylene (0.2101 g., 0.002057 moles) in benzene (25 ml.) was irradiated at 350 nm for ca.100 hr. After irradiation, thin layer chromatography of a sample of the resulting yellow solution on silica gel (developing with chloroform) indicated at least five components, a major component corresponding in  $R_f$  value to that of 1,4-di-o-toluoylbenzene. Benzene solvent was removed by freeze drying to give a yellow solid (0.37 g.), the infrared spectrum of which showed particular absorptions at  $3450\text{ cm}^{-1}$ (w/m),  $1660\text{ cm}^{-1}$ (s),  $1610\text{ cm}^{-1}$ (s) and  $1280\text{ cm}^{-1}$ (s), and several absorptions between  $1000$  and  $700\text{ cm}^{-1}$ . The spectrum corresponded largely to that of 1,4-di-o-toluoylbenzene.

(e) Irradiation of 2-Methylbenzophenone and 1-Heptyne in Benzene

A solution of 2-methylbenzophenone (0.4591 g., 0.002339 moles) and 1-heptyne (0.2249 g., 0.00234 moles) in benzene (20 ml.) was irradiated at 350 nm for 96 hr. Thin layer chromatography of a sample of the resulting yellow solution on silica gel (developing with chloroform)

indicated two major components of  $R_f$  value  $< 0.1$ , and three minor components, one of which corresponded in  $R_f$  value to that of 2-methylbenzophenone. Benzene solvent was removed by freeze drying to give a yellow solid (0.472 g.). An infrared spectrum of the solid showed little residual C=O stretch at  $1660\text{ cm}^{-1}$  and strong absorptions at ca.  $3400\text{ cm}^{-1}$ ,  $1460\text{ cm}^{-1}$ ,  $1040\text{ cm}^{-1}$ ,  $760\text{ cm}^{-1}$  and  $710\text{ cm}^{-1}$ .

The crude solid was dissolved in benzene (100 ml.) and HCl passed through the solution for 4 hr. Thin layer chromatography of a sample of the resulting solution on silica gel (developing with chloroform) indicated five components. Attempted separation and purification of the components as described for irradiation of 1,4-di-o-toluoylbenzene and dimethyl acetylenedicarboxylate was unsuccessful.

(f) Irradiation of 1,4-Di-o-toluoylbenzene and 1,6-Heptadiyne in Benzene

A solution of 1,4-di-o-toluoylbenzene (0.4007 g., 0.001274 moles) and 1,6-heptadiyne (0.1174 g., 0.001274 moles) in benzene (21.5 ml.) was irradiated at 350 nm for 160 hr., during which period a slight yellow precipitate was formed. Thin layer chromatography of a sample of the resulting solution indicated a strong component of  $R_f$  value greater than that of 1,4-di-o-toluoylbenzene. Benzene solvent was removed by freeze drying to give a pale yellow solid (0.375 g.,  $\bar{M}_n = \text{ca. } 1600$ ). An infrared spectrum showed particular absorptions at  $3450\text{ cm}^{-1}(\text{m})$ ,  $1665\text{ cm}^{-1}(\text{s})$ ,  $1605\text{ cm}^{-1}(\text{s})$ ,  $1300\text{ cm}^{-1}(\text{s})$ ,  $1270\text{ cm}^{-1}(\text{s})$  and  $760\text{ cm}^{-1}(\text{s})$ . Attempts to recrystallize the solid were unsuccessful, and precipitation of the solid from benzene into 60-80° petroleum ether and recovery of the precipitated solid by centrifuging rendered no significant change.

APPENDICES AND REFERENCES

APPENDIX A  
APPARATUS, INSTRUMENTS AND GENERAL TECHNIQUES

Vacuum System

Freeze dryings, pyrolyses, freeze-thaw cycles and 'vacuum distillations' requiring pressures of the order of  $10^{-3}$  mm.Hg were undertaken with a conventional vacuum system incorporating a rotary oil pump and a mercury diffusion pump.

Infrared Spectra - see Appendix C.

Mass Spectra - see Appendix B.

Ultraviolet Spectra were recorded on a Unicam SP800 Spectrophotometer.

N.m.r. Spectra were measured with a Varian A56/60 Spectrometer operating at 60 MHz (operating temperature  $40^{\circ}\text{C}$ ), a Bruker Spectrospin HX 90E High Resolution N.M.R. Spectrometer operating at 90 MHz (at ambient temperature), or obtained through the SRC PCMU Service on a Varian HR 220 Spectrometer operating at 220 MHz or on a Varian HA-100D Spectrometer operating at 100 MHz. All spectra were  $^1\text{H}$  spectra, with chemical shifts measured on the  $\delta$  scale relative to internal tetramethylsilane (TMS).

Molecular Weights were recorded on a Perkin-Elmer Model 115 Molecular Weight Apparatus utilizing the vapour pressure (isopiestic) method of determining the number average molecular weight of a solute in a solution. Measurements were made on benzene or DMF solutions of samples (benzene solutions unless otherwise stated) and solutions of benzil were used as standards. An operating temperature of  $40^{\circ}\text{C}$  was employed for benzene solutions and a temperature of  $55^{\circ}\text{C}$  for DMF solutions. Molecular weights could be measured with  $\pm 2\%$  standard deviation.

Analytical Vapour Phase Chromatography

A Perkin-Elmer 452 Gas Chromatograph was used with a column of di-n-decylphthalate/Celite (2.2 m x 7 mm diam.), hydrogen as carrier gas and a hot wire detector.

Carbon and Hydrogen Analyses were carried out with a Perkin-Elmer 240 Elemental Analyzer.

Thermogravimetric Analysis - see Appendix D.

### Irradiations

Irradiations were carried out with Rayonet Type RS Preparative Photochemical Reactors (models RPR-204 or RPR-208). Light sources were either RUL-3500Å lamps emitting in the ~ 325-390 nm region, or RUL-3000Å lamps emitting in the ~ 280-330 nm region. A Rayonet MGR-100 Merry-Go-Round was used in conjunction with the model RPR-208 reactor. Reaction temperature was ca. 30°C.

Reaction vessels were cylindrical Pyrex tubes of such a size that the solutions to be irradiated formed columns ~ 30 cm in length within the reaction vessels.

### Photopolymerization Solvents

#### Benzene

A.R. benzene was dried over sodium wire and then fractionated (using a column ca. 15 cm x 2 cm diameter filled with glass helices), collecting the fraction b.p. 80.0-80.2°C.

#### Dichloromethane

A.R. dichloromethane was dried over anhydrous calcium chloride and then fractionated as above, collecting the fraction b.p. 40-41°C.

#### Isopropanol

A.R. isopropanol was distilled collecting the fraction b.p. 80-81°C.

#### Acetone (supplied by Mr. D. Reid)

A.R. acetone was refluxed with  $\text{KMnO}_4$  and KOH for 2 hr., distilled

and then fractionated (column 60 cm x 2.5 cm diameter filled with glass helices) collecting the fraction b.p. 56.0-56.5°C.

#### Column Chromatography

Silica Gel (silica gel/CT, type code SO col, particle size 75-175 µm) was purchased from Reeve Angel Scientific Ltd.

Alumina (aluminium oxide "Camag" MFC, Brockmann Activity 1 [Alkaline], 100-250 mesh) was purchased from Hopkin and Williams Ltd.

Florisil (60-100 mesh) was purchased from Koch-Light Laboratories Ltd.

Melting Points are uncorrected.

APPENDIX B  
MASS SPECTRA

Mass spectra were measured with an AEI.MS9 spectrometer at an ionising beam energy of 70 eV.

The mass spectra of the benzophenone type aromatic diketones, prepared as described in Chapter 3, and the furan-diketone 2:1 adducts diFM, diFP and diFl are tabulated below. Some of the more important and typical ions are tabulated in the form: mass number (intensity as % of base peak, assignment, possible origin of the ion); charges on ions are omitted. Thus in the example

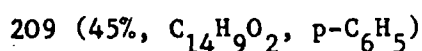

the ion has mass number 209, its intensity is 45% that of the intensity of the base peak of the spectrum, it is assigned the formula  $C_{14}H_9O_2$  and its proposed origin is loss of  $C_6H_5$  from the parent ion p. The base peak is designated B.

Metastable ion peaks, where observed, are tabulated underneath the main spectrum. If assigned they are given in the form

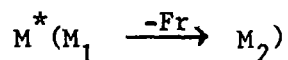

where the metastable ion is understood to have been observed at  $M^* = \frac{M_2^2}{M_1}$  for the loss of neutral fragment Fr, from the ion  $M_1^+$  to give  $M_2^+$ .

m-Dibenzoylbenzene

287 (57%, p + 1), 286 (97%, p), 209 (45%,  $C_{14}H_9O_2$ , p- $C_6H_5$ ), 181 (13%,  $C_{13}H_9O$ , p- $C_6H_5CO$ ), 119 (5%), 106 (10%), 105 (100%,  $C_6H_5CO$ , B), 77 (43%,  $C_6H_5$ ), 76 (6%,  $C_6H_4$ ), 69 (7%), 56 (6%), 55 (20%), 51 (25%,  $C_4H_3$ ,  $C_6H_5-C_2H_2$ ). Metastable ion 157 ( $209 \xrightarrow{-CO} 181$ ).

p-Dibenzoylbenzene

287 (4%, p + 1), 286 (13%, p), 209 (15%, C<sub>14</sub>H<sub>9</sub>O<sub>2</sub>, p-C<sub>6</sub>H<sub>5</sub>), 181 (4%, C<sub>13</sub>H<sub>9</sub>O, p-C<sub>6</sub>H<sub>5</sub>CO), 105 (100%, C<sub>6</sub>H<sub>5</sub>CO, B), 77 (15%, C<sub>6</sub>H<sub>5</sub>), 75 (4%), 69 (4%), 51 (4%, C<sub>4</sub>H<sub>3</sub>, C<sub>6</sub>H<sub>5</sub>-C<sub>2</sub>H<sub>2</sub>).

Metastable ion 56.5 (105  $\xrightarrow{-CO}$  77)

4,4'-Dibenzoyldiphenyl ether

380 (6%, p + 2), 379 (23%, p + 1), 378 (77%, p), 302 (24%, C<sub>20</sub>H<sub>14</sub>O<sub>3</sub>), 301 (100%, C<sub>20</sub>H<sub>13</sub>O<sub>3</sub>, p-C<sub>6</sub>H<sub>5</sub>, B), 273 (3%, C<sub>19</sub>H<sub>13</sub>O<sub>2</sub>, p-C<sub>6</sub>H<sub>5</sub>CO), 196 (8%), 181 (9%, C<sub>13</sub>H<sub>9</sub>O), 121 (33%), 105 (49%, C<sub>6</sub>H<sub>5</sub>CO), 77 (38%, C<sub>6</sub>H<sub>5</sub>), 51 (6%, C<sub>4</sub>H<sub>3</sub>, C<sub>6</sub>H<sub>5</sub>-C<sub>2</sub>H<sub>2</sub>).

Metastable ions 247.5 (301  $\xrightarrow{-CO}$  273)

240

56.5 (105  $\xrightarrow{-CO}$  77)

4,4'-Dibenzoyldiphenyl

364 (7%, p + 2), 363 (31%, p + 1), 362 (100%, p and B), 286 (20%, C<sub>20</sub>H<sub>14</sub>O<sub>2</sub>), 285 (76%, C<sub>20</sub>H<sub>13</sub>O<sub>2</sub>, p-C<sub>6</sub>H<sub>5</sub>), 253 (6%), 149 (9%), 119 (13%), 106 (7%), 105 (31%, C<sub>6</sub>H<sub>5</sub>CO), 92 (9%), 91 (13%), 77 (20%, C<sub>6</sub>H<sub>5</sub>), 57 (8%), 55 (8%), 44 (12%).

4,4'-Dibenzoyldiphenylmethane

378 (4%, p + 2), 377 (24%, p + 1), 376 (77%, p), 300 (23%, C<sub>21</sub>H<sub>16</sub>O<sub>2</sub>), 299 (91%, C<sub>21</sub>H<sub>15</sub>O<sub>2</sub>, p-C<sub>6</sub>H<sub>5</sub>), 271 (4%, C<sub>20</sub>H<sub>15</sub>O, p-C<sub>6</sub>H<sub>5</sub>CO), 196 (7%), 181 (9%, C<sub>13</sub>H<sub>9</sub>O), 165 (15%), 106 (9%), 105 (100%, C<sub>6</sub>H<sub>5</sub>CO, B), 78 (6%), 77 (60%, C<sub>6</sub>H<sub>5</sub>), 51 (9%, C<sub>4</sub>H<sub>3</sub>, C<sub>6</sub>H<sub>5</sub>-C<sub>2</sub>H<sub>2</sub>).

Metastable ions

245.7 (299  $\xrightarrow{-CO}$  271)

56.5 (105  $\xrightarrow{-CO}$  77)

1,2-(4,4'-Dibenzoyldiphenyl)ethane

392 (7%, p + 2), 391 (29%, p + 1), 390 (88%, p), 313 (6%, C<sub>22</sub>H<sub>17</sub>O<sub>2</sub>, p-C<sub>6</sub>H<sub>5</sub>), 233 (16%), 196 (18%), 195 (100%, C<sub>14</sub>H<sub>11</sub>O, p-C<sub>14</sub>H<sub>11</sub>O, B), 124 (15%), 106 (6%), 105 (47%, C<sub>6</sub>H<sub>5</sub>CO), 90 (12%), 77 (18%, C<sub>6</sub>H<sub>5</sub>), 51 (6%, C<sub>4</sub>H<sub>3</sub>, C<sub>6</sub>H<sub>5</sub>-C<sub>2</sub>H<sub>2</sub>).

Metastable ion 143 (195  $\xrightarrow{-CO}$  167)

1,3-(4,4'-Dibenzoyldiphenyl)propane

405 (2%, p + 1), 404 (8%, p), 327 (8%, C<sub>23</sub>H<sub>19</sub>O<sub>2</sub>, p-C<sub>6</sub>H<sub>5</sub>), 257 (11%), 209 (12%, C<sub>15</sub>H<sub>11</sub>O), 196 (28%, C<sub>14</sub>H<sub>12</sub>O), 181 (15%, C<sub>6</sub>H<sub>5</sub>COC<sub>6</sub>H<sub>4</sub>), 167 (7%), 152 (7%), 106 (7%), 105 (72%, C<sub>6</sub>H<sub>5</sub>CO), 91 (6%, C<sub>7</sub>H<sub>7</sub>), 78 (9%), 77 (100%, C<sub>6</sub>H<sub>5</sub>, B), 64 (13%), 63 (10%), 51 (17%, C<sub>4</sub>H<sub>3</sub>, C<sub>6</sub>H<sub>5</sub>-C<sub>2</sub>H<sub>2</sub>).

Metastable ions 95

56.5 (105  $\xrightarrow{-CO}$  77)

52.5

1,4-(4,4'-Dibenzoyldiphenyl)butane

420 (9%, p + 2), 419 (34%, p + 1), 418 (100%, p and B), 342 (16%), 341 (51%, C<sub>24</sub>H<sub>21</sub>O<sub>2</sub>, p-C<sub>6</sub>H<sub>5</sub>), 313 (3%, C<sub>23</sub>H<sub>21</sub>O, p-C<sub>6</sub>H<sub>5</sub>CO), 223 (3%, C<sub>16</sub>H<sub>15</sub>O), 210 (12%), 209 (13%, C<sub>15</sub>H<sub>13</sub>O, p-C<sub>15</sub>H<sub>13</sub>O), 196 (9%, C<sub>14</sub>H<sub>12</sub>O), 195 (7%, C<sub>6</sub>H<sub>5</sub>COC<sub>7</sub>H<sub>6</sub>), 167 (12%, C<sub>13</sub>H<sub>11</sub>), 165 (6%), 132 (7%), 105 (33%, C<sub>6</sub>H<sub>5</sub>CO), 77 (10%, C<sub>6</sub>H<sub>5</sub>).

1,5-(4,4'-Dibenzoyldiphenyl)pentane

434 (8%, p + 2), 433 (35%, p + 1), 432 (100%, p and B), 356 (14%), 355 (50%, C<sub>25</sub>H<sub>23</sub>O<sub>2</sub>, p-C<sub>6</sub>H<sub>5</sub>), 252 (7%), 237 (13%, C<sub>17</sub>H<sub>17</sub>O), 210 (10%), 209 (43%, C<sub>15</sub>H<sub>13</sub>O), 196 (43%, C<sub>14</sub>H<sub>12</sub>O), 195 (11%, C<sub>6</sub>H<sub>5</sub>CO C<sub>7</sub>H<sub>6</sub>), 181 (8%), 167 (20%, C<sub>13</sub>H<sub>11</sub>), 139 (12%), 105 (82%, C<sub>6</sub>H<sub>5</sub>CO), 91 (10%, C<sub>7</sub>H<sub>7</sub>), 90 (11%, C<sub>7</sub>H<sub>6</sub>), 77 (33%, C<sub>6</sub>H<sub>5</sub>), 51 (14%, C<sub>4</sub>H<sub>3</sub>, C<sub>6</sub>H<sub>5</sub>-C<sub>2</sub>H<sub>2</sub>).

Metastable Ions 301 (355  $\xrightarrow{-CO}$  327)

56.5 (105  $\xrightarrow{-CO}$  77)

1,6-(4,4'-Dibenzoyldiphenyl)hexane

448 (9%, p + 2), 447 (43%, p + 1), 446 (98%, p), 370 (9%), 369 (28%,  $C_{26}H_{25}O_2$ , p- $C_6H_5$ ), 341 (4%,  $C_{25}H_{25}O$ , p- $C_6H_5CO$ ), 251 (18%,  $C_{18}H_{19}O$ ), 238 (24%,  $C_{17}H_{18}O$ ), 237 (7%,  $C_{17}H_{17}O$ ), 223 (7%,  $C_{16}H_{15}O$ , p- $C_{16}H_{15}O$ ), 210 (16%), 209 (76%,  $C_{15}H_{13}O$ ), 197 (12%), 196 (67%,  $C_{14}H_{12}O$ ), 195 (10%,  $C_6H_5COC_7H_6$ ), 167 (32%), 165 (10%), 146 (18%), 133 (16%), 131 (11%), 106 (10%), 105 (100%,  $C_6H_5CO$ , B), 91 (10%,  $C_7H_7$ ), 90 (12%,  $C_7H_6$ ), 77 (28%,  $C_6H_5$ ).

Metastable ions 365, 138, 127, 86, 73.5

56.5 (105  $\xrightarrow{-CO}$  77)

1,10-(4,4'-Dibenzoyldiphenyl)decane

504 (5%, p + 2), 503 (19%, p + 1), 502 (46%, p), 425 (2%,  $C_{31}H_{33}O_2$ , p- $C_6H_5$ ), 397 (3%,  $C_{30}H_{33}O$ , p- $C_6H_5CO$ ), 294 (6%), 211 (10%), 210 (47%), 209 (31%,  $C_{15}H_{13}O$ ), 196 (19%,  $C_{14}H_{12}O$ ), 195 (8%,  $C_6H_5COC_7H_6$ ), 183 (7%), 181 (7%,  $C_6H_5COC_6H_4$ ), 174 (8%), 167 (22%,  $C_{13}H_{11}$ ), 165 (8%), 131 (11%), 119 (12%), 118 (10%), 117 (14%), 106 (10%), 105 (58%,  $C_6H_5CO$ ), 104 (17%), 103 (11%), 93 (8%), 92 (53%), 91 (100%,  $C_7H_7$ , B), 78 (16%), 77 (30%,  $C_6H_5$ ), 51 (14%,  $C_4H_3$ ,  $C_6H_5-C_2H_2$ ).

DIFM

423 (7%, p + 1), 422 (19%, p), 393 (7%,  $C_{27}H_{21}O_3$ , p-CHO), 354 (3%,  $C_{24}H_{18}O_3$ , p- $C_4H_4O$ ), 347 (7%), 331 (10%), 330 (7%), 326 (14%,  $C_{23}H_{18}O_2$ , p- $C_4H_4O-CO$ ), 287 (8%), 286 (39%,  $C_{20}H_{14}O_2$ , p- $C_4H_4O-C_4H_4O$ ), 221 (8%), 209 (21%,  $C_{14}H_9O$ , p- $C_4H_4O-C_4H_4O-C_6H_5$ ), 191 (7%), 181 (10%,  $C_{13}H_9O$ , p- $C_4H_4-C_4H_4O-C_6H_5CO$ ), 165 (10%), 117 (11%), 115 (22%), 106 (8%), 105 (100%,

$C_6H_5CO$ , B), 91 (19%), 77 (27%,  $C_6H_5$ ), 68 (69%,  $C_4H_4O$ ), 66 (31%), 44 (7%),  
39 (22%,  $C_3H_3$ ,  $C_4H_4O-CHO$ ), 32 (10%), 29 (7%, CHO).

Metastable ion 56.5 ( $105 \xrightarrow{-CO} 77$ )

#### DiFP

423 (10%, p + 1), 422 (30%, p), 393 (9%,  $C_{27}H_{21}O_3$ , p-CHO), 354 (4%,  $C_{22}H_{18}O_3$ ,  
p- $C_4H_4O$ ), 331 (13%), 330 (12%), 326 (11%,  $C_{23}H_{18}O_2$ , p- $C_4H_4O-CO$ ), 287 (6%),  
286 (24%,  $C_{20}H_{14}O_2$ , p- $C_4H_4O-C_4H_4O$ ), 221 (8%), 209 (18%,  $C_{14}H_9O$ , p- $C_4H_4O-$   
 $C_4H_4O-C_6H_5$ ), 203 (7%), 202 (7%), 191 (7%), 181 (8%,  $C_{13}H_9O$ , p- $C_4H_4O-$   
 $C_4H_4O-C_6H_5CO$ ), 165 (10%), 149 (7%), 145 (8%), 135 (25%), 117 (14%),  
115 (24%), 105 (70%,  $C_6H_5CO$ ), 91 (24%), 86 (13%), 77 (27%,  $C_6H_5$ ), 69 (10%),  
68 (100%,  $C_4H_4O$ , B), 66 (64%), 65 (11%), 57 (12%), 40 (14%), 39 (56%,  
 $C_3H_3$ ,  $C_4H_4O-CHO$ ), 32 (14%), 29 (11%, CHO).

#### DiFl

513 (8%, p + 1), 512 (22%, p), 483 (6%,  $C_{34}H_{27}O_3$ , p-CHO), 444 (15%,  
 $C_{31}H_{24}O_3$ , p- $C_4H_4O$ ), 415 (9%,  $C_{30}H_{23}O_2$ , p- $C_4H_4O-CHO$ ), 376 (22%,  $C_{27}H_{20}O_2$ ,  
p- $C_4H_4O-C_4H_4O$ ), 299 (22%,  $C_{21}H_{15}O_2$ , p- $C_4H_4O-C_4H_4O-C_6H_5$ ), 221 (25%), 217  
(11%), 196 (13%), 115 (11%), 105 (25%,  $C_6H_5CO$ ), 91 (17%), 77 (17%,  $C_6H_5$ ),  
68 (83%,  $C_4H_4O$ ), 44 (55%), 39 (100%,  $C_3H_3$ ,  $C_4H_4O-CHO$ ), 35 (44%), 29  
(50%, CHO).

APPENDIX C  
INFRARED SPECTRA

Infrared spectra were recorded on a Perkin-Elmer 457 Grating Infrared Spectrophotometer (PE457), a Grubb Parsons Spectromaster (GPS) or a Perkin-Elmer 157 Sodium Chloride Spectrophotometer (PE157). Spectra were run using KBr cells under the conditions designated by:

- (A) KBr disc
- (B) Nujol mull
- (C) Thin contact film.

<u>Infrared Spectrum</u>		<u>Substance</u>	
<u>No. (&amp; spectrophotometer)</u>		<u>Diketones</u>	
1.	(GPS)	m-Dibenzoylbenzene	(A)
2.	(GPS)	p-Dibenzoylbenzene	(A)
3.	(GPS)	4,4'-Dibenzoyldiphenyl ether	(A)
4.	(GPS)	4,4'-Dibenzoyldiphenyl	(A)
5.	(GPS)	4,4'-Dibenzoyldiphenylmethane	(A)
6.	(GPS)	1,2-(4,4'-Dibenzoyldiphenyl)ethane	(A)
7.	(GPS)	1,6-(4,4'-Dibenzoyldiphenyl)hexane	(A)
8.	(PE457)	1,3-(4,4'-Dibenzoyldiphenyl)propane	(A)
9.	(PE457)	1,4-(4,4'-Dibenzoyldiphenyl)butane	(A)
10.	(PE457)	1,5-(4,4'-Dibenzoyldiphenyl)pentane	(A)
11.	(PE457)	1,10-(4,4'-Dibenzoyldiphenyl)decane	(A)
<u>TMA-Benzophenone Model System</u>			
12.	(PE457)	Mixture resulting from irradiation of benzophenone and TMA in benzene.	(A)

TMA-Diketone Polymers

13.	(GPS)	PolyTMAM	(A)
14.	(GPS)	Product from treatment of PolyTMAM with HCl	(A)
15.	(GPS)	PolyTMA1	(A)
16.	(PE457)	PolyTMAP	(A)
17.	(PE457)	PolyTMAE	(A)
18.	(PE457)	PolyTMA2	(A)
19.	(PE457)	PolyTMA3	(A)
20.	(PE457)	PolyTMA4	(A)
21.	(PE457)	PolyTMA5	(A)
22.	(PE457)	PolyTMA6	(A)
23.	(PE457)	PolyTMA10	(A)

Furan-Benzophenone 1:1 Adduct

24.	(PE457)	Furan-benzophenone 1:1 adduct (63)	(A)
-----	---------	------------------------------------	-----

Furan-Diketone 2:1 Adducts

25.	(PE457)	DiF3	(A)
26.	(GPS)	DiFM	(A)
27.	(GPS)	DiFP	(A)
28.	(GPS)	Solid from irradiation of 4,4'-Dibenzoyl-diphenyl ether in furan	(A)
29.	(GPS)	DiF1	(A)
30.	(GPS)	'DiF2'	(A)
31.	(GPS)	DiF6	(A)
32.	(PE457)	DiF4	(A)
33.	(PE457)	DiF5	(A)
34.	(PE457)	DiF10	(C)

Benzophenone-Furan 2:1 Adduct

35. (PE157) 2:1 Adduct (66) (B)

Furan-Diketone Polymers

36. (GPS) Polymer ( $\bar{M}_n \sim 1250$ ) from direct irradiation of m-dibenzoylbenzene and furan in benzene (A)

37. (GPS) PolyFM (A)

38. (GPS) PolyFP (A)

39. (PE457) PolyF1 (A)

40. (PE457) PolyF2 (A)

41. (PE457) PolyF3 (A)

42. (PE457) PolyF4 (A)

43. (PE457) PolyF5 (A)

44. (PE457) PolyF6 (A)

45. (PE457) PolyF10 (A)

Furan-Diketone Polymers Containing  
Two Different Diketone Residues

46. (PE457) Polymer from diFM and p-dibenzoylbenzene (A)

47. (PE457) Polymer from diFP and m-dibenzoylbenzene (A)

48. (PE457) Polymer from diFM and 1,6-(4,4'-dibenzoyldiphenyl)hexane (A)

2,5-Dimethylfuran-Diketone Polymers

49. (PE457) 2,5-Dimethylfuran-m-dibenzoylbenzene polymer (A)

50. (PE457) 2,5-Dimethylfuran-1,4(4,4'-dibenzoyl-diphenyl)butane polymer (A)

Polypinacols

(a) From 50:50 Benzene-Isopropanol Mixtures

51.	(PE457)	Polypinacol M	(A)
52.	(PE457)	Polypinacol P	(A)
53.	(PE457)	Polypinacol E	(A)
54.	(PE457)	Polypinacol 1	(A)
55.	(PE457)	Polypinacol 2	(A)
56.	(PE457)	Polypinacol 3	(A)
57.	(PE457)	Polypinacol 4	(A)
58.	(PE457)	Polypinacol 5	(A)
59.	(PE457)	Polypinacol 6	(A)
60.	(PE457)	Polypinacol 10	(A)

(b) From Benzene-Isopropanol Mixtures Containing  
> 50% Benzene

61.	(PE457)	Polypinacol 1	(A)
62.	(PE457)	Polypinacol 2	(A)
63.	(PE457)	Polypinacol 3	(A)
64.	(PE457)	Polypinacol 5	(A)

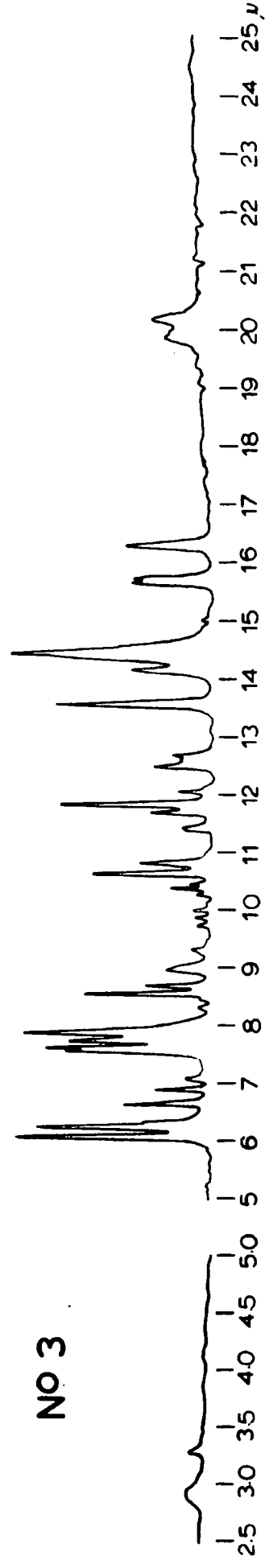
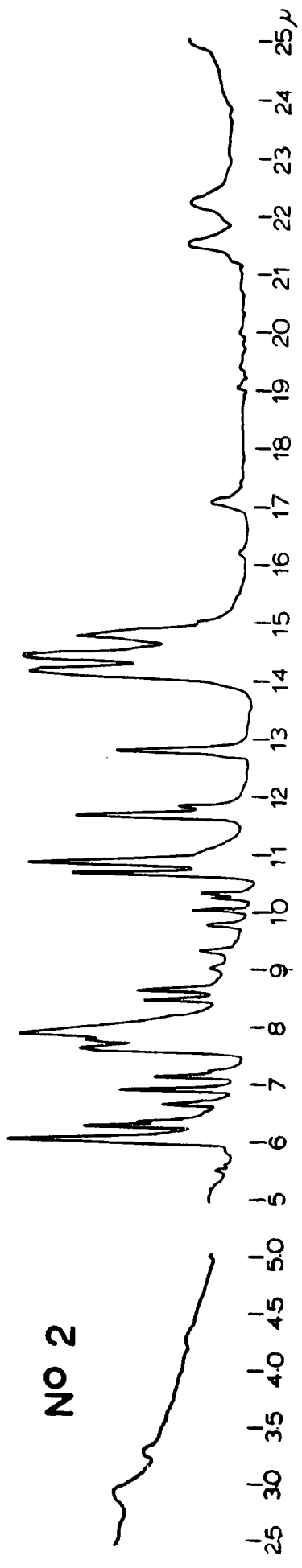
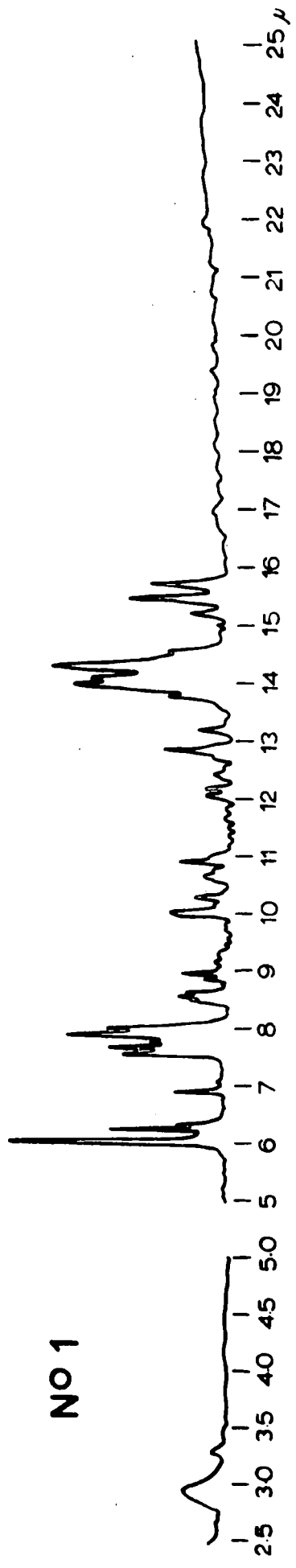

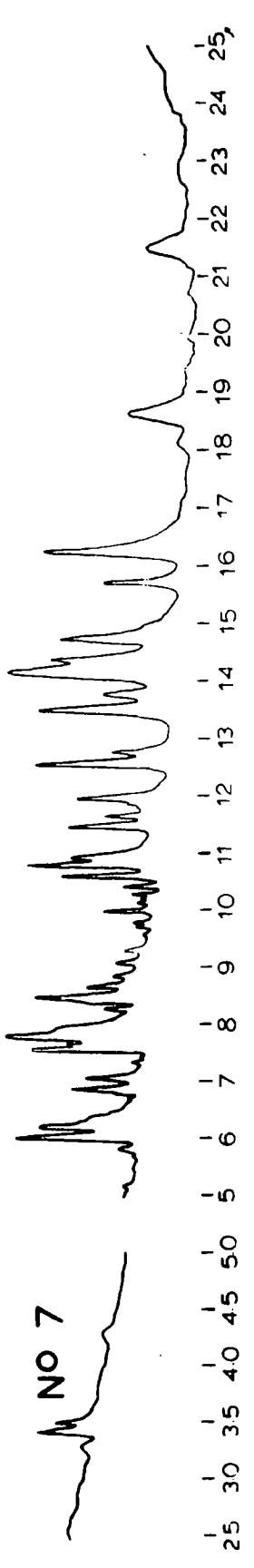
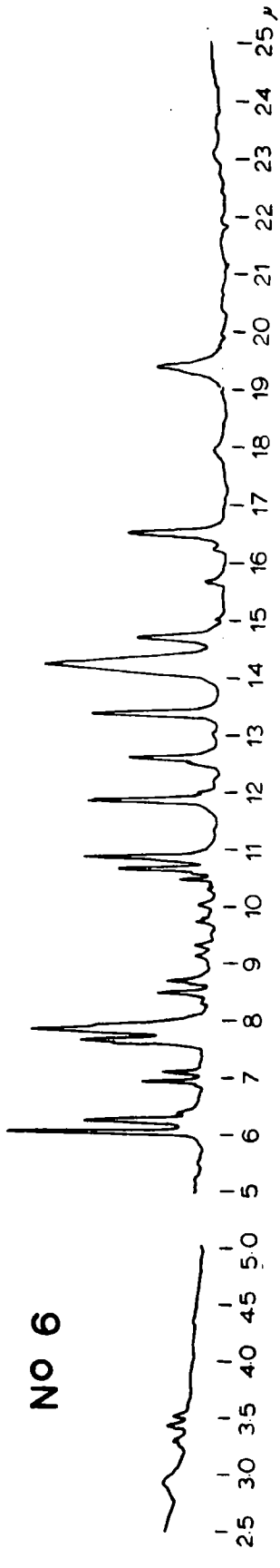
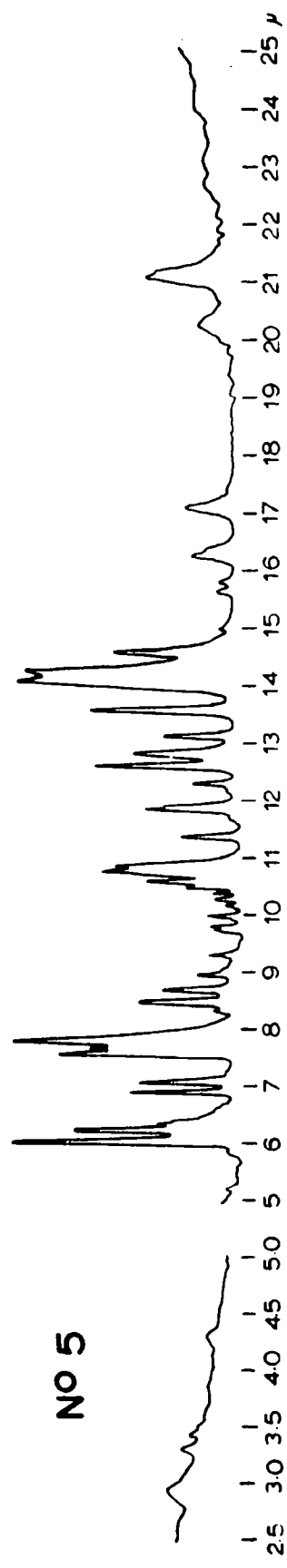
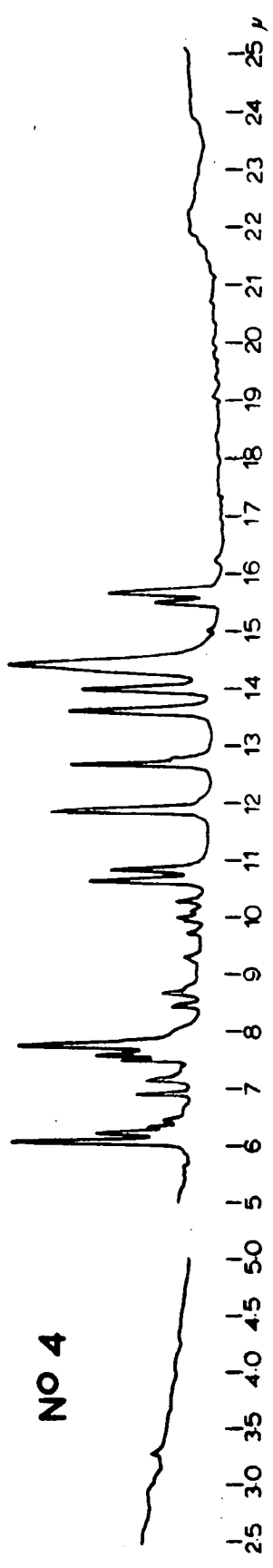

25 30 35 40 45 50 60 70 80 90 10 12 14 16 18 20 25 30 40

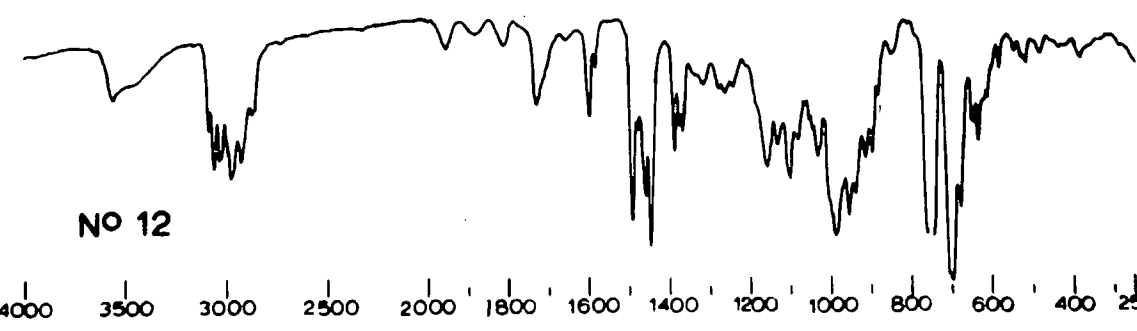
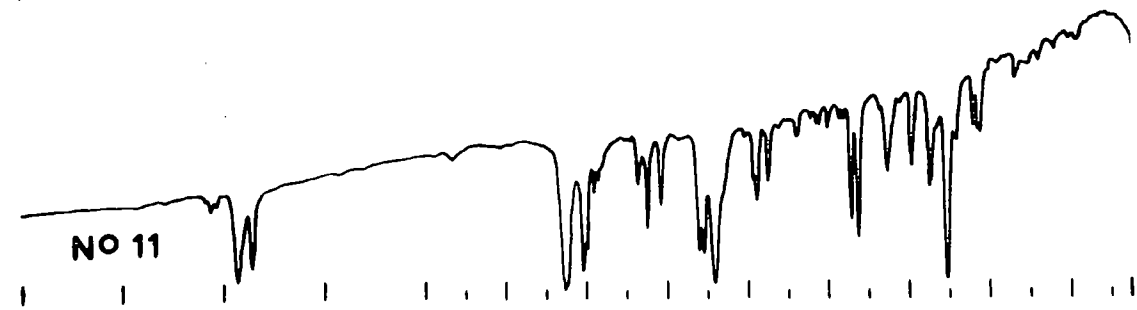
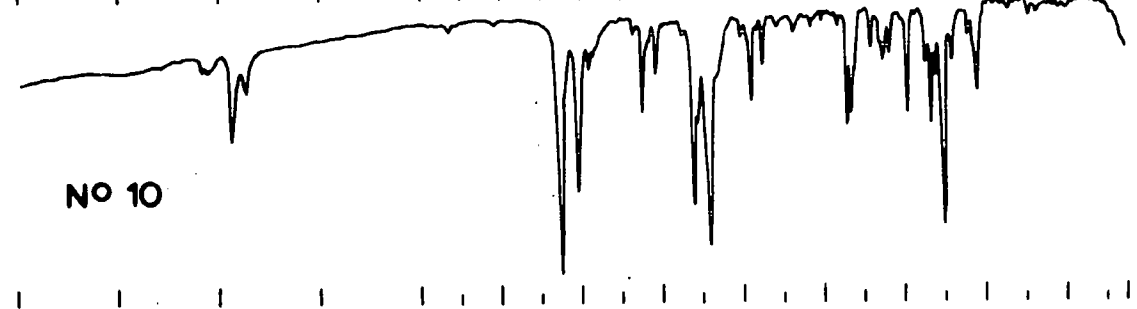
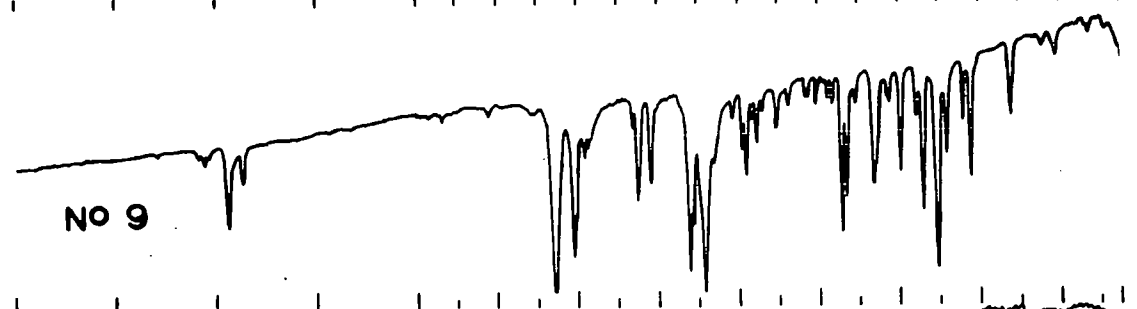
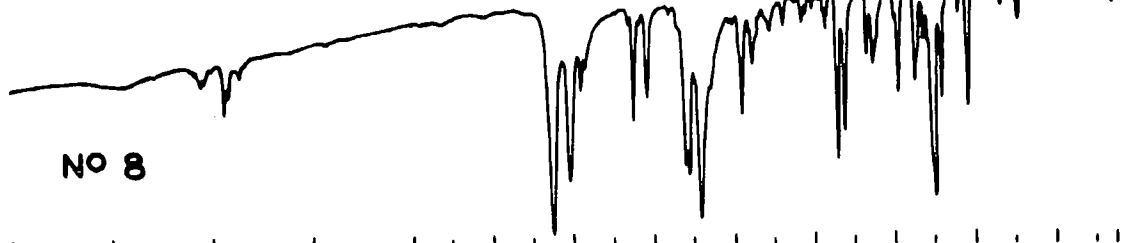

4000 3500 3000 2500 2000 1800 1600 1400 1200 1000 800 600 400 250  $\text{cm}^{-1}$

NO 13

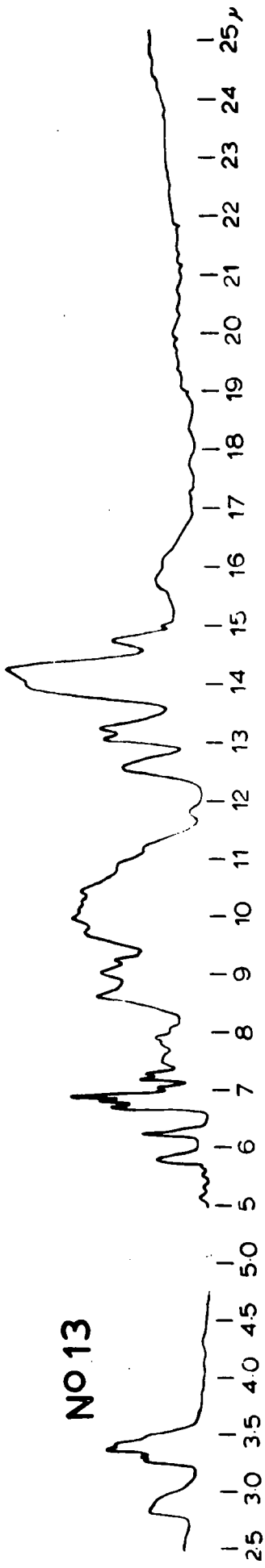

NO 14

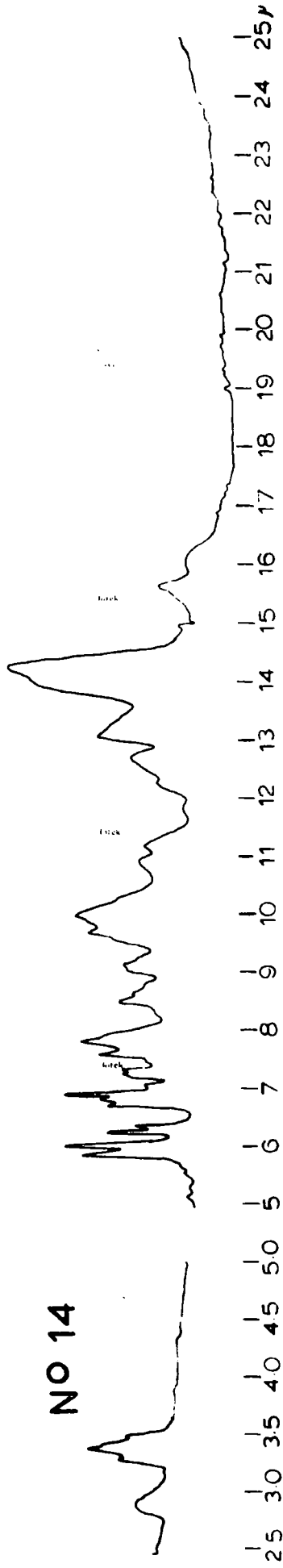

NO 15

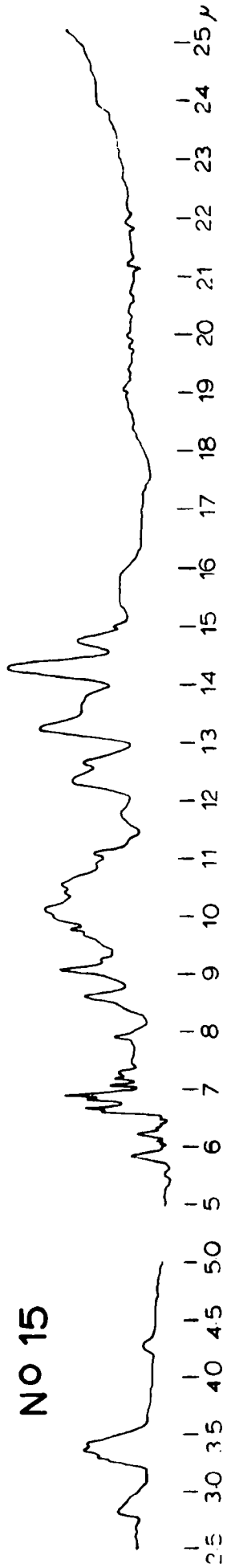

25 30 35 40 45 50 60 70 80 90 10 12 14 16 20 25 30 40 $\mu$

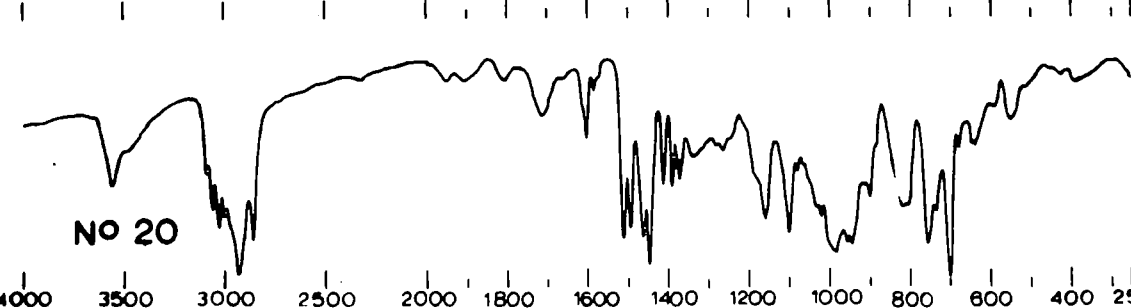
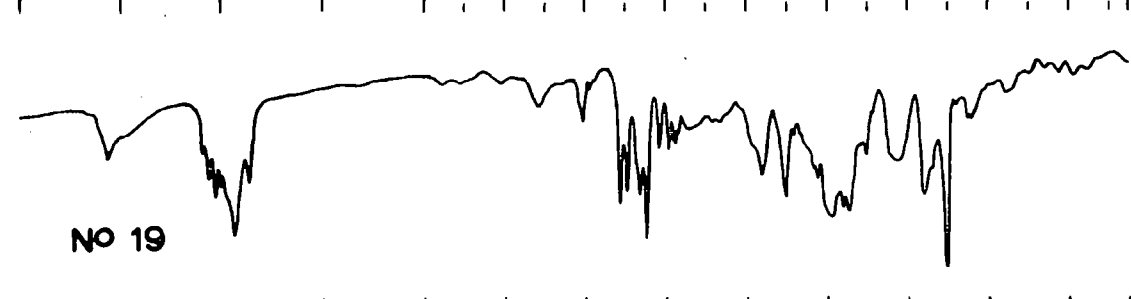
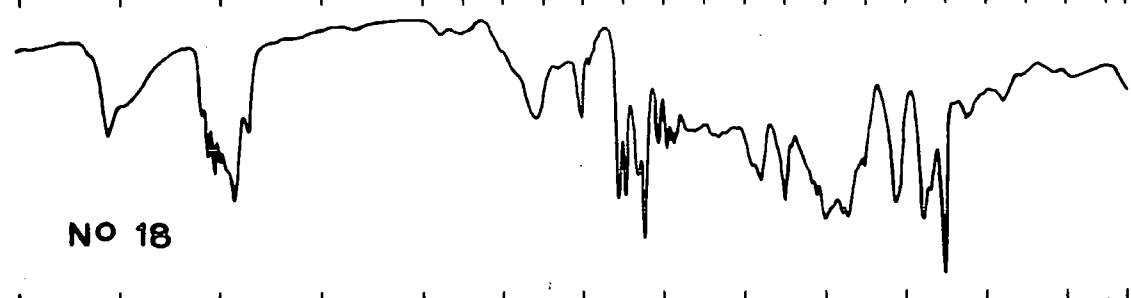
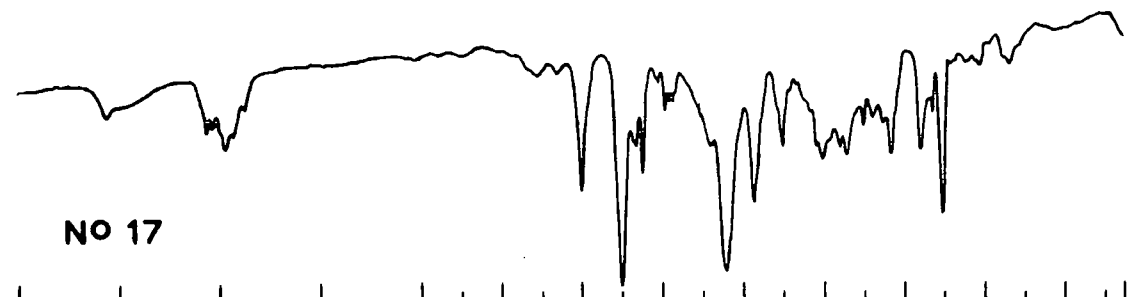
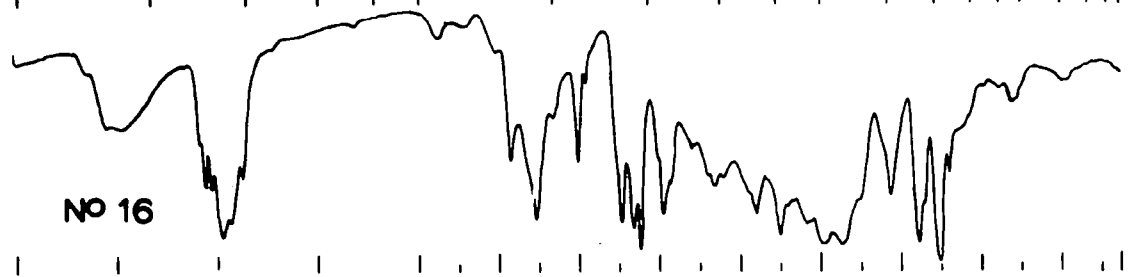

4000 3500 3000 2500 2000 1800 1600 1400 1200 1000 800 600 400 250  $\text{cm}^{-1}$

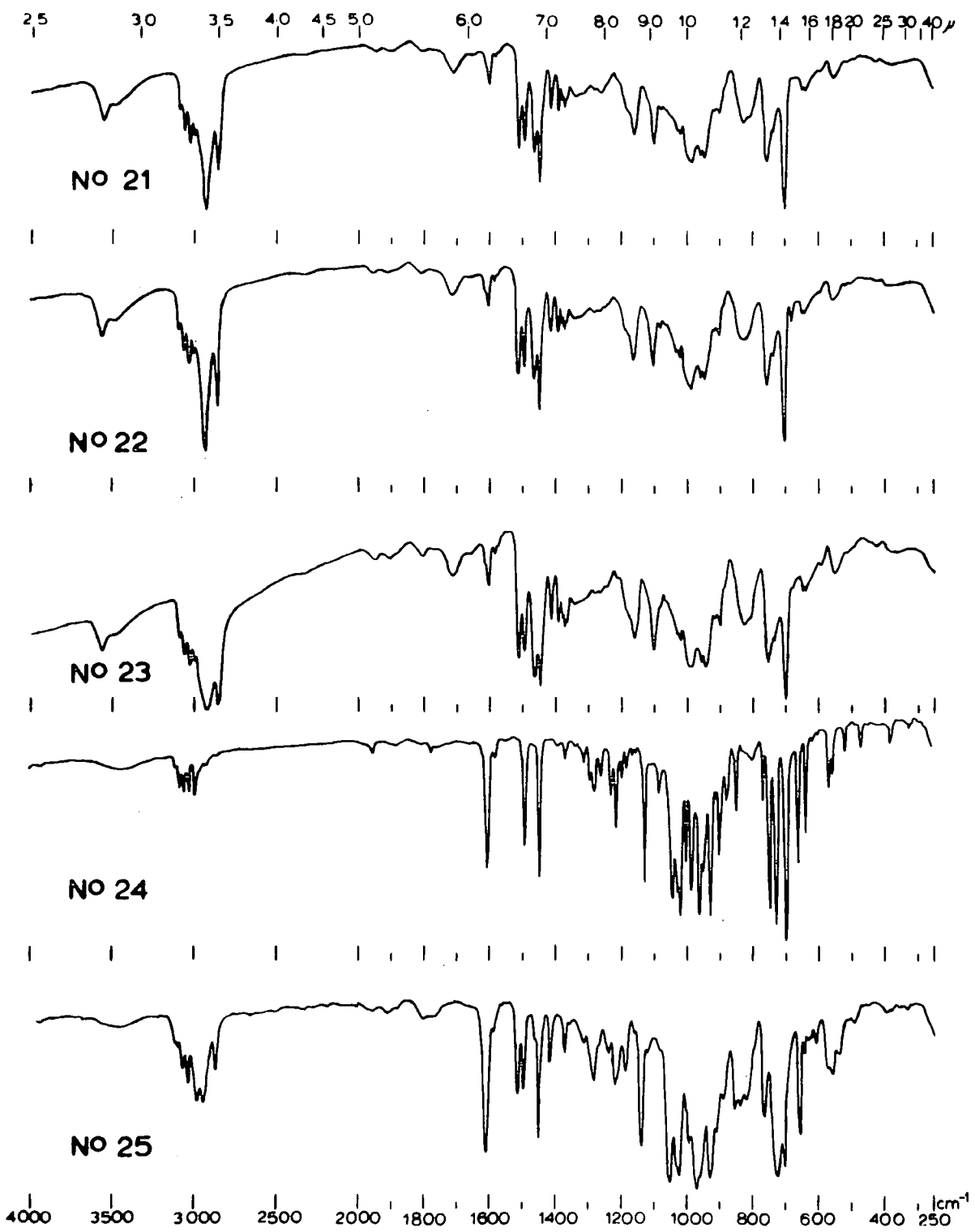

NO 26

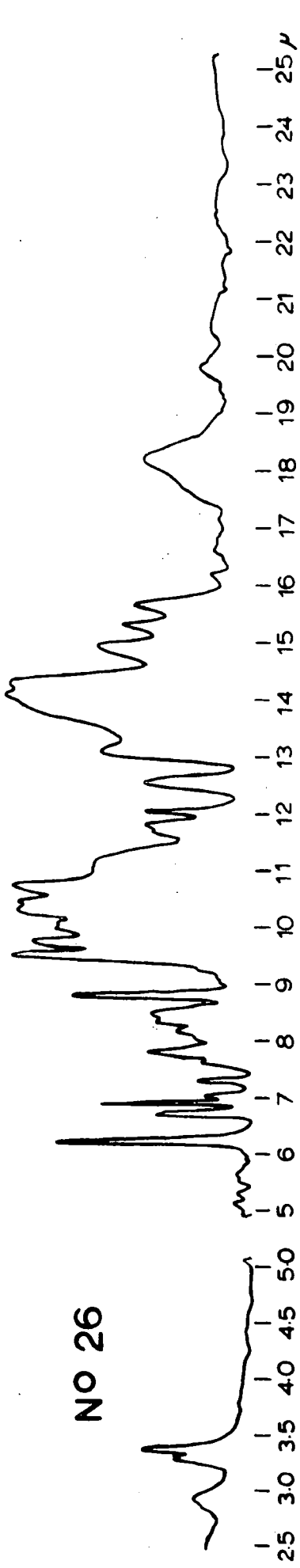

NO 27

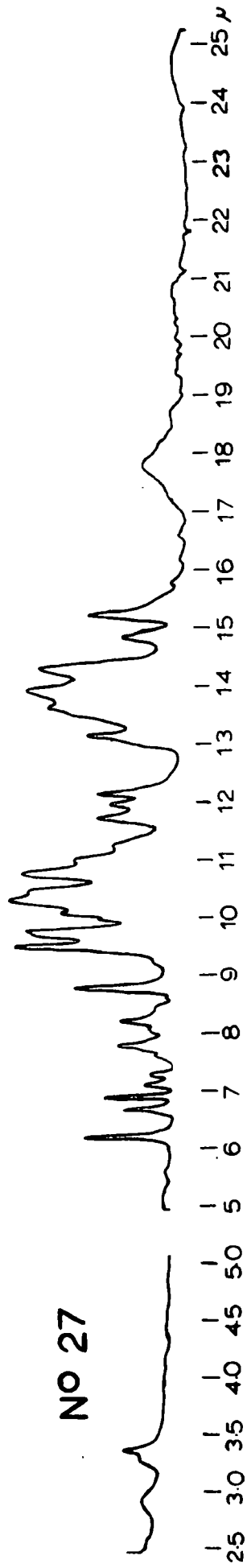

NO 28

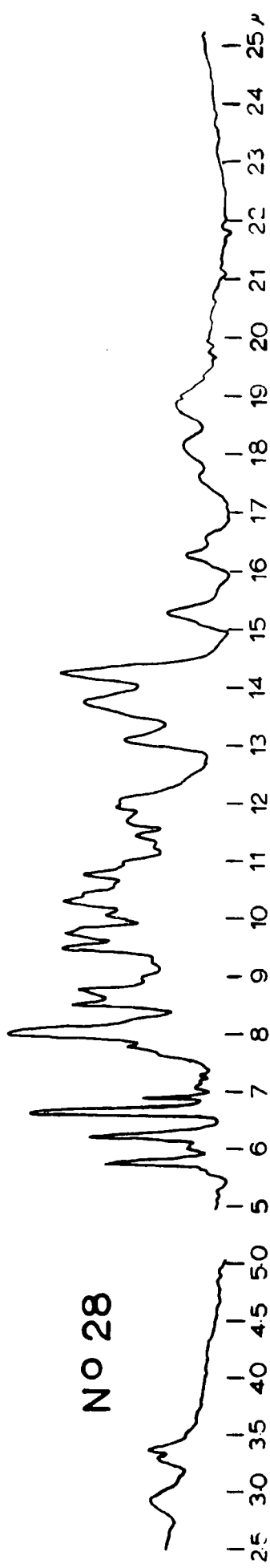

**NO 29**

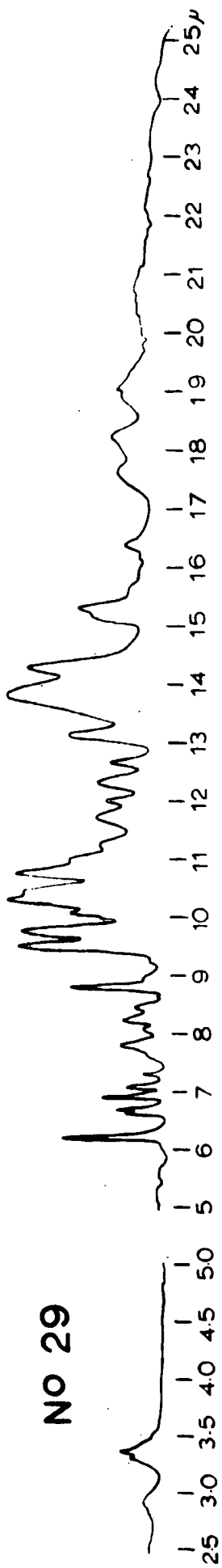

**NO 30**

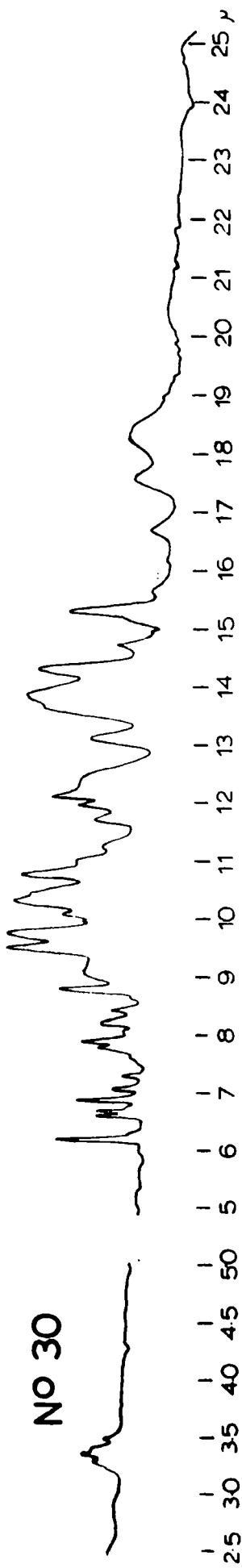

**NO 31**

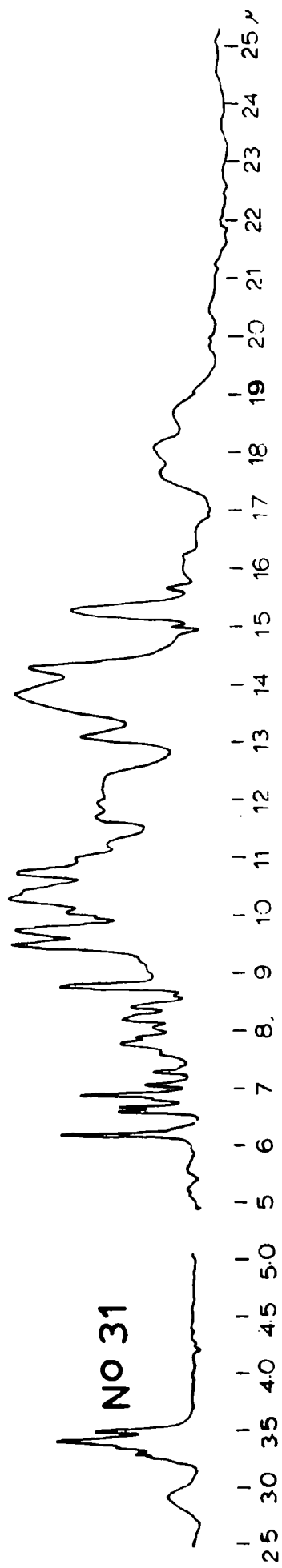

25 30 3.5 4.0 4.5 5.0 60 70 8.0 9.0 10 12 14 16 18 20 25 30 40  $\mu$

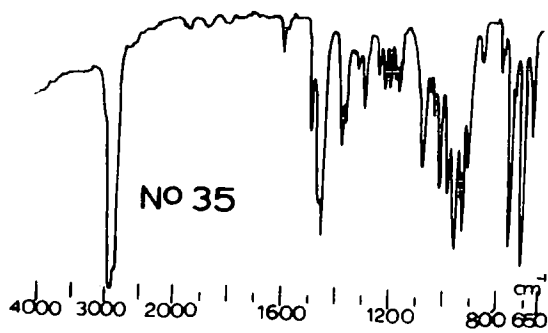
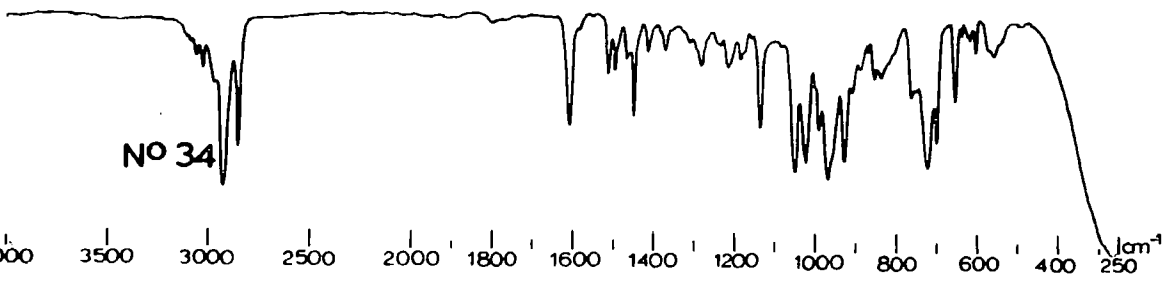
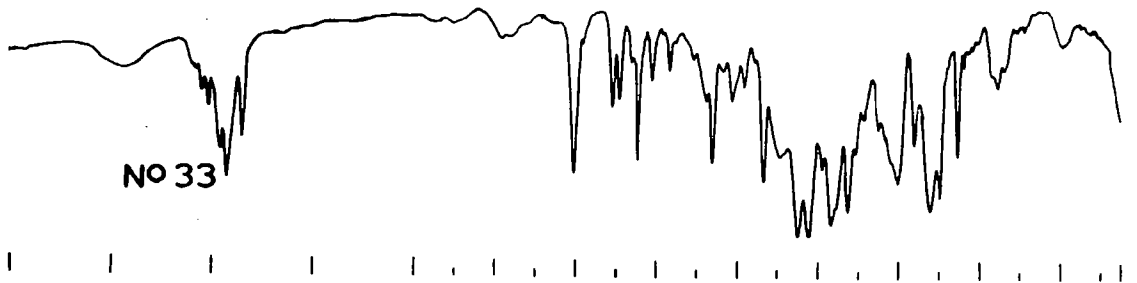
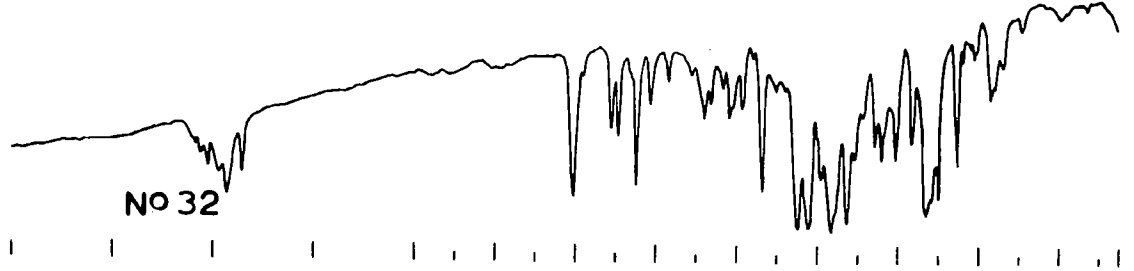

**NO 36**

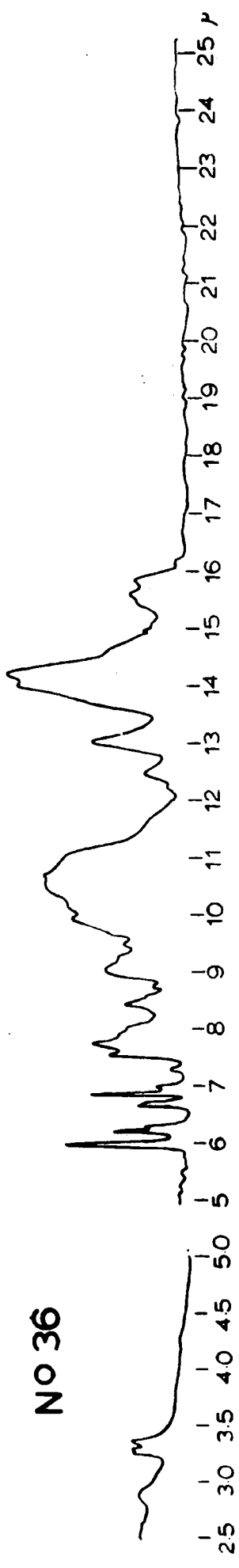

**NO 37**

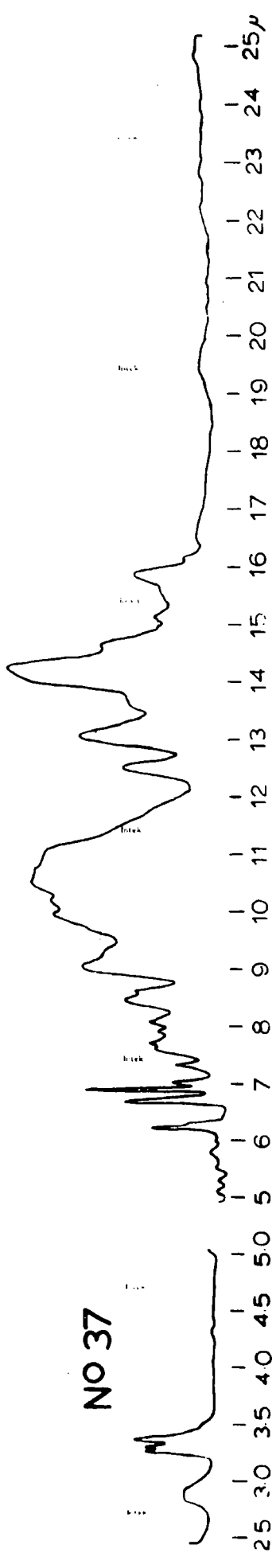

**NO 38**

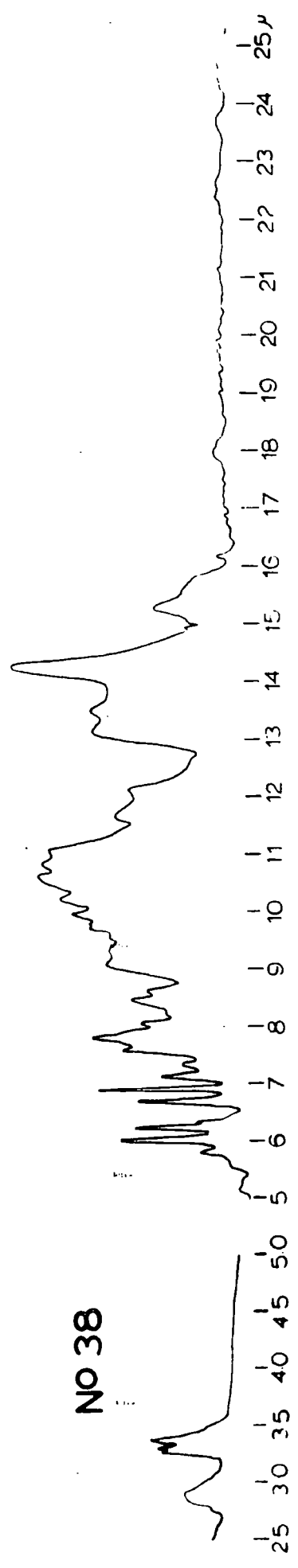

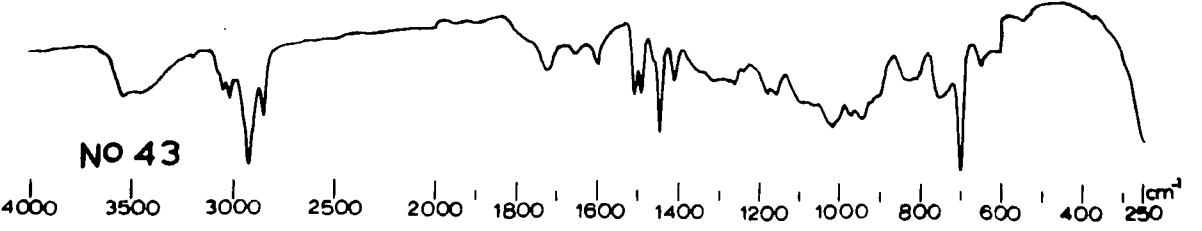
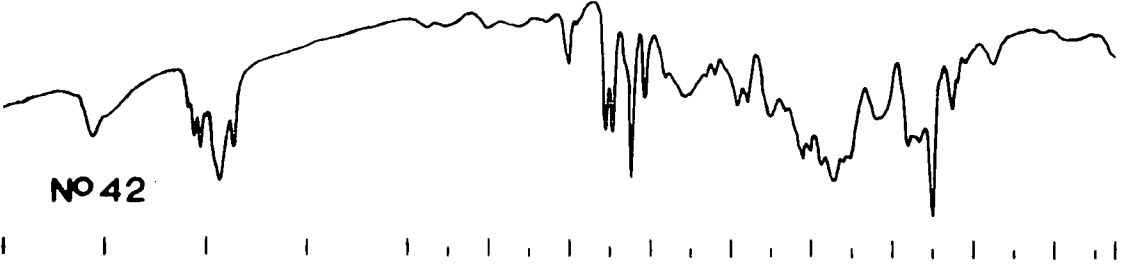
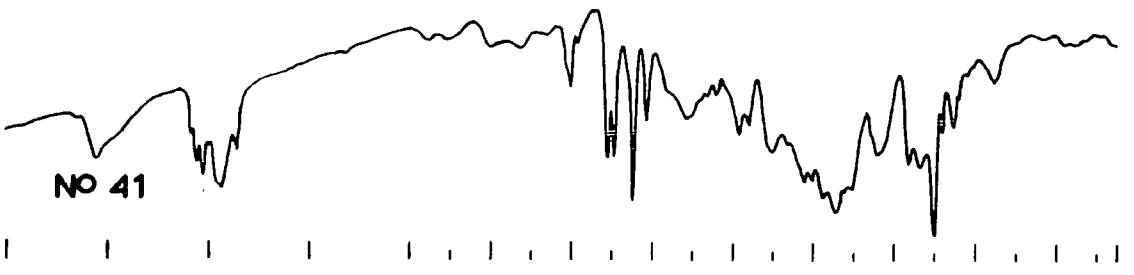
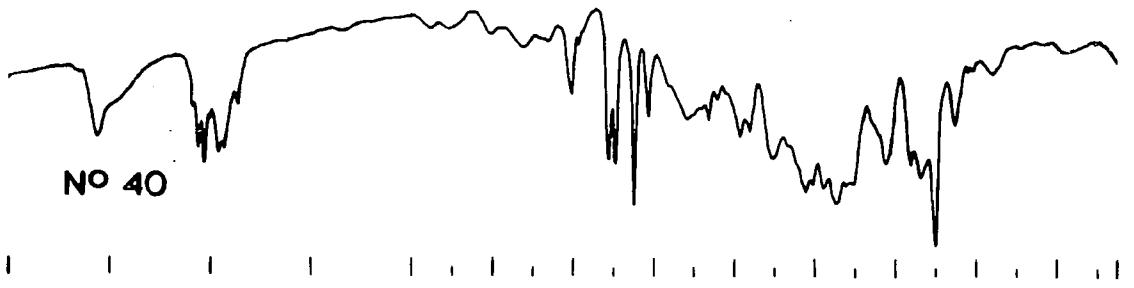
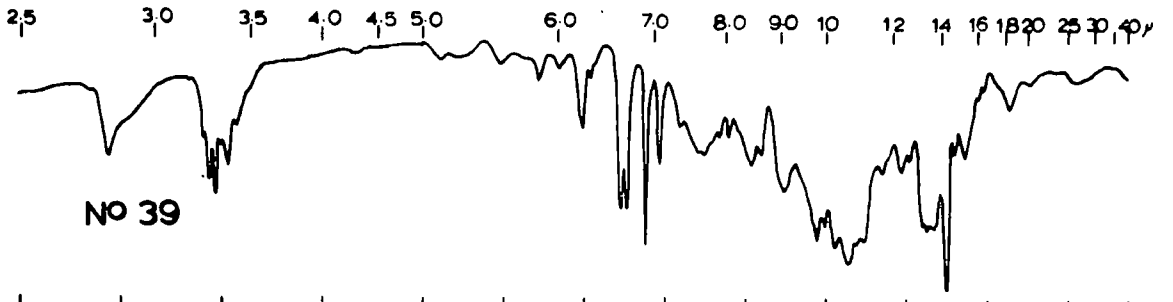

25 30 35 40 45 50 60 70 80 90 10 12 14 16 18 20 25 30 40  $\mu$

NO 44

NO 45

NO 46

NO 47

NO 48

4000 3500 3000 2500 2000 1800 1600 1400 1200 1000 800 600 400 250  $\text{cm}^{-1}$

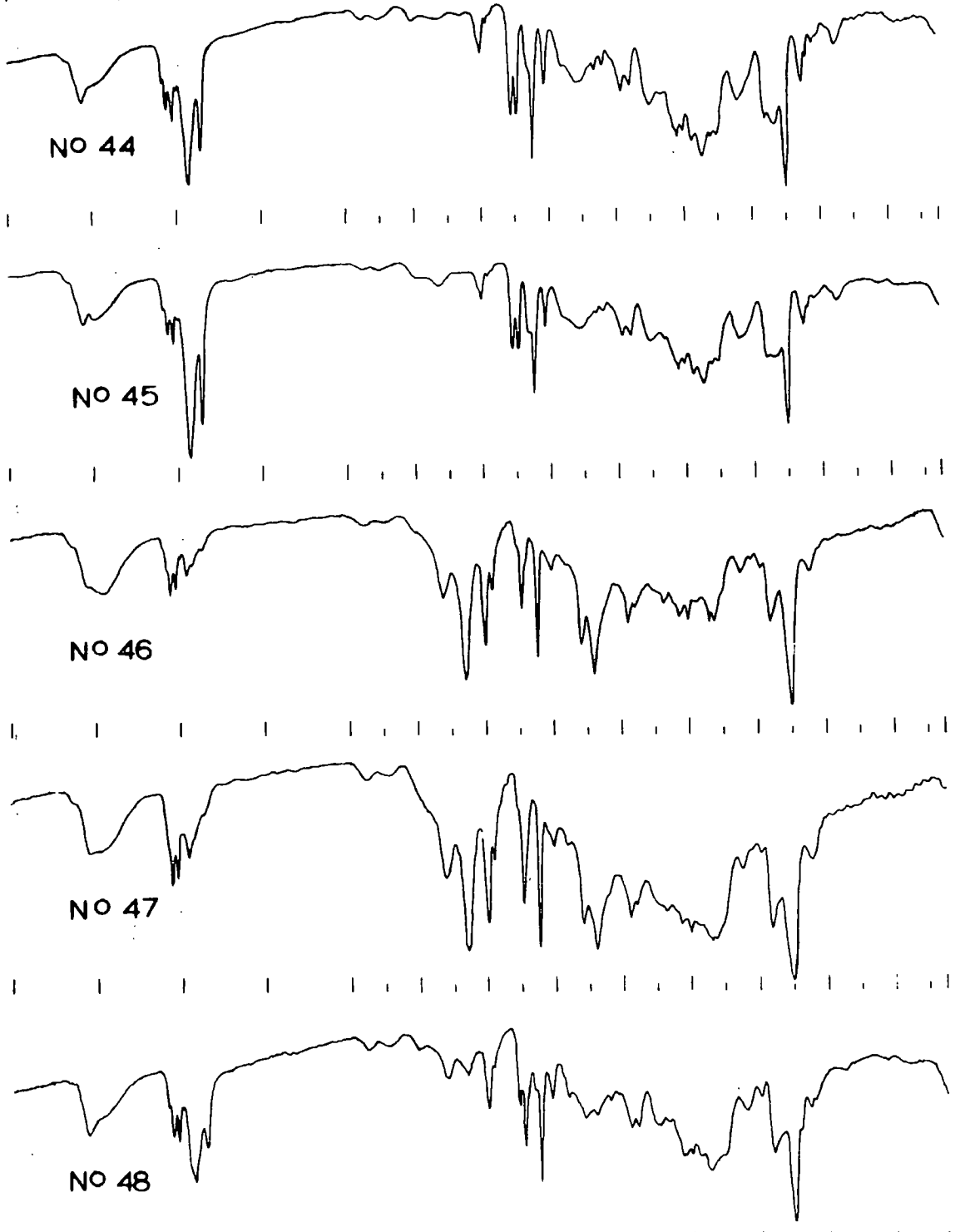

25 30 35 40 45 50 60 70 80 90 10 12 14 16 18 20 25 30 40 $\mu$



NO 49

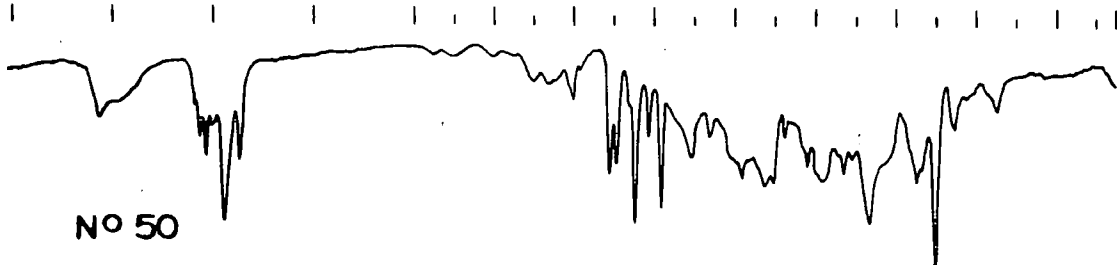

NO 50

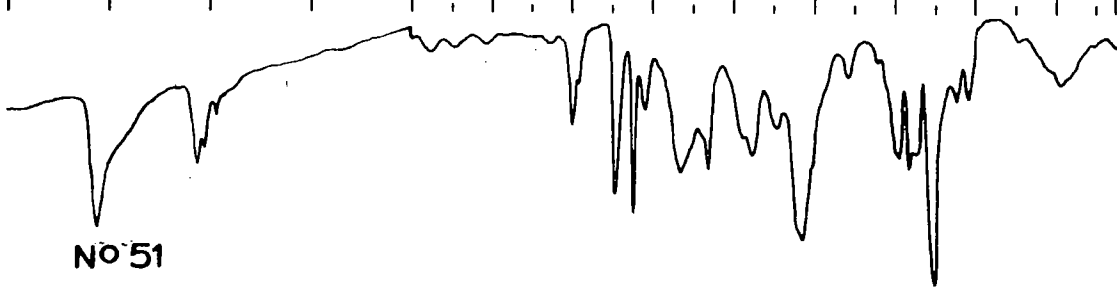

NO 51

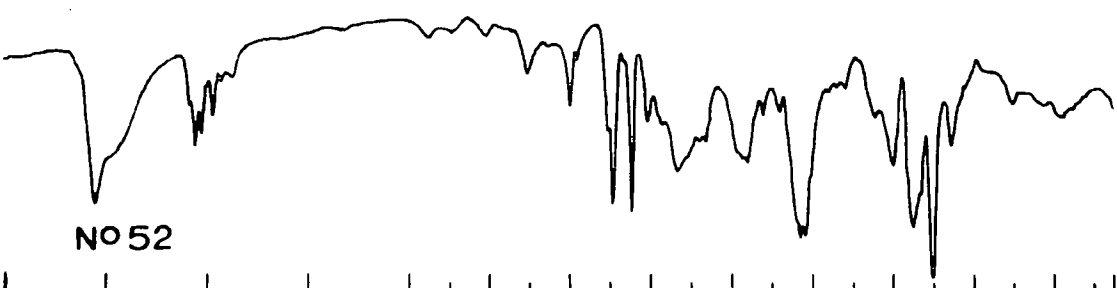

NO 52

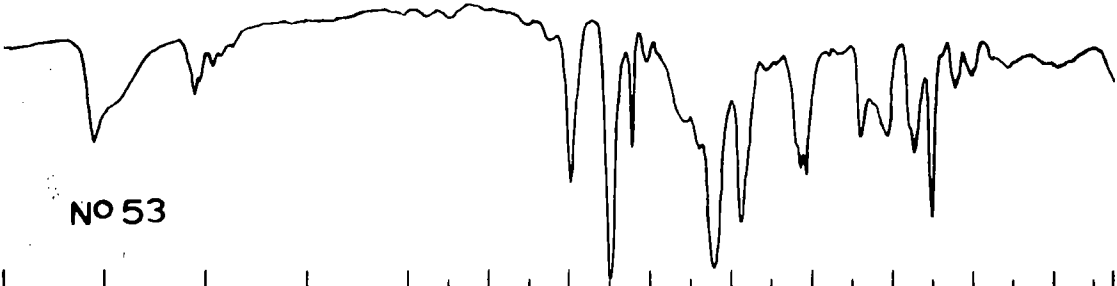

NO 53

4000 3500 3000 2500 2000 1800 1600 1400 1200 1000 800 600 400 250  $\text{cm}^{-1}$

25 30 35 40 45 50 60 70 80 90 10 12 14 16 18 20 25 30 40 $\mu$

NO 54

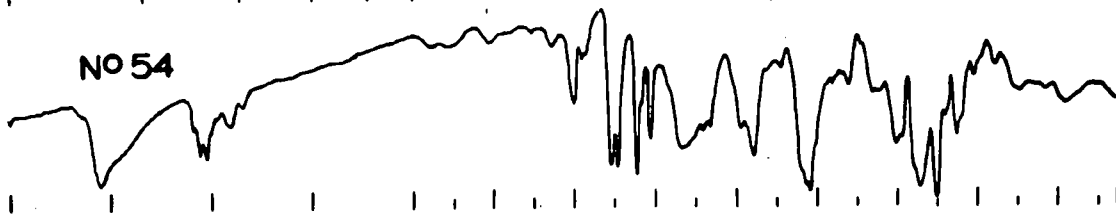

NO 55

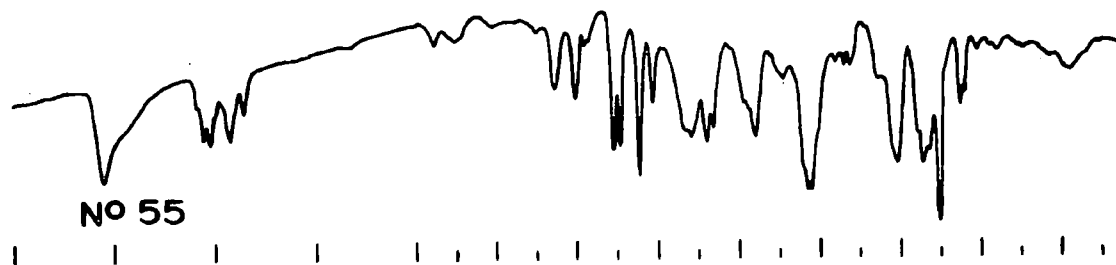

NO 56

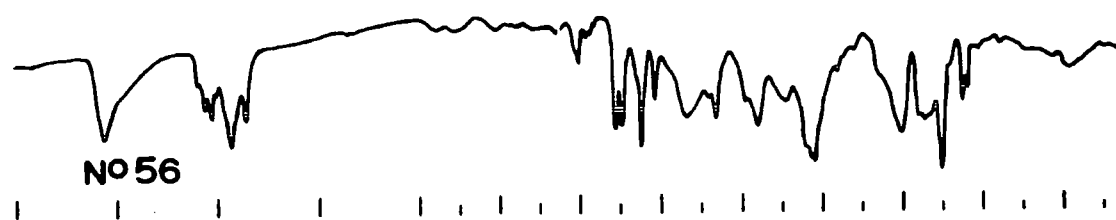

NO 57

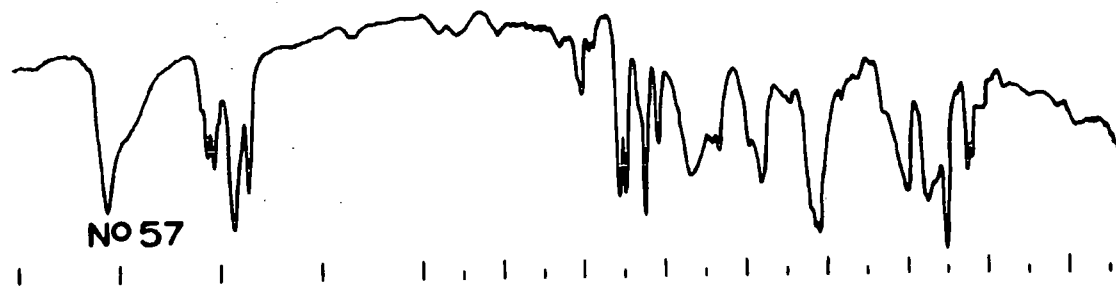

NO 58

4000 3500 3000 2500 2000 1800 1600 1400 1200 1000 800 600 400 250  $\text{cm}^{-1}$

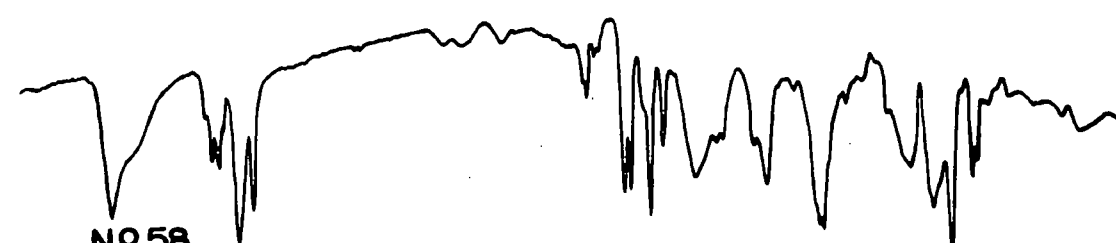

2.5 3.0 3.5 4.0 4.5 5.0 6.0 7.0 8.0 9.0 10 12 14 16 18 20 25 30 40  $\mu$

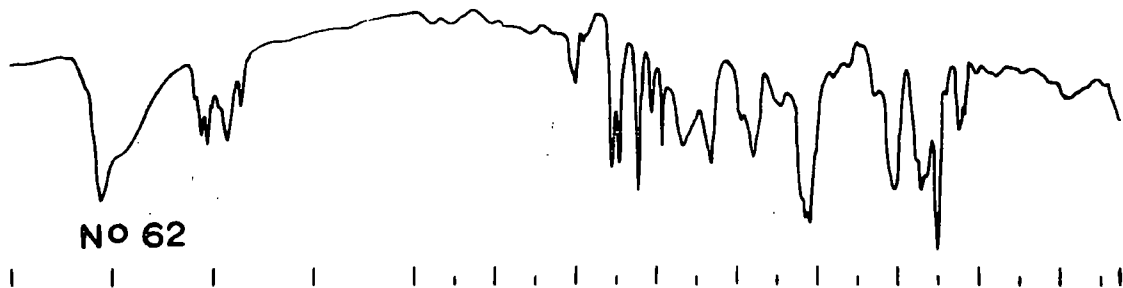
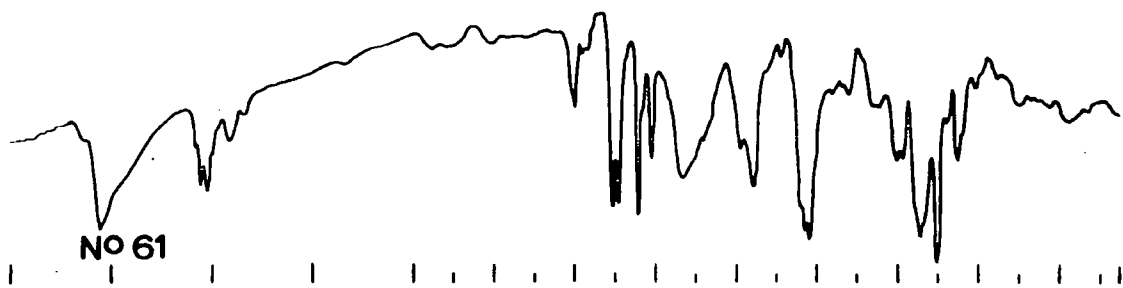
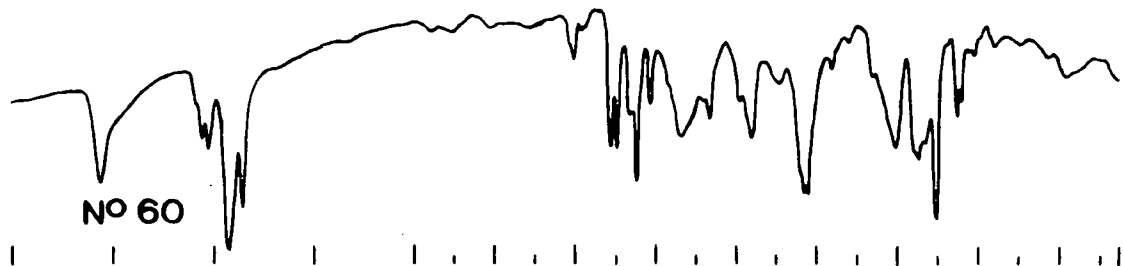

4000 3500 3000 2500 2000 1800 1600 1400 1200 1000 800 600 400 250  $\text{cm}^{-1}$

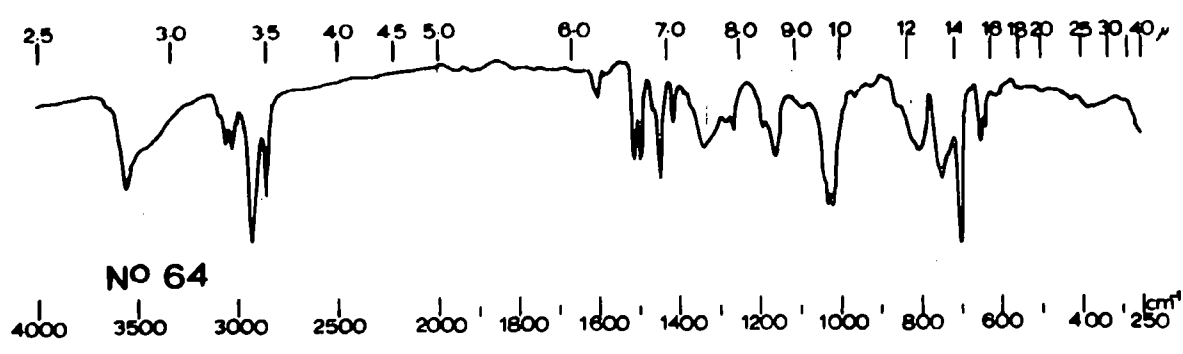

## APPENDIX D

### THERMOGRAVIMETRIC ANALYSES

Thermogravimetric analyses were carried out using a Stanton Redcroft TG-750 Thermobalance. A heating rate of 10<sup>o</sup>C per minute was employed, and for analyses in a nitrogen atmosphere, a nitrogen flow rate of ~ 10 ml. per minute was adopted. Fine powders were compressed into discs before analysis, and ~ 2-3 mg. samples were analysed.

Typical thermograms are recorded in the following four pages:

- TGA 1     TMA-Diketone Polymers  
(PolyTMAM and polyTMA6 in N<sub>2</sub> and static air).
- TGA 2     Furan-Diketone Polymers  
(PolyFM and polyF6 in N<sub>2</sub> and static air).
- TGA 3     2,5-Dimethylfuran-Diketone Polymers  
(PolyDiMeFM and polyDiMeF4 in N<sub>2</sub> and static air)
- TGA 4     Polypinacols Prepared in 50:50 Benzene-Isopropanol  
(Polypinacol M and polypinacol 10 in N<sub>2</sub> and static air).

T.G.A 1

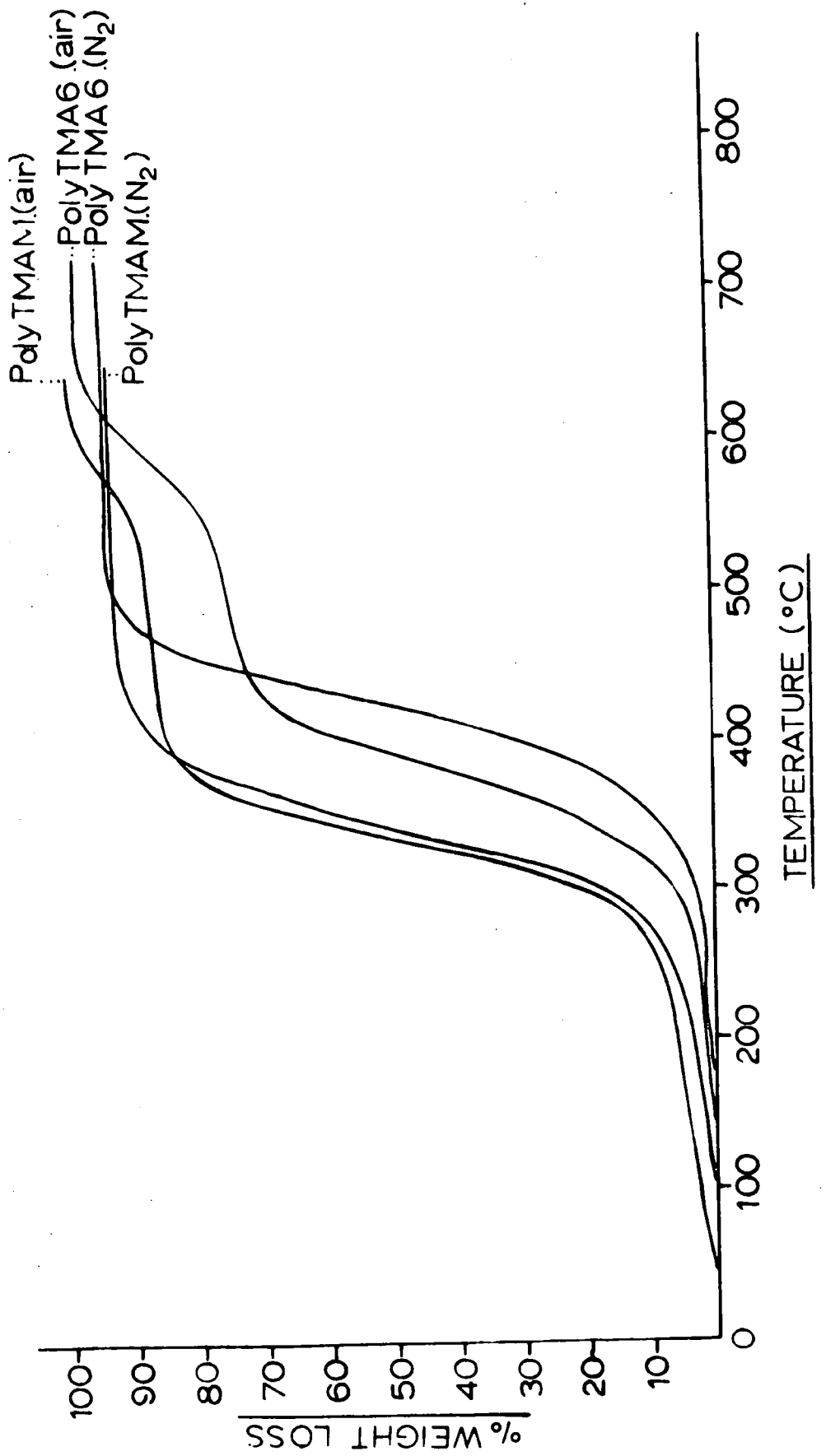

T.G.A 2

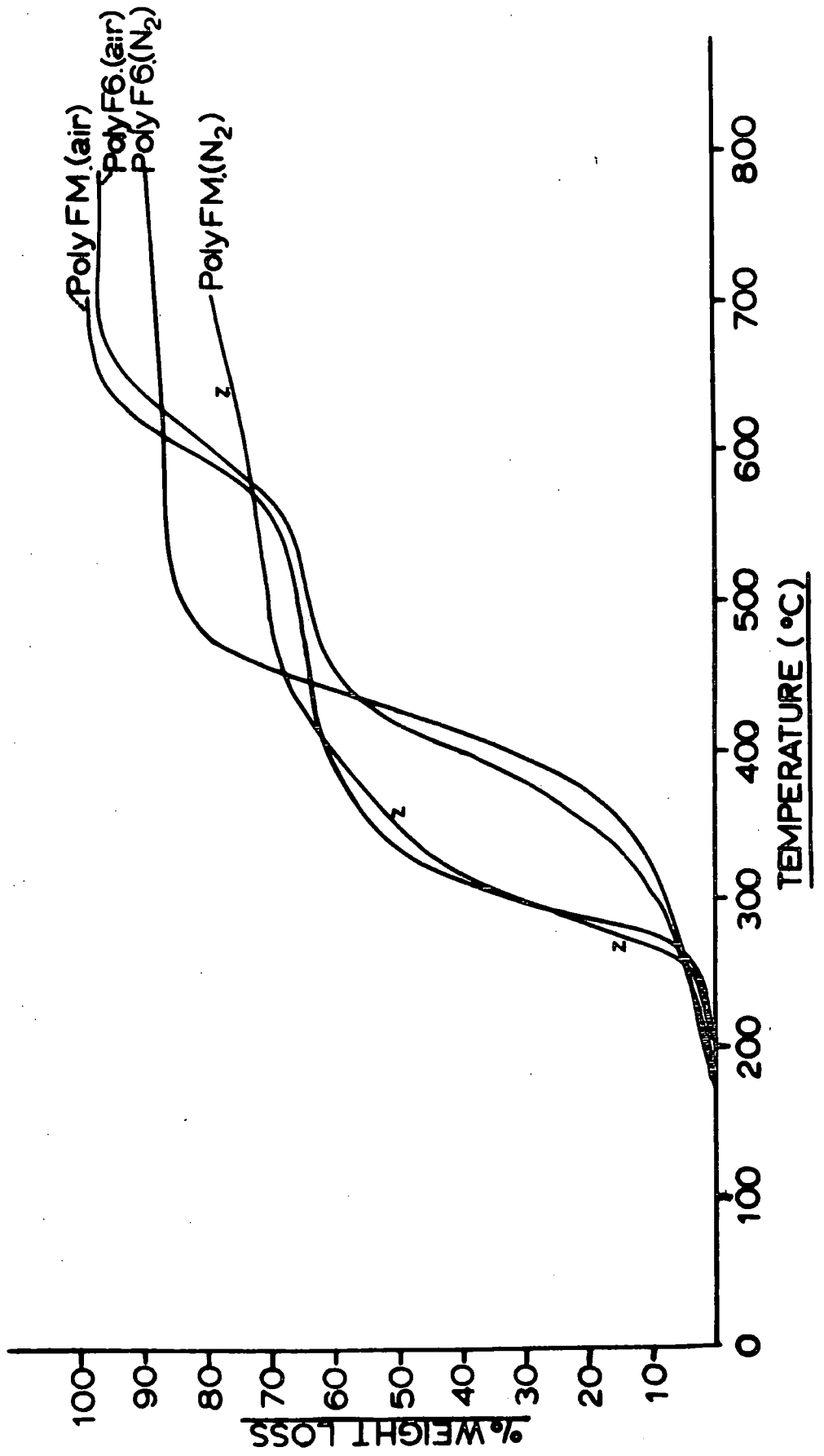

T.G.A 3

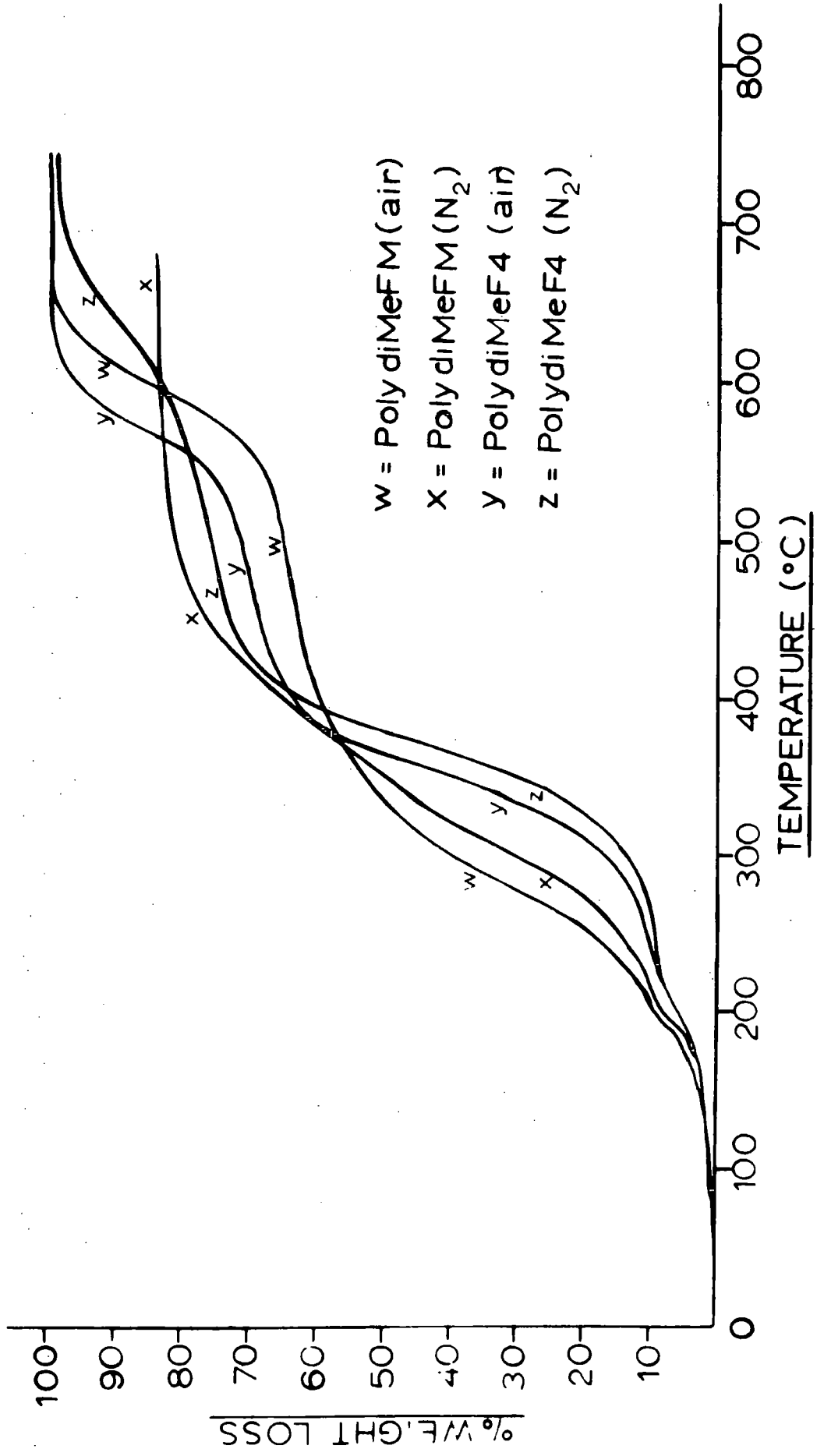

I.G.A. 4

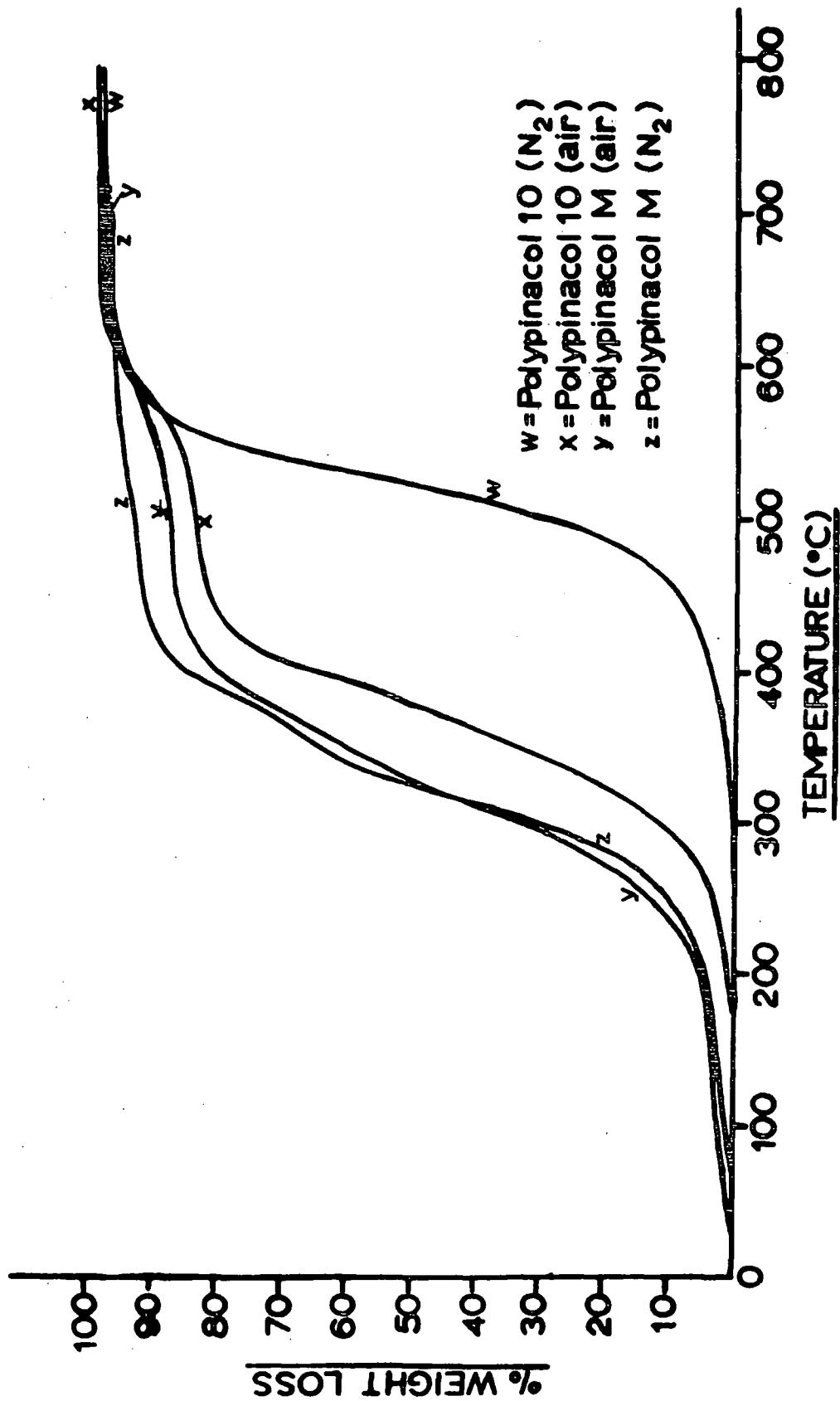

## REFERENCES

1. W.H. Carothers, J. Amer. Chem. Soc., 1929, 51, 2548.
2. P.J. Flory, 'Principles of Polymer Chemistry', Cornell University Press, New York, 1953, Ch.2.
3. R.W. Lenz, 'Organic Chemistry of Synthetic High Polymers', Interscience, New York, 1967.
4. G.D. Buckley, L.H. Cross and N.H. Ray, J. Chem. Soc., 1950, 2714.
5. W.H. Carothers, J.W. Hill, G.E. Kirby and R.A. Jacobson, J. Amer. Chem. Soc., 1930, 52, 5279.
6. G. Oster and N.-L. Yang, Chem. Rev., 1968, 68, 125.
7. N.G. Gaylord, Tech. Papers, Reg. Conf. Soc. Plast. Eng., Mid-Hudson Sect., Nov 6-7, 1967, 32.
8. J. Blyth and A.W. Hofmann, Annalen, 1845, 53, 289.
9. D. Berthelot and H. Gaudechon, Compt. rend., 1900, 150, 1169.
10. I. Ostromislenski, J. Russ. Phys. Chem. Soc., 1912, 44, 204.
11. H.S. Taylor and A.A. Vernon, J. Amer. Chem. Soc., 1931, 53, 2527.
12. H.W. Melville, Proc. Roy. Soc. London (A), 1938, 167, 99.
13. T.T. Jones and H.W. Melville, Proc. Roy. Soc. London (A), 1946, 187, 37.
14. P.F. Onyon, Trans. Faraday Soc., 1956, 52, 80.
15. T.E. Ferington and A.V. Tabolsky, J. Amer. Chem. Soc., 1958, 80, 3215.
16. G.M. Burnett and W.W. Wright, Proc. Roy. Soc. London (A), 1954, 221, 28.
17. M.L. Miller, Canad. J. Chem., 1958, 36, 309.
18. C.H. Bamford, P.A. Crowe, J. Hobbs and R.P. Wayne, Proc. Roy. Soc. London (A), 1966, 292, 153.
19. C.S. Marvel and R.C. Woolford, J. Amer. Chem. Soc., 1958, 80, 830.

20. G. Oster, Nature, 1954, 173, 300.
21. T.G. Fox, W.E. Goode, S. Gratch, C.M. Huggett, J.F. Kincaid, A. Spell and J.D. Stroupe, J. Polymer Sci., 1958, 31, 173.
22. G. Oster, Phot. Sci. Eng., 1960, 4, 237.
23. S. Tazuke, M. Asai, S. Ikeda and S.J. Okamura, J. Polymer Sci., Part B, Polymer Letters, 1967, 5, 453.
24. J.L.R. Williams, Tech. Papers, Reg. Conf. Soc. Plast. Eng., Mid-Hudson Sect., Nov 6-7, 1967, 123.
25. H. Gershein, 'History of Photography', Thames and Hudson, London, 1969, Ch.5.
26. a) L.M. Minsk, J.G. Smith, W.P. Van Deuson and J.F. Wright, J. Appl. Polymer Sci., 1959, 2, 302.  
b) E.M. Robertson, W.P. Van Deuson and L.M. Minsk, ibid., p.308.
27. H. Tanaka, M. Tsuda and H. Nakanishi, J. Polymer Sci., Part A-1, Polymer Chem., 1972, 10, 1729.
28. H. Jacobs and R. Steele, J. Appl. Polymer Sci., 1960, 3, 239, 245. (From Chem. Abs., 1960, 54, 17939i).
29. F.C. De Schryver, N. Boens and G. Smets, J. Polymer Sci., Part A-1, Polymer Chem., 1972, 10, 1687, and references cited therein.
30. F.C. De Schryver and J. Put, Ind. chim. belge, 1972, 37, 1107.
31. J. Put and F.C. De Schryver, J. Amer. Chem. Soc., 1973, 95, 137.
32. F.C. De Schryver, M. De Brackeleire, S. Toppett and M. Van Schorr, Tetrahedron Letters, 1973, 1253.
33. R.B. Fox, Progr. Polymer Sci., 1967, 1, 45, and references cited therein.
34. a) J.E. Guillet and R.G.W. Norrish, Proc. Roy. Soc. London (A), 1955, 233, 153.  
b) K.F. Wissbrun, J. Amer. Chem. Soc., 1959, 81, 58.
35. a) C.V. Stephenson, B.C. Moses and W.S. Wilcox, J. Polymer Sci., 1961, 55, 451.  
b) C.V. Stephenson, B.C. Moses, R.E. Burks, Jr., W.C. Coburn, Jr. and W.S. Wilcox, ibid., p 465.  
c) C.V. Stephenson, J.C. Lacey and W.S. Wilcox, ibid., p 477.

36. H.H.G. Jellinek, Pure Appl. Chem., 1962, 4, 419.
37. P.R.E.J. Cowley and H.W. Melville, Proc. Roy. Soc. London (A), 1952, 210, 461.
38. See, for example, E. D. Owen and R.J. Bailey, J. Polymer Sci., Part A-1, Polymer Chem., 1972, 10, 113.
39. J.E. Guillet, J. Dhanraj, F.J. Glemba and G.H. Hartley, Adv. Chem. Series, 1968, 272.
40. M. Hasegawa, Japan Chem. Quart., 1969, 5, 45.
41. C.F. Koelsch and W.H. Gumprecht, J. Org. Chem., 1958, 23, 1603.
42. M. Hasegawa and Y. Suzuki, J. Polymer Sci., Part B, Polymer Letters, 1967, 5, 813.
43. J.L.R. Williams, J. Org. Chem., 1960, 25, 1839.
44. M.D. Cohen and G.M.J. Schmidt, J. Chem. Soc., 1964, 1996.
45. W. Baker and C.S. Howes, J. Chem. Soc., 1953, 119.
46. M. Hasegawa, Y. Suzuki, F. Suzuki and H. Nakanishi, J. Polymer Sci., Part A-1, Polymer Chem., 1969, 7, 743.
47. M. Hasegawa, F. Suzuki, H. Nakanishi and Y. Suzuki, J. Polymer Sci., Part B, Polymer Letters, 1968, 6, 293.
48. F. Suzuki, Y. Suzuki, H. Nakanishi and M. Hasegawa, J. Polymer Sci., Part A-1, Polymer Chem., 1969, 7, 2319.
49. F. Nakanishi and M. Hasegawa, J. Polymer Sci., Part A-1, Polymer Chem., 1970, 8, 2151.
50. M. Miura, T. Kitami and K. Nagakubo, J. Polymer Sci., Part B, Polymer Letters, 1968, 6, 463.
51. M.J. Holm and F.B. Zienty, J. Polymer Sci., Part A-1, Polymer Chem., 1972, 10, 1311; U.S.P. 3, 312, 668/1967.
52. M. Hasegawa, Y. Suzuki and T. Tamaki, Bull. Chem. Soc. Japan, 1970, 43, 3020.
53. H. Nakanishi, Y. Suzuki, F. Suzuki and M. Hasegawa, J. Polymer Sci., Part A-1, Polymer Chem., 1969, 7, 753.
54. See reference 46, and also: L.J. Bellamy, 'The Infrared Spectra of Complex Molecules', J. Wiley, New York, 1958 (2nd edn.).

55. H. Schechter, W.J. Link and G.V.D. Tiers, J. Amer. Chem.Soc., 1963, 85, 1601.
56. T. Tamaki, Y. Suzuki and M. Hasegawa, Bull. Chem. Soc. Japan, 1972, 45, 1988.
57. Y. Suzuki, M. Hasegawa and N. Kita, J. Polymer Sci., Part A-1, Polymer Chem., 1972, 10, 2473.
58. M. Iguchi, H. Nakanishi and M. Hasegawa, J. Polymer Sci., Part A-1, Polymer Chem., 1968, 6, 1055.
59. H. Nakanishi, N. Nakano and M. Hasegawa, J. Polymer Sci., Part B, Polymer Letters, 1970, 8, 755, and references cited therein.
60. Y. Sasada, H. Shimanouchi, H. Nakanishi and M. Hasegawa, Bull. Chem. Soc. Japan, 1971, 44, 1262.
61. H. Nakanishi, M. Hasegawa and Y. Sasada, J. Polymer Sci., Part A-2, Polymer Phys., 1972, 10, 1537.
62. S. Fujishige and M. Hasegawa, J. Polymer Sci., Part A-1, Polymer Chem., 1969, 7, 2037.
63. H. Kanetsuna, M. Hasegawa, S. Mitsuhashi, T. Kurita, K. Sasahi, K. Maeda, H. Obata and T. Hatakeyama, J. Polymer Sci., Part A-2, Polymer Phys., 1970, 8, 1027.
64. F.C. De Schryver, W.J. Feast and G. Smets, J. Polymer Sci., Part A-1, Polymer Chem., 1970, 8, 1939.
65. F.C. De Schryver, N. Boens and G. Smets, J. Polymer Sci., Part A-1, Polymer Chem., 1972, 10, 1687.
66. a) G.O. Schenck and R. Steinmetz, Bull. Soc. chim. belges, 1962, 71, 781.  
b) G.O. Schenck, W. Hartmann, S.-P. Mannsfeld, W. Metzner and C.H. Krauch, Chem. Ber., 1962, 95, 1642.  
c) R. Steinmetz, Fortschr. Chem. Forsch., 1967, 7, 445.
67. a) Y. Nakayama and G. Smets, J. Polymer Sci., Part A-1, Polymer Chem., 1967, 5, 1619.  
b) M. Yamada, I. Takase and N. Koutou, J. Polymer Sci., Part B, Polymer Letters, 1968, 6, 883.

68. F.C. De Schryver, I. Bhardwaj and J. Put, Angew. Chem., 1969, 81, 224; Angew. Chem. Internat. Edn., 1969, 8, 213.
69. F.C. De Schryver in 'Microsymposium on Photochemical Processes in Polymer Chemistry', Leuven, Belgium, June 1972. Text to be published by Butterworth and Co., London. Preprint made available by Professor F.C. De Schryver.
70. L.H. Leenders, E. Schouteden and F.C. De Schryver, J. Org. Chem., 1973, 38, 957.
71. D. Bryce-Smith and M.A. Hems, Tetrahedron Letters, 1966, 1895.
72. J.S. Bradshaw, Tetrahedron Letters, 1966, 2039; U.S.P. 3, 366, 642/1968 (From Chem. Abs., 1968, 69, 26863h).
73. Y. Musa and M.P. Stevens, J. Polymer Sci., Part A-1, Polymer Chem., 1972, 10, 319.
74. N. Kardush and M.P. Stevens, J. Polymer Sci., Part A-1, Polymer Chem., 1972, 10, 1093.
75. a) J.S. Bradshaw and M.P. Stevens, J. Appl. Polymer Sci., 1966, 10, 1809.  
b) O.A. Almabekov, B.A. Zhubanov and S.R. Rafikov, Tr. Inst. Khim. Nauk., Akad. Nauk. Kaz. SSR, 1970, 28, 83 (From Chem. Abs., 1970, 73, 15599h).
76. H.J.F. Angus and D. Bryce-Smith, Proc. Chem. Soc., 1959, 326; J. Chem. Soc., 1960, 4791.
77. E. Grovenstein, Jr., D.V. Rao and J.W. Taylor, J. Amer. Chem. Soc., 1961, 83, 1705.
78. J.S. Bradshaw, J. Org. Chem., 1966, 31, 3974.
79. D. Bryce-Smith and A. Gilbert, Chem. Comm., 1968, 19.
80. D. Bryce-Smith, Pure Appl. Chem., 1968, 16, 47.
81. D. Bryce-Smith, R. Deshpande, A. Gilbert and J. Grzonke, J. Chem. Soc. (D), Chem. Comm., 1970, 561.
82. J.B. Birks, 'Photophysics of Aromatic Molecules', Interscience, New York, 1970, pp 320,369.
83. a) F.C. De Schryver, L. Anand, G. Smets and J. Switten, J. Polymer Sci., Part B, Polymer Letters, 1971, 9, 777.  
b) F.C. De Schryver and G.A. Delzenne, Ger. Offen. 2,212, 427/1972.

84. D.E. Applequist, M.A. Lintner and R. Searle, J. Org. Chem., 1968, 33, 254.
85. E. Clar, Ber., 1949, 82, 495.
86. G. Ciamician and P. Silber, Ber., 1900, 33, 2911.
87. W.D. Cohen, Rec. Trav. chim., 1920, 39, 243.
88. L.F. Fieser, 'Organic Experiments', D.C. Heath and Co., Boston, 1964, Ch.40.
89. D.E. Pearson and P.D. Thiemann, J. Polymer Sci., Part A-1, Polymer Chem., 1970, 8, 2103.
90. J. Higgins, A.H. Johannes, J.F. Jones, R. Schultz, D.A. McCombs and C.S. Menon, J. Polymer Sci., Part A-1, Polymer Chem., 1970, 8, 1987.
91. D.A. McCombs, C.S. Menon and J. Higgins, J. Polymer Sci., Part A-1, Polymer Chem., 1971, 9, 1261.
92. F.C. De Schryver, T. Tran Van and G. Smets, J. Polymer Sci., Part B, Polymer Letters, 1971, 9, 425.
93. Modification of procedure of Gomberg and Bachmann. See M. Gomberg and W.E. Bachmann, J. Amer. Chem. Soc., 1927, 49, 236.
94. J. Bøeseken, Rec. Trav. chim., 1921, 40, 433.
95. D.A. McCombs, C.S. Menon and J. Higgins, J. Polymer Sci., Part A-1, Polymer Chem., 1971, 9, 1799.
96. A. Padwa, W. Bergmark and D. Pashayan, J. Amer. Chem. Soc., 1969, 91, 2653.
97. P. Beak and C.R. Payet, J. Org. Chem., 1970, 35, 3281, and references cited therein.
98. G. Smets, 'Internat. Symp. Macromolecules', IUPAC, Budapest, 1969 (Proc. Hungarian Acad. Sciences). Quoted in reference 92.
99. D.E. Rice, J. Polymer Sci., Part B, Polymer Letters, 1968, 6, 335.
100. M. Hauptschein, M. Braid and F.E. Lawlor, J. Amer. Chem. Soc., 1957, 79, 6248.
101. J.L. Zollinger, J.R. Throckmorton, S.T. Ting, R.A. Mitsch and D.E. Elrick, 'Symposium on Polymers in Space Research', Pasadena, California, July 15-17, 1968. Published in J. Macromol. Sci. (Chem.), 1969, 3, 1443.

102. J.F. Harris, Jr., J. Org. Chem., 1965, 30, 2182.
103. 3M Company, B.P. 858,671/1961. Also see reference 101.
104. W.A. Noyes, Jr., G.B. Porter and J.E. Jolley, Chem. Rev., 1956, 56, 49.
105. For example:
- a) J.G. Calvert and J.N. Pitts, Jr., 'Photochemistry', J. Wiley, New York, 1966.
  - b) N.J. Turro, 'Molecular Photochemistry', W.A. Benjamin, Inc., New York, 1965.
  - c) R.O. Kan, 'Organic Photochemistry', Mc.Graw-Hill, New York, 1966.
  - d) R.B. Cundall and A. Gilbert, 'Photochemistry', T. Nelson and Sons Ltd., London, 1970.
106. Reference 105a, p. 252.
107. A. Udvarhazi and M.A. El-Sayad, J. Chem. Phys., 1965, 42, 3335.
108. D.E. Freeman and W. Klemperer, J. Chem. Phys., 1966, 45, 52.
109. D.R. Arnold, Adv. Photochem., 1968, 6, 301.
110. K. Brederick, Th. Foerster and H.G. Oesterlin, Chem. Abs., 1963, 58, 7514b. Also see reference 109.
111. C. Walling and M.J. Gibian, J. Amer. Chem. Soc., 1965, 87, 3361.
112. A. Padwa, Tetrahedron Letters, 1964, 3465.
113. N.J. Turro, J.C. Dalton, K. Dawes, G. Farrington, R. Hautala, D. Morton, M. Niemczyk and N. Schore, Accounts Chem. Res., 1972, 5, 92.
114. J.S. Swenton, J. Chem. Educ., 1969, 46, 217.
115. F. Wilkinson, Adv. Photochem., 1964, 3, 241.
116. a) G.S. Hammond and P.A. Leermakers, J. Phys. Chem., 1962, 66, 1148.
- b) G.S. Hammond and R.P. Foss., J. Phys. Chem., 1964, 68, 3739.
117. A. Terenin and V. Ermolaev, Trans. Faraday Soc., 1956, 52, 1042.

118. G.S. Hammond, N.J. Turro and P.A. Leermakers, J. Phys. Chem., 1962, 66, 1144.
119. H. Morrison, J. Amer. Chem. Soc., 1965, 87, 932.
120. D.O. Cowan, and A.A. Baum, J. Amer. Chem. Soc., 1971, 93, 1153.
121. D.R. Arnold, D.J. Trecker and E.B. Whipple, J. Amer. Chem. Soc., 1965, 87, 2596.
122. W.G. Herkstroeter, A.A. Lamola and G.S. Hammond, J. Amer. Chem. Soc., 1964, 86, 4537.
123. R.E. Rebbert and P. Ausloos, J. Amer. Chem. Soc., 1965, 87, 5569.
124. See, for example, N.C. Yang and E.D. Feit, J. Amer. Chem. Soc., 1968, 90, 504.
125. P.J. Wagner and G.S. Hammond, J. Amer. Chem. Soc., 1965, 87, 4009.
126. T.J. Dougherty, J. Amer. Chem. Soc., 1965, 87, 4011.
127. C.H. Nicol and J.G. Calvert, J. Amer. Chem. Soc., 1967, 89, 1790.
128. J.K.S. Wan, R.N. McCormick, E.J. Baum and J.N. Pitts, Jr., J. Amer. Chem. Soc., 1965, 87, 4409, and references cited therein.
129. A. Schönberg, 'Preparative Organic Photochemistry', Springer-Verlag, Berlin, 1968, (Ch.22).
130. (a) W.E. Bachmann, J. Amer. Chem. Soc., 1933, 55, 391.  
(b) References cited in (a).
131. Reference 129, Ch.20.
132. W.D. Cohen, Rec. Trav. chim., 1920, 39, 243.
133. A. Schönberg and A. Mustafa, J. Chem. Soc., 1944, 67.
134. M.R. Kegelman and E.V. Brown, J. Amer. Chem. Soc., 1953, 75, 4649.
135. C. Weizmann, E. Bergmann and Y. Hirshberg, J. Amer. Chem. Soc., 1938, 60, 1530.
136. W.L. Bencze, C.A. Burckhardt and W.L. Yost, J. Org. Chem., 1962, 27, 2865.
137. F. Bergmann and Y. Hirshberg, J. Amer. Chem. Soc., 1943, 65, 1429.
138. J.N. Pitts, Jr., R.L. Letsinger, R.P. Taylor, J.M. Patterson, G. Recktenwald and R.B. Martin, J. Amer. Chem. Soc., 1959, 81, 1068.

139. G.S. Hammond, W.P. Baker and W.M. Moore, J. Amer. Chem. Soc., 1961, 83, 2795.
140. A. Beckett and G. Porter, Trans. Faraday Soc., 1963, 59, 2038.
141. J.N. Pitts, Jr., and J.K.S. Wan in 'Chemistry of the Carbonyl Group', ed. S. Patai, Interscience, New York, 1966, Ch.14.
142. G.S. Hammond and P.A. Leermakers, J. Amer. Chem. Soc., 1962, 84, 207.
143. S.A. Weiner, J. Amer. Chem. Soc., 1971, 93, 424.
144. H. Mauser and V. Bihl, Z. Naturforsch (B), 1967, 22, 1077.
145. N. Filipescu and F.L. Minn, J. Amer. Chem. Soc., 1968, 90, 1544, and references cited therein.
146. N. Filipescu, L.M. Kindley and F.L. Minn, J. Org. Chem., 1971, 36, 861.
147. J. Saltiel, H.C. Curtis and B. Jones, Mol. Photochem., 1970, 2, 331.
148. J. Dedinas, J. Phys. Chem., 1971, 75, 181.
149. D.I. Schuster, T.M. Weil and A.M. Halpern, J. Amer. Chem. Soc., 1972, 94, 8248, and see references cited therein.
150. J.A. Bell and H. Linschitz, J. Amer. Chem. Soc., 1963, 85, 528.
151. A.V. Buettner and J. Dedinas, J. Phys. Chem., 1971, 75, 187.
152. J. Saltiel, H.C. Curtis, L. Metts, J.W. Miley, J. Winterle and M. Wrighton, J. Amer. Chem. Soc., 1970, 92, 410.
153. D.I. Schuster and D.F. Brizzolaro, J. Amer. Chem. Soc., 1970, 92, 4357.
154. G. Porter and P. Suppan, Pure Appl. Chem., 1964, 9, 499; Trans. Faraday Soc., 1965, 61, 1293.
155. G. Porter and P. Suppan, Proc. Chem. Soc., 1964, 191.
156. S.G. Cohen and M.N. Siddiqui, J. Amer. Chem. Soc., 1964, 86, 5047.
157. (a) E.J. Baum, J.K.S. Wan and J.N. Pitts, Jr., J. Amer. Chem. Soc., 1966, 88, 2652.  
(b) References cited in (a).  
(c) S.G. Cohen, M.D. Saltzman and J.B. Guttenplan, Tetrahedron Letters, 1969, 4321.
158. N.C. Yang and C. Rivas, J. Amer. Chem. Soc., 1961, 83, 2213.

159. M. Pfau, N.D. Heindel and T.F. Lemke, Compt. rend., 1965, 261, 1017.
160. E. Paternò and G. Chieffi, Gazz. Chim. Ital., 1909, II, 39, 415.
161. E. Bergmann and S.-I. Fujise, Annalen, 1930, 483, 65.
162. M. Barnard and N.C. Yang, Proc. Chem. Soc., 1958, 302.
163. See reference 129, especially Ch.21.
164. E. Paternò and G. Chieffi, Gazz. Chim. Ital., 1909, 39, 341.
165. G. Büchi, C.G. Inman and E.S. Lipinsky, J. Amer. Chem. Soc., 1954, 76, 4327.
166. L.L. Muller and J. Hamer, '1,2-Cycloaddition Reactions', Interscience, New York, 1967.
167. J.F. Harris, Jr. and D.D. Coffmann, J. Amer. Chem. Soc., 1962, 84, 1553.
168. E.W. Cook and B.F. Landrum, J. Heterocyclic Chem., 1965, 2, 327.
169. J.S. Bradshaw, J. Org. Chem., 1966, 31, 237.
170. N.C. Yang, M. Nussim and D.R. Coulson, Tetrahedron Letters, 1965, 1525.
171. N.C. Yang, Pure Appl. Chem., 1964, 9, 591.
172. D.R. Arnold and A.A. Sousa, U.S.P. 3,418,330/1968; B.P. 1,164,471/1969; U.S.P. 3,498,896/1970.
173. D.R. Arnold, R.L. Hinman and A.H. Glick, Tetrahedron Letters, 1964, 1425.
174. D. Scharf and F. Korte, Tetrahedron Letters, 1963, 821.
175. Y. Shigemitsu, Y. Odaira & S. Tsutsumi, Tetrahedron Letters, 1967, 55.
176. (a) D. Bryce-Smith and A. Gilbert, Proc. Chem. Soc., 1964, 87.  
(b) D. Bryce-Smith, A. Gilbert and M.G. Johnson, J. Chem. Soc.(C), 1967, 383.
177. M.J. Jorgenson, Tetrahedron Letters, 1966, 5811.
178. G. Büchi, J.T. Kofron, E. Koller and D. Rosenthal, J. Amer. Chem. Soc., 1956, 78, 877.
179. D.R. Arnold and A.H. Glick, Chem. Comm., 1966, 813.
180. H. Hogeveen and P.J. Smit, Rec. Trav. chim., 1966, 85, 1188.

181. H. Gotthardt, R. Steinmetz and G.S. Hammond, Chem. Comm., 1967, 480.
182. K. Shima and H. Sakurai, Bull. Chem. Soc. Japan, 1966, 39, 1806  
(From reference 109).
183. L.A. Singer and P.D. Bartlett, Tetrahedron Letters, 1964, 1887.
184. L.A. Singer and G.A. Davis, J. Amer. Chem. Soc., 1967, 89, 158.
185. N.J. Turro, P. Wriede, J.C. Dalton, D.R. Arnold and A.H. Glick,  
J. Amer. Chem. Soc., 1967, 89, 3950, and references  
cited therein.
186. N.C. Yang, J.T. Cohen and A. Shani, J. Amer. Chem. Soc., 1968,  
90, 3264.
187. R.A. Caldwell and S.P. James, J. Amer. Chem. Soc., 1969, 91, 5184,  
and references cited therein.
188. I.H. Kochevar and P.J. Wagner, J. Amer. Chem. Soc., 1970, 92, 5742.
189. See T. Forster, Angew. Chem. Internat. Edn., 1969, 8, 233.
190. R.A. Caldwell, G.W. Sovocool and R.P. Gajewski, J. Amer. Chem.  
Soc., 1973, 95, 2549.
191. N.C. Yang and W. Eisenhardt, J. Amer. Chem. Soc., 1971, 93, 1277.
192. N.J. Turro and P.A. Wriede, J. Amer. Chem. Soc., 1970, 92, 320.
193. N.J. Turro, C. Lee, N. Schore, J. Barltrop and H.A.J. Carless,  
J. Amer. Chem. Soc., 1971, 93, 3079.
194. L.M. Stephenson and T.A. Gibson, J. Amer. Chem. Soc., 1972, 94,  
4599, and references cited therein.
195. S.R. Kurowsky and H. Morrison, J. Amer. Chem. Soc., 1972, 94, 507.
196. J.A. Barltrop, and H.A.J. Carless, J. Amer. Chem. Soc., 1972,  
94, 1951.
197. N.J. Turro, P.A. Wriede and J.C. Dalton, J. Amer. Chem. Soc.,  
1968, 90, 3274.
198. J.A. Barltrop and H.A.J. Carless, Tetrahedron Letters, 1968, 3901.
199. J.C. Dalton, P.A. Wriede and N.J. Turro, J. Amer. Chem. Soc.,  
1970, 92, 1318.
200. J.A. Barltrop and H.A.J. Carless, J. Amer. Chem. Soc., 1972, 94,  
8761, and references cited therein.

201. J. Saltiel, R.M. Coates and W.G. Dauben, J. Amer. Chem. Soc., 1966, 88, 2745.
202. J.A. Barltrop and H.A.J. Carless, J. Amer. Chem. Soc., 1971, 93, 4794.
203. (a) N. Nozaki, I. Otani, R. Noyori and M. Kawanisi, Tetrahedron, 1968, 24, 2183.  
(b) C. De Boer, Tetrahedron Letters, 1971, 4977.  
(c) S. Farid, J.C. Doty and J.L.R. Williams, J. Chem. Soc.(D), 1972, 711.
204. (a) N.C. Yang, R. Loeschen and D. Mitchell, J. Amer. Chem. Soc., 1967, 89, 5465.  
(b) N.C. Yang, Photochem. and Photobiol., 1968, 7, 767.
205. Y. Shigemitsu, Y. Katsuhara and Y. Odaira, Tetrahedron Letters, 1971, 2887.
206. S. Farid and S.E. Sheuler, J. Chem. Soc.(D), Chem. Comm., 1973, 296.
207. S.G. Cohen and S. Aktipis, Tetrahedron Letters, 1965, 579.
208. D. Bryce-Smith and A. Gilbert, Proc. Chem. Soc., 1964, 87;  
Tetrahedron Letters, 1964, 3471.
209. J.F. Harris, Jr., J. Org. Chem., 1965, 30, 2182.
210. For example, J.D. Margerum, J.N. Pitts, Jr., J.G. Rutgers and S. Searles, J. Amer. Chem. Soc., 1959, 81, 1549.
211. M.S. Kharasch, W.H. Urry and B.M. Kuderna, J. Org. Chem., 1949, 14, 248.
212. For example, C. Walling and E.S. Huyser, Org. Reactions, 1963, 13, 91.
213. G. Quinkert, Angew. Chem. Internat. Edn., 1965, 4, 211.
214. S. Cremer and R. Srinivasan, J. Amer. Chem. Soc., 1964, 86, 4197.
215. R. Srinivasan, Adv. Photochem., 1963, 1, 83.
216. Reference 105a, Ch.6.
217. For example, C. Reid, Quart. Rev., 1958, 12, 205.
218. H. Kautsky, Trans. Faraday Soc., 1939, 35, 216.
219. D.F. Evans, Proc. Roy. Soc. London(A), 1960, 255, 55.
220. H. Linschitz and L. Pekkarinen, J. Amer. Chem. Soc., 1960, 82, 2411.

221. K. Gollnick and G.O. Schenck, Pure Appl. Chem., 1964, 9, 507, and references cited therein.
222. C.S. Foote and S. Wexler, J. Amer. Chem. Soc., 1964, 86, 3880.
223. For example, G.O. Schenck, Annalen, 1953, 584, 156.
224. H.S. Johnston and J. Heicklen, J. Amer. Chem. Soc., 1964, 86, 4249.
225. See, for example, D.P.N. Satchell and R.S. Satchell in 'The Chemistry of the Carbonyl Group', ed. S. Patai, Interscience, New York, 1966, Ch.5.
226. C. Friedel and J.M. Crafts, Compt. rend., 1877, 84, 1392.
227. G.A. Olah (ed.), 'Friedel-Crafts and Related Reactions'; Vols.1-4, Interscience, New York, 1963-5.
228. F.R. Jensen and G. Goldman in Ch.36, Vol.3, of reference 227.
229. For example,  
(a) B.P. Susz and I. Cooke, Helv. Chim. Acta, 1954, 37, 1273.  
(b) G.A. Olah, S.J. Kuhn, W.S. Tolgyesi and E.B. Baker, J. Amer. Chem. Soc., 1962, 84, 2733, and references cited therein.
230. P.H. Gore in Ch.21, Vol.3 of reference 227.
231. F. Fairbrother and W.C. Frith, J. Chem. Soc., 1953, 2975.
232. F.R. Jensen and H.C. Brown, J. Amer. Chem. Soc., 1958, 80, 3039.
233. N.O. Calloway, J. Amer. Chem. Soc., 1937, 59, 1474.
234. A.I. Vogel, 'A Text Book of Practical Organic Chemistry', Longman, London, 1956 (3rd. edn.), Ch.4.
235. N.O. Calloway and L.D. Green, J. Amer. Chem. Soc., 1937, 59, 809.
236. P.H. Gore, Chem. Rev., 1955, 55, 229.
237. E. Ador, Ber., 1880, 13, 320.
238. Beilstein, 7, 829 (444).
239. L.M. Long and H.R. Henze, J. Amer. Chem. Soc., 1941, 63, 1939, and references cited therein.
240. G. Wittig and N. Leo, Ber., 1928, 61, 1854.
241. R.C. Fuson and G.P. Speranza, J. Amer. Chem. Soc., 1952, 74, 1621.
242. H. Kipper, Ber., 1905, 38, 2490.

243. W. Dilthey, E. Bach, H. Grutering and E. Hausdorfer, J. prakt. Chem. (2), 1927, 117, 337 (From Chem. Abs., 1928, 22, 769).
244. F. Fieser and M. Fieser, 'Advanced Organic Chemistry', Reinhold Publishing Corp., New York, 1961, Ch.4.
245. I.L. Finar, 'Organic Chemistry', Vol.1, Longman, London, 5th edn., 1967, Ch.20.
246. H.H. Schlubach and E.C. Goes, Ber., 1922, 55B, 2889.
247. W.E. Bachmann and H.T. Clarke, J. Amer. Chem. Soc., 1927, 49, 2089.
248. C.B. Wooster, Chem. Rev., 1932, 11, 1.
249. F.C. Whitmore and H.D. Zook, J. Amer. Chem. Soc., 1942, 64, 1783.
250. A.A. Morton, J.B. Davidson and B.L. Hakan, J. Amer. Chem. Soc., 1942, 64, 2242.
251. (a) E. Le Goff, S.E. Ulrich and D.B. Denney, J. Amer. Chem. Soc., 1958, 80, 622.  
(b) J. Hine, 'Physical Organic Chemistry', McGraw-Hill, New York, 1962, Ch.10.
252. J. Van Alphen, Rec. Trav.chim., 1940, 59, 580.
253. H. Budzikiewicz, C. Djerassi and D.H. Williams, 'Mass Spectrometry of Organic Compounds', Holden-Day, Inc., San Francisco, 1967, (a) Chapter 3; (b) Chapter 1.
254. R.M. Silverstein and G.C. Bassler, 'Spectrometric Identification of Organic Compounds', J. Wiley, New York, 1967, Ch.5.
255. R.F. Rekker and W. Th. Nauta, Rec. Trav. chim., 1961, 80, 747,764.
256. S. Searles, Jr. in 'Heterocyclic Compounds with Three- and Four-membered Rings', Part II, ed. A. Weissberger, Interscience, New York, 1964, Ch.9.
257. H. Gotthardt, R. Steinmetz and G.S. Hammond, J. Org. Chem., 1968, 33, 2774.
258. L.J. Bellamy, 'The Infrared Spectra of Complex Molecules', J. Wiley, New York, 1958 (2nd edn.), Ch.7.
259. A.R. Katritzky and A.P. Ambler, in 'Physical Methods in Heterocyclic Chemistry', Vol.2, ed. A.R. Katritzky, Academic Press Inc., New York, 1963, Ch.10.

260. S.H. Schroeter, Chem. Comm., 1969, 12.
261. D.A. Bitter and W.D. Walters, J. Amer. Chem. Soc., 1955, 77, 1429.
262. G.O. Schenck, W. Hartmann and R. Steinmetz, Chem. Ber., 1963, 96, 498.
263. G.S. Hammond and N.J. Turro, Science, 1963, 142, 1541.
264. D. Gagnaire and E. Payo-Subiza, Bull. Soc. chim. France, 1963, 11, 2623.
265. M. Ogata, H. Watanabe and H. Kano, Tetrahedron Letters, 1967, 533.
266. J. Leitich, Tetrahedron Letters, 1967, 1937.
267. G.R. Evanega and E.B. Whipple, Tetrahedron Letters, 1967, 2163.
268. S. Toki and H. Sakurai, Tetrahedron Letters, 1967, 4119.
269. (a) C. Rivas and E. Payo, J. Org. Chem., 1967, 32, 2918.  
(b) C. Rivas, E. Payo, J. Mantecon and L. Cortés, Photochem. and Photobiol., 1968, 7, 807.
270. E.B. Whipple and G.R. Evanega, Tetrahedron, 1968, 24, 1299.
271. H.H. Jaffé and M. Orchin, 'Theory and Applications of Ultraviolet Spectroscopy', J. Wiley, New York, 1962, Ch.15.
272. S.H. Schroeter and C.M. Orlando, Jr., J. Org. Chem., 1969, 34, 1181.
273. R.C. Schulz, L. Rohe and H. Adler, European Polymer J. Supplement, 1969, 309.
274. K. Shima and H. Sakura, Bull. Chem. Soc. Japan, 1966, 39, 1806.
275. H.B. Henbest and B.B. Millward, J. Chem. Soc., 1960, 3575.  
Also see reference 259.
276. J.D. Margerum, J.N. Pitts, Jr., J.G. Rutgers, and S. Searles, J. Amer. Chem. Soc., 1959, 81, 1549.
277. E.J. Gallegos and R.W. Kiser, J. Phys. Chem., 1962, 66, 136.
278. G.M. Badger and J.W. Clark-Lewis in 'Molecular Rearrangements', ed. P. de Mayo, Interscience, New York, 1963, Ch.10.
279. C.L. Wilson, J. Amer. Chem. Soc., 1947, 69, 3002.
280. P. Schribe, M.R. Monot and J. Wiemann, Tetrahedron Letters, 1967, 5157.
281. Reference 254, Ch.3.

282. Reference 258, Ch.11.
283. S. Searles, Jr. and E.F. Lutz, J. Amer. Chem. Soc., 1959, 81, 3674.
284. A. Robertson, Nature, 1948, 162, 153.
285. R.J. Gritter in 'The Chemistry of the Ether Linkage', ed. S. Patai, Interscience, New York, 1967, Ch.9.
286. H.-D. Becker, J. Org. Chem., 1967, 32, 2140.
287. H.-D. Becker, J. Org. Chem., 1967, 32, 2115.
288. G. Wettermark, Photochem. and Photobiol., 1965, 4, 621.
289. (a) N.C. Yang, D.S. McClure, S.L. Murov, J.J. Houser and R. Dusenbury, J. Amer. Chem. Soc., 1967, 89, 5466.  
(b) N.C. Yang and R.L. Dusenbury, J. Amer. Chem. Soc., 1968, 90, 5899.
290. S.L. Silver and A. Lowy, J. Amer. Chem. Soc., 1934, 56, 2429.
291. R.E. Lutz et al., J. Org. Chem., 1947, 12, 617.
292. E.F. Zwicker, L.I. Grossweiner and N.C. Yang, J. Amer. Chem. Soc., 1963, 85, 2671.
293. N.D. Heindel, E.W. Sarver and M.A. Pfau, Tetrahedron Letters, 1968, 3579.
294. K.R. Huffman, M. Loy and E.F. Ullman, J. Amer. Chem. Soc., 1965, 87, 5417.
295. W.A. Henderson, Jr. and E.F. Ullman, J. Amer. Chem. Soc., 1965, 87, 5424.
296. A. Beckett and G. Porter, Trans. Faraday Soc., 1963, 59, 1481.
297. E.F. Ullman and K.R. Huffman, Tetrahedron Letters, 1965, 1863.
298. N.D. Heindel, J. Molnar and M. Pfau, J. Chem. Soc.(D), Chem. Comm., 1970, 1373.
299. M. Pfau, E.W. Sarver and N.D. Heindel, Compt. rend., 1969, 268C, 1167.
300. G. Porter and M.F. Tchir, J. Chem. Soc.(D), Chem. Comm., 1970, 1372.
301. D. Bryce-Smith and J.E. Lodge, J. Chem. Soc., 1963, 695.
302. E. Grovenstein, Jr., T.C. Campbell and T. Shibata, J. Org. Chem., 1969, 34, 2418.
303. E. Clar, F. John and B. Hawran, Ber., 1929, 62, 944.
304. R.C. Fuson, E.M. Bottorff, R.E. Foster and S.B. Speck, J. Amer. Chem. Soc., 1942, 64, 2573.