

Durham E-Theses

*Studies on the communal roosting of starlings
(stumus vulgaris L.)*

Kevin Charman

How to cite:

Charman, Kevin (1975) Studies on the communal roosting of starlings (stumus vulgaris L.). Doctoral thesis, Durham University.

Use policy

The full-text may be used and/or reproduced, and given to third parties in any format or medium, without prior permission or charge, for personal research or study, educational, or not-for-profit purposes provided that:

- a full bibliographic reference is made to the original source
- a <https://etheses.durham.ac.uk/id/eprint/8335/> is made to the metadata record in Durham E-Theses
- the full-text is not changed in any way

The full-text must not be sold in any format or medium without the formal permission of the copyright holders.

Please consult the [full Durham E-Theses policy](#) for further details.

This thesis, which is entirely the result of my own work, has not been accepted for any degree and is not being submitted concurrently in candidature for any degree.

Kevin Charman

J. C. Coulson
(supervisor)

STUDIES ON THE COMMUNAL ROOSTING OF
STARLINGS (Sturnus vulgaris L.)

A thesis submitted for the
Degree of Doctor of Philosophy
in the University of Durham

by

K. Charman

The copyright of this thesis rests with the author.
No quotation from it should be published without
his prior written consent and information derived
from it should be acknowledged.

September 1975



"... Thinking of these flocks, and at still further remove I noted that my great namesake of Selborne defined 15 September in his Naturalists' Calendar with the few words: 'Ivy fl., Starlings congregate.' And so they did. The Starlings and felts were already in their congregations, and as Rooks were, thus causing many short-sighted shooters to wonder if the second of them were not coveys of Partridges. But note the verb he used. Starlings 'congregate'. One could be struck into a kind of muse, thinking that Starlings have been upon the face of the earth longer than man has been, and wondering what kind of yearly business is transacted at these moots, so much more ancient than the witangemoot from which we trace our dying human parliaments"

From 'The Goshawk' by T. H. White

CONTENTS

	Page
ABSTRACT	iii
ACKNOWLEDGEMENTS	iv
LIST OF MAPS AND FIGURES	v
LIST OF TABLES	viii
LIST OF APPENDICES	xii
I. INTRODUCTION	1
A. THE BACKGROUND	1
B. THE STARLING AND THE SCOPE OF THIS STUDY	5
C. THE STUDY AREA	11
II. METHODS	15
A. ROOST OCCUPATION AND LOCATION	15
B. ARRIVAL AND ROOST ENTRY	16
C. ROOSTING BEHAVIOUR	17
D. ROOST DEPARTURE	19
E. THE MULTIVARIATE ANALYSIS OF ARRIVAL AND DEPARTURE DATA	20
III. RESULTS	27
A. ROOST OCCUPATION AND LOCATION	27
1. Annual roosting cycle	27
a. 1969-70	27
b. 1970-71	29
c. 1971-72	32
d. General pattern of roost occupation	35
2. The roosting population	36
a. Age and sex composition	36
b. Weights	44

	Page
B. ARRIVAL AND ROOST ENTRY	51
1. Arrival behaviour	51
2. Entry pattern	55
3. Preassembly	58
4. Flock sizes	58
5. Time of entry	60
C. ROOSTING	68
1. Behaviour within roost	68
2. Noise	77
D. ROOST DEPARTURE	79
1. Behaviour	79
2. Timing	82
3. Departure pattern	86
a. Departure number	86
b. Departure length	86
c. Gap length	90
4. Departure composition	96
a. Age and sex composition	96
b. Weights	112
5. Dispersal to feeding grounds	118
IV. DISCUSSION	121
REFERENCES	137
APPENDICES I and II	144

ABSTRACT

This study set out to investigate the roosting behaviour of the Starling at rural roosts and in particular to examine the mechanisms of roosting. It was hoped that insights into the function and selective advantage of the social roosting habit would be gained through an understanding of the mechanics of roost entry and departure.

Estimates of the size of major winter roosts were obtained regularly. Random samples of birds were shot, from within one roost, in order to determine the age, sex and origin of the roosting population. Emphasis was placed on the measurement of the light regime together with the observation and timing of roost entry and dispersal. Multivariate analysis was used to investigate the variation of several aspects of roosting behaviour with respect to environmental factors.

Small Starling roosts, occupied during the early autumn, amalgamated to form major roosts, which served large catchments, throughout the winter. At that time of year the resident population was swollen by the arrival of Continental birds. These Continentals constituted 50% of all birds shot at the one roost examined and the sample contained fewer males than did the sample of British birds. The pattern of roost entry varied according to light and weather conditions. The time of entry also varied, being later relative to civil twilight in the middle of the winter. Departure from the roost in the morning was earlier when daylength was shorter. Moreover, departure waves were less numerous and of smaller total duration at that time of year.

The various hypotheses on communal roost functions have been examined in the light of the information gained during this study. The mechanism of wave dispersal, from the communal roosts of Starlings, does offer the opportunity for roosts to act as "information centres" for food finding.

ACKNOWLEDGEMENTS

The work was carried out under a Natural Environment Research Council Research Studentship held from October 1969 to September 1972.

I would like to thank Professor D. Barker for the provision of working facilities in the Zoology Department, University of Durham.

I am most grateful to my Supervisor, Dr. J. C. Coulson, for guidance, help and encouragement throughout my work.

I should like to acknowledge Mr. Hugonin, Mr. Salvin, Mr. Wilson and Greenwich Estates for permission to carry out work on land in Durham and Northumberland.

Both Mr. Lincoln, of the Applied Physics Department, and Mr. Venmore, of the Workshop staff, University of Durham, were very helpful in the design and construction of equipment.

I frequently had useful discussions with friends and colleagues; Mr. J. Gurr, Mr. G. Halliwell, Mr. D. F. Harle, Dr. D. G. Kay, Mr. G. W. Robertson and Mr. P. C. Smith all deserve my thanks. I also owe a deep debt to my parents and to my wife who have been of continual support and encouragement.

I am also grateful to Mrs. E. Dann and Mrs. P. M. Larter, Introskill, for the preparation and typing of this thesis.

LIST OF MAPS AND FIGURES

		Page
Map	1 The "Durham" study area	12
Map	2 The "Northumberland" study area	14
Fig.	1 Examples of the linear regression lines, between log light intensity and log time relative to civil twilight, obtained for clear and cloudy mornings and evenings	22
Fig.	2 The variation in size of the Croxdale roost between October 1969 and March 1970	28
Fig.	3 The variation in size of the Hett and Lambton roosts between September 1970 and April 1971	31
Fig.	4 The variation in size of the Hett and Lambton roosts between July and November 1971	33
Fig.	5 The variation in size of the Newham and Cheswick roosts between November 1971 and April 1972	34
Fig.	6 The relationship between arrival height and arrival time of flocks of Starlings arriving at the Hett roost on six evenings in August 1971	54
Fig.	7 Examples of six different patterns of roost entry expressed as the percentage of the total numbers present in the roost at different times during the entry	56
Fig.	8 The relationship between roost size and entry type for forty evenings in which the entry pattern fell into one of six categories	57
Fig.	9 The percentage frequency of occurrence of different flock sizes at different times during entry (a) preassembled entry (b) partial direct entry (c) entirely direct entry	61

	Page
Fig. 11 The variation in the time at which the first Starling entered the roost (in minutes relative to civil twilight) in relation to time of year	63
Fig. 12 The amplitude and frequency distributions of noise recorded at the Newham roost (a) early evening, (b) mid evening, (c) late evening, (d) early morning, (e) mid morning and (f) late morning	78
Fig. 13 The variation in the time at which the first Starling left the roost (in minutes relative to civil twilight) in relation to time of year	84
Fig. 14 The relationship between the number of departure waves (mean for half monthly periods) and daylength (minutes between sunrise and sunset)	87
Fig. 15 The percentage frequency of occurrence of departures containing different numbers of departure waves for each month	88
Fig. 16 The percentage frequency of occurrence of departure waves of different lengths for each month	91
Fig. 17 The mean length of successive departure waves for each month	92
Fig. 18 The relationship between total departure length (mean for half monthly periods) and daylength (minutes between sunrise and sunset)	93
Fig. 19 The relationship between mean departure length (mean for half monthly periods) and roost size	94

	Page
Fig. 20	The percentage frequency of occurrence of gaps between departure waves of different lengths for each month 95
Fig. 21	The mean length of successive gaps between departure waves for each month 97
Fig. 22	The relationship between total gap length (mean for half monthly periods) and daylength (minutes between sunrise and sunset) 98
Fig. 23	The relationship between mean gap length (mean for half monthly periods) and daylength (minutes between sunrise and sunset) 99
Fig. 24	The percentage of Starlings leaving successive departure waves to feed at one and seven miles from the roost (Cheswick and Detchant respectively) 119

LIST OF TABLES

Table	Page
1 The total number of Starlings shot each evening at the Cheswick roost, together with the number in each age, sex and origin category	37
2 The percentage of British and Continental Starlings shot each month at the Cheswick roost	38
3 The percentage of adult and juvenile Continental Starlings shot each month at the Cheswick roost	40
4 The percentage of adult and juvenile British Starlings shot each month at the Cheswick roost	41
5 The sex ratio of adult British Starlings shot each month at the Cheswick roost	42
6 The sex ratio of adult Continental Starlings shot each month at the Cheswick roost	43
7 The sex ratio of juvenile British Starlings shot each month at the Cheswick roost	45
8 The sex ratio of juvenile Continental Starlings shot each month at the Cheswick roost	46
9 A comparison of the sex ratios of adult British (first two months only) with juvenile British Starlings shot at the Cheswick roost	47
10 A comparison of the sex ratio of adult and juvenile Continental Starlings shot at the Cheswick roost	48
11 A comparison of the sex ratio of adult British (first two months only) with adult Continental Starlings shot at the Cheswick roost	49
12 The mean weight, in grams, of samples of Starlings shot in the evenings at the Cheswick roost	50
13 The results of multiple regression analysis using the occurrence of preassembly as the dependent variable	59

Table	Page
14	The results of multiple regression analysis using the time at which the first Starling entered the roost (in minutes relative to civil twilight) as the dependent variable 65
15	The results of multiple regression analysis using the time at which half the Starlings had entered the roost (in minutes relative to civil twilight) as the dependent variable 66
16	The results of multiple regression analysis using the time at which all Starlings had entered the roost (in minutes relative to civil twilight) as the dependent variable .. 67
17	The results of multiple regression analysis using duration of entry (in minutes) as the dependent variable 69
18	A comparison of the percentage of Starlings perched on the inner and outer halves of branches early and late in the evening on four dates at the Hett roost 70
19	A comparison of the percentage of Starlings perched on the upper, middle, and lower branches of trees early and late in the evening on two dates at the Hett roost 72
20	The mean (+ standard error) nearest neighbour distance of a sample of ten birds observed on two occasions at the Bradford Kaims roost 74
21	The percentage of birds engaged in each of five behavioural activities on the morning of 3.12.71 at the Bradford Kaims roost (time of first departure 07.37h. G.M.T.) 75

Table	Page	
22	The percentage of birds engaged in each of four behavioural activities on the evenings of (a) 4.12.71 and (b) 5.12.71 at the Bradford Kaims roost (time of first arrival 16.09h. and 16.14h. G.M.T. respectively)	76
23	The results of multiple regression analysis using the time at which the first Starling left the roost (in minutes relative to civil twilight) as the dependent variable	85
24	The results of multiple regression analysis using the number of departure waves leaving the roost as the dependent variable	89
25	The total number of Starlings shot at the Cheswick roost in the mornings, together with the number in each age, sex and origin category	100
26	A comparison of the percentage of British and Continental Starlings shot morning and evening at the Cheswick roost between mid January and mid February	102
27	A comparison of the percentage of British and Continental Starlings shot morning and evening at the Cheswick roost between mid February and mid March	103
28	A comparison of the percentage of British and Continental Starlings shot morning and evening at the Cheswick roost between mid March and mid April	104
29	A comparison of the age ratio of Continental Starlings shot morning and evening at the Cheswick roost between mid January and mid February	105
30	A comparison of the age ratio of Continental Starlings shot morning and evening at the Cheswick roost between mid February and mid March	106

Table	Page
31 A comparison of the age ratio of Continental Starlings shot morning and evening at the Cheswick roost between mid March and mid April	107
32 A comparison of the age ratio of British Starlings shot morning and evening at the Cheswick roost between mid January and mid February	108
33 A comparison of the age ratio of British Starlings shot morning and evening at the Cheswick roost between mid February and mid March	109
34 A comparison of the age ratio of British Starlings shot morning and evening at the Cheswick roost between mid March and mid April	110
35 A comparison of the juvenile British sex ratio of Starlings shot morning and evening at the Cheswick roost between mid January and mid April	111
36 A comparison of the sex ratio of adult British Starlings shot morning and evening at the Cheswick roost between mid January and mid March	113
37 A comparison of the sex ratio of adult British Starlings shot morning and evening at the Cheswick roost between mid March and mid April	114
38 A comparison of the sex ratio of adult Continental Starlings shot morning and evening at the Cheswick roost between mid January and mid April	115
39 A comparison of the sex ratio of juvenile Continental Starlings shot morning and evening at the Cheswick roost between mid January and mid April	116
40 The mean weight, in grams, of Starlings shot in the mornings at the Cheswick roost	117

LIST OF APPENDICES

Appendix	Page
I Range changing equipment for light intensity measurement	142
II The microphone/amplifier equipment for noise level recording	144

SECTION ONE

INTRODUCTION

A. THE BACKGROUND

Epinas (1878) was one of the first to suggest that feeding aggregations, through an increased ability to perceive and escape danger, were an adaptation to increase security. Murton (1968) found that solitary Wood Pigeons (Columba palumbus) spent more time looking around than flock birds. He interpreted this finding as individuals looking for conspecifics. Lazarus (1972) has questioned this interpretation since in flocks of White-fronted Geese (Anser albifrons), containing between 100 and 300 birds, individuals in the larger flocks still spent less time alert. In such large flocks it does not seem likely that birds are looking for conspecifics, since they are surrounded by so many. Powell (1974) found that the amount of time individual European Starlings (Sturnus vulgaris), subsequently referred to simply as Starlings, were vigilant declined as flock size increased. Although each individual bird in the flock had more time in which to feed (or carry out other activities), the flock as a whole was quicker to detect and react to danger.

Two important consequences of flocking are thus that: (1) more time is available for non-alert activities and (2) flocks can detect and react to dangers more rapidly than individuals. Moreover, several mathematical models (e.g. Hamilton 1971) have suggested that the detection of prey by a predator is less likely if the prey are in flocks. The advantage of grouping increases as the probability of an individual being detected increases. Even once a flock has been detected, it is still advantageous to remain closely grouped since clumps are more difficult to attack (Lack 1954, Crook 1960, Hamilton 1971).

Given that, in terms of reduced predator risk, forming aggregations



has such advantages, it is surprising that all species do not group. In recent years, increasing favour has been placed on the idea that sociality has evolved as a strategy for exploiting food resources, since dispersion systems are more divergent than one would expect solely on the grounds of predation (Crook 1965, Lack 1968). Murton (1971) has pointed out that being in a flock can influence the food selection of individual Wood Pigeons and therefore the individuals feeding efficiency. Krebs, MacRoberts and Cullen (1971) have shown experimentally that Great Tits (Parus major) in flocks feed more efficiently than individuals; Kruuk (1972) and Schaller (1972) state that groups of predatory mammals are more effective in catching prey than individuals. Murton therefore talks of food being the "primary" reason for flocking, but Lazarus (1972) rightly points out that this is a simplistic view and that both factors are undoubtedly important. Predation is a unifying force all the time, but the fact animals do not always aggregate does not mean that it is less important than feeding efficiency, which as a selection pressure, could act to promote or discourage flocking.

The dispersion pattern, and prey response of food items, may mean that aggregations are incompatible with profitable feeding. For example, Goss-Custard (1970) has suggested that limicoline waders, which rely on tactile clues to obtain their food, can feed at high densities since having other birds nearby does not alter the density of available prey, or the birds ability to respond to cues. In "sight" feeders, however, not only could the prey response to high densities of predator cause a reduction in available prey, but the mere presence of other birds could interfere with an individual's response to cues. Both "touch" and "sight" feeders form large flocks at high tide roosts when the feeding disadvantages to the "sight" feeders no longer operate.

Much of the speculation concerning the gregarious habit has

centred on aggregation one step removed from the food source; that is to say, either at communal breeding or roosting sites. At first it was argued that breeding colonies were solely an adaptation to reduce predation since no direct link between these gatherings and feeding strategies could be seen. It was emphasised that the remarkable synchrony within the breeding colony was an adaptation to ensure breeding at the "correct" time and also to swamp predation (Ward 1972).

One advantage of flocking, with respect to predation, is that flocks are more difficult to locate than evenly dispersed individuals (Hamilton 1971). This of course assumes that flocks of prey are mobile; if they are static for long periods of time, as are breeding colonies of necessity and many communal roosts by choice, then one of the main advantages of grouping would seem to be lost. The predator would always know where to find some of its prey and clumping would be a positive disadvantage.

Crook (1965) and Lack (1968) both have pointed out that, with only one or two exceptions, birds which feed in flocks tend to breed in colonies. They suggest that sociality has evolved as a strategy for exploiting food resources which are spatially and temporarily discontinuous. Such an explanation does, however, require the breeding colony to have a positive influence on food finding.

Several possible advantages of birds adopting the communal, as opposed to solitary roosting habit, have been suggested. Kalambach (1932), Rowan (1938) and Delvingt (1961) considered temperature to be an important factor in Starlings. Both choice of roost site, and the clustering together of animals, serves to reduce heat loss by radiation and convection. Some species, such as the Wren (Troglodytes troglodytes) and the Tree Creeper (Certhia familiaris) (Armstrong 1955, Löhrl 1955), cluster together to roost in cavities during the winter and this is almost certainly an adaptation to reduce heat loss.

Many species which feed in flocks also roost communally. Fogden (1970) has shown, for certain species of bird found in the Sarawak rain forest, that those species which feed in flocks also roost socially. Those species feeding solitarily, on an evenly dispersed food supply, roost singly. Since predation and shelter present a somewhat unitary selection pressure on dispersion, all species might have been expected to roost communally.

The close correlation of feeding and roosting dispersions seems to indicate that roosting might also have evolved as a strategy for exploiting food resources. Again it requires some positive influence of behaviour at the roost with the subsequent location of food.

Ward and Zahavi (1973) have suggested a mechanism by which individuals at a breeding or roosting aggregation could derive information on the distribution of food. Individuals which know the location of suitable patches of food will leave the aggregation purposefully. Individuals which do not know the location of suitable food will hang back. They will see the direction in which successful individuals depart and will in consequence follow, thus locating food. As the spatial distribution of a patchy food changes, so the need to change direction to new feeding grounds will be produced. Evidence for the information centre hypothesis is mainly anecdotal or indirect and much further work is needed in its confirmation or discredit.

Krebs (1974) tried to test this hypothesis as directly as possible at a breeding colony of the Great Blue Heron (Ardea herodias). His findings do not contradict Ward and Zahavi's theory, but neither do they give it much positive support. He states that neighbours in the colony are more likely to be found feeding in the same area than one might expect and that departures from the colony occur in clumps. The fact that herons are attracted to other herons on the feeding grounds, and that feeding success increased with increasing flock size, could

function to enhance the exploitation of an ephemeral food supply without requiring colonial nesting.

In Great Britain the Starling is probably the species with the most highly developed social roosting habit. Not only are its roosts extremely large, but the pre- and post-roosting behaviour is highly developed and shows many adaptations. The Starling therefore seems the most logical species to study in order to answer fundamental questions on the function and mechanics of communal roosting.

B. THE STARLING AND THE SCOPE OF THIS STUDY

The Starling breeds in most of Europe except for Spain, southwest France and western Greece, where it is replaced by the Spotless Starling (S. unicolor). In Britain, southern and western Europe, the Starling population is predominantly resident. Birds breeding in Scandinavia, northern and eastern Europe do however move south and west to winter (Goodacre 1959). At this time the Starling population in this country reaches an estimated 37 million birds, about five times the breeding population (Potts 1967).

During the last century the Starling was regarded as an uncommon species in much of Great Britain. Both Harvie-Brown (1895) and D'urban and Mathew (1895) record it as a rare species, and largely unknown as a breeder, in Scotland and Devon respectively. Similarly, in much of Wales the Starling was uncommon and regarded as a winter visitor characteristic of snow and cold weather (Davies 1949). Since then it has not only extended its range northwards and westwards, but has also colonised much of North America, after its initial release in Central Park, New York in 1897.

It has been suggested that the major factor contributing to the rise of the Starling population is the increasing number of birds wintering on their breeding grounds or between their breeding grounds and their previous wintering areas. Some, but not all, first summer

female Starlings are capable of breeding whilst few males of this age are physiologically able to breed. Experiments have shown that increased proportions of male and female Starlings breed in their first summer and that birds more than two years old show significantly premature gonadal cycle if migration fails to take place. The reduction in the level and extent of migration in the Starling over the past century has therefore, it is claimed, resulted in an early increased number of breeding first year birds and second broods in older birds (Berthold 1968). Coulson (1960) was unable to demonstrate any significant shift in the adult mortality rate between 1926 and 1952. It therefore seems likely that the increased breeding potential of resident populations could have contributed to the increased population density and distribution of the Starling in both Europe and America.

Starlings may nest solitarily, but more commonly form small loose colonies of from 2 to 10 pairs (Kessel 1957). Nests are usually situated in holes or crevices. The first clutch is laid in early April and contains from four to seven pale blue or white eggs. This is usually followed by a second smaller clutch in late May (Dunnet 1955).

The Starling is predominantly an insectivore and its bill is well adapted to probing the ground for prey. Dunnet (1955) found that, during the breeding season, over 80% of the food obtained by Starlings consisted of "leather jackets" (the larvae of Tipulidae). When insects became difficult to obtain in the autumn, when larvae had hatched, or during the winter, when snow cover or frosts could reduce prey availability, alternative foods such as grain were turned to (Dunnet 1956). The Ministry of Agriculture (Anon 1966) conclude that, in terms of the food eaten, the Starling is of net benefit to agriculture, but can cause local damage during the summer to fruit crops such as cherries.

To date most descriptions of roosting in the Starling are of an anecdotal nature. It is not until observations have been placed on a

quantitative basis that behavioural variation can be assessed and comment made on the selective advantage of social roosting. This study could have hoped to shed only a little light on the more fundamental questions but was intended to describe, in qualitative and quantitative terms, the pattern of roosting behaviour in the Starling and to investigate some of the factors influencing its variation. The following brief review of the literature on the roosting behaviour of the Starling aims to identify the gaps in our present knowledge and to outline the aims of this study.

Much of the early work on Starling roosts was carried out by Marples (1934). During the winter of 1932-33 he organised a survey of the Starling roosts of Great Britain. Local observers were asked to complete a questionnaire as to the size, location and period of occupation of roosts used by Starlings that winter. A total of 285 roosts, each containing more than 500 Starlings, were reported. All roosts, except for five, were situated in areas below the 183m. contour. Many of the roost sites had been used in previous years; 107 had been occupied for more than ten years and some had been in existence, with only minor breaks, for as long as 100 years. Season variations were apparent in the roost sites chosen by Starlings. Reed beds and deciduous trees were favoured during the autumn, but were usually deserted for evergreen shrubs or coniferous trees in the winter months.

The roosting together of large numbers of Starlings in sheltered woodlands (often conifers) can result in damage to timber, which is often being grown for commercial reasons. The layers of droppings which form are high in nitrogen and can result in a reduction in the quality of timber and the growth rates of trees, as well as scorching vegetation and smothering ground cover. The sheer weight of numbers of birds perching can also damage branches and distort future growth. To avoid damage attempts are frequently made to disrupt roosts. The methods employed are often expensive and, to be successful, need to be carried

out over a long period of time (Brough 1969).

Several species of bird, including the Starling, normally fly from distant feeding grounds to their roosts in straight lines (Marples 1932). This enables roosting sites to be readily located and the catchment area which they serve to be defined (Wynne-Edwards 1929 and 1931).

Symonds (1965) made regular counts of a Starling roost at Felpham, Sussex, over three winters. His data indicate that the roost was occupied from September through to April, with peak numbers present between December and February. Potts (1967) gives the seasonal variation in size of eight urban roosts. Five (Birmingham, Bristol, Newcastle, Liverpool and Manchester) conform to the pattern found by Symonds. Three (London, Dublin and Huddersfield), however, contained most birds in the early autumn and then declined progressively over the winter period. The increased number of birds at roosts during the winter probably results from the arrival of Continental birds from Scandinavia and eastern Europe from autumn onwards. A possible reason for the difference between the London roost and the others can be found in the results of Cramp, Parrinder and Richards (1957). On the basis of ringing returns they concluded that London roosts did not contain large numbers of Continental birds.

It is not clear to what extent Continental Starlings use the same rural roosts as resident Starlings and if seasonal changes in roost size could be explained solely in terms of reproduction and immigration. Moreover, since Marples data on changes of roost location were derived from questionnaires, they might in part be due to observer bias. There was a clear need for the roosting activities of Starlings to be followed throughout the year in one area.

Delvingt (1963) described the stepwise progression of Starlings from their feeding grounds to their roosts. He stated that initially Starlings congregated in small flocks near their feeding areas. They

then moved along regular flight lines, stopping at secondary and tertiary gathering points along the way where they were joined by other flocks. Finally Starlings assemble into large flocks or preassemblages near to the roost before actually entering the roost (Wynne-Edwards 1929, Eastwood, Isted and Rider 1960). Davis and Lussenhop (1970) provided data on the light levels associated with different stages in the Starlings' progression towards the roost. Although light was not clearly correlated with arrival at the roost, a function of light and time did cause birds to stop feeding and begin to move towards the roost.

Preassembled flocks often perform erratic flights near to the roost and Wynne-Edwards (1962) believed that these were of an epideictic nature and stimulated the adjustment of population levels. Ward and Zahavi (1973), however, advocate that these displays serve to advertise the precise location of roosts.

Symonds (1961) studied some thirty roosts in Shropshire over an eight year period and was able to classify them in terms of final entry behaviour and size. At roosts containing less than 20,000 birds, entry was made immediately on arrival; small flocks and groups dropping directly into the roosting cover. In roosts exceeding 20,000 birds, but containing less than 250,000, Starlings preassembled nearby until around sunset when they entered by what Symonds called a "to and fro" method. Roost sites serving more than 250,000 Starlings were entered from the preassembly points by a continuous stream of birds.

Although many earlier workers investigated the effect of single environmental factors on roost entry none were able to demonstrate significant relationships. It was decided to investigate this problem further using a multivariate approach. In addition, differences in various aspects of arrival behaviour at the preassembly points and on entry to the roost were examined. Since there is no published information on the behaviour of Starlings within a roost, an attempt was

made to describe certain behavioural aspects of roosting in the Starling.

To date little quantitative work has been carried out in the morning dispersal of birds from their communal roosts. Wynne-Edwards (1931) and Boyd (1932) were the first to state that Starlings leave their roosts in discrete groups or departures; several departures going to form the complete exodus. Using radar, Elder (1957) and Ligda (1958) were able to note point echoes which expanded to form an annular "ring of pearls" and to associate these "ring angels" with the morning exodus of Starlings and Red-winged Blackbirds (Agelaius phoeniceus).

Attempts to correlate the time of dispersal with environmental factors have only met with limited success. Eastwood, Isted and Rider (1962) were able to explain 21% of the variation in the time of expansion of the first departure wave in terms of cloudcover. They were of the opinion that light intensity measurements would have been a better correlate but were unable to obtain this information. Wynne-Edwards (1962) believed that each departure was a persistent social unit. He investigated the timing mechanism governing departures and concluded that it was a compromise between a light intensity trigger and a physiological rhythm. The variation in the size of departures and their temporal spacing has previously received little attention and this study was expanded to study the variation of these phenomena with respect to environmental factors, using a multivariate approach to their analysis.

This study sets out to fill some of the gaps in our present knowledge of the roosting behaviour of the Starling and in particular to investigate the mechanisms of roosting in the Starling. It was hoped that insights into the function and selective advantage of the social roosting habit would be gained through an understanding of the mechanics of roost entry and departure and a knowledge of the factors influencing these aspects of behaviour. Although during this investigation a total of 173 roost entries and 181 roost departures were observed, the data

collected has been limited by two major practical problems. First, during the last two winters of the study the major roost was situated in an area in which it was not possible (due to lack of co-operation from the landowner) to carry out the desired observation and sampling programme. Secondly, working at roosts containing many thousands of birds poses certain difficulties in observing and sampling the population at a sufficient intensity. Thus it was not usually possible to carry out more than one task and collect more than one type of information on each visit.

C. THE STUDY AREA

This study was carried out between October 1969 and September 1972 within two study areas in the counties of Durham and Northumberland.

Initially the study was based on the "Durham" study area which extended for some ten kilometres around Durham City (Map 1). The valley of the River Wear crossed the area in a NE/SW direction. Although the river bed itself was less than 100 m. wide in this section, the valley was two kilometres or more in width for much of this length. To the west of the Wear valley the land rose rapidly, attaining a height of some 200 m. at the edge of the study area. In contrast, the slope to the east of the valley rose more gently, reaching approximately 150 m. Underlying coal measures provided the major industry of the area until the decline of the mines in the 1950's. Arable crops of barley, oats and wheat dominated the low lying section of the study area, together with some dairy farming. Livestock rearing was, however, the predominant agricultural activity on the higher ground to the east and west. Woods occurred rarely in the study area, being mainly deciduous trees in the valley bottoms, and coniferous plantings on the more open sites.

Due to certain difficulties in carrying out some aspects of the work in the Durham study area, half of the last winter's field season

MAP 1

THE "DURHAM" STUDY AREA

Major Starling roost sites occupied between
October 1969 and November 1971:

1. Cornforth
2. Croxdale
3. Hett
4. Lambton
5. Newton Aycliffe
6. Flawsworth
7. Sherburn
8. Sherburn Quarry
9. Viewly Grange
10. West Rainton

Map 1

grid
north

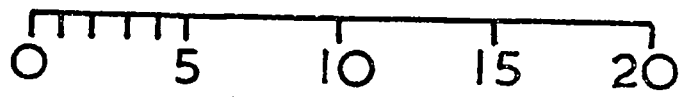
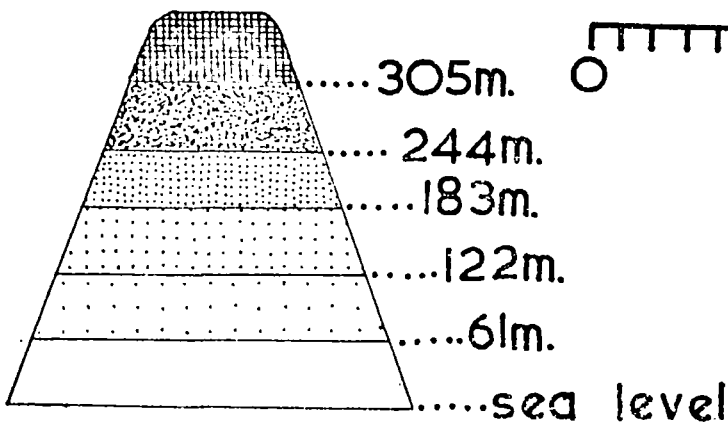
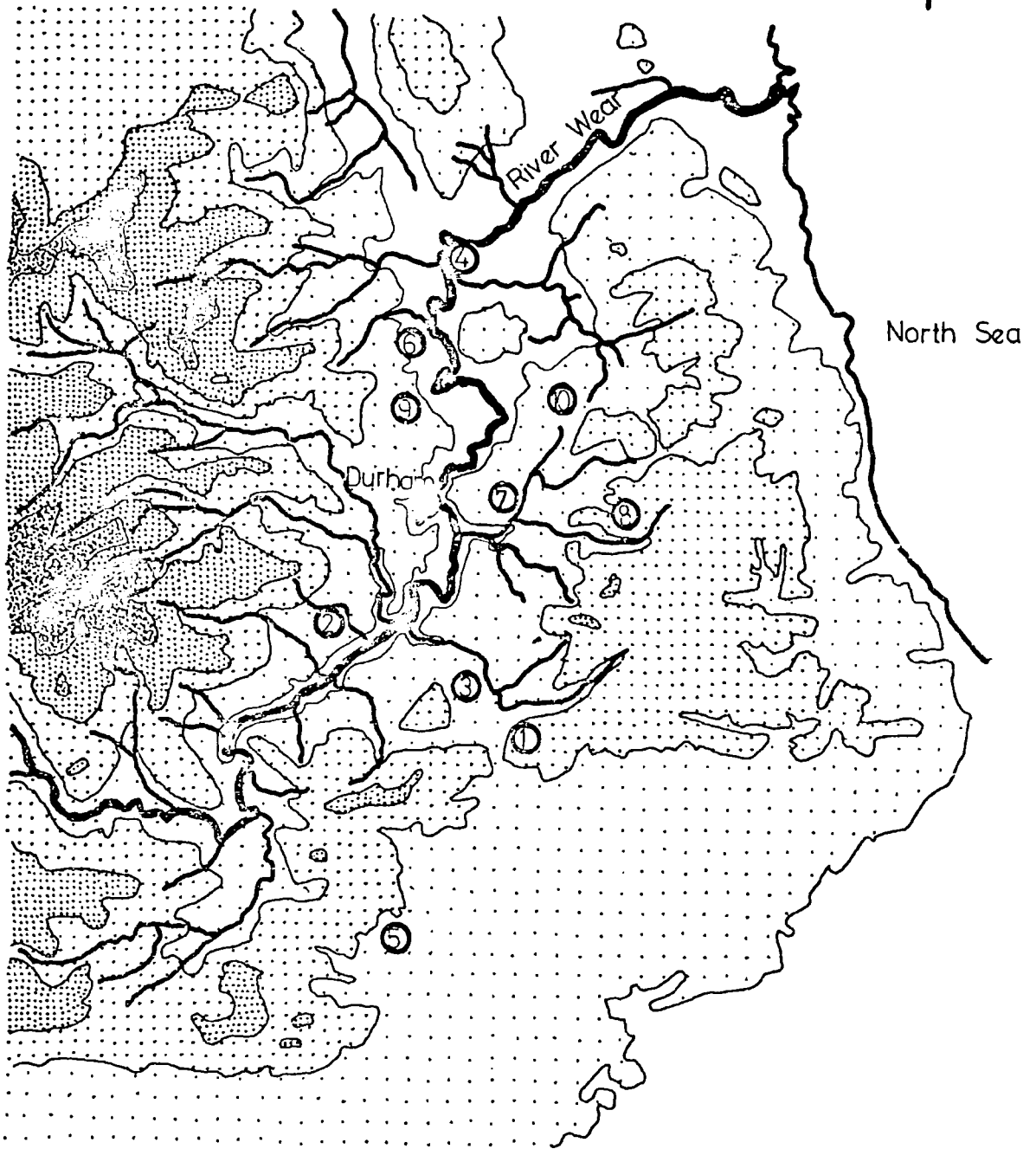

kilometres

1:250000.

O...Roost site

was spent in Northumberland. The "Northumberland" study area (Map 2) extended some 20 kilometres to the north, and 10 kilometres south of the town of Belford, and stretched some 10 kilometres inland from the coast. The seaward, low lying, edge of the study area consisted of a coastal plain which varied in width from two to four kilometres. Inland from this plain the ground rose gently into hill land between 75 and 100 m. in height. Barley, oats and turnips formed the main agricultural crops of the coastal plain, but these soon gave way to sheep grazing on the hills further inland. Deciduous woods were almost non-existent in the area, but several coniferous woods and shelterbelts had been planted.

MAP 2

THE "NORTHUMBERLAND" STUDY AREA

Major Starling roost sites occupied between
November 1971 and May 1972:

1. Bradfield Kaims
2. Cheswick
3. Newham

Map 2

grid
north

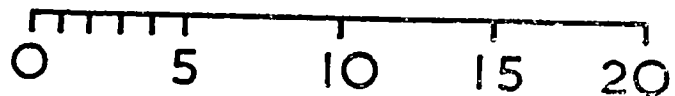
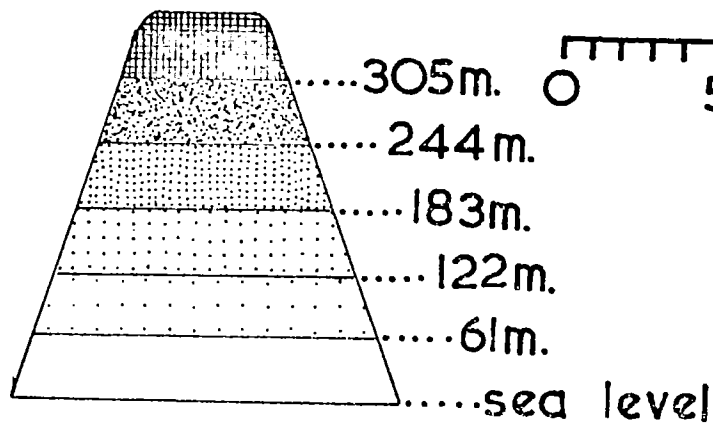
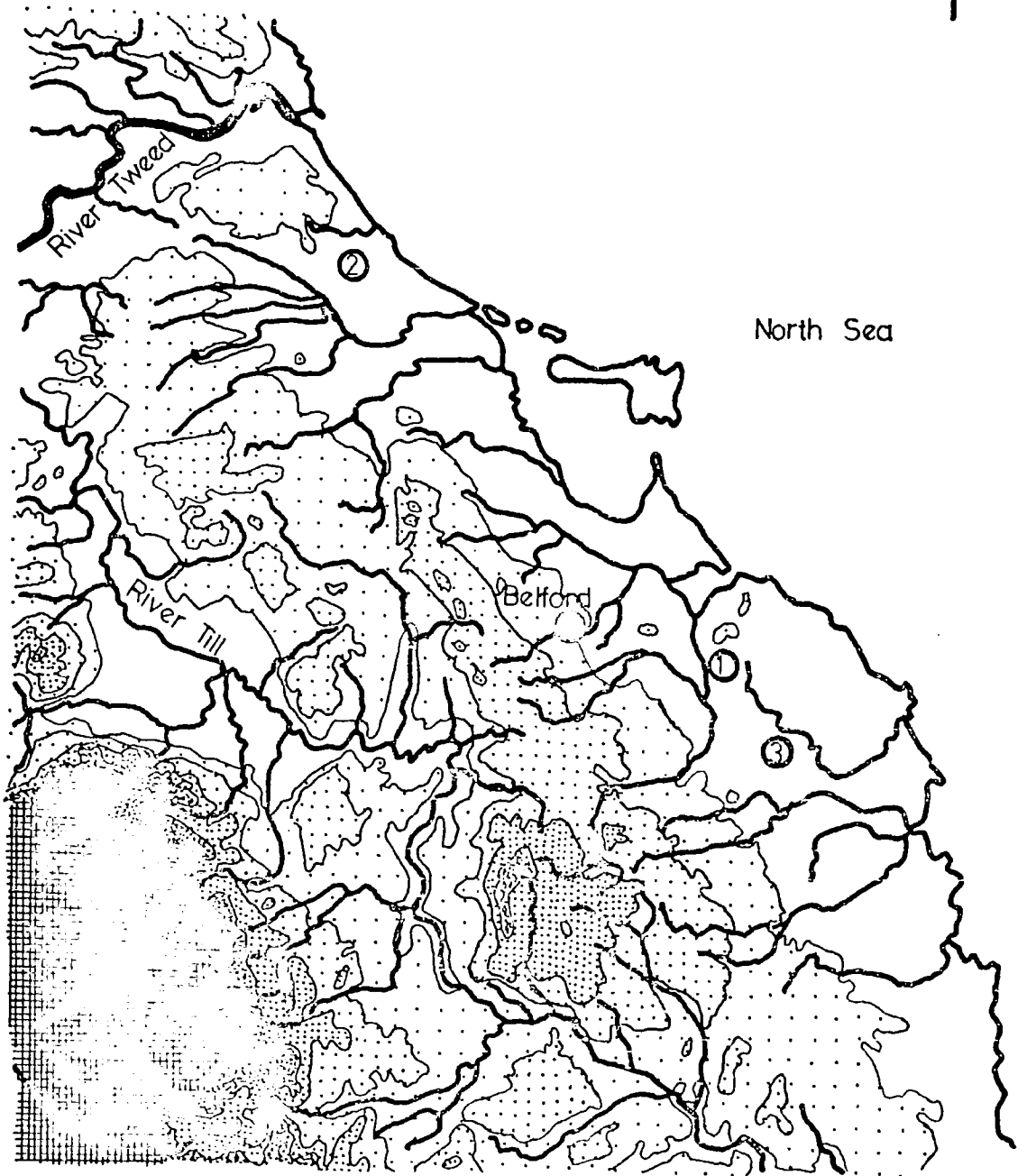

kilometres

1:250000

O...Roost site

SECTION TWO

METHODS

A. ROOST OCCUPATION AND LOCATION

The direction of flight in the evening was used to locate roosts within the study area. A vantage point within the study area was taken up approximately one hour before sunset. The direction of all movements of Starlings (and flock sizes) were noted. If any obvious movement of birds occurred early in the observation period the observer moved to another site, in order to obtain an additional bearing on the roost. By plotting the direction of flight lines noted on several evenings on a 1:63360 Ordnance Survey map it was possible to locate the general area in which the roost was situated and to define the catchment of each individual roost. The precise location of each roost was determined by observations made at the focus of the converging flight lines.

The method adopted in counting the number of Starlings occupying a roost was dependent on the size of the roost. At small roosts of less than one thousand birds it was possible to count individuals as they entered the roost. At roosts containing more than one thousand birds the numbers entering at any one time was too large to count directly and a method of estimation had to be adopted. A "block" of 10 or 100 birds (depending on the size of the flock being estimated) was counted and the size of the flock estimated by comparison of the area covered by the flock with that of the block counted. Counts at the major winter roosts were made at approximately fortnightly intervals throughout the period of roost occupation.

In order to link changes in roost size to the migration and breeding cycle of the Starling, samples of birds were shot in the evenings inside the roosts. Due to lack of co-operation from the owner of the major winter roost site in the Durham study area samples were only obtained from one roost; at Cheswick, Northumberland (Map reference NU 017472),

on nine dates between 27 January and 12 April 1972. A double barreled .410 shotgun with 2" No. 7 Cartridges was used. Larger shot or cartridges caused too much damage to bodies. Large numbers of birds could be obtained quickly by firing at concentrations of perched birds. It was felt that obtaining samples in this way gave a random and unbiased sample of the population. In order to minimise disturbance at the roost, samples were collected at approximately fortnightly intervals.

After collection, birds were taken back to the laboratory where they were labelled, weighed and the colour of the bill noted (especially the extent of any yellow on the upper and lower mandibles). After this preliminary examination, birds were placed in polythene bags and deep frozen. Subsequently, further notes on plumage and measurements of wing, bill, tarsus and the extent of iridescence on the throat hackles were made. Birds were then dissected, sexed and their gonads measured. Using the information given by various authors (Bullough 1942, Dunnet 1956, Davis 1959, Delvingt 1961 and Perdeck 1967) combinations of factors were used to categorise birds on age, sex and origin (British or Continental). Length of iridescence on the throat hackles was used to age Starlings sexed internally. Males with hackles iridescent for 11-15 mm. of their length were considered adults, those between 7-10.5 mm. juveniles; similarly females between 7-10mm. were classified as adult and between 2-6.5 mm. as juveniles. In the spring resident British Starlings mature earlier than Continentals, this is reflected in changing mandible colour. During January and February those birds with more than half of their upper mandible yellow were considered to be British. In March and April only those birds with more than half of their lower mandible yellow were considered to be British.

B. ARRIVAL AND ROOST ENTRY

General observations on arrival and entry behaviour were made

using Zeiss 10 x 50 binoculars and either noted directly into a field notebook or dictated into a Philips portable tape recorder for transcription later. Estimates of the heights at which birds arrived at the roost were made by comparison with objects, such as telegraph poles, of known height.

At each visit to a roost a note was made of (i) cloudcover in octares, (ii) cloud type, (iii) wind direction, (iv) estimated wind strength on the Beaufort scale, and (v) occurrence of precipitation. In addition more detailed weather data were obtained from Durham University and from R.A.F. Acklington depending on the study area being used.

Light intensity measurements were made using an Eel photometer directed at the zenith, either (i) by the observer noting scale readings at approximately minute intervals, or (ii) by continuous monitoring on a Rustrack chart recorder of the potential difference across the photometer head. The latter method reduced the number of tasks required of the observer. The apparatus is described in Appendix I.

In order to obtain accurate timings of the arrival and entry of birds into the roost a position which gave a clear view over the roost was chosen. Several such positions existed and the one used on a particular evening was chosen to give a good view of the roost and the major preassembled flock. The time of entry of individual flocks was noted to the nearest thirty seconds using a wrist watch which was checked daily against the Greenwich time signal. More accurate timings were not possible since the size of individual flocks was being counted or estimated.

C. ROOSTING BEHAVIOUR

Because of the nature of the vegetation used as roost sites, it was not possible to observe the behaviour of birds within the roost for most of the year. However, for a short period in the autumn, when

the leaves of deciduous trees were being shed, and before these roosts were abandoned for sites in conifers, it was possible to make some observations and to measure certain aspects of behaviour within the roost.

Sample trees within the roost were chosen on the basis that they were clearly visible from outside the roost, thus eliminating the need to enter the roost and disturb birds. The numbers of birds in different vertical and horizontal divisions of the trees were noted at regular time intervals. Two horizontal categories were used, the individual perch branches being divided into inner and outer halves. Vertically each tree was divided into three equal height divisions (upper, middle and lower), from the highest to the lowest branch.

On two occasions the nearest neighbour distance of a sample of birds was estimated in bird widths (50 mm.) at regular time intervals. On three occasions the numbers of birds engaged in each of five distinct, and readily identifiable, behavioural categories were noted at five minute intervals. The activity classes used were as follows: singing, resting, stretching, preening and sleeping (eyes closed or head under wing).

Several people have remarked on the considerable amount of noise created by Starlings at their communal roosts (e.g. Eastwood 1962). In order to monitor the noise production at roosts a piece of equipment based on an amplifier and microphone was constructed (see Appendix II). It was powered by a twelve volt car battery and a potential difference proportional to volume was recorded directly on a Rustrack chart recorder. In addition tape recordings were made of the noise produced in the morning and evening at a roost. A Sony portable tape recorder was used and the recordings were subsequently analysed, with respect to frequency and amplitude, using a Kay Electremics Sonograph.

D. ROOST DEPARTURE

The methods used to study the behaviour of Starlings leaving their communal roosts were similar to those adopted for roost arrival and are described above for roost entry.

In order to obtain accurate timings of departures an observation position which gave a clear view of the roost was selected. Usually several positions around the roost gave such a view but one at which a horizontal view across the top of the roost trees onto a clear background was chosen. Use of such an observation point enabled departures to be measured quickly and accurately. The same observation point was used on all visits to a particular roost when quantitative measurements were made.

The time of departure of each dispersal wave (the time when the first birds were seen above the roost) was noted to the nearest five seconds. Light intensity measurements were made using one of the two methods described above.

In order to avoid making several simultaneous measurements at departure time, the length of departures were timed "over the observer". A stop watch was started when the first birds of a departure wave passed overhead and stopped when the last birds passed beyond the observer. Since the radial speed of expansion of each departure in a particular direction would be constant, this measurement would be identical to that obtained by timing birds "over the roost". For similar reasons departure lengths would remain comparable from one roost to another, even if the observer was stationed at different distances from each roost focus. Because the circumference of the wave increased with distance from the roost, the density of birds over the observer is dependent partly on the distance from the expansion point. This measurement is therefore of little use in the comparison of departure patterns from different roosts.

The time of departure of successive waves has enabled the "gap"

time between departures to be calculated by subtraction.

In order to detect any physical differences in birds leaving the roost in different departures, samples of birds were shot as they left the roost. Initially a .410 shotgun was used, but the density and spread of shot was not sufficient for the purpose. A double barreled 12 bore using No. 7 shot was found to be more successful but even then it was very easy to put shot between the birds in a departure. The Starlings collected were processed in the same way as that described above for birds shot at the roost in the evening.

On a number of occasions departures were observed some miles from the roost to try and establish if birds flew differential distances from the roost as suggested by Boyd (1932). The number of Starlings from each departure wave which dropped out to feed, and the number flying directly over a particular feeding area, was noted.

E. THE MULTIVARIATE ANALYSIS OF ARRIVAL AND DEPARTURE DATA

In order to detect complex relationships between the phenomena observed during roost entry and dispersal and environmental factors a multivariate approach has been adopted in the analysis of data. Three basic groupings of environmental factors, plus one group of roost factors have been considered in the analysis. Each group of variables is discussed below and a definition of each individual variable used is given.

(i) Group one: Increase of light intensity.

Under cloudless conditions the time at which light intensity starts to increase (or stops decreasing) each day depends on the time at which the sun reaches a certain position below the horizon (the position which first allows light to reach the observer through deflection). The time of Civil twilight (the time of first or last daylight) is defined as the time at which the centre of the sun is 6° below the horizon. The rate at which light intensity increases or

decreases will, however, vary from day to day, even under cloudless conditions, since the angular ascent or descent of the sun varies seasonally. The sun rises and sets at a more acute angle relative to the horizon during the summer, being at its most acute on the summer solstice. Cloudcover has a modifying influence on the light regime of a particular day, delaying the time of first light and reducing the rate of increase or decrease of light intensity. In order to analyse the behaviour of Starlings with respect to the light regime a simple linear correlation and regression analysis of the light intensity/time values has been carried out. Logarithmic transformations have been used on both dependent and independent variables in order to obtain linear relationships. Figure 1 shows graphically examples of the results of this type of analysis for both clear and cloudy days. The correlation and regression coefficients for each day have been used as independent variables, expressing "Increase of light intensity", in the multivariate analysis of Starling roost arrival and departure.

(ii) Group two: Time of year.

This group of variables consists of those linked with season. For example, daylength, duration of twilight, time of sunset and so on.

(iii) Group three: Weather.

Weather factors can act in two ways. First, indirectly by influencing light intensity itself and thereby bird behaviour. This component is taken into account in "group one" variables. Secondly, by acting directly on the behaviour of the birds.

(iv) Group four: Roost parameters.

This group of factors includes variables such as roost size, entry duration, departure duration which express the characteristics of the roost and roosting behaviour on a particular day.

The following are the definitions of each individual variable, from the four groups, used in all multivariate analyses:

FIGURE 1

EXAMPLES OF THE LINEAR REGRESSION LINES, BETWEEN
LOG LIGHT INTENSITY AND LOG TIME RELATIVE TO CIVIL
TWILIGHT, OBTAINED FOR CLEAR AND CLOUDY MORNINGS
AND EVENINGS.

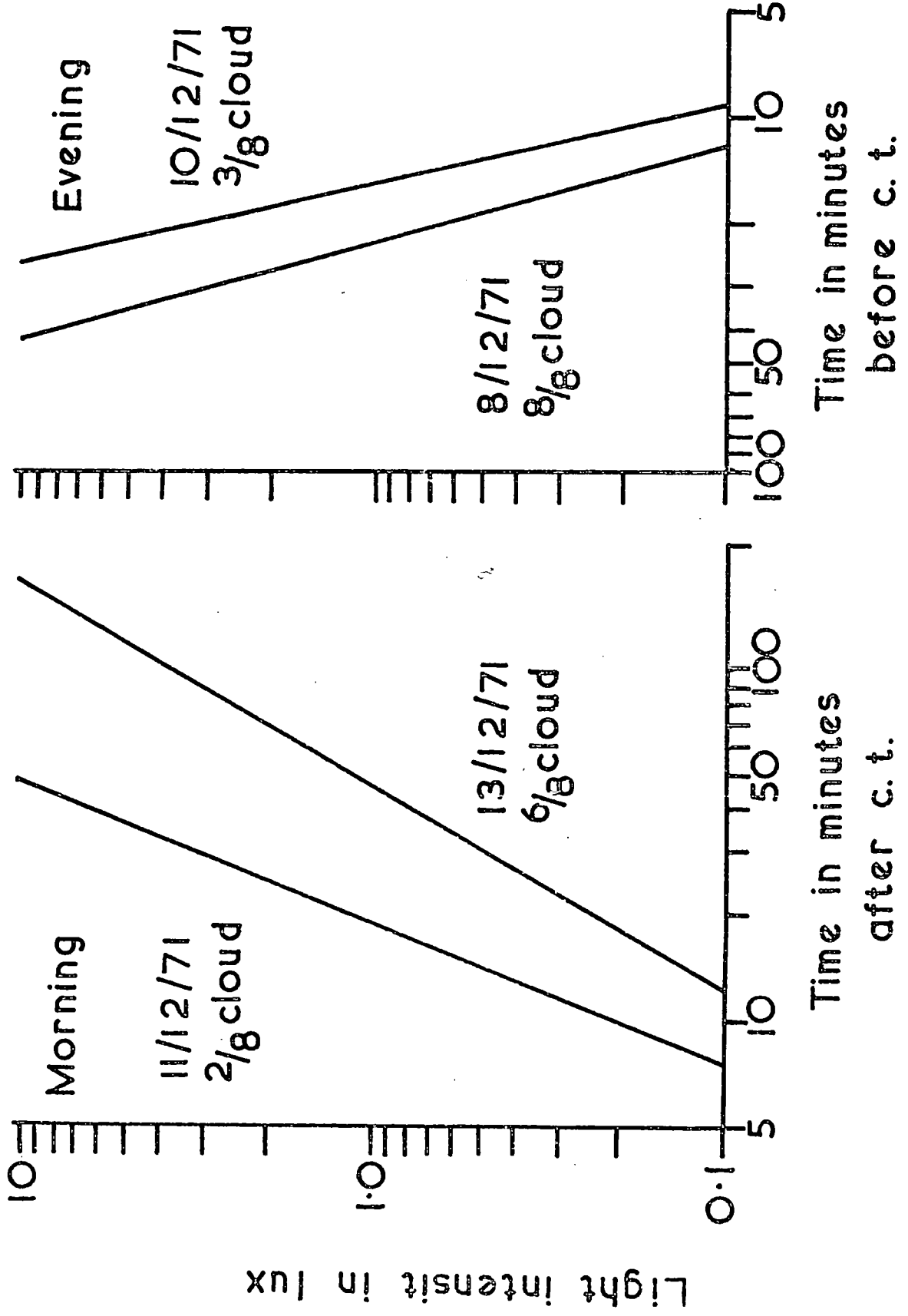

Fig.1

Group one:

Intercept - the constant or intercept term resulting from the linear regression of log light intensity (in lux) on log time relative to civil twilight (in minutes).

Slope - the slope term resulting from the linear regression of log light intensity on log time relative to civil twilight.

Correlation coefficient - the correlation coefficient resulting from the linear regression of log light intensity on log time relative to civil twilight.

Group two:

Daylength - the length of time in minutes between sunrise and sunset.

Civil daylength - the length of time in minutes between morning and evening civil twilight.

Nautical daylength - the length of time in minutes between morning and evening nautical twilight.

Sunrise - the time of sunrise (G.M.T.) expressed as the number of minutes after 04.00h. G.M.T.

Sunset - the time of sunset (G.M.T.) expressed as the number of minutes before (negative) or after 16.00h. G.M.T.

Civil twilight - the duration of time in minutes between sunrise and civil sunrise, or sunset and civil sunset.

Nautical twilight - the duration of time in minutes between sunrise and nautical sunrise, or sunset and nautical sunset.

Day number - the number of days between the day in question and the previous summer solstice.

Day number squared - the square of day number.

Group three:

Maximum temperature - maximum air temperature in degrees centigrade recorded at 09.00h. G.M.T. for the previous twenty-four hours.

Group three (Contd.):

Minimum temperature - minimum air temperature in degrees centigrade recorded at 09.00h. G.M.T. for the previous twenty-four hours.

Grass minimum - minimum ground temperature in degrees centigrade recorded at 09.00h. G.M.T. for the previous twenty-four hours.

Rainfall - rainfall in millimetres recorded at 09.00h. G.M.T. for the previous twenty-four hours.

Snowfall - snowfall in centimetres recorded at 09.00h. G.M.T. as having fallen in the previous twenty-four hours.

Snow lying - the amount of snow in centimetres still lying at 09.00h. G.M.T. but not having fallen in the previous twenty-four hours.

Cloud - the amount of cloud cover in eighths at 09.00h. G.M.T.

Wind speed - the mean wind speed in knots recorded at 09.00h. G.M.T. for the previous twenty-four hours.

Visibility - the visibility at 09.00h. G.M.T. coded as follows:

0-1	40-100m.	6	4-7km.
2	200m.	7	10km.
3	400m.	8	20-30km.
4	1000m.	9	40km.
5	2000m.		

State of ground - the state of ground at 09.00h. G.M.T. coded as follows:

00	dry	12	ground muddy
03	ground dry but grass wet	30	ground frozen
11	ground wet	40	glaze or ice on ground
	50		snow or hail covering less than half ground
	60		snow or hail covering more than half ground
	70		snow or hail covering ground completely

Group three (Contd.):

Wind direction - a total of eight variables indicating the presence of a wind from within 22.5° of N.N.E., E.N.E., E.S.E., S.S.E., S.S.W., W.S.W., W.N.W. and N.N.W. at 09.00h. G.M.T.

Group four:

Roost size - the number of Starlings using the roost.

Departure number - the total number of departure waves occurring on a particular day.

Total departure - the total length of all departure waves, in seconds, on a particular day.

Average departure - total departure divided by departure number.

Total gap - the total duration of all gaps between departure waves on a particular day in minutes.

Average gap - total gap divided by the number of gaps.

Time of first departure - the time (in minutes), relative to civil sunrise, at which the first Starlings left the roost.

Time of first entry - the time (in minutes), relative to civil sunset, at which the first Starling entered the roost.

Time of half entry - the time (in minutes), relative to civil sunset, at which 50% of the Starlings had entered the roost.

Time of last entry - the time (in minutes), relative to civil sunset, at which the last Starling entered the roost.

Duration of entry - the length of time (in minutes) between first and last entry.

Preassembly - the occurrence of preassembly; 1 = complete preassembly, 0.5 = partial preassembly (in which direct entries accounted for an appreciable proportion of the late birds), 0 = direct entry (no preassembly).

The multiple regression analysis used in this study selects the combination of independent variables, significant on the "t-test" basis, which give the best fit to the data. The results of each analysis are given in tabular form and the information is given as follows. The first two columns contain the names of each independent variable and the groups to which they belong. The third column contains the regression coefficient (β) and the fourth column the Student's t-statistic associated with each variable. The partial correlation coefficient of each variable with the dependent variable, assuming other independent variables in the regression set to be held constant, is given in column five. Column six contains the multiple correlation coefficient for each variable in the regression set, after the next iteration, if that variable were eliminated from the regression set during that iteration. The bottom row in each table contains the sample size, the intercept or constant value and the multiple correlation coefficient for the entire regression set.

SECTION THREE

RESULTS

A. ROOST OCCUPATION AND LOCATION

1. Annual Roosting Cycle

a. 1969-70

In October 1969 an initial survey of the study area revealed several roost sites being used. The location, size and habitat type for each of these roosts was as follows. At West Rainton (Map Reference NZ 328487) 1,500 Starlings roosted in Willows (Salix spp.) and Hawthorn (Crataegus monogyna), a further 2,000 birds occupied Hawthorn and Blackthorn (Prunus spinosa) at Sherburn Quarry (M.R. NZ 329415). At Croxdale (M.R. NZ 247378) 4,050 birds used a mixed plantation of Scots Pine (Pinus sylvestris), Larch (Larix decidua), Norway Spruce (Picea abies) and Sycamore (Acer pseudoplatanus).

In addition flight lines indicated the existence of at least a further two roosts; one to the north and one to the west of Durham.

Starlings seen at the coast, flying in off the North Sea on the 11 October, marked the beginning of the arrival of Continental birds. As a consequence, the roost at Croxdale gradually increased in size, reaching over 50,000 in early November and over 100,000 by late November. By this time all other roosts around Durham in deciduous trees had been abandoned in preference for the conifers at Croxdale. Regular counts of the numbers of Starlings using the Croxdale roost were made throughout the winter and are shown graphically in Figure 2.

A comparison of the estimates of numbers obtained at

FIGURE 2

THE VARIATION IN SIZE OF THE CROXDALE ROOST BETWEEN OCTOBER
1969 and MARCH 1970.

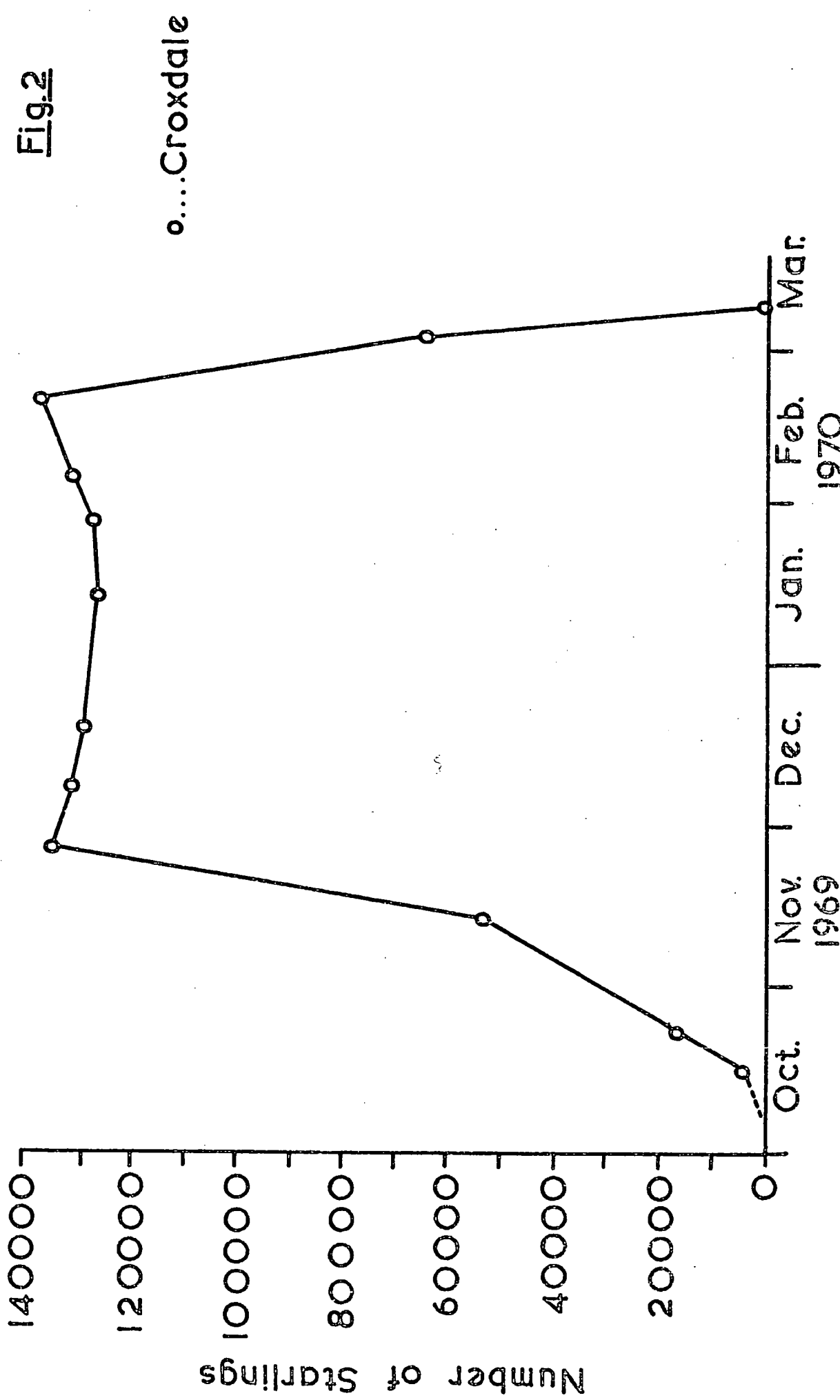

Fig. 2

the same time by two independent observers were within 3.5% in a total of ca 9,000. This is well within acceptable limits of error and bias is, moreover, likely to be consistent for an individual observer. It was therefore felt that differences in the estimates of roost size were a true reflection of the numbers of Starlings using a roost.

By early March the roost at Croxdale was declining rapidly in size and no birds at all were present on the evening of the 9 March. At this time no other major roost was being used in the study area, although small groups of residents were known to be roosting near to their nesting sites in thick and sheltered vegetation such as Holly bushes (Illex aquifolium) and Ivy (Hedera helix) covered walls.

b. 1970-71

The roosting of resident Starlings was centred around the nest site until early June, when the first broods of young were fledged. Initially family groups foraged near to the nest site and roosted either in the nest hole itself, or at sheltered sites nearby. By the second week of June a lot of the first broods were able to feed themselves and several family groups coalesced to form larger feeding flocks. These flocks were more mobile, had a wider feeding range than family flocks, and seemed better able to cope with short term local abundance of food. As family flocks coalesced so did roosts, the resulting communal roost usually being fairly small and of limited catchment. For example, on the 8 June five young and two adult Starlings were roosting in a Holly bush on Finchale Banks (I.R. NZ 297464). The next day the same birds flew towards Plawsworth (I.R. NZ 274487), where a roost of some 200 Starlings had just been established in some coniferous (50 birds) and deciduous (150 birds) trees.

The Plawsworth roost increased rapidly in size, so that by the 24 June 8,830 birds were present and were being drawn from a catchment of some four miles in radius. The next day the roost was disrupted by the local gamekeeper and, although initially only moving to Viewly Grange (M.R. NZ271473), soon broke up completely (other temporary roosts were established for a short time at Sherburn Quarry, West Rainton and Hett (M.R. NZ 292360).

No roosting movements of any scale were seen until early August and it appeared that nearly all the Starlings had left the study area, probably moving to the coastal belt and to the hills, where pasture land was more plentiful. The agricultural land around the Wear Valley consisted mainly of arable crops of wheat, barley and potatoes; such fields were only available as feeding sites after harvest.

In early August roosting movements were again detected, when a roost of some 700 Starlings was discovered in Hawthorn bushes near Sherburn (M.R. NZ 312426). At the same time 200 birds were using the plantation at Croxdale as a roosting site. By September these, and several other small roosts, had amalgamated to form one roost in some Hawthorn bushes at the base of a disused quarry at Hett. The Hett roost continued to increase in size (Figure 3) until late October, at which time birds started to roost in a wood on the Lambton estate (M.R. NZ 294527). The Hett roost rapidly declined; only 200 birds were present on the 10 November, and soon afterwards it was deserted completely.

The Lambton roost was situated in a plantation of 7m. high Scots Pine and was occupied for the rest of the winter (Figure 3). Attempts to displace the roost in early

FIGURE 3

THE VARIATION IN SIZE OF THE HETT AND LAMBTON ROOSTS BETWEEN
SEPTEMBER 1970 and APRIL 1971.

Fig. 3

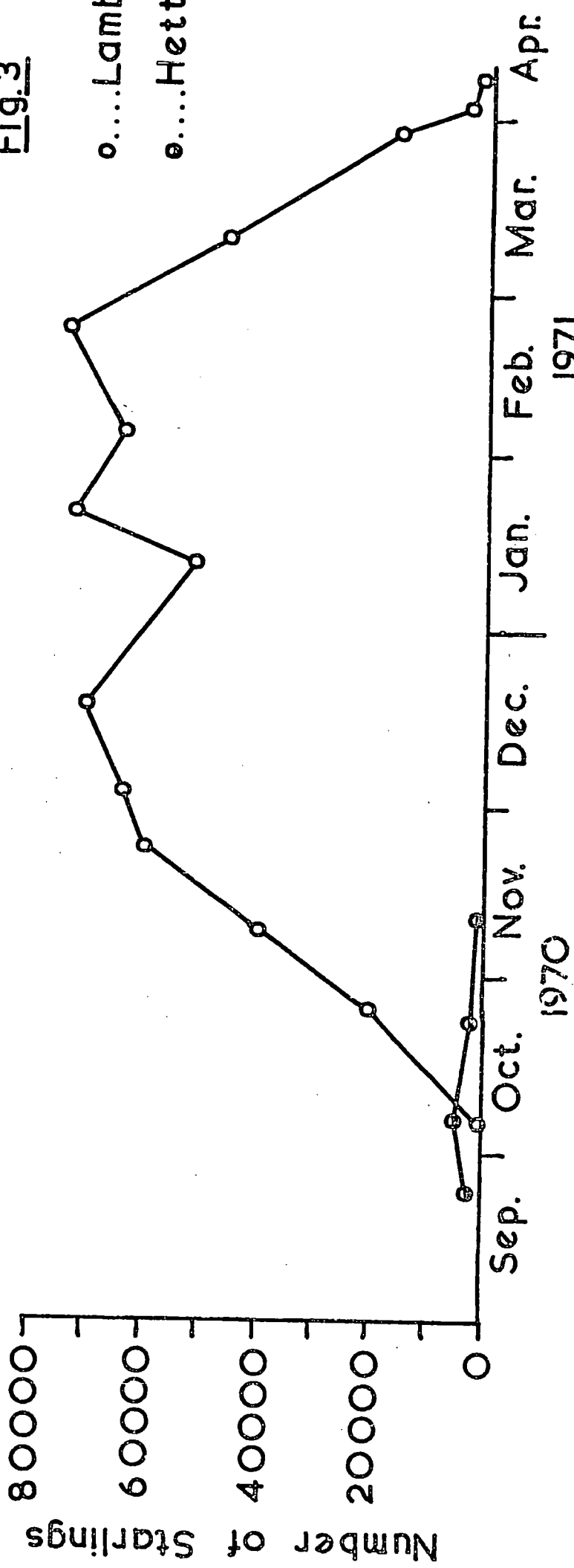

January only succeeded in shifting the concentration of birds to two adjacent plantations. There was some indication, from the counts, that some birds roosted elsewhere for a short time during the period of disturbance, but that these soon returned when scaring was abandoned.

The winter roost broke up in early April and on the evening of the 5 April no birds were present. Resident Starlings roosted at or near their nest sites until June, when the first broods of young were fledged.

c. 1971-72

In early June Starlings began to roost at Plawsworth, as in the previous year. Birds were also found roosting at Hett (500) and Newton Aycliffe (100) (M.R. NZ 275257). These roosts remained in existence until late July, when they were abandoned, and a new roost site at Cornforth (M.R. NZ 304345) was occupied by 2,500 birds. The numbers at Cornforth gradually increased, shifted site to that at Hett used the previous year, and reached a peak of 6,700 (Figure 4) in September. This roost then declined rapidly, whilst that at Lambton increased to 150,000.

Because of limitations placed on the work which I was allowed to carry out at Lambton, observations in the Durham study area were abandoned. A new study area near Belford in Northumberland was adopted where a roost of some 25,000 Starlings was known to exist at Newham (M.R. NU 169313).

The counts made at the Newham roost are shown in Figure 5. The roost was situated in a wood of Larch, Ash (Fraxinus excelsior) and some Norway Spruce (mainly dead) but was later abandoned for a site in a Scots Pine plantation at Cheswick (M.R. NU 017472). At the time of

FIGURE 4

THE VARIATION IN SIZE OF THE HETT AND LAMBTON ROOSTS BETWEEN
JULY AND NOVEMBER 1971.

Fig.4

o...Lambton

o...Hett

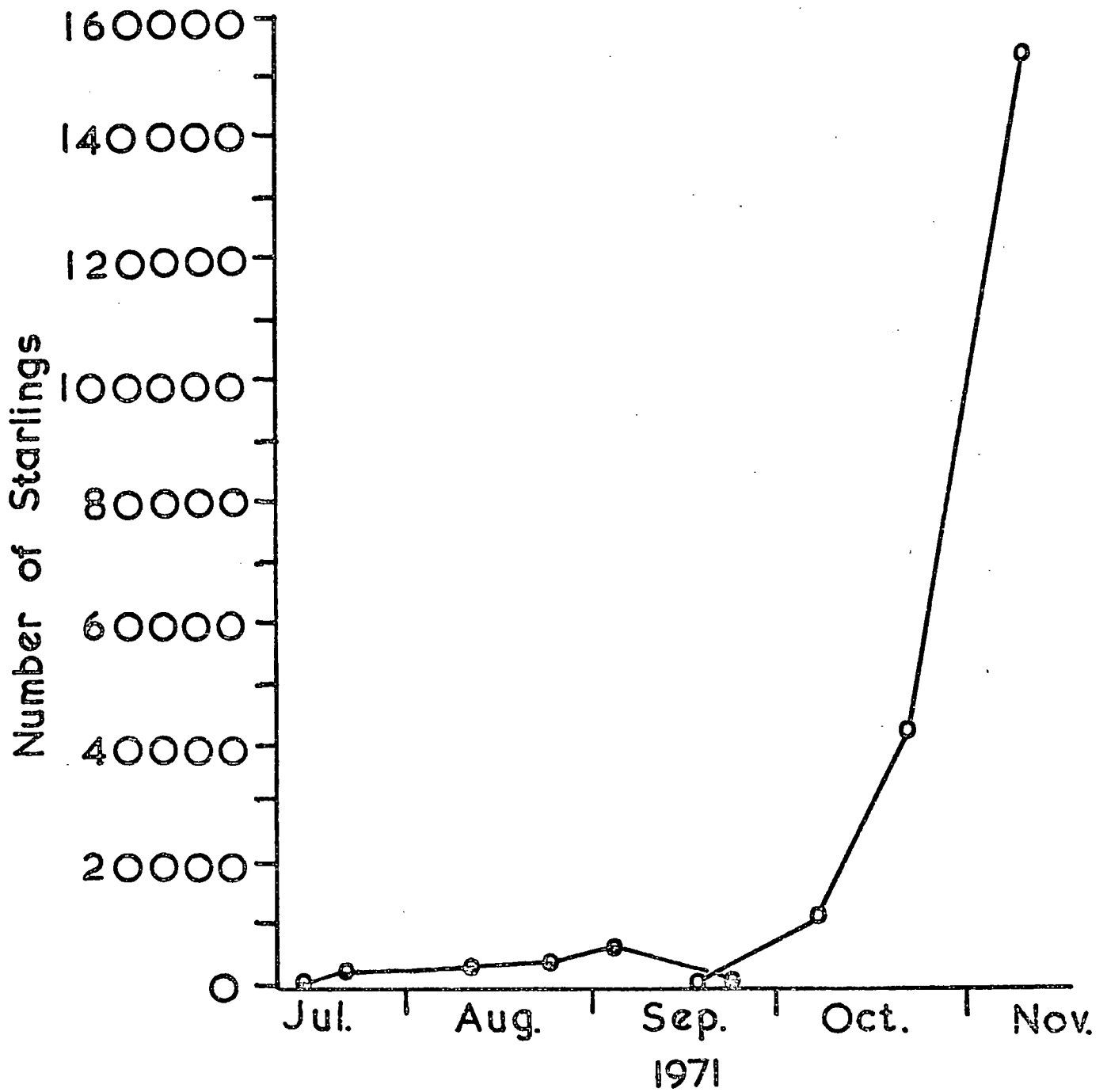
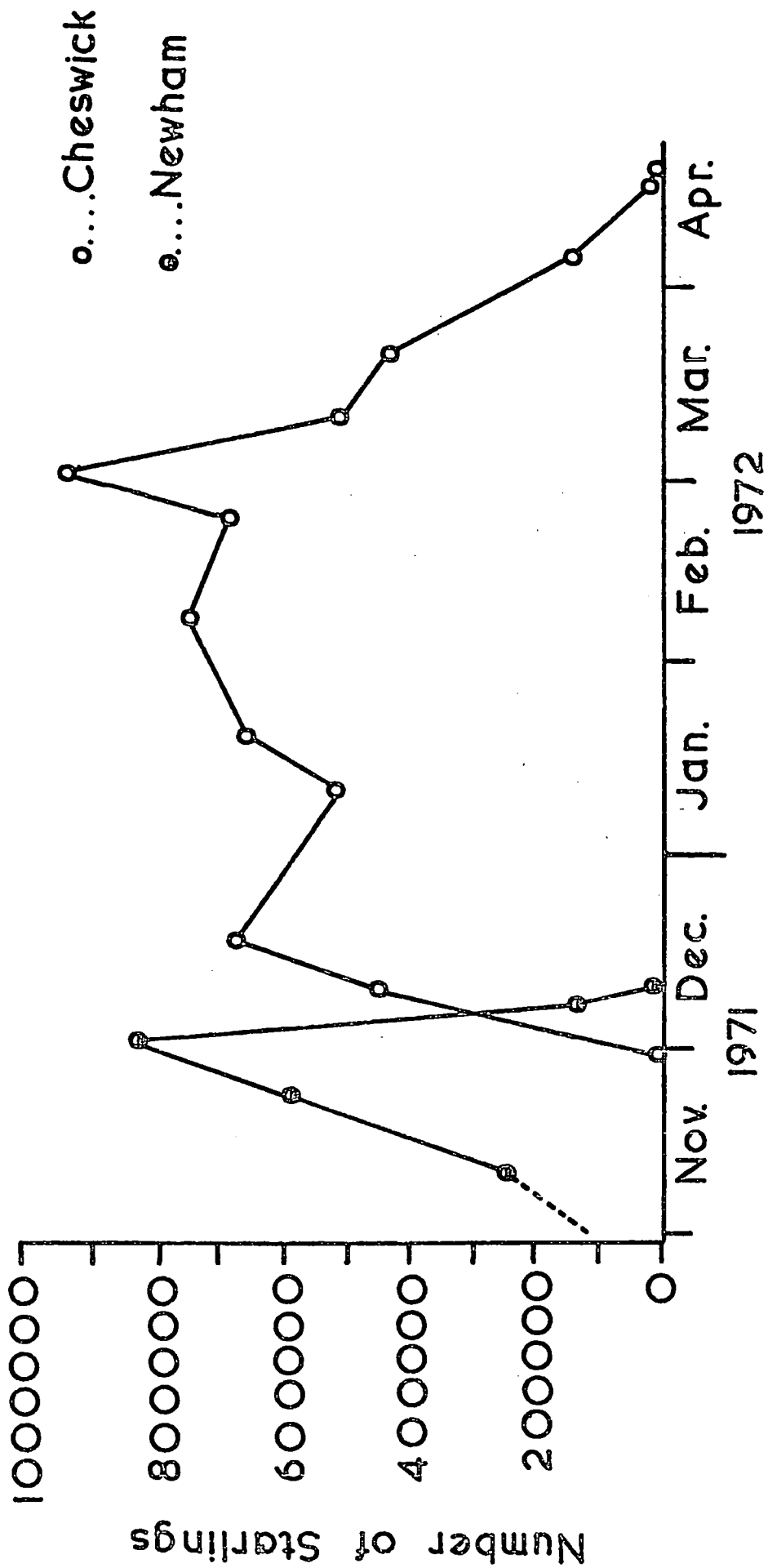

FIGURE 5

THE VARIATION IN SIZE OF THE NEWHAM AND CHESWICK ROOSTS BETWEEN
NOVEMBER 1971 and APRIL 1972.

Fig. 5



the change over Bradford Kaims (W.R. HU 162318) was used as a roost site for a month by up to 10,000 birds. The same change of roost site took place on the 21 December the previous year (P.C. Smith pers. comm.)

Despite attempts to scare the roost at Cheswick only small movements from one adjacent plantation to another occurred. Starlings were present in this roost complex until the latter half of April when it was abandoned completely.

d. General pattern of Roost occupation

The sequence of roost occupation and size variation was observed during the three years of the study. From these observations it was possible to derive a general annual pattern of rural roosting in the Durham and Northumberland region.

During the late spring resident Starlings established nest sites. At this time they usually roosted at the nest site or sometimes in a sheltered tree or copse nearby.

Initially the newly fledged young returned to their nest hole to roost. Soon, however, they gathered in large feeding flocks during the day and roosted communally in a small wood (often of Hawthorn or scrub), near to the feeding grounds, at night. As autumn approached several such roosts, each serving relatively small catchments, coalesced to form one large roost, drawing birds from a radius of up to ten miles.

In each year of the study the major roost used increased rapidly in size in late October and early November. As leaf fall occurred several roosts in deciduous trees declined and amalgamated to form a larger roost in conifers.

Also at this time of year large numbers of migrant Continental Starlings arrived in this country (Lack and Eastwood 1962); some remained in the area whilst others moved further south and west. In addition it seemed probable that some British birds from higher ground or from further north might have swollen the local roosting population at this time.

Roosts remained fairly constant in size throughout the rest of the winter but, as spring approached, so the number of birds using the communal roost declined. Residents took up territories and nest sites and remained there overnight. Continental birds began the return migration to their breeding grounds in Scandinavia and Russia.

2. The Roosting Population

a. Age and Sex Composition of Roosts

Because permission was not granted to shoot Starlings at the Lambton roost, samples of the roosting population were only collected from the Cheswick roost in Northumberland between January and April 1972. The number of birds in each age, sex and origin category, together with the sample size, are given for each sample date in Table 1. Since sample sizes were small the data have been grouped for the purpose of analysis.

The numbers of British and Continental Starlings shot each month are shown in Table 2. The proportion of Continental birds in the population changed during the three month sample period (Homogeneity $\chi^2_3 = 18.03, p < 0.001$). No difference can be detected in the proportion of British and Continental Starlings in the period early January to early March ($\chi^2_1 = 0.0001, p > 0.99$). The proportion of

TABLE 1

THE TOTAL NUMBER OF STARLINGS SHOT EACH EVENING AT THE CHESWICK ROOST, TOGETHER WITH
THE NUMBER IN EACH AGE, SEX, AND ORIGIN CATEGORY

Date	British adult male	Continental adult male	British adult female	Continental adult female	British juvenile male	Continental juvenile male	British juvenile female	Continental juvenile female	Total sample size
27.1.72	4	7	1	3	1	4	0	5	25
28.1.72	8	7	2	2	4	3	0	3	29
7.2.72	14	9	0	3	2	2	0	3	33
28.2.72	11	8	6	6	5	9	0	7	52
10.3.72	26	15	3	10	4	13	2	13	36
16.3.72	7	1	4	5	3	8	0	3	31
27.3.72	9	7	5	3	8	5	2	12	51
7.4.72	11	2	14	0	7	1	7	1	43
12.4.72	5	0	1	0	3	0	1	0	10

TABLE 2

THE PERCENTAGE OF BRITISH AND CONTINENTAL
STARLINGS SHOT EACH MONTH AT THE CHESWICK ROOST

	Mid Jan. to mid Feb.	Mid Feb. to mid Mar.	Mid Mar. to mid Apr.	Total
% British	41.4	41.3	64.4	50.0
% Continental	58.6	58.7	35.6	50.0
Total	87	138	135	360
χ^2 *	2.59	4.17	11.27	18.03
p	> 0.1	< 0.05	< 0.001	< 0.001

* χ^2 calculated on the Null Hypothesis that samples were
taken from a homogeneous population

British and Continental birds shot at the roost in the last month is however different from that in the previous two ($\chi^2_1 = 18.03, p < 0.001$): the proportion of Continental birds in the roost has declined, as has the total roost count (see Figure 5). This appears to be due to Continental birds returning to their breeding grounds.

The numbers of adult and juvenile Continental Starlings shot each month are shown in Table 3. No significant change in the age ratio occurred over the sample period. Table 4 shows similar values for British birds; although no heterogeneity could be detected, the last month does show a different age ratio to the previous two months ($\chi^2_1 = 6.01, p < 0.02$); these were not significantly different from each other ($\chi^2_1 = 0.0003, p > 0.98$). The proportion of adults at the roost declined in the last month as more adults deserted the communal roost in favour of roosting at or near their nest sites.

The decline in British adults at the roost seemed mainly due to a reduction in the number of adult males present, as shown by the change in the adult British sex ratio in Table 5. Adult males would presumably be the first birds to remain near to their nest site in order to establish and maintain territories. There was no significant difference between the sex ratios in the first two months ($\chi^2_1 = 1.13, p > 0.02$), but that for the last month was different from that of the first two ($\chi^2_1 = 11.87, p < 0.001$), fewer males being shot in the sample.

The numbers of Continental adult male and adult female Starlings shot each month is shown in Table 6. No significant variation in the sex ratio could be detected.

TABLE 3

THE PERCENTAGE OF ADULT AND JUVENILE
CONTINENTAL STARLINGS SHOT EACH MONTH AT
THE CHESWICK ROOST

	Mid Jan. to mid Feb.	Mid Feb. to mid Mar.	Mid Mar. to mid Apr.	Total
% Continental adults	60.8	48.1	37.5	48.9
% Continental juveniles	39.2	51.9	62.5	51.1
Total	51	81	48	180
χ^2 *	2.89	0.02	2.49	5.40
p	> 0.05	> 0.80	> 0.1	> 0.1

* χ^2 calculated on the Null Hypothesis that samples were taken from a homogeneous population.

TABLE 4

THE PERCENTAGE OF ADULT AND JUVENILE
BRITISH STARLINGS SHOT EACH MONTH AT THE
CHESWICK ROOST

	Mid Jan. to mid Feb.	Mid Feb. to mid Mar.	Mid Mar. to mid Apr.	Total
% British adults	80.6	80.7	64.4	72.8
% British juveniles	19.4	19.3	35.6	27.3
Total	36	57	87	180
χ^2 *	1.10	1.81	3.11	6.02
p	> 0.2	> 0.1	> 0.05	> 0.1

* χ^2 calculated on the Null Hypothesis that samples were taken from a homogeneous population.

TABLE 5

THE SEX RATIO OF ADULT BRITISH STARLINGS
SHOT EACH MONTH AT THE CHESWICK ROOST

	Mid Jan. to mid Feb.	Mid Feb. to mid Mar.	Mid Mar. to mid Apr.	Total
% British adult males	89.7	80.4	56.4	72.3
% British adult females	10.3	19.6	43.6	27.7
Total	29	46	55	130
χ^2 *	4.36	1.52	6.98	12.86
p	< 0.05	> 0.2	< 0.01	< 0.01

* χ^2 calculated on the Null Hypothesis that samples were taken from a homogeneous population.

TABLE 6

THE SEX RATIO OF ADULT CONTINENTAL STARLINGS
SHOT EACH MONTH AT THE CHESWICK ROOST

	Mid Jan. to mid Feb.	Mid Feb. to mid Mar.	Mid Mar. to mid Apr.	Total
% Continental adult males	74.2	59.0	55.6	63.6
% Continental adult females	25.8	41.0	44.4	36.4
Total	31	39	18	88
χ^2 *	1.49	0.37	0.51	2.37
P	> 0.2	> 0.8	> 0.8	> 0.3

* χ^2 calculated on the Null Hypothesis that samples were taken from a homogeneous population.

Similarly no heterogeneity in either the British or Continental juvenile sex ratios was apparent (Tables 7 and 8).

The sex ratio of British juveniles was not significantly different from that of the adults, between January and March, before the adult sex ratio changed (Table 9).

Coulson (1960) stated that the differential mortality between the sexes took place in the first breeding season, but from the data presented in Table 9 it seems that in the British Starling it has already taken place by the late winter of the first year of life. In the juvenile Continental Starling the sex ratio was significantly different from that of the adult (Table 10) and approximates to the equal sex ratio found at fledging (Coulson 1960). In the case of Continentals the differential mortality between the sexes did not appear to have taken place by this stage. Moreover, if one compared the adult sex ratio of British and Continental birds, not as great a differential mortality appeared to have taken place (Table 11). Alternatively, it may be that there was a differential migration of the sexes in Starlings as has been found in Blackbirds (Turdus merula) by Drost (1935) and Krueger (1940).

g. Weights

No significant difference in the weights of each age, sex and origin class of Starlings shot at the Cheswick roost were found during the three months. The results for all months have therefore been combined and the mean weight, standard error, and sample size are shown in Table 12, for each class of Starling.

In the case of both British and Continental birds the same gradation in weight was found: from adult male to juvenile male to adult female to juvenile female (although

TABLE 7

THE SEX RATIO OF JUVENILE BRITISH STARLINGS
SHOT EACH MONTH AT THE CHESWICK ROOST

	Mid Jan. to mid Feb.	Mid Feb. to mid Mar.	Mid Mar. to mid Apr.	Total
% British juvenile males	100.0	81.8	67.7	75.5
% British juvenile females	0.0	18.2	32.3	24.5
Total	7	11	31	49
χ^2 *	2.26	0.24	1.01	3.51
p	> 0.1	> 0.5	> 0.3	> 0.3

* χ^2 calculated on the Null Hypothesis that samples were taken from a homogeneous population.

TABLE 8

THE SEX RATIO OF JUVENILE CONTINENTAL STARLINGS
SHOT EACH MONTH AT THE CHESWICK ROOST

	Mid Jan. to mid Feb.	Mid Feb. to mid Mar.	Mid Mar. to mid Apr.	Total
% Continental juvenile males	45.0	52.4	46.7	48.9
% Continental juvenile females	55.0	47.6	53.3	51.1
Total	20	42	30	92
χ^2 *	0.12	0.20	0.06	0.39
p	> 0.7	> 0.5	> 0.8	> 0.9

* χ^2 calculated on the Null Hypothesis that samples were taken from a homogeneous population.

TABLE 9

A COMPARISON OF THE SEX RATIOS
OF ADULT BRITISH (First two months only) WITH JUVENILE
BRITISH STARLINGS SHOT AT THE CHESWICK ROOST

British	Adults	Juveniles	Total
% Males	84.0	75.5	80.6
% Females	16.0	24.5	19.4
Total	75	49	124
χ^2 *	1.37		
p	>0.2		

* χ^2 calculated on the Null Hypothesis
that sex ratios were similar for
adults and juveniles.

TABLE 10

A COMPARISON OF THE SEX RATIO OF ADULT AND
JUVENILE CONTINENTAL STARLINGS SHOT
AT THE CHESWICK ROOST

Continental	Adults	Juveniles	Total
Males	63.6	48.9	56.1
Females	36.4	51.1	43.9
Total	88	92	180
χ^2 *	3.96		
p	< 0.05		

* χ^2 calculated on the Null Hypothesis that sex ratios were similar for adults and juveniles.

TABLE 11

A COMPARISON OF THE SEX RATIO OF ADULT BRITISH
(First two months only) WITH ADULT CONTINENTAL STARLINGS
SHOT AT THE CHESWICK ROOST

Adult	British	Continental	Total
% Males	84.0	63.6	73.0
% Females	16.0	36.4	27.0
Total	75	88	163
χ^2 *	8.52		
p	< 0.01		

* χ^2 calculated on the Null Hypothesis
that sex ratios were similar for
British and Continentals.

TABLE 12

THE MEAN WEIGHT, IN GRAMS, OF SAMPLES OF STARLINGS SHOT
IN THE EVENINGS AT THE CHESHICK ROOST

	Adult British male	Adult Continental male	Adult British female	Adult Continental female	Juvenile British male	Juvenile Continental male	Juvenile British female	Juvenile Continental female
Mean	91.30	90.11	86.88	86.38	89.56	88.00	82.46	84.93
S.E.	7.82	9.97	6.57	6.14	6.39	7.28	4.36	6.95
n.	95	38	36	33	40	66	12	46

overlap occurred). For British birds; adult males were significantly heavier than adult females and juvenile females; and juvenile males were significantly heavier than juvenile females. For Continentals; adult males were significantly heavier than juvenile females, but not from adult females or juvenile males.

No significant differences in weight can be detected between British and Continental Starlings of the same age and sex class.

B. ARRIVAL AND ROOST ENTRY

1. Arrival behaviour

As was stated earlier, the method by which roosts were located relied on the direct flight lines used by Starlings to fly from their feeding to their roosting areas. During the observations, whose primary purpose was to locate roosts, it was possible to confirm Delvingt's (1961) observations on pre-roosting behaviour. Towards late afternoon, usually about an hour before sunset, Starling flocks stopped feeding and gathered in groups in trees adjacent to their feeding grounds. Their normal activities were to preen and rest for some while before setting off in the direction of their roost. Along the route to the roost they would frequently join or be joined by other resting flocks, thus producing a stepwise progression towards the roost. The amount of time spent resting en route to the roost seemed to be reduced under dark and stormy conditions, so that birds flew direct towards the roost without stopping. As soon as roost sites were located observations in the roost catchment were reduced.

Through observations at all the roosts located during the study it was possible to build up a general picture of the

behaviour of birds just prior to roosting.

Birds arrived in flocks at the roost site along radial flight lines. Normally no systematic bias in the time of arrival from different directions occurred. However, under windy conditions birds flying towards the roost with a tail wind tended to arrive earlier than those flying into wind. On arrival at the roost, birds would fly directly over the site normally occupied; their subsequent behaviour would depend on whether any birds had already entered the roost and were calling. If this was the case they too would enter directly. If other birds had arrived and not entered (presumably because certain environmental thresholds had not been reached) then the flock would join these birds. Large flocks would soon develop. Sometimes the preassembled flocks would feed in an adjacent field but more usually would rest and preen in fields or in trees in an open situation nearby. Flocks of birds arriving from the feeding grounds, which would have flown over a preassembled flock before reaching the roost site, would not normally continue to the roost itself but join the preassembly direct.

Although the height at which Starlings arrived at the roost varied from day to day, depending on factors such as the wind conditions, on a given evening the arrival height also varied. Those birds arriving early did so at a greater height than those arriving subsequently. For example, on the 25 August, 1971, at Hett, the first birds were at a height of 45m. above ground level when they flew over the roost to join the preassembled flock, but thirty minutes later those arriving were only 15m. above ground level. Despite there being large differences between the height at which Starlings arrived at the roost on

different evenings, it was possible to demonstrate a significant correlation between arrival height and arrival time. Figure 6 shows the relationship between the heights at which flocks arrived at the Hett roost and their time of arrival (classified into early, mid and late arrivals) for six days in August 1971. The correlation is highly significant ($r = -0.58$, $n = 50$, $p < 0.001$) and the gradient of the regression line is significantly greater than zero (slope = -25.54 , S.E. = 5.18).

Occasionally groups of birds from the preassembly, or the whole preassembled flock would fly to the roost site, circle it and then return to their original position. As the time of final roost entry approached, this behaviour would be more frequent and it was at this time that the remarkable aerial manoeuvres noted by several observers occurred. During these aerobatics one or more flocks would weave back and forth over the roost; the actual roost site itself seemed to form the focus of this display. The entry of birds from the preassembled flock into the roost could take several forms. On some occasions, flocks would detach themselves from the preassembly and enter as individual units with considerable gaps between each flock. Sometimes, birds would form an almost continuous stream of entry, and on still other occasions, would rise as one flock and enter in a "to and fro" fashion as described by Symonds (1961). The distinction between direct entry and preassembled entry was not an absolute one dependent on roost size as suggested by Symonds (1961), but seemed to form the two extremes of a continuum. The method of entry on a particular evening seemed mainly to be dependent on environmental factors (see below), such that direct entry might be seen on one rainy and dark evening and yet preassembled entry occur the next

FIGURE 6

THE RELATIONSHIP BETWEEN ARRIVAL HEIGHT AND ARRIVAL
TIME OF FLOCKS OF STARLINGS ARRIVING AT THE HETT
ROOST ON SIX EVENINGS IN AUGUST 1971.

evening at the same roost under clear bright conditions.

2. Entry Pattern

In between the two extremes of direct entry and preassembled entry, a great variety in the degree of preassembly occurred. Starlings might arrive at the roost and gather in a flock for some time and then enter; all subsequent arrivals making a direct entry. The resulting temporal pattern with which the number of birds in the roost built up can be seen if the proportion of the whole roost present at different times during the entry sequence is plotted against time. Although in the nature of a continuum certain types of arrival can be discerned and examples of these for specific days are shown in Figure 7.

Preassembly of the whole roost and a rapid entry of more or less one flock is illustrated in 7 (a). 7 (b) shows the preassembly and entry of the majority of the roost in one group, but some direct entry of late arrivals, producing a gradual tail off in the entry. Gradual entry of small flocks from the preassembled group, followed by a rapid entry of the majority and direct entry of late arrivals is given in Figure 7 (c). A similar type of pattern can be achieved with more than one burst of rapid entry; for example, 7 (d) shows two rapid increases in the numbers of birds in the roost as two different preassembled flocks enter. Direct entry of Starlings into their roost can vary in the time it takes; 7 (e) shows a fairly rapid entry over a period of some twenty-five minutes, whereas Figure 7 (f) shows an entry taking over forty minutes. Roost size appeared to have no influence on entry pattern. Figure 8 shows the relationship between roost size and entry type for 40 evenings in which the entry pattern fell into the categories described above. No significant correlation was apparent

FIGURE 7

EXAMPLES OF SIX DIFFERENT PATTERNS OF ROOST ENTRY, EXPRESSED
AS THE PERCENTAGE OF THE TOTAL NUMBERS PRESENT IN THE ROOST
AT DIFFERENT TIMES DURING THE ENTRY.

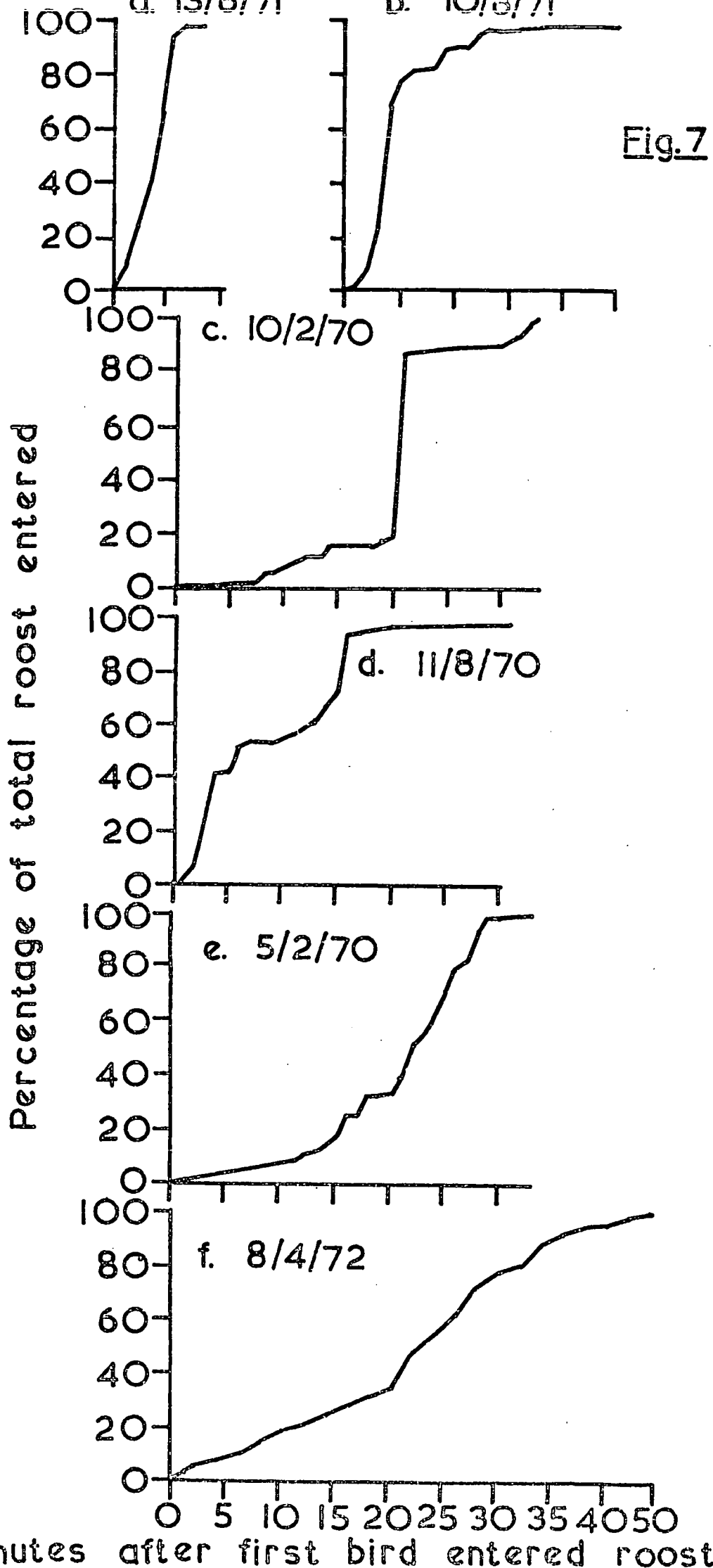
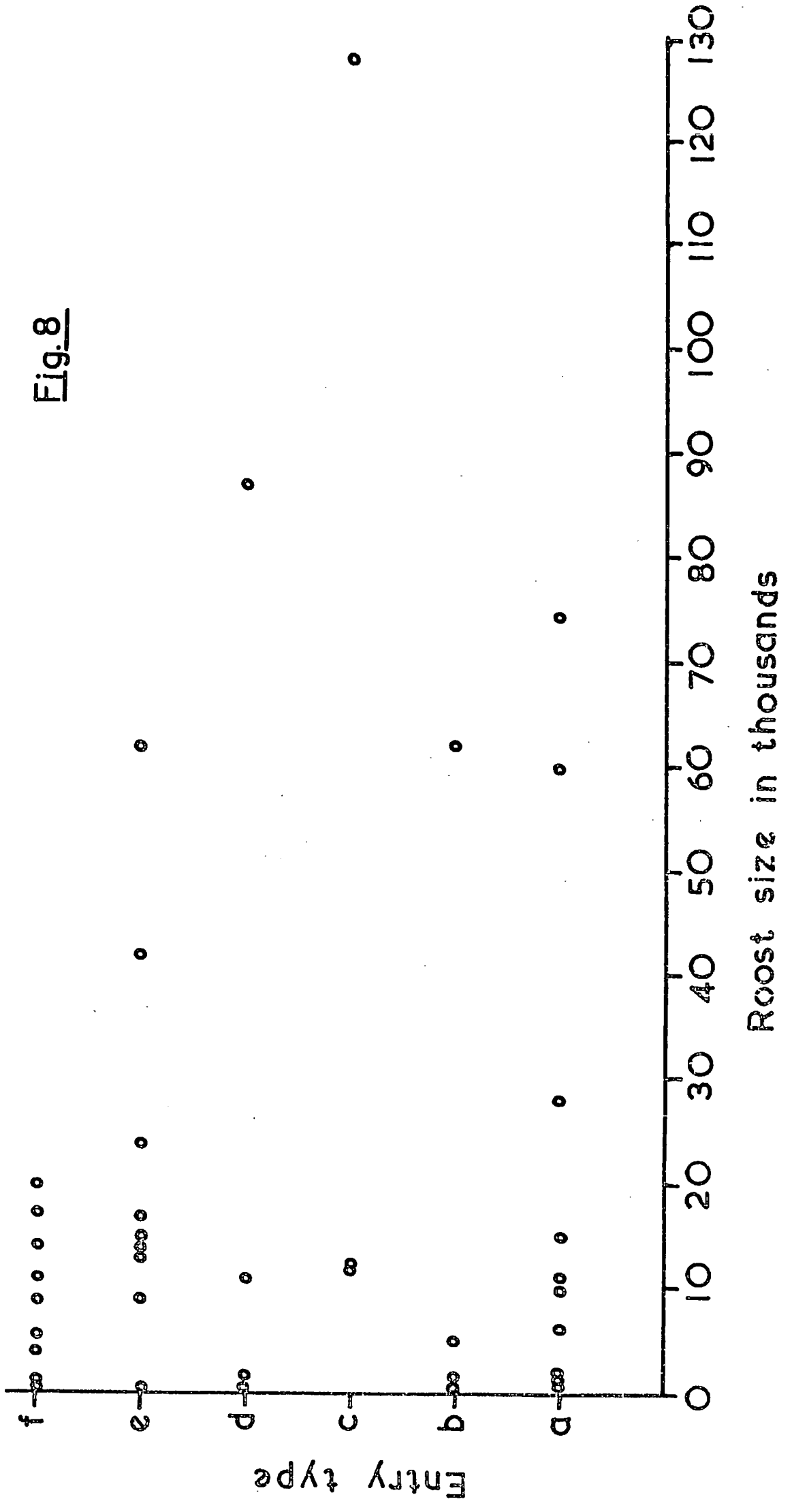

FIGURE 8

THE RELATIONSHIP BETWEEN ROOST SIZE AND ENTRY
TYPE FOR FORTY EVENINGS IN WHICH THE ENTRY PATTERN
FELL INTO ONE OF SIX CATEGORIES (see Fig. 7).

Fig. 8



($r = 0.15$, $n = 40$, $P > 0.1$).

3. Preassembly

Preassembly did not occur on every evening at the roosts studied. Since it appeared that environmental factors had a governing influence over preassembly an attempt was made to analyse this relationship. The dependent variable, preassembly, was divided into three categories (1, 0.5 and 0) on the basis of: observations at the roost revealing complete preassembly; partial preassembly (in which direct entries accounted for an appreciable proportion of the late birds); and direct entry with no preassembly.

Table 13 shows the three independent variables significantly related to the occurrence of preassembly; together they account for 42.9% of the variation found. Although light intensity factors were not found to be significantly related in the multiple regression the variable rainfall will have contained components related to both cloudcover and light intensity. Rain, and therefore cloudcover, was negatively correlated with preassembly. Starlings entering the roost directly on wet dark evenings when, although arriving at the roost at the same time or earlier than on a clear evening, the birds would nevertheless be late relative to light intensity. The occurrence of frozen ground also induced direct entry. It seems likely that cold weather could both increase food requirements and reduce food availability (either through reduced prey activity or availability) and thus increase the need to stay on the feeding grounds longer and arrive at the roost later. Similarly preassembly was less likely to occur during the midwinter period when daylength was at its shortest.

4. Flock sizes

If some of the patterns of entry illustrated in Figure 7

TABLE 13

THE RESULTS OF MULTIPLE REGRESSION ANALYSIS USING THE OCCURRENCE OF
PREASSEMBLY AS THE DEPENDENT VARIABLE

Factor group	Variable	Regression coefficient	"t" Statistic	Partial correlation	Multiple correlation
Group three: Weather)	Rainfall	- 0.0187	3.15	- 0.37	0.582
	State of ground	- 0.0608	2.87	- 0.34	0.595
Group two: Time of year	Sunset	0.0014	2.65	0.32	0.604
n = 67	Intercept value 0.7064		Multiple correlation 0.655		

are further examined in relation to the size of flocks entering over particular time periods it becomes clear that the different rates of entry can be attributed to differences in the sizes of flocks entering. For example Figure 9 shows the percentage of birds entering in different sized flocks on six days in which entry (1) was direct, (2) from preassembled flocks days in which entry was (a) from preassembled flocks, (b) from preassembled flocks early, but direct later and (c) direct. Four flock size categories were used. (1) between 1 and 100, (2) between 101 and 500, (3) between 501 and 1,000 and (4) between 1,001 and 5,000.

throughout the long entry but with a slight increase in flock size halfway through the entry. When partial preassembly occurred initially the flocks entering would mainly be of large size but would be followed by a number of small flocks when the later birds entered directly on arrival. Complete preassembly was followed by the entry of moderately sized flocks initially and a high percentage of large flocks later. Figure 10 shows the percentage frequency of occurrence of the four different flock sizes over the entire entry period for the same six days. Differences in the frequency distributions related to the method of entry are again apparent.

5. Time of Entry

The time at which birds first enter the roost was very variable. Figure 11 shows this variation in entry time graphically in relation to date. Times between 148.8 and 12.8 minutes before civil twilight were recorded during the study (mean = 66.2, S.E. = 4.25, n = 67). An attempt was made to correlate the time of entry of birds into their roost with

FIGURE 9

THE PERCENTAGE FREQUENCY OF OCCURENCE OF DIFFERENT FLOCK
SIZES AT DIFFERENT TIMES DURING ENTRY (a) PREASSEMBLED
ENTRY (b) PARTIAL DIRECT ENTRY (c) ENTIRELY DIRECT ENTRY.

FIGURE 10

THE PERCENTAGE FREQUENCY OF OCCURRENCE OF DIFFERENT
FLOCK SIZES DURING THE ENTIRE ENTRY PERIOD

- (a) PREASSEMBLED ENTRY, (b) PARTIAL DIRECT ENTRY,
(c) ENTIRELY DIRECT ENTRY.

Fig. 10

Percentage frequency of occurrence

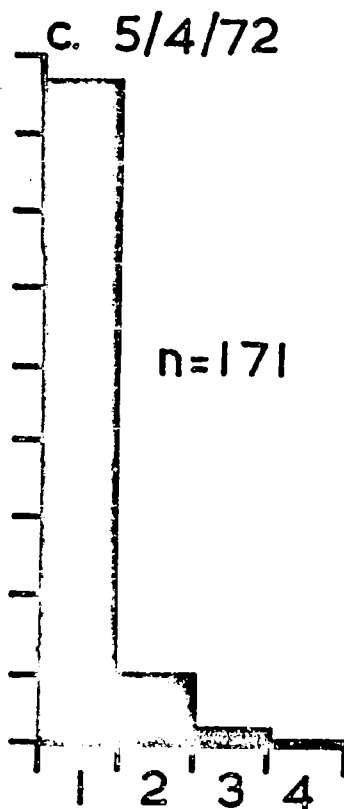
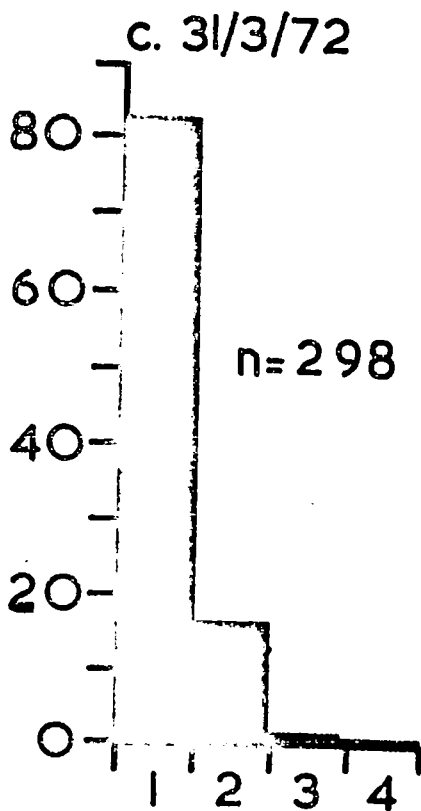
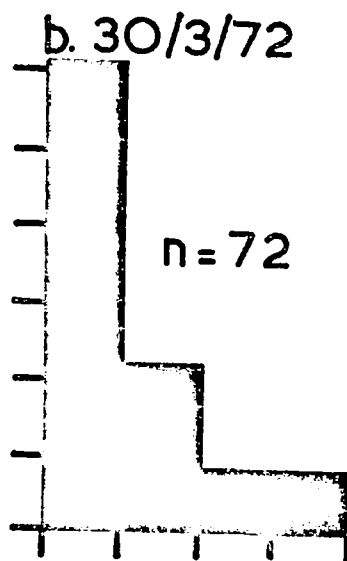
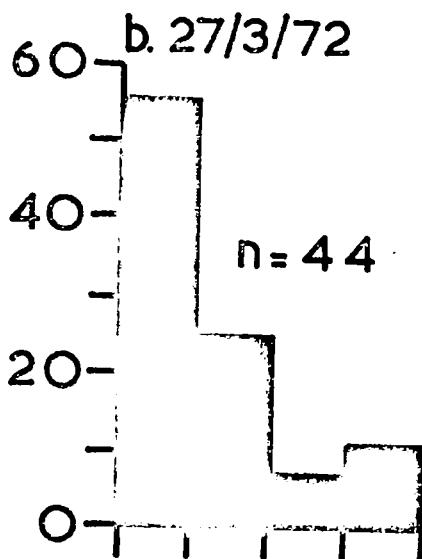
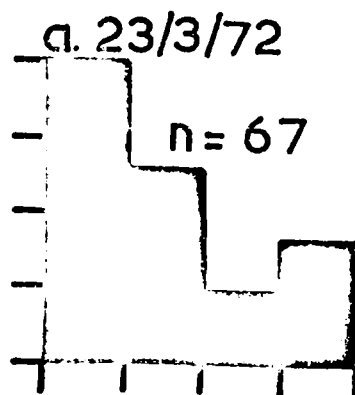
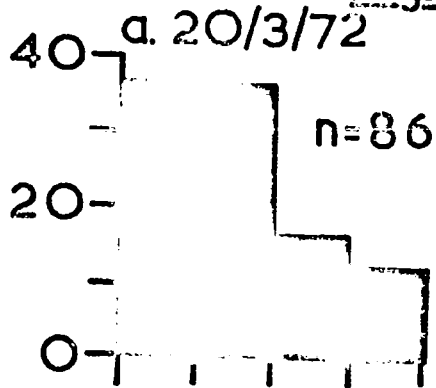

Flock size

1....1-100

2....101-500

3....501-1000

4....1001-5000

FIGURE 11

THE VARIATION IN THE TIME AT WHICH THE FIRST
STARLING ENTERED THE ROOST (in minutes relative
to civil twilight) IN RELATION TO TIME OF YEAR.

Fig. 11

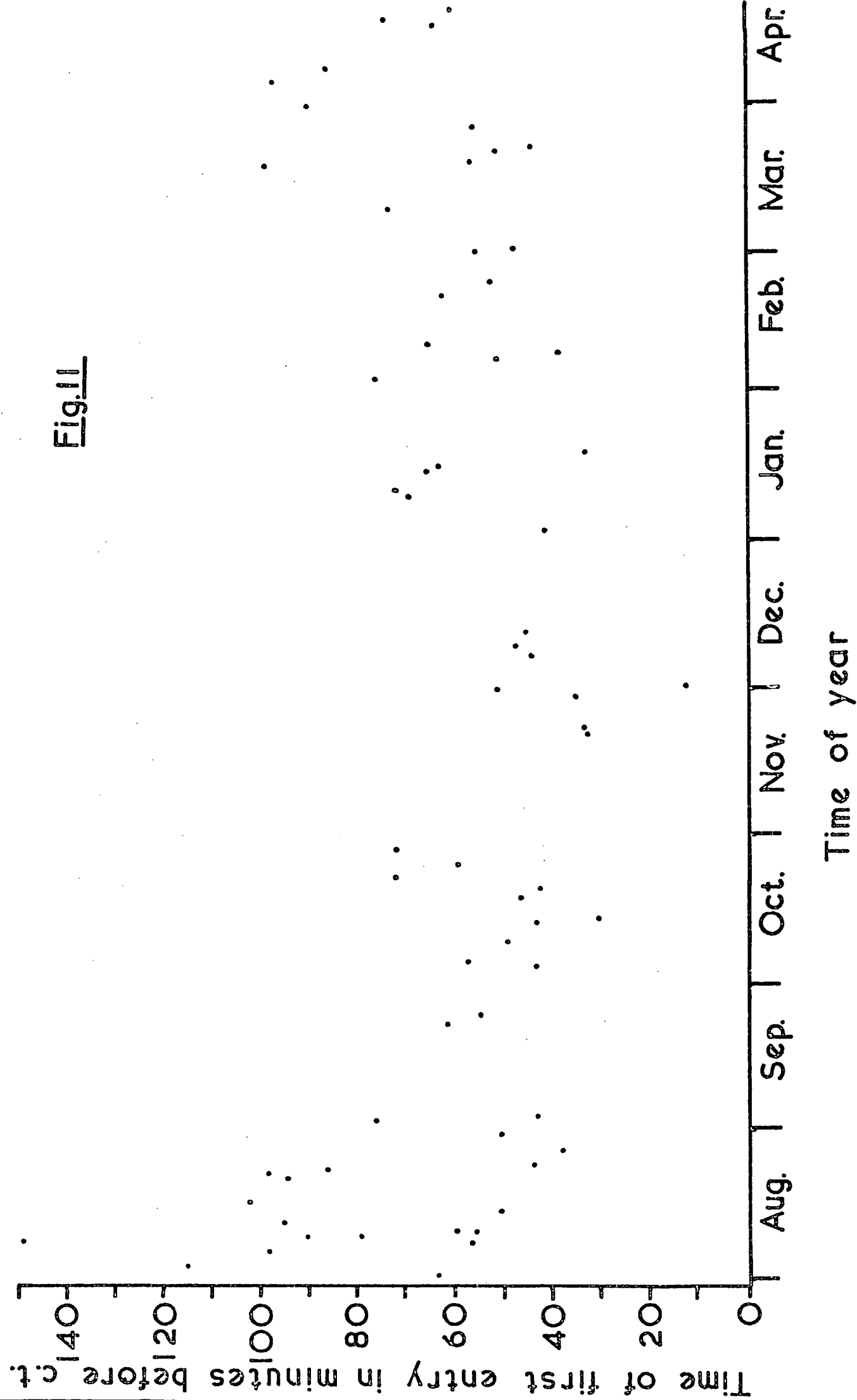

various environmental factors using multivariate techniques.

A total of 80.3% of the variation in the entry time of the first bird into the roost could be explained by variation in other factors (Table 14).

"Time of year" appeared to be the most important group of factors; entry being initiated late relative to civil twilight towards midwinter. Light intensity parameters influenced time of first entry, it being earlier on darker evenings. Snowcover, presumably by influencing the availability of food, retarded entry. The occurrence of preassembly retarded entry relative to civil twilight but made it earlier relative to light intensity, since it itself only occurred on relatively bright evenings. Preassembly was effectively birds waiting for the correct light intensity threshold to be reached, since had it been a lot darker birds would have entered directly on arrival.

Multiple regression analysis on the time at which 50% of the roost had entered and on the time at which all birds had entered the roost was also carried out. The results are shown in Table 15 and 16.

Similar factors influence the time at which half the population has entered the roost as effect first entry. The time of entry of the last bird did not seem to be effected by the occurrence of preassembly. This is, perhaps, what one would expect, since there nearly always appeared to be one or two birds which arrived late and entered the roost directly. In addition to the influence of time of year and light intensity on arrival outlined above low temperatures appeared to retard final entry. Cold weather is likely to increase food requirements and make its collection more difficult; the need to remain longer on the feeding grounds would therefore

TABLE 14

THE RESULTS OF MULTIPLE REGRESSION ANALYSIS USING THE TIME AT WHICH THE FIRST STARLING ENTERED THE ROOST (in minutes relative to civil twilight) AS THE DEPENDENT VARIABLE

Factor group	Variable	Regression coefficient	"t" Statistic	Partial correlation	Multiple correlation
Group two: Time of year { { { {	Nautical twilight	0.3987	9.67	0.78	0.708
	Sunset	0.1362	4.95	0.54	0.851
Group one: Light intensity	Correlation coefficient	- 63.8511	3.51	- 0.41	0.874
Group three: Weather	Snowfall	- 8.0464	3.35	- 0.39	0.876
Group four: Roost parameters	Preassembly	- 17.4680	3.14	- 0.37	0.878
n = 67	Intercept value 83.391		Multiple correlation		0.896

TABLE 15

THE RESULTS OF MULTIPLE REGRESSION ANALYSIS USING THE TIME AT WHICH HALF THE STARLINGS HAD ENTERED THE ROOST (in minutes relative to civil twilight) AS THE DEPENDENT VARIABLE

Factor group	Variable	Regression coefficient	"t" Statistic	Partial correlation	Multiple correlation
Group two: { { { { { Time of year	Nautical twilight	0.2944	8.59	0.86	0.819
	Sunset	0.1706	6.33	0.77	0.884
Group four: Roost parameters	Preassembly	- 20.8864	3.55	- 0.56	0.933
Group one: Light intensity	Correlation coefficient	- 52.2397	2.35	- 0.41	0.945
n = 32	Intercept value	75.004		Multiple correlation	0.955

TABLE 16

THE RESULTS OF MULTIPLE REGRESSION ANALYSIS USING THE TIME AT WHICH ALL STARLINGS HAD ENTERED THE ROOST (in minutes relative to civil twilight) AS THE DEPENDENT VARIABLE

Factor group	Variable	Regression coefficient	"t" Statistic	Partial correlation	Multiple correlation
Group two: Time of year	Nautical twilight	0.2047	7.47	0.82	0.818
Group one: Light intensity	Correlation coefficient	- 91.3194	5.25	- 0.71	0.884
Group three: Weather	Minimum temperature	1.3018	4.43	0.65	0.902
	Rainfall	0.5376	2.59	0.45	0.930
n = 32	Intercept value 55.618		Multiple correlation 0.944		

increase. Similarly rain, associated with cloudy and warmer conditions, would probably reduce food requirements and increase the ease with which food could be collected through bring insect larvae to the surface of the ground and allowing easy penetration of the substrate by the Starling.

The total duration of the entry period was not related to roost size but was dependent mainly on the time of year (Table 17). Entry was shortest during the midwinter period when daylength, and thus feeding time, was shortest. Reduced visibility can appreciably lengthen the duration of entry on a particular evening. Indeed, under very foggy conditions it seems likely that some birds did not reach the roost at all but formed a sub-roost nearer to their feeding grounds.

C. ROOSTING

1. Behaviour within Roost

For the reasons mentioned above few opportunities arose to look at the behaviour of birds within roosts. However, the roost at Hett was situated in Hawthorns at the base of disused quarry and did permit a limited number of observations to be made.

Preliminary observations appeared to indicate that, initially, birds were distributed mainly on the upper and outer portions of the trees, but that as it became darker they moved towards the centre of the trees to roost. On the 18 and 19 October, 1970 one branch was observed closely and the number of birds on its inner and outer half counted at five minute intervals. The results for the first (early) and subsequent (late) fifteen minute periods are shown in Table 18. It was not possible to demonstrate statistically a shift in the number of bird occurrences from the outer to the inner half of the branch during the observation period. The sample size was

TABLE 17

THE RESULTS OF MULTIPLE REGRESSION ANALYSIS USING DURATION OF ENTRY
(in minutes) AS THE DEPENDENT VARIABLE

Factor group	Variable	Regression coefficient	"t" Statistic	Partial correlation	Multiple correlation
(((((((Nautical twilight	0.2251	6.48	0.78	0.575
	Daylength	0.1063	3.50	0.56	0.786
	Sunrise	- 0.0717	2.39	- 0.42	0.825
Group three: Weather	Visibility	3.9046	2.40	0.42	0.825
n = 32	Intercept value - 27.038		Multiple correlation 0.859		

TABLE 18

A COMPARISON OF THE PERCENTAGE OF STARLINGS PERCHED ON THE INNER AND OUTER HALVES OF BRANCHES EARLY AND LATE IN THE EVENING ON FOUR DATES AT THE HETT ROOST

Date	18.10.70		19.10.70		21.10.70		23.10.70		Total	
	Early	Late	Early	Late	Early	Late	Early	Late	Early	Late
% on outer half of branch	66.7	25.0	80.0	44.4	75.0	28.6	75.0	22.2	74.3	28.6
% on inner half of branch	33.3	75.0	20.0	55.6	25.0	71.4	25.0	77.8	25.7	71.4
Total	6	8	5	9	12	14	12	18	35	49
χ^2 *	2.43		2.59		5.57		8.17		17.11	
p	> 0.10		> 0.10		< 0.02		< 0.01		< 0.001	

* χ^2 calculated on the Null Hypothesis that the proportion of Starlings perched on the inner and outer halves of branches were similar early and late.

increased on the 21 and 23 October by observing two branches. The movement towards the centre of the tree during the second quarter of an hour of observation then became significant, (Table 18).

On the 21 and 23 October the numbers of birds in the upper, middle and lower portions of two trees were noted at five minute intervals. On each occasion, there was a significant movement of birds down the tree to the middle section in the latter half of the observation period (Table 19). No birds were ever seen in the lower section of the trees.

The movements of birds within coniferous trees could not be quantified, since most of the perches were obscured by foliage. Birds could not usually be seen from outside the roost and observations from inside usually resulted in disturbance. The general impression, however, was that the sequence of behaviour was similar. Birds landed in the top two whorls of the conifers but moved down to the third and fourth whorls to roost (this was at a height of 4-5 m. in trees 6-7 m. high). The selection of perch sites in the roost might, in part, have been a function of perch width, but it was not feasible to investigate this possibility.

One further opportunity arose to look at behaviour within the roost. This occurred at Bradford Kaims, a small roost, which was occupied for some time during the transition from Newham to Cheswick. The roost was centred on several conifers (Norway Spruce), which were surrounded by deciduous trees of Ash and Hawthorn (with an under storey of Bramble (Rubus spp.)) also used as roost trees. In the evenings a contraction of the area occupied by birds occurred before they went to sleep. This was

TABLE 19

A COMPARISON OF THE PERCENTAGE OF STARLINGS PERCHED ON THE UPPER, MIDDLE AND LOWER BRANCHES OF TREES EARLY AND LATE IN THE EVENING ON TWO DATES AT THE HETT ROOST

Date	21.10.70		23.10.70		Total	
Time period	Early	Late	Early	Late	Early	Late
% on upper branches	75.0	36.4	51.9	17.6	61.7	26.3
% on middle branches	25.0	63.6	48.1	82.4	38.3	73.7
% on lower branches	0.0	0.0	0.0	0.0	0.0	0.0
Total	20	44	27	51	47	95
χ^2 *	8.22		9.93		22.80	
p	< 0.01		< 0.01		< 0.001	

* χ^2 calculated on the Null Hypothesis that the proportion of Starlings perched on upper and middle branches were similar early and late.

accompanied by a reduction in the distance between birds. The reverse appeared to occur in the morning; birds spread out on individual branches and occupied new trees before the departure commenced. On the evening of the 3 December birds started to enter the roost at 16.15h. G.M.T., the last birds entering at 16.40 h. G.M.T. At 16.50 h. G.M.T. the area occupied by birds contracted to that occupied overnight. The nearest neighbour distances in bird widths were estimated for a sample of birds before and after the contraction. The mean nearest neighbour distance (+ S.E.), which was different for the two samples, is shown in Table 20 ($t=6.82, p 0.001$).

Similarly on the following morning the numbers of trees occupied by birds increased between 07.33 h. G.M.T. and the first departure at 07.42 h. G.M.T. The estimates, in bird widths, of the nearest neighbour distance are shown in Table 20., again the mean values were significantly different for the two time periods ($t=3.84, p 0.002$).

On the morning of the 3 December the numbers of birds in a sample engaged in each of five activities were noted at five minute intervals. The results are shown in Table 21. As birds awoke they initially preened and stretched, and then rested. Some birds sang but these appeared to be only adult males (see below). The awakening was not synchronous and some birds remained asleep several minutes later than others.

Table 22 shows similar results obtained on the evenings of the 4 and 5 December. Singing only took place early in the sequence of behaviour, and was missed on the second set of observations due to birds being obscured early in the observation period. Preening seemed to be an important activity prior to sleeping.

TABLE 20

3.12.71 Evening	Mean nearest neighbour distance in bird widths between 16.40 and 16.50 h. G.M.T.	Mean nearest neighbour distance in bird widths after 16.50 h. G.M.T.
	3.55 (S.E. = 0.38)	1.90 (S.E. = 0.30)

4.12.71 Morning	Mean nearest neighbour distance in bird widths before 07.33 h. G.M.T.	Mean nearest neighbour distance in bird widths between 07.33 and 07.42 h. G.M.T.
	1.70 (S.E. = 0.56)	3.00 (S.E. = 0.38)

THE MEAN (+ STANDARD ERROR) NEAREST NEIGHBOUR DISTANCE
OF A SAMPLE OF TEN BIRDS OBSERVED ON TWO OCCASIONS AT
THE BRADFORD KAIMS ROOST

TABLE 21

THE PERCENTAGE OF BIRDS ENGAGED IN EACH OF FIVE BEHAVIOURAL ACTIVITIES

ON THE MORNING OF 3.12.71 AT BRADFORD KAIMS ROOST

(time of first departure 07.37h. G.M.T.)

Time	Singing	Resting	Preening	Sleeping	Stretching	Total
07.30	0.0	9.5	42.9	19.0	28.6	21
07.35	15.0	25.0	35.0	10.0	15.0	20
07.40	13.3	60.0	20.0	6.7	0.0	15
07.45	14.3	57.1	28.6	0.0	0.0	7
07.50	0.0	80.0	20.0	0.0	0.0	5

TABLE 22

THE PERCENTAGE OF BIRDS ENGAGED IN EACH OF FOUR BEHAVIOURAL ACTIVITIES ON THE EVENINGS OF (a) 4.12.71 and (b) 5.12.71 AT THE BRADFORD KAIMS ROOST (time of first arrival 16.09h. and 16.14h. G.M.T. respectively)

(a)

Time	Singing	Resting	Preening	Sleeping	Total
16.13	13.0	65.3	21.7	0.0	23
16.22	15.4	76.9	7.7	0.0	26
16.25	5.5	67.3	18.2	9.0	55
16.30	7.2	75.5	10.1	7.2	69
16.35	1.8	63.7	14.5	20.0	55
16.40	0.0	40.0	22.2	37.8	45
16.45	2.4	19.5	17.1	61.0	41
16.50	0.0	5.9	23.5	70.6	34
16.55	0.0	2.3	16.7	81.0	42
17.00	0.0	5.3	7.0	87.7	57

(b)

16.35	10.0	50.0	40.0	0.0	10
16.37½	0.0	100.0	0.0	0.0	5
16.40	0.0	57.9	42.1	0.0	19
16.42½	0.0	50.0	43.3	6.7	30
16.45	0.0	52.6	26.3	21.1	19
16.47½	0.0	37.5	25.0	37.5	16
18.50	0.0	16.7	0.0	83.3	6

2. Noise

Although an attempt was made to monitor noise levels coming from several roosts using a microphone and amplifier this proved to be unsuccessful. The equipment developed was not sufficiently sensitive; had it been, the interference of background noise would probably have been a problem, unless an expensive filter system was used.

Tape recordings of the sound produced by Starlings at the Newham roost, both morning and evening, were analysed on a sonograph and the results are shown in Figure 12.

Certain difficulties arose in the analysis of the noise since it was being produced by several thousand birds at once. Certain differences in frequency^{are}, however, apparent during the peak of noise produced morning and evening. Four peaks of amplitude were discernable at 1, 2, 3.5 and 5.5 Kilohertz. Hartby (1969) gives the frequency distributions of the calls of the Starling. Attack and aggressive calls have peaks at 2 and 3.5 Kilohertz, the flight call was of low frequency (1 Kilohertz) and the high frequency whistles, common in the song of the Starling, occurred at around 5.5 Kilohertz.

Initially in the evening the low frequency flight calls were given as birds arrived. Birds fought and bickered over perches but did not sing to any great extent. Once all birds have arrived, no further flight calls were given and noise was limited to song and aggressive calls. The pattern was reversed in the morning, singing occurring only early on and no flight calls being given at all.

When Starlings were observed in the roost it was very noticeable that very few actually sang. These were apparently all adult males, judging by the fully yellow bill and long

FIGURE 12

THE AMPLITUDE AND FREQUENCY DISTRIBUTIONS OF NOISE
RECORDED AT THE NEWHAM ROOST, (a) EARLY EVENING,
(b) MID EVENING, (c) LATE EVENING, (d) EARLY MORNING,
(e) MID MORNING AND (f) LATE MORNING.

Fig.12

Evening

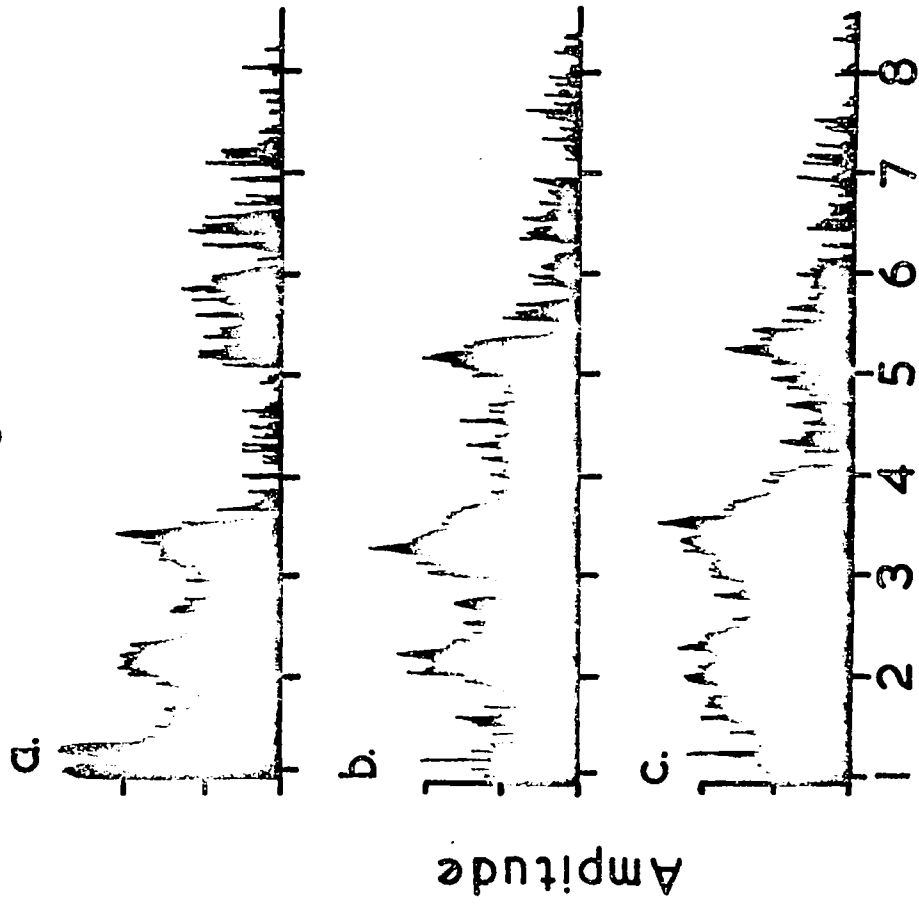

Morning

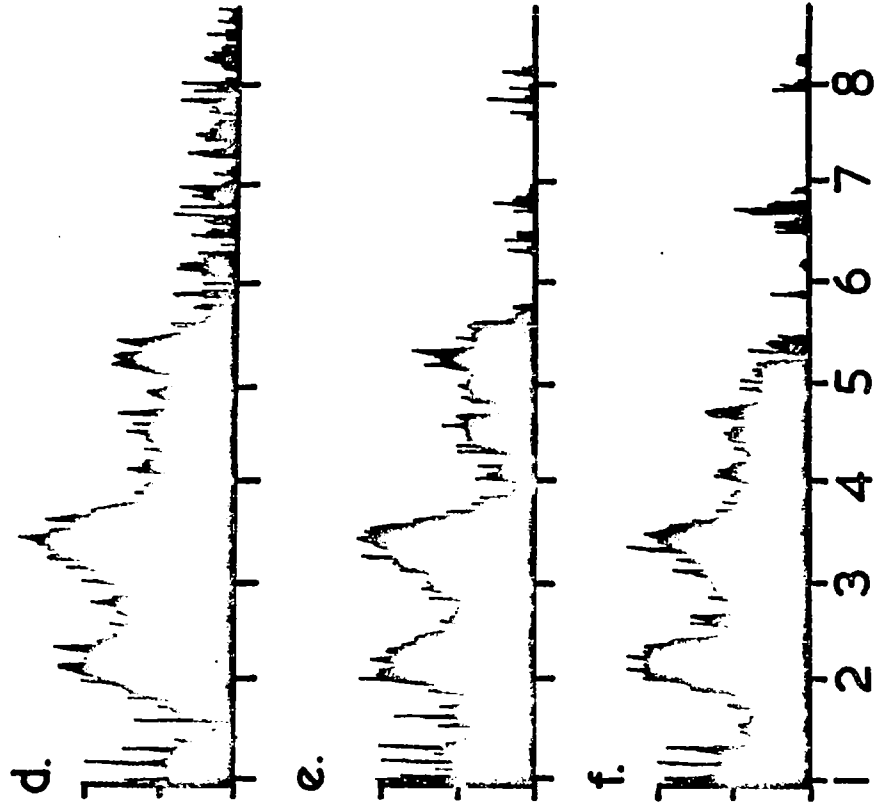

Frequency in kilohertz

iridescent hackles which all birds seen singing possessed.

However, birds of all types of plumage gave short calls.

D. ROOST DEPARTURE

1. Behaviour

Through non-systematic observation, at all the roosts located during the three years, it was possible to build up a general picture of the behaviour of Starlings immediately prior to and during departure. As was stated earlier, as Starlings awoke they started to move to the upper and outer regions of trees and in addition occupied new trees at the edge of the roost area. During the asynchronous awakening noise gradually increased as birds started chattering and calling.

Just prior to the first, and all subsequent departures, the noise suddenly stopped. Birds started to fly out from the roost, in radial paths, forming a circular wave which expanded from the roost focus into the surrounding countryside. There was a tendency for those birds on the newly occupied periphery of the roost to form the departure. That is to say, the birds which were first to disperse radially within the roost were first to disperse radially from the roost. Even after several departures some birds could usually be seen still asleep. As soon as each departure had left the noise level increased once more until the hush of the next departure.

Under calm conditions the behaviour of birds leaving the roost in all directions in the expanding departure wave was usually similar. Birds gradually gained height, until at approximately 400 m. from the roost they were 75-100 m. above ground level. From then onwards, they flew in level flight towards their feeding grounds. If there was a strong wind,

however, those birds flying into it did not gain as much height. In addition, they flew slower and those with a tail wind correspondingly faster. When flying into very strong winds Starlings flew only a few feet above ground level and "hedge hopped" any obstacles.

Frequently the last birds of a departure would return to the edge of the roost, having flown out from between 50 and 150 m. The birds which dropped back into the roost would often do so in a low, fast, irregular, zigzag flight, giving a "bell-like" call. Similar behaviour was noted in Starlings arriving at the roost very late in the evenings. These returning birds seemed to form the nucleus of the next departure. Fog increased the proportion of birds re-entering the roost and also delayed the whole departure pattern. For example, on the misty morning of the 29 August, 1971, the third departure from Hett contained some 300 Starlings, of which approximately 75 returned to the roost trees. During the comparable departure on the clear morning of the 31 August no birds returned to the roost. Moreover, the third departure on the 29 August took place at 18.31 h. G.M.T., whilst that on the 31 August occurred at 18.02 h. G.M.T. A ground mist on the morning of the 6 September, 1971, reduced visibility laterally but was not sufficiently deep to change the light regime. Some Starlings, from the second, third and fourth departure, dropped back into the roost on the 6 September, whereas on the previous day (a clear one) none had returned. The departures did, however, take place at almost identical times and light intensities.

The large amount of flux in the roost prior to dispersal, and the re-entry of birds, is similar to behaviour noted at an

urban roost in Edinburgh (Charman, unpublished). This would support the idea that birds were in a conflict situation, drawn between several urges. Urges which were in turn dependent on factors such as the time of day, the weather and the proximity of other Starlings.

Eastwood, Isted and Rider (1962), in their observation of ring angels, noted several cases in which waves of dispersal from different roosts overlapped. In response to scaring of the roost at Lambton, a number of sub-roosts were established nearby. Frequently two, but sometimes three such sites were used concurrently. On several occasions, during the morning dispersal of these roosts, departures would leave two sub-roosts simultaneously. On no occasion was interference between departure waves noted. However, several times birds from a departure wave from one roost would re-enter the other roost as the wave passed over it. These Starlings were usually those from the tail end of the departure wave.

Two unusual observations were made at the Lambton roost. On the mornings of the 21 and 28 January, 1971, after heavy overnight rain in both cases, the fields surrounding the conifer plantations contained a large number of pools of standing water. The Starlings flew direct from the roost to these fields, which soon became black with birds. Initially, all the birds were gathered around the pools preening and bathing, but after approximately ten minutes in this activity, some started to feed. After a further ten minutes, birds started to disperse in a series of departure waves. It was possible that the Starlings plumage was so dishevelled, because of the overnight rain, that preening and bathing had to take place before the birds were able to disperse. This possibility was supported by the fact that several interactions between Starlings, in which the breast

of one bird was pressed onto the tail and rump of another, were seen. In each case, the contact was followed by preening on the part of the former bird. Preen gland secretion may have been "stolen" in these interactions.

One further observation is worthy of note. On the morning of the 2nd March, 1971, a 2.5 - 5 cm. layer of snow covered much of County Durham. During the third of the five departure waves noted that morning, one group of several hundred Starlings changed their dispersal direction. These birds banked through 180° and joined birds leaving the roost in the opposite direction to their initial dispersal. Ward and Zahavi (1973) have suggested that communal roosting enables birds to exchange information on the distribution of an uneven food supply. They envisaged that unsuccessful individuals, needing information, might hang back and follow more successful birds, which set off purposefully from the roost. Under conditions of snowcover many food sources normally utilised by Starlings would no longer be available and only a limited number of sites would be suitable in which to feed. The need for information would therefore be high and one might expect redirection to occur more frequently. The observation at the Lambton roost might therefore lend some weight to Ward and Zahavi's hypothesis on roost function.

In the short term the number, size and spacing of departures was usually relatively stable, provided weather conditions were not too variable. However, if more than a few days were considered appreciable variation in the departure pattern occurred. This variation is considered in greater depth in the appropriate section.

2. Timing

The time at which the first birds left the roost was very

variable. Figure 13 shows this variation graphically in relation to date. Times between 4.6 and 61.4 minutes after civil twilight were recorded during the study (mean = 23.58, S.D. = 0.72, n = 129). A considerable proportion of the variability (62.3%) could, however, be explained by variation in environmental factors. The variables included as significant in the multiple regression analysis, using time of first departure as the dependent variable, are shown in Table 23 together with their regression coefficients, 't' statistics, partial correlations and multiple correlations.

"Increase of Light intensity" appeared to be the most important group of factors influencing time of departure. Both the time at which it began to get light, and the rate of increase of light intensity, were negatively correlated with time of first departure. That is to say, the sooner and more rapidly it began to get light, the earlier the birds left the roost.

A seasonal component was apparent in the variation in time of departure. The time of departure was earlier, relative to civil twilight, in the midwinter months, as shown by the significant negative partial correlations of three factors in the "time of year" group.

Over and above the effect of weather conditions on the time of departure accounted for by "group one" factors, certain weather conditions influenced departure time in their own right. Both increased cloudcover and maximum temperature delayed departure. Presumably the necessity to leave the roost early in search of food on overcast warm days is reduced, either due to a reduced overnight energy consumption, or to increased food availability. Similarly reduced visibility advanced departure

FIGURE 13

THE VARIATION IN THE TIME AT WHICH THE FIRST
STARLING LEFT THE ROOST (in minutes relative
to civil twilight) IN RELATION TO TIME OF YEAR.

Time of first departure in minutes after c. t.

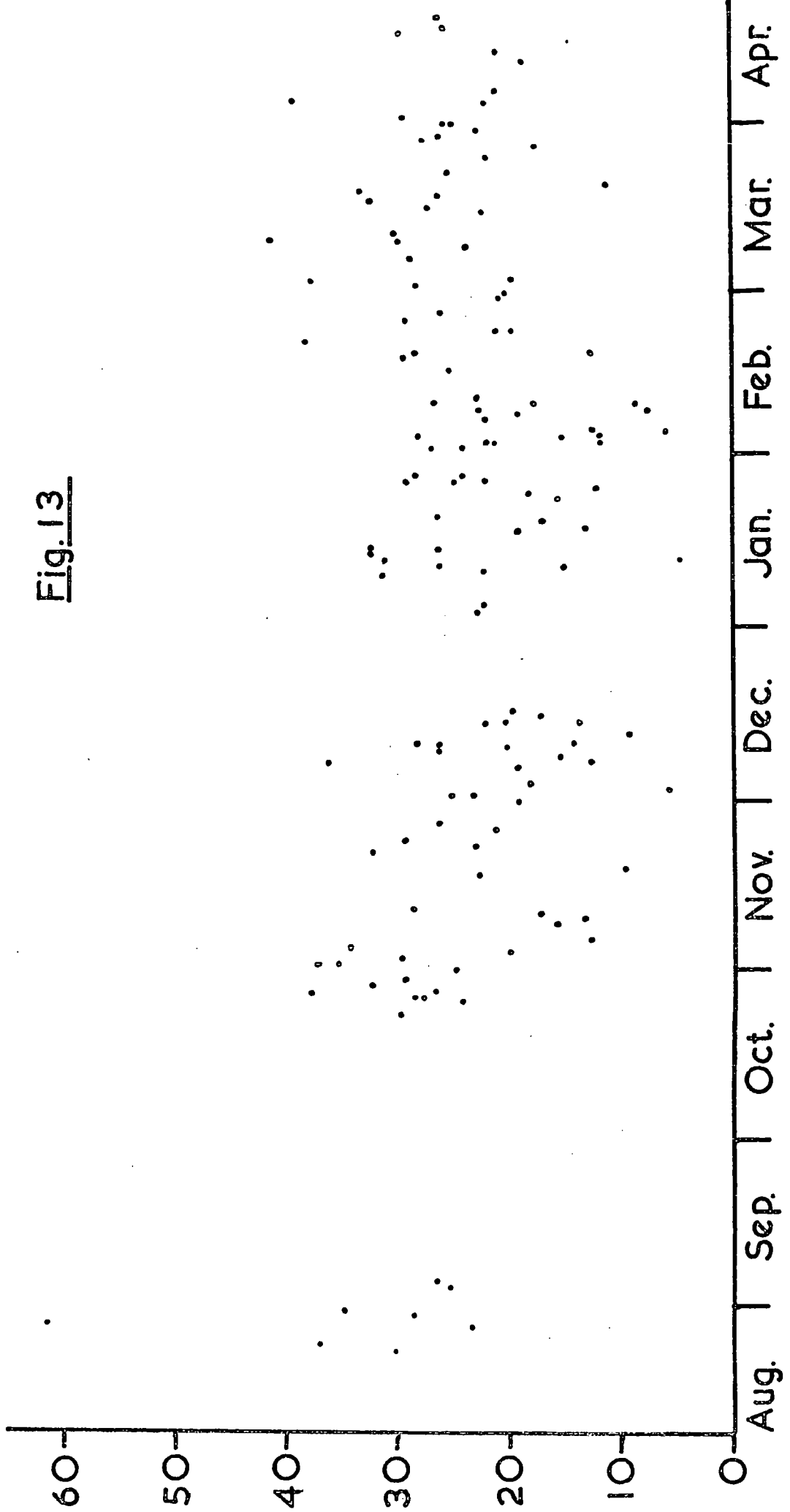

Fig. 13

Time of year

TABLE 23

THE RESULTS OF MULTIPLE REGRESSION ANALYSIS USING THE TIME AT WHICH THE FIRST STARLING LEFT THE ROOST (in minutes relative to civil twilight)

AS THE DEPENDENT VARIABLE

Factor group	Variable	Regression coefficient	"t" Statistic	Partial correlation	Multiple correlation
Group one: Light intensity	Intercept	- 11.517	6.64	- 0.52	0.694
	Slope	- 14.802	5.03	- 0.42	0.736
Group two: Time of year	Nautical twilight	- 0.359	2.95	- 0.26	0.771
	Daylength	- 0.032	2.75	- 0.24	0.774
	Sunrise	- 0.050	4.12	- 0.35	0.754
	Cloud	0.682	2.95	0.26	0.771
Group three: Weather	Maximum temperature	0.275	2.30	0.21	0.778
	Visibility	- 0.844	2.24	- 0.20	0.779
	Snowfall	- 0.444	2.17	- 0.20	0.779
n = 129	Intercept value	62.902	Multiple correlation 0.789		

time, except under the very foggy conditions noted above when navigation became difficult. Because such extreme conditions were infrequent they were not positively correlated with late departure. Snowcover was negatively correlated with departure time, by reducing the availability of food it presumably necessitated early departure.

Roost size did not influence departure time significantly.

3. Departure Pattern

The departure pattern consisted of several constituent parts. The number and size of departures was variable from day to day, as were the number and size of gaps between departures. Each component has been considered separately.

a. Departure number

There was no significant relationship between the total number of departures going to form the total exodus on a particular day and roost size. Departure number was, however, positively correlated with daylength ($r = +0.5080$, $n = 27$) as shown in Figure 14. Similar information is presented in Figure 15 which gives the percentage frequency of occurrence of different departure numbers for the months August to April. As each individual year showed similar patterns the results for all winters have been combined. The months of December, January and February have fewer departures forming the total exodus from the roost. Similarly multivariate analysis of all data on departure number showed significant relationships with factors linked with time of year (Table 24), the midwinter months showing a reduced number of departures.

b. Departure Length

The monthly values of the percentage frequency of

FIGURE 14

THE RELATIONSHIP BETWEEN THE NUMBER OF DEPARTURE WAVES (MEAN
FOR HALF MONTHLY PERIODS) AND DAYLENGTH (MINUTES BETWEEN SUNRISE
AND SUNSET).

$$r = 0.5080, \quad n = 27, \quad p < 0.01$$

$$\text{Slope} = 0.0115 \text{ (S.E.} = 0.0038), \text{ Intercept} = 0.1526$$

Fig.14

●....1969-70

○....1970-71

○....1971-72

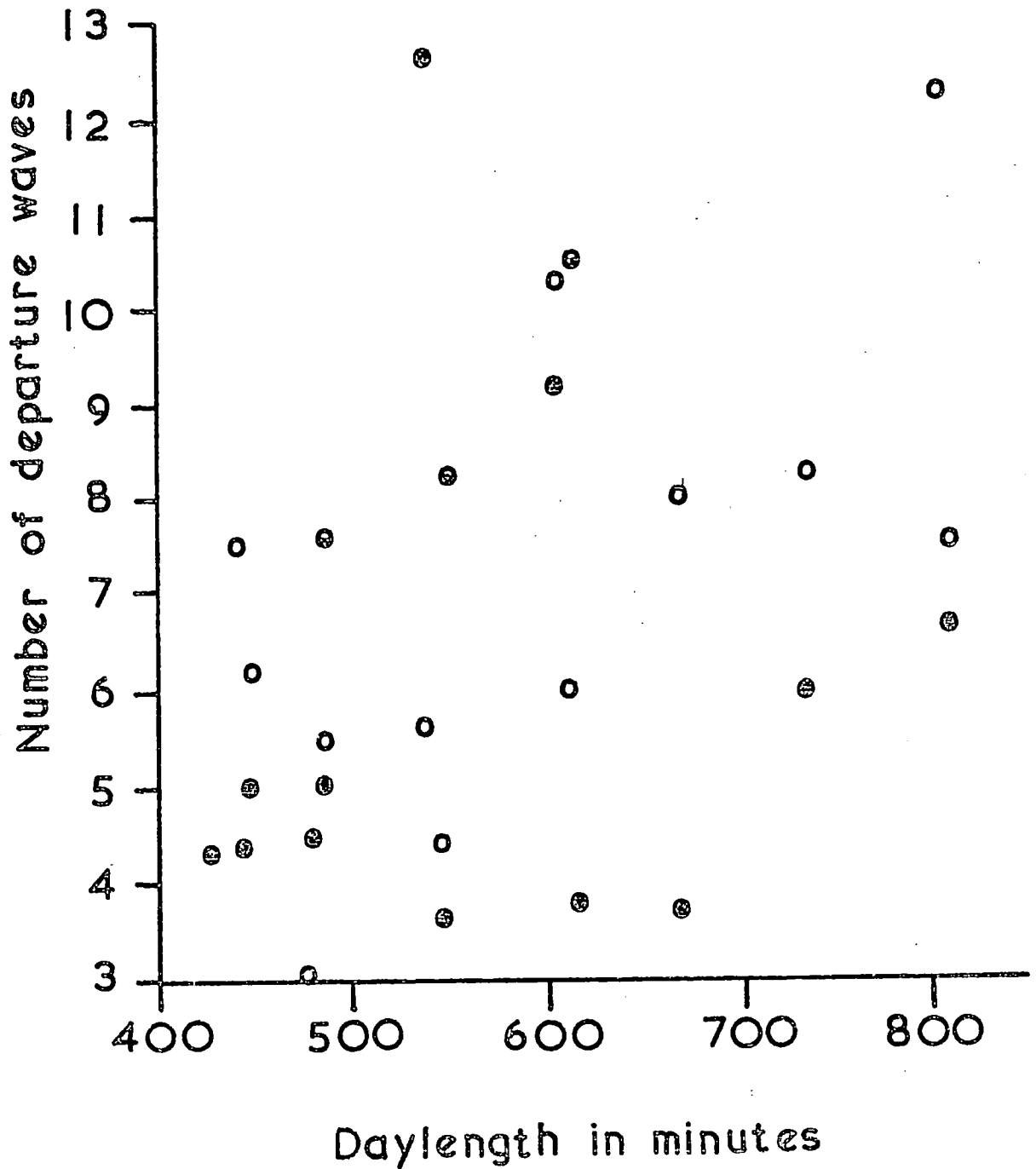
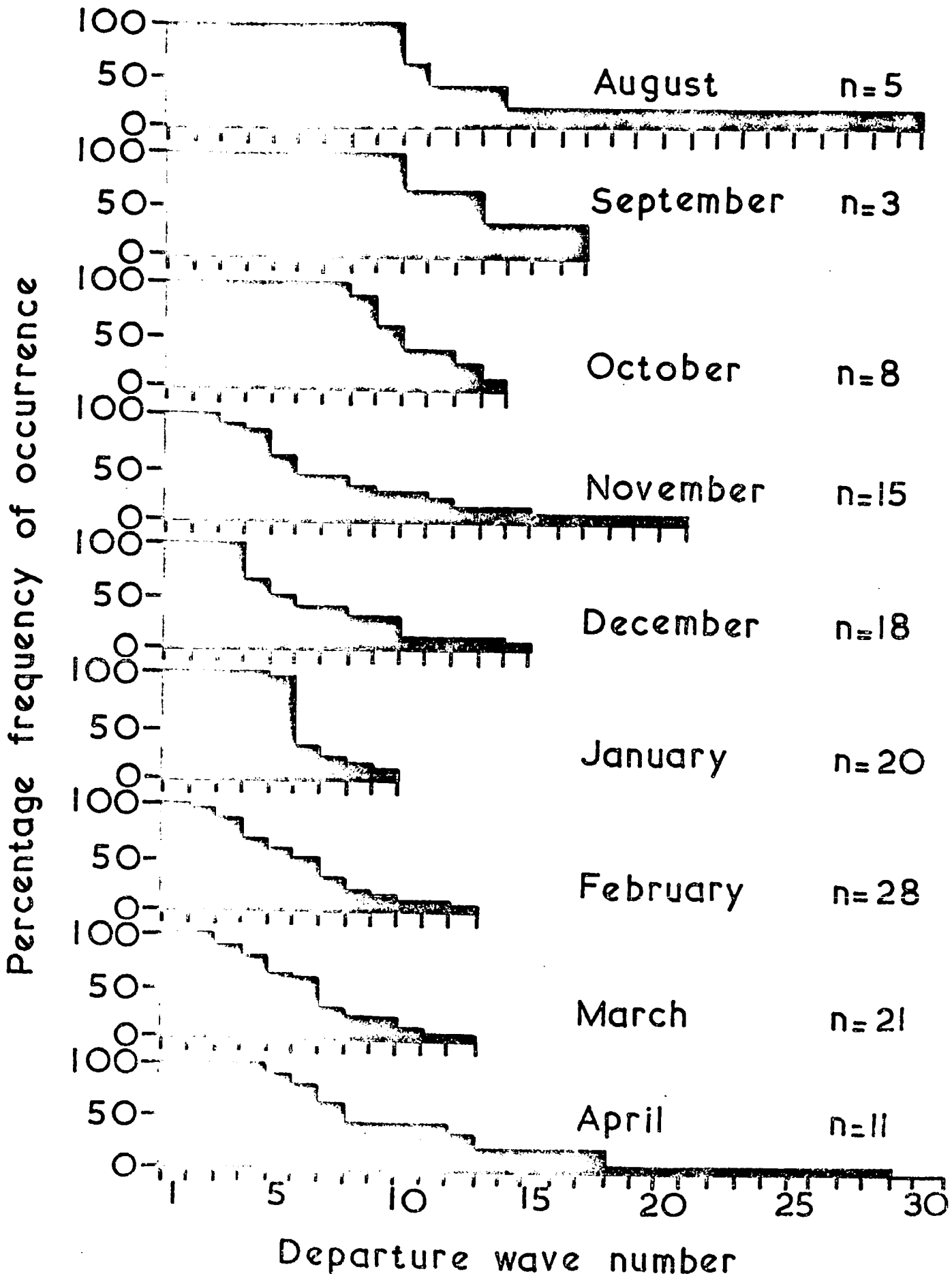

FIGURE 15

THE PERCENTAGE FREQUENCY OF OCCURRENCE OF DEPARTURES
CONTAINING DIFFERENT NUMBERS OF DEPARTURE WAVES FOR
EACH MONTH.

Fig.15



different departure lengths have been combined for each year, since they showed similar patterns, and are given in histogram form in Figure 16. There was a change in the frequency distribution with time of year; the winter months of December, January and February have fewer short departures and a corresponding increase in long departures.

Monthly mean values of departure lengths for the first and all subsequent departures have been calculated and are shown in Figure 17. The general pattern was of the first departure being small, followed by several large departures and the exodus pattern ending with one or more small departures. Again the months of December, January and February have a changed distribution, in this case towards a more even pattern of departure length.

Total departure length (the combined lengths of all departures on a particular day) declined towards the middle of winter (Figure 18). One would have expected that as roost size reached a maximum, so total departure length would show a similar trend. No significant relationship was, however, found with roost size. In contrast mean departure length was correlated significantly with roost size, being larger when the roost is larger (Figure 19). Although the total departure was shorter during the months with the highest numbers of roosting birds, a corresponding decline in number of departures had the net effect of increasing mean departure size at this time of year.

c. Gap Length

The monthly values of the percentage frequency of different gap lengths have been combined for each year since they showed similar patterns and are given in Figure 20.

FIGURE 16

THE PERCENTAGE FREQUENCY OF OCCURRENCE OF DEPARTURE WAVES
OF DIFFERENT LENGTHS FOR EACH MONTH.

Fig.16

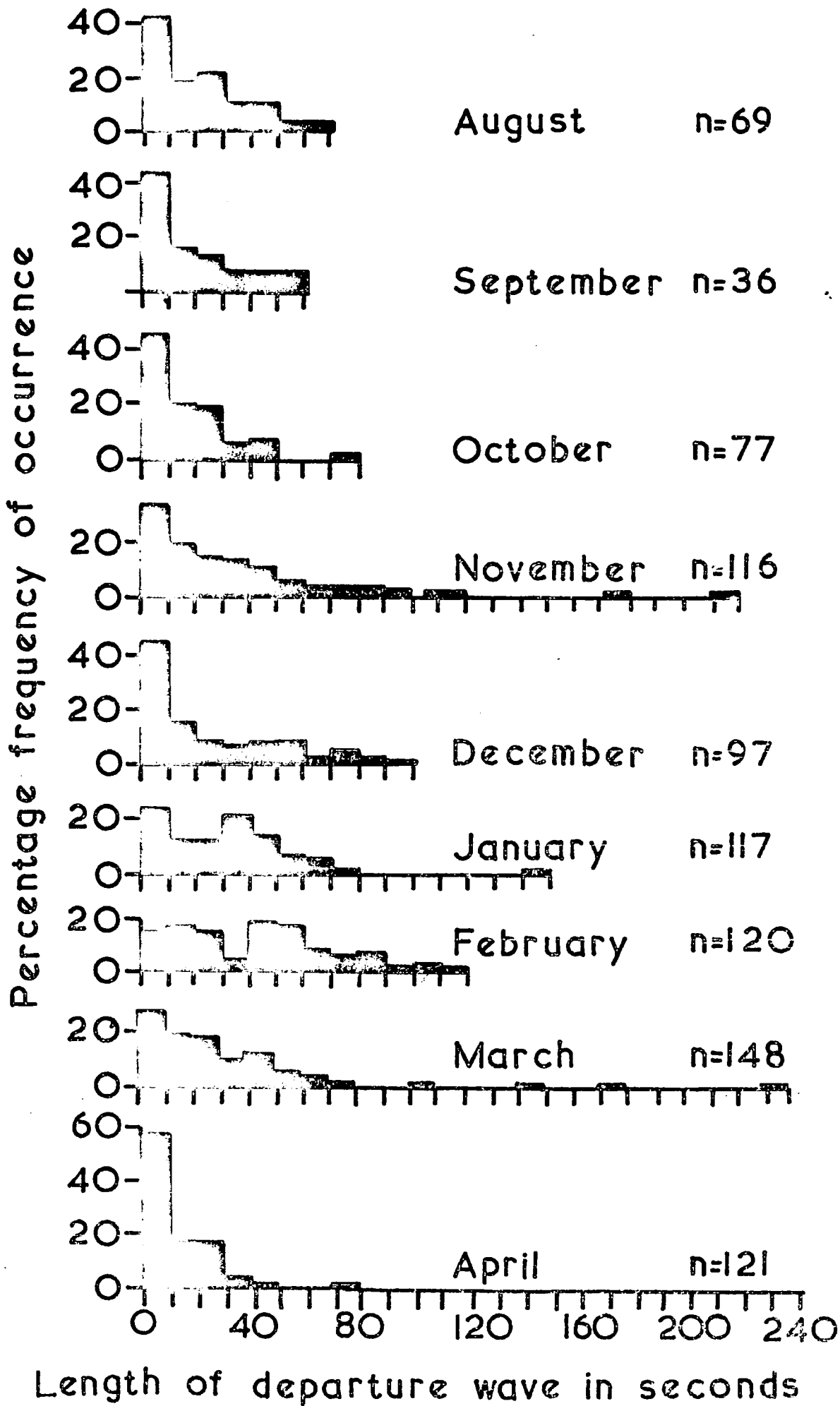

FIGURE 17

THE MEAN LENGTH OF SUCCESSIVE DEPARTURE WAVES
FOR EACH MONTH.

FIGURE 18

THE RELATIONSHIP BETWEEN TOTAL DEPARTURE LENGTH (MEAN
FOR HALF MONTHLY PERIODS) AND DAYLENGTH (MINUTES
BETWEEN SUNRISE AND SUNSET).

$$r = 0.4042, \quad n = 27, \quad p < 0.05$$

$$\text{Slope} = 0.3547 \text{ (S.E.} = 0.1574), \quad \text{Intercept} = 7.5363$$

Fig.18

●...1969-70

●...1970-71

○...1971-72

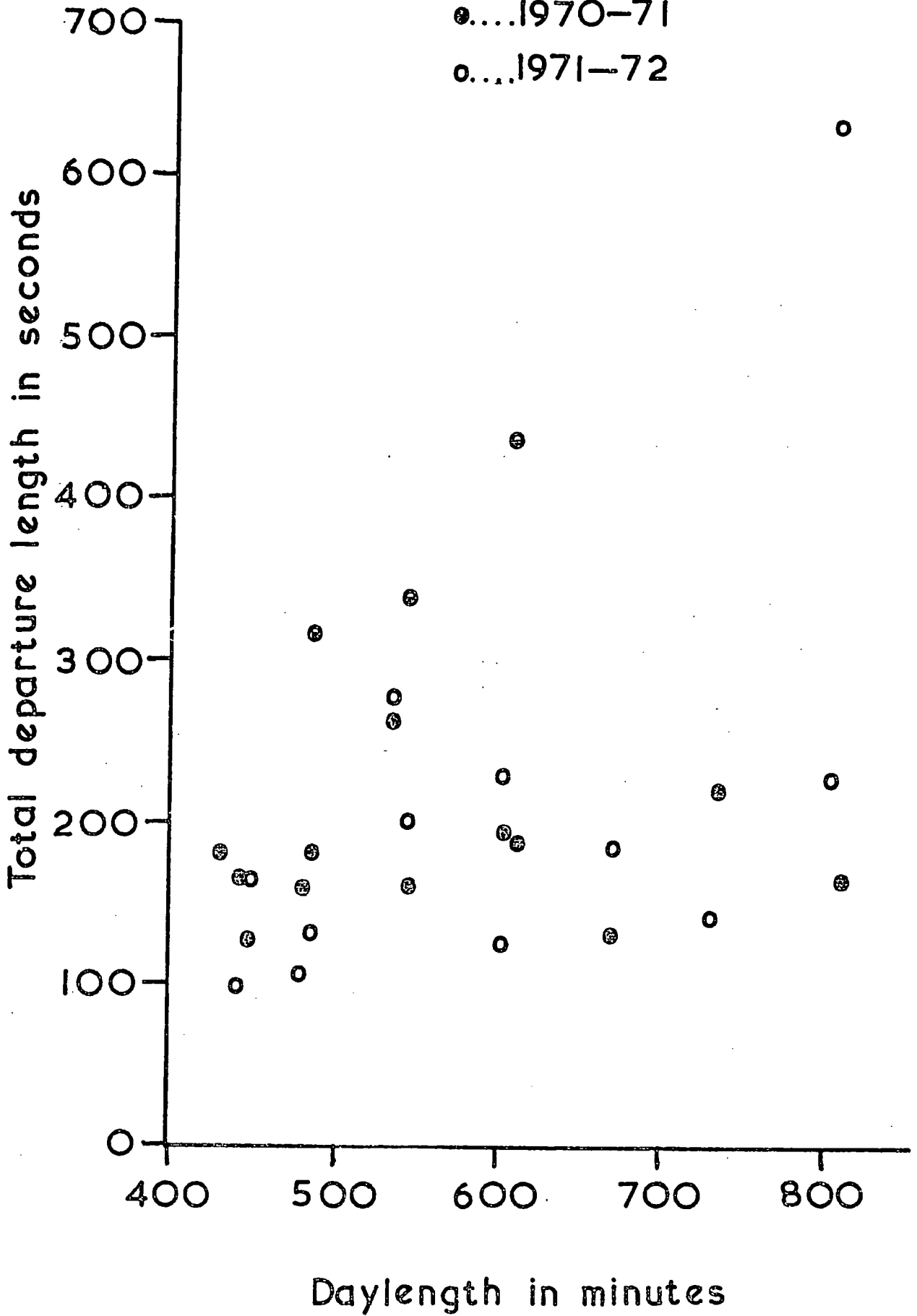

FIGURE 19

THE RELATIONSHIP BETWEEN MEAN DEPARTURE LENGTH (MEAN
FOR HALF MONTHLY PERIODS) AND ROOST SIZE.

$$r = 0.5406, n = 27, p < 0.01$$

$$\text{Slope} = 0.1695 \text{ (S.E.} = 0.0517\text{), Intercept} = 22.1236$$

Fig.19

●...1969-70

●...1970-71

○...1971-72

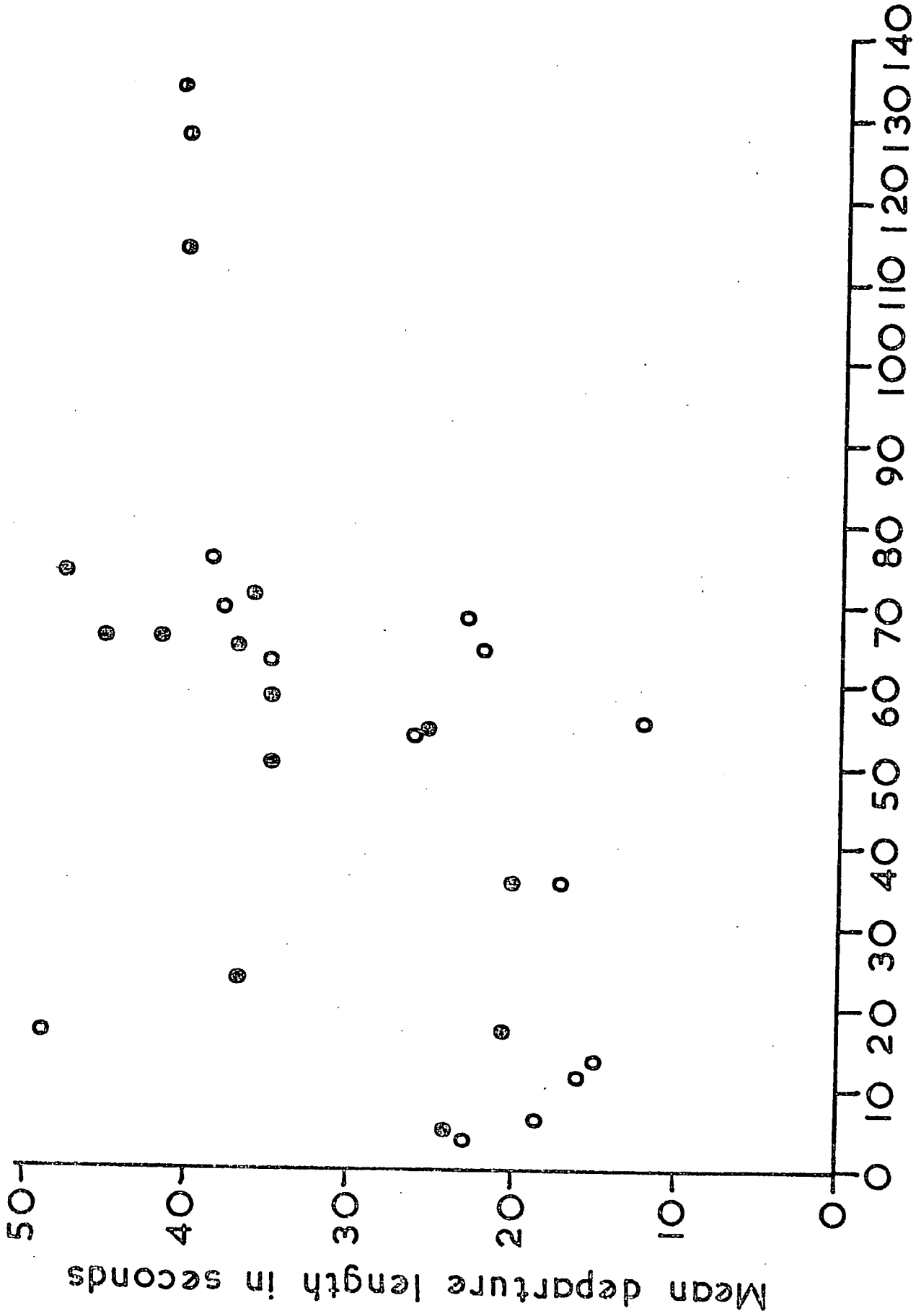

Roost size in thousands

FIGURE 20

THE PERCENTAGE FREQUENCY OF OCCURRENCE OF GAPS BETWEEN
DEPARTURE WAVES OF DIFFERENG LENGTHS FOR EACH MONTH.

Fig. 20

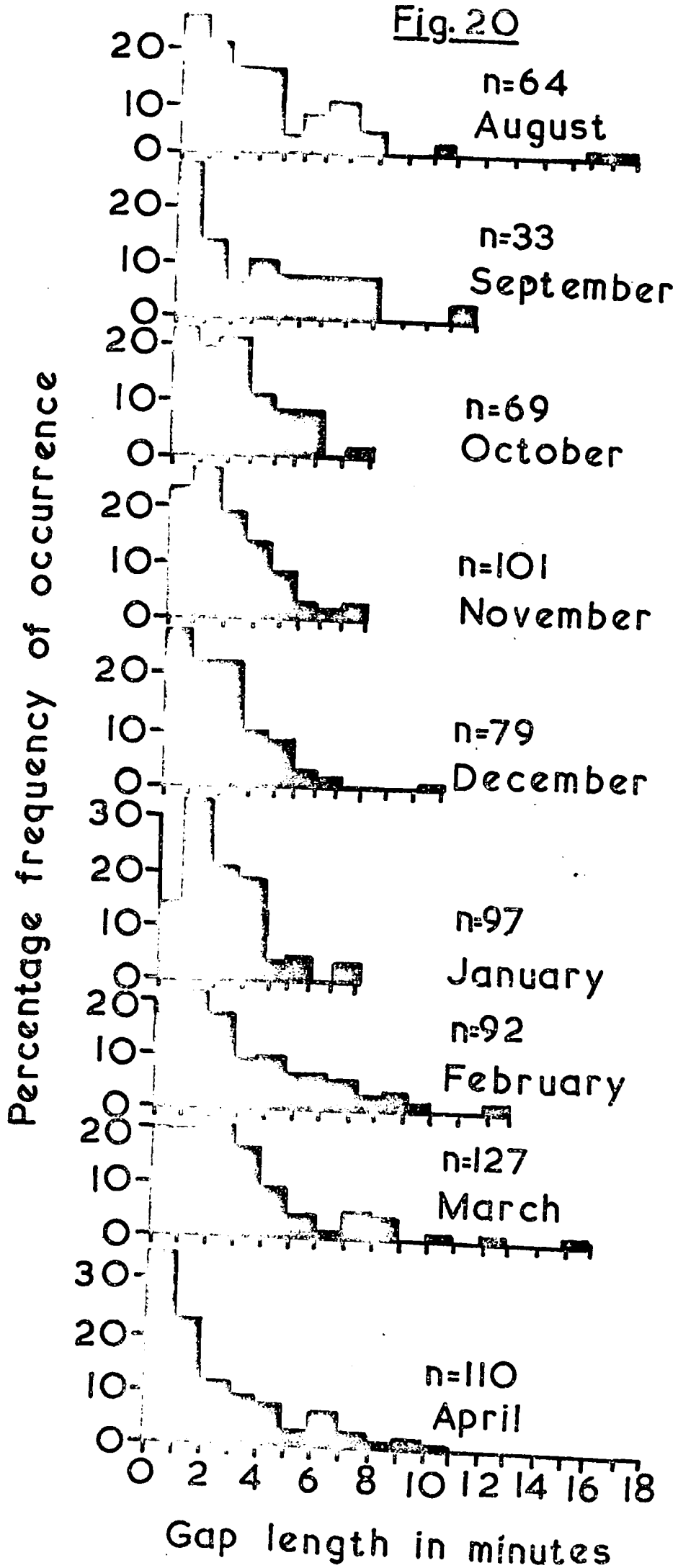

Long gaps were less frequent during the midwinter period. Similarly mean gap lengths for each gap number have been calculated for each month and are shown in Figure 21. The percentage frequency of occurrence of these gap numbers was similar to that shown in Figure 15 for departure number. Mean gap length becomes smaller and less variable towards midwinter. Neither total gap length, nor mean gap length, was correlated with roost size but Figures 22 and 23 show the corresponding significant relationships with daylength. Both declined with decreasing daylength.

4. Departure Composition

a. Age and Sex Composition

For two reasons the data in this section is limited. First, permission to shoot was refused for the Lambton roost; collection of birds was therefore confined to the Cheswick roost, between January and April, 1972. Secondly, because of the small size of the first few departures, no birds were shot from them. The later departures, being thicker, did, however, enable some birds to be collected, provided they were not vertically out of range. Shooting birds was therefore most successful on cloudy, windy days, when birds flying into wind did not gain height rapidly.

If the birds which left the roost early were in any way different from those which left later, then the sample shot in the mornings should be of different composition to the random "total" sample of the roost taken in the evening. The number of the birds shot leaving the roost in the morning which belonged to each age, sex and origin category are given in Table 25, for each date together with the sample size. Because the samples were small, the data have been

FIGURE 21

THE MEAN LENGTH OF SUCCESSIVE GAPS BETWEEN DEPARTURE WAVES
FOR EACH MONTH.

FIGURE 22

THE RELATIONSHIP BETWEEN TOTAL GAP LENGTH (MEAN FOR HALF MONTHLY PERIODS) AND DAYLENGTH (MINUTES BETWEEN SUNRISE AND SUNSET).

$$r = 0.6881, \quad n = 27, \quad p < 0.001$$

$$\text{Slope} = 0.0596 \text{ (S.E.} = 0.0123\text{)}, \quad \text{Intercept} = -116,3492$$

Fig. 22

●....1969-70

●....1970-71

○....1971-72

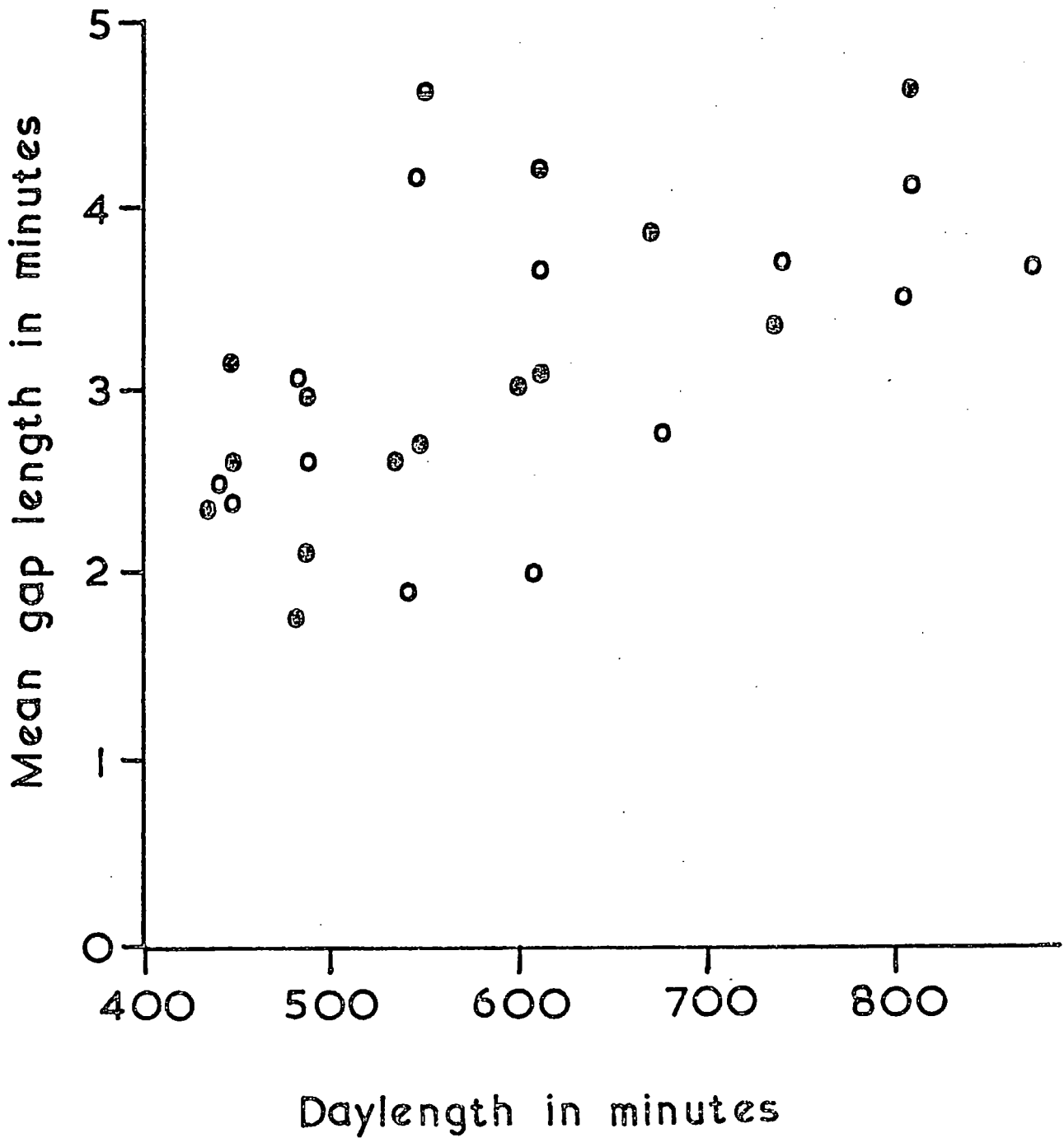

FIGURE 23

THE RELATIONSHIP BETWEEN MEAN GAP LENGTH (MEAN FOR HALF MONTHLY PERIODS) AND DAYLENGTH (MINUTES BETWEEN SUNRISE AND SUNSET).

$$r = 0.5908, n = 27, p < 0.01$$

$$\text{Slope} = 0.0037 \text{ (S.E.} = 0.0010\text{), Intercept} = 0.9329$$

Fig. 23

●...1969-70

●...1970-71

○...1971-72

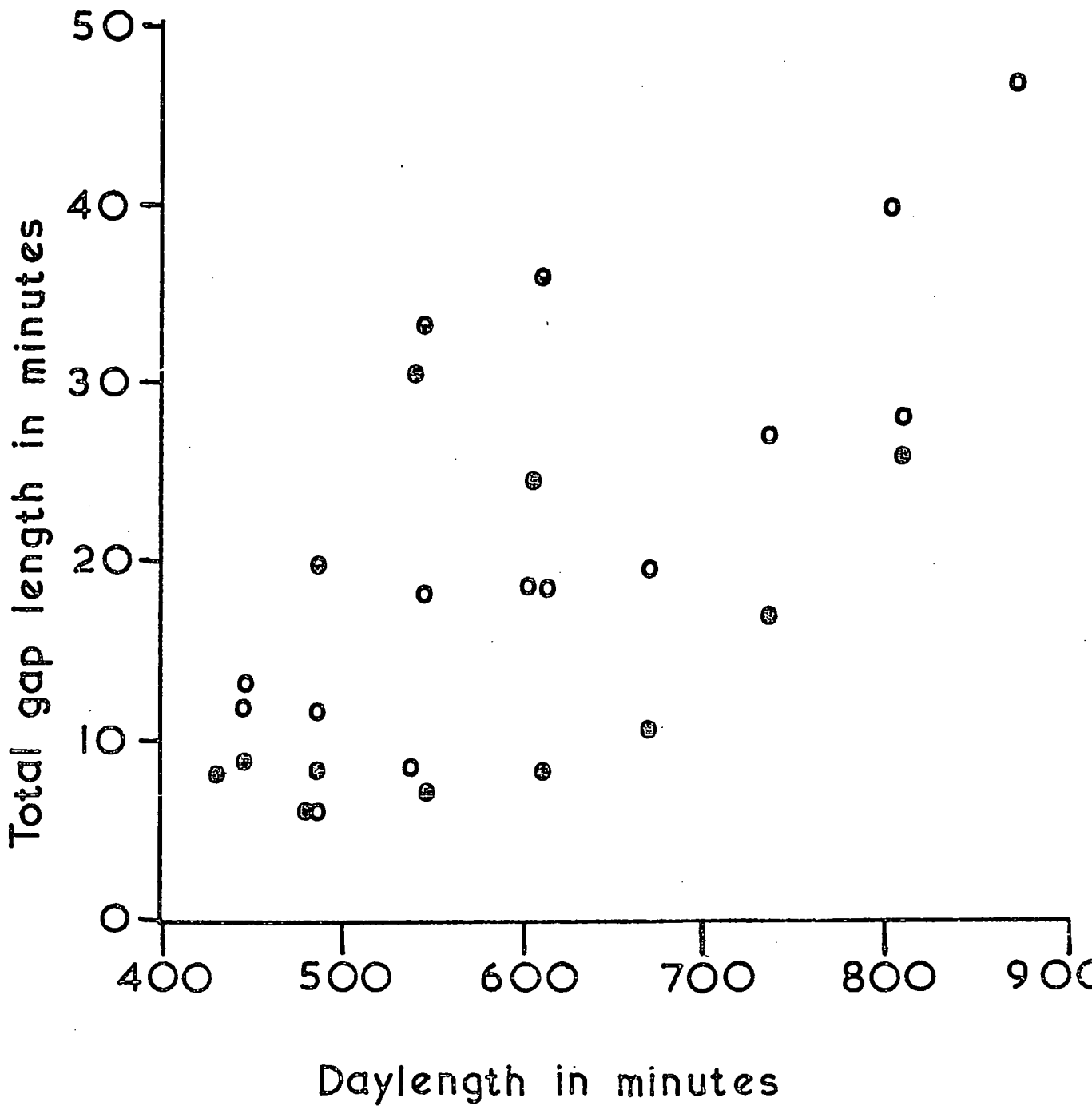

TABLE 25

THE TOTAL NUMBER OF STARLINGS SHOT AT THE CHESWICK ROOST IN THE MORNINGS, TOGETHER WITH THE NUMBER IN EACH AGE, SEX AND ORIGIN CATEGORY

Date	British adult male	Continental adult male	British adult female	Continental adult female	British juvenile male	Continental juvenile male	British juvenile female	Continental juvenile female	Total sample size
2.2.72	0	1	0	0	0	1	0	0	2
7.2.72	0	0	0	1	0	0	0	0	1
22.2.72	0	1	0	0	0	3	0	1	5
24.2.72	0	0	1	0	0	0	0	0	1
1.3.72	3	2	1	1	1	2	0	1	11
2.3.72	2	1	0	1	0	2	0	0	6
3.3.72	4	1	0	2	0	6	0	0	13
7.3.72	3	6	0	1	0	0	1	0	11
9.3.72	4	5	0	2	1	1	0	2	15
10.3.72	1	0	0	1	0	2	0	3	7
17.3.72	0	0	0	0	1	1	0	0	2
20.3.72	1	0	0	0	4	2	0	1	8
22.3.72	2	1	2	1	3	3	0	0	12
23.3.72	1	0	0	2	0	6	1	4	14
24.3.72	0	0	1	1	1	1	0	4	8
27.3.72	0	0	1	0	2	0	2	1	6
28.3.72	3	0	0	0	2	1	0	1	7
30.3.72	1	0	0	0	2	2	0	1	6
2.4.72	0	0	0	1	4	1	2	3	11
3.4.72	0	0	0	0	0	2	0	2	4

grouped for the purposes of comparison with evening samples.

The numbers of British and Continental Starlings shot during the morning departures each month are shown in Tables 26, 27 and 28, together with the corresponding evening values. No significant differences were found in the origin composition between morning and evening samples for the first two months. Neither were these months significantly different from each other (χ^2 , = 1.38, $p > 0.20$), nor as a two month sample from the corresponding evening sample (χ^2 , = 2.63, $p > 0.10$). A significant difference was, however, found in the proportion of the different origins in the last month. The percentage of Continentals being higher in the mornings; that is to say, relatively more British birds left the roost in the early departures.

Tables 29, 30 and 31 show a comparison of the age ratio of Continental birds shot morning and evening for the three months (since the evening ratio did not vary between months), together with the component monthly values. The differences in the overall ratio were due to an increased proportion of juveniles shot in the morning in the last month. Adults appeared to disperse from the roost earlier in the last month but not in the previous two months.

The proportion of adult and juvenile British Starlings shot each month are shown in Tables 32, 33 and 34. Again the last month showed an increased percentage of juveniles shot in the mornings compared with the evenings. A disproportionate number of adult British Starlings left the roost in the early departures of the last month.

The juvenile British sex ratio did not vary significantly in the roost as a whole through the sample period. Table 35,



TABLE 26

A COMPARISON OF THE PERCENTAGE OF CONTINENTAL AND BRITISH
STARLINGS SHOT MORNING AND EVENING AT THE CHESWICK ROOST
BETWEEN MID JANUARY AND MID FEBRUARY

Mid Jan. to mid Feb.	Morning	Evening	Total
% British	0.0	41.6	40.2
% Continental	100.0	48.4	49.8
Total	3	89	92
χ^2 *	2.09		
p	> 0.05		

* χ^2 calculated on the Null Hypothesis that
the proportion of British and Continental
Starlings shot morning and evening were
similar.

TABLE 27

A COMPARISON OF THE PERCENTAGE OF BRITISH AND CONTINENTAL
STARLINGS SHOT MORNING AND EVENING AT THE CHESWICK ROOST
BETWEEN MID FEBRUARY AND MID MARCH

Mid Feb. to mid Mar.	Morning	Evening	Total
% British	31.9	41.0	38.0
% Continental	68.1	59.0	62.0
Total	69	139	208
χ^2 *	1.63		
p	> 0.2		

* χ^2 calculated on the Null Hypothesis
that the proportion of British and
Continental Starlings shot morning
and evening were similar.

TABLE 28

A COMPARISON OF THE PERCENTAGE OF BRITISH AND CONTINENTAL
STARLINGS SHOT MORNING AND EVENING AT THE CHESWICK ROOST
BETWEEN MID MARCH AND MID APRIL

Mid Mar. to mid Apr.	Morning	Evening	Total
% British	46.7	65.4	58.8
% Continental	53.3	34.6	41.2
Total	75	136	211
χ^2 *	7.03		
p	< 0.01		

* χ^2 calculated on the Null Hypothesis that
the proportion of British and
Continental Starlings shot morning and
evening were similar.

TABLE 29

A COMPARISON OF THE AGE RATIO OF CONTINENTAL STARLINGS
 SHOT MORNING AND EVENING AT THE CHESWICK ROOST BETWEEN
 MID JANUARY AND MID FEBRUARY

Mid Jan. to mid Feb.	Morning	Evening	Total
% Adults	66.7	60.8	61.1
% Juveniles	33.3	39.2	38.9
Total	3	51	54
χ^2 *	0.04		
p	> 0.8		

* χ^2 calculated on the Null Hypothesis that
 the proportion of adult and juvenile
 Continental Starlings shot morning
 and evening were similar.

TABLE 30

A COMPARISON OF THE AGE RATIO OF CONTINENTAL STARLINGS SHOT
MORNING AND EVENING AT THE CHESWICK ROOST BETWEEN
MID FEBRUARY AND MID MARCH

Mid Feb. to mid Mar.	Morning	Evening	Total
% Adults	51.1	48.1	49.2
% Juveniles	48.9	51.9	50.8
Total	47	81	128
χ^2 *	0.10		
p	> 0.5		

* χ^2 calculated on the Null Hypothesis that
the proportion of adult and juvenile
Continental Starlings shot morning
and evening were similar.

TABLE 31

A COMPARISON OF THE AGE RATIO OF CONTINENTAL STARLINGS
SHOT MORNING AND EVENING AT THE CHESWICK ROOST BETWEEN
MID MARCH AND MID APRIL

Mid Mar. to Mid Apr.	Morning	Evening	Total
% Adults	14.0	37.5	26.4
% Juveniles	86.0	62.5	73.6
Total	43	48	91
χ^2 *	6.48		
p	< 0.02		

* χ^2 calculated on the Null Hypothesis that
the proportion of adult and juvenile
Continental Starlings shot morning and
evening were similar.

TABLE 32

A COMPARISON OF THE AGE RATIO OF BRITISH STARLINGS SHOT
MORNING AND EVENING AT THE CHESWICK ROOST BETWEEN MID
JANUARY AND MID FEBRUARY

Mid Jan. to mid Feb.	Morning	Evening	Total
% Adults	86.4	80.6	81.7
% Juveniles	13.6	19.4	18.3
Total	22	93	115
χ^2 *	0.39		
p	> 0.5		

* χ^2 calculated on the Null Hypothesis that the proportion of adult and juvenile British Starlings shot morning and evening were similar.

TABLE 33

A COMPARISON OF THE AGE RATIO OF BRITISH STARLINGS SHOT
MORNING AND EVENING AT THE CHESWICK ROOST BETWEEN MID
FEBRUARY AND MID MARCH

Mid Feb. to mid Mar.	Morning	Evening	Total
% Adults	87.4	80.7	82.3
% Juveniles	13.6	19.3	17.7
Total	22	57	79
χ^2 *	0.35		
p	> 0.5		

* χ^2 calculated on the Null Hypothesis that the proportion of adult and juvenile British Starlings shot morning and evening were similar.

TABLE 34

A COMPARISON OF THE AGE RATIO OF BRITISH STARLINGS SHOT
MORNING AND EVENING AT THE CHESWICK ROOST BETWEEN M I D
MARCH AND MID APRIL

Mid Mar. to mid Apr.	Morning	Evening	Total
% Adults	34.3	64.4	55.7
% Juveniles	65.7	35.6	44.3
Total	35	87	122
χ^2 *	9.16		
p	< 0.01		

* χ^2 calculated on the Null Hypothesis that
the proportion of adult and juvenile
British Starlings shot morning and
evening were similar.

TABLE 35

A COMPARISON OF THE JUVENILE BRITISH SEX RATIO OF STARLINGS
 SHOT MORNING AND EVENING AT THE CHESWICK ROOST
 BETWEEN MID JANUARY AND MID APRIL

Mid Jan. to mid Apr.	Morning	Evening	Total
% Males	80.8	75.5	77.3
% Females	19.2	24.5	22.7
Total	26	49	75
χ^2 *	0.27		
p	> 0.5		

* χ^2 calculated on the Null Hypothesis that the proportion of male and female juvenile British Starlings shot morning and evening were similar.

shows the total proportion of each sex shot in the mornings compared with that of the evenings. No significant difference could be detected. Similarly, the first two months adult British sex ratio has been combined and is shown, together with that for the last month, in Tables 36 and 37. No differences between the sex ratio of birds shot morning and evening could be detected.

Both adult and juvenile Continental sex ratios remained constant in the evening samples throughout the three months. The combined results of age ratio for all the samples are therefore shown in Tables 38 and 39, for both adult and juveniles respectively. In neither case did the ratio vary from that of the whole roost.

b. Weights

No significant differences in the weights of each age, sex and origin class of Starlings, shot in the mornings at Cheswick roost, were found during the three months. The results for all months have therefore been combined and the mean weight (\pm S.E.) is shown in Table 40 for each class of Starling. Comparison of these values with those for Starlings shot in the evenings (given in Table 12) indicate that all classes of Starlings bar British juvenile females were significantly lighter in the late morning departures. The comparison is, however, being made with evening shot birds with full stomachs. By morning Starlings have not only emptied their guts but have also metabolised some energy to maintain body temperature and function. Taitt (1973) gives the mean overnight loss in weight (excluding gut contents) of samples of Starlings shot morning and

TABLE 36

A COMPARISON OF THE SEX RATIO OF ADULT BRITISH STARLINGS
 SHOT MORNING AND EVENING AT THE CHESWICK ROOST BETWEEN
 MID JANUARY AND MID MARCH

Mid Jan. to mid Mar.	Morning	Evening	Total
% Males	89.5	84.0	85.1
% Females	10.5	16.0	14.9
Total	19	75	94
χ^2 *	0.36		
p	>0.5		

* χ^2 calculated on the Null Hypothesis that the proportion of male and female adult British Starlings shot morning and evening were similar.

TABLE 37

A COMPARISON OF THE SEX RATIO OF ADULT BRITISH STARLINGS
 SHOT MORNING AND EVENING AT THE CHESWICK ROOST BETWEEN
 MID MARCH AND MID APRIL

Mid Mar. to mid Apr.	Morning	Evening	Total
% Males	66.7	56.4	58.2
% Females	33.3	43.6	41.8
Total	12	55	67
χ^2 *	0.43		
p	>0.5		

* χ^2 calculated on the Null Hypothesis that
 the proportion of male and female adult
 British Starlings shot morning and
 evening were similar.

TABLE 38

A COMPARISON OF THE SEX RATIO OF ADULT CONTINENTAL STARLINGS
 SHOT MORNING AND EVENING AT THE CHESWICK ROOST BETWEEN MID
 JANUARY AND MID APRIL

Mid Jan. to mid Apr.	Morning	Evening	Total
% Males	58.1	63.6	62.2
% Females	41.9	36.4	37.8
Total	31	88	119
χ^2 *	0.30		
p	>0.5		

* χ^2 calculated on the Null Hypothesis that the proportion of male and female adult Continental Starlings shot morning and evening were similar.

TABLE 39

A COMPARISON OF THE SEX RATIO OF JUVENILE CONTINENTAL
STARLINGS SHOT MORNING AND EVENING AT THE CHESWICK
ROOST BETWEEN MID JANUARY AND MID APRIL

Mid Jan. to mid Apr.	Morning	Evening	Total
% Males	56.3	48.9	51.9
% Females	43.7	51.1	48.1
Total	64	92	156
χ^2 *	1.50		
p	>0.2		

* χ^2 calculated on the Null Hypothesis that
the proportion of male and female juvenile
Continental Starlings shot morning and
evening were similar.

TABLE 40

THE MEAN WEIGHT, IN GRAMS, OF STARLINGS SHOT
IN THE MORNINGS AT THE CHESWICK ROOST

	Adult British male	Adult Continental male	Adult British female	Adult Continental female	Juvenile British male	Juvenile Continental male	Juvenile British female	Juvenile Continental female
Mean	85.44	84.63	81.70	81.44	83.11	80.61	79.96	78.65
S.E.	4.00	4.71	3.26	3.46	4.33	5.49	9.92	5.46
n.	25	16	5	13	18	37	5	26

evening at a roost as 8.49 gms. If gut contents had been included this difference would have presumably been larger. The results presented here are well within the normal predicted overnight weight loss. There was therefore no evidence to suggest differences in condition between early and late departures, as might have been expected from Ward and Zahavi's theory of roost function (1973).

5. Dispersal to feeding grounds

Only 17 observations of departures flying over the feeding grounds were obtained. Due to the large differences in dates when these observations were made few conclusions can be drawn. If, however, the percentage of birds leaving departures for the four closest dates are examined, a certain consistency of pattern emerges (Figure 24).

The sites used at Cheswick (M.R. NU 014468) and Detchant (M.R. NU 090366) were one and seven miles from the Cheswick roost respectively. Each was a rich feeding site and almost always had Starlings feeding at it during the day. The Detchant site was a field, devoid of grazing in which sheep were fed on "artificial". That at Cheswick was a partly covered stockyard in which cattle were fed in a similar way. Neither site was on the same bearing from the roost focus and although this might account for some difference between the size of comparable departures, it is unlikely to have influenced the proportion of birds leaving each departure wave.

A larger proportion of birds dropped down to feed at the sample site further from the roost. From the third departure onwards almost no birds flew on directly to more distant feeding

FIGURE 24

THE PERCENTAGE OF STARLINGS LEAVING SUCCESSIVE DEPARTURE WAVES
TO FEED AT ONE AND SEVEN MILES FROM THE ROOST (CHESWICK AND
DETCANT RESPECTIVELY).

Fig. 24

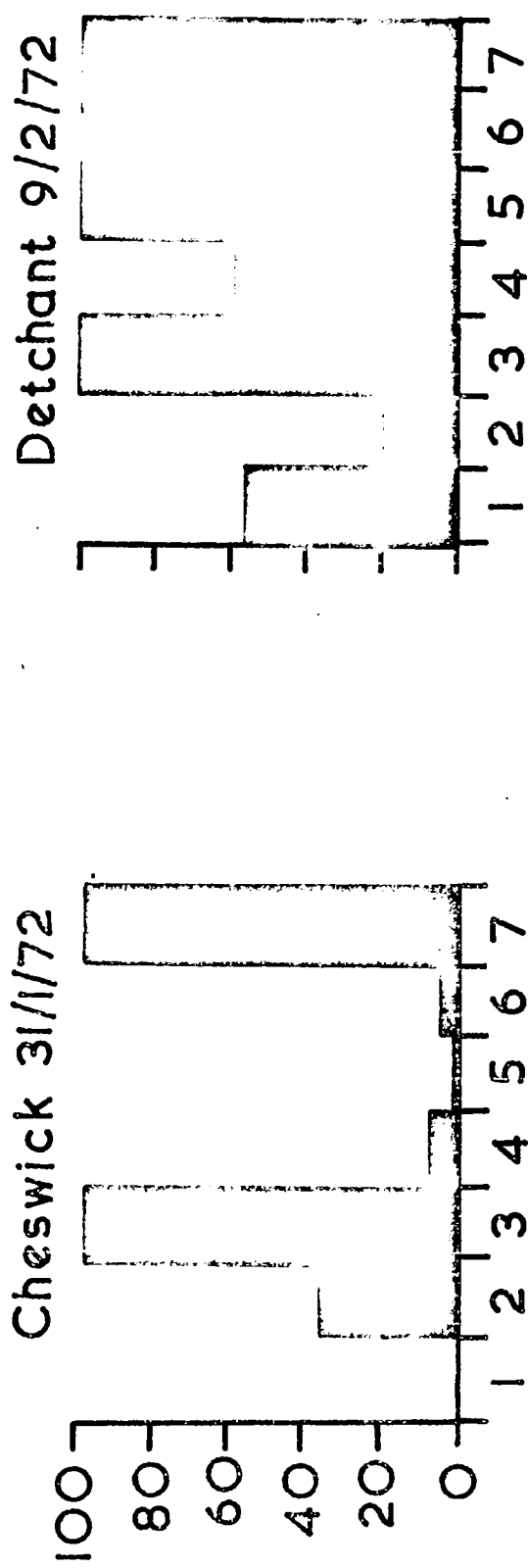
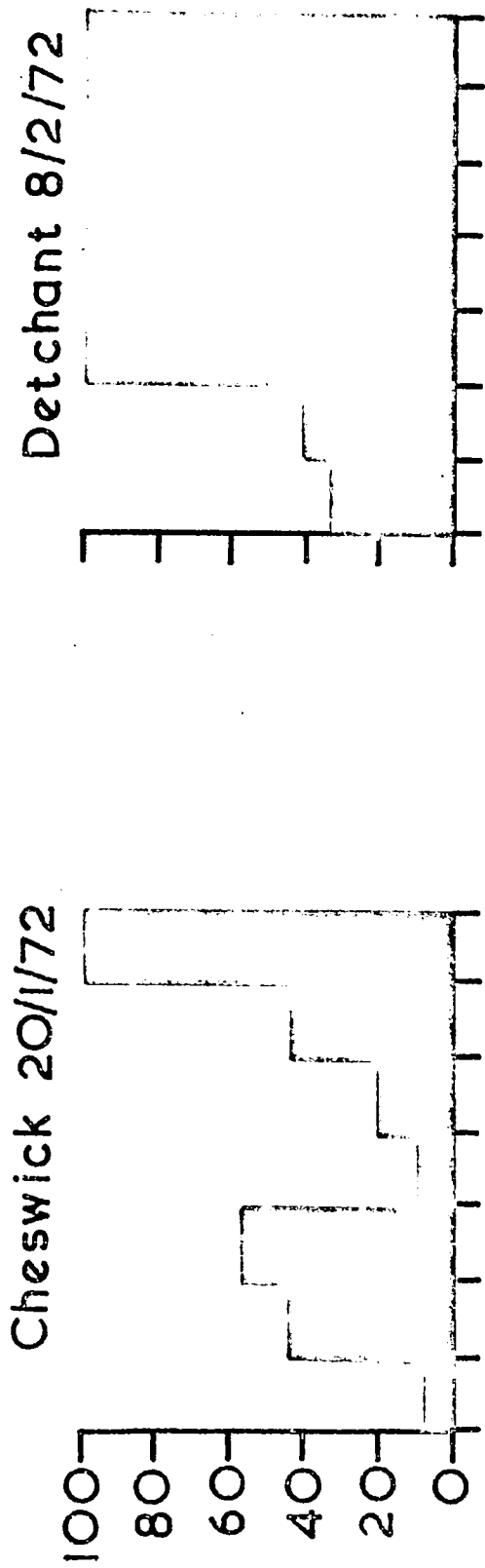

Departure wave number

Percentage of starlings leaving departure wave

grounds. At the near observation site all birds from the last departure stopped but few from the previous waves stopped to feed. On the 31 January all birds in the third departure wave stopped, It was, however, a very cold day. Under such conditions it is possible that a greater proportion of birds are likely to feed in the near ranges before continuing to more distant feeding grounds.

SECTION FOUR

DISCUSSION

The Starling has a highly developed communal roosting habit and therefore provides an opportunity to study the mechanics of social roosting. With one or two exceptions, the majority of previous information collected on the roosting behaviour of the Starling has been of a very qualitative nature. Before the more fundamental questions of the function and selective advantage of communal roosting can be approached a sound knowledge of roosting habits must be gained. This study has set out to collect basic information on the roosting behaviour of the Starling. Because of the size and catchment served by Starling roosts, and the major problems of observation and sampling these pose for one research worker, emphasis has been placed on the mechanics of roosting.

Although several people have speculated on the function of the behaviour of Starlings on arrival and entering their winter roosts, little of this is based on systematically collected information. For example, Symonds (1961) believed that the mode of roost entry adopted by Starlings was largely dependent on the size of the roost and thus the need to adopt an ordered entry. During this study the three methods of entry described by Symonds have been seen at both large (containing over 100,000 birds) and small roosts (containing under 1,000 birds).

The variation observed in the time at which the first Starling entered their roosts was correlated mainly with the time of year. Entry took place later, relative to civil twilight, during the midwinter period. Direct entries took place earlier (in terms of time relative to civil twilight) than preassembled entries, but at a lower light intensity. This showed that birds entering direct were 'late' relative to the light intensity. When preassembly occurred, Starlings entered

the roost later than on comparable evenings when no preassembly occurred, but at a higher light intensity. Preassembly was, perhaps, birds waiting for their light intensity threshold to be reached. Although feeding did, on occasions, take place in the preassembled flock, it did not seem to constitute a significant intake of food and birds usually merely rested. Similarly Peare, Dunnet and Patterson (1974) concluded that pre-roost gatherings of Rooks (Corvus frugilegus) were not primarily to feed.

The occurrence of preassembly in the Starling was closely linked with weather factors and thus the light regime. On clear evenings, when birds arrived at the roost at high light intensities (although possibly at a similar time to a dark evening), they first flew direct to the roost. If no other birds had entered, they then flew to join other flocks nearby, or formed their own preassembly. The height at which flocks flew over the roost was directly related to the light intensity: the darker it became, the lower birds flew and also possibly circled the roost. If flocks arrived and some birds had already entered the roost then they too entered. The noise emanating from an occupied roost seemed to be very important in determining the behaviour of arriving birds.

Preassembled birds usually formed large flocks and perched either on the tops of nearby trees or in open fields. Ward and Zahavi (1973) suggested that preassembly takes place to advertise the location of roosts. This seems rather unlikely in the Starling, since on dark evenings, when no preassembly took place, Starlings located the roost without difficulty. Moreover, the stepwise progression of flocks along regular flight lines to the roost and the traditional nature of many roost sites would seem to make advertisement unnecessary. Ward and Zahavi (1973) cite several cases where birds took up conspicuous

positions during preassembly; these positions do, however, seem to be those which would offer the best all round vision and therefore were the safest in terms of the early detection and avoidance of predators. Furthermore, the erratic flights of Starlings over and near the roost could be forms of "protean defence" as described by Humphreys and Driver (1967); Feare et al. (1974) were of the opinion that this was so with Rooks. Humphreys and Driver (1970) point out that these erratic flights could be advantageous even if no predators were apparently present, if the predators used surprise in their attacks.

One noticeable fact about the erratic flights of Starlings seen during this study was their concentration near to the roost site itself; frequently flocks would pass back and forth over the roost trees. In a situation where birds were present at the roost before some critical factor (possibly light intensity) was at the correct level to trigger entry, natural variation in the response of birds would be expected. Within one flock some birds would be ready to enter the roost, whilst others would not be so for several minutes. Given that individuals would also be influenced by the reactions of other birds in the flock, it is not difficult to envisage a situation in which the conflict between different groups of birds within a flock would produce a pattern of erratic flight between roost and preassembled birds. This was precisely the behaviour observed at roosts during this study.

The pattern of entry into the roost seemed largely dependent on weather conditions and thus on whether preassembly had taken place. The total duration of entry seemed to be influenced more by the time of year; entries in the middle of the winter took less time, despite containing more birds. The size of entering flocks was, however, very dependent on the occurrence of preassembly. On dark evenings birds entered in small flocks as they arrived, forming an almost continuous

stream of entries. In contrast, preassembled birds, which have arrived early, entered in large flocks.

During this study of Starling roosts, shifts in roost occupation from deciduous to coniferous trees have been observed. Similar changes in roost site were noted by Marples (1934). On the basis of questionnaires, he showed that the majority of roosts occupied in the autumn of 1932 were situated in deciduous trees, however, in the winter months which followed roosts in coniferous trees predominated ($\chi^2_1 = 12.55, p < 0.001$, Null Hypothesis that the proportion of roosts located in deciduous trees during the autumn and the winter were similar). Marples suggested that these changes in roost site were prompted by the seeking of more sheltered positions. The shifts in occupation observed in this study did occur approximately at the time of leaf fall and it might have been that, until this time, deciduous trees offered better insulation than conifers. This seems unlikely, since the gaps between Hawthorn (10 out of 12 autumn roosts) trees in roosts are usually large. Alternatively, it might have been because of their thorns and growth form, that Hawthorns offered good protection against predators, at least as long as leaves were present.

In December 1970 and 1971, at the Larbton and Cheswick roosts respectively, attempts were made to disperse the roosts. In both years, a small reduction in roost size was achieved but numbers soon recovered when scaring was abandoned. Both Elgy (1972) and Cameron-Wilson (1972) state that, provided scaring starts within one or two days of roost establishment, dispersal is feasible. Once established, considerable effort and expense is required to achieve satisfactory results. This is certainly borne out by attempts at disrupting these two roosts. At the Cheswick roost, brushing of one section of the plantation did deter Starlings from using that particular part. The temperature regime and shelter effect of the wood would have

changed and therefore influenced its suitability as a roost site.

In the early autumn of all three years of observation several small roosts were found. In the Durham area, in October 1969, the three roosts, at Croxdale, Sherburn and West Rainton, contained over 7,000 birds and in addition a further two small roost locations were known to exist. Since four of the roosts were later abandoned in favour of Croxdale, only part of the increase at the latter was due to the arrival of Continental birds. Similarly, for the other two years, at least part of the roosting population, of the major winter roosts, consisted of resident Starlings which had previously been using smaller local roosts. Besides the obvious similarities in the rate of build up of the Croxdale and Lambton roosts in 1969 and 1971 respectively, their ultimate sizes were of a very similar magnitude. In 1970 the build up at Lambton was far slower and only reached approximately half the size of the major winter roosts in the other two years. None of these roosts conformed to the patterns, of stable numbers or of a late summer peak, found by Potts (1967) at eight urban roosts. It might well be that urban roosts do not normally contain Continental birds (as has been demonstrated for the London roosts).

Symonds (1965) gives graphs of the build up and evacuation of a country roost at Felpham, Sussex, for the winters 1961-62, 1962-63 and 1963-64. A similar pattern of build up and evacuation has been found during this study but the period over which this change in roost size occurred was very different; the roost in Sussex was occupied for a far shorter period. Samples of Starlings shot in the evenings at the Cheswick roost (a random sample of the roosting population) showed birds of both British and Continental origin to be present in approximately equal numbers. Although it was not possible to demonstrate any weight differences between British and Continental Starlings of the same age and sex, the sex ratio of the two groups were very different.

The sample of adult British birds shot between mid January and mid March contained 84% males, but declined to 56% between mid March and mid April, presumably as males took up breeding territories. The sample of adult Continental Starlings, however, contained 64% males and did not change significantly in the three months. Although it is possible that the differential mortality between the sexes might be different for the two groups, it seems more likely that a differential migration of the sexes, as found in Blackbirds (Drost 1935, Krueger 1940), accounts for these differences. Similarly, the almost equal sex ratio in juvenile Continental birds (49% males), as compared with 76% males in the British juveniles, could be produced in the same way.

A relationship between roost size and the number of days it takes a roost to build up or evacuate was found by Symonds (1961, 1965). The number of days taken to evacuate the major winter roosts in the three winters of this study were 20, 41 and 30 days respectively. According to his relationship values of 14, 10 and 12 days would have been predicted. There seems to be no reason to believe that the relationship is of general application. Symonds derived his relationship from counts at several roosts during one winter. The rate of build up of major winter roosts probably depends on several factors. Factors such as: the period of time over which autumn leaf fall occurs and temporary roosts in deciduous trees are abandoned; and the timing and duration of the arrival of Continental migrants. may be important. Because of seasonal and regional variation in climate, it is unlikely that the rate of build up of roosts will be consistent from area to area or from year to year.

Little published information exists on the behaviour of Starlings within their roosts. Wynne-Edwards (1962) states (on the basis of one

albino bird observed by Dagnall-Oakley (1959)) that individual Starlings use the same perches each evening; this did not seem to be borne out by the limited observations made in this study. The actual position of the roost often varied from evening to evening and frequently whole trees, as well as perches, were not occupied on consecutive nights. Movement within a roost wood could have been due to changes in weather conditions, such as wind direction, which in turn changed the most sheltered position within the wood. It was not feasible to test this possibility. The distribution of Starlings, within each tree and within the roost site as a whole, changed as the birds settled to sleep. Starlings came closer together, moved towards the centre of trees and reduced the overall number of trees which they occupied. The fact that birds did not spread out more than was necessary could be taken to indicate that greater spreading of birds would have led to increased predation or energy loss.

The sequence of behaviour noted prior to sleeping, or after awakening, showed no special features related to social roosting and was similar to that expected for a solitarily roosting species. Spectral analysis of tape recordings of the noise created morning and evening confirmed the observation that some birds were singing. This singing, carried out by adult males morning and evening, appeared to have no function, since territorial establishment and defence took place away from the roost. A flight call of low frequency, was given early in the evening as flocks entered the roost. Much of the noise produced at Starling roosts was merely bickering between birds. This chattering and bickering continued, at a very reduced level, throughout the night, from which it can be concluded that some birds were sufficiently aware of danger to alert their neighbours.

Both Eastwood (1962) and Charman (unpublished) noted that noise always stopped being produced, by birds within the roost, when each

departure wave left the roost. This has again been observed in the present study, but the reason is still not fully apparent. The numbers of birds awake and calling would, of course, be greatly reduced when a departure wave occurred. However, many awake birds remained and the noise rapidly increased, such that this could not be explained solely by new birds waking and calling. Starlings already awake, calling and singing, but not destined to leave with the next departure wave, must have stopped vocalising and then restarted.

It has long been known that Starlings leave their communal roosts in discrete groups or departure waves (Wynne-Edwards 1929). Similar behaviour has been noted at large Quelea (Quelea quelea) roosts (Ward 1965). These clumps of birds, so to speak, could be interpreted in the same way as Krebs (1974) has interpreted the clumped dispersal of herons from their breeding colonies; namely that they represent birds following others to feeding grounds. They could, however, be interpreted in quite a different way. Within a population of Starlings responding to a simple light intensity or time trigger, one would expect there to be natural variation in the population and there to be a range of light, or time, over which they would respond. If onto this pattern one imposed a response to bird density, as one might expect in a species that flocked, such that birds already passed their threshold would delay departure until other birds were willing to leave. Yet other birds, not yet at their threshold would go before reaching their threshold, if others were already going. An oscillating departure pattern would result. At present insufficient information is available to test this hypothesis. However, the fact that birds return to the roost from the tail end of some departure waves, would suggest that they are not ready to depart. The observation that these birds then form the beginning of the next departure wave, would also support the latter, rather than the former, explanation.

Krebs (1974) found that neighbouring herons were more likely to leave the colony together for the feeding grounds. Similarly, it has been found that those Starlings which disperse radially within the roost and occupied the outer trees usually left together. These, however, are not necessarily adjacent roosting birds; in fact the presence of birds still asleep throughout the roost suggests that they are probably not neighbours. Moreover, individual flocks entering the roost at night do not appear to occupy one area of the roost but spread themselves out amongst other birds.

Lastwood, Isted and Rider (1962) attempted, with little success, to correlate the time the first departure wave left several Starling roosts with cloudcover. Cloudcover is, however, a poor index of light conditions, since equal amounts of different types of cloud can give totally different light regimes. In this study, the use of multiple regression techniques and a more realistic representation of the light regime has enabled 62.3% of the variation, in time of first departure, to be explained in terms of environmental factors.

Wynne-Edwards' (1962) analysis of Starling roost departures were based on measurements made some miles from the roost and, on these grounds, his conclusions related to the factors influencing departure do not seem to be justified. Towards midwinter the time of departure becomes earlier relative to civil twilight, this may, in part, be an attempt to compensate for the shorter daylength. Hamilton and Gilbert (1969) assumed this would be so but, in fact, found the reverse at a Starling roost in California and suggested that this could be for three reasons. (1) Feeding effort earlier in the winter could be successful in increasing fat reserves and therefore reduce subsequent energy requirements. (2) Food could become increasingly available. (3) Experience in feeding in an area permitted the requirement to be

obtained more rapidly. Their results seem to be the exception, since most other species studied do emerge from their roosts earlier when daylength is at its shortest (e.g. Dunnett and Hinde 1953).

Certain weather factors also had an influence on departure time, probably either by increasing overnight energy consumption or reducing food availability and thus necessitating a longer time in which to collect sufficient food. Similarly, Kuroda (1961) found that rising ambient temperature was correlated with early roost entry in the Grey Starling (S. cinereus).

The number of departures, their size and spacing, varied from day to day and the major factor which influenced this variation appeared to be daylength. During the midwinter months departures were fewer and ~~were~~, on average shorter, indicating that the behaviour was more closely synchronised. Since the sun rises at a greater angle to the horizon (i.e. nearer to the vertical) as the winter solstice approaches, light intensity will change more rapidly at this time of year. The time over which critical changes in light intensity occurred would be shorter and therefore the departure more synchronous.

From a comparison of the samples of birds shot from the late morning departures and a random sample from the whole roost, it was not possible to detect any general differences. The larger dispersal of adult male British birds in the early departures in the last month can be adequately explained in terms of breeding behaviour.

Boyd (1932) suggested that those Starlings which left the roost early flew to the more distant feeding ranges, but he gave no evidence for this belief. The limited data collected in this study did suggest that a greater proportion of early departures stopped at feeding ranges further from the roost when compared with closer ranges. The results are, however, far from conclusive. Hamilton and Gilbert (1969) present data to show that in-transit stops are longer on overcast days.

Similarity in the range of time over which Starlings arrived at different distances from the roost did not suggest departure waves flew different distances.

It can be seen from the above discussion that this study has filled some of the gaps in our knowledge of the roosting behaviour of the Starling.

The answer to the question "What is the function of communal roosting?" is neither simple nor certain. Several authors have expressed their views on the adaptive significance of this form of social behaviour and these will now be discussed, in the light of information gained during this study.

The choice of roost site and the grouping together of birds could serve to reduce heat loss and is undoubtedly an important factor in some species. For example, the groups of Wrens and Tree Creepers (both small species with high surface to volume ratios) found clustering together in holes and crevices during cold weather appear to be an adaptation to conserve energy and maintain body temperature. In the Starling, although birds cluster together linearly along perches, the dispersion of perches themselves means that the large distances between birds, in the other two planes, will negate any effect clustering will have on the ambient temperature of the roost. Under calm conditions the loss of heat vertically, and in windy conditions horizontally, would be considerable. Moreover, energy savings would have to be considerable when weighed against the additional expenditure of flying 30 kilometres or more to and from the roost. Similarly, Peare et al. (1974) point out that the dispersion of Rooks within their roosts makes it unlikely that they congregate for warmth. This, of course, does not mean that the roost site itself is not chosen on the basis of the shelter from the weather that it offers. Kalambach (1935), Howan (1938) and Delvingt (1961)

rightly considered temperature to be an important factor determining the precise location of winter roosts. Many apparently suitable roost sites are not used by Starlings and birds fly many miles to reach others which, to the human eye, are no different. However, in view of the occurrence of communal roosting in some tropical species (Ward 1965, Fogden 1970) and of Starlings in the late summer and early autumn it seems unlikely that energy conservation is the major selective advantage responsible for the widespread phenomenon of social roosting.

It has long been realised that flocking can increase the awareness of danger and reduce the individuals risk of predation. If, however, the aggregation is fixed in space for any length of time some of the anti-predator advantages of clumping are lost. Even when a clump of prey have been located by a predator it is still advantageous to remain in a group. Neill and Cullen (1974) have shown that the "capture time" of prey items by Pike (Essox luvius) was greater when the prey were in groups, they attribute this to confusion on the part of the predator. Alternatively, fear of collision (Tinbergen 1951) or the provision of cover by the group (Williams 1965, Hamilton 1971) could have been responsible. Starling roosts are used for considerable lengths of time without shifting site; predators will always know the location of a food source. Some have suggested, for this reason, that roosts attract predators. Harples (1934) quotes a case, of an estate in Devon, where Sparrow Hawks (Accipiter nisus) had previously been exterminated by keepers, but where a further 11 were shot in 25 days after a Starling roost was established. Ward and Zahavi (1973) correctly point out the striking anti-predator adaptations seen at roosts. They emphasise, however, that this does not indicate that the main function of social roosting is to reduce predation since solitary species often show similar adaptations.

It has been suggested, by Wynne-Edwards (1962), that communal

roosting performs certain social functions which have selection value. He believed that much of the behaviour of Starlings at their roosts functioned as a form of epideictic display. Most of the facts upon which this hypothesis is based do, however, have alternative, far simpler explanations. The occurrence of preassemblies and different modes of entry seem mainly to be a function of the light regime. The ancestral nature of many roosts, far from being a definite indicator of social function in roosting, is a type of conservatism common in many animal populations. Aerial displays near to the roost site could be of anti-predator function, or merely a product of natural variation in the response to critical factors. Similarly, the morning dispersal waves, emanating from roosts could result from the interacting influences of light intensity and bird density.

Lack (1968) has suggested that sociality in birds has evolved as a strategy for exploiting food resources. The grazing ungulates of the African plains, whose food tends to be unpredictable and patchily distributed, aggregate in large herds. Browsing species, whose food tends to be stable and uniformly scattered, live in small groups or pairs (Jarman 1974). In addition, two closely related species of monkey (Colobus badius and C. guereza) have been shown to have differing social organisations, which again reflect the spatial and temporal nature of the food supplies they utilise (Clutton-Brock 1974). The general correlation between flock feeding, on a patchily distributed food supply, and social roosting has led to the belief that communal roosting has also developed to enhance the efficient exploitation of food. This, of course, requires the roosting aggregation to have a positive influence on food finding. Ward and Zahavi (1973) have suggested a method by which certain gatherings of animals could operate as information centres. They believe that individuals that have been unsuccessful in searching for food follow successful individuals out of

the colony or roost on foraging trips. Their interpretation of the function of aerial displays and preassembly at roosts is open to question. The method of morning dispersal of roosts in the Starling, and several other species, does, however, offer the opportunity and mechanism by which information on food distribution and abundance, within a roost catchment, could be achieved. The fact that this study could not detect any differences in weight between early or late departures cannot be taken as evidence against the operation of the information centre hypothesis since sampling and comparison was difficult.

Similarly, the single occurrence of redirection during these observations is, perhaps, less than one might have expected if this was a major function of communal roosting. All three winters of the study were mild and it might well have been that snowcover and frosty conditions were not sufficiently severe, or prolonged, to limit food availability. Measurements, similar to those of this study, made over a period of several days cold weather may be all that is needed to demonstrate the differences in weight, and changes in direction of dispersion, required as evidence in support of Ward and Zahavi's hypothesis.

The adjustment of the distribution of Starlings, in relation to changes in food abundance, could occur not only within each roost catchment but also between different roosts. Ward and Zahavi do not propose a method by which information on food could be exchanged other than on a single roost catchment basis; neither has this study thrown any light on the way this might be achieved. It is interesting to note, however, that radar films have revealed migrant Starlings returning to the Continent direct from roosts (Eastwood 1962). These migrational departures took the form of a series of departure waves leaving the roost in one direction. Cold weather movements might well also take place direct from the roost itself; however the basis on which the decision

on the timing and direction in which to move to new feeding grounds is unknown.

It is now possible to point out four major areas which warrant further investigation.

A logical consequence of the "information centre" hypothesis is that birds that leave roosts early should be heavier than those which follow them. The comparison of weights in this study was rather unsatisfactory. With more time and effort, it should be possible to make a better comparison and to develop methods of obtaining large samples from early and late sections of individual departure waves.

In order to discover more about any differential dispersion of departure waves it would be necessary to carry out simultaneous observations at several ranges from the roost focus. Moreover, such monitoring would enable the effect of changing distribution of food (both natural and artificial) to be related to any changes which might occur in the departure pattern.

Because of the nature of most rural roosts, it is not feasible to study behaviour within the roost. Urban roosts in which Starlings perch linearly along ledges would, however, seem to offer a good opportunity to examine in detail the interactions between birds and changes in their behaviour. If the roost chosen was sufficiently small, or if a group could be established in a large aviary, it would be feasible to mark and watch known birds within a roost.

Shooting or trapping Starlings at a variety of roosts and classifying the samples on the basis of age, sex and origin would give a great deal of information on the distribution of Continental Starlings in Great Britain. It is not known whether Continentals form their own roosts at all or if there is a general mixing with the resident population. It appears that urban roosts may be composed solely of

residents. Collection of samples from several sites could quickly confirm, or reject, this possibility.

The knowledge gained during this study has been examined in relation to Ward and Zahavi's "information centre" hypothesis of communal roost function. Several areas exist in which their interpretation of facts seems to be suspect and alternative explanations appear more likely. These points are, however, minor and do not contradict their main theme. The results of this study, although not of positive support, do not lend any weight to the rejection of their hypothesis.

REFERENCES

- ANONYMOUS. (1966) 'The Starling'. Ministry of Agriculture, Fisheries and Food. Advisory leaflet No. 208.
- ARMSTRONG, E.A. (1955) 'The Wren'. London: Collins.
- BAGNALL-OALELEY, R. P. 'The Egmore Starling roost'. Norfolk Bird Rep., 1958: 22-24.
- BERTHOLD, P. (1968) 'Die Massenvermehrung des Stars in fortpflanzungs-physiologischer'. J. Orn., 109: 11-16.
- BOYD, A. D. (1932) 'A Great Cheshire Starling roost in 1930'. N. West. Nat., 7: 10-18.
- BROUGH, T. (1969) 'The dispersal of Starlings from woodland roosts and the use of bio-acoustics'. J. appl. Ecol., 6: 405-410.
- CAMERON-WILSON, A. (1972) 'Starling roost dispersals in forestry'. Q. Jl. For. 66: 4.
- CHARMAN, K. (Unpublished) 'Some aspects of the roosting behaviour of Starlings'. Hons. Thesis, Edinburgh University.
- CLUTTON-BROCK, T. H. ⁽¹⁹⁷⁴⁾ 'Primate social organisation and ecology'. Nature. Lond., 250: 539-542.
- CRAMP, S., PARRINDER, E. R. and RICHARDS, B.A. (1957) 'The birds of the London area since 1900'. London: Collins.
- CROOK, J. H. (1960) 'Studies on the social behaviour of *Quelea* in French West Africa'. Behaviour, 16: 1-55.
- CROOK, J. H. (1965) 'The adaptive significance of avian social organisations'. Symp. zool. Soc. Lond., 14: 181-218.
- DAVIES, J. L. (1949) 'The breeding status of the Starling in west Wales'. Brit. Birds, 42: 369-375.
- DAVIS, G. J. and LUSSENHOP, J. F. (1970) 'Roosting of Starlings: a function of light and time'. Anim. Behav., 18:362-365.
- DELVINGT, W. (1961) 'Les dortoirs d'étourneaux, de Belgique en 1959-60'. Gerfaut, 51: 1-27.

- DELVINGT, W. (1963) 'Rhythme quotidien des activites de l'etourneau au dortoir'. Gerfaut, 53: 489-507.
- DROST, R. (1935) 'Ueber das Zahlverhältnis von Alter und Geschlecht auf den Herbst-und Frühjahrszuge'. Vogelzug, 6: 177-182.
- DUNNETT, G. E. and HINDE, R. E. (1953) 'The winter roosting and awakening behaviour of captive Great Tits'. Br. J. Anim. Behav., 1: 91-95.
- DUNNETT, G. M. (1955) 'The breeding of Starlings in relation to their food supply'. Ibis, 97: 619-661.
- DUNNETT, G. M. (1956) 'The autumn and winter mortality of Starlings, in relation to their food supply'. Ibis, 98: 220-230.
- D'URBAN, W. S. M. and MATHEW, M.A. (1895) 'The birds of Devon', London.
- EASTWOOD, E. (1962) 'Radar observations of bird movements'. Proc. R. Inst. Gr. Br., 176: 101-117.
- EASTWOOD, E., ISTEAD, G. A. and RIDER, G. C. (1962) 'Radar ring angels and the roosting behaviour of Starlings'. Proc. R. Soc. B., 156: 242-267.
- ELDER, G. (1957) 'Some persistent ring echoes on high powered radar'. Proc. 6th Weath. Radar Conf., Camb. Mass., 281-286.
- ELGY, D. (1972) 'Starling roost dispersals in forestry'. Q. Jl. For., 66: 3.
- EFINAS, A. (1878) 'Des Sociétés animales'. Paris.
- FEARE, C. J., DUNNETT, G. M. and PATTERSON, I. J. (1974) 'Ecological studies of the Rook in north-east Scotland: food intake and feeding behaviour'. J. appl. Ecol., 11: 867-897.
- FOGDEN, M. P. L. (1970) 'Some aspects of the ecology of bird populations in Sarawak'. D. Phil. thesis, Oxford University.
- GOODACRE, M. J. (1959) 'The origin of winter visitors to the British Isles'. Bird Study, 6: 180-192.
- GOSS-CUSTARD, J. D. (1970) in 'Social behaviour of birds and mammals' (ed. J. H. Crook), pp. 3-35. Academic Press.

- HAMILTON, W. D. (1971) 'Geometry for the selfish herd'. J. theor. Biol.
31: 295-311.
- HAMILTON, W. J. III, and GILBERT, J. M. (1969) 'Starling dispersal from
a winter roost'. Ecology, 50: 886-898.
- HARTBY, E (1969) 'The calls of the Starling'. Dansk orn. Foren. Tidsskr.,
62: 205-230.
- HARVE-BROWN, J. A. (1895) 'The Starling in Scotland, its increase and
distribution'. Ann. Scot. nat. Hist., 1895: 26-28.
- HUMPHREYS, D. A. and DRIVER, P. M. (1967) 'Erratic display as a device
against predators'. Science, 156: 1767-1768.
- HUMPHREYS, D. A. and DRIVER, P. M. (1970) 'Protean defence by prey
animals'. Oecologia, 5: 255-302.
- JARLAN, P. J. (1974) 'The social organisation of antelope in relation
to their ecology'. Behaviour, 48: 215-268.
- KALAMBACH, E. R. (1932) 'Winter Starling roosts in Washington'.
Wilson Bull., 44: 65-74.
- KESSEL, B. (1957) 'A study of the breeding biology of the European
Starling in North America'. Am. Midl. Nat., 58: 257-331..
- KREBS, J. R., MacROBERTS, M. H. and CULLEN, J. M. (1972) 'Flocking and
feeding in the Great Tit-an experimental study'.
Ibis, 114: 507-530.
- KREBS, J. R. (1974) 'Colonial nesting and social feeding as strategies
for exploiting food resources in the Great Blue Heron'.
Behaviour, 51: 99-134.
- KRUEGER, C. (1940) 'Nordiske Solsorters forekomst og traek'.
Dansk orn. Foren. Tidsskr., 34: 114-153.
- KRUUK, H. (1972) 'The Spotted Hyena'. Chicago University Press.
- KURODA, N. (1961) 'The roosting behaviour and the influencing factors
in the Grey Starling'. Jap. J. Ecol. 11: 26-34.
- LACK, D. (1954) 'The natural regulation of animal numbers'. Oxford.
- LACK, D. (1968) 'Ecological adaptations for breeding in birds'.
London: Methuen.

- LAZARUS, J. (1972) 'Natural selection and the function of flocking in birds: a reply to Murton'. Ibis. 114: 556-558.
- LIGDA, G. (1958) 'Radar observations of Red-winged Blackbird flights'. Tex. J. Sci., 10: 3.
- LÖERL, H. (1955) 'Schlafgewohnheiten der Baumläufer und anderer Kleinvögel in kaltern Wintermächten'. Vogelwarte, 18: 71-76.
- MARPLES, B. J. (1932) 'Starling roosts and flight lines near Oxford'. Brit. Birds, 25: 314-318.
- MARPLES, B. J. (1934) 'Winter Starling roosts of Great Britain'. J. Anim. Ecol. 3: 187-203.
- MURTON, R. K. (1968) In 'The problems of birds as pests' (ed. R. K. Murton and E. N. Wright), pp. 157-169. London.
- MURTON, R. K. (1971) 'Why do some birds species feed in flocks?' Ibis, 113: 534-536.
- NEILL, S. R. St. J. and CULLEN, J. M. (1974) 'Experiments on whether schooling by their prey affects the hunting behaviour of cephalopods and fish predators'. J. zool. Lond., 172: 549-569.
- POTTS, G. R. (1967) 'Urban Starling roosts in the British Isles'. Bird Study, 14: 25-42.
- POWELL, G. V. N. (1974) 'Experimental analysis of the social value of flocking by Starlings in relation to predation and foraging'. Anim. Behav., 22: 501-505.
- ROWAN, W. (1938) 'London Starlings and the seasonal reproduction in birds'. Proc. zool. Soc. Lond. A., 108: 51-77.
- SCHALLER, G. (1972) 'The Serengeti Lion'. Chicago University Press.
- SYMONDS, A. E. J. (1961) 'The counting of Starlings at country roosts'. Bird Study, 8: 185-193.
- SYMONDS, A. E. J. (1965) 'The rate of build-up and evacuation of country roosts and the effect of severe winter conditions on these procedures'. Bird Study, 12: 8-16.
- TAITT, M. J. (1973) 'The winter food and feeding requirements of the Starling'. Bird Study, 20: 226-236.

- TINBERGEN, N. (1951) 'The study of instinct'. Oxford University Press.
- WARD, P. (1965) 'Feeding ecology of the Black-faced Dioch in Nigeria'.
Ibis. 107: 173-214.
- WARD, P. (1972) 'The functional significance of mass drinking flights
by Sandgrouse: Pteroclididae'. Ibis, 114: 533-536.
- WARD, P. and ZAHAVI, A. (1973) 'The importance of certain assemblages
of birds as "information-centres" for food finding'.
Ibis, 115: 517-534.
- WILLIAMS, G. C. (1965) 'Measurement of consociation among fishes
and comments on the evolution of schooling'. Mich. St.
Univ. Mus. Publs. Biol. Ser. 2: 349-384.
- WYNNE-EDWARDS, V. C. (1929) 'The behaviour of Starlings in winter: an
investigation of the diurnal movements and social roosting
habit'. Brit. Birds, 23: 138-153, 170-180.
- WYNNE-EDWARDS, V. C. (1931) 'The behaviour of Starlings in winter'.
Brit. Birds, 24: 346-353.
- WYNNE-EDWARDS, V. C. (1962) 'Animal dispersion in relation to social
behaviour'. Edinburgh.

APPENDIX I

Range changing equipment for light intensity measurement

In order to reduce the number of tasks required of the observer an automatic light monitoring system was developed. This consisted basically of a 24 volt, two channel (one channel used for light intensity, one for noise level), Rustrack chart recorder (maximum scale deflection 8.4mV.) and the light sensitive head of an Eel Photometer. The range over which it was necessary to make measurements of light intensity and the sensitivity required necessitated the construction of a complex triple scale relay system. It was essential that this relay system would operate in both directions such that increasing or decreasing light intensities could be recorded. The diagram overleaf shows in detail the scale changing relay circuitry.

The most sensitive scale recorded, via R_1 , the potential difference across the photometer head. As light intensity increased a photo-conductor activated the range relay, bringing the shunt resistor (R_2) into the circuit. This made the recorder less sensitive. Further increases in light intensity activated an additional range relay through a further photo-conductor and brought shunt resistor R_3 into the circuit making the recorder even less sensitive. Adjustment of resistors R_1 , R_2 and R_3 enabled each individual scale sensitivity to be varied and in each case R_6 set the light level at which each relay would operate.

APPENDIX I (Contd.)

THE CIRCUIT DIAGRAM OF THE AUTOMATIC RANGE CHANGING
EQUIPMENT DEVELOPED TO RECORD LIGHT INTENSITY

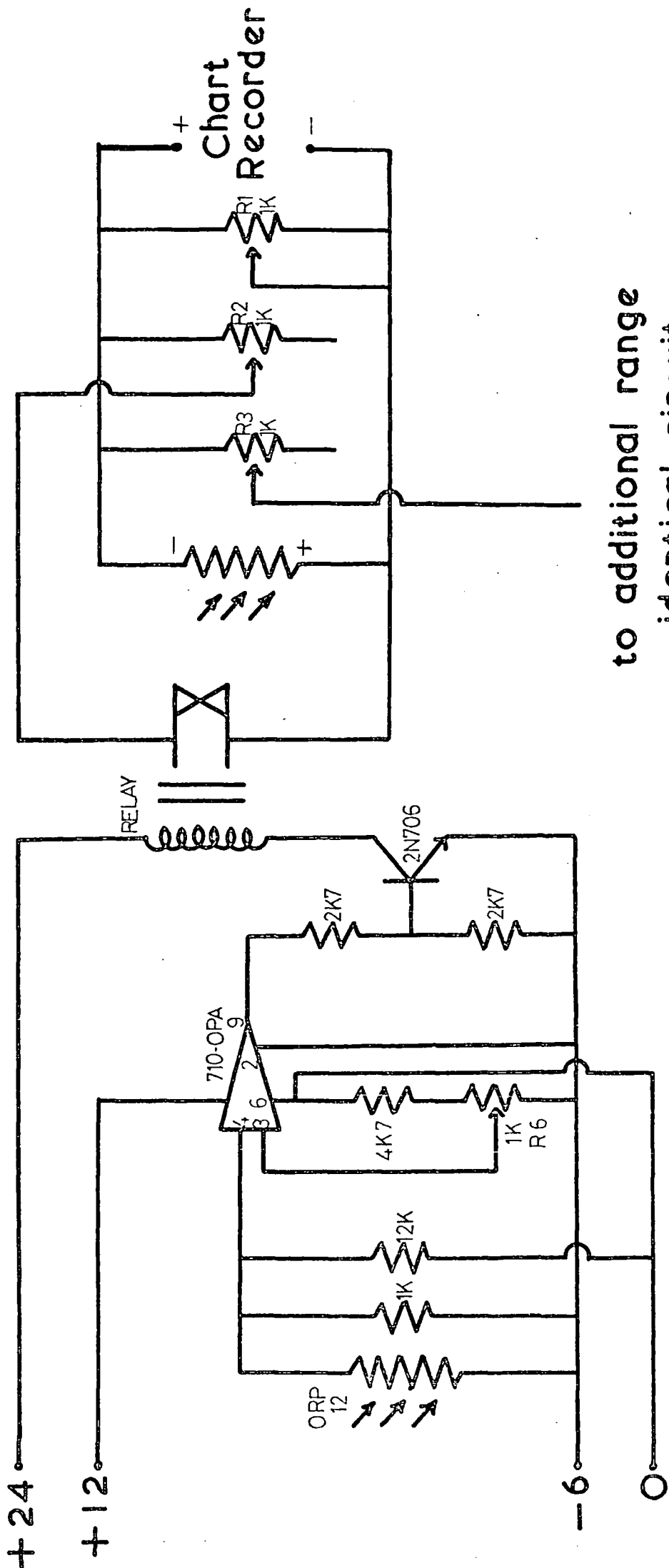

to additional range
identical circuit

APPENDIX II

The microphone/amplifier equipment for noise level recording

With the second channel of the Rustrack chart recorder it was intended to monitor noise levels. The signal from a dynamic microphone was converted to give a 0-1mA. D.C. signal by means of a battery operated audio amplifier. The diagram overleaf shows in detail the circuitry used. Unfortunately the system developed was not sufficiently sensitive to detect the noise produced at the Starling roosts studied. More sensitive equipment would have been expensive to produce.

Appendix II (Contd.)

THE CIRCUIT DIAGRAM OF THE MICROPHONE/AMPLIFIER
EQUIPMENT DEVELOPED TO RECORD NOISE LEVEL

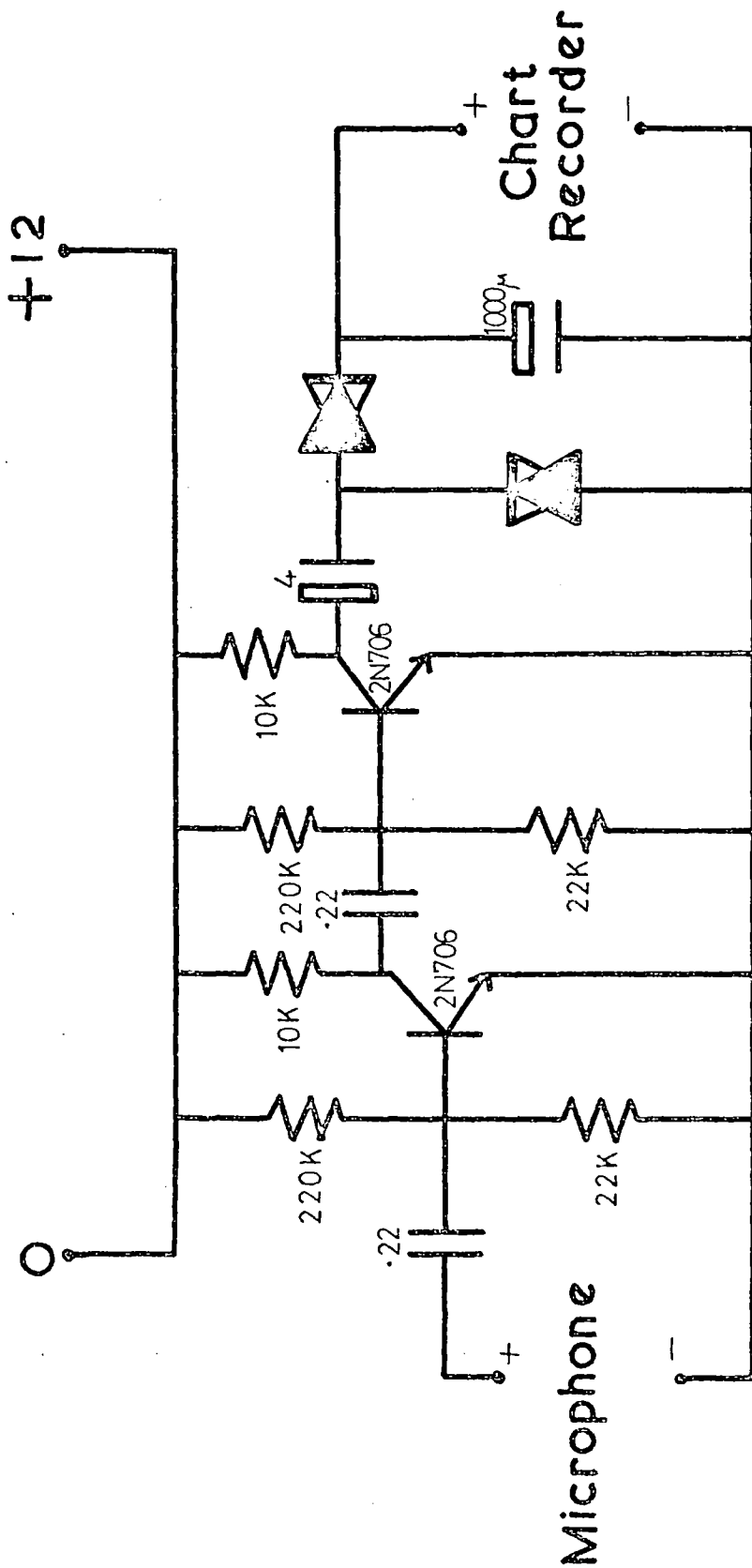

DURHAM UNIVERSITY
 12 JAN 1978
 SECTION
 LIBRARY