

Durham E-Theses

Urban planning: storage and processing of geotechnical data

John C. Cripps

How to cite:

Cripps, John C. (1977) Urban planning: storage and processing of geotechnical data. Doctoral thesis, Durham University.

Use policy

The full-text may be used and/or reproduced, and given to third parties in any format or medium, without prior permission or charge, for personal research or study, educational, or not-for-profit purposes provided that:

- a full bibliographic reference is made to the original source
- a <https://etheses.durham.ac.uk/id/eprint/8291/> is made to the metadata record in Durham E-Theses
- the full-text is not changed in any way

The full-text must not be sold in any format or medium without the formal permission of the copyright holders.

Please consult the [full Durham E-Theses policy](#) for further details.

Urban Planning : Storage and Processing of
Geotechnical Data

by John Canning Cripps, B.Sc., M.Sc.

The copyright of this thesis rests with the author.
No quotation from it should be published without
his prior written consent and information derived
from it should be acknowledged.

A thesis submitted for the degree of Ph.D. to the
Department of Geological Sciences, University of
Durham, May, 1977.



CONTENTS

	<u>Page</u>
Title	1
Contents	ii
List of Figures	iv
List of Tables	ix
List of Plates	xi
Declaration and Statement of Copyright	xii
Abstract	xiii
Acknowledgements	xiv
CHAPTER 1 Introduction - A Brief Consideration of Planning for Urban Development	1
1.1 Aims of Planning	1
1.2 Development Restraints	2
1.3 Urban Models	5
1.4 Geotechnical Engineering in Urban Development	8
CHAPTER 2 Decisions in Planning	13
2.1 Criteria Used in Decision Making	13
2.2 Applied Cost Benefit Analysis	15
2.3 Economics of Tunnelled Urban Roads	21
2.4 Planning Urban Development	29
CHAPTER 3 Geotechnical Site Investigation in Urban Development	42
3.1 Development of the Urban Plan	42
3.2 Geotechnical Site Investigation	47
3.3 Planning Site Investigation	49
3.4 Geotechnical Planning Process	52
CHAPTER 4 Application of Probability Concepts in Geotechnical Engineering	57
4.1 Problems Associated with the Organisation of Site Investigation	57
4.2 Probability Approach in Site Investigation	59
4.3 Probability Distributions	64
4.4 Expected Value of Utility	70
4.5 Merits of Sampling	73
4.6 Modified Investigation Procedure	76

	<u>Page</u>	
CHAPTER 5	Consideration of Geotechnical Data Storage	81
5.1	The Case for Data Storage	81
5.2	The Data Available for Storage	81
5.3	Presentation of Geotechnical Data	83
	5.3.1. Geotechnical Maps	84
	5.3.2. Geotechnical Plans	85
	5.3.3. Geotechnical Models of a Physical Character	86
5.4	Methods of Data Storage	86
5.5	The Financing of a Storage Facility	89
5.6	Concluding Remarks	89
CHAPTER 6	Preface to Data Processing by Computer	94
6.1	Type of Storage System	94
6.2	Computer Facility	95
6.3	<u>Geosys</u>	96
6.4	Operation of <u>Geosys</u>	97
	6.4.1 End Execution	100
	6.4.2 Data Input or Change Units Option	101
	6.4.3. Data Output or Map Plotting Option	101
CHAPTER 7	Geotechnical Data Storage with <u>Geosys</u>	104
7.1	Introduction	104
7.2	Option Specification for Data Storage	105
7.3	Data Preparation	107
7.4	Storage Operation	108
CHAPTER 8	Geotechnical Data Retrieval from <u>Geosys</u>	127
8.1	Styles of Presentation	127
	8.1.1 Tabular Output	128
	8.1.2 Site Investigation Output	128
	8.1.3 Map Output	129
8.2	Option Specification for Data Retrieval	129
8.3	Retrieval Operation	130
	8.3.1 <u>Outp1</u>	132
	8.3.2 <u>Outp2</u>	133
	8.3.3 <u>Outp3</u>	133

	<u>Page</u>	
CHAPTER 9	Geotechnical Data Presented in Three Dimensions	148
9.1	Introduction	148
9.2	Contoured Map	148
9.3	Physical Model	154
9.4	Conclusions on the Value of <u>Geosys</u>	157
CHAPTER 10	Use of <u>Geosys</u> Output in the Economic Appraisal of a Site Investigation	167
10.1	Introduction	167
	10.1.1 The problem to be Considered	167
10.2	Geotechnical Situation	169
	10.2.1 Regional Geology	169
	10.2.2 Site Geology	170
10.3	Consideration of Excavation Heave	172
	10.3.1 Swelling Data	173
	10.3.2 Consolidation Data	175
10.4	Assessment of Data	177
	10.4.1 Economic Analysis	178
	10.4.2 Discussion of the Results of the Economic Analysis	182
10.5	Conclusion	184
CHAPTER 11	Urban Planning in the light of Accessible Geotechnical Data - a conclusion	206
11.1	Pertinence of Engineering Geology to Urban Development	206
11.2	Presentation of Geotechnical Data in Urban Development	208
11.3	Investigation and Evaluation of the Geological Character of a Development Site	209
11.4	Application of the Digital Computer to Problems involving the Utilization of Engineering Geological Data in Urban Planning	210
REFERENCES		213
Appendices		219
A	Derivation of Equations Used in Chapter 4	220
B	Preparation of Site Investigation Data for Storage	228
B.1	Introduction	228
B.2	Borehole Title	229

		<u>Page</u>
B.3	Subsurface data	230
	B.3.1 General Data	232
	B.3.2 Strata and Water Conditions	233
	B.3.3 Test Data	234
C	Computer Programmes for <u>Geosys</u>	246
C.1	Introduction	246
C.2	Structure of Programmes	247
	C.2.1 Geosys	247
	C.2.2 Info	248
	C.2.3 Store	249
	C.2.4 Convt	251
	C.2.5 Read	252
	C.2.6 Outp1	253
	C.2.7 Outp2	253
	C.2.8 Outp3	254
	C.2.9 Outp3a	257
	C.2.10 Number	258
	C.2.11 Check	259
	C.2.12 Swapf	259
	C.2.13 Swapi	259
	C.2.14 Quest	259
	C.2.15 Trend	259

LIST OF FIGURES

<u>Figure</u>		<u>Page</u>
1.1	Changes in Personal Movement Between the Years 1945 and 1965	10
1.2	Percentage of Non -bypassable Traffic in Towns	10
1.3	Prediction of Traffic Numbers for the Years 1967 to 2010	11
1.4	Water Consumption in England and Wales between the Years 1870 and 2000	11
2.1	Variation in the Cost of Reclamation and Provision of Accommodation	32
2.2	Relationship Between Tunnel Diameter and Cost in the United Kingdom	33
3.1	Procedure for Urban Development and the Interaction of Site Investigation	55
4.1	Quadratic and Exponential Utility Functions	78
4.2	Log-normal Probability Distribution for 111 Determinations of Undrained Shear Strength of the Stony and Laminated Clays of the Team Valley, Co. Durham.	78
4.3	Normal Distribution for 26 Determinations of the Tensile Strength of Coarse Carboniferous Sandstone by Brazilian test	79
4.4	Normal Distribution for 26 Determinations of the Tensile Strength of Coarse Carboniferous Sandstone by Brazilian test	79
4.5	Changes in Expected Loss and Cost of Site Investigation with Increased Sampling.	80
5.1	Part of a Geotechnical Map produced by Geological Society of London (1972)	91
5.2	Variation of Shear Strength of Glacial Clays in the Team Valley, Gateshead (After Marshall, 1969).	92
6.1	Diagrammatic Representation of <u>Geosys</u>	102
6.2	The Initiation of a <u>Geosys</u> Execution	103

<u>Figure</u>		<u>Page</u>
7.1	Information Required by <u>Geosys</u> for Data Storage	110
7.2	Execution of a Literal Option Specification for Data Storage	112
7.3	Site Investigation Data to be Processed	113
7.4	Data in Fig. 7.3 on Coding Sheets	116
7.5	Listing of Logs Given in Fig. 7.4	121
7.6	Print Out of Data Processed for Storage	123
7.7	Print Out Obtained when Data is Stored	125
8.1	Information Required by <u>Geosys</u> for Data Retrieval	136
8.2	Option Specification for <u>Outp1</u>	139
8.3	Output Retrieved by <u>Outp1</u>	141
8.4	Output Retrieved by <u>Outp2</u>	142
8.5	Output Retrieved by <u>Outp3</u>	143
9.1	Information Required to Operate <u>Trend</u>	161
9.2	Trend Surface Diagram Produced by <u>Trend</u>	162
10.1	Location of Howdon Sewerage Treatment Works in the Context of the Tyneside Sewerage System as a Whole	187
10.2	Location of Site Investigation Boreholes in the Vicinity of the Settlement Tank	188
10.3	Geological Section Along the N-S Centre Line of the Excavation	189
10.4	Generalized Vertical Section at the Centre of the Tank	190
10.5	Complete Consolidation Curves for Three Samples of Clay	191
10.6	Location of Samples Mentioned in Figure 10.5	192
10.7	Log-normal Distribution of Consolidation Data from Howdon	193

<u>Figure</u>		<u>Page</u>
10.8	Changes in Expected Loss with Increased Sampling and Testing	194
10.9	Section for the Excavation Centre Line at 33620mE from Logs of Boreholes 82 and 44	195
10.10	Changes in Expected Loss with Increased Sampling and Testing - Geological Section of Figure 10.9 used	196
B.1	Examples of Strata Description	238
C.1	Symbols Employed in the Flow Diagrams	261
C.2	Structure of <u>Geosys</u>	262
C.3	Structure of <u>Info</u>	263
C.4	Structure of <u>Store</u>	264
C.5	Structure of <u>Convt</u>	265
C.6	Structure of <u>Read</u>	266
C.7	Structure of <u>Outp1</u>	267
C.8	Structure of <u>Outp2</u>	268
C.9	Structure of <u>Outp3</u>	269
C.10	Structure of <u>Outp3a</u>	272
C.11	Structure of <u>Number</u>	275
C.12	Structure of <u>Check</u>	276
C.13	Structure of <u>Swapi</u> and <u>Swapf</u>	276
C.14	Structure of <u>Quest</u>	276
C.15	Structure of <u>Trend</u>	277

LIST OF TABLES

<u>Table</u>		<u>Page</u>
1.1	Traffic Saturation Levels in Towns	12
2.1	Expected Increase in Tunnel Length in Great Britain (from O.E.C.D., 1970)	34
2.2	Construction Cost Index for the Years 1967 to 1973 (H.M.S.O. 1972a and b, 1974)	34
2.3	Average Cost of Private Building Land in England and Wales (From H.M.S.O., 1972a)	35
2.4	Building Land Cost and Indices (Compiled from H.M.S.O., 1970a and b, and 1974)	35
2.5	Cost of Land in Co. Durham (Pool, 1975)	36
2.6	Cost of Land Near London (Compiled from Stone, 1970)	36
2.7	Cost of Land in London for an Urban Tunnel and Surface Road Schemes (G.L.C., 1973)	37
2.8	Costs of Various Tunnels in Britain at 1973 Prices (After O'Reilly and Munton, 1972)	38
2.9	Expected Cost of Near-Surface and Tunnelled Roads in Britain at 1973 Prices (Compiled from O'Reilly and Munton, 1972)	39
2.10	Data for Comparable Tunnelled and Surface Roads in South London (Compiled from G.L.C., 1973, and H.M.S.O., 1972a and b, 1974)	40
2.11	General Costs of Surface and Tunnelled Roads at 1973 Prices	41
3.1	Allocation of Resources to Site Investigation	56
5.1	Stages of Urban Development and Suitable Types of Geotechnical Data Displays	93
7.1	Errors and Messages in Data Storage	126
8.1	Advice Messages Issued by Retrieval Programme	146
8.2	Data Available with Test Results in <u>Outp3</u>	147
9.1	Error Codes Used in <u>Trend</u>	166

<u>Table</u>	<u>Page</u>
10.1 Values of the Coefficient of Volume Compressibility m_v and Bulk Density γ for Sediments at Howdon	197
10.2 Values of the Constant a for Different Margins of Error and Values of Expected Loss	200
10.3 Value of Expected Loss as a Function of the Number of Oedometer Tests	201
10.4 Recently Quoted Costs for Soft Ground Boring and Testing	202
10.5 Cost of Drilling Boreholes and Conducting Oedometer Tests	203
B.1 Values of the Information Code	239
B.2 Codes Used to Indicate Sample Type	239
B.3 Numeric Strata Description Codes	240
B.4 Mnemonic Strata Description Codes	241
B.5 Examples of Codes for Water Conditions	242
B.6 Units Used in <u>Geosys</u>	243
B.7 Numeric Test Codes	244
B.8 Tests Identified by Mnemonic Code	245

LIST OF PLATES

<u>Plates</u>		<u>Page</u>
9.1	Guide Used for Drawing Sections	159
9.2	Completed Section for 33500 mE	159
9.3	Finished Geotechnical Model	160
10.1	The Western End of the Excavation Underway at Howdon	186
10.2	The Floor of the Partially Completed Excavation at Howdon Viewed Northwards	186

Declaration

This declaration is to indicate that none of the material contained in this thesis has been previously submitted by me for a degree at any university. It is not a joint work and a course of supervised study was not required.

Statement of Copyright

The copyright of this thesis rests with the author. No quotation from it should be published without his prior written consent and information derived from it should be acknowledged.

ABSTRACT

Planning the development of an urban area is a complex operation. In practice, and often intuitively, the required style of the ultimate development is reduced to a series of discrete but converging aims and the plan that is usually adopted attempts to achieve these aims at minimum cost. If only the geological factors which impinge on planning decisions are considered, a particular structure will cost the least to build in locations offering the most favourable ground conditions. A generally more economic venture will also result when the expected cost of building the structures in less geologically-favourable locations is allowed to influence the style of development during the planning process. Unfortunately, suitably precise geological and geotechnical information for conditioning the planning decision is seldom available at this early stage of urban development.

Balanced against the cost of geological data collection are the concomitant savings which arise from a reduced risk of foundation failure. When the two, costs and savings, are equal, further testing and analysis become financially redundant. However, the benefit to the overall urban development costs brought about by performing site investigation can be prone to much uncertainty. In this thesis, a probabilistic method for the evaluation of the economic advantage likely to accrue from site investigation activity has been developed. As a demonstration of the application of this theoretical analysis, the actual site investigation for a settlement tank at Howdon sewage treatment works (near Newcastle-upon-Tyne) has been examined.

During urban development, most geological and geotechnical data are collected immediately prior to the foundation design stage. In order that geotechnical data can be made available at the early stages of planning or for higher level probabilistic evaluation, a digital computation facility for the storage and processing of considerable quantities of data is necessary. In discussing the use of such a facility the thesis describes a suite of computer programmes called Geosys which have been written for the storage, retention, retrieval and presentation of geotechnical data obtained during site investigation studies.

ACKNOWLEDGEMENTS

The author of this thesis would like to express special gratitude to Dr. P.B. Attewell for his guidance and support given as supervisor of the research. Help was also given during the preparation of the thesis.

The valuable assistance given by Mr. J.P. Woodman in the development of the theoretical aspects of the application of probability theory to resource allocation in site investigation is gratefully acknowledged. Dr. D. Rhind of the Department of Geography kindly provided a copy of the original version of the trend surface analysis program.

The framework for the geotechnical model was manufactured by Mr. A. Swann. My mother, Mrs. F.E. Cripps, read parts of the draft copy of the thesis. Thanks must also be extended to Mrs. A. Taylor who has patiently and steadfastly typed this thesis. The help given by Mr. M. Cooper of the Department of Geology, University of Sheffield, who prepared tracings of the computer programme flow diagrams, has been most valuable.

The Northumbrian Water Authority and its predecessor, the Tyneside Joint Sewerage Board, provided the site investigation data used for both the geotechnical data processing and the probability analysis of site investigation.

In addition to those persons mentioned above by name, the author would like to thank all other members of the academic, technical and library staff at Durham University who have assisted him.

Finally, gratitude is expressed to the Natural Environment Research Council for the financial support received during part of the time that this project was underway.

CHAPTER 1

INTRODUCTION - A BRIEF CONSIDERATION OF
PLANNING FOR URBAN DEVELOPMENT

1.1 Aims of Planning.

In order to achieve a desirable distribution of limited resources, and to ensure that future needs are catered for, an urban plan must be formulated. For such a plan, a set of guidelines such as those suggested by Keeble (1964) and listed below can be used:

- (i) promotion of accessibility of homes and other urban facilities;
- (ii) efficient employment of resources;
- (iii) zoning of activities into areas of compatible land use;
- and (iv) pleasant development.

Planning for urban development, with these ideals, must include the consideration of many factors of varying importance. The influence the existing infra-structure, the available sources of energy, and other resources have on the plan must be measured. Eventually, the extent to which the plan fulfils its intended purpose must be measured, and so the consideration of any urban development proposals must be based upon an assessment both of the existing situation and of the expected outcome.

The physical state of the ground is one factor amongst a host of other factors which planners must consider in formulating development proposals. Clearly, any effort to utilize geotechnical engineering in urban development planning will only be successful if it is organized within normal planning procedures. Thus, an examination of methods used for deriving plans may well prove beneficial in the search for suitable means of performing the necessary interaction of data.



1.2 Development Restraints.

The consideration of such planning ideals as accessibility, efficiency, compatibility and pleasantness may only be incorporated in a planning procedure if these factors are quantified in common terms. Without a method, even if it is an informal one, any attempt to compare one set of development proposals with another is unlikely to lead to a conclusive answer. Some difficulty arises over deciding the scope of planning activity which will usually apply, since some situations will be in the sole charge of the planners, and others may be wholly outside their influence. However, it may be expected that the main factors affecting the distribution of facilities within the urban plan will be communications and to a lesser extent the water supply. Because the transportation of goods and people is both expensive and time-consuming, economic urban plans minimize movement. Such planning methods identify the most cost-effective proposals rather than those which most nearly meet the ideals already mentioned. But the application of financial restraints in urban development are inevitable where external financial restrictions are imposed.

The promotion of mobility by increased accessibility, particularly to motor traffic, has itself resulted in a restraint due to the resulting congestion. In fact the wisdom of constructing demand-orientated roads has been questioned on both environmental and economic grounds. The growth of personal movement is shown by O'Flaherty (1969) in Figure 1.1 to be alarming. Although between 1945 and 1965 there was a doubling of the passenger miles travelled, the numbers carried by public transport actually declined. The resulting growth in vehicle population and the

percentage of non-bypassable traffic indicated by statistics published by the Ministry of Transport (H.M.S.O., 1967) in Figure 1.2 suggests that total congestion of some conurbations is a likelihood. If traffic expectations of the Ministry of Transport (H.M.S.O., 1967) in Figure 1.3 are compared with saturation levels derived by O'Flaherty (1969) in Table 1.1, it is clear that this could occur before the year 1980. More recent developments which may tend to curb the proliferation of private transport, due to the generally-acknowledged disproportionate burden of increased fuel costs it bears, are liable to only delay eventual congestion.

A projected demand for water by Oakley (1972), in Figure 1.4, suggests that consumption will more than double the 1950 level by the beginning of the 21st century. Although rainfall in Britain is sufficient to meet this unrestricted demand, large scale storage and distribution systems would be required if short-term or localized shortages are to be avoided. According to Ineson (1970) there are sixty-nine million cubic metres of water per day available in the north of England, of which only an extra 4.4 million cubic metres per day will be required by the year 2000. This figure represents an increase of only 2% per annum compound interest on the present consumption. Other areas such as the south east of England do not have resources so much in excess of demand, but even here it is doubtful whether de-salination will ever be viable as an alternative to surface and groundwater control schemes.

During urban expansion, increased sewage treatment capacity is an obvious requirement. At the present time some urban areas are without

satisfactory sewage treatment facilities, and further urban development coupled with improved pollution standards has added impetus to sewage treatment plant design and construction.

Future urban requirements for land are not regarded as insuperable, since the population of Great Britain is not rising quickly. So although much of the existing housing stock is unsatisfactory, in his allowance for a population rise of 19 millions between 1967 and 2000, Stone (1963 and 1967) expects little change in the proportion of gross national product already devoted to the construction industry. This may be demonstrated by adopting a reasonably low housing density of 124 persons per hectare and assuming that all houses built before 1930 will be replaced by the end of this century. However, since the resulting land requirement of 0.64 million hectares represents only 3% of the total land area of Great Britain, total land needs do not appear to be too great. On the other hand, neither are the resources. Since there is an obvious reluctance to use good agricultural land or very high housing densities to provide the accommodation, it is becoming increasingly necessary to examine hitherto non-developed areas, especially for industrial expansion. The land available may be derelict, may have been used for dumping wastes, or may be in low-lying estuarine areas subject to flooding. All these land areas provide their own special problems, but these problems are mainly due to the variable character of the land, low bearing capacity and high ground compressibility.

Urban development plans are necessary to ensure that limited resources such as land, water and also money are allocated in an effective manner. In performing this allocation the planner must also be mindful of the

ideals already mentioned. Consequently, a successful urban plan will both accommodate the development restraints and comply with the defined objectives. Obviously, the many factors must be considered during the formulation of an urban plan, and the procedure is recognized as a multi-disciplinary activity.

The present objective is to examine avenues in urban planning practice where geological or geotechnical interaction may well be beneficial to the eventual development. Hence, although information gained about ground conditions might aid the harmonization of the development with its environment, it is only by examination of factors already established as development restraints in planning procedures that ways of including others might be obtained.

1.3 Urban Models.

Urban plans must meet not only present but also future needs. Hence, a reliable method must be derived for predicting changes due to the plan and otherwise affecting it. These projections are largely based on extrapolations of past experience utilized by the inter-dependence of sensitive parameters in models. Once calibrated, such models can be used to forecast trends by injecting certain control data. Naturally, the data available, often variable in type, usually comprise statistical information concerning the present levels of movement of people and goods, but factors influencing the location of urban facilities and communications are also employed. The basic types of model are as follows:

- (i) growth factor;
 - (ii) gravity model;
 - (iii) interactance model;
- and (iv) opportunity model.

The growth factor model is a correlative model, which has been used by the Lower Pioneer Valley Regional Planning Commission (1970), in which future urban requirements are predicted by correlation with expected population changes. Unfortunately, since the underlying factors influencing land use are ignored in this re-grading of existing facilities, there is no assurance that the area will develop in a co-ordinated and balanced manner. On the other hand, in the gravity model the amount of expected activity is predicted by assuming that movement is governed analogously to the force exerted between two physical bodies. Hence, the number of physical movements, or trips T_{ab} , between two places a and b is given by:

$$T_{ab} = \frac{k M_a M_b}{D_{ab}^n} \quad \dots 1.1$$

where k is a constant

M_a and M_b are respectively "masses" of a and b;

D_{ab} is the travel impedance between a and b;

and n is a constant.

Population is often used as a measure of the relative "mass" or attractiveness of an urban centre, and the travel impedance is taken as the distance, or the cost of travelling, or the time taken in travelling between a and b. This simple model has been criticized by Tanner (1961) because of the apparent non-linear relationship between population and attractiveness.

He advocates a law of the form:

$$T_{ab} = \frac{k M_a M_b}{D_{ab}} \exp \left[-tD_{ab} \right] \left\{ \frac{1}{C_a} + \frac{1}{C_b} \right\} \quad \dots 1.2$$

where T_{ab} , k , M_a , M_b and D_{ab} are as defined for equation 1.1;

C_a and C_b are constants, such that $C_a = \sum_{i=1}^j M_i \exp \left[tD_{aj} \right]$,

and C_b is given by a similar expression;

j is the number of other attractive centres;

and t is a constant.

The interaction model is more sophisticated than the two models described previously and operates by an iterative process. The model outlined by Cordey-Hayes et al. (1971) begins with the derivation of urban facility allocation formulae based on the assumption that the location of the residential population depends on non-service industry employment, the communications network, and the population density. After the derivation of the basic industry model, the resulting service industry population is added to the basic industry population. The analysis continues with this composite population and the iterative process continues until a stable mode results.

The opportunity model described by Martin et al. (1961) operates on the assumption that all journeys attempt to minimize the journey time between zones which have a specific probability of being able to satisfy the purpose of the trip. The process can be represented by equation

1.3:

$$T_{ab} = T_a \left\{ \exp \left[-P T_c \right] - \exp \left[-P(T_c - T_b) \right] \right\} \quad \dots 1.3$$

where T_{ab} is the number of trips between a and b;

T_a and T_b are respectively the number of trips terminating at a and b;

T_c is the number of destinations nearer to a than b;

and P is the probability that place b will satisfy the purpose of the trip.

In all these models the constants for calibration are generally derived by surveys. However, in the case of P in the opportunity model equation 1.3, very large samples are necessary, but unlike the gravity model, the trip impedance is actively minimized rather than simply

negatively exponentiated. The suitability of a particular model for a planning application depends on a variety of factors, but this choice may only be attempted when a large mass of statistical data are available. This information used for testing and calibration will then be employed to determine the effect of facility location on the extent to which the plan meets its purpose.

1.4 Geotechnical Engineering in Urban Development

Planning urban development has been recognized as a multi-disciplinary activity, the procedures of which involve the manipulation of data concerning the existing situation in order to accommodate future needs as they arise. It is thereby an extrapolative exercise. In such a procedure, the statistical information collected and collated will cover many subjects, so that many factors which influence the plan can be taken into consideration. Any additions to the factors to be incorporated in the planning procedure must fit within the accepted overall strategy. One fundamental requirement for including geotechnical studies in urban planning relates to a means of assessing any resulting benefit. Obviously the best justification for geotechnical involvement will be that better urban development results, and since all plans must be tested to determine their quality, or the extent to which they meet basic planning requirements, the same criteria can be used to determine the value of geotechnical data.

Interaction of geotechnical science with urban development should be initiated at an early planning stage, but must also continue throughout and perhaps after construction. Methods of designing foundation structures that are sympathetic to the ground conditions are well established, although improvements in the predictive techniques involved are always possible.

However, to push this geotechnical interaction with urban development back into planning and forwards into post-construction, some necessary research along three lines is required:

- (i) development of a means of measuring planning quality, both of existing proposals and of their future effect;
- (ii) a method of applying suitable geotechnical data to urban development throughout that development, and of processing the data;
- (iii) a system for assessing the effect of ground conditions on the plan.

Furthermore, it is clear from the consideration of the main restraints to urban development that the practicality of any strategy must be tested by the same criteria as the extent to which the plan fulfils the original objectives is measured.

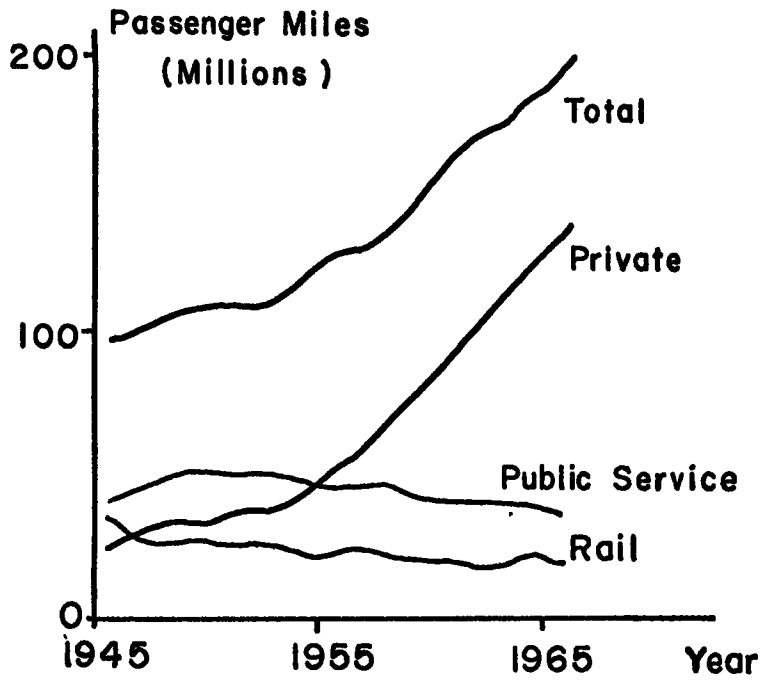

Fig. 1.1 Changes in personal movement between the years 1945 & 1965 (After O'Flaherty 1969)

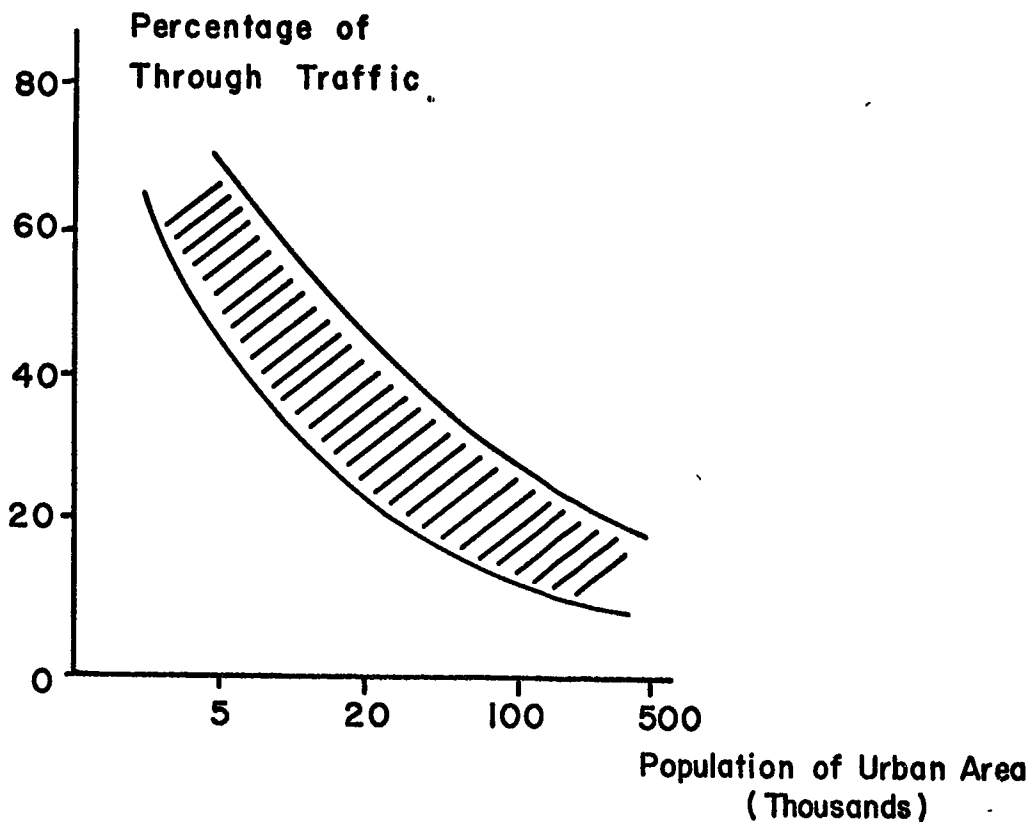

Fig. 1.2 Percentage of non - bypassable traffic in towns (H.M.S.O, 1967)

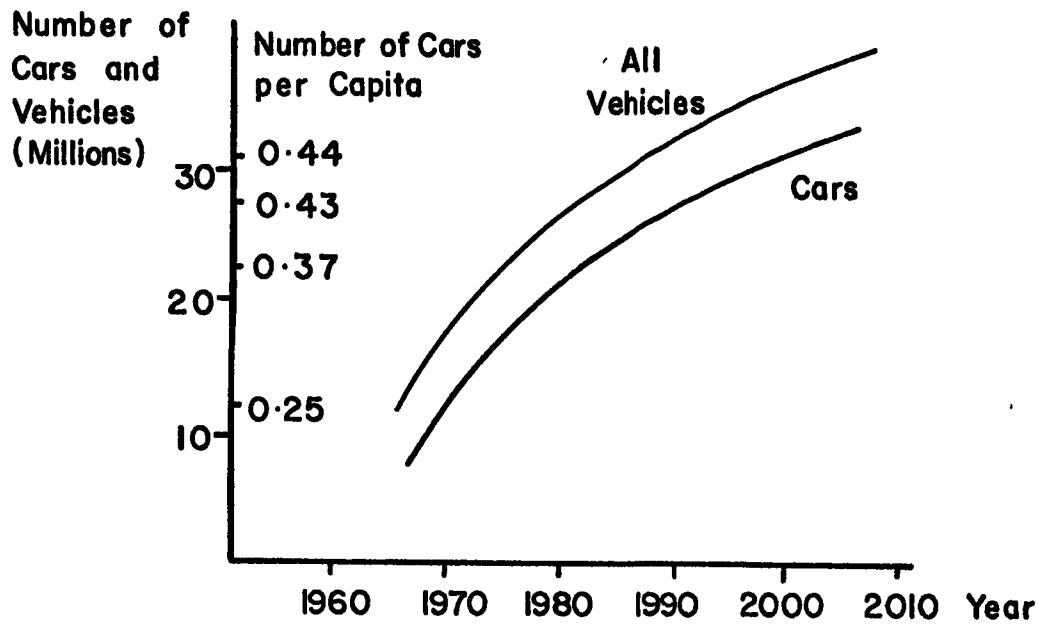

Fig.1.3 Prediction of Traffic Numbers for the Years 1967 to 2010 (H.M.S.O., 1967)

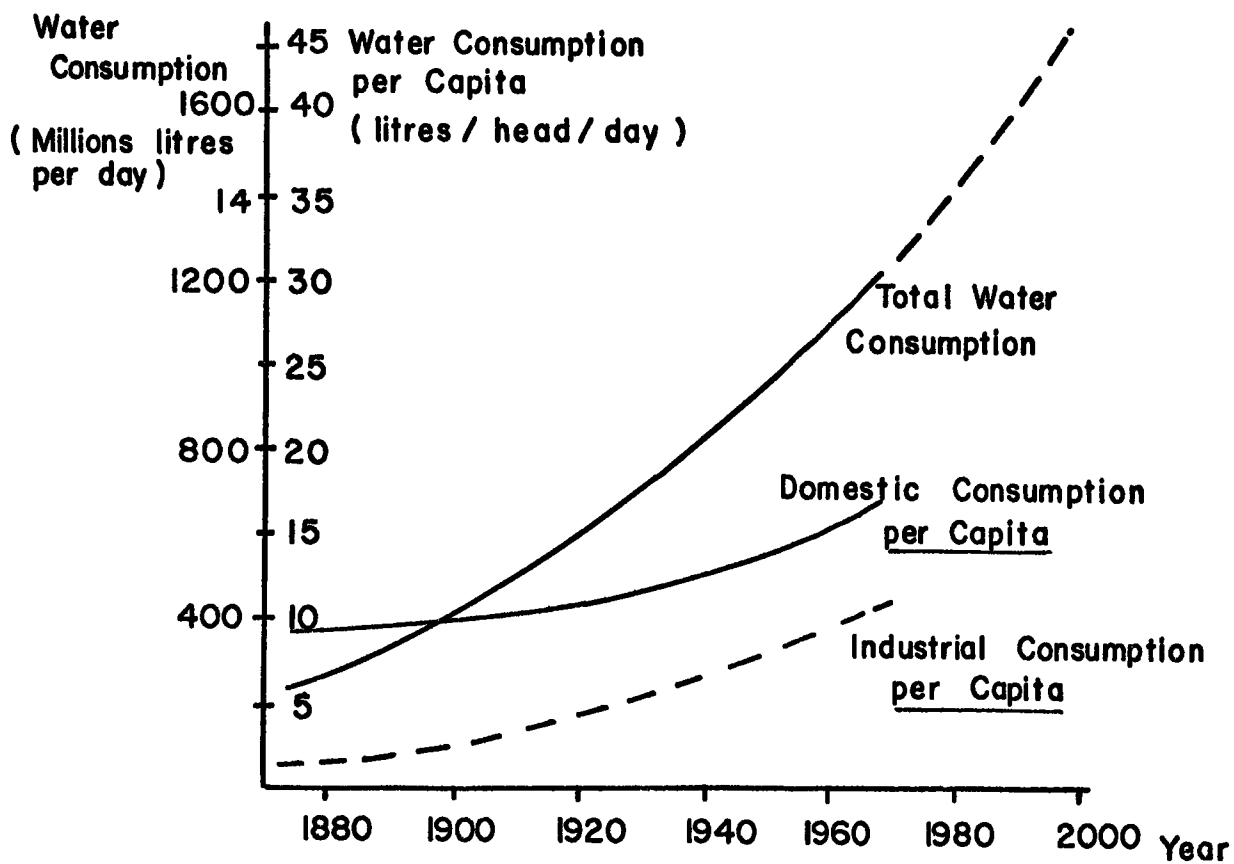

Fig. 1.4 Water Consumption in England and Wales between the years 1870 and 2000 (Oakley 1972)

Locality	Cars per Capita	
	H.M.S.O.(1967)	O'Flaherty (1969)
Inner London	0.325	0.30 - 0.35
Conurbations	0.375	0.35 - 0.40
Medium Towns	0.425	0.40 - 0.45
Typical Counties	0.475	0.45 - 0.50
Rural Areas	0.500	0.50

Table 1.1 Traffic Saturation Levels in Towns

CHAPTER 2

DECISIONS IN PLANNING

2.1 Criteria Used in Decision Making

Most urban plans are formulated so that the environment changes in accordance with certain ideals. The principles upon which urban development operates depend very much on circumstances such as the state of existing development and the resources that are available. However, an urban plan should promote accessibility, an efficient use of resources and protection of the environment. Since any practical plan will eventually be formulated as a compromise, the extent to which these qualities are realised must be quantified as far as possible so that one plan can then be compared with another.

Recently, planners have been attempting to apply objective appraisals of public reaction to changes in the environment. They have adopted two approaches: (i) sociological;
and (ii) economic.

The first method endeavours to prevent intolerable environmental damage by examining the sociological consequences of planning proposals. Luthans (1972), Margulies and Raia (1972) and Hoinville (1971) have all utilized community preferences correlated with behaviour as planning quality criteria. The Wilson report on noise (H.M.S.O., 1963) concluded that panels composed of members of the public could define tolerable levels of pollution, and similar controls could be extended to measure the acceptability of plans. However, since it can be argued that their decisions would be unduly dependent on their composition, the use of special panels seems to have little to recommend it over the use of

planners and elected representatives performing this function.

Economic assessment is the second alternative. It has the advantage of providing an immediate guide that can be included in an economic analysis. This economic penalty incurred by the damaging features of otherwise worthwhile ventures can be derived by applying the compensation principle advocated by both Waller (1968) and Lichfield (1972). For this approach, either the amount of money that people would pay to be without a particular nuisance or the amount of compensation they would require to allow it to affect them is ascertained by surveys. However, a method which measures personal compensation suffers from the difficulty of assessing general lowering of amenity. An alternative approach is to correlate property prices with compensation levels. But, although property prices quickly reflect any changes in environment, the true market value of property is only proved when it changes hands, and thus for areas adversely affected by development plans a depressed value results. However, multiple regression techniques could be utilized to overcome this drawback, so that falls in general property values could be correlated with environmental damage by using control areas to identify sensitive factors.

Another method of economic assessment of environmental damage is to invoke the principle of environmental compensation so that an amenity lost must be replaced elsewhere. However, this would certainly be difficult to apply in practice on anything but a limited scale, and in common with other economic techniques it still sanctions damage.

The whole philosophy of introducing cash value into the analysis can be questioned, but a guide to acceptable limits of environmental

damage indicative of the seriousness and cost of avoidance will always be required where planning allocates constrained financial resources. It may be concluded that the process of up-grading urban facilities inevitably incurs not only monetary costs but also environmental ones. In any scheme, the cost of keeping environmental quality at a constant level by limiting the polluting effect of improvements may be the most satisfactory way of overcoming this difficulty. In particular cases this means that the actual cost of high quality soundproofing, landscaping, removal and rehousing of displaced populations would be included in the cost of development. Other factors offering restraint to urban development may also be included in an economic analysis of planning proposals. Since land and the provision of urban facilities may be costed directly, the limitation of finance may be used as a criterion of planning quality provided that all the costs to individuals and the community are included. It is also necessary to realise that the plan must also be sensitive to some factors which will inevitably be outside an economic analysis.

2.2 Applied Cost Benefit Analysis

The process of cost benefit analysis consists of totalling the monetary costs and comparing this sum with the expected benefits. In a free market, the comparative rarity of a particular commodity is determined by its cash value. Of course, taking the net economic benefit as the sole criterion of planning quality would almost invariably be unsatisfactory since, clearly, many of the costs and benefits are not appropriate to economic evaluation. Even when an economic analysis is feasible, the priorities of a private developer may be quite different from those of the community. However, although financial economy may

be imposed at the expense of what could be regarded as more worthy ideals, without a measure of the relative abundance of the resources required and the degree to which the plan meets the ideals already mentioned, effective planning would be impossible.

The use of cost benefit analysis to derive a satisfactory distribution and use of resources is well established in the justification of road improvements. Many criteria of varying economic importance are included. The analysis of the more economically-dependent factors is well documented, Dawson (1968) having given guidelines to be applied when savings due to time, vehicle maintenance, running costs, accidents and other considerations are calculated. Naturally, the benefit of a particular improvement is highly dependent on the amount of traffic using it. While the numbers of vehicles already using a road can be measured, and the number attracted from other roads can be deduced by fairly simple surveys, the traffic generated by the improvement due to completely new journeys being made is difficult to ascertain without recourse to the urban models already mentioned. Generally speaking, any cost benefit analysis for justifying expenditure will be more complicated than this simple explanation suggests. In their assessment of a projected London to Birmingham motorway, Coburn et al. (1960) found that the economics of such a road were very sensitive to vehicle speed and the cost attributed to people's leisure time.

The monetary costs include those of planning, site investigation, land, materials and construction, but costs due to possible detrimental effects that the improvement has on the environment may also be incurred. Although the cost of special measures, such as landscaping or sound-proofing of buildings, may be incorporated into the overall cost analysis

comparatively easily, other amenity losses are more difficult to price.

When all the costs and benefits have been assembled, the final decision depends on a test of efficiency applied to the economic consequences of the proposals. A straightforward choice of the action which maximizes the difference between costs and benefits during the planning operations may not be suitable for this when the alternative proposals involve different investment programmes. So the net benefits are discounted to a present value over the life of the investment, and the alternative which maximizes the present value will be adopted. As a criterion of priority of alternative expenditure, the internal rate of return which makes the present value zero can be used. Of the two methods, the first is generally preferred since it will maximize the present value of the monetary funds available. In most instances, proposals for which the internal rate of return is less than the discount rate will be deferred.

The difficulties associated with economic cost benefit analysis are particularly relevant to urban road building. It has already been suggested that total congestion of some conurbations is likely to arise before the year 1980. Also, it may be expected that the provision of demand-orientated motor vehicle accessibility would inevitably cause serious amenity loss, especially where additional road capacity is incorporated into existing urban infrastructures. To ease congestion at junctions, multi-level road arrangements have been adopted; elsewhere elevated and depressed roads have been constructed. The construction of these structures has often been accompanied by serious loss of amenity (apart from accessibility) in the immediate locality. Further improvements

in accessibility with a minimum of environmental loss may be achieved by the use of urban road tunnels as an alternative to new surface roads. There are examples of all these features in the Newcastle upon Tyne/Gateshead area.

Projections of tunnelling demand made by the Organization for Economic Co-operation and Development (1970) and shown in Table 2.1 suggests that tunnelling will play an increasingly prominent role in the civil engineering operations associated with urban expansion. Although the greatest percentage increase on a global scale is expected to arise in connection with mining extraction operations, considerable growth of urban tunnelling is expected. This activity will take place in order to aid accessibility by the provision of transportation networks, and to improve services. In contemplating a tunnelling solution to a particular problem, the planner must be mindful of the sensitivity of construction costs to ground conditions. In fact, the analysis of tunnelled roads and their surface counterparts may be used as an example of the manner in which geotechnical matters can affect development costs. Such a comparison is performed later in the thesis.

Space for urban expansion may also be considered in a cost benefit analysis. Although immense problems do arise in the reclamation of land in estuarine areas, Rutledge (1970) concludes that the economics of such a scheme can compare favourably with other inland developments. The main difficulties in providing dry land free from the danger of flooding, and capable of providing foundation support, can be solved by two basic methods. Either dykes can be constructed and the area pump-drained, or the land surface can be raised by the placement of fill to give height and cause consolidation of soft sediments. Of the two, the latter is usually

preferred, since foundation support for low buildings is provided in low bearing-capacity deposits where otherwise even services would require pile-support. The provision of water/land separation is one of the most expensive parts of reclamation. According to Rutledge (1970), a rock-faced dyke of fill material is the cheapest variety of barrier. This costs about £600-1200 per metre run at prices which have been converted from dollars to pounds at the 1970 exchange rate (Whitaker, 1971) and updated to 1973 levels by reference to the construction cost indices in Table 2.2 (H.M.S.O., 1972a & b, 1974). For docks, the least expensive method is to install a cellular sheet pile which costs about £2,500 per metre, but since this is vulnerable to damage in collisions, a pile-relieved platform costing approximately £3,500 per metre may be more suitable for warves, although here an accessible pile-bearing substratum is needed. Overall, it would appear that whatever the thickness of the compressible layer, it is generally more economic to provide accommodation in higher buildings due to the relatively high cost of piling necessary for even low ones. This observation is demonstrated by the curves in Figure 2.1 which relate the thickness of the compressible layer to the cost of unit area floor space in buildings constructed during the development of an extensive area reclaimed by the placement of 3.4m of fill.

Space for urban expansion may be gained by other operations for improving the geotechnical characteristics of the ground in areas of low-bearing capacity, and also in those of urban redevelopment. Such systems as dynamic compaction, vibro-compaction, void filling and grouting have been found to provide economic methods. For a particular site, 10,000 square metres in area

comprising demolition fill between 6 and 7 metres thick and being prepared for two-storey hospital development, Reina (1976) evaluates three alternatives. The same specification of 150 kN/m^2 average bearing stress with a maximum settlement of 25mm, and a maximum differential settlement of 12mm, was used for conventional piling, estimated at a total of £102,000; treatment by vibroflotation at a cost of £60,000; and £50,000 for ground improvement by dynamic compaction. In selecting the type of ground treatment suitable for a particular location, the economy of the particular method will be governed by the ground conditions, required loadings, acceptable settlements and the size of the site. However, on occasions, other factors such as the acceptable levels of vibration and noise, and the site access, must also be considered. Dynamic consolidation is only suitable for non-cohesive soils, and generally speaking is only economic for areas of treatment greater than 7,000 to 10,000 square metres (0.7 to 1 hectare). On the other hand, vibroflotation is economic on smaller sites and may be used for the treatment of most soil types.

Other restraining factors may also be considered as costs in an economic analysis of the development proposals. Thus, for an urban plan, the total implied costs can be calculated for comparison with alternative plans. Naturally, uncertainty regarding some factors affecting the plan will bring about considerable uncertainty in the financial consequences of adopting the plan. But these factors can be identified in the analysis and be given priority in any investigation activity. Obviously, for a planner to be in a position to make a full analysis of the consequences of implementing a particular plan,

the necessary data must be readily available. In the case of geo-technical data affecting the suitability of foundation types, it must be available early in the planning process in a form which the planner can easily utilize.

2.3 Economics of Tunnelled Urban Roads.

The environmental problems associated with the adoption of new urban roads to promote accessibility and ease congestion can be reduced by the construction of tunnels rather than roads at or near the surface. However, the environmental benefits of tunnels must be balanced against their higher cost. Also, tunnels are structures which are particularly sensitive to geological factors, so that justification of tunnelling solutions might be possible where ground conditions are favourable. On the other hand, geology rarely impinges strongly upon the decision process at the design stage.

Tunnels in urban areas would ideally be of the bored type due to the disruption to existing development and shallow services caused by cut and cover construction. As a prime example of such disruption and of consequential environmental reaction, one may quote the Amsterdam Metro under construction in 1976 using either a massive concrete caisson technique or an 'under-the-roof' cut-and-cover technique. Although other tunnels, deep foundations of certain types, the location of access points, and geological and hydrological conditions all inevitably exert some influence on a tunnel route, bored tunnels are easier to incorporate into an existing urban infrastructure since they are less restrained by existing land use. For road tunnels to be most beneficial to urban surface amenity they would have to be of a sufficient size to accommodate all traffic, including heavy goods- and public service-vehicles.

Recent developments in tunnelling have led McBean and Harris (1970) to conclude that the cost of tunnelling is rising less rapidly than are other civil engineering costs. Improvements to the versatility of tunnelling machines, changes to linings, better site investigation and more effective ground treatment techniques are expected to reduce still further the relative cost of tunnelling. The economics of constructing both elevated roads and tunnelled roads are very sensitive to locational factors. Although a general analysis is difficult, a major influence on the cost of surface roads is the price of land. On the other hand, in the case of tunnels the ground conditions exert most influence, but this does not discount the comment made earlier concerning the geology.

The price of land varies enormously depending upon its existing use and location. This dependence is amply demonstrated by reference to Table 2.3 which has been compiled from data published by H.M.S.O. (1971a). The prices in this Table have been adjusted to 1973 levels by use of the building land cost index in Table 2.4 by H.M.S.O. (1972 a & b and 1974). Since in areas where demand for land exceeds supply, a range of prices between £m0.035 and £m0.267 per hectare might be paid, many new urban roads are routed through slum-clearance areas to avoid expensive land and likely environmental damage. Table 2.5 has been compiled from data by Pool (1975) who reports that, in County Durham, houses built at a density of 100 per hectare may be purchased for as little as £30 each if declared unfit. For similar housing which has been improved, a figure of £1,700 is more appropriate. Better quality terraced housing can command prices between £2,500 and £6,000 each.

This intelligence suggests that the operation of clearing residential areas developed at 100 houses per hectare can cost between £m0.003 and £m0.59 per hectare.

A general guide to land costs near to London can be obtained from Stone (1970) who has published the average cost of building land for 1964 as a function of the distance from London. Using these data adjusted to 1973 levels with Table 2.2 produces land costs in Table 2.6. These costs compare well with those computed from the analysis by the Greater London Council (1973) in Table 2.7 (in which prices ranged from £m1.2 to £m4.8 per hectare) if it is remembered that land referred to in the latter case is closer than 16km from London, and the costs also include the diversion of services and some soundproofing involved in tunnel construction. Taking the data in Table 2.5 and 2.6 together, it would appear that the cost of land in urban areas can vary between £m0.25 and £m1.09 per hectare. It may rise higher than this in some areas, such as near to the centre of London or other large conurbations, and it may drop where a high percentage of slum clearance or low density, poor quality housing is involved.

The minimum amount of land required for an urban road with six standard width lanes is about 3 hectares per kilometre. Additional land for side margins, embankments, cuttings, junctions and landscaping may increase this figure to 7 hectares per kilometre. In the case of urban surface roads in London given in Table 2.7, a figure of almost 6 hectares per kilometre was determined by the Greater London Council (1973). Using an areal land requirement of 7 hectares per kilometre with the costs already determined produces an estimated land cost of between

£m0.75 and £m7.63 per kilometre of three lane dual carriageway road.

A quotation of the overall cost of dual three lane roads, and not including the cost of land, by James (1972) suggests an average of £m0.77 per kilometre at 1973 prices. In costing individual jobs, which for 1969 ranged from £m0.45 to £m4.89 per kilometre (at 1973 prices updated with Table 2.2, H.M.S.O., 1972 a and b and 1974) James points out that all the more expensive ones were urban roads, thus indicating that even without land, urban roads are more costly than rural roads to construct. Using the range of land costs already derived, the total cost of building surface roads is likely to total between £m1.2 and £m12.5 per kilometre.

Data published by O.E.C.D. (1970) relating the cost of tunnelling in Britain to the diameter of the tunnel face is presented in graphical form in Figure 2.2. For this graph, the 1969 exchange rate has been used to convert dollars to pounds (Whitaker, 1971) and the costs have been updated by use of the construction cost indices in Table 2.2. From Figure 2.2, the estimated cost of excavation and primary lining erection for a 13.0m diameter tunnel, in ground suitable for free-air working, is between £m2.4 and £m7.2. Reference to the case histories of those tunnels, listed by O'Reilly and Munton (1972) in Table 2.8, requiring ventilation works indicates that the cost of providing services, internal finishings and the road decking amounts to between £m2.31 and £m5.77 per kilometre, the average being £m4.30 per kilometre at 1973 prices. Addition of this figure to the expected cost of tunnelling from the O.E.C.D. (1970) data derived from Figure 2.2 suggests that the overall cost of tunnelling in ground suitable for free air working will be in the region of £m6.7 to £m11.5 per kilometre.

An examination of case histories of existing tunnels has been performed by O'Reilly and Munton (1972) and their findings are summarized in Table 2.8. Unfortunately, average costs arrived at from the tunnels in this Table are liable to overestimate the costs of tunnels generally. The distortion in pricing due to the inclusion of tunnels built as river crossings, suffering from a lack of surface access, unfavourable water conditions and difficulty with site investigation, quite apart from poor geological conditions common in British river valleys, is completely illustrated by examination of the Great Charles Street and Kingsway tunnels. Although both are in essentially the same geological formation, the latter, which was built as a river crossing, cost 56% more per kilometre than the other, constructed beneath a city centre. This difference can be explained partially by adverse water conditions, although they were not considered to be serious. However, O'Reilly and Munton (1972) conclude in Table 2.9 that bored tunnels can be expected to be built at rates competitive with surface roads, especially where land costs rise above £m0.84 (1973) per hectare. With this figure in mind, Table 2.6 reveals that within 32km of London, and also very likely near to the centres of other conurbations, tunnels and surface roads may cost similar sums to construct.

Other data concerning the cost effectiveness of tunnelling as an alternative to surface roads can be obtained from the Greater London Council (1973). In this report, two proposed tunnel equivalents to the now abandoned Ringway 1 in south London are costed for the purposes of comparison with surface alternatives. Both the surface and tunnel routes share the same access points and would provide three lane dual

carriageways to carry traffic between Battersea in south-west London and St.Johns in south-east London, a distance of some 10km by an approximately east-west route.

Illustration of the influence of geological conditions on the cost of tunnelling is afforded by comparison of the construction costs for London Clay and for chalk. For the purposes of the analysis, the roads have been divided into two portions: the western part extending from Battersea to Clapham, and the eastern part from Brixton to St.Johns. The respective unit costs for these from Table 2.10 are £m16.0 per kilometre and £m22.5 per kilometre. This indicates that the cost per kilometre is 34% higher where tunnelling is in wet mixed sands, gravels and clays, and fissured chalk instead of stiff fissured clay, although in both cases free air working is envisaged.

In the plans for alternative surface and tunnelled road, the eastern and western portions would be connected by a surface link. Also, both the surface and tunnelled schemes have equal traffic-carrying capacity and would be provided with the same access from the existing road network. The costs included in Table 2.10 are those incurred due to junctions, the diversion of services, compensation to property owners, necessary soundproofing, and the provision of tunnel services. However, no allowances have been made for the surface link common to both schemes, maintenance and loss of rates to local authorities. It would be expected that maintenance would be higher in the case of tunnels, whereas the loss of rates would be more serious for surface roads.

The total cost estimates presented in Table 2.10 again demonstrate that tunnelling can provide an economic alternative to surface- or near-

surface roads provided that the geological conditions are favourable to tunnelling and land is expensive. However, it should be noted that only 76% of the 10km length of the tunnel proposal route would actually be below ground level. Moreover, although the permanent land requirement is not large when compared with the land absorbed by the surface scheme, over 1000 properties are affected compared with 1700 in the latter case. Even with these relatively high environmental costs, the impact due to noise, visual intrusion, the felling of trees and pollution will be less for the tunnel, and may well be further reduced by fully exploiting unrestrained tunnel routing. The original ringway was planned to run adjacent to railway lines in order to lessen the environmental damage, but in adopting similar alignments for tunnels, any enhancement of cost effectiveness for the latter due to possible advantageous tunnelling conditions has not been considered. Reduction of the number of access points might equally be expected to achieve better economy. In general, environmental factors affecting the siting of access points are easier to accommodate for tunnels than for surface roads, since slight adjustments to the tunnel alignment are easier than similar changes to surface roads.

The difficulty of performing a meaningful generalized comparison of tunnelled and near-surface roads has been amply demonstrated by the foregoing analysis, but the costs derived by this comparison are summarized in Table 2.11. Remembering that surface roads in urban areas have been shown to cost as much as £m12.5 per kilometre, by using land and road cost statistics, it would appear that tunnelled roads may be economic in high land-cost areas with favourable geological and hydrological conditions. Thus, it is demonstrated that under certain

circumstances transportation tunnels will be viable propositions, but in purely economic terms they will not generally serve as the preferred option. However, in environmental terms for the public at large, tunnels must be favoured. In addition to the benefits of tunnels already listed, atmospheric pollution can be lessened and adverse weather conditions do not interrupt their use to the extent experienced on surface roads. However, some people regard tunnels as unpleasant to drive in (they are environmentally disastrous on a local and temporary basis for the person using them), breakdowns can be more disruptive, and accidents and fires are potentially more hazardous than in the case of surface roads.

One feature of the economic comparison between tunnels and surface roads has been neglected so far. Since tunnels and surface roads require rather different investment programmes, the net benefits of each must be discounted to a present value over the life of the investment. Reference to Table 2.10 will show that tunnels can be expected to take about 20% longer to drive than is the case with surface roads having comparable capacity, even when they are constructed from several points concurrently. If, for the Western scheme, the cost of £m110.5 is spread evenly over the projected construction period of 5 years, the initial capital value will be £m192.1, where a constant rate of depreciation of 10% over the construction period of the tunnel has been assumed. In the case of the comparable surface road, if it is assumed to have a life, benefits, and a depreciation rate equal to those operating with the tunnel, then the expenditure of £m99.5 over $3\frac{1}{2}$ years implies an initial capital requirement of £m143.9. This means that the economic advantage of the surface scheme is really £m48.2 and not £m11.0.

Similar analysis of the Eastern scheme shows a difference in the effective capital requirements of about £m139.7 and not £m66.3 . Since, as stated earlier, it is usual for tunnels to take longer to construct than surface roads, a further financial penalty is thereby placed on their economic viability.

2.4 Planning Urban Development

In general, planning is an economic process in which the best allocation of limited resources is the central requirement. Although methods such as those suggested by Williams (1972) can reduce the environmental damage caused by enhancing accessibility, unfortunately purely financial criteria can bring the re-grading of urban facilities - in particular those of transportation - into conflict with those of amenity. However, in order to ensure the fullest interaction between the factors involved, an economic basis is required. Only then can proposals be viewed objectively for comparison with alternatives.

Several techniques have been evolved to minimize costs during urban development. One such technique - threshold analysis - has been utilized by Malisz (1963) to identify - and avoid points - at which sharp rises in costs occur. Although changes of consumption with time are not taken into account, it does encourage the efficient use of resources found to be in excess of immediate requirements. Optimization methodology has been used by Kozłowski (1970) to analyse the upgrading of urban facilities without deprivation of others. By this system, when land has an existing useful purpose, the cost of development must also include the cost of providing that facility elsewhere. From this follows a useful concept in land use assessment, because the additional

costs due to existing land use can be adopted as a suitability criterion of future land utilization.

While it is freely acknowledged that the ground conditions can have great influence on the overall economy of a plan, they are largely an unknown factor at the early planning stages. Unfortunately, the effect on the global cost of development of providing suitable geological and geotechnical information during planning is not known, and frequently can only be calculated in particular cases after the project is completed. Therefore, in order to obtain the best distribution of resources within set total allocations, some measure of the cost effectiveness of site investigation is a fundamental requirement.

Generally speaking, the planner is capable of avoiding what are blatantly obvious incompatibilities between geotechnics and foundation requirements. But comprehensive geotechnical information in these early stages would be valueless unless the planner had access to sophisticated knowledge of individual foundation needs for the various elements required in an urban plan. On the other hand, not only would it be beneficial to formulate the urban plan to suit the geotechnical conditions, but the site investigation should really be arranged within the limits set by a particular plan. It would be regarded as unusual to investigate all geological factors likely to affect an urban plan at the outset. Even if physically possible, it would probably be prohibitively expensive.

The assessment of geotechnical and other influences in planning could be greatly improved by the definition of an additional cost parameter. This would generally be highly dependent on location, and

would indicate the amount above the minimum cost that is implied by a particular proposal. Thus, it follows that there would evolve a type of land use classification system in which the suitability index is directly linked to the additional cost due to the location. Furthermore, to utilize any uncertainty in the value of this parameter as a justification for data capture would also be a beneficial outcome. The economic urban planning method envisaged would be an interactive and cyclic process in which the land use classification would change as data become available, and the index becomes a more reliable measure of the economic consequences of adopting the plan. Such a planning process would be most apt in completely new urban development, although its use in redevelopment might also be expected to yield benefits.

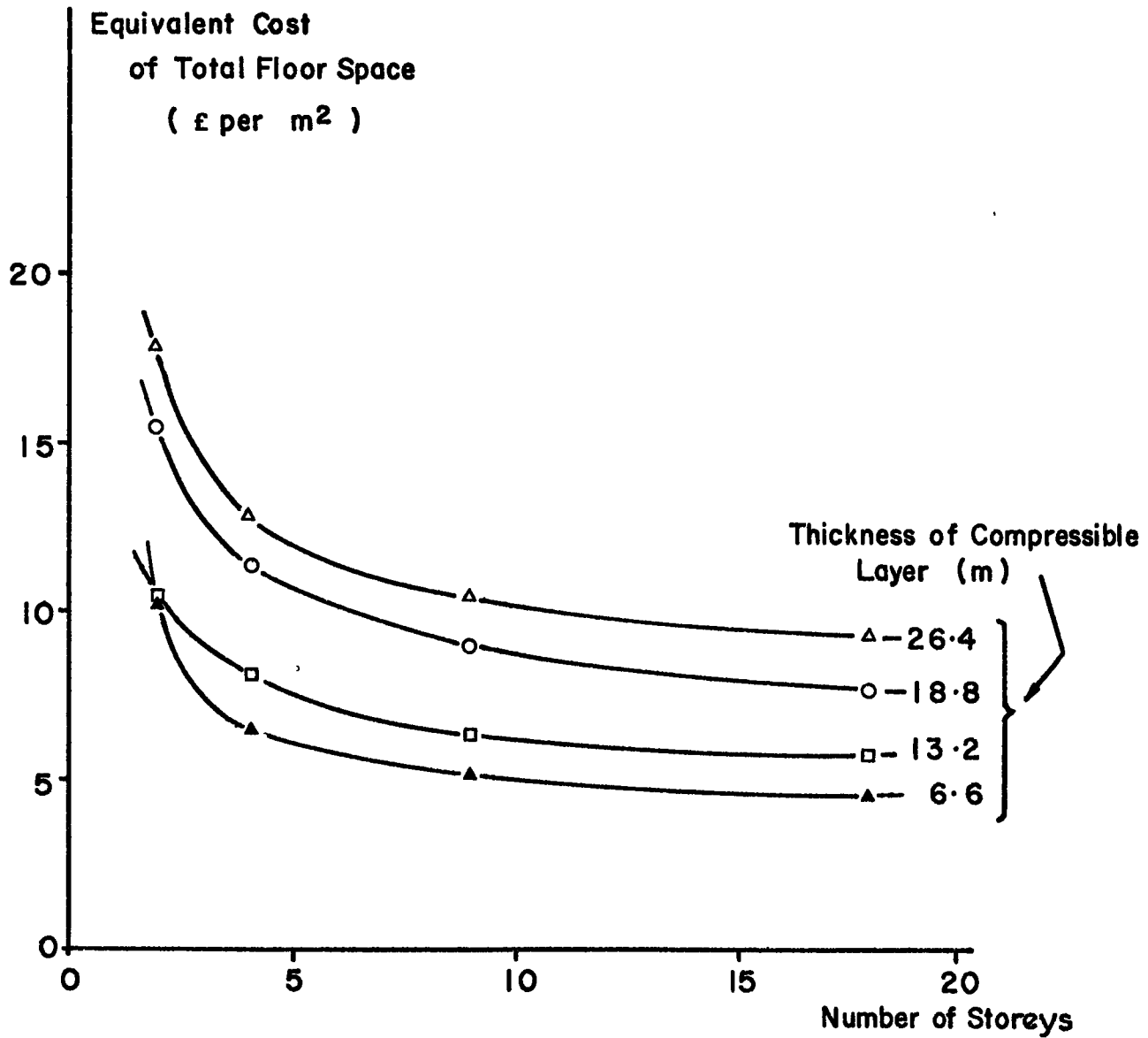

Fig.2.1 Variation in the Cost of Reclamation and Provision of Accommodation.

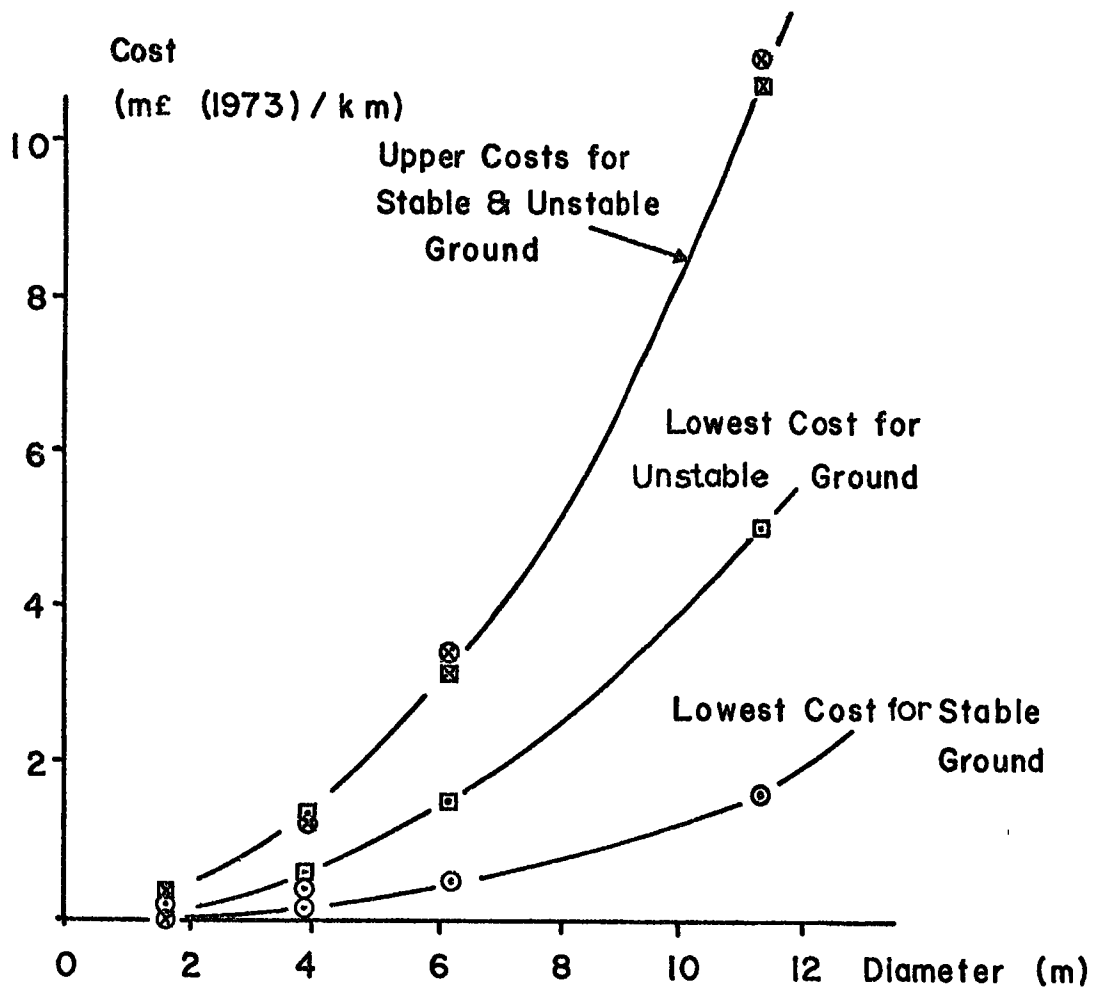

Fig. 2-2 Relationship Between Tunnel Diameter and Cost in the United Kingdom.
(From data by O.E.C.D. 1970)

Use	Length in 1970 (km)	Expected length in 1979 (km)	% Increase Between 1970 & 1979
Transportation	63	212	42.3
Water Resources	90	196	84.9
Utilities	102	183	79.4
TOTAL	225	591	61.5

Table 2.1 Expected Increase in Tunnel Length in Great Britain
(From O.E.C.D., 1970)

Year	Index 1963 = 100				
	Average for Year	Value for Quarter of Year			
		1	2	3	4
1967	113				
1968	118				
1969	123				
1970	131	126	131	133	135
1971	142	138	142	142	146
1972	158	149	152	157	174
1973	194	178	186	199	212

Table 2.2 Construction Cost Index for the Years 1967 to 1973
(H.M.S.O., 1972 a and b, 1974)

Location	£m/ha (1973)
North of England	0.035
Midlands and Wales	0.047
South of England(excl.London)	0.267
England and Wales	0.055

Table 2.3 Average Cost of Private Building Land in England and Wales (From H.M.S.O., 1971a).

Year	Average Price £m per Ha	Cost Index (1966 = 100 units)		
		Ave.for Year	Half Year Jan-June	Half Year July-Dec
1963		74		
1964		84		
1965		94		
1966		100		
1967		102		
1968		118		
1969	0.019	147	144	151
1970	0.021	150	147	156
1971	0.024	185	169	205
1972	0.040	324	268	381
1973	0.062	504	495	516

Table 2.4 Building Land Cost and Indices
(Compiled from H.M.S.O., 1972 a and b, and 1974)

Type of Land	Original Use of Land	Cost of Land £m per ha (1973)
Virgin Land	Agriculture	0.0012-0.0017
	Residential	Up to 0.04
	Industrial with Services	0.02-0.03
Developed Land	Terraced Houses (Slum Clearance)	0.003-0.12
	Habitable Terraced Housing	0.25-0.59
	Industrial	0.062

Table 2.5 Cost of Land in Co. Durham (Pool, 1975)

Distance from the Centre of London (km)	Cost of Land Developed at 100 Houses per Hectare £m per ha (1973)
16.1 - 32.2	1.09
32.2 - 48.3	0.69
48.3 - 64.4	0.61
64.4 - 80.5	0.46

Table 2.6 Cost of Land Near London (Compiled from Stone, 1970)

Item	Scheme for Same Route					
	Road in Tunnel			Surface Road		
	Section			Section		
	East	West	Total	East	West	Total
Length (km)	4.5	6.1	10.6	4.5	5.9	10.4
Total Land Requirement (Ha)	8.0	10.6	18.6	26.0	35.0	61.0
Land Requirement per km (Ha/km)	1.8	1.7	1.8*	5.8	5.9	5.9*
Total Cost of Land (£m)	110.5	149.7	260.2	99.5	83.4	182.9
Cost of Land per Ha (£m/Ha)	4.8	1.2	2.7*	1.7	1.4	1.6*

* average value

Table 2.7 Cost of Land in London for an Urban Tunnel and Surface Road Schemes (G.L.C., 1973).

Tunnel	Date of Construction	Total Cost £m/km, 1973	Cost of Internal Finishing £m/km, 1973	Ground Conditions
Dartford	1956-63	22.51	4.30	Compressed air in river gravels and silts
Clyde	1957-63	25.92	5.77	Compressed air in river silts
Blackwall duplication	1960-67	28.88	4.77	Compressed air in river silts
Tyne	1961-67	17.62	5.03	Compressed air in boulder clay and river deposits
Crindau * (Newport)	1963-67	9.77	5.1	Free air in sandstone, limestones and marls
Gibraltar Hill * (Monmouth)	1965-67	7.11	1.00	Free air in marls, clays and limestones
Heathrow cargo	1966-68	6.07	3.61	Free air in London Clay
Mersey Kingsway	1967-71	8.15	2.31	Free air in Bunter sandstone
Great Charles Street (Birmingham)	1968-70	4.59	0.71	Free air in Keuper sandstone. Partially self ventilating Road deck on invert
Fort Regent * (Jersey)	1968-70	2.22	0.48	Free air in granophyre

* tunnels not requiring ventilation

Table 2.8 Costs of Various Tunnels in Britain at 1973 Prices
(After O'Reilly and Munton, 1972)

Type of Road	Location	Total Cost of 3 Lane, 2 Way Motorway £m/km (1973)
Ground Level	Rural	0.37 - 0.92
	Urban	0.52 - 0.89
Elevated Urban	Embankment	0.89 - 1.76
	Retained	1.04 - 2.21
	Viaduct	2.21 - 5.92
Depressed Urban	Open cut	0.89 - 1.32
	Retained	2.65 - 5.30
Tunnel Urban	Cut and cover	5.15 - 14.72
	Bored (free air)	6.62 - 11.77
	Bored (comp. air)	26.51 - 44.20

Table 2.9 Expected Cost of Near-surface and Tunnelled Roads in Britain at 1973 Prices (Compiled from O'Reilly and Munton, 1972.)

Item		Urban Road Alternative					
		Tunnel			Surface		
		Section			Section		
		West	East	Total	West	East	Total
Lengths (km)	Elevated	} 1.2	} 1.0	} 3.0	3.0	3.0	6.0
	Surface				} 2.9	} 1.5	} 4.4
	Depressed						
	Tunnel	3.3	4.3	7.6	-	-	-
	Total	4.5	6.1	10.6	4.5	5.9	10.4
Costs (£m, 1973)	Construction	72.1	137.0	209.1	39.6	45.9	85.5
	Land & Services	37.6	11.8	49.4	56.5	33.9	90.4
	Land Compensation	0.8	0.9	1.7	3.4	3.6	7.0
	Total	110.5	149.7	260.2	99.5	83.4	182.9
	Total/km	24.6	24.5	24.5*	22.1	14.1	17.6*
Constr/km	16.0	22.5	19.8*	8.8	7.8	8.2*	
Land Require- ment(Ha)	Permanent	8.0	10.6	18.6	26.0	35.0	61.0
	Additional Temporary	1.5	0.7	2.2	-	-	-
Properties	Buildings Demolished	690	300	990	1028	460	1488
	Buildings Acquired	34	17	51	117	104	221
	Total	724	317	1041	1145	564	1709
	Houses Soundproofed	21	554	575	816	1520	2336
	Additional Soundproofing				School, 2 Hospitals Public Hall	2 schools Community Centre	East & West
Time for Construction (yrs)		5½	5-5½	5-5½	4	3-4	4

* average value

Table 2.10 Data for Comparable Tunnelled and Surface Roads in South London. (Compiled from G.L.C., 1973, and H.M.S.O., 1972 a and b, and 1974).

Type of Road		Included in Costs	Cost (£m/km)	Source of Data	Comment
Tunnel or Surface	Accommodation				
Surface	3 lane	Road only	1.2-12.5	James (1972) Pool (1975) Stone (1970)	Cost depends on Urban Density & Land cost.
	2 lane	Road only	0.5-5.9	O'Reilly & Munton(1972)	
	3 lane	Including Junctions	14.1-22.1	G.L.C.(1973)	South London
Tunnel	3 lane	Tunnel & Fittings	6.7-11.5	O.E.C.D.(1970) O'Reilly & Munton(1972)	Free air costs Depend on Ground conditions
	2 lane	Tunnel & Fittings	6.6-11.8	O'Reilly & Munton(1972)	Free air
	3 lane	Including junctions	24.5	G.L.C.(1973)	South London

Table 2.11 General Costs of Surface and Tunnelled Roads at 1973 prices.

CHAPTER 3

GEOTECHNICAL SITE INVESTIGATION IN URBAN DEVELOPMENT

3.1 Development of the Urban Plan

A consideration of the aims and purposes of urban planning would indicate that individual structures are designed so that they perform their intended function in a pleasant, safe and economic manner. Planning has been identified as an economic process in which factors influencing the cost of individual elements are reflected in the global economics of urban development. In order to examine more closely any interaction between the geotechnical character of the ground and the style of urban development it is helpful to follow the stages of development of an individual structure. Engineering construction usually takes place in several stages by a procedure illustrated in Figure 3.1. Four sequential stages are given in this Figure: the development plan, initial plan (of the structure), detailed design (of the structure), construction (of the structure) and monitoring of the behaviour (of the structure).

The planning processes - already outlined - will be employed to identify the desirability, purpose and location of the structure in question. But unfortunately the investigation of ground conditions, so necessary for efficient foundation design, is not often undertaken until fixed urban development proposals have been formulated. Such a procedure obviously hinders the influence that geotechnics and any ensuing analysis might exert on the plan since other locational

factors such as, for instance, journey time are allowed to take precedence. This situation may change, especially in the United States where, by the insistence of the Federal government, environmental impact studies are performed prior to all major Federal projects. In the United Kingdom, no similar statutory obligation rests with the developer, and during the preparation of many plans little consideration is given to the character of the ground. As an example one may quote the cost benefit analysis used as planning guidance carried out for the Third London Airport (H.M.S.O., 1971b) in which, instead of an effort being made to isolate costs due to ground conditions, only general construction costs were considered. This failure to use geotechnical information during planning urban development has been criticized by Price (1971) and the geographical location of new towns such as Skelmersdale and East Kilbride in areas which are subject to ground disturbance due to mining may be cited as further examples.

Once the need for the structure is identified and a location chosen, then it is designed, built and monitored. The type of structure will be dictated by the requirements of the plan, but the actual design will mainly depend also on geotechnical and architectural considerations. At this stage there may be so much uncertainty regarding the ground conditions that even initial foundation design is precluded. Some data collection may be contemplated as shown in Figure 3.1, or alternatively more than one foundation type may be considered.

Several foundation options will usually be available for a particular structure. The criteria employed to appraise these will

depend on the type and function of the proposed structure, the nature of the foundations being contemplated, and the ground conditions.

Structures built to special standards of post-constructional total and differential settlement are not outside the scope of this discussion, but it is considered that such buildings seldom figure prominently in urban development. Therefore, the performance of a foundation may be measured by:

- (i) its load carrying capability;
- and (ii) the resulting limitation of total and differential settlement.

When the type of structure and the basic foundation requirements have been defined, then site investigation for the derivation of geotechnical parameters relevant to the prediction of the performance of the foundation can be initiated. Following detailed design based on the findings of this exploration of ground conditions, contractors are invited to tender for the construction of the structure. The subsequent constructional period offers a greater opportunity for examining the ground conditions but less latitude for changing the design accordingly. However, at this time - and indeed, after construction has been completed - the behaviour of the structure and of the area affected by it, should be monitored. Such measurements of performance may well be obtained by instrumentation, or simply by the extent to which the structure meets its design requirements. In this way, and also by the preparation of constructional reports of the type advocated by Roberts (1973), assertions concerning the interaction of the ground and the foundations may be tested. Constructional reports can be used to ensure that the construction was

carried out in the manner prescribed by the design and also to guide any subsequent modifications or remedial measures made to the structure.

The value of information derived from the actual construction cannot be over-emphasised since it forms the basis of logical improvements in the design process through engineering experience. Such (arguably quite logical) procedures have been advanced by Terzaghi in his 'observation method' of soil mechanics analysis described by Peck (1969). As an example, the case of an embankment failure at Waltons Wood in Staffordshire, reported by Early and Skempton (1972), may be considered. Here the analysis of the failure led not only to a re-designed embankment, but also to a complete re-appraisal of the thinking on the properties of clays subjected to large displacement slides.

The appearance of unexpected settlements, foundation heaves, or other unforeseen phenomena must reflect unfavourably on the design and prediction methods adopted. If this occurs during construction, then it may be possible to alter the design, albeit at the client's expense. More serious deviations from predicted behaviour might necessitate remedial measures being applied to the structure. Such action occasioned by faults in the design is liable to be expensive to rectify and, as noted by Roberts (1973), is likely to become more so the later that it is necessary during the construction process. In the case of the Tyne vehicular tunnel constructed in the north-east of England, a collapse of the working face of the pilot tunnel during its formation suggested that it would be

necessary to undertake an extensive ground treatment programme prior to the widening of the tunnel to its full operational width. With this improvement of the character of the sediments around the tunnel, and the raising of the air pressure during construction, the main tunnel was successfully enlarged without further failure (Falkiner and Tough, 1968). Similar constructional and other difficulties, caused by a failure adequately to predict the geological or geotechnical conditions on the site are not uncommon and have caused Rawlings (1972) to conclude that an engineering geologist would be a worthwhile addition to the staff employed during large construction programmes. This is a somewhat obvious and facile comment which frequently appears in the engineering geology literature and is said at conferences. It is tacitly assumed that the engineering geologist can always offer worthwhile advice, and that many of the monumental failures would never have occurred had his experienced opinion been sought at the outset. In some cases this may be true. The engineering geologist may be able to draw on and extrapolate from his past experience. But worthwhile opinions usually demand objective predictions of the behaviour of the proposed structure and also that of the affected ground, and for these predictions to be meaningful at all stages of engineering construction, they must be backed up by economic arguments. Many engineering geologists just do not have that numerical expertise, nor even a numerical interest.

However, the remedy adopted by a civil engineering contractor faced with unpredicted ground conditions which adversely affect the work being undertaken, might also be used to indicate the additional costs liable to be incurred. The fact that a contractor engaged by a consultant for a client cannot be held responsible for events

which he neither took nor could be expected to take into account in preparing his tender is recognized in the standard conditions of contract (Institution of Civil Engineers, 1973) currently being used in Great Britain. Although such tenders are now usually subject to a variation of price formula, it is to the effect of unfavourable site geology on the overall tender price that we now focus our attention. Under Clause 12 of this contract, this type of additional contractual expenditure incurred by an experienced contractor becomes the burden of the client provided that both parties are satisfied that the adverse conditions could not have been predicted and agree to the measures taken to overcome the difficulty thus caused. So, the extra cost occasioned by unforeseen ground conditions could be used to indicate the relative economic severity of any failure of the theory, or of the available geotechnical data, to facilitate an adequate prediction of the engineering behaviour.

3.2 Geotechnical Site Investigation

From the earlier discussion on the stages of development between the inception of the plan and the actual construction, it is evident that each stage should benefit from the injection of geotechnical data. However, on only relatively few occasions could extensive site investigation be justified before the foundation requirements are known. In fact, in few - if any - but the largest geotechnical site investigations is it feasible to organize the work in phases so arranged that early results condition later stages. Nevertheless, the ideal site investigation, as outlined by Fookes (1967), would consist of at least three phases:

(i) preliminary;

(ii) design;

and(iii) constructional.

It should be noted that these phases do not correspond to those of Figure 3.1 since here an individual site investigation is being considered. Hence, no special provision is made for data collected for planning purposes, but such data would in any case be of a preliminary nature. It is assumed that sufficient information will be obtained during the second stage of investigation in order to obviate the need for data collection specially occasioned by modifications to the design. Also, information derived during construction is entered as a separate stage in the work.

Generally speaking, the preliminary part would comprise a desk-study of existing information. Dumbleton and West (1970) have listed many sources of suitable data for this operation including maps, memoirs and published reports. Next, an effort will usually be made to determine the physical character of the ground to be affected by the proposed structure. Lastly, as geotechnical data become available during construction, or to amplify the previous ground exploration, or to solve problems which have arisen during construction, a further stage of site investigation may be undertaken. With the type of site investigation necessary for the large scale development entailed in the execution of an urban plan, the opportunity arises to initiate low-density geotechnical exploration early in the formulation of that plan. Only with the existence of such data is it possible to produce plans for development and site investigation conditioned by a prior knowledge of the ground conditions. This approach to engineering construction in which the geotechnical character of the ground is considered at

each stage of development from the plan to actual construction is demonstrated in Figure 3.1. Further arguments concerning the presentation of geotechnical data to planners and the storage of geotechnical data are presented later in the thesis.

Obviously the amount and type of information related to the ground conditions will depend on the stage of development. To some extent this is indicated by the data sources relevant to a particular part of the investigation in Figure 3.1. Here the investigation methods are arranged in order of cost since, in general, the more progress that has been made along the path from plan to actual construction, the more specific the data that is required and the more expensive becomes the collection operation.

3.3 Planning of Site Investigation

The procedures of urban planning and development have been identified as economic processes. Those of site investigation are no less so. On the one hand, the cost of investigating a large area, to the extent that further pre-constructional data acquisition is unnecessary before the plan has been finalized, would be prohibitively expensive. On the other hand, it has been shown that some geotechnical data available during the planning stage could result in more economic development. It is clear, from remarks made by Price and Knill (1974), that little guidance is available for specifying the amount of data which could benefit any particular stage of development.

So far as individual structures are concerned, the British Standards Institution (1957) recommends that about $\frac{1}{2}\%$ of the total costs should be allocated to site investigation. But there has been a

recent trend to greater percentage allocations than this, particularly where high-risk, important or expensive structures are considered. However, large variations in the allocation of resources are illustrated by Table 3.1, compiled by Rowe (1972). Although any increase in resources available to site investigation could, in part, be a reflection of its labour-intensive nature, it must also indicate a sharpening awareness of the role that geotechnical exploration can play in overall cost economy. The main influences on site investigation expenditure have been suggested by Price and Knill (1974) to be five-fold:

- (i) type of engineering structure - tolerable levels of stress and required factor of safety;
- (ii) volume of natural materials to be affected by the proposals;
- (iii) complexity of the geology and hydrology of the site;
- (iv) accessibility of existing relevant geotechnical information;
- (v) other factors affecting the economics of construction - such as the investment programme and timing.

In determining the scale of investigation, these authors have measured the ratio of the total volume of ground affected by the proposed structure to that sampled during the investigation, and found values between $10^4\%$ and $10^6\%$. Small engineering projects have the largest percentages of sampled material and large projects such as dams have the lowest percentage volume of samples. The authors do not advocate that resources for geotechnical exploration should be allocated on the basis of percentage sample volume, but they do suggest that levels should be no lower than $10^5\%$ in most site investigations.

Even when a suitable scale of site investigation has been agreed, the allocation of resources within it may be subject to much uncertainty.

Although the practices of ground exploration prior to construction are well established, little guidance of organisation is available. This point is demonstrated by the paucity of relevant literature which consists of either rather vague recommendations by various bodies and people, or case histories from which, by extrapolation, it is tacitly assumed that the reader will solve his own problems.

The most authoritative works on geotechnical site investigation by the British Standards Institution (1957), the American Society of Civil Engineers (1972) and the Geological Society of London (1972) indicate that it should embody the following principles:

- (i) the site should be suitable, or should be capable of being rendered suitable for the intended purpose;
- (ii) an economic design fulfilling the requirements should be possible for the structure;
- (iii) there should be no adverse affects on other structures or facilities.

In order to ensure that the planning proposals for a particular structure do not infringe these principles, the physical properties of the ground are used to predict the interaction of the structure and the ground. The actual parameters chosen for this can be critically important, having a profound influence on the cost and technical quality of the investigation. Therefore, any attempt to justify site investigation in economic terms should also include an identification of the most suitable means of carrying it out.

The need that urban development has for geotechnical information itself changes as development progresses. This is a natural progression, beginning with ignorance and continuing in an atmosphere in which more and more specific data items are collected. Clearly, at any stage

of development too little geotechnical information will result in a design suitable for the worst situation than can be expected. In general, such solutions will be more expensive than ones that are calculated from the actual conditions. It follows from this that the degree of ignorance concerning geotechnical restraints can be used as the justification for, and cost controller of, site investigation.

3.4 Geotechnical Planning Process

The strength, compressibility and condition of strata to be affected by urban development comprise a group of factors which contribute to the locational suitability of structures within an urban plan. Since the practices of cost benefit analysis figure prominently in planning procedures, the difficulties ascribed to siting structures in places providing less than perfect foundation conditions may be most usefully expressed in economic terms. Hitherto, geotechnical considerations have performed only a minor rôle in the overall planning process and geotechnical data upon which planning decisions can be made have either not been available, or have been expressed in an unsuitable form. Several areas of need which would aid the development of a rational involvement of the geological and geotechnical character of the ground in urban development planning are thus defined:

- (i) data to be available early in the planning process;
- (ii) data to be readily usable within planning procedures;
- (iii) development of a resource allocation rationale for site investigation.

These three topics are mutually interactive, but for the operation of all three, geotechnical data acquisition storage and processing are

required. Even in the absence of any pre-existing data - an expected condition in an undeveloped area - data storage and processing of ad hoc investigation data will be necessary if it is to influence the plan.

The interaction of geotechnical considerations in urban development can best be achieved by the reduction to a common base of all factors affecting location. In an urban plan most of the available land will be allocated for purposes such as housing, industry, commerce, transportation, utilities and recreation. So, by calculating the unit costs applicable to relevant types of foundations, roads, site levelling, utilities and overall site development for (in the case quoted by Hunt (1973)) swelling clays, soft rock and hard rock, the total cost of development can be assessed for any particular arrangement of urban facilities in the plan.

During the previous sections of this chapter, three contributions to the global costs of urban development arising from a lack of geotechnical knowledge have been identified:

- (i) costs due to the changes in the plan or design of the structure, and also due to any remedial measures to the structure occasioned by a failure to predict fully the ground conditions or the behaviour of the structure;
- (ii) the cost of performing geotechnical site investigation at each stage of development;
- (iii) the additional construction and material costs due to an unduly conservative design.

Overall project cost economy may be achieved by a balance between these individual costs. Obviously, some investment in site investigation limits both the likelihood of failure (and of claims under Clause 12 of the Conditions of Contract (Institution of Civil Engineers, 1973)),

and also the attractiveness of large safety factors. However, it is axiomatic that the implied expenditure must be identified.

In order that geotechnical considerations may form an integral part of urban planning, decisions must be formulated on the basis of design-dependent exploration of ground conditions. The operation of such a programme would require not only data feed-back to test the validity of decisions, but also as a contribution to any ensuing data capture.

Hence, two areas of need are identified. If geotechnical data are to influence all the stages of the development, then such geotechnical data must be available in a format that is readily understandable. It should be possible to organize the investigation so that existing data may influence and supplement later findings as well. Secondly, some means must be developed whereby, in choosing a suitable level of site investigation, overall cost economy is achieved for the stage of development concerned.

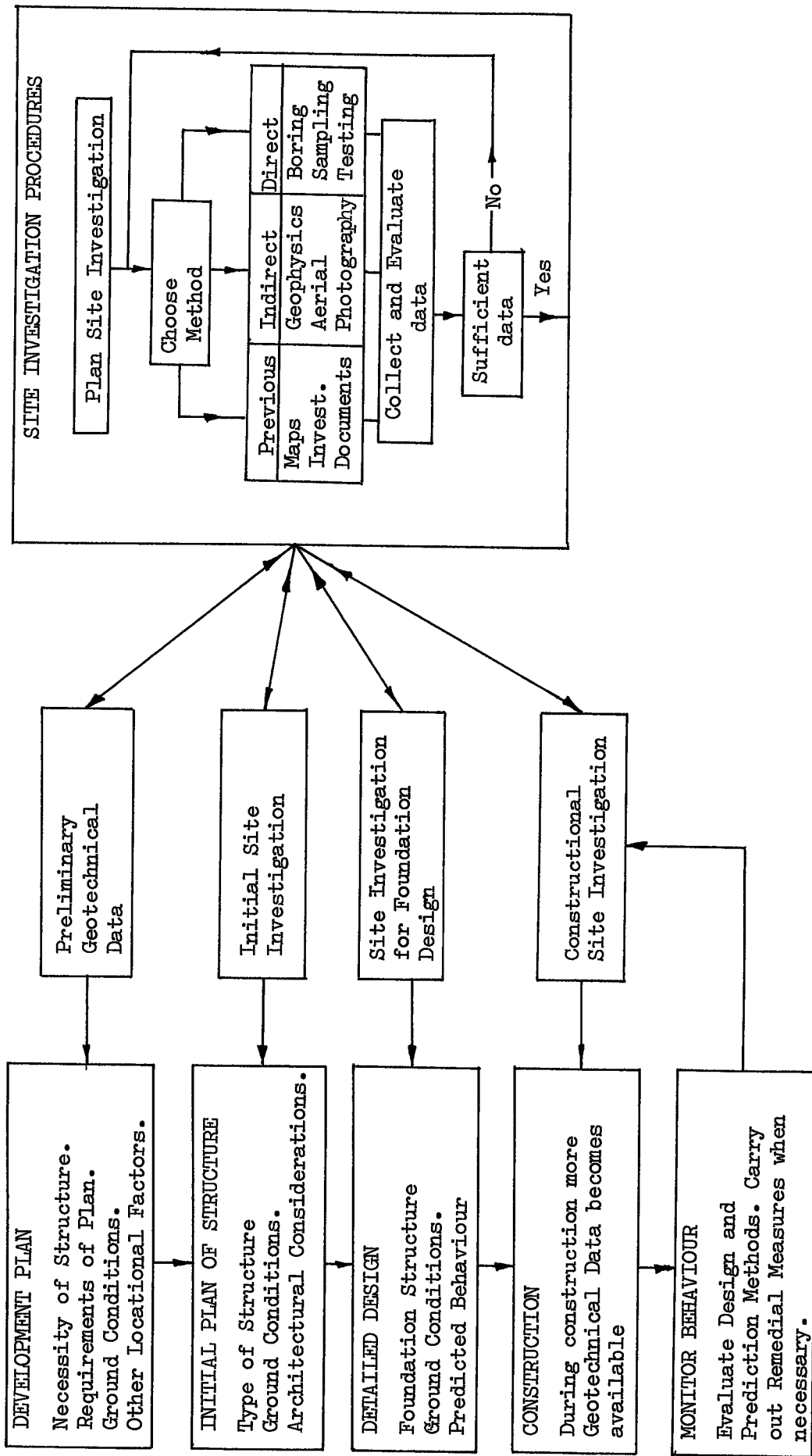

Figure 3.1 Procedure for Urban Development and the Interaction of Site Investigation Data

Type of Structure	Allocation of Resources to Site Investigation % Total Project Cost
Earth Dams	0.89 - 3.30
Railways	0.60 - 2.00
Roads	0.2 - 1.55
Docks	0.23 - 0.50
Bridges	0.12 - 0.50
Buildings	0.05 - 0.22
Embankments	0.12 - 0.19

Table 3.1 Allocation of Resources to Site Investigation
(after Rowe, 1972)

CHAPTER 4

APPLICATION OF PROBABILITY CONCEPTS IN GEOTECHNICAL ENGINEERING

4.1 Problems Associated with the Organization of Site Investigation

The geological or geotechnical environment has been demonstrated to be an important influence on the cost of tunnels. Although other elements in an urban plan may not exhibit the same degree of sensitivity, any study of the ground conditions may enter the planning process as a factor influencing the cost of locating a structure in a particular position. Thus, if a cost penalty due to less than ideal geological or geotechnical conditions is defined, then this may be used within the planning process for comparison with other factors affecting location. Such a cost penalty would necessarily include not only the additional costs of special foundation structures, and ground treatment, but also of investigating the ground conditions to the extent that a sensible design is possible.

Although most geotechnical site investigations share the same objectives of identification, quantification and prediction, each is unique due to the possible variety of ground conditions and structures. This lack of uniform purpose hinders the establishment of a meaningful rationale for the work. However, it is desirable that all site investigations, whether carried out for planning purposes or prior to foundation design, should promote overall cost efficiency. Thus, assuming a safe design is possible, ground exploration may only be justified by a reduction of global costs.

Hitherto it has been common for the resource allocation to ground exploration work to be a fixed percentage of the total project

costs. Rowe (1972) has observed that cost estimates for firm site investigation proposals might be more reliable than the competitive quotations generally used in the selection of ground exploration method. The dangers of offering and accepting fixed price contracts for site investigation in areas, the geological and geotechnical character of which is little known, are well recognized, and there are strong arguments for adopting a more open-ended approach. But even accepting that high professional standards would be applied, this style of site investigation would undoubtedly show increased expense, and unless a more economic design could be produced as a result of a more comprehensive investigation then it would not be worthwhile.

As an example of the difficulty of allocating resources in a fixed price site investigation, it is useful to refer to the investigation for 177 kilometres of road in Fiji as described by Lovegrove and Fookes (1972). These authors attempted initially to assign money to each part of the work according to its original cost. In doing this, they find that no more than £233 (at 1973 prices - see Table 2.2) was allocated for site investigation to each of forty-nine bridges. This figure can only be regarded as paltry and irreconcilable with the cost of the completed structures.

From the earlier consideration of geotechnical site investigation it is clear that the site characteristics, the type of structure, the existing geotechnical information, and the ground conditions are the main factors which should be considered during any allocation

of resources to the activity. Since the structure is only one of several factors, it would not appear sensible to use this as the sole basis for resource allocation. As shown by Lovegrove and Fookes (1972), completely misguided assignments can occur by adopting this approach.

4.2 Probability Approach in Site Investigation.

Since every site investigation is unique, it is not possible to lay down hard and fast rules governing the type or extent of the work. The aims of most site investigations comprise identification, quantification and prediction, but this latter objective can only be attempted with any degree of confidence when the first two elements of the procedure have been successfully accomplished. In order to ensure the most efficient use of global resources, extensive prior investigation needs to be justified in terms of a reduction in construction costs. In practice, this fundamental comparison between, on the one hand, the expense of increased study of geological and geotechnical conditions and, on the other, the saving in terms of reduced construction costs is very difficult to achieve. However, there are means whereby the boundaries of the problem can be more rigorously specified and the problem itself subsequently analysed using probabilistic methods. Measurement of the economic advantage gained by a reduction in geotechnical uncertainty in terms of a reduced likelihood of failure can enable the engineering geologist to make a proper comparison between the cost of site investigation and the consequent probable reduction in construction costs. Although emphasis is placed on the minimization of costs in

civil engineering projects, it should be stressed that the contention in the present argument is not that the cost of site investigation should be limited in any arbitrary way but that the actual procedure should become more efficient through design optimization on a cost-benefit basis.

Such a more scientific approach to the examination of ground conditions can also be used to determine the relative merits of different geotechnical sampling and testing schemes, but its adoption is most valid in large scale projects where there is greater opportunity for economies to be made. The main applications of the probability approach to site investigation can be summarized under four headings:

- (i) formalization of decisions based on preferences;
- (ii) combination of existing and new data;
- (iii) examination of the relative merits of collecting more and different data;
- (iv) communication of design strengths and tolerances between different workers so that the addition of a new safety factor each time is avoided.

In order to identify by a numerical method the best course of action when presented with a choice - for example, of what type of site investigation to adopt or what method of testing to use - it is necessary to define a suitable utility the value of which changes with what decision is taken. By definition, the value of the utility reaches a maximum when the decision optimizes. Sometimes the utility may be quite arbitrary and is chosen to represent subjective preferences. Otherwise - and as is more usual - it will be cash-based.

The utility of a particular decision can be derived from the utilities of all the outcomes of that decision weighted with the probability that each will occur. In general, for any decision, the outcomes dependent on the controlling variables might well be infinite, but as pointed out by Lumb (1974) it is only really feasible to consider a restricted number. Often, the value obtained for the utility is presumed to be proportional to the total cost attributed to the outcomes, and although in most cases this presumption is valid, it is dangerous to assume that it is always so. The actual relationship, which has been discussed by Benjamin and Cornell (1970), depends mainly on the resources of the decision-maker relative to the likely losses. Consequently, it will generally be found that the significance of a loss will be less for a large company or organization than for a small one.

In the subsequent analysis, the utility will be used as a loss function so that the optimum decision coincides with a condition of zero error in the geotechnical parameter measurement. Thus, it can be a continuous function of the extent to which the true value of a parameter (\bar{x}) deviates from the one adopted for design purposes (x_a) as, for example, in the particular expression that is given in equation 4.1. Of course, zero error in a geotechnical measurement, or a near approach to this condition, is an unlikely outcome of a practical site investigation. Such extensive explorative work is unlikely to be justified when the best option is defined by the minimization of global costs. If a linear relationship with cost is assumed, the utility becomes a direct measure of the economic penalty due to error in the determination of a geotechnical parameter. But in applying this

penalty, the entire cost of the investigation into and execution of remedial measures must be included. Such loss functions related to foundation failure have been derived by Rosenblueth (1969) who considers that they should include local and national taxation factors, rent and a consideration for the loss of prestige to the civil engineering operatives and to the owners of the structure that has failed or is at risk. He concludes that the appropriate compensation for the lack of a service should be ten times the normal charge for that service. The magnitude of such a compensation factor is arguable and will tend to vary from place to place. In practice, it is probably valid to include only those costs which are directly attributable to the outcomes of the decision rather than to use speculative losses and arbitrary multiplication factors.

The continuous utility or loss function can take a variety of forms depending upon the geotechnical circumstances. In the case, for example, of structural settlement, Rosenblueth (1969) suggests that the economic loss might be proportional to the square of the degree of settlement (see also Turkstra, 1970). At large settlements, however, it would be reasonable to expect this quadratic function to become progressively less accurate and for the rate of loss to decrease somewhat. The quadratic utility function applies where equal loss will result from positive or negative error in the determination of the parameter. Such a relationship, of which the one drawn in Figure 4.1 is an example, takes an equation of the form:

$$\text{Utility, } U = a_0 + a_1 (\bar{x} - x_a)^2 \quad \dots \quad 4.1$$

where a_0 is a constant which is generally taken as the original cost

of the structure and a_1 is another constant which relates the chosen factor $(\bar{x} - x_a)^2$ to a particular cash value. For the example of the quadratic utility function in Figure 4.1, a_0 is equal to -£10,000 and a_1 is -0.07£ per unit (error)².

Both constants in equation 4.1 usually take the negative sign because they represent a cash outlay. It should be noted that the value of the utility, U , reaches a maximum equal in value to a_0 when the error is zero. This is the minimum expenditure possible, and must equal the original cost of the project. The analysis of settlement, especially where differential movement is expected, often calls for the use of a quadratic utility equation since both under- and over-estimation of the magnitude of the disturbance may necessitate reinstatement work. Frequently, however, it will be found that over-estimation of the parameter will produce only a small possible saving due to the resulting increase in the safety factor as a consequence of the reduced likelihood of failure, but, on the other hand, a large financial loss is probable when the error is positive. In such situations, an exponential utility of the form also illustrated in Figure 4.1 can often be used. In this example, as for the quadratic case, a_0 is -£10,000 but this time a_1 is -0.04 £per unit (exp [error]).

The choice of a suitable utility should be a very important element in the investigation design analysis, since it is only part of the probabilistic procedure in which an assessment of the economic consequences is made. Several utilities, or utilities consisting of several parts, may be required for an adequate description of complex situations. Where the likelihood of failure occurring in the future

is to be considered, then the utility must also be expressed as a function of time.

4.3 Probability Distributions.

Consideration of utility has shown that its value for a particular decision can be determined from the utilities of the outcomes and their respective probabilities. However, when a variable has both a mean value and a distribution, so that it may lie between certain limits, then it may be expressed in terms of a probability density function. The form taken by this function depends upon the variable itself, but from it the probability of the variable taking a particular value can be calculated. It follows that the expected value of a utility, for a particular decision which depends upon a geotechnical parameter and which has a probability distribution, can also be determined.

The development of the probabilistic procedure requires that it should be possible to combine existing data with new data. Variables expressed as probability distributions can thereby be modified by new information as it is acquired. In practice, this modification can be achieved either before or after new information has been collected, and hence, if done before, can be used to assess the economic advantage of collecting more data. Since in all but a few foundation situations the actual loadings will not be known precisely, it is helpful to describe this variable as a probability function in the particular analysis of foundation stability. Other uncertain factors such as live loads, particularly those due to wind and seismic activity, can also be dealt with in this manner. Other examples might range over the whole field of geotechnical engineering.

The theoretical background for combining probability distributions of variables is based on Bayes' theorem which Cramér (1954) derives

from a consideration of conditional probability. If F denotes the as yet unknown true distribution of the variable x , so that the true probability of x is $F(x)$, and F' is one of the probable distributions implied by the result of an experiment, then the probability distribution over all possible F derived from testing can be used to assess how likely any original - or prior - distribution of the variable is to be the true one.

The joint probability distribution of the true distribution F and the apparent distribution F' is given by:

$$P(F, F') = P(F|F') P(F') \quad \dots \quad 4.2$$

where $P(F|F')$ is the conditional probability of F , given that F' has been implied by an experiment. But the probability of the distribution F' conditioned by F is $P(F'|F)$, and

$$P(F'|F) = \frac{P(F, F')}{P(F)} \quad \dots \quad 4.3$$

Combining equations 4.2 and 4.3 gives the posterior distribution of the variable so that:

$$P(F|F') = \frac{P(F'|F) P(F)}{P(F')} \quad \dots \quad 4.4$$

Now $P(F') = \int_{-\infty}^{\infty} P(F'|F) P(F) dF$, where the integration is performed for all the F domain, and so the posterior distribution is given by:

$$P(F|F') = \frac{P(F'|F) P(F)}{\int_{-\infty}^{\infty} P(F'|F) P(F) dF} \quad \dots \quad 4.5$$

Using equation 4.5, the posterior distribution of an unknown distribution F can be obtained from a prior probability distribution and a distribution derived from observation or testing.

In this Chapter, the probability of a parameter, which is conditional upon the values of a number of other parameters, is written in the form

P(Parameter|List of Conditional Parameters) where the conditional parameters are listed in the order of their determination and separated by colons.

The derivation of the prior probability distribution is an extremely important part of the analysis, and it raises a principal objection to the use of Bayes' theorem for combining prior and test data. Although, in theory, the analysis may be conducted without recourse to a particular type of distribution, it is usually necessary to assume one in order to perform the computation. This prior data is normally collected before any field studies are undertaken and is used in an initial appraisal of the proposed site investigation. Folayan et al. (1970) demonstrate how prior assessments of the consolidation characteristics of a clay, as supplied by different people, can be used to determine a suitable level of testing activity. At the same time, it is worth noting the consequence of adopting an inappropriate prior distribution. A narrow prior distribution will tend to dominate the posterior distribution and falsely, perhaps, suggest that it is uneconomic to perform tests. On the other hand, a very wide distribution will have no effect on the form of the posterior distribution. These arguments are justified mathematically in Attewell and Farmer (1976).

Analysis of geotechnical data from Tyneside (as listed by Marshall, 1969) suggests that the probability distribution of the cohesive shear strength parameter, as measured by undrained triaxial tests on 111 samples of the stony and laminated clays of the Team Valley area, follow a log-normal distribution. This distribution is shown in Figure 4.2.

In many situations, a normal or Gaussian curve will be more appropriate, a curve of this type being sketched in Figure 4.3 for data from 26 determinations of the tensile strength of coarse-grained Carboniferous sandstone. Similarly, Rosendiz and Herrera (1969) report that the coefficient of volume compressibility for clays from Mexico City and Chicago follows a normal distribution, although strength data on laminated clays from Tyneside have been found to follow a log-normal distribution.

It is difficult to conjecture upon those factors, both natural and imposed, which directly condition the form of distribution. In some instances, a discrete distribution such as the Poisson distribution, in which very many independent observations of a rare occurrence are made, is a common form of distribution. As a result, such events as storms or earthquakes can often be represented as a Poisson process. In the context of rock engineering, where the presence of discontinuities affects mass stability, the spatial distribution of the discontinuities is often determined using a scan-line technique. If each discrete element of a scan-line has an equal but small chance of intersecting a discontinuity, then these points of intersection constitute a Poisson process and the related spacings between intersections follow a negative exponential distribution (Priest and Hudson, 1976; Attewell and Farmer, 1976).

In spite of all these possibilities, the normal distribution is found to be a very useful form of distribution where prior data on a variable are to be combined with test data, since the conjugate of the distribution is itself normal. This property is proved to be real a little later in the text.

The test distribution may be found by fitting the results of measurements of the parameter to a hypothetical distribution. A normal relationship is appropriate if, when plotted on normal probability paper, the data lie on a straight line. This is demonstrated in Figure 4.4 where the data points from Figure 4.3 have been plotted on normal probability paper and a least squares regression line fitted. Log-normality can be tested in the same manner using normal probability paper if the logarithm of the parameter is used. These and other distributions can be fitted to data by the chi-square test, the method of operation being fully described by Cramér (1954).

The posterior distribution of a geotechnical parameter is derived from the prior and test distributions by means of equation 4.5. In the present analysis, normal probability distributions will be used for this and it will be further assumed that the standard deviation of the true distribution is known. Adoption of this approach does not invalidate the argument, since in general the analysis may proceed provided that a reasonable estimate of the value of this standard deviation is available. In order to perform the analysis in distribution space rather than in sample space, it is necessary to generate the form of the variation of the parametric mean. It is noted that in geotechnics, for example, a simple test for compressive strength or shear strength yields a value which is itself an average of the actual local strengths within the body of the material.

By taking x as the basic parameter, the true distribution being defined by the mean \bar{x} and standard deviation i , then a prior based on m tests - or subjective judgements - with mean \bar{x}_m will have a prior distribution:

$$P(\bar{x} | i : \bar{x}_m) = \frac{\sqrt{m}}{\sqrt{2\pi} i} \exp \left[\frac{-m(\bar{x} - \bar{x}_m)^2}{2i^2} \right] \dots 4.6$$

After more data have been gathered by testing n samples, so producing a distribution with mean \bar{x}_n , the prior may be modified by the test distribution given by:

$$P(\bar{x}_n | i : \bar{x}) = \frac{\sqrt{n}}{\sqrt{2\pi} i} \exp \left[\frac{-n(\bar{x}_n - \bar{x})^2}{2i^2} \right] \dots 4.7$$

Substitution of equations 4.6 and 4.7 for $P(F)$ and $P(F'|F)$ respectively as the numerator of equation 4.5 yields the posterior distribution:

$P(\bar{x} | i : \bar{x}_m)$ is proportional to

$$\exp \left[- \frac{1}{2i^2} \left\{ p(\bar{x}_p - \bar{x})^2 + n\bar{x}_n^2 + m\bar{x}_m^2 - p\bar{x}_m^2 \right\} \right] \dots 4.8$$

where $p = m + n$

$$\text{and } \bar{x}_p = \frac{m\bar{x}_m + n\bar{x}_n}{m + n} \dots 4.9$$

Thus, the posterior distribution is also normal, and is given by:

$$P(\bar{x} | i : \bar{x}_m : \bar{x}_n) = \frac{\sqrt{p}}{\sqrt{2\pi} i} \exp \left[\frac{-p(\bar{x} - \bar{x}_p)^2}{2i^2} \right] \dots 4.10$$

4.4 Expected Value of Utility.

Equation 4.5 provides a method of combining prior data with test data to produce a posterior function. If this procedure is carried out before any testing is undertaken on the basis of the prior distribution, then the benefit likely to accrue from testing can be assessed. This operation can be done for various types of probability distribution and utility function, and, in this instance, analyses for parameters following normal and log-normal distributions are performed. Since, in some cases, the derivation of the necessary equations involves many mathematical stages which would interrupt the text, they have been omitted. Instead, all the missing reasoning may be referred to in Appendix A where it is listed according to the final equation number.

For a random variable x , which follows a normal distribution, the expected value of the utility resulting from m assessments or measurements of x is given by:

$$U_m = \int_{-\infty}^{\infty} U P(\bar{x} | i : \bar{x}_m) d\bar{x} \quad \dots \quad 4.11$$

where \bar{x} represents the unknown mean value of the distribution. So,

$$U_m = \int_{-\infty}^{\infty} \left\{ a_0 + a_1 (\bar{x} - \bar{x}_m)^2 \right\} \frac{\sqrt{m}}{\sqrt{2\pi i}} \exp \left[-\frac{(\bar{x} - \bar{x}_m)^2 m}{2i^2} \right] d\bar{x} \quad \dots \quad 4.12$$

Here, i is the standard deviation, \bar{x}_m the mean of the m determinations of x , and the quadratic utility of equation 4.1 is used. Also, in this equation, the adopted value (x_a) has been assumed to equal the mean value \bar{x}_m ; this is usual in such analyses. Simplifying equation 4.12 yields:

$$U_m = a_0 + \frac{a_1 i^2}{m} \quad \dots \quad 4.13$$

It is thus possible to determine the economic gain, due to testing, from the standard deviation of the resulting distribution, the number of samples tested (or assessments made) and a constant relating the financial consequences of errors incurred to their severity. The value U_m so obtained is the expected loss due to uncertainty in the measured parameter x . The shape of the function defined in equation 4.13 is sketched in Figure 4.5, curve B.

When more sample testing is performed, so that a total of p determinations of the parameter is available, then the new value of the utility can be determined. When the number of tests is increased from m to p , the new utility value may be written:

$$U_{p|m} = \int_{-\infty}^{\infty} U_p P(\bar{x}_p | i : \bar{x}_m) d\bar{x}_p \quad \dots \quad 4.14$$

Since, from equation 4.13, U_p is independent of \bar{x}_p , it follows that:

$$U_{p|m} = a_0 + \frac{a_1 i^2}{p} \quad \dots \quad 4.15$$

As already mentioned, many geotechnical parameters are found to follow a log-normal distribution. Equations 4.13 and 4.15 may be used for plotting the changes in utility value in such cases provided that the quadratic utility remains appropriate with respect to the mean of the underlying normal independent variable, $x = \ln y$.

However, in situations in which a quadratic utility with respect to the mean, \bar{y} , of a log-normal distribution is chosen, more analysis is required. It may easily be shown that $\ln \bar{y} = \bar{x} + \frac{i^2}{2}$ (see Appendix A, equation A.10), from which it follows that if y is measured m times then the probability distribution of \bar{y} will be given by:

$$P(\bar{y} | i : \bar{y}_m) = \frac{\sqrt{m}}{\sqrt{2\pi} i \bar{y}} \exp \left[- \frac{m (\ln \bar{y} - \ln \bar{y}_m)^2}{2i^2} \right] \quad \dots \quad 4.16$$

where

$$\ln \bar{y}_m = \frac{1}{m} \sum_{j=1}^m \ln y_j + \frac{i^2}{2} \quad \dots \quad 4.17$$

Similar expressions also exist for the distributions of the most likely value of y and for the exponential of \bar{x} .

Consider a utility quadratic in \bar{y} of the form:

$$U = a_0 + a_1 (\bar{y} - y_a)^2 \quad \dots \quad 4.18$$

in which y_a is the value of the parameter adopted for design purposes. It follows that the utility resulting from m determinations of the Parameter is:

$$U_m = a_0 + a_1 \exp \left[2\bar{x}_m + i^2 \right] \left(\exp \left[\frac{2i^2}{m} \right] - 2 \exp \left[\frac{i^2}{2m} \right] + 1 \right) \quad \dots \quad 4.19$$

where again the adopted value has been assumed to equal \bar{y}_m as defined in equation 4.17. The change in utility due to a decision to increase the number of tests from m to p can also be determined by following the same procedure as was used for the normal distribution. The expected utility of equation 4.20 relating to a proposed increase in sample testing numbers has been obtained as

$$U_{p|m} = a_0 + a_1 \exp \left[2\bar{x}_m + 2i^2 \left(\frac{1}{m} + \frac{1}{2} \right) \right] \left\{ 1 - 2 \exp \left[-\frac{3i^2}{2p} \right] + \exp \left[-\frac{2i^2}{p} \right] \right\} \quad \dots \quad 4.20$$

The improvement in utility value due to an increase in sampling and testing from m to p can thus be calculated, under several different circumstances, from the sample number, the standard deviation, and a constant relating the economic consequences of errors to their magnitude. For parameters following either a normal or log-normal distribution,

equations 4.13 and 4.15 may be used where the quadratic utility is quadratic in \bar{x} . Situations in which the parameter follows a log-normal law, with a quadratic utility of the type in equation 4.18, require equations 4.19 and 4.20 to give the change in utility value. In addition to the parameters already mentioned previously, in this case the mean value \bar{x}_m of the distribution, is also required.

4.5 Merits of Sampling.

The cost of taking and testing soil or rock samples is expected to be a linear function of the number of samples tested, although in practice there may be a pricing system akin to quantity discounts. If the cost of taking and testing m samples is C_m , then the increase in site investigation costs when the number of tests rises from m to p will be:

$$C_p - C_m = k_0 + k_1 (p - m) \quad \text{where } p > m \quad \dots \quad 4.21$$

where the base cost, k_0 , of initiating a site investigation is incurred, and the unit cost of sampling and testing is k_1 . The cost of site investigation studies will then follow line A in Figure 4.5.

For a parameter following a normal distribution, the benefit of increasing the number of tests, in terms of a reduction in expected loss due to any geotechnical parameter uncertainty, can be found from equations 4.13 and 4.15. If the cash value is presumed to be proportional to the utility value, and a quadratic utility is adopted, then the general reduction in expected loss as sampling increases will be given by curve B in Figure 4.5, and the expected benefit will be given by curve C. This function, found from equation 4.13 and 4.15, can be expressed by the equation:

$$U_m - U_{p|m} = \frac{a_1 i^2}{m} - \frac{a_1 i^2}{p} \quad \dots \quad 4.22$$

It follows from equations 4.21 and 4.22 that the net economic benefit of increasing the number of samples tested from m to p will be:

$$V_{p|m} = \frac{a_1 i^2}{m} - \frac{a_1 i^2}{p} - k_0 - k_1 (p-m) \quad \dots \quad 4.23$$

Reference to Figure 4.5 will demonstrate that economic justification for further sampling will occur only where $V_{p|m}$ in equation 4.23 is positive. Should the cost of site investigation follow line D, so that it is always greater than the reduction in expected loss, then more testing will never be worthwhile. In general, there will be a range of values of p for which it is economic to perform more testing. After performing the substitution $k_0 = 0$, the range of values over which it is economic to increase the number of samples tested is given by:

$$m < p < \frac{a_1 i^2}{k_1 m} \quad \dots \quad 4.24$$

The maximum net economic advantage $V_{p'|m}$ of increased sample testing will occur when an optimum total number of samples p' is tested. This number can be found by the differentiation of equation 4.23 with respect to p, so

$$p' = \sqrt{\frac{a_1 i^2}{k_1}} \quad \dots \quad 4.25$$

In practical terms, this condition is satisfied when the slope of curve C is parallel to line A in Figure 4.5.

Since equations 4.13 and 4.15 may still be used for determining changes in utility value for a log-normal distribution when the quadratic utility in \bar{x} is used, the equations derived for the normal distribution also apply here. Hence, the range of the number of samples for which it is economic to continue testing is given by equation 4.24 and the

optimum number is given by equation 4.25.

When the quadratic utility defined in equation 4.18 is appropriate, the position is rather different, and equations 4.19 and 4.20 must be employed to determine any benefit to be derived from more sample testing. Unfortunately, the final equations do not assume such convenient forms as for the simple quadratic utility in \bar{x} , but solutions by numerical methods could be obtained for specific problems. By following the same procedure as in the previous case the expected net economic advantage, due to an increase from m to p in the number of samples tested, will then be:

$$V_{p|m} = a_1 \exp \left[2\bar{x}_m + 2i^2 \left(\frac{1}{m} + \frac{1}{2} \right) \right] \left\{ \exp \left[-\frac{2i^2}{m} \right] - \exp \left[-\frac{2i^2}{p} \right] \right. \\ \left. - 2 \left(\exp \left[-\frac{3i^2}{2m} \right] - \exp \left[-\frac{3i^2}{2p} \right] \right) \right\} - \left\{ k_0 + k_1(p - m) \right\} \dots 4.26$$

Thus, the range of values for p for which it will be beneficial to take samples will be given by substituting $V_{p|m} = 0$ in equation 4.26 and solving it for p . By differentiation, the optimum sample test number will be found by solving the following equation for p' :

$$\frac{a_1 i^2}{p'^2} \exp \left[2\bar{x}_m + 2i^2 \left(\frac{1}{m} - \frac{1}{p'} + \frac{1}{2} \right) \right] \left\{ 3 \exp \left[-\frac{i^2}{2p'} \right] - 2 \right\} = k_1 \dots 4.27$$

Equations 4.23 and 4.26 provide a means of assessing the economic benefit which may be obtained by sample testing. This can be performed during the time that boring and testing is taking place, and the consequent reduction in expected loss monitored. These equations may also be used to determine a satisfactory degree of ground investigation

prior to any boring or testing being carried out. Presuming that it is shown to be economic to undertake some finite degree of investigation, then the prior probability distributions used in the decision analysis can be combined with the probability distribution obtained from the testing. The necessity for a careful choice of a suitable prior probability distribution must be emphasised at this point since the use of one which is too narrow will always produce an under-estimation of sampling and testing requirements. Where normal distributions are used for the prior and test distributions, then the new mean can be derived from equation 4.9. Thus, a cyclic process is instigated, beginning with an amount of testing derived from a prior probability distribution which is generally subjective in nature. The process is continued with analysis of the test data and the derivation of the posterior distribution, which is then used as a new prior distribution in the analysis of the merits of more sampling. These operations are repeated until it is uneconomic to proceed further, at which stage the value of the required parameter is obtained.

4.6 Modified Investigation Procedure

Since it is possible to determine the economic advantage to be expected from undertaking a site investigation, it is also possible to determine the probable cost of - or incidence of - failure. This may be performed before any field work is carried out by attributing prior probability distributions to the unknown parameters and finding the optimum type of site investigation. After testing, the probability analysis enables the new data to be assimilated with the old, and a new assessment to be made.

There are three main objectives in the analysis of probability:-

- (i) to give an initial guide, from prior data which may be subjective, as to the most desirable level of site investigation activity in terms of the reduction of parameter uncertainty and consequent improvement in foundation design;
- (ii) to compare the relative economic merits of quite different site investigation schemes - in general, this will include the combination of objective and subjective data;
- (iii) to ensure that site investigation activity is optimized with respect to both the final foundation design and the cost of the operation.

The actual geotechnical site investigation method envisaged, in which the probabilistic approach is employed, would begin by identifying variables in the problem which require study. Prior probability distributions would then be established for each variable on the basis of previous experience, or by reference to similar problems elsewhere. Subsequently, the utility equations would be derived for expressing the severity of errors in each of the parameters.

Utilities giving the cost of determining each of these parameters would be needed to determine whether rock or soil samples should be taken, and the number of such samples or tests would also be derived. The test results would yield new probability distributions, which would then modify the prior distribution and yield a posterior distribution. A new prior equation would then be available which would show whether further sampling and/or testing could be justified. Thus, the procedure could be repeated until the optimum decision to minimize global costs is arrived at.

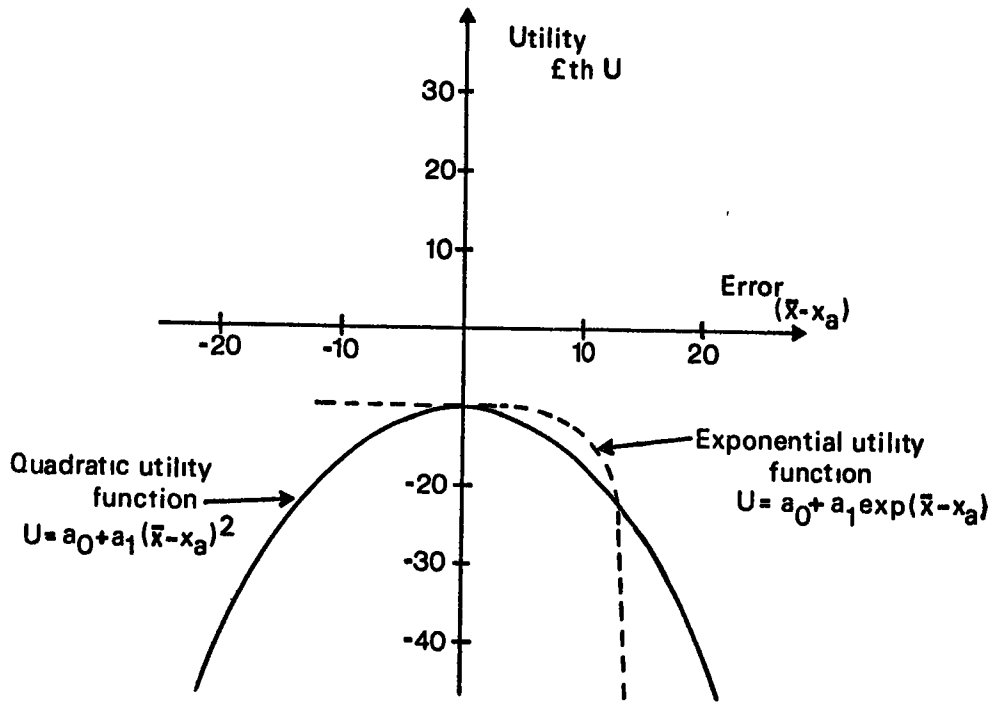

Fig. 4.1 Quadratic and Exponential Utility Functions.

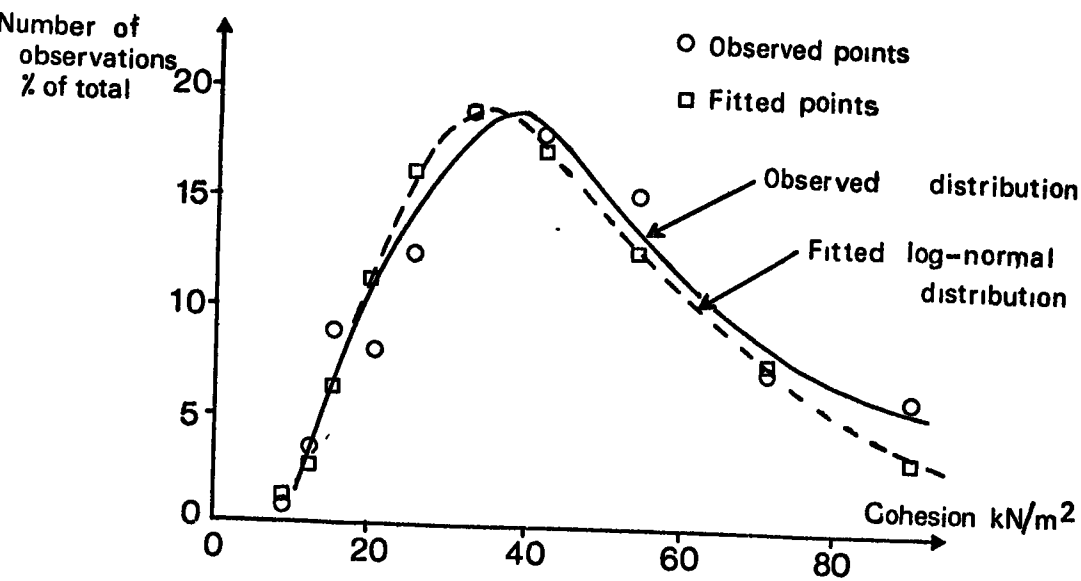

Fig. 4.2 Log-normal Probability Distribution of 111 Determinations of Undrained Shear Strength of the Stony and Laminated Clays of the Team Valley, Co. Durham.

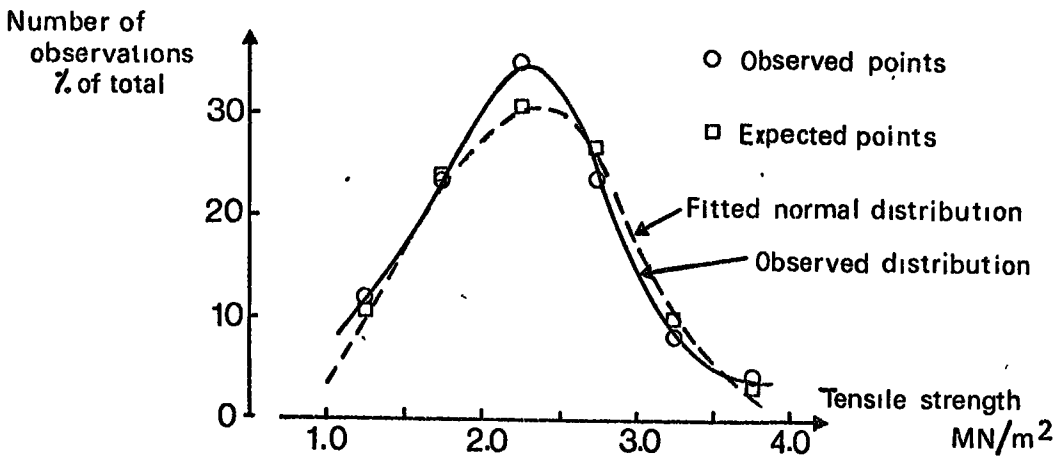

Fig. 4.3 Normal Distribution for 26 Determinations of the Tensile Strength of Coarse Carboniferous Sandstone by Brazilian Test.

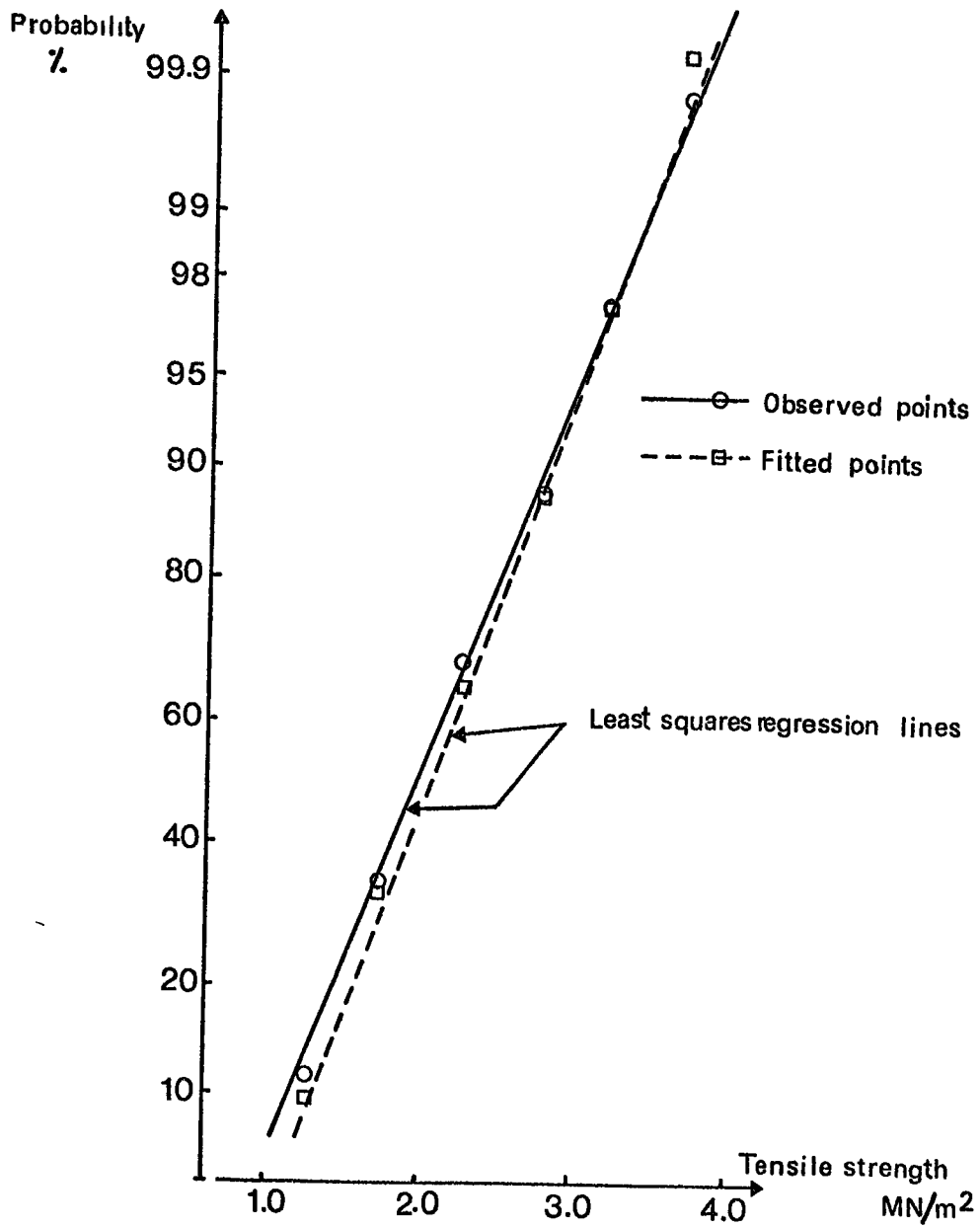

Fig. 4.4. Normal Distribution for 26 Determinations of the Tensile Strength of Coarse Carboniferous Sandstone by Brazilian Test.

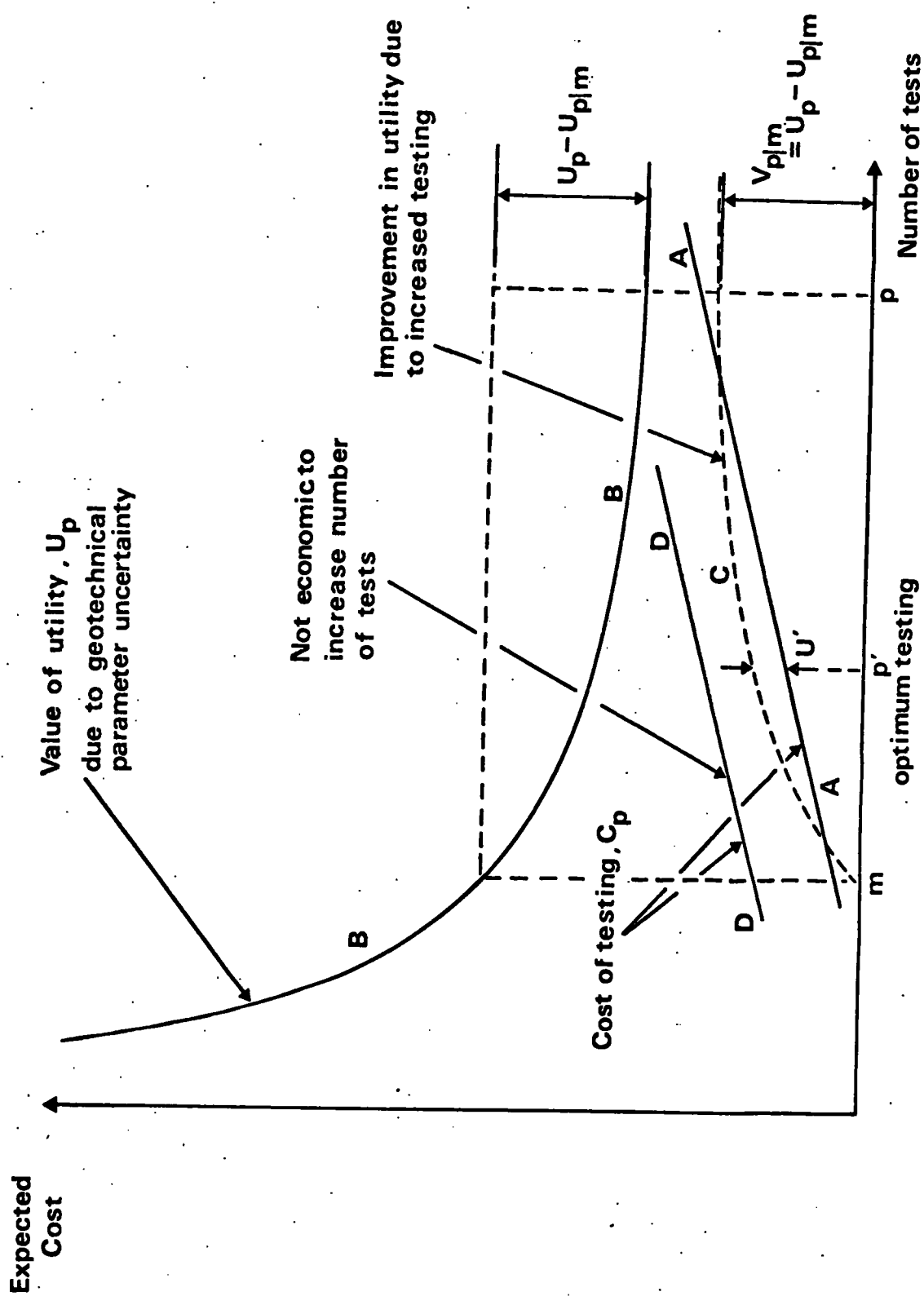

Fig. 4.5 Changes in Expected Loss and Cost of Site Investigation with Increased Sampling.

CHAPTER 5

CONSIDERATION OF GEOTECHNICAL DATA STORAGE

5.1 The Case for Data Storage.

The argument for the use of geotechnical data storage systems consists of three main points arising from previous sections of the thesis. Stated briefly, these are:

- (i) to alleviate the lack of geological and geotechnical data available for planning;
- (ii) to make available data for appraising the benefit likely to accrue from further data collection;
- (iii) to enable data collected early during the development process to influence later data and so that early data may be revised.

It is axiomatic that for the subject of - and established procedures in - engineering geology to make a significant contribution to urban planning as envisaged by Wolashin (1970), then the non-availability of quantitative geotechnical data in existing urban areas apparent from Attewell and Farmer (1973) and Ward (1972) must be remedied.

5.2 The Data Available for Storage.

Probably the most comprehensive list of sources of low cost, existing geotechnical and geological data has been compiled by Dumbleton and West (1971), who indicate that in British urban areas the sources fall into four main categories:

- (i) published maps and memoirs;
 - (ii) government bodies and the nationalized industries;
 - (iii) private industry, including site investigation operatives;
- and
- (iv) local authorities and utilities.

Thus, the data sources comprise maps, memoirs, site investigation reports, published works, photographs, and any available borehole, mining and mineral extraction records.

(i) Published Maps and Memoirs

The Institute of Geological Sciences publish geological maps at scales of about 1:60,000 for the whole of the United Kingdom with partial coverage at a scale of about 1:10,000. However, not all these maps show drift deposits and - as Taylor (1972) remarks - in many urban areas mapping has been hindered by existing development. Little engineering data are included in current geological maps and their accompanying memoirs.

(ii) Government Bodies and the Nationalized Industries.

Several sources of information are available:

- (a) the National Coal Board - records of existing mines, some abandoned mines, and advice about future mining trends;
- (b) the Department of Trade - records of non-coal mines and quarries;
- (c) the Water Resources Board - surface and sub-surface hydrological data;

and

- (d) the Transport and Road Research Laboratory - site investigation data obtained for road works.

(iii) Private Industry Including Site Investigation Operatives.

Practically all the quantitative geological information for urban areas is derived by specialist companies engaged in site investigation. Unfortunately, through constructional, financial and legal obligations, bodies are prevented from or are unwilling to part with, their findings. Practically the whole of the United Kingdom has been surveyed by

aerial photography, which can yield valuable information about the nature of the ground surface, topography, site access, drainage and dynamic geological processes.

(iv) Local Authorities and Utilities

Several data sources are available, as follows:

- (a) site investigation data for public works;
- (b) hydrological and boring records from area water boards; and
- (c) deductions resulting from existing buildings.

Clearly, from the foregoing text, the data available are of a diverse nature. A careful choice of storage system could ensure the retention and later retrieval of all the geotechnical data relevant to urban development.

5.3 Presentation of Geotechnical Data.

Considering the needs of persons engaged in urban development and the remarks of Hunt (1973), Table 5.1 depicts a logical approach to geotechnical data presentation. Thus a map for planning purposes, produced initially from existing data, is revised at each stage of development. But the 'site investigation report' format is retained for the specific data upon which foundation design is based.

In order to pursue further the question of geotechnical data presentation, it is necessary to define the terms 'map' and 'plan'. These are not mutually exclusive, differing from each other in respect of scale, and hence in the data detail displayed. Since, in the United Kingdom, country-wide coverage at scales of about 1:60,000 and 1:10,000 in geological maps is available, it would appear sensible to base

geotechnical maps on these scales. Geotechnical plans with scales of 1:5,000 have been produced by Kalterherberg (1974), and a scale of 1:1,250 is commonly adopted for the plans in site investigation reports.

Three forms of geotechnical data presentation may be used:

- (i) geotechnical maps;
- (ii) geotechnical plans; and
- (iii) geotechnical models of a physical character.

5.3.1 Geotechnical Maps

The fact that much of the existing qualitative data is in map format could suggest that this is also the most suitable presentation mode for all geotechnical data. However, quantitative geotechnical data are not easily processed into maps, which in any case can be misleading or confusing, although the necessary data density may be attained by overlaying transparencies of the type described by Chuzinov et al. (1970). This point may be demonstrated by considering two maps:

- (i) Figure 5.1 is a geological map with notes being produced by the Geological Society of London (1972). Here, a mixture of observation, inference, and sources of additional information is presented. The result is really a 'busy' muddle; interpretation for most purposes is impossible without substantial reference to further documents;
- (ii) Figure 5.2 is a contoured diagram of the variation in shear strength of clays, as drawn from Marshall (1969). Here, there is insufficient information to permit an immediately meaningful appraisal.

Some general remarks about geotechnical maps are appropriate. Most quantitative data are prepared on an ad hoc basis rather than as a systematic enterprise over an extensive area as it is mapped. Such

uneven distributions of the data can have a great influence on its usefulness. Near an area of previous data collection, good quality data may be available, but elsewhere in areas of extrapolation, the map may give an air of authenticity quite unrelated to the distribution and quality of the original data.

A brief perusal in the literature on the subject of geotechnical maps (Aisentein et al, 1974; Hunt, 1974; Janjić and Stepanović, 1974; Kalterherberg, 1974) indicates such a great variety of factors which might affect the suitability of an area for urban development that it is difficult to generalize about the most desirable factors to include on a geotechnical map. Because of this, the Geological Society of London (1972) recommends that data for supplementing the 1:10,000 topographical maps available for Great Britain should include all accessible information concerning the geological, geomorphological and hydrological conditions, seismicity, boreholes, site investigations and testing undertaken, together with the locations of mines, and quarries. However, the workers already mentioned, being engaged in the formation of geotechnical maps for the evaluation of a particular site for urban development, have all preferred to consider only a limited range of factors which enable planners to determine the economic impact of their proposals.

5.3.2 Geotechnical Plans

In general, the necessary data density restricts the production of geotechnical plans to those areas investigated for the design of foundation structures. As with engineering geology maps, it is difficult to give - or to find in the literature - general guidance concerning the information to be displayed. However, since in most

foundation designs the load bearing capacity and the limitation of total and differential settlement are the main considerations, the shear strength and the compressibility of the foundation material, and the water conditions, would appear to be of primary concern.

5.3.3 Geotechnical Models of a Physical Character.

Models are devices for visually representing in three dimensions, in an immediate and clear manner, any complicated geological or geotechnical conditions. Four types of model may be considered:

- (i) solid block - gives a series of intersecting sections on the outside of a block;
- (ii) three intersecting planes - used by Franciss and Puccini (1974); the model consists of three orthogonal intersecting planes and may be used for representing small areas;
- (iii) multi-section model - display is achieved by a series of sections drawn on to transparent perspex sheets. A model of this type has been produced from output obtained from the geotechnical data processing and storage system Geosys described later in the thesis; and
- (iv) borehole model - each borehole is represented by a scale section marked with the findings (usually by a colour code), and arranged on a map of the area of interest.

5.4 Methods of Data Storage.

Three methods of storing geotechnical data may be given the following titles:

- (i) index;
- (ii) register; and
- (iii) map.

These alternatives are arranged in order of increasing amount of data processing required before storage, and therefore are probably in order of real cost.

(i) Index System

The main features of the index system of geotechnical data storage may be listed as follows:

- (a) descriptions of available data are stored, the user referring to the original data, having been told of its existence by the index;
- (b) all types of data on maps and in reports may be retained;
- (c) can be operated by non-skilled personnel;
- (d) can be operated by manual or computer facility, but could become unmanageable when much data is to be stored by manual method;
- (e) key-word cross referencing in the description of the data is needed; and
- (f) the data is presented in an unchanged form.

(ii) Register System

The register system may be summed-up by the following points:

- (a) the actual data (albeit coded)⁺ are stored in the storage facility so that the output is obtained directly from it;
- (b) it is a method which suits the storage of site investigation, numerical, and other quantitative data;
- (c) the output can be specifically prepared to suit the intended purpose;
- (d) non site investigation report data can be accommodated by the reduction of the data to borehole analogues;

⁺Coding or abbreviation of geotechnical data prior to storage is often necessary in order that its volume may be reduced.

- (e) it is eminently suitable for computer operation, since the rapid sorting facility dispenses with extensive key-word cross-referencing;
- (f) data transcription(or coding)[†]is necessary; and
- (g) statistical data may be easily obtained from the storage facility.

(iii) Map System

As with the index and register systems, the attractiveness of the map system depends on the situation in hand. However, the following main criteria may be considered:

- (a) for data other than that already in map form, expensive interpretation and map drawing is required;
- (b) the most satisfactory form of presentation would be by overlay maps each showing one particular feature;
- (c) the computer storage of maps is feasible, but the science is in its infancy; for storage by manual means, difficulties arise with the data revision;
- (d) geotechnical data for the purposes of foundation design could not be stored or presented by this method; and a
- (e) high density of data is required in the first place.

Clearly, from the consideration of the methods of storage, the main factors affecting the choice of storage system will be:

- (i) the amount, density and type of the available data;
- (ii) the required type of output; and
- (iii) the facilities available for storage.

[†]Coding or abbreviation of geotechnical data prior to storage is often necessary in order that its volume may be reduced.

5.5 The Financing of a Storage Facility

A geotechnical data processing system should, and can be, self-financing, expenses being met from economies in planning, site investigation and civil engineering costs. It is clearly desirable for the donor of any information stored to receive some compensation, but the complexity of pricing data by its intrinsic value makes a fixed percentage of the site investigation costs more appropriate. Since the actual value of the information to the recipient is unknown, a charge according to the size of the area for which the data is required would appear to be more reasonable. This charge, and the rate of compensation for data received, would have to be estimated to balance the average savings of users of the data and to cover the administrative costs involved.

5.6 Concluding Remarks.

From the preceding discussion of the needs of planners and others for geotechnical data it is clear that one form of data presentation cannot satisfy all their requirements. On the one hand, planners need general data from which they can produce economic impact analyses of planning proposals. This is an objective which could not be achieved without some prior interpretation of geotechnical data by persons familiar with the planning implications of geotechnical factors. On the other hand, in order to arrive at a safe and economic foundation design, the foundation engineer must have access to quantitative data concerning the properties of the material being affected by the structure being designed. From the data presented to the engineer in a site investigation report, he/she can draw his/her own conclusions, and can also assess its reliability.

It is known that the need for-and type of-geotechnical data required during urban development changes as the development progresses. Hence, the data presentation methods have to accommodate these changes. Since difficulties arise with the display of quantitative data on geotechnical maps, it would appear more sensible to display only general data of planning interest by this method. However, the more-technical data derived by site investigation can be presented in reports and plans without undue fear of misinterpretation. Naturally, it is necessary to up-date geotechnical maps as data becomes available, but only the locations of places for which further data has been collected should be included on the map. Means other than maps and plans for displaying geotechnical data might also be considered - for instance, an immediate representation of a complicated situation in a confined area by the use of a model.

Fig. 5.1 Part of a Geotechnical Map produced by Geological Society of London (1972)

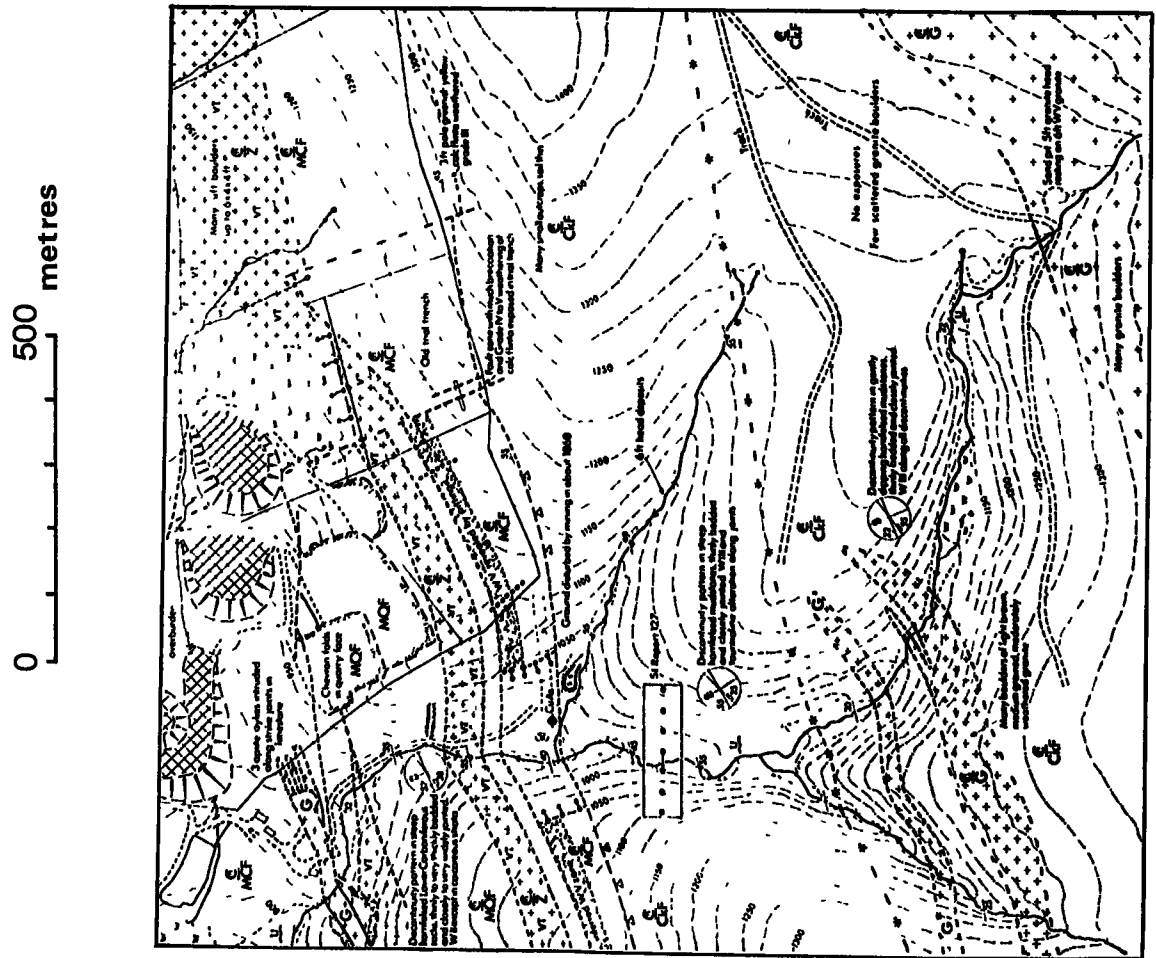

EXPLANATION

SUPERFICIAL DEPOSITS (DRIFT) RECENT AND PLEISTOCENE

Thickness in ft

ALLUVIUM

 On the granite, alluvium is a brownish-yellow, loose sub-angular, coarse grained SAND with some peat and rounded boulders of moderately weathered granite up to 3 ft, and pebbles of quartz. Downstream slightly weathered and gravelly SAND with rounded granite boulders up to 3 ft, and sub-angular cobbles and boulders of the solid rocks. The deposits are moderately to highly permeable. Locally much disturbed by streaming for tin.

up to 8

RIVER TERRACES (UNDIFFERENTIATED)

 Dark yellowish-brown, loose but locally weakly to strongly cemented horizontal layers by mangiferous or ferruginous material. Sub-angular rounded, sandy GRAVEL with rounded to sub-angular cobbles and boulders of the local rocks. Boulders occasionally up to 3 ft. The deposits are highly permeable except where cemented. Locally much disturbed by streaming for tin.

up to 40

HEAD

 Almost everywhere present and largely obscures the solid formations represents soilfluxion debris and grades downslope into alluvium and terrace deposits.

6-10 locally > 40

Within the outcrop of the granite, head comprises alluvium-brown, loose, layered, sandy GRAVEL with some clay, and gravelly silty clay with cobbles and boulders of moderately weathered granite. Grades down into moderately to highly weathered granite in situ. Or the Carboniferous outcrop next to the granite, head is typically reddish-brown, loose to compact, homogeneous, clayey gravelly SAND with many angular cobbles. On steep slopes fines may be absent and head is thin. In some places, clear COBBLES of the local rocks beneath 6 - 12 in of humic soil.

On the Lower Carboniferous rocks, head is reddish-brown, loose to compact, homogeneous silty clayey SAND with some cobbles and boulders of local granite. Head is typically 3 to 6 ft thick and is separated by a black cemented layer typically 3 to 6 in. thick from reddish-brown head down to bedrock.

SOLID FORMATIONS CARBONIFEROUS Upper Carboniferous (Namurian)

CkF

CRACKINGTON FORMATION

Dark to very dark grey, very fine grained, thin bedded to thin laminated, very closely jointed, slightly to moderately weathered, poorly cleaved SHALE, with some micaceous except along open joints. Interbedded with very sub-impure grey to dark greenish grey, fine-grained, very thinly bedded, slightly and cross-laminated, closely jointed, slightly to moderately weathered SLTSTONE, moderately strong, and dark greenish grey medium grained, very thinly to medium bedded, with closely to widely spaced joints slightly to moderately weathered, SANDSTONE.

The shale slates on exposure and is suitable for brick making

SANDSTONE

It has been possible to map groups of beds in which SANDSTONE predominates. Beds are usually less than 12 in. thick and are separated by very thin beds of siltstone and shale.

Sandstones are suitable for aggregate production. Within the contact metamorphic aureole of the granite, dark grey, very pale orange to dusky yellowish brown, fine to medium grained, thinly bedded, closely jointed, slightly to moderately weathered, open jointed SHALE and SANDSTONE, strong, impervious except along developed as silty locally with fine grained black tourmaline with irregular quartz veins up to 1 in. wide along discontinuities and with irregular quartz veins up to 2 in. wide

Lower Carboniferous (Dinantian) MELDON CHERT FORMATION

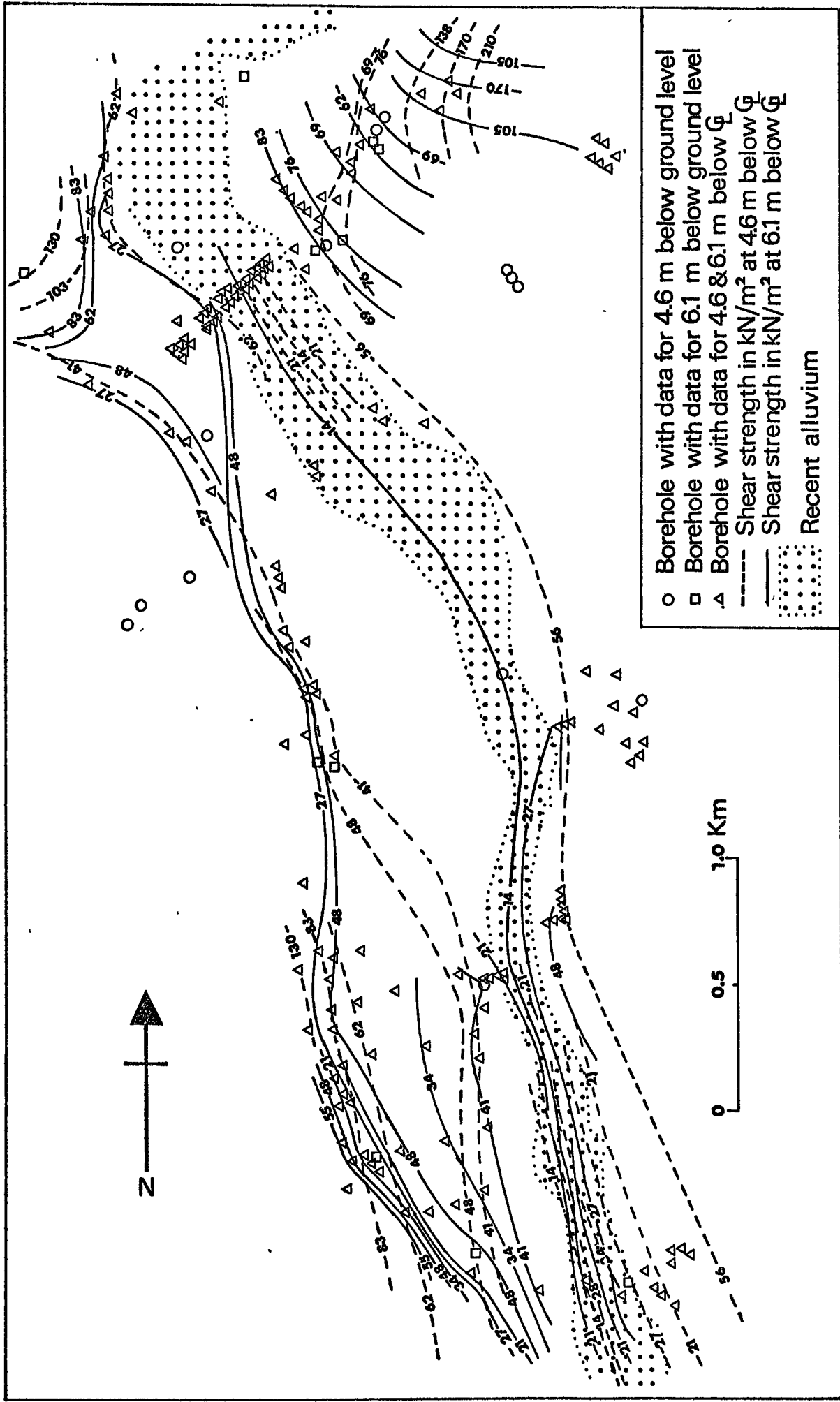

Fig. 5.2 Contoured Map of Undrained Shear Strength of Glacial Clays in Team Valley, Gateshead (Compiled from Marshall, 1969).

Stage of Development	Exploration of Ground Conditions	Type of Display of Geotechnical Conditions
Plan	Search of Existing Data	Geotechnical Map
Initial Design of Structure	Preliminary Site Investigation	Revise Geotechnical Map Prepare Report of Investigations
Final Design of Structure	Site Investigation for Foundation Design	Revise Geotechnical Map Prepare Report of Investigation Prepare Geotechnical Plans
Construction of Structure	More Data Becomes Available from Construction. Further Site Investigation may be Necessary.	Revise Geotechnical Map Revise Geotechnical Plans

Table 5.1 Stages of Urban Development and Suitable Types of Geotechnical Data Displays.

CHAPTER 6

PREFACE TO DATA STORAGE BY COMPUTER

6.1 Type of Storage System

The criteria considered in the selection of a data storage system have been examined in the previous Chapter. The application now to be considered involves a storage method for geotechnical data obtained from site investigations carried out in the Newcastle upon Tyne area. Since the users of the stored data are liable to be engaged in all stages of urban development, the most suitable data output option would appear to consist of direct technical information from which other forms of presentation may be derived.

In the situation described, a computer data handling system has many advantages over alternative means of interfacing the source and presentation of geotechnical data. The most important of these advantages is its flexibility of operation, the availability from it of statistical information, the direct display of data, and the data processing facilities available. Consideration of the methods of data storage suitable for urban development leads to the conclusion that the register system is the most apt method to use. In its operation, various computer programmes are required for the tasks of storing, processing, retrieving and presenting the data. Hence, in the present study, a suite of computer programmes called Geosys has been developed. This system is fully described in later sections, but the mode of operation may be summarized in the following list:

- (i) coding of data from source(s);
- (ii) punched cards prepared and checked;
- (iii) data fed into storage facility;
- (iv) data checked and units changed if necessary;
- (v) data held in storage in a compact form until wanted;
- (vi) specific data accessed from storage file;

and

- (vii) retrieved data displayed in one of several modes.

6.2 Computer Facility

The machine on which Geosys has been developed and operated is the Northern Universities Multiple Access Computer (N.U.M.A.C.). At the time of this work it consisted of an I.B.M. 360 computer housed at Newcastle upon Tyne linked to an 1130 machine at Durham by a land-line. This latter computer acts as an interface between the operations at Durham (where the work was done) and Newcastle (the location of the main computing facility). In addition to the card reader, line printer and graph plotter, direct access modes of operation by both typewriter and visual display unit (V.D.U.) conversational terminals were available. Much of the programme development utilized these terminals, although the majority of the work was carried out by means of card reader/line printer operation due to the pressure of general computing business.

All the programmes are written in Fortran 4, so the data coding and processing system has been designed accordingly. However, it may be expected that small modifications will be required to the programme system for it to be operated on other computer facilities.

6.3 Geosys.

Geosys is the name applied to a complete suite of computer programmes within which the actual computation and data processing is carried out by individual routines concatenated by an overall control programme. Thus all the operations of data storage, processing, and retrieval are performed by the execution of a single main programme in which the requirements for a particular operation - whether it is storage, processing, or retrieval - are specified beforehand in order to guide the overall control of the execution. The expression of these requirements takes the form of a specification of options available in Geosys. Option specifications, in addition to the main ones of storage, processing and retrieval, are also required to operate the individual processes in the programme packages.

The organization of the complete suite of programmes which comprise Geosys is shown in Figure 6.1. In the interests of clarity, the situation has been somewhat simplified so that only the name of the main programme for a particular operation is given. Service programmes are also used where the same actions are required in more than one part of the system. To aid the understanding of Figure 6.1, the processes have been labelled with capitals, and non-capitals indicate the operating programmes. All the modes of operation are indicated; these are summarized in the following list:

- (i) data to be taken from source and stored;
- (ii) data to be taken from source, the units changed and stored;
- (iii) data retrieved from store, the units changed and re-stored;
- (iv) data retrieved from store and selected data output in tabular form;

- (v) data retrieved from store and selected data output in map form;
- (vi) data from external source used to form map output.

The control of these optional modes of operation, both in specifying a particular type of programme execution and in guiding the actual process, is given by a programme named Info. This programme takes from the user the necessary information in two alternative forms for the operation of Geosys. One of these forms is intended primarily for use on direct access terminals, and is performed in the manner of a question and answer routine. The other form relies on a numerical code input. Trend, the part of Geosys which produces a map output, is the only part of the package for which some of the programme control is derived from external sources during the course of its operation. All the other operational programmes in Geosys were developed within its umbrella, and so are directed from Info, which is primed with information before a particular operation is begun.

6.4 Operation of Geosys.

After the programme suite has been loaded into the computer, the version compiled into a computable form may be operated. It is usually convenient to store the compiled version in a file (or files) for use when required. This can save a great deal of computer time and is really the only mode feasible in the case of direct access terminals. In the present study the compiled version of Geosys was stored in three files, called respectively G1, G2 and G3, so that, in each, different parts of the complete package were stored.

The command, shown below, is used for operating Geosys, compiled and stored in the three files already specified:

```
£RUN G1 + G2 + G3 4 = *SOURCE* 5 = *SOURCE* 6 = *SINK*  
7 = GEODATA(FIRST) 8 = GEODATA(FIRST)  
9 = GEODATA(LAST)
```

This command can be broken up into three constituents:

- (i) £RUN - A computer facility system command;
- (ii) G1 + G2 + G3 - The name of the place where the compiled version of Geosys is stored;
- (iii) 4 = *SOURCE* 5 = *SOURCE* 6 = *SINK* 7 = GEODATA (FIRST)
8 = GEODATA (FIRST) 9 = GEODATA (LAST) - The addresses that are used in the programme and computer system for data transfer.

The third part of the command includes the codes for the information transfer in which those numbered 4,5 and 7 refer to data transfer into Geosys and the 6,8 and 9 refer to output.

The practical meanings of these codes is shown below in a list, but it is also illustrated by the numbers on the data transfer paths on Figure 6.1:

- (i) 4 - Input address for option specifications;
- (ii) 5 - input address for geotechnical data input;
- (iii) 6 - output address for option specification, warning and advice messages, and retrieved data;
- (iv) 7 - input address for retrieved data for processing;
- (v) 8 - output address for re-processed retrieved data;
- (vi) 9 - output address for processed geotechnical data input.

The names given with these data transfer codes are either the places from which Geosys will take information, or the output addresses of the data. The first one in the example - *SOURCE* - is the system read-in, being the source from which the computer programme is operated.

Similarly *SINK* is the system print-out. So if Geosys is being executed from a direct access terminal, *SOURCE* input will be expected to come from that device, and output directed to *SINK* will be printed out by it as well. On the other hand, if *SOURCE* is the card-reader, then *SINK* will automatically be the line-printer. Geodata is the name given in the present study for the file used for storing the processed geotechnical data. It must be remembered that in most computer facilities, including the one used during this present work, permanent files such as Geodata, G1, G2 and G3 must be created before being mentioned in any other way.

Generally, the option specification and the geotechnical data will be read into Geosys from the same source (usually *SOURCE*). However, by giving these different internal addresses, respectively 4 and 5, a frequently-used option specification can be held in a separate file and accessed from source 4 when required. Alternatively, the geotechnical data can be put on to another file - source 5 - for the correction of any errors and subsequently used as input.

The output and input addresses require qualification to direct the data reading and output operations:

- (i) FIRST : input data is read from a file or output data replaces the contents of a file;
- (ii) LAST: output data is added to the end of a file.

Figure 6.2 shows a sample run of Geosys. After the run command has been read, the execution begins with a printed statement followed by a question about the way in which the option specification will be read. This can be done by either a literal or a numerical

mode of operation. The literal mode, which is intended for use with conversation computer terminals, comprises a series of questions addressed to the operator. Alternatively, it can be more convenient to insert the numeric codes required for a particular operation. These codes may be derived manually, or otherwise, from a literal option specification after it has been inserted.

Various errors can arise during the operation of both the literal and numeric options, but there are certain safeguards. For instance, should a literal question not be answered sensibly, it will be repeated. However, no more than three attempts may be made at answering the same question, since the execution will be terminated. The information inserted via the numeric codes is tested for inconsistencies. The first error to be found results in a statement showing which of the codes is at fault by printing out the equivalent literal question.

The next stage of the operation of Geosys relates to the system option specification codes which denote the type of job being run. Reference to Figure 6.2 will indicate that there are five possible options, which may be summarized under the following headings:

- (i) end execution (code 0);
 - (ii) data input (code 1) or change units option (code 3);
- and
- (iii) data output (code 2) or map plotting option (code 4).

6.4.1 End Execution

After a particular job is completed, command is returned to the option specification routine. Thus, unless a serious error occurs, the execution may only be terminated by the use of code 0.

6.4.2 Data Input or Change Units Option

To insert data into storage or to process certain of the stored data, code 1 is used. The units in which the stored data are expressed may be changed by the use of code 3.

6.4.3 Data Output or Map Plotting Option

Data output from the storage file is achieved by code 3 and data to be plotted in map form may be read into Geosys when code 4 is specified.

Once the code specifying data output or input has been inserted, information to direct the operation of the particular routine chosen must be given. However, the information required to do this is specified later in the thesis.



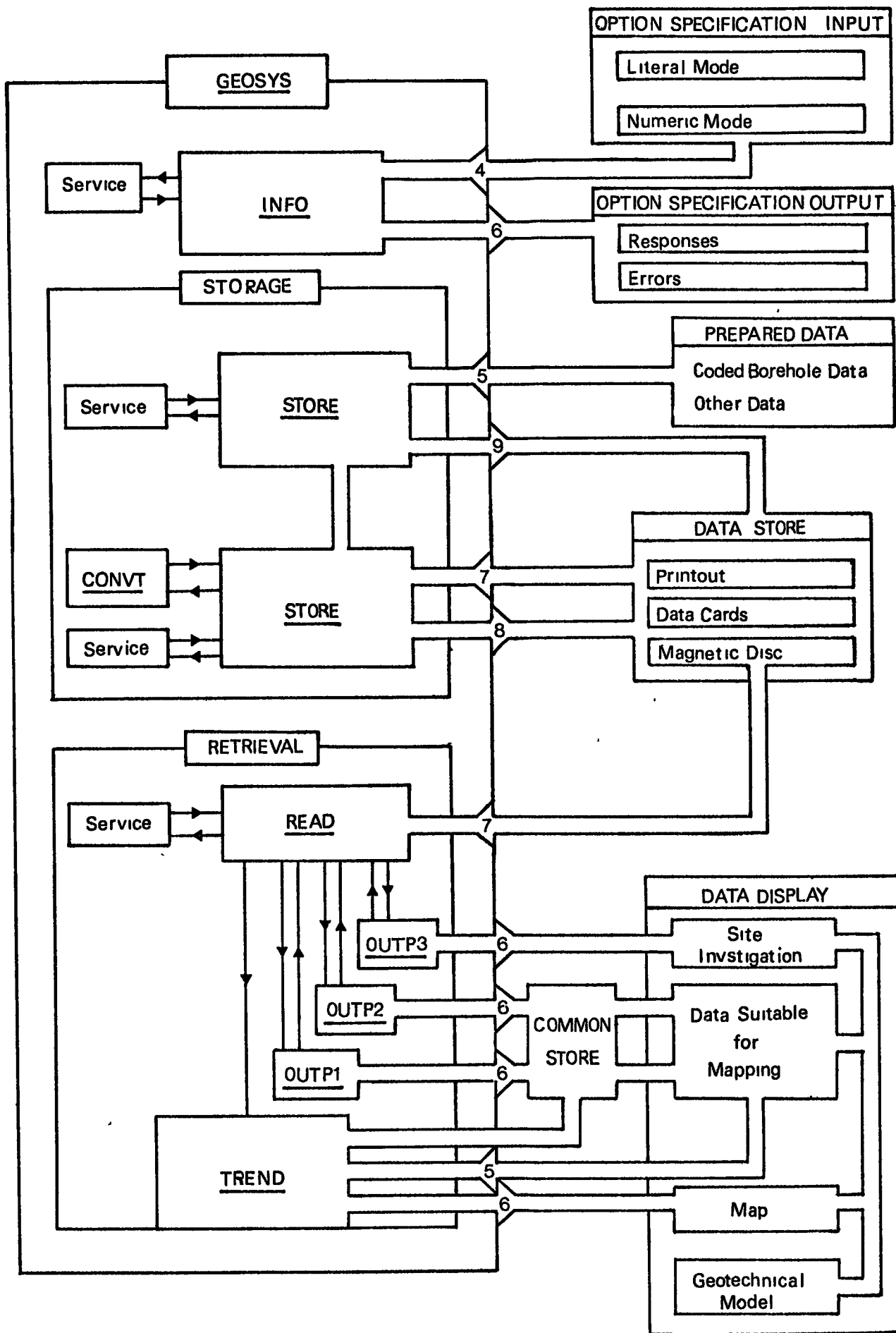

Fig. 6.1 Diagrammatic Representation of Geosys.

```

: $N GEOSYS 4=*SOURCE* 5=*SOURCE* 6=*SINK* 7=GEODATA(FIRST) 8=GEODATA(FIRST) 9=GEODATA(LAST)
EXECUTION BEGINS
OPERATOR'S COMMANDS & RESPONSES ARE INDICATED BY ... '!'

*** GEOTECHNICAL DATA STORAGE, PROCESSING AND RETRIEVAL SYSTEM GEOSYS ***
ENGINEERING GEOLOGY LABORATORIES UNIVERSITY OF DURHAM ENGLAND

WILL THE INSTRUCTIONS BE INSERTED IN THE
NUMERIC OR LITERAL MODE ? (NUM/LIT)
: LIT

SPECIFY TYPE OF JOB:-
0 END EXECUTION
1 PROCESS RAW DATA
2 READ DATA FILE
3 CHANGE UNITS OF STORED DATA
4 CALL SUBR. TREND

WRITE CODE NUMBER NOW
: 1

```

Programme Continues with Option Specification for Data Storage

Fig. 6.2 The Initiation of a Geosys Execution.

CHAPTER 7

GEOTECHNICAL DATA STORAGE WITH GEOSYS

7.1 Introduction

In the storage system presently described, the major data source comprises site investigation reports. Hence, although the system can be rendered compatible with other data sources, the methods used and the data coding have been devised primarily for the data source as specified.

Storage is achieved in a two-tier, borehole analogue data structure by the reduction of each borehole record to a title followed by a series of data lines. Briefly, the title - on one or two lines - giving general information about the boring, is followed by a series of lines of data, at least one line for each depth where there is data for storage. In general, once prepared, the data could be stored in a computer by one of several methods, which include direct typewriter terminal, punched paper tape, and punched cards. In the present study, punched cards were chosen since these give a permanent record which may be read visually and altered quite simply.

A three-stage data storage procedure is performed on the following lines:

- (i) Option Specification prepared;
- (ii) preparation of the data; and
- (iii) storage operation.

These operations are explained in this order in the present Chapter.

7.2 Option Specification for Data Storage

The general initiation of Geosys has been explained in Chapter 6 from which it follows that, for the present application, System Option 1 - appropriate for data storage - should be specified. It should be noted that, when the numeric mode of Option Specification is used, this System Option code should be included in the block of code numbers.

The acceptable literal and numeric responses required by the computer are presented in Figure 7.1. The positions occupied by the codes in the numeric code block are also given in this Figure. When formulating numeric codes it is important that codes redundant to the particular application should not be included.

The information required concerns the following factors:

- (i) whether the data input is new geotechnical data to be stored, or stored data to be re-processed;
- (ii) either - if new geotechnical data are to be processed - the units in which the numerical quantities are expressed; or - if the data are from the storage file - the location in that file*.
- (iii) whether processed data are to be actually stored or printed out;
- (iv) whether the units are to be changed⁺.

* For the literal specification, the borehole identity number at the beginning and end of the required part of the file are given separately. Each of these numbers may start anywhere on the line provided that the numerals do not extend beyond the fifteenth column and the number has no gaps. In the numeric mode of input, such identification of boreholes must consist of two numbers.

⁺ Unlike system option 3, which achieves the conversion of the entire contents of a storage file, by factor (ii) in this list it is possible to specify a portion of a file.

- (v) if new geotechnical data are to be processed, whether two title cards are used for each borehole; and
- (vi) if the data are to be printed out, then the requirement for a title.

When the literal Option Specification is employed, as in Figure 7.2, the answers given are checked for consistency during the operation of the routine. The programme is only able to recognize certain responses, and the use of an unacceptable response results in the question being repeated. Should, after three attempts, an acceptable response not be obtained, then the execution of the programme is terminated. Similar checking of the numeric codes is carried out after the whole group has been read. Here an illogical code will result in the relevant literal question being printed out, and termination of the programme execution. Great care must be taken with the interpretation of these error messages, since an erroneous code can make one appearing later seem to be incorrect. For example, referring to Figure 7.1, if it were intended that unprocessed geotechnical data should be processed, but that code 2 was accidentally substituted for code 1, then if the next code were 4 (quite legitimate for processing raw data), then this latter code would be the one to appear inconsistent and the error message would indicate that the question concerning the units had not been answered correctly. This is caused because had 2 been the correct code, then the reader would have been expecting a code suitable for defining the units.

If no errors are found in the Option Specification, the numeric

equivalent of one inserted in the literal mode may be obtained. This is printed out in the format required for a numeric Option Specification. Once this is done, the programme Store is activated and begins reading the input data (see Figure 7.2).

7.3 Data Preparation

Preparation of site investigation data prior to storage is necessary in order to reduce the amount of storage space required, and to give a common format for storage from the various data sources. Information concerning the stratigraphic column, samples taken during boring, tests on samples, insitu tests, and the ground-water conditions are coded with numeric and mnemonic symbols. Each set of data relevant to a particular borehole is then headed by general information in a title.

The actual procedure for coding site investigation data and for producing the titles is fully described in Appendix B. Once all this data is on coding sheets, cards may be punched and the data are then ready for storage. Before storage, a manual check of the data may well be beneficial to ensure that each borehole begins with a title and finishes with an end card(s) which refers to the greatest depth from which information is available.

After checking, the data may then be used as input for the storage routine with printed output specified. It should be noted that the geotechnical data must be terminated with either a blank card or one with at least one zero in the first five columns acting as an end code. (When two title cards have been used for the borehole data sets, then two end code cards are also required).

It is not necessary to organize the data for storage in any particular order. Provided that the data end code is on the card corresponding to the greatest depth, the storage programme then orders the data. However, this ordering can be disrupted when, in more than seventy lines, data for depths smaller than that referred to on the sixty-ninth card occurs after that card. Such data will not appear amongst the first sixty-nine lines, since each group is ordered separately and given the same title.

7.4 Storage Operation.

The literal Option Specification of Figure 7.2 will be used to illustrate the processing of geotechnical data in Imperial units read from cards into line printer output in S.I. units. Treating freshly prepared data in this manner can aid the identification of many errors, since the internal error-checking routines are activated and it is easier to visually inspect printed output than it is to scan punched cards.

After a group of three typical borehole logs with associated test data in Figure 7.3 have been transcribed on to coding sheets, the information has the appearance of Figure 7.4. The data on these sheets are then punched on to cards, the contents of which appear as in Figure 7.5. Certain errors included for illustrative purposes are clearly marked.

The printed output shown in Table 7.1 may be obtained during the storage operation. Some errors are identified, but since, unlike the serious errors, they are not likely to necessitate clearance of the storage space and re-processing of the data, the execution is not terminated. Amongst the messages given, the user is advised when

units are converted and when more than seventy lines appear for a single borehole. Those errors which cause the programme to stop processing the data are all concerned with the borehole title card. During the storage operation each borehole record is read completely (or the first seventy data cards) before being stored. In consequence of this safeguard, any error bringing about the termination of the execution will cause the borehole preceding the erroneous one to be stored, and to be followed by the data file end code and not by any faulty information.

The errors inserted into Figure 7.5 are identified by the storage programme in Figure 7.6. Rectifying these errors, changing the Option Specification so that the processed geotechnical data will be stored, and re-running the programme, results in the output of Figure 7.7 which shows that the programme is operating correctly.

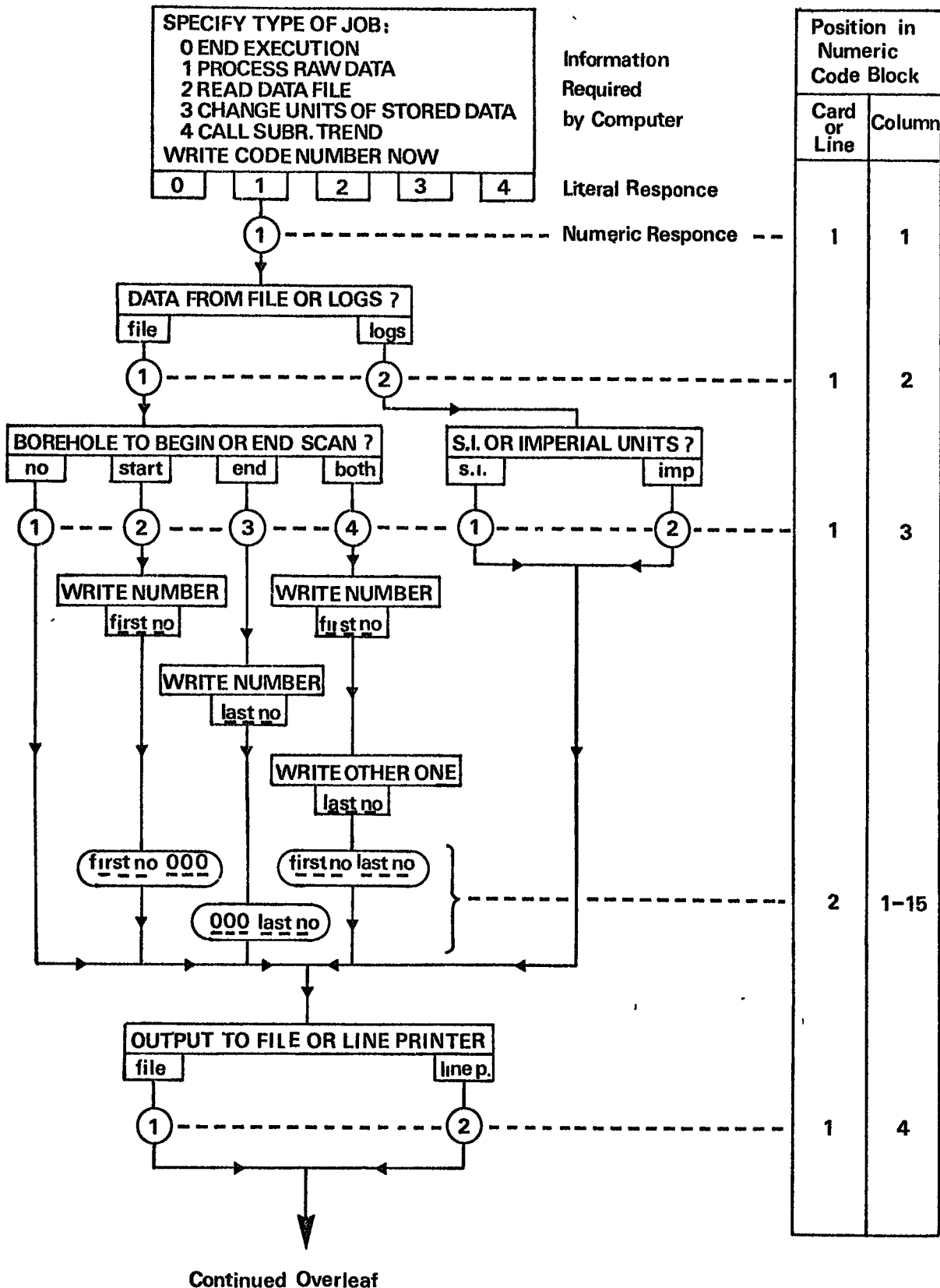
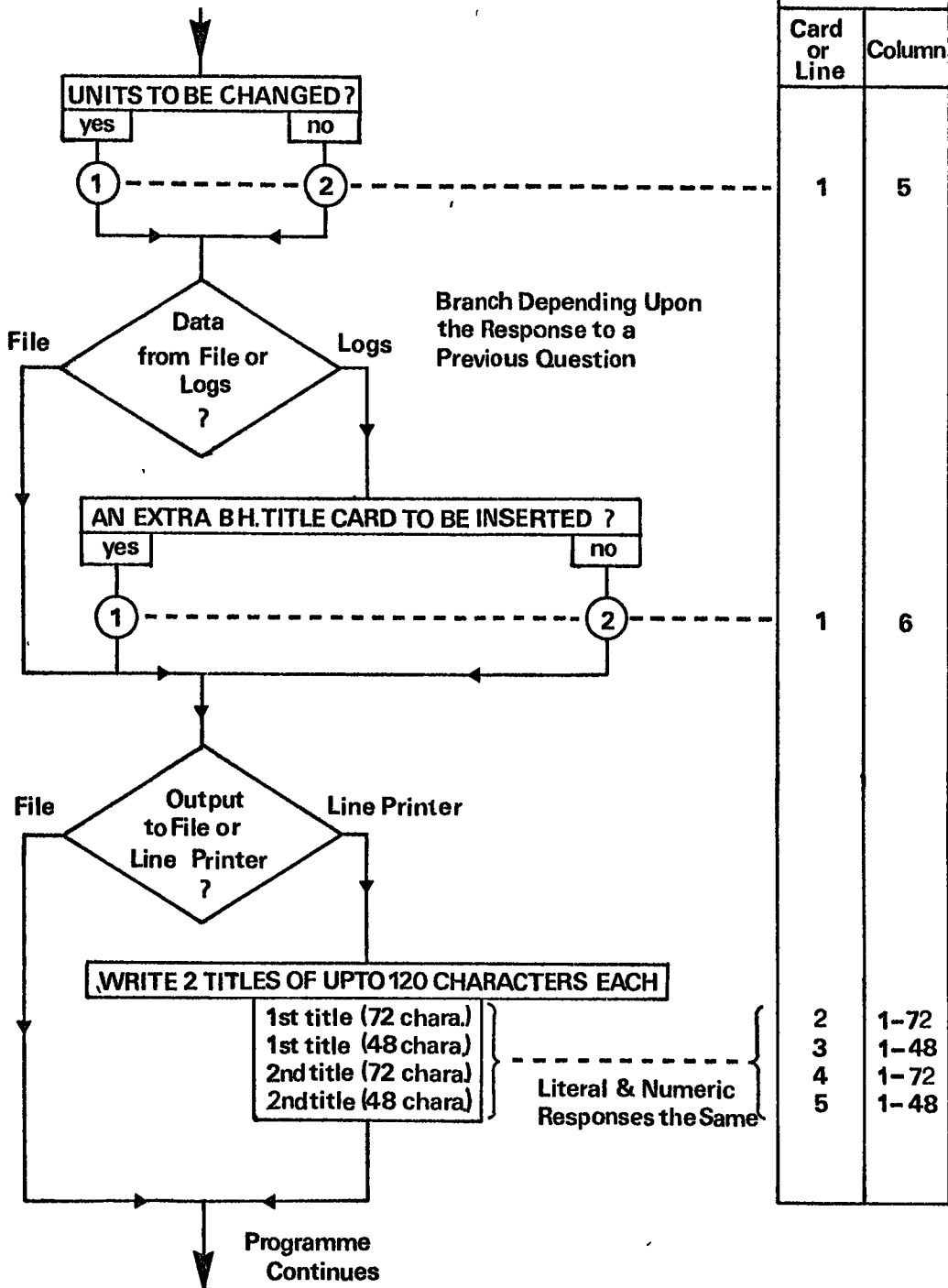

Fig. 7.1 Information Required by Geosys for Data Storage.

Continued from Previous Page



N.B. The literal responses may consist of only the initial letter of the answers.

Fig. 7.1 (cont) Information Required by Geosys for Data Storage

OPERATOR'S RESPONSES ARE PROMPTED BY :

WRITE CODE NUMBER NOW

: 1

DATA FROM FILE OR CODED MH LOGS ? (F/L)

: L

SI OR IMPERIAL UNITS ? (SI/IMP)

: IMP

OUTPUT TO FILE OR LINE PRINTER ? (F/L)

: L

UNITS TO BE CHANGED ? (YES/NO)

: YES

AN EXTRA MH TITLE CARD TO BE INSERTED ? (YES/NO)

: NO

WRITE TWO TITLES OF UP TO 120 CHARACTERS EACH

: GEOTECHNICAL DATA FROM BOREHOLES FOR STORAGE
: BORING RECORDS FOR HOLES M1, M2 & M3
: LABORATORY TEST RESULTS INCLUDED
: DATE OF DATA PROCESSING... 12TH JUNE 1974

NUMERIC DATA CODES TO BE PRINTED OUT ? (YES/NO)

: YES

.....
122212

GEOTECHNICAL DATA FROM BOREHOLES FOR STORAGE
BORING RECORDS FOR HOLES M1, M2 & M3
LABORATORY TEST RESULTS INCLUDED
DATE OF DATA PROCESSING... 12TH JUNE 1974

.....

Programme 'Begins Storage Operation'

Fig. 7.2 Execution of a Literal Specification for Data Storage.

RECORD OF BOREHOLE N.

Ground Level 101.72 ft above O.D. Diameter of Boring 10" to 20" from 20'0" to 70'0"
 Method of Boring Shell and Auger Lining of Hole 10" to 20" from 20'0" to 70'0" to 50'0"

Progress	Samples & Insitu Tests		Description of Strata
	Depth	Type	
19.4.68.	3'0"	D	Fill
	17'0"-18'6"	UL	Soft brown silty clay becoming harder with depth
20.4.68.	27'0"-28'6"	UL	Hard brown sandy silty clay with bands of soft organic material
	36'3"-37'9"	UL	Hard brown sandy silty clay with dispersed pebbles and some cobbles. Some patches of grey sandy silty clay
	39'3"-40'9"	UL	
	42'0"-43'6"	UL	Hard grey or brown sandy silty clay with fragments of sandstone, some boulders and small pieces of coal.
	43'6"-45'0"	UL	
	45'0"-46'6"	UL	
	50'0"-51'6"	UL	End of boring
	55'0"-56'6"	UL	
	60'0"-61'6"	UL	
	22.4.68.	65'0"-66'6"	UL
70'0"			









RECORD OF BOREHOLE N.

Ground Level 97.0 ft above O.D. Diameter of Boring 10" to 30" from 30'0" to 60'3" to 60'3" and 1" from 60'3" to 75'0"
 Method of Boring Shell and auger Rotary core Lining of Hole 10" to 30" from 30'0" to 60'0"

Progress	Samples & Insitu Tests		Description of Strata	
	Depth	Type		
17.4.68.	8'0"	D	Fill comprised of 6" Farnac, 1'0" loose brown clay soil and 1'6" silty clay	
	2'10"-13'6"	UL	Hard brown sandy silty clay with some patches of gravel. Band of sand at 12'3" 3" thick. Some sandstone fragments below 13'3".	
7'0"-18'6"	UL			
18.4.68.	8'0"-19'6"	UL	Hard to stiff grey sandy silty clay with dispersed gravel-(some angular sandstone fragments). Possible boulder at 16'3".	
	19'3"-20'6"	UL		
	21'0"-22'6"	UL	Hard brown sandy silty clay with boulders and thin bands of sand	
	25'0"	D		
	26'0"-26'9"	P(50)	Dense brown sand with a high percentage of silt. Some gravelly patches.	
	30'0"-31'6"	UL		
	33'0"-33'6"	UL	Hard sandy silty clay with some gravel in patches. Mostly grey, but some brown material here and there. Occasional cobbles.	
	35'0"-36'6"	UL		
	19.4.68.	37'9"-38'9"	P(60)	Dense brown sand with silt & gravel Boulder at 39'6"
		38'9"-40'9"	P(65)	
40'0"-41'9"		UL	Stiff grey sandy silty clay with some coal down to 41'3", a sandstone boulder at 44'6" and a hard clay band at 46'9"	
42'0"-44'0"		UL		
45'3"-46'9"		UL	Hard grey sandy silty clay with gravel in patches. Boulder and stiff brown clay at 58'0". Sand and gravel at 59'9".	
48'3"-49'3"		UL		
50'0"-51'6"	UL	Well jointed sandstone with shale bands below 60'5". Shale dominates below 62'6" then sandstone below 63'8" with current bedding below 64'2"		
53'0"-54'6"	UL			
22.4.68.	56'6"-58'0"	Core recovery	Grey shale grading into jointed grey mudstone below 66'5". Yellow or brown fine sandstone below 68'3" with a possible fault at 69'10" then becoming more massive jointed grey shale becoming more fragmented below 72'3". Current bedded sandstone at 73'11".	
	60'5"	50%		
	62'5"	30%	End of boring	
	63'8"	60%		
	65'0"	42%		
69'10"	10%			
70'3"	60%			
71'5"	40%			
72'3"	35%			
73'11"	52%			

Fig. 7.3 Site Investigation Data to be Processed

Ground Level 0.0 ft above O.D. Diameter of Boring 10" to 25'6", 8" below 25'6"
 Method of Boring Shell and auger Lining of Hole 10" to 25'6", 8" from 25'6" to 50'0"

Progress	Samples & Insitu Tests		Strata		Description of Strata
	Depth	Type	Key	Depth	
22.1.68.	5'0"	D		5'0"	Fill
	7'0"	D		7'0"	Soft yellow or brown sandy silty clay and gravel
	10'0"-11'6"	UL		11'0"	Hard brown sandy silty clay with pebbles, cobbles and sandstone fragments
	20'0"-21'6"	UL		10'0"	
	30'0"-31'6"	UL			
	35'0"-36'6"	UL			
	38'0"	D			
	40'0"-41'6"	UL			
	45'0"-46'6"	UL			
	50'0"-51'6"	UL			
55'0"-56'0"	UL*		56'0"		
23.1.68.					

Borehole M1 Water was first encountered at a depth of 6'6"
 M2 Water was standing at a level of 17'9" below ground level on the morning of 18.1.68. Water was then encountered during drilling at a depth of 24'0" when it rose to a depth of 22'0". Water was again encountered at a depth of 31'6". After the lining was removed water attained a level of 19'0" below ground level.
 M3 Water was encountered during drilling at depths of 20'0" and 31'6".

Borehole M1 3355766857
 M2 3374966900
 M3 3398566980

Symbol U4 4" diameter undisturbed sample
 U4* Incomplete 4" diameter undisturbed sample
 D Disturbed sample
 P(Blow) Standard penetration test giving the blows necessary for a penetration given in the depth column.

Fig. 7.3 (cont.) Site Investigation Data to be Processed.

LABORATORY TEST RESULTS

Borehole	Depth	Description of Strata	Moisture Content	Liquid Limit %	Plastic Limit %	Coef. of Vol Comp ft ³ /T	Type of Test	Cohesion lb/in ²	Angle of Friction degrees	Bulk Density lb/ft ³	Sample Diam in	Date
V1	10'-0" - 12'-0"	Hard brown sandy clay	12	25	10	-	V	100	-	130	1	13.5.68.
V1	12'-0" - 14'-0"	Hard brown sandy clay with silty part.	12	25	10	-	V	100	-	130	1	13.5.68.
V1	14'-0" - 16'-0"	Hard grey sandy clay with silty part.	12	25	10	-	V	100	-	130	1	13.5.68.
V1	16'-0" - 18'-0"	Hard grey sandy clay with silty part.	12	25	10	-	V	100	-	130	1	13.5.68.
V2	20'-0" - 22'-0"	Hard brown sandy clay with silty part.	12	25	10	-	V	100	-	130	1	13.5.68.
V2	22'-0" - 24'-0"	Hard brown sandy clay with silty part.	12	25	10	-	V	100	-	130	1	13.5.68.
V2	24'-0" - 26'-0"	Hard brown sandy clay with silty part.	12	25	10	-	V	100	-	130	1	13.5.68.
V2	26'-0" - 28'-0"	Hard brown sandy clay with silty part.	12	25	10	-	V	100	-	130	1	13.5.68.
V2	28'-0" - 30'-0"	Hard brown sandy clay with silty part.	12	25	10	-	V	100	-	130	1	13.5.68.
V2	30'-0" - 32'-0"	Hard brown sandy clay with silty part.	12	25	10	-	V	100	-	130	1	13.5.68.
V2	32'-0" - 34'-0"	Hard brown sandy clay with silty part.	12	25	10	-	V	100	-	130	1	13.5.68.
V2	34'-0" - 36'-0"	Hard brown sandy clay with silty part.	12	25	10	-	V	100	-	130	1	13.5.68.
V2	36'-0" - 38'-0"	Hard brown sandy clay with silty part.	12	25	10	-	V	100	-	130	1	13.5.68.
V2	38'-0" - 40'-0"	Hard brown sandy clay with silty part.	12	25	10	-	V	100	-	130	1	13.5.68.
V2	40'-0" - 42'-0"	Hard brown sandy clay with silty part.	12	25	10	-	V	100	-	130	1	13.5.68.
V2	42'-0" - 44'-0"	Hard brown sandy clay with silty part.	12	25	10	-	V	100	-	130	1	13.5.68.
V2	44'-0" - 46'-0"	Hard brown sandy clay with silty part.	12	25	10	-	V	100	-	130	1	13.5.68.
V2	46'-0" - 48'-0"	Hard brown sandy clay with silty part.	12	25	10	-	V	100	-	130	1	13.5.68.
V2	48'-0" - 50'-0"	Hard brown sandy clay with silty part.	12	25	10	-	V	100	-	130	1	13.5.68.
V2	50'-0" - 52'-0"	Hard brown sandy clay with silty part.	12	25	10	-	V	100	-	130	1	13.5.68.
V3	20'-0" - 22'-0"	Hard brown sandy clay with silty part.	12	25	10	-	V	100	-	130	1	13.5.68.
V3	22'-0" - 24'-0"	Hard brown sandy clay with silty part.	12	25	10	-	V	100	-	130	1	13.5.68.
V3	24'-0" - 26'-0"	Hard brown sandy clay with silty part.	12	25	10	-	V	100	-	130	1	13.5.68.
V3	26'-0" - 28'-0"	Hard brown sandy clay with silty part.	12	25	10	-	V	100	-	130	1	13.5.68.
V3	28'-0" - 30'-0"	Hard brown sandy clay with silty part.	12	25	10	-	V	100	-	130	1	13.5.68.
V3	30'-0" - 32'-0"	Hard brown sandy clay with silty part.	12	25	10	-	V	100	-	130	1	13.5.68.
V3	32'-0" - 34'-0"	Hard brown sandy clay with silty part.	12	25	10	-	V	100	-	130	1	13.5.68.
V3	34'-0" - 36'-0"	Hard brown sandy clay with silty part.	12	25	10	-	V	100	-	130	1	13.5.68.
V3	36'-0" - 38'-0"	Hard brown sandy clay with silty part.	12	25	10	-	V	100	-	130	1	13.5.68.
V3	38'-0" - 40'-0"	Hard brown sandy clay with silty part.	12	25	10	-	V	100	-	130	1	13.5.68.
V3	40'-0" - 42'-0"	Hard brown sandy clay with silty part.	12	25	10	-	V	100	-	130	1	13.5.68.
V3	42'-0" - 44'-0"	Hard brown sandy clay with silty part.	12	25	10	-	V	100	-	130	1	13.5.68.
V3	44'-0" - 46'-0"	Hard brown sandy clay with silty part.	12	25	10	-	V	100	-	130	1	13.5.68.
V3	46'-0" - 48'-0"	Hard brown sandy clay with silty part.	12	25	10	-	V	100	-	130	1	13.5.68.
V3	48'-0" - 50'-0"	Hard brown sandy clay with silty part.	12	25	10	-	V	100	-	130	1	13.5.68.
V3	50'-0" - 52'-0"	Hard brown sandy clay with silty part.	12	25	10	-	V	100	-	130	1	13.5.68.

PARTICLE SIZE ANALYSIS	
Borehole	Depth
V2	32'-0" - 34'-0"
V2	34'-0" - 36'-0"

SUPHATE ANALYSIS				
Borehole	Depth	Soluble Sulphate		Acidity pH
		Water p.p.m.	Soil % dry wt	
V1	55'-0" - 56'-0"	60	0.07	7.3
V2	17'-0"	260		7.1
V2	49'-0"	30		7.3
V3	20'-0"			7.3

KEY	
V	Triaxial Test - One sample tested at overburden pressure
T	Triaxial Test - Three samples tested at different pressures
P	One Peak Strength, Triaxial Test
C	Remolded Sample Consolidation Test

Fig. 7.3 (cont.) Site Investigation Data to be Processed

COUS	ELI	FORBANN	COUS	JOB CODE/HOI	COL	DATA
1-5	Statement	Statement No.	1-71	Statement	1-70	Or according to GREAT
6-80	Statement	Statement Continuation	71-80	Option if Statement		Statement in program

PROGRAM **Geotechnical Data Storage** PAGE **1** OF **5**
 PROGRAMMER **J.C. Cripps** DATE **7/7/72**

	6	10	20	30	40	50	60	70	80
8001	M1		3355766857	101.7	19-22/4/68				
0.0	3					TOP SOIL			
3.0	3 2								
16.0	471								
17.75	117 18	4219		2400.0	138.0	WETDEN	4		
20.0	475	3 2							
27.75	116 15			5600.0	136.0	WETDEN	4		
37.0	2 1								
40.0	2 1								
42.75	1 1								
44.25	2 1								
45.75	1 1								
49.0	459	3				BLD. SST. COAL			
50.75	116 14			3350.0	148.0	WETDEN	4		
55.75	117 13	2914		3600.0	140.0	WETDEN	4		
60.75	116 14			1600.0	144.0	WETDEN	4		
65.75	1 1								
55.75	194				0.07	DWT'S03	7.3		
61.5	6 1								
70.0	0								
8002	M2		3374966900	97.0	17-23/4/68				
0.0	3					TARMAC			
0.5	3					LOOSE SOIL			
1.5	3 3					FILL			
3.0	59	3				FILL			

WRITTEN	0	1	letter	number 1
PUNCH	zero	letter O	letter	number 1

Fig. 7.4 Data in Fig. 7.3 on Coding Sheets.

PLI	COUS	FOR TIONS	COUS	FOR CONTROL	COUS	DATA
77	15	Statement No	171	Statement	180	Or according to FOR AT
780	0	Statement Continuation	7180	Optional Sequence		Statement in program
	77	Statement				
	780	Optional Sequence				

PROGRAM	Geotechnical Data Storage	PAGE	5	OF	5
PROGRAMMER	J.C. Capps	DATE	7/7/72		

1	20.75	116 17	900.0	1132.0	WEIDEN	4
	30.75	11				
	35.75	11				
	38.0	397			44 P/L	
	40.0	435			W BLOS. KSSIT	
	40.75	11				
	45.75	117 13	2150.0	134.0	WEIDEN	4
	50.75	116 14	3300.0	136.0	WEIDEN	4
	55.75	11				
	20.0	524		0.00003	PTS SO3	7.3
	20.0	61				
	31.5	61				
	55.5	0				

WRITTEN	0	1		
PUNCH	zero	letter 0	letter 1	number 1

Fig 7.4 (cont.) Data in Fig. 7.3 on Coding Sheets

80001	M1	3355766857	101.7	19-22/4/68	
0.0	9				TOP SOIL
3.0	57	3 2			
16.0	471	2			
17.75		117 1H	4219	2400.0138.0	WETDEN 4
20.0	475	3 2			
27.75		116 15		5600.0136.0	WETDEN 4
37.0		2 1			
40.0		2 1			
42.75		1 1			
44.25		2 1			
45.75		1 1			
49.0	459	3			BLD, SST, COAL
50.75		116 14		3350.0148.0	WETDEN 4
55.75		117 13	2914	3600.0140.0	WETDEN 4
55.75		194		0.07	DWTXS03 7.3
60.75		116 14		1660.0144.0	WETDEN 4
65.75		1 1			
61.5		6 1			
80002	M2	3374966940	97.0	17-23/4/68	
70.0		0			
0.0	9	3			TARMAC
0.5	9	3			LOOSE SOIL
1.5	98	3 3			FILL
3.0	59	3			FILL
0.0	474	3 2			
12.25	19	3			THIN BAND
12.5	474	2			
12.75		1 1			
13.25	475	3			SST FRAGS
14.5	434	2			
15.25		1 1			
17.75		2 1			
18.25		2 3			(BOULDER ?)
18.75		1 1			
20.0		2 1			
21.75		194		130.0	WETDEN .
23.0	475	3			+BLD, BN SAND
25.0		397 18	2416		LL PL
26.25	724	2			
26.4		73			50 9
30.0	435	2			
30.75		115		3200.0128.0	WETDEN 4
33.75		297 20	2715		LI. PL
35.75		116 16		2800.0135.0	WETDEN 4
38.0	724	2			
38.23		73			60 12
38.73		73			65 12
39.5	9	3			BOULDER
40.25	435	2			
40.75		2 1			
41.25	435	3			AND COAL
43.25		1 1			
44.5	9	3			
45.0	435	2			
46.0		1 1			
46.75	79	3			HARD BAND
47.4	434	2			
48.5		136 12		4800.0135.0	9 DEN 4

Fig. 7.5 Listing of Logs Given in Fig. 7.4

50.75	117	14	3314	3550.0139.0	WETDEN	4	
53.75	116	12		3850.0137.0	WETDEN	4	
57.75	1	1					
58.0	9	3			HOULDER		
59.0	79	3			STIFF BROWN		
59.75	906	2					
60.25	9	3			JOINTED		
60.4	9	3			SHALE BANDS		
62.5	4	3			GY JNT SHALE		
63.7	1	2					
64.2	9	3					
65.0	90	3			CURRENT BED		
66.4	49	3			SHALE		
68.25	9	3			JOINTED GREY		
69.8	3	3			JNT YEL/BRN		
70.25	9	3			FAULT ?		
71.4	4	3			MASSIVE		
72.25	9	3			JNT GRY SHL		
73.0	9	3			FRAG GRY SHL		
77.75	7	3			JNT CURRENT		
24.0	7	3			OVER NIGHT		(E1)
31.5	6	1			NOSE HY	2	
49.0	7	3					
17.75	594				LNG REMD		
49.75	594			0.00006	PTS SO3	7.3	
11.5	336	15		0.00026	PTS SO3	7.4	
11.5	194			4840.0135.0	B R WDEN	4	
21.75	194			0.007	CONS MV	13	(E2)
35.75	194			0.008	CONS MV	21	
53.75	194			0.01	CONS MV	18	
33.75	393			0.012	CONS MV	14	
50.75	393				SIEV SAND		
25.0	353				SIEVSND&GRAV		
33.75	353				56002800		
75.0	0				54003400		
00.0	43		3390506080	94.1	22-23/4/68		
3.0	9	3			FILL		
7.0	494	3			STIFF YEL/BRN		
10.75	1	1					
11.0	475	3			W SST FRAGS		
20.75	116	17		900.0132.0	WETDEN	4	
30.75	1	1					
35.75	1	1					
38.0	397		3114		LI PL		
40.0	435	3			W HLOS RSST		
40.75	1	1					
45.75	117	13	3113	2150.0134.0	WETDEN	4	
50.75	116	14		3300.0136.0	WETDEN	4	
55.75	1	1					
20.0	6	1					
31.5	6	1					
20.0	594						
55.5	0			0.00003	PTS SO3	7.3	(E3)

- ERRORS**
- E1 OVERNIGHT extends into field M - abbreviate to O/NIGHT
 - E2 CONS misspunched as COMS
 - E3 Line with end code does not refer to the greatest depth

Fig. 7.5 (cont.) Listing of Logs Given in Fig. 7.4

-123-

BORHOLE R001 M1 GRID REF 3355/60057 MT UD 31.0
 DATE 19-22/4/68 COMMENT UNITS S.I.

UNITS CONVERTED FROM IMP. TO S.I.

DEPTH	SAMPLE STRATA	INFO TEST	LIMITS MC LI PL	SHEAR STGTH	OTHER DATA	TESTS&STRATA COMMENTS
0.0	900	0 1 3				TOP SOIL
0.91	570	3 0 2				
4.88	471	1 1 2				
5.41		1 1 7	14 42 19	117.1	2210.6	WET DEN 10.2
6.07	475	3 0 2				
8.46		1 1 6	15			
11.23		2 1 1				
12.19		2 1 1				
13.03		1 1 1				
13.40		2 1 1				
13.94		1 1 1				
14.93	459	0 1 3				
15.47		1 1 6	14	163.5	2371.0	WET DEN 10.2
16.90		1 1 5		175.7	2242.8	WET DEN 10.2
16.99		1 1 4			1.07	DWT&SN3 7.3
18.52		1 1 5		11.1	2300.0	WET DEN 10.2
18.74		1 1 1				
19.96		1 1 1				
21.34		0 1 0				

BORHOLE R002 M2 GRID REF 33/4900900 MT UD 29.6
 DATE 17-23/4/68 COMMENT UNITS S.I.

UNITS CONVERTED FROM IMP. TO S.I.

TYPE OF TEST NOT RECOGNISED CUMS
 AT A DEPTH OF 11.5 FEET 3.51 METRES
 UNEXPECTED NON-NUMERIC CHARACTER MT
 AT A DEPTH OF 17.8 FEET 5.41 METRES
 MORE THAN 70 LINES

DEPTH	SAMPLE STRATA	INFO TEST	LIMITS MC LI PL	SHEAR STGTH	OTHER DATA	TESTS&STRATA COMMENTS
0.0	900	0 0 3				TAMMAC
0.15	900	0 1 3				LOOSE SOIL
0.46	900	3 0 3				FILL
0.91	500	0 0 3				FILL
2.44	474	3 0 2				
3.51		3 3 6	15	234.2	2167.7	WET DEN 10.2
3.51		1 0 4			1.07	13
3.74	19	0 1 3				THIN SAND
3.81	474	0 0 2				
3.89		1 1 1				
4.04	475	0 1 3				SST FRAGS
4.42	434	0 1 2				
4.65		1 1 1				
5.41		2 1 1				
5.41		7 0 3				
5.41		5 0 4			0.00000	PTS SN3 7.3
5.56		2 1 3				(HOLDER ?)
5.72		1 1 1				
6.10		2 0 1				
6.63		1 0 4			2002.6	WET DEN
6.63		1 0 4			74.0	CONS MV 21
7.01	475	0 1 3				ORLO, BN SAND
7.32		7 1 3				WET BY 10.6
7.62		1 1 7	14 24 16			
8.40	724	0 1 2				
8.65		1 1 1				SN 22.9

Fig. 7.6 Print Out of Data Processed for Storage

9.14	435	0 0 2						
9.38		1 1 5						
9.61		6 0 1			156.2	2050.6	WETDEN	10.2
10.29		2 9 7	20	27	15			
10.29		3 9 3						
10.9		1 1 6	16					
10.9		1 9 4			136.6	2162.7	SIEV SAND	
11.58	724	0 0 2					WETDEN	10.2
11.65		0 7 3					CONS MV	18
11.80		0 7 3					60	30.5
12.04	900	0 0 3					65	30.5
12.26	435	0 0 2						
12.42		2 0 1						
12.57	435	0 0 3						
13.18		1 0 1						
13.56	900	0 0 3						
13.72	435	0 0 2						
14.02		1 0 1						
14.25	790	0 0 3						
14.25	434	0 0 2						
14.78		1 3 6	12					
14.93		7 0 3			234.2	2162.7	9 WDEN	10.2
15.17		5 9 4					LNG REMD	
15.47		1 1 7	14	33	14		0.000026	PPTS S03 7.4
16.38		1 1 6	12					WETDEN 10.2
16.38		1 9 4			173.2	2226.8		WETDEN 10.2
17.45		1 0 1			187.9	2194.7		CONS MV 14
17.68	900	0 0 3						
17.98	790	0 0 3						
18.21	906	0 0 2						
18.36	090	9 0 3						
18.41	090	9 0 3						
19.05	900	9 0 3						
19.42	090	9 0 2						
19.57	090	9 0 3						
19.81	990	9 0 3						
20.24	890	9 0 3						
20.80	090	9 0 3						
21.28	090	9 0 3						
21.41	090	9 0 3						
21.76	900	9 0 3						
22.02	900	9 0 3						
22.52	090	9 0 3						
22.53		0 0 0						

BOREHOLE 8002 M2 GRID REF 3374966900 HT OD 29.6
 DATE 17-23/4/68 COMMENT UNITS S.I.
 UNITS CONVERTED FROM IMP. TO S.I.

DEPTH	SAMPLE STRATA	INFO TEST	LIMITS MC LI PL	SHEAR STGTH	OTHER DATA	TESTS&STRATA COMMENTS
7.62		3 5 3				273,136.
10.29		3 5 3				263,166.
15.47		3 9 3				SIEVSND&GRAV
22.87		0 0 0				

BOREHOLE 8003 M3 GRID REF 3998566980 HT OD 28.7
 DATE 22-23/4/68 COMMENT UNITS S.I.

LAST CARD WITHOUT END CODE

Execution Terminates

Fig. 7.6 Print Out of Data Processed for Storage

OPERATOR'S RESPONSES ARE PROMPTED BY ... :

★ GEOTECHNICAL DATA STORAGE, PROCESSING AND RETRIEVAL SYSTEM GEOSYS ★
ENGINEERING GEOLOGY LABORATORIES UNIVERSITY OF DURHAM ENGLAND

WILL THE INSTRUCTIONS BE INSERTED IN THE
NUMERIC OR LITERAL MODE ? (NUM/LIT)

: NUM

INSERT NUMERIC CODES

.....
: 122112
.....

BOREHOLE B001 M1
UNITS CONVERTED FROM IMP. TO S.I.
LOG TRANSFERED TO GEODATA

BOREHOLE B002 M2
UNITS CONVERTED FROM IMP. TO S.I.
MORE THAN 70 LINES
LOG TRANSFERED TO GEODATA

BOREHOLE B003 M3
UNITS CONVERTED FROM IMP. TO S.I.
LOG TRANSFERED TO GEODATA

END OF DATA

★ GEOTECHNICAL DATA STORAGE, PROCESSING AND RETRIEVAL SYSTEM GEOSYS ★
ENGINEERING GEOLOGY LABORATORIES UNIVERSITY OF DURHAM ENGLAND

WILL THE INSTRUCTIONS BE INSERTED IN THE
NUMERIC OR LITERAL MODE ? (NUM/LIT)

Programme Begins a New Operation

Fig. 7.7 Printout Obtained when Data is Stored.

Messages and Advice (Non-terminable)	
* BORE HOLE	Gives each borehole processed
UNITS CONVERTED FROM TO ...	Shows change of units.
TYPE OF TEST NOT RECOGNIZED *+AT A DEPTH OF MTRS..... FEET.	Non-standard mnemonic code used. The depth of the offender is given.
UNEXPECTED NON-NUMERIC CHARACTER *+AT A DEPTH OF MTRS FEET.	A non-numeric character in field M was not expected. The depth of the offender is given.
MORE THAN 70 LINES	Warning that data may not be correctly ordered.
*LOG TRANSFERRED TO STORE	Borehole successfully processed.
Errors which Cause Termination	
UNITS NOT RECOGNIZED	Incorrect unit identifier.
INVALID VALUE IN B.H. TITLE CARD	Incorrect character found in the title card. The whole card is printed out.
LAST CARD WITHOUT END CODE	After sorting the data the card for the greatest depth is devoid of any end code in field E.

* Not given for print-out

+ Only one system of units is employed where no change is specified.

Table 7.1 Errors and Messages in Data Storage.

CHAPTER 8

GEOTECHNICAL DATA RETRIEVAL FROM GEOSYS

8.1 Styles of Presentation

Various types of data presentation formats are available for data stored by Geosys. The existing output routines Outp1, Outp2, Outp3, and Trend produce respectively tabular data concerning the strata, information about the borings, site investigation data and contoured maps. But other routines added to the system could increase the number of presentation modes available.

During data retrieval the whole of the storage file is accessed by programme Read, but only data which satisfies the requirements of the Option Specification are available to the output routines. The restrictions such as location, depth or type applied to the data acquisition may act concurrently or independently. In practical terms, in the instance of a tunnel feasibility study, for example, the file could be accessed to give a description of the strata and the undrained shear strength of the ground along the tunnel line, and to a defined distance on either side.

The data output from Geosys is of three types:

- (i) tabular output;
- (ii) site investigation output; and
- (iii) contoured map.

8.1.1 Tabular Output

Tabular output produced by routines Outp1 and Outp2 may be retained within Geosys for eventual plotting by Trend to form contoured maps. The output produced by Trend will be described in Section 8.1.3, but here the tabular output given by Outp1 and Outp2 is detailed.

(i) Outp1

This routine selects occurrences of laminated clay from data which satisfy the other criteria of the Option Specification. All layers of laminated clay are indicated by their mid-point depth, but in order to aid the search for reasonably flat, sub-horizontal strata, the data selected for treatment by Trend can be limited to that lying between particular levels. This range of levels can be progressively increased from a specified location.

(ii) Outp2

This routine forms a convenient means of listing all the boreholes which fulfil such specified criteria as position and number. The levels of the boreholes and their location are printed out and may be retained within Geosys for processing into a contoured map by Trend.

8.1.2. Site Investigation Output

The output derived by the use of Outp3 comprises a borehole title followed by selected data concerning the strata, hydrology and testing. Various alternative types of strata description and test results are available in a tabular form, with all the data concerning

a particular boring given in the same record.

8.1.3 Map Output

As already mentioned, the contouring routine may be used as part of Geosys, in which case the data are supplied from either Outp1 or Outp2. Alternatively, data from external sources may be used by System Option 4. The mode of operation of Trend in both cases is quite similar, since only a little additional information, including of course the input data, is required for Option 4 operation.

8.2 Option Specification for Data Retrieval

Data retrieval by Geosys is initiated in the same manner as is the storage operation illustrated in Figure 6.2, except that System Option 2 must be specified. The actual Option Specification for data retrieval shown in Figure 8.1 following this can be performed in either the literal or the numeric mode. As before, the input (apart from the titles) must lie within the first fifteen columns.

The information required to operate the data retrieval routines is as follows:

- (i) identification letter preceding the site investigation
borehole identity number;
- (ii) whether or not a sequence of boreholes is to be specified;
- (iii) if a sequence of boreholes to be accessed, then whether two
boreholes or one borehole and either the beginning or end
of the file are to define the ends of the sequence;
- (iv) if a sequence of boreholes is to be accessed, then the
required borehole number(s)*;

* When identification numbers or depths are included in a numeric Option Specification, then if only one of two of these is to be specified then the other must be replaced by a dummy zero.

- (v) whether or not the data to be accessed are within a N-S,E-W, rectangular area defined by grid references;
- (vi) if the data scan is to be confined to a particular area, then the easting and northing, each expressed in five figures to the nearest metre, of two diagonal corners of the area of interest;
- (vii) whether or not the level of the data scan is to be defined;
- (viii) if the level of the data search is to be defined, then whether these levels are to be expressed with respect to the datum or the tops of the holes;
- (ix) if the level of the data search is to be defined, then whether a range of levels is to be specified, or whether the data required lies between either the top or the bottom of the holes and a defined depth;
- (x) if the level of the data scan is to be defined, then the level(s) expressed in metres;^{*+}
- (xi) the type of data presentation - test result and strata description codes;
- (xii) if Outp1 is specified, the range of depths⁺ for which instances of laminated clay are to be recorded for further processing by Trend;
- (xiii) if Outpl is specified, the reference location given by two, five digit, co-ordinates to the nearest metre for a linear increase in the depth range to begin;

* When identification numbers or depths are included in a numeric Option Specification, then if only one of two of these is to be specified then the other must be replaced by a dummy zero.

⁺The Option Specification programme operates in SI units. For data expressed in Imperial units, the specifications are automatically converted.

- (xiv) if Outp1 is specified, the rate of increase of the depth range expressed as the tangent of the slope of the surface with respect to the horizontal; and
- (xv) the requirement for a two-line title to be printed with the output (each line has 120 characters and is entered on two cards as follows: first card columns 1-72, second card columns 1-48).

The literal specification codes are checked as they are inserted and, as for the storage Option Specification, unacceptable responses cause the relevant question to be repeated up to three times before the execution is terminated. The numeric codes are also checked so that any inconsistent codes may be identified by the equivalent literal question before termination of the execution.

The complete procedure of Option Specification for Outp1 is illustrated in Figure 8.2. Once it has been checked, it may be printed out in the format of the equivalent numeric Option Specification after the complete procedure illustrated in Figure 8.2. is finished; then programme Read is activated and data may be accessed from storage.

8.3 Retrieval Operation.

During data retrieval, certain advice messages given in Table 8.1 are issued to aid diagnostics in the event of failure and also warn the user when the data are stored in Imperial units. This latter warning is necessary, since the column headings for the print-out supplied by the output routines are for S.I. units. This does not affect the operation of the programmes except that, if the

warning is given, the parameters will then be expressed in units given in Table B.6 as the Imperial equivalents of the heading S.I. units.

As explained in Section 8.1, geotechnical data can be output from Geosys via following three routines;

- (i) Outp1;
- (ii) Outp2; and
- (iii) Outp3.

Trend is also an output routine of Geosys, but since its data input originates from either one of the above programmes, or sources external to Geosys, it is more convenient to describe it in Chapter 9.

8.3.1 Outp1

The example of the printed output obtained from Outp1 given in Figure 8.3 includes the grid references and identities of boreholes in which laminated clay has been detected. These data are given in the output together with the depths of the tops, bottoms and mid-points of laminated clay layers. Should the boring be terminated in a layer, then the mid-point depth will be calculated using this depth as the bottom of the layer, and an appropriate message issued.

If further processing by Trend has been specified, a message is issued when a mid-point depth satisfies the depth criteria, and the easting (X), northing (Y), and the mid-point depth (Z) coordinates are retained within Geosys. Processing by Trend occurs after the Outp1 operation is completed and, since the programme can handle only five-hundred sets of data points, a warning is given when this number is exceeded because only the first five-hundred will be processed.

8.3.2. Outp2

The programme Outp2 is also suitable for pre-processing data suitable for Trend. As with Outp1, co-ordinate data may be retained for the eventual construction of contoured diagrams. Here, the grid reference (easting X and northing Y) and the datum level (Z) of the top of the borings are recorded. Other information, as shown by Figure 8.4, is also given in the printed output.

8.3.3 Outp3

After processing the data selected from the data file, Outp3 gives a style of data presentation akin to a site investigation report. Various options of test results, descriptions of the strata, and indications of the water conditions, facilitate a simple format for the output. A two-tier structure is used in which general particulars about the boring in a title precede the sub-surface information. These data are arranged in columns each of which is headed by the names of the parameters and the units being used. Each new page started in mid-boring is re-headed, but a new page will be started if fewer than ten lines remain on the page currently accepting output.

The sub-surface data output comprises information concerning the following factors:

- (i) the strata;
- (ii) the hydrological conditions; and
- (iii) the testing performed.

(i) The Strata

Several alternative styles of strata description are available:

- (a) no description;
- (b) only when a test result is printed; and
- (c) at each change of strata.

When a description of the data is required, then this can take

two forms:

- (a) detailed : a full literal interpretation of the numeric strata codes;
- (b) coded : a literal interpretation of only the main material (see Table B.3) numeric strata code.

(ii) The Hydrological Conditions

The groundwater conditions are indicated by encounters during boring and piezometric levels. In addition, the depth of installation of a piezometer or slip indicator, the rise or fall of a water strike, and the dates of piezometer readings may be recorded.

(iii) Testing Performed

A full list of test data output alternatives, and the parameters obtained, is given in Table 8.2. Codes 1, 2, 3 and 4 give various combinations of test results printed out to a set format. Code 5 shows the samples taken and the type of tests performed, but not the results, and code 6 gives all the tests and accompanying results. In this last alternative, all the parameters mentioned in codes 1-4, plus particle size and permeability, will be output.

The need to confine the thesis to an acceptable length inhibits a comprehensive illustration of the various styles of strata description and test result output formats. However, some of the possibilities are given in Figures 8.5a, b and c. In these three examples of output full descriptions of the material tested, a full description of the strata and a coded description of the strata are illustrated.

After a retrieval operation by routines Outp1 or Outp2 has been completed, and if a contoured diagram is required, then further information must be supplied to control the operation of Trend. This may only be performed in numeric code and, since this is almost the same as that used for Main Option 4, the Option Specification is dealt with in Chapter 9. At the end of other retrieval operations, command is returned to the Main Option Specification so that further work can be carried out or the execution terminated.

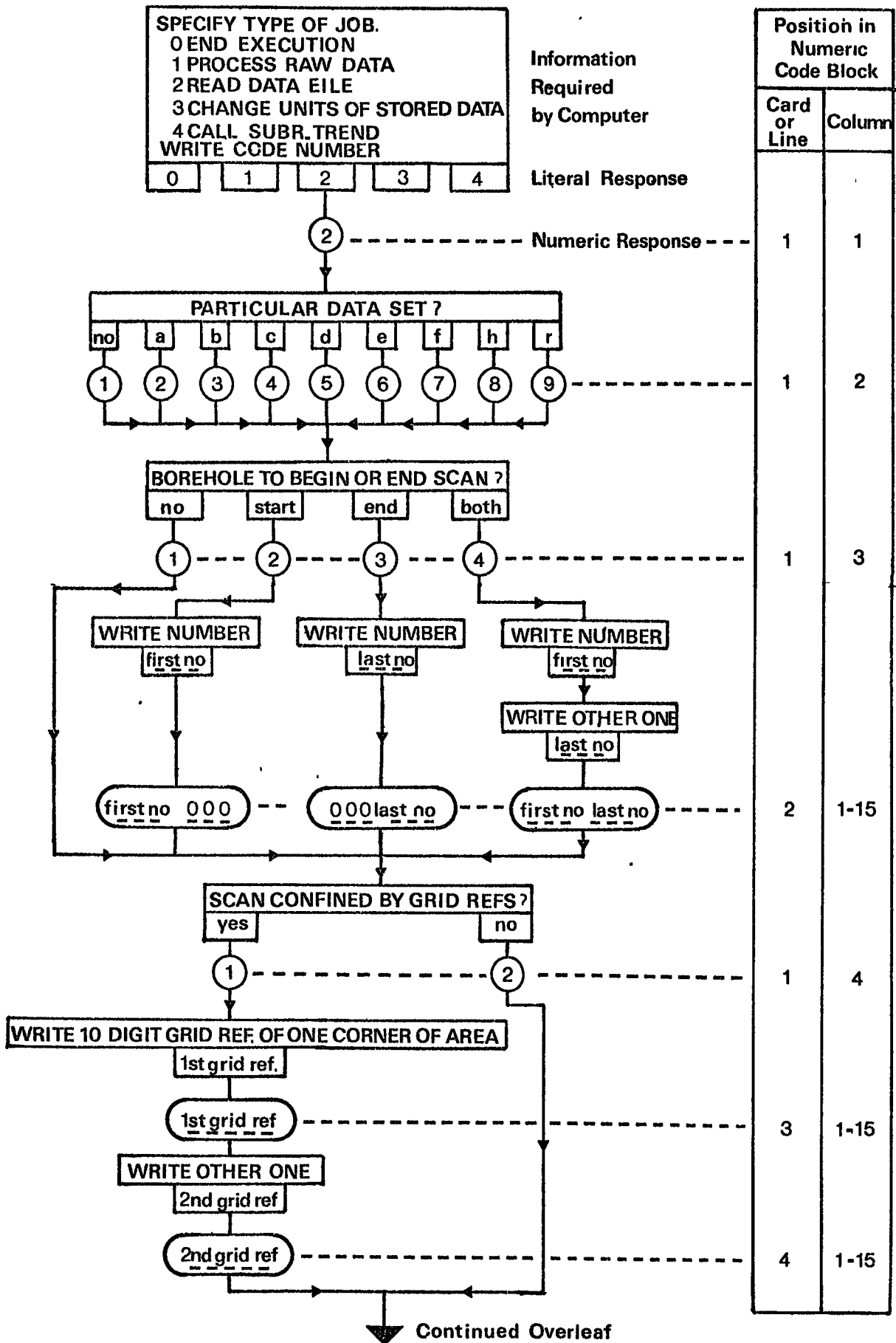
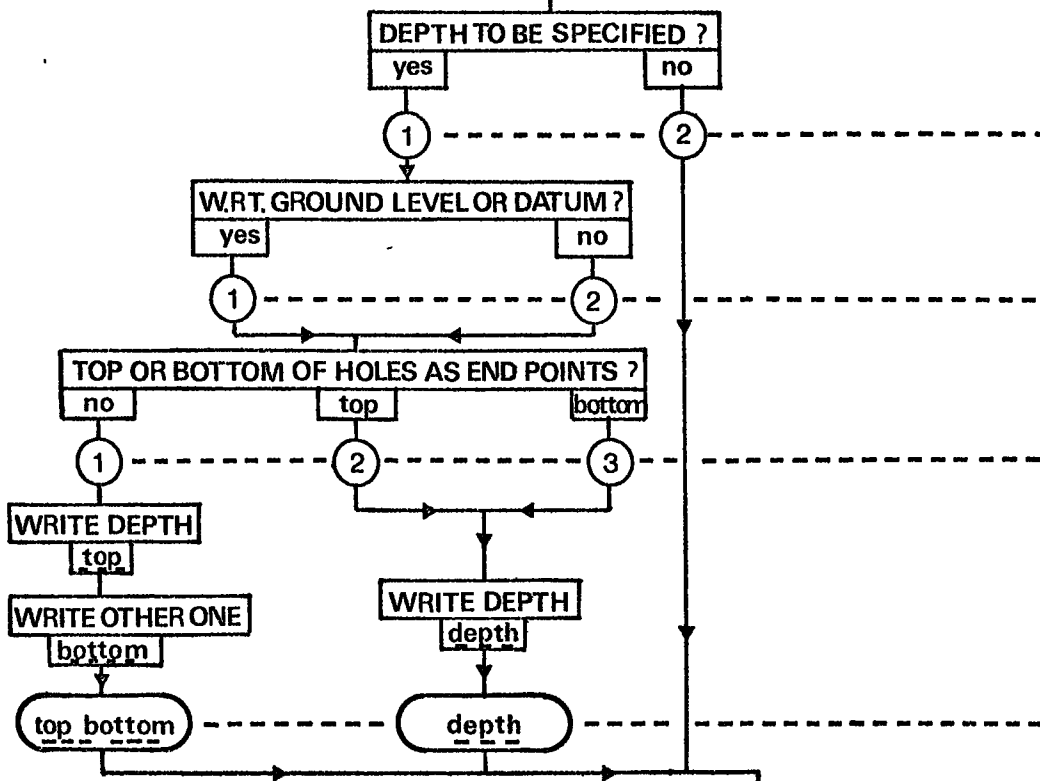

Fig. 8.1 Information required by Geosys for Data Retrieval.

Continued from Previous Page



Position in Numeric Code Block	
Card or Line	Column
1	5
1	6
1	7
6	1-15
1	8
1	9

TEST CODE	DESCRIPTION CODE
0 NO TEST RESULTS	0 NO DESCRIPTION
1 VANE,PENETRATION & SHR BX	1 DETAILED STRATA & WATER CON.
2 SULPH,MOIST.CONT & LIMITS	2 DET.DESCR OF MATERIAL TESTED
3 TRIAXIAL & UNIAXIAL TESTS	3 DET DES MAT TEST & WATER COND
4 CONSL,COMP,CBR & WET DEN	4 CODED DESCRIPTION OF STRATA
5 RECORD OF U4'S & TESTS	5 WATER CONDITIONS ONLY
6 ALL TESTS	6 CODED DESCR.MATERIAL TESTED
7 SUBR. OUTP1	7 SUBR. OUTP2

TEST CODE 6 MUST ACCOMPANY DESCR. CODES 0,4,5 OR 6 WHEN OUTPUT FROM OUTP1 OR OUTP2 IS TO BE ANALYSED BY TREND,THE DESCR OR TEST CODE MUST BE 1 OR 2.WHEN THE RESTRICTION OF DEPTH IS TO BE APPLIED TO OUTP1,THE TEST CODE SHOULD BE 2. FURTHER ANALYSIS WILL NOT TAKE PLACE WHEN THIS CODE IS 0.

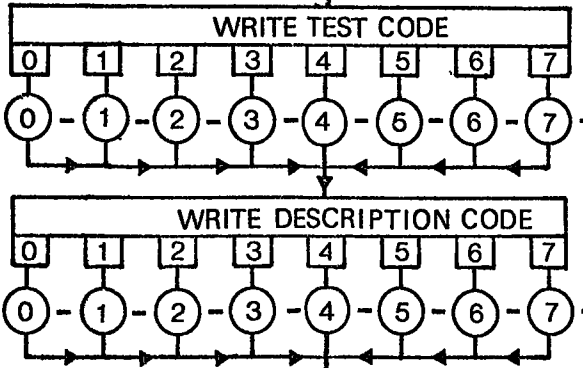

Continued on Next Page

Fig. 8.1 (cont) Information Required by Geosys for Data Retrieval

Continued from Previous Page

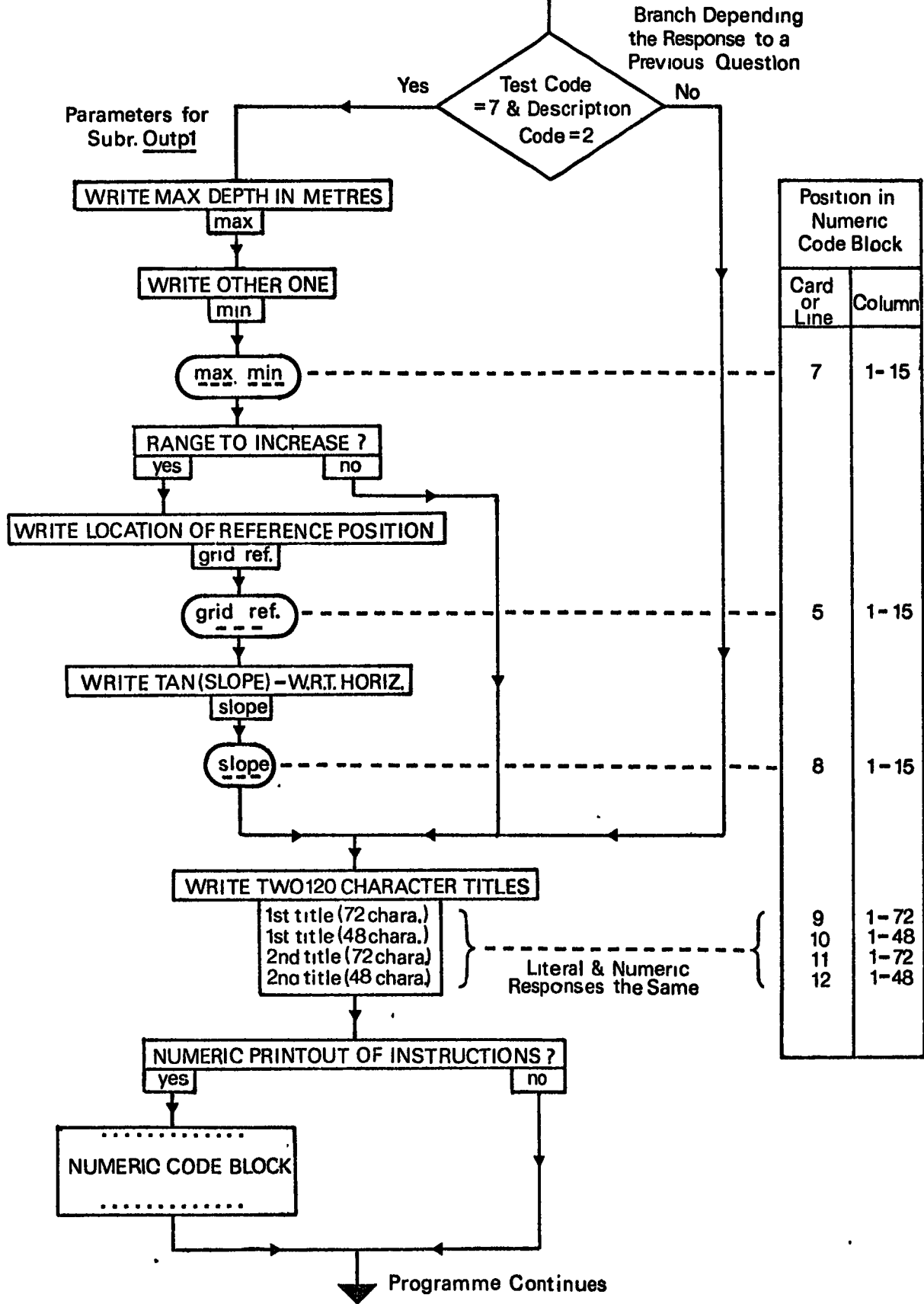

N.B. The literal responses may consist of only the initial letter of the answers

Fig. 8.1 (cont). Information Required by Geosys for Data Retrieval.

OPERATOR'S RESPONSES ARE PROMPTED BY ... :

WRITE CODE NUMBER

: 2

PARTICULAR DATA SET ? (NO/A/B/C/D/E/F/H/R)

: H

BOREHOLE TO BEGIN OR END SCAN ? (NO/START/END/BOTH)

: BOTH

WRITE NUMBER

: 7011

WRITE OTHER ONE

: 7046

SCAN CONFINED BY GRID REFS ? (YES/NO)

: YES

WRITE 10 DIGIT GRID REF. OF A CORNER OF AREA

: 3350066600

WRITE OTHER ONE

: 3370066200

DEPTH TO BE SPECIFIED ? (YES/NO)

: YES

WITH RESPECT TO GROUND LEVEL OR DATUM ? (GL/OD)

: GL

WRITE DEPTH IN METRES

: 20

TOP OR BOTTOM OF HOLES AS END POINTS ? (NO/TOP/BOTTOM)

: NO

WRITE DEPTH IN METRES

: 1

FORMS OF OUTPUT TO BE LISTED ? (YES/NO)

: 7

FORMS OF OUTPUT TO BE LISTED ? (YES/NO)

: YES

TEST CODE

0 NO TEST RESULTS

1 VANE PENETRATION & SHEAR BOX

2 SULPH. ANAL., MOIST. CONT., & LIM.

3 DRAINED & U/D TRIAX. & UNIAX.

4 CONS., COMPACT., CBR & WET DEN.

5 RECORD OF U4S AND TESTS

6 ALL TESTS

7 SUBR. OUTP1

0 NO DESCRIPTION

1 DETAILED STRATA & WATER COND.

2 DET. DESCR. TESTED MATERIAL

3 DET. DESCR. TEST MAT. & WATER COND.

4 CODED DESCR. OF STRATA

5 WATER CONDITIONS

6 CODED DESCR. TESTED MATERIAL

7 SUBR. OUTP2

Continued ...

Fig. 8.2 Option Specification for Outp1

TEST CODE 6 MUST ACCOMPANY DESCR. CODES 0,4,5 OR 6. WHEN OUTPUT FROM
OUTP1 OR OUTP2 IS TO BE ANALYSED BY TREND, THE DESCR. OR TEST CODE
MUST BE 1 OR 2. WHEN THE RESTRICTION OF DEPTH IS TO BE APPLIED TO
OUTP1 THE DESCR. CODE SHOULD BE 2. FURTHER ANALYSIS WILL NOT TAKE
PLACE WHEN THIS CODE IS 0.

WRITE TEST CODE

: 7

WRITE DESCRIPTION CODE

: 2

PARAMETERS FOR OUTP1

WRITE MAX DEPTH IN METRES ABOVE DATUM

: -5

WRITE OTHER ONE

: 0

LINEAR INCREASE IN RANGE FROM REF. POSITION ? (YES/NO)

: NO

WRITE TWO TITLES OF UP TO 120 CHARACTERS EACH

: SEARCH OF STORED DATA FOR LAMINATED CLAY LAYERS
: AREA... 3350066600 3370066200
: DEPTH.. -5.0 TO 0.0 M O.D. BOREHOLES.. M13 TO M45
: 20TH FEB 1974

NUMERIC PRINTOUT OF OPTION SPECIFICATION ? (YES/NO)

: YES

.....
284111172
7011 7046
3350066600
3370066200
2.0 1.0
-5.0 0.0

SEARCH OF STORED DATA FOR LAMINATED CLAY LAYERS
AREA... 3350066600 3370066200
DEPTH.. -5.0 TO 0.0 M O.D. BOREHOLES.. M13 TO M45
20TH FEB 1974

.....

Programme continues

Fig. 8.2 (cont.) Option Specification for Outp1

SEARCH OF STORED DATA FOR LAMINATED CLAY LAYERS AREA... 3350066600 3370066202
 DEPTH... -5.4 TO 0.0 M O.D. BOREHOLES... H13 TO H45 20 FEB 1974

SYSTEM OF UNITS... S.I.

BOREHOLE	EAST (X)	NORTH (Y)	TOP	BOTTOM	MID (Z)	THICK	
H17A	33657	66262	-19.7	-19.5	-19.1	0.8	
H21	33615	66321	-18.5	-20.0	-19.2	1.5	
H21A	33620	66325	-6.7	-7.6	-7.1	0.9	B.H.ENDS IN LAYER
H22	33692	66337	-1.7	-3.4	-2.6	1.7	XYZ IN COMMON
H22	33692	66337	-3.4	-6.0	-4.7	2.6	XYZ IN COMMON
H25	33529	66336	7.7	4.7	6.2	3.1	
H25	33529	66339	-1.9	-6.0	-3.9	4.1	XYZ IN COMMON
H25	33529	66339	-6.0	-7.3	-6.7	1.4	
H26	33681	66411	0.0	-5.3	-2.6	5.3	XYZ IN COMMON
H27	33618	66458	1.5	-1.2	0.2	2.7	
H29	33599	66564	9.2	5.4	7.3	3.8	B.H.ENDS IN LAYER
H29	33599	66564	1.6	-0.8	0.4	2.4	B.H.ENDS IN LAYER
H30	33620	66364	2.8	1.9	2.4	0.9	
H30	33620	66364	-0.8	-3.7	-2.3	2.9	XYZ IN COMMON
H31	33588	66357	1.6	0.3	1.0	1.4	
H31	33588	66357	-1.1	-4.1	-2.6	3.1	XYZ IN COMMON
H34	33622	66412	10.6	7.7	9.1	2.9	
H34	33622	66412	-0.1	-1.9	-1.0	1.8	XYZ IN COMMON
H35	33551	66397	4.2	-2.9	0.7	7.2	
H36	33533	66292	-0.5	-9.5	-5.0	9.0	XYZ IN COMMON
H37	33517	66250	-2.6	-4.6	-3.5	2.0	XYZ IN COMMON
H39	33626	66397	9.6	7.9	8.7	1.7	
H39	33626	66397	1.3	-3.5	-1.1	4.9	XYZ IN COMMON
H40	33588	66391	7.4	6.3	6.8	1.2	
H40	33588	66391	6.1	4.5	5.3	1.5	
H41	33654	66433	13.7	10.6	12.1	3.1	B.H.ENDS IN LAYER
H44	33615	66489	18.8	18.4	18.6	0.5	
H45	33622	66347	-17.4	-18.5	-17.9	1.1	

END OF DATA

Fig. 8.3 Output Retrieved by Outpl

FILE SCAN TO DETERMINE THE GRID REFERENCES OF BOREHOLES 7050 TO 7070

NUMERIC OPTION SPECIFICATION CODE .0211220007 13 DEC 1974

BOREHOLE	EAST(X)	NORTH(Y)	HT OD(Z)	DTM OD	DATE	UNITS
7050	33382	66402	21.37	10.67	18-19/6/69	M
7051	33437	66484	20.45	10.67	20-21/6/69	M
7052	33590	66616	22.10	6.10	3-4/9/69	M
7053	33530	66603	19.78	5.91	5-6/9/69	M
7054	33409	66617	23.87	6.19	8-9/9/69	M
7055	33050	66458	18.44	-4.72	13-15/2/70	M
7056	33153	66463	17.10	-2.41	6-10/2/70	M
7057	33220	66469	17.31	-2.81	3-5/2/70	M
7058	33271	66480	17.43	-2.99	20-23/2/70	M
7059	33370	66491	19.20	13.10	19/2/70	M
7060	33375	66543	19.84	12.22	18-19/2/70	M
7061	33949	66445	13.11	-6.55	30/1-3/2/70	M
7062	33103	66463	16.55	-2.65	10-12/2/70	M
7063	33333	66563	23.16	9.57	22-23/12/70	M
7064	33369	66553	22.40	9.42	19-21/12/70	M
7065	33365	66535	22.16	6.92	5-8/2/71	M
7066	33646	66568	22.62	10.28	1-2/3/71	M
7067	33621	66591	21.98	8.11	2-3/3/71	M
7068	33693	66568	23.56	11.22	4-6/3/71	M
7069	33701	66510	23.07	10.88	8-10/3/71	M
7070	33682	66598	24.02	5.58	6-8/9/71	M

END OF DATA

Fig. 8.4 Output Retrieved by Outp2

GEOTECHNICAL DATA OUTPUT - CONSOLIDATION, COMPACTION, CBR AND WET DENSITY TEST RESULTS

BOREHOLES 7004 AND 7005 12TH NOVEMBER 1974

DEPTH MTRS	B.M.	BOREHOLE	M5	GRID REF	DESCRIPTION	HT OD	16.7	METRES	CONS MV	COMP D.DEN	CBR	W.DEN	MOIST.
U.D.	ACT.	TYPE						SQM/GN	KG/CUM	%	%	KG/CUM	CONT.%
15.2	1.7	S&A	DSE/STIFF BRN SDY-STY CLAY COAL (FRAGS)	W.ASH					1537.9			1650.1	13
11.8	4.9	S&A	DSE/STIFF GR SDY-STY CLAY	COAL					1666.1			1986.5	16
9.5	7.2	S&A	DSE/STIFF BRN SILTY CLAY GRAVEL & COAL	LAM./PT SILT								1794.2	
2.8	13.9	S&A	DSF STIFF BRN SDY-STY CLAY GRAVEL & COBLS	OC. BOULDERS								2130.7	
-6.8	23.5	S&A											

BOTTOM OF HOLE

DEPTH MTRS	B.M.	BOREHOLE	M6	GRID REF	DESCRIPTION	HT OD	4.6	METRES	CONS MV	COMP D.DEN	CBR	W.DEN	MOIST.
U.D.	ACT.	TYPE						SQM/GN	KG/CUM	%	%	KG/CUM	CONT.%
2.7	5.4	S&A	LSE/SOFT MKN	SAND	GRAVEL				223.8			1826.3	36
3.8	8.5	S&A	LSE/SOFT BRN	SAND	GRAVEL				121.2			1650.1	37
6.6	11.5	S&A	LSF/SOFT BRN	SAND	GRAVEL							2210.8	
14.5	15.2	S&A		BOULDER					65.3			2242.8	13
16.6	21.3	S&A	DSE/STIFF GRY	SILTY CLAY	GRAVEL & COAL	LAM/SLT	PTG					2082.6	
-21.3	26.0	S&A											

BOTTOM OF HOLE

END OF DATA

Fig. 8.5a Output Retrieved by Outp3

GEOTECHNICAL DATA OUTPUT - SULPHATE ANALYSIS, MOISTURE CONTENT AND CONSISTENCY TEST RESULTS

BOREHOLES 7M14 AND 7M15 27TH JANUARY 1975

BOREHOLE 7M14		H16	GRID REF 3362566185	HT OD -4.8 METRES				
DEPTH MTRS	H.M.	DESCRIPTION				SULPHATE ANALYSIS	MOIST. LIMITS	
O.D.	ACT	TYPE					S03	PH CONT.% LL PL LI
-4.8	0.0	S&A	LSE/SOFT BLK URG SLTY CLY					90
-5.7	0.8	S&A	LSF/SOFT BLK ORG SLTY CLY LAM.FN SAND					
-5.9	1.1	S&A	DSE/STFF G-8 SILTY SAND	ORG.MAT/PLNT COAL &SHELLS	730.0	DWTZX1000	7.3	
-6.8	2.0	S&A	DSE/STFF BRN SDY-STY CLAY GRAVL.&COBLS IN POCKETS					37 50 26 0.5
-17.5	5.7	S&A						23 27 18 0.6
-11.8	7.0	S&A						
-13.7	8.9	S&A						
-15.5	10.7	S&A						
BOTTOM OF HOLE								

BOREHOLE 7M15		H17	GRID REF 3362166252	HT OD -5.4 METRES						
BOREHOLE 7M15		H17	GRID REF 3362166252	HT OD -5.4 METRES						
DEPTH MTRS	O.M.	DESCRIPTION				SULPHATE ANALYSIS	MOIST. LIMITS			
O.D.	ACT	TYPE					S03	PH CONT.% LL PL LI		
-5.4	0.0	S&A	V.SFT BK ORG SDY-STY CLAY					58		
-6.2	0.8	S&A						58		
-7.0	1.6	S&A								
-7.2	1.8	S&A								
-7.7	2.3	S&A	DSE BN FN/CSE SAND &GRAVEL GRAVL.&COBLS					100.0	DWTZX1000	7.7
-9.4	4.0	S&A								
-11.5	6.1	S&A								
BOTTOM OF HOLE										

END OF DATA

Fig. 8.5b Output Retrieved by Outp3

GEOTECHNICAL DATA OUTPUT - ALL TESTS AND CODED DESCRIPTIONS OF THE STRATA
 BOREHOLE 7234 22ND MAY 1974

DEPTH	MTRS	R.H.	DESCRIPTION	C	TRIAxIAL	VANE(KN/SQM)&PETN.	OTHER TESTS	LIMITS
U.D.	ACT.	TYPE		KN/SQM	PHI	TYPE	UNIT VALUE	LL PL MC
21.0	0.4	S&A 0	TOP SOIL					
21.7	0.3	S&A 9	SDY-STY CLAY 4					
19.9	1.1	S&A		253.6 0	*R 3.3	U/D	PT S03 X1000	150.0 7.5 PH VAL
19.3	1.7	S&A 5	SDY-STY CLAY 4				WETDEN KG/CUM	2194.7 3.8 DIA CM 30 15 12
19.2	1.7	S&A 9	SDY-STY CLAY 4				CMP DD KG/CUM	1954.4 12% OPT.MC
19.6	2.4	S&A					PT S03 X1000	30.0 7.4 PH VAL
18.6	2.4	S&A		52.7	1.1	U/D	WETDEN KG/CUM	2466.6 10.2 DIA CM 41 15 19
16.9	4.1	S&A		17.2		DRD	WETDEN KG/CUM	2176.7
15.6	5.4	S&A						
14.0	6.9	S&A						
14.0	6.9	S&A 9	SANDY SILT 0					
13.8	7.2	S&A 9	SANDY SILT 0					
12.5	8.5	S&A						
12.0	9.0	S&A						
11.0	10.0	S&A 9	SILTY CLAY 8					
9.2	11.7	S&A		88.6 8	1.3	U/D	WETDEN KG/CUM	2038.4 10.2 DIA CM 31 15 15
7.9	13.0	S&A		28.7 0		DRD		
6.4	14.5	S&A		69.4 0	3.3	U/D	WETDEN KG/CUM	2114.6 3.8 DIA CM 31 15 16
6.4	14.5	S&A					CON.MV SQM/GN	74.6
5.4	15.5	S&A 9	SDY-STY CLAY 4	141.2 0	1.3	U/D	WETDEN KG/CUM	2242.8 10.2 DIA CM 29 14 11
3.4	17.6	S&A					CON.MV SQM/GN	28.0
3.4	17.6	S&A						
1.6	19.3	S&A 5	LAM.STY CLAY 8	55.1 6	1.3	U/D	WETDEN KG/CUM	1954.4 10.2 DIA CM 70 27 29
0.3	20.6	S&A						
-1.4	22.4	S&A 3	SDY-STY CLAY 9	416.6	1.1	U/D	WETDEN KG/CUM	2242.8 10.2 DIA CM 23 15 11
-3.6	24.6	S&A						
-5.0	26.0	S&A						

END OF DATA

Fig. 8.5c Output Retrieved by Outp3

Message	Meaning
* READ * UNITS NOT RECOGNIZED	Identifyer missing - may be due to a card having erroneous end code.
*READ * Warning : Imperial units in use in B.h.	Stored data & output units of parameters in Imperial units.
*READ * End of data file reached	File end code read

Table 8.1 Advice Messages Issued By Retrieval Programme

Code	Type of Tests	Parameters Given in Output
0	No test results	-
1	Vane test Penetration test Shear box test	Peak and/or remoulded shear strength; whether laboratory or <u>in situ</u> test. Whether standard or dynamic cone type; penetration or number of blows for 12". Peak and residual cohesion; peak and residual values of ϕ .
2	Sulphate analysis Moisture content and limits	% by weight of SO_3 in dry soil or amount of soluble SO_3 in water; pH value. Value of moisture content and liquid and plastic limits expressed as % water of dry weight.
3	Drained triaxial test Undrained triaxial test	Whether or not a remoulded sample used, whether or not pore pressure measurement; value of cohesion, value of ϕ' , diameter of sample. Type of test (on 1 sample or 3 samples); value of cohesion or shear strength, value of ϕ , diameter of sample.
4	Consolidation test Compaction test C.B.R. test Wet density	Value of coefficient of volume compressibility for a pressure range of overburden to overburden plus 1 ton/ft ² ; moisture content as a % of dry weight. Value of maximum dry density and corresponding optimum moisture content. Value of C.B.R. and natural moisture content. Value of wet or bulk density of a soil
5	Record of all U ₄ 's and tests	Positions of any U ₄ samples, and the type of any <u>in situ</u> or laboratory tests performed.
6	All tests	All parameters given by codes <u>1</u> - <u>4</u> plus chief particle size from particle size analysis and permeability and distance between packers in permeability tests.

Table 8.2 Data Available with Test Results in Outp3.

CHAPTER 9

GEOTECHNICAL DATA PRESENTED IN THREE DIMENSIONS

9.1 Introduction

In this portion of the thesis are described two means of displaying complicated geological and geotechnical conditions in a simple visual manner. The three dimensional data presentations which can be used for this purpose are as follows:

- (i) contoured map;
- (ii) physical model.

The contoured map, produced by processing output from either Outp1 or Outp2, comprises an array in which numbers and letters are used to indicate contours respectively above and below a reference value. Various ways of forming a physical three dimensional replica were mentioned in Chapter 5, but the one developed in the present work is the multi-section model.

9.2 Contoured Map

Polynomial expressions of surfaces derived from the cartesian co-ordinates of up to 500 data points may be obtained by operational programme Trend (see Figure 6.1). Since each measurement location is defined by two co-ordinates on a horizontal plane and an independent variable above - or below - it, the map is a contoured representation, with respect to the plane, for the selected degree of polynomial-conjectured surface. The programme and its operation have been described by O'Leary et al. (1966) but minor modifications for incorporation into Geosys have been necessary.

The manner of Trend operation depends upon the source of the data used to form the surface:

- (i) Data from sources external to Geosys may be formed into a trend surface diagram by Main Option 4 of Geosys (see Figure 6.2). To operate this routine, the Option Specification for Trend, always in a numeric mode, must be entered immediately Option 4 has been specified.
- (ii) Data may be retrieved from storage by Main Option 2 of Geosys for the construction of trend surface maps. For this, either Outp1 or Outp2 must be specified as output routines with the Option Specification for Trend following this. Rather less information is required for the operation of this mode of Geosys since, for instance, the actual data to be plotted are transferred automatically.

In the present study, two output routines have been used for accessing data for direct treatment by Trend. These are:

- (i) Outp1 for plotting the mid-point depths above a datum of laminated clay layers;
- (ii) Outp2 for expressing the areal variation in the elevation of the tops of boreholes.

It is more convenient to illustrate the output of Trend later in the text, but here it is helpful to note that the following information can be given:

- (i) maps produced on the line printer, consisting of blocks of characters representing contour ranges over the area of interest;

- (ii) the equations of the polynomials with other statistical parameters;
- (iii) plots of the original data; and
- (iv) the residual values may also be plotted.

A coding sheet containing specification instructions for Trend is given in Figure 9.1. In this Figure, those cards not required for Option 2 operation are distinguished by cross-hatching. The following information is required for the operation of Trend where the instructions are labelled as in Figure 9.1 and an asterisk indicates ones that are not required for Main Option 2.

- (i) A1* Columns 1 and 2 I2 Number of data sets.

The number of data sets to be analysed.

- (ii) B1 Columns 2 to 80 19A4,A2 Title

A title which appears on each page of Trend output.

- (iii) B2* Columns 2 to 4 I3 Number of data points in set.

The number of data points in the current data set. This number must lie between 1 and 500.

- (iv) B2 Columns 6 to 11 6I1 Degrees of polynomials.

The degree of polynomials to be used in the surface plotting routine, a 1 in column 6 indicates 1st degree, a 1 in column 7 indicates 2nd degree, and so on.

- (v) B3* Columns 1 to 72 18A4 Format statement.

The Fortran format (enclosed in brackets) of the co-ordinate data given in the cards labelled C1 onwards.

- (vi) C1* onwards Format as defined by instruction B3. The co-ordinate data. The data expressed as two cartesian horizontal co-ordinates (X and Y) to form a plan, and a vertical co-ordinate (Z).

The number of three co-ordinate data points must correspond with the value on card B2.

- (vii) D1 Columns 1 to 5 I5 Number of Maps.

The total number of contour maps to be drawn. This is the number of E1 and E2 instructions.

- (viii) Column 7 I1 Requirement for original data plot D1.

A code 1 indicates that a plot of the original data is required, otherwise a 0 is inserted.

- (ix) E1 Column 2 I1 Degree of polynomial.

A code between 1 and 6 indicating the degree of polynomial to be plotted.

- (x) E1 Column 3 I1 Orientation code.

A code which indicates the orientation of the plot according to the convention:

<u>Code</u>	<u>Orientation</u>
1	Axis of 1st parameter (X) horizontal.
2	Axis of 2nd parameter (Y) horizontal.
3	So that the plot occupies the maximum space.
4	So that the plot occupies the minimum space.

- (xi) E1 Column 4 I1 Maximum and minimum plotting limits.

A code which equals 1 if the axes of the plot are to equal the maximum and minimum values of the X and Y co-ordinates used in the data, otherwise a 0 is inserted.

(xii) E1 Column 5 I1 Lines per inch code.

If this code is 1, the output will be listed at 6 lines to the inch, otherwise a 0 indicates that 10 lines to the inch are required (the latter gives equal X and Y scales).

(xiii) E1 Columns 6 to 9 I4 Number of columns.

A number between 12 and 120, giving ten more than the number of horizontal columns of output required.

(xiv) E1 Columns 10 to 19 F10.2 The contour increment.

(xv) E1 Columns 20 to 29 F10.2 The reference contour.

(xvi) E2 Columns 2-61 4F15.6 Position of the Axes.

This instruction is only included if the value in column 4 of card E1 is 0. The information comprises:

the maximum axis value of the first parameter (X);

the minimum axis value of the first parameter (X);

the maximum axis value of the second parameter (Y); and

the minimum axis value of the second parameter (Y).

The instructions on cards E1 and E2 must be repeated in that order for each plot specified in columns 1 to 5 of card D1.

(xvii) F1 Columns 1 to 5 I5 Number of plots of original data and residuals.

This code is only required when the code of column 7 of card D1 is 1. The total number of plots of original data and residuals must equal the number of sets of G1, G2 instructions.

(xviii) G1 Column 2 I1 Original data/degree of residual indicator.

A code which equals 0 when original data are to be plotted, or which has a value between 1 and 6 corresponding to the degree of residual to be plotted.

(xix) G1 Columns 3 to 9 3I1, I4 Orientation, plotting limits, lines per inch and number of columns .

The orientation, the maximum and minimum plotting limits, the lines per inch, and number of columns indicators which serve the same functions as the codes described for the same positions of card E1. (On G1 the number of columns specified may lie between 16 and 120, and the number plotted will be 15 less than this).

(xx) G2 Columns 2 to 61 4F15.6 Position of axes.

This card is only included when the code in column 4 of card G1 is 0 and it performs a similar function to that of card E2.

The instructions on codes G1 and G2 must be repeated in that order for each plot specified on card F1.

The Trend Option Specification and the data are checked for acceptability. Some twenty-eight errors are recognized and given the codes by O'Leary et al. (1966) in Table 9.1. The output from a typical run of Trend, in which a plot of the original data and residual values have been specified, gives the following information:

- (i) the coefficients of the equations fitted to the data of the desired degree equations;
- (ii) the error measures for each degree of polynomial (these include the standard deviation, the variation explained by the surface, the variation not explained by the surface, the total variation, the coefficient of determination, and the coefficient of correlation);
- (iii) contoured maps for each of the degrees, the scale, the contour interval, and the reference contour;

- (iv) a plot of the original data values and the scale being used;
- (v) plots of the residuals for each of the desired degrees.

The choice of the most suitable surface depends primarily on the residuals, or deviation of the fitted surface from the original data. However, by the choice of a high-degree polynomial, the surface may be made to fit the data exactly. Therefore, a balance between a low-degree surface - since these laminated clay layers are almost flat - and low residuals is required. Further analysis of possible boreholes which do not penetrate laminated clay in the areas between ones which do, is also required. Plotting the distribution of all holes within the area in question, and shown in Figure 9.2, by overlay A on the chosen trend surface, with the holes which did penetrate laminated clay within the defined depths on overlay B, gives an indication of the probable areal extent of those layers. The resulting contoured map of the distribution of the laminated clay is shown by overlay C in this Figure.

9.3 Physical Model

The model developed for use with Geosys output comprises a series of sections across the area of interest. These are produced from data retrieved from storage by using output routine Outp3. Such a model as the one described is suitable for displaying many geological or geotechnical features, but can be very useful for demonstrating complicated ones in a simple direct manner.

The model was constructed from a series of thin transparent sheets arranged vertically as geological sections. Each sheet

has the logs of nearby boreholes projected on to it, and is then located to represent the actual positions of the sections. Perspex was found to be the most suitable material for the sections - it is easily obtainable, transparent, cheap, easily cut to size, and easy to clean. Temporary marks can be made with wax pencil - several colours of Chinagraph pencil are available - and permanent marks made with ink. The process of model making takes the following form:

- (i) define the area to be modelled;
- (ii) devise suitable sections to present geological conditions;
- (iii) devise areas for computer data scans to retrieve data for model sections;
- (iv) scan data file, selecting descriptions of the strata from Outp3 for the areas of sections;
- (v) interpret Geosys output and transfer the logs on to the transparent sheets according to a scale;
- (vi) draw in provisional boundaries (a subjective indication of uncertainty may be used at this point);
- (vii) arrange the sheets in the model to represent the geological sections; and
- (viii) examine boundaries on the sections for each sheet in turn and adjust them to comply with the overall pattern which emerges.

In the present study, a model of an area to the north of the River Tyne, about 7km east of Newcastle-upon-Tyne centre, has been produced. Since preliminary examinations of the data for the area

in question indicated that the ground was a formation of southward-dipping laminated and stony clay strata overlying boulder clay, sections along north-south lines were chosen. The spacing, dictated by the expected variability of the strata and the amount of data available, was arranged to accommodate a reasonable number of boreholes on each perspex sheet. In the work being described, a regular spacing of 100m was selected. However, irregular spacings and sections other than north-south ones could have been adopted, although the use of either north-south or east-west sections does simplify data retrieval. Having arrived at a suitable scale, so that all the relevant information could be included on a model of a manageable size, the data processing could commence. With a horizontal scale of 25mm equal to 100m and a vertical scale of 10mm to 1m, the area in question was represented by 5 sheets of 3mm thick Perspex, 254mm by 467mm in size. The data file was scanned for the logs relating to each section from an area within, and to 50m either side, the section. Although specific test results were not obtained in these data retrievals, their use could aid geological interpretation.

A piece of squared paper (Plate 9.1) was prepared with the grid lines, datum and the vertical scale, so that when the Perspex sheets were positioned on it the boreholes could be located and drawn in. In this study, it was convenient to use Ordnance Datum as a basis for levels, but in higher ground another datum would be more appropriate. Like the completed section for 33500mE in Plate 9.2, each was marked with stippling to represent the various geological strata.

Provisional boundaries were drawn on to each section on the opposite side of the sheet to that of the boreholes records. Following this, a frame containing a base marked with the borehole locations and grid lines, and a side and back incorporating a vertical scale and grid lines, was manufactured. Then, taking groups of adjacent sections together in the frame of squared paper to aid measurement, the boundaries were adjusted to accommodate adjacent ones. In the finished model, in Plate 9.3, the sections have been completed and are assembled in the frame with the boundaries and horizons marked.

9.4 Conclusions on the Value of Geosys.

The geotechnical data storage and processing system Geosys has been designed to make site investigation data more readily accessible. Obviously, the extent to which data from Geosys can meet the needs of urban developers depends primarily on the styles of data presentation that are available. It has been recognized that the requirements of persons engaged in urban development change as the development progresses. A sequence can be identified in which, if site investigation data form the primary data source, then more data processing is required for the production of output suitable for application in increasingly early stages during proposed development. Geosys can satisfy, not only these requirements with the map and model facilities, but also the need for on-going data processing as development progresses.

One of the stated objectives of data processing in Chapter 5 comprised an assessment of the advantage to accrue from performing

site investigation. The theory for such an analysis was developed in Chapter 4, and Geosys can provide in suitable form the data necessary to utilize this theory in practical problem form. Two styles of output are required for this operation, since in the problem examined in Chapter 10 the outcome in the form of a decision depends on both the geological conditions pertaining and the operative value of a specific geotechnical parameter. Hence, the model is used to evaluate the geological conditions, and values of the parameter are derived from storage by means of Outp3. Thus, this application of data retrieval from storage by Geosys forms the conclusion to data presentation and analysis by means of probability techniques.

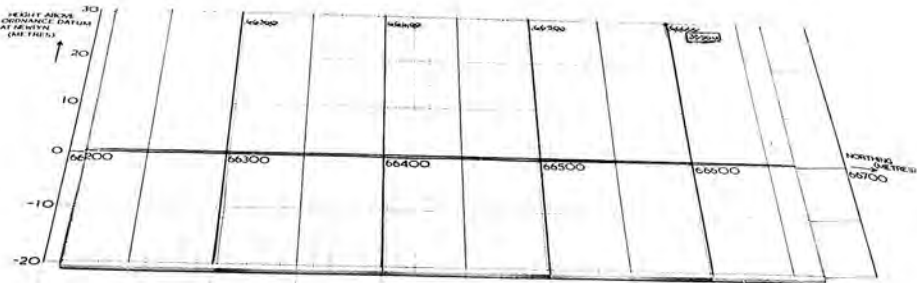

Plate 9.1 Guide Used for Drawing Sections

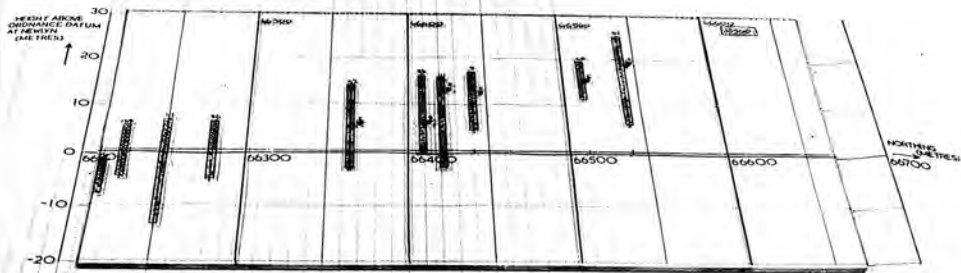

Plate 9.2 Completed Section for 3350mE

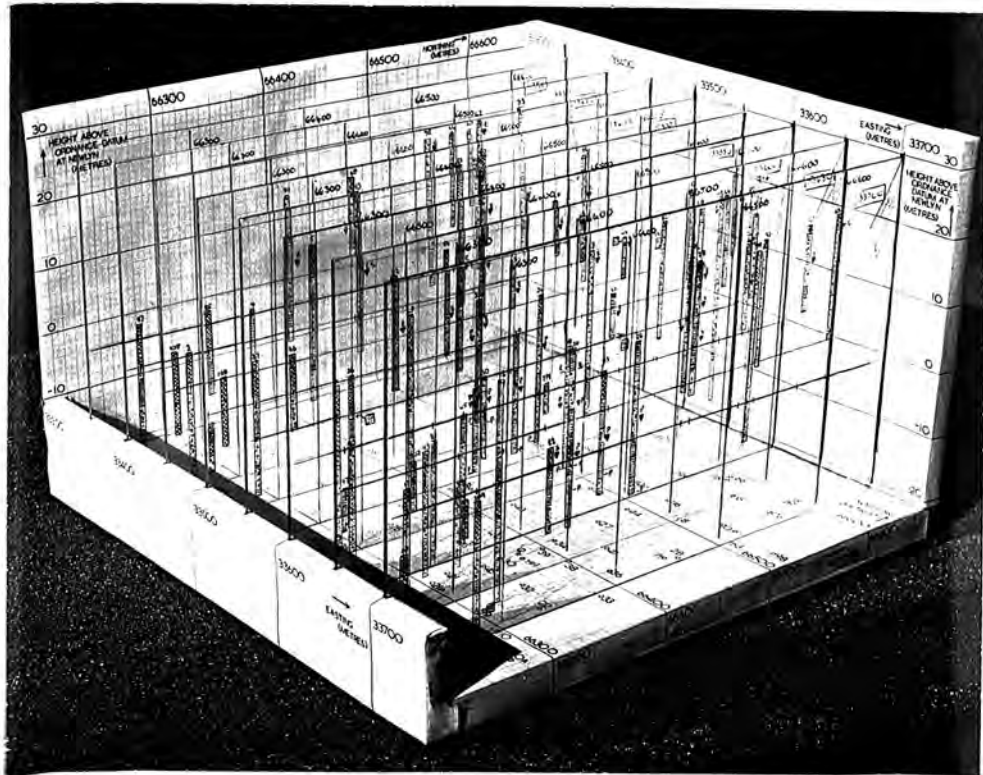
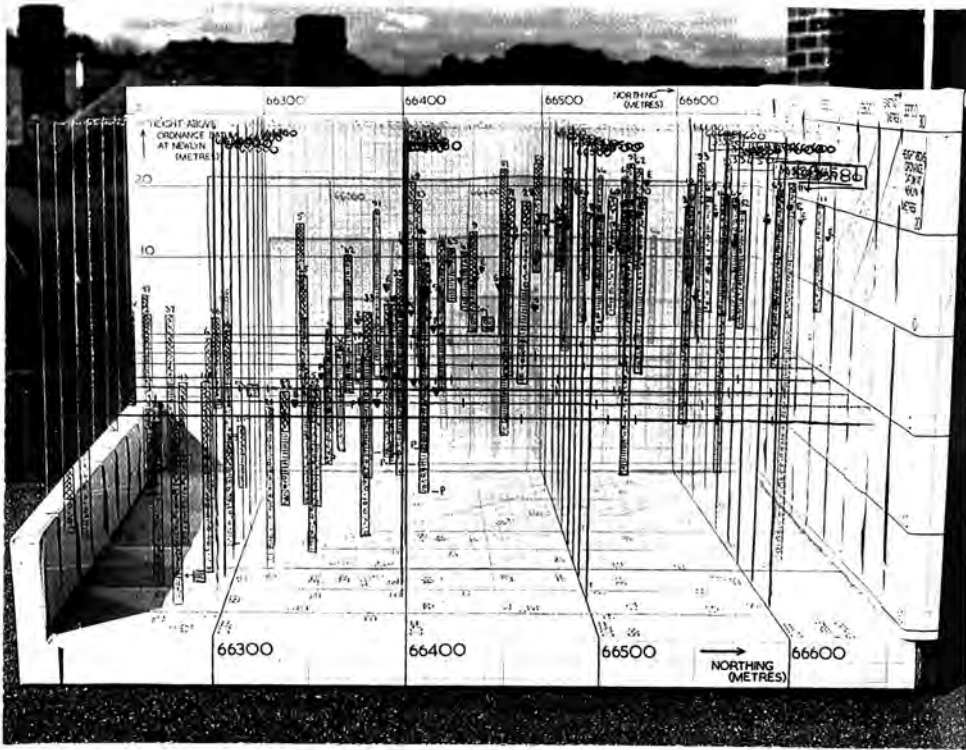
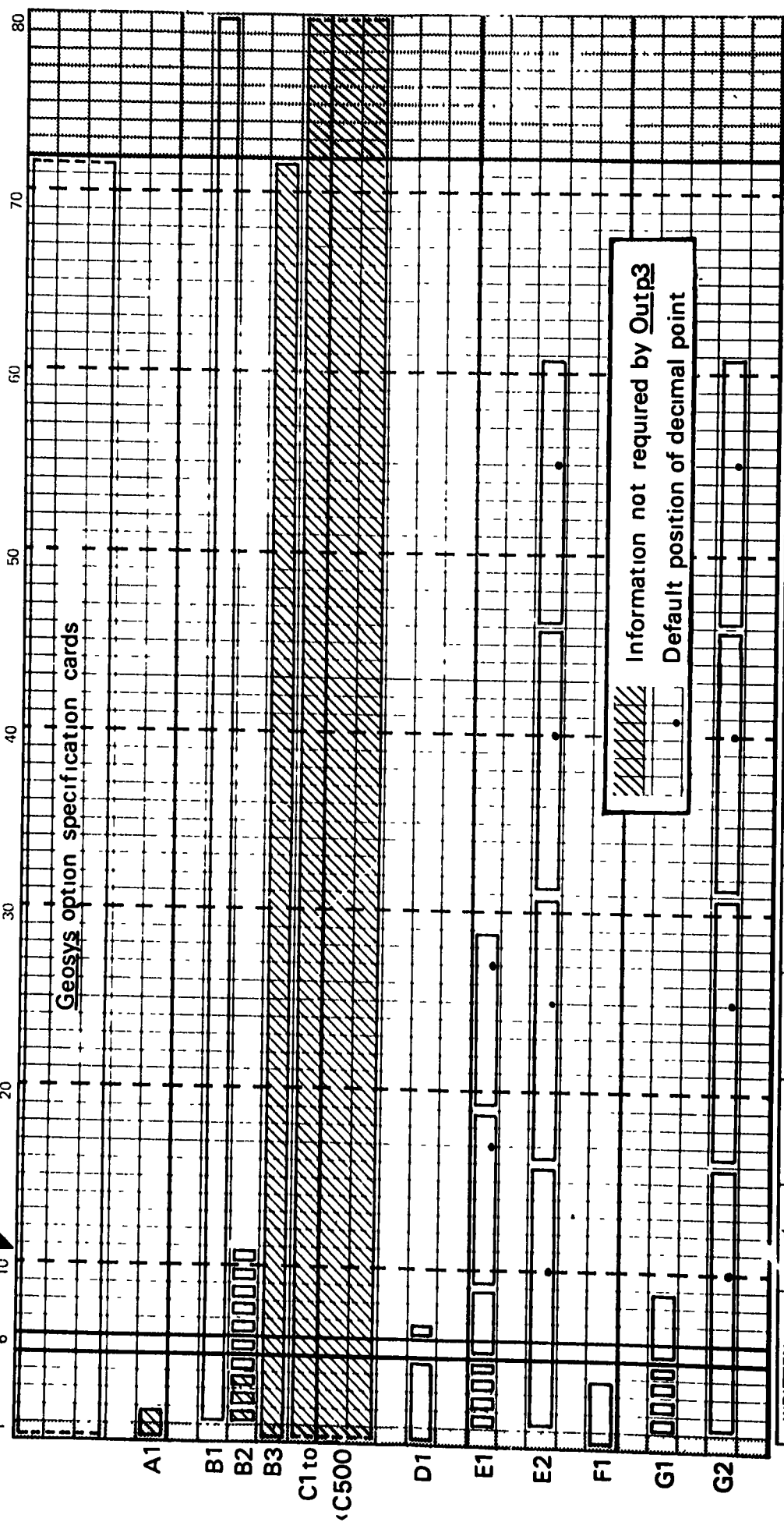

Plate 9.3 Finished Geotechnical Model.

COLS	PLI	COLS	FORTHAN	COLS	JOB CONTROL	COLS	DATA
7380	Statement	15	Statement No.	171	Statement	180	According to FORMAT
	Optional Sequence	6	Statement Continuation	7380	Optional Sequence		Statement in program
		77	Statement				
		7380	Optional Sequence				

CARD COLUMN

PROGRAM PAGE OF
PROGRAMMER DATE DATE



WRITTEN	0	1					
PUNCH	letter 0	letter	number 1				

Fig. 9.1 Information Required to Operate Trend

Overlay C

Contours drawn for the mid-point of a Laminated Clay layer (shown ornamented) between 12.0m and 20.0m above ordnance data (Newlyn)

Northing (m)

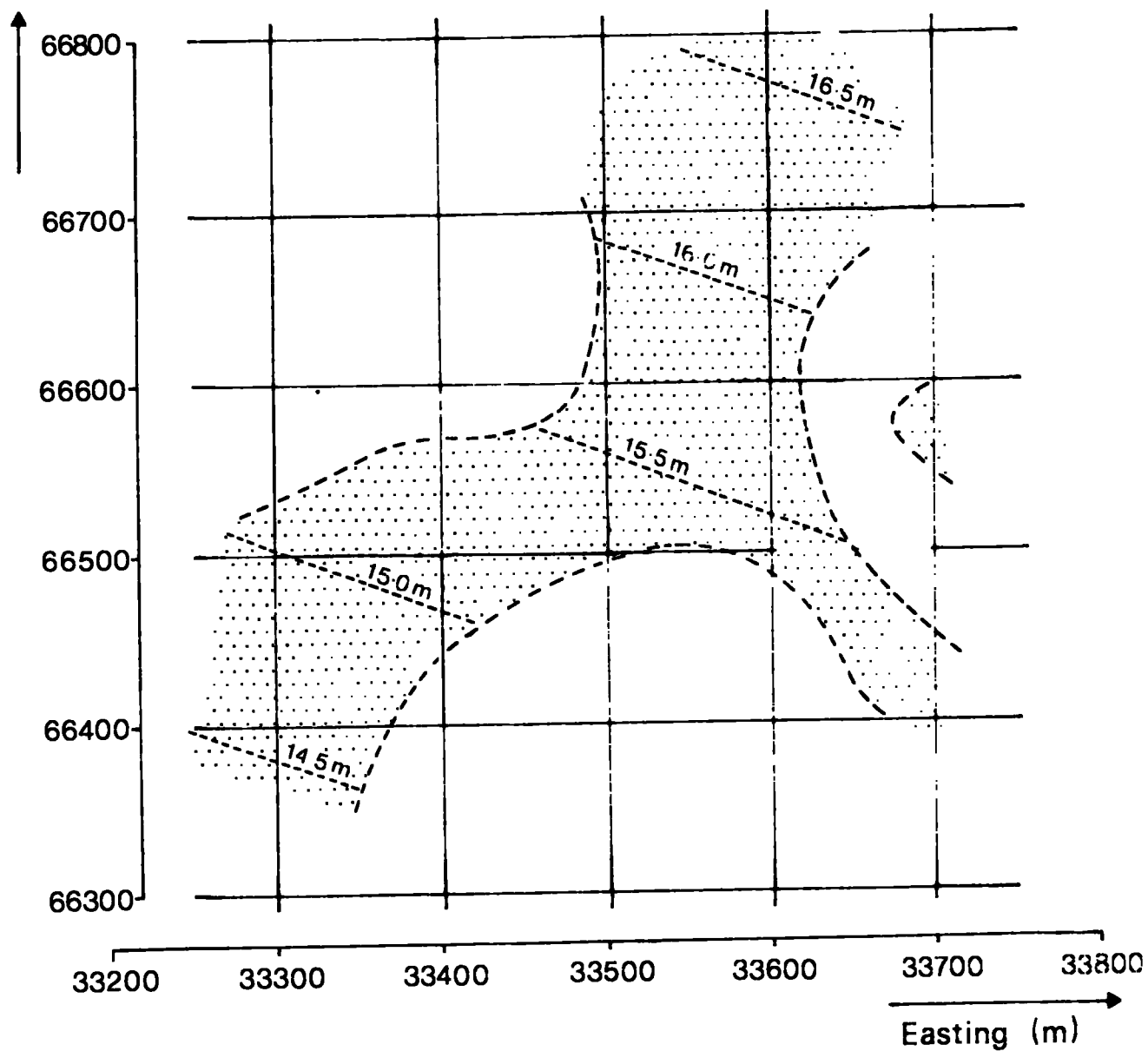

Fig. 9.2 Trend Surface Diagram Produced by Trend.

Overlay B

Map of output from Outp1 of boreholes which penetrate Laminated Clay between 12.0m and 20.0m above ordnance datum (Newlyn).

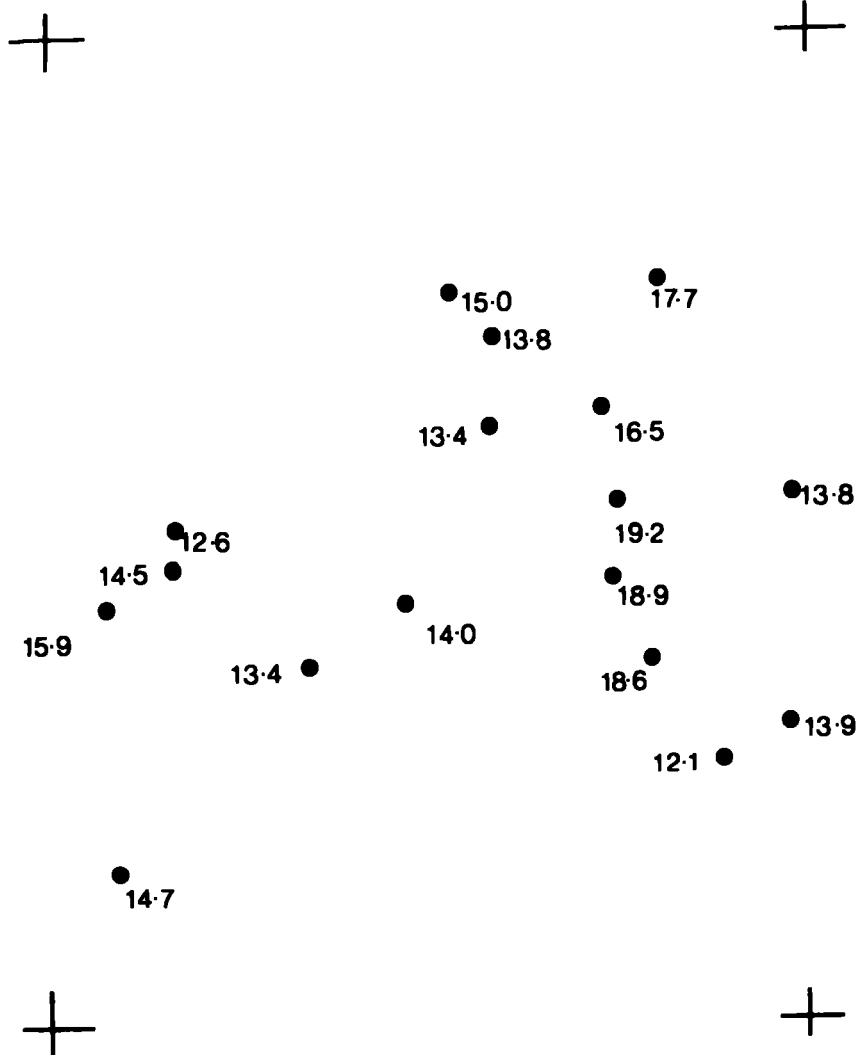

Figure 9.2 Trend Surface Diagram Produced by Trend

Overlay A

Map of output from Outp2 of all boreholes of sufficient depth to penetrate Laminated Clays between 12.0m and 20.0m above ordnance datum (Newlyn)

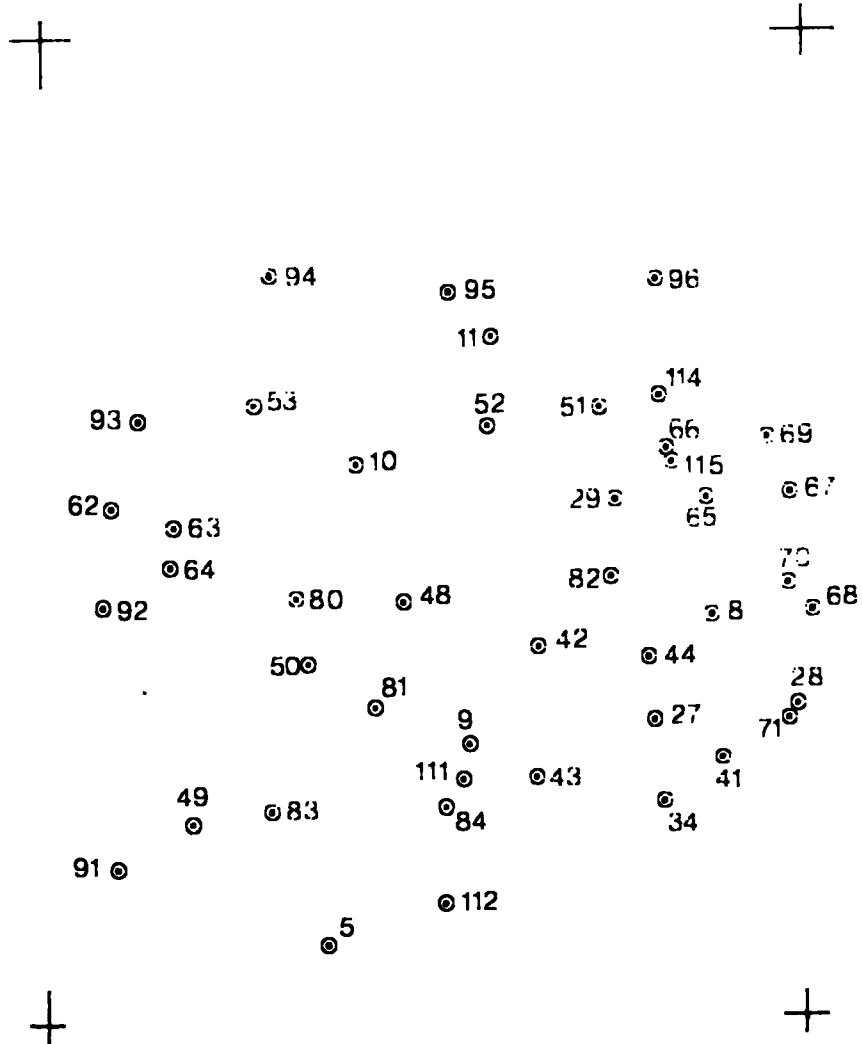

Fig. 9.2 Trend Surface Diagram Produced by Trend.

Program Error	Card (column)	Nature of Error for Main Programme	Contur Error	Card (column)	Nature of Error for Contouring Programme
1	B2 (2-1)	Number of three co-ordinate data points outside allowable range (1-500).	1	E1 (2)	Indicator for evaluation not between <u>1</u> and <u>6</u>
2	B2 (6)	Indicator for the calculation of first degree equation not <u>0</u> or <u>1</u>	2	E1 (3)	Indicator for orientation not between <u>1</u> and <u>4</u>
3	B2 (7)	Indicator for the calculation of second degree equation not <u>0</u> or <u>1</u>	3	E1 (5)	Lanes to the inch code not <u>1</u> or <u>0</u>
4	B2 (8)	Indicator for the calculation of third degree equation not <u>0</u> or <u>1</u>	4	E1 (6-9)	Number of columns of output not between <u>12</u> and <u>120</u>
5	B2 (9)	Indicator for the calculation of fourth degree equation not <u>0</u> or <u>1</u>	5	E1 (10-19)	Contour interval specified negative or zero
6	B2 (10)	Indicator for the calculation of fifth degree equation not <u>0</u> or <u>1</u>	6	E2 (2-31)	Maximum X axis not greater than minimum X axis value
7	B2 (11)	Indicator for the calculation of sixth degree equation not <u>0</u> or <u>1</u>	7	E2 (32-61)	Maximum Y axis not greater than minimum Y axis value
8	B2 (6-11)	Indicators for all degrees of equations are all <u>0</u>	Plot5 Error	Card (column)	Nature of Error for Original Data and Residual Plot Routines
9	E1 (2)	Residual plot indicator lies outside range <u>0</u> to <u>6</u>	1	B2 (2-4)	Number of points to be plotted not between <u>1</u> and <u>500</u>
10	E1 (4)	Plotting limit indicator for residual map not <u>0</u> or <u>1</u>	2	G1 (3)	Orientation indicator not between <u>1</u> and <u>4</u>
11	D1 (7)	Indicator for plotting original data not <u>0</u> or <u>1</u>	3	G1 (6-9)	Number of columns of output not between <u>16</u> and <u>120</u>
12		Attempt to plot residuals or original data without correct specification	4	G1 (5)	Lanes to the inch code not <u>1</u> or <u>0</u>
13	E1 (2)	Contour map indicator does not lie between <u>1</u> and <u>6</u>	5		Previous ordering of elements indicator not between <u>0</u> and <u>2</u>
14	G1 (4)	Plotting limit indicator for contour map not <u>1</u> or <u>0</u>	6	G2 (2-31)	Maximum X axis not greater than minimum X axis value
			7	G2 (32-61)	Maximum Y axis not greater than minimum Y axis value.

Table 9.1 Error Codes used in Trend (after O'Leary et al., 1966)

CHAPTER 10

USE OF GEOSYS OUTPUT IN THE ECONOMIC APPRAISAL OF A SITE INVESTIGATION

10.1 Introduction.

Methods of evaluating the benefit likely to accrue from undertaking site investigation studies were proposed in Chapter 4. The output from Geosys as a source of suitable data provides an opportunity to utilize these methods and hence to demonstrate that rational organization of site investigation work can result from the storage and processing of geotechnical data. It is now proposed to take as an example one application of Geosys in the context of site investigation economics. This example is a very pertinent one in the context of urban development.

10.1.1 The Problem to be Considered.

As part of a major scheme to upgrade the sewage disposal facilities of Greater Tyneside in the north east of England, a treatment works is under construction at Howdon on the north bank of the River Tyne. A location plan for the treatment works, in the context of other elements of the scheme, is shown in Figure 10.1. When referring to this Figure, it should be mentioned that a northerly extension of the coastal sewer beyond Whitley Bay is now probable following reorganisation and rationalisation of local government boundaries. There is also the possibility that the treatment works at Dunston could be removed from the scheme.

Sewage settlement tanks comprise a major part of the treatment works at Howdon and, in order to satisfy the required sewer gradients

for sewage flow to the tanks, considerable excavation work was required. For the construction of one particular settlement tank with an approximate plan size of 280 metres by 100 metres and a depth of 6 metres^{*}, glacial and post-glacial clays had to be excavated to a thickness of up to 14 metres for the base of the tank. Although these clays are regarded as being normally-consolidated, removal of such a thickness of cover was expected to result in a vertical expansion of the base of the excavation. But, whereas short-term expansion prior to construction of the tank would not have proved to be problematical, any long-term attenuated heave, although being partially offset by the imposed loadings during construction and also possibly alleviated by some technical solution involving, for example, the use of a cavity method, could have had a deleterious effect upon the operation of the system. It was therefore necessary to attempt to predict the uplift magnitude. This could be achieved by analysis of prior site investigation data and by ensuring the adequacy of that data. It was also deemed advisable by the Authority responsible for the works to institute an extensive in situ instrumentation programme in order that the components of ground movement could be observed directly as excavation proceeded. The instrumentation installation can be seen in Plates 10.1 and 10.2, which show respectively the western side and both the northern side and floor of the partially-completed excavation. In the event, measurements made during the course of the excavation suggest that the final uplift will be smaller than the predicted amount. But it is to the accuracy side of the problem with respect to the cost effectiveness of the

* It should be realized that these dimensions are ones adopted during the early stages of the design of the works.

site investigation that is presently being considered.

10.2 Geological Situation

10.2.1 Regional Geology

The drift (or surficial) deposits of the region have been largely laid down by - or as a result of - glacial activity, the succession now usually being regarded as comprising three glacial episodes separated by two inter-glacial periods. The whole of eastern Durham and also the Tyne valley is characterised by a succession of mainly clay deposits infilling a system of buried valleys. At the mouth of the River Tyne, 43 metres of drift deposits have been found to be overlying rock head, while at Dunston the equivalent figure is 51 metres. A general succession of the drift deposits in the area begins with the weathered Carboniferous land surface. This is covered with a fairly even thickness of Boulder Clay (sometimes referred to as the Western Ice Boulder Clay) which is associated with the retreat of the main ice sheets at the end of the last glacial epoch. Some thickening of the clay is found in valley floors, but the valleys themselves are infilled with mainly sandy silty Buried Valley Deposits. Recent Tyne or Wear clay of fluviatile origin overlies these glacial clays along and adjacent to the courses of the present rivers.

The Buried Valley Deposits, consisting of a succession of laminated and stony clays, are of most relevant concern in the area under current consideration. The laminated clays are generally considered to be the result of lacustrine deposition in lakes

formed in the valleys dammed by coastal ice sheets. Observational evidence from tunnelling research measurements on the south bank of the Tyne just west of the area of present interest (Attewell and Farmer, 1973) has suggested that the laminated clays have quite irregular contacts with the overlying stony clays. The mode of formation of the stony clays is more problematical. They exhibit obvious similarities with boulder clay although the stones in them are smaller than those normally found in boulder clays. However, the underlying laminated clays are only marginally - if at all - over-consolidated making it unlikely that they have borne the weight of a thick overlying ice sheet. By their nature, and since these stony clays are lying on an eroded surface of laminated clay, it seems probable that they are re-worked till and/or slump deposits derived during brief re-advances of the ice sheets.

10.2.2 Site Geology

The detailed geology at the actual excavation site would appear to be quite complicated after a cursory examination of the 84 site investigation boreholes sunk in the vicinity of the proposed tank and located in Figure 10.2. Processing of the data from these original boreholes has already been described in Chapter 9. In this Chapter geotechnical data were retrieved from geotechnical storage system Geosys for the area in question and, from this data, the model in Plate 9.3 was constructed. For the present work, this model has been utilized to deduce the geological section along the

north-south centre line of the excavation as shown in Figure 10.3.⁺

The base of the succession of drift deposits at the centre of the excavation is represented by hard brown boulder clay which overlies the weathered surface of the Carboniferous bed rock. Above this unknown thickness of boulder clay* is about 5.8 metres of stiff grey and brown laminated clay. The base of the tank is located near to the bottom of a 5.6 metre layer of overlying stiff brown sandy silty clay with gravel. This horizon is overlain by 5.2 metres of firm brown laminated clay with numerous lenses of medium grade sand. The upward succession is completed with approximately 2.4 metres of soft brown sandy silty clay with gravel and areas of blue-grey veining overlain by a variable thickness of fill. From the stratigraphical relationships between these clays, they have been termed respectively boulder clay, lower laminated clay, lower stony clay, upper laminated clay, upper stony clay and fill material. The phreatic surface, as indicated in Figures 10.3 and 10.4 has been deduced from piezometric measurements, standing water levels recorded each day, and ground water encounters recorded during the site investigation boring. Many of the sand lenses observed in the laminated clays appeared to be water-bearing, but their interconnection and water storage capabilities were difficult to ascertain from the information available. Nevertheless, it was fully appreciated that they could constitute a possible slope stability hazard in view of the quite steep design of the batters and the typical problems that have been and are

* A generalized geological section above the boulder clay is given in Figure 10.4.

⁺ It should be realized that this section is based only upon early site investigation data.

being experienced in sandy silt-lensed laminated clays forming much shallower slopes in Durham City. However, questions of slope stability and associated problems of structural protection are not the concern of the present analysis.

10.3 Consideration of Excavation Heave.

Observations of heave resulting from deep excavation have been reported by Hyde and Leach (1975) for the Gault Clay and May (1975) for London Clay. Butler (1975) also presents some case histories of heave in heavily over-consolidated clays. It is often found in heavily overconsolidated clay that estimated rebound values derived from consolidation tests are higher than actual measured values. While Ohoka (1975) has attributed this to sampling disturbance of the clay, Serota and Jennings (1959) - see also Bozozuk (1963) - have suggested that anomalies in heave from predictions based on the Steinbrenner(1934) formula may be related to groundwater control.

Little data concerning the expansion characteristics of the particular clays presently in question were available, since although the vertical coefficient of volume compressibility m_v had been determined for 29 samples from the immediate vicinity of the tank, the swelling part of the complete consolidation curve had been monitored for only 3 samples. The results of laboratory determinations of bulk density and the coefficient of volume compressibility as retrieved from Geosys are listed in Table 10.1. Omitted from this Table are those test results for which it has not been possible to assign a quite definite sample horizon. In addition to the data in Table 10.1 there are the test results in Figure 10.5 for three samples

allowed to swell from pressures near to the effective overburden pressure. Hence, it is convenient to consider the data in two parts:

- (i) swelling data;
- (ii) consolidation data.

10.3.1 Swelling Data

The amount of swelling that might be expected to take place as a result of the reduction in the overburden pressure can be determined using the curves plotted in Figure 10.5. The use of 1-dimensional simple consolidation theory can show that, for a particular stratum, the degree of swelling s will be given by equation 10.1:

$$s = \frac{(e_2 - e_1) H}{(1 + e_1)} \quad \dots 10.1$$

where e_1 and e_2 are the void ratios before and after the effective stress is reduced from q_1' to q_2' respectively and H is the thickness of the stratum. It was assumed that the new phreatic surface, when fully established, would follow the base of the tank, and if it could be further assumed that the tank would be filled with effluent to a depth of 6 metres, then by reference to Figure 10.3 the change in effective stress, dq' , due to the removal of the overburden may be calculated from equation 10.2:

$$dq' = \gamma_F H_F + \gamma_{USC} H_{USC} + \gamma_{ULC} H_{ULC} + \gamma_{LSC} H'_{LSC} - \gamma_\omega dH_\omega - \gamma_E H_T \quad \dots 10.2$$

where H'_{LSC} is the thickness of lower stony clay excavated;

γ_ω is the density of water;

dH_ω is the change in height of the water table;

γ_E is the density of the effluent ($\frac{\rho}{\rho_\omega} \gamma_\omega$);

and H_T is the designed depth of effluent in the tank.

* This is a notional depth assumed for the purposes of this calculation.

$$\begin{aligned} dq' &= (1.67 \times 1.2) + (2.10 \times 2.4) + (1.96 \times 5.2) + (2.12 \times 4.6) - \\ &\quad (1.0 \times 8.2) - (1.0 \times 6.0) \text{ Mgf/m}^2 \\ &= 0.13 \text{ MN/m}^2. \end{aligned}$$

In the determination of the magnitude of swelling, no account was taken of any change in effective stress with depth. If the medium is assumed to be elastic and isotropic, Boussinesq influence charts indicate that such changes are insignificant for the large areal extent of the excavation in question. However, it was not considered valid to consider changes which occurred at depths greater than the excavated depth below the base of the tank.

The original effective stresses of the three samples under consideration can be calculated from their original positions in the geological successions shown by the borehole records in Figure 10.6 and the bulk density values in Table 10.1. Adopting curve A in Figure 10.5, the original effective stress for sample A will be given by:

$$q'_1 = \gamma_F H_F + \gamma_{USC} H_{USC} + \gamma_{ULC} H_{ULC} + \gamma_{LSC} H_{LSC}^* - \gamma_w H_w^* \quad \dots 10.3$$

where H_{LSC}^* is the depth of the sample below the top of the lower stony clay,

and H_w^* is the height of the water table above the sample location.

Substitution into equation 10.3 of the thicknesses of strata and the bulk density values gives the following value for q'_1 :

$$\begin{aligned} q'_1 &= (1.67 \times 1.3) + (2.10 \times 7.7) + (1.96 \times 4.0) + (2.12 \times 3.0) \\ &\quad - (1.0 \times 3.0) \text{ Mgf/m}^2 \end{aligned}$$

or $q'_1 = 0.29 \text{ MN/m}^2.$

Since the change in effective stress dq' is expected to be 0.13 MN/m^2 from the earlier calculation, subtraction results in a q'_2 value of 0.16 MN/m^2 . Substitution of the values e_1 and e_2 , corresponding to q'_1 and q'_2 from Figure 10.5 curve A, into equation 10.1 gives:

$$s_{LSC} = \frac{(0.386 - 0.383) 1.0 \times 10^3}{1.383} = 2\text{mm.}$$

It should be noted that here 1.0m of lower stony clay remains beneath the base of the tank after excavation, since from Figure 10.4:

$$H_{LSC} - H'_{LSC} = 1.0\text{m.}$$

Similar treatment of curves B and C produces respective values of swelling for the lower laminated clay of 26mm and 33mm, an average of 29.5mm.

Unfortunately, no further data concerning the swelling characteristics of the stony, laminated and boulder clays were available. However, some 29 determinations of the coefficient of volume compressibility were considered worthy of analysis as a guide to the expected total swelling.

10.3.2 Consolidation Data

Using the m_v value as an indication of the swell potential, the extent to which a particular stratum will swell is given by:

$$s = m_v dq' H \quad \dots 10.4$$

Adopting the values of H in Figure 10.4, and the values given for m_v in Table 10.1, substitution into equation 10.4 gives the estimated amount of swelling for each stratum in turn as:

$$\begin{aligned} s_{LSC} &= m_{v_{LSC}} \quad dq'(H_{LSC} - H'_{LSC}) \\ &= (125 \times 0.13 \times 1.0)mm = 16mm; \end{aligned}$$

$$\begin{aligned} s_{LLC} &= m_{v_{LLC}} \quad dq' H_{LLC} \\ &= (220 \times 0.13 \times 5.8)mm = 166mm; \end{aligned}$$

and for the upper 6.6 metres of the boulder clay,

$$\begin{aligned} s_{BC} &= m_{v_{BC}} \quad dq'H_{BC} \\ &= (60 \times 0.13 \times 6.6)mm = 51mm. \end{aligned}$$

Thus, by summation, the total predicted ground uplift at the base of the tank may be estimated as 233mm where a thickness equal to the excavated depth has been considered.

Comparing the individual values of swelling for the lower stony clay and the lower laminated clay, obtained using the curves in Figure 10.5, with the corresponding values found by using m_v , it would appear that the latter method has over-estimated the amount of ground heave. In the case of the lower stony clay, the 2mm amplitude of swelling predicted from the swelling data is only 12.5% of the 16mm which results from adopting the m_v value. The respective figures for the lower laminated clay are 29.5mm, 16% and 183mm. This suggestion, that the average predicted swelling magnitude is only 15% of the equivalent magnitude derived from the m_v value, was not unexpected in view of the different techniques used in determining the consolidation and swelling characteristics. Since the m_v values were determined for a range of pressure from overburden - equivalent for the sample depth to overburden -

equivalent plus 0.11 MN/m^2 (1 ton/ft^2), the tests were continued to higher pressures than were used for the swelling tests. When determining the magnitude of swelling, the pressure increments were increased only up to overburden - equivalent, at which point expansion of the samples was permitted as the pressure was reduced in stages to zero.

10.4 Assessment of the data

In this rapid appraisal, the main sources of possible error comprise the measurement of the thickness of the strata, the position of the water table, the swelling parameters and the bulk density measurements. The properties of the material which govern its expansion when pressure is released are subject to considerable uncertainty, but the consolidation characteristics of all the clays have been investigated to some extent.

The commonly accepted method of reducing geotechnical uncertainty is to increase the borehole density, the amount of sampling and the number of tests performed. In the event of uncertainty, design can either take place on the basis of the most unfavourable conditions, or more data can be collected. Obviously, the economics of these two options bear heavily on the ultimate decision, and a very conservative design based on the worst situation likely to occur could sometimes prove to be very expensive. On the other hand, in geological situations such as have been found to exist at Howdon, where inherent variations in the measured parameters are encountered, there may be little improvement in the precision of the results when more determinations are made. Hence, it becomes uneconomic to

increase sampling and testing beyond a certain level, and design must either take place according to some personal weighting on the basis of the available data, or other measures have to be considered.

10.4.1 Economic Analysis

The value of testing samples, in terms of reduction in the loss due to a decrease in geotechnical parameter uncertainty, can be determined by calculating the expected loss due to the likely error. It was shown in Chapter 4 that the reduction in probable loss can be monitored for the case of a random variable which can be described by a probability distribution. Comparison of this reduction with the cost of performing tests indicates the economic benefit of site investigation studies. Thus, in the present situation, the economic advantage of being able to predict the ground movement with greater precision can be equated with the cost of improving ones knowledge concerning the consolidation parameters of the strata.

By plotting on log-normal probability paper in Figure 10.7 the consolidation data available for the clays in the vicinity of the tank - but excluding those determinations on fill and alluvium - the close proximity of the least squares regression line for these data to that line for a fitted distribution clearly establishes that the data conform to a log-normal law. For a parameter which follows a log-normal distribution, it has been shown in Chapter 4, Equation 4.13 that the cash value of the expected loss, U_p , due to errors may be obtained from:

$$U_p = a_0 + \frac{a_1 i^2}{p} \quad \dots 10.5$$

In equation 10.5, a_0 is the original cost of the structure, a_1 is a constant relating the cost of error to the square of its magnitude, i is the standard deviation of \bar{x}_p which is defined as the mean of p determinations of \bar{x} . For the purposes of the analysis leading to equation 10.5, it was assumed that the magnitude of an error is equal to the arithmetic difference between the mean and the true value of a parameter. Hence, by applying suitable values for a_0 , i , a_1 and p in equation 10.5, it is possible to calculate the expected loss, due to geotechnical parameter uncertainty, as a function of the number of tests undertaken.

The type of relation between the cost of errors and their magnitude depends upon the circumstances of the situation in question. In this particular problem, heave or settlements a little more or less than the predicted amount could possibly result in breakage of pipes at the tank. Larger movements could affect the difference in level between the settlement tank and other parts of the treatment plant, such amplitudes having an even greater detrimental effect on the operation of the system. For these reasons, costs proportional to the square of the error would seem to be applicable in this analysis.

For the purposes of this analysis, the original cost of the structure, a_0 , will be assumed to equal zero. This will have little effect on the outcome, since this constant serves only to move the curves in Figures 10.8 and 10.10 up or down. The choice of a suitable cost factor, a_1 , in equation 10.5 rests with a consideration of the cost of necessary remedial measures or loss of function occasioned by an error. In order to analyse the change in the

uncertainty in the amount of the predicted uplift as a function of the number of tests undertaken, the potential heave will be assumed to equal that derived from the m_v value. However, also to be borne in mind is an earlier suggestion, from comparison of predictions of the amount of heave as calculated from the consolidation data in Table 10.1 and from the swelling data in Figure 10.5, that the magnitude liable to occur is only 15% of the value calculated from m_v . In order simply to illustrate the present argument, if a 20% margin of error in the value of m_v is assumed, then a ground heave prediction ranging between 186mm and 280mm results. Substitution of this implied ± 47 mm error back into equation 10.4 shows that this degree of uncertainty represents a potential error of $\frac{47}{0.13 \times 13.4} = 27.0 \text{ m}^2/\text{GN}^*$ in the value of m_v , where again a pressure change of 0.13 MN/m^2 , but a layer of thickness of $H_{LSC} - H'_{LSC} + H_{LIC} + H_{BC} = 13.4\text{m}$ has been used. If, as an example, the expected loss due to the 20% margin of error in the uplift could be quantified quite arbitrarily at around £15,000 ⁺, then $a_1 = \frac{15,000}{27.0^2} = £20.6 \text{ per } (\text{m}^2/\text{GN})^2$. Repeating this procedure for other margins of error and different expected losses can produce a range of values of a_1 such as those shown in Table 10.2. Adopting solely for the purposes of this analysis the value corresponding to a 20% error and an expected loss of £15,000, and remembering that the oedometer test results in Table 10.1 can be utilized to determine

* $1 \text{ GN} = 10^9 \text{ N}$

⁺ Changes in the allocated cost of this margin of error serve simply to change the vertical scales in Figures 10.8 and 10.10.

values of \underline{i} , substitution into equation 10.5 will enable the expected loss for progressive sampling to be calculated.

One of the main pre-requisites in the derivation of equation 10.5 in Chapter 4 was that the data used to determine \underline{i} should conform to a log-normal probability distribution. Since it has already been proved in Figure 10.7 that all the data taken together comprise a log-normal distribution, in order to ensure that groups of m_v values progressively increasing in number approximate to the same form of distribution, the m_v values have been arranged in order of descending alternate deviation from the mean of the log-normal distribution for all the test results. Hence, in the determination of U_4 for the first four test results in Table 10.3, two test results lying at the furthest points of each extreme have been used to calculate \underline{i} . This process, of continuing to add test results to the group, one at a time, from alternate extremes of the remaining ones, produces near log-normal distributions. Plotting the values of U_p , derived by this procedure, in Figure 10.8 shows that the expected loss due to geotechnical parameter uncertainty follows an exponential-type decay with increased testing activity.

The cost C_p of collecting samples and performing tests has been estimated from recently quoted prices for soft-ground boring and testing in the Tyneside area, the appropriate prices being listed in Table 10.4. These prices are by no means firm, but may be expected to vary not only between contractors but also with time and location. Use of these costs for boreholes of Figure 10.2, arranged in Table 10.5 in the order in which they were sunk, gives

the estimated cost of geological investigation and coefficient of volume compressibility determination as a function of the number of oedometer tests in Table 10.3. Plotting these costs in Figure 10.8 indicates that the cost of site investigation in this case is a linear function of the number of samples tested.

If the economic justification for increased site investigation is taken as the reduction in expected loss, it would follow that when the cost of one test exceeds the corresponding reduction in expected loss it will not then be prudent to perform any more tests. In Figure 10.8 this situation will arise when the curve of combined cost of site investigation and reduction in expected loss begins to rise. Thus, the optimum sampling number will be found where the curve $C_p + U_p$ becomes horizontal. In view of the near-flatness of this curve, Figure 10.8 indicates that there is little advantage to be derived from testing more samples.

10.4.2 Discussion of the Results of the Economic Analysis

Use of this analysis would seem to imply that the designer has access to insufficient site investigation data concerning the swelling properties of the sediments forming the foundation area of the settlement tank. Although the expected loss was reduced rapidly by the initial testing, later tests have contributed little to reducing the likely loss. However, since it would appear that even after the optimum number of samples has been tested, a large predicted loss indicates that there is still a high probability that the heave will not be the predicted value, it would appear sensible to search for methods of either refining the prediction or

accommodating the imprecision in the predicted swelling.

Instrumentation of the excavation, so that any swelling during excavation is monitored, can certainly be justified. However, the value of this present type of analysis arises from the fact that it is possible realistically to appraise the consequences of uncertainty about the ultimate amount of ground uplift.

The relatively simple method adopted for estimating ground heave may be claimed to be deficient in several respects; the time variant, for example, has been ignored in the problem. But, since the primary aim of the exercise has been to demonstrate how changes in economic benefit of sampling and testing can be monitored during the course of one particular site investigation programme, it may be argued that such a lack of refinement can be justified.

Variations in the thicknesses of the strata over the excavation area have not been considered. Although such variations might be expected to cause changes in the actual magnitude of the ground heave, the optimum number of tests derived from Figure 10.8 is insensitive to changes in detail of the geological section, since only the value of the constant a_1 is changed. This point can be demonstrated by examining the result of further analysis in which the expected loss is calculated on the basis of the geological section shown in Figure 10.9. This section is generated from the records of boreholes 44 and 82 only (see Figure 10.2 for their locations). Use of this section gives a value of $a_1 = £25.4$ per $(m^2/GN)^2$, where again a loss of £15,000 has been assumed to correspond with a 20% error. Hence, the expected losses given in Table 10.3

and drawn in Figure 10.10 are produced. Although there is no change in the predicted optimum number of tests found from Figure 10.8, and the magnitude of the predicted ground heave was 274mm instead of 233mm calculated for the section in Figure 10.4, the fact that both the change in the effective stress and the thickness of the most compressible stratum are increased has led to a higher expected loss.

It may be considered that investigation of parameters other than m_v would be beneficial in a situation such as the one analysed, since the bulk density, the thickness of the strata and the level of the water table are all subject to some degree of uncertainty. More data collection, such as careful consolidation-swelling tests on bulk samples removed during the excavation, would be expected to reduce the expected loss for very little additional cost. It should also be remembered that in this analysis the value of a borehole has been under-estimated; no account has been taken of factors such as, for example, the economic merit of determining properties other than that of the coefficient of volume compressibility. Such additional information may usually be obtained at relatively small extra expense.

10.5 Conclusion

It was observed in the Introduction Section 10.1 that the analysis of site investigation options being considered in the present work would be incomplete. The factors mentioned in the foregoing section 10.4.2 would tend to confirm this view. However, it seems likely that a general conclusion to the effect that little refinement of the ground heave prediction could be achieved by measuring the coefficient of volume compressibility is a reasonable

one. Hence, it would be difficult to justify further data collection even if the consolidation data used are assumed to be representative of the swelling potential of the clay according to the constitutive laws used in the appraisal.

This analysis has demonstrated the use and application of geotechnical data derived from storage by Geosys. By analysing the uncertainty - and its consequences - in just one important parameter, it may be concluded that similar analyses of other parameters could lead to the more rational cost effective approach to site investigation envisaged in Chapter 3.



Plate 10.1 The Western End of the Excavation
Underway at Howdon



Plate 10.2 The Floor of the Partially Completed
Excavation at Howdon Viewed Northwards

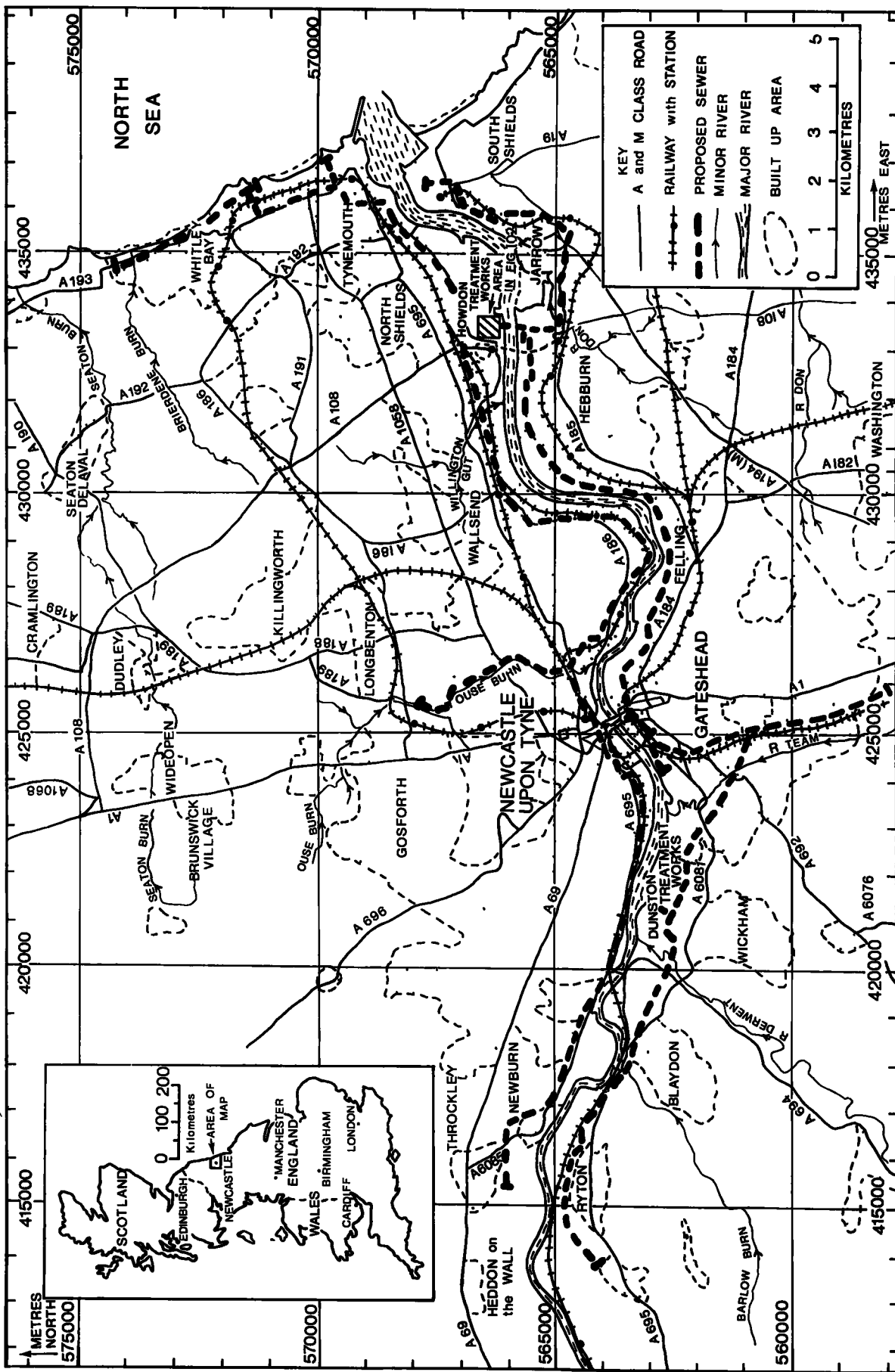

Fig. 10.1 Location of the Howdon Sewerage Treatment Works in the Context of the Tyneside Sewerage System as a Whole.

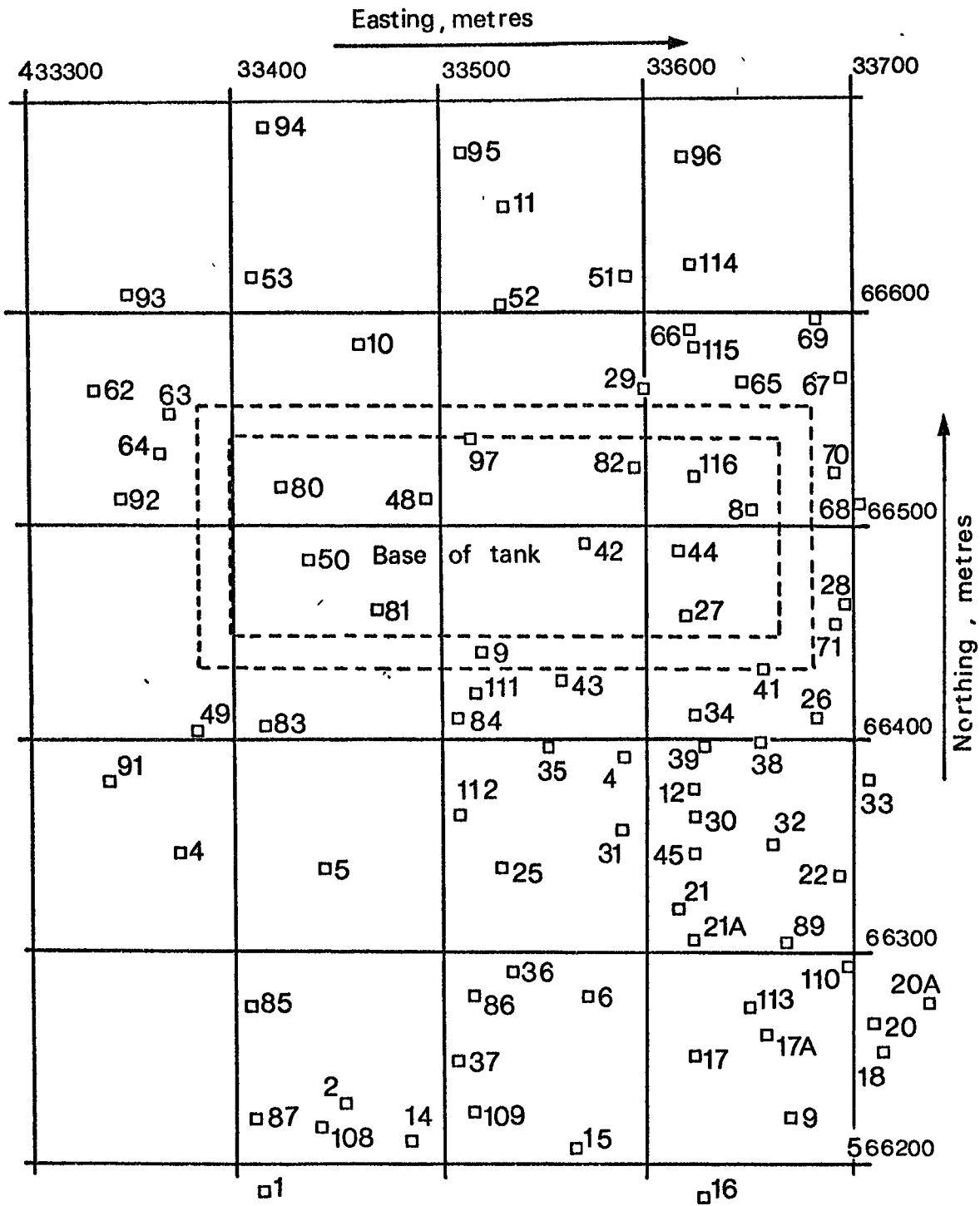

Fig. 10.2 Location of Site Investigation Boreholes in the Vicinity of the Settlement Tank.

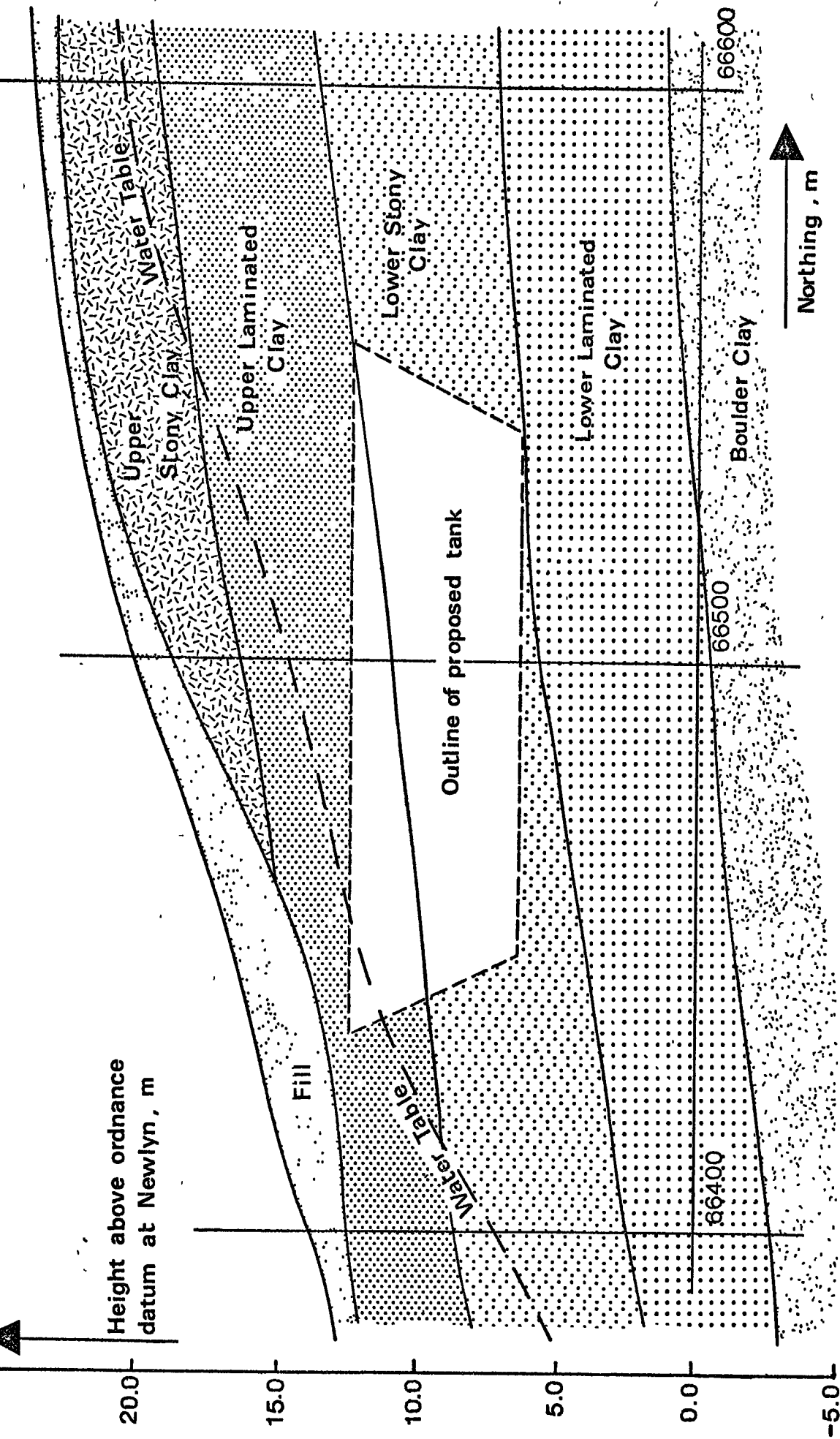

Fig. 10.3 Geological Section Along the N-S Centre Line of the Execution

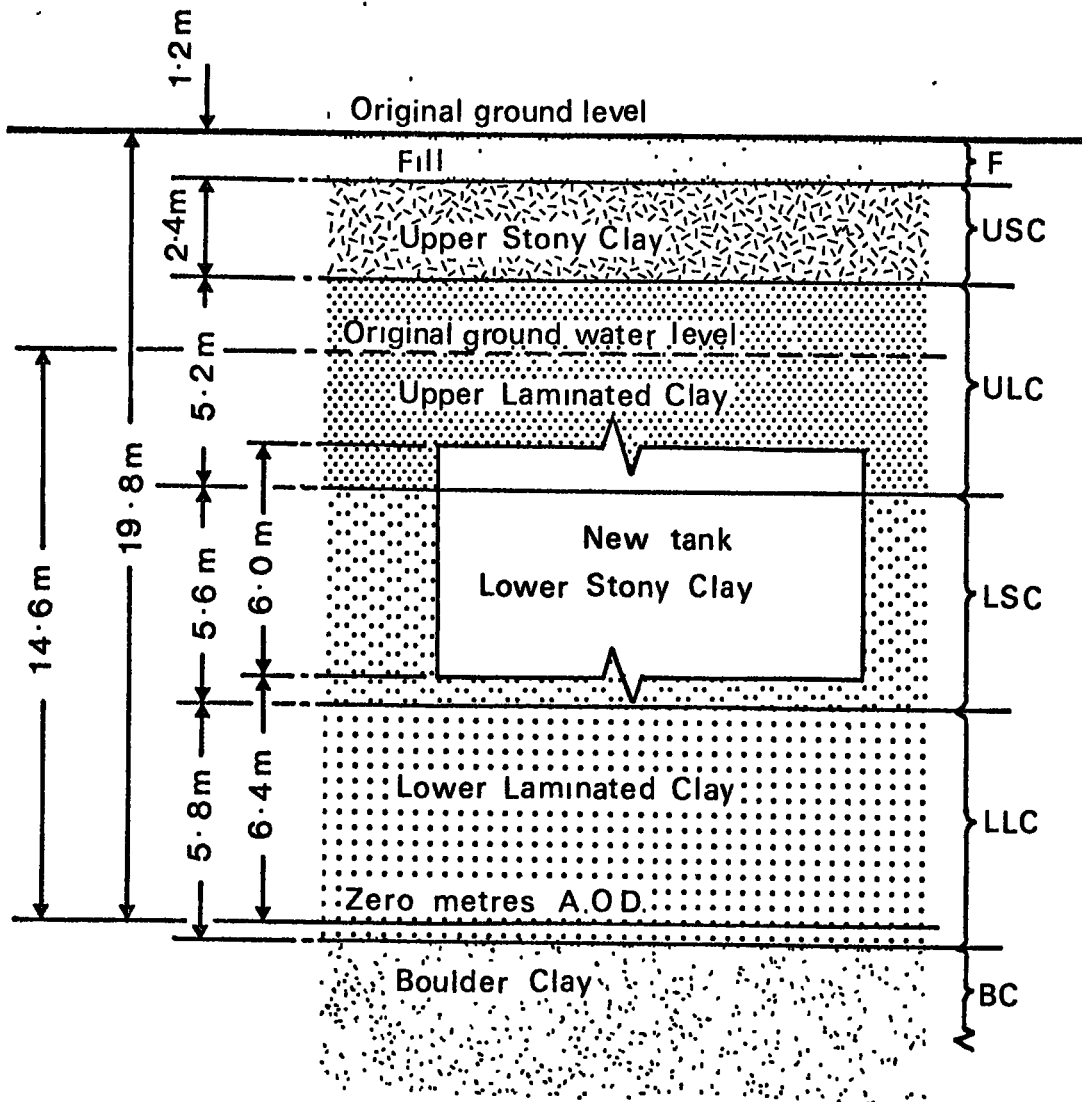

Fig. 10.4 Generalised Vertical Section at the Centre of the Tank.

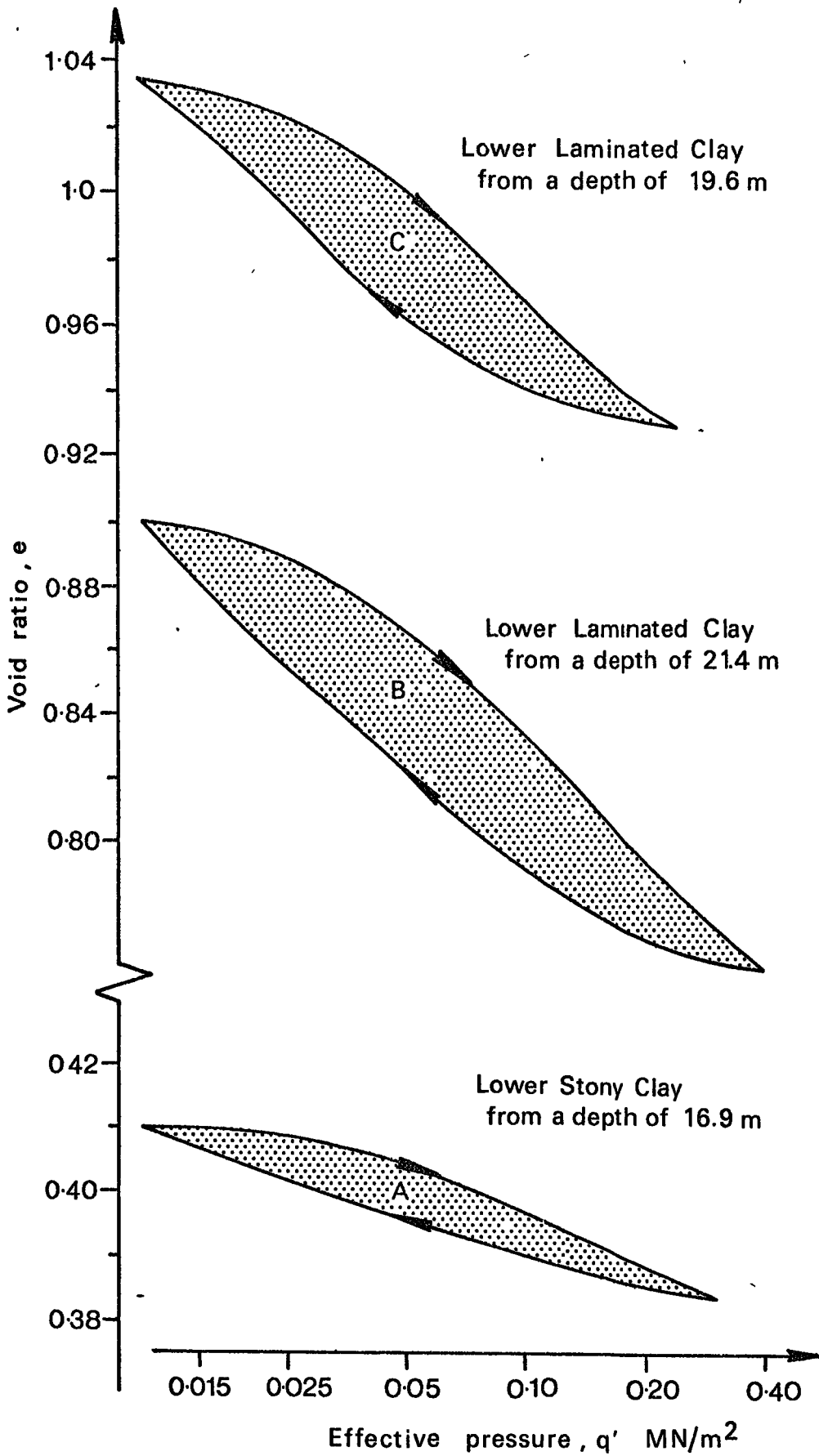

Fig. 10.5 Complete Consolidation Curves for Three Samples of Clay

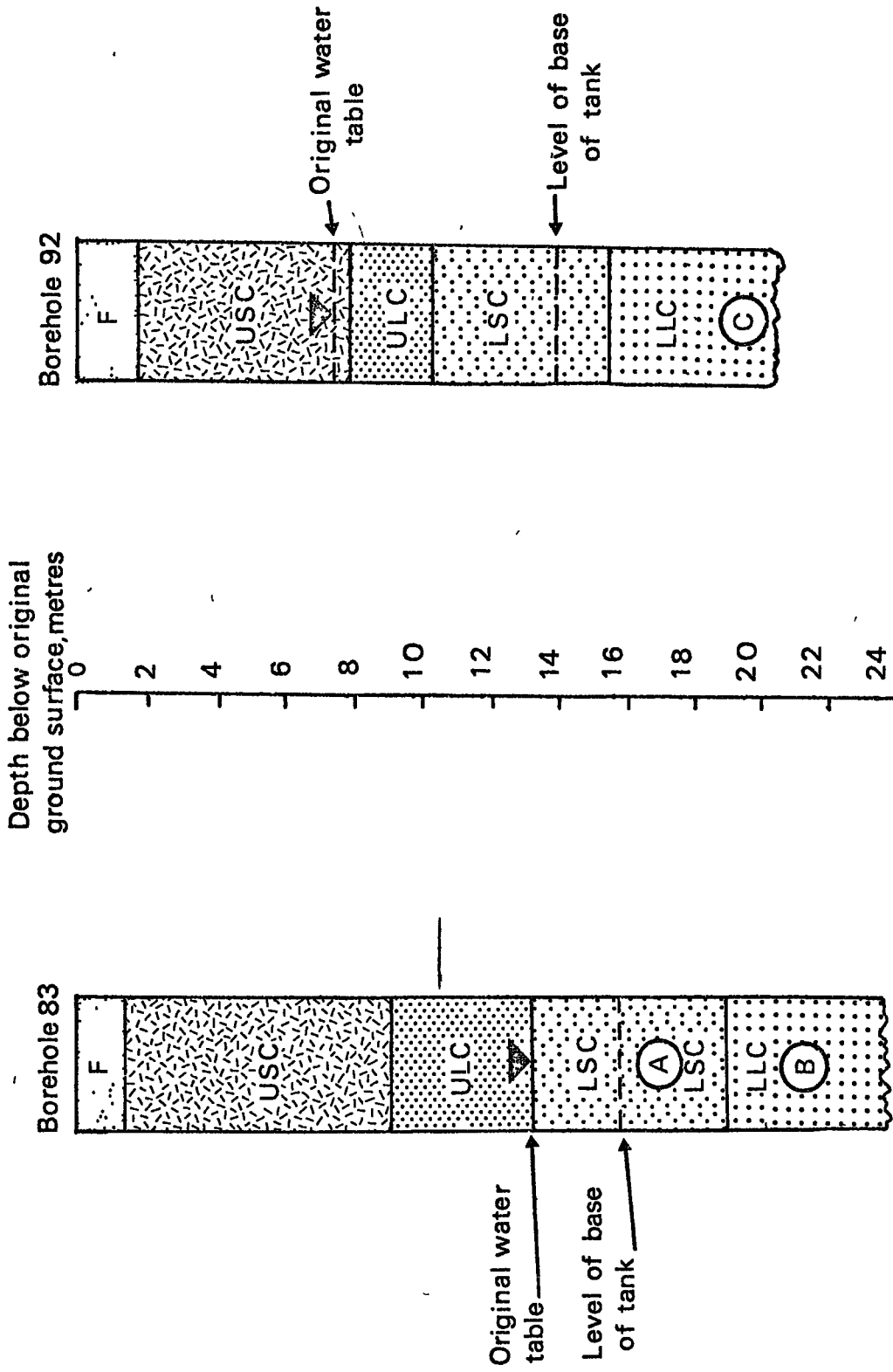

Fig. 10.6 Location of Samples Mentioned in Figure 10.5.

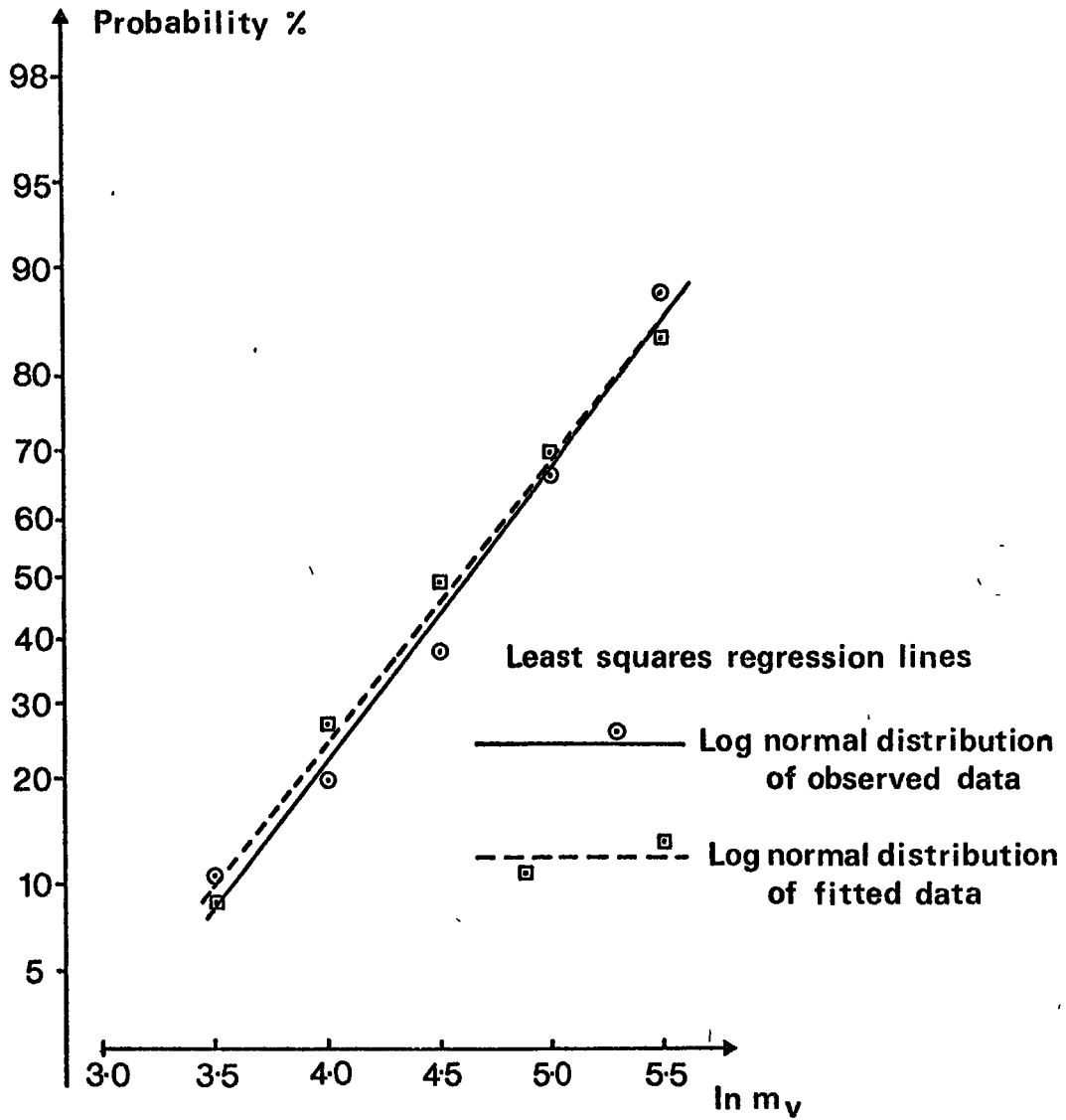

Fig. 10.7 Log-normal Distribution of Consolidation Data from Howdon.

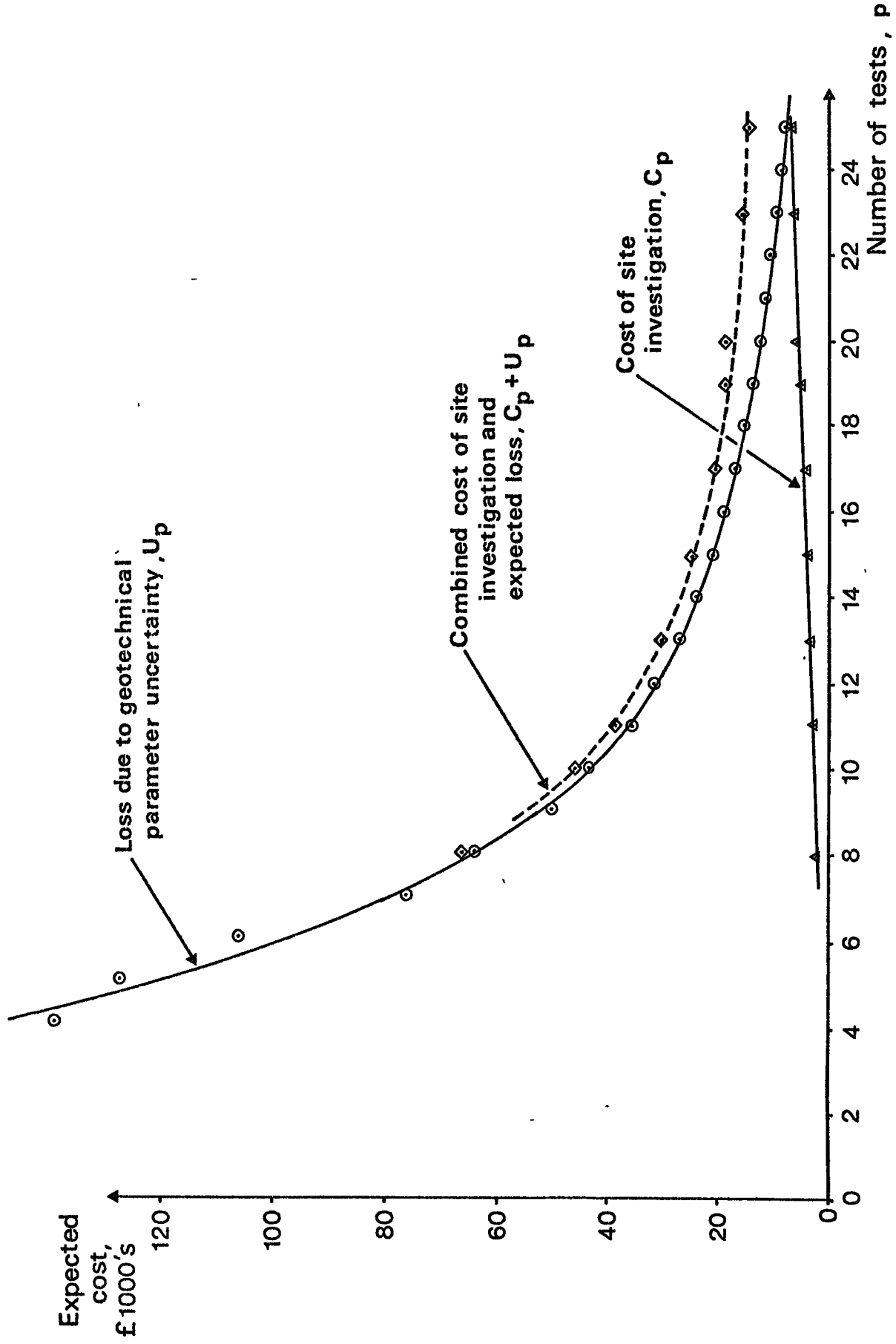

Fig. 10.8 Charges in Expected Loss with Increased Sampling and Testing.

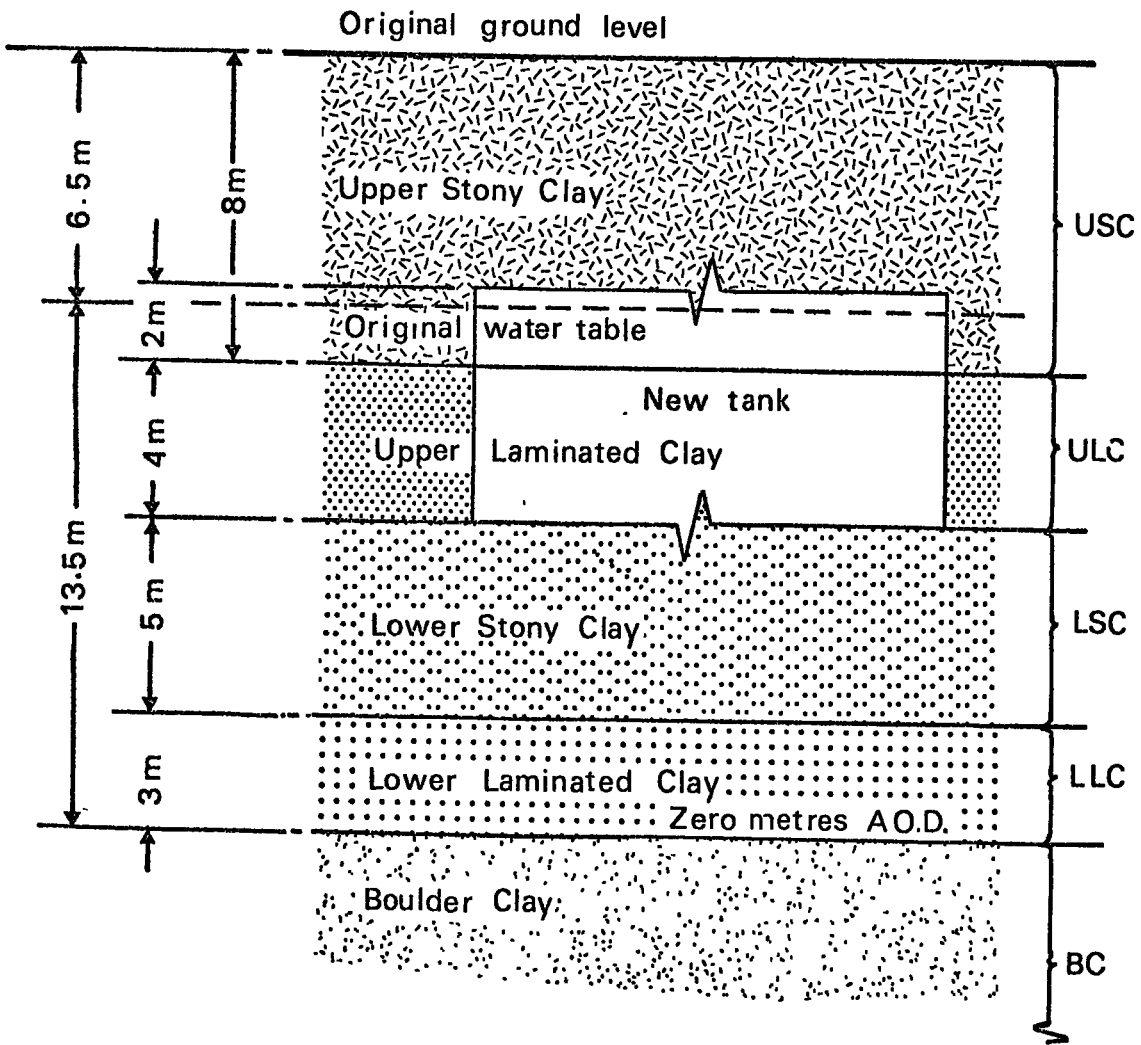

Fig. 10.9 Section for the Excavation Centre Line of 33620 mE from Logs of Boreholes 82 and 44.

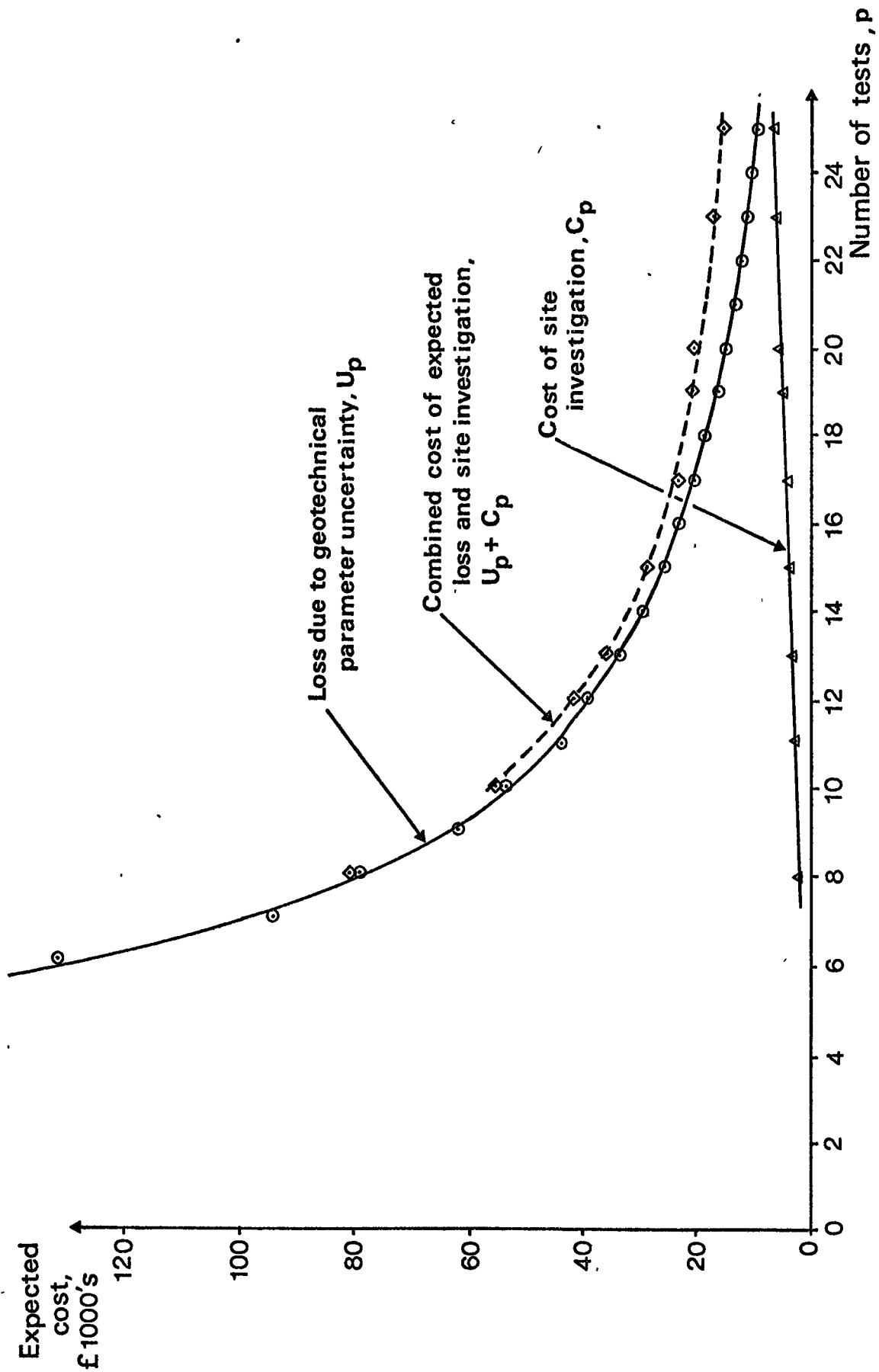

Fig. 10.10 Changes in Expected Loss with Increased Sampling and Testing - Geological Section of Figure 10.9 Used.

BOREHOLE NO.	STRATUM											
	FILL OR ALLUVIUM		UPPER STONY CLAY		UPPER LAM. CLAY		LOWER STONY CLAY		LOWER LAM. CLAY		BOULDER CLAY	
	m_v^F m ² /GN	γ_F Mg/m ³	m_v^{USC} m ² /GN	γ_{USC} Mg/m ³	m_v^{ULC} m ² /GN	γ_{ULC} Mg/m ³	m_v^{LSC} m ² /GN	γ_{LSC} Mg/m ³	m_v^{LLC} m ² /GN	γ_{LLC} Mg/m ³	m_v^{BC} m ² /GN	γ_{BC} Mg/m ³
2	430	1.62									30 30	2.24 2.39
4				2.13		1.81		2.16				
5		1.65		1.99		1.79		2.13				
6	225	1.62							120	1.81	65	2.16
8				2.13 2.16		1.94		2.39 2.13				
9						1.94		2.18				
10				2.07 2.05								
11			65	2.08	85	2.08		2.18				
12							160	1.99 2.05 2.24	190 190	1.89 1.87 1.87		1.94 2.21
14	840	1.59										
15	655	1.57									110	2.08
18	625	1.57									105	2.21
20A											75	2.23 2.23
21									375	2.03	75	2.31 2.32 2.26
21A												2.20 2.26

TO BE CONTINUED

Table 10.1 Value of the Coefficient of Volume Compressibility m_v and Bulk Density γ for Sediments at Howdon.

Continuation

BOREHOLE NO.	STRATUM											
	FILL OR ALLUVIUM		UPPER STONY CLAY		UPPER LAM. CLAY		LOWER STONY CLAY		LOWER LAM. CLAY		BOULDER CLAY	
	m_v^F m ² /GN	γ_F Mg/m ³	m_v^{USC} m ² /GN	γ_{USC} Mg/m ³	m_v^{ULC} m ² /GN	γ_{ULC} Mg/m ³	m_v^{LSC} m ² /GN	γ_{LSC} Mg/m ³	m_v^{LLC} m ² /GN	γ_{LLC} Mg/m ³	m_v^{BC} m ² /GN	γ_{BC} Mg/m ³
22									335	1.91 1.84 2.15		
26						1.86		2.15		1.91		
27				2.12		2.02		2.16				
28						2.08 2.08						
29				2.07 2.18 2.18	75	1.99 2.12		2.24		1.95	30	2.24
30	300	1.87					55	2.05	205	1.89		
31	325					1.97 1.97		2.00	230 140	1.94 1.94		2.24
32							150	2.08	130	2.00		2.24
33				1.92	170	1.84		2.15				
35								2.13		1.91		2.32
36										1.84		2.18 2.21 2.12
37							130	1.81	140	1.97		2.22
38								2.10		1.89		2.12
40										1.84		2.34
41				2.15		2.05						
42				2.18								
43								1.89 1.83				

TO BE CONTINUED

Table 10.1 (cont..) Values of the Coefficient of Volume Compressibility m_v and Bulk Density γ for Sediments at Howdon.

Continuation

BOREHOLE NO.	STRATUM											
	FILL OR ALLUVIUM		UPPER STONY CLAY		UPPER LAM. CLAY		LOWER STONY CLAY		LOWER LAM. CLAY		BOULDER CLAY	
	m_v^F m^2/GN	γ_F Mg/m^3	m_v^{USC} m^2/GN	γ_{USC} Mg/m^3	m_v^{ULC} m^2/GN	γ_{ULC} Mg/m^3	m_v^{LSC} m^2/GN	γ_{LSC} Mg/m^3	m_v^{LLC} m^2/GN	γ_{LLC} Mg/m^3	m_v^{BC} m^2/GN	γ_{BC} Mg/m^3
44							2.11					
45						1.85 1.85			345	2.20	50 50	2.21 2.20 2.22
48				1.99		1.94						
49				2.04		1.86						
50				1.94		2.05 1.99						
62				2.12								
63				2.08		1.92 1.90						
69				2.18		2.16 2.21						
70				2.18			2.05 2.21					
71				1.97		1.89	2.15		2.18			
80				2.16 2.15		1.89	2.05 2.16		1.94			
81				2.00			2.16					
82				2.20 2.20 2.20 2.15		1.91	2.07					
MEAN VALUES	485	1.69	65	2.10	110	1.96	125	2.12	220	1.94	60	2.22

Table 10.1 (cont..) Values of the Coefficient of Volume Compressibility m_v and Bulk Density γ for Sediments at Howdon.

Size of Error, % of swell	Expected Loss due to Error,£			
	10,000	15,000	20,000	25,000
10	54.9	82.4	109.9	137.3
15	24.4	36.6	48.8	61.0
20	13.7	<u>20.6</u>	27.5	34.3
25	8.8	13.2	17.6	22.0

Table 10.2 Values of the Constant a for Different Margins of Error and Values of Expected Loss.

No. of Tests, p	Borehole	m _v m ² /GN	C _p £	a = £20.6 per (m ² /GN) ²		a = £25.4 per (m ² /GN) ²	
				£ U _p	£ U _p +C _p	£ U _p	£ U _p +C _p
1	21	370					
2	2	30	300				
3	45	345					
4	2	30	700	138500	139500	170800	171500
5	22	335		127200		156900	
6	29	30		105900		130900	
7	31	230	1100	76300	77400	94100	95200
8	45	50	1900	64100	66000	79000	80900
9	30	205		50000		61700	
10	45	50	2200	43500	45700	53700	55900
11	12	190	2300	35700	38000	44000	
12	30	55	2500	31600	34100	39000	41500
13	13	190	2700	26900	29600	33100	35800
14	6	65		24000		29600	
15	12	160	3300	20800	24100	25700	29000
16	21	75		18800		23100	
17	32	150	3400	16500	19900	20400	23800
18	21	75		15100		18600	
19	31	140	4400	13500	17900	16600	21000
20	18	105	5600	12200	17800	15100	20700
21	37	140		11100		13600	
22	15	110		10100		12500	
23	32	130	5900	9200	15100	11400	17300
24	6	120		8500		10500	
25	37	130	6000	7800	13800	9600	15600

Table 10.3 Value of Expected Loss as a Function of the Number of Oedometer Tests.

Cost Item	Cost £
Initiating Drilling	120
Moving Rig and Stoppages	20
Average Cost of Boring per Metre	7
Cost of sampling and Oedometer Testing	12

Table 10.4 Recently Quoted Cost of Soft Ground Boring and Testing.

Borehole	Date Started	Depth m	Cost of Boring	No. of Tests p	C _p £
2	23.4.68.	23.3	183	2	327
5	26.4.68.	23.5	185		512
6	26.4.68.	26.0	202	4	738
4	3.5.68.	14.2	119		857
12	6.5.68.	23.0	181	7	1074
8	9.5.68.	12.3	106		1180
11	10.5.68.	12.5	108		1288
10	13.5.68.	12.5	108		1396
9	14.5.68.	12.3	106		1502
1	15.5.68.	39.6	278		1780
14	14.3.69.	6.4	65		1845
15	14.3.69.	8.3	78	8	1935
21	15.3.69.	27.4	212	10	2171
22	15.3.69.	12.2	105	11	2288
16	21.3.69.	10.7	95		2383
17	21.3.69.	6.1	63		2446
18	2 .3.69.	6.9	68	12	2526
20	22.3.69.	5.3	57		2583
20A	25.3.69.	18.8	152	13	2747
17A	26.3.69.	18.0	146		2893
25	10.4.69.	27.4	212		3105
21A	13.4.69.	7.2	70		3175
31	18.4.69.	12.2	105	15	3280
32	21.6.69.	12.5	108	17	3388
33	22.4.69.	18.6	150		3538
26	25.4.69.	21.5	171		3709
34	29.4.69.	21.5	171		3870
35	2.5.69.	18.6	150		4030

Table 10.5 Cost of Drilling Boreholes and Conducting Oedometer Tests

Borehole	Date Started	Depth m	Cost of Boring	No. of Tests	C _p £
36	6.5.69.	21.3	169		4199
37	9.5.69.	19.8	159	19	4382
38	16.5.69.	18.3	148		4530
40	21.5.69.	17.4	142		4662
28	23.5.69.	19.4	156		4828
39	28.5.69.	17.5	143		4971
41	30.5.69.	6.1	63		5034
27	31.5.69.	24.1	189		5223
42	21.5.69.	6.1	63		5286
43	31.5.69.	6.1	63		5349
29	2.6.69.	24.8	194	20	5567
44	6.6.69.	6.1	63		5618
48	11.6.69.	8.2	77		5695
45	13.6.69.	19.2	154	23	5885
30	16.6.69.	12.2	105	25	6014
49	18.6.69.	10.7	95		6109
50	20.6.69.	9.8	89		6198
51	3.9.69.	16.0	132		6330
52	5.9.69.	13.9	117		6447
53	8.9.69.	17.7	144		6591
63	19.12.70	12.9	110		6701
62	22.12.70	13.6	152		6853
64	15.2.71.	15.2	126		6979
80	25.2.71.	16.9	138		7117
81	28.2.71.	12.0	104		7221
65	1.3.71.	12.3	106		7327
66	2.3.71.	13.9	117		7444
82	3.3.71.	17.5	143		7587

Table 10.5 (cont.) Cost of Drilling Boreholes and Conducting Oedometer Tests.

Borehole	Date Started	Depth m	Cost of Boring	No. of Tests	C _p £
67	4.3.71.	12.3	106		7693
68	8.3.71.	12.2	105		7798
69	6.9.71.	18.4	149		7947
70	8.9.71.	18.4	149		8096
71	11.9.71.	18.3	148		8244
85	17.7.72.	12.8	110		8354
86	18.7.72.	11.1	98		8452
84	21.7.72.	15.7	130		8582
83	25.7.72.	25.0	195		8777
89	28.7.72.	18.6	150		8927
90	28.7.72.	20.0	160		9087
87	11.8.72.	48.0	356		9441
91	28.9.72.	22.6	178		9621
93	17.10.72.	24.0	188		9835
94	8.12.72.	22.3	176		9985
92	18.12.72.	23.8	187		10172
96	18.12.72.	23.9	187		10359
97	13.1.73.	19.4	156		10515
95	19.1.73.	19.8	159		10674
108	28.3.73.	12.3	106		10780
109	30.3.73.	10.0	90		10870
110	3.4.73.	20.0	160		11030
113	10.4.73.	17.7	144		11174
112	13.4.73.	17.0	139		11313
111	16.4.73.	19.1	154		11467
114	15.5.73.	45.5	339		11806
116	18.5.73.	1.4	31		11837
115	21.5.73.	31.5	239		12076

Table 10.5 (cont.) Cost of Drilling Boreholes and Conducting Oedometer Tests

CHAPTER 11

URBAN PLANNING IN THE LIGHT OF ACCESSIBLE
GEOTECHNICAL DATA - A CONCLUSION

11.1 Pertinence of Engineering Geology to Urban Development.

Satisfactory evaluation of the geological suitability of a site for a particular land use may only be achieved by an awareness of:

(i) the geological character of the land;

and

(ii) appropriate foundation options for those ground conditions.

Included in the process of urban development are not only the initial planning but also the design and actual construction work. Hence, the required information becomes potentially available at stages in the development procedure subsequent to planning.

Changes to the urban environment are planned so that they enhance the accessibility of urban facilities, employ available resources efficiently, and preserve desirable amenities. Such ideals are usually maintained by zoning the development into areas of compatible land use. Urban models assist this operation, especially where an infra-structure is already established. Due to the diversity and complex interdependency of factors affecting zoning, planning options are usually evaluated by testing their cost efficiency. Thus, provided that geological factors can be shown to influence the global cost of development, then the geological suitability of a proposed location for a particular structure may be measured.

A list of geological factors, the importance of which to planning depends upon the particular circumstances to hand, would include:

- (i) depth of the water table from ground surface;
- (ii) strength and compressibility of the foundation material;
- (iii) depth to rock head;
- (iv) lateral and vertical variability of the geological conditions;
- (v) sources of suitable construction materials;

and

- (vi) the present stability of the foundation area.

Unfortunately, comprehensive information of the type listed above is seldom available during the formulation of urban plans. However, even if it were, the planner would need to be unusually familiar with the influence that geological conditions impose upon the suitability of foundation options. Hence, for the successful and early application of geotechnical knowledge to urban planning, two basic requirements may be defined:

- (i) geotechnical data must be available during the formulation of the plan;
- (ii) the data should be presented to the planner in a form that is suitable for him to use without too much further processing.

Only after these requirements have been satisfied may the constraints imposed by the geological character of the ground enter into the cost analysis of any planning proposals.

11.2 Presentation of Geotechnical Data in Urban Development

Clearly, if geotechnical data are to influence the style of urban development, suitable means of presentation must be sought. Since site investigation prior to foundation design constitutes the chief primary source of relevant data during urban development, data made available for earlier stages of development necessitate the use of storage and processing facilities. However, only the eventual presentation of the information is to be considered in this section.

The application of geotechnical maps, seemingly a suitable method for displaying the spatial variation of geotechnical parameters to urban planners, can suffer from two important drawbacks:

- (i) important detail may be masked;
- (ii) there may be some dubious and subjective interpolation and extrapolation.

Other methods more directly applicable to the analysis of the economic impact of planning proposals may be more appropriate. For example, certain high and low limits to the values of geotechnical parameters conditioned by geological factors could be defined so that additional costs, due to adverse geological conditions, are expressed as functions of the deviation of these parameters from an optimum value.

Therefore, the spatial variation of geotechnical parameters, or geological strata where the two bear a close correlation, is an essential feature of geotechnical data presentation for planning purposes. However, it should not be the aim to present the planners

with direct geotechnical data. It is most undesirable that data, which in general requires considerable and cautious interpretation, should be presented in a form with such apparent authority as is inevitably implied on a map.

11.3 Investigation and Evaluation of the Geological Character of a Development Site.

A failure to anticipate fully the actual ground conditions before construction can give rise to unsatisfactory foundation design and extra expense. Those charges occasioned by claims under Clause 12 of the Conditions of Contract (Institution of Civil Engineers, 1973) can make considerable contributions to the overall development costs. On the other hand, site investigation work is performed to reduce the state of ignorance with respect to the ground conditions so that a less conservative, more economic, design can be adopted. Logically, therefore, a desirable degree of site investigation work will have been performed when its cost becomes exactly balanced by the savings in construction costs that result from the input of direct geotechnical knowledge derived from the site investigation. Continuous checks for convergence towards this equality are required, and it is shown in the text that the progress towards such a terminal condition can be monitored using probabilistic methods of analysis.

The application of the probability method to the present problem involves an 'on-going' assessment of the adequacy and quality of current geotechnical data with respect to the economic advantage liable to accrue from the collection of further data. Although site investigation costs constitute only up to a maximum of around 3%⁺ of total project construction costs, the facility for cost saving on expensive works is

⁺3% is not a usual amount. Probably 1% would be a more realistic figure in the present context.

potentially large and provides the impetus for considering the techniques outlined in this thesis.

11.4 Application of the Digital Computer to Problems Involving the Utilization of Engineering Geological Data in Urban Planning.

Several reasons for adopting geotechnical data storage systems for increasing the geological awareness of planners, and for improving cost effectiveness of site investigation, have already been mentioned. For reliable determination of probability distributions, correlations between parameters, and of output data, the stored information should be comprehensive both in the number of different factors recorded and in the sense of time (so that storage continues through development from the initial plan to eventual construction).

Geotechnical data may be stored by several methods. It is usually available in the form of a report containing both factual and (if requested) interpretive information. However, data stored in this form could be difficult to utilize efficiently. Unless extensive cross-referencing were a feature of the storage system, long searches would be necessary to access all the information bearing on a particular geotechnical factor such as, for example, the shear strength of a geological horizon. Storage by digital computer can overcome this problem because of the rapid data sorting facility it offers. Other reasons for adopting a computer information system may also be listed:

- (i) the objective technical data which become available when individual structures are being designed may be utilized during the planning and other stages of urban development;
- (ii) the stored data may be used for probabilistic and statistical purposes;

- (iii) data may be added to the store, modified, and output whenever required;
- (iv) a variety of output modes can easily be made available.

Geosys is a computer data handling facility created and operated during the present study for site investigation data collected in the Newcastle-upon-Tyne area. This facility, which comprises a suite of storage and retrieval programmes, incorporates the following features:

- (i) the stored data are structured in a two-tier arrangement comprising a title giving (amongst other information) the location of the boring, followed by the available sub-surface data;
- (ii) mnemonic and numerical codes are used to conserve storage space and simplify the storage operation;
- (iii) serious errors in the data are detected automatically;
- (iv) either an Imperial - or an S.I. - based system of units may be used;
- (v) the units may be changed from one system to the other during or after storage;
- (vi) the computer operation may be performed in either a conversational or a numerical mode.

Unfortunately, the manual coding of site investigation data prior to its storage could be regarded as an onerous task, even though it has been simplified by the use of mnemonic codes. However, this procedure could be made easier by employing specially prepared borehole

log and laboratory test result sheets from which the computer input could be punched directly. It follows, by implication, that ultimately the conventional site investigation report could be dispensed with. Within the industry there would be opposition and reluctance to adopt any such a system which appeared to reduce the demands on subjective interpretation, but industry would receive more favourably the associated arguments for higher quality control, stratigraphical, and structural identification on site at the borehole or trial pit.

Once stored, the data may be accessed in several forms. Such a range of options is necessary in order to accommodate the range of uses to which such geotechnical data is put during urban development.

When accessed, the styles of data presentation may take the form of:

- (i) the factual element of the site investigation report;
- (ii) output from which three-dimensional physical models may be constructed;
- (iii) the virtual instantaneous production of contoured maps;
- (iv) 'on-going' guidance concerning the collection of geotechnical data in terms of the global cost of development.

The adoption of a systematic geotechnical handling procedure is a fundamental requirement for the consideration of geotechnical factors during urban planning. Other advantages associated with enhanced data accessibility would also result from such a proposal. Geotechnical data available in a variety of modes, including forms suitable for statistical analysis are expected to be of immense value throughout the processes of urban development.

REFERENCES

- AISENTEIN, B., SCHULMAN, N. and ISRAEL, A. 1974 The geotechnical map of Jerusalem. Proc. 2nd Int. Cong. of Int. Ass. of Eng. Geol., São Paulo, 18-24 Aug., 1974, Brazil, v.1, pp III 9.1-9.13.
- AMERICAN SOCIETY OF CIVIL ENGINEERS 1972 Subsurface investigation for design and construction of foundations of buildings, J. Soil Mech. Found.Div., A.S.C.E., v.98, pp 481-490, 557-587, 749-754, 754-764, 771-799 and 779-785.
- ATTEWELL, P.B. and FARMER, I.W. 1973 Measurement and Interpretation of Ground Movements During Construction of a Tunnel in Laminated Clay at Hebburn, County Durham. Report to the Transport and Road Research Laboratory, Department of the Environment on Research Contract No. ES/GW/842/68.
- ATTEWELL, P.B. and FARMER, I.W. 1976 Principles of Engineering Geology. Chapman and Hall, London
- BENJAMIN, J.R. and CORNELI, C.A. 1970 Probability statistics and decision for Civil Engineers. McGraw-Hill, New York, 684 pp.
- BOZOZUK, M. 1963 Modules of elasticity of Leda Clay from field measurements, Canadian Geotechnical Journal, v.1, No. 1, pp 43-51.
- BRITISH STANDARDS INSTITUTION 1957 Site Investigations, British Standard Code of Practice CP 2001, (1957), London, (British Standards Institution), 123 pp.
- BUTLER, F.G. 1975 Heavily overconsolidated clays, B.G.S. Conf. on Settlement of Structures, Cambridge Univ., April, 1974, Publ. Pentech.Press, London, pp 531-578.
- CHURINOV, M.V., TSYPIA, I.M. and LAZAREVA, V.P. 1970 The principles of compiling the engineering geological maps of the U.S.S.R. territory on the scale of 1/2,500,000. First Int. Cong.Int. Ass. Eng. Geol., Paris, 8-11 Sept., 1970, France, pp 850-860.
- COBURN, T.M., BEESLEY, M.E. and REYNOLDS, D.J. 1960 The London-Birmingham Motorway. Road Research technical paper No. 46 parts 1 and 2, Road Research Laboratory, H.M.S.O., London, 83p. -

- CORDEY-HAYES, M., BROADBENT, T.A. and MASSEY, D.B. 1971 Towards operation urban development plans in Regional Forecasting (Ed. Chrisholm, M. Frey, A.E. and Haggett, P.) Proc. 22nd Sym. Colstron Res.Soc., Bristol, Pub. Butterworths, London, pp 221-254.
- CRAMÉR, H. 1954 The Elements of Probability Theory, John Wiley & Sons, New York, 281 pp.
- DAWSON, R.E.F. 1968 The economic assessment of Road Improvement Schemes. Road research technical paper no. 75, Road Research Laboratory, H.M.S.O., London, 56p.
- DUMBLETON, M.J. and WEST, G. 1971 Preliminary Sources of Information for Site Investigations in Britain. Road Research Laboratory report LR403, 55p.
- EARLY, K.R. and SKEMPTON, A.W. 1972 Investigations of the landslide at Waltons Wood, Staffs. Quart. Jl Eng. Geol., v.5, pp.19-42.
- FALKNER, R.H. and TOUGH, S.G. 1968 The Tyne Tunnel 2 : construction of the main tunnel. Proc. Inst.Civ. Eng., v.39, pp 213-234.
- FOLAYAN, J.I., HÖEG, K. and BENJAMIN, J.R. 1970 Decision theory applied to settlement predictions. Jl Soil Mech. & Found.Division, A.S.C.E., v.96, pp 1127-1141.
- FOOKES, P.G. 1967 Planning and stages of site investigation. Engineering Geology, v.2, pp 81-106.
- FRANCISS, F.O. and PUCCINI, A.L. 1974 Technique of modal group identification and its application in rock mechanics. Proc. 2nd Int. Cong. of Int. Ass. of Eng. Geol., São Paulo, 18-24 Aug., 1974, Brazil, v.2, pp VI 4.1-4.8.
- GEOLOGICAL SOCIETY OF LONDON 1972 The preparation of maps and plans in terms of engineering geology, Quart. Journ. Eng. Geol., v.5, pp 291-382.
- GREATER LONDON COUNCIL 1973 Roads in Tunnel (Report to G.L.C. by Sir William Halcrow & Partners and Mott, Hay and Anderson) Greater London Council, 1 x 33, 2-49, 3-25 p.
- H.M.S.O. 1963 Noise: Final Report Report of the Committee on the Problem of noise (Chairman: Sir Alan Wilson), H.M.S.O., London, 235p.

- H.M.S.O. 1967 Cars for Cities, Ministry of Transport, H.M.S.O., London, 107p.
- H.M.S.O. 1971a An Index of Housing Land Prices, Economic Trends No. 208, Central Statistical Office, H.M.S.O., London, 60p.
- H.M.S.O. 1971b London Airport. Third site. Commission on the Third London Airport Report, H.M.S.O., London, 275p.
- H.M.S.O. 1972a Local Housing Statistics : England and Wales, No. 21, Department of the Environment, H.M.S.O., London, 85p.
- H.M.S.O. 1972b Local Housing Statistics : England and Wales, No.22 Department of the Environment, H.M.S.O., London, 96p.
- H.M.S.O. 1974 Housing and Construction Statistics, No. 9, Department of the Environment, H.M.S.O., London, 96p.
- HOINVILLE, G. 1971 Evaluating community preferences. Environment and Planning, v.3, pp 33-50.
- HUNT, R.E. 1973 Round Rock, Texas new town: geologic problems and engineering solutions. Bull. Ass. of Eng. Geol. v.10, pp 231-242.
- HUNT, R.E. 1974 Engineering geology and urban planning for the Canada del Oro area, Tucson, Arizona, U.S.A. Proc. 2nd Int. Cong. of Int. Assoc. of Eng. Geol. São Paulo, 18-24 Aug., 1974, Brazil, v.1, pp III 1.1-1.9.
- HYDE, R.B. and LEACH, B.A. 1975 Settlement at Didcot Power Station, B.G.S. Conf. on Settlement of Structures, Cambridge University, April, 1974, Publ. Pentech. Press, London, pp 177-182.
- INESON, J. 1970 Water resource planning and development in Northern England. in Geological Aspects of Development and Planning in Northern England. Ed. P.J. Warren, a symposium report, Yorkshire Geological Society, pp 4-13.
- INSTITUTION OF CIVIL ENGINEERS 1973 Conditions of Contract and Forms of Tender Agreement and Bond for use in connection with Works of Civil Engineering Construction. Institution of Civil Engineers, Westminster, 37p.

- JAMES, J.G. 1972 Quantities and Prices in New Road Construction, 1969. A Brief Analysis of 60 Successful Tenders. Transport and Road Research Laboratory report LR 513, 17p.
- JANJIĆ, M. and STEPANOVIĆ, B. 1974 Stability of Karst and Marshland for Urban Development from the Point of View of Engineering Geology. Proc. 2nd Int. Cong. of Int. Ass. of Eng. Geol., São Paulo, 18-24 Aug., Brazil, v.1, pp III PC 4.1-4.8.
- KALTHERBERG, J. 1974 An engineering geology map of a township on the lower Rhine. Proc. 2nd Int. Cong. of Int. Ass. of Eng. Geol., São Paulo, 18-24 Aug., 1974, Brazil, v.1, pp III 10.1-10.8.
- KEEBLE, L. 1964 Principles and Practice of Town and Country Planning, 3rd Ed., Estates Gazette, London, 382p.
- KOZIŁOWSKI, J. 1970 Towards an Integrated Planning Process. Centre for Environmental Studies, Conference Paper CP3.
- LICHFIELD, N. 1972 The evaluation of amenity in relation to transport costs and benefits. Transportation Engineering, 1972, Conf. of the Inst. of Civ. Engrs, pp 103-108.
- LOVEGROVE, G.W. and FOOKES, P.G. 1972 The planning and implementation of a site investigation for a highway in tropical conditions in Fiji. Quart. Journ. Eng. Geol., v.5, pp 43-68.
- LOWER PIONEER VALLEY REGIONAL PLANNING COMMISSION 1970 A Preliminary Regional Development Plan. Lower Pioneer Valley Regional Planning Commission, West Stringfield, Mass. 39p.
- LUMB, P. 1974 Application of statistics in soil mechanics, In Soil Mechanics - New Horizons, Ed. I.K. Lee, Publ. Newnes-Butterworths, London, pp 44-111.
- LUTHANS, F. 1972 Contemporary Readings in Organizational Behaviour, McGraw Hill, New York, 480p.
- MALISZ, B. 1963 The Economics of Shaping Towns, Polish Academy of Sciences.

- MARGULIES, N. and RAI, A.P. 1972 Organizational Development : Values Process and Technology. McGraw Hill, New York, 704p.
- MARSHALL, A. 1969 Some Geotechnical Aspects of the Glacial Deposits of the Team Wash, Dissertation : M.Sc. Advanced Course in Engineering Geology, University of Durham.
- MARTIN, B.V., MEMMOTT, F.W., BONE, A.J. 1961 Principles and Techniques of Predicting Future Demand for Urban Area Transportation. Report No.3 of Massachusetts Inst. Tech. Press, 214p.
- MAY, J. 1975 Heave on a deep basement in the London Clay. B.G.S. Conf. on Settlement of Structures, Cambridge Univ. April, 1974, Publ. Pentech. Press, London, pp 177-182.
- McBEAN, R.J. and HARRIES, D.A. 1970 The development of high speed soft ground tunnelling using pre-cast concrete segments and tunnelling machines. The Technology and Potential of Tunnelling, v.1, Ed. Cook, N.G.W., Lancaster, F.H., Ortlopp, W.D. and Robinson, L.R., The South African Tunnelling Conference, 1970, pp 129-134.
- OAKLEY, H.R. 1973 Advances in Sewage Treatment - The Future. Proc. Conf. Inst. Civ. Eng., 14th Nov. 1972, Ed. K. Mayall, Publ. Thomas Telford Ltd., for I.C.E., pp 67-79.
- O.E.C.D. 1970 Proceedings of an Advisory Conference on Tunnelling. Report on Tunnelling Demand 1960-1980 Organization for Economic Co-operation and Development, Washington, 26p.
- O'FLAHERTY, C.A. 1969 Passenger Transport Present and Future, Univ. of Leeds Press, 75p.
- OHOKA, T. 1975 Discussion: Session III Heavily overconsolidated cohesive material, B.G.S., Conf. on Settlement of Structures, Cambridge Univ. April 1974, Publ. Pen tech. Press, London, p.725.
- O'LEARY, M., LIPPERT, R.H. and SPITZ, O.T. 1966 Fortran IV and Map Programme for Computation and Plotting of Trend Surfaces for Degrees 1 through to 6. Publication of Kansas Geological Survey, 47p.

- O'REILLY, M.P. and MUNTON, A.D. 1972 Prospects of urban highways in tunnels. Transportation Engineering 1972, Conf. of Inst. of Civ. Engrs., pp 43-53.
- ORGANIZATION FOR ECONOMIC CO-OPERATION AND DEVELOPMENT, 1970 Proceedings of an Advisory Conference on Tunnelling, Report on Tunnelling Demand 1960-1980, O.E.C.D., Washington, 26p.
- PECK, R.B. 1969 Advantages and limitations of the observational method in applied soil mechanics. Geotechnique, v.19, pp 171-187.
- POOL, R. 1975 Cost of Land in Co. Durham, Personal Communication.
- PRICE, D.G. 1971 Engineering geology in the urban environment. Quart. Journ. Eng. Geol., v.4, pp 191-208.
- PRICE, D.G. and KNILL, J.L. 1974 Scale in the planning of site investigations. Proc. 2nd Int. Cong. of Int. Ass. of Eng. Geol., São Paulo, 18-24 Aug., 1974, Brazil, v.1, pp, III, 3.1-3.8.
- PRIEST, S.D. and HUDSON, J.A. 1976 Discontinuity spacings in rock, Int. J. Rock Mech. Min Sci., and Geomech. Abs., v.13, pp 135-148.
- RAWLINGS, G.E. 1972 The role of the engineering geologist during construction. Quart. Journ. Eng. Geol., v.4, pp 209-220.
- REINA, P. 1976 London takes to new techniques. New Civil Engineer, 29th April, 1976, p.21
- RESENDIZ, D. and HERRERA, I. 1969 A probabilistic formulation of settlement controlled design, Proc. 7th Int. Conf. of Soil Mech. & Found. Eng., Mexico, v.2, pp 217-225.
- ROBERTS, G.D. 1973 Foundation "as built" reports, Bull. Ass. Eng. Geol., v.10, pp 145-156.
- ROSENBLUETH, E. 1969 Contribution to main session 2: Foundations of buildings in clay. Proc. 7th Int. Conf. on Soil Mech. and Found. Eng., Mexico, v.3, pp 230-242.
- ROWE, P.W. 1972 The relevance of soil and fabric to site investigation practice. Geotechnique, v.22, pp 195-300.

- RUTLEDGE, P.C. 1970 Utilization of marginal lands for urban development. Journ. Soil Mech. Found. Div., A.S.C.E., v.96, pp 3-22.
- SEROTA, S. and JENNINGS, R.A.J. 1959 The elastic heave at the bottom of excavations, Géotechnique, London, v.9, pp 62-72.
- STEINBRENNER, W. 1934 Tafeln zur Setzungsberechnung, Die Strasse, v.1, pp 121-124.
- STONE, P.A. 1963 Housing, Town Development, Land and Costs, Estates Gazette, London, 154p.
- STONE, P.A. 1967 Urban economics Arena, pp 266-270.
- STONE, P.A. 1970 Urban Development in Britain: Standards, Costs and Resources, 1964-2004, v.1, Population Trends & Housing. National Institute of Economic and Social Research, Cambridge University Press, 414p.
- TANNER, J.C. 1961 Factors Affecting the Amount of Travel. Road research technical paper, No. 51, Road Research Laboratory, H.M.S.O., London, 28p.
- TAYLOR, R.K. 1972 The functions of the engineering geologist in urban development. Quart. Journ. Eng. Geol., v.4, pp.221-240.
- TURKSTRA, C.J. 1970 Applications of Bayesian decision theory, In Structural Reliability and Codified Design, Ed. N.C. Lind, Soil Mech. Div. Study No.3, Univ. of Waterloo, Canada, pp 49-71.
- WALLER, R.A. 1968 Environmental quality, its measures and control. Regional Studies, v.4, p. 177.
- WARD, W.H. 1972 Some field techniques for improving site investigation and engineering design. In R.H.G. Parry (ed), Stress-Strain Behaviour of Soils, Foulis, Oxon., pp 676-682.
- WHITAKER, J. 1971 Almanack, Published by J. Whitaker & Sons Ltd., London.
- WILLIAMS, R.J. 1972 The implementation of the elements in the urban transport plan for the city of Liverpool, Transportation Engineering, 1972, Conf. of Inst. Civ. Engrs., pp 85-102.
- WOLOSHIN, A.J. 1970 Geoenvironmental information systems - their use in urban planning. First Int. Cong. Int. Ass. Eng. Geol., Paris, 8-11 Sept., 1970, France, pp 871-881.

APPENDIX A

DERIVATION OF EQUATIONS USED IN CHAPTER 4

In order to be in a position to perform the required mathematical operations, it is first necessary to derive certain equations.

If a normal distribution is written as:

$$P(x|\bar{x};i) = \frac{1}{\sqrt{2\pi i}} \exp \left[\frac{-(x - \bar{x})^2}{2i^2} \right] \quad \dots \text{ A.1}$$

then a log-normal distribution may be derived by using the following transform:

$$x = \ln y \quad \dots \text{ A.2}$$

Hence, by substitution of equation A.2 into A.1, a log-normal distribution is obtained as:

$$P(y|y^*,i) = \frac{1}{\sqrt{2\pi i} y} \exp \left[- \frac{(\ln \{y/y^*\})^2}{2i^2} \right] \quad \dots \text{ A.3}$$

where,

$$y^* = \exp \bar{x}. \quad \dots \text{ A.4}$$

Now the mean value, \bar{y} , of the log-normal distribution is given

by

$$\bar{y} = \int_{-\infty}^{\infty} \frac{1}{\sqrt{2\pi i}} \exp \left[- \frac{(\ln \{y/y^*\})^2}{2i^2} \right] dy \quad \dots \text{ A.5}$$

which by transform A.2 becomes

$$\bar{y} = \int_{-\infty}^{\infty} \frac{1}{\sqrt{2\pi i}} \exp \left[x - \frac{(x - \bar{x})^2}{2i^2} \right] dx \quad \dots \text{ A.6}$$

Taking note of the identity:

$$(z - z')^2 - 2i^2 r (z - z') = \left\{ z - (z' + ri^2) \right\}^2 - r^2 i^4 \quad \dots \text{A.7}$$

and its consequence

$$\int_{-\infty}^{\infty} \frac{1}{\sqrt{2\pi} i} \exp \left[r(z - z') - \frac{1}{2i^2} (z - z')^2 \right] dz = \exp \left[\frac{r^2 i^2}{2} \right] \quad \text{A.8}$$

after transformation to a form similar to A.8 with $r = 1$, equation

A.6 can be written as

$$\bar{y} = \exp \left[\bar{x} + \frac{i^2}{2} \right] \quad \dots \text{A.9}$$

or

$$\ln \bar{y} = \bar{x} + \frac{i^2}{2} \quad \dots \text{A.10}$$

Equation 4.13

The simplification of equation 4.12 is carried out by the following procedure commencing with

$$U_m = \int_{-\infty}^{\infty} \left\{ a_0 + a_1 (\bar{x} - \bar{x}_m)^2 \right\} \frac{\sqrt{m}}{\sqrt{2\pi} i} \exp \left[- \frac{(\bar{x} - \bar{x}_m)^2 m}{2i^2} \right] d\bar{x} \quad \dots \text{4.12}$$

Re-arranged, equation 4.12 becomes:

$$U_m = \int_{-\infty}^{\infty} \frac{\sqrt{m}}{\sqrt{2\pi} i} \left\{ a_0 \exp \left[- \frac{(\bar{x} - \bar{x}_m)^2 m}{2i^2} \right] + a_1 (\bar{x} - \bar{x}_m)^2 \exp \left[- \frac{(\bar{x} - \bar{x}_m)^2 m}{2i^2} \right] \right\} d\bar{x} \quad \dots \text{4.12a}$$

Now since $\int_{-\infty}^{\infty} z^2 \exp [-az^2] dz = \frac{1}{a} \int_0^{\infty} \exp [-az^2] dz = \frac{1}{2a} \sqrt{\frac{\pi}{a}}$... 4.12b

it follows that

$$U_m = a_0 + \frac{a_1 i^2}{m} \quad \dots \text{4.13}$$

Equation 4.15.

$$\text{Since } U_{p|m} = \int_{-\infty}^{\infty} U_p P(\bar{x}_p | i : \bar{x}_m) d\bar{x}_p \quad \dots 4.14$$

it is first necessary to determine the form of $P(\bar{x}_n | i : \bar{x}_m)$

where $n = p - m$. $P(\bar{x}_n | i : \bar{x}_m)$ may be found in the following

manner:

$$P(\bar{x}_n | i : \bar{x}_m) = \int_{-\infty}^{\infty} P(\bar{x}_n | i : \bar{x}) P(\bar{x} | i : \bar{x}_m) d\bar{x} \quad \dots 4.14a$$

$$= \int_{-\infty}^{\infty} \frac{\sqrt{n}}{\sqrt{2\pi i}} \exp \left[\frac{-n(\bar{x}_n - \bar{x})^2}{2i^2} \right] \frac{\sqrt{m}}{\sqrt{2\pi i}} \exp \left[\frac{-m(\bar{x} - \bar{x}_m)^2}{2i^2} \right] d\bar{x} \quad \dots 4.14b$$

where equations 4.6 & 4.7 have been used, Hence,

$$P(\bar{x}_m | i : \bar{x}_m) = \int_{-\infty}^{\infty} \frac{\sqrt{mn}}{2\pi i^2} \exp \left[-\frac{p\bar{x}^2 - 2p\bar{x}\bar{x}_p + p\bar{x}_p^2 - \frac{1}{p}(n\bar{x}_n + m\bar{x}_m)^2}{2i^2} + \frac{n\bar{x}_n^2 + m\bar{x}_m^2}{2i^2} \right] d\bar{x} \quad \dots 4.14c$$

So, by the substitution of equation 4.9, and simplification,

equation 14c becomes:

$$P(\bar{x}_m | i : \bar{x}_m) = \frac{\sqrt{mn}}{\sqrt{2\pi p} i} \exp \left[\frac{-mn}{2i^2 p} (\bar{x}_n - \bar{x}_m)^2 \right] \quad \dots 4.14d$$

Hence, by using equation 4.9 again, it follows that:

$$P(x_p | i : x_m) = \frac{\sqrt{pm}}{\sqrt{2\pi n}} \frac{1}{i} \exp \left[\frac{-pm (x_p - x_m)^2}{2i^2 n} \right] \quad \dots 4.14e$$

Now since it follows from equation 4.13 that:

$$U_p = a_0 + a_1 \frac{i^2}{p}, \quad \dots 4.14f$$

then substitution of equations 4.14e and 4.14f into equation 4.14 gives the following result:

$$U_{p|m} = \left\{ a_0 + \frac{a_1 i^2}{p} \right\} \int_{-\infty}^{\infty} \frac{\sqrt{pm}}{\sqrt{2\pi n}} \frac{1}{i} \exp \left[\frac{-pm (\bar{x}_p - \bar{x}_m)^2}{2i^2 n} \right] d\bar{x}_p \quad \dots 4.14g$$

which, from equation A.8, may be written as:

$$U_{p|m} = a_0 + \frac{a_1 i^2}{p} \quad \dots 4.15$$

Equation 4.19

As for the normal case, the derivation of U_m starts from equation 4.11 . Hence expressions for U and $P(\bar{y} | i : \bar{y}_m)$ are required.

Now

$$U = a_0 + a_1 (\bar{y} - y_a)^2 \quad \dots \quad 4.18$$

so, by using equation A.9, this becomes,

$$U = \left(a_0 + a_1 \exp \left[2 \bar{x}_m + i^2 \right] \right) \left\{ \exp \left[(\bar{x} - \bar{x}_m) - 1 \right] \right\}^2 . \quad \dots \quad 4.18a$$

From equation 4.11 it follows that U_m is given by the

following equation:

$$U_m = \int_{-\infty}^{\infty} U P(\bar{y} | i : \bar{y}_m) d\bar{y} \quad \dots \quad 4.18b$$

which, by the substitution of equation 4.18a and 4.16, becomes

$$U_m = \int_{-\infty}^{\infty} \left(a_0 + a_1 \exp \left[2\bar{x}_m + i^2 \right] \right) \left\{ \exp \left[(\bar{x} - \bar{x}_m) - 1 \right] \right\}^2 \frac{\sqrt{m}}{\sqrt{2\pi} i \bar{y}} \exp \left[- \frac{m(\ln \bar{y} - \ln \bar{y}_m)}{2i^2} \right] d\bar{y} . \quad \dots \quad 4.18c$$

The use of the transform given in equation A.10 then yields :

$$U_m = \int_{-\infty}^{\infty} \left(a_0 + a_1 \exp \left[2\bar{x}_m + i^2 \right] \right) \left\{ \exp \left[(\bar{x} - \bar{x}_m) - 1 \right] \right\}^2 \frac{\sqrt{m}}{\sqrt{2\pi i}} \exp \left[\frac{-m(\bar{x} - \bar{x}_m)^2}{2i^2} \right] d\bar{x} . \quad \dots \quad 4.18d$$

Therefore, by the use of equation A.8, the following expression is

obtained:

$$U_m = a_0 + a_1 \exp \left[2\bar{x}_m + i^2 \right] \left\{ \exp \left[\frac{2i^2}{m} \right] - 2 \exp \left[\frac{i^2}{2m} \right] + 1 \right\} . \quad \dots \quad 4.19.$$

Equation 4.20

Since the derivation of equation 4.20 takes the same form as equation 4.15, the expressions for U_p and $P(\bar{x}_p | i : \bar{x}_m)$ are required for substitution into equation 4.14 . From equation 4.19 it follows that:

$$U_p = \left(a_0 + a_1 \exp \left[2\bar{x}_p + i^2 \right] \right) \left\{ \exp \left[\frac{2i^2}{p} \right] - 2 \exp \left[\frac{i^2}{2p} \right] + 1 \right\} . \quad \dots \quad 4.19a$$

Substitution of equations 4.14e and 4.19a into equation 4.14 gives the following relationship:

$$U_{p|m} = \int_{-\infty}^{\infty} \left\{ a_0 + a_1 \exp \left[2\bar{x}_p + i^2 \right] \left(\exp \left[\frac{2i^2}{p} \right] - 2 \exp \left[\frac{i^2}{2p} \right] + 1 \right) \right\} \frac{\sqrt{pm}}{\sqrt{2\pi m}} \frac{1}{i} \exp \left[\frac{-pm}{2i^2 n} (\bar{x}_p - \bar{x}_m)^2 \right] d\bar{x}_p . \quad \dots \quad 4.19b$$

Re-arrangement of equation 4.19b yields:

$$U_{p|m} = a_0 + a_1 \left[\exp 2\bar{x}_m + i^2 \right] \left(\exp \left[\frac{2i^2}{p} \right] - 2 \exp \left[\frac{i^2}{2p} \right] + 1 \right) \frac{\sqrt{pm}}{\sqrt{2\pi m} i} \int_{-\infty}^{\infty} \exp \left[2(\bar{x}_p - \bar{x}_m) \frac{-pm(\bar{x}_p - \bar{x}_m)^2}{2i^2 n} \right] d\bar{x}_p \dots 4.19c$$

and therefore simplification by equation A.8 results in:

$$U_{p|m} = a_0 + a_1 \exp \left[2\bar{x}_m + 2i^2 \left(\frac{1}{m} + \frac{1}{2} \right) \right] \left\{ 1 - 2 \exp \left[\frac{-3i^2}{2p} \right] + \exp \left[\frac{-2i^2}{p} \right] \right\} \dots \quad 4.20$$

Equation 4.24

$$\text{Now if } V_{p|m} = \frac{a_1 i^2}{m} - \frac{a_1 i^2}{p} - k_0 - k_1 (p - m), \quad \dots \quad 4.23$$

and if $k_0 = 0$, then there will be no economic benefit in sampling

when $V_{p|m} = 0$, so

$$\frac{a_1 i^2}{m} - \frac{a_1 i^2}{p} = k_1 (p - m) \quad \dots \quad 4.23a$$

Equation 4.23a is a quadratic in p having the two solutions

$$\text{obtained by formula: } p = m \text{ and } p = \frac{a_1 i^2}{k_1 m} \quad \dots \quad 4.23b$$

$$\text{Hence, } m < p < \frac{a_1 i^2}{k_1 m} \quad \dots \quad 4.24$$

Equation 4.25

The value of p for the maximum economic advantage occurs when

$\frac{d}{dp} V_{p|m} = 0$. Differentiation of equation 4.23 gives:

$$\frac{dV_{p|m}}{dp} = \frac{a_1 i^2}{p^2} - k_1 = 0 \quad \dots \quad 4.23d$$

$$\text{So, } p' = \frac{a_1 i^2}{k_1}, \text{ where } p' \text{ is the optimum value of } p. \quad \dots \quad 4.25$$

Equation 4.27

Equation 4.27 follows from equation 4.26, since the optimum

sample number occurs when $\frac{d}{dp} V_{p|m} = 0$:

$$V_{p|m} = a_1 \exp \left[2x_m + 2i^2 \left(\frac{1}{m} + \frac{1}{2} \right) \right] \left\{ \exp \left[\frac{-2i^2}{m} \right] - \exp \left[\frac{-2i^2}{p} \right] - 2 \left(\exp \left[\frac{-3i^2}{2m} \right] - \exp \left[\frac{-3i^2}{2p} \right] \right) \right\} \\ - \left\{ k_0 + k_1 (p - m) \right\} \quad , \quad \dots \quad 4.26$$

$$\frac{d}{dp} V_{p|m} = a_1 \exp \left[2\bar{x}_m + 2i^2 \left(\frac{1}{m} + \frac{1}{2} \right) \right] \left\{ \frac{2i^2}{p^2} \exp \left[\frac{-2i^2}{p} \right] + \frac{3i^2}{p^2} \exp \left[\frac{-3i^2}{2p} \right] \right\} k_1 = 0 \quad \dots \quad 4.26a$$

Hence the optimum sample number, p' , is given by the solution of equation 4.27 for p' :

$$k_1 = \frac{a_1 i^2}{p'^2} \exp \left[2\bar{x}_m + 2i^2 \left(\frac{1}{m} - \frac{1}{p'} + \frac{1}{2} \right) \right] \left\{ 3 \exp \frac{i^2}{2p'} - 2 \right\} \cdot \dots \quad 4.27$$

APPENDIX B

PREPARATION OF SITE INVESTIGATION DATA FOR STORAGE

B.1 Introduction

This Appendix describes the procedure for abstracting data from site investigation reports for storage by geotechnical data processing system Geosys. Since this system has been devised for storing geotechnical data collected in the vicinity of Newcastle-upon-Tyne, some modification would be required for its application elsewhere. Four alternative ways of coding stratum descriptions can be mentioned:

- (i) automatic coding by the computer would necessitate the use of a very large routine capable of recognizing many names and strata descriptions;
- (ii) data stored without first being coded would require a large amount of storage space;
- (iii) to manually code the data requires some interpretative skill by the coding personnel;
- (iv) by the adoption of standard names and formats which would only be successful with the co-operation of site investigation operatives.

An absolutely universal method of numerically coding strata to produce a description with the precision proposed by the Geological Society of London (1972) could be devised if eleven code numbers were used. In the system described, three-figure manually coded descriptions supplemented by twelve character expressions have been found to be adequate due to the restricted range of sediments encountered.

The stored data have a two-tier structure comprising:

- (i) borehole title;
- (ii) sub-surface data.

These are described in this order in this Appendix.

B.2 Borehole Title

The title comprises general information concerning the boring presented in the following format:

- (i) Columns 1 to 5 - Borehole identity number.

An I5 non-zero number given to the borehole as a unique identity within the storage file.

- (ii) Columns 7 to 10 - Site investigation borehole number.

An A4 identity which may include both letters and numbers taken from the site investigation report.

- (iii) Columns 15 to 25 - Grid reference.

The easting and northing of the surface of the boring to the nearest metre are given by a 2I5 number. This can be given with respect to either a local or national reference position.

- (iv) Columns 30 to 34 - Level of top of hole.

This F5.1 number gives the level in feet or metres of the top of the boring with respect to a common datum. In the present study, all levels have been expressed with respect to ordnance datum at Newlyn.

- (v) Columns 40 to 52 - Date (s) of boring.

The date of boring, or the dates over which boring was carried out, are shown in this twelve character space. Such dates are expressed in numbers in the order day/month/year.

- (vi) Columns 56 to 68 - Extra information.

Another twelve character space is provided for additional information, such as the method of boring, the system of units, the lining required for the hole and so on.

The use of an additional title card is useful sometimes to change a particular piece(s) of information on a series of cards. The second card carries only the alteration(s) which must lie in the field(s) allocated in the foregoing list.

B.3 Sub-surface Data.

The data may be prepared using a system of units based on either the Imperial or the S.I. system. All the units used in a particular borehole must conform to one system or the other, but only the units of distance respectively, feet or metres, need be mentioned here.

The data format consists of the series of fields shown below:

- (i) Field A Columns 1 to 6, F6.2 Depth below surface.

This is a positive number showing the depth below the top of the hole (as defined by the datum on the title card, in the same units as this).

- (ii) Field B Columns 7 to 9, I3 Strata code.

This describes the strata according to a numeric code.

- (iii) Field C Column 11, I1 Sample code.

A code which indicates the type of sample taken.

- (iv) Field D Column 12, I1 Test code.

A number which indicates the type of test performed.

- (v) Field E Column 13, I1 Information code.

A number which indicates the amount of information appearing on the line. This code also serves to show the depth of the bottom of the hole by a zero value.

- (vi) Field F Columns 15 and 16, I2 Moisture content.

A number showing the moisture content of a soil sample expressed as a percentage of the dry weight. A single figure number must appear to the right hand side of this field.

(vii) Field G Columns 20 and 21, I2 Liquid limit.

A number showing the liquid limit determined for a sample of soil expressed as a percentage moisture content. A single figure number must appear in column 21.

(viii) Field H Columns 22 and 23, I2 Plastic limit.

A number showing the plastic limit determined for a sample of soil expressed as a percentage moisture content. A single figure number must appear in column 23.

(ix) Field I Columns 34 to 39, F6.1 Cohesion value.

The cohesion or shear strength of a soil sample determined in an undrained triaxial test.

(x) Field J Columns 40 to 47, F8.3 Test results.

This space is intended for test results other than cohesion determined by an undrained triaxial test.

(xi) FIELDS K, L & M Columns 50 to 61, 3A4 Twelve character string.

This space is for additional information about the strata, the tests performed, the test results given in field J and the mnemonic codes for tests. The three fields are as follows:

K (50-53), L (54-57), M (58-61), and when any numeric quantity is put in one of these it must be wholly within that field.

The sub-surface data is of three types:

- (i) general data;
- (ii) strata and water conditions; and
- (iii) test data.

All cards must include general information, and either a description of the strata (alternatively the water conditions) or test results.

B.3.1 General Data

(i) Depth and Information Codes

The minimum amount of information on a data card indicates the length of the boring by the greatest depth of boring in field A and a field E code of 0*.

The field E code serves as an instruction to the storage routine in the allocation of storage space required for the card it appears on, so the higher its value the greater the space made available. Considerable economies of storage space are possible by using the lowest value of this code, compatible with the storage requirement. Table B.1 shows the way in which incrementing the code by one makes one more field available, but also leaves those fields free that are already allocated by lower values of the code. When field E code is 0 it serves to indicate the bottom of a boring.

(ii) Sample Code

When a sample of strata or water has been removed from the borehole, the depth of its mid-point must be indicated in field A and its type in field C according to the scheme given in Table B.2. When no other information appears on a card with a sample code, then, from Table B.1, the field E code should be 1.

The number of hammer blows required to drive a U4 sampler may be recorded in field M with the legend U4 BLOWS in fields K and L. In this case, the field E code must equal 3. Samples removed from a standard penetration sampler may be recorded by a 9 in field C and a 7 in field D. In this case the appropriate

* In consequence of the default value of this code being zero, its omission from any card indicates that the depth on that card is the bottom of the hole.

field E code will be 2.

B.3.2 Strata and Water Conditions.

(i) Strata Description

The top of each new hole is signified by a description of the surface material with a depth code of zero. This, and subsequent, strata descriptions at the top of each horizon are formed by either a three figure code with an information code of 2 or a three figure code and a twelve character string with an information code of 3.

The three figure strata code in field B consists of the following elements:

- 1st Figure - basic material;
- 2nd Figure - competence and colour;
- 3rd Figure - extra constituent.

The codes used to form numeric strata descriptions may be derived from Table B.3. When a material cannot easily be described by this simple code, information in the 12 character string may substitute for the first or second figure, or may supplement the code. Examples of all these types of strata code are illustrated in Figure B.1. Obviously, some abbreviation of the information in fields K, L and M may be necessary, but by using the longest mnemonic codes in Table B.4 that can be accommodated, the meaning can usually be conveyed. When this is not possible, then a series of cards, all for the same depth, may be used to construct a more lengthy description. Any such group of cards should be headed by a card which gives a numeric description, with a statement in the twelve character space to the effect that the following cards carry more of the description.

No other information may appear on a strata description card but the depth, the three figure numeric code, the information code, and the twelve character string. Should a record of the water conditions, a test, or a sample be required at the same depth as the top of a stratum, then such information must appear on a separate card.

(ii) Ground Water Conditions.

The ground water conditions encountered both during, and observed after, boring are indicated by one of the field C codes shown in Table B.5. Also included in this Table are some examples of the type of information which could appear in the twelve character string. Data may be inserted in this space with each of the water condition codes, provided that the information code is increased from 2 to 3.

B.3.3 Test Data

The test data cards may only carry the depth, the information code, the type of sample (if applicable), the type of test, and any test results. In some instances, more than one test at the same depth may be placed on a single card. Otherwise, more than one card must be used when several tests occur at the same depth.

Tests may be identified in three ways:

- (i) field D code;
- (ii) field E code; and
- (iii) mnemonic code in fields K and L.

The data may be stored in either Imperial - or S.I.-based systems of units. The acceptable units for individual parameters are given in Table B.6.

(i) Field D code

Reference to the tests of this type listed in Table B.7 indicate that several varieties of undrained triaxial test may be distinguished by the field D code. These are listed below:

- Code 1 One sample tested at a confining pressure equal to the effective overburden pressure of the sample in situ.
- Code 2 Three samples tested at different confining pressures.
- Code 3 One sample tested, but on at least two occasions the confining pressure is incremented when failure is imminent.

When a remoulded sample is tested, then this may be recorded by the letters *REM in field K. When this location is occupied by an angle of internal friction, then *REM may replace the sample diameter in field M. The results of penetration tests consist of the number of blows to drive the instrument from 3"(7.5cm) to 15" (37.5cm) recorded in field K with 12"(30cm) recorded in field M.

(ii) Field E Code

Tests identified by a field E code may accompany other tests on the same card, provided that care is taken to ensure that the positions of parameters recorded are consistent with the value of the code. The tests which can be identified by the field E code are shown below:

- Code 6 Field F. Moisture content of soil sample expressed as a percentage of the dry weight.
- Code 7 Fields F, G and H. The moisture content and the liquid and plastic limits, expressed as the percentage of water comprising the dry weight, are respectively entered in these fields.

(iii) Mnemonic Codes in Fields K and L.

With a mnemonic code, a test in addition to one identified by another method may be recorded on the same card. If another test is not present then the field D code must be 9. The mnemonic codes shown in Table B.8 are inserted in either field K or fields K and L, and the parameters occupy positions also given in this Table. The tests may be formed into a list as follows:

- (a) Sulphate analysis. If this is performed on water, the fraction (parts) of soluble sulphate is measured. For a soil, the sulphate content is expressed as a percentage of the dry weight of the sample. The acidity can also be recorded as a pH value.
- (b) Consolidation test data. It is not possible to store all the data which may be obtained by a consolidation test. But the coefficient of volume compressibility, for a pressure range of equivalent overburden for the sample in situ to that pressure plus $107 \text{ m}^2/\text{GN}$ ($1 \text{ ft}^2/\text{tonf}$), is quoted together with the natural moisture content.
- (c) Standard dynamic compaction test. The maximum dry density and the corresponding optimum moisture content are recorded for certain standard conditions.
- (d) Shear box test. The peak and residual values of cohesion and angle of friction are recorded on two different cards distinguished respectively by BX*P and BX*R.
- (e) Drained triaxial test. The effective values of cohesion and angle of friction are measured. Tests on remoulded samples or with pore pressure measurement are distinguished respectively by REM or PPM in field L.

- (f) California Bearing Ratio. The C.B.R. value and the natural moisture content are recorded.
- (g) Natural Moisture Content. Unlike the alternative methods of storing a moisture content, those with the percentage of water with respect to dry solids greater than 100% can be stored.
- (h) Bulk Density. The value of wet or bulk density is recorded.
- (i) Particle Size Analysis. A mnemonic code given in Table B.4 is used to indicate the chief material in the soil.
- (j) Permeability Test. The permeability is recorded with the distance between the packers in a field test or the diameter of the sample in a laboratory test. The depth given for the field test is the mid-point of the measurement length.

Field B Code			Field E Code	12 Character String												Description		
				K				L				M						
4	3	4	2															Hard grey sandy silty clay with gravel
-	8	0	2															Loose soft sand and gravel
3	8	1	3	P	T	G		F	I	N	E		S	N	D			Soft brown clay with organic matter and partings of fine sand.
4	9	4	3	S	T	I	F	F	/	V			S	F	F			Stiff to very stiff sandy silty clay with gravel

Figure B.1 Examples of Strata Description.

Field <u>E</u> Code	Fields Made Available by Code												
	A	B	C	D	E	F	G	H	I	J	K	L	M
0	X				X								
1	X		X		X								
2	X	X	X		X								
3	X	X	X		X							X	
4	X		X	X	X					X	X		
5	X		X	X	X				X	X	X		
6	X		X	X	X		X	X	X	X	X		
7	X		X	X	X	X	X	X	X	X	X		

Table B.1 Values of the Information Code

Field <u>C</u> Code	Type of Sample
0	None (default value of code)
1	U4 undisturbed 100mm diameter sample
2	U4 disturbed 100mm diameter sample
3	Small disturbed sample
4	Large or block soil sample
5	Water sample
9	Rotary core drilling sample

Table B.2 Codes Used to Indicate Sample Type.

Value of Field B Code	Basic Material 1st	Competence/Colour 2nd	Extra Constituent 3rd
-	Sand & Gravel	-	-
0	Sandstone	None	None
1	Sand	Dense/hard black	Organic matter
2	Silty Sand	Loose/soft black	Wood & timber
3	Sandy silt	Dense/hard grey	Coal
4	Sandy silty clay	Loose/soft grey	Gravel
5	Silty clay	Dse/hard grey- brown	Gravel & cobbles
6	Laminated silty clay	Lse/soft grey- brown	Gravel & sand
7	Clay	Dense/hard brown	Sand
8	Mudstone	Loose/soft brown	Laminae fine sand
9	Other	Other	Oc.gravel & coal

Table B.3 Numeric Strata Description Codes

Mnemonic	Code	Mnemonic	Code	Mnemonic	Code
AG ARG	Argillaceous	FG FRAG	Fragment(s)	SD SND	Sand
BN BNS	Band(s)	GV GRAV	Gravel	S-S	Sandy-silty
BD BDS	Bed(s)	G' GYGRY	Grey	SA SHA SHL	Shale
BK BLK	Black	H HD	Hard	SHT	Shattered
BR BRK	Broken	J JNT	Jointed	SH	Shells
B BN BRN	Brown	LM LAM	Laminat- (ions/ed)	SL SILT	Silt
CA CARB	Carbonaceous			SLY	Silty
CM CMT	Cemented	L LIT	Light	SG	Slight(ly)
CY CLY	Clay	ING	Lining	ST SFT	Soft
CL COL	Coal	LS LSE	Loose	SF SFF	Stiff
C CSE	Coarse	M MDMED	Medium	SN STN	
CBL	Cobble(s)	MT MOT	Mottled	STNY	Stony
CP COMP	Compact	MOTL		TB TIMB	Timber
CT CONC	Concrete	MST	Mudstone	TC TRC	Traces
D DK	Dark	OC OCC	Occasionally		
DS DSE	Dense	OG ORG	Organic	V	Very
FL	Fill	PT PTG	Parting(s)	VN VNS	Vein(s)
F FN	Fine	P PK	Peak	W +	With
FM FRM	Firm	PL	Plant(s)	WT	White
FSL FISL	Fissile	PK PKT	Pocket(s)	WD	Wood
FS FIS FISS	Fissured	R RD	Red	Y YEL	Yellow
FOS	Fossil(s)	RES	Residual	/	To
		RB RUB	Rubble	>	To more
		RUBL		<	To Less

Table B.4 Mnemonic Strata Description Codes

Field <u>C</u> Code	Field <u>E</u> Code	12 Character String												Water Conditions
		Field <u>K</u>				Field <u>L</u>				Field <u>M</u>				
6	1													Encountered in boring
6	3	R	O	S	E		T	O		1	2	.	4	Encountered and rose up boring
7	1													Standing or piezometric level.
7	3	P	M			2	2	/	4	/	7	5		Standing or piezometric level.
8	1													Standpipe installed
8	3	&	S	L	I	P			I	N	D	C	T R	Standpipe and slip indicator installed

Table B.5 Examples of Codes for Water Conditions.

Variable	Metric System of Units	Imperial System of Units
Distance	metres	feet
Cohesion	kN/m ²	lbf/in ²
Shear strength	kN/m ²	lbf/in ²
Friction angle	degrees	degrees
Penetration	cm	inches
Diameter of sample	cm	inches
Density	kg/m ³	lb/ft ³
Moisture content	%	%
Limits	%	%
Coef.vol.comp.	m ² /GN	ft ² /Tf
C.B.R.	%	%
Permeability	cm/s	cm/s
Range	Metres	feet
Particle size	BS Sieve size	BS Sieve size
Sulphate(water)	pts per unit	pts per million
Sulphate(soil)	% SO ₃ in dry wt.	% dry wt x 100

Table B.6 Units Used in Geosys.

Field D Code	Type of Test	Alternative Fields	Parameter
0	None (default value of code)		
1	Undrained triaxial - 1 sample at overburden equivalent	KJI M	Shear strength Diameter of Sample
2	Undrained triaxial - More than 3 samples tested.	JI L M	Cohesion Friction Diameter of sample
3	Undrained triaxial - 1 sample at 3 pressures	JI L M	Cohesion Friction Diameter of Sample
4	Unconfined compression test	KJI M	Uncon.Comp.Strength Diameter of Sample
5	Laboratory vane test	K L	Peak } Shear Resid. } Strength
6	Field vane test	K L	Peak } Shear Resid. } Strength
7	Standard penetration field test	K M	Number Blows Penetration
8	Dynamic cone penetration field test	K M	Number of Blows Penetration
9	Other test identified by mnemonic	See Table B.8	

Table B.7 Numeric Test Codes.

Mnemonic for Test							Test Represented ⁺	Parameters Stored	
Field <u>K</u>				Field <u>L</u>				Field <u>J</u>	Field <u>M</u>
C	M	P		D	D		Compaction Test	Maximum dry density	Optimum moisture content
C	M	T		D	D				
C	P	T		D	D				
C	O	M	P		D	D			
C	O	N	S		M	V	Consolidation	Coef.vol- ume comp- ressibility	Nat.moist. cont. content
C	B	R					California bearing ratio	CBR value	Nat.moist.
D	3	X		R	E	M	Drained remoulded triaxial Drained triaxial Drained triaxial,pore water pressure measurement	Effective cohesion	Effective angle friction
D	R	D		3	A	X			
3	A	X		P	P	M			
P	T	S		S	O	3	Sulphate anal.on water	Parts SO ₃	pH
D	W	T	%	S	O	3	Sulphate anal.on soil	% SO ₃	pH
S	H	R		B	X	* P	Shear box (peak)	Peak cohesion	Peak friction
S	H	R		B	X	* R	Shear box (residual)	Resid. cohesion	Resid.friction
M		C	O	N	T		Moisture content	Nat.moist. cont.	
W	E	T		D	E	N	Bulk density determination	Bulk density	
W	E	T	D	E	N				
W	D	E	N	S	I	T Y			
	W	E	T		D	E			
P	E	R	M	E	A	B	Permeability determination	Permeability	Range
P	A	R	T				Particle size dist.	-	Field L & M
S	I	E	V						Major retaining sieve

Table B.8 Tests Identified by Mnemonic Code.

⁺Any one of the mnemonics may be used when several alternatives are given for one type of test.

APPENDIX C

COMPUTER PROGRAMMES FOR GEOSYS

C.1 Introduction.

Geosys is a suite of computer programmes written for the purpose of storage, processing and retrieval of geotechnical data. As explained in Chapter 6, the system comprises elements for transposing prepared borehole analogue data into a form suitable for retention in a computer file, where it may be processed or accessed. Also available are options for altering the units in which any data are expressed, and various modes of output, including a facility for producing contoured maps. The necessary programmes to perform these operations are concatenated in chains by the overall control programme Geosys according to directions given by the user to programme Info at the initiation of each execution.

The whole of Geosys has been formed as a unit, with only the part labelled Trend (Figure 6.1) attributed to O'Leary et al. (1966). The operation of each of the constituent programmes forming the chains is illustrated by a flow diagram intended to show the basic structure rather than the inherent intricacies. In the flow diagrams, the convention of symbols illustrated in Figure C.1 has been employed to mark branches, operations, output, input, and transfer-to and transfer-from other programmes.

Each programme has a single starting point marked by the appropriate symbol with the name of the programme. The command then

follows the flow path according to the options given on the arms of branches until either an end or a return is reached. An end indicates that the execution is terminated, but a return transfers command back to the accessing programme at the point of calling. Operation symbols all show their function, which may be carried out within the same programme; otherwise another programme is accessed. The names of programmes called in this way are shown with the access symbol at the place from which they are called and, as already mentioned, on returning, command is transferred to this point. Input and output operations are titled respectively read and write. The flow lines usually approach all operation symbols vertically downwards and emerge similarly, although occasionally space on the paper has prevented strict adherence to this rule. At branches, the approaching flow line is always vertically downwards but the arms may be horizontal and/or vertical.

C.2 Structure of Programmes.

C.2.1 Geosys

This programme is the main concatenating agent between Info, which receives instructions from the operator, and the operating programmes. This brief programme, shown in Figure C.2 consists of elements for printing titles and accessing Info, Store, Read and Trend. After a particular operation has been completed, command is returned to Geosys so that, unless a serious error has occurred, another operation may be started.

C.2.2 Info

This programme receives option specifications from the operator for the operation of Geosys in either a literal or numeric mode. When the literal mode is used, the operator is asked questions which must be answered in a particular manner. Info includes elements for recognising the answers and also for evaluating numeric quantities. During the operation of Info, programmes Number, Quest, Check, Swapf and Swapi may be called to perform certain repetitive tasks.

The operation of Info is illustrated by the flow diagram in Figure C.3. The programme is accessed at the initiation of each run of Geosys when the operator is asked whether the following specification is to be literal or numeric. As with all other literal questions, it is accompanied by acceptable replies and failure to use one of these, or one inconsistent with respect to previous answers, constitutes an error, so that the question is repeated. The detection of this error is performed by Quest which also reads the answer and transfers it into the numeric code. The same question may only be asked three times, since Check counts the number of times that a particular question is asked and will terminate the execution if it becomes necessary.

Presuming that a literal specification is required, the type of job must next be specified. Further Option Specification is required for the storage and retrieval of geotechnical data, whereas for the operation of the Trend or Convert options, command is returned to Geosys. In the literal branch, the operations of storage and retrieval are separated from each other. Titles are read in to

head the page of retrieved data or data print-out during data storage. The numeric print-out equivalent to the literal Option Specification may be requested, and it is then output in the form that it may be read in for the numeric style of Option Specification.

The numeric operation is performed in a similar manner for the store and retrieve operations. The values of the codes and their consistency are checked, and the first faulty code that is detected results in an error message which includes the equivalent literal question.

C.2.3 Store

Store is the main element for preparing geotechnical data for storage. It compresses the data to conserve storage space, but may also be employed for changing the units of the parameters. Since there is a facility for accessing data, not only from coded borehole logs but also from data already stored in a file, the units may be altered during storage or subsequently. Whatever the mode of input, the output from Store can be either file storage or directly to the line printer. Hence, a number of options are available, including the operation of Geosys in which the whole of a file is converted from one set of units to another. This is really just a special application of Store in which unrestricted file input, conversion, and file output are chosen.

The beginning of programme Store, which is given in Figure C.4, is divided into two parts: one part for accessing information from the storage file, and the other for coded borehole logs. This latter alternative, labelled log input, requires rather more error checking

elements than data directly from the file. The store procedure begins with the first borehole title being read, which may be on either one or two lines. This operation comprises the evaluation of the borehole number, since the detection of an invalid value constitutes an error.

The length of each borehole record is defined by an end code on the last data line. Consequently, each borehole log should begin with a title, finish with an end code, and be followed by either another title or a data end code. In order to ensure that each borehole is complete before the next one is begun, the title of that subsequent log is read before the data are processed. Thus, in the case of the first borehole in a set of data, the data lines for the subsurface information will be read next, and be followed by the title of the next borehole. The sub-surface information may then be processed as required, but once this is done, the next batch of sub-surface borehole data lines will be read and again followed by the next title.

The programme is only equipped to deal with seventy data lines at a time, and this is the maximum that may be stored in one particular borehole analogue. More than seventy lines in a particular log may be accommodated by regarding information following the sixty-ninth line (the seventieth is taken up by a borehole end code supplied by the programme) as belonging to a new analogue with the same title as the first sixty-nine lines. When this occurs, an advice message is issued, since the order of the data may be upset. The next process is to put the data into order of depth by accessing programmes Swapi and Swapf.

The acceptability of the mnemonic codes may next be checked and also, perhaps, the units of the parameters may be changed. An error detected during this process, which is carried out by subroutine Convt, results in a message specifying the faulty data.

As already mentioned, in the case of data direct from the storage file, the procedure is simplified by the fact that fewer error checks are required, and also since no more than seventy lines will be found in any record. Here, there is no need to check that the line following the last one of a borehole record is a title, since the number of lines in a particular borehole is recorded in the stored data.

C.2.4 Convt

Convt may only be accessed in the Geosys programme suite by Store. Its primary role is to convert the units of the parameters which appear in data either being stored or already stored. It has another important function which is that of checking the incoming data for unacceptable codes. The two systems of units which may be used in Geosys comprise Imperial and S.I. .

As may be ascertained from Figure C.5, the first operation is to set the conversion factors. These are set according to the input units and whether or not a change is required. Conversion begins with the depth, which appears on each line, and the user is advised of the change being carried out. If any result cannot be converted because of an error in the data an advice message is given. This message includes the unexpected characters. Otherwise, after conversion has been completed, command is then returned to Store.

C.2.5 Read

The purpose of programme Read, shown in Figure C.6, is to act as an interface between the data storage file and the output routines. All the data in the file are read, but only those fulfilling the requirements of the Option Specification may become output. Further data selection is carried out by the output routines which may include the production of contoured maps performed by sub-routine Trend.

The data file is headed by the first borehole title line which is read. An error check, performed to ensure that each expected title line is indeed such, consists of a detection of the units code. An error found in the title results in a suitable message and the execution is terminated. The presence of Imperial units in the stored data prompts an advice message, since all the headings printed by the output routines are for S.I. units. The Option Specification is used to set up a reject code, which is then applied to each borehole title and the data of those not fulfilling the criteria are passed over. When a depth restriction is given in the Option Specification, those lines not already rejected are then tested for depth. If the data are then required, one of the output routines is accessed. After processing of the data line-by-line in this manner and the printing of the required output, control passes out from the reading cycle and an advice message is printed to show that the end of the file has been reached. At this point Trend may be called to form contoured maps of parameters determined

by one of the output routines Outp1 or Outp2.

C.2.6 Outp1

The mechanics of Outp1 may be ascertained from the flow diagram reproduced in Figure C.7. On the first occasion that this routine is called, a title and the column headings are written out. The column headings are also given when new pages are subsequently started. The search for laminated clay is only conducted within data lines in which information concerning strata is recorded. The test for laminated clay is first attempted according to the basic material description (see Table B.3). The presence of the mnemonic code for "laminated" is also detected, but more care in the interpretation of this material is necessary (see Table B.4). Each time a laminated clay layer is detected, the output line comprises information about the depth of the mid-point below the top of the boring, the depth of the mid-point with respect to the datum, the thickness, the grid co-ordinates, and messages indicating whether the bottom of the layer was penetrated, or whether the co-ordinates and mid-point depth are to be later processed by Trend. One further message may be printed out, since Trend may only process up to 500 data sets. The programme Outp1 continues to operate normally when more sets of co-ordinates are available for Trend, but only the first 500 are actually processed.

C.2.7 Outp2.

The programme in Figure C.8 is the second of three which give output from the stored data by means of Read. Read will sort geotechnical data required by the Option Specification and Outp2 gives certain information from the borehole titles. Thus, the programme

provides a quick and simple means of determining the identity, exact location, dates of boring, height and depth of boreholes. In addition, analysis of the height above the datum of the tops of the geological sections can be performed by Trend to produce contoured maps of the ground surface. Again, Trend may only accept 500 sets of data points, so that, if this figure is exceeded, an advice message is given and Trend only operates with the first 500 points.

C.2. 8 Outp3

Outp3 is a data sorting and selection routine which takes data from Read a data line-at-a-time and prints out relevant data found in any particular line.

In this analysis, the operation of Outp3 may be simplified by dividing the procedure into the three elements shown in Figures C.9a, C.9b and C.9c. In essence, in part a the headings and description formats are prepared. Part b is devoted to determining the strata description and checking the data line for relevant test results, and in section c the depth, description and test results are printed out. Outp3 utilizes object-time format in the printing of strata description and other output. Thus, the format, necessary to output data in a logical form, is derived according to the needs of the data. This facility has resulted in a flexible programme capable of handling material retained in the storage file in several different forms.

The first part of the operation, shown in Figure C.9a, is only performed on the first occasion that Outp3 is called. In this section the titles given during the Option Specification are written

out and the page layout is determined to centralize the output. Presuming that either some test results or some form of strata description is required (otherwise only the borehole title information is output), the format for the heading to appear at the top of the columns of tabulated sub-surface data is derived. This heading is printed at the beginning of each new boring for the sub-surface data and for each new page started in mid-borehole.

In the second portion of the programme, shown in Figure C.9b, the data lines are checked for relevant test results, if such output is required, when a description of the material tested has been specified. The alternative mode of operation is to give a description of the strata or water conditions and then to search for incidental test results. With respect to the former, only where relevant tests are found will the strata be described, whereas, in the latter, each stratum, together with any possible water conditions, will be described, and a check for test results is not performed until this information has been output by the section illustrated in Figure C.9c.

Taking here the case where only a description of material tested, or no description at all, is required, then if the end of the boring is not at hand, the stratum codes are re-set each time a new stratum is encountered. The operation then continues by checking the current data line for relevant test results through accessing Outp3a. If this sub-routine determines that no such information is present, control is then returned to Read. Otherwise, when a description of the strata tested has been specified, the

execution continues with its printing by the section given in Figure C.9c. Thus, the description of the strata precedes the printing of the test results.

For situations where a description of the strata and/or the water conditions has been specified, then a change in the data signifies an accession of control directly to section c (Fig.C.9c) for this information to be written. Afterwards, any relevant test results must be detected and ultimately printed by Outp3a in section b (Fig.C.10b). When the bottom of the hole is indicated by the relevant code, a message to record this depth is printed.

As already mentioned, the third portion of programme Outp3, given in Figure C.9c, evaluates the strata codes, writes out the borehole title headings, the depth of data below ground surface, and the description of strata or materials tested and/or water conditions. It has two modes of operation. Strata description may be printed each time a new stratum is encountered or water condition information is available. Alternatively, a description may be given only where test results are printed. First, the borehole title is written if this has not already been done. This title is printed on a new page when fewer than 10 lines are left on the old page. Assuming data line information is to be output, the headings are written and then the type of boring and strata codes are evaluated if necessary. The depth is then evaluated, and, if the bottom of a page has been reached, a new page is started with appropriate headings. The descriptions of the data and/or the water conditions are then written. If a check of the test results on the line being written has not

already been made because the description of strata rather than the material tested has been specified, then control is returned to section b, otherwise the operation to write the test results, if any are present, is performed by accessing Outp3a. When no test results are specified, control directly returns to Read; alternatively this occurs after return from Outp3a.

C.2.9 Outp3a

Outp3a is only addressed by Outp3, which uses it in the search for stored geotechnical data from a particular test result and then for printing such information. The results of tests required and detected are interpreted and printed after the depth, type of boring, and, if applicable, a description of the strata have been output by Outp3. Object-time format is used extensively in Outp3a so that the output is organized while the test results and ensuing codes are being derived. Since the test data may be stored in one of a variety of forms, the use of object-time format obviates the incorporation of many complicated format statements in the programme.

The searches for test results are carried out in the categories given both in Figures 10a, 10b and 10c and below:

- (i) vane, penetration, or shear-box test;
- (ii) sulphate analysis, moisture content, and limits;
- (iii) drained and undrained triaxial;
- (iv) consolidation, compaction, and wet density;
- (v) U₄'s and tests; and
- (vi) all test results.

Once the search path required by the Option Specification has been located, the line is checked for relevant data and codes set accordingly.

When a needed test has been identified, and the appropriate code set, control returns to Outp3 for the depth and other information to be printed. After this operation has been completed, Outp3a is recalled so that the output codes and format for the test results are derived according to the data available. The results to be printed are substituted into the output line, otherwise blanks are used to fill unoccupied spaces. When the test results data have been written, control returns to Outp3, which in turn returns it to Read so that another line of stored data can be processed.

C.2.10 Number

This programme, illustrated in Figure C.11, is employed to evaluate strings of numeric characters read from the data one at a time. Its presence in Geosys is necessary because of the possibility of an unexpected non-numeric character in the input, halting the execution. Such errors could be very difficult to trace, although in general they are insufficiently serious faults to justify more than a warning.

The number to be read may appear anywhere in the input field, since blanks are scanned until a character is detected. This character may be a decimal point, a minus sign, or a number, and an error results from non-recognition. The process of examining each character in the field in turn continues, and then the value is assigned to the variable according to the minus sign, decimal point and numeric characters detected. Should a blank be detected in the middle of a number, or a minus sign appear anywhere but as the first

character, or more than one decimal point be present, then an error occurs.

C.2.11 Check

The programme Check, shown schematically in Figure C.12, is called by Info during literal Option Specification in order to ensure that no question is left unanswered after three attempts. A code is set the first time that a particular question is asked, and it is incremented each time the same question is asked up to three times, at which point an error message is written out and the execution is terminated.

C.2.12 Swapf and C.2.13 Swapi

These two programmes, illustrated in Figure C.13, are used for exchanging values in two registers. Swapf is used for floating point numbers and Swapi for integers.

C.2.14 Quest.

Quest., whose mode of operation may be ascertained from Figure C.14, reads answers to literal questions and matches the responses to standard forms, then setting a code appropriately.

C.2.15 Trend

This is a suite of programmes for plotting trend surfaces of co-ordinate data from either Geosys or in the manner described by O'Leary et al. (1966). The operation of the programme is shown diagrammatically in Figure C.15. For direct data read-in, that is Main Option 4 of Geosys, the data parameter including the number of data sets, the format of the co-ordinate data and the number of data points are first read. These are checked by Range, and provided that no error is detected, the co-ordinate data sets are then read in. Should an error occur, a message is given and execution is terminated.

In the next part of the programme, the plotting symbols are generated and the matrices for determining the coefficients of the required order equations derived and solved. After this, the original data and residual values, error measures, and the equations of surfaces are calculated. Next, the Link1 control cards are read to govern the size and scale of the trend surface plots. These input are checked by Range so that errors result in a message and termination of the execution. Presuming that no errors are present, the original data, residual values, errors measures and the equations of the surfaces are written out. These are followed by the titles for the maps so that the calculated trend surfaces may be written out.

If original data or residual value plots are required, the operation continues by the Link2 control cards being read. The detection of an error by Range results in a message and termination of the execution. The map titles are written next and then the original data and residuals are evaluated and arranged in a suitable order to be plotted on maps. The procedure then follows the same path, whether residuals are required or not, so that, for data to be read in directly (Geosys Main Option 4), more data is then accepted; otherwise control is returned to Geosys.

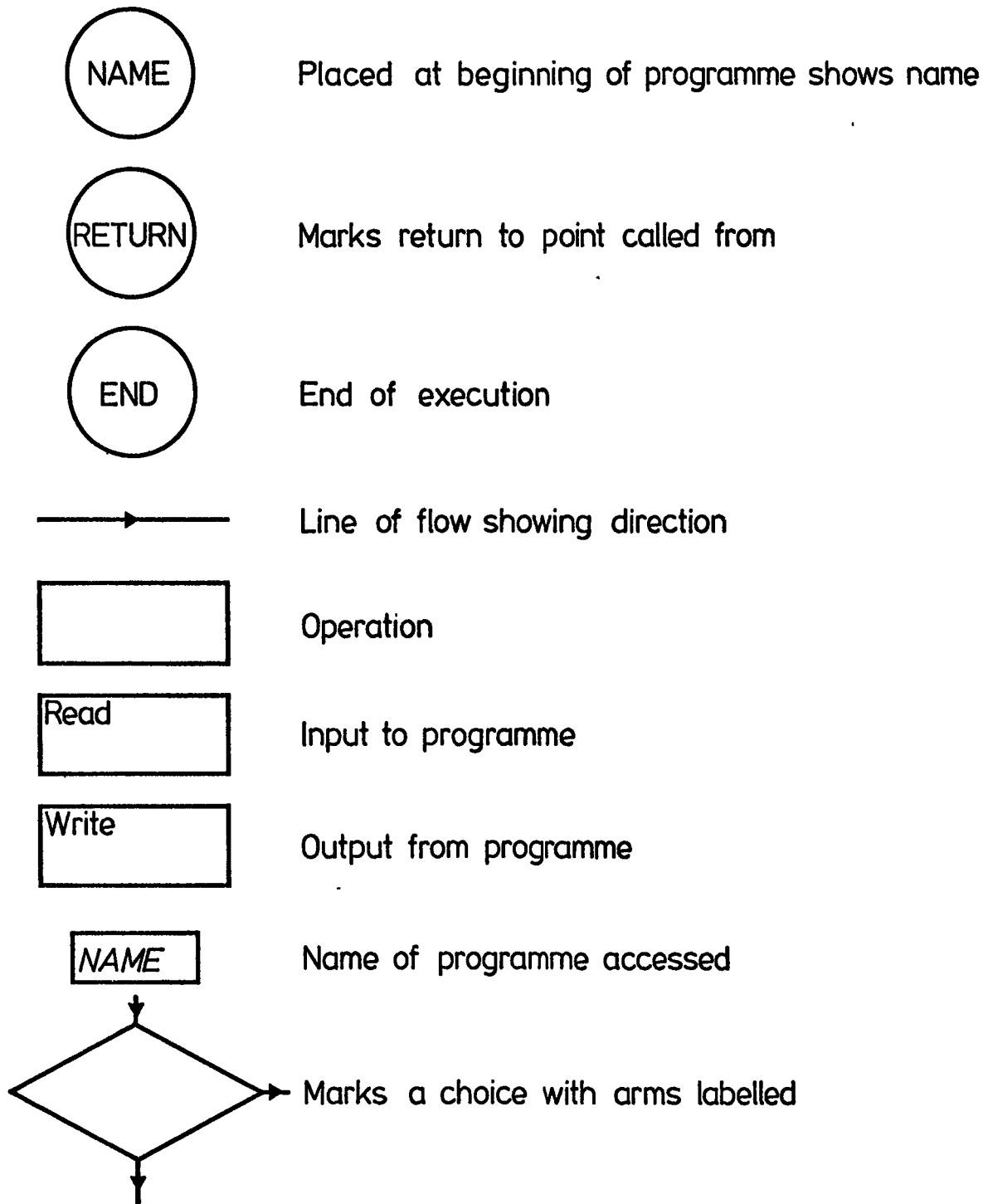

Fig. C.1 Symbols employed in the flow diagrams

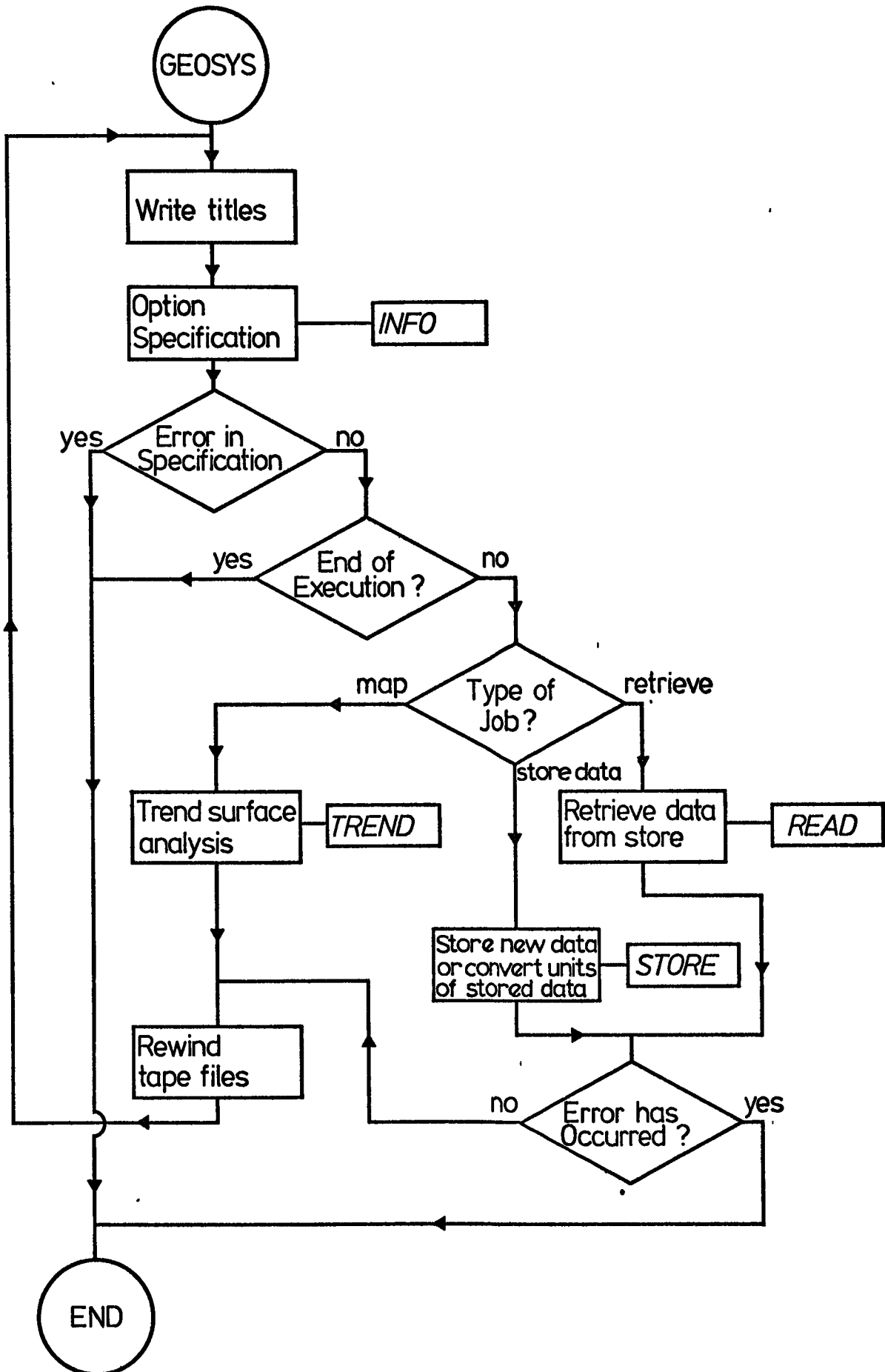

Fig C.2 Structure of Geosys

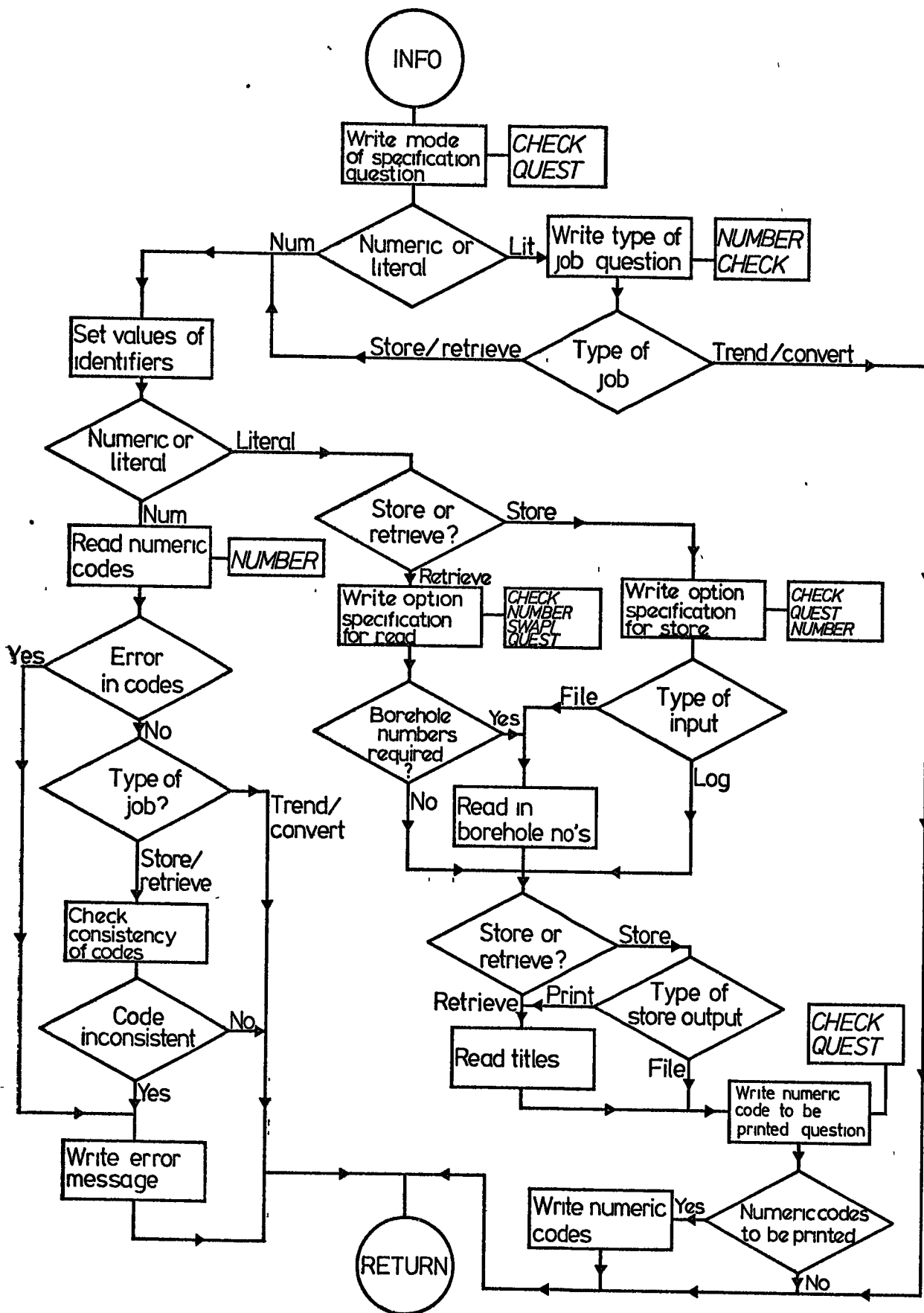

Fig C3 Structure of Info

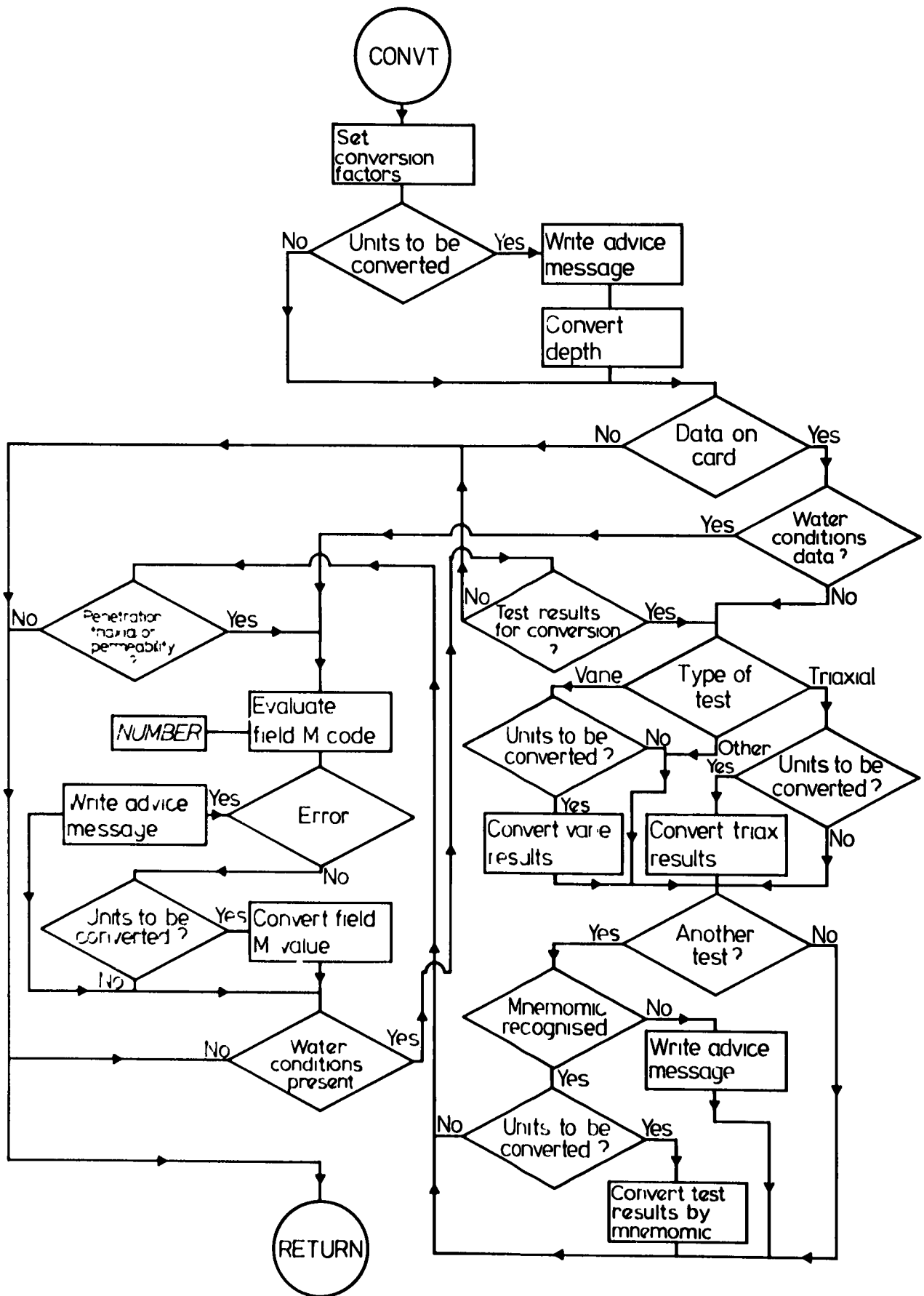

Fig C5 Structure of Convt

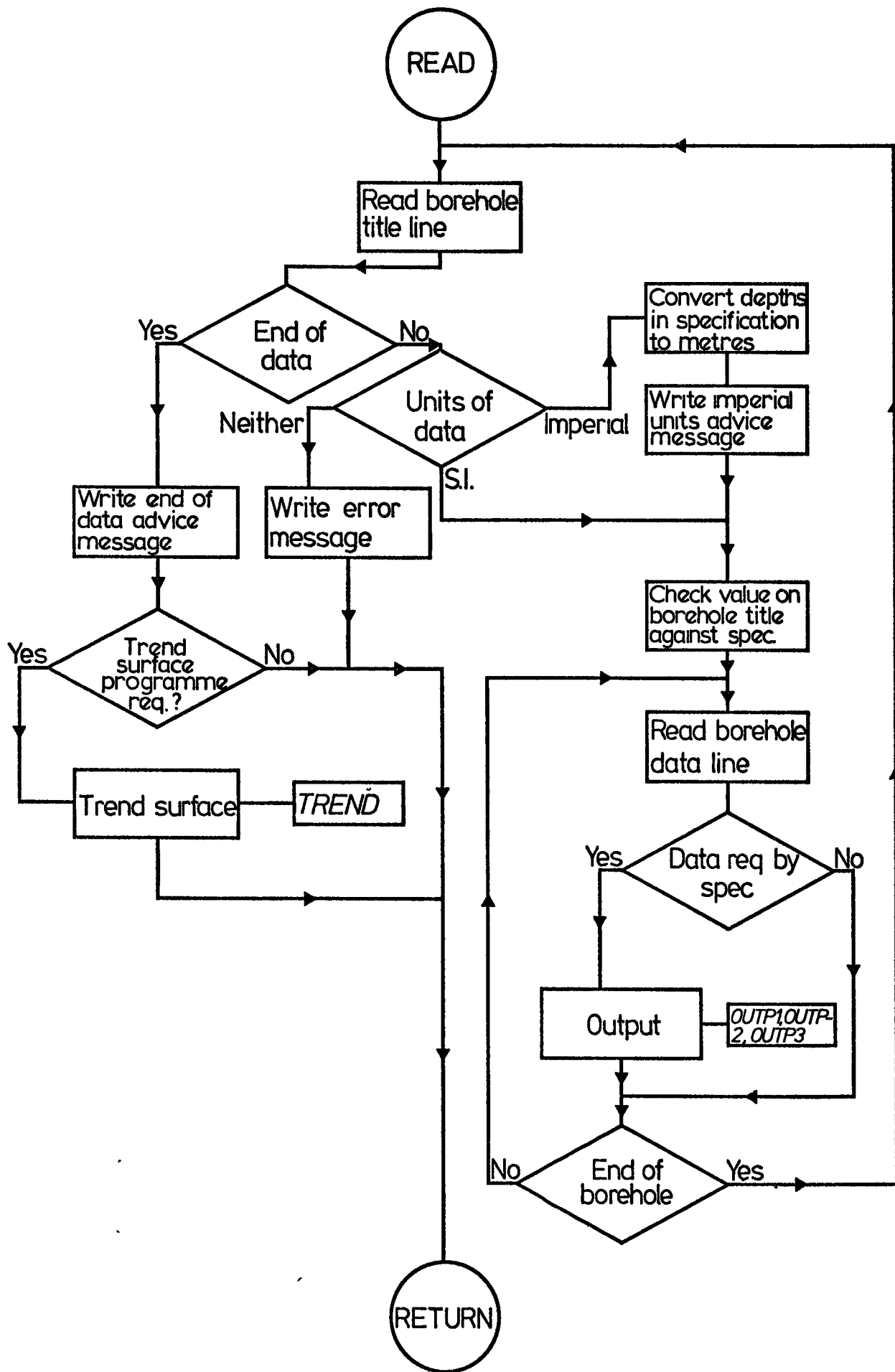

Fig. C.6. Structure of Read

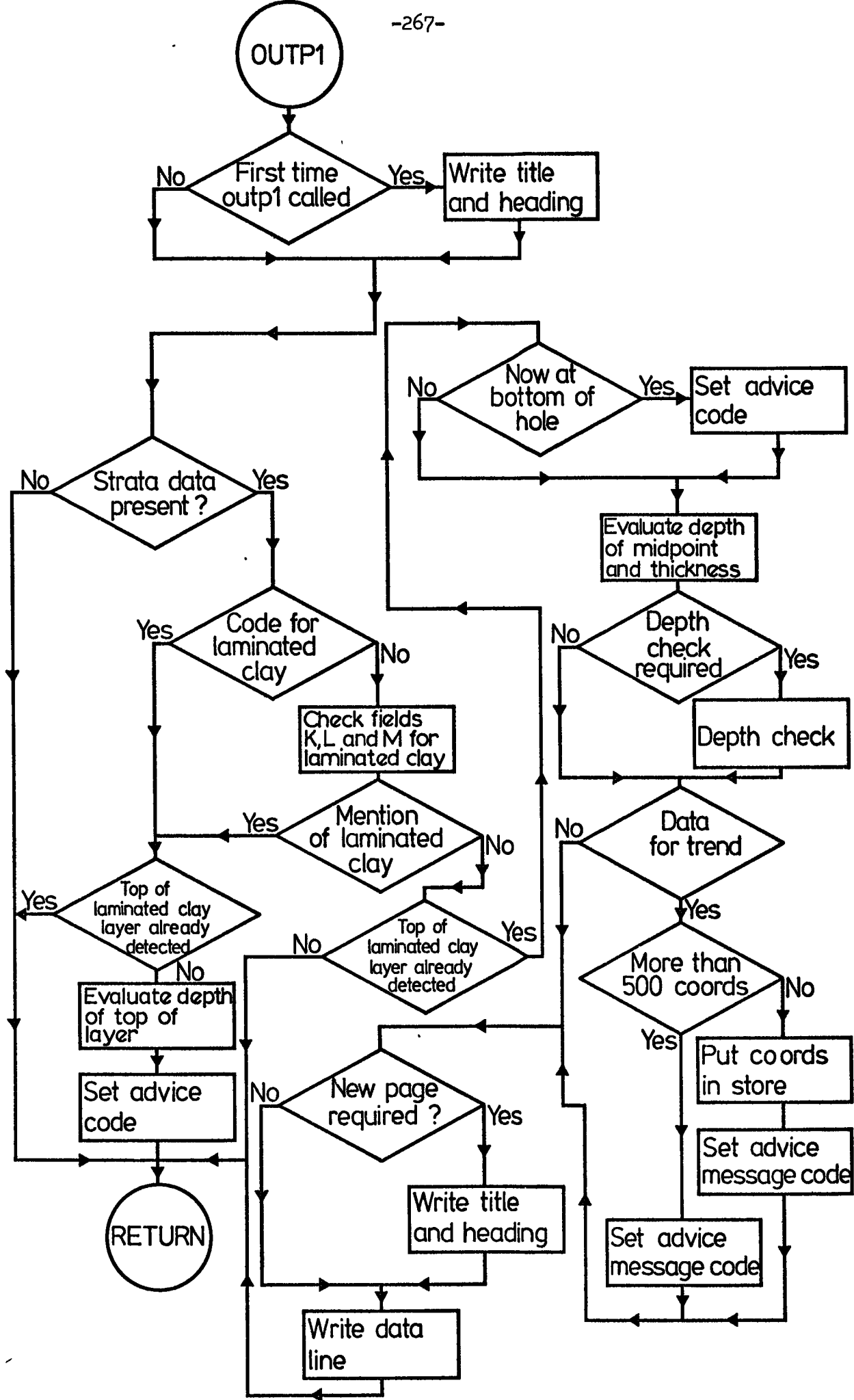

Fig. C.7 Structure of Outp1

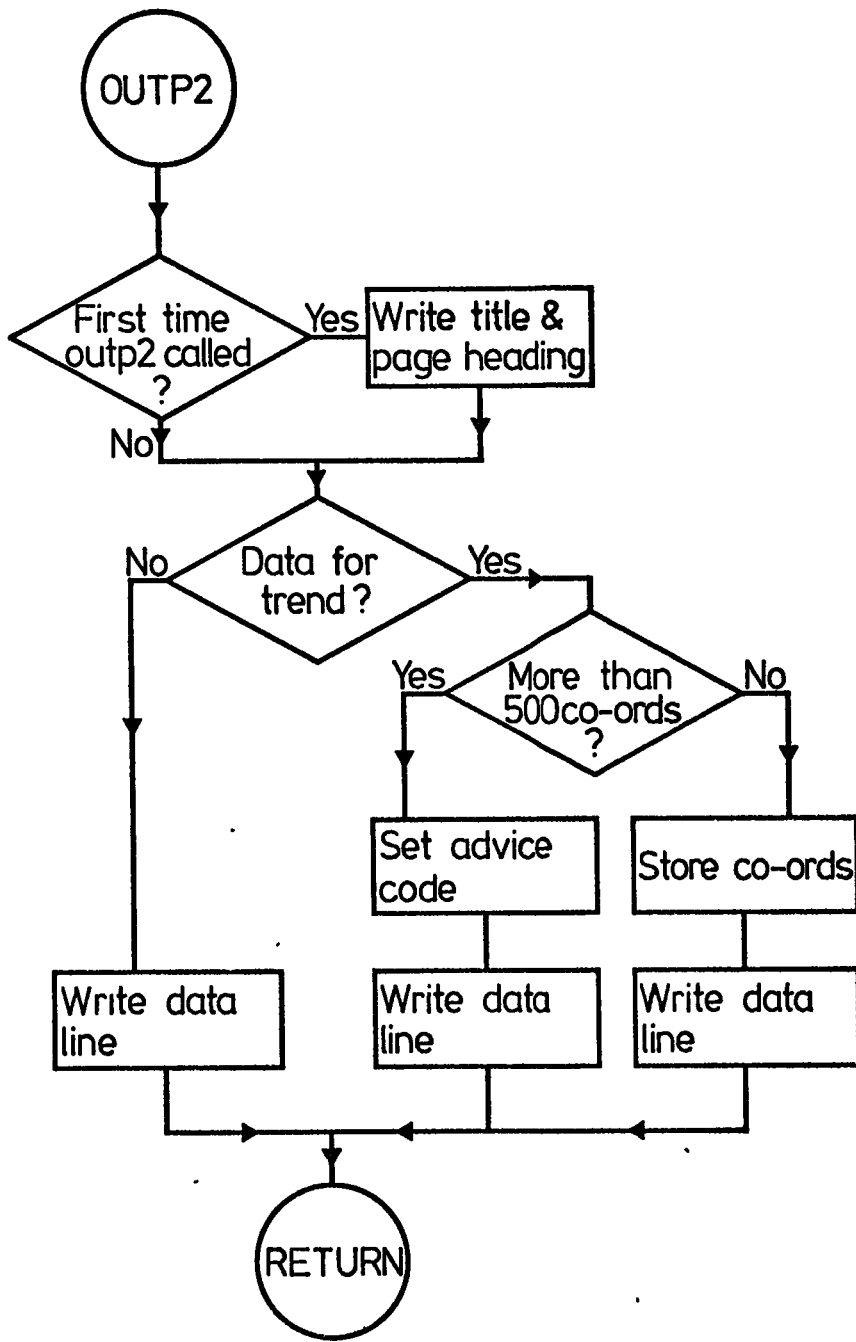

Fig. C.8. Structure of Outp2

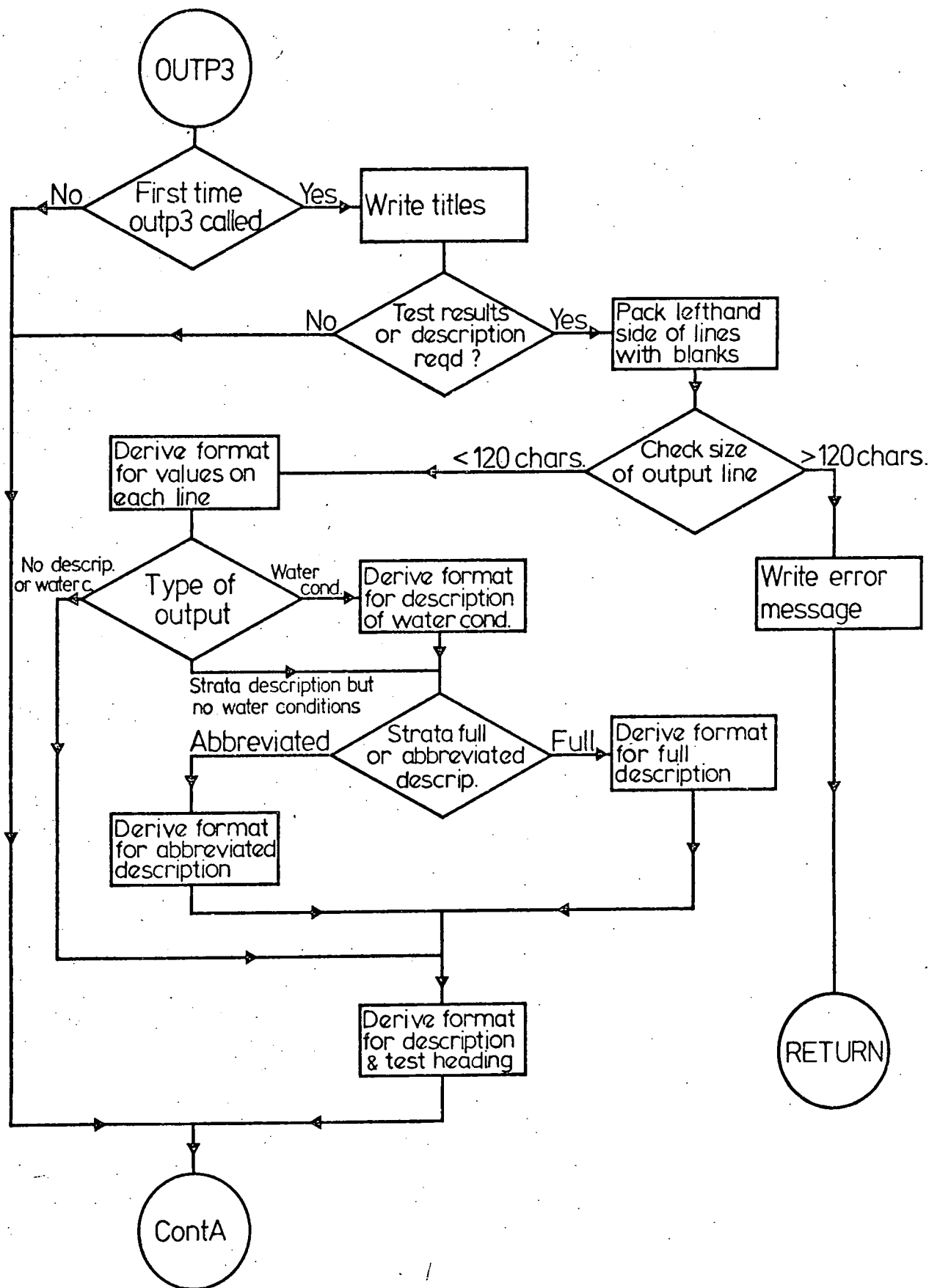

Fig.C.9a Part a of the structure of Outp3

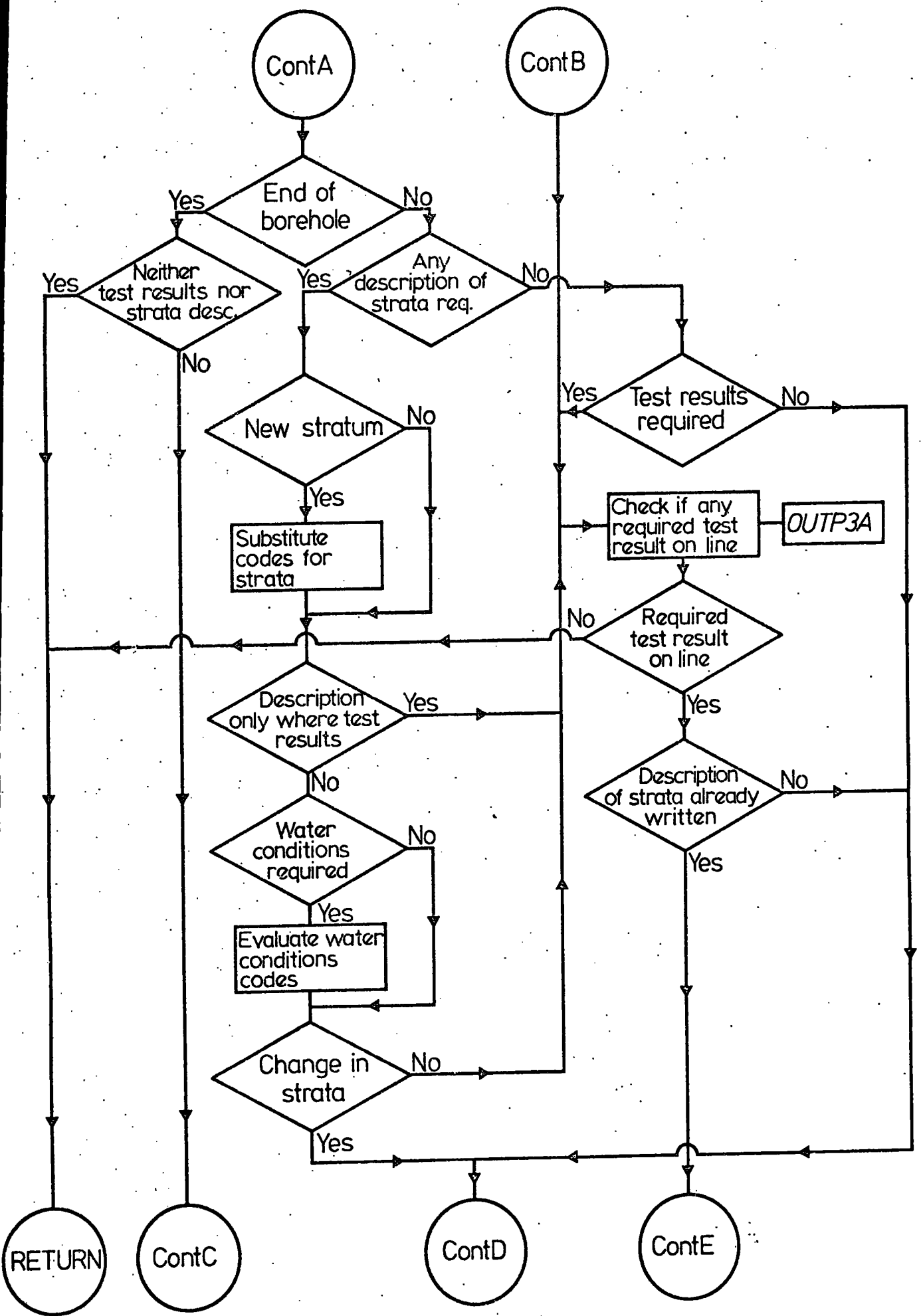

Fig. C.9b Part b of the structure of Outp3

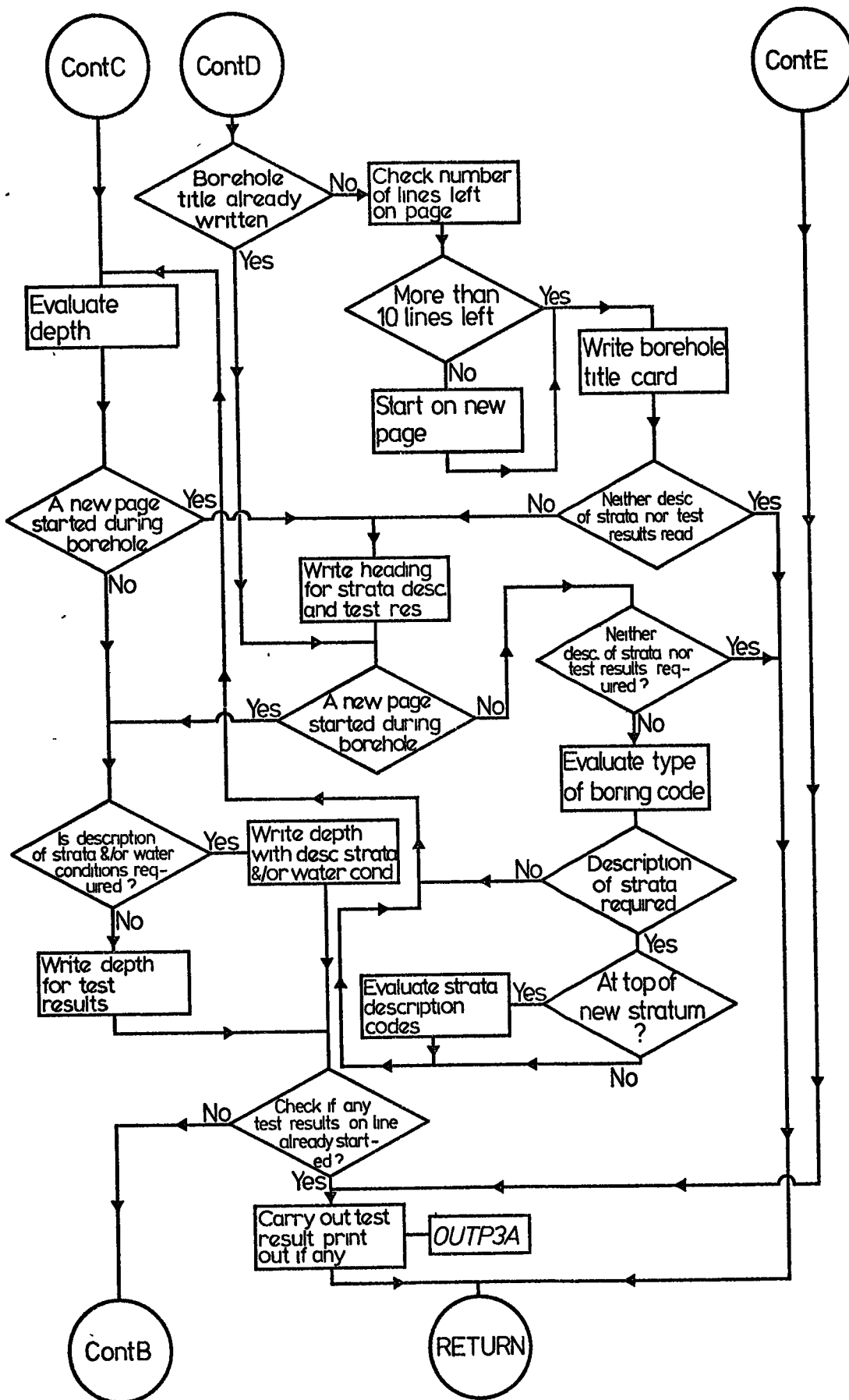

Fig C9c Part c of the Structure of Outp3

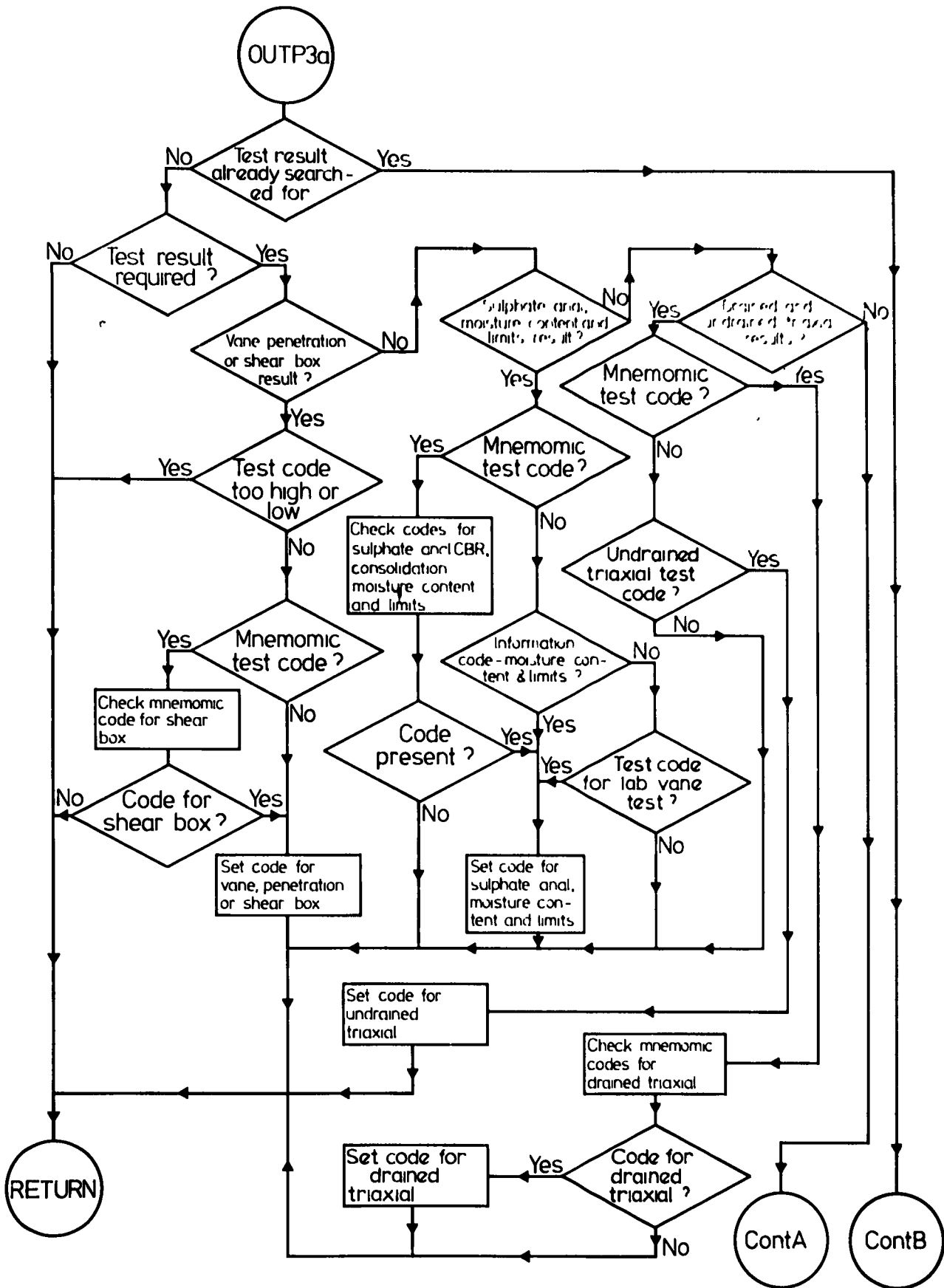

Fig C10a Part a of the Structure of Outp3a

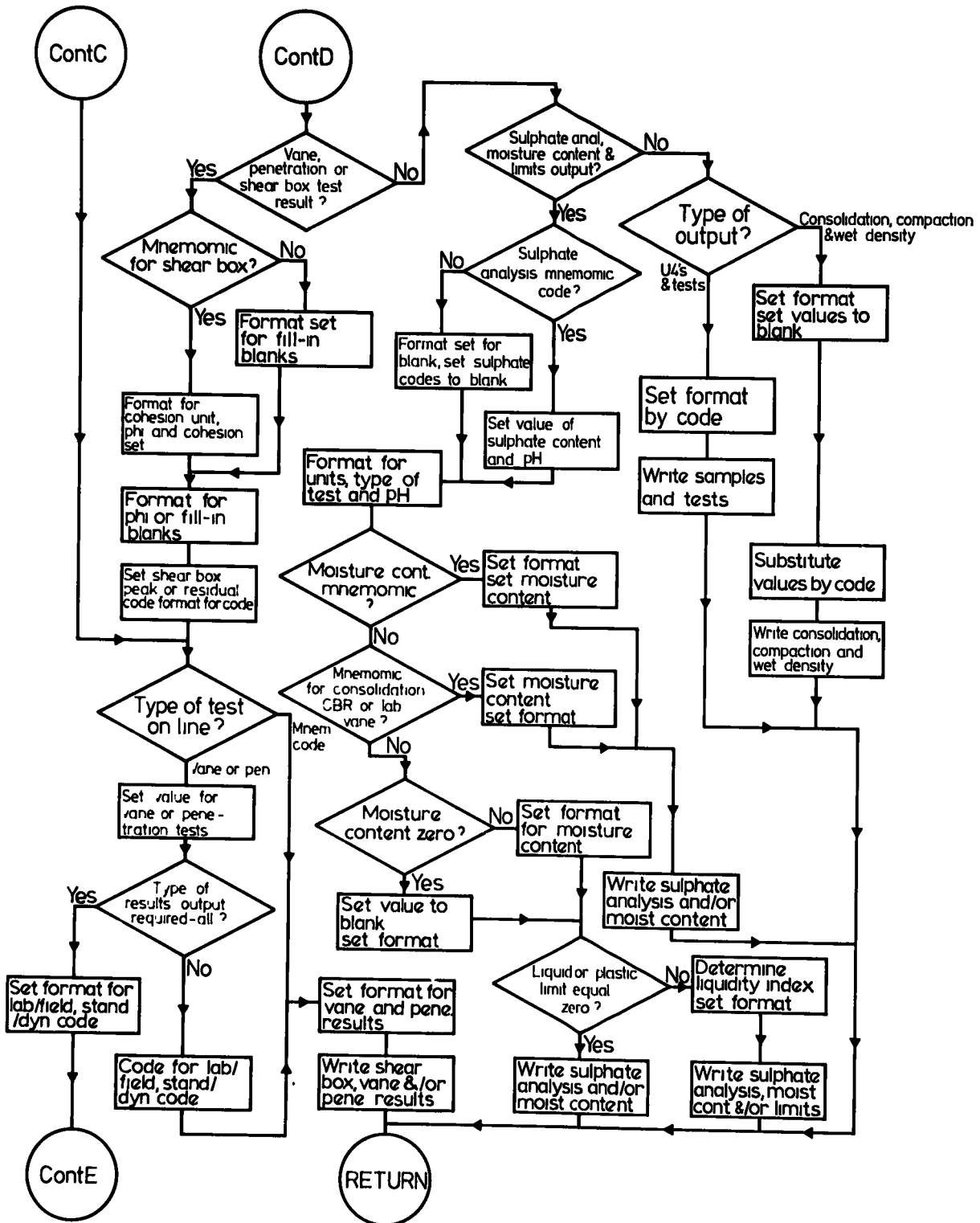

Fig C10c Part c of the structure of Outp3a

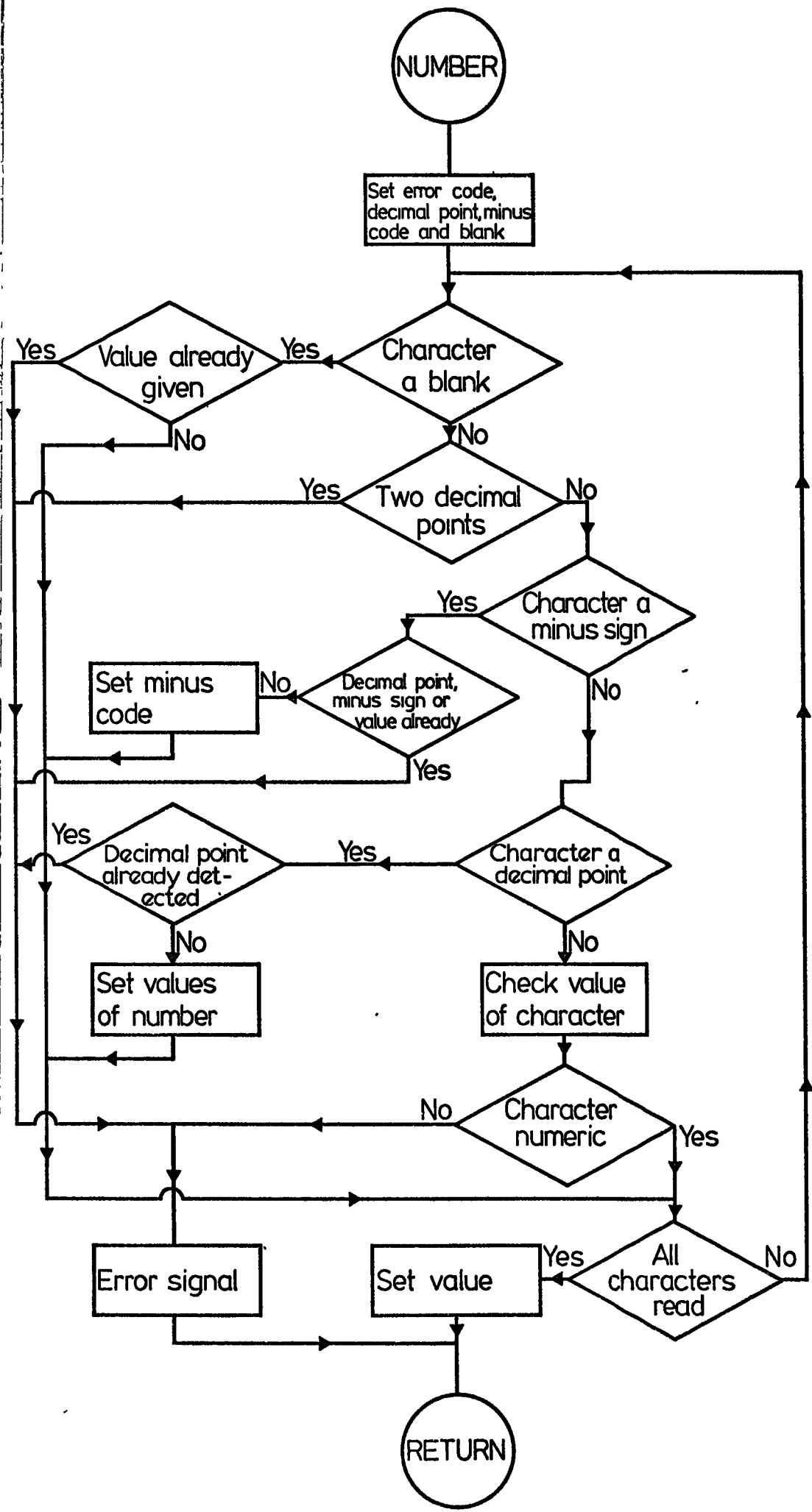

Fig.C.11 Structure of Number

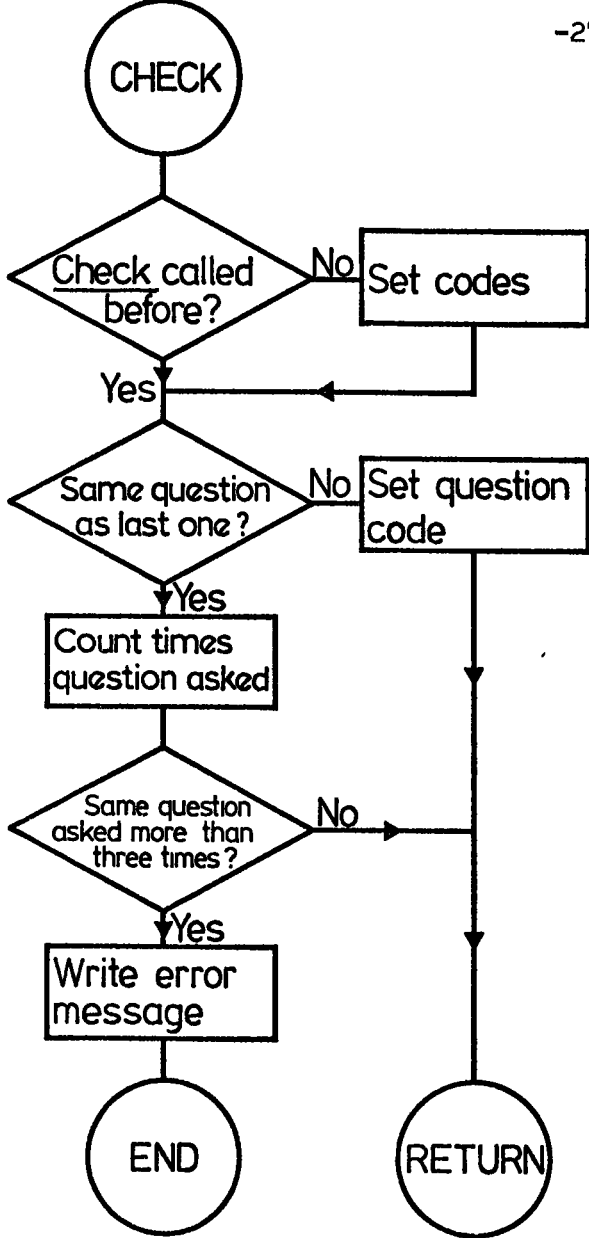

Fig. C.12 Structure of Check

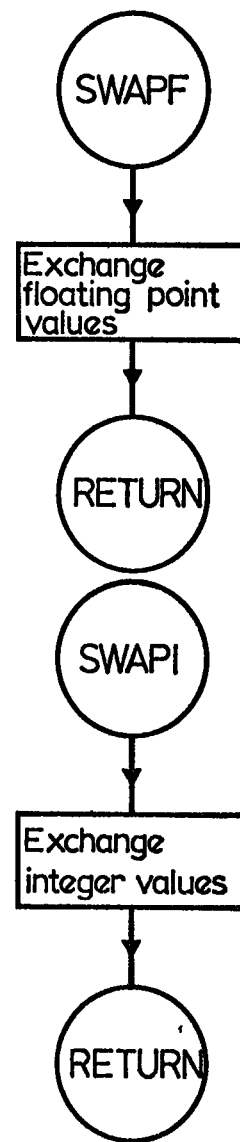

Fig. C.13 Structure of Swapf and Swapi

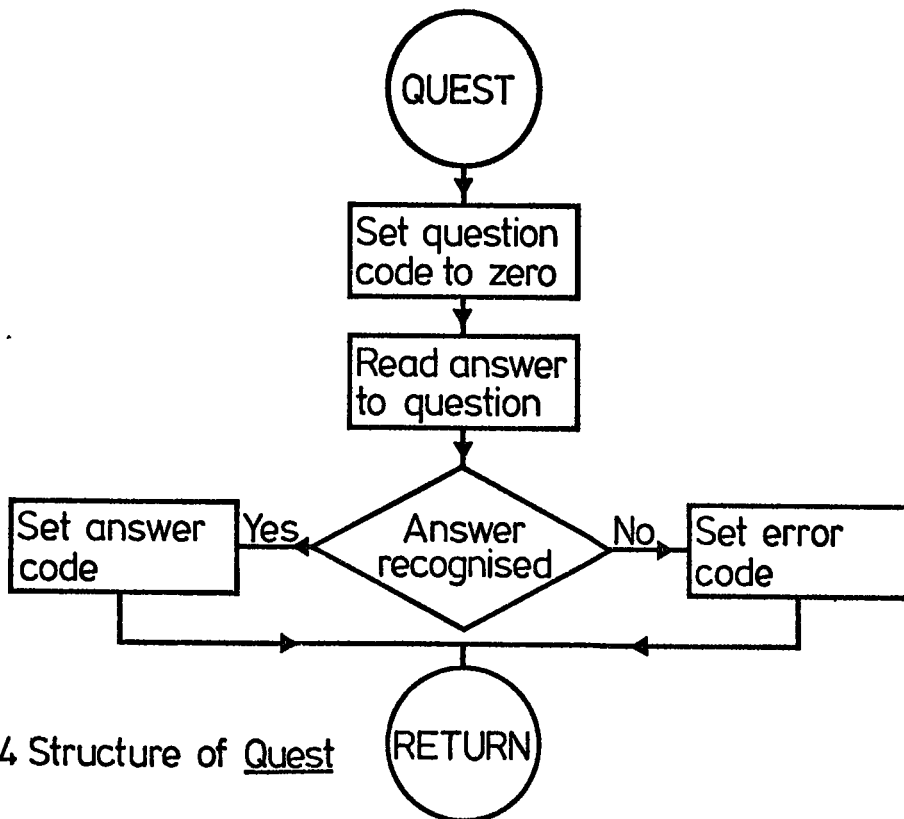

Fig. C.14 Structure of Quest

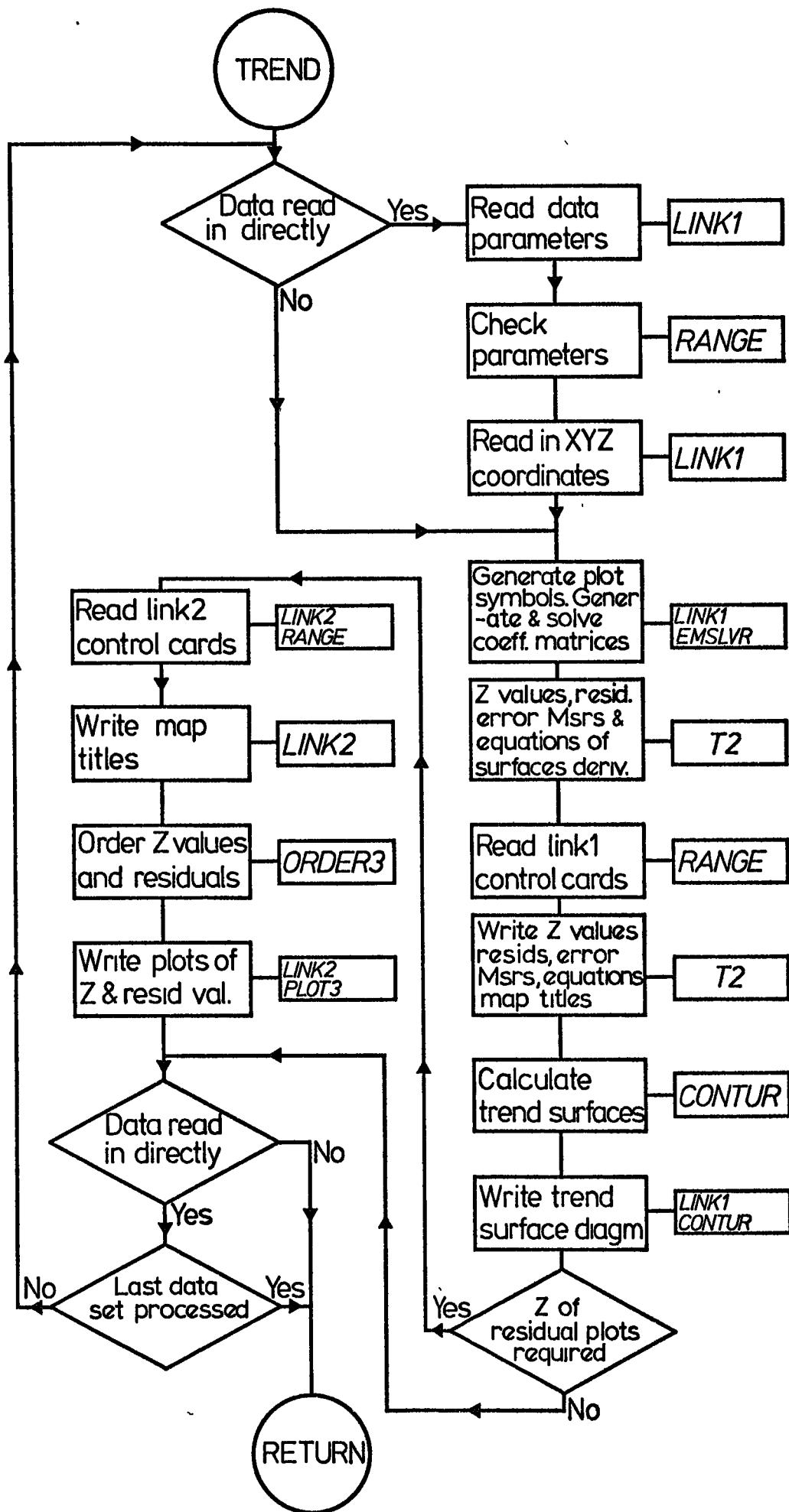

Fig C.15 Structure of Trend

