

Durham E-Theses

Topological problems in concordance and isotopy

A. K. Jobbing

How to cite:

Jobbing, A. K. (1976) Topological problems in concordance and isotopy. Doctoral thesis, Durham University.

Use policy

The full-text may be used and/or reproduced, and given to third parties in any format or medium, without prior permission or charge, for personal research or study, educational, or not-for-profit purposes provided that:

- a full bibliographic reference is made to the original source
- a <https://etheses.durham.ac.uk/id/eprint/8229/> is made to the metadata record in Durham E-Theses
- the full-text is not changed in any way

The full-text must not be sold in any format or medium without the formal permission of the copyright holders.

Please consult the [full Durham E-Theses policy](#) for further details.

**TOPOLOGICAL PROBLEMS
IN
CONCORDANCE AND ISOTOPY**

A K Jobbings

The copyright of this thesis rests with the author
No quotation from it should be published without
his prior written consent and information derived
from it should be acknowledged

A thesis submitted for the degree of Doctor of Philosophy

University of Durham

1976



PREFACE

Many people, in various ways, have assisted me during the course of this work. I am indebted to them all, and especially to the Science Research Council for the provision of a research studentship, and to Mrs. J.T.Jobbings, who has made such an excellent, dedicated job of the typing.

Finally, I reserve my deepest gratitude for Dr. M.A.Armstrong who has guided and encouraged me for several years, and without whom this thesis would have been neither commenced nor oncluded.

Andrew K. Jobbings

August 1976

C O N T E N T S

	Page	
Introduction	(v)	
Glossary	(xi)	
Chapter I	Topological Handlebody Theory	1
	1 Preliminaries - collaring and taming	2
	2 The Whitney process	8
	3 Handles	14
	4 Handle decompositions	26
	5 The h-cobordism theorem	33
Chapter II	Critical Level Embeddings	36
	1 Definitions	37
	2 Subdivision	42
	3 The critical level theorem	47
	4 Handle moves	59
Chapter III	Concordance and Isotopy	68
	1 The main theorem	69
	2 Further results	85
References		98

LIST OF FIGURES

FIGURES	appear between	PAGES
1, 2		7 and 8
3, 4		13 and 14
5, 6, 7, 8, 9, 10, 11, 12, 13, 14		25 and 26
15, 16		32 and 33
17, 18, 19, 20, 21		41 and 42
22, 23, 24, 25, 26		58 and 59
27, 28, 29		66 and 67
30, 31		97 and 98

Figures 4, 5, 8, 10, 11, 12, 13, 14, 15, 16 are based on [32] Figs. 41, 43, 45, 47, 48, 49, 50, 52, 53, 54.

INTRODUCTION

A well-known result of both piecewise-linear and differential topology is that concordance implies isotopy for suitable embeddings. The aim of this thesis is to present topological counterparts to these results. The treatment given is heavily dependent on sophisticated handle techniques, and, as a means of introducing notation as well as preparing the conceptual framework for these techniques, we also give a proof of a topological h-cobordism theorem. This not only lays the groundwork for later chapters, but provides a detailed proof on the lines of Smale's original one for smooth manifolds.

A topological manifold is smooth, or piecewise linear, if there exists a smoothly, or piecewise linearly, respectively, compatible atlas of charts. By definition, smooth and piecewise linear manifolds are topological manifolds. The question arises as to which manifolds are smoothable, and which are triangulable - that is, can be given a smooth structure, or a piecewise linear structure, respectively.

There is not, as yet, a complete answer to this question, but we have the following information. All smooth manifolds are triangulable (Cairns [6]); there exist piecewise linear and general topological manifolds which are not smoothable. (Kervaire [20]). Kirby and Siebenmann [22] have shown that in each dimension ≥ 5 there exists a non-triangulable

topological manifold, and, further, they have reduced the question of the triangulability of any given manifold M to the vanishing of an obstruction in $H^4(M, Z_2)$. That all 2-manifolds are triangulable is a classical result of Rado [29], and Moise [26] proved that all 3-manifolds are triangulable.

We give an example of a non-triangulable manifold taken from Kirby [21]. By theorem 17 of [21] §7, there exists a piecewise linear structure \textcircled{H} on $S^3 \times S^2$ which is not isotopic to the standard structure \textcircled{Z} (that is, the identity, $\text{id} : (S^3 \times S^2)_{\textcircled{Z}} \longrightarrow (S^3 \times S^2)_{\textcircled{H}}$ is not isotopic (see Glossary) to a piecewise linear homeomorphism $(S^3 \times S^2)_{\textcircled{Z}} \longrightarrow (S^3 \times S^2)_{\textcircled{H}}$). In [36], Sullivan shows that piecewise linear structures up to homotopy on a manifold Q are equivalent when the Bockstein homomorphism $\beta : H^3(Q; Z_2) \longrightarrow H^4(Q; Z)$ is zero. But $H^4(S^3 \times S^2; Z) = 0$, so there exists a piecewise linear homeomorphism $h : (S^3 \times S^2)_{\textcircled{H}} \longrightarrow (S^3 \times S^2)_{\textcircled{Z}}$. Then $h : (S^3 \times S^2)_{\textcircled{Z}} \longrightarrow (S^3 \times S^2)_{\textcircled{H}}$ is not isotopic to a piecewise linear homeomorphism, for if it were, $h^{-1}h = \text{id} : (S^3 \times S^2)_{\textcircled{Z}} \longrightarrow (S^3 \times S^2)_{\textcircled{H}}$ would be isotopic to a piecewise linear homeomorphism, by composing the given isotopy with h^{-1} , and this would contradict the fact that \textcircled{H} and \textcircled{Z} are not isotopic. Furthermore, stability ($\pi_3(\text{TOP}_m, \text{PL}_m) \simeq \pi_3(\text{TOP/PL})$, see [21]) shows that $h \times \text{id} : S^3 \times S^2 \times R \longrightarrow S^3 \times S^2 \times R$ is not isotopic to a piecewise linear homeomorphism, where

$S^3 \times S^2 \times R$ is given the standard piecewise linear structure. Since $S^3 \times S^2 \times R \cong (R^4 \times S^2) \setminus (0 \times S^2)$ we can form the manifold

$$M^6 = (R^4 \times S^2)_{U_h \times \text{id.}} (R^4 \times S^2).$$

Suppose that M^6 had a piecewise linear structure. Then since piecewise linear structures on $R^4 \times S^2$ are unique up to isotopy, the piecewise linear structures induced from M on each copy of $R^4 \times S^2$ would each be isotopic to the standard structure. This would imply that $h \times \text{id.}$ was isotopic to a piecewise linear homeomorphism, which is false. Hence M^6 has no piecewise linear structure, i.e., is non-triangulable.

The work of Kirby and Siebenmann, then, shows that endeavours to extend piecewise linear results to cover topological manifolds are not vain. The concept of handles (I § 3) was first introduced by Smale [35] to prove the h-cobordism theorem (I 5.1) for smooth manifolds, and these techniques were extended to prove the piecewise linear case by several authors (including Stallings, and Zeeman.) In the smooth category, handle theory has now been replaced by the more amenable Morse theory. The existence of handlebody decompositions (I § 4) is a classical result for all piecewise linear and smooth manifolds, and, in [22], Kirby and Siebenmann give a proof for all topological manifolds of dimension ≥ 6 . We use this last result, together with an extension of Smale's proof to the topological case, to prove a topological h-cobordism theorem. (A weak

topological h-cobordism theorem, that is having a conclusion $W \cong M \times [0, 1)$, was proved by Lees, in his thesis [75], and by Connell [8] - this result was used to prove the topological Poincare conjecture). This proof occupies Chapter I of the thesis, where we also prove a relative theorem. Notice that Kirby and Siebenmann also show that there exists a topological manifold, of dimension 4 or 5, which does not have a handle decomposition.

That concordance implies isotopy (see Glossary for definitions) was first proved by Hudson [12], [14] for piecewise linear embeddings of polyhedra in manifolds and smooth embeddings of manifolds in manifolds. An extension to piecewise linear embeddings of polyhedra in manifolds using the ideas of embedded handle theory and critical level embeddings (II § 1) appears in Rourke [31]. Rourke's methods also prove the result for smooth embeddings of smooth manifolds. To show the existence of critical level embeddings, Rourke resorts to results of Kosinski [23] on singularities of piecewise linear maps. Kearton and Lickorish give a more direct approach in [19], and it is their treatment that we follow in Chapter II, which is devoted to the study of critical level embeddings. (Note that more care is required than Kearton and Lickorish suggest in [19] theorem 3, with regard to subdivision (see II § 2).)

Armstrong extended concordance implies isotopy to include topological embeddings of manifolds in Euclidean space, [2]. He also laid the foundations of a theorem for embeddings into general topological manifolds in [3], upon which results the proof of III 2.2 (concordance implies isotopy for topological embeddings of manifolds in manifolds) given in Chapter III § 1 is based. Using entirely different methods, Pederson has proved a similar result to this in [28], but he imposes stronger conditions - that M^n is a handlebody, that $q \geq 5$, and that if $q = 5$ then ∂Q is a stable manifold (in our notation) - and he relies on less elementary results, notably the s-cobordism theorem. Pederson's work was drawn to the author's attention after the majority of this work was completed.

The remainder of Chapter III is concerned with further results deduced more or less directly from III § 1 : a relative theorem; concordance implies isotopy for topological embeddings of polyhedra in manifolds; concordance implies isotopy for suitable embeddings of polyhedra in polyhedra; δ -concordance implies ε -isotopy for topological embeddings of manifolds in manifolds.

The layout then is this. Chapter I, § 1, presents preliminaries fundamental to the remainder of the thesis. The rest of Chapter I deals with a proof of h-cobordism.

Chapters II and III are independent from Chapter I mathematically (except for I § 1), but conceptually, Chapter II is heavily dependent upon it. Proofs of concordance implies isotopy, appear in Chapter III, making use of the results on critical level embeddings occurring in Chapter II.

Throughout the thesis, ALL EMBEDDINGS ARE ASSUMED TO BE LOCALLY FLAT. We assume that the reader is familiar with the standard results of piecewise linear topology, as found in [13], [32], or [38] and also with relative regular neighbourhood theory (see [16], [17]). References are given in the text when other specific results are used.

There follows a glossary of notation and definitions.

GLOSSARY

Notation

$I = [0, 1]$, the closed unit interval

$B = [-1, 1]$, $B^P = [-1, 1]^P$, $D^2 = B^2$

$\epsilon B^P = [-\epsilon, \epsilon]^P$ (where $0 < \epsilon \leq 1$)

$\underline{0} = (0, \dots, 0) \in B^P \subset R^P$.

$\text{cl}X$: the closure of X

$\overset{\circ}{X}$

$= \text{int } X$: the interior of X

∂X : the boundary of X

$A \setminus B = \{x \mid x \in A, x \notin B\}$

$A \times t = A \times \{t\}$, (for $t \in I$, usually)

// denotes the end of a proof, or a result
stated without proof.

Definitions

Let M, Q be polyhedra, or manifolds, and

let $\pi : Q \times I \longrightarrow Q$ be the projection onto
the first factor.

- (1) Two embeddings $f, g : M \longrightarrow Q$ are concordant if there
is an embedding $F : M \times I \longrightarrow Q \times I$ which satisfies
 $F^{-1}(Q \times 0) = M \times 0$, $F^{-1}(Q \times 1) = M \times 1$, $F \mid M \times 0 = f$
and $F \mid M \times 1 = g$.

Definitions (continued)

- (2) The concordance F is vertical over a subset X of M if $F(x, t) = (f(x), t)$ for all $x \in X, t \in I$.
- (3) A map $\alpha : Q \times I \rightarrow Q \times I$ is level-preserving if $\alpha(Q \times t) \subset Q \times t$ for all $t \in I$. Then $\alpha_t : Q \rightarrow Q$ is defined by $\alpha(x, t) = (\alpha_t(x), t)$.
- (4) An ambient isotopy of Q is a level-preserving homeomorphism $\alpha : Q \times I \rightarrow Q \times I$ for which α_0 is the identity.
- (5) The ambient isotopy α is fixed on the subset X , of Q if α_t is the identity on X for all $t \in I$. α has support in a subset U of Q if α is fixed on $Q \setminus U$.
- (6) Two embeddings $f, g : M \rightarrow Q$ are ambient isotopic if there is an ambient isotopy α of Q such that $\alpha_1 f = g$.
- (7) A homotopy $H : M \times I \rightarrow Q$ is an ϵ -homotopy if, for each $(x, t) \in M \times I, d(H(x, 0), H(x, t)) < \epsilon$.
- (8) An ambient isotopy $\alpha : Q \times I \rightarrow Q \times I$ is an ϵ -ambient isotopy if $\pi \circ \alpha : Q \times I \rightarrow Q$ is an ϵ -homotopy.

Definitions (continued)

- (9) A concordance $F : M \times I \longrightarrow Q \times I$ is an ϵ -concordance if $\pi \circ F : M \times I \longrightarrow Q$ is an ϵ -homotopy.

CHAPTER I

TOPOLOGICAL HANDLEBODY THEORY

In this chapter we develop the techniques necessary for a proof of the topological h-cobordism theorem which we give in §5. The ideas are essentially those involved in the piecewise linear proof, which argument we follow closely (see, for example, Rourke and Sanderson [32] Ch.6.) - firstly represent the cobordism as a handlebody, then use the algebraic conditions to eliminate the handles, so that finally we must have a product. In §3 we introduce handles and the handle lemmas of reordering, cancellation, introduction and adding. In §4 we discuss handle decompositions and use the §3 lemmas to simplify them, given certain algebraic constraints. The Whitney lemma is an essential part of this procedure, and we give a topological version in §2.

Note that several of these results have a dimension restriction not present in the corresponding piecewise linear cases, but that this does not affect the final theorem, whose statement is equivalent to that of the piecewise linear theorem. We also prove a relative theorem.

In most cases, the technique of proof is to tame locally and then use the piecewise linear proofs, and in §1 we quote, and deduce, the important tools required for this process, both in this chapter and in subsequent ones. This first section will be referred to frequently.

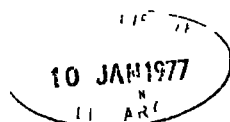

§1 Preliminaries - taming and collars

This section deals with results, all but two of them quoted, which will be used in proofs throughout the remainder of the thesis.

1.1 Lemma (Lacher [24])

Let $B \subset M$ be a locally flat ball in the topological manifold M^m . Then there exists a chart U of M such that

- (i) $(B, U) \cong (B^k, R^n)$, a standard pair, if B is closed,
- (ii) $(B, U) \cong (R^k, R^n)$, a standard pair, if B is open. //

Taming

Let M, Q be piecewise linear manifolds and $f : M \rightarrow Q$ a (topological) embedding. Then f is said to be tame if there is an ambient isotopy α of Q such that $\alpha_1 f$ is piecewise linear. f is ϵ -tame if for each $\epsilon > 0$ there exists an ϵ -ambient isotopy α of Q such that $\alpha_1 f$ is piecewise linear, and α_t is the identity outside the ϵ -neighbourhood of $f(M)$, for all t . In each case, the embedding is strongly tame, strongly ϵ -tame, if, furthermore, $\alpha_1 f$ is locally unknotted.

1.2 Theorem (Cantrell and Rushing [7] Theorem 1)

A locally flat embedding $f : B^k \rightarrow \text{int } Q^q$, $q \geq 5$, of B^k into the interior of a piecewise linear q -manifold Q , is strongly ε -tame. //

1.3 Theorem - (Rushing [33] Theorem 1)

Let $f : M^n \rightarrow Q^q$, $q - n \geq 3$, be an embedding of the piecewise linear manifold M^n in the piecewise linear manifold Q^q , for which $f^{-1}(\partial Q)$ is a piecewise linear $(n - 1)$ -submanifold (possibly empty) of ∂M , and such that $f|_{f^{-1}(\partial Q)}$ and $f|_{(M \setminus f^{-1}(\partial Q))}$ are locally flat. Then f is ε -tame.

Furthermore, if $f|_{f^{-1}(\partial Q)}$ is piecewise linear, then the taming isotopy is fixed on ∂Q . //

Definition

If $X_0 \subset X$ are polyhedra, then the pair (X_0, X) is admissible if $X = X_0 \cup (\bigcup_0^r M_1^{n_1})$, where M_1 is an n_1 -dimensional piecewise linear manifold such that $M_1 \cap (X_0 \cup (\bigcup_0^{1-1} M_j))$ is either empty or an $(n_1 - 1)$ -dimensional piecewise linear submanifold of ∂M_1 for which $X_0 \cup (\bigcup_0^{1-1} M_j)$ is link-collapsible on $M_1 \cap (X_0 \cup (\bigcup_0^{1-1} M_j))$, $i = 0, \dots, r$.

1.4 Theorem (Rushing [33] Theorem 2)

Let (X_0, X) be an admissible pair of polyhedra, where $\text{cl}(X \setminus X_0)$ is n -dimensional, and let Q^q , $q - n \geq 3$, be a piecewise linear q -manifold. Suppose that $f : X \rightarrow \text{int } Q$ is an embedding which is locally flat on the open simplices of some triangulation of X , and is such that $f|_{X_0}$ is piecewise linear. Then f can be ϵ -tamed by an isotopy α so that

$$\alpha_t|_{\{f(X_0) \cup [Q - N(\text{cl}[f(X \setminus X_0)], Q])\}} = 1. //$$

Collars

Let $X \subset Y$ be polyhedra, or topological manifolds. Then a collar on X in Y is a piecewise linear, or topological, homeomorphism, respectively, $c : X \times I \rightarrow Y$ such that $c(x, 0) = x$ and $c(X \times [0, 1))$ is an open neighbourhood of X in Y ; we also call $c(X \times I)$ a collar, and X is said to be collared in Y .

If X can be covered by a collection of open subsets, each of which is collared in Y , then X is locally collared in Y .

Existence of collars is given by the following results.

1.5 Theorem (Rourke [30])

Let $P \subset Q$ be polyhedra and suppose P is locally collared in Q . Then there is a collar on P in Q . //

1.6 Theorem (Brown [4], [5], see also Connelly [9])

Let $M \subset N$ be topological manifolds and suppose M is locally collared in N . Then M is collared in N . //

1.7 Corollary

Let M be a (piecewise linear or topological) manifold. Then ∂M is collared in M . //

We also require the following uniqueness result for collars of piecewise linear manifolds. (See Armstrong [2] for a similar result for locally flat collars of topological manifolds.)

1.8 Theorem (Hudson and Zeeman [15] , Theorem 4)

Let M be a piecewise linear manifold, and let $c_1, c_2 : M \times I \rightarrow M$ be two collars, then there exists an ambient isotopy α of M , fixed on ∂M , with $\alpha_1 c_1 = c_2$. //

We now deduce the following two results.

1.9 Lemma

Let $f : S^1 \rightarrow M^n$ be locally flat embedding into the topological manifold M , $n \geq 5$, $\partial M = \emptyset$, and suppose the homotopy class of f , $[f] = 0 \in \pi_1(M)$. Then there exists

a locally flat embedding $f^1 : D^2 \rightarrow M$ which extends f , that is, $f^1 \Big| \partial D^2 = f$.

Proof

Since $[f] = 0 \in \pi_1(M)$, f extends to a map $\bar{f} : D^2 \rightarrow M$. Let $\{B_i, i = 0, \dots, s\}$ be a cover of D^2 by closed balls such that $\bar{f}(B_i) \subset U_i$, a chart of M , for each i , and $A_k = \bigcup_{i=0}^k B_i$ is a ball for each k . Now work inductively over the A_k : suppose we have homotoped $\bar{f} \text{ rel } S^1$ so that $\bar{f} \Big| A_k$ is an embedding. By 1.4 we can ε -ambiently isotope U_i so that $\bar{f} \Big| \{B_{k+1} \cap (A_k \cup S^1)\}$ is a piecewise linear embedding, and then by general position replace \bar{f} by a homotopic map which embeds B_{k+1} . Now apply the inverse isotopy of U_i to replace S^1 to its former position. By 1.1, A_k lies piecewise linearly in a chart, so that by taming and general position we can remove the intersections of B_{k+1} with A_k . This gives A_{k+1} embedded, and the result follows. //

Note. Indeed this result follows more directly on application of Newman's engulfing theorem (see [27]).

1.10 Lemma

Let Q^q be a topological manifold, and M^q a compact, locally flat q -dimensional submanifold of $\text{int } Q$ which supports a piecewise linear structure. Suppose

$(X_0, X) \subset \text{int } Q$ are an admissible pair of polyhedra with $\text{cl}(X \setminus X_0)$ n -dimensional, $q - n \geq 3$, where X_0 is a piecewise linear subpolyhedron of M , and suppose that the open simplexes of some triangulation of X are locally flat in Q . Then there exists an ε -ambient isotopy α of Q such that $Y = \alpha_1(X) \cap M$ is a piecewise linear subpolyhedron of M , and

$$\alpha_t \Big| \{ X_0 \cup [Q \setminus N_\varepsilon(M, Q)] \} = 1.$$

Proof. See Figure 1.

By 1.6, let $\tilde{M} = M \cup (\text{Collar on } \partial M)$, the collar being chosen so that $\tilde{M} \subset N_\varepsilon(M, Q)$. Then \tilde{M} supports a piecewise linear structure. Let Y_0 be $X \cap M$. Triangulate X by the triangulation of the statement, and subdivide finely enough so that $N(Y_0)$, a regular neighbourhood of the simplicial neighbourhood of Y_0 in X , satisfies $N(Y_0) \subset \tilde{M}$.

Now by 1.4 we can choose $\varepsilon_0 \leq \varepsilon$ and find an ε_0 -ambient isotopy α of \tilde{M} such that $\alpha_1(N(Y_0))$ is a piecewise linear subpolyhedron of \tilde{M} , $\alpha_t \Big| (\partial \tilde{M} \cup X_0) = 1$, and $(\alpha_1 X \cap M) \subset N(Y_0)$. Extending α to Q by the identity gives the result. //

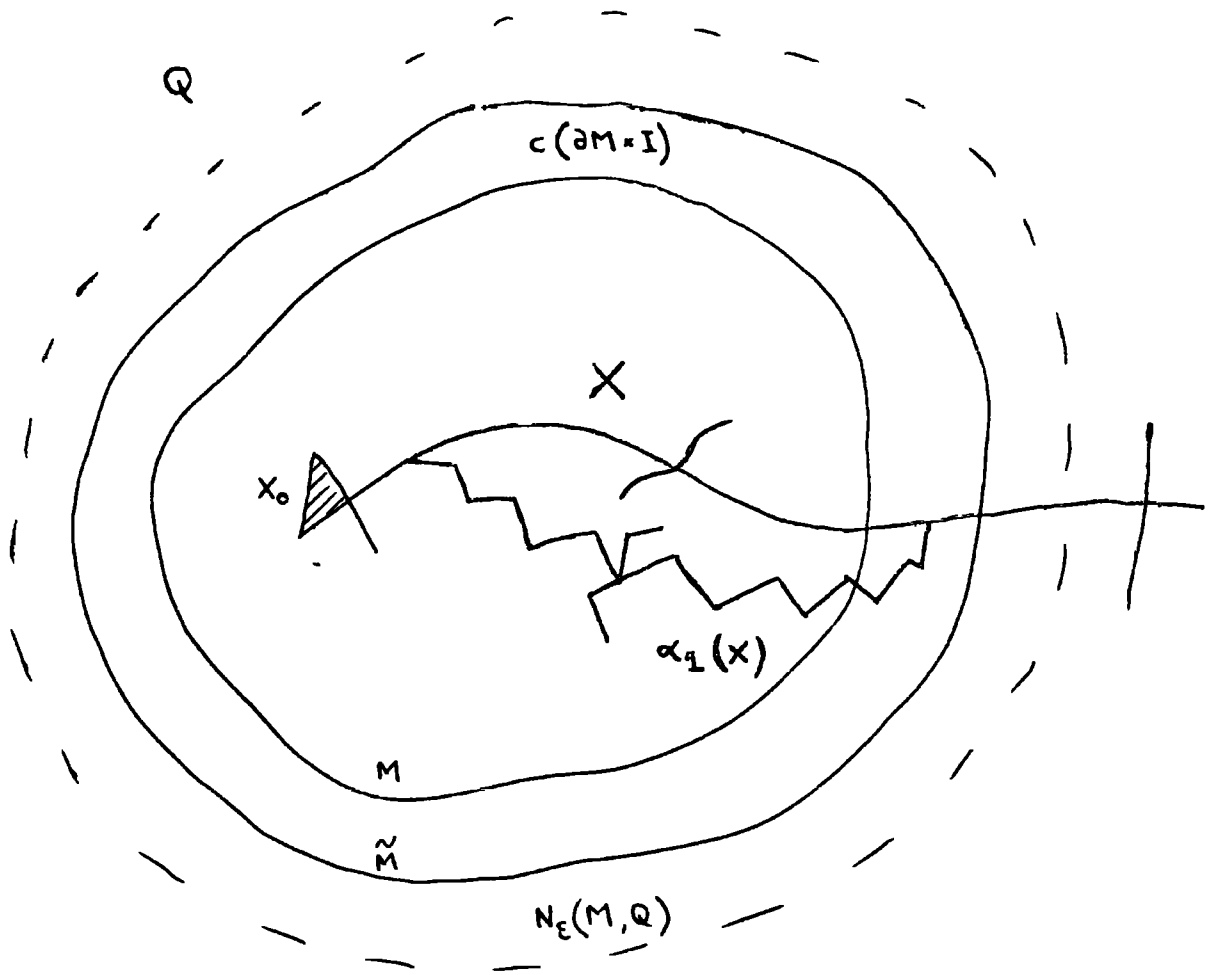

Figure 1
Lemma I 1.10

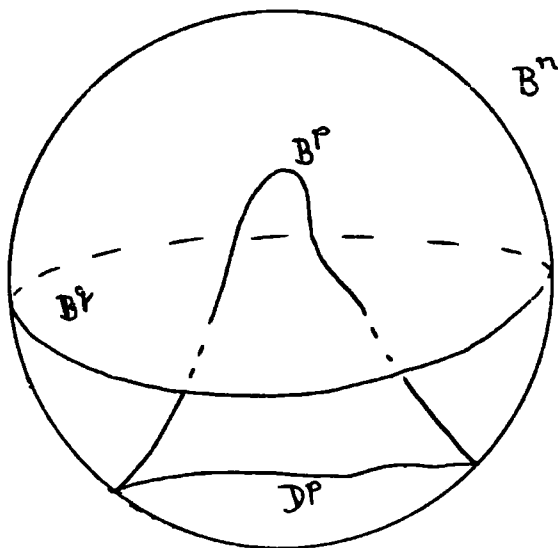

Figure 2
Lemma I 2.4

§2 The Whitney Process

Intersection signs

Suppose we have oriented manifolds $P^p, Q^q \subset M^n$, where P, Q are of complementary dimension in M ; that is, $p + q = n$. Suppose also that P and Q intersect transversally in a finite number of points.

Let $x \in P \cap Q$. Then by transversality there exists a neighbourhood U of x and a coordinate chart

$$\chi : (U, U \cap P, U \cap Q, \{x\}) \longrightarrow (R^{p+q}, R^p \times \underline{0}, \underline{0} \times R^q, \underline{0})$$

which we can suppose preserves orientation on $U \cap P$ and $U \cap Q$, where the Euclidean spaces are given the natural orientation.

Define the intersection number of P, Q at x , $\varepsilon(x)$, by $\varepsilon(x) = +1$ if χ preserves orientation on U , $\varepsilon(x) = -1$ otherwise. The intersection number of P and Q , $\varepsilon(P, Q)$

$$= \sum_{x \in P \cap Q} \varepsilon(x).$$

Now suppose we have $P^p, Q^q \subset M^n$, where P, Q are connected locally flat submanifolds of the topological manifold M which are of complementary dimension. Further assume that P and Q both support a piecewise linear structure, and that $\partial M = \emptyset$. Under these conditions we state the following.

2.1 Topological Whitney Lemma

Suppose that $x, y \in P \cap Q$ satisfy $\xi(x) = -\xi(y)$.

Then there is an isotopy of M carrying P to P' , with P' transverse to Q in M and with $P' \cap Q = P \cap Q \setminus \{x\} \setminus \{y\}$, provided either

(i) $p \geq 3, q \geq 3$ and $\pi_1(M) = 0$

or (ii) $p = 2, q \geq 3$ and $\pi_1(M \setminus Q) = 0$.

Moreover the isotopy has support in a compact set which does not meet any other intersection points.

2.2 Corollary

If $\xi(P, Q) = 0$, with the above hypotheses, then we can ambiently isotope P off Q by an isotopy with compact support. //

2.3 Remark

If $p \geq 3$, then $\pi_1(M \setminus Q) = 0$ implies $\pi_1(M) = 0$, so that the lemma can be restated with the single hypothesis $\pi_1(M \setminus Q) = 0$.

Proof of Remark

Let $i_* : \pi_1(M \setminus Q) \rightarrow \pi_1(M)$ be the homomorphism induced by inclusion. It is sufficient to show that i_* is onto. Let $f : S^1 \rightarrow M$ represent $[f] \in \pi_1(M)$.

We wish to find g homotopic to f with $\text{Im } g \subset M \setminus Q$, then $[g] \in \pi_1(M \setminus Q)$ and $i_* [g] = [f]$.

Cover Q by charts U_i , and by 1.1 find charts V_i of M with $V_i \cap Q = U_i$ and $(U_i, V_i) \cong (R^q, R^n)$, the standard pair. Now cover S^1 by closed intervals $J_j \cong I$, with $J_j \cap J_k \subset \partial J_j \cap \partial J_k$, $j \neq k$, such that, if $f(J_j) \cap Q \neq \emptyset$, then $f(J_j) \subset V_i$ for some i .

Using small general position moves where necessary, we may assume that $(\bigcup_j f(\partial J_j)) \cap Q = \emptyset$. If $f(J_k) \cap Q = \emptyset$, define $g_k : J_k \rightarrow M$ by $g_k = f|_{J_k}$. If $f(J_k) \cap Q \neq \emptyset$, by general position for maps we can find a piecewise linear map $g_k : J_k \rightarrow V_i$ homotopic mod ∂J_k to $f|_{J_k}$, and, again by general position, we may assume that $g_k(J_k) \cap Q = \emptyset$.

Now define $g : S^1 \rightarrow M$ by $g|_{J_k} = g_k$. //

Before we prove the Whitney lemma, we require the next result.

2.4 Lemma

Suppose $B^p, B^q \subset B^n$ are properly piecewise linearly embedded balls of complementary dimension, that $q \geq 3$, and that B^q is unknotted. Suppose also that B^p meets B^q transversally in two points x, y with $\varepsilon(x) = -\varepsilon(y)$. Then there exists an ambient isotopy of B^n , keeping ∂B^n fixed, which moves B^p off B^q .

Proof

We have

$$\pi_{p-1}(B^n \setminus B^q) \cong H_{p-1}(B^n \setminus B^q) \cong H_{p-1}(S^{p-1}) \cong Z$$

and the element of $H_{p-1}(B^n \setminus B^q)$ determined by ∂B^p is represented by the sum of two spheres which in turn represent opposite generators in Z , since $\varepsilon(x) = -\varepsilon(y)$.

Hence ∂B^p is null homotopic in $B^n \setminus B^q$. By Irwin's embedding theorem (see [18]) we can span ∂B^p by a piecewise linearly embedded p -disc D^p in $B^n \setminus B^q$. See Figure 2.

Since $p \leq n-3$, we can unknot both B^p and D^p ; let

$$h_0 : (B^n, B^p) \longrightarrow (B^n, B^p), \quad h_1 : (B^n, D^p) \longrightarrow (B^n, B^p),$$

be the homeomorphisms to the standard pair. We define the

required isotopy $\alpha : B^n \times I \longrightarrow B^n \times I$ by the Alexander trick:

$$\begin{aligned} \alpha|_{B^n \times 0} &= h_0 \\ \alpha|_{B^n \times 1} &= h_1 \\ \alpha|_{\partial B^n \times I} &= (h_0|_{\partial B^n}) \times \text{identity} \\ \alpha(\underline{0}, \frac{1}{2}) &= (\underline{0}, \frac{1}{2}) \end{aligned}$$

and $\alpha|_{B^n \times I}$ is defined by conical extension from $(\underline{0}, \frac{1}{2})$, since $B^n \times I$ is a cone with base $(B^n \times 0) \cup (\partial B^n \times I) \cup (B^n \times 1)$, cone-point $(\underline{0}, \frac{1}{2})$. //

Proof of Whitney lemma

Join x and y by locally flat arcs α, β , in P, Q , respectively, which do not pass through any other intersection points. We have two cases. See Figure 3.

Case (i) $p \geq 3$. By 1.9 there exists a non-singular disc D^2 spanning $\alpha \cup \beta$, and by 1.1 $D^2 \subset U$ so that $(D, U) \cong (B^2, R^{\lambda^n})$ the standard pair. Let $X = P \cup Q \cup D^2$ and $X_0 = D^2$. Then by 1.10 we can ambiently isotope M so that $X \cap U$ is a piecewise linear subpolyhedron of U , leaving D^2 fixed. By general position we may assume that $\text{int } D^2 \cap (P \cup Q) = \emptyset$. Now proceed as in the piecewise linear situation - let (N, B_1, B_2) be a regular neighbourhood of (D^2, α, β) in $(U, P \cap U, Q \cap U)$. Then B_2 is unknotted in N , and the above lemma, 2.4, applies - hence we can move B_1 off B_2 , and thus P off Q . We have moved Q in our earlier application of 1.10; we now return it to its original position with the inverse ambient isotopy, and the result is proved.

Case (ii) $p = 2$. Since codimension $Q = 2$ we have difficulty removing the intersection of Q with D , and we use the extra hypothesis to surmount this. Let B be a regular neighbourhood of β in Q . Then B is a ball, and by 1.1 there exists a chart V of M , with $B \subset V$ so that $(B, V) \cong (B^q, R^n)$, a standard pair. Let $B' \subset V$ be such that $(B, B') = (B^q, B^n)$, a standard pair; we can assume that $B' \cap P \cap Q = \{x\} \cup \{y\}$. Then by 1.10 there exists an ϵ -ambient isotopy of M , leaving B fixed, such that $P \cap B'$ is a piecewise linear subpolyhedron of B' . By suitable choice of ϵ we can assume that we introduce no new intersection points of P and Q - choose ϵ so that $d[(P \cap N_\epsilon B'), (Q \setminus B) \cap N_\epsilon B'] < \epsilon$.

Now choose a regular neighbourhood of β in $(B', P \cap B', B)$, say (N, N_0, N_1) , see Figure 4. Then there is a homeomorphism

$$h : (N, N_0, N_1) \cong (B^p \times B^{q-1} \times [-2, 2], B^p \times 0 \times \partial B, 0 \times B^{q-1} \times [-2, 2])$$

We can assume that $h(\alpha \cap N_0) = [0, 1] \times 0 \times \partial B$. Let $\alpha' = \text{cl}(\alpha \setminus (\alpha \cap N_0))$, $\beta' = h^{-1}(1 \times 0 \times [-1, 1])$, $D_1^2 = h^{-1}([0, 1] \times 0 \times [-1, 1])$. Then $\alpha' \cup \beta' \subset M \setminus Q$, and using the extra hypothesis and 1.9, we can find a non-singular disc $D_2^2 \subset M \setminus Q$ spanning $\alpha' \cup \beta'$. Again, as in case (1), by 1.10 and general position we may assume that $\text{int } D_2 \cap (P \cup D_1) = \emptyset$.

Let $D = D_1 \cup D_2$, a 2-disc, so that by 1.1 D is contained in some chart U of M , and we may assume that $B \subset U$. Then the homeomorphism $(B, U) \cong (B, V)$ defines a piecewise linear structure on U with B a piecewise linear submanifold. As outlined above, by choosing a ball B' in U such that $D \subset \text{int } B'$, and applying 1.10 with suitable ϵ , we can assume that $D \cup (P \cap B')$ is a piecewise linear subpolyhedron of B' . Now proceed as in case (1). //

The Whitney Lemma

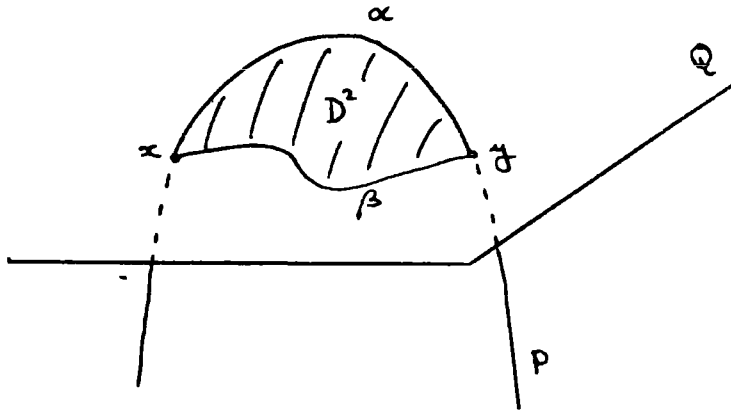

Figure 3

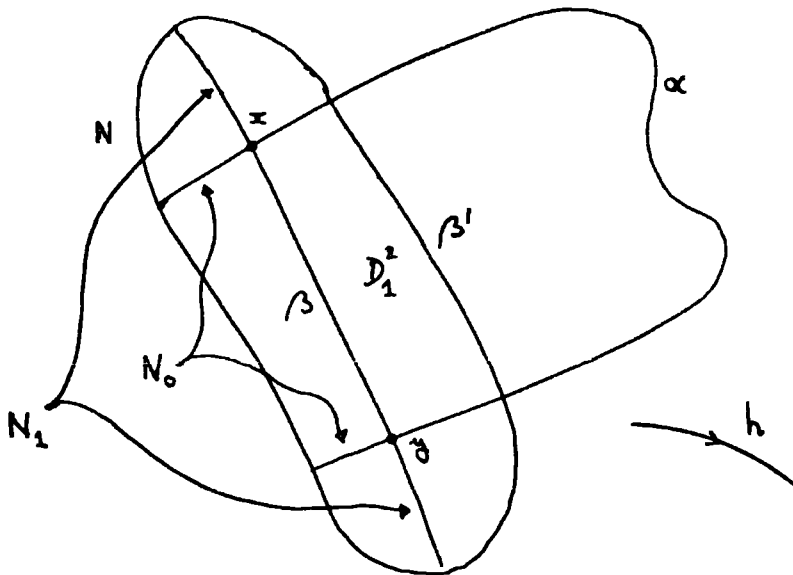
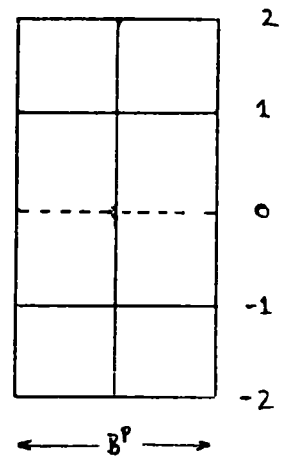

Figure 4



§3. Handles

Let W^W be a topological manifold with boundary, and suppose we have a locally flat embedding

$$f : \partial B^P \times B^{W-P} \longrightarrow W .$$

Then we say that the manifold

$$W' = W \cup_f (B^P \times B^{W-P})$$

is formed from W by attaching a handle of index p (or a p -handle). We write $W' = W \cup h^P$, and f is called the attaching map. See Figure 5.

Let $e : B^P \times B^{W-P} \longrightarrow W'$ be the natural embedding, called the characteristic map. We use the following terminology (Figure 5):

- $e (B^P \times 0)$ is the core
- $e (\partial B^P \times 0)$ is the attaching sphere
- $e (\partial B^P \times B^{W-P})$ is the attaching tube
- $e (0 \times B^{W-P})$ is the fibre (or cocore)
- $e (0 \times \partial B^{W-P})$ is the belt-sphere
- $e (B^P \times \partial B^{W-P})$ is the belt-tube

The compact manifold W^W is a cobordism (W, M_0, M_1) if ∂W is the disjoint union of the $(w-1)$ -manifolds M_0 and M_1 .

See Figure 6.

If we have a handle h attached to W , with $h \cap W \subset W_1$, we say that h is a handle on the cobordism. Then $W' = W \cup h$ is a cobordism $(W', M_0, \partial W' - M_0)$ obtained from W by attaching a handle.

The following lemma shows that W' depends only on the isotopy class of the attaching map of h .

3.1 Lemma

Let $f, g : \partial B^p \times B^{n-p} \rightarrow M_1$ be ambient isotopic embeddings. Then there is a homeomorphism

$$F : W \cup_f h \xrightarrow{\cong} W \cup_g h$$

which is the identity outside a collar of M_1 in W .

Proof

Let $\alpha_t : M_1 \rightarrow M_1$ be the given isotopy, and (by 1.7) let c be a collar of M_1 in W . Define $\beta_t : W \rightarrow W$ by

$$\beta_t(x, s) = \begin{cases} (\alpha_{t-s}(x), s) & s \leq t \\ (x, s) & s \geq t \end{cases}$$

where $(x, s) \in \text{Im}(c)$, and extend by the identity to $W \setminus \text{Im}(c)$.

$$\text{Then } F = \begin{cases} \beta_1 & \text{on } W \\ \text{identity on } h. & // \end{cases}$$

Pairs of handles

We form $W' = W \cup h^p \cup h^q$ by attaching a p -handle h^p to W and then attaching a q -handle h^q to the cobordism $W \cup h^p$.

We wish to echo the results used in the proof of the piecewise linear h -cobordism theorem to reorder, cancel or "add" consecutive pairs of handles. To do this we tame locally (allowed by lemma 3.1) and then use the techniques of the piecewise linear proofs. This imposes a restriction on $w = \dim W$.

Let $M_2 = \partial(W \cup h^p) \setminus M_0$, $e : B^p \times B^{w-p} \rightarrow W \cup h^p$ be the characteristic map of h^p , and $f : \partial B^q \times B^{w-q} \rightarrow M_2$ be the attaching map of h^q . Then e, f induce piecewise linear structures on the submanifolds P, Q of M_2 , respectively, where

$$\begin{aligned} P &= e(B^p \times \partial B^{w-p}) \cup \text{collar on its boundary} \\ &= (\text{belt-tube of } h^p) \cup \text{collar on its boundary} \end{aligned}$$

and $Q = \text{Im} f \cup \text{collar on its boundary}$

$$= (\text{attaching tube of } h^q) \cup \text{collar on its boundary.}$$

See Figure 7. We use 1.6 here.

3.2 Reordering lemma

Let $W' = W \cup h^p \cup h^q$ with $q \leq p$. Then $W' \cong W \cup h^q \cup h^p$ with h^p and h^q disjoint, provided that $w \geq 5$.

Proof

We wish to ambiently isotope f so that $\text{Im}(f)$ and $\text{Im}(e)$ are disjoint, then we can attach the handles in reverse order, and the result follows from lemma 3.1.

Let $S_1 = e(0 \times \partial B^{w-p}) =$ belt-sphere of h^p

$S_2 = f(\partial B^q \times 0) =$ attaching sphere of h^q .

In the piecewise linear case, since $p \geq q$, we can assume that $S_1 \cap S_2 = \emptyset$ by general position. Choose regular neighbourhoods N_1, N_2 of S_1, S_2 which are disjoint. See Figure 8. Isotope N_1 onto the belt-tube of h^p , N_2 onto the attaching tube of h^q by uniqueness of regular neighbourhoods, and the proof is complete.

In the topological case, we have two instances. If $w-q \geq 3$, then S_2 has codimension ≥ 3 in M_2 so that 1.10 applies. Hence we may assume that $S_2 \cap P$ is a piecewise linear subpolyhedron of P , and, by general position, that $S_1 \cap S_2 = \emptyset$. If $w-q < 3$, then, since $w \geq 5$ and $p \geq q$, $p \geq 3$, so that S_1 has codimension ≥ 3 in M_2 . Apply 1.10 to obtain $S_1 \cap Q$ a piecewise linear subpolyhedron of Q , and again, by general position, that $S_1 \cap S_2 = \emptyset$.

In either instance, we can now use the above regular neighbourhood argument, being sure to take regular neighbourhoods N_1, N_2 of S_1, S_2 in P, Q respectively. This completes the proof. //

Handles of adjacent index

Suppose $W' = W \cup h^p \cup h^{p+1}$ and that $w \geq 6$. Then the spheres $S_1 =$ belt sphere of h^p , $S_2 =$ attaching sphere of h^{p+1} are of complementary dimension in M_2 , so that, as in the last proof, by a small ambient isotopy of the attaching map f of h^{p+1} we can assume that S_1 and S_2 are in general position, and hence that S_1 meets S_2 transversally in a finite number of points.

Indeed, we can achieve more than this. For each $x \in S_1 \cap S_2$, let N_x be a closed ball neighbourhood of x in P (our previously defined submanifold of M_2 with piecewise linear structure), chosen so that $N_x \cap N_y = \emptyset$ for all $y \neq x$. Let $B \subset \text{int } N_x$ be a ball neighbourhood of x of the form $B = D^p \times D^{w-p-1} \subset f(\partial B^{p+1} \times B^{w-p-1})$. Choose ϵ so that $N_\epsilon(S_1, P) \cap S_2 \cap N_x \subset B$ and $N_\epsilon(B_1 N_x) \subset \text{int } N_x$. Now using 1.2 we can ϵ -ambient isotope N_x , leaving ∂N_x fixed, such that B is a piecewise linear submanifold of P . Our choice of ϵ ensures that now $S_1 \cap S_2 \cap N_x \subset D^p$. See Figure 9. By general position in B , we can assume that D^p is piecewise linearly transversal to S_1 . If we repeat this process for each $x \in S_1 \cap S_2$, we ambient isotope f so that S_1, S_2 intersect transversally in a finite number of points, and near each $x \in S_1 \cap S_2$, f is a piecewise linear embedding into P .

So, further to transversality, we now have $S_1 \cap S_2$ locally nice near each intersection point, that is, locally a piecewise linear subpolyhedron of $P \subset M_2$.

Incidence number

Now define the incidence number of h^p, h^{p+1} , $\epsilon(h^p, h^{p+1})$, to be equal to the intersection number of S_1, S_2 , $\epsilon(S_1, S_2)$ (as defined in § 2).

Next, we see that the incidence number depends only on the homotopy class of the attaching map, f , of h^{p+1} .

3.3 Lemma

Let $q : W \cup h^p \longrightarrow S^p$ be the map which sends W to a basepoint $\ast \in S^p$, collapses h^p onto its core $B^p \times 0$, and identifies $B^p / \partial B^p$ with S^p / \ast . Let $g : S_2 \longrightarrow S^p$ be the restriction of q to S_2 , and let $w \geq 6$, then g has homological degree $\epsilon(h^p, h^{p+1})$.

Proof

The degree of g is unaffected by an isotopy of f . Let $x \in S_1 \cap S_2$, and let $D_x = \epsilon(B^p \times \{x\})$ be the standard transverse disc to S_1 at x . We wish to ambiently isotope f so that S_2 agrees with D_x near x .

In the piecewise linear case, this follows from the definition of transversality and the disc theorem for pairs. In general, since we have f a piecewise linear map near x , the same applies.

Do this for each intersection, and then, after an isotopy of P (defined as before) which carries a standard neighbourhood of S_1 in P onto the belt tube of h^P , we have $S_2 \cap h^P = U \{ D_x \mid x \in S_1 \cap S_2 \}$. Now $q \mid D_x$ is the standard identification of $D_x / \partial D_x$ with S^P ; and the result follows. //

Complementary handles

Suppose that, in the above notation, we have $S_1 \cap S_2 = \text{one point}$. Then h^P, h^{P+1} are called complementary handles.

In this case, the pair of handles can be eliminated:

3.4 Cancellation lemma

Let $W' = W \cup h^P \cup h^{P+1}$, where h^P, h^{P+1} are complementary. Then there exists a homeomorphism $W' \cong W$, fixed outside a neighbourhood of $h^P \cup h^{P+1}$, provided that $w \geq 6$.

Proof

As in the previous proof, we may assume that $S_2 \cap$ (belt tube of h^P) = D_x , where $x = S_1 \cap S_2$, and also that f is piecewise linear near D_x . By the disc theorem for pairs, we may also assume that $e(B^P \times B_1) = f(B_2 \times \epsilon B^{w-p-1})$ where $0 < \epsilon < 1$ and B_1, B_2 are neighbourhoods of x in S_1, S_2

respectively. Now after an ambient isotopy of Q (defined above) shrinking $f(B_2 \times B^{w-p-1})$ to $f(B_2 \times \varepsilon B^{w-p-1})$, followed by an ambient isotopy of P expanding a standard neighbourhood of S_1 onto the belt tube of h^P , we can assume that

$$h^P \cap h^{P+1} = e(B^P \times B_1) = f(B_2 \times B^{w-p-1}).$$

See Figure 10.

$h^P \cup h^{P+1}$ is, then, a w -ball attached to W by a face.

The result follows. //

3.5 Corollary

Suppose that $W' = W \cup h^P \cup h^{P+1}$ and M_1 is simply-connected, $w - p \geq 4$, $p \geq 2$, and $w \geq 6$. Then, if $\varepsilon(h^P, h^{P+1}) = \pm 1$, $W' = W$.

Proof

We wish to use the Whitney lemma to ambiently isotope M_1 so that $S_1 \cap S_2 = \text{one point}$, and then use lemma 3.4 to cancel. Now, $\text{codimension } S_1 \geq 2$, $\text{codimension } S_2 \geq 3$.

Also

$$\begin{aligned} \pi_1(M_1 \setminus S_1) &\cong \pi_1(M_1 \setminus \text{attaching tube of } h^P) \\ &\cong \pi_1(M_1 \setminus \text{attaching sphere of } h^P) \end{aligned}$$

Using 1.9, 1.10 and general position, we can show that $(M_1 \setminus \text{attaching sphere of } h^P)$ is simply-connected. Hence the Whitney lemma applies. //

We shall need the reverse procedure to lemma 3.4. That is, given a ball attached to a cobordism by a face, we replace that ball by a pair of complementary handles of arbitrary index, by means of the following lemma.

3.6 Introduction lemma

Suppose that $W' = W \cup B^w$ where $B^w \cap W = B^w \cap M_1 = B_1$, a face of B . Then we can write $W' = W \cup h^p \cup h^{p+1}$, with h^p and h^{p+1} complementary, for any $0 \leq p < w$.

Moreover, if $D^p \subset B_1$ is any locally flat disc then we can assume that the attaching sphere of h^p is ∂D^p and that $W \cap$ (attaching sphere of $h^{p+1}) \subset D^p$.

Proof

Consider the standard complementary pair

$$h_1 = B^p \times ([1, 3] \times B^{w-p-1})$$

$$h_2 = B^{p+1} \times B^{w-p-1}$$

with $h_1 \cup h_2 = B^p \times [-1, 3] \times B^{w-p-1}$, a ball with face

$$E = (\partial B^p \times [-1, 3] \times B^{w-p-1}) \cup (B^p \times -1 \times B^{w-p-1}).$$

Identifying $(h_1 \cup h_2, E)$ with (B, B_1) gives the required result. See Figure 11.

For the last part, identify D^p with $(\partial B^p \times [-1, 2]) \cup (B^p \times -1)$, using the fact that two locally flat embeddings of a disc into $\text{int } B_1$ are ambient isotopic with compact support. //

Adding handles

We wish to isotope the attaching map of a p -handle by sliding it over an adjacent p -handle, with the effect of adding (or subtracting) the incidence numbers of the p -handles with those of $(p-1)$ -handles.

3.7 Adding lemma

Suppose that $W' = W \cup_{f_1} h_1^p \cup_{f_2} h_2^p$, with $\text{Im}(f_1)$ and $\text{Im}(f_2)$ disjoint, that $w - p \geq 2$, $p \geq 2$, $w \geq 6$, and $\pi_1(M_1) = 0$. Then there exists an f_3 isotopic to f_2 such that $\text{Im}(f_3) \cap \text{Im}(f_1) = \emptyset$ and

$$[f_3] = [f_2] \pm [f_1],$$

where $[f_1] \in \pi_p(M_1)$ is the class determined by $f_1 | (\partial B^p \times 0)$.

Proof

Let e_1 be the characteristic map of h_1 . By 1.6 there exists $c : \partial B^p \times \partial B^{w-p} \times I \rightarrow \text{cl}(M_2 \setminus h_1 \setminus h_2)$,

a collar on the boundary of the attaching tube of h_1 ,
 where $M_2 = \partial(W \cup h_1) \setminus M_0$, with $\text{Im}(c) \cap h_2 = \emptyset$.

Let $S_1 = c(\partial B^p \times \{x\} \times I)$ for some $x \in \partial B^{w-p}$.

Then S_1 bounds the embedded p -disc

$$D_1 = c(\partial B^p \times \{x\} \times I) \cup e_1(B^p \times \{x\}).$$

Define $S_2 =$ attaching sphere of h_2 . See Figure 12.

We can pipe S_1 and S_2 in M_2 in the following manner. Join

S_1 and S_2 by a locally flat arc α in M_2 , disjoint from D_1 .

By 1.1 we have a chart U containing α with $(\alpha, U) \cong (B^1, R^{w-1})$

the standard pair and thus by 1.2 we can tame S_1 and S_2 , near

the end points of α , in U by an ambient isotopy H of U .

Again join S_1 and S_2 by a (piecewise linear) arc β in U ,

with end points those of α . Now we can construct a

pipng tube in the usual (piecewise linear) fashion, and

then apply H^{-1} . Let $S_3 = S_1 \# S_2$, defined by the piping,

and $D =$ solid piping tube.

Then S_2 is ambient isotopic to S_3 by two cellular
 moves - firstly across D and then across D_1 . (See Figure 13).

Call this isotopy K . By a regular neighbourhood argument

we can assume that $\text{Im}(f_3 = K_1 \circ f_2)$ is disjoint from $\text{Im}(f_1)$.

The result follows; the choice of sign comes from the

choice of orientation of S_1 . //

3.8 Corollary

Suppose, in the above situation, that

$W = W_1 \cup h^{p-1}$. Then there is an h_3^p such that

$$\varepsilon(h_3, h^{p-1}) = \varepsilon(h_2, h^{p-1}) \pm \varepsilon(h_1, h^{p-1}).$$

Proof

h_3 is attached by the map f_3 of 3.7; the formula follows from 3.3. //

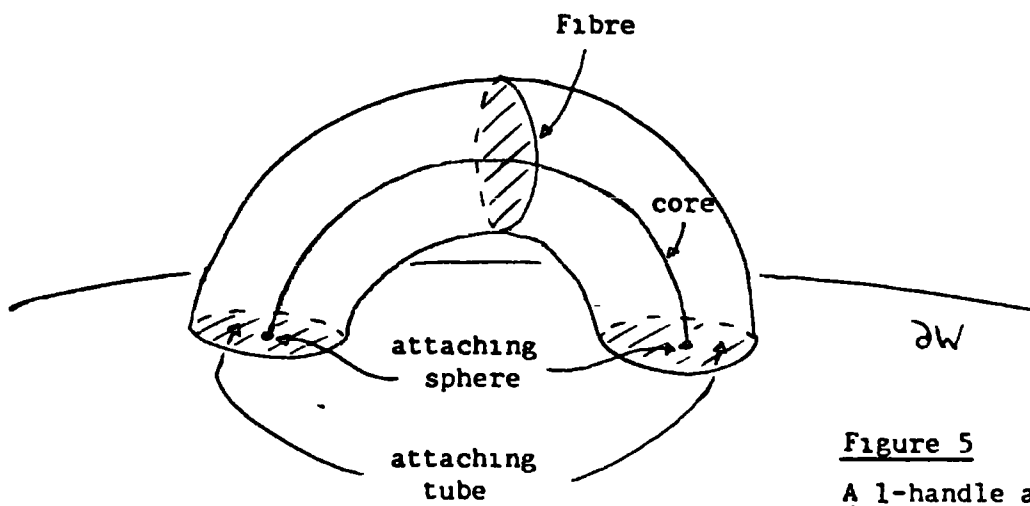

Figure 5

A 1-handle attached to a 3-manifold

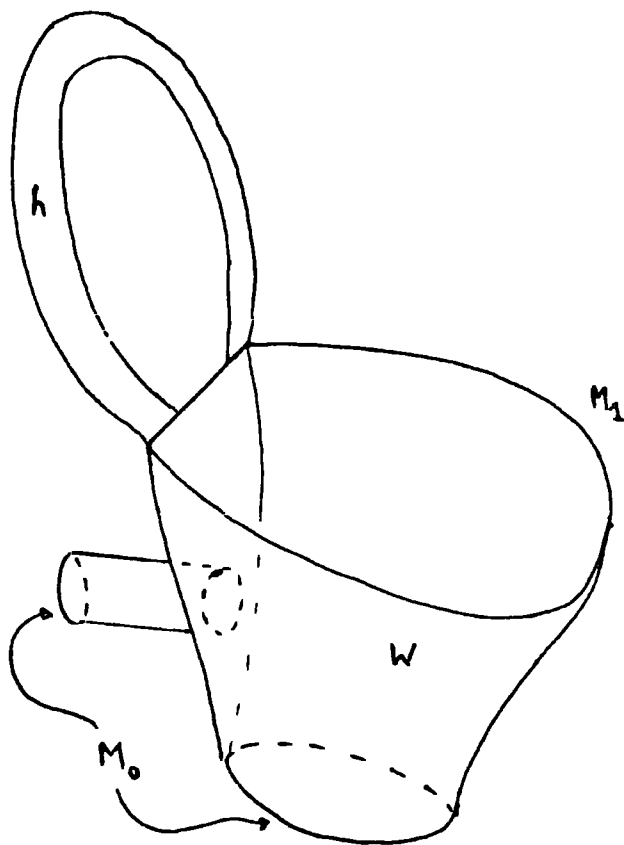

Figure 6

A handle on a cobordism

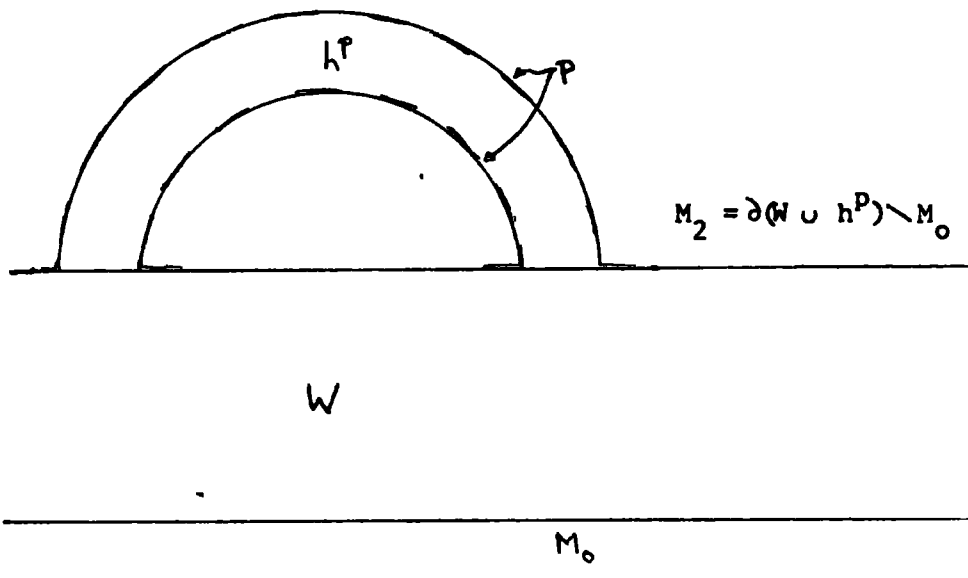
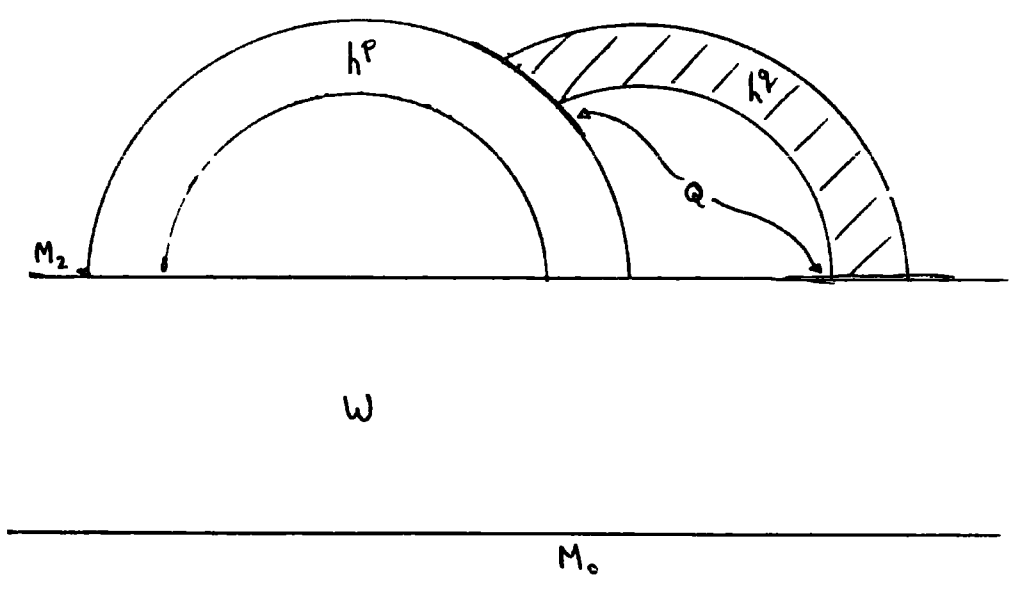

Figure 7



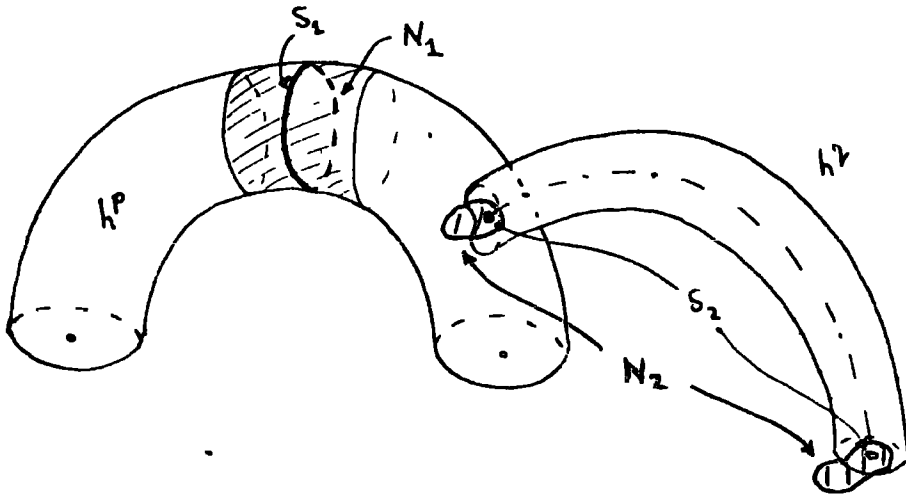

Figure 8
Lemma I 3.2

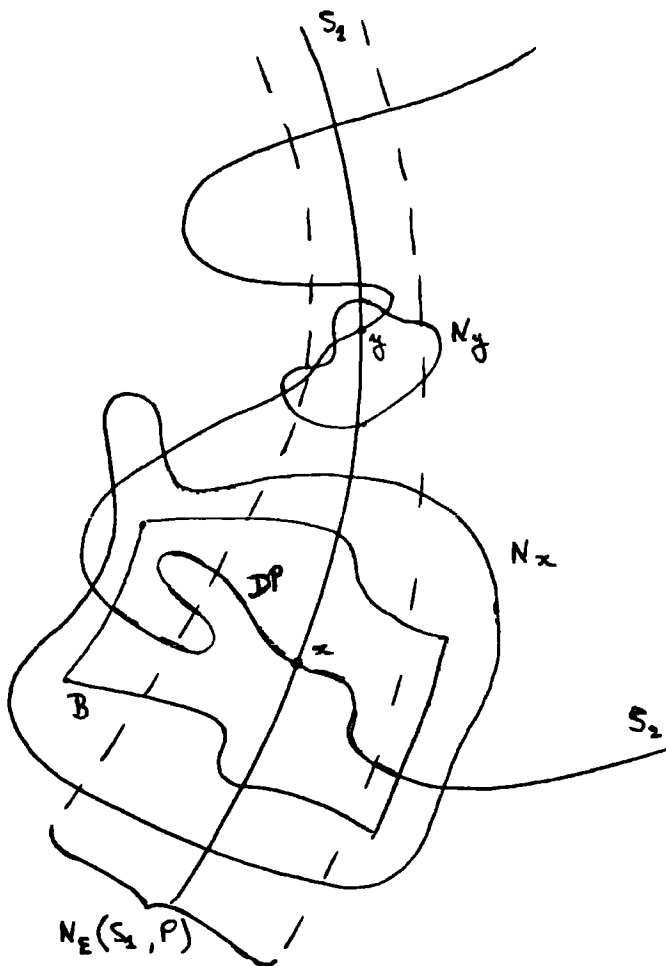

Figure 9

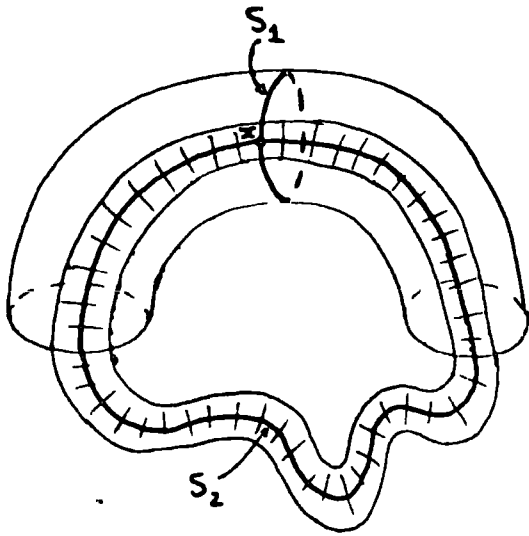

Figure 10
Cancellation Lemma I 3.4

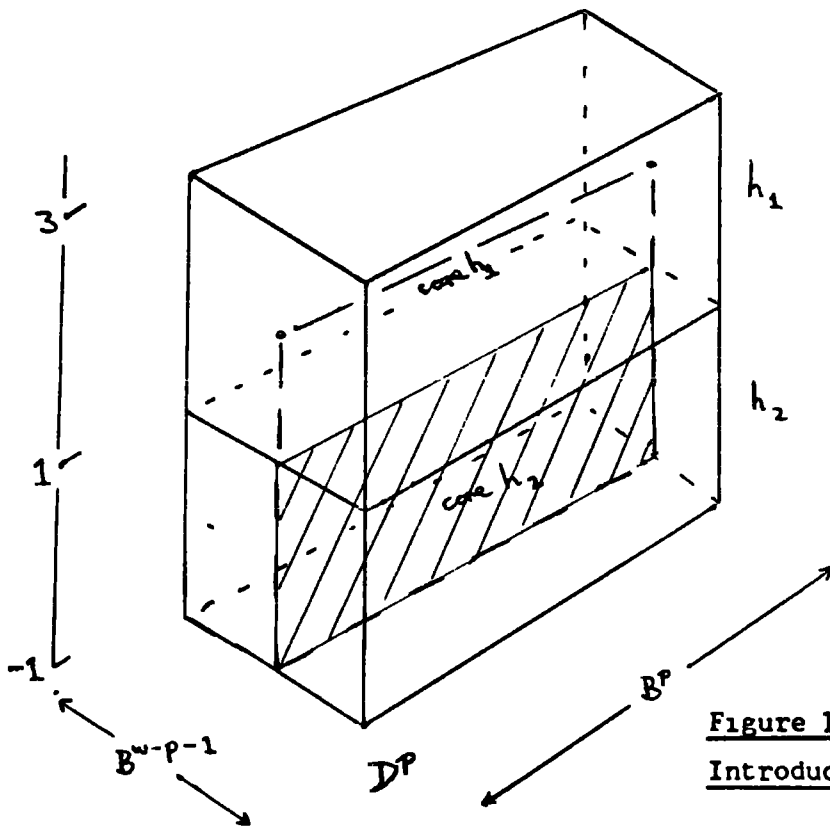

Figure 11
Introduction lemma I 3.6

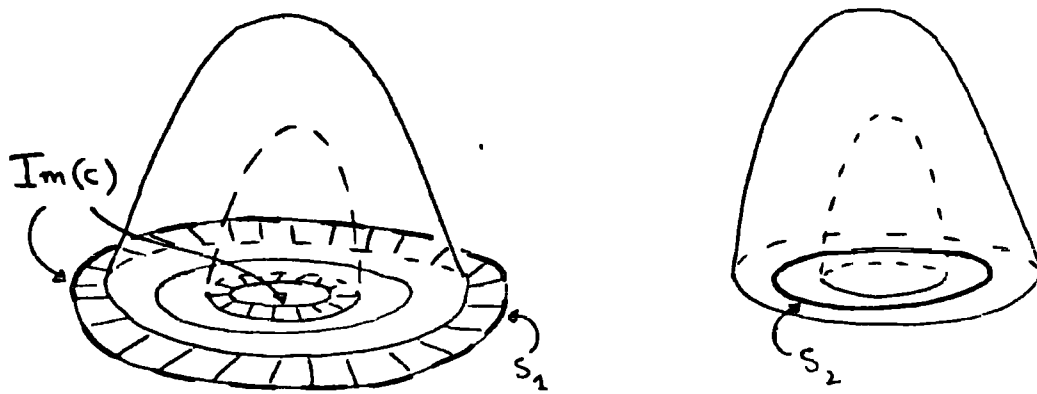

Figure 12

Adding lemma I 3.7

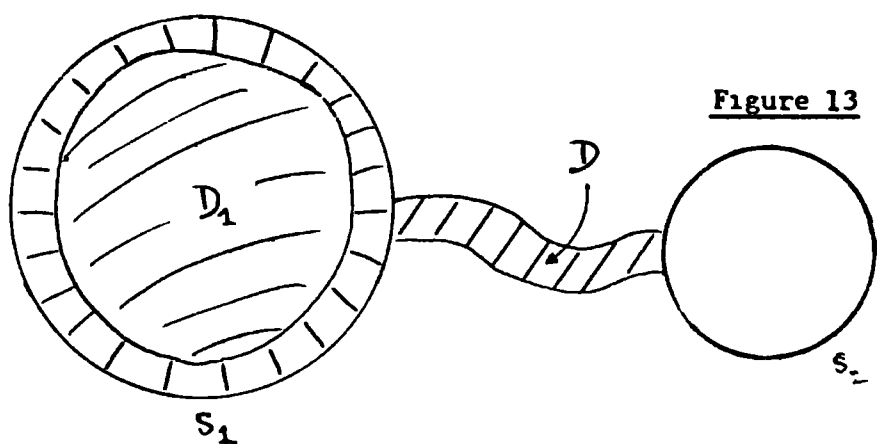

Figure 13

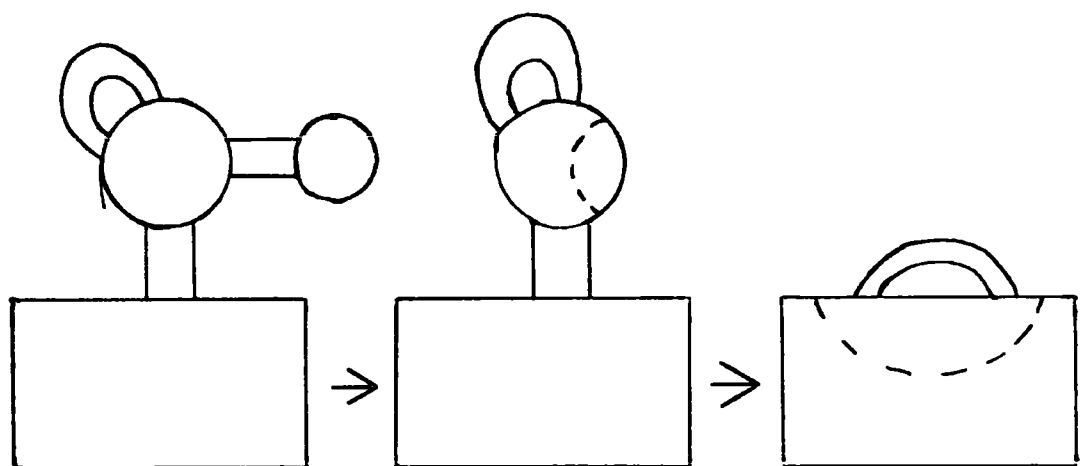

Figure 14
Elimination of 0-handles
I 4.4

§ 4 Handle decompositions

Let W^W be a closed manifold, than a handle decomposition of W is a presentation

$$W = h_0 \cup h_1 \cup \dots \cup h_t ,$$

where h_0 is a w -ball, and h_i is a handle on $W_{i-1} = \bigcup_{j < i} h_j$, for each i .

More generally, let (W, M_0, M_1) be a cobordism.

Then a handle decomposition of W on M_0 is a presentation

$$W = C_0 \cup h_1 \cup \dots \cup h_t ,$$

where C_0 is a collar on M_0 in W , and, for each i , h_i is a handle on the cobordism

$$W_{i-1} = C_0 \cup \left(\bigcup_{j < i} h_j \right).$$

Adding a collar C_1 to M_1 does not alter W , and gives us the symmetrical decomposition

$$W = C_0 \cup h_1 \cup \dots \cup h_t \cup C_1 .$$

In this case, define

$$W_{i+1}^* = C_1 \cup \left(\bigcup_{j > i} h_j \right),$$

then h_i can be regarded as a handle h_i^* on W_{i+1}^* with

characteristic map $e_i^* = e_i \circ T$, where

$T : B^{W-p} \times B^p \longrightarrow B^p \times B^{W-p}$ is defined by $T(x, y) = (y, x)$,

for $x \in B^{W-p}$, $y \in B^p$. This gives us the dual decomposition

$$W = C_1 \cup h_t^* \cup \dots \cup h_1^* \cup C_0$$

of W on M_1 .

Note that $\text{index } (h_1^*) = w - \text{index } (h_1)$, and that the attaching tube of h_1 is the belt tube of h_1^* .

We call a decomposition nice if $\text{index } (h_{i+1}) \geq \text{index } (h_i)$ for each i , and if handles of the same index are disjoint. By lemma 3.2 we get the following.

4.1 Lemma

Given a handle decomposition of W , there exists a nice decomposition of W with the same number of handles of each index as the original. //

Note that the dual decomposition of a nice decomposition is also a nice decomposition.

The existence of handle decompositions in general is given by the following theorem of Kirby and Siebenmann which we state without proof. For piecewise linear cobordisms the result is comparatively simple - see, for example Rourke and Sanderson [32] 6.9

4.2 Theorem (Kirby and Siebenmann [22] Chapter III, theorem 2.1)

Let (W, M_0, M_1) be a cobordism, and suppose $w \geq 6$. Then there exists a handle decomposition of W on M_0 , with C_0 any collar of M_0 in W .

Handles and homology

Given any decomposition of W on M_0 we construct a CW complex K attached to M_0 , of the same homotopy type as W and with one p -cell for each p -handle, as follows:

Suppose, inductively, that we have defined K_{1-1} and a homotopy equivalence

$$l_{1-1} : W_{1-1} \longrightarrow K_{1-1}, \text{ rel } M_0.$$

Let $r_1 : h_1^p \longrightarrow \text{core}(h_1) \cup \text{attaching tube}(h_1)$ be the obvious deformation retraction. Then $W_{1-1} \cup_{f_1} h_1$ is homotopy equivalent to $K_{1-1} \cup_{g_1} h_1$, where $g_1 = l_{1-1} \circ f_1$, which deformation retracts by $l_{1-1} \circ r_1$ on $K_{1-1} \cup_{g_1} B^p$.

Then $K_1 = K_{1-1} \cup_{g_1} B^p$ is a cell complex K_{1-1} attached p -cell, and we have constructed $l_1 : W_1 \longrightarrow K_1$.

If the decomposition was nice, the cells will be attached in order of increasing dimension and K will be a CW complex.

Now let h^p, h^{p+1} be handles in the decomposition and e^p, e^{p+1} the corresponding cells of K . Then, by niceness, we can assume that h^p, h^{p+1} are consecutive. By lemma 3.3 we have $\varepsilon(h^p, h^{p+1}) = \varepsilon(e^p, e^{p+1})$, the incidence number of e^p, e^{p+1} in K .

By considering the CW complexes associated to a decomposition and its dual we get the following.

4.3 Lemma

Let $W = C_0 \cup h_1 \cup \dots \cup h_c$ be a nice decomposition
 and $W^{(s)} = C_0 \cup (\bigcup_{p \leq s} h_1^p)$, $M^{(s)} = \partial W^{(s)} \setminus M_0$.

Then

$$(a) \quad \pi_1(W, W^{(s)}) = 0 \text{ for } i \leq s$$

$$(b) \quad \pi_1(W, M^{(s)}) = 0 \text{ for } 1 \leq s, w - s - 1.$$

Proof

(b) follows since $\pi_1(W^{(s)}, M^{(s)}) = 0$ for
 $i \leq w - s - 1$ from (a). //

Simplification of handle decompositions

In this section, we use the handle lemmas of § 3,
 together with the ideas above, to simplify handle decompositions
 under algebraic conditions. This translation of algebraic
 statements into geometric results provides the major steps
 in the proof of the h-cobordism theorem.

4.4 Lemma (Elimination of 0-handles)

Suppose given a handle decomposition of W on M_0 with
 i_p - p -handles for each p , and that each component of W meets
 M_0 . Then there exists another decomposition with no 0-handles,
 $(i_1 - i_0)$ 1-handles and i_p p -handles for $p > 1$.

Proof

By lemma 4.1 we may assume that the decomposition is nice. By hypothesis, for each 0-handle we can find a distinct 1-handle which connects it to either C_0 or another 0-handle. These form a complementary pair, which can be cancelled by lemma 3.4. See Figure 14. //

4.5 Corollary

Suppose W is connected, and $M_0, M_1 \neq \emptyset$, then W has a handle decomposition with no 0-handles, or w -handles, provided $w \geq 6$.

Proof

Apply the lemma to a decomposition, which exists by lemma 4.2, and its dual. //

4.6 Lemma (Elimination of 1-handles)

Suppose W is connected, and that we are given a handle decomposition of W on M_0 with no 0-handles and 1_p p -handles for $p > 0$. Suppose that $\pi_1(W, M_0) = 0$ and $w \geq 6$. Then there is another decomposition with 1_p p -handles, $p \neq 1, 3$, no 1-handles, and $(1_1 + 1_3)$ 3-handles.

Proof

By 4.1 we can assume the given decomposition is nice. Let h_1 be a 1-handle with characteristic map e_1 . We replace h_1 by a 3-handle and the result follows by induction.

Let $\alpha = e_1(B^1 \times \{x\})$ be an arc in the belt tube of h_1 . As in the proof of reordering (lemma 3.2), by taming, general position, and regular neighbourhoods, we can assume that α misses the 2-handles, and hence lies in $M^{(2)} = \partial W^{(2)} \setminus M_0$. Since $\pi_1(W^{(2)}, C_0) = 0$ by 4.3, we can find a map $f : D^2 \rightarrow W^{(2)}$ with $f(\partial D^2) = \alpha \cup \beta$, where β lies in C_0 . Similarly, we can assume that β is embedded in $M^{(2)}$ disjoint from all 1-handles and 2-handles. Again by 4.3, we can homotop $f \text{ rel } \partial D^2$ into $M^{(2)}$, and by 1.9 we can replace f by a locally flat embedded disc D^2 in $M^{(2)}$. See Figure 15.

The introduction lemma 3.6 can now be used to replace a neighbourhood of D^2 by a complementary 2-handle and 3-handle pair (h_2, h_3) so that the attaching sphere of h_2 is ∂D^2 . h_1 and h_2 are then complementary and can be cancelled by 3.4. This proves the lemma. //

4.7 Lemma (Elimination of p-handles, $2 \leq p \leq w - 4$)

Suppose given a handle decomposition of W on M_0 with no handles of index $< p$ and i_q q -handles for $q \geq p$.

Then if M_0 is simply-connected, $2 \leq p \leq w - 4$, $w \geq 6$ and $H_p(W, M_0) = 0$, we can find a new decomposition with the same number of q -handles for $q \neq p, p + 1$, with no p -handles and with $(i_{p+1} - i_p)$ $(p + 1)$ -handles.

Proof

We can assume the decomposition is nice (4.1) and then we can compute $H_p(W, M_0)$ from the incidence numbers. Let h^p be a typical p -handle. We show how to eliminate h^p and the result follows by induction. Let h_1^{p+1} be the $(p + 1)$ -handles and $n_1 = \epsilon(h_1^{p+1}, h^p)$. Using 3.8 we can add the $(p + 1)$ -handles so as to reduce $\sum_i |\tau_i|$ as far as possible. Finally, only n_1 , say, is non-zero, and since $H_p(W, M_0) = 0$ we must have $n_1 = \pm 1$. h^p, h^{p+1} are then algebraically complementary, and the result follows from lemma 3.5. //

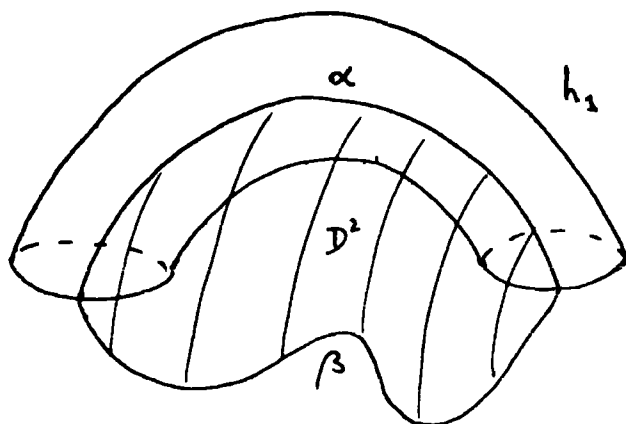

Figure 15
Elimination of 1-handles

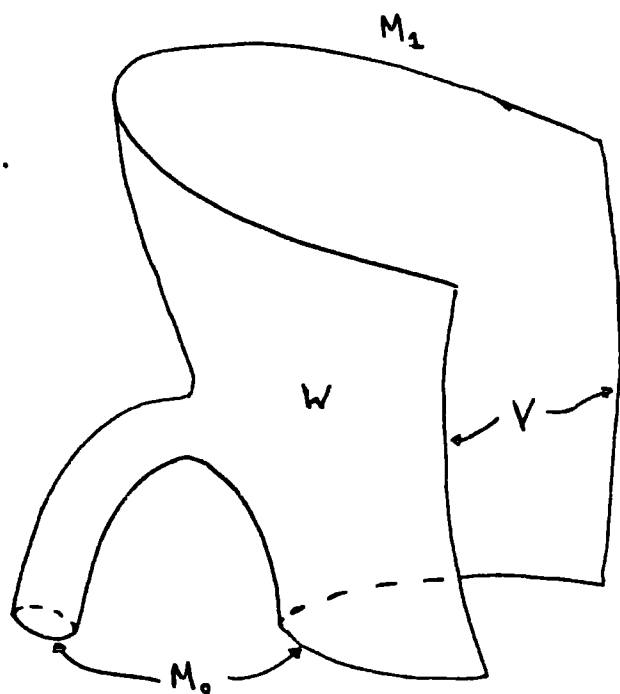

Figure 16
Cobordism with boundary

§5 The h-cobordism theorem

A cobordism (W, M_0, M_1) is an h-cobordism if both inclusions $M_0 \subset W, M_1 \subset W$ are homotopy equivalences. In this instance, the results of the last section lead to the important result that any simply-connected h-cobordism, of dimension greater than 5, is a product. To prove this, we express the cobordism as a handle decomposition, and use the algebraic conditions to simplify completely.

5.1 Theorem

Let (W^w, M_0, M_1) be a simply-connected h-cobordism. Then if $w \geq 6$, $W \cong M_0 \times I$.

Proof

By 4.2 we have a handle decomposition $W = C_0 \cup h_1 \cup \dots \cup h_t \cup C_1$. We show how to eliminate all the h_i , so that $W \cong C_0 \cup C_1$ and the result is proved. By 4.5 and 4.6 we can assume there are no 0-handles or 1-handles, and, by applying these results to the dual decomposition, that there are no w -handles or $(w-1)$ -handles. Now use 4.7 to eliminate all p -handles, $1 < p \leq w - 4$, and 4.7 applied to the dual decomposition to eliminate $(w-2)$ -handles. Then we have only $(w-3)$ -handles left. But $H_{w-3}(W, M_0) = 0$, which implies that there are no $(w-3)$ -handles left. //

The relative case

By a cobordism with boundary, (W, M_0, M_1) , we mean a compact w -manifold W , together with two disjoint $(w-1)$ -dimensional submanifolds M_0, M_1 of ∂W . Then $V = \text{cl}(\partial W \setminus (M_0 \cup M_1))$ is a cobordism between ∂M_0 and ∂M_1 . See Figure 16.

W is an h -cobordism if $M_0 \subset W, M_1 \subset W, \partial M_0 \subset V, \partial M_1 \subset V$ are all homotopy equivalences.

5.2 Theorem

Let (W, M_0, M_1) be a simply-connected h -cobordism with boundary, and suppose that $V \cong \partial M_0 \times I$ and $w \geq 6$.

Then $(W, V) \cong (M_0, \partial M_0) \times I$.

Proof

Using techniques of Connelly [9] we can extend $\partial M_0 \times I \cong V$ to a collar on M_0 . Then by 4.2 there exists a handle decomposition on this collar. By 1.6 we may assume that this decomposition is symmetrical, and it only remains to observe that each step in the proof of the absolute theorem goes through in this case, each constructed homeomorphism being fixed on V . Hence $W \cong C_0 \cup C_1 \text{ rel } V$ and the result follows. //

CHAPTER II

CRITICAL LEVEL EMBEDDINGS

This chapter is concerned with embeddings, $F : W \longrightarrow Q \times I$, of a cobordism into a product. In § 1 we define critical level embeddings, an equivalent notion in this context to that of handle decompositions of a cobordism, (I § 4), and § 3 is devoted to existence under requisite conditions.

If W is a product $M \times I$, and we know that the handle decomposition of F cancels completely, then we can realise this cancellation by an ambient isotopy of $Q \times I$. The result is that F becomes at least setwise vertical over M . These ideas correspond to I § 3, and are proved in § 4.

In the case that M is piecewise linear, the way to achieve such a cancelling handle decomposition is by relating it to an appropriate triangulation. This is discussed in § 1 and explains the statement of 3.6. When using the inductive process in Chapter III, we shall be concerned with preserving such critical level embeddings under the operation of subdivision of the triangulation, and § 2 deals with the lemmas required for this purpose.

Again, as all the results of this chapter are for application in the next, we deal with the relative case as much as possible.

§ 1 begins with an extension of the definitions of I § 4 to the case of a cobordism with boundary (as defined in I § 5).

§ 1 Definition

Let (W, M_0, M_1) be a cobordism with boundary (see I § 5) and $V = \text{cl}(\partial W \setminus (M_0 \cup M_1))$ the cobordism between ∂M_0 and ∂M_1 .

If we have a handle h attached to W by a map

$$f : \partial B^p \times B^{w-p} \longrightarrow \partial W$$

with $h \cap \partial W \subset M_1$, then we call h a handle on the cobordism (as in I § 3) provided that h is of one of the following two forms.

If h is a handle on W , with $h \cap \partial W \subset \text{int } M_1$ then we call h an interior handle. If $h \cap \partial W \not\subset \text{int } M_1$, but $h \cap \partial M_1 = f(\partial B^p \times B^{w-p-1} \times 1)$ then h is called a boundary handle. Note that in this latter case $B^p \times B^{w-p-1} \times 1$ is a p -handle \tilde{h} attached to B by $f|$, in the usual sense. See Figure 17.

In these two cases, $W' = W \cup h$ is a cobordism with boundary (W', M_0, M_1') where

$$M_1' = \begin{cases} \text{cl}[\partial W \setminus (M_0 \cup V)] & \text{for interior } h \\ \text{cl}[\partial W \setminus (M_0 \cup V \cup \tilde{h})] & \text{for boundary } h, \end{cases}$$

that is, M_1' is given by the surgery defined by h , and the cobordism V' between M_0 and M_1' is given by

$$V' = \begin{cases} V & \text{for interior } h \\ V \cup \tilde{h} & \text{for boundary } h \end{cases}$$

Handle decomposition, symmetrical decomposition, etc., are now defined, as in I § 4, for a cobordism with boundary. We also require another type of decomposition. A collared handle decomposition of a cobordism with boundary (W, M_0, M_1) is a decomposition of the form

$$W = (M_0 \times I) \cup h_1 \cup (M_{(1)} \times I) \cup h_2 \cup \dots \cup h_r \cup (M_1 \times I)$$

where each h_i is a handle attached to the cobordism with boundary

$$W_{(1-1)} = (M_0 \times I) \cup h_1 \cup (M_{(1)} \times I) \cup \dots \cup h_{r-1} \cup (M_{(1-1)} \times I)$$

and $M_{(1)}$ is obtained from $M_{(1-1)}$ by the surgery given above.

Let Q be a manifold and $F : W \rightarrow Q \times I$ an embedding such that $F^{-1}(Q \times 0) = M_0$, and $F^{-1}(Q \times 1) = M_1$. Then F is a critical level embedding if there exists a collared handle decomposition of W such that F embeds each handle h_i in $Q \times t_i$ for some $t_i \in I$, and on each collar $M_{(1)} \times I$, F is the product of an embedding of $M_{(1)}$ in Q with a direction preserving embedding of I in I .

The particular decomposition occurring in this definition will be called a handle decomposition of F , and F is critical with respect to this collared handle decomposition.

Each h_i , identified with the image of $F|_{h_i} : h_i \rightarrow Q \times t_i$ will be called a critical level of F . See Figure 18.

Now suppose that we have a piecewise linear structure on W , and that we are given a piecewise linear handle decomposition.

$$W = (M_0 \times I) \cup h_1 \cup h_2 \cup \dots \cup h_r \cup (M_1 \times I).$$

Then we form the associated collared handle decomposition by iterating the following procedure. See Figure 19.

Suppose that M_- is an $(m-1)$ -manifold with boundary, and that we add a p -handle $h = B^p \times B^{m-p}$ to $M_- \times I$ with attaching map

$$f : \partial B^p \times B^{m-p} \longrightarrow M_- \times I$$

Let $M = (M_- \times I) \cup_f h$.

In the case when h is an interior handle, we have $f : \partial B^p \times B^{m-p} \longrightarrow (\text{int } M_-) \times I$. Let $f(\partial B^p \times B^{m-p})$ be $T \times I$, the attaching tube. Now

$M = (M_- \times [0, \frac{1}{2}]) \cup ((M_- \setminus T) \times [\frac{1}{2}, 1]) \cup (T \times [\frac{1}{2}, 1]) \cup_f (B^p \times B^{m-p})$
 Let \bar{h}^p be $(\pi f(\partial B^p \times \frac{1}{2} B^{m-p}) \times [\frac{1}{2}, 1]) \cup_f (B^p \times \frac{1}{2} B^{m-p})$,
 where $\pi : M_- \times I \longrightarrow M_-$ is the projection; this is a p -handle added to $M_- \times [0, \frac{1}{2}]$. But $(T \times [\frac{1}{2}, 1]) \cup_f (B^p \times B^{m-p})$ collapses to $(\partial T \times [\frac{1}{2}, 1]) \cup (T \times \frac{1}{2}) \cup \bar{h}^p$, so that, if $a(\bar{h})$ and $b(\bar{h})$ denote the attaching and belt tubes of the handle \bar{h} , the closure of $\{(T \times [\frac{1}{2}, 1]) \cup_f (B^p \times B^{m-p})\} \setminus \bar{h}$ is homeomorphic to $\{(T \times \frac{1}{2} \setminus a(\bar{h})) \cup b(\bar{h})\} \times [\frac{1}{2}, 1]$. This homeomorphism can be explicitly recorded, it being the identity

on $\partial T \times [\frac{1}{2}, 1]$. Thus we have

$M = (M_- \times [0, \frac{1}{2}]) \cup \bar{h} \cup (M_+ \times [\frac{1}{2}, 1])$ where M_+ is the manifold obtained from M_- by the surgery defined by \bar{h} . See [19], from which this argument is taken.

We reduce the boundary handle case to an interior problem by considering the manifold

$$M'_- = M_- \cup_{\partial M_- \times 1} (\partial M_- \times [1, 3])$$

and the p -handle $h' = B^p \times B^{m-p-1} \times [-1, 2]$ attached to $\text{int } M'_- \times 1$ by $f' : \partial B^p \times B^{m-p-1} \times [-1, 2] \rightarrow M'_- \times 1$, where

$$f' = \begin{cases} f \text{ on } \partial B^p \times B^{m-p} \\ (f \mid B^p \times B^{m-p-1} \times 1) \times \text{identity on} \\ \partial B^p \times B^{m-p-1} \times [1, 2] . \end{cases}$$

Let M' be the manifold so formed. Then applying the above procedure to M' , h' gives a decomposition

$M' = (M'_- \times [0, \frac{1}{2}]) \cup \bar{h}' \cup (M'_+ \times [\frac{1}{2}, 1])$, where \bar{h}' is the handle associated to h' . Now define the boundary handle $\bar{h} = \bar{h}' \cap M$ to recover $M = (M_- \times [0, \frac{1}{2}]) \cup \bar{h} \cup (M_+ \times [\frac{1}{2}, 1])$ where M_+ is the manifold obtained from M_- by the surgery defined by \bar{h} .

If we have a triangulation K of W , then taking second derived neighbourhoods of barycentres of the first derived

subdivision gives us the second derived handle decomposition with respect to K . (Figure 20). (Note that these handles are either interior or boundary as required.) By cancelling complementary pairs of handles in this decomposition, we will obtain other handle decompositions of W . (See I § 3).

Let $K_0 \subset K$ be a subcomplex, and suppose that we form in this way a decomposition of W by cancelling those handles determined by barycentres of simplexes belonging to K_0 . Let $F : W \rightarrow Q \times I$ be a critical level embedding with respect to the associated collared handle decomposition. Then we say that F is critical with respect to $K \setminus K_0$. (K_0 may be empty).

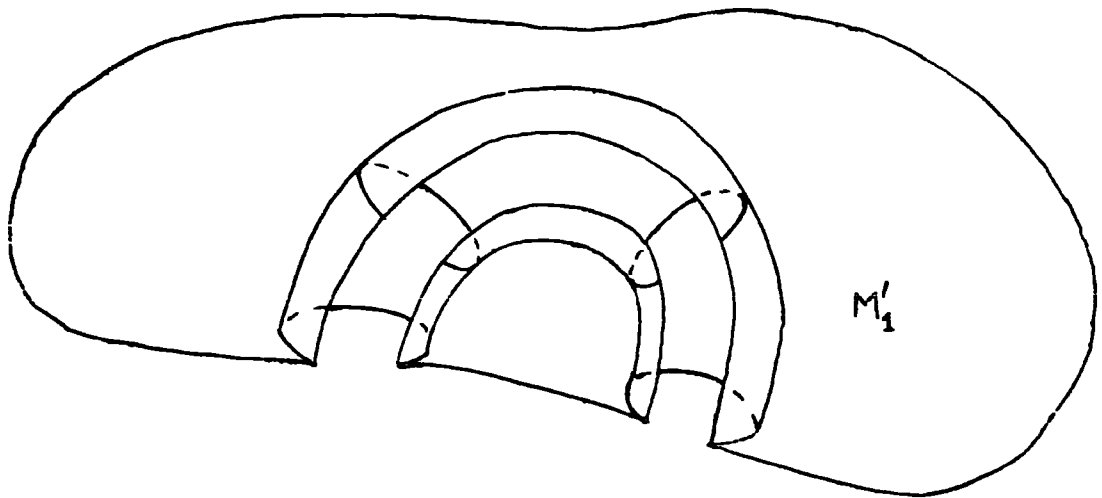
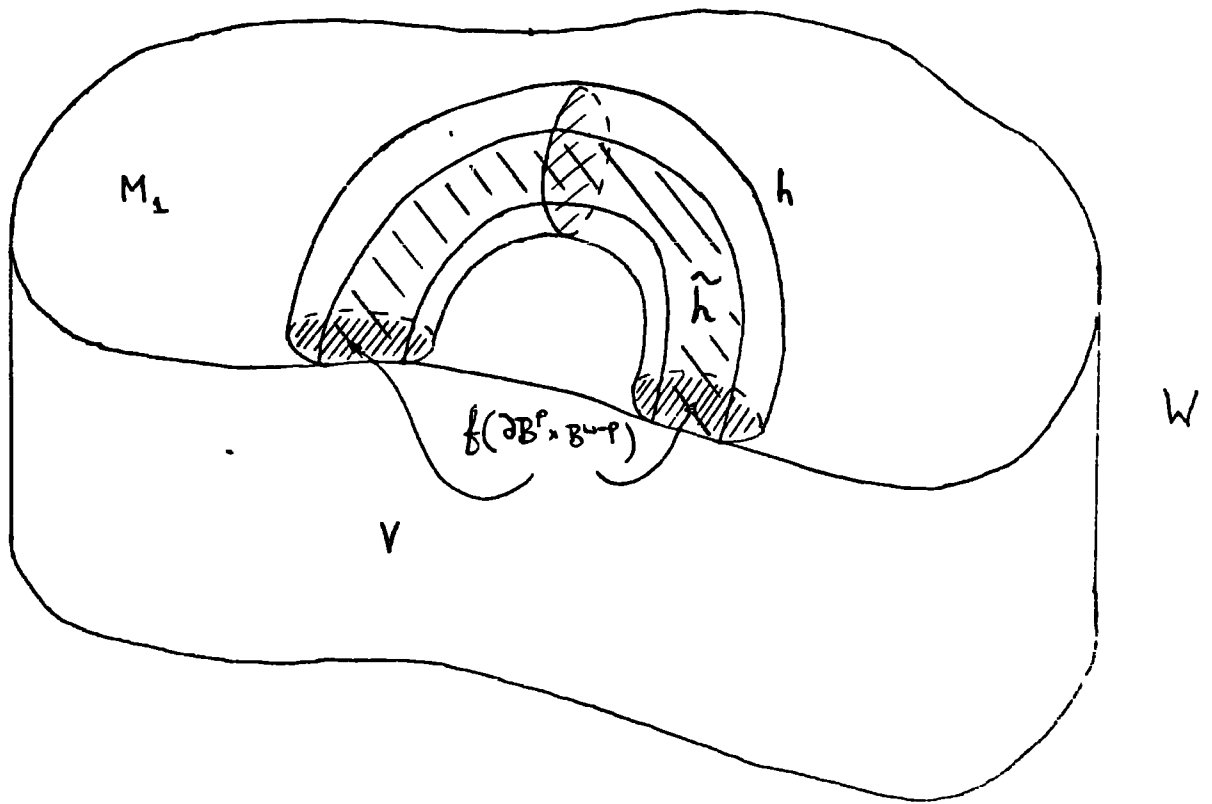
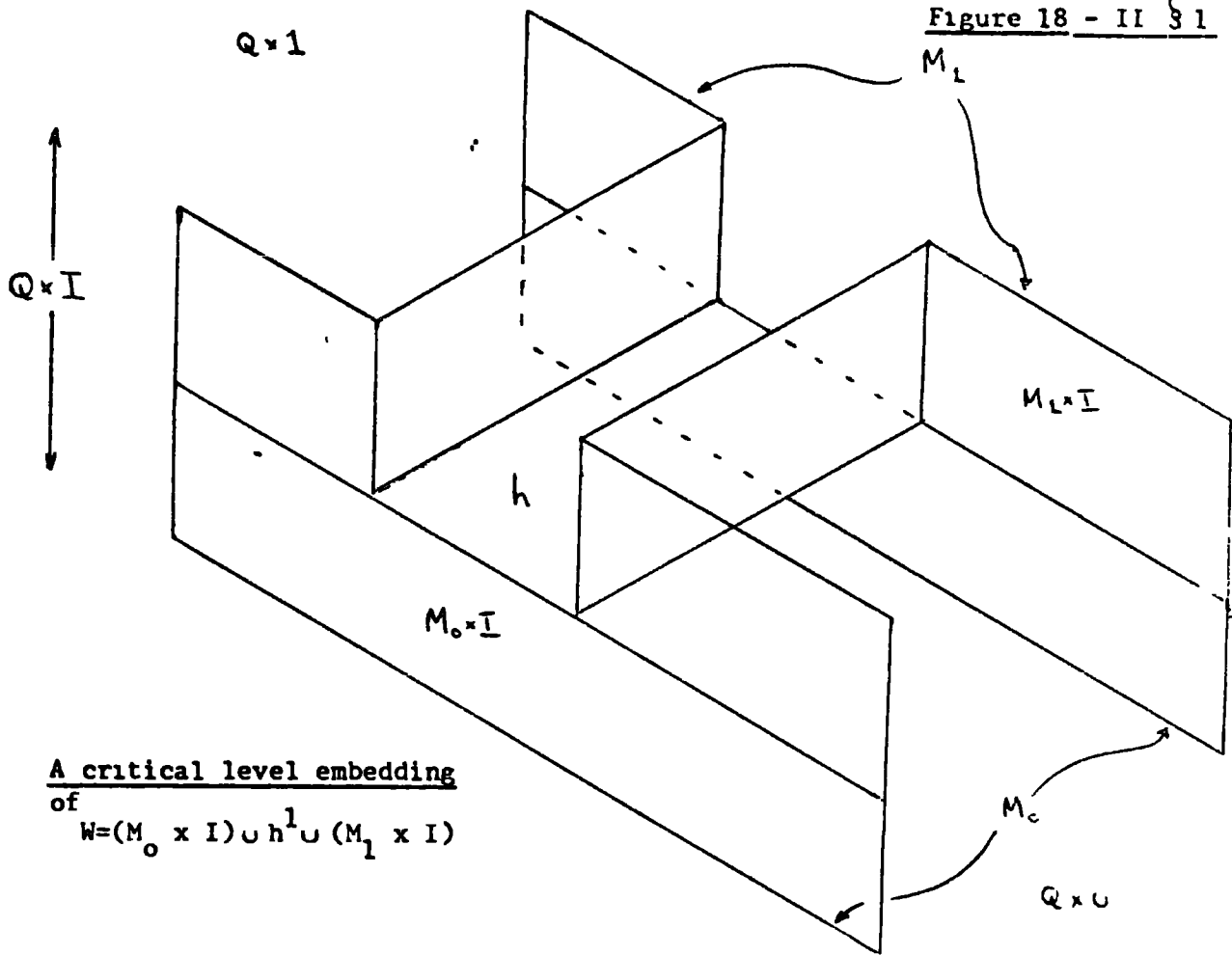

Figure 17

A boundary handle on a cobordism with boundary



A critical level embedding
of
 $W = (M_0 \times I) \cup h^1 \cup (M_1 \times I)$

A handle decomposition
 $W = (M_0 \times I) \cup h_1^0 \cup h_2^1 \cup \dots$

The associated collared handle decomposition
 $W = (M_0 \times I) \cup \bar{h}_1 \cup (M_{(1)} \times I) \cup \bar{h}_2 \cup (M_{(2)} \times I) \cup \dots$

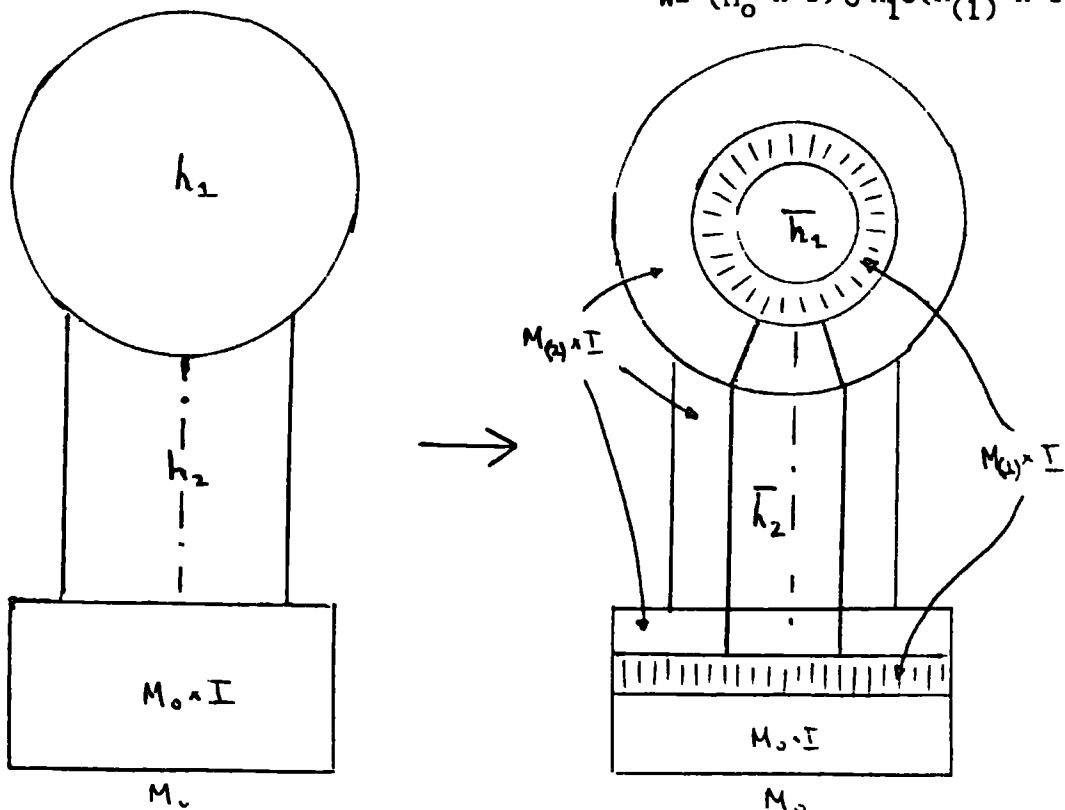

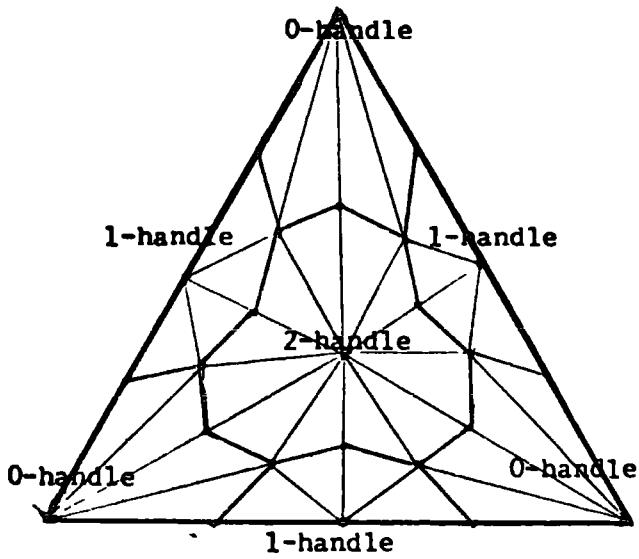

A second derived handle decomposition of a 2-simplex

Figure 20

Second derived handle decompositions II 1.

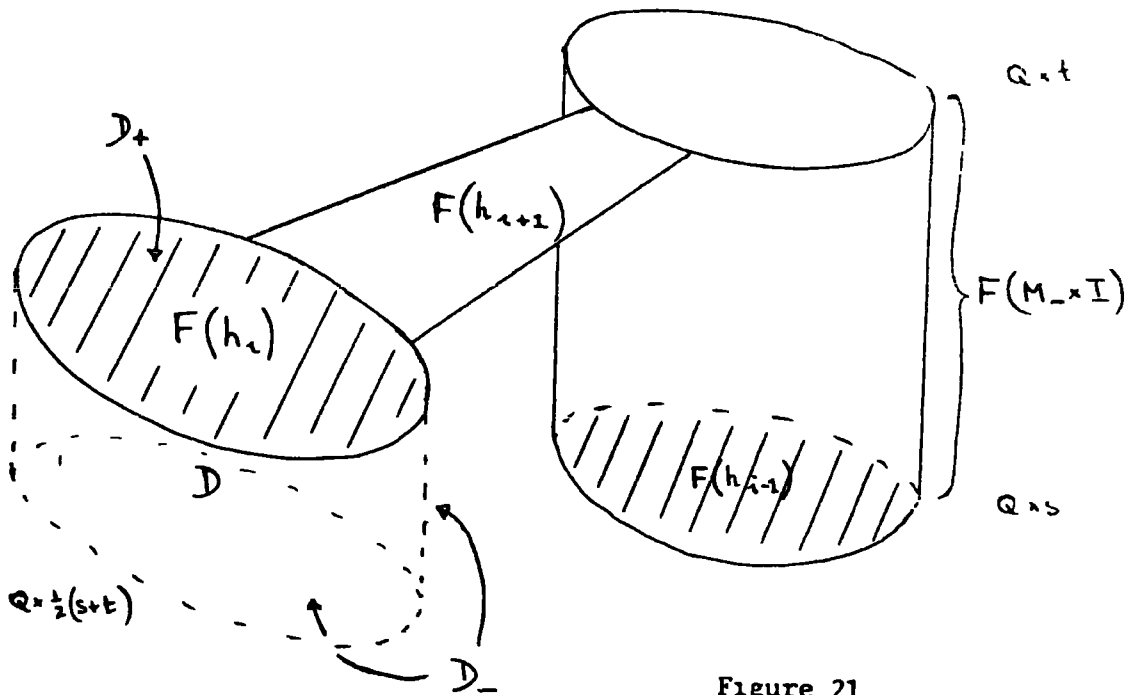

Figure 21

II Lemma 2.1

§2 Subdivision

Suppose that F is a critical level embedding with respect to some triangulation K . Is it possible to ambient isotope F so that it is critical with respect to any subdivision of K ? This section deals with this and related results.

Firstly, a preliminary lemma.

2.1 Lemma

Let W be a piecewise linear cobordism and let $F : W^{\text{int}} \longrightarrow Q \times I$, $\partial Q = \emptyset$, $q - w \geq 2$, be a critical level embedding with respect to the decomposition

$$W = (M_0 \times I) \cup h \cup (M_1 \times I).$$

Suppose given a new decomposition

$$W = (M_0 \times I) \cup h_1 \cup \dots \cup h_r \cup (M_1 \times I)$$

where $U h_1 = h$. Then there exists an ambient isotopy α of $Q \times I$, fixed on $(Q \times 0) \cup (Q \times 1)$, such that $\alpha_1 F$ is a critical level embedding with respect to the new decomposition.

Proof

By I 1.1 and I 1.10 we can assume that W and F are piecewise linear.

Let $\pi: Q \times I \rightarrow Q$ be the projection and suppose that $F(h) \subset Q \times t$. We now use induction on the h_1 . See Figure 21.

Suppose that $F(h_1)$ is attached to $F(M_- \times I)$ where $F|_{M_- \times I}: M_- \times I \rightarrow Q \times [s, t]$ is the product of an embedding of M_- in Q and a linear map of I onto $[s, t]$. Let D be the $(w+1)$ -ball $\pi F(h_1) \times \left[\frac{s+t}{2}, t\right]$ and let $N(D)$ be a regular neighbourhood of $D \bmod cl(\text{Im } F \setminus D)$ in $\text{int}(Q \times I)$. Define w -balls

$$D_+ = F(h_1) \cup \left\{ \pi F(\text{belt tube of } h_1) \times \left[\frac{1}{2}(s+t), t\right] \right\}$$

$$\text{and } D_- = \left\{ \pi F(h_1) \times \frac{1}{2}(s+t) \right\} \cup \left\{ \pi f(\text{attaching tube of } h_1) \times \left[\frac{1}{2}(s+t), t\right] \right\}$$

which are complementary in ∂D , with $\partial D_- = \partial D_+ = \partial D \cap \partial N(D)$.

Since $q-w \geq 2$, there exists an ambient isotopy β^1 of $N(D)$, fixed on $\partial N(D)$, such that $\beta_1^1(D_+) = D_-$. Moreover, β^1 can be chosen so that $\beta_1^1 F|_{\{(M_- \times I) \cup h_1\}}$ is critical with respect to the associated collared handle decomposition to $(M_- \times I) \cup h_1$.

$$\text{Define } \alpha = \beta^r \circ \beta^{r-1} \circ \dots \circ \beta^1. //$$

We use this last result to prove the following subdivision lemma.

2.2 Lemma

Let $F : W^w \longrightarrow Q^q \times I$, $\partial Q = \emptyset$, $q - w \geq 2$ be a critical level embedding with respect to some triangulation K of W , and suppose given a subdivision σK of K . Then there exists an ambient isotopy α of $Q \times I$, fixed on $Q \times 0$, such that $\alpha_1 F$ is critical with respect to σK .

Proof

Suppose that F is critical with respect to the decomposition

$$W \cong (M_0 \times I) \cup h_1 \cup (M_{(1)} \times I) \cup \dots \cup h_r \cup (M_1 \times I)$$

determined by K , and let

$$W \cong (M_0 \times I) \cup H_1 \cup \dots \cup H_s \cup (M_1 \times I)$$

be the second derived handle decomposition with respect to σK .

Suppose that h_j is the handle determined by the barycentre of a simplex $\Delta \in K$. We can assume that H_1 are ordered so that the handles determined by simplexes in $\sigma \Delta \setminus \partial(\sigma \Delta)$ are $\{H_i \mid t_{j-1} < i \leq t_j\}$.

Define $W_{(j)} = (M_0 \times I) \cup h_1 \cup (M_{(1)} \times I) \cup \dots \cup h_j \cup (M_{(j)} \times I)$. Then by uniqueness of regular neighbourhoods, there exists an ambient isotopy α of W such that for each j

$$\alpha_1 \left[(M_0 \times I) \cup \left(\bigcup_{i=1}^{t_j} H_i \right) \right] = W_{(j)}.$$

Now introduce the collars $\alpha_1^{-1} (M_{(j)} \times I)$ and by collar uniqueness (I 1.8) assume that $\alpha_1^{-1} (M_0 \times I) = M_0 \times I$ and $\alpha_1|_{(M_0 \times I)} = \text{identity}$, so that we have a decomposition

$$W = (M_0 \times I) \cup \left(\begin{array}{c} t_1 \\ \cup \\ 1=1 \end{array} H_1 \right) \cup (M_{(1)} \times I) \cup \dots \cup \left(\begin{array}{c} t_r \\ \cup \\ 1=t_{r-1}+1 \end{array} H_1 \right) \cup (M_1 \times I)$$

and an isotopy α of W such that

$$\alpha_1 \left(\begin{array}{c} \cup \\ 1=t_{j-1}+1 \end{array} H_1 \right) = h_j$$

and $\alpha_1|_{M_{(j)} \times I} = \text{identity}$.

By Edwards and Kirby [10], the isotopy α' of $F(W)$, defined by $\alpha'_t \circ F = F_0 \alpha_t$, can be extended to an ambient isotopy β of $Q \times I$. Now apply the preceding lemma, 2.1 r times to βF . //

Similar arguments lead to the following.

2.3 Lemma

Let $F : W^w \rightarrow Q^q \times I$, $q - w \geq 2$, be a critical level embedding with respect to $K \setminus K_0$, where (K, K_0) is a triangulation of $(W, F^{-1}(\partial Q \times I))$, and suppose given a subdivision σK of K . Then there exists an ambient isotopy α of $Q \times I$, fixed on $(Q \times 0) \cup (\partial Q \times I)$ such that $\alpha_1 F$ is critical with respect to $\sigma K \setminus \sigma K_0$.

If we further assume that W is compact, then α has compact support. //

2.4 Lemma

Let M^n , M_0^n , M_1^n , and T^{n-1} be manifolds, with $M = M_0 \cup M_1$ and $T = M_0 \cap M_1 = \partial M_0 \cap \partial M_1$, and let K , and the subcomplexes K_0 , K_1 , L , triangulate $M \times I$, $M_0 \times I$, $M_1 \times I$, $T \times I$ respectively. Let σK be a subdivision of K and suppose that $F : M \times I \longrightarrow Q^q \times I$, $\partial Q = \emptyset$, $q - n \geq 3$, is an embedding such that $F|_{M_0 \times I}$ is critical with respect to K_0 , and $F|_{M_1 \times I}$ is critical with respect to the handle decomposition determined by L on $T \times I$ and σK_1 on $(M_1 \setminus T) \times I$. Then there exists an ambient isotopy α of $Q \times I$, fixed on $Q \times 0$, such that $\alpha_1 F$ is critical with respect to σK . //

§3 The Critical Level Theorem

The purpose of this section is to show that, under appropriate conditions, we can ambient isotope a piecewise linear embedding of a cobordism so that it is a critical level embedding with respect to some triangulation.

In [19], Kearton and Lickorish prove results of this type, but either for interior embeddings of closed manifolds, or for concordances of closed manifolds with the ambient space a closed manifold. We require results, however, of a relative nature, but the techniques of [19] can be extended to prove them. This section, then, is based entirely on their work - 3.1 (a), 3.2 (a) being [19] Lemma 1 and Addendum, 3.1 (b), 3.2 (b), 3.4, 3.5 and their proofs being simple extensions of [19] Lemma 1, Addendum, Lemma 2 and Lemma 3 to the relative case. Likewise, the proofs of Theorem 3.6 and its Corollary are based on [19] Theorem 3 and the remarks that follow it.

The statement of 3.6 is necessarily involved - the theorem is used in Chapter III as a local piecewise linear tool to provide critical level embeddings of topological objects - and is based on Armstrong [3] observation (c).

3.1 Lemma

Let (Q_-^{q-1}, M_-^{m-1}) be a piecewise linear manifold pair, $m < q$. Let the pair (Q, M) be formed from $(Q_-, M_-) \times I$ in one of the following ways:

- (a) by attaching a p -handle pair $H^p = B^p \times (B^{q-p}, B^{m-p})$ to $(\overset{\circ}{Q}_-, \overset{\circ}{M}_-) \times 1$, where (B^{q-p}, B^{m-p}) is a standard ball pair, and then adding a $(p+1)$ -handle H^{p+1} which cancels the p -handle just added to $Q_- \times I$;
- (b) by attaching a p -handle pair $H^p = B^p \times (B^{q-p}, B^{m-p})$ to $(\overset{\circ}{Q}_-, M_-) \times 1$, where $(B^{q-p}, B^{m-p}) = (B^{q-p-1}, B^{m-p-1}) \times (B^1, [0, 1])$, (B^{q-p-1}, B^{m-p-1}) is a standard ball pair, and the handle added to $M_- \times 1$ is a boundary handle with $B^p \times B^{m-p-1} \times 0$ attached to $\partial M_- \times 1$, and then adding a $(p+1)$ -handle H^{p+1} which cancels the p -handle just added to $Q_- \times I$.

Suppose that the attaching tube of H^{p+1} does not meet M . Then there is a homeomorphism $h : Q_- \times I \rightarrow Q$ such that

- (i) $h^{-1} : M \rightarrow Q_- \times I$ is a critical level embedding with respect to the associated collared handle decomposition of M on $M_- \times I$;
- (ii) h is the identity outside a regular neighbourhood of $(Q_- \times 1) \cap (H^p \cup H^{p+1}) \text{ rel } \partial [(Q_- \times 1) \cap (H^p \cup H^{p+1})]$.

Proof

As the handles added to $Q_- \times I$ cancel, we may write $H^p = B^p \times (B^{q-p}, B^{m-p}) = B^p \times (I \times B^{q-p-1}, B^{m-p})$ where $B^{m-p} \subset \frac{1}{2} \times B^{q-p-1}$, and $H^{p+1} = B^{p+1} \times B^{q-p-1} = (B^p \times I) \times B^{q-p-1}$.

If a_1 and a_2 are the respective attaching maps, and e_1 the characteristic map of H^p , we may assume that

$a_2((B^p \times I) \times B^{q-p-1}) = e_1(B^p \times (0 \times B^{q-p-1}))$ but that otherwise the attaching tube of H^{p+1} misses H^p . It may

also be assumed that

$a_2((B^p \times I) \times \frac{1}{2} B^{q-p-1}) = e_1(B^p \times (0 \times \frac{1}{2} B^{q-p-1}))$. Now

consider the following p -handle and $(p+1)$ -handle attached to $Q_- \times [0, \frac{1}{2}]$. See Figure 22.

$$\overline{H^p} = \{B^p \times ([0, \frac{1}{2}] \times \frac{1}{2} B^{q-p-1})\} \cup_{a_1} \{a_1(\partial B^p \times [0, \frac{1}{2}] \times \frac{1}{2} B^{q-p-1}) \times [\frac{1}{2}, 1]\}$$

$$\overline{H^{p+1}} = \{B^{p+1} \times \frac{1}{2} B^{q-p-1}\} \cup_{a_2} \{a_2((B^p \times 0 \cup \partial B^p \times I) \times \frac{1}{2} B^{q-p-1}) \times [\frac{1}{2}, 1]\}.$$

These form a cancelling pair of handles, and $\overline{H^p}$ contains in its boundary the handle for M in the associated collared handle decomposition of M . Thus $\overline{H^p} \cup \overline{H^{p+1}}$ is a q -ball

D with boundary the union of two $(q-1)$ -balls D_- and D_+ ,

where $D \cap (Q_- \times \frac{1}{2}) = D_-$. Let $h: D_- \times [0, \frac{1}{2}] \rightarrow (D_- \times [0, \frac{1}{2}]) \cup D$

be a homeomorphism such that $h(D_-) = D_+$ and h is the identity

on $\partial D_- \times [0, \frac{1}{2}]$ and near $D_- \times 0$. Let E be the q -ball

$H^p \cup H^{p+1}$ with the boundary $E_- \cup E_+$, where E_- and E_+ are $(q-1)$

-balls and $E \cap (Q_- \times 1) = E_-$.

Now $E \cup (E_- \times [\frac{1}{2}, 1]) \setminus (\partial E_- \times [\frac{1}{2}, 1]) \cup (E_- \times \frac{1}{2}) \cup D \cup (M \cap E)$
 and $M \cap E \setminus (M \cap D) \cup (M \cap \{(E_- \times \frac{1}{2}) \cup (\partial E_- \times [\frac{1}{2}, 1])\})$.

Hence by standard results on regular neighbourhoods, the closure of $\{E \cup (E_- \times [\frac{1}{2}, 1])\} \setminus D$ is homeomorphic to

$\{(E_- \times \frac{1}{2}) \setminus D_- \cup D_+\} \times [\frac{1}{2}, 1]$, the homeomorphism being the identity on $\partial E_- \times [\frac{1}{2}, 1]$, and compatible with the

collar structure in the associated collared handle

decomposition of M . Thus h can be extended by the

identity on $\{(Q_- \setminus D_-) \times [0, \frac{1}{2}]\} \cup \{(Q_- \setminus E_-) \times [\frac{1}{2}, 1]\}$.

and by means of the above homeomorphism on $E_- \times [\frac{1}{2}, 1]$.

Then $h : Q_- \times I \longrightarrow Q$ has the required properties. //

3.2 Lemma

Suppose that, in the statement of 3.1, the following conditions hold in the respective cases:

- (a) the $(p+1)$ -handle H^{p+1} is a standard pair $B^{p+1} \times (B^{q-p-1}, B^{m-p-1})$ which cancels the p -handle pair added to $(\overset{\circ}{Q}_-, \overset{\circ}{M}_-) \times I$;
- (b) the $(p+1)$ -handle H^{p+1} is a pair $B^{p+1} \times (B^{q-p-1}, B^{m-p-1})$ where $(B^{q-p-1}, B^{m-p-1}) = (B^{q-p-2}, B^{m-p-2}) \times (B^1, [0, 1])$, (B^{q-p-2}, B^{m-p-2}) is standard and $B^{p+1} \times B^{m-p-2} \times [0, 1]$ is a boundary handle with $B^{p+1} \times B^{m-p-2} \times 0$ attached to the boundary, and that H^{p+1} cancels the p -handle pair added to $(Q_-, M_-) \times I$.

Then there exists a pairwise homeomorphism
 $h : (Q_-, M_-) \times I \longrightarrow (Q, M)$ and property (11) still
 holds.

Proof

$H^p \cup H^{p+1}$ is an unknotted ball pair (case (a)) or
 triple (case (b)) attached to $Q_- \times 1$ by an unknotted
 face pair, or triple, respectively. Then results of
 Zeeman [37] show that an h can be constructed of the
 required form. h then simply "stretches" the original
 collar pair over (Q, M) . //

3.3 Lemma

Suppose that the conditions of 3.2 are satisfied.
 Then there exists a homeomorphism $h : Q_- \times I \longrightarrow Q$ such
 that

- (i) $h^{-1} : M \longrightarrow Q_- \times I$ is a critical level embedding
 with respect to the associated collared handle
 decomposition of M on $M_- \times I$;
- (ii) h is the identity outside a regular neighbourhood
 of $(Q_- \times 1) \cap (H^p \cup H^{p+1})$ rel $\partial [(Q_- \times 1) \cap (H^p \cup H^{p+1})]$.

Proof

We can assume that $H^p \cup H^{p+1}$ is a standard pair $(B^q, B^m) = B^p \times B \times (B^{q-p-1}, B^{m-p-1})$ attached by a on $\{\partial B^p \times B \times (B^{q-p-1}, B^{m-p-1})\} \cup \{B^p \times -1 \times (B^{q-p-1}, B^{m-p-1})\}$, where $H^p = B^p \times \{[0, 1] \times (B^{q-p-1}, B^{m-p-1})\}$ and $H^{p+1} = (B^p \times [-1, 0]) \times (B^{q-p-1}, B^{m-p-1})$. Introduce the cancelling $(p+1)$ -handle and $(p+2)$ -handle pair

$$\tilde{H}^{p+1} = (B^p \times [-1, 0]) \times ([\frac{1}{2}, 1] \times B^{q-p-2})$$

$$\tilde{H}^{p+2} = (B^p \times [-1, 0]) \times ([\frac{1}{2}, \frac{3}{4}]) \times B^{q-p-2}$$

and let $H_*^{p+1} = H^{p+1} \setminus (\tilde{H}^{p+1} \cup \tilde{H}^{p+2})$. Then the pairs (H^p, \tilde{H}^{p+1}) and $(H_*^{p+1}, \tilde{H}^{p+2})$ are also cancelling pairs, and they each satisfy the conditions of lemma 3.1.

See Figure 23. Applying 3.1 twice gives the result. //

Let Q be a piecewise linear manifold, with boundary, and suppose that d is a collar of the pair $(Q \times 0, \partial Q \times 0)$ in $(Q \times I, \partial Q \times I)$ with $d(\partial Q \times I) = \partial Q \times I$ and $d \mid d^{-1}(Q \times 1)$ a collar of $\partial Q \times 1$ in $Q \times 1$. Now, given a handle decomposition of $Q \times I$ on $d(Q \times I)$ together with a procedure for cancelling these handles in pairs, we can construct a homeomorphism $h : Q \times I \rightarrow Q \times I$, with $h \mid (Q \times 0) \cup (\partial Q \times I) = 1$, by stretching this collar over each pair of cancelling

handles in the usual way. We say that an h so constructed is associated with d and the given handle cancelling procedure.

3.4 Lemma

If h and h' are homeomorphisms of $Q \times I$ to itself both associated with a collar d , of the above form, and a given handle cancelling procedure, then h and h' are isotopic keeping $(Q \times 0) \cup (\partial Q \times I)$ fixed.

Proof

By induction on the number of pairs of cancelling handles, it is sufficient to suppose that there is just one pair, and that h , and h' , are associated with collars d , and d' , respectively, and with this single cancelling pair of handles, where $d(Q \times I) = d'(Q \times I)$ and $d^{-1}d'$ is isotopic to the identity keeping $(Q \times 0) \cup (\partial Q \times I)$ fixed.

Let B^q be the union of the two handles. See Figure 24. Then $Q \times I = d(Q \times I) \cup B^q$ where $B^q \cap d(Q \times I) = B^{q-1} = \partial B^q \cap d(Q \times I)$. Let $\alpha, \alpha' : d(Q \times I) \rightarrow Q \times I$ be homeomorphisms sending B^{q-1} to $\partial B^q \setminus \text{int } B^{q-1}$ and which are the identity outside a regular neighbourhood of $B^{q-1} \text{ rel } \{ \partial B^{q-1} \cup (Q \times 0) \cup (\partial Q \times I) \}$.

Then α^{-1} is isotopic to the identity, for the isotopy can be constructed firstly on the ball B^{q-1} and then on the regular neighbourhood of B^{q-1} in $d(Q \times I)$. But $h = \alpha \circ d$ and $h' = \alpha' \circ d'$, for some α and α' with the above properties, and $d^{-1} \circ \alpha^{-1} \circ \alpha' \circ d'$ is isotopic to the identity, hence h and h' are isotopic. //

Suppose that $Q \times I$ is triangulated in such a way that $Q \times I \xrightarrow{s} Q \times 0$ by a cylindrical collapse (see Zeeman [38]). Then this collapse induces a cancelling procedure for the handles of the second derived handle decomposition with respect to this triangulation. Suppose this second derived is chosen so that the simplicial neighbourhood of $Q \times 0$ in the second derived is $Q \times [0, t]$ for some small t . Let d be a collar of $Q \times 0$ in $Q \times I$, whose image is the second derived neighbourhood of $(Q \times 0) \cup (\partial Q \times I)$, such that $d|_{\partial Q \times I}$ is the identity, for simplexes A of $Q \times 0$, with $A \subset \text{int } Q$, $d|_{A \times I}$ is the product of the identity on the first factor and the linear map of I onto $[0, t]$ on the second factor, and, for other simplexes A , $d(A \times I) \subset A \times I$. See Figure 25.

3.5 Lemma

Let $h : Q \times I \longrightarrow Q \times I$ be a homeomorphism associated with a collar d , of the above form, and a cancelling procedure given by a cylindrical collapse. Then h is isotopic to the identity keeping $(Q \times 0) \cup (\partial Q \times I)$ fixed.

Proof

By 3.4, we can assume that h is chosen so that $h(A \times I) = A \times I$ for each simplex A in $Q \times 0$. Now construct the isotopy inductively over each $A \times I$. //

3.6 Relative piecewise linear critical level theorem

Let (W^w, M_0, M_1) be a piecewise linear cobordism with boundary, and let P be a compact piecewise linear manifold of dimension $w - 2$. Suppose that $P \times I \times I$ is a piecewise linear submanifold of W such that (see Figure 26)

$$(P \times I \times I) \cap \partial W = (P \times I \times 0) \cup (P \times 0 \times I) \cup (P \times 1 \times I) \cup (\partial P \times I \times I)$$

$$(P \times I \times I) \cap M_i = P \times i \times I, \quad i = 0, 1.$$

$$(P \times I \times I) \cap \partial M_i = (P \times i \times 0) \cup (\partial P \times i \times I), \quad i = 0, 1.$$

Let Q^q be a piecewise linear q -manifold, and $F : W \longrightarrow Q \times I$ a piecewise linear embedding, with $w \leq q$ and Q compact, such that $F^{-1}(Q \times i) = M_i$, $i = 0, 1$, $F^{-1}(\partial Q \times I) = P \times I \times 0$, and F is vertical over $P \times 0 \times I$.

Let (K, K_0) be a triangulation of $(W, P \times I \times 0)$. Then there exists an ambient isotopy α of $Q \times I$, fixed on $(Q \times 0) \cup (\partial Q \times I)$, and a subdivision $(\sigma K, \sigma K_0)$, such that $\alpha_1 F$ is a critical level embedding with respect to $\sigma K \setminus \sigma K_0$.

3.7 Corollary

Given $\varepsilon > 0$, α and σ can be chosen so that α is an ε -ambient isotopy.

Proof of theorem

Let $c : M_0 \times I \rightarrow W$ be a collar on $(M_0, \partial M_0)$ in $(W, \partial W)$ which agrees with the structure of $P \times I \times I$, i.e. $c((x, 0, t) \times I) \subset \{x\} \times I \times t$ for $x \in P$, $t \in I$. Such a collar exists by Rourke and Sanderson [32] 4.21. (Extending collars).

By Rourke and Sanderson's level-preserving lemma [32] 4.23 (or see Hudson's results in [13] VI § 3 on compatible collars), we can choose t_0 small enough, and assume that $F(c(x, t)) = (F(x, 0), t)$ for $x \in M_0$, $0 \leq t \leq t_0$.

Now $\pi F(P \times 0 \times I)$ is a collar of $\pi F(P \times 0 \times 0) \subset \partial Q$ in $\pi F(M_0) \subset Q$, so, by collar extension again, there exists a collar $c' : \partial Q \times [0, \delta] \rightarrow Q$ with $c'(\pi F(x, 0, 0), t) = \pi F(x, 0, t)$ for $x \in P$ and $0 \leq t \leq \delta \leq 1$. We can assume that

$\text{Im}(c') \cap \pi F(W) = \pi F(P \times 0 \times [0, \delta])$. Define
 $c'' : (\partial Q \times I) \times [0, \delta] \rightarrow Q \times I$ by $c''(q, s, t) = (c'(q, t), s)$,
 then c'' is a collar of the pair $(\partial Q \times I, \partial Q \times \partial I)$ in
 $(Q \times I, Q \times \partial I)$, and $\text{Im}(c'') \cap F(W) = F(P \times I \times [0, \delta])$,
 with $c''(\pi F(x, s, 0), t) = (F(x, 0, t), s)$ for
 $x \in P, t \in [0, \delta]$.

Triangulate $Q \times I$, and subdivide K so that F is
 simplicial and $Q \times [0, t_0]$, $\text{Im}(c'')$, are subcomplexes of
 $Q \times I$. Subdivide $Q \times I$ so that $\pi : Q \times I \rightarrow Q \times 0$
 is simplicial, and take the further subdivision of K , σK ,
 induced by F . We can take the second derived of
 $Q \times I$ in such a way that the simplicial neighbourhood of
 $(Q \times 0) \cup (\partial Q \times I)$ in this second derived is
 $(Q \times [0, t_1]) \cup c''(\partial Q \times I \times [0, \varepsilon])$ for some
 $0 < t_1 < t_0$, and $0 < \varepsilon < \delta$. Now the second derived
 neighbourhood of $(Q \times 0) \cup (\partial Q \times I)$ is a collar d of the
 pair $(Q \times 0, \partial Q \times 0)$ in $(Q \times I, \partial Q \times I)$ with
 $d((\partial Q \times 0) \times I) = \partial Q \times I$. Since π is simplicial we
 have a cylindrical collapse $Q \times I \xrightarrow{d} Q \times 0$, which defines
 a cancelling procedure for the handles of the second
 derived handle decomposition of $Q \times I$ on $\text{Im}(d)$. By 3.1,
 3.2, and 3.3, we can construct a homeomorphism
 $h : Q \times I \rightarrow Q \times I$ associated to d and this cancelling
 procedure, such that $h^{-1}F$ is in critical level position
 with respect to $\sigma K \setminus \sigma K_0$. Furthermore, h will be isotopic

to the identity rel $\{(Q \times 0) \cup (\partial Q \times I)\}$ by lemma 3.5.

Define α to be this isotopy. //

Proof of corollary

Divide $Q \times I$ into a number of consecutive slabs $Q \times [\beta, \gamma]$ with $\gamma - \beta < \varepsilon$, so that $F(W)$ meets each slab in a cobordism, and apply the theorem to each slab in turn. Now all isotopies used are ε , except, possibly, on application of 3.5. When 3.4 is used in 3.5, and hence in using 3.5, each $A \times I$ is never isotoped outside $(\text{star } A) \times I$. Hence by taking a suitably fine initial subdivision of K , the corollary follows. //

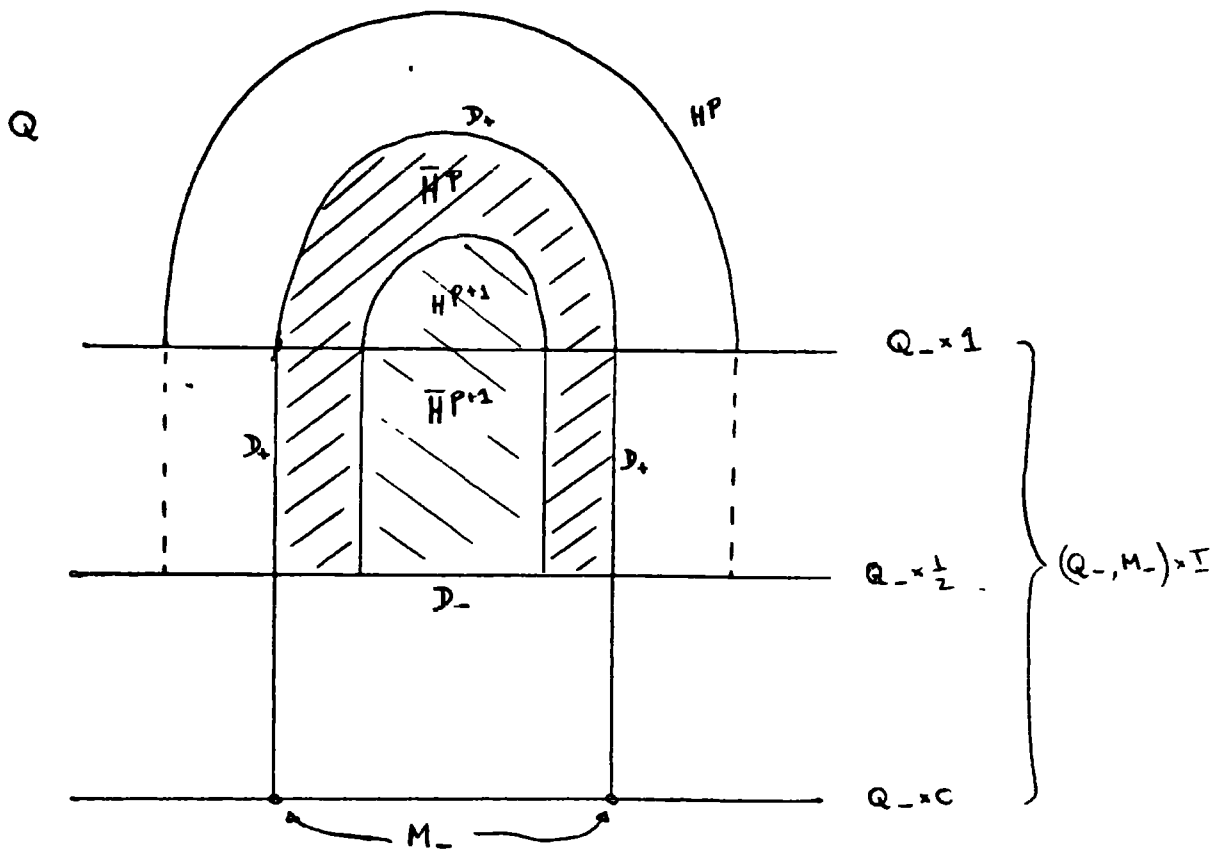
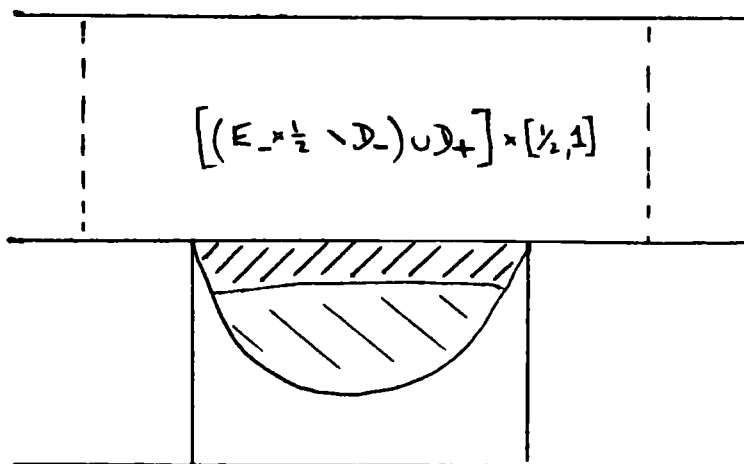

Figure 22

II Lemma 3.1



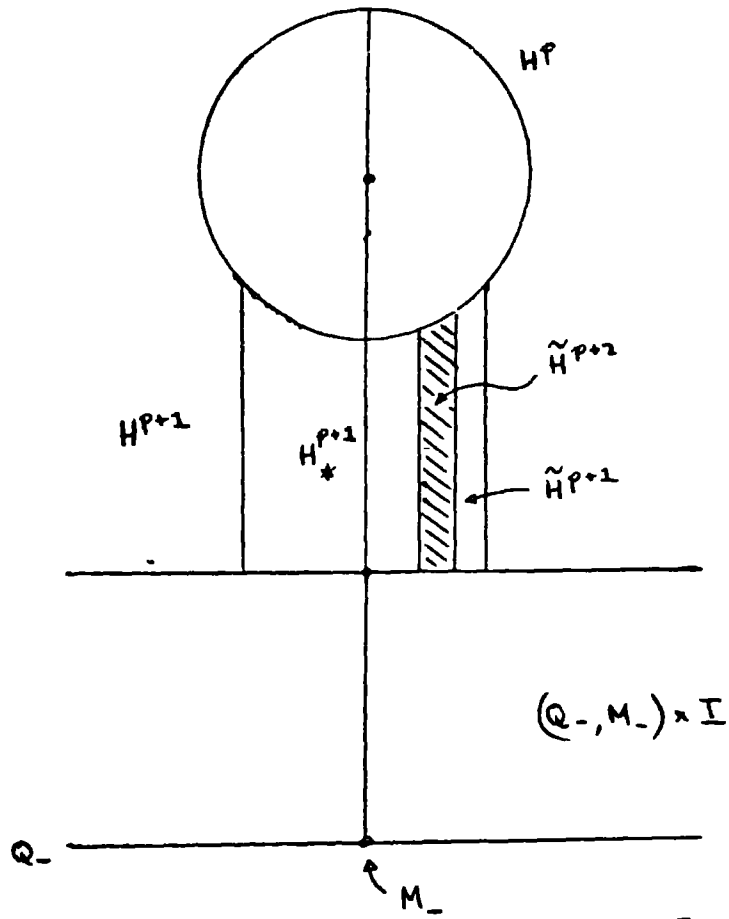

Figure 23
Lemma II 3.3

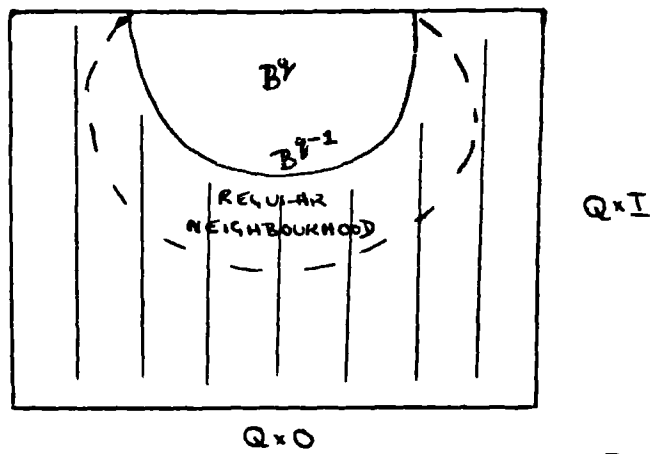

Figure 24
Lemma II 3.4

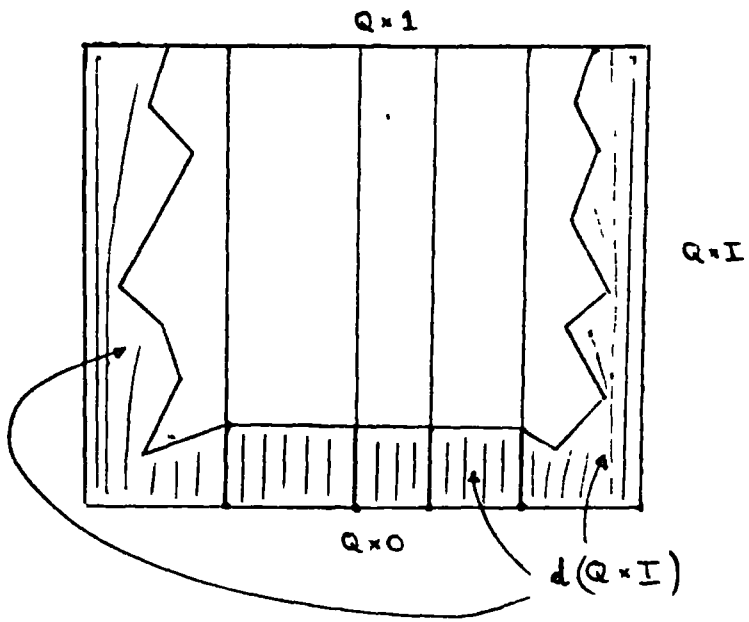

Figure 25

Lemma II 3.5

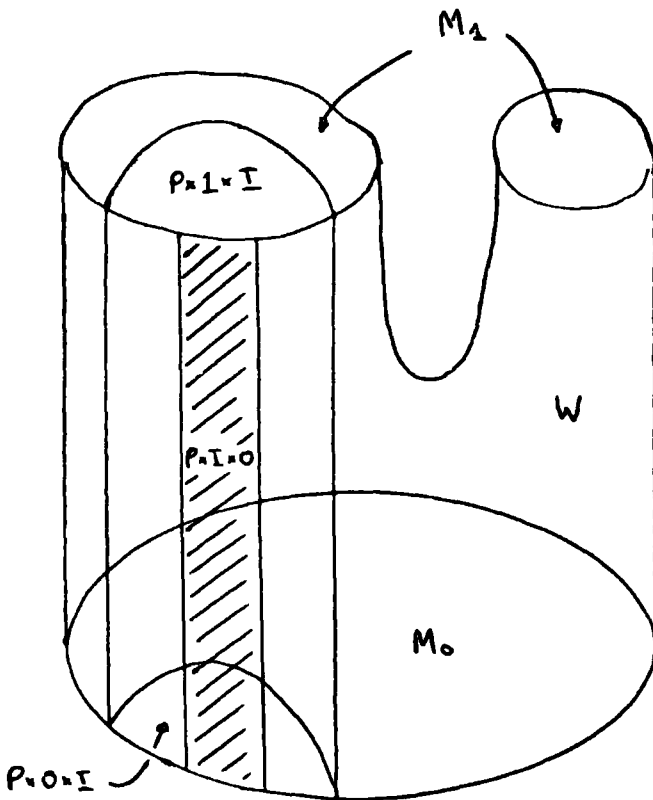

Figure 26

Lemma II 3.6 Relative
piecewise linear critical
level theorem

§4 Handle moves

Viewing a critical level embedding as an embedded handle decomposition, can we simplify the decomposition by embedded handle moves similar to the handle lemmas of I § 3? Since we will be looking at concordances, and hence dealing with products so that we can arrange for the decomposition to cancel simply, we only require two lemmas - reordering and cancellation. Order here is in the following sense.

Suppose that $F : W \longrightarrow Q \times I$ is a critical level embedding, with each critical level of F contained in $(\text{int } Q) \times I$. Now by a small ambient isotopy, we can assume that the critical levels lie in distinct $Q \times t_i$, for some $0 < t_1 < \dots < t_n < 1$. This gives a new ordering for the handles in the handle decomposition of F , determined by the order of the indices of their levels.

In the following two lemmas we assume that W and Q are piecewise linear manifolds and that $F : W^W \longrightarrow Q^Q \times I$ is a piecewise linear embedding. In theorem 4.3 we revert to the topological situation. 4.1 and 4.2 first appeared, with sketch proofs, in Rourke [31], as Lemmas 3 and 5.

4.1 Lemma (Reordering Handles)

Suppose $q - w \geq 2$, and that we are given a handle decomposition of F with handles h^p, h^r consecutive, and with $r \leq p$. Then we can find another decomposition with the same number of handles of each index, and the same ordering except that h^r precedes h^p .

Proof

Let $\pi: Q \times I \rightarrow Q$ be the projection. Suppose that h^p, h^r , are embedded in $Q \times t, Q \times t'$, respectively, and that h^r is attached to $M \times [t, t']$. Identify $\pi h^p, \pi h^r$, with $B^p \times B^{w-p}, B^r \times B^{w-r}$, respectively. Note that $\pi h^p \cap M = B^p \times \partial B^{w-p}$ and $\pi h^r \cap M = \partial B^r \times B^{w-r}$.

The arguments of the proof of the standard reordering lemma (see I 3.2) give us an ambient isotopy of M moving $\pi h^r \cap M$ off $\pi h^p \cap M$. Extend this isotopy to one of Q with the same property. See Figure 27.

Choose $0 < \eta < 1$ large enough so that $(\pi \text{ core } h^r \cap \pi h^p) \subset \text{int } (\eta B^r \times 0)$. Let N be a regular neighbourhood of $\eta B^r \times 0$ in Q , such that $N \cap M = \emptyset$. By general position there exists an ambient isotopy of Q , with support in N , carrying $(\pi \text{ core } h^r) \cap N$ off π fibre h^p , that is, an ambient isotopy of Q moving $\pi \text{ core } h^r$ off π fibre h^p leaving M fixed.

Choose a collar c of $\partial B^r \times \partial B^{w-r}$ in $M \setminus \pi h^r$, and $0 < \varepsilon < 1$ small enough so that $(\pi \text{ fibre } h^p) \cap (B^r \times \varepsilon B^{w-r}) = \emptyset$. Then the isotopy of πh^r , shrinking $B^r \times B^{w-r}$ fibrewise to $B^r \times \varepsilon B^{w-r}$, extends to an isotopy of $M \cup \pi h^r$ simply by stretching c in M , leaving $M \setminus \text{Im}(c)$ fixed. Then by the covering isotopy theorem for polyhedra (see, for example, Hudson [14] §9, or Rourke and Sanderson [32] 4.24) there exists an ambient isotopy of Q which extends the isotopy of $M \cup \pi h^r$. This gives us an ambient isotopy of Q , setwise fixed on M , moving πh^r off $\pi(\text{fibre } h^p)$.

Now let N_1, N_2 , be regular neighbourhoods of h^p mod M , $(0 \times B^{w-p}) \cup (B^p \times \partial B^{w-p})$ mod $(M \cup \pi h^r)$, respectively. Then both are regular neighbourhoods of $(0 \times B^{w-p}) \cup (B^p \times \partial B^{w-p})$ mod M , so that, by uniqueness, there exists an ambient isotopy of Q , leaving M fixed, and moving N_2 to N_1 , i.e. shifting πh^r off πh^p .

Let $\alpha: Q \times I \longrightarrow Q \times I$ be the composition of these ambient isotopies. Note α leaves M setwise fixed.

Define $\beta: Q \times I \times I \longrightarrow Q \times I \times I$ by

$$\beta(x, u, r) = \begin{cases} (x, u, r) & \text{for } (x, u, r) \in Q \times [0, t] \times I \\ \left(\alpha\left(x, \frac{u-t}{t'-t}, r\right), r \right) & \text{for } (x, u, r) \in Q \times [t, t'] \times I \\ (\alpha(x, r), r) & \text{for } (x, u, r) \in Q \times [t', 1] \times I \end{cases}$$

Then β is an ambient isotopy of $Q \times I$, shifting h^{Γ} such that $\pi\beta_1 h^{\Gamma} \cap \pi h^{\Gamma} = \emptyset$, and leaving $\text{Im}(F)$ setwise fixed below h^{Γ} .

Choose $0 < s < t$ such that no other critical levels of F lie in $Q \times [s, t]$. We now push $\beta_1 h^{\Gamma}$ down to level s in the following manner; this proves the result.

Let D be the ball $\beta_1(B^{\Gamma} \times B^{W-\Gamma}) \times [s, t]$ and $N(D)$ a regular neighbourhood of $D \bmod \text{cl}(\text{Im}(F) \setminus D)$ in $Q \times I$. Then the w -balls

$$D_- = \{\alpha_1(B^{\Gamma} \times B^{W-\Gamma}) \times s\} \cup \{\alpha_1(B^{\Gamma} \times \partial B^{W-\Gamma}) \times [s, t]\}$$

$$\text{and } D_+ = \{\alpha_1(B^{\Gamma} \times B^{W-\Gamma}) \times t\} \cup \{\alpha_1(\partial B^{\Gamma} \times B^{W-\Gamma}) \times [s, t]\}$$

are complementary in $\partial D = D_- \cup D_+$, with

$$\partial D_- = \partial D_+ = \partial D \cap \partial N(D). \quad \text{Hence there exists an ambient}$$

isotopy of $N(D)$, fixed on $\partial N(D)$, moving D_+ to D_- , since we have codimension three. Extend to an ambient

isotopy of $Q \times I$, replacing $\beta_1 h^{\Gamma}$ in level t by $\pi\beta_1 h^{\Gamma} \times s$ in level s . (This process is similar to 2.1, Figure 21). //

4.2 Lemma (Cancelling Complementary Handles)

Suppose that h^p and h^{p+1} are complementary handles in a handle decomposition of F . Then there is another handle decomposition of F , with the same number of handles of each index, except that h^p and h^{p+1} are missing, provided that $q - w \geq 2$.

Proof

Let h^{p+1} , h^p , be in levels $Q \times t'$, $Q \times t$, respectively, and be attached to $M \times [t, t']$, $M \times [s, t]$. Let $\pi: Q \times I \rightarrow Q$ be projection, and $\pi(h^{p+1}) = B^{p+1} \times B^{w-p-1}$, $\pi(h^p) = B^p \times B^{w-p}$. Note that $M \cap \pi(h^{p+1}) = \partial B^{p+1} \times B^{w-p-1}$, $M \cap \pi(h^p) = B^p \times \partial B^{w-p}$, and $(\partial B^{p+1} \times 0) \cap (0 \times \partial B^{w-p}) = \{x\}$, the one point in the definition of complementary handles. Let N be a regular neighbourhood of $B^{p+1} \times 0 \text{ mod } M$. Then by general position there exists an ambient isotopy of Q , fixed outside $\text{int } N$, such that $(\text{int } B^{p+1} \times 0) \cap (0 \times B^{w-p}) = \emptyset$, that is, shifting $\pi(\text{core } h^{p+1})$ such that $\pi(\text{core } h^{p+1}) \cap \pi(\text{fibre } h^p) = \{x\}$, and leaving M fixed.

Choose $\varepsilon > 0$ such that $(\partial B^{p+1} \times \varepsilon B^{w-p-1}) \cap (0 \times B^{w-p}) = \{x\} \times \varepsilon B^{w-p-1}$. Let $X = (B^{p+1} \times 0) \cup (\{x\} \times \varepsilon B^{w-p-1})$, and let N_1 , N_2 be regular neighbourhoods of $B^{p+1} \times \varepsilon B^{w-p-1} \text{ mod } M$, $X \text{ mod } [(0 \times B^{w-p}) \cup M]$, respectively. Then N_1 , N_2 are both regular neighbourhoods

of $X \text{ mod } M$, so that by uniqueness there exists an ambient isotopy of Q moving N_1 onto N_2 , and leaving M fixed. This carries $B^{p+1} \times \in B^{w-p-1}$ off into $\pi(\text{fibre } h^p)$.

Now, using similar arguments to those of the reordering lemma, 4.1, we can ambiently isotope $Q \times I$ so that

$\pi(h^{p+1}) \cap \text{int } \pi(h^p) = \emptyset$, leaving $\text{Im}(F)$ setwise fixed below h^{p+1} .

We now alter F by pushing h^{p+1} into the same level as h^p . This level then consists of a "step" - a disc attached to M_- by a face - which we remove by pushing it vertical. F will then have a handle decomposition of the required form.

Let D be the ball $B^{p+1} \times B^{w-p-1} \times [t, t']$ and $N(D)$ a regular neighbourhood of $D \text{ mod } c_1$ ($\text{Im}(F) \setminus D$) in $Q \times I$. Then the balls $D_- = (B^{p+1} \times B^{w-p-1} \times t) \cup (B^{p+1} \times \partial B^{w-p-1} \times [t, t'])$ and $D_+ = (B^{p+1} \times B^{w-p-1} \times t') \cup (\partial B^{p+1} \times B^{w-p-1} \times [t, t'])$ are complementary in $\partial D = D_- \cup D_+$, with

$\partial D_- = \partial D_+ = \partial D \cap \partial N(D)$. Hence there exists an ambient isotopy of $N(D)$ fixed on the boundary, moving D_+ to D_- . Extend to an ambient isotopy of $Q \times I$, replacing h^{p+1} in $Q \times t'$ by $\tilde{h}^{p+1} = \pi(h^{p+1}) \times t$ in the same level as h^p . See Figure 28.

Since h^p, \tilde{h}^{p+1} are complementary, we now have

$\pi(h^p \cup \tilde{h}^{p+1}) = E$, a ball attached to M_- by a face E_- .

Let E_+ be the complementary face to E_- in ∂E . Then,

as above, there exists an ambient isotopy α of Q , with support in a regular neighbourhood $N(E)$ of $E \bmod \text{cl}(M_- \setminus E_-)$

such that $\alpha_1(E_+) = E_-$. Define $\beta : Q \times I \times I \longrightarrow Q \times I \times I$

by

$$\beta(x, u, r) = \begin{cases} (x, u, r) & \text{for } (x, u, r) \in Q \times [0, t] \times I \\ (\alpha(x, r, \frac{u-t}{t-t'}), r) & \text{for } (x, u, r) \in Q \times [t, t'] \times I \\ (\alpha(x, r), r) & \text{for } (x, u, r) \in Q \times [t', 1] \times I \end{cases}$$

Then $E_- \times [t, t']$ and $\beta_1\{(E \times t) \cup (E_+ \times [t, t'])\}$ are balls with common boundary, so move the latter to the former by an ambient isotopy supported in a regular neighbourhood of $N(E) \times [t, t'] \bmod \beta_1(\text{cl}[\text{Im}(F) \setminus \{(E \times t) \cup (E_+ \times [t, t'])\}])$

See Figure 29.

F is now in critical level position, with respect to the original decomposition with h^p and h^{p+1} cancelled. //

We apply the preceding two lemmas in the next theorem to simplify completely a cancelling handle decomposition of a topological embedding $F : M \times I \longrightarrow Q \times I$, where M is a codimension three piecewise linear manifold.

4.3 Theorem

Suppose that $F : M \times I \longrightarrow Q \times I$ is an embedding, where M is a piecewise linear n -manifold and Q is a topological q -manifold, which is a critical level embedding with respect to a cancelling handle decomposition of $M \times I$. Further suppose that $F^{-1}(\partial Q \times I) = X \times I$, where X is a closed subset of M , and that F is vertical over a neighbourhood of a closed subset Y of M that contains X . Then, if $q-n \geq 3$, there exists an ambient isotopy α of $Q \times I$, fixed on $(Q \times 0) \cup (\partial Q \times I)$ and on a neighbourhood of $F(Y \times I)$ in $Q \times I$, such that

$$\alpha_1 F(M \times I) = \left[\alpha_1 F(M \times 0) \right] \times I.$$

Proof

Using I 1.1 and I 1.10, we can apply the proofs of lemmas 4.1, 4.2 in the topological situation, in a manner similar to that of I § 3.

As we have a cancelling decomposition, the result follows. //

4.4 Remark

In the case that M is compact, we may assume that the ambient isotopy α of 4.3 has compact support. //

Figure 27
Lemma II 4.1 (Reordering)

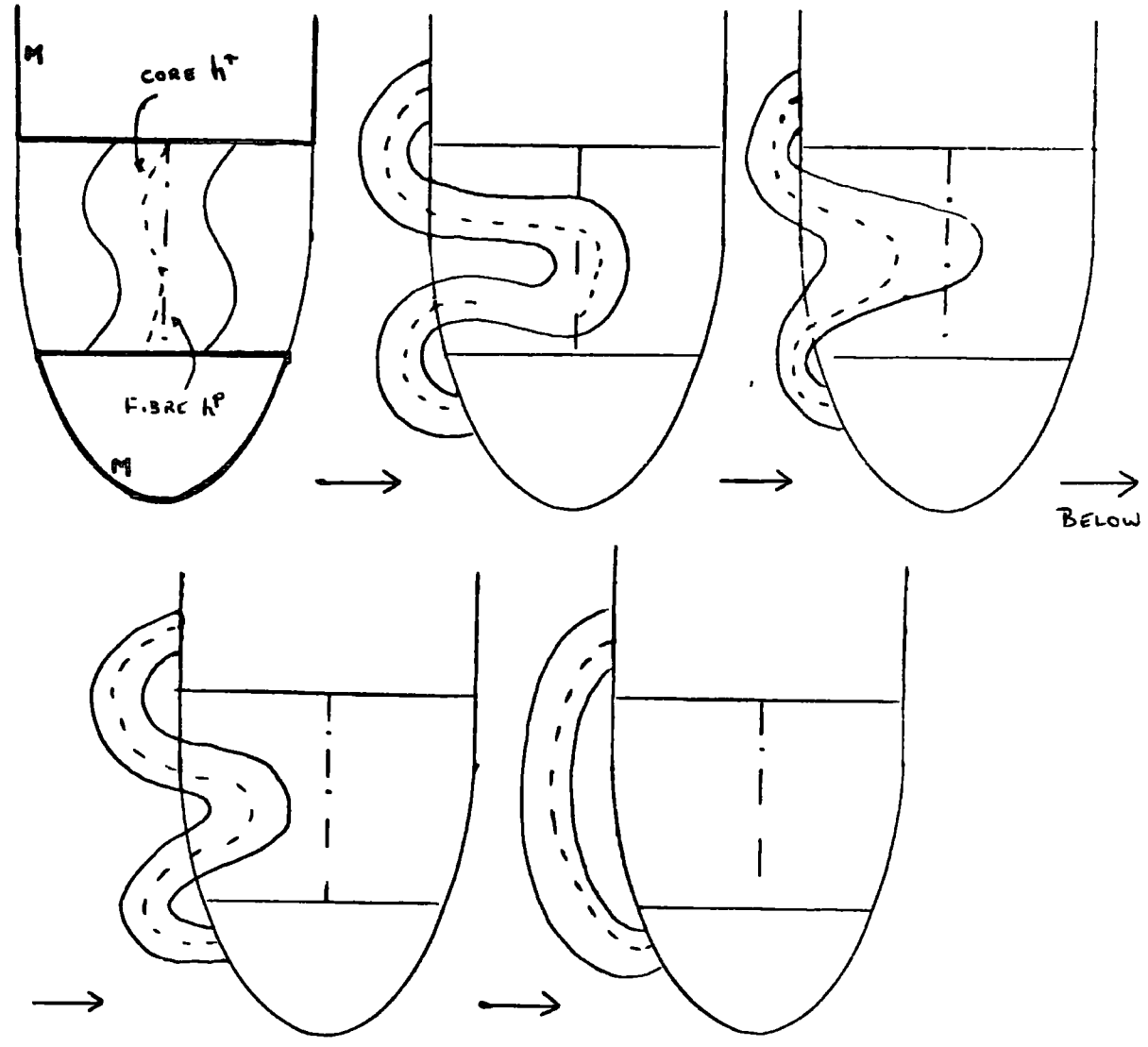
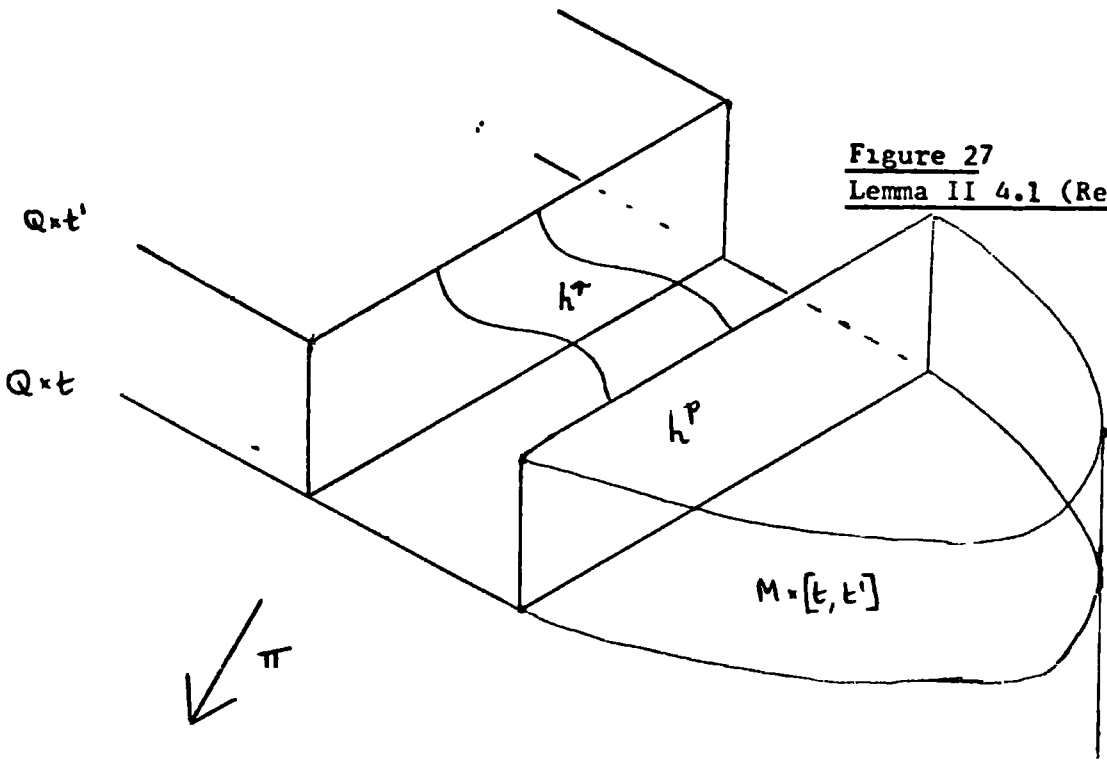

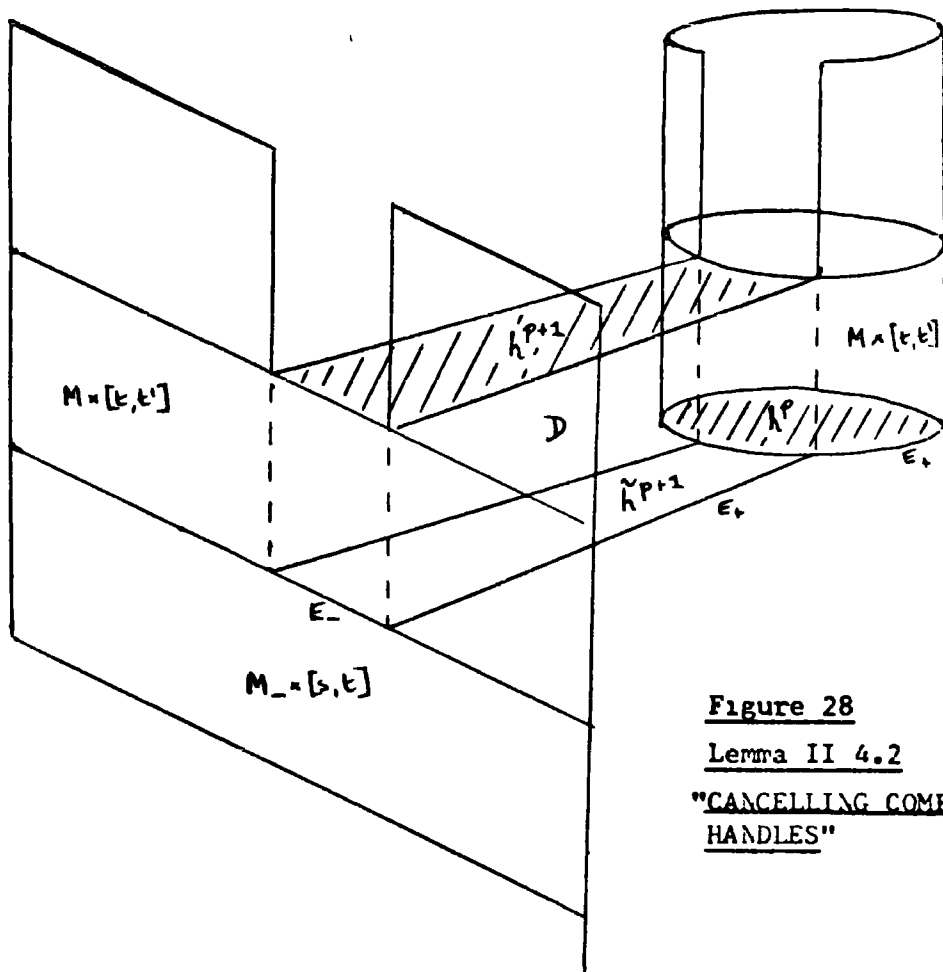

Figure 28
Lemma II 4.2
"CANCELLING COMPLEMENTARY HANDLES"

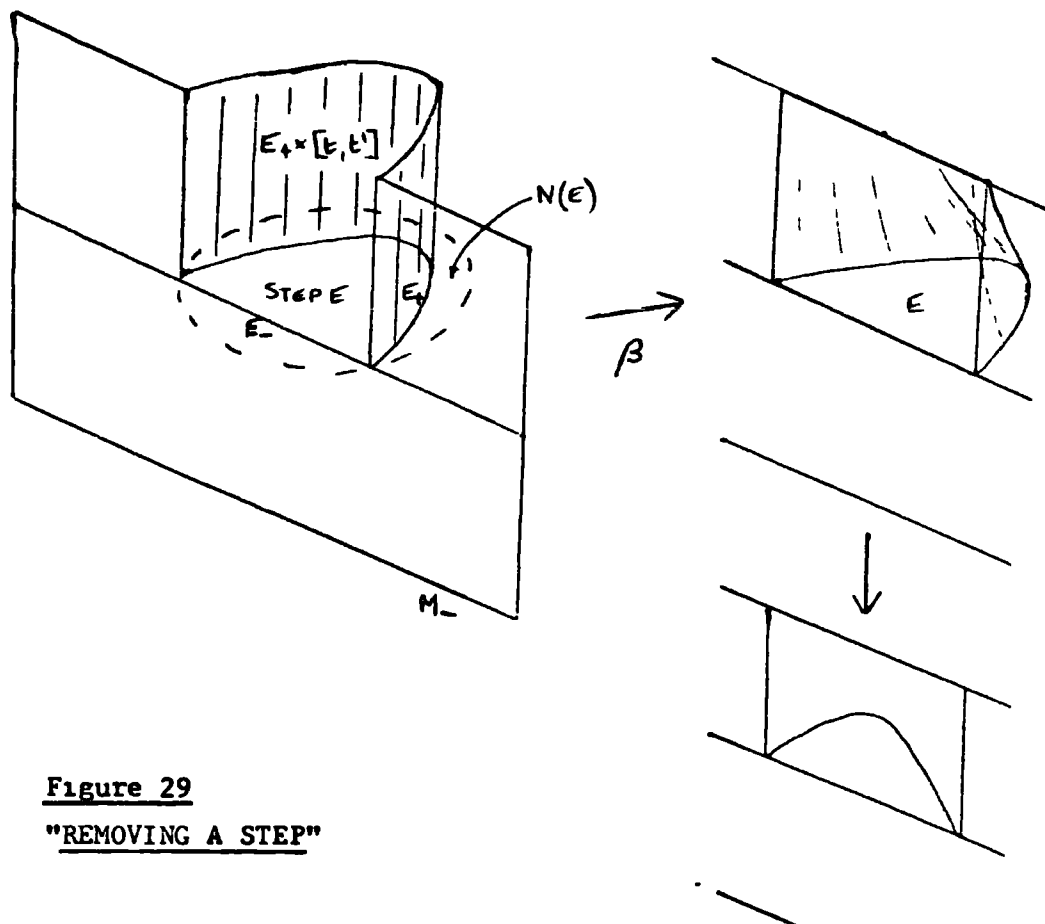

Figure 29
"REMOVING A STEP"

CHAPTER III

CONCORDANCE AND ISOTOPY

The final chapter is divided into two sections. In the first we develop the proof of the main theorem (1.5) from the results and techniques of Chapter II. This theorem has as a corollary that concordance implies isotopy for embeddings of manifolds in manifolds. To simplify the proof, we have stated 1.5 as an absolute theorem - we give a more general relative result in § 2, together with versions for embeddings of polyhedra in manifolds, and, at the end of that section, for embeddings of polyhedra in polyhedra. We also prove that given $\epsilon > 0$, there exists a $\delta > 0$ such that, if two close embeddings of a manifold in a manifold are concordant by a concordance within δ of the vertical concordance, then those embeddings are ϵ -ambient isotopic.

We begin § 1 with some definitions, then state and quote the proof of the Approximation theorem of Armstrong [3] . This result is used in conjunction with an inductive application of Proposition 1.2 to change topological concordances into critical level embeddings, a major step of 1.5.

§ 1 The Main Theorem

Two embeddings f, g of M in Q are concordant if there is an embedding $F : M \times I \rightarrow Q \times I$ which satisfies $F^{-1}(Q \times 0) = M \times 0$, $F^{-1}(Q \times 1) = M \times 1$, $F|_{M \times 0} = f$ and $F|_{M \times 1} = g$.

Let $\pi : Q \times I \rightarrow Q \times 0$ be the projection. A concordance F is regular over a subset U of M if the set $\pi F(U \times I)$ lies in a compact q -dimensional submanifold of Q which supports a piecewise linear structure. When Q is a manifold with boundary we shall call a concordance F allowable if $F^{-1}(\partial Q \times I) = X \times I$, where X is a closed subset of M , and F is vertical over a neighbourhood of a closed subset Y of M that contains X .

Suppose that Q is a non-triangulable manifold (see the Introduction), and let f be a space-filling curve $f : I \rightarrow Q$ (see [11]). Then the embedding F defined by

$$\begin{aligned} F : I &\rightarrow Q \times I \\ t &\mapsto (f(t), t) \end{aligned}$$

is a concordance of a point in Q which is not regular.

However, Armstrong [3] has proved the following theorem for allowable concordances, in codimension three, so that we can ambient isotope such a concordance to be regular over the members of some open cover. (In fact Armstrong's proof is for $q \geq 4$, but $q - n \geq 3$ works equally well).

1.1 Theorem (Approximation; Armstrong [3] theorem 1)

Let M^n, Q^q be manifolds, M compact and $q - n \geq 3$, and let $F : M \times I \rightarrow Q \times I$ be an allowable concordance. Then there is an ambient isotopy K of $Q \times I$, and a covering of M by open sets U_1, U_2, \dots, U_s such that:

- (i) K is fixed on $Q \times 0$, on $\partial Q \times I$ and on a neighbourhood of $F(Y \times I)$ in $Q \times I$;
- (ii) K has compact support;
- (iii) $K_1 F$ is regular over $U_1, 1 \leq i \leq s$.

Proof

We shall content ourselves with examining the case where $\partial M, \partial Q$ and Y are all empty, leaving the extra details required for the relative case to the reader.

Since M is compact it is enough to find an ambient isotopy K of $Q \times I$ rel $Q \times 0$ and a neighbourhood $U(x)$ for

each point x of M such that $K_1 F$ is regular over $U(x)$ for all $x \in M$. Let $\{V_\alpha\}$ be a collection of closed locally flat balls in Q whose interiors cover Q . By Lebesgue's lemma we can find a covering of M by balls B_1, B_2, \dots, B_r and a partition $0 = t_0 < t_1 < \dots < t_n = 1$ of I so that if $1 \leq i \leq r$ and $1 \leq j \leq n$ then there exists α_j^1 with $F(B_i \times [t_{j-1}, t_j]) \subseteq \text{int } V_{\alpha_j^1} \times I$. Let \hat{B}_1 denote a slightly enlarged copy of B_1 (say B_1 plus a collar) so that this property remains true with B_1 replaced by \hat{B}_1 . Consider first those points that lie in the ball B_1 . We shall show by induction that given k , $1 \leq k \leq n$, there exists an ambient isotopy G^k of $Q \times I$ rel $Q \times 0$ and a neighbourhood $U^k(x)$ for each $x \in B_1$ such that

- (i) $\pi G_1^k F(U^k(x) \times [0, t_k])$ lies in a compact q -dimensional submanifold of Q that supports a piecewise linear structure, and
- (ii) $G_1^k F(\hat{B}_1 \times [t_{j-1}, t_j]) \subseteq \text{int } V_{\alpha_j^1} \times I$, $1 \leq i \leq r$
 $1 \leq j \leq n$.

The induction begins with $k = 1$. By construction $\pi F(\hat{B}_1 \times [0, t_1])$ lies in the interior of the ball $V_{\alpha_1^1}$, so we may take G^1 to be the identity and $U^1(x)$ to be \hat{B}_1 for all x in B_1 . Inductive step $k \rightarrow k + 1$. The interiors of

the sets $U^k(x)$ form an open cover of B_1 . Let $\text{int } U^k(x_1), \dots, \text{int } U^k(x_s)$ be a finite subcover. By assumption there are compact q -dimensional submanifolds W_1, \dots, W_s of Q , each of which supports a piecewise linear structure, such that

$$(iii) \quad \pi G_1^k F(U^k(x_m) \times [0, t_k]) \subseteq \text{int } W_m \text{ for } 1 \leq m \leq s. \quad (\text{We can write } \text{int } W_m \text{ by collaring.})$$

Choose $\epsilon > 0$ small enough so that altering G^k by composing it with an ϵ -ambient isotopy of $Q \times I$ will not destroy condition (ii) or condition (iii). We know that

$$G_1^k F(\hat{B}_1 \times [t_k, t_{k+1}]) \subseteq \text{int } V \times I \text{ where } V = V_{\alpha^1}^{k+1}.$$

Give \hat{B}_1 and V piecewise linear structures as balls, and, using the taming theorem I 1.3, perform an ϵ -ambient isotopy H of $Q \times I$ rel $Q \times 0$ such that $H_1 G_1^k F$ is piecewise linear on $\hat{B}_1 \times [t_k, t_{k+1}]$. Set $G^{k+1} = H G^k$. Now let $x \in B_1$ and suppose that x lies in $U^k(x_m)$. We shall enlarge W_m so as to include $\pi G_1^{k+1} F(\{x\} \times [t_k, t_{k+1}])$ in its interior. Set $A = \pi G_1^{k+1} F(U^k(x_m) \times [0, t_k])$ and $X = \pi G_1^{k+1} F(\{x\} \times [t_k, t_{k+1}])$. Then $A \subseteq \text{int } W_m$ and $X \subseteq \text{int } V$. Note that X is a finite 1-complex in V .

Let \hat{W}_m denote an enlarged copy of W_m formed by adding an open collar $\partial W_m \times [0, 1)$ to its boundary. Let $h : Q \times 0 \rightarrow Q \times 0$ be a homeomorphism such that

- (a) $h(X)$ is piecewise linear in W_m near where it meets ∂W_m and $h(X)$ meets ∂W_m transversally in a finite number of points.

- (b) h is sufficiently small so that $h(A) \subseteq \text{int } W_m$.

We now replace W_m by $h^{-1}W_m$. Note that $A \subseteq \text{int } h^{-1}W_m$ and that X meets $\partial(h^{-1}W_m)$ in a very nice way. We can now enlarge $h^{-1}W_m$ to include all of X simply by adding a finite number of 1-handles (corresponding to thickening X) and extending the piecewise linear structure of $h^{-1}W_m$ over these. This process gives a compact q -dimensional submanifold W of Q which has a piecewise linear structure and which contains $A \cup X$ in its interior. So W contains $\pi_1^{k+1} G^k F(U(x) \times [0, t_{k+1}])$ in its interior for some neighbourhood $U(x)$ of x in M . This completes the inductive step.

In this way, at the end of the induction, we have an ambient isotopy G^n and a neighbourhood $U(x)$ for each point x of B_1 such that $G_1^n F$ is regular over $U(x)$ for all $x \in B_1$. Let $\text{int } U(x_1), \dots, \text{int } U(x_l)$ be a finite subcover of B_1 chosen from the family $\{\text{int } U(x)\}$. We now move on and deal with points of B_2 in exactly the same way. Any

isotopies used are made small enough so as to preserve regularity over $U(x_1), \dots, U(x_l)$. In other words, in dealing with points of B_2 we respect our work over B_1 . The process is complete after r steps. //

We use this result to change concordances into critical level embeddings with the aid of the next proposition. First we need a technical definition. Let $K_0 \subset K$ be complexes, then define K restricted to $|K_0|$, $K \mid (|K_0|)$, to be K_0 .

1.2 Proposition

Let M^n and Q^q be manifolds, $q-n \geq 3$, M with a piecewise linear structure, and let $F : M \times I \rightarrow Q \times I$ be an allowable concordance. Let $M_0 \subset M$ be a piecewise linear submanifold with $Y \subset M_0$, h a handle, and $M = M_0 \cup h$, with N a regular neighbourhood of the attaching tube of h in M_0 . Let k triangulate $M \times I$, with $M \times 0$, $M \times 1$, $M_0 \times I$, $h \times I$, $Y \times I$ and $N \times I$ as subcomplexes and suppose that F is regular over $h \cup N$, and $F \mid M_0 \times I$ is critical with respect to $(K \mid M_0 \times I) \setminus (K \mid Y \times I)$. Then there exists an ambient isotopy α of $Q \times I$, and a subdivision σK of K such that:

- (i) α is fixed on $(Q \times 0) \cup (\partial Q \times I)$, and on a neighbourhood of $F(Y \times I)$ in $Q \times I$;
- (ii) α has compact support;
- (iii) $\alpha_1 F$ is critical with respect to $\sigma K \setminus (\sigma K \mid Y \times I)$.

Proof

Since F is regular over $h \cup N$, there exists a compact q -dimensional submanifold A of Q , which supports a piecewise linear structure, such that $\pi F([h \cup N] \times I) \subset \text{int } A$.

We can assume that $F|_{M_0 \times I}$ has critical levels H_i in $Q \times \{c_i\}$, $i = 1, \dots, s$, with $c_1 < c_{i+1}$ given i . Choose $\{t_i\}$ by $t_0 = 0$, $t_s = 1$, and $c_1 < t_1 < c_{i+1}$ for $i = 1, \dots, s-1$. Then each $Q \times [t_i, t_{i+1}]$ contains one and only one critical level, $F(H_i)$, which can be of two types:

either (I) $H_i \cap (h \times I) \neq \emptyset$;

or (II) $H_i \cap (h \times I) = \emptyset$.

From now on we work in $A \times I$, keeping $\partial A \times I$ fixed - extending all isotopies to $Q \times I$ by the identity will give us the result. Let T be the attaching tube of h , then $N = T \times J$ (where $J = [0, 1]$) with $\partial T \times J \subset \partial M_0$.

Consider $F|_{([h \cup N] \times 0)} : [h \cup N] \times 0 \rightarrow A \times 0$. By I 1.4, there exists an ε -ambient isotopy β of $A \times 0$, fixed on $\partial A \times 0$, such that $\beta_1 F|_{([h \cup N] \times 0)}$ is piecewise linear. Then the ambient isotopy $\beta \times 1$ of $A \times I$ preserves the properties of F , so let $\bar{F} = (\beta_1 \times 1)F$.

We wish to deal with the first slab, $Q \times [t_0, t_1]$. First choose t', t'' by $c_1 < t' < t_1 < t'' < c_2$ and let V be

the piecewise linear submanifold of $N \times I$,

$$V = (N \times I) \cap \bar{F}^{-1}(A \times [t_0, t'']).$$

Then V is a cobordism between $V_0 = (N \times I) \cap \bar{F}^{-1}(A \times t_0)$ and $V_1 = (N \times I) \cap \bar{F}^{-1}(A \times t'')$ of the form

$$V = (V_0 \times [t_0, c_1]) \cup (V \cap H_1) \cup (V_1 \times [c_1, t'']).$$

Case (I)

$H_1 \cap (h \times I) \neq \emptyset$, so H_1 is associated to the barycentre of a simplex of K' lying in $T \times I$. Hence $H_1 \cap (T \times [\delta, 1] \times I) = \emptyset$ for some $[\delta, 1] \subset J$. Let $P = V_0 \cap [(T \times 1) \times I]$ and choose a neighbourhood $P \times I$ in V_0 , with $\partial P \times I \subset \partial V_0$, such that $P \times I \subset V_0 \cap (T \times [\delta, 1] \times I)$. Then $\bar{F}|_V : V \rightarrow A \times [t_0, t'']$ is vertical over $P \times I$, so we can define $P \times I \times [t_0, t''] \subset V$ with $\bar{F}|_{(P \times I \times [t_0, t''])} : P \times I \times [t_0, t''] \rightarrow A \times [t_0, t'']$ piecewise linear. Now, by I 1.4, there exists an \mathcal{E} -ambient isotopy γ of $A \times t''$, fixed on $P \times I \times t''$, and with support in a neighbourhood of $V_1 \setminus (P \times I \times t'')$, (and hence keeping $\bar{F}([M_0 \setminus N] \times I) \cap (A \times t'')$ fixed), such that $\gamma_1 \bar{F}|_{V_1} : V_1 \rightarrow A \times t''$ is piecewise linear. Define the ambient isotopy $\bar{\gamma}$ of $A \times I$ by

$$\bar{\gamma}_t = \begin{cases} \gamma_t \times 1 & \text{on } A \times [t', 1] \\ \gamma_{st} & \text{on } A \times \{(1-s)t_0 + st'\}, s \in [0, 1] \\ 1 & \text{on } A \times t_0 \end{cases}$$

Then $\bar{\gamma}$ preserves all other critical levels of \bar{F} , and $\bar{\gamma}_1 \bar{F} | \{V_0 \cup (V_1 \times [t', t'']) \cup (P \times I \times [t_0, t''])\}$ is a piecewise linear map into $A \times [t_0, t'']$.

We now wish to make $\bar{\gamma}_1 \bar{F} (h \times I) \cap (A \times t_1)$ a piecewise linear submanifold of $A \times t_1$. Consider the closed subset of $[h \cup N] \times I$, $C = ([h \cup N] \times I) \cap (\bar{\gamma}_1 \bar{F})^{-1}(A \times t_1)$, and let U be a regular neighbourhood of the simplicial neighbourhood of C in $[h \cup N] \times I$. By subdivision of K , if necessary, we may assume that $\bar{\gamma}_1 \bar{F}(U) \subset \text{int } A \times (t', t'')$, and by I 1.4 and general position, we can ε -ambient isotope $A \times [t', t'']$, leaving the boundary and $V_1 \times [t', t'']$ fixed, so that $\bar{\gamma}_1 \bar{F} | U : U \rightarrow A \times [t', t'']$ is piecewise linear, and also maps U piecewise linearly transversal to $A \times t_1$.

Hence we can define a piecewise linear submanifold of $[h \cup N] \times I$, $W = ([h \cup N] \times I) \cap (\bar{\gamma}_1 \bar{F})^{-1}(A \times [t_0, t_1])$, which is a piecewise linear cobordism between

$W_1 = ([h \cup N] \times I) \cap (\bar{\gamma}_1 \bar{F})^{-1}(A \times t_1)$, $i = 0, 1$, with $P \times I \times [t_0, t_1]$ as a piecewise linear submanifold. Also $\bar{\gamma}_1 \bar{F} | W : W \rightarrow A \times [t_0, t_1]$ can be assumed piecewise linear by I 1.4, so let $B \subset A$ be a regular neighbourhood of $\pi \bar{\gamma}_1 \bar{F}(W) \text{ rel } \bar{\gamma}_1 \bar{F}(P \times I \times t_0)$ not meeting

$\pi(\bar{\gamma}_1 \bar{F}(M_0 \times I) \cap (A \times [t_0, t_1]))$, and consider

$\bar{\gamma}_1 \bar{F} | W : W \rightarrow B \times [t_0, t_1]$. Then, applying II 3.7 we can assume that $\bar{\gamma}_1 \bar{F} | W$ is in critical level position

with respect to $(\sigma K | W) \setminus (\sigma K | P \times 0 \times [t_0, t_1])$ for some subdivision σK of K which has W and $P \times 0 \times [t_0, t_1]$ as subcomplexes. Call this last CONDITION I.

Case (II)

$H_1 \cap (h \times I) = \emptyset$. We can assume that

$$\pi(\bar{F}(h \times I) \cap (Q \times [t_0, t''])) \cap \pi\bar{F}(H_1) = \emptyset \dots (*)$$

For, if not, choose $t_0 < r_0 < c_0 < r_1 < t''$ so that

$$\pi(\bar{F}(h \times I) \cap (Q \times [r_0, r_1])) \cap \pi\bar{F}(H_1) = 0$$

and apply the following argument to each of the slabs $Q \times [t_0, r_0]$, $Q \times [r_0, r_1]$, $Q \times [r_1, t'']$, as described in the induction process later.

Now $\bar{F} | V : V \rightarrow A \times [t_0, t'']$ is vertical over $P = V_0 \cap (T \times I)$ and hence defines a piecewise linear submanifold $P \times [t_0, t'']$ of V , and $\bar{F} | (P \times [t_0, t'']) : P \times [t_0, t''] \rightarrow A \times [t_0, t'']$ is piecewise linear. Using the techniques of case (I) we can assume that $\bar{F}(h \times I) \cap (A \times t_1)$ is a piecewise linear submanifold of $A \times t_1$, and can define the piecewise linear submanifold of $[h \cup N] \times I$, $W = (h \times I) \cap \bar{F}^{-1}(A \times [t_0, t_1])$, which is a piecewise linear cobordism between $W_1 = (h \times I) \cap \bar{F}^{-1}(A \times t_1)$, $i = 0, 1$, with $P \times [t_0, t_1]$ a piecewise linear submanifold of ∂W . Again, by I 1.4, $\bar{F} | W : W \rightarrow A \times [t_0, t_1]$ can be assumed piecewise linear, and (using (*) to define B as in case (I)) we are in a position to apply II 3.7, except that \bar{F} is not vertical

Over a neighbourhood $P \times I$ of P in W_0 . However, this can be remedied by uniqueness of collars, so that II 3.7 applies, and we have $F \mid W$ in critical level position with respect to $(\sigma K \mid W) \setminus (\sigma K \mid P \times [t_0, t_1])$ for some subdivision σK of K , which has W and $P \times [t_1, t_1]$ as subcomplexes. Call this last CONDITION II.

We now use the above procedure (modified for $A \times [t_s, 1]$) in conjunction with II 2.2, inductively over the slabs $A \times [t_1, t_{i+1}]$ to give us a single subdivision σK of K , and an isotopy β' of $A \times I$, so that $\beta'_1 F$ satisfies a condition of the form of CONDITION I or CONDITION II in each slab.

Further subdivide K , so that, for each slab of type I, $\sigma K \mid W$ is the subdivision determined by the following lemma, (1.3). Then on application of this lemma to each slab in turn we have $\beta'_1 F \mid M_0 \times I$ critical with respect to $K_0 \setminus L$, and $\beta'_1 F \mid h \times I$ critical with respect to the collared handle decomposition determined by K_0 on $T \times I$, and σK on $(h \setminus T) \times I$.

Using a combination of II 2.3 and II 2.4 now gives the result, except that $\beta'_t \mid A \times 0$ is not the identity. Define α by

$$\alpha = [(\beta' \mid A \times 0)^{-1} \times 1] \beta' //$$

1.3 Lemma

Let V, V', W, Z be piecewise linear cobordisms, with $W = V \cup V', Z = V \cap V' = \partial V \cap \partial V'$, and let $V = (V_0 \times I) \cup h \cup (V_1 \times I)$ be a collar handle decomposition of V . Let K triangulate W , and suppose that $F : W \rightarrow Q \times I, \partial Q = \emptyset$, is critical with respect to K . Then there exists a subdivision σK of K , with V' and Z as subcomplexes, and an ambient isotopy α of $Q \times I$, fixed on $Q \times 0$, such that $\alpha_1 F \upharpoonright V$ is critical with respect to the given collar handle decomposition, and $\alpha_1 F \upharpoonright (V' \setminus Z)$ is critical with respect to the collar handle decomposition determined by σK .

Note

If $\partial Q \neq \emptyset$, the lemma still holds, provided that $F^{-1}(\partial Q \times I) = P \times I \subset (\partial V \setminus Z)$ and, if $L \subset K$ triangulates $P \times I$, then we assume that F is critical with respect to $K \setminus L$.

Proof

Choose σK as follows : so that V, V', h and core (h) are subcomplexes; so that $V_0 \times I \xrightarrow{s} V_0 \times 0, V_1 \times I \xrightarrow{s} V_1 \times 0, h \xrightarrow{s} (\text{core}(h) \cup \text{attaching tube}(h))$ and $(\text{core}(h) \setminus \overset{\circ}{\Delta}) \xrightarrow{s} \partial \text{core}(h)$, where Δ is a top-dimensional simplex of core (h) . Now II 2.2 applies to put F in

critical level position with respect to σK , and then we use II 4.1, II 4.2 to cancel those handles determined by $(\sigma K | V) \setminus \overset{\circ}{\Delta}$. Now simply adjust $F | V$ to give the result. //

1.4 Remark

Notice that all isotopies in the proof of the proposition are ϵ , except for those given by the use of the subdivision lemmas II 2.2, II 2.3, II 2.4, and that given by lemma 1.3 above. By introducing more slabs $Q \times [t_i, t_{i+1}]$ we control this last isotopy at least in the vertical direction, and provided the triangulation K in the statement of the proposition is fine enough, all these isotopies, and hence α , can be assumed ϵ . (In the subdivision lemmas, no simplex Δ of K is moved outside star Δ).

1.5 Theorem

Let M^n, Q^q be manifolds without boundary, M compact and $q-n \geq 3$, and let $F : M \times I \rightarrow Q \times I$ be a concordance. Then there is an ambient isotopy α of $Q \times I$, with compact support and fixed on $Q \times 0$, such that $\alpha_1 F$ is vertical.

Proof

Cover M by balls B_1, \dots, B_r . We wish to show inductively that we can make F vertical over a neighbourhood of $B_1 \cup B_2 \cup \dots \cup B_k = A_k$. Then, when $k = r$, we have F vertical over M .

So, assume that we have an ambient isotopy α^k of $Q \times I$ rel $(Q \times 0)$ such that $\alpha_1^k F$ is vertical over a neighbourhood U_k of A_k . The induction starts by taking $U_0 = A_0 = \emptyset$, and $\alpha^0 = \text{identity}$, in the following. Let B be a locally flat ball in M with $B_{k+1} \subset \text{int } B$. By I 1.1 we may assume that $F_0(B)$ is standard inside a chart E of $Q \times 0$. Now $\alpha_1^k F(A_k \times I)$ and $\alpha_1^k F([B \setminus \text{int } U_k] \times I)$ are disjoint compact subsets of $Q \times I$. Therefore, there exists a neighbourhood O of $\alpha_1^k F(A_k \times I)$ in $Q \times I$ disjoint from $\alpha_1^k F([B \setminus \text{int } U_k] \times I)$. Let V be an open neighbourhood of $F_0(A_k)$ in $Q \times 0$ such that $V \times I \subset O$. Triangulate E with $F_0(B)$ as a subcomplex, and subdivide finely enough so that the simplicial neighbourhood S of $F_0(A_k \cap B)$ in E lies in V . Let N be a second derived neighbourhood of S inside V . Define

$$X = B \setminus F_0^{-1}(\text{int } N)$$

$$\text{and } Y = (Q \times 0) \setminus [\text{int } N \cup F_0(A_k)],$$

and consider the concordance $\alpha_1^k F : X \times I \rightarrow Y \times I$.

Note that X has a piecewise linear structure, and is a top-dimensional submanifold of B ; also, $\alpha_1^k F$ is vertical over a neighbourhood of $F_0^{-1}(\partial Y)$. Now make use of theorem 1.1 to find an ambient isotopy β of $Y \times I$ and an open covering of X so that $\beta_1 \alpha_1^k F$ is regular over each member of the open cover. Since β has compact support and is fixed on $(Y \times 0) \cup (\partial Y \times I)$ we can extend it by the identity to the whole of $Q \times I$.

Let L be a triangulation of X so that $F_0^{-1}(\partial Y)$ is a subcomplex, and let $X_0 = N(F_0^{-1}(\partial Y), L)$. Then X has a second derived handle decomposition with respect to L

$$X = X_0 \cup h_1 \cup \dots \cup h_s.$$

Let $X_t = X_0 \cup (\bigcup_{i=1}^t h_i)$; then X_t are subcomplexes of L .

If T_t is the attaching tube of h_t , let N_t be the simplicial neighbourhood of T_t in X_{t-1} .

Since $\beta_1 \alpha_1^k F$ is vertical over a neighbourhood of $F_0^{-1}(\partial Y)$, we can choose L fine enough so that $\beta_1 \alpha_1^k F$ is vertical over X_0 , and each $(h_t \cup N_t)$ lies in some member of the chosen open cover. We now wish to use proposition 1.2 inductively over the X_t . For this we require the ambient isotopy at each stage to be ϵ , in order to preserve regularity over later handles. This we can

do, by remark 1.4, provided that we choose a sufficiently fine initial triangulation K of $K \times I$, with each of $X \times 0$, $X \times 1$, $X_t \times I$, $h_t \times I$ and $N_t \times I$ as subcomplexes. Thus, when $t = s$, we have an ambient isotopy of $Y \times I$ moving $\beta_1 \alpha_1^k F$ into critical level position with respect to $\sigma K \setminus (\sigma K | X_0)$ for some subdivision σK of K . By II 2.3 we can assume that σK is chosen so that $X \times I \xrightarrow{s} X \times 0$ cylindrically. Then, since this provides a cancelling decomposition, theorem II 4.3 applies, with the result that the concordance becomes setwise vertical over $X \times 0$. Hence the concordance now lies inside $E \times I$, and we can apply Armstrong [2] theorem 4 to make it vertical over X . Defining α^{k+1} to be α^k composed with the above isotopies provides the result, since $\alpha^{k+1} F$ is vertical over B and over a neighbourhood of A_k , and hence over a neighbourhood of A_{k+1} . (Note that all isotopies of $Y \times I$ have compact support, and are fixed on $(Y \times 0) \cup (\partial Y \times I)$, so they can be extended to $Q \times I$ by the identity.) //

2 Further Results

Relative theorem

The proof of 1.5 is a relative proof, and as such can be used in a straightforward manner to prove the following. See p.67 for the definition of an allowable concordance, (and Y).

2.1 Theorem

Let M^n , Q^q be manifolds, $q-n \geq 3$, and let $F : M \times I \rightarrow Q \times I$ be an allowable concordance. Suppose $\text{cl}(M \setminus Y)$ is compact. Then there is an ambient isotopy α of $Q \times I$, with compact support and fixed on $(Q \times 0) \cup (\partial Q \times I)$ and on a neighbourhood of $F(Y \times I)$ in $Q \times I$, such that $\alpha_1 F$ is vertical. //

2.2 Corollary (Concordance implies Isotopy)

Let M^n , Q^q be manifolds, $q-n \geq 3$. If $f, g : M \rightarrow Q$ are embeddings which are allowably concordant, and if $\text{cl}(M \setminus Y)$ is compact, then f, g are ambient isotopic keeping $\partial Q \cup f(Y)$ fixed.

Proof

The corollary follows from 2.1 by considering $\alpha | Q \times 1$. //

Polyhedra in manifolds.2.3 Theorem

Let Q^n be a manifold, and (X, X_0) a polyhedral pair, with $\text{cl}(X \setminus X_0)$ compact and $\dim(X \setminus X_0) = n$.

Let $F : X \times I \rightarrow Q \times I$ be a concordance, which is locally flat on the simplexes of some triangulation K of $X \times I$, and for which $F^{-1}(\partial Q \times I) = X_0 \times I$. Suppose further that F is vertical over some neighbourhood U of a closed subset Y of X that contains X_0 . Then, if $n \geq 3$, there is an ambient isotopy α of $Q \times I$, with compact support and fixed on $(Q \times 0) \cup (\partial Q \times I)$ and on a neighbourhood of $F(Y \times I)$ in $Q \times I$ such that $\alpha_1 F$ is vertical.

Proof

For simplicity we consider the absolute case $\partial Q = \emptyset$, $U = \emptyset$. The relative case follows similarly.

The proof is by induction over the skeleta K^i of $K|X \times 0$, $i = 0, 1, \dots, n$. Applying 2.1 to the 0-skeleta, $|K^0|$, we can ambient isotope $Q \times I$ so that F is vertical over $|K^0|$. Now suppose we have ambient isotoped $Q \times I$ so that F is vertical over $|K^i|$. Then

by I 1.4 and Hudson [14], theorem 1.1 (concordance implies isotopy for piecewise linear embeddings of polyhedra) we may assume that F is vertical over a regular neighbourhood N of $|K^r|$ in X . Let N' be a neighbourhood of $F_0(|K^r|)$ in Q such that $F_0^{-1}(N') \subset \text{int } N$ and consider $F|_{\text{cl}(|K^{r+1}| \setminus F_0^{-1}(N')) \times I}$, an embedding into $\text{cl}(Q \setminus N') \times I$.

On application of 2.1 to this concordance, we obtain F vertical over $|K^{r+1}|$. The proof follows. //

As with 2.2, we have the following corollary.

2.4 Corollary (Concordance implies Isotopy for embeddings of Polyhedra)

Let X be a polyhedron, Q a manifold and $f, g : X \rightarrow Q$ two embeddings which are concordant by a concordance F . Suppose that X, Q, F satisfy the conditions of theorem 2.3. Then f and g are ambient isotopic keeping $\partial Q \cup f(Y)$ fixed. //

ϵ -concordances

We recall the definition. A concordance $F : M \times I \longrightarrow Q \times I$ is an ϵ -concordance if $\pi \circ F : M \times I \longrightarrow Q \times I$ is an ϵ -homotopy, that is, given any $(x, t) \in M \times I$, $d(\pi F(x, 0), \pi F(x, t)) < \epsilon$, where $\pi : Q \times I \longrightarrow Q$ is the projection onto the first factor.

Corresponding to 2.2, we can ask whether two embeddings which are δ -concordant by an allowable concordance, are in fact ϵ -ambient isotopic.

The proof of 1.5 is almost sufficient to answer in the affirmative. The extra work required is a version of Rourke's technique in [31] which straightens concordances inductively over handles. This allows us to work locally, and hence to restrict the size of ambient isotopies.

We first give an absolute theorem.

2.5 Theorem

Let M^n, Q^q be manifolds without boundary, M compact, and $q-n \geq 3$, and let $f, g : M \longrightarrow Q$ be embeddings. Then, given $\epsilon > 0$, there exists a $\delta > 0$ such that if f, g are concordant by a δ -concordance then f, g are ϵ -ambient isotopic.

Proof

The general argument is that of the proof of 1.5 - we induct over a covering of M by balls. Here we give the inductive step, using the notation of 1.5.

We can follow the proof of 1.5 to δ -ambient isotope the given δ -concordance $F : X \times I \rightarrow Y \times I$ to a critical level embedding which is in turn a 2δ -concordance. To do this we use remark 1.4, and notice that the ambient isotopy β , occurring as a result of the application of 1.1 is not required - a δ -concordance is by nature regular over some open cover.

When we apply II 4.3 to make F setwise vertical, since we have a cylindrical collapse, $\Delta \times I$ is not moved outside $\text{star}(\Delta) \times I$ for any simplex Δ of X . Hence, if γ is the composition of all isotopies to this point, $\gamma(Y \times I) \times I$ is 3δ -ambient, also $\gamma_1 F$ is setwise vertical, lying in $E \times I$, and is itself a 3δ -concordance.

We may assume that F_0 is piecewise linear, for, if not, let τ be a δ -taming of $F_0 : X \rightarrow E$; apply $\tau \times 1$ to $E \times I$, then, at the end of the proof, compose with $\tau^{-1} \times 1$. We use induction over the handles h_t of X , making F vertical over each X_{t-1} in turn; suppose that F is vertical over X_{t-1} .

By theorem 2.1 (or theorem 4 of Armstrong [2]) we can assume that F is vertical over core h_t . Using I 1.3 let the ambient isotopy γ of E be a δ -taming of $F_1 | h_t$ keeping F (core $h_t \cup X_{t-1}$) fixed, and define the ambient isotopy $\bar{\gamma}$ of $E \times I$ by $\bar{\gamma}_s(x, r) = \gamma(x, rs)$. Then $\bar{\gamma}_1 F | h_t \times I$ is piecewise linear. Now use I 1.3 again to δ -tame $\bar{\gamma}_1 F | h_t \times I$ leaving $F_0(h_t)$, $\bar{\gamma}_1 F_1(h_t)$ and F ([core $h_t \cup X_{t-1}$] $\times I$) fixed. We now use Rourke's techniques in this piecewise linear situation. By relative regular neighbourhoods, and isotopy extension, we can assume that F is setwise vertical over h_t (we shall omit $\bar{\gamma}$ for simplicity), and, further, that F is also setwise vertical over a collar neighbourhood $h_t \cup (\partial h_t \times I)$ of h_t . We wish to use the Alexander trick (p.11) to straighten F on this collar neighbourhood, finally extending by isotopy extension.

Now F is concordant to $F_0 \times I$ by the concordance $G : (X \times I) \times I \rightarrow (Y \times I) \times I$, which is vertical over $(X_{t-1} \times I)$, defined by

$$G(x, u, v) = \begin{cases} \left(y, \frac{v + r(1 - u)}{1 - u + v}, \frac{v(1 - r)}{1 - u + v} \right) & \text{when } s \geq t \\ \text{where } (y, r) = F(x, u - v) \\ (F_0(x), u, v) & \text{when } s \leq t, \end{cases}$$

see Figure 30, and so $F_0 (F_0^{-1} \times 1)$ is concordant to the identity via $G_0 (F_0^{-1} \times 1 \times 1)$. Hence we can define a map $H : [h_t \cup (\partial h_t \times I)] \times I \rightarrow [h_t \cup (\partial h_t \times I)] \times I$ by $H|_{h_t \times I} = F_0(F_0^{-1} \times 1)|_{h_t \times I}$ and, for $x \in \partial h_t$, $H((x \times v) \times u) = G_0(F_0^{-1} \times 1 \times 1)(x \times u \times v)$, so that $H|_{(\partial h_t \times 1)} = 1$.

Applying the Alexander trick to H , with the cone point chosen in $(\text{core } h_t) \times 1$ gives an isotopy β of $[h_t \cup (\partial h_t \times I)] \times I$, leaving the intersection with $X_{t-1} \times I$ fixed, moving H to the identity. Then $(F_0 \times 1 \times 1) \circ \beta$ moves F to $F_0 \times 1$ on h_t , and, by isotopy extension, we have an ambient isotopy of $Y \times I$, with support in a regular neighbourhood of $h_t \times I \text{ rel } (X_{t-1} \times I)$, and hence preserving previous work, which makes F vertical over X_t .

In this way, at the end of the induction, we have an ambient isotopy α of $Y \times I$ such that $\alpha_1 F$ is vertical, and $\alpha|_{Y \times 1}$ is an ϵ -ambient isotopy for suitably chosen ϵ .

This proves the inductive step of 1.5 for this case. The remainder of the proof is that of 1.5, plus corollary 2.2.

//

A relative result follows by similar arguments:

2.6 Theorem

Let M^n, Q^q be manifolds, M compact and $q-n \geq 3$, and let $f, g : M \rightarrow Q$ be embeddings. Then, given $\epsilon > 0$, there exists a $\delta > 0$ such that, if f, g are concordant by an allowable δ -concordance, then f, g are ϵ -ambient isotopic keeping $\partial Q \cup f(Y)$ fixed. //

Polyhedra in Polyhedra

Let X be a polyhedron. For each $x \in X$ we associate an integer $I(X, x)$, the intrinsic dimension of X at x , in either of the following equivalent ways, as in Armstrong [1].

- (i) $I(X, x)$ is the largest integer t for which there is a cone V , with vertex v , and an embedding $f : (D^t \times V, 0 \times v) \rightarrow (X, x)$.
- (ii) There is a triangulation of X with x in the interior of a t -simplex if and only if $t \leq I(X, x)$.
- (iii) Let L be the link of x in X (defined up to piecewise linear homeomorphism). Then $I(X, x)$ is the largest t such that L is a t -fold suspension.

Define the t -stratum $X^{(t)}$ to be the set of all points $x \in X$ such that $I(X, x) = t$. Then $X^{(t)}$ is an open manifold of dimension t . See Figure 31.

Define the intrinsic t -skeleton X^t to be the set of all points $x \in X$ with $I(X, x) \leq t$. Then $X^t = \bigcup_{s \leq t} X^{(s)}$, and X^t is a polyhedron of dimension t , since, from (ii) above, X^t equals the intersection of the t -skeletons of all triangulations of X . See Figure 31.

We shall be concerned with topological concordances of polyhedra, $F : X \times I \longrightarrow Y \times I$. In order to apply the preceding manifold theory, we require that $F^{-1}(Y^j \times I) = X^i \times I$ for some $i \leq j - 3$. This condition is equivalent, when X and Y are manifolds with boundary, of codimension 3, to requiring that $F^{-1}(\partial Y \times I) = \emptyset$ or $\partial X \times I$ - that is, F_0 and F_1 are interior embeddings, or proper embeddings, which are concordant through interior, or proper, embeddings, respectively. We also need to impose a local flatness condition - note that $F^{-1}(Y^{(j)} \times I)$ is a non-compact subpolyhedron of $X \times I$.

2.7 Theorem

Let X, Y be polyhedra, X compact, and suppose that $F : X \times I \longrightarrow Y \times I$ is a concordance for which, given j , $F^{-1}(Y^j \times I) = X^i \times I$ for some $i \leq j - 3$. Suppose also that $F \mid F^{-1}(Y^{(j)} \times I) : F^{-1}(Y^{(j)} \times I) \longrightarrow Y^{(j)} \times I$ is locally flat on the open simplexes of some triangulation of $X \times I$, for all j . Then there exists an ambient isotopy α of $Y \times I$ such that $\alpha_1 F$ is vertical.

Proof

The proof is by induction over the intrinsic skeleta of Y . The initial step of the induction is also covered by the following argument for the $k \longrightarrow k + 1$ step.

Suppose $F^{-1}(Y^k \times I) = X^p \times I$, and suppose that we have constructed an ambient isotopy α^k of $Y \times I$ such that $\alpha_1^k F$ is vertical over X^p . We have to construct an ambient isotopy α^{k+1} of $Y \times I$ such that $\alpha_1^{k+1} F$ is vertical over X^q , where $F^{-1}(Y^{k+1} \times I) = X^q \times I$, $p \leq q \leq k - 2$.

If $p = q$, let $\alpha^{k+1} = \alpha^k$.

If $p < q$, we restrict our attention to $\alpha_1^k F \mid X^q \times I : X^q \times I \rightarrow Y^{k+1} \times I$. This concordance is vertical over X^p and maps $X^p \times I$ into $Y^k \times I$. Let N be a regular neighbourhood of Y^k in Y^{k+1} , and let N_0 be a regular neighbourhood of X^p in X^q such that $\alpha_1^k F(N_0 \times I) \subset (\text{int } N) \times I$.

We now use induction over the components of $N \setminus Y^k$, to put $\alpha_1^k F$ vertical over N_0 . Let U be one such component. Then $V = \text{cl } (U, Y^{k+1})$ is a piecewise linear manifold with boundary (a subpolyhedron of Y^{k+1}), and $P = F_0^{-1}(V) \cap N_0$ is a closed subpolyhedron of N_0 , so consider $\alpha_1^k F \mid P \times I : P \times I \rightarrow V \times I$. This is a concordance of a polyhedron in a piecewise linear manifold, for which $(\alpha_1^k F)^{-1}(\partial V \times I) = P_0 \times I$ for some subpolyhedron $P_0 \subset P$, and, since $P_0 \subset X^p$, $\alpha_1^k F$ is vertical over P_0 .

We may assume that $\alpha_1^{k_F} \mid P \times 0$ is a piecewise linear embedding into $V \times 0$. (For, if not, by I 1.4 let ζ be an ambient isotopy of V which tames $\alpha_1^{k_F} \mid P \times 0$; apply $\zeta \times 1$ to $V \times I$, and compose $\zeta^{-1} \times 1$ with the final isotopy of $V \times I$ given below.) Then $\alpha_1^{k_F} \mid P_0 \times I$ is a piecewise linear embedding into $\partial V \times I$. By I 1.4, let $\gamma: V \times I \rightarrow V \times I$ be an ambient isotopy fixed on $\partial V \times I$ such that $\gamma_1(\alpha_1^{k_F} \mid P \times 1)$ is piecewise linear. Define $\bar{\gamma}$, an ambient isotopy of $V \times I$, by $\bar{\gamma}_t(x, s) = \gamma(x, st)$ for $(x, s) \in V \times I$. Then $\bar{\gamma}_1 \alpha_1^{k_F} \mid [(P \times 0) \cup (P \times 1) \cup (P_0 \times I)]$ is a piecewise linear embedding into $V \times I$. After another application of I 1.4, we have $\alpha_1^{k_F} \mid P \times I$ a piecewise linear embedding into $V \times I$, and so we can apply Hudson's theorem ([14]theorem 1.1) to give an ambient isotopy of $V \times I$, fixed on $\partial V \times I$, which makes $\alpha_1^{k_F}$ vertical over P . Extend to $Y^{k+1} \times I$ by the identity. Proceed thus for each component of $N \setminus Y^k$, and define β to be the composition of all these isotopies of $Y^{k+1} \times I$. Then $\beta_1 \alpha_1^{k_F}$ is vertical over N_0 .

We are now in a situation similar to theorem 2.3. Let $N' \subset N$ be another regular neighbourhood of Y^k in Y^{k+1} , such that $F_0^{-1}(N') \subset \text{int } N_0$ and consider the

concordance $\beta_1 \alpha_1^k F \mid \text{cl} (X^q \setminus F^{-1}(N')) \times I$ into
 $\text{cl} (Y^{k+1} \setminus N') \times I$. An application of 2.3 gives an
 ambient isotopy γ , which can be extended by the identity
 to $Y^{k+1} \times I$, such that $\gamma_1 \beta_1 \alpha_1^k F$ is vertical over
 X^q . Using Siebenmann's isotopy extension theorem,
 [34] 6.5, we can extend $\gamma\beta$ to $Y \times I$. Define
 $\alpha^{k+1} = \gamma\beta\alpha^k$.

At the end of the induction, then, $\alpha = \alpha^n$, where
 $n = \dim Y$. //

We have the following corollary, as with 2.2, 2.4.

2.8 Corollary (Concordance implies Isotopy for embeddings
 of Polyhedra in Polyhedra)

Let X, Y be polyhedra, X compact, and suppose that
 $f, g : X \rightarrow Y$ are two embeddings which are concordant
 by a concordance F which satisfies the conditions of 2.7.
 Then f, g are ambient isotopic. //

Figure 30

Theorem II 2.5

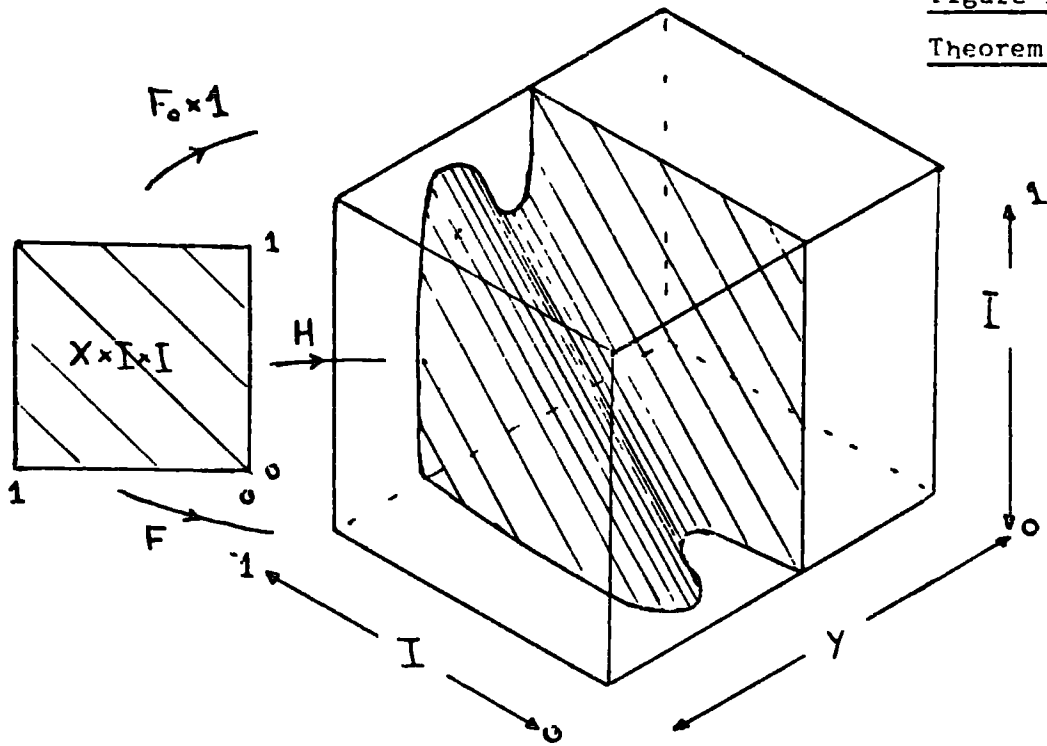
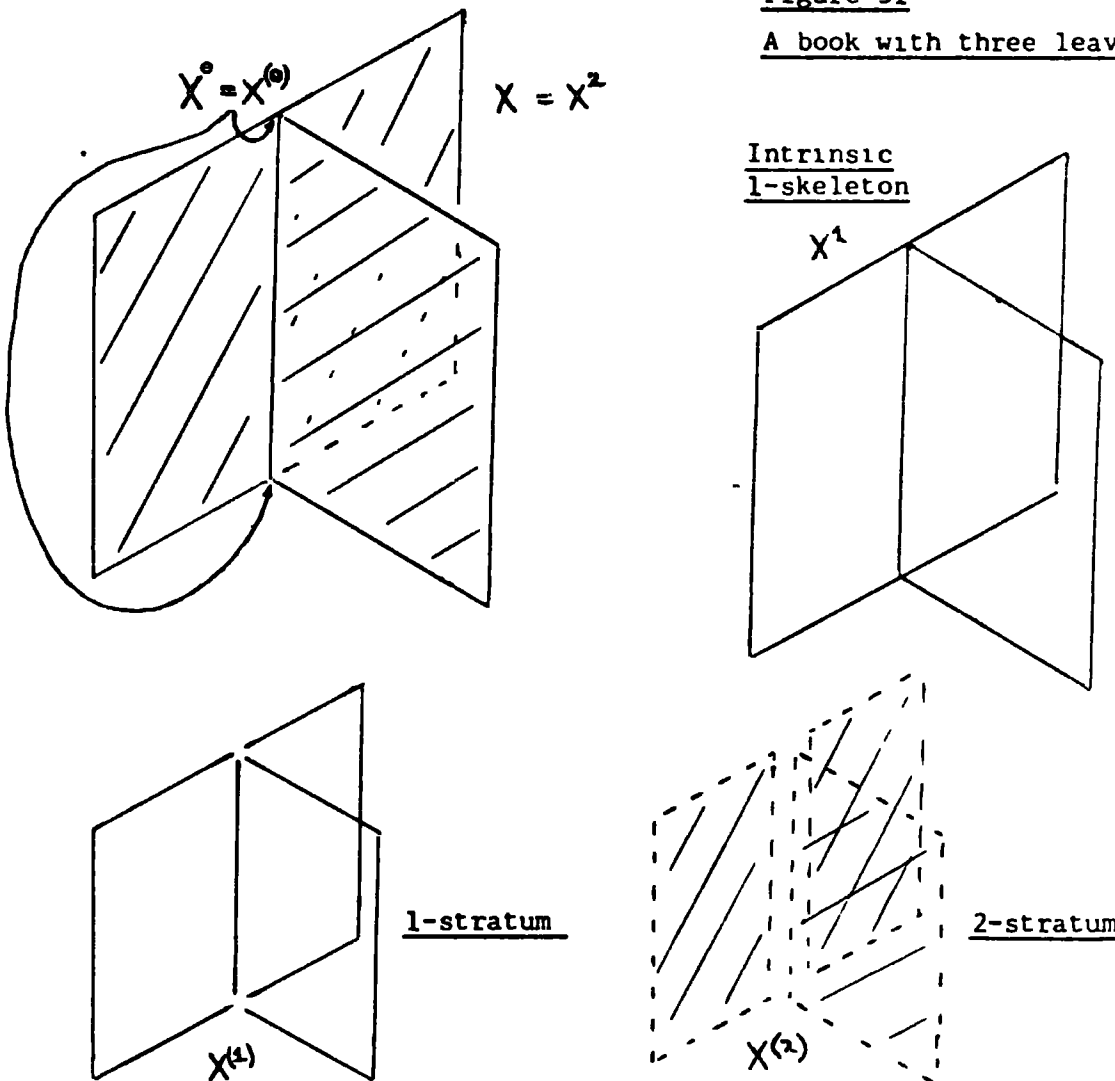

Figure 31

A book with three leaves



REFERENCES

1. M.A. Armstrong, "Transversality for polyhedra", Ann. of Math. 86 (1967), 172-191.
2. _____, "Collars and concordances of topological manifolds", Comment. Math. Helv. 45 (1970) 119-128.
3. _____, "Approximating topological concordances", Greek Math. Soc. Symposium (1973), 35-45.
4. M. Brown, "Locally flat embeddings of topological manifolds", Ann. of Math. 75 (1962), 331-341.
5. _____, "Locally flat embeddings of topological manifolds", Topology of 3-Manifolds and Related Topics, Prentice Hall (1962), 83-91.
6. S.S. Cairns, "A simple triangulation method for smooth manifolds", Bull. Amer. Math. Soc. 67 (1961), 389-390.
7. J.C. Cantrell and T.B. Rushing, "On low codimensional taming", Topology of Manifolds (Proceedings of the 1969 Georgia Institute), Markham (1970), 353-357.
8. E.H. Connell, "A topological H-cobordism theorem for $n > 5$ ", Illinois J. Math. 11 (1967), 300-309.

9. R. Connelly, "A new proof of Brown's collaring theorem",
Proc.Amer. Math. Soc. 27 (1971), 180-182.
10. R.D. Edwards and R.C. Kirby, "Deformations of spaces of
imbeddings", Ann. of Math. 93 (1971), 63-88.
11. J.G. Hocking and G.S. Young, Topology, Addison-Wesley (1961).
12. J.F.P. Hudson, "Concordance and isotopy of PL embeddings",
Bull. Amer. Math.Soc. 72 (1966), 524-535.
13. _____, Piecewise Linear Topology (Math. Lecture
Note Ser.), Benjamin (1969).
14. _____, "Concordance, isotopy and diffeotopy",
Ann. of Math. 91 (1970), 425-448.
15. J.F.P. Hudson and E.C. Zeeman, "On combinatorial isotopy",
Publ. I.H.E.S. (Paris) 19 (1964), 69-94.
16. _____, "On regular neighbourhoods",
Proc.London Math. Soc. (3) 14 (1964), 719-745.
17. _____, "Correction to 'On regular
neighbourhoods'", Proc. London Math. Soc.
(3) 21 (1970), 513-524.

18. M.C. Irwin, "Embeddings of polyhedral manifolds", Ann. of Math. 82 (1965), 1-14.
19. C. Kearton and W.B.R. Lickorish, "Piecewise Linear critical level embeddings and collapsing", Trans. Amer. Math. Soc. 170 (1972), 415-424.
20. M.A. Kervaire, "A manifold which does not admit any differentiable structure", Comment. Math. Helv. 34 (1960), 257-270.
21. R.C. Kirby, "Lectures on the triangulation of manifolds", Notes, Univ. of California, Los Angeles (1969).
22. R.C. Kirby and L.C. Siebenmann, "Essays on topological manifolds smoothings and triangulations", Notes, Orsay (1972).
23. A. Kosinski, "Singularities of PL mappings, I", Bull. Amer. Math. Soc. 68 (1962), 110-114.
24. R.C. Lacher, "Locally flat strings and half-strings", Proc. Amer. Math. Soc. 18 (1967), 299-304.
25. J.A. Lees, "h-cobordism and locally flat imbeddings of topological manifolds", Thesis, Univ. of Chicago (1967).

26. E.E. Moise, "Affine structures in 3-manifolds, V",
Ann. of Math. (2) 56 (1952), 96-114.
27. M.H.A. Newman, "The engulfing theorem for topological
manifolds", Ann. of Math. 84 (1966), 555-571.
28. E.K. Pederson, "Topological concordances", Bull. Amer.
Math. Soc. 80 (1974), 658-660.
29. T. Rado, "Über den Begriff der Riemanschen Fläche", Acta
Univ. Szeged. [2] (1924-1926), 101-121.
30. C.P. Rourke, "Covering the track of an isotopy", Proc.
Amer. Math. Soc. 18 (1967), 320-324.
31. ———, "Embedded handle theory, concordance and
isotopy", Topology of Manifolds (Proceedings
of the 1969 Georgia Institute), Markham (1970),
431-438.
32. C.P. Rourke and B.J. Sanderson, Introduction to Piecewise
Linear Topology, Ergebnisse 69, Springer-Verlag
(1972).
33. T.B. Rushing, "Locally flat embeddings of PL manifolds are
 ϵ -tame in codimension 3", Topology of Manifolds
(Proceedings of the 1969 Georgia Institute),
Markham (1970), 439-452.

34. L.C. Siebenmann, "Deformation of homeomorphisms on stratified sets", *Comment. Math. Helv.* 47 (1972), 123-163.
35. S. Smale, "Structure of manifolds", *Amer. J. Math.* 84 (1962) 387-399.
36. D. Sullivan, "On the hauptvermutung for manifolds", *Bull. Amer. Math. Soc.* 63 (1967), 598-600.
37. E.C. Zeeman, "Unknotting combinatorial balls", *Ann. of Math.* 78 (1963), 501-526.
38. ———, "Seminar on combinatorial topology", Notes, I.H.E.S. (Paris) and Univ. of Warwick (Coventry) (1963-1966).

