

Durham E-Theses

The colour vision of the pigeon

J. A. Emmerton

How to cite:

Emmerton, J. A. (1975) The colour vision of the pigeon. Doctoral thesis, Durham University.

Use policy

The full-text may be used and/or reproduced, and given to third parties in any format or medium, without prior permission or charge, for personal research or study, educational, or not-for-profit purposes provided that:

- a full bibliographic reference is made to the original source
- a <https://etheses.durham.ac.uk/id/eprint/8223/> is made to the metadata record in Durham E-Theses
- the full-text is not changed in any way

The full-text must not be sold in any format or medium without the formal permission of the copyright holders.

Please consult the [full Durham E-Theses policy](#) for further details.

THE COLOUR VISION OF THE PIGEON

The copyright of this thesis rests with the author
No quotation from it should be published without
his prior written consent and information derived
from it should be acknowledged

Thesis submitted for the degree of Ph D.
to Durham University

J A Emmerton

1975



CONTENTS

	<u>Page No</u>
ACKNOWLEDGEMENTS	1
ABSTRACT	11
CHAPTER 1 Introduction	1
CHAPTER 2 Wavelength Discrimination in Pigeons	25
CHAPTER 3 A Relative Saturation Discrimination Function for the Pigeon	55
CHAPTER 4 The Pigeon's Spectral Sensitivity to Ultraviolet Radiation	85
CHAPTER 5 Wavelength Discrimination in the 'Visible' and Ultraviolet Spectrum	113
CHAPTER 6 Overview and Conclusions	146
APPENDIX	170
REFERENCES	176

ACKNOWLEDGEMENTS

Foremost I would like to express my gratitude to Dr Juan Delius, who supervised me throughout the course of this work with expertise, patience and much good humour. In particular I would thank him for developing the computer programs used in the final experiment, to Mrs C Thompson I am also grateful for additional advice on computing. I would especially like to thank Mr David Harper for his help in several ways for running part of the last experiment for me and collecting data, for his photographic work and for other technical help. I am indebted to Messrs D Barton, J Dobson, S Teesdale, A Perry, M Rolling and J. Thompson for much technical advice and assistance and to Mrs Marie Harper and Mrs J Emery for their help in maintaining the animals used. To Dr G Granger I am grateful for the loan of various items of optical equipment and to Prof F V Smith for making available to me the laboratories and facilities of the Psychology Department at Durham. The research was in part supported by a Durham University Research Studentship.

Finally I wish to thank Mrs M Rogers and Miss J Scholz of University College of Swansea for typing this thesis, together with Mrs D Salt and Miss C Brookshaw whose help was invaluable in completing the typing at such short notice.

To all concerned I acknowledge my debt and gratitude for their help.

THE COLOUR VISION OF THE PIGEONABSTRACT

The pigeon's colour vision was examined, using behavioural and physiological techniques. Avian colour vision has aroused interest because of the suggestion that chromatic discrimination in birds is mediated by a single cone pigment, combined with several types of retinal oil-droplets which act as differential colour filters.

Using an operant conditioning method, difference thresholds were measured throughout the spectrum (400 - 680 nm) to generate a wavelength discrimination function, which yields information about the type of visual system an animal possesses. Earlier work had suggested that birds are trichromatic, but the finding of three clearly defined regions of optimum discrimination at 595, 530 and 460 nm indicates instead that the pigeon's colour vision is at least tetrachromatic.

The pigeon's saturation discrimination abilities were also studied using a similar technique. Saturation increased towards the spectral extremes while a point of least saturation occurred at 597 nm. Additional subsidiary saturation minima were found at 443, 496, 536 and 662 nm. These results largely corroborated those of the wavelength discrimination experiment but indicated that the pigeon's visual system may be more complex than a tetrachromatic one.

Preliminary to an extension of the wavelength discrimination study, the pigeon's spectral sensitivity was measured electroretinographically. The resulting spectral sensitivity curve peaked at 560 - 580 nm, in agreement with previously reported data. Furthermore, spectral sensitivity extended well into the ultraviolet region (< 400 nm), where sensitivity was quite high. In a second study of wavelength discrimination, results of the first experiment showing three threshold minima were confirmed and, additionally, pigeons maintained good discrimination between wavelengths within the ultraviolet range.

Experimental findings were discussed in terms of the physiological mechanisms underlying visual performance, in particular, the present results, together with other evidence, suggest that the retinal oil-droplets are not basic to avian colour vision. The functional significance of the pigeon's colour vision was also considered.

CHAPTER 1

INTRODUCTION

The sensory systems of an animal enable it to detect changes in physical energy in its environment and to use the information thus obtained in modifying its behaviour in response to conditions in the world about it. Which information an animal can extract and utilise depends, in the first instance, on the filtering properties of its sensory systems. These systems are adapted to detect certain types and ranges of physical energy. The normal human visual system, for example, is sensitive to electromagnetic radiation ranging from about 390 - 760 nm in wavelength (Graham, 1965).

In addition to the limitations imposed by an animal's sensory equipment, other factors may be important in determining the final behavioural responses. Thus the effectiveness of a stimulus in eliciting an overt response may be influenced by, amongst other factors, the stimulus context, and the animal's attentional or motivational state. One example of selective responding which is not solely related to sensory limitations is found in the colour preferences shown by neonate gulls (Tinbergen and Perdeck, 1950, Hailman, 1967), which peck most frequently at long and short wavelength stimuli while responding little

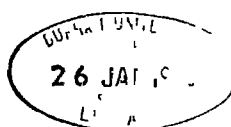

to middle wavelengths. This behaviour seems to be due not to the filtering attributes of the bird's visual system but instead to some post-perceptual filtering mechanism (Delius et al., 1972). However, the primary concern here is with the properties of sensory systems themselves and a discussion of other factors influencing the effectiveness of stimuli in controlling overt behaviour can be found in Hinde (1970).

For any sensory modality, the properties of a particular sensory system need not be the same for all species. It is only advantageous if an animal's sensory systems select and transmit information to which it could subsequently make an appropriate behavioural response. Hence an organism's sensory equipment should be adapted to provide it with information necessary for its survival within a particular environment.

In the visual modality, one particularly important property of the sensory system is the ability to detect contrast in the environment. This contrast response could be to differences in energy levels, irrespective of wavelength content, i.e. the system could make a brightness discrimination. But another visual ability is that of detecting contrast available in terms of wavelength differences even when there are no differences in stimulus intensity. An animal whose visual system can encode wavelength differences is said to have colour vision, a perceptual ability that will be considered in detail here.

While colour vision has been demonstrated in insects (Goldsmith, 1961), fish (Yager, 1968), amphibians (Muntz, 1964; Hailman and Jaeger, 1974), reptiles (Graf, 1967; Ticmann, 1970), birds (Lashley, 1916; Martin, 1974) and some mammalian species (De Valois and Jacobs, 1968,

Jacobs and Yolton, 1971), these diverse groups of animals do not all share the same colour vision abilities. The visual spectrum of bees, for example, is shifted to shorter wavelengths when compared with that of man the bee's eye is highly sensitive to short wavelengths, particularly those in the ultraviolet range (Autrum, 1965, von Helversen, 1972) to which man is insensitive, while longer wavelengths, seen as red by humans, are quite invisible to the bee. This characteristic adaptation in the bee's colour vision enables it to detect and respond to flower patterns which the human eye cannot see (Daumer, 1958, Jones and Buchmann, 1974). Thus, the bee's wavelength sensitivity is highly advantageous to the animal in facilitating its foraging activity.

The extent to which an animal can differentiate wavelengths will depend on the functioning of components of its visual system the number of receptor types, the range of wavelengths to which each receptor is sensitive and the mode of interaction of chromatically responsive components at all levels of the visual system can all play a part in modifying colour vision. Interspecific differences relating to colour vision will, therefore, obviously be expected in the physiological functioning of different animals' visual systems. To extend a previous example, both bees and humans possess three types of receptor cells which are differentially sensitive to wavelength, making vision in both species trichromatic. Because of discrepancies in the wavelength ranges to which each receptor is sensitive, however, the regions of the spectrum in which both subjects make their best discriminations are not the same (von Helversen, 1972).

Again, differences in colour vision may also be found in much more closely related species, Old and New World monkeys. While the psychophysical functions of the macaque closely resemble those of a normal human, results on colour vision tests with the squirrel monkey are more similar to those typical of a protanomalous human observer (De Valois and Jacobs, 1968). It seems that both species have three visual pigments in their cone receptor cells but that one of the pigments has a different sensitivity range in the two monkeys. Another difference between the species is in the numbers and relative activity rates of two types of opponent-cell, a mechanism whose response depends on the input from two differentially sensitive receptors. Both these factors therefore underlie the discrepancies in colour vision abilities.

Another interspecific variation is that not all animals have three receptor types as humans do. There are only two groups of receptor cells in ground squirrels, for instance, making this animal's colour vision dichromatic (Jacobs and Yolton, 1971, Michael, 1968).

Some animals, although possessing the necessary mechanisms for colour discrimination, are said to show only 'weak' colour vision. Cats, for example, appear to have the receptor basis for colour vision (Daw and Pearlman, 1970) but their ability to discriminate wavelengths can only be demonstrated with difficulty in behavioural tests (Brown et al., 1973, Mello and Peterson, 1964, Sechzer and Brown, 1964). Central opponent units, sensitive to wavelength differences, are scarce in this animal (Pearlman and Daw, 1970), which more readily learns a brightness discrimination than a colour discrimination (Meyer and Anderson, 1965).

As the above examples illustrate, interspecific differences in colour vision may be considered at two levels -

1) the adaptive function of colour vision as a sensory capability which has been moulded to suit an animal's behaviour and survival requirements,

2) the mechanisms by which colour vision is attained and the modifications of structure and physiological function by which a species achieves its characteristic colour vision abilities.

In view of the characteristically different colour vision abilities of some other animals when compared with those of humans, we might expect that in pigeons, whose behaviour and survival needs are so different from our own, correlated adaptations would be found in this animal's colour vision. Instead, several experimental studies of colour vision in this species have indicated that its perceptual abilities closely parallel those of man. One of the first detailed examinations of the pigeon's hue discrimination abilities was performed by Hamilton and Coleman (1933), employing a jumping-stand method. Birds were trained to either jump towards a constant wavelength while the wavelength of a second stimulus was systematically altered or else to avoid a fixed wavelength while choosing a stimulus whose wavelength was progressively changed. Stimulus luminance was randomly varied so that this dimension could not act as a reliable discrimination cue. When a pigeon could no longer discriminate between a pair of wavelengths, after one had been varied,

its difference threshold was recorded and tests were repeated at other points in the spectrum to discover the pigeon's ability to discriminate between wavelengths over a wide range of the spectrum. Results showed that the pigeon's colour vision appeared to be trichromatic and very similar to that of man pigeons, like humans (Wright and Pitt, 1934), made their finest discriminations in the yellow-orange (580 - 590 nm) and blue-green (500 nm) spectral regions

Certain similarities between avian and human colour vision have also been reported by other authors. Pigeons trained to respond to a red stimulus will generalise their responses to a blue stimulus (Guttman, 1956 Wright and Cumming, 1971) Similarly, chickens trained to peck a purple stimulus also generalise their behaviour to red and blue stimuli (Guttman, 1956). This would suggest that the colour vision of birds, like that of man, can be represented on a 'colour circle' (Kling and Riggs, 1971), in which the long and short wavelength extremes of the spectrum are linked by extra-spectral purples.

Mori et al. (1969), working with pigeons, put forward some evidence of a pairing of red with green and blue with yellow, similar to the opponent pairing of colours by humans (Hurvich and Jameson, 1957) After first training birds on a red-green colour discrimination task, two matched groups of subjects were obtained. One of these groups was then maintained for 5 months under monochromatic green illumination while a control group was kept for a similar period under white light illumination.

When retested on the red-green discrimination problem, the birds kept in green light showed an initial marked deterioration in their discrimination performance and took a prolonged time to re-acquire the learning criterion whereas the control group started at a high level of correct responding and quickly relearned the discrimination problem. After a further 3 months, the two groups were tested on a blue-yellow discrimination and again on the red-green discrimination. There were no significant differences between the two groups for the acquisition of the blue-yellow discrimination task but results of the red-green discrimination resembled those in the first re-test of this problem. Thus, in the animals which had been kept for prolonged periods in green light, the ability to discriminate between green and red greatly decreased whereas blue-yellow discrimination was unaffected. The authors postulated that these results were due to some neurological change related only to the contrast of red and green. It should be noted that less prolonged exposure to monochromatic illumination conditions does not significantly affect acquisition of wavelength differences encountered in stimulus-generalisation tests (Rudolph and Honig, 1972, Mountjoy and Malott, 1968, Riley and Leuin, 1971, Tracy, 1970).

A similar pairing of red with green and blue with yellow for chickens is also implied by behaviour which appears to rely on simultaneous colour contrast (Révész, 1921), since one explanation of simultaneous contrast effects in human vision is that these phenomena are a product of red-green and blue-yellow opponent processes within the visual system (Jameson and Hurvich, 1964).

Finally, similarities between the pigeon's and man's colour vision have been claimed by Skinner and Beishon (1971), based on the results of their experiment on colour discrimination using a matching-to-sample technique. They argue that the relative sizes of retinal colour zones in the pigeon's eye are similar to human retinal zones within which different colours can be detected. This conclusion was based upon the distribution of responses to the four colours presented. After the matching-to-sample task had been acquired, the greatest proportion of correct responses were made to blue stimuli, with a smaller ratio of correct responses being directed to yellow, red and green stimuli respectively. The conclusions they draw from their results seem unwarranted, however, since the response distributions could more convincingly be attributed to the pigeon's colour preferences (see, for example, Delius, 1968), an explanation which they reject. Nevertheless, Kovach and Hickox (1971) have demonstrated that unlearned colour preferences in chicks play a significant part in their acquisition of colour discrimination. Even after prior reinforcement on exposure to either a preferred blue or an unpreferred green stimulus, chicks tested on a blue-green discrimination, in which the previously reinforced colour was the positive stimulus, learned the discrimination more quickly when the preferred blue was the rewarded discrimination stimulus.

Such similarities in colour vision are surprising, not only in view of the different survival needs which would be expected of pigeons and men, but also because of anatomical differences in their visual systems

which would lead us to look for concomitant adaptations in physiological functioning. The colour vision of pigeons, along with that of other birds, has aroused particular interest since certain distinctive features of the avian retina have, in fact, led to conjecture that the mechanisms mediating colour vision in birds operate in a way different from those in many of the other animal groups tested (e.g. fish Yager, 1967, amphibians Muntz, 1964, mammals Jacobs and Yolton, 1971, De Valois and Jacobs, 1968). Included in the avian retinal cones are oil-droplets coloured by the light-stable carotenoid pigments they hold (Bridges, 1962 Meyer et al., 1965, Strother and Wolken, 1960, Wald and Zussman, 1938). These oil-droplets are positioned adjacent to the photopigment-containing outer segments in such a way that incoming light must pass through an individual cone oil-droplet before reaching that receptor's visual pigment (Morris and Shorey, 1967). In diurnal birds, 3 or 4 groups of brightly coloured oil-droplets have been described (Meyer and Cooper, 1966, Strother, 1963, Strother and Wolken, 1960) while in nocturnal species, such as owls, the strong colouration is absent and only colourless or pale yellow droplets occur (Walls and Judd, 1933). In the pigeon, 4 types of large droplets have been observed, red, orange, yellow and greenish-yellow in colour (van Genderen Stort, 1887, King-Smith, 1969, Donner, 1960, Fujimoto et al., 1957, Adams, 1967, Galifret, 1968), as well as a large number of red microdroplets in the red cones of the dorsal retina (Pedler and Boyle, 1969). Studies of the absorption spectra of the oil-

droplets have shown them to have sharp cut-off characteristics towards the shorter wavelength end of the spectrum (King-Smith, 1969, Fujimoto et al., 1957, Strother, 1963). The droplets may thus act as individual colour filters, restricting the range of wavelengths that will be transmitted to each cone outer segment.

Krause (1863) and Schultze (1866) early on proposed that the oil-droplets are actually basic to avian colour vision. Studies of the cone visual pigments of birds have not so far been able to refute this idea. In contrast to the situation in fish, man and other primates, in which microspectrophotometric measures of single cones have disclosed three separate cone pigments (Marks, 1965, Marks et al., 1964), each examination of avian retinæ has revealed only a single cone pigment. Iodopsin, with its absorption peak at 562 nm, has been extracted from the retinæ of turkeys, chickens and pigeons (Crescitelli et al., 1964, Wald et al., 1955, Wald, 1958). Bridges (1962), on the other hand, failed to find iodopsin in the pigeon retina but instead reported a single cone pigment having its λ_{\max} at 544 nm. Attempts to directly measure the photopigment content of avian cones using microspectrophotometry have met with optical problems posed by the slenderness of the cone outer segments. But Liebman's (1972) measurements from pigeons, chickens and laughing gulls may lend support for the occurrence of iodopsin in the retinæ of these species. The broadness of the pigment absorption peak, at 560 - 575 nm, and the poor agreement between repeated measures of the absorption spectrum, makes the conclusion

that there is only a single cone pigment for these animals rather tentative however. But as a result of these findings it has been hypothesised that colour discrimination in birds is achieved by the differential filtering action of the oil-droplets upon light falling on one photopigment in all cone cells.

Several authors, in considering the physiological mechanisms mediating a bird's wavelength discrimination abilities, have adhered to this 'single pigment hypothesis' of avian colour vision (Bloch and Martinoya, 1971, Hailman, 1964, King-Smith, 1969, Wald, 1937, Wald and Zussman, 1938) Hailman (1964), in particular, demonstrated that the pecking responses of gull chicks in tests of colour preference could be matched by a model assuming subtractive interaction between classes of cones containing different oil-droplets but the same underlying pigment. This model has proved inadequate, however, to account for gull chicks' behaviour in other experimental situations in which their colour preferences were monitored (Delius et al., 1972).

In another experiment in which support was claimed for the single pigment hypothesis, Bloch and Martinoya (1971) tested the pigeon's discrimination of wavelengths within the long (570 - 610 nm) and short (470 - 530 nm) wavelength parts of the spectrum. While no clear-cut results were obtained within the shorter wavelength range, a region of good discrimination at wavelengths 590 - 600 nm was found within the longer wavelengths. Because this area of best discrimination corresponded closely with the cut-off slope of the red droplets' absorption spectrum they concluded that the red droplets are the fundamental mediators of

long wavelength discrimination. However, the coincidence of good wavelength discrimination with the steep cut-off slopes of the oil-droplets might be expected, whether they are combined with one or several visual pigments. Thus, this experiment by itself does little to resolve the argument of whether or not avian colour vision can depend on a single pigment in combination with several oil-droplets.

But the single pigment hypothesis has, by no means, received unanimous support. Le Grand (1962), for example, calculated that, if the chicken's retina contained only iodopsin in combination with three types of oil-droplets, its colour vision would be almost dichromatic and discrimination would be particularly poor in the long wavelengths (above 560 nm). Lashley (1916) had already shown that the hen's discrimination abilities were better than the single pigment hypothesis would appear to predict. Le Grand, finding that the differential filtering action of the droplets was inadequate as the sole basis for colour discrimination in this animal, argued instead for the existence of additional photopigments. Le Grand's calculations might be inaccurate, though, because of his use of Wald and Zussman's (1938) data on oil-droplet transmission spectra. These data are derived from extracts, in hexane, of the oil-droplet carotenoid pigments which give transmission curves rather different from those measured from droplets *in situ* (cf. King-Smith, 1969).

More generalised criticisms of the idea that oil-droplets may be basic to colour vision, and other speculations about their role, have come from Walls and Judd (1933) and Walls (1942). They considered

the oil-droplets' function in conjunction with that of other ocular filters, provided in other species by yellow lenses or corneae, maculae luteae, and retinal capillaries. The oil-droplets were regarded as modifiers of colour vision rather than being basic to it. Yellow droplets, in common with other yellow filters, were said to serve a quadruple purpose, under normal illumination conditions, of -

- 1) reducing chromatic aberration and thus increasing acuity,
 - 2) reducing glare and dazzle resulting from scattered short wavelength light,
 - 3) enhancing detail by absorbing atmospheric 'blue haze'
- and 4) enhancing the contrast of objects seen against their backgrounds.

The red droplets, which occur only in birds and turtles, were said to supplement and improve on the functions of the yellow droplets when illumination levels were high. Furthermore, cones bearing red droplets were thought to act independently of cones with yellow or orange droplets, receptors of the latter type being a functionally intermediate mechanism brought into operation as light conditions changed. Some of these functions were related to the variations in the proportions of the differently coloured oil-droplets, both between species and within the retina of a particular species, such as the pigeon. In particular, the ability to reduce glare and dazzle over water surfaces was said to account for the high proportion of red droplets in turtles and diving birds. Further evidence, which appears to confirm this relationship between an animal's behavioural environment and the differential proportions of coloured oil-droplets, is given by Cullen, cited by Muntz (1972). An additional proposal of

Walls and Judd, that the varying distribution of types of oil-droplet within the pigeon's retina is related to the enhancement of contrast of objects seen against various backgrounds, has, however, been criticised by Muntz. He instead proposes that the presence of red droplets within certain regions of the retina is associated with better colour vision whereas these droplets are lacking when sensitivity to brightness differences is of primary importance

Other functions have been attributed to the oil-droplets. Muntz argued that their sharp cut-off characteristics would act to increase the rate of change of a receptor's output in response to a given wavelength change. By this means the oil-droplets would improve wavelength discrimination at certain regions, an idea which has also been put forward by Donner (1960)

Further evidence is reviewed by Muntz which indicates that, in turtles and lizards, oil-droplets can actually enrich an animal's colour vision by combining with one or more photopigments to increase the number of functionally distinct receptor types. Of particular importance to the argument of whether avian oil-droplets are a prerequisite of wavelength discrimination or whether they modify cone sensitivities in such a way as to enhance colour vision is the demonstration that the retinae of turtles, which are structurally similar to those of birds, contain 3 cone photopigments as well as accommodating a number of brightly coloured droplets (Liebman and Granda, 1971, Liebman, 1972).

More than one photopigment might also be expected in owls. Although only a rhodopsin pigment has been extracted from the owl's retina (Sillman, 1969), spectral sensitivity measures from one species, the

tawny owl, show two peaks of sensitivity, one of which may be attributed to the rod receptors and the other to a photopic system (Martin and Gordon, 1974, Martin et al., 1975). From colour discrimination tests it appears that this bird has colour vision of a dichromatic or anomalous trichromatic type (Martin, 1974). Since the oil-droplets of this nocturnal species lack the various bright colours found in diurnal birds (Walls and Judd, 1933), vision in this avian species could not be attributed to differential filtering by the oil-droplets and must presumably rely on the presence of more than one photopigment in the bird's retina

Another chance of directly assessing the effect of the oil-droplets' filtering action upon avian colour vision has been offered by experiments in which quail with only colourless oil-droplets have been hatched after exclusion of carotenoids from the parents' diet (Meyer, 1971, Meyer et al., 1971). Although investigations of the spectral sensitivity of these animals were reported to be in progress, unfortunately no reports of these experiments appear to be available to date.

However, some insight into the part played by the oil-droplets might also be gained by considering other psychophysical data, which have been largely collected from the pigeon. Contrary to the previously described experiments in which close similarities between the colour vision of man and pigeons are claimed, these data begin to point to inter-specific differences. Many authors report that the avian photopic spectral sensitivity curve, whether obtained by behavioural or physiological means, shows a shift in peak sensitivity towards longer wavelengths when compared with the sensitivity function of man and most other diurnal animals (Donner, 1953, Granit, 1942, Blough, 1957, Grief, 1969, Meissner, 1970,

Blough et al , 1972, Graf and Norren, 1974). Several of these authors have related this shift in sensitivity relative to the filtering action of the oil-droplets

There is some disagreement about the effect on colour vision of the differential distribution of oil-droplets within the pigeon's retina (Galifret, 1968) King-Smith (cited by Muntz, 1972) has reported a discrepancy between the sensitivity curves of tectal units which had their receptive fields in the yellow or red retinal fields of the pigeon. The sensitivity function of units receiving input from the dorsal red field is shifted to longer wavelengths, a displacement which appears to relate to the higher proportion of red and orange droplets found in this part of the retina. Blough et al., (1972), who also measured the pigeon's photopic spectral sensitivity in both red and yellow fields using the electroretinogram, found, by contrast, that the sensitivity functions from both these parts of the retina were identical. Similarly, wavelength discrimination functions which most likely depended on stimulation of the red field (Wright, 1972a) and yellow field (Riggs et al , 1972) also show good agreement in the positions of the spectral regions of best discrimination.

Another study investigated the effect of differences in the proportions of the coloured oil-droplets in various areas of the pigeon's retina upon colour recognition (Bloch and Maturana, 1971) Pigeons trained to discriminate between a pair of colours presented in the frontal or posterior visual field were then tested using the same stimuli displayed in some other part of the visual field. Colour discrimination learned using one

part of the visual field was found to transfer immediately to another part of the visual field. From these results, the authors concluded that colour recognition does not depend on the proportions of the 4 types of coloured droplets found in different retinal areas. In this case, though, any differences which might exist would, most likely, only be revealed by rather more detailed psychophysical tests than were performed in this experiment. So far, however, there appears to be little evidence that the differential distribution of oil-droplet types within the pigeon's retina has any substantial effect on the results of colour vision tests.

Although arguments about the functions of the oil-droplets have yet to be resolved, there has been a growing body of information in recent years about the pigeon's colour vision. Most of these studies show that the pigeon's colour vision does, in fact, differ from that of man in an important respect, that is, in its ability to discriminate between wavelengths which, to the human eye, appear to be of the same green hue. Wright and Cumming (1971) plotted 'colour-naming' functions, which describe how the pigeon groups together wavelengths which presumably appear, to its eye, to have similar hues. In this experiment the spectral range they tested was grouped, by the pigeon, into three hues, which intersected at 595 and 540 nm. The positions of wavelengths representing transition points in pigeon hues have also been confirmed by Riggs et al. (1972), who derived a wavelength discrimination function from electroretinographic responses produced

when the eye of this animal was stimulated by different pairs of wavelengths. Results of these two experiments indicate that the pigeon has a trichromatic colour vision system. Wright (1972a), though, who measured the pigeon's wavelength discrimination thresholds across the spectrum using a conditioning technique, found an additional point of good discrimination at 500 nm as well as other regions at 540 - 550 nm and 600 nm where wavelength discrimination was optimal. His results would imply that the pigeon's vision is tetrachromatic.

The shapes of wavelength generalisation gradients are now also shown to be related to the pigeon's wavelength discrimination abilities. Gradients of generalisation about test wavelengths which were positioned in the centre of a pigeon hue or at regions of good wavelength discrimination or at transition points between pigeon hues were found to be symmetrical. The steepest gradients occurred at 600 nm and 540 nm, where other authors have found discrimination to be best. If generalisation was tested at a wavelength slightly displaced from a region of best discrimination, the gradient was asymmetrical, with the steeper slope being towards the area of good wavelength discriminability (Blough, 1972).

In another type of conditioning experiment, pigeons were trained to rate pairs of wavelengths as being 'the same' or 'different' (Schneider, 1972). The 'psychological spacing' of wavelengths along the spectrum was then estimated and the widest spacing was found between wavelengths which, in other experiments, were the most

readily discriminated whereas wavelengths which were less discriminable, or were grouped together as constituting a single pigeon hue, were more closely spaced. This relationship between 'psychological spacing' and hue discriminability was also predicted by Shepard (1965), who, by transforming the wavelength scale, was able to show that wavelength generalisation gradients obtained previously by Guttman and Kalish (1956) and Blough (1961) all represented a uniform function.

These results, which are discussed in more detail in subsequent chapters, all show that the wavelength discrimination abilities of pigeons do not correspond as closely to those of man as Hamilton and Coleman's original hue discrimination experiment indicated. The greatest discrepancy between the colour vision of man and pigeon occurs within the 'green' part of the spectrum, where the pigeon's wavelength discrimination surpasses that of the human eye. There is also some disagreement arising about the type of visual system the pigeon possesses. Whereas the wavelength discrimination function of Riggs et al. (1972) concurs with Hamilton and Coleman's in showing two regions of fine discrimination, indicative of a trichromatic system, Wright's (1972a) function includes a third threshold minimum, which would instead suggest that the pigeon has tetrachromatic colour vision.

Tests of wavelength discrimination are only one type of psychophysical investigation of an animal's colour vision. In Schneider's (1972) study, mentioned above, data were also obtained about the pigeon's ability to detect differences in spectral saturation. Results of this experiment showed that the extremes of the spectrum appeared

the most highly saturated to the pigeon, as they do to man (Martin et al., 1933), but that the wavelength which was least saturated was displaced 20 nm towards a shorter wavelength when compared with the minimum position in the human saturation discrimination curve. Thus, while the pigeon can detect differences in saturation across the spectrum, the details of its discrimination performance again differ in some respects from the performance of the human visual system.

Apart from the above behavioural studies, which, in reassessing the pigeon's performance on colour vision tests, show some important interspecific differences between pigeon and man, much interest has also been centred on the physiological mechanisms which may mediate the pigeon's discrimination abilities. Some information has been obtained, using chromatic adaptation techniques, about the separate photopic channels which contribute to the compound chromatic response, represented by the spectral sensitivity curve. Ikeda (1965), using the electroretinographic response to assess the photopic spectral sensitivity of the pigeon, revealed two functionally distinct chromatic processes with peak sensitivities at 547 nm and 605 nm. The short-wavelength sensitivity peak closely corresponded with the maximum absorption of pigment 544, extracted from the pigeon's retina by Bridges (1962). A similar electroretinographic study of spectral sensitivity in the chicken (Bonaventure et al., 1972) gave comparable results. In this species, systems with different response characteristics and with

peak sensitivities at 605 nm and 560 nm were found. The cone pigment iodopsin, obtained from the chicken retina by Wald et al. (1955), also has its maximal absorption at about 560 nm. However, the sensitivity curves produced after chromatic adaptation did not match the characteristic shape of visual pigment absorption curves (Dartnall, 1953) therefore these experiments do not in themselves constitute evidence of separate pigments underlying the sensitivity functions. Evidence of an additional 'blue' pigment in the pigeon has been put forward by Graf and Norren (1974) though. The electroretinographic sensitivity function following chromatic adaptation this time closely matched Dartnall's nomogram for a pigment with maximal absorption at 400 nm.

A behavioural study of the effects of chromatic adaptation on the pigeon's spectral sensitivity function has also been performed by Meissner (1970). The results tend to corroborate Ikeda's (1965) findings, since sensitivity, following chromatic adaptation, was most depressed in spectral regions served by the long- and short-wavelength processes identified by Ikeda.

Another way of investigating the pigeon's colour vision mechanisms is to directly record the responses of chromatically driven units within the visual system. The pigeon's visual system consists of two major central pathways. From the optic nerve one projection goes to the optic tectum and thence via the thalamic nucleus rotundus to the ectostriatum. The other pathway to the dorsolateral anterior thalamic complex then ascends via the lateral forebrain bundle to

terminate in the hyperstriatum accessorium and hyperstriatum dorsale (Karten, 1969)

Single unit recordings have been made from the retinal ganglion cells themselves (Donner, 1953) Donner found units whose response patterns conformed to the type labelled by Granit (1947) as 'dominators' and 'modulators'. The photopic dominator showed a broad range of response, peaking at 580 - 590 nm, in agreement with the maximal photopic sensitivity that has been found by other authors, using both behavioural and physiological techniques. Other units, the modulators, gave much narrower response curves, which rose particularly steeply towards the shorter wavelength end of the spectrum. This finding Donner attributed to the corresponding cut-off characteristics of the cone oil-droplets. The majority of the modulator units fell into three groups with sensitivity peaks in the 'red', 'green' and 'blue' at about 600, 540 and 480 nm respectively

Recording from diencephalic units, in the nucleus geniculatus lateralis and nucleus superficialis synencephali, Galifret (1961) also grouped the units' responses into three types showing maximal sensitivities at 590, 540 and 500 nm. Confirmation for three regions of peak sensitivity in diencephalic unit responses comes from Granda and Yazulla (1971), who recorded from the nucleus rotundus. Peaks of activity were found at 500, 540 and 600 - 620 nm

The results of all these studies, showing three families of peak sensitivity, would appear to confirm the conclusions of Hamilton and Coleman (1933) and Riggs et al. (1972) that the pigeon's colour vision is

trichromatic. However, if the sensitivity peaks are directly representative of cone receptor sensitivities, then the sensitivity maxima of the pigeon's cones would correspond little with those of human cones, which contain pigments with absorption maxima at 445, 535 and 570 nm (Marks et al., 1964)

As well as the above types of unit, which all responded unidirectionally with either excitation or inhibition, cells with an opponent mode of response have been reported in the nucleus rotundus by Yazulla and Granda (1973). All these opponent-process units responded maximally with either excitation or inhibition in the 'blue' and 'yellow' regions of the spectrum but two groups of cells were defined by the wavelengths at which the response pattern changed direction. In one group, a changeover in activity occurred at about 500 nm while the crossover point for the second group of units fell at about 520 nm. A few units also showed a more complex pattern of 'on' and 'off' responding, similar to complex response functions of an opponent nature which have been demonstrated in units from the pretectal region and in the anterior part of the optic lobe (Galifret, 1960). Opponent-process units have been reported in a variety of other animals with colour vision (Michael, 1968, MacNichol et al., 1961, De Valois et al., 1966, Pearlman and Daw, 1970) and may well be a feature common to all animals which can discriminate between wavelengths.

Some discrepancies amongst the results of behavioural investigations of the pigeon's colour vision are mentioned in the above review. Some experiments indicate that this species' colour vision is very similar

to our own and others that it differs in several important respects. The aim of the present thesis is therefore to obtain more information about certain aspects of the pigeon's colour vision, using behavioural and physiological techniques. The data obtained can then be compared with previous results from both avian and human subjects to clarify the nature of the pigeon's colour vision, in particular whether its vision is trichromatic or is more complex than that. The results of these investigations can also be interpreted in terms of what is known about the above mentioned physiological mechanisms which underlie visual performance. Furthermore the role of the multi-coloured oil-droplets in the pigeon's colour vision can be considered, since brightly-coloured droplets are a feature peculiar to the retinae of avian and chelonian species. The characteristic adaptations of visual structure, function and performance in the pigeon can then be related to this animal's mode of life, thus analysing one of the sensory processes of this animal, at another level, in terms of the pigeon's behavioural needs.

CHAPTER 2

WAVELENGTH DISCRIMINATION IN PIGEONS

INTRODUCTION

Anatomical differences between the retinae and the central visual projections of the pigeon and man make it surprising that the colour vision of these two species should be so similar. A close similarity in their hue discrimination abilities has been demonstrated, however, by Hamilton and Coleman's (1933) study. Their results imply that pigeons, like man, are trichromatic and can discriminate most finely in the spectral regions in which human wavelength discrimination capabilities are also at their best. On the other hand, the occurrence in the pigeon's retina of four types of oil-droplets, which can act as independent chromatic filters, would lead us to expect that this animal's visual system is, at least, of a tetrachromatic type.

Hamilton and Coleman's experiment, upon which much of the argument relating to the pigeon's colour vision has been based (e.g. King-Smith, 1969), does not seem very satisfactory however. Their method, in which some animals were required to choose a stimulus whose wavelength was constantly changing during a threshold test, appears to have presented their subjects with certain difficulties

which resulted in some inconsistencies in their animals' response pattern. All three animals tested showed spontaneous reversals in their mode of response at certain wavelengths two birds, for example, which had consistently chosen the shorter wavelength stimulus of all wavelength pairs above 530 nm would unexpectedly jump towards the longer wavelength when stimuli were used which were of shorter wavelengths than 530 nm. Furthermore, it is unclear how many of the results they plotted on their wavelength discrimination function could have been obtained using the procedure they described.

The results of more recent studies relating to the pigeon's wavelength discrimination abilities (Wright and Cumming, 1971, Blough, 1972, Riggs, Blough and Schafer, 1972, Schneider, 1972, Wright, 1972a) do not entirely concur with Hamilton and Coleman's data. There is also some disagreement amongst these authors about the number and spectral positioning of the regions of best wavelength discrimination.

An experiment was therefore designed to re-examine the nature of the pigeon's colour discrimination, using a method which would avoid the problems met by Hamilton and Coleman. This study includes an examination of discrimination within the shorter wavelength end of the spectrum, for which there is less information. The results of the ensuing behavioural investigation can then be compared with previous data and can be related to the physiological mechanisms

which may mediate wavelength discrimination. The role played by the pigeon's oil-droplets in its colour vision can also be assessed in the light of the results.

METHOD

Subjects

Five pigeons (Columba livia) of mixed breed were used as subjects and maintained at approximately 80% of their free-feeding body weight. Two subjects, S1 and S3, had been used in a previous colour-preference study while the rest were naive. In the latter experiment, using the same Skinner box as in this study, red- and blue-illuminated response keys were simultaneously presented to the birds which were rewarded for pecks to either key. No deliberate discrimination training was given and it was assumed that the birds' performance in the colour-preference test would not, after quite prolonged discrimination training, affect the present results. The precaution was taken, however, of not using the preferred blue wavelength in the first pair of discrimination stimuli given in this study.

Apparatus

A Skinner box of dimensions 38 x 36 x 36 cm, constructed of aluminium painted matt grey, was used for testing. On one panel were situated two circular ground perspex response keys. In the opposite panel of the box was a food hopper aperture. On the floor was a platform which, when depressed, activated a microswitch beneath it (Fig. 1).

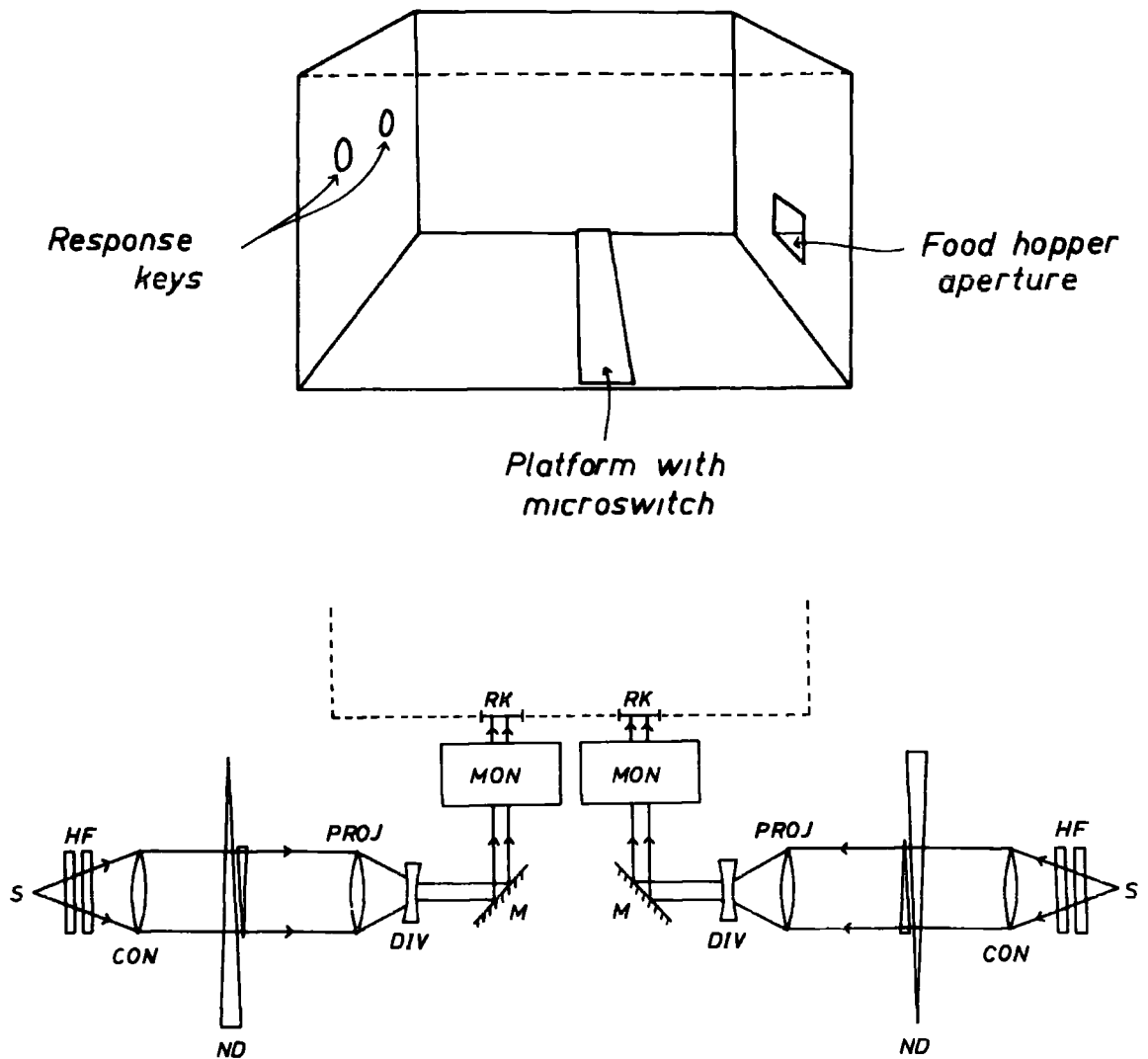

Fig. 1

Top - Skinner box used for discrimination testing.

Bottom - Optical system, providing coloured horizontal bar stimuli which were back-projected onto the response keys of the Skinner box.

S = light source, HF = heat filters, CON = condensor lens,

ND = compcnatcd neutral density wedge, PROJ = projection lens,

DIV = diverging lens, M = front-silvered mirror,

MON = monochromator, RK = response key.

A ceiling lamp was used to signal an incorrect choice during discrimination trials. With this light on, photometer readings showed the luminance of the back wall of the box to be 0.02 mL and of the side walls 0.01 mL. With the food hopper light on the luminance of the hopper aperture was 5.0 mL.

Two identical optical systems were constructed, providing the light stimuli which were projected onto the backs of the response keys (Fig. 1). In each system the light source was a 50W 12V tungsten halogen lamp, shielded to minimise stray light. Heat filters were placed adjacent to the lamp. The condenser and projection lenses were 5 cm diameter achromatic doublets. The luminance of the stimulus could be controlled by means of a compensated neutral density wedge. A low power diverging lens brought the beam of light onto a front-silvered mirror that deflected it through a grating monochromator (Hilger & Watts D292). The stimulus projected onto the response keys was a narrow horizontal bar, 10 x 1 mm.

With slit widths of 1 mm the monochromators had half-bandwidths of 6.6 nm. Spectral discharge lamps (mercury and helium) and a cadmium sulphide photoconductive detector together with a digital voltmeter were used to check the calibration of each monochromator.

Using an SEI photometer and adjusting the neutral density wedges, stimuli were equated in subjective luminosity for the human eye to a value of 17.1 mL at 10 nm intervals over the range of wavelengths

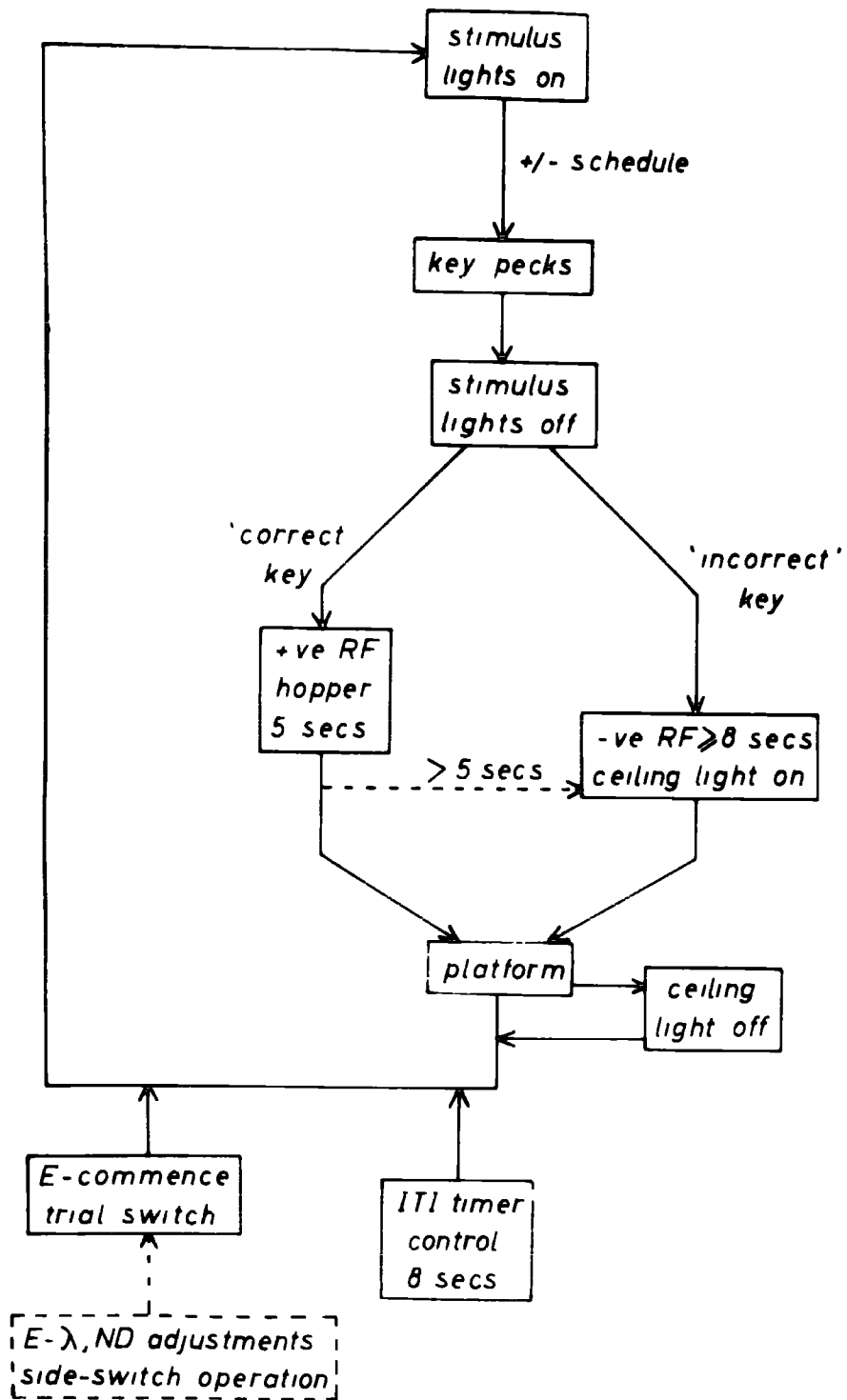

WAVELENGTH DISCRIMINATION
 Sequence of events in Skinner box

Fig. 2

400 - 700 nm Several readings were taken at each point and the neutral density setting recorded when the repeated readings agreed within a range of 1.7 mV. Using Blough's (1957) data, that compare the pigeon's photopic spectral sensitivity with that of the human fovea, adjustments in the neutral density settings were then calculated to give a spectrum of equal subjective luminosity for the pigeon. The accuracy of these settings, calculated on the basis of photometer measures, was checked using a calibrated thermopile (Hilger-Watts FT 17). Radiometric measures of the unattenuated stimuli were corrected for the neutral density wedges' attenuation and compared with Blough's spectral sensitivity curve. The agreement was satisfactory.

The training apparatus was housed in a darkened room while the programming apparatus, that partially controlled the operation of the Skinner box, was kept in a separate room.

Conventional programming equipment was used to control the sequence of events in the Skinner box (Fig. 2) as follows - pecks to the response keys turned off the stimuli. If pecks were made to the 'positive' key 5 secs food reward was given. The ceiling lamp came on if responses were made to the 'negative' key. To turn off the ceiling lamp and enable the next trial to begin the animal had to depress the floor platform, thus operating a microswitch beneath it. Because of its position, this was done automatically during positive reinforcement when the bird crossed the box from the response keys to the food hopper.

An inter-trial interval of approximately 8 secs allowed the experimenter to make any necessary adjustments of the monochromator and neutral density settings and to operate a switch determining which response key would be positive. Another switch, bringing on the stimuli, started the next trial.

Procedure

After preliminary shaping in a Skinner box with a single response key, positioned on the same panel as the food hopper aperture, the pigeon was transferred to the Skinner box used for discrimination training. Here the animal was trained to peck at both response keys and move away to the hopper for food reward. Any initial position preferences were broken down and a fixed ratio (FR 5/1) reinforcement schedule introduced, prior to the use of a special 'add/subtract' ratio schedule in discrimination training itself. Throughout shaping, response keys were illuminated with white light.

During training two monochromatic horizontal-slit shaped stimuli were presented simultaneously onto the response keys. Responding was reinforced on a fixed ratio schedule in which 5 consecutive pecks to one key produced either positive or negative reinforcement. If the bird changed to pecking on the other key before a run of 5 consecutive pecks was completed, say after 3 pecks, then, to obtain reinforcement, it had to make 3 pecks to cancel out the previous pecks on the first key plus 5 additional pecks. To prevent the possibility of oscillation from one key to the other ad infinitum,

the 'add/subtract' schedule was overridden if a total of 10 pecks to either key failed to produce reward. The bird was then reinforced for the 5th peck following this total.

Note that the schedule did not require the bird to cross the platform between each peck, this was only necessary between trials. In this respect the 5 consecutive pecks are not independent choices as are the responses made on different trials. The fixed ratio schedule used was helpful in maintaining responding in a situation in which fairly long inter-trial intervals were necessary and where the bird had to make a difficult discrimination. The 'add/subtract' schedule was used to reduce the chances of a pigeon being reinforced while merely making random choices. In addition this schedule enabled the bird to change its initial decision as to which stimulus was correct before reinforcement was given. But after making the new decision it had to indicate that the second choice was the definite one by cancelling the previous pecks and also responding a further five times. Thus, after altering its choice, a pigeon had to do more pecks than if it had kept to its original decision. (In fact, changes in response from one key to another were observed mainly at the beginning of the experiment, when the discrimination task was still quite new to the animals, and when discrimination was presumably becoming more difficult for them, shortly before thresholds were reached).

Table I.
Wavelengths of stimuli used in discrimination training.

Wavelength of positive stimulus	Wavelength of negative stimulus	
	'S+ > S-' series	'S+ < S-' series
400 nm	460 nm	460 nm
420	490	490
440	490	490
460	400	520
480	430	530
500	450	550
520	470	570
540	490	590
560	510	610
580	530	630
590	540	640
595	550	650
600	550	650
620	570	690
640	590	590
680	580	580

Two sessions of trials were given daily, with 20 trials per session. The positions of positive and negative stimuli were randomly alternated according to a Gelleimann (1933) schedule. The total number of trials, number of positive and of negative reinforcements given were recorded on counters. From these numbers the percentage of successful and unsuccessful discrimination trials was calculated.

Each bird was given a series of discrimination tests. A test involved between 9 and 40 sessions. For each test the birds were given a number of initial training sessions with one of 16 pairs of stimuli that covered the spectrum between 400 and 680 nm. (Table 1). The order in which stimulus pairs were used was randomised. For 3 of the subjects the positive stimulus was, except at the extremes of the spectrum, always of longer wavelength than the negative stimulus. For the other 2 pigeons, the positive stimulus was paired with a negative stimulus of shorter wavelength. This division of subjects was made to allow for any differences which might arise if the positive stimulus was approached from different ends of the spectrum.

For each stimulus pair the bird was trained to choose always the positive stimulus until it reached, on 2 consecutive sessions, a criterion of at least 90% of correct responses. Over the following sessions, with the positive stimulus remaining the same, the wavelength of the negative stimulus was changed such that the difference between the stimuli decreased. Initially the wavelength difference was diminished in steps of 10 nm per session, when the accuracy

S7

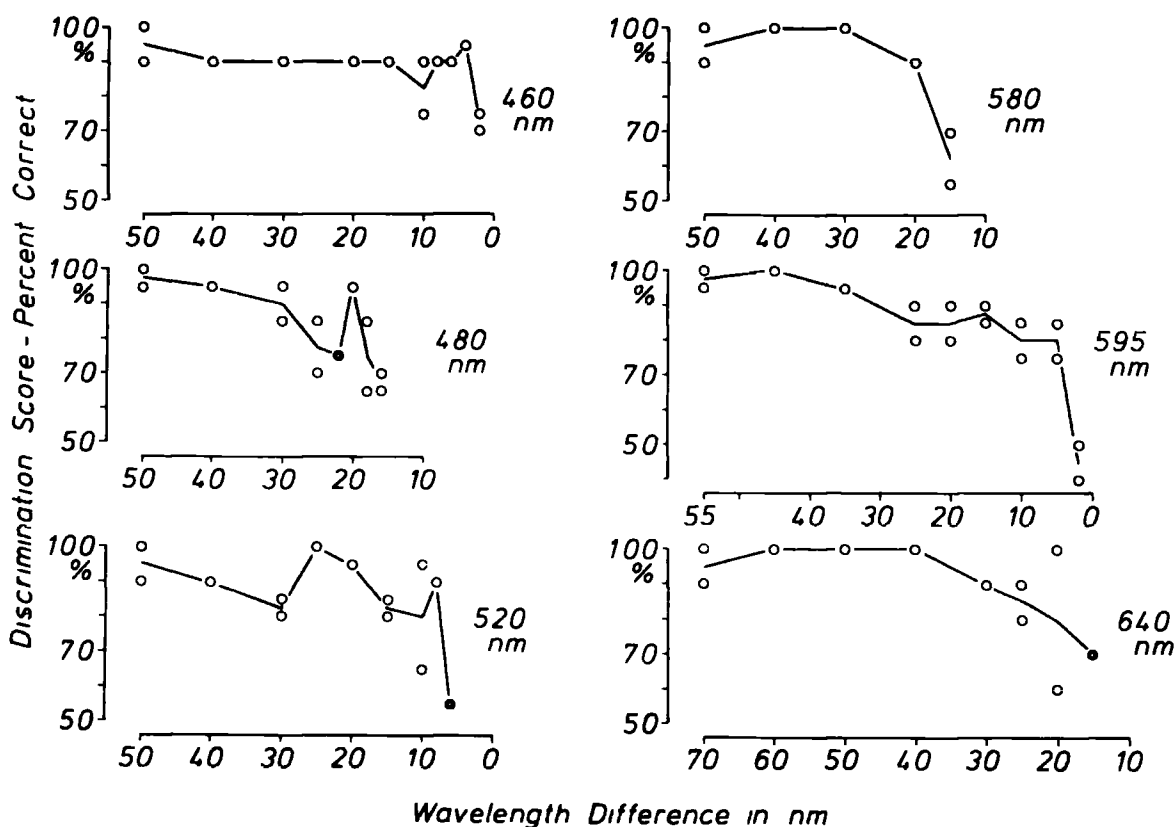

Fig. 3

Course of discrimination for a sample of threshold tests for two subjects.

Each graph shows the percentage discrimination score on each session as the wavelength difference between positive and negative stimuli was decreased by 10, 5 or 2 nm steps (see Procedure). A variable number of sessions were needed at the start of each test to learn which stimulus was the correct one. The results of these acquisition sessions are not displayed, so the graphs show scores once the initial criterion of 90% correct choices had been reached. Single points show the discrimination scores on each session. Where the score fell below 90% correct, a session was repeated using the same wavelength settings. The solid line joins the mean scores at each wavelength difference value. Thresholds were obtained when the scores on repeated sessions both fell at or below 70% correct.

Beside each graph is shown the wavelength of the positive stimulus. For S7, except for $S_{+\lambda} = 640$ nm, $S_{+\lambda}$ was less than $S_{-\lambda}$. For S9, $S_{+\lambda}$ was greater than $S_{-\lambda}$ throughout. Graphs were chosen to illustrate the course of discrimination to threshold for thresholds at or near both peaks and troughs in the wavelength discrimination function (see Table IIA,B and Fig. 4).

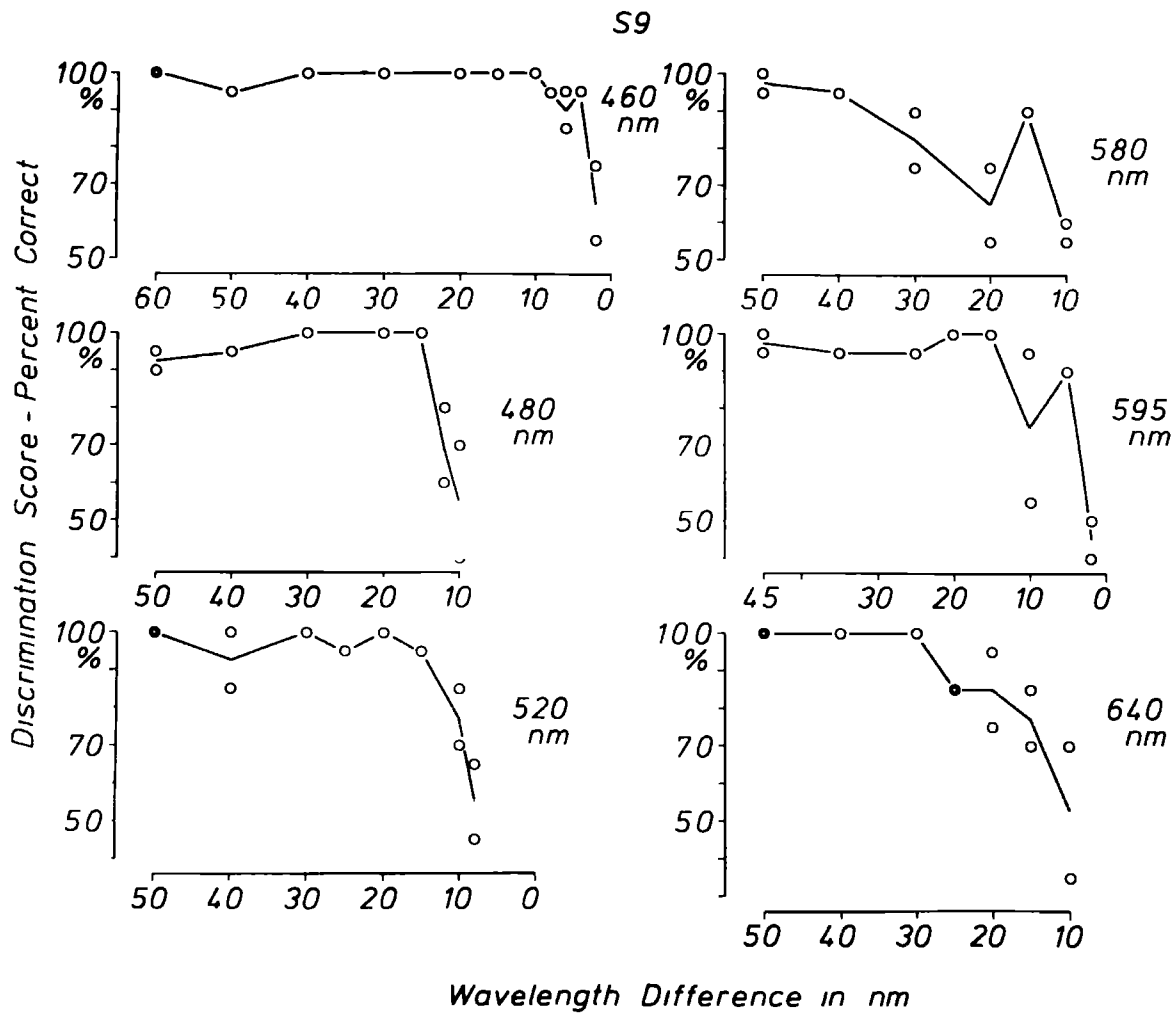

Fig. 3 cont.

of discrimination began to deteriorate steps of 5 nm and 2 nm were introduced. If the bird's score was still above criterion after a given change, the wavelength difference was further decreased on the next session. If the bird's performance fell below criterion, the subject was given one more training session with this same wavelength difference. Then, irrespective of whether or not the bird showed improvement in performance after this second training session at that wavelength difference, a further decrease in the wavelength difference was made. This procedure continued until the pigeon's performance fell to a level of 70% or less correct trials on 2 consecutive sessions. At this point the wavelengths of the positive and final negative stimuli were recorded for calculation of the threshold.

The pigeon was then retrained using a new pair of stimulus values and the above procedure repeated.

RESULTS

In Fig 3 are given some examples of the course of discrimination scores during threshold tests. Since the number of sessions required to initially learn which of a pair of wavelengths was the correct one varied widely (between 1 and 38 sessions to reach a learning criterion of 90% or more correct choices), only scores after the learning criterion had been reached are shown. Thereafter, on many tests a high discrimination score was maintained until shortly before the threshold of wavelength discrimination was reached. But this was

Table II
Individual results on wavelength discrimination tests

Figures show the threshold values in nm,
 given by the formula

$$\Delta\lambda = |S_{+\lambda} - S_{-\lambda}|$$

$S_{+\lambda}$	Subjects				
	S1	S3	S7	S9	S10
400					
420					
440					
460	2			2	8
480	12			10	8
500	16			24	24
520	15			8	14
540	5			2	5
560	12			2	12
580	10			10	10
590	6			8	8
595	10			2	2
600	6			4	6
620	8			8	14
640	10	15	15	10	10
680	55	40	40	35	35

$S_{+} > S_{-}$ = wavelength of positive stimulus always
 longer than that of negative stimulus.

$S_{+} < S_{-}$ = wavelength of positive stimulus always
 shorter than that of negative stimulus.

$S_{+\lambda}$ = wavelength of positive stimulus.

Table II cont.

S^+ λ	Subjects				
	S1	S3	S7	S9	S10
400	34	38	36	38	40
420	22	24	25	26	26
440	6	6	4	6	6
460		2	2		
480		18	16		
500		12	8		
520		4	6		
540		5	10		
560		14	16		
580		10	15		
590		4	10		
595		10	2		
600		8	6		
620		10	12		
640					
680					

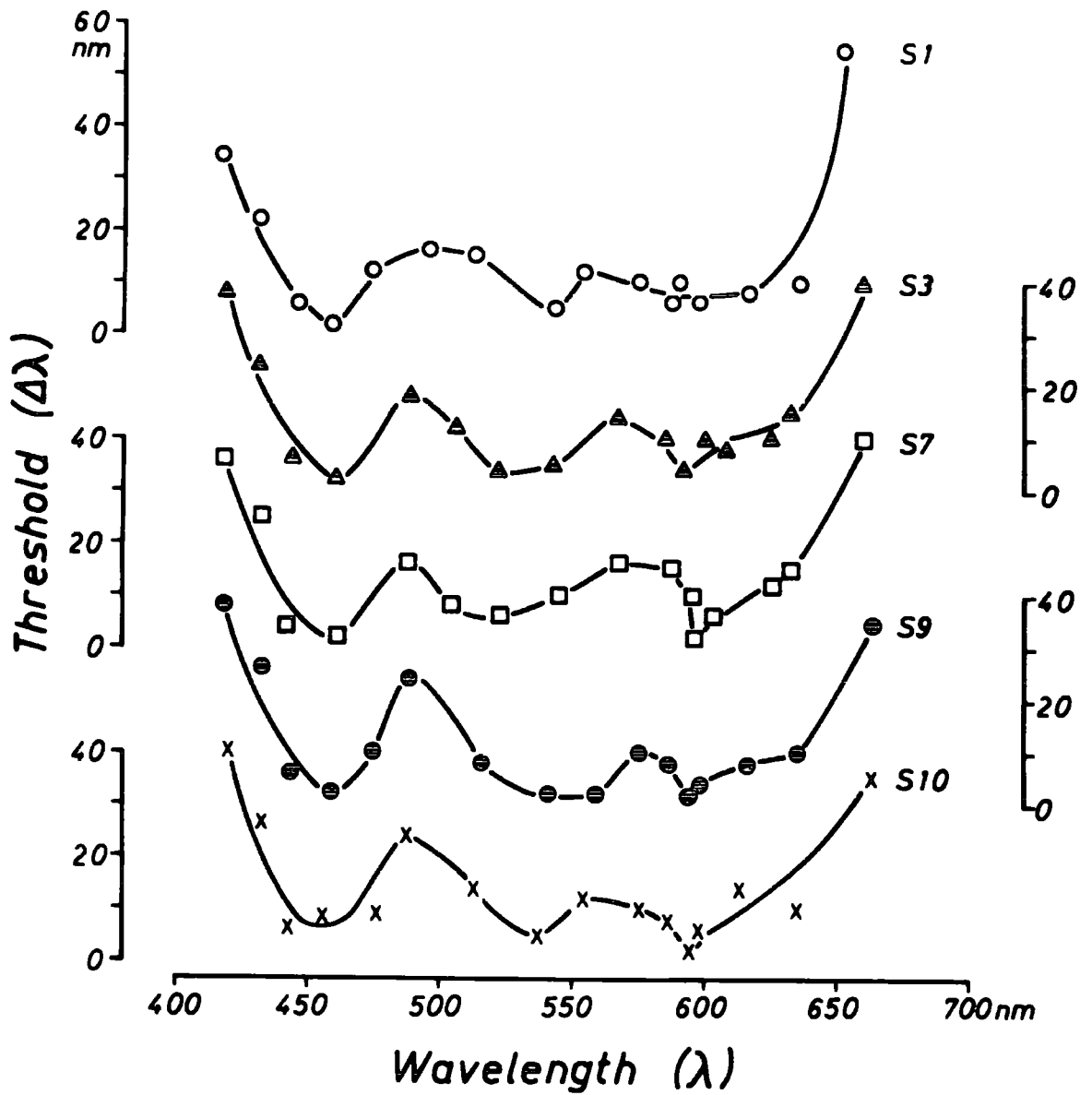

Fig. 4

Wavelength discrimination functions for individual subjects, S1 - 10.

not always so and the cases in which the course of discrimination scores was more irregular did not appear to relate to any particular wavelengths, nor subjects there was some variability in the patterns of graphs for all subjects and wavelengths but the agreement amongst subjects' final threshold results was good

The wavelength difference between the positive and the negative stimulus when the bird's performance had just fallen below 70% correct was taken as threshold value ($\Delta\lambda$) 16 such thresholds spread more or less evenly over the spectrum were obtained for each of the 5 pigeons (Table IIA, B).

Wavelength discrimination functions were then plotted from the data for each individual (Fig. 4) Each threshold was plotted at an abscissal wavelength value which fell at the midpoint of the interval between the two just distinguishable wavelengths.

Thus, where $S_{+\lambda}$ represents the wavelength of the positive stimulus of a discrimination pair and $S_{-\lambda}$ the final negative stimulus wavelength, threshold value is given by

$$\Delta\lambda = |S_{+\lambda} - S_{-\lambda}| \text{ in nm}$$

which is plotted at a wavelength value given by

$$\lambda = S_{+\lambda} \pm \frac{\Delta\lambda}{2} \text{ nm}$$

Mean thresholds were calculated for all 5 subjects taken together (Fig 5) For this, thresholds obtained using a particular wavelength as positive stimulus and under the same conditions of testing (i. e. with the negative wavelength either greater or smaller) were averaged ($\overline{\Delta\lambda}$).

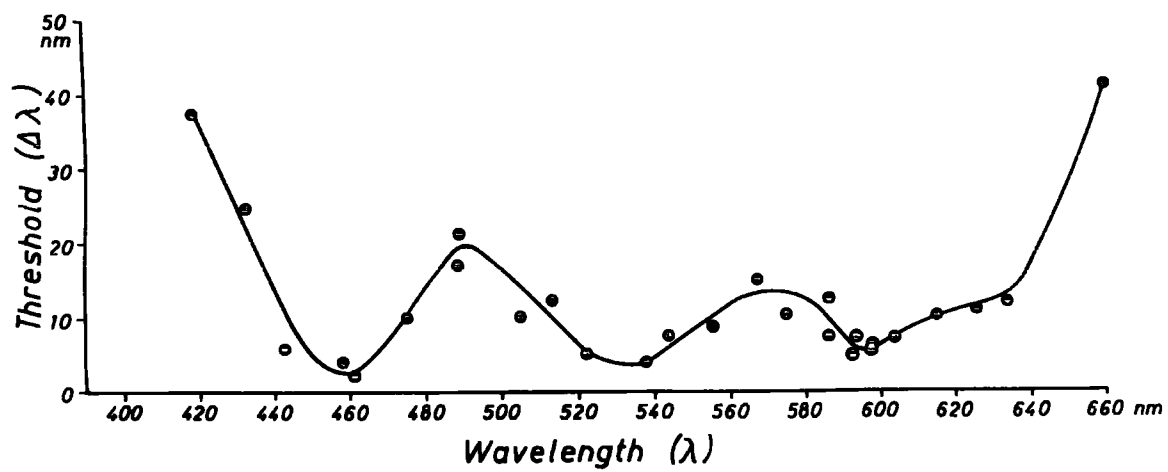

Fig. 5

Mean wavelength discrimination function.

Table III.
Data of Mean Wavelength Discrimination Function.

S^+_{λ}	$S^+ > S^-$		$S^+ < S^-$	
	λ	$\bar{\Delta\lambda}$	λ	$\bar{\Delta\lambda}$
400	—	—	418.6	37.2
420	—	—	432.3	24.6
440	—	—	442.8	5.6
460	458	4	461	2
480	475	10	488.5	17
500	489.3	21.3	505	10
520	513.8	12.3	522.5	5
540	538	4	543.8	7.5
560	555.6	8.7	567.5	15
580	575	10	586.3	12.5
590	586.3	7.3	593.5	7
595	592.6	4.7	598	6
600	597.3	5.3	603.5	7
620	615	10	625.5	11
640	634	12	—	—
680	659.5	41	—	—

$S^+ > S^-$ = wavelength of positive stimulus always longer than that of negative stimulus.

$S^+ < S^-$ = wavelength of positive stimulus always shorter than that of negative stimulus.

S^+_{λ} = wavelength of positive stimulus.

λ = abscissal wavelength value in nm.

$\bar{\Delta\lambda}$ = mean threshold in nm.

These values were plotted at a point on the wavelength axis given by

$$\lambda = S_{\lambda} \pm \frac{\Delta\lambda}{2} \text{ nm}$$

The individual and mean curves were fitted by eye. The coordinates of the points in Fig. 5 are set out separately, in Table III, according to the conditions of testing under which they were obtained.

The method of plotting thresholds differs from that used by several other authors (Wright and Pitt, 1934, De Valois and Jacobs, 1968, Jacobs and Yolton, 1971). Usually the experimental design is such that, for every subject, each positive stimulus is approached with the negatives from both ends of the spectrum giving two thresholds at each point tested. The mean threshold of these two is then plotted at the wavelength value of the common positive stimulus

It can be argued that this conventional plotting method is unsatisfactory. If thresholds are to be obtained over the maximum spectral range then a balanced design, approaching the negative to the positive stimulus from both ends of the spectrum, is obviously impossible at the spectral extremes where choice of stimuli is limited to those which are actually visible to the animal. The usual methods of plotting results also ignore consistent discrepancies found in thresholds obtained when the positive stimulus is approached from different ends of the spectrum. In the present experiment these differences are clearly seen if thresholds obtained under the two conditions of testing are plotted separately (Fig. 6).

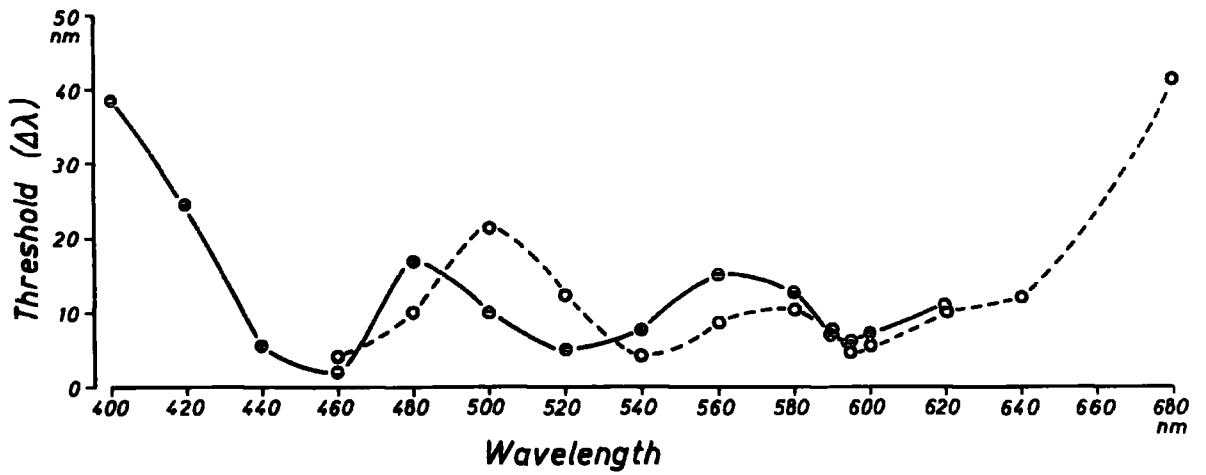

Fig. 6

Thresholds plotted at S^+_{λ} under two conditions of testing, in which the wavelength of the negative stimulus was, in one case, always longer than and, in the other, shorter than that of the positive stimulus. Note the discrepancies in the threshold results for the separate test conditions.

●——● Thresholds for $S^+ < S^-$
 ○-----○ Thresholds for $S^+ > S^-$

In effect, using former methods of plotting, the spectral range of threshold data was being curtailed in order to keep a balanced design or else two different sets of data were being shown on the same graph. This latter situation arises, as the authors themselves point out, in the plot of the ground squirrel's wavelength discrimination function given by Jacobs and Yolton (1971). In their Fig 14, at the extremes of the spectrum the data were obtained using only one direction of approach of the negative to the positive test stimulus, while in the middle portions the threshold values plotted are the means of the thresholds obtained after testing in both spectral directions. Insufficient information is given in the paper to see whether or not the mean threshold values also hide discrepancies of the type found here.

The previous plotting methods are presumably derived from the procedure used for plotting difference thresholds under circumstances in which Weber's Law applies. However, the Weber Law, $\frac{\Delta I}{I} = k$, is not applicable in the case of colour discrimination since there is clearly not a monotonic increase in the threshold value across the spectrum as is found, for example, across a large range of values in intensity discrimination. The present method of plotting results is instead based on the rationale that, at threshold, positive and negative stimuli are interchangeable, i. e. it is not important whether, in the case of two wavelengths being 500 and 510 nm at threshold, 500 nm is the positive or the negative stimulus

To the bird they will be more or less indistinguishable so that a threshold of 10 nm would be expected if a positive stimulus of 500 nm were to be approached from the longer wavelength end of the spectrum, similarly a threshold of 10 nm would be predicted for a positive stimulus of 510 nm approached with shorter wavelengths. Where the results allow comparison, approximate confirmation for this is found. Because of this interchangeability of results the thresholds are actually plotted at points midway between the wavelengths at threshold of the two stimuli in each discrimination pair.

The overall shapes of the discrimination functions are very similar for all individual subjects (Fig. 4), each curve has three troughs where discrimination thresholds fall to a minimum. The only exception occurs in the case of the results for S1 in which the trough at the long wavelength end of the spectrum is not very clear. The narrow range of individual differences for each threshold value, together with the lower absolute threshold values found in the present experiment, when compared with the results of Hamilton and Coleman's (1933) study, point to the reliability of this method of obtaining data.

DISCUSSION

Comparison of results with other studies relating to wavelength discrimination

The results of the present study, showing three regions of optimum wavelength discrimination at about 595, 530 and 460 nm, may be compared with findings of similar previous experiments (Fig. 7). Using

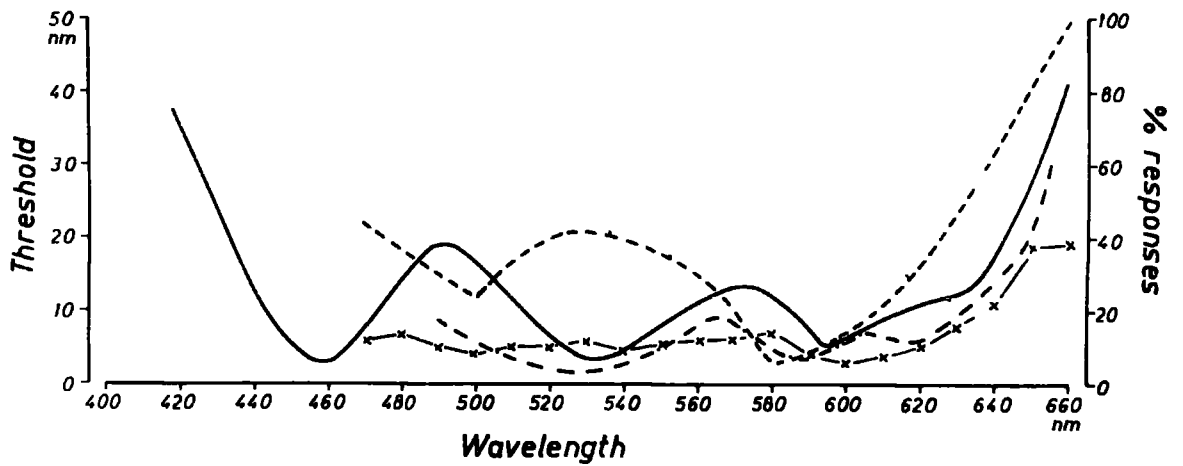

Fig. 7

Comparison of wavelength discrimination function (————) with that of Hamilton and Coleman (1933) (-----), of Wright (1972a) (* ———*), function derived from ERG experiment by Riggs, Blough and Schafer (1972) (- - - - -) and 'colour-naming' functions (Wright and Cumming, 1971) (.).

Wavelength discrimination functions: scale on left.

Colour-naming functions: scale on right.

a jumping-stand discrimination method, Hamilton and Coleman (1933) obtained a wavelength discrimination function showing a long wavelength minimum at 580 - 590 nm, in approximate agreement with that found here, but no correspondence is found with their results at shorter wavelengths. Although their thresholds appear to be plotted at the longer wavelength stimulus of a test pair, this difference in plotting does not substantially affect the position of minima in the graph and a direct comparison may be made between the two discrimination functions.

Closer agreement for two of the minima is obtained, however, with points of intersection at 540 and 595 nm in colour-naming functions for the pigeon (Wright and Cumming, 1971). This experiment used a 'matching-to-sample' technique, colour-naming functions being calculated from the percentage of responses to training stimulus wavelengths shown on side keys when a particular 'probe' wavelength was presented as the 'sample' on the centre key.

A wavelength discrimination function, derived from a study of ERG responses of the pigeon's eye to different wavelengths (Riggs, Blough and Schafer, 1972), shows similar features to the present function with optimal discrimination in the range 510 - 540 nm, another point of good discrimination at about 585 nm and poor discrimination above 630 nm.

Another recent hue discrimination curve for the pigeon, determined by a signal detection procedure (Wright, 1972a), has minima at 600, 540 - 550 and 500 nm. The spectral positions of the first two minima are close to the long and middle wavelength minima obtained in this experiment. The present function also concurs with Wright's in showing three discrimination minima instead of only two as previously reported but the third minimum found here occurs at a shorter wavelength of 460 nm, which is below the spectral range tested by Wright. At 500 nm, a point of optimum discrimination in Wright's function, the thresholds for all five pigeons are increasing as is the case in the experiment of Riggs et al. (1972).

Further experiments relating to the pigeon's wavelength discrimination abilities are reported by Blough (1972) and Schneider (1972). In the former study generalisation gradients around a number of training wavelengths across the spectrum were examined and showed variations in their degree of asymmetry and steepness. Blough argues that a steeper gradient is found where wavelengths are more discriminable to the pigeon and a flatter gradient indicates that the animal is less sensitive to wavelength differences. From the data, two regions of higher discriminability are shown at 600 nm and 540 nm while a third region of increased sensitivity occurs at about 460 nm.

Schneider's experiment, in which pigeons were required to discriminate between 'same' and 'different' pairs of wavelengths, generates a 'colour circle' on which the spacing between wavelengths

is proportional to their perceived similarity or dissimilarity. Here, perceptual dissimilarity corresponds to widespread spacing of wavelengths. The results of this work point to three regions of good discrimination at 500, 540 and 600 nm. A similar scale of the 'psychological spacing' of wavelengths was calculated by Shepard (1965), who applied a transformation to the earlier generalisation gradient data of Guttman and Kalish (1956). Maximal spacing, consistent with good wavelength discrimination, was at about 490, 530 and 610 nm on this scale.

In a further wavelength discrimination function, obtained from the jackdaw, three minima have also been reported (Wessels, 1974). Two of these minima, at about 590 and 530 nm, agree with regions of good wavelength discrimination in the pigeon data. However, the third minimum at 570 nm in the jackdaw's wavelength discrimination function finds no counterpart in the results obtained from pigeons. In addition Wessels reports a 'reversal' in the jackdaw's response behaviour when a positive wavelength of 500 nm was used, after the jackdaw had been tested at a series of longer wavelengths. At this wavelength the birds made consistently 'wrong' choices and Wessels concluded that 500 nm represents a 'hue border' to the jackdaw, but there is no evidence of a minimum in the discrimination function at this point.

For comparison, the regions of best wavelength discrimination reported in all the studies on pigeons are tabulated in Fig. 8, which shows that the most noticeable discrepancies are found amongst the

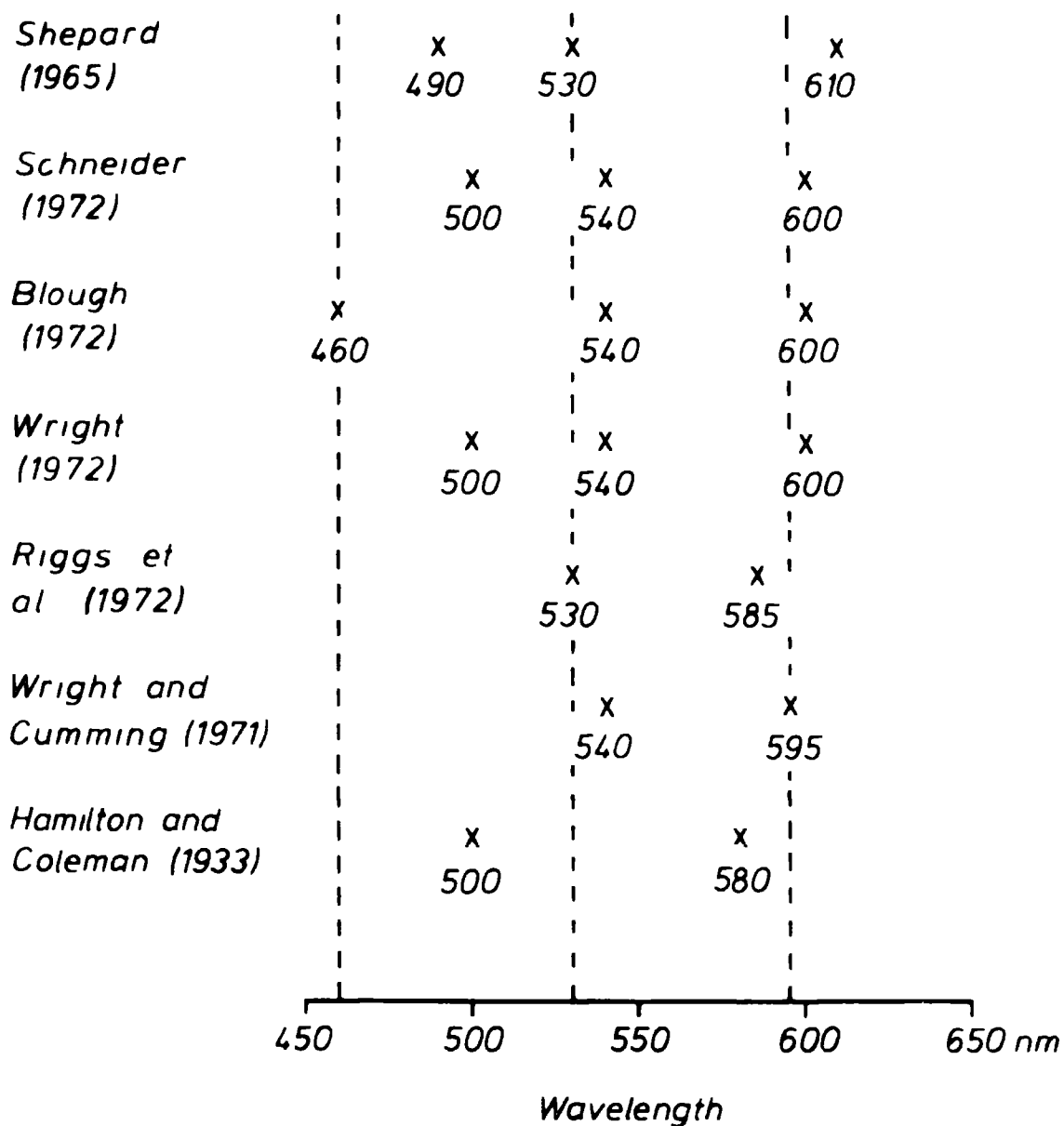

Fig. 8

Summary of results from wavelength discrimination experiments and related studies on pigeons.

x = region of good discrimination.

- - - - = position of a minimum in present wavelength discrimination function.

Note that the experiments by Shepard, Wright, Riggs et al. and Wright and Cumming did not explore far enough into the short-wavelength spectral region to detect a 460 nm minimum. Stimulus luminance levels varied widely amongst experiments but did not correlate with the presence of either a 500 nm or 460 nm short-wavelength minimum (see text).

positions of short wavelengths minima. In several cases, a minimum occurs at about 500 nm rather than at 460 nm, as in the present experiment. In the studies by Shepard, Wright, Riggs et al. and Wright and Cumming the stimulus range did not extend far enough into the short-wavelength region to test for a 460 nm minimum. However, the disparity amongst existing results remains to be explained

In humans, several wavelength-dependent psychophysical functions are modified by a change in stimulus luminance. For instance, the most pronounced short-wavelength minimum in the hue discrimination function shifts from 480 to 460 nm with a decrease in luminance (Weale, 1951). This, and other functions which are modified by luminance changes, have been accounted for in an opponent-process model of human colour vision in which Hurvich and Jameson (1955) postulate that the blue-yellow chromatic system predominates at high luminance levels while reds and greens predominate at lower luminances. Using pigeons, Blough (1972) reports a slight shift in the generalisation gradient to a 600 nm stimulus with luminance change. This result, while demonstrating some effect of luminance, differs in two respects from comparable human data. For humans, the position of the long-wavelength discrimination minimum remains stable at different luminance levels. Also, for pigeons, an increase in luminance produced a shift towards shorter wavelengths whereas, in humans, any shifts in this direction in the wavelength discrimination function result from a luminance decrease. The presence of any further gradient displacements there may have been at other wavelengths in Blough's experiment were

masked by the flatness of gradients which were usually generated with lower luminance stimuli

However, since stimulus luminance may be a critical factor in fixing the positions of wavelength discrimination minima, the occurrence of a minimum at 460 nm or 500 nm in the tabulated experiments was compared with the stimulus luminance levels used, where these data (given for wavelengths between 560 and 580 nm) were available. Schneider's experiment, which gave a 500 nm minimum, employed stimuli of higher luminance (30 mL as opposed to a luminance of 16 mL for the present experiment). On the other hand, in Wright's work, which also showed a 500 nm minimum, the luminance level was much lower (8.6 mL), while there was evidence of a 460 nm minimum in Blough's generalisation gradient study, in which a luminance level of about 0.04 mL was used. Clearly, these results, obtained from a variety of test methods, lead to contradictory conclusions about the effect of luminance on wavelength discrimination thresholds. Less equivocal results might be given if luminance level were manipulated within a standard wavelength discrimination test procedure.

Interpretation of the wavelength discrimination function

A minimum in the discrimination curve indicates a point of maximum sensitivity to wavelength change. Since wavelength responsiveness is initiated by the receptors, an animal's discriminative abilities must ultimately depend on the response characteristics of these cells. While

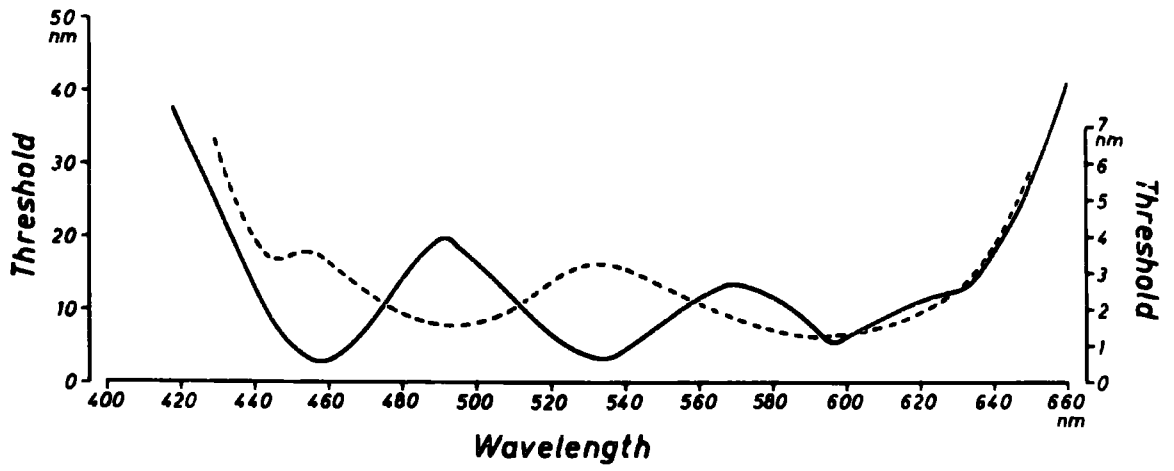

Fig. 9

Wavelength discrimination functions of pigeon (— left-hand scale) and man (- - - right-hand scale) (Wright and Pitt, 1934).

psychophysical data, dependent on the processing capacities of the whole visual system, are difficult to relate in any quantitative ways to the receptors' sensitivities, the shape of the curve does indicate the type of visual system possessed by the subject. A wavelength discrimination function showing two well-defined minima is characteristic of the performance of a trichromat (De Valois and Jacobs, 1968, Wright and Pitt, 1934). From the finding of three minima in the pigeon's discrimination curve, this animal's visual system appears to be tetrachromatic rather than trichromatic as previous behavioural and physiological information has indicated (Hamilton and Coleman, 1933, Donner, 1953, Galifret, 1961, Riggs et al., 1972). A secondary dip in the blue-violet part of the spectrum, however, often appears in the human wavelength discrimination curve (Wright and Pitt, 1934) (Fig 9). This subsidiary minimum becomes more distinct with decrease in stimulus intensity, or with peripheral stimulus presentation (Weale, 1951). Under certain conditions, human colour vision is tetrachromatic (Cornsweet, 1970). Since eye movements could lead to extra-foveal stimulation of the retina, and as, in Wright and Pitt's work, intensity was matched for each discrimination test rather than across the entire spectrum, suggesting that short wavelength stimuli were of low intensities, it is possible that the rods were acting as a fourth colour processing mechanism for short wavelengths (Trezona, 1970). The clearly defined short wavelength minimum in the pigeon data, together with the two other regions of optimum discrimination show that this animal has at least four colour processing mechanisms.

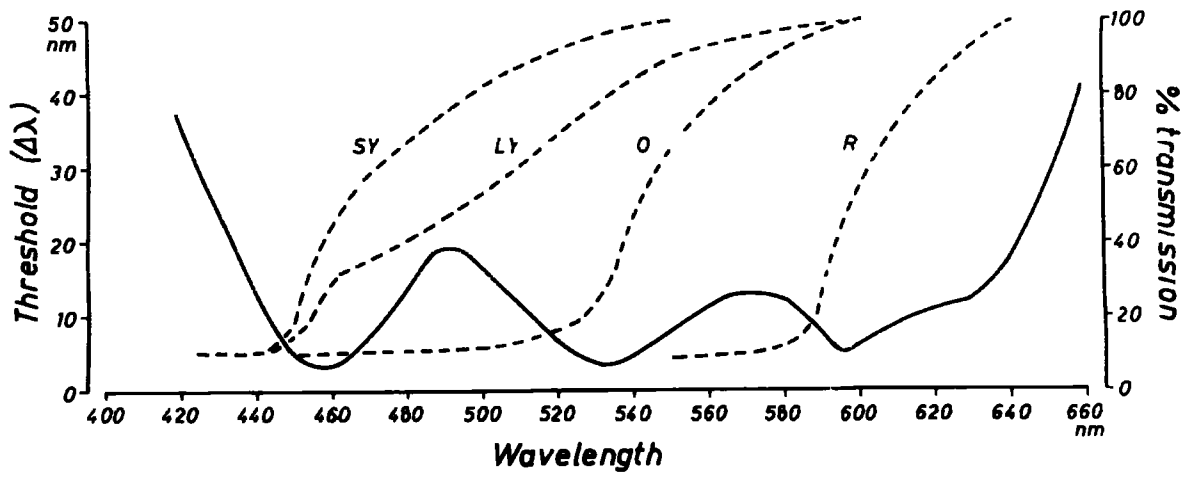

Fig. 10

Wavelength discrimination function compared with oil-droplet transmission spectra (King-Smith, 1969. data from yellow field of retina).

- mean wavelength discrimination function.
- - - - - oil-droplet transmission spectra for red(R), orange (O), large yellow (LY) and small yellow (SY) droplets.

Physiological basis of wavelength discrimination

1. Comparison with receptor characteristics

Studies of the pigeon's photopigments using extraction techniques have revealed only a single cone pigment, claimed by Wald (1958) to be iodopsin with a peak sensitivity at 562 nm while Bridges (1962) has found a pigment with maximal absorption at 544 nm. Support for the occurrence of iodopsin in pigeons' cones comes from Liebman (1972) who, with microspectrophotometry, could detect just one cone pigment having a broad absorption peak at 560 - 575 nm. For all droplets from both red and yellow retinal fields (King-Smith, 1969) transmission spectra are at a minimum below 450 nm, thus, combination of the oil-droplet filters with either of these pigments might allow discrimination amongst longer wavelengths. Comparing the wavelength function with oil-droplet transmission spectra (Fig. 10), the pigeon's capacity to discriminate between shorter wavelengths suggests that there is another short wavelength sensitive receptor.

Evidence for such a receptor, with maximum sensitivity at 400 nm, has recently been provided by an experiment by Graf and Norren (1974) using an ERG technique. Indeed their experiment not only demonstrated an independent blue photopic mechanism but chromatic adaptation revealed that the sensitivity curve of this mechanism was closely matched by the nomogram for a pigment with peak sensitivity at 400 nm, thus arguing for the presence of an additional visual pigment. Furthermore, Wright (1972b) has shown that pigeons can

detect ultraviolet light (i. e. wavelengths below 400 nm). Possibly this sensitivity to very short wavelengths is common to other groups of birds since UV sensitivity has also been reported in a hummingbird, an unrelated species (Huth and Burkhardt, 1972)

Other ERG experiments provide evidence of separate chromatic channels in the avian visual system. Studying the pigeon's photopic spectral sensitivity, Ikeda (1965) demonstrated that there were at least two colour-responsive mechanisms, showing maximum sensitivity at 547 and 605 nm. She suggests a third visual pigment, in addition to rhodopsin and pigment 544, to account for the long wavelength sensitivity. While she clearly shows that there are two independent photopic mechanisms, her results do not meet Abramov's (1972) criteria for claiming an additional underlying visual pigment since the response function of the 605 nm mechanism is much narrower than the nomogram curve for a pigment with this peak wavelength. But further support for separate photopic systems comes from other avian species (Bonaventure, Wioland and Karli, 1972. ERG experiments on the chicken, Thompson, 1971. ERG and pupillometric studies on gulls). While the assumption of several visual pigments in the avian retina might account for the results, these ERG data cannot at present refute the single pigment hypothesis of avian colour vision since multiple chromatic channels could also be explained by a model of neural interaction between receptors containing different oil-droplet filters (e. g. Thompson, 1971)

However, if the function of the oil-droplets in birds is to permit colour discrimination, it would be expected that in another species, whose retina also had oil-droplets of several colours, these droplets would serve a similar purpose. Recent work, though, by Liebman and Granda (1971) on turtles, which have three or four types of oil-droplets (Strother, 1963, Granda and Haden, 1970), has shown that the cone cells contain three different visual pigments.

Although oil-droplets may, therefore, not be a necessity for wavelength discrimination in birds, they may still modify the sensitivity of the colour processing mechanisms. As well as reducing chromatic aberration by eliminating most of the short wavelengths (Walls and Judd, 1933), the relatively sudden decrease in cone sensitivity towards the shorter wavelength end of the spectrum, given by the cut-off characteristics of the oil-drop filter, could be involved in enhancing wavelength discrimination at certain regions of the spectrum. This argument has been made by Muntz (1972) and by Donner (1960), who also suggests that oil-droplets form an adaptive mechanism providing a means of inter-specific variations in wavelength discrimination ability to suit the demands of the animal's behavioural environment. This view is extended by Wessels (1974), who reasons that, if it were easier to modify the pigment content of the oil-droplets during the course of evolution than to generate new photopigments themselves, the oil-droplets may have been instrumental in adapting the cone sensitivities to meet an avian species' needs.

Several other hypotheses of oil-droplet function have been put forward by Walls and Judd (1933). Their view that the yellow and red filters provided by oil-droplets of these colours act to enhance the contrast of objects viewed against different backgrounds has recently been critically discussed by Muntz (1972). An alternative hypothesis of theirs remains a possibility. This is that birds, and other species with oil-droplets of several colours, have 'multiplex' retinæ, in which different cone populations (as defined by their oil-droplet colour) come into use as conditions of illumination change. Presumably then, the yellow droplets, supposed to operate at average intensities, must be associated with several visual pigments to give polychromatic vision, while in bright illumination red and at least orange droplets must function in combination for even dichromatic vision to be maintained.

2. Comparison with characteristics of neural mechanisms

Donner (1953), recording electrophysiologically from the ganglion cells in the pigeon's retina, found modulator units with maxima at 480, 540 and 600 nm with possibly a fourth type of unit giving peak activity at 440 nm. Although only three units showed maximum sensitivity at this wavelength, the 440 nm modulator curves were shown to be clearly different in origin from those of other units. He believed these modulator curves closely represent the sensitivity spectra of the receptors themselves, although Dartnall (1960) suggests that modulator activity does not correspond with maximum sensitivity.

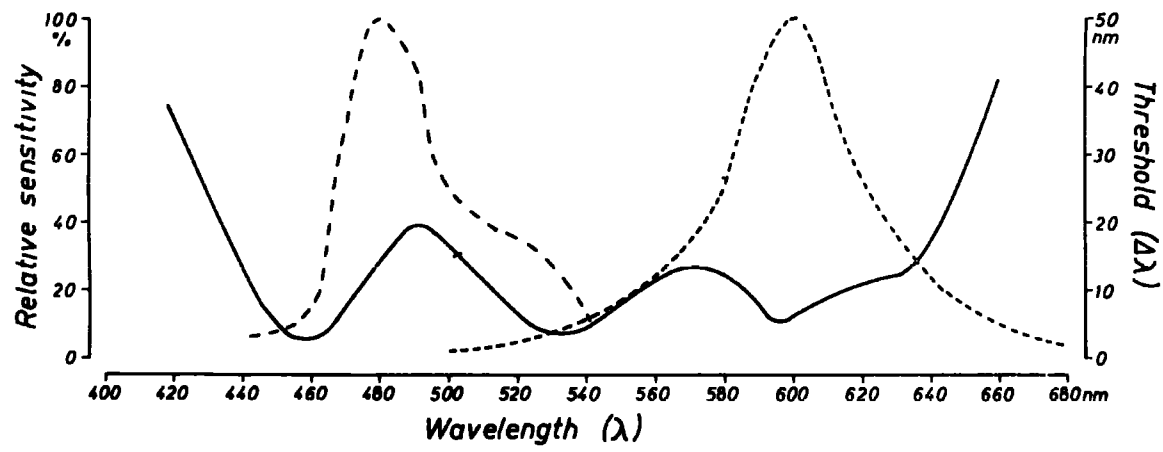

Fig. 11

Comparison of mean wavelength discrimination function (————) with Dommer's (1953) modulators: - - - - - red, green and - - - - - blue.

of a receptor but may be related to differences in sensitivity between two photopigments

Comparison of the modulator curves with the pigeon's wavelength discrimination function shows, in fact, that the maxima of 'red' and 'green' modulators correspond more closely with regions of optimum wavelength discrimination than would be expected if these areas represent points of changing sensitivity between two colour-processing systems (Fig. 11). But, the fact that there is little difference between the wavelengths of peak sensitivity in the modulators and of minima in the discrimination function may be explained by the increased gradient of cone sensitivity functions at shorter wavelengths produced by the transmission spectra of the oil-droplets. In that case the discrepancies between peak sensitivities and discrimination minima might be less than would be expected in animals whose cones are not subjected to additional filtering effects.

However, other physiological work lends support to Donner's findings. Ikeda's (1965) ERG studies showed response curves matching Donner's 'red' and 'green' modulators, single unit recordings from various diencephalic nuclei (Galifret, 1961) gave response maxima at 589, 540 and 499 nm, while Granda and Yazulla (1971), recording from the nucleus rotundus, found spectral sensitivity functions with peaks at 500 nm, 540 nm and 600 - 620 nm. Donner's data have furthermore been supported by the results of a behavioural study of the jackdaw's spectral sensitivity (Wessels, 1974). The photopic sensitivity curve

of this bird showed four maxima which could be fitted by theoretically derived cone sensitivity functions having their maxima at 605, 540, 480 and 420 nm.

The lack of correspondence between regions of optimum discrimination and points of change from one sensitivity function to that of a different cone system, with respect to the modulator curves, is not altogether surprising. In primates, the cone sensitivities by themselves cannot be used to predict the animal's wavelength discrimination capacities, which are more closely reflected by the response characteristics of cells whose activity is modulated by two different receptor mechanisms (De Valois and Jacobs, 1968). Such opponent-cells have recently been reported in the pigeon also (Yazulla and Granda, 1973). While one type of unit, which shows a rapid change in response pattern at 520 nm, may underlie the 530 nm minimum in the wavelength discrimination function, the other units they discovered, with a crossover-point at 500 nm, do not at all correspond with the 460 nm minimum of this experiment but instead provide a better match for the short-wavelength minimum found in several other studies of the pigeon's wavelength discrimination abilities.

Since completion of this experiment, Wright (1972b), as previously mentioned, has shown that pigeons are able to detect UV light arising from higher order transmission spectra in interference filters.

Unfortunately no blocking filters were used for the suppression of

higher order wavelengths in the present experiment. With the monochromators used, second order sidebands within the UV region could have occurred at nominal wavelengths above 600 nm. When using a tungsten light source whose emission spectrum is much reduced in the UV, the intensity of these sidebands would be very low and certainly could not be detected with the thermopile available. But it cannot be sure that their presence did not contaminate the experimental results. Consequently, another experiment was later set up to extend the investigation of wavelength discrimination into the UV part of the spectrum and to attempt to validate the results of this experiment by repeating some of the threshold tests, using UV blocking filters at the appropriate wavelengths to eliminate sidebands.

CHAPTER 3

A RELATIVE SATURATION DISCRIMINATION FUNCTION FOR
THE PIGEON

INTRODUCTION

A perceptual attribute of any colored light, that can be distinguished from its hue (largely dependent on the wavelength of that light) and its brightness (related to the stimulus energy), is the saturation. Saturation refers to the spectral purity of a light thus a light is maximally pure when it is monochromatic and (while the total luminance is held constant) its purity can be altered by mixing with it other wavelengths, particularly a mixture of all wavelengths constituting 'white' light. The light then appears to become paler or more desaturated until it cannot be distinguished from white light.

Saturation is conventionally defined as the reciprocal of colorimetric purity, which is a measure of the proportion of chromatic light in the total heterogeneous mixture. The reciprocal of colorimetric purity is calculated using the formula

$$\log \left(\frac{L_w + L_\lambda}{L_\lambda} \right)$$

in which, in a heterogeneous stimulus, L_λ is the luminance of the chromatic component, of a specified wavelength, and L_w is the

luminance of a white light with which it is mixed. Saturation is minimal when the stimulus consists only of white light while, for any particular wavelength, saturation is at a maximum when the stimulus contains only the chromatic component.

As well as being able to detect a change in saturation for any single dominant wavelength, any subject with colour vision can distinguish differences in saturation between various monochromatic lights. However, as with the problem of estimating luminance differences across wavelengths, the task of rating this disparity in saturation for different wavelengths is not an easy one.

It is possible, though, to obtain a fairly objective rating of these variations in saturation across the spectrum using the measure of colorimetric purity. In order to compare the saturations of lights of different dominant wavelength, white light may be added to a monochromatic light until the colour just disappears (or conversely chromatic light may be added to a white light until colour is just detectable.) The reciprocal of colorimetric purity at this point represents the saturation threshold at that wavelength and the variation in saturation for different spectral lights may then be compared, drawing up a relative saturation scale for the whole spectrum.

As with the wavelength discrimination function, the type of saturation function obtained is characteristic of the subject's colour vision system. A monochromat, unable to differentiate wavelengths, can match any spectral light to a white light by making an adjustment

in luminance. A subject with dichromatic vision is unable to distinguish a very restricted portion of the spectrum, the neutral point, from white light (Chapanis, 1944, Jacobs and Yolton, 1971, Jacobs and Pulliam, 1973). If the organism has at least a trichromatic system, although the saturation index will vary at different wavelengths, there is no spectrally pure light which cannot be distinguished from a white light of the same luminance (De Valois and Jacobs, 1968, Jameson and Hurvich, 1955, Yager, 1967).

The performance characteristics of the human visual system, which is known to be trichromatic, are often represented by a colour triangle (Graham, 1965), on which pure monochromatic lights are situated at points along the perimeter of the triangle while white light is depicted as a point in the centre of the triangle, with lights of a dominant wavelength but varying degrees of saturation featured along axes joining the white to the spectrally pure lights.

Since the saturation function is another quantifiable aspect of an animal's colour perception and may yield further information about the visual system, an experiment was designed to measure this psychometric function for the pigeon.

METHOD

Subjects

The same 5 pigeons were used as in the wavelength discrimination experiment, since these animals were already well-trained in performing a complex discrimination task and some information had been obtained

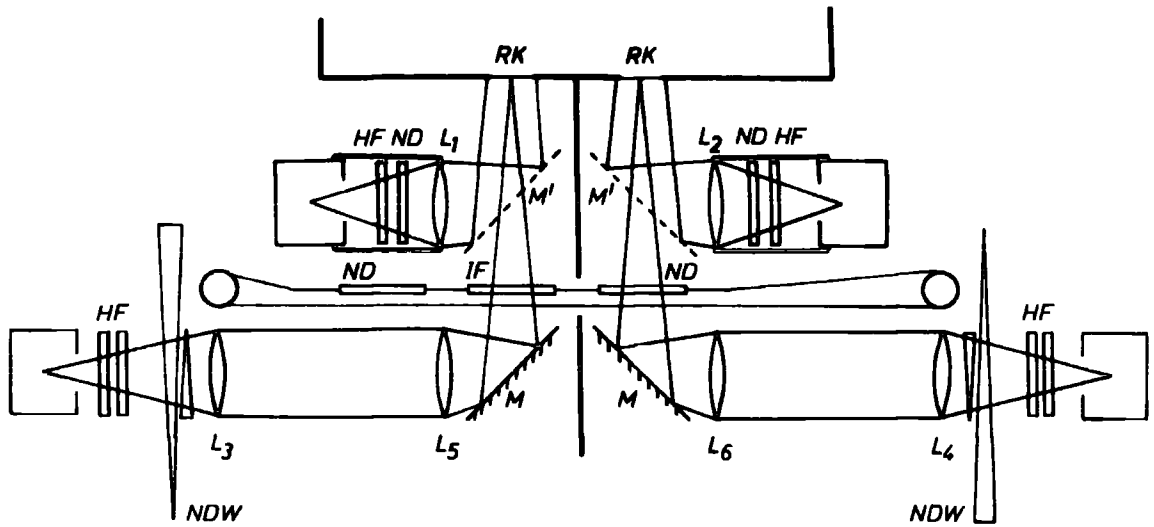

Fig. 1

Optical system giving two bar-shaped stimuli superimposed on diffuse white backgrounds. Interchange of chromatic and achromatic bar stimuli was effected by a motor-operated slide and pulley system.

HF = heat filter

IF = interference filter

$L_1 - L_6$ = achromatic doublet lenses

M = front-silvered mirror

M' = half-silvered mirror

ND = neutral density filter

NDW = calibrated neutral density wedge

RK = response key of Skinner box

about their visual abilities. These animals were maintained at 80% of their ad-lib weight.

Apparatus

The Skinner box was that used in the wavelength discrimination experiment (see Ch. 2). This apparatus was operated in a darkened room.

The optical system (Fig. 1), used in conjunction with the Skinner box, gave a bar stimulus superimposed on an achromatic background. Achromatic doublet lenses (L_1, L_2) and half-silvered mirrors (M') were used to project a diffuse 'white' light from two 50W tungsten-iodine lamps (with a colour temperature of about 3000°K), onto the back of each response key (RK). In each beam was interposed a heat-filter (HF) and a 1.3 Kodak Wratten neutral density filter (ND). The irradiance of each light, as measured by a calibrated thermopile (Hilger-Watts FT 17.1/526), placed in front of the response key, was $104 \mu\text{W}/\text{cm}^2$.

A second part of the optical system, employing 50W tungsten-iodine bulbs, heat-filters, lenses ($L_3 - L_6$) and front-silvered mirrors (M), provided a stimulus light of the bulb filament focused onto the centre of each key. This stimulus appeared as a horizontal bar 10×3 mm. Each beam could be attenuated by a calibrated neutral density wedge (NDW). One of the beams passed through an interchangeable Balzer interference filter (IF), to give a chromatic stimulus, while, in

the other light-path, was a suitable neutral density filter, giving a 'white' stimulus. The positions of the interference filter and neutral density filters were altered by a motor-operated slide and pulley system, controlled by the programming apparatus. The lamps and parts of the optical system were shielded to minimise light scatter.

16 different interference filters, having peak transmissions at wavelengths between 702 and 403 nm, were used. The half-bandwidths of these filters varied between 8 and 14 nm.

Calibration of white match

If the pigeon were required to discriminate a positive stimulus of a coloured bar upon a white background from a negative stimulus of the white background alone, it would be possible to make a discrimination based on the detection of a brightness difference between the superimposed bar stimulus and its background, irrespective of whether or not the bar appeared coloured to the animal. This is because the luminance of the central bar would compound both the luminance of the bar stimulus and that of the background at this point. The central white bar, superimposed on the white ground of the negative stimulus, was designed to overcome this problem.

However, since the maximum energy available at each wavelength varies, due to both the transmission characteristics of the interference filters and the emission spectrum of the light source, no single white stimulus can be expected to be equal in energy to all the chromatic stimuli to be used in this experiment. Furthermore, because of

variations in the pigeon's spectral sensitivity, if a white bar stimulus of constant energy were used, it would appear different in luminance from at least some of the chromatic stimuli

Therefore, for each test wavelength, an approximate match in luminance, for a pigeon, was calculated between the coloured stimulus bar and the white bar. The match was obtained as follows -

With the background light off, the maximum energy available with each of the interference filters in position was measured. The attenuation, in log units, necessary to give a spectrum of equal physical energy was then calculated. Using the lowest energy reading obtained (with the 403 nm filter), the appropriate neutral density filters were found empirically that would give this same thermopile reading at all the other wavelengths. Further neutral density filter compensation was then made for the pigeon's spectral sensitivity, using Blough's (1957) data, and the total neutral density attenuation to give a spectrum of equal subjective brightness to the pigeon was computed.

Luminance matches (for a pigeon) of a white stimulus to each of the chromatic stimuli were obtained using the match to the 619 nm filter as a standard. A red polaroid filter, used by Blough (1956) to find a photopic threshold, had a sharp, short-wavelength cutoff with 50% transmission at about 610 nm. Since the pigeon's sensitivity decreases rapidly at longer wavelengths (Blough, 1957) it was estimated that the effective wavelength maximum of this filter, for the pigeon's eye, would

Table I
Stimulus Filters

Wavelengths of peak transmission of interference filters and log unit attenuation values of neutral density filters, used to give 'matching' white stimuli.

λ Filter	ND Filter
702 nm	2.4
685	2.2
662	1.8
639	1.6
619	1.3
597	1.3
584	1.2
558	1.2
536	1.4
521	1.6
496	1.8
477	2.2
464	2.5
443	3.0
422	2.9
403	3.0

fall at approximately 620 nm. Blough found that the luminance values of this red and a white stimulus, at the pigeon's photopic threshold for the two stimuli, were the same. A similar luminance match between these red and white stimuli was apparent to a human subject thus suggesting 'that the relative photopic sensitivities to these red and white stimuli are comparable in the pigeon and man'. (Blough, 1956 p 430).

Since for this particular wavelength a luminance match, to the human eye, would also match for a pigeon, a suitable neutral density filter, for attenuation of the white stimulus beam, was found (using an SEI photometer) that would give a photometric match to the red stimulus of the 619 nm filter. This luminance match between the red and white stimulus bars was obtained by inserting a 1.3 ND filter in the white beam. Using this neutral density value as a 'zero' standard and maintaining differences in attenuation between the 619 nm stimulus and other wavelengths, necessary to give a spectrum of equal subjective brightness to the pigeon, other neutral density values could be calculated that would give approximate luminance matches of the white light to each of the other wavelengths used.

Neutral density filters to give matches to each of the interference filters are set out in Table I.

Standard electromechanical programming equipment, used to control the sequence of events in the Skinner box (see Fig 2 and Procedure), was housed in a separate room.

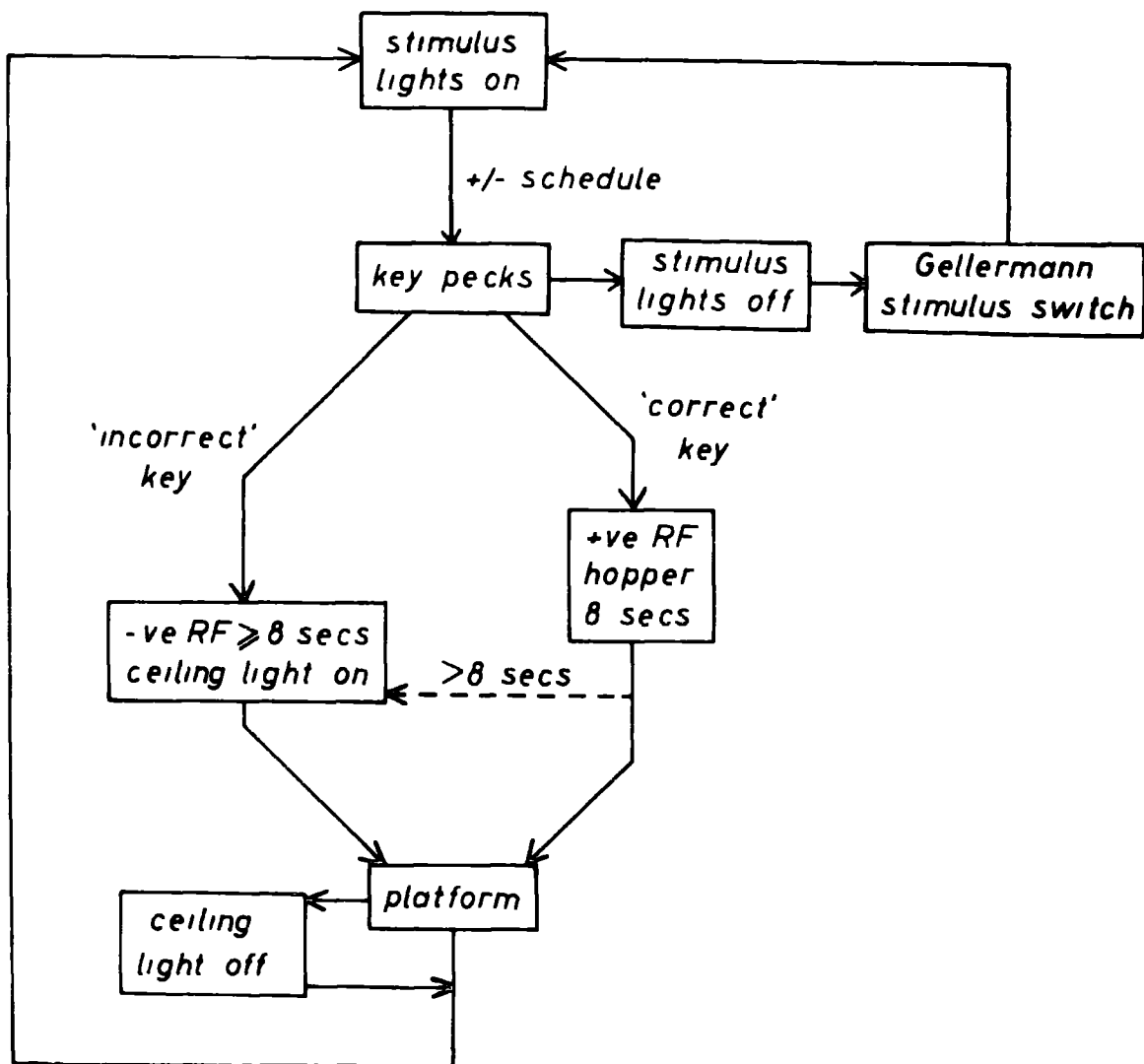

SATURATION DISCRIMINATION

Sequence of events in Skinner box

Fig. 2

Procedure

The procedure was similar to that used in the wavelength discrimination experiment, except that the sequence of events in the Skinner box (Fig 2) was entirely automated

Key pecking, on an 'add/subtract' schedule in which 5 consecutive pecks to the same key were necessary to terminate a trial, turned off the stimulus and background lights and led to reinforcement (RF). A 'correct' choice of pecking the response key bearing the coloured bar produced a reward of 8 secs access to food (+ve RF) from the hopper, which was illuminated by a small lamp. 'Incorrect' pecks towards the 'white' bar turned on the ceiling lamp for at least 8 secs (-ve RF). If, during this time, the platform had not been depressed, the ceiling lamp stayed on until the pigeon had crossed to the back of the box, thus operating the platform microswitch. Similarly if the platform microswitch was not activated within the 8 secs reward interval the ceiling lamp came on until the bird had moved away from the response keys. During the 8 secs reinforcement intervals, the positions of the interference and neutral density filters were alternated according to a Gellermann (1933) schedule. At the end of the reinforcement interval, or after the platform had been depressed, the four key lights came on and the next trial commenced.

A test session, lasting about 15 mins, ended after 50 trials. The number of positive and negative reinforcements received were recorded

on counters, the percentage of trials on which 'correct' and 'incorrect' choices were made could then be computed. Each bird was given two test sessions daily.

Saturation discrimination thresholds were derived from a series of 16 tests given to each subject. A different wavelength stimulus, with its matching white stimulus, was presented on each test, and the order in which the interference filters were used was random.

At the beginning of each test, coloured and white stimulus bars of high luminance were presented. The neutral density wedges were initially set to give a minimal attenuation of 0.6 log units or, in later tests, in order to reduce the amount of time needed to complete a test, to give an attenuation of 1.0 to 1.6 log units. Since the birds were well practised on the discrimination procedure, which had been used to find wavelength discrimination thresholds, they quickly transferred to the discrimination of chromatic and achromatic stimuli and, on many of the discrimination tests, performed at a level of more than 90% correct choices in the first test session (see Table V). After two consecutive sessions in which the animal performed at a level of more than 90% correct choices, the neutral density attenuation was increased by 0.2 log units. At each session the luminances of the coloured and white bar stimuli were further decreased by 0.2 log units until performance had fallen to a level of less than 90% correct choices. At this point a session was repeated, using the same wedge settings,

then luminance was decreased by 0.1 log unit steps. Each time a subject performed at less than 90% correct, the session was repeated with the same wedge settings before moving on to the next values. When performance accuracy was nearing the 70% correct criterion chosen as a 'threshold' level of discrimination (i.e. when two consecutive sessions with the same neutral density settings gave discrimination scores of less than 80% correct), 0.05 log unit changes in luminance were made

A discrimination test was completed when the accuracy of performance had fallen to 70% or less of choices being correct on two consecutive sessions. The setting of the neutral density wedges was then recorded for calculation of the threshold of saturation discrimination.

Test for effect of luminance mismatch

Using this procedure of steadily decreasing the stimulus luminance, the coloured and white stimulus bars appeared to 'fade' at the same rate against their constant background of white light until a point was reached at which they were no longer detectable. It was assumed that discrimination was based on the visibility of the coloured stimulus, in order to make a correct choice, but since the luminance matches between the white and coloured bars may not have been exact this supposition was checked

Following several threshold tests the luminance of the white bar was systematically altered, to produce a mismatch between the white

and coloured bars, by increasing or decreasing its luminance by 1 or 0.5 log units relative to the 'matching' value. The effect of such a mismatch was tested after the luminance of both stimuli had been reduced to threshold level and again when the luminance of the two stimuli was increased to a point just above the threshold (this point being chosen to give about 80-90% correct discrimination using the matching stimuli).

The percentage of correct responses for a session in which mismatched stimuli were used was compared with the percentage score for an immediately preceding session using matched stimuli. Some variation between individuals as well as variability in the scores obtained on different sessions and on different days would be expected, so that a comparison was made of the percentage difference in accuracy between a pair of consecutive match and mismatch sessions with the percentage range of correct responses over several sessions in which matching stimuli were used

Preliminary tests showed that with very large luminance differences (3 log units with 443 nm) pigeons tended initially to choose the brighter stimulus, and, if this was white, to then, after 2 or 3 incorrect choices, avoid this stimulus and switch its choice to the dimmer coloured stimulus

Further tests were carried out with the smaller, although still appreciable, differences in luminance between the two stimuli of 1 or 0.5 log units. Table IIA summarises the results of these tests. In nearly all cases the percentage difference of responses (given in single

Table IIA
Summary of results for luminance mismatch tests

Filter Subject	At Threshold				Above Threshold				Inter-session Variation		
	M vs 1B	M vs 0.5B	M vs 1D	M vs 0.5D	M vs 1B	M vs 0.5B	M vs 1D	M vs 0.5D	M	M	M
443 S 1	75	70	62	63	0.2ND units above threshold				50	72	72
	> (8)	< (1)	< (1)	< (1)	88	83	90	70			
S 7	70	68	68	72	60	56	68	54	86	72	84
	> (2)	< (4)	< (4)	< (4)	> (4)	> (4)	> (4)	> (4)	((14))		
496 S 7	72	80	70	66	76	62*	73	68	06	62	74
	< (8)	> (4)	> (14)	< (10)	> (16)	< (10)	< (10)	< (10)	((12))		
S10	76	84	96	90	66	84	58	68	78	58	70
	< (8)	> (6)	< (18)	< (10)	> (4)	< (4)	= (0)	= (0)	((20))		
536 S 3	86	98	70	50	0.1ND units above threshold				60	50	74
	< (12)	> (20)	> (20)	> (2)	96	100	98	94			
S 9	70	88*	60	62*	74	98*	74	94*	65	65	64
	< (18)	< (2)	< (2)	< (2)	< (4)	< (20)	> (6)	> (6)	((1))		

M = percentage score on session in which white and coloured stimuli were matched in luminance for 1 pigeon.

1B = percentage score on session in which luminance of white stimulus was 1 log unit brighter than value of matching white.

0.5B = percentage score on session in which luminance of white stimulus was 0.5 log units brighter than value of matching white.

1D = percentage score on session in which luminance of white stimulus was 1 log unit darker than value of matching white.

0.5D = percentage score on session in which luminance of white stimulus was 0.5 log units darker than value of matching white.

Figures in double parentheses = % range of scores over repeated sessions using matched stimuli.

Figures in single parentheses = % difference between scores on paired match and mismatch sessions.

> = discrimination score on session with matching stimuli was greater than that on mismatch session.

< = discrimination score on session with matching stimuli was less than that on mismatch session.

* = % difference exceeded % range but note exceptionally small range for S9 at 536m.

Table IIB
Pooled data from Table IIA

Filter	Subject	White stimulus <u>brighter</u> than matching value		White stimulus <u>dimmer</u> than matching value	
		M vs 1B	M vs 0.5B	M vs 1D	M vs 0.5D
443	S1	> =		< >	
	S7	> >		< >	
496	S7	< >	>	> <	>
	S10	< >	>	< =	<
536	S3	< <	<	> >	
	S9	< <	<	< >	
		Sign test: for N = 15 p = 0.5 (1 tailed)		Sign test: for N = 13 p = 0.5 (1 tailed)	

parentheses) on the match versus mismatch conditions fell within the range (figures in double parentheses, final column) of inter-session variation of choice accuracy when matched stimuli at threshold luminance level were used. An exception to this is found in the test on S9 at 536 nm in which the scores on the repeated tests with matching stimuli were particularly consistent (see percent range in last column of Table)

To check whether the discrepancies between the percentage scores on paired match and mismatch sessions were significant, on each test the discrimination score for a session with mismatched stimuli was classified as greater than or less than the score on the preceding session in which matched stimuli had been used. This classification of the differences between scores is presented in Table IIB. All the data from tests in which the stimulus was brighter than the match value were pooled as were the results for tests in which dimmer white stimuli were employed. It was hypothesised that any luminance difference between the bar stimuli would tend to facilitate discrimination i.e. if the positive stimuli were clearly brighter, this additional cue would lead to an improved discrimination score while the score would also be greater if the luminance of the negative stimulus was increased, since (as in the initial tests) the birds could quickly learn to avoid a more distinctive negative stimulus. However, applying a sign test (Siegel, 1956) to these sets of pooled data gave, in each case, a p value of 0.5 on a one-tailed test

Fig 3 (facing)

Course of discrimination for half of the threshold tests for two subjects

Each graph displays the change in discrimination score as stimulus attenuation is increased by 0.2, 0.1 or 0.05 log units (see Procedure). Single points show the discrimination score at a particular neutral density setting for one session. Where the percentage score fell below 90%, a session was repeated using the same wedge setting. Solid lines are drawn through the mean discrimination scores for different attenuation values. A threshold test was terminated when both scores on repeated sessions fell at or below 70% correct. The final ND setting was then used in the calculation of the threshold of saturation discrimination (see Results).

S3 generally required fewer sessions to reach a threshold than did S7.

Wavelength values of interference filters in each test are given beside each graph.

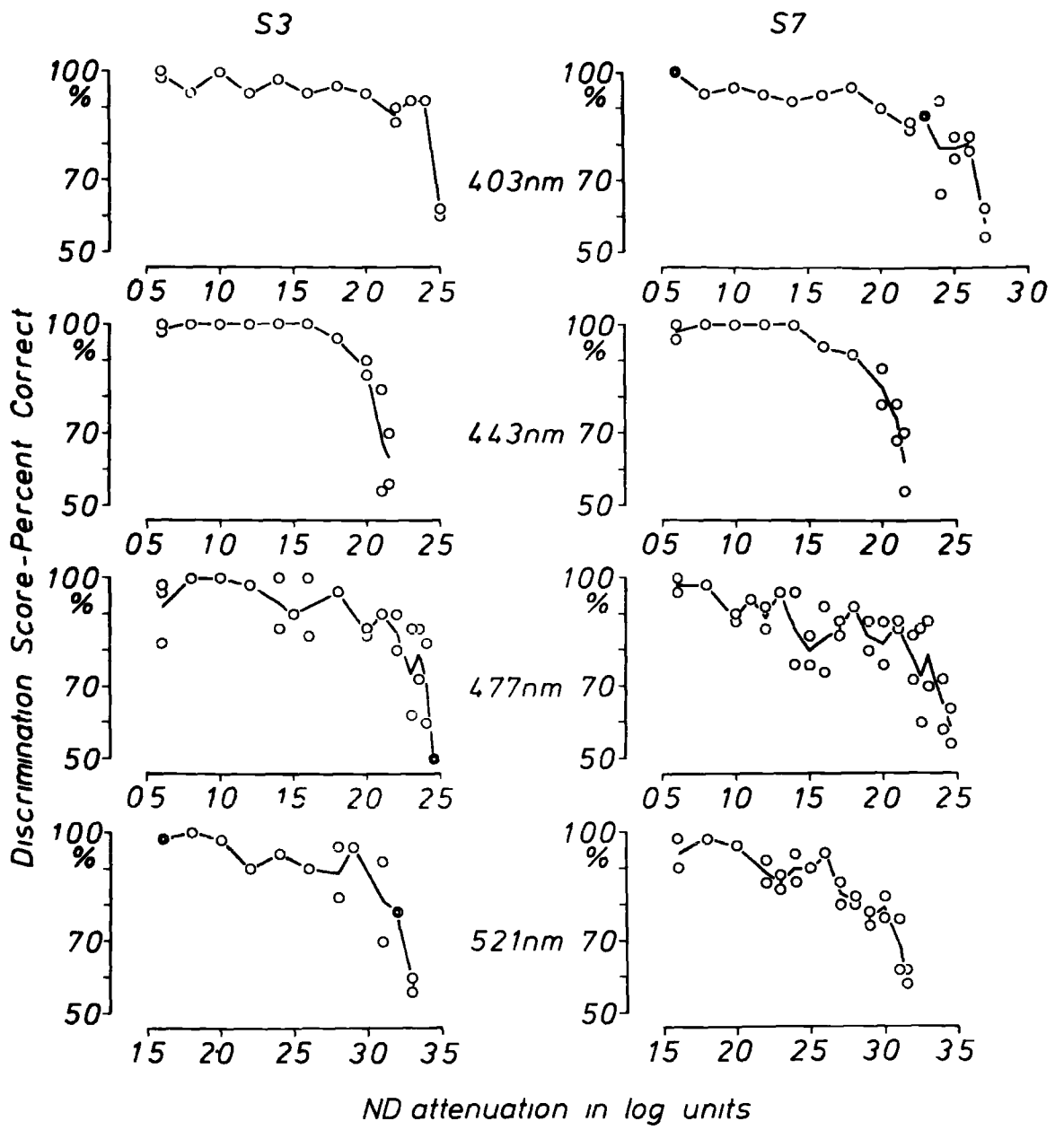

Fig. 3

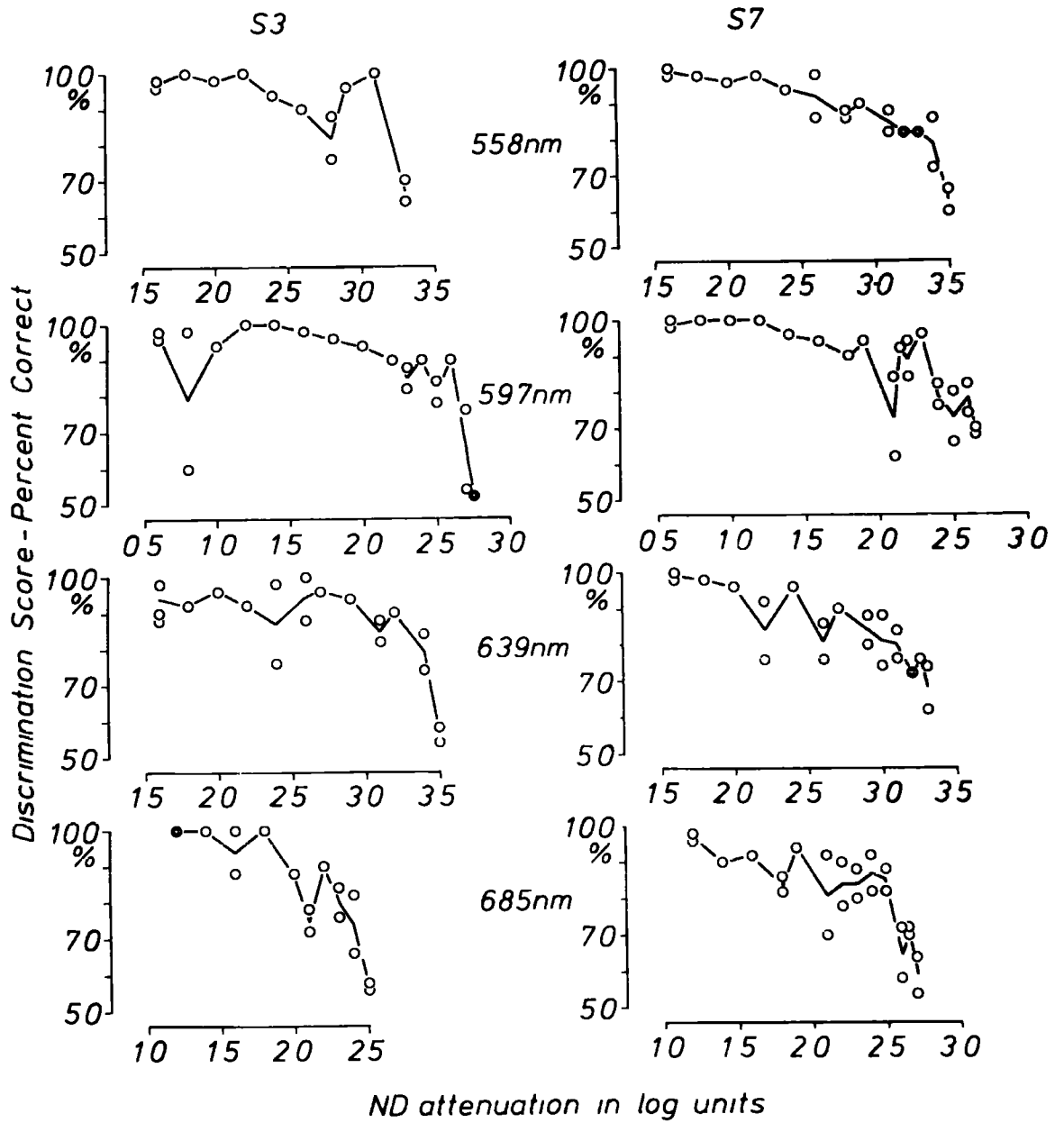

Fig. 3 cont.

Since no consistent improvement or decrement in choice accuracy could be discerned when changes in luminance of 1 or 0.5 log units were used then presumably much smaller mismatches in luminance, which might be the result of errors of estimation in the calibration procedure, would be unlikely to act as reliable cues in the determination of saturation thresholds

RESULTS

The number of sessions required to obtain a threshold measurement for each wavelength ranged from 13 to 44 sessions per threshold test. Figure 3 gives examples of the course of discrimination for half of the threshold tests for each of two birds, one which generally required fewer sessions to reach a threshold (S3 mean number of sessions per test = 20) and another which took somewhat longer to complete threshold tests (S7 mean number of sessions per test = 24). On each graph is plotted the results for an entire threshold test in terms of the percentage of correct choices on each session versus the stimulus attenuation in log units for a particular session.

Examination of these and other graphs showed no consistent pattern of discrimination results for specific wavelengths or subjects. For some tests, the discrimination scores were quite stable until the saturation threshold was reached (e. g. test at 403 nm for S3) while on other tests the response pattern was more variable. For instance, S7, tested at 521 nm, exhibited some variability in the discrimination scores as the stimulus was more attenuated but showed quite a high

Table III
Attenuation, in log units, of stimulus at threshold

λ	Subjects					Mean ND
	S1	S3	S7	S9	S10	
702	2.3	2.25	2.4	2.65	2.4	2.4
685	2.4	2.5	2.7	2.7	2.6	2.58
662	2.8	2.85	2.55	2.7	2.7	2.72
639	3.3	3.5	3.4	3.8	3.55	3.51
619	3.3	3.15	3.45	3.8	3.45	3.43
597	2.35	2.75	2.65	2.8	2.75	2.66
584	3.35	3.4	3.4	3.6	3.2	3.39
558	3.3	3.3	3.5	3.5	3.45	3.41
536	3.1	3.1	3.25	3.25	2.75	3.09
521	3.15	3.3	3.15	3.5	3.05	3.23
496	2.3	2.75	2.4	3.15	2.4	2.6
477	2.1	2.45	2.45	2.85	2.2	2.41
464	3.1	2.8	2.85	3.1	2.55	2.88
443	2.05	2.15	2.15	2.25	2.1	2.14
422	2.8	2.75	2.7	2.8	2.7	2.75
403	2.7	2.5	2.7	2.7	2.4	2.6

degree of consistency between scores when a session was repeated using the same neutral density wedge settings. In other cases (e.g. S7 at 477 nm) scores changed more erratically both between repeated sessions and as the stimulus attenuation was altered

Nevertheless, the results, in terms of the attenuation of the stimulus beams at the ends of threshold tests at each wavelength, were found to show good agreement across subjects. These attenuation figures, in log units, are set out in Table III.

Calculation of energy values of stimuli at threshold

Energy measures were obtained with just one of the central stimulus lights operative. A motor driven sector, positioned in the collimated beam, was used to provide a stimulus flashing at 1 Hz, allowing for AC amplification of the thermopile potential (Fig 4).

The output from the thermopile, centred in front of the response key, was amplified by a Grass P15 AC preamplifier and displayed on a Tektronix Type 564B storage oscilloscope. The irradiance of the unattenuated bar stimulus, with each of the interference filters in place, was calculated and converted to a log scale

The thermopile was also used to find the minimum attenuation given by the neutral density wedge. This minimum was 0.6 log units at the five wavelengths tests (443, 464, 496, 558 and 643 nm). Additional attenuation values were calculated from manufacturer's calibrations of the wedges. The log irradiance of each stimulus at saturation threshold was then computed from the figures in Table III.

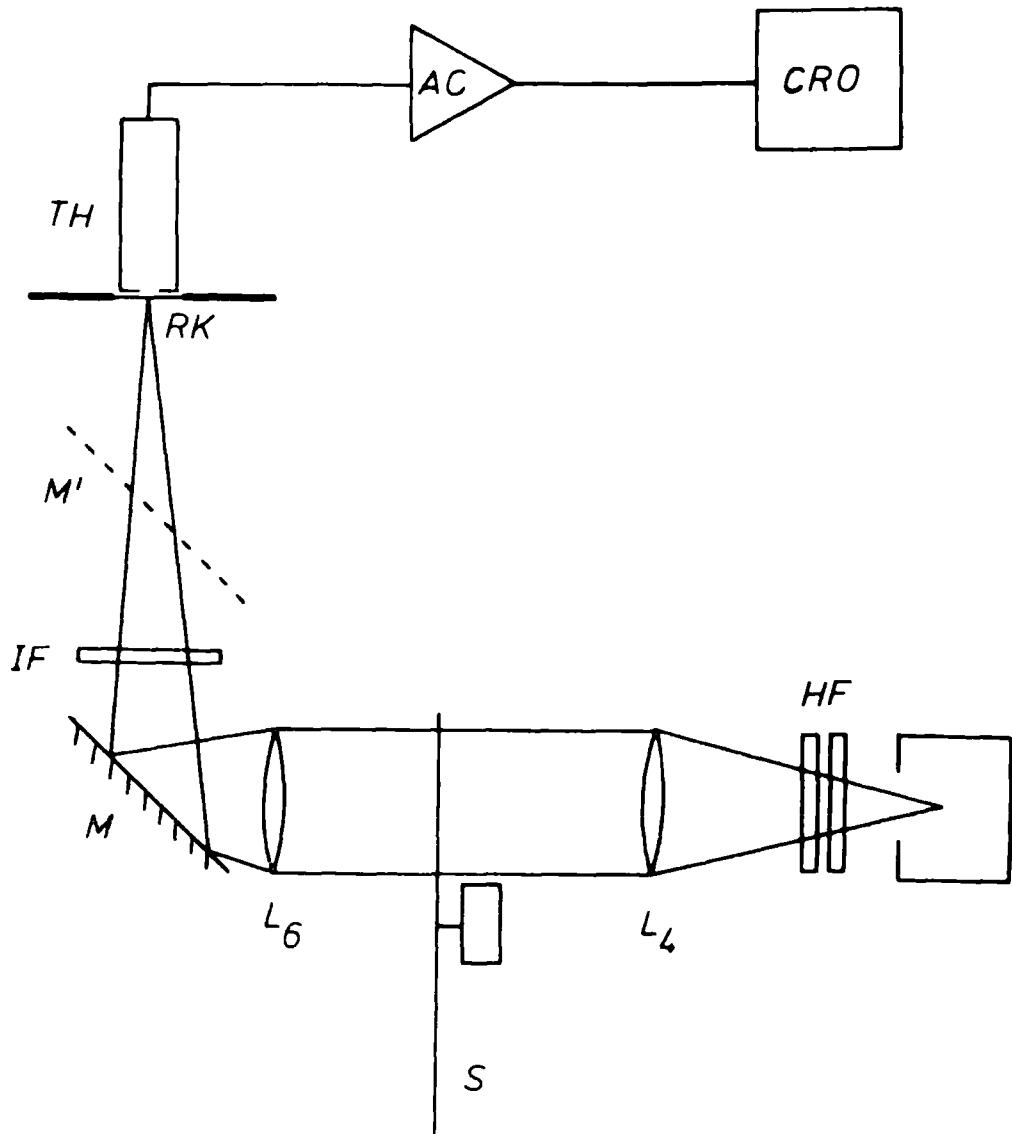

Fig. 4

Part of the optical system, providing a flashing stimulus for the thermopile, used in calibrating the energy of the central stimulus bar.

AC = AC preamplifier

CRO = cathode ray oscilloscope

TH = thermopile

Other abbreviations as in Fig. 1

Computation of results

The saturation discrimination function specifies the relative colorimetric purity across the spectrum and it is usually expressed as the reciprocal of least colorimetric purity required for the detection of a saturation difference at each wavelength. As mentioned previously the reciprocal of least colorimetric purity is given by the ratio

$$\log \left(\frac{L_w + L_\lambda}{L_\lambda} \right)$$

In order to calculate the value of the saturation index, measures must be obtained, on a luminance scale, of the components of the stimulus at threshold. However, since the pigeon's photopic sensitivity curve is known to differ from a human's a suitable luminance scale must be constructed for the pigeon.

Having measures of the log energy at saturation threshold, a conversion used by Yager (1967) was applied to transform energy units into luminance units for the pigeon. Such a pigeon luminance scale (L_λ) can be computed by taking the log ratio of energy of a stimulus at the saturation threshold ($E_{\text{sat thres}}$) to energy of the same stimulus at its absolute photopic threshold ($E_{\text{abs thres}}$).

$$\log L_\lambda = \log \left(\frac{E_{\text{sat thres}}}{E_{\text{abs thres}}} \right)$$

$$\therefore \log L_\lambda = \log E_{\text{sat thres}} - \log E_{\text{abs thres}}$$

Table IV
Index of colorimetric purity

Calculated values of $\log \left(\frac{1}{L_\lambda} \right)$ for individual subjects
 and from mean results.

λ	Subjects					Mean value of $\log \left(\frac{1}{L_\lambda} \right)$
	S1	S3	S7	S9	S10	
702	3.60	3.55	3.70	3.95	3.70	3.70
685	3.33	3.43	3.63	3.63	3.53	3.51
662	3.07	3.12	2.82	2.97	2.97	2.99
639	3.12	3.32	3.22	3.62	3.37	3.33
619	2.75	2.60	2.90	3.25	2.90	2.88
597	1.86	2.26	2.16	2.31	2.26	2.17
584	2.79	2.84	2.84	3.04	2.64	2.83
558	2.72	2.72	2.92	2.92	2.87	2.83
536	2.59	2.59	2.74	2.74	2.24	2.58
521	2.83	2.98	2.93	3.18	2.73	2.91
496	2.15	2.60	2.25	3.00	2.25	2.45
477	2.39	2.74	2.74	3.14	2.49	2.70
464	3.56	3.26	3.31	3.56	3.01	3.34
443	2.65	2.75	2.75	2.85	2.70	2.74
422	4.06	4.01	3.96	4.06	3.96	4.01
403	4.24	4.04	4.24	4.24	3.94	4.14

The subtracted energy levels at absolute photopic threshold were taken from Blough's (1957) data

Similarly, L_w in the saturation index can be found by comparing the irradiance of a white light, which is just discriminable from a white background, with the absolute photopic threshold for white light.

The more desaturated a chromatic stimulus, the more of it must be added to a white background for it to be visible. Thus, at a wavelength which appears highly desaturated the ratio becomes small, this being dependent upon the amount of chromatic light which must be added. With an unchanging white background, as in this experiment, L_w is constant and the relative saturation discrimination function can be expressed by

$$\log\left(\frac{1}{L_\lambda}\right)$$

plotted against wavelength

Mean and individual saturation discrimination functions were plotted (Figs. 5 and 6) from calculated values of $\log\left(\frac{1}{L_\lambda}\right)$ given in Table IV.

On all graphs there is a minimum at 597 nm while saturation increases at the longest and shortest wavelengths tested. Troughs subsidiary to the minimum also occur at 443, 496, 536 and 662 nm, except in the case of S10 for which the minima at 496, 536 and 597 nm are almost equal.

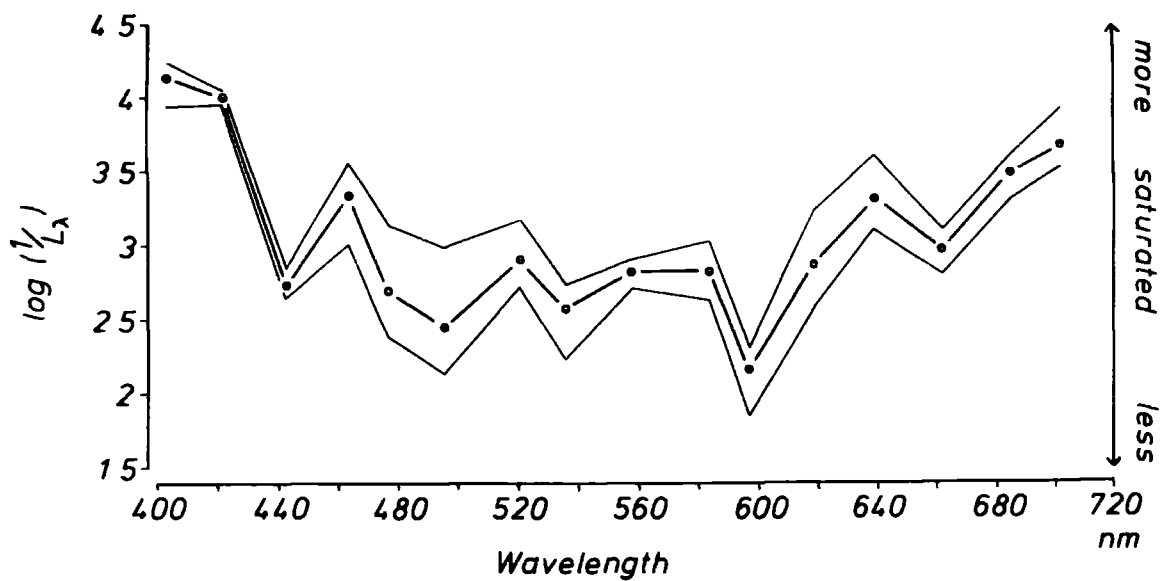

Fig. 5

Mean saturation discrimination function

● — ● = mean values of $(\frac{1}{L_\lambda})$

▬ = range of individual results

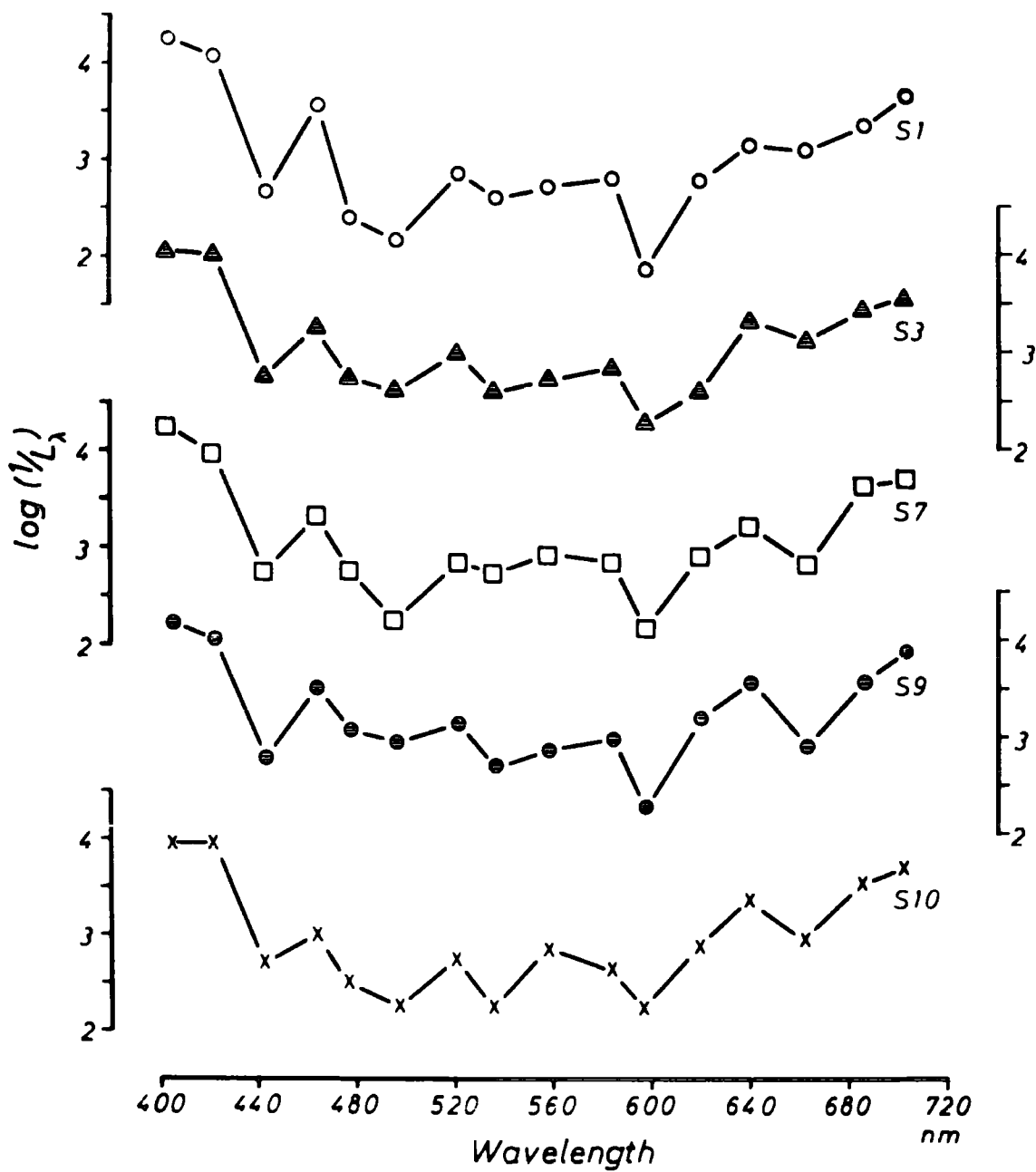

Fig. 6
 Individual saturation discrimination functions
 for subjects 1 - 10

DISCUSSION

Although the graphs of entire saturation discrimination tests show some variability (Fig. 3) there is fairly good agreement in the threshold results of individual subjects as shown by the range of results (Fig. 5) and the coincidence of the position of minima in the graphs of individual animals (Fig. 6). Saturation thresholds were only tested every 20 nm, at wavelengths for which interference filters were available. It would have been preferable to perform further tests at other intermediate wavelengths to see if the positions of peaks and troughs in the saturation function and the relative differences between these maxima and minima could be assessed with greater precision. However, the occurrence of several minima in the saturation discrimination function is unlikely to be due to a haphazard variation between threshold results since the same maxima and minima were found for each individual.

From these results, the light appearing least saturated to the pigeon had a dominant wavelength of 597 nm, by comparison the point of lowest saturation for humans is at a shorter wavelength of 570 nm (e.g. Martin, Warburton and Morgan, 1933, Jameson and Hurvich, 1955) (Fig. 7).

Clearly, at the start of threshold tests, when stimulus luminance is high, there is no point in the spectrum which pigeons confuse with white light. For the majority of saturation tests for each animal,

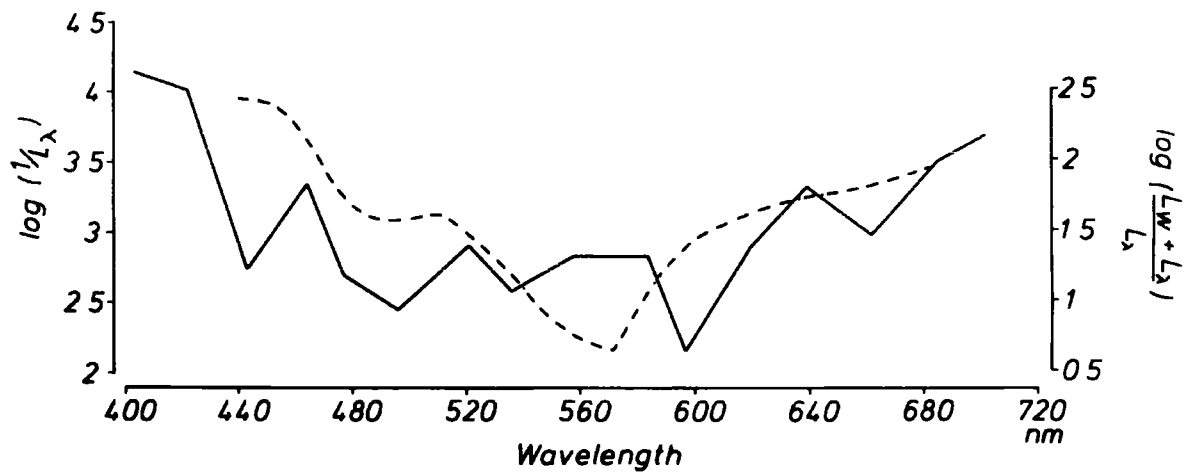

Fig. 7

Comparison between the saturation discrimination functions of pigeon (—) and man (---), showing the shift to a longer wavelength of the point of least saturation in the avian curve. The reciprocals of least colorimetric purity for the pigeon's function are plotted against the left-hand scale in terms of $\log(\frac{1}{L_\lambda})$; corresponding reciprocal measures for the human curve are plotted against the right-hand scale, using values of $\log(\frac{L_w + L_\lambda}{L_\lambda})$. The human data are those of one individual in the study by Martin, Warburton and Morgan (1933).

the learning criterion of two consecutive sessions in which performance was at a level of 90% correct choices was met very quickly. As shown in Table V, except for tests at the first wavelength of 662 nm, for which an introductory procedure was used, this early criterion was reached, in 70 out of 75 tests, within the initial 2 or 3 sessions. Thus, the pigeon has neither a monochromatic nor a dichromatic visual system. However, the occurrence of 5 minima in the saturation function indicates that its visual system is more complex than that of a trichomat since with such subjects, although there is some variability in results, theoretical and empirical saturation functions have shown 2 minima (Jameson and Hurvich, 1955, Yager, 1967).

Comparison of results with other saturation discrimination data for pigeons

The only other avian data on saturation discrimination come from an experiment by Schneider (1972) in which pairs of stimuli of matched luminance were rated for their 'similarity' or 'dissimilarity' of appearance to pigeons. The results were presented in terms of a 'colour circle' in which the spacing between stimuli represented their psychological separation. As with the colour triangle used as a notation of the perceptual capabilities of the human visual system, white light was depicted as a point within the colour circle. The distance, however, between different wavelengths and this white

Table V
Initial discrimination scores on each saturation test

Figures listed are the percentage correct scores until criterion is reached of 2 consecutive test sessions at 90% accuracy.

Order of tests	Subject									
	1	3	7	9	10					
λ										
662	+	+	+	+	+					
443	62, 94, 83 88, 94, 96	98, 100	96, 100	86, 100, 98	90, 100					
597	78, 98, 100	96, 98	98, 100	94, 100	100, 100					
477	90, 90	82, 96, 98	96, 100	100, 100	44, 80, 94 100					
496	100, 100	98, 98	92, 96	93, 100	100, 95					
464	100, 100	9 sessions with position preference, 2 correction procedure then 84, 100, 100	74, 94, 100	59, 100, 100	100, 100					
422	60, 52, 60, 98, 100 *	50, 96, 100 *	52, 100, 100 *	94, 96, 100	84, 100, 100					
619	90, 100	98, 96	98, 100	90, 100	100, 98					
536	92, 100	98, 94	92, 98	98, 100	98, 100					
639	98, 95	98, 88, 98, 98	98, 100	100, 100	96, 100					
552	98, 100	98, 100	92, 100	100, 92	96, 100					
685	100, 100	100, 100	90, 98	100 96	98, 100					
521	94, 96	93, 98	90, 98	94, 92	95, 100					
584	100, 98	95, 100	98, 98	90, 90	100, 100					
702	98, 94	100, 100	96, 98	100, 100	100, 100					
403	100, 92	100, 98	100, 100	100, 100	100, 98					

+ Introductory tests with no white background and occasional extra reinforcements administered by the experimenter before full test conditions were used.

* Position preference, which resulted in low scores of some initial sessions, was probably due to one key being faulty during preceding session, which has been discounted.

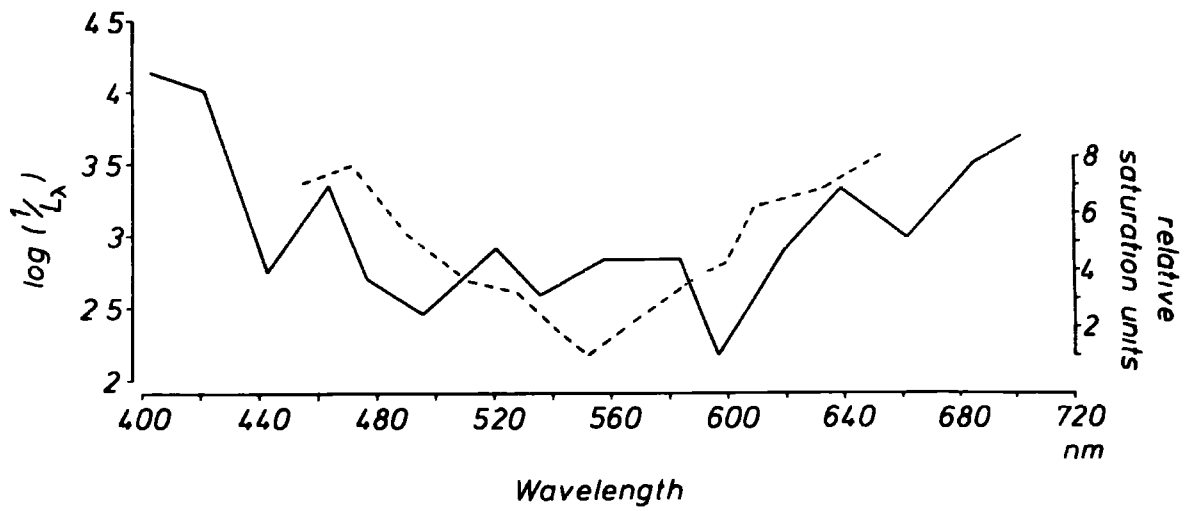

Fig. 8

Comparison between mean saturation discrimination function (solid line and scale on left) and derived function from Schneider's (1972) results (dashed line and right-hand scale: arbitrary units of relative saturation).

point varied. From this information a relative saturation discrimination function may be derived for comparison with the results of the present experiment (Fig 8). There is little agreement between the two sets of results. Schneider's data point to only one clear saturation minimum at about 550 nm. There is no obvious explanation for this discrepancy in results. In a function depending on a comparison between a coloured and white light, the location of minima could be expected to depend on the colour temperature of the white light, with a shift in the position of minima to longer wavelengths if a light of lower colour temperature is used. However, this factor could not account for the disagreement in results since tungsten-iodine lamps, of the same colour temperature, were used in both experiments.

One marked difference between the two experiments was in the presentation and luminance of the stimuli. In Schneider's study a bipartite field was presented in which one half of the stimulus was a monochromatic light and the other half a white light. He reported the luminance of a 580 nm stimulus to be 30 mL. In the present experiment the white and coloured stimulus bars were always projected onto a background white of approximately 25 mL. In calculating values for the matching white bar stimuli, the 619 nm stimulus was found to have a luminance of about 502 mL, with minimal neutral density attenuation of 0.6 log units. Knowing the

log attenuation of the stimulus at threshold it was estimated that, at mean threshold for this wavelength, the stimulus luminance would be 0.75 mL, which is of a much lower order than the stimulus luminances used in Schneider's experiment. However, once more this difference in experimental conditions is unlikely to explain the discrepant results. Hurvich and Jameson (1955), studying the effect of stimulus luminance on the saturation discrimination function of human subjects, report slight differences in sensitivity between functions obtained under conditions of high and low luminance and a more pronounced subsidiary minimum when high luminance stimuli were used. But there were no major shifts in the position of minima that might have predicted the difference in results of the two studies on pigeons.

Physiological basis of saturation discrimination

For some other species it has been possible to explain the saturation discrimination function in terms of known physiological characteristics of that species' visual system. For example, in the goldfish, for which the sensitivity curves of the three cone pigments and the response characteristics of opponent-process cells can be specified, this information can be used to predict a theoretical saturation function, having two minima (Yager, 1967). While there are large discrepancies between the results obtained on individual fish, there is reasonably good agreement between the theoretical function and the experimental function if the overall curve of the range of results is considered.

Similarly, in humans, which also have three cone pigments, Jameson and Hurvich (1955) were able to derive a theoretical saturation discrimination function which matched the psychometric function. In macaque monkeys, whose visual functions closely compare with those of man, much data about their colour vision has been gathered from physiological and behavioural tests (De Valois and Jacobs, 1968). In these animals, saturation appears to be related to the ratio of response of the opponent cells (most strongly driven by chromatic stimuli) to non-opponent cells (responding to both wavelength and intensity information but driven most strongly by broadband achromatic light) at each wavelength, or similarly, to the proportion of the total neural response at any wavelength contributed by the opponent cells

At this point, it should be noted that the present use of $\log \left(\frac{1}{L_\lambda} \right)$ as the saturation index rather than the ratio of $\log \left(\frac{L_w + L_\lambda}{L_\lambda} \right)$ imposes certain limitations upon the direct comparison of the psychophysical saturation function with any functions derived from physiological data. Using the reciprocal measure, in which the constant value of L_w is omitted, gives a saturation function in which the relative occurrence of peaks and troughs of saturation are shown. But the inclusion of the term L_w is needed to define the absolute differences between maxima and minima. This becomes important if, in the pigeon as well as the fish and monkey, the saturation function could be predicted from numerical

data about the mechanisms involved in the perception of the luminance of both chromatic and achromatic stimuli. While this restriction is borne in mind, the relative saturation function obtained from the present experiment remains valid. To specify the absolute values in the function more accurately would require finding the photopic threshold for the white light used, relative to the thresholds for monochromatic lights. Within the time available, it was not felt worthwhile to set up a complete photopic sensitivity experiment to provide this one additional measurement.

Compared with other species mentioned, such necessarily detailed information from the pigeon's visual system, though, is not yet available so that a similar interpretation, in physiological terms, of this animal's saturation discrimination function cannot be made at present. In the work on monkeys, the response curve of the non-opponent cells was used to account for the relative saturation at different wavelengths, with low saturation being mediated by a large response from the achromatic cells combined with low activity of chromatic units. Donner (1953) reported dominator cells in the pigeon's retina which had a broad-band response similar to that of the monkey's non-opponent cells. The shift in the peak response of these units to longer wavelengths, between 580 and 590 nm, (compared with the maximum sensitivity of non-opponent cells at about 570 nm (De Valois and Jacobs, 1968)) may partially explain

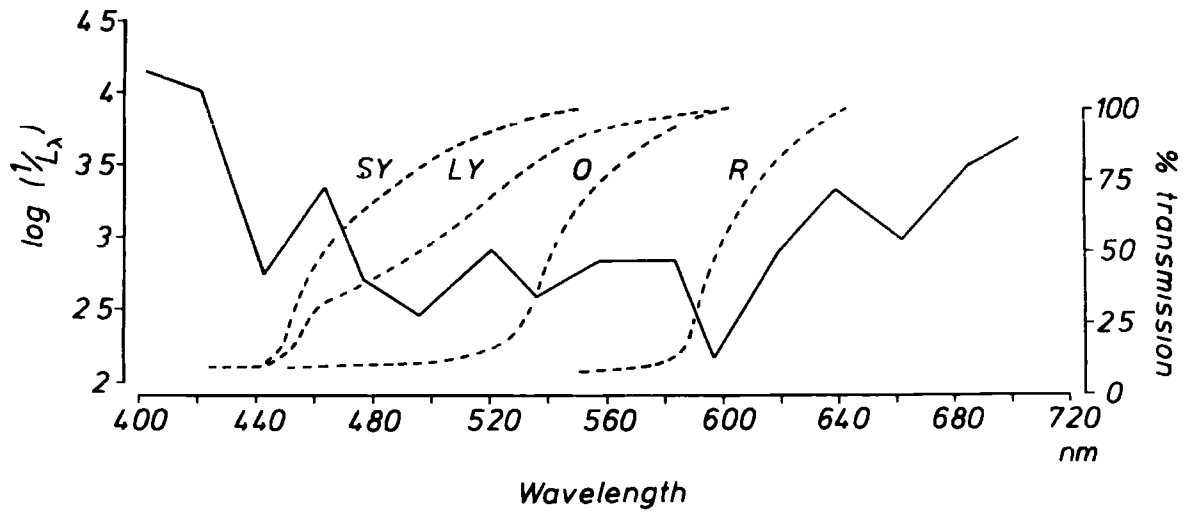

Fig. 9

Comparison of mean saturation discrimination function with transmission curves of oil-droplets (King-Smith, 1969). Short-wavelength cut-off characteristics of oil-droplets are taken to indicate corresponding decreases in cone sensitivity.

SY = small yellow droplet

LY = large yellow

O = orange

R = red

the similar displacement of the saturation minimum to a longer wavelength than in the macaque's function. This would only be significant, however, if opponent-cell activity at these longer wavelengths is low. Opponent-cells have been reported in the pigeon (Yazulla and Granda, 1973) with crossover points at 500 nm, which is a point of low saturation in the psychophysical function, and 520 nm, a region of higher saturation, but the data are too incomplete to provide a quantitative account of the entire saturation discrimination curve.

If the psychophysical function is compared with the oil-droplet transmission curves (Fig. 9) then, as appears to be the case, decreased sensitivity of each cone mechanism, here indicated by a low percentage transmission value for the oil-droplet, can be expected to coincide with a minimum of saturation. In addition, saturation is high at 400 nm, the point of maximum sensitivity of a blue mechanism which has been demonstrated in the pigeon retina (Graf and Norren, 1974). On the other hand, as with the wavelength discrimination function, there is little difference between the positions of peak activity in modulator units (Donner, 1953) and points of minimum saturation, whereas it might be expected that chromatic units should show low response at these points (Fig 10). Once again, this might arise if the steeply rising short wavelength arms of the cones' spectral sensitivity curves, caused by the oil-droplets' filtering action, together with neural interaction produced only a very small shift of discrimination minima away from the points of maximum response in the modulators.

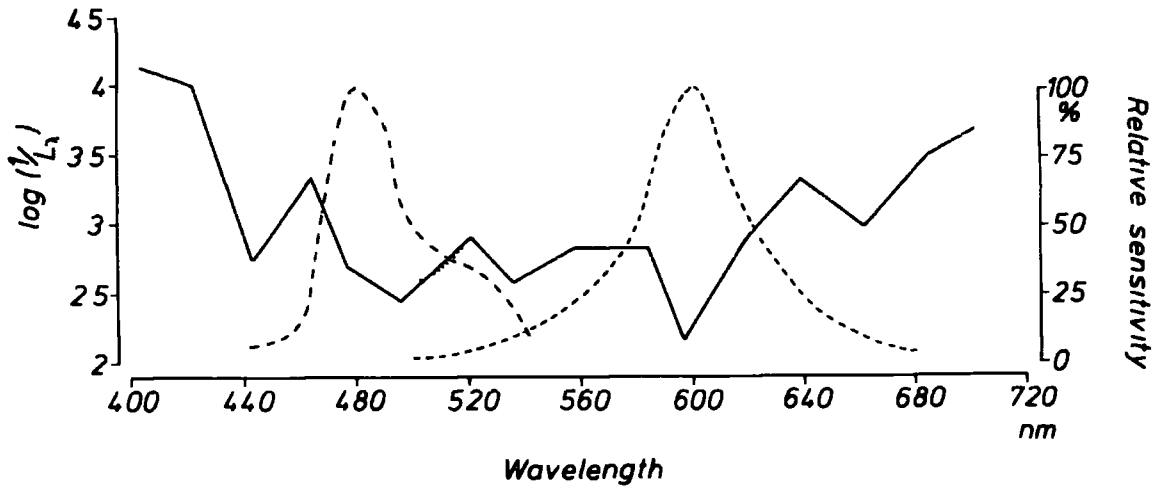

Fig. 10

Comparison of mean saturation discrimination function with Donner's (1953) modulator curves:-

- - - - - blue modulator
- green
- - - - - red

In summary, while the operation of specific neural mechanisms mediating the perception of saturation differences remains obscure, the saturation discrimination function once more indicates the complexity of the colour-processing abilities of the pigeon's visual system, which appears to be more intricate than the trichromatic system to which previous evidence has pointed.

CHAPTER 4

THE PIGEON'S SPECTRAL SENSITIVITY TO ULTRAVIOLET RADIATION

INTRODUCTION

Pigeons, amongst other vertebrates (e.g. humming-bird Huth and Burkhardt, 1972, frog Govardovskii and Zueva, 1974, aphakic human Tan, 1971), are now known to be capable of detecting ultraviolet radiation (i. e. wavelengths below 400 nm) Wright (1972b) has demonstrated that pigeons can distinguish between a monochromatic 520 nm stimulus and a mixture of this wavelength together with a 366 nm component given by unsuppressed sideband transmission of an interference filter Accordingly it seemed necessary to more thoroughly investigate the pigeon's discrimination of wavelengths within the ultraviolet region. But, to do this, more information is needed about the range of short wavelength sensitivity in this animal. Also precise measurements of this sensitivity must be made in order to calibrate stimuli, and equate them in luminance for the pigeon's eye, in a subsequent wavelength discrimination experiment.

Numerous workers have previously studied the pigeon's spectral sensitivity but very few experiments provide sensitivity measures at shorter wavelengths nor do they estimate the detection limits of this bird's eye. Several methods are available for assessing spectral

sensitivity. These include behavioural procedures (e.g. threshold-tracking methods Blough, 1957, Meissner, 1970, flicker photometry Graf, 1969) and physiological techniques (e.g. pupillometry Laurens, 1923, microelectrode recording of retinal spike discharge Granit, 1942, electroretinogram Blough, Riggs and Schafer, 1972, Graf and Norren, 1974, Ikeda, 1965). Since there is reasonable agreement amongst results obtained with these various procedures, it was decided to use a method which provides relatively quick and reliable data. Thus spectral sensitivity in this experiment was measured using the varying electroretinographic response to different wavelengths

The electroretinogram (ERG) has a complex waveform, whose components originate in receptor and inner nuclear layers of the retina (Brown, 1968, Ogden and Wylie, 1971). Since these layers are likely to contain mechanisms of differing spectral sensitivities, detailed interpretation of the waveform and its variation in response to changes in stimulating wavelength is difficult. However, by using special conditions of chromatic adaptation (Graf and Norren, 1974, Norren, 1973) or by measuring the amplitudes of the constituent waves (a-, b-waves and off-response) of the ERG response to a single flash (e.g. Ikeda, 1965) it has been possible to estimate the spectral sensitivities of contributory processes. However, in the present study the total amplitude of the electroretinographic response was measured to estimate the compound sensitivity of the underlying retinal mechanisms.

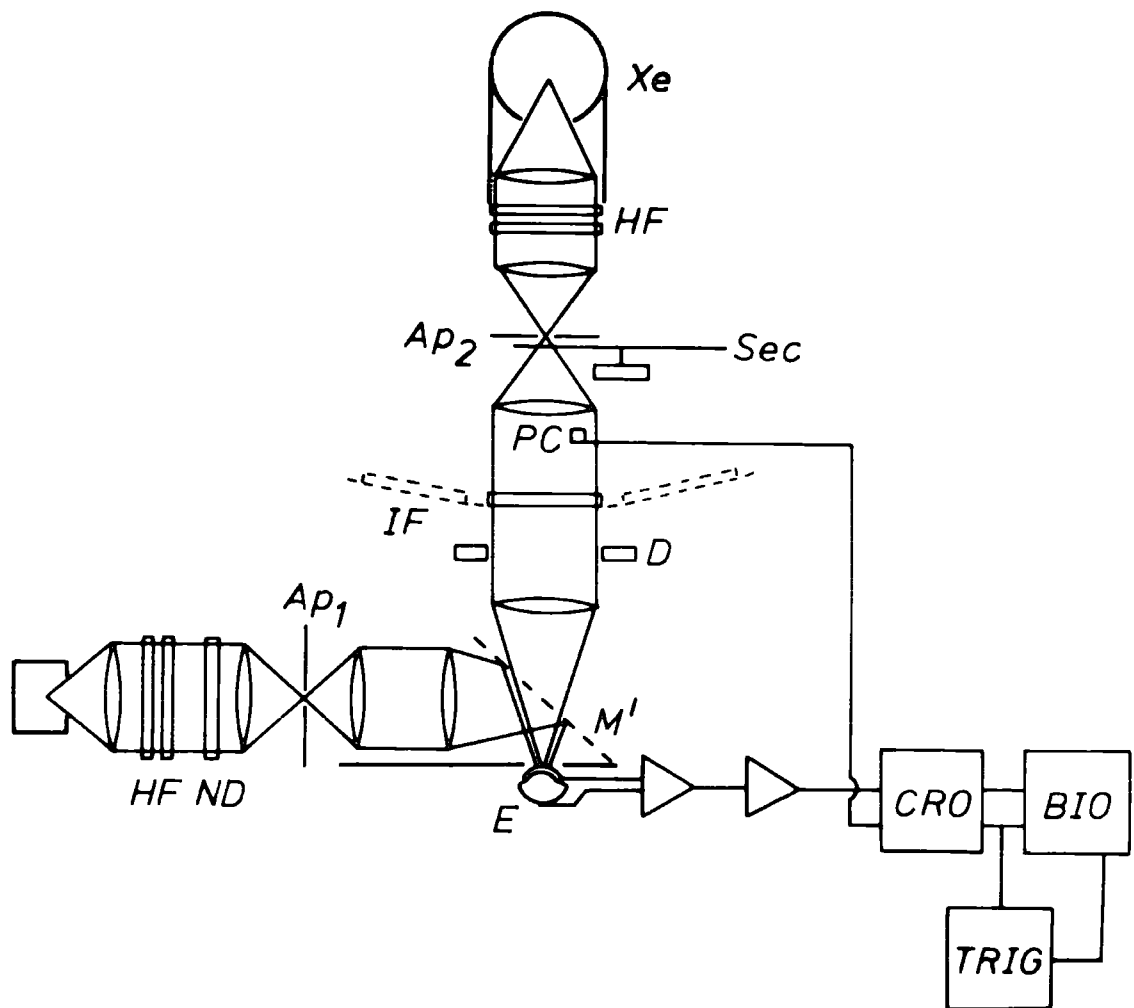

Fig. 1

Optical apparatus used to generate flashing chromatic stimuli superimposed upon a constant white light background. All stimuli were presented to the pigeon's left eye in axial Maxwellian view. ERG potentials were amplified, monitored on an oscilloscope and relayed to a Biomac transient averaging computer. Stimulus onset and offset were detected by a photocell whose output was used to trigger the Biomac.

Ap_1 = 3 mm aperture

Ap_2 = 2 mm aperture

BIO = Biomac

CRO = cathode ray oscilloscope

D = iris diaphragm

E = pigeon's left eye

HF = heat filter

IF = interference filter

M' = half-silvered mirror

ND = neutral density filter

PC = photocell

Sec = motor-driven sector disc

TRIG = monostable trigger device

Xe = high pressure xenon lamp

EXPERIMENT I

METHOD

Apparatus

Optics

Stimuli consisting of repeated flashes of narrow bandwidth light superimposed on a constant white light background were generated using the optical system diagrammed in Fig. 1. In one channel, light from a tungsten iodine 50W projector bulb was collimated and passed through heat filters (HF) and a neutral density filter (ND) before being focused onto a 3 mm aperture (Ap_1). A second pair of achromatic doublet lenses then projected the light onto a thin piece of glass, acting as a half-silvered mirror (M') which partially reflected the beam into the pigeon's eye (E). The light source of the second optical channel was a 75W xenon pressure lamp (Xe). Light was once more directed through heat filters before being focused onto a 2 mm aperture (Ap_2), behind which was a motor-driven sector disc (Sec) giving a 1:1 ratio dark-light flash. By interchanging the sector disc or motor, stimuli flashing at 6, 20 or 30 Hz could be used. The flashed beam was then collimated and passed through one of 19 interference filters (IF), mounted in a large rotatable wheel so that filters were quickly interchangeable, and through a diaphragm (D) and finally projected through the half-silvered mirror into the bird's eye. Onset and offset of the flashed

stimulus was detected by a small photocell (PC). Baffles were used to prevent as much stray light as possible from entering the animal's eye. All optical components were mounted on standard optical benches, aligned at right angles to each other.

This optical system provided coloured stimuli and an achromatic background, focused at the centre of the pupil so that stimuli were presented in axial Maxwellian view. The adapting beam which was constantly presented to the eye, subtended a visual angle of about 21° . The energy of this white light, measured with a calibrated thermopile positioned in place of the bird's eye, was $2.22 \mu\text{W}$. Since the adapting beam was focused as near as possible to the pupil plane and the axial length of the pigeon's eye between pupil and retina is about 9.5 mm (Marshall, Mellerio and Palmer, 1973, Chard and Gundlach, 1938), it is estimated that the stimulus irradiance, on an illuminated retinal area of 8 mm^2 , was approximately $28 \mu\text{W}/\text{cm}^2$. This value would be only slightly reduced by absorption by the optic media, which are relatively clear, absorbing only appreciably (up to 0.26 log units) at wavelengths shorter than 450 nm (Graf and Norren, 1974).

The Balzer interference filters provided chromatic stimuli with peak wavelengths ranging from 337 to 702 nm. Filters with maximum transmission at 403 nm or longer wavelengths had half bandwidths of 8 - 14 nm while the half bandwidths of the ultraviolet filters were

17 - 19 nm. Neutral density filters were unsuitable for attenuating chromatic stimuli in this experiment since they show non-uniform transmission characteristics in the ultraviolet part of the spectrum. The iris diaphragm was used instead since it provided stimulus attenuation which was independent of wavelength. The diaphragm has the disadvantage though that as the aperture size decreases so does the visual angle of the stimulus presented to the bird's eye. With a maximum aperture size, the stimulus visual angle was $11^{\circ} 24'$. It was calculated that the visual angle would be reduced to $1^{\circ} 48'$ with the minimum diaphragm aperture used but this reduction would be somewhat counterbalanced by stimulus diffraction and light scatter within the eye.

This factor of size alteration would be important if colour-sensitive mechanisms were differentially distributed in the retina, more particularly if there was a large difference between peripheral and central retinal processing mechanisms. The most noticeable difference in the distribution of cell-types in the pigeon's retina occurs between the dorso-temporal red field and the yellow field (Galifret, 1968).

There is conflicting evidence regarding spectral sensitivity differences between these two areas. King-Smith (cited by Muntz, 1972) recorded from tectal units whose receptive fields fell in either the red or yellow retinal areas and found a sensitivity shift towards longer wavelengths in neurones which had their receptive fields in

the red area. Blough, Riggs and Schafer (1972), on the other hand, in an electroretinographic study of the pigeon's spectral sensitivity, stimulated both the central yellow field and the red field and found the sensitivity curves obtained from these two areas to be identical. From the size of the chromatic stimuli used in the present experiment, however, it is unlikely that, even with maximum diaphragm aperture, the red field of the pigeon's eye would be stimulated. Differential effects of stimulus area must therefore be considered within the yellow retinal field. Ikeda (1965) tested the effects on the ERG response of axial stimulation compared with stimulus presentation at 10° or 30° peripheral to the optic axis. She reported no marked alterations in b-wave amplitude as a function of stimulus position but there was a decrease in response amplitudes of the a-wave and off-response as the stimulus was more peripherally placed. Since the off-response, or d-wave, in the present study generally does not contribute to the total trough to peak amplitude used as a response measure, any errors arising from a change in stimulus area are likely to be attributed to differences occurring in the a-wave amplitude. But as final results over much of the spectrum in this experiment replicated findings of previous spectral sensitivity studies, it is concluded that any error introduced by the use of the diaphragm must be relatively small.

Stimulus calibration

Using a calibrated thermopile (Hilger-Watts FT 17) in place of the bird's eye and a digital voltmeter to measure the thermopile

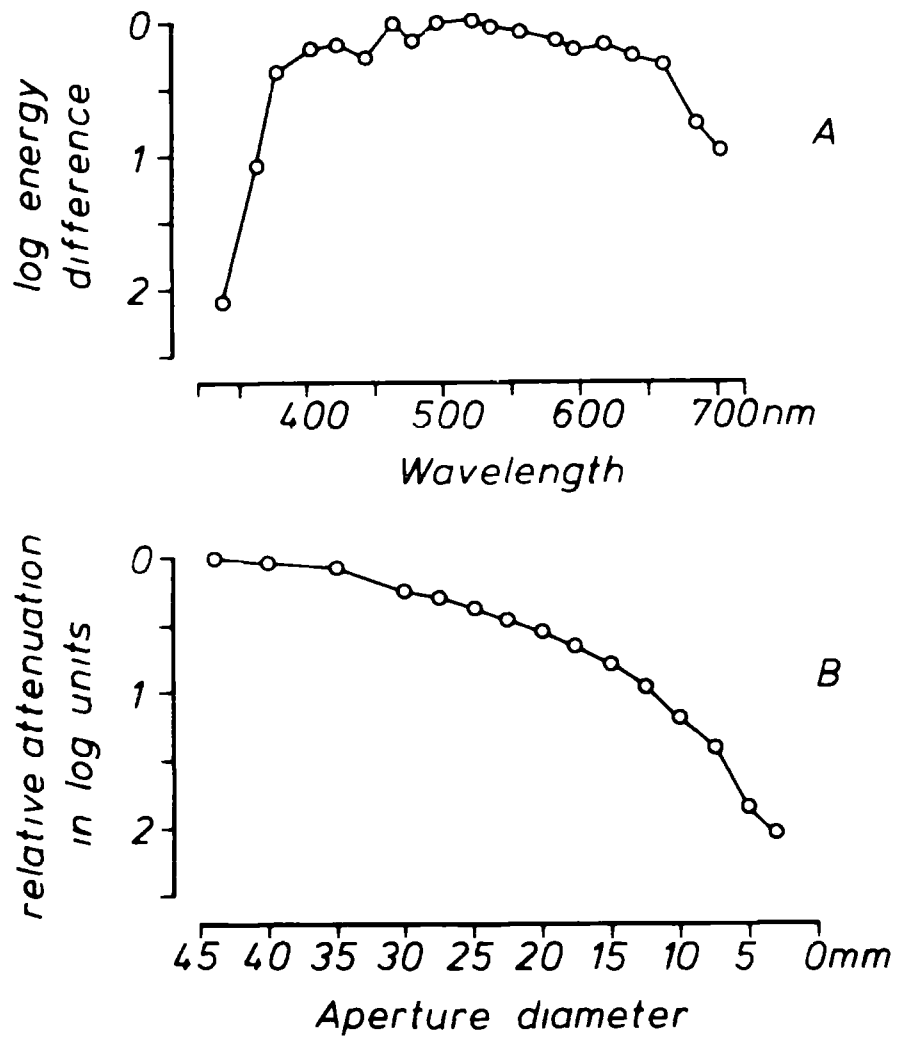

Fig. 2

- A Relative energy available at each stimulus wavelength. The maximum energy output of the xenon light source, with each of the narrow bandwidth interference filters in position, was measured with a calibrated thermopile. The log difference in energy at each wavelength was computed relative to the radiant energy ($168.5 \mu\text{W}$) of the 521 nm stimulus.
- B Attenuation function of the diaphragm in log units. The log decrease in energy for various aperture diameters was measured using a thermopile. Detailed measurements were made with a high energy 521 nm stimulus but the diaphragm's attenuation function is independent of wavelength.

potential, the maximum energy available with each of the interference filters in position was calculated. While doing this the adapting beam was switched off. For later computations on the results, the difference in log units between the maximum energy output, of $168.5 \mu\text{W}$, with the 521 nm filter and the energy transmitted by each of the other filters was then calculated (Fig. 2A).

The diaphragm's attenuation function was also measured, at a wavelength for which there was the highest energy output. Aperture settings, 1mm diameter, were marked on the rim of the diaphragm and repeated energy readings at several of these settings were taken. The mean energy readings at each aperture width were calculated and the log unit attenuation given by the diaphragm was plotted (Fig. 2B). Seven aperture settings, giving an attenuation of between 0 and 1.8 log units, were then chosen for obtaining response-intensity functions in the experiment.

Preparation of subjects

Adult pigeons of mixed breed and unknown sex were used as subjects. An initial operation was performed, enabling the bird's head to be supported by a special head-holder. This operation was carried out either immediately before the ERG experiment began or 4 to 5 days prior to a test session, allowing for the bird's recovery.

For both this operation, and for recording ERGs, birds were anaesthetised with Equithesin (intramuscular, 0.25 ml/100 gm body-weight). During prolonged recording sessions supplementary doses

(0.08 ml/100 gm) were administered if there were signs of recovery.

The preparatory operation consisted of incising and retracting the scalp, pitting the skull with a dental drill and cementing to the skull, with dental acrylic, a small brass block (5 x 7 x 3 mm) which had two tapped holes. During the ERG experiment this block was then screwed onto an adjustable bar, supporting the head and rigidly maintaining its position in line with the visual stimulus. The overhead bar was part of a specially constructed table on which the bird lay. This table was mounted on the end of one of the optical benches and could be rotated around the vertical axis, or moved along any of three axes. Thus the bird's left eye, from which all ERG recordings were taken, could be precisely positioned so that stimulation was axial and Maxwellian. The bird's body rested upon the table which was covered by a thermostatically controlled heated blanket to maintain the body temperature at 37°C.

Because of problems with a build-up of tracheal secretions during prolonged experiments, for many recording sessions the birds were intubated and artificially ventilated. Warmed air, at constant pressure, was passed into the lungs by inserting a narrow plastic tube through the mouth into the trachea. A hole was then drilled through the sacral bone to allow air to escape from a dorsal air sac. Birds which had been intubated were sacrificed at the end of an experiment.

Prior to ERG recording, the bird's left eye was treated with a solution containing atropine, tubocurarine chloride and benzalkonium

chloride in physiological saline (Campell and Smith, 1962)

Application of this solution produced complete mydriasis and gave a good electrical contact with the recording electrode. The nictitating membrane and eyelids were held open with small retractors.

Recording equipment

A silver-silver chloride ring electrode, which was mounted on a second adjustable arm, fixed to the table, was positioned against the bird's left eye. This electrode just surrounded the dilated pupil. An indifferent electrode of silver-silver chloride was inserted beneath the scalp or postorbitally through the frontal bone. The bird was earthed via a needle electrode placed beneath the rump skin.

Electrical potentials from the corneal and indifferent electrodes were amplified differentially using a Grass P15 preamplifier, set with a bandwidth of 0.3 to 100 Hz. Further amplification was provided by an A1m low-noise amplifier. The amplified potential, together with the photocell signal of stimulus onset and offset, was monitored on a Tektronix 564B storage oscilloscope. The photocell output was also led into a monostable device which provided triggering pulses for a Biomac 500 transient averaging computer on which the averaged electroretinographic responses and a stimulus trace were finally displayed. These displays could then be photographed for subsequent scoring.

Procedure

At the beginning of each experiment and at 4 or 5 subsequent intervals the response to a standard stimulus of the unattenuated 584 nm filter was recorded to monitor the stability of the ERG over a prolonged session.

An alternating order of wavelength presentation was used so that an ascending and descending series of wavelengths was given within each recording session. Each wavelength stimulus was initially presented with the diaphragm fully open to give minimal attenuation. Attenuation was then increased in steps of 0.23, 0.55, 0.79, 0.96, 1.40 and 1.83 log units until an averaged ERG response was no longer discernible, at which point recordings were begun at a different wavelength.

At the end of recording with each wavelength-attenuation setting a photograph was taken of the 3 or 4 ERG curves displayed on the Biomac screen. Each of these ERGs was the average of 64 responses. Between separate wavelength-attenuation recordings the chromatic stimulus was occluded but the white background light was always visible. This procedure was aimed to minimise chromatic adaptation while maintaining the eye in a light-adapted state.

A few drops of the mydriatic solution were occasionally administered to bathe the eye and so to keep a good electrical contact with the ring electrode. When this was done the bird was left for about 5 mins before continuing recordings.

At the end of each recording session a calibration trace of known voltage (an oscillator signal) was displayed on the Biomac and photographed. From this calibration trace a grid could be prepared for subsequent measurement of the amplitudes of ERG responses.

Recording sessions were completed on 5 different subjects using a stimulus presentation rate of 6 Hz and on 2 birds using flicker rates of 20 and 30 Hz.

RESULTS

Using grids constructed from photographs of calibration traces, the peak to trough amplitude of each averaged ERG recording was measured in μV . Where 3 or 4 ERGs were displayed on one record, the mean amplitude was then calculated. If the amplitude of response to the 584 nm standard stimulus varied over time, correction factors were calculated and the mean amplitude measurements of all ERGs recorded during the intervals between standard stimulus presentation were adjusted

From stimulus calibrations of the maximum relative energy available at each wavelength and the attenuation function of the diaphragm (Fig 2), the total relative attenuation for each recording was obtained from the sum of the log difference in energy (from the maximum energy available with the 521 nm filter) and the attenuation in log units, given by the diaphragm. From these amplitude and totalled attenuation figures, response-intensity functions could then be constructed for all wavelengths.

6 Hz flash

For a 6 Hz flash each photographic record showed three ERG responses. Adequate responses over a range of intensities were only obtainable for wavelengths between 363 and 662 nm. With the

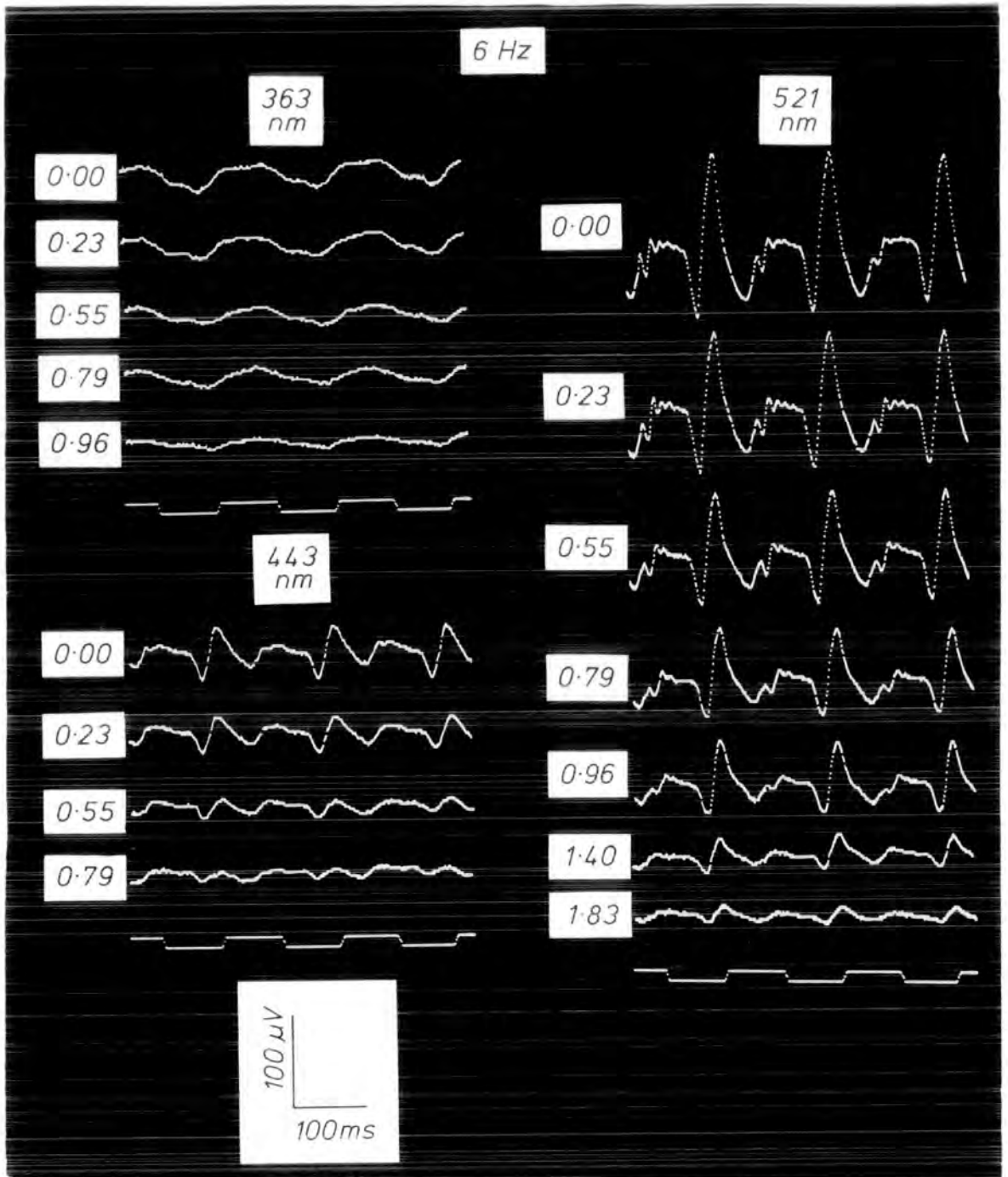

Fig. 3

Electroretinograms of one subject, stimulated with a 6 Hz flash. Response amplitude decreased linearly as stimulus intensity, indicated by increasing log unit attenuation figures beside each record, diminished. Stimulus wavelength is shown above each series; a similar response-intensity relationship was found throughout the spectrum. Stimulus onset and offset are displayed as downward and upward deflections respectively on the bottom traces. Response amplitude and stimulus duration calibrations are presented on the inset scale.

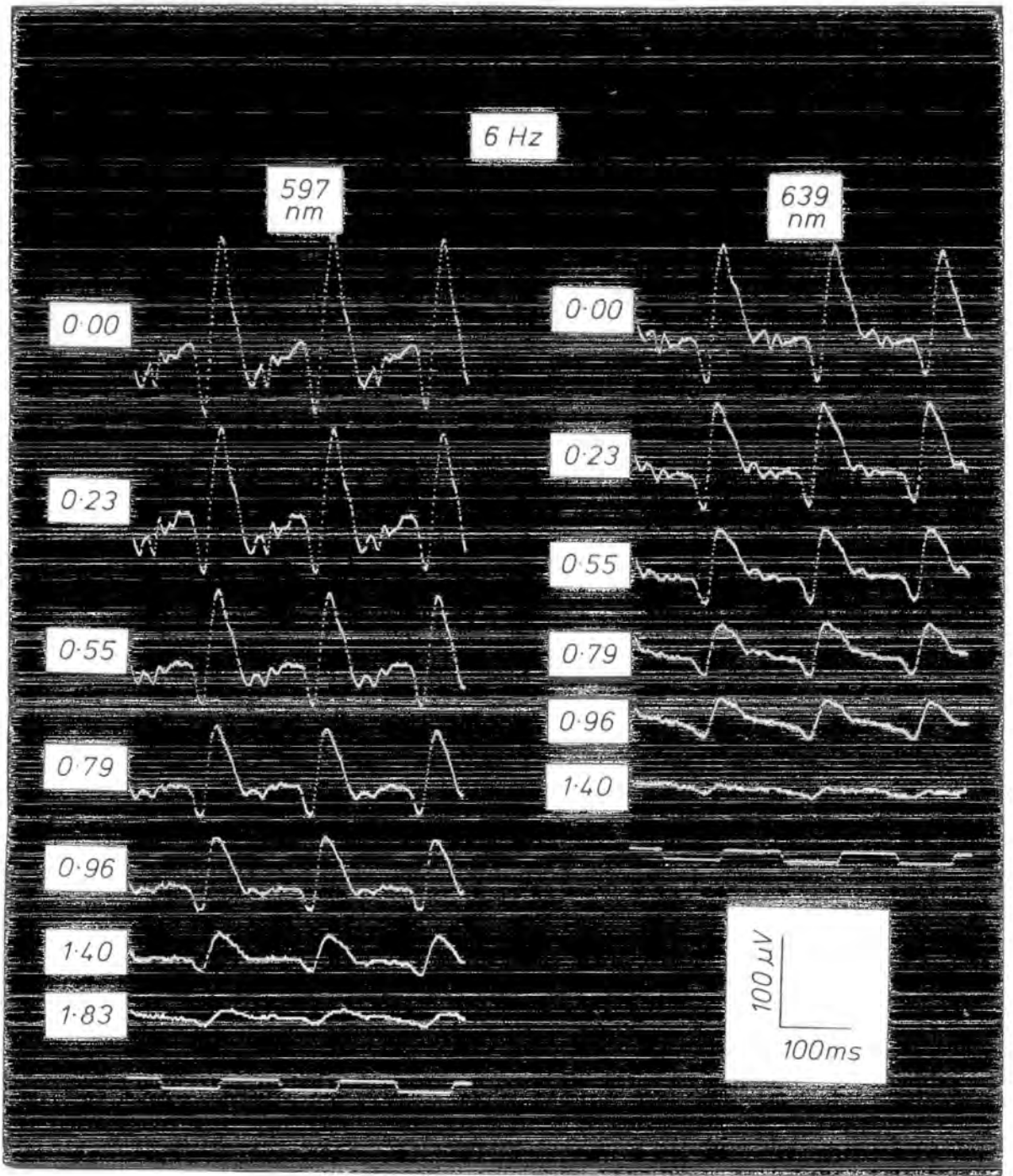

Fig. 3 cont.

present optical system, the energy available at 337 nm was particularly low while the relative energy at the longest wavelengths is also reduced. In addition, previous measures of the pigeon's photopic spectral sensitivity (Blough, 1957, Graf, 1969) have shown sensitivity to decline at longer wavelengths

With the technique of using a flickering stimulus rather than a single flash, it was difficult to define a baseline from which the separate component waves of the ERG could be measured. Additionally, in spite of efforts to obtain good electrode contact and positioning, the quality of ERG records taken from different subjects varied widely and it was not always possible to clearly distinguish a- and b-wave components. On all recordings, as stimulus intensity decreased and the response amplitude diminished, the component waveforms became indistinguishable (Fig. 3). Response amplitude was therefore measured in all recordings as the maximum amplitude difference between peak and trough on the ERG. While this does not permit separation of mechanisms with varying spectral sensitivities (Ikeda, 1965), the overall spectral sensitivity of the pigeon's eye can still be assessed.

Response-intensity functions from the first complete set of records obtained are shown in Fig. 4. As stimulus attenuation increased, response amplitude decreased in a linear fashion. Recordings from all other subjects were of much lower amplitudes, furthermore, the amplitude range varied widely between these subjects. Because of this lack of overlap in amplitude range, the criterion chosen to define the spectral sensitivity curve was a voltage level which was a constant ratio (0.12) of the maximum response voltage recorded from each bird.

Fig 4 (facing)

Response-intensity functions for one pigeon which were obtained using a 6 Hz stimulus. Numbers above each line indicate stimulus wavelength. Attenuation figures were calculated from log energy differences between chromatic stimuli plus log attenuation by the diaphragm. Relative spectral sensitivity was computed at a response criterion of 0.12 of the maximum response voltage recorded for each subject. For this individual the criterion level, shown by the horizontal dashed line, was 25 μ V. At wavelengths of 496 and 662 nm, for example, attenuation at criterion was 1.42 and 1.05 log units respectively, together with attenuation figures for other wavelengths, these data were used to calculate relative sensitivity.

Response-intensity functions were fitted by eye and are displaced along the abscissa by 1 log unit for clarity of display.

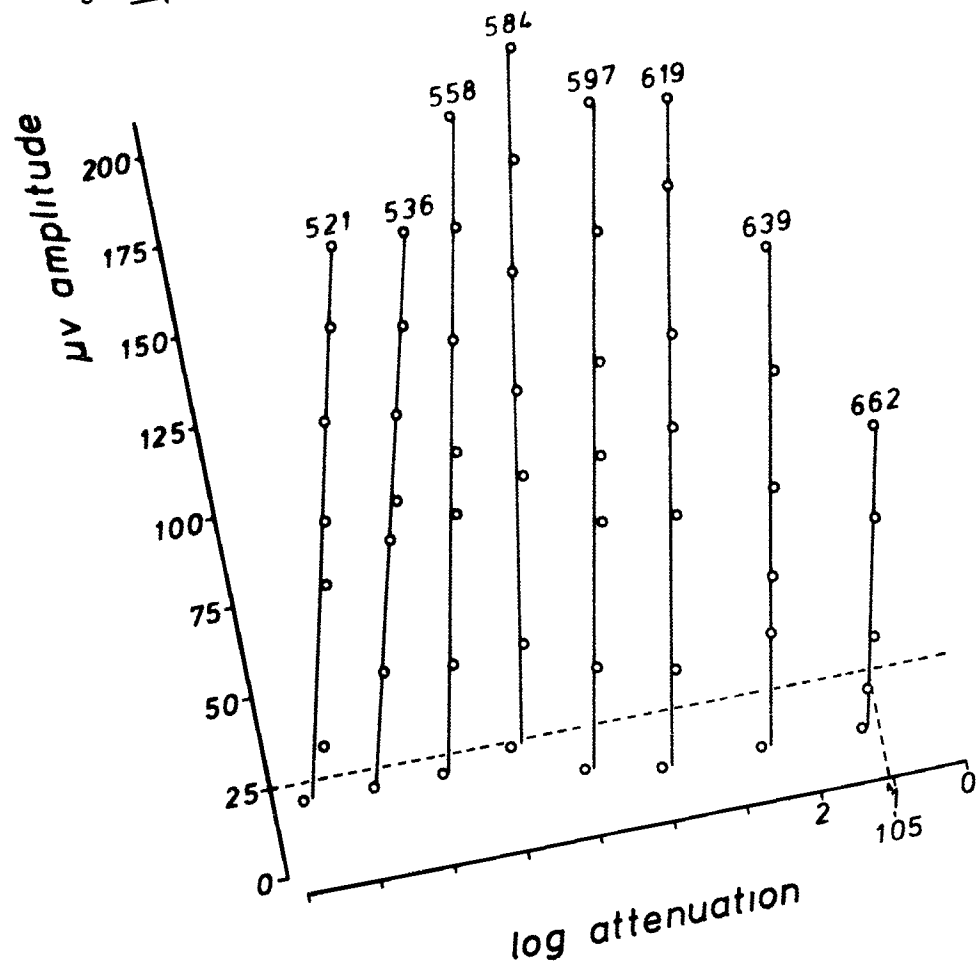
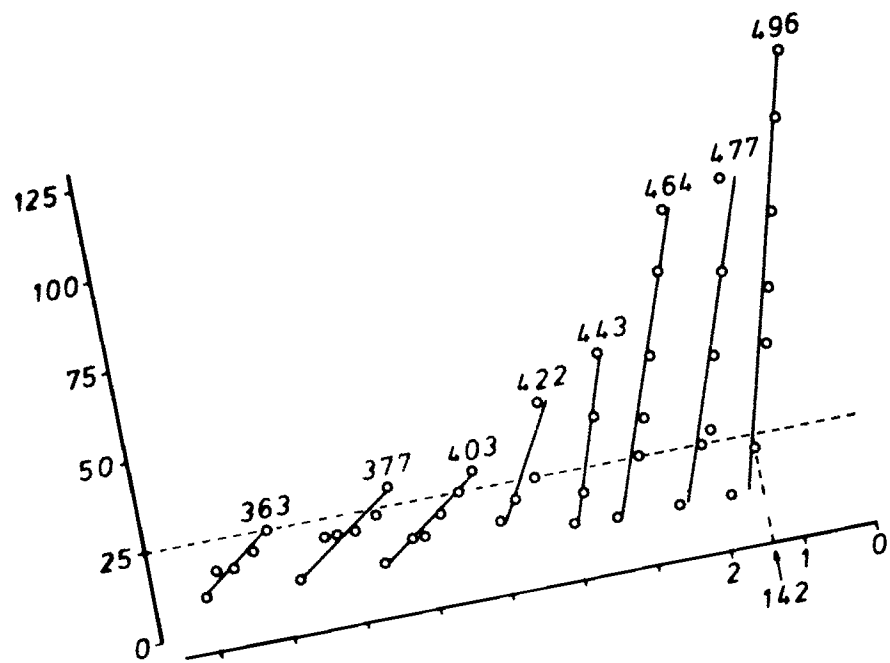

FIG. 4

From each response-intensity function the relative attenuation corresponding to the criterion or 'threshold' amplitude was found. Since relative attenuation figures already embodied both the energy differences between wavelengths and the attenuation provided by the diaphragm, the wavelength at which the greatest attenuation figure was given at threshold indicated the point of peak spectral sensitivity. The log difference between this and all other threshold attenuation figures was calculated. The differences, representing relative energy differences of the stimuli, could then be plotted directly to give a relative spectral sensitivity curve.

Examination of these curves, for 5 birds, showed that only the spectral sensitivity curve of the first bird (Fig. 5) resembled previous spectral sensitivity curves obtained by other investigators. The spectral sensitivity curve of this bird had its maximum at 558 nm. Sensitivity decreased towards longer and shorter wavelengths but in addition there was a sensitivity minimum at 403 nm before a further increase in sensitivity within the ultraviolet region.

The other 4 curves did not even have the familiar inverted-U shape. Examination of the response-intensity functions of these animals also showed noticeable deviations from linearity at the lower stimulus intensity settings. The maximum ERG amplitudes were of much lower voltage than those of the first pigeon (ranging from 30-110 μ V as opposed to a maximum response of 210 μ V for the first bird). Much of the difficulty in obtaining good recordings of high amplitude in this experiment may be attributable to the length of time required

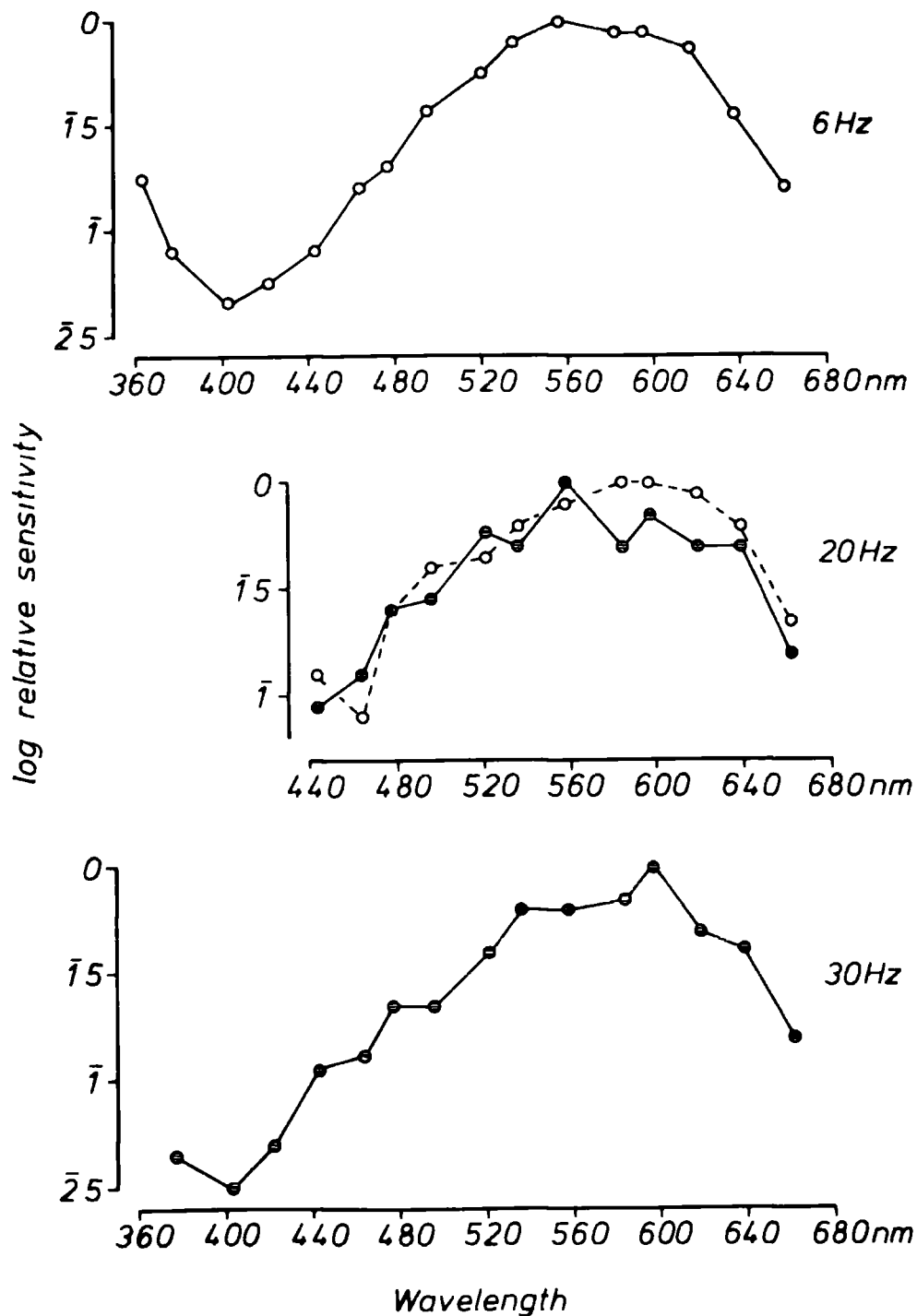

Fig. 5

Relative spectral sensitivity curves of individual subjects in Expt. I. Stimulus flash rates are indicated beside each graph.

6 Hz stimulus: sensitivity curve of one subject, calculated at a criterion voltage of $25 \mu\text{V}$ from data of Fig. 3.

20 Hz stimulus: relative sensitivity functions of two animals using a response criterion of $20 \mu\text{V}$.

30 Hz stimulus: sensitivity curve from bird also tested with 20 Hz stimulus (solid circles on both graphs), criterion voltage was $5 \mu\text{V}$.

to complete measurements. An entire test session lasted for several hours and maintaining an animal under an even, deep level of anaesthesia and in good condition for this amount of time was problematic. In addition, while the shapes of the average ERGs displayed on the Biomac screen during recording appeared normal, the signal amplification during these recordings may have been insufficient to provide an input voltage which would be reliably digitized by the Biomac when only a small ERG potential was given at lower intensity levels. Such an error in recording, together with the physiological state of the animal, may explain the haphazard sensitivity curves of the other 4 birds.

Since no reliance could be placed on most of the sensitivity curves calculated from this experiment, a subsequent attempt was made to obtain more consistent results, using a modified recording method in which data could be collected more quickly (See Experiment II)

20 Hz flash

While the achromatic beam should have been adequate to maintain the retina in a light-adapted state, the additional use of faster flicker rates of stimulus presentation was tried to isolate the cones' response, since the rods cannot follow a flicker frequency greater than about 20 - 25 Hz (Dodt and Wirth, 1953, Granit, 1955). More difficulty was encountered, however, in eliciting clear and measurable ERGs with higher flash rates, even when a bird had already shown a clear response

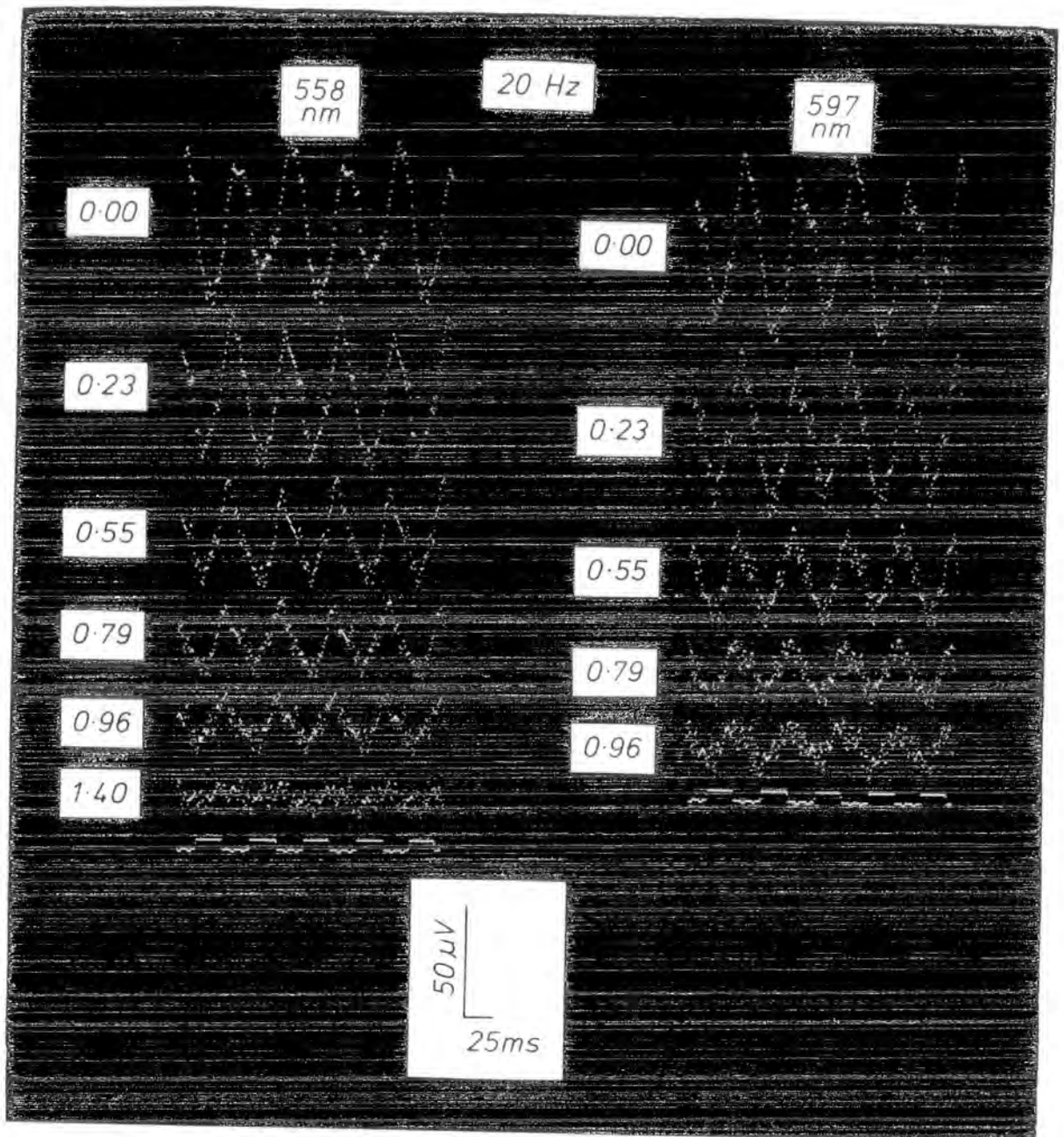

Fig. 6

Electroretinograms elicited by a 20 Hz flickering stimulus, at sample wavelengths indicated above each series. Note the 'noisy' appearance of each response and the alternating magnitude of response amplitude. Increasing log unit attenuation, corresponding to a decrease in response amplitude, is displayed beside each record. Stimulus onset and offset appear as downward and upward deflections on the stimulus trace below each series.

to a 6 Hz stimulus. For both rod- and cone-dominated retinae, response amplitude gradually diminishes as stimulus frequency increases (Dodt and Wirth, 1953). For the pigeon, unless the off-response is eliminated by changing the stimulus light-dark ratio, this progressive decrease in response amplitude is complicated by the interference of a-waves and off-responses at certain stimulus frequencies for which there is a marked additional decline or enhancement of response amplitude.

With 2 birds, though, recording sessions were successfully completed using a 20 Hz rate of stimulus presentation. At this rate, only wavelengths between 443 and 662 nm gave ERGs with a distinguishable waveform. All records appeared more 'noisy' than those obtained with a 6 Hz stimulus. Also another effect was noticeable in the waveform: there was a consistent alternation between ERG responses of larger and smaller amplitude in most recordings, especially in responses to higher intensity stimuli in which the peak to trough amplitudes were greater (Fig. 6). For these 2 subjects, the maximum amplitudes given to the unattenuated 597 nm stimulus were on average 95 μ V and 85 μ V, the amplitude differences between alternate responses were in these cases 25 μ V and 3.5 μ V respectively. It is difficult to understand what the basis for these regularly alternating responses might be. Although Dodt and Wirth (1953) found a systematic change in response amplitude as stimulus frequency was altered there

was no corresponding change between successive responses to a flickering stimulus of a fixed frequency. In that case their recordings show that, for any particular frequency, the amplitudes of repeated responses remained stable. Similarly Adrian (1945) reported that successive cone responses in man have the same amplitude when stimulus frequency is less than 20 Hz, while for higher stimulus rates only the amplitude of the first ERG response in a series is greater than that of the rest. Parker (1971), on the other hand, obtained a very irregular response at a stimulus frequency of 10 Hz when pigeons were anaesthetised with urethane. No such irregularities were obtained at higher or lower stimulus frequencies and a regular response was given to a 10 Hz stimulus when equithesin anaesthesia was used. The interpretation of the present peculiar response pattern with a 20 Hz stimulus is especially difficult when considering that we are dealing with records of averaged ERG responses, since large and small ERG responses should have averaged out over repeated runs.

Response-intensity functions were calculated as for the 6 Hz stimulus condition and relative spectral sensitivity functions computed using a $20 \mu\text{V}$ criterion level of response amplitude. The relative sensitivity curves for the two birds showed peak sensitivity to come at about 560 and 590 nm in each case (Fig. 5)

30 Hz flash

Recordings were made, using a 30 Hz stimulus, on the same 2 birds

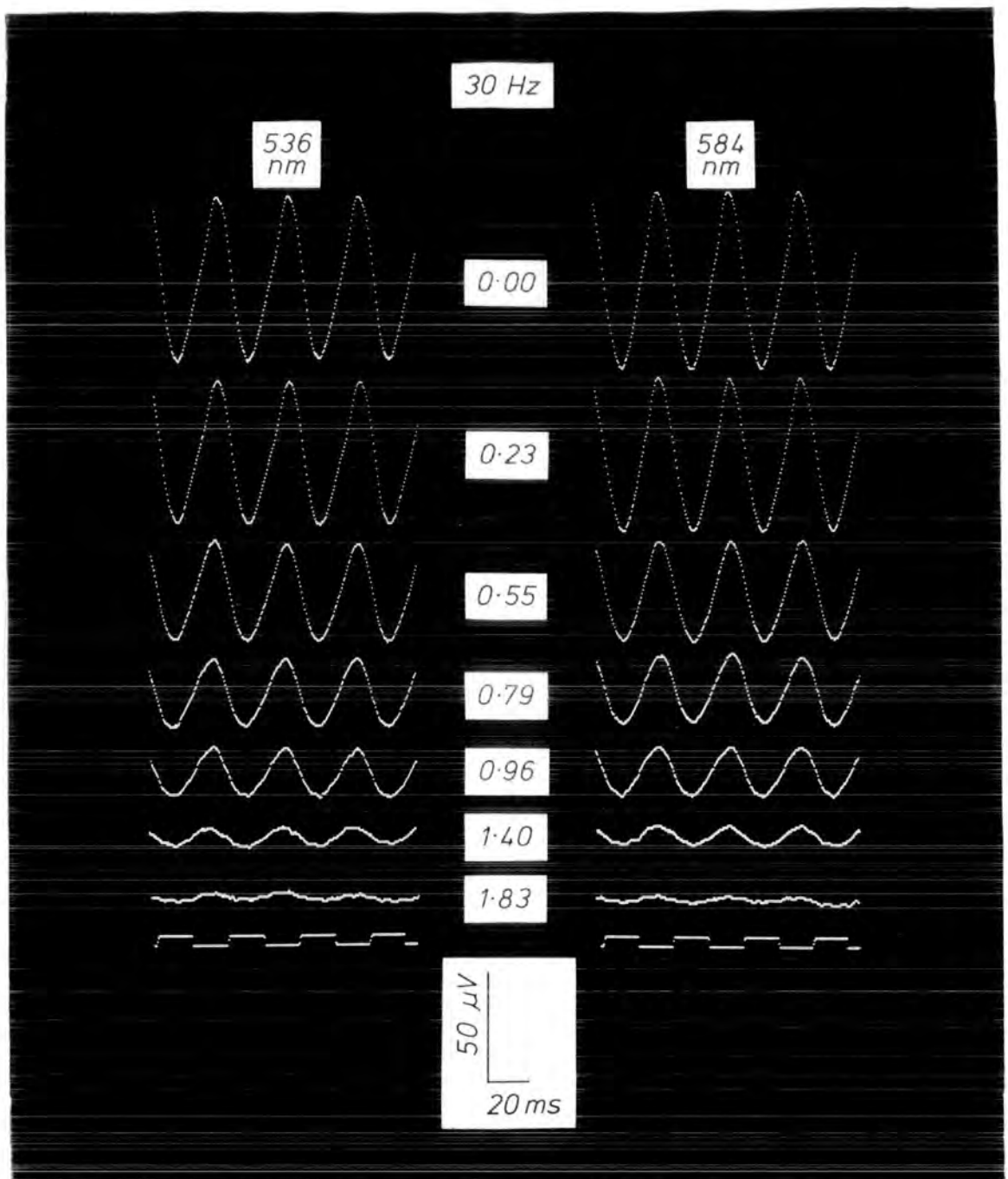

Fig. 7

Electroretinographic responses to a 30 Hz flickering stimulus at sample wavelengths specified above each series of recordings. Note the approximately sinusoidal waveform, found at all wavelengths, which may be contrasted with the response at lower stimulus frequencies (Figs. 3 and 6). Stimulus attenuation figures, in log units, are given between recordings. Stimulus onset and offset correspond to downward and upward deflections of the stimulus trace below each series.

that were used in the 20 Hz condition and during the same recording sessions. For one animal, a maximum response amplitude of $80 \mu\text{V}$ was given to the unattenuated 597 nm stimulus whereas for the second bird, which had given the greater response amplitudes to the 20 Hz stimulus, the maximum amplitude at this wavelength was only about $14 \mu\text{V}$. Because of its low amplitude ERGs, the range of wavelengths at which response-intensity functions could be plotted for this animal were very limited so only the data of the first bird were used to calculate a spectral sensitivity curve.

From both subjects, though, smoothly oscillating ERG responses were recorded which, at higher stimulus intensities, were approximately sinusoidal in waveform (Fig 7). These ERGs may be contrasted with the irregular responses obtained with a 20 Hz stimulus (Fig 6).

For the one animal, from which response-intensity functions could be plotted over a wavelength range of 377 to 662 nm, a response criterion of $5 \mu\text{V}$ was used to calculate a relative spectral sensitivity curve, which had its maximum at 597 nm. This curve also showed a slight increase in sensitivity in the ultraviolet region after a minimum at 403 nm (Fig. 5).

EXPERIMENT II

In spite of recording problems, ERG responses in the first experiment had been most easily obtained using a 6 Hz stimulus. Upon finding that the majority of spectral sensitivity curves derived from the results of Experiment I were unsatisfactory, a second

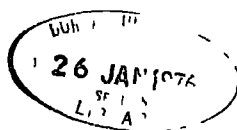

experiment was set up to retest the pigeon's electroretinographic spectral sensitivity function, again employing a 6 Hz rate of stimulus presentation but with a slightly modified method of recording results which did not require the extended measurements needed to plot response-intensity functions. This method was previously used by Thompson (1971) to estimate the spectral sensitivity curve of gulls.

METHOD

Apparatus

The optical apparatus and electronic recording equipment was identical to that used in the first experiment.

Preparation of subjects

Two adult pigeons were prepared for the experiment by attaching small, tapped brass blocks to their heads several days prior to the recording sessions. In order to record ERGs, each bird was lightly anaesthetised with Equithesin (intramuscular, 0.18 ml/100 gm body-weight) with supplementary doses (0.06 ml/100 gm) readministered if there were signs of recovery. This use of a light dose of the liquid anaesthetic alleviated the problem of excessive tracheal secretions thus obviating the need to intubate the bird. But so that a lightly dosed animal would accept the corneal electrode, placed against its eye, the left eye was bathed with Xylocaine solution to anaesthetise it, as well as with the mydriatic solution. During the recording session, a good electrical contact between the eye surface and the ring electrode was maintained by application of physiological saline to the eye. When

this was done, the bird was left for a few minutes before recording was continued.

Procedure

Stimulus wavelengths were presented in alternate order so that each test run contained an ascending and descending series of wavelengths. From Experiment I it was ascertained that, of the wavelengths which produced clearly recordable responses, the unattenuated 363 nm stimulus gave an ERG with the minimum amplitude in the UV part of the spectrum, which is the region of particular interest in this experiment. Rather than plot response-intensity functions, and, from a constant voltage criterion level, calculate spectral sensitivity functions, the data for a sensitivity curve were found more directly by using the maximum amplitude obtained at 363 nm as a criterion and finding the stimulus energies at all other wavelengths which would give an ERG response which matched the response amplitude at 363 nm. Using an oscillator giving an output of known voltage, the Biomac display was calibrated. For each of the two birds tested, the mean maximum response obtained over repeated runs with the 363 nm stimulus had a peak to trough amplitude of about 30 and 35 μV respectively.

The Biomac was set to display one electroretinogram curve, this was the average of 32 responses. The trough to peak heights, in centimetres, of averaged ERGs were measured using a grid placed over the Biomac screen. At each wavelength, the diaphragm was adjusted until

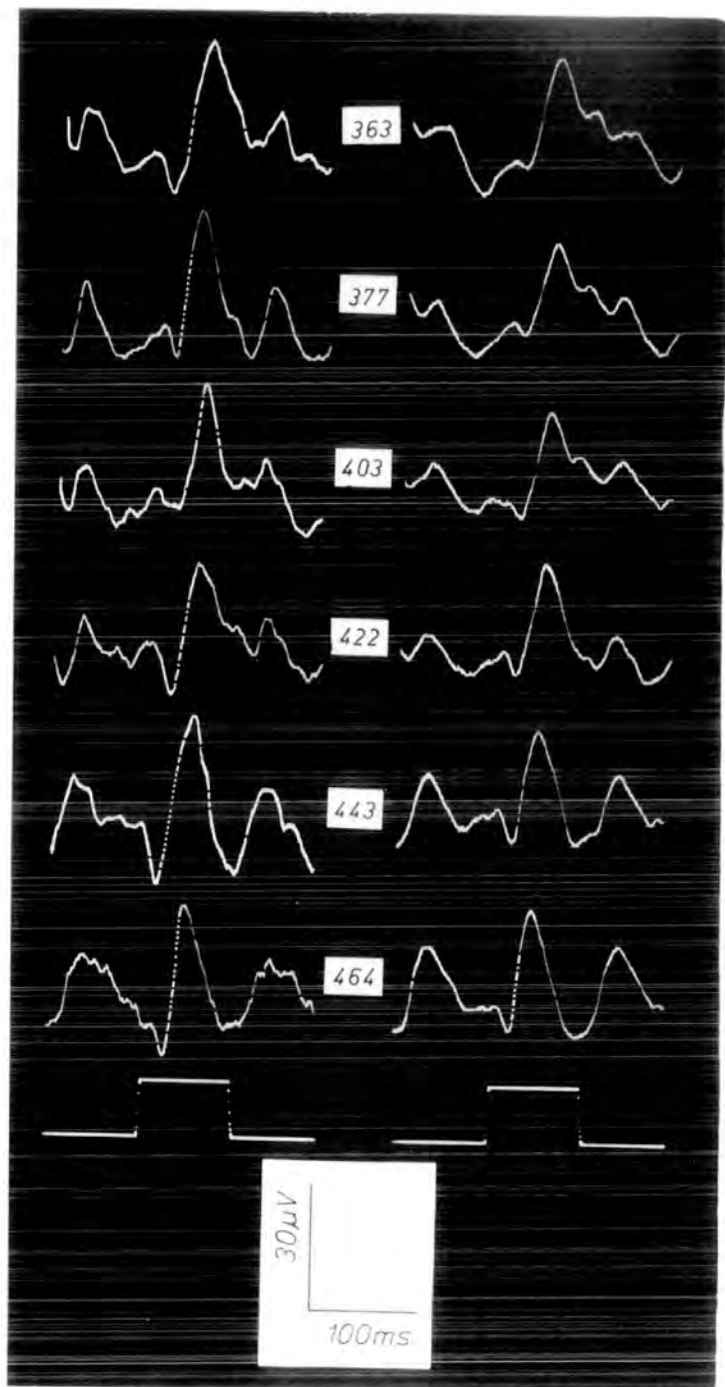

Fig. 8

Averaged electroretinograms of criterion response amplitude ($35 \mu\text{V}$) for two consecutive test runs on Bird 2. Stimulus wavelength is indicated beside each pair of recordings. The flash rate was 6 Hz. Stimulus onset corresponds to upward deflection, and offset to downward deflection, of the stimulus trace displayed beneath each set of ERGs. Calibration scale of response amplitude and stimulus duration is shown below the records.

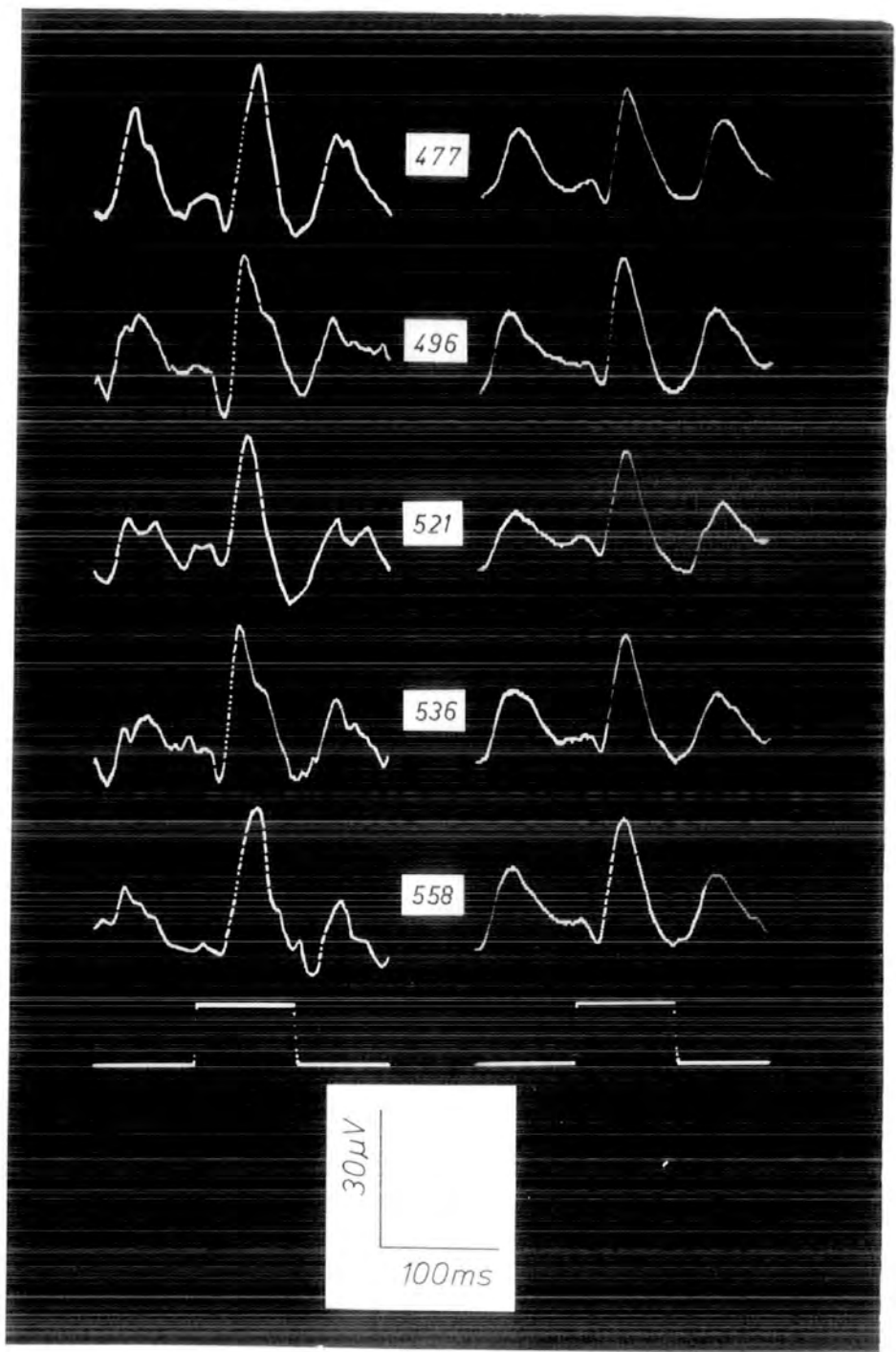

Fig. 8 cont.

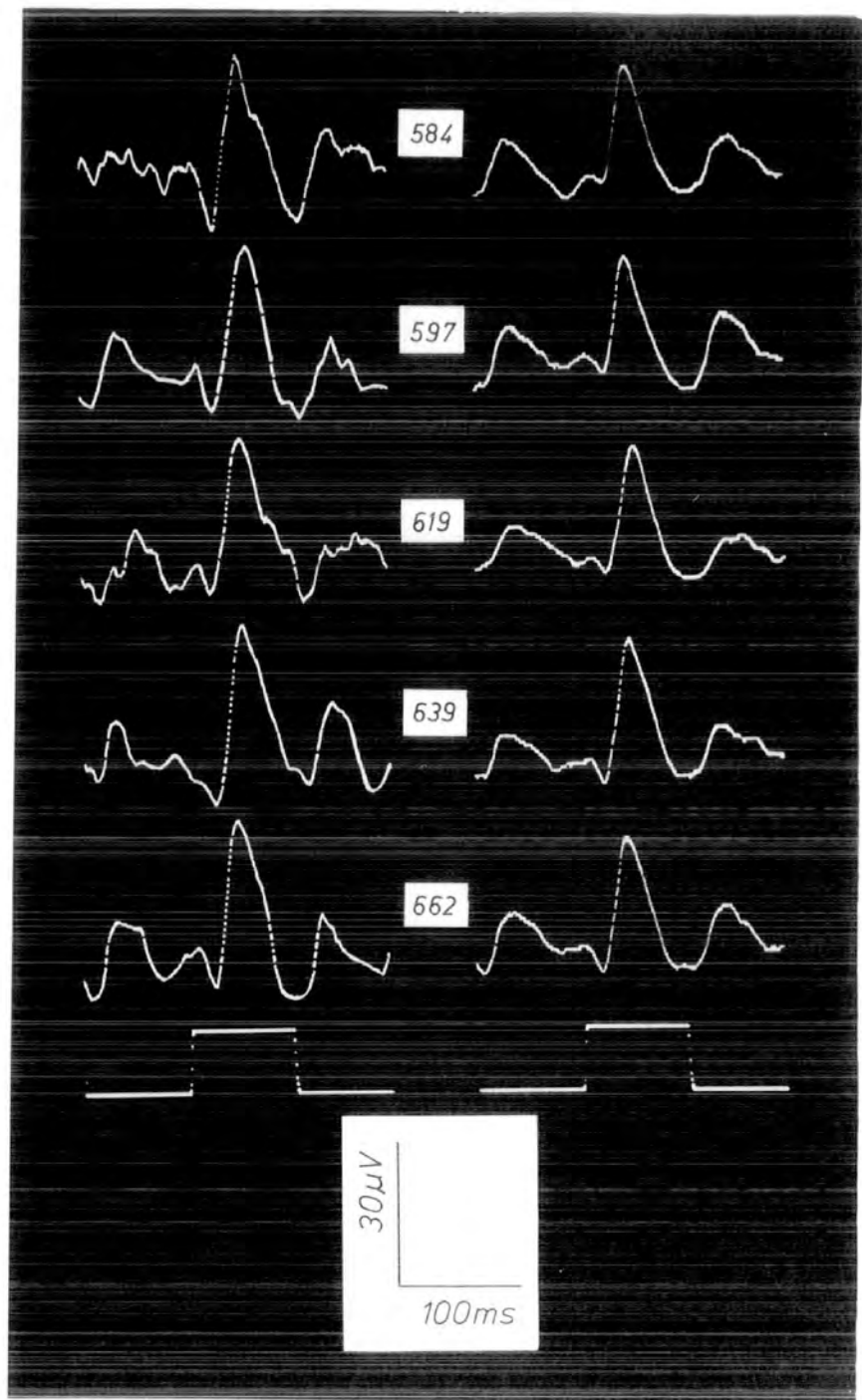

Fig. 8 cont.

a setting was found at which the height of the ERG equalled that of the response to the unattenuated 363 nm criterion stimulus. The diaphragm setting was noted before measuring the response to the next wavelength. On two test runs through all wavelengths for the second bird, the averaged ERGs of matching criterion-level amplitudes were photographed. Because of the speed of this method it was possible to complete 3 consecutive test runs at all wavelengths on each of the 2 birds.

RESULTS

Clear electroretinograms, of sufficient amplitude to match the response to an unattenuated 363 nm stimulus, were recorded over the wavelength range of 363 to 662 nm. While no detailed analysis of components was made in ERGs produced by repetitively flashing stimuli, since there is not a stable baseline from which to measure the amplitudes of constituent waves, some variation of waveform was noticed at different wavelengths. Comparison of ERGs obtained on separate test runs shows that there are slight differences in response to the same wavelengths, with all the recordings made on the second test run with Bird 2 appearing smoother than those on the first run (Fig. 8). Nevertheless, some general remarks may be made about the form of these electroretinograms -

- 1) In all electroretinograms, stimulus offset was followed by a peaked response, the d-wave, which is characteristic of cone-dominated retinae (Brown, 1968). This response consisted of both positive and negative phases and may be contrasted with the off-response, a sharp

positive deflection alone, which can be seen in the ERG recordings made by Ikeda (1965) and Ogden and Wylie (1971). A prominent d-wave is found following light adaptation of the pigeon retina (Frost, 1972), thus the form of this ERG component indicates that the retinas of the birds used in this experiment were maintained in a photopic state of adaptation.

2) Each electroretinogram includes a sharp, biphasic b-wave response. This peaked waveform, as compared with a more rounded b-wave, typical of the pigeon's rod response (Ikeda, 1965), is a further indication of the predominantly photopic response elicited by each wavelength in the experiment.

3) The latency between stimulus onset and b-wave peak increases slightly at shorter wavelengths. This latency effect is particularly noticeable in the photographic records of the second test run on Bird 2, in which the latency at 363 nm is 45 ms, decreasing to a latency of about 32 ms at wavelengths longer than 422 nm

4) There are differences in the waveform of responses to shorter wavelengths which are again more obvious in the recordings of the second run. A secondary peak or shoulder can be seen on the falling side of the b-wave. The latency of 80 ms between stimulus onset and the peak of this component indicates that the smaller secondary peak may be a rod response. Although a small shoulder can be seen in recordings at several widely separated wavelengths in the first test run, it is not apparent in the second run at wavelengths greater than 422 nm. Presumably the rod response is masked by cone responses during most of the recordings

Table I
Voltage measures, proportional to stimulus energy
recorded at criterion levels of
intensity for each chromatic stimulus

The table shows, at each wavelength for the two birds tested, the mean voltage output in log mV of a calibrated thermopile together with the standard deviations of these readings, averaged from the measures of repeated rest runs.

λ	Day 1		Day 2	
	Mean log mV	SD	Mean log mV	SD
363	2.34	0.00	2.34	0.00
377	2.64	0.01	2.64	0.11
403	2.77	0.02	2.69	0.03
422	2.72	0.00	2.72	0.11
443	2.55	0.08	2.69	0.12
464	2.34	0.03	2.51	0.00
477	2.17	0.04	2.33	0.08
496	1.87	0.05	1.96	0.04
521	1.59	0.09	1.63	0.15
536	1.56	0.11	1.50	0.13
558	1.49	0.11	1.46	0.07
584	1.49	0.09	1.46	0.06
597	1.49	0.06	1.53	0.12
619	1.68	0.09	1.71	0.13
639	1.96	0.10	2.09	0.10
662	2.52	0.05	2.50	0.06

However, the measure of central interest in this experiment was the overall trough to peak amplitude.

Energy calibration of stimuli at criterion level of intensity

With only the xenon lamp operative, the energy of each chromatic stimulus, at an intensity level for which a criterion amplitude of response had been registered, was measured using a calibrated thermopile in place of the bird's eye. At each wavelength, the amplified thermopile potential to the flashing stimulus was measured on a calibrated oscilloscope with the diaphragm set to provide the attenuation which gave criterion ERG responses on individual test runs with each bird. The voltage output of the thermopile was directly proportional to stimulus irradiance so that voltage readings could be used directly to calculate relative spectral sensitivity functions. The mean voltage measures for stimulus settings used on repeated runs were calculated, together with the standard deviations, for each bird. These data are given in Table I and show the stability of recordings made on repeated runs.

From the mean log voltage figures, proportional to stimulus energy, sensitivity differences were calculated. Since sensitivity would be maximal at a wavelength for which the energy of the criterion stimulus was least, all the voltage readings were adjusted to a relative zero level and these figures plotted to give relative sensitivity curves for the 2 birds (Fig 9). These curves too showed very little difference between birds and, together with the stability of repeated measures, indicate the reliability of this recording method.

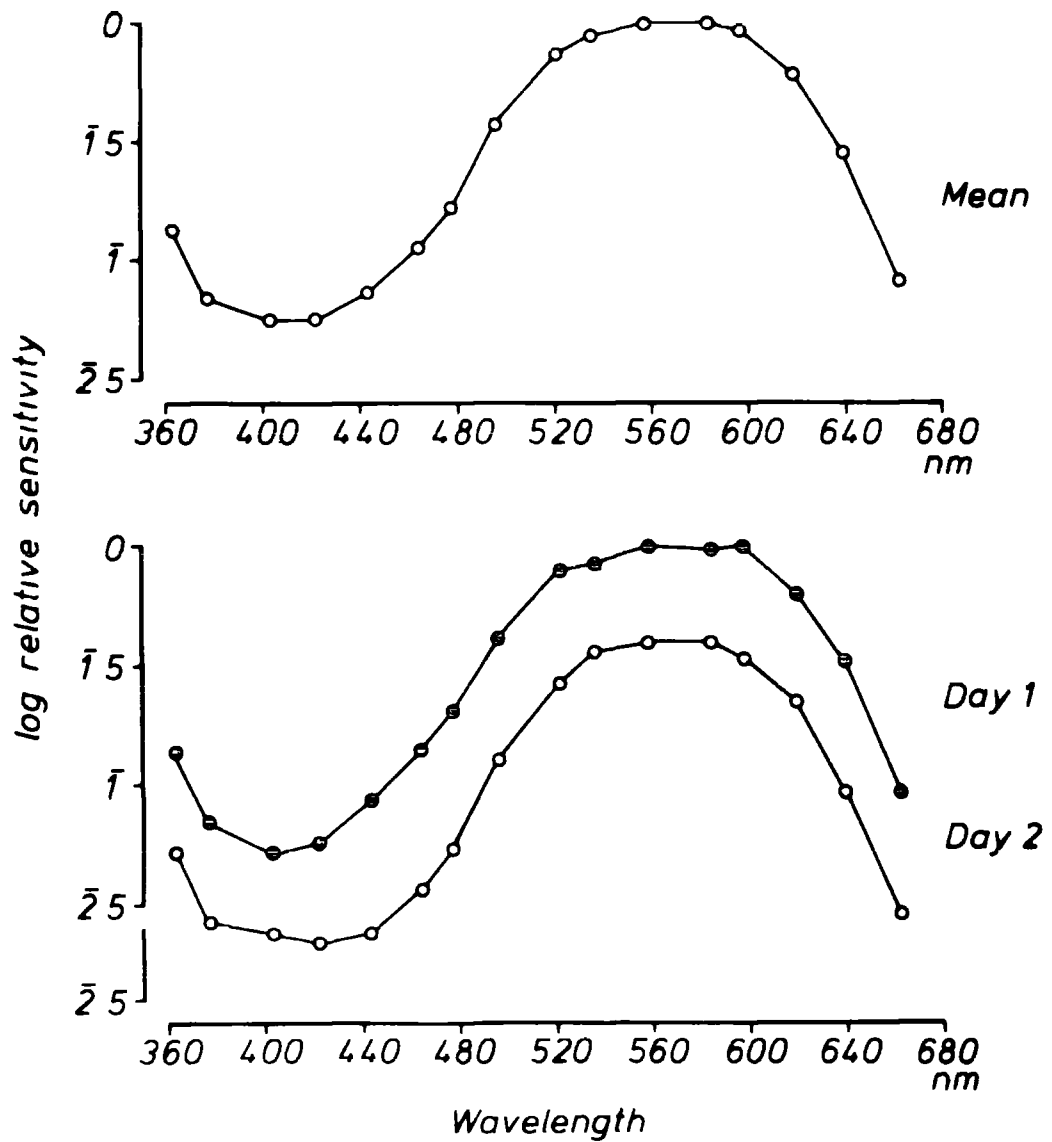

Fig. 9

Relative spectral sensitivity curves obtained using a 6 Hz stimulus in Expt. II.

Bottom graphs show the sensitivity curves of the two subjects tested on Day 1 and Day 2. Curves are plotted from the mean data over repeated test runs for each individual. (Some individual ERGs of the second bird are shown in Fig. 5.) Response criterion for Day 1 was 30 μ V and for Day 2, 35 μ V.

The top curve is the mean sensitivity function of these two animals.

A mean spectral sensitivity function was calculated from the two curves obtained from separate subjects (Fig. 9). This curve showed that peak sensitivity fell between about 560 and 580 nm. Sensitivity decreased towards longer wavelengths and towards a minimum at 400 - 420 nm before a further increase in the UV region.

DISCUSSION

If all the sensitivity curves obtained in Experiments I and II are compared (Figs. 5, 9) there is a high degree of consistency in the results, in spite of the varying test conditions used to generate these data. Maximum sensitivity falls between about 560 and 600 nm, which is well within the range of peak sensitivity position reported by other authors. (Ikeda, (1965), for instance, found maximum photopic sensitivity to lie at 544 nm while the peak sensitivity in Graf and Norren's (1974) curves ranged up to about 600 nm.) The experimental results also tally quite well in the range of log difference in sensitivity at comparable wavelengths. (For example, on all graphs there is a sensitivity decrease of approximately 1 log unit between peak sensitivity and that at 440 nm.) All the animals tested with 6 Hz and 30 Hz flashing stimuli show a sensitivity minimum at 400 - 420 nm followed by an increase in sensitivity at shorter wavelengths in the UV region. In one of the two birds for which a 20 Hz flash rate was used, a short wavelength minimum occurs at 464 nm.

Since the results of Experiment II are known to be particularly reliable, the mean sensitivity curve computed in that experiment was

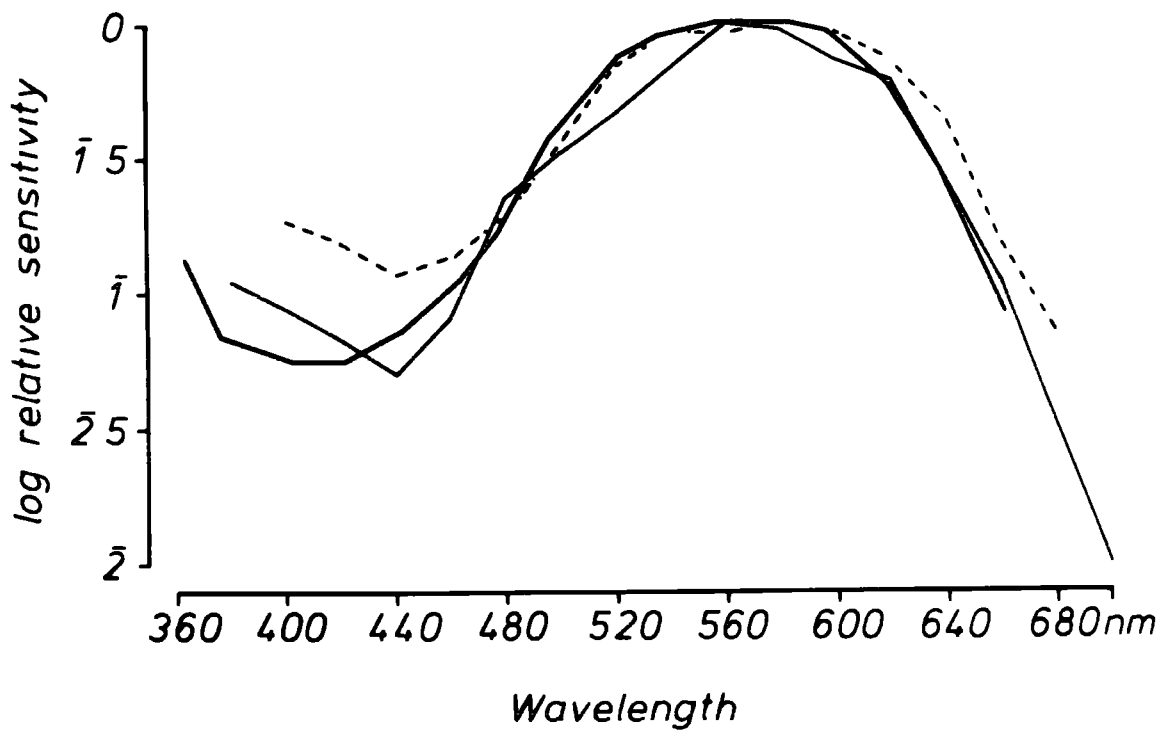

Fig. 10

Comparison of the mean relative sensitivity curve obtained in Expt. II (————) with the photopic spectral sensitivity curve from Blough's (1957) experiment, employing a threshold-tracking technique (————), and results of an ERG study by Graf and Norren (1974) (-----) in which flickering chromatic stimuli were superimposed upon a white background. ERGs in Expt. II were elicited by a 6 Hz stimulus, relative sensitivity was computed at a response amplitude criterion of 30 - 35 μ V. Graf and Norren's experiment used a 25 Hz stimulus and a 2 μ V criterion.

directly compared (Fig. 10) with the data from two spectral sensitivity studies for which measures of short wavelength sensitivity are available Blough's (1957) investigation employed a behavioural test method and Graf and Norren (1974) used the ERG response. The greatest discrepancy in the results occurs at the shorter wavelengths. While all the curves show an increase in sensitivity at the shortest wavelengths (also seen in the gull's spectral sensitivity curve (Thompson, 1971), the other authors' experiments find a sensitivity minimum at 440 nm rather than 400 - 420 nm, as in the present work. When using an ERG test method this difference may be attributable to the criterion voltage level at which relative sensitivity was calculated Graf and Norren's sensitivity curve shown in Fig 10 was obtained using a criterion of $2 \mu\text{V}$ whereas, with a higher voltage criterion of 9 - $20 \mu\text{V}$, which is closer to the 30 - $35 \mu\text{V}$ criterion used in Experiment II, they report a shift in the sensitivity minimum to 420 nm.

The higher voltage criterion in their experiment also produced an overall reduction in the relative spectral sensitivity at shorter wavelengths, which is another difference between their curve and the present function shown in Fig. 10. However, it should be mentioned that this is not the only factor which might account for some individual variation in sensitivity to shorter wavelengths (see Graf and Norren's Fig 3a). Relative sensitivity differences at these wavelengths have also been reported in the results obtained from juvenile and adult gulls (Thompson, 1971) While the reasons for this age-dependent change are

not very obvious, one suggestion is that in older birds the lens or cornea, which are both unpigmented, might show an increase in turbidity, accompanied by relatively greater scattering of shorter wavelengths and hence a loss of sensitivity at this end of the spectrum. This type of change in the ocular media is part of the ageing process in the human eye (Weale, 1968). Some such age-dependent change might also partly contribute to variations in short-wavelength sensitivity in pigeons.

The results of the present experiments, together with those of other workers, thus clearly demonstrate the pigeon's sensitivity to ultraviolet light but the short wavelength range of this sensitivity may yet extend beyond the 363 nm limit for which adequate measurements could be taken here. A 337 nm stimulus occasionally elicited a slight response but the energy emitted, using the present optical system, was too low at this wavelength to allow the acquisition of precise data. For a more extensive investigation of the response of the pigeon's eye at shorter wavelengths it would be necessary to set up a system in which quartz instead of glass optics were used.

There are a number of possible mechanisms underlying the pigeon's sensitivity in the ultraviolet. The absorption spectra of visual pigments which have been extracted from the pigeon's retina (rhodopsin, pigment 544 Bridges, 1962 iodopsin Wald, 1958) all extend into the near-ultraviolet. In the case of iodopsin, a cis-peak, similar to that found in human rhodopsin (Collins, Love and Morton, 1952) occurs at 370 nm (Wald, Brown and Smith, 1955). This secondary absorption maximum

may be due to the twisted configuration of the pigment molecule or could be attributed to breakdown products of the visual pigment, having their maximum absorption at ultraviolet wavelengths (Metaiodopsin II (Yoshizawa, 1972), for example, which reacts in a way similar to Metarhodopsin II, an intermediate product of rhodopsin Yoshizawa and Wald, 1963). Note that Heller (1968) found that, in very pure preparations of rhodopsin, the cis-peak is absent but appears upon slight exposure of the pigment solution to light. As is the case with aphakic humans (Tan, 1971), the pigeon's sensitivity to UV light could be based on the absorption of UV wavelengths by the photopigments themselves or their intermediate products.

An alternative mechanism for detecting UV wavelengths may be found in a visual pigment which is maximally sensitive at 400 nm but once more has an absorption spectrum extending into the ultraviolet (Graf and Norren, 1974). Support for the 'blue' receptor, containing this visual pigment, being the basis of the pigeon's UV sensitivity comes from examination of the response-intensity functions obtained in Experiment I of the present study (Fig 4). At 422 nm there is a change in slope of the response-intensity function, delineating a family of functions at longer wavelengths, which all have steep and more or less parallel slopes, from a group at shorter wavelengths which all show parallel but shallower gradients. This differentiation, in terms of slope, is usually taken to indicate the presence of separate receptor mechanisms.

Separate mechanisms are also expected from the changes in response latencies mentioned in Experiment II. It remains to be seen whether the pigeon's retina contains only one or two short wavelength receptors with peak sensitivity below 420 nm.

Since the pigeon's spectral sensitivity extends to wavelengths below 400 nm under both photopic and scotopic adaptation conditions, as shown by the present experiments and those of Graf and Norren (1974), it may well be that the pigeon relies on a combination of photopigment mechanisms to detect UV radiation. While inspection of ERG records indicated that the retina was maintained in a light-adapted condition, this does not necessarily preclude the operation of rods during the photopic state.

CHAPTER 5

WAVELENGTH DISCRIMINATION IN THE 'VISIBLE' AND
ULTRAVIOLET SPECTRUM

INTRODUCTION

The previous electroretinographic experiments provided both confirmation and measurements of the pigeon's relative sensitivity to ultraviolet wavelengths as well as to other parts of the spectrum. Next an experiment was designed to explore further Wright's (1972b) discovery that pigeons can distinguish between a pure monochromatic light and a heterochromatic stimulus containing a UV component.

In the following piece of research, differential discrimination within the ultraviolet region was examined and also difference thresholds were estimated for other points of the spectrum in order to verify the results of the earlier investigation of wavelength discrimination, described in Ch 2. In the latter experiment no precautions had been taken to suppress possible UV components arising from second order spectra when using grating monochromators. However, it would be expected that short wavelength components, falling within the pigeon's visible range, could only have contaminated the longer wavelength stimuli, above 600 nm. This experiment, in which appropriate blocking filters were included, should therefore reveal the effects, if any, on the wavelength discrimination function

of omitting to use these filters.

Since the original wavelength discrimination experiment had taken about 18 months to complete, this time a slightly modified testing procedure was used which would not take so long to yield data from which thresholds could be calculated. This procedure was adapted from a threshold-tracking method, developed by Blough (1958), in which the stimulus values oscillate about a threshold level in a manner dependent on the pigeon's response pattern. This type of method has already proved useful in collecting information about other aspects of the pigeon's psychophysical performance (Blough, 1956, 1957, Meissner, 1970)

Previous experiments employing this 'titration' method (Rosenberger, 1970) have aimed to find an animal's absolute threshold on some stimulus parameter, such as intensity, and subjects have thus been required to respond to apparent 'presence' or 'absence' of a single stimulus. Stimulus intensity was then modulated as a consequence of each response. In such cases a threshold was calculated from a graph of change in stimulus intensity level over time. The following experiment is concerned with difference thresholds rather than absolute thresholds, so that a pigeon is required to compare two stimuli rather than detect the presence of only one stimulus. For the purpose of estimating wavelength difference thresholds and of comparing these threshold results with the data previously reported in Ch. 2, the contingencies of the titration procedure were modified

slightly. Instead of a stimulus value changing after every response, a new stimulus setting was made consequent upon the number of correct responses made within a block of 10 trials. Thresholds could then be estimated from graphs of the scores of correct responses made in successive blocks of trials versus wavelength difference values on each block of trials. Thus the actual discrimination scores are taken into account in calculating a difference threshold, rather than just the limits between which stimulus values are made to vary.

In spite of using this titration method, the experimental conditions were still sufficiently similar to those of the original wavelength discrimination experiment to be able to compare the results of the two studies. While, in the following experiment, the wavelength value of the negative stimulus changed within a test rather than being altered over a number of successive sessions, the stimulus display and the response sequence required of a pigeon in both experiments were very similar. The criterion level at which difference thresholds in the two studies were calculated was the point at which a pigeon could make a correct discrimination 70% of the time and, finally, difference thresholds estimated in each of the two studies were plotted in the same way so that wavelength discrimination functions could be directly compared.

Fig 1 (facing)

Optical system by which monochromatic stimuli, each consisting of a bright central square extending into a dimmer vertical bar, were back-projected onto the response keys of the Skinner box (see text).

BL_{1, 2} = attenuating blinds, rotated by stepper motors

L_{1 - 6} = achromatic doublet lenses

M = front-silvered mirror

MON = monochromator, driven by stepper motor

NG = loudspeaker of white noise generator

RK_{1, 2} = response keys of Skinner box

SC = screen

Sh = solenoid-operated shutter

UVF = ultraviolet blocking filter

Xe = xenon pressure lamp

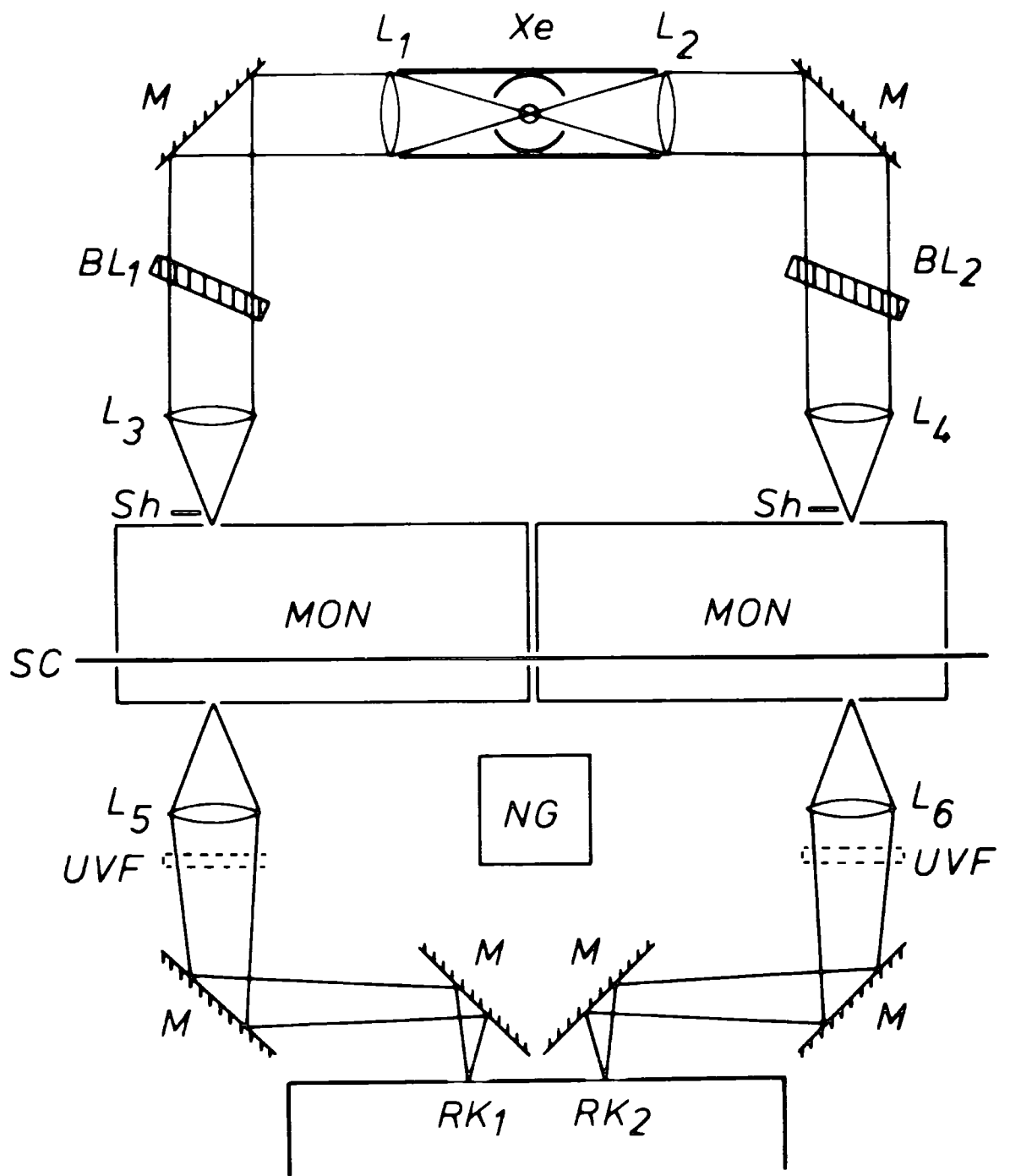

Fig. 1

METHOD

Subjects

Four of the five pigeons previously used for behavioural testing again acted as subjects in this experiment. These subjects were once more maintained at 80% of their ad-lib weight. S1 was not used as it had contracted an incapacitating disease.

Apparatus

Skinner Box

The Skinner box was the same one that had been employed before in testing wavelength discrimination and saturation discrimination. For the present experiment the perspex response keys were replaced by keys of ground glass, which does not fluoresce when irradiated with UV light (Muntz and Northmore, 1970).

Optics

A 75W high pressure xenon lamp (Xe) served as the light source (Fig. 1). Two beams were directed from this source via exit holes in the lamp housing and were collimated by achromatic doublet lenses (L_1 , L_2). After reflection off front-silvered mirrors (M), reflecting both 'visible' and UV radiation, each beam was transmitted through specially constructed blinds (BL_1 , BL_2), mounted on stepper motors. Rotation of these blinds about the vertical axis attenuated the intensity of each beam. The blinds' attenuation function was independent of wavelength but, unlike the iris diaphragm used to attenuate stimuli in the ERG experiment (Ch.4), movement of the blinds did not alter

the stimulus geometry. Light was then focused by further lenses ($L_{3,4}$) onto the entrance slits of two Hilger-Watts grating monochromators (MON), driven by stepper motors. The light paths could be occluded by solenoid operated shutters (Sh), placed in front of the monochromator entrance slits. The widths of the monochromators' entrance and exit slits were adjusted to 2 mm so that light with a bandwidth of 4.8 nm was produced by each monochromator. A lens and mirror system then focused the monochromatic light onto the back of each response key ($RK_{1,2}$) on the Skinner box. Wratten 2B filters (UVF) were used in conjunction with the monochromators to suppress ultraviolet sidebands for nominal wavelengths above 600 nm.

A large matt black painted screen (SC), placed over the monochromators, and additional shielding around the xenon lamp prevented as much stray light as possible reaching the response keys.

The chromatic stimuli back-projected onto the keys by this optical system appeared as two bright squares of light (3 x 3 mm) centred on the keys with a fainter 3 mm wide vertical band of light extending above and below this square.

All noise made by the stepper motors was masked by white noise from a loudspeaker (NG) placed in front of the Skinner box. This masking noise, measured by a sound level meter placed inside the closed Skinner box, had an intensity of 70 db (re $0.0002 \text{ dynes/cm}^2$)

Fig 2 (facing)

Apparatus used to separately calibrate stimuli generated
by each optical channel.

BIO = Biomac transient averaging computer

CRO = storage oscilloscope

PC = photocell

TH = thermopile

TRIG = monostable trigger device

Sec = rotating sector

Other abbreviations as in Fig 1

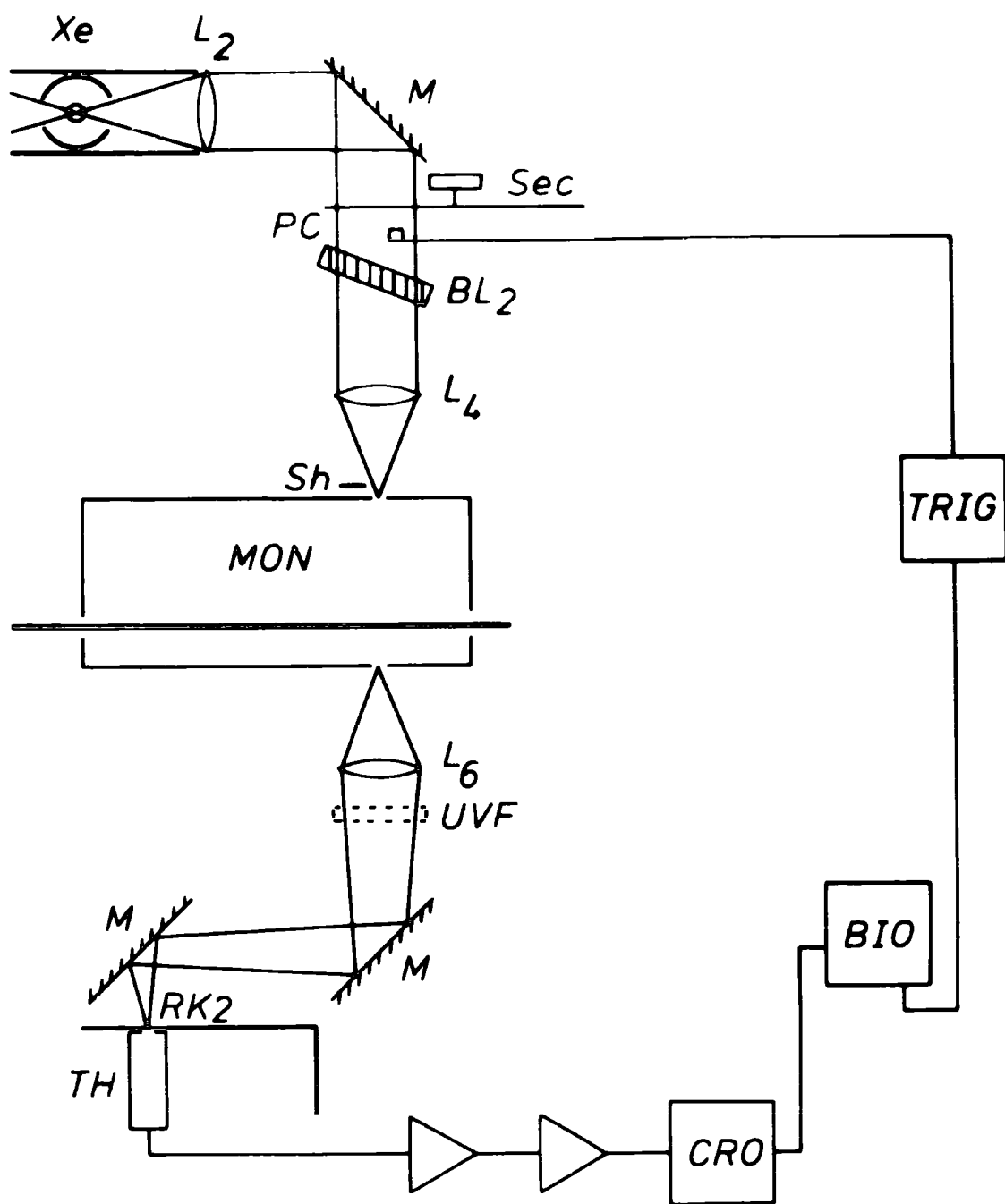

Fig. 2

Control of events

Stimulus settings, given by the motor driven monochromators and blinds, were controlled by an IBM 1130 computer through a WDV interface. The computer also controlled the shutters of the optical system and the food hopper and ceiling light of the Skinner box. In addition it performed timing operations and sensed responses to the keys and depression of the Skinner box's floor platform. Response data were collected on-line and were printed out together with a record of the varying wavelength settings of the stimuli.

Stimulus calibration

The wavelength calibration of both monochromators was checked using a mercury discharge lamp and was adjusted to agree within 0.5 nm for the two instruments.

The apparatus used to calibrate the energy available on each response key is shown in Fig. 2. A rotating sector (Sec) gave a sinusoidally modulated light, flashing at 1 Hz, as a stimulus for a Hilger-Watts FT17 thermopile (TH). This thermopile was positioned behind a response key to detect the irradiance of the bright central stimulus square. The thermopile's output was amplified by a Grass P16 preamplifier and an additional Aim low noise amplifier. The output voltage was monitored on a storage oscilloscope (CRO) and relayed to a Biomac transient averaging computer (BIO). A photocell (PC), placed behind the sector and used in combination with a monostable trigger device (TRIG), provided a triggering pulse for the Biomac.

So that data could be collected for controlling stimulus settings by computer during experimental sessions, the computer was used to drive the motors and adjust the monochromator readings and blind positions during the calibration procedure. For this procedure special programs were written which allowed the experimenter to make stepwise changes in stimulus settings by operating a panel of microswitches and which, when appropriate, recorded on the computer the number of steps by which the motors had been moved.

Firstly, the position of each blind was found which gave the least stimulus attenuation i.e. the maximum energy reading for any particular wavelength. This position was marked on the optical apparatus and was the 'zero' setting from which all subsequent blind adjustments were made.

Next the stimulus attenuation necessary to give a spectrum of equal subjective brightness for a pigeon was found, using spectral sensitivity data taken from the electroretinographic study reported in Experiment II of the previous chapter. Since, in spite of trying to match the two channels of the optical system, more energy was generally available on key 1 than on key 2, attenuation settings for each channel were calculated independently.

Calibrating first the key 2 stimuli, for which least energy was available, the maximum thermopile potential, with the blind set in the zero position, was measured for a 380 nm stimulus. At that wavelength stimulus energy was relatively low as is the sensitivity of the pigeon's

eye. The thermopile's voltage output, directly proportional to stimulus energy, was recorded in terms of centimetres deflection of the Biomac trace.

Attenuating all other stimulus wavelengths until the thermopile potential matched that obtained with the 380 nm stimulus would give an equal energy spectrum. Therefore, to produce a spectrum of equal subjective brightness, factors were calculated, from the sensitivity data, by which the thermopile's output at 380 nm had to be adjusted for other wavelength settings. Having calculated the desired energy readings for other wavelengths at 10 nm intervals between 360 and 660 nm, the blind settings which would give these energy measures were found empirically. At each wavelength the blind was moved stepwise by the experimenter until the required deflection reading on the Biomac was obtained. Above 600 nm a UV blocking filter (Wratten 2B) was used to suppress second order wavelengths, calibrations at these longer wavelengths were made with the filter in position.

After the correct blind setting had been found at each wavelength, the wavelength and the number of steps by which the blind had been moved away from its zero position were recorded on the computer.

For key 1, a blind position also had to be found which attenuated the 380 nm stimulus on this key so that it was of equal energy, and thus of equal brightness, to the 380 nm stimulus on key 2. At all

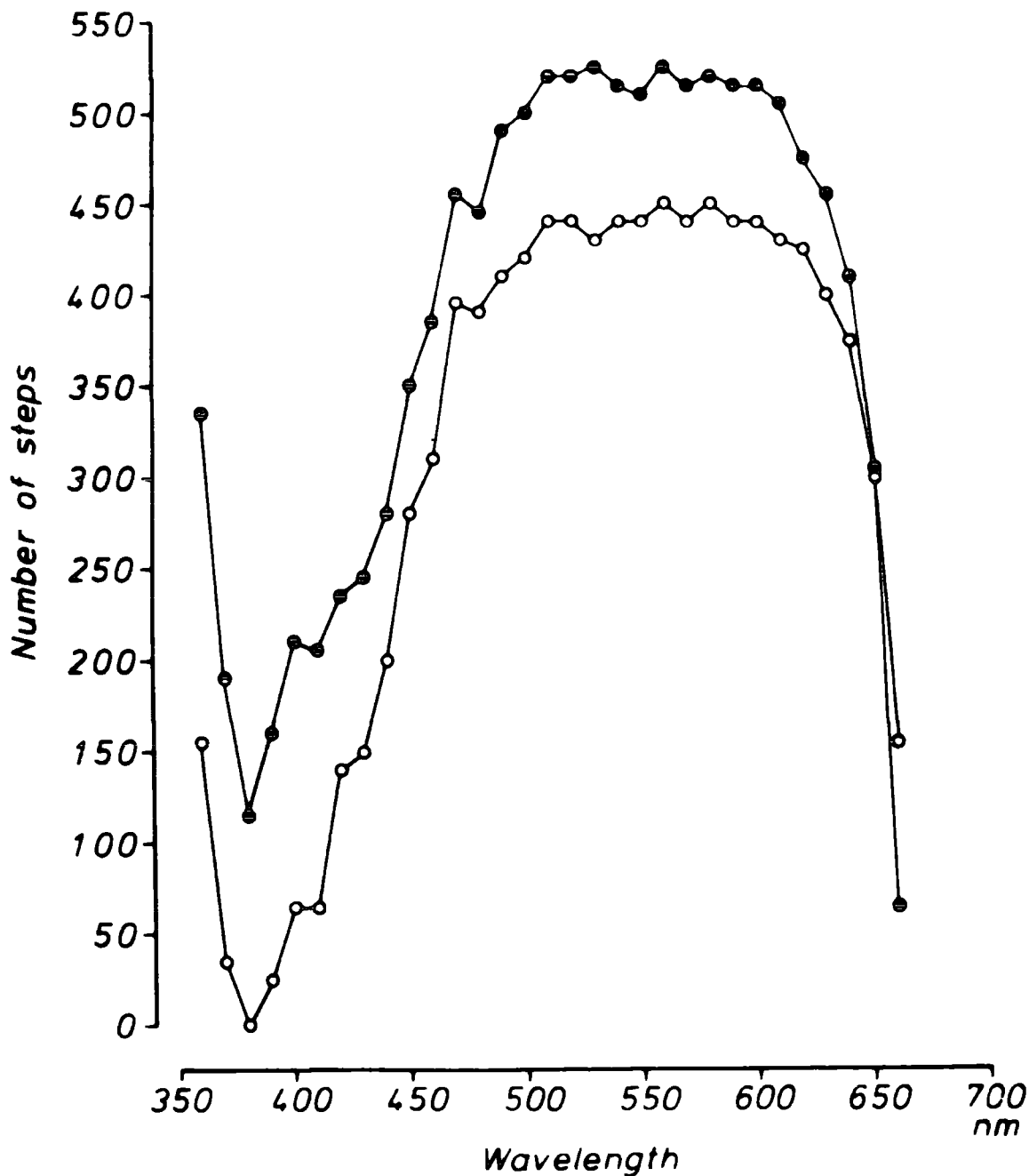

Fig. 3

Blind positions, measured at 10 nm intervals, which gave a spectrum of equal subjective luminance for a pigeon on both response keys.

The ordinate shows the number of steps by which each blind has been moved away from its initial 'zero' position, at which stimulus attenuation was minimal.

- — ● = settings for blind 1 (BL₁), attenuating stimuli on key 1 (RK₁)
- — ○ = settings for blind 2 (BL₂), attenuating stimuli on key 2 (RK₂)

other wavelengths, blind settings were found which would give a spectrum of equal subjective brightness, using the energy values which had been calculated for key 2 stimuli. By this procedure, stimuli of the same wavelength should also be of equal brightness on the two keys. Once more, wavelengths and appropriate blind settings were recorded on the computer.

Subsequently, a comparison between the two keys was made by the experimenter when both stimuli were of the same wavelengths, at 10 nm intervals. Blind settings for each wavelength were taken from the above calibration procedure but, instead of matching in brightness, at some wavelengths there were slight discrepancies in the brightness of the two stimuli. At these wavelengths, fine adjustments were made to the blind positions until the brightness of a particular wavelength on the two keys appeared equal to the experimenter. Where discrepancies had occurred the brightness difference between stimuli was ≤ 0.2 log units

After these adjustments, a graph was drawn of the blind settings at the wavelengths calibrated for each key (Fig. 3). Using this graph, values were interpolated to give blind settings at 1 nm intervals between 360 and 660 nm. These values were stored on the computer so that, during the discrimination experiment, for every wavelength on each key, a corresponding blind position could be set up which would equate the brightness of different spectral stimuli to the pigeon's eye. As an

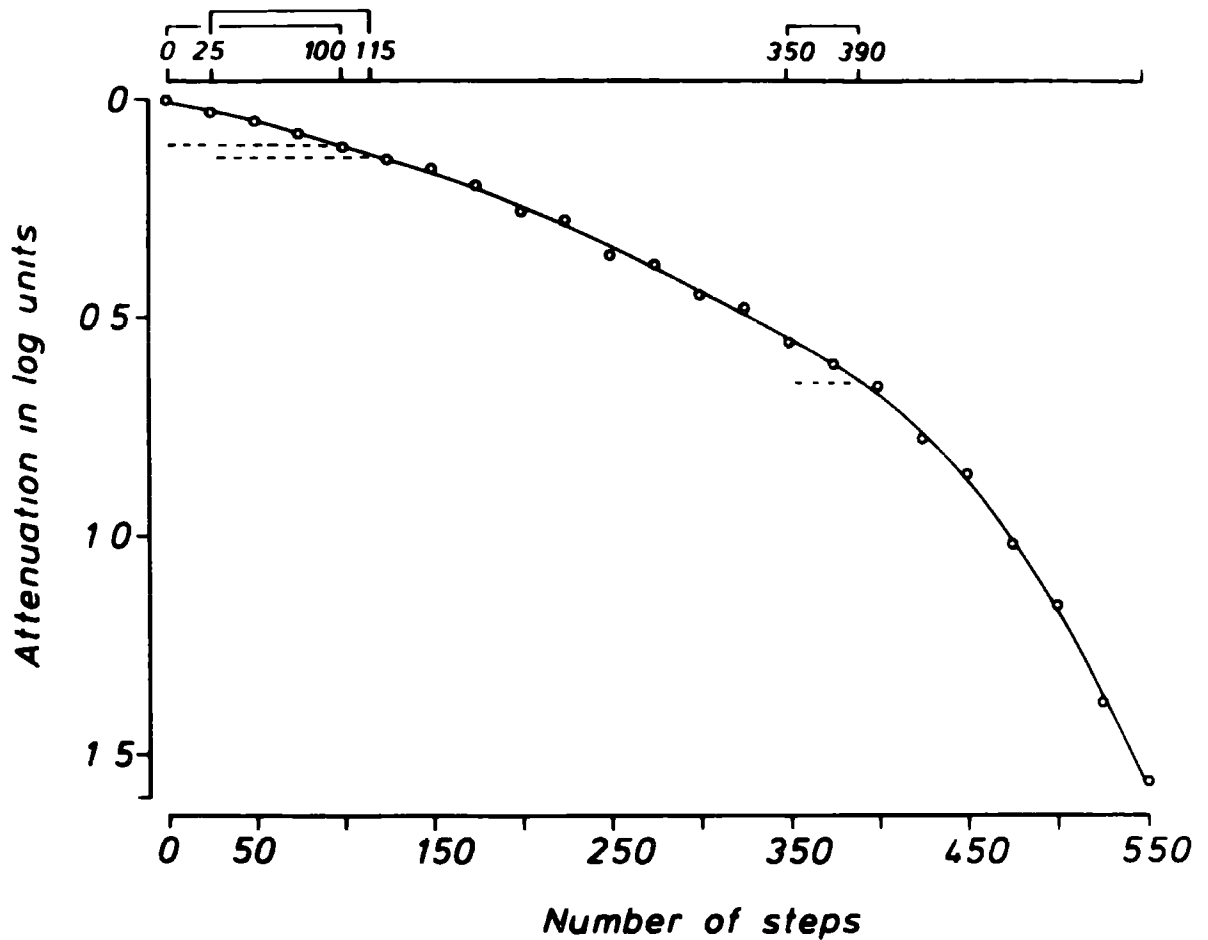

Fig. 4

Attenuation function of blind, measured in terms of log unit attenuation of stimulus energy per number of steps by which blind has been moved from its initial 'zero' position.

From this graph, the number of steps were calculated which would provide an attenuation increment of 0.1 log units for any blind setting. For example, where the attenuation function is of low slope, increment values were calculated for every 25 steps of blind movement. Thus at the zero blind position, additional attenuation of 0.1 log units is given by moving the blind by 100 steps. At 25 steps, an additional movement of 90 steps will increment attenuation by the same amount. As the function's slope becomes steeper, after 350 steps, 0.1 log unit increments were calculated at 10-step intervals. The same step increment values were assigned to all intervening blind positions within the 25- or 10-step intervals.

= 0.1 log unit increase in attenuation

----- = number of steps required to produce this increase, at a particular blind position.

indication of the luminance levels used, the luminance of a 580 nm stimulus, when attenuated by the blind, was 5.4 mL, as measured by an SEI photometer.

While these calibration procedures should have been adequate to provide spectral stimuli, all of the same pigeon luminance, a precaution was taken to ensure that brightness differences could not be used as a discrimination cue. During the experiment the attenuation of one stimulus (sometimes the positive and sometimes the negative stimulus) was increased by approximately 0.1 log units on random trials. Before calculating the blind values that would provide these attenuation increments, the attenuation function of the blinds was measured at a high energy wavelength (520 nm). The decrease, in log units, of the thermopile potential was measured as the blind was moved by intervals of 25 steps from the zero position.

From the plot of log attenuation versus number of steps the blind had moved, additional attenuation values of 0.1 log units could be worked out for various blind positions (Fig. 4). Where the attenuation function was of low slope (between 0 and 350 steps), the number of additional step movements necessary to provide equal increments of attenuation were calculated at intervals of 25 steps. For example, when the blind was set in its initial zero position, it had to be moved by 100 steps in order to increase the stimulus attenuation by 0.1 log units, at a blind setting of 25 steps, a further 90 steps would increase the attenuation by this amount. Since the changes in the incremental step values at successive interval points were small, the same step

increment was assigned to all blind settings within the 25 step interval.

For blind settings greater than 350 steps, where the attenuation function had a steeper slope, similar calculations for incremental attenuation values were performed at 10-step intervals. For example, for all blind settings between 350 and 359 steps, an additional movement of the blind by 40 steps would increase attenuation by 0.1 log units.

To check the accuracy of these calculations, stimuli were subsequently set up on both keys which were of the same wavelength and were both attenuated by an additional 0.1 log units to the attenuation values which had previously been found to give a good brightness match. The brightness matches at each wavelength still appeared to be satisfactory to the experimenter.

From the various calibration procedures, data were obtained and stored on the computer so that during the experiment both the wavelength and attenuation of the stimulus presented on each response key could be finely controlled. For each wavelength value there was an associated blind setting, calculated to equate the brightness of all stimuli for the pigeon eye. In addition, for each blind setting, values were available which allowed an equal attenuation increment to be applied randomly to either stimulus.

Procedure

Sequence of events in Skinner box

The computer-controlled sequence of events, during a training or testing session, is summarised in Fig. 5

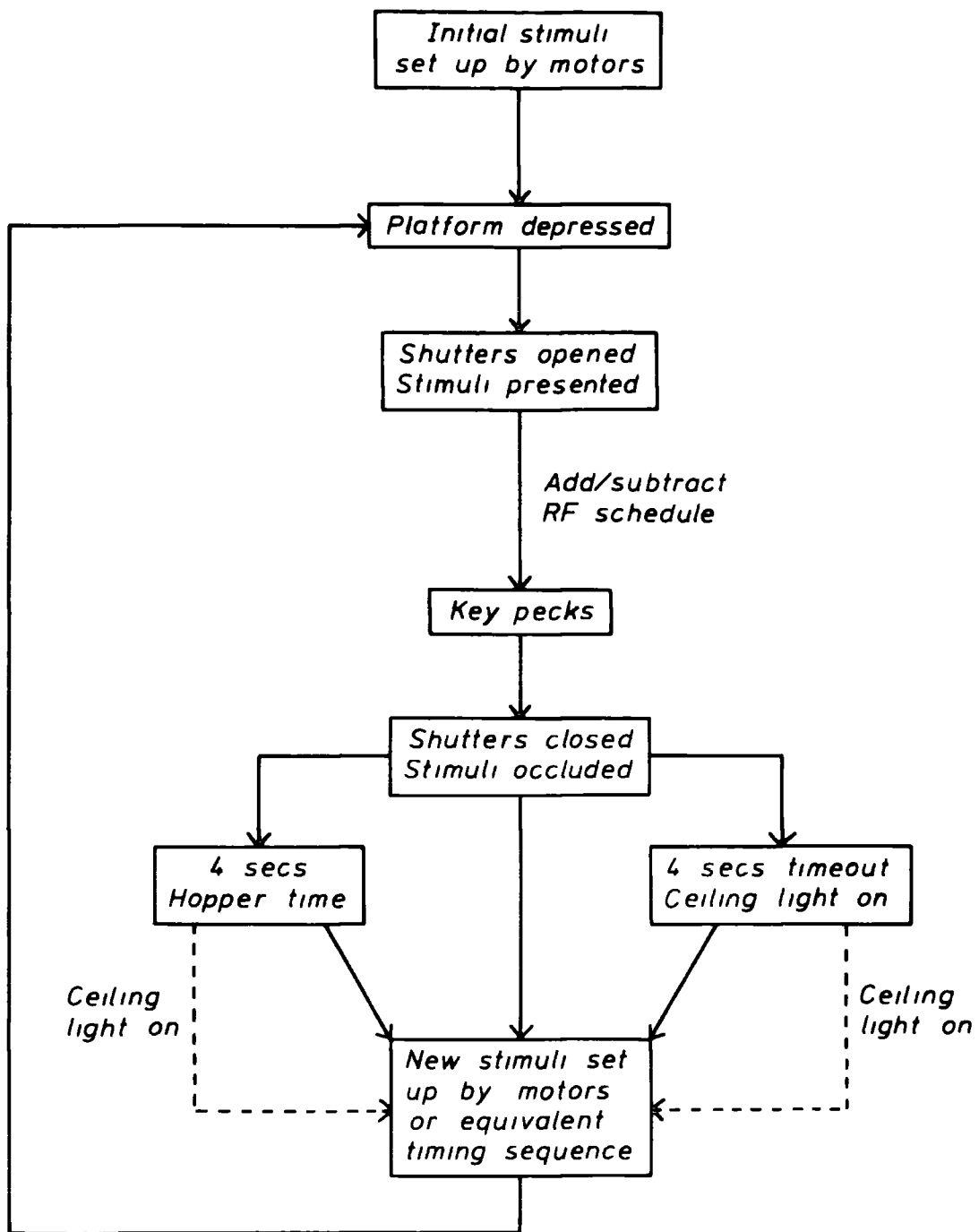

Sequence of events in Skinner box

Fig. 5

At the beginning of each session the monochromators were set up to the initial positions of the predetermined positive and negative wavelengths and the blinds were rotated to give attenuation appropriate to these wavelengths. Once the stimulus positions had been reached and the bird had depressed the floor platform, operating a concealed microswitch, the shutters opened and the stimuli appeared on the response keys.

As in the earlier discrimination experiments, pecking behaviour was reinforced on an 'add/subtract' schedule, in which reinforcement was given following 5 consecutive pecks to one key. If the bird changed its pecking from one key to the other before a run of 5 pecks had been completed, the first responses had to be cancelled by making the same number of pecks to the second key in addition to 5 more consecutive pecks. Also, if a total of 10 pecks had been made to either key, the add/subtract schedule was overridden and positive and negative reinforcement followed the 10th peck.

After a run of responses was completed, the shutters closed to occlude the stimuli and a reinforcement period started. Choice of the positive stimulus was followed by 4 secs access to food and incorrect responding by 4 secs illumination of the ceiling light.

Presentation of positive and negative stimuli on right or left keys was semi-randomly alternated using a Gellermann sequence. Immediately the reinforcement period began, new stimulus positions

were set up by operation of the stepper motors (if the positions of positive and negative stimuli were interchanged, if the negative wavelength was altered, or if the attenuation of one of the stimuli was incremented by 0.1 log units on the subsequent trial). If, instead, the stimulus values and positions were to remain the same on the next trial, a timing sequence started concurrently with the beginning of the reinforcement period. This allowed for a time period which was approximately equal in duration to the time required for the motors to set up new stimuli. (This mostly consisted of the time taken to drive the monochromators). Since the motors operated at a constant speed, this time depended on the wavelength difference between positive and negative stimuli. Thus the bird could have no cues from differences in the duration of inter-trial intervals as to which side the positive or negative stimulus would appear on the next trial.

If the wavelength difference was small, the new stimulus positions would be reached (or the timing sequence completed) within the 4 secs reinforcement period. However, if the wavelength difference was large and more than 4 secs were needed in which to change the stimuli, the ceiling light came on (or remained on) after the 4 secs allowed for the reinforcement period had elapsed.

When the new stimulus positions had been set up (or the equivalent time period completed) and the bird had depressed the floor platform, the next trial was commenced by re-opening the shutters to reveal the stimuli on the keys.

Data recording

Experimental data were recorded on-line on a computer printout. Following each trial a record was made of the positive and negative wavelength values and whether positive or negative reinforcement had been given, as well as other information monitoring stimulus presentation, e. g. side on which the positive stimulus appeared (right or left key), addition of attenuation increment to one stimulus. After every tenth trial, the number of correct choices made on the previous 10 trials was presented.

At the end of each session a summary table of results was printed out giving the wavelength values and number of correct choices for each block of 10 trials.

Training and test sessions

A total of 29 experiments were completed on the 4 subjects. (An experiment here means the complete procedure which yielded threshold data for one particular positive wavelength, tested on an individual subject.) About two thirds of the threshold results were collected from 2 birds. One other animal virtually ceased responding after 5 experiments, in spite of being adequately food deprived, while the fourth bird became overweight several times. When in a presumably less motivated state, this animal's response latencies became very lengthy and its response pattern was highly erratic. If this happened, test sessions were terminated before completion and the animal was deprived for a few days, but it then took longer to collect results.

Thresholds were tested at wavelengths throughout the spectrum, between 360 and 660 nm, with the negative wavelength being sometimes longer and sometimes shorter than the positive wavelength, as in the first wavelength discrimination study. In that investigation, presentation order of the threshold tests had appeared unimportant and since the subjects were by this time well practised in colour discrimination tasks, the order of presentation in this study was designed, as far as possible, to reduce problems of reversal learning.

To measure wavelength discrimination thresholds, two types of experimental session were used -

1) Each new experiment started with a training session. In this type of session, consisting of 50 trials, the positive and negative wavelength values, differing by 50 - 80 nm, remained constant. One session lasted for about 20 mins. Training sessions were repeated until a learning criterion had been reached of at least 9 choices being correct in each of the last 2 blocks of 10 trials, although usually this criterion was achieved within the initial training session.

2) Training sessions were followed by 'titration' sessions of 150 trials, taking 45 mins to 1 hr to complete. During this type of session the positive wavelength was the same throughout but the negative wavelength could change after each block of 10 trials, depending on the discrimination score for the previous block. Within a block of 10 trials both positive and negative wavelength values remained constant. Thus in a titration session it was expected that the wavelength

difference would fluctuate about the difference threshold point and the direction of this change would be controlled by the bird's response pattern. Therefore if the block score was ≥ 8 , the negative wavelength for the succeeding 10 trials was altered so that the wavelength difference on these 10 trials was decreased by one fifth (to the nearest integer value) of the wavelength difference on the preceding trials. If the discrimination score had been 7, the wavelength of the negative stimulus remained the same on the next trials. If, however, the block score was ≤ 6 , the wavelength difference on the following trials was increased by one fifth of the previous wavelength difference.

In each experiment, a series of titration sessions were used, in the first of which the positive and negative wavelengths were initially set to be the same as those employed in the training session. Generally, on the first few blocks of trials when there were large wavelength differences between the two stimuli, scores of 9 or 10 correct choices per block of 10 trials were obtained before the threshold level of responding was approached. If such a 'plateau' of high scores occurred, where discrimination was apparently easy for many of the trials at the beginning of this session, then the negative wavelength at the start of the second titration session was altered so that the threshold level was reached more quickly. The initial wavelengths used in the third titration session were similarly determined. If, on the other hand, during the first titration session the initial block scores were low, in

spite of the learning criterion having been reached on the prior training session, then the results of this session were ignored and the bird was either given another training session or the titration session was repeated

RESULTS

The raw scores used in the analysis of results were the numbers of correct choices per block of 10 trials for a particular wavelength difference value.

Analysis of data

^a
On/titration session, discrimination scores of 9 or 10 were initially obtained before further changes in the wavelength difference between 2 stimuli produced scores of 8, 7, 6, etc, above and below the threshold level. In the data analysis, results within this 'plateau', where scores of 9 or 10 showed that discrimination continued to be easy, were ignored. Only the last score of this plateau series of blocks of trials plus the scores on subsequent blocks were considered.

These results could be plotted on a graph of block scores versus wavelength difference, for each positive wavelength value tested. A least squares line was then fitted to these data (Spiegel, 1972). By interpolation the wavelength difference threshold was calculated for a block score of 7, i.e. the point at which discrimination was 70% correct, which was the threshold level used in the first wavelength discrimination study. This threshold, or value on the X axis when the Y axis value is 7, is most easily and accurately calculated using the formula

$$\text{Threshold} = \frac{7 - \text{intercept}}{\text{slope}}$$

Table 1
Raw scores from one complete titration session for
bird S3 tested at 360 nm

Block of 10 trials	Positive Wavelength	Negative Wavelength	Wavelength Difference	Discrimination Score
1	360	430	70	8
2	360	415	55	10
3	360	403	43	10
4	360	394	34	10
5	360	387	27	10
6	360	381	21	10
7	360	376	16	9
8	360	372	12	8
9	360	369	9	7
10	360	369	9	8
11	360	367	7	6
12	360	369	9	8
13	360	367	7	7
14	360	367	7	7
15	360	367	7	6

The first graph in Fig. 6 was plotted from the data enclosed by dashed lines, the 'plateau' of high scores in the initial blocks were not used for the threshold evaluation.

Fig. 6 (facing)

Results of third titration session at all wavelengths tested for S3.

During a session, the positive wavelength, given beside each graph, stayed the same but the negative wavelength could change, depending on the discrimination score of the number of correct choices made in the preceding block of 10 trials. Within each block of 10 trials the difference between positive and negative wavelengths remained constant. Each graph displays, for every block of 10 trials that were analysed, the score for the corresponding wavelength difference on that block. Data were fitted by a least squares line and a threshold was calculated by interpolation when the discrimination score was 7. The threshold values obtained from these graphs are shown below the abscissae.

More than 2 coincident data points are shown by closed circles.

Data from which the 360 nm graph was plotted are given in Table I

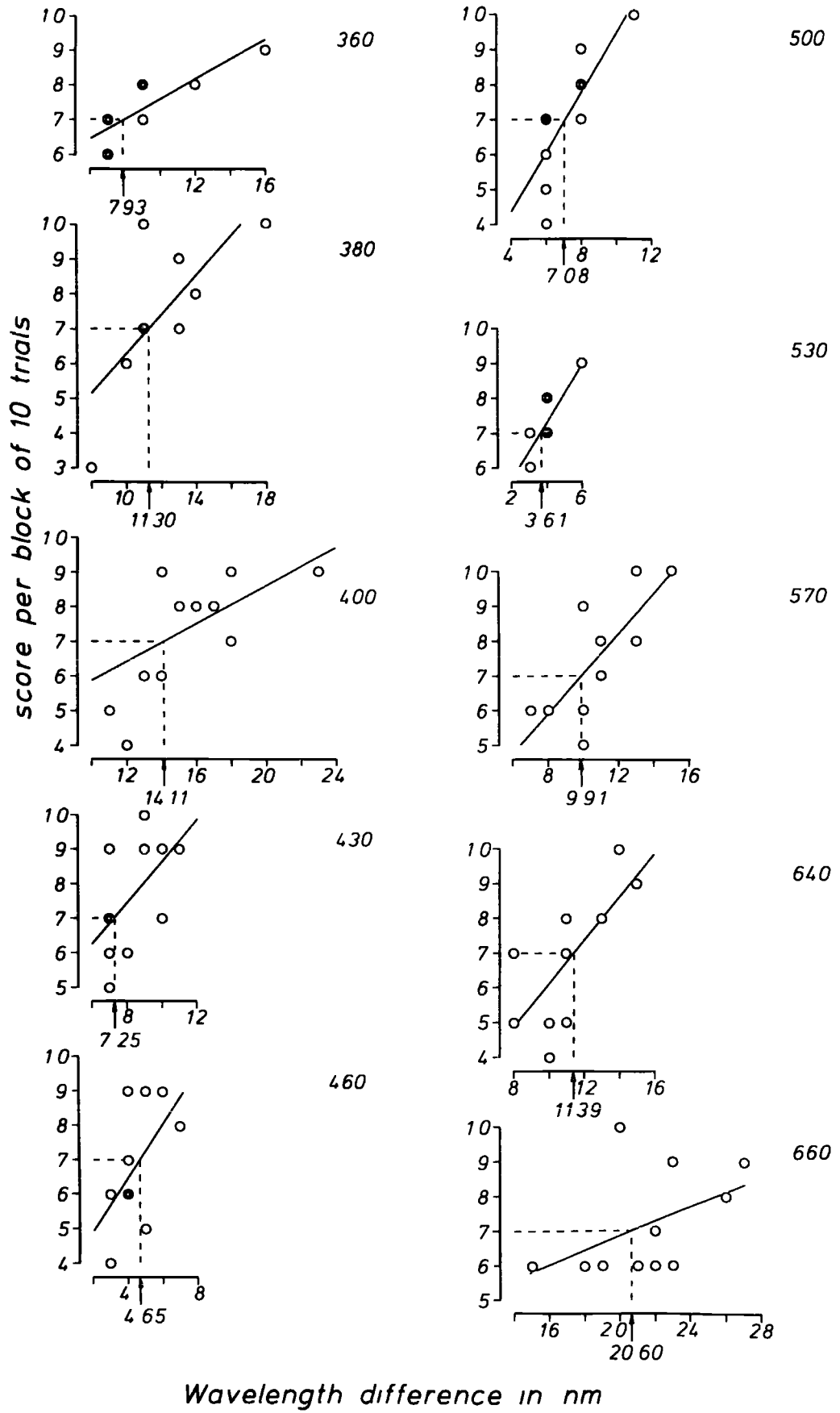

Fig. 6

where intercept is the value of Y when X = 0. Values for both this intercept value and the slope of the graph were obtained in computing the line of best fit. Data from each of the titration sessions were analysed in the same way. Examples of the raw scores for one complete titration session are presented in Table I. The one threshold value at 360 nm, calculated from these scores, together with thresholds computed for other spectral positions, were obtained from graphs as shown in Fig. 6.

Calculation of mean thresholds

When the results of repeated titration tests at a particular wavelength were examined, in the majority of cases there was an overall decrease in threshold values over successive sessions. This decrease was most marked (about 2 - 12 nm) between the thresholds of the first and second sessions. In computing the thresholds for individual subjects, the results of the first titration sessions were therefore not used but an average was taken of the thresholds calculated from the second and third sessions.

Further mean thresholds were then taken by pooling the results of individuals tested at a particular positive wavelength and under the same stimulus conditions, i. e. positive wavelength greater than or less than negative wavelength. As in the prior wavelength discrimination study, a wavelength discrimination function (Fig. 7) was constructed by plotting each of these mean thresholds at a point (λ) given by the formula

$$\lambda = S_{+\lambda} \pm \frac{\Delta\lambda}{2}$$

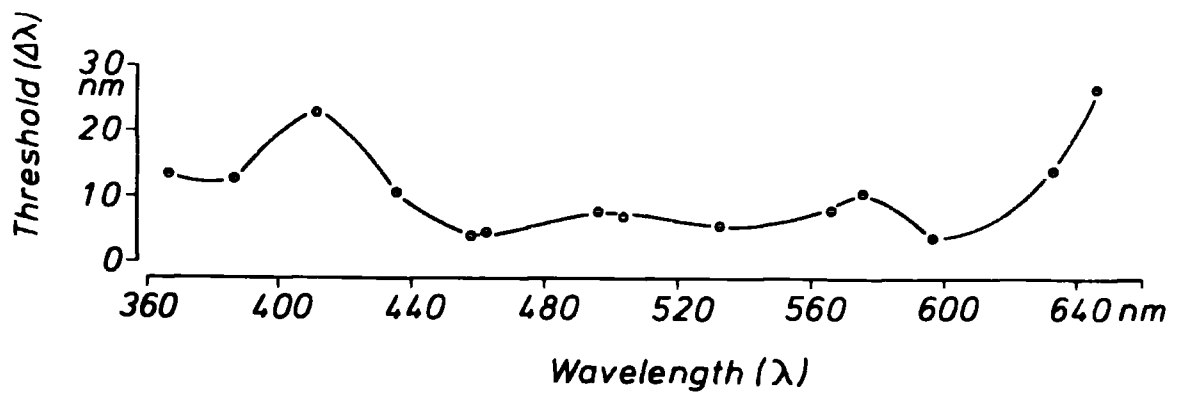

Fig. 7

Mean wavelength discrimination function.

Each mean discrimination threshold (calculated as explained in text) was plotted at an abscissal wavelength (λ) given by

$$\lambda = S_{t_{\lambda}} \pm \frac{\bar{\Delta\lambda}}{2}$$

where $S_{t_{\lambda}}$ = positive wavelength

$\bar{\Delta\lambda}$ = mean discrimination threshold

Table II
Co-ordinates for mean wavelength discrimination function

S^+_{λ}	$S^+ > S^-$		$S^+ < S^-$	
	λ	$\bar{\Delta\lambda}$	λ	$\bar{\Delta\lambda}$
360			366.70	13.40
380			386.29	12.57
400			411.43	22.86
430			435.28	10.56
460	457.97	4.07	462.25	4.50
500	496.12	7.76	503.50	6.99
530			532.80	5.60
570	566.01	7.97	575.23	10.47
595			596.87	3.74
640	633.02	13.96		
660	646.66	26.69		

S^+_{λ} = wavelength of positive stimulus

$S^+ > S^-$ = wavelength of positive stimulus greater than that of negative stimulus

$S^+ < S^-$ = wavelength of positive stimulus less than that of negative stimulus

λ = abscissal wavelength value in nm given by formula:-

$$\lambda = S^+_{\lambda} \pm \frac{\bar{\Delta\lambda}}{2}$$

$\bar{\Delta\lambda}$ = mean difference threshold in nm

For calculation of $\bar{\Delta\lambda}$ see text

Preponderance of data for $S^+ < S^-$ condition was due to inability to obtain a full set of results from 2 birds, S9 and S10.

where $S_{+\lambda}$ is the positive wavelength and $\bar{\Delta\lambda}$ the mean of the pooled difference thresholds. This is similar to the way in which results on the former discrimination function were plotted at points midway between the values of positive and negative wavelengths at threshold. The data from which the wavelength discrimination function was plotted are given in Table II.

Post-threshold tests of UV discrimination

Several additional tests of discrimination behaviour by 2 birds were performed following titration sessions at positive wavelengths of 360 and 380 nm. To the experimenter, a 380 nm stimulus appeared as a very dim purplish light whereas a 360 nm stimulus looked like a faint greenish-white light. However, this stimulus, which was very slightly attenuated by interposing an ultraviolet blocking filter (Wratten 2B) in the light-path, was eliminated by a Wratten 18A filter, which blocks a wide band of 'visible' wavelengths. The appearance, to the human eye, of a 360 nm stimulus was therefore attributed to the unavoidable transmission of stray light by the monochromators. This stray light component would also be present, but masked, at all other stimulus wavelengths.

The post-threshold discrimination tests, of 20 trials each, at ultraviolet wavelengths were designed to test whether the pigeon's discrimination was based on the visibility of an ultraviolet stimulus (tests 1 and 2) or whether responding was controlled in some other way e.g. by extraneous cues provided by operation of the apparatus or by avoidance of the negative stimulus (tests 3 and 4). After titration sessions at 380 nm, which had been originally paired with a 440 nm

negative stimulus, the following 4 tests were carried out -

1) After correctly responding on the first one or two trials, using the wavelength pairs 380 and 440 nm, the negative 440 nm stimulus was occluded (by the experimenter placing a black card in the path of the randomly alternating incorrect stimulus). The 380 nm positive stimulus was detected correctly every time on the subsequent 18 or 19 trials

Since each animal responded correctly when only the positive stimulus was presented, it would appear that this ultraviolet wavelength was visible to the pigeon.

2) The second test examined discrimination between a 380 nm positive stimulus and an incorrect stimulus in which the 380 nm UV component had been blocked by a filter, leaving only stray light. The Gellermann sequence of stimulus alternation had previously been determined for a 20-trial run by the experimenter so that the filter could be inserted in the path of the incorrect stimulus before each trial.

Once more, when only the correct stimulus on each trial contained a UV component, each bird maintained discrimination, choosing the 380 nm stimulus on 100% of trials.

Use of a blocking filter with a 360 nm stimulus, which to the human eye contained no colour component, very slightly decreases the luminance of the stray light. However, such a luminance difference acting as a discrimination cue would be prevented by the random addition

of 0.1 log units blind attenuation on one key. Therefore supposing the UV component did not constitute a 'colour' to the bird, discrimination in this test could not have been due to brightness differences alone. Similarly it seems unlikely that discrimination between a 380-440 nm stimulus pair would have been made by the bird using a brightness cue and avoiding a bright negative stimulus in preference for a dim positive stimulus, comparable to the stray light stimulus.

3) In the above two tests it appeared that ultraviolet light constitutes a chromatic stimulus to which a pigeon is able to respond. It could be, though, that the animal's discrimination behaviour was based upon other non-visual cues arising from the experimental procedure. Therefore, for the third test, a 380 nm stimulus was presented on each of the response keys. When the 2 stimuli were identical then, as expected, discrimination broke down and the birds adopted a position preference instead. Discrimination at this and other wavelengths could not have been due at any time to artifacts of the experimental procedure.

4) On the last test, 'transfer' of discrimination was tested by pairing a 380 nm correct stimulus with a 590 nm incorrect stimulus. The pigeons had not previously encountered the latter wavelength during the present wavelength discrimination study. If the animals had been basing their discrimination, during the threshold testing procedure, on choice of the positive stimulus rather than on avoidance of a clear negative stimulus, then the introduction of this new wavelength

Table III
Results of post-threshold tests of UV discrimination
on two birds

Stimulus conditions	Discrimination score % of correct choices
1) 380 vs blank	100%, 100%
2) 380 vs stray light 360 vs stray light	100%, 100% 100%, 100%
3) 380 vs 380 360 vs 360	60%, 50% 60%, 45%
4) 380 vs 590	95%, 100%

should not have disrupted discrimination, the 'correct' pattern of responding should have been immediately transferred to the novel discrimination situation. This hypothesis was confirmed. For each animal, a correct choice was made without hesitation on the first transfer test trial and discrimination was maintained for the two birds at a level of 95% and 100% of correct choices respectively

Tests 2) and 3) were also carried out after completion of titration sessions for a 360 nm positive wavelength. With this UV wavelength instead of the 380 nm stimulus the results were once more as expected. When a 360 nm correct stimulus was paired with a 'stray light' negative stimulus, discrimination behaviour was maintained, whereas when two identical 360 nm stimuli were used discrimination broke down. The results of all these discrimination tests are summarised in Table III.

While the above tests demonstrate that discrimination was based upon the choice of ultraviolet stimuli, which were in some sense visible, rather than upon avoidance of some other chromatic stimulus, or upon non-visual cues, they do not exclude the possibility that discrimination was mediated by detection of fluorescence produced upon the ocular media by ultraviolet light. The response keys themselves did not fluoresce (This could be checked using a UV blocking filter which, by eliminating UV wavelengths, would also have removed any fluorescence.) But the apparatus, in which stimuli were displayed on two quite separate keys, was unsuitable for testing whether

discrimination was based on fluorescence of biological tissues. The results of Wright's (1972b) experiment, however, argues against such a possibility since, in his apparatus, stimuli were juxtaposed on a small bipartite field. With such a stimulus arrangement, in which both halves of the field would have been viewed simultaneously, if ultraviolet light had produced fluorescence of ocular structures, this fluorescence would have been diffused over the retina and could not serve as a discrimination cue.

From the results of the control tests listed above and from Wright's own experiment, it is concluded that ultraviolet light constitutes a genuine chromatic stimulus which a pigeon can readily discriminate from other stimuli of longer wavelength.

DISCUSSION

The wavelength discrimination function

The results of this set of experiments, together with those of the previous ERG study, indicate that the pigeon is not only sensitive to UV light but can also discriminate quite well between wavelengths within this spectral region. If wavelength discrimination had been tested to the limits of the bird's visible spectrum, however, steadily increasing threshold values would be expected, as are found at the long wavelength end of the spectrum (Fig. 7). Instead the discrimination function shows an increase followed by a decrease in the size of thresholds at the shortest wavelengths tested. Similarly, instead of

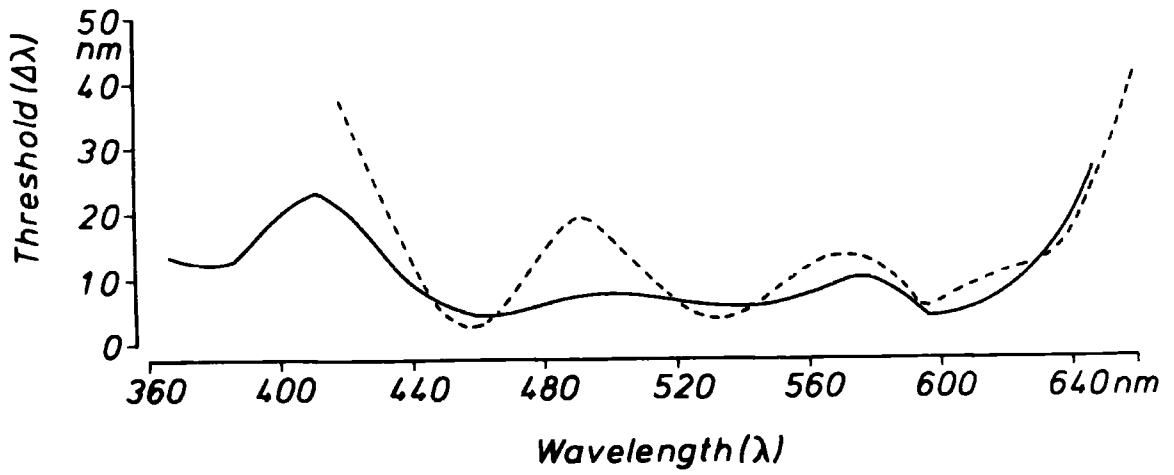

Fig. 8

Comparison between the present mean wavelength discrimination function and the mean function obtained from the prior wavelength discrimination experiment, described in ch. 2.

- = discrimination function from first study
- = discrimination function from second study

obtaining a decrease in sensitivity within the ultraviolet region, the sensitivity curve was still rising towards 360 nm (ch. 4, Fig. 9). Both these findings would suggest that the pigeon's visible range extends to shorter wavelengths than it has been possible to test here

It would also be interesting to have further information about discrimination below 360 nm to find out whether the lowered thresholds between about 365 and 385 nm in fact constitute a subsidiary minimum in the discrimination function. This might suggest that more than one mechanism participates in UV detection.

Comparing the present wavelength discrimination function with the one found in the original wavelength discrimination study, the occurrence of 3 minima at 460, 530 and 595 nm is confirmed (Fig. 8). The most noticeable change between the two functions is in the flattening of the curve at 500 nm. In the first case there was a clear peak in the discrimination function, with a maximum threshold of about 20 nm, whereas in the later results this peak is far less pronounced and the maximum threshold value is only about 8 nm. Over much of the rest of the spectrum there are not such marked discrepancies between threshold values at comparable points on the two functions. Because of this it seems unlikely that this discrepancy could be due to differences in the procedures used to obtain results

The overall agreement between the two functions also shows that omitting to suppress any UV wavelengths in the first experiment made very little difference to the major features of the discrimination function. But only the longer wavelengths, above about 600 nm, would have been contaminated by possibly visible second order components. If the apparent colour of these wavelengths had been altered by this contamination, this might explain the slight inflection seen at about 630 nm in the first wavelength discrimination function. But unfortunately there was insufficient data within this part of the spectrum to test this hypothesis in the second discrimination study.

In ch 2 the results of several studies related to wavelength discrimination were collated and it was noticed that some authors report that the region of best discrimination towards the 'blue' end of the spectrum is centred at 500 nm while in other cases the results indicate a threshold minimum at 460 nm instead. An attempt to correlate this difference with stimulus luminance levels used in the various experiments led to equivocal conclusions but any correlation that might have existed would have been confounded by the lack of standardisation in conditions of stimulus presentation and testing procedure. Since there was a close similarity in stimulus presentation for the two wavelength discrimination studies discussed here and also testing procedures were based upon the same principles, a re-consideration of the effect of stimulus luminance may be more worthwhile.

Stimulus luminance in the first experiment was about 16 mL at

Table IV
Thresholds calculated from each titration session in
extended series of tests

Session Number	Threshold values in nm		
	S3 $S_{T\lambda} = 660 \text{ nm}$	S7 $S_{T\lambda} = 640 \text{ nm}$	S7 $S_{T\lambda} = 660 \text{ nm}$
1	33.06	25.39	32.55
2	25.35	18.57	36.18
3	20.60	12.61	24.61
4	20.49	14.28	16.27
5	17.62		
6	12.33		

Each threshold for S3 was calculated from graphs
displayed in Fig. 9

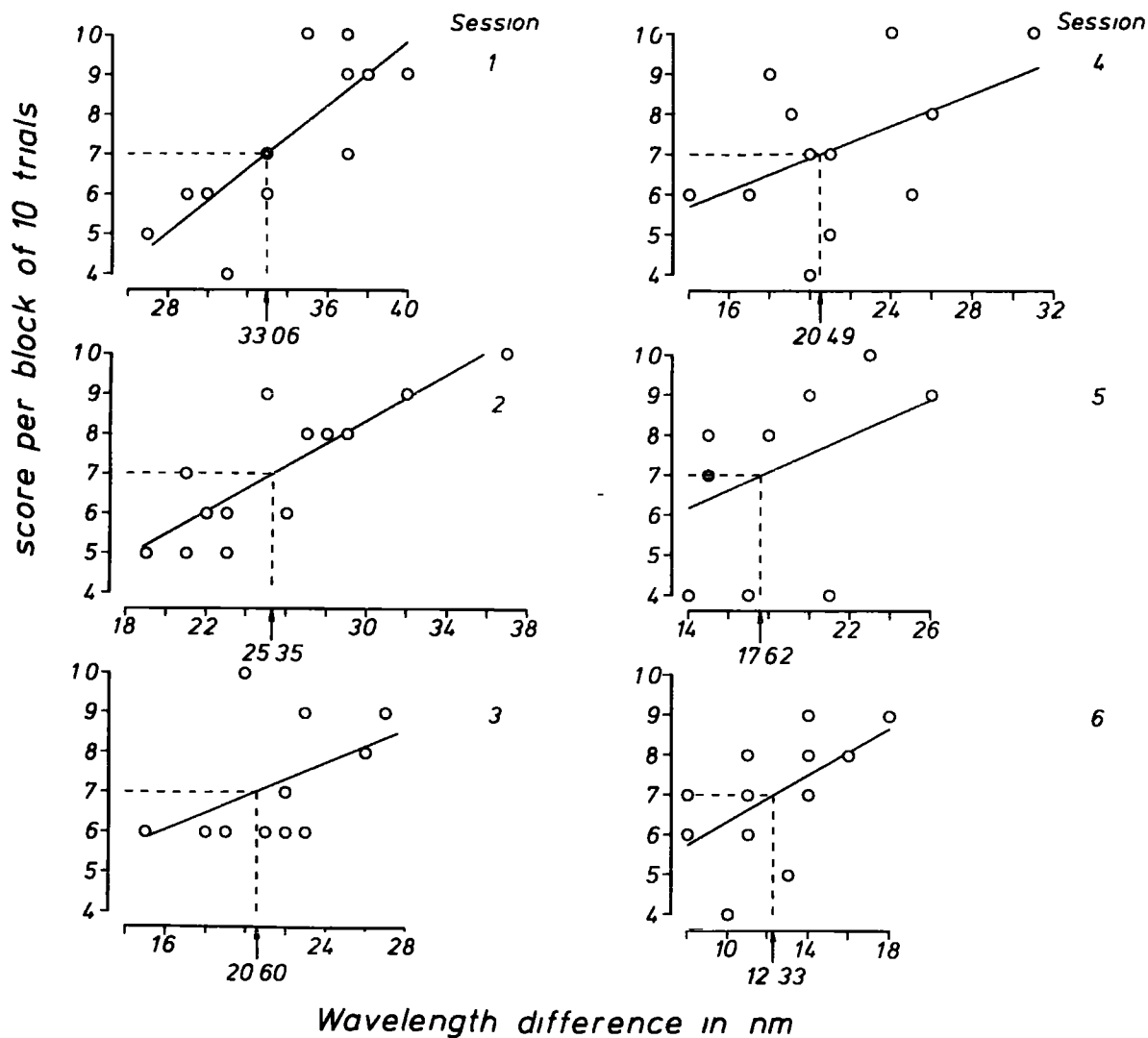

Fig. 9

Results of extended titration testing on S3 at a positive wavelength of 660 nm. There is a steady decrease in the threshold value calculated from sessions 1 to 6. There is also an overall decrease in the range of wavelengths within which the negative stimulus varies (indicated by the abscissal wavelength difference numbers). But the range of wavelengths does not vary consistently between successive sessions nor is there any progressive change in the slope of the graph, which might have indicated a more finely controlled discrimination performance.

560 - 580 nm while luminance at 580 nm in the second study was 5.4 mL. The flattening of the discrimination curve at 500 nm (Fig 8) may represent a situation midway in the progressive change-over from the occurrence of a 460 nm minimum to one at 500 nm, (see ch. 2, Fig 8). If this is the case then it must be concluded from this research that a decrease in luminance produces a shift in the minimum towards longer wavelengths. This would concur with Blough's (1972) report of a shift towards longer wavelengths in a 600 nm generalisation gradient as luminance was decreased. It is not clear though what underlying mechanisms in the avian visual system might mediate such shifts.

Methodological considerations

It has already been mentioned that there was often an overall decrease in the threshold values calculated from successive titration sessions at a particular wavelength. In three cases an extended number of titration tests were given and the thresholds calculated from each of these sessions are set out in Table IV. These results indicate that the difference threshold is still decreasing even after 6 sessions. There is, however, no consistent change in the slope of graphs from which thresholds were calculated (Fig 9), which might have been expected if responding came to be more precisely controlled by fine differences in the stimulus wavelengths. Instead improvement in discrimination performance may be partially reflected

by the range of wavelength difference within which the stimulus settings were made to vary. Looking at the sample results overall, this range became more limited when titration sessions were repeated but again the variation in the range of wavelength differences was not a progressive and consistent change. In order to get a better estimate of the absolute threshold levels that could be obtained with this stimulus arrangement and testing procedure it would have been preferable to continue with test sessions until the threshold values had stabilised. This was not possible though in the time available. But by always considering results of corresponding titration sessions (mean results of the second and third sessions at each wavelength), information about relative discrimination performance across the spectrum is still gained and thus the results may be compared with those from other experiments.

Functional significance of ultraviolet detection

While the pigeon's discrimination abilities within the ultraviolet might tell us a little more about the physiological mechanisms underlying this animal's colour vision it is also worth considering whether ultraviolet sensitivity is merely an outcome, serving no specific purpose, of a visual system in which there is no pre-retinal filtering of the longer UV wavelengths or if the bird can actually make some use of its abilities. In a wide variety of animals, including man, transmission of a range of UV wavelengths is blocked by the yellow pigmented lens or cornea (Muntz, 1972). The human eye, at least, is still sensitive to UV if the lens has been removed (Tan, 1971). The clear optic media of the pigeon, on the other hand, transmit UV wavelengths down to 320 nm (Walls and

Judd, 1933), although these wavelengths may then be absorbed by the oil-droplets contained in the majority of its cone cells. Presumably the cells able to detect UV are those without droplets, such as the rods or the accessory elements of the double cone pairs (Cohen, 1963, but note there has been some contention about whether this type of cell contains an oil-droplet in other avian species Meyer et al, 1965).

In another avian species, the humming-bird, which can detect UV light (Huth and Burkardt, 1972), it has been suggested that the sensitivity of this bird's eye is an adaptation which enables it to search for flowers. Furthermore, this animal would be able to orientate itself to a nectar source, using 'honey-guides', distinctive patterns revealed when some flower petals are illuminated with UV light. This ability has already been demonstrated in bees, which are also UV sensitive (Daumer, 1958).

From what is known about its normal behaviour it seems unlikely that a pigeon would use its UV discrimination abilities in such a way to differentiate amongst terrestrial cues in its immediate surroundings. The most obvious source of ultraviolet to which a pigeon could respond in its natural environment would be the UV component of skylight, produced by molecular scattering of sunlight in the atmosphere. By such scattering processes light in the sky also becomes polarized. As wavelength decreases, the light becomes more strongly scattered and thus more strongly polarized, with maximal polarization of UV wavelengths (Sears and Zemansky, 1964) The intensity of the sky's polarization pattern will then be greatest for these shorter wavelengths.

Since pigeons can both detect and orientate themselves by the axis direction of linearly polarized light (Delius et al, in press, Kreithen and Keeton, 1972), it would also be advantageous to be able to see wavelengths at which the polarization pattern is at its most intense. Response to polarized light is linked to stimulus colour in a complex way (Delius et al, in press) and is clearly not specific to UV wavelengths. It is therefore envisaged that the mechanisms responsible for the sensitivity to UV wavelengths will enhance the pigeon's ability to detect polarization patterns, while other colour mechanisms, by responding to a lesser extent to partially polarized sunlight of other wavelengths, may supplement this detection ability.

It is argued then that, in terms of its functional significance, the pigeon's sensitivity to UV wavelengths is advantageous not so much as an additional colour discrimination mechanism but as a means of extending its visual spectrum in order to detect and respond to polarized light, a cue frequently encountered in its natural environment.

CHAPTER 6

OVERVIEW AND CONCLUSIONSSimilarities between wavelength and saturation discrimination functions

Since psychophysical results on colour vision are all dependent on the functioning of the same population of visual mechanisms, some interrelationship between the psychophysical functions would be expected. In monkeys, for instance, the shapes of spectral sensitivity curves, wavelength discrimination and saturation discrimination functions can all be related to the functioning of known opponent cells (driven by chromatic stimuli) or non-opponent cells (responding especially to broadband achromatic stimuli) or a combination of both (De Valois and Jacobs, 1968). These central units are themselves subserved by the differentially sensitive retinal cones. A comparison of the results of the wavelength discrimination and saturation experiments performed on the pigeon would therefore be of particular interest in trying to elucidate the mechanisms that may underlie these functions.

The three functions obtained from the work described here are shown in Fig 1. As previously mentioned the two curves of wavelength discrimination thresholds have minima at 460, 530 and 595 nm, while the curve from the second experiment is more flattened than that from

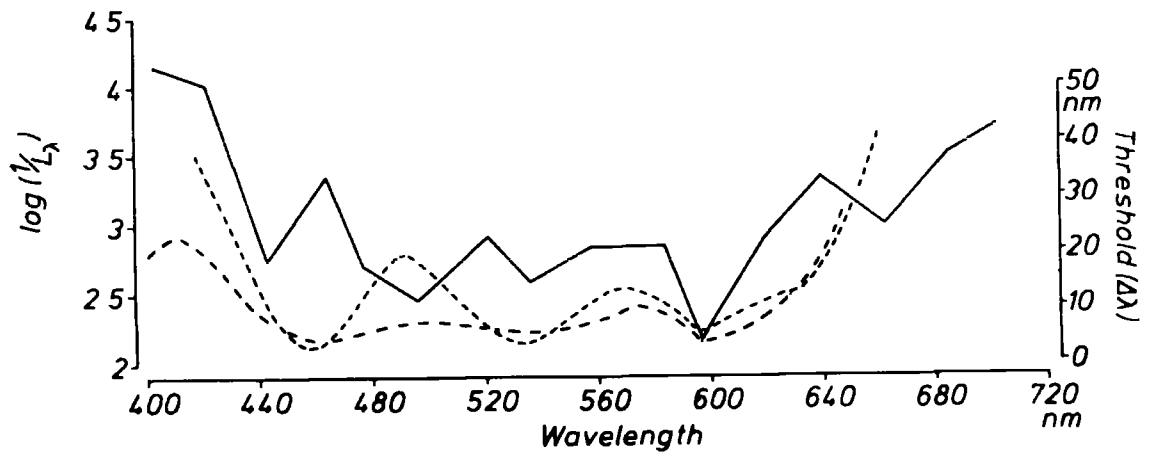

Fig. 1

Comparison of mean wavelength discrimination and saturation discrimination functions obtained from the behavioural experiments.

- = wavelength discrimination function from first experiment, described in ch. 2
- - - - - = wavelength discrimination function from last experiment, see ch. 5
- = saturation discrimination function from experiment described in ch. 3

Scale of wavelength discrimination thresholds is shown on the right and scale of saturation discrimination thresholds on the left-hand ordinate.

the first study in the region of 500 nm, a point at which some other authors have instead found a short wavelength minimum. The saturation discrimination function showed several minima, all of which were displayed in the results of individual subjects. Although saturation discrimination thresholds were only tested at 20 nm intervals so that the positions of peaks and troughs in the curve may not be very precise, these minima show an approximate agreement with the features of the wavelength discrimination function, particularly in the positions of minima at 597 and 536 nm. A subsidiary minimum also occurs in the saturation function at 662 nm which may be related to an inflection at about 630 nm in one of the wavelength discrimination curves. Since it was not possible to make detailed threshold measurements within this long wavelength region in the subsequent discrimination experiment, it is not certain whether this inflection was an artifact due to detection of unsuppressed UV components or was a real feature of the discrimination curve. That this may be the case though is suggested by the finding of a similar inflection in the wavelength discrimination function reported by Riggs et al (1972) and the occurrence of a minimum in the saturation discrimination function.

A greater discrepancy in results is seen at the shortest wavelengths. The 443 nm trough in the saturation function appears to be slightly displaced from the 460 nm minimum of the wavelength curve while a more pronounced saturation minimum occurs at 496 nm, corresponding to a point of good wavelength discrimination reported in other

investigations and to the region of greatest change between the wavelength discrimination thresholds of the two functions found here. Measurements of visual function at short wavelengths are both the most difficult to obtain and also the most variable (Graf and Norren, 1974, Hurvich and Jameson, 1955; Weale, 1951, Delius, 1968). The 'blue' system(s) seems to be particularly affected by stimulus conditions. In the saturation experiment, the superimposition of chromatic stimuli upon a diffuse white background would have produced a key stimulus whose overall luminance was high and may account for the more emphasised minimum at 496 nm. It is surprising, however, that in the wavelength discrimination experiment a possible changeover from a pronounced 460 nm minimum towards the occurrence of a 500 nm trough appears to depend on a decrease in stimulus luminance. At present it seems that a minimum may occur at either short wavelength position but the conditions controlling which minimum predominates are not yet clear.

Close correspondences in the positions of minima in wavelength and saturation discrimination functions are also found in other species. Opponent-process models have been formulated to quantitatively account for the forms of these functions. For instance, the wavelength discrimination functions from trichromatic humans and macaques show two minima at 480 - 490 nm and 570 - 590 nm (Graham, 1965, De Valois and Jacobs, 1968). De Valois found that these minima, denoting marked sensitivity to changes in wavelength, correspond closely with points of changing activity in two types of opponent cells

in the macaque, one type of cell receiving dual input from cones maximally sensitive to long- and short-wavelengths while the other type has inputs from the long- and middle-wavelength receptors. In humans, whose visual pigments are very similar to the macaque's (Marrks et al, 1964), chromatic vision also seems to operate along two-channel opponent-process lines and the two minima in the wavelength discrimination function are explicable in terms of the operation of these two channels (Jameson and Hurvich, 1955)

As in the wavelength discrimination function, the saturation discrimination functions of macaque and man show a pronounced minimum at 570 nm (Graham, 1965, De Valois and Jacobs, 1968). In the human function there is also a subsidiary minimum at 480 - 500 nm, which again is a region of good wavelength discrimination. These minima in the saturation functions can be matched by calculating the ratio of response of the opponent and non-opponent cells (or ratios of the chromatic and achromatic processes in the Jameson and Hurvich (1955) scheme). Minima are predicted at regions in which the non-opponent cell output is relatively high while the opponent cell activity is neutral. The latter will occur at wavelengths where the response pattern of opponent cells changes from excitation to inhibition or vice versa. A similar situation is found in the goldfish whose saturation minima can also be predicted by an opponent-process theory (Yager, 1967). Thus in all these subjects the positions of minima in both wavelength and saturation functions seem to be closely related to changes in response of underlying

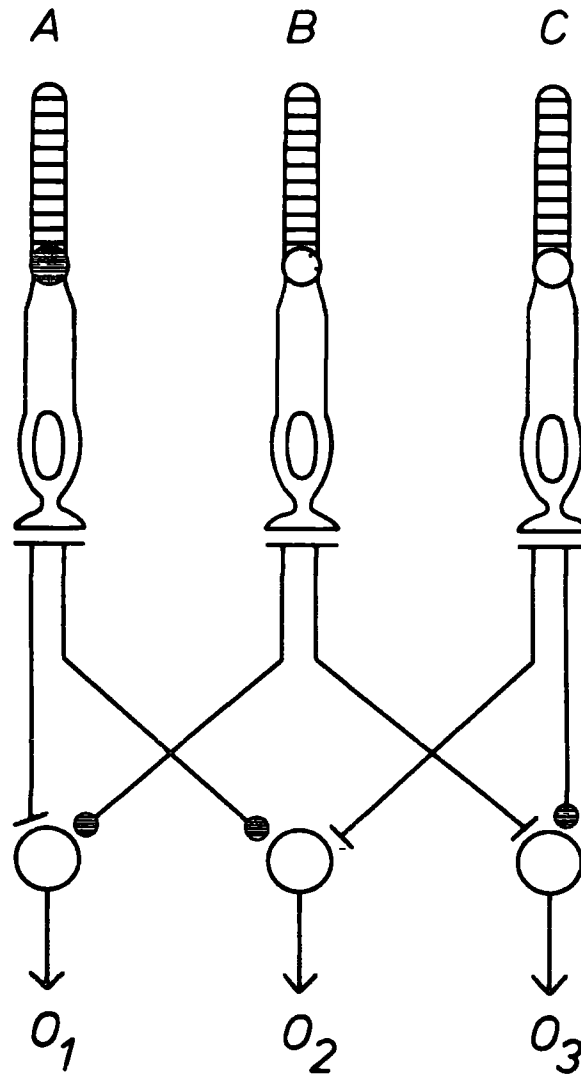

Fig. 2

Model by which neural connections amongst three differentially sensitive cones, A, B and C, could produce three classes of opponent-cells, which act as separate channels with different outputs, O_1 , O_2 and O_3 .

opponent channels

This opponent-process model may also be considered in relation to the psychophysical data from pigeons. If two types of opponent cell underlie the two minima of the trichromat's wavelength discrimination function, by analogy one would expect to find at least three opponent channels in the pigeon visual system. Logically, these three types of opponent cell could still be obtained if there were only three cones of differential spectral sensitivity in the retina, if neural connections of the type shown in Fig. 2 were postulated.

There is evidence of two types of opponent cell found in the pigeon nucleus rotundus (Yazulla and Granda, 1973), having crossover points at 520 and 500 nm. These cells may correlate with the minima found at about 530 nm in both wavelength and saturation discrimination functions and also with the minimum near 500 nm found in the saturation data and which has been recorded in other wavelength discrimination functions. In order to explain the wavelength discrimination minima near 600 nm and at 460 nm, one would predict that there are other classes of opponent cells with crossover points at these wavelengths. Here it is assumed that the 460 and 500 nm minima would be relatively independent since, in spite of the depression of the second wavelength discrimination function at 500 nm, there was no shift in the position of the 460 nm trough which might be expected if the two minima are based on the same mechanisms. However, at least four differentially sensitive cone types would be necessary to provide all these opponent channels.

There are several other reasons for arguing that the pigeon's visual system is at least tetrachromatic in its operation. The available evidence in pigeons of differentially sensitive colour systems peaking at about 600, 540 and 500 nm (Donner, 1953, Galifret, 1961, Granda and Yazulla, 1971, Ikeda, 1965) would not account for the results reported here. A fourth cone type, containing a 400 nm pigment, as described by Graf and Norren (1974), would be an additional minimum requirement. Furthermore, the results summarised in the saturation discrimination function suggests that, under some conditions, the avian visual system may operate in a way more complex than would be expected of a tetrachromatic system.

Besides assuming that all the minima in the psychophysical functions can be explained by this type of opponent cell model, other models could also provide the basis for some of the present data. Under some circumstances, psychophysical functions can be related to the independent responses of differentially sensitive cones rather than depending upon their interaction. In fish, for instance, the receptor systems underlying the photopic spectral sensitivity curve appear to operate independently (Muntz and Northmore, 1971). But to discriminate between simultaneously presented wavelengths, as in the wavelength discrimination studies, some sort of differencing mechanism, whether central or peripheral, is required to compare cone outputs to different wavelengths. In the saturation discrimination experiment, although the most convenient method was used for testing saturation differences across the spectrum, no direct comparison between

wavelengths was required. Instead each comparison was made between a monochromatic light and a broad-bandwidth achromatic light. The saturation function, but not the wavelength function, might therefore be fitted by the cone sensitivity curves themselves. Alternatively, a combination of the responses of opponent cells and independent chromatic channels could underlie the minima in the saturation function. Such a model, in which the red and green cones interact but the output of the blue cones remains independent, has been postulated by Sperling and Harwerth (1971) to account for the monkey's increment-threshold spectral sensitivity, tested under conditions of high light adaptation.

One complicating factor in the interpretation of psychophysical data is that the stimulus conditions (e.g. stimulus size, duration, background) very much influence the relative predominance in responsiveness of the underlying visual mechanisms (King-Smith, 1975). Thus, while general similarities between functions may be expected, opponent cell activity, for example, may only be a complete predictor of psychophysical results obtained under a limited set of stimulus conditions and other chromatic channels may be activated under different circumstances. These channels, corresponding to responses of separate cone populations, are perhaps found in the central mechanisms with differential peaks of activity reported by Granda and Yazulla (1971). Although these thalamic units respond unidirectionally with either excitation or inhibition, the relative sensitivity of their peaks is modified in a complex way by altering the stimulus luminance.

so it is not certain at present to what extent the peaks are representative of independent channels

De Valois' model, based on descriptions of the average activities of different groups of cells, is the most comprehensive model to date which can account for performance on several psychophysical tests, relating behavioural data to known physiological mechanisms. However, recent re-investigations by Padmos and Norren (1975) have shown that the input to opponent and non-opponent cells may be more complex than has been generally stated by De Valois. Also, experiments of the type performed by Spelling and Harwerth suggest that a more detailed model may be needed to construe some psychophysical results with greater precision

A model of colour vision similar to De Valois' may partially account for the present results, as it does for results from other species, and would explain the similarities found between saturation and wavelength discrimination functions. However, the details of a model applicable to birds will probably differ from one suitable to describe psychophysical data in monkeys and will depend on the number and sensitivities of cone mechanisms together with a knowledge of the mode and extent of their interactions. It is not possible to specify the number of cone types, nor how they interact, from the present discrimination functions alone. The available evidence about the pigeon's chromatic mechanisms, both at a retinal and central level, is incomplete so that more physiological

information is needed together with further psychophysical data, perhaps involving chromatic adaptation techniques to try and isolate colour channels. Then a more detailed correlation between physiological and psychophysical data could be made to test how far an opponent-process model would be appropriate for explaining the results from pigeons and also to elucidate whether the pigeon's colour vision is tetrachromatic or maybe more complex than that

Speculations upon the retinal mechanisms of colour vision in the pigeon

At present no coherent picture emerges concerning the relatively sparse physiological information about either retinal or central mechanisms of colour vision in the pigeon. However, by drawing together a number of disparate observations and considering parallels with another group of animals, turtles, which also have multi-coloured oil-droplets and for which the retinal situation is better known, speculations may be made about the cone mechanisms which might exist in the pigeon retina.

Firstly, the type of cones found in two species of turtle will be described. Microspectrophotometric measurements of single cells made by Liebman and Granda (1971) revealed that each species possessed three cone pigments. In Pseudemys scripta these pigments were identified as P450₂, P518₂ and P620₂ whereas the cones of Chelonia mydas contained pigments P440₁, P502₁ and P562₁. In addition to the three pigments, each retina is equipped with three types of oil-droplet, red, orange and colourless droplets in the case of Pseudemys and orange, yellow and colourless in Chelonia. However, some of these oil-droplets may combine with more than one of the cone

Table I
Summary of cone types found in two species of
turtles (after Liebman, 1972)

	Pigment λ max	Oil-drop colour	Effective λ max of cone sensitivity
Pseudemys	450	C	450
	518	—	518
	518	O	560
	620	O	620
	620	R	640
Chelonia	440	—	440
	502	—	502
	502	C	502
	502	Y	520
	562	C	562
	562	Y	562
	562	O	575

C = colourless oil-drops

Y = yellow

O = orange

R = red

pigments (Liebman, 1972) In both species the rod pigment, 518 or 502, occurs in the accessory cones, too, which contain no oil-droplets. This pigment is also found in some of the single cones where, in Pseudemys, it is filtered by an orange droplet and, in Chelonia, it is combined with either colourless or yellow droplets. The pigment with λ_{\max} at shortest wavelengths is either unfiltered or is combined with a colourless oil-droplet. The longest wavelength pigment is found in conjunction with orange and red droplets in Pseudemys and with all types of droplets, but mostly orange and yellow ones, in Chelonia. Where the cut-off of a particular oil-droplet is found at shorter wavelengths than the λ_{\max} of the pigment with which it is combined, the peak sensitivity of that cone is unaltered. However some oil-droplets, which cut-off at longer wavelengths relative to the peak absorption of the underlying pigments, shift the effective peak sensitivity of the cones to a longer wavelength. As described by Liebman, and summarised in Table I, due to the filtering effects of these oil-droplets, cones, in each species, have peak sensitivities at 5 spectral regions rather than the 3 regions at which the absorption of the pigments themselves is maximal.

The retinae of turtles closely resemble those of birds, not only in possessing a number of coloured oil-droplets but also in the morphology of the receptor cells. Thus in both groups of animals rods and cones are found and, furthermore, there are single cones as well as double cones, consisting of paired principal and accessory elements (Cohen 1963, Walls, 1942) Because of such close structural resemblances,

it seems highly likely that there are also similarities in the functional properties of the cone mechanisms of colour vision in the two groups of animals

There is now mounting evidence that the 'single pigment theory' is inadequate to account for the more recent findings about the pigeon's colour vision. In particular, in addition to a cone pigment found by extraction techniques (Bridges, 1962, Wald, 1958), a short wavelength pigment has been demonstrated (Graf and Norren, 1974) which better explains the pigeon's fairly good sensitivity to and discrimination of short wavelengths. In another avian species, a short wavelength pigment with λ_{\max} at 415 nm has also been inferred by Wessels (1974) to explain the peak obtained near this wavelength in the jackdaw's spectral sensitivity curve. The occurrence of a short wavelength sensitive system, with peak sensitivity at 400-420 nm, has just been confirmed electroretinographically in the jackdaw as well as in the pigeon and chicken by Norren (1975)

Neural colour-responsive mechanisms have been consistently reported to have sensitivity peaks at about 540 and 600 - 605 nm (Donner, 1953, Galifret, 1961, Granda and Yazulla, 1971, Ikeda, 1965) Bridges' 544 pigment is more likely than Wald's iodopsin, with λ_{\max} at 562 nm, to underlie the 540 nm peak since none of the pigeon's oil-droplets (King-Smith, 1969) have transmission cut-offs which could shift the effective peak sensitivity of an iodopsin-bearing cone to shorter wavelengths. While there is no independent evidence of a longer wavelength pigment at the moment, the repeated finding of

processes with peak sensitivities at 600 nm or longer is suggestive that a pigment with maximum sensitivity at about that wavelength might exist, especially as the transmission spectrum of the pigeon's red oil-droplets would drastically reduce the sensitivity of a cone containing a pigment with a much shorter λ_{\max}

Of particular interest was the occurrence in turtles of a rhodopsin pigment, usually associated with rods, in accessory cones and some other types of cones. The accessory cones of frogs also contain rhodopsin (Liebman and Entine, 1968). Bridges (1962) has reported that rhodopsin constitutes a large proportion of the extractable yield of visual pigment from the pigeon's retina and may be involved in cone vision, while Wessels (1974) attributes one of the peaks obtained in the photopic spectral sensitivity function of jackdaws to a cone system containing rhodopsin. So rhodopsin might be found in accessory cones, and possibly some of the single cones, in the avian retina too.

Bearing in mind that each type of oil-droplet is not just associated with one type of visual pigment in turtles, the combination of the pigeon's 4 oil-droplets with the known or putative avian cone pigments can also be considered.

As previously mentioned, combination of a red droplet with all but a long wavelength pigment would very much attenuate a cone's effective sensitivity. As a first approximation, it is suggested that a red droplet could be combined with a 605 nm pigment. As in turtles, it is then unlikely that this red droplet would be associated with any other pigments with a shorter λ_{\max} . However, a 605 nm pigment

could also be combined with an orange droplet, which would little affect its maximum sensitivity. The suggested red pigment plus red droplet, on the other hand, would have its maximum sensitivity at 620 - 640 nm. (The sensitivity curves of these, and other, pigment-droplet combinations are presented in Fig 4a)

An orange droplet could also effectively filter the 544 nm pigment, shifting its peak sensitivity to about 570 nm. The large yellow type of oil-droplet has its cut-off edge too far towards the blue to make any difference to the sensitivity of a 605 nm or other red pigment and is therefore assumed to be combined only with the 544 pigment, whose peak sensitivity would be slightly reduced but shifted very little.

If these assumptions were approximately correct, they might explain why Donner (1953) reported 2 or 3 peaks on many modulator curves, if cones containing the same pigment combined with more than one droplet were to provide inputs to a single ganglion cell. For example, it is suggested that the activity of cones containing pigment 605 plus an orange or a red droplet would be transmitted to the red modulator. In many modulator units the main sensitivity peak occurred at 596 nm but in other units a second peak, which Donner thought might be of a separate modulator, was often found at a longer wavelength of 613 nm. Similarly the green modulator, tested under conditions of light-adaptation, had its main peak at 543 nm but showed a subsidiary hump or peak of activity at 560 - 580 nm. Such a response pattern in a green modulator could depend on input from a

Fig 3 (facing)

- a, b Effective cone spectral sensitivity curve whose input to single ganglion cells could produce red and green double-peaked modulator units of the type described by Donner (1953) In 3a is shown the sensitivity spectrum of a red modulator with a single maximum at 596 nm, together with part of the sensitivity curve of a second type of modulator which had a small subsidiary peak at 613 nm The green modulator (3b) has its maximum sensitivity at 540 nm and a pronounced hump in the sensitivity curve at 560 - 580 nm.
- c Spectral sensitivity curves of two types of thalamic unit, described by Granda and Yazulla (1971), and effective sensitivity functions of two classes of cones which might underlie these units

Pigment absorption spectra were calculated from Dartnall's (1953) nomograms λ_{\max} of unfiltered pigments is indicated above the cone sensitivity curves (e.g. P502) together with the colour of an oil-droplet with which a pigment may be combined (e.g. P544 + O). Transmission spectra of red (R), orange (O), large yellow (LY) and small yellow (SY) droplets are taken from King-Smith (1969). Effective λ_{\max} of each cone sensitivity function is shown by allowed figures below these functions Wavelengths of peak sensitivity of modulator and thalamic units are given above sensitivity curves of these units

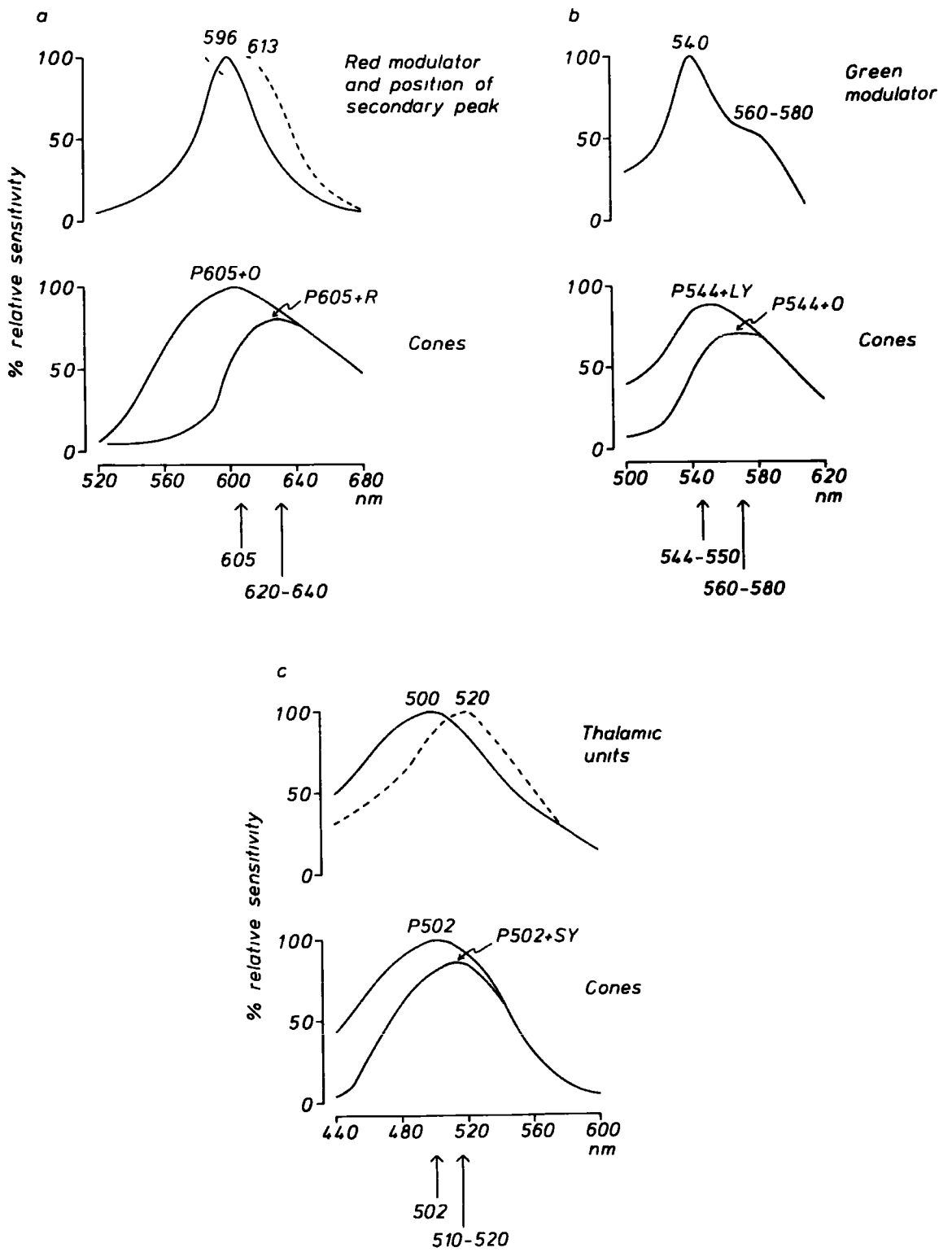

Fig. 3

544 pigment together with an orange or large yellow droplet. Furthermore, the maximum peak sensitivity of each of these modulators, which might be fed by more than one pigment-droplet combination, corresponds to the combination which would have the higher relative sensitivity for that pigment, and the subsidiary peak corresponds to the combination whose sensitivity would be lower - see Fig. 3a, b.

If, as in turtles and frogs, the pigeon's accessory cones contain rhodopsin then this pigment, with λ_{\max} at 502 nm (Bridges, 1962, Sillman, 1969), would be unfiltered, since the pigeon's accessory cones appear to be free of oil-drops (Cohen, 1963). The similarity with turtles might extend even further, with rhodopsin also being found in some of the pigeon's other cones. If so it could also be combined with a small yellow droplet, whose transmission spectrum would not substantially alter the sensitivities of any longer wavelength pigments. The maximum sensitivity of such a cone would then be at 510 - 520 nm.

The sensitivity of rhodopsin-containing cones would not coincide very well with the peak sensitivity at 480 nm of Donner's blue modulator. Wessels (1974), who also reports a peak at 480 nm in the jackdaw's sensitivity function, attributes this sensitivity peak to a class of cones containing a pigment with λ_{\max} at 455 nm and filtered by a green oil-droplet. Indeed, in a paper just published by Norren (1975), a cone system, maximally sensitive at 480 nm, was revealed by electroretinography in three avian species, the pigeon, jackdaw and chicken. According to Norren, the sensitivity curve of

this system could be mimicked by filtering a 460 nm pigment with a yellow oil-droplet. This combination (not shown in Fig. 4a) may therefore constitute another short-wavelength sensitive system in the pigeon's retina.

However, other investigations have reported processes with maximum sensitivity at 500 nm instead (Galifret, 1961, Granda and Yazulla, 1971). In addition, Granda and Yazulla found several thalamic units whose peak sensitivities occurred at 520 nm instead of 500 nm. This peak difference could not be effected by changes in stimulus luminance, for example, so did not merely represent a Purkinje shift in the units' sensitivity. As well as having separate peak sensitivities, the sensitivity curves of the two groups of units did not concur at shorter wavelengths but closely coincided at wavelengths longer than 570 nm. This pattern could be produced quite well at shorter wavelengths by unfiltered cones containing rhodopsin and cones with this pigment combined with a small yellow droplet but as Granda and Yazulla showed, the longer wavelength arm of the two sensitivity functions is displaced towards the red compared with the absorption spectrum of rhodopsin at the longest wavelengths (Fig. 3c).

Finally the 400 nm pigment may or may not be filtered (Graf and Norren, 1974). Since all the droplets transmit only about 10% of the incident light below 450 nm, any droplet would certainly very much reduce the sensitivity of this pigment throughout its spectrum.

Since this model of possible droplet-pigment combinations in the pigeon's cones is based upon a number of assumptions it must be

Fig. 4 (facing)

a Absorption spectra (Dainall, 1953) of known or putative cone pigments in the pigeon together with effective spectral sensitivity curves of cones which may contain these pigments in combination with one or more of the pigeon's retinal oil-droplets (King-Smith, 1969) λ_{\max} of cone pigments is indicated above the absorption spectra and pigment-droplet combinations (e.g. 605 + R) are given beside the effective sensitivity curves of the cones. Absorption spectra are drawn in solid lines (————) and sensitivity functions of pigments combined with droplets are illustrated by dashed lines (- - - - -). Arrows below the abscissa represent positions of minima found in wavelength and saturation discrimination functions, described previously. These mean functions are also given in the lower half (b) of the figure (see legend of Fig. 1)

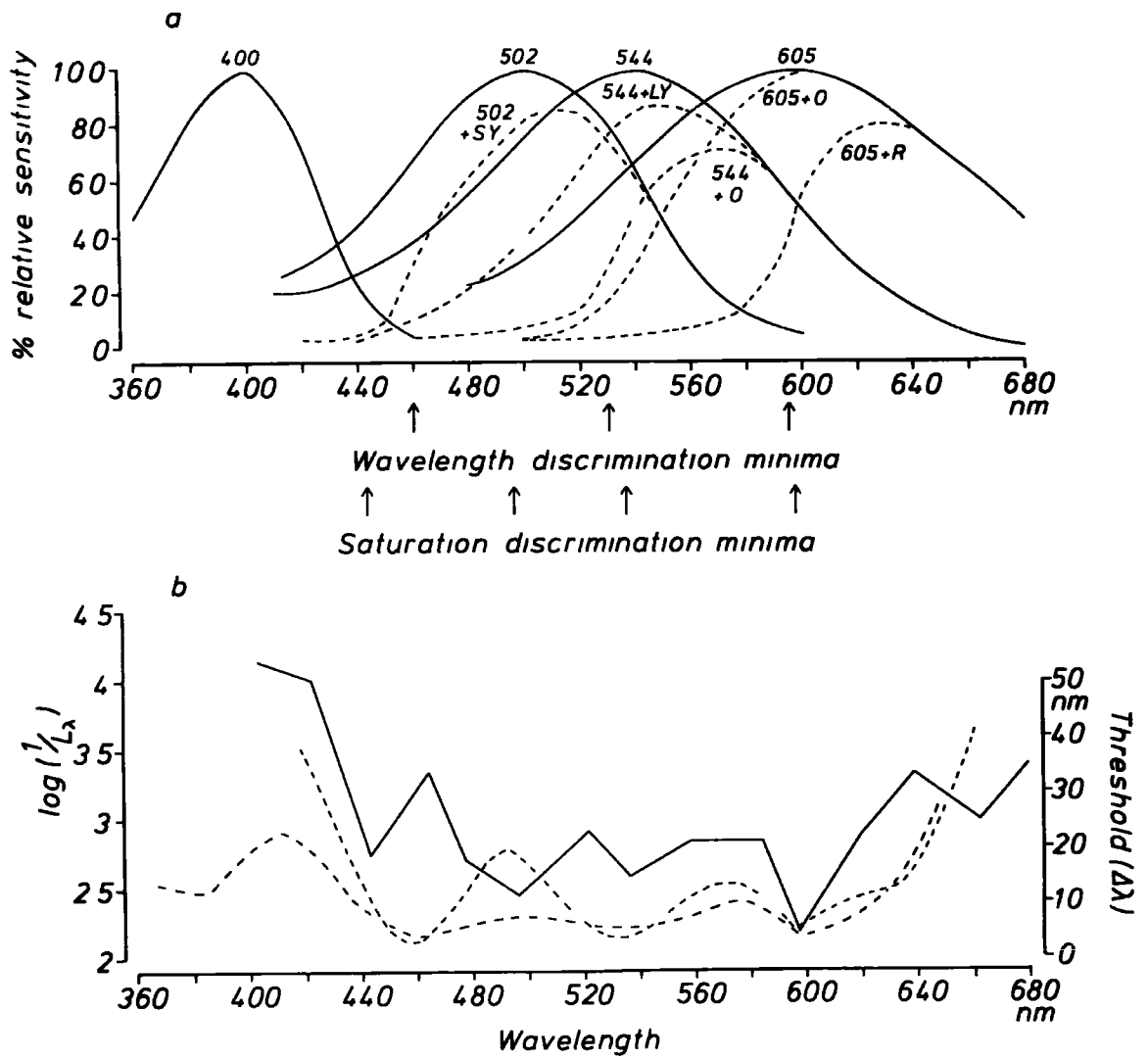

Fig. 4

regarded as highly tentative but it does concure with some of the circumstantial evidence of anomalous sensitivity peaks reported during physiological recordings (Donner, 1953, Granda and Yazulla, 1971) Also it does not contradict any of the psychophysical results reported here and would provide appropriate mechanisms to underlie the minima found in both wavelength and saturation discrimination functions see Fig 4 The type of arrangement whereby one pigment is combined with several oil-droplets and vice versa would account for the apparent complexity of the pigeon's colour vision if the retina still contains relatively few visual pigments Since this model has been presented at a fairly descriptive level it would obviously remain substantially similar if slightly different pigments were assumed instead Also some of the droplets, the small yellow droplet, for instance, could be combined with some of the longer wavelength pigments but would not modify their sensitivity spectra very much, since its main effect would be to attenuate only the shortest wavelengths. Therefore, in broad outline, the model seems feasible when it is compared with the available information about the pigeon's colour vision but could still be inaccurate in detail

A problem that still remains is what function the oil-droplets themselves serve in modifying the sensitivities of the cones. As has been previously pointed out by Donner (1960) and Muntz (1972) they would make the short-wavelength sides of the cones spectral sensitivity curves steeper, thus producing a more rapid change in a cone's response for a given wavelength change This in itself would

improve discrimination at points in the spectrum where this enhanced sensitivity to wavelength change occurs. In addition, as Donner comments, by modifying the cones' outputs, the oil-droplets could shift these regions of fine wavelength discrimination to parts of the spectrum in which improved discrimination abilities are biologically advantageous to the pigeon.

By combining a number of oil-droplets with several cone pigments, in a way that has been outlined above, the oil-droplets would also serve to increase the complexity of the pigeon's colour vision system. This increased complexity might only be apparent under the appropriate stimulus conditions. Thus the quite complicated psychophysical results found in the saturation discrimination function here could still rely on only a few visual pigments if some of the pigments underwent differential filtering by oil-droplets. In lizards and turtles the oil-droplets appear to enrich the animal's colour vision, converting systems apparently containing one or two visual pigments to dichromatic and tetrachromatic systems respectively (Orlov and Maximova, 1964, cited in Muntz, 1972). The pigeon's oil-droplets could quite feasibly serve a similar function.

One of the ideas put forward by Walls and Judd (1933) to explain the inter-specific diversity in the proportions of the variously coloured oil-drops was that cones containing differently coloured droplets became operative at different levels of light intensity. Red droplets, in particular, are said to function under high light intensities and animals which commonly encounter such conditions, or

a lot of 'glare', are noted to have a greater proportion of red droplets (Cullen, cited in Muntz, 1972). Separate cone populations, as defined by the colours of their oil-droplets, are then said to function more or less independently as illumination conditions change, so that cones with red droplets are primarily operative at high light intensity levels and cones containing yellow droplets operate under 'normal' daylight conditions with a functional bridge being provided by orange-droplet containing cones

While this function of the oil-droplets was regarded as only secondary in the majority of birds, presumably this idea of a 'multiplex' retina cannot be limited to only a few avian species (e.g. kingfishers) and not others since it implies a fundamental functional organisation of the avian, and also turtle, retina. The argument that only a very limited population of cones are operative under certain light conditions seems unlikely, as this would restrict the animal's colour discrimination abilities as well as the eye's acuity. The hypothesis could be tested, however, by a re-examination of modulator units. If, as suggested, a modulator can receive inputs from more than one type of cone sharing the same pigment but with different oil-droplets, a change in luminance should be reflected by a shift from the predominant sensitivity of one cone to that of another. For instance, by increasing stimulus luminance the 540 nm peak of the green modulator should be superseded by a peak at about 570 nm

In view of the multiple peaks that some of the modulators appeared to have, further investigations into the sensitivity functions of the

ganglion cells and their inputs would be worthwhile. However if, as suspected, a ganglion cell can receive its input from cones containing the same pigment but different oil-droplets, it would be difficult to apply the usual techniques of chromatic adaptation to isolate different sensitivity functions and obtain clear cut results. If the modulators can receive dual excitatory inputs, though, the narrowness of their sensitivity curves is surprising. While the oil-drops would restrict short wavelength sensitivity, resulting in the steeply rising sensitivity functions at these shorter wavelengths, additional inhibitory inputs to ganglion cells might also account for the overall narrowness of the curves. Of relevance here is the recent work by Padmos and Noiren (1975), showing that the non-opponent cells of monkeys, formerly thought to receive either all excitatory or all inhibitory inputs, can also have antagonistic inputs. These make the sensitivity curves of individual non-opponent cells slightly narrower than would be predicted from the fundamental cone sensitivity functions. Alternatively the modulator curves' narrowness might be due to Donner's use of a diffuse stimulus light since Michael (1968), recording from optic nerve fibres in the ground squirrel, found that, while the maximum sensitivity of the units remained stable, sensitivity functions were broader when a spot of light was restricted to the receptive field than when the retina was diffusely illuminated.

In general, little is known about the interaction between differentially sensitive colour channels in the pigeon's visual system. Little can be inferred from Yazulla and Granda's (1973) investigations

of thalamic units about the precise nature of cone inputs to opponent cells other than that mechanisms contributing to these cells's functions are sensitive to wavelengths longer and shorter than 500, 520 and 560 nm

Similarly Galifret (1960) has described some diencephalic units which seem to act in a complex opponent fashion. In one unit, stimulation with 675 nm light produced a response pattern opposite to that elicited by shorter wavelengths. After stimulation onset, at shorter wavelengths there was an initial spike discharge which was followed by inhibition of spontaneous activity. During maintained stimulation (about 650 ms), spontaneous activity returned before stimulus offset, but this then produced response blockage again. A 675 nm stimulus, on the other hand, produced an initial suppression of spike activity following stimulus onset. Spike frequency then increased instead of being inhibited during the stimulus period. After stimulus offset, response inhibition was delayed, and instead occurred when spontaneous activity was being resumed at shorter wavelengths. Only a few widely spaced wavelengths were tested so it is difficult to see the complete transition in this response pattern. However, this unit's activity bears some resemblance to the opponent action described by Yazulla and Granda in a few units, in which an on-response changed to a delayed off-response as wavelength was altered. A further unit mentioned by Galifret, but of which few details are given, produced a response pattern to 614 nm stimulation which was most in opposition to the activity generated by 499 nm light. It was also interesting to note that the changeover in response pattern seemed to occur with a

589 nm stimulus. This is near to the point at which a minimum was found in both the wavelength and saturation discrimination functions obtained from the present experiments and which were presumed to depend on neural opponent activity. Since the peak activity in the macaque's opponent cells (De Valois et al, 1966) does not correspond very precisely with peak sensitivity in its retinal cones, knowledge of the cone inputs to avian opponent units must really await further neurophysiological work to investigate the sensitivity spectra of underlying cone mechanisms.

De Valois' approach of correlating neurophysiological response data with psychophysical functions has proved very profitable in revealing the ways in which retinal and neural units may interact and form the basis of behavioural results. It is hoped that more information may soon be forthcoming about physiological chromatic mechanisms in birds to similarly elucidate the increasing number of behavioural observations on their colour vision. The precise number of pigments in the avian retina and their combinations with the various oil-droplets would best be decided by microspectrophotometric studies of single retinal receptors. So far these investigations have met with technical difficulties because of the slenderness of the avian cone outer segments (Liebman, 1972). Further to that, the ways in which cone systems interact would have to be known before precise quantitative models of avian colour vision could be formulated. While the 'single pigment theory' no longer seems adequate to account for the psychophysical data, we are still some way from knowing what other

mechanisms do actually underlie the bird's discriminatory abilities

In conclusion, the present results support other recent work on the pigeon's colour discrimination in showing that this animal's colour vision differs in several respects from our own. It is now apparent that the pigeon's visual system is at least tetrachromatic, as shown by the wavelength discrimination results, but the saturation discrimination function indicates that its vision may be even more complex than that. This added complexity might be attributed to the retinal oil-droplets, overlying possibly 4 or even 5 basic cone pigments

Also notable is the biological adaptiveness of the pigeon's colour vision. It is particularly good at discriminating between wavelengths in the 'orange' and 'green' regions and no doubt makes use of these abilities in searching for grain and other food. Besides aiding in these discrimination abilities and adding to the complexity of the pigeon's colour vision, the oil-droplets, by eliminating short wavelengths, would also act as filters within individual cone cells to reduce any deleterious effects of chromatic aberration and scattered light. In this respect the oil-droplets also serve to maintain visual acuity by acting as an alternative mechanism to a homogeneous yellow filter provided in the lenses of some other animals. However, the pigeon's sensitivity to blue and UV light shows that some photopic receptors, probably without oil-droplets, still respond quite adequately to these shorter wavelengths. The retention of receptors without droplets in the pigeon's retina would be useful in order to maintain this short

wavelength sensitivity, since an important environmental visual stimulus is found in the scattered light of a blue sky, which may be used as a cue in homing and navigation behaviour. With such a diffuse light source only a coarse detector mechanism, provided by relatively few and scattered receptors, would be necessary rather than fine-grained mechanisms, which have good resolving power and are differentially responsive to colour. These latter mechanisms, needed for the discrimination of other objects in the environment, would be provided by the oil-drop bearing cones which form the majority of the receptor population in diurnal birds (Walls, 1942, Morris, 1970)

APPENDIX

BEHAVIOURAL TECHNOLOGYComparison of discrimination performance on behavioural tests

Since the same subjects were used for all behavioural tests, their performance in the three experiments can be compared to assess the relative difficulties of the tasks required of them. The closest similarities in procedure were between the first wavelength discrimination experiment and the saturation task. In the first case, each animal had to discriminate between stimuli differing in hue whereas in the latter instance the pigeon had to respond to the chromatic rather than achromatic component of the stimulus display. Examination of the course of discrimination performance between the learning criterion of 90% correct choices per session and the threshold level of 70% correct choices showed that in both experiments, the change in discrimination scores varied from one wavelength to the next and also from one subject to another (see Fig. 3, ch 2 and Fig 3, ch 3). The most marked difference was in the numbers of sessions to acquisition i.e. 90% correct criterion. The saturation experiment had sessions of 50 trials and, in most cases, the acquisition criterion was reached within the first two sessions (see Table V, ch 3).

This was not so for the first wavelength discrimination experiment. Sessions of 20 trials were used and this time the number of sessions

needed to reach criterion level varied between 1 and 38. Sometimes the discrimination criterion was quickly acquired, within the first three sessions, but more often several (6 - 8) or many sessions were needed to reach the 90% level. Although discrimination scores cannot be compared on a trial-by-trial basis, since only the total scores for each session were recorded, on the whole more trials were obviously taken to achieve a criterion level of performance in the initial wavelength discrimination experiment than in the saturation discrimination procedure.

This difference might have been because, by the time of doing the saturation discrimination experiment, the birds were particularly well-trained using this apparatus and method and so had developed a type of 'learning set' for the procedure they had to follow. Thus in the second experiment they would learn more quickly. However, in the first wavelength discrimination study there was not much evidence of quicker acquisition by the end of that experiment. From an examination of the number of sessions to acquisition over the complete experiment, the only conclusion that could be drawn was that there was a wide variation from one wavelength test to another, with high and low numbers of sessions occurring throughout the course of the experiment. This would suggest that familiarity with the task was not the basic reason for the quicker acquisition on new tests in the saturation experiment.

Apart from the task familiarity factor, another explanation for the difference between the wavelength and saturation discrimination

acquisition times may be that colour is a particularly salient visual cue to a pigeon (Jones, 1954, Pritz et al, 1970) Because of this, in the saturation experiment the birds may have immediately chosen the 'coloured' versus the 'non-coloured' stimulus, even when a 'new' colour was presented Hence, on this sort of detection task, acquisition would be quicker

During wavelength discrimination, all the stimuli were coloured so the birds did not have an immediate cue enabling a simple choice In this case they had to learn to choose one colour rather than a different colour, although both stimuli may have been equally salient cues to the animals Analysing the initial discrimination task in the same way that Over (1967) has done, the pigeon not only had to be able to perceptually differentiate between the stimuli but also had to learn to attach its responses to the correct stimulus, this latter requirement may have presented more difficulty in the acquisition of wavelength discrimination In this experiment also, in some but not all cases, the prolonged time taken to reach the learning criterion could be attributed to what was a reversal learning problem in which the positive wavelength of one test became the negative wavelength of the next test, or vice versa This type of problem is moderately difficult for the pigeon (Bitterman, 1965, Bullock and Bitterman, 1962) On the other hand, not all reversals of wavelengths proved problematical, nor were all prolonged learning times due to an obvious reversal problem

Comparison between acquisition times of the first wavelength

discrimination experiment and the saturation work becomes more complicated when the results of the later wavelength discrimination study are also considered. In this experiment, discrimination tests were ordered so as to circumvent any reversal learning problems. On the majority of discrimination tests, the learning criterion of 90% correct responding on two successive blocks of trials was achieved within the first 50-trial session, often within the initial 20 to 30 trials of that session. Why this should be in the second but not in the first wavelength discrimination study is not clear.

Casual observation suggested that the threshold testing procedure used in the second of the wavelength discrimination studies was a more difficult one for the birds than that of the initial experiment. In this first experiment the pair of stimulus wavelengths used in each session remained constant whereas in the last experiment the negative wavelength was frequently changed within a titration session. Responding was then occasionally interrupted by bouts of wing-flapping which had generally been encountered before when there was some apparatus failure e.g. key contacts were non-functional. It was also unexpected that one pigeon, S9 should have virtually ceased responding even though it had been extensively tested on colour discrimination tasks in the same apparatus. Perhaps the difficulty in this procedure lay again in remembering which stimulus was the correct one, especially when the negative stimulus was changed at short intervals.

Procedural improvements

Because of the difficulties encountered by birds in the second

wavelength discrimination experiment, which led to the loss of one experienced subject, one way of making the titration procedure slightly less demanding would be to limit the number of times that the setting of the negative wavelength was made to vary. In the titration procedure, any discrimination score on a block of 10 trials which was greater than or less than 7 produced an alteration in the negative stimulus setting on a subsequent block of trials. Wavelength values only remained the same if a bird happened to get a score of exactly 7, the response criterion defined as the threshold level. This constraint produced very frequent changes in wavelength setting.

One way of overcoming this would be to allow initial discrimination scores to decrease until a level of 7 (or less) out of 10 correct choices was reached and then to keep the wavelength difference stable as long as scores of between 6 and 8 were obtained. (The wavelength difference would be allowed to decrease following the first discrimination score of 8 in a session, since the wavelength difference for the initial score of 8 was sometimes above the apparent threshold level (see ch 5, Table I). The wavelength difference might otherwise remain at this high level throughout a session). This modification in procedure might make the stimulus situation seem less transient to a pigeon and possibly this introduction of longer periods during which stimulus values remained stable might have a less disruptive effect on behaviour.

In the second wavelength discrimination study, it was also noticed that, over successive sessions, the calculated wavelength difference

thresholds became smaller given practice, the birds apparently learned to make finer discriminations. As mentioned before, it would therefore be better to continue with titration sessions until the threshold level tested at each point in the spectrum had stabilised. Although no formal tests were carried out to see if thresholds could be similarly lowered, it would probably also have been true of the first wavelength discrimination and saturation discrimination experiments that discrimination could have improved if more prolonged testing had been carried out. This would have entailed repeating sessions at the same wavelength settings, or neutral density values, more than once after discrimination was at a level of less than 90% correct (see procedures of ch 2 and 3). While more prolonged testing may have produced more stabilised thresholds, with perhaps even less individual variation in results, and would have given a more accurate estimate of the absolute discrimination abilities of the pigeon on the two types of visual discrimination problem, such increases in accuracy would be gained at the expense of a considerably prolonged time needed to complete the experiments. Instead, it is believed that by applying, throughout an experiment, a predetermined criterion level from which to define a threshold, the more useful and meaningful information about relative wavelength difference and saturation thresholds was obtained.

REFERENCES

- ABRAMOV, I (1972) Retinal mechanisms of colour vision. pp 567 - 607 in Fuortes. M G F. (Ed) Handbook of Sensory Physiology VII/2 Springer, Berlin
- ADAMS, J. (1967) Retinal oil droplets in the pigeon. Unpublished dissertation, Durham University.
- ADRIAN, E D (1945) The electric response of the human eye. J. Physiol., Lond. 104, 84 - 104.
- AUTRUM, H (1965) The physiological basis of colour vision in honeybees. pp. 286 - 300 in de Reuck, A V S. and Knight, J (Eds.) Colour vision Physiology and Experimental Psychology Churchill, London
- BITTERMAN, M E. (1965) The evolution of intelligence Scient. Am. 212, 92 - 100
- BLOCH, S. and MARTINOYA, C (1971) Are colour oil droplets the basis of the pigeon's chromatic space ? Vision Res Suppl. No 3, 411 - 418.
- BLOCH, S. and MATURANA, H.R. (1971) Oil droplet distribution and colour discrimination in the pigeon Nature New Biology 234, 284 - 285.
- BLOUGH, D.S. (1956) Dark adaptation in the pigeon J. comp. physiol. Psychol. 49, 425 - 430.
- BLOUGH, D.S. (1957) Spectral sensitivity in the pigeon. J. opt. Soc Am 47, 827 - 833.
- BLOUGH, D S (1958) A method for obtaining psychophysical thresholds from the pigeon. J exp Analysis Behav. 1, 31 - 43
- BLOUGH, D.S (1961) The shape of some wavelength generalization gradients J. exp Analysis Behav 4, 31 - 40

- BLOUGH, P.M (1972) Wavelength generalization and discrimination in the pigeon *Percept. Psychophys* 12, 342 - 348.
- BLOUGH, P.M , RIGGS, L A and SCHAFER, K L (1972) Photopic spectral sensitivity determined electroretinographically for the pigeon eye *Vision Res.* 12, 477 - 485.
- BONAVENTURE, N., WIOLAND, N. and KARLI, P (1972) Photopic spectral sensitivity of the chicken retina in various conditions of adaptation. An electroretinographic study. pp. 249 - 258 in Arden, G.B. (Ed) *The Visual System Neurophysiology, Biophysics and their Clinical Applications.* Plenum, New York.
- BRIDGES, C D B (1962) Visual pigments of the pigeon (*Columba livia*) *Vision Res* 2, 125 - 137
- BROWN, K T (1968) The electroretinogram its components and their origins. *Vision Res.* 8, 633 - 677.
- BROWN, J L , SHIVELY, F D., LAMOTTE, R.H. and SECHZER, J A. (1973) Colour discrimination in the cat *J. comp. physiol. Psychol.* 84, 534 - 544.
- BULLOCK, D H. and BITTERMAN, M E (1962) Habit reversal in the pigeon. *J. comp. physiol Psychol.* 55, 958 - 962.
- CAMPBELL, H S. and SMITH, J L (1962) The pharmacology of the pigeon pupil *Archives of Ophthalmology* 67, 501 - 504.
- CHAPANIS, A. (1944) Spectral saturation and its relation to colour-vision defects. *J. exp Psychol* 34, 24 - 44
- CHARD, R D and GUNDLACH, R H (1938) The structure of the eye of the homing pigeon *J comp. Psychol* 25, 249 - 272.
- COHEN, A I (1963) The fine structure of the visual receptors of the pigeon *Expl. Eye Res.* 2, 88 - 97

- COLLINS, F.D , LOVE, R M and MORTON, R A (1952) Studies in rhodopsin. 4 Preparation of rhodopsin Biochem. J. 41, 292 - 298.
- CORNSWEET, T (1970) Visual Perception Academic Press, London.
- CRESCITELLI, F , WILSON, B W and LILYBLADE, A L (1964) The visual pigments of birds. I. The turkey. Vision Res. 4, 275 - 280.
- DARTNALL, H J A. (1953) The interpretation of spectral sensitivity curves. Brit. med. Bull. 9, 24 - 30
- DARTNALL, H J A. (1960) Visual pigments of colour vision in Galifret, Y. (Ed) Mechanisms of Colour Discrimination. Pergamon Press, London.
- DAUMER, K (1958) Blumenfarben, wie sie die Bienen sehen. Z. vergl Physiol 41, 49 - 110.
- DAW, N W and PEARLMAN, A.L (1970) Cat colour vision evidence for more than one cone process. J Physiol , Lond 211, 125 - 137.
- DE VALOIS, R.L., ABRAMOV, I. and JACOBS, G H (1966) An analysis of response patterns of LGN cells. J. opt Soc. Am 56, 966 - 977.
- DE VALOIS, R.L. and JACOBS, G.H (1968) Primate colour vision. Science, N.Y. 162, 533 - 540.
- DELIUS, J.D. (1968) Colour preference shift in hungry and thirsty pigeons Psychon. Sci. 13, 273 - 274.
- DELIUS, J.D , PERCHARD, R J and EMMERTON, J A. (in press) Polarized light discrimination by pigeons and an electroretinographic correlate J comp Physiol
- DELIUS, J D., THOMPSON, G., ALLEN, K.L. and EMMERTON, J.A (1972) Colour mixing and colour preferences in neonate gulls Experientia 28, 1244 - 1246.

- DODT, E and WIRTH, A (1953) Differentiation between rods and cones by flicker electroretinography in pigeon and guinea pig Acta Physiol. Scand. 30, 80 - 89
- DONNER, K O (1953) The spectral sensitivity of the pigeon's retinal elements J Physiol, Lond. 122, 524 - 537.
- DONNER, K O (1960) On the effect of the coloured oil droplets on the spectral sensitivity of the avian retina. Proc. XIIth Int. Ornithol Congress, Helsinki 1958, 167 - 172.
- FROST, B.J. (1972) The effect of light adaptation on the D-wave of the pigeon ERG. Physiol and Behav., 8, 829 - 835.
- FUJIMOTO, K, YANASE, T. and HANAOKA, T (1957) Spectral transmittance of retinal coloured oil globules re-examined with microspectrophotometer. Jap J Physiol. 7, 339 - 346.
- GALIFRET, Y (1960) Discussion pp 116 - 117 in Galifret, Y. (Ed) Mechanisms of colour discrimination. Pergamon Press, London
- GALIFRET, Y. (1961) Rétinopie au niveau tectal et réponses spectrales diencéphaliques chez le Pigeon pp 212 - 215 in Jung, R and Kornnuber, H. (Eds.) Neurophysiologie und Psychophysik des Visuellen Systems. Symposium Freiburger Springer, Berlin.
- GALIFRET, Y. (1968) Les diverses aires fonctionelles de la rétine du Pigeon Z. Zellforsch mikrosk. Anat. 86, 535 - 545
- GELLERMANN, L W (1933) Chance orders of alternating stimuli in visual discrimination experiments J genet Psychol 42, 205 - 208
- GENDEREN STORT, A G H van (1887) Ueber Form- und Ortsveränderungen der Netzhautelemente unter Einfluss von Licht und Dunkel V. Graefes Arch Ophthal. 33, 229 - 292

- GOLDSMITH, T.H (1961) The colour vision of insects in
McElroy, W.D and Glass, B (Eds.) Light and Life.
John Hopkins Press, Baltimore
- GOVARDOVSKII, V.I and ZUEVA, L.V (1974) Spectral sensitivity of the frog eye in the ultraviolet and visible region Vision Res. 14, 1317 - 1321.
- GRAF, V (1967) A spectral sensitivity curve and wavelength discrimination for the turtle Chrysemys picta picta Vision Res 7, 915 - 928.
- GRAF, V A (1969) A spectral luminosity function in the pigeon determined by flicker photometry Psychon Sci 17, 282 - 283
- GRAF, V and NORREN, D V (1974) A blue sensitive mechanism in the pigeon retina λ_{\max} 400 nm. Vision Res 14, 1203 - 1209.
- GRAHAM, C H (Ed) (1965) Vision and Visual Perception
Wiley, New York.
- GRANDA, A.M and HADEN, K W (1970) Retinal oil globule counts and distributions in two species of turtles Pseudemys scripta elegans (Wied) and Chelonia mydas mydas (Linnaeus). Vision Res. 10, 79 - 84.
- GRANDA, A M and YAZULLA, S (1971) The spectral sensitivity of single units in the nucleus rotundus of pigeon, Columba livia J gen. Physiol 57, 363 - 384.
- GRANIT, R (1942) The photopic spectrum of the pigeon Acta Physiol. Scand 4, 118 - 124.
- GRANIT, R (1947) Sensory Mechanisms of the Retina. Oxford University Press
- GRANIT, R. (1955) Receptors and Sensory Perception. Yale University Press, New Haven.

- GUTTMAN, N (1956) The pigeon and the spectrum and other perplexities Psychol Rep. 2, 449 - 460.
- GUTTMAN, N and KALISH, H I (1956) Discriminability and stimulus generalization J. exp. Psychol 51, 79 - 88.
- HAILMAN, J P. (1964) Coding of the colour preference of the gull chick. Nature, Lond. 204, 710.
- HAILMAN, J.P (1967) The ontogeny of an instinct. Behaviour Suppl. 15.
- HAILMAN, J.P and JAEGER, R G. (1974) Phototactic responses to spectrally dominant stimuli and use of colour vision by adult anuran amphibians a comparative survey Anim Behav. 22, 757 - 795
- HAMILTON, W F. and COLEMAN, T B (1933) Trichromatic vision in the pigeon as illustrated by the spectral hue discrimination curve J. comp. Psychol. 15, 183 - 191
- HELLER, J (1968) Structure of visual pigments. I Purification, molecular weight and composition of bovine visual pigment₅₀₀ Biochemistry, Easton 7, 2906 - 2913.
- HELVENSEN, O von (1972) Zur spektralen Unterschiedsempfindlichkeit der Honigbiene J comp Physiol. 80, 439 - 472.
- HINDE, R A (1970) Animal Behaviour A Synthesis of Ethology and Comparative Psychology 2nd edition. McGraw-Hill
- HURVICH, L M and JAMESON, D (1955) Some quantitative aspects of an opponent-colours theory II Brightness, saturation and hue in normal and dichromatic vision J opt. Soc Am 45, 602 - 616.

- HURVICH, L M. and JAMESON, D (1957) An opponent-process theory of colour vision. Psychol Rev. 64, 384 - 404.
- HUTH, H-H and BURKHARDT, D. (1972) Der spektrale Sehber-eich eines Violettrohr-Kolibris Naturwiss. 12, 650
- IKEDA, H (1965) The spectral sensitivity of the pigeon (Columba livia). Vision Res 5, 19 - 36
- JACOBS, G.H and PULLIAM, K A (1973) Vision in the Prairie Dog Spectral sensitivity and colour vision J comp. physiol. Psychol. 84, 240 - 245.
- JACOBS, G H. and YOLTON, R L. (1971) Visual sensitivity and colour vision in ground squirrels Vision Res. 11, 511 - 537.
- JAMESON, D. and HURVICH, L M (1955) Some quantitative aspects of an opponent-colours theory I Chromatic responses and spectral saturation. J. opt. Soc Am. 45, 546 - 552
- JAMESON, D and HURVICH, L M. (1964) Theory of brightness and colour contrast in human vision. Vision Res 4, 135 - 154.
- JONES, L V. (1954) Distinctiveness of colour, form and position cues for pigeons J comp physiol Psychol 47, 253 - 257
- JONES, C E and BUCHMANN, S.L. (1974) Ultraviolet floral patterns as functional orientation cues in hymenopterous pollination systems. Anim. Behav 22, 481 - 485.
- KARTEN, H J (1969) The organisation of the avian telencephalon and some speculations on the phylogeny of the amniote telencephalon. Ann. N Y Acad Sci 167, 164 - 179

- KING-SMITH, P.E (1969) Absorption spectra and function of the coloured oil drops in the pigeon retina *Vision Res.* 9, 1391 - 1399
- KING-SMITH, P E (1975) Visual detection analysed in terms of luminance and chromatic signals *Nature, Lond.* 255, 69 - 70.
- KLING, J W and RIGGS, L A. (1971) Woodworth and Schlosberg's *Experimental Psychology* Methuen, London.
- KOVACH, J K and HICKOX, J.E. (1971) Colour preferences and early perceptual discrimination learning in domestic chicks *Devl. Psychobiol* 4, 255 - 267.
- KRAUSE, W (1863) Ueber die Endigung der Muskelnerven *Zeits f. rat Med* 20, 1 - 18
- KREITHEN, M.L. and KEETON, W.T (1973) Detection of polarized light by the homing pigeon, *Columba livia*. *J comp Physiol* 89, 83 - 92.
- LASHLEY, K.S (1916) The colour vision of birds I The spectrum of the domestic fowl *J Anim. Behav* 6, 1 - 26.
- LAURENS, H (1923) Studies of the relative physiological value of spectral lights. III The pupillomotor effects of wavelengths of equal energy content. *Amer. J Physiol* 64, 97 - 119.
- LE GRAND, Y. (1962) Colorimétrie du poulet théorique. *Vision Res* 2, 81 - 83.
- LIEBMAN, P A (1972) Microspectrophotometry of photoreceptors pp 481 - 528 in Dartnall, H J A. (Ed) *Handbook of Sensory Physiology VII/1* Springer, Berlin
- LIEBMAN, P A and ENTINE, G (1968) Visual pigments of frog and tadpole *Vision Res.* 8, 761 - 775

- LIEBMAN, P A and GRANDA, A M. (1971) Microspectrophotometric measurements of visual pigments in two species of turtle, Pseudemys scripta and Chelonia mydas Vision Res 11, 105 - 114
- MACNICHOL, E F , WOLBARSHT, M L and WAGNER, H G. (1961) Electrophysiological evidence for a mechanism of colour vision in the goldfish pp 795 - 813 in McElroy, W D and Glass, B. Light and Life. John Hopkins Press, Baltimore.
- MARKS, W B (1965) Visual pigments of single goldfish cones J. Physiol , Lond 178, 14 - 32
- MARKS, W B , DOBELLE, W.H. and MACNICHOL, E F (1964) Visual pigments of single primate cones Science, N Y 143, 1181 - 1183.
- MARSHALL, J , MELLERIO, J and PALMER, D.A (1973) A schematic eye for the pigeon. Vision Res 13, 2449 - 2453.
- MARTIN, G.R. (1974) Colour vision in the tawny owl (Strix aluco) J comp physiol Psychol 86, 133 - 141.
- MARTIN, G.R and GORDON, I.E. (1974) Increment-threshold spectral sensitivity in the tawny owl (Strix aluco). Vision Res 14, 615 - 621.
- MARTIN, G R , GORDON, I E and CADLE, D.R. (1975) Electroretinographically determined spectral sensitivity in the tawny owl (Strix aluco) J. comp physiol. Psychol 89, 72 - 78
- MARTIN, L C , WARBURTON, F L. and MORGAN, W J (1933) The determination of the sensitivities of the eye to differences in the saturation of colours Medical Research Council (Britain) Special Report Series No 188.

- MEISSNER, D C (1970) The effect of selective chromatic adaptation on the spectral sensitivity of the pigeon (Columba livia). Ph D. Thesis, University of Maine.
- MELLO, N K and PETERSON, N.J. (1964) Behavioural evidence for colour discrimination in cat J Neurophysiol 27, 323 - 333.
- MEYER, D B (1971) The effect of dietary carotenoid deprivation on avian retinal oil droplets Ophthal Res. 2, 104 - 109.
- MEYER, D B and ANDERSON, R.A (1965) Colour discrimination in cats pp 325 - 339 in de Reuck, A V S and Knight, J (Eds) Colour vision Physiology and Experimental Psychology Churchill, London
- MEYER, D B and COOPER, T.G (1966) The visual cells of the chicken as revealed by phase contrast microscopy Am J Anat 118, 723 - 734.
- MEYER, D.B , COOPER, T G and GERNEZ, C. (1965) Retinal oil droplets. pp. 521 - 533 in Rohen, J.W. (Ed.) The Structure of the Eye II Symposium Schattauer-Verlag, Stuttgart.
- MEYER, D B , STUCKEY, S R and HUDSON, R A (1971) Oil droplet carotenoids of avian cones I. Dietary exclusion Models for biochemical and physiological studies Comp Biochem Physiol 40B, 61 - 70
- MICHAEL, C.R. (1968) Receptive fields of single optic nerve fibres in a mammal with an all-cone retina III Opponent colour units. J Neurophysiol. 31, 268 - 282
- MORI, S , MITARAI, G and MORI, S (1969) Effect of monochromatic light environment on colour discrimination learning in pigeons Ann Report of Res. Inst of Environmental Medicine, Nagoya Univ 17, 35 - 43.

- MORRIS, V B (1970) Symmetry in a receptor mosaic demonstrated in the chick from the frequencies, spacing and arrangement of the types of retinal receptors
J comp. Neurol 140, 359 - 398.
- MORRIS, V B and SHORREY, C D (1967) An electron microscope study of types of receptor in the chick retina
J. comp. Neurol 129, 313 - 340.
- MOUNTJOY, P T and MALOTT, M K (1968) Wavelength generalization curves for chickens reared in restricted portions of the spectrum Psychol Rec. 18, 575 - 583.
- MUNTZ, W R A (1964) Vision in frogs Scient. Am 210, 110 - 119
- MUNTZ, W.R A. (1972) Inert absorbing and reflecting pigments. pp 530 - 565 in Dartnall, H J A (Ed)
Handbook of Sensory Physiology VII/1 Springer, Berlin.
- MUNTZ, W.R.A and NORTHMORE, D.P M. (1970) Vision and visual pigments in a fish, Scardinius erythrophthalmus (the Rudd) Vision Res 10, 281 - 298
- MUNTZ, W.R A and NORTHMORE, D.P M. (1971) The independence of the photopic receptor systems underlying visual thresholds in a teleost Vision Res 11, 861 - 876.
- NORREN, D.V. (1973) Spectral sensitivity of the cones measured by means of electroretinography Ophthalmologica 167, 363 - 366.
- NORREN, D V (1975) Two short wavelength sensitive cone systems in pigeon, chicken and daw. Vision Res 15, 1164 - 1166
- OGDEN, T E and WYLIE, R M (1971) Avian retina I Micro-electrode depth and marking studies of local ERG
J. Neurophysiol 34, 357 - 366

- ORLOV, I O.U and MAXIMOVA, E M (1964) On the role of the intra-bulbar light filters Dokl. Akad. Nauk SSSR u Otd. Biol Ch. 154, 463 - 466 cited in Muntz, W R A (1972).
- OVER, R (1967) Detection and recognition measures of shape discrimination Nature, Lond. 214, 1272 - 1273.
- PADMOS, P and NORREN, D V. (1975) Cone systems interaction in single neurons of the lateral geniculate nucleus of the macaque Vision Res. 15, 617 - 619.
- PARKER, D (1971) Electrophysiological and behavioural studies of vision in the pigeon. Ph.D thesis, University of Durham
- PEARLMAN, A L and DAW, N W (1970) Opponent colour cells in the cat lateral geniculate nucleus. Science, N.Y 167, 84 - 86
- PEDLER, C. and BOYLE, M. (1969) Multiple oil droplets in the photoreceptors of the pigeon Vision Res. 9, 525 - 528.
- PRITZ, M B , MEAD, W R and NORTHCUTT, R.G. (1970) The effects of Wulst ablations on colour, brightness and pattern discrimination in pigeons (Columba livia) J comp Neur 140, 81 - 100.
- RÉVÉSZ, G (1921) Tierpsychologische Untersuchungen. Z f. Psychol u Physiol d Sinnesorgane, Abt. I 87, 130 - 137
- RIGGS, L A., BLOUGH, P M and SCHAFFER, K L (1972) Electrical responses of the pigeon eye to changes in wavelength of the stimulating light Vision Res 12, 981 - 991.

- RILEY, D A and LEUIN, T C (1971) Stimulus-generalization gradients in chickens reared in monochromatic light and tested with a single wavelength value. *J. comp physiol Psychol* 75, 399 - 402
- ROSENBERGER, P B. (1970) Response-adjusting stimulus intensity. pp. 161 - 184 in Stebbins, W.C. (Ed) *Animal Psychophysics*. Appleton-Century-Crofts, New York
- RUDOLPH, R L and HONIG, W K (1972) Effects of monochromatic rearing on spectral discrimination learning and the peak shift in chicks. *J. exp Analysis Behav* 17, 107 - 111.
- SCHNEIDER, B. (1972) Multidimensional scaling of colour differences in the pigeon *Percept Psychophys* 12, 373 - 378
- SCHULTZER, M (1866) Zur Anatomie und Physiologie der Retina *Arch. mikrosk. Anat* 2, 175 - 286
- SEARS, F W and ZEMANSKY, M.W (1964) *University Physics Part 2*. Addison-Wesley (Reading, Mass.)
- SECHZER, J A. and BROWN, J L (1964) Colour discrimination in cat *Science, N Y.* 144, 427 - 429.
- SHEPARD, R.N (1965) Approximation to uniform gradients of generalization by monotone transformations of scale pp. 94 - 110 in Mostofsky, D I. (Ed.) *Stimulus Generalization* Stanford.
- SIEGEL, S (1956) *Nonparametric statistics for the behavioural sciences* McGraw-Hill, Tokyo.
- SILLMAN, A J (1969) The visual pigments of several species of birds *Vision Res* 9, 1063 - 1077
- SKINNER, N F and BEISHON, R J (1971) Similarities in the colour vision of pigeons and man *J genet Psychol* 119, 25 - 28

- SPERLING, H G and HARWERTH, R S (1971) Red-green cone interactions in the increment-threshold spectral sensitivity of primates Science, N Y. 172, 180 - 184.
- SPIEGEL, M R (1972) Theory and Problems of Statistics. McGraw-Hill, New York
- STROTHER, G.K (1963) Absorption spectra of retinal oil globules in turkey, turtle and pigeon. Expl. Cell Res 29, 349 - 355
- STROTHER, G K. and WOLKEN, J.J. (1960) Microspectrophotometry. I Absorption spectra of coloured oil globules in the chicken retina. Expl Cell Res. 21, 504 - 512.
- TAN, K E W.P. (1971) Vision in the ultraviolet. Ph.D. Thesis, University of Utrecht
- THOMPSON, G (1971) The photopic spectral sensitivity of gulls measured by electroretinographic and pupillometric methods. Vision Res 11, 719 - 731.
- TIEMANN, G. (1970) Untersuchungen über die Entwicklung und Bedeutung der farbigen Ölkugeln in der Retina von Lacerta vivipara Experientia 26, 1274.
- TINBERGEN, N and PERDECK, A.L. (1950) On the stimulus situation releasing the begging response in the newly hatched gull chick (Larus argentatus argentatus Pont) Behaviour 3, 1 - 39.
- TRACY, W.K. (1970) Wavelength generalization and preference in monochromatically reared ducklings. J. exp Analysis Behav. 13, 163 - 178.
- TREZONA, P W (1970) Rod participation in the 'blue' mechanism and its effect on colour matching. Vision Res 10, 317 - 332.

- WALD, G (1937) Photo-labile pigments of the chicken retina Nature, Lond 140, 545 - 546.
- WALD, G (1958) The Selig Hecht Commemorative Lecture Nat Phys Lab. Symp , No. 8, 7 - 61 HMSO, London
- WALD, G., BROWN, P K and SMITH, P.H (1955) Iodopsin J. gen Physiol. 38, 623 - 681.
- WALD, G and ZUSSMAN, H (1938) Carotenoids of the chicken retina J. Biol Chem 122, 449 - 460.
- WALLS, G L. (1942) The Vertebrate Eye and its Adaptive Radiation Cranbrook Inst Science, Michigan.
- WALLS, G L and JUDD, H.D. (1933) The intra-ocular colour filters of vertebrates. Br J. Ophthal. 17, 641 - 675, 705 - 725.
- WEALE, R.A. (1951) Hue-discrimination in para-central parts of the human retina measured at different luminance levels J. Physiol., Lond. 113, 115 - 122
- WEALE, R.A. (1968) From Sight to Light. Oliver and Boyd
- WESSELS, R H A. (1974) Tetrachromatic vision in the daw (Corvus monedula L) Ph D Thesis, University of Utrecht.
- WRIGHT, A A. (1972a) Psychometric and psychophysical hue discrimination functions for the pigeon Vision Res. 12, 1447 - 1464.
- WRIGHT, A A (1972b) The influence of ultraviolet radiation on the pigeon's colour discrimination J. exp Analysis Behav. 17, 325 - 337.
- WRIGHT, A.A and CUMMING, W.w (1971) Colour-naming functions for the pigeon J exp Analysis Behav 15 7 - 17.