

Durham E-Theses

The kinematics of normal and pathological hip joints

Trevor A. Gore

How to cite:

Gore, Trevor A. (1980) The kinematics of normal and pathological hip joints. Doctoral thesis, Durham University.

Use policy

The full-text may be used and/or reproduced, and given to third parties in any format or medium, without prior permission or charge, for personal research or study, educational, or not-for-profit purposes provided that:

- a full bibliographic reference is made to the original source
- a <https://etheses.durham.ac.uk/id/eprint/8058/> is made to the metadata record in Durham E-Theses
- the full-text is not changed in any way

The full-text must not be sold in any format or medium without the formal permission of the copyright holders.

Please consult the [full Durham E-Theses policy](#) for further details.

THE KINEMATICS OF NORMAL AND PATHOLOGICAL HIP JOINTS

by

Trevor A GORE, B Sc.

Thesis submitted for the degree of Doctor of Philosophy
in the Faculty of Science, University of Durham

January, 1980



The copyright of this thesis rests with the author
No quotation from it should be published without
his prior written consent and information derived
from it should be acknowledged



Plate 1 : The electrogoniometer

ABSTRACT

The design and construction of an electrogoniometer for measuring angular displacements of the hip is discussed. It has been used to measure hip movements for a number of activities, including walking, climbing and descending stairs, and standing and sitting.

Data from the goniometer are recorded on magnetic tape and are then processed and printed out in graphical format by minicomputer.

A large number of healthy people have been examined to establish the normal movement patterns for the various exercises. These patterns are compared with those produced by people suffering from pathological hip conditions, especially osteoarthritis. Measurements have been made on patients who have undergone hip replacement surgery.

The degeneration of the movement patterns associated with osteoarthritis are demonstrated, as are the improvements following arthroplasty.

It is intended that the goniometer be used to provide prognostic and therapeutic guidelines in the clinical environment.

ACKNOWLEDGEMENTS

Many people have offered me help and advice over the past three years, but none more so than Professor G R Higginson under whose direction this research has been completed. Above all, he inspired me with the confidence necessary to complete this project.

Being work of an interdisciplinary nature has meant involvement with a number of people from the medical profession and I would like to thank in particular Mr M Flynn F.R.C.S. who instigated this project and was a source of much encouragement and enthusiasm in its early days. I wish also to thank Professor J Stevens F.R.C.S. for his help and vigour in the later stages.

Dr C Preece of the University of Durham Engineering Department must be thanked for his help and patience in overcoming the problems encountered whilst computing, and Professor D J Newell of the University of Newcastle for his valuable advice on statistics.

I would like to thank the technicians of the department, especially Mr T Brown who constructed the goniometer.

I am greatly indebted to the Northern Regional Health Authority who financed this project, and to Miss Judith Willis who typed this thesis so well.

LIST OF CONTENTS

<u>Section</u>	<u>Heading</u>	<u>Page</u>
	Abstract	1
	Acknowledgements	11
	List of contents	111
	List of figures	1X
	List of tables	X111
	List of plates	XV
	Notation	XV1
1	INTRODUCTION	1
2	LITERATURE REVIEW	5
3	APPARATUS	18
	3 1 Introduction	18
	3 2 Development of pelvic girdle and kneeclamp	20
	3 3 Development of the goniometer assembly	22
	Design of the footswitch unit	28
	3 4 The power supply	29
	3 5 The instrumentation recorders	29
	3 6 The metronome	30
	3 7 Miscellaneous equipment	33
	3 8 The computer installation	33
4	EXPERIMENTAL PROCEDURE	35
	4 1 Introduction	35
	4 2 The pilot study	35
	4 3 Finalised experimental procedure	40
	4 4 Population sampling techniques	44

<u>Section</u>	<u>Heading</u>	<u>Page</u>
5	DATA REDUCTION	57
5 1	Introduction	57
5 2	Programme "AOITG1"	58
5 3	Programme "AOITG2"	59
5 4	Programme "AOITG5"	59
5 5	Programme "AOITG3"	59
5 6	Utility subroutines	59
5 7	Service programmes	60
5 8	Statistical programmes	61
5 9	Programme "AOIST1"	61
5 10	Programme "AOIST2"	63
5 11	Programme "AOIST3"	63
5 12	Programme "AOIST5"	65
5 13	Programme "AOIST4"	66
5 14	Interpretation of computations	67
5 15	Utility subroutines (statistical)	70
5 16	Programme "TABLES"	70
5 17	Programme "MSD"	71
5 18	Programme "AREA1"	71
5 19	Programme "AREA2"	71
5 20	Programme "AREA3"	72
5 21	Programme "AOIST7"	72
5 22	Programme "AOIST8"	72
5 23	Programme "AOIFIT"	72
5 24	Section summary	73
6	SYSTEM ACCURACY	74
6 1	General	74
6 2	The accuracy of the goniometer assembly	74
6 3	Analysis of the accuracy of attachment	76
6 4	Analysis of error arising from the electronic instrumentation	86

<u>Section</u>	<u>Heading</u>	<u>Page</u>
7	ANALYSIS AND DISCUSSION OF NORMAL RESULTS	112
7 1	Introduction	112
7 2	Male ambulation	112
7 2 1	Description of normal walking - male	112
7 2 2	Comparison Groups 1 and 2 (M)	116
7.2 3	Comparison Groups 2 and 3 (M)	118
7 2 4	Comparison Groups 3 and 4 (M)	118
7 2 5	Comparison Groups 4 and 5 (M)	119
7 2 6	Comparison Groups 5 and 6 (M)	120
7 2 7	Synopsis of male ambulation	122
7 3	Ascending stairs (male)	135
7 3 1	Description of normal ascension of stairs - male	135
7 3 2	Comparison Groups 1 and 2 (M)	137
7 3 3	Comparison Groups 2 and 3 (M)	138
7 3 4	Comparison Groups 3 and 4 (M)	139
7 3 5	Comparison Groups 4 and 5 (M)	139
7 3 6	Comparison Groups 5 and 6 (M)	140
7 3 7	Synopsis of climbing stairs (male)	140
7 4	Descending stairs	152
7 4 1	Description of normal descending of stairs - male	152
7 4 2	Comparison Groups 1 and 2 (M)	153

<u>Section</u>	<u>Heading</u>	<u>Page</u>
7 4.3	Comparison Groups 2 and 3 (M)	154
7.4.4	Comparison. Groups 3 and 4 (M)	155
7 4 5	Comparison Groups 4 and 5 (M)	156
7 4.6	Comparison Groups 5 and 6 (M)	156
7.4.7	Synopsis of descending stairs (male)	157
7.5	Sitting down on and rising from a chair male results	160
7.6	The global range test male	162
7.7	Female ambulation	163
7 7.1	Description of normal walking (female)	163
7.7.2	Comparison Groups 1 and 2 (F)	180
7.7 3	Comparison Groups 2 and 3 (F)	181
7 7 4	Comparison Groups 3 and 4 (F)	182
7 7 5	Synopsis of female ambulation	183
7.8	Ascending stairs (female)	192
7 8 1	Description of normal ascension of stairs - female	192
7 8 2	Comparison Groups 1 and 2 (F)	193
7 8 3	Comparison Groups 2 and 3 (F)	194
7.8.4	Comparison Groups 3 and 4 (F)	195
7 8.5	Synopsis of climbing stairs (female)	195
7 9	Descending stairs (female)	203
7 9.1	Description of normal descension of stairs - female	203

<u>Section</u>	<u>Heading</u>	<u>Page</u>
	7 9 2 Comparison Groups 1 and 2 (F)	204
	7 9 3 Comparison Groups 2 and 3 (F)	205
	7 9 4 Comparison Groups 3 and 4 (F)	205
	7 9 5 Synopsis of descending stairs (female)	205
	7 10 Sitting down on and rising from a chair female results	208
	7.11 The global range test female	209
	7 12 Comparison of male and female hip kinematics	209
8	ANALYSIS AND DISCUSSION OF PATHOLOGICAL RESULTS	213
	8 1 Introduction	213
	8 2 Discussion of patient 1	215
	8 2 1 Patient 1 level walking	215
	8 2 2 Patient 1 ascending stairs	216
	8 2 3 Patient 1 descending stairs	216
	8.2 4 Patient 1 sitting and standing	219
	8 3 Discussion of patient 2	219
	8 3 1 Patient 2 ambulation	219
	8 3 2 Patient 2 ascending stairs	221
	8 3 3 Patient 2 descending stairs	221
	8.3 4 Patient 2 sitting and standing	222
	8 4 Discussion of patient 3	224
	8 4 1 Patient 3 ambulation	224
	8 4 2 Patient 3 ascending stairs	225
	8 4 3 Patient 3 descending stairs	226
	8 4.4 Patient 3 sitting and standing	226
	8 5 Discussion of patient 4	228
	8 5 1 Patient 4 ambulation	228

<u>Section</u>	<u>Heading</u>	<u>Page</u>
	8 5 2 Patient 4 sitting and standing	229
8 6	Summary of movement degeneration due to osteoarthritis	229
8 7	Discussion of interesting cases	230
	8 7 1 Patient 5 bilateral Charnley arthroplasty	233
	8 7 2 Patient 6 osteotomy and McKee arthroplasty	237
	8 7 3 Patient 7 bilateral congenital dislocation of the hips	241
9	CONCLUSIONS	245
10	FUTURE WORK	246
	BIBLIOGRAPHY	249

LIST OF FIGURES

<u>Fig. No</u>	<u>Title</u>	<u>Page No.</u>
1	The pelvic girdle	19
2	Detail of anterior adjustment	19
3	The knee clamp	19
4	Jackson transducer circuitry	24
5	Maurey transducer circuitry	25
6	(a) Construction of a footswitch (b) Footswitch encoder circuit	25 27
7	Metronome circuit diagram	31
8	Event marker cct diagram	32
9	Pilot study results	37
10	Schematic of apparatus	43
11	Male - age 18-24 height v weight	47
12	" " 25-34 " "	48
13	" " 35-44 " "	49
14	" " 45-54 " "	50
15	" " 55-64 " "	51
16	" " 65-74 " "	52
17	Female - age 18-24 height v weight	53
18	" " 25-34 " "	54
19	" " 35-44 " "	55
20	" " 45-54 " "	56
21	(a) Ambulation with an arthrodesed hip - run 1 (b) Ambulation with an arthrodesed hip - run 2	78 79
22	Femur bending moment diagram	83
23	Normal male walking 5 steps	88

<u>Fig. No</u>	<u>Title</u>	<u>Page No</u>
24	Normal male walking average of 5 steps	89
25	Rectangular plot of male ambulation	90
26	Non-centred plots for males group 1	93
27	Centred plots for males group 1	94
28	Non-centred plots for males group 2	95
29	Centred plots for males group 2	96
30	Non-centred plots for males group 3	97
31	Centred plots for males group 3	98
32	Non-centred plots for males group 4	99
33	Centred plots for males group 4	100
34	Non-centred plots for males group 5	101
35	Centred plots for males group 5	102
36	Non-centred plots for males group 6	103
37	Centred plots for males group 6	104
38	Ascending stairs, male 4 steps	125
39	Ascending stairs male average of 4 steps	126
40	Rectangular plot, ascending stairs	127
41	Descending stairs, male 4 steps	143
42	Descending stairs, male average of 4 steps	144
43	Rectangular plot, descending stairs	145

<u>Fig. No.</u>	<u>Title</u>	<u>Page No.</u>
44	Sitting and standing, male	158
45	Normal female walking 5 steps	164
46	Normal female walking average of 5 steps	165
47	Rectangular plot of female ambulation	166
48	Non-centred plots for females group 1	168
49	Centred plots for females group 1	169
50	Non-centred plots for females group 2	170
51	Centred plots for females group 2	171
52	Non-centred plots for females group 3	172
53	Centred plots for females group 3	173
54	Non-centred plots for females group 4	174
55	Centred plots for females group 4	175
56	Ascending stairs, female 4 steps	184
57	Ascending stairs, female average 4 steps	185
58	Rectangular plot, ascending stairs	186
59	Descending stairs, female 4 steps	196
60	Descending stairs, female average 4 steps	197
61	Rectangular plot, descending stairs	198
62	Sitting and standing, female	206
63	Patient 1	214

<u>Fig. No</u>	<u>Title</u>	<u>Page No</u>
64	Patient 2	217
65	Patient 3	223
66	Patient 4 a,b Patients1-4 sitting and standing, c to f	227
67	Patient 5	231
68	Patient 6	235
69	Patient 7	240

LIST OF TABLES

<u>Table No</u>	<u>Title</u>	<u>Page No.</u>
1	Table of Fourier coefficients	91
2	Male groups' height and weight ambulation	92
3	Key to A, SU, and SD tables	106
4	Male groups' height and weight ascending and descending stairs	128
5	Female groups' height and weight ambulation	167
6	Female groups' height and weight ascending and descending stairs	187
A1(M)		105
A2(M)		107
A3(M)		108
A4(M)		109
A5(M)		110
A6(M)		111
SU1(M)		129
SU2(M)		130
SU3(M)		131
SU4(M)		132
SU5(M)		133
SU6(M)		134
SD1(M)		146
SD2(M)		147
SD3(M)		148
SD4(M)		149
SD5(M)		150

<u>Table No</u>	<u>Page No.</u>
SD6(M)	151
A1(F)	176
A2(F)	177
A3(F)	178
A4(F)	179
SU1(F)	188
SU2(F)	189
SU3(F)	190
SU4(F)	191
SD1(F)	199
SD2(F)	200
SD3(F)	201
SD4(F)	202

LIST OF PLATES

<u>Plate No</u>	<u>Title</u>	<u>Page No.</u>
1	The electrogoniometer	Frontispiece
2	(a) Capacitive goniometric cluster	23
	(b) Resistive goniometric cluster	23
3	Hip arthrodesis	77
4	(a) Patient 2	218
	(b) Patient 4	218
5	(a) Patient 5	232
	(b) Right prosthesis	232
	(c) Left prosthesis	232
6	(a) Patient 6	236
	(b) Patient 7	236

NOTATION

<u>Symbol</u>	<u>Definition</u>
a)) b)	Numerical constants, Fourier coefficients
C L A	Centre line adjusted (C L.A plots are referred to in the text as "centred plots". The two terms are used interchangeably, and in this thesis are exactly equivalent to each other.)
C P U	Central processing unit
C O M	Centre of movement
C.O R.	Centre of range
d	Deflection
D.I N	Deutsches Institut für Normung
E	Expected frequency of an event
EI	Stiffness (Young's Modulus multiplied by second moment of area)
F	Female
F.M	Frequency modulated
1, 1	Integer numbers
J F E T	Junction field effect transistor
L	Length
M	Male
n	Integer number
O	Observed frequency of an event
p	Level of probability of the existence of a significant difference

<u>Symbol</u>	<u>Definition</u>
P O M	Pattern of movement
P.V.C	Polyvinyl chloride
R.O M	Range of movement
statistic A,B,C,D,E,F,G	See section 5.14, and Table 3
t	Student's t statistic
\bar{t}	Mean value of t in the t-array
t(0)	Either or both t(0,0) and t(0,1)
t(0,0), t(0,1)	See text, sections 5.12 and 5 13
tests 1, 2, 3	See text section 5.14, and Table 3
U V	Ultra-violet light
V D U	Visual display unit
W	Load
x_j	jth point on the abscissa
y_{jn}	Ordinate value at jth point on nth curve
\bar{y}_{jn}	Mean value of y_{jn} over n curves
σ_{cj}	Combined standard deviation at jth point
σ_{tc}	Combined standard deviation of two t-arrays
σ_{tx}	Standard deviation in the t-array
σ_{yj}	Standard deviation of the ordinate at jth point
χ	Statistical parameter
Ω	Ohms

Common units are noted in S I conventions
 Circuits are marked to B S 1852

1. INTRODUCTION

The standard clinical method of measuring the movement of human joints, described by The American Academy of Orthopaedic Surgeons (1965) employs a system of spherical polar co-ordinates in which flexion-extension, abduction-adduction and axial rotation are estimated by visual observation as three orthogonal rotations, which are then recorded in degrees from a defined starting point, the so-called 'zero position'. Using this conventional notation of joint motion, joints are then classified as uniaxial, biaxial or polyaxial or they are described as having one, two or three degrees of freedom. This standard method of measurement and notation of joint movements, although simple and apparently precise, has many serious short-comings.

1. The ranges of movement are usually 'passive' being produced by the examiner in a relaxed subject. For lower extremity joints, this is usually done with the subject lying on an examination couch and the results may thus bear little relation to purposeful activities in the upright, sitting, squatting or kneeling positions
- 2 The movements determined by this means are rendered even more artificial since each is confined to a single plane with a fixed axis. They therefore differ from purposeful 'active' movements which occur as compound rotations.



3. Accurate measurements of purposeful movements of a single joint cannot readily be made in the usual clinical surroundings because of the inter-related movements of limb segments and the trunk. Furthermore, the compound rotations of the articulating surfaces are masked by changes in shape of the overlying soft tissues.
4. Objective comparisons of the functional movement of paired joints in one subject, or of similar joints in different subjects, are impossible using only observational techniques and no instruments which will give accurate and repeatable measurements are in common use.

With the present enormous expansion of joint replacement surgery, it is desirable to know which part of a possible total or 'global' range of joint movement is most useful in normal activities and how far the operations in common use are successful in providing this. Thus, guide-lines would be provided for the patient as well as his remedial therapist to indicate the potential for achievement following joint reconstruction or through non-surgical forms of treatment.

A number of techniques are available which can be used to measure joint movements. These include cinematography, interrupted light photography, low energy radiography, accelerometry, goniometry and video techniques. The comparative advantages of these techniques are discussed in Chapter 2, but the instrument

developed had to satisfy the following criteria

- (a) It should be unobtrusive so that movements would be restricted as little as possible or not at all.
- (b) It should be applicable to all shapes, sizes, and states of health of the people to be examined.
- (c) It should be light but robust, and easily transportable.
- (d) It should be sufficiently accurate and give repeatable results yet remain simple and inexpensive.

The technique that satisfied these criteria most acceptably was goniometry.

Pathologies of the hip are amongst the most common disorders that inhibit the ambulatory capacity of the population. It was therefore desirable to design an instrument suitable eventually for clinical use, capable of giving a precise description of the patterns of movement used during functional activities.

The instruments and techniques described in the following chapters were used to assess the hip joint movement capabilities of a population sample in order to establish the levels of performance to be expected in age graded groups of healthy people. The age groups were from 18 to 24 (group 1), 25 to 34 (group 2) and then in decades to 65 to 74 (group 6). The results obtained are compared with the capabilities of patients suffering from various pathologies of the hip, in particular, osteoarthritis.

Although these techniques were pioneered in the

research environment it must be emphasised that they are intended for routine clinical use, with rapid or even instant data reduction and presentation. These techniques must necessarily evolve into microprocessor electro-goniometry.

2. LITERATURE REVIEW

The literature is approached from two directions, firstly, examining the published works on goniometry, electro-goniometry, its reliability and application, and secondly, examining publications concerning joint kinematics and gait analysis, with respect to the hip joint in particular.

The choice of electro-goniometry as a technique is discussed in the Introduction, and some justification can be found in the literature.

Mechanical goniometers have been used for many years, but their accuracy, repeatability and susceptibility to user variations have been often questioned. Hellebrandt et al (1949) concluded that a well trained physiotherapist using a standard goniometer could measure R.O.M.* with a high degree of accuracy, but that where the interreliability of different physiotherapists had not been established, different observers should not be used interchangeably to obtain measurements on the same patient.

Baldwin and Cunningham (1974) having assessed 62 physiotherapists for their ability to make visual estimates and goniometric measurements of R.O.M. decided that visual estimates were more accurate in normal cases, but in abnormal cases the reverse was true, and concluded that a more accurate and reproducible method was required.

* For abbreviations see Notation

Mitchell et al (1975) report that they were surprised to find that the degree of inter- and intra-observer variation recorded was minimal but emphasised that observer errors must be quantitated for individuals to make objective assessments. Mitchell quotes Mandel (1956) and Wright (1973) who both called for simple accurate and reliable methods of measuring joint motion. Both Baldwin and Mitchell conducted their tests in accordance to the publication on joint motion by the American Academy for Orthopaedic Surgeons (1965) which was an attempt to rationalise and standardise measurement of joint motion, and remains the standard text. They recommended that the use of a goniometer (as opposed to visual assessment) should be selective and used according to the surgeon's discretion. This publication encompasses the numerous previous works to that date.

The publications above related more specifically to static goniometry and usually to passive movements, whereas the major concern of this report is that of dynamic goniometry during active movements. No attempts have been made to standardise such a procedure beyond the establishments of the various research workers. Of the techniques referred to in the Introduction, electrogoniometry is the most convenient, but significant problems still arise.

The term electrogoniometer usually refers to the measurement of angles using potentiometers. The early

tests conducted by the author used capacitive position transducers, but potentiometers were adopted later for reasons discussed in later chapters.

The major problems in dynamic electrogoniometric measurements made on human joints are -

- (1) How to arrange rotational position transducers to determine true angular displacements in specific planes between connecting body segments, during a multi-dimensional, possibly polycentric rotation of one segment relative to another.
- (11) How to attach the device to the appropriate body segments such that it measures as accurately as possible the angular displacement of the corresponding bones despite the interposed layer of soft tissue

A variety of solutions to (1) appear in the literature but each falls into one of four distinct groups.-

- (a) A single transducer aligned as closely as possible with the joint's major axis, such as used by Karpovich & Karpovich (1959), Wright et al (1964) Moffat et al (1966), Carvzoneri et al (1969), Leavitt et al (1970) and Trnkoczy and Bajd (1975).
- (b) A transducer cluster approximately aligned with the joint's rotational axes with a subsequent computational correction, as described by Ebskov and Long (1967), Johnston and Smidt (1969 and 1970), Kettlecamp et al (1970), Chao et al (1970), Smidt

(1971), Kinzel et al (1972a,b), Townsend et al (1977).

- (c) Use of double-parallellogram linkages to carry the potentiometers aligned parallel to, but not co-linear with the joint axis as used by Thomas and Long (1964), Lamoreux (1970, 1971 and 1974), Cousins (1975), McKechnie and Cousins (1976).
- (d) The use of accelerometers instead of potentiometers, Morris (1973).

The authors referenced did not confine themselves to hip kinematics, but the techniques developed tend to be applicable to most joints.

Group (a) goniometers are very simple but do not provide adequate detailed information about a joint. They may be useful in comparative assessments.

Group (c) goniometers are capable of great accuracy but the precision linkages required (as used by Lamoreux) are very expensive to manufacture. An alternative is to use moulded hinges of the type designed by Cousins (1975), but these took over three years to develop, and are expensive due to high initial tooling costs and low production runs.

The use of accelerometers as described by Morris demands massive computation before the data can be presented in a positional format.

Group (b) seems to hold a reasonable compromise, Chao, Johnston, Kettelcamp, Smidt and Walker, all working together at some stage, produced an orthogonal

three potentiometer system which in its improved form as described by Smidt (1971) was sufficiently accurate that the computational corrections derived by Chao et al (1970) were unnecessary. The systems described by Kinzel and by Townsend are both 6 degree of freedom goniometers for use on the knee, and are consequently highly complex

The fact remains however, that no matter how accurate the goniometer is, it is no more precise than its attachment to the body. Excessive movement between body segments and the attachment completely negates any attempt to produce accurate and reproducible results.

Solutions to problem (11) are thus a very important and difficult matter. Most previous approaches utilise a framework strapped to the body, the exceptions being direct bone fixation as described by Kinzel et al (1972a,b) who attached a goniometer to a dog. Close and Inman (1952) used direct bone fixation techniques on men, but this is obviously out of the question for routine clinical examinations. Discussion with Smidt, G. L. revealed that he had found direct bone fixation entirely unsatisfactory after conducting cadaveric experiments. He found that there was severe loosening of the bone pins due to movements of the overlying soft tissues relative to the bone.

The importance of secure attachments to skeletal structures cannot be over emphasised, and it is in this consideration that previous workers have been content

with unsatisfactory solutions

Lamoreux (1971) however, took a sledge hammer to the problem with a nine point pelvic location frame which must be totally unusable in routine clinical applications. Most other authors have used straps around limbs and the associated musculature resulting in inadequate fixation due to the considerable masses of mobile tissue. A suitable compromise must be found, the author's solution appearing in following chapters

Considering now joint kinematics and gait analysis, there are many other techniques available alongside electro-goniometry. Photographic techniques are popular in the literature, but for routine clinical applications their disadvantages far outweigh their desirable features.

Marey (1895) invented the interrupted light method which in its ever-improving form has been used in many studies on human gait:- Muller and Hettinger (1952), Saunders et al (1953), Drillis (1958), Murray et al (1964, 1969, 1972), D R Gore et al (1975), Milner et al (1973), Crowninshield (1978). The reader is referred to Glanville and Kreezer's (1937) comprehensive review of the literature on gait measurements prior to 1937.

Cinematography is another well practised technique in the accumulation of kinematic data and in the literature appear the names of Levens et al (1948), Liberson (1965), Sutherland and Hagy (1972), and

Cappozzo et al (1975). Some authors have evolved techniques using mirrors to obtain multiple views on the same photograph - Murray et al (1967), Ryker (1952) Ayoub et al (1970) used stereophotography to record three dimensional displacements. Data reduction can be speeded and simplified if it is mechanised through the use of a motion analyser such as described by Sutherland and Hagy (1972).

In more recent years cinematography has evolved into the electronics era, where videotape has taken the place of film, Cheng (1974) and Winter et al (1974a and 1974b). Analytical techniques have also been automated, the ultimate being direct conversion of television data into accurate planar co-ordinates This has been attempted by Winter et al (1972), Lindholm (1974) and Oberg (1974)

All optical techniques have a similar fundamental problem to those found in goniometry, the problem of attempting to measure the movement of skeletal structures beneath significant amounts of soft tissue coverage. The solutions to this tend to be as varied as they are ineffective

Again, direct bone fixation is the ultimate method, where targets are attached to pins drilled into the bone, Saunders et al (1953), Levens et al (1948). Many authors use much simpler adhesive reflective targets such as those described by Murray et al (1964) and consequently tend to measure movements of the skin rather

than movements of the skeleton. Crowninshield et al (1978) used light emitting diodes attached to the various body segments, but again made fastenings to large muscle masses. Milner et al (1973) dressed their subjects in tightfitting black catsuits and placed markers over the various joints.

Reduction of photographic data is time consuming and laborious, and the technique requires permanent laboratory space, and costly equipment, making it unsuitable for routine use. Its advantages are that data acquisition is rapid, and the test subject is comparatively free from encumbrance.

Optoelectronic procedures of the fully automated variety eliminate tedious data processing, but require expensive equipment and permanent installations.

In a hybrid field by itself, is the polarised light goniometer, which uses an optical technique to measure angles directly. This device was pioneered by D. L. Mitchelson of the University of Loughborough and is being used for gait assessment at a number of British centres, including Durham. Although it is a very convenient tool, its main disadvantage is that its use is confined to a single plane unless multiple units or angled mirrors are used.

Of the references quoted so far the authors whose work is of most relevance to this report are Johnston and Smidt, Murray, and Lamoreux, who, using different techniques, produced objective data in similar formats.

Of lesser importance are the works of Levens and Sutherland.

Johnston and Smidt, and Lamoreux produced kinematic data from the hip for rotations in three planes, of the femur relative to the pelvis. They used electrogoniometers. Murray, using photographic techniques worked in the sagittal and transverse planes, but only produced data for rotations of femur relative to pelvis in the sagittal plane. Levens et al (1948) confined themselves to the transverse plane, while Sutherland and Hagy (1972) only present data of absolute rotations in the transverse plane alone for femoral and pelvic rotations

Hannah et al (1978) in a paper describing an electrogoniometer developed jointly by the Canadian Arthritis Research Society and the University of British Columbia present examples of graphical data for orthogonal rotations at the hip, but do not enter into any discussions of their results

Most previous workers in the field have confined themselves to the analysis of level walking but Johnston and Smidt (1970) analysed hip movements for selected activities of daily living. The activities that they selected were shoe-tying, sitting, squatting, stooping to pick up an object from the floor, and climbing and descending stairs.

Johnston and Smidt are obviously prolific writers in the field and their works demand a full and thorough investigation

In 1969 their electrogoniometer was launched after they had decided that insufficient reliable data existed for movements in three planes of the hip joint. Their 1969 publication shows the apparatus they used in their initial gait studies.

The apparatus is bulky, and has the appearance of not being especially accurate. Pelvic location is provided by a wide leather strap which seems to fasten around the waist rather than around the pelvis. This would explain some of the discrepancies to be discussed later. The goniometer assembly is rather large and projects an excessive distance from the subject's hip. The coronal and transverse plane potentiometers appear to be at least 15 cm from the hip joint. This assembly is attached to the pelvic belt by an adjustable sliding link.

The femoral attachment is via a suprapatellar cuff strapped around the thigh and links with the potentiometers via a plexiglass rod. The arrangement looks extremely susceptible to inaccuracies in the transverse plane.

The published results are difficult to assess due to their small size but the following observations can be made. Sagittal plane rotations appear to be fairly similar to those published by Murray and Lamoreux and also bear a resemblance to those featured later in this report. Movements in this plane however, are the easiest to measure accurately and are also the largest angular rotations. Coronal plane rotations measured by

Johnston and Smidt are similar to those produced in Durham when a goniometer was attached to a "soft" denim belt (a modified denim lumbar support) instead of to the rigid aluminium belt. It was found that the denim belt was unable to follow rotations at frequencies beyond the first harmonic for movements in this plane. It is noticeable that the traces produced by Johnston and Smidt are also rather devoid of frequencies above the fundamental (step cycle frequency) Hannah et al (1978) who published results without comment shows coronal plane traces similar to Johnston's but used a goniometer attached by a very loose system of slings

Transverse plane rotations are certainly the most variable, the only common feature produced by the various investigators seems to be the existence of some sort of peak in external rotation at toe-off. This is a pronounced feature of transverse rotations discussed in this report. However, Hannah et al (1978) have published results showing a very definite peak in internal rotation at toe-off.

Published values for range of angular movement in the three planes also vary widely between individual investigators. In the sagittal plane for normal subjects at medium speeds Murray records around 44° , Johnston and Smidt 52° , and Lamoreux about 47° . Reference should be made to the original publications for full qualifications for these results, but the reader is

referred to Table A1(M) for results presented by the author.

Johnston and Smidt appear to be the only authors to publish data on activities such as climbing stairs and standing and sitting. This is probably because Lamoreux was confined to his tread mill by the nature of his apparatus and Murray equally restricted due to the immovability of her cameras and walkway.

Johnston and Smidt (1970) used the same version of their goniometer as they used in 1969 though it was later modified to bring the potentiometers much closer to the hip

In the measurements of sitting and standing the average amount of flexion used was 112° compared with around 62° (Table SS(M)) as measured by the author. This could be because of the high positioning of Johnston's pelvic belt which would follow lumbar rotations as well as pelvic rotations. Rotations in the other planes were around 20° abduction and external rotation.

Their analysis of climbing and descending stairs is very difficult to compare with the work reported in this volume. Their tests were conducted on two steps only. The subjects climbed two steps on to a platform then descended two steps down the opposite side. This whole exercise when presented on 6 cm of paper leads to a confused plot which masks the importance of the dominant features. Johnston and Smidt do however,

appear to be entirely satisfied with the reliability of their results

Lamoreux, in comparison to Johnston and Smidt, took the proverbial sledge hammer to the problem, and exhaustively examined intersegment rotations for the whole of the lower limb. His results were published in an exemplary piece of work in the Bulletin of Prosthetics Research - Spring 1971

Lamoreux heavily emphasised the necessity for simple equipment and rapid data reduction, but unfortunately his apparatus was of such complexity that it would be unusable in the routine clinical environment. He did however, pinpoint many of the potential pitfalls in the field and produced some meaningful results

Lamoreux showed a major concern for the variability of gait parameters with walking speed, and presents his results as families of 6 curves for 6 speeds ranging from very slow to very fast walking. His measurements however, were made on one individual alone, and although all attempts were made to certify his normality, it cannot be argued with certainty that his gait patterns typified the norm. Lamoreux presented his data in a similar format to that used in this report, and so direct comparisons of results are fairly easy to make. As previously mentioned, sagittal plane rotations appear very similar, and no major discrepancies between any authors are apparent for rotations in this plane. Lamoreux does mark his zero point in an unusual place,

such that his subject appears to exhibit almost as much extension as he does flexion (22° and 25° respectively).

In the coronal plane, the patterns of movement that Lamoreux presents for low speed walking bear a close resemblance to those obtained by the author, but at a cadence corresponding exactly with Lamoreux's mid range speeds. Such a similarity is encouraging, because, of the goniometry systems presented so far, Lamoreux's, although bulky, is probably the most rigorous.

Lamoreux recorded that he found transverse rotations most difficult to measure accurately as it seems did most other authors. The results he presented for lower mid range walking speeds would not look out of place amongst the results of this study remembering that transverse rotations are the most variable between individuals.

Lamoreux's results are the most compatible with those of this study and they are so far probably the most accurate, due to his rigorous apparatus and technique and due also to the fact that he presented data averaged from many walking cycles. He stressed the importance of this technique for eliminating minor variations and producing a much greater degree of consistency.

By the time Lamoreux's work had been investigated by the author, the major determinants for producing a rigorous gait survey had already been instigated, and bore a remarkable similarity to the techniques that Lamoreux had found imperative.

3. APPARATUS

3.1 Introduction

Before entering into a detailed description of the equipment and apparatus used, it is necessary to justify the philosophy of the desired approach to the problem, this being to isolate and describe the components of hip joint movement for a variety of activities, and establish the patterns of normal movements for particular age groups.

The desire to establish normal patterns poses the fundamental problem of examining large numbers of people which immediately emphasises the importance of simplicity, reliability, and speed of accumulation and reduction of data. Of the techniques currently available, goniometry provides data in the most readily available form, illuminating the need for manual transcription from film or plate

The use of a computer has the obvious advantages of speedy numerical manipulation for scaling and plotting, but more importantly for averaging and normalising. These latter two techniques are of the utmost importance if comparative surveys are to be undertaken. Once a computer has been incorporated into the system every advantage should be taken of its presence. On line computations obviate the necessity for elaborate parallelogram linkages included to eliminate unwanted linear displacements, and compensate for the off-axis

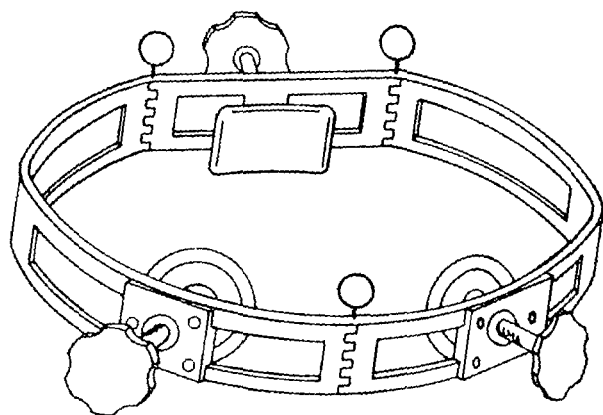


Figure 1 The pelvic girdle

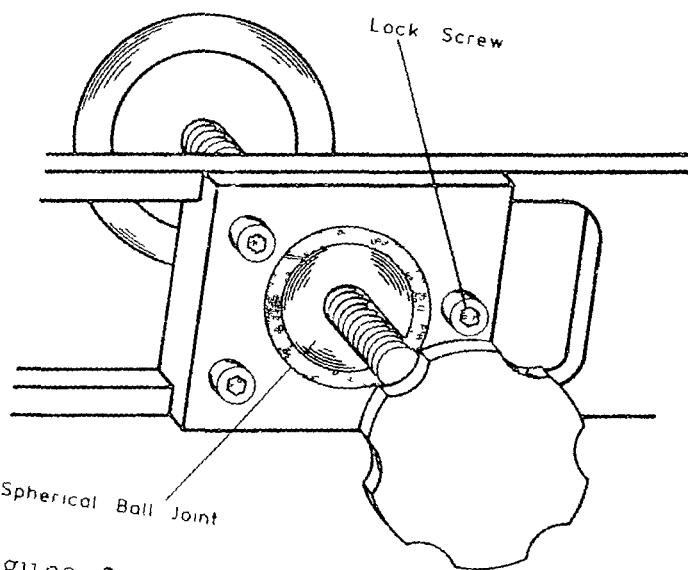


Figure 2 Detail of the anterior adjustment

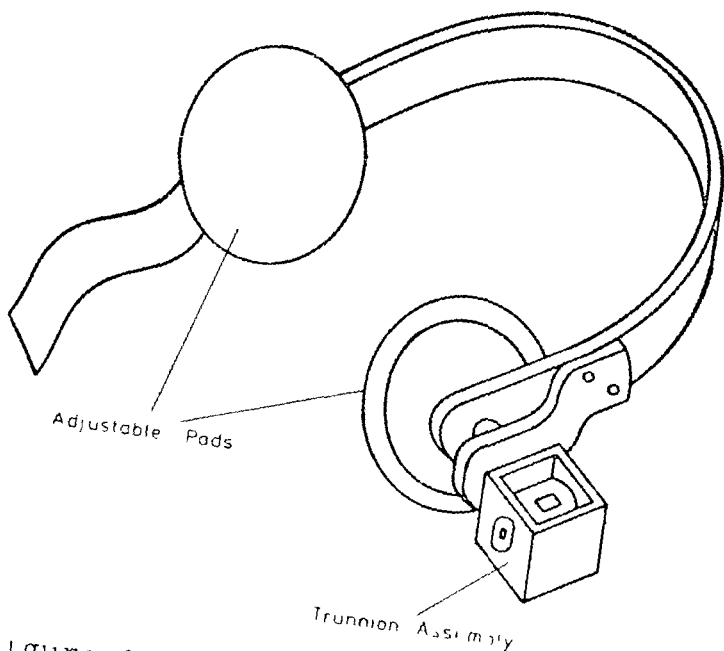


Figure 3 The knee clamb

location of transducers. Corrections can be made as part of the operating program. High resolution analogue to digital converters facilitate otherwise unattainable accuracy and reduce the data to easily storable form either on magnetic disc, or tape, or paper tape and cards. By further numerical manipulation it can be stored in its most concise form as Fourier coefficients, the three orthogonal rotations of the hip throughout a complete cycle can be regenerated from a maximum of only 45 coefficients, and a minimum of 33. Readily accessible bulk data storage facilitates rapid retrieval for further analysis.

Once such a system has been created and a data bank of norms established, a routine clinical version of the equipment can be designed. At the time of writing a completely self contained micro-processor based system is under development.

Thus the advantages of electro-goniometry and computerisation demanded that they be used extensively.

3.2 Development of the pelvic girdle and knee clamp

The pelvic girdle used in the whole of this investigation was developed by the author from a basic idea resulting from discussions with Professor G. R. Higginson, Dr R. J. Minns and Mr M. Flynn, F.R.C.S.

The pelvic girdle (Fig. 1) is constructed of 50 x 6 mm flat bar aluminium alloy, the circumference of which stands away from the body, and is located on the pelvis by three adjustable pads. By incorporating three

hinge joints the circumference of the girdle can be altered by inserting longer or shorter components at the rear. Weight is reduced by machining slots in all components of the girdle. When in use the pads are adjusted to give positive location on the anterior superior iliac spines and the sacrum.

The pad locating on the sacrum is mounted on a simple swivel head and is screw adjustable through the rear component in the anterior-posterior plane. The attachments to the anterior superior iliac spines are of a more sophisticated design in order to be sufficiently adjustable to fit subjects of differing size and sex. The dished circular pads are mounted on swivel heads on the ends of screw adjusters which are themselves mounted in ball and socket swivelling joints. Each ball and socket is integral with a slider running in a trackway machined in the belt (Fig. 2). The adjusters can be released or locked in any position by loosening or tightening a single screw. This arrangement accommodates a variety of pelvic widths as well as allowing for pelvic tilt and any difference in orientation of the anterior superior iliac spines. The assembly weighs 1.1 kg.

In the series of tests performed on patients suffering from osteoarthritis a number of excessively obese patients were encountered. These people presented two problems to the investigator. Firstly, it was very difficult to fit the girdle to them, and secondly, if

they could be squeezed in, it was very difficult to locate the girdle on bony prominences. The problem was partially solved by modifying a denim lumbar support so that the transducer cluster, (the electrogoniometer assembly) could be attached to it. This was not a perfect solution because there was insufficient stiffness in the transducer mount in the coronal plane. However, it must have been as secure as Johnston and Smidt's arrangement, and did allow these patients to be measured.

The knee clamp (Fig. 3) consists of two pads, adjustable laterally, which locate on the subcutaneous femoral condyles. An elastic velcro strap fastening around the distal thigh gives greater security whilst allowing freedom of movement, but holds the pads on the condyles whilst applying only light pressure. A trunnion assembly is mounted on the knee clamp via a swivel on the lateral side, and is designed to allow the square section rod from the transducer cluster to slide freely but not rotate about its long axis. The knee clamp complete with trunnion assembly weighs 260 g.

3.3 Development of the goniometer assembly

At the inception of this investigation, Minns, having surveyed the market, decided that capacitive rotatory position transducers offered the most accurate and convenient method of measuring angular displacements. He selected the Jackson Brothers 19,000 series transducer which featured 0.2% linearity with a sensitivity

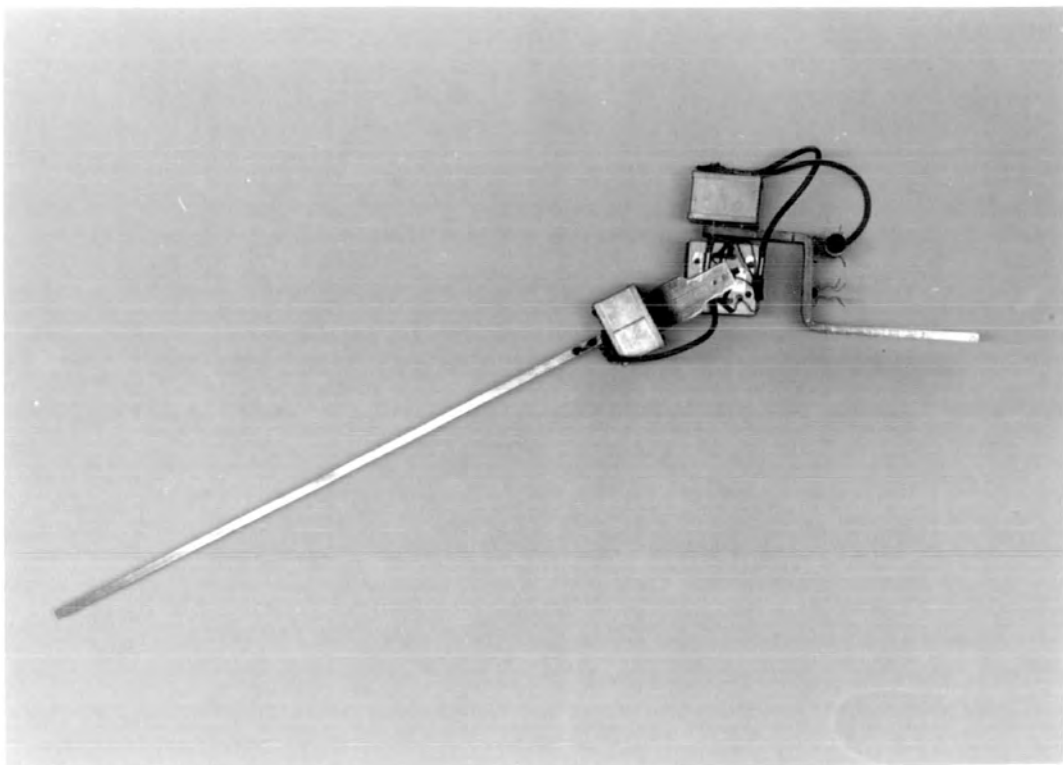


Plate 2a : Capacitive goniometric cluster

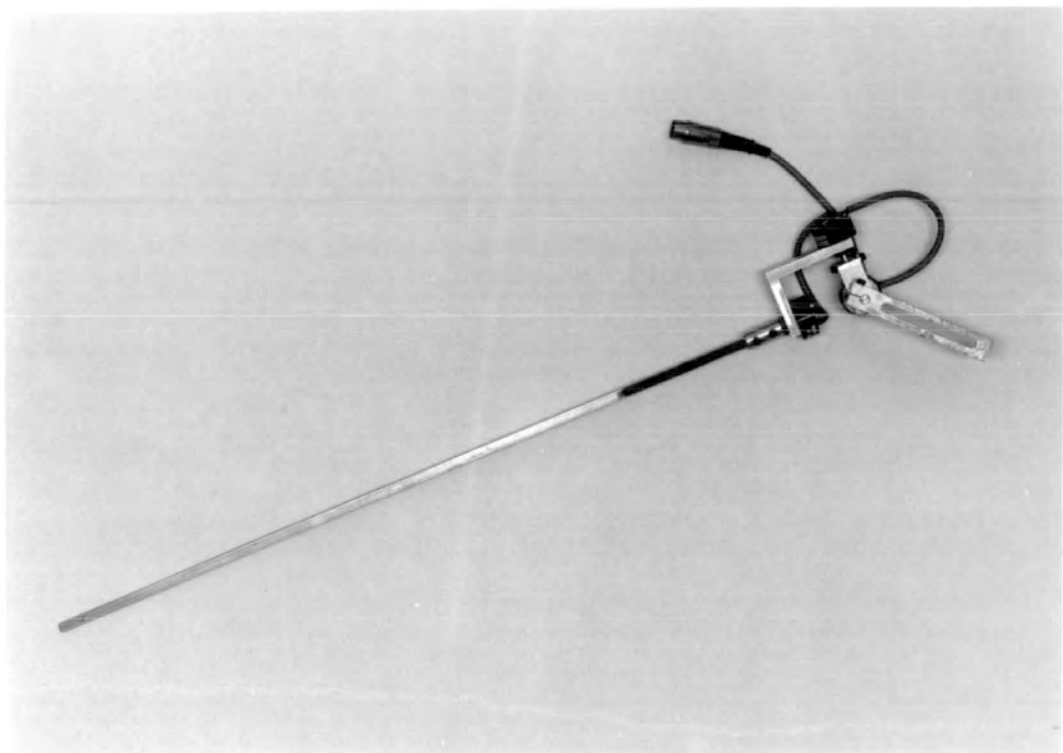
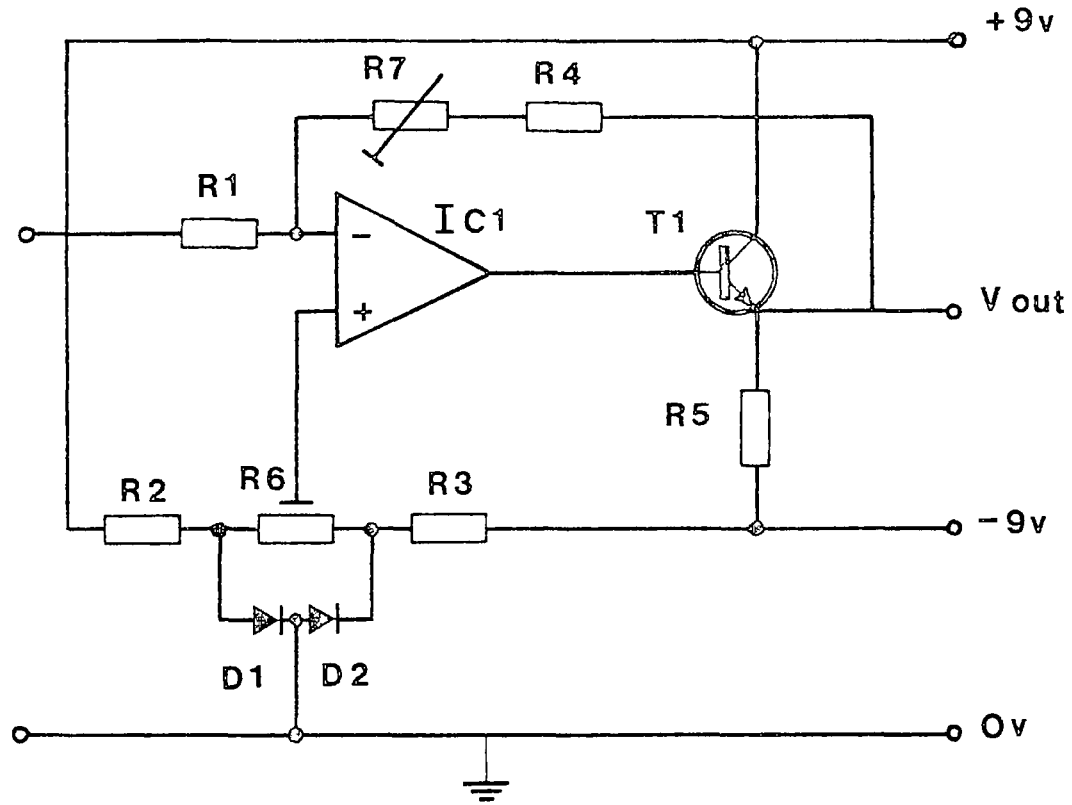
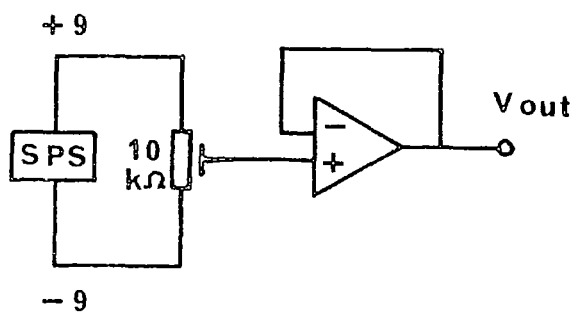


Plate 2b : Resistive goniometric cluster



Component	Value
R1	10K
R2	820R
R3	820R
R4	12K
R5	820R
R6	1K0
R7	220K
D1	1N4001
D2	1N4001
T1	BFR51
I C 1	LM741

Figure 4 Jackson transducer circuitry



SPS Stabilised Power Supply

Figure 5 Maurev transducer circuitry

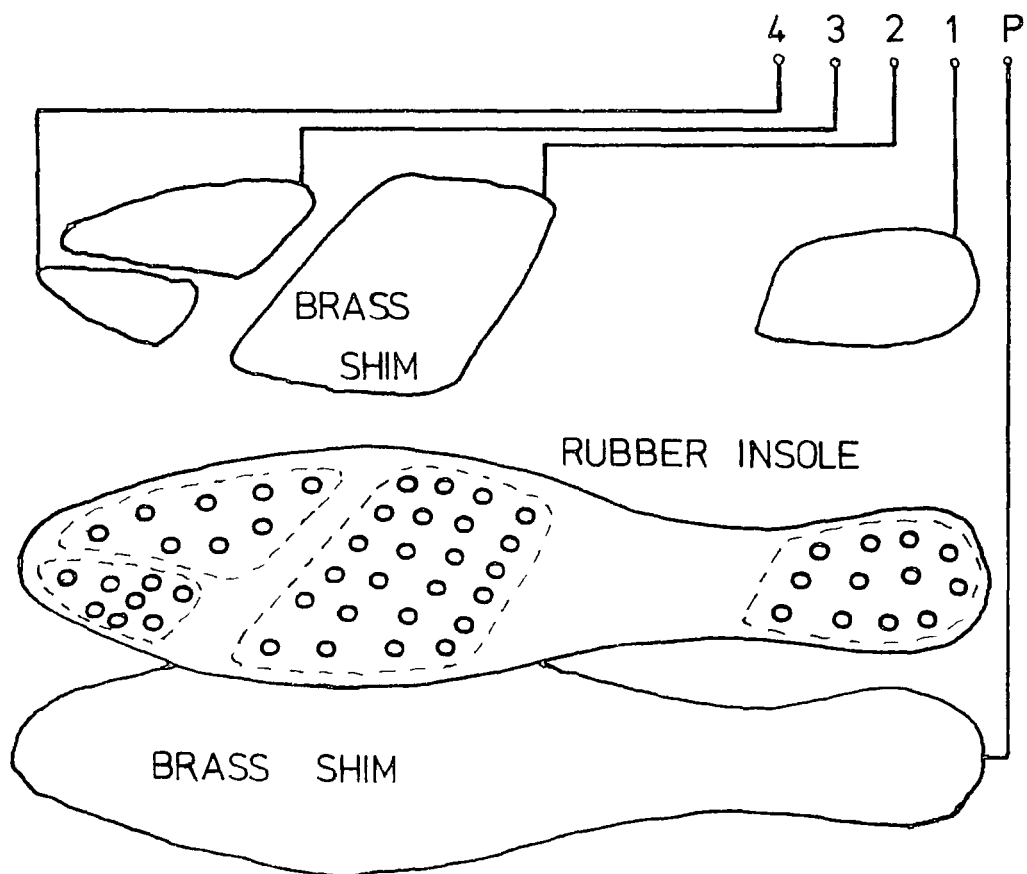
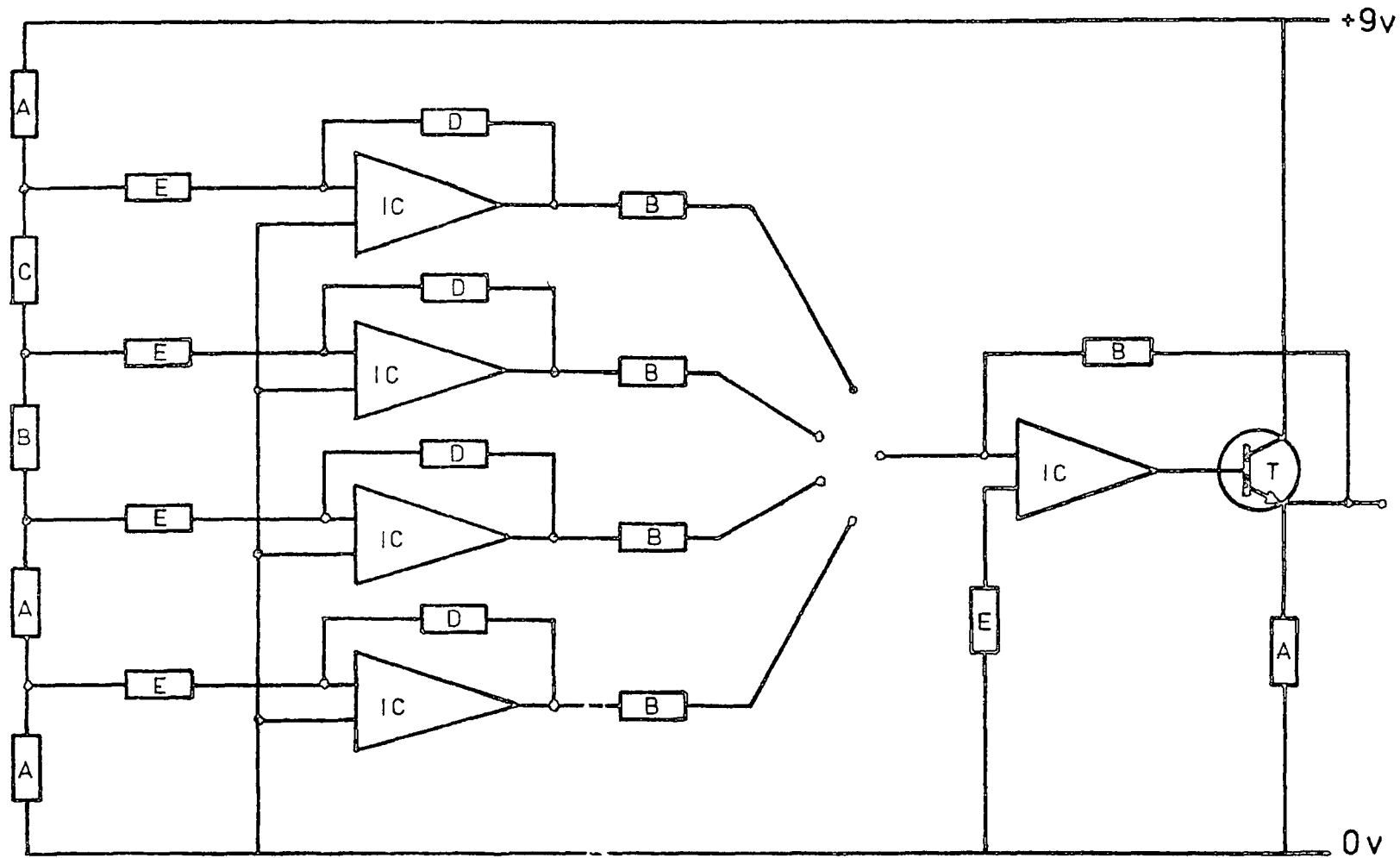


Figure 6a Construction of a footswitch

of 10 mV per degree of rotation with infinite resolution. These units, three of which were necessary measure 47 x 47 x 33 mm and weigh 130 g each. When assembled orthogonally for goniometric use the whole transducer cluster weighs 650 g. This arrangement, shown in plate (2a) was used in an initial pilot study and in the investigation of pathological gaits. The circuitry used with these transducers is shown in Fig 4

Consequent to the pilot study and the clinical tests the author concluded that the capacitive transducers were bulky and excessively heavy. A further review of the market revealed the existence of light-weight precision conductive plastic film potentiometers. The author found that these offered several advantages over the capacitive transducers. They were very much lighter weighing only 27 g each, much smaller, being 27 mm in diameter and 12 mm deep, and far more robust. Three units were supplied by Maurey Instruments Ltd., of the type Pt No 112-P138-9. These featured infinite resolution, independent linearity better than $\pm 0.5\%$ over 340 degrees and a sensitivity of better than 50 mV per degree when run with the associated circuitry, Fig 5. This circuitry is simpler than that required by the Jackson transducers. The potentiometer assembly was found to be far superior to the capacitive transducers, and was used throughout all subsequent tests. The potentiometer assembly



Component	Value
A	1KO
B	2KO
C	4KO
D	50K
E	100K
T	BFR51
IC	LM741

Figure 6b Footswitch encoder circuit

weighs 247 gms complete with linkages, plate (2b).

Design of the footswitch unit

In the analysis of gait, which is a cyclic movement, time reference points are required within each cycle. These are provided by pressure-sensitive switches (Pressex Modules) incorporated in commercially available shoe insoles, which switch a voltage through different discrete levels determined by the contact pattern of the foot on the ground. The foot-switch is designed to be inserted in the subject's own footwear.

The construction of a footswitch is shown in Fig. 6a. A number of these devices were manufactured by the author and individual units were replaced when they wore out (usually due to fatigue fractures in wiring and soldered contacts).

The device is constructed by sandwiching perforated foam rubber insoles between sheets of brass shim. The shim was 0.004" thick as this proved to be the optimum from the flexibility and durability aspect. The sandwich formed as shown in the diagram, the shim being glued to the rubber taking care to keep the contact areas for the Pressex Modules clean and dirt free. Both sides of the unit are covered with clear adhesive film and the edges bound with P.V.C. tape. The signal cable terminates in a five pin D.I.N. type connector.

The unit is essentially a four pole switch which

is incorporated into the encoder circuitry as shown in the circuit diagram. The circuit shown (Fig. 6b) is not that used in the investigation, but it is more than adequate for the purpose. The one used was a modification of a circuit which was initially designed to drive a high sensitivity U V. galvanometer, and consequently the final circuit was not as succinct as it might have been. The circuit is basically that of a digital adder.

3.4 The power supply

The power supply used to drive all the instrumentation circuitry is a Farnell sub-bench 'S' series unit, delivering up to one amp at ± 9 v with an adjustment of ± 2 volts. The unit is highly stabilised and has excellent low noise characteristics.

3.5 The instrumentation recorders

Two machines were used during these tests. The first was a vintage machine manufactured by Epsilon Ltd and named "Labcorder". It was a four channel F.M recorder with a single level input and output of up to 1 volt. It was a bulky machine weighing over 25 kg and was only just portable. The machine was fly-wheel governed and this combined with the excessive noise levels of old germanium transistors and dry electrolytic capacitors did nothing to enhance the signal to noise ratio. The machine was retired after proving unreliable in the first series of tests on pathological subjects.

Its replacement, combined with the use of the potentiometer goniometer was an unqualified success. The machine used is a Racal Thermionics Store 4D instrumentation recorder. It is a four channel F. M. machine with a servo governed tape transport. The machine is very much smaller and lighter and can be easily handled by one person. A number of calibrated input levels can be used so that optimum signal to noise ratios can always be achieved. Three channels are used to record angular data in the three planes, and the other channel is used to record footswitch data.

Signals from the subject are fed to the tape recorder via an umbilical cable. This consists of 25 m of miniature 15 core screened cable, terminated at each end by 'D' subminiature multiple connectors. Five lines are used for footswitch data, three for goniometer data, two for power, and one a common earth. A small junction box also containing the footswitch recorder enables the four signal lines to be connected to the tape recorder.

3.6 The Metronome

A metronome was used to govern the cadence of the subject being tested. This was designed and built by the author and is basically an elaboration on a standard a-stable multivibrator. The metronome has a number of fixed frequencies and can also be set to provide an infinitely variable number of frequencies. A frequency

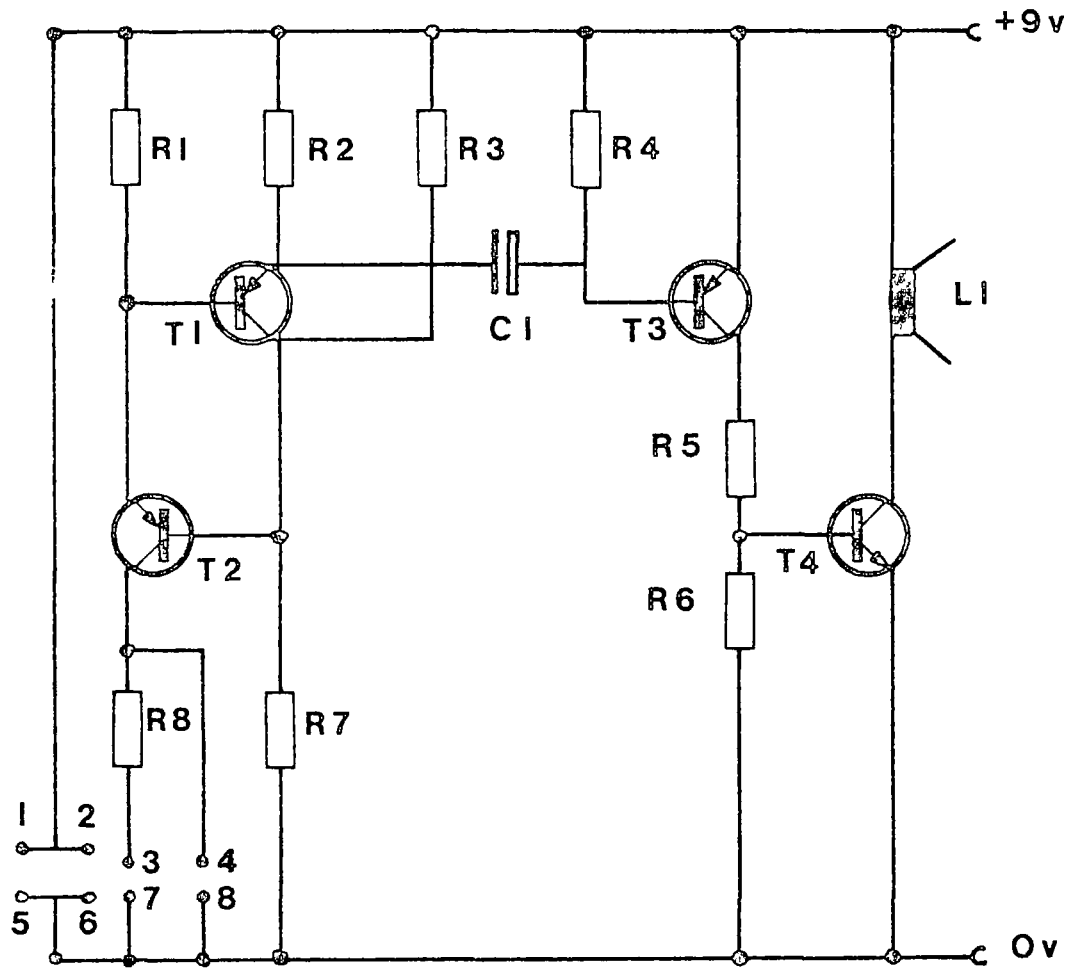
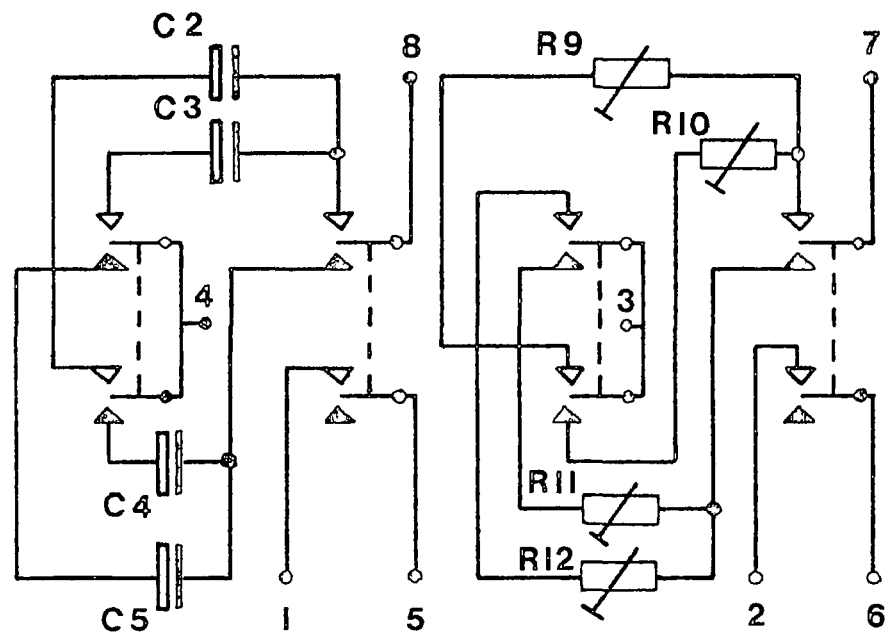
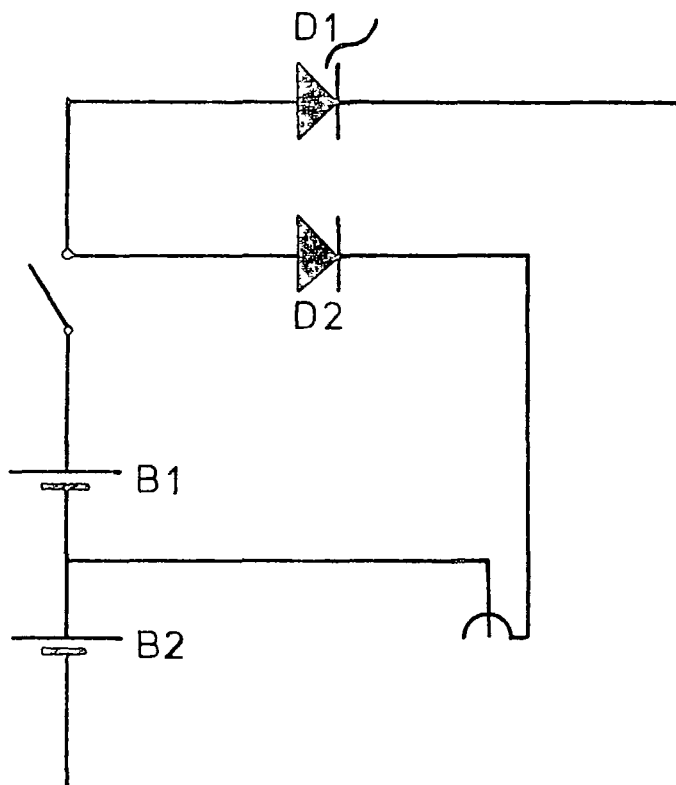


Figure 7 Metronome circuit diagram



Component	Value	Component	Value
R1	1K0	R12	4K7
R2	68R	C1	25uF
R3	390R	C2	100uF
R4	150R	C3	100uF
R5	120R	C4	100uF
R6	150R	C5	50uF
R7	470R	T1	BFR61
R8	3K9	T2	BFR61
R9	4K7	T3	BFR61
R10	4K7	T4	BFR51
R11	4K7	L1	3R0



Component	Value
D1	L E D
D2	1N4001
B1	HP7
B2	HP7

Figure 8 Event marker cct diagram

of 1.8 HZ was used during the gait tests for normal subjects. The circuit diagram is shown in Fig. 7.

3.7 Miscellaneous equipment

A number of small pieces of apparatus were used to make testing more convenient.

An event marker was designed and built by the author so that the beginning and end of data streams could be noted on magnetic tape. Integral with the marker was a light emitting diode to indicate the state of the marker (on or off) and inform the subject that a test was about to be made. Fig. 8 is the circuit diagram.

An accurate set of bathroom scales was used to determine the subject's weight.

A steel tape was used to measure the subject's height.

All the aforementioned equipment is portable and was transported between various sites in the boot of a small car.

3.8 The computer installation

This is a permanent installation at the University of Durham, Department of Engineering Science.

The basic computer is a Varian V73 24 kilo-byte mini-computer. Operator interface is via an A.S.R. 33 teletype or integral visual display unit. The Adapts IV system used is a disc based system operating in EBASIC language and is suitable for general purpose

programming Peripherals include a Pertec magnetic disc unit for bulk data storage, a Centronics high speed printer, a high speed paper tape punch and a high speed paper tape reader The tape recorder was interfaced to the computer using four channels of the sixteen channel analogue to digital converter, and reduced data were displayed on a Hewlett-Packard X-Y plotter interfaced via two channels of the eight channel digital to analogue converter Both converters operated at ± 10 volts The analogue to digital converter was a 13 bit device and the digital to analogue converter a 10 bit device. The author wishes to acknowledge the indispensable aid of Dr Clive Preece who helped overcome the many technical difficulties encountered

 The programming of the installation is discussed later and the program listings may be found in the Appendix

4. EXPERIMENTAL PROCEDURE

4.1 Introduction

The final experimental procedure was developed over a period of time whilst the precise capabilities of the equipment, and in particular the computer installation, were thoroughly investigated. A pilot study was instigated with the cooperation of a number of University students to evaluate various test procedures and examine the integrity of the equipment.

4.2 The pilot study

The undergraduate students of Durham University, Department of Engineering Science were asked in a questionnaire to provide details of their age, height, and weight. As it is a predominantly male department, there were very few female participants. Using data from the completed questionnaires, graphs were plotted of height against weight, age against weight and age against height. Because the age range was so small (less than four years between youngest and oldest) no correlations at all was found between age and either height or weight. There was however, a general trend on the height against weight graph. Taller people were generally heavier, as might be expected. Examples of this type of plot may be found later in the text.

Using this graph a group of students were selected who were very closely similar in age, height and weight. A group of ten were chosen who were all either

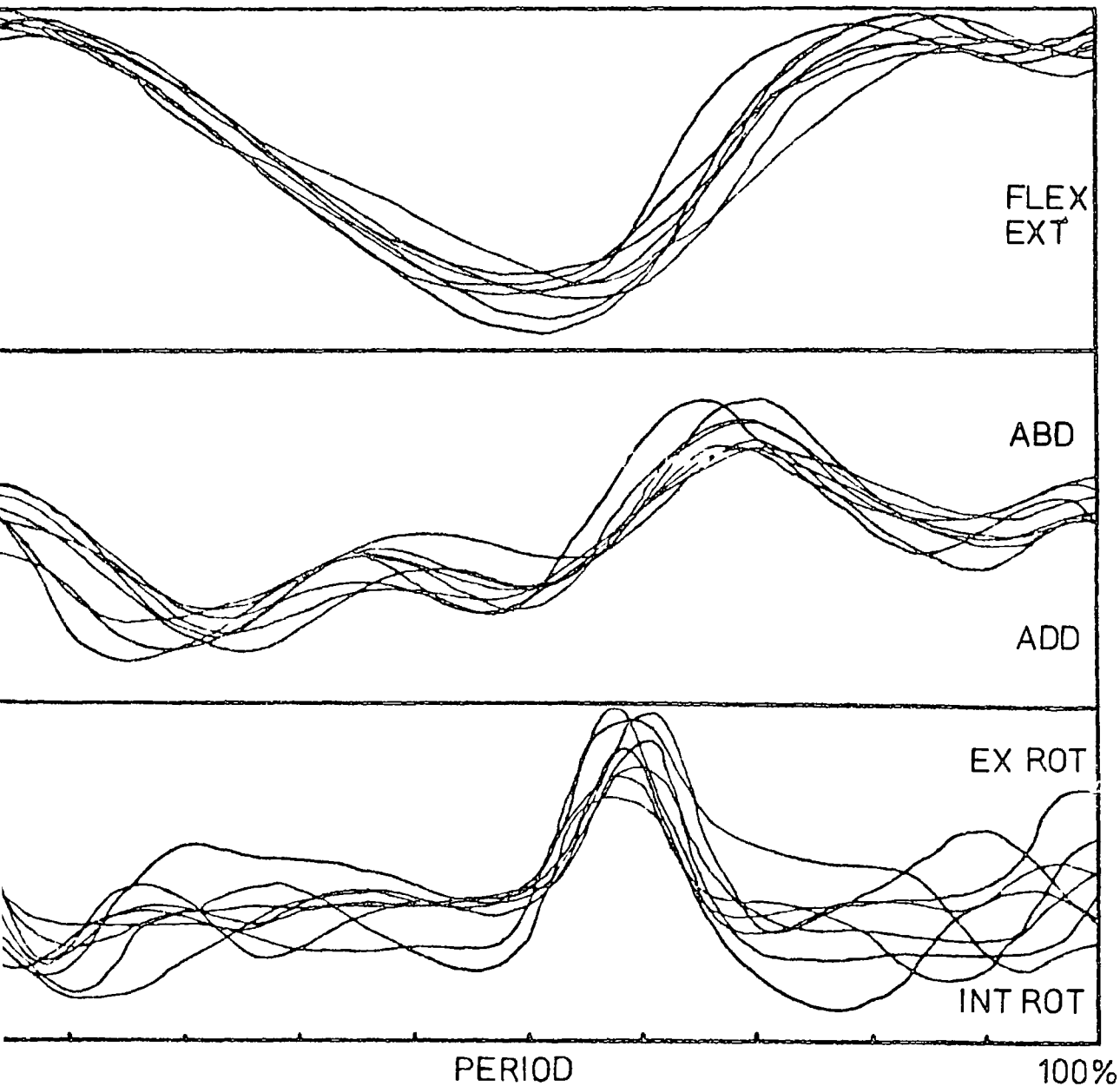
19 or 20 years old, between 1.81 and 1.83 m in height and between 650 and 680 N in weight. Of these ten people, one had recently fractured a leg and was consequently eliminated from the study, and one was female. Her results provided an interesting comparison with the other eight male results.

The tests were conducted in a 7 m long room, using the whole length as a walkway. The capacitive goniometer was used at this stage and was connected directly to a portable light oscillograph.

The exercises examined were level walking, climbing three steps of a portable stairway, descending these steps, sitting and standing and a measurement of the 'global range'. Each of these tests will be discussed in turn along with conclusions drawn from them and subsequent alterations in technique.

The walking tests were conducted with the subject wearing normal clothing and his own footwear. He was asked to walk down the room in a normal fashion and return. The subject was encouraged to walk at a reasonable pace, but this was not governed, and neither was his cadence. This comparatively simple test taught many lessons.

Firstly, gait analysis in small rooms is impossible. This is because as space becomes more confined, walking speed seems to be automatically and subconsciously reduced, so free gait speeds are never achieved. If the subject can be encouraged to reach a normal speed



NAME		PILOT STUDY			
NO 8	FILE — —		FLEX	ABD.	EXROT
EXERCISE	AMBULATION	POLARITY	↑	↑	↑
LEFT	RIGHT	SCALE%div	10	5	5
NOTES					
<p><u>Figure 9</u> Pilot study results</p>					

he can only maintain it for a maximum of two steps before he runs out of room. Subsequent to this, all further tests were executed in rooms or corridors with a minimum of 25 m of unobstructed walkway. It also became obvious that some form of speed control was necessary. Direct speed control is impossible without a treadmill, but even if one is available subjects have to be trained to walk on them. Speed control is possible by governing step length and cadence, and this can quite simply be done by using floor markings (e.g. floor tiles) and a metronome. However, this has the disadvantage that one stride length-cadence combination would not be suitable for all subjects, they would either be pulling or pushing their natural stride, leading to an unnatural and abnormal gait. It was decided therefore, to govern cadence only using a metronome, thus allowing the subject the freedom of finding a comfortable step length. During subsequent tests subjects who walked too quickly or too slowly were requested to moderate their speed accordingly. Walking speeds were generally in the range 1.3 to 1.7 metres per second.

The results of this short series of tests are shown in Fig. 9. These results were manually reduced by digitizing with a scale from the oscillograph trace and plotting by hand on graph paper. From raw data to Fig. 9 took the larger part of a week and emphasised more than ever the necessity for automatic data handling.

The accuracy of the oscillograph and manual scaling leaves much to be desired, and so no great time need be spent considering these results. What was undeniably demonstrated was the existence of a common pattern of movement between individuals, and the ability of the goniometer to measure them. These results were very encouraging and provided the basis for the approach to the systematic analysis of large numbers of people

The tests carried out on the portable stairway proved very unsatisfactory. It became clear that to get people to walk normally on a stairway, one had to supply them with normal stairs. Consequently, all further tests were carried out on a main stairway with a continuous flight of not less than 12 stairs. No data were reduced for these tests due to the difficulty in establishing a representative step on the oscillograph trace

The sitting and standing test demonstrated the need for an event marker to indicate the start of the data stream and to provide the subject with a preparatory signal

The global range test involves attempting to measure the total active range of a hip joint, in all three planes. This is done with the subject standing on one leg, using handholds for balancing, whilst moving the other hip through the fullest possible range of circumduction. It is appreciated that this precludes

the fullest possible adduction. This test never proved to be entirely satisfactory due to the fact that it is difficult to encourage subjects to use their fullest possible range of motion

The lessons learned during the pilot study were extremely valuable, demonstrating the areas where procedures could be streamlined and rationalised before attempting to examine large numbers of people.

Following the pilot study, effort was concentrated on automating the procedure by establishing the computer software and finalising the analytical details. Data acquisition and analysis is discussed in the next chapter. There follows a description of the techniques used to acquire data from the chosen sample.

4.3 Finalised experimental procedure

The use of at least 25 m of walkway allows large numbers of consecutive steps to be examined. The importance of averaging a number of steps was discussed in the literature review, and the use of this technique was further reinforced in the pilot study. The large amount of data required for this type of analysis demanded the use of strict procedures to keep it under control. A standard procedure was followed as closely as possible.

First, the subject was briefed, the goniometer fitted firmly but comfortably and a period of acclimatisation allowed. The subject was asked to walk about during this period to become relaxed in the

equipment.

The tests started with walking. A datum position was established in an upright stance with the feet together and the toes pointing forward. Some subjects were unable to reach this position. In healthy subjects this was usually due to mild valgus deformities at the knee causing the knee clamp to impinge on the opposite limb. No healthy subjects had any difficulty with this whilst walking. These subjects were asked to assume a position with the feet parallel one foot apart (the size of standard vinyl floor tiles). This created an offset in the standard starting position but this was corrected in the data reduction process always to give a standard plot. The offset was measured as being 0° degrees in flexion and rotation, and 6 ± 0.5 degrees in abduction for all subjects. Subjects with hip diseases were examined by standard clinical methods (The American Academy of Orthopaedic Surgeons (1965)) to determine the magnitudes of any fixed rotations. Measurements were then taken from a datum as close to the standard as possible.

Starting from his datum position the subject was asked to walk along the walkway (approximately 25 m, straight and level) whilst the signals from the goniometer and footswitch were recorded on the tape recorder. Whilst walking his cadence was governed by a metronome set at 1.8 Hz. At the end of the walkway

the subject turned around and the test was repeated in the opposite direction. For each direction at least 10 consecutive steps (20 paces) were recorded of which 5 were analysed when the subject was in steady motion.

Having completed the walking tests, the subject was tested whilst descending then climbing stairs.

The subject was asked to assume his datum position at the top of a flight of stairs. These had a tread width of 255 mm and a pitch of 160 mm. On command he was asked to descend the stairs in a normal manner keeping time with the metronome. On reaching the bottom, he was asked to turn and assume his datum position again. After a few seconds he was allowed to proceed up the stairs, again in time with the metronome. Tests on the stairs were concluded when the subject reached the top. Data from the goniometer and footswitch were recorded throughout, allowing the analysis of usually four cycles (8 stairs) taken from the centre of the flight.

Sitting and standing exercises were recorded next. A standard straight backed chair was used which had a seat height of 450 mm, width of 400 mm, and depth of 400 mm. The footswitch data line was removed from the tape recorder input and replaced with the previously described eventmarker. From his datum position the subject sat down on the chair in his normal manner, remained there for a second or two then stood up again.

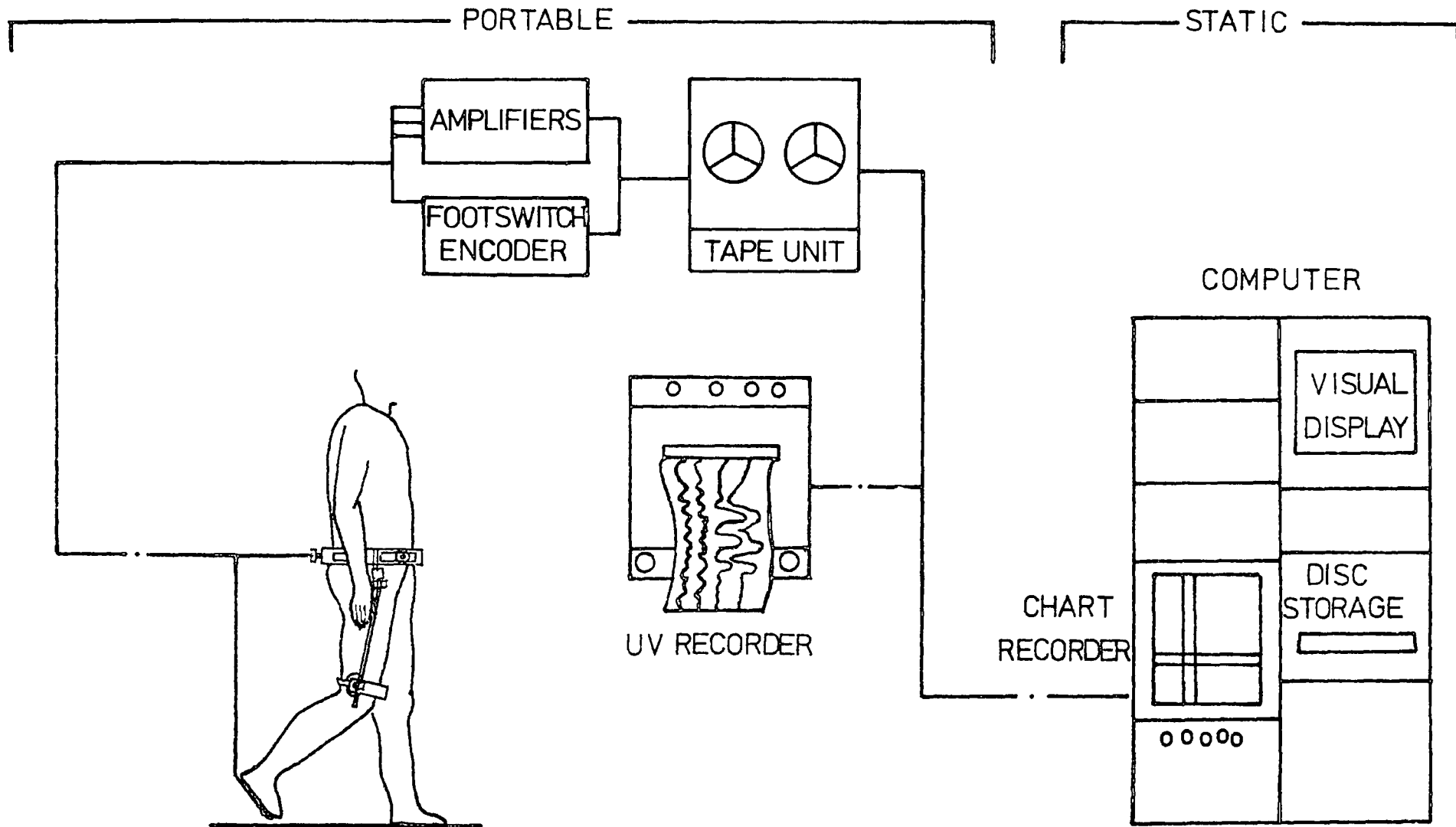


Figure 10 Schematic of apparatus

The event marker was switched on just before the activity started, and was switched off immediately after its conclusion. The computer analyses the data recorded whilst the event marker is on.

The global range exercise was measured in much the same way. From his datum position the subject moved his hip through his maximum range of circumduction and returned to the datum position. The exact procedure was demonstrated to the subject until he had a proper understanding of the requirement, and he was allowed practice attempts until his performance was satisfactory. The eventmarker was operated exactly as recorded above. This concluded the tests and the equipment was removed.

Throughout the tests notes were taken of the tape index so that data could be easily recovered. Each subject had a personal data sheet on which this was recorded, along with his personal measurements and brief notes of any medical history. The complete tests took under half an hour per person for healthy subjects. Old and infirm people took slightly longer. A schematic of the apparatus is shown in Fig. 10.

4 4 Population sampling techniques

The sample of people examined in the pilot study was obtained as described in section 4 2.

One of the goals of this study was to identify if possible the normal performance envelopes to be expected of people from each age decade from the second to the eighth. This involved selecting at least ten

people from each decade, both male and female. The most readily available population from which to take samples were the employees of the University of Durham who were based on the Science Site complex.

Questionnaires and covering letters were sent to all academic, research and technical staff in the faculty to obtain volunteers. The overall response was excellent and the author wishes to thank again all who participated. Each volunteer returned his or her sex, age, height and weight. The returns were sorted into age groups 18 to 24, 25 to 34, 35 to 44 and so on up to 74, and for each group graphs were plotted of height against weight. These appear as figures (11) to (20). In total about 280 replies were processed. The older groups were augmented by volunteers who had retired from university employment. Using the graphs, samples were chosen such that the individuals had similar height and weight characteristics. The response was not evenly distributed over the age spectrum so some groups had greater differences in height and weight between individuals than others. The volunteers were subsequently called for examination at their convenience. Most testing was arranged in the afternoon between the hours of two and five.

It is appreciated that this was not a completely accurate representative sample of the British population, but was weighted towards the middle classes and people of above average intelligence.

Professor J. Newell, Professor of Medical Statistics, Newcastle, when consulted, indicated that a satisfactory sample had been obtained.

The people examined in the studies on pathological cases were selected from Mr. M. Flynn's arthritis patients. These cases were examined as they appeared or were located from patient files. Attention was concentrated on cases of osteoarthrosis but other interesting pathological cases were examined as they appeared. Most of these patients attended the Hartlepool Accident Hospital, where the tests were performed.

MALE - AGE 25 - 34 HEIGHT, WEIGHT

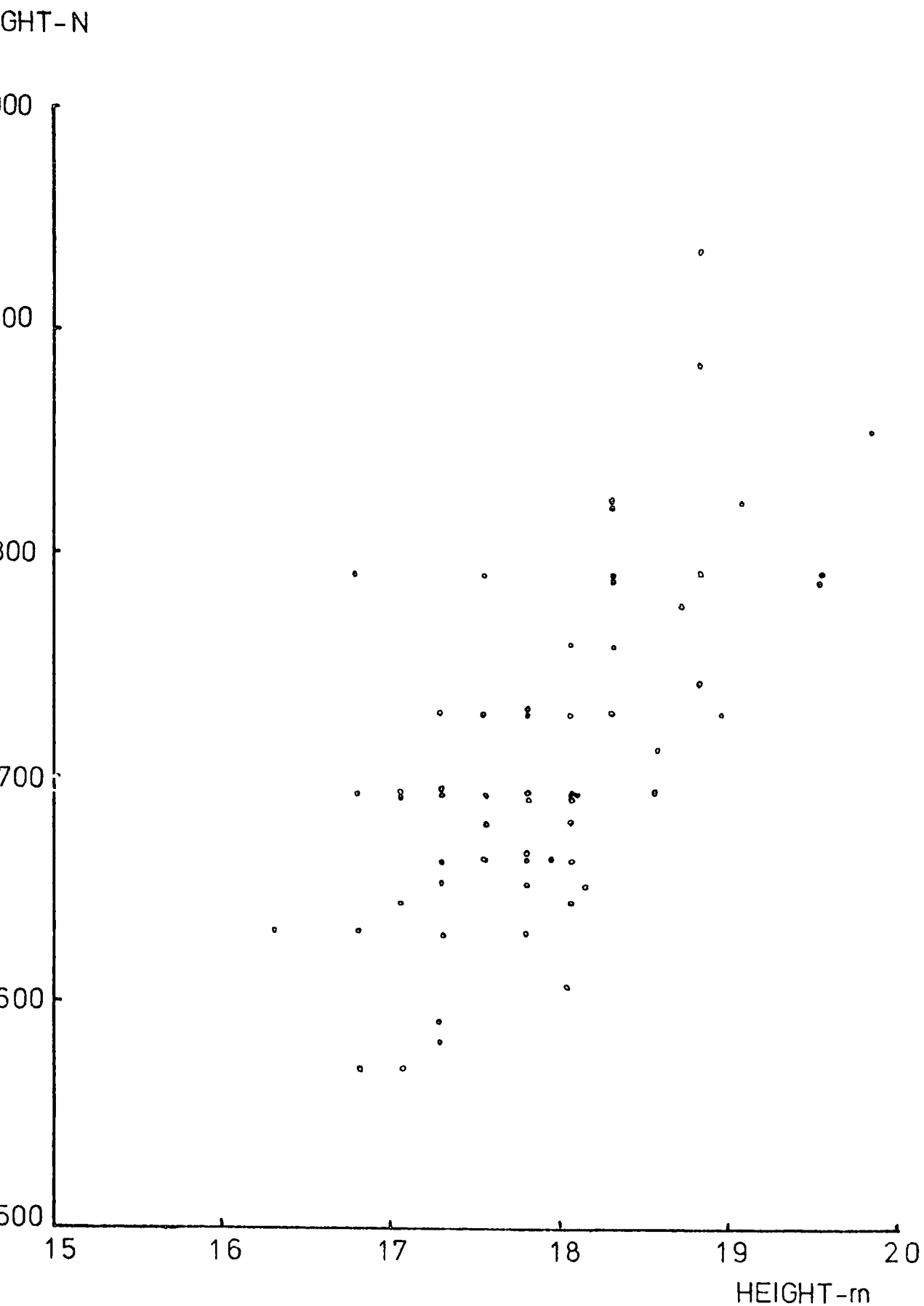


Figure 12

MALE - AGE 35-44 HEIGHT v WEIGHT

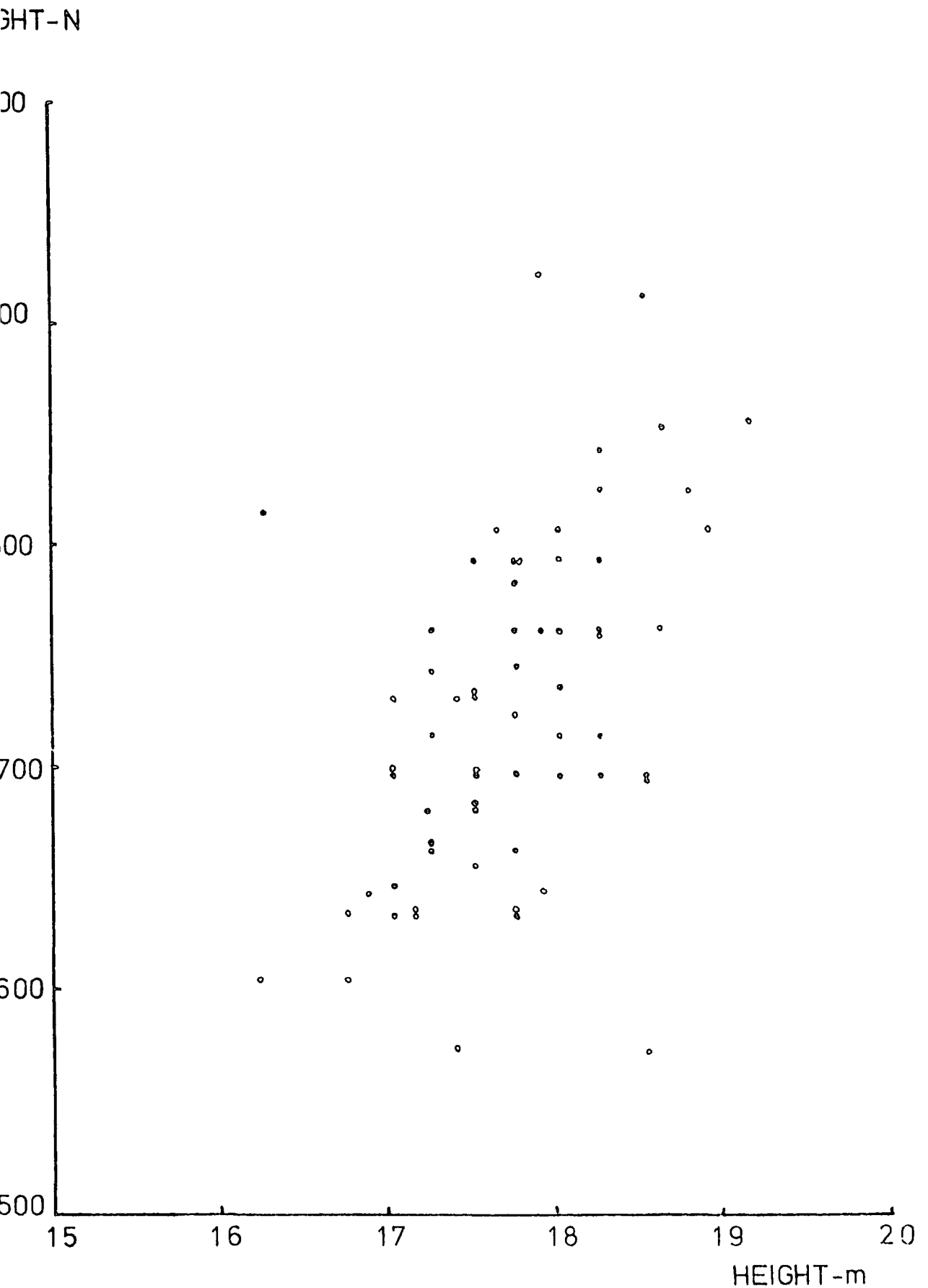


Figure 13

MALE - AGE 45-54 HEIGHT v WEIGHT

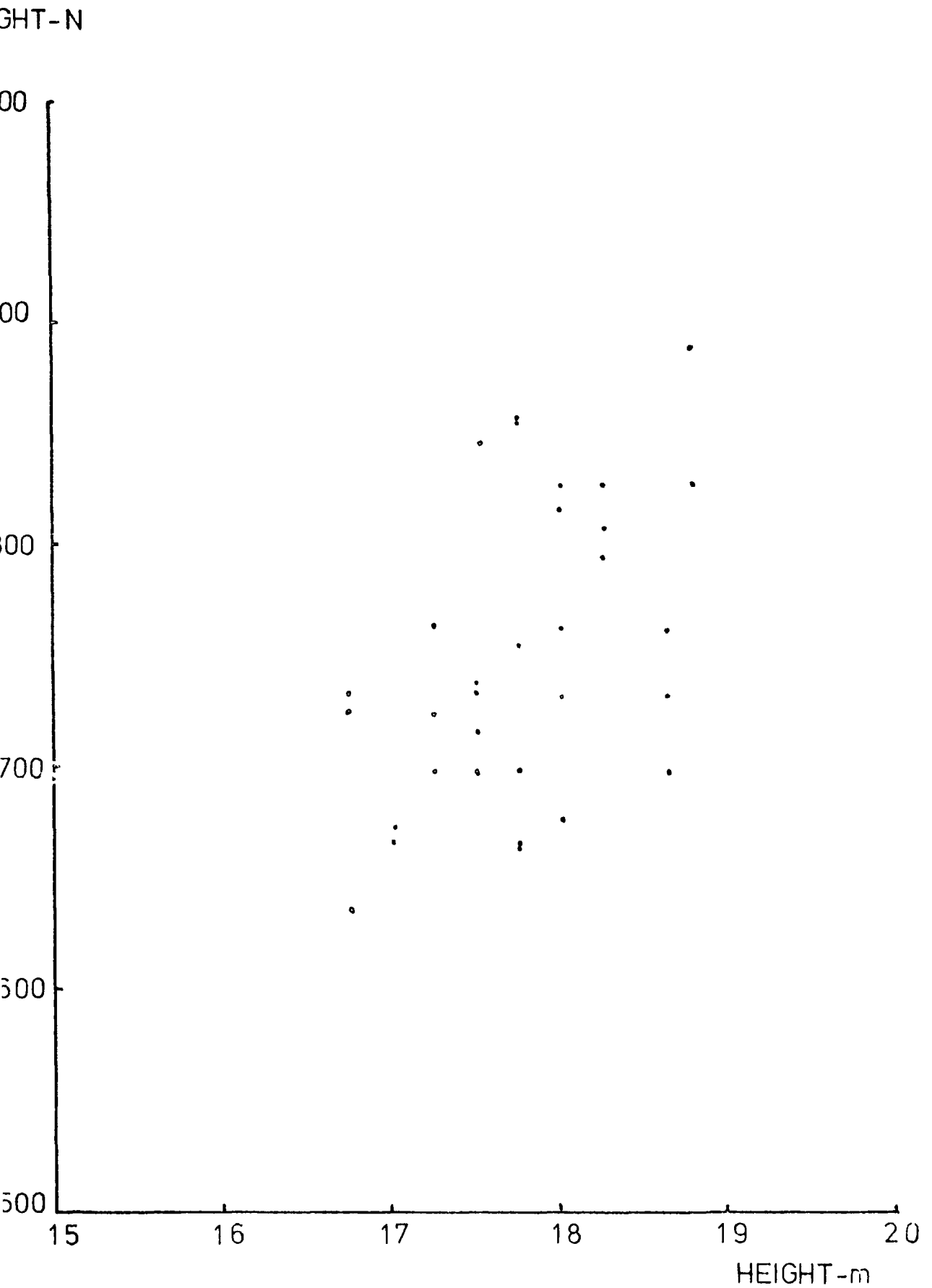


Figure 14

MALE - AGE 55 - 64 HEIGHT v WEIGHT

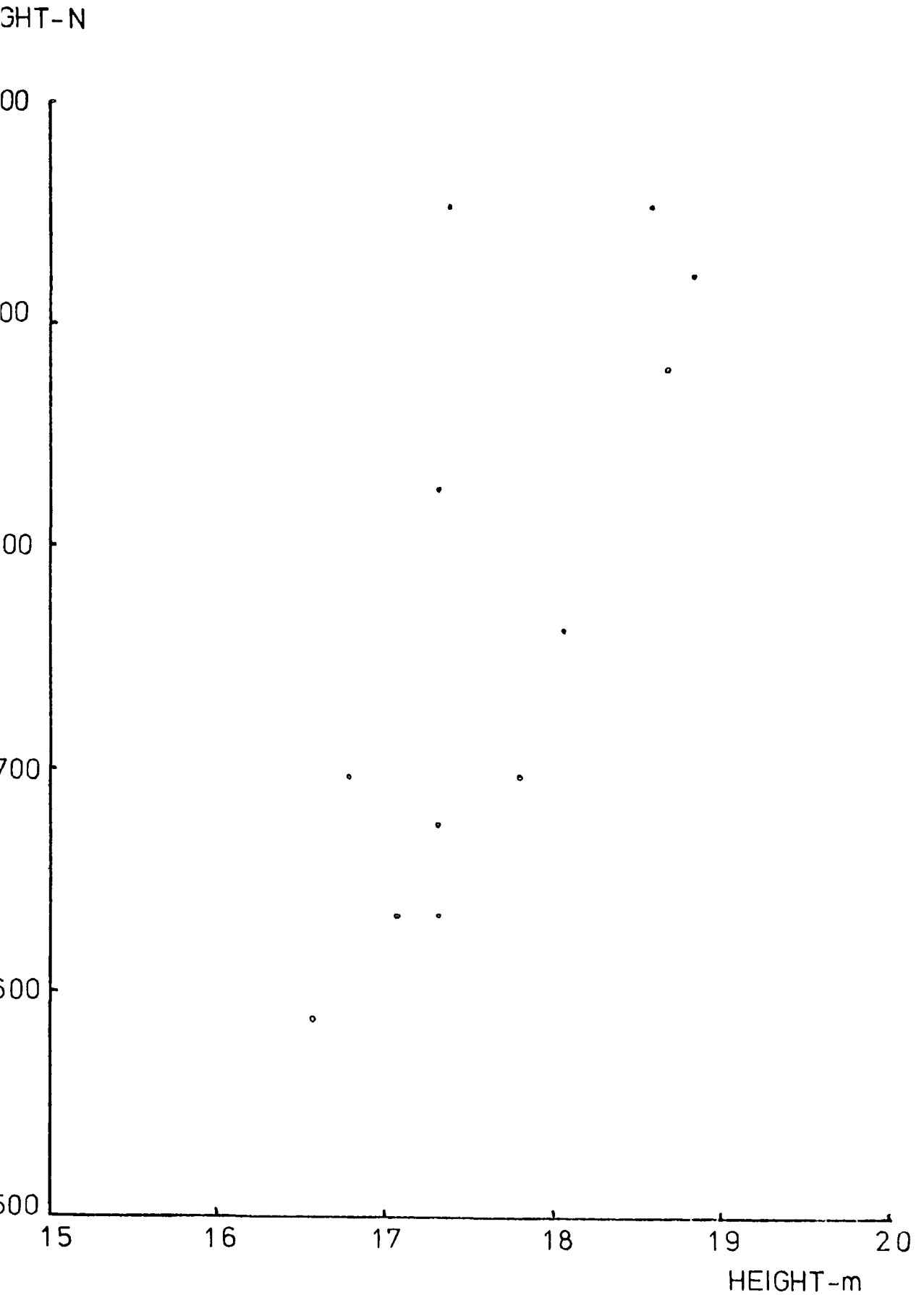


Figure 16

MALE - AGE 65 - 74 HEIGHT v WEIGHT

HEIGHT-N

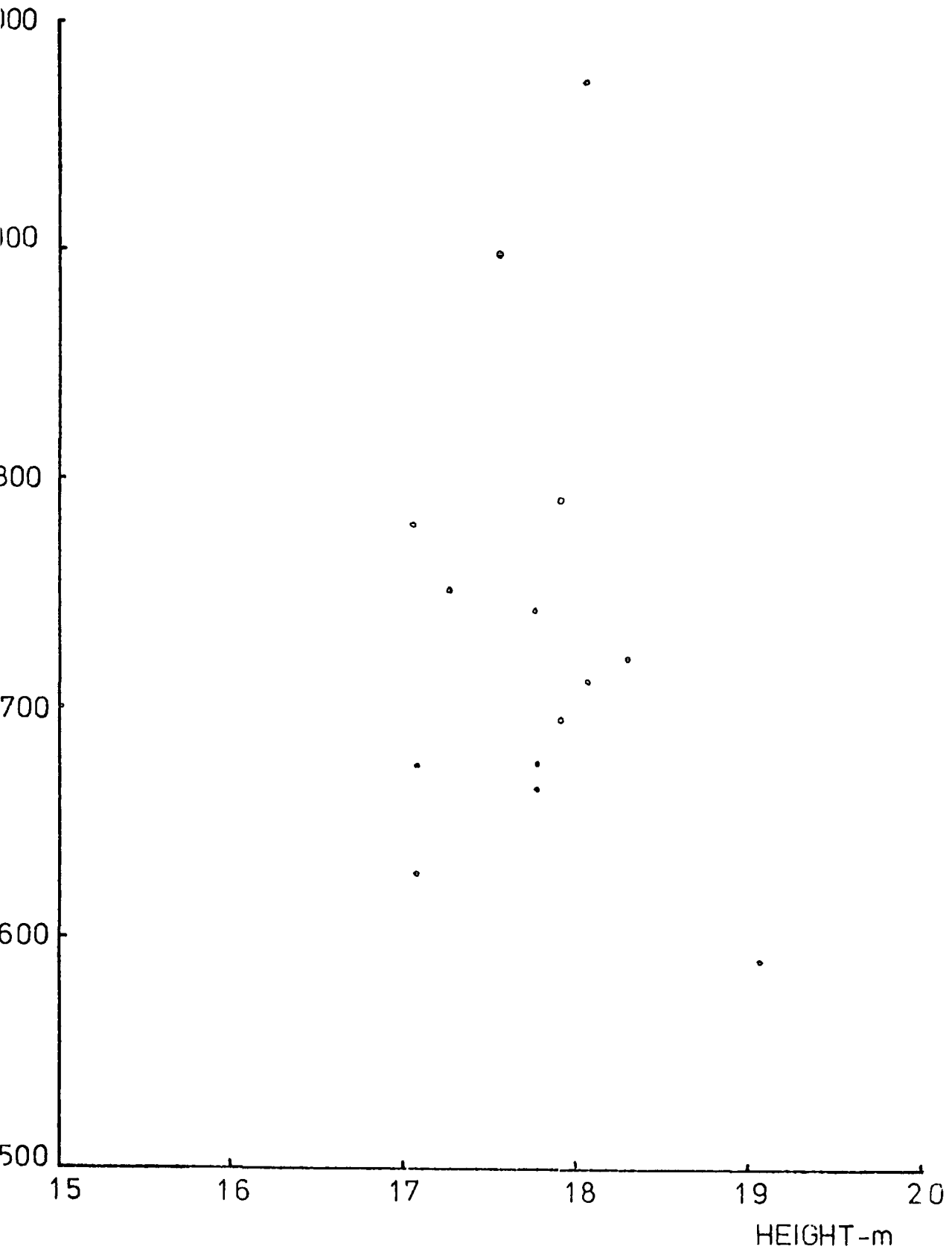
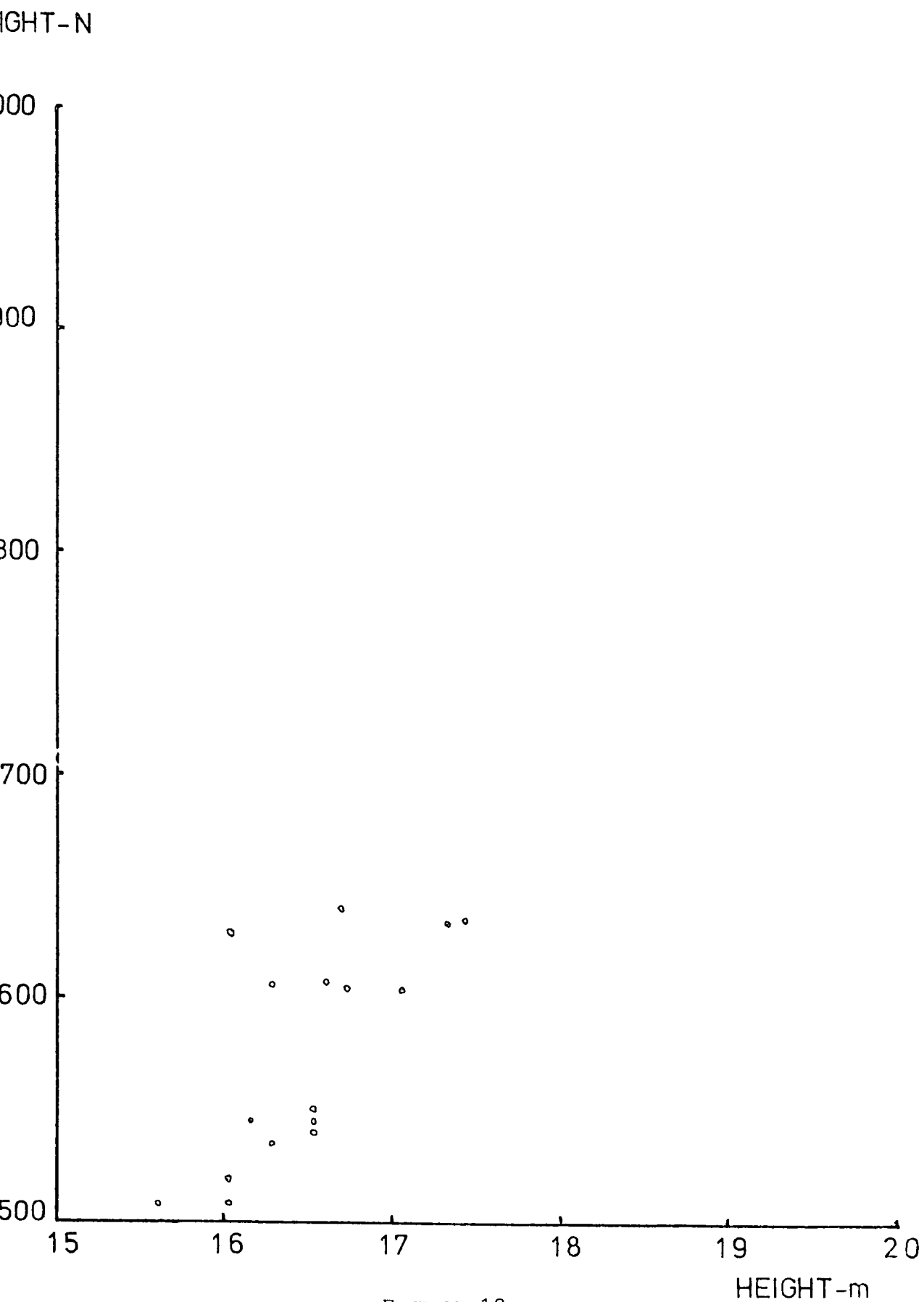
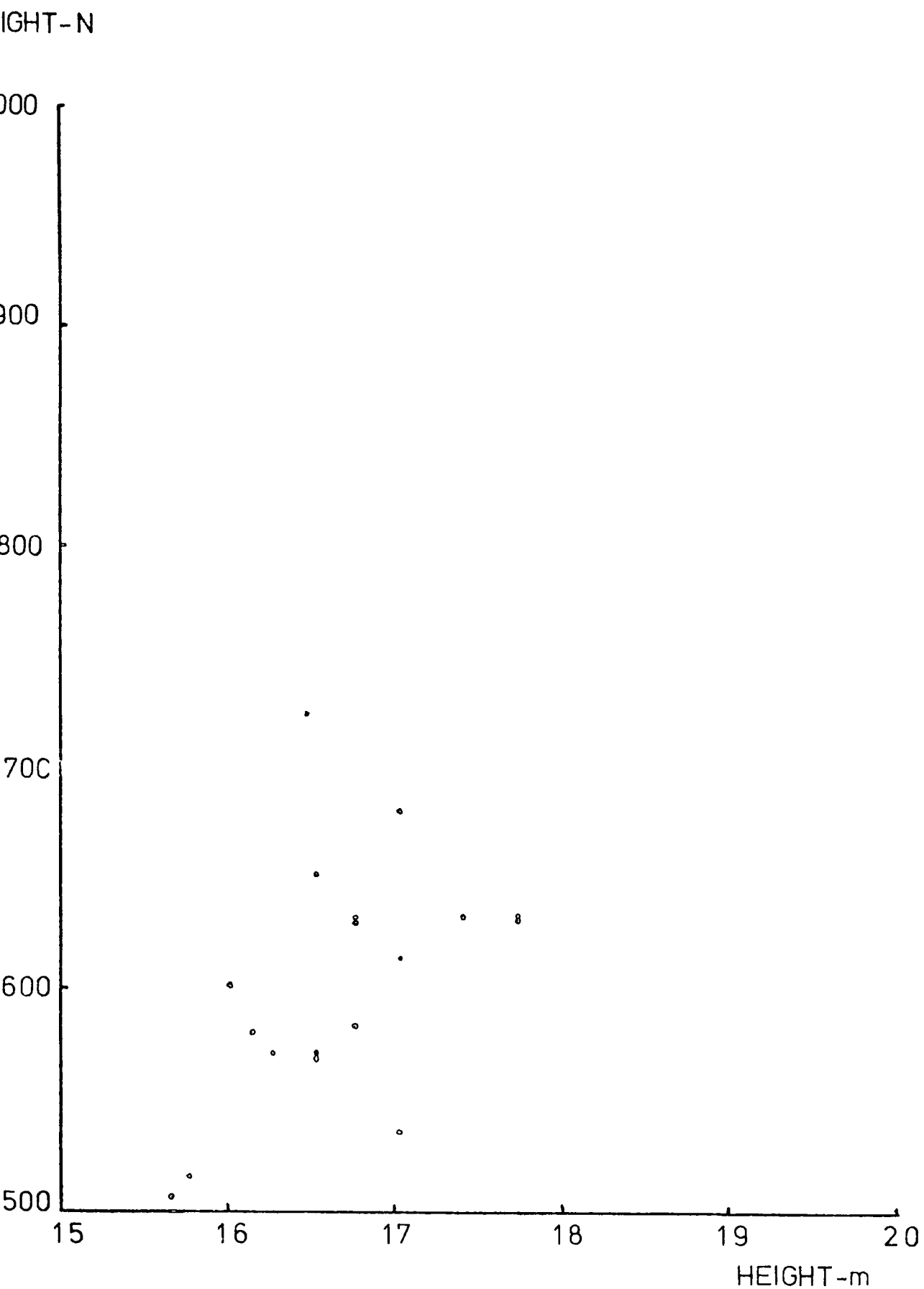


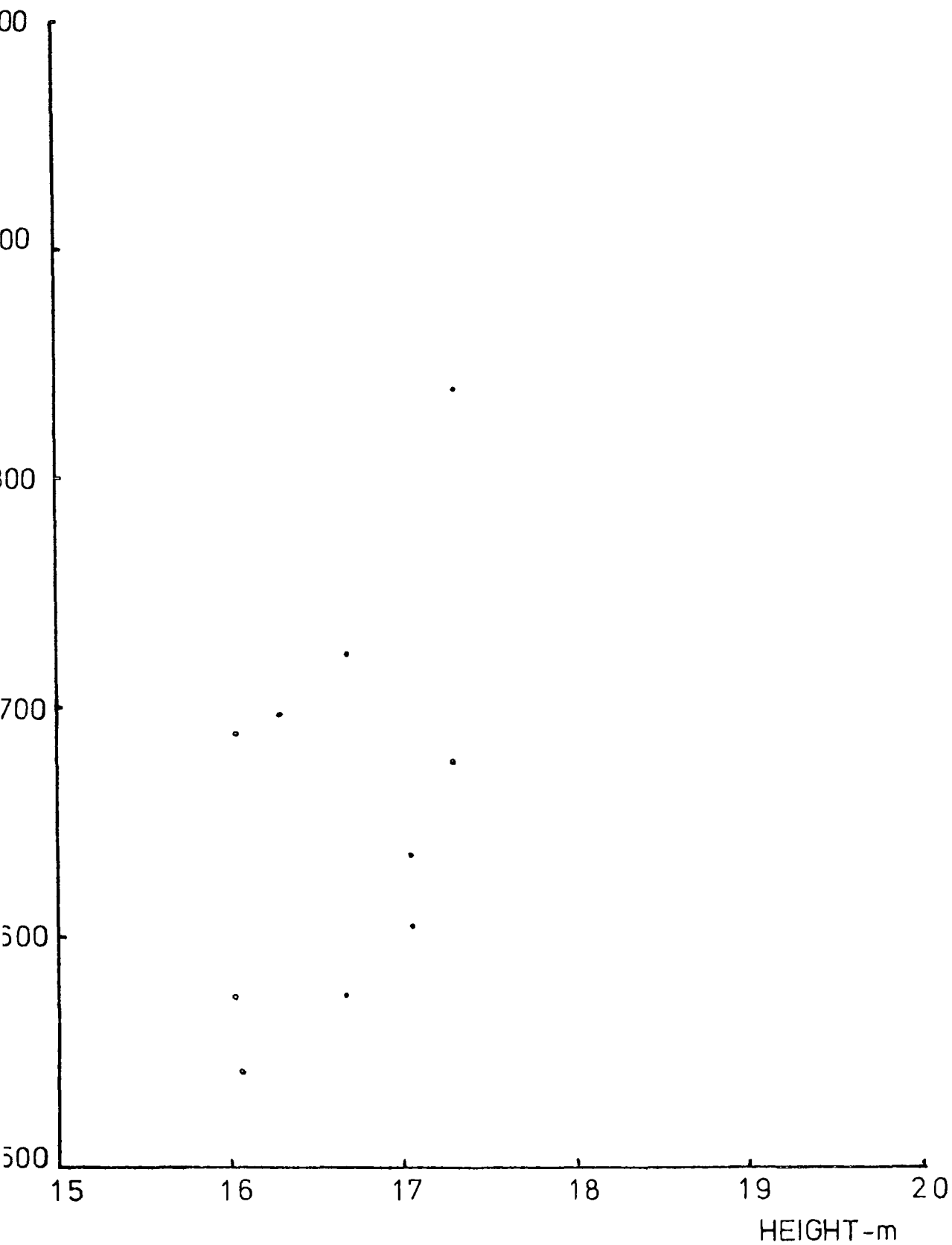
Figure 17

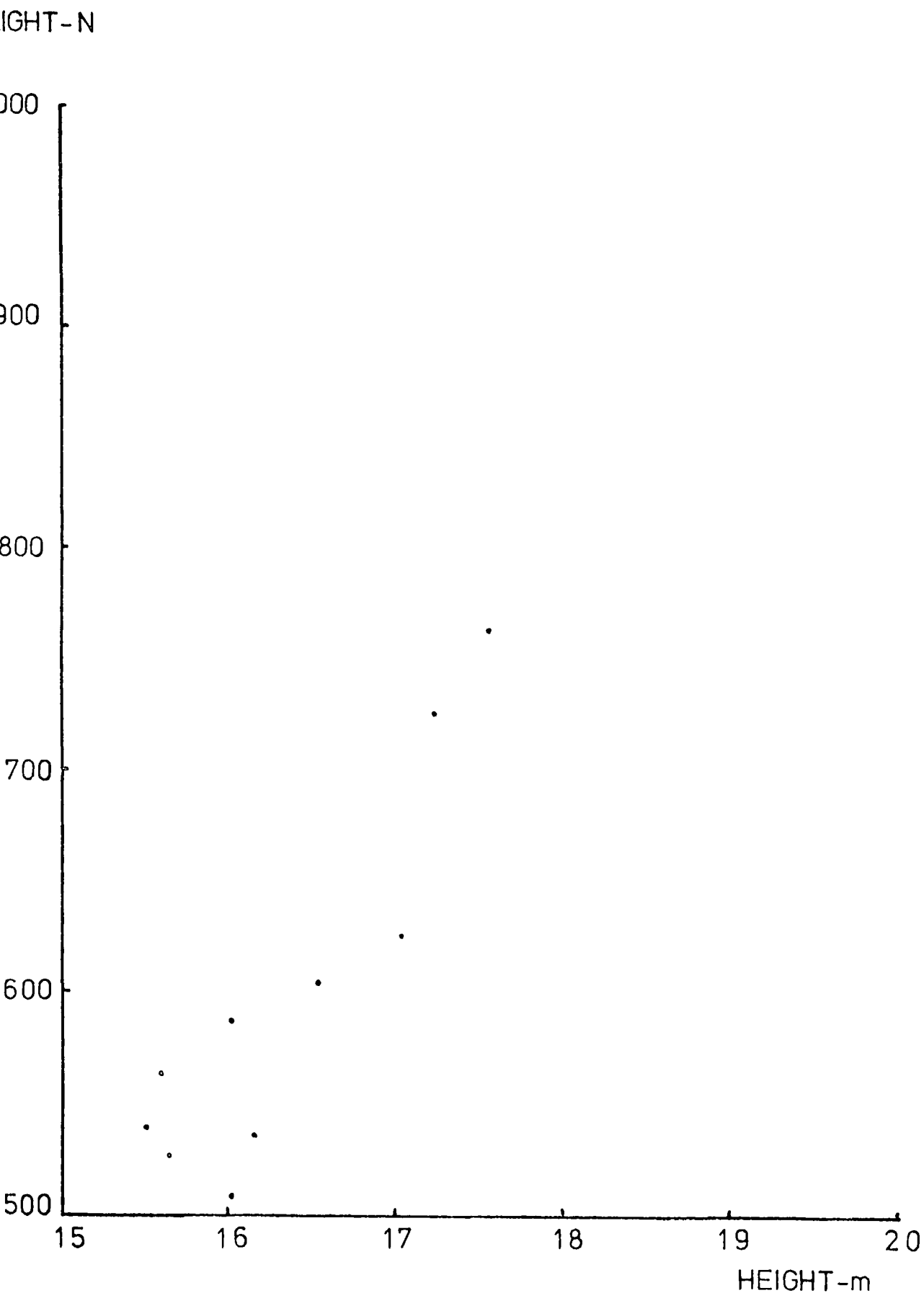
FEMALE - AGE 18-24 HEIGHT v WEIGHT

FEMALE - AGE 25-34 HEIGHT v WEIGHTFigure 19

FEMALE - AGE 35-44 HEIGHT v WEIGHT

HEIGHT-N

Figure 19

FEMALE - AGE 45-54 HEIGHT v WEIGHTFigure 20

5. DATA REDUCTION

5 1 Introduction

The brevity of the following descriptions will tend to disguise the complexity of the involved techniques necessary in creating a comprehensive interfacing and analysis system. Although the computer used is comparatively small, its strength is in its versatility. The enormous amount of data handled demanded the utmost efficiency in the use of active computer memory. Consequently programmes had to be written in a modular format such that they could be efficiently rotated without corrupting data arrays. Hard copy back up was necessary to protect against accidental loss of data or programmes due to hardware failure. Hardware and software failures always resulted in some loss of data but this was always minimal. Significant hardware problems usually centred on the disc drive unit. All software was written by the author and much of the specialised hardware designed and built by him. All programming was in EBASIC on the Durham Engineering Science Adapts IV system. This is an operator interactive system, compiling whilst running. Although this system is extremely convenient for rapid programme writing and editing it can prove excessively slow when running long programmes. Fitting a Fourier series to the eighth harmonic through 200 points for three separate curves

takes approximately 45 minutes of C.P U. time, but this is an extreme example. The programmes and their functions will be discussed in the order in which they would be used in a data reduction session.

5.2 Programme "AOITG1"

This is the master programme which initialises all equipment, accepts raw data and reduces it to provide a graphical hard copy.

The four data channels are scanned by the analogue to digital converter at a frequency of 200 Hz. The points are buffered through computer core and 8000 of them stored on disc. This gives a sampling time of 10 seconds which is equivalent to 8 or 9 steps (16 to 18 paces). Data are reloaded back into core in blocks of 800 points for analysis. The footswitch data is examined until the beginning and end of the first complete step has been found. This identifies the beginning and end of the step for the goniometer data also. The data are scaled to output as degrees per centimetre and normalised so that there are always 200 data points for each channel between one heelstrike and the next. The data is displayed on the V.D.U. and if satisfactory, it is plotted and stored in an array. The raw data for that step is dumped and the immediately following 800 points reloaded from disc and analysed in exactly the same manner. When five steps have been accumulated and plotted they are averaged and that plotted. Five steps and their

average are shown in Figs 23, 24 This programme is used for the walking exercises and climbing and descending stairs

5.3 Programme "AOITG2"

This programme loads immediately after the average has been plotted and replots the data in rectangular format, flexion against abduction (See Fig. 25.)

5.4 Programme "AOITG5"

A permanent file on disc is initialised for the data by this programme.

5.5 Programme "AOITG3"

This programme operates in a very similar way to AOITG1. It is used in the analysis of sitting and standing and global range measurements. Less data is handled so the use of the disc is unnecessary. The event marker is used as a timing reference instead of footswitch data. AOITG3 is followed by AOITG2 to obtain rectangular plots If a permanent record is required this can be provided by AOITG5.

5.6 Utility subroutines

A number of utility subroutines may be used with the above programmes so that minor variations can be rapidly accomplished

MOD1X2, MOD1X3, MOD1X4 can be loaded along with AOITG1 so that the average of either 2, 3 or 4 steps

may be taken, instead of the average of five.

SCALE5 may be loaded with AOITG2 to produce a rectangular plot scaled at $5^{\circ}/\text{cm}$ rather than the usual $10^{\circ}/\text{cm}$. This is given as an option when running AOITG2.

RIGHT1 can be loaded as an automatic option whilst running AOITG1. It ensures correct polarity of output when the right limb is analysed instead of the left

RIGHT3 works similarly for AOITG3.

5.7 Service programmes

These programmes exist to promote the rapid handling of data when transferring it from one medium to another.

AOITG4 allows for the use of an updatable data averaging system. This programme was not used in this study

AOITG6 is for use when transferring data from one disc to another. It is used in the recovery from a system collapse

AOITG7 punches data out on to paper tape for hard copy.

AOITG8 reads punched data and transfers it to disc for manipulation

AOITG9 corrects the abductor trace to the normalised zero position for subjects unable to stand in the standard datum position.

5.8 Statistical programmes

This is a family of programmes used in the statistical analysis of data prepared by the AOITG series programmes. The AOIST series programmes are fully interactive with AOITG programmes when necessary. They can share the same service programmes but have their own utility subroutines. In the sections that follow are general descriptions of each programme and details of the statistical analysis involved.

5.9 Programme "AOIST1"

This programme is used to produce the combi-plot diagrams and the mean and standard deviation diagrams featured in the results section. This programme is used to produce both the centred and uncentred plots. The centred plots have the zero line arranged such that the area above the line equals the area below. This is done so that direct comparisons can be made of P.O.M. and R O M., disregarding C.O.M. (see Notation for definitions of abbreviations). The normal plot with the natural zero is used when comparing the C.O.M. of different plots. The option of choosing the centred or non-centred version is given on running the programme.

The programme calls for each person's data in turn and plots it while maintaining a running record of the mean plot for that group, and the standard deviation within the group. The mean and standard deviations for the group are plotted when all members

of that group have been incorporated AOITG5 is used to establish a permanent file of this data The data can be previewed on the V.D U before plotting

An analysis of the mathematics follows It should be remembered that each plot consists of three curves, or groups of curves in the case of the combi-plots These represent sagittal, coronal and transverse plane rotations, reading from the top downwards. The polarities are flexion, abduction and external rotation in the positive y-direction (upward). In the horizontal or x-direction there are 200 points on each curve

For the centred plot the position of the zero line relative to the natural zero is found by summing the ordinates, and finding their mean value.-

$$(1) \text{ Position} = \sum_{j=1}^{200} y_{jn}/200 \quad \text{for each curve}$$

The value of the ordinate at point x_j ($j = 1$ to 200) along the mean curve of $(n+1)$ curves is given by -

$$(2) \quad \bar{y}_{j(n+1)} = [n(\bar{y}_{jn}) + y_{j(n+1)}] / n+1$$

The standard deviation in the ordinate at point x_j ($j = 1$ to 200) is derived using the basic expression below The standard deviation is given by σ_{y_j} where -

$$(3) \quad \sigma_{y_j}^2 = \frac{1}{n-1} \sum_{i=1}^n (y_i - \bar{y}_n)^2$$

for n curves

This is laid out for looped use in lines 470 to 630 of AOIST1 (see Appendix).

5.10 Programme "AOIST2"

Having computed the mean and standard deviation for a group of curves, for each of the 200 points along the curves, AOIST2 will analyse the means of two such groups and compute a value of Student's t statistic for each point along the curves. This gives 200 values of Student's t statistic for each of the three rotational axes. When this array has been computed it is allocated a permanent file on disc using AOITG5.

Student's t statistic, computed on the ordinate \bar{y}_j at position x_j ($j = 1$ to 200) for the means of two curves (\bar{y}_{j1} and \bar{y}_{j2}) is given by -

$$(4) \quad t_{y_j} = \frac{|\bar{y}_{j1} - \bar{y}_{j2}|}{\sigma_{c_j} \sqrt{\frac{1}{n_1} + \frac{1}{n_2}}}$$

where n_1 and n_2 are the numbers of subjects in groups 1 and 2 respectively and σ_{c_j} is given by the expression -

$$(5) \quad \sigma_{c_j}^2 = \frac{(n_1 - 1)\sigma_{y_{j1}}^2 + (n_2 - 1)\sigma_{y_{j2}}^2}{n_1 + n_2 - 2}$$

The derivation and applications of expressions 1 to 5 may be found in Rektorys (1969)

5.11 Programme "AOIST3"

The majority of this programme is identical to AOIST2, but, having computed the t-array this programme then analyses the distribution of values of t

to be found in the array. The t values are sorted by magnitude into one of nine sets, each set being delineated by two limiting values in t. The programme thus finds the number of values of t occurring in each set, and proceeds to perform a chi-squared test, where -

$$(6) \quad \chi^2 = \sum \frac{(O - E)^2}{E} \quad \text{ref Moroney (1951)}$$

and O is the observed frequency of an event and E the expected frequency of that event as predicted by some hypothesis. The computed value of χ^2 when cross referenced in tables gives a measure of the similarity existing or otherwise between the data and the hypothesis.

The hypothesis was that the distribution of the values of Student's t calculated along the movement curves, would be as a Student's-t distribution. This is similar to a normal distribution but the tails of the curve are somewhat higher. This hypothesis proved inadequate, for the reasons given below.

If the frequency of an event occurring is to be described by a Student's t distribution, the samples taken to compute that frequency must be taken randomly. The values of t computed in the t-array were not computed from random data but from curves of a continuous nature. The hypothesis is therefore invalid.

This test was conducted in an attempt to obtain a measure of the similarity between two mean curves.

compiled from the data of two different groups. If by chance the two groups had returned identical means, and the groups were statistically large, there is justification for these two groups to be lumped together as one. However, a Student's t test producing the t array for these two identical means would give an array, every element of which would be zero. Now if this 'distribution' of zero values of t is compared by χ^2 test to a Student distribution, there would be no similarity and one would be inclined to form an incorrect opinion that the two identical curves were dissimilar. Thus the χ^2 test to investigate existence of similarities was rejected from this point of view, but this programme was run in preference to AOIST2 because a check could be kept on the distribution of t values in the t-array by monitoring the relative sizes of the sets that the t-values had been sorted into.

5.12 Programme "AOIST5"

This programme applies the version of Student's t-test which is appropriate for judging the difference between a sample average and an assumed expectation. It is applied to the t-array computed by programme AOIST3, which it compares with the perfect match situation, where two means are identical, and where a t-array produced under such circumstances would be zero for all elements. The mean value of the t's in such an array would of course be zero, as also would

the standard deviation

In the analysis of the t-array the mean value of the t-array is given by -

$$(7) \quad \bar{t} = \frac{1}{200} \sum_{j=1}^{200} t_j \quad .$$

three values of \bar{t} being computed, one for each plane of rotation

The standard deviation in the t-array in the x-direction along each of the three curves is given by

$$(8) \quad \sigma_{tx} \quad \text{where -}$$

$$\sigma_{tx}^2 = \frac{1}{199} \sum_{j=1}^{200} (t_j - \bar{t})^2$$

The expression for Student's t when comparing \bar{t} , from the t-array with the expectation, mean equal to zero, standard deviation equal to zero is -

$$(9) \quad t(0,0) = \frac{\bar{t} \sqrt{200}}{\sigma_{tx}} \quad \text{ref Rektorys (1969)}$$

5 13 Programme "AOIST4"

The probability of finding two mean curves which are absolutely identical over two hundred points in these sort of tests approximates very closely to zero. One must therefore allow for some sort of scatter in the expectations. This is done in AOIST4 by matching the measured t array with an array having a mean of zero and a standard deviation of unity, instead of zero as in AOIST5

\bar{t} and σ_{tx} are computed using (7) and (8) and the expression for Student's t in this case is -

$$(10) \quad t(0,1) = \frac{\bar{t}}{\sigma_{tc} \sqrt{\frac{1}{200} + \frac{1}{200}}}$$

which is a derivation from equation (4), where

$$\begin{aligned} \sigma_{tc}^2 &= \frac{199(\sigma_x^2 + 1)}{200 + 200 - 2} \\ &= \frac{(\sigma_x^2 + 1)}{2} \end{aligned}$$

Probability values corresponding to the distribution of Student's t were read from tables (Fisher and Yates 1957).

5 14 Interpretation of computations

Programmes AOIST4 and AOIST5 are always used in combination with each other to provide comparative values of $t(0)$. This ensures that results can be more fully described. These two programmes are applied to three t-arrays derived from the same two groups but derived each in a separate way. This gives, in all, six tests in each plane when the means of two groups are checked for similarities and differences. The three τ -arrays are derived as follows.

The first is computed using data from the non-centred plots, the non-centred means of the two groups, and the non-centred standard deviations. From this array are derived test 1 statistics.

The second t-array is computed using data from the centred plots, the centred means of each group and the centred standard deviation. Test 2 statistics are

derived from this array.

The third t-array from which test 3 statistics are derived, is computed using data from both types of plot, the centred means of each group and the non-centred standard deviations. Cross coupling of the data like this is done because the centred plots tend to produce standard deviations unnaturally narrow for the spread in the data. By computing the extra values a better picture of the results is obtained.

When AOIST4 and 5 are used on t-arrays of the first type the parameters under observation are R O M., P O M and in particular C O M. A high value of $t(0,1)$ or $t(0,0)$ here would indicate low probability of a similarity between two initial curves due either to major differences in R.O.M., P O M. or C.O.M.

When AOIST4 and 5 are used on arrays of the second kind the parameters under observation are R.O.M and P.O M. C O.M. has been eliminated due to the fact that the initial curves have been centred. A high value of $t(0,0)$ or $t(0,1)$ here would indicate radical differences in R.O M. and/or P O.M. between the two curves under test. Low $t(0)$ values here with high values of $t(0)$ computed for the respective array of the first kind would indicate that differences existed in C O M., but that otherwise the curves were very similar ($t(0)$ means both $t(0,0)$ and $t(0,1)$.)

Applying AOIST4 and 5 to arrays of the third kind provides a useful check against 'rogue' results. Such results can occur when, even though there are

comparatively large variations between the mean curves, the value of \bar{t} happens to be very small. This tends to produce low values of $t(0)$. If this condition arises when analysing arrays of the second kind, it is very unlikely to occur in arrays of the third kind also, so the value of $t(0)$ for arrays of the third kind would be larger than the value of $t(0)$ computed for an array of the second kind. This result would be unusual because generally values of $t(0)$ computed for arrays of the third kind are smaller due to the larger values of standard deviation used to compute these arrays.

Although this is not a particularly concise method of analysing such data, it is probably the most descriptive. The nature of the data is such that the distribution of values of t in the t arrays is not analogous to any particular hypothetical distribution. Conducting a chi-squared test against any hypothetical distribution only reveals that the hypothesis is not a good description of the data and gives no particular indication of its true nature. The value of conducting the Student's t tests as described above is that one can judge whether two curves are exactly alike ($t(0,0)$ test), as alike as may be reasonably expected ($t(0,1)$ test), somewhere in between or not alike at all.

In Chapter 7, where the results are analysed and discussed, $t(0,0)$ and the corresponding probability value are referred to as statistics D and E respectively. Statistics F and G refer to $t(0,1)$ and its probability value.

Statistic A is the mean of the modulus of $t(0)$, B is the mean of the signed values of $t(0)$, and C the standard deviation in $t(0)$

5 15 Utility subroutines (statistical)

Programmes "MINTOR", "SINTOR", "PSTOR" and "NSTOR" are subroutines for "AOIST1" which allow arrays to be interchanged.

"FSHIFT" is a service programme to shift the plotting axis such that the flexion trace remains on the paper plot during the peaks in flexion found in the exercise of mounting steps

"AOIST6" is another service programme, and is used for rotating data files

5 16 Programme "TABLES"

This programme accepts six data files at a time (usually files of mean data for the groups) and analyses each file to find various parameters in each plane of rotation. The parameters computed are -

"MAX", the peak maximum value for each trace

"MIN", the minimum value for each trace

"ROM", the range of movement for each trace which equals (MAX-MIN)

"COR", the centre of range, defined as the point equidistant from MAX and MIN

"COM", the centre of movement, defined as the magnitude of the displacement of the centred zero from the natural zero. The position of the centred zero is computed as in programme AOIST1

These values, when computed, are output in tabulated format on the high speed printer.

5 17 Programme "MSD"

"MSD" is for use in the analysis of standard deviation files. It finds the maximum, minimum and mean values of standard deviation in each plane for up to six files at a time. It is based on programme "TABLES".

5 18 Programme "AREA1"

This programme computes the area enclosed when the flexion and abduction traces are plotted against each other. It is very simple and works by multiplying the width between two x-coordinates with half the height of the two corresponding y-coordinates, then sums the areas over 200 points. To be accurate the shape of the plot needs to be a closed loop. Figure of eight type shapes cannot be accommodated.

5 19 Programme "AREA2"

Unlike "AREA1" which employs a basic trapezoidal structure "AREA2" is a much more involved programme which will compute the area enclosed by any one contour, regardless of shape. The programme effectively draws vertical grid lines on the plot and sums the areas enclosed between the grid lines and the contour.

When used on closed contours and checked against "AREA1" the two programmes compute answers within a maximum of 5% of each other, and normally much closer (0.5%). Both programmes give answers in units of degrees squared.

5.20 Programme "AREA3"

"AREA3" was evolved from "AREA2" in the search for greater accuracy. The modification reduced the accuracy so this programme was not used.

5.21 Programme "AOIST7"

This programme is used to find the individual areas for a group, and then computes the mean and standard deviation in areas within the group. It utilises much of "AREA2".

5.22 Programme "AOIST8"

"AOIST8" computes Student's t statistic when comparing simple parameters, for example, the mean heights of two groups of people.

5.23 Programme "AOIFIT"

A superlative programme which fits a Fourier series up to any specified harmonic (limited only by the size of computer core) using a least squares fit, and utilising a Crout reduction technique to solve the resulting simultaneous equations by matrix algebra.

The disadvantage of this programme is that it takes 45 minutes of C P U. time to compute values up to the 8th harmonic for one subject, so its use was necessarily limited. The programme can be used to give a Fourier break-down of a curve, it can be used to filter out unwanted harmonics (signal or electrical noise), it can be used to ensure closure of a contour (see AREA1, 2), and by noting coefficients

it is a very concise way of storing data

5.24 Section Summary

Through this project some 400 hours were spent actively computing, with around 20 million data points being handled of which around 1 million remain on permanent record. This may seem excessive but, "I could have done it in a much more complicated way". (Lewis Carroll in, "Alice through the looking glass".)

6 SYSTEM ACCURACY

6.1 General

Between a person walking and a representation of his movements on a piece of paper there are many operations, all of which have limitations and possible inaccuracies. There follows an analysis of the errors likely to arise in the system, and discussion on the sources of error that cannot be adequately measured.

6.2 The accuracy of the goniometer assembly

Each potentiometer has an independent linearity of better than 0.5% of full scale deviation from a straight line. The axes of the potentiometers intersect to within 0.2 mm. The transducers, operating as a unit with the knee clamp are limited in accuracy only by the linearity of the potentiometers in the sagittal and coronal planes. In the transverse plane accuracy is limited by the backlash in the sliding assembly on the knee clamp. This was measured as less than 1° when new and less than 1.8° after 100 hours use.

Assuming the goniometer is clamped rigidly to the skeleton, the errors arising in the mechanism will be due to off axis alignment of the potentiometer cluster with the axis of the hip. The author estimates that the axes can always be adjusted to within 2 cm. This leads to maximum errors in the sagittal plane of 2.5° in 90° or 2.8%. If however, the axis normal to the transverse plane can be kept parallel to the long axis

of the femur this error is reduced, ultimately to zero, due to the sliding mechanism at the knee absorbing translatory motion, ref Cousins (1975) In the coronal plane, parallelogram geometry, or a very close approximation to it, is maintained throughout all the normal physiological range in this plane. Errors here should be less than 1% of range Transverse plane rotations are accurate to within 1% over the 20° physiological range involved in the measured activities.

Due to the non coincidence of the axes involved in transverse plane measurements, rotations in this plane cause rotations to be measured in the sagittal and coronal planes. For a femur length of 400 mm, the shortest likely to be encountered in a normal adult woman, which would produce the maximum error, the correction in the sagittal plane amounts to 0.25° per degree of transverse rotation The correction in the coronal plane amounts to 0.03° per degree of transverse rotation The sagittal plane correction was applied for an average length of femur during computation in "AOITG1", giving an overall error in that plane of less than 3% The coronal plane correction was determined to be small enough to be negligible, giving an overall error in that plane of less than 3% In the transverse plane, backlash in the slider reduced the accuracy to within a maximum of ± 1.8 degrees of the measured value. Chao et al (1970) conducted a complete analysis of the errors arising out of off-axis positioning of the

goniometer with reference to the hip, but concluded that they were negligibly small for gait activities.

6.3 Analysis of the security of attachment

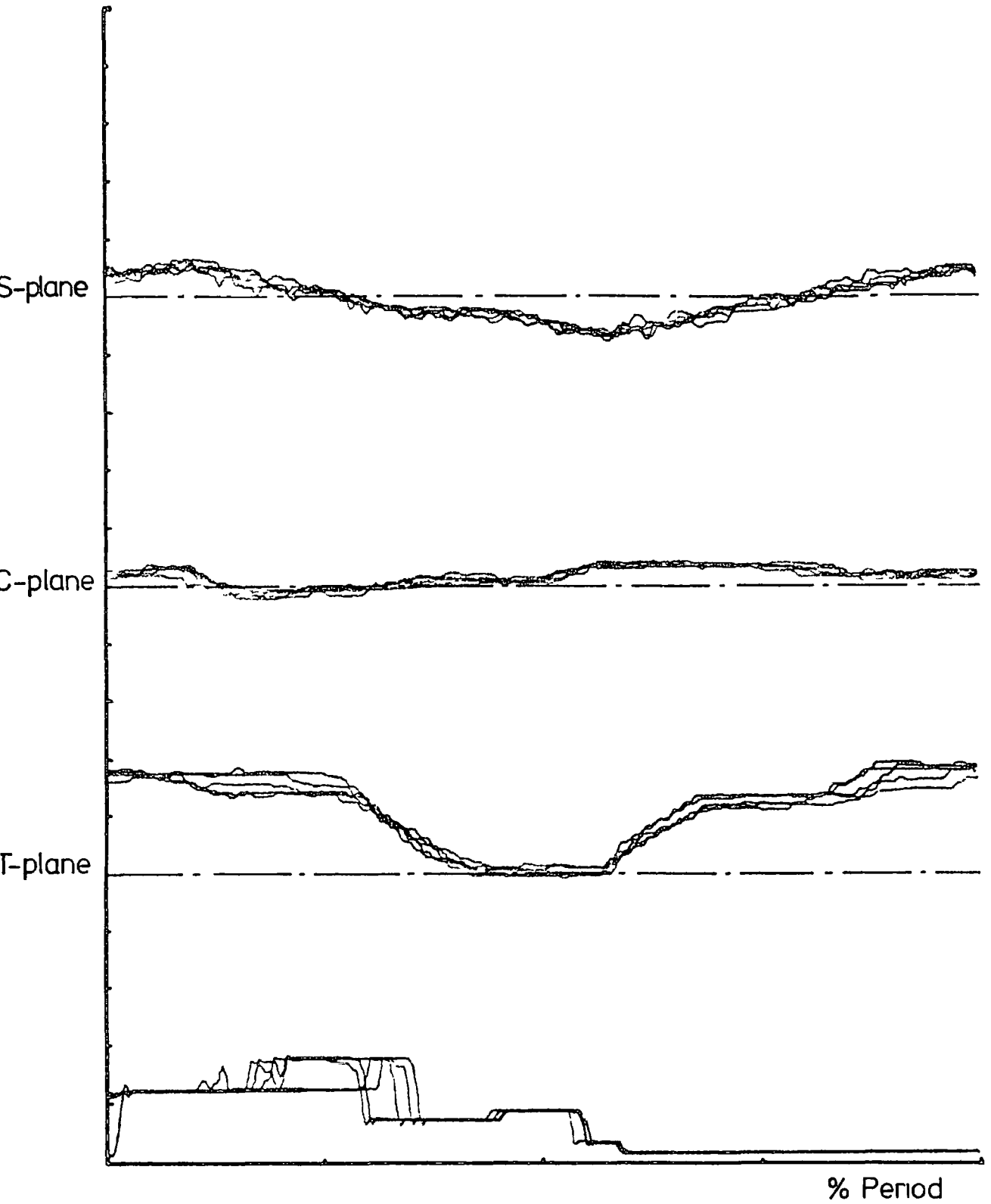
In the above section the assumption was made that the goniometer was clamped rigidly to the skeleton. This is not completely accurate, and it is in this area that the largest possibility for error arises, and these errors are also the most difficult to quantify.

Johnston and Smidt (1969) analysed the reliability of their data by a test-retest procedure. Reliability is the degree to which consistent results are obtained from the use of the same method by the same person. They tested a group of 16 people twice, and in each case found the mean R O M for the group in each plane, then examined for a significant difference between the two means using Student's t-test. The difference was not significant at the $p=0.01$ level. Such a test however relates nothing of the shape of the curves, and is somewhat dependent on an individual's ability to reproduce his gait pattern. Such a test does not indicate the accuracy of the measurements but examines the ability of the system to produce consistent measurements. Movements of the goniometer relative to the skeleton cannot be measured easily but may be assumed unimportant if consistent repeatability can be obtained.

The author conducted tests for accuracy and repeatability on a patient with a unilateral hip

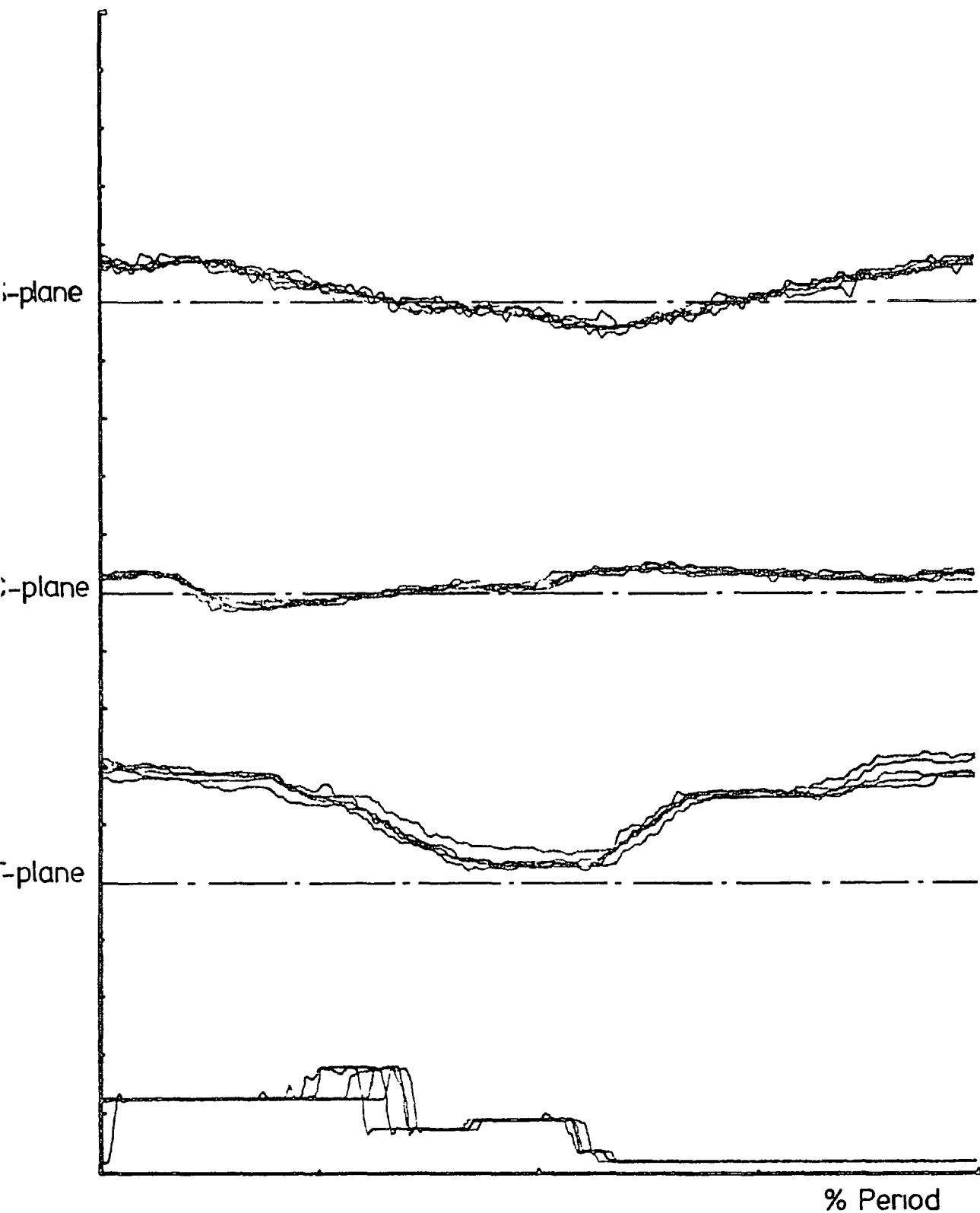


Plate 3 : Hip Arthrodesis



NAME ♂ HIP ARTHRODESIS					
NO 1	FILE		FLEX	ABD	EXROT
EXERCISE	AMBULATION	POLARITY	↑	↑	↑
LEFT ✓	RIGHT	SCALE%cm	10	5	5

NOTES Figure 21a Ambulation with an arthrodesed hip - run 1



NAME ♂ HIP ARTHRODESIS					
NO 2	FILE		FLEX	ABD	EXROT
EXERCISE AMBULATION		POLARITY	↑	↑	↑
LEFT ✓	RIGHT	SCALE %cm	10	5	5
NOTES <u>Figure 21b</u> Ambulation with an arthrodesed hip - run 2					

arthrodesis, a patient who measuring 5'7" (1.702 m) and weighing 15 stones (950 N) was considered to be one of the most difficult patients likely to be encountered. A radiograph of this patient's hip is shown in plate 3. The traces produced during level walking are shown in Figs. 21a and 21b. Between test and retest the equipment was removed and reapplied to the patient.

The patterns of movement for all planes are virtually identical, the major differences being the noise patterns on the data wave form! The limits of resolution imposed by these noise levels are discussed in the next section.

Differences are apparent however in the position of the C.O.M. between tests. In this case this is a measure of the reproducibility of the datum position. This patient had obvious difficulties in attaining the datum position, but nevertheless managed to do so with incredible consistency. The differences between the two tests were 1.8° in the sagittal plane, 0.1° in the coronal plane and 1.0° in the transverse plane. His measured ranges of movement in each plane differed by 0.2° in the sagittal plane, 0.8° in the coronal plane, and 0.7° in the transverse plane. These differences (computed by "TABLES") when taken from single tests only instead of large averaged groups are less than the noise levels in the instrumentation, and well within the minimum mechanical accuracy of the goniometer. If data were taken from many subjects and averaged these results

would only be improved upon, especially so if normal people of normal weight were examined.

A patient with a hip arthrodesis walks with a lurching gait which is very jerky in comparison to the relatively smooth forward progression of a healthy person. This inevitably means that the loosening forces on the goniometer are greater when examining an arthrodesed hip. The results however show that the apparatus was definitely not moving about in any random manner relative to the skeleton.

An absolutely necessary further discussion must be written concerning the walking patterns of men with unilateral surgical hip arthrodeses, with particular reference to the aforementioned patient.

It is the opinion of the author that however rigidly a hip may be fused measurable relative motion still occurs between the anterior superior iliac spines and the femoral condyles of the arthrodesed extremity, during ambulation.

Initially when the movements measured were recorded as 12° in the sagittal plane, 3° in the coronal plane, and 8.5° in the transverse plane, the results were regarded with much doubt and suspicion. However, using published data, the author performed a simple calculation to estimate the deflection of the femoral shaft due to bending. Only the femoral shaft was considered, the pelvis and hip joint were assumed rigid.

The modulus of elasticity of bone in the human

femur has been calculated by various authors. Mather (1967) computed a value of $1.32 \times 10^{10} \text{ N/m}^2$, Sedlin (1965) $1.55 \times 10^{10} \text{ N/m}^2$, and Sedlin and Hirsch (1966) $1.56 \times 10^{10} \text{ N/m}^2$. These values are applicable to the bone in bending. The average of these values is $1.48 \times 10^{10} \text{ N/m}^2$, which was the value used in the calculations.

Martin and Atkinson (1977) computed the mean second moment of area in bending for all directions, for a number of human femora. Their sample included 14 adult males ranging in age from 19 to 71. The mean second moment of area for this sample was $2.78 \times 10^{-8} \text{ m}^4$.

The length of the femur of a man of 1.702 m may be taken to be 0.42 m after Drillis and Contini (1966).

Saunders et al (1953) found the vertical floor reaction force for a fused hip to be about 25% greater than for a normal hip.

The forces in an arthrodesed hip may be considered in the following way.

There are two systems relevant to the leg shortly after heel strike.* Initially, the moment at the knee is tending to extend it, when, if the muscles are active, the loading will be taken by the two joint flexors of the knee at the back of the thigh. This would give zero moment at the knee section of the shaft of the femur and a very small moment along the length

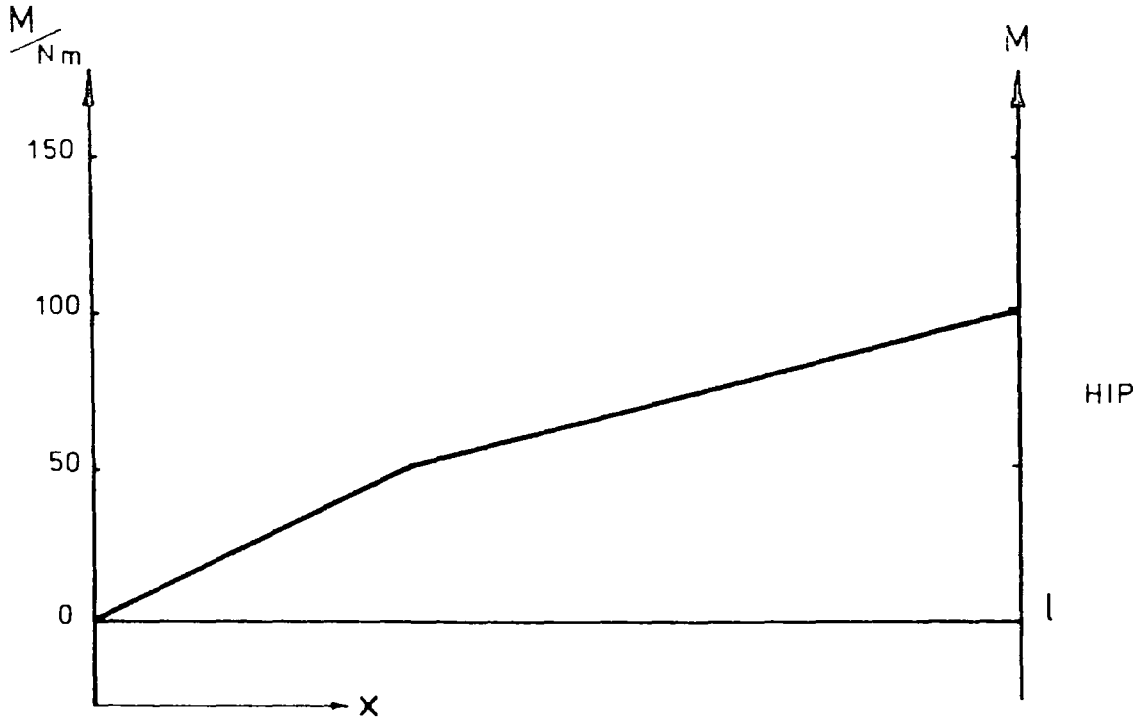
* Paul, J. P. Private Communication

of the femur, because the hip moment will also be transmitted by these two joint muscles.

If the muscles are not active, the knee moment might be transmitted by the ligamentous structure at the back of the knee, giving a moment at the end of the femur which would be part of the hip moment, the balance being transmitted by the gluteal muscles with no additional moment at the hip acting on the femur

Later, in early stance, when the knee is tending to be flexed against muscular resistance, the moment, which may be of value 50 Nm, is in the opposite direction to that developed by the hip muscles. The deflection of the hip in this situation therefore will be less than the situation approaching toe-off, where there is the condition that the moment tending to flex the knee, also tends to extend the hip.

This latter situation, which is probably the worst case of potential bending, may be analysed with say, a knee moment of 50 Nm and a hip moment in the opposite direction of 100 Nm, Paul (1972), these being figures for normal subjects. The hip moment is transmitted by the muscles at the front of the joint which are overlaid very closely on to the femoral head, and one at least has its insertion into the femur close to the head, implying that the hip moment is transmitted largely by the shaft of the femur. Similarly at the knee, the flexing moment is resisted by tension in



Femur bending moment diagram

$$EI \frac{d^2v}{dx^2} = M = \frac{150x}{l} - \frac{150}{2l} \left[x - \frac{l}{3} \right] \quad \left[\quad \right] = 0 \text{ for } x < \frac{l}{3}$$

$$\frac{l}{150} EI \frac{dv}{dx} = \frac{x^2}{2} - \frac{1}{4} \left[x - \frac{l}{3} \right]^2 - \frac{7l^2}{18}$$

$$\frac{l}{150} EI v = \frac{x^3}{6} - \frac{1}{12} \left[x - \frac{l}{3} \right]^3 - \frac{7l^2}{18} x + \frac{20l^3}{81}$$

at $x = 0$ $v = \frac{20l^2}{81} \frac{150}{EI} = \underline{0.016m}$

measured angle = $\tan^{-1} \frac{v}{l} = \underline{2.2^\circ}$

the quadriceps muscles which are inserted over approximately the distal one third of the length of the femur.

This implies a bending moment diagram for the shaft of femur starting with zero at the knee, increasing to 50 Nm approximately at $\frac{1}{3}$, and thereafter increasing to 100 Nm (Fig. 22).

This would yield a deflection at the knee which would be measured as 2.2° of extension, remembering that the figures used were derived from normal subjects. For a subject with an arthrodesed hip, and especially for the rather heavy patient (950 N) involved in these tests, one could possibly expect this deflection to increase (to say 4°), and this is clearly of the order of that measured experimentally (5°).

This analysis takes account only of femoral deflections, and assumes the pelvis and joint are absolutely rigid, when this is probably not so.

Authors, therefore, who attempt to measure the efficiency of their goniometers by assuming they should measure zero motion in an arthrodesed hip, Johnston and Smidt (1969) and Hannah et al (1978), are possibly quite mistaken.

Gore, D. R. et al (1975) using photographic techniques measured the walking patterns of men with unilateral surgical hip fusion. Their results (Fig. 2, p. 762) for sagittal plane rotations show a straight

line for the mean motion for a fused hip, but the standard error (from Fig. 2, p. 762) given is around 1.5° . Now

$$\text{Standard Error} = \frac{\text{Standard Deviation}}{\sqrt{\text{Sample size}}} \quad (\text{Moroney (1951)})$$

which gives a standard deviation of 8° . So, although Gore et al have not stated the fact in their discussion, they must have been encountering fused hips in which a measured motion of $\pm 8^{\circ}$ was not unusual.

In the author's analysis of errors, the inaccuracies measured are those for the total goniometer assembly, pelvic girdle and knee clamp. It is the anomalous relative movements between the two which produce the errors.

The opportunity arose to measure a patient wearing the goniometer using video-radiography in conjunction with image intensification. The patient examined had had a unilateral Charnley total hip arthroplasty twelve days previously. The patient was asked to flex at the hip, then abduct at the hip whilst the goniometer was viewed against the outline of the pelvis. A video recording was made during this test. Later examination of the tape revealed that objective measurements of relative movement of the pelvic girdle relative to the pelvis were difficult to make, even though a scale was radiographed during the tests.

A frame by frame analysis of the tape showed

little or no relative motion occurring during coronal plane movements. The patient was being viewed in the anterior-posterior plane with the goniometer girdle being referenced against the lateral edge of the pelvis. For sagittal plane movements, viewed in the same plane as previously, no relative movements could be detected again, but no suitable reference points showed in sufficient contrast for the test to produce definitive results.

The problem of quantifying any relative motion that might occur between the goniometer and the skeleton has no easy answer, and so one must be content to prove consistency of data acquisition.

6.4 Analysis of errors arising from the electronic instrumentation

The instrumentation between the goniometer and the paper record is as follows:

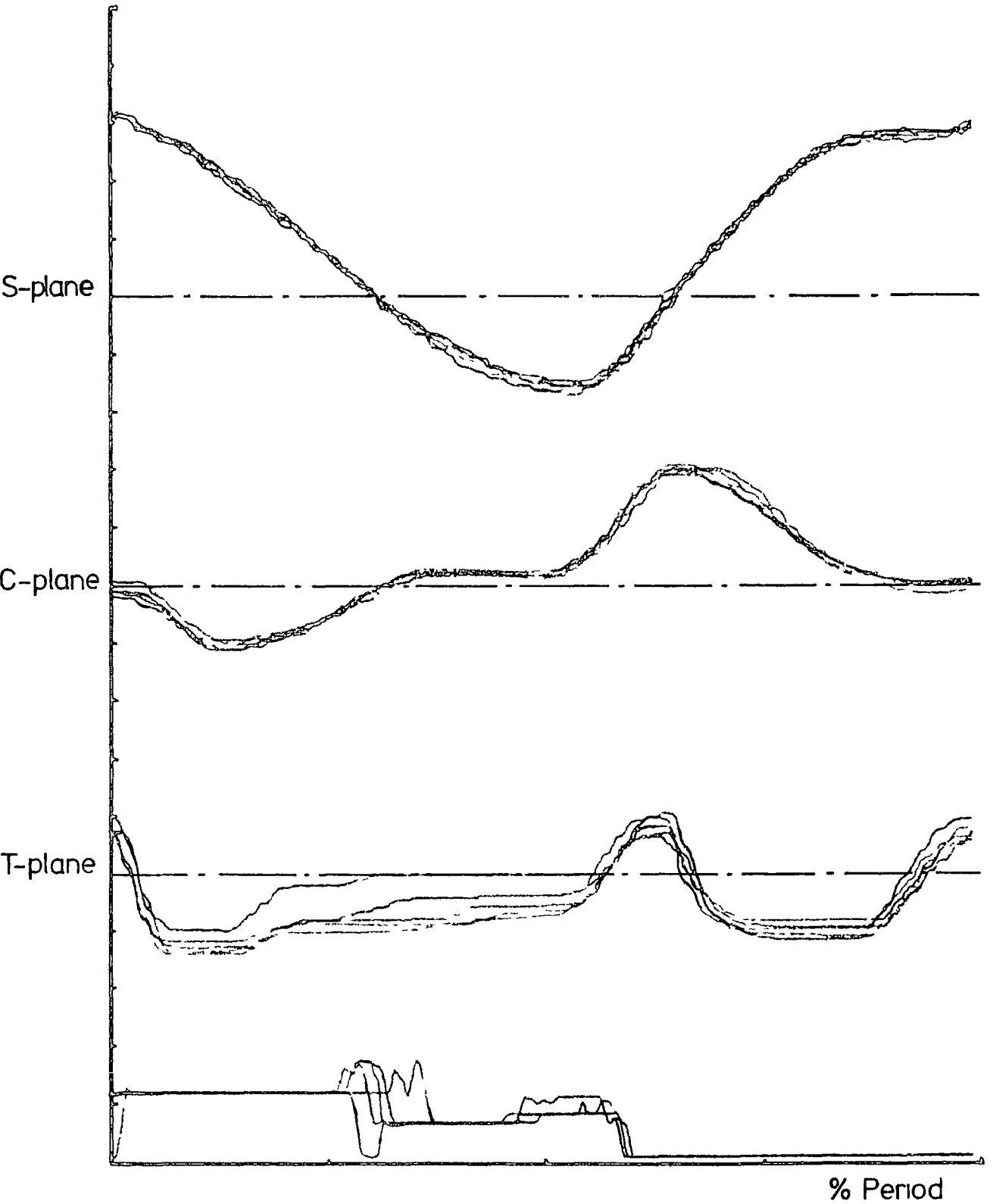
The goniometer is buffered via the high input impedance ($10^{12} \Omega$) J.F.E.T. operational amplifier circuit to the Racal Store 4D recorder. Output from the recorder is direct to the computer which in turn outputs to the Hewlett Packard X-Y plotter.

The major source of electrical noise is the tape recorder, but this is only so because the remainder of the instrumentation features extremely low noise circuitry. The manufacturer's specification for the tape recorder rates the signal to noise ratio at 48 dB, the overall linearity as $\pm 0.3\%$ deviation from the

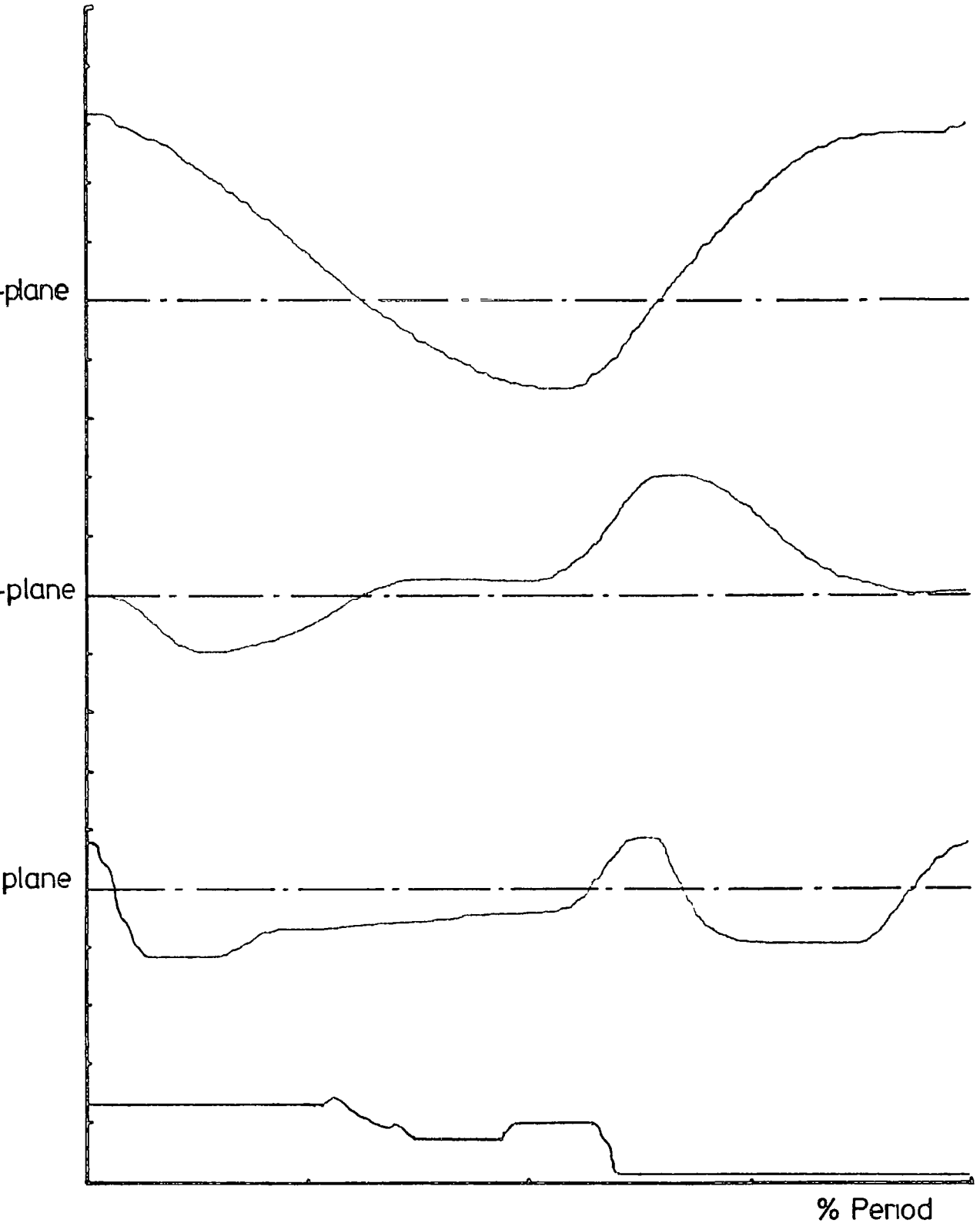
best straight line through zero, and harmonic distortion at less than 1.2% at maximum modulation level

Taking the system as a whole, its accuracy can be measured by introducing a known voltage at the buffers and reading the corresponding output from the X-Y plot. This procedure gave an overall accuracy of within 2% for large signals. However, for small signals the limiting factor became the resolution due to noise appearing on the paper plot. For a single step this amounted to a maximum of 2° , which when averaged for five steps, due to the random nature of the noise, reduced to less than 1° .

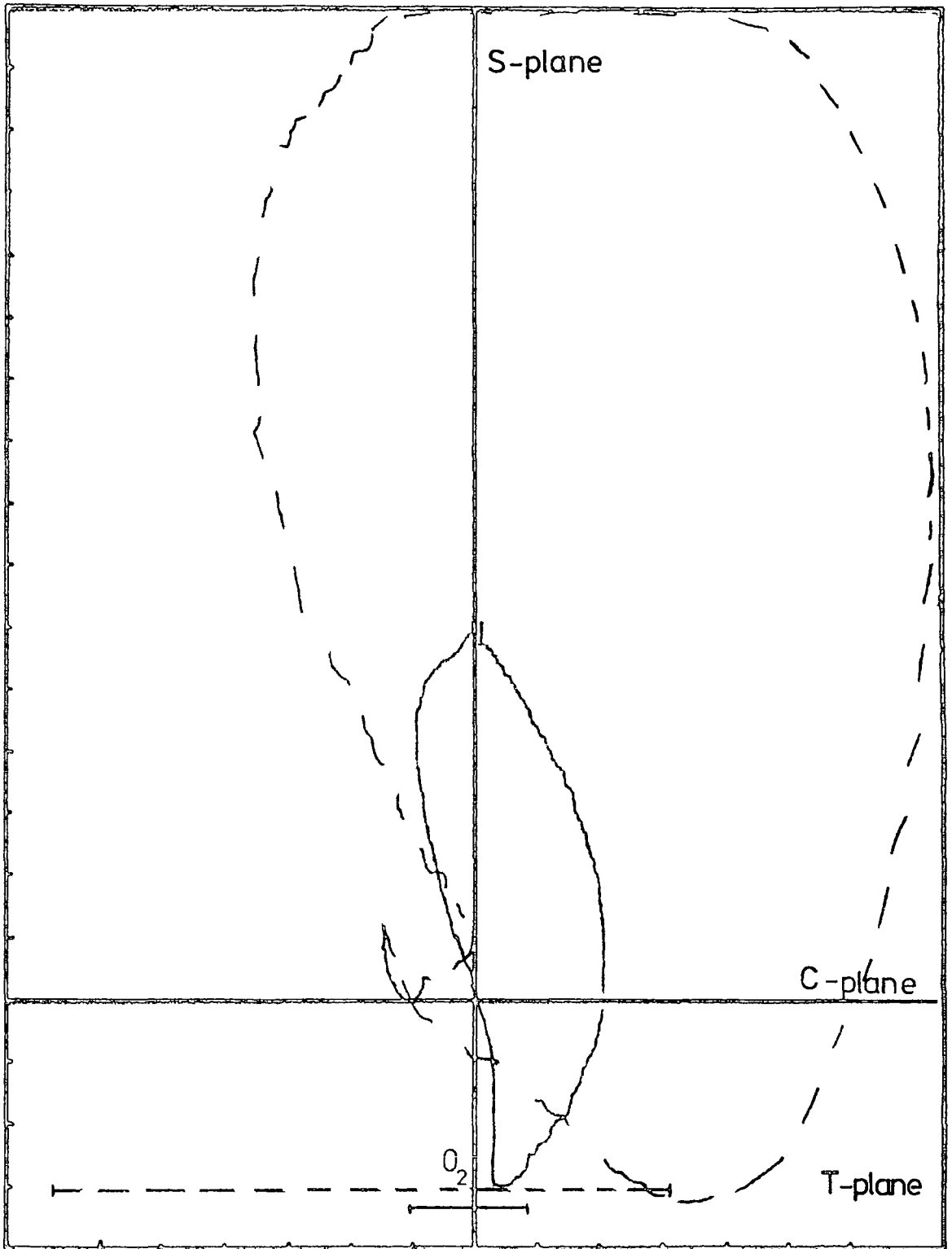
For the system as a whole, for a person's averaged plot, the paper representation of his movements is within a maximum of 3° of his actual movements, and in many cases much closer.



NAME ♂					
NO	FILE		FLEX	ABD	EXROT
EXERCISE AMBULATION		POLARITY	↑	↑	↑
LEFT ✓	RIGHT	SCALE %cm	10	5	5
NOTES <u>Figure 23</u> Normal male walking 5 steps					



NAME ♂					
NO	FILE		FLEX	ABD	EXROT
EXERCISE AMBULATION		POLARITY	↑	↑	↑
LEFT ✓	RIGHT	SCALE%cm	10	5	5
NOTES					
<p style="text-align: center;"> <u>Figure 24</u> Normal male walking average of 5 steps </p>					



NAME ♂					
NO	FILE		FLEX	ABD	EXROT
EXERCISE AMB+GLOBAL		POLARITY	↑	→	→
LEFT ✓	RIGHT	SCALE%/cm	5	5	5
NOTES					
<p style="text-align: center;"><u>Figure 25</u> Rectangular plot of male ambulation</p>					

Exercise	Component	Coefficient	Coefficient Subscript								
			0	1	2	3	4	5	6	7	8
AMBULATION	FLEX	a	52 36	114 39	-12 99	1 07	0 85	0 21	1 48	-0 16	0 83
		b		-17 20	-4 56	7 44	-0 20	2 98	0 68	0 34	0 78
	ABD	a	17 86	-26 44	-9 94	21 69	-0 27	1 43	1 44	-1 22	0 24
		b		-47 75	4 34	4 80	-2 80	3 25	0 28	1 81	0 46
	ROT	a	-20 89	-8 36	17 69	22 77	2 76	13 46	6 71	-0 43	4 52
		b		-10 85	6 07	-16 84	-6 54	2 81	-7 90	0 37	0 03
ASCENDING STAIRS	FLEX	a	101 13	112 51	-0 02	3 15	-2 47	-0 16	0 98	-0 49	0 01
		b		-46 94	-14 83	-1 95	-4 29	1 25	-2 18	-0 21	-0 05
	ABD	a	39 50	-70 63	-7 03	-7 07	1 37	0 46	-2 08	0 36	-0 22
		b		-25 24	3 83	-0 21	-3 07	1 10	0 34	1 59	-0 25
	ROT	a	-43 66	-41 35	11 76	16 15	-12 57	5 44	2 00	-2 61	1 60
		b		-4 20	11 64	-11 67	-0 55	4 00	-7 30	2 55	-0 39
DESCENDING STAIRS	FLEX	a	57 25	4 58	-5 98	-2 49	-3 42	0 90	-0 55	0 46	0 01
		b		-41 67	5 62	1 24	0 31	0 13	-2 41	0 12	0 69
	ABD	a	42 63	10 14	-4 20	8 42	-2 97	0 84	-0 56	-0 96	0 01
		b		5 66	8 10	-1 99	2 32	2 68	0 08	1 20	0 34
	ROT	a	14 17	28 83	22 35	-10 27	0 67	8 04	3 31	2 70	-2 14
		b		38 98	-34 22	-8 38	4 71	3 43	0 92	-0 32	0 95

TABLE 1 TABLE OF FOURIER COEFFICIENTS (SEE TEXT)

GROUP		BODY WEIGHT (N)				HEIGHT (m)			
	SIZE	MEAN	S.D.	t	p	MEAN	S.D.	t	p
1	10	691	17.1			1.804	0.016		
				0.065	0.9+			2.840	0.01
2	12	690	18.7			1.781	0.021		
				2.046	0.06			0.496	0.62
3	21	723	53.2			1.776	0.031		
				0.330	0.74			0.094	0.9+
4	10	717	37.9			1.777	0.019		
				1.093	0.28			0.311	0.75
5	10	763	124.2			1.769	0.079		
				1.374	0.18			0.412	0.68
6	10	700	73.1			1.755	0.073		

MALE GROUPS' HEIGHT AND WEIGHT: AMBULATION

TABLE 2

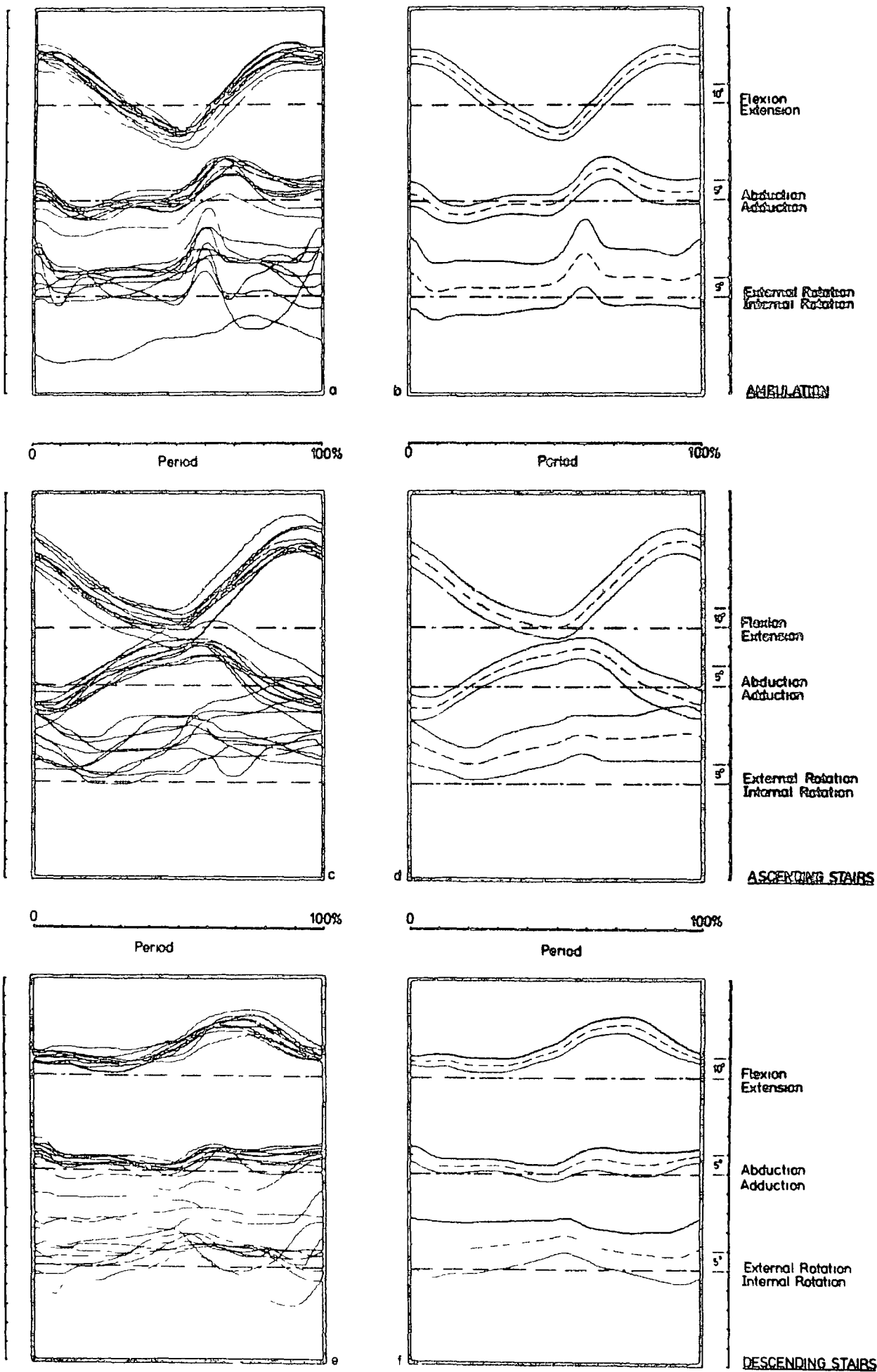


Figure 26 Non-control plot for male group 1

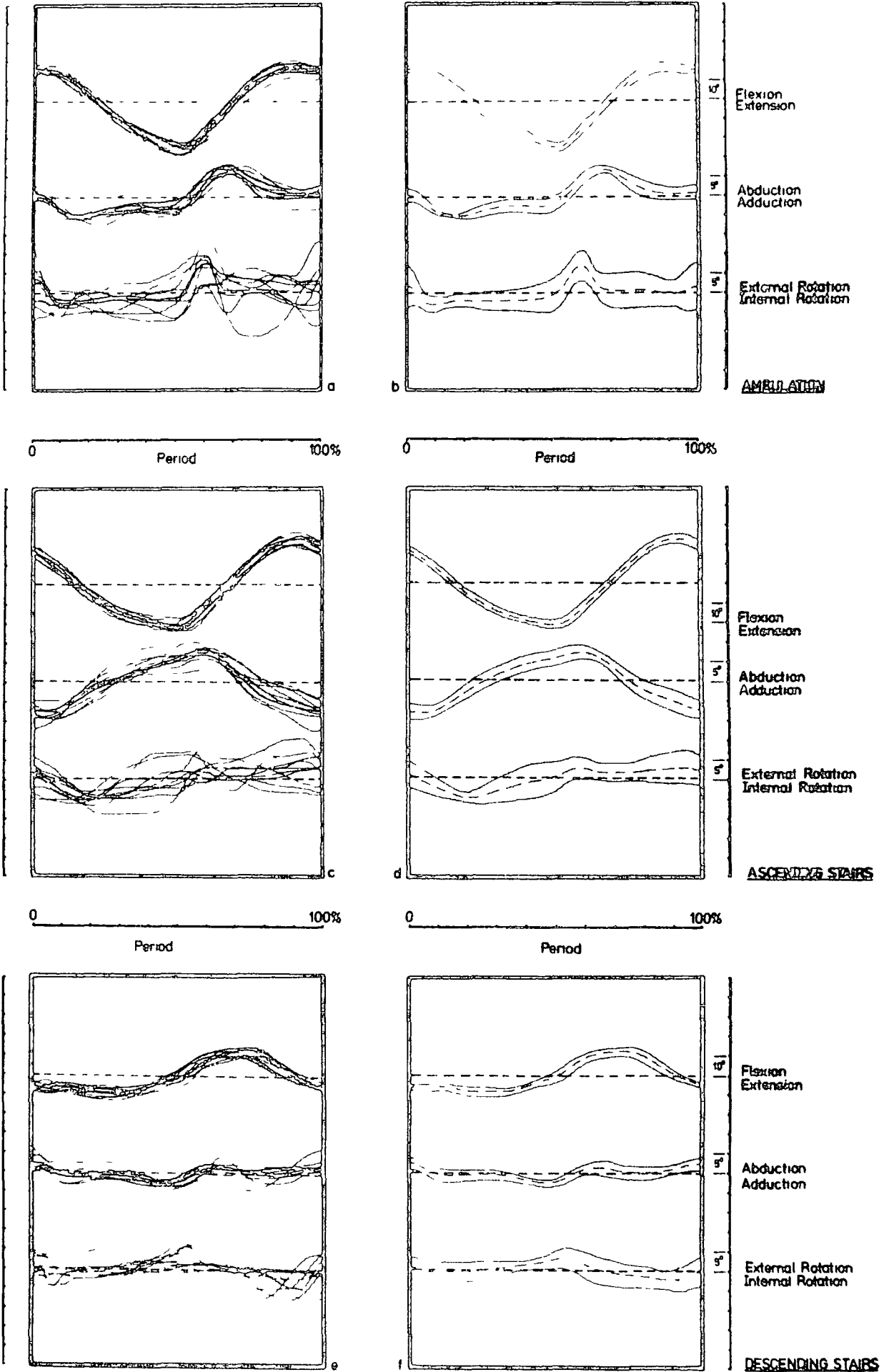


Figure 27 Centred plots for males (n = 10)

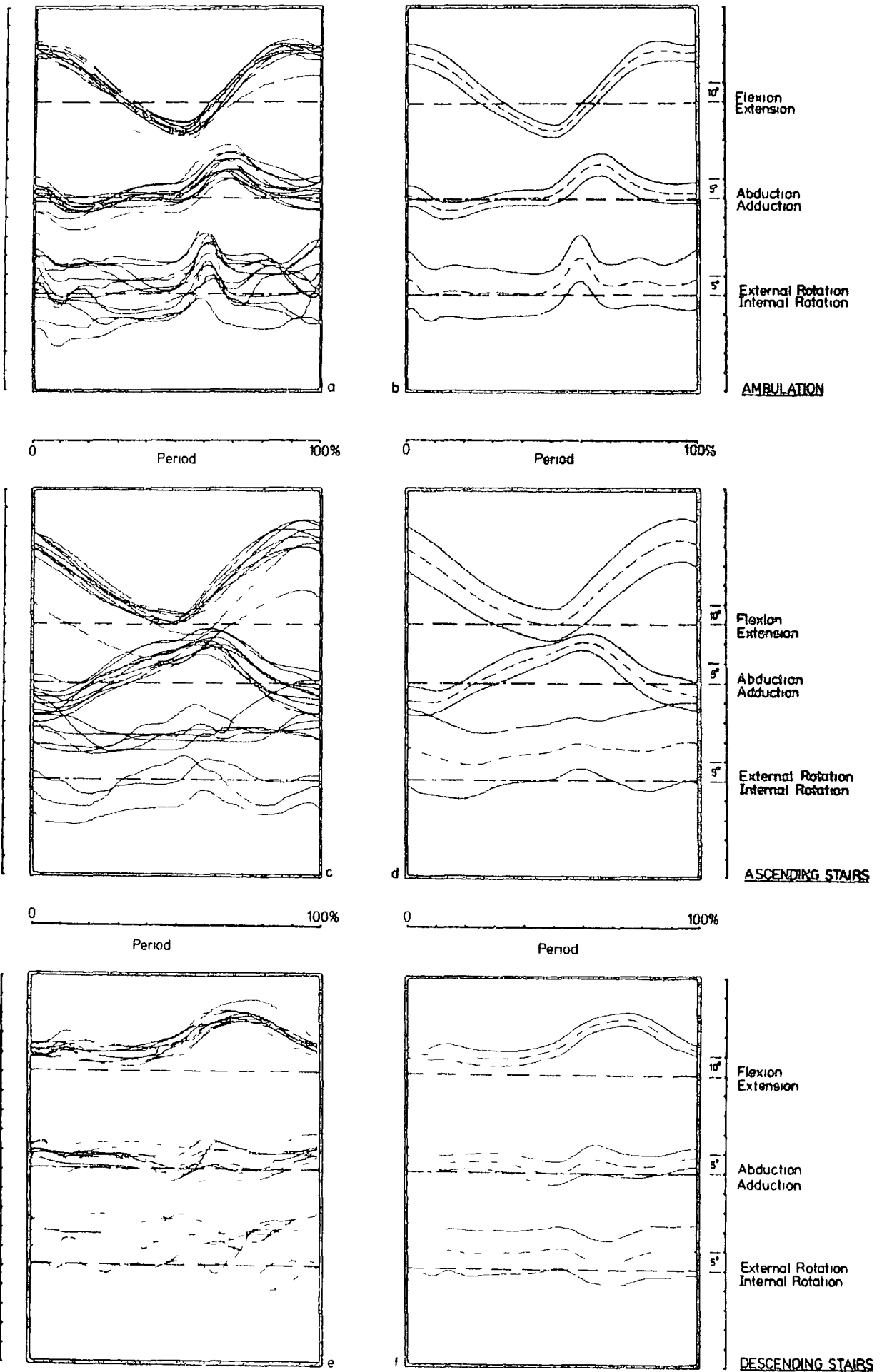


Figure 28 Non-centred plots for males Group 2

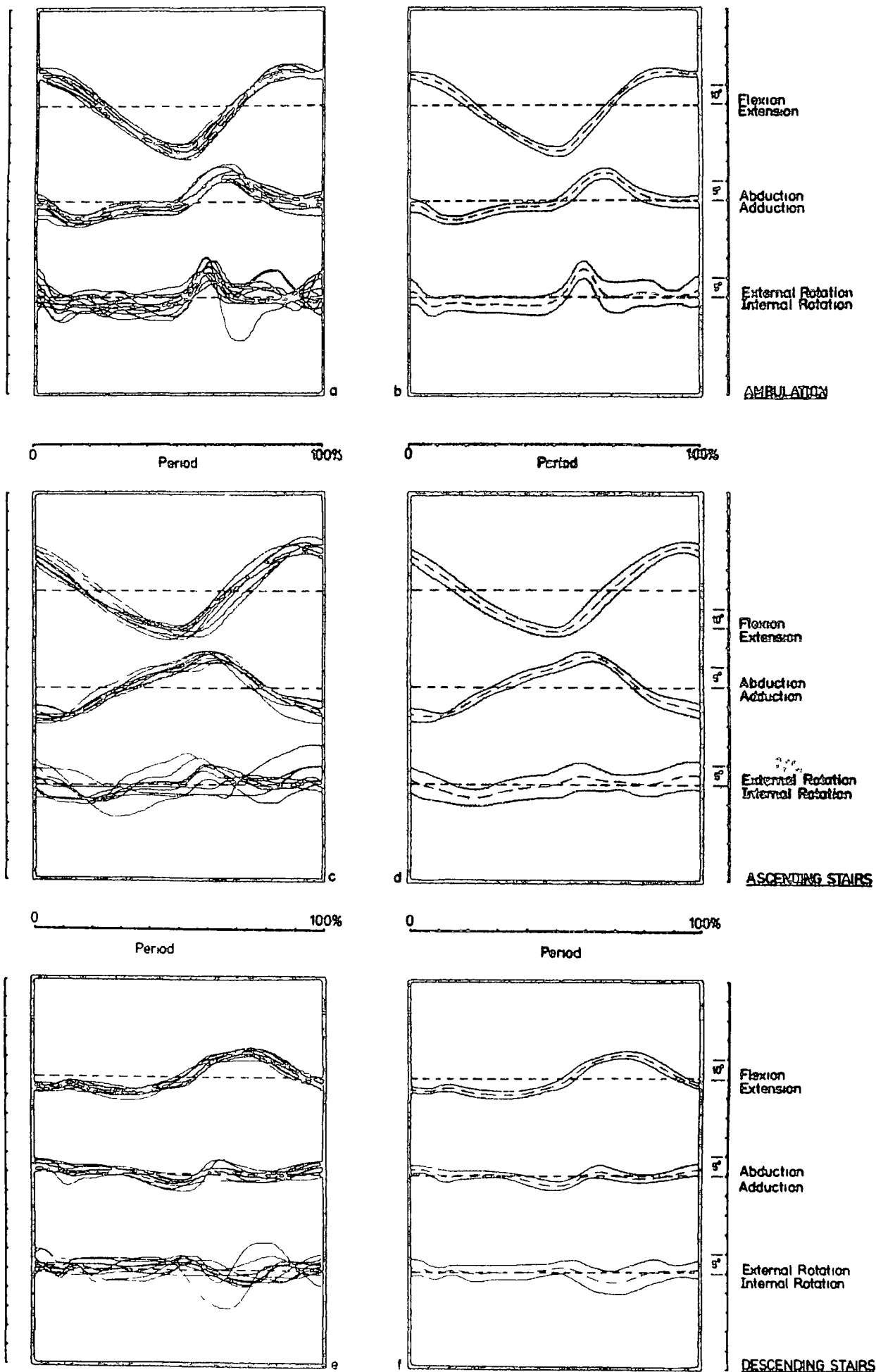


Figure 29 Centred plots for males group 2

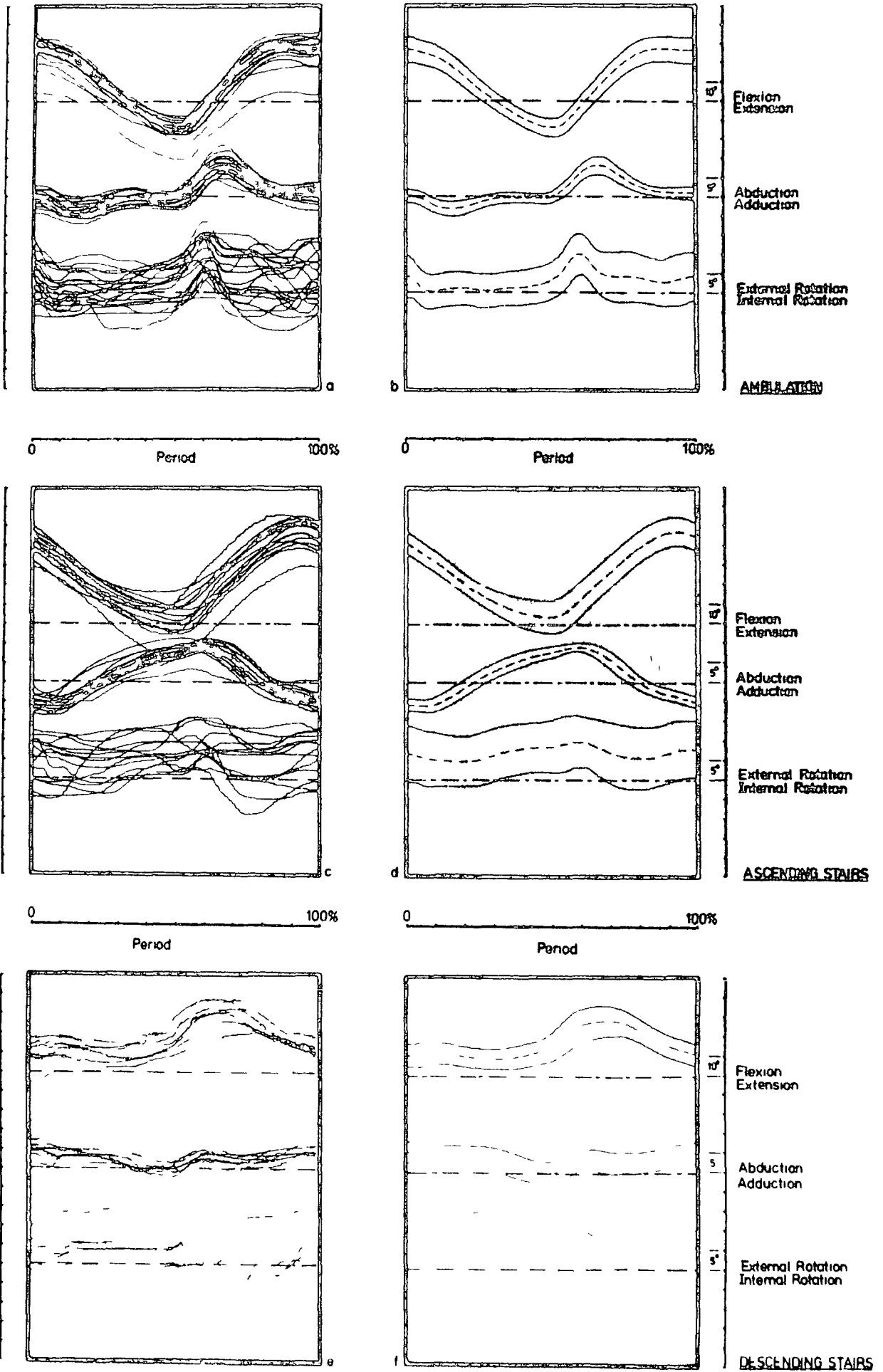


FIGURE 30. Non-controlled plot for male group 3.

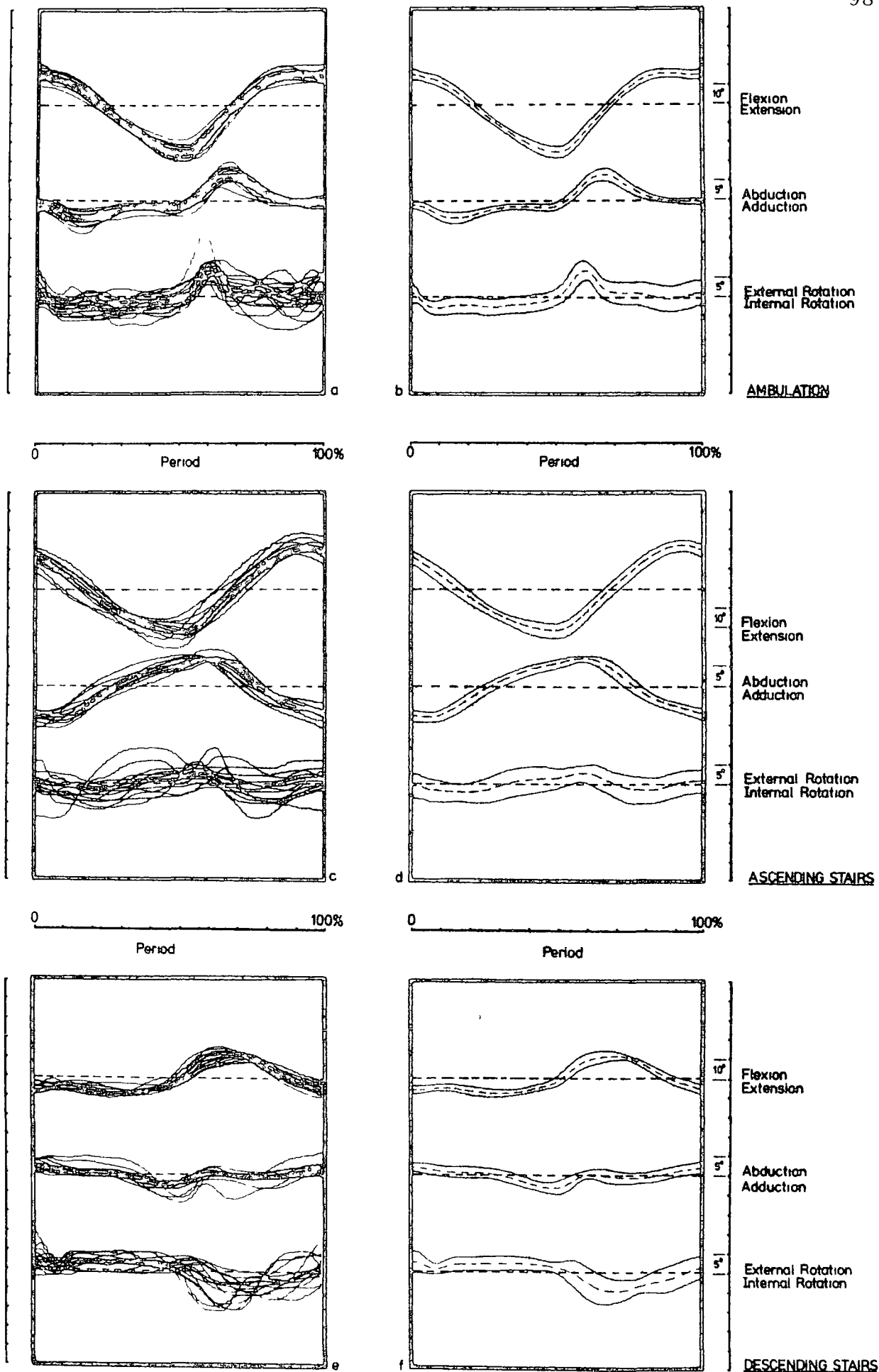


Figure 31 Centred plot for male group 3

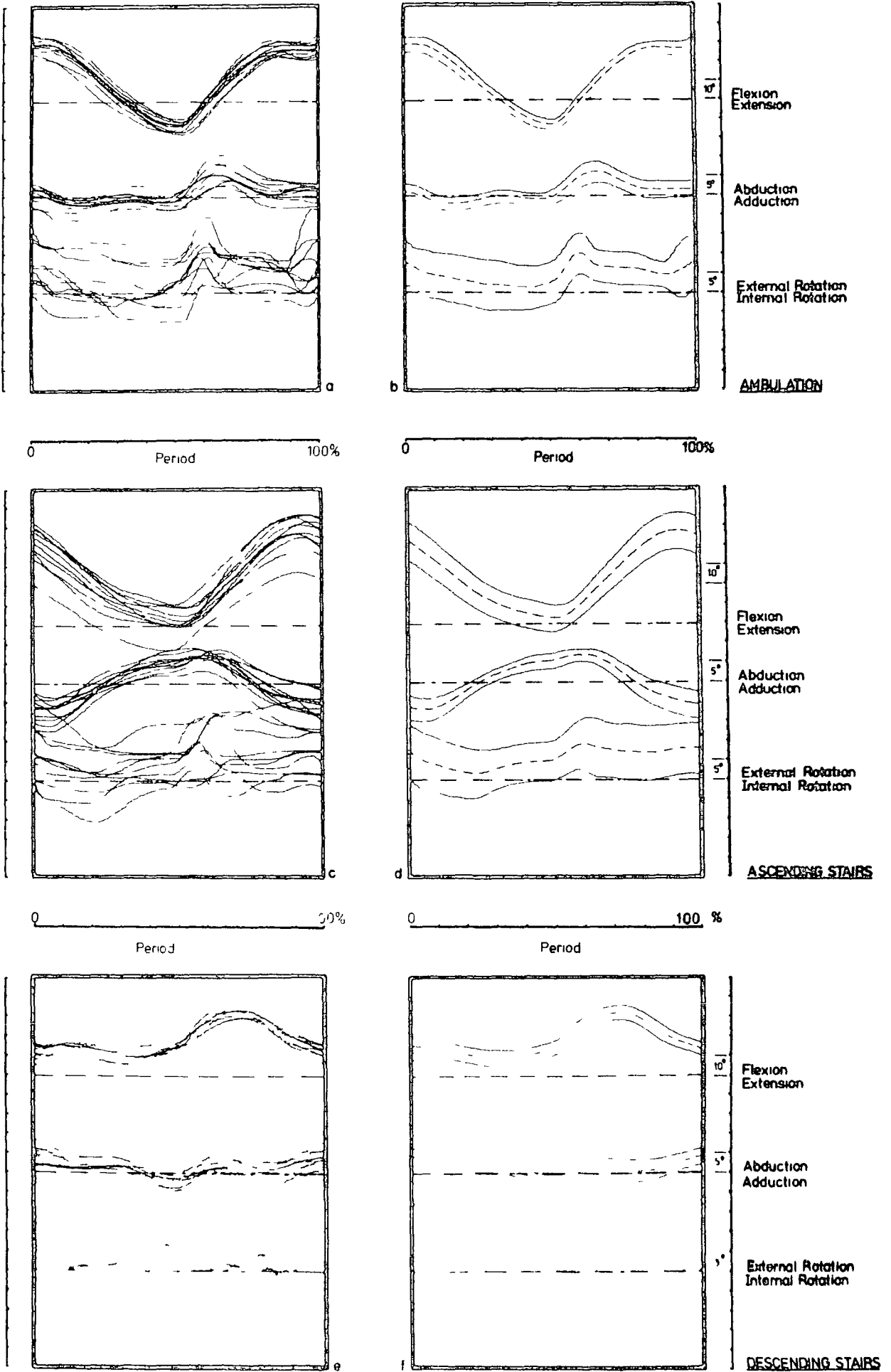


Figure 32 Non-centered plots for males group 4

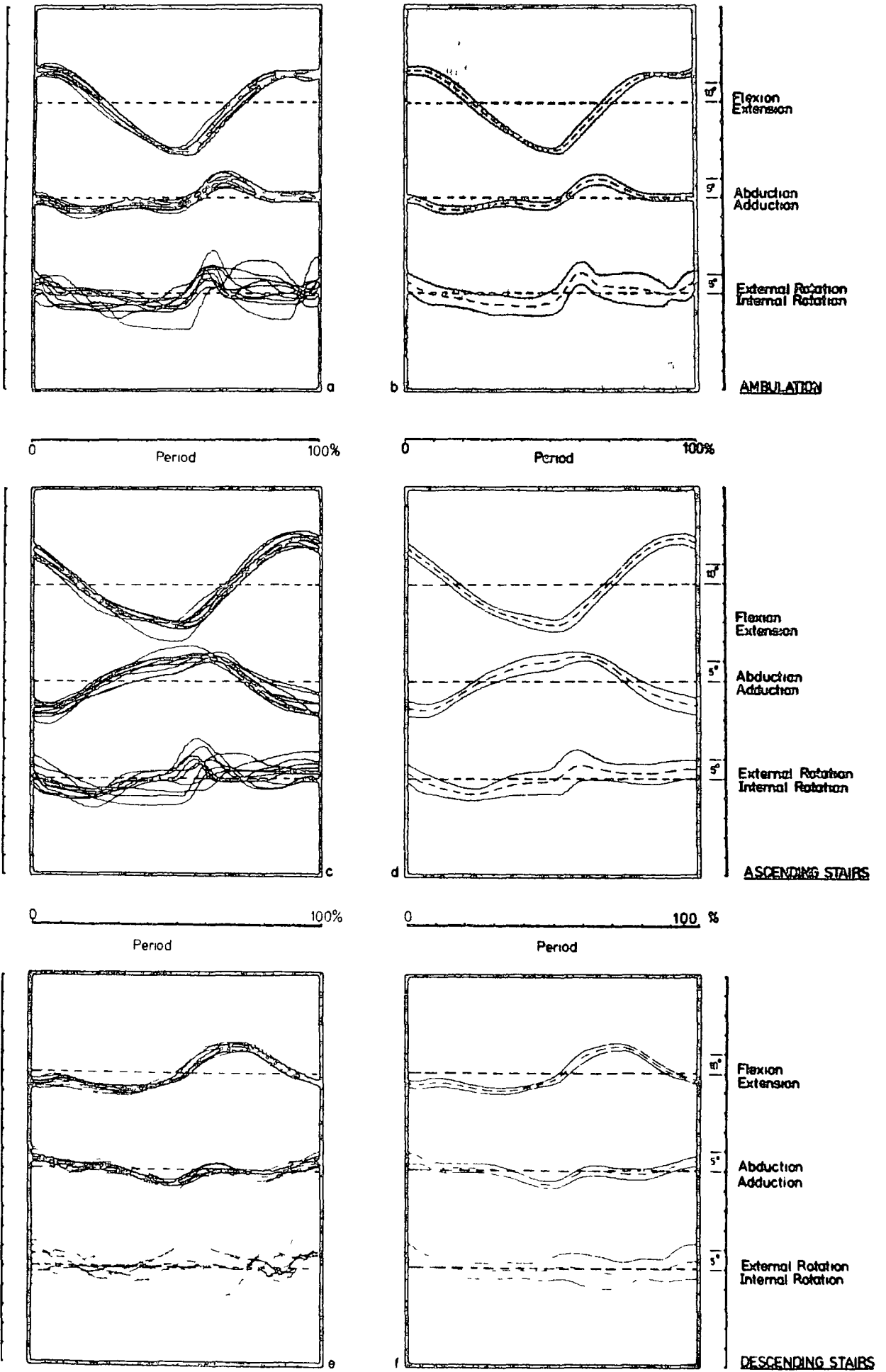


Figure 33 Centred plot for males Group 4

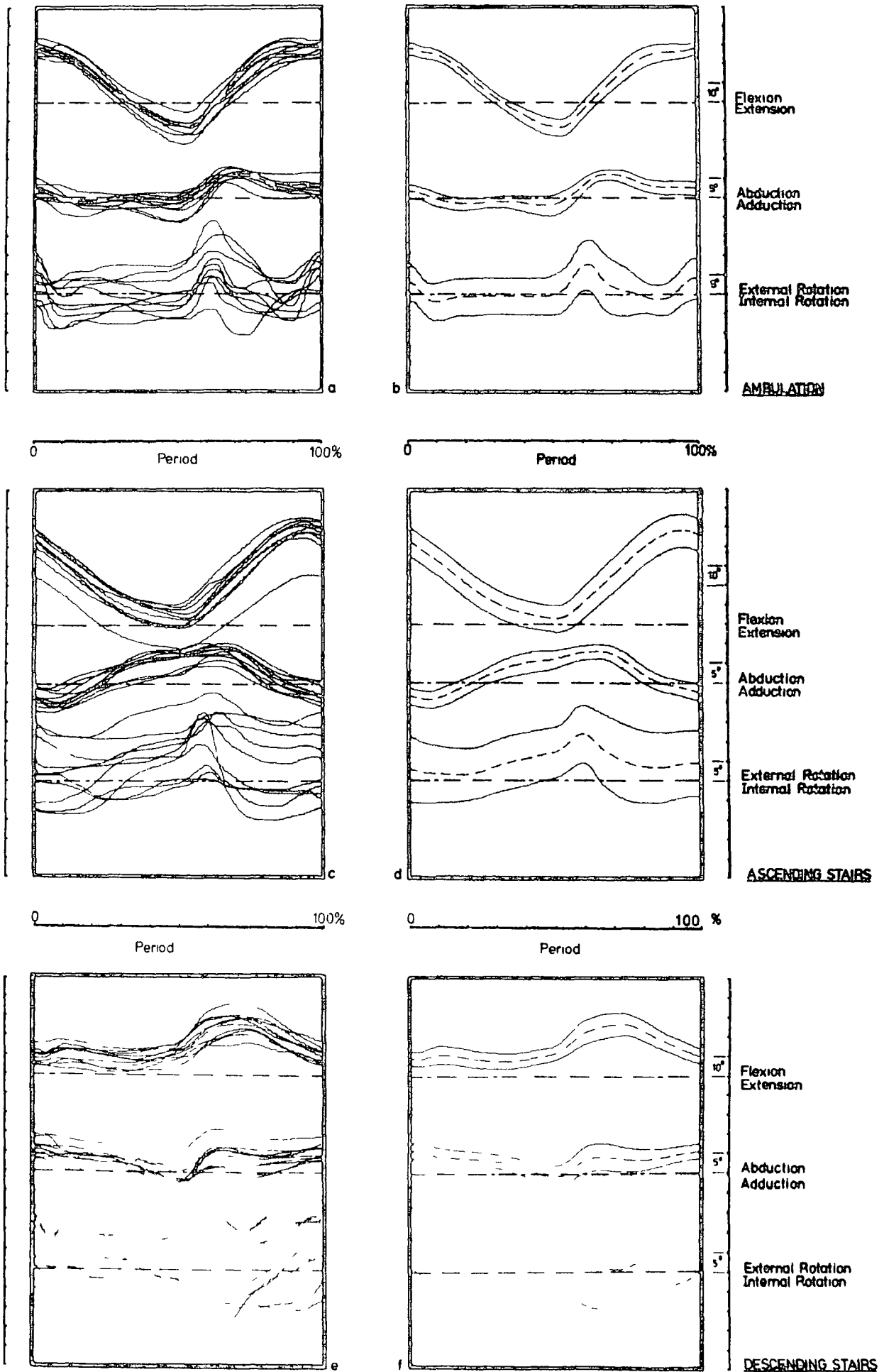


Figure 34 Non-centred plots for males group 5



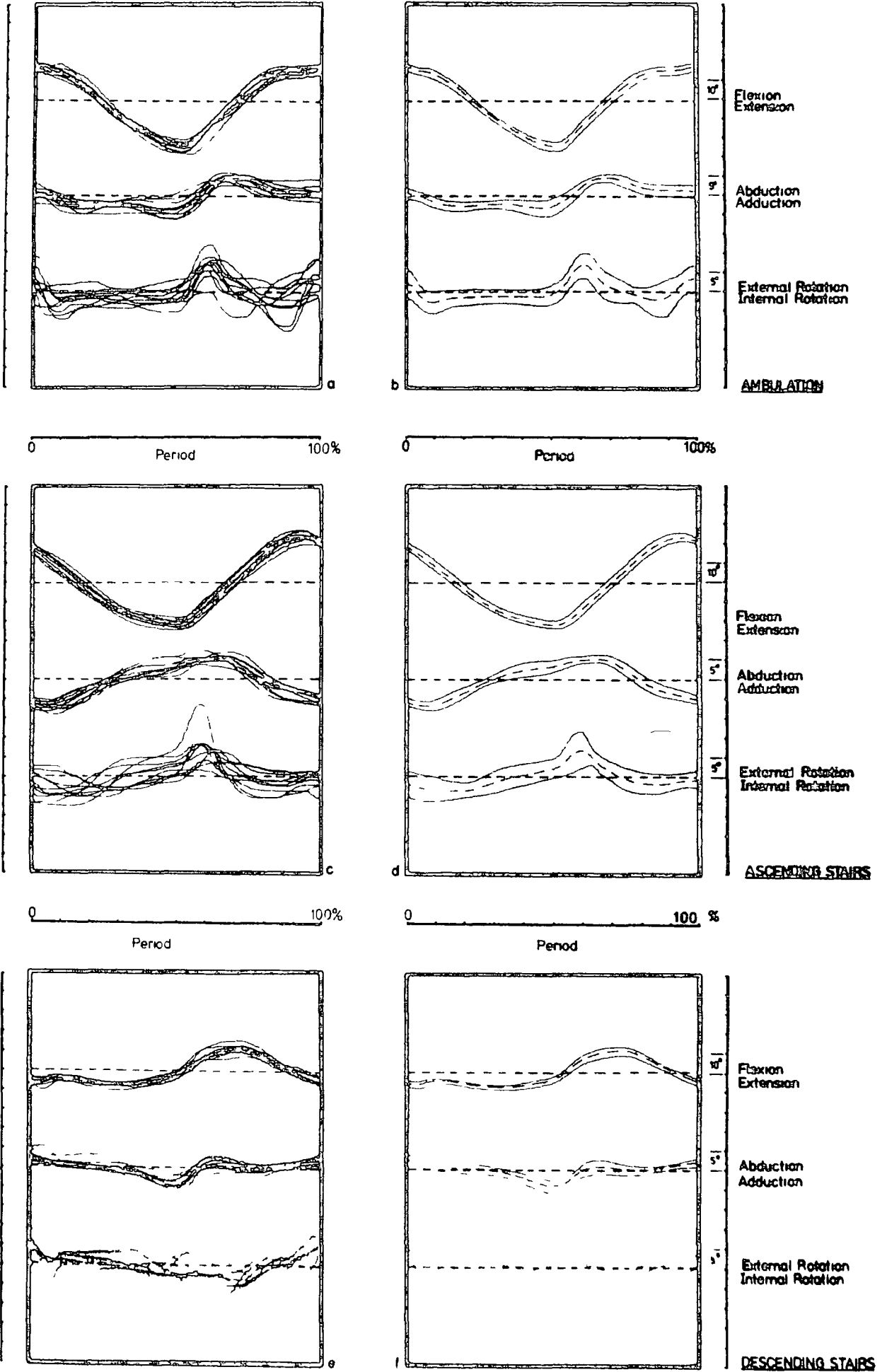


Figure 35 Centred plots for males group 5

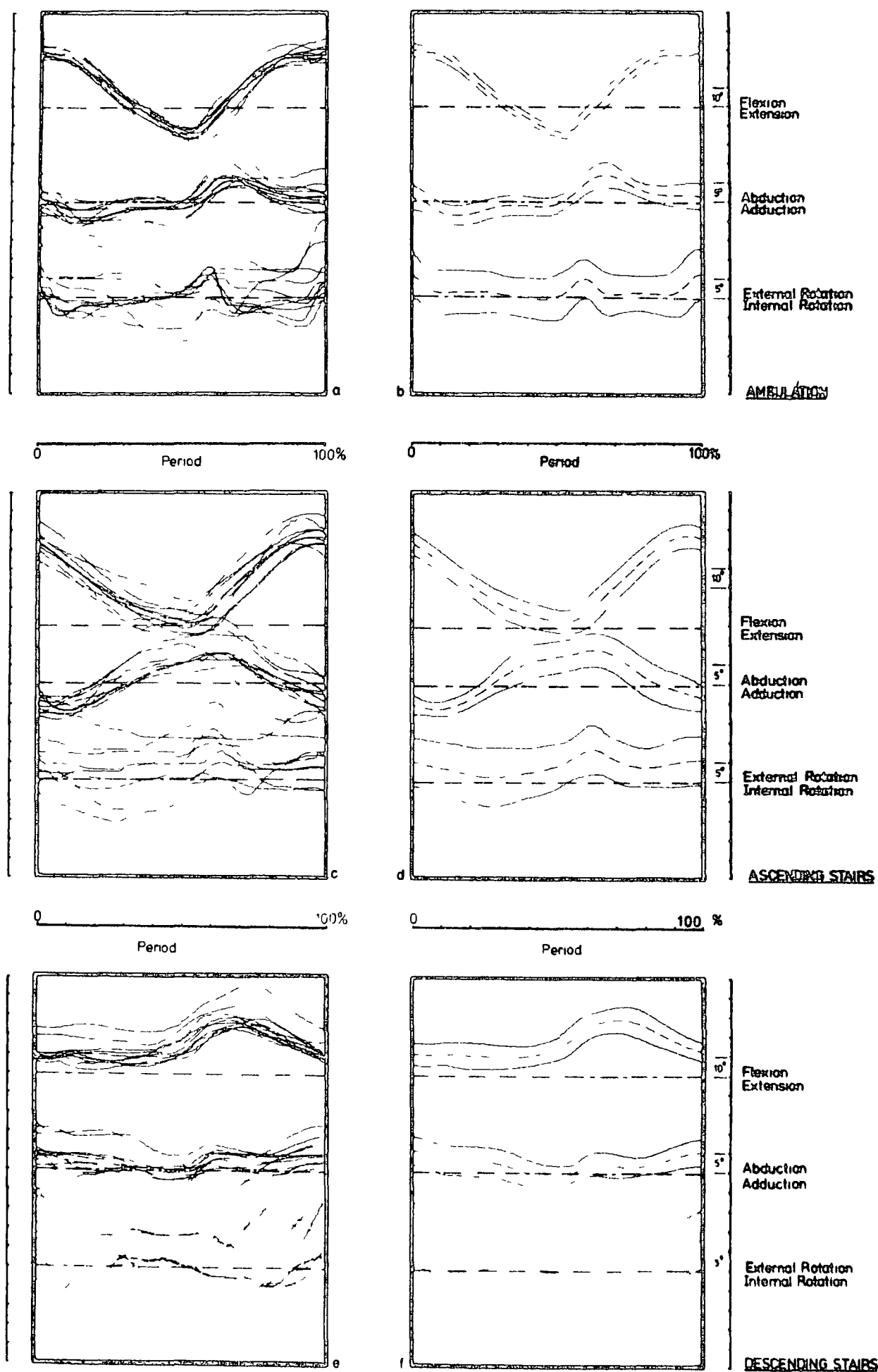


Figure 36 Non-centred plot, for males group 6

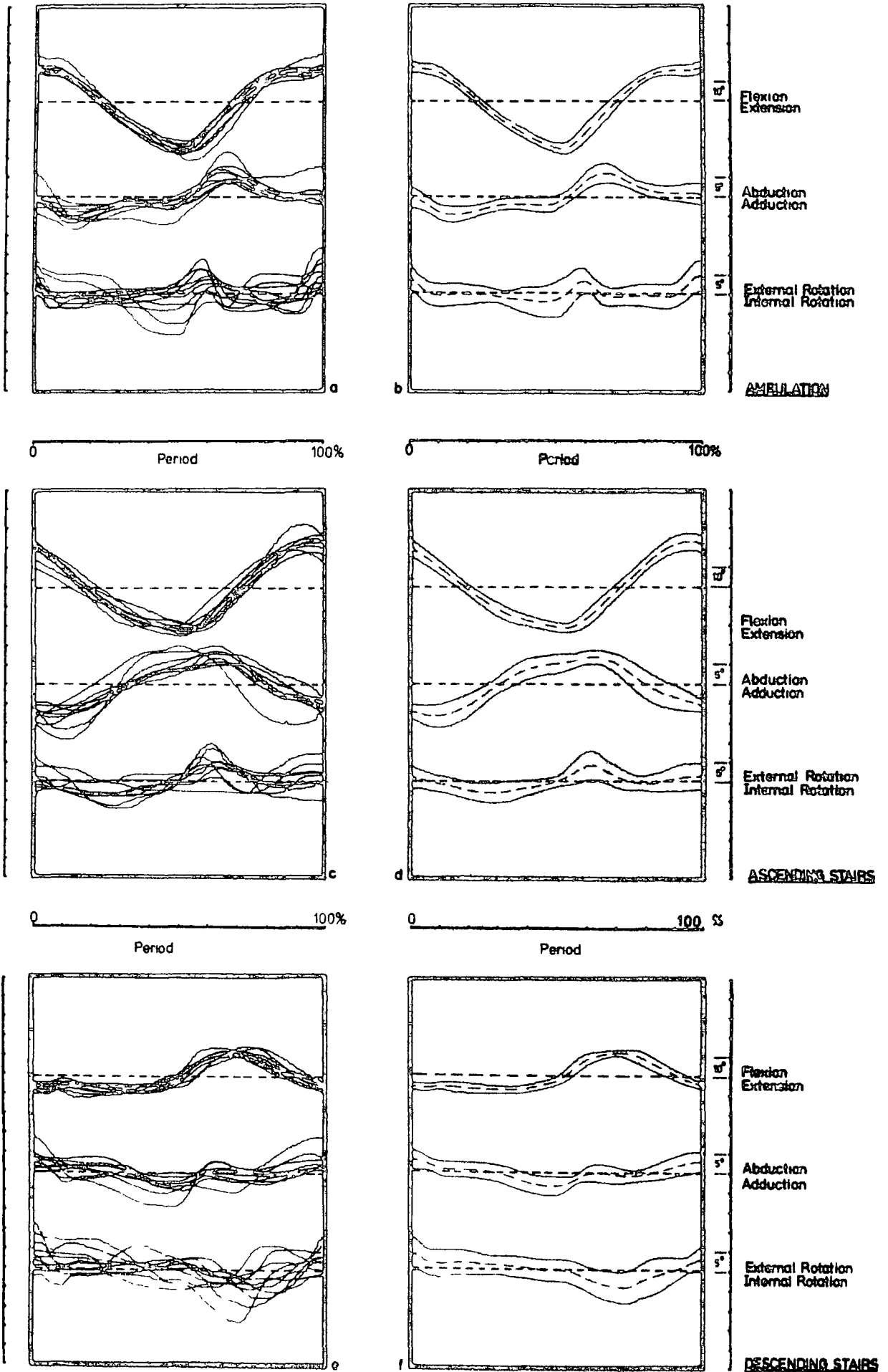


Figure 3/ Centred plots for males group 6

GRP	SAMP NUMB	ROT COMP	MAX	MIN	ROM	COR	COM	S.D. (NO CLA)			S.D. (CLA)			AREA		t	p
								MAX	MIN	AVE	MAX	MIN	AVE	MEAN	S.D.		
1	10	FLEX	26.6	-15.5	42.1	5.6	8.9	4.9	3.2	4.3	3.4	1.5	2.6	319.9	55.7	0.146	0.87
		ABD	8.7	- 3.5	12.2	2.6	1.4	3.5	2.1	2.8	2.2	0.4	1.5				
		ROT	11.5	1.5	10.0	6.5	4.5	9.5	5.7	7.2	6.6	1.4	3.5				
2	12	FLEX	27.6	-14.3	41.9	6.6	9.8	5.8	3.1	4.5	3.8	1.3	2.4	287.0	84.7	0.384	0.7
		ABD	8.2	- 3.8	12.0	2.2	0.9	3.1	1.8	2.4	1.9	1.0	1.4				
		ROT	9.8	0.2	9.6	5.0	2.5	7.7	5.1	6.1	4.0	1.6	2.5				
3	21	FLEX	28.0	-13.6	41.6	7.2	10.7	6.9	4.3	5.7	3.3	1.6	2.5	277.2	87.6	2.66	0.01
		ABD	8.4	- 3.0	11.4	2.7	1.4	2.4	1.2	1.7	1.7	0.6	1.1				
		ROT	10.2	0.3	9.8	5.2	3.2	6.7	4.2	5.3	3.5	1.4	2.5				
4	10	FLEX	30.5	-12.3	42.8	9.1	12.5	4.6	2.6	3.7	3.4	0.7	2.1	192.8	67.3	0.118	0.9+
		ABD	6.4	- 1.8	8.2	2.3	1.2	2.9	1.6	2.1	1.4	0.6	1.0				
		ROT	10.2	1.3	8.9	5.7	4.7	7.7	3.2	5.4	4.2	1.3	2.5				
5	10	FLEX	29.1	-12.9	42.0	8.1	11.1	5.6	2.6	3.9	3.2	1.4	2.3	189.1	49.6	2.147	0.03
		ABD	6.3	- 1.9	8.2	2.2	1.3	2.8	1.3	1.8	2.3	0.9	1.4				
		ROT	7.7	- 1.8	9.5	3.0	0.9	7.3	3.8	5.1	4.8	1.7	2.8				
6	10	FLEX	30.1	-13.2	43.3	8.4	11.5	5.5	2.4	3.4	4.7	1.9	2.8	286.3	140.4		
		ABD	7.3	- 3.6	10.9	1.8	1.0	3.5	1.9	2.6	2.8	1.3	1.9				
		ROT	6.3	- 0.7	7.0	2.8	1.6	7.3	4.5	5.5	4.7	1.7	3.0				

TABLE A1(M)

STATISTIC	TEST	1			2			3		
		CALCULATED USING NON CLA MEANS AND S.D.'S IN Y DIRECTION			CALCULATED USING CLA MEANS AND S.D.'S IN THE Y DIRECTION			CALCULATED USING CLA MEANS AND NON CLA S.D.'S IN THE Y DIRECTION		
		FLEX	ABD	ROT	FLEX	ABD	ROT	FLEX	ABD	ROT
A	MEAN OF MODULUS OF t's IN THE X DIRECTION									
B	MEAN OF SIGNED VALUES OF t's IN THE X DIRECTION									
C	STANDARD DEVIATION OF t's IN THE X DIRECTION									
D	t-TESTING FOR A SIMILARITY TO A PERFECT LIKENESS $t(0,0)$									
E	RESULTING PROBABILITY OF A SIMILARITY EXISTING									
F	t- TESTING FOR A SIMILARITY TO A DISTRIBUTED FIT $t(0,1)$									
G	RESULTING PROBABILITY OF A SIMILARITY EXISTING									

TABLE 3 KEY TO A, SU AND SD TABLES

COMPARISON GROUPS 1 & 2 MALE AMBULATION	CALCULATED USING NON CLA MEANS AND S.D.'S IN Y DIRECTION			CALCULATED USING CLA MEANS AND S.D.'S IN THE Y DIRECTION			CALCULATED USING CLA MEANS AND NON CLA S.D.'S IN THE Y DIRECTION		
	FLEX	ABD	ROT	FLEX	ABD	ROT	FLEX	ABD	ROT
MEAN OF MODULUS OF t's IN THE X DIRECTION	0.5	0.65	0.72	0.55	1.14	0.34	0.32	0.65	0.14
MEAN OF SIGNED VALUES OF t's IN THE X DIRECTION	0.47	-0.46	-0.72	-0.01	0.08	0.06	0.003	0.05	-0.005
STANDARD DEVIATION OF t's IN THE X DIRECTION	0.39	0.68	0.21	0.66	1.23	0.44	0.38	0.71	0.17
t-TESTING FOR A SIMILARITY TO A PERFECT LIKENESS $t(0,0)$	17.29	-9.62	-47.77	-0.22	0.93	2.03	0.122	0.99	-0.45
RESULTING PROBABILITY OF A SIMILARITY EXISTING	0	0	0	0.83	0.37	0.05	0.9+	0.31	0.65
t- TESTING FOR A SIMILARITY TO A DISTRIBUTED FIT $t(0,1)$	6.24	-5.41	-9.92	-0.12	0.72	0.824	0.04	0.58	-0.08
RESULTING PROBABILITY OF A SIMILARITY EXISTING	0	0.0001	0	0.9+	0.45	0.41	0.9+	0.55	0.9+

TABLE A2(M)

COMPARISON GRUUPS 2 & 3 MALE AMBULATION	CALCULATED USING NON CLA MEANS AND S.D.'S IN Y DIRECTION			CALCULATED USING CLA MEANS AND S.D.'S IN THE Y DIRECTION			CALCULATED USING CLA MEANS AND NON CLA S.D.'S IN THE Y DIRECTION		
	FLEX	ABD	ROT	FLEX	ABD	ROT	FLEX	ABD	ROT
MEAN OF MODULUS OF t's IN THE X DIRECTION	0.50	0.68	0.36	0.45	0.60	0.54	0.21	0.36	0.31
MEAN OF SIGNED VALUES OF t's IN THE X DIRECTION	0.50	0.68	0.36	-0.04	0.04	-0.03	-0.02	0.02	0.01
STANDARD DEVIATION OF t's IN THE X DIRECTION	0.22	0.46	0.36	0.52	0.70	0.79	0.25	0.42	0.36
t-TESTING FOR A SIMILARITY TO A PERFECT LIKELESS $t(0,0)$	32.5	20.6	12.7	-1.26	0.80	-0.54	-1.04	0.78	0.31
RESULTING PROBABILITY OF A SIMILARITY EXISTING	0	0	0	0.21	0.45	0.55	0.30	0.45	0.75
t- TESTING FOR A SIMILARITY TO A DISTRIBUTED FIT $t(0,1)$	6.90	8.62	4.33	-0.58	0.46	-0.34	-0.23	0.30	0.10
RESULTING PROBABILITY OF A SIMILARITY EXISTING	0	0	0.0001	0.55	0.65	0.75	0.83	0.75	0.9+

TABLE A3(M)

COMPARISON GROUPS 3 & 4 MALE AMBULATION	CALCULATED USING NON CLA MEANS AND S.D.'S IN Y DIRECTION			CALCULATED USING CLA MEANS AND S.D.'S IN THE Y DIRECTION			CALCULATED USING CLA MEANS AND NON CLA S.D.'S IN THE Y DIRECTION		
	FLEX	ABD	ROT	FLEX	ABD	ROT	FLEX	ABD	ROT
MEAN OF MODULUS OF t's IN THE X DIRECTION	0.94	1.02	0.91	1.68	1.78	1.33	0.75	1.04	0.62
MEAN OF SIGNED VALUES OF t's IN THE X DIRECTION	0.91	-0.10	0.70	0.04	0.21	0.02	0.02	0.09	0.01
STANDARD DEVIATION OF t's IN THE X DIRECTION	0.85	1.18	0.79	1.84	2.00	1.74	0.82	1.19	0.79
t-TESTING FOR A SIMILARITY TO A PERFECT LIKE'ESS $t(0,0)$	15.2	-1.25	13.5	0.33	1.48	0.19	0.28	1.03	0.20
RESULTING PROBABILITY OF A SIMILARITY EXISTING	0	0.25	0	0.75	0.15	0.85	0.75	0.25	0.85
t- TESTING FOR A SIMILARITY TO A DISTRIBUTED FIT $t(0,1)$	9.82	-0.95	8.32	0.29	1.32	0.17	0.18	0.79	0.13
RESULTING PROBABILITY OF A SIMILARITY EXISTING	0	0.35	0	0.75	0.20	0.85	0.85	0.45	0.9

TABLE A4(M)

COMPARISON GROUPS 4 & 5 MALE AMBULATION	CALCULATED USING NON CLA MEANS AND S.D.'S IN Y DIRECTION			CALCULATED USING CLA MEANS AND S.D.'S IN THE Y DIRECTION			CALCULATED USING CLA MEANS AND NON CLA S.D.'S IN THE Y DIRECTION		
	FLEX	ABD	ROT	FLEX	ABD	ROT	FLEX	ABD	ROT
MEAN OF MODULUS OF t's IN THE X DIRECTION	0.82	1.0	1.71	0.77	1.52	1.20	0.43	0.98	0.66
MEAN OF SIGNED VALUES OF t's IN THE X DIRECTION	-0.81	0.14	-1.71	0.13	0.07	0.17	0.03	0.03	-0.06
STANDARD DEVIATION OF t's IN THE X DIRECTION	0.48	1.06	0.96	0.94	1.64	1.34	0.51	1.06	0.773
t-TESTING FOR A SIMILARITY TO A PERFECT LIKEHOOD $t(0,0)$	-24.03	1.85	-25.3	2.02	0.59	1.76	0.77	0.42	-1.03
RESULTING PROBABILITY OF A SIMILARITY EXISTING	0	0.07	0	0.06	0.55	0.1	0.45	0.68	0.31
t- TESTING FOR A SIMILARITY TO A DISTRIBUTED FIT $t(0,1)$	-10.34	1.35	-17.5	1.38	0.50	1.42	0.35	0.30	-0.63
RESULTING PROBABILITY OF A SIMILARITY EXISTING	0	0.19	0	0.19	0.62	0.15	0.73	0.76	0.53

TABLE A4(M)

COMPARISON GROUPS 5 & 6 MALE AMBULATION	CALCULATED USING NON CLA MEANS AND S.D.'S IN Y DIRECTION			CALCULATED USING CLA MEANS AND S.D.'S IN THE Y DIRECTION			CALCULATED USING CLA MEANS AND NON CLA S.D.'S IN THE Y DIRECTION		
	FLEX	ABD	ROT	FLEX	ABD	ROT	FLEX	ABD	ROT
MEAN OF MODULUS OF t's IN THE X DIRECTION	0.57	1.08	0.81	0.63	1.32	1.02	0.45	0.99	0.55
MEAN OF SIGNED VALUES OF t's IN THE X DIRECTION	0.34	-0.43	0.34	0.16	-0.08	0.05	0.12	-0.04	0.04
STANDARD DEVIATION OF t's IN THE X DIRECTION	0.56	1.21	0.68	0.71	1.57	1.26	0.53	1.19	0.67
t-TESTING FOR A SIMILARITY TO A PERFECT LIKENESS $t(0,0)$	8.51	-4.97	7.04	3.24	-0.71	0.56	3.12	-0.52	0.85
RESULTING PROBABILITY OF A SIMILARITY EXISTING	0	0.0001	0	0.003	0.47	0.57	0.002	0.61	0.41
t- TESTING FOR A SIMILARITY TO A DISTRIBUTED FIT $t(0,1)$	4.17	-3.83	3.98	1.88	-0.60	0.44	1.46	-0.40	0.47
RESULTING PROBABILITY OF A SIMILARITY EXISTING	0.0001	0.001	0.001	0.09	0.55	0.66	0.17	0.70	0.65

TABLE A6(M)

7 ANALYSIS AND DISCUSSIONS OF NORMAL RESULTS

7 1 Introduction

Results are discussed for ambulation, climbing, descending, and standing and sitting in that order. Firstly, typical results are discussed then the direct comparison of each age group with the next senior group is considered. Trends and consequences developing through all groups are then discussed. All male exercises are analysed first, followed by the female groups.

The derivation and interpretations of the figures are explained in Chapter 5. Abbreviations are defined under the section headed "Notation".

It should be noted that exercises on the stairs are regulated both in time and distance, step length and cadence both being predetermined. Ambulation on the other hand is a comparatively free exercise with only cadence set, step length being free.

7 2 Male ambulation

7 2 1 Description of normal walking - male

Figs. 23 and 24 are full size reproductions of computer graphics obtained as previously described. Superimposed upon them are scaling marks and three horizontal zero axes. These results are typical of normal male results.

Fig. 23 shows five consecutive steps plotted such that each successive heelstrike occurs at 0% period

The topmost line records hip rotations in the sagittal plane. These are closely similar, and it can be seen that the performance envelope for rotations in this plane is quite narrow. The maximum width is 2.5° , or 5.6% of R O M. The scale for rotations in this plane is 10 degrees/cm.

The second top line represents rotations in the coronal plane. These are also very similar, again showing a narrow performance envelope, having a maximum width of 2° or 12.5% of R O M. The scale here is $5^{\circ}/\text{cm}$.

Transverse plane rotations are represented on the third line, and exhibit a lack of precise repeatability, yet over large proportions of the curve the performance envelope is quite narrow. The maximum width is 5° which in this case is 40% of R O M. The scale is again $5^{\circ}/\text{cm}$.

The bottom line is generated by footswitch data. Heelstrike occurs at 0% of cycle and toe-off at about 60% of cycle. The point of toe-off varies by a maximum of 1.3% of cycle, which at the set cadence of 108 steps per minute (1.8 Hz), is a spread of 14.3 ms. The varying vertical levels on this trace represent the differing contact patterns of the foot on the ground.

The five steps recorded on this diagram are averaged to give the set of single curves of Fig. 24.

Examination of the top-most line (flexion-extension) reveals that a total of 47° of movement is employed. The limb passes through the zero position at a point

corresponding well to midstance as indicated by the footswitch (lowermost line) at 30% of period. From this zero position some 32° of flexion and 15° of extension are employed, flexion being greatest just before and at heelstrike, and extension being greatest just before toe-off.

If a Fourier series of the form -

$$y = a_0 + a_1 \cos x + b_1 \sin x + a_n \cos nx + b_n \sin nx$$

is fitted to this curve, as one might expect, it is heavily weighted to the fundamental, to the extent that terms above the third harmonic may be sensibly neglected. The Fourier coefficients for ambulation curves are given in Table 1

The second top line representing abduction-adduction reveals adduction of 5° during the first half of stance, returning to abduction of 10° during the first half of swing. During early stance the hip is adducted to allow the centre of gravity of the subject to be positioned directly above the supporting foot. This adduction reverts to zero as the contralateral foot approaches heelstrike at 50% period. As the swing phase commences the hip is abducted to swing the foot around the contralateral supporting limb which would now be in adduction.

A Fourier analysis of this wave form reveals again a bias to the lower harmonics, but the coefficients of the first three harmonics are more even in magnitude. Coefficients above the 5th harmonic may be sensibly

assumed to be zero

The second bottom line represents rotation about the long axis of the femoral shaft. An initial external rotation of 5° is rapidly reversed to an internal rotation of 5° shortly after heelstrike as the hip moves into the aforementioned adduction. At toe-off, the hip rapidly passes from internal to external rotation, and back to internal rotation, producing a characteristic hump in the rotational plot. Movement is then into external rotation immediately prior to heelstrike.

A Fourier analysis here indicates movements up to the 7th harmonic after which terms may be neglected.

It should be noted that the points of high loading in the hip, namely heelstrike and toe-off, Paul (1967) correspond to points of high angular velocity in all planes. The vector sum of these velocities may prove significantly higher than those used previously in calculations on the lubrication regimes existing in the hip.

Fig. 25 shows a plot record in rectangular coordinates of sagittal plane rotations against coronal plane rotations, on a scale of $5^{\circ}/\text{cm}$. The continuous loop is the ambulation data recorded previously. As the recorded movements are cyclic, a closed loop is formed, the area of which gives a measure of P.O.M. and R.O.M. This plot has a characteristic shape for each exercise, the one being a typical shape for ambulation.

In order that three dimensional movement may be represented in a two dimensional plot, a second zero coordinate (O_2) for rotation is introduced at the bottom of the plot

The broken line on this rectangular plot represents the global range of movement, and is discussed further elsewhere

7 2 2 Comparison Groups 1 and 2 (M)

Referring to Table A1(M), one finds that for group 2 the C O M is higher (i.e. further into the flexion region) for sagittal plane rotations, than the C.O.M in flexion for group 1. However, in the coronal plane, group 1 demonstrate a greater value for C O.M. than group 2, although the greatest adduction for group 1 corresponds closely to the level attained by group 2. This would indicate that the maximum amount of adduction used corresponds to a placing of the foot close to the centre line of the traversed path, and adduction at the hip by 2° - 4° until the centre of gravity is over the centre of the foot. One would expect this to be the normal mode of progression for all physically able groups

It should be noted that this effectively limits the amount of adduction that is used during normal walking and as such, any increases in the range of movement in the coronal plane will tend to occur from the abduction region, cause a positive shift in C O R, and almost certainly in C O M also. The converse also seems to

hold true, decreases in R O M causing negative shifts in C O R and C O M

Although both groups exhibit similar levels of adduction, and also a similar R O M (122° for group 1 and 12° for group 2) the C O M for group 1 is 05° further into the abduction region

In the transverse plane the junior group demonstrate a C O M 2° further into the external rotation region than the senior group, Table A1(M)

Referring now to Table A2(M), test 1 statistics D, E, F and G indicate highly significant differences existing in the hip movements of these two groups

Reference to the same statistics for tests 2 and 3 show that the major reason for this is shifts in C.O.M Test 3 statistic G illustrates the fact that the range and pattern of movements in the sagittal and transverse planes are very similar, with motion in the coronal plane also exhibiting a marked similarity Differences here are that group 2 move in slightly more abduction in mid and late stance phase, and slightly less adduction in swing phase and early stance

Reference to the ambulation curves of Fig 26b and Table A1(M) shows that the standard deviation for transverse rotations is proportionately much higher than for rotations in other planes In the sagittal and coronal planes respectively the standard deviation between individuals amounts to approximately 10% and 20% of R O M , whereas in the transverse plane the

proportion is 65% of R O M This result is in accordance with the works of Murray (1964) and Smidt (1971) who both observed a greater spread in measurements of transverse rotations

7 2 3 Comparison Groups 2 and 3 (M)

Referring to Table A3(M) one notes that test 1 statistics A and B are the same for all planes, indicating that everywhere along the curves of flexion, abduction and rotation, group 3 exhibits a positive shift in movement pattern, resulting of course in a positive shift in C O M for all components of rotation, (Table A1(M)) Although these shifts in C O M are small, amounting to 0 9 in the sagittal plane, 0 5° in the coronal plane and 0 7° in the transverse plane, test 1 statistics D, E, F and G show that they are very significant.

On the otherhand, although there exists a systematic positive shift in C O M examination of tests 2 and 3, statistics D, E, F and G reveals that R O M. and P.O.M are very similar, and indeed, if the two centred plots are overlaid it is difficult to distinguish between them

Again the standard deviation for transverse plane rotations are larger than for rotations in the other planes, Table A1(M) and Fig 28b

7 2 4 Comparison Groups 3 and 4 (M)

Reference to Table A1(M) shows that there are quite large shifts in C O M in the sagittal and coronal planes for the senior group These amount to 1 8°

and 1.5° respectively. However, in the coronal plane the senior group demonstrate a small negative shift in C O M of 0.2° . Examination of Fig 32b reveals that there is a compression evident in the R O M and P O M of the senior group for movements in this plane. As mentioned previously, this compression will tend to occur as a reduction from the abduction region, with a consequential negative shift in C O.M. These changes in C O M and P O M in the coronal plane are reflected in statistics D, E, F and G, Table A4(M), showing comparatively low similarities between age groups. The reduction in R O M for group 4 is 3.2° .

Statistics D, E, F and G for test 1 show highly significant differences in sagittal and transverse plane rotations due almost entirely to shifts in C O.M., as is illustrated by statistics D, E, F and G in tests 2 and 3 which indicate close similarities in R.O M and P O M.

7 2 5 Comparison Groups 4 and 5 (M)

Table A5(M), test 1 statistic B shows negative shifts in C O M for rotations in the sagittal and transverse planes, 1.4° and 3.8° respectively (Table A1(M)), and a small positive shift of 0.1° in C O M for rotations in the coronal plane.

This negative shift in C O M in the sagittal plane for the senior group is accounted for by a reduction in R O M of 0.8° occurring mainly from the flexion region, and by a flattening of the flexion

curves in late swing and early stance

The negative shift in C.O M for group 5 in the transverse plane corresponds to a 3.8° shift into internal rotation as compared with group 4

The small positive shift in C O M in the coronal plane, with the low figures for statistics D, E, F and G, test 1, Table A5(M), indicate differences in the shape of the curves rather than significant differences in C O M Test 3 statistic G for flexion shows a slightly smaller probability of similarity than usual due to the previously mentioned reduction in R O M and change in P O M In the coronal plane the probability of similarity is rated higher than for groups 1/2, 2/3 and 3/4 due to the proportionately larger standard deviations

Rotations in the transverse plane are less similar than in other groups, the figures (test 3, statistics D, E, F and G) reflecting changes in C O M , P O.M and R O M

7 2 6 Comparison Groups 5 and 6 (M)

Referring to Tables A1(M) and A6(M), it can be seen that there are positive shifts in C O M for the senior group in both the sagittal and transverse planes (0.4° and 0.7°), but a negative shift in C O.M in the coronal plane (0.3°) Also of note in group 6, Table A1(M), is that the standard deviations for the central plots for this group are rather larger than for other groups, indicating a greater variability between

individual members of this group

In the senior age groups throughout these tests, the physical variations between individuals are more marked than in the younger age groups (Table 2) In group 6 especially, although all efforts were made to reduce inter-subject differences, considering the population available, it was noticeable that some subjects completed their tests in a much spritelier fashion than others. Indeed, this group was noticeable for the number of subjects who were "super-normal", in that their general health and fitness were far better than could have been expected. It is probably true to say that an average person in this age range suffers to some degree from arthritis, and it is more unusual to find examples who do not. The above reasons explain to some extent the reversals in some of the trends developed so far, (changes in R O M for example). For the senior group there is an increase in R O M of 1.3° in the sagittal plane and 2.7° in the coronal plane, but a reduction of 2.5° in the transverse plains

In the sagittal plane, tests 2 and 3 statistics D, E, F and G (Table A6(M)) indicate low probabilities of similarities existing, reflecting changes in R O M and P O M as well as in C O M

Although the standard deviations for coronal and transverse rotations are higher than other groups, the middle range similarity figures indicate changes in

P O M as well as C O M The differences are quite marked compared to differences in the younger groups

7 2 7 Synopsis of male ambulation

Analysis of the data acquired, (statistic G test 2, Tables A2(M) to A6(M)) reveals that between consecutive groups there are no significant variations at the level $p \leq 0.1$ in the R O M and P O M used during walking, except for sagittal plane rotations in the comparison between groups 5 and 6 ($p = 0.09$)

Examination of the data indicates that at this level of probability there exist no significant differences between any two groups Indeed, only two tests exhibit values of p less than 0.5 for test 3 statistic G, abduction groups 3/4, ($p = 0.45$), and flexion groups 5/6 ($p = 0.17$) The difference illustrated in the latter test is in fact an increase in R O M in the senior group of 13° , but this only emphasises the spriteliness of group 6 as previously discussed

Trends developing as far as R O M is concerned, which may be substantiated by examining larger samples, are as below

In groups 1, 2 and 3 range of movement in all planes diminishes systematically with increasing age In coronal and transverse plane rotations this trend continues through group 4 All groups except group 6 exhibit diminishing R O M with increasing age for coronal plane rotations No trends seem to exist between

groups 4, 5 and 6 probably reflecting the larger variations between individuals in these groups.

Significant changes in C O M ($p \leq 0.001$) occur between all age groups in all cases except the coronal plane for groups 3, 4 and 5. For groups 1 to 4 C O M when R O M is also taken into account (see section 7.3.1) possibly indicates that with advancing age one tends to walk with angular changes occurring about points proportionately further into regions of flexion and abduction.

This would perhaps suggest that with advancing age and depletion of the neuro-musculo-skeletal system this mechanism is used to obtain greater stability.

Murray et al (1964) noted no systematic differences in sagittal plane rotations during walking for healthy men in the age range 20 to 65 years, but did note this change for men over 65 years, (Murray et al (1969)). Murray also notes that wide variations exist between all individuals concerning rotations in the transverse plane, as also found in these tests.

Further notable observations are that there is an indication that during walking, the complete normal range of extension is used, and that walking is performed in such a way that the individual shifts his C O M from stance such that when walking in the resultant "flexion contracture" he can still achieve an adequate amount of hip extension to accommodate a reasonable stride length.

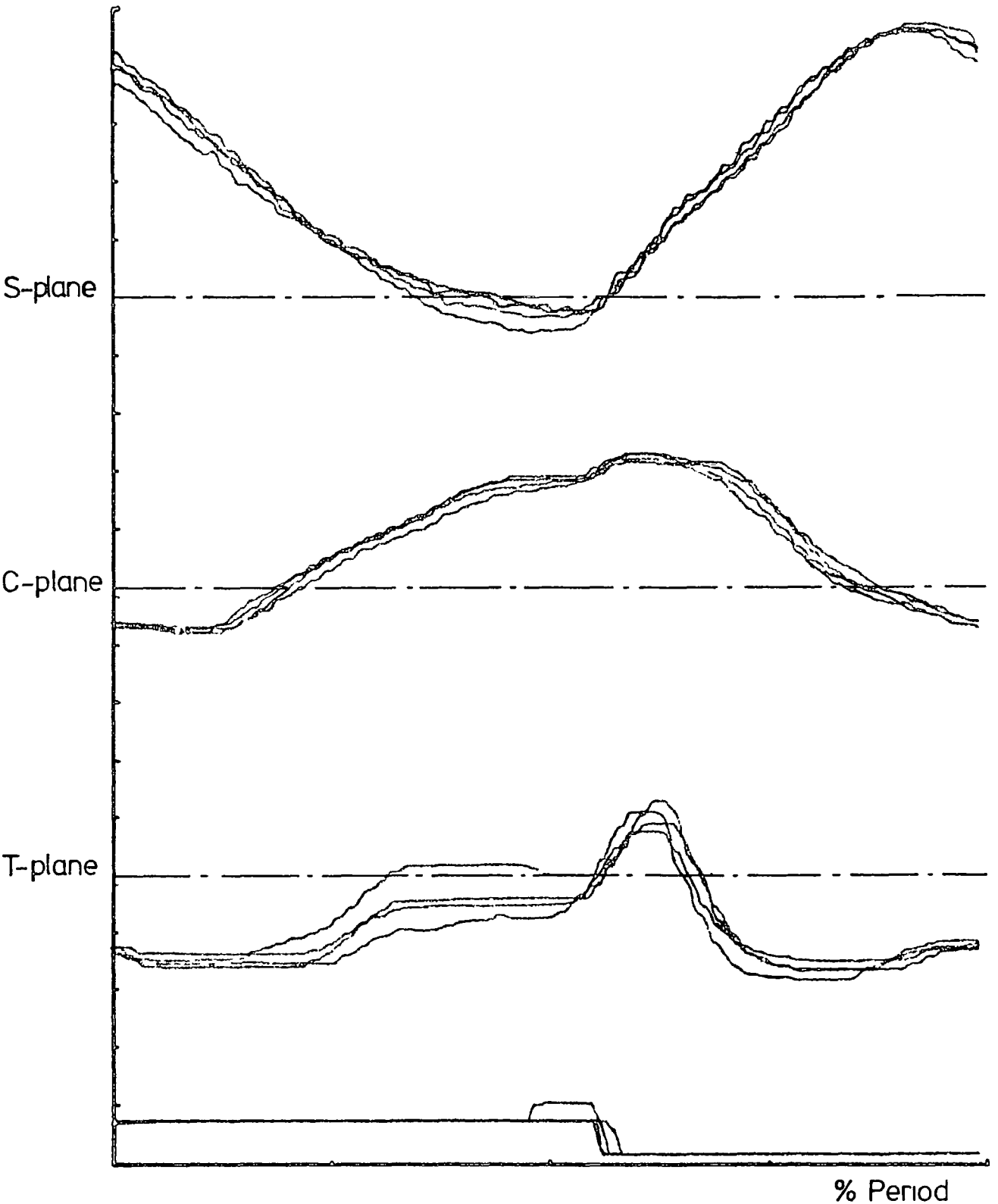
A further parameter available for analysis is the area enclosed on the flexion-abduction rectangular plot (see Fig 25) This area represents only two components of angular variation, transverse rotations being the one omitted since they are so variable between both individuals and groups (The standard deviation for transverse rotations often approaches 70% of the measured mean) However, the area enclosed is a useful parameter because it allows numerical measurements incorporating information on P O M as well as R O.M.

The mean area for a group can be measured in two ways.

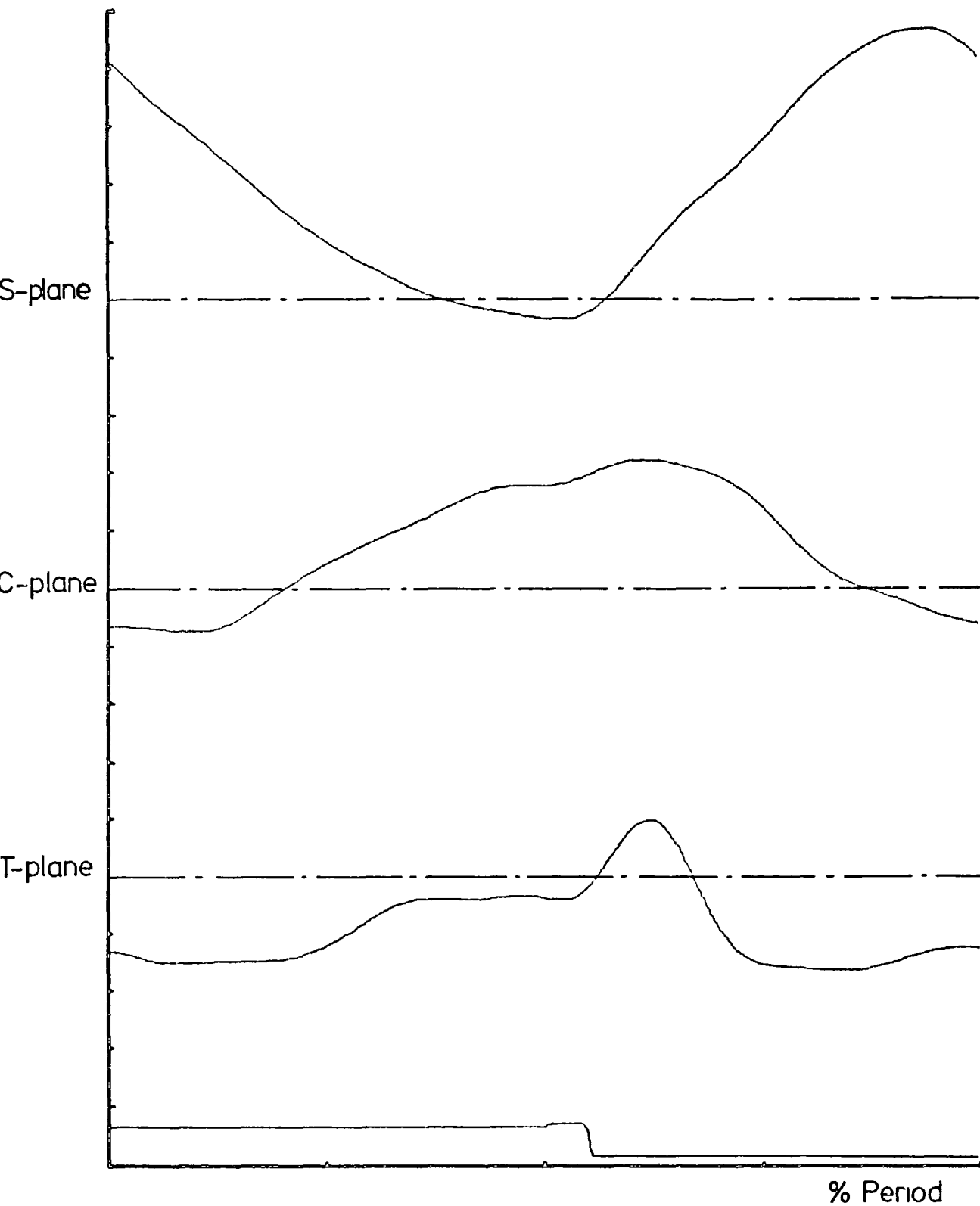
- (a) by measuring the area enclosed by the mean data for that group, and
- (b) by measuring the area for each individual in the group and taking the mean area for the group

Ideally, the same answer should result from either method. Both methods were used with differences of up to 5% appearing due to the trapezoidal approximations used in the programme (see section 5 21) and approximations in diagrams that do not produce closed contours. The method labelled (a) is a more accurate way of measuring the means, because the mean data tend to produce contours closing to a greater accuracy Method (b) must be employed also, however, to enable the standard deviation in area to be calculated

The results show a decrease in area with advancing age, a trend held through groups 1 to 5. Group 6 is



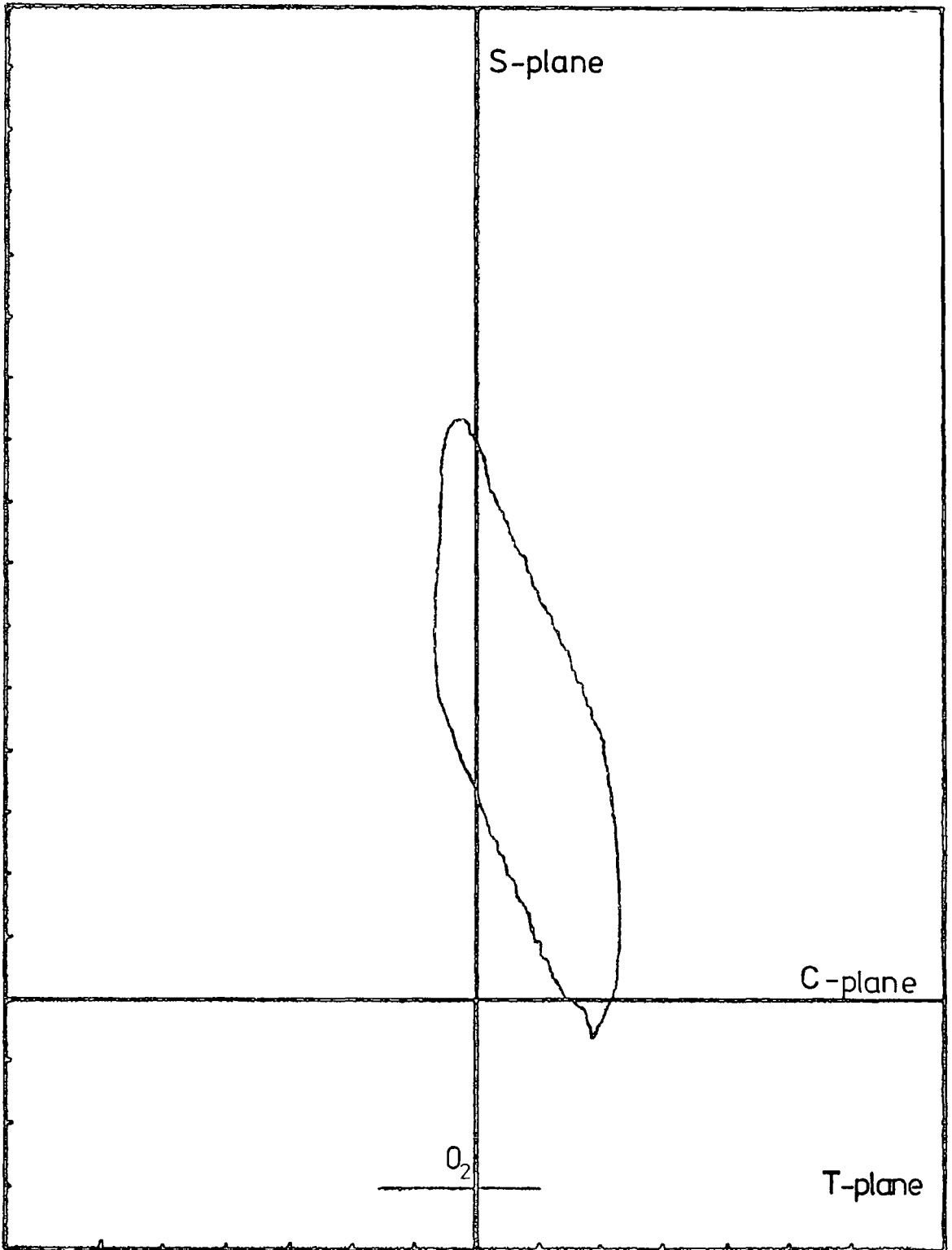
NAME ♂					
NO	FILE		FLEX	ABD	EXROT
EXERCISE	STEPS UP	POLARITY	↑	↑	↑
LEFT ✓	RIGHT	SCALE%cm	10	5	5
NOTES					
Figure 38 Ascending stairs, male 4 steps					



NAME ♂					
NO	FILE		FLEX	ABD	EXROT
EXERCISE: STEPS UP		POLARITY	↑	↑	↑
LEFT ✓	RIGHT	SCALE%cm	10	5	5

NOTES

Figure 39 Ascending stairs, male average of 4 steps



NAME ♂					
NO	FILE		FLEX	ABD	EXROT
EXERCISE STEPS UP		POLARITY			
LEFT ✓	RIGHT	SCALE%cm	5	5	5
NOTES <u>Figure 40</u> Rectangular plot, ascending stairs					

GROUP		BODY WEIGHT (N)				HEIGHT (m)			
	SIZE	MEAN	S.D.	t	p	MEAN	S.D.	t	p
1	10	691	17.1			1.804	0.016		
				0.124	0.9+			2.990	0.008
2	10	692	18.9			1.779	0.021		
				1.039	0.32			1.124	0.25
3	15	709	51.3			1.767	0.029		
				0.384	0.71			0.958	0.33
4	10	717	37.9			1.777	0.019		
				1.093	0.28			0.311	0.75
5	10	763	124.2			1.769	0.079		
				1.374	0.18			0.412	0.68
6	10	700	73.1			1.755	0.073		

MALE GROUPS' HEIGHT AND WEIGHT: ASCENDING AND DESCENDING STAIRS

TABLE 4

GRP	SAMP NUMB	ROT COMP	MAX	MIN	ROM	COR	COM	S.D. (NO CLA)			S.D. (CLA)			AREA		t	p
								MAX	MIN	AVE	MAX	MIN	AVE	MEAN	S.D.		
1	10	FLEX	45.4	1.2	44.2	23.3	22.0	6.6	5.4	6.1	3.1	1.7	2.3	301.5	83.4	0.804	0.43
		ABD	10.5	-5.1	15.5	2.7	2.9	4.3	2.1	3.0	2.8	1.3	2.0				
		ROT	10.4	2.5	7.8	6.5	7.4	7.2	4.0	5.5	2.8	1.3	2.0				
2	9	FLEX	43.6	-0.2	43.7	21.7	21.1	11.7	7.8	9.9	5.7	2.3	3.6	326.5	90.6	0.687	0.50
		ABD	10.7	-4.7	15.5	3.0	2.6	3.9	1.9	2.9	1.9	0.5	1.3				
		ROT	7.1	1.3	5.8	4.2	4.5	10.6	6.4	8.6	3.8	1.8	2.9				
3	15	FLEX	47.9	4.0	43.9	25.9	24.9	9.2	4.8	7.1	4.4	2.3	3.4	294.6	82.9	0.828	0.42
		ABD	9.5	-5.7	15.2	1.9	1.9	2.4	1.0	1.8	2.1	0.7	1.4				
		ROT	7.1	2.0	5.1	4.6	4.2	8.2	6.3	7.1	3.6	2.0	3.0				
4	10	FLEX	48.3	3.3	45.0	25.8	24.3	9.7	5.8	8.1	4.0	2.1	2.9	266.9	109.0	0.058	0.9+
		ABD	7.3	-6.7	14.0	0.3	0.6	3.6	1.5	2.3	2.3	0.9	1.7				
		ROT	6.3	-1.2	7.5	2.6	2.8	7.5	4.9	6.3	4.8	1.4	2.6				
5	10	FLEX	48.5	3.0	45.5	25.8	24.3	9.3	6.6	7.8	3.3	1.5	2.4	280.3	87.7	1.237	0.23
		ABD	8.3	-4.1	12.4	2.1	2.5	2.7	1.8	2.2	1.8	0.9	1.4				
		ROT	9.1	-1.4	10.5	3.9	2.0	9.7	6.5	7.8	5.0	1.8	2.7				
6	9	FLEX	47.9	3.3	44.6	25.6	24.0	8.3	5.3	6.4	4.5	2.3	3.4	325.5	177.7		
		ABD	9.6	-5.9	15.4	1.9	2.2	4.9	1.7	3.7	3.7	1.4	2.6				
		ROT	5.8	-1.4	7.2	2.2	1.5	7.6	4.9	6.2	3.8	1.4	2.5				

TABLE S.U.1(M)

COMPARISON GROUPS 1 & 2 MALE STEPS UP	CALCULATED USING NON CLA MEANS AND S.D.'S IN Y DIRECTION			CALCULATED USING CLA MEANS AND S.D.'S IN THE Y DIRECTION			CALCULATED USING CLA MEANS AND NON CLA S.D.'S IN THE Y DIRECTION		
	FLEX	ABD	ROT	FLEX	ABD	ROT	FLEX	ABD	ROT
MEAN OF MODULUS OF t's IN THE X DIRECTION	0.40	0.85	0.90	0.98	1.43	0.74	0.35	0.82	0.27
MEAN OF SIGNED VALUES OF t's IN THE X DIRECTION	-0.23	-0.39	-0.90	0.12	-0.02	0.11	0.04	-0.11	0.03
STANDARD DEVIATION OF t's IN THE X DIRECTION	0.41	0.94	0.30	1.17	1.60	0.93	0.41	0.91	0.31
t-TESTING FOR A SIMILARITY TO A PERFECT LIKENESS $t(0,0)$	-8.00	-5.78	-42.73	1.43	-0.15	1.64	1.22	-1.72	1.23
RESULTING PROBABILITY OF A SIMILARITY EXISTING	0	0.0001	0	0.18	0.88	0.12	0.25	0.10	0.23
t- TESTING FOR A SIMILARITY TO A DISTRIBUTED FIT $t(0.1)$	-3.01	-3.97	-12.14	1.09	-0.13	1.12	0.47	-1.16	0.37
RESULTING PROBABILITY OF A SIMILARITY EXISTING	0.005	0.001	0	0.30	0.90	0.25	0.65	0.25	0.71

TABLE S.U.2(M)

COMPARISON GROUPS 2 & 3 MALE STEPS UP	CALCULATED USING NON CLA MEANS AND S.D.'S IN Y DIRECTION			CALCULATED USING CLA MEANS AND S.D.'S IN THE Y DIRECTION			CALCULATED USING CLA MEANS AND NON CLA S.D.'S IN THE Y DIRECTION		
	FLEX	ABD	ROT	FLEX	ABD	ROT	FLEX	ABD	ROT
MEAN OF MODULUS OF t's IN THE X DIRECTION	1.06	1.00	0.38	0.65	1.50	1.00	0.28	0.91	0.40
MEAN OF SIGNED VALUES OF t's IN THE X DIRECTION	1.06	-0.65	-0.06	-0.11	0.05	0.02	-0.06	0.03	0.04
STANDARD DEVIATION OF t's IN THE X DIRECTION	0.22	0.97	0.42	0.72	1.62	1.06	0.31	0.98	0.43
t-TESTING FOR A SIMILARITY TO A PERFECT LIKENESS $t(0,0)$	69.7	-9.43	-2.03	-2.20	0.47	0.23	-2.70	0.36	1.26
RESULTING PROBABILITY OF A SIMILARITY EXISTING	0	0	0.05	0.04	0.65	0.82	0.01	0.73	0.21
t- TESTING FOR A SIMILARITY TO A DISTRIBUTED FIT $t(0,1)$	14.7	-6.58	-0.78	-1.29	0.40	0.17	-0.79	0.25	0.50
RESULTING PROBABILITY OF A SIMILARITY EXISTING	0	0.0001	0.45	0.21	0.68	0.87	0.45	0.80	0.62

TABLE S.U.3(M)

COMPARISON GROUPS 3 & 4 MALE STEPS UP	CALCULATED USING NON CLA MEANS AND S.D.'S IN Y DIRECTION			CALCULATED USING CLA MEANS AND S.D.'S IN THE Y DIRECTION			CALCULATED USING CLA MEANS AND NON CLA S.D.'S IN THE Y DIRECTION		
	FLEX	ABD	ROT	FLEX	ABD	ROT	FLEX	ABD	ROT
MEAN OF MODULUS OF t's IN THE X DIRECTION	0.25	1.72	0.72	0.54	0.73	1.43	0.23	0.56	0.61
MEAN OF SIGNED VALUES OF t's IN THE X DIRECTION	-0.17	-1.72	-0.55	0.03	-0.05	-0.03	0.003	-0.079	-0.05
STANDARD DEVIATION OF t's IN THE X DIRECTION	0.27	0.98	0.72	0.63	0.91	1.56	0.27	0.71	0.68
t-TESTING FOR A SIMILARITY TO A PERFECT LIKE'ESS $t(0,0)$	-8.9	-24.9	-10.83	0.59	-0.83	-0.30	0.13	-1.58	-1.08
RESULTING PROBABILITY OF A SIMILARITY EXISTING	0	0	0	0.55	0.44	0.77	0.90	0.15	0.30
t- TESTING FOR A SIMILARITY TO A DISTRIBUTED FIT $t(0,1)$	-2.32	-17.43	-6.32	0.32	-0.56	-0.25	0.03	-0.91	-0.60
RESULTING PROBABILITY OF A SIMILARITY EXISTING	0.02	0	0	0.75	0.58	0.8	0.9+	0.36	0.55

TABLE S.U.4(M)

COMPARISON GROUPS 4 & 5 MALE STEPS UP	CALCULATED USING NON CLA MEANS AND S.D.'S IN Y DIRECTION			CALCULATED USING CLA MEANS AND S.D.'S IN THE Y DIRECTION			CALCULATED USING CLA MEANS AND NON CLA S.D.'S IN THE Y DIRECTION		
	FLEX	ABD	ROT	FLEX	ABD	ROT	FLEX	ABD	ROT
MEAN OF MODULUS OF t's IN THE X DIRECTION	0.16	1.74	0.64	0.69	1.66	1.71	0.16	1.14	0.66
MEAN OF SIGNED VALUES OF t's IN THE X DIRECTION	-0.005	1.74	-0.19	0.03	-0.11	-0.11	-0.0003	-0.17	0.07
STANDARD DEVIATION OF t's IN THE X DIRECTION	0.18	1.00	0.69	0.59	1.77	1.87	0.18	1.22	0.72
t-TESTING FOR A SIMILARITY TO A PERFECT LIKENESS $t(0,0)$	-0.39	24.5	-3.90	0.72	0.89	0.85	-0.02	-1.91	1.32
RESULTING PROBABILITY OF A SIMILARITY EXISTING	0.7	0	0.001	0.45	0.39	0.41	0.9+	0.08	0.20
t- TESTING FOR A SIMILARITY TO A DISTRIBUTED FIT $t(0.1)$	-0.07	17.3	-2.23	0.36	-0.77	-0.75	-0.0034	-1.47	0.77
RESULTING PROBABILITY OF A SIMILARITY EXISTING	0.9+	0	0.04	0.75	0.45	0.45	0.9+	0.18	0.45

TABLE S.U.5(M)

COMPARISON GROUPS 5 & 6 MALE STEPS UP	CALCULATED USING NON CLA MEANS AND S.D.'S IN Y DIRECTION			CALCULATED USING CLA MEANS AND S.D.'S IN THE Y DIRECTION			CALCULATED USING CLA MEANS AND NON CLA S.D.'S IN THE Y DIRECTION		
	FLEX	ABD	ROT	FLEX	ABD	ROT	FLEX	ABD	ROT
MEAN OF MODULUS OF t's IN THE X DIRECTION	0.44	0.91	0.57	1.13	1.20	1.48	0.46	0.86	0.56
MEAN OF SIGNED VALUES OF t's IN THE X DIRECTION	-0.04	-0.39	-0.19	0.20	0.09	0.03	0.08	-0.16	-0.025
STANDARD DEVIATION OF t's IN THE X DIRECTION	0.48	1.13	0.64	1.21	1.47	1.63	0.49	1.09	0.63
t-TESTING FOR A SIMILARITY TO A PERFECT LIKENESS $t(0,0)$	-1.31	-4.87	-4.09	2.30	0.84	0.24	2.24	-2.10	-0.57
RESULTING PROBABILITY OF A SIMILARITY EXISTING	0.21	0.0001	0.0005	0.03	0.42	0.81	0.03	0.05	0.57
t- TESTING FOR A SIMILARITY TO A DISTRIBUTED FIT $t(0,1)$	-0.56	-3.65	-2.21	1.73	0.70	0.21	0.98	-1.54	-0.30
RESULTING PROBABILITY OF A SIMILARITY EXISTING	0.58	0.002	0.03	0.10	0.49	0.83	0.32	0.15	0.77

TABLE S.U.6(M)

anomolous, probably for reasons previously discussed.

None of the variations between consecutive groups were significant at the $p = 0.01$ level, but the comparison between groups 3 and 4 approached this ($p = 0.013$) due to the 3.2° difference in range of coronal plane rotations (see Table A1(M)) This trend might be substantiated by taking larger samples.

7.3 Ascending stairs (Male)

7.3.1 Description of normal ascension of stairs - male

Figs 38 and 39 are full size reproductions of computer graphics, obtained as previously described. The plots are typical normal male results obtained as a subject climbs stairs.

The format of these plots is the same as that for ambulation, and the patterns reproduced also bear a resemblance to those for ambulation.

Examination of Fig. 38 again reveals a fairly narrow performance envelope for the individual, but not perhaps so narrow as that for ambulation. This is because the subject does not have the opportunity to attain even movement patterns due to the comparatively short continuous length of stairway available, 12 steps. In most cases this precluded the monitoring of more than 4 complete cycles.

The performance envelope for sagittal plane rotations has a maximum width of 5° , which is 10% of R.O.M. The pattern resembles that for ambulation, but

the peak in flexion in the late swing phase is narrower, and heelstrike occurs later after peak flexion. Examination of the Fourier coefficients for sagittal plane rotations (Table 1) shows again a heavy bias towards the fundamental with terms above the second harmonic being negligible. In comparison to the sagittal movements of walking the C O M for ascending stairs is much higher, by on average 12.7° in a R O M approaching 50° which in most cases is totally in the flexion region.

Considering now coronal plane rotations, Fig. 38 reveals a performance envelope of maximum width 2.5° which is 17% of range. Range of movement in this plane is around 15° , 11° of which is in abduction and 4° in adduction. C O M is on average about 1.5° higher than for ambulation, and the pattern of movement demonstrates the way in which the pelvis is tilted in order to lift the limb. The Fourier analysis (Table 1) indicates that coronal plane movements are confined to the low harmonics, those above the 3rd being negligible.

Transverse plane rotations are similar to those for ambulation with the characteristic peak in external rotation appearing immediately after toe-off. However, the peak at heelstrike that appears in the ambulation trace does not manifest itself in the trace for ascending stairs. The performance envelope has a maximum width of 5° which is 30% of range. R O M is 14° in this example, 5° in external rotation and 9° in internal

rotation The Fourier analysis of this trace shows movements up to the 6th harmonic, above which coefficients may sensibly be regarded as zero

The footswitch trace shows that this subject, in common with most others, supported his weight entirely on the ball and toes of his foot throughout the stance phase of this exercise, so heelstrike is not strictly the correct term to use for the first instant of foot contact with the ground Toe-off is at 57% of period

Fig 40 is the corresponding rectangular plot of these data, producing the characteristic shape for the normal execution of this exercise It is plotted on a scale of $5^{\circ}/\text{cm}$ The format of the plot is the same as that for ambulation

As previously mentioned the exercises on the stairs are regulated in a more severe manner than free walking. The negotiation of steps therefore provides a test which is precisely the same for each individual subject, in that all parameters except the three angular displacements being measured are fully controlled. Thus one may perhaps expect to find a suppression of individuality in these tests and that variations, if existing between age groups, are rather more age correlated because of this

7.3 2 Comparison Groups 1 and 2 (M)

Referring to Table SU2(M), test 1, statistics D, E, F and G indicate that there are significant differences between these two groups ($p < 0.01$), but

test 2 for these statistics show it to be mainly due to changes in C O M. The R O M for both groups are very similar in both flexion and abduction, but the senior group displays a 2° reduction in R O M in the transverse plane. The changes in C O.M are 0.9° , 0.4° and 2.9° for flexion, abduction and rotation respectively. Test 3, statistics D, E, F and G show that no major differences are apparent as far as P.O.M. is concerned.

7.3.3 Comparison Groups 2 and 3 (M)

Table SU3(M), statistics D, E, F and G for test 1 reveal that there are extreme differences between the groups in sagittal plane rotations, significant differences in the coronal plane, although rotations in the transverse plane show a similarity. The major disparity between the flexion traces is due to a shift into flexion of C O M of 3.8° (Table SU1(M)) by the senior group, who also exhibit a 5° advance in phase angle. (A group demonstrates an advance in phasing when, aligning the axes for two comparable plots, corresponding peaks on the trace of the group in question are advanced in comparison to the other group.)

The C O M in the coronal plane shows a significant ($p = 0.001$) shift of 0.6° into adduction for the senior group. In this group a reduction in mean standard deviation indicates less variation between individuals tested. It should be noted though that there are very large variations between individuals for transverse

rotations, the mean standard deviation approaching and sometimes exceeding 100% of R O M for all groups

7 3 4 Comparison Groups 3 and 4 (M)

Reference to Table SU4(M) test 1, statistics D, E, F and G indicates that there are only small similarities in sagittal plane movements between groups 3 and 4. No similarities appear in the other planes. Although there are differences in R O M between the groups (Table SU1(M)), the main differences are changes in C O M. These amount to 0.5° , 1.3° and 1.4° in sagittal, coronal, and transverse planes respectively. The junior group's movements are centred further into the regions of flexion, abduction and external rotation. Apart from variations in C O M, it is evident (test 2, statistics D, E, F and G) that the patterns of movement for these two groups are markedly similar.

7 3 5 Comparison Groups 4 and 5 (M)

Movements in the sagittal plane for these two groups are very similar, Table SU5(M) tests 1, 2 and 3 statistics D, E, F and G with the same C O M and only a small difference in R O M. However, rotations in the coronal plane are markedly dissimilar, showing a 1.9° shift in C O M into the abduction region for the senior group, and also a 1.5° reduction in R O M. Changes in P O M are also evident. Transverse plane rotations illustrate the continued variability of motion patterns in this plane.

7 3 6 Comparison Groups 5 and 6 (M)

Examination of Table SU6(M) shows a variability in the figures for tests 1, 2 and 3 statistics D, E, F and G are indicative more of variations in P O M rather than in other parameters. Comparison of the flexion traces reveals a lag of approximately 7° in phase angle for the senior group. In the sagittal plane similarities are evident, but the senior group shows a 0.9° reduction in R O M and a 0.3° reduction in the level of the C O M (Table SU1(M)). In the coronal plane the senior group exhibits a 3° increase in R O M and a 9° lag in phase angle. There is a 3.3° decrease in R O M for the senior group in the transverse plane.

7 3.7 Synopsis of climbing stairs (male)

Between consecutive groups the analysis reveals that no significant variations exist in R O M and P O M at the level $p = 0.1$ (SU(M) tables, test 2 statistic G), and the data suggest that at this level of probability there exist no significant differences between any two groups. Test 2, statistic E, tables SU3(M) and SU6(M) show variations in sagittal rotations approaching significance at the level $p = 0.04$. For groups 2 and 3 this is a change in P O M manifested by the 5° advance in phase angle for the senior group as previously mentioned. For groups 5 and 6 the difference exists as a 7° lag in phase angle for the senior group combined with a 0.9° reduction in R.O M.

For all groups the R O M in the sagittal plane

fall within 1.8° of each other. Transverse plane rotations are notable only for their variability in range

In the coronal plane, a progressive depletion of R O M with advancing age is evident in groups 1 to 5. This may be substantiated significantly if larger samples are taken

Analysis of the C O M. reveals some interesting trends which are statistically significant or closely approaching significance

Table SU1(M) shows similar C O M for groups 1 and 2 and similar values of C.O M. for groups 3, 4, 5 and 6, but between groups 2 and 3 there is a step change of almost 4° for the senior groups This could be indicative of a significant change in physical capability occurring between these two groups

For coronal plane rotations, the position of the C O M moves towards the adduction region for groups 1 to 4, but this trend is reversed in groups 5 and 6. All variations between groups are significant at the $p = 0.002$ level.

In the transverse plane there is a trend held throughout all groups, the C O M moves progressively farther out of external rotation with advancing age. Despite the high values for M.S D (non centred, Table SU1(M)), this trend is approaching or exceeding significance at the $p = 0.01$ level, between all groups except 2/3, ($p = 0.45$)

These observations indicate a tendency to ascend stairs progressively assuming postures farther into the regions of flexion, adduction and internal rotation, with increasing age. This is not in particularly good agreement with the hypothesis formed for ambulation patterns.

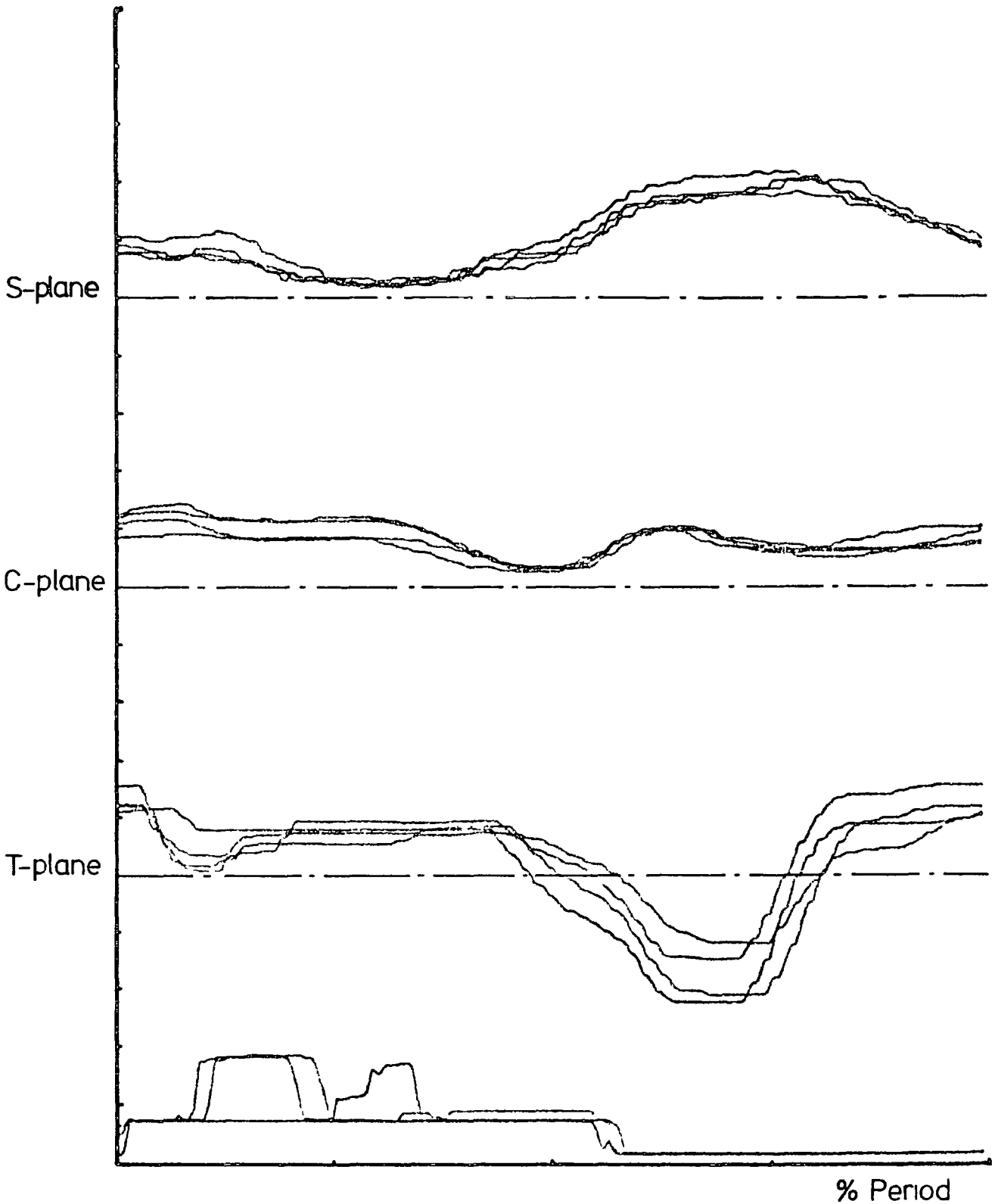
The senior groups appear to be unconcerned about seeking increasing lateral stability, and appear to have adopted their optimum antero-posterior attitude by the age of 35 years.

The apparent lack of concern with lateral stability may be due to the fact that a banister is usually in close proximity. Equally, this mediolateral attitude may prove to be a more comfortable position from which to apply the locomotive force.

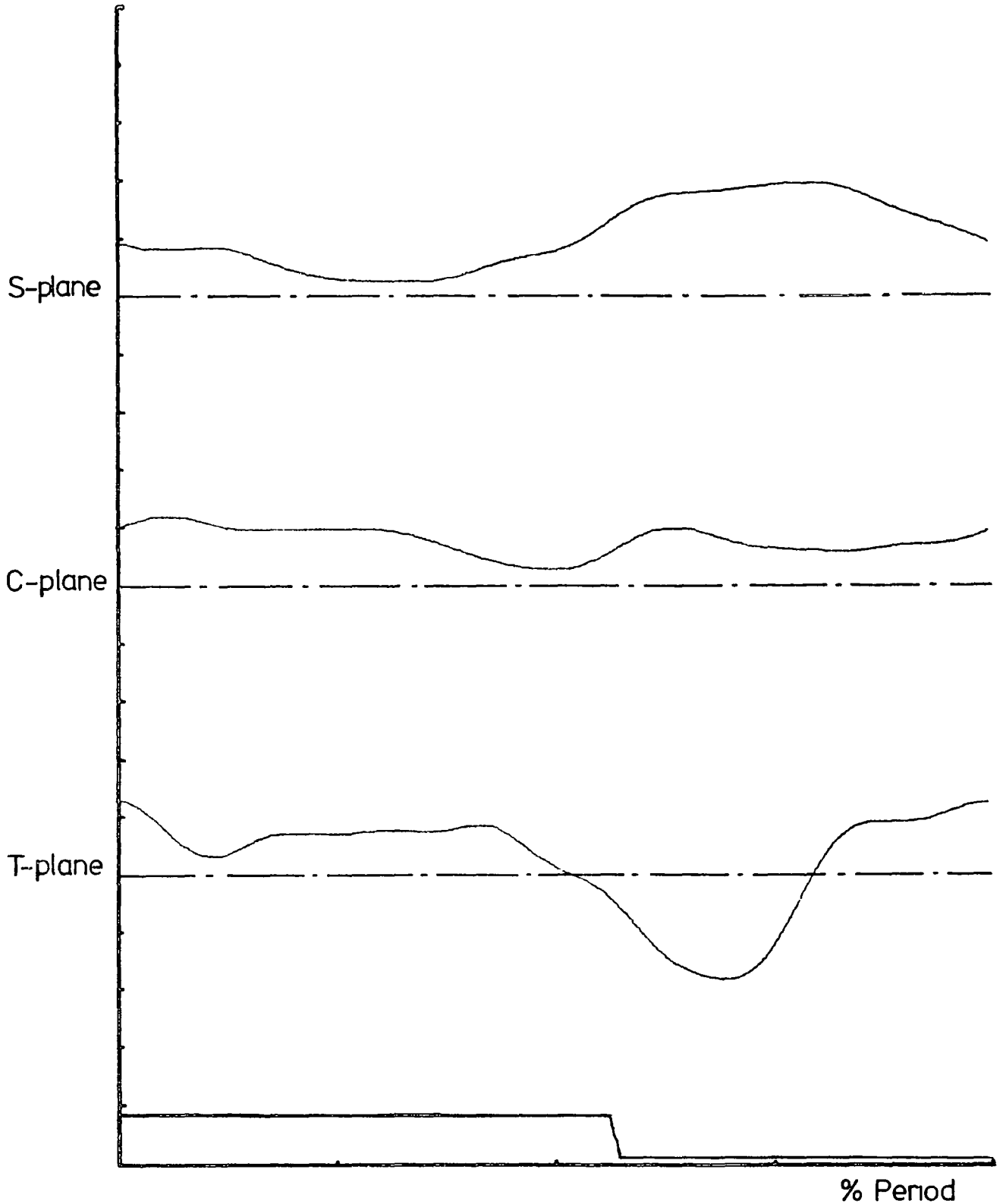
The ascending tests were executed with the subject climbing steps one by one, without using any additional support. The younger groups probably more used to taking steps two or three at a time and thus requiring more stability (albeit dynamic) may retain such a postural attitude while ascending in a more conservative manner.

Examination of the area parameter reveals that no trends are developing, and that there are no significant differences beyond the $p = 0.23$ level.

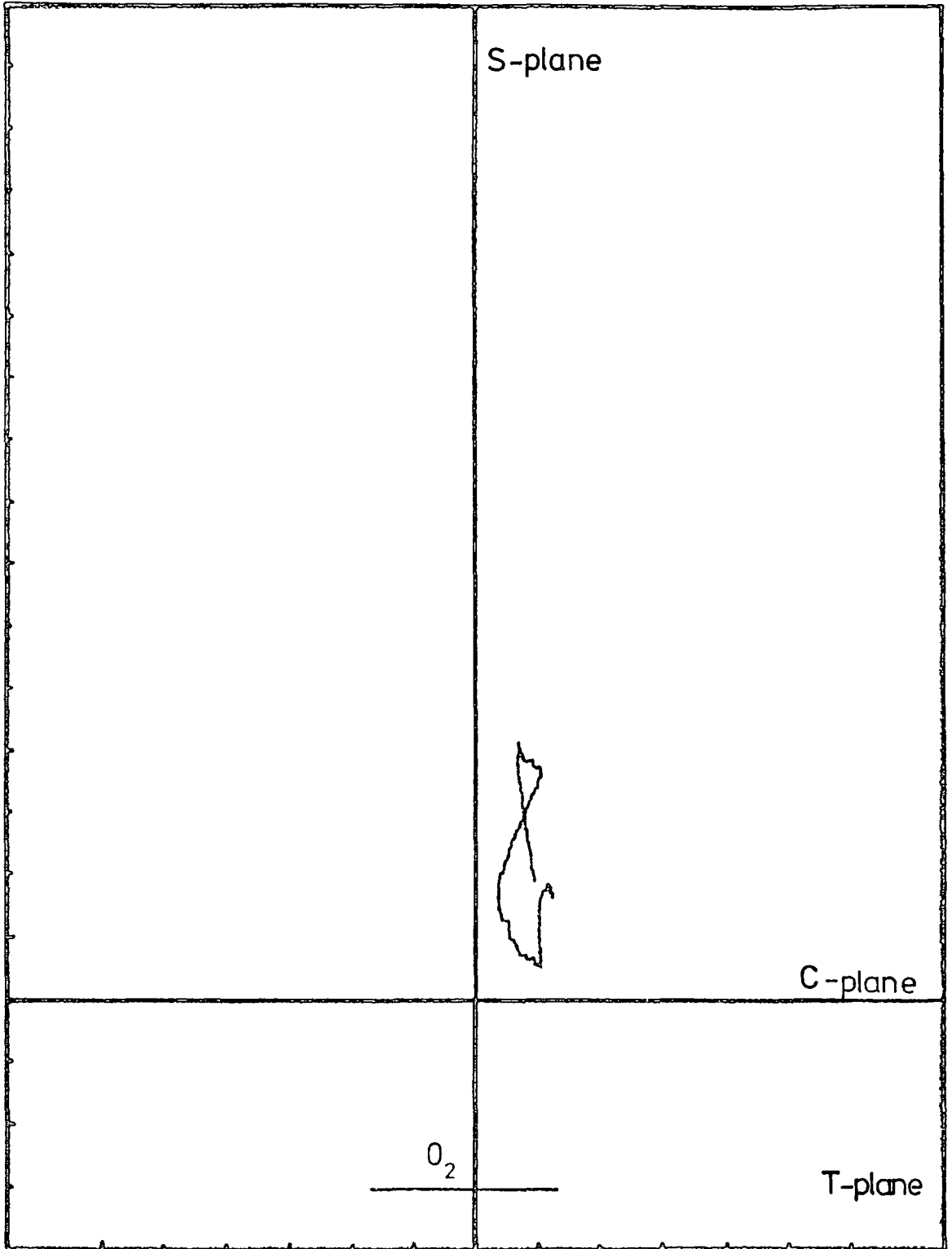
Apart from variations in C O M the stairs were negotiated in a very similar manner by all age groups.



NAME ♂					
NO	FILE		FLEX	ABD	EXROT
EXERCISE: STEPS DOWN		POLARITY	↑	↑	↑
LEFT ✓	RIGHT	SCALE%cm	10	5	5
NOTES					
<p style="text-align: center;"> <u>Figure 41</u> Descending stairs, male 4 steps </p>					



NAME ♂					
NO	FILE		FLEX	ABD	EXROT
EXERCISE STEPS DOWN		POLARITY	↑	↑	↑
LEFT ✓	RIGHT	SCALE%cm	10	5	5
NOTES					
<p style="text-align: center;"> <u>Figure 42</u> Descending stairs, male average of 4 steps </p>					



NAME ♂					
NO	FILE		FLEX	ABD	EXROT
EXERCISE STEPS DOWN		POLARITY			
LEFT ✓	RIGHT	SCALE%/cm	5	5	5
NOTES					
<p style="text-align: center;"><u>Figure 43</u> Rectangular plot, descending stairs</p>					

GRP	SAMP NUMB	ROT COMP	MAX	MIN	ROM	COR	COM	S.D. (NO CLA)			S.D. (CLA)			AREA		t	p
								MAX	MIN	AVE	MAX	MIN	AVE	MEAN	S.D.		
1	10	FLEX	27.7	6.7	20.9	17.2	15.0	5.2	2.4	3.6	3.5	1.2	2.2	44.2	20.0	0.328	0.75
		ABD	5.4	0.3	5.2	2.9	2.8	3.2	1.4	2.2	2.1	0.7	1.4				
		ROT	9.2	3.4	5.8	6.3	6.1	7.8	4.4	6.0	3.8	1.1	2.6				
2	10	FLEX	29.5	8.6	20.8	19.1	16.6	4.3	2.4	3.6	2.9	1.2	1.9	41.4	17.9	0.704	0.48
		AED	4.5	0.1	4.4	2.3	2.6	3.8	1.8	2.6	1.8	0.7	1.2				
		ROT	5.8	1.7	4.1	3.8	4.3	6.7	5.4	5.9	3.5	1.1	2.2				
3	15	FLEX	29.1	9.5	19.5	19.3	16.8	8.5	5.0	6.2	6.9	4.3	5.7	49.3	32.1	0.822	0.42
		ABD	5.7	0.3	5.4	3.0	3.4	3.2	2.6	2.9	2.4	1.2	1.7				
		ROT	7.3	-0.3	7.6	3.5	4.6	8.7	7.6	8.2	6.7	4.2	5.3				
4	10	FLEX	32.6	9.7	22.9	21.1	18.4	4.2	3.1	3.7	3.0	0.8	1.7	59.1	23.8	0.298	0.77
		ABD	4.8	-1.9	6.7	1.4	1.5	2.9	1.4	2.0	1.5	0.8	1.2				
		ROT	8.0	4.3	3.7	6.1	5.7	10.4	6.3	7.5	4.5	1.9	3.0				
5	10	FLEX	27.3	8.3	19.0	17.8	15.4	6.1	3.5	4.5	2.6	1.0	1.6	55.5	29.8	0.594	0.58
		ABD	6.2	-0.4	6.6	2.9	3.5	3.5	1.7	2.4	1.9	0.5	1.2				
		ROT	8.8	0.7	8.1	4.8	4.4	10.0	6.6	8.3	3.7	1.6	2.5				
6	10	FLEX	29.6	10.1	19.5	19.9	17.0	7.6	4.8	6.1	3.7	1.3	2.3	69.8	70.3		
		ABD	5.8	-1.0	6.8	2.4	2.4	3.9	2.2	3.2	2.7	1.2	2.1				
		ROT	9.0	0.7	8.3	4.8	5.0	8.7	4.7	6.9	4.7	2.0	3.2				

TABLE S.D.1(M)

COMPARISON GROUPS 1 & 2 MALE STEPS DOWN	CALCULATED USING NON CLA MEANS AND S.D.'S IN Y DIRECTION			CALCULATED USING CLA MEANS AND S.D.'S IN THE Y DIRECTION			CALCULATED USING CLA MEANS AND NON CLA S.D.'S IN THE Y DIRECTION		
	FLEX	ABD	ROT	FLEX	ABD	ROT	FLEX	ABD	ROT
MEAN OF MODULUS OF t's IN THE X DIRECTION	1.28	0.65	0.81	1.52	1.22	1.23	0.89	0.58	0.50
MEAN OF SIGNED VALUES OF t's IN THE X DIRECTION	1.01	-0.14	-0.72	0.14	0.10	-0.02	0.04	0.10	-0.04
STANDARD DEVIATION OF t's IN THE X DIRECTION	1.05	0.69	0.64	1.76	1.35	1.43	1.04	0.72	0.58
t-TESTING FOR A SIMILARITY TO A PERFECT LIKENESS $t(0,0)$	13.56	-2.83	-15.71	1.11	1.07	-0.19	0.49	2.06	-1.05
RESULTING PROBABILITY OF A SIMILARITY EXISTING	0	0.01	0	0.28	0.3	0.85	0.64	0.04	0.3
t- TESTING FOR A SIMILARITY TO A DISTRIBUTED FIT $t(0,1)$	9.83	-1.60	-8.51	0.96	0.86	-0.15	0.35	1.20	-0.53
RESULTING PROBABILITY OF A SIMILARITY EXISTING	0	0.12	0	0.35	0.40	0.87	0.71	0.26	0.60

TABLE SD2(M)

COMPARISON GROUPS 2 & 3 MALE STEPS DOWN	CALCULATED USING NON CLA MEANS AND S.D.'S IN Y DIRECTION			CALCULATED USING CLA MEANS AND S.D.'S IN THE Y DIRECTION			CALCULATED USING CLA MEANS AND NON CLA S.D.'S IN THE Y DIRECTION		
	FLEX	ABD	ROT	FLEX	ABD	ROT	FLEX	ABD	ROT
MEAN OF MODULUS OF t's IN THE X DIRECTION	0.84	0.78	0.59	2.04	0.89	1.92	0.80	0.42	0.57
MEAN OF SIGNED VALUES OF t's IN THE X DIRECTION	0.04	0.77	0.13	-0.18	-0.003	0.46	-0.10	0.015	0.012
STANDARD DEVIATION OF t's IN THE X DIRECTION	1.01	0.52	0.63	2.51	1.00	2.08	1.02	0.48	0.63
t-TESTING FOR A SIMILARITY TO A PERFECT LIKENESS $t(0,0)$	0.50	20.85	2.94	-1.04	-0.05	3.12	-1.42	0.45	0.28
RESULTING PROBABILITY OF A SIMILARITY EXISTING	0.63	0	0.008	0.31	0.9+	0.002	0.17	0.65	0.78
t- TESTING FOR A SIMILARITY TO A DISTRIBUTED FIT $t(0,1)$	0.36	9.68	1.57	-0.96	-0.034	2.81	-1.01	0.19	0.15
RESULTING PROBABILITY OF A SIMILARITY EXISTING	0.72	0	0.14	0.32	0.9+	0.008	0.32	0.85	0.88

TABLE SD3(M)

COMPARISON GROUPS 3 & 4 MALE STEPS DOWN	CALCULATED USING NON CLA MEANS AND S.D.'S IN Y DIRECTION			CALCULATED USING CLA MEANS AND S.D.'S IN THE Y DIRECTION			CALCULATED USING CLA MEANS AND NON CLA S.D.'S IN THE Y DIRECTION		
	FLEX	ABD	ROT	FLEX	ABD	ROT	FLEX	ABD	ROT
MEAN OF MODULUS OF t's IN THE X DIRECTION	0.81	1.84	0.68	1.95	0.52	2.23	0.65	0.26	0.67
MEAN OF SIGNED VALUES OF t's IN THE X DIRECTION	0.75	-1.84	0.31	0.16	0.02	-0.54	0.01	0.006	-0.015
STANDARD DEVIATION OF t's IN THE X DIRECTION	0.77	0.36	0.74	2.41	0.70	2.52	0.76	0.35	0.74
t-TESTING FOR A SIMILARITY TO A PERFECT LIKELESS $t(0,0)$	13.73	-72.18	5.85	0.68	0.49	-3.03	0.19	0.23	-0.29
RESULTING PROBABILITY OF A SIMILARITY EXISTING	0	0	0.0001	0.5	0.63	0.008	0.85	0.82	0.78
t- TESTING FOR A SIMILARITY TO A DISTRIBUTED FIT $t(0,1)$	8.39	-24.52	3.47	0.63	0.29	-2.81	0.11	0.075	-0.17
RESULTING PROBABILITY OF A SIMILARITY EXISTING	0	0	0.002	0.53	0.77	0.02	0.92	0.9+	0.85

TABLE SD4(M)

COMPARISON GROUPS 4 & 5 MALE STEPS DOWN	CALCULATED USING NON CLA MEANS AND S.D.'S IN Y DIRECTION			CALCULATED USING CLA MEANS AND S.D.'S IN THE Y DIRECTION			CALCULATED USING CLA MEANS AND NON CLA S.D.'S IN THE Y DIRECTION		
	FLEX	ABD	ROT	FLEX	ABD	ROT	FLEX	ABD	ROT
MEAN OF MODULUS OF t's IN THE X DIRECTION	1.59	2.01	0.42	1.37	0.86	1.19	0.53	0.47	0.38
MEAN OF SIGNED VALUES OF t's IN THE X DIRECTION	-1.59	2.01	-0.35	0.23	-0.07	0.16	0.05	-0.09	0.01
STANDARD DEVIATION OF t's IN THE X DIRECTION	0.54	0.32	0.41	1.63	0.97	1.33	0.63	0.52	0.42
t-TESTING FOR A SIMILARITY TO A PERFECT LIKENESS $t(0,0)$	-41.29	89.75	-12.04	1.98	-0.99	1.68	1.12	-2.56	0.45
RESULTING PROBABILITY OF A SIMILARITY EXISTING	0	0	0	0.05	0.32	0.11	0.25	0.02	0.65
t- TESTING FOR A SIMILARITY TO A DISTRIBUTED FIT $t(0.1)$	-19.76	27.14	-4.60	1.69	-0.69	1.34	0.60	-1.18	0.17
RESULTING PROBABILITY OF A SIMILARITY EXISTING	0	0	0.0001	0.11	0.50	0.19	0.55	0.24	0.85

TABLE SD5(M)

COMPARISON GROUPS 5 & 6 MALE STEPS DOWN	CALCULATED USING NON CLA MEANS AND S.D.'S IN Y DIRECTION			CALCULATED USING CLA MEANS AND S.D.'S IN THE Y DIRECTION			CALCULATED USING CLA MEANS AND NON CLA S.D.'S IN THE Y DIRECTION		
	FLEX	ABD	ROT	FLEX	ABD	ROT	FLEX	ABD	ROT
MEAN OF MODULUS OF t's IN THE X DIRECTION	0.68	0.90	0.25	0.61	0.58	0.49	0.22	0.36	0.19
MEAN OF SIGNED VALUES OF t's IN THE X DIRECTION	0.68	-0.90	0.20	0.03	0.01	0.08	0.02	0.03	0.03
STANDARD DEVIATION OF t's IN THE X DIRECTION	0.29	0.42	0.23	0.82	0.71	0.55	0.30	0.45	0.21
t-TESTING FOR A SIMILARITY TO A PERFECT LIKENESS $t(0,0)$	32.65	-29.98	12.76	0.45	0.27	2.01	1.10	0.91	1.81
RESULTING PROBABILITY OF A SIMILARITY EXISTING	0	0	0	0.65	0.78	0.06	0.28	0.37	0.08
t- TESTING FOR A SIMILARITY TO A DISTRIBUTED FIT $t(0.1)$	9.20	-11.67	2.80	0.29	0.16	0.97	0.31	0.37	0.37
RESULTING PROBABILITY OF A SIMILARITY EXISTING	0	0	0.01	0.77	0.8	0.32	0.76	0.72	0.72

TABLE SD6(M)

7 4 Descending stairs

7 4 1 Description of normal descending of stairs - male

For the normal subject, stepping up appears almost as a variation of normal walking, whereas the pattern of movement recorded in stepping down is considerably different

Figs 41 and 42 are full size reproductions of computer graphics derived from the movements of a normal subject descending stairs. Again the format is as previously described, and in general no more than four steps are monitored due to factors already mentioned.

On inspection of Fig 41 one finds that the P.O.M s are generally flatter than those for previous exercises

Sagittal plane rotations show a performance envelope of 4° but total range is only 18° It is noticeable that during the stance phase of this exercise only small rotations occur in any plane. This is due to the fact that the body is lowered from one step to the next by flexion of the knee while the hip remains comparatively stationary In the sagittal plane, after toe-off movement is initiated by a flexion of the hip to lift the limb, followed by extension as the foot seeks the next step All movements in this plane are in the flexion region of motion.

Table 1 shows that the Fourier coefficients are negligibly small above the second harmonic

Coronal plane rotations during this exercise are

somewhat vestigial, in that movements that do occur are small and take place around toe-off as load is transferred from one foot to the other. The performance envelope has a maximum width of 2° over a range of $4-5^{\circ}$, but the established pattern of movement although small is noticeably held. Referring again to table 1, the Fourier coefficients are of course small, but only become insignificant beyond the 4th harmonic.

Transverse plane rotations are on the other hand quite extensive with, in this case, excursions of 15° . Although an observable pattern is maintained throughout, the performance envelope is large at 5° , (33% of range). Variations between steps and between individuals appear to be features of transverse plane measurements throughout all the exercises.

The main feature of the movements in this plane is the traverse from low levels of external rotation to about 8° of internal rotation. This occurs immediately prior to toe-off, and is fully reversed toward the end of the swing phase.

Fourier analysis of this trace indicates that the coefficients are significant up to the 5th harmonic, beyond which they become negligibly small.

Again, as for ascending stairs, this is a highly regulated exercise and the observations recorded previously hold in this instance also.

7.4.2 Comparison Groups 1 and 2 (M)

Referring to Tables SD1(M) and SD2(M) test 1 statistics D, E, F and G, significant variations are

found in movements in the sagittal and transverse planes

In the sagittal plane there is a shift in C O M of 17° into the flexion region for the senior group. They also exhibit a 18° shift in C O M in the transverse plane, towards the internal rotation region, along with a 16° reduction in R O M. Test 2 statistics D, E, F and G show comparatively low values of p (0.35-0.4). Further examination of Fig. 26f and Fig. 28f reveal an 8° lag in phase angle for the senior group. Statistic G, tests 2 and 3 indicate no significant variations in P O M and R O M. beyond the level $p = 0.26$.

7.4.3 Comparison Groups 2 and 3 (M)

The comparison between these two groups indicates a major similarity in movements in the sagittal plane, (Table SD3(M) test 1, statistics D, E, F and G), but also of note is the fact that variations between individuals in group 3 are large compared with other groups. The reduction in p value from test 1 to test 2 for this plane hints of other variations, and examination of Table SD1(M) reveals a 13° reduction in R O M. Examination of Fig. 28f and Fig. 30f shows that there is also an advance in phase angle of 14° for the senior group.

Statistics D, E, F and G, test 1 and 2 indicate a marked similarity in R O M and P O M but a shift in C O M for rotations in the coronal plane. This shift amounts to 0.8° toward the flexion region for the

senior group

Transverse rotations exhibit high values for p (test 3) due to the large standard deviation, but test 2 statistics D, E, F and G indicate significant ($p < 0.008$) variations in R O M. The senior group shows a 3.5° increase in R O M.

7.4.4 Comparison Groups 3 and 4 (M)

Examination of Table SD4(M) test 1, statistics D, E, F and G reveals that little or no similarity exists between these two groups, but test 2 indicates that this is almost entirely due to shifts in C O M. These amount to a 1.6° shift into flexion, and a 1.9° shift out of abduction for the senior group (Table SD 1(M)).

In the coronal plane, the patterns of movement are very similar, but with a small departure into abduction by the senior group around heelstrike. However, this does not account for the 1.2° increase in R O M in the senior group.

The figures for test 2, statistics D, E, F and G suggest slight variations between the groups in the sagittal plane. Studying Fig. 30f and Fig. 32f reveals a 7° lag in phase angle in the senior group for movements in this plane.

Transverse plane rotations, again notable for their variability, show little similarity when comparing tests 1 and 2. Table SD1(M) shows a remarkable 3.9° (50%) reduction in R O M for the senior group, leaving

this group with a 37° R O M , a particularly flat trace. However, because of the large standard deviations (amounting to 200% of range for the senior group) test 3 indicates no significant change in pattern

7 4 5 Comparison Groups 4 and 5 (M)

Examination of Table SD5(M), test 1, statistics D, E, F and G indicate that there are large differences between these two groups, test 2 for the same statistics revealing that they are due to changes in P O M as well as C O M. Low values of p occur in the sagittal and transverse planes especially.

Referring to Table SD1(M), sagittal plane, there exists a 39° reduction in R O M occurring almost exclusively from the flexion extremity of motion. This accounts for the 3° shift in C O M out of flexion for the senior group

Coronal plane rotations are broadly similar in R O M and P O M , but show a 2° shift in C O M. further into abduction for the senior group

R O M in the transverse plane for the senior group reverts to 81° and a P O M more resembling the other groups, (group 4 having a notably flat P O M). Test 3 statistics D, E, F and G show no significant variations in P O M due again to large values of standard deviation

7 4 6 Comparison Groups 5 and 6 (M)

The comparison between these two most senior groups shows variations in C O M in all planes, (Table SU6(M),

test 1, statistics D, E, F and G), but otherwise quite similar ranges and patterns of movement, (tests 2 and 3, statistics D, E, F and G) The changes in C O M are 1.6° into flexion, 1.2° out of abduction and 0.6° into external rotation for the senior group.

7 4 7 Synopsis of descending stairs (male)

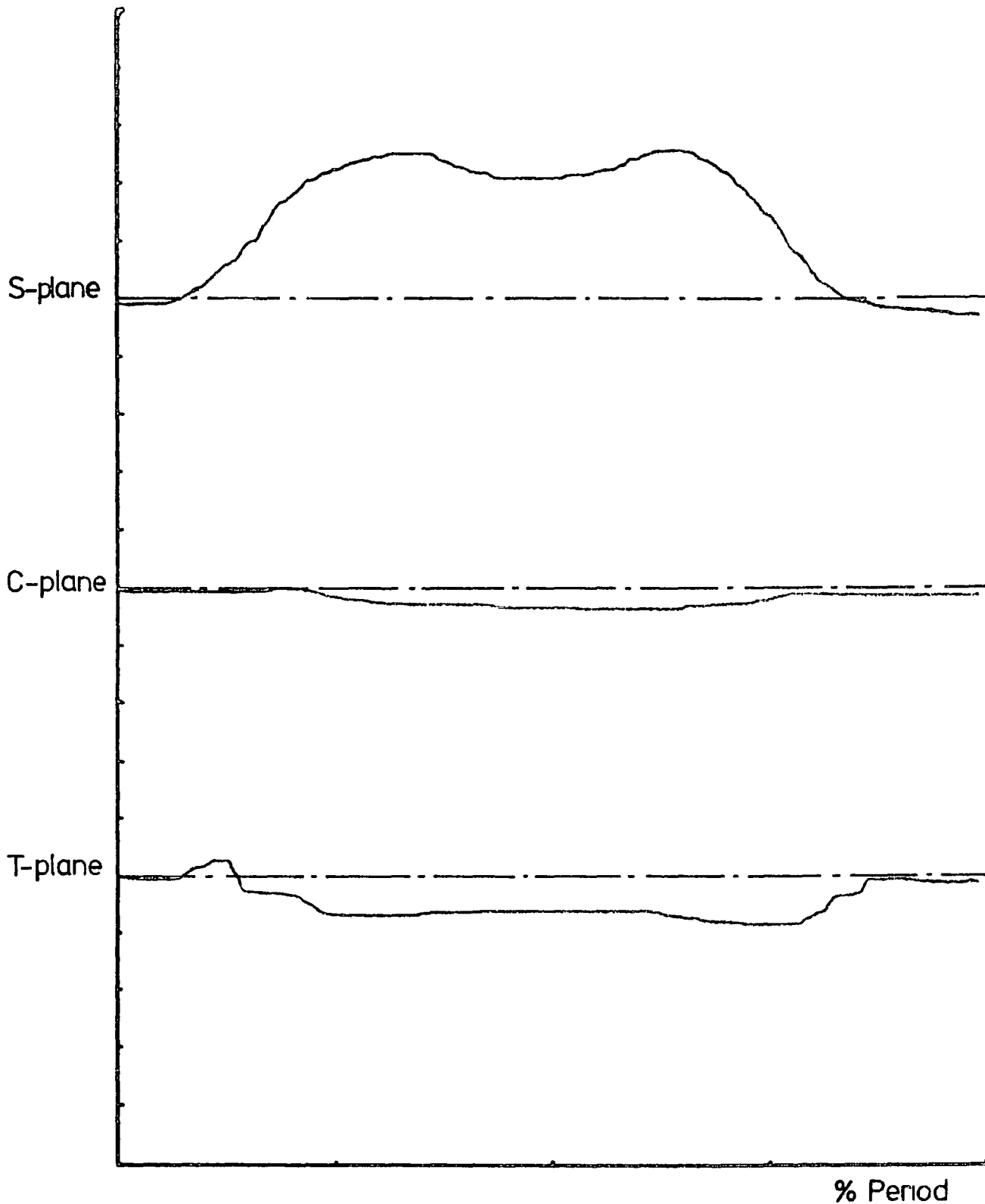
Between consecutive age groups, the analysis reveals no significant variations in R.O.M and P.O M at the level $p \leq 0.1$ (SD(M) tables, test 2 statistic G), except for two cases in the transverse plane. These occur in the comparisons between groups 2 and 3 and groups 3 and 4 and are both due to variations occurring in R O M

Discernable features are present in the pattern of movement in the transverse plane for all groups except group 4 The group 4 trace, having a range of only 3.7° is devoid of these features.

For the sagittal and coronal planes the data indicate that no significant differences exist between any two groups at the level $p \leq 0.1$

In the transverse plane, rotations are notably variable, with the non-centred M S D being greater than the R O.M. for all groups except group 6.

In the sagittal plane R.O.M differs by a maximum of 3.9° between any two groups, and differences existing are nowhere significant No discernable trends are developing in R O M or C O M across the age spectrum for movements in this plane



NAME ♂					
NO	FILE		FLEX	ABD	EXROT
EXERCISE SITTING		POLARITY	↑	↑	↑
LEFT ✓	RIGHT	SCALE%cm	10	5	5
NOTES					
<p><u>Figure 44</u> Sitting and standing; male</p>					

GROUP	MEAN RANGE			STANDARD DEVIATION			FOR S-PLANE ONLY	
	S	C	T	S	C	T	t	P
1	58.3	4.6	11.0	7.21	1.35	5.75		
2	61.7	4.3	12.5	6.72	2.08	3.19	1.133	0.2
3	62.0	4.9	11.3	7.08	2.09	3.33	0.131	0.9
4	65.2	4.9	12.5	3.88	1.66	5.15	1.686	0.1
5	61.0	6.6	13.4	9.83	1.84	4.43	1.720	0.1
6	63.3	6.7	10.0	9.82	3.24	5.81	0.516	0.6

S=Sagittal plane, C=Coronal plane, T=Transverse plane, in degrees.

SS(M) ANALYSIS OF SITTING AND STANDING, MALE.

Coronal plane rotations are also deficient in age related trends. Features which do appear in the coronal and sagittal plane P O M 's do recur in all age groups.

Although there are significant variations in C O M between most groups, usually in at least 2 planes, these variations exhibit no age related patterns.

When the area parameter is considered, an age related trend does become apparent. In groups 2 to 6 inclusive the area enclosed by the flexion against abduction curve increases with increasing age. However, the standard deviation on these figures is such that the probability of such differences between consecutive groups occurring by chance does not fall below $p = 0.42$. There is a strong indication that some differences between non-consecutive groups would be approaching significance, which favours the hypothesis that the overall trend may be substantiated significantly if larger samples were to be examined.

7.5 Sitting down on and rising from a chair male results

This exercise was accomplished easily by all normal subjects, and the patterns of movement were very similar in all cases. Referring to Fig 44 which is a full size reproduction of computer graphics one can see the general characteristics of the movements. The scales on this plot are different from those on previous plots in that flexion is scaled at $20^{\circ}/\text{cm}$ and

abduction and rotation at $10^{\circ}/\text{cm}$.

As the subject sits the hip is flexed with little rotation in either of the other two planes. The subject was allowed to sit in his usual manner, there being two basic ways of accomplishing this, sitting with knees together, and sitting with knees apart.

Sitting with knees together results in a slight adduction and internal rotation as the subject flexes at the hip, while sitting with the knees apart results in slight abduction and external rotation at the hip.

As the weight of the subject is taken by the chair there is a slight extension of the hip as the centre of gravity is moved from being over the feet to over the chair.

Standing is almost the exact reverse of sitting. The centre of gravity is moved over the feet by flexing the hips and then progressive extension occurs until the subject attains the initial standing posture.

Movements in lumbar spine have a quite considerable involvement in this exercise, especially in the sagittal plane. Depending upon the flexibility of the lumbar spine, and the freedom of movement at the hips, the 90° of rotation required to sit down is distributed through the associated joints. In pathological cases, where movements in either lumbar spine or the hips are severely restricted, compensatory rotations are made in the sound joints.

As movements in the spine were not measured, it is

impossible to make definitive statements about the overall movement pattern, but the results of the hip tests do cast some light on the situation

Referring now to Table SS(M) one can see that the average ranges of movement for the groups vary between 58.3° and 65.2 degrees, in the sagittal plane. R.O.M. in this plane increases with age from group 1 to group 4. This trend, however, is not significant beyond the level $p = 0.1$, for the probability of such differences between groups occurring by chance, but it may prove significant if larger samples were to be examined. This trend though does suggest the hypothesis that the lumbar spine may become stiffer in comparison to the hips over this age range. Beyond this range, the hips may also stiffen, resulting in a more even distribution of rotation.

In the other planes of rotation the angular changes are much smaller, and are perhaps more governed by conscious action. Groups 1 to 4 show very similar R.O.M. in the coronal plane, as do groups 5 and 6, but there is an increase of 1.5° between groups 4 and 5. The additional abduction in the senior groups may be a mechanism for easing movement by allowing the joint capsule to unspiral to a greater extent.

Transverse plane rotations are again notable only for their variability.

7.6 The global range test male

As previously mentioned, this was not a very

satisfactory test. The main problem was the inability of subjects to repeat their results

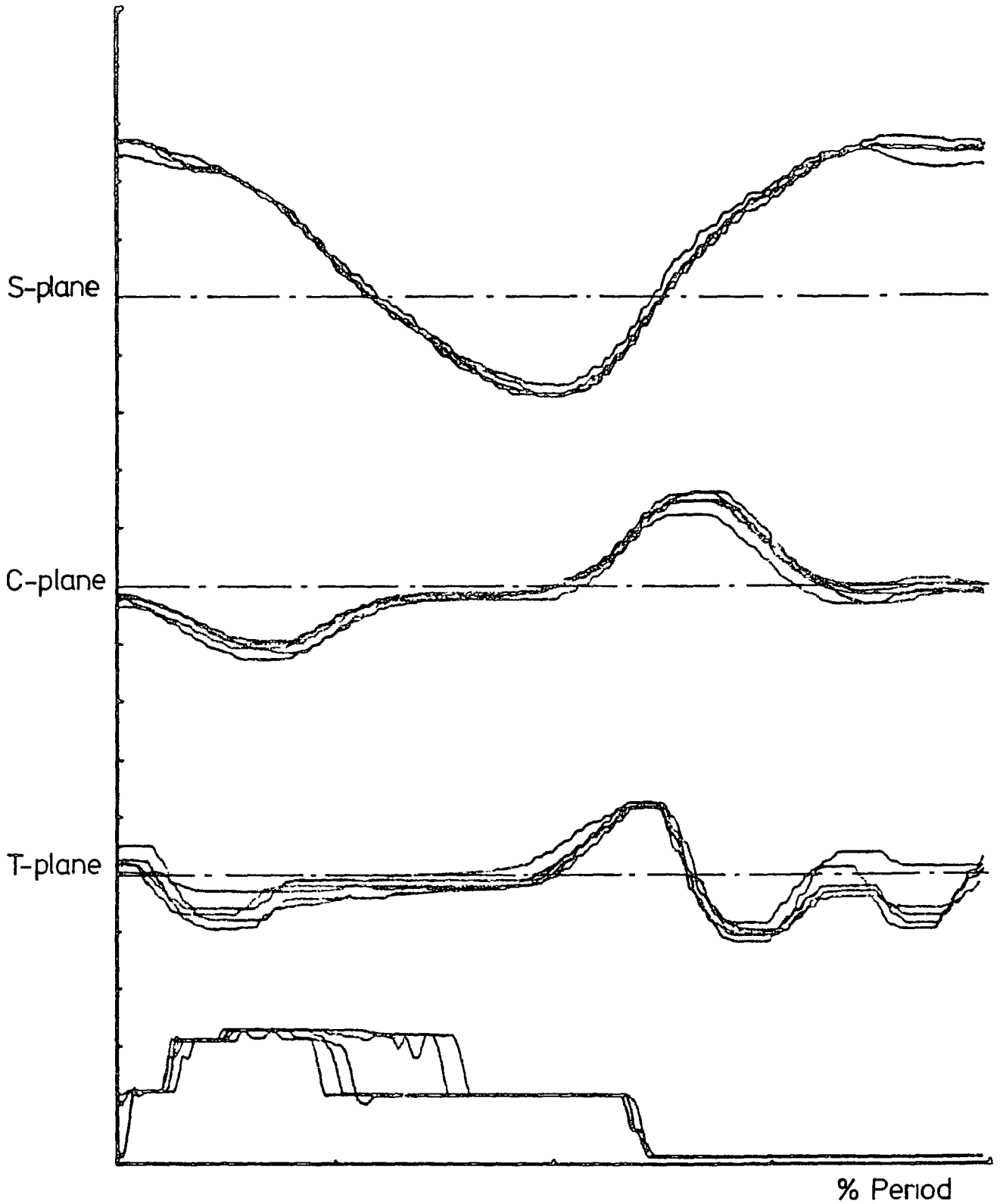
When executed properly this is a very demanding test, and as such, the ranges of movement measured are also dependent upon the clothing worn by the subject. For this sort of activity any sort of clothing restricts the fullest possible movement. The most athletic of the people tested had no trouble in bringing their knees up to their chests, but this could not be measured accurately, because with the knee at that height the pelvic girdle was dislodged as the thigh came up to the stomach. Individual results for this test cannot be summed and averaged for a group because there are no timing references through the exercise. For an exercise such as this it is also inappropriate purely to take the R.O M. in each plane as a parameter to compare performances

Considering the inadequacies mentioned above, an in-depth analysis of the data gathered cannot be justified as the result would be virtually meaningless. However, for the individual, one could perhaps go as far as to say his movement capability was good, fair, or poor, but statements beyond that are unjustified

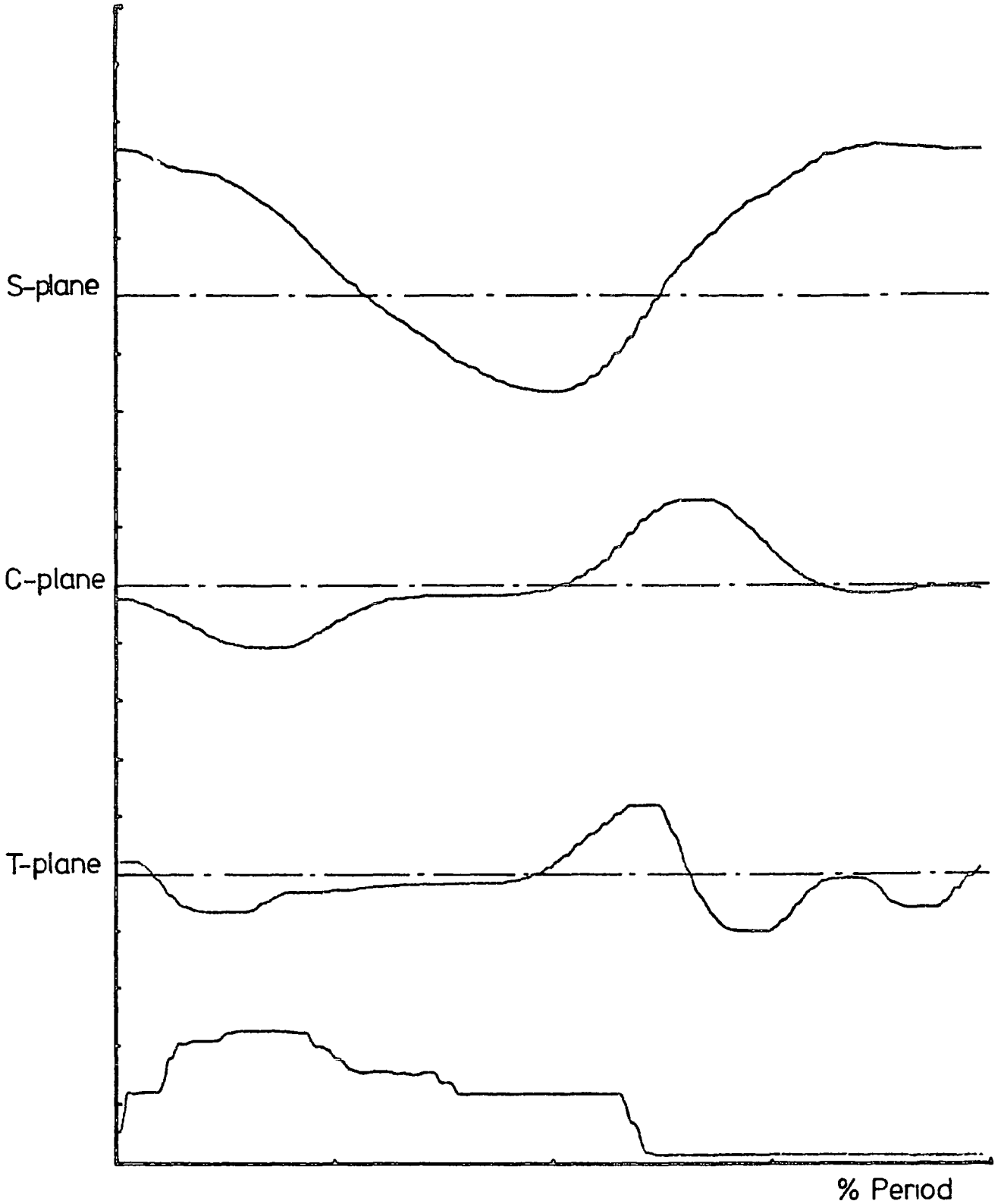
7.7 Female ambulation

7.7 1 Description of normal walking (female)

Figs. 45, 46 47 show typical movement patterns obtained for women during level walking. The data acquisition procedure and presentation format are identical



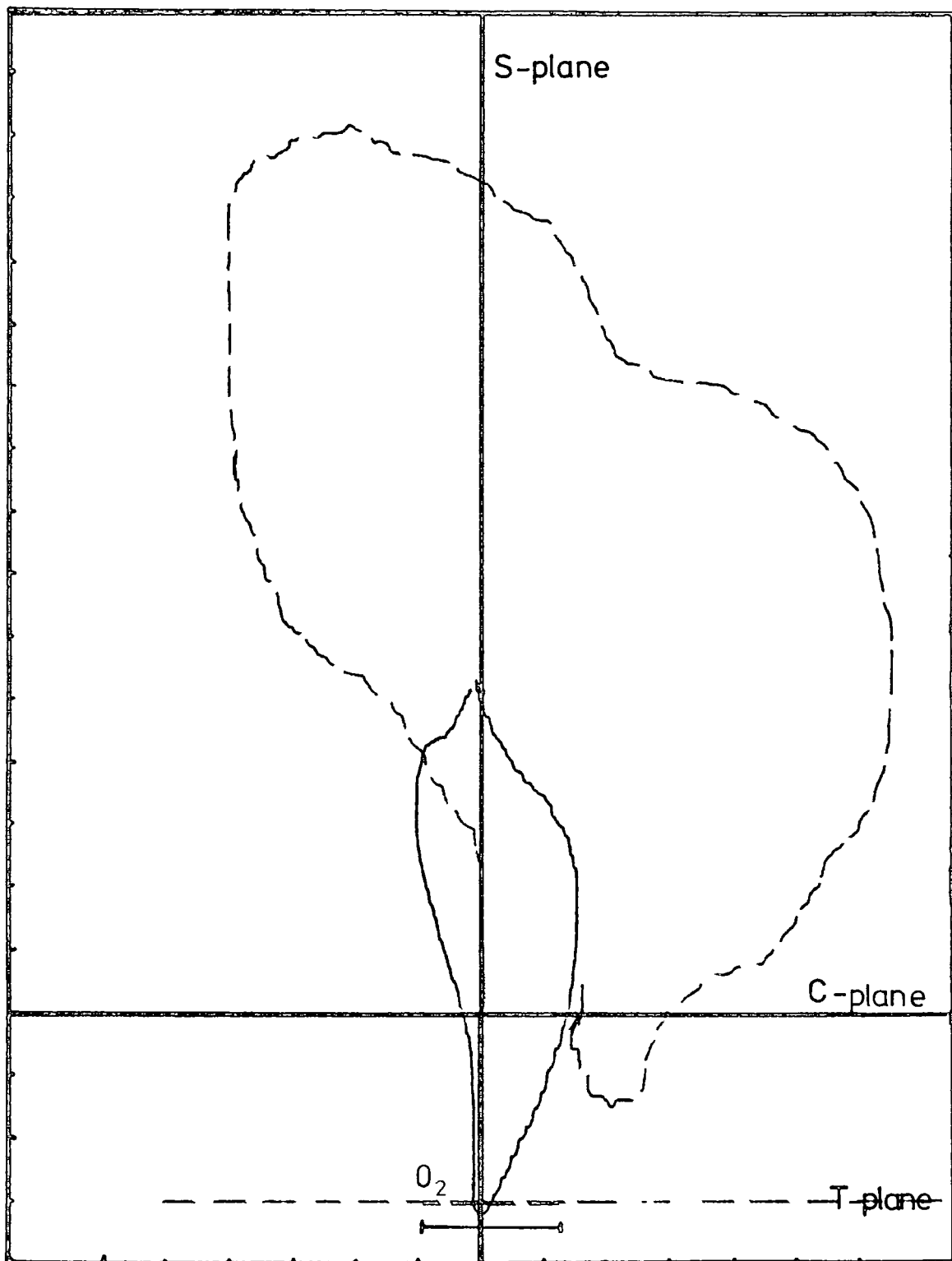
NAME		♀			
NO	FILE		FLEX	ABD	EXROT
EXERCISE: AMBULATION		POLARITY	↑	↑	↑
LEFT ✓	RIGHT	SCALE %cm	10	5	5
NOTES					
Figure 45 Normal female walking 5 steps					



NAME ♀					
NO	FILE		FLEX	ABD	EXROT
EXERCISE AMBULATION		POLARITY	↑	↑	↑
LEFT ✓	RIGHT	SCALE%cm	10	5	5

NOTES

Figure 46 Normal female walking average of five steps



NAME ♀					
NO	FILE		FLEX	ABD	EXROT
EXERCISE AMB+GLOBAL		POLARITY	↑	→	→
LEFT ✓	RIGHT	SCALE%cm	5	5	5

NOTES.

Figure 47 Rectangular plot of female ambulation

GROUP		BODY WEIGHT (N)				HEIGHT (m)			
	SIZE	MEAN	S.D.	t	p	MEAN	S.D.	t	p
1	9	584	33.4			1.669	0.049		
				1.154	0.27			0.765	0.45
2	10	603	41.1			1.663	0.063		
				2.365	0.04			0.754	0.45
3	9	671	84.8			1.660	0.045		
				1.043	0.31			0.694	0.50
4	10	625	102			1.640	0.075		

FEMALE GROUPS' HEIGHT AND WEIGHT: AMBULATION

TABLE 5

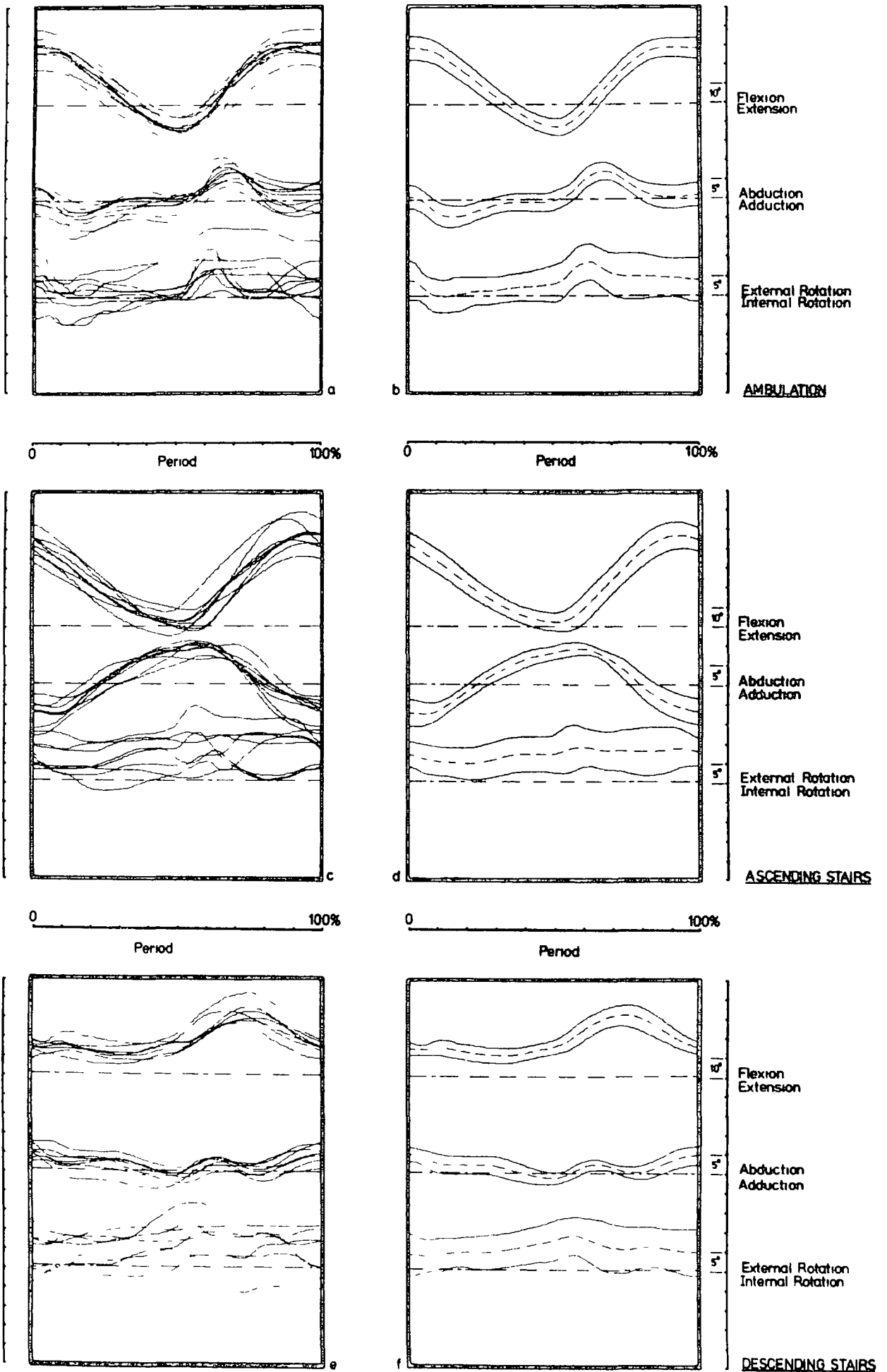


Figure 48 flex-centred plot for female group 1

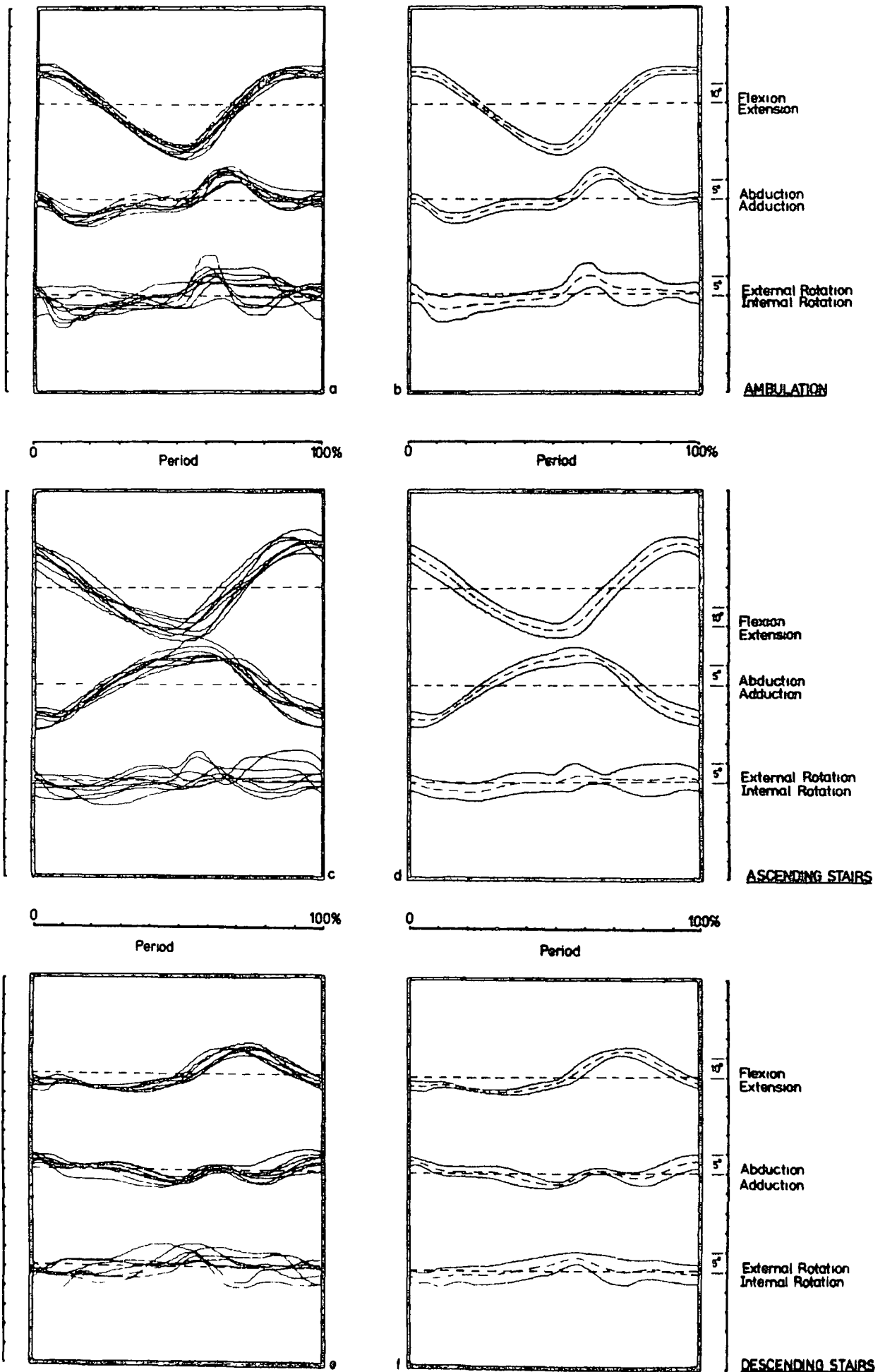


Figure 49 Centred plots for females group 1

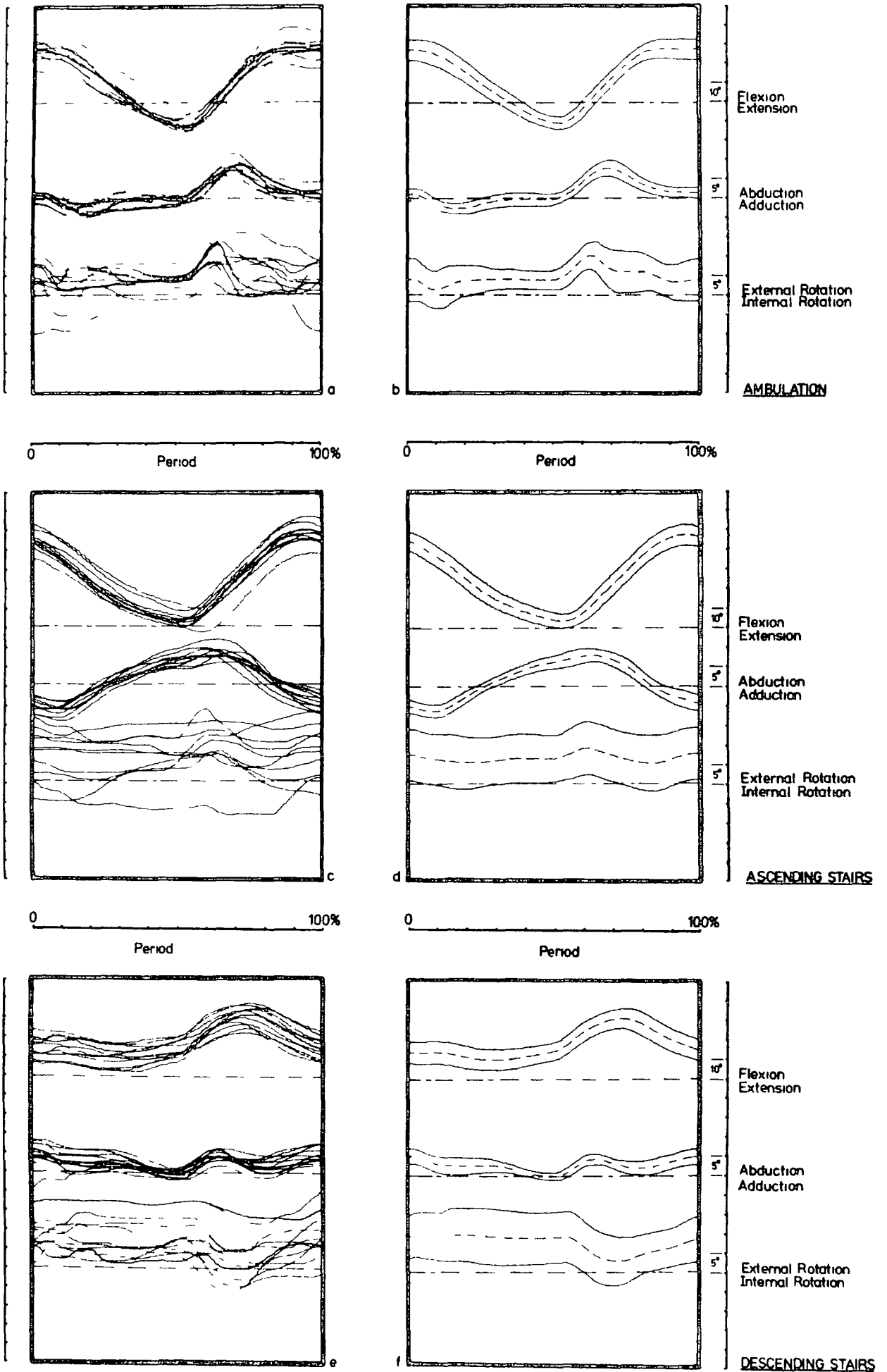


Figure 50 Non-centred plots for females group 2

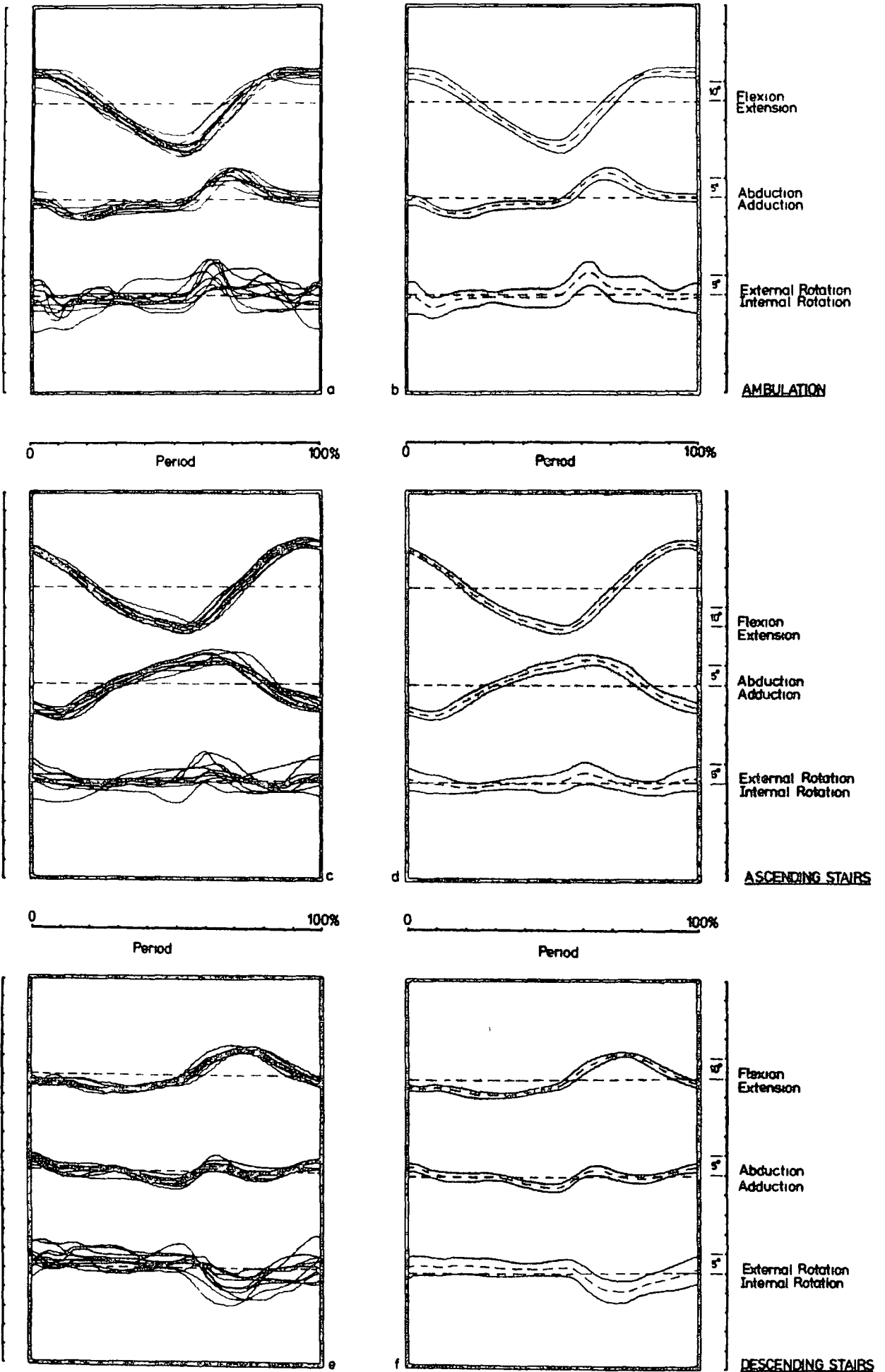


Figure 51 Centred plots for females group 2

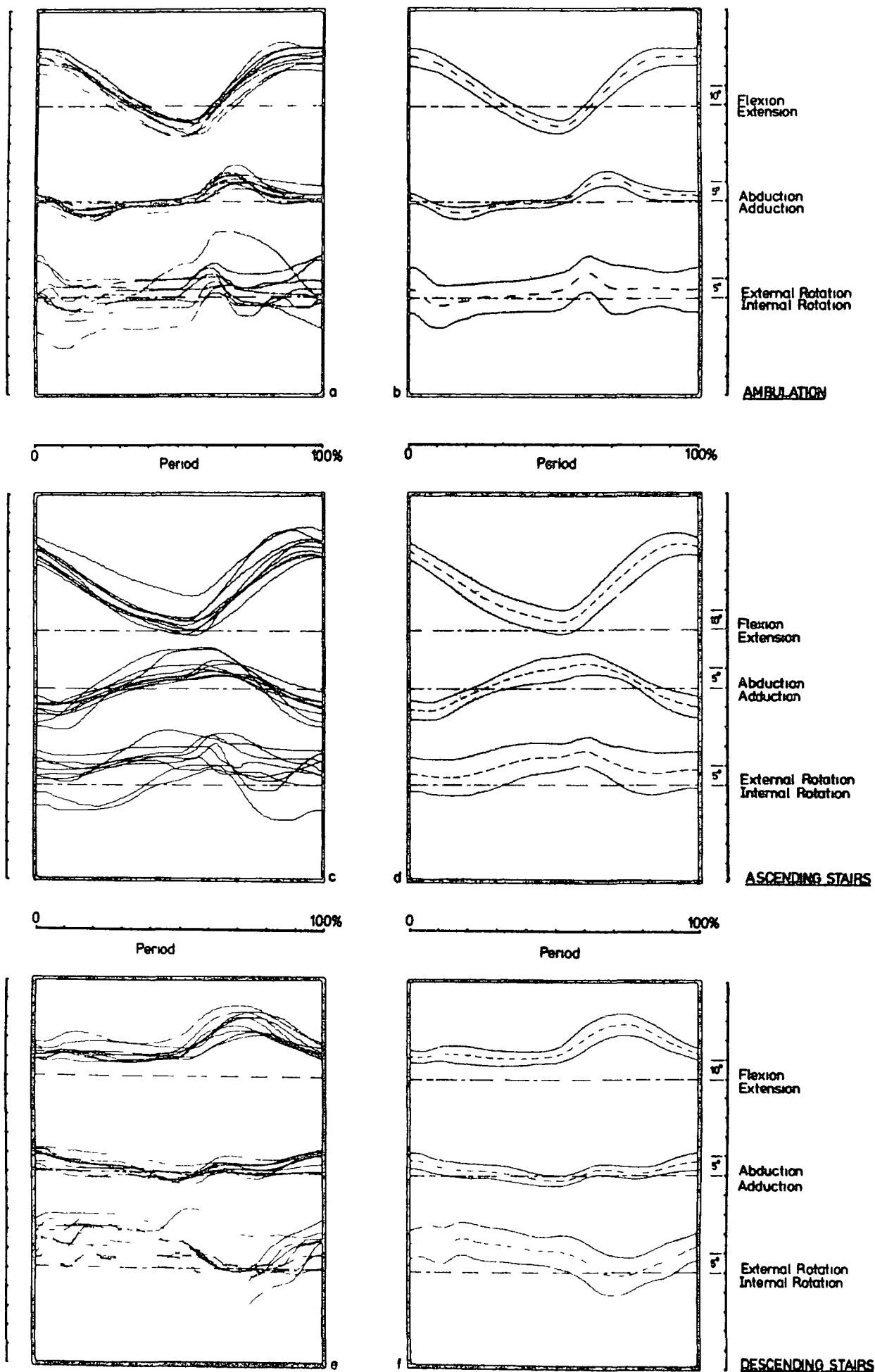


Figure 5.2 Non-centred plots for females group 3

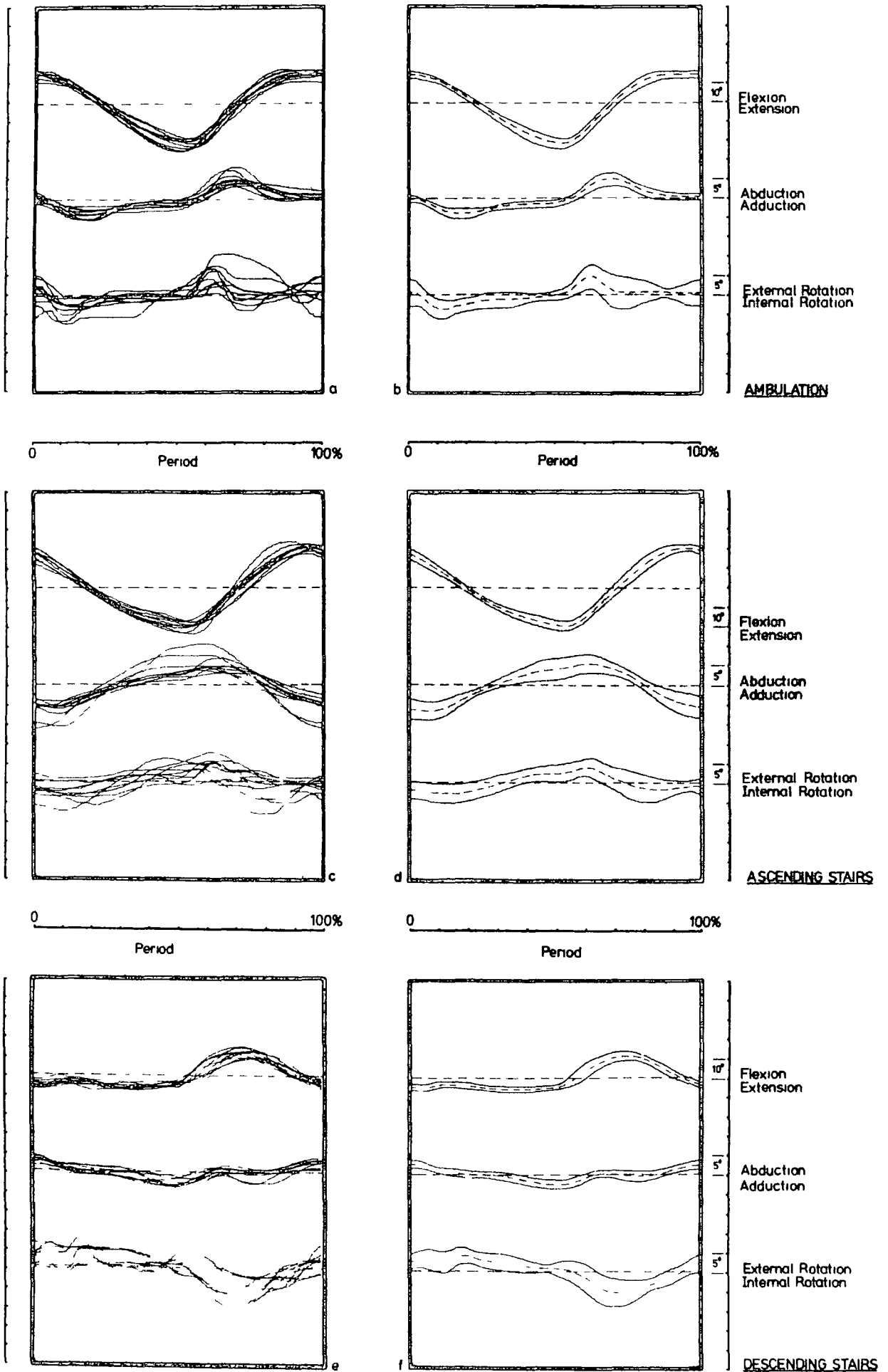


Figure 53 Centred plots for females group 3

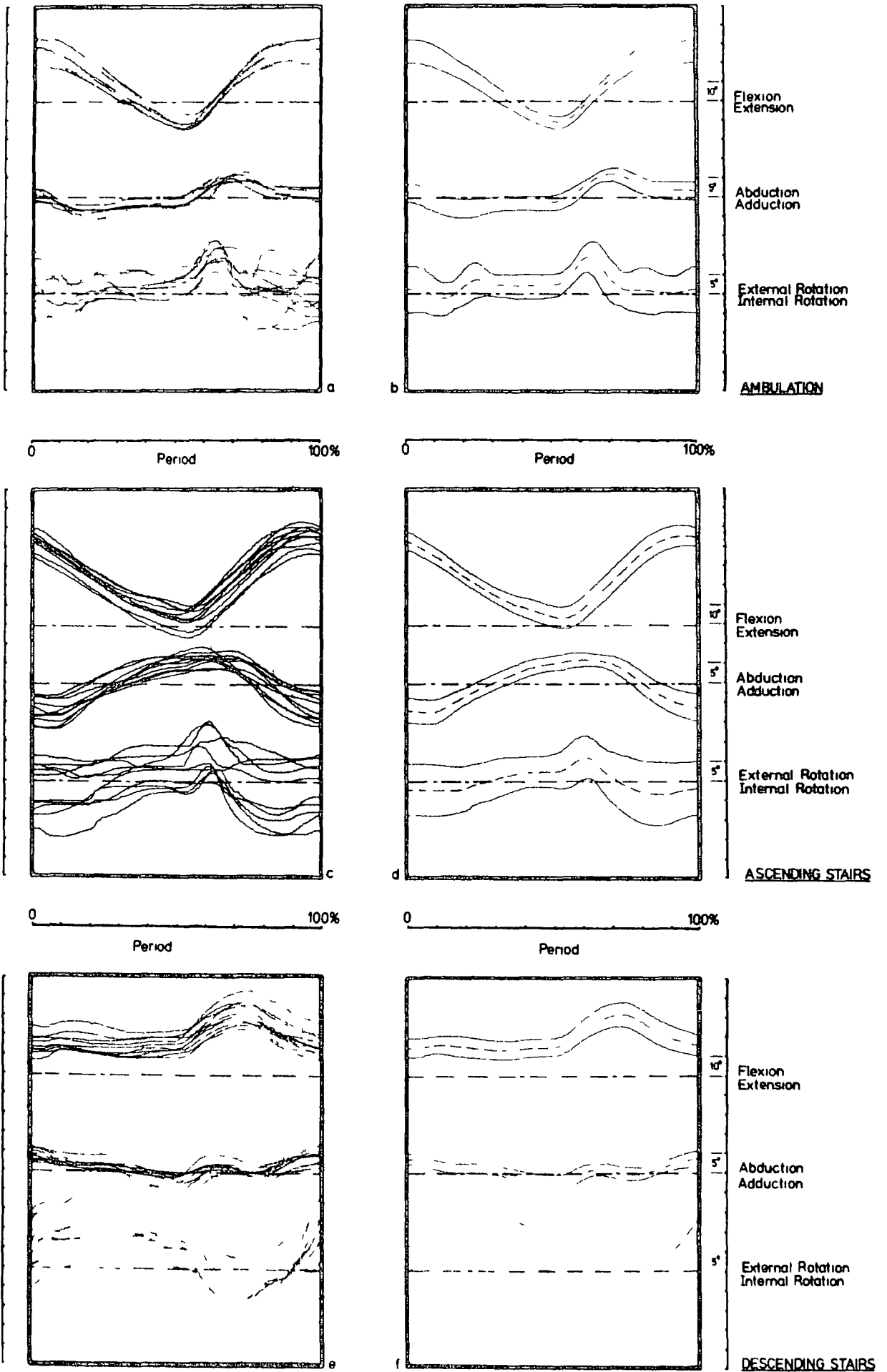


Figure 54 Non-centred plots for females group 4

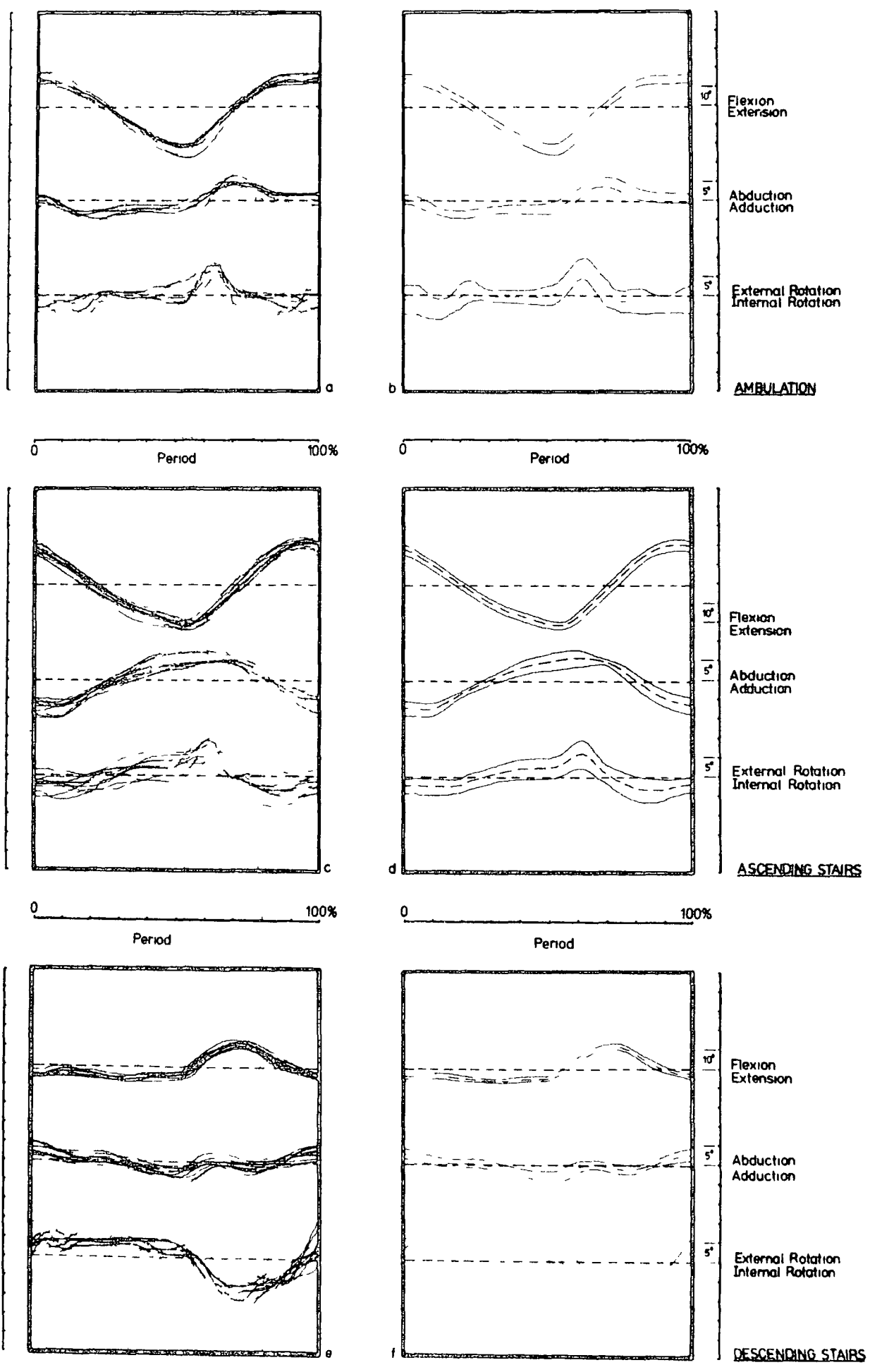


Figure 55 Centred plots for females group 4

GRP	SAMP NUMB	ROT COMP	MAX	MIN	ROM	COR	COM	S.D. (NO CLA)			S.D. (CLA)			AREA		t	p
								MAX	MIN	AVE	MAX	MIN	AVE	MEAN	S.D.		
1	9	FLEX	29.8	-12.0	41.8	8.9	12.2	6.1	4.0	5.1	4.1	1.6	2.5	272.0	97.4	0.702	0.48
		ABD	7.5	-4.3	11.8	1.6	0.7	3.2	2.0	2.6	1.9	1.0	1.4				
		ROT	8.8	0.1	8.9	4.4	3.6	6.0	3.4	4.6	4.3	1.4	2.6				
2	10	FLEX	28.2	-10.9	39.1	8.6	12.1	6.2	2.9	4.6	4.8	1.5	2.9	245.7	64.2	1.640	0.18
		ABD	7.9	-2.6	10.5	2.6	1.4	2.3	1.2	1.6	1.8	0.8	1.2				
		ROT	10.2	1.4	8.8	5.8	4.7	5.6	2.3	4.0	4.2	1.2	2.7				
3	9	FLEX	26.2	-10.7	36.9	7.7	10.6	5.6	3.2	4.2	3.3	1.1	2.2	193.6	74.4	0.048	0.9+
		ABD	6.2	-2.8	9.1	1.7	1.0	1.9	0.8	1.3	1.8	0.5	1.0				
		ROT	6.3	-2.1	8.5	2.1	1.5	6.3	4.0	4.9	4.2	0.9	2.3				
4	10	FLEX	27.4	-10.8	38.2	8.3	11.5	6.1	2.7	4.3	3.6	1.4	2.2	192.0	66.3		
		ABD	6.1	-2.7	8.7	1.7	0.8	2.7	1.2	2.1	1.8	0.9	1.3				
		ROT	9.6	-1.2	10.7	4.2	2.2	6.1	2.6	4.3	3.9	1.5	2.7				

TABLE A1(F)

COMPARISON GROUPS 1 & 2 FEMALE AMBULATION	CALCULATED USING NON CLA MEANS AND S.D.'S IN Y DIRECTION			CALCULATED USING CLA MEANS AND S.D.'S IN THE Y DIRECTION			CALCULATED USING CLA MEANS AND NON CLA S.D.'S IN THE Y DIRECTION		
	FLEX	ABD	ROT	FLEX	ABD	ROT	FLEX	ABD	ROT
MEAN OF MODULUS OF t's IN THE X DIRECTION	0.49	0.81	0.71	0.91	0.90	0.82	0.50	0.54	0.46
MEAN OF SIGNED VALUES OF t's IN THE X DIRECTION	0.005	0.77	0.60	-0.09	0.02	0.07	0.03	-0.01	0.05
STANDARD DEVIATION OF t's IN THE X DIRECTION	0.55	0.61	0.65	1.04	1.03	1.10	0.55	0.62	0.58
t-TESTING FOR A SIMILARITY TO A PERFECT LIKESS $t(0,0)$	0.14	17.78	12.98	-1.28	0.36	0.94	0.77	-0.29	1.22
RESULTING PROBABILITY OF A SIMILARITY EXISTING	0.88	0	0	0.23	0.72	0.36	0.45	0.77	0.22
t- TESTING FOR A SIMILARITY TO A DISTRIBUTED FIT $t(0,1)$	0.07	9.29	7.10	-0.92	0.24	0.69	0.37	-0.15	0.62
RESULTING PROBABILITY OF A SIMILARITY EXISTING	0.9+	0	0	0.36	0.82	0.50	0.71	0.9+	0.53

TABLE A2(F)

COMPARISON GROUPS 2 & 3 FEMALE AMBULATION	CALCULATED USING NON CLA MEANS AND S.D.'S IN Y DIRECTION			CALCULATED USING CLA MEANS AND S.D.'S IN THE Y DIRECTION			CALCULATED USING CLA MEANS AND NON CLA S.D.'S IN THE Y DIRECTION		
	FLEX	ABD	ROT	FLEX	ABD	ROT	FLEX	ABD	ROT
MEAN OF MODULUS OF t's IN THE X DIRECTION	0.73	0.63	1.62	0.55	0.77	0.72	0.36	0.58	0.38
MEAN OF SIGNED VALUES OF t's IN THE X DIRECTION	-0.71	-0.57	-1.62	-0.003	0.15	0.001	0.078	0.092	-0.0024
STANDARD DEVIATION OF t's IN THE X DIRECTION	0.39	0.62	0.58	0.70	0.89	0.89	0.48	0.69	0.45
t-TESTING FOR A SIMILARITY TO A PERFECT LIKENESS $t(0,0)$	-25.54	-13.14	-39.33	-0.06	2.44	0.02	2.27	1.90	-0.08
RESULTING PROBABILITY OF A SIMILARITY EXISTING	0	0	0	0.9+	0.03	0.9+	0.04	0.08	0.9+
t- TESTING FOR A SIMILARITY TO A DISTRIBUTED FIT $t(0.1)$	-9.31	-6.90	-19.84	-0.03	1.61	0.01	0.99	1.07	-0.03
RESULTING PROBABILITY OF A SIMILARITY EXISTING	0	0	0	0.9+	0.12	0.9+	0.32	0.30	0.9+

TABLE A3(F)

COMPARISON GROUPS 3 & 4 FEMALE AMBULATION	CALCULATED USING NON CLA MEANS AND S.D.'S IN Y DIRECTION			CALCULATED USING CLA MEANS AND S.D.'S IN THE Y DIRECTION			CALCULATED USING CLA MEANS AND NON CLA S.D.'S IN THE Y DIRECTION		
	FLEX	ABD	ROT	FLEX	ABD	ROT	FLEX	ABD	ROT
MEAN OF MODULUS OF t's IN THE X DIRECTION	0.49	0.66	0.80	0.58	0.95	1.21	0.31	0.65	0.64
MEAN OF SIGNED VALUES OF t's IN THE X DIRECTION	0.47	-0.34	0.43	0.09	0.02	0.06	-0.027	-0.07	0.07
STANDARD DEVIATION OF t's IN THE X DIRECTION	0.36	-0.77	0.82	0.71	1.06	1.51	0.39	0.75	0.78
t-TESTING FOR A SIMILARITY TO A PERFECT LIKELESS $t(0,0)$	18.41	-6.30	7.49	1.81	0.28	0.52	-0.97	-1.32	1.26
RESULTING PROBABILITY OF A SIMILARITY EXISTING	0	0	0	0.08	0.78	0.61	0.33	0.20	0.22
t- TESTING FOR A SIMILARITY TO A DISTRIBUTED FIT $t(0,1)$	6.22	-3.85	4.74	1.05	0.20	0.43	-0.35	-0.79	0.78
RESULTING PROBABILITY OF A SIMILARITY EXISTING	0	0.001	0.0001	0.30	0.85	0.66	0.73	0.44	0.44

TABLE A4(F)

to those for the male exercises. Because the female results show a marked similarity to the male results, containing all their characteristic features, lengthy descriptions will not be entered into, but the reader is referred to the appropriate sections earlier in this chapter. Differences occurring are essentially minor, and are primarily concerned with differences in R O M rather than P O M. It should be noted that the results presented as typical male and female results are those for one individual respectively. Consequently, conclusions should not be drawn from direct comparisons between the two, as individual variations may not be completely representative of that group or that sex.

Figures for the magnitude of the performance envelope may be measured from the appropriate plot as the reader requires, but they are basically very similar to the male results. Reference may be made to Tables A1(F), SD1(F) and SU1(F) for representative figures for the various group parameters. Unfortunately it was only possible to complete tests on groups 1 to 4, due to the unavailability of female subjects in the two senior groups.

The harmonic content of the waveforms presented as typical is the same as that for men.

7 7 2 Comparison Groups 2 and 1 (F)

In the comparison of sagittal plane rotations exhibited by these two groups (ref. Table A2(F)),

initially there appears to be an anomaly Test 1, statistics D, E, F and G indicate a very close likeness between groups 1 and 2 for sagittal plane rotations However, this similarity is not reflected as strongly in tests 2 and 3 The reason for this is because statistic B for test 1 is very small even though a 27° difference in R O M exists This statistic has such a low value because the differences between the two curves is such that the positive and negative differences have similar magnitudes producing an almost zero value for the mean of the signed values of Student's t in the sagittal t-array

This result illustrates the value of the three test system as described in section 5 14

Nonetheless, the curves exhibit similar P O M characteristics and each falls well within the others one standard deviation line, Figs 48b and 50b

Test 1 statistics D, E, F and G show major differences between groups both in coronal and transverse rotations, but these are shown to be almost entirely due to shifts in C O M , (Tests 2 and 3, statistics D, E, F and G) These amount to 07° in the coronal plane and 11° in the transverse plane The senior group demonstrates a reduction in R O M of 1.3° in the coronal plane

7 7 3 Comparison Groups 2 and 3 (F)

Test 1 statistics D, E, F and G (Table A3(F)) show almost no probability of similarities existing between

these two groups in any plane For sagittal and transverse plane rotations, however, statistics D, E, F and G, test 2, show this to be due to shifts in C O M This amounts to 1.5° in the sagittal plane and 3.2° in the transverse plane The large difference in value for statistic E, tests 2 and 3 indicates a further difference existing for sagittal plane rotations This manifests itself as a 2.2° reduction in R O M for the senior group The comparatively small values for statistic E and G tests 2 and 3 for coronal plane rotations are due almost entirely to the 1.4° reduction in R O M shown by the senior group P O M characteristics for rotations in this plane remain remarkably similar

7.7.4 Comparison Groups 3 and 4 (F)

Referring to Table A4(F), test 1, statistics D, E, F and G indicate only a small probability of similarities existing between these two groups for rotations in any plane, but again, these statistics for tests 2 and 3 show this to be due mainly to shifts in C O M These amount to 0.9 , 0.2 and 0.7 degrees for sagittal, coronal and transverse plane rotations respectively The low values of statistics E and G, test 2, for sagittal plane rotations suggest further variations in this plane The 1.3° increase in R O M for the senior group explains this to a limited extent, but there is also a change in pattern of movement Sagittal plane rotations during the swing phase are

very similar, but during the early stance phase the senior group demonstrate a broader peak to the flexion curve with a resulting increase in the gradient of the curve during late stance

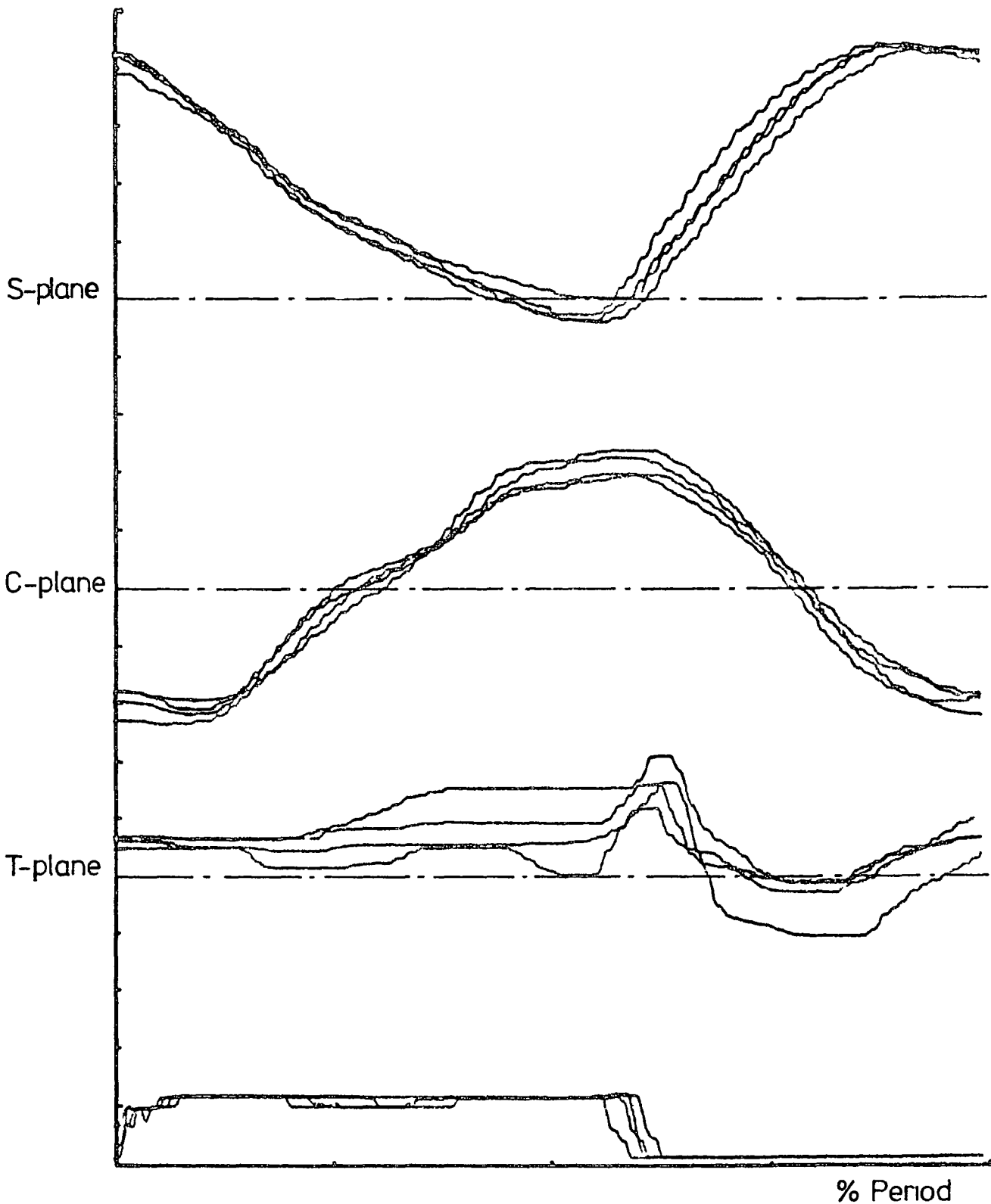
Coronal and transverse plane rotations are broadly similar between groups, each mean line falling within the others one standard deviation lines Figs. 52a and 54a

7 7 5 Synopsis of female ambulation

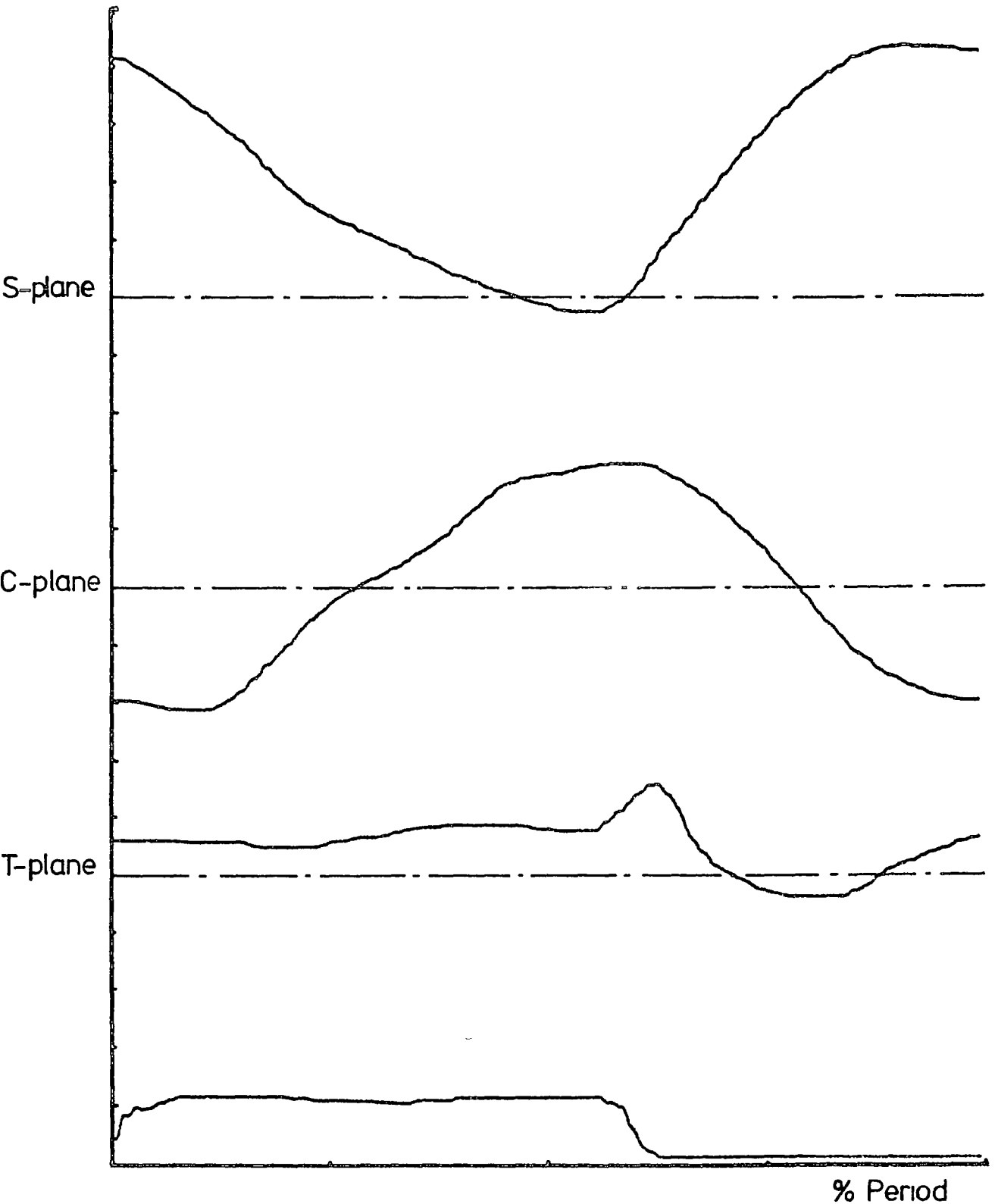
Between consecutive groups the analysis reveals no significant variations in R O M and P O M beyond the level $p = 0.1$ (test 2, statistic G, A(F) tables) For the same statistic test 3, this value is raised to the level $p = 0.3$ For these tests, the statistics are indicative of no significant variations in R O M and P O M existing between any two groups beyond these levels of probability

Although significant variations do occur in C.O M for all planes (test 1, statistics E and G), there appear to be no systematic variations with age throughout all groups. This possibly reflects the comparatively large within group variations of the sample taken due to the limited population available for examination However, there are age related trends appearing in the R O M used

From groups 1 to 3 the R O M used decreases with increasing age, for all plane of rotation, this trend continuing through group 4 for coronal plane rotations.



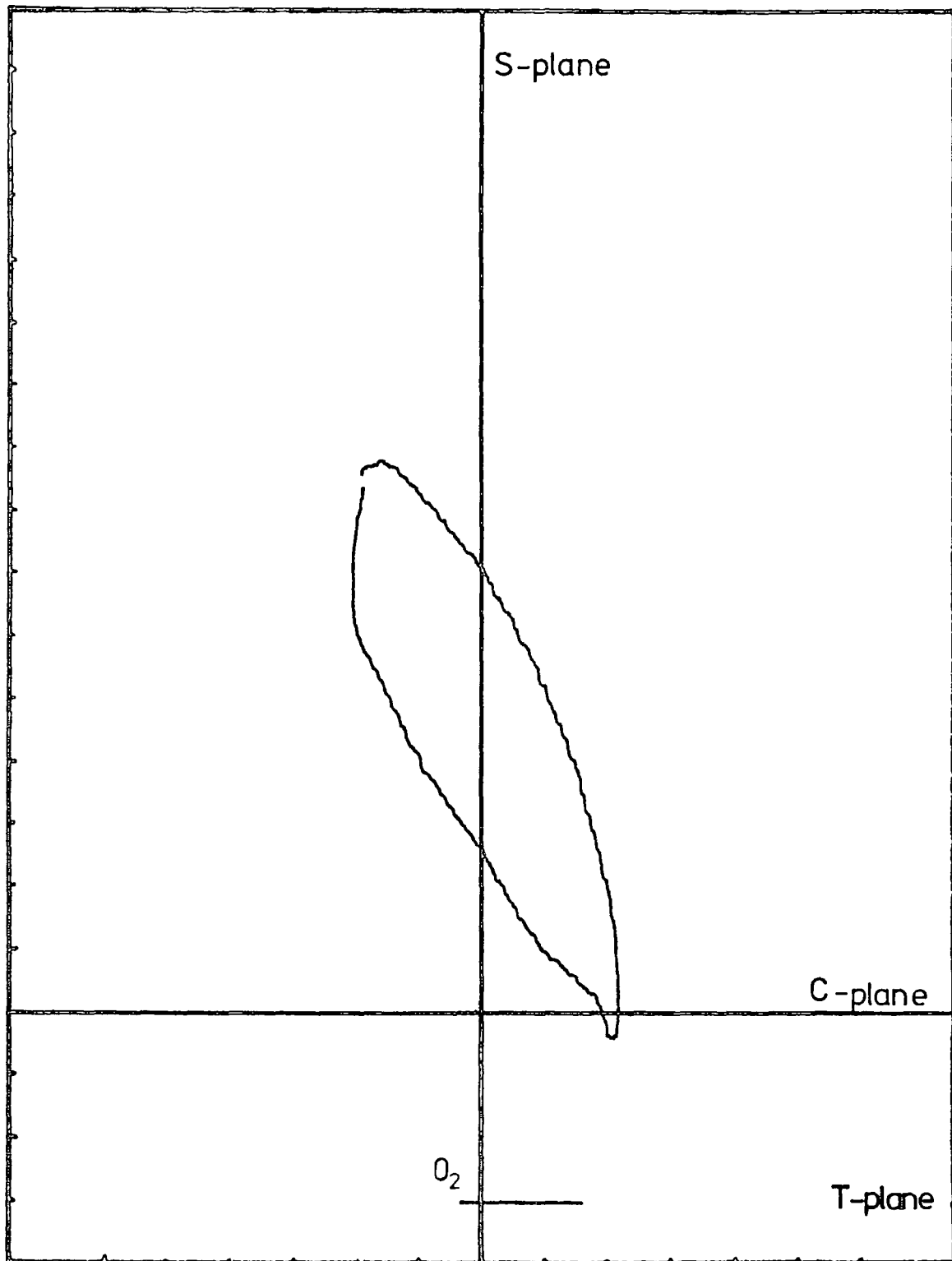
NAME		♀				
NO	FILE		FLEX	ABD	EXROT	
EXERCISE	STEPS UP	POLARITY	↑	↑	↑	
LEFT ✓	RIGHT	SCALE%cm	10	5	5	
NOTES						
<p><u>Figure 56</u> Ascending stairs, female 4 steps</p>						



NAME		♀			
NO	FILE		FLEX	ABD	EXROT
EXERCISE STEPS UP		POLARITY	↑	↑	↑
LEFT /	RIGHT	SCALE %cm	10	5	5

NOTES

Figure 57 Ascending stairs, female average of 4 steps.



NAME ♀					
NO	FILE		FLEX	ABD	EXROT
EXERCISE STEPS UP		POLARITY	↑	→	→
LEFT ✓	RIGHT	SCALE%cm	5	5	5
NOTES					
<p>Figure 58 Rectangular plot, ascending stairs</p>					

GROUP		BODY WEIGHT (N)				HEIGHT (m)			
	SIZE	MEAN	S.D.	t	p	MEAN	S.D.	t	p
1	8	594	41.7			1.683	0.043		
				1.154	0.27			0.765	0.45
2	11	603	39.0			1.673	0.068		
				2.365	0.04			0.754	0.45
3	9	671	84.8			1.660	0.045		
				1.043	0.31			0.694	0.50
4	10	625	102			1.640	0.075		

FEMALE GROUPS' HEIGHT AND WEIGHT: ASCENDING AND DESCENDING STAIRS

TABLE 6

GRP	SAMP NUMB	ROT COMP	MAX	MIN	ROM	COR	COM	S.D. (NO CLA)			S.D. (CLA)			AREA		t	p
								MAX	MIN	AVE	MAX	MIN	AVE	MEAN	S.D.		
1	8	FLEX	46.5	2.1	44.3	24.3	23.5	7.8	4.1	6.0	6.6	3.3	4.5	292.3	139.7	0.035	0.9+
		ABD	9.3	-7.5	16.9	0.9	1.2	3.4	1.2	2.3	2.2	0.8	1.6				
		ROT	6.0	1.7	4.3	3.8	4.1	6.3	3.3	4.8	4.3	1.2	2.7				
2	11	FLEX	47.6	3.6	44.0	25.6	24.8	5.7	3.4	4.8	3.4	1.2	2.3	290.6	54.8	2.420	0.03
		ABD	8.2	-6.3	14.4	1.0	1.5	2.2	1.1	1.6	1.8	1.0	1.3				
		ROT	6.4	2.3	4.1	4.3	3.7	7.3	5.9	6.6	3.2	1.0	2.0				
3	9	FLEX	44.4	4.2	40.1	24.3	23.7	7.9	4.1	6.1	3.8	1.2	2.3	210.0	92.7	0.632	0.54
		ABD	6.4	-5.7	12.1	0.4	0.7	3.2	1.5	2.3	3.0	0.8	2.3				
		ROT	5.8	-0.9	6.7	2.4	1.8	5.6	3.4	4.6	3.7	1.3	2.3				
4	10	FLEX	46.7	4.5	42.2	25.6	25.3	6.3	3.5	5.0	3.0	1.8	2.4	233.2	66.0		
		ABD	6.6	-7.0	13.6	-0.2	0.4	3.5	1.5	2.4	2.3	0.7	1.6				
		ROT	3.6	-6.0	9.6	-1.2	-2.5	8.1	3.9	6.0	3.7	1.8	2.5				

TABLE S.U.1(F)

COMPARISON GROUPS 1 & 2 FEMALE STEPS UP	CALCULATED USING NON CLA MEANS AND S.D.'S IN Y DIRECTION			CALCULATED USING CLA MEANS AND S.D.'S IN THE Y DIRECTION			CALCULATED USING CLA MEANS AND NON CLA S.D.'S IN THE Y DIRECTION		
	FLEX	ABD	ROT	FLEX	ABD	ROT	FLEX	ABD	ROT
MEAN OF MODULUS OF t's IN THE X DIRECTION	0.79	1.67	0.31	0.94	2.25	0.76	0.61	1.73	0.30
MEAN OF SIGNED VALUES OF t's IN THE X DIRECTION	0.58	-0.07	-0.13	0.09	-0.20	0.12	0.07	-0.33	0.02
STANDARD DEVIATION OF t's IN THE X DIRECTION	0.70	1.82	0.35	1.00	2.44	0.89	0.65	1.86	0.36
t-TESTING FOR A SIMILARITY TO A PERFECT LIKENESS $t(0,0)$	11.70	-0.56	-5.19	1.28	-1.13	1.87	1.56	-2.50	0.75
RESULTING PROBABILITY OF A SIMILARITY EXISTING	0	0.58	0.0001	0.23	0.25	0.08	0.15	0.02	0.45
t- TESTING FOR A SIMILARITY TO A DISTRIBUTED FIT $t(0.1)$	6.73	-0.49	-1.70	0.90	-1.05	1.24	0.84	-2.20	0.25
RESULTING PROBABILITY OF A SIMILARITY EXISTING	0	0.62	0.11	0.37	0.30	0.23	0.41	0.04	0.80

TABLE SU2(F)

COMPARISON GROUPS 2 & 3 FEMALE STEPS UP	CALCULATED USING NON CLA MEANS AND S.D.'S IN Y DIRECTION			CALCULATED USING CLA MEANS AND S.D.'S IN THE Y DIRECTION			CALCULATED USING CLA MEANS AND NON CLA S.D.'S IN THE Y DIRECTION		
	FLEX	ABD	ROT	FLEX	ABD	ROT	FLEX	ABD	ROT
MEAN OF MODULUS OF t's IN THE X DIRECTION	0.64	1.06	0.77	1.43	1.01	1.35	0.60	0.84	0.53
MEAN OF SIGNED VALUES OF t's IN THE X DIRECTION	-0.48	-0.77	-0.70	-0.17	0.08	0.05	-0.023	0.045	0.026
STANDARD DEVIATION OF t's IN THE X DIRECTION	0.69	1.00	0.60	1.62	1.24	1.57	0.67	1.03	0.63
t-TESTING FOR A SIMILARITY TO A PERFECT LIKENESS $t(0,0)$	-9.82	-10.81	-16.54	-1.53	0.95	0.46	-0.49	0.61	0.57
RESULTING PROBABILITY OF A SIMILARITY EXISTING	0	0	0	0.15	0.34	0.65	0.66	0.55	0.57
t- TESTING FOR A SIMILARITY TO A DISTRIBUTED FIT $t(0,1)$	-5.58	-7.65	-8.57	-1.30	0.74	0.39	-0.27	0.44	0.31
RESULTING PROBABILITY OF A SIMILARITY EXISTING	0.0001	0	0	0.21	0.45	0.70	0.78	0.66	0.76

TABLE SU3(F)

COMPARISON GROUPS 3 & 4 FEMALE STEPS UP	CALCULATED USING NON CLA MEANS AND S.D.'S IN Y DIRECTION			CALCULATED USING CLA MEANS AND S.D.'S IN THE Y DIRECTION			CALCULATED USING CLA MEANS AND NON CLA S.D.'S IN THE Y DIRECTION		
	FLEX	ABD	ROT	FLEX	ABD	ROT	FLEX	ABD	ROT
MEAN OF MODULUS OF t's IN THE X DIRECTION	0.71	0.57	-1.77	0.94	0.76	0.66	0.41	0.55	0.30
MEAN OF SIGNED VALUES OF t's IN THE X DIRECTION	0.70	-0.26	-1.77	0.07	-0.01	-0.007	0.06	0.05	0.04
STANDARD DEVIATION OF t's IN THE X DIRECTION	0.55	0.59	0.32	1.08	0.86	0.85	0.47	0.61	0.38
t-TESTING FOR A SIMILARITY TO A PERFECT LIKENESS $t(0,0)$	17.80	-6.14	-79.2	0.96	-0.19	-0.12	1.77	1.23	1.62
RESULTING PROBABILITY OF A SIMILARITY EXISTING	0	0	0	0.32	0.85	0.9+	0.08	0.24	0.12
t- TESTING FOR A SIMILARITY TO A DISTRIBUTED FIT $t(0,1)$	8.61	-3.13	-23.86	0.71	-0.13	-0.08	0.75	0.59	0.58
RESULTING PROBABILITY OF A SIMILARITY EXISTING	0	0.007	0	0.48	0.89	0.9+	0.46	0.57	0.57

TABLE 3U4(F)

The centred combi-plot for group 4 (Fig 55a) shows two groups establishing themselves in the set of flexion traces. One set containing 3 subjects has a R O M 10° larger than the other, which is enough to increase the mean range for the group by 3° , reversing the previous trend for sagittal plane rotations by 13° . C O M also would otherwise show a systematic decrement with increasing age, (contrary to the male results) but this would be a reflection of the decreasing R O M which is mainly from the flexion limit of motion rather than from the extension limit.

Examination of the area parameter reveals a progressive decrease in area with increasing age, but a significant difference is not established between any two consecutive groups. This trend may be substantiated by examining larger samples.

7.8 Ascending stairs (female)

7.8.1 Description of normal ascension of stairs - female

Figs 56, 57 and 58 are full size reproductions of computer graphics obtained from data collected from a woman climbing stairs. The format is the same as for all the previous plots illustrated full size. Again the female results are closely similar to the male results, bearing all the characteristic features associated with climbing stairs. The reader is referred to section 7.3.1 for a full description of these characteristics. The general observations noted in

section 7 7 1 hold also for climbing stairs

7 8.2 Comparison Group 1 and 2 (F)

Firstly, the coronal plane rotations for these groups will be discussed, as the variations occurring there are rather more apparent than variations in either of the other planes

Examination of Table SU2(F) statistics E and G reveal decreasing values of p from test 1 through to test 3, instead of the more usual increases This has occurred because of the small value computed for statistic B, indicating a particularly well balanced distribution of values of Student's t statistic calculated in the t-array along the x-axis (percentage period) of the plot (Ref section 5 14) Manipulations performed on the curves, such as centering) have the effect of upsetting this balance, increasing the value of statistic B with a resultant decrease in values for statistics E and G This again demonstrates the value of the three test procedure, adopted so that results such as these may be viewed in their proper perspective. In this plane the P O M are very similar but there is a 2.5° reduction in R.O M for the senior group, who also show a 0.3° rise in C O M

Sagittal plane rotations are basically similar in P O M , but the junior group seem to move more quickly through the stance phase, indicating a faster rise rate, resulting in lowering the C O M compared with the senior group

Transverse plane rotations are minimal for both groups, R O M being 4.3 and 4.1 degrees for groups 1 and 2 respectively. The P.O M for these curves are virtually featureless, retaining only a small peak to external rotation at toe-off. Figs. 48d and 50d. The mean standard deviations across the curves of transverse plane rotations are 4.8 and 6.6 degrees for the junior and senior groups respectively, well in excess of the averaged R O M in this plane. This again demonstrates the large variations between individuals for transverse rotations, and results in the high probability value (0.8) for test 3 statistic G.

7.8.3 Comparison Groups 2 and 3 (F)

Table SU3(F), test 1, statistics D, E, F and G show that there is little chance of a similarity existing between these two groups due mainly to shifts in C O.M

For sagittal plane rotations the senior group show a 3.9° reduction in R O M occurring predominantly from the flexion region, having the effect of reducing the C O M by 1.1°. The reduction in R O M. is reflected by the comparatively low values obtained for statistics E and G test 2.

Coronal plane rotations are markedly similar, but the junior group does demonstrate a R.O M greater by 2.3 degrees.

Transverse plane rotations are also very variable

between individuals in group 3, but there is a more apparent peak to external rotation at toe-off. Because the large standard deviations, statistics E and G tests 2 and 3 are fairly high.

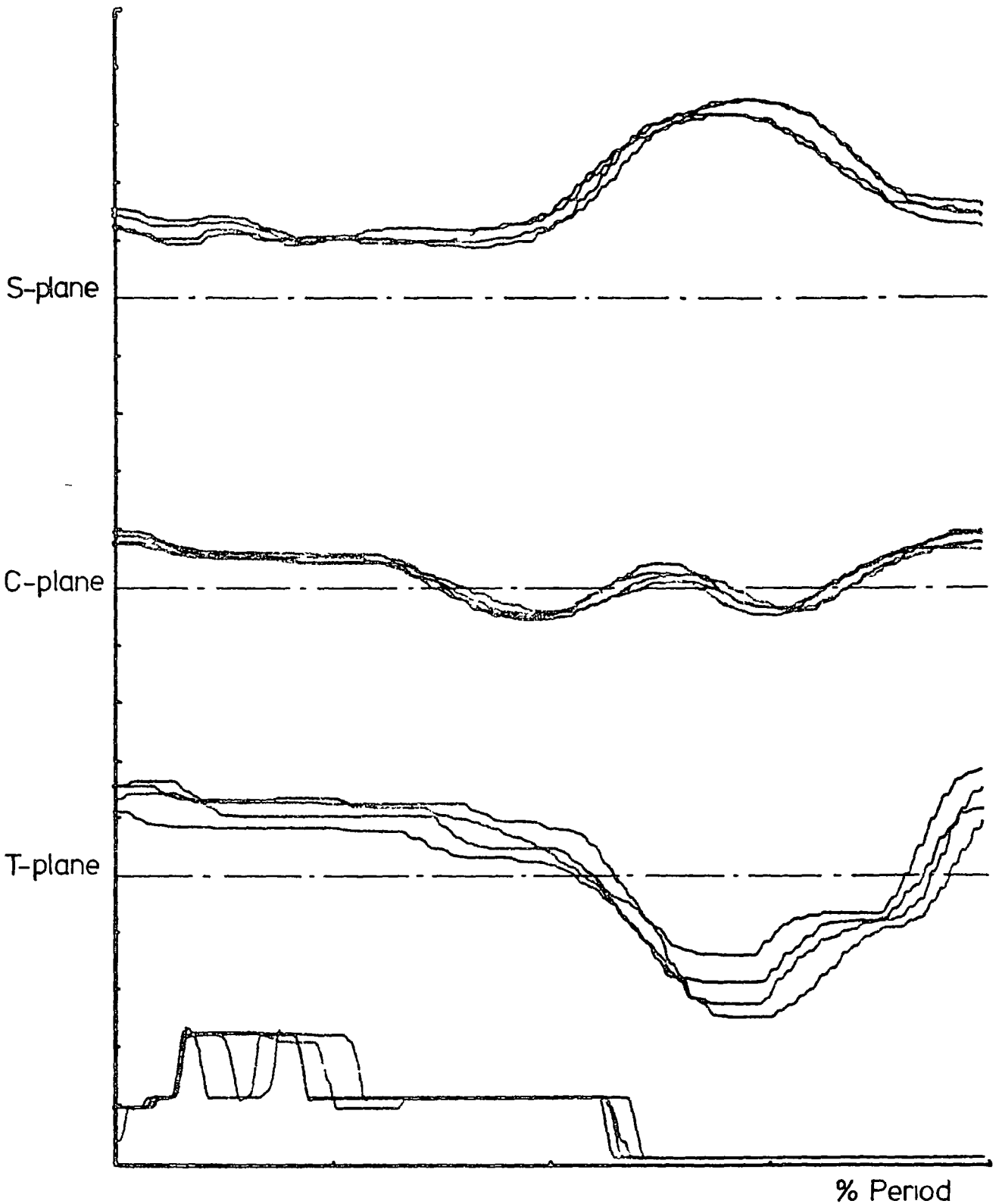
7.8.4 Comparison Groups 3 and 4 (F)

Referring to Table SU4(F) it can be seen that test 1, statistics D, E, F and G show that there is little resemblance between the movement patterns of groups 3 and 4 in any plane due to shifts in C.O.M. Test 2 statistics E and G show that coronal and transverse plane rotations are very similar indeed, even though there are variations in R.O.M. (ref. Table SU1(F) group 4).

In the sagittal plane, the increase in R.O.M. for the senior group occurring almost entirely in the flexion zone has the effect of raising the C.O.M. in this plane, and produces the lower range probability of similarity figures of test 3 statistic E. However, the flexion traces are broadly similar in R.O.M. and P.O.M. (test 2, statistics D, E, F and G).

7.8.5 Synopsis of climbing stairs (female)

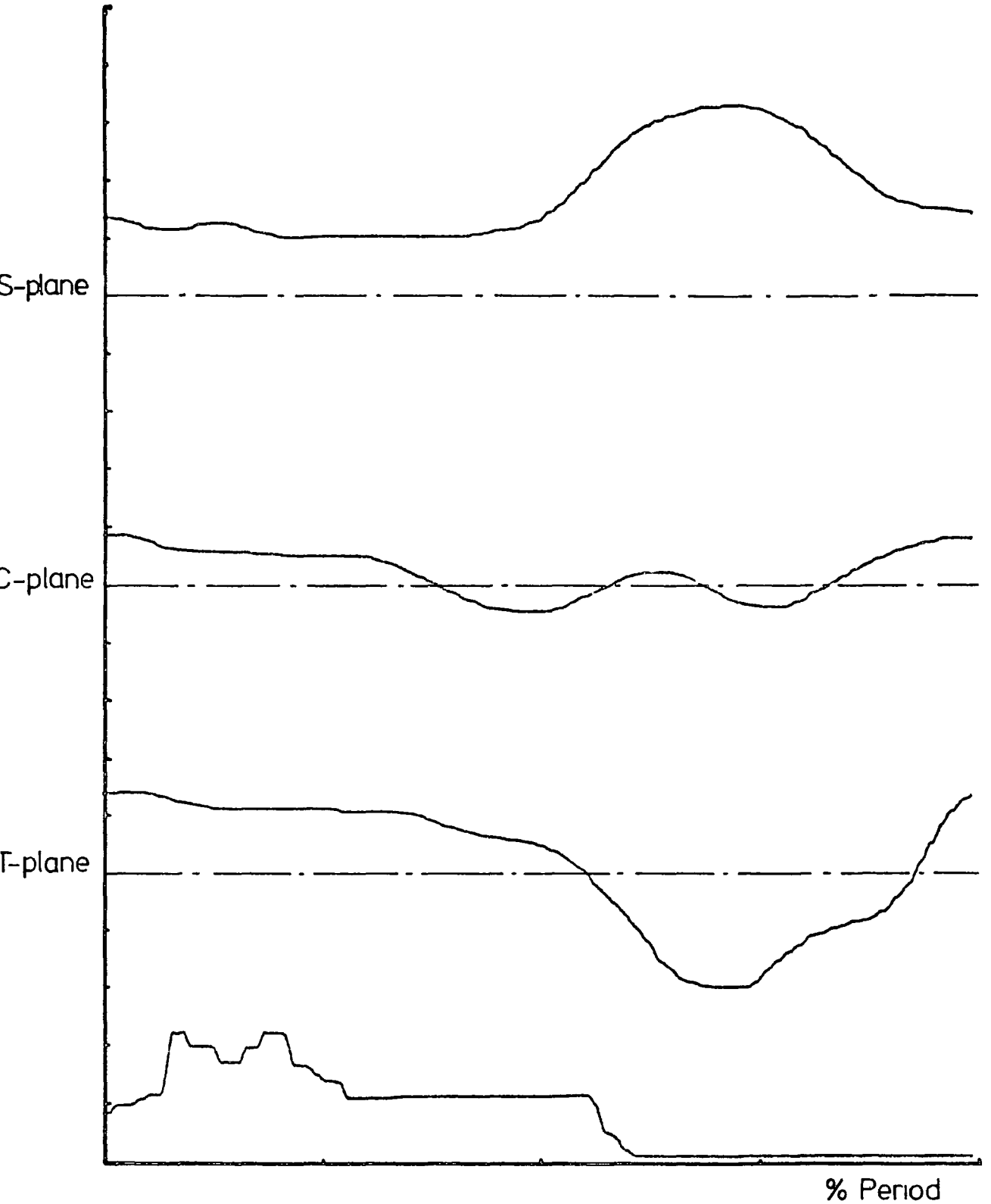
Bearing in mind the comments concerning coronal plane rotations in the comparison between groups 1 and 2, statistic G, tests 2 and 3 show no significant variations between consecutive groups in R.O.M. and P.O.M. beyond the level $p = 0.2$. The statistics are also indicative of there being no significant variations appearing between any two groups.



NAME ♀					
NO	FILE		FLEX	ABD	EXROT
EXERCISE STEPS DOWN		POLARITY	↑	↑	↑
LEFT ✓	RIGHT	SCALE%cm	10	5	5

NOTES

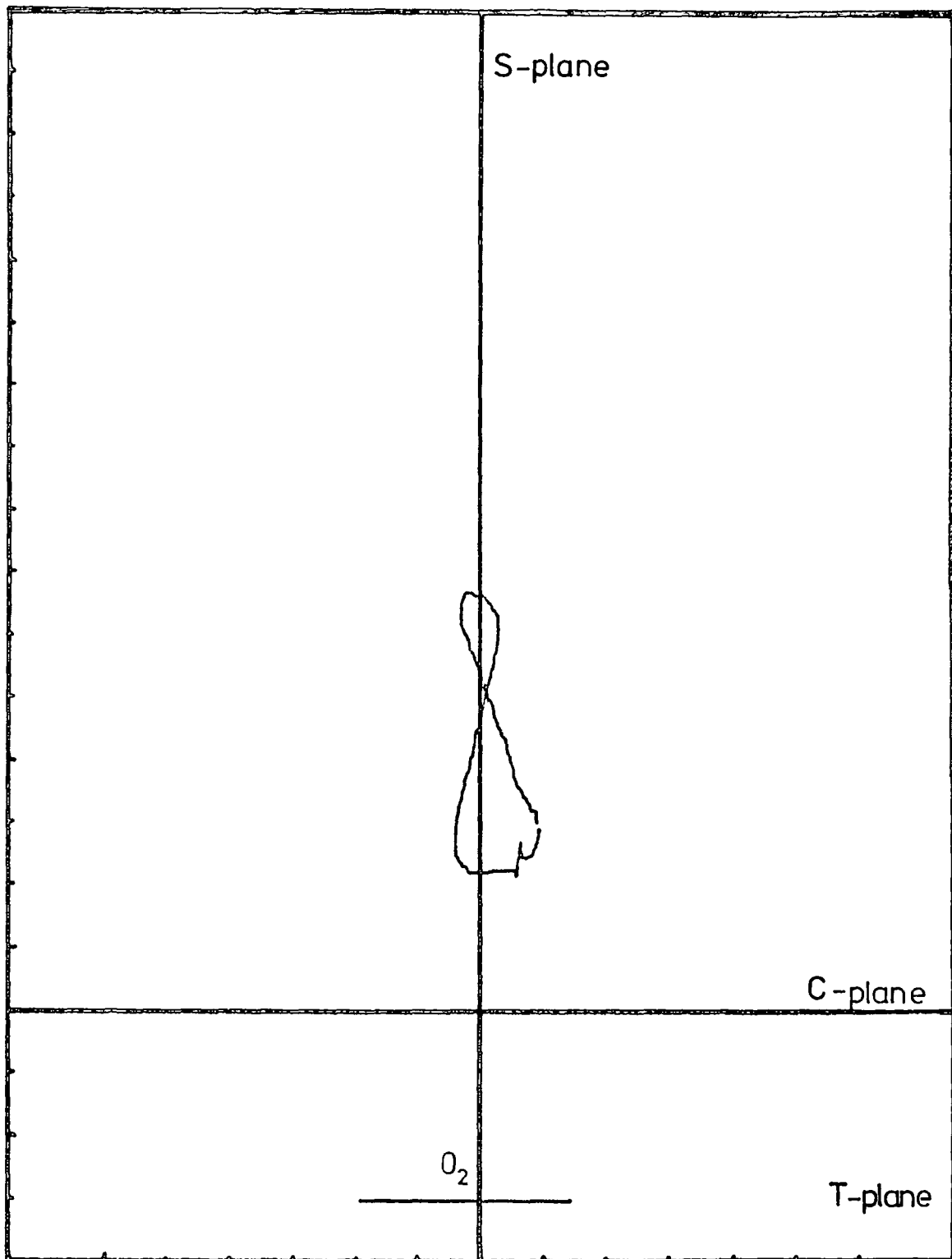
Figure 59 Descending stairs, female 4 steps



NAME ♀					
NO	FILE		FLEX	ABD	EXROT
EXERCISE STEPS DOWN		POLARITY	↑	↑	↑
LEFT ✓	RIGHT	SCALE%cm	10	5	5

NOTES

Figure 60 Descending stairs, female average of 4 steps



NAME ♀					
NO	FILE		FLEX	ABD	EXROT
EXERCISE STEPS DOWN		POLARITY	↑	→	→
LEFT ✓	RIGHT	SCALE%cm	5	5	5
NOTES					
<p><u>Figure 61</u> Rectangular plot, descending stairs</p>					

GRP	SAMP NUMB	ROT COMP	MAX	MIN	ROM	COR	COM	S.D. (NO CLA)			S.D. (CLA)			AREA		t	p
								MAX	MIN	AVE	MAX	MIN	AVE	MEAN	S.D.		
1	7	FLEX	31.9	10.8	21.1	21.3	18.6	6.1	2.4	4.3	3.8	0.4	2.1	52.9	21.7	1.228	0.22
		ABD	4.8	-1.5	6.3	1.6	1.5	2.6	1.0	2.0	2.3	0.5	1.4				
		ROT	8.8	3.4	5.4	6.1	5.5	6.4	3.7	5.0	3.5	1.1	2.4				
2	11	FLEX	31.4	10.4	21.0	20.9	18.2	6.1	4.3	5.3	2.8	0.8	1.6	43.1	12.7	1.124	0.28
		ABD	5.4	-0.1	5.5	2.7	2.8	2.2	0.9	1.6	1.3	0.6	1.0				
		ROT	9.9	2.9	7.1	6.4	7.7	7.3	4.9	6.3	3.6	1.5	2.4				
3	9	FLEX	28.8	11.2	17.5	20.0	17.1	6.1	2.8	4.2	4.0	1.1	1.9	35.9	15.8	0.052	0.9+
		ABD	4.1	-1.2	5.3	1.5	1.3	2.3	1.2	1.7	1.4	0.7	1.0				
		ROT	9.0	-0.9	9.9	4.0	4.8	5.4	3.5	4.3	3.8	0.9	2.3				
4	10	FLEX	32.6	14.3	18.2	23.4	20.1	6.4	4.3	5.2	2.3	0.9	1.5	36.4	20.8		
		ABD	4.2	-1.8	6.0	1.2	1.1	2.0	1.1	1.5	1.7	0.8	1.2				
		ROT	8.1	-4.7	12.8	1.7	3.3	7.5	5.0	6.0	3.4	1.2	1.8				

TABLE S.D.1(F)

COMPARISON GROUPS 1 & 2 FEMALE STEPS DOWN	CALCULATED USING NON CLA MEANS AND S.D.'S IN Y DIRECTION			CALCULATED USING CLA MEANS AND S.D.'S IN THE Y DIRECTION			CALCULATED USING CLA MEANS AND NON CLA S.D.'S IN THE Y DIRECTION		
	FLEX	ABD	ROT	FLEX	ABD	ROT	FLEX	ABD	ROT
MEAN OF MODULUS OF t's IN THE X DIRECTION	0.20	1.67	1.10	0.34	0.87	2.17	0.13	0.61	0.89
MEAN OF SIGNED VALUES OF t's IN THE X DIRECTION	-0.15	1.67	0.79	-0.02	0.05	0.19	5.5E-4	0.12	4.4E-3
STANDARD DEVIATION OF t's IN THE X DIRECTION	0.16	1.05	1.03	0.43	1.05	2.48	0.16	0.76	1.02
t-TESTING FOR A SIMILARITY TO A PERFECT LIKENESS t(0,0)	-12.56	22.42	10.82	-0.60	0.67	1.08	0.048	2.28	0.06
RESULTING PROBABILITY OF A SIMILARITY EXISTING	0	0	0	0.55	0.51	0.29	0.9+	0.04	0.9+
t- TESTING FOR A SIMILARITY TO A DISTRIBUTED FIT t(0.1)	-2.03	16.2	7.75	-0.24	0.49	1.00	0.007	1.38	0.04
RESULTING PROBABILITY OF A SIMILARITY EXISTING	0.06	0	0	0.81	0.63	0.31	0.9+	0.19	0.9+

TABLE SD2(F)

COMPARISON GROUPS 2 & 3 FEMALE STEPS DOWN	CALCULATED USING NON CLA MEANS AND S.D.'S IN Y DIRECTION			CALCULATED USING CLA MEANS AND S.D.'S IN THE Y DIRECTION			CALCULATED USING CLA MEANS AND NON CLA S.D.'S IN THE Y DIRECTION		
	FLEX	ABD	ROT	FLEX	ABD	ROT	FLEX	ABD	ROT
MEAN OF MODULUS OF t's IN THE X DIRECTION	0.74	2.12	1.16	1.54	0.96	0.84	0.51	0.64	0.36
MEAN OF SIGNED VALUES OF t's IN THE X DIRECTION	-0.55	-2.12	-1.16	0.20	0.05	0.039	0.006	-0.079	-.0002
STANDARD DEVIATION OF t's IN THE X DIRECTION	0.59	1.13	0.41	1.84	1.25	0.94	0.59	0.90	0.39
t-TESTING FOR A SIMILARITY TO A PERFECT LIKENESS $t(0,0)$	-13.28	-26.53	-39.58	1.50	0.39	0.59	0.15	-1.24	-0.07
RESULTING PROBABILITY OF A SIMILARITY EXISTING	0	0	0	0.15	0.70	0.57	0.87	0.24	0.94
τ - TESTING FOR A SIMILARITY TO A DISTRIBUTED FIT $t(0,1)$	-6.72	-19.87	-15.10	1.32	0.31	0.40	0.076	-0.83	-0.023
RESULTING PROBABILITY OF A SIMILARITY EXISTING	0	0	0	0.20	0.76	0.69	0.9+	0.42	0.9+

TABLE SD3(F)

COMPARISON GROUPS 3 & 4 FEMALE STEPS DOWN	CALCULATED USING NON CLA MEANS AND S.D.'S IN Y DIRECTION			CALCULATED USING CLA MEANS AND S.D.'S IN THE Y DIRECTION			CALCULATED USING CLA MEANS AND NON CLA S.D.'S IN THE Y DIRECTION		
	FLEX	ABD	ROT	FLEX	ABD	ROT	FLEX	ABD	ROT
MEAN OF MODULUS OF t's IN THE X DIRECTION	1.43	0.41	0.66	0.74	0.53	1.80	0.25	0.38	0.65
MEAN OF SIGNED VALUES OF t's IN THE X DIRECTION	1-43	-0.30	-0.59	0.03	0.02	0.15	0.02	0.009	0.03
STANDARD DEVIATION OF t's IN THE X DIRECTION	0.46	0.44	0.72	0.96	0.60	2.14	0.33	0.44	0.74
t-TESTING FOR A SIMILARITY TO A PERFECT LIKELESS $t(0,0)$	44.42	-9.66	-11.66	0.45	0.50	0.98	0.87	-0.29	0.57
RESULTING PROBABILITY OF A SIMILARITY EXISTING	0	0	0	0.67	0.61	0.32	0.39	0.78	0.58
t- TESTING FOR A SIMILARITY TO A DISTRIBUTED FIT $t(0,1)$	18.43	-3.90	-6.79	0.31	0.26	0.88	0.27	-0.12	0.34
RESULTING PROBABILITY OF A SIMILARITY EXISTING	0	0.001	0	0.76	0.80	0.39	0.80	0.9+	0.75

TABLE SD4(F)

Statistic E, test 1, for all inter-group comparisons shows that significant variations in C O.M exist in all cases except the previously mentioned group 1/2 coronal plane comparisons

Examination of Table SU1(F) reveals no systematic variations with age for most of the parameters studied, an exception being C O M in the transverse plane. Here, there is a shift in C O M farther into the internal rotation region with advancing age This is significant between all consecutive groups at the level $p = 0.001$ (statistic E, test 1, SU(F) tables) This trend is held very strongly by the male population also As with the men, there does seem to be a trend establishing itself whereby the subject assumes a posture progressively farther into flexion, adduction and internal rotation with increasing age

Trends becoming apparent, but again not substantiated significantly are decreasing R O M in the sagittal and coronal planes and increasing R O M in the transverse plane with advancing age This of course is reflected to some extent in the area parameter which seems to show some reduction in area with increasing age.

It is clear that more definitive results would have been obtained had the samples available been larger

7 9 Descending stairs (female)

7.9 1 Description of normal descension of stairs - female

Figs 59, 60 and 61 are full size reproductions of

computer graphics obtained from a woman descending a flight of stairs. The format is as previously described. The female results exhibit all the characteristic features of the male results, and the reader is referred to section 7.4.1 where these are fully described.

On the individual records reproduced the rotations in flexion during the swing phase show a more pronounced hump than in the male equivalent, but this difference is basically individualistic, and is not as apparent in the group means. Again the reader is referred to the general observations made in section 7.7.1.

7.9.2 Comparison Groups 1 and 2 (F)

Test 1 statistics D, E, F and G, Table SD2(F) show little possibility of a total similarity existing due mainly to shifts in C.O.M. (test 2, statistics D, E, F and G, Table SD1(F)).

Rotations in the sagittal plane show a pronounced similarity (tests 2 and 3 statistics E and G) in R.O.M. and P.O.M. and these tests also indicate the presence of a strong resemblance for transverse plane rotations.

The figures, (tests 2 and 3, statistics D, E, F and G) for coronal plane rotations hint of some underlying differences, and these emerge as variations in pattern of movement. Although the fundamental features are retained by both groups, there are differences in magnitude between corresponding peaks. The senior

group also shows a 0.8° reduction in R O M

7.9.3 Comparison Groups 2 and 3 (F)

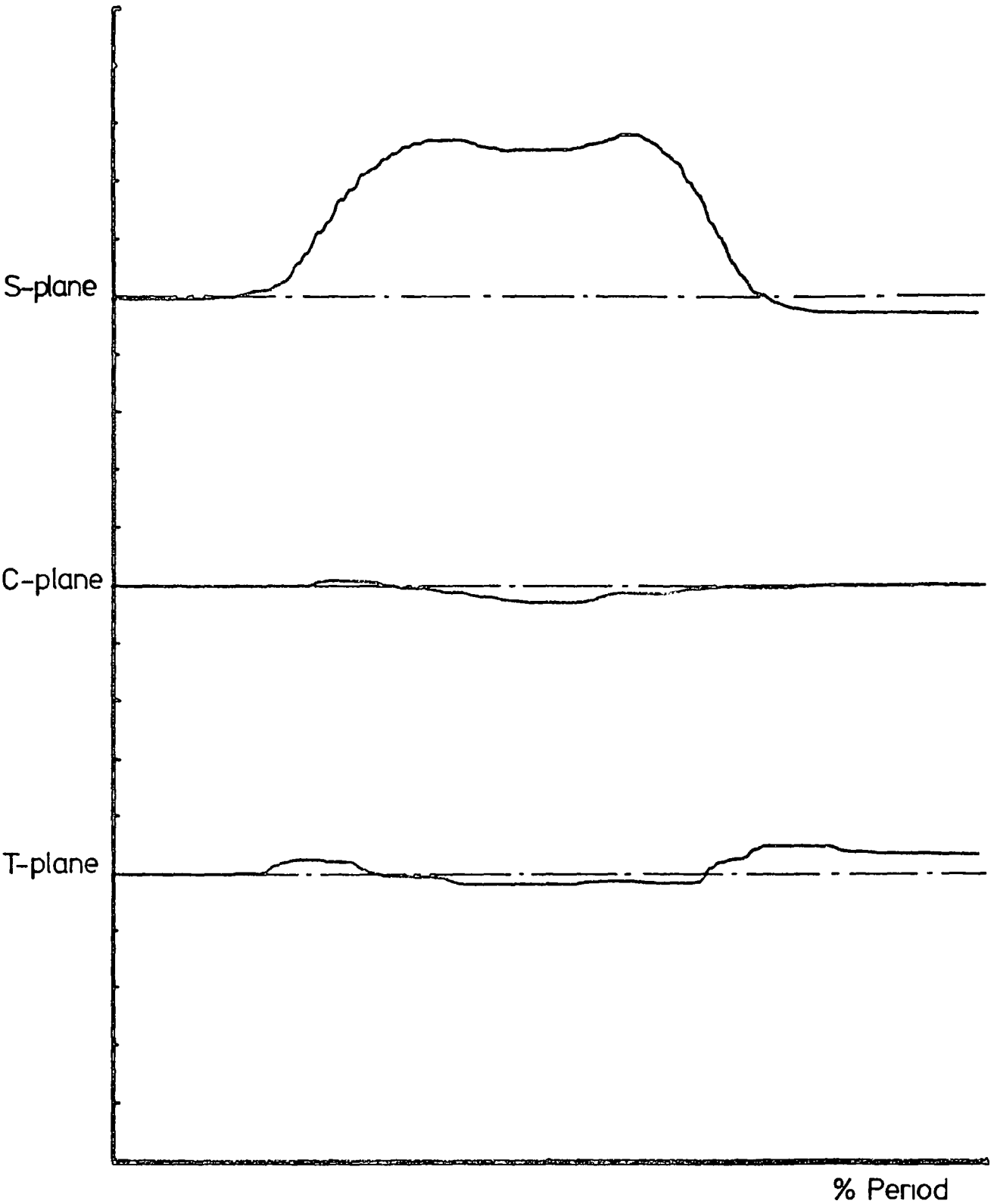
These two groups show highly significant differences in C O M for rotations in all planes, (test 1, statistics D, E, F and G, Tables SD3(F) and SD1(F)), but marked similarities, especially in the sagittal and transverse planes, in R.O M and P.O M. In the sagittal plane this similarity exists despite the 3.5° reduction in R O M. for the senior group, this variation in R O.M. changing the P.O.M over only a small length of the curve In the coronal plane the the rotations of group 3 are more similar to those of group 1 for P.O M , Figs 50f and 52f, the magnitude of the peaks being more closely matched This is reflected in the figures, tests 2 and 3, statistics D, E, F and G

7.9.4 Comparison Groups 3 and 4 (F)

Test 3 statistic G (Table SD4(F)) shows that these traces possess a high degree of similarity in R O M and P O.M for all planes, but there are variations in C O M greatest in the transverse plane (Table SD1(F)) There also exists a 2.9° increase in R O M in the transverse plane for the senior group This increase occurs during the excursion into internal rotation during the stance phase

7.9.5 Synopsis of descending stairs (female)

Examination of the SD(F) tables reveals that the differences existing between consecutive groups for



NAME		♀			
NO	FILE		FLEX	ABD	EXROT
EXERCISE	SITTING	POLARITY	↑	↑	↑
LEFT ✓	RIGHT	SCALE%cm	10	5	5

NOTES

Figure 62 Sitting and Standing, female

GROUP	MEAN RANGE, DEG'S			STANDARD DEVIATION			FOR S-PLANE ONLY	
	S	C	T	S	C	T	t	P
1	61.6	5.6	7.3	9.85	2.24	5.02		
2	63.7	5.4	8.6	5.62	1.78	4.35	0.590	0.57
3	60.9	5.0	10.5	5.14	3.25	4.00	1.098	0.30
4	64.2	5.7	14.2	8.82	2.11	5.69	0.941	0.37

S=Sagittal plane, C=Coronal plane, T=Transverse plane, in degrees.

SS(F) ANALYSIS OF SITTING AND STANDING, FEMALE

R O M and P O M are not significant beyond the level $p = 0.15$ for movements in any plane. There are, however, very significant variations in C O M in all planes for all groups, with the exception of flexion groups 1/2 (Table SD2(F), statistic G, $p = 0.06$)

No age related trends exist for movements in any plane for the C O M parameter, but trends are difficult to establish with only four groups being considered. In all planes a pattern of progression is held by three groups, but the remaining group, which may appear anywhere in the series, does not hold this progression. The previous statement also holds when R O M is considered in the sagittal and coronal planes, but there is a trend in R O M held throughout all groups for transverse plane rotations. This exists as a progressive increase in R O M in the transverse plane, with increasing age.

A trend becoming apparent, but not substantiated as significant, is a progressive decrease in the area parameter with increasing age. There is a small reversal in this trend for group 4, but for this group the standard deviation in the area parameter is quite large.

7 10 Sitting down on and rising from a chair female results

Fig 62 shows a typical plot obtained by measuring the hip movements of a woman while sitting then standing. As can be seen by comparing this result with Fig 44, the male equivalent, there is little difference between the two, remembering that the timing of the exercise is

not controlled

For a complete description of this exercise the reader is referred to section 7.5

The only difference between male and female movements for this exercise was that the women tended to keep their knees closer together, and not relax into abduction. Examination of Table SS(F) shows an increase in coronal plane R O M of about 1° when the women's and men's results are compared. This increase occurs mainly on the adduction side of the movement range.

Sagittal plane rotations seem to be very similar to those for men, whereas transverse plane rotations show a progressive increase in the R O M used.

7.11 The global range test - female

The inadequacies of this test were outlined in section 7.6, and are equally applicable to the female results. In depth analysis of the female results was also considered to be inappropriate.

7.12 Comparison of male and female hip kinematics

A question often put to the author is, "Do women walk differently from men?"

Although a complete comparison of this nature is considered inappropriate in this particular investigation (it would add at least another twenty pages to this report), having collected the necessary data, the author is in a position to make some comment on the subject.

For the exercises of walking, climbing and descending stairs three parameters will be considered briefly, namely C O M , R O M and the area parameter. It should be understood that the basic patterns of movement observed with the characteristic features for each exercise are broadly similar for both men and women, as has been previously noted.

Firstly, considering ambulation, Tables A1(M) and A1(F), the ranges of movement used by the male sample are almost everywhere larger than the ranges used by the female sample. The exceptions are abduction and rotation in group 4. This difference in range is by no means a newly discovered fact, and is generally attributed to sociological differences, as there seems to be no physiological reasons for such a difference. Although the women tested wore much the same clothing as the men, (i.e. the vast majority of women tested wore trousers) a major difference was noted in the type of footwear worn. The women tended to walk in shoes with heel heights seldom below 50 mm, whereas the men wore shoes with heel heights seldom above 25 mm. A high heel is a source of instability during the initial load transfer immediately after heel-strike, with the result that the wearer places the foot such that the period of single point support on the heel is much reduced, if not eliminated. To accomplish this for a given heel height and a comfortable amount of plantar-flexion the range of hip flexion is limited. A

compression in the sagittal plane results in a compression in range in the other two planes also

If the corresponding C O M 's are compared for the first 4 groups little of significance can be noted. No trends are apparent in the coronal and transverse planes though in the sagittal plane there is a greater variability in the male results. The younger men walk with a more upright stance than their female counterparts.

The area parameter is greater for all the male groups, as might be expected, but the difference is very small for group 4 due to the 0.5 degree greater range in the coronal plane for the female group.

The exercises on the stairs, where the movement patterns are far more regulated, show that the ranges of movement used are consequently more similar (Tables S U 1 (M), S U 1 (F), and S D 1 (F) and S.D 1(M)). However, differences do appear to get larger with increasing age. The male groups 3 and 4 use more flexion and abduction than their female counterparts. Interestingly, the differences between the sexes change sign between groups two and three for sagittal and coronal rotations, for both exercises. This relationship almost holds for transverse rotations too.

The younger males appear to maintain their more upright stance whilst descending stairs, but not whilst ascending.

For ascending stairs, the area parameter is always

larger for the male groups, but not significantly so. For descending stairs the males appear to show an increase in the area parameter with increasing age whilst the females show a decrease. The difference between the groups again changes sign between groups 2 and 3.

Comparing the sitting and standing ranges (Tables SS(M) and SS(F)) for sagittal plane rotations the difference in range between the sexes again changes sign between groups 2 and 3. The range of rotation used in the coronal plane is greater in all the female groups. This is due to the women moving their knees together as they sit down, as previously mentioned.

Overall then, "do women walk differently from men?" The answer is "not very much", and generalising broadly "they use a smaller range of movement".

8 ANALYSIS AND DISCUSSION OF PATHOLOGICAL RESULTS

8 1 Introduction

Results presented in this section are from data gathered from patients of the Hartlepool Accident Hospital selected by Mr M Flynn, F R C S , consultant orthopaedic surgeon. The author wishes to record his gratitude for the help and guidance of Mr. Flynn during the early part of this project.

The patients tested suffered from a variety of pathologies of the hip, but were mainly people suffering from osteo-arthrosis. During the course of the project, a number of interesting cases appeared, and these people were also tested. As the emphasis of this part of the project was to be placed on the analysis of osteo-arthrotic gait, this will be examined in some considerable detail, followed by a brief discussion on some of the other interesting cases.

It became clear at an early stage in the examination of pathological gaits that each case had to be treated individually, and that for the patients considered, grouping into sets could not be done because any rigid classification could not be justified. The results presented are those judged to be typical of various stages of pathological involvement. Four sets are considered commencing at early diagnosed osteo-arthrosis and progressing through to a case of severe osteo-arthrosis. Radiographs were available for patients

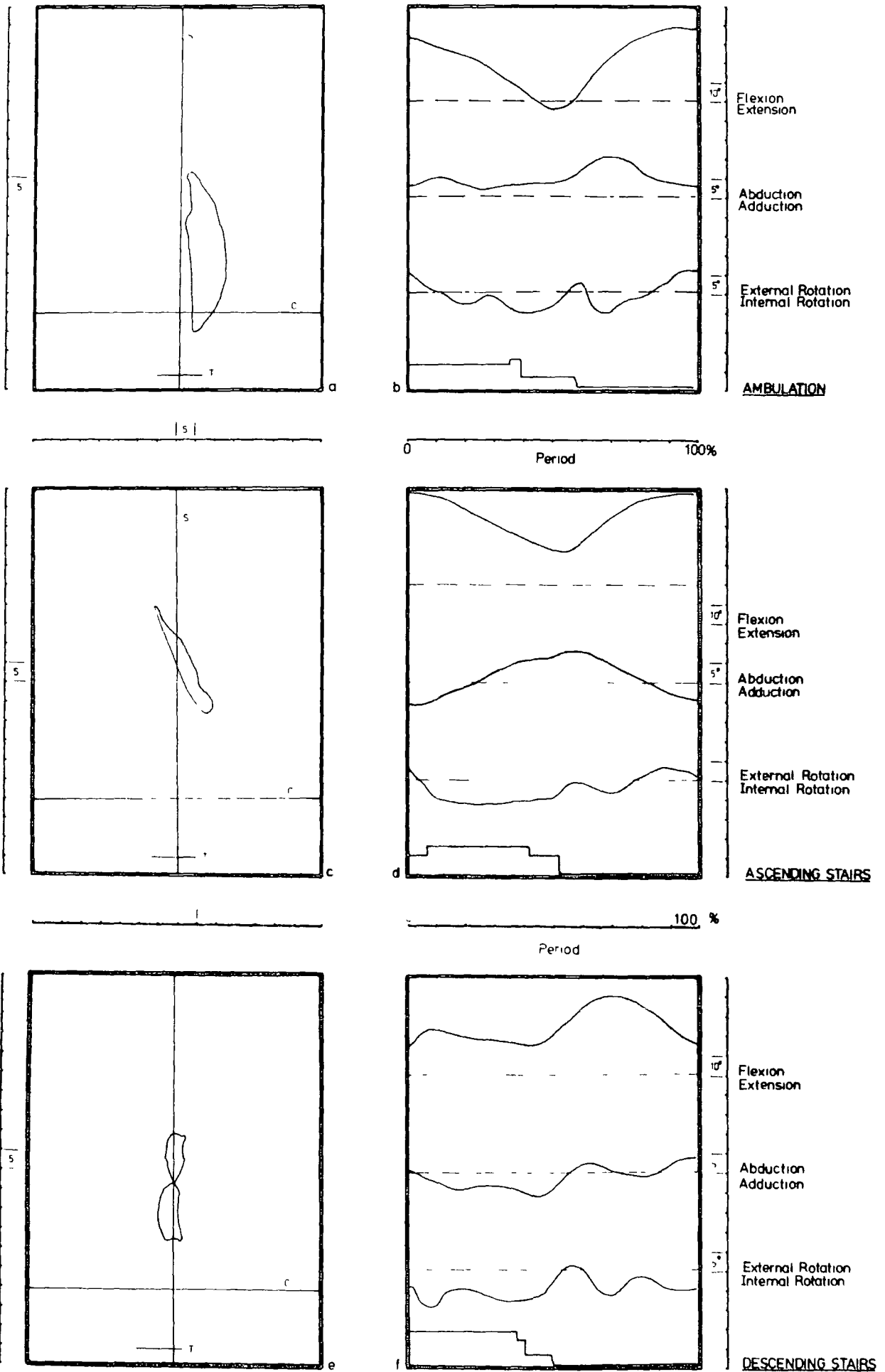


Figure 53 Patient 1

2 and 4 and are presented as Plates (4a) and (4b). Patients 1 and 2 are male and patients 3 and 4 female. Their results are presented in the same format as that used for the normal groups and so direct comparisons should be possible.

8.2 Discussion of patient 1

At the time of examination patient 1 was aged 54 years, weighed 750 N, and stood 1.675 m tall. He worked as a boiler maker and suffered pain in the right thigh after prolonged activity. He was diagnosed as having osteo-arthrosis of the right hip. There were no fixed rotations present in this hip.

8.2.1 Patient 1 · level walking

Referring to Fig 63b this patient still retains most of the features of a normal gait pattern, but the shapes of the curves are beginning to change.

Sagittal plane rotations are substantially normal, the patient demonstrating a normal range of 42° and a normal pattern of movement.

Coronal plane rotations are slightly reduced in magnitude from the normal range of 8.2° to around 7.9° which is hardly significant, but a more important change is the variation in P O M from the normal, the peaks becoming broader and flatter.

In the transverse plane the patient retains the characteristic peak into external rotation at toe-off, but this region of the curve has undergone a shift into internal rotation. The R O M. in this plane is 12° .

compared with the normal range of 89° . The level of external rotation at heelstrike is a sign that this patient is already beginning to swivel on the hip, internally rotating during the stance phase and externally rotating during the swing phase of gait.

8.2.2 Patient 1 ascending stairs

The notable point about these curves (Fig. 63d) is that the range of flexion used to negotiate the stairs has been reduced by approximately 15° . The normal range used is in the region of 45° , but this patient manages with only 30° . This loss of flexion at the hip is accommodated by increasing the R.O.M. in flexion at the knee. The basic P.O.M. is however quite normal.

Coronal plane rotations are similar to those used by healthy people in both pattern and range.

This patient again demonstrates the beginnings of a swivelling action in the transverse plane

8.2.3 Patient 1 descending stairs

For this exercise, rotations in the coronal and sagittal planes exhibit basically normal patterns of movement, but they are somewhat extended in range. In the sagittal plane 27° R.O.M. is used, and in the coronal plane 10° R.O.M. The normal ranges are 23° and 67° respectively, with centred standard deviations of around 15° . In the sagittal plane the extra range is due to further flexion during the swing phase, and in the coronal plane the extra range is due to increased

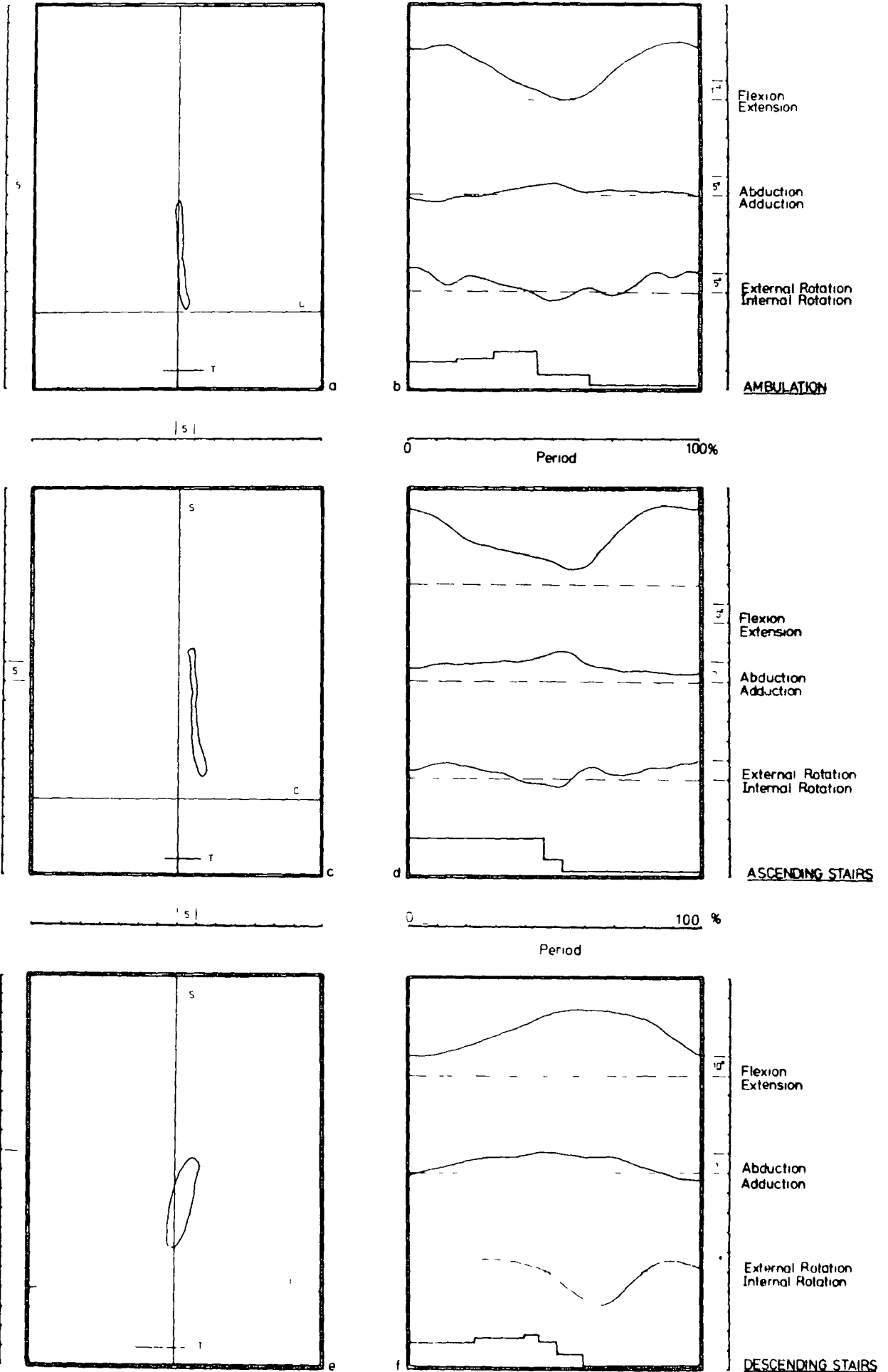


Figure 64 Patient 2

1

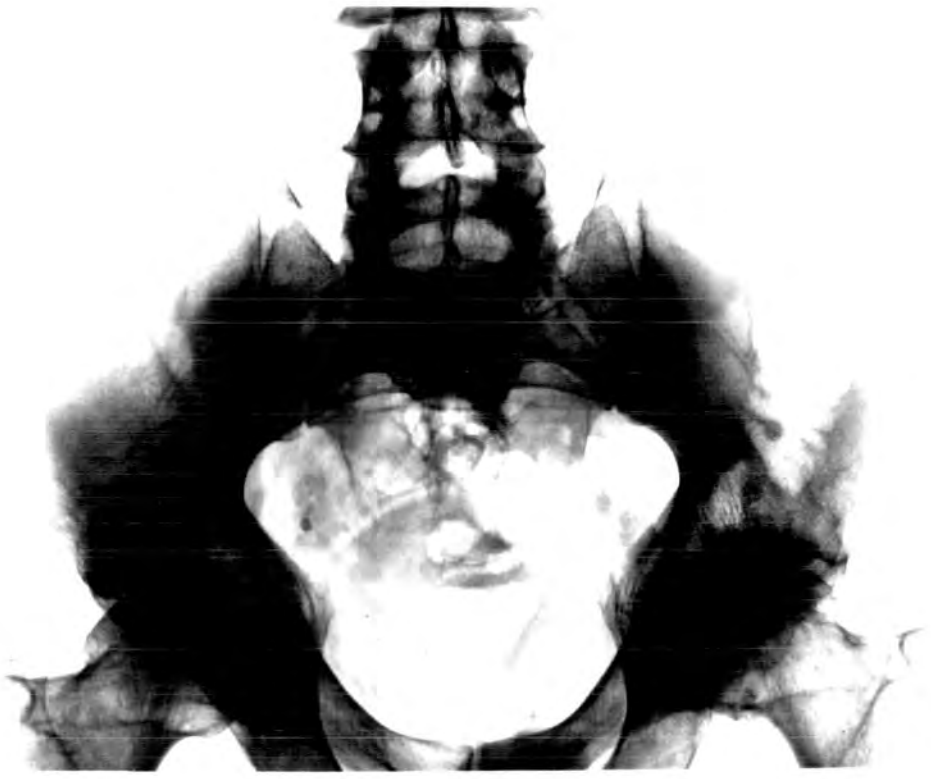


Plate 4a : Patient 2



Patient 4b : Patient 4

pelvic tilt around toe-off

Transverse plane rotations resemble those of walking rather than the usual pattern which bears a likeness to the inverted flexion pattern, but the group 4 normal results were notably flat, and rotations in this plane are highly variable between individuals

8 2 4 Patient 1 sitting and standing

This patient had no problems accomplishing this exercise, but like all arthritics had to change position, he could not sit down comfortably with his feet together and toes pointing forwards. He completed the exercise by abducting and externally rotating at the hip. The range of movement used was 50° , 15° , and 28° for flexion, abduction, and rotation respectively. This varies substantially from the normal (ref. Table SS(M) and Fig 66c).

8 3 Discussion of patient 2

At the time of examination patient 2 was aged 56 years, weighed 665 N, and stood 1.715 m tall. He complained of pain while negotiating stairs. He was diagnosed as having osteoarthritis of the left hip and was treated with physiotherapy. He had a mild flexion contracture of the left hip of approximately 15° . For radiograph, refer to plate 4a. There is a loss of congruity and a reduction in joint space in the left hip.

8.3 1 Patient 2 ambulation

The ambulation records from this patient show the onset of a typical decline into total immobility associated

with extreme osteoarthrosis. This patient was examined at a stage when he still had adequate mobility, but was beginning to feel significant restrictions

In the sagittal plane, this patient's movements are confined totally to the flexion region. Although a flexion contracture is present at a low level, he much prefers to move in a range centred rather higher than this. Due to the manner in which the zero point is measured this patient shows the highest level of C.O.M., as associated with flexion contractures. For patients 3 and 4, the zero points measured by the goniometer were far from anatomical zero, and were located well into the flexion zone, but this is not shown on the computer graphics, as these indicate movements relative to the patient's stance position, if not corrected.

This patient's P O M in the sagittal plane is still notably similar to normal, but the range is much reduced. R O M. in the sagittal plane for this patient is 30° , Fig 64b

In the coronal plane the movements used are reduced in magnitude, and the pattern changed. R.O.M is around 5° , with the reduction occurring mainly from the abduction region. The peaks on the trace are flattened and broadened to a progressively larger extent

Transverse plane rotations show a marked reduction in the peak to external rotation at toe-off which is such a feature of normal ambulation. A pattern of movement initiated in external rotation at heelstrike and

progressing through internal rotation at toe-off and reverting again to external rotation is beginning to take precedence as the patient begins to rely more on a swivelling action to promote forward progression.

8.3 2 Patient 2 ascending stairs

For this exercise, the most noticeable feature is the dramatic reduction in movements in the coronal plane. From a normal range of around 14° this patient exhibits only 5° of movement. The P.O M. is similar to normal in that the wave form has only one peak (into abduction at toe-off) but for this patient the peak is shorter and sharper, (see Fig 64d).

In the sagittal plane, there is evidence of a plateau appearing in the movement curve during mid-stance. This hesitation is probably due to pain during this part of the cycle, where joint loadings are high. The range of movement in this plane is about 32° .

Little can be said about transverse rotations, due to the variability found between healthy subjects. The R.O M. is 7° which is slightly less than normal. The P O M shows an inversion of the curve during the stance phase, which suggests again that the patient is employing a swivelling action.

8.3 3 Patient 2 descending stairs

It is in this exercise that patients first feel an inability to cope. The patient begins to recognise his physical limitations and fears a disaster such as

falling forward down stairs. The result is that such obstacles are treated with some considerable apprehension, which is reflected in their movement patterns, and they seek further support by utilising handrails if available.

Examining this patient's hip rotations in the sagittal plane, a quite marked change in P O M can be seen. The peak into flexion during the swing phase is much broader, and has a flatter approach. This corresponds to a lengthening of the stance phase of the cycle, and a slower move into flexion as loading on the pathological hip is reduced by transferring it to a handrail. The R O M in this plane remains within normal limits.

The P O.M in the coronal plane has changed, until it has been reduced to a simple swaying action as the centre of gravity is tilted from one side to the other. The R O M used in this plane is similar to that used by healthy people.

Movements in the transverse plane have a pattern similar to that used by many healthy people, but the R O M is increased to compensate for the variance from normal pattern in the other planes. See Fig 64f

8.3 4 Patient 2 sitting and standing

This patient's movement patterns for this exercise are difficult to distinguish from normal, but he used hand supports to lower himself onto the chair. This patient seemed to have remarkable freedom of movement

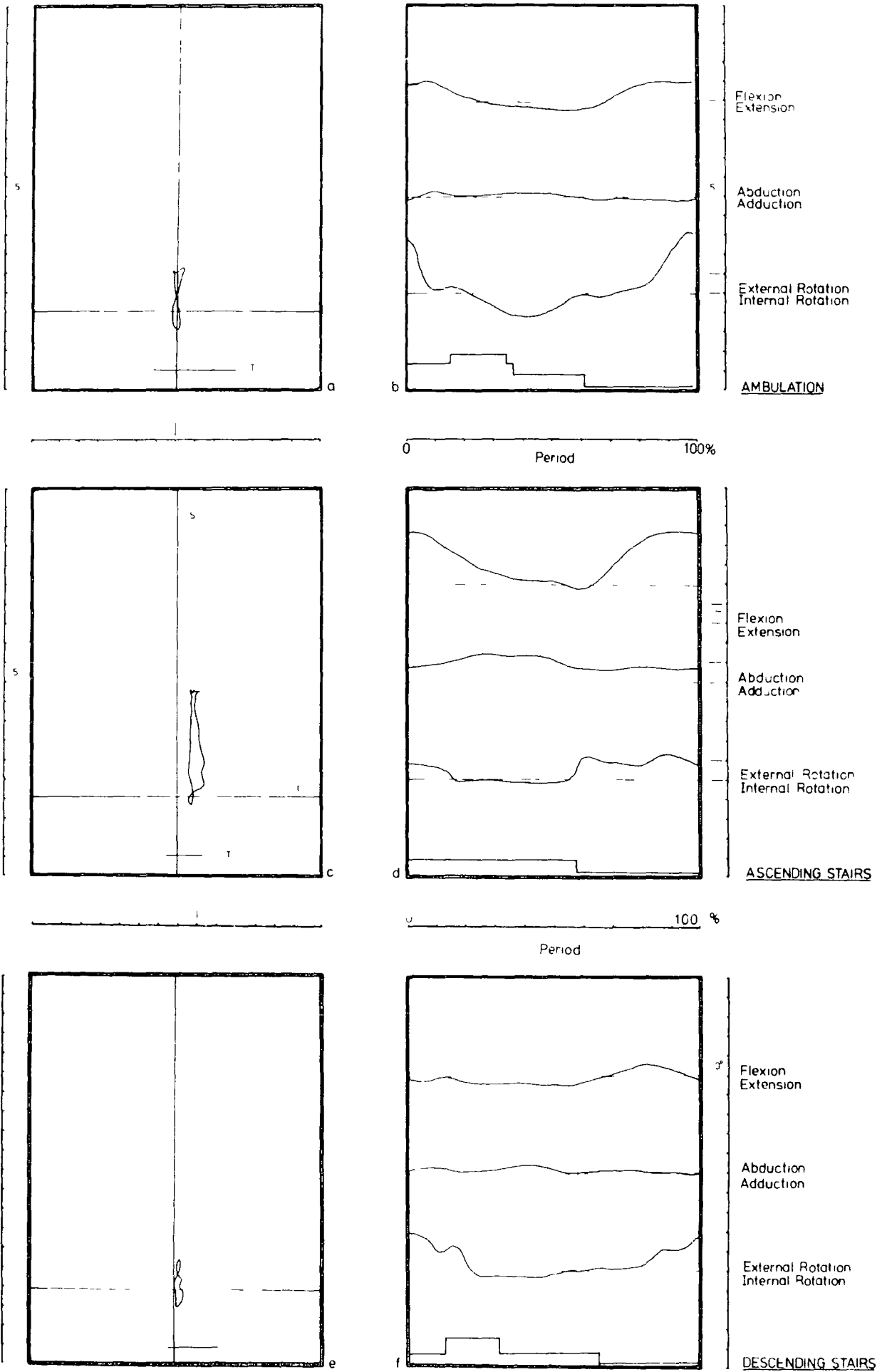


Figure 65 Patient 3

until the joint was loaded, when the resulting pain caused him to restrict his more athletic activities, with corresponding restraints appearing in his movement patterns, Fig 66d

8 4 Discussion of patient 3

At the time of examination patient 3 was aged 50 years, weighed 820 N, and stood 1 748 m tall. She worked as a probation officer, and complained of pain in both thighs and hips. She was diagnosed as having osteoarthritic hips and was treated by the physiotherapy department, and entered on the waiting list for bilateral low friction arthroplasty Her left hip was examined, in which there was found to be a flexion contracture of 25° and an external rotation contracture of 15° The left hip was the more severely affected of the two

8 4 1 Patient 3 ambulation

The patterns of movement shown in Fig 65 are those of a person heavily restricted by advanced osteoarthrosis, and classically demonstrate the movement patterns used by people with such a handicap

This patient shows a further degeneration of movement in the sagittal plane until the total range used in walking is only 15° Even with such a small range of movement the basic pattern remains the same as for all flexion traces previously mentioned.

Movements in the coronal plane have virtually

ceased to exist, the total amount measureable during walking being only 25°

Transverse rotations however have far from ceased. They have now completely undergone the changes shown to be developing in patients 1 and 2, and show a pattern radically changed from normal, with a quite extensive range. The total range used is 21° , 15° in external rotation and 6° in internal rotation. This pattern of transverse rotations is the key to the ambulatory mechanism employed by people suffering from advanced osteo-arthrosis.

Using short steps only the patient places one foot ahead of the other by swivelling at the hips. Weight is transferred by tilting the whole body and the contralateral limb is swung forward by swivelling on the other hip. Hence the virtually sinusoidal gait pattern at cycle frequency for transverse plane rotations.

8.4.2 Patient 3 ascending stairs

For a patient suffering from advanced osteo-arthrosis a staircase epitomises pain and fear, and is an obstacle to be avoided if at all possible. This patient volunteered to attempt the stairs but it was not without considerable pain and apprehension. However, she did manage extremely well considering her condition.

The movement patterns used by this patient bear a very close resemblance to those used by patient 2, and the ranges involved are also markedly similar. To avoid

unnecessary repetition the reader is referred to section 8 3 2 for a full description. This patient also used the hand rail for support. The movement patterns for this exercise are shown in Fig 65d

8 4 3 Patient 3 descending stairs

Patient 3 managed to descend the stairs using only small levels of hip excursion. Movements were transferred to the knees as far as possible, with further compensation by tilting the body and swivelling at the hips. The handrail was used to assist balancing.

Sagittal plane rotations show a fairly normal sort of pattern although the range is reduced to approximately half the normal R.O M, see Fig 65f.

Coronal plane rotations are virtually absent, only a 2.5° range being measured.

Some evidence of swivelling can be found at the hip in the transverse plane, but a significant amount of rotation is achieved by spinning on the ball of the foot. This patient exhibits quite a lengthy stance phase for this exercise, extending to 70% of period.

8 4 4 Patient 3 sitting and standing

Patient 3 accomplished this exercise by lowering herself down with her hands, and keeping the hip comparatively immobile in the coronal and transverse planes. A range of 40° of flexion was used in the sagittal plane. Her movements during this exercise are shown in Fig 66e.

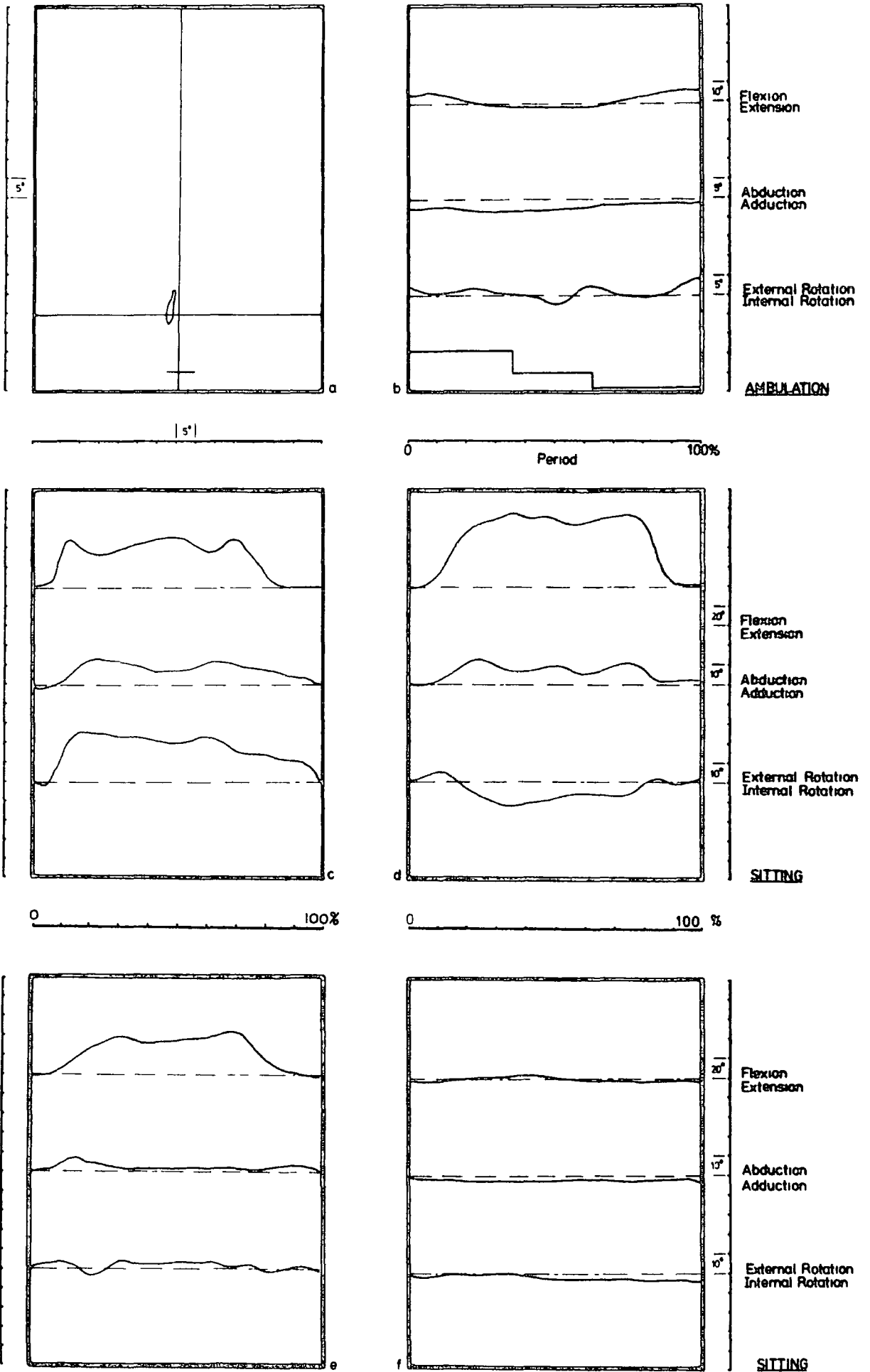


Figure 66 Patient 4 a,b. Patients 1 to 4 sitting and standing, c to f

8 5 Discussion of patient 4

Patient 4 at the time of examination was a 65 year old housewife who weighed 665 N and stood 1 606 m tall. She was diagnosed as having bilateral osteoarthritis of the hips with severe involvement of the left joint. This hip was very painful and she relied heavily on the contralateral joint. When walking she kept the left hip virtually immobile and progressed using the right limb only. She could climb and descend stairs but used only the right limb, putting both feet on each step. She was happier descending stairs backwards. Exercises on the stairs were measured, but are not presented as virtually no movements occurred, as one might expect.

8 5 1 Patient 4 Ambulation

Figs 66a and b show the movement patterns of a seriously affected joint rendered virtually immobile by severe osteoarthritis.

Sagittal plane movements have a range of 10° , and coronal plane movements a range of 2.5° . The movements in the transverse plane amount to 7.5° , a range accomplished during a small peak to external rotation at toe-off. There is less movement measurable in this hip than the "fused" hip referred to in section 6 3. One must remember though that this patient's hip was very painful and she was minimising loading as far as possible.

8 5 2 Patient 4 sitting and standing

As can be seen from the plot (Fig. 66f) this patient used virtually no movement at all in the left hip. She managed to sit down by lowering herself on to the chair keeping her left leg stiff. By utilising the flexibility in the lumbar spine, and the right hip, she could sit quite comfortably on the edge of her chair. Standing up was a problem, but she managed using her right leg and both arms.

8 6 Summary of movement degeneration due to osteoarthrosis

Although no one patient could be followed through from the early stages of osteoarthrosis of the hip to the level of a severe involvement, the four patients discussed above show the typical degeneration from a minor disability to a severe handicap.

The progressive decline alters the movement patterns in the following way

In the early stages the patient feels no major disability, but soon begins to equate pain with movement, resulting in a reduction of his movement range for normal activities. This, for a male patient, would be a reduction in his gait range, through the slightly smaller female ranges, until the patterns of movement produced begin to flatten out. Although the major loss in range is from the sagittal plane (because it is the largest range) the losses from the coronal plane range are a greater proportion of total R.O.M. during

the early stages. Movements in this plane are seriously reduced and a patient producing a flat P O M in this plane with little range can be suspected of having a degenerative pathology of the hip.

As the R O M. diminishes in the sagittal and coronal planes, the pattern of movement in the transverse plane undergoes a progressive change and an increase in range. A swivel walking technique begins to evolve, presumably because the patient finds this less painful, if somewhat more tedious and inefficient. As the level of involvement reaches the advanced stage, movement in the coronal plane virtually disappears and forward progression is purely by the rocking and swivelling technique. Eventually, the joint space collapses totally and geometric changes take place in the joint, and by the time the patient has declined to a severe osteoarthrosis functional movements of the joint have virtually ceased.

This would be a typical case history. However, the time scale from first diagnosis to severe involvement varies greatly. In the authors somewhat limited experience it can cover a span from 18 months to 6 years.

8.7 Discussion of interesting cases

A number of interesting cases appeared during the course of the investigation into arthritic movement patterns. These included a number of patients who had undergone surgery. Patient 5, when first examined by the author had a prosthetic left hip, and was about to

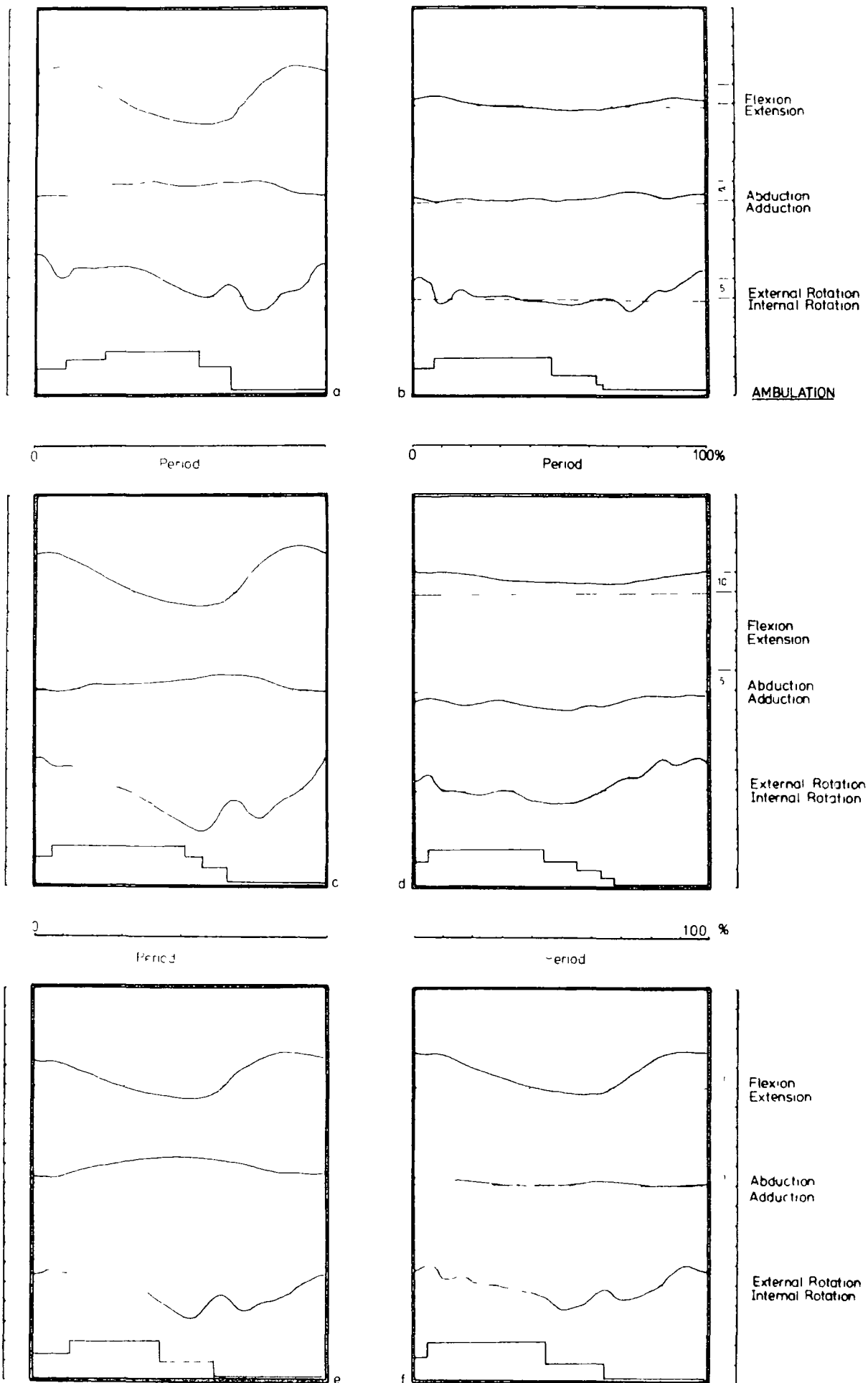


Figure 67 Patient 5

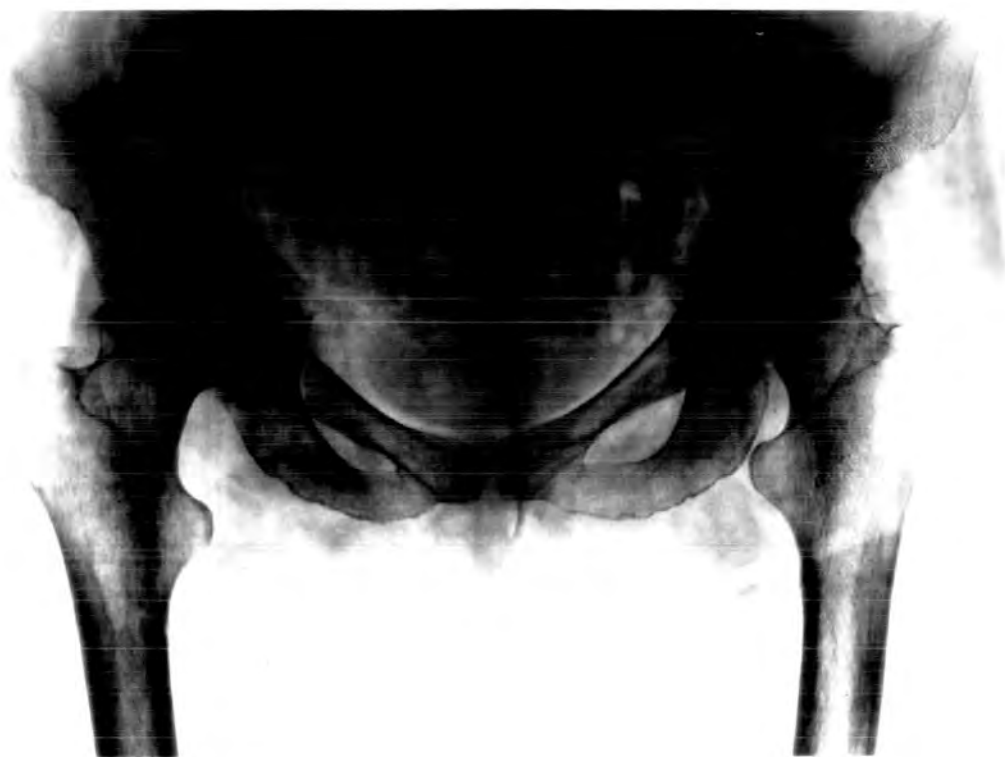


Plate 5a : Patient 5



Plate 5b : Right Prosthesis



Plate 5c : Left Prosthesis

be admitted for a right hip arthroplasty Patient 6 had had an osteotomy of the left hip in 1967, and a McKee arthroplasty of the right hip in 1971. He was undergoing physiotherapy for recurrent pain in the left hip when examined in September 1977 Patient 7 had a bilateral congenital dislocation of the hips, and had been admitted for treatment when examined Each of these patients is discussed with reference to normal and arthritic gait patterns.

8 7 1 Patient 5 Bilateral Charnley Arthroplasty

At the time of first examination this patient was aged 72 years, weighed 665 N, and stood 1 67 m tall. She was examined on the 8 August 1977, having been admitted for a right hip arthroplasty The left hip had been replaced in May 1976. She was re-examined 9 days later after bed rest and physiotherapy, immediately prior to her second operation This patient was examined a third time on 5 December 1977 when she could walk reasonably well, but used a stick on the left side. Both hips were examined each time, and the results for walking are presented in Fig. 67, the earliest being the top pair (left and right) and the latest being the bottom pair of traces.

The first trace shows the left hip results, and demonstrates the movement available using a Charnley arthroplasty This pattern resembles those produced by patients in the second stage of osteo-arthrosis The range of movement are 30° in the sagittal plane,

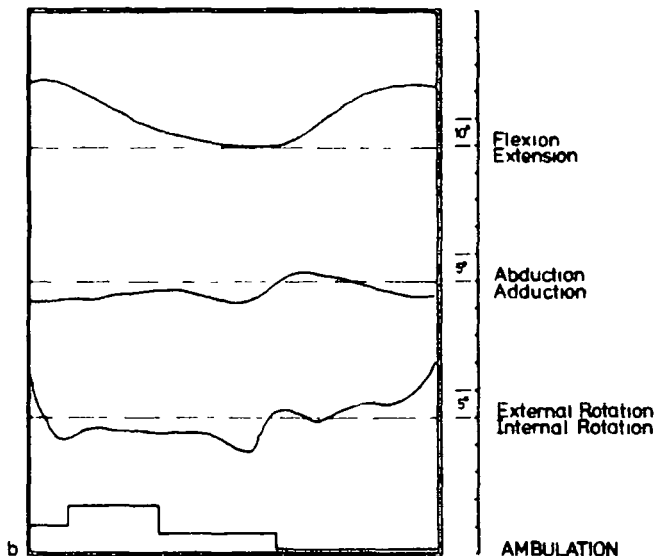
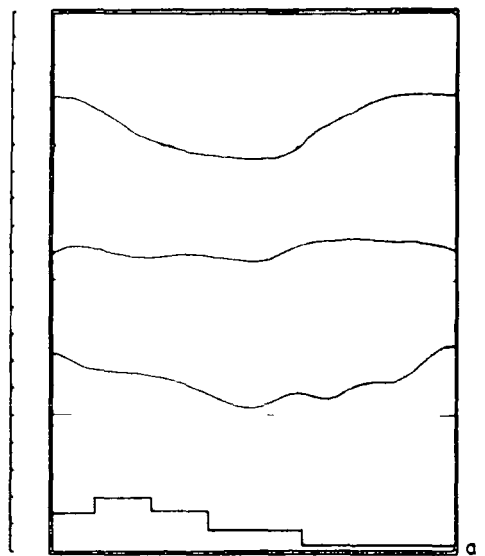
6° in the coronal plane, and 15° in the transverse plane. This patient used a swivelling technique to progress due to the extreme level of osteo-arthrosis in the right hip (See plate 5a, this radiograph was taken prior to the first operation). Movement in the right hip has been reduced to less than 8° in the sagittal plane, 25° in the coronal plane, and 11° in the transverse plane. The right hip was very painful, but the left pain free. This patient could not negotiate a stairway.

The middle pair of results were produced 9 days later, after bed rest and physiotherapy. The P.O.M.'s are much the same with only a slight change around toe-off for transverse plane rotations. The ranges of movement here are 30°, 5°, and 20° for sagittal, coronal and transverse plane rotations respectively, for the left (Charnley) hip. The right hip was still very stiff, but there was a small increase in R.O.M. The movement ranges for this hip were 8°, 4° and 12° for the sagittal, coronal and transverse planes respectively.

By the time the third examination was conducted, the patient had shown considerable improvement and was walking satisfactorily on two pain-free prostheses. The patient was still improving rapidly and could look forward to an almost normal gait. During this examination she used a stick for additional balance, which she held in her left hand. She had had only

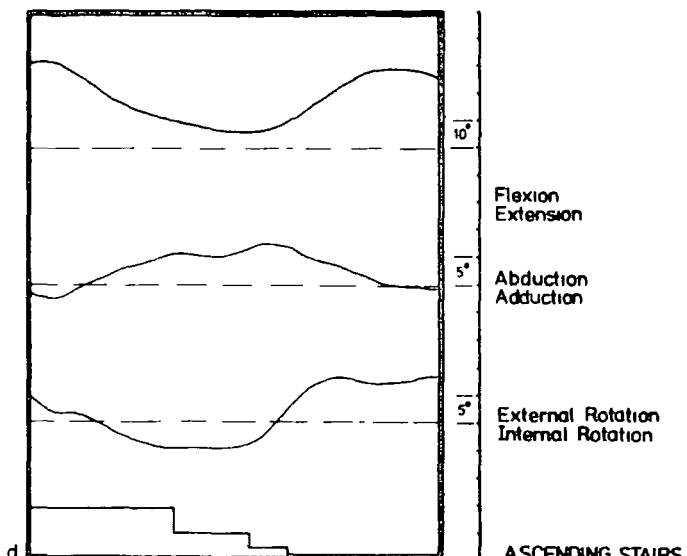
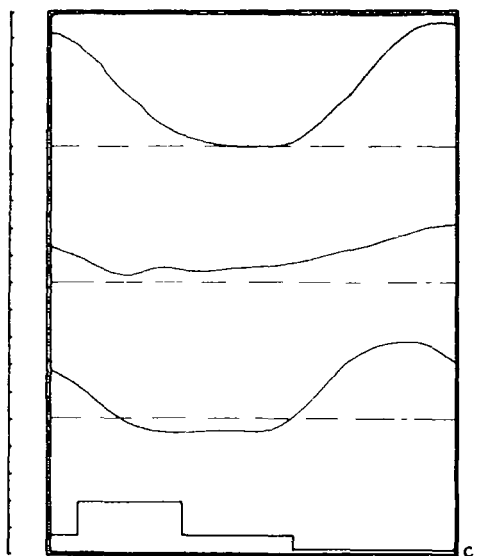
LEFT

RIGHT



0 Period 100%

0 Period 100%



0 Period 50%

0 Period 100 %

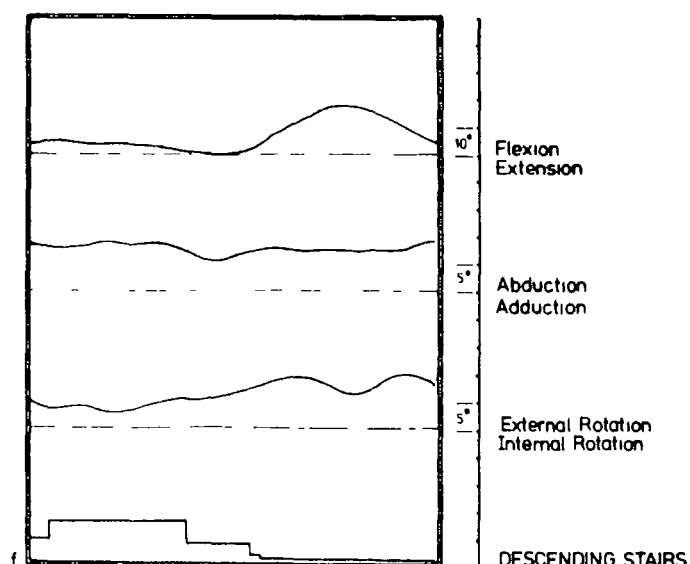
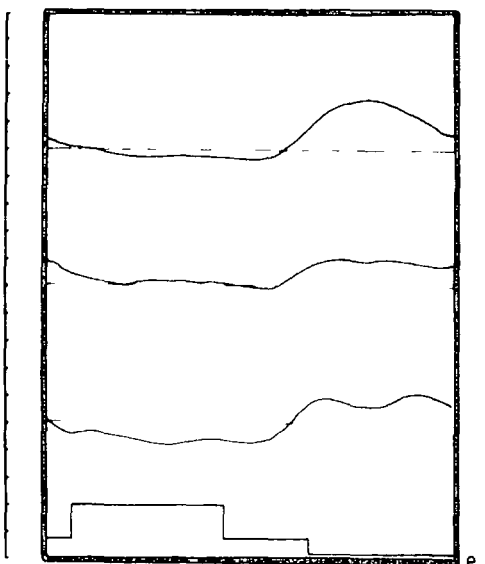


Figure 68 Patient 6



Plate 6a : Patient 6

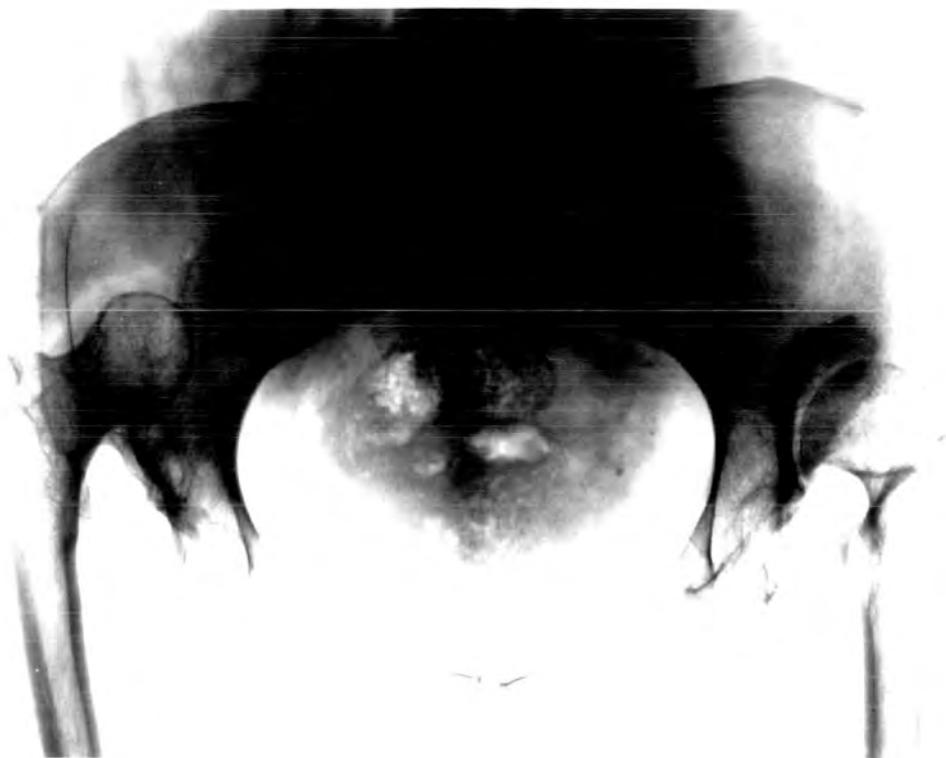


Plate 6b : Patient 7

minor physiotherapy while in hospital, and none after discharge

It can be seen from the third set of traces that the left and right movement patterns are far better balanced. She was using 24° of rotation in the sagittal plane for both hips. The coronal plane rotations are interesting. The patient had gained a level of confidence in her left hip that she had not yet attained for her right. The left hip was taking full abductor loads and coronal plane range was 6° . The right hip however, shows virtually no movement, only 2.5° , because the centre of gravity has not been moved over to the right due to lack of confidence in her ability to maintain a supportive abductor force. The necessary equilibrium force is provided through the stick in her left hand. The levels of rotation are beginning to subside as a more normal gait pattern begins to take over.

At 4 months after the second operation it appears that this woman's recovery to efficient ambulation could be speeded by physiotherapy, especially to the abductors, concentrating mainly on the right hip.

Plates 5b and 5c are radiographs of the implanted prostheses.

8.7.2 Patient 6 Osteotomy and McKee Arthroplasty

The author examined this patient in September 1977 when he was 73 years old, weighed 745 N and stood 1.65 m tall. He had undergone an osteotomy of the left

hip in 1967 and had a McKee total hip replacement (right hip) in 1971. He had presented himself because of recurrent pain in the left hip, and lumbar spine, although he still had substantial pain free periods. He wore a lumbar support belt. The radiograph shown (plate 6a) was taken in May 1976. On the day of examination he was comparatively pain free. The results of his movement analysis are shown in Fig. 68. Taking the left side first, his patterns of movement, are, on the whole, satisfactory, but he does show a much reduced range in the sagittal and coronal planes, and there is evidence of swivelling in the transverse plane during ambulation.

He negotiated the stairs very well, using the handrail for secondary support. His movement patterns while descending the stairs are good, showing normal range and pattern in the sagittal and coronal planes. Transverse plane rotations cannot be considered to be far from normal.

Movement patterns while ascending the stairs varied from normal, a situation caused mainly by a deficiency in the coronal plane. Movement here was limited to 8° , just over half the normal range. To accommodate the loss of elevation due to pelvic tilt, the hip was flexed more and a greater range of rotation used, swinging from external rotation at heelstrike to internal rotation around toe-off.

His sitting and standing patterns varied little

from normal. He managed to complete this exercise with his feet and knees together, which is itself a faculty found usually only in healthy joints.

Considering now his right hip, the McKee arthroplasty, the results are shown on the right side of Fig. 68. During ambulation, it appears that he makes more use of this hip. Movements in the sagittal and coronal planes are slightly greater than in the left hip, and show patterns corresponding fairly well with normals. Although there is a peak into external rotation at toe-off there is still much evidence of a swivelling gait in this record.

Right hip movements while ascending stairs vary significantly from the movements of the left hip. He is able to utilise a range and pattern corresponding closely to normal in the coronal plane, but sagittal plane movements have diminished. In the transverse plane he is using a compensating mechanism similar to that used in the left hip.

His movements while descending stairs are slightly different from those exhibited by his left hip, but are essentially normal. There has been a slight flattening of both the coronal plane and transverse plane curves.

His results for sitting and standing point to some interesting hypotheses. The range in the sagittal plane is only 30° for the right hip, as opposed to 60° for the left hip. In the coronal plane there is

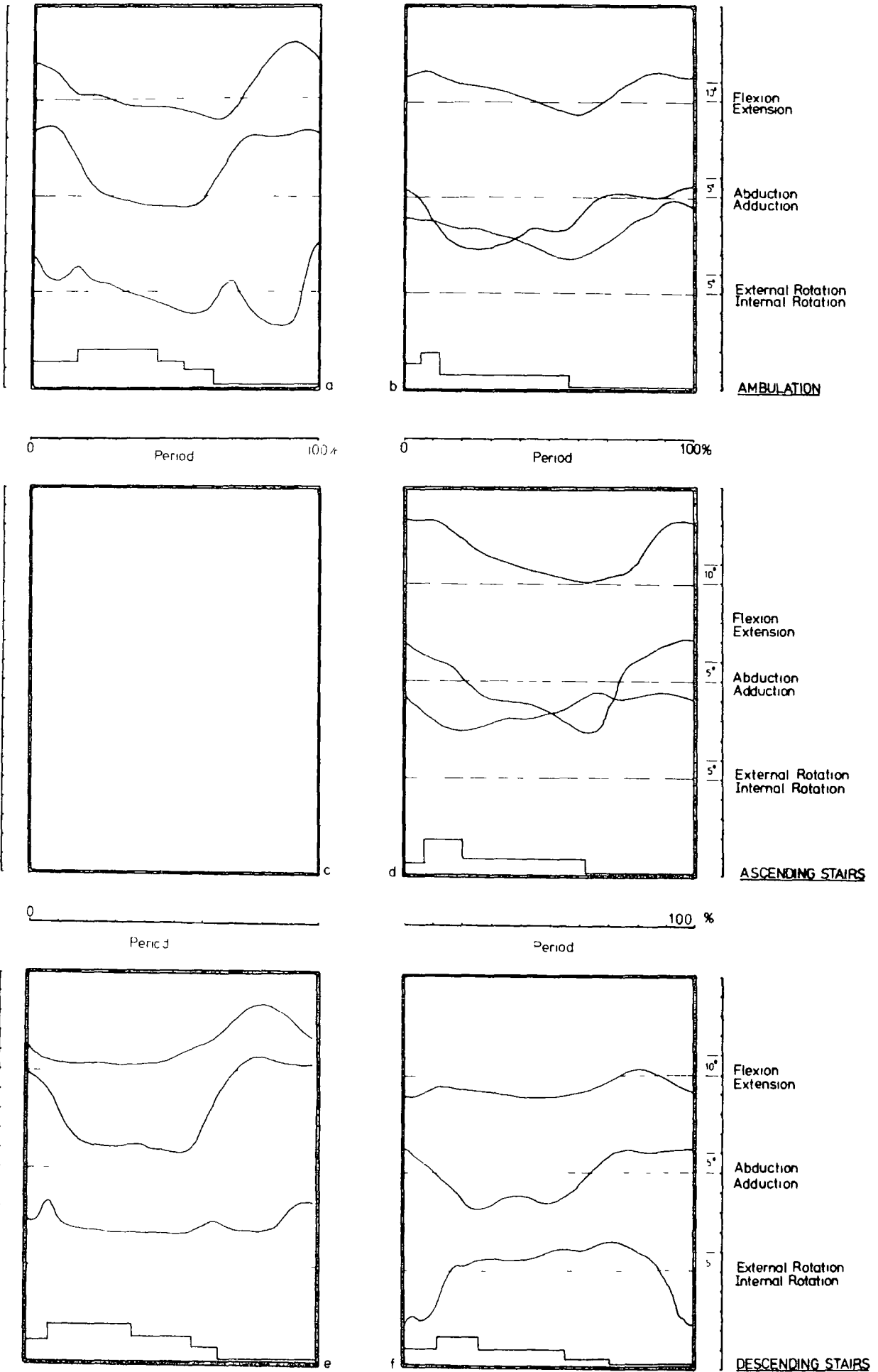


Figure 69 Patient 7

virtually no movement, but 24° are shown in the transverse plane

From these results it appears that this patient had a far greater range of movement in the left hip than the right, but that he was limited, possibly by pain or reduced muscle power, in the amount he could functionally use. The range over which he could apply a satisfactory muscular force was only a small part of the range available in the joint, particularly in the coronal plane. It cannot be discounted that this may also be due to the geometry of the osteotomy, but it is almost certain that he has his present, quite extensive, capability because of it. Although the patient seems to have only a limited amount of movement in the right hip, as evidenced by the range used in sitting and standing, he does seem to be able to generate effective forces over that range.

Considering this man's age (73 years) when tested he was still a very active man, and completely independent. At that stage the surgery performed can only be regarded as completely satisfactory.

8 7 3 Patient 7 Bilateral congenital dislocation of the hips

When this patient was admitted for treatment in December 1977, she was aged 47 years, weighed 610 N and stood 1 537 m tall. The condition of her hips can be seen from the radiograph (plate 6b). On the left side there is a false acetabulum on the iliac. It is very

shallow, and the femoral head seems to run in a slide-way approximately 20 mm long. Judging from the outline of the lesser trochanter, the left femur seems to be held in a large angle of external rotation.

There appears to be no location at all for the right femoral head in the pelvis. The original radiograph showed some evidence for the existence of a slideway on the iliac which may have been up to 70 mm long. There also appears to be a scoliosis present, but this is probably secondary to the hip condition. Her movement patterns are shown in Fig. 69.

Starting with the left hip during ambulation, one can see that the movement patterns are grossly abnormal, but nonetheless, easily explainable. The major disparity is in the coronal plane, and to explain the pattern of movement one must consider both hips, and in particular, for this trace, the anatomical position of the left hip just before heelstrike. The foot has been swung forward by flexion at the hip and knee, while holding the limb in abduction from the hip. As weight is transferred on to the left hip, the right side of the pelvis tilts downwards because there is not a fixed fulcrum about which to apply a levelling torque. This adduction continues as the centre of gravity moves over the foot, until the femoral head stops sliding and the other foot can be lifted off the ground. Although this is an adduction motion, the hip is never rotated past the stance position. The other foot is brought forward,

and weight transferred to this. An abduction motion then ensues in the left hip as the pelvis sways to the right until the right femoral head ceases to slide up the iliac, the trunk is now tilted over the supporting foot as the left limb is swung forward. Quite large amounts of transverse rotation are used during this procedure. The amount of movement used in the coronal plane seems proportional to the length of slide in the contralateral joint.

The ambulation pattern of the right hip is similar in pattern in the sagittal and coronal planes, though a smaller range is used in the latter. The C O M for transverse rotations however, is far into the external rotation region, but this can be explained as follows. When taking the zero position, at feet together, toes forward, this patient had to internally rotate at the right hip to bring this foot into line with the other, which from the radiograph, one can see to be held in quite large amounts of external rotation. With the feet in line with the direction of forward progression, the pelvis is at an oblique angle to this line with the left iliac forward. When the patient walks however, the pelvis oscillates about a position perpendicular to the direction of progression, with the right hip in line with the plane of progression, but externally rotated from the measured zero position. The external rotation of the left hip, then, is finally measured as an external rotation of the right hip!

The movement patterns for the other exercises may be explained by similar mechanisms. One must remember, however, that in such a case as this, the rotational axes are not fixed relative to the pelvis or the goniometer, so one must be very careful about the interpretation of the results.

9 CONCLUSIONS

The methods and techniques developed to measure hip joint movements have been shown to be usable for large numbers of people, in the research environment.

The necessity for security of attachment of the goniometer, and the averaging of data to eliminate minor fluctuations and produce repeatable meaningful results, cannot be overemphasised

The patterns of movement derived from normal people are the minimum movement levels required to accomplish the given exercises at the set speed. Any deviation from these patterns will tend to produce an increase in range in at least one plane

For healthy men, the ranges and patterns of movements used do not vary significantly between the ages of 18 and 74 years. For healthy women the ranges and patterns of movements used do not vary significantly between the ages of 18 and 54.

In the pathological hip, reductions in range and variation in movement pattern are first apparent in the coronal plane. As function is lost, a swivelling mechanism is employed to compensate, until in extreme cases, functional movement capacity diminishes to almost nothing

The value of a goniometer in prognosis and progress analysis has been demonstrated. Therapeutic guidelines to be employed by remedial therapists can be easily derived.

10 FUTURE WORK

It seems inevitable that research poses as many problems as it solves, but answers are usually found more rapidly if there is a continuum of ideas between successive workers

Before any more major work is attempted, it is important that the techniques used be improved in speed and efficiency

Improvements can still be made in the design of the goniometer itself. Although the girdle would be difficult to improve upon from the fixation aspect, major weight savings can still be achieved. The girdle has already been halved in weight once, and in the author's opinion it should be possible to halve it again. Weight may be reduced by machining more holes, the spherical swivels presently made from 1" diameter steel balls may be machined from H.D.P., the screw handles may be drilled out, and the screw shafts bored. The links in the transducer assembly may be drilled out, and the connecting shaft need only be tubular plastic over much of its length. The potentiometers would be difficult to improve upon.

The present design of the knee clamp leaves much to be desired. Although the swivelling trunnion assembly must remain, the stirrup itself requires a complete redesign. The screw system should be omitted and replaced by a spring clamp system. It is important

that the medial width of the device be kept to an absolute minimum. The pads themselves should be made lighter, from dished aluminium sheet for example, but they should not be reduced in diameter. The spring stirrup could possibly be made of a plastic. The footswitches would be difficult to improve upon. It is absolutely necessary to ensure that the equipment remain totally reliable, especially when used in the clinical situation.

The importance of weight reduction cannot be over emphasised. Although the bulk and weight seem negligible to a fit young person, the necessity for light weight equipment is amply illustrated when working with elderly and infirm patients. It is in this situation that a laterally balanced goniometer would ease attachment problems.

Use of parallelogram links as described by Cousins (1975) would be advantageous. They would desensitise the alignment problem and thus speed the fitting of the equipment.

Radio transmission of data would be a luxury rather than a necessity.

From the data handling and instrumentation aspect, an on-line dedicated microprocessor system, outputting direct to an X-Y plotter would give a presentation format as previously described, but would do so virtually instantly. The complexity of this modification should not be underestimated. It would however be necessary

for routine clinical work. The construction of such a system is currently being undertaken by the Department of Medical Physics, Newcastle University.

It would be desirable to consolidate the bank of normal data, but to do this effectively would require in the order of 100 volunteers per group. To delineate age related trends it would be advantageous to arrange for 6 groups, 20 to 25, 30 to 35 up to 70 to 75. The use of a "zero board" as used by Johnston and Smidt (1969) would be useful in providing a standardised starting position.

It would be interesting to use a bilateral goniometer so that both hips could be examined at once. The hypothesis that significant differences in the movement patterns of a person's hips were indicative of a pathology could then be investigated.

These few suggestions may prove helpful to future workers.

BIBLIOGRAPHY

- American Academy of Orthopaedic Surgeons (1965)
Joint Motion - Method of Measuring and Recording
(Reprinted by B O A)
- AYOUB, M A , AYOUB, M M , RAMSEY, J D (1970)
A stereometric system for measuring human motion
Human Factors 12, 6, 523-535, 1970.
- BALDWIN, J , CUNNINGHAM, K (1974) Goniometry under
attack a clinical study involving physiotherapists.
Physiotherapy Canada May 1974 Vol 26 No 2 pp 74-77.
- CANZONERI, J , PETERSON, C R , LEAVITT, L A ' (1969)
Aquisition and analysis of data obtained from an
instrumental prosthetic leg. I.E E E. Proceeding
1969, International Conference on Medicine and
Biology
- CAPPOZZO, A , LEO, T , PEDOTTI, A (1975) A general
computing method for the analysis of human
locomotion J Biomechanics 8, 307-320 (1975).
- CHAO, E Y S , RIM, K , SMIDT, G L., JOHNSTON, R J.
(1970) The application of the 4x4 matrix method
to the correction of the measurements of hip
joint rotations Jnl Biomechanics, 3, 4, July
1970
- CHENG, I.S (1974) Computer-television analysis of
biped locomotion The communication and control
systems laboratory, Dept Electrical Engineering,
Ohio State University, Columbus, Ohio, U S.A
- CLOSE, J R , INMAN, V.T (1952) The action of the
ankle joint Prosthetic Devices Research Project,
Institute of Engineering Research, University of
California, Berkeley
- COUSINS, S J (1975) A parallelogram chain designed
to measure human joint motion M App Sci.
Thesis, University of British Columbia, Vancouver,
July 1975
- CROWNINSHIELD, R D , JOHNSTON, R C , ANDREWS, J G.,
BRAND, R A (1978) A biomechanical investigation
of the human hip J Biomechanics 11 pp 75-85
1978
- DRILLIS, R (1958) Objective recording and biomechanics
of pathological gait Ann N Y Acad. of Science,
74, 86-109, 1058

DRILLIS, R , CONTINI (1966) 'Body segment parameters' Report No 1166-73 Office of Vocational rehabilitation Dept of Health, Education and Welfare, New York N.Y Univ School of Eng and Science

EBSKOV, B , LONG, C (1967) A method of electro-myographic kinesiology of the thumb Arch. Phys Med 48, 78, 1967

FISHER and YATES (1957) Statistical tables for biological, agricultural and medical research Published by Oliver and Boyd, 1957

GLANVILLE, A. D., KREEZER (1937) The characteristics of gait of normal male adults J exp. Psychol 21, 277-301.

GORE, D.R , MURPAY, M P , SEPIC, S B , GARDNER, G M (1975) Walking pattern of men with unilateral surgical hip fusion Journal Bone and Joint Surgery, 57-A, 6, 1975.

HANNAH, R , COUSINS, S., FOORT, J (1978) The C.A.R S. - U B C electrogoniometer - a clinically viable tool Proc 7th Canadian Medical and Biological Engineering Conference, 1978

HELLEBRANDT, F A , DUVAL, E N., MOORE, L (1949) The measurement of joint motion Part III - Reliability of Goniometry. The Physical Therapy Review Vol 29 No 7 pp 302-307, 1949.

JOHNSTON, R J., SMIDT, G L. (1969) Measurement of hip joint motion during walking evaluation of an electrogoniometric method. Jnl. Bone and Joint Surgery 51-A, 6, 1083-1094, Sept 1969

JOHNSTON, R J , SMIDT, G L (1970) Hip motion measurements for selected activities of daily living Clinical Orthopaedics and Related Research, 72, 205-215, 1970

KARPOVICH, P.V , KARPOVICH, G.P (1959) Electro-goniometer a new device for a study of joints in action Fed Proc 18, 79, 1959.

KETTEL CAMP, D.B , JOHNSTON, R J , SMIDT, G L., CHAO, E.Y.S , WALKER, M (1970) An electrogoniometric study of knee motion in normal gait Jnl Bone and Joint Surgery, 52-A, 4, 775-790, June 1970.

KINZEL, G.L , HILLBERRY, B.M., HALL, A S (1972a, 1972b) Measurements of the total motion between two body segments (a) analytical development, (b) description of application Jnl Biomechanics (a) Jan 1972 (b) June 1972

LAMOREUX, L w (1970) Experimental kinematics of human walking Ph D thesis. University of California. Berkeley. 1970

- LAMOREUX, L W (1971) Kinematic measurements in the study of human walking Bulletin Prosthetics Research, Spring 1971, 3-84.
- LAMOREUX, L W (1974) A self aligning goniometer for simplified gait analysis Presentation to World Congress of I S P O /Interbor/A P O , Montreux, October 1974
- LEAVITT, L A , PETERSON, C R , CANZONERI, J , POZ, R , MALLENBURG, A L , RHYNE, V T (1970) Quantative method to measure the relationship between prosthetic gait and the forces produced at the stump-socket interface American Journal of Physical Medicine, 49, 3, June 1970
- LEVENS, A S , INMAN, V T , BLOSSER, J A (1948) Transverse rotation of the segments of the lower extremity in locomotion Journal of Bone and Joint Surgery, 30-A, 4, 1948
- LIBERSON, W R (1965) Biomechanics of gait A method of study Archives Physical Medicine and Rehabilitation 46, 37-48, 1965
- LINDHOLM, L E (1974) An optoelectronic instrument for remote on-line movement monitoring In Biomechanics IV (Edited by R C Nelson and C A Morehouse) pp 570-572, University Park Press, Baltimore
- MANDEL, L (1956) Assessment of therapeutic agents in rheumatoid arthritis Canadian Medical Association Journal 74, 515, 1956
- MAREY, E J (1895) Movement Appleton, New York (originally published in French by Masson Paris 1894)
- MARTIN, R B , ATKINSON P J. (1977) Age and sex-related changes in the structure and strength of the human femoral shaft J Biomechanics, 10 pp 223-231, 1977
- MATHER, B S (1967) The symmetry of the mechanical properties of the human femur J Surg Res 7, 222, 1967
- McKECHNIE, R E , COUSINS, S J (1976) A parallelogram chain mechanism for measuring human joint motion A S M E proc Design Engineering Technical Conference, Quebec, Canada, Sept 26-29, 1976

- MILNER, M , DALL, D , McCONNELL, U S , BRENNAN, P K ,
HERSHLER, C (1973) Angle diagrams in assessment
of locomotion function South African Medical
Journal 47, 957-957, 1973
- MITCHELL, W.S , MILLAR, J STURROCK, R.D. (1975)
An evaluation of goniometry as an objective
parameter for measuring joint motion. Scottish
Medical Journal 1975, Vol 20 pp 57-59
- MOFFAT, C A , HARRIS, E H , HASLEM E.T (1966)
An experimental determination of prosthetic knee
movement for normal gait Am. Soc Mech Engrs
Paper no 66-WA/BHF-8, 1966.
- MORONEY, M J (1951) Facts from figures. Published
by Pelican Books Ltd , Harmondsworth, Middlesex,
England
- MORRIS, J.R.W (1973) Kinematics of the lower limb
in humans. Ph.d thesis, University of Oxford,
July 1973
- MULLER, E A , HETTINGER, T. (1952) Energy study of
different above-knee prostheses Z Orthop
81, 525-545, 1952.
- MURRAY, M P (1967) Gait as a total pattern of
movement American Journal of Physical Medicine
46, 290-333, 1967.
- MURRAY, M.P., BREWER, B J., ZUEGE, R C (1972)
Kinesiological measurements of functional performance
before and after McKee-Farrar total hip replacement.
Journal Bone and Joint Surgery, 54-A, 2, 1972.
- MURRAY, M.P , DROUGHT, A.B., KORY, R.C. (1964)
Walking pattern of normal men Journal Bone and
Joint Surgery, 46-A, 2, 335-360, 1964.
- MURRAY, M P., KORY, R.C , CLARKSON, B.H. (1969)
Walking patterns in healthy old men. Journal
Gerontology, 24, 169-178, 1969
- OBBERG, K. (1974) Mathematical modelling of human
gait An application of SELSPOT-system. In
Biomechanics IV (edited by R.C. Nelson and
C A. Morehouse) pp 79-84, University Park Press,
Baltimore
- PAUL, J P. (1967) Forces transmitted by joints in the
human body Proc. Instn. Mech Engrs 1966-7
vol 181, Pt 3J.
- PAUL, J. P. (1972) Comparison of E.M.G. signals from
leg muscles with the corresponding force actions
calculated from walkpath measurements. Inst. Mech.
Eng. Conf. Human Locomotor Engineering, Univ.
Sussex, England.

- REKTORYS (1969) Survey of applicable mathematics
pp 1275-5, Prof. RNDr. Karel Recktorys, Dr.Sc
Published by Iliffe Books Ltd , London English
translation by Dr. R Výborný et al, 1968.
- RYKER, N J Jr. (1952) Glass walkway studies of normal
subjects during normal level walking Prosthetic
devices research project, Institute of Engineering
Research, University of California, Berkeley,
Series II, issue 20, Berkeley, The Project
- SAUNDERS, J B , INMAN, V T , EBHART, H D (1953)
The major determinants in normal and pathological
gait Jnl of Bone and Joint Surgery, 35-A, 3,
1953
- SEDLIN, E D (1965) A rheological model for cortical
bone, a study at the properties of human femoral
samples Acta Orthop Scand Suppl 83 1, 1965
- SEDLIN, E D , HIRSCH, C. (1966) Factors affecting
the determination of the physical properties of
femoral cortical bone Acta Orthop. Scand.
37 29, 1966
- SMIDT, G L (1971) Hip motion and related factors in
walking Physical Therapy 51, 1, January 1971.
- SUTHERLAND, D H , HAGY, J L (1972) Measurement of
gait movements from motion picture film. Journal
of Bone and Joint Surgery, 54-A, 4, 1972
- THOMAS, D H , LANG, C (1964) An electrogoniometer
for the finger. American Journal of Medical
Electronics 3, 96-100, June-July 1964.
- TOWNSEND, M A , IZAK, M , JACKSON, R W (1977)
Total knee motion goniometry Jnl. Biomechanics
10, 183-193, 1977
- TRNKOCZY, A , BAJD, T (1975) A simple electro-
goniometric system and its testing I E E E
Trans Biomed Eng May 1975, 257-259.
- WINTER, D A , GREENLAW, R K., HOBSON, D A. (1972)
Television-computer analysis of kinematics of
human gait Comp Biomedical Research, 5, 498-
504, 1972
- WINTER, D A., SIDWALL, H.G , HOBSON, D.A. (1974a)
Measurement and reduction of noise in the kinematics
of locomotion J Biomechanics 7, 157-159, 1974.
- WINTER, D A , QUANBURY, A O , HOBSON, D A , SIDWALL, H.G.,
REINER, G , TRENHOLM, B.G , STEINKE, T , SHLOSSER, H.
(1974b) Kinematics of normal locomotion - A
statistical study based on T V data J Biomechanics
7, 479-486, 1974.

- WRIGHT, D G , DESAI, S.M , HENDERSON, W H (1964)
Action of the subtalar and ankle joint complex
during the stance phase of walking Jnl Bone
and Joint Surgery, 64-A, 2, 361-382, 1964.
- WRIGHT, V (1973) Use and abuse of remedial therapy
methods of evaluation Proceedings of the Royal
Society of Medicine, 66, 8, 787, 1973

APPENDIX

```

PAGE 1      10/9/79      4011G1      40AMPTS
10  REM %4011G1* CHAN 5, SUB 1=FLEX; C4 S2=ADD; C7 S3=ROT; C8 S4=FS
20  DIM A(3),M(6),N(3),O(3),D(8,250),F(2,250),Z(4,200),R(4,200)
30  S1=Z(3),S(4)
40  READ N(1),M(2),N(3),M(4),M(5),M(6)
50  DATA 5,-1,5,6,7,8
60  READ N(1),M(2),N(3),O(1),O(2),O(3),T
70  DATA 2,-1,5,2,-1,6,0
80  READ S(1),S(2),S(3),S(4)
90  DATA .222991, .443787, .422621, 4
100 READ I,N,D,V,W,X,D,K,H
110 DATA 1,2,250,4,120,8,200,50,125
120 CALL DATA1,M(1),A(1),3,30000,100
130 PRINT %4011G1, LEFT OR RIGHT I=L 2=R";
140 INPUT 50
150 IF 50= 1 THEN 190
160 IF 50= 2 THEN 180
170 END
180 LOAD "RIGHTS"
190 PRINT "ATTENUATION";
200 INPUT V(1),V(2),V(3)
210 ASSIGN "ASHIP"=1
220 CALL DATA1,M(1),1,3000,7875,225
230 FOR U=1 TO 5
240 OPEN 1,1
250 IF T=0 THEN 320
260 FOR S=1 TO 0
270 FOR F=1 TO X
280 GET 1,D(P,G)
290 GET P
300 NEXT G
310 GOTO 400
320 FOR F=1 TO X*Y
330 GET 1,H0

```

PAGE 2 10/8/79 A01TS1 A56PTS

```
340 NEXT P
350 FOR S=I TO C
360 FOR P=I TO X
370 GET 1,D(P,G)
380 NEXT P
390 NEXT G
400 CLOSE 1
410 FOR E=I TO W
420 FOR A=V TO X STEP V
430 IF D(A,E)>H THEN 450
440 IF D(A,E+I)>H THEN 470
450 NEXT A
460 NEXT E
470 FOR C=K TO W
480 FOR A=V TO X STEP V
490 IF D(A,E+C+I)>H THEN 510
500 IF D(A,E+C+N)>H THEN 530
510 NEXT A
520 NEXT C
530 LET T=T+2+C
540 REM LIMITS OF HELL STRIKE, D(A,E+1), & D(A,E+2+C)
550 FOR C=N TO N+C STEP N
560 LET F(I,G/N)=-512+ 512/C*(Q-I)
570 LET F(N,G/N)=-512+ 512/C*Q
580 NEXT G
590 LET E= 1
600 LET F= 0
610 FOR G=I TO N
620 IF F(G,E)>-512+ 5.12*F THEN 640
630 NEXT G
640 LET E=E+ 1
650 GOTO 610
660 LET Z( 4,F+ 1)=D(G* 4,E+E)/S( 4)
670 LET Z( 3,F+ 1)=(D(G* 4- 1,E-3)-A( 3))*S( 3)*V( 3)
```

```

PAGE 3      10/9/79      A01TG1      ADAPTS
650 LET Z( 2,F+ 1)=(D(G* 4- 2,B+E)-A( 2))*S( 2)*V( 2)
690 LET Z( 1,F+ 1)=(D(G* 4- 3,B+E)-A( 1))*S( 1)*V( 1)+Z( 3,F+ 1)/V
700 LET F=F+ 1
710 IF F=D THEN 730
720 GOTO 610
730 CALL INIT
740 CALL POS,-512, 399, 0
750 CALL VECT,-512,-400, 0
760 CALL VECT, 512,-400, 0
770 FOR P=1 TO V
780 LET L= 400-P* 200
790 CALL POS,-512,L, 0
800 FOR Q=1 TO 199
810 CALL VECT,Q* 5.12- 512,Z(P,Q)+L, 0
820 NEXT Q
830 NEXT P
840 PRINT "PLOT IT? 1=Y 2=N 0=END";
850 INPUT GO
860 IF GO= 1 THEN 890
870 IF GO= 2 THEN 240
880 END
890 IF UW 1 THEN 970
900 FOR R=1 TO D
910 LET R( 1,R)=Z( 1,R)
920 LET R( 2,R)=Z( 2,R)
930 LET R( 3,R)=Z( 3,R)
940 LET R( 4,R)=Z( 4,R)
950 NEXT R
960 GOTO 1030
970 FOR R=1 TO D
980 LET R( 1,R)=R( 1,R)+Z( 1,R)
990 LET R( 2,R)=R( 2,R)+Z( 2,R)
1000 LET R( 3,R)=R( 3,R)+Z( 3,R)
1010 LET R( 4,R)=R( 4,R)+Z( 4,R)

```

PAGE 4 10/9/79 601TG1 ADAPTS

```
1010 NEXT R
1020 IF UR 1 THEN 1240
1040 GOSUB 1060
1050 GOTO 1240
1060 CALL PULSE, 5
1070 WAIT 1000
1080 CALL DATAG,N( 1),-384, 1, 1000, 200
1090 CALL DATAG,O( 1), 511, 1, 1000, 200
1100 WAIT 2000
1110 CALL PULSE, 6
1120 WAIT 1000
1130 FOR R=1 TO D/N
1140 CALL DATAG,O( 1), 512-R* 10.24, 1, 30000, 200
1150 WAIT 10
1160 NEXT R
1170 FOR R=1 TO 75
1180 CALL DATAG,N( 1),R* 10.24- 384, 1, 30000, 200
1190 WAIT 10
1200 NEXT R
1210 CALL PULSE, 5
1220 WAIT 1000
1230 RETURN
1240 FOR Y=1 TO V
1250 LET M= 513-Y* 256
1260 CALL DATAG,N( 1),-384, 1, 1000, 100
1270 CALL DATAG,O( 1),Z(Y, 1)+M, 1, 1000, 200
1280 WAIT 2000
1290 CALL PULSE, 6
1300 WAIT 1000
1310 FOR J=1 TO D
1320 CALL DATAG,N( 1),-384+( 3.84*(J- 1)), 1, 1000, 200
1330 CALL DATAG,O( 1),Z(Y,J)+M, 1, 1000, 200
1340 WAIT 10
1350 NEXT J
```

```
AGE 5      10/9/79  A01TG1  ADAPTS
360 CALL PULSE, 5
370 WAIT 1000
380 NEXT Y
390 NEXT U
400 FOR R=I TO D
410 LET R( 1,R)=R( 1,R)/ 5
420 LET R( 2,R)=R( 2,R)/ 5
430 LET R( 3,R)=R( 3,R)/ 5
440 LET R( 4,R)=R( 4,R)/ 5
450 NEXT R
460 PRINT:"AVERAGE? 1=Y 0=N";
470 INPUT GO
480 IF GO= 1 THEN 1500
490 END
500 GOSUB 1060
510 FOR Z=I TO V
520 LET M= 518-Z* 256
530 CALL DATA,D( 1),-384, 1, 1000, 200
540 CALL DATA,D( 1),R(Z, 1)+M, 1, 1000, 200
550 WAIT 2000
560 CALL PULSE, 6
570 WAIT 1000
580 FOR J=I TO D
590 CALL DATA,N( 1),-384+( 3.84*(J- 1)), 1, 1000, 200
600 CALL DATA,D( 1),R(Z,J)+M, 1, 1000, 200
610 WAIT 10
620 NEXT J
630 CALL PULSE, 5
640 WAIT 1000
650 NEXT Z
660 PRINT "LOAD A01TG2? 2=Y 0=END";
670 INPUT GO
680 IF GO= 2 THEN 1700
690 END
```

PAGE 6 10/9/79 A01T61 ADAPTS
1700 LOAD "A01T62"
1710 GOTO 10

```

PAGE 1      10/9/79  A01TGZ  ADAPTS
10  REM *** A01TG2 RECTANGULAR PLOTTER ***
20  REM
30  REMOVE 900 TO 1800
40  PRINT "5 OR 10 DEG/CM, KEY 5 OR 10";
50  INPUT GO
60  IF GO= 5 THEN 90
70  IF GO= 10 THEN 100
80  END
90  LOAD "SCALES"
100 PRINT "LOAD PLOTTER, READY, 1=Y 0=N";
110  REM
120  INPUT GO
130  IF GO= 1 THEN 150
140  END
150  CALL PULSE, 5
160  CALL DATAG,N( 1), 0, 1, 1000, 200
170  CALL DATAG,G( 1), 511, 1, 1000, 200
180  WAIT 2000
190  CALL PULSE, 4
200  WAIT 1000
210  FOR R= 1 TO 100
220  CALL DATAG,G( 1), 512-R* 10.24, 1, 1000, 200
230  WAIT 10
240  NEXT R
250  CALL PULSE, 5
260  WAIT 1000
270  CALL DATAG,N( 1),-384, 1, 1000, 200
280  CALL DATAG,G( 1), 0, 1, 1000, 200
290  WAIT 2000
300  CALL PULSE, 4
310  WAIT 1000
320  FOR R= 1 TO 75
330  CALL DATAG,N( 1),R* 10.24- 384, 1, 1000, 200

```

PAGE 2 10/9/79 A01TG2 ADAPTS

```
340 WAIT 10
350 NEXT R
360 CALL PULSE, 5
370 WAIT 1000
380 CALL DATAD,N( 1),-384, 1, 1000, 200
390 CALL DATAD,O( 1), 511, 1, 1000, 200
400 WAIT 2000
410 CALL PULSE, 6
420 WAIT 1000
430 FOR R= 1 TO 100
440 CALL DATAD,O( 1), 512-R* 10.24, 1, 30000, 200
450 WAIT 10
460 NEXT R
470 FOR R= 1 TO 75
480 CALL DATAD,N( 1),R* 10.24- 384, 1, 30000, 200
490 WAIT 10
500 NEXT R
510 FOR R= 1 TO 100
520 CALL DATAD,O( 1),R* 10.24- 512, 1, 30000, 200
530 WAIT 10
540 NEXT R
550 FOR R= 1 TO 75
560 CALL DATAD,N( 1), 384-R* 10.24, 1, 30000, 200
570 WAIT 10
580 NEXT R
590 CALL PULSE, 5
600 WAIT 1000
610 CALL DATAD,N( 1),R( 2, 1)/ 2, 1, 1000, 200
620 CALL DATAD,O( 1),R( 1, 1), 1, 1000, 200
630 WAIT 2000
640 CALL PULSE, 6
650 WAIT 1000
660 FOR R= 1 TO 200
670 CALL DATAD,N( 1),R( 2,R)/ 2, 1, 1000, 200
```

```
PAGE 3      10/9/79  A01T62  ADAPTS
650 CALL  DATAO,C( 1),R( 1,R), 1, 1000, 200
660 WAIT  50
700 NEXT R
710 CALL  PULSE, 5
720 WAIT 1000
730 CALL  DATAO,C( 1),-461, 1, 1000, 200
740 CALL  DATAO,N( 1),R( 3, 1)/ 2, 1, 1000, 200
750 WAIT 2000
760 CALL  PULSE, 6
770 WAIT 1000
780 FOR R= 1 TO 200
790 CALL  DATAO,N( 1),R( 3,R)/ 2, 1, 1000, 200
800 WAIT 10
810 NEXT R
820 CALL  PULSE, 5
830 WAIT 1000
840 PRINT "THIS WAS A01T62, LOAD A01T65 1=Y 0=END";
850 INPUT GO
860 IF GO= 1 THEN 880
870 END
880 LOAD "A01T65"
890 GOTO 10
```

```

PAGE 1      10/9/79      A01TGG      ADAPTS
10  REM *A01TGG* CHAN 5, SUB 1=FLEX; C6 S2=AED; C7 S3=ROT; C8 S4=FS
20  PRINT "A01TGG, TAKE ZERO? 1=Y 0=N";
30  INPUT GO
40  IF GO= 0 THEN 220
50  DIM A(3),B(3,250),M(6),N(3),O(3),R(3,200)
60  READ M( 1),M( 2),N( 3),M( 4),M( 5),N( 6),S1,S2,S3,S4
70  DATA 5,-1, 5, 6, 7, 8, .223881, .443787, .426621,-20
80  READ N( 1),N( 2),N( 3),O( 1),O( 2),O( 3)
90  DATA 2,-1, 5, 2,-1, 6
100 CALL DATA1,M( 1),A( 1), 3, 30000, 100
110 PRINT "LEFT OR RIGHT, 1=L 2=R";
120 INPUT GO
130 IF GO= 1 THEN 170
140 IF GO= 2 THEN 160
150 END
160 LOAD "RIGHT2"
170 PRINT "ATTENUATION";
180 INPUT V1,V2,V3
190 PRINT "GO AHEAD? 1=Y 0=N";
200 INPUT GO
210 IF GO= 1 THEN 230
220 END
230 CALL DATA1,N( 1),D( 1), 2000, 30000, 100
240 FOR I= 1 TO 5 STEP 4
250 FOR J= 1 TO 250
260 LET D(I+ 2,J)=(D(I+ 2,J)-A( 3))*S3*V3
270 LET D(I+ 1,J)=(D(I+ 1,J)-A( 2))*S2*V2
280 LET D(I,J)=(D(I,J)-A( 1))*S1*V1+D(I+ 2,J)/ 4
290 NEXT J
300 NEXT I
310 FOR B= 1 TO 100
320 FOR A= 4 TO 8 STEP 4
330 IF D(A,B)<S4 THEN 360

```

```

PAGE 2      10/9/79   A01TG3   ADAPTS
340 NEXT A
350 NEXT B
360 FOR C= 1 TO 200
370 FOR A= 4 TO 8 STEP 4
380 IF D(A, B+C)>S4 THEN 410
390 NEXT A
400 NEXT C
410 FOR D= 2 TO 2*C STEP 2
420 LET D( 4, D/ 2)=-512+ 512/C*(D- 1)
430 LET D( 8, D/ 2)=-512+ 512/C*D
440 NEXT D
450 LET E= 1
460 LET F= 0
470 FOR G= 4 TO 8 STEP 4
480 IF D(G, E)>-512+ 5.12*F THEN 520
490 NEXT G
500 LET E=E+ 1
510 GOTO 470
520 LET R( 1, F+ 1)=D(G- 3, B+E)
530 LET R( 2, F+ 1)=D(G- 2, B+E)
540 LET R( 3, F+ 1)=D(G- 1, B+E)
550 LET F=F+ 1
560 IF F> 199 THEN 580
570 GOTO 470
580 CALL INIT
590 CALL POS, -512, 399, 0
600 CALL VECT, -512, -400, 0
610 CALL VECT, 512, -400, 0
620 FOR K= 1 TO 3
630 LET L= 400-K* 200
640 CALL POS, -512, L, 0
650 FOR H= 1 TO C
660 CALL VECT, D( 4, H), (D(K, H+B)+L)/ 2, 0
670 CALL VECT, D( 8, H), (D(K+ 4, H+B)+L)/ 2, 0

```

PAGE 3 10/9/79 A01T03 ADAPTS

```
680 NEXT H
690 NEXT K
700 PRINT "PLOT IT? I=Y O=N";
710 INPUT GO
720 IF GO= 1 THEN 740
730 END
740 CALL PULSE, 5
750 WAIT 1000
760 CALL DATAD,N( 1),-384, 1, 1000, 200
770 CALL DATAD,O( 1), 511, 1, 1000, 200
780 WAIT 2000
790 CALL PULSE, 6
800 WAIT 1000
810 FOR R= 1 TO 100
820 CALL DATAD,O( 1), 512-R* 10.24, 1, 30000, 200
830 WAIT 10
840 NEXT R
850 FOR R= 1 TO 75
860 CALL DATAD,N( 1),R* 10.24- 384, 1, 30000, 200
870 WAIT 10
880 NEXT R
890 CALL PULSE, 5
900 WAIT 1000
910 FOR Y= 1 TO 3
920 LET M= 513-Y* 256
930 CALL DATAD,N( 1),-384, 1, 1000, 200
940 CALL DATAD,O( 1),R(Y, 1)/ 2+M, 1, 1000, 200
950 WAIT 2000
960 CALL PULSE, 6
970 WAIT 1000
980 FOR J= 1 TO 200
990 CALL DATAD,N( 1),-384+ 3.84*(J- 1), 1, 1000, 200
1000 CALL DATAD,O( 1),R(Y, J)/ 2+M, 1, 1000, 200
1010 WAIT 10
```

PAGE 4 10/9/79 A01T63 ADAPTS

```
1020 NEXT J
1030 CALL PULSE, 5
1040 WAIT 1000
1050 NEXT Y
1060 PRINT "THIS WAS A01T63, LOAD A01T62? Z=Y O=N";
1070 INPUT G0
1080 IF G0= 2 THEN 1100
1090 END
1100 LOAD "A01T62"
1110 GOTO 10
```

```

PAGE 1      10/9/79  A01G4  ADAPTS
110  REM ***A01G4  PUT ROUTINE ***
120  REMOVE 353 TO 1800
130  PRINT "*** A01G4  PUT ROUTINE ***"
140  PRINT "TYPE IN - 70 ASSIGN (FILE NAME) = 2 "
150  PRINT "THEN TYPE IN GOTO 70 "
160  END
170  ASSIGN "DATDUM"=Z
180  OPEN 2, 1,W
190  FOR B= 1 TO 200
200  FOR A= 1 TO 3
210  GET 2,D(A,B)
220  NEXT A
230  NEXT B
240  GET 2,N
250  CLOSE 2
260  REM N= NUMBER OF RECORDS ON THIS FILE
270  FOR B= 1 TO 200
280  FOR A= 1 TO 3
290  LET D(A,B)=(D(A,B)*N+Z(A,B))/(N+ 1)
300  NEXT A
310  NEXT B
320  LET N=N+ 1
330  OPEN 2, O
340  FOR B= 1 TO 200
350  FOR A= 1 TO 3
360  PUT 2,D(A,B)
370  NEXT A
380  NEXT B
390  PUT 2,N
400  CLOSE 2
410  PRINT "LOAD A01G1  1=YES 0=END "
420  INPUT 50
4300  IF GO= 1 THEN 350

```

PAGE 2 10/9/79 A01T34 ADAPTS
340 END
350 PRINT "TYPE - SCRATCH - LOAD (A01T31) "
352 END

```
PAGE 1 10/9/79 A01T65 ADAPTS
10 REM *****A01T65, DATA FILE INITIATION*****
20 PRINT "*****A01T65, DATA FILE INITIATION*****"
30 REMOVE 221 TO 1800
40 PRINT "TYPE IN - 70 ASSIGN (FILE NAME) = 2 "
50 PRINT "THEN TYPE IN GOTO 70"
60 END
70 ASSIGN "HELENG"=2
80 OPEN 2, 0
90 FOR B= 1 TO 200
100 FOR A= 1 TO 3
110 PUT 2,R(A,B)
120 NEXT A
130 NEXT B
140 LET N= 1
150 PUT 2,N
160 CLOSE 2
170 PRINT "LOAD A01T61 1=Y 0=END";
180 INPUT GO
190 IF GO= 1 THEN 210
200 END
210 PRINT " TYPE - SCRATCH - LOAD (A01T61) "
220 END
```

```
PAGE 1      10/9/79  A01TG6  ADAPTS
10  REM A01TG6 FILE DATA TRANSFER PROGRAM
20  DIM D(36,200)
30  LET N= 0
40  PRINT "ASSIGN FILE TO 2 ON LINE 60"
50  END
60  ASSIGN "DUMMY"=2
70  OPEN  2, 1,W
80  FOR B= 1 TO  200
90  FOR A= 1 TO  3
100 GET  2,D(A+N,B)
110 NEXT A
120 NEXT B
130 LET N=N+ 3
140 IF N= 36 THEN 160
150 GOTO 40
160 CLOSE 2
170 END
200 LET N= 0
210 PRINT "ASSIGN FILE TO 2 ON LINE 230"
220 END
230 ASSIGN "DUMMY"=2
240 OPEN  2, 0
250 FOR B= 1 TO  200
260 FOR A= 1 TO  3
270 PUT  2,D(A+N,B)
280 NEXT A
290 NEXT B
300 LET N=N+ 3
310 IF N= 36 THEN 330
320 GOTO 210
330 CLOSE 2
340 END
```

```
PAGE 1      10/9/79      A01T67      ADAPTS
110  REM A01T67 FILE DATA PUNCH PROGRAM
120  DIM D(3,200)
130  LET N=0
140  PRINT "ASSIGN FILE TO 2 ON LINE 60 "
150  END
160  ASSIGN "A130L"=2
170  OPEN 2, 1
180  FOR B= 1 TO 200
190  FOR A= 1 TO 3
200  OCT 2, D(A,B)
210  LET N=N+ 1
220  NEXT A
230  NEXT B
240  CLOSE 2
250  PRINT "TAPE UNIT OK 1=Y 0=END";
260  INPUT GO
270  IF GO= 1 THEN 190
280  END
290  CALL SPUNCH
300  FOR B= 1 TO 200
310  FOR A= 1 TO 3
320  CALL EPUNCH, D(A,B)
330  NEXT A
340  NEXT B
350  PRINT N; "DATA POINTS PUNCHED"
360  CALL EPUNCH
370  PRINT "NEXT FILE 1=Y 0=END";
380  INPUT GO
390  IF GO= 1 THEN 40
400  END
```

```

10/9/79  A01TC8  A0ARTS
DITGO PUNCH DATA FILE PROGRAM
(3,200)
= 0
"LOAD TAPE READER 1=Y 0=END";
GO
= 1 THEN 80

FPUNCH
= 1 TO 200
A= 1 TO 3
GRUNCH, D(A,B), Z
N=N+ 1
= 1 THEN 160
A
B
T N; "DATA POINTS READ"
T "ASSIGN DATA FILE TO 2 ON LINE 190"

3N "DUMMY"=Z
2, 0
3= 1 TO 200
3= 1 TO 3
2, D(A,B)
A
B
T "NEXT DATA FILE 1=Y 0=END";
T GO
)= 1 THEN 40

```

```
PAGE 1      10/9/79      A01059      ADAPTS
10  REM **A01059 ZERO SHIFT PROGRAM**
20  DIM D(3,200)
30  PRINT "ASSIGN FILE TO 1 ON LINE 50"
40  END
50  ASSIGN "DUMMY"=1
60  OPEN 1, 1
70  FOR B= 1 TO 200
80  FOR A= 1 TO 3
90  GET 1,D(A,B)
100 NEXT A
110 NEXT B
120 CLOSE 1
130 FOR B= 1 TO 200
140 LET D( 2,B)=D( 2,B)+ 61.4398
150 NEXT B
160 OPEN 1, 0
170 FOR B= 1 TO 200
180 FOR A= 1 TO 3
190 PUT 1,D(A,B)
200 NEXT A
210 NEXT B
220 CLOSE 1
230 END
```

PAGE 1 10/9/79 UTILITY ADAPTS

*** RIGHT1 ***

00 REM DUMMY DIM

10 REM DUMMY DIM

70 LET Z(3,F+ 1)=(D(B* 4- 1,B+E)-A(3))*S(3)*(-V(3))

90 LET Z(1,F+ 1)=Z(3,F+ 1)/V-((D(B* 4- 3,B+E)-A(1))*S(1)*V(1))

*** RIGHTS ***

00 REM DUMMY DIM

10 LET D(I+ 2,J)=(D(I+ 2,J)-A(3))*S3*(-V3)

90 LET D(I,J)=D(I+ 2,J)/ 4-(D(I,J)-A(1))*S1*V1

READY

*** MOD1X2 ***

410 LET R(1,R)=R(1,R)/ 2

420 LET R(2,R)=R(2,R)/ 2

430 LET R(3,R)=R(3,R)/ 2

440 LET R(4,R)=R(4,R)/ 2

*** MOD1X4 ***

410 LET R(1,R)=R(1,R)/ 4

420 LET R(2,R)=R(2,R)/ 4

430 LET R(3,R)=R(3,R)/ 4

440 LET R(4,R)=R(4,R)/ 4

*** MOD1X3 ***

410 LET R(1,R)=R(1,R)/ 3

420 LET R(2,R)=R(2,R)/ 3

430 LET R(3,R)=R(3,R)/ 3

440 LET R(4,R)=R(4,R)/ 3

READY

*** SCALE5 ***

00 CALL DATAD, D(1), -307, 1, 1000, 200

10 CALL DATAD, N(1), R(2, 1), 1, 1000, 200

PAGE 3 10/9/79 UTILITY ADAPTS
620 CALL DATAD,Q(1),R(1, 1)* 2- 307, 1, 1000, 200
670 CALL DATAD,N(1),R(2,R), 1, 1000, 200
680 CALL DATAD,Q(1),R(1,R)* 2- 307, 1, 1000, 200
740 CALL DATAD,N(1),R(3, 1), 1, 1000, 200
790 CALL DATAD,N(1),R(3,R), 1, 1000, 200

```

PAGE 1      11/2/79  A01S11  ADAPTS
10  REM ***A01S11 HIP PLOT STATISTICAL REDUCTION PROG***
20  LET N= 0
30  DIM D(3,200),R(3,200),X(3,200),S(3,200),M(3,200),N(3),O(3)
40  READ N( 1),N( 2),N( 3),O( 1),O( 2),O( 3)
50  DATA 2,-1, 5, 2,-1, 6
60  PRINT "C. L. A. OR NON C. L. A. 1=C. L. A. 0=NON C. L. A. ";
70  INPUT 60
80  IF 60= 1 THEN 100
90  REMOVE 240 TO 310
100 PRINT "NEXT FILE 1=Y";
110 INPUT 60
120 IF 60# 1 THEN 650
130 PRINT "NEXT LINE ON 150"
140 END
150 ASSIGN "SU126L"=1
160 OPEN 1, 1
170 FOR B= 1 TO 200
180 FOR A= 1 TO 3
190 GET 1,D(A,B)
200 NEXT A
210 NEXT B
220 LET D1=D2=D3= 0
230 FOR B= 1 TO 200
240 FOR E= 1 TO 200
250 LET D1=D1+D( 1,B)
260 LET D2=D2+D( 2,B)
270 LET D3=D3+D( 3,B)
280 NEXT E
290 LET D1=D1/ 200
300 LET D2=D2/ 200
310 LET D3=D3/ 200
320 FOR B= 1 TO 200
330 LET R( 1,B)=D( 1,B)-D1

```

```

PAGE 2      11/9/79   A01ST1   ADAPTS
340 LET R( 2,B)=D( 2,B)=D( 2,B)-D2
350 LET R( 3,B)=D( 3,B)=D( 3,B)-D3
360 NEXT B
370 IF N# 0 THEN 390
380 GOSUB 1090
390 GOSUB 1270
400 IF N# 0 THEN 470
410 FOR B= 1 TO 200
420 FOR A= 1 TO 3
430 LET N(A,B)=D(A,B)
440 NEXT A
450 NEXT B
460 GOTO 520
470 FOR B= 1 TO 200
480 FOR A= 1 TO 3
490 LET M(A,B)=(N*M(A,B)+D(A,B))/(N+ 1)
500 NEXT A
510 NEXT B
520 LET N=N+ 1
530 FOR B= 1 TO 200
540 FOR A= 1 TO 3
550 IF N# 1 THEN 580
560 LET X(A,B)=D(A,B)*D(A,B)
570 GOTO 620
580 LET X(A,B)=X(A,B)*D(A,B)*D(A,B)
590 LET S1=(N*M(A,B))^ 2/N
600 LET S2=(X(A,B)-S1)/(N- 1)
610 LET S(A,B)=SQR(S2)
620 NEXT A
630 NEXT B
640 GOTO 100
650 PRINT "PLOT OUT MEAN +/- 1 S. D; 1=Y";
660 INPUT GO
670 IF GO# 1 THEN 140

```

```

PAGE 3      11/9/79  A01ST1  ADAPTS
680 REM ***PLOTIT***
690 LET C1= 0
700 PRINT "MEAN 1=Y 0=N";
710 INPUT GO
720 IF GO# 1 THEN 750
730 LOAD "MINTOR"
740 GOTO 870
750 PRINT "POSITIVE STANDARD DEVIATION 1=Y 0=N";
760 INPUT GO
770 IF GO# 1 THEN 800
780 LOAD "PSTOR"
790 GOTO 870
800 PRINT "NEGATIVE STANDARD DEVIATION 1=Y 0=N";
810 INPUT GO
820 IF GO# 1 THEN 850
830 LOAD "NSTOR"
840 GOTO 870
850 END
860 REM ***MINTOR***
870 FOR B= 1 TO 200
880 FOR A= 1 TO 3
890 LET R(A,B)=M(A,B)
900 NEXT A
910 NEXT B
920 CALL INIT
930 CALL POS,-512, 399, 0
940 CALL VECT,-512,-400, 0
950 CALL VECT, 512,-400, 0
960 FOR P= 1 TO 3
970 LET L= 400-P* 200
980 CALL POS,-512,L, 0
990 FOR Q= 1 TO 199
1000 CALL VECT,Q* 5.12- 512,R(P,Q)+L, 0
1010 NEXT Q

```

PAGE 4 11/9/79 A01ST1 ADAPTS

```
1020 NEXT P
1030 PRINT "PLOT IT I=Y O=N";
1040 INPUT O
1050 IF O# 1 THEN 850
1060 GOSUB 1090
1070 GOSUB 1270
1080 GOTO 1430
1090 CALL PULSE, 5
1100 WAIT 1000
1110 CALL DATA, N( 1), -384, 1, 1000, 200
1120 CALL DATA, O( 1), 511, 1, 1000, 200
1130 WAIT 2000
1140 CALL PULSE, 6
1150 WAIT 1000
1160 FOR R= 1 TO 100
1170 CALL DATA, O( 1), 512-R* 10.24, 1, 30000, 200
1180 WAIT 10
1190 NEXT R
1200 FOR R= 1 TO 75
1210 CALL DATA, N( 1), R* 10.24- 384, 1, 30000, 200
1220 WAIT 10
1230 NEXT R
1240 CALL PULSE, 5
1250 WAIT 1000
1260 RETURN
1270 FOR Z= 1 TO 3
1280 LET M= 513-Z* 256
1290 CALL DATA, N( 1), -384, 1, 1000, 200
1300 CALL DATA, O( 1), R(Z, 1)+M, 1, 1000, 200
1310 WAIT 2000
1320 CALL PULSE, 6
1330 WAIT 1000
1340 FOR J= 1 TO 200
1350 CALL DATA, N( 1), -384+( 3.84*(J- 1)), 1, 1000, 200
```

```
PAGE 5      11/9/79  A01ST1  ADAPTS
1360  CALL  DATAD,C( 1),R(Z,J)+M, 1, 1000, 200
1370  WAIT  10
1380  NEXT  J
1390  CALL  PULSE, 5
1400  WAIT  1000
1410  NEXT  Z
1420  RETURN
1430  LET  C1=C1+ 1
1440  IF  C1= 1 THEN 750
1450  IF  C1= 2 THEN 800
1460  IF  C1= 3 THEN 850
```

```

PAGE 1      11/9/79   A01STZ   ADAPTS
10  REM ***A01STZ*** SIG OF DIFF TESTING PROG
20  DIM A(3,200),B(3,200),S(3,200),T(3,200)
30  PRINT "PUT IN N1 & N2";
40  INPUT N1,N2
50  LET N3=N1- 1
60  LET N4=N2- 1
70  LET N5=N1+N2
80  LET N6=N1+N2
90  LET N7=N1+N2- 2
100 LET N= 1
110 PRINT "1=XBAR, 2=YBAR, 3=XSD, 4=YSD"
120 PRINT "ASSIGN FILE";N;"ON LINE 140"
130 END
140 ASSIGN "B2534S"=1
150 OPEN 1, 1
160 FOR B= 1 TO 200
170 FOR A= 1 TO 3
180 IF N= 1 THEN 230
190 IF N= 2 THEN 250
200 IF N= 3 THEN 270
210 GET 1,T(A,B)
220 GOTO 280
230 GET 1,A(A,B)
240 GOTO 280
250 GET 1,B(A,B)
260 GOTO 280
270 GET 1,S(A,B)
280 NEXT A
290 NEXT B
300 CLOSE 1
310 LET N=N+ 1
320 IF N# 5 THEN 120
330 PRINT "FLEXION", "ABDUCTION", "ROTATION"

```

```
PAGE 2      11/9/79      A01ST2      ADAPTS
340 FOR B= 1 TO 200
350 FOR A= 1 TO 3
360 LET S1=SQR((S(A,B)*S(A,B)*N3+T(A,B)*T(A,B)*N4)/N7)
370 LET T(A,B)=(A(A,B)-E(A,B))/(S1*SQR(N4/N5))
380 NEXT A
390 PRINT ABS(T( 1,E)),ABS(T( 2,B)),ABS(T( 3,E))
400 NEXT B
410 LET T1=T2=T3= 0
420 FOR B= 1 TO 200
430 LET T1=T1+ABS(T( 1,E))
440 LET T2=T2+ABS(T( 2,B))
450 LET T3=T3+ABS(T( 3,B))
460 NEXT B
470 LET T1=T1/ 200
480 LET T2=T2/ 200
490 LET T3=T3/ 200
500 PRINT "FLEXION", "ABDUCTION", "ROTATION"
510 PRINT T1,T2,T3
520 END
```

```

PAGE 1      11/9/79   A018T3   ADAPTS
10  REM ***A018T3***SIG OF DIFF (A018T2) + CHI SQUARE ON S-DIST
20  DIM A(3,200),B(3,200),S(3,200),T(3,200)
30  PRINT "PUT IN N1 & N2";
40  INPUT N1,N2
50  LET N3=N1- 1
60  LET N4=N2- 1
70  LET N5=N1*N2
80  LET N6=N1+N2
90  LET N7=N1+N2- 2
100 LET N= 1
110 PRINT "1=XBAR, 2=YBAR, 3=XSD, 4=YSD"
120 PRINT "ASSIGN FILE";N; "ON LINE 140"
130 END
140 ASSIGN "B25348"=1
150 OPEN 1, 1
160 FOR B= 1 TO 200
170 FOR A= 1 TO 3
180 IF N= 1 THEN 230
190 IF N= 2 THEN 250
200 IF N= 3 THEN 270
210 GET 1,T(A,B)
220 GOTO 280
230 GET 1,A(A,B)
240 GOTO 280
250 GET 1,B(A,B)
260 GOTO 280
270 GET 1,S(A,B)
280 NEXT A
290 NEXT B
300 CLOSE 1
310 LET N=N+ 1
320 IF N# 5 THEN 120
330 CALL TERM, 1, 1, 5

```

```

PAGE 2      11/9/79      A01ST3      ADAPTS
340 PRINT " "
350 FOR E= 1 TO 200
360 FOR A= 1 TO 3
370 LET S1=SQR((S(A,E)*S(A,E)*N3+T(A,E)*T(A,E)*N4)/N7)
380 LET T(A,E)=(A(A,E)-E(A,B))/(S1*SQR(N6/N5))
390 NEXT A
400 NEXT E
410 LET T1=T2=T3= 0
420 FOR E= 1 TO 200
430 LET T1=T1+ABS(T( 1,E))
440 LET T2=T2+ABS(T( 2,E))
450 LET T3=T3+ABS(T( 3,E))
460 NEXT E
470 LET T1=T1/ 200
480 LET T2=T2/ 200
490 LET T3=T3/ 200
500 PRINT " ", "FLEXION", "ABDUCTION", "ROTATION"
510 PRINT "MEAN T'S", T1, T2, T3
520 LET B1=B9= 9
530 LET B2=B8= 13
540 LET B3=B7= 24
550 LET B4=B6= 34.5
560 LET B5= 39
570 FOR A= 1 TO 3
580 LET A1=A2=A3=A4=A5=A6=A7=A8=A9= 0
590 FOR B= 1 TO 200
600 IF T(A,B)<1.75 THEN 700
610 IF T(A,B)<1.25 THEN 720
620 IF T(A,B)<.75 THEN 740
630 IF T(A,B)<.25 THEN 760
640 IF T(A,B)<.25 THEN 780
650 IF T(A,B)<.75 THEN 800
660 IF T(A,B)<1.25 THEN 820
670 IF T(A,B)<1.75 THEN 840

```

```
PAGE 3      11/9/79      AO1ST3      ADAPTS
680 LET A9=A9+ 1
690 GOTO 850
700 LET A1=A1+ 1
710 GOTO 850
720 LET A2=A2+ 1
730 GOTO 850
740 LET A3=A3+ 1
750 GOTO 850
760 LET A4=A4+ 1
770 GOTO 850
780 LET A5=A5+ 1
790 GOTO 850
800 LET A6=A6+ 1
810 GOTO 850
820 LET A7=A7+ 1
830 GOTO 850
840 LET A8=A8+ 1
850 NEXT B
860 PRINT A1; A2; A3; A4; A5; A6; A7; A8; A9
870 LET X9=(A1-B1)*(A1-B1)/B1+(A2-B2)*(A2-B2)/B2+(A3-B3)*(A3-B3)/B3
880 LET X8=(A4-B4)*(A4-B4)/B4+(A5-B5)*(A5-B5)/B5+(A6-B6)*(A6-B6)/B6
890 LET X7=(A7-B7)*(A7-B7)/B7+(A8-B8)*(A8-B8)/B8+(A9-B9)*(A9-B9)/B9
900 LET X2=X9+X8+X7
910 PRINT X2
920 NEXT A
930 CALL TTY
940 END
```

```
PAGE 1      11/9/79   A01ST4   ADAPTS
10  REM ***T TEST ON T(0,1),   A01ST4***
20  LET D1=D2=D3=C( 1)=C( 2)=C( 3)=.0
30  DIM D(3,200),C(3),E(3),S(3),T(3),V(3)
40  PRINT "FILE NAME ON 60"
50  END
60  ASSIGN "T2544U"=1
70  OPEN  1, 1
80  FOR B= 1 TO  200
90  FOR A= 1 TO  3
100 GET  1,D(A,B)
110 NEXT A
120 NEXT B
130 CLOSE 1
140 FOR B= 1 TO  200
150 LET D1=D1+D( 1,B)
160 LET D2=D2+D( 2,B)
170 LET D3=D3+D( 3,B)
180 NEXT B
190 LET E( 1)=D1/ 200
200 LET E( 2)=D2/ 200
210 LET E( 3)=D3/ 200
220 FOR A= 1 TO  3
230 FOR B= 1 TO  200
240 LET C(A)=C(A)+D(A,B)*E(A,B)
250 NEXT B
260 LET S1= 200*E(A)*E(A)
270 LET V(A)=(C(A)-S1)/ 199
280 NEXT A
290 FOR A= 1 TO  3
300 LET S(A)=(V(A)+ 1)/ 2
310 LET T(A)= 10*E(A)/SQR(S(A))
320 NEXT A
330 CALL  TERM, 1, 1, 5
```

```
PAGE 2      11/9/79      A018T4      ADAPTS
340 PRINT
350 PRINT
360 PRINT "FIT ON T(0,1)"
370 PRINT "          FLEX          ADB          ROT"
380 PRINT "MEANS          ";E( 1);E( 2);E( 3)
390 PRINT "STANDARD DEVIATIONS ";SQR(V( 1));SQR(V( 2));SQR(V( 3))
400 PRINT "STUDENT'S T          ";T( 1);T( 2);T( 3)
410 CALL      TTY
420 END
```

```

PAGE 1      11/9/79      A018T5      ADAPTS
10  REM *** T TEST ON T(0,0),  A018T5 ***
20  LET D1=D2=D3=C( 1)=C( 2)=C( 3)= 0
30  DIM D(3,200),C(3),E(3),S(3),T(3),V(3)
40  PRINT "FILE NAME ON 60"
50  END
60  ASSIGN "T120"=1
70  OPEN  1, 1
80  FOR B= 1 TO  200
90  FOR A= 1 TO  3
100 GET  1,D(A,B)
110 NEXT A
120 NEXT B
130 CLOSE  1
140 FOR B= 1 TO  200
150 LET D1=D1+D( 1,B)
160 LET D2=D2+D( 2,B)
170 LET D3=D3+D( 3,B)
180 NEXT B
190 LET E( 1)=D1/ 200
200 LET E( 2)=D2/ 200
210 LET E( 3)=D3/ 200
220 FOR A= 1 TO  3
230 FOR B= 1 TO  200
240 LET C(A)=C(A)+D(A,B)*D(A,B)
250 NEXT B
260 LET S1= 200*E(A)*E(A)
270 LET V(A)=(C(A)-S1)/ 199
280 NEXT A
290 FOR A= 1 TO  3
300 LET S(A)=V(A)
310 LET T(A)=E(A)*SQR( 200)/SQR(S(A))
320 NEXT A
330 CALL  TERM, 1, 1, 5

```

```
PAGE 2      11/9/79  A018T5  ADAPTS
340 PRINT
350 PRINT
360 PRINT "FIT ON T(0,0)"
370 PRINT "
      FLEX      ADD      ROT"
380 PRINT ";E( 1);E( 2);E( 3)
390 PRINT "STANDARD DEVIATIONS ";SOR(V( 1));SOR(V( 2));SOR(V( 3))
400 PRINT "STUDENT'S T      ";T( 1);T( 2);T( 3)
410 CALL TTY
420 END
```

```

PAGE 1      11/9/79  A01ST6  ADAPTS
10  REM A01ST6 PHASING CORRECTOR
20  DIM D(3,200),R(3,200),N(3),O(3)
30  READ N( 1),N( 2),N( 3),O( 1),O( 2),O( 3)
40  DATA 2,-1, 5, 2,-1, 6
50  PRINT "FILE TO 1 ON 70"
60  END
70  ASSIGN "DUMMY"=1
80  OPEN 1, 1
90  FOR B= 1 TO 200
100 FOR A= 1 TO 3
110 GET 1,D(A,B)
120 NEXT A
130 NEXT B
140 CLOSE 1
150 PRINT "INPUT NUMBER OF POINTS TO BE SHIFTED";
160 INPUT N
170 FOR B=N+ 1 TO 200
180 FOR A= 1 TO 3
190 LET R(A,B)=D(A,B-N)
200 NEXT A
210 NEXT B
220 FOR B= 1 TO N
230 FOR A= 1 TO 3
240 LET R(A,B)=D(A, 200-N+B)
250 NEXT A
260 NEXT B
270 CALL INIT
280 CALL POS,-512, 399, 0
290 CALL VECT,-512,-400, 0
300 CALL VECT, 512,-400, 0
310 FOR P= 1 TO 3
320 LET L= 400-P* 200
330 CALL POS,-512,L, 0

```

```

PAGE 2      11/9/79   A018T6   ADAPTS
340 FOR Q= 1 TO 199
350 CALL VECT,Q* 5.12- 512,R(P,Q)+L, 0
360 NEXT Q
370 NEXT P
380 PRINT "PLOT IT 1=Y 0=N";
390 INPUT GO
400 IF GO# 1 THEN 60
410 CALL PULSE, 5
420 WAIT 1000
430 CALL DATA,D( 1),-384, 1, 1000, 200
440 CALL DATA,Q( 1), 511, 1, 1000, 200
450 WAIT 2000
460 CALL PULSE, 6
470 WAIT 1000
480 FOR R= 1 TO 100
490 CALL DATA,D( 1), 512-R* 10.24, 1, 30000, 200
500 WAIT 10
510 NEXT R
520 FOR R= 1 TO 75
530 CALL DATA,N( 1),R* 10.24- 384, 1, 30000, 200
540 WAIT 10
550 NEXT R
560 CALL PULSE, 5
570 WAIT 1000
580 FOR Z= 1 TO 3
590 LET M= 513-Z* 256
600 CALL DATA,N( 1),-384, 1, 1000, 200
610 CALL DATA,Q( 1),R(Z, 1)+M, 1, 1000, 200
620 WAIT 2000
630 CALL PULSE, 6
640 WAIT 1000
650 FOR J= 1 TO 200
660 CALL DATA,N( 1),-384+( 3.84*(J- 1)), 1, 1000, 200
670 CALL DATA,D( 1),R(Z,J)+M, 1, 1000, 200

```

PAGE 3 11/9/79 A015T6 ADAFTS

680 WAIT 10

690 NEXT J

700 CALL PULSE, 5

710 WAIT 1000

720 NEXT Z

730 END

```

PAGE 1      11/9/79   AO1ST7   ADAPTS
10  REM NAME... AO1ST7
20  REM FINDS MEANS & S. D. 'S OF AREAS
30  DIM D(3,200),A(30)
40  LET C= 1
50  LET T= 0
60  PRINT "FILE TO 1 ON 80"
70  END
80  ASSIGN "SU239L"=1
90  OPEN  1, 1
100 FOR B= 1 TO  200
110 FOR A= 1 TO  3
120 GET  1,D(A,B)
130 NEXT A
140 NEXT B
150 CLOSE 1
160 LET A= 0
170 LET I= 3
180 LET N=V=W= 1
190 FOR I1= 1 TO  199
200 IF D( 2,I1+ 1)>D( 2,V) THEN 220
210 GOTO 230
220 LET V=I1+ 1
230 NEXT I1
240 FOR I6= 1 TO  199
250 IF D( 2,I6+ 1)<D( 2,W) THEN 270
260 GOTO 280
270 LET W=I6+ 1
280 NEXT I6
290 LET P=M= 1
300 LET X1=D( 2,V)-(N*I)
310 FOR I2=P TO  200
320 IF X1-D( 2,I2)< 0 THEN 350
330 NEXT I2

```

```
340 GOTO 430
350 LET Y(M)=I2
360 FOR I3=I2 TO 200
370 IF X1-D(2,I3)>0 THEN 390
380 NEXT I3
390 LET Y(M+1)=P=I3
400 LET M=M+2
410 IF I3=200 THEN 430
420 GOTO 300
430 FOR I4=1 TO M-1
440 LET C(I4)=D(1,Y(I4))
450 NEXT I4
460 LET L=1
470 FOR I7=L TO M-2
480 IF C(I7+1)>C(L) THEN 500
490 GOTO 530
500 LET F=C(L)
510 LET C(L)=C(I7+1)
520 LET C(I7+1)=F
530 NEXT I7
540 LET L=L+1
550 IF L=M-1 THEN 570
560 GOTO 470
570 IF N#1 THEN 640
580 FOR I8=1 TO M-1
590 LET B(I8)=C(I8)
600 NEXT I8
610 LET N=2
620 LET U=M-1
630 GOTO 290
640 IF M-1>U THEN 660
650 LET U=M-1
660 FOR I5=1 TO U STEP 2
670 LET C(1)=C(I5)+B(I5)
```

```

PAGE 3      11/9/79  A01S17  ADAPTS
680 LET O( 2)=C(I5+ 1)+B(I5+ 1)
690 LET A=A+(O( 1)-O( 2))*I
700 NEXT I5
710 FOR I9= 1 TO M- 1
720 LET B(I9)=C(I9)
730 NEXT I9
740 LET U=M- 1
750 LET N=N+ 1
760 IF D( 2,V)-(N*I)<D( 2,W) THEN 780
770 GOTO 790
780 LET A(C)=A/ 10.24/ 10.24
790 PRINT "AREA";C;"=";A(C)
800 IF C# 1 THEN S30
810 LET T=A(C)
820 GOTO 840
830 LET T=((C- 1)*T+A(C))/C
840 IF C# 1 THEN S70
850 LET X=A(C)*A(C)
860 GOTO 910
870 LET X=X+A(C)*A(C)
880 LET S1=T*T*8C
890 LET S2=(X-S1)/(C- 1)
900 LET S=SQR(S2)
910 PRINT "NEXT FILE, 1=Y 0=N";
920 INPUT GO
930 IF GO# 1 THEN 960
940 LET C=C+ 1
950 IF GO= 1 THEN 60
960 CALL TERM, 1, 1, 5
970 PRINT
980 PRINT
990 PRINT "FILE", "AREA (DEGREES SQUARED)"
1000 FOR J3= 1 TO C
1010 PRINT J3, A(J3)

```

PAGE 4 11/9/79 601ST7 ADAPTS
1020 NEXT JS
1030 PRINT "MEAN AREA=";T
1040 PRINT "STANDARD DEVIATION IN AREA =";S
1050 CALL TTY
1060 END

```
PAGE 1      11/9/79  A01ST8  ADAPTS
10  REM NAME... A01ST8
20  REM SIG OF DIFF BETWEEN MEANS TEST
30  PRINT "PUT IN N1 & N2";
40  INPUT N1,N2
50  LET N3=N1- 1
60  LET N4=N2- 1
70  LET N5=N1*N2
80  LET N6=N1+N2
90  LET N7=N1+N2- 2
100 PRINT "PUT IN XBAR, YBAR, XSD, YSD";
110 INPUT X1,Y1,X2,Y2
120 LET S1=SQR((X2*X2*N3+Y2*Y2*N4)/N7)
130 LET T=(X1-Y1)/(S1*SQR(N6/N5))
140 PRINT T
150 END
```

PAGE 1 11/9/79 UTILITY ADAPTS

```
*** MINTOR ***  
30 REM DUMMY DIM  
560 REM ***MINTOR***  
890 LET R(A,B)=M(A,B)
```

```
READY  
*** SINTOR ***  
30 REM DUMMY DIM  
860 REM ***SINTOR***  
890 LET R(A,B)=S(A,B)
```

READY.

```
*** PSTOR ***  
30 REM DUMMY DIM  
860 REM ***PSTOR***  
890 LET R(A,B)=M(A,B)+S(A,B)
```

```
READY  
*** NSTOR ***  
30 REM DUMMY DIM  
860 REM ***NSTOR***  
890 LET R(A,B)=M(A,B)-S(A,B)
```

READY

```
PAGE 1      11/9/79      FSHIFT      ADAPTS
.278      REM      ***FSHIFT***
.279      REM      SHIFTS ZERO 2CM DOWN PAPER ON STEP PLOTS (AOIST1)
1280      LET P( 1)= 155
1281      LET P( 2)= 1
1282      LET P( 3)=-225
1300      CALL  DATA0( 1),R(Z, 1)+P(Z), 1, 1000, 200
1360      CALL  DATA0( 1),R(Z,J)+P(Z), 1, 1000, 200
```

```

PAGE 1      11/9/79  TABLES  ADAPTS
00 REM NAME... TABLES... FINDS ROM, COR, COM
00 DIM D(18,200)
00 LET N1=F= 1
00 LET N= 0
00 PRINT "INPUT NUMBER OF GROUPS";
00 INPUT NO
00 PRINT "ASSIGN FILE ";N1;" TO 1 ON LINE 90"
00 END
00 ASSIGN "B4N"=1
00 OPEN 1, 1
00 FOR B= 1 TO 200
00 FOR A= 1 TO 3
00 GET 1, D(A+N, B)
00 NEXT A
00 NEXT B
00 LET N=N+ 3
00 LET M1=N1+ 1
00 IF N=NO* 3 THEN 200
00 GOTO 70
00 CLOSE 1
00 LET N= 0
00 LET V=N+ 1
00 FOR A= 1 TO 3
00 LET G= 1
00 IF A= 1 THEN 270
00 GOTO 280
00 LET G= 2
00 FOR E= 1 TO 199
00 IF D(A+N, B+ 1)>D(A+N, V) THEN 310
00 GOTO 320
00 LET V=B+ 1
00 NEXT B
00 LET T(F, A)=D(A+N, V)/ 10.24*G

```

PAGE 2 11/9/79 TABLES ADAPTS

```
340 FOR B= 1 TO 199
350 IF D(A+N, B+ 1)<D(A+N, W) THEN 370
360 GOTO 380
370 LET W=B+ 1
380 NEXT B
390 LET B(F, A)=D(A+N, W)/ 10.24*G
400 LET R(F, A)=T(F, A)-B(F, A)
410 LET C(F, A)=(T(F, A)+B(F, A))/ 2
420 LET S= 0
430 FOR B= 1 TO 200
440 LET S=S+D(A+N, B)
450 NEXT B
460 LET S=S/ 200
470 LET M(F, A)=S/ 10.24*G
480 NEXT A
490 LET F=F+ 1
500 LET N=N+ 3
510 IF N=NO* 3 THEN 530
520 GOTO 220
530 CALL TERM, 1, 1, 5
540 PRINT
550 PRINT TAB( 12)"MAX", TAB( 24)"MIN", TAB( 36)"ROM", TAB( 48)"COR", TAB( 60)"COM"
560 PRINT
570 FOR F= 1 TO NO
580 PRINT "GROUP"; F
590 PRINT "FLEXION";
600 PRINT TAB( 12), T(F, 1); TAB( 24), B(F, 1); TAB( 36), R(F, 1); TAB( 48), C(F, 1);
610 PRINT TAB( 60), N(F, 1)
620 PRINT "ABDUCTION";
630 PRINT TAB( 12), T(F, 2); TAB( 24), B(F, 2); TAB( 36), R(F, 2); TAB( 48), C(F, 2);
640 PRINT TAB( 60), M(F, 2)
650 PRINT "ROTATION";
660 PRINT TAB( 12), T(F, 3); TAB( 24), B(F, 3); TAB( 36), R(F, 3); TAB( 48), C(F, 3);
670 PRINT TAB( 60), M(F, 3)
```

PAGE 3 11/9/79 TABLES ADAPTS -----"

680 PRINT
690 NEXT F
700 CALL TTY
710 END

```
PAGE 1      11/9/79   MSD      ADAPTS
10  REM NAME...MSD...FINDS MEANS AND PEAKS OF S. D. TRACES
20  DIM D(10,200)
30  LET N1=F= 1
40  LET N= 0
50  PRINT "INPUT NUMBER OF GROUPS";
60  INPUT NO
70  PRINT "ASSIGN FILE";N1;"TO 1 ON LINE 90"
80  END
90  ASSIGN "B65748"=1
100 OPEN 1, 1
110 FOR B= 1 TO 200
120 FOR A= 1 TO 3
130 GET 1, D(A+N, B)
140 NEXT A
150 NEXT B
160 LET N=N+ 3
170 LET N1=N1+ 1
180 IF N=NO* 3 THEN 200
190 GOTO 70
200 CLOSE 1
210 LET N= 0
220 LET V=W= 1
230 FOR A= 1 TO 3
240 LET G= 1
250 IF A= 1 THEN 270
260 GOTO 280
270 LET G= 2
280 FOR B= 1 TO 199
290 IF D(A+N, B+ 1)>D(A+N, V) THEN 310
300 GOTO 320
310 LET V=B+ 1
320 NEXT B
330 LET T(F, A)=D(A+N, V)/ 10.24*G
```

```

PAGE 2      11/9/79   MSD      ADAPTS
340 FOR B= 1 TO 199
350 IF D(A+N,B+ 1)<D(A+N,W) THEN 370
360 GOTO 380
370 LET W=B+ 1
380 NEXT B
390 LET B(F,A)=D(A+N,W)/ 10.24*G
400 LET S= 0
410 FOR B= 1 TO 200
420 LET S=S+D(A+N,B)
430 NEXT B
440 LET S=S/ 200
450 LET M(F,A)=S/ 10.24*G
460 NEXT A
470 LET F=F+ 1
480 LET N=N+ 3
490 IF N=NO* 3 THEN 510
500 GOTO 220
510 CALL TERM, 1, 1, 5
520 PRINT
530 PRINT TAB( 12)"MAX",TAB( 24)"MIN",TAB( 36)"MEAN"
540 PRINT
550 FOR F= 1 TO NO
560 PRINT "GROUP";F
570 PRINT "FLEXION";
580 PRINT TAB( 12),T(F, 1);TAB( 24),B(F, 1);TAB( 36),M(F, 1)
590 PRINT "ABDUCTION";
600 PRINT TAB( 12),T(F, 2);TAB( 24),B(F, 2);TAB( 36),M(F, 2)
610 PRINT "ROTATION";
620 PRINT TAB( 12),T(F, 3);TAB( 24),B(F, 3);TAB( 36),M(F, 3)
630 PRINT "-----"
640 NEXT F
650 CALL TTY
660 END

```

```
PAGE 1      11/9/79   AREA1      ADAPTS
10 REM NAME... AREA1
20 DIM D(3,200)
30 PRINT "FILE TO 1 ON 50"
40 END
50 ASSIGN "DUMMY"=1
60 OPEN 1, 1
70 FOR B= 1 TO 200
80 FOR A= 1 TO 3
90 GET 1, D(A, B)
100 NEXT A
110 NEXT B
120 CLOSE 1
130 LET A= 0
140 FOR I= 1 TO 199
150 LET X=D( 2, I+ 1)-D( 2, I)
160 LET Y=D( 1, I+ 1)+D( 1, I)
170 LET A=A+X*Y
180 NEXT I
190 PRINT "AREA="; A/ 10. 24/ 10. 24; "DEGREES SQUARED"
200 END
```

```

1000 AGE J      11/9/79      AREAZ      ADAPTS
1001 REM NAME...AREA2
1002 DIM D(3,200)
1003 PRINT "FILE TO 1 ON 50"
1004 END
1005 ASSIGN "C25978"=1
1006 OPEN 1, 1
1007 FOR B=1 TO 200
1008 FOR A=1 TO 3
1009 GET 1,D(A,B)
1010 NEXT A
1011 NEXT B
1012 CLOSE 1
1013 LET A=0
1014 LET I=3
1015 LET N=V=W=1
1016 FOR I1=1 TO 199
1017 IF D( 2,I1+ 1)>D( 2,V) THEN 190
1018 GOTO 200
1019 LET V=I1+ 1
1020 NEXT I1
1021 FOR I6=1 TO 199
1022 IF D( 2,I6+ 1)<D( 2,W) THEN 240
1023 GOTO 250
1024 LET W=I6+ 1
1025 NEXT I6
1026 LET P=M=1
1027 LET X1=D( 2,V)-(N*I)
1028 FOR I2=P TO 200
1029 IF X1-D( 2,I2)< 0 THEN 320
1030 NEXT I2
1031 GOTO 400
1032 LET Y(M)=I2
1033 FOR I3=I2 TO 200

```

PAGE 2 11/9/79 AREA2 ADAPTS

340 IF X1-D(2,I3)> 0 THEN 360

350 NEXT I3

360 LET Y(N+ 1)=P=I3

370 LET N=M+ 2

380 IF I3= 200 THEN 400

390 GOTO 270

400 FOR I6= 1 TO M- 1

410 LET C(I6)=D(1,Y(I6))

420 NEXT I6

430 LET L= 1

440 FOR I7=L TO M- 2

450 IF C(I7+ 1)>C(L) THEN 470

460 GOTO 500

470 LET F=C(L)

480 LET C(L)=C(I7+ 1)

490 LET C(I7+ 1)=F

500 NEXT I7

510 LET L=L+ 1

520 IF L=M- 1 THEN 540

530 GOTO 440

540 IF N# 1 THEN 610

550 FOR I9= 1 TO M- 1

560 LET B(I9)=C(I9)

570 NEXT I9

580 LET N= 2

590 LET U=M- 1

600 GOTO 260

610 IF M- 1>U THEN 630

620 LET U=M- 1

630 FOR I5= 1 TO U STEP 2

640 LET O(1)=C(I5)+B(I5)

650 LET O(2)=C(I5+ 1)+B(I5+ 1)

660 LET A=A+(O(1)-O(2))*I

670 NEXT I5

```
11/9/79 AREA2 ADAPTS
9= 1 TO M- 1
1(I9)=C(I9)
I9
I=M- 1
I=N+ 1
I 2, V)-(N*I)<D( 2, M) THEN 750
260
["AREA="A/ 10.24/ 10.24"DEGREES SQUARED"
```

```

11/9/79  A01FIT  ADAPTS
FIT... FOURIER FIT UPTO 8TH HARMONIC.
5,200),R(3,200)
7,17),Z(17,17),E(17),F(17),Q(17),X(17),Y(1,17)
8
2*0+ 1
1
'FILE TO 1 ON 90"

"DUMMY"=1
1, 1
= 1 TO 200
= 1 TO 3
1,D(A,B)
A
3
= 1 TO 3
1= 3.14159E-02
=ZER(N,N)
=ZER(N)
= 1 TO 200
2=H*PI
( 1)= 1
2= 1 TO 0
( 2*H2)=COS(H2*P2)
( 2*H2+ 1)=SIN(H2*P2)
H2
= 1 TO N
( 1,E)=X(E)
E
=X*Y
=(D(G,H))*X
= 1 TO N
(C)=B(C)+G(C)

```

PAGE 2 11/9/79 A01FIT ADAPTS

```
340 NEXT C
350 FOR A= 1 TO N
360 FOR B= 1 TO N
370 LET A(A,B)=A(A,B)+Z(A,B)
380 NEXT B
390 NEXT A
400 NEXT H
410 REM NOW WE START THE ELIMINATIONS.
420 FOR I= 1 TO N
430 REM HERE WE LOOK FOR THE LARGEST ELEMENT IN A COLUMN.
440 LET X=-1
450 FOR K=I TO N
460 IF ABS(A(K,I))<X THEN 490
470 LET Q=K
480 LET X=ABS(A(K,I))
490 NEXT K
500 IF X> 0 THEN 530
510 PRINT "MATRIX OF COEFFICIENTS IS SINGULAR...."
520 END
530 REM HERE WE START THE INTERCHANGE, IF NEEDED.
540 IF I=Q THEN 650
550 FOR J= 1 TO N
560 LET T=A(I,J)
570 LET A(I,J)=A(Q,J)
580 LET A(Q,J)=T
590 NEXT J
600 FOR J= 1 TO N
610 LET T=B(I,J)
620 LET B(I,J)=B(Q,J)
630 LET B(Q,J)=T
640 NEXT J
650 REM NOW WE ELIMINATE ON THAT ONE ROW.....
660 FOR J= 1 TO N
670 IF I<J THEN 700
```

PAGE 8 11/9/79 A01FIT ADAPTS

```
680 LET M1=J- 1
690 GOTO 710
700 LET M1=I- 1
710 LET S= 0
720 FOR K= 1 TO M1
730 LET S=S+A(I,K)*A(K,J)
740 NEXT K
750 LET A(I,J)=A(I,J)+S
760 IF I=J THEN 780
770 LET A(I,J)=-A(I,J)/A(I,I)
780 NEXT J
790 NEXT I
800 REM NOW WE HAVE THE REDUCED LEFT HAND SIDE. . NOW STARTS THE RIGHT.
810 FOR J= 1 TO M
820 FOR I= 1 TO N
830 LET S= 0
840 FOR K= 1 TO I- 1
850 LET S=S+A(I,K)*B(K,J)
860 NEXT K
870 LET B(I,J)=-B(I,J)+S/A(I,I)
880 NEXT I
890 FOR I=N TO 1 STEP -1
900 LET S= 0
910 FOR K=I+ 1 TO N
920 LET S=S+A(I,K)*B(K,J)
930 NEXT K
940 LET B(I,J)=-B(I,J)+S
950 NEXT I
960 NEXT J
970 REM NOW WE START THE PRINTOUT. ....
980 FOR J= 1 TO M
990 PRINT
1000 PRINT "ANSWER SET " ; J
1010 FOR I= 1 TO N
```

PAGE 4 11/9/79 A01FIT ADAPTS

```
1020 PRINT B(I,J),
1030 NEXT I
1040 PRINT
1050 NEXT J
1060 REM NOW WORK OUT THE CURVES
1070 FOR H= 1 TO 200
1080 LET P2=H*PI
1090 LET X( 1)= 1
1100 FOR H2= 1 TO 0
1110 LET X( 2*H2)=COS(H2*P2)
1120 LET X( 2*H2+ 1)=SIN(H2*P2)
1130 NEXT H2
1140 LET F1= 0
1150 FOR I1= 1 TO N
1160 LET F(I1)=X(I1)*E(I1)
1170 NEXT I1
1180 FOR I2= 1 TO N
1190 LET F1=F1+F(I2)
1200 NEXT I2
1210 LET R(G,H)=F1
1220 NEXT H
1230 NEXT G
1240 CALL INIT
1250 CALL POS,-512, 399, 0
1260 CALL VECT,-512,-400, 0
1270 CALL VECT, 512,-400, 0
1280 FOR P= 1 TO 3
1290 LET L= 400-P* 200
1300 CALL POS,-512,L, 0
1310 FOR V= 1 TO 199
1320 CALL VECT,V* 5.12- 512,L(P,V)+L, 0
1330 NEXT V
1340 CALL POS,-512,L, 0
```

PAGE 5 . 11/9/79 ADIFIT ADAPTS
1340 CALL VECT, V* 5.12- 512, R(P, V)+L, 0
1370 NEXT V
1380 NEXT P
1390 END

