

Durham E-Theses

Studies on the herring gull population in North Yorkshire

Marianthe C. Mericas Leach

How to cite:

Leach, Marianthe C. Mericas (1980) *Studies on the herring gull population in North Yorkshire*. Masters thesis, Durham University.

Use policy

The full-text may be used and/or reproduced, and given to third parties in any format or medium, without prior permission or charge, for personal research or study, educational, or not-for-profit purposes provided that:

- a full bibliographic reference is made to the original source
- a <https://etheses.durham.ac.uk/id/eprint/7801/> is made to the metadata record in Durham E-Theses
- the full-text is not changed in any way

The full-text must not be sold in any format or medium without the formal permission of the copyright holders.

Please consult the [full Durham E-Theses policy](#) for further details.

Studies on the Herring Gull Population
in North Yorkshire

Marianthe C. Mericas Leach, B.Sc.
(Tulane University)

being a thesis presented in candidature
for the degree
Masters of Science in the University of Durham, 1980

The copyright of this thesis rests with the author.
No quotation from it should be published without
his prior written consent and information derived
from it should be acknowledged.



Abstract

A census of Herring Gulls (Larus argentatus) breeding along the Cleveland and Yorkshire coast was conducted during 1978 and 1979. Herring Gulls present between Hedcar and Black Nab, south of Whitby and between Black Nab and Filey Brigg were observed throughout the year July 1978 to July 1979. The Herring Gulls observed included a proportion with colour-rings on their legs. Ringing of Herring Gulls was carried out both in the study area and north of it from 1976 onwards by a team from the University of Durham Zoology department. Population estimates are obtained from the census of breeding Herring Gulls as well as from 'mark and recapture' observations throughout the year. Movements of the Herring Gulls are examined together with the distances of these movements. The behaviour of 1st and 2nd year Herring Gulls is compared with that of Herring Gulls older than 2 years. The data from the census of breeding Herring Gulls, the population estimates and the movement data are compared with data previously obtained in this and other areas by other authors to obtain colony growth rates and establish immigration and emigration patterns to and from the area of study. The rates of increase and the movements throughout the year observed in the study area are discussed.

Acknowledgements

I would like to thank Dr. J.C.Coulson who supervised this research for his advice and guidance.

This research was performed while at the University of Durham, and I am grateful to Professor D.F.Baker for the facilities provided in the Department of Zoology.

My thanks go to Sue V.Kearsey for the use of her census data on Herring Gulls nesting on buildings in Cleveland and Yorkshire coastal towns, as well as for ideas and practical assistance in this work. I also want to thank C.Wells for the use of his census data on Herring Gulls nesting along cliffs between Speeton and Gull Nook.

I wish to thank all of the people who have ringed Herring Gulls in N.E.England and have collected sighting information on these birds. My appreciation also goes to members of the Department of Zoology who provided stimulation and ideas.

I am grateful to Mrs.J.Hardman for the preparation of this manuscript.

My particular thanks go to my husband, Colin, for preparing the figures in this work, and for his encouragement and patience, without which this work could not have been completed.

Table of Contents

	page
I. Introduction.	1.
II. History.	3.
III. Methods.	4.
A. Census of breeding Herring Gulls.	4.
B. Census of Herring Gulls throughout the year.	5.
IV. Results.	9.
A. Differences in behaviour between 1st and 2nd year Herring Gulls and Herring Gulls older than 2 years.	9.
1. Observed changes in age ratios.	9.
2. Uniformity of daily age ratios.	11.
3. Resighting probabilities for age classes.	12.
B. Population estimates.	15.
1. Census of breeding Herring Gulls.	15.
2. Census of Herring Gulls throughout the year.	19.
a. Herring Gulls older than 2 years.	19.
1.) Mark and recapture population estimates.	19.
2.) The breeding season population.	24.
a.) Breeding season population age composition : Life Tables.	25.
b.) Breeding season population estimates derived from the life tables.	28.
c.) Comparison of mark and recapture population estimates with the breeding season population estimates.	30.

Table of Contents./ Contd...

	page
b. 1st and 2nd year Herring Gulls.	33.
1.) Mark and recapture population estimates.	33.
2.) Comparison of the estimated age ratios with the observed age ratios.	37.
C. Movements.	41.
1. Movements throughout the year : Immigration and Emigration.	41.
a. Herring Gulls older than 2 years.	41.
b. 1st and 2nd year Herring Gulls.	50.
2. Distances of movements.	53.
a. Movement of colour-ringed Herring Gulls in relation to Areas 1 and 2.	53.
b. Distances travelled by colour-ringed Herring Gulls.	54.
V. Discussion.	57.
VI. Summary.	62.
Bibliography.	72.
Appendices.	77.

Table of Tables

	page
Table 1. The stretches of cliff examined from either below the cliffs or from the cliff tops.	4.
Table 2. The proportion of 1st and 2nd year Herring Gulls in observation samples grouped by marking periods.	10.,11.
Table 3. χ^2 test for consistency of the ratio of 1st and 2nd years : older Herring Gulls in observation samples.	12.
Table 4. The probability of a colour-ringed Herring Gull being resighted.	14.
Table 5. Number of pairs of Herring Gulls nesting on cliffs from surveys in 1969-1970 and 1978-1979.	16.
Table 6. Number of pairs of Herring Gulls nesting on buildings, from the 1969-1970, 1976, and 1978-1979 surveys.	17.
Table 7. A comparison of Herring Gull populations nesting on buildings and cliffs from the 1969/1970 and the 1978/1979 surveys (taken from the data in Tables 5 and 6).	17.
Table 8. Numbers of Herring Gull pairs nesting on particular cliff areas censused in both 1978 and 1979, and compared with counts from 1969.	18.
Table 9. Mark and recapture population estimates for Herring Gulls older than 2 years in Area 1 using the ratios of marked individuals seen to individuals with visible legs in Appendix 6B.	20.
Table 10. Mark and recapture population estimates for the October and November marking periods in Area 1 using the same sighting periods, (for Herring Gulls older than 2 years).	22.

Table of Tables./ Contd...

	page
Table 18. Changes in the proportion of marked to unmarked Herring Gulls older than 2 years following each marking period in Area 1.	42, 43.
Table 19. Changes in the proportion of marked to unmarked Herring Gulls older than 2 years following each marking period in Area 2.	48.
Table 20. The movement of colour-ringed Herring Gulls in relation to Areas 1 and 2.	53.
Table 21. The median for all colour-ringed Herring Gulls of the furthest distance that individual colour-ringed Herring Gulls were observed to have travelled from data in Appendix 8.	54.

Table of Figures

- Figure 1. Herring Gull legs with 1 monel and 3 Darvic rings.
- Figure 2. Observation sites on the Cleveland - Yorkshire coast in N.E. England.
- Figure 3. Number of pairs of nesting Herring Gulls on the Yorkshire and Cleveland coast, 1978-1979.
- Figure 4. Mark and recapture population estimates for Herring Gulls older than 2 years.
- Figure 5. Mark and recapture population estimates for 1st and 2nd year Herring Gulls.
- Figure 6. Changes in the proportion of marked to unmarked Herring Gulls older than 2 years in sample groups of approx. 1000 individuals, following each marking period in Area 1.
- Figure 7. Changes in the proportion of marked to unmarked Herring Gulls older than 2 years in sample groups of approx. 1000 individuals, following each marking period in Area 2.
- Figure 8. Movements throughout the year of Herring Gulls older than 2 years in Area 1 and Area 2.
- Figure 9. Changes in the estimated population level and the proportion in the observed population of 1st and 2nd year Herring Gulls in Areas 1 and 2.
- Figure 10. The number of colour-ringed Herring Gulls resighted at or beyond successive distances, (Areas 1 and 2 combined - 381 individuals).

I. Introduction.

The major concentration of Herring Gulls (Larus argentatus) breeding in N.E. England occurs south of the River Tees on the Cleveland and Yorkshire coast between Saltburn (Cleveland) and Bridlington (Yorkshire), where the gulls nest both on seacliffs and on buildings in coastal towns. North of Saltburn, the nearest colony is Sunderland (43 km), and from the River Tees to the Scottish border there are only about 600 pairs of breeding Herring Gulls. (Coulson pers comm.). There are no coastal colonies south of Bridlington until Orfordness, Suffolk, (Cramp 1971).

Herring Gulls disperse from their breeding colonies in the autumn, travel variable distances, and return to their breeding areas in the spring. Individual populations disperse in different directions and distances in distinct patterns, (Olsson 1958, Moore 1976). Some populations travel long distances, such as those in N. Norway that travel as far south as the English Channel, (Olsson 1958). British Herring Gulls are not known to travel long distances, and the furthest recoveries have been in Denmark and Germany, from the Isle of May in Scotland, (Parsons and Duncan 1978). It is unlikely that British Herring Gulls travel as far as S.France, Spain, or Portugal, (Harris 1964).

Herring Gulls that breed in north and east Scotland and northern Norway are known to winter in N.E. England, (Thomson 1924, Olsson 1958, Parsons and Duncan 1978). The winter Herring Gull population north of the River Tees in N.E. England consists mostly of Scottish and Norwegian breeding birds with a small proportion of locally breeding birds, (Monaghan 1976).

The purpose of this study was to measure the size of the Herring Gull populations breeding and wintering in coastal N.E. England south of the River Tees between Saltburn (Cleveland) and Bridlington (Yorkshire) in 1978 and 1979, and determine what population changes occurred throughout



the year, (July 1978 to July 1979). This was done by examining the flux in numbers using the mark and recapture technique with colour-ringed individuals. The mark and recapture method of population estimation is limited in that it assumes that there are no differences in emigration, mortality and probability of recapture between marked and unmarked individuals. It also assumes that there is no immigration nor mortality between marking and recapture. If there is immigration after marking but before recapture, the estimate is an overestimate for the time of marking but is accurate for the population size at the time of recapture, although it ignores mortality. If there is no immigration, the estimate is accurate at the time of marking but may be an overestimate at the time of recapture due to emigration or mortality. This thesis is an attempt to test the potential of the use of this method in studying population flux of the Herring Gulls in the Cleveland and Yorkshire study area.

II. History of coastal Herring Gull colonies in N.E. England south of the River Tees.

The first detailed record of Herring Gull colonies on the Yorkshire and Cleveland coasts was in 1907 when Nelson reported Herring Gulls nesting on cliffs between Saltburn and Robin Hood's Bay, and between Gristhorpe Cliffs and Filey; with colonies at Boulby, Staithes, Kettleness, and Whitby Highheights. There were also a few nests at Old Peak and Ravenscar, Burniston Bay, Speeton and Dane's Dyke. Attempts to nest at Bempton, at that time, were prevented by egg collectors protecting the auk colonies. (All of these location names are on the 1:50,000 series Ordnance Survey map, sheets 94 and 101.)

Herring Gulls were first recorded nesting on rooftops in Whitby in 1942, Scarborough in 1967, Runswick in 1969, (B.T.Fewster, A.Wallis, and W.Norman respectively in Cramp, 1971); in Staithes, Cowbar and Robin Hood's Bay in 1947, (Chislett 1953); and in Fylingthorpe and Filey in 1976, (Monaghan and Coulson 1977).

These town and cliff populations were covered in a national census of seabirds, 'Operation Seafarer', in 1969-1970, with the exception of the Runswick to Sandsend cliffs. The town populations were surveyed again in 1976, in a national census of gulls nesting on buildings in Britain and Ireland, (Monaghan and Coulson 1977). The data from these two surveys have been included in this work for comparison with the 1978-1979 counts.

III. Methods.

A. Census of breeding Herring Gulls.

Herring Gulls breeding on coastal cliffs between Saltburn and Filey, and between Gull Nook and Bridlington were censused. Due to the distances involved and the difficulty of access to the shore under some of the cliffs, this survey was carried out over two breeding seasons, 1978 and 1979. Nesting Herring Gulls were counted from beneath the cliffs where possible, and from the clifftops otherwise, as detailed in Table 1.

Table 1. The stretches of cliff examined from either below the cliffs or from the clifftops. (All names are from the Ordnance Survey maps, 1:50,000 series, sheets 94 and 101.)

<u>Below Cliffs</u>	<u>Clifftops</u>
Saltburn to Port Mulgrave	Port Mulgrave to Lingrow Knock
Lingrow Knock to Loop Wyke	Loop Wyke to Whitby
Whitby to Lighthouse near Black Nab	Lighthouse to Maw Wyke Hole
Maw Wyke Hole to south end of Ravenscar	Ravenscar to Cromer Point
Cromer Point to Cayton Bay	Cayton Bay to Bridlington

Most counts were taken during the breeding seasons' peaks. It was not possible to cover the entire area within these peak time periods due to the large area covered and the limited time available for this census. A few counts were taken early and late in the season, and possibly were underestimates; but these were only a small portion of the overall census.

Most colonies were censused only once, but certain easily accessible colonies censused in 1978 were counted again in 1979 to check the extent of yearly fluctuations of the nesting population, (shown in Table 8).

Cliff faces were clearly visible from their bases with only a few potential nesting sites obscured by tall grasses or rocks. Most of the cliff faces were clearly visible from the clifftops, with less than 10% obscured by jutting rocks or the overall structure of the cliffs. Since the cliff

faces observed from the clifftops were inaccessible from beneath, these counts should be comparable with previous surveys along the same areas. Nests were found mainly on rock ledges, with some on grassy slopes well out of human reach. The numbers of breeding pairs were minimal counts, as there may have been obscured nests, and included visible nests and groups of chicks.

A 1978-1979 survey of Herring Gulls nesting on buildings in coastal towns between Saltburn and Bridlington by S.V.Kearsey (pers comm.) and a 1979 survey of Herring Gulls nesting on cliffs between Speeton and Gull Nook by C.Wells (pers comm.) were used in this study to give a complete census of coastal breeding Herring Gulls between Saltburn and Bridlington.

B. Census of Herring Gulls throughout the year.

Due to the large distances involved, half of the area stretching along the coast from the River Tees to Bridlington was studied to investigate the changes in the Herring Gull population throughout the year. This area was subdivided into Area 1, between Redcar (O.S. map reference NZ600255) and Black Nab (NZ928103), and Area 2, between Black Nab and Filey (TA119800).

Ringing of wintering Herring Gulls between Co. Durham and Scarborough has been carried out by the University of Durham since 1976. Varying colour combinations of three or four Davis coloured rings plus one British Trust for Ornithology monel ring have been used, each colour combination identifying a single individual, (Figure 1).

Counts of Herring Gulls were made on the coast, on refuse tips, and in fields where the birds were feeding or loafing. Emphasis was placed on easily accessible areas regularly frequented by Herring Gulls. Other sighting areas which were not easily accessible or reliable were not visited

Figure 1. Herring Gull legs with 1 monel and 3 Darvic rings.

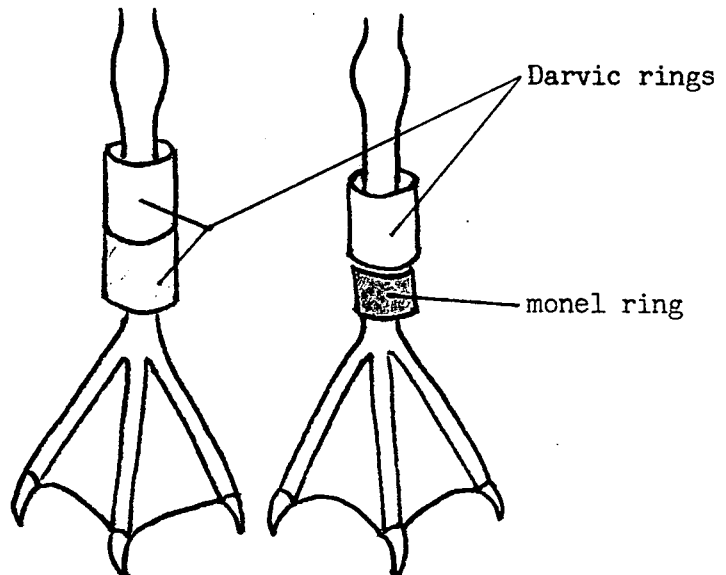
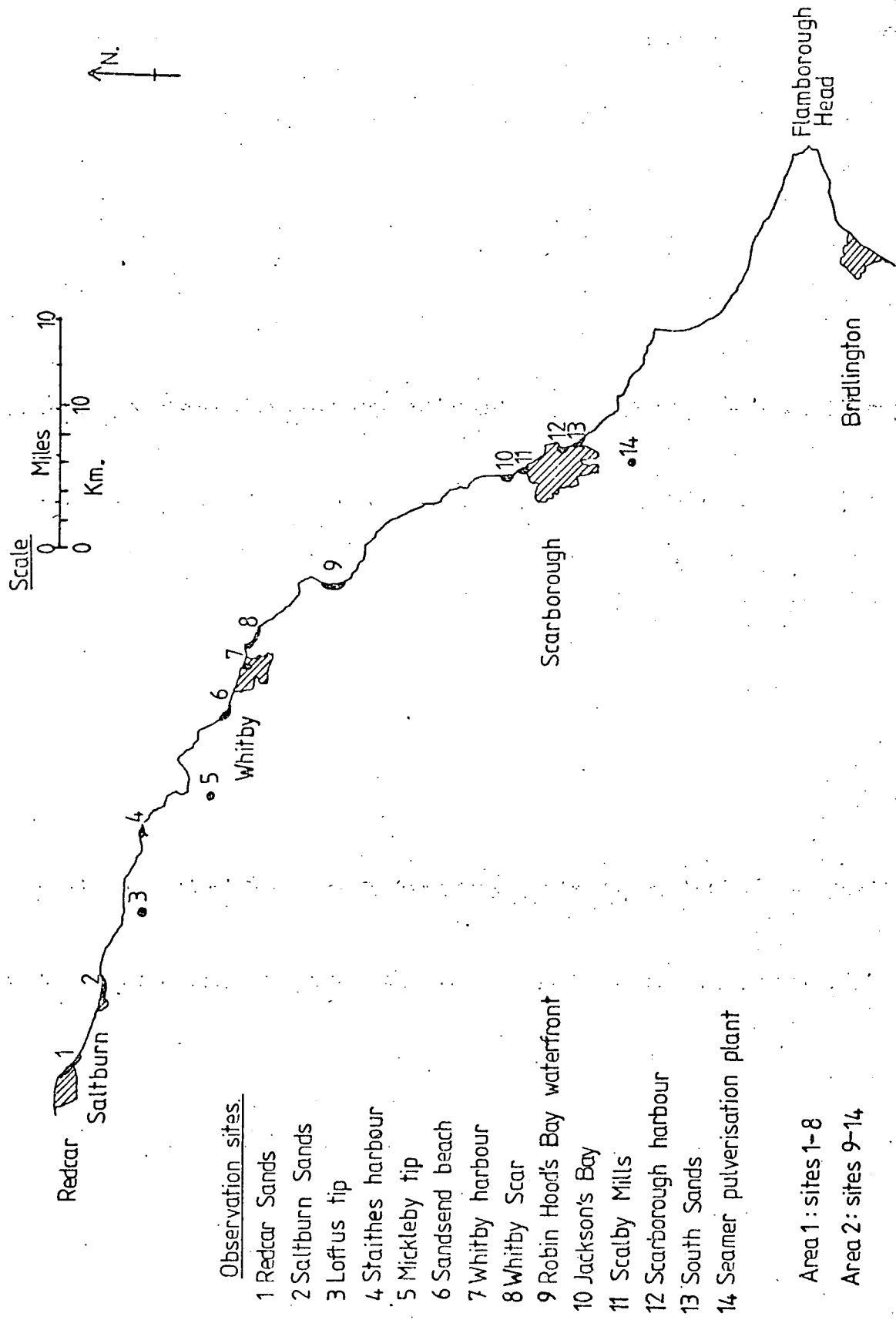

Figure 2. Observation sites on the Cleveland-Yorkshire coast in N.E.England.



as often. A map of observation sites and their emphasis is shown in Figure 2.

Observations, taken between July 1978 and July 1979, included the total number of Herring Gulls seen; the number of 1st and 2nd year birds; the number with visible legs; the number of 1st and 2nd year birds with visible legs; and the number of colour-ringed individuals, their colour-ring combinations and their ages. Unidentifiable colour-ring combinations were ignored.

The number of Herring Gulls present and the number with visible legs in each daily sighting sample are shown in Appendix 2. The number of 1st and 2nd year birds and the number of older birds present in each sample are shown in Appendix 3.

The number of 1st and 2nd year birds with visible legs in each sample was not always known. During sightings, a count of the number of Herring Gulls present and the ratio of 1st and 2nd year to older Herring Gulls were taken first. Then a count of individuals with visible legs and colour-ring observations were made. The Herring Gulls occasionally flew away before an age ratio could be measured on birds with visible legs. The ratio of the proportion of 1st and 2nd year birds in the number of Herring Gulls present, (Appendix 3), to the proportion of 1st and 2nd year birds in the number of Herring Gulls with visible legs, (Appendix 4), was examined in individual samples where both proportions were available, (Appendix 5). These ratios showed a mean of 0.99 with a standard deviation of 0.083 in Area 1, and a mean of 1.01 with a standard deviation of 0.016 in Area 2. From this it was assumed that the proportion of 1st and 2nd year birds in the number of Herring Gulls present was also the proportion in the number of Herring Gulls with visible legs, in samples where both proportions were not available. The number of 1st and 2nd year birds with visible legs in each sample is shown in Appendix 6A; and the number of older Herring Gulls with visible legs in each sample is shown in

Appendix 6B.

Observation sites were grouped into Area 1 and Area 2 to avoid discrepancies between individual sites in the frequency at which marked individuals were seen.

The probability of seeing a 1st and 2nd year colour-ringed individual more than once, and the probability of seeing a colour-ringed individual older than 2 years more than once were calculated, to determine whether 1st and 2nd year birds moved around differently than older birds, (Table 4).

To determine what changes occurred in the population through the year, population estimates were calculated. The mark and recapture method was used. Birds were marked during a certain period of time called a "marking period". A marked bird was a colour-ringed individual that was ringed, or a previously ringed individual seen during the "marking period". The number of birds marked on any one day was small, so "marking periods" ranged in length from one to three months. "Marking periods" are listed in Appendix 6A and 6B.

The proportion of marked birds to birds with visible legs, (also in Appendix 6A and 6B), was observed in a period of time immediately following the "marking period" called the "sighting period". The number of colour-ringed individuals seen on any one day was small, so "sighting periods" ranged in length from 26 days to nine months. They included consecutive sighting dates that showed uniformity in the proportion of marked birds to birds with visible legs as tested by the χ^2 homogeneity test, (Appendix 9a and 9b). The length of a "sighting period" was determined by the number of consecutive sighting dates that showed this uniformity. This removed from the population estimate any changes in the population that occurred after the "marking period", which would have changed the proportion of marked to unmarked individuals in the observed population.

The proportion of marked birds to birds with visible legs, and the number of birds actually marked were used to calculate the overall number of birds that had been present in the area at any time during the "marking period".

The formula used was the basic mark and recapture relationship with minor adjustments proposed by Bailey (1952):

$$p = \frac{a(n+1)}{r+1}$$

where p = the population estimate;

a = the number of Herring Gulls marked during the period in question;

n = the number of Herring Gulls with visible legs in the sighting period; and

r = the number of sightings of marked Herring Gulls.

Variance of the population estimate was calculated by the formula:

$$\text{var } P = \frac{a^2(n+1)(n-r)}{(r+1)^2(r+2)}$$

and the standard error of the population estimate was the square root of the variance.

Individual colour-ringed Herring Gulls were examined to determine the nature and distance of their movements. The proportion of colour-ringed Herring Gulls seen in Areas 1 and 2 between July 1978 and July 1979 that were seen more than once during this period, though not necessarily within Areas 1 and 2, was determined, (Appendix 7). The movements of these individuals in relation to Areas 1 and 2 were examined, (Table 20). The furthest distance moved by each bird between the first and subsequent sightings was calculated, (Appendix 8).

IV. Results.

A. Differences in behaviour between 1st and 2nd year Herring Gulls and Herring Gulls older than 2 years.

The ratios of 1st and 2nd year birds to older Herring Gulls in observation samples, and the probability of resighting 1st and 2nd year birds and older Herring Gulls were examined to determine whether there were differences between the behaviour of 1st and 2nd year birds and older Herring Gulls in the study area.

1. Observed changes in age ratios.

The means of the observed proportion of 1st and 2nd year birds in daily samples were calculated for each marking period, in both Areas 1 and 2, (Table 2). The proportion of 1st and 2nd year birds decreased from 31% in July-September 1978 to 17% in May-July 1979 in Area 1. In Area 2, the proportion decreased marginally from 27% in July-October 1978 to 23% in April-June 1979.

The expected decreases in these proportions through the year due to the higher mortality rate of 1st year birds were calculated, (Table 2). A mortality rate of 0.20 for 1st year birds, and of 0.06 for 2nd year and older birds were used, (Chabrzyk and Coulson 1976). The expected decrease due to different age survival was 27% to 23% in Area 2, which completely accounts for the observed change. In Area 1, the expected decrease due to different age survival was 31% to 26%, which accounted for less than half of the observed decrease from 31% to 17%.

This discrepancy suggests that there were different amounts of movement between 1st and 2nd year birds and older birds into and out of Area 1. Different amounts of movement between 1st and 2nd year and older Herring Gulls have also been observed by Monaghan (1976) in N.E. England, north of the River Tees, and by Lloyd (1968) in Aberdeenshire.

Table 2. The proportion of 1st and 2nd year Herring Gulls in observation samples grouped by marking periods.

Area 1

Marking period	Total number of Herring Gulls	Number of 1st and 2nd year Herring Gulls	Percentage of 1st and 2nd year Herring Gulls	S.E. of percentage	Expected decrease for different age survival rates
5. 7.78 to 28. 9.78	3220	1005	31.2	+0.82	31.2
29. 9.78 to 30.10.78	2449	636	26.0	+0.89	↓
1.11.78 to 21.11.78	4419	790	17.9	+0.58	
27.11.78 to 18. 1.79	2859	546	19.1	+0.74	
25. 1.79 to 8. 3.79	3765	654	17.4	+0.62	
14. 3.79 to 26. 4.79	2809	468	16.7	+0.70	
2. 5.79 to 23. 7.79	3904	681	17.4	+0.61	

Area 2

21. 7.78 to 30.10.78	2313	628	27.2	+0.93	27.2
1.11.78 to 18. 1.79	5047	1302	25.8	+0.62	↓
25. 1.79 to 8. 3.79	1321	346	26.2	+1.21	

Table 2. /Contd...

Area 2

Marking period	Total number of Herring Gulls	Number of 1st and 2nd year Herring Gulls	Percentage of 1st and 2nd year Herring Gulls	S.E. of percentage	Expected decrease for different age survival rates
13. 3.79 to 23. 4.79	3633	895	24.6	+0.71	↓ 22.8
26. 4.79 to 29. 6.79	4213	975	23.1	+0.65	

2. Uniformity of daily age ratios.

Observations taken during each marking period were tested for homogeneity of the proportion of 1st and 2nd year birds to older Herring Gulls by χ^2 , (Table 3). None of the marking periods in Area 1 or Area 2 showed homogeneity; so the 1st and 2nd year birds were separated from the older birds in the observation samples before use in the mark and recapture population estimates.

This indicates that 1st and 2nd year Herring Gulls and older Herring Gulls did not behave uniformly in both Areas 1 and 2, and supports the possibility that there were different amounts of movement between the two age groups. Different behaviour between immatures and adults has been observed by Verbeek(1977), who noted that they were less efficient feeders than adults, and by Davis(1975) and Cooke and Ross(1972), who noted that

they moved around more, and spent more time feeding than adults. Spaans (1971) and Moore (1976) observed that 1st and 2nd years travel further in their winter dispersal than older birds.

Table 3. χ^2 Test for consistency of the ratio of 1st and 2nd years: older Herring Gulls in observation samples.

Area 1

Time period	χ^2	Degrees of freedom	p
1.11.78 to 18. 1.79	113.4	10	<0.001
25. 1.79 to 8. 3.79	25.8	7	<0.001
14. 3.79 to 26. 4.79	128.2	8	<0.001
2. 5.79 to 23. 7.79	125.1	12	<0.001

Area 2

1.11.78 to 18. 1.79	64.6	6	<0.001
8. 2.79 to 8. 3.79	85.5	5	<0.001
13. 3.79 to 23. 4.79	56.8	6	<0.001
26. 4.79 to 29. 6.79	261.5	9	<0.001

3. Resighting probabilities for age classes.

The probabilities of resighting a colour-ringed 1st or 2nd year Herring Gull or a colour-ringed Herring Gull older than 2 years are shown in Table 4. The probability of seeing a colour ringed Herring Gull older than 2 years more than once on different days, (0.50 ± 0.03 in Area 1 and 0.45 ± 0.03 in Area 2), was greater than the probability of seeing a colour-ringed 1st or 2nd year Herring Gull again, (0.32 ± 0.05 in Area 1 and 0.17 ± 0.11 in Area 2). This indicated that some 1st and 2nd year Herring Gulls frequented the observation sites less consistently and moved around more than older Herring

Gulls. The probability of sighting either aged individual 3 or more times on different days was equal. This indicated that a portion of the 1st and 2nd year birds visited the observation sites as consistently as the older Herring Gulls.

The frequency at which colour-ringed Herring Gulls older than 2 years were seen more than once was equal for both Area 1 and Area 2; but marked individuals were more likely to be seen at least three times or more in Area 1 than in Area 2 (approximately 41% more than were seen in Area 2). This may account for the discrepancy between the two study areas in the probability of sighting a colour-ringed individual on three or more occasions.

This correlates with the non-uniform behaviour of 1st and 2nd year birds with older Herring Gulls in Areas 1 and 2 demonstrated by the χ^2 test on daily age ratios, (page 11). Older Herring Gulls may have been more consistent in their behaviour than some of the 1st and 2nd year Herring Gulls due to specialized feeding by older Herring Gulls. Davis (1974) similarly observed that adults were more consistent in their feeding sites than immatures. Specialized feeding by adult Herring Gulls was observed by Davis (1975).

Table 4. The probability of sighting a colour-ringed Herring Gull more than once within a particular study area.

Area 1

Number of sightings	Number of Herring Gulls older than 2 years sighted on at least this many occasions	Probability of seeing a Herring Gull older than 2 years on at least this many occasions	Number of 1st and 2nd year Herring Gulls sighted on at least this many occasions	Probability of seeing a 1st or 2nd year Herring Gull on at least this many occasions
1	321	1.0	101	1.0
2	161	.50 ± 0.03	32	.32 ± 0.05
3	67	.21 ± 0.02	18	.18 ± 0.04
4	33	.10 ± 0.02	9	.09 ± 0.03
5	22	.07 ± 0.01	5	.05 ± 0.02
6	9	.02 ± 0.01	2	.02 ± 0.01
7	4	.01 ± 0.01		
8	3	.01 ± 0.01		

Area 2

1	228	1.0	12	1.0
2	103	.45 ± 0.03	2	.17 ± 0.11
3	25	.11 ± 0.02	2	.17 ± 0.11
4	8	.04 ± 0.01	1	.08 ± 0.08
5	4	.02 ± 0.01	1	.08 ± 0.08

B. Population estimates.

1. Census of breeding Herring Gulls.

The distribution of nesting Herring Gulls in the 1978-1979 census along the Yorkshire and Cleveland coast, between Saltburn and Bridlington, is shown in Figure 3. These data are presented along with observation dates in Appendix 1. Major concentrations of breeding pairs were found at Huntcliff, near Saltburn; between Skinningrove and Staithes; at Kettleness; between Whitby and Robin Hood's Bay; at Ravenscar; Cloughton Wyke and Hunsdale Point; Scarborough; Lebberston Cliffs; between Gristhorpe Cliffs and Filey Brigg; and between Speeton and Flamborough Head.

The mean annual rate of increase for the whole coast was 4% over the last ten years, (Table 7).

Comparison of the cliff populations in 1978-1979 with the data from the 1969-1970 survey showed that these populations had been growing at a mean rate of 3% per annum during this time period, (Table 5).

The number nesting on buildings in 1978-1979, compared with those of the previous surveys, showed a mean annual growth rate of 22% over the last ten years, with the exceptions of Runswick and Filey where the colonies were not yet established, (Table 6).

Between the 1969-1970 and the 1978-1979 surveys, the proportion of Herring Gulls nesting on buildings rose from 3% to 12% of the total population along the Yorkshire and Cleveland coast, (Table 7).

Figure 3. Number of pairs of nesting Herring Gulls on the Yorkshire and Cleveland coast, 1978-1979.

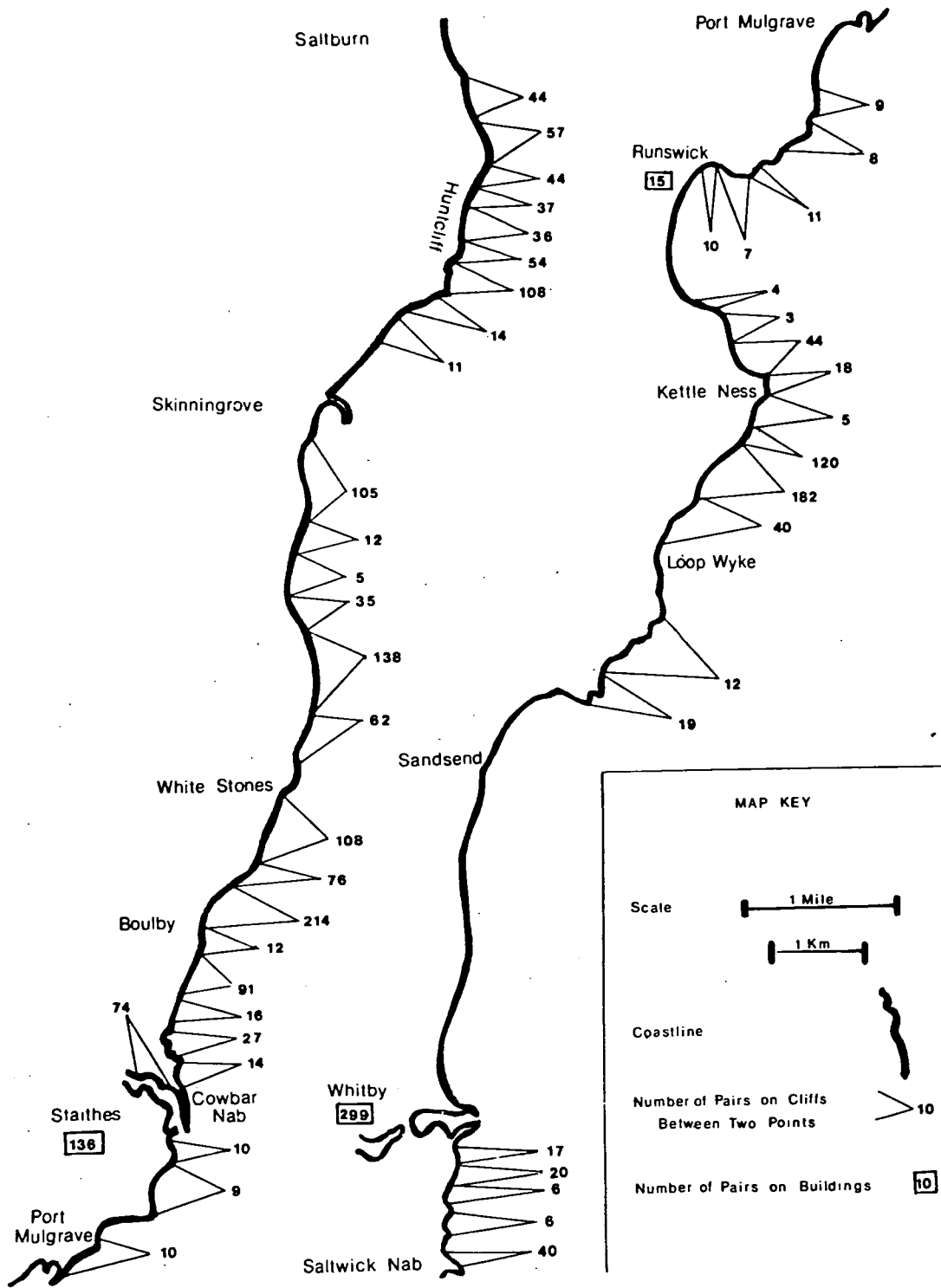

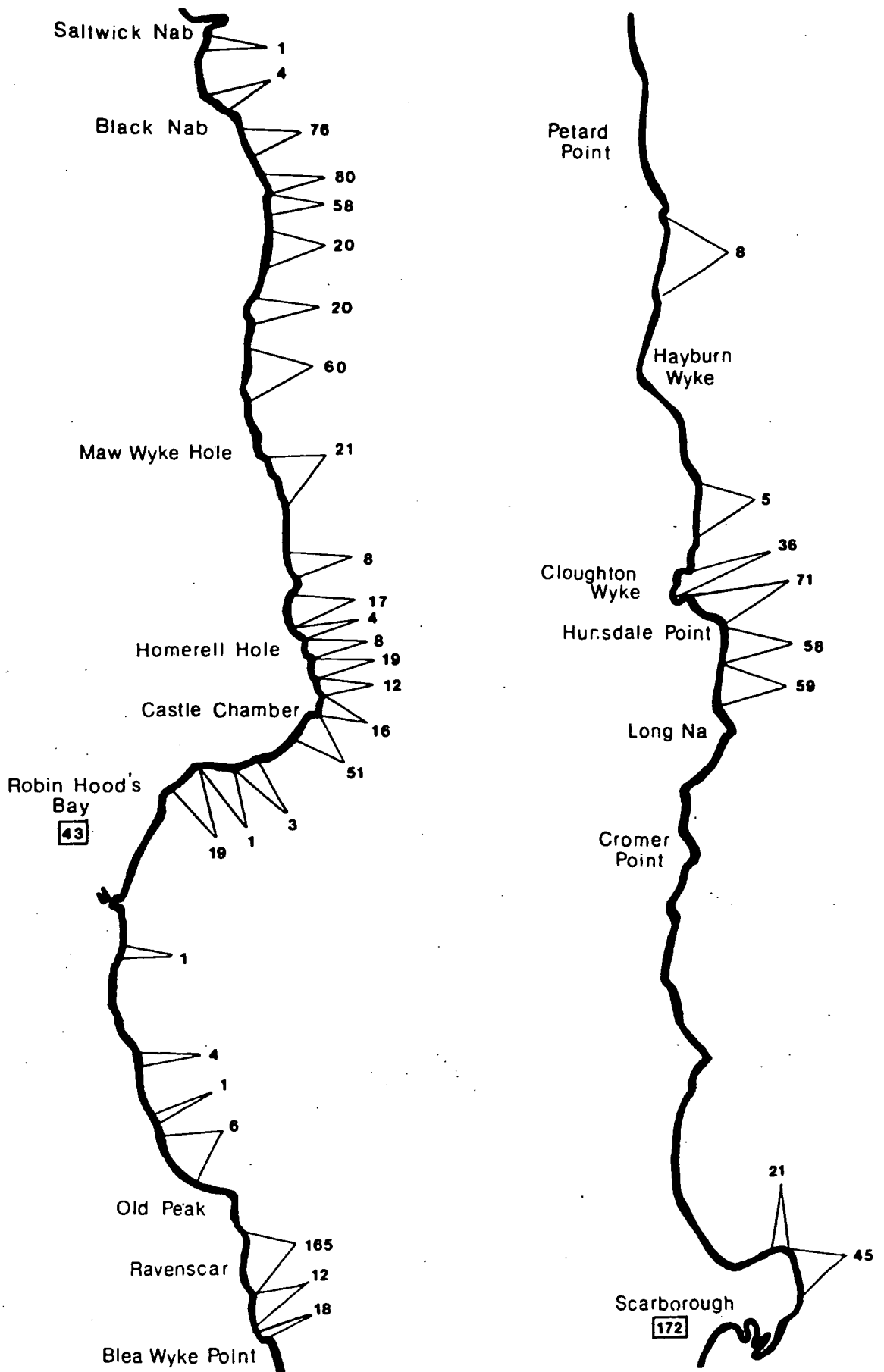

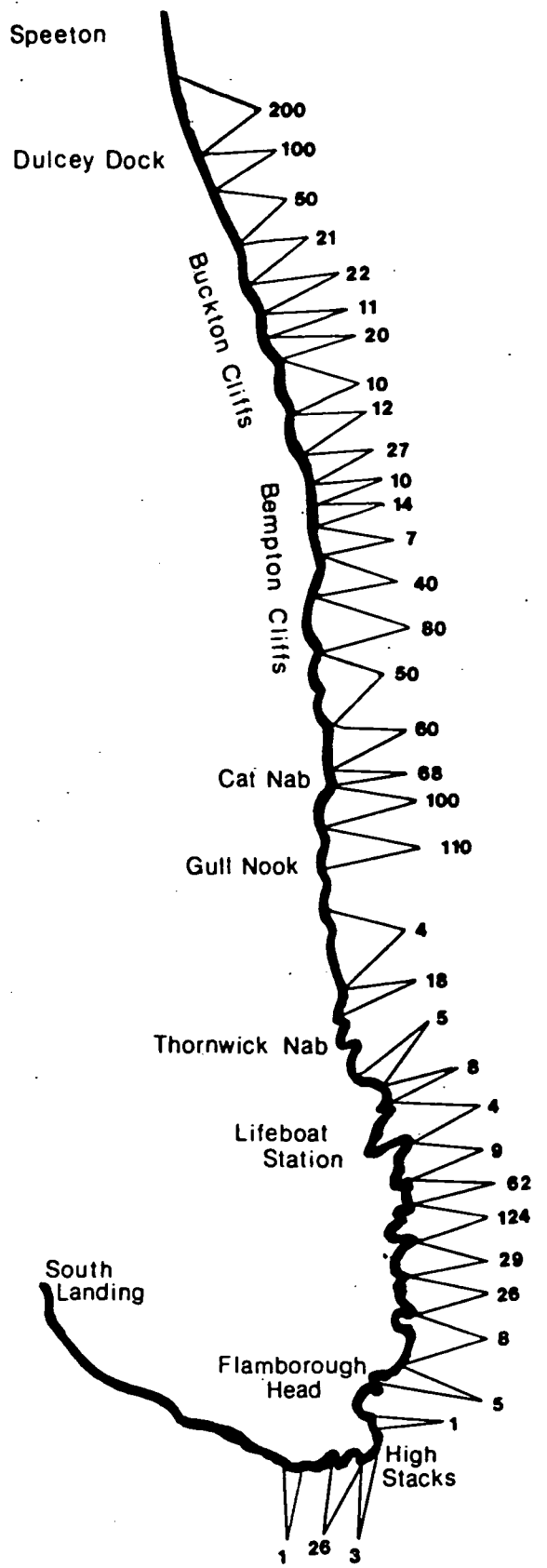
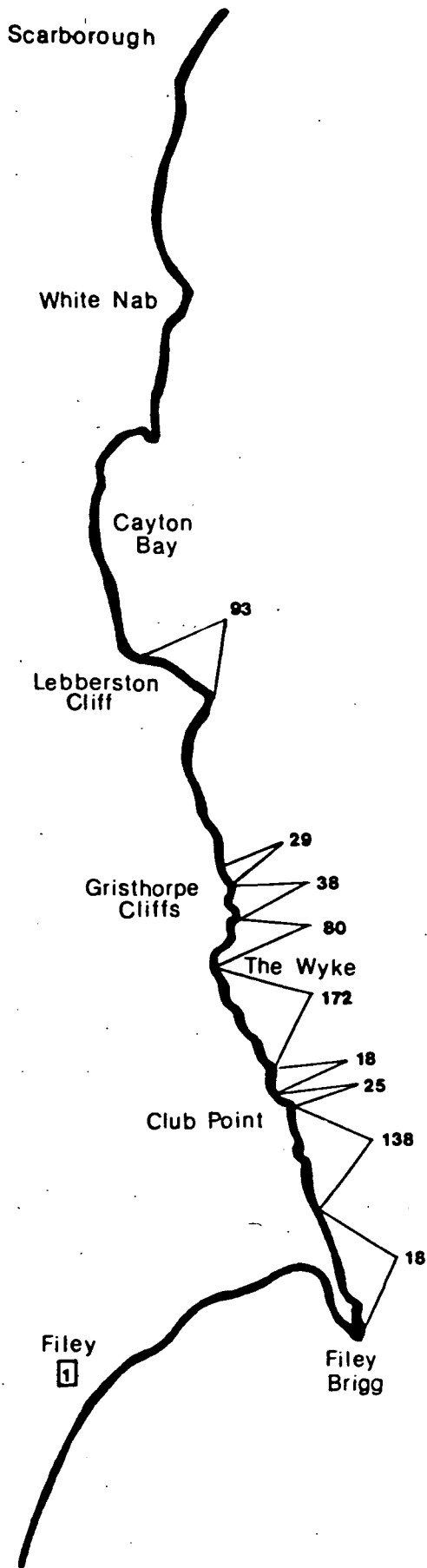

Table 5. Number of pairs of Herring Gulls nesting on cliffs from surveys in 1969-1970, and 1978-1979.

Location	1969	1970	1978	1979	1969-70 to 1978-79 Change per annum
Saltburn to Skinningrove	259		405	325	+2%
Skinningrove to Staithes and Cowbar	757		989		+3%
Staithes to Port Mulgrave	15		29		+8%
Port Mulgrave to Runswick	135		45		-13%
Runswick to Sandsend	(340)**		447		(+3%)
Whitby to Robin Hood's Bay		200 ⁺ 10	587		+14%
Robin Hood's Bay to Old Peak	*			12	*
Ravenscar	200 ⁺ 10			195	-0.3%
Petard Point to Cloughton Wyke	*			13	*
Cloughton Wyke	68 ⁺ 10			107	+5%
Hunsdale Point to Scarborough	50 ⁺ 2			117	+9%
Castle Cliff, Scarborough	60 ⁺ 10			66	+1%
Lebberston Cliffs to Filey Brigg	281			611	+8%
Red Cliff to Flamborough	1275			1345	+0.5%
MEAN					+3.3%

* this was not surveyed in 1969-1970

** also not surveyed in 1969-1970, but as a value was required for Table 7 this was calculated using the mean annual growth rate.

Table 6. Number of pairs of Herring Gulls nesting on buildings, from the 1969-1970, 1976, and 1978-1979 surveys.

Location	1969	1970	1976	1978	1979	Growth rate per annum			
						1969/70 to 1976	1976 to 1978	1976 to 1979	1969/70 to 1978/79
Staithes and Cowbar		3	78	136		72%	32%		61%
Runswick	2		0	15					-
Whitby	97		200+	299		11%	22%		13%
Robin Hood's Bay and Fylingthorpe	3+		31	43		40%	18%		34%
Scarborough	4		120		172	63%		13%	46%
Filey			5	1	1				-
MEAN						22%	22%		22%

Table 7. A comparison of Herring Gull populations nesting on buildings and cliffs from the 1969/70 and the 1978/79 surveys (taken from the data in Tables 5 and 6).

	1969/70	1978/79	Mean annual rate of growth
Number of pairs on cliffs	3640	4969	3% *
Number of pairs on buildings	109	666	22% **
Total	3749	5634	4%
Percentage in towns	3%	12%	

* Taken from Table 2

** Taken from Table 3

The numbers of nesting pairs of Herring Gulls along five areas of the cliffs, censused both in 1978 and in 1979, showed a mean increase of 44% from 1978 to 1979, with the exception of along the Saltburn to Skinningrove cliffs, where the number decreased by 20%, (Table 8). Although all the areas showed great annual variation in numbers, each showed an increase of less than 5% over the last ten years. The combined percentage change for the five areas between 1978 and 1979 of 4% differed little from the mean annual rate for the previous ten years of 6%, suggesting that the large annual variation in each area may have been due to movement of breeding pairs between the years. The counts in 1979 along these areas were taken on dates similar to those of the 1978 counts, with the exceptions of Cloughton Wyke and Castle Cliff whose 1978 census dates (14/7/78 and 13/7/78 respectively) were later than the 1979 dates (21/6/79 and 21/6/79 respectively), (see Appendix 1a). The lateness of the 1978 counts may account for the lower numbers recorded during that season as compared with those in 1979 for Cloughton Wyke and Castle Cliff.

Table 8. Numbers of Herring Gull pairs nesting on particular cliff areas censused in both 1978 and 1979, and compared with counts from 1969.

Location	Percentage change per annum					
	1969	1978	1979	1969 to 1978	1978 to 1979	1969/70 to 1978/79
1. Saltburn to Skinningrove	259	405	325	+5%	-20%	+2%
2. Bias Scar to Cowbar		41	63		+54%	
3. Cowbar Cliffs		74	101		+36%	
4. Cloughton Wyke	68 ± 10	78	107	+2%	+37%	+5%
5. Castle Cliff	60 ± 10	41	66	-4%	+61%	+1%
TOTAL	387*	639	662	+7%*	+4%	+6%*

* This value does not include areas 2 and 3, as these areas were not detailed in the 1969-1970 survey.

2. Census of Herring Gulls throughout the year.

a. Herring Gulls older than 2 years.

1.) Mark and recapture population estimates.

In the observation samples of Herring Gulls, there were 59.2% in Area 1, and 50.8% in Area 2 that had visible legs, and were used in the mark and recapture method, (Appendix 2).

Area 1

The mark and recapture population estimates for Herring Gulls older than 2 years in Area 1, and the data from which they were derived are shown in Table 9. The number of marked individuals available in each marking period varied between 19 and 104; and the number of sightings of marked individuals varied between 16 and 54. The number of Herring Gulls with visible legs sampled in a sighting period ranged from 1438 to 9388 individuals.

The mark and recapture population estimates for Herring Gulls older than 2 years in Area 1 were plotted against time to illustrate the changes in the number of birds estimated to be present, (Figure 4a). The highest population estimate, 8549, was 2.39 times greater than the lowest estimate, 3583. The estimated number of Herring Gulls dropped significantly ($p < 0.02^1$) from 6861 ± 1319^2 between July and September to 3583 ± 472 in October. In November, the estimated number increased significantly ($p < 0.02$) from October, and peaked at 8549 ± 2003 . During December to mid-January, the estimated number showed a non-significant decrease to 6854 ± 230 . The estimated number dropped sharply and significantly ($p < 0.01$) by approximately 47% to 3612 ± 488 during late January to early March. During mid-March to April, the estimated number showed a non-significant increase to 3850 ± 588 .

-
1. This value of p was calculated using the t-test and student's t-distribution.
 2. This marking period had a particularly low number of available marked individuals; and this estimate may not be as accurate as that of other marking periods.

Table 9. Mark and recapture population estimates for Herring Gulls older than 2 years in Area 1 using the ratios of marked individuals seen to individuals with visible legs in Appendix 6B.

Marking period	Sighting period	Number of marked Herring Gulls available (a)	Total sample of Herring Gulls with visible legs (n)	Number of marked Herring Gulls seen (r)	Population estimate $p = \frac{a(n + 1)}{r + 1}$	S.E. \pm
5. 7.78 to 28. 9.78	29. 9.78 to 25. 6.79	19	9388	25	6861	\pm 1319
29. 9.78 to 30.10.78	1.11.78 to 27.11.78	104	1894	54	3583	\pm 472
1.11.78 to 23.11.78	27.11.78 to 17. 1.79	101	1438	16	8549	\pm 2003
27.11.78 to 18. 1.79	25. 1.79 to 14. 3.79	102	2418	35	6854	\pm 230
25. 1.79 to 8. 3.79	8. 3.79 to 23. 7.79	53	3611	52	3612	\pm 488
14. 3.79 to 26. 4.79	2. 5.79 to 23. 7.79	77	2049	40	3850	\pm 588

The October and November population estimates included recapture data for 7 November, 21 November, and 13 December, all of which were large samples and showed a higher than normal proportion of marked to unmarked birds, (see Appendix 6B). The reason for the relationship between these large counts and a high proportion of ringed birds is not clear. A possible explanation could be that the more experienced, local birds, which probably include most of the marked birds, know a wider range of feeding places in the area.

Figure 4. Mark and recapture population estimates for Herring Gulls older than 2 years.

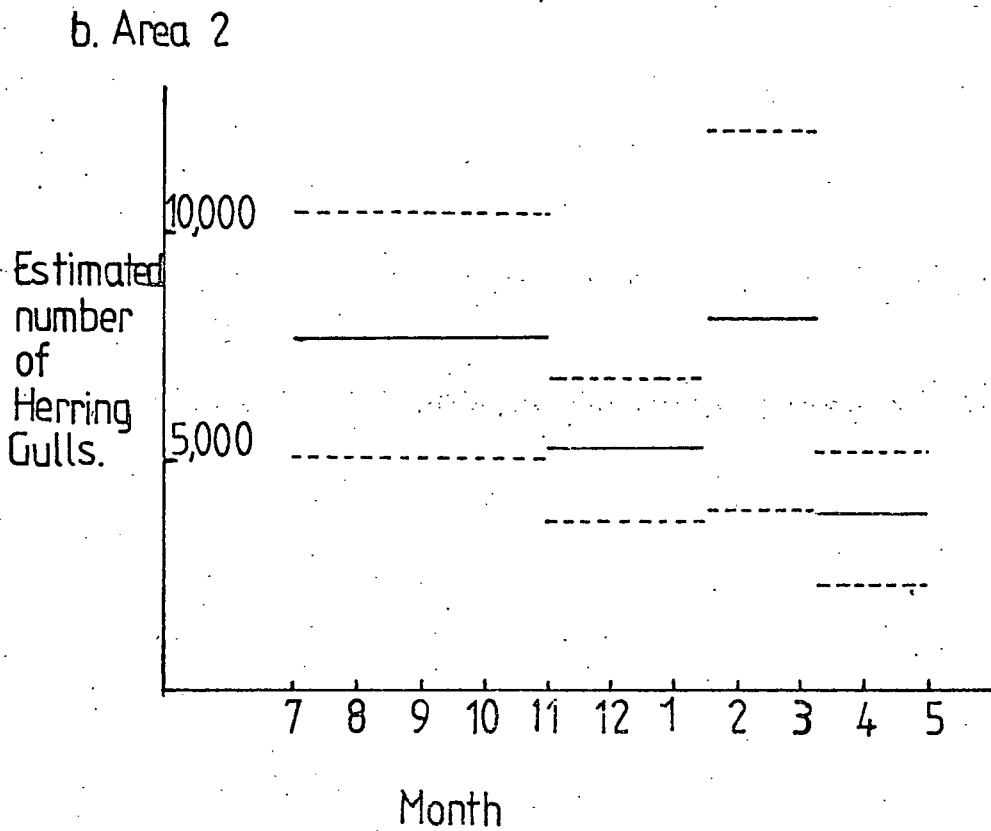
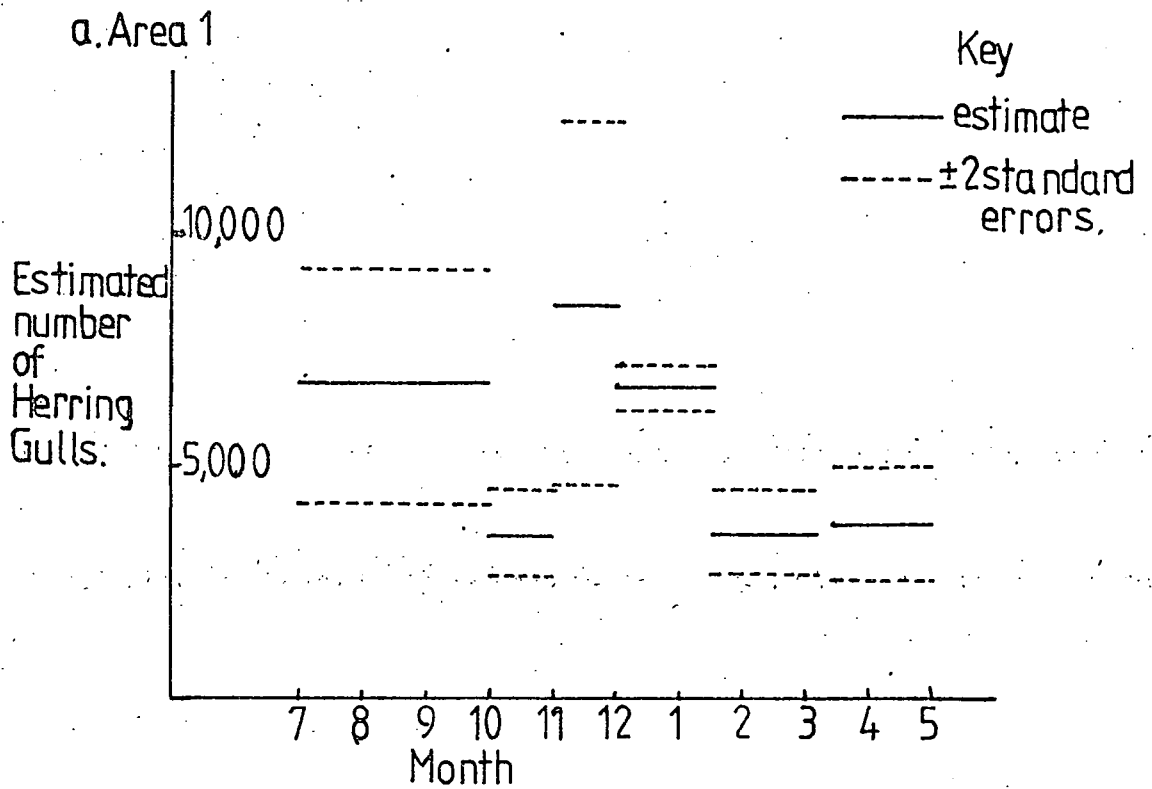

A consequence of this is that they visit refuse dumps less frequently than "immigrant" birds. Bad weather conditions¹ may make some of these secondary feeding sites unusable, when the marked birds congregate at refuse sites, appearing as a larger proportion of the total population. Such a hypothesis requires investigation since it implies that the mark-recapture estimates may well be over-estimates, but no time was available for this investigation in the present study. These counts formed a higher proportion of the total sightings for October than for November, and therefore tended to lower the October estimate to a greater extent.

To examine the effect of this on the population estimates, a second October estimate was calculated using the same sighting period as was used for the November estimate, thus weighting these large, (and possibly abnormal), counts to the same extent in the October and November estimates, (Table 10). The new October estimate, (6507 ± 1318) , increased the population estimate to an appreciable extent, bringing it closer to the November value, from which it did not differ significantly. Since there is no evidence of a change in the proportion of marked to unmarked birds in the area during October and November, there probably was little or no immigration at that time; and this suggests that there was no population increase, (see page 44). It is possible that the difference between the October and November population levels was not as great as the original October estimate suggests; and there is probably little change in population size during these two months. The population level in Area 1 probably did not change significantly from September to mid-January; and it probably dropped by approximately 47% from that in December to mid-January to that in late January to early March, after which it probably did not change. The implications of these changes in the estimated population level are discussed later, in the section on movements throughout the year, (see page 44).

1. Each of these three days in question followed windy spells of weather.

Table 10. Mark and recapture population estimates for the October and November marking periods in Area 1 using the same sighting periods, (for Herring Gulls older than 2 years).

Marking period	Sighting period	Number of marked Herring Gulls available (a)	Total sample of Herring Gulls with visible legs (n)	Number of marked Herring Gulls seen (r)	Population estimate $p = \frac{a(n+1)}{r+1}$	S.E.
29. 9.78 to 30.10.78	1.11.78 to 27.11.78	104	1894	54	3583	± 472
29. 9.78 to 30.10.78	27.11.78 to 17. 1.79	104	1438	22	6507	± 1318
1.11.78 to 23.11.78	27.11.78 to 17. 1.79	101	1438	16	8549	± 2003

Area 2

The mark and recapture population estimates for Herring Gulls older than 2 years in Area 2, and the data from which they were derived are shown in Table 11. The number of marked individuals available in each marking period varied between 38 to 61; and the number of sightings of marked individuals varied between 13 and 42. The total sample of Herring Gulls with visible legs sampled in a sighting period ranged from 1687 to 5820 individuals.

The mark and recapture population estimates were plotted against time to illustrate the changes in the number of birds estimated to be present, (Figure 4b). The highest population estimate, 8167 was 2.13 times greater than the lowest estimate, 3830.

Table 11. Mark and recapture population estimates for Herring Gulls older than 2 years in Area 2 using the ratios of marked individuals seen to individuals with visible legs in Appendix 6B.

Marking period	Sighting period	Number of marked Herring Gulls available (a)	Total sample of Herring Gulls with visible legs (n)	Number of marked Herring Gulls seen (r)	Population estimate $p = \frac{a(n+1)}{r+1}$	S.E.
21. 7.78 to 30.10.78	1.11.78 to 29. 6.79	43	5820	31	7822	± 1358
1.11.78 to 18. 1.79	8. 2.79 to 29. 6.79	61	3739	42	5306	± 795
8. 2.79 to 8. 3.79	13. 3.79 to 29. 6.79	38	3008	13	8167	± 2104
13. 3.79 to 23. 4.79	26. 4.79 to 29. 6.79	59	1687	25	3830	± 731

The estimated number of Herring Gulls showed a non-significant drop from 7822 \pm 1358 between July and October to 5306 \pm 795 between November and mid-January. During February to early March, the estimated number showed a non-significant increase to 8167 \pm 2104. The estimated number showed a decrease to 3830 \pm 731 in late March and April. This was not a significant change from the February-March estimate, but was a significant ($p < 0.01$) decrease of approximately 50% from the July-October estimate.

There was an approximately 50% drop in the estimated number of Herring Gulls observed in Area 2 from July-October to late March-April. No other significant changes occurred between any mark and recapture population estimates; and as there was no apparent immigration into Area 2 after October,

(as shown by the lack of changes in the proportion of marked to unmarked Herring Gulls, see page 47), there probably were no other changes in the population level in Area 2. The implications of the changes in these estimated population levels are discussed later, in the section on movements throughout the year, (see page 49).

2.) The breeding season population.

The age composition of the breeding season Herring Gull population attached to the local breeding colonies was determined so that a breeding season population estimate could be calculated from the known breeding population. To determine the age composition of the breeding season population, it was necessary to assume that the immature birds fledged from the locally breeding population remained in the local summer population and eventually became part of the locally breeding population. Previously it has been observed that immature Herring Gulls disperse from the natal colony area during the first two years; and contraction of this dispersion occurs in the 3rd and 4th years, with only a portion of these birds returning to their natal colony to breed, (Parsons and Duncan 1978). Therefore the summer population estimate is not applicable to the 1st and 2nd year population, and can only be applied to the population older than 2 years with the understanding that the 3rd and 4th year age classes may not be accurate. Further work is necessary to determine a summer population estimate for 3rd and 4th year birds that is free from this assumption.

a.) Breeding season population age composition : Life Tables.

The age composition of the breeding season Herring Gull population was determined by constructing a life table, (Table 12), using mortality rates calculated by Chabrzyk and Coulson (1976) and the formulae:

$$X_{n+1} = S \cdot I \cdot X_n \text{ for birds older than 5 years, up to 30 years,}$$

(it was assumed that senility would increase the death rate, (Coulson and Wooler 1976), and this is the cutoff age used in Monaghan's model (1976),

where X_n = the number of birds aged n years;

S = the adult survival rate (0.94); and

I = the rate of increase of the population.

This must be applied in a deductive manner to calculate the number of birds in older age classes.

The Cleveland Yorkshire coastal population showed an increase of 4% per annum = $\frac{100}{104} = 0.96$, (Table 7).

$$X_{n-1} = \frac{X_n}{S \cdot I} \text{ for birds 4, 3, and 2 years old.}$$

The life table was calculated using the initial assumption that there were 1000 five year old birds.

The proportion of non-breeding adults was unknown. Kadlec and Drury (1968) observed 20% non-breeding adults in a New England Herring Gull population. The number of 1st year birds was estimated four different ways in this table, assuming that the proportion of adults (5 years old and older) that was non-breeding was 0%, 15%, 20%, and 25%. This gave a possible range to the summer population estimate. The average breeding success of the remaining adult population was assumed to be 1 chick per pair surviving to August, (Chabrzyk and Coulson 1976).

The expected winter ratios were derived by applying the year's mortality in September. A 20% annual mortality was applied to the number of first year birds, and 6% was applied to all other age classes.

The life tables show that the expected proportion of 1st and 2nd year birds in a Herring Gull population growing at a rate of 4% per annum is: 31% if none of the adults are non-breeding; 29% if 15% of the adults are non-breeding; 28% if 20% of the adults are non-breeding; and 27% if 25% of the adults are non-breeding.

Table 12. Life table for a Herring Gull population increasing at an annual rate of 4%.

Percentage of adults (5 years and older) that are non-breeding	Age group	Number of Herring Gulls	Number of Herring Gulls after mortality rates are taken in September	Percentage of age groups
0%	1	4588	3670	23%
	2	1383	1300	8%
	3	1241	1167	7%
	4	1114	1047	7%
	5 and older	9176	8625	55%
15%	1	3900	3120	20.4%
	2	1383	1300	8.5%
	3	1241	1167	7.6%
	4	1114	1047	6.9%
	5 and older	9176	8625	56.5%
20%	1	3670	2936	19%
	2	1383	1300	9%
	3	1241	1167	8%
	4	1114	1047	7%
	5 and older	9176	8625	57%
25%	1	3441	2753	18%
	2	1383	1300	9%
	3	1241	1167	8%
	4	1114	1047	7%
	5 and older	9176	8625	58%

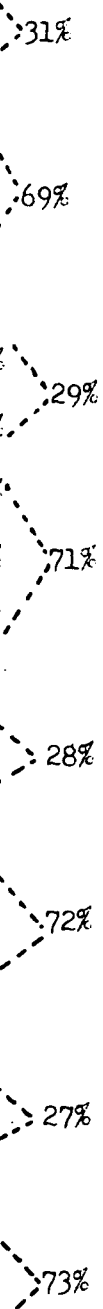

- b.) Breeding season population estimates derived from the life tables.

Breeding season population estimates for Areas 1 and 2, shown in Table 13, were calculated from the breeding population, (Appendix 1), using the life table ratios, (Table 12).

The breeding season population in Area 1 consisted of: 3013 1st and 2nd year birds and 6707 older birds if 0% of the adults were non-breeding; 3228 1st and 2nd year birds and 7904 older birds if 15% of the adults were non-breeding; 3283 1st and 2nd year birds and 8442 older birds if 20% of the adults were non-breeding; and 3318 1st and 2nd year birds and 8972 older birds if 25% of the adults were non-breeding.

In Area 2, the breeding season population consisted of: 1821 1st and 2nd year birds and 4055 older birds if there were no non-breeding adults; 1951 1st and 2nd year birds and 4778 older birds if 15% of the adults were non-breeding; 1985 1st and 2nd year birds and 5103 older birds if 20% of the adults were non-breeding; and 2006 1st and 2nd year birds and 5424 older birds if 25% of the adults were non-breeding.

Table 13. Estimates of the breeding season Herring Gull populations in Areas 1 and 2, using the number of adults known to be breeding, (Appendix 1), and the life table ratios, (Table 12).

	Area 1 (Redcar to Lighthouse near Black Nab)	Area 2 (Lighthouse to Filey Brigg)
Breeding population	5346	3232
0% non-breeding adults (5 years and older)		
Breeding season population	9720	5876
Number of birds older than 2 years	6707	4055
Number of 1st and 2nd year birds	3013	1821
15% non-breeding adults		
Breeding season population	11132	6729
Number of birds older than 2 years	7904	4778
Number of 1st and 2nd year birds	3228	1951
20% non-breeding adults		
Breeding season population	11725	7088
Number of birds older than 2 years	8442	5103
Number of 1st and 2nd year birds	3283	1985
25% non-breeding adults		
Breeding season population	12290	7430
Number of birds older than 2 years	8972	5424
Number of 1st and 2nd year birds	3318	2006

c.) Comparison of mark and recapture population estimates with the breeding season population estimates.

Herring Gulls usually return to their breeding colonies by March, (Cramp et al 1974). To determine whether the mark and recapture population estimates for the March to April marking periods in Areas 1 and 2, (Tables 9 and 11), represented the breeding season population, these mark and recapture population estimates were compared with the breeding season population estimates, (derived from the number of breeding birds surveyed on nest sites, given in Table 13). The mark and recapture population estimates for July to September in Area 1, and for July to October in Area 2, (Tables 9 and 11), were also compared with the breeding season population estimates, to determine whether these represented the breeding season population. These comparisons are shown in Table 14.

Area 1

The mark and recapture estimate for Herring Gulls older than 2 years in Area 1, 3850 ± 588 , was less than two thirds of the lowest of the breeding season population estimates, 6707, for a population without non-breeding adults. It is therefore likely that a significant portion of the breeding season population of Herring Gulls older than 2 years did not visit the observation sites during the March to April marking period. This suggests that there were feeding and loafing sites in Area 1, other than the observation sites, where the unobserved portion of the population present in Area 1 could be found, such as beneath the cliffs or out at sea.

The mark and recapture population estimate for Herring Gulls older than 2 years during July to September, 6861 ± 1319 , did not significantly differ from any of the breeding season population estimates, 6707 to 8972, for populations with 0% to 25% non-breeding adults. Therefore the population observed in Area 1 from July to September may have represented the breeding season population. The implications of these comparisons are discussed later in the section on movements throughout the year, (see page 46).

Table 14. A comparison of the mark and recapture population estimates for July-September and late March-April, (from Tables 9 and 11), with the breeding season population estimates, (Table 13).

	Population estimates for Herring Gulls older than 2 years	
	Area 1	Area 2
Mark and recapture marking period:		
5. 7.78 to 28. 9.78	6861 ± 1319	
21. 7.78 to 30.10.78		7822 ± 1358
13/14. 3.79 to 23/26. 4.79	3850 ± 588	3830 ± 731
Breeding season population with:		
0% non-breeding adults	6707	4055
15% non-breeding adults	7904	4778
20% non-breeding adults	8442	5103
25% non-breeding adults	8972	5424

Area 2

There was no significant difference between the mark and recapture population estimate for Herring Gulls older than 2 years during late March-April, 3830 ± 731, and any of the breeding season population estimates, 4055 to 5103, for populations with 0% to 20% non-breeding adults. Therefore the population observed during the late March-April marking period in Area 2 may have represented the breeding season population, and thus, the whole population present in Area 2.

The mark and recapture population estimate for Herring Gulls older than 2 years during July to October in Area 2, 7822 ± 1358 , was within range of the largest of the breeding season population estimates, 5424, for a population with 25% non-breeding adults. Therefore the observed population in Area 2 during July to October may have represented the breeding season population. The implications of these comparisons are discussed later in the section on movements throughout the year, (see page 49).

b. 1st and 2nd year Herring Gulls.

1.) Mark and recapture population estimates.

Area 1

The mark and recapture population estimates for 1st and 2nd year Herring Gulls in Area 1, and the data from which they were derived are shown in Table 15. The number of marked individuals available in each marking period varied between 8 to 55; and the number of sightings of marked individuals varied between 0 (see next paragraph) and 33. The number of Herring Gulls with visible legs sampled in a sighting period ranged from 456 to 2244 individuals.

In Figure 5a, the mark and recapture population estimates are plotted against time to illustrate the changes in the number of birds estimated to be present. The estimated number of 1st and 2nd year Herring Gulls increased from 1982 \pm 330 in July-September to 3368 \pm 814 during October, but this was not a significant increase. In November, there was a non-significant decrease to 1995 \pm 388. The estimated number dropped further to 1145 \pm 329 during December to mid-January. This was not a significant decrease from the November estimate; but it was a significant decrease ($p < 0.02$) of approximately 60% from the October estimate. It was not possible to obtain a population estimate for late January to early March, as there were no resightings of individuals marked during this period. The estimated number of Herring Gulls decreased to 914 \pm 102 during late March to April. This was not a significant decrease from the December to mid-January estimate; but this was a significant decrease ($p < 0.02$, $p < 0.01$, and $p < 0.01$ respectively) of at least 53% from the November, the October, and the July to September estimates.

This suggests that there was at least a 50% decrease in the observed number of 1st and 2nd year Herring Gulls in Area 1 between October and December-mid-January, and between July-November and late March-April. The

implications of these decreases are discussed later, in the section on movements throughout the year, (see page 50).

Table 15. Mark and recapture population estimates for 1st and 2nd year Herring Gulls in Area 1, using the ratios of marked individuals seen to individuals with visible legs in Appendix 6A.

Marking period	Sighting period	Number of marked Herring Gulls available (a)	Total sample of Herring Gulls with visible legs (n)	Number of marked Herring Gulls seen (r)	Population estimate $p = \frac{a(n+1)}{r+1}$	S.E.
5. 7.78 to 28. 9.78	29. 9.78 to 31. 1.79	55	1224	33	1982	± 330
29. 9.78 to 30.10.78	1.11.78 to 23. 7.79	24	2244	15	3368	±814
1.11.78 to 23.11.78	23.11.78 to 27.11.78	33	1510	24	1995	± 388
27.11.78 to 18. 1.79	25. 1.79 to 23. 7.79	11	1144	10	1145	± 329
25. 1.79 to 8. 3.79	14. 3.79 to 23. 7.79	12	702	0	-	-
14. 3.79 to 26. 4.79	2. 5.79 to 23. 7.79	8	456	3	914	±102

Figure 5. Mark and recapture population estimates for 1st and 2nd year Herring Gulls.

a. Area 1.

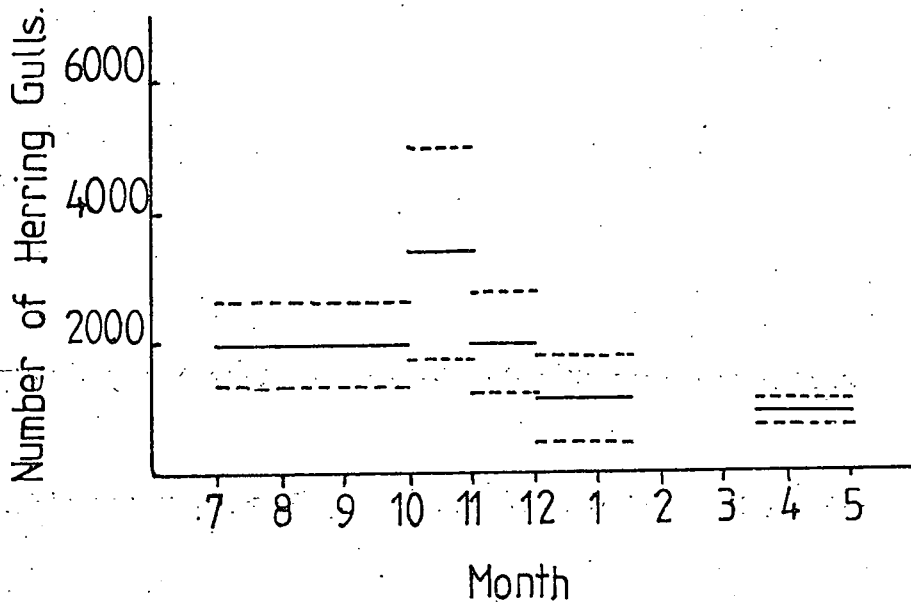

Key

— estimate

- - - ± 2 standard errors

b. Area 2.

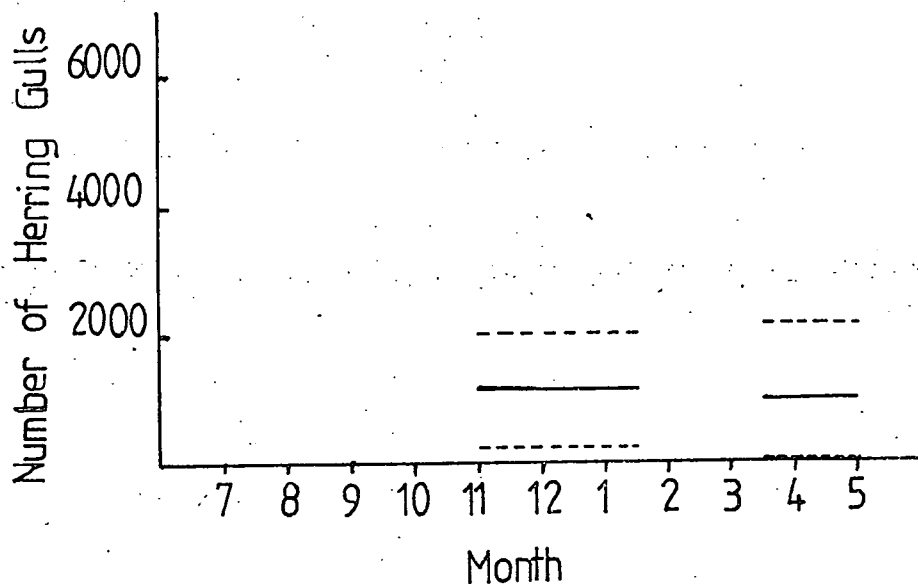

Area 2

The mark and recapture population estimates for 1st and 2nd year Herring Gulls in Area 2, and the data from which they were derived are shown in Table 16. The number of marked individuals available in each marking period varied between 0 (see next paragraph) and 6; and the number of sightings of marked individuals varied between 0 (see next paragraph) and 5. The number of Herring Gulls with visible legs sampled in a sighting period ranged from 499 to 1846 individuals.

In Figure 5b, the mark and recapture population estimates for 1st and 2nd year Herring Gulls in Area 2 are plotted against time to illustrate the changes in the number of birds estimated to be present. It was not possible to calculate a population estimate for July to October, (no birds were marked during this period), and for February to early March, (there were no resightings of birds marked during this period). The estimated number of 1st and 2nd year Herring Gulls dropped from 1153 ± 435 in November-mid-January to 1000 ± 576 in late March-April, but this was not a significant decrease.¹ This suggests that the observed population level of 1st and 2nd year Herring Gulls in Area 2 did not change appreciably between November-mid-January and late March-April. More information is needed to confirm that no changes occurred, due to lack of mark and recapture population estimates for July-October and February-early March. The implications of these results are discussed later, in the section on movements throughout the year, (see page 52).

1. Few marked individuals were used in the calculation of these estimates, which therefore had large standard errors; but as the difference between these two estimates was small, the large standard errors probably did not affect the significance of the decrease.

Table 16. Mark and recapture population estimates for 1st and 2nd year Herring Gulls in Area 2, using the ratios of marked individuals seen to individuals with visible legs in Appendix 6A.

Marking period	Sighting period	Number of marked Herring Gulls available (a)	Total sample of Herring Gulls with visible legs (n)	Number of marked Herring Gulls seen (r)	Population estimate $p = \frac{a(n+1)}{r+1}$	S.E. \pm
21. 7.78 to 30.10.78	1.11.78 to 29. 6.79	0	1846	0	-	-
1.11.78 to 18. 1.79	8. 2.78 to 29. 6.79	6	1152	5	1153	\pm 435
8. 2.79 to 8. 3.79	13. 3.79 to 29. 6.79	2	916	0	-	-
13. 3.79 to 23. 4.79	26. 4.79 to 29. 6.79	4	499	1	1000	\pm 576

2.) Comparison of the estimated age ratios with the observed age ratios.

The range of the proportion of 1st and 2nd year Herring Gulls in the mark and recapture estimated population levels, (from Tables 9, 11, 15 and 16), was calculated for each marking period in each area; (Table 17). The upper end of this range was the proportion in the sum of the estimate for Herring Gulls older than 2 years, (minus two standard errors), plus the estimate for 1st and 2nd years, (plus two standard errors). The proportion found in the sum of the estimate for Herring Gulls older than 2 years, (plus two standard errors), plus the estimate for 1st and 2nd years, (minus two standard errors), was taken as the lower end of the range. This range was then compared with the proportion of 1st and 2nd year Herring Gulls observed in sighting samples during each marking period, (from Table 2), to determine whether or not the age ratio found in the samples represented the age ratio in the estimated population, (also shown in Table 17).

Area 1

In Area 1, the proportion of 1st and 2nd year Herring Gulls in the sighting samples during the October marking period, (26.0 ± 0.89), fell short of the range of the proportion found in the estimated population, (27.8% to 65.4%, Table 17). The proportions observed in the sighting samples during the July-September, November, December-mid-January, and late March-April marking periods, ($31.2 \pm 0.82\%$, $17.9 \pm 0.58\%$, $19.1 \pm 0.74\%$ and $15.0 \pm 0.68\%$ respectively), fell within range of the proportions found in the estimated populations, (12.2% to 38.6%, 8.8% to 38%, 6.4% to 22% and 12.4% to 29.6% respectively). As there was no mark and recapture population estimate for 1st and 2nd year Herring Gulls during late January-early March, (see page 33), no proportion could be calculated for the estimated population; and a comparison was not possible for this period.

Table 17. The proportion of 1st and 2nd year Herring Gulls in the mark and recapture estimated populations for each marking period in Area 1 and Area 2, and comparison with proportions observed in the sighting samples.

Marking period	Area 1		Percentage of 1st and 2nd year Herring Gulls in the estimated population	Percentage of 1st and 2nd year Herring Gulls in the sighting samples
	Mark and recapture population estimates Herring Gulls older than 2 years (Table 9)	1st and 2nd year Herring Gulls (Table 15)		
5. 7.78 to 28. 9.78	6861 ⁺ 1319	1982 ⁺ 330	12.2 to 38.6%	31.2 ⁺ 0.82%
29. 9.78 to 30.10.78	3583 ⁺ 472	3368 ⁺ 814	27.8 to 65.4%	26.0 ⁺ 0.89%
1.11.78 to 23.11.78	8549 ⁺ 2003	1995 ⁺ 388	8.8 to 38%	17.9 ⁺ 0.58%
27.11.78 to 18. 1.79	6854 ⁺ 230	1145 ⁺ 329	6.4 to 22%	19.1 ⁺ 0.74%
25. 1.79 to 8. 3.79	3612 ⁺ 488	—	—	17.4 ⁺ 0.62%
14. 3.79 to 26. 4.79	3850 ⁺ 588	914 ⁺ 102	12.4 to 29.6%	15.0 ⁺ 0.68%
Marking period	Area 2		Percentage of 1st and 2nd year Herring Gulls in the estimated population	Percentage of 1st and 2nd year Herring Gulls in the sighting samples
	Mark and recapture population estimates Herring Gulls older than 2 years (Table 11)	1st and 2nd year Herring Gulls (Table 16)		
21. 7.78 to 30.10.78	7822 ⁺ 1358	—	—	27.2 ⁺ 0.93%
1.11.78 to 18. 1.79	5306 ⁺ 795	1153 ⁺ 435	3.8 to 35.4%	25.8 ⁺ 0.62%
8. 2.79 to 8. 3.79	8167 ⁺ 2104	—	—	26.2 ⁺ 1.21%
13. 3.79 to 23. 4.79	3830 ⁺ 731	1000 ⁺ 576	0 to 47.6%	24.6 ⁺ 0.71%

It is therefore probable that the age ratio in the observation sample was representative of the age ratio of the observed population in Area 1 during July-September, November, December-mid-January and late March-April. During October, the proportion of 1st and 2nd year Herring Gulls in the estimated population was higher than that found in the observation sample. This suggests that during October the 1st and 2nd year Herring Gulls that visited the observation sites were more dilute and moved around more beyond the observation sites than the Herring Gulls older than 2 years that visited the observation sites; but during July-September, November, December-mid-January and late March-April, birds of both age groups in the observed population probably moved around similarly.

The proportion of 1st and 2nd year birds in the estimated population in Area 1 peaked at 27.8-65.4% during October, and then decreased to 12.4-29.6% during late March-April. This corresponds with a significant decrease ($p < 0.02$) in the proportion observed in sighting samples from $26.0 \pm 0.89\%$ in October to $15.0 \pm 0.68\%$ in late March-April. This indicates that there probably was more movement away from the observation sites in Area 1 amongst 1st and 2nd years than there was amongst Herring Gulls older than 2 years. The implications of these results are discussed later, in the section on movements throughout the year, (see page 50).

Area 2

The proportion of 1st and 2nd year Herring Gulls observed in sighting samples in Area 2 during November-mid-January and late March-April, ($25.8 \pm 0.62\%$ and $24.6 \pm 0.71\%$ respectively), fell within range of the proportion found in the corresponding estimated populations, (3.8 to 35.4% and 0 to 47% respectively, Table 17). As there were no mark and recapture estimates available for July-October, and late January-early March, (see page 35), no proportions could be calculated for these estimated populations; and comparisons were not possible for these periods.

It is likely that the age ratio found in the observation samples represented the age ratio of the estimated population in Area 2 during November-mid-January and late March-April; and the observed 1st and 2nd year Herring Gulls and Herring Gulls older than 2 years probably moved around similarly during these periods.

The proportion of 1st and 2nd year Herring Gulls in the sighting samples declined from July-October to late March-April; but as this was not significantly different to the decline expected due to the higher mortality rate of 1st years compared to older age classes, the proportion probably did not change, (see page 9). The proportion in the November-January estimated population, (3.8 to 35.4%), fell within the range of the late March-April estimated population's proportion, (0 to 47%); and these two ranges of proportion did not differ significantly. It is possible that there was no significant change in the proportion of 1st and 2nd year birds to older Herring Gulls in the observed population throughout the year; but further studies are needed to confirm this hypothesis. Implications of these results are discussed later, in the section on movements throughout the year, (see page 52).

C. Movements.

1. Movements throughout the year: Immigration and Emigration.

a. Herring Gulls older than 2 years.

To further examine the changes in the observed populations of Herring Gulls older than 2 years in Area 1 and Area 2, sighting samples following each marking period were clumped in groups of approximately 1000 individuals with visible legs. The proportion of marked to unmarked birds in these groups was expressed in the number of marked individuals per 1000 birds, and plotted against time to illustrate any changes that may have occurred in this proportion, (Tables 18 and 19, Figures 6 and 7).

Area 1

The proportion of marked to unmarked birds in Area 1 following the July-September marking period was significantly higher ($p < 0.05$) in the 1-7 November group of samples, (5.97 ± 2.45 marked individuals per 1000 birds), than in the 12 June to 23 July sample group, (0.69 ± 0.83 marked individuals per 1000 birds); but otherwise, it showed no significant changes, (Table 18 and Figure 6). The proportion of marked to unmarked birds following the October estimate was significantly ($p < 0.002$) higher in the first three groups of samples, (1-7 November, 27.81 ± 5.20 per 1000; 10-21 November, 29.41 ± 5.34 per 1000; and 27 November to 19 December, 20.81 ± 4.51 per 1000), than in the 17-31 January group, (4.45 ± 2.10 per 1000), after which the proportion showed no significant changes. The proportion of marked to unmarked birds following the November, and late January-early March marking periods showed no significant change. There was a progressive increase in the proportion of marked to unmarked Herring Gulls following the December-mid-January marking period; but the overall increase was not significant.

Table 18. Changes in the proportion of marked to unmarked Herring Gulls older than 2 years following each marking period in Area 1.

Marking period	Dates	Number of Herring Gulls older than 2 years with visible legs	Number of marked Herring Gulls seen	Number of marked birds per 1000 birds with visible legs
5. 7.78 to	29. 9 to 16.10	957	1	1.07 \pm 1.02
	1.11 to 7.11	827	5	5.97 \pm 2.45
28. 9.78	10.11 to 21.11	1054	5	4.74 \pm 2.17
	27.11 to 19.12	1009	3	2.97 \pm 1.72
	17. 1 to 31. 1	1124	1	0.89 \pm 0.94
	8. 2 to 27. 2	932	2	2.15 \pm 1.46
	1. 3 to 30. 3	1008	2	0.99 \pm 1.41
	3. 4 to 12. 4	889	3	3.37 \pm 1.83
	20. 4 to 6. 6	942	2	2.12 \pm 1.46
	12. 6 to 23. 7	1455	1	0.69 \pm 0.83
29.9.78 to	1.11 to 7.11	827	23	27.81 \pm 5.20
	10.11 to 21.11	1054	31	29.41 \pm 5.34
30.10.78	27.11 to 19.12	1009	21	20.81 \pm 4.51
	17. 1 to 31. 1	1124	5	4.45 \pm 2.10
	8. 2 to 27. 2	932	5	5.36 \pm 2.31
	1. 3 to 30. 3	1008	5	4.96 \pm 2.22
	3. 4 to 12. 4	889	4	4.50 \pm 2.12
	20. 4 to 6. 6	942	16	16.19 \pm 4.09
	12. 6 to 23. 7	1455	4	2.75 \pm 1.66

Table 18. /Contd...

Marking period	Dates	Number of Herring Gulls older than 2 years with visible legs	Number of marked Herring Gulls seen	Number of marked birds per 1000 birds with visible legs
1.11.78	27.11 to 19.12	1009	14	13.88 \pm 3.70
to	17. 1 to 31. 1	1124	4	3.56 \pm 1.88
23.11.78	8. 2 to 27. 2	932	2	2.15 \pm 1.46
	1. 3 to 30. 3	1008	7	6.94 \pm 2.63
	3. 4 to 12. 4	889	5	5.62 \pm 2.36
	20. 4 to 6. 6	942	16	16.99 \pm 4.09
	12. 6 to 23. 7	1455	9	6.19 \pm 2.48
27.11.78	25. 1 to 27. 2	1627	23	14.14 \pm 3.73
to	1. 3 to 30. 3	1008	22	21.83 \pm 4.62
18. 1.79	3. 4 to 12. 4	889	19	21.37 \pm 4.57
	20. 4 to 6. 6	942	22	23.35 \pm 4.78
	12. 6 to 23. 7	1455	37	25.43 \pm 4.98
25. 1.79	14. 3 to 12. 4	997	17	17.05 \pm 4.09
to	20. 4 to 6. 6	942	15	15.92 \pm 3.96
8. 3. 79	12. 6 to 23. 7	1455	20	13.75 \pm 3.68

There was a significant decrease ($p < 0.02$) in the proportion of marked to unmarked Herring Gulls from that before 19 December to that after 17 January following the October marking period, and from that before 7 November to that after 12 June following the July-September marking period. There were no other significant changes in the observed proportion of

Figure 6. Changes in the proportion of marked to unmarked Herring Gulls older than 2 years in sample groups of approx. 1000 individuals, following each marking period in area 1.

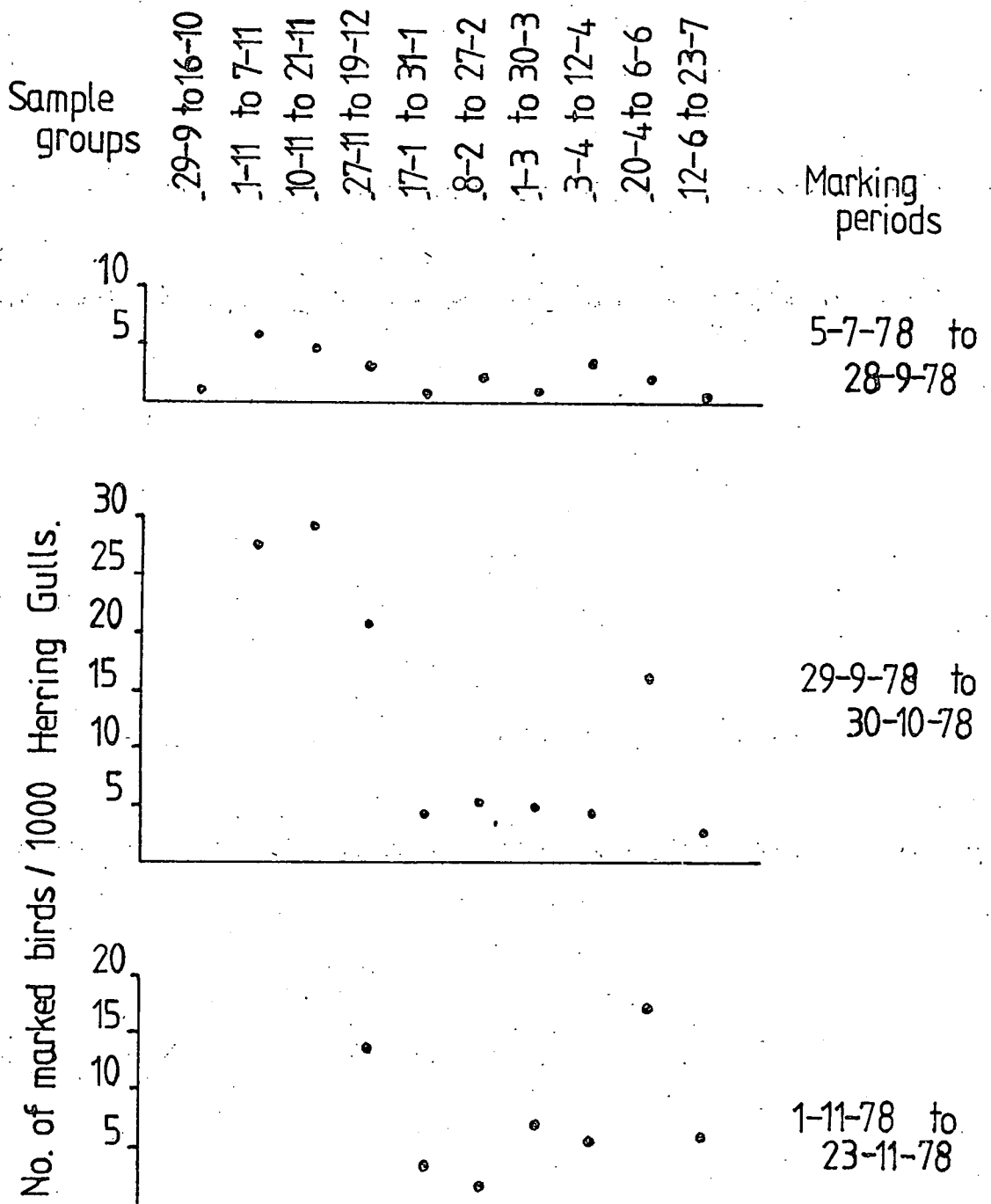

(continued over)

Figure 6 . (continued)

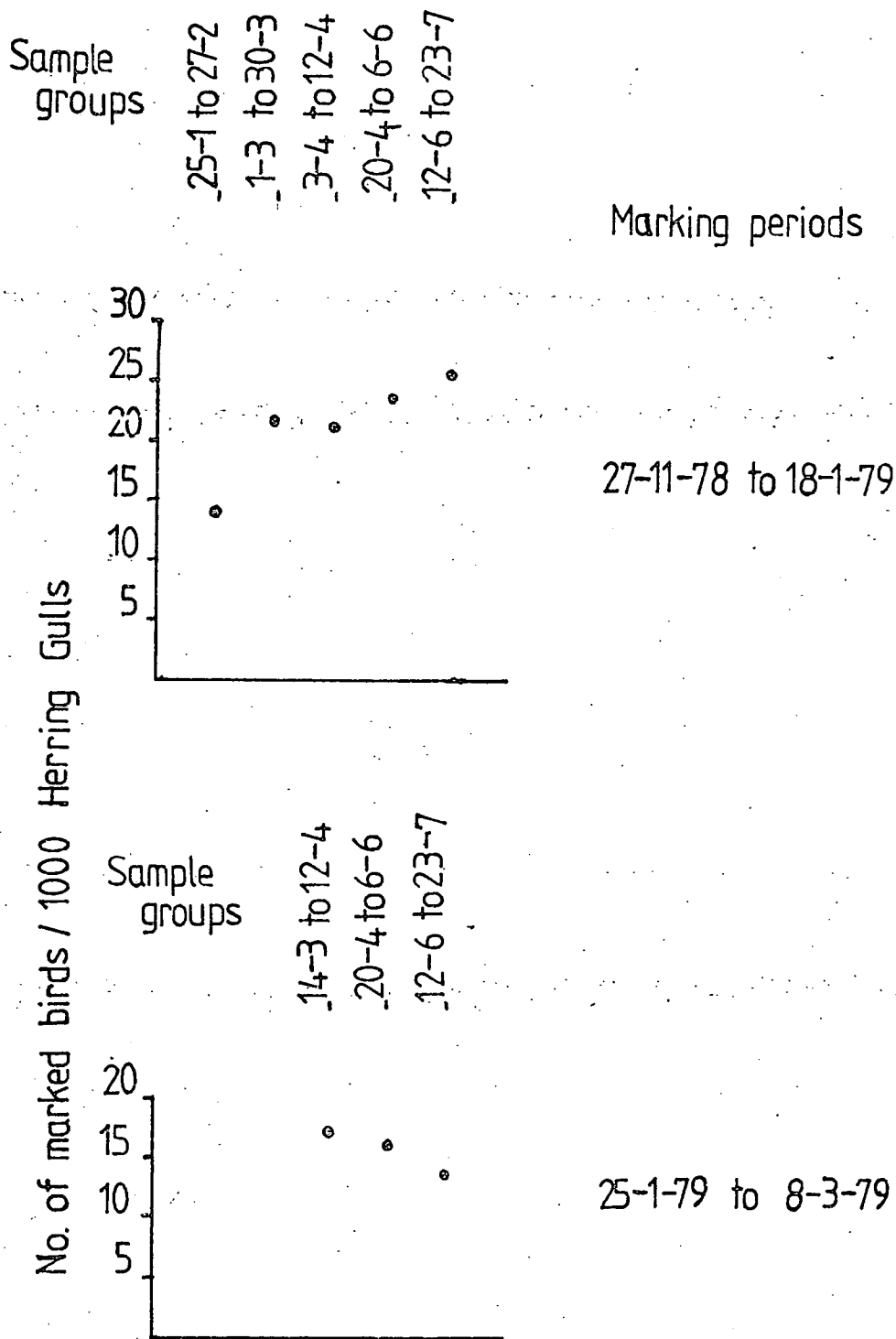

marked to unmarked birds. Assuming that marked and unmarked birds behaved similarly, emigration would have involved the same proportion of marked and unmarked birds leaving the area and would not have affected the proportion of marked to unmarked individuals observed in the study area. Likewise, the return of these emigrant birds would have involved the return of the same proportion of marked and unmarked birds, and would not have changed the observed proportion. Immigration into the area of non-local unmarked birds after the end of the marking period would decrease the proportion of marked to unmarked birds observed; and later emigration of these immigrant birds would subsequently increase the proportion towards its previous level. There is no evidence that marked and unmarked birds did not behave similarly. It is therefore likely that there was no immigration into the area between early October and late December; and during January there probably was immigration into Area 1 of unmarked Herring Gulls older than 2 years that did not leave the area before 23 July. These immigrant birds were probably part of the breeding season population.

The population level of Herring Gulls older than 2 years in Area 1 may have dropped during October and, in November, risen again to its previous level where it remained through December-mid-January, (as indicated by the mark and recapture estimates, see page 19). As there probably was no immigration into Area 1 between early October and January, (see above), this dip in the population level probably involved Herring Gulls that left Area 1 for a few weeks during October and returned in November; and it is likely that the population level did not change appreciably between July to September and December to mid-January. During October, the estimated population level of 1st and 2nd year Herring Gulls in Area 1 peaked, as did the proportion of 1st and 2nd years among Herring Gulls in sighting samples and in the estimated population, (see page 38).

1st and 2nd year birds probably were more dilute and probably moved around more among feeding and loafing sites other than the observation sites than Herring Gulls older than 2 years in Area 1 during October, (as indicated by the larger proportion of 1st and 2nd years found in the estimated population than found in the observation samples, see page 39). This suggests that during October, some Herring Gulls older than 2 years may have found feeding and loafing sites other than the observation sites, such as in fields following ploughs, at which they specialized in feeding; and some Herring Gulls older than 2 years remained at the observation sites and did not move around among the other feeding and loafing sites. At the same time, the 1st and 2nd year Herring Gulls may have frequented all of the available feeding and loafing sites. Davis (1975) observed specialized feeding by adult Herring Gulls, and also noted that immatures moved around more among feeding sites than adults.

Since the population level probably did not change appreciably between July to September and December to mid-January, (see above), and emigration without immigration would cause the population level to drop, there probably was no emigration of Herring Gulls older than 2 years out of Area 1 between early October and December-mid-January, besides those that returned in November. Locally breeding Herring Gulls that entered Area 1 during January, had probably left Area 1 after the previous breeding season and before the end of September (shown in Figure 8a). There were colour-ringed Herring Gulls older than 2 years sighted in Area 1 during the breeding season (from late March onward) that had been previously sighted in Area 1 during July-September, October, November and December-mid-January, (see Appendix 6B); so it is probable that a portion of the breeding season population remains in Area 1 throughout the year, (shown in Figure 8a). The mark and recapture estimated population levels during late January-early March, (3612 ± 488) , and late March -April, (3850 ± 588) , probably included only the local breeding season birds, (see next paragraph), and

Figure 8. Movements throughout the year of Herring Gulls older than 2 years in Areas 1 and 2.

a. Area 1

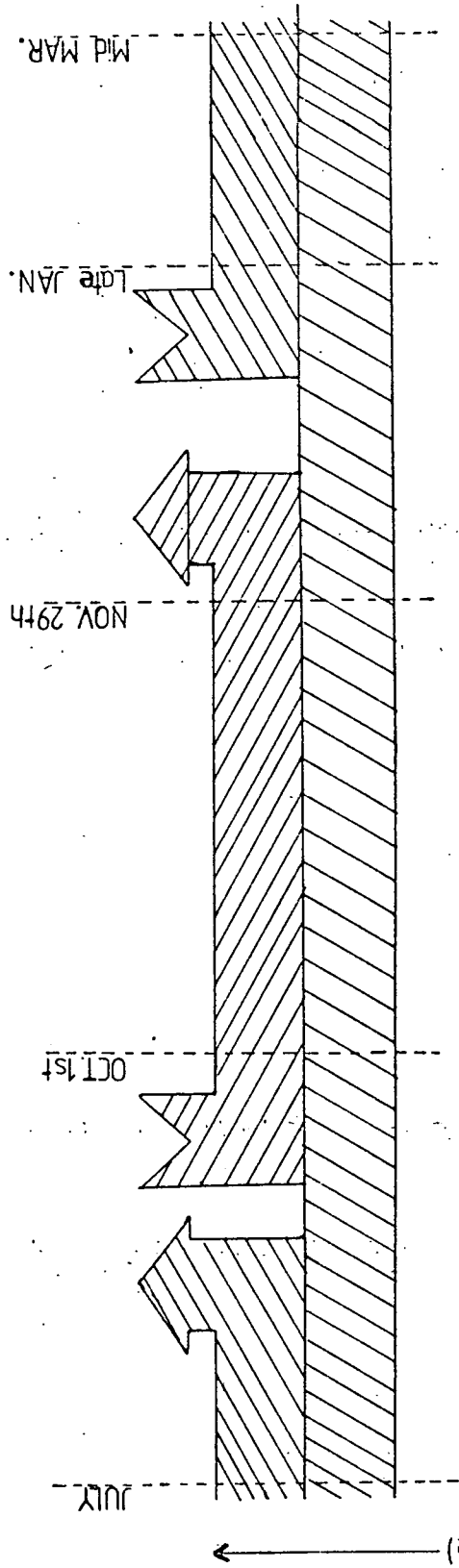

b. Area 2

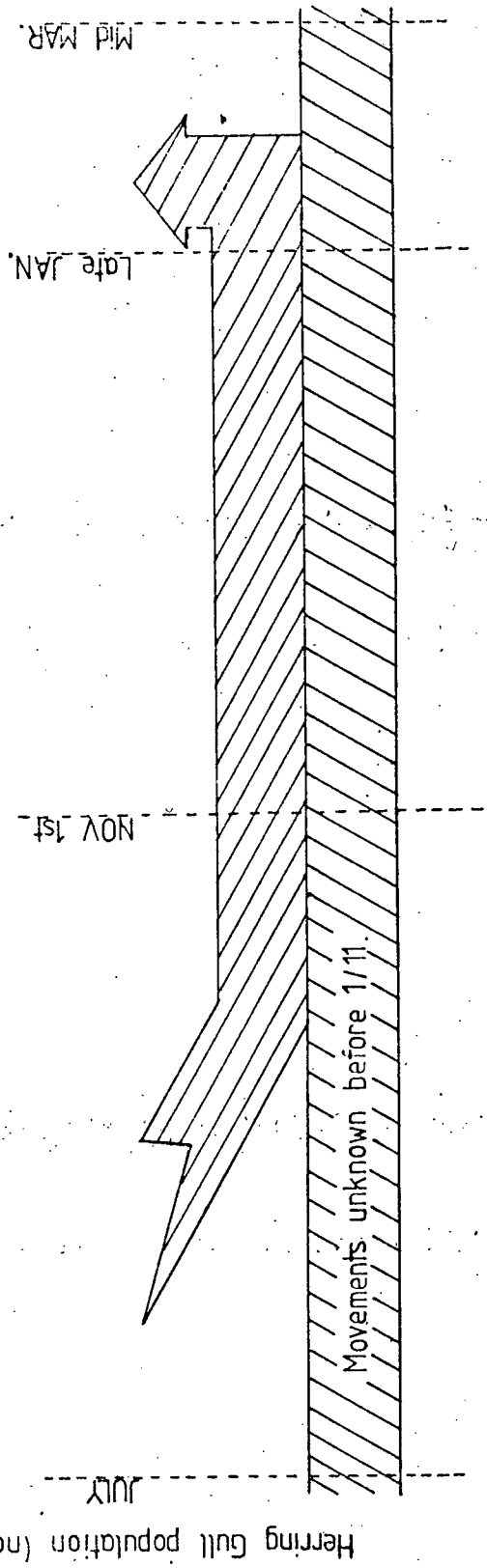

were approximately 44% short of the level estimated for the breeding season population, (6707 to 8972, see page 30). It is therefore likely that approximately 2950 Herring Gulls older than 2 years were in Area 1 but did not visit the observation sites and were not observed between late January and late April. It is not possible to determine the number of Herring Gulls that had left Area 1 before September and had returned during January, and the number that remained in Area 1 throughout the year from the data in this study. Further investigations are needed to determine these details.

Since there probably was emigration of locally breeding Herring Gulls before the end of September, (see above), this probably caused the population level in Area 1 to drop below that of the breeding season population. The mark and recapture estimated population level during July to September did not differ significantly from that estimated for the breeding season population, (see page 30); and the population level probably did not change appreciably from July-September up to December-mid-January, (as indicated by the mark and recapture population estimates, see above). It is therefore likely that there was immigration of Herring Gulls older than 2 years old, associated with non-local colonies, into Area 1 before October. The mark and recapture population estimates indicated that the population level probably dropped by approximately 47% from that in December-mid-January, (estimated at 6854 ± 230), to that in late January-early March, (estimated at 3612 ± 488 , see page 19), or that approximately 3200 Herring Gulls older than 2 years probably left the observed population in Area 1 between December and mid-January. Since the population level in Area 1 probably did not change appreciably from late January-early March to late March-April, (as indicated by the mark and recapture estimates, see page 21), and the late March-April population probably included only the breeding season birds, (see page 30), the late

January-early March population probably also included only breeding season birds. It is therefore likely that the Herring Gulls associated with non-local colonies that entered Area 1 before October probably remained in Area 1 until December and left the area before mid-January, (illustrated in Figure 8a), but it is not possible to assess how many of these Herring Gulls there were from the data in this study. Further studies are necessary to provide these details.

Monaghan (1976) similarly observed that some adults and immatures remained throughout the year in the area north of the River Tees in N.E. England. The winter dispersal movement of Herring Gulls before October in Area 1 was similar to the 16 July to 31 October winter dispersal recorded by Spaans (1971) in the Netherlands. The January return movement in Area 1 was earlier than the February to April movement noted by Spaans (1971); but is corresponded with Cramp et al (1974), who noted that British Herring Gulls usually return to their breeding colonies by March.

Area 2

There were no significant changes in the proportion of marked to unmarked Herring Gulls older than 2 years in sample groups following any of the marking periods in Area 2, (Table 19 and Figure 7); and there probably was no immigration into Area 2 after the end of the first marking period, 30 October, until the end of June when sampling ceased. It is therefore probable that Herring Gulls older than 2 years associated with the local breeding colonies were present in Area 2 from the beginning of November onwards, (illustrated in Figure 8b). Colour-ringed Herring Gulls older than 2 years sighted in Area 2 during the breeding season (late March onwards) had also been sighted in Area 2 during each of the marking periods, (see Appendix 6B);

Table 19. Changes in the proportion of marked to unmarked Herring Gulls older than 2 years following each marking period in Area 2.

Marking period	Dates	Number of Herring Gulls older than 2 years with visible legs	Number of marked Herring Gulls seen	Number of marked birds per 1000 birds with visible legs
21. 7.78 to	1.11 to 16.11	875	5	5.71 \pm 2.38
	5.12 to 17. 1	1206	5	4.15 \pm 2.03
30.10.78	8. 2 to 8. 3	731	3	4.10 \pm 2.02
	13. 3 to 23. 4	1321	7	5.30 \pm 2.30
	26. 4 to 19. 6	946	6	6.34 \pm 2.51
	21. 6 to 29. 6	741	5	6.75 \pm 2.59
1.11.78 to	8. 2 to 8. 3	731	5	6.84 \pm 2.61
	13. 3 to 23. 4	1321	13	9.84 \pm 3.12
18. 1.79	26. 4 to 19. 6	946	15	15.86 \pm 3.95
	21. 6 to 29. 6	741	9	12.15 \pm 3.46
8. 2.79 to	13.3 to 23. 4	1321	5	3.79 \pm 1.94
	26. 4 to 19. 6	946	4	4.23 \pm 2.05
8. 3.79	21. 6 to 29. 6	741	4	5.40 \pm 2.32

so there probably were Herring Gulls older than 2 years that remained in Area 2 throughout the year, (shown in Figure 8b). If any of the locally breeding birds had left Area 2 after the breeding season, they had probably returned before November; but it is not possible to determine whether or not such movement occurred from the data in the present study. Further investigations are needed to examine the movements of the locally breeding population in Area 2 before November.

Figure 7 . Changes in the proportion of marked to unmarked Herring Gulls older than 2 years in sample groups of approx. 1000 individuals, following each marking period in area 2.

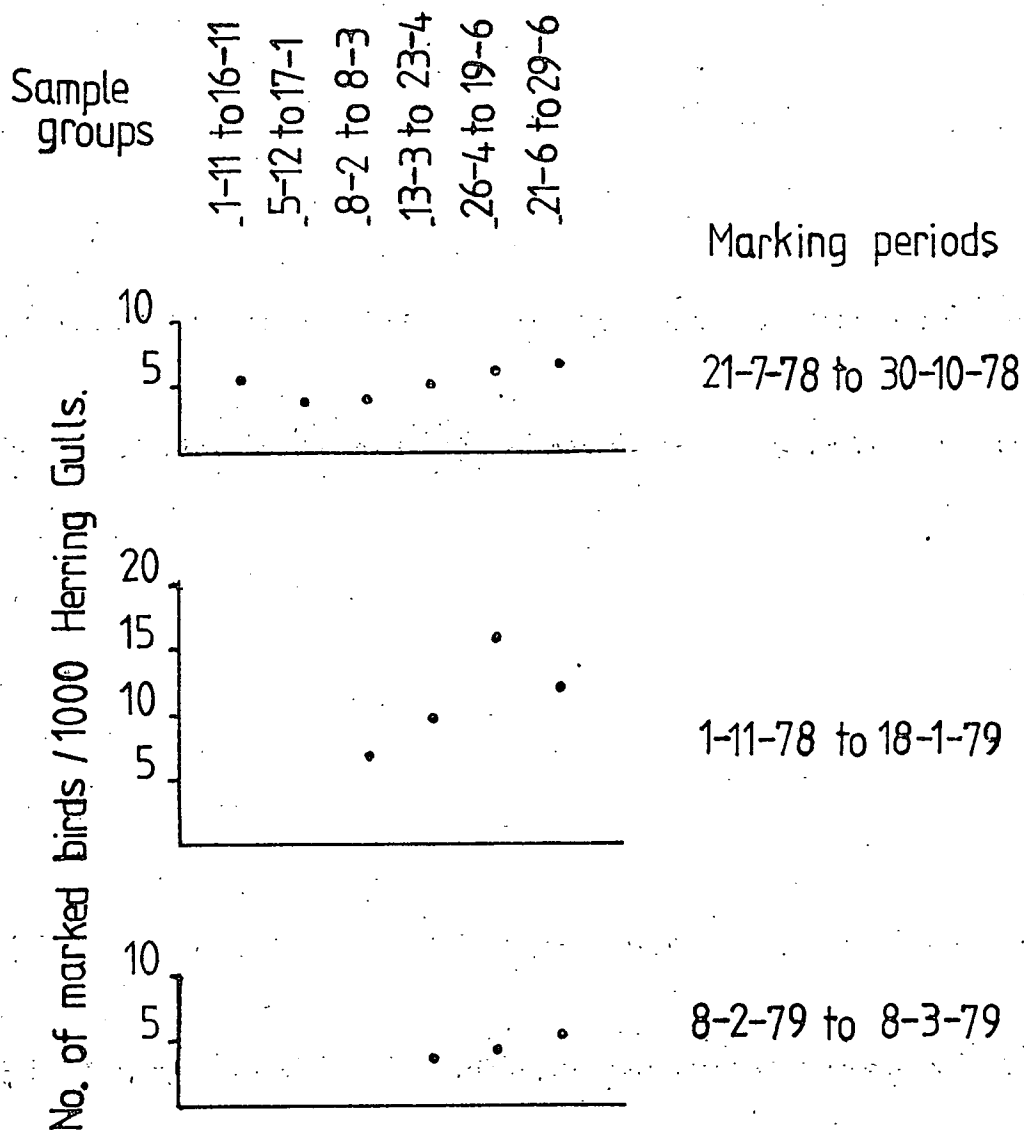

In Area 1 it was similarly observed that some Herring Gulls older than 2 years remained in the area throughout the year; but unlike in Area 2, there were local breeding season birds that left Area 1 before October, wintered elsewhere, and returned during January, (see page 45, and Figure 8a).

The mark and recapture estimated population level of Herring Gulls older than 2 years in Area 2 for July to October, (7822 ± 1358), was within range of that estimated for the breeding season population if 25% adults were non-breeding, (5424, see page 32). There probably was no immigration into the area after October, (see above); so any emigration out of Area 2 after October probably would have caused a drop in the population level. The population level of Herring Gulls older than 2 years in Area 2 probably did not change appreciably between July-October and February-early March, (as indicated by the mark and recapture population estimates, see page 23); so there probably was no emigration out of Area 2 before February-early March. The mark and recapture estimates indicated that the population level in Area 2 during late March to April, (3830 ± 731) was a significant decrease from that during July to September, (7822 ± 1358 , see page 23); and the late March-April estimated population level did not significantly differ from that estimated for the breeding season population, if 0 to 20% adults were non-breeding, (4055-5103, see page 31). It is therefore likely that approximately 4000 Herring Gulls older than 2 years emigrated out of Area 2 between early February and early March. This suggests that approximately 4000 Herring Gulls older than 2 years, unassociated with the local breeding colonies, entered Area 2 before November, wintered in the area, and left the area between February and early March, (illustrated in Figure 8b)¹. Similarly in Area 1 there was immigration of non-locally breeding birds into the area before September; but these birds probably left Area 1 between

1. This also suggests that less than 25% of the adults in the breeding season population in Area 2 was non-breeding.

December and mid-January, which was earlier than the return movement observed in Area 2, (see page 47, and Figure 8a).

Monaghan (1976) also observed that some adult and immature Herring Gulls remained in the area north of the River Tees in N.E. England throughout the year. The influx into Area 2 of non-locally breeding birds before November corresponds with the July-October winter dispersal noted by Spaans (1971) in the Netherlands. The February and March emigration out of Area 2 also correlates with the February to April return movement recorded by Spaans (1971), and corresponds with Cramp *et al* (1974) who noted that British Herring Gulls usually return to their breeding colonies by March.

b.) 1st and 2nd year Herring Gulls

It was not possible to examine the changes in the proportion of marked to unmarked 1st and 2nd year birds in either Area 1 or Area 2, due to insufficient numbers of marked individuals and small sighting samples of birds with visible legs, (see Appendix 6A). There also were insufficient resightings of individual colour-ringed 1st and 2nd year birds to determine whether or not any of these birds remained in Area 1, or remained in Area 2 throughout the year.

Area 1

The mark and recapture estimated population level of 1st and 2nd year Herring Gulls in Area 1 decreased by at least 50% from that in July-November (1982 ± 330 to 3368 ± 814) to that in late March-April (914 ± 102), (see page 33). The proportion of 1st and 2nd year Herring Gulls in the mark and recapture population estimates, and in the observation samples also decreased significantly from that in October (27.8-65.4%, $26.0 \pm 0.89\%$ respectively) to that in late March-April (12.4-29.6%, $15.0 \pm 0.68\%$ respectively), (see page 39).

The decrease of the proportion of 1st and 2nd year birds in the sighting samples was greater than that expected due to the higher mortality rate of 1st years compared with that of older Herring Gulls, (see page 9). Therefore it is likely that approximately 1000 1st and 2nd year Herring Gulls moved out of the observed population from October to late March-April (shown in Figure 9a); and a greater proportion of 1st and 2nd year birds left the observed population than Herring Gulls older than 2 years during this period of time.

The population of Herring Gulls older than 2 years in Area 1 during late January to April probably included only all of the local breeding season birds, (see page 46); and approximately 2950, or 44% of these birds did not visit the observation sites and were not observed, (as indicated by a comparison of the mark and recapture estimated population levels with that estimated for the breeding season population, (see page 46). It is not possible to determine whether or not the whole population of 1st and 2nd year Herring Gulls in Area 1 visited the observation sites and hence was observed during late January to April, from the data in this study. Further investigation is required to determine whether the 1st and 2nd year Herring Gulls that left the observation sites in Area 1 between October and April actually left Area 1, or remained in Area 1 beneath the cliffs or out at sea, but did not return to the observation sites. Monaghan (1976) suggested that there may have been a shift of immature Herring Gulls that fed at tips early in the fall to feeding sites off fishing boats later in the season, to explain an observed decrease in the proportion of immatures among Herring Gulls feeding at tips through the winter and spring, and an observed high proportion of immatures amongst Herring Gulls feeding off fishing boats during the same period. Further studies, involving larger numbers of colour-ringed 1st and 2nd year Herring Gulls than were used in this work, are needed to determine whether or not there was immigration of 1st and 2nd year birds into Area 1, and whether or not some individuals remained in Area 1 throughout the year.

Figure 9. Changes in the estimated population level and the proportion in the observed population of 1st and 2nd year Herring Gulls in Areas 1 and 2.

a. Area 1

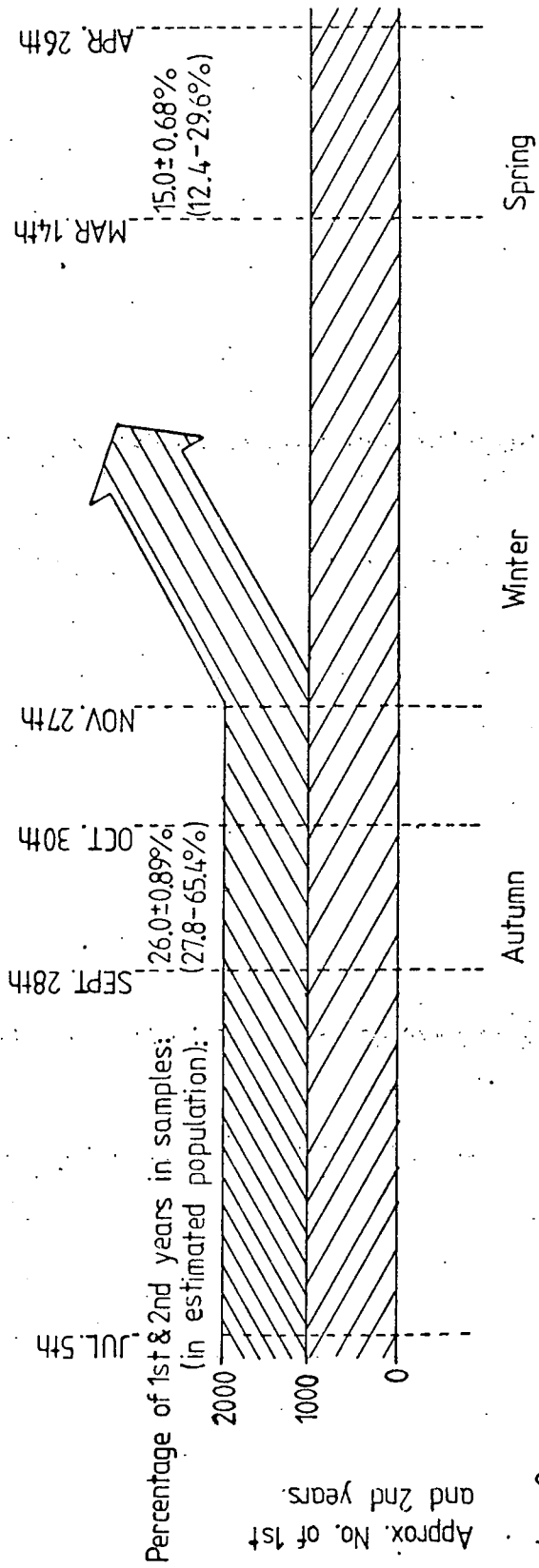

b. Area 2

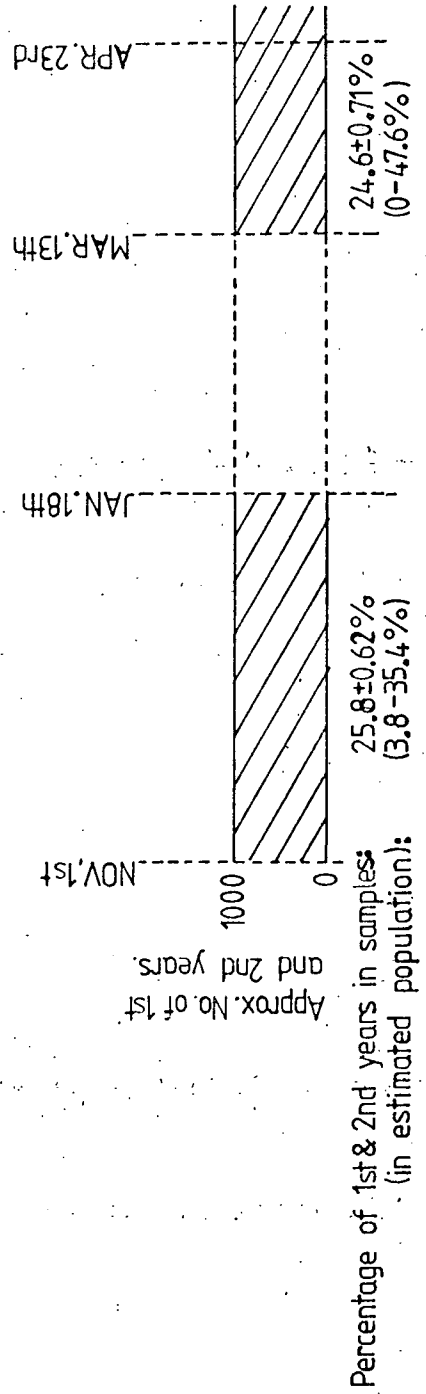

Area 2

The mark and recapture estimates suggested that the population level of 1st and 2nd year Herring Gulls in Area 2 during November to January, (1153 ± 435), probably did not significantly differ from that during late March and April, (1000 ± 576), as shown in Figure 9b, (see page 35). Due to the small number of available marked individuals, it was not possible to calculate population estimates for July to October and February to early March, (page 35), and more information is needed to confirm that no changes in the population level occurred through the year. There was no significant change in the proportion of 1st and 2nd year birds in the estimated population, and in the observation samples, from November-January, ($3.8-35.4\%$ and $25.8 \pm 0.62\%$ respectively), to late March-April, ($0-47.6\%$ and $24.6 \pm 0.71\%$ respectively), (see page 40). The decrease in the proportion of 1st and 2nd year birds in observation samples from July-October to late March-April did not significantly differ from the expected decrease due to a higher mortality rate in 1st years than in older Herring Gulls, (see page 9); and this suggests that there was no significant decrease in the proportion of 1st and 2nd year Herring Gulls in the observed population in Area 2, (shown in Figure 9b). This contrasts with the emigration of 1000 individuals out of Area 1 from October to April (Figure 9a) and the significant decrease in the proportion of 1st and 2nd years among Herring Gulls frequenting the observation sites in Area 1, where there was more movement of 1st and 2nd years away from the observation sites than there was of Herring Gulls older than 2 years, (see page 51).

No changes were observed in the 1st and 2nd year Herring Gull population in Area 2 throughout the year; but more information is needed to confirm that no changes actually occurred. Further studies, involving mark and recapture estimates using larger numbers of available marked birds, and examination of individual movements of colour-ringed Herring Gulls, might provide more details about the movements throughout the year of 1st and 2nd year Herring Gulls in Area 2.

2. Distances of Movements.

a. Movement of colour-ringed Herring Gulls in relation to Areas 1 and 2.

Table 20. The movement of colour-ringed Herring Gulls in relation to Areas 1 and 2.

Area 1	Movement of colour-ringed Herring Gulls between two areas	Number of colour-ringed Herring Gulls	Percentage of total resighted colour-ringed Herring Gulls
	Area 1 → Area 1	191	75%
	Area 1 → Area 2	24	9%
	Area 2 → Area 1		
	Area 1 → North of Area 1	37	15%
	North of Area 1 → Area 1		
	Area 1 → South of Area 2	2	1%
	South of Area 2 → Area 1		
		<u>254</u>	
Area 2	Area 2 → Area 2	106	70%
	Area 2 → Area 1	24	16%
	Area 1 → Area 2		
	Area 2 → North of Area 1	18	12%
	North of Area 1 → Area 2		
	Area 2 → South of Area 2	3	2%
	South of Area 2 → Area 2		
		<u>151</u>	

Of those colour-ringed Herring Gulls observed in Areas 1 and 2 between July 1978 and July 1979, 60% in Area 1, and 63% in Area 2 were seen more than once during this time period, though not necessarily within Areas 1 and 2, (Appendix 8). The movements of these individuals in relation to Area 1 and Area 2 were charted in Table 20.¹

Most of these 381 individuals remained within Area 1 or Area 2, (75% and 70% respectively), with some exchange between Areas 1 and 2, (9% and 16%), some exchange with the region north of Area 1, (15% and 12%), and little exchange with the region south of Area 2, (1% and 2%). This suggests that the majority of individual movement was local.

b. Distances travelled by colour-ringed Herring Gulls.

The median for all colour-ringed Herring Gulls of the further distance that an individual colour-ringed Herring Gull was observed to have travelled, (derived from the data in Appendix 8), is shown in Table 21. The overall median was 5.9 km. This suggests that most individuals travelled short distances.

Table 21. The median for all colour-ringed Herring Gulls of the furthest distance that individual colour-ringed Herring Gulls were observed to have travelled from data in Appendix 8.

Number of resighted colour-ringed Herring Gulls	381
Median distance of furthest resightings	5.9 km.

1. There was not enough data to determine any pattern in the timing of these movements.

The number of resighted colour-ringed Herring Gull individuals was plotted against the distance of their furthest resightings shown in successive 10 km zones on a logarithmic scale, so that the slope showed the rate of change between the zones, (Figure 10). The number of resightings expected at each zone if there was a constant rate of decrease between zones was also plotted; and the rate of dispersal was calculated using this line and the formula from Coulson and Brazendale (1968):

$P_{(j)} = r^j$, where P = the proportion of birds that moved
beyond zone j out of all the birds
observed;

j = the number of 10 km zones in question,
(example: for 70 km, j = 7); and

r = the rate of dispersal.

The rate of decrease was greater in the first 20 km than between the 20 and 40 km zones for the furthest resightings; however if the rate of decrease had been constant the dispersal rate would have been $r = 0.525$. Between 40 km and 130 km there was an even lower rate of decrease that was constant and had a dispersal rate of $r = 0.765$. The furthest resightings continued to 310 km¹, which was further than expected for a constant rate of decrease between 10 km zones. Most of the resightings showed a linear movement along the coast. It is likely that some birds were sedentary, and there was a short range dispersal movement up to 130 km. There probably was a different movement over distances greater than 130 km. The longer movement may have involved winter dispersal; but due to the small number of resightings (3 individuals) at these distances, further studies are needed to determine the precise details of this movement.

-
1. The three birds that moved beyond 130 km were between 3 and 5 years of age; and the movements were between the study area and Scotland. One was seen in the study area during May, and was recovered in the Firth of Forth in July. Another was seen in Glasgow during December, and was resighted in the study area in March. The third moved from the study area in early December to Glasgow in late December.

Figure 10. The number of colour-ringed Herring Gulls resighted at or beyond successive distances, (areas 1 and 2 combined - 381 individuals).

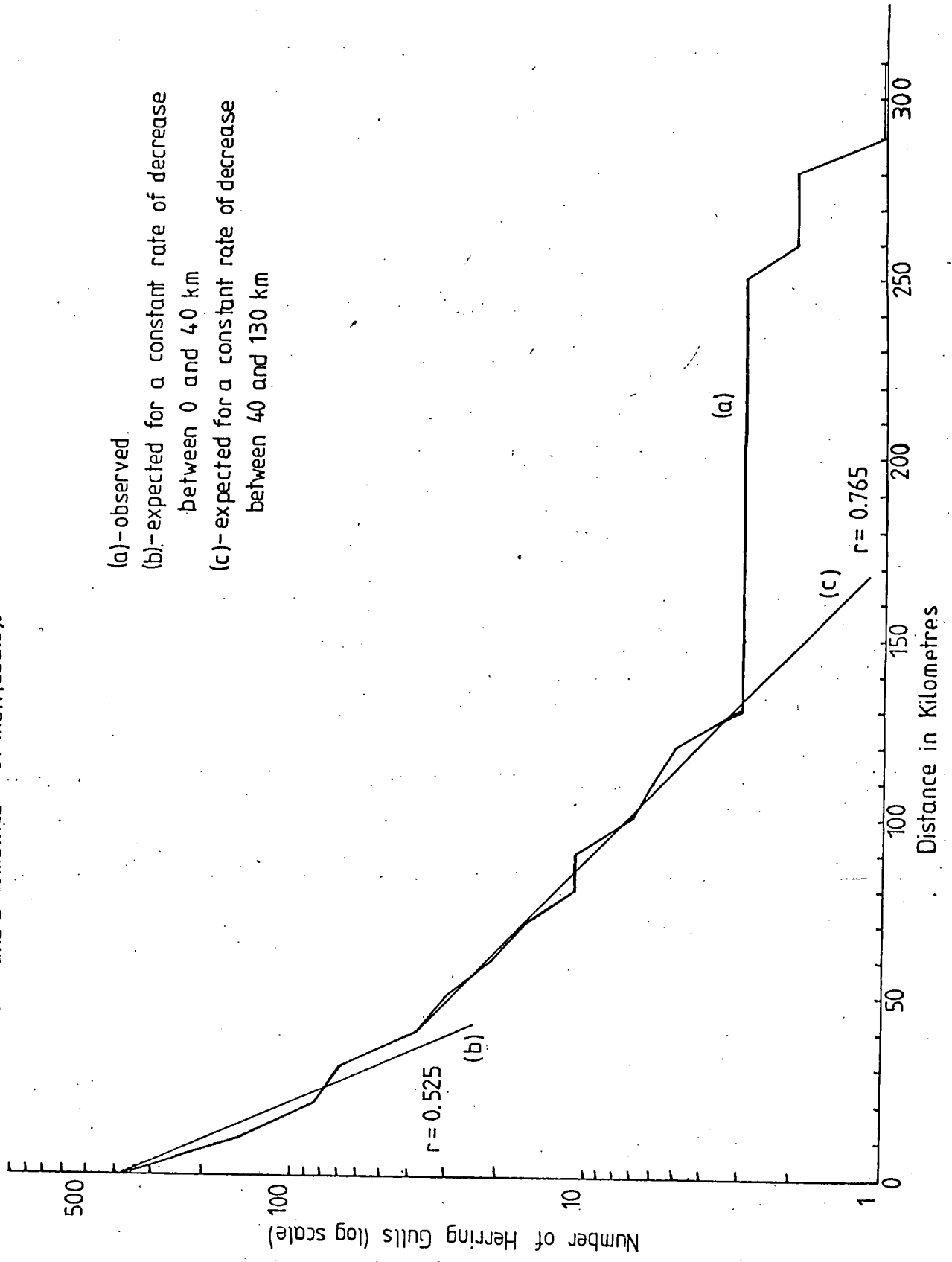

Parsons and Duncan (1968) noted a comparable dispersal rate, ($r = 0.650 \pm 0.016$), for Herring Gulls moving southward (the direction of greatest dispersal) from the Isle of May. Dispersal has also been recorded by Witherby et al (1940) and Gross (1940), who noted that the major dispersal of Herring Gulls was within 300 and 100 miles respectively. Non-random dispersal was noted by Hofslund (1959), who recorded that fall movement of Herring Gulls in Minnesota was not explosive, but followed coastlines and rivers, and by Olsson (1958), who recorded that individual colonies in Norway disperse to specific wintering grounds.

V. Discussion

The Herring Gull colonies on the Cleveland and Yorkshire coast have been growing at a mean rate of 4% per annum over the last ten years, (page 15); and the majority are on coastal cliffs and have increased by 3% per annum over the same period, (page 15). These colonies have had a much lower growth rate than that of most other British colonies, which average 13% per annum, (Chabrzyk and Coulson 1976, Monaghan and Coulson 1977). Herring Gull colonies that have been studied recruit 40-65% of their young breeding birds from other colonies, many of which are nearby, (Ludwig 1963, Duncan and Monaghan 1977, Gross 1940, Tinbergen 1953, Drury and Nisbet 1972); but Herring Gulls ringed as chicks have been found breeding as far as 420 km away from their colony of origin, (Duncan and Monaghan 1977). In this context, Herring Gulls ringed as chicks on the Isle of May have been found breeding on cliffs and in towns in the Whitby and Scarborough area, (S.V.Kearsey pers comm.). 30-50%¹ of young Herring Gulls return to their natal colonies to breed,² (Ludwig 1963, Chabrzyk and Coulson 1976, Parsons and Duncan 1978). Chabrzyk and Coulson (1976) have shown that a colony's growth rate is dependent on its attractiveness to recruits, (i.e. size and density). Much of the cliffs between Saltburn and Bridlington are not suitable for use by nesting Herring Gulls. Some areas are crumbling shale that could not support a nest; some stretches are accessible to predators such as foxes and man; and other areas have rock ledges that are too small for Herring Gull nests. Cliffs that had suitable nesting places were used by Herring Gulls; and few observed potential nesting sites within these areas were unoccupied. This suggests that these long established colonies along the Cleveland and Yorkshire coast have a high density, closer to saturation than that of most other British colonies, and have a surplus of young birds which are recruited into colonies elsewhere.

-
1. Earlier work by Gross (1940), Tinbergen (1953), Harris (1964 and 1970) and Spaans (1971) suggested that most Herring Gulls returned to their natal colonies to breed and that only individuals from disturbed colonies were prone to breed elsewhere; but later evidence has disproved this.
 2. Attachment to the natal colony also occurs in Fulmars, (Fisher 1952), and Common Terns, (Austin 1949), as well as in many other species.

The colonies of Herring Gulls on buildings in Cleveland and Yorkshire coastal towns have grown at a mean rate of 22% per annum over the last ten years, (page 15), which is a much higher rate than that of the local cliff colonies, (see above). It is unlikely that a Herring Gull colony could have a growth rate greater than 14% per annum without recruitment of immigrants into the breeding population, (Chabrzyk and Coulson 1976, Monaghan and Coulson 1977); so there probably is appreciable recruitment into these town colonies from outside. Herring Gulls reared on the Isle of May have been found breeding on buildings in S. Shields and Sunderland, (Duncan and Monaghan 1977); and Monaghan and Coulson (1977) suggested that town nesting gulls originate from large colonies of natural sites in the vicinity which are approaching saturation and are producing a surplus of young. They also noted that the growth rate of town colonies in N.E. England was higher than that of town colonies in other regions of Britain, which was possibly due to the higher density of Herring Gull colonies in this region (in particular the Firth of Forth) than in other regions. It is likely that there is considerable recruitment into these town colonies on the Cleveland and Yorkshire coast of young reared on local cliff colonies which are approaching saturation.

A portion of the group of Herring Gulls older than 2 years present between Redcar and Whitby Scar (the northern part of the study area) during the breeding season, left the area before October, wintered elsewhere and returned before the breeding season; and the rest of those present during the breeding season remained in the area throughout the year, (page 45). There is no evidence that Herring Gulls older than 2 years present between Black Nab, south of Whitby Scar, and Filey Brigg (the southern portion of the study area) during the breeding season ever left the area; and if there was any movement of these birds out of the area and back again, sightings of colour-ringed birds suggest that it probably occurred before November, (page 48).

Thus birds breeding in the northern part of the study area behave differently to those breeding in the southern portion. Different colonies of Herring Gulls disperse in different directions and patterns, (Olsson 1958)¹; and the evidence in this work suggests that there are at least two separate groups breeding between Redcar and Filey Brigg.

The winter dispersal of breeding birds in the northern study area, (see above), corresponded with the pre-October arrival of a group (size unknown) of immigrant Herring Gulls older than 2 years that wintered in the area, (page 47). Approximately 4000 such immigrants also entered the southern study area before November and wintered there, (page 49). Other work has shown that Herring Gulls from other breeding colonies also disperse during the fall, (Thomson 1924, Gross 1940, Tinbergen 1953, Hofslund 1959), with individual variations between the times of dispersal and distances travelled, (Smith 1959). Scottish Herring Gulls move southward along the east coast of England during July to September; and Norwegian Herring Gulls arrive on the same coastline later on, during November and December, (J.C. Coulson pers. comm.). It is therefore likely that immigrant Herring Gulls that arrived in early autumn and wintered between Redcar and Filey Brigg were from Scotland or N.E. England.

Immigrant Herring Gulls that had wintered in the northern study area moved out during January, and birds associated with the local colonies, that had wintered elsewhere, returned, (page 47). Later, during February and early March, the immigrant gulls that had wintered in the southern study area left, (page 49); and this correlates with the February to April return movement recorded in the Netherlands by Spaans (1971). The return movements observed in both of these areas agree with Cramp et al (1974) who noted that British Herring Gulls usually return to their breeding colonies by March.

1. Cormorants also disperse differently from different colonies, (Coulson and Brazendale 1968).

The difference between the time of the return movement in the northern study area and that of the return movement in the southern area suggests that the immigrants wintering in these areas may stem from two different groups of Herring Gulls associated with different breeding areas.

A population is a panmictic group of individuals that have restricted gene flow with other similar groups, (McGraw-Hill Encyclopedia of Science and Technology). The Herring Gulls breeding on the Cleveland and Yorkshire coast have an open gene flow with other groups of Herring Gulls on the east coast, and are only a portion of a much larger population. A similar genetic flow between colonies occurs in seabirds such as terns, (Austin 1938, 1951), skuaas Catharacta skua, (Sladen et al 1968), and shags, (Potts 1968), and in land birds such as the Sand Martin Riparia riparia, (Bergstrom 1951). Recoveries of Herring Gulls ringed as chicks on the Isle of May, (Parsons and Duncan 1978: Figure 2), suggest that there is gene flow over distances of up to several hundred kilometres between one generation and the next, with movement particularly marked along the coasts. To study a population in a species of this sort, it is necessary either to cover a very large area which includes the whole population, or to examine a few small areas and assume that the portion of the population in these areas is typical. Since only one year was allotted to this work, it would not have been possible to have covered a larger area. The data from this study were compared with those from other breeding areas in order to show the differences between them and to establish patterns of behaviour, such as rates of growth, age ratios and seasonal movements. This approach provided detailed information on small groups of Herring Gulls. It is worthwhile to examine a large population in small blocks, such as in this work, because each ensuing investigation will have more previous work available on other areas for comparison, and eventually a picture of the whole population's behaviour will emerge.

It is evident from this study that it should not be assumed that the gulls in each of these blocks behave similarly and have the same proportions of resident and immigrant birds. The factors causing these differences remain to be elucidated.

This discussion has been written with the assumption that the mark and recapture method of population estimation was applicable. The accuracy of this method of estimation is flawed in the following ways:

- 1) The marking and recapture periods used with this method were at least 26 days in length, (page 7). Immigration that occurred during a recapture period would have diluted the proportion of marked birds, and would have been included at least in part in the population estimate for the preceding marking period. Such an estimate would have prematurely shown immigration. Therefore the timing of the changes in the population size in either study area is less precise than would have been preferred.
- 2) Consistency of daily samples varied; and unusually large numbers of marked individuals seen on a few days affected the estimate significantly, as shown by the October estimate for Area 1, (see page 21).

It was not possible to examine the population flux by looking at movements of individual colour-ringed Herring Gulls because there were not enough resightings of these individuals and there were too few marked birds available. The mark and recapture population estimates did illustrate the changes in the size of the Herring Gull populations in the study areas and the general timing of these changes. These estimates can certainly act as a basis for more detailed studies on the movements of Herring Gulls along the Cleveland and Yorkshire coast.

VI. Summary

1. A census of the Herring Gulls breeding along the Cleveland and Yorkshire coast was conducted during 1978 and 1979. 4969 pairs of Herring Gulls were observed nesting on cliffs; and 666 pairs were found nesting on buildings in towns.
2. This 1978-1979 census of breeding Herring Gulls was compared with that in 'Operation Seafarer' during 1969-1970 and the 1976 survey of gulls nesting on buildings in Ireland and Britain, (Monaghan and Coulson 1977). Over the last ten years on the Cleveland and Yorkshire coast, (i) the cliff nesting population has grown at a rate of 3% per annum; (ii) the town nesting population has had a growth rate of 22% per annum, and has increased from 3% to 12% of the coastal population; and (iii) the overall population has grown at a rate of 4% per annum.
3. The number of Herring Gulls nesting along particular portions of cliffs in 1978 were compared with that of Herring Gulls nesting along the same areas in 1979. There were large variations of -20 to +60% in the numbers from 1978 to 1979; although these same areas showed less than 6% per annum growth over the previous ten years. This suggested that breeding Herring Gulls may move nesting sites from year to year, or that the number of recruits and non-breeding adults varied from one year to the next according to environmental conditions; but further studies are needed to confirm these hypotheses.
4. Herring Gulls present between Redcar and Black Nab, south of Whitby, (Area 1), and those between Black Nab and Filey Brigg, (Area 2), were observed throughout the year July 1978 to July 1979.
 - (i) Observations included information on colour-ringed Herring Gulls as well as Herring Gulls without rings; and the types of data collected and the locations of sighting areas were discussed.

- (ii) A mark and recapture method for estimation of population size was discussed.
 - (iii) The year July 1978 to July 1979 was divided into "marking periods" and "sighting periods"; and the method used for this was discussed.
5. The behaviour of 1st and 2nd year Herring Gulls was compared with that of Herring Gulls older than 2 years.
- (i) In Area 1, the proportion of 1st and 2nd years in observation samples decreased from 31% (July-September) to 17% (May-July); and this decrease was significantly greater than that expected for the higher mortality rate of 1st years compared with older birds, 31% to 26%. This suggested that there was more movement of 1st and 2nd year birds out of this area than there was of Herring Gulls older than 2 years.
 - (ii) The proportion of 1st and 2nd years in observation sightings in Area 2 decreased from 27% to 23%, which did not differ significantly from the expected decrease due to the high mortality rate of 1st year birds. This suggested that there was not any differential amounts of movement in or out of the area between the age classes.
 - (iii) The age ratios in samples taken during each marking period (in each study area), when tested for uniformity using the χ^2 test did not show homogeneity. This indicated that the behaviour of 1st and 2nd year birds was not identical to that of Herring Gulls older than 2 years; and the 1st and 2nd year birds data was separated from that of the older birds data for use in later mark and recapture population estimates.

- (iv) Resighting probabilities for the two age classes were calculated for each study area. The probability of resighting a colour-ringed Herring Gull older than 2 years more than once on different days, (0.51 ± 0.04 in Area 1 and 0.40 ± 0.04 in Area 2), was greater than the probability of seeing a colour-ringed 1st and 2nd year Herring Gull again, (0.32 ± 0.05 in Area 1 and 0.20 ± 0.13 in Area 2); and this indicated that some 1st and 2nd year birds frequented the observation sites less consistently and moved around more than the older Herring Gulls. The probability of sighting either aged individual 3 or more times on different days was equal, which indicated that a portion of the 1st and 2nd year birds visited the observation sites as consistently as the older Herring Gulls.
- (v) These results suggested that Herring Gulls older than 2 years may have been more consistent in their behaviour than some of the 1st and 2nd year Herring Gulls due to specialized feeding by older Herring Gulls.
6. (i) Mark and recapture population estimates for Herring Gulls older than 2 years in Area 1 and Area 2, during each marking period, were calculated and discussed.
- (ii) The age composition of the breeding season Herring Gull population was determined and a life table was constructed for each study area using the observed growth rate of the overall Cleveland and Yorkshire coastal breeding population (4% per annum).
- (iii) Breeding season population estimates were derived from the life tables and the known breeding population for each study area; and these were compared with mark and recapture population estimates during July to September/October and late March to April.

(iv) These results showed the following:

- (a) In Area 1, the mark and recapture estimated population level of Herring Gulls older than 2 years did not change appreciably between July to September and December to mid-January, (6507 ± 1318 to 8549 ± 2003), and remained approximately equivalent to that estimated for the breeding season population, (6707 to 6753). It dropped, by approximately 47%, from that during July to mid-January to that during late January to April, (3612 ± 488 to 3850 ± 588). This late January to April level was significantly lower than that estimated for the breeding season population; and this indicated that a portion of the population present in Area 1 during this period did not visit the observation sites, which suggests that there were loafing and feeding sites in Area 1, other than the observation sites, where the unobserved portion of the population could be found, such as beneath the cliffs or out at sea.
- (b) In Area 2, the mark and recapture estimated population level of Herring Gulls older than 2 years did not change significantly between July to October and February to early March, (5306 ± 795 to 8167 ± 2104), and was at least 25% higher than that estimated for the breeding season population. The level dropped by approximately 50% from that during July to October, (7822 ± 1358), to that during late March and April, (3830 ± 731 , which did not differ significantly from the level estimated for the breeding season population, 4055 to 4083).

7. Mark and recapture population estimates for 1st and 2nd year Herring Gulls in Area 1 and in Area 2, during each marking period, were calculated and discussed.

(i) In Area 1, the estimated population level decreased by at least 50% from that during October, (3368 ± 814), to that during December to mid-January, (1145 ± 329), and from that during July to November, (1982 ± 330 to 3368 ± 814), to that during late March and April, (914 ± 102).

(ii) In Area 2, the estimated population level during November to mid-January, (1153 ± 435), did not differ significantly from that during late March and April, (1000 ± 576). Estimates could not be calculated for July to October and February to early March; and more information is needed to confirm that no changes occurred in the population level through the year.

8. The ratio of 1st and 2nd years to Herring Gulls older than 2 years in the estimated population level during each marking period was calculated; and the method used was discussed. These ratios were compared with those observed in sighting samples during the same periods.

(i) In Area 1, the following results were found:

(a) The ratios in the estimated population levels during July to September (12.2-38.6%), November (8.8-38%), December to mid-January (6.4-22%) and late March to April (12.4-29.6%) overlapped those in the observation samples ($31.2 \pm 0.82\%$, $17.9 \pm 0.58\%$, $19.1 \pm 0.74\%$ and $15.0 \pm 0.68\%$ respectively). No comparison was possible for late January to early March. During October, the ratio in the estimated population, (27.8-65.4%), was higher than that in observation samples, ($26.0 \pm 0.89\%$).

This suggests that during October the 1st and 2nd year Herring Gulls that visited the observation sites were more dilute and moved around more beyond the observation sites than the Herring Gulls older than 2 years that visited the observation sites; but during July to September, November, December to mid-January and late March to April, gulls of both age groups in the observed population probably moved around similarly.

- (b) The ratio in the estimated population level peaked at 27.8-65.4% during October and then decreased to 12.4-29.6% during late March and April; and this corresponded with a significant decrease ($p < 0.02$) in the ratio observed in sighting samples from $26.0 \pm 0.89\%$ in October to $15.0 \pm 0.68\%$ in late March and April. This indicated that there probably was more movement away from the observation sites in Area 1 amongst 1st and 2nd years than there was amongst Herring Gulls older than 2 years.

(ii) In Area 2, the following results were found:

- (a) The ratios in the only two estimated population levels available, November to mid-January (3.8-35.4%) and late March to April (0-47.6%), overlapped the ratios found in observation samples during the same time periods ($25.8 \pm 0.62\%$ and $24.6 \pm 0.71\%$ respectively). This suggested that the 1st and 2nd years and the Herring Gulls older than 2 years observed during these months moved around similarly; but more information was needed to determine whether the ratios in the observation samples represented the ratio in the observed population during July to October and February to early March.

- (b) The ratio in the estimated population level during November to mid-January overlapped that during late March and April (values shown above); and the ratios in the observation samples during these periods (also shown above) also did not differ significantly. It had previously been shown that the ratios in the observation samples suggested that there was no change in the proportion of the two age classes throughout the year (see 5.ii); but it was not possible to confirm this from the estimated population ratios.
9. The proportion of marked to unmarked birds in samples following each marking period was examined in Herring Gulls older than 2 years; and the method used was discussed.
- (a) In Area 1, there was a significant decrease ($p < 0.02$) in the proportion from that before 19 December (20.81 ± 4.51 marked birds per 1000 birds with visible legs) to that after 17 January (4.45 ± 2.10) following the October marking period, and from that before 7 November (5.97 ± 2.45) to that after 12 June (0.69 ± 0.83) following the July to September marking period. Possible causes of change in the proportion of marked to unmarked birds were discussed. These results suggested that there was no immigration into Area 1 between early October and late December, and during January there probably was immigration of unmarked birds into Area 1 that did not leave before 23 July (when sampling ceased).
- (b) There were no significant changes in the proportion of marked to unmarked Herring Gulls following any of the marking periods in Area 2. This indicated that there probably was no immigration into Area 2 after the end of the first marking period, 30 October, until the end of June when sampling ceased, and suggested that the birds associated with the local breeding colonies were present in Area 2 from the beginning of November onwards.

10. The findings from the changes in the proportion of marked to unmarked birds were compiled with those from the changes in the mark and recapture population estimates and with information on resightings of marked individuals to determine the movements of Herring Gulls older than 2 years throughout the year in each study area. This showed the following:
 - (a) A portion (size unknown) of the Herring Gulls present during the breeding season left Area 1 before October, wintered elsewhere and returned during January; and the rest of those present during the breeding season remained in Area 1 throughout the year.
 - (b) A group (size unknown) of Herring Gulls associated with non-local colonies entered Area 1 before October, wintered in the area and then left during December to Mid-January.
 - (c) The Herring Gulls present in Area 2 during the breeding season were in the area from November onwards. If any of them left the area and returned, they did so before November, but it was not possible to determine whether any movement occurred before November.
 - (d) Approximately 4000 Herring Gulls associated with non-local colonies entered Area 2 before November, wintered in the area and left during February and early March.

11. The changes in the mark and recapture estimated population level were examined together with the changes in the proportion of 1st and 2nd years in the estimated population and in the observation samples to determine the movements of 1st and 2nd year Herring Gulls throughout the year in each study area. This showed the following:
 - (a) At least 50%, or approximately 1000 1st and 2nd years present during July to November moved out of the observed population in Area 1 by late March to April.

There was more movement of 1st and 2nd years out of the observed population in Area 1 than there was of older Herring Gulls; but it was not known whether this movement of 1st and 2nd year birds was out of Area 1 or to sites within Area 1 beneath the cliffs or out at sea.

- (b) No changes were observed in the 1st and 2nd year population in Area 2 throughout the year; but more information is needed to confirm that no changes actually occurred.
12. Further studies that would provide more details on the movements of Herring Gulls in these study areas were discussed.
 13. Examination of the movements of colour-ringed individuals showed that 75% of those observed in Area 1 remained in Area 1, 70% of those observed in Area 2 remained in Area 2 and smaller percentages were observed to have moved further afield.
 14. The median of the furthest distance that a colour-ringed individual was observed to have travelled, for all colour-ringed Herring Gulls, was determined to be 5.9km.; and this suggested that most individuals travelled short distances.
 15. The furthest resightings of colour-ringed individuals were examined; and from this a dispersal rate was calculated, and the method used was discussed. There was one short range dispersal movement up to 130 km., with a dispersal rate of $r = 0.651 \pm 0.024$. There was a different movement over distances greater than 130 km., which may have involved winter dispersal; but further information was needed to confirm this.
 16. The growth rates of the colonies on cliffs (3% per annum) and of the overall breeding population (4% per annum) along the Cleveland and Yorkshire coast were much lower than that of other areas in Britain (which average 13% per annum); and this suggested that these long

established coastal colonies have a high density, closer to saturation than most other British colonies, and have a surplus of young birds recruited into colonies elsewhere.

17. The growth rate of the Cleveland and Yorkshire coastal town colonies (22% per annum) was much higher than the highest rate of growth likely for a population without immigration of recruits (14% per annum); and this suggested that there was considerable recruitment into the town colonies of young Herring Gulls reared in the local cliff colonies.
18. The differences between the movements of the locally breeding Herring Gulls in Area 1 and Area 2 suggested that there were at least two separate breeding groups between Redcar and Filey Brigg.
19. The timing of the immigration of Herring Gulls older than 2 years into both Areas 1 and 2 during the early autumn suggested that these birds were from Scotland or N.E. England.
20. The difference between the times of the return movements of immigrants observed in the two areas (Area 1 - January, Area 2 - February and early March) suggested that the immigrants that wintered in the two study areas were two separate groups originating from different breeding areas.
21. The gene flow in the breeding population on the Cleveland and Yorkshire coast and the problems involved in studying such a population were discussed.

BIBLIOGRAPHY

- Austin, O.L. (1938) Some results from adult tern trapping in the Cape Cod colonies. *Bird-Banding* 9 : 12-25.
- Austin, O.L. (1949) Site tenacity, a behaviour trait of the Common Tern (*Sterna hirundo* L.). *Bird-Banding* 20 : 1-39.
- Austin, O.L. (1951) Group adherence in the Common Tern. *Bird-Banding* 22 : 1-15.
- Bailey, N.T. (1951) On estimating the size of mobile populations from capture - recapture data. *Biometrika* 38 : 293-306.
- Bailey, N.T. (1952) Improvements in the interpretation of recapture data. *J. Anim. Ecol.* 21 : 120-127.
- Bailey, N.T. (1976) Statistical Methods in Biology. Hodder and Stoughton, London.
- Begon, Michael (1979) Investigating Animal Abundance; capture - recapture for biologists. Edward Arnold (Publishers) Ltd., London.
- Bergstrom, E.A. (1951) The South Windsor bank swallow colony. *Bird-Banding* 22 : 54-63.
- Chabrzyk, G. and Coulson, J.C. (1976) Survival and recruitment in the Herring Gull *Larus argentatus*. *J. Anim. Ecol.* 45 : 187-203.
- Chislett, R. (1953) Yorkshire Birds. London.
- Cooke, F. and Ross, R.K. (1972) Diurnal and seasonal activities of a post-breeding population of gulls in Southeastern Ontario. *The Wilson Bulletin* 84 : 164-172.
- Coulson, J.C. (1976) Evaluation of the reliability of rings used on Herring Gulls and Lesser Black Backed Gulls. *Bird Study* 23 : 21-26.

- Coulson, J.C. and Brazendale, M.G. (1968) Movements of cormorants ringed in the British Isles and evidence of colony specific dispersal. *Brit. Birds* 61 : 1-21.
- Cramp, S. (1971) Gulls nesting on buildings in Britain and Ireland. *British Birds* 64 : 476-87.
- Cramp, S., Boruen, W.R.P. and Saunders, D. (1974) The Seabirds of Britain and Ireland. Collins, London.
- Davis, J.W.F. (1974a) Herring Gull population and man. *Nature in Wales* 14(2) : 85-90.
- Davis, J.W.F. (1974b) Variations in the number of Herring Gulls at a feeding site. *Nature in Wales* 14 : 234-240.
- Davis, J.W.F. (1975) Feeding specializations in Herring Gulls. *J. Anim. Ecol.* 44 : 795-804.
- Drury, W.H. and Kadlec, J.A. (1974) The current status of the Herring Gull population in N.E. U.S.A. *Bird Banding* 45(4) : 297-306.
- Drury, W.H. and Nisbet, C.T. (1972) The importance of movements in the biology of Herring Gulls in New England. In 'Population Ecology of Migratory Birds; A Symposium' U.S. Dept. of the Interior, Wildlife Research Report, 2 : 173-212.
- Duncan, W.N.M. and Monaghan, P. (1977) Infidelity to the natal colony by breeding Herring Gulls. *Ringed and Migration* 1 : 166-172.
- Fisher, J. (1952) The Fulmar. London, Collins, New Nat.
- Gray, P. (1967) The Dictionary of the Biological Sciences. Reinhold Publ. Corp., London.
- Gross, A.O. (1940) The migration of Kent Island Herring Gulls. *Bird Banding* 11 : 129-154.

- Harris, M.P. (1964) Recoveries of ringed Herring Gulls. *Bird Study* 11 : 183-191.
- Harris, M.P. (1970) Rates and causes of increases of some British gull populations. *Bird Study* 17 : 325-335.
- Hickling, R.A.O. (1954) The wintering of gulls in Britain. *Bird Study* 1 : 129-148.
- Hickling, R.A.O. (1967) The inland wintering of gulls in Britain, 1963. *Bird Study* 14 : 104-113.
- Hickling, R.A.O. (1973) Inland wintering of gulls in England and Wales. *Bird Study* 24 : 79-88.
- Hofslund, P.B. (1959) Fall migration of Herring Gulls from Knife Island, Minnesota. *Bird Banding* 30 : 104-113.
- Jørgensen, O.H. (1973) Some results of Herring Gull ringing in Denmark, 1958-1969. *Dansk. Orn. Foren. Tidsskr.* 67 : 53-63.
- Kaklec, J.A. and Drury, W.H. (1968) The structure of the New England Herring Gull population. *Ecol.* 49 : 644-676.
- Kihlmann, J. and Larsson, L. (1974) On the importance of refuse dumps as a food source for wintering Herring Gulls. *Ornis Scandinavica* 5 : 63-70.
- Lack, D. (1944) The problem of partial migration. *Brit. Birds* 37 : 122-130, 143-150.
- Lincoln, F.C. (1928) The migration of young North American Herring Gulls. *Auk* 45 : 49-59.
- Lincoln, F.C. (1930) Calculating wildfowl abundance on the basis of banding return. U.S. Dept. Agric. Circ. 118 p.p. 1-4.
- Lloyd, D.E.B. (1968) The use of Inland Habitats by Gulls (*Larus* spp) in the Ythan Valley, Aberdeenshire. Unpubl. M.Sc. Thesis. University of Aberdeen.
- Ludwig, J.P. (1963) Return of Herring Gulls to natal colony. *Bird Banding* 34 : 68-72.

- Monaghan, P. (1976) The Utilization of Urban Resources by the Herring Gull.
D.Phil Thesis. University of Durham.
- Monaghan, P. (1978) The role of refuse tips as a winter food supply of
Herring Gulls. *Ibis* 120 : 115 p.p.
- Monaghan, P. and Coulson, J.C. (1977) Status of large gulls nesting on
buildings. *Bird Study* 24(2) : 89-104.
- Moore, F.R. (1976) The dynamics of seasonal distribution of Great Lakes
Herring Gulls. *Bird Banding* 47(2) : 141-159.
- Mudge, G.P. (1979) Ecological Studies of Herring Gulls and other Larini
in an Urban Environment. D.Phil. Thesis.
University of Wales, Cardiff.
- Nelson, T.H. (1907) Birds in Yorkshire. Brown, Hull.
- Olsson, V. (1958) Dispersal migration, longevity and death causes of
Strix aluco, Buteo buteo, Ardea cinerea and Larus
argentatus. *Acta Vertebratica* 1 : 91-189.
- Operation Seafarer (1969-1970) MSS. deposited in the library of the Edward
Grey Institute, Oxford.
- Parsons, J. and Duncan, N. (1978) Recoveries and dispersal of Herring Gulls
from the Isle of May. *J. Anim Ecol.* 47 : 993-1005.
- Paynter, R.A.Jr. (1947) The fate of banded Kent Island Herring Gulls.
Bird Banding 18 : 156-170.
- Potts, G.R. (1968) The influence of eruptive movements, age, population
size and other factors on the survival of the shag
(Phalacrocorax aristotelis (L.)). *J. Anim. Ecol.*
38 : 53-102.
- Schreiber, R.W. (1968) Seasonal population fluctuations of Herring Gulls
in central Maine. *Bird Banding* 39(2) : 81-106.
- Sladen, W.J.L., Wood, R.C. and Monaghan, E.P. (1968) The U.S.A. R.P. bird
banding program, 1958-1965. *Antartic Res. Ser.* 12 :
213-262.

- Smith, W.J. (1959) Movements of Michigan Herring Gulls. Bird Banding
30(2) : 69-104.
- Southern, W.E. (1968) Dispersal patterns of subadult Herring Gulls from
Rogers City, Michigan. Jack-Pine Warbler 46 : 2-6.
- Southwood, T.R.E. (1966) Ecological Methods. Methuen, London. 75 p.p.
- Spaans, A.L. (1971) On the feeding ecology of the Herring Gull Larus
argentatus in the northern part of the Netherlands.
Ardea 59 : 75-188.
- The McGraw-Hill Encyclopedia of Science and Technology. (1977) Mc Graw-
Hill Book Company, New York. Volume 12.
- Thomson, A.L. (1924) The migrations of the Herring Gull and the Lesser
Black Backed Gull; results of the marking method.
Brit. Birds 18 : 34-44.
- Threlfall, W. (1978) Dispersal of Herring Gulls from the Witkens Bay Sea
Bird Sanctuary, Newfoundland. Bird Banding 49(2) :
116-124.
- Tinbergen, N. (1953) The Herring Gull's World. Collins, London, New Nat.
- Verbeek, N.A.M. (1977a) Age differences in the digging frequency of
Herring Gulls on a dump. The Condor 79 : 123-125.
- Verbeek, N.A.M. (1977b) Comparative feeding behaviour of immature and adult
Herring Gulls. The Wilson Bulletin 89(3) : 415-421.
- Verbeek, N.A.M. (1977c) Interactions between Herring Gulls and Lesser
Black Backed Gulls feeding on refuse. The Auk 94 :
726-735.
- Whitherby, H.F., Jourdain, F.G.R., Ticehurst, N.F. and Tucker, B.W. (1940)
The Handbook of British Birds. Whitherby, London.

APPENDIX 1

Distribution of nesting Herring Gulls between Saltburn and Bridlington, on the Yorkshire and Cleveland coast, 1978-1979.

<u>Location</u>	<u>O.S. map ref.</u>	<u>Observation date</u>	<u>Number of pairs</u>
Teesmouth to Saltburn			0
Saltburn to Huntcliff	NZ670217- NZ690218	23/6/78	182
Huntcliff to Seal Goit	NZ690218- NZ700217	22,23/6/78	198
Seal Goit to Skinningrove	NZ700217- NZ711204	22/6/78	25
Skinningrove to White Stones	NZ711204- NZ748201	9/6/78	357
White Stones to Boulby	NZ748201- NZ764192	7/6/78	398
Boulby to Cowbar	NZ764192- NZ783191	21/6/78	160
Cowbar Cliffs	NZ783191- NZ781189	26/5/78	74
Cowbar Buildings	NZ782189	21/6/78	15
Staithes Buildings	NZ782187	May-June/78	121
Staithes to Port Mulgrave	NZ785188- NZ799177	6/6/78	29
Port Mulgrave to Lingrow Knock	NZ799177- NZ809169	3/5/78	17
Lingrow Knock to Runswick	NZ809169- NZ810160	27/7/78	28
Runswick Buildings	NZ810160	3/5 & 4/7/78	15
Runswick to Kettleness	NZ810160- NZ832163	3/5 & 4/7/78	51
Kettleness to Loop Wyke	NZ832163- NZ848147	4/7/78	365
Loop Wyke to Sandsend	NZ848147- NZ860130	19/4/78	31
Sendsend to Whitby	NZ860130- NZ899116	5/7/78	0

Appendix 1. /Contd...

<u>Location</u>	<u>O.S. map ref.</u>	<u>Observation date</u>	<u>Number of pairs</u>
Whitby Buildings	NZ900110	May-June/78	299
Whitby to Saltwick	NZ902115- NZ916114	5/7/78	89
Saltwick to lighthouse near Black Nab	NZ916114- NZ928103	7/7/78	219
Lighthouse to Maw Wyke Hole	NZ928103- NZ942084	19/7/78	100
Maw Wyke Hole to Homerell Hole	NZ942084- NZ957070	21/7/78	77
Homerell Hole to Robin Hood's Bay	NZ957070- NZ954048	20/7/78	102
Robin Hood's Bay Buildings	NZ951054	5/6/78	43
Robin Hood's Bay to Old Peak	NZ954048- NZ980024	12,17/5/79	12
Ravenscar	NZ980024- NZ987017	13,17/5/79	165
Ravenscar to Blea Wyke	NZ987017- NZ992015	14/5/79	30
Blea Wyke to Petard Point	NZ992015- TA006989	14/5/79	0
Petard Point to Cloughton Wyke	TA006989- TA021953	15/5/79	13
Cloughton Wyke	TA021953- TA026948	21/6/79	107
Hunsdale Point to Long Nab	TA026948- TA030940	21/6/79	117
Long Nab to Scarborough	TA030940- TA036906	16/5/79	0
Scarborough Buildings	TA042885	May/June/79	172
Castle Cliff, Scarborough	TA050895- TA053890	21/6/79	66
Castle Cliff to Osgodby Point	TA053890- TA065854	May/79	0
Osgodby Point to Yons Nab	TA065854- TA085843	24/5/79	93

Appendix 1. /Contd...

<u>Location</u>	<u>O.S. map ref.</u>	<u>Observation date</u>	<u>Number of pairs</u>
Yons Nab to The Wyke	TA085843- TA100831	29/5/79	67
The Wyke to Filey	TA100831- TA119800	29/5/79	451
Filey Buildings	TA119800	29/5/79	1
Filey to Speeton	TA119800- TA150757	29/5/79	0
Speeton Gap to Dulcey Dock	TA150757- TA168748	25/6/79	200
Dulcey Dock to Buckton Cliffs	TA168748- TA182746	21/6/79	193
Buckton Cliffs to Bempton Cliffs	TA182746- TA193744	20/6/79	53
Bempton Cliffs to Gull Nook	TA193744- TA222727	12/6/79	566
Gull Nook to Lifeboat Station	TA222727- TA239720	12/7/79	39
Lifeboat Station to Stottle Bank Nook	TA239720- TA254713	12/7/79	258
Stottle Bank Nook to Head Farm	TA254713- TA252697	28/6/79	36
Head Farm to Bridlington	TA252697- TA194678	28/6/79	0

APPENDIX 1a

Counts taken of cliff colonies censused both in 1978 and 1979.

<u>Location</u>	<u>O.S. map ref.</u>	<u>Observation date</u>	<u>Number of pairs</u>
Saltburn to Skinningrove	NZ670217- NZ690218	22-23/6/78	405
		12/6/79	325
Bias Scar to Cowbar	NZ766191- NZ783191	21/6/78	41
		25/6/79	63
Cowbar Cliffs	NZ783191- NZ781189	21/6/78	74
		25/6/79	101
Cloughton Wyke	TA021953- TA026948	14/7/78	78
		21/6/79	107
Castle Cliff	TA050895- TA053890	13/7/78	41
		21/6/79	66

APPENDIX 2

The number of Herring Gulls present and the number with visible legs in each sighting sample.

Area 1

Date	Number of Herring Gulls	Number with Visible Legs	Percentage of Herring Gulls with Visible Legs
5. 7.78	118	102	86
7. 7.78	343	219	64
27. 7.78	12	9	75
11. 8.78	300	270	90
31. 8.78	950	270	28
2. 9.78	555	172	31
7. 9.78	434	89	21
19. 9.78	508	246	48
29. 9.78	215	163	76
3.10.78	643	270	42
4.10.78	337	285	85
6.10.78	76	71	93
9.10.78	333	205	62
12.10.78	400	288	72
16.10.78	444	27	6
1.11.78	718	31	4
7.11.78	996	932	94
10.11.78	1305	379	29
14.11.78	175	55	31
16.11.78	25	20	80
21.11.78	1200	844	70
27.11.78	21	21	100
5.12.78	347	321	93
13.12.78	1248	934	75
19.12.78	85	55	65
17. 1.79	1158	488	42
25. 1.79	318	169	53
31. 1.79	711	650	91
8. 2.79	265	186	70
9. 2.79	832	585	70
27. 2.79	567	322	57
1. 3.79	629	566	90
6. 3.79	299	160	54
8. 3. 79	144	114	79
14. 3.79	120	120	100
30. 3.79	383	258	67
3. 4.79	812	646	80
5. 4.79	77	58	75
9. 4.79	431	224	52
12. 4.79	80	80	100
20. 4.79	54	54	100
23. 4.79	180	80	44
26. 4.79	618	288	47
2. 5.79	354	175	49
17. 5.79	143	106	74
23. 5.79	92	82	89

Appendix 2. /Contd...

Date	Number of Herring Gulls	Number with Visible Legs	Percentage of Herring Gulls with Visible Legs
30. 5.79	245	169	69
6. 6.79	200	185	93
12. 6.79	75	44	59
19. 6.79	350	280	80
21. 6.79	550	330	60
25. 6.79	295	184	62
28. 6.79	450	200	44
29. 6.79	450	300	67
4. 7.79	300	250	83
23. 7.79	400	200	50
	<u>23370</u>	<u>13831</u>	

p = Mean Proportion of Herring Gulls with Visible Legs.

p = 0.592 \pm 0.003

Appendix 2. /Contd...

Area 2

Date	Number of Herring Gulls	Number with Visible Legs	Percentage of Herring Gulls with Visible Legs
21. 7.78	54	33	61
16. 8.78	800	400	50
5. 9.78	526	450	86
7. 9.78	39	39	100
19. 9.78	30	30	100
29. 9.78	100	50	50
4.10.78	80	70	88
6.10.78	634	130	21
23.10.78	1050	27	3
1.11.78	230	180	78
10.11.78	288	255	89
14.11.78	551	424	77
16.11.78	814	360	44
5.12.78	1010	713	71
19.12.78	752	652	87
17. 1.79	1402	191	14
8. 2.79	151	144	95
9. 2.79	385	342	89
27. 2.79	308	110	36
1. 3.79	42	29	69
6. 3.79	239	183	77
8. 3.79	196	159	81
13. 3.79	932	484	52
24. 3.79	228	95	42
30. 3.79	150	80	53
5. 4.79	302	203	67
12. 4.79	810	329	41
20. 4.79	775	273	35
23. 4.79	436	274	63
26. 4.79	330	95	29
12. 5.79	24	18	75
13. 5.79	3	3	100
15. 5.79	145	142	98
16. 5.79	170	118	69
17. 5.79	26	26	100
12. 6.79	968	381	39
19. 6.79	500	475	95
21. 6.79	180	164	91
29. 6.79	1867	764	41
	<u>17527</u>	<u>8895</u>	

p = Mean Proportion of Herring Gulls with Visible Legs.

$$p = 0.508 \pm 0.004$$

APPENDIX 3

The proportion of 1st and 2nd year Herring Gulls in each sample.

Area 1

Date	Number of 1st and 2nd year Herring Gulls	Number of Herring Gulls older than 2 years	Percentage of 1st and 2nd year birds in sample
5. 7.78	55	63	47
7. 7.78	220	123	64
27. 7.78	3	9	25
11. 8.78	45	255	15
31. 8.78	230	720	24
2. 9.78	111	444	20
7. 9.78	174	260	40
19. 9.78	167	341	33
29. 9.78	151	65	70
3.10.78	168	475	26
4.10.78	54	283	16
6.10.78	40	36	53
9.10.78	40	293	12
12.10.78	72	328	18
16.10.78	111	333	25
1.11.78	144	574	20
7.11.78	139	857	14
10.11.78	222	1083	17
14.11.78	54	121	31
16.11.78	4	21	16
21.11.78	227	973	19
27.11.78	8	13	38
5.12.78	61	286	18
13.12.78	331	917	27
19.12.78	7	78	8
17. 1.79	139	1019	12
25. 1.79	52	266	16
31. 1.79	105	606	15
8. 2.79	40	225	15
9. 2.79	125	707	15
27. 2.79	125	442	22
1. 3.79	115	514	18
6. 3.79	71	228	24
8. 3.79	21	123	15
14. 3.79	12	108	10
30. 3.79	63	320	16
3. 4.79	67	745	8
5. 4.79	0	77	0
9. 4.79	101	330	23
12. 4.79	15	65	19
20. 4.79	0	54	0
23. 4.79	10	170	6
26. 4.79	146	472	24

Appendix 3. /Contd...

Area 1 (Contd.)

Date	Number of 1st and 2nd year Herring Gulls	Number of Herring Gulls older than 2 years	Percentage of 1st and 2nd year birds in sample
2. 5.79	66	288	19
17. 5.79	24	119	17
23. 5.79	2	90	2
30. 5.79	35	210	14
6. 6.79	50	150	25
12. 6.79	16	59	21
19. 6.79	100	250	29
21. 6.79	120	430	22
25. 6.79	47	248	16
28. 6.79	50	400	11
29. 6.79	36	414	8
4. 7.79	80	220	27
23. 7.79	55	345	14

Appendix 3. /Contd...

Area 2

Date	Number of 1st and 2nd year Herring Gulls	Number of Herring Gulls older than 2 years	Percentage of 1st and 2nd year birds in sample
21. 7.78	0	54	0
16. 8.78	160	640	20
5. 9.78	105	421	20
7. 9.78	10	29	26
19. 9.78	0	30	0
29. 9.78	50	50	50
4.10.78	16	64	20
6.10.78	254	380	40
23.10.78	33	17	66
1.11.78	37	193	16
10.11.78	74	214	26
14.11.78	168	383	30
16.11.78	277	537	34
5.12.78	252	758	25
19.12.78	144	608	19
17. 1.79	350	1052	25
8. 2.79	22	129	15
9. 2.79	61	324	16
27. 2.79	97	211	31
1. 3.79	6	36	14
6. 3.79	109	130	46
8. 3.79	51	145	26
13. 3.79	196	736	21
24. 3.79	46	182	20
30. 3.79	12	138	8
5. 4.79	60	242	20
12. 4.79	219	591	27
20. 4.79	240	535	31
23. 4.79	122	314	28
26. 4.79	43	287	13
12. 5.79	7	17	29
13. 5.79	0	3	0
15. 5.79	43	102	30
16. 5.79	28	142	16
17. 5.79	10	16	38
12. 6.79	389	579	40
19. 6.79	75	425	15
21. 6.79	63	117	35
29. 6.79	317	1550	17

APPENDIX 4

The observed proportion of 1st and 2nd year birds
in samples of Herring Gulls with visible legs.

Area 1

Sample date	Number of Herring Gulls with visible legs	Number of 1st and 2nd year birds	Percentage of 1st and 2nd year birds
29. 9.78	163	114	70
3.10.78	270	70	26
4.10.78	285	46	16
6.10.78	71	-	-
9.10.78	205	26	13
12.10.78	288	52	18
16.10.78	27	7	26
1.11.78	31	6	19
7.11.78	932	-	-
10.11.78	379	67	18
14.11.78	55	17	31
16.11.78	20	3	15
21.11.78	844	-	-
27.11.78	21	8	38
5.12.78	321	58	18
13.12.78	934	-	-
19.12.78	55	44	80
17. 1.79	488	4	1
25. 1.79	169	27	16
31. 1.79	650	-	-
8. 2.79	186	26	14
9. 2.79	585	87	15
27. 2.79	322	48	15
1. 3.79	566	102	18
6. 3.79	160	38	24
8. 3.79	114	17	15
14. 3.79	120	12	10
30. 3.79	258	41	16
3. 4.79	646	-	-
5. 4.79	58	0	0
9. 4.79	224	52	23
12. 4.79	80	15	19
20. 4.79	54	0	0
23. 4.79	80	5	6
26. 4.79	288	69	24
2. 5.79	175	33	19
17. 5.79	106	-	-
23. 5.79	82	2	2
30. 5.79	169	-	-
6. 6.79	185	46	25
12. 6.79	44	9	20
19. 6.79	280	81	29
21. 6.79	330	73	22

Appendix 4. /Contd...

Area 1 (Contd)

Sample date	Number of Herring Gulls with visible legs	Number of 1st and 2nd year birds	Percentage of 1st and 2nd year birds
25. 6.79	184	29	16
28. 6.79	200	22	11
29. 6.79	300	24	8
4. 7.79	250	67	27
23. 7.79	200	28	14

Area 2

8. 2.79	144	22	15
9. 2.79	342	55	16
27. 2.79	110	34	31
1. 3.79	29	4	14
6. 3.79	183	80	44
8. 3.79	159	41	26
13. 3.79	484	-	-
24. 3.79	95	19	20
30. 3.79	80	6	8
5. 4.79	203	41	20
12. 4.79	329	-	-
20. 4.79	273	85	31
23. 4.79	274	75	27
26. 4.79	95	12	13
12. 5.79	18	5	28
13. 5.79	3	0	0
15. 5.79	142	43	30
16. 5.79	118	19	16
17. 5.79	26	10	38
12. 6.79	381	152	40
19. 6.79	475	-	-
21. 6.79	164	57	35
29. 6.79	764	130	17

APPENDIX 5

The distribution of the ratio of the proportion of 1st and 2nd year birds among Herring Gulls present: proportion of 1st and 2nd year birds among Herring Gulls with visible legs.

Area 1

Dates of samples	Number of samples	Mean of the ratio	S.D. of the mean	Dates of freak samples that were omitted	Dates of samples where ratios were unavailable
29.9.78 through 23.7.79	38	0.99	0.083	19.12.78 17. 1.79	6.10.78 7.11.78 21.11.78 13.12.78 31. 1.79 3. 4.79 17. 5.79 30. 5.79

Area 2

8.2.79 through 29.6.79	19	1.01	0.016	13.5.79	13.3.79 12.4.79 19.6.79
------------------------	----	------	-------	---------	-------------------------------

APPENDIX 6A

The recoveries of marked 1st and 2nd year Herring Gulls from each "marking period" in Area 1 and Area 2.

Area 1

Date	Number of 1st and 2nd year Herring Gulls with visible legs	Number of 1st and 2nd year birds marked between the following dates, resighted.			
		5. 7.78 to 28. 9.78	29. 9.78 to 30.10.78	1.11.78 to 23.11.78	27.11.78 to 18. 1.79
29. 9.78	114	2			
3.10.78	70	0			
4.10.78	46	0			
6.10.78	37	1			
9.10.78	26	0			
12.10.78	52	3			
16.10.78	7	0			
1.11.78	6	0			
7.11.78	131	9	4		
10.11.78	65	1	1		
14.11.78	17	1	0		
16.11.78	3	0	0		
21.11.78	160	7	2		
27.11.78	8	0	0	0	
5.12.78	58	0	0	0	
13.12.78	252	6	1	8	
19.12.78	44	0	0	0	
17. 1.79	4	0	0	0	
25. 1.79	27	2	0	0	0
31. 1.79	97	1	1	0	1
8. 2.79	26	0	0	0	0
9. 2.79	87	3	2	3	2
27. 2.79	48	0	0	0	0
1. 3.79	102	0	0	0	0
6. 3.79	38	1	0	0	0
8. 3.79	17	0	0	0	0
14. 3.79	12	1	0	1	2
30. 3.79	41	0	0	0	0
3. 4.79	52	2	1	2	1
5. 4.79	0	0	0	0	0
9. 4.79	52	0	0	0	0
12. 4.79	15	2	0	1	0
20. 4.79	0	0	0	0	0
23. 4.79	5	0	0	0	0
26. 4.79	69	1	1	1	0
2. 5.79	33	0	0	0	0
17. 5.79	18	0	0	0	0
23. 5.79	2	0	0	0	0
30. 5.79	24	0	0	0	0
6. 6.79	46	1	0	0	0
12. 6.79	9	0	0	0	0
19. 6.79	81	3	1	3	1

Appendix 6A. /Contd...

Area 1 (Contd)

Date	Number of 1st and 2nd year Herring Gulls with visible legs	Number of 1st and 2nd year birds marked between the following dates, resighted.			
		5. 7.78 to 28. 9.78	29. 9.78 to 30.10.78	1.11.78 to 23.11.78	27.11.78 to 18. 1.79
21. 6.79	73	3	0	2	2
25. 6.79	29	1	0	1	0
28. 6.79	22	0	0	0	0
29. 6.79	24	1	1	1	1
4. 7.79	67	2	0	1	0
23. 7.79	28	0	0	0	0

Date	Number of 1st and 2nd year Herring Gulls with visible legs	Number of 1st and 2nd year birds marked between the following dates, resighted.	
		25. 1.79 to 8. 3.79	14. 3.79 to 26. 4.79
14. 3.79	12		
30. 3.79	41		
3. 4.79	52		
5. 4.79	0		
9. 4.79	52		
12. 4.79	15		
20. 4.79	0		
23. 4.79	5		
26. 4.79	69		
2. 5.79	33		0
7. 5.79	18		0
23. 5.79	2		0
30. 5.79	24		0
6. 6.79	46		0
12. 6.79	9		0
19. 6.79	81		1
21. 6.79	73		0
25. 6.79	29		1
28. 6.79	22		0
29. 6.79	24		0
4. 7.79	67		1
23. 7.79	28		0
		0	3

Appendix 6A. /Contd...

Area 2

Date	Number of 1st and 2nd year Herring Gulls with visible legs	Number of 1st and 2nd year birds marked between the following dates, resighted.			
		21. 7.78 to 30.10.78	1.11.78 to 18. 1.79	8. 2.79 to 8. 3.79	13. 3.79 to 23. 4.79
8. 2.79	22		0		
9. 2.79	55		0		
27. 2.79	34		0		
1. 3.79	4		0		
6. 3.79	80		0		
8. 3.79	41		0		
13. 3.79	102		1		
24. 3.79	19		0		
30. 3.79	6		0		
5. 4.79	41		0		
12. 4.79	89		2		
20. 4.79	85		0		
23. 4.79	75		1		
26. 4.79	12		0		0
12. 5.79	5		0		0
13. 5.79	0		0		0
15. 5.79	43		0		0
16. 5.79	19		0		0
17. 5.79	10		0		0
12. 6.79	152		0		0
19. 6.79	71		0		0
21. 6.79	57		0		0
29. 6.79	130		$\frac{1}{5}$		$\frac{1}{1}$
		$\bar{0}$		$\bar{0}$	

APPENDIX 6B

The recoveries of marked Herring Gulls older than 2 years from each "marking period" in Area 1 and Area 2.

Area 1

Date	Number of Herring Gulls older than 2 years with visible legs	Number of Herring Gulls older than 2 years marked between the following dates, sighted.			
		5. 7.78 to 28. 9.78	29. 9.78 to 30.10.78	1.11.78 to 23.11.78	27.11.78 to 18. 1.79
29. 9.78	49	0			
3.10.78	200	0			
4.10.78	239	0			
6.10.78	33	0			
9.10.78	180	0			
12.10.78	236	1			
16.10.78	20	0			
1.11.78	25	0	0		
7.11.78	802	5	23		
10.11.78	315	1	4		
14.11.78	38	0	0		
16.11.78	17	0	0		
21.11.78	684	4	27		
27.11.78	13	0	0	0	
5.12.78	263	2	0	3	
13.12.78	682	1	21	11	
19.12.78	51	0	0	0	
17. 1.79	429	1	1	2	
25. 1.79	142	0	0	0	0
31. 1.79	553	0	4	2	9
8. 2.79	160	0	0	0	0
9. 2.79	498	2	5	2	14
27. 2.79	274	0	0	0	0
1. 3.79	464	1	3	3	0
6. 3.79	122	0	0	0	1
8. 3.79	97	0	0	0	3
14. 3.79	108	0	2	2	8
30. 3.79	217	1	0	2	10
3. 4.79	594	2	2	3	15
5. 4.79	58	0	0	1	0
9. 4.79	172	1	2	1	2
12. 4.79	65	0	0	0	2
20. 4.79	54	0	0	0	0
23. 4.79	75	0	1	1	0
26. 4.79	219	0	12	13	10
2. 5.79	142	0	0	0	0
17. 5.79	88	1	1	0	8
23. 5.79	80	0	0	0	1
30. 5.79	145	1	1	0	0

Appendix 6B. /Contd...

Area 1 (Contd.)

Date	Number of Herring Gulls older than 2 years with visible legs	Number of Herring Gulls older than 2 years marked between the following dates, sighted.			
		5. 7.78 to 28. 9.78	29. 9.78 to 30.10.78	1.11.78 to 23.11.78	27.11.78 to 18. 1.79
6. 6.79	139	0	2	2	3
12. 6.79	35	0	0	0	0
19. 6.79	199	0	0	0	0
21. 6.79	257	0	1	3	2
25. 6.79	155	1	1	2	7
28. 6.79	178	0	1	2	9
29. 6.79	276	0	0	1	7
4. 7.79	183	0	1	1	7
23. 7.79	172	0	0	0	5

Date	Number of Herring Gulls older than 2 years marked between the following dates, sighted.	
	25. 1.79 to 8. 3.79	14. 3.79 to 26. 4.79
14. 3.79	4	
30. 3.79	6	
3. 4.79	5	
5. 4.79	0	
9. 4.79	1	
12. 4.79	1	
20. 4.79	1	
23. 4.79	0	
26. 4.79	6	
2. 5.79	0	0
17. 5.79	4	5
23. 5.79	1	1
30. 5.79	0	0
6. 6.79	3	4
12. 6.79	0	0
19. 6.79	0	0
21. 6.79	4	3
25. 6.79	2	5
28. 6.79	8	8
29. 6.79	3	4
4. 7.79	2	4
23. 7.79	1	6

Appendix 63. /Contd...

Area 2

Date	Number of Herring Gulls older than 2 years with visible legs	Number of Herring Gulls older than 2 years marked between the following dates, sighted.			
		21. 7.78 to 30.10.78	1.11.78 to 18. 1.79	8. 2.79 to 8. 3.79	13. 3.79 to 23. 4.79
1.11.78	151	2			
10.11.78	189	1			
14.11.78	297	0			
16.11.78	238	2			
5.12.78	535	2			
19.12.78	528	3			
17. 1.79	143	0			
8. 2.79	122	1	1		
9. 2.79	287	1	0		
27. 2.79	76	0	0		
1. 3.79	25	1	0		
6. 3.79	103	0	2		
8. 3.79	118	0	2		
13. 3.79	382	2	5	1	
24. 3.79	76	0	0	0	
30. 3.79	74	0	0	0	
5. 4.79	162	1	1	1	
12. 4.79	240	1	2	0	
20. 4.79	188	0	2	1	
23. 4.79	199	3	3	2	
26. 4.79	83	1	3	0	1
12. 5.79	13	1	1	0	1
13. 5.79	3	0	0	0	0
15. 5.79	99	1	1	0	1
16. 5.79	99	0	1	0	0
17. 5.79	16	0	0	0	0
12. 6.79	229	1	4	0	2
19. 6.79	404	2	5	4	8
21. 6.79	107	2	1	2	0
29. 6.79	634	3	8	2	12

APPENDIX 7

The proportion of colour-ringed individuals seen more than once out of the total number of colour-ringed individuals seen in Areas 1 and 2.

	<u>Area 1</u>	<u>Area 2</u>
Total number of colour-ringed individuals seen	422	240
Number of colour-ringed individuals seen more than once	254	151
The proportion of colour-ringed individuals seen more than once	60%	63%
Number of colour-ringed individuals seen more than once within this study area	193	74
Proportion of colour-ringed individuals seen more than once within this study area.	46%	44%

APPENDIX 8

The furthest distance between sightings
of a colour-ringed individual Herring Gull,
from July 1978 to July 1979.

Furthest apart sighting locations for an individual colour-ringed Herring Gull		Distance between the two locations (km)	Number of colour- ringed individuals for which these two locations were the furthest apart sightings
Saltburn	Seaton Carew	17.6	1
"	Mickleby Tip	16.2	2
Mickleby Tip	Wingate	48.8	1
"	Coxhoe	53.4	6
"	Seaton Carew	33.6	15
"	Redcar	22.4	1
"	Mickleby Tip	0.0	57
"	Loftus Tip	10.8	46
"	Staithes	5.9	10
"	Whitby	9.3	8
"	Hawsker	14.1	2
"	Robin Hood's Bay	17.6	1
"	Cloughton Wyke	28.5	1
"	Scalby Mills	33.3	1
"	Scarborough	34.6	1
"	Seamer P.P.	38.7	12
"	Grimsby	115.0	1
Loftus Tip	Glasgow	283.0	1
"	Wingate	36.6	1
"	Seaton Carew	25.9	6
"	Loftus Tip	0.0	51
"	Whitby	19.2	2
"	Seamer P.P.	49.9	1

Appendix 8. /Contd...

Furthest apart sighting locations for an individual colour-ringed Herring Gull		Distance between the two locations (km)	Number of colour-ringed individuals for which these two locations were the furthest apart sightings
Staithes	Coxhoe	49.3	1
"	Staithes	0.0	1
Sandsend	Robin Hood's Bay	12.8	1
Whitby	Seaton Carew	42.9	5
"	Whitby	0.0	5
"	Whitby Scar	0.5	1
"	Scalby Mills	25.0	1
"	Grimsby	121.0	1
Whitby Scar	Whitby Scar	0.0	7
"	Scalby Mills	24.5	2
"	Seamer P.P.	36.2	1
Robin Hood's Bay	Firth of Forth	256.0	1
"	Seaton Carew	51.5	2
"	Robin Hood's Bay	0.0	6
"	Jackson's Bay	14.7	1
"	Scalby Mills	16.0	1
"	Cornelian Bay	20.8	1
"	Seamer P.P.	24.2	3
"	Wakefield	108.0	1
Cloughton Wyke	Seaton Carew	62.7	1
"	Cloughton Wyke	0.0	1
"	Scalby Mills	4.8	5
"	Cornelian Bay	9.9	1
"	Seamer P.P.	13.4	7
Jackson's Bay	Coxhoe	65.6	1

Appendix 8. /Contd...

Furthest apart sighting locations for an individual colour-ringed Herring Gull		Distance between the two locations (km)	Number of colour ringed individuals for which these two locations were the furthest apart sightings
Jackson's Bay	Hayburn Wyke	5.8	1
"	Seamer P.P.	10.2	5
"	Scalby Mills	1.6	2
Scalby Mills	Maw Wyke Hole	19.8	1
"	Scalby Mills	0.0	5
"	Scarborough	2.2	5
"	Seamer P.P.	8.6	15
"	Cornelian Bay	5.4	1
"	Hull	61.9	1
Scarborough	Coxhoe	68.5	2
"	Scarborough	0.0	2
"	Seamer P.P.	7.0	4
Seamen Pulverization Plant			
"	Glasgow	312.0	1
"	Consett	128.0	1
"	Coxhoe	94.0	4
"	Seaton Carew	75.8	5
"	Seamer P.P.	0.0	34
"	Cornelian Bay	5.8	4
"	Gristhorpe	5.8	1
"	Hull	53.8	1

APPENDIX 9a

χ^2 Test for homogeneity in mark and recapture observations
on Herring Gulls 3 years old and older.

Area 1

Marking period	Sighting period	χ^2	Degrees of freedom	p	Number of marked Herring Gulls seen
5. 7.78 to 28. 9.78	29. 9.78 to 25. 6.79	2.514	3	n.s.	25
29. 9.78 to 30.10.78	1.11.78 to 27.11.78	4.348	2	n.s.	54
1.11.78 to 23.11.78	27.11.78 to 17. 1.79	3.173	1	n.s.	16
27.11.78 to 18. 1.79	25. 1.79 to 14. 3.79	0.159	2	n.s.	35
25. 1.79 to 8. 3.79	14. 3.79 to 23. 7.79	5.761	6	n.s.	52
14. 3.79 to 26. 4.79	2. 5.79 to 23. 7.79	14.429	5	n.s.	40

Area 2

21. 7.78 to 30.10.78	1.11.78 to 29. 6.79	1.340	4	n.s.	31
1.11.78 to 18. 1.79	8. 2.79 to 29. 6.79	7.561	6	n.s.	42
8. 2.79 to 8. 3.79	13. 3.79 to 29. 6.79	0.392	1	n.s.	13
13. 3.79 to 23. 4.79	26. 4.79 to 29. 6.79	1.914	2	n.s.	25

n.s. = 0.95 > p > 0.05

APPENDIX 9b

χ^2 Test for homogeneity in mark and recapture observations on Herring Gulls in their 1st and 2nd year.

Area 1

Marking period	Sighting period	Number of marked Herring Gulls seen	χ^2	Degrees of freedom	p
5. 7.78 to 28. 9.78	29. 9.78 to 31. 1.79	33	5.29	3	n.s.
29. 9.78 to 30.10.78	1.11.78 to 23. 7.79	15	2.08	1	n.s.
1.11.78 to 23.11.78	27.11.78 to 23. 7.79	24	3.89	3	n.s.
27.11.78 to 18. 1.79	25. 1.79 to 23. 7.79	10	0.23	1	n.s.
25. 1.79 to 8. 3.79	14. 3.79 to 23. 7.79	0	insufficient data		
14. 3.79 to 26. 4.79	2. 5.79 to 23. 7.79	3	"	"	"

Area 2

21. 7.78 to 30.10.78	1.11.78 to 29. 6.79	0	insufficient data		
1.11.78 to 18. 1.79	8. 2.79 to 29. 6.79	5	"	"	"
8. 2.79 to 8. 3.79	13. 3.79 to 29. 6.79	0	"	"	"
13. 3.79 to 23. 4.79	26. 4.79 to 29. 6.79	1	"	"	"

Figure 3. Number of pairs of nesting Herring Gulls on the Yorkshire and Cleveland coast, 1978-1979.

