

Durham E-Theses

The chemistry of some fluorinated internal olefins

Julian Russell Kirk

How to cite:

Kirk, Julian Russell (1982) The chemistry of some fluorinated internal olefins. Doctoral thesis, Durham University.

Use policy

The full-text may be used and/or reproduced, and given to third parties in any format or medium, without prior permission or charge, for personal research or study, educational, or not-for-profit purposes provided that:

- a full bibliographic reference is made to the original source
- a <https://etheses.durham.ac.uk/id/eprint/7684/> is made to the metadata record in Durham E-Theses
- the full-text is not changed in any way

The full-text must not be sold in any format or medium without the formal permission of the copyright holders.

Please consult the [full Durham E-Theses policy](#) for further details.

UNIVERSITY OF DURHAM

A THESIS

ENTITLED

THE CHEMISTRY OF SOME FLUORINATED INTERNAL OLEFINS

submitted by

JULIAN RUSSELL KIRK, B.Sc.(HONS)(DUNELM)

(Van Mildert College)

A CANDIDATE FOR THE DEGREE OF DOCTOR OF PHILOSOPHY

1982

The copyright of this thesis rests with the author.
No quotation from it should be published without
his prior written consent and information derived
from it should be acknowledged.

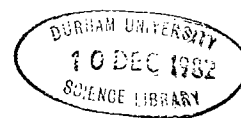

This thesis is dedicated to Mum, Dad, and Uncle Sid.

ACKNOWLEDGEMENTS

I would like to offer my thanks to the following people:

Professor R.D. Chambers for his continued helpful advice and for many useful theoretical discussions,
Dr. R.L. Powell and his colleagues at I.C.I. Mond Division for their interest, for the splendid hospitality shown to me on my visits and for the use of their analytical services,

Fellow members of the lab. for their comradeship and for their many useful suggestions regarding experimental technique; especially Colin G.P. Jones, Colin R. Sargent, Michael J. Silvester, Robert N. Barnes, and Brian Grievson, The glassblowers, Mr. W.H. Fettis and Mr. R. Hart, for their exemplary friendliness and efficiency of service; details of other technical staff are given in the appendix.

I would also like to thank:

Rob, Sarah, Rob, Ann, Julie, Alan, Chris, and Dick for their friendship,

Members of D.U.L.O.G. too numerous to mention,

Mum and Dad,

Anne Pilling, for her continued understanding and encouragement,

the Science Research Council for a maintenance grant and I.C.I. for co-operation in the award.

MEMORANDUM

The work described in this thesis was carried out in the University of Durham between October 1979 and September 1982. This work has not been submitted for any other degree and is the original work of the author except where acknowledged by reference.

Parts of this work were presented at the 7th European Symposium on Fluorine Chemistry, Venice, September 1980 and at the 10th International Symposium on Fluorine Chemistry, Vancouver, August 1982.

Further, parts of this work have been the subject of the following papers:

R.D. Chambers, J.R. Kirk, G. Taylor, and R.L. Powell, J. Chem. Soc., Perkin Trans. I, 1982, 673.

S. Bartlett, R.D. Chambers, J.R. Kirk, A.A. Lindley, H.C. Fielding, and R.L. Powell, J. Chem. Soc., Perkin Trans. I, submitted for publication.

R.D. Chambers, J.R. Kirk, and R.L. Powell, J. Chem. Soc., Perkin Trans. I, submitted for publication.

"Volcanoes have a splendour that is grim,
And earthquakes only terrify the dolts,
But to him who's scientific,
There is nothing that's terrific,
In the falling of a flight of thunderbolts."

W.S. Gilbert

'The Mikado'

NOMENCLATURE

- 1) The prefix 'perfluoro' is used to denote that the compound or the part of the compound following the prefix is fully fluorinated.
- 2) A capital F in a ring denotes that the ring and all its unspecified substituents are fully fluorinated; also, throughout this thesis, all unmarked bonds in diagrams of molecules are attached to fluorine.
- 3) Throughout this thesis, the term 'internal olefin' is used to describe an olefin with at least one perfluoroalkyl group at each end of the double bond. Thus, in a 'tetrasubstituted internal olefin', all four substituents at the double bond are perfluoroalkyl.

NOTE

A variety of olefins appear throughout this thesis which exist normally as a mixture of E and Z isomers and the reactions described in the discussion were normally carried out using these olefins as a E/Z isomer mixture. However, in most diagrams, only one isomer of such olefins is shown. This is done for simplicity and, unless otherwise indicated, should not be interpreted in such a way that only the particular isomer drawn was used in the reaction being described.

ABSTRACT

This thesis deals with the chemistry of some fluorinated internal olefins which are oligomers of either tetrafluoroethylene or perfluorocyclobutene.

A trimer of perfluorocyclobutene isomerises in the presence of fluoride ion to a cycloheptene derivative. The mechanism of this isomerisation is discussed - it is proposed that the cyclisation involves an unusual displacement of fluoride ion from a saturated site. Attempts were made to provide further examples of this process using closely related systems. Substitution and addition reactions of the cycloheptene derivative were investigated and attempts made to develop routes, via this compound, to other, simpler, cycloheptenes. The reactivity of the cycloheptene derivative is compared with that of its trimer precursor. Some reactions of perfluorocyclobutene dimers are also described - one of the dimers shows remarkable reactivity in cycloaddition reactions.

The second part of the discussion deals with reactions of internal olefins that are oligomers of tetrafluoroethylene with various enolate anions. Reactions of appropriate cyclic olefins are also described. When the enolate anions used were derived from relatively acidic precursors, a variety of cyclisations forming furan and pyran derivatives was observed. In contrast, reactions involving the anion derived from the less acidic diethyl malonate generally gave unusual diene derivatives.

The preparation and reactions of fluorinated epoxides derived from internal olefins has also been studied. Epoxidation using sodium hypochlorite solution works well for all internal olefins except those which are highly susceptible

to nucleophilic attack. A rationalisation of this observation is given. The epoxides obtained from tetra-alkylated olefins show considerable thermal and chemical stability but, under forcing conditions, clean fragmentations occur giving olefin and ketone products. Epoxidation of the tetrafluoroethylene tetramer gave the expected product together with an unusual bi-product arising from degradation of the carbon chain.

CONTENTS

INTRODUCTION

CHAPTER ONE - AN INTRODUCTION TO THE CHEMISTRY OF

FLUORINATED INTERNAL OLEFINS

I

IA	SYNTHESES OF SOME SIMPLE, FULLY FLUORINATED OLEFINS	I
IB	BEHAVIOUR OF FLUORINATED OLEFINS IN REACTIONS	3
IB.1	Nucleophilic attack	3
IB.2	Orientation and reactivity	5
IB.2.a	Intermediate carbanion stability	5
IB.2.b	Frontier orbital theory	6
IB.3	Schemes for nucleophilic attack and product formation	7
IC	NUCLEOPHILIC OLIGOMERISATION OF SIMPLE FLUORINATED OLEFINS	9
IC.1	Oligomerisation of tetrafluoroethylene	9
IC.2	Oligomerisation of hexafluoropropene	II
IC.3	Oligomerisation of perfluoroisobutene	II
IC.4	Oligomerisation of cyclic olefins by F^-	I3
IC.5	Pyridine induced oligomerisation of perfluorocyclobutene	I4
ID	SOME ILLUSTRATIVE REACTIONS OF INTERNAL OLEFINS	I6
ID.1	Internal olefins containing vinylic fluorines	I6

ID.I.a	Nucleophilic attack	I6
ID.I.b	Addition reactions	I8
ID.2	Tetrasubstituted internal olefins	I8
ID.2.a	Nucleophilic attack	I8
ID.2.b	Addition reactions	20
IE	RECENT PREPARATIONS OF FLUORINATED INTERNAL OLEFINS	21
IE.I	Preparations via sulphur intermediates	21
IE.2	Fluoride ion induced processes	22
IE.2.a	Isomerisation	22
IE.2.b	Co-oligomerisation	23
IE.2.c	Cationic co-oligomerisation	24
IE.3	Preparations via phosphorus intermediates	25
IF	RECENT REACTIONS OF FLUORINATED INTERNAL OLEFINS	26
IF.I	Reactions of hexafluoropropene dimer (I5)	26
IF.2	Reactions of trimer (35)	29
IF.3	Miscellaneous reactions	31
IG	REACTIONS OF CYCLIC SYSTEMS	33
IG.I	Four and five membered rings	33
IG.2	Preparation of the penta(trifluoromethyl)- cyclopentadienyl anion (37)	34
IG.3	Six membered rings	35
IG.4	Preparation of eight membered rings	36
IG.4.a	Coupling reactions	36
IG.4.b	Syntheses via cyclobutadiene intermediates	36
IH	PREPARATION OF FLUORINATED EPOXIDES	39
	Introduction	39

IH.1	Early syntheses	39
IH.2	Recent syntheses	43
IH.3	Syntheses of epoxides from hexafluoropropene derivatives	45
IH.4	Miscellaneous syntheses	45
IJ	REACTIONS OF FLUORINATED EPOXIDES	46
IJ.1	Reactions with nucleophiles	46
IJ.2	Oligomerisation and polymerisation	49
IJ.3	Molecular rearrangements	51
IJ.4	Miscellaneous reactions involving epoxides	52
IK	REACTIONS OF FLUORINATED OLEFINS WITH ACTIVE METHYLENE COMPOUNDS	53
IK.1	General chemistry of active methylene compounds	53
IK.2	Some typical reactions of enolate anions	55
IK.3	Formation of cyclic products	56
IK.4	Application to organofluorine chemistry	57

DISCUSSION

CHAPTER TWO - THE CHEMISTRY OF SOME INTERNAL OLEFINS

	<u>DERIVED FROM PERFLUOROCYCLOBUTENE</u>	59
	Introduction	59
2A	FORMATION OF THE CYCLOHEPTENE DERIVATIVE (52) AND RELATED CHEMISTRY	60
2A.1	Reaction of trimer (27) with fluoride ion	60
2A.2	Proposed mechanism of formation of compound (52)	61

2A.3	Related chemistry	65
2A.3.a	Displacement of fluorine from a saturated site	65
2A.3.b	Attempts at further displacements of fluorine from saturated sites	66
2A.3.b.I	Using a model for compound (27)	66
2A.3.b.2	Using a model for compound (II)	67
2B	REACTIONS OF COMPOUND (52)	68
2B.I	Pyrolysis over a platinum surface	68
2B.2	Pyrolysis over a silica surface	70
2B.3	Other pyrolyses	72
2B.4	Reaction with methoxide ion	72
2B.5	Reaction with diazomethane	73
2B.6	Reactions with free radicals	73
2B.7	Attempted fluorination	74
2C	RELATED REACTIONS OF TRIMER (27)	74
2C.I	Reaction with methoxide	74
2C.2	Reaction with free radicals	74
2C.3	Fluorination	74
2C.4	Reaction with diazomethane	75
2D	REACTIVITY CORRELATION OF COMPOUNDS (27) AND (52) IN ADDITION REACTIONS	76
2E	CHEMISTRY OF PERFLUOROCYCLOBUTENE DIMERS (25) AND (26)	77
2E.I	Cycloadditions	77
2E.I.a	Introduction	77
2E.I.b	Reaction of dimer (25) with 1,3-butadiene	79
2E.I.c	Reaction of a mixture of (25) and (26) with 1,3-butadiene	80

2E.I.d	Reaction of dimers (25) and (26) with 1,3-cyclohexadiene	80
2E.I.e	Reactions of dimers (25) and (26) with cyclopentadiene	82
2E.I.f	Reactions of perfluorocyclobutene with cyclopentadiene	82
2E.2	Polymerisation	84
2E.3	Nucleophilic attack	84
2E.4	Free radicals	86

CHAPTER THREE - REACTIONS OF INTERNAL OLEFINS WITH
ENOLATE ANIONS 88

	Introduction	88
3A	REACTIONS OF PERFLUORO-3,4-DIMETHYL-3- -HEXENE (IO)	88
3A.I	With diethyl malonate	88
3A.2	With acetyl acetone	91
3A.3	With ethyl acetoacetate	91
3A.4	With diethyl malonate in the presence of fluoride ion	93
3A.5	Other reactions	95
3B	REACTIONS OF PERFLUORO-3-METHYL-3-PENTENE	96
3B.I	With diethyl malonate	96
3B.2	With ethyl acetoacetate	97
3B.3	With acetyl acetone	98
3C	REACTIONS OF THE TETRAFLUOROETHYLENE PENTAMER (II)	99
3C.I	With diethyl malonate	99
3C.2	With ethyl acetoacetate	100

3D	REACTIONS OF PERFLUORO-2-BUTENE (8)	IOI
3D.I	With acetyl acetone	IOI
3D.2	With ethyl acetoacetate	IOI
3D.3	With diethyl malonate	IO2
3E	REACTIONS OF PERFLUOROCYCLOHEXENE (6)	IO4
3E.I	With acetyl acetone and ethyl acetoacetate	IO4
3E.2	With diethyl malonate	IO4
3F	REACTIONS OF PERFLUOROCYCLOPENTENE (5)	IO8
3F.I	With diethyl malonate	IO8
3F.2	With ethyl acetoacetate	IO8
3F.3	With acetyl acetone	IO9
3G	REACTIONS OF PERFLUOROCYCLOBUTENE (4)	II0

CHAPTER FOUR - PREPARATIONS AND REACTIONS OF EPOXIDES

DERIVED FROM FLUORINATED INTERNAL OLEFINS

4A.I	Introduction	III
4A.2	General considerations	III
4B	EPOXIDATION REACTIONS	II3
4B.I	Epoxidation of perfluoro-3,4-dimethyl- 3-hexene (IO)	II3
4B.2	Epoxidation of perfluorocyclobutene trimers	II7
4B.3	Epoxidation of perfluoro-3-methyl-3-pentene (9)	II8
4B.4	Epoxidation of cycloheptene derivative (52)	II9
4B.5	Attempted epoxidation of perfluoro-2,3- dimethyl-butadiene	II9
4B.6	Attempted epoxidation of perfluoro- bicyclobutylidene (25)	II9

4C	REACTIONS OF EPOXIDE (I37)	I20
	Introduction	I20
4C.I	Reactions with fluoride ion	I21
4C.2	Pyrolysis reactions of epoxide (I37)	I22
4C.3	Other reactions of epoxide (I37)	I23
4D	REACTIONS OF EPOXIDE (I38)	I23
4D.I	Introduction	I23
4D.2	Reaction of epoxide (I38) with methoxide ion	I24
4D.3	Reaction of epoxide (I38) with fluoride ion	I24
4D.4	Fluorination of epoxide (I38)	I25
4E	STATIC PYROLYSIS OF EPOXIDE (I39)	I25

EXPERIMENTAL

Chemicals, solvents and instrumentation

<u>CHAPTER FIVE - EXPERIMENTAL TO CHAPTER TWO</u>		I27
5A	PREPARATION OF PERFLUOROCYCLOBUTENE OLIGOMERS, THE CYCLOHEPTENE DERIVATIVE (52), AND RELATED REACTIONS	I27
5A.I	Pyridine induced oligomerisation of perfluorocyclobutene	I27
5A.2	Fluoride ion induced oligomerisation of perfluorocyclobutene	I28
5A.3.a	Preparation of cycloheptene derivative (52)	I29

5A.3.b.I	Reaction of dimer (26) with hexafluoropropene in the presence of fluoride ion	I29
5A.3.b.2	Reaction of olefin (7I) with fluoride ion	I30
5A.3.b.3	Reaction of trimer (24) with triethylamine and water	I3I
5B.I	Pyrolysis of cycloheptene derivative (52) over platinum and general procedure for flow pyrolyses reactions	I3I
5B.2	Flow pyrolysis of compound (52) over silica	I32
5B.3.a	Flow pyrolysis of compound (52) over iron	I33
5B.3.b	Static pyrolyses of compound (52) Other reactions of compound (52)	I33
5B.4	With methoxide	I34
5B.5	With diazomethane	I34
5B.6	With acetaldehyde	I35
5B.7	Attempted fluorination	I35
5C	REACTIONS OF TRIMER (27)	I35
5C.I	With methoxide	I35
5C.2.a	With acetaldehyde	I36
5C.2.b	With methanol	I36
5C.3	Fluorination	I36
5D	Reaction of trimer (27) with diazomethane	I37
5E	REACTIONS OF DIMERS (25) AND (26)	I37
5E.I.a	Reaction of a mixture of dimers (25) and (26) with 1,3-butadiene	I37
5E.I.b	Reaction of dimer (25) with 1,3-cyclo- hexadiene	I38

5E.I.c	Reaction of a mixture of dimers (25) and (26) with cyclopentadiene in the presence of fluoride ion	I39
5E.I.d	Reactions of perfluorocyclobutene with cyclopentadiene	I39
5E.2	Reaction of dimer (26) with acetaldehyde	I40
<u>CHAPTER SIX - EXPERIMENTAL TO CHAPTER THREE</u>		I41
	General procedures	I41
6A	REACTIONS OF PERFLUORO-3,4-DIMETHYL-3-HEXENE (10)	I42
6A.1	With diethyl malonate	I42
6A.2	With acetyl acetone	I43
6A.3	With ethyl acetoacetate	I43
6A.4	With diethyl malonate in the presence of fluoride ion	I45
6A.5.a	With malononitrile	I45
6A.5.b	With ethyl acetoacetate using sodium ethoxide as base	I45
6B	REACTIONS OF PERFLUORO-3-METHYL-3-PENTENE (9)	I46
6B.1	With diethyl malonate	I46
6B.2	With ethyl acetoacetate	I46
6B.3	With acetyl acetone	I47
6C	REACTIONS OF TETRAFLUOROETHYLENE PENTAMER (II)	I47
6C.1	With diethyl malonate	I47
6C.2	With ethyl acetoacetate	I48

6D	REACTIONS OF PERFLUORO-2-BUTENE (8)	I48
6D.I	With acetyl acetone	I48
6D.2	With ethyl acetoacetate	I49
6D.3	With diethyl malonate	I49
6E	REACTIONS OF PERFLUOROCYCLOHEXENE (6)	I49
6E.I.a	With acetyl acetone	I49
6E.I.b	With ethyl acetoacetate	I50
6E.2	With diethyl malonate	I50
6E.3	Reaction of compound (I24) with fluoride ion	I5I
6F	REACTIONS OF PERFLUOROCYCLOPENTENE (5)	I5I
6F.I	With diethyl malonate	I5I
6F.2	With ethyl acetoacetate	I52
6F.3	With acetyl acetone	I52
6G	REACTIONS OF PERFLUOROCYCLOBUTENE (4)	I52
<u>CHAPTER SEVEN - EXPERIMENTAL TO CHAPTER FOUR</u>		I53
7A	GENERAL PROCEDURES USED IN EPOXIDATION REACTIONS	I53
7B	EPOXIDATION REACTIONS	I54
7B.I	Epoxidation of perfluoro-3,4-dimethyl- 3-hexene (IO)	I54
	Control reaction in the absence of solvent	I55
	Reaction of epoxide (I37) with sodium hypochlorite solution	I55
7B.2.a	Epoxidation of perfluorocyclobutene trimer (27)	I56
7B.2.b	Epoxidation of perfluorocyclobutene trimer (24)	I56

7B.3	Epoxidation of perfluoro-3-methyl-3-pentene (9)	I56
7B.4	Epoxidation of cycloheptene derivative (52)	I57
7B.5	Attempted epoxidation of perfluoro-2,3- dimethyl-butadiene	I57
7B.6	Attempted epoxidation of perfluoro- bicyclobutylidene (25)	I58
7C	REACTIONS OF EPOXIDE (I37)	I58
7C.I	With fluoride ion	I58
7C.I.a	Flow pyrolysis of epoxide (I37) over hot CsF	I58
7C.I.b	Reaction of epoxide (I37) with CsF at low temperatures	I58
7C.I.c	Static pyrolysis of epoxide (I37) over CsF	I59
7C.2	Pyrolysis reactions of epoxide (I37)	I59
7C.2.a	Flow pyrolyses	I59
7C.2.b	Static pyrolyses	I60
7C.3	Other reactions of epoxide (I37)	I60
7C.3.a	With methoxide ion	I60
7C.3.b	With n-Butyl Lithium	I61
7C.3.c	With acetaldehyde	I61
7D	REACTIONS OF EPOXIDE (I38)	I62
7D.I	Unsuccessful reactions	I62
7D.I.a	Flow pyrolysis over platinum	I62
7D.I.b	Static pyrolysis	I62
7D.I.c	Reaction with acetaldehyde	I62
7D.I.d	Reaction with diazomethane	I63
7D.I.e	Reaction with sodium	I63

7D.2	Reaction with methoxide ion	I63
7D.3	Reaction with fluoride ion	I64
7D.4	Fluorination of epoxide (I38)	I64
7E	STATIC PYROLYSIS OF EPOXIDE (I39)	I65

APPENDICES

	COMPOUND INDEX	I66
APPENDIX I	N.M.R. SPECTRA	I69
APPENDIX II	INFRARED SPECTRA	I9I
APPENDIX III	MASS SPECTRA	200
APPENDIX IV	DEPARTMENTAL COLLOQUIA AND INDUCTION COURSE FOR POSTGRADUATES	244

<u>REFERENCES</u>		25I
-------------------	--	-----

INTRODUCTION

CHAPTER ONE

AN INTRODUCTION TO THE CHEMISTRY OF INTERNAL FLUORINATED
OLEFINS

Introduction

In the course of this chapter the syntheses of some fully fluorinated internal olefins from simple, non-fluorinated starting materials will be demonstrated and relevant chemistry of these olefins will be discussed. In addition, a more detailed review of recent work in the field will be described.

As well as introducing the subject of the thesis, it is intended that this chapter will provide the reader with a sense of the tremendous contribution made to the field by the synthetic chemist.

IA SYNTHESSES OF SOME SIMPLE FULLY FLUORINATED OLEFINS

The most important building blocks in organofluorine chemistry are fluorinated olefins and, of these, the most significant is tetrafluoroethylene. The formation of this and other simple olefins is illustrated in table I.

The ultimate source of fluorine in these compounds is the mineral fluorspar (CaF_2) which, when treated with sulphuric acid, produces HF.

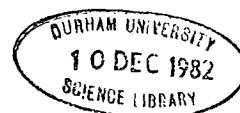

IB BEHAVIOUR OF FLUORINATED OLEFINS IN REACTIONS

IBI Nucleophilic attack²⁹

When the hydrogen atoms in ethylene are replaced by fluorine, the carbon-carbon σ bond is drained of electron density by inductive withdrawal by the electronegative fluorine atoms and photoelectron spectroscopy shows that the energy of the σ bond is reduced by 3eV²⁷. A similar inductive effect applies to the π bond but this is virtually offset by the repulsive forces between the π system and the electron lone pairs on the fluorine atoms. The gross result is a π stabilisation of only 0.5eV. Therefore overall, the double bond in tetrafluoroethylene is electron deficient compared with ethylene and so the fluorinated olefin is susceptible to nucleophilic attack.

The effect is more striking if a vinylic fluorine is replaced by a perfluoroalkyl group. For example, a CF_3 group has an electron withdrawing capability similar to fluorine but it has no capability for the lone pair - π -system interaction and the overall result is a much greater drain of electron density from the double bond. All of these effects are demonstrated in the following diagram^{29a}.

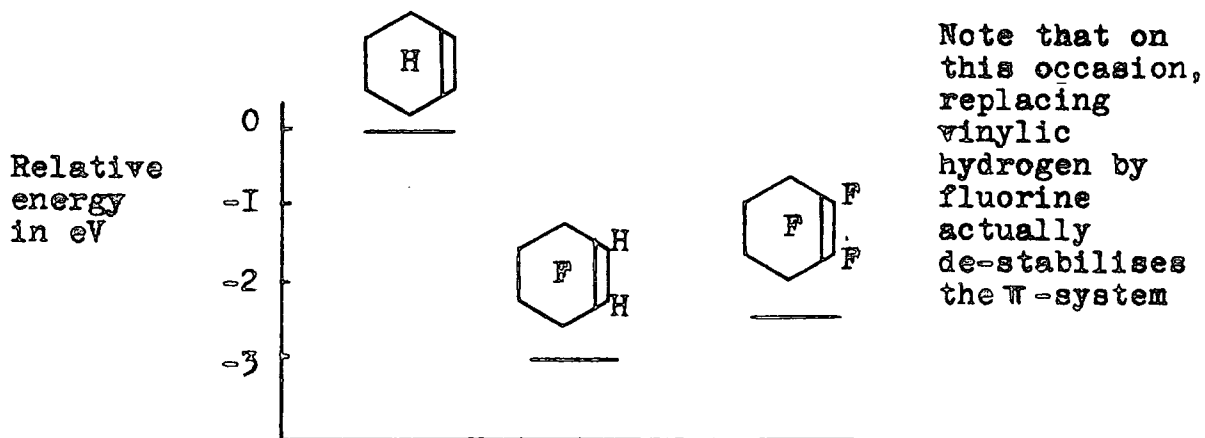

Orbital correlation diagram for the π orbitals in cyclohexene and fluorinated derivatives

The nucleophilic susceptibility of fluorinated olefins is clearly complementary to the electrophilic susceptibility of hydrocarbon olefins and a review has been written ³⁰.

The destabilising effect of a vinylic fluorine atom relative to a perfluoroalkyl group is featured in the following example, which also illustrates the relative stability of small rings in fluorocarbon systems compared with their hydrocarbon counterparts.

Consider the following equilibria ²⁸ :

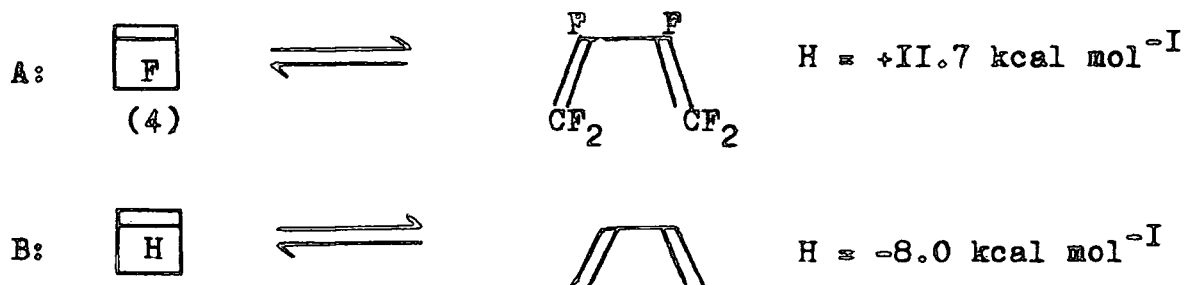

Clearly, in case B the position of equilibrium is a manifestation of the ring strain in the cyclobutene form.

In case A however, ring closure reduces the number of destabilising vinylic fluorines from six down to two and this is sufficient to offset the ring strain. A recent publication describes an extension of this process ^{28a}. Here, the thermodynamically stable product cannot be predicted from consideration of the total energies of all the bonds in each molecule and the result must be explained on the basis of the number of vinylic fluorines present in each isomer. This pyrolysis of (4) affords complete conversion to the acetylene.

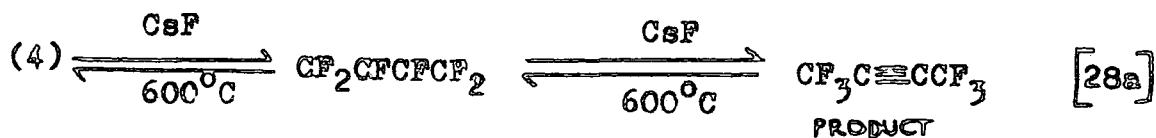

The discussion so far has concentrated on ground state effects. In the next section, the orientation and relative rates of reactivity of different perfluoro-olefins to nucleophiles will be described with regard to transition state considerations.

IB2 Orientation and Reactivity of Perfluoro-olefins to Nucleophilic Attack ⁶

IB2.a Intermediate Carbanion Stability ^{3I}

Consider attack by a negatively charged nucleophile on hexafluoropropene. Obviously, two carbanionic ³² intermediates could be formed.

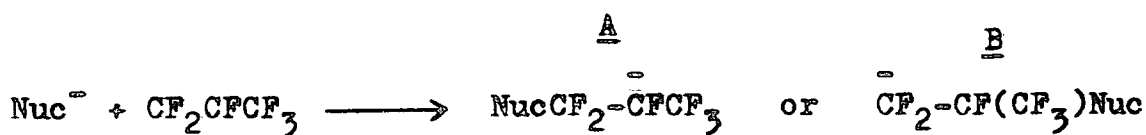

Just as a vinylic fluorine atom destabilises a system with respect to a perfluoroalkyl group, so a fluorine directly attached to a negative centre is destabilising compared to a perfluoroalkyl group. Therefore in the diagram above, A is the most stable intermediate and attack occurs preferentially at the terminal difluoromethylene group. This is the general case for all terminal olefins. For internal olefins, attack occurs at the least substituted end of the double bond to produce the most stable intermediate.

These considerations lead directly to predictions concerning the relative rates of attack of a given nucleophile on different perfluoro-olefins. The most reactive olefin would be the one which forms the most stable carbanion. Hence in the following series, the reactivity towards nucleophilic attack increases in the order $A < B < C$.

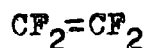

A

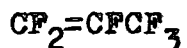

B

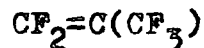

C

IB2.b Frontier Orbital Theory Approach 33

This approach envisages a change in coefficients in the HOMO of the double bond when a vinylic fluorine is replaced by a perfluoroalkyl group e.g. CF_3 . Inductive electron withdrawal by CF_3 results in a greater electron density in the HOMO lying on the carbon atom attached to the CF_3 group. This causes the coefficients of the LUMO to change in the opposite direction. Greater orbital overlap between the attacking nucleophile's orbital and the LUMO thus takes place when the initial attack of the nucleophile is at the least substituted end of the double bond. This again explains the observed orientation.

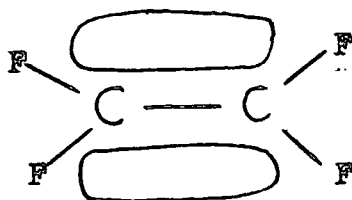

HOMO in
Tetrafluoroethylene

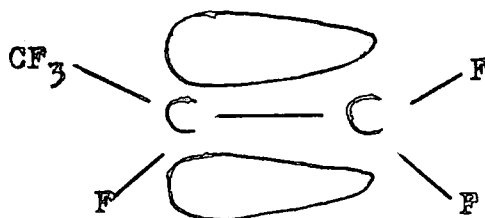

HOMO in
Hexafluoropropene

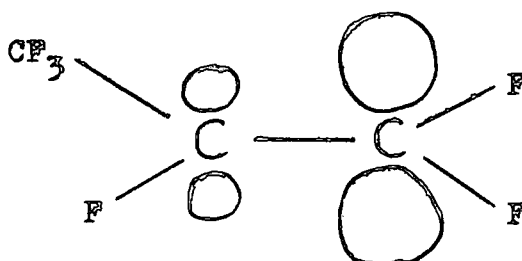

LUMO in
Hexafluoropropene

IB3 Schemes for Nucleophilic Attack and Product Formation

The nature of the products formed by nucleophilic attack can be regarded as being dependent on the fate of the intermediate carbanion. There are three possible product forming routes from the intermediate. They are :-

- a) addition of a proton or, potentially, another electrophile,
- b) elimination of fluoride ion (vinylic displacement of F^-),
- c) substitution with rearrangement (allylic displacement of F^-).

These processes are shown in the following diagram.

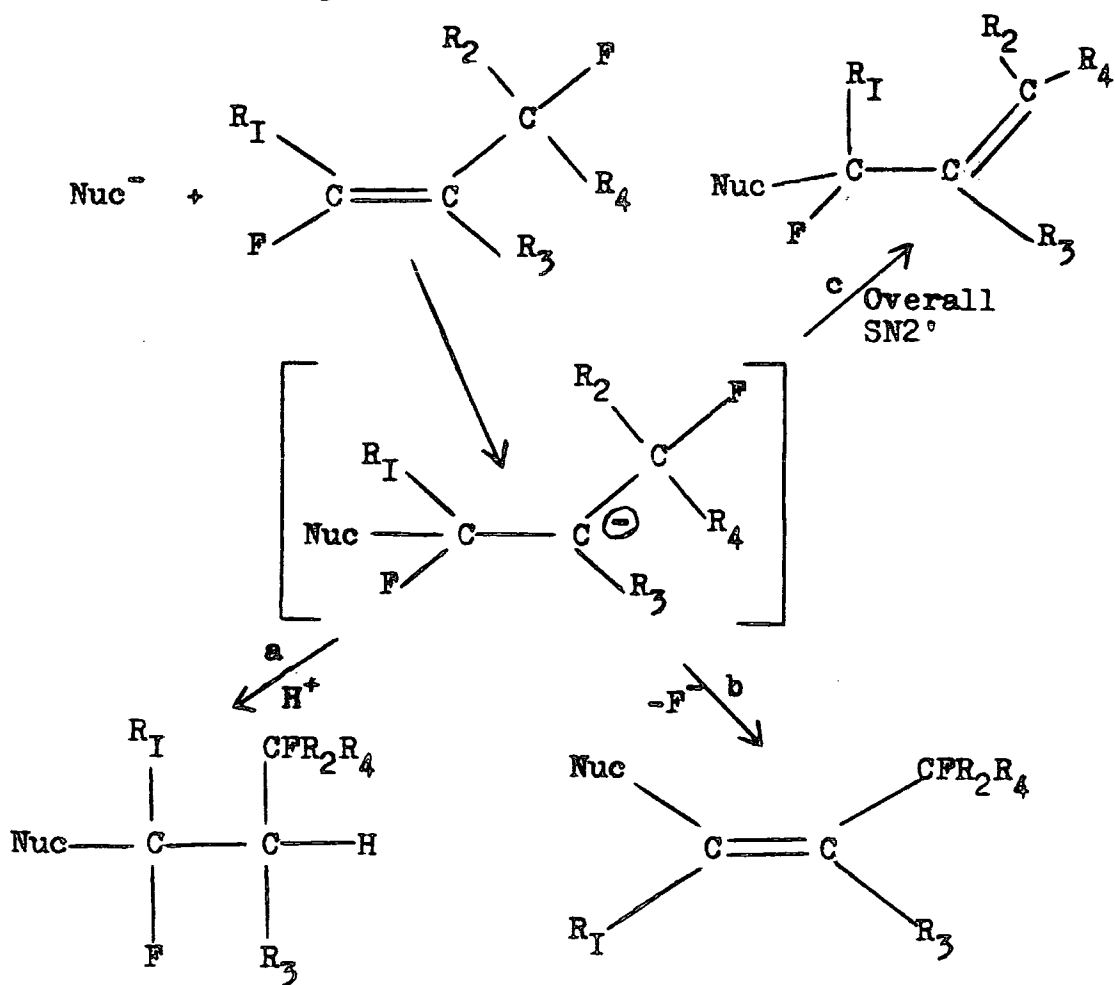

Sequence a) is the most common one for simple fluoroethylenes ³⁰, regardless of the nucleophile, but the tendency towards sequence b) increases with higher fluoro-olefins and cyclic fluoro-olefins ^{34,35}.

The sequence b) preference for higher fluoro-olefins is due to stabilisation of the carbanionic intermediate by the electron withdrawing perfluoroalkyl groups which leads to a reduced nucleophilicity.

With very strong nucleophiles, polysubstitution may occur.

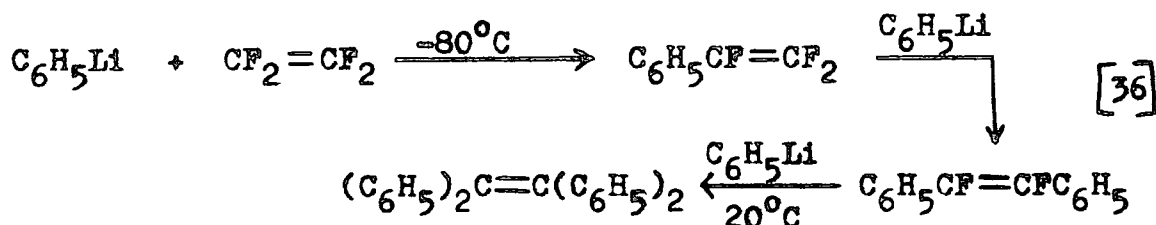

The $\text{SN}2^\circ$ mechanism is a common occurrence in perfluoro-olefin chemistry and is of particular relevance to work carried out by the author where some of the compounds studied have no vinylic fluorines.

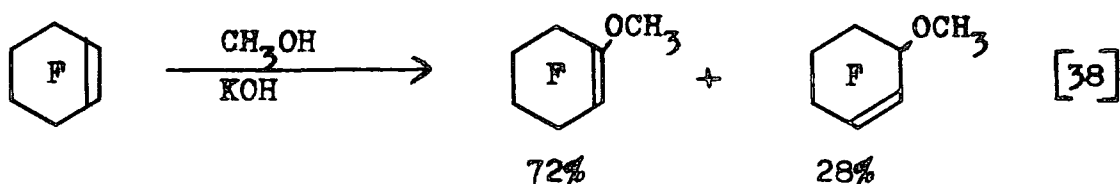
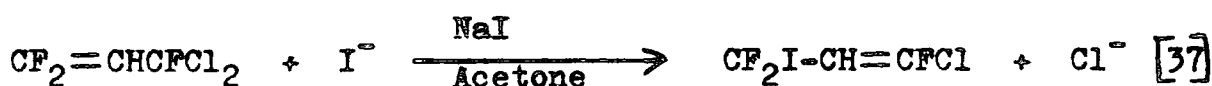

Throughout this thesis the terms $\text{SN}2$ and $\text{SN}2^\circ$ will be used as abbreviations for vinylic and allylic displacement respectively. It should be noted however that the processes are not truly concerted; the formation of a discrete intermediate has been demonstrated in one case from kinetic data ³⁹.

In spite of the theories outlined in the previous pages, it is by no means possible to predict the exact products of a reaction in all cases and it seems probable that the final product identity depends not just on intermediate carbanion stability but also on such factors as ring strain, nucleophilicity, steric hindrance and solvent effects.

The formation of simple, perfluorinated olefins has now been demonstrated and some basic principles^{II} affecting reactions have been discussed. In the next section the aim is to show how simple, readily-available fluoro-olefins can be converted into sophisticated and synthetically useful systems by simple processes.

IC NUCLEOPHILIC OLIGOMERISATION OF SIMPLE FLUORINATED OLEFINS

ICI Oligomerisation of Tetrafluoroethylene

Scheme I shows the way in which a variety of olefins are produced. Note that the continual susceptibility to isomerise produces a highly branched structure and that this produces olefins where the double bond is more and more sterically crowded.

Consider, for example, the pentamer (II). It exists exclusively in the form written, with the CF_3 groups lying cis to one another. This is because a CF_3 group is appreciably bigger than a single fluorine atom and there is simply not enough space to accommodate both a C_6F_{13} group and a CF_3 group on the same side of the double bond. This explains why the hexamer formed from pentamer is exclusively (I2); even though it possesses the thermodynamically unstable terminal CF_2 group, it possesses considerable kinetic stability because of the steric factors affecting alternative (I4).

These steric factors clearly explain the inability to form polymers by this method.

Scheme I ^{I2, I3}

Oligomerisation of Tetrafluoroethylene

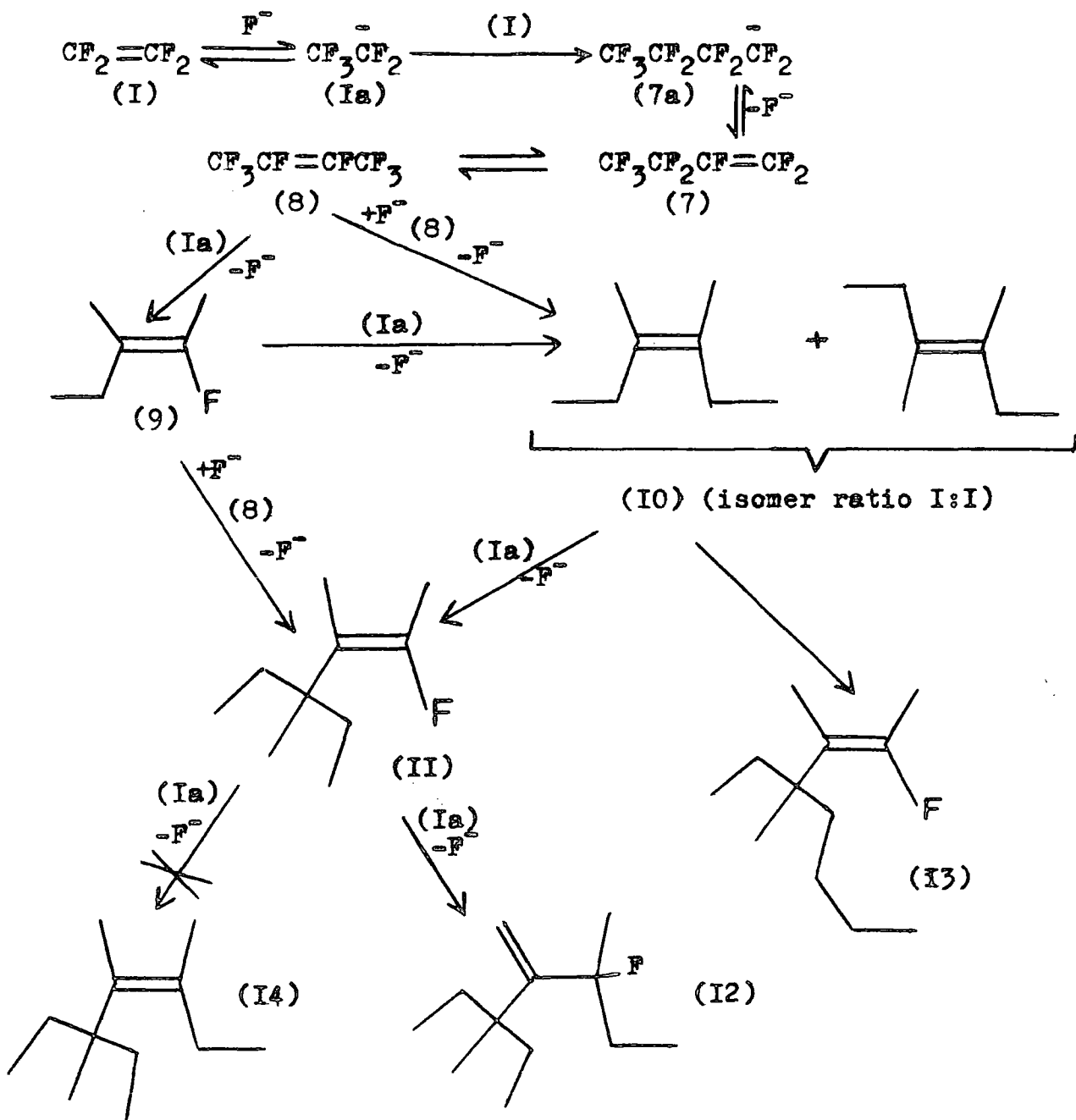

Typical Conditions - CsF, Diglyme, 100°C, 10-20 p.s.i. of C₂F₄,
 - Total Yield 60%

Typical Product Composition -	(8) Dimer	0
(expressed as percentages)	(9) Trimer	1
	(I0) Tetramer	10
	(II) Pentamer	54
	Hexamers	20
	Higher Olefins	15
	TOTAL	<u>100</u>

Greater quantities of the smaller oligomers can be produced by degradation of the larger ones I4.

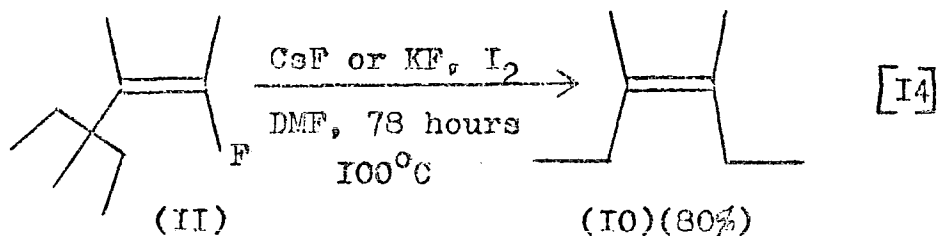

IC2 Oligomerisation of Hexafluoropropene

The structures of the oligomers formed and a probable mechanism for their formation are given in Scheme 2 (overleaf). Several of these oligomers can be produced exclusively in high yields by subtle variations in the reaction conditions I5, I6.

IC3 Oligomerisation of Perfluoroisobutene

Fluoride ion induced oligomerisation of perfluoroisobutene produces two dimers I2 as shown below.

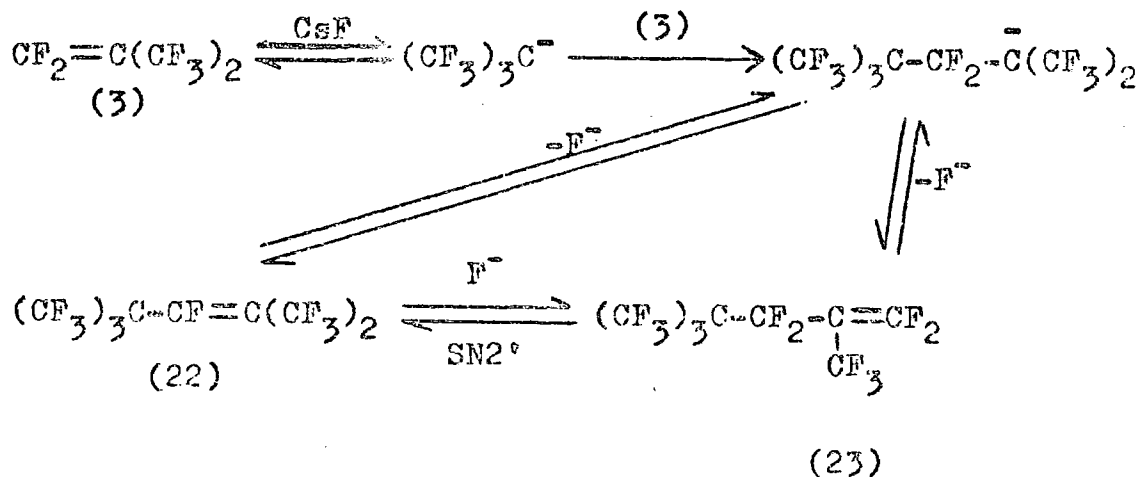

Scheme 2

Oligomerisation of Hexafluoropropene

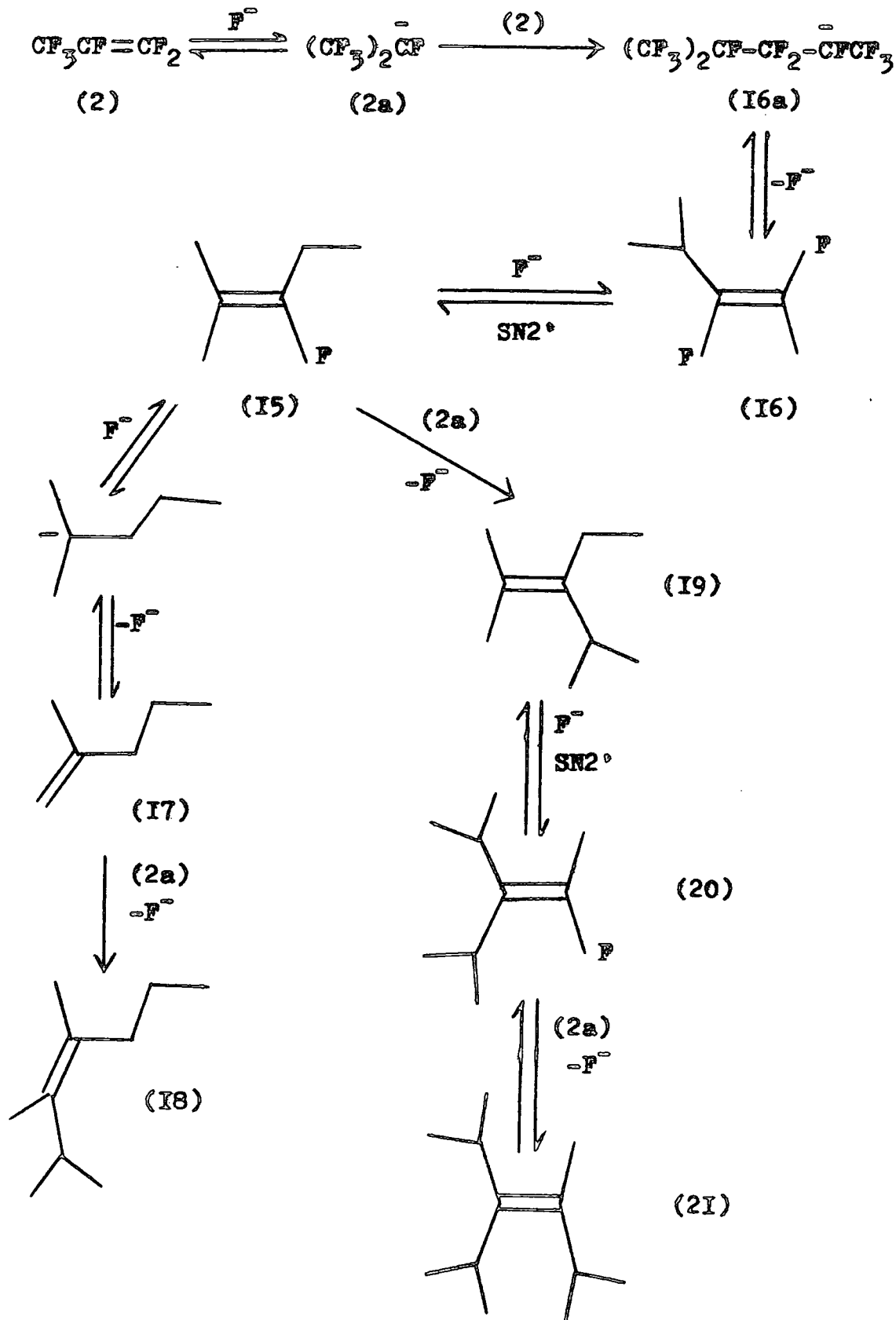

Typical Conditions - CsF, KF in crown ethers, THF or CH₃CN solvent, 20-100°C, 24 hours.

IC4 Oligomerisation of Cyclic Olefins by Fluoride Ion

Perfluorocyclobutene readily oligomerises forming dimers and a trimer but perfluorocyclopentene and perfluorocyclohexene require more forcing conditions - and then only dimers are produced. All the products may be rationalised by the expected mechanism ¹⁹. The exact forms adopted however require explanation.

The proximity in space of adjacent fluorine atoms in the saturated parts of cyclic olefins gives rise to destabilising inter-atom lone pair electron repulsions, or eclipsing interactions. The exact structures adopted by the

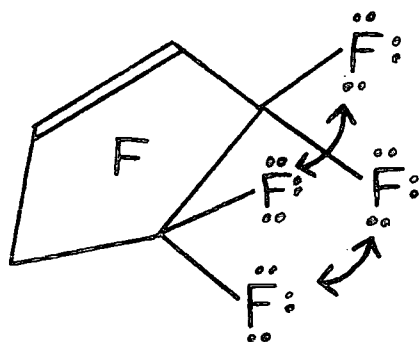

cyclic olefin oligomers are due to a 'trade-off' between reducing the eclipsing interactions at the expense of forming destabilising vinylic fluorines. This 'trade-off' is clear cut in the cases of the F-cyclopentene and F-cyclohexene dimers. Both

Eclipsing interactions in perfluorocyclopentene

F-cyclobutene dimers, however, exist in roughly equal amounts, indicating that the energy difference between the two structures is insignificant.

Table 2

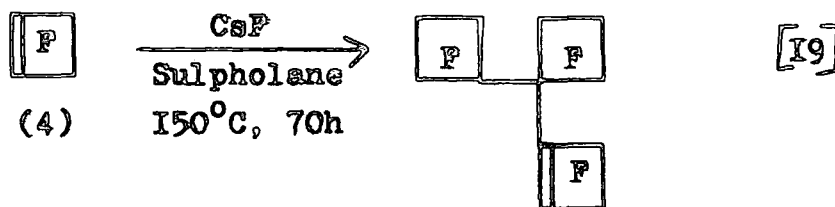

(24)(67%)

Table 2 (continued)

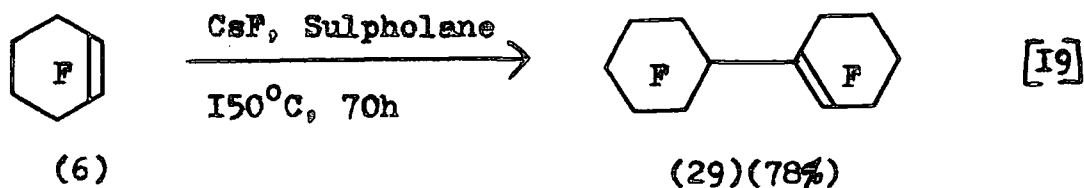
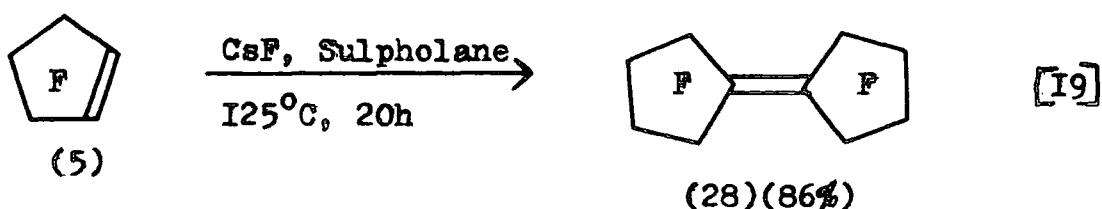
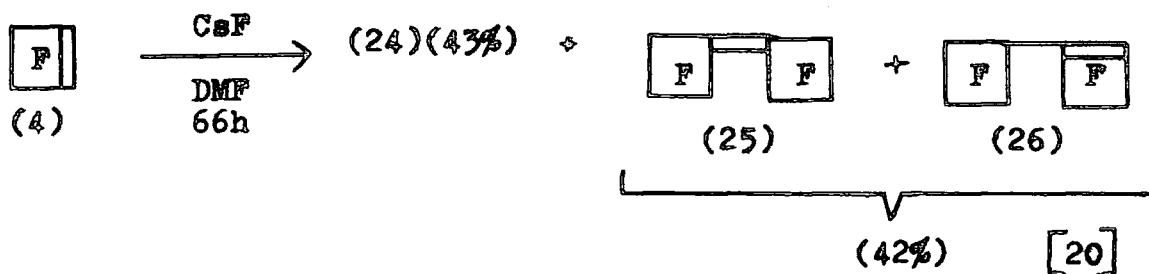

IC5 Pyridine induced Oligomerisation of Perfluorocyclobutene

In this reaction, dimers (25) and (26) are again produced but a different trimer is obtained.

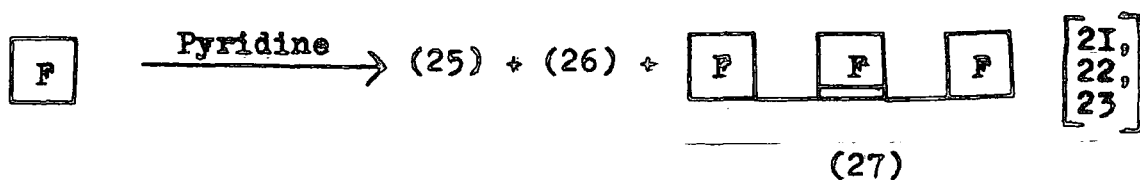

<u>F-cyclobutene/pyridine ratio</u>	<u>Reaction time in hours</u>	<u>% composition</u>	
		<u>dimers</u>	<u>trimer</u>
15:1	130	63	34
12:1	130	43	56
9:1	15	21	79

A mechanism which accounts for the formation of the new trimer (27) has been suggested ²³.

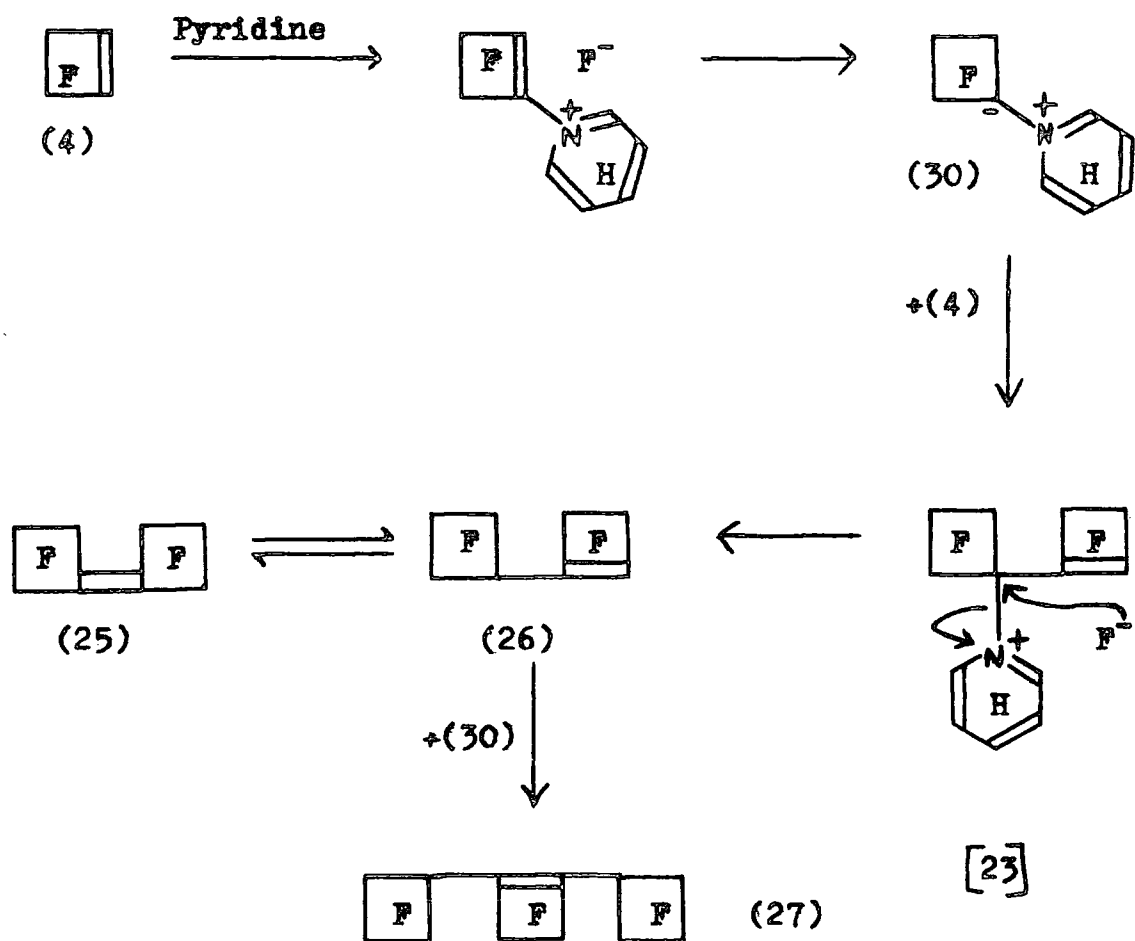

It is interesting that (30) reacts exclusively with (26) to give (27) and that there is no reaction between (25) and (30), which would give (24). Presumably the intermediate (30) is too bulky to approach the reactive centre of (25).

The mechanism has some precedent due to the isolation of ylides by Burton and his co-workers^{24,25,26}.

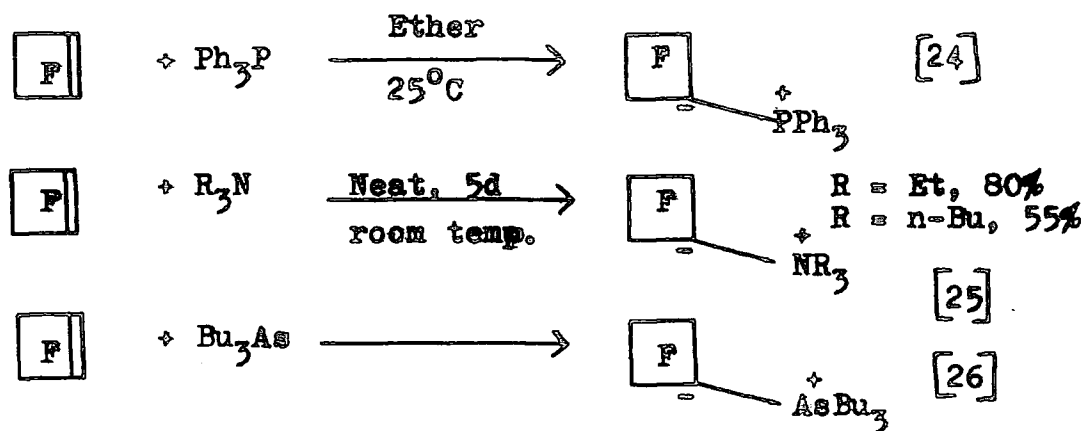

IN SOME ILLUSTRATIVE REACTIONS OF INTERNAL OLEFINS

An extensive study of various internal olefins has been carried out over the years and in this section selected reactions will be described which demonstrate the general chemistry of these systems.

IDI Internal Olefins containing Vinylic Fluorines

IDI.a Nucleophilic attack

The three possible reaction sequences are :-

- a) overall addition across the double bond,
- b) vinylic displacement of fluorine,
- c) allylic displacement of fluorine.

As will be seen in table 3, sequence b is the most prevalent, though the other sequences do occur. Note that quite subtle variations in the reaction conditions can substantially alter the final reaction products, as is shown by the reactions of hexafluoropropene dimer (I5) with oxygen nucleophiles. Note also how vinylic oxygen can activate a CF_3 group to nucleophilic attack ^{4I}.

Table 3

Nucleophilic Reactions of Highly Substituted Olefins

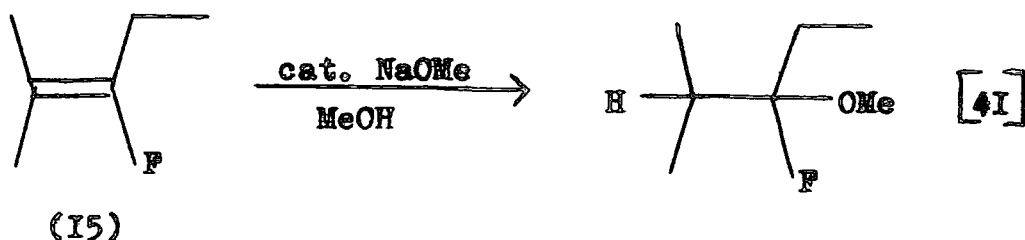
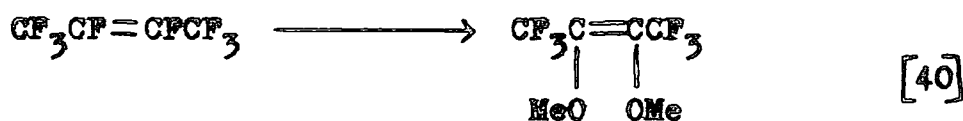
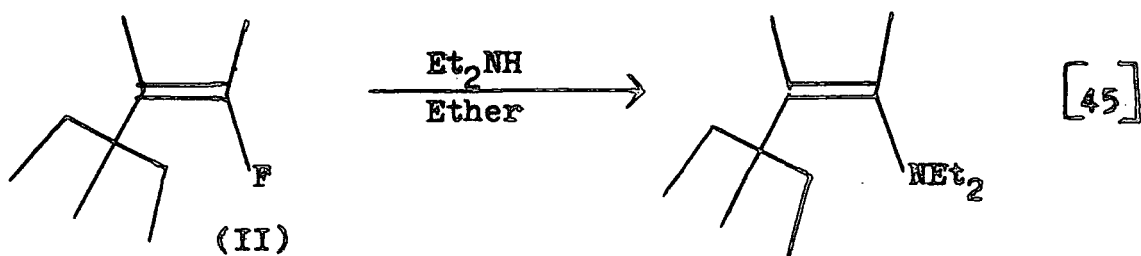
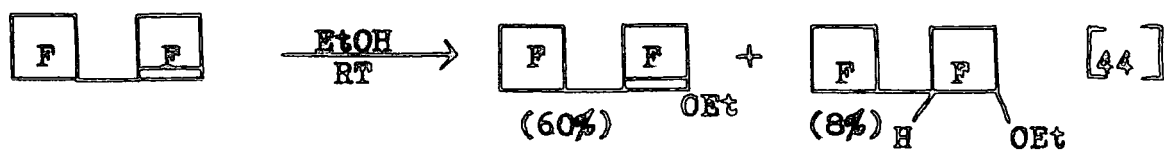
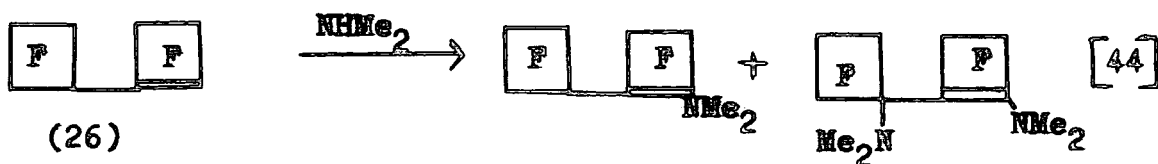
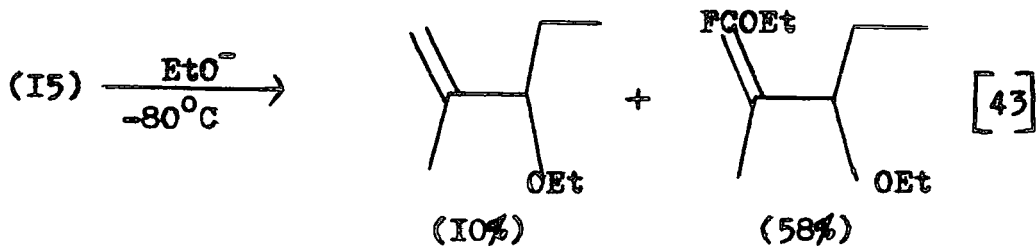
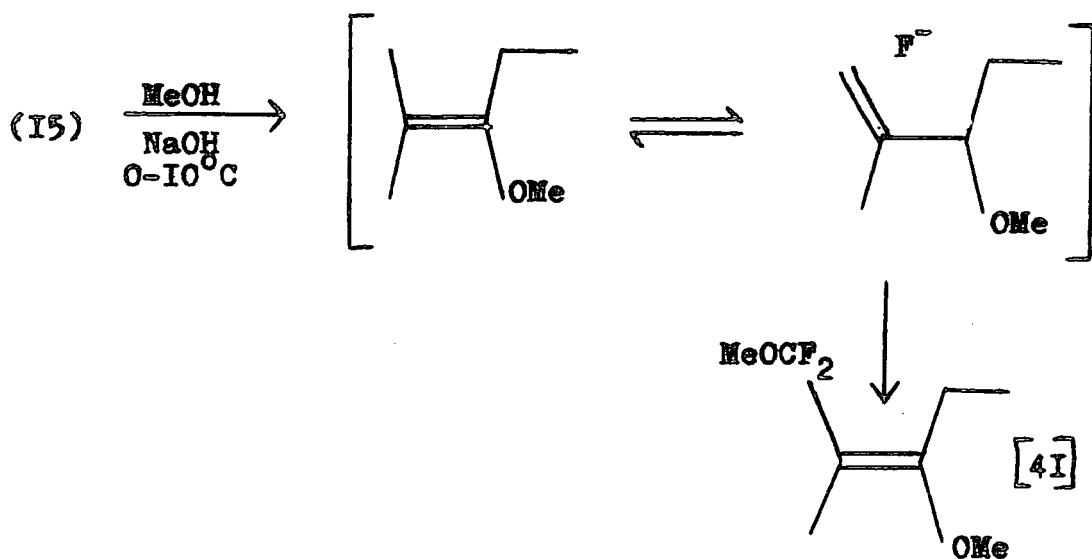
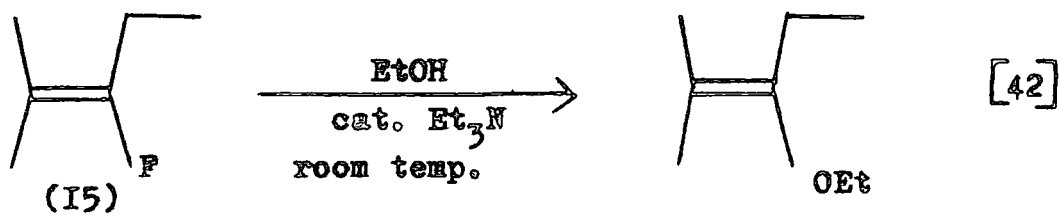
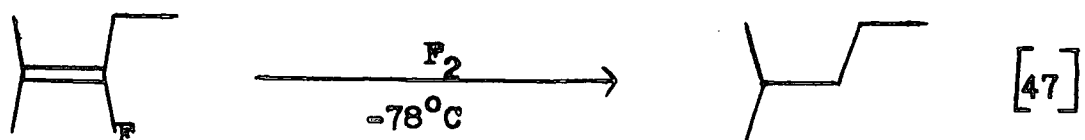
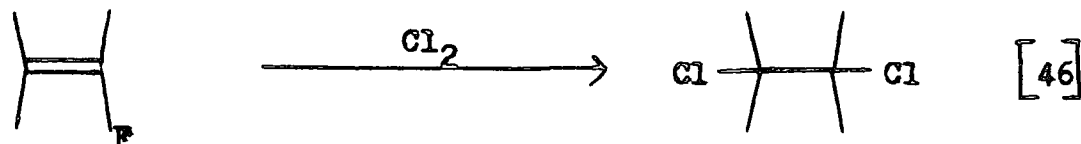
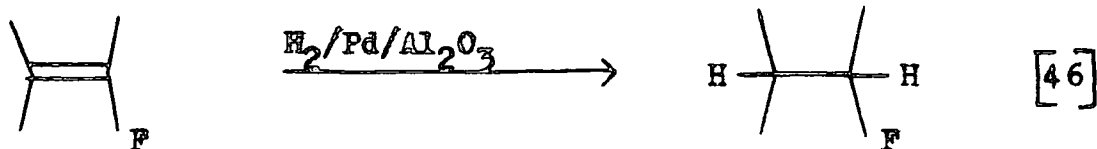

Table 3 (continued)



IDI.b Addition Reactions

Some typical addition reactions are detailed below.



ID2 Tetrasubstituted Internal Olefins

Workers at Durham have been particularly responsible for exploring the chemistry of these systems and further chemistry of some of them is contained in the discussion chapters.

ID2.a Nucleophilic attack

The key difference in this case is that initial substitution can only occur via an overall $SN2^o$ or allylic displacement. This process produces a new olefin with a vinylic fluorine and further reaction by vinylic substitution often occurs.

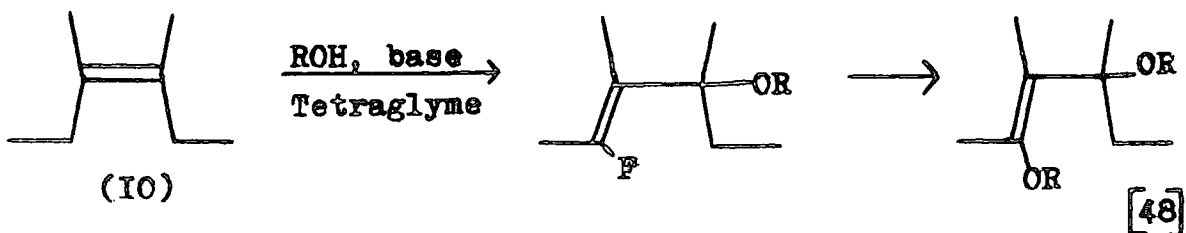

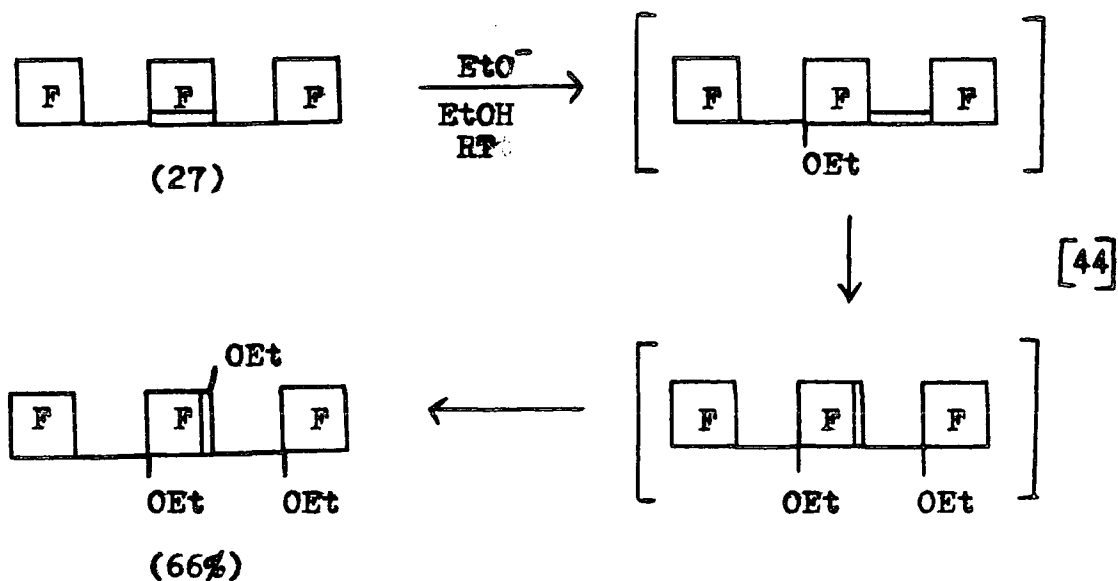
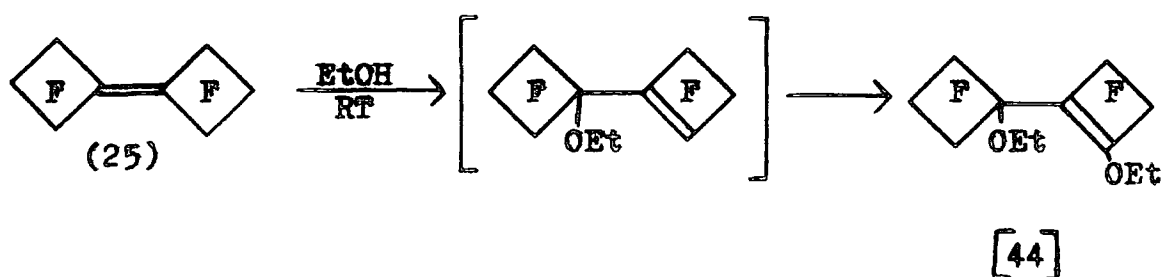

With disubstitution readily occurring, reactions with bifunctional nucleophiles can give cyclised products.

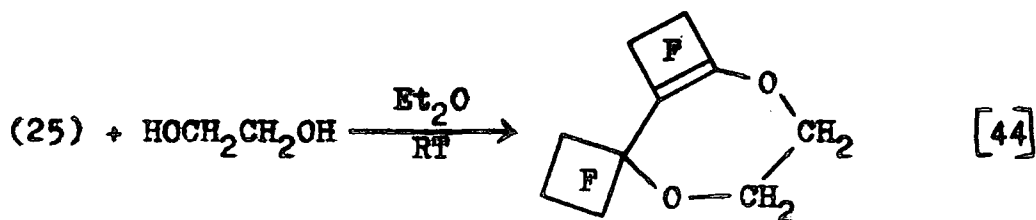

In principle, allylic displacement of fluorine from (10) could occur from either the CF₃ group or the C₂F₅ group and indeed, both processes are observed in the reaction with methyl lithium.

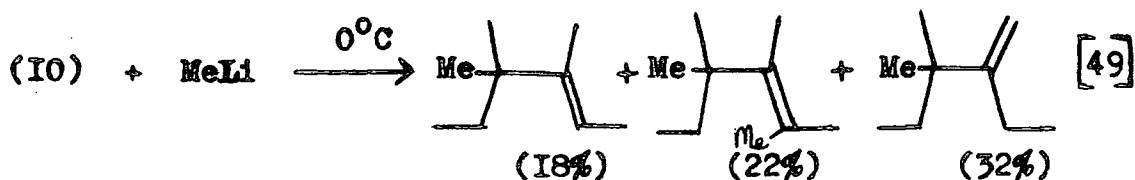

The formation of the thermodynamically less stable terminal olefin is attributed to steric factors.

In the final example, overall addition occurs rather than substitution which would give a compound with a terminal difluoromethylene group.

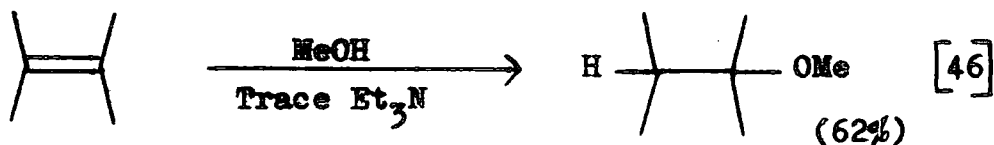

ID2.b Addition reactions

Tetrasubstituted perfluoro-olefins readily react with diazomethane, presumably because four perfluoroalkyl groups together provide the double bond with a better energy match to the attacking 1,3-dipolarophile.

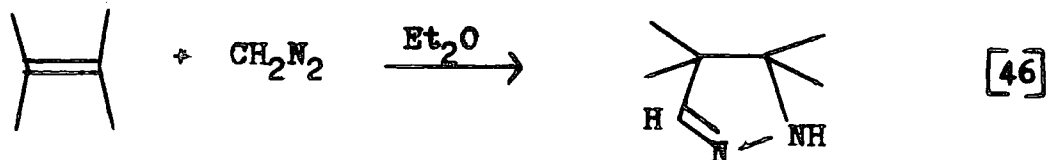
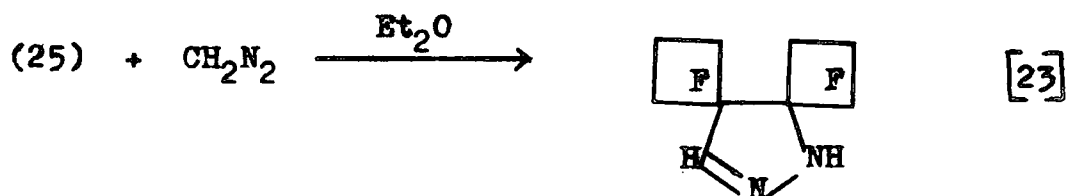
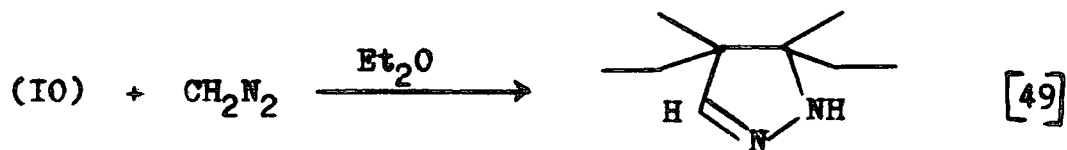

Free radical additions also occur.

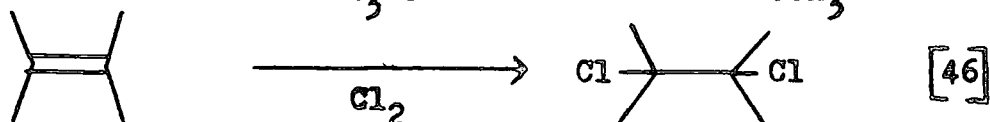
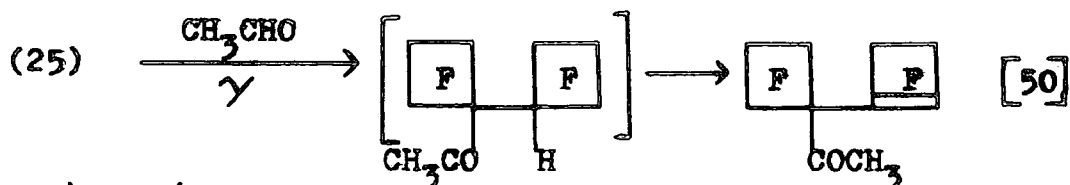
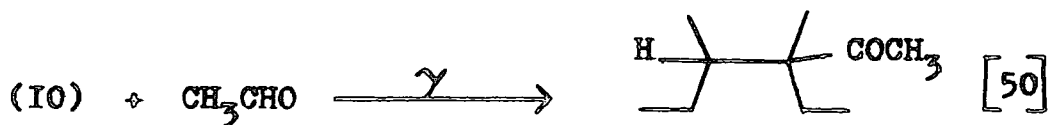

RECENT PREPARATIONS OF FLUORINATED INTERNAL OLEFINS

Preparations via Sulphur intermediates

The reaction of hexafluoropropene (2), sulphur and KF produces a dithietane in good yield.

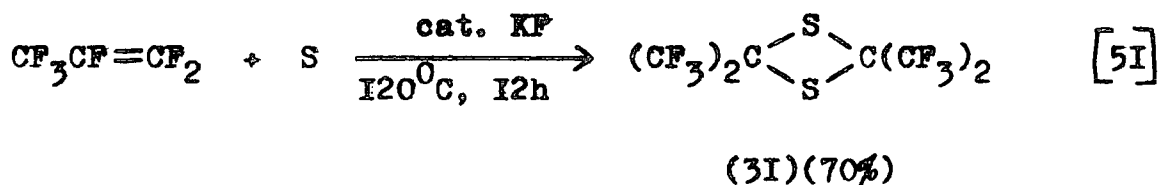

Compound (31) readily forms an ylide with which successful Wittig reactions may be carried out.

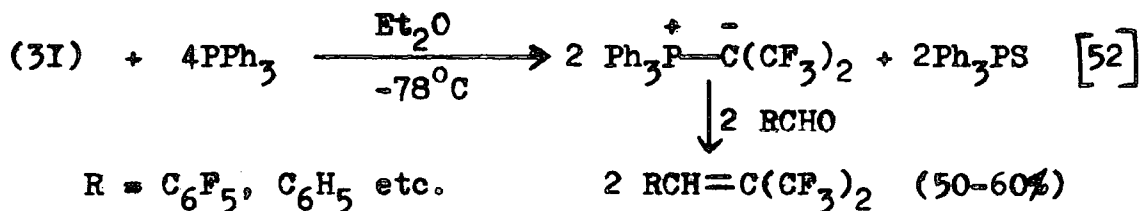

Simple pyrolysis of (31) gives the relatively unavailable perfluoro-2,3-dimethyl-2-butene (32)

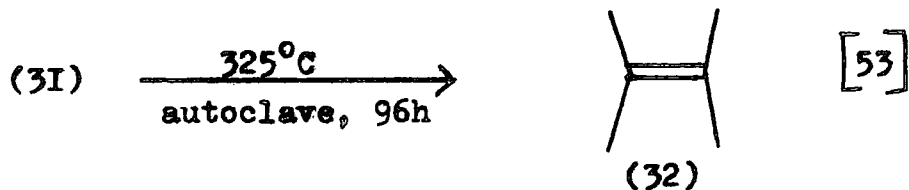

Two other routes to this olefin have been described recently.

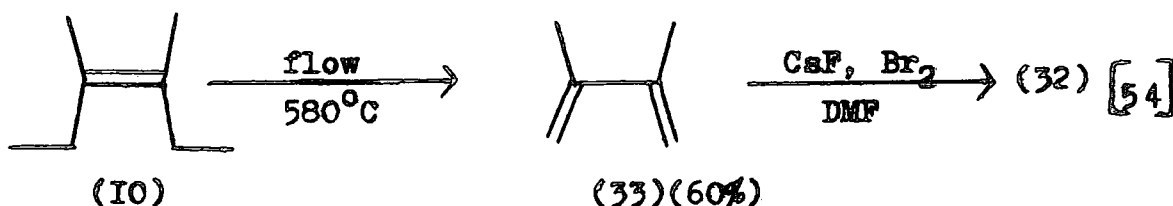
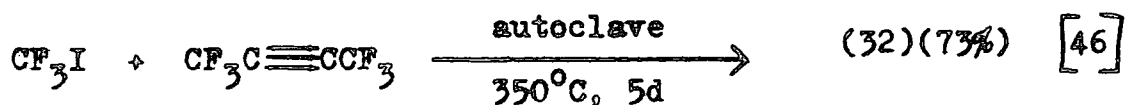

IE2 Fluoride ion induced processes

IE2. a Isomerisation

The simplest possible method of obtaining an internal olefin is a fluoride ion induced isomerisation of a terminal olefin. These reactions, however, can give some surprising results.

A reported way of producing a fluorinated terminal olefin is to react a perfluoroalkyl halide with a Grignard reagent.

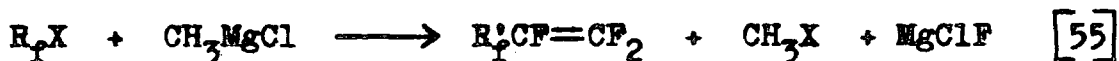

Fluoride ion induced isomerisation generally produces olefins with the perfluoroalkyl groups lying on opposite sides of the double bond, as would be expected in order to minimise steric crowding.

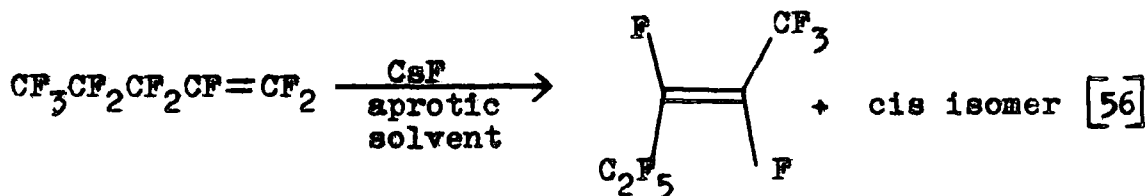

ratio cis : trans = 1 : 6



<u>X</u>	<u>cis:trans ratio</u>
F	1 : 3
Cl	1 : 4.3
Br	1 : 5

But workers at Montpellier, using n.m.r. methods, claim that in the case of the higher, straight-chain perfluoro-olefins, fluoride ion induced isomerisation produces internal olefins with a cis configuration.

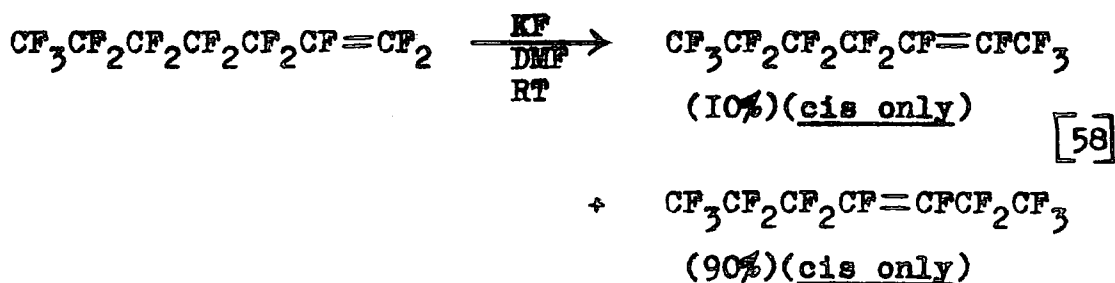

This unusual result is explained by suggesting a cyclic transition state involving the cation. The cis isomers are produced directly from the transition state which exhibits the smallest perfluoroalkyl group eclipsing interactions.

IE2.b Co-oligomerisation

In most cases, fluoride ion induced reactions between two different olefins result in the anion formed by the least substituted olefin reacting with the most substituted olefin.

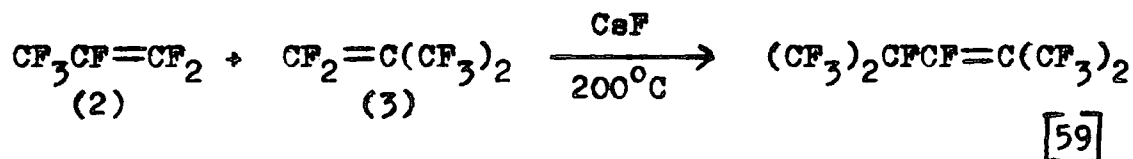

Although this involves the formation and reaction of the more unstable and therefore less prevalent ion, steric factors and final product stability are, presumably, the overriding considerations.

However, a recent paper describes a synthesis where compounds (2) and (3) do indeed react the other way round.

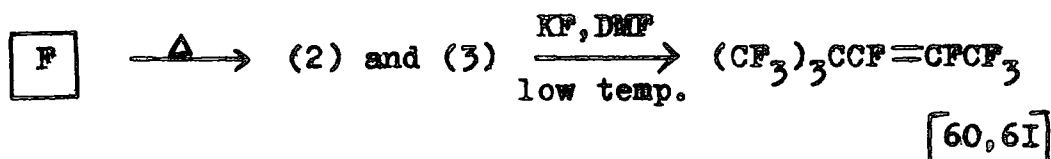

Co-trimerisation can also occur.

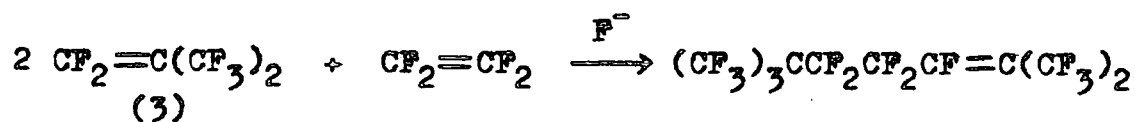

IE2.c Cationic Co-oligomerisation

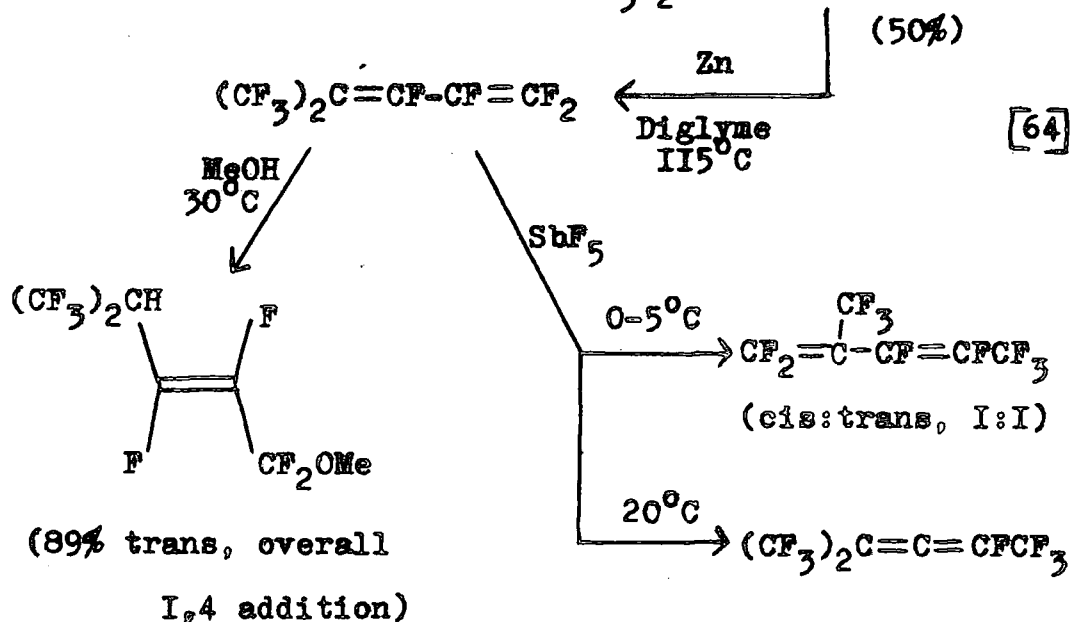
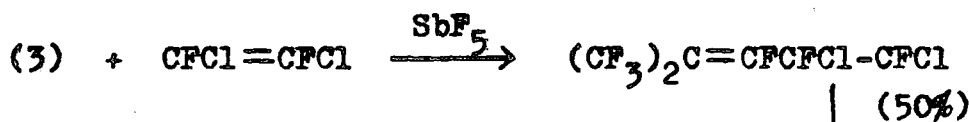
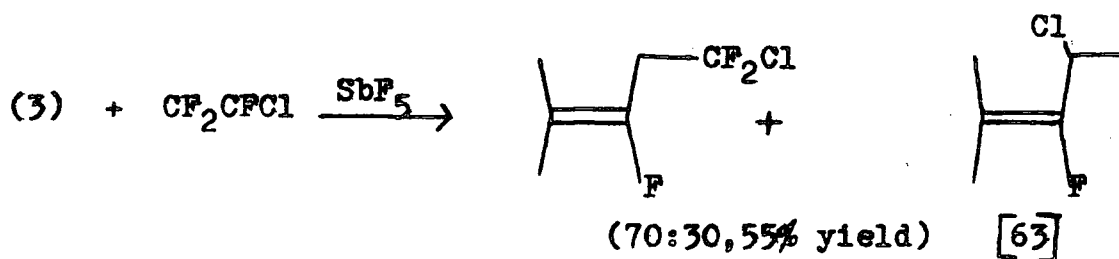
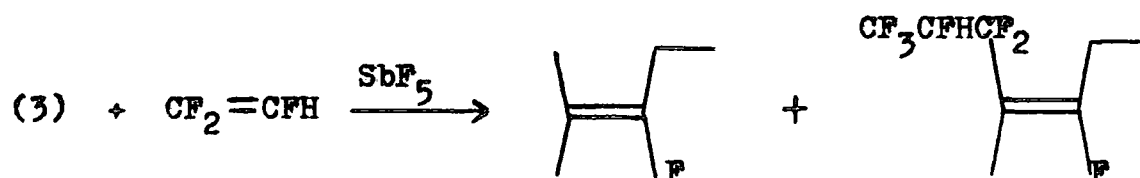
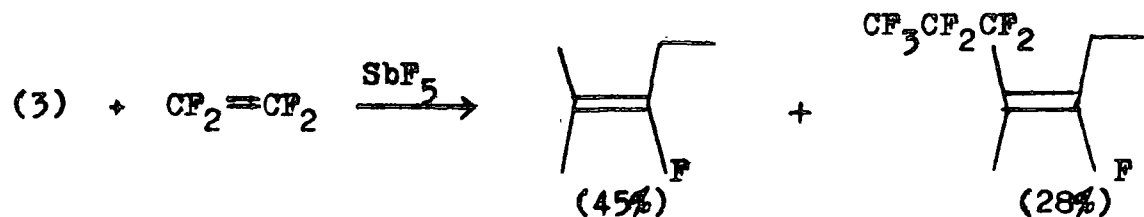

IE3 Preparations via Phosphorus intermediates.

Barton and co-workers have described many syntheses of fluorinated olefins via Wittig reactions, primarily, though not exclusively, with the aim of developing high yield routes to terminal fluorinated olefins ⁶⁵.

In complete contrast to these results, other workers, intending no doubt to produce new, stable ylides, have found that phosphines can also act as defluorinating agents.

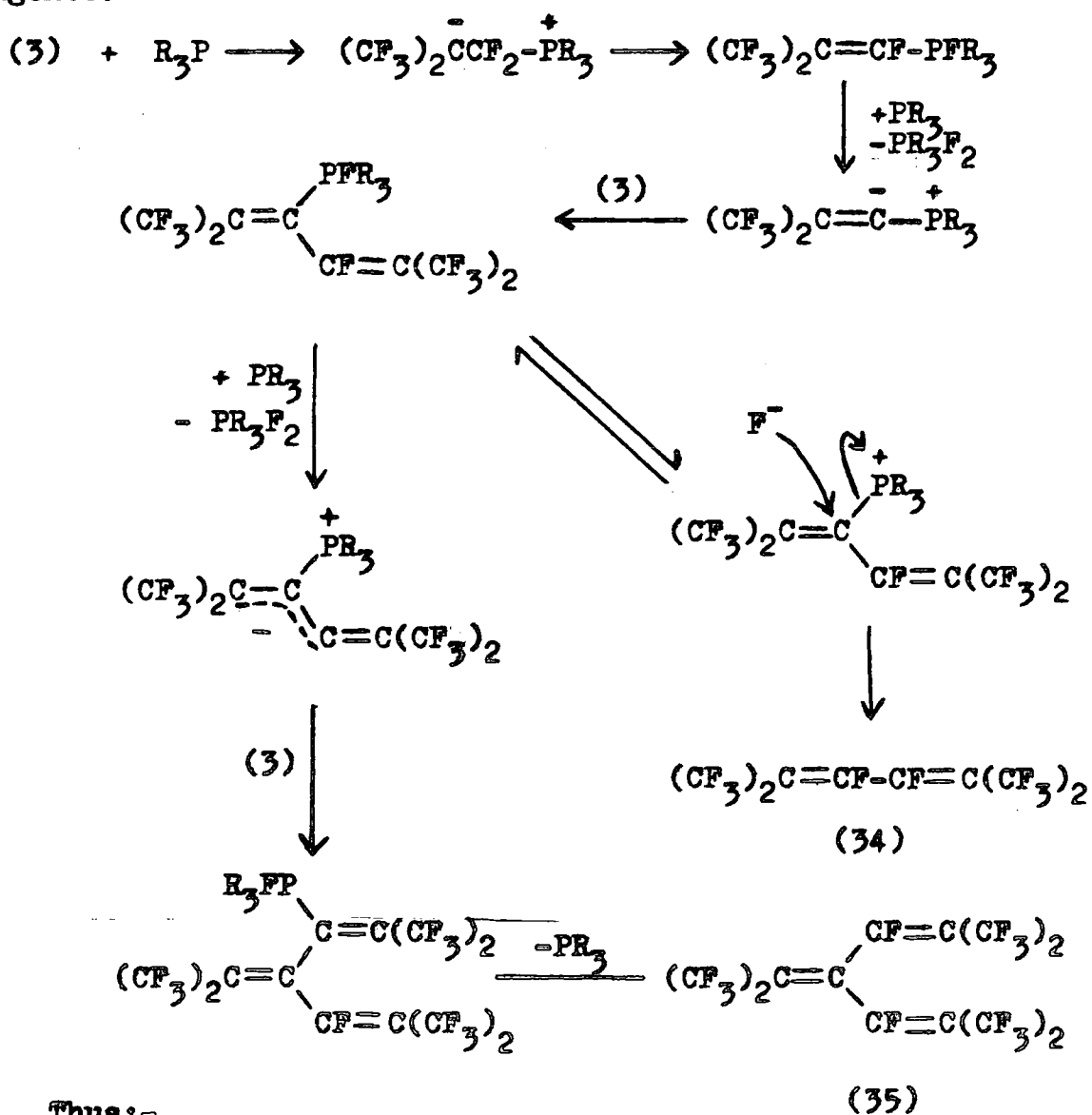

Thus:-

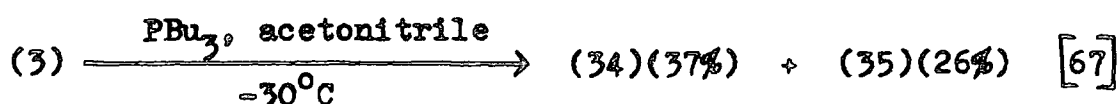

This defluorination technique has been used with internal olefins.

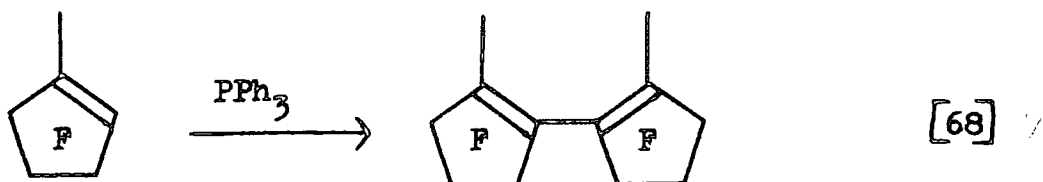

IE4 Miscellaneous Examples

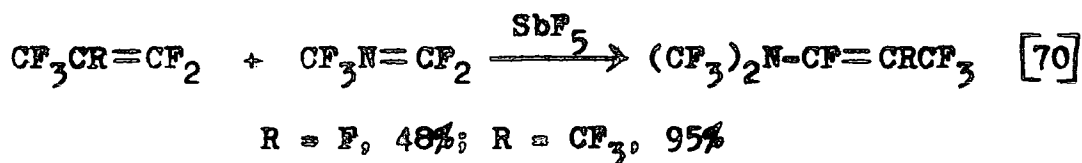
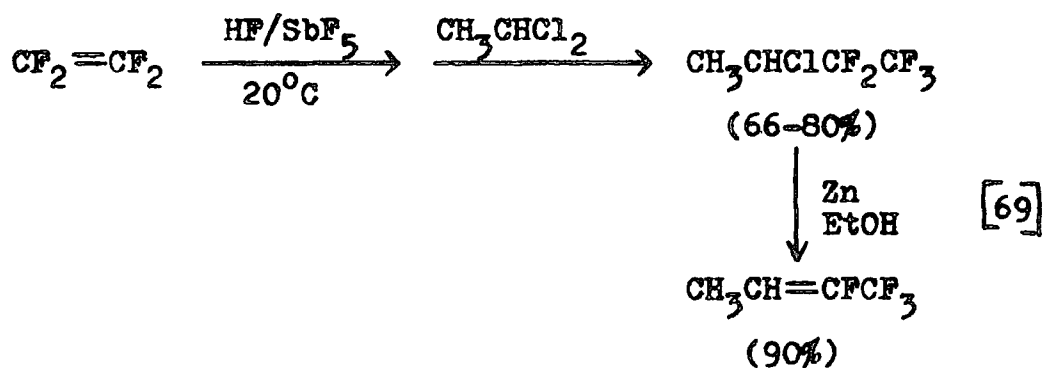

IF RECENT REACTIONS OF FLUORINATED INTERNAL OLEFINS

IFI Reactions of hexafluoropropene dimer (I5)

Several new reactions of this easily obtainable olefin with nucleophiles have been described in the last few years.

Reaction of (I5) with acids and higher alcohols gives addition products but, in the presence of a little base, overall vinylic substitution occurs.

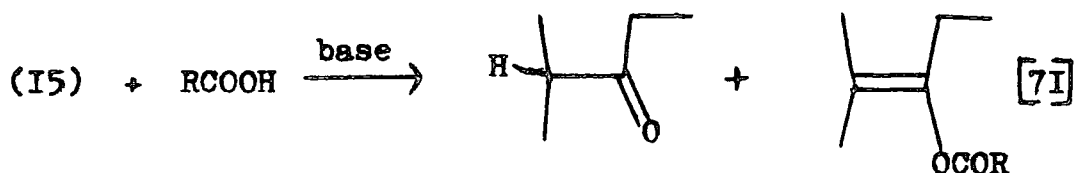
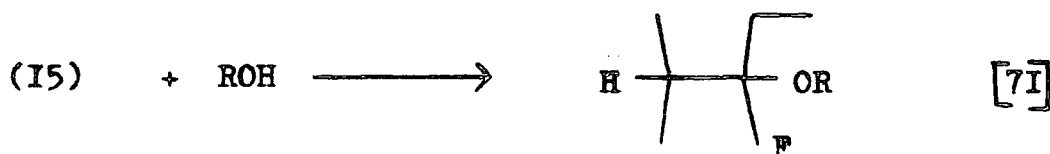
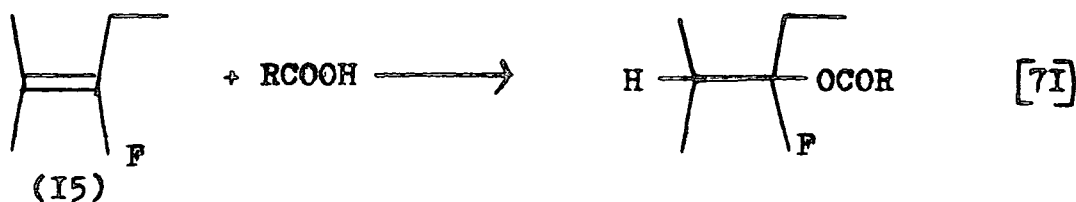

In the reaction with a sulphur nucleophile, mono- and di-substitution products are observed when a molar equivalent of nucleophile is used. The SR group is clearly seen to deactivate the adjacent unsaturated site to nucleophilic attack with respect to fluorine or a perfluoroalkyl group.

When a large excess of nucleophile is used, polysubstitution occurs, apparently via an unusual I,4 elimination of RSP.

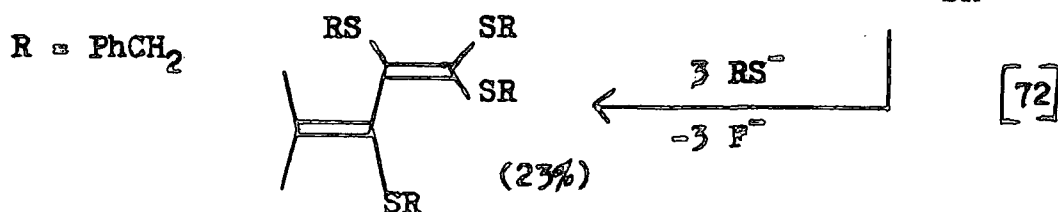
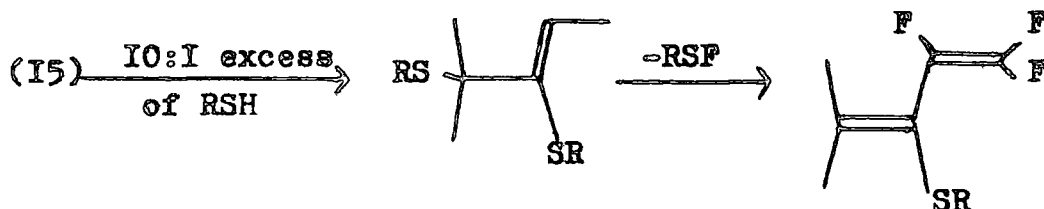
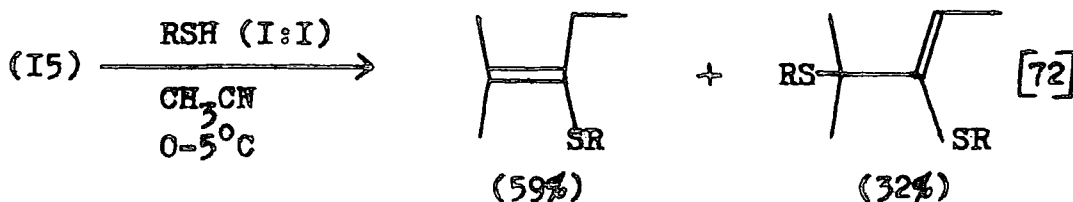

Reactions of (I5) with ortho disubstituted benzenes give cyclised products arising from initial allylic displacement of fluorine.

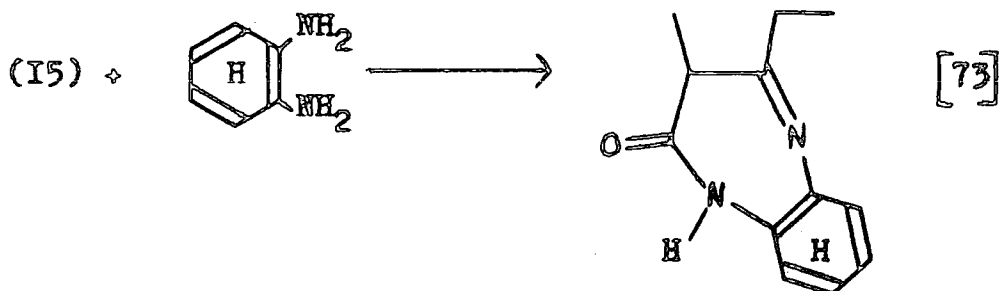
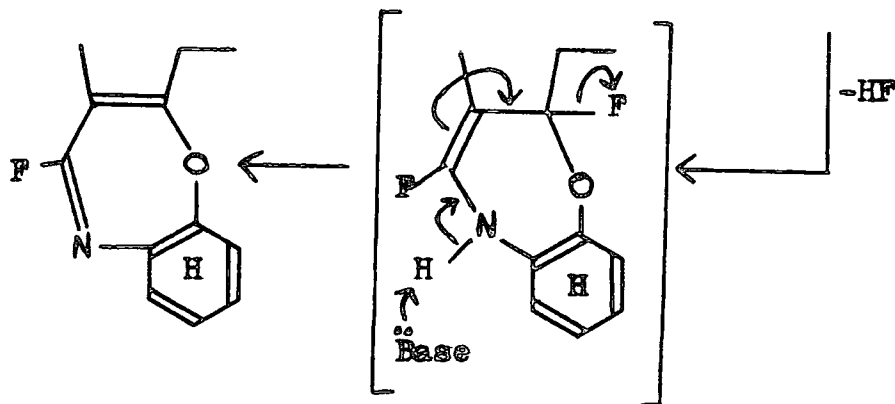
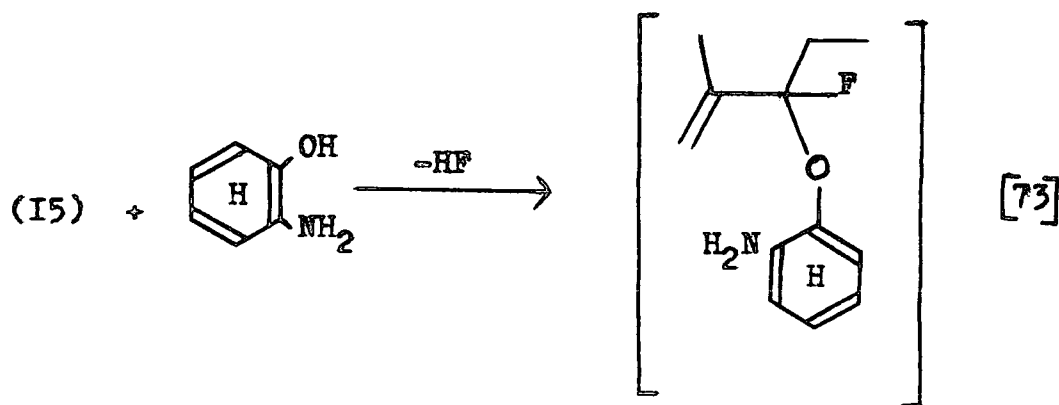
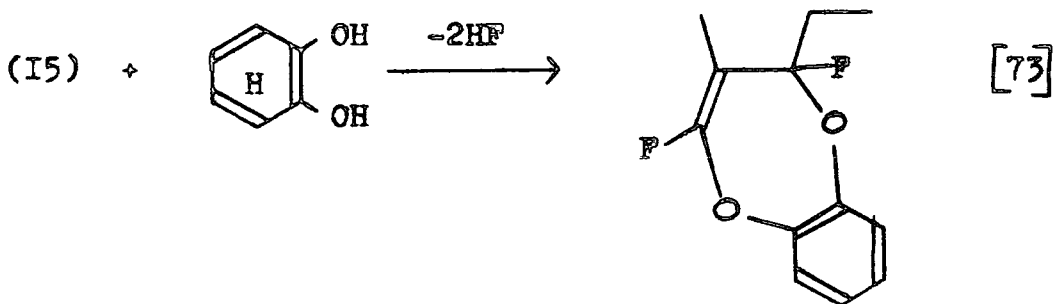

The product formed from reaction with HCN is not the expected 1,4 adduct but instead arises from cyclisation.

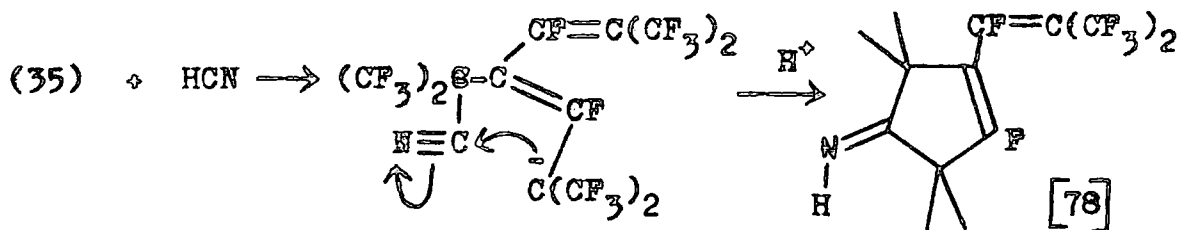

Another cyclisation has also been observed.

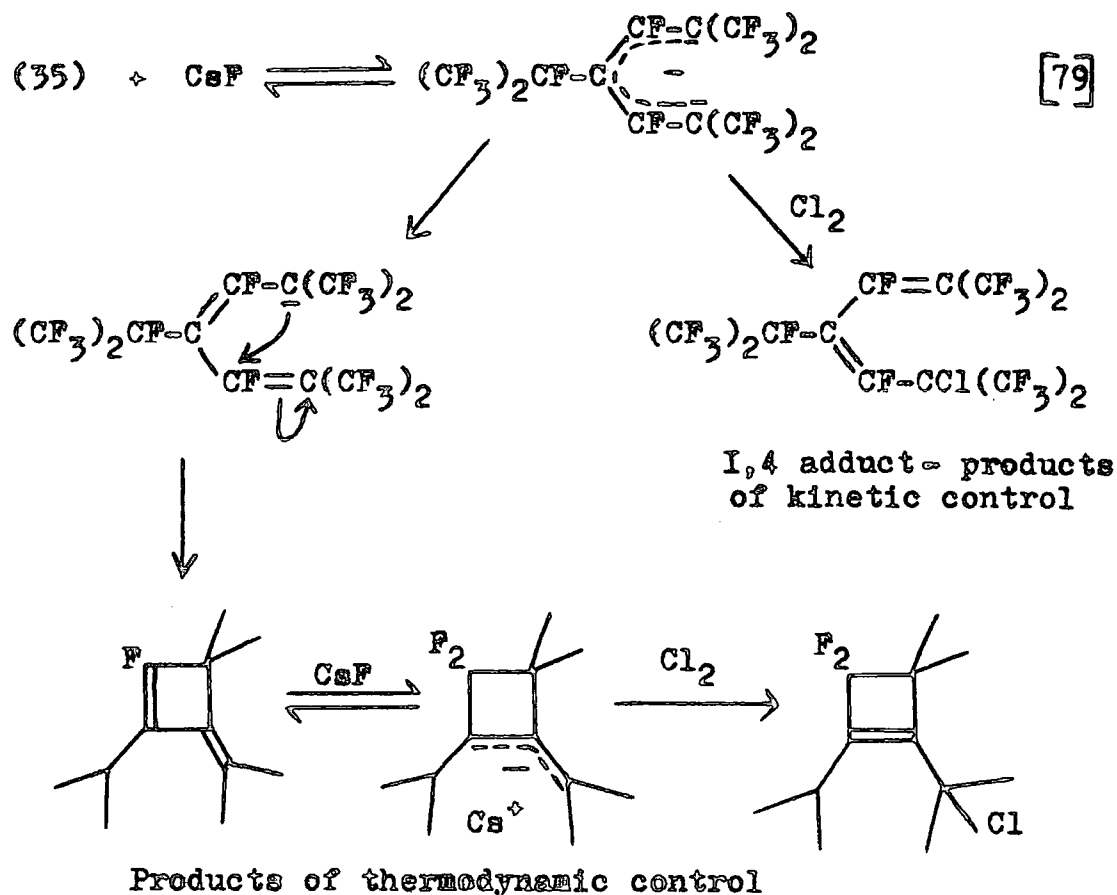

IF3 Miscellaneous Reactions of Internal Olefins

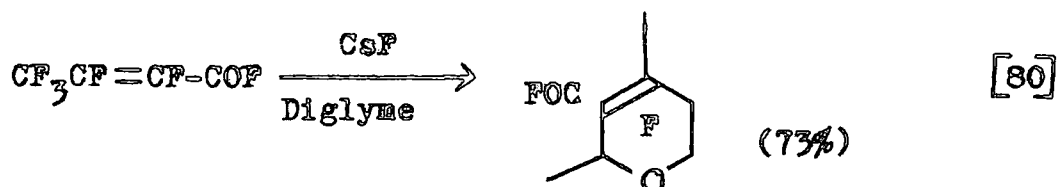

- an unusual pyran synthesis.

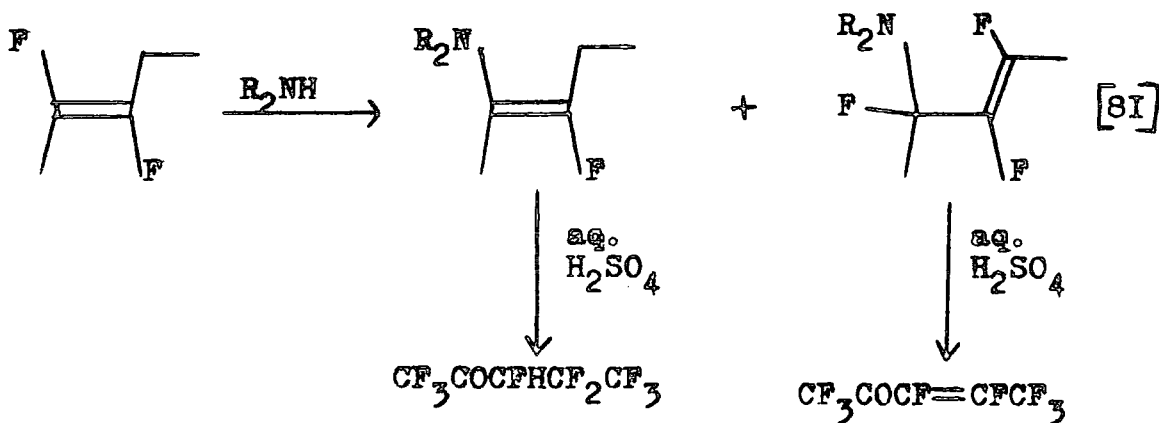

Note that initial nucleophilic attack occurs exclusively at the least hindered end of the molecule.

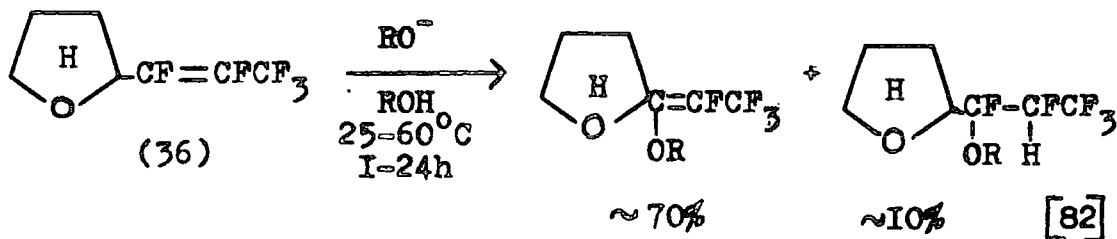

R = various alkyl groups

Perhaps surprisingly, attack occurs at the most hindered and, ostensibly, least electrophilic end of the double bond. However, this attack does produce an intermediate stabilised by a CF_3 group.

Compound (36) may be prepared by free radical addition of tetrahydrofuran to hexafluoropropene, followed by dehydrofluorination.

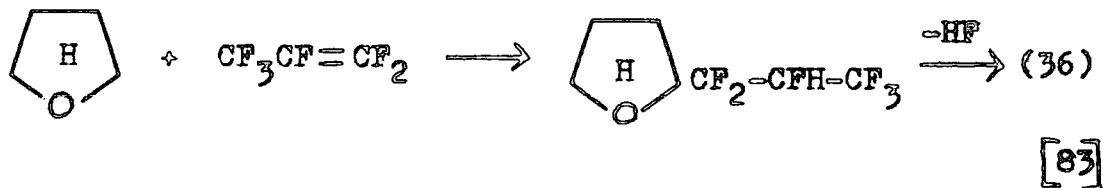

IG REACTIONS OF CYCLIC SYSTEMS

IGI Four and Five membered Rings

Some recent preparations and reactions of substituted cyclic systems are detailed below.

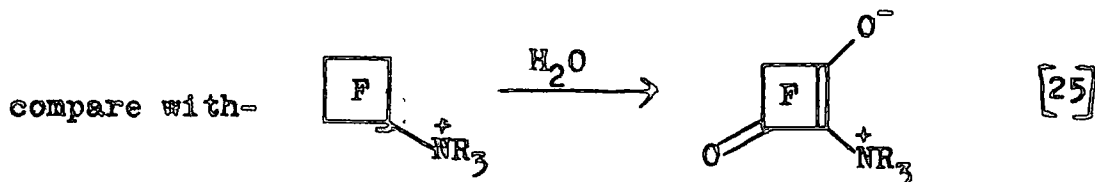
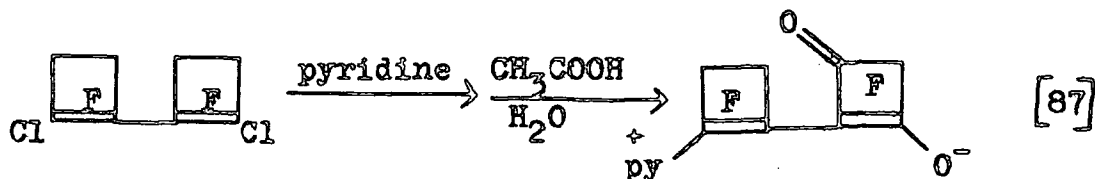
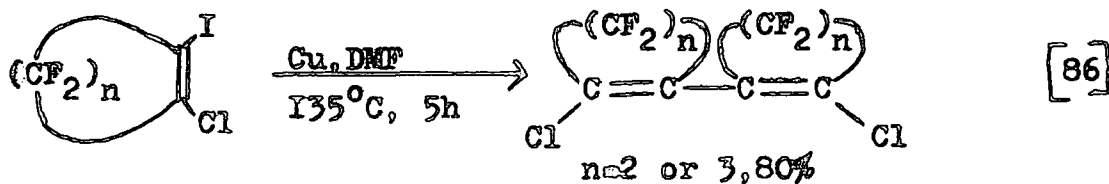
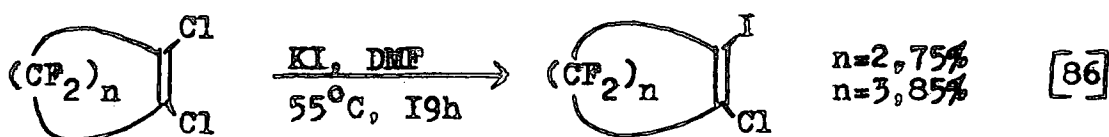
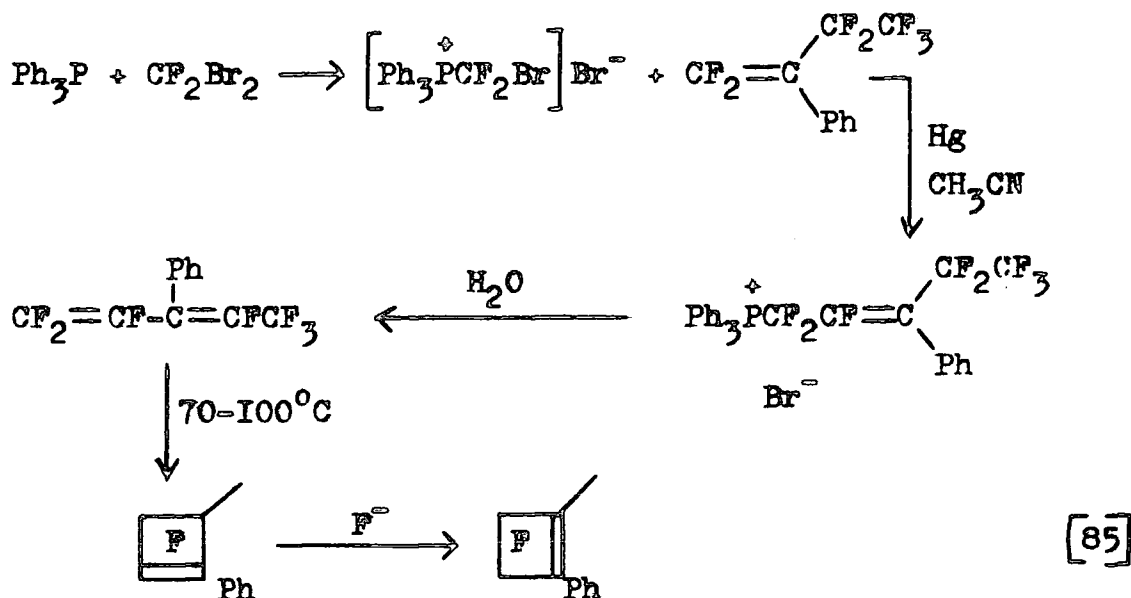
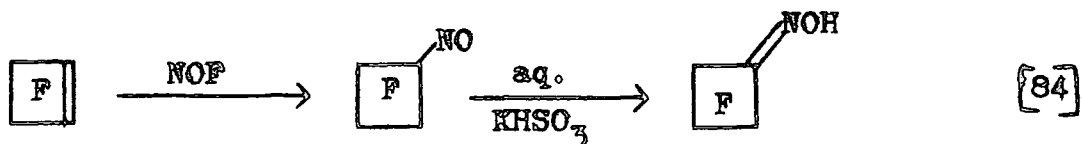

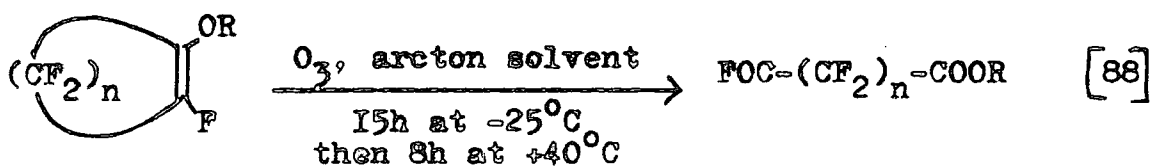

IG2 Preparation of the Penta(trifluoromethyl)-cyclopentadienyl-anion (37)

The first synthesis of (37) was recently reported.

Compound (37) appears to be the strongest unconjugated carbon acid yet known. It should be noted however that the synthesis was repeated many times but the reporters could not obtain a yield of greater than 11% from the pyrazoline precursor on any occasion.

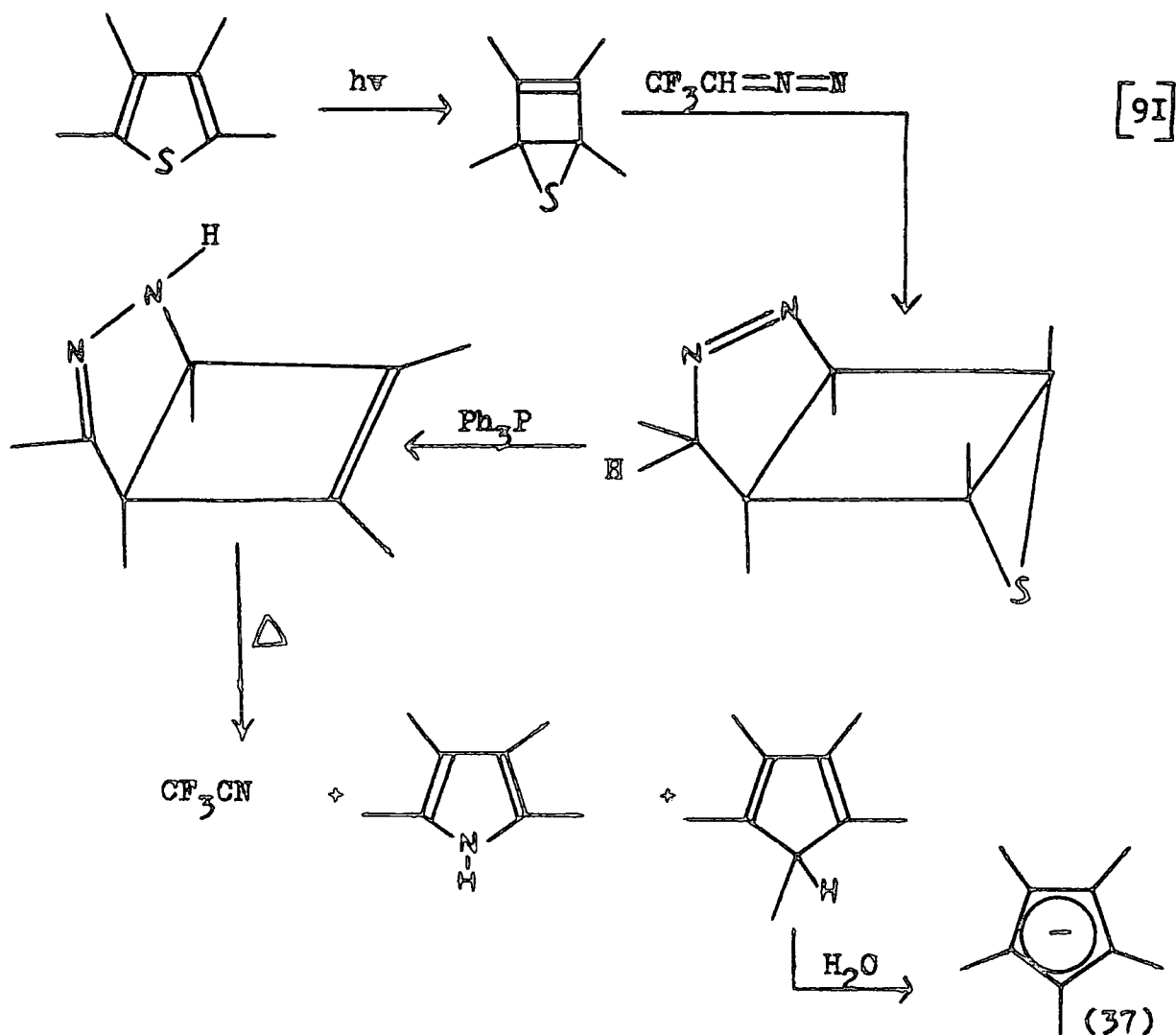

IG3 Six Membered Rings

The preparations of perfluorocyclohexenol and its use in forming other substituted cyclohexenes has been described ⁸⁹.

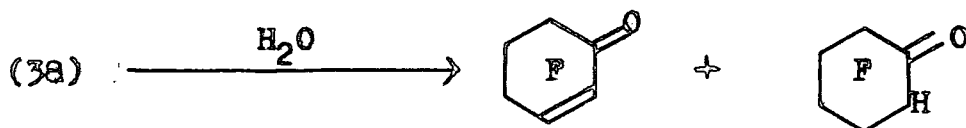
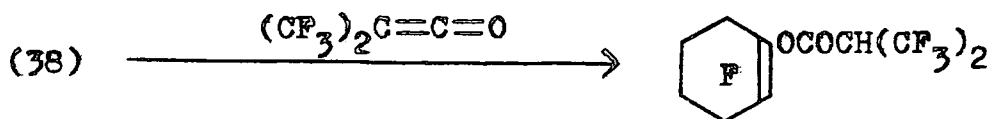
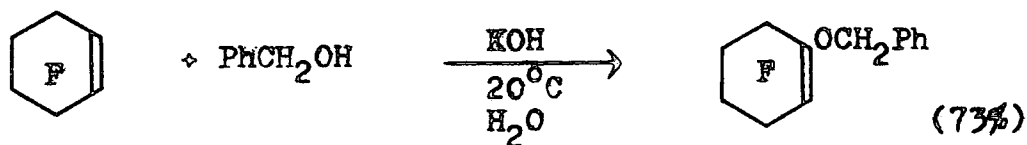

Cyclodienones undergo nucleophilic substitution reactions at the expected position meta to the carbonyl group.

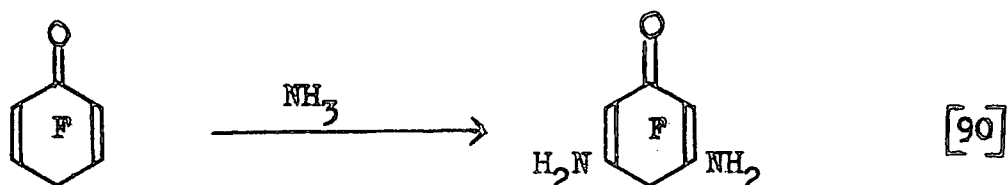

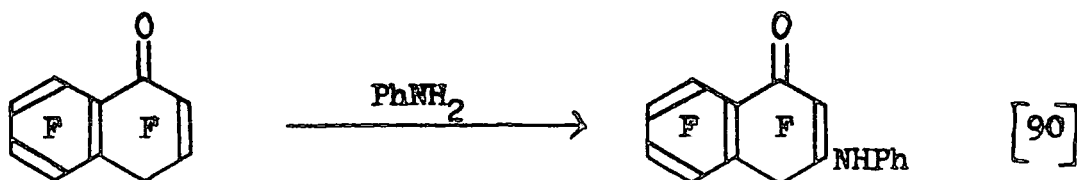

A variety of nucleophiles were used; the products were all analogous to those above.

IG4 Preparation of 8 Membered Rings and Related Reactions

IG4.a Coupling Reactions

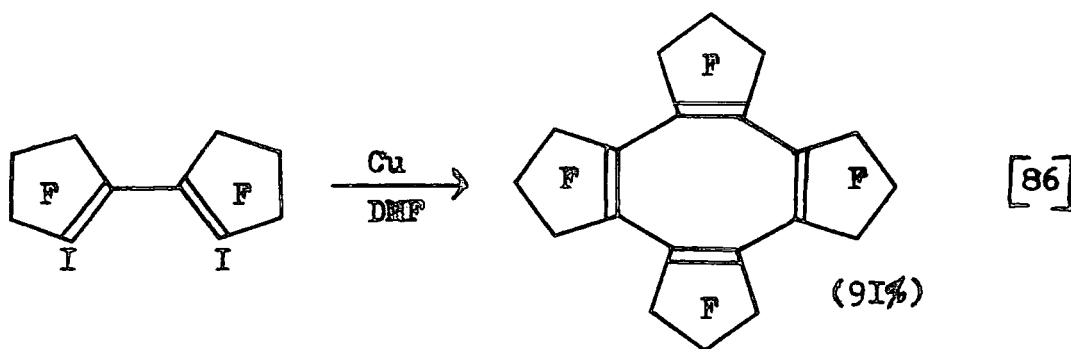
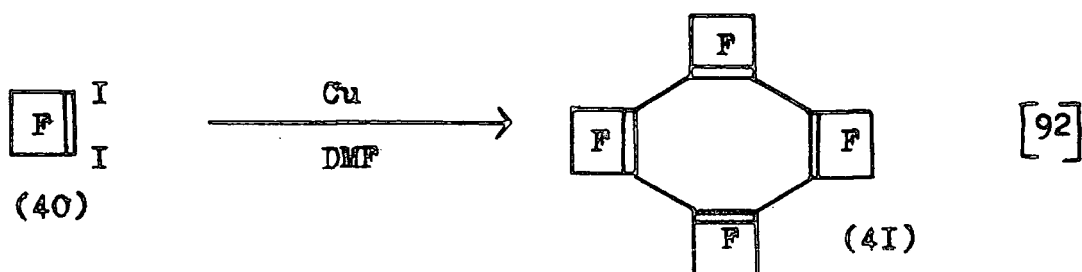

An X-ray structure of (4I) shows that the molecule is planar and that there is delocalisation of electron density in the cyclo-octatetraene ring.

IG4.b Syntheses via a Cyclobutadiene intermediate and Related Reactions

Pyrolysis of 3,4-di-iodo-perfluorocyclobutene (42) under different conditions produces a variety of products. Examples are shown overleaf.

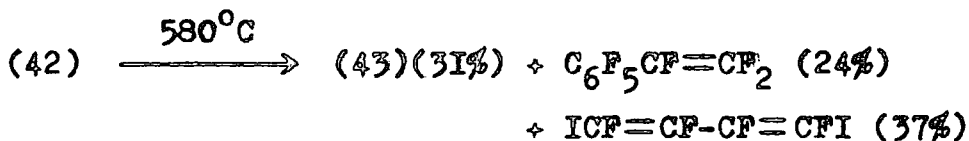
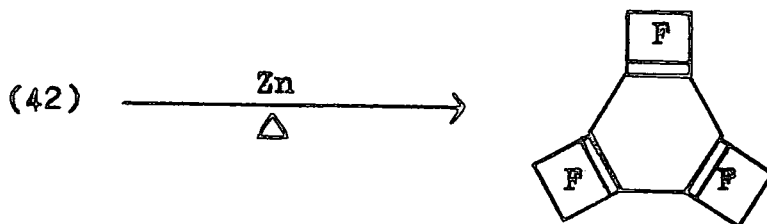
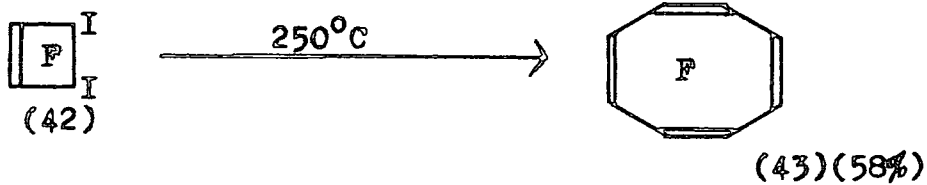

A possible mechanism is suggested below.

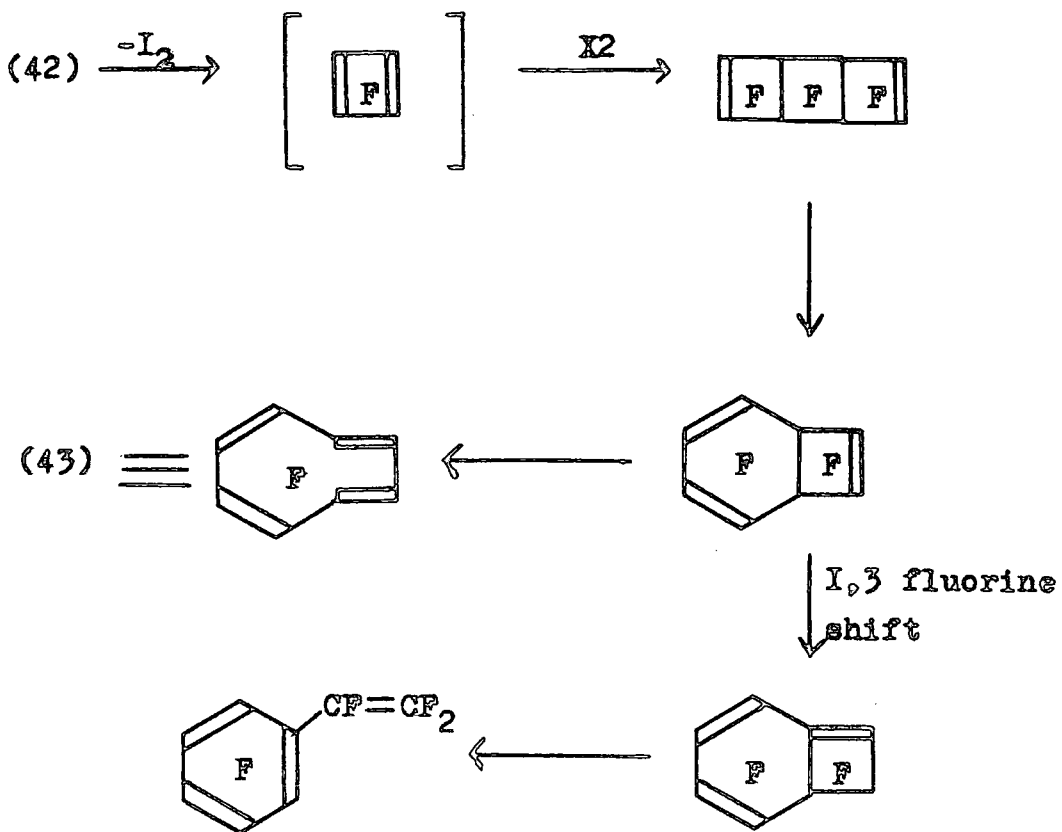

The reactions on this page are contained in reference 93.

Lemal and co-workers have devised routes to (43) starting from hexafluorobenzene.

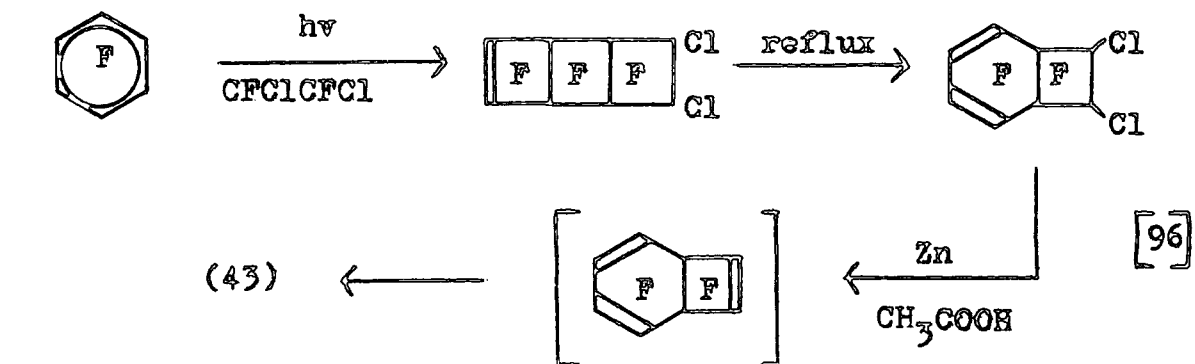
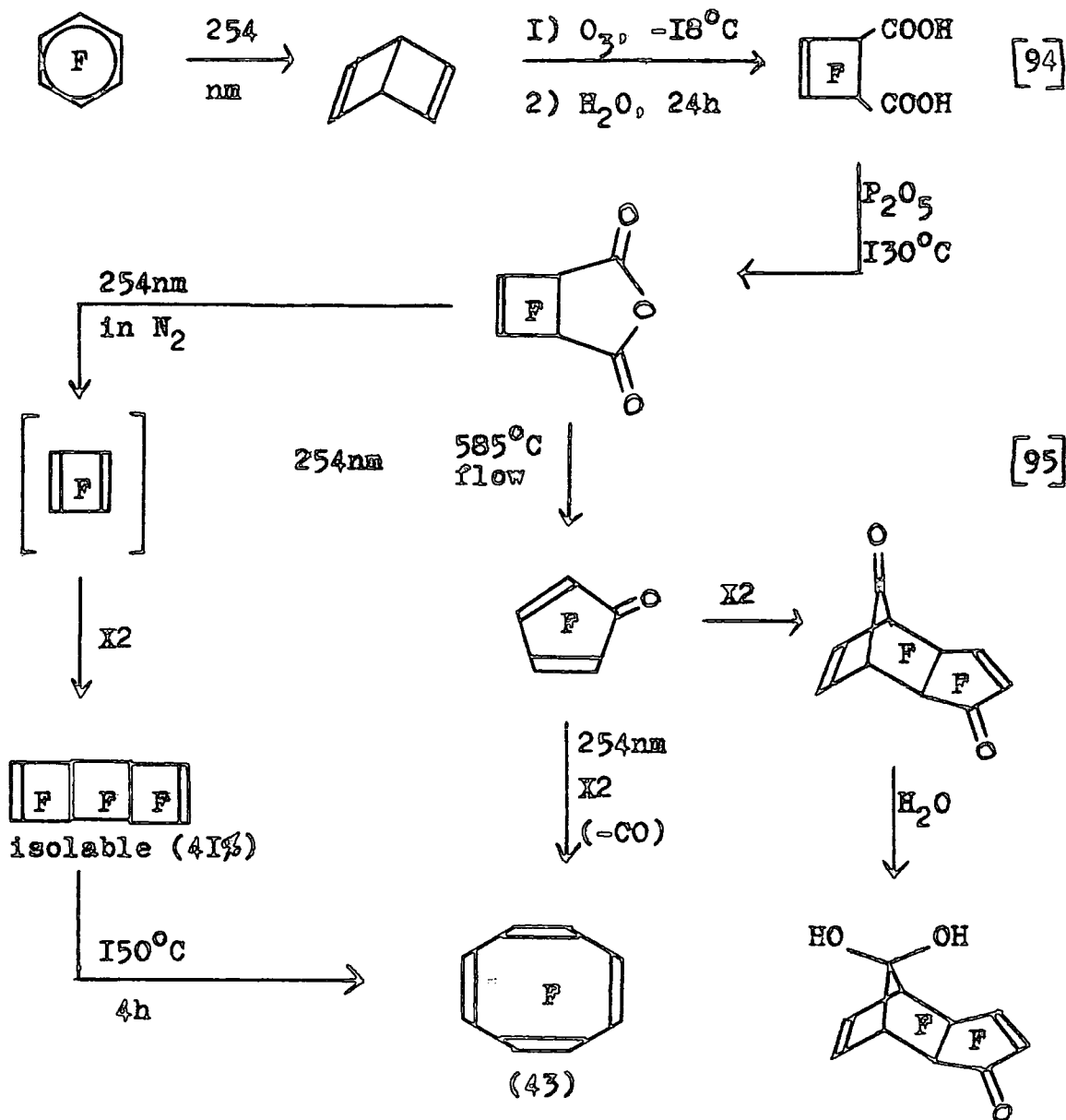

IH PREPARATIONS OF PERFLUORINATED EPOXIDES

Introduction

Hydrocarbon epoxides are important intermediates in many laboratory and industrial processes and therefore it is not surprising that chemists should be interested in fluorine-containing epoxides.

Much of this interest stems from the possibility of using fluorinated epoxides as monomers to prepare fluorinated polyethers, which could offer useful properties such as elastomeric behaviour, while at the same time retaining the chemical inertness and temperature stability of better known fluorinated polymers such as polytetrafluoroethylene.

Little wonder, then, that much of the literature in the field is in the form of patents and that the patent literature abounds with novel, refined or modified syntheses of epoxides from the simplest and most readily available perfluorinated olefins.

Several reviews of the field have appeared (see references I31, I45 and I46).

IHI Early Syntheses

The first general synthesis of perfluorinated epoxides was developed by chemists at DuPont⁹⁷, using alkaline hydrogen peroxide at low temperatures.

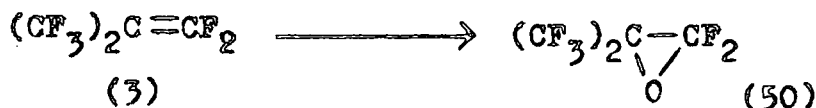

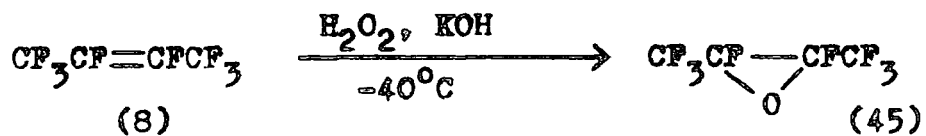

Similarly,

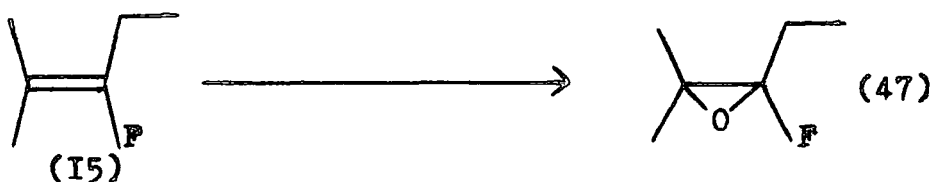
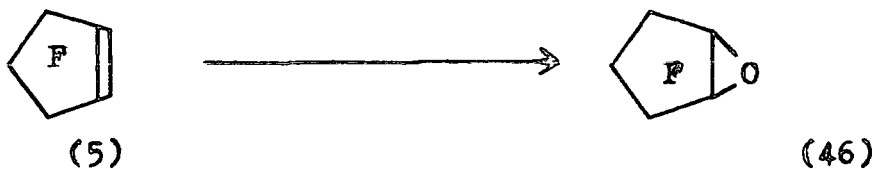

This method cannot be used to prepare tetrafluoroethylene oxide. It can be prepared by bubbling a mixture of tetrafluoroethylene (I), air, oxygen and catalytic amounts of bromine through a quartz tube at 110°C , using U.V. radiation.

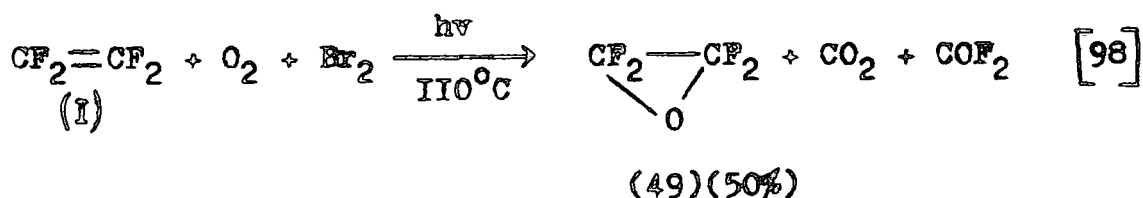

A similar technique was later applied to (2).

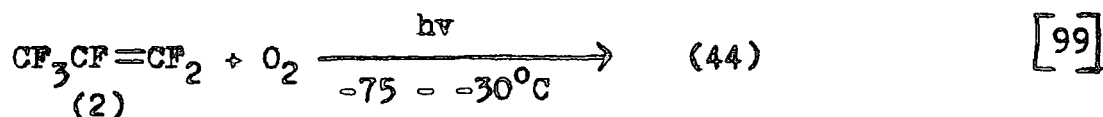

Compounds (44) and (49) have also been prepared in an interesting reaction involving KMnO_4 . It is suggested that the first step of the reaction is an electrophilic attack on the double bonds of (I) and (2) by the acid fluoride of permanganic acid I00.

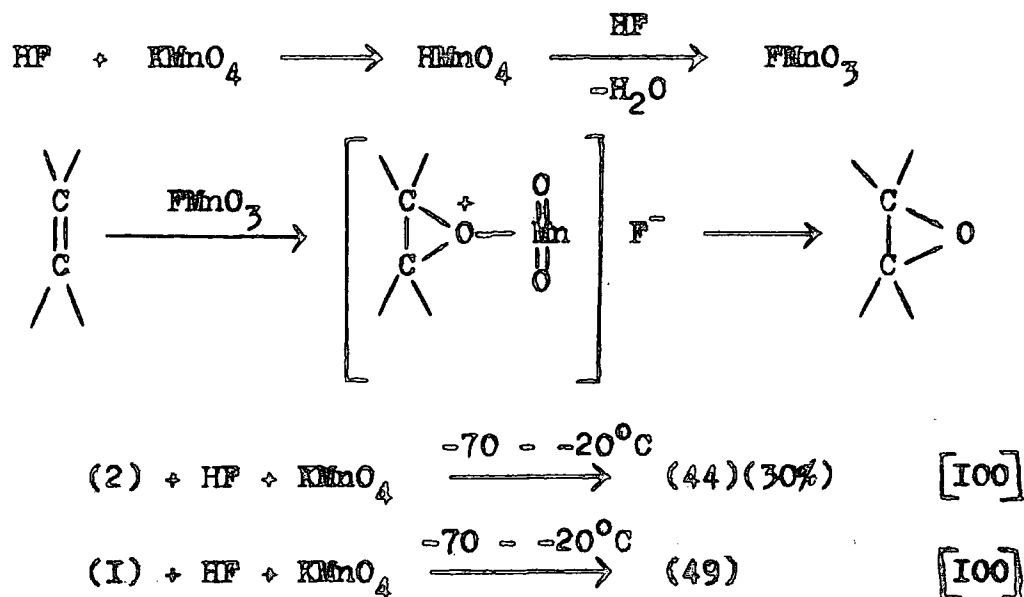

Another unusual method of epoxidation utilises the reaction of certain perfluoro-olefins with oxygen difluoride.

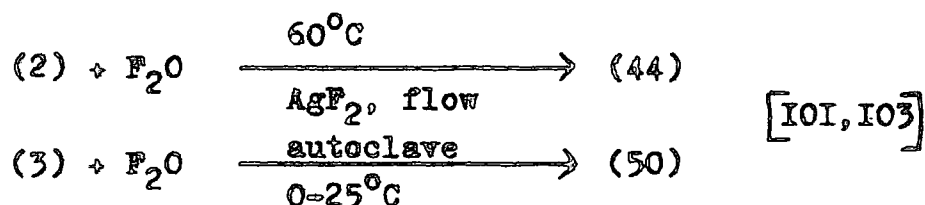

Rokhlin and co-workers developed three specific syntheses to produce compound (5I), though mostly in low yield I02.

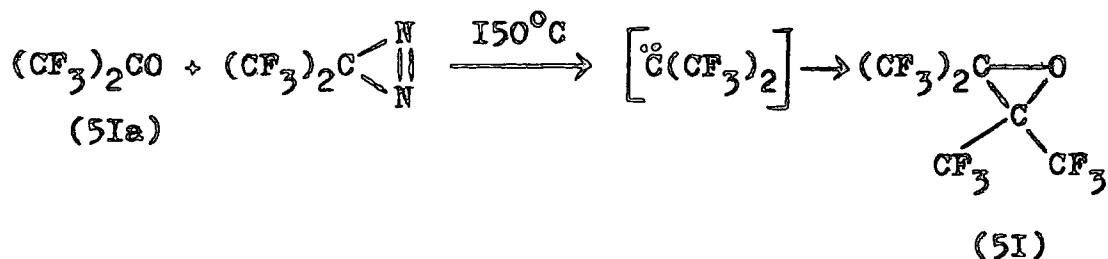

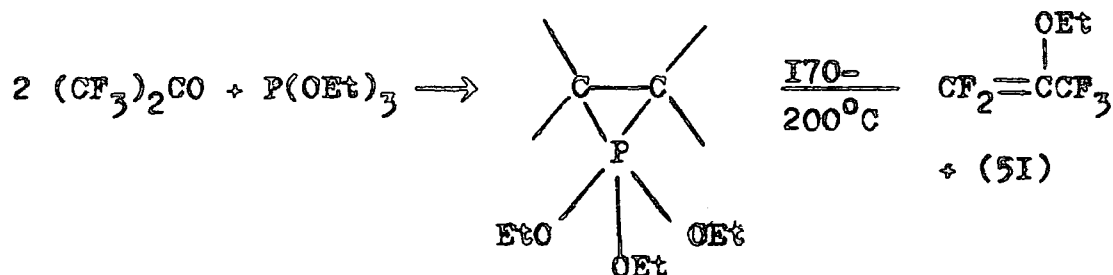
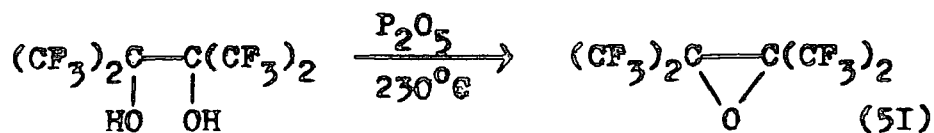

The driving force for these syntheses was presumably the inability to form (5I) from the olefin precursor by the alkaline peroxide route i.e. the route is not very successful for epoxidising highly substituted olefins.

It was discovered that (44) could act as a source of difluorocarbene and this fact was harnessed in a new synthesis of epoxides from perfluorinated ketones ¹⁰⁴.

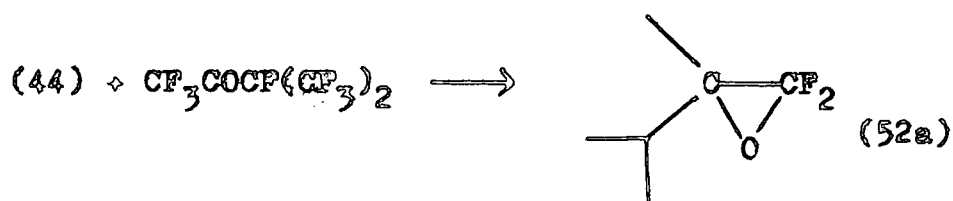
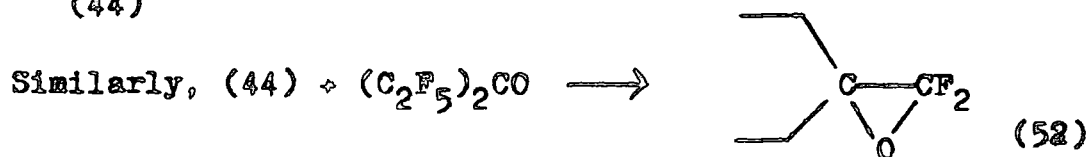
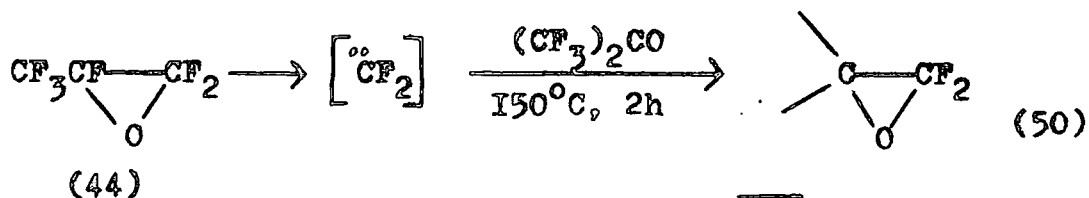

IH2 Recent Syntheses

Of the many epoxide syntheses developed, few produce epoxides in significant yields from internal olefins. A recent paper, however, describes an epoxidation procedure similar to the early DuPont method ⁹⁷ but using hypochlorite instead of hydroperoxide. This gives good yields of internal epoxides.

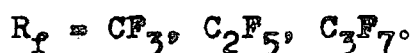

The dimers of hexafluoropropene also form epoxides by this route.

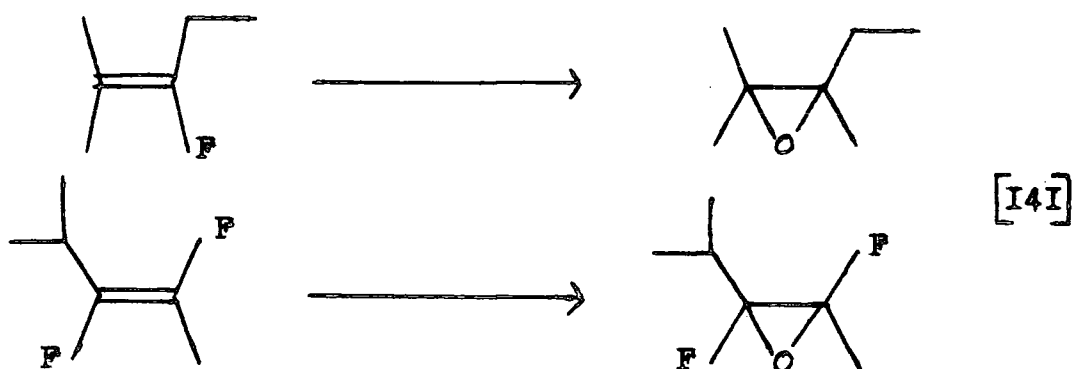

The 1,2-disubstituted olefins which can exist in cis and trans forms allow us to examine the stereospecificity of these reactions. In fact, the stereochemistry is preserved when epoxidation occurs ^{I40}.

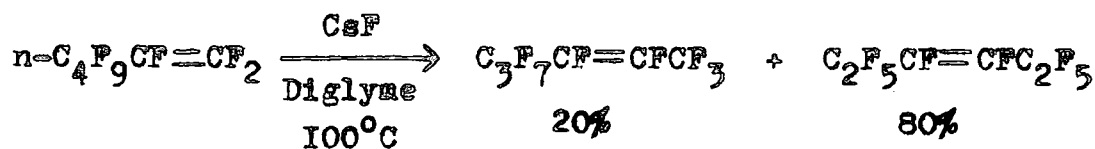

Both isomers in trans forms only

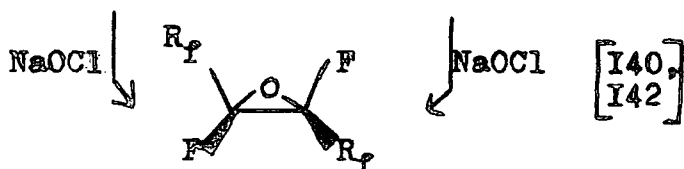

This retention of stereochemistry is also seen in the following reactions.

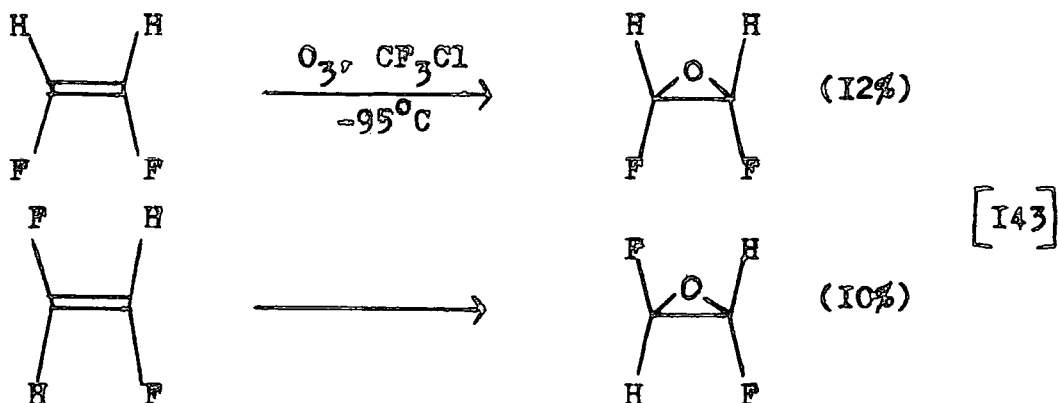

An epoxidation using other alkali salts has also been described I44.

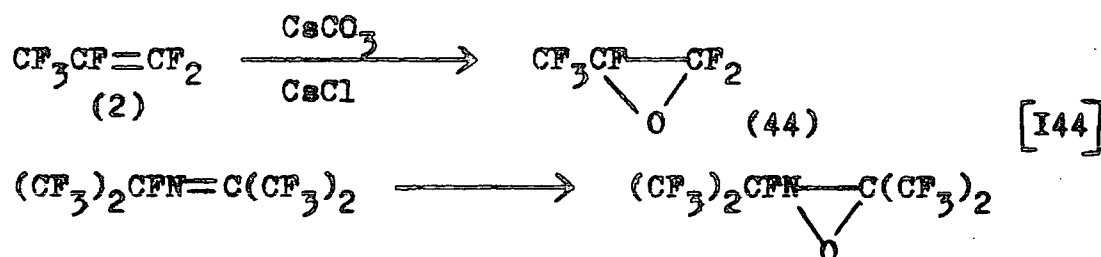

New methods for producing the simplest fluorinated epoxides are continually sought by industry and the following are two typical examples from the patent literature.

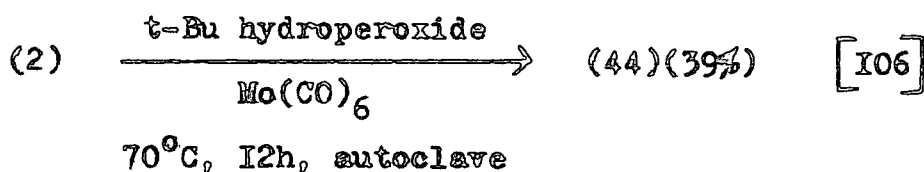
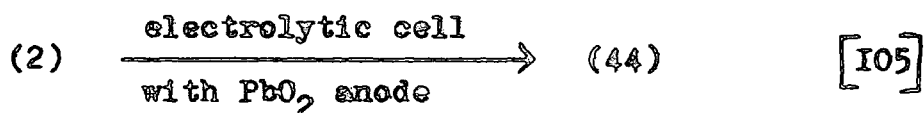

IH3 Syntheses of Epoxides from Hexafluoropropene Derivatives

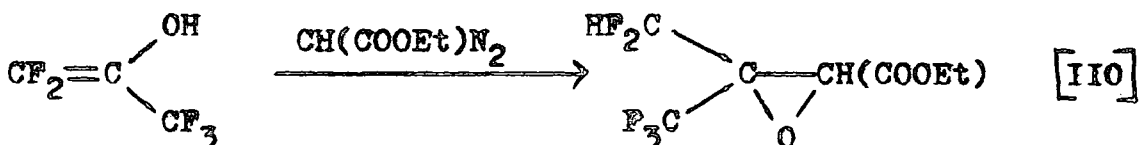
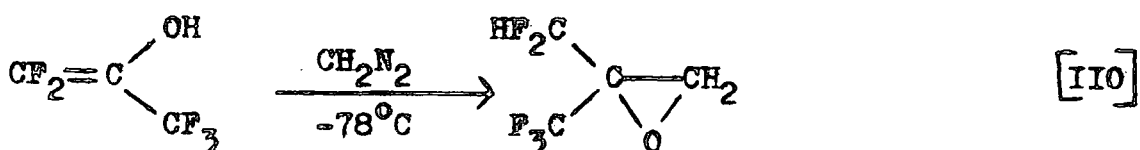
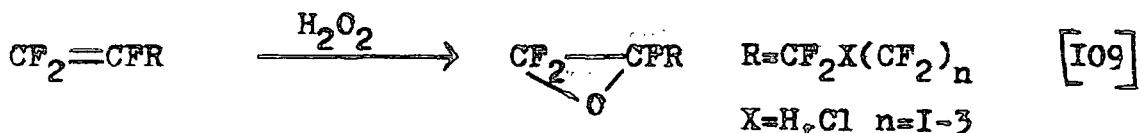
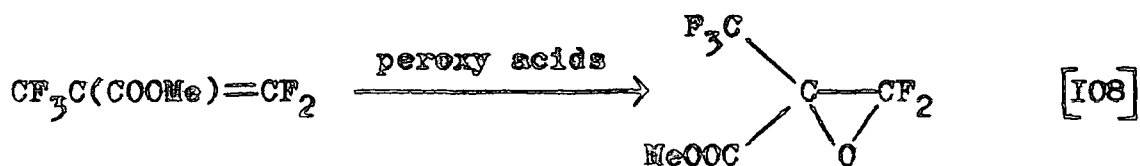

IH4 Miscellaneous Syntheses

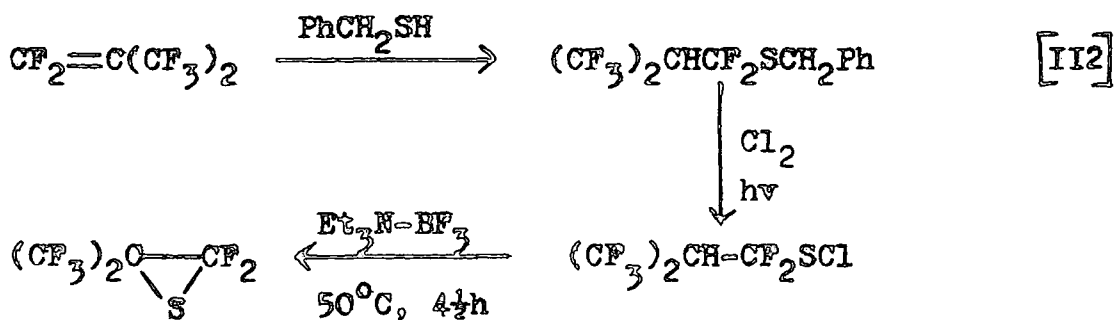
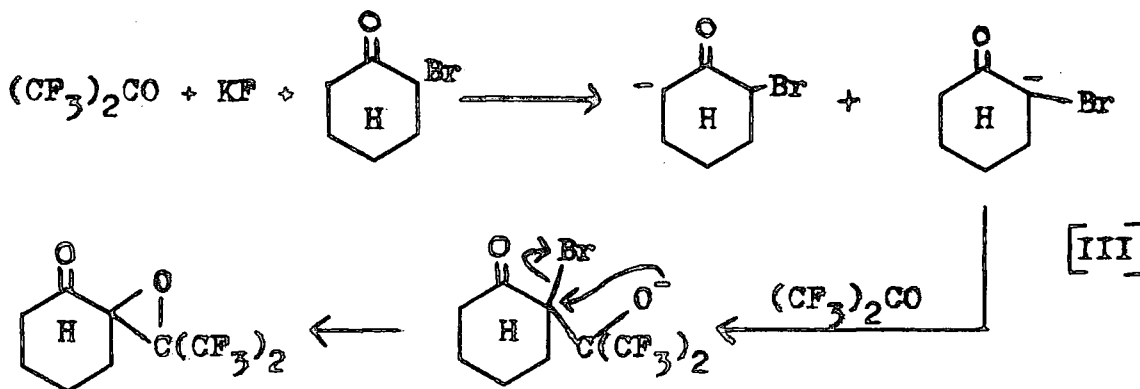

Thiiranes have also been made via difluorocarbenes.

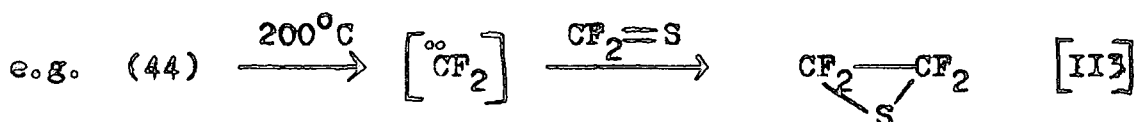

IJ REACTIONS OF PERFLUORINATED EPOXIDES

IJI Reactions with Nucleophiles

Many epoxides react readily with nucleophiles. The first step in the reaction is the attack of the nucleophile with subsequent ring opening. This is usually followed by expulsion of fluoride ion. In an unsymmetrically substituted epoxide, the initial nucleophilic attack could occur at one of two sites but experiment shows that the most substituted carbon atom in the ring is attacked. The final product is thus a carbenyl fluoride which can either hydrolyse to an acid or react with a second molecule of the nucleophile. Note that the attacking nucleophile could be fluoride ion, in which case the overall result of reaction would be simply a molecular rearrangement.

This discussion is illustrated schematically in the diagram below.

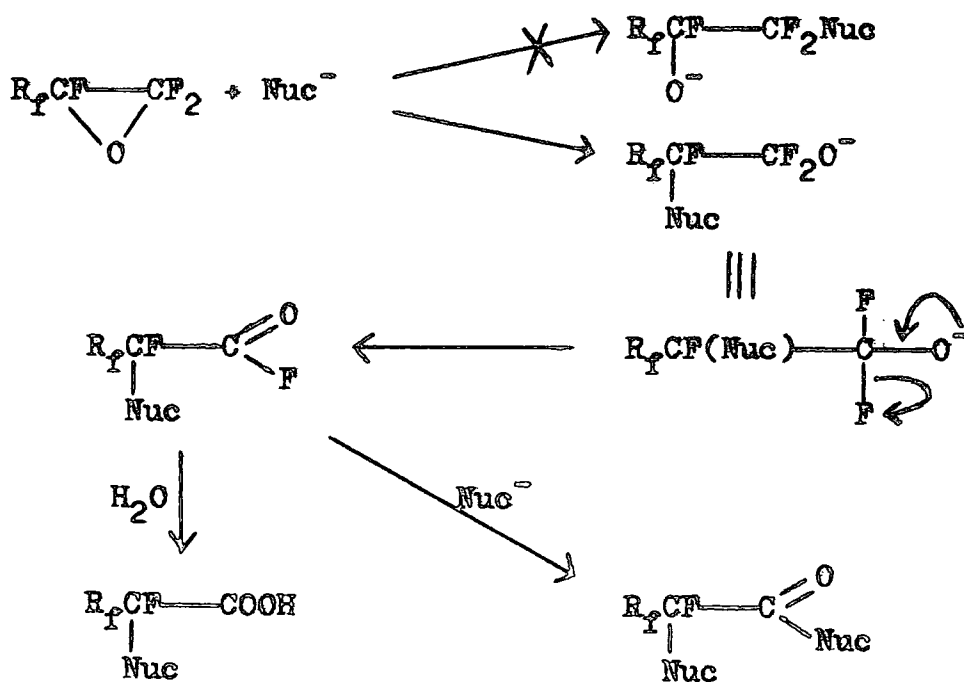

Hexafluoropropene oxide (44) has been the subject of most research, probably because it can be prepared readily,

it can be handled fairly easily and it is stable for long periods of time at normal temperatures but several reactions of other epoxides are also described in the following table.

Table 4
Reactions of epoxides with nucleophiles.

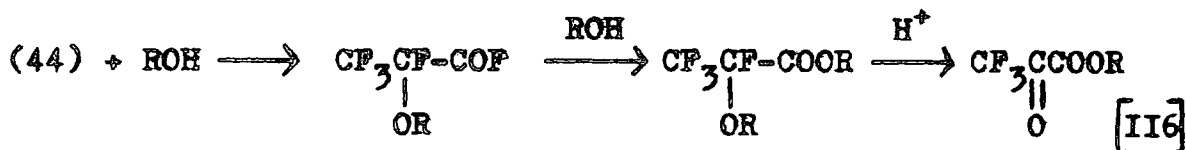
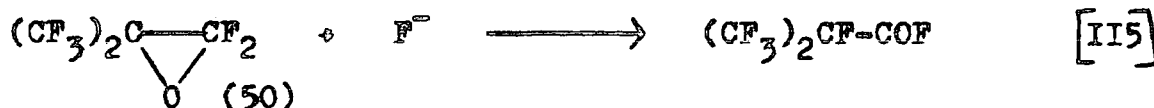
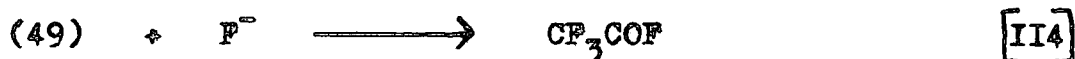
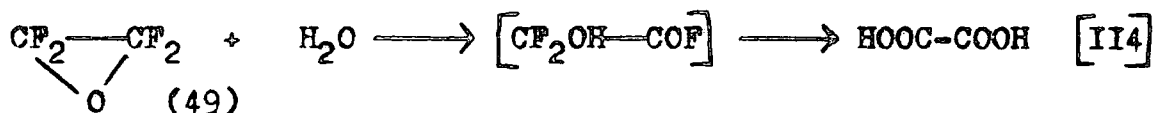

Since disubstitution can occur ^{II6}, bifunctional nucleophiles could be used.

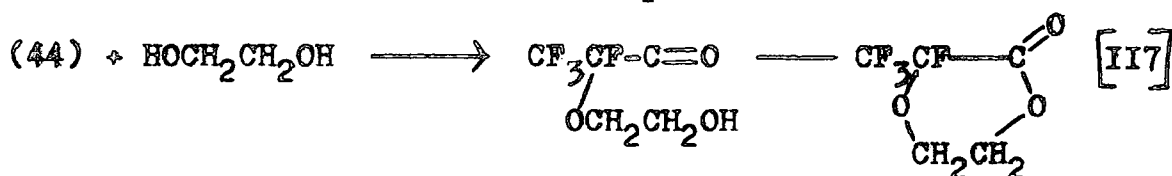

Similarly, reaction of (44) and HSCH₂CH₂SH gives a cyclic product.

Table 4 (continued)

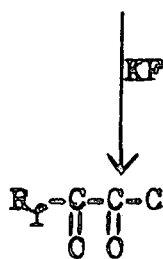
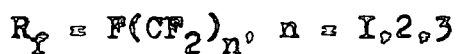
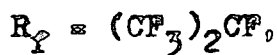
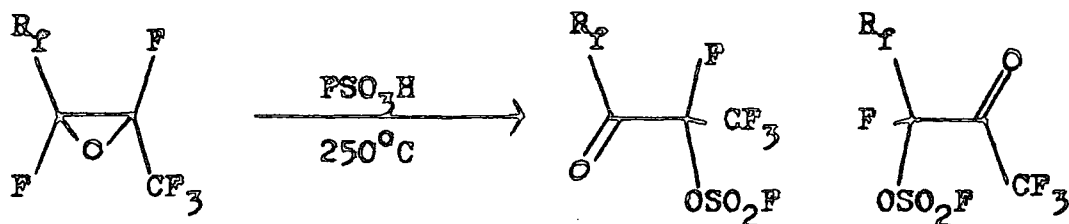

[I18]

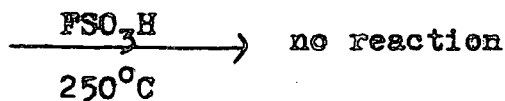
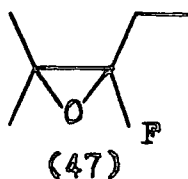

[I18]

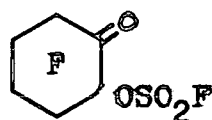
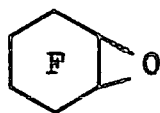

[I18]

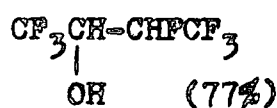
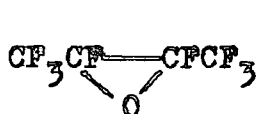

[I19]

(47)

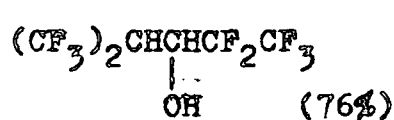
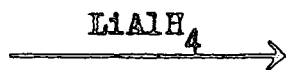

[I19]

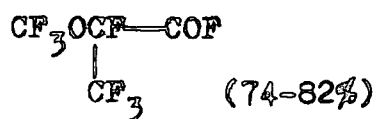
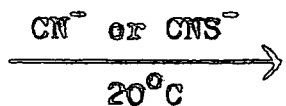
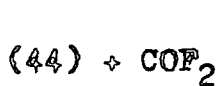

[I20]

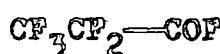
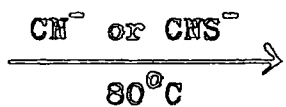
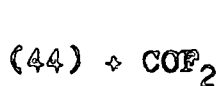

[I20]

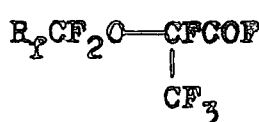
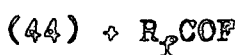

[I21, I22]

Recent kinetic studies on the system below show that as the group R gets bigger, the rate of attack of F⁻ slows down but reaction still proceeds via attack at the most substituted carbon atom.



However, if the nucleophile itself is very bulky, then attack is forced towards the terminal site.

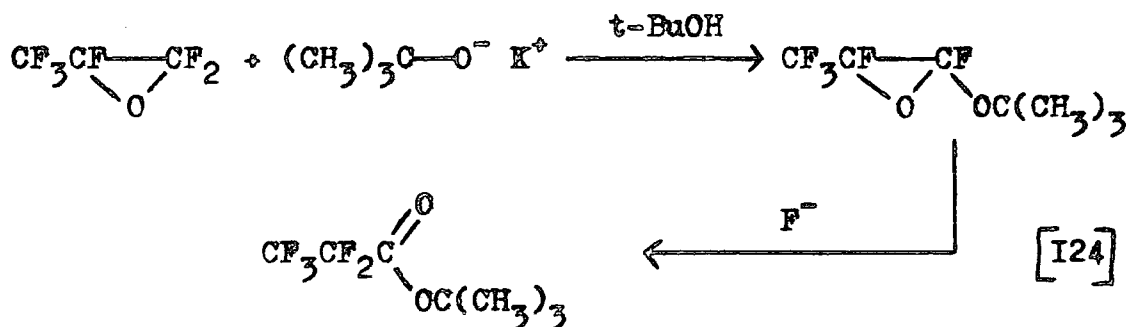

IJ2 Oligomerisation and Polymerisation

In the previous section, the anion produced by ring-opening undergoes an internal elimination. However, it is possible for the anion to act as a nucleophile for a second epoxide molecule thus producing the higher molecular weight products of interest to industry. This can be achieved in the presence of fluoride ion alone, or in conjunction with perfluoro-acid fluorides I2I or perfluoroketones I26, I27.

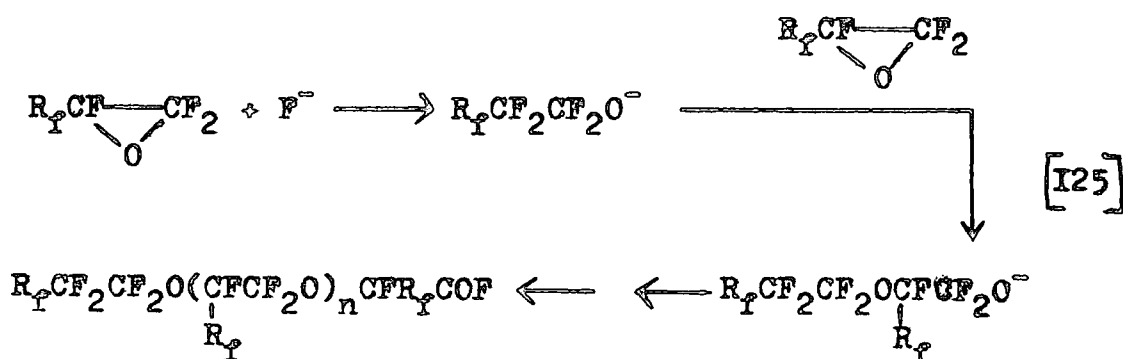

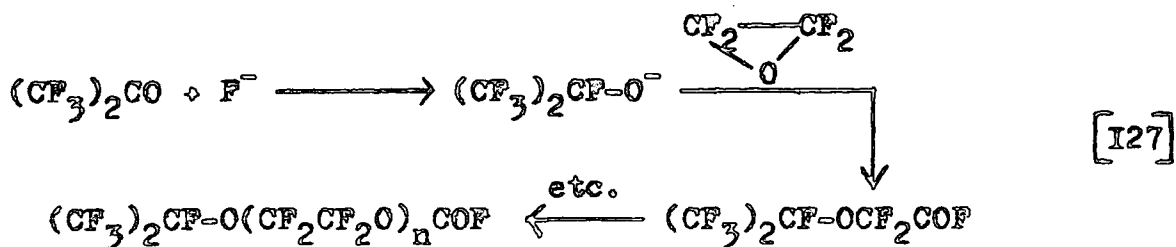

The acid fluoride end group is, of course, too reactive to be used as such in a polymer and must be converted to some inert structure.

The acid fluoride end group may, for example, be replaced by fluorine to give fluorocarbon polyethers, which are thermally stable, chemically resistant fluids which are liquid over a wide temperature range.

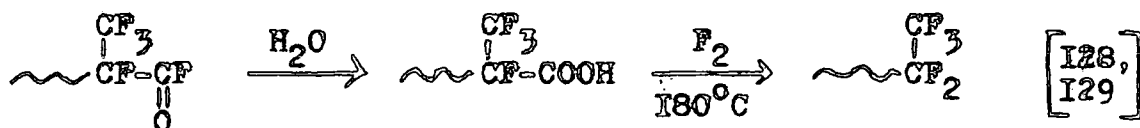

Alternatively, it could be condensed with a methacrylate derivative to give, ultimately, a polymer useful in the textiles industry.

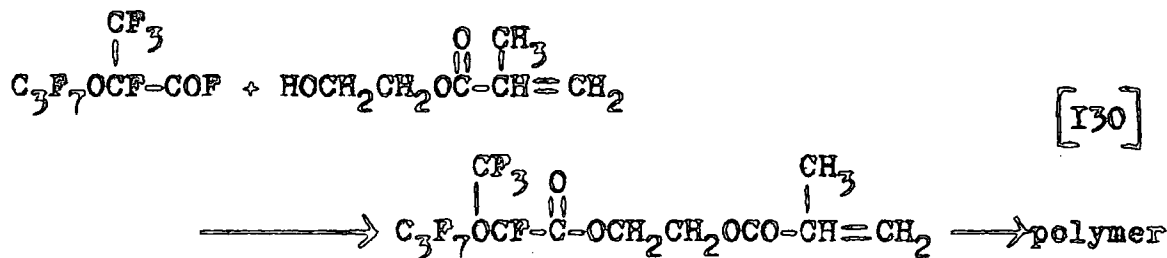

These are just a few illustrative processes but many more are described in the literature. A review has been written¹³¹.

IJ3 Molecular Rearrangements

Rearrangement of an unsymmetrically substituted epoxide could give two products.

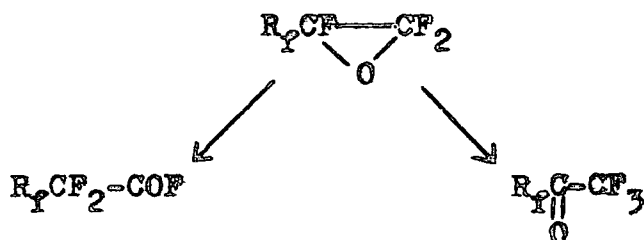

The fluoride ion induced processes in the previous section all conform to process A, under mild conditions.

In contrast, reactions of epoxides with electrophiles require very forcing conditions but result in rearrangement by process B.

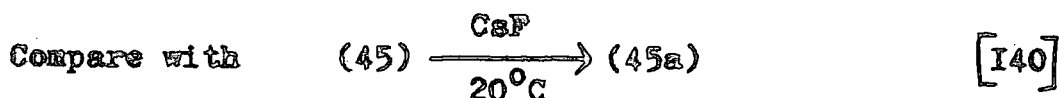
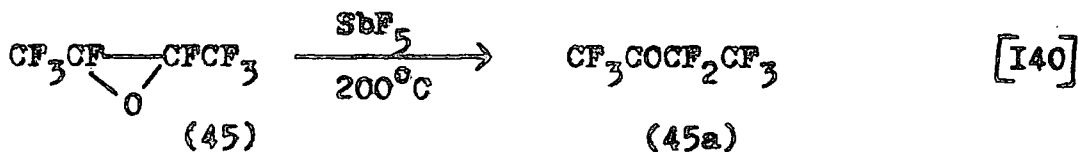
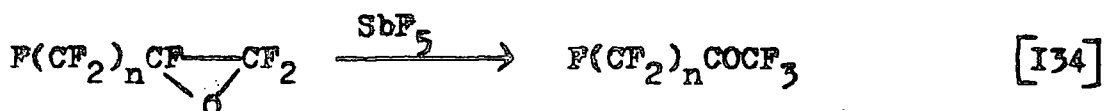
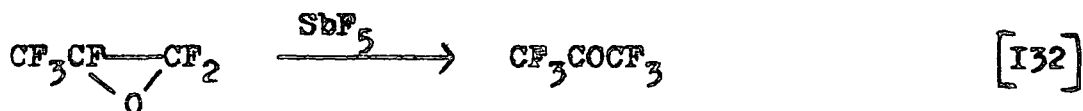

Under similar electrophilic conditions, perfluoroisobutene oxide rearranges to give a carbonyl fluoride as the presence of two geminal perfluoroalkyl groups prevents ketone formation.

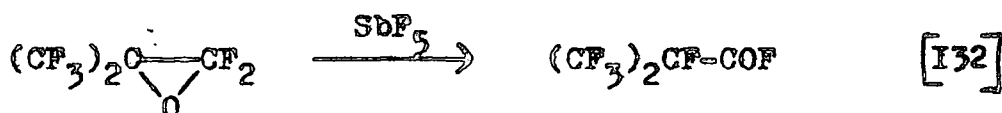

Hydrogen fluoride, alone or in conjunction with SbF_5 , surprisingly causes 'abnormal' ring opening to give the tertiary alcohol.

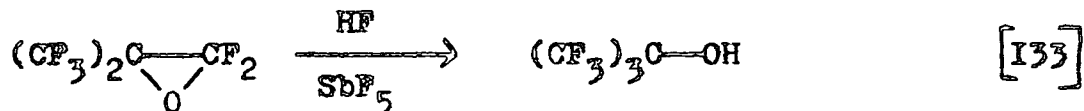

IJ4 Miscellaneous Reactions involving Epoxides

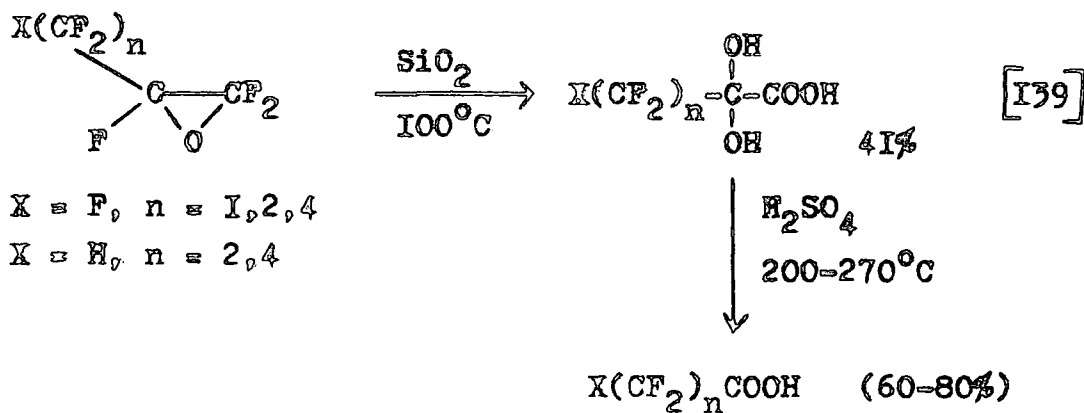
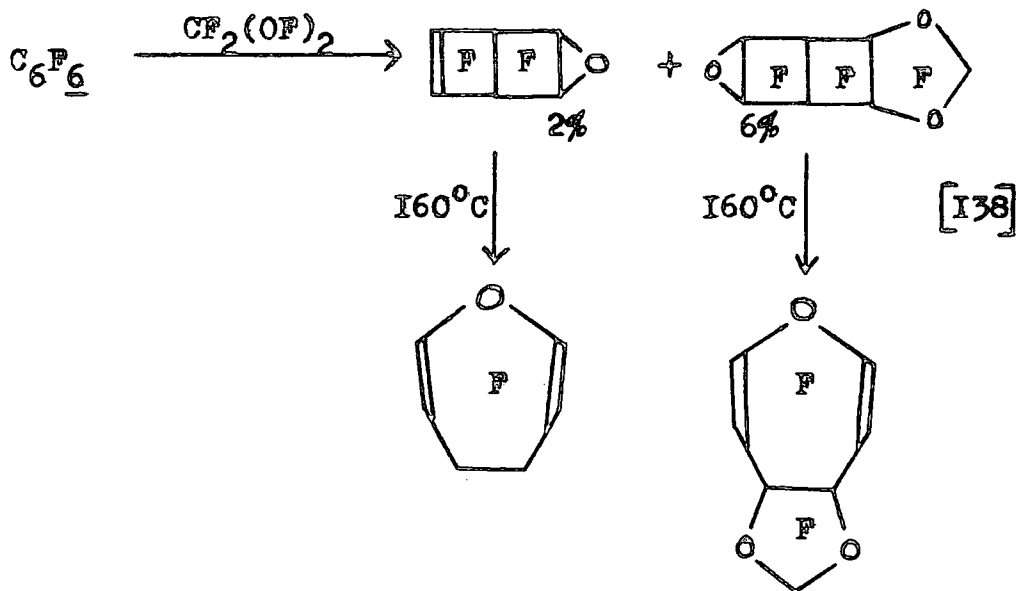
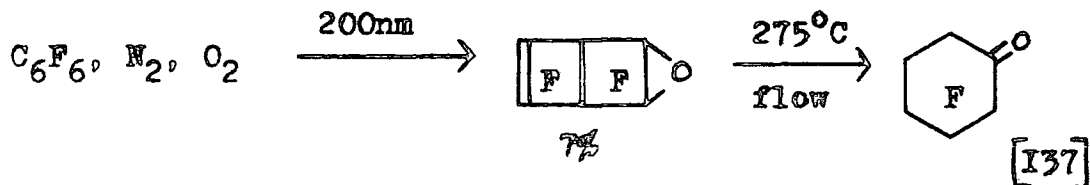
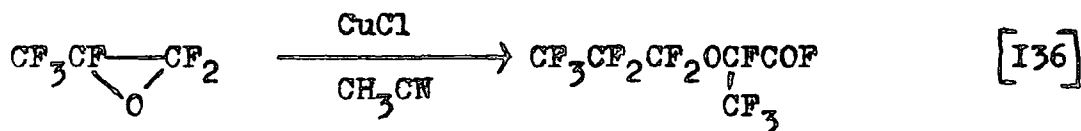

IK REACTIONS OF FLUORINATED OLEFINS WITH ACTIVE METHYLENE

COMPOUNDS

IKI General Chemistry of Active Methylene Compounds I47

The presence of certain unsaturated functions, such as phenyl or carbonyl groups, at a saturated carbon atom with hydrogens attached to it render those hydrogen atoms acidic. The acidity of the hydrogen atoms in these compounds, often called active methylene compounds, can be attributed to the electron withdrawing ability of the unsaturated substituents, together with the ability of those substituents to delocalise the negative charge produced when a proton is removed.

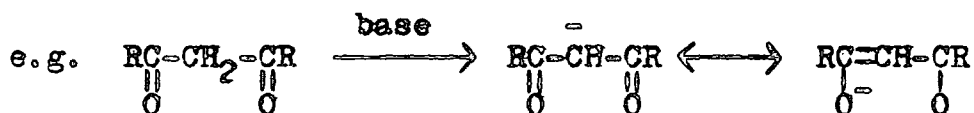

The acidity of the active hydrogen atoms can be seen to vary according to the substituents in the following table of pKa values.

<u>Compound</u>	<u>Approx. pKa</u>	<u>Compound</u>	<u>Approx. pKa</u>
CH ₂ (NO ₂) ₂	4	CH ₂ (COOC ₂ H ₅) ₂	13
CH ₃ COOH	5	H ₂ O	16
CH ₂ (COCH ₃) ₂	9	CH ₃ CN	25
CH ₃ COCH ₂ COOC ₂ H ₅	II	CH ₃ COOC ₂ H ₅	25
CH ₂ (CN) ₂	II		

Procedures that involve the formation and subsequent reaction of anions derived from active methylene compounds constitute a very important and synthetically

useful class of organic reactions. Perhaps the most common reactions are those in which the anion has been derived by removal of a proton from the carbon atom adjacent to a carbonyl group. These anions, usually called enolate anions are to be distinguished from enols, which are present in equilibrium with the active methylene compound starting materials.

Keto - enol Equilibria

In the case of mono-ketones and esters, only a very small amount (1%) of enol form is present but the enol form of 1,3-di-ketones is seen to have a conjugated structure and this explains the greater proportions of enol forms present in these compounds.



% of Enol Form Present in Equilibrium with some Typical Carbonyl Compounds

<u>Compound</u>	<u>% enol</u>	<u>Solvent</u>
CH_3COCH_3	< .002%	H_2O
	.004%	H_2O
$\text{CH}_2(\text{COOEt})_2$	< 1%	H_2O
$\text{CH}_3\text{COCH}_2\text{COEt}$	10-13%	EtOH
"	49%	C_6H_{14}
$\text{CH}_2(\text{COCH}_3)_2$	16%	H_2O
"	83%	EtOH
"	92%	C_6H_{14}

As can be seen from the table, the choice of solvent has a profound effect on the proportion of enol form present.

IK2 Some Typical Reactions of Enolate Anions

Clearly, an enolate anion is an example of an ambident nucleophile i.e. one which can attack through one of two possible sites. It is found in practise that the relative reactivity of C^- versus O^- depends on a number of factors such as the actual nature of the anion itself, the counter cation, the solvent, the temperature and the nature of the site to be attacked. A discussion of C^- versus O^- reactivity has appeared ^{I48}.

Reaction through C^- is by far the 'normal state of affairs', despite the fact that one may surely consider that the greater amount of negative charge lies on the most electronegative atom (oxygen). Experiment shows that reaction through O^- can compete particularly well under the following circumstances :-

- a) when the active methylene compounds involved are relatively acidic,
- b) when polar, aprotic solvents are used,
- c) when the cation present is relatively large,
- d) when the site under attack is bonded to a highly electronegative atom i.e. the site is a hard acid site ^{I49}.

An example which illustrates some of these points is given on the next page.

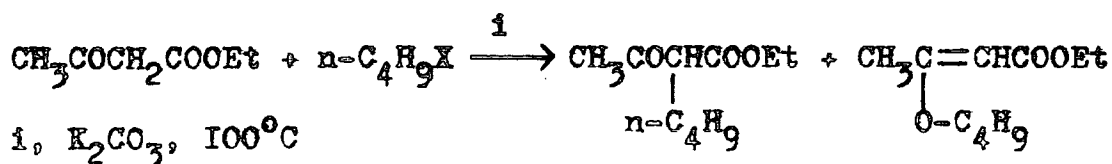

<u>Solvent</u>	<u>X</u>	<u>% composition</u>	
CH_3COCH_3	Cl	90	I0
CH_3CN	Cl	81	I9
CH_3SOCH_3	Cl	54	46
DMF	Cl	53	47
DMF	Br	67	33
DMF	I	99	I

IK3 Formation of Cyclic Products

If the enolate anion reacts with an electrophilic reagent with two reactive sites, the initial product may lose a further proton and undergo an intramolecular nucleophilic displacement forming a cyclised product.

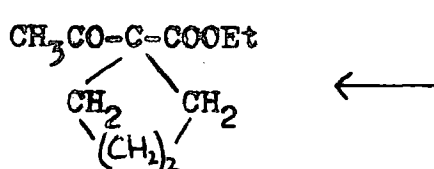
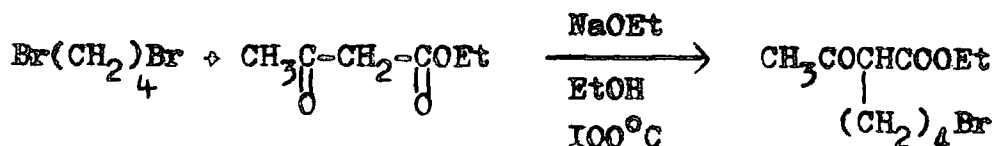

Just as there is a possibility that an enolate anion can react through either C^- or O^- , there is also the possibility that in the second stage in a cyclisation reaction, cyclisation may occur through either C^- or O^- . This is demonstrated overleaf.

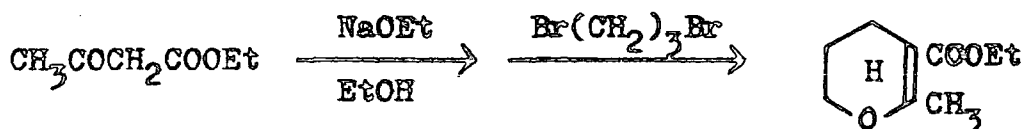
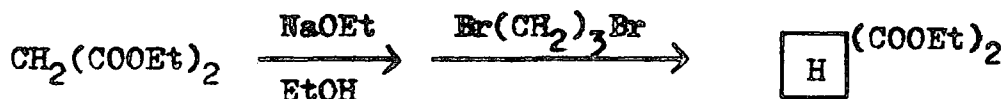

IK4 Application to Organofluorine Chemistry

Quite a limited number of examples exist of reactions between fluorinated materials and active methylene compounds, a fact which is rather surprising. Indeed, summing up a review of these reactions, Hudlicky described the examples in the literature as 'meager and lacking in experimental detail' ¹⁵⁰. Some of those and some more recent reactions are described below, together with some relevant, related chemistry.

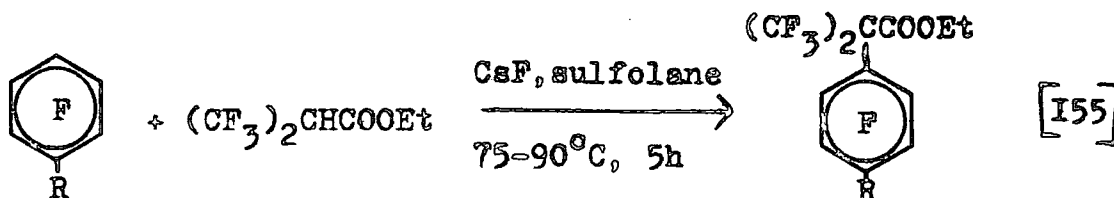
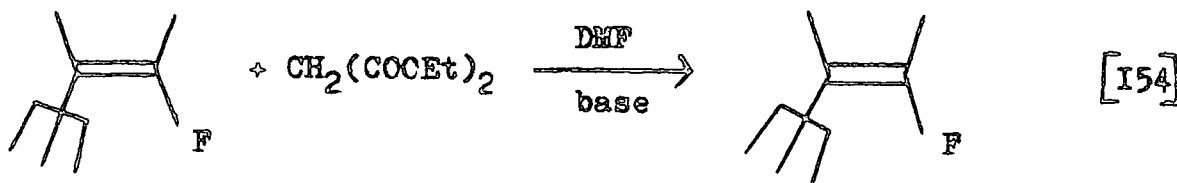
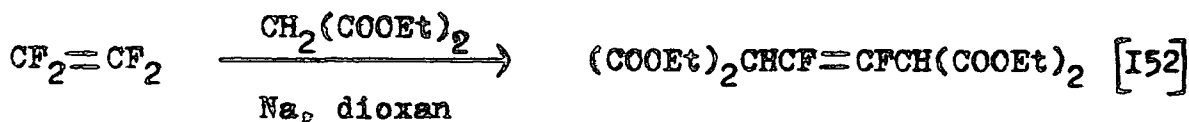
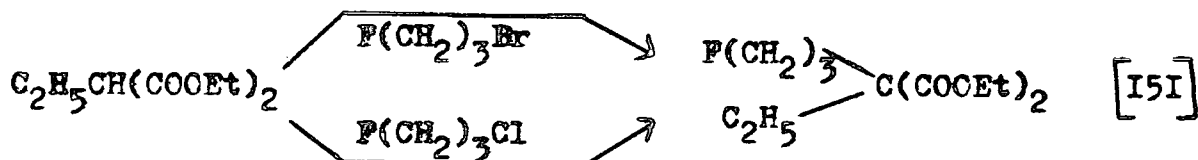

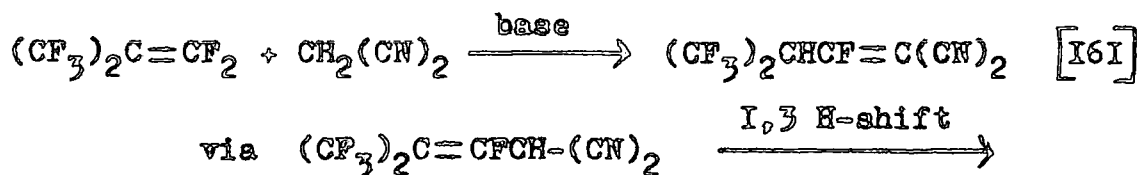
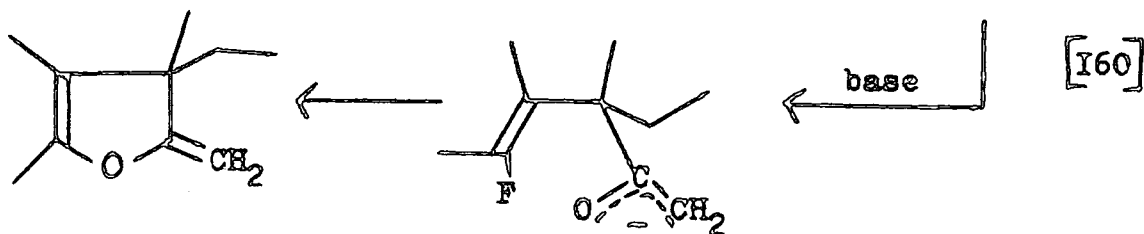
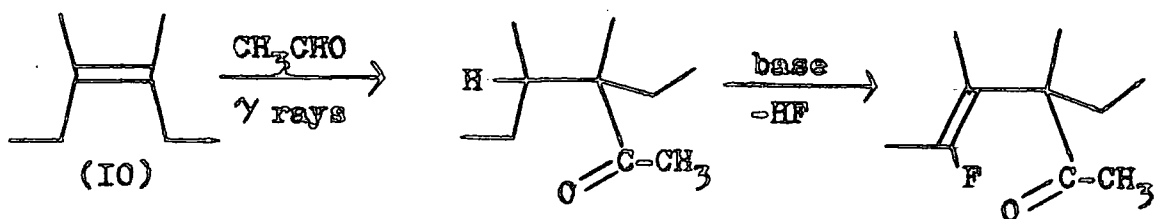
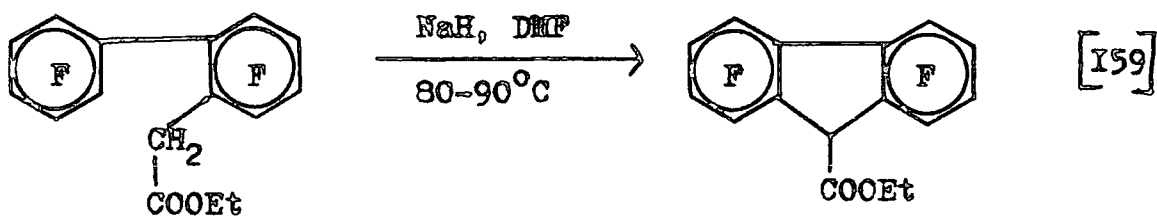
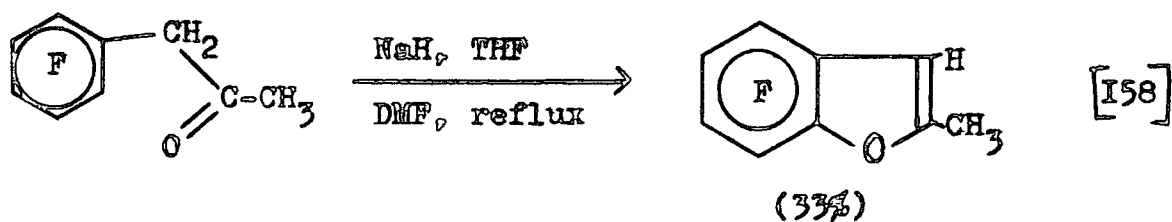
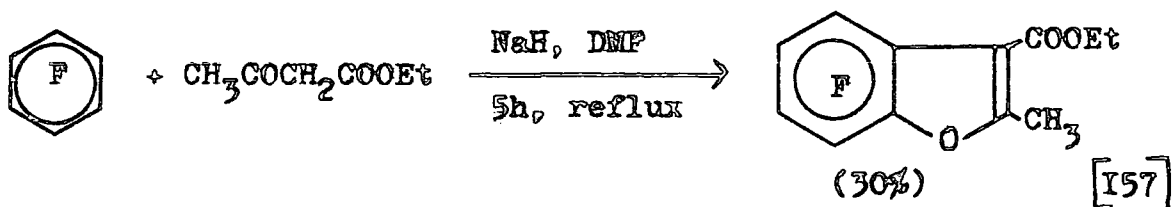
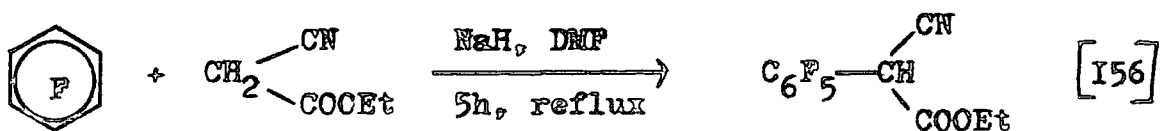

DISCUSSION

CHAPTER TWO

THE CHEMISTRY OF SOME INTERNAL OLEFINS DERIVED FROM
PERFLUOROCYCLOBUTENE

Introduction

The preparation of oligomers from perfluorocyclobutene was demonstrated in the introduction chapter.

The best reaction from an experimental viewpoint is the formation of trimer (24) from perfluorocyclobutene (4) using fluoride ion. This is a clean reaction which produces a high yield of (24) but, unfortunately, (24) is only of limited interest to the chemist. Since there is no vinylic fluorine at the site arrowed which can be displaced by nucleophilic attack in the cyclobutene ring, the two cyclobutyl groups are essentially inert and the chemistry of trimer (24) becomes simply the chemistry of a substituted polyfluorocyclobutene.

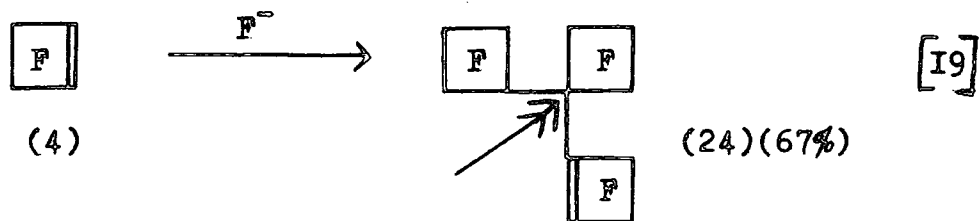

In contrast, the three oligomers formed from (4), using pyridine as a catalyst, can exhibit chemistry resulting from participation by any of the rings and therefore these systems may be considered to hold greater interest.

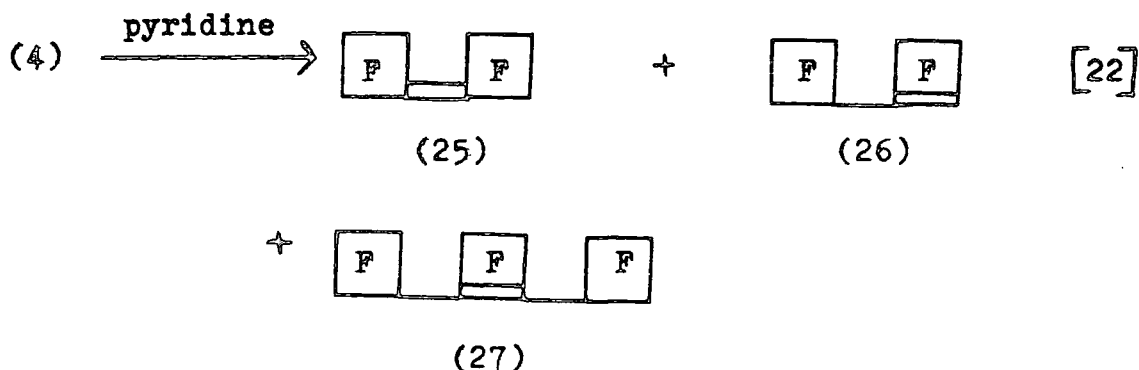

Unfortunately, the formation of (25), (26), and (27) is less clean than that of (24) and is accompanied by some tar formation. Nevertheless, it is possible to isolate a mixture of dimers (25) and (26), and (27), with a total experimental yield of 70% and so these compounds are all fairly accessible for further investigation.

Dimers (25) and (26) are difficult to separate pure from each other without resort to laborious preparative scale g.l.c., for their boiling points are only 5°C apart. In spite of this, Taylor⁴⁴ was able to carry out a substantial amount of chemistry on the pure isomers.

2A FORMATION OF THE CYCLOHEPTENE DERIVATIVE (52) AND

RELATED CHEMISTRY

2AI Reaction of Trimer (27) with Fluoride Ion

When trimer (27) is reacted with caesium fluoride in DMF solvent at room temperature, it might be expected to form a stable anion in a similar manner to other highly substituted fluoro-olefins¹⁶³; an example of one such process is given overleaf.

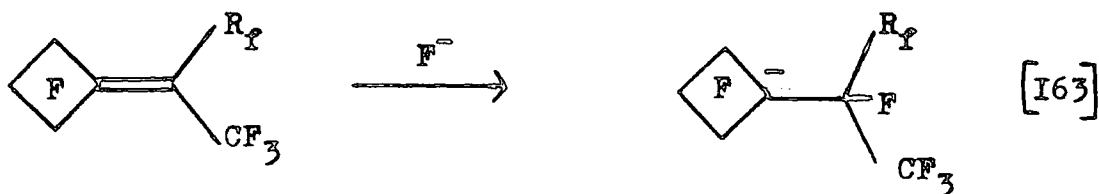

In fact, it undergoes a surprisingly rapid rearrangement giving a high yield of a single product (52) I64, the structure of which follows from a combination of spectral data and further reactions which are described later.

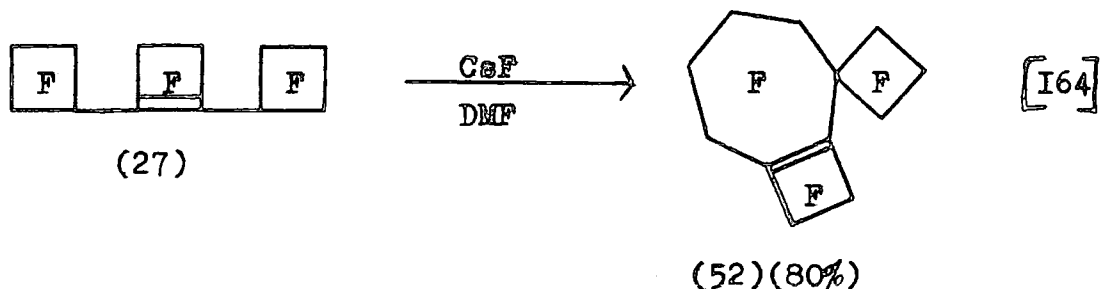

2A2 Proposed mechanism of formation of compound (52)

A mechanism to account for the formation of (52) is given in scheme 3. This incorporates addition of fluoride ion to (27) and then ring opening of the resultant anion (53). There is precedent for ring opening of cyclobutylmethyl anions I65. In this case, in addition to relief of angle strain, ring opening of (53) would also be assisted by relief of eclipsing interactions by introducing an unsaturated site into a remaining four membered ring i.e. (54), an effect which seems to be especially important with fluorinated compounds I9, I63.

Compound (55) is not observed but simple allylic displacement by fluoride ion would lead to (52). The step (54) \longrightarrow (55) involves intramolecular nucleophilic displacement of fluorine from a saturated site and, until recently, there was no precedent for this process ^{I66}.

Scheme 3

Preferred Mechanism of Formation of Compound (52)

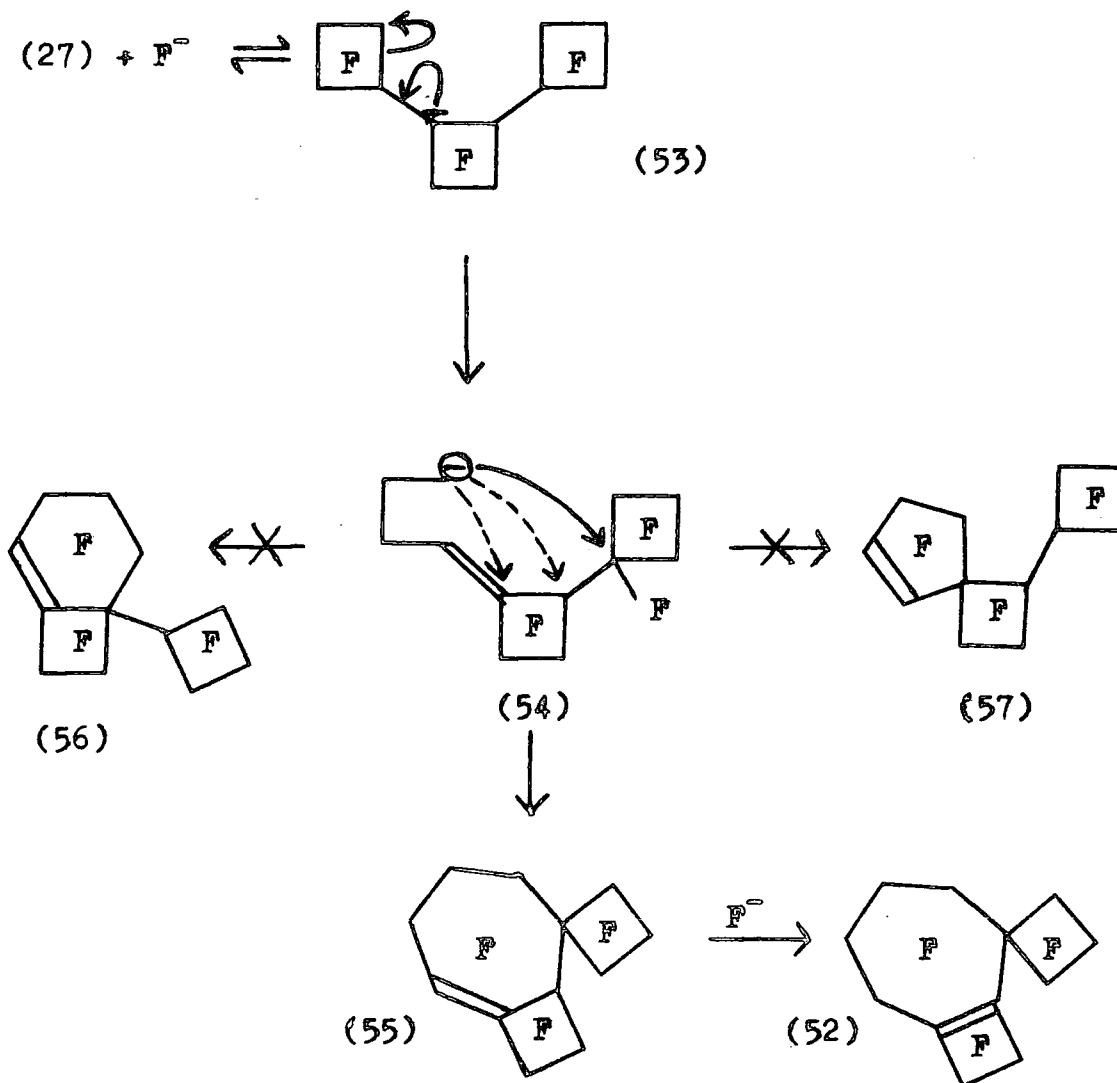

One cannot be definitive about the mechanism of formation of (55) and (52) since an alternative approach

is, in principle, possible; this is outlined in scheme 4.

Scheme 4

Alternative Mechanism of Formation of Compound (52)

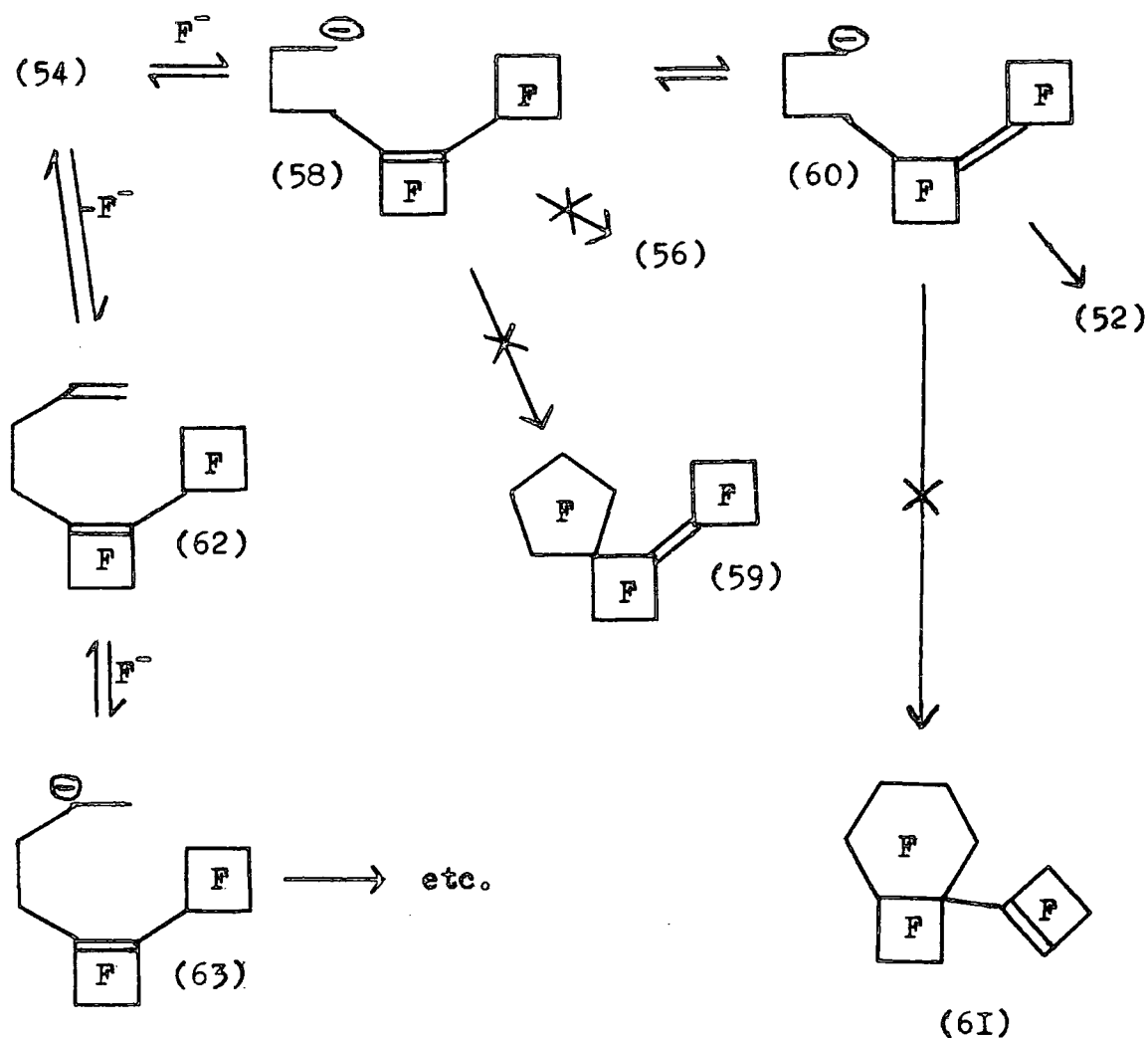

Here, the key process would be rearrangement of the double bond in (54), eventually giving (60), and then the cyclisation step would be the more conventional nucleophilic addition to an unsaturated site with allylic displacement of fluorine (60) \rightarrow (52). If, however, the ion (54) has any prolonged lifetime, one would anticipate elimination of fluoride ion giving (62) and then readdition to give the more stable anion (63) (the instability

of primary perfluoroalkyl anions is well documented^{I67}). However, no products arising from (63) have been observed.

The formation of a seven membered ring exclusively and easily is surprising when the alternatives of five or six membered rings seem to be available i.e. forming (56), (57) and (59) but none of these was detected in the product. This complete selectivity is more understandable through inspection of models and by consideration of the 'Baldwin Rules'^{I68} for nucleophilic ring closure reactions. The favourable stereochemistry for attack at a tetrahedral site is (64) and for exo- and endo- ring closure at a trigonal site (65) and (66) respectively.

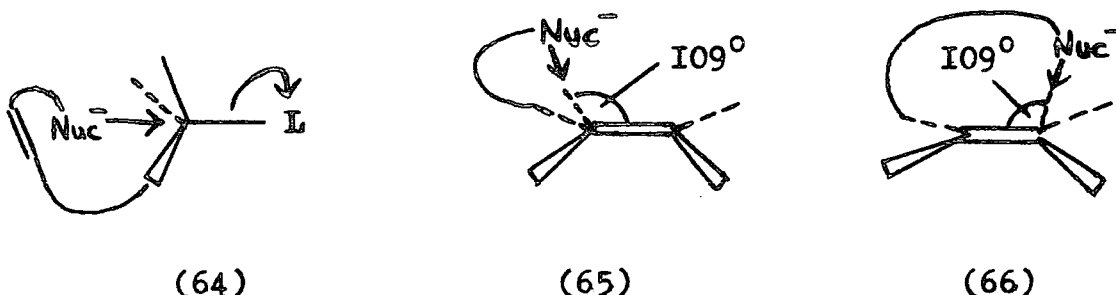

Models indicate that the conversion of (54) into (55) can be achieved with an ideal arrangement of groups (64) in the transition state for a nucleophilic displacement of fluorine. In contrast, it is not possible to adopt an ideal arrangement for the conversion of (54) into (56). Likewise, models show that ring closure of (54) into (57) cannot achieve the favourable approach (66)

In contrast, however, if we consider the process described in scheme 4 then there is great difficulty in explaining the selective formation of (52) rather than (56), (59) or (6I). Models show that conversion of (58) into (56) would be difficult, since the approach (66) could not be adopted, but the conversions (58) to (59) and (60) to (6I),

both through (65), are examples of highly favourable closure processes I68. Therefore, overall, the observations seem to be most adequately explained by the unusual mechanism contained in scheme 3.

2A3 Related Chemistry

2A3.a Displacement of Fluorine from a Saturated Site

An unambiguous example of this process has appeared in the literature I66.

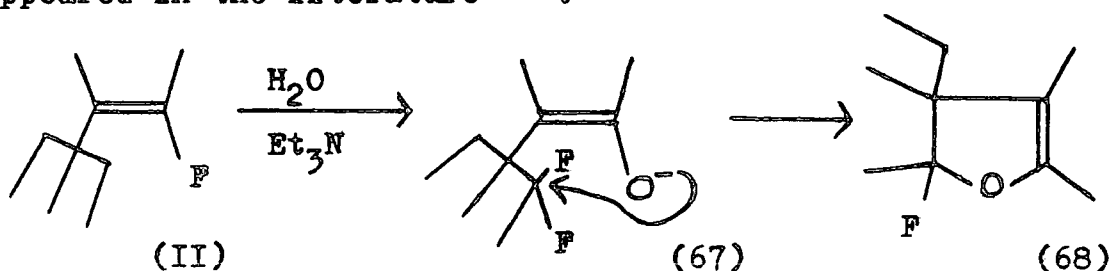

An alternative radical mechanism has been suggested for this reaction I69, which incorporates two relatively stable radical intermediates, but this leads to a different product.

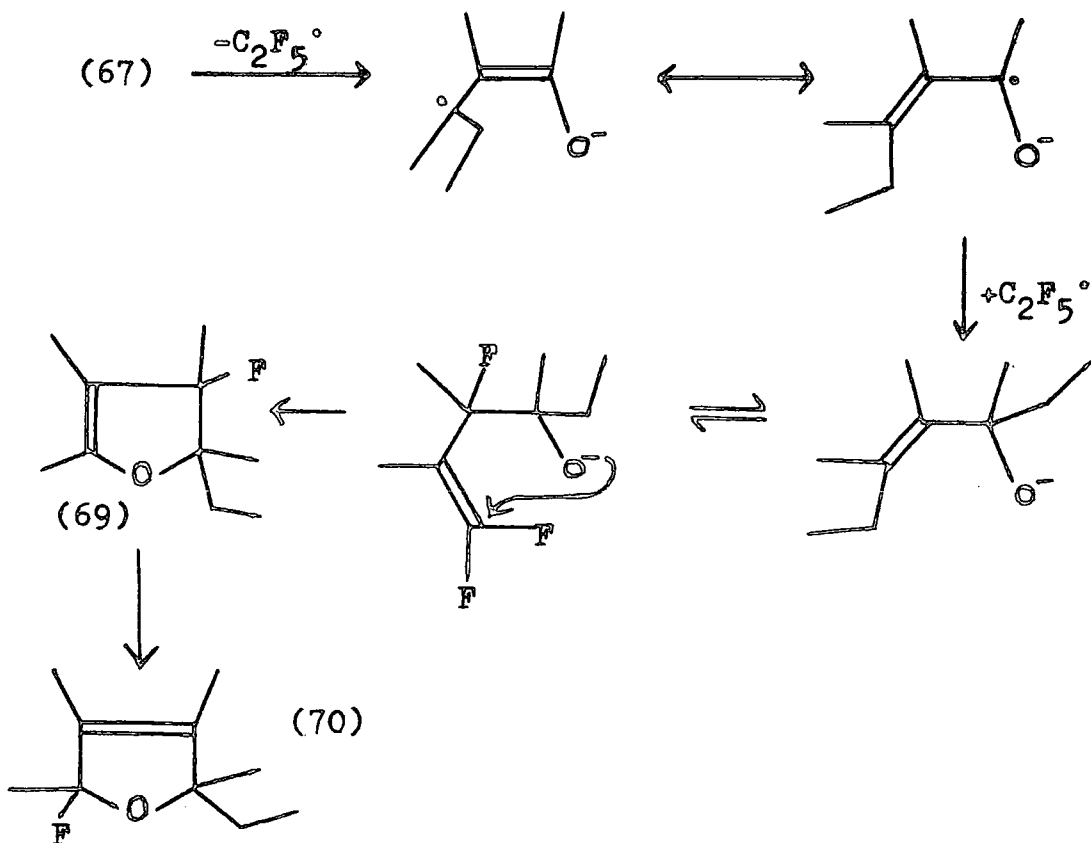

Clearly, it is necessary to be able to verify the product structure and to differentiate between the possibilities (68), (69) and (70), and recent studies of ^{13}C and ^{19}F n.m.r. data unambiguously prove structure (68) 170 .

2A3.b Attempts at Further Displacements of Fluorine from Saturated Sites

2A3.b.I Using a Model for Compound (27)

A particularly close model to (27) would be one where one of the perfluorocyclobutyl rings was replaced by another perfluoroalkyl group. Such a compound was prepared by the following reaction (the reaction is described in more detail later in the chapter).

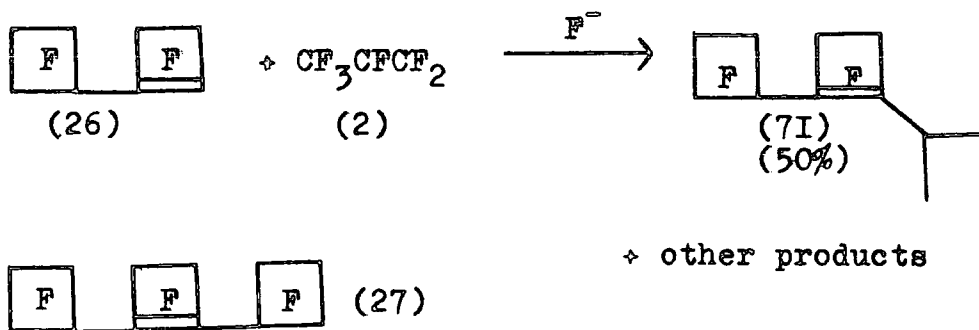

When compound (7I) was reacted with CsF in DMF and worked up in an analogous way to the reaction between (27) and CsF (which gave (52)), the recovered fluorocarbon was shown to be unchanged starting material.

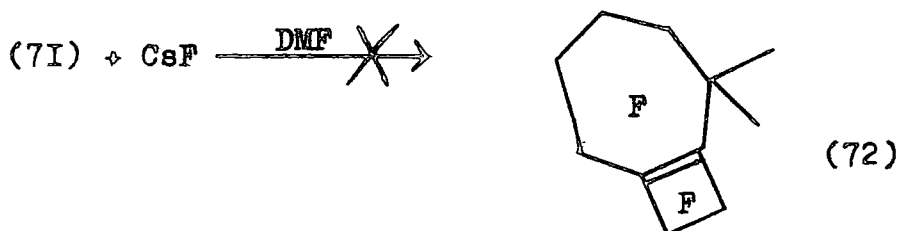

Since (2) and (26) react together in the presence of fluoride ion, it may be considered possible that the cyclisation would occur immediately to give (72) rather than (7I). However, the observed ^{19}F n.m.r. data clearly discriminates in favour of structure (7I).

2A3.b.2 Using a Model for Compound (II)

Compound (24) is a very good model for compound (II) and so it was hoped that the reaction of (24) with water using triethylamine as base would produce a cyclic product analagous to (68). Surprisingly however, the observed product was quite different.

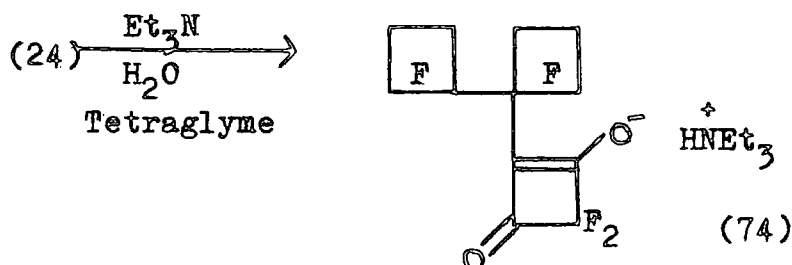
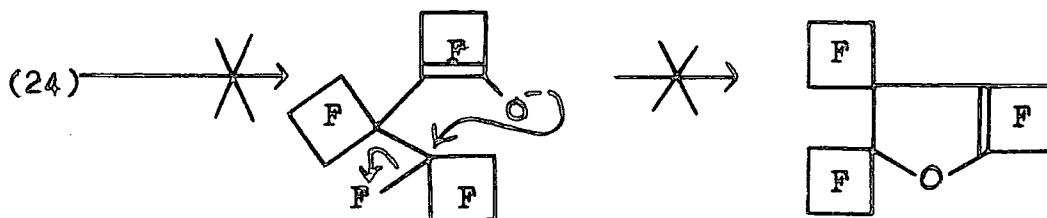

This compares with the following known reactions.

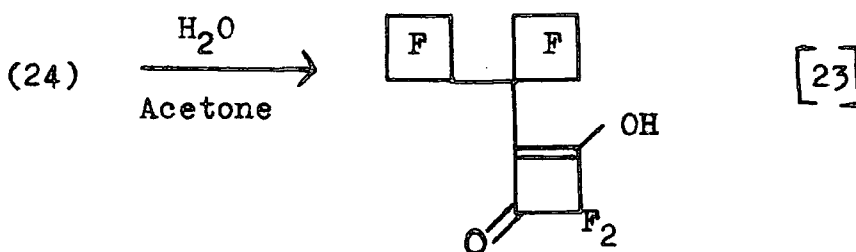
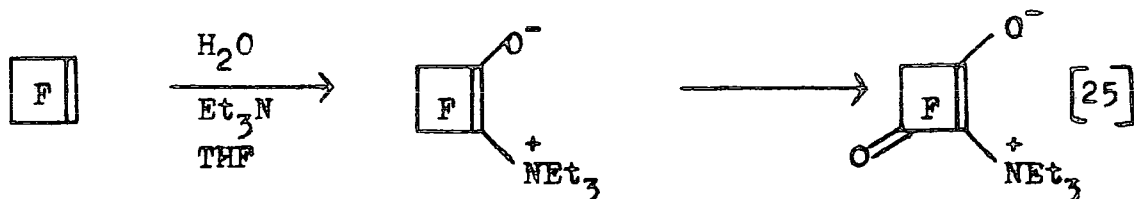

2B REACTIONS OF CYCLOHEPTENE DERIVATIVE (52)

2BI Pyrolysis over a Platinum Surface

Compound (52) is a difficult molecule to characterise solely by analytical methods.

The ^{19}F n.m.r. spectrum of (52) shows only overlapping signals corresponding to $-CF_2-$ groups; the infrared spectrum shows a weak absorption typical of a tetra-substituted double bond; the mass spectrum and elemental analyses indicate the molecular formula $C_{12}F_{18}$. Such data does not conclusively identify (52).

Further, substantial proof of the structure comes from pyrolysis experiments which were originally carried out by Taylor¹⁶⁴.

Flow pyrolysis of (52) through a platinum-lined tube at $590^\circ C$ produced a liquid which consisted of four main components, which are shown overleaf.

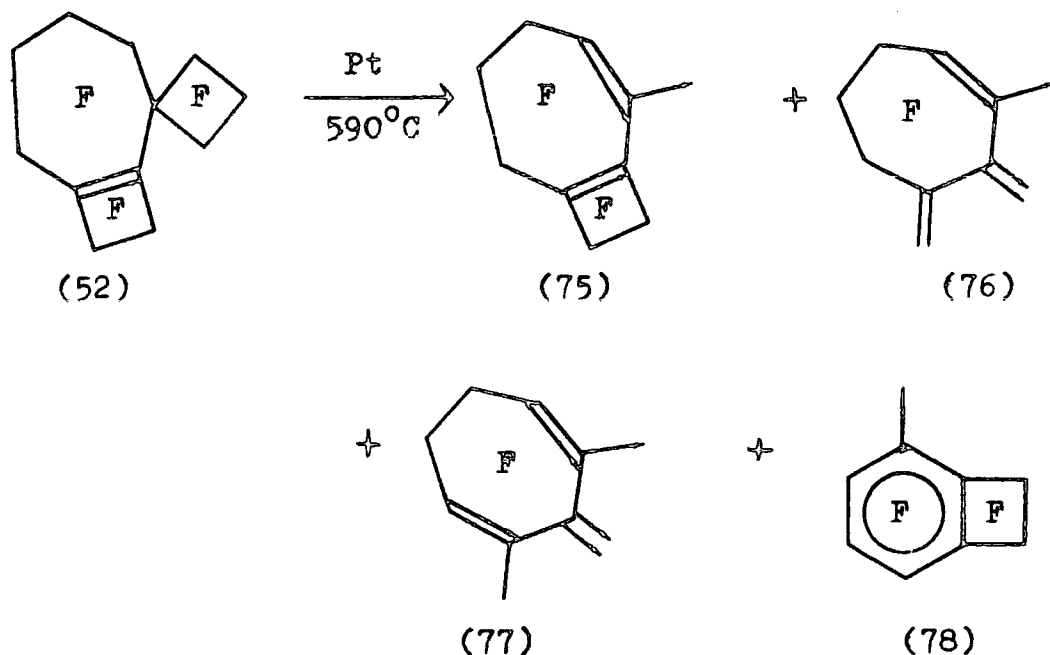

When pure samples of (75) and (76) were separately recycled through the pyrolysis tube, a comparable mixture of all four products was obtained in each case.

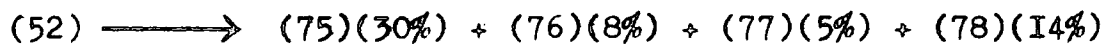

Compound (77) can be characterised easily by ^{19}F n.m.r. since it is a symmetrical molecule and the interconversion experiments, together with other analytical data, enable the structures of (75) and (76) to be determined. Compound (75) is produced by loss of C_2F_4 from a cyclobutyl ring for which there is precedent ¹⁷I. So, by working backwards from (77) the structure of (52) may be deduced.

Compound (78) was not characterised but was tentatively assigned the structure shown.

The results of the pyrolysis experiments are so significant that it was important to establish that they

are reproducible. In the present work, a repeat of the crucial pyrolysis experiment using a more efficiently lined platinum tube gave a liquid which consisted mainly of (75), (76) and (77) in the ratio 70:15:15. There was no trace of the fourth component.

Variations in pyrolysis conditions were also investigated in the present studies, in the hope that a) improved yields of some of the seven membered rings could be obtained and b) that the product range could be simplified; the results are described below.

2B2 Pyrolysis over a Silica Surface

The pyrolysis of compound (52) over silica at 600°C gave a liquid mixture which, in addition to several inseparable low molecular weight fragmentation products, produced two components which could be obtained pure and characterised. One of these was shown to be (78) by comparison of the analytical data with that available from the previous reaction. The new component (79) was, like (78), shown to be a benzene derivative.

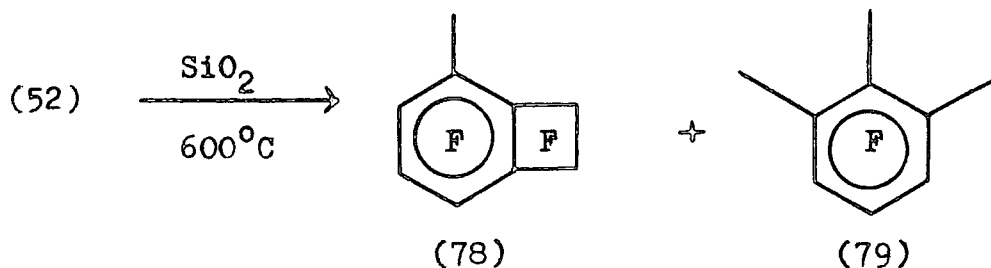

It is likely that the products of the pyrolyses depend on the surface used. When the surface is platinum, the products are (75), (76) and (77). The formation of (78) in the first pyrolysis may be attributed to inefficient

lining of the reaction tube which enabled some of the starting material to react in contact with the glass.

A possible mechanism for the formation of (78) and (79) is given below, via (75) as an intermediate. A similar scheme could also be drawn via (76) and (77). In fact, there are various possible sequences for getting from (52) to (78) and (79) but note that the loss of :CF_2 , which must occur in order to produce the observed six membered ring, results in the formation of two allyl radicals which are, of course, known to possess considerable relative stability.

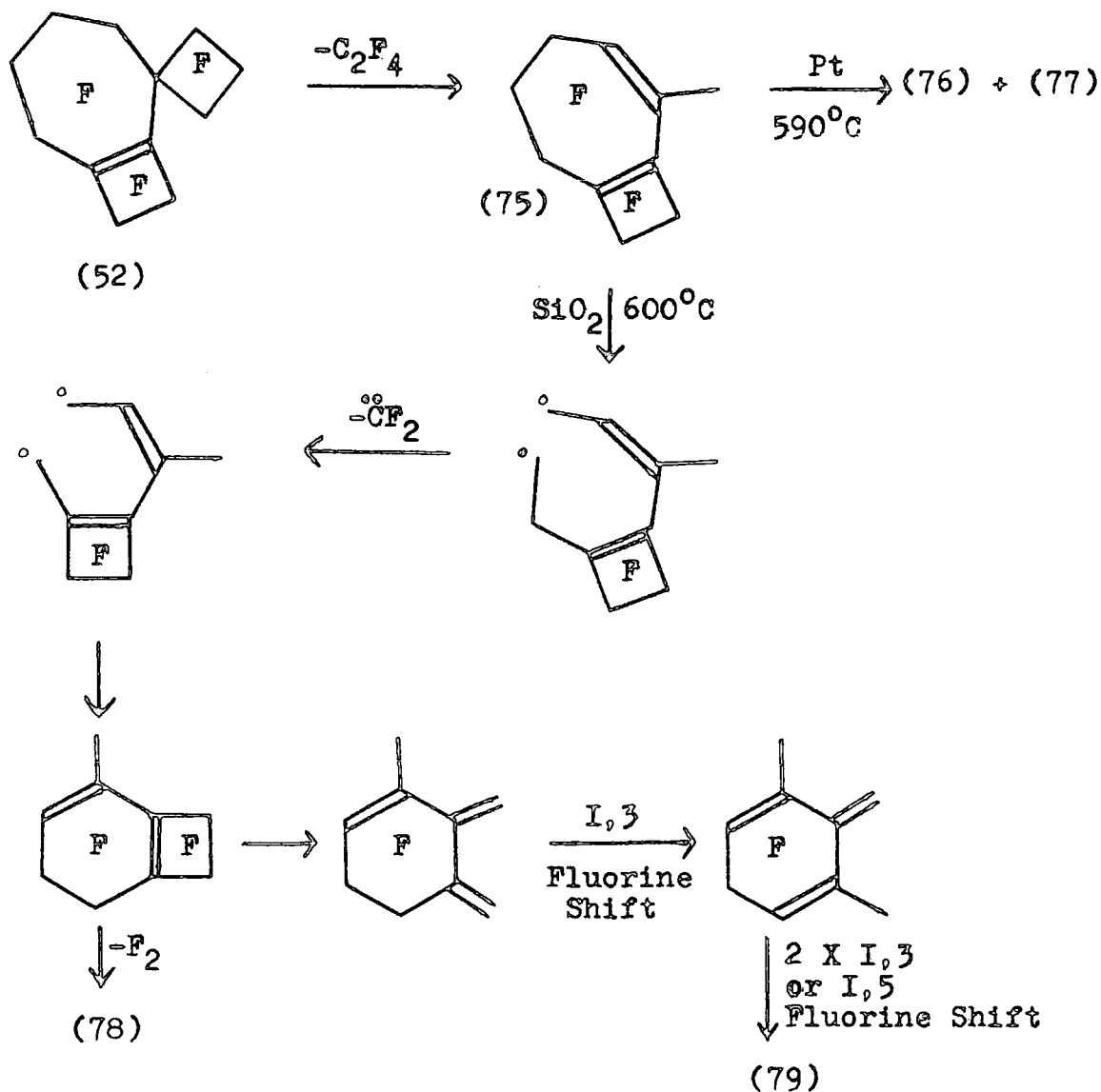

It appears then, that pyrolysis of (52) over silica enables the reaction to progress right through to (78) and (79); pyrolysis over platinum enables the intermediates (75), (76) and (77) to be isolated.

2B3 Other Pyrolyses

There are very few methods for producing polyfluorinated cycloheptenes easily and in good yields and, consequently, it is particularly relevant in this case to determine whether (52) can be converted into other, simpler, cycloheptene derivatives (such as (77)) in high yields.

A variety of static and flow pyrolyses of (52) under different conditions were therefore carried out but none of them gave clean conversions of any significance to simpler systems.

Further Reactions of Compound (52)

2B4 Reaction with Methoxide Ion

Whereas, as expected, there is no reaction between (52) and neutral methanol, reaction of compound (52) with a molar equivalent of freshly prepared methoxide ion produces mono- and di-substituted products in a 3:1 ratio respectively. The structural assignments of the products are made on consideration of analytical data, molecular strain in the possible products and the known preferential mechanism of allylic displacement in substituted fluoro-cyclobutenes.

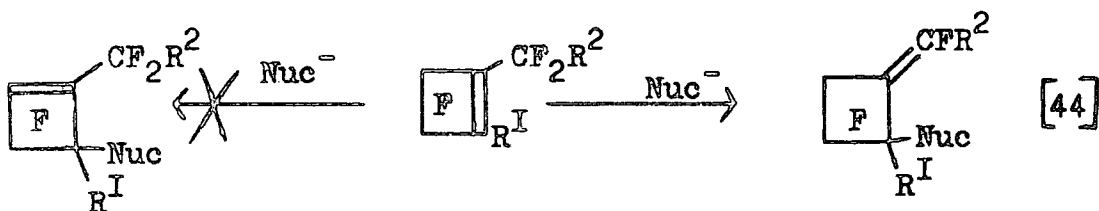
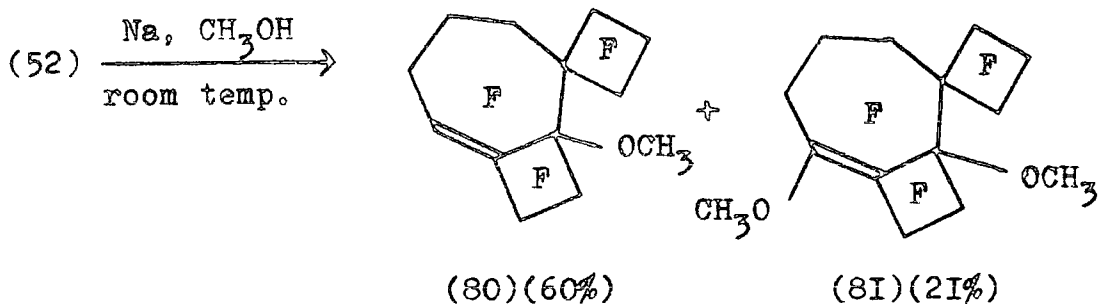

2B5 Reaction with Diazomethane

As has been found with other tetrasubstituted perfluoro-olefins, compound (52) reacted with diazomethane to give a 1:1 adduct. The exact stereochemistry is not clear; both adducts have probably been formed.

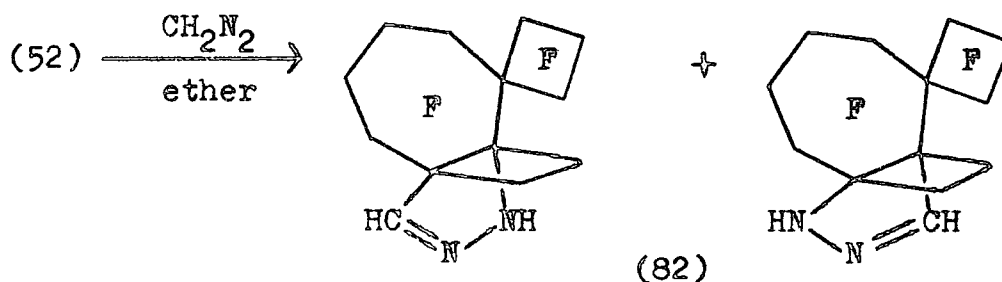

2B6 Reactions with Free Radicals

There was no reaction between (52) and acetaldehyde using γ -ray initiation; the crowding of perfluoroalkyl groups around the double bond possibly prevents approach of the radical.

2B7 Attempted Fluorination

Compound (52) was stable to fluorination using cobalt trifluoride at 180°C.

2C RELATED REACTIONS OF TRIMER (27)

2CI Reaction of Trimer (27) with Methoxide Ion

Reaction of trimer (27) with a molar equivalent of methoxide ion produced a mixture of products which consisted mainly of mono-, di-, and tri-substituted derivatives in a 53:34:23 ratio. These products could not be isolated by preparative scale g.l.c. Clearly however, this system reacts further than the analagous one containing compound (52).

2C2 Reaction of Trimer (27) with Free Radicals

Like compound (52), trimer (27) was unreactive to both methanol and acetaldehyde under both γ -ray and peroxide initiation conditions.

2C3 Fluorination of Trimer (27)

When trimer (27) was passed over a cobalt trifluoride bed at 180°C in a similar manner to (52), a 70% conversion to the fluorinated product was observed.

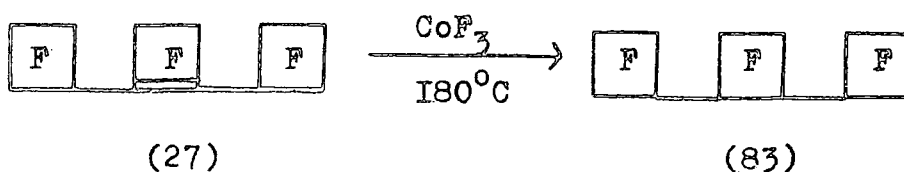

2C4 Reaction of Trimer (27) with Diazomethane

Trimer (27) has been reacted with diazomethane previously ²³ to give a compound assigned structure (86).

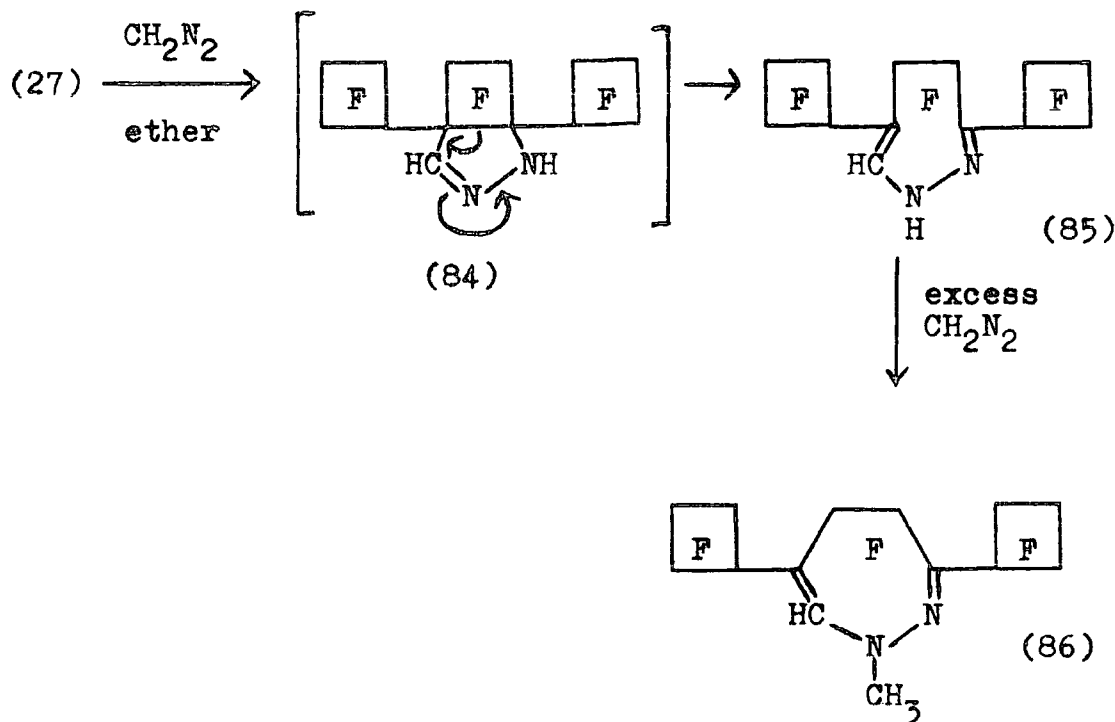

When this reaction was repeated in the present investigation, the product arising from reaction with only one molecule of diazomethane was formed (85).

Assignment (86) was made on the basis of two absorptions in the infrared spectrum, corresponding to two double bonds, and the fact that intermediate (85) has an acidic, allylic hydrogen which would be methylated readily with more diazomethane.

In a separate experiment, (85)(which also shows two double-bond absorptions in the infrared spectrum) was converted into (86) using diazomethane ^{I72}.

The form of the product (86) has been verified recently by ¹³C n.m.r. spectroscopy and by X-ray crystallography ^{I72a}.

2D REACTIVITY CORRELATION OF COMPOUNDS (27) AND (52) IN
ADDITION REACTIONS

There appears to be an enhanced reactivity for (27) over (52) in addition reactions.

Consider first the respective diazomethane adducts. The fact that ring opening of (84) occurs and of (82) does not (only one double bond absorption is seen in the infrared spectrum of (82)) may, at first sight, seem rather unusual since the major driving force for ring opening might be expected to be the relief of ring strain. The construction of three dimensional models, however, illustrates the importance of other factors.

In the case of trimer (27), the two bulky perfluorocyclobutyl groups lie in the same plane as the cyclobutene ring and are directed 120° apart in space. When diazomethane is added to give (84), the cyclobutyl groups are pushed close enough together to give rise to a strong, steric interaction.

However, if the ring opening (84) \longrightarrow (85) occurs, the two perfluorocyclobutyl groups come to lie on opposite sides of the ring and the steric interaction is reduced. Molecular models show that an analogous ring opening for (82) bears no such advantages.

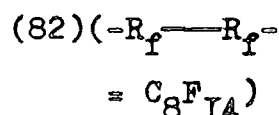
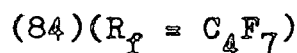
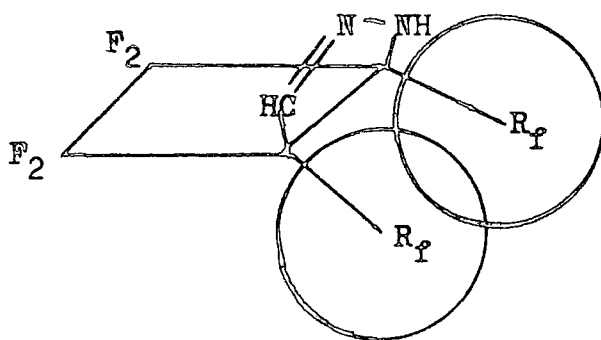

Further evidence to support the importance of steric factors comes from the fluorination experiments. Under similar conditions, trimer (27) undergoes a 70% conversion to the saturated alkane (83) whereas compound (52) remains unchanged. In this case, the overall addition of fluorine can occur trans to the double bond in (27) and this again produces a product where interaction between the perfluorocyclobutyl groups is minimised.

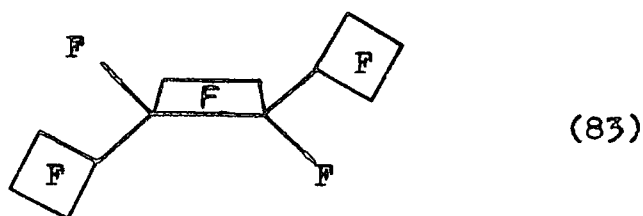

Most of the chemistry described so far in this chapter is essentially derived from the perfluorocyclobutene trimer (27). The next section deals with some chemistry of the perfluorocyclobutene dimers (25) and (26). Many reactions of the individual dimers have been performed previously so the emphasis in the present work is on a comparison of the reactivity of (25) with (26) and also some cases, with olefin (10).

2E CHEMISTRY OF PERFLUOROCYCLOBUTENE DIMERS (25) AND (26)

2E1 Cycloadditions

2E1.a Introduction

There are many examples of cycloaddition reactions of fluorinated olefins in the literature and the subject has been reviewed ^{I73, I74}. The most common process is the $2\pi + 2\pi$ cycloaddition, which is thermally forbidden but for which there is strong evidence to suggest a step-wise process involving a biradical intermediate ^{I75}.

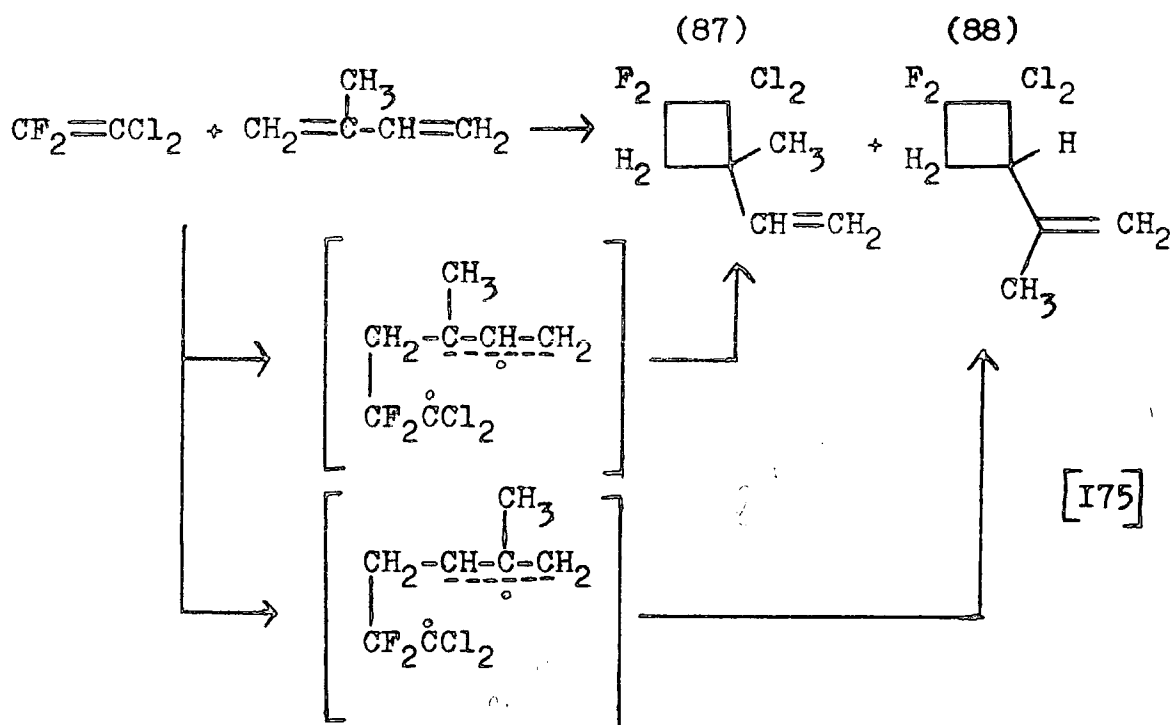

The observed product ratio (87) : (88) is 6 : 1 and this is explained by suggesting two biradical intermediates of which the more stable one (which is stabilised by the direct effect of a CH₃ group) gives the major product.

This latter reaction also demonstrates that, where a diene is involved, a 2π + 2π cycloaddition can occur instead of the Diels Alder reaction. This is also shown in the following example.

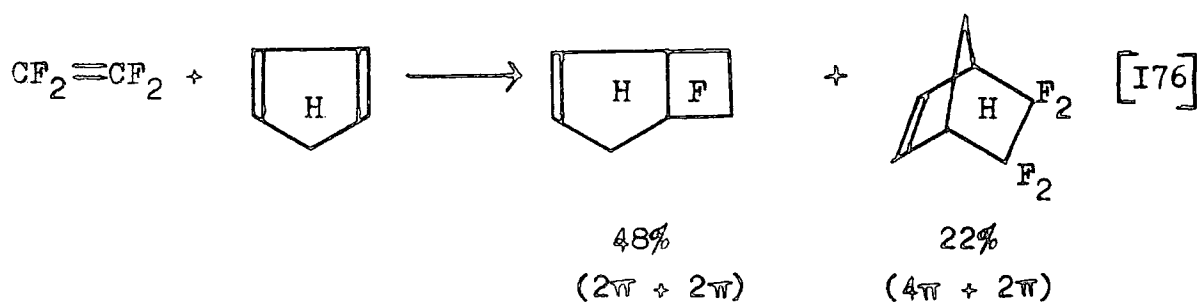

In fact, there are relatively few fully fluorinated olefins that undergo Diels Alder reactions and most of these are very simple olefins; examples involving substituted or internal perfluoro-olefins are rare.

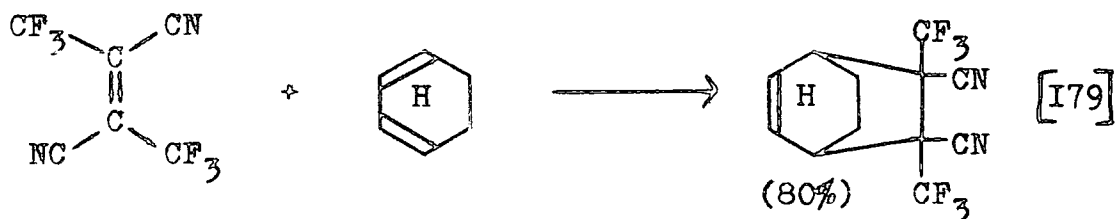
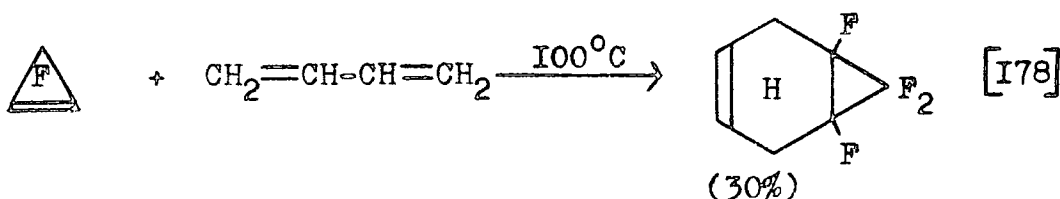
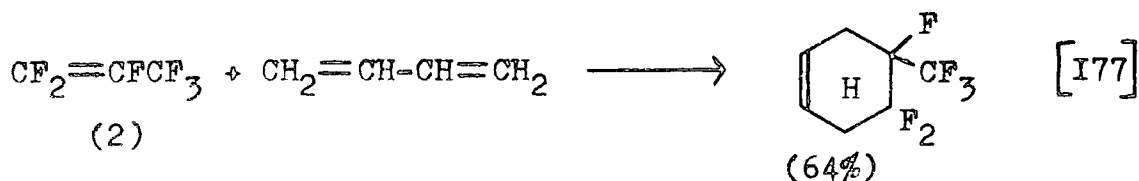

2EI.b Reaction of Dimer (25) with 1,3-butadiene

In complete contrast to the preceding discussion, dimer (25) exhibits remarkable reactivity in Diels Alder reactions. The reaction with butadiene was carried out previously.

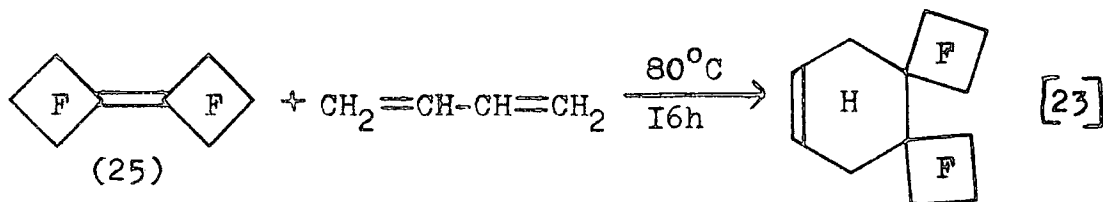

The area was worthy of further investigation for two reasons. Firstly, to see whether (25) would react easily with other dienes. Secondly, to see whether the phenomenon of enhanced reactivity could be used either to

effect a chemical separation of (25) from (26) (since physical separation is difficult) or as a way of producing (25) in higher yields.

2EI.c Reaction of a Mixture of (25) and (26) with 1,3-butadiene

When 1,3-butadiene was reacted with a mixture of dimers (25) and (26), adduct (89) was produced and (26) was recovered unreacted.

Dimers (25) and (26) interconvert in the presence of fluoride ion via the stable anionic intermediate (25a) I⁶³ and, therefore, the previous reaction was repeated in the presence of a catalytic amount of caesium fluoride. This time, there was complete conversion to adduct (89) and no fluorocarbon starting material was recovered. Thus, dimer (26) has also been converted into (89).

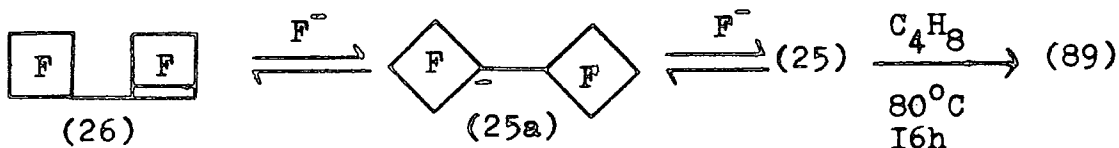

2EI.d Reactions of Dimers (25) and (26) with 1,3-cyclohexadiene

In an unusual reaction, pure (25) reacted with 1,3-cyclohexadiene to give, not a Diels Alder adduct but a reduced product. The structure of compound (90) follows directly from its simple I¹⁹F and I¹H n.m.r. spectra (there is only one signal in the I¹H n.m.r.).

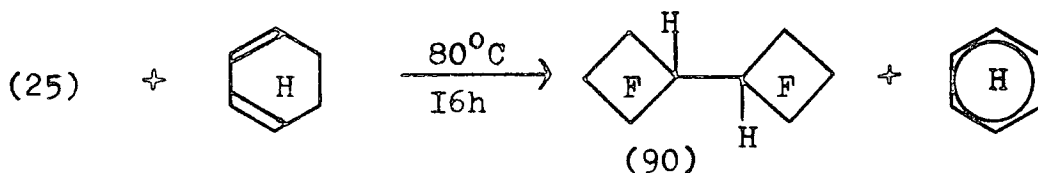

There is some precedent for this process ¹⁸⁰, involving reaction of a fully fluorinated benzene valence isomer derivative.



Two possible mechanisms were suggested; one involving a concerted 6 electron movement, the other involving the 'ene' reaction, presumably followed by a proton transfer.

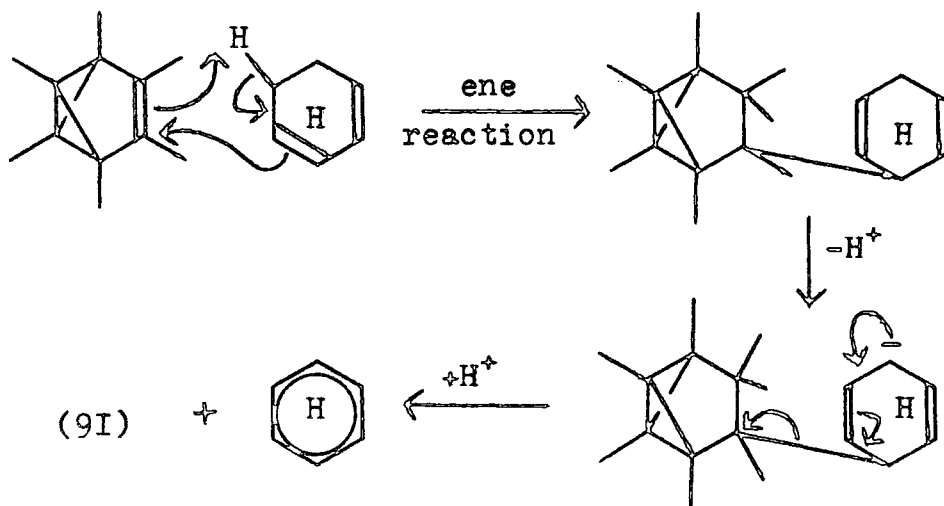
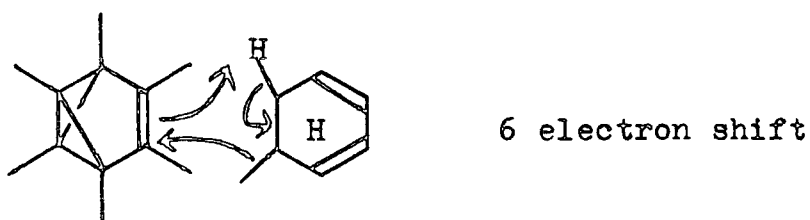

Reaction of 1,3-cyclohexadiene with a mixture of (25) and (26) gave benzene and compound (90) as the only products. Dimer (26) was recovered unchanged.

Reaction of 1,3-cyclohexadiene with a mixture of

(25) and (26) in the presence of fluoride ion produced (90) in high yield arising from reaction of all the fluorinated starting material.

2EI.e Reactions of Dimers (25) and (26) with Cyclopentadiene

The pure dimer (25) readily reacted with cyclopentadiene to give the expected $4\pi + 2\pi$ adduct.

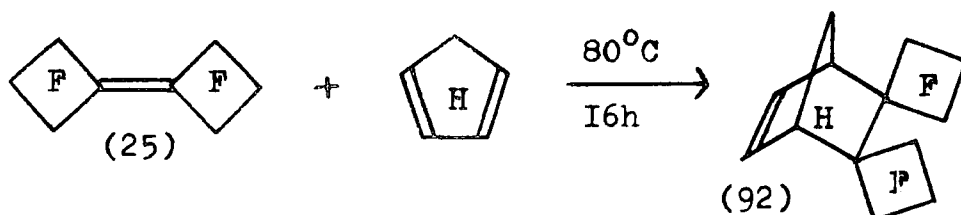

As before, reaction of a mixture of (25) and (26) with the diene produced (92) and unreacted (26). In the presence of caesium fluoride, dimers (25) and (26) gave only adduct (92) in high yield.

Since the dimers are produced as intermediates in the formation of trimer (24), by fluoride ion induced oligomerisation of perfluorocyclobutene, it may be possible to produce (92) directly from perfluorocyclobutene by trapping the dimers.

2EI.f Reactions of Perfluorocyclobutene with Cyclopentadiene

In the presence of fluoride ion, no adduct (92) was obtained because the diene dimerises faster than the dimers (25) and (26) are formed.

However, the reaction was repeated using pyridine as the oligomerisation catalyst. This time, the product consisted of some tar and adduct (92) as the major product. No dimers or trimers of perfluorocyclobutene were observed and very little fluorocarbon starting material

was recovered. Clearly in this latter case, the cyclopentadiene is competing favourably with (4) for dimer (25).

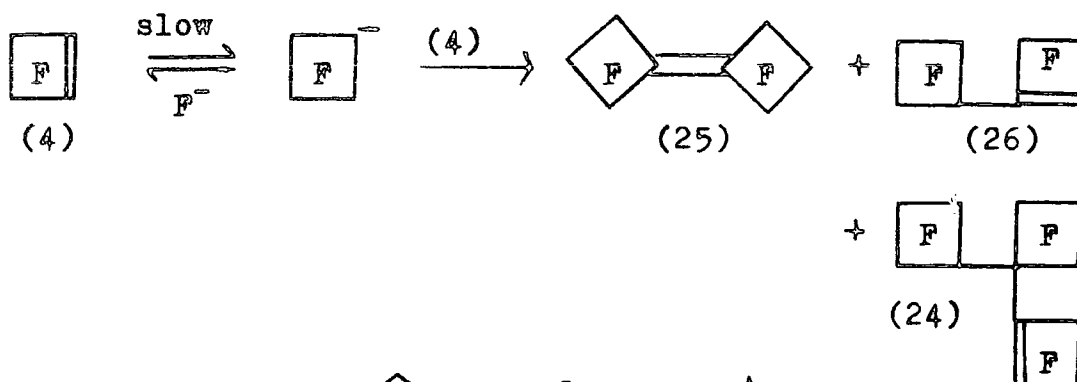

First step above is slow compared with-

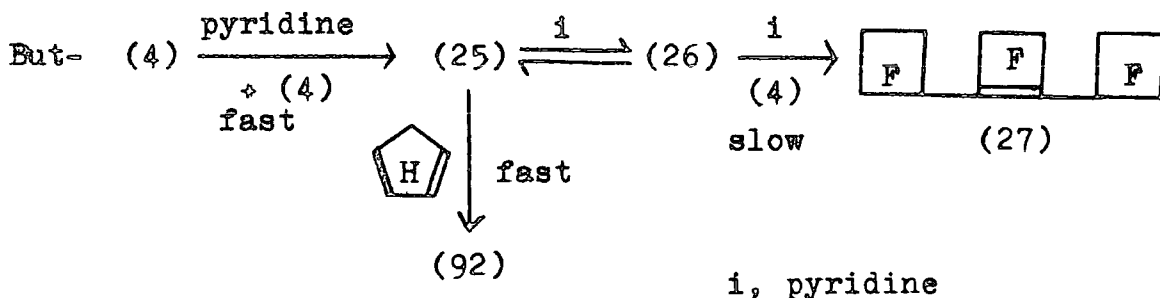
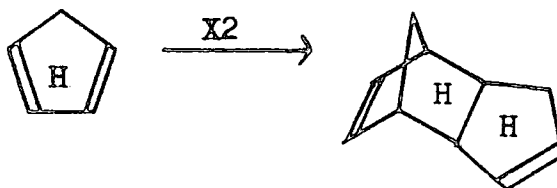

Thus, experiment shows that dimer (25) has a remarkable anomalous reactivity to dienes compared with (26) or the similarly tetrasubstituted olefin (10). This observation can be explained by the relief of the exceptional angle strain in (25) consequent upon reaction.

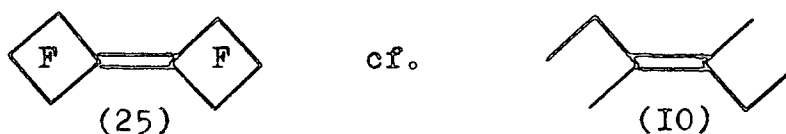

2E2 Polymerisation

Taylor ²³ showed that dimer (25) also underwent reaction with butadiene under free radical conditions to give a co-polymer and, that under similar conditions, molecules such as (10) and (26) were unreactive.

In the present work, a mixture of dimers (25) and (26) was reacted with butadiene but the dimers were recovered unchanged. In this case, it is not clear whether (26) is behaving as an inert diluent or is positively inhibiting the reaction.

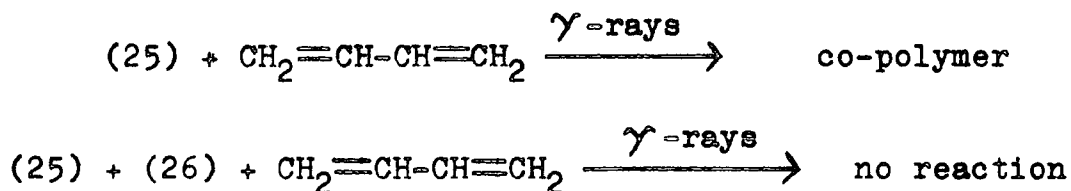

2E3 Nucleophilic Attack

Dimer (25) reacts with neutral methanol, albeit slowly, whereas dimer (26) is unreactive ²³, suggesting again an enhanced reactivity for (25).

In contrast, reaction of (25) and, separately, (26) with hexafluoropropene (2) in the presence of fluoride ion gave, in each case, the same proportions of products with the major product (7I) arising from reaction of (26). No products were seen arising from reaction of anion (25a) with (2).

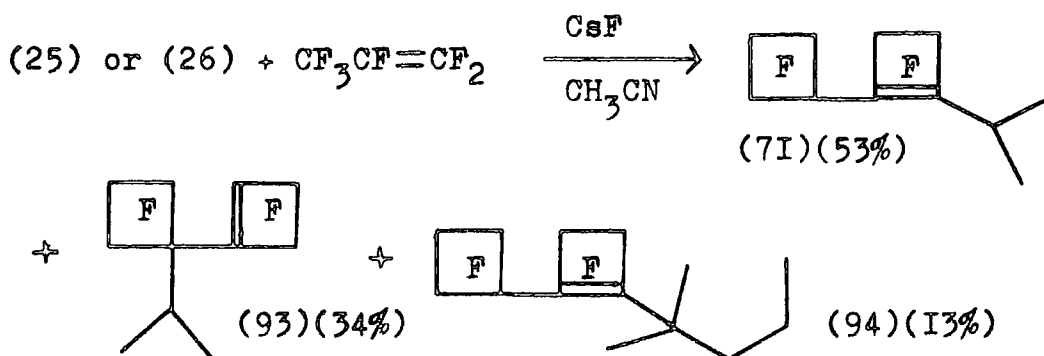

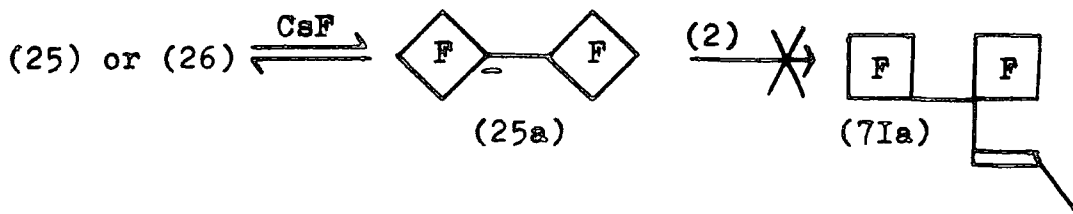

The fluoride ion is therefore rapidly isomerising (25) and (26) as well as forming the anion of (2)

A mechanism to account for the products is given below.

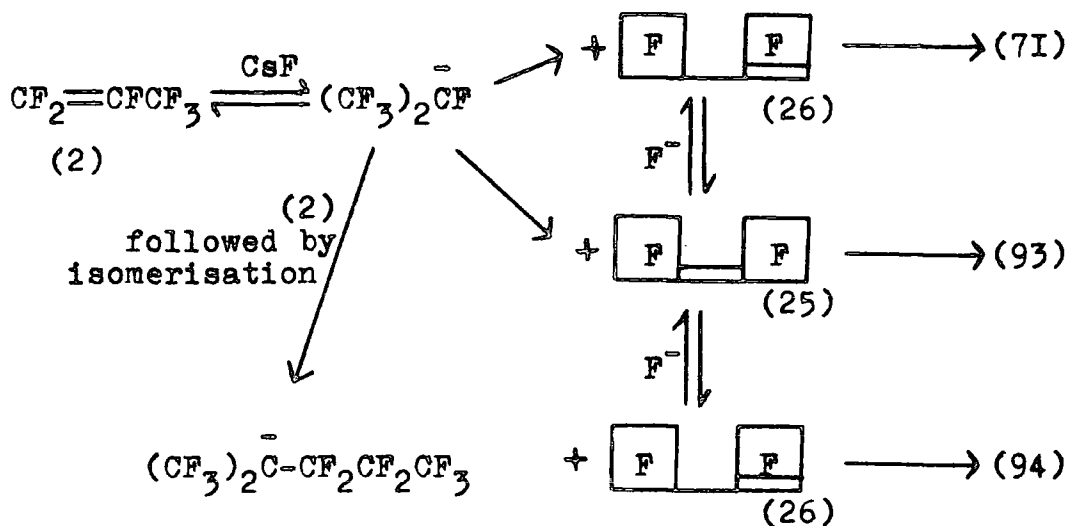

These results could be interpreted such that (26) is more reactive to nucleophiles than (25). However, the sheer bulk of the perfluoroisopropyl anion may prevent rapid attack on (25), in which case the product distribution would be simply due to kinetic control.

The formation of (7I) by this reaction rather than alternative (7Ia) allows us to consider the relative reactivities of several anions. Consider the process outlined below:-

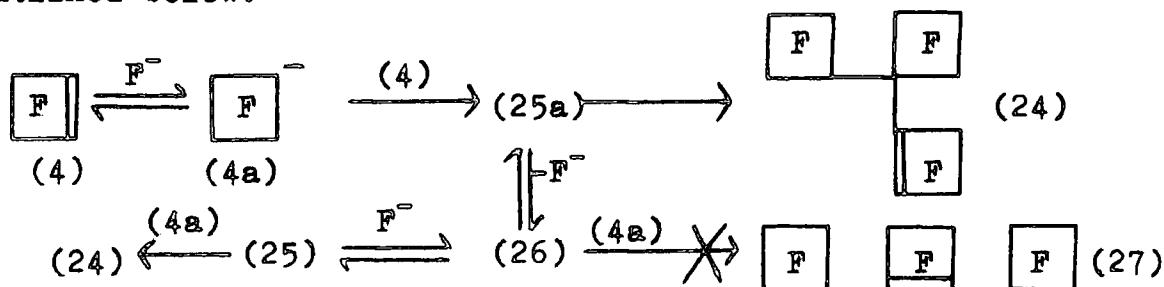

The oligomerisation of perfluorocyclobutene (4) to give trimer (24) must occur via reaction of (25a) with (4). No products arise from reaction of (4a) with (25) and (26) which would give a mixture of (24) and (27). Since compound (7I) is produced by reaction of (2a) with (26), the reactivity of the anions must increase in the following series.

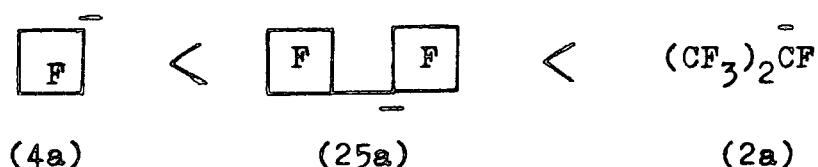

This is confirmed by the reaction of (2) and (4) in the presence of fluoride ion which gives products arising from attack by (2a) on (4) rather than by (4a) on (2).

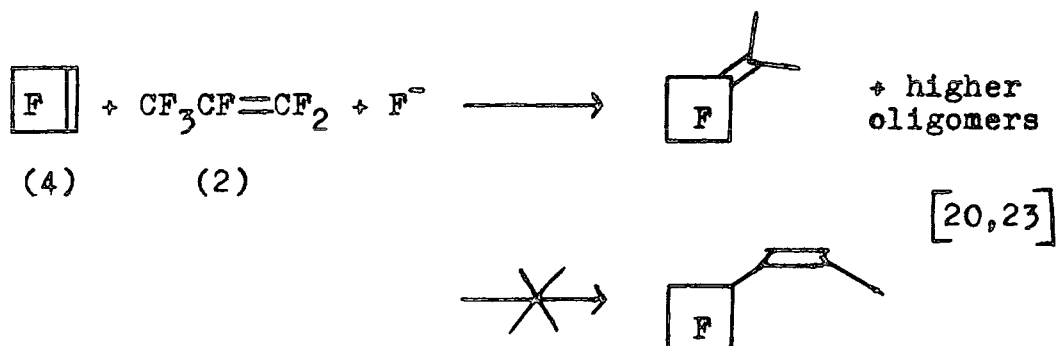

2E4 Free Radicals

In spite of the fact that a mixture of (25) and (26) does not co-polymerise with butadiene, both dimers do react, separately, with simple molecules. The reaction between (25) and acetaldehyde has been reported previously 50.

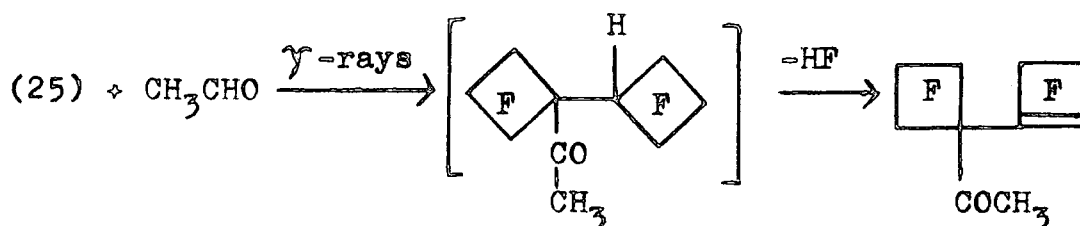

Reaction of dimer (26) and acetaldehyde is also successful though, surprisingly, a 1:1 adduct is formed with no elimination of HF. The assignments of the isomers produced in this latter case are made by comparison of the ^{19}F n.m.r. chemical shifts of the 'tertiary fluorines' with model compounds ^{18}I .

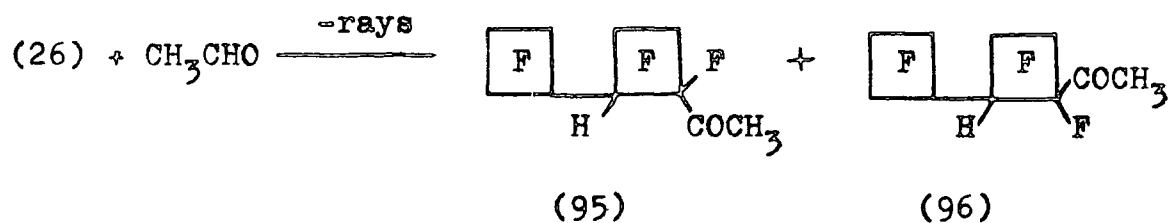

The ratio (95):(96) is 2:1.

CHAPTER THREE

REACTIONS OF INTERNAL OLEFINS WITH ENOLATE ANIONS

Introduction

Although nucleophilic attack on perfluoro-olefins has been, for very many years, one of the most important areas for study in organofluorine chemistry³⁰, there are, surprisingly, very few examples in the literature of reactions involving enolate anions as the nucleophile.

Workers at Durham and elsewhere have, over the years, investigated reactions of the tetrafluoroethylene tetramer (IO) with various oxygen and nitrogen centred nucleophiles and, latterly, with carbon nucleophiles such as alkyl lithiums and Grignard reagents. It therefore seemed logical to extend this work to include enolate anions. The interesting results which were obtained led to the investigation encompassing firstly other oligomers of tetrafluoroethylene and, secondly, related, cyclic olefins.

All the reactions described in this chapter were carried out at room temperature in tetraglyme solvent, using sodium hydride as base, unless otherwise stated.

3A REACTIONS OF PERFLUORO-3,4-DIMETHYL-3-HEXENE (IO)

3AI With Diethyl Malonate

As a result of a previous investigation of this reaction⁴⁹, it was suggested that two products were obtained, by allylic displacement of fluorine from both the CF_3 and C_2F_5 groups.

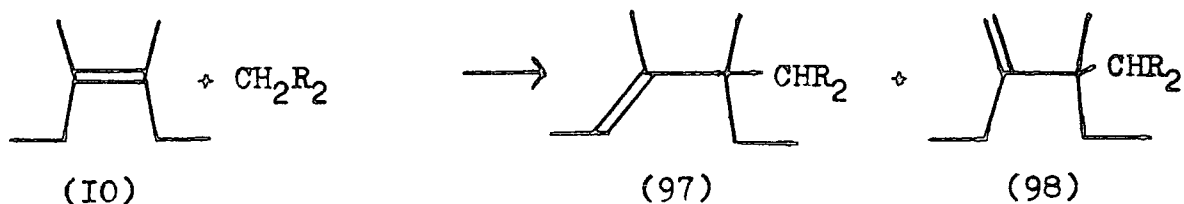

When this reaction was repeated in the present work, identical analytical data was obtained. However, in both cases only I4 fluorine atoms could be accounted for in the ^{19}F n.m.r. spectrum, indicating an overall loss of two molecules of HF (there are, of course, two acidic protons in the hydrocarbon starting material). No parent peak appears in the conventional electron impact ion source mass spectrum but the molecular mass of the product was verified using chemical ionisation mass spectrometry. This indeed gave a mass of 520. Clearly the reaction has gone further than was originally thought.

Some possible reaction sequences are given in the diagram below.

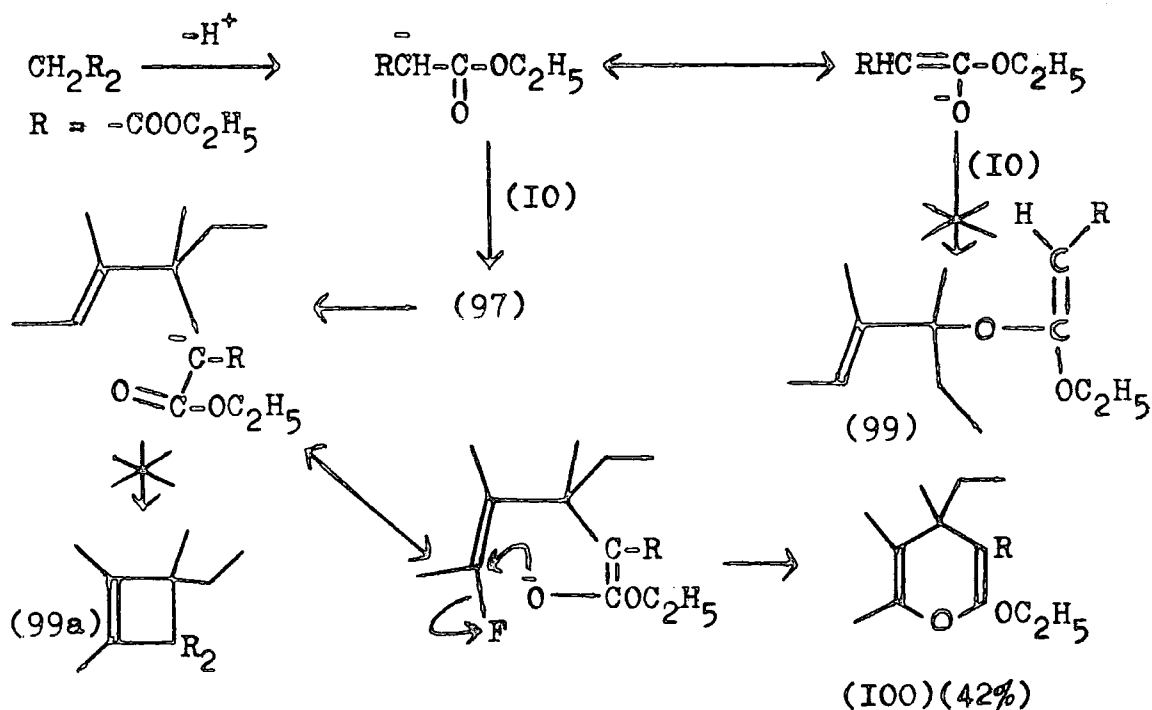

When the enolate anion is produced (by removal of a proton by hydride ion) , it could, in principle, attack (IO) either through carbon or oxygen. However, if attack through oxygen occurred, the resultant product (99) would have a vinylic hydrogen which would be non-acidic and reaction could not then progress further.

Hence initial reaction must proceed via nucleophilic attack by carbon to give either (97), (98) or both as intermediates. One would correctly anticipate, however, that the more likely intermediate would be the one with the fewer vinylic fluorines i.e. (97).

Loss of the acidic proton in (97) gives a new enolate anion which, via an intramolecular cyclisation, can displace the newly formed vinylic fluorine. Once again, attack by carbon is, in principle, possible but ring closure of this kind, forming a four membered ring, is known to be unfavourable ^{I68}. Ring closure through oxygen thus occurs to give the observed product.

Other, highly fanciful processes can be drawn which would give other products but only structure (IOO) fits the analytical data.

It is worth mentioning here that ¹⁹F n.m.r. spectroscopy was found to be an extremely powerful tool in the elucidation of many of the structures which appear throughout this chapter. In the present example, the precise chemical shifts and fine structure of the signals enable structure (IOO) to be assigned unambiguously.

When the reaction of (IO) with diethyl malonate was repeated, using DMF as solvent instead of tetraglyme,

compound (I00) was again the major product but the yield was only 24%.

3A2 With Acetyl Acetone

This reaction gave one product, in 32% yield, which was a pyran derivative analagous to (I00).

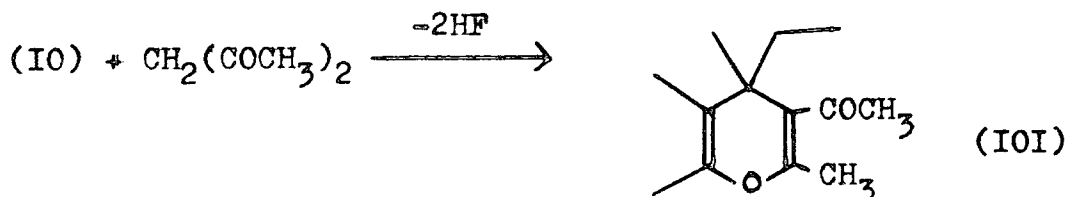

3A3 With Ethyl Acetoacetate

The expected pyran derivative was produced, initially in a 58% yield.

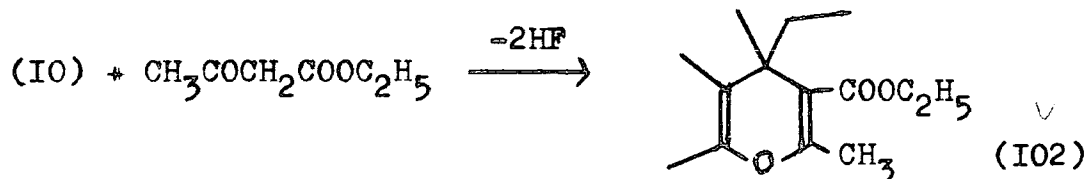

Note that cyclisation occurs through the oxygen atom of an acetyl group rather than a carboethoxy group. This is in keeping with precedent ^{I57} and with the known trend of enolate anions to react increasingly through oxygen as the acidity of the active methylene compounds from which they are derived increases- acetyl acetone is more acidic than diethyl malonate (see chapter one).

The efficiency of this reaction was investigated by repeating it many times, varying the reaction conditions each time. The effect of different solvents, concentrations of reactants and precise reaction procedure was noted. Full

results of this are given in the experimental section. It should be noted that, since the system is heterogenous at the start of the reaction, the efficiency of mixing may be important. On the other hand, reaction takes place with evolution of heat, implying that reaction may be more or less finished after about one hour, in which case mixing efficiency would be less important since the reaction mixture was stirred typically for 16 hours.

All the solvents used (DMF, tetraglyme, and acetonitrile) appear to work equally well but there is a marked increase in both yield and percentage conversion when an excess of either sodium hydride or enolate anion is used.

<u>Molar Ratio</u>	<u>Yield of (IO2)</u>
hydrocarbon:fluorocarbon:NaH	
I:I:I	26%
I:I:2	36%
2.I:I:I	58%
2.33:I:I	65%

These results may be explained by observing that two molar equivalents of base are required to convert olefin (IO) into product (IO2). The first comes from sodium hydride; the second could come, in principle, from the fluoride ion produced in the course of the reaction but the results show that both sodium hydride and enolate anion itself are stronger bases for the proton in intermediate (IO3) than the fluoride ion. Since enolate anion therefore acts as both a base and a nucleophile,

an excess must be used with compound (I0) if good conversions to the product (I02) are to be achieved.

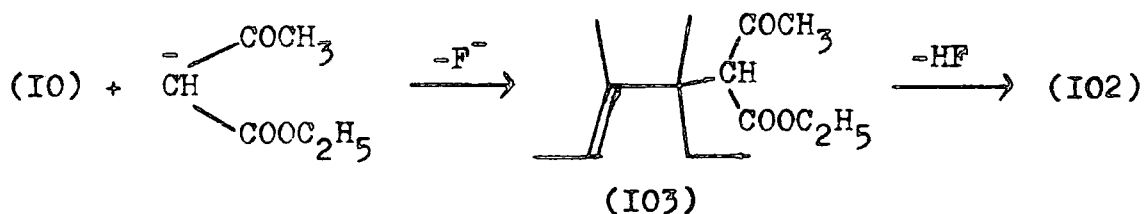

The fact that intermediate (I03) is not seen may be explained by suggesting that the initial attack to form (I03) is reversible but a more likely explanation is that the active hydrogen in (I03) is more acidic than those in ethyl acetoacetate and hence subsequent reaction of (I03) is much faster than the rate of attack of enolate anion on (I0). This would, of course, lead to a very short lifetime for (I03) and only a very small concentration of it would be present in the reaction mixture at any given time.

3A4 With Diethyl Malonate in the Presence of Fluoride ion

In the presence of fluoride ion, isomeric forms of (I0) are known to exist in equilibrium concentrations¹⁸⁸.

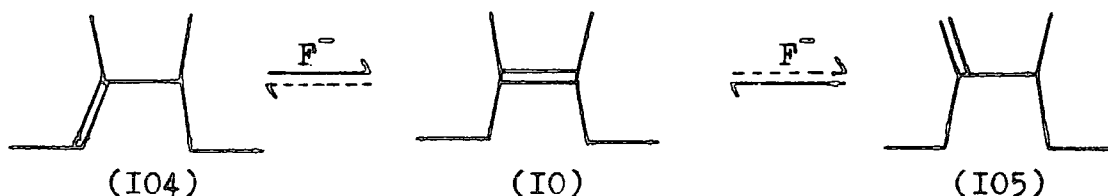

The purpose of this reaction was to set up the equilibrium above and then react the mixture with enolate anion to try and produce products arising from (I04) or (I05).

When the reaction was carried out, the major product resulted from reaction with (IO) to give (IOO). However, a small amount of another product (c. 5%) was produced. This was shown to have a molecular mass of 520 (by chemical ionisation m.s.) and its ^{19}F n.m.r. spectrum showed the presence of four CF_3 groups, one CF_2 group and two isomers.

The only structure which could arise from (IO) and might fit the data is (99a).

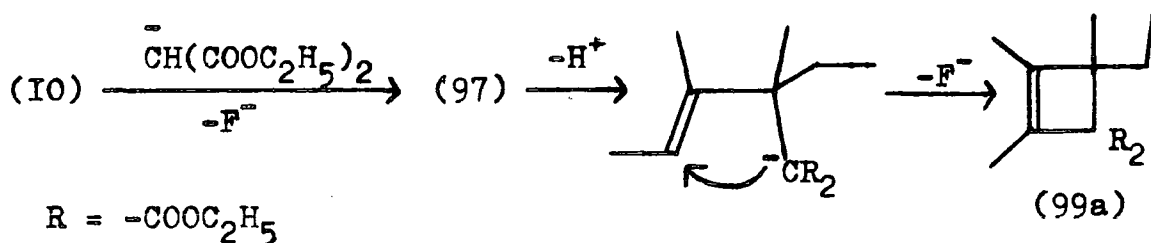

As was stated earlier, formation of (99a) must occur via a very unfavourable ring closure process.

It is more likely that reaction has taken place with (IO4). Possible reaction pathways are given overleaf.

Initial attack would involve vinylic displacement of fluorine giving (IO6). In the second stage, loss of a proton could be accompanied by a 1,3-fluoride ion induced isomerisation and concomitant cyclisation through oxygen with allylic displacement of fluorine giving (IO7). However, once again no isomeric forms of the product are possible.

The preferred second stage mechanism is loss of the proton followed by an internal allylic displacement of fluorine giving (IO8). Obviously in this case cis and trans isomers are possible.

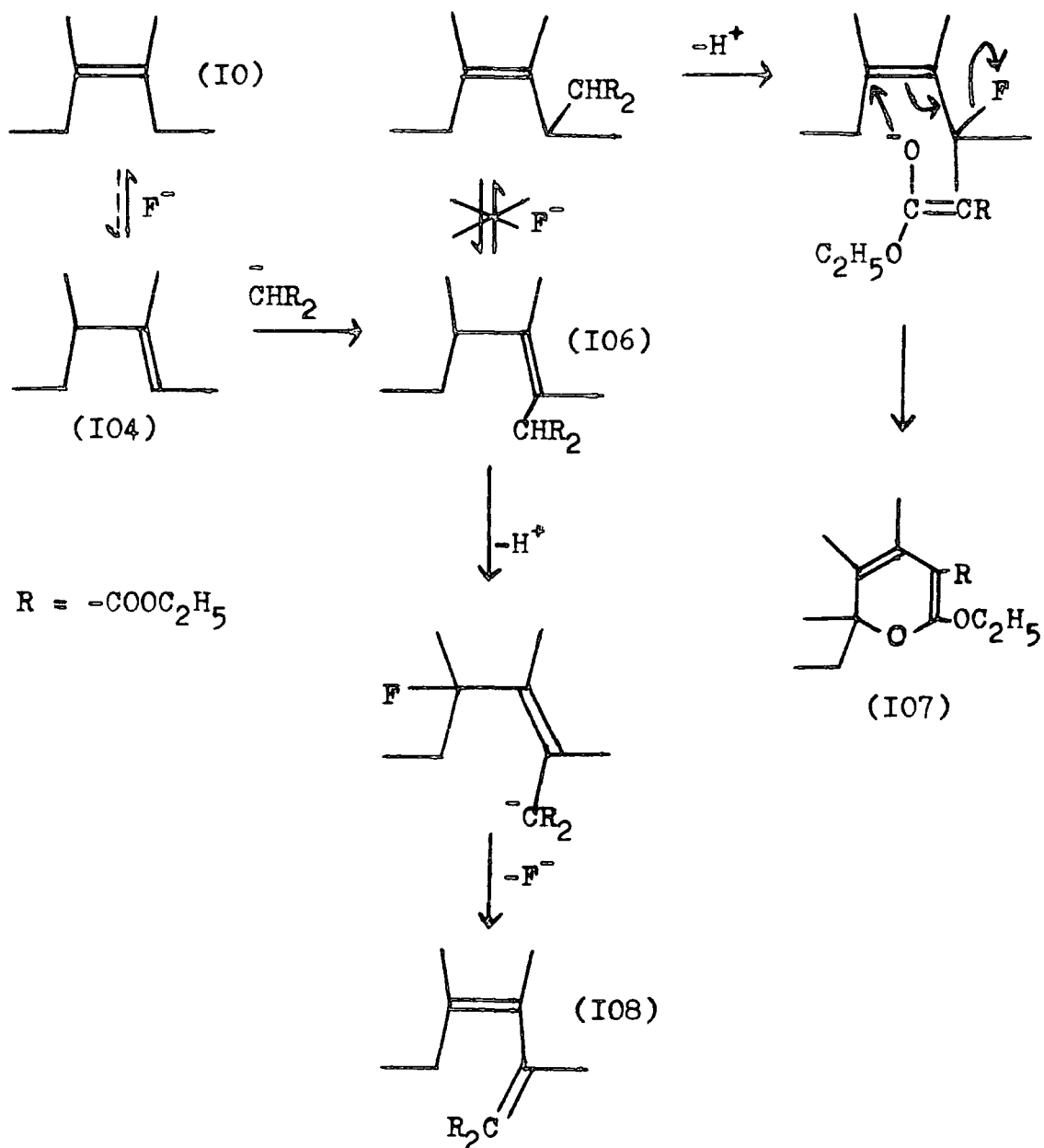

3A5 Other Reactions

A reaction of (IO) with malononitrile produced a tar from which no volatile products could be recovered.

A reaction of (IO) with ethyl acetoacetate using sodium ethoxide as base produced a complex fluorocarbon mixture from which no pure products were isolable. Clearly this system is more complicated than the others since ethoxide could itself compete with enolate anion for (IO).

3B REACTIONS OF PERFLUORO-3-METHYL-3-PENTENE (9)

Olefin (9), which is the trimer formed from anionic oligomerisation of tetrafluoroethylene, is formally similar to (I04) since they both have two CF_3 groups, one vinylic fluorine and one perfluoroalkyl group at the double bond. One might therefore expect similarities in behaviour.

3BI With Diethyl Malonate

Reaction of (9) with diethyl malonate gave a product which consisted of E and Z isomers of a molecule produced by initial vinylic displacement of fluorine followed by loss of H^+ and then internal allylic displacement of fluorine. The product (I09) was formed in a 57% yield and the Z:E isomer ratio was 4:1.

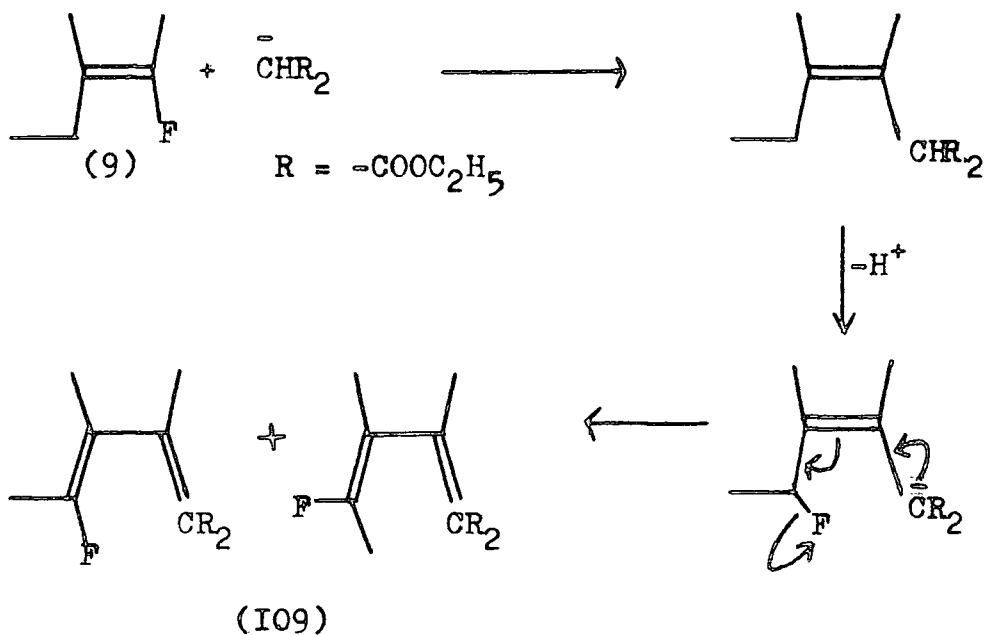

3B2 With Ethyl Acetoacetate

Reaction of (9) with ethyl acetoacetate gave two separable products. The major one was (II0) which corresponds to the acyclic diene (I09). In principle, four isomeric forms of compound (II0) are possible; the isomers at the fluorinated double bond were distinguished by ^{19}F n.m.r. spectroscopy but the arrangement at the other double bond was not clear.

The minor product (III) is a pyran derivative; it is sensible to assume that it is formed by a 6 electron cyclisation of the diene (II0).

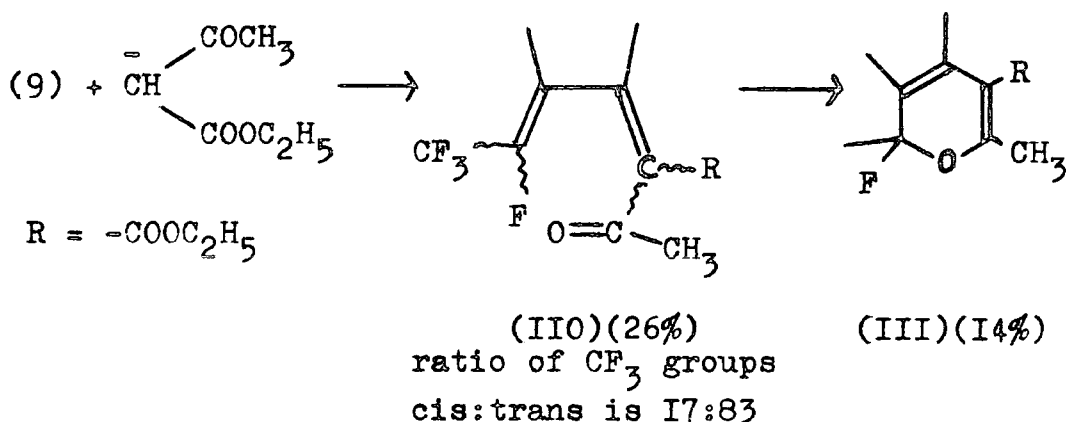

As before, one would anticipate that cyclisation would not occur preferentially through the oxygen of the carboethoxy group. This would explain why no cyclised products were seen in the reaction of (9) with diethyl malonate. Another factor assisting cyclisation must be the presence of a vinylic fluorine in (II0) compared with diene (I08). Indeed, in later examples in this chapter, an intermediate diene with a terminal difluoromethylene group is seen to cyclise completely such that no diene is detected in the product.

Note that if cyclisation of (II0) through the acetyl group is to occur, only the isomeric configuration shown can give (III). Hence (II0) may exist in only one isomeric form with respect to the hydrocarbon groups and this idea is supported by the fact that prolonged heating of (II0) produced only a small conversion to (III). Unfortunately, the absolute configurations could not be deduced by ^1H n.m.r. spectroscopy.

3B3 With Acetyl Acetone

This reaction gave a product mixture from which no components could be isolated pure but the ^{19}F n.m.r. spectrum of the crude product mixture contained signals attributable to an acyclic diene corresponding to (I09) and (II0).

While the present work was in progress, a paper was published in which Japanese workers described reactions of hexafluoropropene dimer (I5) with enolate anions ¹⁸². Pyrans were produced via similar reaction mechanisms to those described earlier.

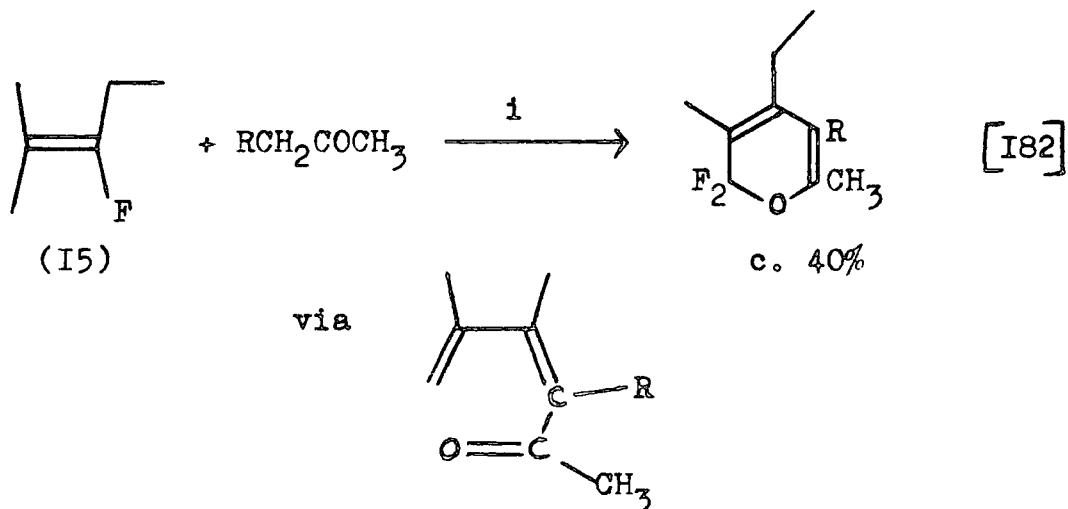

1, 'freeze dried' KF^{183} , CH_3CN ; $\text{R} = -\text{COOC}_2\text{H}_5$

Ethers were also produced. These arise from initial attack by the oxygen site in the enolate anion.

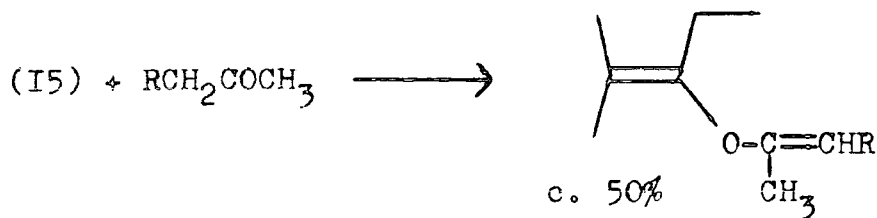

In contrast to these results, no ethers were detected during the present studies.

3C REACTIONS OF THE TETRAFLUOROETHYLENE PENTAMER (II)

3CI With Diethyl Malonate

A single product (II5) was obtained in this reaction in 54% yield. Applying the same rationale to (II) as was applied to (9), one might expect an acyclic diene to be formed which would not readily cyclise owing to the inactivity of the carbonyl moiety in a carboethoxy group. The ^{19}F n.m.r. spectrum of (II5) fits the structure of this expected diene.

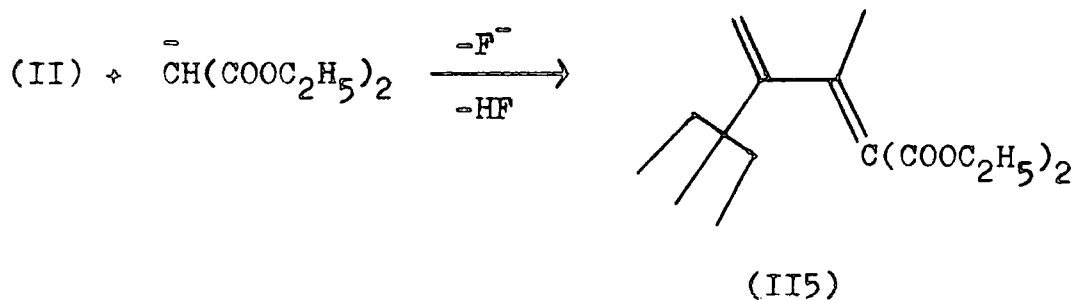

3C2 With Ethyl Acetoacetate

This reaction gave one major product (II4) in 39% yield. Compound (II) is formally similar to (9) and (IO4) and a similar mechanistic pathway for the reaction can be envisaged. A probable mechanism is given below.

The intermediate (II2) is not observed because of the reactivity of both the terminal difluoromethylene and the acetyl groups.

Structure (II3) is not observed presumably because of the very unfavourable steric requirements of the bulky fluorocarbon groups in an enforced cis arrangement on a double bond. Compare (II3) with starting material (II) which exists exclusively as the geometric isomer shown. Structure (II4) follows easily from the ^{19}F n.m.r. spectrum which contains a high field signal corresponding to one 'tertiary' fluorine atom.

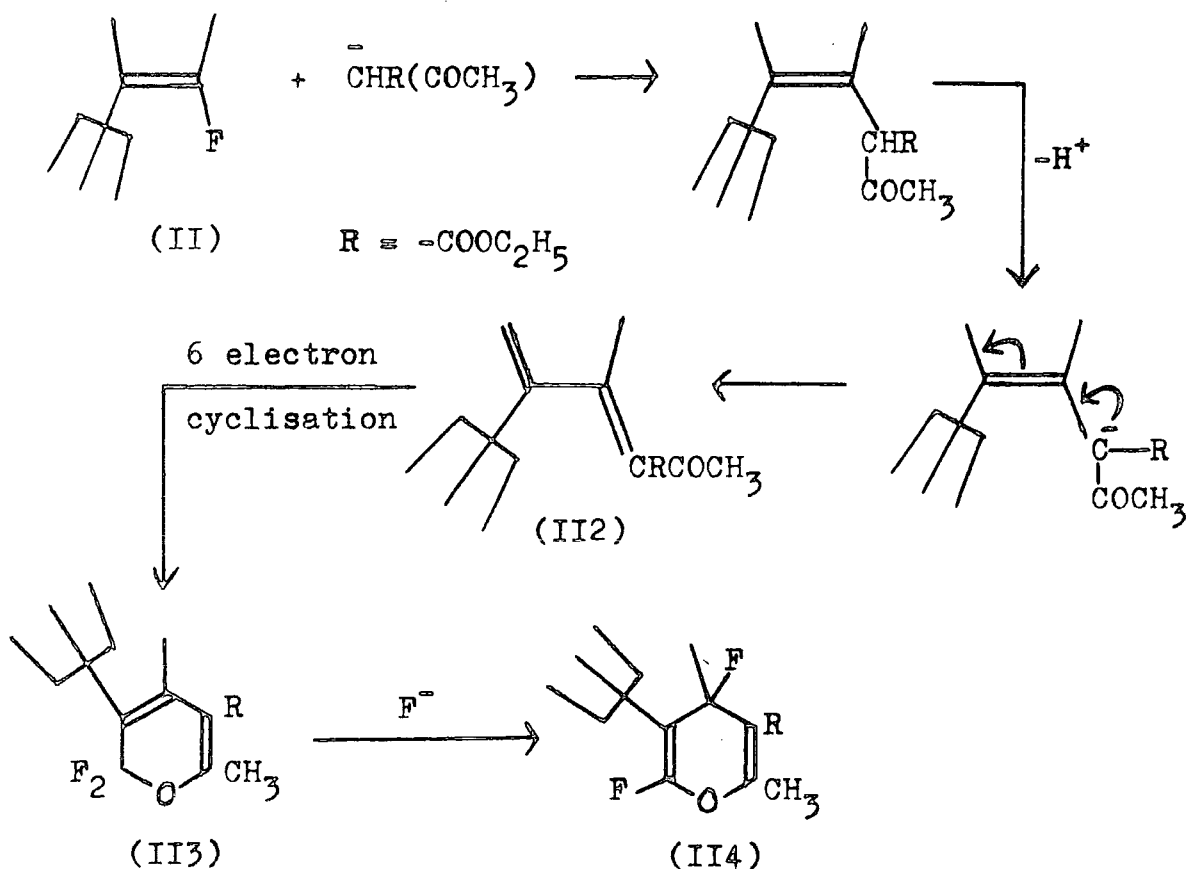

3D REACTIONS OF PERFLUORO-2-BUTENE (8)

The formation of benzofuran derivatives in reactions of enolate anions with hexafluorobenzene is well established¹⁵⁷ but, surprisingly, analogous syntheses involving acyclic olefins have not been described. This section shows how furan derivatives were obtained from compound (8), which is the dimer of tetrafluoroethylene.

3DI With Acetyl Acetone

One major product was obtained in this reaction in 37% yield. It is produced by vinylic displacement of fluorine by the enolate anion attacking through carbon, followed by cyclisation through oxygen with displacement of the second vinylic fluorine.

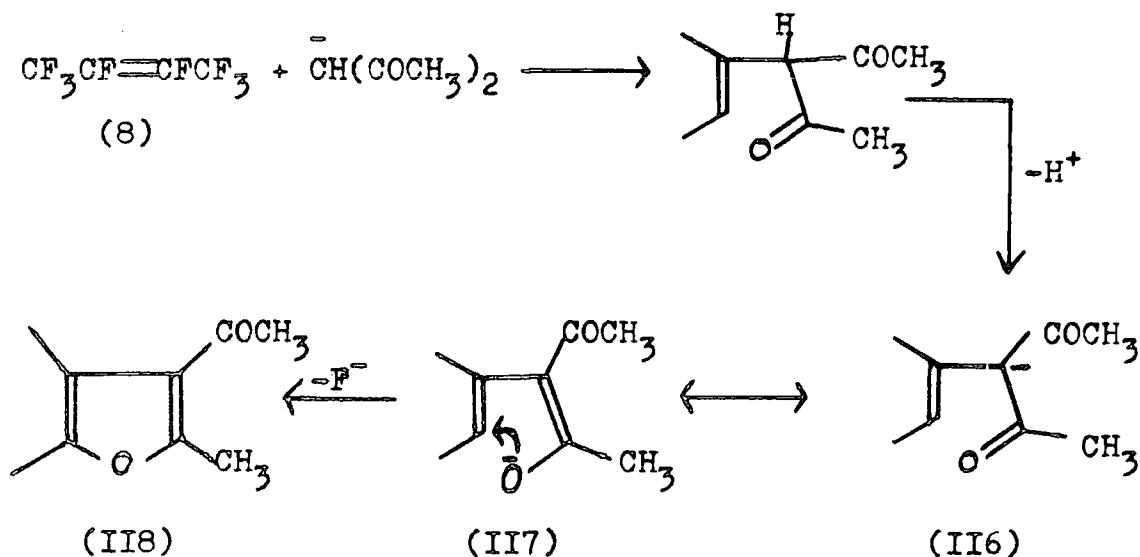

3D2 With Ethyl Acetoacetate

In a similar manner, reaction of (8) with ethyl acetoacetate produced furan (II9) in 46% yield.

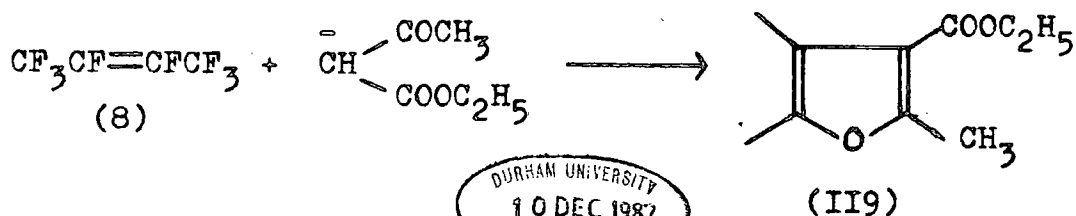

3D3 With Diethyl Malonate

The product in this reaction (I20)(27% yield) has a more complicated ^{19}F n.m.r. spectrum than either (II8) or (II9) implying a different reaction pathway has been followed. Several reaction pathways could be envisaged, which would in turn lead to a variety of possible furan and pyran derivatives as products but the analytical data is only consistent with structure (I20).

There are three possible ways of arriving at (I20), two of these involve an initial allylic displacement of fluorine, the third involves the previously described process of vinylic displacement followed by internal elimination of HF and finally cyclisation.

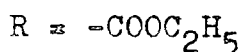
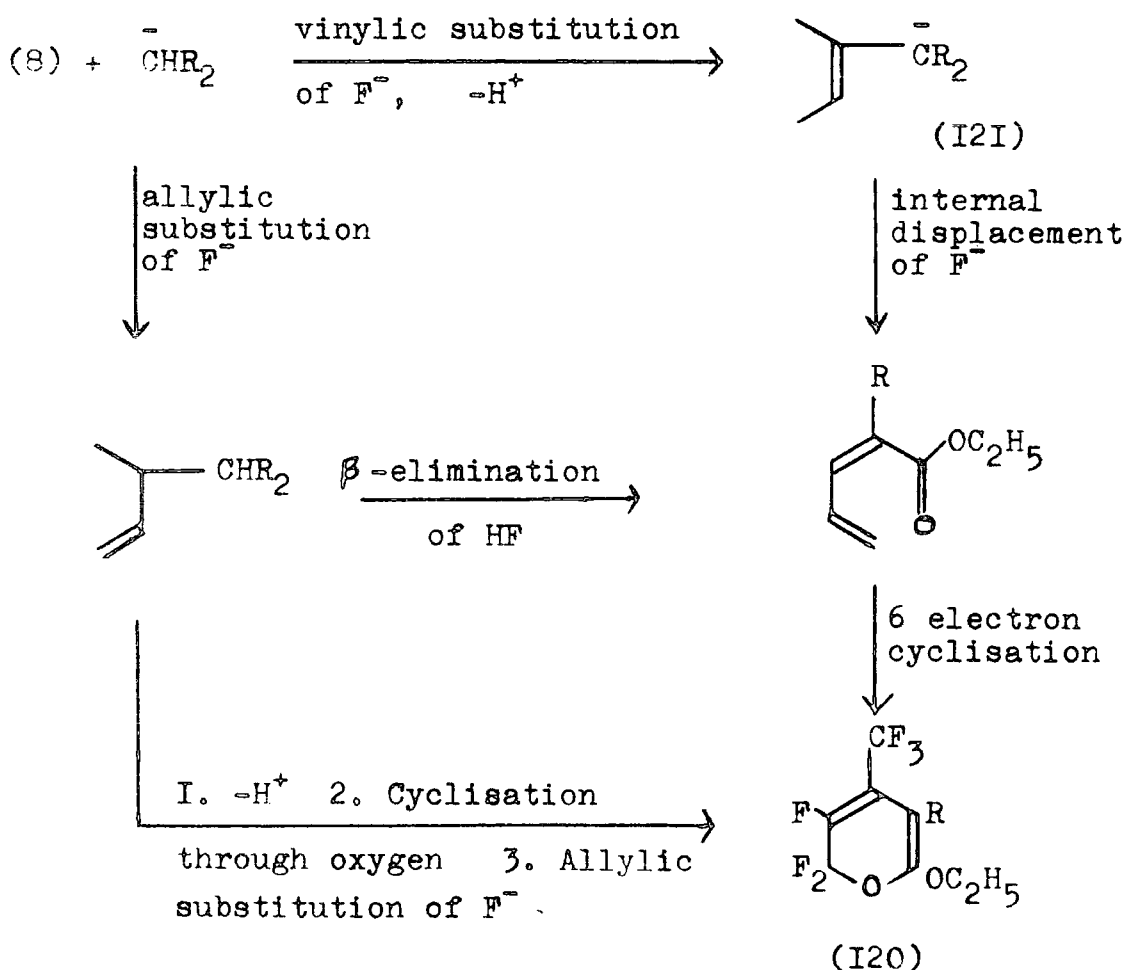

Russian workers obtained a corresponding pyran product when reacting perfluoroisobutene with diethyl malonate during an allene synthesis ^{I6I} and suggested a sequential allylic displacement pathway, based on their observation of allylic substitution products when perfluoroisobutene was reacted with organomagnesium compounds.

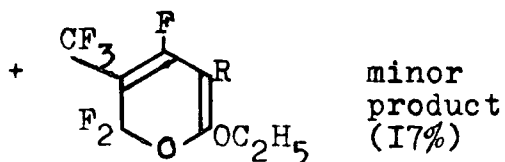
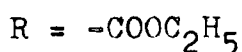
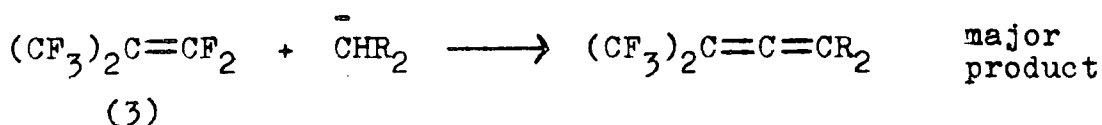

Since furans (II8) and (II9) must stem from initial vinylic displacement of fluorine by the enolate anions, it seems likely that the diethyl malonate anion also reacts initially causing vinylic displacement of fluorine and hence the different overall behaviour probably stems from the relative amounts of charge on carbon versus oxygen in the anions (II7) and (I2I) which is reflected in the acidities of the enolate anion precursors. It is informative that diethyl malonate is the least acidic of the active methylene compounds studied. Similar arguments have been used elsewhere to account for other differences in the chemistry of these reagents ^{I47}.

REACTIONS OF CYCLIC OLEFINS

These olefins are, in essence, models for compound (8) where the perfluoroalkyl groups are tied together in a ring.

3E REACTIONS OF PERFLUOROCYCLOHEXENE (6)

3E1 With Acetyl Acetone and Ethyl Acetoacetate

As expected, furan derivatives were formed which were analagous to those obtained from reactions with perfluoro-2-butene (8).

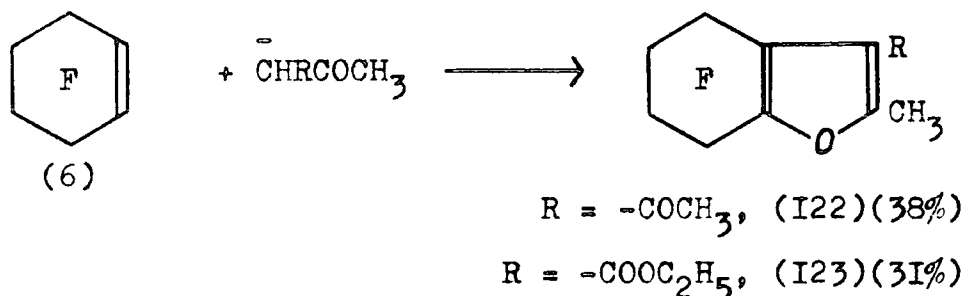

3E2 With Diethyl Malonate

One major product was obtained in this reaction in 31% yield. It was not a furan but its structure was successfully elucidated by ¹⁹F n.m.r. spectroscopy.

Consider the diagram and n.m.r. data on the following page. Structures (I25) and (I28) can be ruled out on the basis of the number and relative intensities of the resonances.

The resonance at 152.0 p.p.m. has a fine structure which is typical of a vinylic fluorine adjacent to a -CF₂ group in a ring ^{I87}. If the product had structure (I27), the 'tertiary' fluorine would have to be assigned a chemical shift of 130.0 p.p.m. It is known however that

only a 'tertiary' fluorine atom adjacent to another highly electronegative atom (such as in a -CFO- group) can exhibit such a relatively low chemical shift and consequently structure (I27) is eliminated.

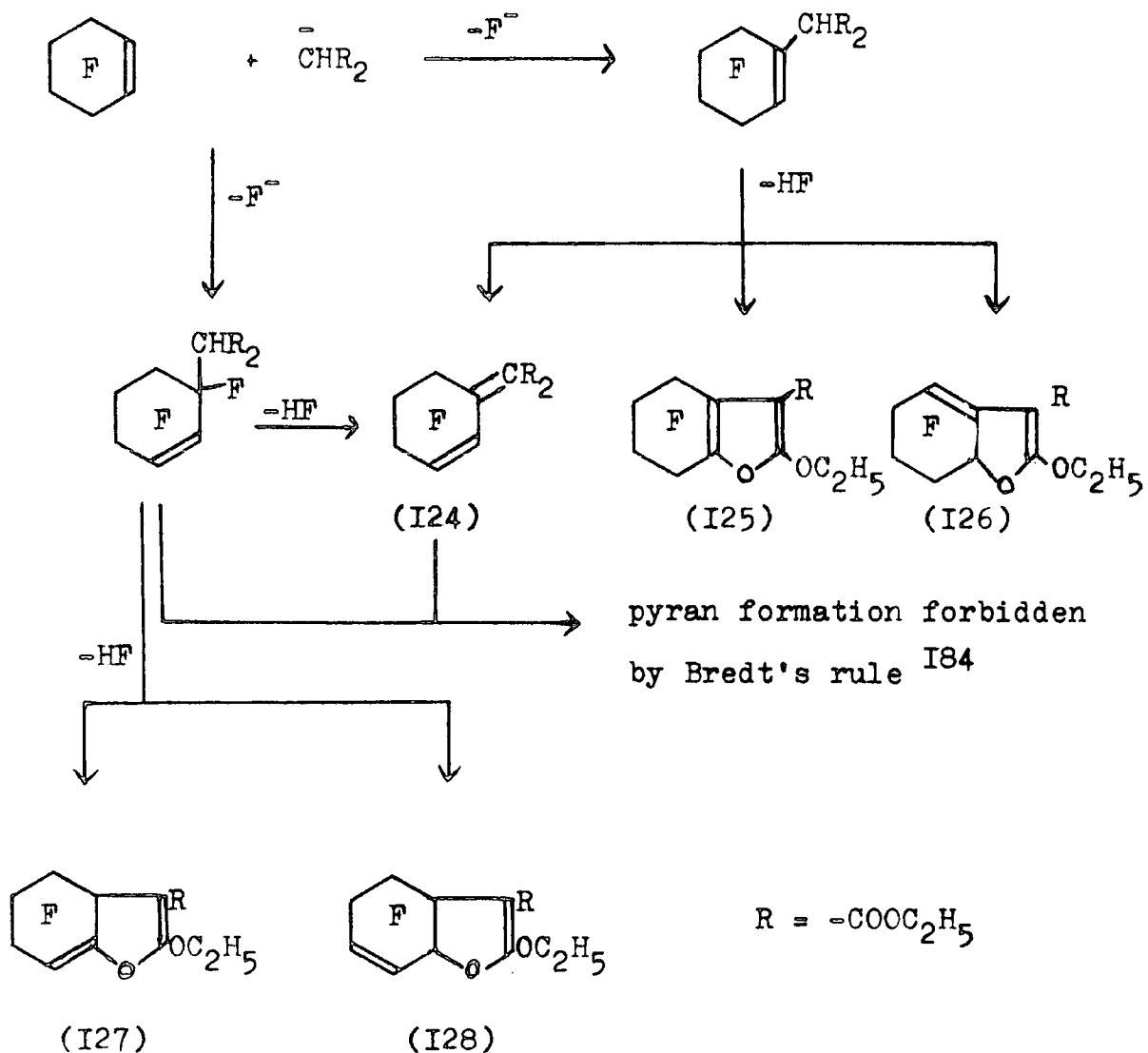

^{19}F n.m.r. data of product

<u>Shift in p.p.m.</u>	<u>Integration</u>	<u>Fine Structure</u>
II6.3	2	M
I20.2	2	M
I30.0	I	M
I34.3	2	M
I52.0	I	T, J = 2I Hz

In order to distinguish between structures (I24) and (I26), it is necessary to compare the chemical shift of the $-CF_2-$ group in a $-CF_2-\underline{CF_2}-CF_2-$ system with that in a $-CF_2-\underline{CF_2}-C=$ system.

The examples below show that allylic CF_2 groups exhibit a resonance in the region 108-120 p.p.m. whereas CF_2 groups adjacent only to other CF_2 groups or to the electronically similar $-CFO-$ group exhibit a resonance in the 130-135 p.p.m. range.

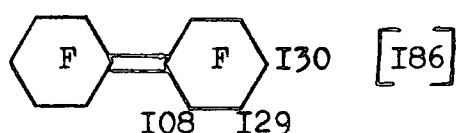
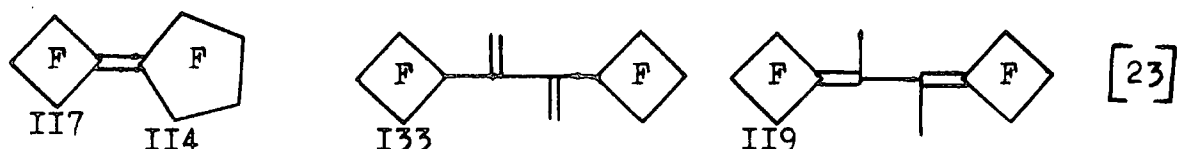
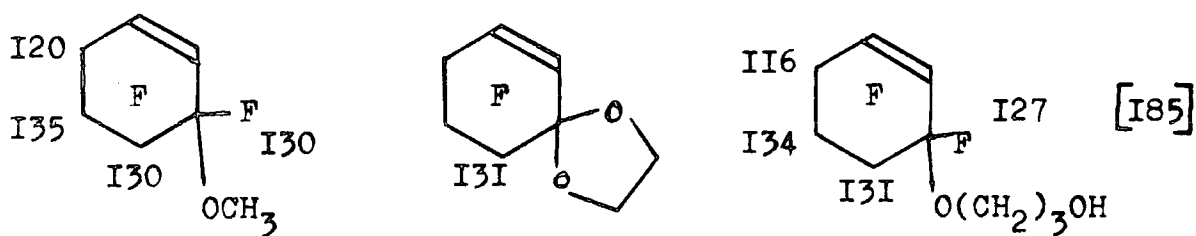

Numbers indicate the chemical shifts in p.p.m. of the various fluorines (relative to external $CFCl_3$)

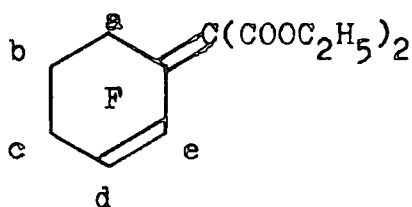

(I24)

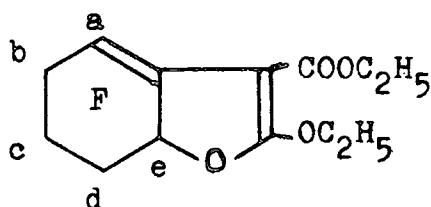

(I26)

Clearly for structure (I26), both F_2 c and F_2 d should show resonances around 130 p.p.m., while the allylic CF_2 group F_2 b should show resonance in the region 108-120 p.p.m.

For structure (I24), the resonances for F_2 a and F_2 c should both occur in the range 108-120 p.p.m. and, for F_2 b, in the range 130-135 p.p.m.

In summary, structure (I26) should show one low-field CF_2 and two high-field CF_2 signals, whereas (I24) should show two low-field and one high-field CF_2 signals. The observed spectrum clearly discriminates in favour of structure (I24).

Further evidence supporting structure (I24) instead of (I26) came from a reaction of the observed product with fluoride ion. The progress of this reaction was monitored by ^{19}F n.m.r. spectroscopy. The signals attributable to starting material disappeared after about 30 minutes and a new, complex spectrum was produced. After work-up, starting material was completely recovered. These results suggest a stable anion has been formed which originates from (I24); it may be assumed that reaction of (I26) with fluoride ion would cause rapid, irreversible isomerisation to the more stable, aromatic furan (I25).

The formation of this product is consistent with the preferred mechanistic pathway in the reaction between perfluoro-2-butene and diethyl malonate. In the case of perfluorocyclohexene however, the final cyclisation step would result in the formation of a bridged product with the double bond in the bridge. This is considered

unfavourable (Bredt's rule ¹⁸⁴) and anyway, the products would be inconsistent with the n.m.r. data.

3F REACTIONS OF PERFLUOROCYCLOPENTENE (5)

Reactions of enolate anions with perfluorocyclopentene produced the only observations of products arising from elimination of both one and two molecules of HF.

3F1 With Diethyl Malonate

Two products were isolated; their structures follow easily from the ¹⁹F n.m.r. data.

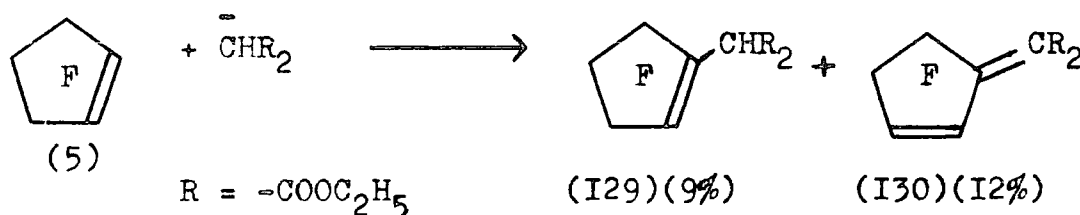

Compound (I30) obviously corresponds (I24) in the previous section.

3F2 With Ethyl Acetoacetate

The reaction gave one major product (in 31% yield) which is the simple product arising from vinylic substitution of fluoride ion.

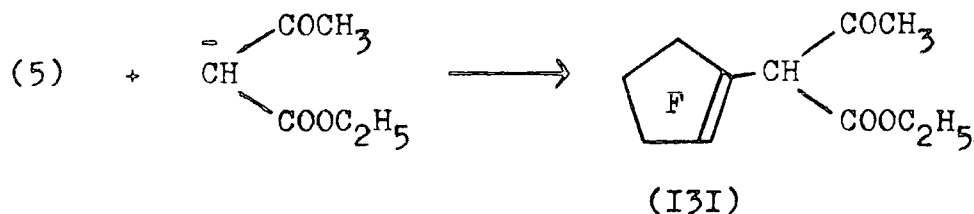

If nucleophilic attack had occurred through an

oxygen atom of the enolate anion, the resultant product would have a vinylic hydrogen which would occur at low field in the ^1H n.m.r. spectrum. No low field signal was seen but a signal at higher field was observed. This corresponds to the 'tertiary' hydrogen in (I31).

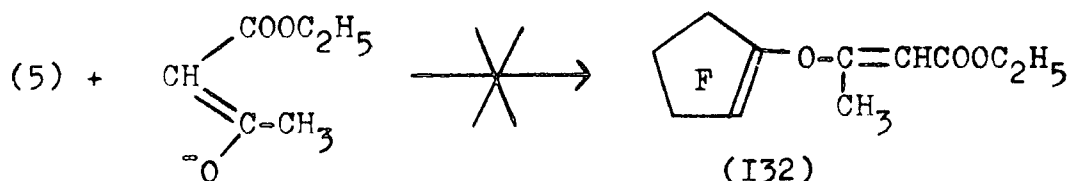

3F3 With Acetyl Acetone

As with section 3FI, two major components were isolated. One was a furan derivative corresponding to the furans (I22) and (I23) in section 3EI; the other was a mixture of two compounds, each with seven fluorine atoms in the ratio 2:2:2:1. This is probably a mixture of (I33) and (I34) i.e. the enolate anion has attacked both through oxygen and through carbon. Although this phenomenon has not been seen before during this investigation, it is explicable on the basis that, out of the three enolate anions used, the one formed from the most acidic precursor (acetyl acetone) would stand the best chance of attacking through oxygen.

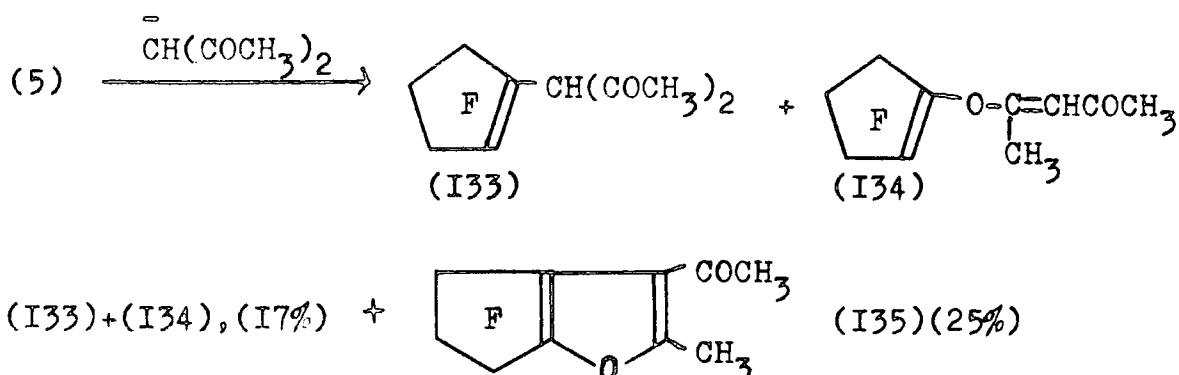

3G REACTIONS OF PERFLUOROCYCLOBUTENE (4)

Reactions of compound (4) with the various enolate anions were very vigorous and, in all cases, tars were formed from which no volatile products could be obtained.

CHAPTER FOUR

PREPARATIONS AND REACTIONS OF EPOXIDES DERIVED FROM
FLUORINATED INTERNAL OLEFINS

4A1 Introduction

Although the formation and reactions of fluorinated epoxides have been a source of much interest to chemists for many years, until recently no satisfactory general syntheses of epoxides from internal olefins had appeared in the literature. Then, Russian workers demonstrated the value of a new route ^{I40} (using hypochlorite) for these internal systems. The present investigation extends this progress to include, for the first time, the preparations and reactions of epoxides derived from tetrasubstituted internal olefins, together with other appropriate internal olefins.

4A2 General Considerations

The epoxidation reactions in the present work were carried out in acetonitrile solvent using hypochlorite ion which was freshly made for each reaction by bubbling chlorine gas through a 25% aqueous solution of cold sodium hydroxide. When prepared in this way, the hypochlorite solution contains a large excess of hydroxide ion. In principle, therefore, nucleophilic attack on a given fluorinated olefin by either hydroxide ion (giving substitution products) or by hypochlorite ion (giving epoxide products) could occur and, in fact, a successful epoxidation synthesis is a manifestation of the substantially

greater nucleophilicity of the hypochlorite anion compared to the hydroxide anion. It is considered that this enhanced nucleophilicity is due to overlap of the orbital containing the electrons on the nucleophilic atom of ClO^- with the orbital of the lone pair of the chlorine atom; this overlap produces two new molecular orbitals of which one is a high energy HOMO relative to hydroxide ³³.

After the epoxidation reaction has been carried out, the most commonly used work-up of these systems involves reaction of the crude product mixture with bromine in sunlight; this converts any unreacted starting material into a relatively involatile dibromo derivative which may be separated easily from the epoxide product by distillation (epoxides and their parent olefins tend to have very similar boiling points). However, most of the olefins under investigation in the present work are unreactive to bromine. This potential snag has been overcome by using a known excess of hypochlorite and monitoring the progress of the reaction by ^{19}F n.m.r. spectroscopic methods. By this means, all the starting material can be converted into product.

The single most important factor which affects the rate of reaction is the efficiency of mixing for, at the start, the fluorocarbon, hypochlorite solution, and acetonitrile solvent form, in order of decreasing density, three layers. The presence of the solvent is crucial; control reactions in the absence of solvent produced no measurable conversion to epoxide products.

4B EPOXIDATION REACTIONS

4BI Epoxidation of perfluoro-3,4-dimethyl-3-hexene (IO)

Reaction of compound (IO) with aqueous sodium hypochlorite solution proceeded smoothly at room temperature. Surprisingly, two products were formed. The major product, obtained in 62% yield, was the epoxide (I37). As previous workers have seen in other systems ^{I40}, addition across the double bond was accompanied by retention of configuration; thus a I:I cis:trans isomer mixture of (IO) gave a I:I mixture of epoxide isomers. Pure samples of these isomeric epoxides were obtained by preparative scale g.l.c. and their structures distinguished by ^{I9F} n.m.r. spectroscopy; the CF₃ in the CF₃CF₂ groups of the E isomer shows a distinctive heptet splitting. The retention of configuration demonstrates the influence of the counter cation in the reaction, even though it is presumably solvated by the acetonitrile.

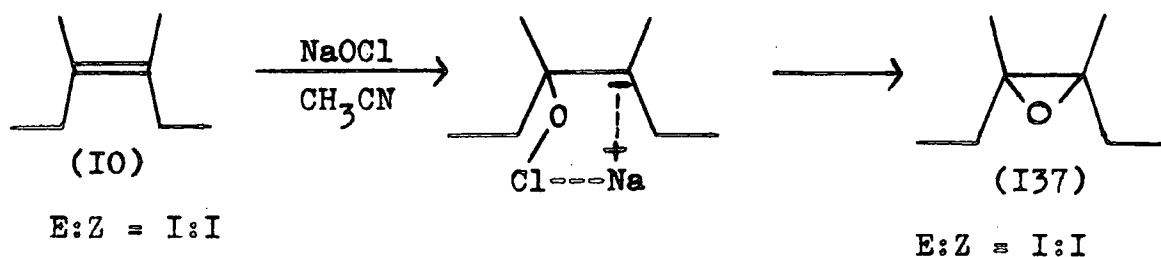

Structural determination of epoxide (I37) and all the other epoxides in this chapter was made using conventional techniques of which the most valuable was mass spectrometry. The parent ions and/or breakdown patterns for the epoxides are quite different to those for the olefin precursors and, in each case, are explicable only by an

overall addition of a single oxygen atom to the appropriate olefin precursor. The infrared spectra of the epoxides show no absorptions which could indicate a ketone moiety but usually show a weak absorption between 1500 and 1600 cm^{-1} which is characteristic of an epoxide ring.

The form of the by-product (which is produced in 28% yield) was, for some time, uncertain. Apparently, loss of a C_2F_5 group occurs with replacement by a single hydrogen atom.

Initially, it was thought that the by-product was formed by further reaction of (I37). A plausible mechanism for such a process involves free radical steps and is, in some ways, similar to the well-known Stevens rearrangement. It also bears similarities to the mechanism described in section 2A3.a .

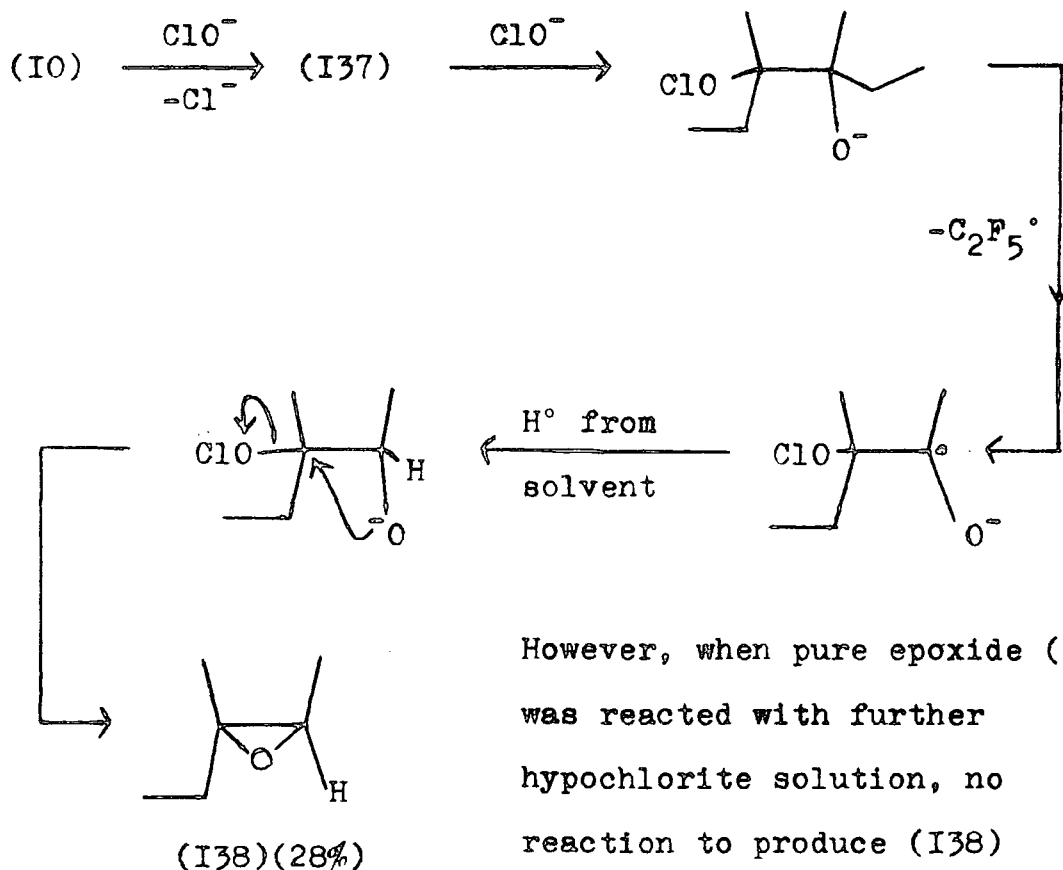

However, when pure epoxide (I37) was reacted with further hypochlorite solution, no reaction to produce (I38) occurred.

There is some precedent for the loss of a C_2F_5 group in reactions of compound (10) with nucleophiles.

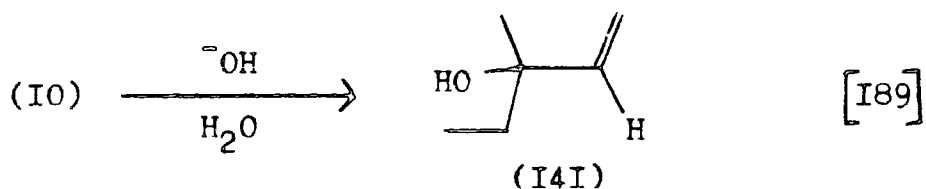

A suggested mechanism for the formation of (I41) involves a haloform cleavage which causes a reduction in the carbon chain length.

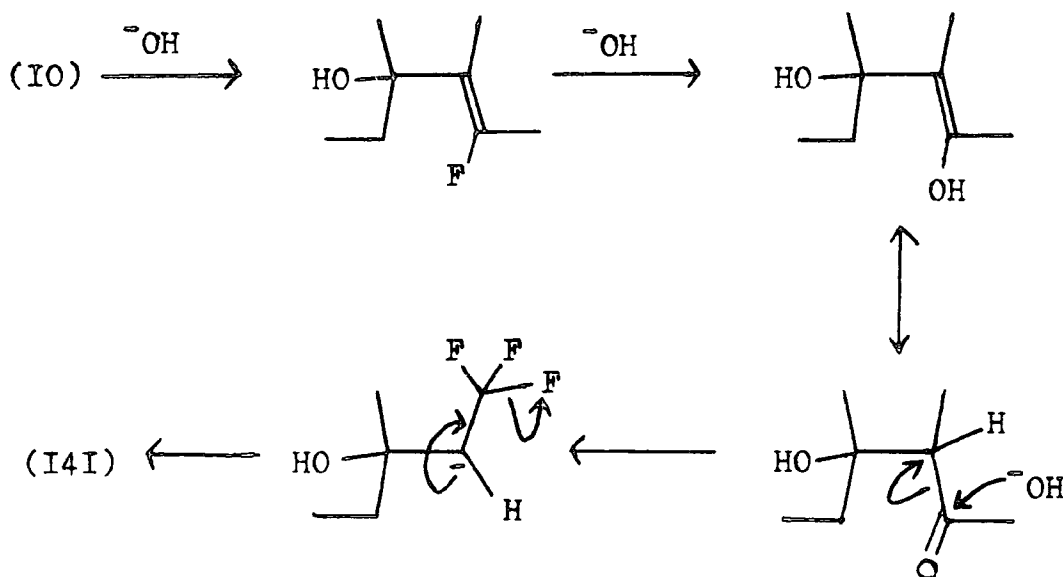

A similar mechanism can be drawn in the epoxide case (see overleaf), where the first nucleophilic attack by ClO^- produces an anion (I42) which may either ring close (forming epoxide (I37) directly) or eliminate fluorine by allylic displacement to form (I43). This then undergoes hydrolysis, eventually giving (I44). In the final step, ring closure occurs exclusively to give epoxide (I38) rather than elimination of fluorine which would give a compound with a terminal difluoromethylene group.

As would be expected, stereochemistry is not retained during the formation of (I38); the observed isomer

Evidence for this mechanism of formation of (I38) is provided by the presence in the ^{19}F n.m.r. spectrum of the aqueous layer in the reaction mixture of a single resonance at 77 p.p.m. corresponding to the fluorines in a CF_3COO^- group.

This appears to be the first recorded instance of a bi-product such as (I38) being formed and identified.

4B2 Epoxidation of Perfluorocyclobutene Trimers

Reactions of trimers (24) and (27) with sodium hypochlorite solution gave the corresponding epoxides in good yield.

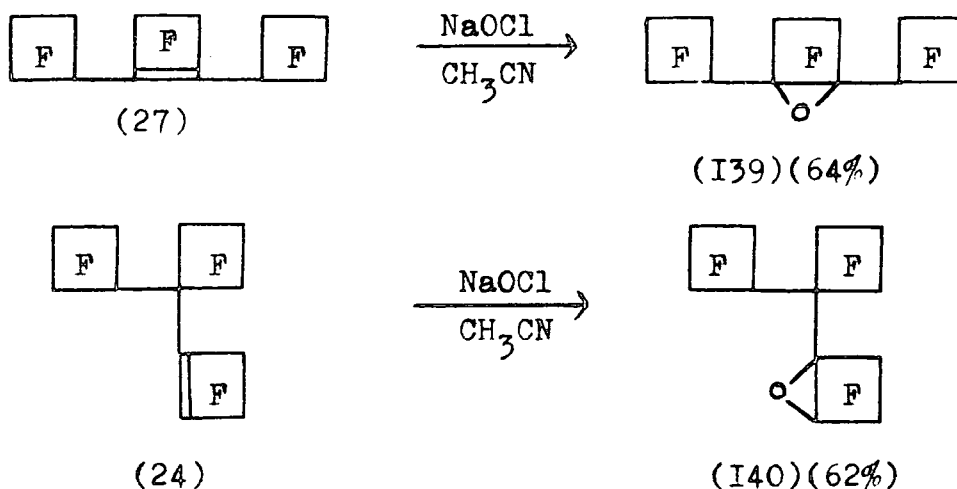

Note that the cyclobutyl groups in (I39) are in an enforced eclipsed configuration; there is no possibility in this case for relief of this interaction by a ring-opening process analogous to that occurring in the reaction of (27) with diazomethane (see section 2C4).

A further point of interest is that the difference in structure between (I39) and (I40) is nicely borne out

by their respective mass spectral breakdown patterns.

For molecule (I39), all the substituents on the epoxide ring are perfluoroalkyl groups and the high molecular weight ions seen are produced by loss of perfluoroalkyl fragments.

Compound (I40), in contrast, has a 'tertiary' fluorine attached to the epoxide ring and the molecular disintegration occurs by initial loss of C_2F_3O .

High Molecular Weight Ions in the Mass Spectra of (I39) and (I40)

<u>(I39)</u>		<u>(I40)</u>	
<u>Ion Mass</u>	<u>Fragment Lost</u>	<u>Ion Mass</u>	<u>Fragment Lost</u>
502	-	502	Not seen
433	CF_3	433	CF_3
402	$CF_3 + F$	405	CF_3CO
383	$CF_3 + CF_2$	355	$CF_3CO + CF_2$
333	$CF_3 + CF_2 + CF_2$	305	$CF_3CO + CF_2 + CF_2$

4B3 Epoxidation of Perfluoro-3-methyl-3-pentene (9)

Reaction of compound (9) with sodium hypochlorite solution gave the expected epoxide in good yield. The starting material consisted of a 4:1 mixture of E and Z isomers respectively and these were also the proportions of isomers in the epoxide product, indicating once again a retention of stereochemistry.

In contrast to the epoxidation of olefin (10), no by-products arising from carbon chain degradation were detected.

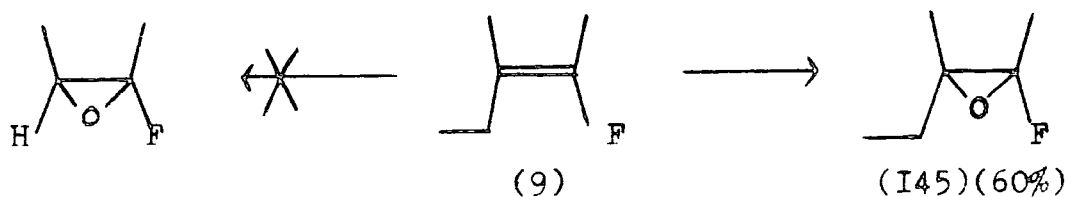

4B4 Epoxidation of Cycloheptene Derivative (52)

The expected epoxide was obtained.

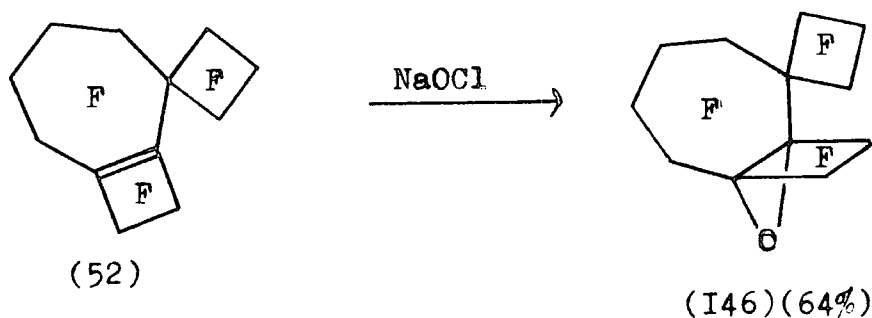

4B5 Attempted Epoxidation of Perfluoro-2,3-dimethyl-butadiene

This reaction was carried out in a similar fashion to the epoxidations already described. However, no epoxide products were obtained. The fluorocarbon, present initially as a lower layer, had homogenised with the aqueous layer after stirring for 16 hours and the ^{19}F n.m.r. spectrum of this layer showed it to contain a complex mixture of fluorocarbon species.

4B6 Attempted Epoxidation of Perfluoro-bicyclobutylidene (25)

In a similar manner, no epoxide products were obtained from the reaction of compound (25) with sodium hypochlorite solution.

The failure to produce epoxides from either compound (25) or perfluoro-2,3-dimethyl-butadiene probably stems from the extra reactivity (and therefore lower selectivity) of these systems to nucleophilic attack. Since there is a large excess of hydroxide compared to hypochlorite in the reaction mixture, the preferred reaction, in these reactive systems, is hydrolysis, which could be expected to give a variety of water-soluble products.

4C REACTIONS OF EPOXIDE (I37)

Introduction

The chemistry of several epoxides was illustrated in the introduction chapter. In particular, several nucleophilic reactions and rearrangements were described.

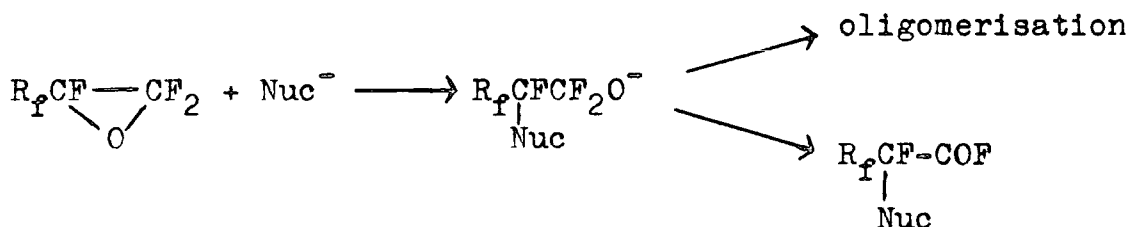

Since compound (I37) is formed from the tetrasubstituted olefin (I10), clearly in this case the straight forward nucleophilic reaction forming a carbonyl fluoride cannot occur but, surprisingly, no detailed reactions involving highly substituted epoxides such as (I37) seem to have appeared in the literature.

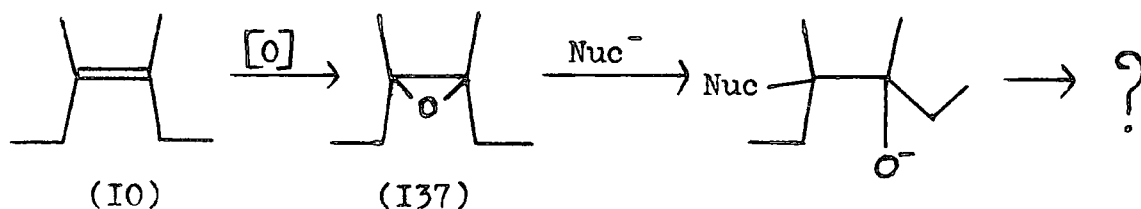

4CI Reactions with Fluoride Ion

The dominating feature of the chemistry of (I37) is its surprising overall stability, presumably due to the kinetic effect of the bulky perfluoroalkyl groups preventing close approach of the nucleophile but possibly also due to the thermodynamic effect of the electronegative perfluoroalkyl groups withdrawing electron density from the ring.

Thus, when compound (I37) was passed over hot CsF (240°C) in a flow of nitrogen, starting material was recovered unchanged. Similarly, stirring compound (I37) with fluoride ion in an aprotic solvent at room temperature for 16 hours produced no detectable reaction. When stirring was continued for 7-10 days however (at room temperature), a cleavage reaction occurred, producing two volatile compounds, perfluoro-2-butene and perfluoro-2-butanone.

Surprisingly, the perfluoro-2-butene did not, as has been found by other workers, dimerise in the presence of the fluoride ion ^{I9I} to form the tetrafluoroethylene tetramer (I0). This may be rationalised by virtue of the known propensity of fluorinated ketones (in this case the perfluoro-2-butanone) to form stable complexes with caesium fluoride ^{I92}. Thus, no active fluoride ion is likely to be available for the dimerisation process.

This cleavage reaction also occurred when compound (I37) was heated in the presence of CsF to 200°C for 16 hours in a carius tube. Complete conversion to a I:I mixture of ketone and olefin was observed.

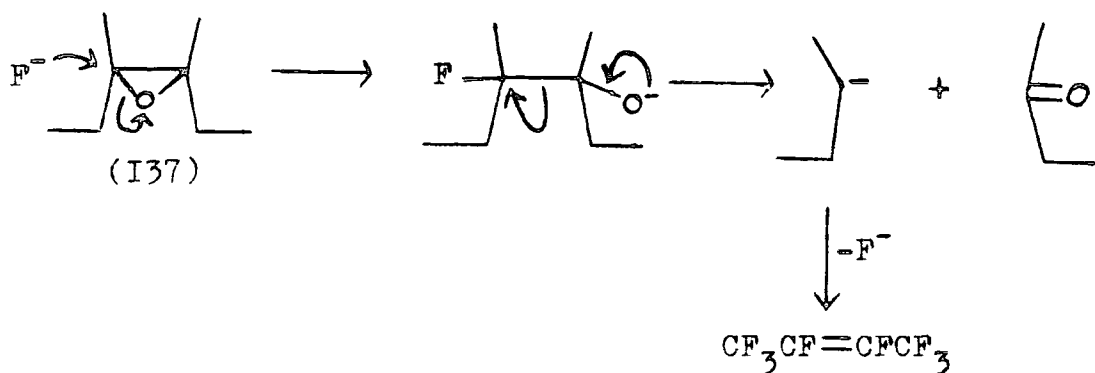

Note that the cleavage occurs exclusively to produce the most stable possible anion.

No products arising from a 'ring walk' isomerisation were observed at any stage.

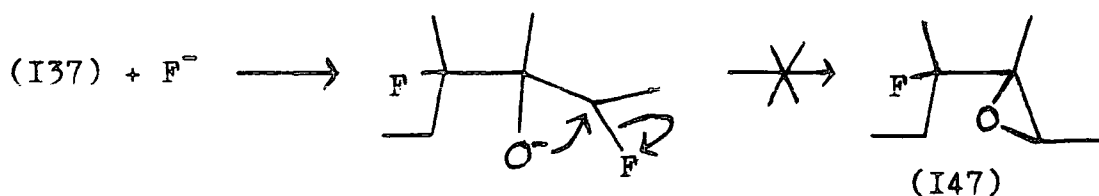

4C2 Pyrolysis reactions of Epoxide (I37)

No reaction occurred when (I37) was passed in a flow of nitrogen through a platinum lined tube at temperatures up to $530^\circ C$ and in each case there was a good recovery of starting material.

When epoxide (I37) was heated to $200^\circ C$ for 16 hours in a carius tube in the absence of fluoride ion, no cleavage reaction was seen but there was some isomerisation of the starting material. A repeat of this pyrolysis using a pure, specific isomer of (I37) gave a 1:1 mixture of the E and Z isomers of (I37) as the product. The reaction was therefore repeated in the presence of, separately, bromine and cyclohexene but no products arising from radical trapping could be detected.

4C3 Other reactions of Epoxide (I37)

The stability of epoxide (I37) was shown by a series of unsuccessful reactions with nucleophiles and free radicals as shown below.

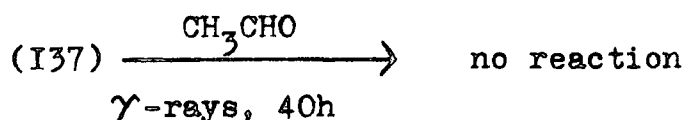
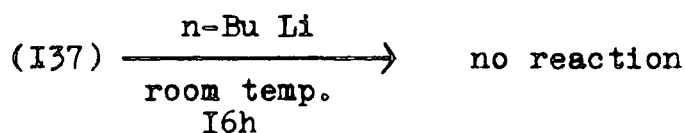
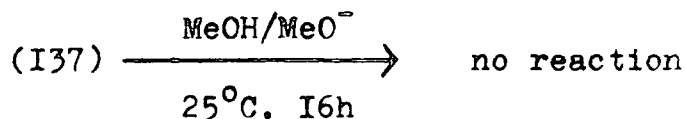

4D REACTIONS OF EPOXIDE (I38)

4DI Introduction

Epoxide (I38), like (I37), has no fluorine atoms directly attached to the ring and hence no facile nucleophilic reactions or rearrangements are to be expected.

Compound (I38) shows, if anything, greater thermal stability than (I37) but is more susceptible than (I37) to nucleophilic attack. Thus, (I38) was stable even at 580°C in a flow pyrolysis reaction and was also recovered intact from a static pyrolysis at 200°C in the presence of fluoride ion.

No reaction was observed between (I38) and acetaldehyde under free radical conditions and the proton was not affected either by diazomethane or by sodium metal.

4D2 Reaction of Epoxide (I38) with Methoxide Ion

This reaction proceeded smoothly at room temperature to give, initially, a stable salt in solution. On acidification, an alcohol was produced. Two isomers were seen, both of the anion in the salt and of the final alcohol and this is consistent with initial attack of methoxide ion occurring at either of the ring carbon atoms.

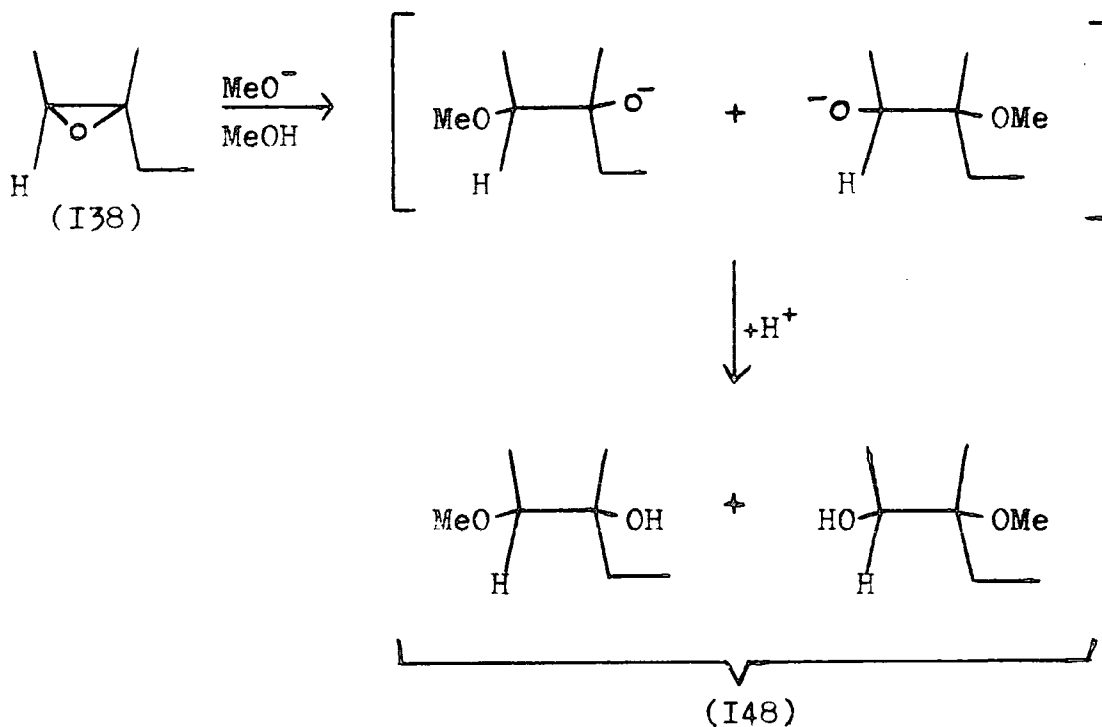

The over-riding evidence for product (I48) is provided by the chemical ionisation mass spectrum which indicates the molecular weight of 330; no parent ion is seen in the electron impact mass spectrum.

4D3 Reaction of Epoxide (I38) with Fluoride Ion

A similar process occurred with fluoride ion as occurred with methoxide ion; two isomers of a stable anion were formed. Unlike the previous reaction however, the anion was destroyed when the solvent was removed by

vacuum transfer and the starting material was reproduced. The anion could be trapped by adding acid but it did not prove possible to separate the alcohol thus formed from the solvent.

4D4 Fluorination of Epoxide (I38)

Fluorination of (I38) using a hot cobalt trifluoride bed was successful only if the temperature was raised beyond 280°C. Under those conditions, all the starting material reacted.

At 280°C, there was a 30% conversion to the expected product (I45). At 380°C, all the starting material reacted to give 70% of (I45) together with two minor which appear to result from the loss of a C₂F₄ unit from (I45). This was indicated by g.l.c./mass spectrometry but only the epoxide (I45) was obtained pure by preparative scale g.l.c.

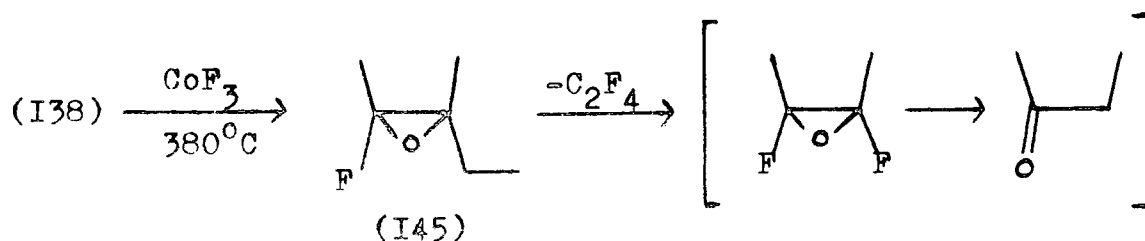

It is quite clear however that even under these vigorous conditions, the epoxide ring remains intact.

4E STATIC PYROLYSIS OF EPOXIDE (I39)

In an analagous manner to the reaction between (I37) and fluoride ion, this reaction resulted in essentially quantitative molecular cleavage to produce two compounds; a gas, which was identified as perfluorocyclobutene, and

the ketone (I49).

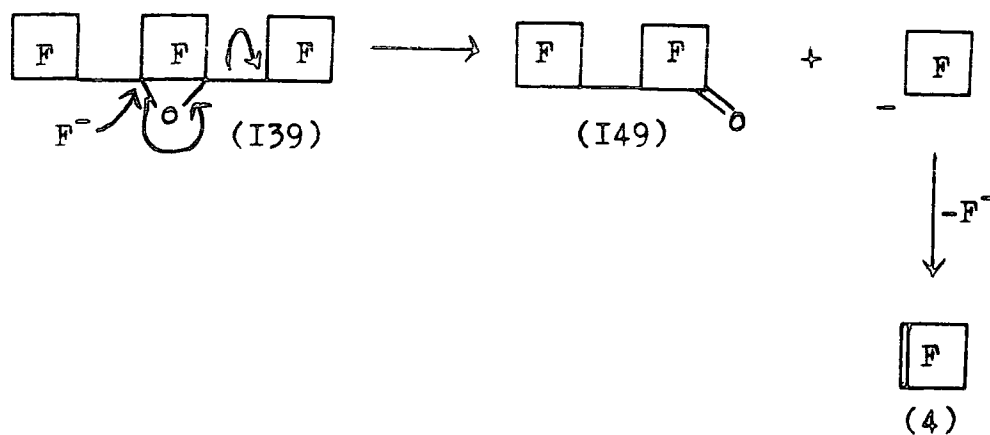

Compound (I49) gives a strong ketone absorption in its infrared spectrum and shows a parent peak and a consistent breakdown pattern in its mass spectrum.

EXPERIMENTAL

Chemicals

The caesium fluoride used was reagent grade and was dried with strong heating (c. 180°C) under high vacuum with frequent agitation and periodic grinding in a glove bag. It was stored under dry nitrogen.

Perfluorocyclobutene was either bought commercially or was made by the standard route⁸, by either the author or technical staff.

Perfluoro-3,4-dimethyl-3-hexene was supplied by I.C.I. Ltd. It was purified by washing with dilute HCl (to remove amines), then with water, dried over anhydrous MgSO₄ and then redistilled.

Solvents

Dimethyl Formamide (DMF) was fractionally distilled under vacuum, the middle fraction being collected over dry molecular sieve (type 4A) and stored under nitrogen.

Tetraglyme was purified by stirring with sodium metal at 95°C for 24 hours, followed by fractional distillation under vacuum, the middle fraction being collected over molecular sieve (type 4A) and stored under nitrogen.

Any other solvents used were pre-dried by standard methods.

Instrumentation

Spectroscopic data were obtained using the following spectrometers:

infrared, Perkin-Elmer 457 or 577;

mass, A.E.I. MS9 or V.G. Micromass I2B linked to a Pye IO4 g.l.c.

n.m.r., Varian A56/60D, EM360L, or Bruker HX90E.

G.l.c. was carried out using a Pye IO4 fitted with a flame ionisation detector. Quantitative g.l.c. was carried out using a Varian Aerograph 920 fitted with a gas density balance detector. Three columns were used: column A, 20% di-isodecyl phthalate on Chromosorb P; column O, 30% SE30 on Chromosorb G60-80; and column K, 20% 'Krytox' on Chromosorb W.

Fischer-Spaltrohr MMS 200 and HMS 500 concentric tube systems were used for fractional distillation. Carbon, hydrogen, and nitrogen analyses were obtained using a Perkin-Elmer 240 Elemental Analyser. Fluorine analyses were obtained using the literature method¹⁹³.

CHAPTER FIVE

EXPERIMENTAL TO CHAPTER TWO

5A PREPARATION OF PERFLUOROCYCLOBUTENE OLIGOMERS, THE
CYCLOHEPTENE DERIVATIVE (52), AND RELATED REACTIONS

5AI Pyridine induced Oligomerisation of Perfluorocyclobutene

This process was repeated many times during the course of the work. A typical reaction is described below.

Pyridine (2.07 g, 12.8 mmol) was placed in a glass vessel fitted with a 'rotaflo' tap, a side-arm, and containing a magnetic stirrer, and then perfluorocyclobutene (29.9 g, 184 mmol) was transferred in to the vessel under vacuum. The tap was closed and the mixture was stirred at room temperature for 16 hours. After this time, the reaction was checked for completion by fitting a rubber teat to the side-arm and then carefully opening the 'rotaflo' tap. Deflation of the teat indicated that all the perfluorocyclobutene had been used up. Volatile material was then transferred out from the vessel into a cold trap using a vacuum line. The pale yellow liquid thus obtained was washed with water to remove the pyridine, dried over P_2O_5 and transferred under vacuum to a cold trap. The resulting liquid (25.3 g) was shown by g.l.c. (col. A, 90°C) to be a 5 component mixture comprising: unreacted perfluorocyclobutene (2%), 1,2-dichloro-hexafluorocyclobutane (2%), (this is an impurity in the starting material), and three major components, which were the dimers (25) and (26) (total 33%) and trimer (27) (62%). The mixture was

distilled to give a mixture of the two dimers (by collecting the fraction between 80 and 85°C) and pure trimer (27) (by collecting the fraction between 145 and 147°C). The compounds were identified by comparing their analytical data with that from authentic samples.

Results from some of the other reactions are given in the table below. Note that, in general, increasing the proportion of pyridine in the starting mixture increases the proportion of trimer (27) in the product.

<u>mass in g</u>		<u>molar ratio</u>	<u>%</u>	<u>% product composition</u>	
C_5H_5N	C_4F_6	$C_4F_6:C_5H_5N$	<u>recovery</u>	dimers	trimer
2.00	46.9	11.4:1	84	46	44
1.82	33.0	8.84:1	85	37	58
2.07	29.9	7.04:1	69	33	62
4.12	40.8	4.83:1	67	23	68
4.01	35.7	4.30:1	72	20	74

5A2 Fluoride Ion induced Oligomerisation of Perfluorocyclobutene

Tetraglyme (30 ml) and CsF (5.9 g, 39 mmol) were placed in a 100 ml round bottomed flask fitted with a 'rotaflo' tap and a side-arm. Perfluorocyclobutene (28.6 g, 177 mmol) was transferred in under vacuum. The tap was closed and the contents were stirred at room temperature for 5 days. After this time, water (50 ml) was added and the lower fluorocarbon layer thus formed was washed with more water, dried using P_2O_5 and transferred under vacuum to a cold trap. The resulting fluorocarbon (24.2 g, 84% recovery) was shown by g.l.c. (col. A, 90°C) to consist

of trimer (24) (94%) together with small amounts of dimers (25) and (26), and a tetramer. The fluorocarbon was therefore suitable for further reaction without further purification.

5A3.a Preparation of Cycloheptene Derivative (52)

Trimer (27) (7.67 g, 15.8 mmol) was stirred with CsF (4.67 g, 30.7 mmol) and DMF (20 ml) at room temperature for 40 hours. Water (20 ml) was then added and the lower fluorocarbon layer thus formed was removed, washed with water, dried over P_2O_5 and transferred under vacuum to a cold trap. The resulting liquid (6.56 g, 84%) was shown to be pure compound (52) by g.l.c. (col. A, 80°C) and by comparing its analytical data with that obtained from an authentic sample.

5A3.b.I Reaction of Dimer (26) with Hexafluoropropene in the Presence of Fluoride Ion

Dimer (26) (1.84 g, 5.68 mmol) was placed in a glass reaction vessel containing a magnetic stirrer and fitted with a 'rotaflo' tap and a side-arm, together with CsF (0.62 g, 4.08 mmol) and acetonitrile (5 ml). Then, hexafluoropropene (1.23 g, 8.20 mmol) was transferred into the vessel under vacuum. The tap was closed and the mixture was stirred at room temperature for 16 hours. After checking that all the gaseous starting material had been used up, water (20 ml) was added to the reaction mixture and the lower layer thus formed was removed, washed with water, dried over P_2O_5 and transferred under vacuum to a cold trap. The resulting liquid (2.87 g, 93.4% recovery)

was shown by g.l.c. (col. A, 80°C) to consist of dimers and trimers of hexafluoropropene together with three components present in the ratio 53:34:13. Pure samples of these three were obtained by preparative scale g.l.c. (col. A, 80°C) and were subsequently identified respectively as Perfluoro-I-cyclobutyl-2-isopropyl-cyclobutene (7I), (Found: F, 71.6%; M⁺, 474. C₁₁F₁₈ requires F, 72.2%; M, 474). Spectra no. I. Perfluoro-I-(I'-isopropyl)-cyclobutyl-cyclobutene (93), (Found: F, 72.5%; M⁺, 474. C₁₁F₁₈ requires F, 72.2%; M, 474). Spectra no. II; and Perfluoro-I-(I'-(I,I-dimethyl)-n-butyl)-2-cyclobutyl-cyclobutene (94), (Found: C, 26.9; F, 73.4%; M⁺, 624. C₁₄F₂₄ requires C, 26.9; F, 73.1%; M, 624). Spectra no. I2.

A similar reaction using dimer (25) instead of dimer (26) gave a product which again consisted of compounds (7I), (93), and (94) in a 53:34:13 ratio.

5A3.b.2 Reaction of Olefin (7I) with Fluoride Ion

Olefin (7I) (0.25 g, 0.53 mmol), CsF (0.41 g, 2.7 mmol) and DMF (1.5 ml) were stirred together at room temperature for 5 days after which water (3 ml) was added and the lower fluorocarbon layer was removed. It was shown by g.l.c. (col. A, 60°C and col. K, 70°C) to consist of unreacted starting material only.

5A3.b.3 Reaction of Trimer (24) with Triethylamine and Water

Trimer (24) (9.31 g, 19.2 mmol), water (0.51 g, 28.0 mmol), tetraglyme (1.5 ml), and two drops of 'Monfluor 31' (a surfactant which aids homogeneity) were placed in a 100 ml round bottomed flask, which was fitted with a reflux condenser and was cooled in an ice bath, and triethylamine (4.38 g, 43.0 mmol) was added dropwise, with stirring, over a period of 2.5 hours. The resultant tarry single layer was washed with water and then ether extracted (3x7 ml). The ether was removed using a rotary evaporator to give an off-white solid product which was washed sequentially with HCl to remove amines, water, and a little cold ether. The resultant solid (5.44 g) was heated to 100°C under vacuum to remove any remaining solvents or washing agents and a portion of it was then purified by vacuum sublimation and subsequently characterised as Triethylammonium Perfluoro-2-(1'-cyclobutylcyclobutyl)-cyclobut-3-one-1-ene-1-oxide (74), (50%), m.p. 108°C; (Found: C, 38.2; H, 3.06; F, 51.2; N, 2.4%; (P-19), 544. $C_{18}H_{16}F_{15}NO_2$ requires C, 38.4; H, 2.84; F, 50.6; N, 2.48%; M, 563). Spectra no. 2.

5BI Pyrolysis of Cycloheptene Derivative (52) over Platinum and General Procedure for Flow Pyrolyses Reactions

Dry nitrogen was bubbled through compound (52) (3.75 g, 7.71 mmol), which was heated to 80°C, and the reactant was then passed in the stream of nitrogen through a silica tube (30 cm x 1 cm) which was lined with platinum foil, filled with platinum turnings and maintained at 580°C.

The product (2.25 g) was collected in two traps in series, each cooled in liquid air. The nitrogen flow rate used gave a contact time of about 30 seconds. The product liquid thus obtained was shown by m.s./g.l.c. (cols. A and O) to consist of compounds (75), (76) and (77) in the ratio 70:15:15. In addition, a ^{19}F n.m.r. spectrum of the product liquid showed a set of signals from which signals attributable to compound (75) could be distinguished by the relative intensities and by a comparison of the chemical shifts with the literature values.

5B2 Flow Pyrolysis of Compound (52) over Silica

The same procedure that was used in section 5BI was used here, except that the reaction tube was filled with silica wool rather than platinum.

Compound (52) (6.15 g, 12.7 mmol) was pyrolysed at 600°C and the product liquid (1.56 g) was shown by g.l.c. (col. A, 140°C) to consist of several volatile minor components together with two less volatile components. These latter two were obtained pure by preparative scale g.l.c. (col. A, 135°C) and were subsequently identified as Perfluoro-1-methyl benzocyclobutane (78), (17%), (Found: C, 36.5; F, 64.2%; M^+ , 298. C_9F_{10} requires C, 36.2; F, 63.8%; M, 298). Spectra no. 3; and Perfluoro-1,2,3-trimethylbenzene (79), (8%), (Found: M^+ , 336. C_9F_{12} requires M, 336). Spectra no. 3a.

When the pyrolysis temperature was reduced below 500°C , only starting material was recovered; between 500 and 600°C , starting material was recovered in concert with products.

5B3.a Flow Pyrolysis of Compound (52) over Iron

The reaction was carried out as per section 5B1 but using a reaction tube packed with '60 Mesh' iron filings.

Compound (52) (0.55 g, 1.13 mmol) was pyrolysed at 450°C and the product (0.25 g) was shown by g.l.c. (col. A, 100°C) to consist of a complex mixture of components with no single component present in any significant quantity.

5B3.b Static Pyrolyses of Compound (52)

Compound (52) (0.33 g, 0.68 mmol) was sealed in a small carius tube under high vacuum and this was heated in a carius furnace to 300°C for 14 hours. After cooling, the tube was opened and the liquid product was shown by g.l.c. (col. A, 90°C) to be mainly (>95%) starting material.

A similar pyrolysis using (52) (0.36 g, 0.74 mmol) and CsF (0.3 g, 2.0 mmol) produced a liquid (0.26 g) which consisted of 8 components comprising mainly starting material.

Compound (52) (3.35 g, 6.90 mmol) and CsF (2.60 g, 17.0 mmol) were sealed in a clean nickel tube which was then heated to 420°C for 72 hours. The product liquid, which was pumped out from the tube under vacuum, was shown by g.l.c. to contain at least 15 components, there being no starting material.

Other Reactions of Compound (52)

5B4 With Methoxide

Compound (52) (4.69 g, 9.65 mmol) was stirred at room temperature for 40 hours with an equimolar amount of freshly prepared sodium methoxide in methanol (10 ml). Water (10 ml) was then added and the lower milky layer thus formed was removed, washed with water (2x5 ml), dried using P_2O_5 and transferred under vacuum to a cold trap. The product (3.80 g) was shown by g.l.c. (col. 0, 200°C) to consist of two major components, samples of which were separated pure by preparative scale g.l.c. (col. 0, 240°C) and subsequently identified as 1-methoxy-perfluorospiro-(bicyclo-5,2,0-non-6,7-ene)-2,1'-cyclobutane (80), (60%), (Found: C, 31.2; H, 0.35; F, 64.7%; M^+ , 498. $C_{13}H_3F_{17}O$ requires C, 31.3; H, 0.60; F, 64.9%; M, 498). Spectra no. 4; and 1,6-dimethoxy-perfluorospiro-(bicyclo-5,2,0-non-6,7-ene)-2,1'-cyclobutane (81), (21%), (Found: C, 32.9; H, 1.15; F, 59.8%; M^+ , 510. $C_{14}H_6F_{16}O$ requires C, 32.9; H, 1.18; F, 59.6%; M, 510). Spectra no. 5.

5B5 With Diazomethane

The diazomethane was prepared in ether solution by the standard literature method ¹⁹⁰.

Compound (52) (2.06 g, 4.24 mmol) was stirred in a 50 ml round bottomed flask and a solution of diazomethane in dry ether was slowly added with stirring until the pale yellow colour of the diazomethane solution did not disappear on contact with the fluorocarbon. The mixture was allowed to stand overnight, the ether was removed

using a rotary evaporator and then by pumping on a vacuum line and the viscous oily liquid thus produced was vacuum sublimed to give a white solid (1.82 g, 81%) which was identified as (6,7- Δ^2 -pyrazoline)-perfluorospiro-(bicyclo-5,2,0-nonane)-2,1'-cyclobutane (82); m.p. 96°C; (Found: C, 29.2; H, 0.20; F, 64.8%; M^+ , 528. $C_{13}H_2F_{18}N_2$ requires C, 29.6; H, 0.4; F, 64.8%; M , 528). Spectra no. 6.

5B6 With Acetaldehyde

Compound (52) (1.39 g, 2.86 mmol) and acetaldehyde (0.61 g, 14 mmol) were placed in a small carius tube and degassed, and then the tube was sealed under vacuum and irradiated with γ -rays for 21 days. After this, two immiscible liquids were recovered in high yield which were shown by m.s./g.l.c. to be the starting materials.

5B7 Attempted Fluorination

Compound (52) (3.44 g, 7.08 mmol) was introduced dropwise in a flow of nitrogen into a cobalt trifluoride fluorination bed maintained at 170°C. The liquid recovered (2.50 g) was shown to consist only of starting material.

5C REACTIONS OF TRIMER (27)

5CI With Methoxide

The procedure for this reaction was the same as that described in section 5B4. Thus, trimer (27) (2.08 g, 4.28 mmol) and methanol (20 ml, containing 4.28 mmol of methoxide ion) gave, after reaction, a colourless liquid

product (1.75 g) shown by m.s./g.l.c. (col. K, 140°C) to consist of mono-, di-, and tri-substituted products in the ratio 43:34:24 respectively. It was not possible to isolate the products pure by preparative scale g.l.c.

5C2.a With Acetaldehyde

Trimer (27) (2.25 g, 4.63 mmol), acetaldehyde (0.36 g, 8.2 mmol), and benzoyl peroxide (0.06 g, 0.3 mmol) were degassed, sealed under vacuum in a carius tube and heated to 80°C for 16 hours. No products were formed and starting materials were recovered in good yield.

5C2.b With Methanol

In a similar manner, starting materials were recovered in good yield from a mixture containing trimer (27) (2.38 g, 4.90 mmol), methanol (0.33 g, 10 mmol) and benzoyl peroxide (0.06 g, 0.3 mmol).

5C3 Fluorination

The fluorinator used consisted of a metal tube packed with cobalt trifluoride, moderated with calcium fluoride and fitted with an electrical heater. The reactant was introduced directly into the bed in a stream of dry nitrogen carrier gas by means of a suitably modified burette. The outlet consisted of a metal reflux column, which was also electrically heated, leading to a cold trap in which the products collected.

Thus trimer (27) (5.11 g, 10.5 mmol) was fluorinated at 170°C. The product liquid (4.12 g) was

shown by g.l.c. (col. K, 110°C) to consist of small amounts of fragmentation products, starting material (20%), and a single product (70%) which was subsequently identified as Perfluoro-1,2-di(cyclobutyl)-cyclobutane (83), (62%), (Found: F, 72.2%; (P-69), 455. C₁₂F₂₀ requires F, 72.5%; M, 524). Spectra no. 7.

5D With Diazomethane

A similar reaction procedure to that described in section 5B5 using trimer (27) (1.20 g, 2.47 mmol) gave, after work-up, a white solid product identified as 3,6-di(heptafluorocyclobutyl)-4,4,5,5-tetrafluoro-1,2-diazepine (85), (0.83 g, 64%), (Found: C, 29.8; H, 0.60; F, 64.5; N, 5.5%; M⁺, 528. C₁₃H₂F₁₈N₂ requires C, 29.6; H, 0.4; F, 64.8; N, 5.3%; M, 528). Spectra no. 8.

5E REACTIONS OF DIMERS (25) AND (26)

5E1.a Reaction of a Mixture of Dimers (25) and (26) with 1,3-Butadiene

A 1:1 mixture of dimers (25) and (26) (2.52 g, 7.78 mmol) and 1,3-butadiene (1.65 g, 30.6 mmol) were heated together in a sealed carius tube at 80°C for 66 hours. Volatile material (1.60 g) was then removed and was shown by g.l.c. (cols. A and K, 130°C) to consist only of dimer (26) and compound (89) in equimolar amounts. An involatile white solid (0.58 g) was also removed from the carius tube; it was not investigated but was presumably a homopolymer of 1,3-butadiene.

A repeat reaction using a mixture of dimers (25) and (26) (2.10 g, 6.58 mmol), butadiene (2.06 g, 38.1 mmol), and CsF (0.18 g, 1.18 mmol) gave, after reaction and work-up, volatile material (1.66 g) which was shown by g.l.c. (col. A, 130°C) to consist of the Diels Alder adduct (89) only.

5EI.b Reaction of Dimer (25) with 1,3-cyclohexadiene

Dimer (25) (1.10 g, 3.40 mmol) and 1,3-cyclohexadiene (0.45 g, 5.63 mmol) were heated together to 80°C for 24 hours after which the two original layers of liquid were seen to have homogenised. Volatile material (1.45 g) was then collected and shown by g.l.c. (col. A, 80°C) to consist of one fluorocarbon product, an equimolar amount of benzene and, finally, a small amount of unreacted 1,3-cyclohexadiene. The fluorocarbon component (90% yield) was separated by preparative scale g.l.c. (col. A, 120°C) and subsequently identified as 1-hydro-1-(1°-hydro)-perfluoro-cyclobutyl-cyclobutane (90), (Found: C, 29.8; H, 0.7; F, 70.0%; M^+ , 326. $C_8H_2F_{12}$ requires C, 29.4; H, 0.6, F, 70.0%; M , 326). Spectra no. 9.

The reaction was repeated using a mixture of dimers (25) and (26) (0.84 g, 2.6 mmol) and 1,3-cyclohexadiene (0.38 g, 4.8 mmol). The volatile material thus obtained (0.90 g) was shown to consist of equal amounts of compounds (26), (90), and benzene, together with a small amount of unreacted 1,3-cyclohexadiene.

A repeat reaction using dimer mixture, 1,3-cyclohexadiene, and CsF resulted in complete conversion of the dimers to the single fluorocarbon product (90).

5EI.c Reaction of a Mixture of Dimers (25) and (26) with
Cyclopentadiene in the Presence of Fluoride Ion

A mixture of dimers (25) and (26) (1.14 g, 3.52 mmol), CsF (0.26 g, 1.71 mmol) and freshly distilled cyclopentadiene (0.31 g, 4.6 mmol) were heated at 80°C for 16 hours and the resultant liquid product was shown by g.l.c. (col. K, 140°C) to consist of unreacted (26) (5%), a minor product which was not characterised (10%), and the expected adduct, a sample of which was obtained pure by preparative scale g.l.c. (col. K, 140°C) and was identified as Dispiro-2,3-(hexafluorocyclobutane)-norborn-5-ene (92), (85%), (Found: C, 40.3; H, 1.7; F, 58.2%; M⁺, 390. C₁₃H₅F₁₂ requires C, 40.0; H, 1.5; F, 58.5%; M, 390). Spectra no. 10.

5EI.d Reactions of Perfluorocyclobutene with Cyclopentadiene

Cyclopentadiene (3.0 g, 55.6 mmol), CsF (1.16 g, 7.63 mmol), and tetraglyme (5 ml) were placed in a round bottomed flask fitted with a 'rotaflo' tap and a side-arm and perfluorocyclobutene (4.30 g, 26.5 mmol) was transferred in under vacuum. The reaction mixture was stirred for 16 hours at 50°C and for 5 days at room temperature after which perfluorocyclobutene (3.66 g) was recovered unreacted.

A similar experiment was carried out using perfluorocyclobutene (6.57 g, 41.4 mmol), cyclopentadiene (3.51 g, 53.2 mmol) and pyridine (0.42 g, 5.31 mmol). After stirring for 5 days at room temperature, all the fluorocarbon had reacted. Volatile material (5.23 g) was then transferred under vacuum to a cold trap and this was

shown by g.l.c. and by n.m.r. methods to consist of adduct (92) (70%), giving an overall yield from perfluorocyclobutene of 46%. No oligomers of perfluorocyclobutene were detected.

5E2 Reaction of Dimer (26) with Acetaldehyde

Dimer (26) (1.91 g, 5.90 mmol) and acetaldehyde (0.37 g, 8.4 mmol) were placed in a curius tube; the liquids were degassed and the tube was sealed under vacuum and irradiated with γ -rays for 21 days after which the tube was opened and volatile material was transferred out (1.82 g) into a cold trap. The volatile material was shown to consist of small amounts of starting materials (5%) and two major components which were isolated by preparative scale g.l.c. (col. A, 120°C) and identified as E and Z isomers of 2-acetyl-1-hydro-perfluoro-1-cyclobutyl-cyclobutane. The Z isomer (95) showed C, 32.4; H, 0.9; F, 62.3%; (P-67), 301. $C_{10}H_4F_{12}O$ requires C, 32.6; H, 1.1; F, 62.0%; M, 368. Spectra no. 13. The E isomer showed C, 32.8; H, 0.9; F, 61.7%; (P-15), 353. Spectra no. 14.

CHAPTER SIX

EXPERIMENTAL TO CHAPTER THREE

General Procedures

A) Liquid Fluorocarbon Starting Material

Tetraglyme and the required active methylene compound were placed in a round bottomed flask together with a magnetic stirrer. The enolate anion was generated either by adding a known molar equivalent of pure sodium hydride a little at a time or by adding aliquots of a 50% dispersion of sodium hydride in oil until no further evolution of hydrogen occurred.

The reaction mixture was cooled using a cold water-bath and then the fluorocarbon was added from a pipette in a single aliquot. The mixture was stirred for 16 hours at room temperature after which either one of two work-up procedures was adopted.

1) All volatile material was transferred under vacuum to a cold trap. Two layers were formed after warming to room temperature; the lower fluorocarbon one was removed and, since a ^{19}F n.m.r. spectrum of the upper layer showed the presence of further fluorocarbon material, water was added to form a new two-phase system. The lower layer was again removed and was combined with the original lower layer.

2) Water (50ml) was added and the thick, oily lower layer thus formed was removed. Volatile material from this layer was transferred under vacuum to a cold trap.

The crude fluorocarbon product mixture thus obtained was washed with water, dried over P_2O_5 , and transferred under vacuum to a cold trap. The yields quoted in the text are based on g.l.c. analysis of the product liquid at this stage and are based on the actual fluorocarbon consumed.

B) Gaseous Fluorocarbon Starting Material

Reactions were carried out as in section A but using a reaction vessel fitted with a 'rotaflo' tap and a side arm. The fluorocarbon was manipulated by means of a vacuum line. After reaction was complete, unreacted fluorocarbon was collected by letting it escape through the side arm into a flexible gas reservoir.

6A REACTIONS OF PERFLUORO-3,4-DIMETHYL-3-HEXENE (IO)

6AI With Diethyl Malonate

Compound (IO) (4.23 g, 10.6 mmol) was reacted with an equimolar amount of sodium diethylmalonate in tetraglyme (5 ml) to produce, after work-up, a liquid (4.30 g) which was shown by g.l.c. (col. K, $140^{\circ}C$) to contain starting materials and one major product. A sample of this was obtained pure by preparative scale g.l.c. (col. K, $160^{\circ}C$) and identified as 5-carboethoxy-6-ethoxy-2,3,4-tri(trifluoromethyl)-4-pentafluoroethyl-pyran (IOO), (42%), (Found: C, 34.7; H, 2.1; F, 51.2 %; (P-45), 475; (Chemical Ionisation)(P+I), 521. $C_{15}H_{10}F_{14}O_4$ requires C, 34.6; H, 1.9; F, 51.2 %; M, 520). Spectra no. 15.

6A2 With Acetyl Acetone

Reaction of compound (IO) (6.22 g, 15.6 mmol), acetyl acetone (3.53 g, 35.3 mmol), sodium hydride (35.3 mmol), and tetraglyme (10 ml) gave, after work-up, a liquid (6.10 g) which was shown by g.l.c. to contain one major product. A sample of this was obtained pure by preparative scale g.l.c. (col. K, 150°C) and identified as 5-acetyl-6-methyl-2,3,4-tri(trifluoromethyl)-4-pentafluoro-ethyl-pyran (IO1), (32%), (Found: C, 33.7; H, 1.53; F, 58.1%; (P-I5), 445. $C_{13}H_6F_{14}O_2$ requires C, 33.9; H, 1.30; F, 57.8%; M, 460). Spectra no. I6.

6A3 With Ethyl Acetoacetate

Reaction of compound (IO) (12.0 g, 30.0 mmol), ethyl acetoacetate (9.1 g, 70.0 mmol), sodium hydride (70 mmol) and tetraglyme (20 ml) gave, after work-up, a liquid (10.03 g) which was shown by g.l.c. to consist of hydrocarbon starting material (10%) and a single product (90%) only. All the fluorocarbon starting material had reacted. The product, after further purification, was identified as 5-carboethoxy-6-methyl-2,3,4-tri(trifluoromethyl)-4-pentafluoroethyl-pyran (IO2), (65%), (Found: C, 34.0; H, 1.85; F, 53.8%; (P-45), 445. $C_{14}H_8F_{14}O_3$ requires C, 34.3; H, 1.63; F, 54.3%; M, 490). Spectra no. I7.

The reaction described above was the most successful of a series of reactions between compound (IO) and ethyl acetoacetate designed to study the effects of solvent, reactant amounts, reaction procedure etc. The results are tabulated overleaf.

<u>C₈F₁₆</u> in mmol	<u>Ethyl Acetoacetate</u> in mmol	<u>Ratio HC : FC</u>	<u>NaH</u> in mmol	<u>Tetraglyme</u> in ml	<u>Reaction Time</u> in hours	<u>% yield</u> based on (IO) consumed
9.5	21	2.21:1	21	15	16	58
10	10	1:1	10	5	16	26
10	10	1:1	20	5	16	36
10	10	1:1	0	5	16	100% of (IO) recovered
10	10	1:1	10	3	16	18
10	10	1:1	10	15	16	15
10	10	1:1	10	5	40	20
10	10	1:1	10	5	22	22
10	10	1:1	10	5 ml DMF	16	34
10	10	1:1	10	5 ml CH ₃ CN	16	25
10	10	1:1	10	5	22	22
30	70	2.33:1	70	20	16	65

Reaction Procedure - add ethyl acetoacetate to solvent, then add sodium hydride; allow to cool and add fluorocarbon in one aliquot.

Except - a, add anion slowly to FC (6 hrs.) (maintains an excess of anion)

- b, add FC slowly to anion (6 hrs.) (maintains an excess of FC)

6A4 With Diethyl Malonate in the presence of Fluoride Ion

Compound (IO) (3.95 g, 9.88 mmol) was stirred with CsF (1.95 g, 12.8 mmol) in tetraglyme (3 ml) for 30 minutes. Separately, diethyl malonate (1.64 g, 10.3 mmol) was reacted with a molar equivalent of sodium hydride in tetraglyme (5 ml). The two solutions were quickly mixed and then they were stirred at room temperature for 36 hours. After the usual work-up, the resultant liquid (2.53 g) was shown by g.l.c. (col. K, 150°C) to contain starting materials together with two products; a major one identified as compound (IO0)(35%) and a minor one which was isolated pure by preparative scale g.l.c. (col. K, 160°C) and identified as I,I-di(carboethoxy)-perfluoro-2,3,4-tri(trifluoromethyl)-hexa-1,3-diene (IO8), (7%), (Found: C, 34.2; H, 2.0; F, 50.9%; (P=28), 492. $C_{15}H_{10}F_{14}O_4$ requires C, 34.6; H, 1.9; F, 51.2%; M, 520). Spectra no. I8.

6A5.a With Malononitrile

Reaction of compound (IO) (5.73 g, 14.3 mmol), malononitrile (2.45 g, 37.1 mmol), sodium hydride (37.1 mmol), and tetraglyme (10 ml) gave, after work-up, unreacted starting fluorocarbon (2.46 g) only.

6A5.b With Ethyl Acetoacetate using Sodium Ethoxide as base.

Ethanol (7 ml) was placed in a 50 ml round bottomed flask and sodium metal (0.40 g) was dissolved in it thus forming 18 mmol of ethoxide ion. Ethyl acetoacetate (2.28 g, 14.3 mmol) was then added dissolved

in tetraglyme (2 ml) followed by compound (10) (3.45 g, 8.63 mmol). The mixture was stirred for 45 minutes after which a ^{19}F n.m.r. spectrum showed that all the starting fluorocarbon had been used up. All volatile material was transferred to a cold trap (thus removing NaF and NaOC_2H_5), ethanol was removed by distillation and water was added to the residue. The lower fluorocarbon layer thus formed was removed (3.38 g) and was shown by g.l.c. (col. K, 140°C) to consist of at least 6 components, none of which could be isolated pure by preparative scale g.l.c.

6B REACTIONS OF PERFLUORO-3-METHYL-3-PENTENE (9)

6BI With Diethyl Malonate

A mixture containing (9) (3.00 g, 10.0 mmol), diethyl malonate (2.40 g, 15.0 mmol), sodium hydride (15.0 mmol) and tetraglyme (5 ml) gave, after reaction and work-up, a liquid (3.84 g) which contained one major product, subsequently isolated pure by preparative scale g.l.c. (col. K, 130°C) and identified as a 1:4 mixture of E and Z isomers of 1,1-di(carboethoxy)-2,3-di(trifluoro-methyl)-tetrafluoro-penta-1,3-diene (109), (57%), (Found: C, 37.0; H, 2.43; F, 45.4%; M^+ , 420. $\text{C}_{13}\text{H}_{10}\text{F}_{10}\text{O}_4$ requires C, 37.1; H, 2.38; F, 45.2%; M , 420). Spectra no. 19.

6B2 With Ethyl Acetoacetate

A mixture containing (9) (3.00 g, 10.0 mmol), ethyl acetoacetate (1.95 g, 15.2 mmol), sodium hydride (15.2 mmol) and tetraglyme (5 ml) gave, after reaction and work-up, a liquid (2.70 g) which contained two

products, subsequently isolated pure by preparative scale g.l.c. (col. K, 130°C) and identified as Z/E/Z/E - I-acetyl-I-carboethoxy-2,3-di(trifluoromethyl)-tetrafluoro-penta-1,3-diene (II0), (26%), (Found: C, 37.1; H, 2.15; F, 49.1%; M⁺, 390. C₁₂H₈F₁₀O₃ requires C, 36.9; H, 2.05; F, 48.7%; M, 390). Spectra no. 20, and 5-carboethoxy-I-fluoro-6-methyl-1,2,3-tri(trifluoromethyl)-2H-pyran (III), (14%), (Found: C, 36.8; H, 2.12; F, 48.9%; M⁺, 390. C₁₂H₈F₁₀O₃ requires C, 36.9; H, 2.05; F, 48.7%; M, 390). Spectra no. 21.

6B3 With Acetyl Acetone

A mixture containing (9) (3.00 g, 10.0 mmol), acetyl acetone (1.50 g, 15.0 mmol), sodium hydride (15.0 mmol) and tetraglyme (5 ml) gave, after reaction and work-up, a liquid (2.31 g), which was shown by g.l.c. (col. K, 130°C) to consist of at least four components and from which no pure products could be isolated.

6C REACTIONS OF THE TETRAFLUOROETHYLENE PENTAMER (II)

6CI With Diethyl Malonate

A mixture containing (II) (5.07 g, 10.1 mmol), diethyl malonate (3.44 g, 21.5 mmol), sodium hydride (21.5 mmol) and tetraglyme (8 ml) gave, after reaction and work-up, a liquid (4.25 g) shown by g.l.c. to consist of starting materials together with one major product. A sample of this was obtained pure by preparative scale g.l.c. (col. K, 170°C) and identified as I,I-di(carboethoxy)-perfluoro-2-methyl-3-(3^a-(3-methyl)-pentyl)-buta-1,3-diene (II5), (54%),

(Found: C, 32.7; H, 1.50; F, 55.4%; (P-45), 575; (Chemical Ionisation) (P+I), $62I.C_{17}H_{10}F_{18}O_4$ requires C, 32.9; H, 1.61; F, 55.2%; M, 620). Spectra no. 23.

6C2 With Ethyl Acetoacetate

A mixture containing (II) (5.00 g, 10.0 mmol), ethyl acetoacetate (2.70 g, 21.0 mmol), sodium hydride (21.0 mmol) and tetraglyme (5 ml) gave, after reaction and work-up, a liquid (5.43 g) which was shown by g.l.c. to consist of starting materials together with one major product. A sample of this was isolated pure by preparative scale g.l.c. (col. K, 160°C) and identified as 5-carboethoxy-2,4-difluoro-6-methyl-3-(perfluoro-3'-(3-methyl)-pentyl)-4-trifluoromethyl-pyran (II4), (39%), (Found: C, 30.3; H, 1.52; F, 57.8%; (P-45), 545. $C_{16}H_8F_{18}O_3$ requires C, 30.5; H, 1.36; F, 58.0%; M, 590). Spectra no. 22.

6D REACTIONS OF PERFLUORO-2-BUTENE (8)

6DI With Acetyl Acetone

Reaction of compound (8) (4.93 g, 24.7 mmol), acetyl acetone (3.06 g, 30.6 mmol), sodium hydride (30.6 mmol) and tetraglyme (10 ml) gave, after work-up, 1.64 g of unreacted fluorocarbon, and a liquid (1.91 g) which was shown by g.l.c. to consist of one major product. A sample of this was obtained pure by preparative scale g.l.c. (col. K, 110°C) and identified as 4-acetyl-5-methyl 2,3-di(trifluoromethyl)-furan (II8), (37%), (Found: C, 41.3; H, 2.2; F, 44.3%; M^+ , 260. $C_9H_6F_6O_2$ requires C, 41.5; H, 2.3; F, 43.9%; M, 260). Spectra no. 24.

6D2 With Ethyl Acetoacetate

Reaction of compound (8) (4.06 g, 20.3 mmol), ethyl acetoacetate (3.00 g, 23.0 mmol), sodium hydride (23.0 mmol) and tetraglyme (5 ml) gave, after work-up, 0.94 g of unreacted fluorocarbon, and a liquid (3.61 g) which was shown to consist of one major product. A sample of this was obtained pure by preparative scale g.l.c. (col. K, 115°C) and identified as 4-carboethoxy-5-methyl-2,3-di(trifluoromethyl)-furan (119), (57%), (Found: C, 41.7; H, 2.9; F, 39.8%; M^+ , 290. $C_{10}H_8F_6O_3$ requires C, 41.4; H, 2.8; F, 39.3%; M, 290). Spectra no. 25.

6D3 With Diethyl Malonate

Reaction of compound (8) (3.64 g, 18.2 mmol), diethyl malonate (3.14 g, 19.6 mmol), sodium hydride (19.6 mmol) and tetraglyme (5 ml) gave, after work-up, 0.50 g of unreacted fluorocarbon and a liquid (2.72 g) which was shown to consist of one major product. A sample of this was obtained pure by preparative scale g.l.c. (col. K, 140°C) and identified as 5-carboethoxy-6-ethoxy-2,2,3-trifluoro-4-trifluoromethyl-2H-pyran (120), (27%), (Found: C, 41.1; H, 3.1; F, 35.8%; M^+ , 320. $C_{11}H_{10}F_6O_4$ requires C, 41.3; H, 3.1; F, 35.6%; M, 320). Spectra no. 26.

6E REACTIONS OF PERFLUOROCYCLOHEXENE (6)

6E1.a With Acetyl Acetone

Reaction of compound (6) (4.16 g, 15.9 mmol), acetyl acetone (2.50 g, 25.0 mmol), sodium hydride (25.0 mmol) and tetraglyme (10 ml) gave, after work-up, a liquid (2.28 g)

which contained one major product. A sample of this was isolated pure by preparative scale g.l.c. (col. K, 140°C) and subsequently identified as 3-acetyl-2-methyl-4,4,5,5,6,6,7,7-octafluoro-4H,5H,6H,7H-benzofuran (I22), (38%), (Found: C, 41.1; H, 2.0; F, 46.9%; M⁺, 322. C₁₁H₆F₈O₂ requires C, 41.0; H, 1.9; F, 47.2%; M, 322). Spectra no. 27.

6E1.b With Ethyl Acetoacetate

Reaction of compound (6) (4.08 g, 15.6 mmol), ethyl acetoacetate (2.04 g, 15.8 mmol), sodium hydride (15.8 mmol) and tetraglyme (5 ml) gave, after work-up, a liquid (1.63 g) which contained one major product. A sample of this was isolated pure by preparative scale g.l.c. (col. K, 140°C) and subsequently identified as 3-carboethoxy-2-methyl-4,4,5,5,6,6,7,7-octafluoro-4H,5H,6H,7H-benzofuran (I23), (31%), (Found: C, 41.2; H, 2.3; F, 43.2%; M⁺, 352. C₁₂H₈F₈O₃ requires C, 40.9; H, 2.3; F, 43.2%; M, 352). Spectra no. 28.

6E2 With Diethyl Malonate

Reaction of compound (6) (6.30 g, 24.0 mmol), diethyl malonate (5.82 g, 36.4 mmol), sodium hydride (36.4 mmol) and tetraglyme (10 ml) gave, after work-up, a liquid (6.03 g) which contained one major product. A sample of this was obtained pure by preparative scale g.l.c. (col. K, 140°C) and subsequently identified as Di(carboethoxy)-methylene-octafluorocyclohex-2-ene (I24), (31%), (Found: C, 40.8; H, 2.7; F, 40.2%; M⁺, 382. C₁₃H₁₀F₈O₄ requires C, 40.8; H, 2.6; F, 39.8%; M, 382). Spectra no. 29.

6E3 Reaction of compound (I24) with Fluoride Ion

Compound (I24) (0.60 g, 1.57 mmol) was added to CsF (0.30 g, 1.97 mmol) in tetraglyme (1 ml). A deep red colouration was produced. The mixture was stirred for 16 hours at room temperature after which a sample was removed and its ^{19}F n.m.r. spectrum run. This showed a complex set of signals and the complete disappearance of signals due to starting material. Volatile material was transferred out from the reaction mixture to a cold trap. The ^{19}F n.m.r. spectrum of this clear liquid showed only signals due to starting material.

6F REACTIONS OF PERFLUOROCYCLOPENTENE (5)

6FI With Diethyl Malonate

Reaction of compound (5) (4.58 g, 21.6 mmol), diethyl malonate (3.20 g, 20.0 mmol), sodium hydride (20.0 mmol) and tetraglyme (5 ml) gave, after work-up, a liquid (2.93 g) which contained two products. Pure samples of these were isolated pure by preparative scale g.l.c. (col. K, 150°C) and subsequently identified as Octafluorocyclopent-1-enyl-diethyl malonate (I29), (9%), (Found: C, 40.8; H, 3.3; F, 37.4%; (P-45), 307. $\text{C}_{12}\text{H}_{11}\text{F}_7\text{O}_4$ requires C, 40.9; H, 3.1; F, 37.8%; M, 352). Spectra no. 30, and Di(carboethoxy)-methylene-hexafluorocyclopent-2-ene (I30), (I2%), (Found: C, 43.6; H, 3.2; F, 34.7%; M^+ , 332. $\text{C}_{12}\text{H}_{10}\text{F}_6\text{O}_4$ requires C, 43.4; H, 3.0; F, 34.3%; M, 332). Spectra no. 31.

6F2 With Ethyl Acetoacetate

Reaction of compound (5) (3.75 g, 17.7 mmol), ethyl acetoacetate (3.90 g, 30.0 mmol), sodium hydride (30.0 mmol) and tetraglyme (5 ml) gave, after work-up, a liquid (2.95 g) containing one product, a sample of which was isolated pure by preparative scale g.l.c. (col. K, 150°C) and identified as Octafluorocyclopent-1-enyl-ethyl-acetoacetate (131), (31%), (Found: C, 40.6; H, 2.9; F, 41.5%; M^+ , 322. $C_{11}H_9F_7O_3$ requires C, 41.0; H, 2.8; F, 41.3%; M , 322). Spectra no. 32.

6F3 With Acetyl Acetone

Reaction of compound (5) (3.65 g, 17.2 mmol), acetyl acetone (3.00 g, 30.0 mmol), sodium hydride (30.0 mmol) and tetraglyme (10 ml) gave, after work-up, a liquid (2.47 g) which was shown by g.l.c. (col. K, 130°C) to contain 5 components. Two were identified as starting materials and one was a very minor component. Samples of the other two were isolated by preparative scale g.l.c. (col. K, 120°C). The first (17%) was shown by ^{19}F n.m.r. spectroscopy to consist of two compounds, each containing nine fluorine atoms. The second was identified as 3-acetyl-2-methyl-4,5-hexafluorocyclopentyl-furan (135), (25%), (Found : C, 44.4; H, 2.4; F, 41.6%; M^+ , 272. $C_{10}H_6F_6O_2$ requires C, 44.1; H, 2.2; F, 41.9%; M , 272). Spectra no. 33.

6G REACTIONS OF PERFLUOROCYCLOBUTENE (4)

Separate reactions of (4) with the enolate anions derived from diethyl malonate, acetyl acetone and ethyl acetoacetate resulted in each case in the rapid formation of thick tars from which no volatile products could be obtained.

CHAPTER SEVEN

EXPERIMENTAL TO CHAPTER FOUR

7A GENERAL PROCEDURES USED IN EPOXIDATION REACTIONS

In a typical reaction, a three phase mixture comprising the fluorinated olefin, a 50% excess of sodium hypochlorite solution, and acetonitrile (a volume corresponding to 15% of the volume of the hypochlorite solution) was stirred at room temperature for 40 hours.

The sodium hypochlorite solution was made by bubbling chlorine gas through a 25% solution of aqueous sodium hydroxide, which was maintained within the temperature range $-20 - -10^{\circ}\text{C}$ using an acetone/dry-ice slush bath. The amount of ClO^- thus produced was estimated either by measuring the pH of the solution (pH 9-10 is ideal) or by a titration method. Typically, 10 ml of hypochlorite solution were diluted 20 times and 10 ml of this were acidified (using 5 ml of glacial acetic acid), excess KI was added and then this mixture was titrated against standard 0.1 M sodium thiosulphate solution. The following equations explain the chemistry involved.



The progress of the reaction was monitored by ^{19}F n.m.r. spectroscopy. After reaction was complete, the lower fluorocarbon layer was removed, washed with water,

dried using anhydrous magnesium sulphate, and transferred to a cold trap. The yields quoted in the text are based on g.l.c. analysis of the liquid obtained at this stage. If this liquid was not pure product, distillation or preparative scale g.l.c. were used as appropriate to effect purification.

7B EPOXIDATION REACTIONS

7BI Epoxidation of Perfluoro-3,4-dimethyl-3-hexene (I0)

Olefin (I0) (33.0 g, 82.5 mmol), sodium hypochlorite solution (85 ml, containing 159 mmol of ClO^-), and acetonitrile (15 ml) gave, after reaction and work-up, a liquid (27.0 g). This was shown by g.l.c. (col. K, 60°C) to consist of several components. The liquid was distilled at atmospheric pressure and the following fractions were obtained: $58-63^\circ\text{C}$, shown to be pure epoxide (I38); $63-90^\circ\text{C}$, shown by g.l.c. to be a multi-component mixture; $90-93^\circ\text{C}$, shown to consist of a small amount of starting material together with 3-methyl-perfluoro-(3-methyl pentane), which is an impurity in the starting material; and $95-100^\circ\text{C}$, shown to be mainly (90%+) epoxide (I37). The pot residue was shown to consist of epoxide (I37) only. Samples of the individual isomers of (I37) were obtained pure by means of preparative scale g.l.c. (col. K, 40°C) and samples of the individual isomers of (I38) were obtained pure likewise, using col. A, 40°C .

(Z)-perfluoro-3,4-dimethyl-3,4-epoxy-hexane (I37Z),

(3I%), (Found: C, 23.0; F, 72.7%; (P-I9), 397. $\text{C}_8\text{F}_{16}\text{O}$ requires C, 23.1; F, 73.1%; M, 416). Spectra no. 34.

(E)-perfluoro-3,4-dimethyl-3,4-epoxy-hexane (I37E), (31%),
(Found: C, 23.2; F, 72.6%; (P-I9), 397. $C_8F_{16}O$ requires
C, 23.1; F, 73.1%; M, 416). Spectra no. 35.

(Z)-2-hydro-perfluoro-(3-methyl-2,3-epoxy-pentane) (I38Z),
(20%), (Found: C, 24.1; H, 0.3; F, 69.4%; M^+ , 298.
 $C_6HF_{11}O$ requires C, 24.2; H, 0.3; F, 70.1%; M, 298). Spectra
no. 36. (E)-2-hydro-perfluoro-(3-methyl-2,3-epoxy-pentane)
(I38E), (8%), (Found: C, 23.9; H, 0.2; F, 70.4%; M^+ , 298.
 $C_6HF_{11}O$ requires C, 24.2; H, 0.3; F, 70.1%; M, 298).
Spectra no. 37.

Control Reaction in the Absence of Solvent

Tetramer (I0) (33.0 g, 82.5 mmol) and sodium hypochlorite solution (100 ml) were stirred together at room temperature for 72 hours after which a ^{19}F n.m.r. spectrum of the lower fluorocarbon layer showed only signals due to unchanged starting material.

Reaction of Epoxide (I37) with Sodium Hypochlorite solution

Epoxide (I37) (2.08 g, 5.00 mmol), sodium hypochlorite solution (10 ml, containing more than 5 mmol of ClO^-), and acetonitrile (1 ml) were stirred together for 3 days after which a comparison of the g.l.c. traces of the starting and finishing fluorocarbons clearly showed that none of the degraded epoxide (I38) had been produced.

7B2.a Epoxidation of Perfluorocyclobutene Trimer (27)

Compound (27) (3.24 g, 6.67 mmol), sodium hypochlorite solution (40 ml), and acetonitrile (10 ml) gave, after reaction and work-up, a liquid (2.15 g) shown to consist of a single product subsequently identified as Perfluoro-1,2-di(cyclobutyl)-1,2-epoxy-cyclobutane (I39), (64%), (Found: C, 28.8; F, 68.3%; M^+ , 502. $C_{12}F_{18}O$ requires C, 28.7; F, 68.1%; M, 502). Spectra no. 38.

7B2.b Epoxidation of Perfluorocyclobutene Trimer (24)

Compound (24) (2.15 g, 4.42 mmol), sodium hypochlorite solution (20 ml), and acetonitrile (3 ml) gave, after reaction and work-up, a liquid (1.57 g) shown to consist of one major product. A sample of this was obtained pure by preparative scale g.l.c. (col. A, 125°C) and identified as Perfluoro-1-(1'-cyclobutylcyclobutyl)-1,2-epoxy-cyclobutane (I40), (62%), (Found: F, 68.3%; (P-69), 433. $C_{12}F_{18}O$ requires F, 68.1%; M, 502). Spectra no. 43.

7B3 Epoxidation of Perfluoro-3-methyl-3-pentene (9)

Compound (9) (3.15 g, 10.5 mmol), sodium hypochlorite solution (30 ml), and acetonitrile (5 ml) were reacted at room temperature for 16 hours in a round-bottomed flask fitted with a flexible gas reservoir. After this time, no gas had been produced. The lower fluorocarbon layer (2.00 g) was removed and was shown to consist of one product identified as Perfluoro-3-methyl-2,3-epoxy-pentane (I45), (60%), (Found: C, 23.1; F, 72.5%; (P-19), 297.

$C_6F_{12}O$ requires C, 22.8; F, 72.2%; M, 316). Spectra no.40. There was no trace of any products arising from degradation of the pentafluoroethyl group (this would probably have been gaseous).

7B4 Epoxidation of Cycloheptene Derivative (52)

Compound (52) (1.23 g, 2.53 mmol), sodium hypochlorite solution (6 ml), and acetonitrile (1.5 ml) gave, after reaction and work-up, a liquid (0.81 g) shown to consist of a single component, subsequently identified as Perfluorospiro-(bicyclo-(5,2,0)-1,7-epoxy-nonane-2,1'-cyclobutane (I46), (64%), (Found: C, 28.0; F, 68.4%; (P-I9), 483. $C_{12}F_{18}O$ requires C, 28.7; F, 68.1%; M, 502). Spectra no. 39.

7B5 Attempted Epoxidation of Perfluoro-2,3-dimethyl-butadiene

A mixture of perfluoro-2,3-dimethyl-butadiene (2.62 g, 10.0 mmol), sodium hypochlorite solution (10 ml), and acetonitrile (2 ml) were stirred at room temperature for 16 hours. After this time, no lower fluorocarbon layer remained. A ^{19}F n.m.r. spectrum of the single layer remaining showed a complex set of signals attributable to several fluorocarbon species. The investigation was not pursued.

A control reaction using a mixture of fluorocarbon (1.72 g, 6.56 mmol), sodium hydroxide solution (10 ml of a 25% solution i.e. 62.5 mmol), and acetonitrile (2 ml) produced a thick brown tar after being stirred at room temperature for 1 hour.

7B6 Attempted Epoxidation of Perfluoro-bicyclobutylidene (25)

A mixture of compound (25) (0.90 g, 2.78 mmol), sodium hypochlorite solution (10 ml), and acetonitrile (2 ml) was stirred for 16 hours at room temperature after which no fluorocarbon layer remained.

7C REACTIONS OF EPOXIDE (I37)

7CI With Fluoride Ion

7CI.a Flow Pyrolysis of Epoxide (I37) over hot CsF

Epoxide (I37) (5.06 g, 12.2 mmol) was passed in a flow of dry nitrogen through a silica tube which was filled with dry CsF and maintained at a temperature of 240°C. The products were collected in a cold trap. The liquid thus collected (4.32 g) was shown by g.l.c. (col. A, RT) to consist of starting material only (85% recovery).

7CI.b Reaction of Epoxide (I37) with CsF at low temperatures

A mixture of epoxide (I37) (2.28 g, 5.48 mmol), CsF (0.78 g, 5.13 mmol), and tetraglyme (2 ml) was stirred at 60°C for 5 hours and then at room temperature for 16 hours. Water (3 ml) was then added and the lower layer thus formed was removed (2.03 g) and was shown to consist of starting material only.

In a repeat reaction, epoxide (I37) (4.16 g, 10.0 mmol), CsF (1.80 g, 11.8 mmol), and tetraglyme (5 ml) were stirred at room temperature for 10 days in a flask to which a flexible gas reservoir was attached. After this time, the gas reservoir had inflated. The gas inside

(1.86 g) was shown to consist of one major component (85%+), identified as perfluoro-2-butene by mass spectrometry and by comparing its infrared and n.m.r. spectra with those obtained from an authentic sample. A second fluorocarbon species remained dissolved in the solvent. This was subsequently identified as perfluoro-2-butanone by mass spectrometry and by comparing its n.m.r. data with the literature values. Warming the reaction flask to 60°C enabled the ketone to be collected in a second flexible gas reservoir.

7CI.c Static Pyrolysis of Epoxide (I37) over CsF

Epoxide (I37) (1.57 g, 3.77 mmol) and CsF (0.50 g, 3.29 mmol) were sealed under vacuum in a carius tube which was then heated to 200°C for 16 hours. After this time, volatile material (1.44 g) was transferred out from the tube into a cold trap and thence to a pyrex n.m.r. tube which was sealed under vacuum. A ¹⁹F n.m.r. spectrum showed that the product consisted of two components, identified as perfluoro-2-butene and perfluoro-2-butanone by comparing the n.m.r. data obtained with the literature values ¹⁸⁵.

7C2 Pyrolysis reactions of Epoxide (I37)

7C2.a Flow Pyrolyses

Epoxide (I37) (5.50 g, 13.2 mmol) was passed in a flow of nitrogen through a platinum lined tube at 450°C (contact time 30 seconds). The product (5.0 g) which was collected in a cold trap was shown to consist of unreacted starting material only. A good recovery of starting

material was also obtained from a similar pyrolysis reaction at 530°C.

7C2.b Static Pyrolyses

Epoxide (I37) (0.65 g, 1.56 mmol) was sealed in a carius tube which was then heated to 200°C for 16 hours. After cooling, the tube was opened and the liquid recovered (0.56 g) was shown to be starting material.

A similar reaction using the Z isomer of (I37) (0.55 g, 1.32 mmol) produced a liquid which was shown by g.l.c. (col. K, 50°C) to consist of a 1:1 mixture of Z and E isomers of (I37). Because of this, attempts to trap a possible radical intermediate were carried out. Similar static pyrolysis reactions to those above using firstly, epoxide (I37) (0.92 g, 2.21 mmol) and cyclohexene (0.28 g, 3.41 mmol) and, secondly, epoxide (I37) (1.00 g, 2.40 mmol) and bromine (0.42 g, 2.63 mmol) gave, in each case, good recoveries of starting materials. No products arising from radical trapping were detected.

7C3 Other Reactions of Epoxide (I37)

7C3.a With Methoxide Ion

Epoxide (I37) (2.12 g, 5.10 mmol) was stirred for 72 hours at room temperature with methanol (10 ml) in which sodium metal (0.82 g, 3.57 mmol) had been dissolved. The lower fluorocarbon layer remaining after this time was removed (1.96 g) and was shown to consist of (I37) only.

7C3.b With n-Butyl Lithium

The apparatus for this reaction was placed in an oven for 30 minutes and thus was thoroughly dry. It was then quickly assembled and purged with nitrogen, which had been bubbled sequentially through conc. H_2SO_4 to dry it and KOH pellets to remove any acid, for 30 minutes. After the reaction had started, the apparatus was constantly kept under nitrogen by means of a demand gas system.

The apparatus consisted of a 100 ml round bottomed, three-necked flask fitted with a reflux water condenser and a self-pressurising dropping funnel. The flask was kept initially at 0°C , using an external ice/salt bath. Epoxide (I37) (2.08 g, 5.00 mmol) was dissolved in ether (4 ml) and placed in the flask. N-Bu Li (20 ml of a 0.65 M solution in hexane i.e. containing 13.0 mmol of n-Bu Li) was then placed in the dropping funnel, using a pre-dried, warm syringe. The n-Bu Li was added dropwise to the stirred epoxide solution over a period of 30 minutes. Stirring was continued for 1 hour at 10°C and then for 16 hours at room temperature. After this time, the reaction mixture had retained the orange colour of the n-Bu Li solution and the ^{19}F n.m.r. spectrum of a sample of the liquid showed only signals due to starting material.

7C3.c With Acetaldehyde

Epoxide (I37) (1.20 g, 2.88 mmol) and acetaldehyde (0.54 g, 12 mmol) were degassed three times in a carius tube which was then sealed under vacuum. The tube was

irradiated with γ -rays for 40 hours, then opened and the lower fluorocarbon layer removed (1.05 g). It was shown by g.l.c./m.s. to consist of unreacted epoxide (I37) only.

7D REACTIONS OF EPOXIDE (I38)

7DI Unsuccessful Reactions

7DI.a Flow Pyrolysis over Platinum

Epoxide (I38) (1.28 g, 4.30 mmol) was passed in a flow of nitrogen through a platinum lined tube at 580°C (contact time 30 seconds). The product (1.05 g) which was collected in a cold trap was shown to consist of unreacted epoxide (I38) only.

7DI.b Static Pyrolysis

Epoxide (I38) (0.58 g, 1.9 mmol) and CsF (0.30 g, 1.97 mmol) were sealed under vacuum in a carius tube and heated to 200°C for 16 hours. After this time, the tube was allowed to cool, opened and volatile material (0.42 g) removed. This was shown by g.l.c. (col. K, 60°C) to consist only of unreacted starting material.

7DI.c Reaction with Acetaldehyde

Epoxide (I38) (1.27 g, 4.30 mmol) and acetaldehyde (0.38 g, 8.6 mmol) were placed in a carius tube. A single homogenous layer was produced. The mixture was degassed three times, sealed in the tube under vacuum and irradiated with γ -rays for 40 hours. After this time the tube was opened and the liquid was shown by ^{19}F n.m.r. spectroscopy and by g.l.c. (col. K, 70°C) to contain unreacted epoxide (I38) as the only fluorocarbon species present.

7DI.d Reaction with Diazomethane

Epoxide (I38) (0.85 g, 2.9 mmol) was placed in a flask and a solution of diazomethane in ether was added. There was no obvious decolouring of the yellow diazomethane solution. The mixture was stirred for 48 hours at room temperature. A sample of the resultant liquid was shown by ^{19}F n.m.r. spectroscopy to contain (I38) as the only fluorocarbon species present.

7DI.e Reaction with Sodium

Epoxide (I38) (0.75 g, 2.5 mmol) was placed in a 5 ml flask and sodium metal (0.06 g, 2.6 mmol) was added. The mixture was stirred at room temperature for 7 days after which volatile material was removed (0.70 g) and was shown to consist only of unreacted starting material.

7D2 Reaction with Methoxide Ion

Epoxide (I38) (1.50 g, 5.03 mmol) was placed in a flask together with an equimolar amount of freshly made sodium methoxide dissolved in the minimum amount of methanol. The mixture was stirred at room temperature for 40 hours after which volatile material was transferred out. No fluorine-containing species were contained in the volatile material. Conc. HCl (5 ml of 10 M) was then added to the solid residue. Two layers were thus produced, of which only the lower layer contained fluorocarbon species. The lower layer was removed (1.48 g) and was found to be a mixture of two isomers. These could not be separated by preparative scale g.l.c. but the mixture was identified as 2-hydroxy-3-hydroxy-2-methoxy-perfluoro-3-methyl-pentane and

2-hydro-2-hydroxy-3-methoxy-perfluoro-3-methyl-pentane (I48), (89%), (Found: C, 25.8; H, 1.7; F, 63.1%; (P-39), 29I, (P-69), 26I; (Chemical ionisation), (P+I), 33I. $C_7H_5F_{11}O_2$ requires C, 25.5; H, 1.5; F, 63.3%; M, 330). Spectra no. 4I.

7D3 Reaction with Fluoride Ion

Epoxide (I38) (2.07 g, 6.95 mmol), CsF (1.85 g, 12.2 mmol), and DMF (2 ml) were stirred together at room temperature for 65 hours. After this time, a ^{19}F n.m.r. spectrum of the reaction mixture showed no signals due to starting material but new signals apparently due to two isomeric forms of an anion. Volatile material was transferred to a cold trap. A ^{19}F n.m.r. spectrum of this material showed that epoxide (I38) had been reproduced and that the anions had been destroyed. The volatiles were therefore added back to the solid residue and stirred until all the starting material had reacted again (45 minutes). Conc. HCl (2 ml of 10 M) was then added and the lower layer thus formed was removed. This was shown to consist of two isomeric products together with some solvent. The products could not be separated pure from the solvent by preparative scale g.l.c.

A repeat reaction using tetraglyme as the solvent met with the same difficulties of separation in the final stages of the experiment.

7D4 Fluorination of Epoxide (I38)

Epoxide (I38) (2.17 g, 7.28 mmol) was introduced dropwise in a flow of nitrogen into a cobalt trifluoride bed maintained at 380°C. The liquid product (1.60 g) which was

collected in a cold trap, was shown by m.s./g.l.c. (cols. A and K, RT) and ^{19}F n.m.r. spectrometry to contain the expected fluorinated product (I45) (70%) together with small amounts of two volatile minor products which were assigned molecular masses of 2I6 by mass spectrometry.

A similar reaction at 280°C gave a 30% conversion to epoxide (I45), with starting material accounting for the rest of the product liquid.

7E STATIC PYROLYSIS OF EPOXIDE (I39)

Epoxide (I39) (2.07 g, 4.12 mmol) and CsF (0.53 g, 3.49 mmol) were sealed under vacuum in a carius tube and then heated to 200°C for 16 hours. The tube was cooled, opened and volatile material was transferred out under vacuum to a cold trap. The resultant product (1.83 g) was shown to consist of perfluorocyclobutene, which was collected in a flexible gas reservoir, together with a liquid which was shown by g.l.c. (col. A, 60°C) to consist of a little starting material (5%), some dissolved perfluorocyclobutene (20%) and a product, a sample of which was obtained pure by preparative scale g.l.c. (col. A, 60°C) and subsequently identified as Perfluoro-2-cyclobutyl cyclobutanone (I49), (Found: C, 27.9; F, 67.5%; M^+ , 340. $\text{C}_8\text{F}_{12}\text{O}$ requires C, 28.2; F, 67.5%; M, 340).
Spectra no. 42.

APPENDICES

COMPOUND INDEX

Spectra no.

- I) Perfluoro-I-cyclobutyl-2-isopropyl-cyclobutene (7I)
- 2) Triethylammonium perfluoro-2-(I°-cyclobutylcyclobutyl)-cyclobut-3-one-I-ene-I-oxide (74)
- 3) Perfluoro-I-methyl-benzocyclobutene (78)
- 3a) Perfluoro-I,2,3-trimethyl Benzene (79)
- 4) I-methoxy-perfluorospiro-(bicyclo-(5,2,0)-non-6,7-ene-2,I°-cyclobutane) (80)
- 5) I,6-dimethoxy-perfluorospiro-(bicyclo(5,2,0)-non-6,7-ene-2,I°-cyclobutane) (8I)
- 6) (6,7- Δ^2 -pyrazoline)-perfluorospiro-(bicyclo(5,2,0)-nonane-2,I°-cyclobutane) (82)
- 7) Perfluoro-I,2-bicyclobutyl-cyclobutane (83)
- 8) 3,6-di(heptafluorocyclobutyl)-4,4,5,5-tetrafluoro-I,2-diazepine (85)
- 9) I,I°-dihydro-perfluoro-I-cyclobutyl-cyclobutane (90)
- I0) 2,3-dispiro-(hexafluorocyclobutyl)-norbornane (92)
- II) Perfluoro-I-(I°-isopropyl)-cyclobutyl-cyclobutene (93)
- I2) Perfluoro-I-(I°-(I,I-dimethyl)-n-butyl)-2-cyclobutyl-cyclobutene (94)
- I3) (Z)-2-acetyl-I-hydro-perfluoro-I-cyclobutyl-cyclobutane (95)
- I4) (E)-2-acetyl-I-hydro-perfluoro-I-cyclobutyl-cyclobutane (96)
- I5) 5-carboethoxy-6-ethoxy-2,3,4-tri(trifluoromethyl)-4-pentafluoroethyl-pyran (I00)
- I6) 5-acetyl-6-methyl-2,3,4-tri(trifluoromethyl)-4-pentafluoroethyl-pyran (I0I)
- I7) 5-carboethoxy-6-methyl-2,3,4-tri(trifluoromethyl)-4-pentafluoroethyl-pyran (I02)

- 18) I,I-di(carboethoxy)-perfluoro-2,3,4-trimethyl-hexa-I,3-diene (I08)
- 19) I,I-di(carboethoxy)-2,3-di(trifluoromethyl)-tetrafluoro-penta-I,3-diene (I09)
- 20) I-acetyl-I-carboethoxy-2,3-di(trifluoromethyl)-tetrafluoro-penta-I,3-diene (II0)
- 21) 5-carboethoxy-I-fluoro-6-methyl-I,2,3-tri(trifluoromethyl)-2H-pyran (III)
- 22) 5-carboethoxy-2,4-difluoro-6-methyl-3(perfluoro-3°-(3-methyl)-pentyl)-4-trifluoromethyl-pyran (II4)
- 23) I,I-di(carboethoxy)-perfluoro-2-methyl-3-(3°-(3-methyl)-pentyl)-buta-I,3-diene (II5)
- 24) 4-acetyl-5-methyl-2,3-di(trifluoromethyl)-furan (II8)
- 25) 4-carboethoxy-5-methyl-2,3-di(trifluoromethyl)-furan (II9)
- 26) 5-carboethoxy-6-ethoxy-2,2,3-trifluoro-4-trifluoromethyl-2H-pyran (I20)
- 27) 3-acetyl-2-methyl-4,4,5,5,6,6,7,7-octafluoro-4H,5H,6H,7H-benzofuran (I22)
- 28) 3-carboethoxy-2-methyl-4,4,5,5,6,6,7,7-octafluoro-4H,5H,6H,7H-benzofuran (I23)
- 29) Di(carboethoxy)-methylene-octafluoro-cyclohex-2-ene (I24)
- 30) Octafluorocyclopent-I-enyl-diethyl malonate (I29)
- 31) Di(carboethoxy)-methylene-hexafluoro-cyclopent-2-ene (I30)
- 32) Octafluorocyclopent-I-enyl-ethyl acetoacetate (I31)
- 33) 3-acetyl-2-methyl-4,5-(hexafluorocyclopentyl)-furan (I35)
- 34) (Z)-perfluoro-3,4-dimethyl-3,4-epoxy-hexane (I37Z)
- 35) (E)-perfluoro-3,4-dimethyl-3,4-epoxy-hexane (I37E)
- 36) (Z)-2-hydro-perfluoro-3-methyl-2,3-epoxy-pentane (I38Z)
- 37) (E)-2-hydro-perfluoro-3-methyl-2,3-epoxy-pentane (I38E)

- 38) Perfluoro-1,2-di(cyclobutyl)-1,2-epoxy-cyclobutane (I39)
- 39) Perfluorospiro-(bicyclo-(5,2,0)-1,7-epoxy-nonane-
2,1'-cyclobutane) (I46)
- 40) Perfluoro-3-methyl-2,3-epoxy-pentane (I45)
- 41) 2-hydro-3-hydroxy-2-methoxy- and 2-hydro-2-hydroxy-
3-methoxy- perfluoro-3-methyl-pentane (I48)
- 42) Perfluoro-2-cyclobutyl-cyclobutanone (I49)
- 43) Perfluoro-1-(1'-cyclobutylcyclobutyl)-1,2-epoxy-
cyclobutane (I40)

APPENDIX I

N.M.R. SPECTRA

The following abbreviations are used in this appendix:
S, singlet; D, doublet; T, triplet; Q, quartet; M, multiplet; Br, broad.

Unless otherwise stated, spectra were recorded as neat liquids using CFCl_3 and TMS as external references for ^{19}F and ^1H spectra respectively.

For ^{19}F spectra upfield shifts are quoted as positive whilst for ^1H spectra, downfield shifts are quoted as positive (delta scale).

Shift p.p.m.	Fine structure J values in Hz	Relative intensity	Assignment
-----------------	----------------------------------	-----------------------	------------

I. Perfluoro-1-cyclobutyl-2-isopropyl-cyclobutene (71)

77.3	S	6	a
113.7	S	4	b
129.3 134.7	AB, J = 229	2	c
126.0 132.7	AB, J = 240	4	d
175.0	D, J _{ef} = 4I	I	e or f
183.0	D, J _{fe} = 4I	I	f or e

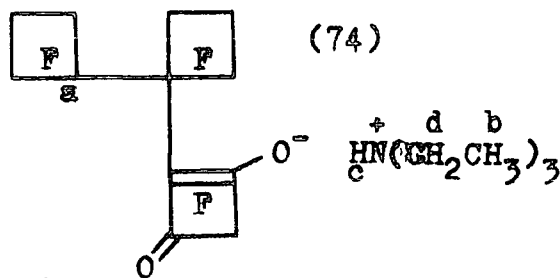
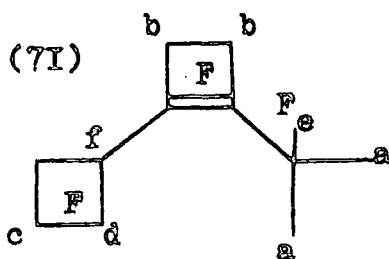

2. Triethylammonium perfluoro-2-(1'-cyclobutylcyclobutyl)-cyclobut-3-one-1-ene-1-oxide (74)

I_F

176.3	M	I	a
-------	---	---	---

Signals between 113 and 140 p.p.m. corresponding to 14 fluorines were unassigned.

I_H

0.97	T, J _{bd} = 7.6	9	b
2.50	S	I	c
2.93	Q, J _{db} = 7.6	4	d

Shift p.p.m.	Fine structure J values in Hz	Relative intensity	Assignment
-----------------	----------------------------------	-----------------------	------------

3. Perfluoro-1-methyl-benzocyclobutene (78)

62.6	Broad S	3	a
105.1	S	2	b or c
108.1	S	2	e or b
121.4	M	1	-
124.8	M	1	-
146.9	M	1	-

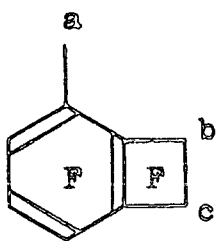

(78)

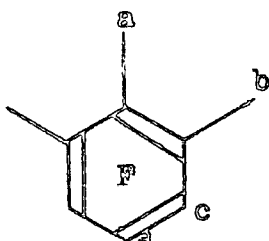

(79)

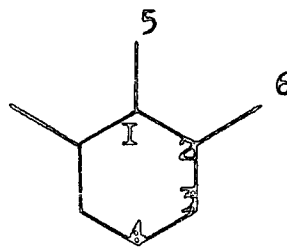

(79)(Carbon Skeleton)

3a. Perfluoro-1,2,3-trimethyl Benzene (79)

^{19}F

54.4	Heptet, $J_{ab} = 15$	3	a
57.4	M	6	b
124.7	M	2	c
150.2	T, $J_{dc} = 18$	1	d

^{13}C (relative to external T.M.S)

117.3	Broad S	-	2
119.9	"	-	5 and 6
125.3	"	-	1
141.8	"	-	4
151.4	"	-	3

Spectra and assignments for (79) provided by Dr. J. Wood of I.C.I. p.l.c.

Shift p.p.m.	Fine structure J values in Hz	Relative intensity	Assignment
-----------------	----------------------------------	-----------------------	------------

4. 1-methoxy-perfluorospiro-(bicyclo-(5.2.0)-non-6,7-ene-2,1'-cyclobutane) (80)

I_F

89.0	Broad	I	a
------	-------	---	---

Signals between 107 and 137 p.p.m. corresponding to 16 fluorines were unassigned.

I_H

3.9	S	3	b
-----	---	---	---

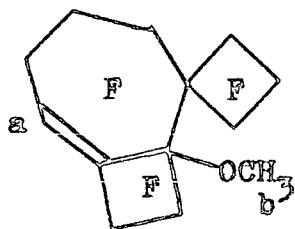

(80)

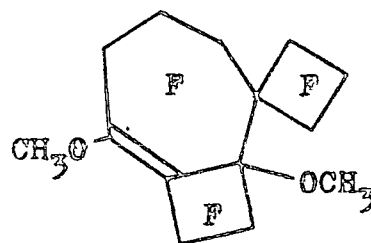

(81)

5. 1,6-dimethoxy-perfluorospiro-(bicyclo(5.2.0)-non-6,7-ene-2,1'-cyclobutane) (81)

I_F

Signals between 108 and 136 p.p.m. corresponding to 7 CF₂ groups were unassigned.

I_H

2.90	S	3	-
3.70	S	3	-

Spectra for (81) run in d⁶-acetone.

Shift p.p.m.	Fine structure J values	Relative intensity	Assignment
-----------------	----------------------------	-----------------------	------------

6. (6,7- Λ^2 -pyrazoline)-perfluorospiro-(bicyclo(5.2.0)-nonane-2,1'-cyclobutane) (82)

Spectra run in d^6 -acetone

I_F

Signals between 111 and 139 p.p.m. corresponding to the 18 fluorines were unassigned.

I_H

6.66	Broad S	I	a
8.83	Broad	I	b

Spectra run in 'Arcton II3'

I_H

6.66	Broad, overlapping	-	a
6.83	peaks	-	b

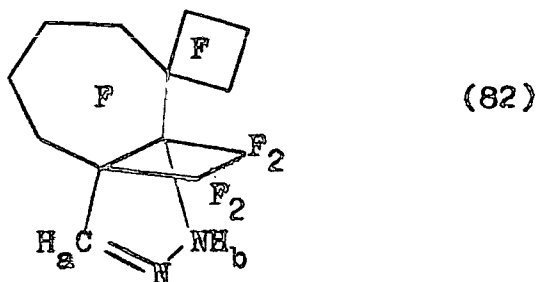

7. Perfluoro-1,2-bicyclobutyl cyclobutane (83)

189.5	Broad	4	a and b
-------	-------	---	---------

Signals between 128.5 and 136.0 p.p.m. corresponding to 16 fluorines were unassigned.

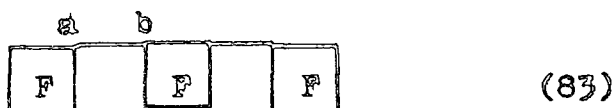

Shift p.p.m.	Fine structure J values in Hz	Relative intensity	Assignment
-----------------	----------------------------------	-----------------------	------------

8. 3,6-di(heptafluorocyclobutyl)-4,4,5,5-tetrafluoro-1,2-diazepine (85)

I_F

I54.0	Broad	I	a or b
I64.0	Broad	I	b or a

Signals between I20.0 and I40.0 p.p.m. corresponding to I6 fluorines were unassigned.

I_H

6.60	Broad	I	c
7.90	Broad	I	d

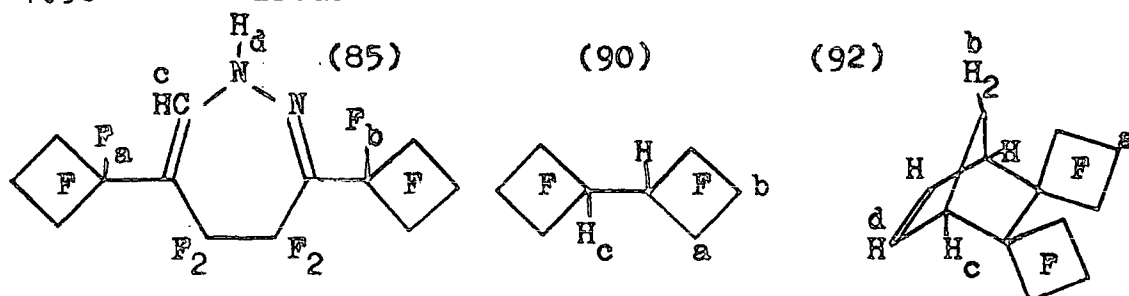

9. 1,1'-dihydro-perfluoro-1-cyclobutyl-cyclobutane (90)

I_F

I13.7 I29.0	AB, J = 226	4	a
I30.3 I35.3	AB, J = 226	2	b

I_H 3.33 (Br, S, H_c)

10. 2,3-dispiro-(hexafluorocyclobutyl)-norbornane (92)

I_F

I30.3 I34.7	AB, J = 229	4	a
----------------	-------------	---	---

Signals between I12 and I24.3 p.p.m. corresponding to 8 fluorines were unassigned.

I_H I.13 (S, H_b), 3.13 (S, H_c), and 6.00 (S, H_d)

Shift p.p.m.	Fine structure J values in Hz	Relative intensity	Assignment
-----------------	----------------------------------	-----------------------	------------

II. Perfluoro-I-(I'-isopropyl)-cyclobutyl-cyclobutene (93)

74.3	M	6	a
89.0	Broad S	I	b
113.0	Broad S	2	c or d
123.7	M	2	d or c
115.0 125.3	AB, J = 213	4	e f
Signal f	D, J _{fh} = 64		
128.0 133.3	AB, J = 226	2	g
179.0	T, J _{hf} = 64		h

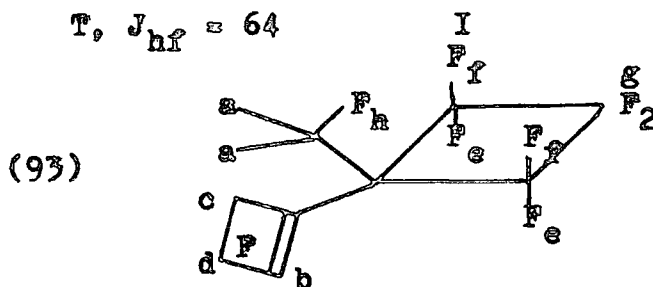

II. Perfluoro-I-(I'-(I, I-dimethyl)-n-butyl)-2-cyclobutyl-cyclobutene (94)

63.0	M	6	a
82.8	T, J = 13	3	b
107.7	Broad M	2	-
112.0	"	2	-
114.7	"	2	-
124.2	"	2	-
126.0 131.3	AB, J = 225	4	c
129.0 134.7	AB, J = 225	2	d
179.0	Broad M	I	e

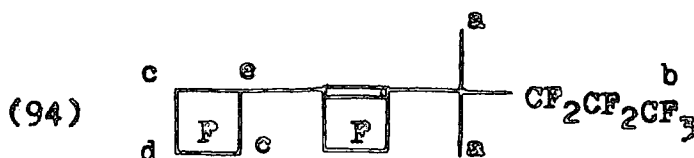

Shift p.p.m.	Pine structure J values in Hz	Relative intensity	Assignment
-----------------	----------------------------------	-----------------------	------------

I3. (Z)-2-acetyl-1-hydro-perfluoro-1-cyclobutyl-cyclobutane
(95)

I_F

I12.7 I22.7	AB, J = 225	2	-
I22.0 I33.7	AB, J = 218	2	-
I27.3 I34.7	AB, J = 236	2	-
I27.7 I34.7	AB, J = 236	4	a
I87.3	M	I	b or c
I92.7	M	I	c or b

I_H

2.37	D, J _{db} = 7	3	d
4.23	Broad	I	e

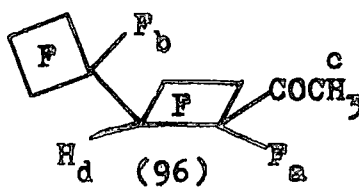
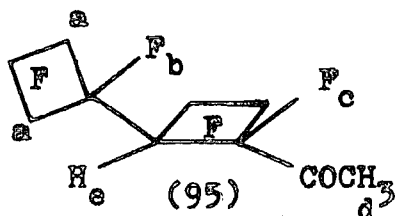

I4. (E)-2-acetyl-1-hydro-perfluoro-1-cyclobutyl-cyclobutane
(96)

I_F

I63.0	M	I	a
I87.7	M	I	b

Signals between I06.7 and I38.3 corresponding to 5 CF₂ groups were unresolved.

I_H

2.57 (M, 3H_c) and 3.90 (Br, H_d)

Shift p.p.m.	Fine structure J values in Hz	Relative intensity	Assignment
-----------------	----------------------------------	-----------------------	------------

I5. 5-carboethoxy-6-ethoxy-2,3,4-tri(trifluoromethyl)-4-pentafluoroethyl-pyran (I00)

I_F

53.3	M	3	a
62.8	M	3	b
66.7	Q, J _{ac} = 17	3	c
80.8	S	3	d
113.3	M	2	e

I_H

1.33	Broad M	6	f, f'
4.33	Broad M	4	g, g'

I6. 5-acetyl-6-methyl-2,3,4-tri(trifluoromethyl)-4-pentafluoroethyl-pyran (I01)

I_F

54.0	M	3	a
62.0	M	3	b
67.0	Q, J _{ac} = 19	3	c
81.3	S	3	d
112.7	M	2	e

I_H

2.00	S	3	f or g
2.40	S	3	g or f

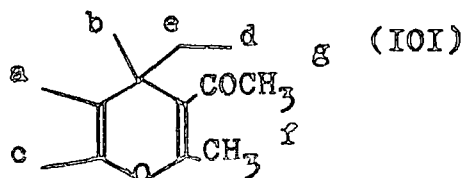
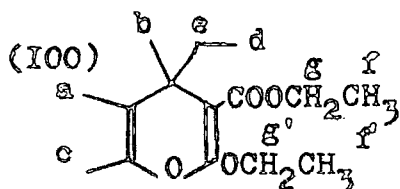

Shift p.p.m.	Fine structure J values in Hz	Relative intensity	Assignment
-----------------	----------------------------------	-----------------------	------------

I7. 5-carboethoxy-6-methyl-2,3,4-tri(trifluoromethyl)-
4-pentafluoroethyl-pyran (I02)

I_F

53.7	M	3	a
62.7	M	3	b
67.2	Q, J _{ac} = 17	3	c
81.3	S	3	d
113.3	M	2	e

I_H

1.33	T, J _{fh} = 7	3	f
2.13	S	3	g
4.27	Q, J _{hf} = 7	2	h

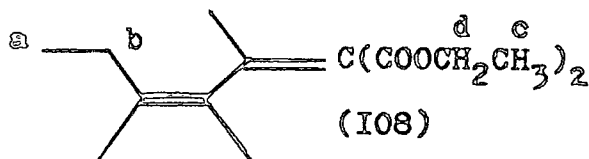
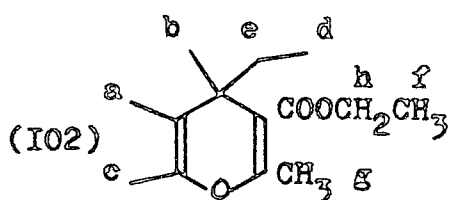

I8. 1,1-di(carboethoxy)-perfluoro-2,3,4-tri(trifluoromethyl)-
hexa-1,3-diene (I08) (E & Z isomers)

I_F

58.3	Broad	6	-
61.7	Broad	3	-
80.7	M	3	a(E & Z isomers)
82.0	M	3	a(E & Z isomers)
106.0	M	2	b(E & Z isomers)
107.5	M	2	b(E & Z isomers)

I_H

0.93	Broad M	6	c
4.00	Broad M	4	d

Shift p.p.m.	Fine structure J values in Hz	Relative intensity	Assignment
-----------------	----------------------------------	-----------------------	------------

19. 1,1-di(carboethoxy)-2,3-di(trifluoromethyl)-tetrafluoro-
penta-1,3-diene (I09)

I_H

0.80	Broad	6	e
------	-------	---	---

3.87	Broad	4	f
------	-------	---	---

$I_{19}F$ (Z isomer)

62.7	D, $J_{ad} = 17$	3	a
------	------------------	---	---

65.3	Broad S	3	b
------	---------	---	---

72.0	Broad D, $J_{cd} = 9$	3	c
------	-----------------------	---	---

111.7	Q, $J_{da} = 17$ of		
	Q, $J_{dc} = 9$	I	d

Fine structure was verified using decoupling procedure

$I_{19}F$ (E isomer)

59.2	M	3	a'
------	---	---	----

65.3	Broad S	3	b'
------	---------	---	----

71.3	M	3	c'
------	---	---	----

108.3	Broad	I	d'
-------	-------	---	----

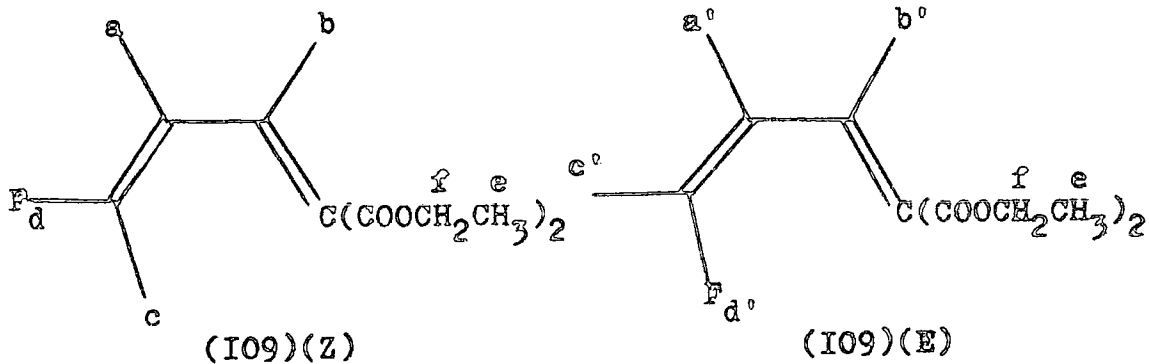

Shift p.p.m.	Fine structure J values in Hz	Relative intensity	Assignment
-----------------	----------------------------------	-----------------------	------------

20. I-acetyl-I-carboethoxy-2,3-di(trifluoromethyl)-tetrafluoro-
penta-1,3-diene (II0)

I_H

1.15	Broad	3	e
2.90	S	3	f
5.70	Broad	2	g

I^9_F (CF_3 groups trans)

62.3	D, $J_{ad} = 17$	3	a
63.3	S	3	b
71.7	Broad D, $J_{cd} = 7.5$	3	c
111.3	Q, $J_{da} = 17$ of		
	Q, $J_{dc} = 7.5$	1	d

Fine structure was verified using decoupling procedure

I^9_F (CF_3 groups cis)

58.7	Broad	3	a'
63.3	S	3	b'
71.7	Broad	3	c'
108.3	M	1	d'

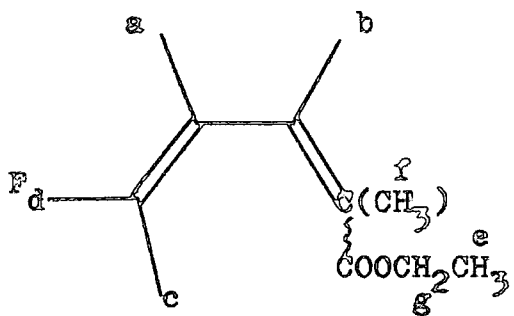

(II0)(CF_3 groups trans)

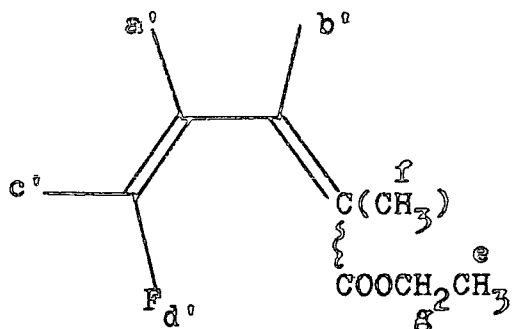

(II0)(CF_3 groups cis)

Shift p.p.m.	Fine structure J values in Hz	Relative intensity	Assignment
-----------------	----------------------------------	-----------------------	------------

21. 5-carboethoxy-1-fluoro-6-methyl-1,2,3-tri(trifluoromethyl)-2H-pyran (III)

I_F

58.0	M	3	a
59.0	M	3	b
82.3	Q, $J_{ca} = 11$	3	c
102.0	M	1	d

I_H

1.20	T, $J_{eg} = 7$	3	e
2.33	S	3	f
4.20	Q, $J_{ge} = 7$	2	g

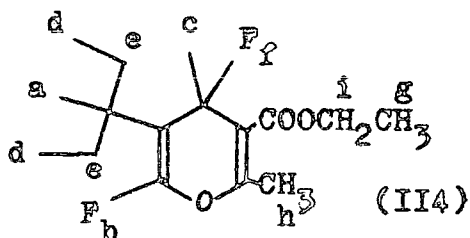
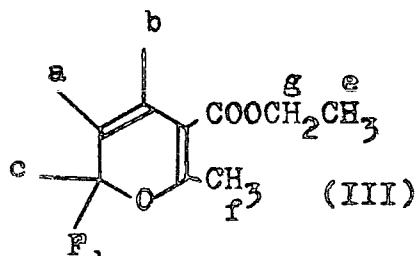

22. 5-carboethoxy-2,4-difluoro-6-methyl-3(perfluoro-3'-methyl)-pentyl-4-trifluoromethyl-pyran (II4)

I_F

53.0	M	3	a	Decoupling
62.3	M	1	b	signal a
78.3	Broad S	3	c	from signal
79.8	Broad S	6	d	f reduces
103.7	M	4	e	signal f
158.7	Q, $J_{fa} = 55$	1	f	to a singlet

I_H

0.96 (T ($J_{g1} = 7$), 3H_g), 2.00 (S, 3H_h), and 3.86 (Q ($J_{ig} = 7$), 3H_i).

Shift p.p.m.	Fine structure J values in Hz	Relative intensity	Assignment
-----------------	----------------------------------	-----------------------	------------

23. 1,1-di(carboethoxy)-perfluoro-2-methyl-3-(3'-(3-methyl)-pentyl)-buta-1,3-diene (II5)

I_F

54.7	S	I	a or b
58.7	Broad	7	b or a plus
60.0	Broad		c and d
79.3	M	6	e
102.3	M	2	f or g
105.0	Broad	2	g or f

I_H

1.33	Broad M	6	h
4.33	Broad M	4	i

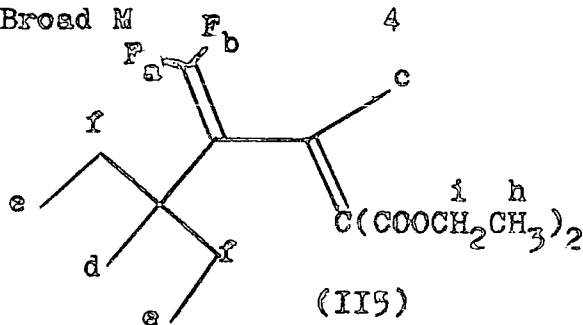

24. 4-acetyl-5-methyl-2,3-bis(trifluoromethyl)-furan (II8)

I_F

57.3	Q, $J_{ab} = 9$	3	a or b
63.7	Q, $J_{ba} = 9$	3	b or a

I_H

2.00	S	3	c or d
2.17	S	3	d or c

(II8)

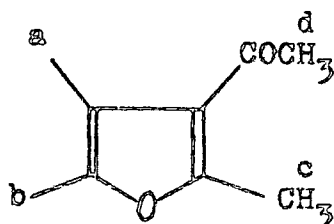

Shift p.p.m.	Fine structure J values in Hz	Relative intensity	Assignment
-----------------	----------------------------------	-----------------------	------------

25. 4-carboethoxy-5-methyl-2,3-bis(trifluoromethyl)-furan (II9)

I_F

60.0 Q, J_{ab} = 9.4 3 a or b

63.7 Q, J_{ba} = 9.4 3 b or a

I_H

0.80 T, J_{ce} = 7 3 c

2.14 S 3 d

3.73 Q, J_{ec} = 7 2 e

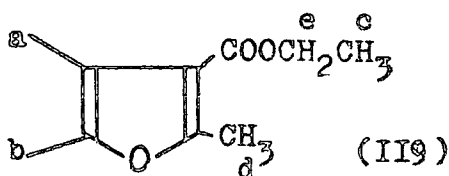

26. 5-carboethoxy-6-ethoxy-2,2,3-trifluoro-4-trifluoromethyl-2H-pyran (I20)

I_F

60.7 D, J_{ac} = 26 3 a

62.3 D, J_{bc} = 21 2 b

183.0 M 1 c

I_H

1.2 Broad M 6 d

4.2 Broad M 4 e

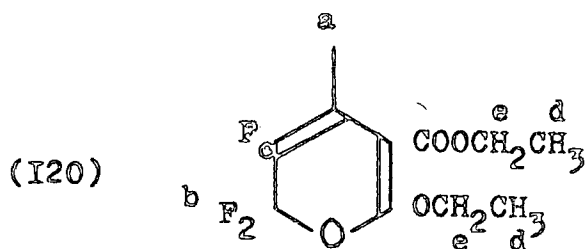

Shift p.p.m.	Fine structure J values in Hz	Relative intensity	Assignment
-----------------	----------------------------------	-----------------------	------------

27. 3-acetyl-2-methyl-4,4,5,5,6,6,7,7-octafluoro-4H,5H,6H,

7H-benzofuran (I22)

I_F

I06.8	Broad M	2	a or b
I13.2	Broad M	2	b or a
I34.0	Broad M	2	c or d
I34.8	Broad M	2	d or c

I_H

2.33	S	3	e or f
2.60	S	3	f or e

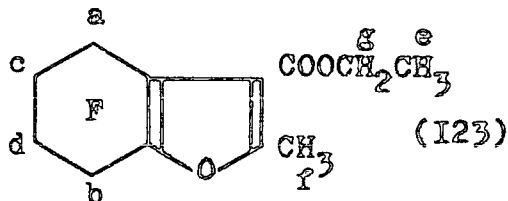
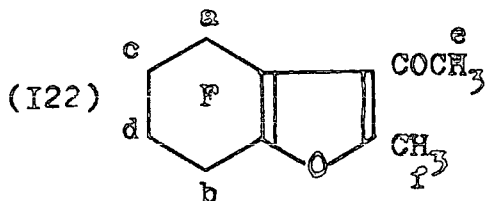

28. 3-carboethoxy-2-methyl-4,4,5,5,6,6,7,7-octafluoro-

4H,5H,6H,7H-benzofuran (I23)

I_F

I08.7	Broad M	2	a or b
I13.3	Broad M	2	b or a
I34.0	Broad M	2	c or d
I35.0	Broad M	2	d or c

I_H

I.27	T, J _{eg} = 7	3	e
2.60	S	3	f
4.30	Q, J _{ge} = 7	2	g

Shift p.p.m.	Fine structure J values in Hz	Relative intensity	Assignment
-----------------	----------------------------------	-----------------------	------------

29. Di(carboethoxy)-methylene-octafluoro-cyclohex-2-ene (I24)

I_F

116.3	Broad M	2	a Decoupling
120.2	"	2	b from e
130.0	"	1	c reduces e
134.3	"	2	d to a broad
152.0	T, J _{eb} = 2I, of M	1	e singlet

I_H

1.20	T, J _{fg} = 7	6	f
4.27	Q, J _{gf} = 7	4	g

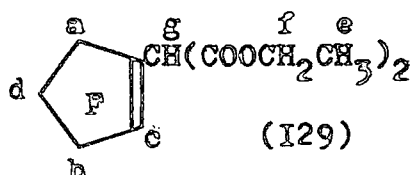
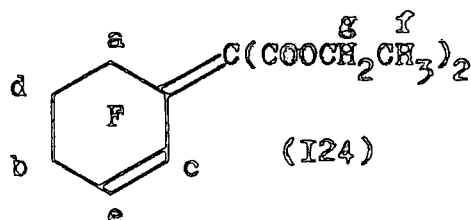

30. Octafluorocyclopent-1-enyl-diethyl malonate (I29)

I_F

111.5	M	2	a or b
121.0	M	2	b or a
125.0	M	1	c
131.7	M	2	d

I_H

1.20	T, J _{eg} = 7	6	e
3.47	Broad	1 1	f
4.13	Q, J _{ge} = 7	4	g

Shift p.p.m.	Fine structure J values in Hz	Relative intensity	Assignment
-----------------	----------------------------------	-----------------------	------------

31. Di(carboethoxy)-methylene-hexafluoro-cyclopent-2-ene (I30)

I_F

116.2	D, J _{ad} = 4.7	2	a	Fine structure was verified
120.2	D, J _{bc} = 14 of			
	D, J _{bd} = 11	2	b	using
133.7	T, J _{db} = 11 of			decoupling
	T, J _{da} = 4.7	1	d	procedure
151.0	T, J _{cb} = 14	1	c	

I_H

1.20	T, J _{ef} = 7	6	e
4.20	Q, J _{fe} = 7	4	f

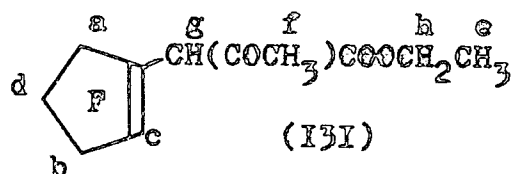
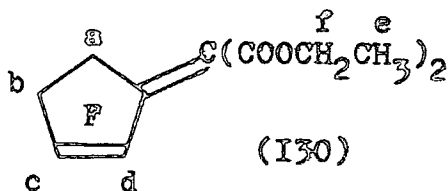

32. Octafluorocyclopent-1-enyl-ethyl acetoacetate (I31)

I_F

112.3	M	2	a or b
122.3	M	2	b or a
129.3	M	1	c
133.3	S	2	d

I_H

0.74 (Br, m, 3H_e), 1.41 (Br, s, 3H_f), 2.88 (Br, m, H_g),
and 3.55 (Br, m, 2H_h)

Shift p.p.m.	Fine structure J values in Hz	Relative intensity	Assignment
<u>33. 3-acetyl-2-methyl-4,5-(hexafluorocyclopentyl)-furan (I35)</u>			
<u>I_F</u>			
104.8	S	2	a or b
111.3	S	2	b or a
121.3	S	2	c
<u>I_H</u>			
2.27	S	3	d or e
2.53	S	3	e or d

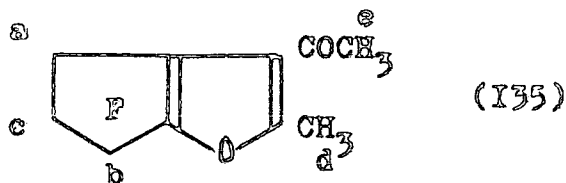

Shift p.p.m.	Fine structure J values in Hz	Relative intensity	Assignment
-----------------	----------------------------------	-----------------------	------------

34. (Z)-perfluoro-3,4-dimethyl-3,4-epoxy-hexane (I37)

66.0	Broad S	6	a
79.3	Broad S	6	b
107.3	Broad D	4	c

The nature of signal c illustrates that the fluorine atoms in each CF_2 group are non-equivalent.

35. (E)-perfluoro-3,4-dimethyl-3,4-epoxy-hexane (I37)

66.0	M	6	a
80.3	Heptet, $J_{ba} = 9$	6	b
108.3	Unsymmetrical M	4	c

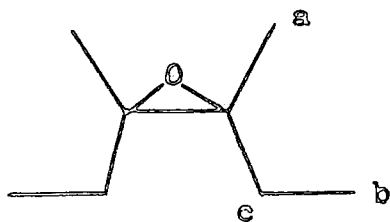

(I37) (Z)

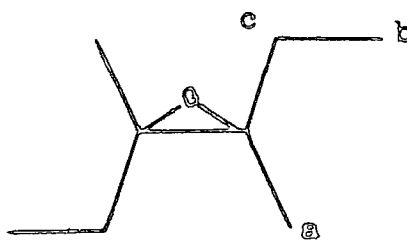

(I37) (E)

Shift p.p.m.	Fine structure J values in Hz	Relative intensity	Assignment
-----------------	----------------------------------	-----------------------	------------

36. (Z)-2-hydro-perfluoro-3-methyl-2,3-epoxy-pentane (I38)

I_F

69.3	Broad M	6	a and b
84.3	Q, $J_{cb} = 7.5$	3	c
122.6	Q, $J_{db} = 9$	I	d or e
123.0	Q, $J_{eb} = 9$	I	e or d

I_H

3.77	Q, $J_{fa} = 5.3$	I	f
------	-------------------	---	---

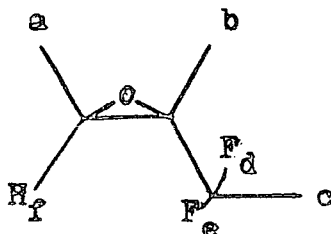

(I38) (Z)

37. (E)-2-hydro-perfluoro-3-methyl-2,3-epoxy-pentane (I38)

I_F

69.3	M	3	a
75.2	M	3	b
84.3	Q of Q, $J_{cb} = 5.6$	3	c
117.0	Unsymmetrical M	2	d

I_H

3.87	Q, $J_{ea} = 5.3$	I	e
------	-------------------	---	---

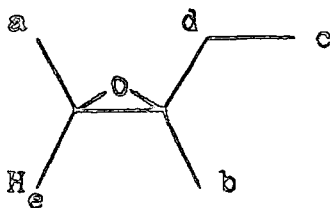

(I38) (E)

Shift p.p.m.	Fine structure J values in Hz	Relative intensity	Assignment
-----------------	----------------------------------	-----------------------	------------

38. Perfluoro-1,2-di(cyclobutyl)-1,2-epoxy-cyclobutane (I39)

I18.9 I27.9	AB, J = 203	4	a
I29.6 I35.5	AB, J = 229	4	b
I28.1 I33.5	AB, J = 229	8	c
I83.7	Broad S	2	d

39. Perfluorospiro-(bicyclo-(5,2,0)-1,7-epoxy-nonane-2,1'-cyclobutane) (I46)

Signals between I09 and I37 p.p.m. corresponding to the 18 fluorines were unassigned.

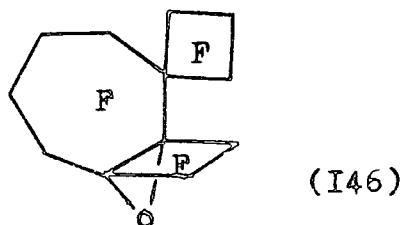
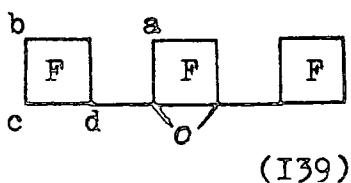

40. Z/E-perfluoro-3-methyl-2,3-epoxy-pentane (I45)

68.7	Complex M	3	a, a'
76.7	Q, J _{ba} = 13 over M	3	b, b'
84.7	M	3	c, c'
I16.3	M	2	d, d'
I49.3	M		e
I51.7	Q, J _{d'a'} = 22	I	e'

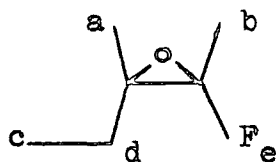

(I45)(Z isomer)

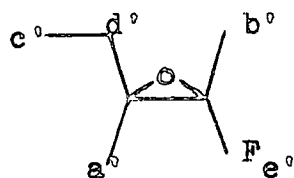

(I45)(E isomer)

Shift p.p.m.	Fine structure J values in Hz	Relative intensity	Assignment
--------------	-------------------------------	--------------------	------------

41. 2-hydroxy-3-hydroxy-2-methoxy- and 2-hydroxy-2-hydroxy-3-methoxy- perfluoro-3-methyl-pentane (I48)

I_F

71.0 73.7	Overlapping M	6	a, a'
80.3	M	3	b, b'
117.8	M	2	c or c'
120.5	Broad		c' or c

I_H Signals between 3.93 and 4.40 p.p.m. were unassigned

42. Perfluoro-2-cyclobutyl-cyclobutanone (I49)

I75.4	Broad S	I	a or b
I87.1	Broad S	I	b or a

Signals between I20 and I36 p.p.m. corresponding to 10 fluorines were unassigned.

43. Perfluoro-1-(1'-cyclobutylcyclobutyl)-1,2-epoxy-cyclobutane (I40)

I73.7	Broad S	I	a or b
I78.0	Broad S	I	b or a

Signals between I12 and I35 p.p.m. corresponding to 16 fluorines were unassigned.

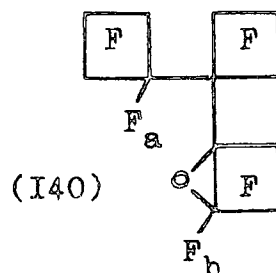
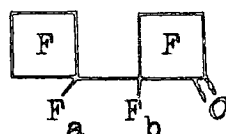
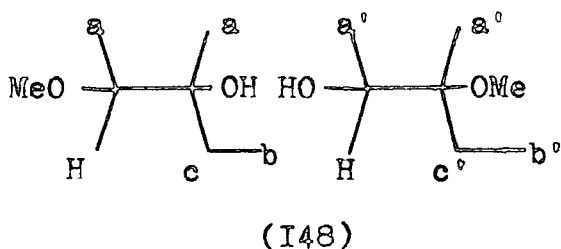

APPENDIX II

INFRARED SPECTRA

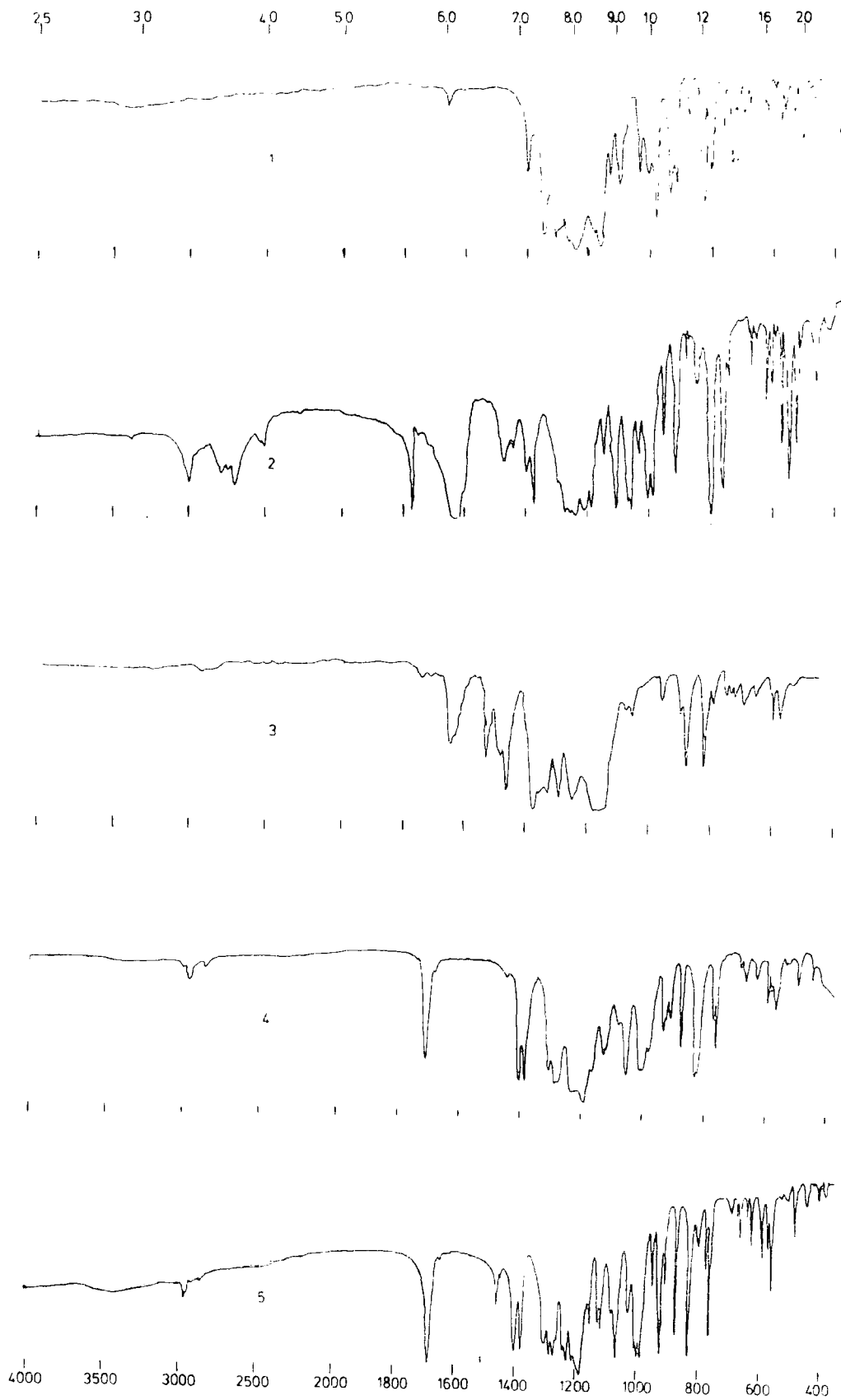

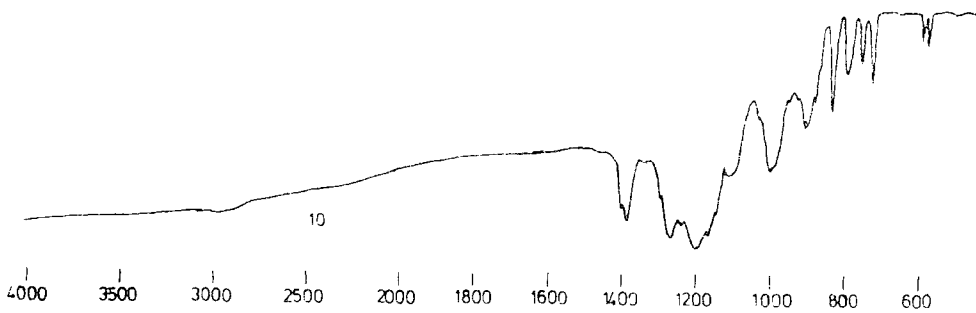
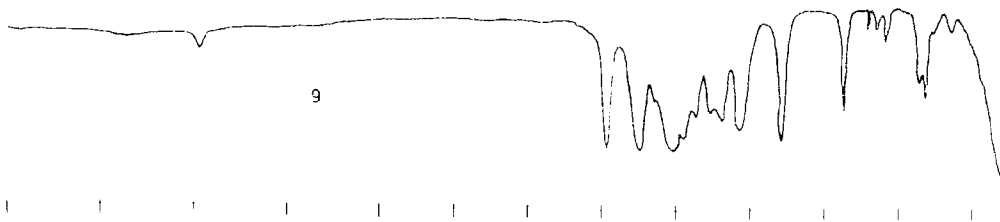
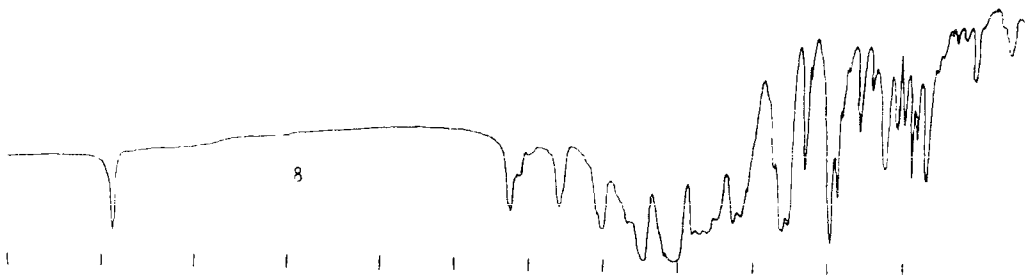
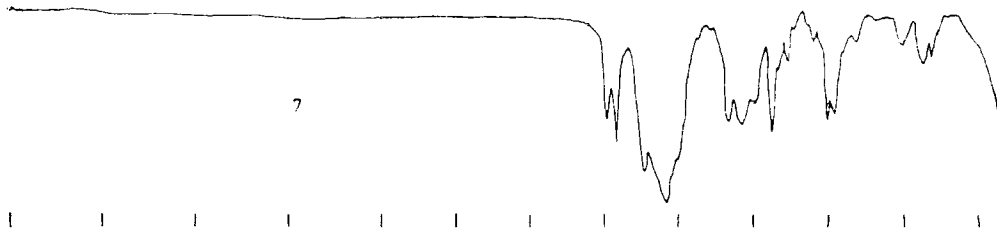
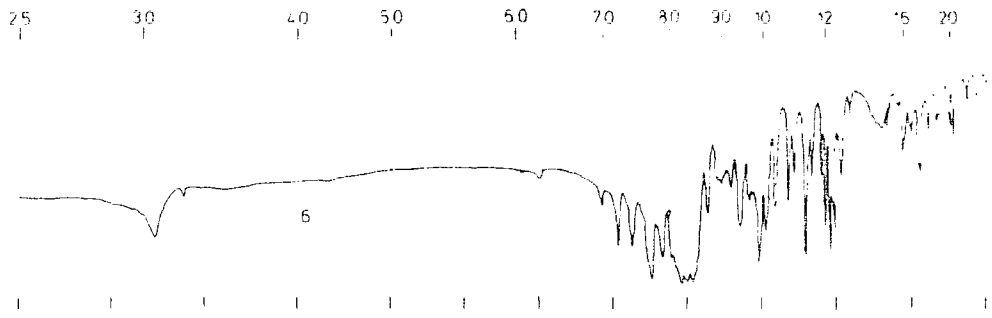

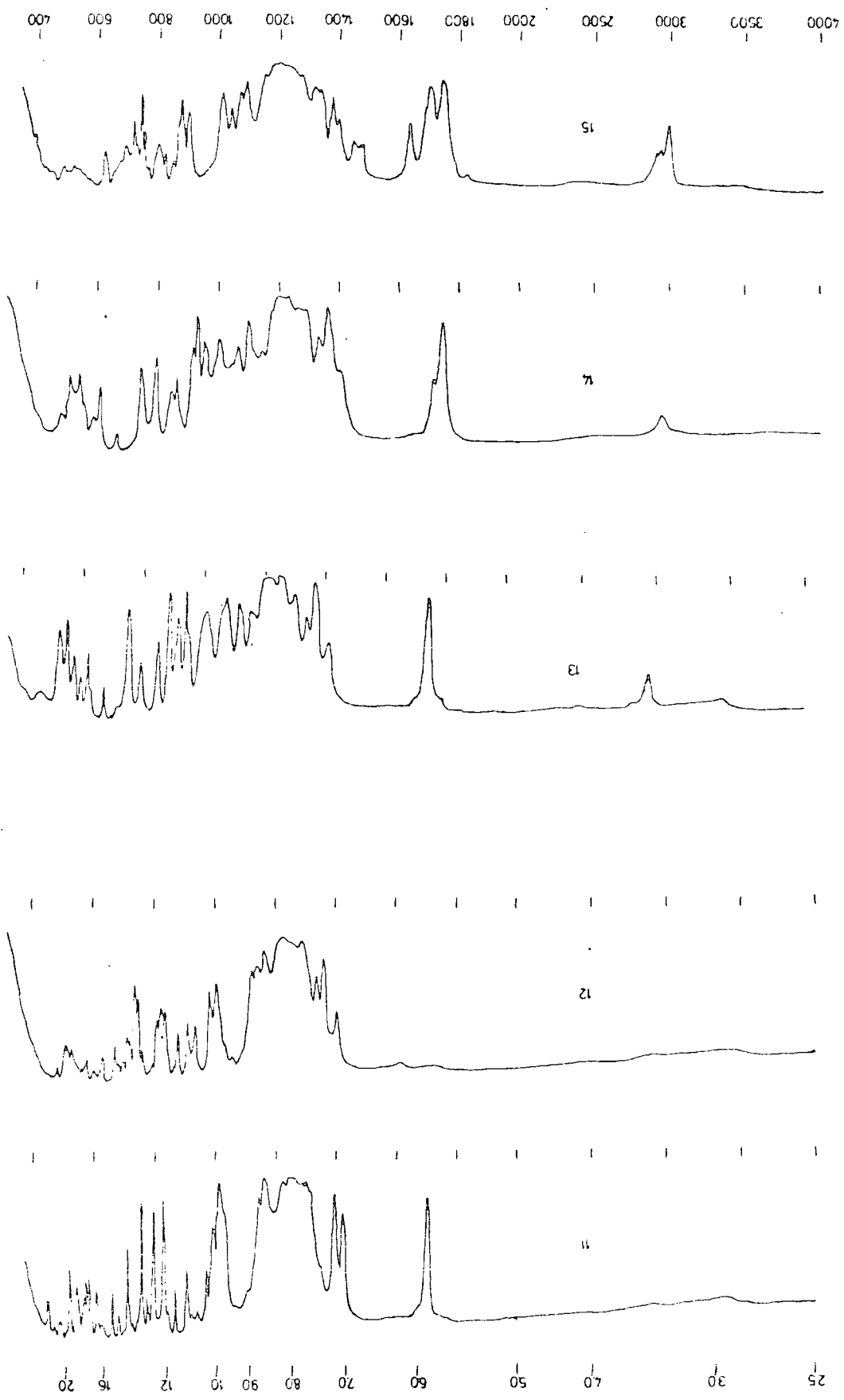

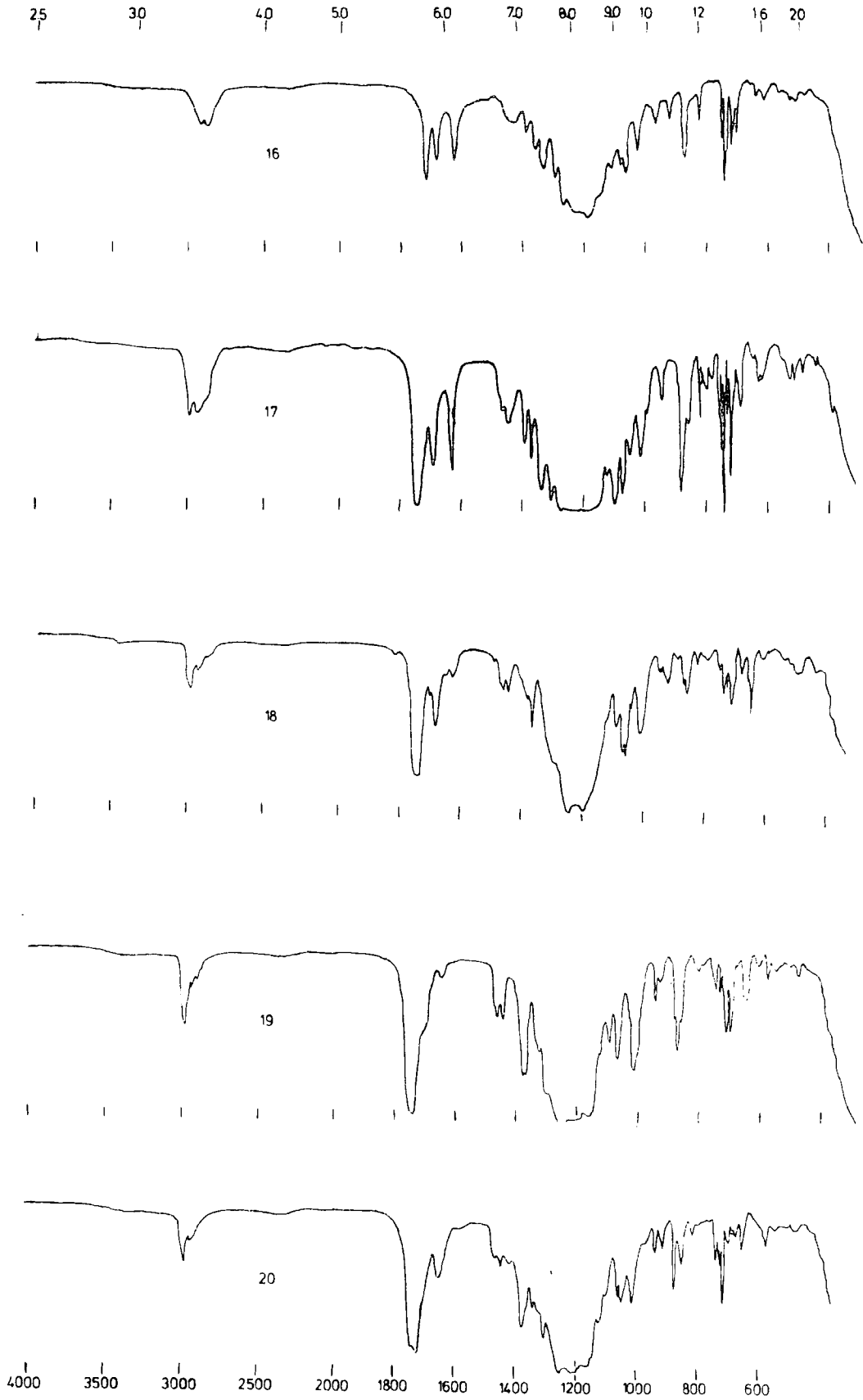

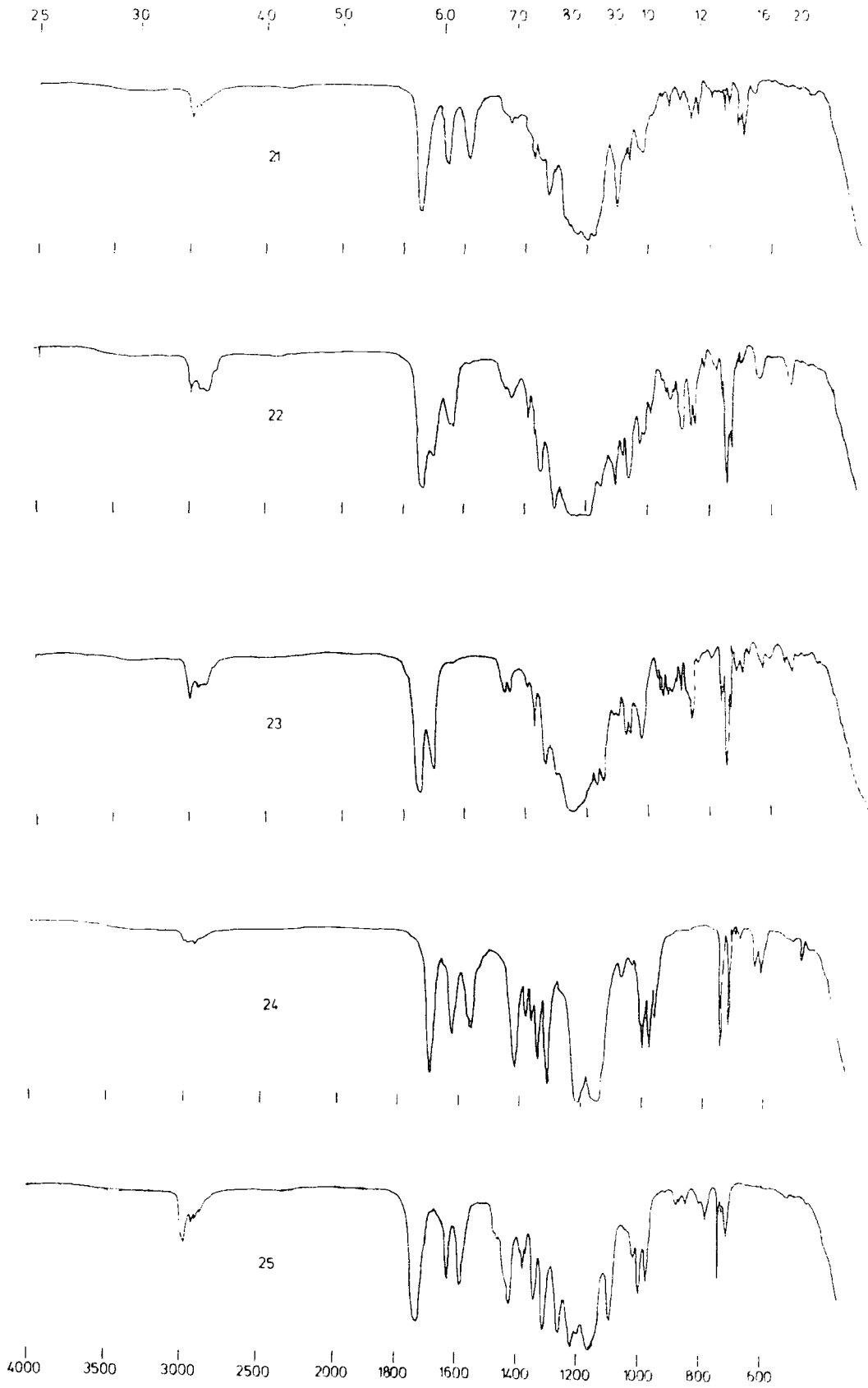

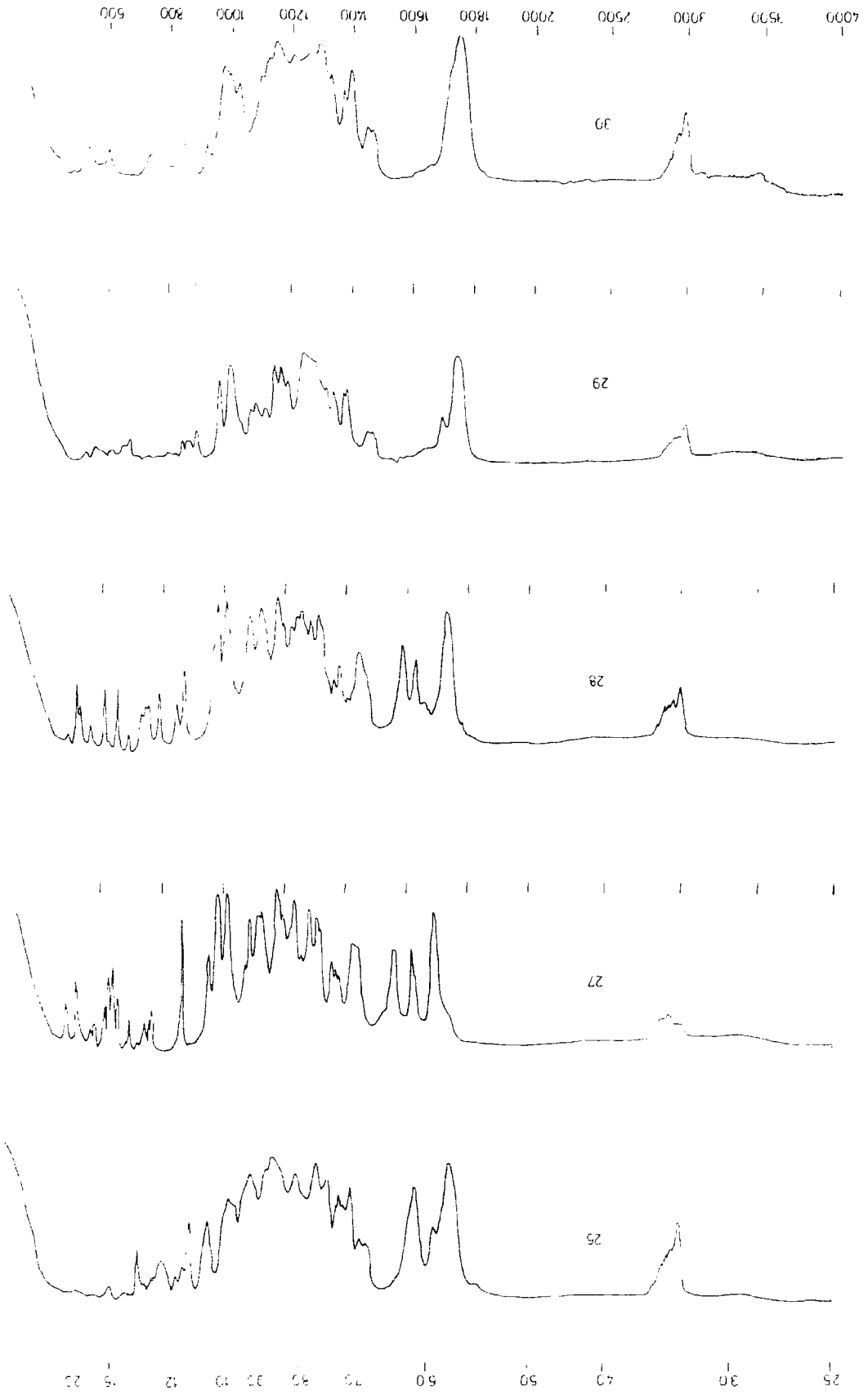

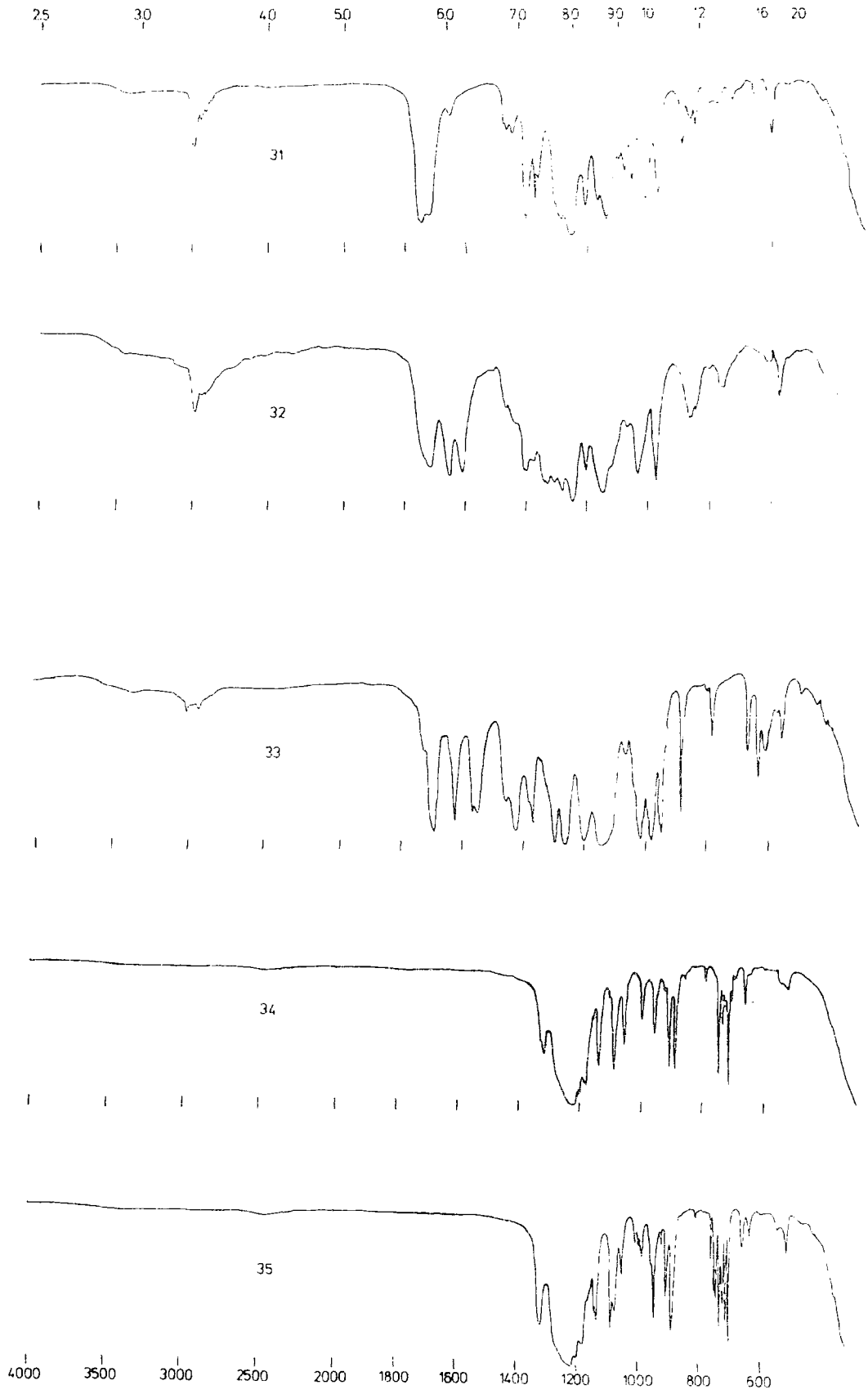

4000 3500 3000 2500 2000 1800 1600 1400 1200 1000 800 500

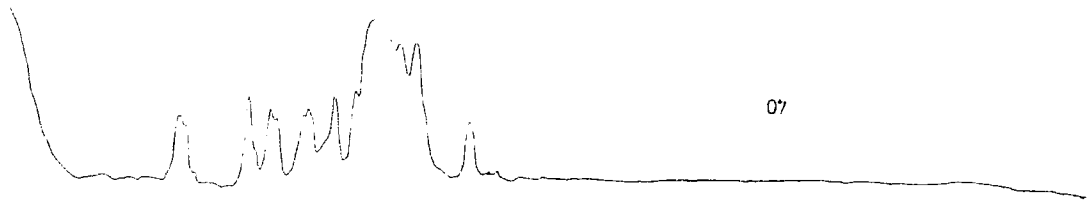

07

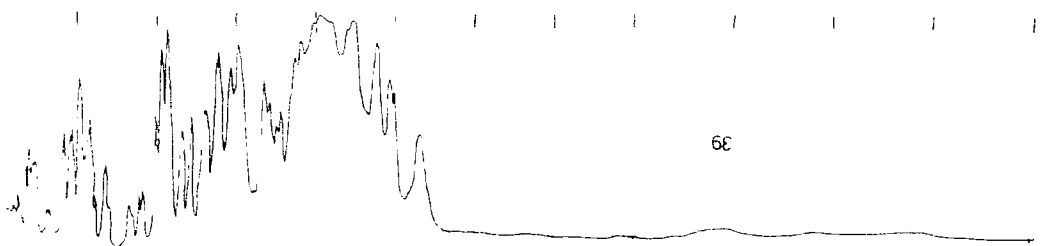

39

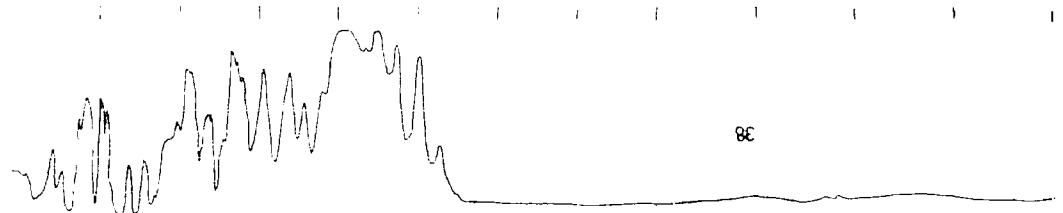

38

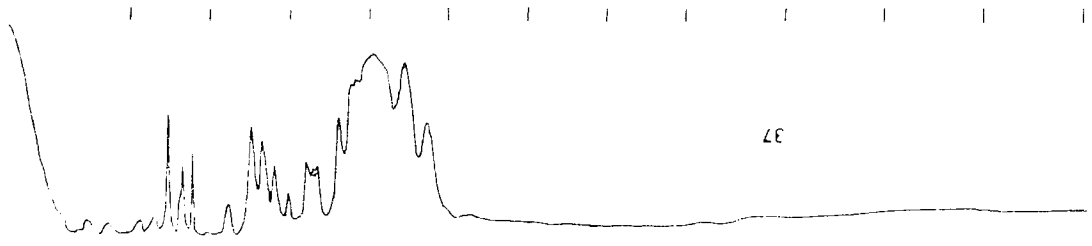

37



36

25 30 40 50 60 70 80 90 100 110 120 130 140 150 160 170 180 190 200

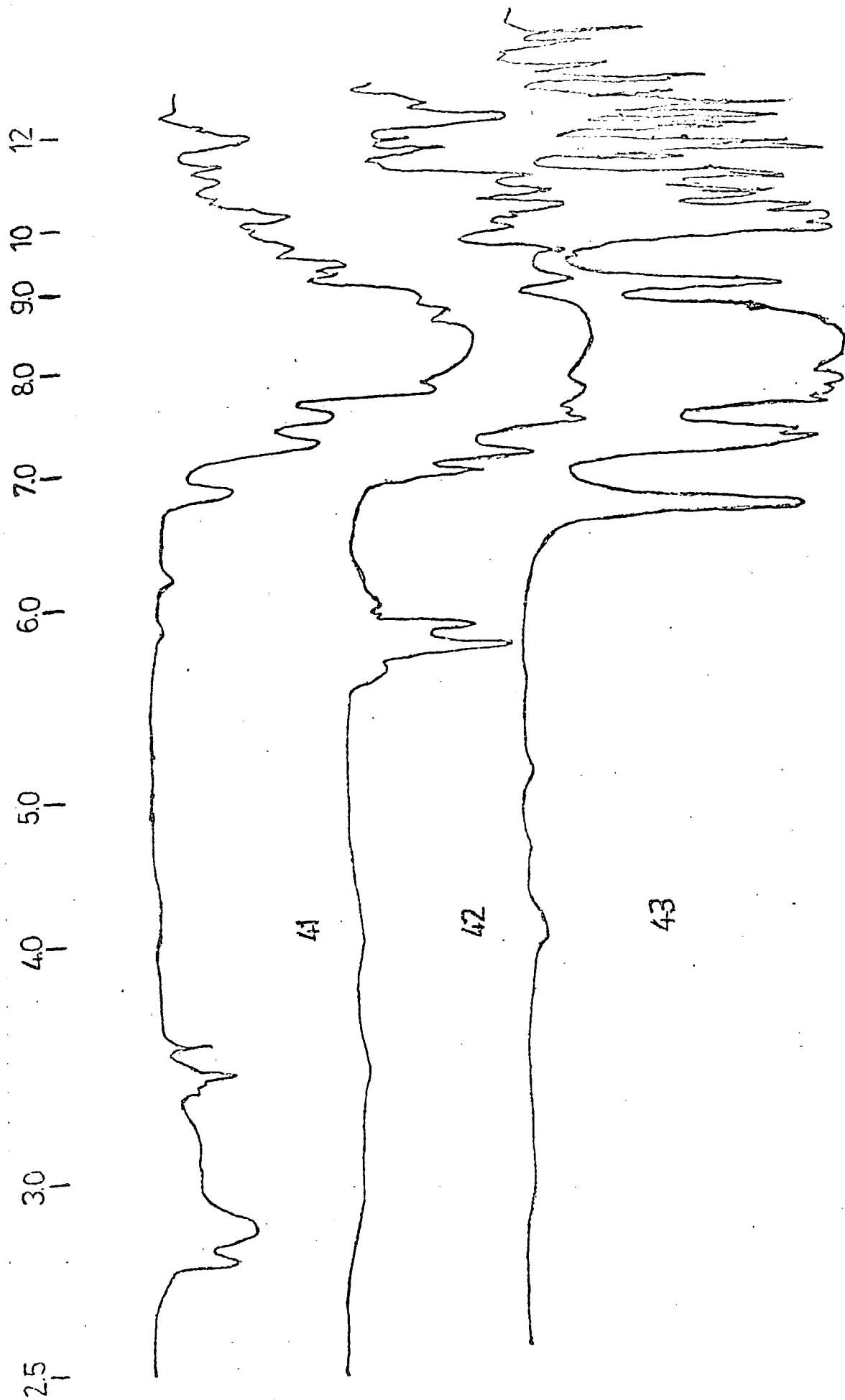

APPENDIX III

MASS SPECTRA

72A1
JRKXZB 11 J.R.KIRK
CHLICAL19

No. I (MW 474)

20-NOV-80

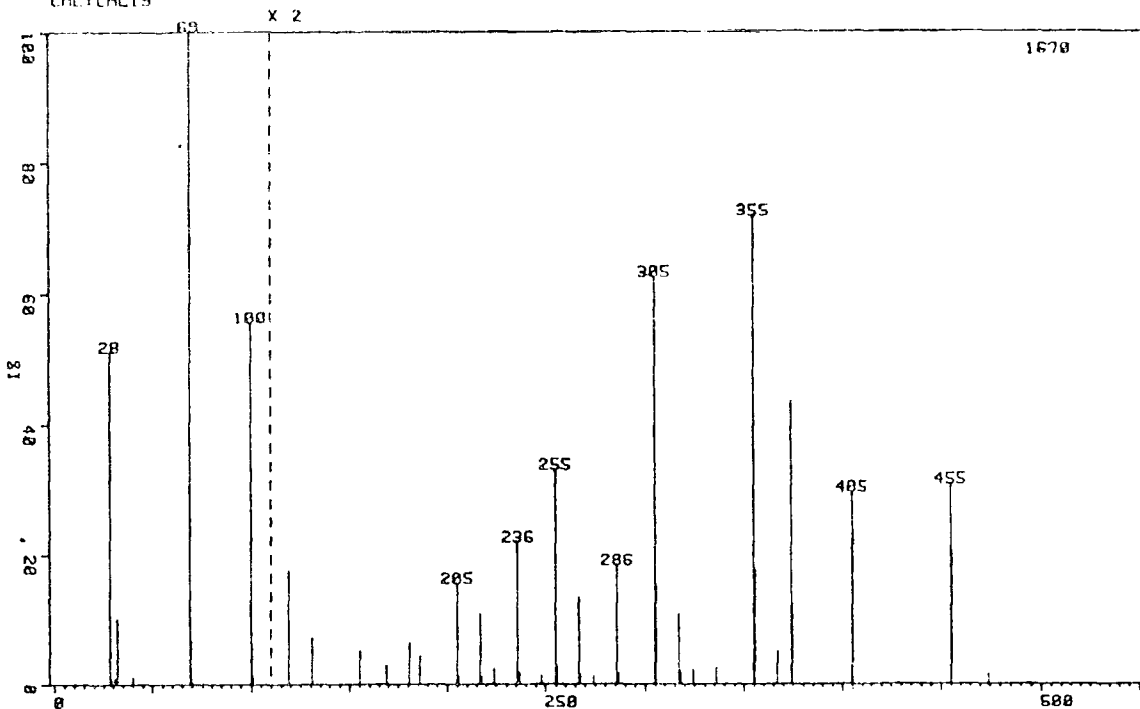

PEAK NO.	MASS	ZHT. BASE	31	32	33
			285.96	286.95	304.86
			9.16	0.84	31.20
1	28.13	51.08	34	35	36
2	28.22	0.66	305.66	316.91	318.02
3	30.92	0.84	7.54	5.39	0.96
4	32.02	10.06	37	38	39
5	39.84	1.14	323.94	335.93	354.82
6	68.95	100.00	1.08	1.26	35.87
7	69.10	6.83	40	41	42
8	69.89	0.96	355.63	366.90	373.79
9	99.89	55.57	8.80	2.51	21.68
10	100.11	5.93	43	44	45
11	100.91	1.26	374.65	404.79	405.38
12	118.90	8.74	6.17	14.73	11.80
13	130.90	3.59	46	47	48
14	154.94	2.57	454.75	455.55	473.95
15	168.85	1.56	15.33	10.24	0.78
16	180.87	3.23			
17	185.93	2.16			
18	204.93	7.72			
19	205.92	0.66			
20	216.87	5.39			
21	217.91	0.54			
22	223.93	1.20			
23	235.90	10.90			
24	236.90	0.90			
25	247.94	0.66			
26	254.92	16.47			
27	255.86	1.44			
28	266.92	6.65			
29	267.94	0.78			
30	273.95	0.66			

JX30R4 13 J.H.KIRK
CHL1:CHL12

No. 2 (MW 563)

12-NOV-81

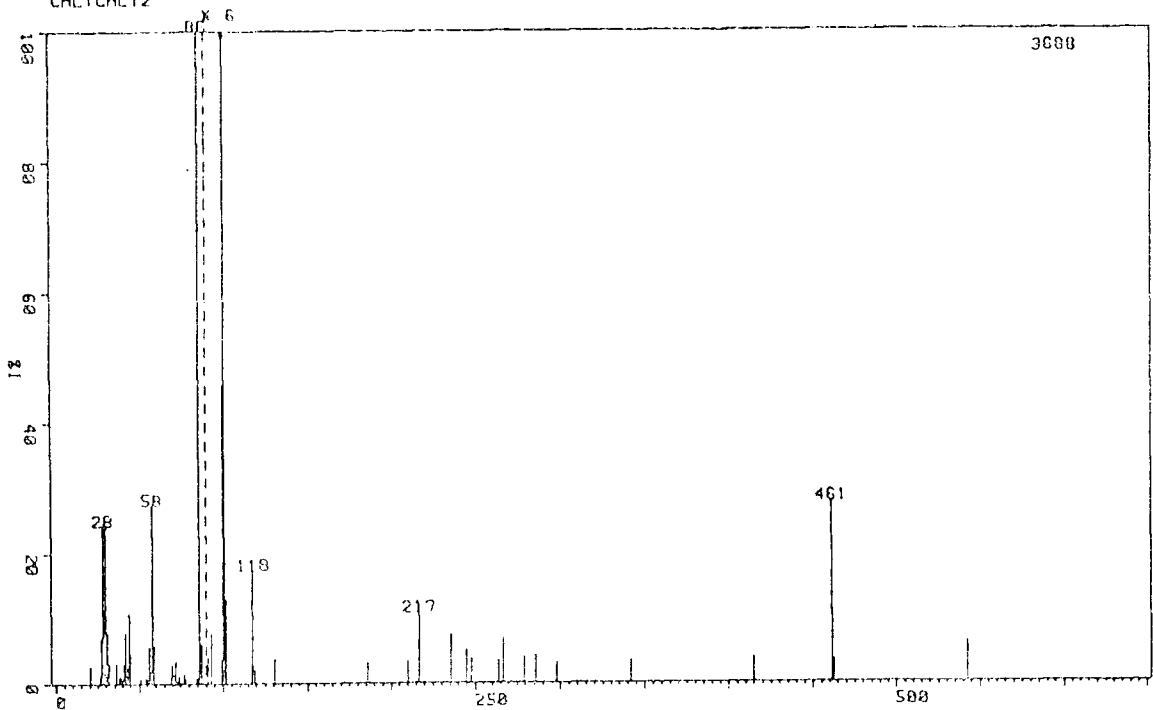

PEAK NO.	MASS	ZHT. BASE	PEAK NO.	MASS	ZHT. BASE
1	20.66	2.66	36	90.93	0.68
2	26.56	1.22	37	92.95	1.27
3	27.44	6.89	38	99.00	0.62
4	28.29	24.19	39	99.92	7.62
5	29.14	10.90	40	100.97	21.66
6	29.95	23.86	41	102.02	2.14
7	31.01	7.65	42	116.94	0.46
8	32.06	3.06	43	117.94	2.90
9	36.09	3.01	44	118.95	0.35
10	37.99	1.08	45	130.84	0.60
11	38.95	0.89	46	185.86	0.52
12	39.83	0.52	47	209.92	0.57
13	40.89	2.98	48	216.80	1.82
14	41.96	7.78	49	235.81	1.25
15	43.02	2.41	50	244.83	0.84
16	44.03	10.79	51	247.89	0.62
17	45.06	4.53	52	263.94	0.57
18	50.92	0.68	53	266.89	1.14
19	54.07	0.84	54	278.91	0.65
20	55.10	0.62	55	285.90	0.70
21	56.07	5.61	56	297.84	0.52
22	57.08	1.74	57	341.82	0.57
23	58.03	27.30	58	414.70	0.62
24	58.98	5.72	59	461.49	4.61
25	68.95	1.00	60	462.68	0.57
26	69.95	2.90	61	542.64	1.03
27	71.01	1.27			
28	72.04	3.36			
29	73.08	0.38			
30	74.07	1.22			
31	77.00	1.41			
32	78.00	0.60			
33	84.05	0.84			
34	86.01	100.00			
35	87.00	6.02			

JRK3BB 2G
CALICH

No. 3 (MW 298)

11-JAN-88

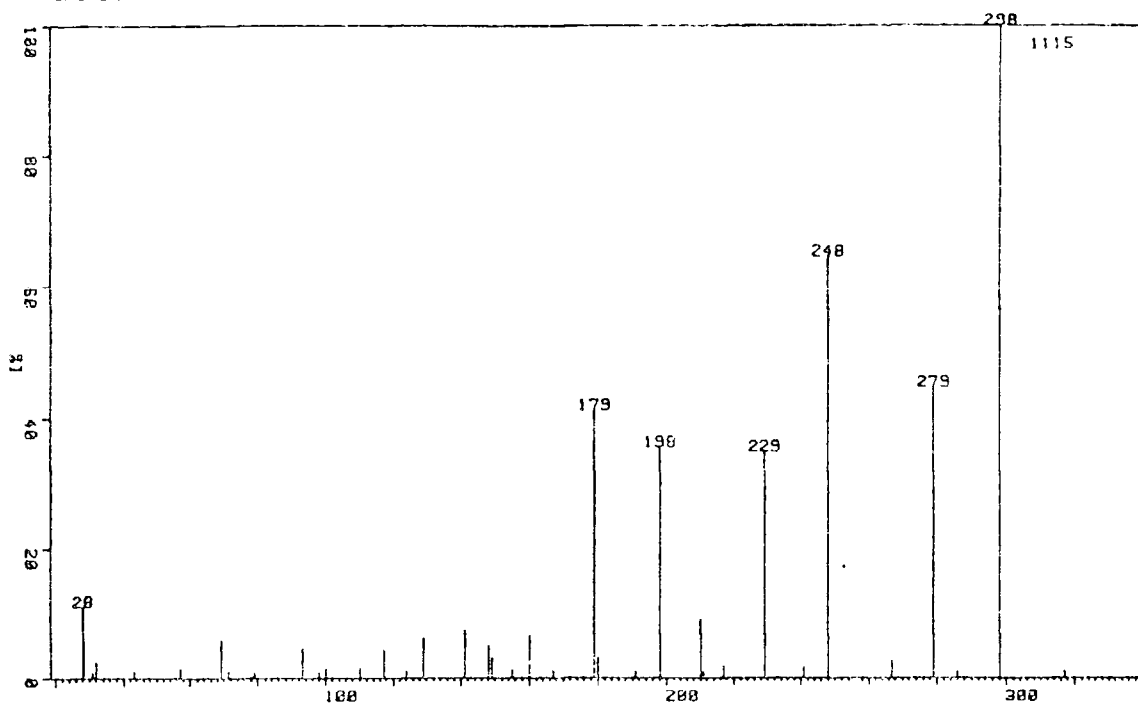

PEAK NO.	MASS	%HT. BASE	31	248.05	64.57
1	28.15	11.03	32	266.99	2.60
2	30.93	0.81	33	279.05	44.57
3	32.04	2.42	34	285.94	0.99
4	43.16	0.99	35	298.07	100.00
5	57.20	1.43	36	317.01	1.17
6	69.08	5.92	37	366.93	0.81
7	71.15	1.08			
8	79.02	0.81			
9	93.09	4.57			
10	98.07	0.81			
11	99.98	1.52			
12	110.00	1.52			
13	117.08	4.39			
14	124.09	1.17			
15	129.05	6.19			
16	141.07	7.44			
17	148.07	4.93			
18	149.08	3.14			
19	155.13	1.35			
20	160.05	6.55			
21	167.09	1.17			
22	179.04	41.17			
23	179.99	3.23			
24	191.06	0.99			
25	198.17	35.52			
26	210.01	8.97			
27	211.05	0.90			
28	217.06	1.88			
29	229.09	34.80			
30	240.98	1.70			

JRK3BB 35
CALICA

No. 3a (MW 336)

11-JAN-80

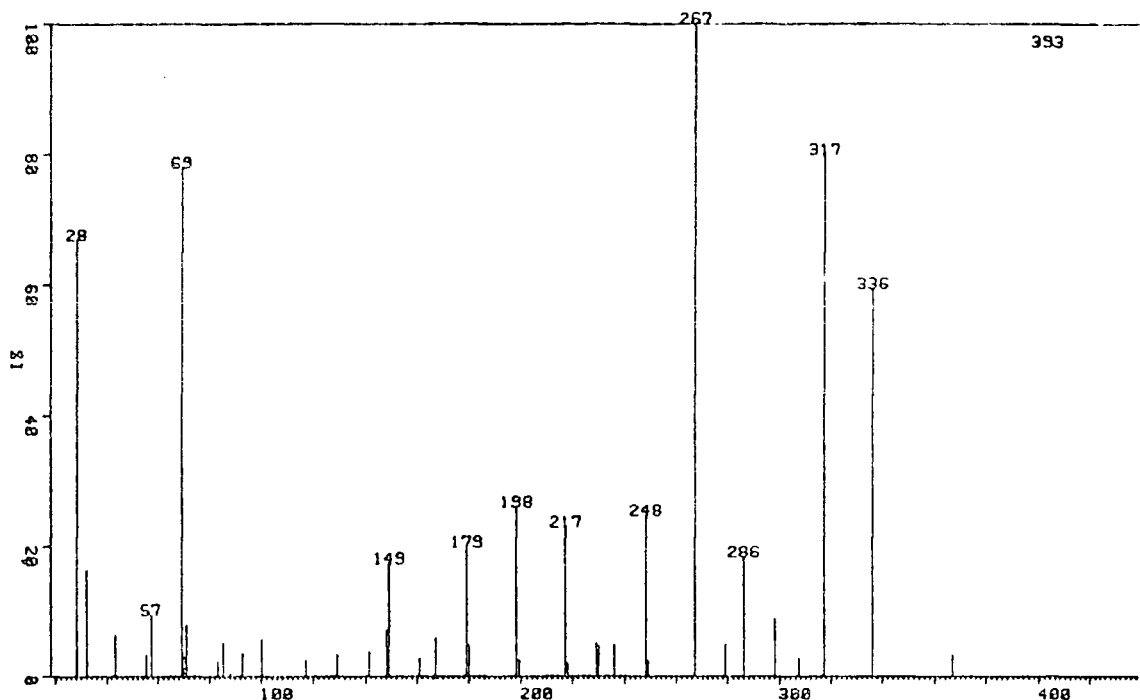

PEAK NO.	MASS	ZHT. BASE	31	267.08	100.00
			32	279.01	4.83
			33	286.00	18.32
1	28.15	66.92	34	297.99	8.91
2	32.04	16.28	35	307.20	2.80
3	43.16	6.36	36	317.08	79.90
4	55.21	3.31	37	336.06	59.29
5	57.21	9.41	38	366.94	3.31
6	69.07	77.86			
7	70.08	3.05			
8	71.15	7.89			
9	83.17	2.29			
10	85.21	5.09			
11	93.09	3.56			
12	99.97	5.60			
13	117.10	2.54			
14	129.03	3.31			
15	141.16	3.82			
16	148.07	7.12			
17	149.06	17.30			
18	161.06	2.80			
19	167.08	5.85			
20	179.01	19.85			
21	180.00	4.83			
22	198.09	25.95			
23	199.07	2.54			
24	217.07	22.90			
25	218.06	2.04			

JRK8E 6
CAL:CA

No.6 (MW 528)

28-APR-80

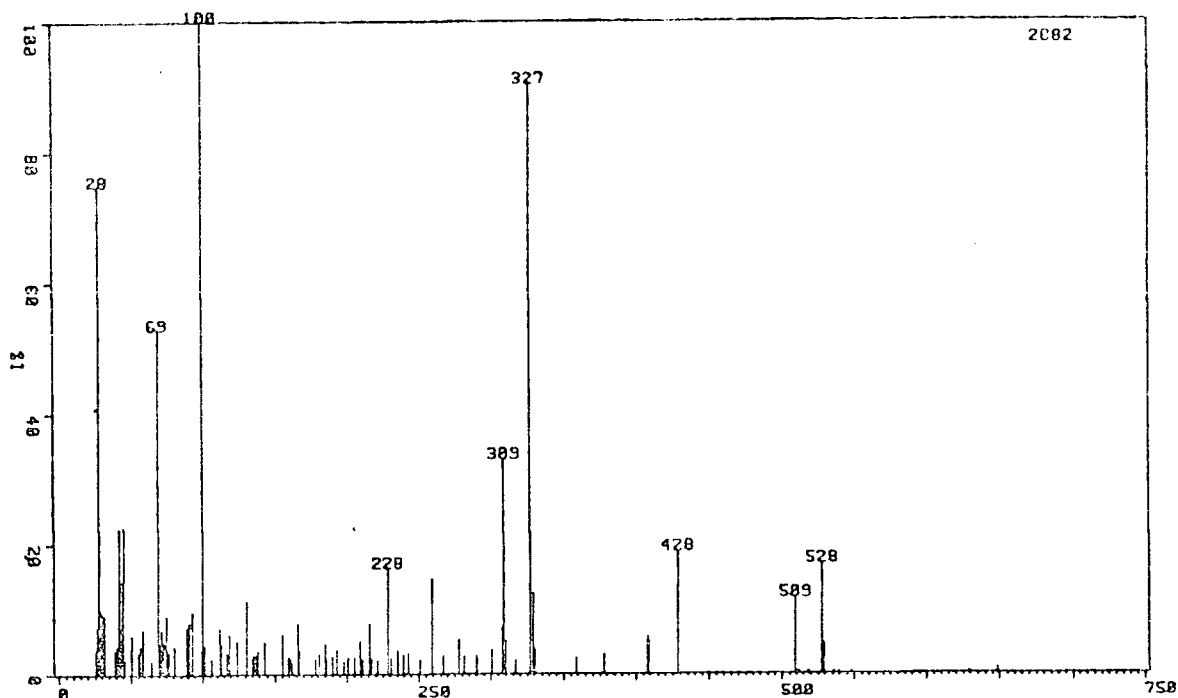

PEAK NO.	MASS	%HT. BASE	67	93.08	9.54	191	217.03	2.39
			75	99.07	3.68	195	221.12	2.12
			76	100.00	100.00	203	228.14	16.24
3	26.20	3.68	78	101.07	4.41	205	231.01	2.60
4	27.12	7.25	83	106.15	2.29	209	235.01	3.71
5	28.00	74.84	89	112.08	7.01	210	235.85	3.26
6	28.89	9.72	90	113.12	4.61	213	238.99	3.05
7	29.72	2.98	94	117.14	3.23	214	239.84	2.85
8	30.74	9.26	96	119.03	6.14	218	243.03	3.26
9	31.83	9.06	101	124.11	5.14	224	251.04	2.15
13	38.88	3.68	108	131.02	11.10	229	259.18	14.61
15	40.86	4.34	112	135.15	2.39	234	266.96	2.81
16	41.94	22.31	113	136.10	2.88	244	277.88	5.17
17	43.01	14.26	114	137.10	2.19	248	281.65	2.74
18	44.03	12.18	115	138.06	2.81	252	290.16	2.81
19	45.08	22.52	116	139.05	3.54	258	300.98	3.64
20	46.08	2.19	120	143.05	4.96	261	307.86	7.18
24	49.90	3.96	131	155.05	6.04	262	308.99	33.00
25	50.98	5.93	135	159.06	2.78	263	310.24	5.03
29	55.16	3.30	137	161.07	2.43	267	316.99	2.05
30	56.15	2.19	138	162.10	2.19	272	327.17	90.39
31	57.14	4.34	141	166.03	7.74	273	328.92	12.32
32	58.09	2.15	143	167.03	3.57	274	330.77	3.75
33	59.04	6.80	152	178.09	2.39	286	358.60	2.50
38	64.09	2.05	155	181.05	3.23	294	377.97	3.02
43	69.01	52.78	159	185.03	4.58	309	407.80	5.66
44	69.99	4.65	160	186.03	2.26	310	408.89	5.07
45	71.11	2.74	165	190.00	2.78	315	428.35	18.91
46	72.12	6.73	168	192.99	3.64	329	509.05	11.76
47	73.13	4.82	172	198.03	2.05	330	511.05	0.49
49	75.07	8.88	177	200.99	2.60	331	512.17	0.42
51	77.07	3.37	181	204.99	2.60	332	518.12	0.49
55	81.01	4.27	185	208.95	5.10	333	527.77	16.93
63	89.02	7.15	187	210.99	2.29	334	529.21	4.61
65	91.08	7.88	190	215.88	7.74			

JK9B1 5
CALICALMG

No. 7 (MW 524)

25-MAY-82

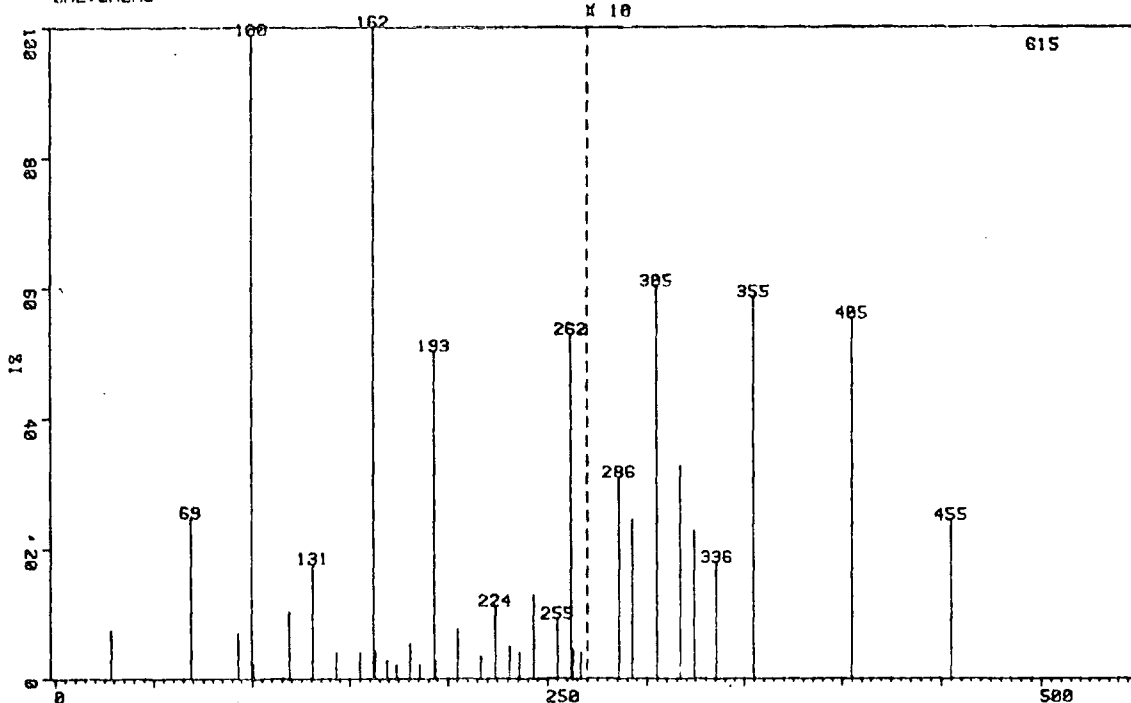

PEAK NO.	MASS	%HT. BASE
1	28.13	7.48
2	68.95	24.72
3	92.94	6.99
4	99.84	98.86
6	118.94	10.24
7	130.89	17.72
8	142.91	4.07
9	154.92	4.07
10	161.89	100.00
11	162.95	4.23
14	180.90	5.37
16	192.89	50.24
18	204.85	7.64
20	223.94	11.22
21	230.89	4.88
22	235.94	4.07
23	242.88	12.85
24	254.90	9.27
25	261.87	52.85
26	262.92	4.39
27	266.92	4.07
30	304.91	6.02
34	354.94	5.85
35	404.82	5.53
36	454.76	1.44

JRK9R 11 J.R.KTRK
CAL 1 CH

No. 8 (MW 528)

15-MAY-80

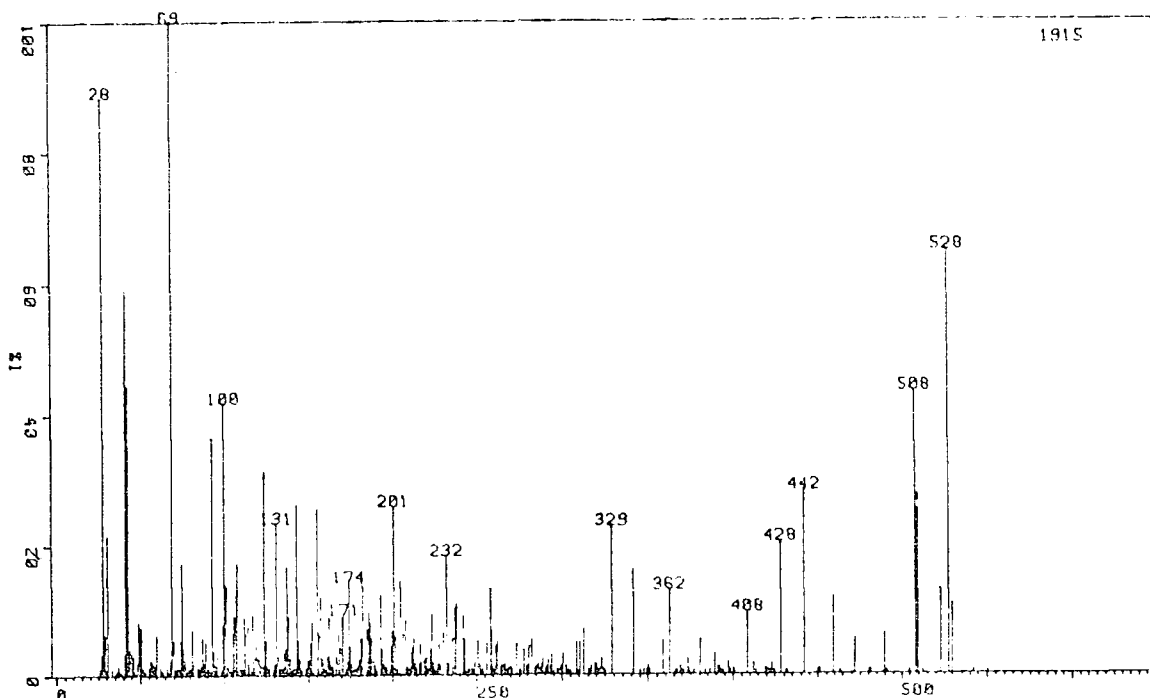

PEAK NO.	MASS	ZHT. BASE
----------	------	-----------

2	27.12	3.19	109	143.07	26.11	181	221.02	3.39
3	28.00	88.41	117	152.12	8.25	183	223.00	3.97
4	28.88	6.16	119	155.05	25.54	184	223.95	9.30
6	30.72	21.36	120	155.92	6.63	188	228.05	5.38
12	40.86	3.29	121	157.09	11.91	190	230.66	6.37
13	41.95	59.06	122	158.08	2.66	191	232.17	18.33
14	43.01	44.44	123	159.11	2.45	194	235.76	5.69
37	69.02	100.00	125	161.14	2.87	195	237.01	10.29
38	70.00	5.33	126	162.08	8.93	196	238.26	10.91
42	74.15	5.38	127	163.13	2.19	198	241.81	9.14
43	75.11	17.18	130	166.08	4.44	199	243.42	5.38
44	76.09	4.07	131	167.07	2.82	205	249.06	2.25
45	77.09	2.30	132	168.02	6.32	206	250.66	5.38
49	81.02	7.00	133	169.03	4.49	210	256.09	5.07
54	87.12	5.74	134	170.01	8.77	211	257.93	13.26
56	89.04	5.17	135	170.98	9.35	266	328.59	22.87
60	93.09	36.50	137	173.14	2.14	267	341.29	16.14
61	94.15	3.71	139	174.03	14.31	273	358.40	5.33
63	96.16	2.98	140	175.02	4.39	274	362.24	13.00
65	99.08	7.57	145	179.96	2.40	280	373.07	2.45
66	100.03	41.78	146	181.01	5.54	285	380.52	5.43
67	101.08	13.73	147	182.19	16.08	288	388.85	3.13
71	105.16	6.42	148	184.60	6.95	297	408.22	9.71
72	106.11	9.09	149	185.90	9.66	307	427.96	20.47
73	107.07	13.11	150	186.91	7.89	310	441.94	28.30
74	108.04	17.23	151	187.88	5.64	313	459.30	11.91
90	124.13	31.28	152	189.08	2.14	315	471.87	5.54
91	125.11	5.22	155	192.87	12.22	318	489.25	6.21
96	131.04	23.34	156	193.95	3.86	320	504.27	0.57
97	132.11	2.87	161	198.99	4.49	321	507.86	43.39
100	135.14	3.50	162	199.86	6.79	322	509.46	27.52
101	136.10	4.02	163	201.01	25.90	323	512.41	0.47
102	137.08	16.61	164	201.91	5.90	324	522.90	13.11
103	138.05	8.98	166	204.97	14.36	325	527.72	64.91

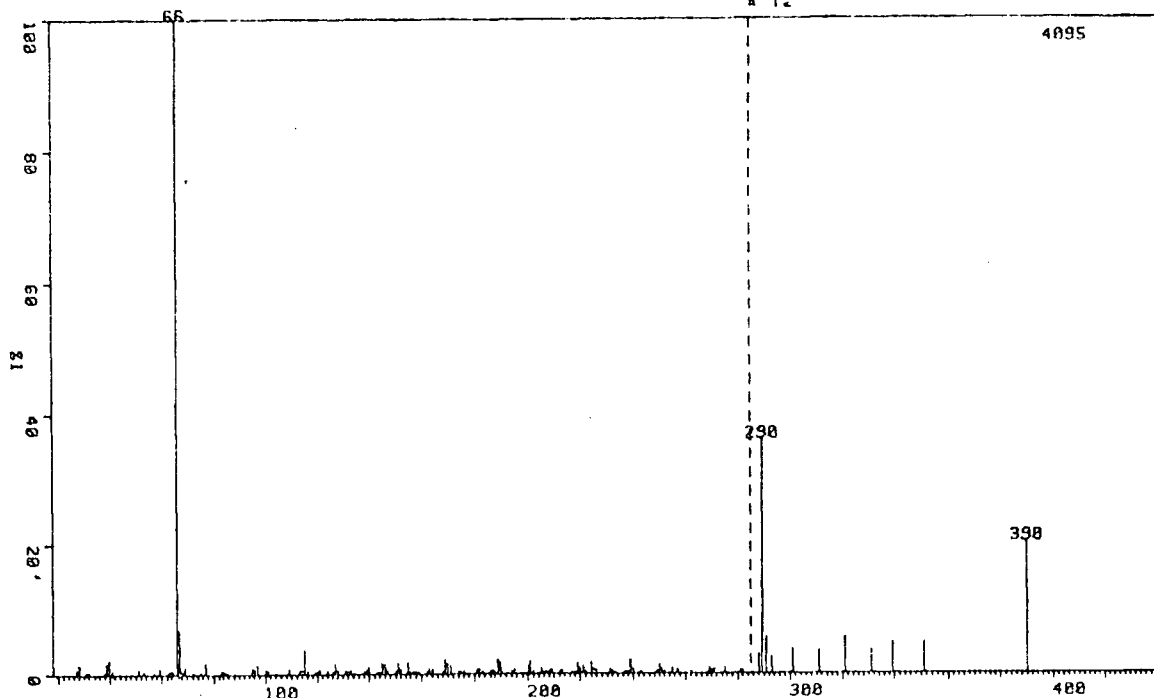

PEAK NO.	MASS	ZHT. BASE
7	39.91	2.20
20	65.98	100.00*
21	66.77	6.81
22	67.33	4.35
41	115.11	3.79*
74	169.02	2.27*
87	189.04	2.15*
93	201.00	1.95*
117	239.04	2.08*
133	288.28	0.24*
134	289.57	3.00*
135	291.03	0.46*
136	293.14	0.22*
137	301.07	0.32*
138	311.00	0.29*
139	321.10	0.46*
140	331.12	0.29
141	339.13	0.39*
142	351.08	0.39*
143	390.03	1.68

72A2
JRKXZB 14 J.R.KIRK
CALICALIS

No. II (MW 474)

20-NOV-80

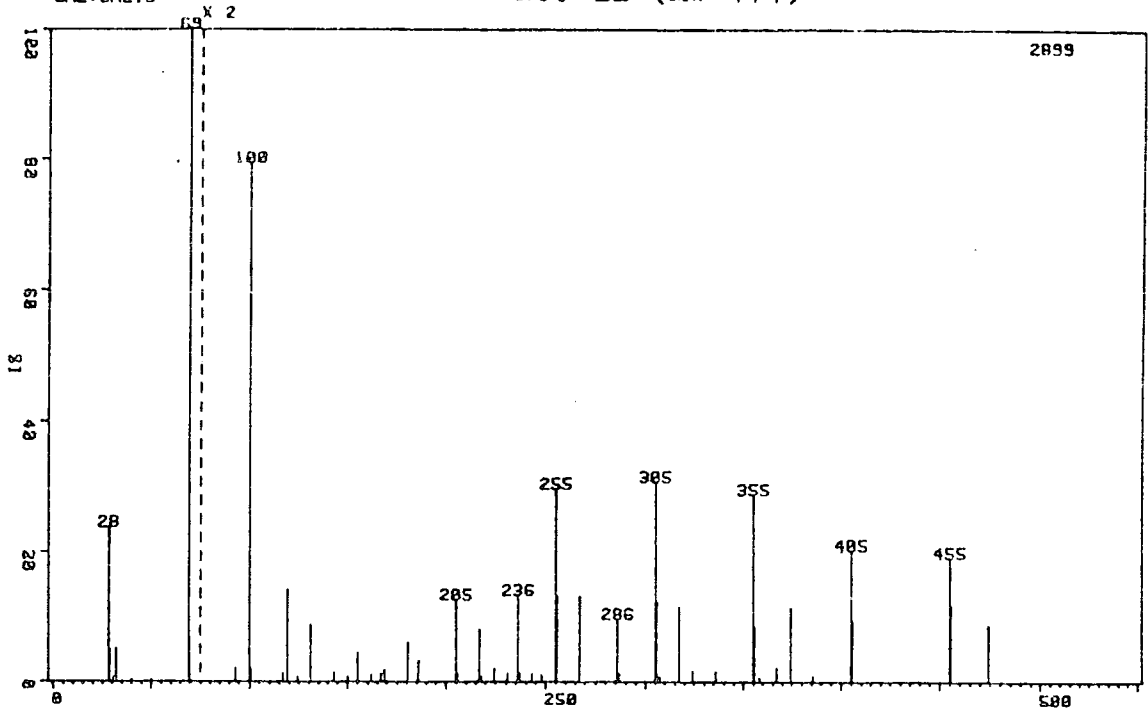

PEAK NO.	MASS	%HT. BASE	31	230.91	0.69
			32	235.97	6.62
			33	236.87	0.66
1	28.13	23.77	34	242.99	0.62
2	28.20	4.93	35	247.99	0.48
3	30.93	0.76	36	254.93	14.80
4	32.05	5.21	37	255.52	6.59
5	39.86	0.45	38	267.11	6.55
6	49.90	0.38	39	285.95	4.79
7	68.99	100.00	40	286.90	0.66
8	69.22	6.73	41	304.86	15.35
9	69.87	1.14	42	305.61	6.17
10	92.99	1.07	43	306.88	0.38
11	99.90	39.74	44	307.59	0.34
12	100.56	0.34	45	317.07	5.73
13	100.89	0.97	46	323.94	0.86
14	117.04	0.69	47	335.94	0.79
15	118.98	7.11	48	354.83	14.38
16	124.04	0.38	49	355.70	4.28
17	130.97	4.38	50	357.87	0.31
18	142.99	0.72	51	366.85	1.14
19	149.91	0.38	52	374.03	5.69
20	154.99	2.24	53	385.90	0.45
21	161.95	0.52	54	404.74	10.11
22	166.95	0.62	55	405.60	4.73
23	168.93	0.90	56	454.79	9.52
24	180.89	3.04	57	455.58	5.83
25	185.98	1.62	58	474.06	4.38
26	204.99	6.28			
27	205.88	0.62			
28	216.97	3.97			
29	217.97	0.38			
30	224.00	1.00			

22A3
JRKX2B 31 J.R.KIRK
CALICHL19

No. I2 (MW 624)

20-NOV-88

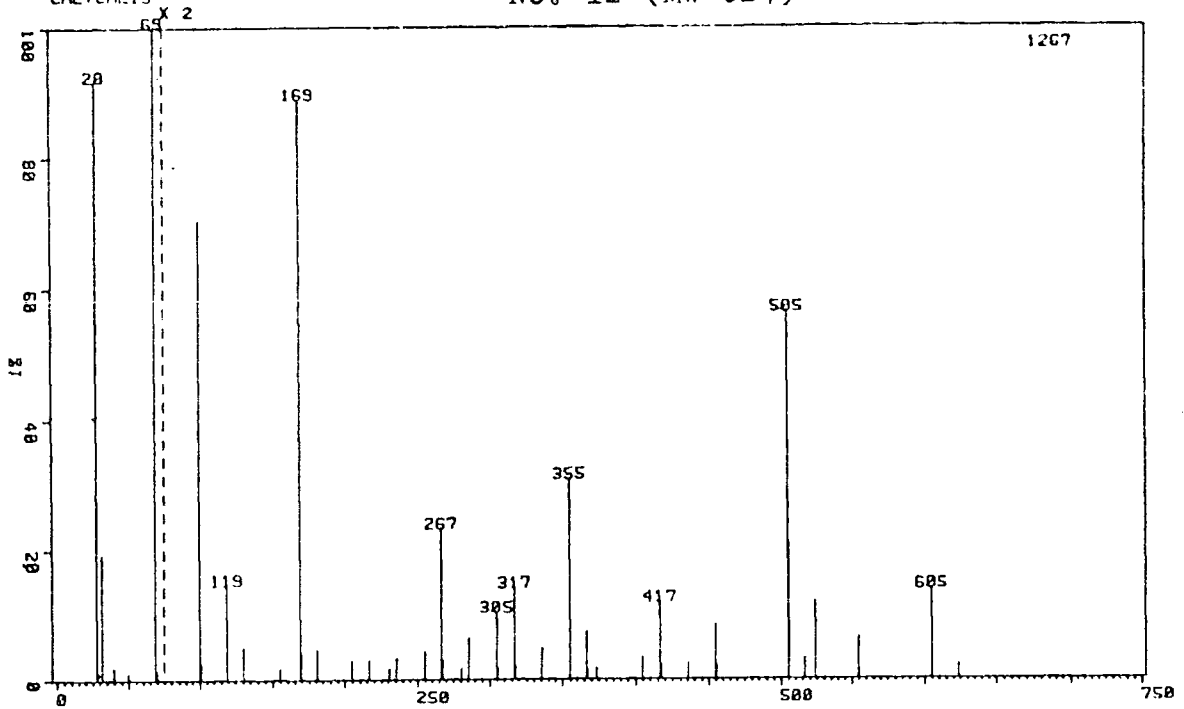

PEAK NO.	MASS	ZHT.	BASE		
			31	335.90	2.37
			32	354.98	15.39
			33	366.78	3.63
1	28.13	91.71	34	367.92	0.71
2	28.99	0.87	35	373.84	0.87
3	30.91	0.95	36	404.75	1.66
4	32.02	19.26	37	416.85	5.92
5	39.83	1.82	38	417.85	1.10
6	49.86	0.87	39	435.87	1.18
7	68.95	100.00	40	454.77	4.18
8	69.55	0.79	41	455.80	1.03
9	69.88	1.34	42	504.71	28.18
10	99.87	35.20	43	505.70	10.50
11	100.93	1.26	44	516.78	1.58
12	118.90	7.26	45	523.87	5.92
13	130.89	2.45	46	554.75	3.24
14	154.97	0.87	47	555.67	0.71
15	168.88	44.44	48	604.74	6.87
16	169.90	1.97	49	623.81	1.10
17	180.91	2.29			
18	204.89	1.50			
19	216.90	1.50			
20	230.93	0.87			
21	235.91	1.66			
22	254.90	2.13			
23	266.81	11.60			
24	267.74	1.50			
25	280.90	0.87			
26	285.95	3.24			
27	304.90	5.13			
28	305.92	0.87			
29	316.86	7.02			
30	317.95	1.03			

JK17A2 15
OIL OIL 25

No. 13 (MW 368)

07-APR-81

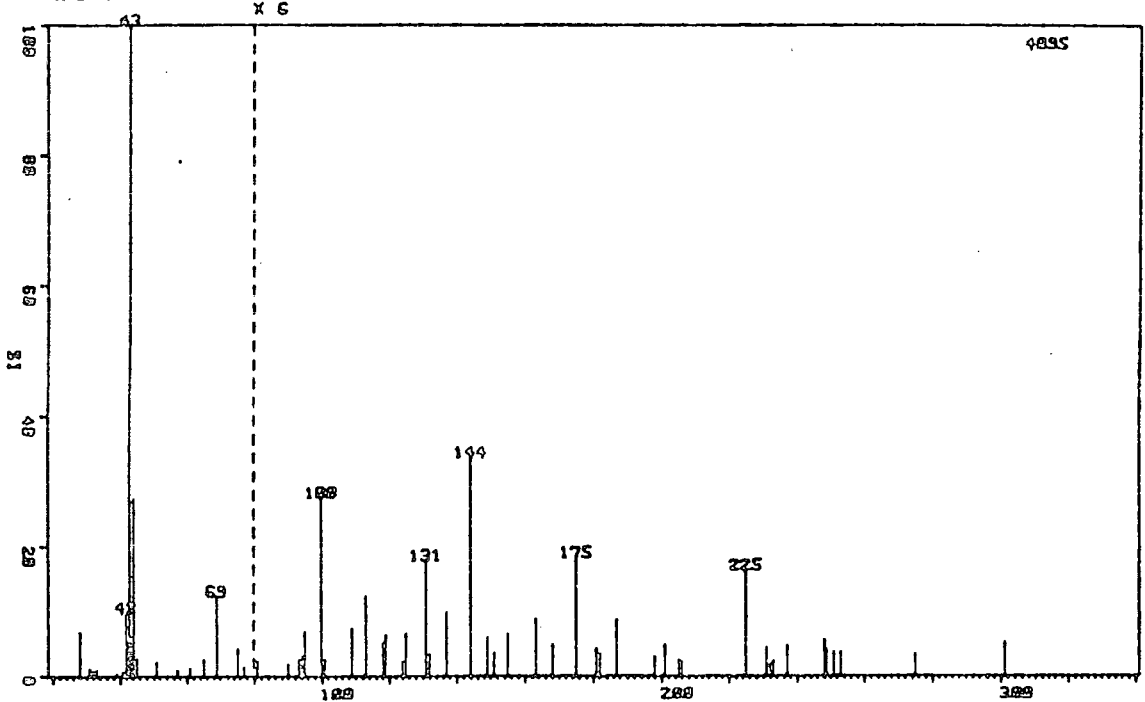

PEAK NO.	RET. TIME	AREA	NO.	RET. TIME	AREA
1	25.13	6.74	33	118.97	1.05
2	30.77	1.00	34	124.05	0.37
3	32.13	0.66	35	125.04	1.10
4	33.14	0.93	36	130.94	2.95
5	39.07	0.39	37	132.00	0.56
6	40.97	0.86	38	137.02	1.64
7	41.28	0.37	39	143.99	5.59
8	41.38	0.66	40	148.99	0.92
9	42.05	9.74	41	150.98	0.59
10	43.01	100.00	42	155.01	1.07
11	43.42	6.01	43	163.00	1.47
12	43.80	0.44	44	168.02	0.81
13	43.95	0.49	45	174.99	3.03
14	44.18	27.35	46	180.96	0.71
15	45.10	2.81	47	182.04	0.56
16	50.95	2.17	48	186.98	1.44
17	57.13	0.90	49	198.01	0.49
18	60.88	1.34	50	200.96	0.81
19	65.11	2.51	51	204.98	0.42
20	68.72	12.28	52	206.02	0.37
21	70.05	4.27	53	225.00	2.71
22	77.07	1.62	54	230.98	0.73
23	80.91	0.39	55	232.04	0.37
24	89.89	0.32	56	233.02	0.47
25	93.00	0.44	57	236.03	0.75
26	94.02	0.51	58	243.00	0.95
27	95.03	1.15	59	248.90	0.61
28	99.88	4.57	60	251.01	0.61
29	100.99	0.44	61	253.02	0.61
30	108.96	1.22	62	275.03	0.56
31	113.00	2.05	63	300.99	0.85
32	118.03	0.85			

JK17A3 30 J.R.KIRK
CALIFORNIA

No. I4 (MW 368)

08-APR-81

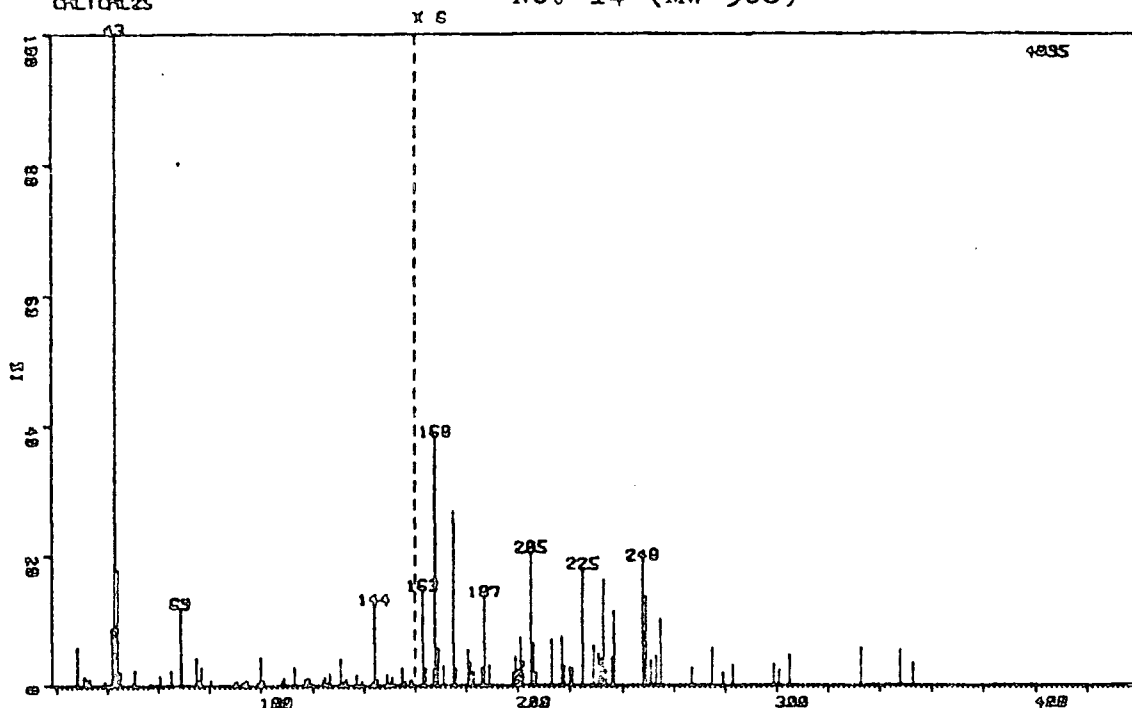

PEAK NO.	MASS	INT. BASE	35	99.91	4.32	81	200.95	1.25
			36	101.00	0.81	82	201.98	0.61
			37	108.01	0.65	83	204.97	3.39
1	28.14	5.91	38	108.97	1.15	84	205.97	1.07
2	29.00	0.32	39	113.03	2.83	85	206.97	0.32
3	30.92	1.34	40	117.02	0.81	86	212.98	1.17
4	32.03	0.81	41	118.04	1.12	87	212.97	1.25
5	33.14	1.05	42	118.97	1.00	88	217.94	0.49
6	39.01	0.54	43	119.99	0.32	89	217.99	0.45
7	40.98	0.39	44	124.05	0.66	90	221.00	0.44
8	42.05	8.84	45	125.07	1.32	91	224.99	2.98
9	42.06	0.98	46	126.08	0.39	92	229.01	1.00
10	43.10	100.00	47	127.04	1.81	93	230.97	0.31
11	43.68	5.40	48	130.97	4.00	94	231.99	0.68
12	43.76	0.29	49	132.00	0.47	95	232.97	3.71
13	43.81	0.32	50	133.05	0.88	96	233.99	0.39
14	43.86	0.42	51	137.02	1.54	97	235.99	0.71
15	44.16	17.85	54	144.01	12.46	98	236.97	1.90
16	45.17	2.03	55	145.03	0.90	99	242.94	3.20
17	49.37	0.49	56	149.01	1.64	100	248.92	2.27
18	50.95	2.22	57	149.95	0.32	101	250.92	0.63
19	57.10	0.37	58	150.96	1.07	102	252.93	0.76
20	60.96	1.54	59	151.99	0.32	103	254.90	1.68
21	65.11	0.15	60	155.01	2.69	104	266.91	0.44
22	68.93	11.84	61	156.05	0.63	105	275.01	0.95
23	69.01	3.39	62	157.98	0.68	107	283.04	0.51
24	69.90	0.24	63	158.97	0.66	108	292.92	0.54
25	75.04	4.22	64	163.00	2.42	109	300.91	0.32
26	76.06	0.66	65	164.05	0.44	110	304.93	0.78
27	77.01	2.81	66	166.99	0.39	111	332.88	0.95
28	80.89	0.76	67	167.99	6.32	112	342.85	0.90
29	89.89	0.54	68	168.95	0.95	113	352.91	0.56
30	91.00	0.66	69	170.99	0.47			
31	93.01	0.46	70	175.01	4.44			
32	94.05	0.66	71	176.00	0.44			

-215-

JK41R1 25 J.R.KIRK
CALICAM10

No. 15 (MW 520)

19-FEB-82

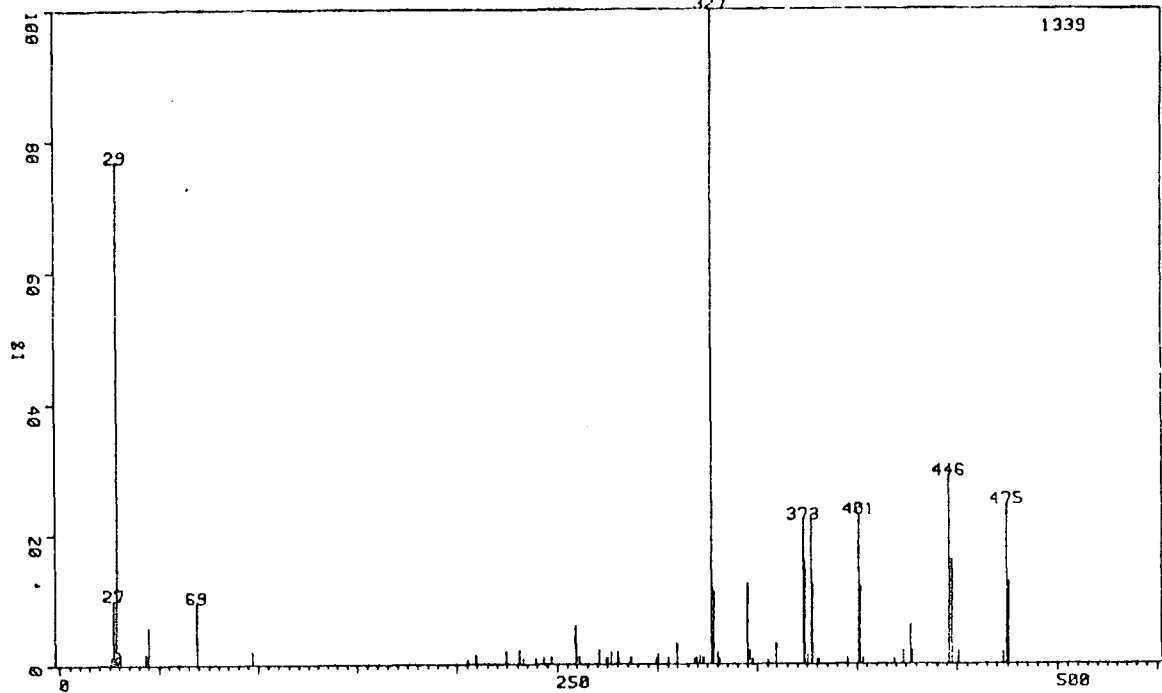

PEAK NO.	MASS	%HT. BASE	PEAK NO.	MASS	%HT. BASE
1	26.31	1.27	36	319.50	1.19
2	27.25	9.93	37	321.06	1.42
3	28.14	3.81	38	322.52	1.19
4	29.02	76.92	39	323.28	0.90
5	29.85	2.24	40	326.83	100.00
6	30.92	1.72	41	328.11	11.28
7	43.12	1.72	42	330.05	1.87
8	44.18	1.34	43	331.11	0.97
9	45.19	5.83	44	345.06	12.32
10	69.01	9.56	45	346.48	2.09
11	97.10	1.94	46	347.86	0.90
12	205.25	0.75	47	355.05	0.67
13	209.09	1.42	48	359.07	3.21
14	224.20	2.02	49	373.04	22.11
15	231.12	2.09	50	373.73	15.61
16	233.14	1.05	51	375.36	1.49
17	239.05	0.90	52	377.17	22.78
18	243.04	1.12	53	377.75	12.10
19	247.09	1.27	54	380.39	0.67
20	259.07	5.90	55	381.27	0.90
21	260.06	0.97	56	395.27	1.12
22	261.04	1.27	57	401.01	22.93
23	271.05	2.17	58	401.75	11.87
24	274.24	1.12	59	403.28	1.05
25	275.11	1.12	60	418.99	0.75
26	277.03	1.87	61	423.15	2.17
27	280.04	1.94	62	427.00	6.05
28	281.08	0.97	63	428.04	2.02
29	286.39	0.90	64	446.26	28.75
30	287.01	1.19	65	447.57	16.06
31	299.07	0.90	66	450.91	1.94
32	300.07	1.57	67	473.05	1.87
33	305.07	1.12	68	474.98	24.42
34	309.40	3.21	69	475.90	12.47
35	318.40	0.82			

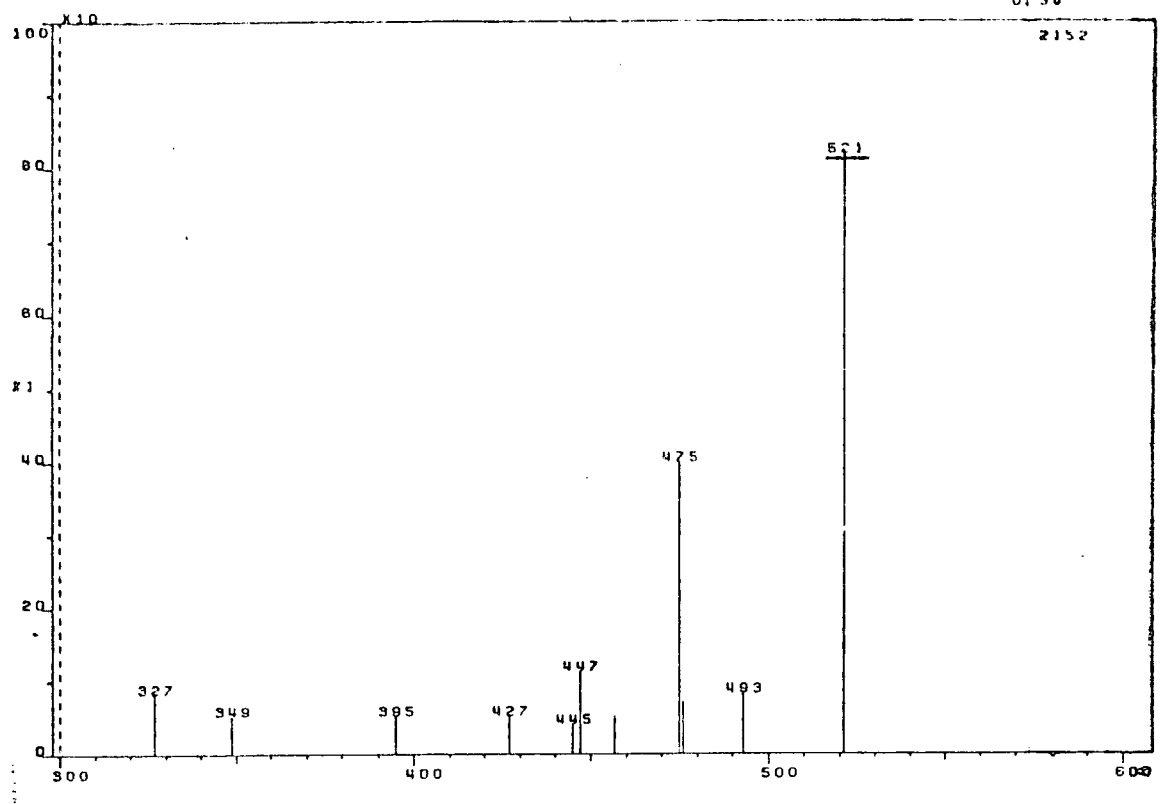

Compound No. 15 (MW 520) - Chemical Ionisation m.s.

JK50A1 4 J.R.KIRK
CALICCALMIS
X 2

No. I6 (MW 460)

15-APR-82

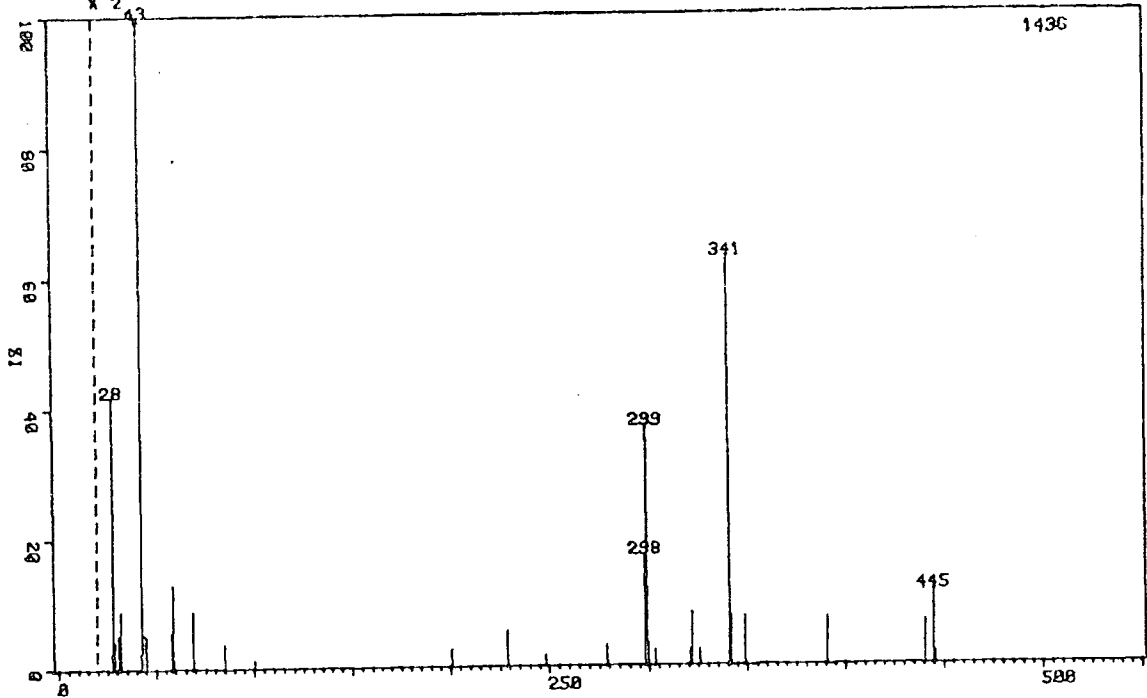

PEAK NO.	MASS	ZHT. BASE
1	27.26	1.25
2	28.13	20.96
3	29.02	2.09
4	30.93	2.58
5	32.02	4.46
6	42.05	1.18
7	43.11	100.00
8	44.15	2.65
9	45.16	2.51
10	58.07	2.86
11	59.02	6.48
12	68.95	4.39
13	85.03	1.88
14	99.95	0.63
15	200.96	1.32
16	228.94	2.72
17	247.91	0.84
18	278.93	1.60
19	297.88	8.57
20	298.95	18.45
21	299.93	1.67
22	302.97	1.18
23	320.95	1.18
24	321.98	4.04
25	325.97	1.18
26	340.89	31.41
27	341.90	3.76
28	348.93	3.69
29	390.93	3.62
30	440.95	3.34
31	444.94	5.78
32	445.95	0.91

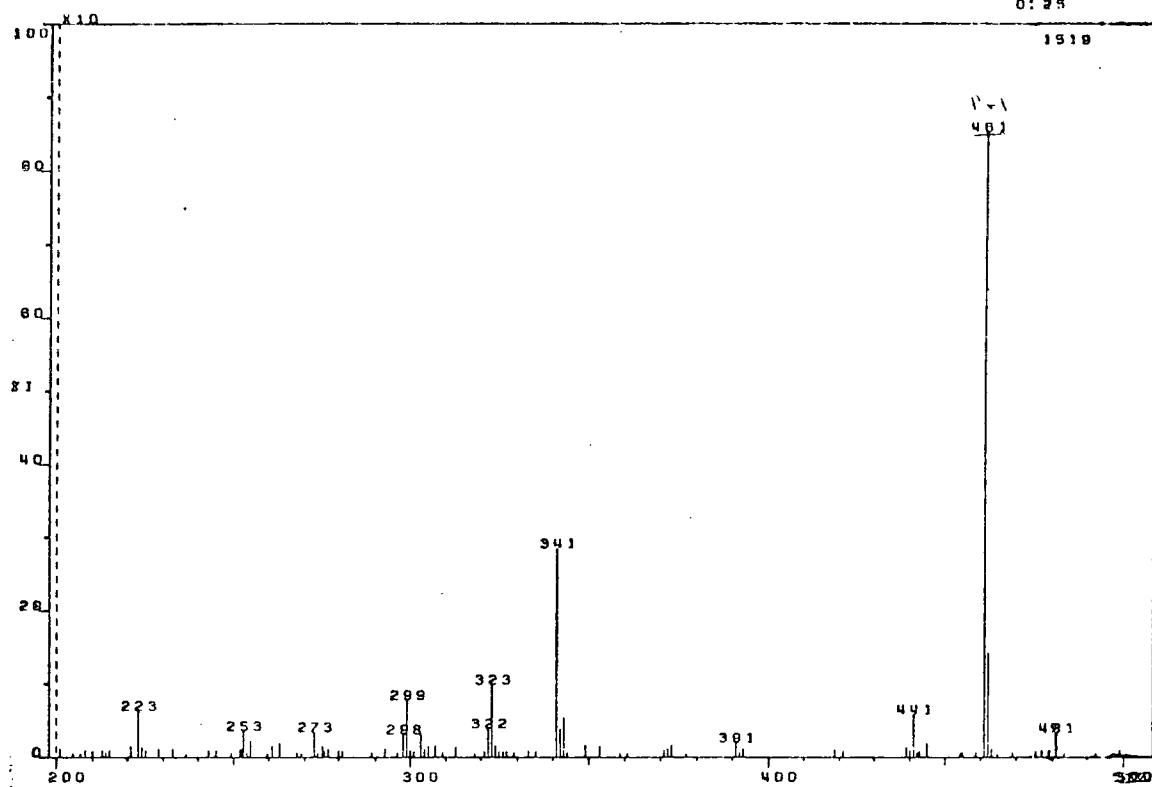

Compound No. I6 (MW 460) - Chemical Ionisation m.s.

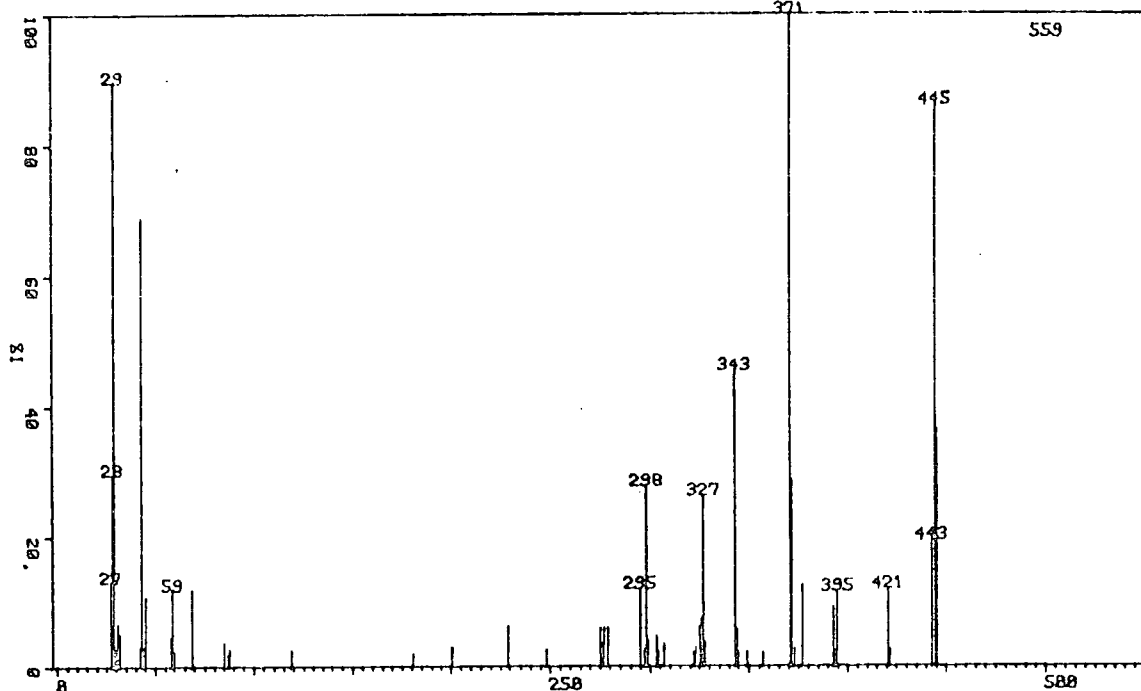

PEAK NO.	MASS	%HT. BASE	PEAK NO.	MASS	%HT. BASE
1	27.25	13.06	36	324.96	6.08
2	28.13	29.52	37	325.93	7.33
3	29.02	89.62	38	326.96	26.30
4	29.86	2.68	39	327.93	3.76
5	30.92	6.62	40	342.90	45.44
6	32.01	5.01	41	343.90	5.72
7	42.02	3.04	42	344.93	2.15
8	43.09	68.87	43	348.96	2.33
9	44.13	3.04	44	356.97	2.15
10	45.16	10.73	45	370.84	100.00
11	58.06	4.47	46	371.63	28.44
12	59.00	11.81	47	372.95	2.68
13	59.92	2.33	48	376.94	12.52
14	68.93	11.81	49	392.93	9.12
15	85.00	3.76	50	393.98	2.15
16	86.98	1.97	51	394.96	11.63
17	87.98	2.68	52	420.88	11.99
18	118.89	2.50	53	422.03	2.50
19	180.87	1.97	54	442.96	19.50
20	200.89	3.04	55	444.84	86.05
21	228.88	6.26	56	445.61	36.31
22	247.91	2.50			
23	274.84	5.90			
24	275.95	3.40			
25	276.92	5.90			
26	278.91	5.90			
27	294.89	11.99			
28	296.94	2.50			
29	297.92	27.73			
30	298.86	3.94			
31	302.96	4.65			
32	303.98	2.33			
33	306.87	3.40			
34	321.93	2.33			
35	322.96	2.86			

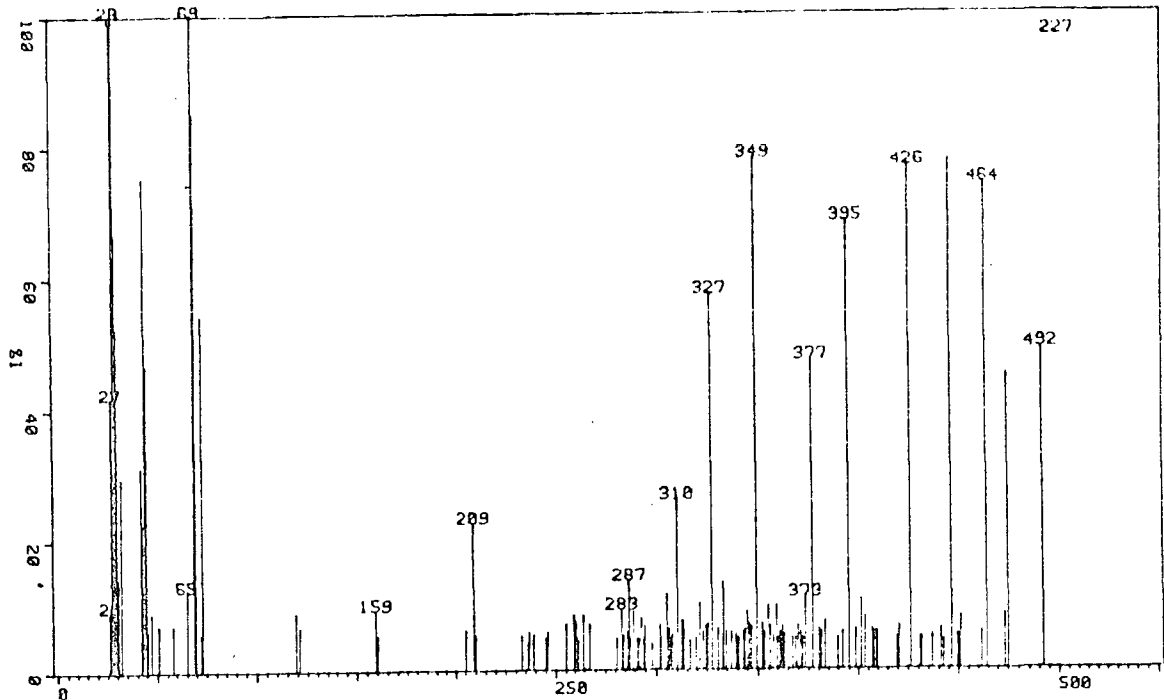

PEAK NO.	MASS	ZHT. BASE	PEAK NO.	MASS	ZHT. BASE	PEAK NO.	MASS	ZHT. BASE
1	26.31	1.19	61	294.96	0.85	129	426.38	9.87
2	27.25	5.39	63	302.04	0.91	133	441.20	0.79
4	28.13	21.33	65	304.88	1.47	134	442.60	0.57
7	29.01	100.00	66	306.08	0.79	135	446.51	9.98
8	29.14	8.56	69	310.09	3.35	136	449.26	0.68
10	29.85	6.75	70	312.09	0.96	137	449.85	0.68
11	30.93	1.82	71	312.99	0.96	138	450.92	1.02
12	32.02	3.80	72	313.57	0.79	139	461.71	0.74
13	42.07	4.03	75	321.18	1.30	140	464.28	9.53
14	43.12	2.89	77	324.38	0.85	141	473.23	1.08
15	44.18	9.70	78	325.19	0.91	142	475.14	5.79
16	45.17	6.01	79	327.25	7.37	143	492.10	6.30
17	45.41	0.79	80	330.34	0.79			
18	47.13	1.13	82	332.88	1.70			
19	50.94	0.91	89	343.63	0.79			
20	58.09	0.91	90	344.72	1.13			
21	65.14	1.59	91	345.76	0.91			
22	68.75	0.79	92	346.96	0.85			
23	69.00	12.88	93	349.31	10.04			
24	69.05	10.95	94	352.17	0.91			
26	73.11	6.98	96	355.09	1.25			
27	118.99	1.13	97	356.21	0.85			
28	121.01	0.85	99	359.15	1.25			
29	158.99	1.19	103	362.00	0.85			
31	205.07	0.79	108	369.77	0.85			
32	208.98	2.89	111	373.27	1.42			
42	255.03	0.91	112	376.87	6.07			
43	258.95	1.08	113	380.01	0.79			
44	260.50	0.96	116	383.11	0.96			
47	264.09	1.08	119	395.07	8.79			
48	267.05	0.91	120	398.47	0.79			
50	283.02	1.19	121	401.51	1.36			
53	286.95	1.76	122	403.31	1.02			
55	288.99	1.13	123	406.98	0.79			
58	293.04	1.02	128	420.61	0.85			

JXS9A2 6 J.R.KIRK
CAL I CALMG

No. I9 (MW 420)

01-JUN-82

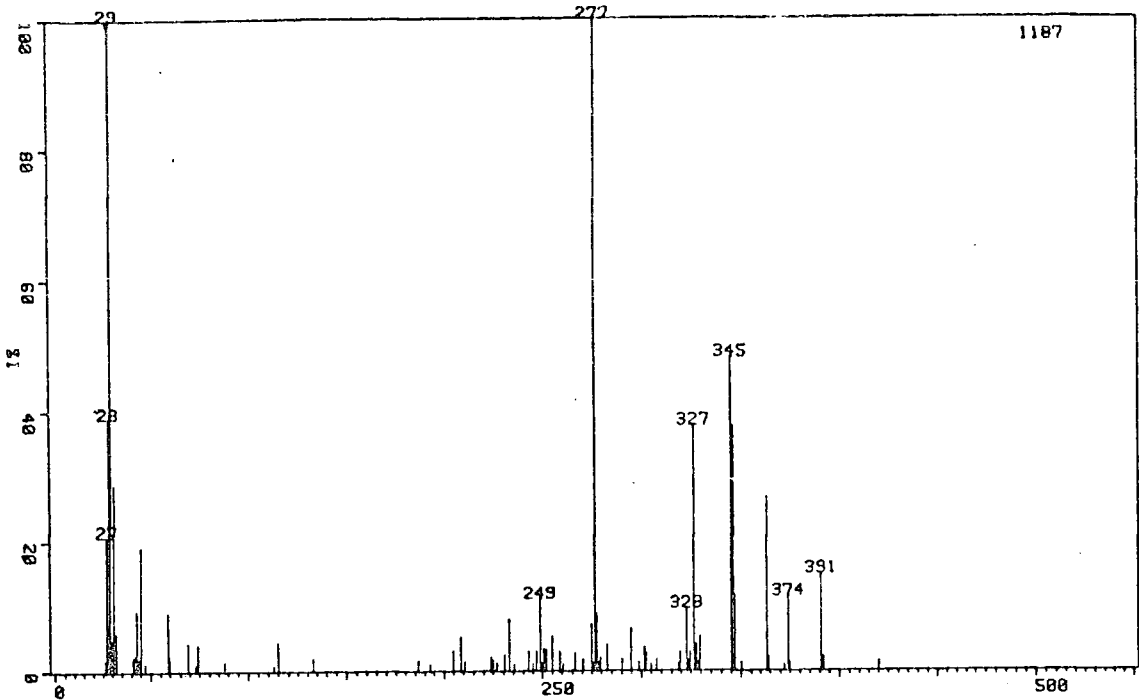

PEAK NO.	MASS	ZHT. BASE	PEAK NO.	MASS	ZHT. BASE	PEAK NO.	MASS	ZHT. BASE
1	26.31	0.88	36	246.72	1.47	71	347.27	5.38
2	27.25	9.84	37	248.67	5.30	72	350.42	0.60
3	28.13	18.41	38	249.70	0.56	73	363.27	12.59
4	29.02	100.00	39	250.68	1.59	74	364.11	1.08
5	29.85	2.27	40	251.71	1.55	75	372.05	0.48
6	30.92	13.55	41	254.72	2.47	76	373.97	5.46
7	32.01	2.83	42	258.75	1.39	77	375.02	0.60
8	40.96	1.04	43	260.72	0.52	78	391.01	7.09
9	42.02	1.16	44	266.67	1.27	79	392.07	1.00
10	43.09	4.42	45	270.64	0.84	80	419.96	0.72
11	44.11	0.92	46	274.70	3.39			
12	45.14	9.04	47	275.76	0.60			
13	47.10	0.60	48	276.67	47.29			
14	58.98	4.26	49	277.64	4.10			
15	59.89	0.88	50	278.65	0.64			
16	68.92	2.03	51	279.66	0.96			
17	73.02	0.48	52	282.64	1.87			
18	74.06	1.95	53	290.56	0.88			
19	87.94	0.68	54	294.64	3.07			
20	112.88	0.44	55	298.54	0.64			
21	114.92	2.15	56	301.54	1.71			
22	132.85	0.92	57	302.57	1.35			
23	186.72	0.76	58	304.57	0.52			
24	192.74	0.48	59	307.59	0.84			
25	204.68	1.51	60	318.58	0.52			
26	208.63	2.47	61	319.58	1.43			
27	210.65	0.68	62	322.59	4.58			
28	223.68	1.00	63	323.61	0.80			
29	224.73	0.84	64	324.53	1.35			
30	226.79	0.60	65	326.53	17.85			
31	230.77	1.16	66	327.56	1.95			
32	232.79	3.78	67	328.53	0.64			
33	235.76	0.48	68	329.45	2.51			
34	242.65	1.47	69	345.38	22.79			
35	244.75	0.56	70	346.41	17.73			

JX59C1 30 J.R.KIRK
CALICALM15

No. 20 (MW 390)

21-APR-82

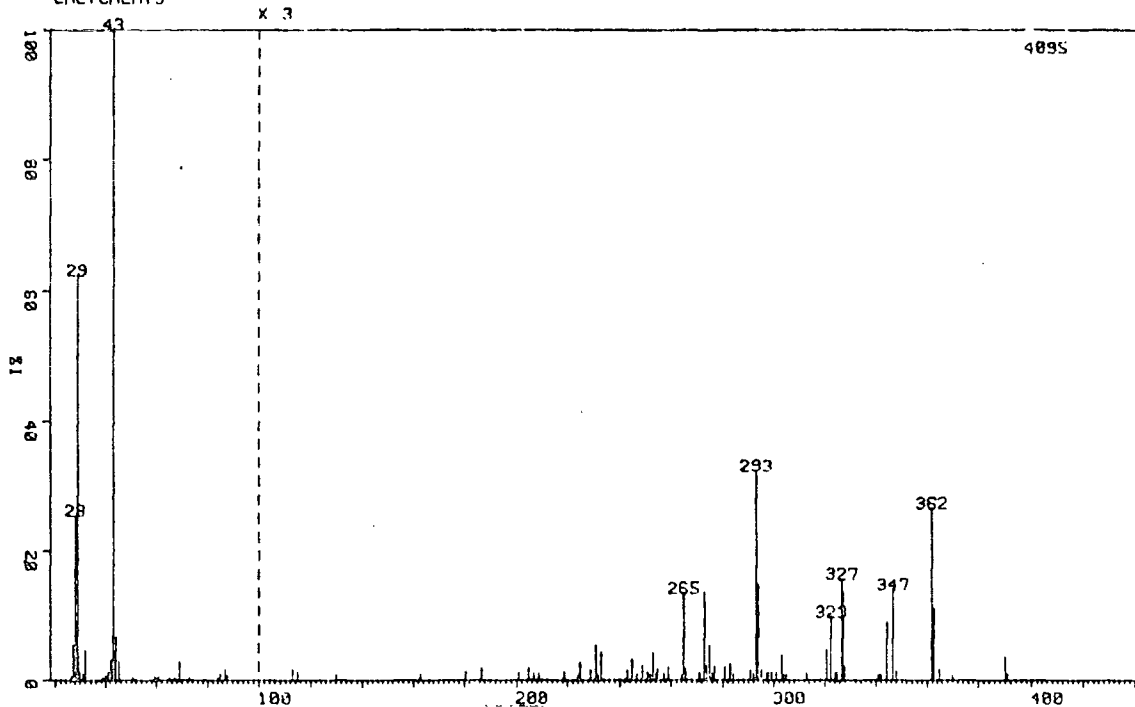

PEAK NO.	MASS	%HT. BASE	PEAK NO.	MASS	%HT. BASE
1	26.31	0.37	36	186.72	0.42
2	27.25	4.27	37	198.66	0.46
3	28.13	19.10	38	204.64	0.46
4	29.02	39.05	39	208.59	0.42
5	29.85	0.83	40	218.68	0.37
6	30.92	1.54	41	224.66	0.59
7	32.01	3.37	42	228.64	0.34
8	38.99	0.66	43	230.59	1.05
9	39.83	0.32	44	232.63	0.66
10	39.89	0.59	45	242.51	0.46
11	40.97	3.25	46	244.53	0.90
12	42.03	2.32	47	248.52	0.56
13	43.09	100.00	48	250.51	0.37
14	44.13	3.69	49	252.52	0.81
15	45.15	4.49	50	254.53	0.37
16	47.11	0.32	51	258.50	0.44
17	58.06	1.44	52	264.53	2.42
18	58.99	1.88	62	264.87	4.47
19	59.91	0.78	67	272.90	4.54
20	60.96	0.61	77	292.93	10.72
21	67.06	0.66	78	293.67	4.91
22	68.02	0.37	91	324.92	0.46
23	68.94	3.35	92	326.76	5.20
24	69.90	0.32	93	327.14	4.47
25	73.03	0.46	94	327.92	0.71
26	83.98	0.56	95	340.93	0.29
27	84.98	3.49	96	342.02	0.29
28	86.95	3.83	97	344.26	3.00
29	87.95	1.37	98	346.73	4.66
30	88.91	0.27	99	347.89	0.46
31	101.94	0.46	100	361.87	8.82
32	112.93	0.51	101	362.68	3.69
33	114.96	1.34	102	364.97	0.56
34	129.87	0.39	103	370.03	0.27
35	136.85	0.22	104	390.01	1.20

JX59C1 S4 J.R.KIRK
CALICALM15

No. 2I (MW 390)

21-APR-82

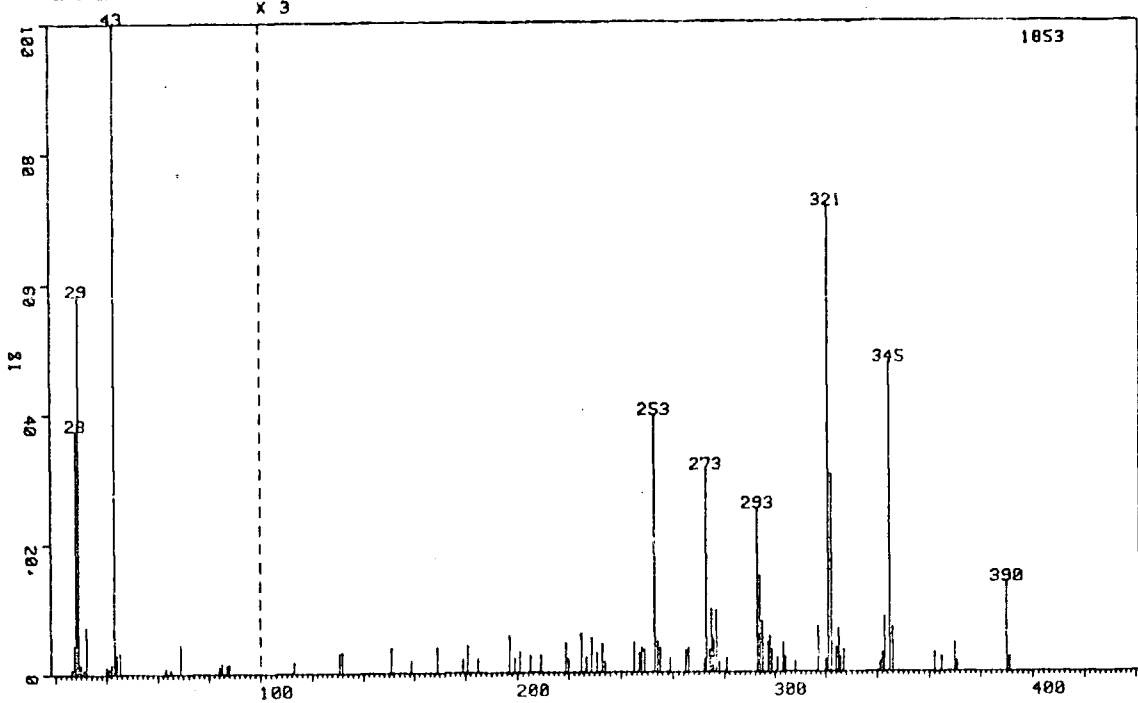

PEAK NO.	MASS	%HT. BASE
2	27.25	4.48
3	28.13	37.51
4	29.03	58.34
7	32.02	7.29
11	43.10	100.00
16	68.93	4.43
47	252.89	13.17
54	272.91	10.36
61	292.94	8.36
62	293.92	4.91
73	320.97	23.85
74	322.21	10.09
76	324.94	2.21
77	325.54	0.65
78	325.92	0.81
79	326.94	1.13
80	340.98	0.54
81	341.96	0.97
82	342.94	2.81
83	344.89	15.81
84	345.95	2.27
85	362.01	1.03
86	365.02	0.81
87	369.96	1.46
88	371.01	0.59
89	390.00	4.59
90	391.04	0.81

JK46D2 S J.R.KIRK
CALICAMIS

No. 22 (MW 590)

15-APR-82

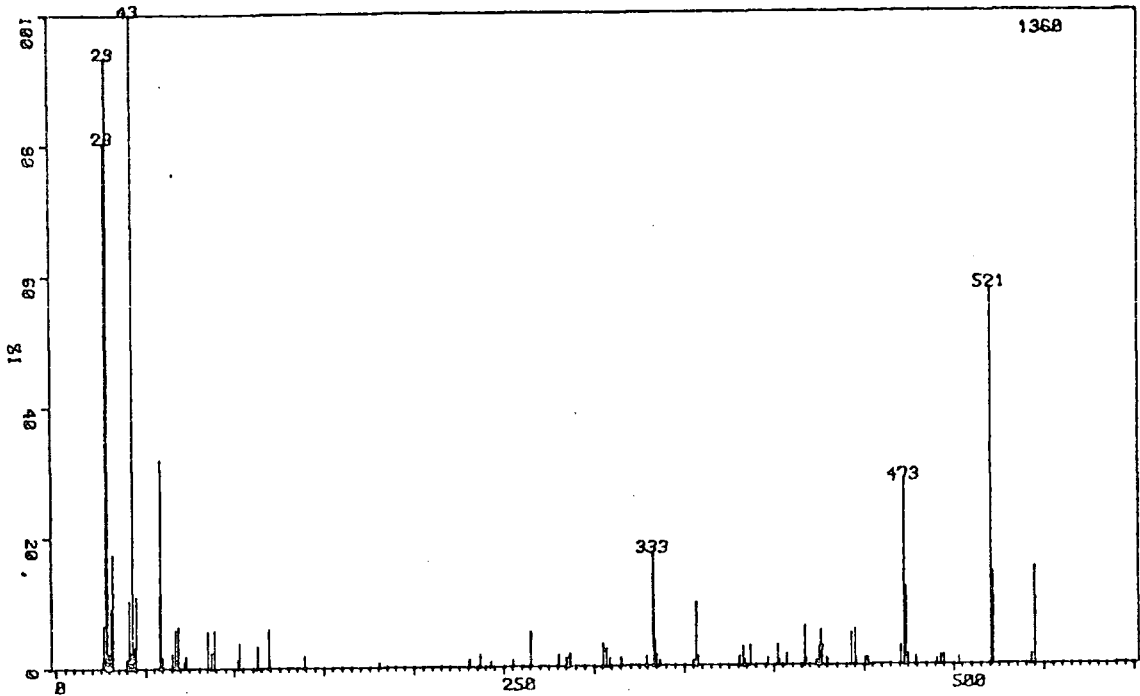

PEAK NO.	MASS	%HT. BASE	PEAK NO.	MASS	%HT. BASE	PEAK NO.	MASS	%HT. BASE
1	26.32	1.18	36	242.96	0.81	71	444.94	5.44
2	27.25	6.54	37	254.96	0.96	72	445.95	1.10
3	28.13	80.37	38	264.90	5.22	73	450.90	1.10
4	29.03	93.38	39	280.98	1.76	74	452.03	1.25
5	29.86	2.21	40	284.98	1.25	75	453.00	1.03
6	30.93	9.04	41	286.98	1.99	76	470.95	2.87
7	32.02	17.43	42	304.90	3.46	77	472.80	28.24
8	39.01	1.25	43	306.93	2.65	78	473.62	11.84
9	39.83	1.47	44	308.91	1.25	79	474.93	1.62
10	39.90	1.47	45	314.94	1.25	80	478.93	1.18
11	40.99	10.37	46	328.94	1.47	81	491.03	0.88
12	42.05	2.43	47	332.93	17.35	82	493.02	1.47
13	43.11	100.00	48	333.93	3.75	83	495.00	1.54
14	44.14	3.09	49	334.94	1.84	84	502.96	1.18
15	45.17	10.96	50	336.89	0.81	85	520.98	57.57
16	58.07	11.10	51	355.01	0.81	86	522.06	14.04
17	59.02	31.84	52	356.91	9.71	87	542.93	1.47
18	59.94	1.69	53	357.97	1.40	88	545.03	14.85
19	65.11	2.28	54	380.93	1.47			
20	67.05	5.74	55	382.97	2.79			
21	68.02	0.74	56	383.93	0.81			
22	68.93	6.32	57	386.92	3.01			
23	72.00	0.96	58	396.90	1.10			
24	73.01	1.91	59	401.90	3.09			
25	84.99	5.51	60	402.97	0.81			
26	87.00	2.43	61	406.97	1.69			
27	88.93	5.74	62	416.88	5.96			
28	102.02	1.25	63	417.94	1.03			
29	103.03	3.90	64	423.00	0.74			
30	113.02	3.31	65	424.96	2.72			
31	118.90	6.10	66	426.01	5.29			
32	138.94	1.84	67	426.99	2.87			
33	180.90	0.74	68	429.01	1.18			
34	230.89	1.10	69	430.20	0.81			
35	236.98	1.84	70	442.98	4.93			

JK46B1 3 J.R.KIRK
CALICOLM15

No. 23 (MW 620)

15-APR-82

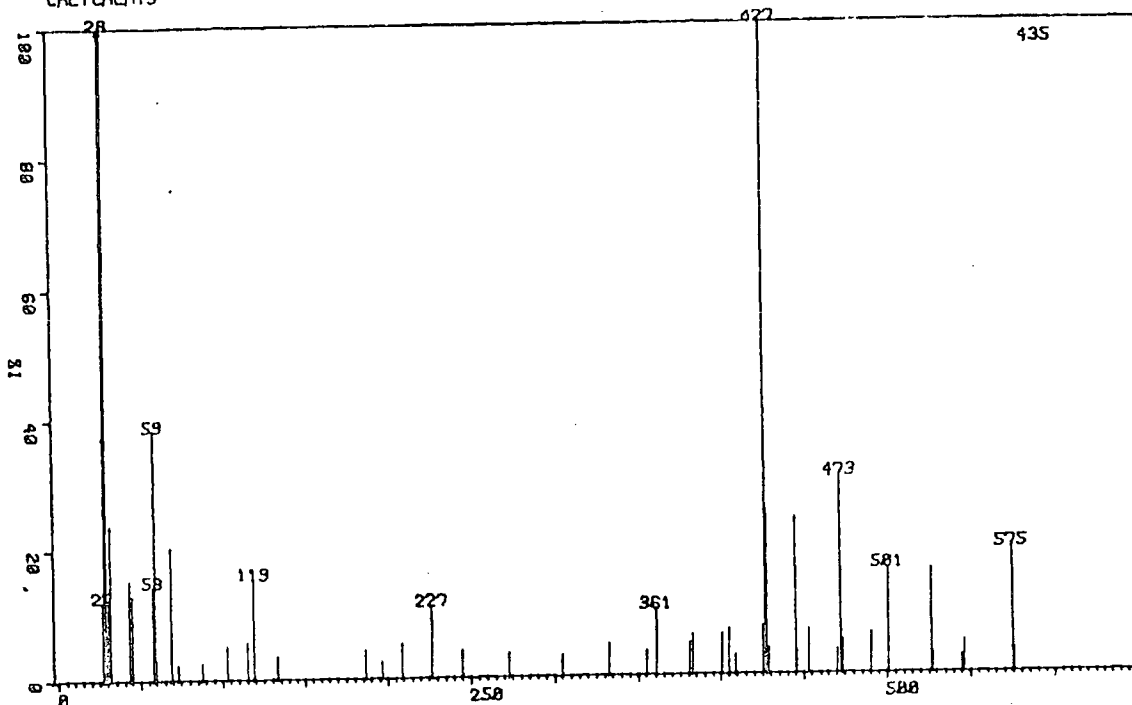

PEAK NO.	MASS	%HT. BASE	PEAK NO.	MASS	%HT. BASE
1	27.25	4.17	36	426.88	34.86
2	28.13	42.63	37	427.68	8.73
3	29.02	100.00	38	429.01	1.36
4	29.85	2.48	39	444.98	8.33
5	30.92	4.17	40	446.00	1.20
6	32.01	8.25	41	452.94	2.32
7	43.11	5.29	42	470.89	1.28
8	44.12	1.68	43	472.92	10.58
9	45.16	4.49	44	473.99	1.76
10	58.07	4.97	45	490.94	2.16
11	59.01	13.30	46	500.95	5.61
12	59.93	1.04	47	526.92	5.53
13	68.94	7.05	48	527.91	1.04
14	73.03	0.80	49	544.85	0.88
15	88.01	0.88	50	546.99	1.68
16	103.06	1.76	51	574.91	6.65
17	115.02	1.92	52	576.05	1.20
18	118.91	5.37			
19	133.02	1.20			
20	186.89	1.52			
21	196.92	0.88			
22	208.89	1.84			
23	226.92	3.85			
24	244.89	1.44			
25	272.95	1.28			
26	304.90	1.12			
27	332.88	1.68			
28	354.91	1.28			
29	360.90	3.53			
30	380.90	1.68			
31	382.88	2.16			
32	400.90	2.16			
33	404.90	2.40			
34	408.90	1.04			
35	424.92	2.56			

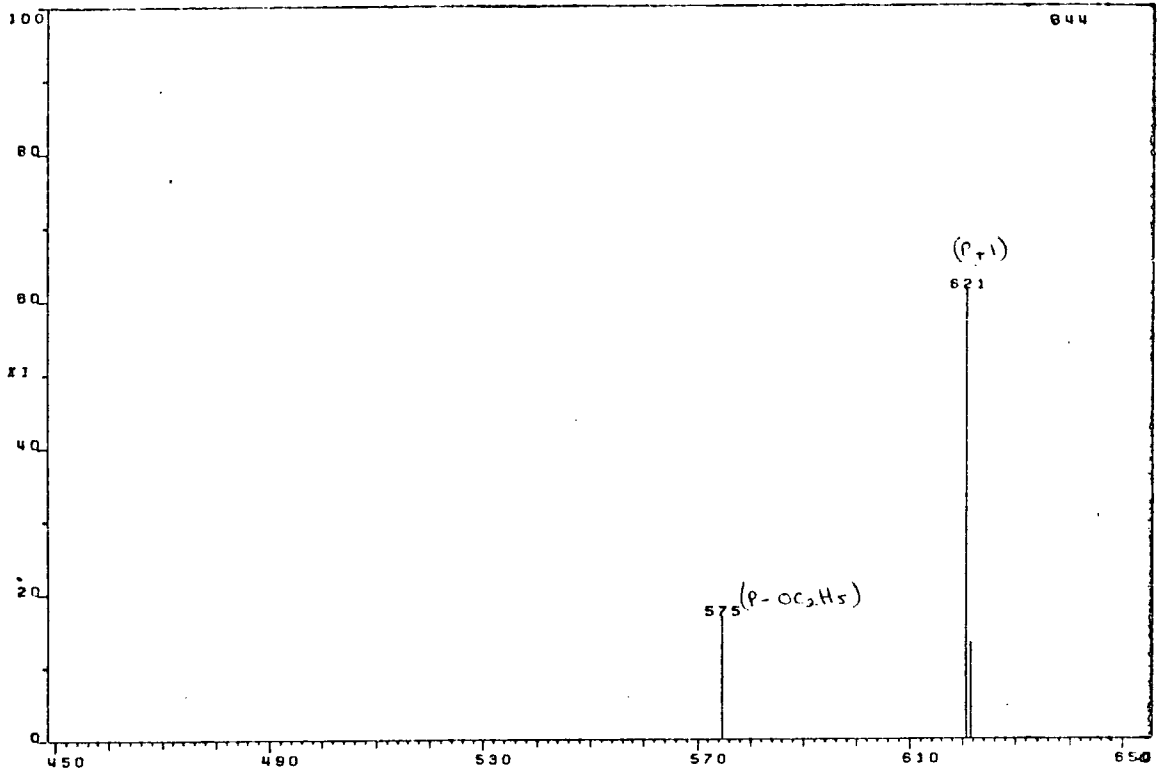

Compound No. 23 (MW 620) - Chemical Ionisation m.s.

JKSRC15 J.R.KIRK
CALTCALMG

No. 24 (MW 260)

01-JUN-82

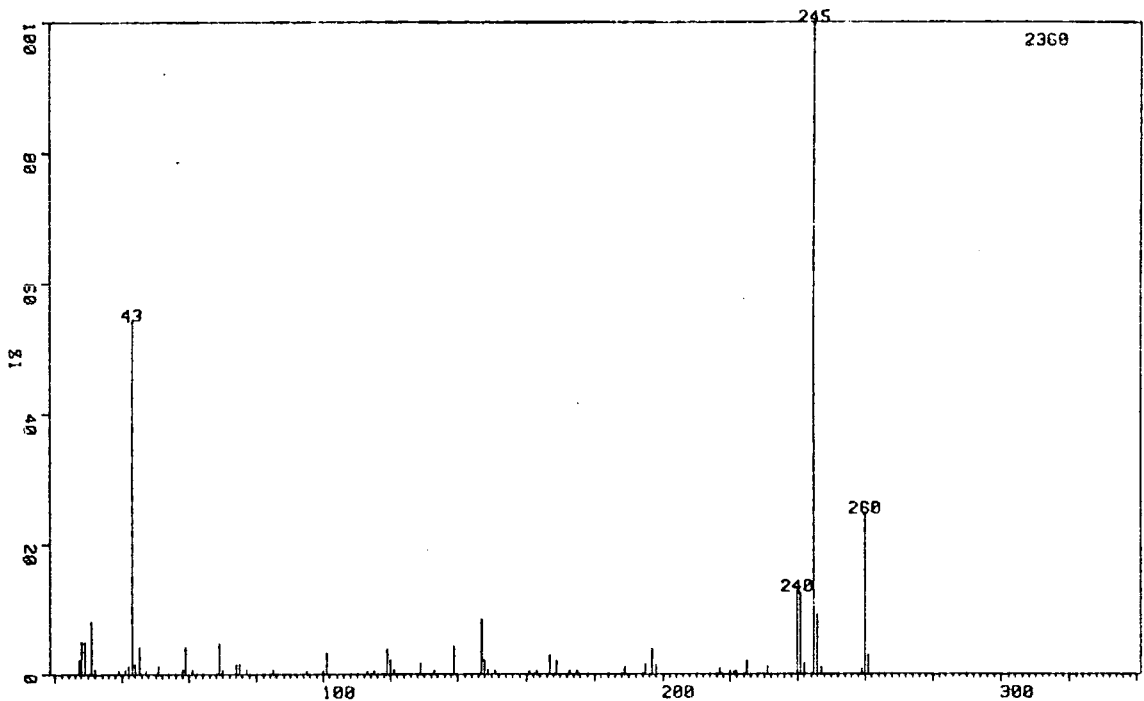

PEAK NO.	MASS	%HT. BASE	PEAK NO.	MASS	%HT. BASE
1	27.25	2.08	36	148.90	0.81
2	28.13	4.96	37	150.90	0.59
3	29.02	5.00	38	160.95	0.47
4	30.92	8.09	39	162.97	0.59
5	32.01	0.89	40	166.96	2.97
6	38.99	0.55	41	168.93	2.12
7	40.97	0.68	42	172.96	0.59
8	42.03	1.27	43	174.95	0.55
9	43.10	54.36	44	188.85	1.02
10	44.14	1.57	45	194.91	1.57
11	45.15	4.15	46	196.86	3.86
12	47.11	0.55	47	197.91	1.48
13	50.94	1.23	48	216.94	0.97
14	58.06	0.72	49	219.93	0.64
15	59.01	4.15	50	221.17	0.38
16	60.95	0.72	51	221.77	0.59
17	68.94	4.75	52	224.98	2.08
18	69.90	0.76	53	230.91	1.23
19	74.09	1.57	54	239.82	12.75
20	75.03	1.57	55	240.87	12.50
21	77.00	0.76	56	241.97	1.65
22	85.00	0.76	57	244.90	100.00
23	94.98	0.55	58	245.82	9.11
24	99.87	0.55	59	247.06	1.02
25	100.92	3.22	60	258.99	0.81
26	112.96	0.55	61	259.97	24.66
27	115.01	0.51	62	260.97	3.01
28	118.93	3.90			
29	119.91	2.25			
30	120.95	0.76			
31	128.91	1.74			
32	132.95	0.64			
33	138.86	4.24			
34	146.90	8.47			
35	147.90	2.25			

JX58B1 5 J.R.KIRK
CALICALMS

No. 25 (MW 290)

01-JUN-82

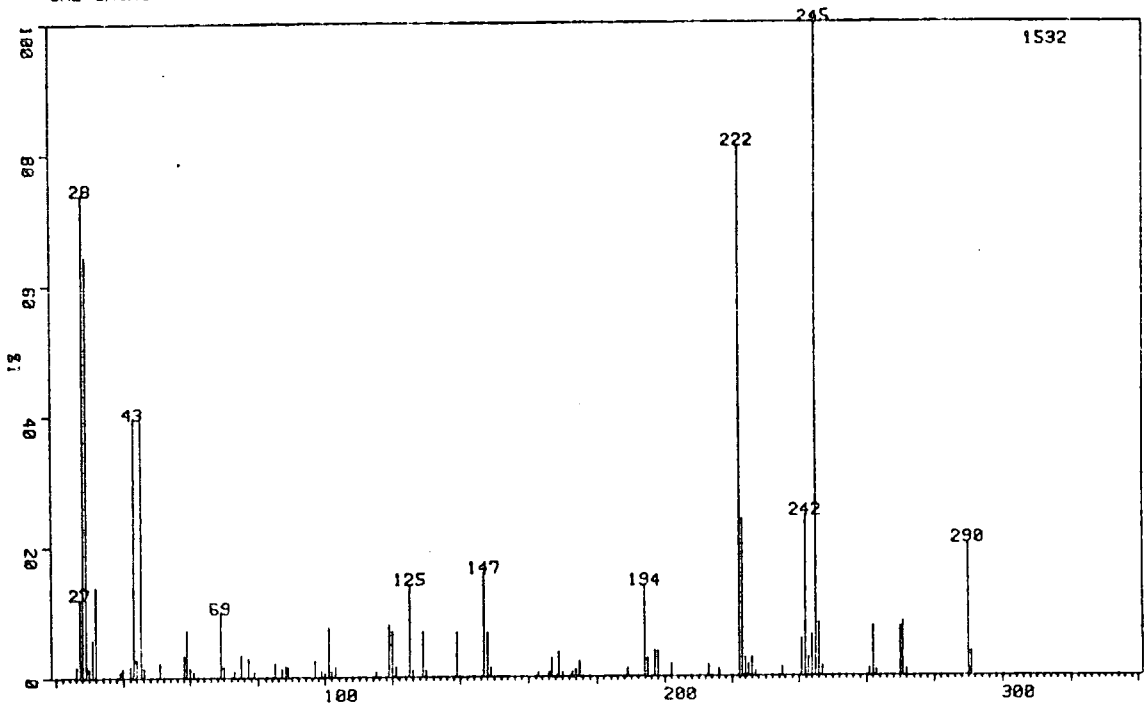

PEAK NO.	MASS	ZHT. BASE	PEAK NO.	MASS	ZHT. BASE	PEAK NO.	MASS	ZHT. BASE
1	26.32	1.76	36	115.00	0.85	71	240.83	5.68
2	27.26	11.95	37	118.96	8.03	72	241.90	24.54
3	28.13	73.83	38	119.94	6.98	73	242.93	2.87
4	29.02	64.43	39	120.98	1.50	74	243.92	6.33
5	29.85	1.37	40	125.00	14.10	75	244.90	100.00
6	30.92	5.74	41	126.00	1.11	76	245.94	8.16
7	32.01	13.77	42	128.93	6.98	77	246.92	1.50
8	39.00	0.91	43	129.93	1.04	78	260.87	1.24
9	39.82	1.37	44	138.89	6.79	79	261.88	7.64
10	42.04	1.76	45	146.95	15.86	80	262.93	0.98
11	43.10	39.56	46	147.94	6.72	81	269.91	7.51
12	44.11	2.81	47	148.94	1.44	82	270.91	8.29
13	45.15	40.27	48	162.94	0.78	83	272.02	1.11
14	46.15	1.44	49	165.96	0.72	84	289.88	20.30
15	50.94	2.28	50	166.93	3.07	85	290.88	3.79
16	58.06	3.33	51	168.90	3.85			
17	59.01	7.18	52	169.92	0.72			
18	59.92	1.44	53	172.93	0.85			
19	60.97	0.91	54	173.92	1.24			
20	68.95	9.79	55	174.95	2.42			
21	69.91	1.63	56	188.87	1.37			
22	73.04	0.98	57	193.89	13.97			
23	75.02	3.46	58	194.89	2.81			
24	77.00	2.87	59	196.94	3.98			
25	78.91	0.85	60	197.92	3.85			
26	84.99	2.15	61	201.88	1.96			
27	86.97	1.31	62	212.93	1.83			
28	87.97	1.76	63	215.96	1.17			
29	88.91	1.50	64	221.96	81.14			
30	96.95	2.55	65	222.97	23.89			
31	98.89	0.98	66	223.99	2.87			
32	99.87	0.78	67	224.93	1.89			
33	100.95	7.51	68	225.94	2.94			
34	102.00	0.98	69	226.96	0.85			
35	103.04	1.50	70	234.89	1.44			

JX58R1 14 J.R.KIRK
CALICHLM17

No. 26 (MW 320)

17-MAR-82

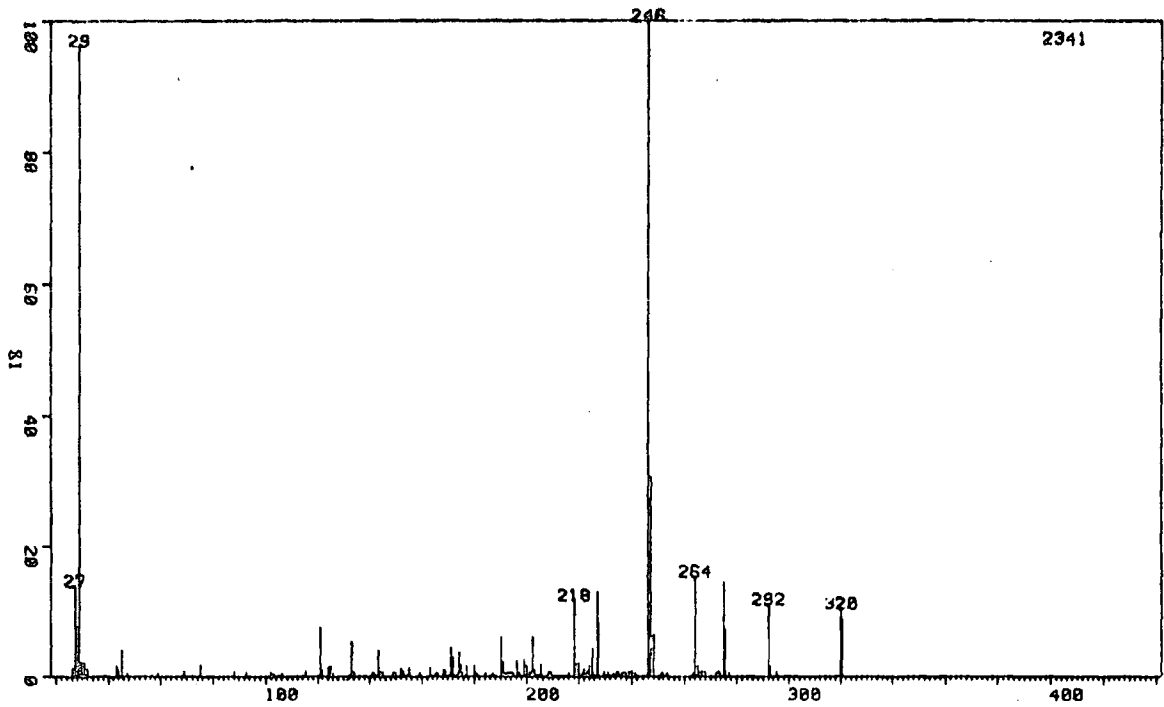

PEAK NO.	MASS	INT. BASE
2	27.24	13.97
3	28.13	7.65
4	29.01	93.15
21	190.98	7.48
26	133.60	5.34
50	190.00	3.11
72	202.06	3.11
78	217.92	11.56
87	226.93	12.94
88	227.53	9.16
100	247.91	100.00
101	247.92	30.54
102	248.12	1.56
107	264.02	15.34
116	275.06	14.48
117	275.53	7.25
119	272.09	11.06
122	320.00	10.47
133	220.68	9.59

JK52R1 5 J.R.KIRK
CAL1 CALH15
X 2

No. 27 (MW 322)

15-APR-82

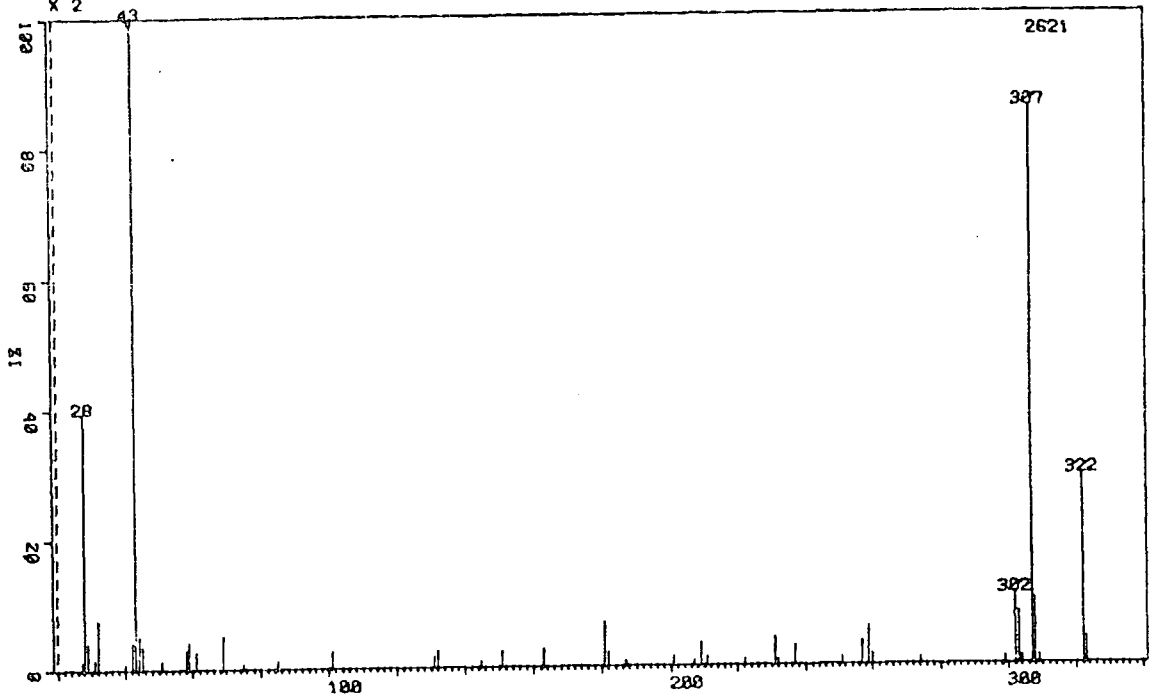

PEAK NO.	MASS	%HT. BASE	PEAK NO.	MASS	%HT. BASE
1	27.26	0.57	36	256.89	1.79
2	28.13	19.73	37	258.88	2.94
3	29.02	2.02	38	259.94	0.80
4	30.93	0.72	39	274.00	0.53
5	32.02	3.78	40	298.93	0.57
6	39.84	0.38	41	301.94	5.46
7	42.04	2.10	42	302.95	4.01
8	43.11	100.00	43	303.97	0.57
9	44.15	2.52	44	306.86	42.77
10	45.16	1.76	45	307.76	5.00
11	50.94	0.69	46	308.99	0.61
12	58.07	1.45	47	321.99	14.54
13	59.02	2.06	48	323.02	1.98
14	60.97	1.30	49	340.95	0.95
15	68.94	2.56	50	370.96	0.80
16	75.02	0.42	51	444.92	0.72
17	85.00	0.61	52	520.95	0.65
18	100.96	1.30			
19	130.93	0.88			
20	131.96	1.26			
21	144.99	0.50			
22	150.91	1.18			
23	162.95	1.34			
24	180.90	3.36			
25	181.95	1.07			
26	186.98	0.42			
27	200.89	0.72			
28	206.95	0.38			
29	208.95	1.72			
30	210.95	0.61			
31	221.98	0.53			
32	230.92	2.10			
33	231.94	0.46			
34	236.90	1.53			
35	250.91	0.57			

JKS2D2 2 J.R.KIRK
CALICALM15

No. 28 (MW 352)

15-APR-82

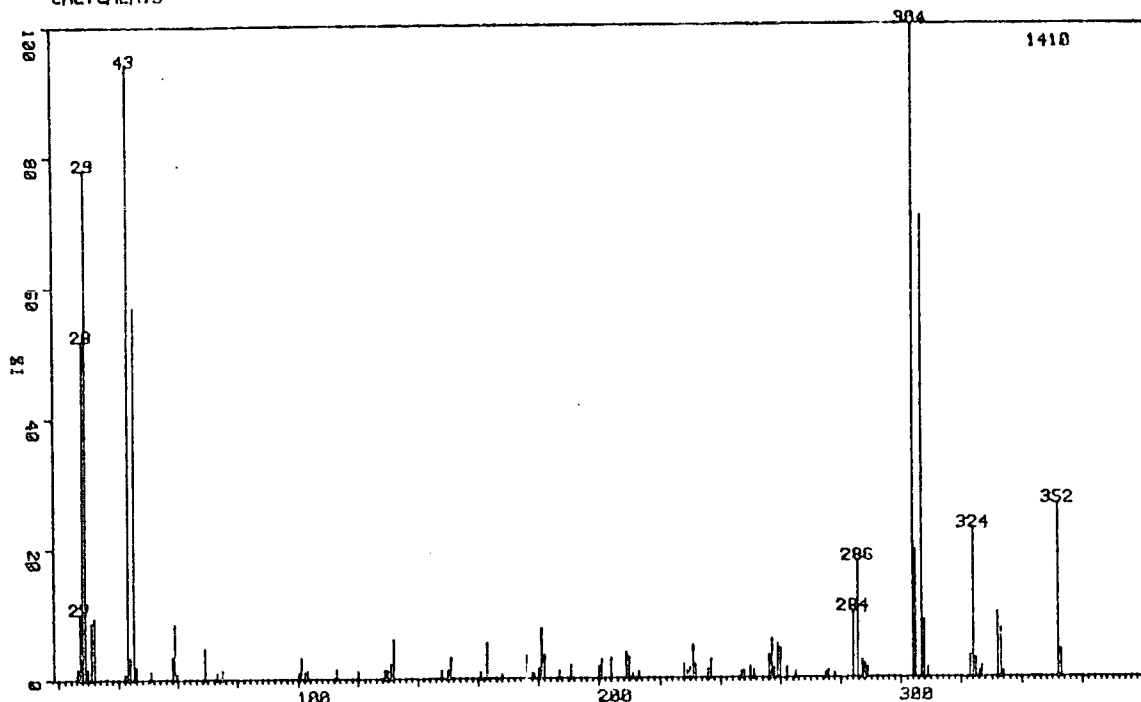

PEAK NO.	MASS	%HT. BASE	PEAK NO.	MASS	%HT. BASE	PEAK NO.	MASS	%HT. BASE
1	26.31	1.63	36	175.95	3.55	71	277.95	0.78
2	27.25	10.14	37	177.95	0.92	72	283.98	10.21
3	28.13	51.99	38	178.91	0.78	73	285.65	17.87
4	29.02	78.01	39	179.91	1.56	74	286.98	2.77
5	29.85	1.63	40	180.89	7.66	75	287.94	2.34
6	30.92	8.72	41	181.95	3.62	76	288.93	1.63
7	32.01	9.36	42	186.95	1.21	77	303.88	100.00
8	42.03	0.85	43	190.96	2.06	78	304.82	19.50
9	43.09	94.11	44	199.92	1.91	79	306.85	70.64
10	44.13	3.33	45	200.95	2.84	80	307.80	8.72
11	45.16	57.09	46	203.98	3.12	81	309.07	1.49
12	46.14	1.91	47	208.94	3.97	82	323.09	3.33
13	50.94	1.28	48	209.91	3.26	83	324.07	22.84
14	58.07	3.40	49	210.95	0.78	84	325.09	3.05
15	59.00	8.44	50	212.96	1.06	85	326.12	0.92
16	59.93	0.85	51	227.93	2.13	86	327.01	1.77
17	68.94	4.75	52	228.91	1.21	87	331.98	9.93
18	73.02	1.06	53	229.89	1.56	88	333.04	7.45
19	75.01	1.42	54	230.94	5.04	89	334.05	0.99
20	99.90	0.99	55	231.96	2.06	90	352.02	26.60
21	100.93	3.26	56	235.90	1.35	91	353.03	4.18
22	101.99	1.06	57	236.95	2.91	92	370.93	0.71
23	103.04	1.28	58	246.94	1.06	93	371.99	1.13
24	112.97	1.49	59	247.96	1.21			
25	119.90	1.21	60	249.85	1.77			
26	128.89	1.42	61	250.98	1.21			
27	129.90	1.35	62	255.94	3.48			
28	130.93	2.27	63	256.97	5.96			
29	131.94	6.03	64	257.95	1.77			
30	147.94	1.35	65	258.93	5.18			
31	149.88	1.35	66	259.92	4.54			
32	150.94	3.26	67	261.95	1.63			
33	160.91	1.06	68	264.93	1.06			
34	162.96	5.46	69	274.99	0.85			
35	167.90	0.71	70	275.96	1.21			

41
JKIB1 14 J.R.KIRK
CAL CALMG

No. 29 (MW 382)

11-NOV-81

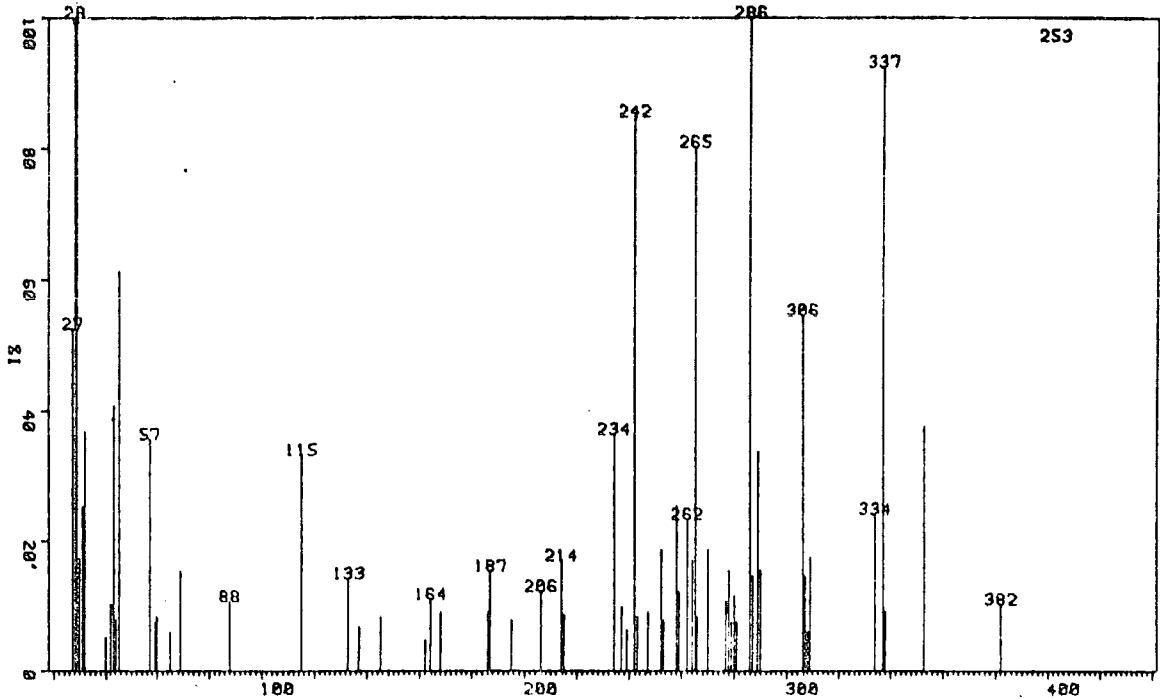

PEAK NO.	MASS	%HT. BASE	PEAK NO.	MASS	%HT. BASE
1	27.25	6.03	36	242.98	0.95
2	28.13	23.33	37	246.94	1.04
3	29.03	100.00	38	251.92	2.13
4	29.13	0.59	39	253.03	0.91
5	29.85	1.99	40	257.95	2.90
6	30.93	2.90	41	258.97	1.40
7	32.02	4.21	42	261.95	2.67
8	39.85	0.59	43	263.98	1.95
9	42.06	1.18	44	265.00	9.20
10	43.13	4.67	45	266.02	0.95
11	44.15	0.91	46	269.95	2.13
12	45.18	7.02	47	276.93	1.22
13	57.13	4.08	48	277.98	1.77
14	59.02	0.86	49	278.99	0.86
15	59.93	0.95	50	279.95	1.31
16	65.13	0.68	51	280.99	0.86
17	68.96	1.77	52	285.92	11.46
18	88.03	1.22	53	286.97	1.68
19	115.03	3.81	54	288.91	3.85
20	133.04	1.63	55	289.90	1.77
21	137.01	0.77	56	305.97	6.25
22	145.04	0.95	57	307.04	1.68
23	162.00	0.54	58	307.91	0.68
24	163.99	1.27	59	308.98	1.99
25	167.98	1.04	60	333.94	2.76
26	186.01	1.04	61	336.94	10.60
27	186.97	1.77	62	337.94	1.04
28	195.05	0.91	63	352.90	4.30
29	205.99	1.40	64	382.05	1.18
30	213.98	1.95			
31	214.98	1.00			
32	233.93	4.17			
33	236.95	1.13			
34	238.87	0.72			
35	241.92	9.74			

JK67A1 16
CALI CALM10

No. 30 (MW 352)

11-JUN-82

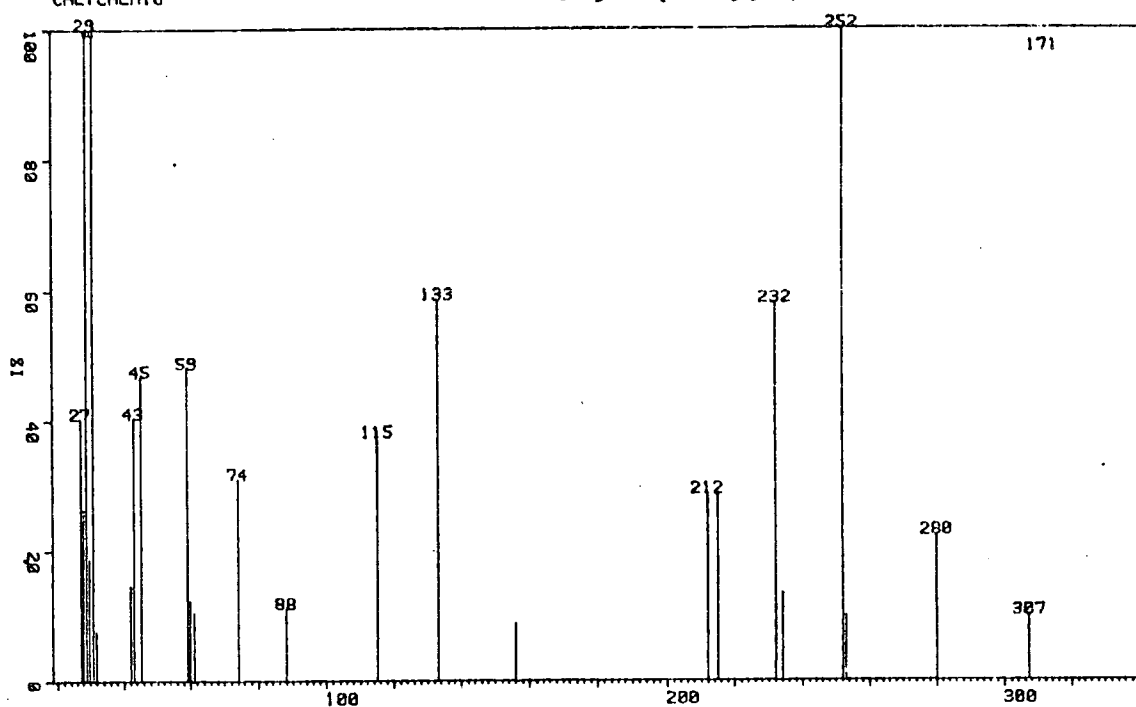

PEAK NO.	MASS	%HT. BASE
1	27.26	10.87
2	28.14	7.09
3	29.03	100.00
4	29.86	5.04
5	30.93	30.08
6	32.02	2.05
7	42.06	3.94
8	43.13	10.87
9	45.19	12.60
10	59.04	12.91
11	59.95	3.31
12	61.03	2.83
13	74.15	8.35
14	88.03	2.99
15	115.11	10.08
16	133.08	15.75
17	156.08	2.36
18	212.04	7.72
19	215.08	7.72
20	232.03	15.59
21	234.08	3.62
22	252.08	26.93
23	253.11	2.68
24	280.10	5.98
25	307.10	2.68

-23I-

JKG7A2 20
CALI CALM18

No. 3I (MW 332)

11-JUN-82

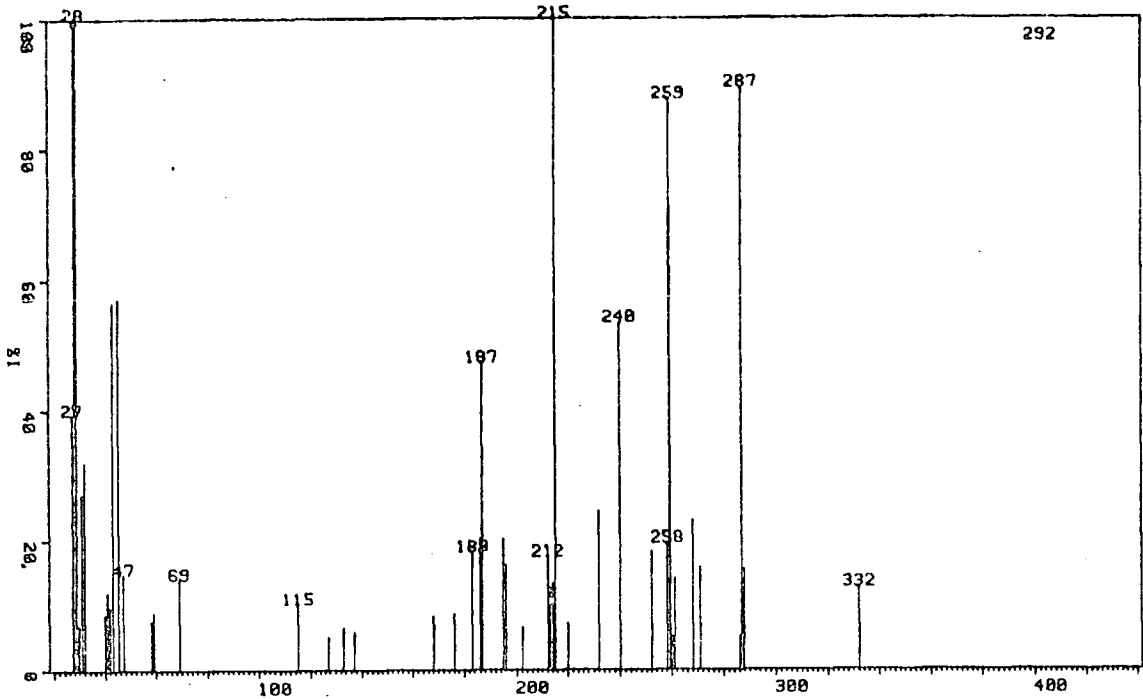

PEAK NO.	MASS	ZHT. BASE	PEAK NO.	MASS	ZHT. BASE
1	27.26	10.31	36	258.10	5.11
2	28.14	50.04	37	259.04	22.96
3	29.03	100.00	38	259.21	18.57
4	29.86	1.79	39	260.12	1.35
5	30.94	7.09	40	260.98	3.68
6	32.03	8.34	41	268.09	6.01
7	39.86	2.24	42	271.12	4.13
8	41.01	3.14	43	286.26	1.35
9	42.06	2.51	44	287.01	23.41
10	43.13	14.80	45	287.97	4.04
11	45.21	14.98	46	332.04	3.32
12	47.14	3.86			
13	58.10	1.97			
14	59.06	2.33			
15	69.03	3.68			
16	115.16	2.69			
17	127.20	1.35			
18	133.10	1.70			
19	137.06	1.52			
20	168.11	2.15			
21	176.16	2.24			
22	183.04	4.75			
23	186.02	5.29			
24	186.98	12.38			
25	195.02	5.29			
26	196.07	4.22			
27	202.01	1.70			
28	212.09	4.57			
29	213.10	3.32			
30	214.09	3.50			
31	215.03	26.19			
32	219.97	1.88			
33	232.03	6.37			
34	240.02	13.99			
35	252.09	4.75			

JK67B1 3 J.R.K1RK
CALICLMI3
X 20

No. 32 (MW 322)

15-JUL-82

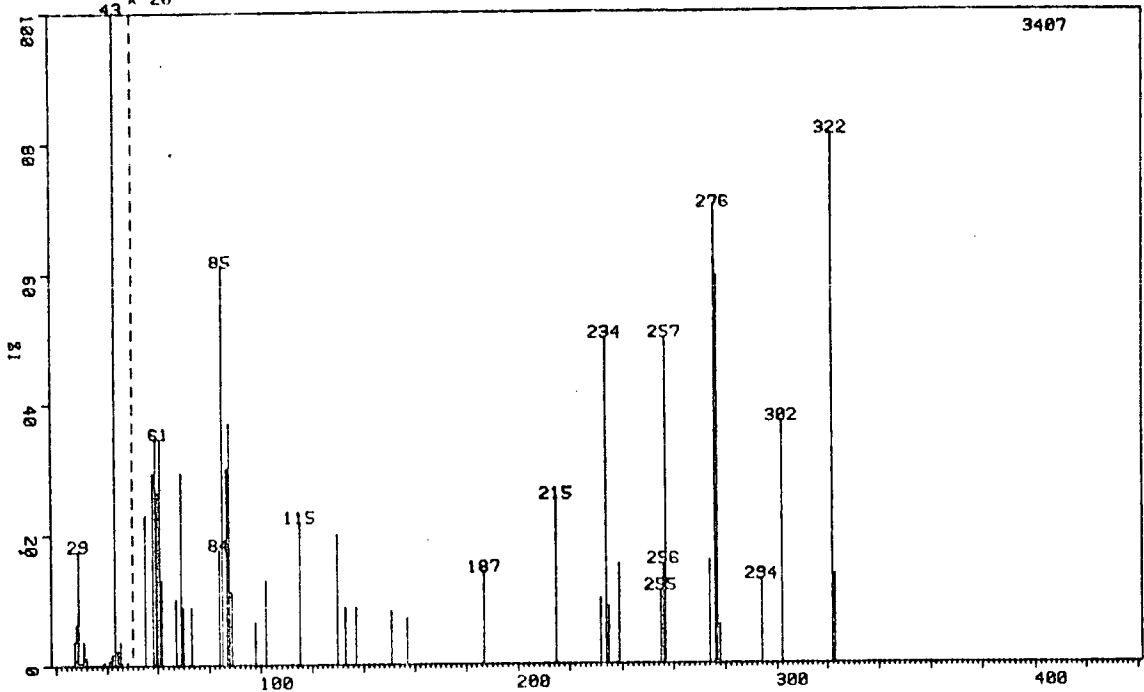

PEAK NO.	MASS	% IIT. BASE
1	27.25	3.67
2	28.13	6.28
3	29.02	17.46
5	30.93	3.58
6	32.02	1.17
9	42.04	1.64
10	43.11	100.00
11	44.14	2.35
12	45.16	3.64
15	55.11	1.14
16	58.07	1.47
17	59.01	1.73
18	59.91	1.32
19	60.98	1.73
22	69.03	1.47
26	85.10	3.05
27	87.05	1.50
28	88.04	1.85
32	115.07	1.09
39	214.90	1.26
41	233.91	2.49
46	256.86	2.49
48	275.93	3.49
49	276.94	2.96
52	301.91	1.85
53	321.91	4.05
54	322.94	0.68

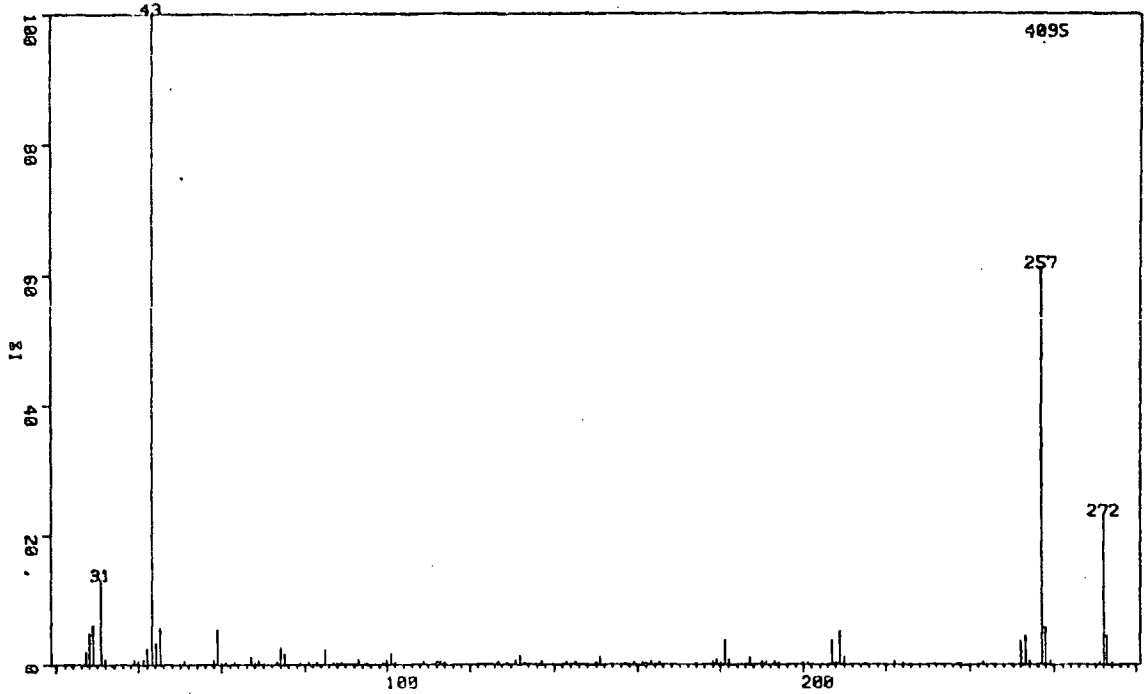

PEAK NO.	MASS	ZHT. BASE
1	27.26	2.03
2	28.14	4.79
3	29.03	6.01
4	30.93	13.06
9	42.06	2.49
10	43.13	100.00
11	44.17	3.35
12	45.19	5.69
15	59.06	5.45
19	67.12	1.15
23	74.13	2.64
24	75.04	1.78
28	95.03	2.39
36	100.99	1.71
45	132.04	1.37
51	151.06	1.27
62	181.05	3.76
64	187.08	1.10
71	207.11	3.71
73	209.05	5.10
74	210.06	1.20
81	252.03	3.66
82	253.06	4.40
84	257.06	60.93
85	257.96	5.79
87	271.09	0.44
88	272.10	22.88
89	272.81	4.47
90	274.06	0.27

JX25H1 36 J.R.KIRK
CALICAL25

No. 34 (MW 416)

26-MAR-81

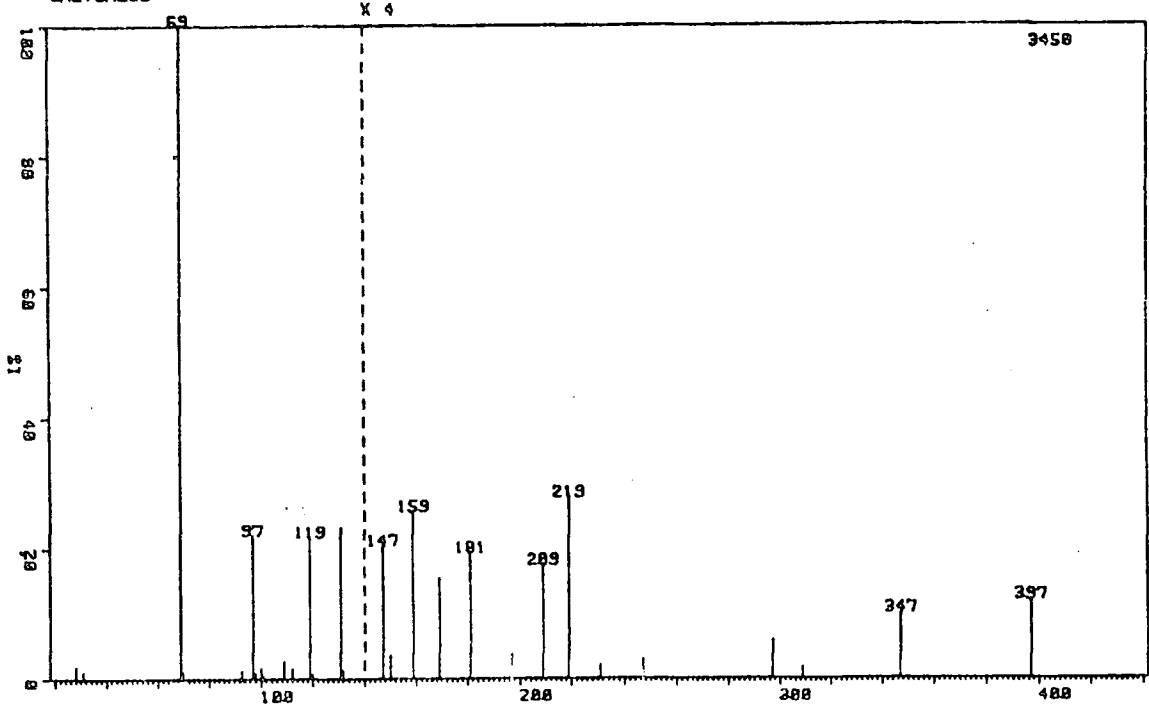

PEAK NO.	MASS	%HT. BASE
1	28.13	1.88
2	30.90	1.01
3	68.96	100.00
4	69.91	0.96
5	93.01	1.30
6	97.00	22.00
7	97.99	0.84
8	99.92	1.68
9	100.95	0.49
10	108.94	2.72
11	111.97	1.59
12	118.97	21.71
13	119.98	0.67
14	130.96	23.07
15	132.02	1.19
16	147.00	5.10
17	149.95	0.90
18	158.96	6.41
19	168.98	3.86
20	180.99	4.81
21	197.03	0.96
22	209.00	4.35
23	218.99	6.96
24	231.14	0.52
25	246.99	0.75
26	297.02	1.48
27	308.85	0.46
28	346.99	2.49
29	396.91	2.99

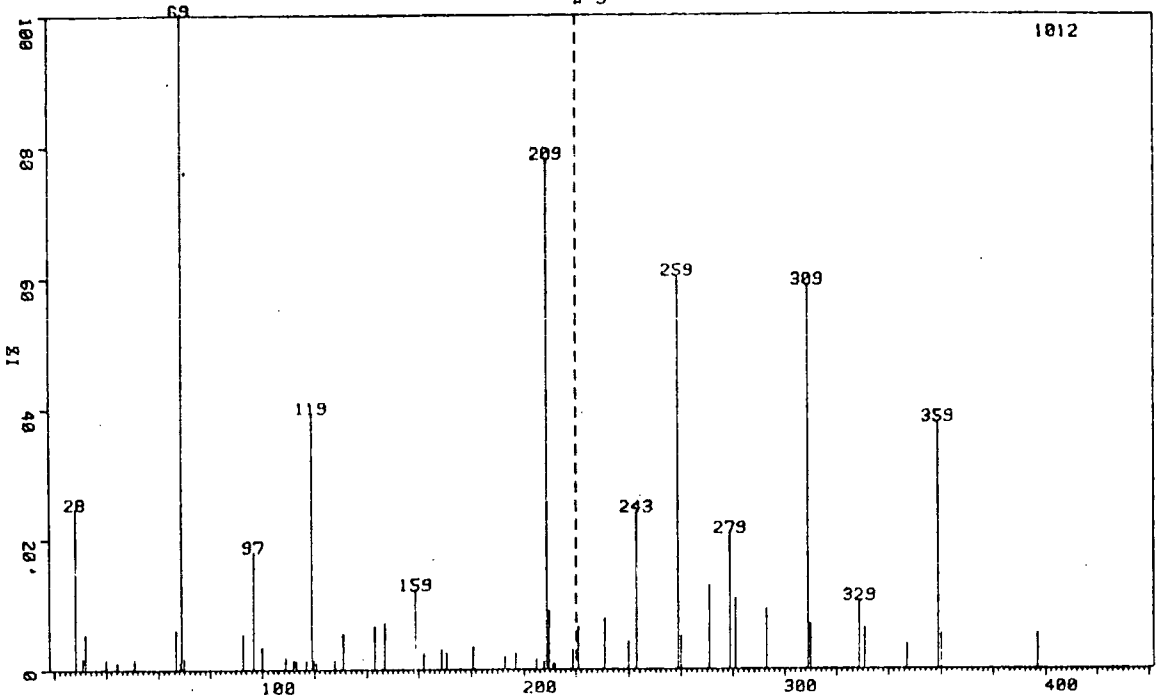

PEAK NO.	MASS	ZHT. BASE			
			31	196.91	2.37
			32	204.72	1.48
			33	207.56	1.28
1	28.13	24.60	34	208.86	77.96
2	30.91	1.68	35	209.62	8.89
3	32.01	5.34	36	210.95	0.99
4	39.82	1.48	37	211.88	0.89
5	44.10	1.09	38	218.93	2.96
6	50.92	1.48	39	220.93	2.17
7	67.01	6.03	40	230.92	2.57
8	68.64	1.19	41	239.89	1.38
9	68.91	100.00	42	242.93	8.00
10	69.83	1.78	43	258.86	20.06
11	92.96	5.34	44	259.92	1.68
12	96.95	17.98	45	270.89	4.25
13	99.85	3.36	46	278.94	6.92
14	108.88	1.78	47	280.88	3.56
15	111.93	1.38	48	292.90	3.06
16	112.97	1.28	49	308.83	19.57
17	116.98	1.38	50	309.94	2.27
18	119.92	39.23	51	328.88	3.46
19	119.88	1.38	52	330.86	2.08
20	120.93	0.99	53	346.96	1.28
21	127.99	1.38	54	358.84	12.55
22	130.95	5.43	55	359.95	1.78
23	142.92	6.62	56	396.83	1.78
24	146.93	7.02			
25	158.87	12.15			
26	161.91	2.37			
27	168.88	2.96			
28	170.91	2.57			
29	180.88	3.46			
30	192.94	1.98			

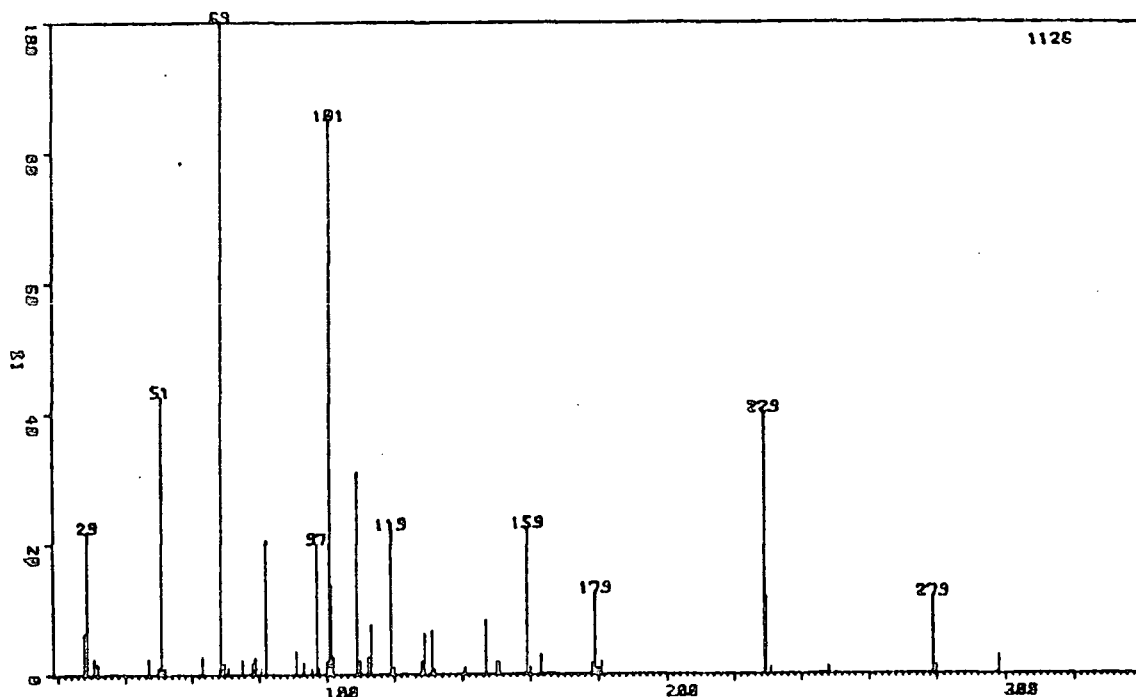

PEAK NO.	MASS	ZHT. BASE			
			31	111.99	2.66
			32	113.02	7.64
			33	118.95	22.20
			34	119.96	1.15
1	28.13	6.22	35	127.98	1.95
2	28.99	21.76	36	128.96	6.31
3	30.91	2.40	37	130.97	6.66
4	32.03	1.69	38	131.88	0.80
5	47.09	2.40	39	140.95	1.15
6	49.88	1.07	40	147.02	8.26
7	50.95	42.63	41	149.96	1.95
8	52.04	0.98	42	150.99	1.78
9	63.07	2.75	43	159.00	22.38
10	68.61	0.80	44	160.01	1.15
11	68.98	100.00	45	163.01	3.02
12	69.91	1.78	46	177.97	1.69
13	70.96	1.07	47	178.98	12.43
14	75.07	2.22	48	179.98	0.98
15	77.98	1.78	49	180.94	2.04
16	78.93	2.58	50	228.97	40.05
17	81.97	20.60	51	229.52	11.90
18	90.93	3.55	52	230.87	1.07
19	93.01	1.87	53	248.03	1.15
20	95.58	0.89			
21	97.02	19.98	54	278.86	11.81
22	97.73	0.93	55	279.85	1.33
23	99.97	2.04	56	298.03	2.84
24	100.29	0.98			
25	100.48	0.98			
26	100.97	84.90			
27	101.18	13.77			
28	101.92	2.75			
29	108.92	30.99			
30	109.58	2.04			

JK25N9 19 J. R. KIRK
CALICALOM

No. 37 (MW 298)

09-JUL-81

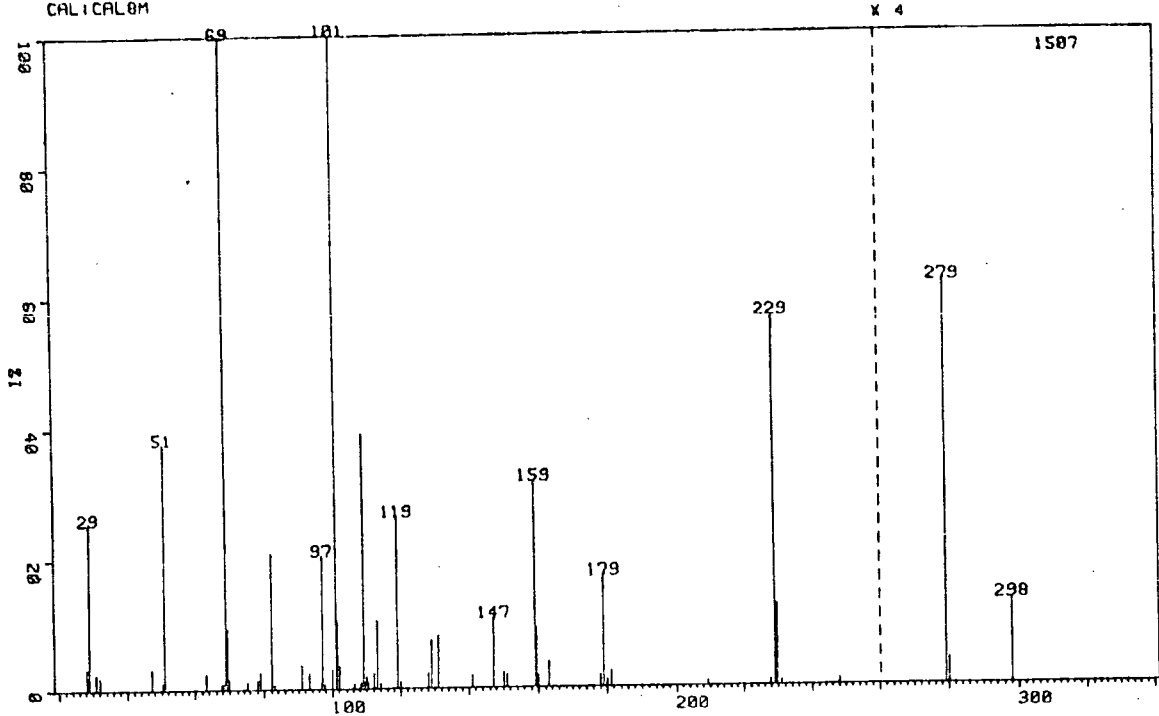

PEAK NO.	MASS	ZHT. BASE	33	108.33	0.86
			34	109.08	38.95
			35	109.43	1.00
1	28.14	3.25	36	110.03	1.79
2	29.01	25.41	37	110.44	1.00
3	30.93	2.39	38	112.13	2.32
4	32.04	1.86	39	113.14	10.42
5	47.11	3.12	40	114.12	0.80
6	50.46	1.00	41	119.05	26.34
7	50.98	37.56	42	120.02	0.93
8	63.13	2.39	43	128.10	2.32
9	67.75	0.80	44	129.06	7.50
10	68.10	0.73	45	131.05	8.03
11	68.51	0.80	46	141.07	1.99
12	69.01	99.67	47	147.10	10.68
13	69.24	9.36	48	150.06	2.32
14	69.61	1.19	49	151.10	1.99
15	69.72	1.00	50	159.07	31.59
16	69.97	1.53	51	159.26	8.96
17	75.13	1.19	52	160.03	1.92
18	78.01	1.39	53	163.09	4.05
19	78.96	2.59	54	178.08	1.79
20	82.00	20.70	55	179.07	17.05
21	83.03	0.73	56	180.05	1.13
22	91.01	3.65	57	181.07	2.39
23	93.07	2.39	58	209.18	0.73
24	96.79	1.06	59	227.64	0.86
25	97.13	20.37	60	229.03	56.54
26	97.82	0.80	61	229.64	12.41
27	100.06	3.05	62	230.97	0.73
28	101.09	100.00	63	248.18	1.00
29	101.36	10.42	64	279.13	15.39
30	101.76	1.06	65	280.12	1.00
31	102.20	3.45	66	298.09	3.25
32	106.35	0.73			

JX25E1 14 J.A.KIRK
CAL1 CALM4

No. 38 (MW 502)

10-MAR-81

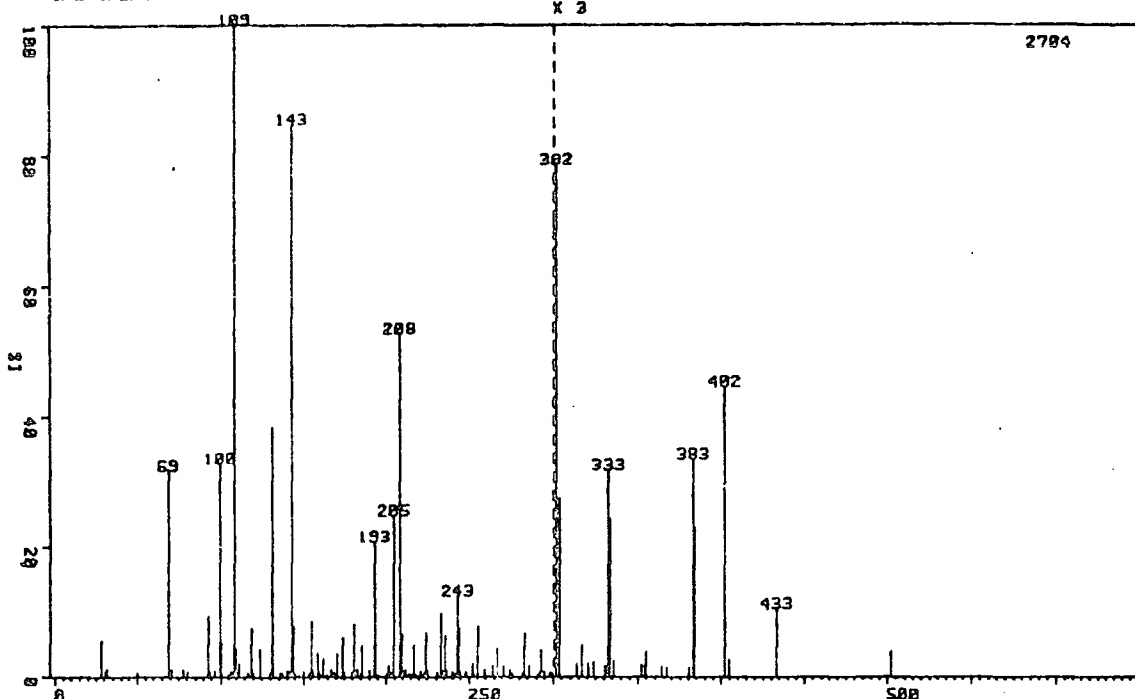

PEAK NO.	MASS	ZHT. BASE	39	142.99	84.76	113	283.21	6.77
			40	143.77	7.73	114	286.04	1.85
			63	181.00	8.14	115	291.16	0.48
1	28.13	5.62	64	182.17	0.78	116	292.14	0.55
2	30.93	0.92	65	183.06	1.29	117	293.13	4.14
3	32.03	1.33	66	185.15	0.59	118	294.47	0.59
4	49.90	0.70	67	185.95	4.84	119	295.01	0.85
5	69.00	31.58	68	189.96	1.00	120	298.05	0.63
6	70.99	1.04	69	192.89	20.75	121	299.38	0.59
7	78.00	1.07	70	193.66	5.10	122	299.92	0.55
8	80.88	0.85	71	195.15	0.41	123	301.81	26.18
9	93.06	9.36	72	200.61	0.48	124	303.76	9.13
10	93.55	0.52	73	201.97	1.85	125	313.84	0.70
11	94.10	0.85	74	203.07	0.48	126	316.97	1.63
12	97.05	1.00	75	203.68	0.63	127	320.88	0.70
13	99.94	32.73	76	204.91	24.74	128	321.29	0.44
14	100.16	5.44	77	208.49	52.63	129	323.93	0.78
15	100.92	0.63	78	209.65	6.69	130	330.60	0.59
16	105.46	0.41	88	224.01	6.77	131	331.10	0.48
17	106.90	0.78	89	224.72	0.52	132	332.72	10.58
18	107.35	0.44	90	225.17	1.00	133	333.52	8.10
19	107.68	0.48	91	230.95	0.70	134	335.92	0.81
20	108.95	100.00	92	233.03	9.76	135	352.06	0.63
21	109.90	4.33	93	234.13	1.15	136	354.37	0.55
22	110.89	0.81	94	235.94	6.40	137	355.08	1.29
23	112.04	2.03	95	236.96	1.11	138	364.10	0.55
24	117.09	0.59	96	239.98	0.74	139	367.17	0.52
25	119.00	7.43	97	241.08	0.52	140	380.70	0.52
26	120.06	0.67	98	241.90	0.44	141	382.80	11.13
27	124.08	4.25	99	242.96	12.39	142	383.74	7.66
28	129.66	0.70	100	243.53	7.54	143	402.06	14.83
29	129.94	0.44	101	244.88	0.78	144	405.06	0.92
30	131.00	38.35	102	248.09	0.78	145	433.24	3.48
31	131.31	5.81	103	252.01	2.11	146	502.15	1.33
32	131.67	0.52	104	252.90	0.41			
			105	255.11	7.77			

JX25J1 17 J.R.KTRK
CAL1 CAL25

No. 39 (MW 502)

30-MAR-81

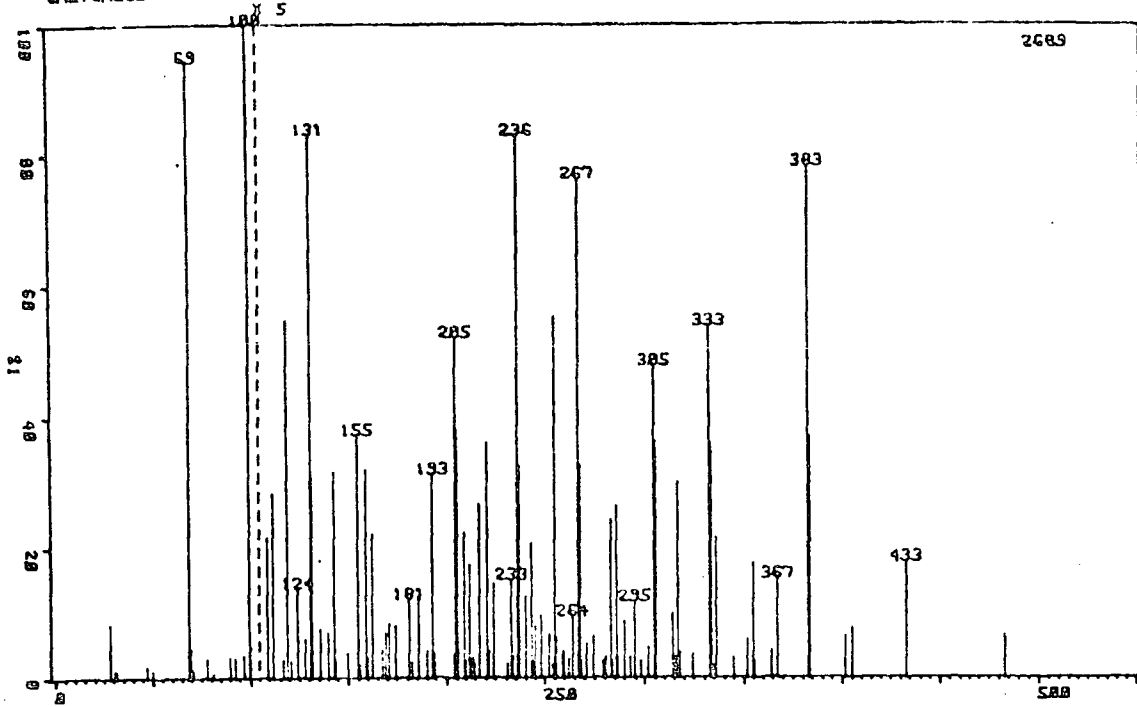

PEAK NO.	MASS	%HT. BASE	34	142.99	6.32	69	236.01	16.59
			35	144.05	0.52	70	236.63	6.51
			36	149.97	0.74	71	240.01	2.49
1	28.13	9.22	37	155.01	7.44	72	242.99	4.13
2	30.93	1.08	38	155.97	0.41	73	243.97	0.48
3	32.03	1.15	39	158.96	6.40	74	245.03	1.56
4	47.11	1.67	40	159.90	0.63	75	247.97	1.90
5	49.89	1.00	41	162.01	4.43	76	252.02	1.34
6	68.61	0.63	42	167.06	0.86	77	254.20	0.41
7	68.99	94.35	43	169.01	1.38	78	255.02	11.04
8	69.16	4.54	44	171.03	1.67	79	255.96	1.23
9	69.34	0.45	45	174.06	1.60	80	258.95	0.82
10	69.89	1.34	46	181.00	2.42	81	259.84	0.71
11	70.98	1.08	47	182.97	0.48	82	262.18	0.56
12	78.02	2.94	48	186.06	2.49	83	264.04	1.90
13	80.99	0.60	49	190.01	0.82	84	266.96	15.28
14	89.93	3.12	50	193.01	6.25	85	267.67	6.51
15	93.05	3.01	51	194.08	0.78	100	304.82	9.56
16	97.03	3.38	52	204.07	0.71	101	305.48	7.25
17	98.04	0.56	53	205.00	10.41	102	313.95	1.97
18	99.92	100.00	54	205.27	7.62	103	315.95	0.63
19	100.23	4.72	55	206.00	0.86	104	316.95	6.02
20	100.57	0.82	56	208.95	4.46	107	332.89	10.78
21	100.94	2.57	57	210.02	0.52	108	333.59	7.21
22	108.94	4.31	58	211.97	3.46	109	335.09	0.37
23	111.97	5.69	59	212.65	0.60	110	336.14	4.31
24	117.04	0.56	60	214.05	0.63	111	344.91	0.63
25	118.95	10.93	61	214.66	0.45	112	351.97	1.19
26	120.96	0.52	62	216.97	5.32	113	354.94	3.53
27	124.04	2.75	63	220.97	7.21	114	355.90	0.48
28	127.98	1.19	64	222.02	0.82	115	363.92	0.86
29	130.94	16.62	65	224.01	2.90	116	366.99	3.05
30	131.14	6.14	66	231.09	0.45	117	382.83	15.66
31	131.93	0.82	67	232.94	3.01	118	383.71	7.40
32	135.99	1.49	68	233.80	0.67	119	401.93	1.30
						120	405.13	1.52
						121	433.07	3.57
						122	483.04	1.30

JK66D1 20 J.R.KIRK X66D1
CALICALMG

No. 40 (NW 316)

26-MAY-82

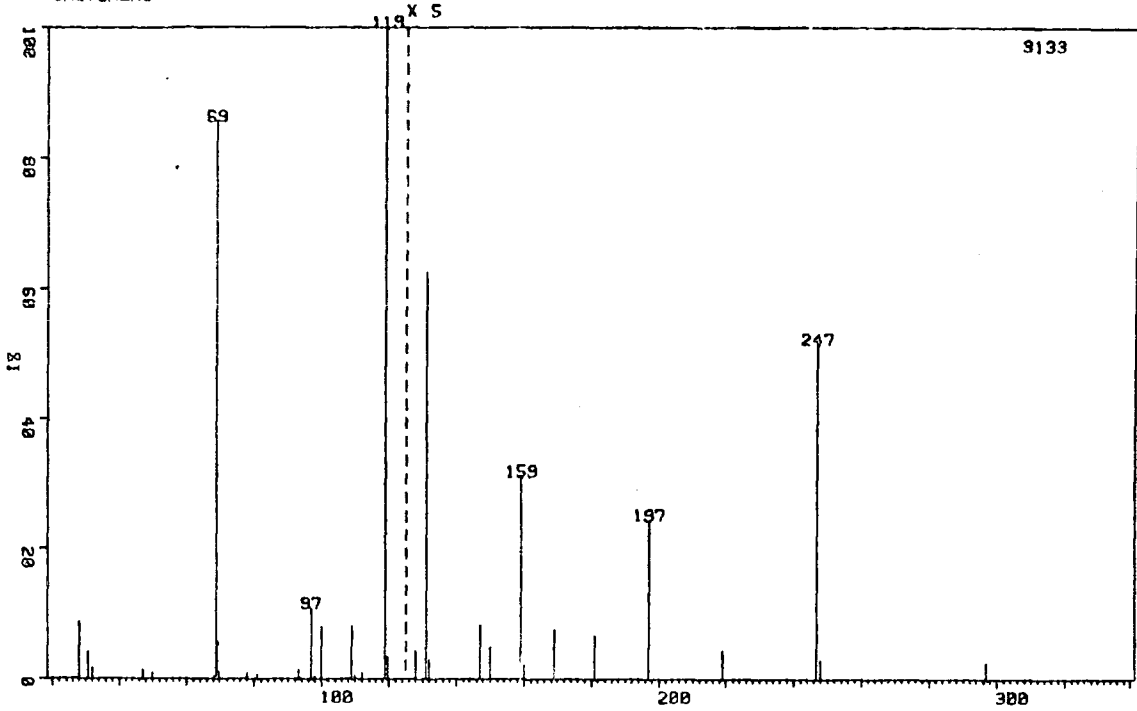

PEAK NO.	MASS	%HT. BASE
1	28.13	8.78
2	30.91	4.12
3	32.02	1.63
4	47.09	1.44
8	68.98	85.51
9	69.17	5.59
11	69.88	1.02
14	92.99	1.44
15	97.00	10.85
17	99.89	8.01
18	108.95	8.08
21	118.97	100.00
22	119.63	3.42
24	130.98	12.48
26	147.00	1.66
28	158.95	6.22
30	168.96	1.50
31	180.97	1.34
32	196.95	4.88
33	218.99	0.86
34	246.85	10.28
35	247.95	0.61
36	296.90	0.51

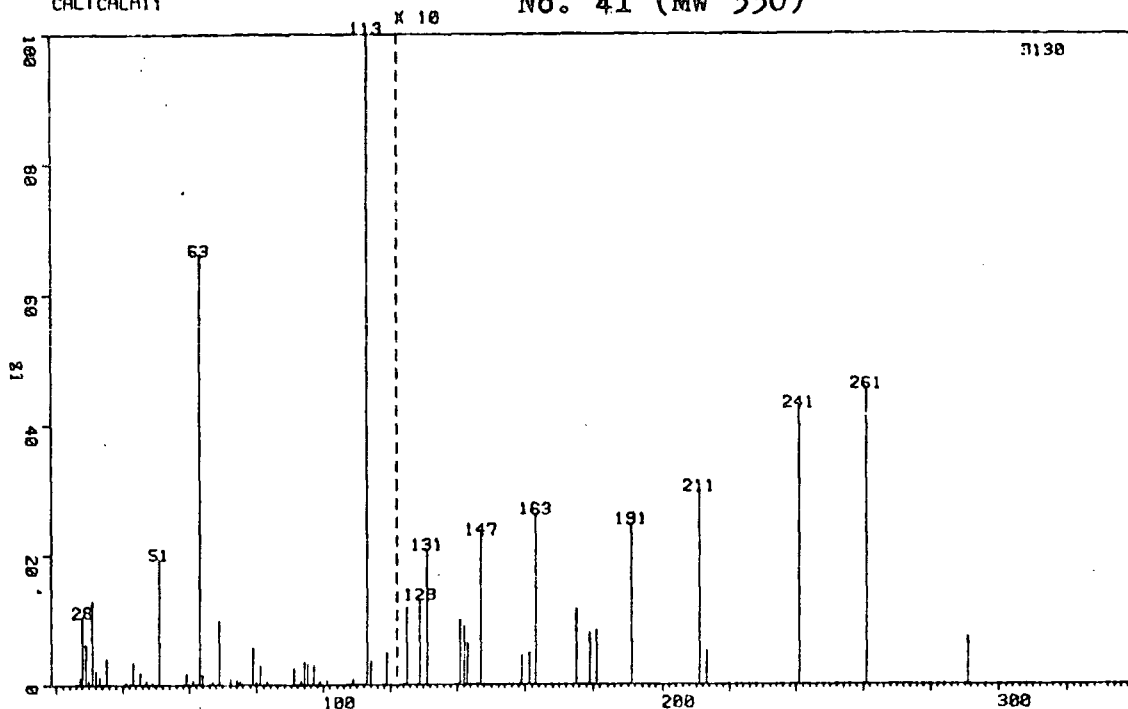

PEAK NO.	MASS	ZHT. BASE	PEAK NO.	MASS	ZHT. BASE
1	27.26	1.05	36	113.01	100.00
2	28.13	10.42	37	114.05	3.67
3	29.01	6.23	38	118.96	4.86
4	29.84	0.58	39	125.06	1.18
5	30.94	12.88	40	128.98	1.31
6	32.05	2.11	41	130.98	2.08
7	33.14	1.15	42	140.96	0.99
8	35.22	3.99	43	142.01	0.89
9	41.00	0.38	44	143.02	0.64
10	43.13	3.29	45	147.01	2.30
11	45.19	1.92	46	159.01	0.45
12	47.13	0.61	47	161.02	0.48
13	48.99	0.42	48	163.06	2.62
14	50.96	19.23	49	175.08	1.15
15	59.04	1.63	50	178.97	0.80
16	61.01	0.61	51	181.03	0.83
17	63.12	65.94	52	191.02	2.46
18	64.11	1.50	53	211.03	2.97
19	67.04	0.48	54	213.08	0.51
20	68.95	9.87	55	241.01	4.25
21	72.02	0.93	56	261.01	4.54
22	74.12	0.83	57	291.08	0.73
23	75.05	0.54			
24	78.92	5.69			
25	79.87	0.54			
26	80.96	2.88			
27	83.04	0.51			
28	90.94	2.49			
29	93.03	0.61			
30	94.04	3.42			
31	95.05	3.16			
32	96.97	3.00			
33	98.95	0.54			
34	100.94	0.70			
35	108.91	0.80			

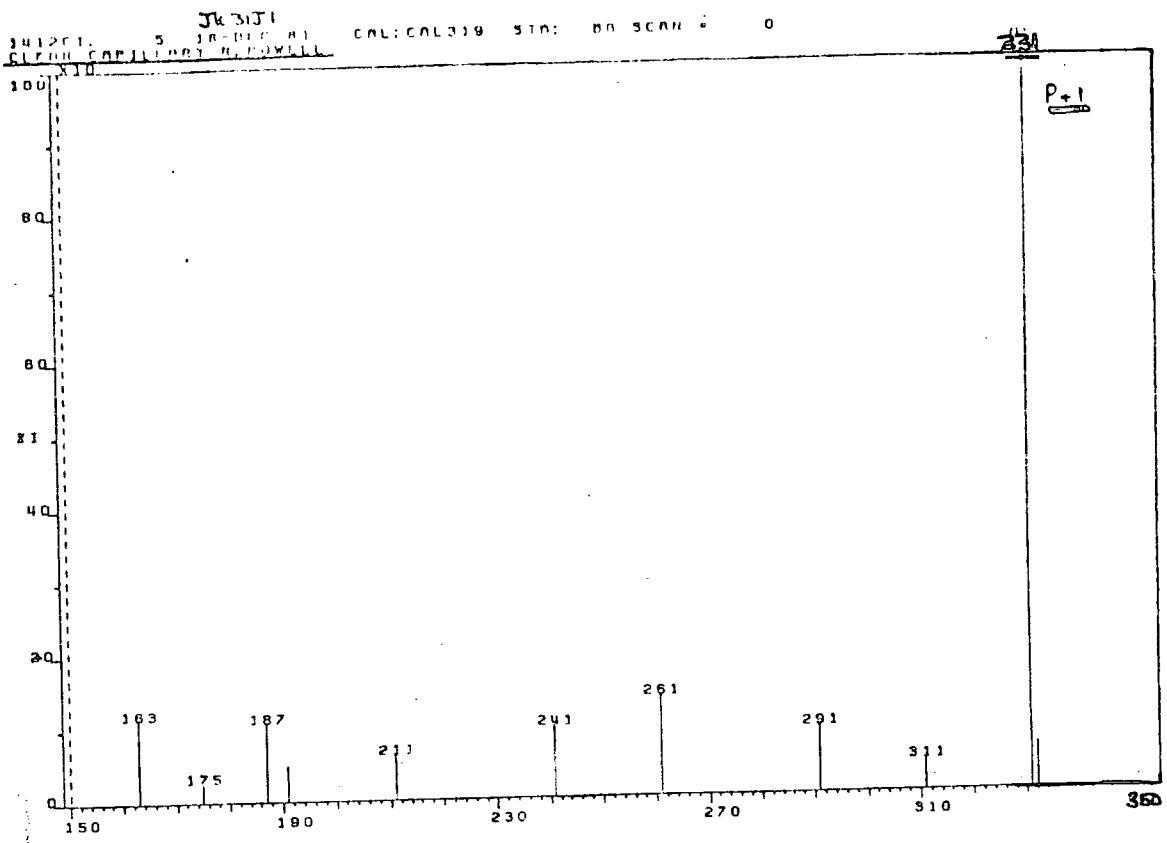

Compound No. 4I (MW 330) - Chemical Ionisation m.s.

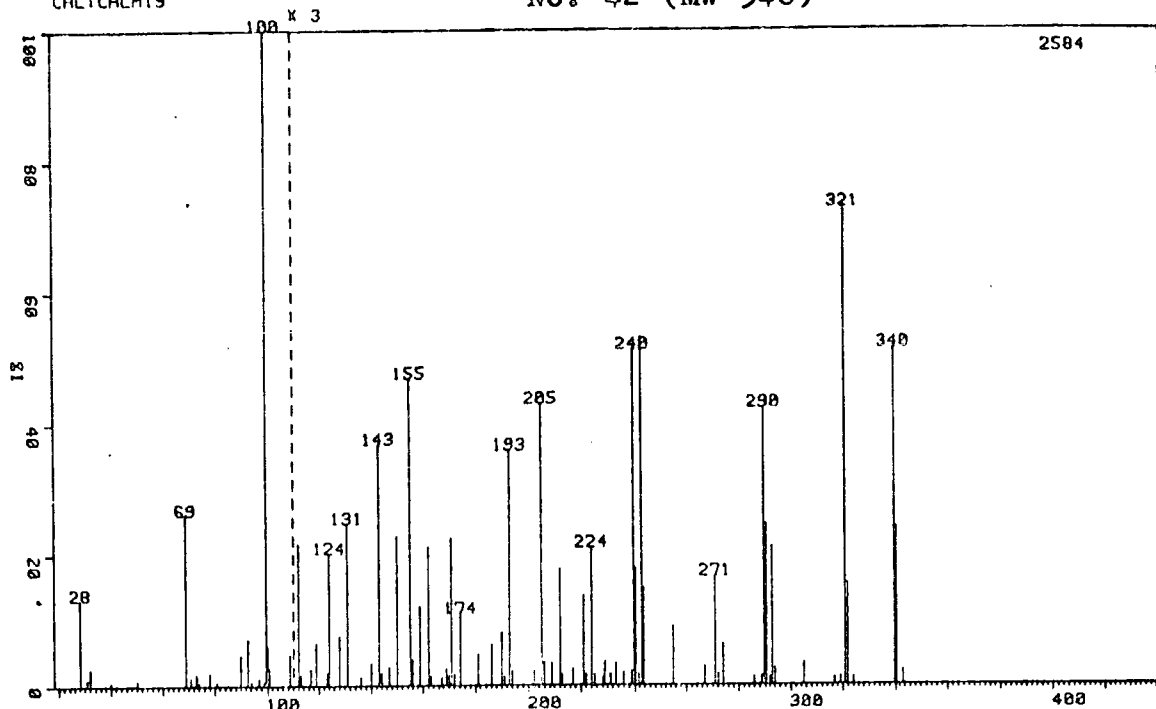

PEAK NO.	MASS	%HT. BASE	PEAK NO.	MASS	%HT. BASE	PEAK NO.	MASS	%HT. BASE
1	28.13	13.20	36	147.05	0.93	71	233.06	1.12
2	30.91	1.01	37	150.02	7.59	72	236.08	0.66
3	32.02	2.52	38	155.09	15.60	73	238.98	0.74
4	39.84	0.46	39	155.60	0.39	74	239.92	17.07
5	49.88	0.77	40	155.99	1.32	75	240.66	5.92
6	68.99	26.01	41	159.04	3.99	76	241.64	0.54
7	70.97	1.24	42	162.06	7.04	77	243.00	17.65
8	73.12	1.78	43	163.14	0.46	78	243.61	4.91
9	74.04	0.43	44	167.10	0.43	79	255.03	2.98
10	77.98	1.97	45	169.06	0.89	80	267.09	0.93
11	80.94	0.54	46	170.02	0.54	81	271.02	5.53
12	89.89	4.68	47	171.04	7.47	82	272.12	0.54
13	93.03	7.16	48	172.09	0.58	83	274.06	2.05
14	94.07	0.58	49	174.07	3.68	84	286.08	0.43
15	97.03	1.20	50	181.04	1.59	85	289.03	0.46
16	98.90	0.46	51	186.07	2.05	86	289.93	14.09
17	99.20	0.50	52	190.02	2.67	87	290.57	8.17
18	99.34	0.62	53	191.06	0.46	88	292.24	0.43
19	99.89	100.00	54	193.08	11.96	89	293.02	7.04
20	100.14	6.11	55	194.09	0.74	90	294.05	0.89
21	100.83	2.75	56	202.08	0.74	91	305.01	1.12
22	108.96	4.72	57	205.06	14.32	92	316.99	0.39
23	111.99	7.20	58	206.12	1.16	93	319.04	0.43
24	113.08	0.54	59	209.03	1.12	94	320.91	24.26
25	117.04	0.85	60	212.01	5.92	95	321.77	5.15
26	118.99	2.17	61	212.51	0.46	96	324.10	0.43
27	123.40	0.66	62	213.09	0.50	97	339.99	17.11
28	124.06	6.73	63	217.11	0.81	98	340.62	8.01
29	128.01	2.52	64	220.98	4.53	99	343.13	0.74
30	131.00	8.24	65	222.07	0.58			
31	136.11	0.43	66	224.06	7.00			
32	139.99	1.12	67	225.04	0.50			
33	143.03	12.27	68	228.01	0.43			
34	143.75	0.50	69	229.10	1.20			
35	144.11	0.66	70	231.06	0.58			

JK39A1 34 J.R.KIRK
CALICAL2

No. 43 (NW 502)

04-NOV-81

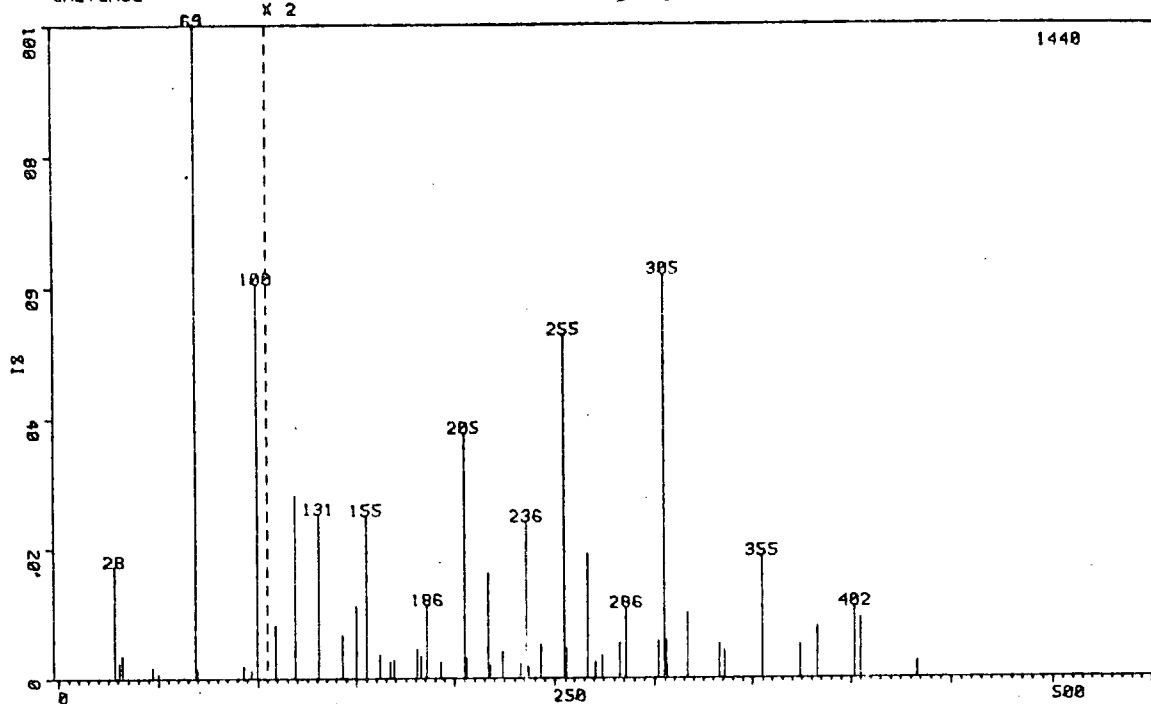

PEAK NO.	MASS	%HT. BASE	PEAK NO.	MASS	%HT. BASE
1	28.13	17.22	36	270.96	1.32
2	30.91	2.29	37	273.94	1.74
3	32.02	3.40	38	282.92	2.71
4	47.10	1.60	39	285.98	5.42
5	49.88	0.69	40	301.92	2.85
6	68.97	100.00	41	304.95	30.90
7	69.92	1.39	42	305.96	2.92
8	93.01	1.87	43	306.66	0.97
9	97.04	1.25	44	316.95	5.00
10	99.92	60.49	45	333.00	2.64
11	108.97	4.10	46	336.00	2.15
12	118.97	14.03	47	354.97	9.37
13	130.96	12.64	48	374.02	2.57
14	143.02	3.33	49	382.91	3.96
15	149.98	5.56	50	401.87	5.49
16	155.04	12.50	51	404.90	4.58
17	162.00	1.81	52	433.06	1.25
18	167.03	1.25			
19	168.95	1.46			
20	180.99	2.22			
21	183.02	1.74			
22	186.02	5.62			
23	193.03	1.25			
24	205.00	18.82			
25	206.03	1.53			
26	217.00	8.06			
27	218.01	0.97			
28	224.04	2.01			
29	233.02	1.11			
30	236.00	12.01			
31	237.02	0.90			
32	242.98	2.57			
33	254.93	26.32			
34	256.00	2.29			
35	266.95	9.51			

APPENDIX IV

DEPARTMENTAL COLLOQUIA AND INDUCTION COURSE FOR POSTGRADUATES

The Board of Studies in Chemistry requires that each postgraduate research thesis contains an appendix listing

a) all research colloquia, research seminars and lectures arranged by the department of Chemistry during the period of the writer's residence as a postgraduate student;

b) all research conferences attended and papers read out by the writer of the thesis during the period when the research for the thesis was carried out;

c) details of the postgraduate induction course.

Events in a) which were attended are marked + .

Research Colloquia, Seminars and Lectures

I. Durham University Chemical Society

Academic Year 1979-1980

- + Oct. 18 Dr. G. Cameron (Aberdeen): "Synthetic Polymers".
- + Oct. 25 Prof. P. Gray (Leeds): "Oscillatory Combustion Reactions".
- + Nov. 1 Dr. J. Ashby (I.C.I. Toxicological Laboratory): "Does Chemically-induced Cancer make Chemical Sense".
- + Nov. 8 Prof. J.H. Turnbull (R.M.C. Shrivenham): "Luminescence of Drugs".
- Nov. 15 Prof. E.A.V. Ebsworth (Edinburgh): "Stay still you brute- the Shape of some Simple Silyl Complexes".
- Jan. 24 Prof. R.J.P. Williams (Oxford): "On first looking into Biology's Chemistry".
- + Feb. 14 Prof. G. Gamlen (Salford): "A yarn with a new Twist- Fibres and their Uses".
- + Feb. 23 Dr. M.L.H. Green (Oxford): "Synthesis of Highly Reactive Organic Compounds using Metal Vapours".
- + Feb. 28 Prof. S.F.A. Kettle (East Anglia): "Molecular Shape, Structure and Chemical Blindness".
- + Mar. 6 Prof W.D. Ollis (Sheffield): "Novel Molecular Rearrangements".

Academic Year 1980-1981

- + Oct. 16 Dr. D. Maas (Salford): "Reactions a go-go".
- + Oct. 23 Prof. T.M. Sugden (Cambridge): "Reactions in Flames".
- + Oct. 30 Prof. N. Grassie (Glasgow): "Inflammability Hazards in Commercial Polymers".

- + Nov. 6 Prof. A.G. Sykes (Newcastle): "Metalloproteins-an inorganic chemist's approach".
- + Nov. 13 Prof. N.N. Greenwood (Leeds): "Metalloborane Chemistry".
- + Dec. 4 Rev. R. Lancaster (Kimbolton School, Cambridgeshire) : "Fireworks".
- + Jan. 22 Prof E.A. Dawes (Hull): "Magic and Mystery through the ages".
- + Jan. 29 Mr. H.J.F. MacLean (I.C.I.): "Managing the chemical industry in the 1980's".
- + Feb. 5 Prof. F.G.A. Stone (Bristol): "Chemistry of carbon to metal triple bonds".
- + Feb. 12 Dr. I. Fleming (Cambridge): "Some uses of silicon compounds in organic synthesis".
- + Mar. 17 Prof. W.P. Jencks (Brandeis, U.S.A.): "When is an intermediate not an intermediate".
- + May 7 Prof. M. Gordon (Essex): "Do scientists have to count".

Academic Year 1981-1982

- + Oct. 22 Dr. P.J. Corish (Dunlop): "What would life be like without rubber?".
- Oct. 29 Miss. J.M. Cronyn (Durham): "Chemistry in archeology".
- + Nov. 12 Prof. A.I. Scott (Edinburgh): "An organic chemist's view of life through the n.m.r. tube".
- + Nov. 19 Prof. B.L. Shaw (Leeds): "Big rings and metal-carbon bond formation".
- Dec. 3 Dr. W.O. Ord (Northumbria Water Authority): "The role of the scientist in a regional water authority".

- Jan. 28 Prof I. Fells (Newcastle): "Balancing the energy equations".
- Feb. 11 Dr. D.W. Turner (Oxford): "Photoelectrons in a strong magnetic field".
- + Feb. 18 Prof. R.K. Harris (East Anglia): "NMR in the 1980's".
- + Feb. 25 Prof. R.O.C. Norman (York): "Turning points and challenges for the organic chemist".
- Mar. 4 Dr. R. Whyman (I.C.I. Runcorn): "Making metal clusters work".

The author is pleased to report his tenure of the post of Treasurer of the society during the period April 1980 - October 1981.

2. Durham University Chemistry Colloquia

Academic Year 1979-1980

- + Nov. 21 Dr. J. Miller (Bergen): "Photochemical reactions of ammonia".
- + Nov. 28 Dr. B. Cox (Stirling): "Macrobicyclic cryptate complexes".
- + Dec. 5 Dr. G.C. Eastmond (Liverpool): "Synthesis and properties of some multi-component polymers".
- Dec. 12 Dr. C.I. Ratcliffe: "Rotor motions in solids".
- + Dec. 19 Dr. K.E. Newman (Lausanne): "High pressure n.m.r. for fast reaction mechanisms".
- + Feb. 6 Dr. J.M.E. Quirke (Durham): "Degredation of chlorophyll-A in sediments".
- + May 14 Dr. R. Hutton (Water Associates, U.S.A.): "Recent developments in HPLC"

- + May 21 Dr. T.W. Bentley (Swansea): "Medium and structural effects in solvolytic reactions".
- + July 10 Prof. D. DesMarteau (Heidelberg): "Developments in Organonitrogen Fluorine chemistry".

Academic Year 1980-1981

- Oct. 7 Prof. T. Fehler (Notre Dame, U.S.A.): "Metallo-boranes — cages or co-ordination compounds ?".
- + Oct. 15 Dr. R. Alder (Bristol): "Medium ring bicyclic molecules".
- Nov. 12 Dr. M. Gerlock (Cambridge): "Magnetochemistry is about chemistry".
- + Nov. 19 Dr. T. Gilchrist (Liverpool): "Nitroso-olefins as synthetic intermediates".
- + Dec. 3 Dr. J.A. Connor (Manchester): "Thermochemistry of transition metal compounds".
- + Dec. 18 Dr. R.F. Evans (Adelaide): "The Australian journal of failed chemistry".
- Feb. 18 Prof. S.F.A. Kettle (East Anglia): "Variations of the molecular dance at the crystal ball".
- + Feb. 25 Dr. K. Bowden (Essex): "Transmission of polar effects of substituents".
- Mar. 4 Dr. S. Craddock (Edinburgh): "Pseudolinear pseudohalides".
- + Mar. 11 Dr. J.F. Stoddart (I.C.I.): "Stereochemistry of synthetic molecular receptors".
- Mar. 18 Dr. P.J. Smith (Int. tin research inst.): "Organotin compounds".

- + Apr. 9 Dr. W.H. Meyer (Zurich): "Properties of aligned polyacetylene".
- May 6 Prof. M. Szwarcz: "Ions and Ion-pairs".
- + May 8 Prof. H.F. Koch: "Proton transfer during elimination reactions".
- + June 10 Dr. J. Rose (I.C.I.): "New engineering plastics".
- June 17 Dr. P. Moreau (Montpellier): "Perfluoro-organometallic chemistry".
- June 26 Prof. A.P. Schaap (U.S. Office of Naval Research): "Molecular dynamics in molecular crystals".

Academic Year 1981-1982

- Oct. 14 Prof. E. Kluk (Katowice): "Chemoluminescence and photo-oxidation".
- Oct. 28 Dr. R.J.H. Clark (U.C.L.): "Resonance raman spectroscopy".
- + Nov. 6 Dr. W. Moddeman (Monsanto): "High energy materials".
- + Nov. 18 Prof. M.J. Perkins (London): "Spin trapping and nitroxide radicals".
- + Nov. 25 Dr. M. Baird (Newcastle): "Intramolecular reactions of carbenes and carbenoids".
- Dec. 2 Dr. G. Beamson (Durham): "Photoelectron spectroscopy in a strong magnetic field".
- + Nov. 30 Dr. B.T. Heaton (Kent): "NMR studies of carbonyl clusters".
- Jan. 20 Dr. M.R. Bryce (Durham): "Organic Metals".
- + Jan. 27 Dr. D.L.H. Williams (Durham): "Nitrosation and nitrosoamines".
- Feb. 3 Dr. D. Parker (Durham): "Modern methods of determining enantiomeric purity".

- + Feb. 10 Dr. D. Pethrick (Strathclyde): "Conformation of small and large molecules".
- + Feb. 17 Prof. R.D. Chambers (Durham): "Recent reactions of fluorinated internal olefins".
- + Feb. 24 Dr. L. Field (Oxford): "Application of n.m.r. to biosynthetic studies on penicillin".
- + Mar. 3 Dr. P. Bamfield (I.C.I.): "Computer aided design in synthetic organic chemistry".
- Mar. 17 Prof. R.J. Haines (Natal): "Clustering around Ru, Fe, and Rh".
- + Apr. 7 Dr. A. Pensak (DuPont, U.S.A.): "Computer aided synthesis".
- + May 5 Dr. G. Tennant (Edinburgh): "The aromatic nitro group in heterocyclic reactions".
- May 7 Dr. C.D. Garner (Manchester): "Molybdenum centres in enzymes".
- + May 26 Dr. A. Welch (Edinburgh): "Conformation and distortion in Carbometalloboranes".

Research Conferences Attended

3rd Annual Congress of the Chemical Society, Durham,
9-II April 1980.

7th European Symposium on Fluorine Chemistry, Venice, Italy,
15-19th September 1980.

Postgraduate Induction Course

In each part of the course, the uses and limitations of the various services available were explained by those responsible for them.

Departmental Organisation - Dr. E.J.F. Ross

Electrical appliances and infrared spectroscopy - Mr. R.N. Brown

Chromatography - Mr. J.A. Parkinson

Microanalysis - Mr. T.F. Holmes and Mrs. M. Cocks

Atomic absorption spectrometry and inorganic analysis - Mr. R. Coult

Mass spectrometry - Dr. M. Jones

N.M.R. spectrometry - Dr. R.S. Matthews

Glassblowing techniques - Mr. W.H. Pettis and Mr. R. Hart

Safety matters - Dr. M.R. Crampton

REFERENCES

- I. J.D. Park, A.F. Benning, F.B. Downing, J.F. Lancius, and R.C. McHarness, Ind. Eng. Chem., 1947, 39, 354.
2. D.A. Nelson, U.S. Patent 2,758,138 (1956); Chem. Abstr., 51, 3654, (1957).
3. J. Wesley Clayton, Fluorine Chem. Revs., 1967, I, 226.
4. J.A. Young and T.M. Reed, J. Org. Chem., 1967, 32, 1682.
5. A.T. Morse, P.B. Ayscough, and L.C. Leitch, Can. J. Chem., 1955, 33, 453.
6. R.D. Chambers, 'Fluorine in Organic Chemistry', Wiley, New York, 1973, page 10.
7. E.A. Belmore, W.M. Ewalt, and B.H. Wojcik, Ind. Eng. Chem., 1947, 39, 338.
8. A.L. Henne and R.P. Ruh, J. Amer. Chem. Soc., 1947, 69, 279.
9. J.T. Maynard, J. Org. Chem., 1963, 28, 112.
10. A.K. Barbour, H.D. MacKenzie, M. Stacey, and J.C. Tatlow, J. Appl. Chem., 1954, 4, 347.
- II. Reference 6 provides a good general discussion of many fluorochemical principles.
12. D.P. Graham, J. Org. Chem., 1966, 31, 355.
13. D.P. Graham, U.S. Patent 3,403,191 (1968).
14. W.R. Deem, Ger. Offen., 1,901, 006 (1969).
15. W. Dmowski, W.T. Flowers, and R.N. Haszeldine, J. Fluorine Chem., 1977, 9, 94.
16. A.A. Lindley, Ph.D. Thesis, Durham University, 1978.
17. I.L. Knunyants, Dokl. Akad. Nauk SSSR, 1976, 228, 1344.
18. E.G. Ter-gabrielyan, N.P. Gambaryan, and I.L. Knunyants, Izv. Akad. Nauk SSSR, Ser. Khim., 1981, 2, 383.
19. R.D. Chambers, M.Y. Gribble, and E. Marper, J. Chem. Soc., Perkin Trans. I, 1973, 1710.

20. K.J.R. Fraticelli, Ph.D. Thesis, Cornell University, Ithica, 1965.
21. R.L. Pruett, C.T. Bahner, and H.A. Smith, J. Amer. Chem. Soc., 1952, 74, 1638.
22. R.D. Chambers, G. Taylor, and R.L. Powell, J. Chem. Soc., Chem. Commun., 1978, 431.
23. G. Taylor, Ph. D. Thesis, Durham University, 1979.
24. M.A. Howells, R.D. Howells, N.C. Baenziger, and D.J. Burton, J. Amer. Chem. Soc., 1973, 95, 5366.
25. D.J. Burton, R.D. Howells, and P. Van der Valk, J. Amer. Chem. Soc., 1977, 99, 4830.
26. D.J. Burton and P. Van der Valk, J. Fluorine Chem., 1981, 18, 413.
27. C.R. Brundle, M.B. Robin, and N.A. Kuebler, J. Amer. Chem. Soc., 1972, 94, 1466.
28. J.P. Cheswick, J. Amer. Chem. Soc., 1966, 88, 4800.
- 28a. R.D. Chambers, C.G.P. Jones, G. Taylor, and R.L. Powell, J. Fluorine Chem., 1981, 18, 407.
29. First demonstrated by W.T. Miller, J. Amer. Chem. Soc., 1948, 70, 431.
- 29a. L.N. Domelsmith, K.N. Houk, C. Piedrahita, and W.J. Dolbier Jr., J. Amer. Chem. Soc., 1978, 100, 6908; E. Heilbronner, 'Molecular Spectroscopy', Ed. R.S. West, Heyden and Sons, 1977, page 443.
30. R.D. Chambers and R.H. Mobbs, Adv. Fluorine Chem., 1965, 4, 50.
31. J.D. Park, R.J. McMurtry and J.H. Adams, Fluorine Chem. Revs., 1968, 2, 55.
32. D.W. Wiley, U.S. Patent 2,988,537 (1961); Chem. Abstr., 1962, 56, 330.

33. I. Fleming, 'Frontier Orbitals and Organic Chemical Reactions', Wiley, London, 1976; R.D. Chambers, personal communication.
34. W.E. Hanford and G.W. Rigby, U.S. Patent 2,409,274 (1948); Chem. Abstr., 1947, 41, 982.
35. I.L. Knunyants, L.S. German, and B.L. Dyatkin, Chem. Abstr., 1957, 51, 8037.
36. S. Dixon, J. Org. Chem., 1956, 21, 400.
37. J.H. Fried and W.T. Miller, J. Amer. Chem. Soc., 1959, 81, 2078.
38. A.B. Clayton, J. Roylance, D.R. Sayers, R. Stephens, and J.C. Tatlow, J. Chem. Soc., 1965, 7358.
39. H.F. Koch and A.J. Kielbania, J. Amer. Chem. Soc., 1970, 92, 729.
40. C.G. Krespan, U.S. Patent 4,005,104 (1977); Chem. Abstr., 1977, 86, I7146I.
41. D.C. England, Angew. Chem. Int. Ed. (Eng.), 1973, 12, 1023; U.S. Patent 3,825,599 (1974); Chem. Abstr., 1974, 81, I04757.
42. N. Ishikawa and A. Nagashima, Bull. Chem. Soc. Jpn., 1976, 49, 502.
43. W. Brunskill, W.T. Flowers, R. Gregory, and R.N. Haszeldine, J. Chem. Soc., Chem. Commun., 1970, I444.
44. R.D. Chambers and G. Taylor, J. Fluorine Chem., 1980, 16, I6I.
45. H.C. Fielding, Brit. Patent I,148,486 (1969).
46. H.H. Evans, R. Fields, R.N. Haszeldine, and M. Illingworth, J. Chem. Soc., Perkin Trans. I, 1973, 649.
47. S.P. Van Halasz, F. Kluge, and T. Martini, Chem. Ber., 1973, 106, 2950.

48. R.D. Chambers, A.A. Lindley, P.D. Philpott, H.C. Fielding, J. Hutchinson, and G. Whittaker, J. Chem. Soc., Perkin Trans. I, 1979, 214.
49. S. Bartlett, Ph. D. Thesis, Durham University, 1979.
50. N.M. Kelly, Ph. D. Thesis, Durham University, 1979.
51. B.L. Dyatkin and I.L. Knunyants, Tetrahedron, 1973, 2759.
52. D.J. Burton and Y. Inouye, Tetrahedron Lett., 1979, 3397.
53. N.A. Bell, R. Fields, and R.N. Haszeldine, J. Chem. Soc., Perkin Trans., 1980, 487.
54. R.D. Chambers, A.A. Lindley, and H.C. Fielding, J. Chem. Soc., Perkin Trans. I, 1981, 939.
55. E.S. Lo, J. Org. Chem., 1971, 36, 364.
56. M.A. Kurykin and L.S. German, Izv. Akad. Nauk SSSR, Ser. Khim., 1981, II, 2646.
57. T. Filyakova, A.Ya. Zapevalov, I.P. Kolenko, and L.S. German, Izv. Akad. Nauk SSSR, Ser. Khim., 1979, 12, 2789.
58. A. Battais, B. Boutevin, and P. Moreau, J. Fluorine Chem., 1979, 13, 391.
59. J.A. Young and M.H. Bennet, J. Org. Chem., 1977, 42, 4055.
60. D.C. England and C.G. Krespan, J. Amer. Chem. Soc., 1966, 88, 5582.
61. K.V. Scherer and T.F. Terranova, J. Fluorine Chem., 1979, 13, 89.
62. S.A. Postovoi and Yu. V. Zeifman, Izv. Akad. Nauk SSSR, Ser. Khim., 1981, 6, 1434.
63. V.A. Petrov, G.G. Belen'kii, L.S. German, and E.I. Mysov, Izv. Akad. Nauk SSSR, Ser. Khim., 1981, 9, 2098.
64. Reference 63, page 1920.
65. D.J. Burton, private communication.

66. I.L. Knunyants et al., Dokl. Akad. Nauk SSSR, 1976, 228, 1344.
67. E.G. Ter-Gabrielyan, N.P. Gambaryan, and I.L. Knunyants, Izv. Akad. Nauk SSSR, Ser. Khim., 1981, 2, 383.
68. A.A. Stepanov, I.N. Rozhkov, and I.L. Knunyants, Izv. Akad. Nauk SSSR, Ser. Khim., 1981, 3, 702.
69. G.G. Belen'kii, V.A. Petrov, and L.S. German, Izv. Akad. Nauk SSSR, Ser. Khim., 1980, 5, 1099.
70. A.S. Vinogradov, A.F. Gontar, and I.L. Knunyants, Izv. Akad. Nauk SSSR, Ser. Khim., 1980, 6, 1453.
71. Y. Shozo, Y. Noji, and M. Okahara, Bull. Chem. Soc. Jpn., 1981, 54, 1151.
72. M. Maruta and N. Ishikawa, J. Fluorine Chem., 1979, 13, III.
73. M. Maruta, T. Kitazume, S. Kubota, N. Yoshimura, and N. Ishikawa, Chem. Lett., 1979, 3, 291.
74. L.L. Gervits, K.N. Makarov, Yu. A. Cherbukov, and I.L. Knunyants, J. Fluorine Chem., 1977, 9, 45.
75. L.L. Gervits, K.N. Makarov, and I.L. Knunyants, Izv. Akad. Nauk SSSR, Ser. Khim., 1981, 5, 1085.
76. N.B. Kaz'mina, G.S. Krasnikov, E.P. Lur'e, E.I. Mysov, and I.L. Knunyants, Izv. Akad. Nauk SSSR, Ser. Khim., 1975, 2525.
77. E.G. Ter-Gabrielyan, N.P. Gambaryan, E.P. Lur'e, and P.V. Petrovskii, Izv. Akad. Nauk SSSR, Ser. Khim., 1979, 5, 1061.
78. E.G. Ter-Gabrielyan and N.P. Gambaryan, Izv. Akad. Nauk SSSR, Ser. Khim., 1980, 5, 1214.
79. E.G. Ter-Gabrielyan, N.P. Gambaryan, E.P. Lur'e, and I.L. Knunyants, Dokl. Akad. Nauk SSSR, 1980, 254, 898.
80. L.M. D'yachishina, Zh. Vses. Khim. O-va, 1980, 25, 709.

81. M.A. Kurykin, L.S. German, and I.L. Knunyants,
Izv. Akad. Nauk SSSR, Ser. Khim., 1980, 9, 2172.
82. W. Dmowski, Chem. Abstr., 93, II42I4.
83. H. Muramatsu, K. Inukai, and T. Ueda, Bull. Chem. Soc. Jpn., 1967, 40, 903.
84. R.E. Banks and N. Dickinson, J. Fluorine Chem., 1981, 19, 97.
85. D.J. Burton, Y. Inouye, and J.A. Headley,
J. Amer. Chem. Soc., 1980, 102, 3980.
86. A.W. Wu, S.K. Choi, J.D. Park, and R.L. Soulen,
J. Fluorine Chem., 1979, 13, 379.
87. W.R. Cullen and R.L. Soulen, J. Fluorine Chem., 1981, 17, 453.
88. Jpn. Kokai Tokkyo Koho 79,109,911; Chem. Abstr., 92, 4I36I.
89. R.A. Bekker and V.Ya. Popkova, Izv. Akad. Nauk SSSR, Ser. Khim., 1978, 12, 2775.
90. N.E. Akhmetsova, N.G. Kostina, and V.D. Shteingarts,
Zh. Org. Khim., 1979, 15, 2I37.
91. E.D. Laganis and D.M. Lemal, J. Amer. Chem. Soc., 1980, 6633.
92. F.W.B. Einstein, A.C. Willis, W.R. Cullen, and R.L. Soulen,
J. Chem. Soc., Chem. Commun., 1981, 526.
93. M.G. Barlow, M.W. Crawley, and R.N. Haszeldine,
J. Chem. Soc., Perkin Trans. I, 1980, I22.
94. M.J. Gerace, D.M. Lemal, and H. Ertl, J. Amer. Chem. Soc., 1975, 97, 5584.
95. M.W. Grayston, W.D. Saunders, and D.M. Lemal,
J. Amer. Chem. Soc., 1980, 102, 4I3.
96. D.M. Lemal, J.M. Buzby, and A.C. Barefoot, J. Org. Chem., 1980, 45, 3I18.
97. E.I. DuPont de Nemours and Co., Brit. Patent 904,877 (1962).
98. E.I. DuPont de Nemours and Co., Brit. Patent 93I,587 (1963).

99. F. Gozzo and G. Camaggi, U.S. Patent 3,392,097 (1968).
100. G.C. Belen'kii, L.S. German, and I.L. Knunyants, Izv. Akad. Nauk SSSR, Ser. Khim., 1967, 12, 2780.
101. Monsanto, Brit. Patent 1,036, 174 (1966).
102. E.M. Rokhlin, Yu. V. Zeifman, Yu. A. Cherbukov, N.P. Gambaryan, and I.L. Knunyants, Dokl. Akad. Nauk SSSR, 1965, 161, 1356.
103. J.W. Dale, U.S. Patent 3,622,601 (1971).
104. E.P. Moore, U.S. Patent 3,338,978 (1967).
105. W.L. Millauer, Ger. Offen., 2,658,382 (1978).
106. Y. Oda, K. Uchida, and S. Morikawa, Jpn. Kokai, 77,108,914 (1977).
107. L.F. Sokolov, E.A. Manuilova, and V.P. Sass, Zh. Prikl. Khim., 1979, 52, 621.
108. Yu. V. Zeifman, E.M. Rokhlin, and U. Utabaev, Dokl. Akad. Nauk SSSR, 1976, 226, 1337.
109. A. Ya. Zapevalov, I.P. Kolenko, and V.S. Plashkin, Zh. Org. Khim., 1973, 9, 2013.
110. R.A. Bekker, G.G. Melikyan, B.L. Dyatkin, and I.L. Knunyants, Zh. Org. Khim., 1976, 12, 1377.
111. C. Wakselman and J. Leroy, J. Fluorine Chem., 1978, 12, 101.
112. R.A. Bekker, V. Popkova, and I.L. Knunyants, Izv. Akad. Nauk SSSR, Ser. Khim., 1980, 7, 1692.
113. F.C. McGrew, Brit. Patent 943,373 (1963).
114. F. Gozzo and G. Camaggi, Tetrahedron, 1966, 22, 1765.
115. E.I. DuPont de Nemours and Co. Brit. Patent 1,019,788 (1966).
116. D. Sianesi, A. Pasetti, and F. Tarli, J. Org. Chem., 1966, 31, 2312.
117. H. Kawa, H.A. Hamouda, and N. Ishikawa, Bull. Chem. Soc. Jpn., 1980, 53, 1694.

- I18. T.I. Filyakova, A.Ya. Zapevalov, I.P. Kolenko, and E.P. Lur'e, Izv. Akad. Nauk SSSR, Ser. Khim., 1979, 8, 1878.
- I19. Reference I18, 1980, 5, I185.
- I20. Ya.M. Vilenchik, G.I. Lekontseva, and G.I. Yakurnova, Zh. Org. Khim., 1980, 16, 1555.
- I21. E.P. Moore, A.S. Milian, and H.S. Eleuterio, U.S. Patent 3,250,808 (1966).
- I22. C.G. Fritz, E.P. Moore, and S. Selman, U.S. Patent 3,114, 778 (1963).
- I23. G.M. Tyulga, V.A. Gubanov, D.S. Rondarev, R.M. Ryazonova, and I.M. Delgopol'skii, Zh. Org. Khim., 1980, 16, 300.
- I24. R.A. Bekker, G.V. Asratyan, B.L. Dyatkin, and I.L. Knunyants, Tetrahedron, 1974, 30, 3539.
- I25. E.P. Moore, U.S. Patent 3,322,826 (1967).
- I26. S. Selman, U.S. Patent 3,274,239 (1966).
- I27. J.L. Warnell U.S. Patent 3,250,806 (1966).
- I28. E.I. DuPont de Nemours and Co., Brit. Patent 1,000,802 (1965).
- I29. W.T. Miller, U.S. Patent 3,242,218 (1966).
- I30. M. Zanger, U.S. Patent 3,459,722 (1969).
- I31. P. Tarrant, C.G. Allison, K.P. Barthold, and E.C. Stump, Fluorine Chem. Revs., 1971, 5, 77.
- I32. D.E. Morin, U.S. Patent 3,213,134 (1965).
- I33. F.J. Pavlik, U.S. Patent 3,385,904 (1968).
- I34. A.Ya. Zapevalov, I.P. Kolenko, V.S. Plashkin, and P.G. Neifel'd, Zh. Org. Khim., 1978, 14, 259.
- I35. E.P. Moore and A.S. Milian, U.S. Patent 3,321,515 (1967).
- I36. G. Kuehne and F. Heller, Ger. Offen., 2,756,919 (1979).
- I37. M.G. Barlow, R.N. Haszeldine, and C.J. Peck, J. Chem. Soc., Chem. Commun., 1980, 4, 158.

- I38. M.S. Toy, U.S. Patent Appl., 182,563 (1980).
- I39. V.I. Solontin, I.A. Piterskikh, K.I. Pashkevitch, M.I. Kodess, and I. Postovskii, Izv. Akad. Nauk SSSR, Ser. Khim., 1980, 10, 2403.
- I40. I.P. Kolenko, T.I. Filyakova, A.Ya. Zapevalov, and E.P. Lur'e, Izv. Akad. Nauk SSSR, Ser. Khim., 1979, 11, 2509.
- I41. A.Ya. Zapevalov, T.I. Filyakova, and I.P. Kolenko, Izv. Akad. Nauk SSSR, Ser. Khim., 1979, 12, 2812.
- I42. T.I. Filyakova, A.Ya. Zapevalov, N.V. Peschanskii, M.I. Kodess, and I.P. Kolenko, Izv. Akad. Nauk SSSR, Ser. Khim., 1981, 11, 2612.
- I43. J.W. Agopovitch and C.W. Gillies, J. Amer. Chem. Soc., 1982, 104, 813.
- I44. C.T. Ratcliffe, U.S. Patent 4,287,128 (1981).
- I45. P.R. Resnick, Encycl. Chem. Technol., 3rd Edition, Kirk Othmer, 1980, 10, 956.
- I46. M. Pralus, J.C. Lecoq, and J.P. Schirman, Fundam. Res. Homogenous Cat., 1979, 3, 327.
- I47. A detailed review appears in H.O. House, 'Modern Synthetic Reactions', Benjamin, 1972, pages 493-546, from which much of the data in this section was taken.
- I48. R. Gompper, Angew. Chem. Internat. Edn., 1964, 3, 560.
- I49. R.G. Pearson, J. Chem. Education, 1968, 45, 581 and 643.
- I50. M. Hudlicky, 'Chemistry of Organic Fluorine Compounds', 2nd Revised Edn., 1976, 323.
- I51. W.T. Bruce and R. de V. Huber, J. Amer. Chem. Soc., 1953, 75, 4468.
- I52. D.C. England, L.R. Melby, M.A. Dietrich, and R.V. Lindsey, J. Amer. Chem. Soc., 1960, 82, 5116.
- I53. Reference I50, page 300.

- I54. H.C. Fielding, Brit. Patent I, I43,599 (I969).
- I55. V. Vlasov, V.V. Aksenov, and G.G. Yakobson,
Zh. Org. Khim., I979, I5, 2I56.
- I56. R.F. Maisey, Brit. Patent 90I, 892 (I962).
- I57. G.G. Yakobson, T.D. Petrova, L.I. Kann, T.I. Savchenko,
A.K. Petrov, and N.N. Vorozhtsov,
Dokl. Akad. Nauk SSSR, I964, I58, 926.
- I58. G.M. Brooke, Tetrahedron Lett., I968, 2029.
- I59. R. Filler and A.E. Fiebig, J. Chem. Soc (D), I970, 546.
- I60. N.M. Kelly, Ph. D. Thesis, Durham University, I979.
- I6I. S.R. Sterlin, L.G. Zhuravkova, B.L.Dyatkin, and I.L.
Knunyants, Izv. Akad. Nauk SSSR, Ser. Khim., I969, I396.
- I62. L.A. Rozov, N.S. Mirzabekyants, Yu.V. Zeifman, Yu.A.
Cherbukov, and I.L. Knunyants, Izv. Akad. Nauk SSSR,
Ser. Khim., I974, 6, I274 (English Translation).
- I63. R.D. Chambers, R.S. Matthews, G. Taylor, and R.L. Powell,
J. Chem. Soc., Perkin Trans. I, I980, 435.
- I64. R.D. Chambers, G. Taylor, and R.L. Powell,
J. Chem. Soc., Chem. Commun., I979, I062.
- I65. D.J. Cram, 'Fundamentals of Carbanion Chemistry',
Academic Press, New York, I965.
- I66. R.D. Chambers, A.A. Lindley, P.D. Philpott, H.C. Fielding,
J. Hutchinson, and G. Whittaker, J. Chem. Soc.,
Perkin Trans. I, I979, 2I4.
- I67. Reference 6, page 347.
- I68. J.E. Baldwin, J. Chem. Soc., Chem. Commun., I976, 734.
- I69. Kirby V. Scherer, unpublished communication.
- I70. R.D. Chambers and R.S. Matthews, unpublished results.
- I7I. W.J. Feast, R.R. Hughes, and W.K.R. Musgrave,
J. Fluorine Chem., I977, IO, 585.

- I72. Reaction carried out in collaboration with M. Bryce.
- I72a. T.J. King, unpublished results.
- I73. D.R.A. Perry, Fluorine Chem. Revs., 1967, I, 253.
- I74. For a review, see reference I50, pages 443-481.
- I75. P.D. Bartlett, Quart. Revs., 1970, 24, 473.
- I76. J.J. Drysdale, W.W. Gilbert, H.K. Sinclair, and
W.H. Sharkey, J. Amer. Chem. Soc., 1958, 80, 3672.
- I77. E.T. McBee, C.G. Hsu, O.R. Pierce, and C.W. Roberts,
J. Amer. Chem. Soc., 1955, 77, 915.
- I78. P.B. Sargent and C.G. Krespan, J. Amer. Chem. Soc.,
1969, 91, 415.
- I79. S. Proskow, H.E. Simmons, and T.L. Cairns,
J. Amer. Chem. Soc., 1963, 85, 2341; and 1966, 88, 5254.
- I80. Y. Kobayashi, M. Honda, Y. Hanzawa, I. Kumadaki, and
A. Ohsawa, J. Chem. Soc., Perkin Trans. I, 1979, 1743.
- I81. R.D. Chambers, N.M. Kelly, J.W. Emsley, and W.G.M. Jones,
J. Fluorine Chem., 1979, I3, 49.
- I82. T. Kitazume, C. Kuritaki, and N. Ishikawa,
J. Fluorine Chem., 1981, I8, 213.
- I83. N. Ishikawa, T. Kitazume, and M. Nakabayashi, Chem. Lett.,
1980, 1089.
- I84. J. March, 'Advanced Organic Chemistry', McGraw-Hill,
New York, 1968, page 122.
- I85. G.A. Webb, 'Annual Reports on NMR Spectroscopy',
vol. 10 B, Academic Press, 1980.
- I86. G. Camaggi and F. Gozzo, J. Chem. Soc. (C), 1971, 925.
- I87. J.W. Emsley and L. Philips, 'Fluorine Coupling
Constants', Pergamon Press, Oxford, 1977.
- I88. S. Bartlett, R.D. Chambers, A.A. Lindley, and H.C.
Fielding, J. Chem. Soc., Perkin Trans I, 1980, 1551.

- I89. H.C. Fielding, Brit. Patent I,176,492 (I970).
- I90. T.J. de Boer and H.J. Backer, Org. Synthesis, 1954, 34, 96.
- I91. R.D. Chambers, J.A. Jackson, S. Partington,
P.D. Philpot, and A.C. Young, J. Fluorine Chem., 1975, 6, 5.
- I92. M.E. Redwood and C.J. Willis, Can. J. Chem., 1967, 45, 389.
- I93. R.E. Banks, F. Cuthbertson, and W.K.R. Musgrave,
Anal. Chim. Acta., 1955, 13, 442.

