

Durham E-Theses

*The development of spectroscopy and its applications
to the constitution of the universe during the
nineteenth century*

Richard Malcolm Golightly

How to cite:

Golightly, Richard Malcolm (1981) The development of spectroscopy and its applications to the constitution of the universe during the nineteenth century. Masters thesis, Durham University.

Use policy

The full-text may be used and/or reproduced, and given to third parties in any format or medium, without prior permission or charge, for personal research or study, educational, or not-for-profit purposes provided that:

- a full bibliographic reference is made to the original source
- a <https://etheses.durham.ac.uk/id/eprint/7641/> is made to the metadata record in Durham E-Theses
- the full-text is not changed in any way

The full-text must not be sold in any format or medium without the formal permission of the copyright holders.

Please consult the [full Durham E-Theses policy](#) for further details.

ABSTRACT.

M. Sc.

Title:- THE DEVELOPMENT OF SPECTROSCOPY
AND ITS APPLICATIONS TO THE CONSTITUTION
OF THE UNIVERSE DURING THE NINETEENTH CENTURY.

RICHARD MALCOLM GOLIGHTLY

The thesis looks at the discovery of spectrum analysis by Bunsen and Kirchhoff and how application was made of this analysis in attempting to understand the structure of the sun, stars, comets and nebulae by observation of their spectra.

The early part of the thesis looks at the preliminary studies of Melvill, Fox Talbot and Wollaston on the spectra of flames. Then the ever increasing interest in spectra by a whole series of notable scientists is touched upon where mention is made of Fraunhofer's major contribution due to his perfection of the manufacture of glass prisms. The thesis points out that although there was considerable interest in the subject, progress was hampered by great technical difficulties.

The breakthrough came during 1859-1862 with the work of Bunsen and Kirchhoff, but with the credit going to Kirchhoff alone for its celestial applications. Their observations convinced them that gases and vapours had the power of absorbing those very rays which they themselves gave out when in a state of incandescence.

Once the work of Kirchhoff had been published there was a rush to use it in the study of the structure of the various heavenly bodies. Faye, Huggins and Lockyer (amongst others) were all interested in the structure of sun spots and the corona.

Techniques were devised to observe the coronal spectrum during an eclipse and photographic methods started to make an ever increasing contribution towards the research work. These techniques led to arguments as to the correct classification of protuberances mainly between Respighi, Secchi and Zollner. Considerable work was done on the study of chromospheric lines (Lockyer, Respighi and Young) and various methods were devised for viewing the prominences.

From 1864 onwards work was done on the structure of comets indicating that the coma has a different spectrum from that of the nucleus.

The spectra of the fixed stars were observed and Secchi proposed a star classification (1868) which held a linkage with their colours. Further, the technique of using a shift in the position of spectral lines was used to determine the motion of stars in the line of sight.

Finally, the thesis looks at the detailed research work on variable stars and nebulae ending with some notes on the instruments and techniques used by the observers.

THE DEVELOPMENT OF SPECTROSCOPY AND ITS APPLICATIONS

TO THE CONSTITUTION OF THE UNIVERSE

DURING THE NINETEENTH CENTURY

A Thesis submitted for the degree of

MASTER OF SCIENCE

of the

UNIVERSITY OF DURHAM

by

RICHARD MALCOLM GOLIGHTLY

1981

The copyright of this thesis rests with the author.
No quotation from it should be published without
his prior written consent and information derived
from it should be acknowledged.

Department of Philosophy
University of Durham.



DEDICATION

To my son,

RICHARD ALEXANDER JAMES GOLIGHTLY

ACKNOWLEDGEMENTS.

I would like to thank Mr. John F. Partington, the Director of Education for North Tyneside, for encouraging me to undertake this work.

My colleagues, too, have been very helpful in their support and I record my gratitude to them with a special mention for Mr. R. Sanderson.

I would like to thank the late Professor Grant for letting me use the facilities of the Philosophy Department.

I am indebted to Dr. D.M. Knight for his guidance, encouragement, and unending patience during the writing of this thesis.

Finally, I would like to thank my friend, Dr. J.A. Dickson, for his encouragement and support over the years of preparation for this thesis.

C O N T E N T S.

ACKNOWLEDGEMENTS	
CHAPTERS						Page
1	The Birth of Spectrum Analysis	...				1
2	Fraunhofer Line Theories			14
3	Solar Spectroscopy (1860 - 1869)	...				23
4	Sun and Corona	32
5	Nature of the Chromosphere and Prominences	...				45
6	Comets	72
7	Fixed Stars	83
8	Motion in the Line of Sight			114
9	Nova Cygni	127
10	Spectra of Nebulae	134
11	Instruments	147
REFERENCES	I
READING LIST	XIII

CHAPTER 1.

THE BIRTH OF SPECTRUM ANALYSIS.

The refraction or bending of light takes place when the ray passes obliquely from one medium to another of different density. This effect and something more had been observed by Ptolemy and later by Kepler who referred to it in his "Dioptrics". When a ray of white light is used a band of colours, or spectrum is produced.

Sir Isaac Newton in his classic experiments on light and colour put forward several propositions, namely:-

"Lights which differ in colour differ in refrangibility."

"The light of the sun consists of rays differently refrangible."

"White light is compounded of light of different degrees of refrangibility." (1)

It should be noted that Newton although he made many experiments on prisms including use of a liquid prism (an aqueous solution of lead acetate, *saccharum saturni*) to overcome the poor optical qualities of solid glass prisms, he used a round or oblong hole in a shutter for his experiments and not a slit. The hole gave rise to a spectrum which was not a pure one but a slit prevented the individual colours overlapping and hence a pure spectrum was produced.

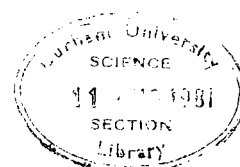

Thomas Melvill (1726-1753)⁽ⁱ⁾ was an early worker in the study of spectra. He used a prism in his examinations of flames (1752) (2). He investigated the spectrum of burning spirits, into which were introduced sal ammoniac, potash, alum, nitre, and sea salt. He observed a particular shade of yellow light (under almost all circumstances) with darkness on either side of it. The yellow predominance was perfectly definite in its degree of refrangibility - in other words took up a definite position in the spectrum. He offered no explanation, and did not suggest that the observation might be of use in chemical analysis.

The experimental works of Melvill were repeated by W.H. Wollaston (3)⁽ⁱⁱ⁾, J. von Fraunhofer (1787-1826) and Rev. W. Morgan. Fraunhofer with great precision discovered Melvill's yellow ray and measured its position in the spectrum. This ray has become well known as the "sodium line" and has played an important part in the history of spectroscopy.

Early in 1826 William Henry Fox Talbot (1800-1877)⁽ⁱⁱⁱ⁾ discovered that if the cotton wick of a spirit lamp was soaked in solution of common salt and then dried before being lit, the homogeneous light so obtained was far stronger than that of Brewster's lamp. After noting

-
- (i) Thomas Melvill (1726-1753), b. Scotland, d. Geneva.
- (ii) William Hyde Wollaston (1760-1828), b. East Dereham, d. London. Copely Medal, Secretary F.R.S.
- (iii) William Henry Fox Talbot (1800-1877), b. Dorset, d. Wiltshire. M.A., F.R.S.

that other sodium salts had a similar effect on the flame, he cautioned: "the yellow rays may indicate the presence of soda, but they, nevertheless, frequently appear when no soda can be present" (4).

Talbot listed numerous observations of flame spectra in support of this statement, but did not suggest that the effect might be due to the presence of sodium compounds as impurities in the samples tested. In the course of these studies he discovered a red ray which appeared to be characteristic of the salts of potash, as the yellow ray is of the salts of soda although from its feeble illuminating power it is only to be detected with a prism.

Fox Talbot hesitated to predict concerning his experimental work. The yellow ray appeared, indeed, without fail, where sodium was; but it also appeared where it might be reasonable to assume that sodium was not. William Swan (5) thirty years later pointed out the great delicacy of a spectral test which would show up minute fragments of impurities. Had Fox Talbot realised this then perhaps he would more forcibly pointed out that the presence in the spectrum of any individual ray told unerringly of a particular substance.

William Hyde Wollaston in 1802 used a slit instead of a round hole (as a light source) and in so doing made a great leap forward in solar physics. Dr. Wollaston (6) examined sunlight with the new arrangement and found that the solar spectrum, instead of being an unbroken rainbow band of light, was really broken by a succession of beautifully fine black lines. Newton by using a round

hole had found that the sunlight spectrum was continuous. The slit which was 1/20" in width caused the abolition of overlapping images and as a result seven dark lines were observed. These lines he took to be natural boundaries of the various colours and did no further work on the subject. He also observed bright spectral bands due to blue light at the base of a candle flame. This work was repeated by William Swan at St. Andrews and recorded in 1856. Sir William Herschel (7) (1738-1822)⁽ⁱ⁾ in 1800 discovered that there were infra-red solar rays in recording the unequal distribution of heat in the solar spectrum.

Joseph Von Fraunhofer (1787-1826)⁽ⁱⁱ⁾ of Straubing in Bavaria published the first great research on solar dark lines in 1814/1815. Fraunhofer joined Utzschneider and Reichenbach in Benediktbeuern as head of optical work in 1806. Later in 1817 he joined Reichenbach and formed the Optical Institute at Munich. He was a man of high genius combining penetrating insight with great practical skill. He invented machinery and measuring instruments for grinding and polishing lenses and later on (1811) he was able to produce large pieces of crown and flint glass free of veins. He also discovered a method of computing accurately the shape of lenses and vastly improved the achromatic telescope.

Fraunhofer wished to determine as exactly as possible the extent to which different kinds of glass dispersed the different colours of the spectrum, but found this difficult

(i) Sir William Herschel (1738-1822), b. Hanover, d. Slough. Court Astronomer.

(ii) Joseph Von Fraunhofer (1787-1826), d. Munich.

because the colours themselves appeared to have no definite boundaries. However, he used the dark lines that he found in the solar spectrum (8) as fixed points. He mapped 576 of these lines, using a telescope to examine them more closely. Some of the most conspicuous had their positions checked with a theodolite and assigned to them certain letters of the alphabet by which they are still known. He noted particularly a double dark line in the yellow-orange region of the spectrum which coincided exactly with a bright line he had already observed in the spectra of a number of flames. Fraunhofer remarked that the quality of the glass of the prism used was of critical importance, noting that English flint glass was never free from streaks. He then used the same apparatus to examine the rest of the solar system and showed that the moon and planets exhibited the same dark lines as sunlight.

When he turned his attention to the stars he obtained different results (9). The spectra of Sirius and Castor instead of giving a solar type spectra were seen to have three bands of darkness - one in the green and two in the blue. Pollux, Capella, Betelgeuse and Procyon were more similar to sunlight. One solar line - the D line - proved common to all the last four stars and again coincided with the yellow sodium line. Moreover, both the dark solar and bright terrestrial D line were displayed by the refined spectroscope as double.

Fraunhofer himself failed to realise the true significance of the spectral lines nor did he clearly

define the role which the spectral lines were destined to play in chemical analysis. He had pursued the investigations with practical optics as his main interest, but he hoped that other skilful physicists would follow this line of research.

Sir David Brewster (1781-1868)⁽ⁱ⁾ in 1822 published a paper (10) entitled "Descriptions of a monochromatic lamp for microscopical purposes etc. with remarks on the absorption of prismatic rays by coloured media" He knew of Melvill's work and also that of Thomas Young (1773-1829)⁽ⁱⁱ⁾ who showed that a good yellow light could be obtained by putting salt on the wick of a candle or spirit lamp. Brewster observed a similar light in the spectra of numerous flames and tentatively suggested that it was due to incomplete combustion. He went on to describe the spectra of flames coloured by different minerals though without suggesting their use in chemical analysis.

The above work was known to Sir John Herschel (1792-1871)⁽ⁱⁱⁱ⁾ who had been searching for a reliable monochromatic light (11). He rejected the use of coloured filters and used flames as an alternative. He observed the spectra of more types of flame than Brewster had done but saw the chief use of these data in the accurate determination of the dispersive power of glasses for light of different colours. He made no

(i) Sir David Brewster (1781-1868), b. Jedburgh, d. Melrose, F.R.S., F.R.S.E., Principal St. Andrews and Edinburgh Universities, Copley and Rumford medals.

(ii) Thomas Young (1773-1829), b. Milverton, d. London. F.R.S.

(iii) Sir John Frederick William Herschel (1792-1871), b. Slough, d. Collingwood, Kent. Master of the Mint. F.R.S.

mention of the work of Fraunhofer and it should be noted that all three investigated the spectrum via the problem of chromatic aberration in optical instruments and that none of them suggested that the effect might be used in chemistry or astronomy or offered a hypothesis concerning its origin.

Brewster translated Fraunhofer's paper into English (1823) (12) and in 1824 Herschel visited Fraunhofer and remarked on the quality of his glass prisms, which were so perfect as to be capable of showing the black lines in stellar, as well as solar spectra. Herschel gave a summary of the state of spectrum studies to date in his essay on light for the Encyclopaedia Metropolitana (13) in 1827. He noted that the pattern of dark lines, though irregular, was constant, provided that solar light was always used and that the prism was made of the same material in successive experiments. The use of different materials for the prism did not affect the number, order or intensity of the lines, but caused variations in the relative distances between them.

"In the light of the stars, on the other hand, in electric light and that of flames, though similar bands are observed in their spectra, yet they are differently disposed; and the spectrum of each several star, and each flame has a system of bands peculiar to itself and characteristic of its light, which it preserves unalterably at all times and under all circumstances."

He concluded his remarks in the 1827 essay as follows:

"The colours thus communicated by the different bases to flame afford in many cases a ready and neat way of detecting extremely minute quantities of them; but this rather belongs to chemistry than to our present subject."

In 1832 Brewster first suggested a physical mechanism for the production of line spectra (14); however his explanation met with considerable opposition, since it relied on the obsolete corpuscular theory of light. He described dark line spectra, formed by the absorption of rays passing through coloured glass and through certain gases. Because fuming nitric acid absorbs lines, while the liquid does not, Brewster saw an argument against the wave theory of light; for a gas ought to offer less impediment to motion of the ether than its denser liquid.

Brewster in 1834 announced that he was able to detect a number of vegetable and mineral substances by the absorption spectra of their aqueous solutions, using Fraunhofer's lines as reference marks. He also discovered that by raising the temperature of nitrogen dioxide gas he could broaden and intensify the absorption spectrum lines. This work caused heated discussions between Brewster, G.B. Airy⁽ⁱ⁾, Fabian von Wrede, Sir John Herschel and Fox Talbot concerning the theoretical explanation of the phenomenon and the relative merits of the wave and corpuscular theories of light (15).

In 1835 Fox Talbot suggested that the definite rays

(i) Sir George Biddell Airy (1801-1892), b. Alnwick, d. Greenwich. Lucasian and Plumian Professor at Cambridge. Astronomer Royal. F.R.S.

of the spectrum might be analogous to the definite proportion of chemical combination (16) and in 1845 W.A. Miller⁽ⁱ⁾ passed sunlight through glowing vapours (17) and examined the superimposed spectra, but failed to realise the significance of the results.

It may be of interest to note that Auguste Comte⁽ⁱⁱ⁾ in 1835 in his Cours de Philosophie Positive (18), wrote of the celestial bodies:-

"We understand the possibility of determining their shapes, their distances, their sizes, their motions but never their chemical composition or mineralogic structure."

J.W. Draper (1811-1882), Professor of Chemistry at the University of New York in 1842 mapped the solar spectrum lines accurately by the use of photography (19) and noticed three wide bands in the infra red region. Later in 1847 he published his research on the investigation of the effect of temperature changes on spectra (20). He concluded that all solids became incandescent at the same temperature, i.e. red hot 525°C whilst below this temperature invisible rays were emitted. When the temperature was raised above 525°C rays of greater refrangibility were added successively and continuously.

J.L. Foucault (1819-1868)⁽ⁱⁱⁱ⁾ in 1849 suggested as a result of the prismatic analysis of the voltaic arc

-
- (i) William Allen Miller (1817-1870). Professor at King's College, London. M.D., F.R.S.
- (ii) Isidore Auguste Marie Francoix Xavier Comte (1798-1857).
- (iii) J.L. Foucault (1819-1868), b. Paris. Copley medal. F.R.S.

formed between charcoal poles that the absorption of sodium when cool gave us a dark line in the yellow, as its radiation when hot gave us a bright line in the yellow (21).

The explanation of this coincidence which extended the grasp of spectrum analysis from terrestrial substances to the skies was put forward by G.G. Stokes (1819-1903) in about 1850.

W.~~A~~^H. Miller did a series of rigorous experimental tests to confirm the coincidence of the lines. The conclusions of Stokes were accepted by Sir William Thomson (Lord Kelvin) and included in his lectures at Glasgow University, five to six years before the publishing of the work of Kirchoff.

Johann Christian Doppler (1803-1853)⁽ⁱ⁾ of Salzburg, Austria, was in 1835 made Professor of Mathematics at the Realschule in Prague. In 1842 he put forward the theory (23) that the colour of a luminous body, like the pitch of a sound must be changed by movements of approach or recession. Doppler argued that all stars emitted white light and that the colour of some of them was due to their motion either towards or away from the observer.

C.H.D. Buys-Ballot (1817-1890) showed that Doppler had made an erroneous conclusion and that an approach of a star would simply produce a slight shift of the whole spectrum towards the ultra-violet end of the spectrum.

Hippolyte Louis Fizeau (1819-1896)⁽ⁱⁱ⁾, a wealthy

(i) Johann Christian Doppler (1803-1853), b. Salzburg, d. Venice. Professor at Prague and Vienna.

(ii) Hippolyte Louis Fizeau (1819-1896), b. Paris, d. Chateau de Venteuil. Rumford medal. F.R.S.

Frenchman, pointed out that the shifting of the spectrum must become noticeable through the examination of the spectral lines. The shift is so slight that many years were to pass before accurate measurements could be taken (24).

Anders Jonaes ^oÅngström (1814-1874)⁽ⁱ⁾, Professor of Physics at Uppsala, revived Euler's theory of equivalence between emission and absorption but failed to mention the qualifying proviso of the temperature being the same. He could not decide between absorption and interference as the origin of Fraunhofer's dark rays. However, he did show that the spectrum of a spark discharge was compound in nature being the spectrum of the electrodes superimposed on that of the gas through which the discharge passes (25).

In about 1840, Simms and Swan independently improved the spectroscope by placing a lens in front of the prism so arranged that the slit was in the focus of the lens (26). The light passing through the slit was formed into a cylindrical beam, and so the light fell parallel on the full face of the prism. This greatly improved the quantity of light and the fine definition.

In conclusion, it appeared that many scientists had not followed up the early work on spectra done in the 1820s. Several reasons could be put forward for this including their unawareness of the existence of such work and their inability to foresee the significance of the work.

Progress during these years was hindered by technical

(i) Anders Jonaes ^oÅngström (1814-1874), b. Medelpas, d. Uppsala. Rumford medal. F.R.S.

problems in the construction of suitable instruments and in their manipulation. One of the greatest obstacles met by all early workers was the great difficulty in obtaining satisfactory glass prisms, free from optical imperfections. Those made by Fraunhofer or his associates were superior to any other types but quality prisms remained scarce up to the 1860s. Several spectroscopists used a liquid prism containing carbon disulphide which had a higher dispersive coefficient than glass but here again changes in temperature caused convection currents to form in the liquid. Nevertheless this type of prism had been used with some considerable success by astronomers after 1860.

Another technical problem was that to make the spectral lines more sharply defined, the slit in front of the prism had to be as narrow as possible. Furthermore to obtain a larger line separation then a series of prisms should be used rather than a single one in order to give a greater dispersion. These improvements, in turn, caused a reduction in the intensity of the spectrum and therefore for accurate experimental work a powerful light source was necessary. The Bunsen burner produced such a powerful light source.

At this point it is interesting to observe that Bunsen did not use his burner as a spectroscopic source between 1855 and his collaboration with Kirchhoff (1859). There was also the oxy-hydrogen blowpipe in use by Brewster and Miller as an alternative

to the alcohol burner as well as the electric arc used by Wheatstone⁽ⁱ⁾ (1835) (27) and Ångström (1850s) (28).

The delay in progress in spectroscopy it may be fairly said was mainly due to a lack of interest in attempting to grapple with unsolved theoretical problems of chemical analysis with spectra. For, once scientists had their interest in the subject stimulated by Bunsen and Kirchhoff the "technical barrier" was quickly broken down.

(i) Charles Wheatstone (1802-1875). Professor at King's College, London. F.R.S.

CHAPTER 2.

FRAUNHOFER LINE THEORIES.

An early attempt at explaining the dark Fraunhofer lines in the solar spectrum was put forward by Zantedeschi⁽ⁱ⁾ (29) who suggested that they were caused by interference patterns which in turn were due to imperfections in the optical system.

Another idea suggested was that the atmosphere of the earth caused the dark lines in sunlight. However, the vast majority of lines in the solar spectrum remain unaffected by the thickness of air travelled through.

Fraunhofer himself held a suspicion of the perfect coincidence of position of certain lines in the solar spectrum and the bright lines in the spectrum of a lamp especially the double yellow line of sodium and a certain double black line of the solar spectrum.

Sir David Brewster discovered the coincidence of two yellow rays with the two deficient ones at D with the existence of definite bright rays in the nitre flame and was sure that it indicated a regular connection between the two classes of phenomena (30).

Now we must turn our attention to Gustav Kirchhoff (1824-1887)⁽ⁱ⁾ of Königsberg, who was appointed ordinary Professor at Heidelberg in 1854 and later Professor at Berlin in 1875. It was at Heidelberg during the years 1859-1862 that he made the great discoveries of spectrum

(i) Gustav Kirchhoff (1824-1887), b. Königsberg, d. Berlin.

(ii) Francesco Zantedeschi (1797 - 1873)

analysis. He was joined in these experiments by the great chemist Robert Wilhelm Bunsen (1811-1899)⁽ⁱ⁾.

Kirchhoff formed a solar spectrum (31) by projection and then allowed the solar rays to pass through some vapour of sodium from a salt flame. He observed that the dark Fraunhofer lines D was deepened and thickened by the superposition.

He repeated the experiment but used a Drummond light instead of sunlight and observed the two dark lines of remarkable sharpness and fineness, which in that respect agree with the lines D of the solar spectrum, to show themselves in their stead. Thus the lines D of the solar spectrum are artificially evoked in a spectrum in which naturally they are not present.

He concluded from these observations that coloured flames in the spectra of which bright sharp lines present themselves, so weaken rays of the colour of these lines, when such rays pass through the flames, that in place of the bright lines dark ones appear as soon as there is brought behind the flame a source of light of sufficient intensity, in the spectrum of which these lines are otherwise wanting. He further concluded that the dark lines of the solar spectrum which are not evoked by the atmosphere of the earth exist in consequence of the presence, in the incandescent atmosphere of the sun, of those substances which in the spectrum of a flame produce bright lines in the same place. Hence he concluded that sodium formed an ingredient in the glowing atmosphere of the sun.

(i) Robert Wilhelm Bunsen (1811-1899), Professor at Marburg and Heidelberg.

Kirchhoff now took the complex spectrum of iron where 460 lines had already been mapped throughout the whole length of the spectrum and found absolute coincidence in position, width and darkness between the bright iron spectral lines and the black Fraunhofer lines in the solar spectrum (32). He was now convinced that gases and vapours have the power of absorbing those very rays which they themselves give out when in a state of incandescence, but also that iron as well as sodium was present in the sun. Further experiments showed that sodium, iron, calcium, magnesium, nickel, barium, copper zinc were in the solar atmosphere.

Kirchhoff and Bunsen together founded spectrum analysis as a terrestrial science, but its celestial applications were due to Kirchhoff alone (33). Hemholtz writing on this research work of Kirchhoff said ~~(33)~~

"It had in fact most extraordinary consequences of the most palpable kind, and has become of the highest importance for all branches of natural sciences. It has excited the admiration and stimulated the fancy of men as hardly any other discovery has done, because it has permitted an insight into worlds that seemed forever veiled for us."

The discovery made by Kirchhoff had almost been anticipated by several great scientists between 1845 and 1859. So nearly had these great men attained to Kirchhoff's results that prolonged arguments arose on matters of priority. Kirchhoff was not aware of these researches at the time and in any case his work was by far the most rigorous and complete.

Kirchhoff later added a postscript saying:

"If I had been earlier acquainted with his (34) (Foucault) observations I should not have neglected to introduce some notice of it in my communication, but I should nevertheless have considered myself justified in representing my observations as essentially new." (37)

In 1859 Balfour Stewart (1828-1887)⁽ⁱ⁾ quite independently of Kirchhoff discovered the law binding radiation and absorption at any constant temperature, i.e. "If there be a group of bodies of nearly the same refractive index the particles of which always radiate the same quality of heat at the same temperature, and if we take slices of these bodies of thicknesses such that they all permit to pass the same proportion of any one kind of heat, then they will also possess the same proportion of any other kind of heat" (35). He showed that this was an extension of Prevost's law of exchanges in the case of heat rays and put forward a general conclusion for all rays.

Kirchhoff himself established the same law for light rays in 1859 (36) showing that the ratio of the radiating and absorbing powers of all bodies at the same temperature is the same (36). In a postscript by Kirchhoff relating to the published work of Balfour Stewart, he writes

"From this circumstance he draws certain conclusions, and is led to a result similar

(i) Balfour Stewart (1828-1887). Director of Kew Observatory and Professor at Manchester. F.R.S.

to that which I have established concerning the connection between the powers of absorption and emission. The principle enunciated by Mr. Stewart is, however, less distinctly expressed, less general, and not altogether so strictly proved as mine." (37)

George Gabriel Stokes (1819-1903), Lucasian Professor of Mathematics at Cambridge, told Professor Sir William Thomson (Lord Kelvin) that he was convinced that the sun was surrounded by an absorbing atmosphere of sodium. Stokes suggested to Thomson the following conclusions: (156)

- (1) That the double D line, whether bright or dark was due to sodium vapour.
- (2) That sodium atoms are susceptible to regular elastic vibrations and that they have two fundamental vibrations of approximately equal pitch and that the periods of these vibrations are precisely the periods of the two slightly different yellow lights constituting the double D line.
- (3) That the Fraunhofer D line of the solar spectrum is due to the presence of sodium vapour in the sun's atmosphere.
- (4) That other metallic vapours are to be found in the sun's atmosphere.
- (5) That when sodium vapour is at a sufficiently high temperature to become luminous then each atom undergoes simultaneously the two fundamental vibrations.

(6) That when vapour of sodium is present in space across which light from another source is propagated, its atoms are set to vibrate in either or both of those fundamental modes if some of the incident light is one or other of their periods or some of one and some of the other; so that the energy of the waves of those particular qualities of light is converted into thermal vibrations of the medium and dispersed in all directions, while light of all other qualities, even though very nearly agreeing with them, is transmitted with comparatively no loss.

Stokes so impressed Thomson that he included the above in his lectures at Glasgow University from about 1852. Stokes did no experimental work on whether or not sodium vapour had the absorbing power described but he had known of the experiments of L. Foucault and, unfortunately, did not publish his work.

Thomson amongst others pressed Stokes' claim for precedence over Kirchhoff, but in 1875 Stokes published the following postscript:

"I have never attempted to claim for myself any part of Kirchhoff's admirable discovery and cannot help thinking that some of my friends have been over zealous in my case." (38)

Ångström^o in 1853 published work where he used Euler's principle of the equivalence of emission and absorption.

He attempted to show that a body in a state of glowing heat emits just the same kinds of light and heat which it absorbs under the same circumstances. However he missed out the qualifying proviso of the temperature having to be the same for the relationship to hold (39) true, but he did show that a spark spectrum was compound in nature being that of the gaseous medium together with the spectrum of the metallic electrodes.

Dr. W.A. Miller, Professor of Chemistry in King's College, London, made observations of the spectra of flames under the most simple of conditions (40). His experiments were published in 1845 and they had the merit of being the first published diagrams of the spectra of flames. These diagrams were but slightly successful and Miller did not propose any solution to the nature of the lines of incandescent gases. Miller said that he had little to say in explanation of those lines but that these facts he presented may at a future period assist in arriving at some general conclusion.

At the close of W.A. Miller's paper on coloured flames, he states

"It may be interesting to remark, in connection with the speculations on the absorptive action of the sun's atmosphere, that if solar light be transmitted through a flame exhibiting well-marked black lines, the lines reappear in the compound spectrum, provided the light of day be not too intense compared with that of the coloured flame. This may be seen in the red light of the nitrate

of strontia, and less perfectly in the green light of the chloride of copper. It would therefore appear that the luminous atmospheres exist in which not only certain rays are wanting, but which exercise a positive absorptive influence on other lights."

Sir William Crookes wrote with reference to the above (41),

"This paragraph shows that Professor Miller has anticipated by nearly sixteen years the remarkable discovery, ascribed to Kirchhoff, of the opacity of certain coloured flames to light of their own colour."

Professor Kirchhoff replied to the above

"We need only to read Miller's words with some slight attention to perceive, not only that the conclusion to which he arrives is exactly the opposite of mine, but likewise that his conclusion is incorrect. If weak daylight be allowed to pass through a coloured flame, the absorption of the latter is not noticeable; its bright lines appear brighter than the surrounding parts, because in them the light of the flame is present in addition to the daylight." (42)

Kirchhoff goes on to say that he had received a letter from Lord Kelvin in which it records that Professor W.H. Miller of Cambridge⁽ⁱ⁾, probably about

(i) William Hallows Miller (1801-1880). Professor at Cambridge. M.D., F.R.S.

ten years ago, had made an experiment testing to a very high degree of accuracy the agreement of the double dark line D of the solar spectrum with the double bright line constituting the spectrum of the spirit-lamp burning with salt, and that it was this experiment which caused Professor Stokes to put forward to Kelvin his mechanical explanation of the cause.

CHAPTER 3.

1860-1869

SOLAR SPECTROSCOPY.

As previously stated Kirchhoff demonstrated the existence of sodium (and later other metals) in the relatively cool atmosphere of the sun. He went on to construct the first map and catalogue of the lines of the solar spectrum.

Ångström, also, was constructing a map of the solar spectrum, the scale of which was based on the wavelengths of light whereas Kirchhoff's was an arbitrary scale.

Ångström had two main objectives: first, to determine the wavelengths for the seven principal lines already determined by Fraunhofer (43) and also a considerable number of intermediate lines; second, the determination of the wavelengths for the various sorts of light which enter the gas spectra of different metals.

He obtained a spectrum by diffraction rather than by refraction and was able to measure the wavelength to a ten millionth of a millimetre. Some tables of results are shown ~~(44)~~.

Kirchhoff used a Ruhmkorff induction coil to produce the iron lines; but Ångström compared the solar spectrum with the spark given between iron electrodes from a battery of 50 cells, which gives a far greater number of iron lines, and with this apparatus was able to observe 460 coincidences. Ångström went on to say that he could add to Kirchhoff's statement concerning magnesium, that the third of the lines marked b, reckoning towards F, was

double, and belonged accordingly both to magnesium and iron.

To the four bodies which Kirchhoff had thus shown to exist in the sun, Ångström^o could, as a result of his own researches, add calcium, aluminium, manganese, and probably strontium and barium. He assumed that the line C belonged to hydrogen and obtained the following general view of lines of the spectrum:-

The two lines H belong to calcium

The line G belongs to iron

F to strontium and iron

b magnesium and iron

D sodium

C hydrogen

B potassium

As to the constitution of the sun, Kirchhoff suggested

"There is a solid or liquid something in the sun, giving a continuous spectrum, and around this there are vapours of sodium, iron, calcium, etc; all these are existing, in an atmosphere and are stopping the sun's light. If the sun were not there, and if these things were observed in an incandescent state, we should get exactly these bright lines from them." (45)

Kirchhoff went on to suggest that the sun was a liquid and that between the earth and the incandescent liquid surface there was an enormous atmosphere built up of the various metallic vapours and that the

molecules of the metallic substances absorbed certain rays, those namely which they produced when they were in an incandescent state.

Ångström arrived at very nearly the same conclusions as Kirchhoff in that he thought the dark spectral lines came from the photosphere or the envelope which surrounded the sun.

Professor G. Johnstone Stoney⁽ⁱ⁾ of Queen's University, Belfast, in a long article (44) to the Royal Society suggested that the upper layers of the sun's atmosphere of hydrogen, magnesium and sodium were cooler than those of iron and calcium and that these were cooler in turn than the layers of nickel, cobalt, copper and zinc. He further suggested a probable order of elements in the atmosphere dependent on their atomic weights.

Sir William Huggins⁽ⁱⁱ⁾ applied a large spectroscope to the examination of the spectrum of the umbra of a large sun-spot. He noted (48) that he had previously tried to discover if the spectrum of light near the sun's limb differed from the light from the central parts of the disc and reported that he had been unable to detect any difference in the spectra of different parts of the sun's disc by any of the methods used. Huggins also investigated the spectra of the red prominences which were seen during a solar eclipse. The observations made in India of the eclipse of August 18th, 1868, showed that the spectra of the prominences were discontinuous and the approximate

(i) George Johnstone Stoney (1826-1911). Secretary to Dublin University.

(ii) Sir William Huggins (1824-1910). P.R.S.

position of three bright lines were measured by Lieut. John Herschel.

Huggins used a direct-vision spectroscope of Hofmann, which was arranged so that light first was allowed to reflect from a prismatic solar eyepiece and then the image of the sun was formed on a slit. The light from the umbra appeared as a narrow band which was dark against the bright solar spectrum. The observed Fraunhofer lines appeared stronger and thicker in the spectrum of the umbra.

Lockyer⁽ⁱ⁾ in 1866 quite independently had made similar investigations and reported (46) that the absorption lines in the solar spectrum appeared thicker where they crossed the sun spot. The results he obtained showed no indication of the presence of bright lines. These findings went against the theory of the constitution of the sun put forward by Faye⁽ⁱⁱ⁾ where he suggested that the umbra of a sunspot should be compound consisting of a continuous spectrum of dark lines and a second spectrum of bright lines (47).

Huggins in 1868 on 15th April had the opportunity to examine a large spot. Its spectrum appeared as a feebly illuminated band upon the bright solar spectrum and the increase of thickness of the Fraunhofer lines was very marked. He carefully examined the spectrum of the umbra with that of the adjoining parts of the solar surface but was not able to detect any line of absorption in the spectrum of the umbra which was not also present in that of the sun's normal surface, or

(i) Joseph Norman Lockyer (1836-1920). F.R.S.
Editor of Nature.

(ii) Herve Faye (1814-1902). Professor at Ecole Polytechnique.

that any ordinary solar line was wanting in that of the umbra.

Faye suggested that the interior of the sun was a nebulous gaseous mass of feeble radiating power at a temperature of dissociation and that surrounding this was a highly radiating photosphere. Thus in a sun spot, the nebulous interior mass was revealed through an opening in the photosphere caused by an upward current and that the spot was dark, was due to the feeble radiating power of the nebulous mass. British scientists⁽ⁱ⁾ explained the sun spot phenomena by suggesting that a downcurrent of the sun's external atmosphere caused absorption and cooling effects thus leaving it cooler than the photosphere.

Lockyer in 1865 made observations (49) which suggested that a sun spot was caused by a downward current because a dimming of the brightness was seen. As stated above he also noticed a thickening and darkening of certain lines and the continuous absorption, especially in the case of the sodium lines, thus indicating that a sun spot was produced by an increased amount of absorption.

Ångström["] tried to ascertain (43) if there were any differences between the spectra of the centre and the limits but did not discover any remarkable change apart from the fact that spectral intensity was somewhat less from the edge.

It is useful at this juncture to remember that the spectroscopist can differentiate between radiation and absorption. Solids and liquids which are radiating

(i) E. FRANKLAND, J. N. LOCKYER, BALFOUR - STEWART see (65)

give rise to a continuous spectra without bright lines whereas gases and vapours give rise to bright lines with or without continuous spectra. The spectroscope also indicates that absorption dims the spectrum throughout its entire length when the absorption is general and dims it here and there when the absorption is selective.

Lockyer in March 1866 investigated sun spots spectroscopically. His results showed a dark band running across the ordinary spectrum indicating that general absorption had taken place in a sun spot as well as a widening of the Fraunhofer lines as they crossed the spot indicating in turn selective absorption. These results confirmed by Huggins supported the English theory that a sun spot was dark because the solar light was absorbed by a cool, non-luminous absorbing atmosphere cascading down on to the photosphere.

Balfour-Stewart and Lockyer employed a considerable number of prisms in their spectroscope in order to eliminate the illumination of the earth's atmosphere. The many prism system caused an increase in dispersion which considerably dimmed the continuous spectrum because it made it extend over a much larger area but it did not dim the brightness of a spectral line. Thus they were able to determine the nature of the surrounding solar atmosphere as well as the chemical nature of sun spots. On October 20th, 1868, a bright line was observed with the spectroscope fixed on a solar prominence the line being coincident with (50) the line C of the solar spectrum. Later lines were found near D and F. These showed that the

red flames (prominences) were composed in part, at least, of incandescent hydrogen gas. The line near D had no dark line in the solar spectrum and several other scientists had no record of its existence. Further observations indicated that the prominences were merely local heapings up of a hydrogen envelope which entirely surrounded the sun. The examination of light from all parts of the sun's edge showed that outside the photosphere the prominence spectrum was never absent (51).

Plucker⁽ⁱ⁾ and Hittorf⁽ⁱⁱ⁾ were working on the effect of temperature on different spectra, the temperature of the discharge of the induction coil being increased by increasing the power of the inducing current. When a Geissler tube was filled with rarefied hydrogen the spectrum produced by a spark of low temperature consisted of three lines of the same width as the slit - one red $H\alpha$, one blue-green $H\beta$, and ^{the} other violet $H\gamma$. The places of those lines in the solar spectrum being at C, F, and one some way from G towards F. As the temperature was increased $H\gamma$ expanded first towards both ends of the spectrum, then $H\beta$, $H\alpha$ remained almost unchanged. When the tenuity was increased, $H\alpha$ disappeared first with $H\beta$ remaining well defined and the colour of the ignited gas changed. Lastly new lines appeared in the spectrum especially in the neighbourhood of the sodium line. Similar changes in the bright line spectra

(i) Julius Plucker (1801-1868). Professor at Halle and Bonn.

(ii) Johann Wilhelm Hittorf (1824-1914). Professor at Munster.

of the prominences were observed. The above observations coupled with Frankland's⁽ⁱ⁾ work which showed that hydrogen burning in oxygen under a pressure of ten atmospheres gave out a bright continuous spectrum from red to violet, led the scientific world to accept that the chromosphere and the photosphere formed the true atmosphere of the sun and that under ordinary circumstances the absorption was continuous from the top of the chromosphere to the bottom of the photosphere.

E. Frankland and J.N. Lockyer continued the above research being particularly interested in what caused the thickening of the bright line at F and also the study of the hydrogen spectrum under varying conditions. They were convinced that (53) the widening out was due to pressure and not appreciably to temperature. In the higher prominences it seemed that the gaseous medium of which they were composed existed in a condition of excessive tenuity, and that at the lower surface of the chromosphere itself the pressure was very far below the pressure of the earth's atmosphere.

The bulbous appearance, according to Frankland and Lockyer, of the F line may be taken to indicate violent convection currents or local generations of heat, the condition of the chromosphere being one of the most intense action. They further indicated that the atmosphere gave mainly the spectrum of hydrogen and the tenuity of this incandescent atmosphere

(i) Edward Frankland (1825-1899). Professor at Royal College of Science.

indicated that it was improbable that any atmosphere existed outside it. Further the spectrum of the photosphere contained bright lines when the limb was observed which indicated that the outer part of the photosphere was gaseous in nature.

CHAPTER 4.

SUN AND CORONA.

Sir Norman Lockyer, in November 1866, asked the question:

"May not the spectroscope afford us evidence of the existence of the red flames, which total eclipses have revealed to us in the sun's atmosphere, though they escape all other methods of observation at other times?"

The spectrum of the red flames (prominences) seemed likely to be that of a gas, consisting of bright lines only, and thus it was conceivable that the spectroscope might be able to weaken by dispersion (54) the air glare relative to the bright lines which would remain undispersed so that the bright lines of the flames might become visible through the atmospheric glare.

This technique (see later) proved to be successful so that at the total eclipse of the sun, 1868, August 18th, several observers saw bright lines appear in the field of view of their spectroscopes whilst observing red flames among which the lines of hydrogen were recognised. Amongst the observers at the time, Janssen ⁽ⁱ⁾ saw some of the bright lines again the next day by the above method but this time of course there was no eclipse. This was soon followed by Lockyer observing three bright lines of a fine prominence on October 20th.

So far all observers had only seen the lines of the

(i) Pierre Jules Cesar Janssen (1824-1907). Director of Meudon Observatory.

prominences and nothing of their forms. To do this it was necessary to design the apparatus to take into account the variation in length of the lines as the slit was made to pass over the prominence. Huggins, in February 1869, showed that by widening the opening of the slit, the form of the prominence and not its lines only, might be directly observed.

Huggins sought to discover if the spectrum of the light from near the sun's limb differed in any sensible degree from that of the light from the central parts of the disc. Since the weaker intensity of the marginal parts of the sun was probably due to the greater depth of solar atmosphere passed through, it was conceivable that by its spectrum the light of these parts of the solar disc might exhibit some indications of the larger amount of absorbing medium which it had traversed.

He tried two different observational methods. Firstly the telescope mounted with one of the spectroscopes constructed for stellar observations was directed towards the sun. The telescope was then moved with the aid of the finder so as to bring in succession upon the slit different parts of the solar disc. Any considerable alteration would certainly have been noticed although the method depended upon the memory of the observer.

The other plan was to reflect sun light from a plane mirror attached to a clockwork mechanism so as to fall on to an achromatic object-glass of 6 feet focal length. This focussed an image of the sun on the slit of a large spectroscope. Neither of the methods gave rise to any results.

Huggins was also trying to view the red prominences which can be seen during a solar eclipse. He thought that they consisted of gaseous material which would give rise to bright line spectra and that if a powerful spectroscope was employed then the light from our atmosphere near the sun's limb would be greatly reduced in intensity due to the dispersion produced by the prism system while the bright lines of the prominences would remain very little diminished. These experiments also brought him little success.

The solar eclipse of August 18th, 1868, brought some results forward. The observers in India of the above eclipse showed that the spectra of the prominences were discontinuous. Lieut. J. Herschel determined with some approximation the position of three bright lines: one in the red about C, one almost coincident with D and one near F.

Faye (August 1866) suggested to Huggins that solar spots should be examined by the spectroscope, since, according to his theory of the constitution of the sun, the spectrum of the umbra of a spot should be compound, consisting of a continuous spectrum of dark lines, and a second spectrum of bright lines. Huggins took up the idea and used a direct vision spectroscope of Hofmann which was so arranged that the image of the sun was formed upon the slit, after the intensity of the light had been reduced by reflection from a prismatic solar eyepiece.

When a spot was brought upon the slit, the feeble light from the umbra appeared as a narrow dark band

upon the bright solar spectrum. The Fraunhofer lines appeared stronger and thicker in the spectrum of the umbra. Lockyer quite independently made similar observations (see later) where he stated (56) that he observed the lines of absorption of the solar spectrum to appear thicker where they crossed the spectrum of the spot.

On April 15th, 1868, Huggins was able to examine a large sun spot with a new spectroscope. The hazy state of the atmosphere allowed the spectroscope to be attached directly to the telescope, the slit being placed at the focus of the objective lens. When the middle of the umbra fell upon the slit its spectrum appeared as a feebly illuminated band upon the bright solar spectrum. The band appeared divided into two parts by the spectrum of the bright prominence which extended nearly across the umbra. The thickening of the Fraunhofer lines was very marked. When the telescope was moved so as to bring the sun's limb across the slit it was noticed that the spectrum of light from our atmosphere was less bright than the spectrum of the umbra of the spot. This indicated that the light did not in fact come from the illuminated intervening atmosphere.

Huggins then attempted to estimate how much of the apparent light from the umbra really came from it. For this experiment he used a graduated wedge of neutral-tinted glass. The spectrum of the earth's atmosphere at the sun's limb became so dark that the lines could not be distinguished when part of the wedge marked 10

was in front of the eye. When the wedge was moved so that the part marked 20 was in front of the eye the spectrum of the umbra became dark as above. A photometric scan of the wedge showed that the light intercepted at 10 to that at 20 is 1:3 thus $3/4$ which formed the spectrum of the umbra was really due to the umbra of the spot.

The feebler spectrum of the illuminated atmosphere near the sun's limb was next observed and it was seen that the lines appeared only very slightly stronger thus indicating that the light from the umbra had really suffered more powerful absorption. He now carefully examined the spectrum of the umbra with that of the adjoining parts of the solar surface from A to G (Kirchhoff's maps) but was not able to discover any absorption line in the spectrum of the umbra which was not also present in that of the sun's normal surface. Huggins also noted that the increase of thickness, however, did not appear to take place in the same proportion for all lines. The lines C and F, due to hydrogen appeared to be hardly altered. Again the group of lines between 1601/1609 on Kirchhoff's scale (marked as coincident with chromium) were especially noticeable for their increased thickness. The line nearly central between the two lines could have been due, in part at least, to sodium. These lines appeared slightly broader as if by the addition of a faint and narrowed nebulosity at both edges and also that many of the lines marked in Kirchhoff's map as coincident with iron appeared much stronger in the spectrum of the spot.

Huggins felt that the greater breadth of the lines seemed to point to a condition of the gases in which their power of absorption embraced for each line an increased range of wavelength. The variation in absorption power was indicated by the increase of breadth which some of the bright lines of some gases assumed under altered conditions of temperature and pressure.

Dawes⁽ⁱ⁾ discovery of the existence within the umbrae of spots of a still darker spot almost wholly devoid of light started rival theories concerning the cause of such areas. Balfour Stewart suggested that it showed a still cooler and less luminous part of the down-rushing solar atmosphere rather than an unveiling of the inner part of the sun. The former explanation seemed to connect a lower temperature with the broader lines of absorption.

Huggins (57) suggested that by using a powerful spectroscope the light reflected from our atmosphere near the sun's edge would be greatly reduced in intensity by the dispersion of the prisms, while the bright lines of the prominences, if present, would remain but little diminished in brilliancy, but reported no success so far at the time of publication.

Huggins (58) suggested that a number of coloured glass screens or other absorptive media could isolate portions of the spectrum. It appeared to him highly probable that if the parts of the spectrum which then alone remained were identical with those in which the

(i) William Rutter Dawes (1799-1868). F.R.S.

bright lines of the flames occur then these objects would become visible. This method became very promising once the position of the bright lines in the spectrum was established. He experimented (59) with different coloured media and found difficulty in combining two media which absorbed all light of all refrangibilities except precisely that of the line C or F. He found the most promising to be that of carmine in ammonia which cut off all the light more refrangible than C combined with that of a solution of chlorophyll which gave a strong band of absorption, taking away the brighter part of the light less refrangible than C. This method was not wholly successful as the chlorophyll band encroached a little upon C and so weakened the light of the prominences.

By 1885 (60) the sun was still the only star to have had its corona observed. After the eclipse of 1882 some information was obtained of the sun's condition in relation to that of the brighter stars. Huggins in 1879 had suggested (61) that the stars could be arranged in a serial order considering their brightness. Huggins ventured to suggest that the differences in their spectra were due primarily to temperature. The position of the sun comes some distance down in the series near to Capella and just above the stars which begin to show a yellow tinge in their light. In the ordinary solar spectrum it had proved difficult to distinguish the ultra-violet group of hydrogen lines upon the character of which the serial arrangement was mainly based.

However the photographic spectrum of the corona by Schuster⁽ⁱ⁾ and Abney taken during the Egyptian eclipse showed up the very thin bright lines corresponding to the lines of this group (62). These lines were not due to the corona but to prominences at the base of the corona. The thin condition of these lines, as well as the breadth of the lines of calcium at H and K confirmed the sun as belonging to the least fervid of the white stars.

Professor Langley⁽ⁱⁱ⁾ thought that the absorption and scattering of sun light by the earth's atmosphere came to almost 40% (63). The spectroscopic method by which the prominences could be seen without an eclipse failed for the corona, because a small part only of the coronal light was resolved by the prism into bright lines and of these lines no one was sufficiently bright and coextensive with the corona to enable one to see the corona by its light.

The spectroscope had given definite information as to the condition of the matter of the corona. The spectrum of the corona was compound and consisted of three superposed spectra. Firstly a bright continuous spectrum which indicated that it came from incandescent solid or liquid matter. Secondly, a solar spectrum which showed that the incandescent solid or liquid matter of the corona reflected to us light from the

(i) Arthur Schuster (1851-1934). Professor at Manchester.

(ii) Samuel Pierpont Langley (1834-1906). Secretary of the Smithsonian Institution.

photosphere. Thirdly, a spectrum of bright lines, which was relatively faint and varied greatly at different eclipses. Further spectroscopic evidence showed the coronal gas to consist of substances which existed also in the photosphere. The structure seen in the corona was much more in harmony with the view that matter was going up from the sun than that it was coming down upon the sun.

The varying amount of gas in different parts of the corona was illustrated by the report of Abney and Schuster on the eclipse of 1882.

"As regards the corona, we may perhaps point out that hitherto the position of only one true coronal line had been fixed, though two other lines had been suspected. The corona during the late eclipse seems to have been especially rich in lines." (64)

Thollan⁽ⁱ⁾ observed some in the violet without being able to fix their position and Tacchini⁽ⁱⁱ⁾ could determine the position of four true coronal lines in the red; from the photograph Lockyer was able to measure about thirty additional lines, thus increasing the number of lines considerably. The spectrum of the corona had fewer lines in the Cardine Island eclipse (1883) than in the Egyptian eclipse (1882) and the corona was much brighter at one limb than at the other in 1883.

Lockyer's experiments suggested that at the time of the eclipse of 1883 the amount of light-emitting

(i) Louis Thollan (1829-1887). Nice Observatory.

(ii) Pietro Tacchini (1838-1905). Director, Collegio Romano Observatory.

gas was smaller relatively to the number of incandescent particles than at the time of the eclipse the previous year. This supposition agreed with the fact that the scattered solar light showing the Fraunhofer lines was strong in 1883.

In June 1865 Lockyer communicated to the Royal (65) Astronomical Society some observations which led him independently as to the same conclusions as De la Rue, Stewart and Loewy as to the theory of the structure of sun spots. The observations indicated that instead of a spot being caused by an upward current it was caused by a downward one. He thought that the current had a downward direction because one of the cloud-masses passed in succession, in the space of about two hours, through the various orders of brightness exhibited by faculae, general surface and penumbrae. On March 4th Lockyer commenced (66) spectroscopic investigations of sun spots. He applied a direct-vision spectroscope to his equatorial telescope with its axis coincident with the axis of the telescope. The image of the sun was received on a screen which also possessed a narrow slit. The apparatus was arranged towards the sun so that the centre of the umbra of a small spot fell on the middle of the slit on the screen. The solar spectrum was then observed in the field of view of the spectroscope with its central portion reduced in brilliance.

The absorption bands visible in the photosphere spectrum were visible in the spectrum of the spot and appeared thicker where they crossed the spot-spectrum. No bright bands could be observed at this time. It would seem therefore that the sun spot phenomena was not due to radiation.

In a paper (67) presented to the Royal Society in 1866 Lockyer concluded that the use of the spectroscope could afford evidence of the red flames which could be observed during eclipses.

Lockyer lacked a spectroscope of sufficient dispersive power to both widen the spectrum and weaken the atmospheric light (68). A new instrument was constructed by Cooke and Browning with the aid of a Government Grant. This instrument produced a dimly coloured background dark enough to render a bright line distinctly visible. Initially his searches for the prominences were unsuccessful but on the 20th October, 1868, he saw a bright line flash into the field. The line was absolutely coincident with the line C of the solar spectrum and he thought it to be a prolongation of that line.

He then commenced to search for more lines. This was a laborious task requiring several movements and adjustments of the instrument. The first results were obtained when he worked from the line at C towards D. He detected another single and less vivid line estimated as $8^{\circ}/9^{\circ}$ of Kirchhoff's scale more refrangible than the more refrangible of the strongest D lines, and noted that he could not detect any line corresponding to it in the solar spectrum.

He later on in the same series of experiments detected a line at F. The exact position of the line at F was difficult to determine.

On the 22nd October Lockyer had another chance to view the spectrum of a prominence when he was able to

confirm his previous observations. Although all the spectral lines were bright enough to be easily visible with a slit of normal width, the line at C was sufficiently bright to allow the use of a wider slit whilst a narrower slit was best for D and F.

Lockyer on 27th October altered his method of observation and superimposed the spectrum of a prominence with that of the spectrum of the sun's limb. Under these circumstances the dark line in the spectrum at C was replaced by a vivid bright band. On the other hand the line at F was eclipsed when the spectrum of the prominence at some distance from the sun was observed. This led Lockyer to suggest that away from the sun's surface the substance gave out less refrangible light than it did when apparently at the surface. In a series of experiments undertaken in November he discovered that in every solar latitude both the C and F bright lines were seen extending above the solar spectrum. This indicated the presence of a solar envelope. The spectrum of the envelope shed light on the unusual behaviour of the F line. He was able to see that the base of the bright line widened out as the solar spectrum was approached. The line away from the sun corresponded in the case of an ordinary prominence in refrangibility and thickness to the Fraunhofer line F. When close to the sun it widened out so as to overlap the F line on both sides so that it was about three times broader. In the spectrum of a prominence the line thickened out in the same manner at some distance above the limb. There was no thickening of the line C at the base.

Lockyer in the same series of experiments observed a bright line in the solar spectrum close to the line at C. Lockyer gave notice of the existence of three lines in the spectrum of the prominences and their approximate positions on October 20th. The exact position of the line near D was taken from the mean of three careful micrometrical measurements taken on the 15th November. This line fell in a region on Kirchhoff's map where no line had been measured. The existence of the envelope was confirmed on 5th November and called the chromosphere. Its general thickness was determined to be about 5000 miles with the level of its upper surface being not absolutely uniform in all latitudes.

On 8th November Lockyer succeeded in observing a definite bright band extending for a certain distance on the sun near the limb. The position of this band was near C, but slightly less refrangible. He thought it possible that this bright region, the light of which was variable, was due to faculae: this conclusion was strengthened because careful sweeping within the limb did not reveal the bright lines of the chromosphere spectrum. If this was so, then the faculae were not the prominences but there could be a possible connection.

CHAPTER 5.

NATURE OF THE CHROMOSPHERE AND PROMINENCES.

Janssen concluded from the coincidence of two of the bright lines with C and F that the prominences were composed of hydrogen. However this did not explain the two other bright lines near D and C.

Similar changes to the observations of Plucker and Hittorf in the bright line spectra of the prominences were observed. The above observations coupled with Frankland's work which showed that hydrogen burning in oxygen under a pressure of ten atmospheres gave out a bright continuous spectrum from red to violet led the scientific world to accept that the chromosphere and the photosphere formed the true atmosphere of the sun and that under ordinary circumstances the absorption was continuous from the top of the chromosphere to the bottom of the photosphere.

Lockyer thought that the density of the chromosphere could not be very great (assuming it was composed mainly of hydrogen) for if it were great then the spectrum would be most probably continuous. Observations of bright lines in several stars but especially the remarkable star in Corona had been made by Huggins. These showed that under certain conditions a chromosphere may be part of the regular star make-up. In the outburst from the star Corona it was observed that two of the lines of the chromosphere were coincident with C and F, and that two other lines were visible. If either or both these lines

were due to hydrogen, then one could regard that star as being of lower temperature than our sun.

Prominences had appeared in all parts of the sun's limb and this had indicated that they were not connected with spots. They might still however arise from some unknown common cause.

The continuity of the solar envelope, apart from its nature had been suspected for many years. Observations of phenomena in the eclipses that took place between 1706 and 1842 might be divided into two groups:

(a) Observations of the prominence proper.

(b) Observations of the chromosphere.

All observations of both these groups had been studied by Arago⁽ⁱ⁾ and Grant⁽ⁱⁱ⁾ (69). Arago considered the prominences to be clouds floating in the sun's atmosphere. To these clouds he ascribed the spots without a nucleus.

Grant (70), who had Arago's results, considered before the eclipse of 1851 that

"The observations of solar eclipses would seem to indicate that above the luminiferous envelope there exists a stratum of nebulous matter which is visible only by means of reflected light. Various interesting questions present themselves for solution in connection with the admitted existence of such a stratum. In the first place, does this third envelope exercise an influence in the production of any of the other phenomena which have been disclosed by observations on the

(i) Dominique Francois Jean Arago (1786-1853). Professor of Geometry at the Ecole Polytechnique and Director of the Paris Observatory.

(ii) Robert Grant (1814-1892). Professor at Glasgow.

physical constitution of the sun?"

Grant went on to refer to the hypothesis of Sir J. Herschel⁽ⁱ⁾ concerning convection currents throwing up the then imagined non-luminous envelope below the photosphere through the photosphere -

"This view of the subject while it carries with it considerable probability, obviates the necessity of introducing into the theory of the physical constitution of the sun, the idea of a third envelope independent of the two others."

Swann⁽ⁱⁱ⁾ in 1851 published several papers concerning the eclipse of that year with special reference to the prominences. He assumed that they existed in the solar atmosphere and thought they existed in the solar atmosphere and thought them to be cloudy masses of the most excessive tenuity (71)

"... the simplest view that can be taken of this phenomenon, is to regard the red fringe and the red prominences as of the same nature; and all the observations will then confirm the idea that the matter composing these objects is distributed all round the sun. It therefore seems probable that when we are furnished with observations of a tangential phase of the eclipse from stations on the north side of the moon's shadow, it will be found that a sierra appeared towards the sun's

(i) Sir John Frederick William Herschel (1792-1871). Secretary of the Royal Society. Master of the Mint.

(ii) William Swann (1818-). Professor at St. Andrews.

north point, of which the detached prominences seem in that region, by observers situated near the middle of the moon's shadow, were only the highest peaks Since then it has been highly probable that the matter composing the red prominences is distributed with little interruption all round the sun: we may conceive the luminous strata of the solar atmosphere to be surmounted by an envelope of clouds of which the higher portions are visible beyond the moon's limb, at the central phase of a total eclipse, and which then constitute the red prominences. If it be thought that the hypothesis of two envelopes of cloud, one above and other below the luminous strata of the sun's atmosphere, introduces too great complication, we may avoid the objection by supposing that the envelope which occasions the penumbrae around the spots penetrates the luminous stratum and exists although in greatly different degrees of density, both above and below it."

"If, then we conceive that a stratum of cloudy matter surrounds the sun, of which the red prominences are the higher portions, the serrated appearance of the long range of prominences, seen by Dawes and Hind⁽ⁱ⁾, sufficiently indicates that its general surface is exceedingly uneven, presenting the appearance of being covered with

(i) John Russel Hind (1823-1895). Royal Greenwich Observatory. Later, Superintendent of the Nautical Almanac Office.

numerous eminences or ridges. But those irregularities are small when compared with the large hook-shaped prominence and its companion the detached cloud, which were seen by most observers of the eclipse. ... now, as the spots have been supposed to arise from upward currents causing apertures in the sun's luminous atmosphere, I conceive the higher red prominences, or those which remain visible at the middle at the total phase of a central eclipse, may in like manner be formed by the same or similar currents in the sun's atmosphere, breaking through the envelope of cloud that surrounds it, bending back the edges of the apertures they have formed and sometimes carrying up detached masses of cloud such as that which was seen at the late eclipse. We may, however, suppose the envelope of cloud to be sometimes simply raised, without being broken through; and in that state it may form the conical prominences which were observed at the late eclipse. Since the prominences reflect, they must also absorb light; and thus the hypothesis which has been proposed regarding them assumes the presence of an envelope of cloud surrounding the sun's luminous atmosphere, capable of absorbing part of its light and subject to occasional interruptions of its continuity."

Swann summed up the situation as follows. We have now four envelopes:

- (1) The dark cloud below the photosphere
(Herschel's cloudy stratum).
- (2) The photosphere itself.
- (3) The envelope of cloud.
- (4) The sun's atmosphere surrounding all, in
which the other envelopes may be supposed
to float.

Liasis⁽ⁱ⁾ a member of the Brazilian Commission sent a report to the Paris Academy of Science concerning the eclipse of 1851 which was observed in Brazil (72). This work was reported by Faye.

In a separate work Liasis stated distinctly that (73)

- (i) there was a continuous envelope overlying
the photosphere;
- (ii) that it is not the corona;
- (iii) that it is the locus of the general
absorption of the photospheric light; and
- (iv) that its height is about 3".3.

This was an immense step forward on the ideas of Arago and at the same time Liasis was convinced that the corona was in reality a solar appendage.

Observations of the Spanish eclipse of 1860 required both Le Verrier⁽ⁱⁱ⁾ and Secchi⁽ⁱⁱⁱ⁾ to use the word "envelope" to explain all the phenomena observed. Le Verrier later endorsed the idea of the complete continuity of the envelope and made it at the same time not only the only

-
- (i) Emmanuel Liasis (1826-1882?). Director of the Observatory at Rio de Janeiro.
 - (ii) Urbain Jean Joseph Le Verrier (1811-1877). Director of the Paris Observatory.
 - (iii) Pietro Angelo Secchi (1818-1878). Director Collegio Romano Observatory.

solar atmosphere, but the origin of spots (74). He went on to show that the darkening of the limb was due to this envelope and entirely endorsed Swann's assertion of the continuity of the cloudy envelope although the hypothesis put forward to explain the envelope was completely discordant with observations then and is much more so now.

In England, Sir Edward Sabine⁽ⁱ⁾, Balfour Stewart and Challis⁽ⁱⁱ⁾ arrived quite independently at the conclusion that red flames were solar aurorae - a theory which indicated that the idea that they formed part of a continuous envelope was not in their minds. Balfour Stewart in a lecture at the Royal Institution remarked (75)

"In support of this hypothesis it may be remarked that during the late total eclipse in Spain, De la Rue⁽ⁱⁱⁱ⁾, by means of the Kew photoheliograph proved that these red flames belong to the sun and that they extended in one case to the distance of 70,000 miles beyond this photosphere. But, considering the gravity of the sun, we are naturally unwilling to suppose that there can be any considerable amount of atmosphere at such a distance from this surface; and we are therefore induced to seek for an explanation of these red flames amongst those phenomena which require the smallest possible amount of atmosphere for their

-
- (i) Sir Edward Sabine (1788-1883). President of the Royal Society.
- (ii) James Challis (1803-1882). Plumian Professor at Cambridge.
- (iii) Warren de la Rue (1815-1889). F.R.S. President of the Royal Astronomical Society (1864/66).

manifestation. Now the experiments of Grassiot and the observed height of the terrestrial aurora alike convince us that this meteor will answer our requirements best. And besides this, the curved appearance of these red flames and their high achmic power in virtue of which one of them, not visible to the eye, was photographed by De la Rue are bonds of union between these and terrestrial aurora."

It was not till December 1867 that the real meaning of the photographs in this particular case was grasped. Stoney in a paper (76) referred to his hypothesis that the sun had an enormous atmosphere, which in eclipses projected far beyond the disc of the moon, in which atmosphere the vapours which gave rise to selective absorption of the photospheric light were situated at various heights according to their vapour density wrote as follows:

"Directly outside the photosphere there lies a stratum of the sun's atmosphere which is still hotter than the photosphere and on the outer boundary of this hot region there appears to be a shell of excessively faint cloud, part of which is seen in De la Rue's photographs of the eclipse of 1860. It probably extends the whole way round the sun. It is therefore desirable that this faint shell, which seems to lie at a distance of 8" or 10" from the edge of the sun's disc, should be observed both from a central station and from stations

close to the northern and southern limits of totality so as to ascertain whether we have reason to presume it is continuous round the disc."

Frankland and Lockyer discovered the third line of hydrogen in the spectrum of the chromosphere at the position 2796 on Kirchhoff's scale (77). It was excessively faint and was extremely difficult to observe. Therefore with the exception of the bright yellow line, the observed spectra of the prominences and of the chromosphere corresponded exactly with the spectrum of hydrogen under different conditions of pressure.

If one assumed that no other extensive atmosphere besides the chromosphere overlies the photosphere, the darkening of the limb being due to the general absorption of the chromosphere it follows

- (1) that an additional selective absorption near the limb is extremely probable;
- (2) that the hydrogen Fraunhofer lines indicating the absorption of the outer shell of the chromosphere will vary somewhat in thickness;
- (3) that it is not probable that the prominences will be visible on the sun's disc.

Lockyer next reported the extreme rates of movement in the chromosphere, namely: vertical movement 40 miles/sec. and horizontal or cyclonic movement 120 miles/sec. (78).

He also noted that spots had sometimes been

accompanied by prominences whereas at other times they had not and said that one could have spots visible without prominences in the same region and also prominences without spots.

Lockyer supplied a list of bright lines, the positions of which in the chromosphere he had determined absolutely.

He pointed out that taking iron as an entrance, and assuming that the iron lines mapped by Ångström and Kirchhoff were due to iron only he had only been able to detect three lines out of the total number (460) in the spectrum of the lower regions of the chromosphere.

HYDROGEN

C	1868	Oct. 20th
F	1868	Oct. 20th
near D	1868	Oct. 20th
near G	1868	Dec. 22nd
h	1869	March 14th

SODIUM

D	1869	Feb. 28th
---	------	-----------

BARIUM

1989.5	1869	March 14th
2031.2	1869	July 5th

OTHER LINES

Iron

1474	1869	June 6th
?		
1515.5	1869	June 6th

Iron

2001.5	1869	June 26th
?		
2003.4	1869	June 26th

Bright line

1529.5	1869	July 5th
--------	------	----------

?

1567.5	1869	March 5th
1613.8	1869	June 6th

MAGNESIUM AND INCLUDED LINE

b^1, b^2, b^3, b^4	1869	Feb. 21st
----------------------	------	-----------

Iron

1867.0	1869	June 26th
--------	------	-----------

Bright line

1871.5	1869	June 26th
--------	------	-----------

Frankland and Lockyer further suggested that the continuous widening out of the sodium line in a spot must be regarded as furnishing an additional argument in favour of the theory of the physical constitution of the sun put forward by themselves - namely, that the chromosphere and the photosphere form the true atmosphere of the sun, and that under ordinary circumstances the absorption was continuous from the top of the chromosphere to the bottom of the photosphere, at whatever depth from the bottom of the spot that bottom may be assumed to be.

Secchi however published several papers which were opposed to the above theory (79) in the sense that his observations differed so much from Lockyer's. Secchi stated that the chromosphere was often separated from the photosphere, and that between the chromosphere and the photosphere there existed a stratum giving a continuous spectrum, which he considered to be the base of the solar atmosphere, and in which he thought that the inversion of the spectrum took place.

Lockyer reacted to this work by first stating that all the observations he had made had led him to a contrary conclusion. Secondly, Secchi had employed an instrument of comparatively small dispersive power in which the widening out of the F line at the base of the chromosphere was not clearly indicated hence it was extremely difficult to determine whether the chromosphere rests on the sun or not as the chromosphere was an envelope and they were not dealing merely with a section. He pointed out that an instrument of great dispersive power could quickly settle

the question: namely, that an increase of pressure caused the F line to widen out and that as the sun was approached the pressure increased, the continuity of curvature must indicate really the spectrum of a section, and one should not get a widening due to pressure if the chromosphere was suspended merely at a certain height above the photosphere: such a widening always occurs.

Lockyer proceeded to remark that he failed to see how one could regard a possible continuous spectrum giving envelope as being a region of selective absorption. His observations had indicated no such stratum although he had regularly observed injections of sodium and magnesium into the chromosphere which did not exceed the limit of the sun's limb by 2" and even discovered small quantities of barium in the chromosphere less than 1" high. He therefore felt that his instrument was not lacking in delicacy and since his instrument had been in perfect adjustment he attributed the observations to some instrumental error. He suggested that

"such a phenomenon might arise from a localised injection of particles into the chromosphere, if such injection were possible. But to date no such injection has been observed".

The widening of the lines in the sun spot spectra clearly indicated according to Lockyer that the base of the atmosphere was below the spot and not above it and he would not accept Secchi's statement as being final against another part of the theory to which he had already referred. *

* FOR LOCKYER'S DISSOCIATION HYPOTHESIS SEE (158)

The dispute between the two scientists continued as Secchi related that the F line was produced by the absorption of other bodies besides hydrogen, because it never disappeared. Lockyer replied saying that "this conclusion was also incorrect according to his own observations for it had often been observed to disappear altogether and to be replaced by a bright line".

Further if there was an increase of dispersive power then the spectra became much more clear and at the same time more simple. The selective absorption which Lockyer had discovered in 1866 came out in its most intense form, but without any of the more complex appendages announced by Secchi. However Lockyer did say that if he used three prisms then this simplicity vanished to a considerable extent. Certain random portions of the spectrum were abnormally bright which probably were the cause of some of the statements of Secchi; but the bright lines were as variable as they were in any other part of the disc, but not much more so. Lockyer did agree on interpretation of sun spot phenomena which ascribed the appearances to anything but selective plus general absorption was erroneous (80).

Lockyer and Frankland now took a special interest in the yellow bright line, near D, in the spectrum of the chromosphere with the hope of differentiating it, if possible, from the line C.

With a tangential slit Lockyer had seen the yellow line bright below the chromosphere while the C line had been dark; the two lines being in the same field of view (81). Further, in the case of a bright prominence

over a spot on the disc, the C and F lines had been seen bright, while the yellow line had been invisible. The circumstances that this line was so rarely seen dark upon the sun made Lockyer suspect a connection between it and the line 5015 Ångström which was also a bright line, and was often seen bright in the chromosphere, and then higher than the sodium and magnesium lines (when visible). Lockyer posed the question,

"must we not attribute these lines to a substance which exists at a higher temperature than those mixed with it, and to one of very great levity? for its absorption line remains invisible, as a rule in spot spectra".

As a result of this work Lockyer suggested that one could divide the prominences in two classes:

- "(a) Those in which great action is going on, lower vapours being injected; in the majority of cases these are not high, they last only a short time - are throbs and are often renewed, and are not so frequently near the sun's poles as near the equator. They often accompany spots but are not limited to them. These are the intensely bright prominences of the American photographs.
- (b) Those which are perfectly tranquil, so far as wavelength evidence goes. They are often high, are persistent and never very bright. These do not as a rule accompany spots."

Zöllner⁽ⁱ⁾ in a paper of the 2nd June 1870 to the Saxon Academy announced that he had arrived at the same results (82).

"The forms of the protuberances may be divided into two characteristic groups - into the vapour or cloud-like, and into the eruptive formations. The preponderance of the one or the other type appears partly to be dependent on local conditions on the surface of the sun, partly on the time; so that at particular periods the one, at others the other type preponderates. The striking resemblance of the cloud-like formations to terrestrial clouds is readily explained, when it is considered that the forms of our clouds are due not to the particles of water suspended in them, but essentially to the nature and matter in which the differently heated and agitated masses of air are spread out. The particles of aqueous vapour are, in terrestrial clouds, simply the material by mean of which the above-mentioned differences between the masses of air rendered evident to us. The flow of the incandescent masses of hydrogen is the cause of the visibility of the clouds of the protuberances."

Young⁽ⁱⁱ⁾ quickly accepted this classification:

"About forty different prominences have been more or less carefully observed from September 10th to October 3rd, 1870; sixteen have been sketched.

(i) Johann Karl Friedrich Zöllner (1834-1882).
Professor at Leipzig.

(ii) Charles Augustus Young (1834-1908). Professor
at Dartmouth and Princeton.

Most of them fall naturally enough into the categories established by Zöllner and Lockyer." (83)

Respighi⁽ⁱ⁾ put forward a very elaborate classification of protuberances using a 1-7 classification.

"The delicate and well-defined jets are observed more often in the locality of spots, where generally they are seen to rise above the chromosphere in very light threads ... " (84)

In October 1871 Secchi submitted (85) to the Paris Academy a classification of his own. It agreed with the groupings of former observers, to whom he made no reference.

He mentioned three classes, Amas, jets and panaches. The first class he sub-divided into brillants and cumuli-forms. They included all the massive and dense prominences with the first sub-classes consisting of local upheavals of the chromosphere no higher than 15" or 20". The second class included all the narrow and pointed prominences. The third class included all not comprehended in the two former classes. Later on he returned to an accepted Lockyer's classification.

(i) Lorenzo Respighi (1824-1889). Professor at Bologna and Rome.

Chromospheric Lines.

Lockyer submitted a list of lines to the Royal Society which was accepted on July 8th, 1869. This list was checked by Young who, however, added one further line (86), namely 2581.5 (Kirchhoff). This line which was conspicuous in the eclipse of 1869 seemed to be always present in the spectrum of the chromosphere. It had no corresponding dark line in the ordinary solar spectrum and Young suspected that it may be due to the same substance that produces D3.

"The reversal of the sodium and magnesium lines is not at all uncommon. In some instances these lines were so bright, that on opening the slit, the form of the prominence could be made out through them."

Young continued to make a special study of this subject first publishing a list of 103 lines followed by a second list containing 273 lines. He agreed with Lockyer in that at times every line appeared reversed.

Table No.1 shows the first catalogue of Young up to September 1871. Only those lines which have been observed at least twice are included (87).

Young drew special attention to lines Nos. 1-82; although faint they were persistently present and could be distinctly seen in the spectroscope to belong to the chromosphere as such. He also pointed out the presence of titanium vapour in the prominences and chromosphere, noting that no less than 20 out of total of 103 lines were due to this metal. Young's second catalogue used observations made in the Rocky Mountains. He stated

" ... although I was never quite able to realize my hope of seeing all the Fraunhofer lines reversed, unless once or twice for a moment during some unusual disturbances of the solar surface. (88) Everything I saw however confirmed my belief that the origin of the dark lines is at the base of the chromosphere and that the ability to see them all reversed at any moment depends merely upon instrumental power and atmospheric conditions".

Young stated as a summary:

"No one, of course, can fail to be struck with the number of cases in which lines have associated with them the symbols of two or more elements. The coincidences are too many and too close to be all the result of accident, as for instance in the case of iron and calcium or iron and titanium. Two explanations suggest themselves. The first, which seems rather the most probable is that the metals operated upon by the observer who mapped their spectra were not absolutely pure - either the iron contained traces of calcium and titanium or vice versa. If this supposition is excluded then we seem to be driven to the conclusion that there is some such similarity between molecules of the different metals as renders them susceptible of certain synchronous periods of vibrations - a resemblance, as regards the manner in which the molecules are built up out of the constituent atoms, sufficient to establish between them an

important physical (and probably chemical) relationship."

Young made further observations that he felt would enable one to distinguish to some extent, between the substances ejected from the sun and those constituting the atmosphere into which the irruption takes place (89). Certain lines during these outbursts were distorted and displaced while others near them equally conspicuous were wholly unaffected.

"Thus on August 3rd and 5th the former class included the lines of hydrogen, D₃, the lines of sodium and magnesium and many of those of iron; in the latter were K534, 1474, 1505, 1515, 1528, 1867, 2007 (1870 and 2000 were greatly disturbed), 2581 and probably the two Hs. The barium lines also seldom seemed to participate in any disturbance."

The same communication also contained the following: "It is noteworthy that of the 170 new lines found in the chromosphere spectrum, not a single one lies below C. The only new lines of much importance are the two Hs at the extreme violet end of the spectrum. These were found almost constantly reversed."

Respighi also made many observations of the chromospheric lines (99):

"... the chromosphere or the gaseous stratum which envelopes the bright surface of the sun or the photosphere is not composed only of hydrogen but also of many other gases and

metallic incandescent vapours, limited however to its base, and reduced to exceedingly thin strata. At the beginning of the totality of the eclipse when the extreme solar limb at the appearance of the chromosphere not only the bright lines of hydrogen were to be seen but an unlimited quantity of bright lines, as if there had been a total reversal of the lines of the solar spectrum: the same phenomenon presented itself at the end of totality, some moments before the appearance of the extreme solar limb - a clear proof that at the base of the chromosphere the hydrogen is mixed with many other substances in the condition of gaseous incandescence. ... I have often been able to observe at the base of the chromosphere through long tracts of the limb, bright lines besides those of hydrogen, the two red lines between a, B and B,C almost always and very marked. These regions I believe to be those in which Tacchini finds the lines of magnesium reversed." see also (100/101)

Lorenzoni⁽ⁱ⁾ gave the following statement of the frequency of appearance of some of the lines seen reversed. Of 26 protuberances seen in one month (July)

C D3 F H	were	seen	in	26
f	"	"	"	19
h	"	"	"	17
The four bs	"	"	"	8
The two Ds	"	"	"	6

(i) Giuseppe Lorenzoni (1843-1914). Professor of Astronomy at Padua.

The three lines, one of which is between B and C and the other two between b and F were seen once (102).

Line 1474 (Kirchhoff).

Lockyer observed this line on June 6th, 1869, in the chromosphere and it was further observed by several American workers in the corona in the eclipse of that year. Lockyer suggested that this line was not an iron line because the re-reversal into brightness in the chromosphere of the line 1474 K was not due to iron vapour due to the fact that the coincident line in the iron spectrum is one of the shortest lines in the whole spectrum whereas invariably the reversed lines are simply those which are longest in the spectrum.

Young quite independently considered this line as probably not due to iron because of its lack of correlation with other iron lines.

"The corresponding line in the spectrum of iron is feeble, and on several occasions when the neighbouring lines of iron 1463 have been greatly disturbed this has wholly failed to sympathise; hence I have marked the Fe with a ?" (103) *see also (104)*

The continuous spectrum at the base of the chromosphere.

Lockyer was able to detect the bright line C in every part of the contour of the whole limb. Secchi published several papers between 1868/69 stating that between the photosphere and chromosphere there existed a layer giving a continuous spectrum (105). This layer

although extremely thin was deep enough for observations to take place.

Lockyer was not in agreement with Secchi on two counts. Firstly he had never observed an absolutely continuous spectrum in the position indicated although he had observed a nearly continuous spectrum given by faculae. This observation was confirmed by Capt. Herschel (106). Secondly that the two spectra were superimposed easily accounted for the observed considerable reduction in the number of absorption lines.

Young on observing the reversal of many lines considered it might be the layer to which Secchi referred, although he never said that the stratum was separate from the sun's limb nor did he observe a continuous spectrum (107).

Methods of viewing the prominences.

(90) Janssen and Lockyer in communications to the Royal Society gave drawings of prominences obtained by allowing the slit to pass slowly over the prominence. This enabled a number of sections of varying length to be obtained, which when placed side by side gave an idea of the shape. The slit used at this time was narrow and was radial to the sun's limb. Thus unless the slit was moved quickly enough to allow the persistences of images then the true form of the prominence could not be observed. Janssen tried to overcome this problem by giving a rotatory motion to his direct vision spectroscope and Lockyer by causing the slit of his spectroscope to have an oscillatory motion.

Young, using a suggestion of Professor Morton⁽ⁱ⁾, placed a diaphragm at the focus of the eyepiece which was to turn with the vibrating slit, the light of the neighbouring portions of the spectrum might thus be cut off and dilution avoided (91).

At the time the working of the mechanical arrangement was such as to always cause an oscillation of the equatorial which, in turn, interfered with the definition of detail although the prominences themselves always appeared very bright.

Zöllner was the first to indicate the open slit method now generally adopted. In a paper to the Royal Saxon Academy he made the following remarks on the method of seeing the prominences without an eclipse.

"With a moveable slit the brightness would be diminished in proportion to the distance travelled over the slit. Especially in the rotating spectro- scope the brightness of the protuberance itself would decrease from the centre of rotation to the edge, and thus prevent the observation of the natural brightness of its parts."

He went on to state the principles upon which his arrangement was based (92)

"(1) The apparent brightness of a protuberance is independent of the opening of the slit, provided that it retains an appreciable breadth on the retina.

(2) The brightness of the superposed spectrum increases in proportion to the width of the slit.

(i) Henry Morton (1836-1902?). Secretary of the Franklin Institute.

(3) In oscillating or rotating slits the brightness of the superposed spectrum remains unchanged, while that of the image of the protuberance by the permanence of light, decreases depending on the number and duration of the impressions on the retina, and on the refrangibility of the observed band of the protuberance

"If we suppose that the whole surface over which the slit travels in its rotation or oscillation is filled with the protuberance and that the intensity of the produced secondary image is in inverse ratio to that surface then the relation of the intensity of the background to that of the protuberance would remain the same whether we first decrease the brightness of the protuberance by means of oscillation of the slit, and thereby leave the brightness of the superposed spectrum or background unchanged or, secondly, open the stationary slit so widely that the opening extends over the space travelled over by the oscillation of the slit in the first case. Thus the apparent brightness of the protuberance remains unchanged while that of the background is increased in the same ratio in which it was diminished before with a constant background."

"... By polarizing or absorbing media, placed before the eyepiece the light in the whole field of view can be so diminished that the proper relation of intensity between the protuberances and the

superposed spectrum may be obtained."

Huggins very soon afterwards (16th February 1869) announced a method of observation using a combination of an open slit and ruby glass.

"This slit limited the light entering the telescope to that of the refrangibility of the part of the spectrum immediately about the bright line coincident with C (93). The slit of the spectro- scope was then widened sufficiently to admit the form of the prominence being seen. The spectrum then became so impure that the prominence could not be distinguished. A great part of the light of the refrangibilities removed far from that of C was then absorbed by a piece of deep ruby glass, the prominence was then distinctly perceived ... "

Lockyer heard of this paper and thought that the absorptive media employed by him were useless and proposed to use merely an open slit.

Lockyer continued to point out that the proposed arrangement of Huggins (94) went against all optical principles. Huggins later corrected his paper (95) by stating that

"narrow slit was found to be best at the focus of the little telescope with positive eyepiece".

Captain Herschel in May 1869 suggested the use of a red glass prism without a slit and used the open slit method (96) with considerable success. Whatever type of slit is used the image should be enlarged by the spectro- scope lenses and not by the objective of the telescope employed to throw the image on to the slit. This was

accomplished by having the observing telescope longer than the collimator (97).

Another method which could be used consists of placing a small angled prism in front of the objective of the telescope and another by placing a direct vision prism in front of the slit.

Thus the slit of the spectroscope situated in its ordinary position could be placed in light of any required refrangibility the dispersion being increased to a large extent. When an eclipse occurs the dark moon covers the sun's disc and so it is possible to do away with the slit and the corona is practically its own slit. *see also (98)*

CHAPTER 6.

COMETS. *

Huggins made several unsuccessful attempts to obtain spectroscopic information from Comet I in 1864. Donati⁽ⁱ⁾ was better placed to see the comet and had better weather.

"It resembled the spectra of the metals; in fact the dark portions are broader than those which are more luminous, and we may say these spectra are composed of three bright lines." (108)

Huggins in turn made successful observations of Comet I in 1866, January 9th. When the centre of the comet was brought onto the middle of the slit it gave the appearance of a broad continuous spectrum fading away at both edges. The more diffused parts of the comet gave rise to the fainter parts of the spectrum. A bright spot was observed in the middle of the broad spectrum placed between b and F of the solar spectrum. The lack of breadth of this spot seemed to indicate that the monochromatic light was emitted from an object almost lacking any magnitude as far as the telescope was concerned.

The above observation seemed to show that the light from the coma of this comet was different from that of the tiny nucleus. The nucleus appeared to be self luminous and the matter within it was in the state of ignited gas. Huggins (109) could not suppose the coma consisted of incandescent solid matter and so suggested

(i) Giovan Battista Donati (1826-1873). Arcetri Observatory.

* SEE W. CROOKES CHEMICAL NEWS, 4 EDITORIAL,
72. CHEMISTRY OF THE COMET (1861)

that the continuous spectrum produced indicated that it shone by reflected solar light.

Because the spectrum of the light of the coma was different to that from the nucleus, the nucleus was not the source of the light by which the coma was rendered visible. At this point in time the material of the comet's tail and coma was known to be in a state of high diffusion and as such would be unable to retain the amount of heat necessary to cause incandescence of any solid or liquid matter. It seemed therefore that the coma of this particular comet reflected light from an external source, i.e. the sun. Huggins suggested that if a very bright comet were to enter our system then it might be possible to observe any dark lines in the coma spectrum which distinguish solar light.

Several nebulae which he had examined gave a spectrum of one line only which corresponded with the bright line of the comet nucleus. Other nebulae also contained one or two fainter lines as well as the bright line. Huggins was unable to detect their presence in the spectrum of the comet as the light was feeble and the continuous spectrum made detection even more difficult.

Huggins made a series of observations during the early part of May 1868 on Brorsen's comet.

The spectrum consisted of three bright bands, the width of these bands showed that they were not just due to the nucleus but also caused by the light from the brighter portions of the coma.

These bands resembled the expanded lines observed

in some gases (110), e.g. the line F in the spectrum of hydrogen at atmospheric pressure. When the slit was narrowed the two fainter bands in the yellow and in the blue faded out without any increase in definition. Here they differed from bright lines in nebulae, which become narrow as the slit is narrowed.

The very much brighter middle band possessed similar characteristics. Sometimes two shorter bright lines were detected which could be due to the nucleus itself. There was also present as a background a very faint continuous spectrum. The bright band which lay in the green portion of the spectrum was almost in the same position as the brightest line of nebulae which was coincident with the double line in the spectrum of nitrogen with the comet band being slightly the less refrangible.

The band in the blue was considerably more refrangible than F and was nearly as refrangible as the group of bright lines in the air spectrum. The least refrangible of the bands lay in the yellow part of the spectrum fairly close to E. The bright bands of this comet coincided with the bright bands observed by Donati in his observations (111) of Comet I 1864. The positions of the bands in the comet indicated a different constitution from that of nebulae which gave rise to bright line spectra. Although the brightest band in the comet spectrum lay very close to the brightest line in the nebulae spectrum the other bands are out of position which could indicate different molecular and temperature states existing between comets and nebulae.

A new comet was discovered in June 1868 by

Winnecke⁽ⁱ⁾ and later on in the month detailed spectroscopic observations took place by W.A. Miller and Huggins. The spectrum consisted of three very broad bright bands.

The light was brightest at the less refrangible end of the two more refrangible bands followed by a diminution of intensity as you approached the other end of the band. The middle (brightest) band consisted of non-uniform gradation of light.

The least refrangible of the bands did not exhibit gradation of intensity but was of uniform brightness throughout. Huggins took repeated micrometer measurements of the position of the bands.

First band 1094/1196. Second band 1298/1440.
Third band 1589/1700.

Huggins was unable to resolve the bands into lines for when he narrowed the slit the bands became smaller in length and width but he suspected the presence of two or three bright lines in the centre part of the middle band.

On employing a more powerful spectroscope the middle band was clearly observed with the abrupt commencement as if caused by a bright line easily seen.

It was decided to compare directly in the spectroscope the comet spectrum with that of carbon sparked in ethylene gas.

They noticed that there was coincidence between the brightest edge of the middle band of the comet spectrum with that of the leading edge of the corresponding band in the carbon spectrum. There was much less certainty

(i) Friedrich August Theodor Winnecke (1835-1897).
Professor at Strasburg.

about coincidence between the other bands as the band limits were not clearly seen. However apart from the coincidence of the middle bands there was a general resemblance throughout both spectra concerning their general characters and relative brightness.

They discounted the idea that phosphorescence or fluorescence could cause the production of the discontinuous spectra since phosphorescence was not seen whilst the object was exposed to light whereas here whilst in the full glare of the sun the bands produced were very bright.

It seemed probable therefore that the nucleus had been condensed from the gaseous state in which it had once existed and consisted of carbon in a highly divided state. Thus it could quickly absorb almost all the sun's energy and easily attain a temperature high enough to cause vapourisation. The important differences which existed between the spectrum of Brorsen's comet and that of Comet II, 1868, appeared to show that comets may vary in their constitution.

On November 8th, 1871, a spectroscopic examination took place of ~~Encke's~~ comet. The spectrum consisted of a main bright band in the green part and gradually faded towards the blue. A micrometer gave the wavelength of the least refrangible edge as 5160×10^{-6} mm. Two other bright bands were suspected and no continuous spectrum could be detected (112).

The spectrum of the comet was then observed together with that of the carbon spectrum and the band in the green was found to be coincident with the brightest of the carbon

bands and to have a similar graduation of brightness.

Short glimpses of the second more refrangible band were seen on the 9th November and it was found to be coincident with the third band in the carbon spectrum and with the less refrangible limit having a wavelength of 4735. Later observations showed that the least refrangible band commenced from the red with a wavelength of 4632.

Coggia⁽ⁱ⁾ detected a bright comet in 1874, April 17th, and Huggins examined it during July of that year. A broad spectrum was observed consisting of the three bright bands (exhibited by Comet II) crossed by a linear continuous spectrum. There was also a faint broad continuous spectrum present between and beyond the bright bands. This comet therefore presented three types of spectra, namely the bright band spectrum, the continuous spectrum of the nucleus and the continuous spectrum which accompanied the gaseous spectrum in the coma.

The three bright bands were similar to those observed for Comet II, 1868, but here the bands could be partially resolved into lines. The bands were again compared directly with the spectrum of an induction coil spark in a current of ethylene gas. A small shift of all the bands to the more refrangible end of the spectrum was suspected. Huggins investigated the lack of coincidence of the less refrangible edge of the middle and brightest band with the corresponding part of the blue spectrum of an oil lamp flame. A small shift was detected and the other bands were similarly displaced with respect to the

(i) Jerome Eugene Coggia (1849-). Editor of the Marseilles Journal.

bands of the terrestrial spectrum.

When the comet's bands were superimposed on the carbon spectrum the shift which was observed indicated a relative motion of approach of the comet and earth of about 40 miles per second, which was nearly twice their actual relative motion. Huggins wondered whether any part of the shift was due to the motion of matter within the comet. He also felt it important to note that the bright line near G which is with the three bands in the carbon spectrum appeared to be absent in the comet spectrum, and suggested its absence might be due to the low temperature of the cometary matter.

He further noted the remarkable connection of the orbits of comets with those of meteors. This, together with the presence of hydrocarbons in many meteorites, gave rise to the probability of the carbon (if present) is in combination with hydrogen.

No dark lines or bright lines (except the three bright bands) could be detected in the continuous spectrum of the nucleus. The blue end of the spectrum started to fade a little beyond G and this was taken to show the absence of violet rays and thus a low temperature in the nucleus. Later observations suggested that the above could not be accepted as a trustworthy proof as the human eye was untrustworthy at these wavelengths.

The continuous spectrum which accompanies the gaseous spectrum was observed in every part of the coma and in the dark space behind the nucleus. When the slit of the spectroscope was passed over the brighter

parts of the comet, the gaseous spectrum did not increase in brightness to the same extent.

Huggins satisfied himself that polarised light was present in every part of the comet but tended to increase in the region of the tail. He posed many questions concerning the nature of the comet but few answers were forthcoming.

He suggested that a large part of the continuous spectrum could be accounted for by reflected solar light but he was at a loss to account for it. He wondered if it could be due to incandescent solid particles or reflection from particles too large for polarisation effects. There was also the question of the heat required to give the observed spectrum. Various ideas were proposed, i.e. a chemical reaction set up within the comet by the sun's heat, electricity set up by the effect of solar radiation upon the material of the comet or friction between the particles which increased as the comet approached the sun. However at this time no firm conclusions were put forward.

Several years after the above observations, Huggins was interested in investigating the ultra-violet spectrum of comets. He had to wait until 1881 before a comet appeared of sufficient brightness when he used the apparatus previously employed to photograph the spectra of stars.

The spectroscope was turned onto the nucleus of the head of comet b so arranged that the nucleus was on one half of the slit. After exposure the other half of the slit was directed towards the star Arcturus for comparison.

The spectrum consisted of two spectra superimposed on each other: a continuous spectrum ranging from F to just beyond H. Various Fraunhofer lines could be distinguished, namely G, h, H, K, etc. and thus this continuous spectrum seemed to be due to reflected solar light.

The second spectrum was two sets of bright lines together with a suggestion of a third set. The strongest set consisted of two bright lines at the start of the ultra-violet region. The wavelengths of these bright lines were measured as 3883 and 3870. The stronger line was the least refrangible. These lines represented the brightest ends of the ultra violet group which appeared under certain conditions in the carbon spectrum.

A faint impression of a group of lines between G and h were also seen superimposed on the continuous solar spectrum and further an increase of brightness in the continuous spectrum was observed between h and H which could have been due to other bright lines.

In late June Huggins obtained a second photograph which showed quite distinctly the bright lines in the ultra-violet and the continuous spectrum and this confirmed that part of the light from comets was reflected sunlight and part was original light, some of it due to carbon. The bright groups observed in the comet's spectrum were thought to indicate the presence of cyanogen by Dewar⁽ⁱ⁾ and Liveing⁽ⁱⁱ⁾. Further that hydrocarbons did not exhibit these groupings unless nitrogen was also present (113).

(i) James Dewar (1842-1923). Professor at Cambridge.
(ii) George Downing Liveing (1827-1924). Professor at Cambridge.

Thus if the previous suggestions were true then there was strong evidence that nitrogen as well as carbon and hydrogen were present in the comet's spectrum.

There would seem to be no doubt of the existence of carbon in comets but as to the state of combination in which it existed there was a great variation of opinion. Thus Lockyer considered the two bright groups to be due to carbon vapour at different temperature levels (114).

Huggins obtained a photograph of the spectrum of Comet I (Wells) in 1882 using the spectrum of α Ursae Majoris as a comparison.

The photograph showed a strong continuous spectrum extending from F to beyond H and he was not able to distinguish any Fraunhofer lines. He suggested therefore that the original light causing the continuous spectrum must be much stronger compared to the reflected sunlight than was observed in the comet of the previous year (115). This faintness necessitated the use of a more open slit which in turn would mean that any Fraunhofer lines would be less distinct. The lines G, H and K in the comparison stars spectrum were clearly seen.

Huggins described the continuous spectrum which extended from below F to a little distance beyond H as containing five brighter spaces which he thought were groups of bright lines but which he could not resolve into lines. These areas of increased brightness could be detected beyond the boundary of the continuous spectrum on the side next to the sun. The light from this part of the comet gave rise to a much fainter continuous

spectrum and thus on the photograph it appeared to be almost completely resolved into the bright groups.

The five strong bright groups were very faint at their two edges and thus the brightest part of each space could only be given an estimated position, e.g.

4769 4634 4507 4412 4253

CHAPTER 7.

FIXED STARS.

Donati published some notes on the Striae of Stellar spectra in August 1860. He made subsequent observations using a burning lens of diameter 0.41 m combined with slit, prism and achromatic telescope.

He observed (120) the solar spectrum by day, arranging a cover so that only the requisite quantity of light was transmitted, and fixed the prism to correspond to one or the other of the solar striae. Then fixing the position of the telescope, he turned the moveable bar until one of its arms touched the striae at its minimum position when the micrometer reading was noted. The lens was then turned towards the star he wished to observe (during the evening) and by means of the micrometer the position of the stellar striae was obtained compared with the solar position. He also attempted to determine the extremes of the spectra themselves (see table of results). He denoted the striae of the stellar spectra by α , β , γ starting from the least refracted end of the spectrum. The unlettered striae were not measured but simply estimated. He also grouped separately the separate coloured stars giving first place in each grouping to the most conspicuous striae. Donati suggested that the table showed that stellar striae bear a certain relationship to the colour of the star. There seemed for instance to be a family likeness within the white

star groups and so on with each group in turn. He also noticed a great difference in the lengths of the spectra. The spectra from the three yellow stars had almost the same maxima position whereas the minimum refraction position varied considerably. The red stars gave the reverse of this situation. Donati did however point out that the measurements of these positions were very uncertain. With his apparatus Donati measured the angle of refraction of the D line in the solar spectrum as $49^{\circ} 55' 05''$. The intermediate angles were as follows:

BC	10'57"	Eb	7'45"	FG	72'9"
CD	30 35	bF	29 16	GH	65 56
DE	40 41				

He also indicated that his results were hindered by poor atmospheric conditions and that his lens was not achromatic.

His published measurements were the mean of many observations. Each star had its striae α referred to the solar F. Thus, for Sirius, $\alpha = F\theta - 15''$ meaning Sirius α was refracted $15''$ less than Sun F; also Vega $\alpha = F\theta + 40''$ meaning Vega was refracted $40''$ more than Sun F. ($r\alpha$) meant the angle between the minimum refracted end of the stella spectra and its striae α ; (α, β), (β, γ) were the angles between α and β and β with γ . (α, V) (β, V) and (γ, V) were the angles made by α, β, γ respectively with the maximum end V of its spectrum. He further gave an eye estimated breadth of the striae taken with respect to their least refracted edge. (See table of results.) Donati then compared his results with the work of Fraunhofer.

Secchi performed a long series of experiments,

DONATI

FRAUNHOFER

Sirius: Striae in the blue region.

Sirius: Very fine striae in the green region.

No such line observed - perhaps due to the weakness of stella light - appear to have a lavender tint along the whole spectrum length.

Pollux, Capella, Orionis, Procyon all exhibit a striae = D in the solar spectrum.

He suggested that Fraunhofer had not measured the positions of the striae but had merely given an eye estimation. For instance, Donati gave an estimation of Sirius to be equivalent to E0 but on exact measurement it was found to be Sirius = F0.

Procyon: Striae much clearer and sharper than Capella.

Procyon: Observational difficulties.

Capella: Observational difficulties.

Capella: No comment.

Donati suggested that the striae positions may change as the stars change in colour and further that perhaps the most brilliant striae that he observed may not have been the most brilliant ones to Fraunhofer.

Donati continued by stating that almost all of the fifteen stars under observation had a striae very little differing from F0. He presumed that all these F striae were constant, but with a greater or less refraction due to the difference in the light from the particular star.

investigating the spectra of stars between 1862-1867. The early part of his work was concerned with observations of the principal stars only due to the limitations of his instruments. He examined several hundreds of stars of every magnitude down to the sixth. His last work was an examination of the red stars of smaller magnitude. Secchi by 1868 had reached the following conclusions from his principal results.

- (1) "All stars in relation to their spectrum can be divided into four groups, for each of which the type of spectrum is quite different (121)."

First type.

The spectra consisted of an almost uniform prismatic series of colours, crossed by four intense black lines. The black line in the red was coincident with the line C in the solar spectrum; the line in the blue was coincident with F; the two remaining lines were also in the sun's spectrum, but were not prominent. Secchi indicated that the lines all belonged to the element hydrogen. This type of star proved to be very numerous and counted for almost one half of the visible stars under observation. There were however some differences, e.g. in some stars the lines were broader, in others more narrow. The more intensely bright stars were sometimes seen to possess extra fine lines. When this happened the red portion was faint compared with the green, blue and violet regions which caused the star to have a blue tint.

Examples of this type of star are Sirius, Vega, all the white stars such as Regulus, Castor etc.

Second type.

The spectra consisted of a form exactly like that of our sun, i.e. crossed by many fine lines. He noted that when the atmospheric conditions were poor a continuous spectrum could be observed. Sometimes the magnesium lines were very intense giving rise to strong bands and some stars produced strong iron lines in the green.

These stars were of a rich yellow colour and examples are: Capella, Pollux, Aldebaran etc. They are very numerous and include almost all of the other half of the stars.

Third type.

The spectra showed a row of columns at least eight in number which were formed by strong luminous bands alternating with darker ones, arranged so that they appeared as a series of round pillars.

All the pillars were generally resolved more or less completely in different stars into smaller and finer lines which were very sharp and clear. In certain of the stars some of the divisions of the pillars corresponded to the Fraunhofer D and b lines; others were very close but not coincident with such as C and F. The presence of hydrogen seemed certain due to the lines C and F being found in the vast majority of stars.

The divisions of the pillars were found to agree perfectly in all the stars and he catalogued twenty five of them.

The lines that were observed were described as narrow and sharp strips whereas the bands were shaded

although he pointed out that each band could be composed of very small lines but could not be confirmed with the instrument at his disposal.

Star types two and three seemed to differ from each other, not in metallic lines but in the nebulous bands. Aldebaran and Arcturus showed the same metallic lines as α Orionis, but this exhibited bands as well. He also noted that the luminous sides of the pillars were towards the red whilst the shadowed sides of the pillars were towards the violet. Stars of this type:

o Ceti	Nova	234
α Ceti	137	254
\int Persei	160	β Pergasi
Schjel 44	162	266
45	Arcturus	267
59	Schjel 178	α Idrae
Orionis	Antares	δ Virginis
67	α Herculis	
120	Nova	

Fourth type.

This type resulted from an in-depth study of red colour stars some of which were very small and none of them exceeded the sixth magnitude.

The spectra consisted of three large bands of light with alternating dark spaces so distributed that the luminous side was towards the violet. He noted that occasionally there were several interruptions in the yellow and red regions which divided the large luminous spaces into smaller ones. Many of the red stars in

Lalande's⁽ⁱ⁾ catalogue and also that of Schjellerup⁽ⁱⁱ⁾ belonged to this or the preceding type. Secchi noted that the line of magnesium b fell almost exactly at the end of the second luminous band in the green; but the full aspect of the spectrum did not justify the presence of the metal, but rather of a gas like carbon, which had luminous bands corresponding almost to the dark ones of the star. He suspected that these stars were in a different condition from the others perhaps partly in the gaseous state or perhaps having a different atmosphere from that of the others.

He further mentioned that he felt that V Cassiopeiae was unique in that it showed the lines of hydrogen in a luminous state, exactly the reverse of the dark lines of the stars of the first type.

He said as a summary that there existed a fundamental distinction between the stars according to a small number of types.

(2). Another important observation was that stars of the same type were sometimes crowded into the same part of the sky. For instance the white stars were thickly gathered in Leo, in Ursa Major in Lyra etc., whilst the yellow ones were frequent in Cetus, Hydra etc. The region of Orion was remarkable in that it was covered all over with green stars of the first type which had very narrow lines and with scarcely any red colour. Secchi noted that this kind of star was seen through the great nebula

(i) Joseph ~ Jérôme Lefrançois de Lalande (1732 ~ 1807)

(ii) Hans Carl Friedrich Christian Schjellerup (1827- 1887).
Professor at Copenhagen.

of Orion, whose spectrum may contrast with the primitive spectrum of the stars. Sirius he felt was too near to be affected by this. He suggested that this distribution of stars indicated a particular distribution of matter or temperature in different regions.

(3). All the spectra of the third and fourth type belonged to variable stars. For instance Mira Ceti when it was only of the seventh magnitude had the same typical spectrum, only reduced to its few bright columns. Aldebaran and Arcturus seemed to be smaller and of more of a red hue than the past year and traces of columns appeared which were not seen the year before. He suggested that the change of these stars depended on a periodical change which happened in their atmospheres. Algol, however, had the same spectrum of the first type in every stage of magnitude.

(4). Secchi wondered whether a star had a proper motion and suggested that the displacement of lines should take place in the spectrum due to the combined motion of the star and the propagation of light. The star α Lyrae had not given any such displacement. Secchi discovered a little displacement in some stars such as ϵ Ursae Majoris but this seemed due to the different breadth of the hydrogen line in the star spectrum and in the chemical spectrum. He used the comparison of the direct image of the star with its own spectrum but found no appreciable displacement. His early researches used the superposition of Sirius when there was coincidence of the hydrogen with those of the star. He later was informed that Huggins had found a little difference for Sirius.

Soon after the observations of Kirchhoff were published (117) on the connection between the dark lines of Fraunhofer with the bright lines of artificial flames, W.A. Miller and Huggins developed a spectroscopic system which permitted the immediate comparison of stellar spectra with those of terrestrial flames. They made observations of the principal lines in Sirius, Betelgeuse and Aldebaran (see diagram). The position in the stellar spectra corresponding to the Fraunhofer D line from which the others were measured was obtained by coincidence with a sodium line, whose position in the telescope was compared with the line D in the solar spectrum. L.M. Rutherford⁽ⁱ⁾ (USA) published work of a similar nature, the apparatus used being very similar to that employed by Miller and Huggins.

Prior to the discoveries of Kirchhoff the knowledge of the constitution of the fixed stars was limited to the observations that some of them were subject to the same laws of gravitation as members of the solar system, coupled with the probability that they must be self luminous bodies.

Great difficulties were encountered by the early spectra observers. The light from even the brightest of stars became so feeble due to the large dispersion necessary for accurate comparison between the dark lines of stellar spectra and the bright terrestrial lines. Further problems were encountered, the main one being the lack of homogeneity of the earth's atmosphere. Prior to the observations starting in the early 1860's very little work had been

(i) Lewis Morris Rutherford (1816-1892).

published on star spectra. Fraunhofer (1823) had found the D line in Capella, Betelgeuse, Procyon and Pollux and mentioned the presence of the b line in Capella and Betelgeuse. Donati published observations on fifteen stars (1862) but the positions ascribed to the lines of the different spectra relative to the solar spectrum did not agree with the results obtained by Fraunhofer, Huggins and Miller.

By the end of 1862 Huggins and Miller had constructed an apparatus which possessed sufficient dispersive and defining power to resolve such lines as D and b of the solar spectrum (118). They hoped that the instrument could be further adapted to give accurate measurement of the observed lines and that the spectra of the chemical elements could be observed simultaneously with the spectra of the stars. Here the relative position of the two sets of spectra had to be such that coincidence (or not) could be established between the bright line and dark line spectra. During 1863 the first published results were appearing. Rutherford (*Silliman's Journal*) and Secchi produced figures on a few stellar spectra and by March 1863 the Astronomer Royal presented a map to the Royal Astronomical Society showing the positions of the main spectral lines in sixteen stars.

The instrument designed by Huggins proved to have sharp definition and considerable dispersion. The D line in the solar spectrum was divided to permit the line within it (marked as coincident with nickel on Kirchhoff's map) to be seen. When turned towards the stars fine line spectra was observed, the dark lines being as fine and

plentiful as those in the solar spectrum. The great breadth of lines in the green and more refrangible parts of the stars were now seen to be not so abnormally broad as to require these stars to be placed in a class of their own. No stars giving rise to a spectrum were observed without lines and each star gave a different grouping and arrangement of the line structure.

Huggins and Miller took a few of the more characteristic lines of twenty-nine of the elements^{which} were measured using the spectroscope and were then laid down to scale to be used as a comparison between the stellar lines and probable lines in the elements' spectra.

They examined approximately fifty stars but concentrated their efforts on four of the brightest. In general, they found the star spectra to be as rich and varied as that of the sun itself.

Results.

Aldebaran (α Tauri).

This star gave strong lines particularly in the orange, green and blue portions. The positions of about seventy lines were measured but other lines particularly in the blue were not measured due to the feebleness of the light. The spectra of sixteen terrestrial elements were compared with the star spectrum by simultaneous observation. Nine of these terrestrial spectra showed lines coincident with lines in the spectrum of the star.

- (1) Sodium: Double D line coincidence with a double line in stellar spectrum.
- (2) Magnesium: The three components of the group at b coincident with three lines in the star spectrum.

- (3) Hydrogen: The line in the red at C, and the line in the green corresponding to F in the solar spectrum, were coincident with strong lines in the star spectrum.
- (4) Calcium: Four lines in its spectrum coincided with four stella lines.
- (5) Iron: A double line corresponding to E in the solar spectrum and three other more refrangible well marked lines coincident with lines in the star spectrum.
- (6) Bismuth: Four strong lines in the metal spectrum were coincident with four in the star spectrum.
- (7) Tellurium: As for Bismuth.
- (8) Antimony: Here three lines were coincident.
- (9) Mercury: Four of the brightest lines in the mercury spectrum gave coincidence.

Comparisons of this kind proved to be extremely fatiguing for the observers and accurate results were only obtained for the stronger lines and thus other lines in the element spectra could well exhibit coincidence.

Further seven other elements were compared with this star: Ni, Co, Sn, Pb, Cd, Li and Ba but no coincidence was observed.

α Orionis (Betelgeux)

This star showed the most complex spectrum of those under investigation. The red, green and blue portions especially exhibiting strong groups of lines. Miller measured the position of about eighty of the stronger lines.

The star spectrum was compared with a total of sixteen element spectra and coincidence was found with five of these: Na, Mg, Ca, Fe, and Bi.

- (1) Sodium: The lines coincident with D were fainter than in Aldebaran.
- (2) Magnesium: The group at b gave coincidence with a group of 3 stellar lines.
- (3) Calcium: Four lines gave coincidence.
- (4) Iron: At E the double line and 3 further lines gave coincidence.
- (5) Bismuth: Four lines gave coincidence in each spectrum.

Thallium: Due to the dispersive power of the instrument, coincidence could not be proved since the bright green line could be due to calcium.

Hydrogen: In these sets of observations there was no coincidence with the red line C of hydrogen nor with the line at F.

Nitrogen, Tin and Lead: No coincidence was found.

Gold, Cadmium, Silver, Mercury, Barium, Lithium:

No coincidence.

β Pegasi.

This spectrum was similar to that of α Orionis, considering the group arrangement and strength of lines within the groups. The star was observed very carefully but the atmospheric conditions and faintness of the spectrum caused problems.

Nine terrestrial elements were compared, two of these, sodium and magnesium, gave coincidence with lines in the star spectrum. The observers were greatly concerned

as to the accuracy of their results as the faintness of the star coupled with shifting atmospheric conditions gave rise to probable errors.

At the time (see later) lines corresponding to hydrogen were not observed in the spectrum of α Orionis and β Pegasi. This was considered important as the lines C and F are highly characteristic of the solar spectrum and by most of the stars observed up to that time.

Sirius.

The spectrum was very intense, but shifting atmospheric conditions caused the observations of the finer lines to be very difficult. When the improved version of the spectroscope was used the lines in the green and blue appeared but a little broader than F and G can be in the solar spectrum. This result differed from earlier observations due to the increase in dispersive power and the use of a narrower slit.

Three elements gave spectral lines which coincided with lines in Sirius.

- (1) Sodium: A faint double line in the star gave coincidence.
- (2) Magnesium: Three lines in the star coincided with the triple group of magnesium.
- (3) Hydrogen: The F and C lines coincided with very strong lines in the star. Sirius being a brilliant white star was noticed to have the hydrogen lines abnormally strong compared with the solar spectrum. The whole spectrum being covered by a large number of faint and fine lines, all the metallic lines being very faint.

α Lyrae (Vega).

The star spectrum was observed to contain sodium (Double line at D), magnesium (triple line at b) and hydrogen (coincidence of lines with C and F). In general terms the spectrum contained many lines and was similar to Sirius.

Capella.

The spectrum contained many lines and was similar to that of the sun.

Arcturus (α Bootis).

A red star whose spectrum resembled that of the sun.

Pollux.

A spectrum rich in lines and observed coincidences for sodium and magnesium.

α Cygni and Procyon.

Both had a many lined spectrum with coincidence showing for the double sodium D line. A further thirty six fixed stars were observed but at the time no comparison had been made with metallic element spectra.

Secchi (119) published in the Journal of Rome his observations on the Nebula of Orion. He stated that the whole spectrum of this Nebula was reduced to three lines * see Nebula chapter.

Colours of the Stars.

It had been noticed for many years that certain stars shine with special colours instead of the more common white. The colour difference had been much more noticeable when the observations were made in a still atmosphere lacking

humidity. The source of solar and stellar light must be matter held in an incandescent state due to it being at an extremely high temperature.

The source of the colour difference was thought by Huggins to be due to the difference of the constituents of the investing atmospheres. For light from incandescent matter gives rise to an unbroken spectrum which is connected with the state of the matter and not with its chemical nature. The atmosphere of the star should vary as the constituents of the star vary. The latter fact had been established by experimentation as far as the elements of composition are concerned. The light from each star would thus be lessened by the loss of the rays corresponding to the bright lines which the constituents of the various atmospheres would be capable of emitting. When these dark lines predominate in specific areas of the spectrum then the colours in which they occur be weaker and consequently other colours will predominate.

The blue and green parts of the spectrum of α Orionis were relatively dark due to the close grouping of the many dark lines, whilst they were much less strong in the orange region. Thus an orange tint could be expected as noted by Smyth⁽ⁱ⁾ (122). Smyth described β Pegasi as deep yellow and the appearance indicated by its spectrum supported this observation. Smyth described Aldebaran as having a pale rose colour. There were few strong lines apart from C (hydrogen) in the red section whereas there

(i) Charles Piazzi Smyth (1819-1900). Astronomer Royal for Scotland.

were many in the orange portion and several in the blue and green. Sirius was described as brilliant white and having a bright continuous spectrum apart from five strong lines which did little to affect it. The spectrum did possess many fine lines but these were very faint and had minimal effect. The great intensity of the light from Sirius lead one to think that the atmosphere itself was incandescent, thus replacing the light it had absorbed from the photosphere. Whatever the reason for the brightness there was a marked difference on the colour emission of α Orionis considering the close grouped dark lines in the blue and green regions and corresponding region in Sirius where the faint and fine dark lines seemed to have little effect on subduing the blue and green rays.

Huggins at this time had not tested experimentally the foregoing hypothesis on the class of stars whose light was green, blue or violet in colour due to their feeble emission of light and close proximity to much brighter stars.

The apparatus in use was also adapted so as to view the spectra of the components of double stars. The spectra of the components of β Cygni could thus be examined separately. The star colours were very different but the spectra were extremely faint and it proved difficult to observe the lines. The lines b and D were measured but the other lines were only roughly estimated. In both stars the sections of the spectrum corresponding to the colours which were deficient in the light of the stars were those which were darkened with bands of absorption lines. The light from A was yellow tinted with orange

whereas B was blue but under certain atmospheric conditions the colour added on a greenish hue. In the case of star A, the absorption was most marked in the violet and blue. The yellow region and some of the green had no strong lines and the strong lines in the orange and red were narrow and hence had little effect on reduction of the light.

The spectrum of B was observed to have very faint orange and yellow sections due to several groups of closely formed fine lines, together with a few strong lines widely separated at the more refrangible end of the spectrum.

The changes in the appearance of B were considered to be due to the presence of water vapour in the atmosphere which caused more absorption on the more refrangible portions of the spectrum.

The same apparatus and method of observation were used to observe α Herculis. The spectrum of A contained intense groups of lines in the green, blue and violet regions, the yellow and orange sections held fainter bands whilst there were two strong bands in the red.

B appeared to be blue green in colour. The absence of strong bands in the more refrangible parts of the spectrum caused them to appear very bright. Further the yellow and orange sections showed several groups of lines.

It has been proposed that the stars of exceptional colours had special physical conditions due to the star system of which they formed a part. Now stars of the more highly refrangible colours were always observed in close contact with much brighter stars usually being of a red or orange colour.

Arago (123) indicated that there were no stars other than white, red and yellow to be found amongst approximately eighty thousand ISOLATED stars listed in the various catalogues available. The stars emitting blue and green light appeared to have the requisite conditions under MULTIPLE systems.

These stars were all of a low intensity. The faint blue or violet light could not be due to a lower temperature of the radiating surface and hence producing less incandescence since the more refrangible rays would be the first to fade as the temperature was lowered and thus the star should appear dull red.

By the year 1863, Miller and Huggins (124) had obtained a picture of the spectrum of Sirius using a photographic plate. A sharp image of the more refrangible part of the spectrum was seen and although fairly well defined at the edges no indications of lines were observed.

Other work prevented the continuation of observations using photography but in 1876 work was started again using a more accurate driving clock designed by Howard Grubb⁽ⁱ⁾ (125). The apparatus was arranged so that the solar or electric spark spectrum could be taken on the same plate as the spectrum of the star. Results were obtained for Sirius, Vega, etc.

The photograph showed seven well defined lines, all of them being shaded at the sides. The two least refrangible lines being coincident with two hydrogen lines in the solar spectrum.

(i) Sir Howard Grubb (1844-1931). Dublin University.

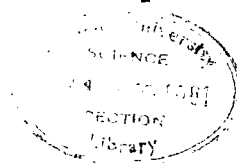

Measurement of the wavelengths.

The map of the solar spectrum by Cornu⁽ⁱ⁾ was taken between the positions h and O by Huggins together with the wavelengths of the lines of cadmium in the ultra-violet as found by Mascart⁽ⁱⁱ⁾.

The spectra of the brighter stars could be traced on the photographic plate from b to beyond S. However in the map provided, the section from hydrogen (γ) to O in the ultra-violet was shown.

A Dolland wire micrometer was used which gave 2.947 hundredths of a revolution for each 0.1×10^{-6} mm of wavelength at the position H.

A large scale curve was drawn connecting the measurements on the micrometer against the wavelength intervals. For this curve photographs of the solar spectrum together with those of iron, cadmium, calcium and magnesium were employed. The positions of the lines as measured in wavelengths were compared with solar lines by actual measurement under the microscope, giving a probable error of $\pm 2 \times 10^{-7}$ mm.

Huggins chose to examine stars of the same class as Sirius. The attached map shows the spectra of the chosen stars together with the spectrum of Arcturus which represents a different star class.

White stars.

The photographic spectra obtained showed the great similarity between all stars in this class. It was felt

-
- (i) Marie Alfred Cornu (1841-1902). Professor at the E'cole Polytechnique.
- (ii) Eleuthere Elie Nicolas Mascart (1837-1908). Director of the Central Bureau for Meteorology.

that the slight differences observed could be considered as a modification of a spectrum common to the whole of the white classification.

Very strong lines of hydrogen at C and F were observed as well as very fine lines corresponding to sodium, magnesium and iron. When compared to the solar spectrum the hydrogen lines appeared more intense whereas the metallic lines were very faint (126).

The photographs showed a spectrum of twelve strong lines, whilst beyond this range a continuous spectrum free of any lines was seen as far as S. The least refrangible of these lines was coincident with the γ line of hydrogen. The second line agreed with h and the third line with H. The nine lines which remained did not appear to be coincident with any of the more prominent lines of the solar spectrum.

As the refrangibility increased, these nine lines diminished in breadth, and the distance between any two adjacent lines became less. Further, it was observed that the groups possessed a great deal of symmetry indicating perhaps that they represented the spectrum of one substance.

(i) <u>Vogel's numbers</u>	<u>Huggins' numbers</u>
3968	3968 H
3887	3887.5 α
3834	3834 β
3795	3795 γ

The lines could be from the spectrum of hydrogen (127). Amongst other lines, the ones above agree in position

(i) Carl Hermann Vogel (1842-1907). Director of the Potsdam Observatory.

with four of the typical lines. Johnstone Stoney in a letter to Huggins (24th January 1880) agreed that the above lines were due to hydrogen.

Further the spectrum did not end with this group of lines. The continuous spectrum ran on far beyond S in the ultra-violet. The wavelengths of these lines are to be seen under Vega. The spectrum of Vega being typical of the whole class of stars. The modifications of the typical spectrum took place in three directions.

- (a) In terms of diffuseness and breadth of line.
- (b) Whether K is present or not. If present, in terms of brightness and breadth relative to H.
- (c) The number and distinctness of the other lines present in the spectrum.

It was observed that in all stars of the white class that the K line was either absent or very narrow compared to the solar spectrum whilst H remained broad and intense.

When one considered the spectrum of Arcturus which belonged to another class, the K line exceeded the solar spectrum K in breadth and intensity.

The spectra of these stars could thus be arranged in a continuous series in which the K line was first absent, then appearing as a thin line, then distinct; and in the solar spectrum has become broad, and finally in Arcturus it was a broad band of high intensity.

The lines H and K coincided with two strong lines in the spectrum of calcium and thus H and K could be due to the presence of calcium vapour. When we take the

typical spectrum case then the calcium line 3736.5 falls half way between ϵ and ζ and the line 3705.5 is close to θ

Vega (α Lyrae).

The photograph showed the typical 12 strong distinct lines with a thin line at position K. There was a complete absence of lines in the spectrum beyond 3698 at which point the spectrum became continuous and extended beyond S into the ultra-violet.

Sirius.

The spectrum was similar to that of Vega. No line at K was detected. Due to the rather poor quality of the photograph there was uncertainty about the existence of any lines beyond δ .

η Ursae Majoris.

Here again the spectrum was similar to that of Vega but the lines being somewhat less broad. Eleven lines were observed with K being also absent. There was a strong continuous spectrum extending beyond S with four fine lines being seen.

α Virginis.

The twelve lines were seen to be quite narrow and more fine lines were observed.

α Aquilae.

All the lines observed were well defined and more narrow than those of Vega. The K line was strong as well as twelve strong lines amongst many other fine lines. The spectrum could be considered as moving towards that of the solar type.

α Cygni.

This spectrum was altered in the direction of the solar type but a few lines beyond the typical ones were present.

Arcturus.

Here the K line was very broad and winged and was stronger than it was in the solar spectrum. It was considered to be a red star, the spectrum resembling that of the sun. Amongst the thirty lines measured a double sodium line at D was noted and a triple line of magnesium coincident with b was so well seen that use of them was made in 1871 to determine the stars motion in the line of sight. The whole appearance of the star especially between b and G made it dissimilar from the class of white stars where it followed the solar spectrum.

Limit of solar/stellar light in the U.V. part of the spectrum.

Several attempts were made to obtain the limit in the ultra-violet for stellar light but it required to observe a bright star at a high altitude and at a time when the atmosphere was very clear.

Three successive photographs of Vega were obtained, each with increasing exposures taken on the same plate. The exposures were 10 minutes, 20 minutes and 70 minutes respectively. When a comparison was made of the extent of the spectrum between the second and third spectrum it was seen that the third spectrum had reached the limit imposed by atmospheric absorption and had not stopped as a result of insufficient exposure time of the plate (133).

The original plate was enlarged four times and compared with similarly enlarged spectra of magnesium and calcium as

well as with the stellar spectrum. A short scale only was placed over the spectrum where the light of Vega ended.

The light of Vega suddenly weakened at λ 3000 and then continued as a very faint line to its extinction point at λ 2970.

Further studies over a four year period using the same spectroscope showed an average sudden weakening at about λ 3000 and an apparent total extinction at about λ 2985.

The sudden narrowing of the spectrum at the end towards the red was due to the rapid falling off of sensitiveness of the silver bromide for light of increasing wavelength.

The increase of breadth of the spectra with increase of exposure time was due to the same causes which produced the increase of diameter of stellar discs on photographic plates with longer exposures when a reflector was used.

Cornu investigated the limit of the solar spectrum and its connection with the altitude with the place of observation. At 8414 feet the spectrum went to λ 2932, whilst at 2163 feet the spectrum stopped at λ 2954. Cornu felt that the absorption was due to the gaseous constituents and not to the aqueous vapour in the atmosphere (134).

(i)
Hartley in 1881 stated that a quantity of ozone proportional to the average quantity in a vertical section of the atmosphere caused a similar absorption to that observed in the solar spectrum with a termination point of λ 2950 (135).

(i) Sir Walter Noel Hartley (1846 - 1913)

Sirius (new lines).

Huggins had long suspected the presence of another group of broad lines farther on in the ultra-violet region. In 1890 a photograph of the spectrum was obtained after a long exposure whilst using a very narrow slit (136). On examination, the plate showed that the spectrum remained free of strong lines after the termination of the hydrogen series until one reached a position in the ultra-violet at λ 3338. Here, the first line of a group of six appeared all being nearly as broad as the hydrogen series with the third line (λ 3278) being the broadest.

The sixth line occurred where the spectrum was faint and there was some uncertainty as to whether this line completed the group or whether there were still further lines.

1st Line	λ 3338	4th Line	λ 3254
2nd Line	λ 3311	5th Line	λ 3226
3rd Line	λ 3278	6th Line	λ 3199

Bright-Line Stars in Cygnus.

Three small stars in Cygnus were seen in 1867 to have several lines upon a continuous spectrum with all three having a very bright band in the blue part of the spectrum (137).

Vogel described (138) their spectra in 1873 and again but more fully in 1883. His measurements of the blue band placed it in a star No. 3956 between λ 468 to λ 461, with a maximum at λ 464; in star No. 4001 the blue band commenced at λ 470 reaching a maximum at λ 468 and ending at λ 465.

Vogel's later measurements showed that the blue band had not an identical position in all three stars, however they still substantially showed that the bright lines,

including the blue band were not due to Carbon which was contrary to the statements of Secchi.

<u>Vogel's results</u>	<u>Beginning of the band</u>	<u>Brightest part</u>	<u>End of band</u>
Star No. 4001	λ 470	468	λ 465
Star No. 4013	-	464	-
Star No. 3956	λ 468	464	λ 461

The diagram shows the positions of the bright bands in the three stars (Nos. 1, 2 and 3), according to Vogel's measurements relative to the blue band of the hydrocarbon flame.

The diagram showed that the band in No. 4013 to start and finish at about the same positions as in Star No. 3956.

It was felt at the time that the bright blue band in all three stars was the carbon band in the blue, commencing near λ 474; and that more recently direct comparisons showed an absolute coincidence of the band in all three stars with the blue band of a spirit lamp flame (notwithstanding the observations of Vogel).

Huggins felt it of great importance to confirm the presence or absence of carbon in these stars and so decided to make a direct comparison of the spectra of these stars with that of the hydrocarbon flame under a large enough dispersion so as to determine whether Vogel's observations were in essence correct.

When Vogel employed a small dispersion as in the experiments of 1873 he was unable to detect the large difference of position (λ 0040) of the band in Star No. 4001 as compared with its position in the other two stars.

The star spectra was examined firstly by a direct vision prism of small dispersion, then with a spectroscope (A) consisting of one 60° prism, and finally with a spectroscope (B) of two compound prisms (equivalent to four 60° prisms). An initial examination using (B) showed the striking difference of position of the band in star No.4001 from that which it held in the other two stars as well as the general accuracy of Vogel's measurements. The lack of agreement of the bands in the stars and the blue band of the bunsen flame was immediately apparent, and it would appear that the star bands differed in character as well as in position from the blue band of the hydrocarbon flame, and also in some respects from each other.

The continuous spectrum could be traced up to the blue band quite easily and indeed could be detected a fair distance into the violet. Photographs of star No.4001 showed bright hydrogen lines at λ 434, 397, 389, which lay beyond the blue band and other bright lines at λ 462, 455, 420, 406, 395 and 388. The stars numbered 4013 and 3956 showed only one well defined line at λ 470 (E.C. Pickering)⁽ⁱ⁾.

Star No.4001.

The bright blue band was less refrangible than in the other two stars and so approached the position of the blue band in the hydrocarbon flame. (See No.4 in the diagram.)

The brightest part of the band (λ 468- λ 469) fell away quickly in brightness but could be traced into

(i) Edward Charles Pickering (1846-1919). Professor at Harvard.

the red (λ 471.5) and into the blue (λ 465.5).

The relative brightness of the flutings of the blue hydrocarbon band could be so changed that the position of maximum intensity was moved towards the blue end but the five flutings remained without any change of their position in the spectrum. Haselberg⁽ⁱ⁾ obtained a nearly pure spectrum of the order of that in a hydrocarbon flame mixed with only faint lines of hydrogen using the vapour of benzole.

His results showed that maximum of intensity of the blue group moved from the first to the third line, i.e. to λ 4698.

Huggins felt that the star band was not sufficiently similar in character and position with the band of the hydrocarbon flame to justify attributing the blue band in the star to carbon. There appeared to be no coincidence of the position of the band in the star with that of the blue band of the Bunsen flame as far as Huggins and Vogel were concerned and further the lack of agreement of its general characters was so great as to make it very improbable that its origin was carbon. To support this, no traces of beginnings of the more brilliant green and orange bands could be detected in any of the stars.

When the other two stars were examined, the brightest part of the blue band lay between λ 464 to λ 465, but nearer to λ 465 which was quite outside the ordinary visible limit of the carbon band. Here there was agreement between the measurements of Vogel, Copeland⁽ⁱⁱ⁾ and Huggins.

(i) Bernard Haselberg (1848 - 1922) Professor at Stockholm

(ii) Ralph Copeland (1837- 1905). Trinity College Observatory.

Star No.4013.

Vogel gave only the position of the brightest part of the band, i.e. λ 464 but did indicate a spectrum diagram where the bright blue band was essentially coincident in position and character with that in the spectrum of star No.3956.

Huggins' observations in the main agreed with Vogel but he suggested that the band lay in two parts - a bright part (λ 466- λ 464) and a very faint band somewhat detached (λ 4685- λ 4705). The bright band seemed to consist of a group of bright lines without fluting or being broken up into widely separated maxima (see diagram No.5). The bulk of the bright radiation lay beyond the normal visible limit of the blue carbon band and there appears to be no connection with carbon at all. They examined the continuous spectrum with great care and could not detect any brightening of the spectrum at the positions of the green and of the orange bands of the Bunsen flame.

Star No.3956.

The brightest part of the band was placed at λ 464 (Vogel), i.e. a position beyond the carbon band (see No.6 in the diagram). The position of the band relative to that of the Bunsen flame as determined by using the bright fluting intervals agreed substantially with the work of Vogel when the position of maximum brightness was placed at λ 465. The sub-band as observed in star No.4013 was very much fainter in this star.

Copeland and Pickering quite independently discovered

other bright line spectra stars near to those above. The brightest of these stars had a spectrum of several bright lines near D and a very bright band at λ 464 (139). The very brilliant blue band was in a position which corresponded to that in star No.4001. The band started at λ 467 and continued to λ 470.5. It consisted of a group of lines of almost uniform brightness throughout the length of the band. The band is shown in fig. 7 of the diagram.

Absorption.

A general absorption exists in the atmosphere of stars hence one must be careful when one determines the relative temperatures of the stars from the relative intensities of the red and blue radiations as if the stars were heated black bodies.

There are three independent causes which may bring a diminution of the brightness of the blue and violet parts of the spectrum of a star relatively to the red end:

- (a) The selective absorption of the chemical substances of the stars atmosphere (stronger in the more refrangible parts of the spectrum).
- (b) A general absorption, and a scattering of the stars atmosphere acting more on the shorter wavelengths.
- (c) A possible diminution of light in space acting more on the shorter wavelengths of the star's spectrum due to possible absorption or scattering.

CHAPTER 8.

MOTION IN THE LINE OF SIGHT.

In the period before the advent of spectroscopy it was only possible to measure the motion of stars when they moved across the line of sight. The other component in the line of sight could not be measured since it caused no change of position nor any measurable alteration in size or brightness.

The position of light in a spectrum and indeed its colour depends upon its wavelength and frequency. Any motion between the source of light and the observer must change the apparent wavelength and the frequency. Such a wavelength change would cause the light to occupy a new place in the spectrum and thus from the size of the positional change the velocity of the relative motion between the source of light and the observer.

The idea of a change in colour due to motion between the source of light and the observer was announced in 1841 by Doppler⁽ⁱ⁾. He showed that the impression received by the eye was determined by the time interval in which the light falls on the eye, hence it follows that the colour and intensity of light would be altered by a relative movement between the light source and the observer. Doppler tried to account for the colour differences which were possessed by some binary stars but without success. Sestini⁽ⁱⁱ⁾ published two papers

(i) Johann Christian Doppler (1803-1853). Professor at Vienna.

(ii) Fausto Sestini (1839-1904). Professor at Pisa.

on star colours in connection with the work of Doppler during 1847. During 1866 Klinkerfues⁽ⁱ⁾ published a paper connecting refrangibility with the motion of the light source. He used an achromatic prism and it did not seem possible (Miller and Huggins) to obtain any information concerning the motion of the stars for the difference of period of the waves would be as far as possible annulled.

Secchi (1868) also published some work on this subject stating that he had been unable to detect any change of refrangibility in the case of some stars equal to the difference between the parts of the double line D.

As well as the above workers, Clerk Maxwell⁽ⁱⁱ⁾ and Fizeau made some important theoretical contributions to the subject but no attempts had been made to discover by this principle the motion of stars in the line of sight (1866) for it was necessary to know the original wavelength of light before it left the star.

Once it was shown that certain earth elements were present in the stars and the original wavelengths of their lines became known then any small discrepancy of coincidence between stella lines and those of the earth lines indicated a relative velocity of approach or recession between the star and the earth. Huggins and W.A. Miller were in 1866 engaged in constructing a spectroscope of sufficient power to detect a true line shift due to stellar motion. Two years later in 1868

(i) Ernst Friedrich Wilhelm Klinkerfues (1827-1884). Professor at Göttingen.

(ii) James Clerk Maxwell (1831-1879). Professor at Aberdeen, London and Cambridge.

they were able to publish work on a method which enabled motion in the line of sight to be measured (128). The work was subsequently confirmed by Vogel who at a later date, using photographic techniques, measured the relative velocity of about fifty stars with an accuracy of 1 mile/sec.

The original apparatus consisted of two flint glass prisms with refracting angles of 60° which permitted the comparisons to be made with great accuracy. The stars examined included Aldebaran, Pollux, Orionis etc. and they all gave rise to negative results.

The later successful apparatus and techniques will be described later on.

Observations.

Once again the poor quality and unsteadiness of the English atmosphere caused a large number of observations to be rejected.

Sirius.

This star was selected for the brilliance of its light and the particular intensity of four of the spectrum lines. The strong line at position F was selected and compared with the corresponding line in the hydrogen spectrum. The early experiment used hydrogen at atmospheric pressure but it was found impossible to determine with sufficient accuracy the coincidence due to the width of the band of hydrogen being greater than the line in Sirius. When hydrogen at low pressure was used together with a very narrow slit, the resulting line from the spark was very narrow being about one-fifth of the width of the line in Sirius. After many observations

it was decided that the narrow hydrogen line did not coincide with the middle of the line in Sirius and that the lack of coincidence was apparently equal to about one third/one fourth of the interval separating the components of the double line D. Using the micrometer attached the mean value of the difference was 0.040 of a division. Some attempts were made to compare the strong line at C with the corresponding hydrogen line but using the large spectroscope, the lines were not bright enough to give an accurate measurement of their relative positions. Taking the velocity of light as 185,000 miles per sec. and the wavelength at F to be 486.50×10^{-6} mm. it was shown that a motion of recession existed between the earth and the star of 41.4 miles per sec.

Of this motion part was due to the earth's motion in space. At the time of the observations the earth was moving from the star with a velocity of 12 miles per sec. Therefore the motion of recession from the earth due to the star was 29.4 miles per sec. Further observations and measurements were made on Castor, Betelgeux, Aldebaran and other stars but the results were not published at the time as a further re-examination was deemed necessary due to the poor atmospheric conditions.

The investigation resumed in 1872 by which time a satisfactory technique had been developed of comparing star spectra with terrestrial spectra. There were still many difficulties concerned with the method causing the

necessity of numerical estimations. Even when using a system of high magnifying power the observed change in refrangibility was very small. The use of a narrow slit caused the light to become faint and the unsteadiness of the atmosphere caused further complications (129).

Sirius.

Comparison was made of the line at F with the corresponding line of hydrogen. The observations confirmed the earlier work showing that the star was moving from the earth but it now seemed to have a smaller velocity than was originally thought. The observations showed a change of refrangibility corresponding to a velocity of 26/36 miles per second. The earth's orbital motion was 10/14 miles per second, leaving 18/22 miles per second for the star.

Betelgeux (α Orionis).

The early work showed no lines of any strength coincident with the hydrogen lines at C and F. However with the new more powerful spectroscope a narrow defined line in the red was observed apparently coincident with $H \alpha$, and a similar line in the position of $H \beta$ but they were much less intense than the lines C and F in the solar spectrum. The most suitable lines for comparison were thought to be those of sodium and of magnesium. The double character of the one line agreeing exactly with that of sodium and further the comparative brightness of three lines which precisely correspond to the triple group of magnesium showed that these lines were produced by the vapours of the two metals.

The amount of displacement for the sodium lines was estimated at about one-fifth of the distance of D_1 from D_2 giving rise to a velocity of separation of 37 miles per second. The earth was moving from the star at 15 miles per second leaving 22 miles per second for the star.

Rigel.

The lines of hydrogen were strong in this star and were used for comparison. The line of terrestrial hydrogen fell above the middle of the line in the star which indicated that the star was receding from the earth. The velocity of recession was estimated at 30 miles per second and after taking the earth's motion into consideration it was reduced to 15 miles per second.

Castor.

The spectra of the components of this double star blended into one spectrum when using the spectroscope. The line $H \beta$, was observed giving rise to a shift of about 40/45 miles per second or 25 miles per second after corrections.

Regulus.

This was not an accurate observation. The line at F was rather wide and the atmospheric conditions were unfavourable. The corrected star velocity being 12/17 miles per second.

Arcturus.

Here the lines of sodium, magnesium and hydrogen could all be used for comparison purposes. Magnesium proved to give the best results with the magnesium

lines falling on the less refrangible side of the corresponding lines of the star's spectrum, showing that the star was approaching the earth. The displacement observed indicated a velocity of approach of 50 miles per second. When the earth's orbital motion of 5.25 miles per second was added the stars motion became 55 miles per second.

α Lyrae.

Here the line H β was used. The velocity of approach was calculated as 40/50 miles per second to which must be added 3.9 miles per second for the earth's motion from the star.

Pollux.

In this star the lines due to magnesium and sodium were very distinct but at the time of the observations the atmospheric conditions were very poor. The three magnesium lines were less refrangible than the corresponding star lines by an amount which indicated a velocity of approach of 32 miles per second. The earth's motion from the star was 17.5 miles per second giving an apparent velocity of approach of 49 miles per second.

α Ursae Majoris.

Here the lines at b were more distinct and strong enough for comparison with the bright lines of magnesium. The bright lines fell on the less refrangible side of the dark lines, the displacement indicating a motion of approach of 35/50 miles per second, to which must be added the earth's motion of 11.8 miles per second.

The wavelengths used were those given by Ångström (1868) and the velocity of light taken as 185,000 miles per second.

The velocities worked out were those which existed between the star and the sun. Since the sun was moving in space, some of the velocity must be due to solar motion. No attempt was made, however, to make a correction for this factor.

In general, stars situated in space towards which the sun was advancing, the spectroscope showed as moving from the earth, whilst other regions showed stars as having a motion of approach. There were, of course, exceptions and other considerations to take into account as to the cause of the proper motions of the stars. Here one could consider groups of stars having the same motion but at the time little published work was available.

From the experiments conducted at Potsdam in 1887, H.C. Vogel was able to show that due to the extremely sensitive photographic methods employed he was able to produce great enough dispersion so that he could detect and measure any displacement of the spectral lines produced by motion in the line of sight. It was soon realised that this method produced a much higher degree of accuracy than direct observation and that the method was much less affected by atmospheric disturbances. More than two hundred negatives of forty seven stars were produced.

The great accuracy resulted from a careful construction of the apparatus, its exact adjustment and by the special methods employed in measuring the photographs.

It should be noted that great care was taken in the selection of suitable dimensions for the prisms, collimator

and camera objectives, in order to obtain sufficient brightness with the greatest possible dispersion. Further the photographic plate was carefully adjusted to keep it in the focal plane of the camera objective as well as keeping the star on the slit of the spectrograph.

The slit illuminated by a Geissler tube, which furnished the comparison spectrum, appeared in the telescope as a narrow line of light with the star in the middle and was easily held in position by means of slow motions of the refractor.

The place of the slit was adjusted to lie in the focus for the rays of wavelength $H \gamma$, for which the prisms were set at the angle of minimum deviation and which appeared on the middle of the negative. For nearly all the observations, hydrogen was chosen for the comparison spectrum. The Geissler tube was so arranged as to be at right angles to the optical axis of the refractor as well as to the slit, and therefore its light was dispersed on reaching the slit. It was found to be more advantageous to leave the width of the slit unchanged at 0.02 mm. and to give a uniform exposure of one hour. The performance of the apparatus was tested on the sun by direct observations and by photographs. Near the position of $H \gamma$, where the spectrum was sharpest, nearly all the lines were visible which are contained in Rowland's large photograph of the solar spectrum. The apparatus was further checked by comparing several photographs of the moon's spectrum with that of

hydrogen and an absolute coincidence of the corresponding lines was observed.

Most stars of the first spectral class showed, in addition to the broad and strongly marked hydrogen lines, a great number of other lines, so fine, however, that they could be distinctly recognised only in the case of brighter stars. The majority of these lines belonged to the iron spectrum, and could be readily identified with solar lines, the measurement of the displacement could therefore either be made by reference to the solar negative, or the iron spectrum be used for comparison.

In the case of fainter stars of this class, one was restricted to the hydrogen lines. This presented no problem when the pronounced maximum intensity lay outside the artificial line, but this seldom was the case. The maximum of intensity was generally not very sharply bounded, and with this gradual decrease of blackening on the negative, it could be accurately observed only in cases of much greater displacement. In order to overcome these difficulties a method of covering the H γ star line with an artificial line was used when a broad strip was brought exactly over the middle of the H γ line in the star. Thus, when the thread of the micrometer was set on the middle of the strip and the latter was then removed with the thread set on the artificial line, the difference in the readings then gave the displacement.

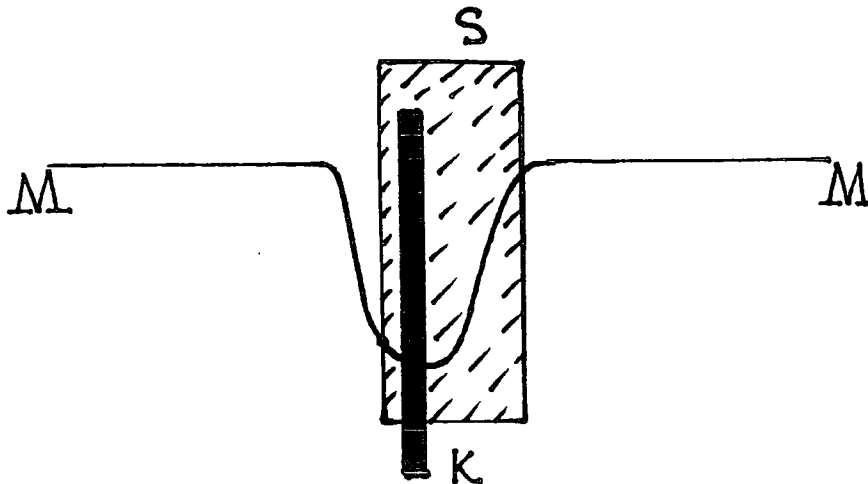

MM shows the intensity curve of the star spectrum near H γ , K is the artificial H γ , displaced from the middle by the star's motion and S is the strip covering the middle of the position of maximum intensity and the line K.

The setting of the strip over the middle of the broad H γ line could be accurately accomplished by using the density of the silver grains on either side of the strip.

When the line in the star spectrum was very broad and without a distinct position of maximum intensity another method was used for those stars having large velocities. A number of lines of varying breadth and

blackness were photographed on small glass plates, and one was selected which was nearest in blackness and breadth to the artificial H γ on the negative to be measured. The plate was then laid on the star negative and was adjusted so as to be symmetrical with the artificial H γ .

In the diagram the star line is represented by the dipping of the curve MM, K is the line from the Geissler tube, to which is symmetrically set the line S on the glass plate.

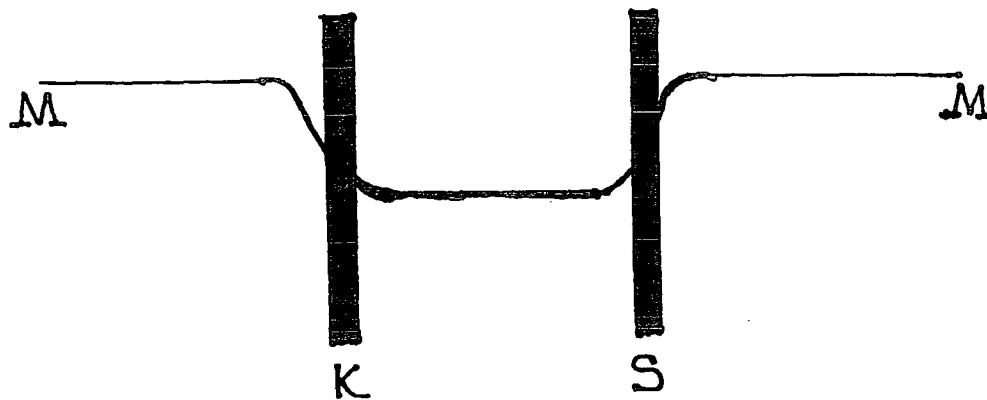

The micrometer measurement of the distance KS gives the double value of the displacement.

The first result of any importance which the spectrographic method furnished was the proof of the influence of the earth's motion on the displacement, which the earlier direct observations had failed to show with certainty. Changes in the motion of Algol were detected by this method and hence the existence of a dark satellite was proved. This was quickly followed by the discovery of the periodic motion of α Virginis.

CHAPTER 9.

NOVA CYGNI.

Vogel published details of his investigations of the spectrum of the new star in Cygnus where he put forward his own views as to the physical condition of the star as well as giving a criticism of those of other observers. (130) He observed the spectrum on sixteen different nights with the star varying in magnitude between 4.5 and 8.3. He showed that the spectrum of the new star was continuous, showing many dark lines and bands and several bright lines. The intensity of the continuous spectrum fell sharply from being initially very brilliant to being barely visible after a period of three months' viewing. The decrease in intensity was not uniform over the whole spectrum since the blue and violet rays faded much more rapidly than the green and yellow rays. The red part of the spectrum, having initially been dim and crossed by broad absorption bands, soon disappeared altogether leaving a bright line in the red quite isolated.

During the early observations the most conspicuous parts were a dark band in the green and a very broad dark band in the blue. At first the bright lines with the exception of a bright line in the red were only a little more brilliant than the continuous spectrum and so were seen with difficulty. As the intensity of the continuous spectrum decreased then the bright lines became more easily discernible. Indeed, the hydrogen lines $H\alpha$ and $H\beta$

became very bright as well as a line at a wavelength of λ 499. This last mentioned line remained longest when the spectrum faded away and finally became more bright than the hydrogen lines; whilst the red hydrogen line was the first to grow fainter.

Vogel said his results were not too accurate due to the poor atmospheric conditions but they did at least prove that the following bright lines appeared in the spectrum:-

- (1) The hydrogen lines $H \alpha$, $H \beta$ with $H \gamma$ being probable.
 - (2) A line of 499λ . This line showed fair coincidence with the brightest line in the nitrogen spectrum under ordinary pressure.
 - (3) An indistinct line at 580λ .
 - (4) An indistinct line at 497λ . This line nearly coincided with a group of lines in the atmospheric spectrum.
 - (5) Some bright lines were seen near to b and E but their position could not be measured.
- On December 5th and December 8th two lines were observed and measured in the blue (λ 474, 470), but later on only the second one was observed which by now was a blurred band of 467 .

Vogel now continued by discussing the views of other astronomers, dealing first with Cornu (131). Cornu measured several bright lines in the spectrum, wavelengths 661 ($H \alpha$), 558, 531, 517, 500, 483 ($H \beta$),

451, 435 (H γ). He saw no dark bands distinctly in the continuous spectrum, because according to Vogel he doubtless observed with a spectroscope of too great a power of dispersion and, therefore, many details escaped his notice. Cornu published a drawing of the spectrum showing it to consist of two parts and which contained no other details apart from the bright lines (132).

Since the line 588 λ as measured in the star spectrum corresponded closely with D₃ and the line 531 λ with the known corona line 531.6 λ as well as the 517 λ line with the centre of the magnesium lines b, Cornu decided that the chemical composition of the atmosphere of the star coincided completely with the chromosphere of the sun. Vogel however did not think that this conclusion was altogether justified, since a line (500 λ) which did not occur in the chromosphere was distinctly visible with the other bright lines in the spectrum and in time became the brightest line in the whole spectrum. Vogel pointed out that he and Cornu agreed with regard to the presence of the three hydrogen lines, and that of the brightest line of the atmospheric spectrum, or the principal line of the nebulae spectrum (500 λ). He could not determine the position of the bright green lines with any accuracy but quoted 527 λ and 514 λ for them respectively which varied considerably from Cornu's figures. Other variations were noted, i.e. in the blue region a 466 λ line was reported as 451 by Cornu and Vogel did not observe the 588 λ line except on one occasion.

Secchi said (133) that Cornu's description of the spectrum of the new star was correct, with the exception that the bright lines were not indistinct but well defined like the lines in spectra of nebulae. Secchi was positive that one of the bright lines was hydrogen, another a magnesium line and the third a sodium line. However, Vogel disagreed with these findings and stated that the bright lines observed were a considerable distance away from the sodium and magnesium groups respectively, their wavelengths being 500λ and 580λ .

Copeland using a spectroscope of Vogel's construction found the spectrum to be very bright, consisting of a faint continuous spectrum crossed by five bright lines of which he noted the following wavelengths:-

- (a) intense bright red λ 655;
- (b) 581λ in a bright band in the yellow;
- (c) 504λ ;
- (d) 486λ ;
- (e) 456λ in the violet.

It would seem that (a) and (d) were hydrogen lines whilst (c) was the brightest line of the nebulae spectrum. The maximum intensity of the continuous spectrum was near 525λ . Copeland's observations were similar to those of Vogel, the exception being the violet line λ 456 for which Vogel found a greater wavelength. Possibly the line λ 414 was an error of observation as λ 434 would make it the third hydrogen line H γ which was clearly visible.

Backhouse of Sunderland observed the spectrum in

January and found the brightest line to be at 503λ . He remarked (134) that the previous December the line at F was the brightest. These results agreeing with observations made by Vogel. Vogel considered a stellar spectrum with bright lines to be always a highly interesting phenomenon and worthy of considerable consideration. Although in the chromosphere of the sun, near the limb, one sees numerous bright lines, yet only dark lines appear in the spectrum whenever a small image of the sun was produced and examined through a spectroscope. It was generally believed that the bright lines in some few star spectra resulted from gases which broke forth from the interior of the luminous body, and the temperature of which was higher than that of the surface of the body. But this was not the only explanation. The atmosphere of a star, consisting of incandescent gases, was on the whole colder than the nucleus and with regard to the latter was extremely large. Vogel could not well imagine how the phenomenon could last for any long period if the first hypothesis was correct. The gas breaking forth from the hot interior of the body would impart a portion of its heat to the surface of the body and thus raise its temperature; as a result the difference of temperature between the incandescent gas and the surface would soon be insufficient to produce bright lines, and these would disappear from the spectrum. This view applied perfectly to stars which suddenly appeared and soon disappeared again, i.e. for so-called new stars, in the spectra of which bright lines

were apparent, if the hypothesis mentioned below is admitted for their explanation. For more stable states the second hypothesis seemed to Vogel to be more adapted; stars like β Lyrae, γ Cassiopeiae which showed the hydrogen lines and line D_3 bright on a continuous spectrum, with only small oscillations of intensity, possessed very large atmospheres in proportion, consisting of hydrogen and the unknown element which produces the line D_3 . With regard to the new star, Vogel pointed to a hypothesis of Zollner in which he supposed that upon the surface of a star, through the constant emission of heat, the products of cooling, accumulated in such a way that finally the whole surface of the body was covered with a colder stratum which gave much less light or none at all. Through a sudden tear of the stratum, the interior incandescent material broke out and according to the extent of its eruption, caused larger or smaller patches of the dark envelope of the body to become luminous again. To a distant observer such an eruption must appear as the sudden flashing up of a new star. That this evolution of light may under certain circumstances be an extremely powerful one, could be explained by the circumstance that all the chemical compounds which under the influence of a lower temperature had already formed upon the surface, are again decomposed through the sudden eruption of these hot materials, and that this decomposition took place under the evolution of light and heat. Thus the bright flashing up was not only ascribed to the parts of the surface which through the eruption of the incandescent matter have again become luminous, but also to a simultaneous process of

combustion, which was initiated through the colder compounds coming into contact with the incandescent matter.

Zollner's hypothesis on the gradual development of heavenly bodies had been confirmed in its main points by spectrum analysis. One could recognise the different states of cooling in the spectrum, and in the cases of some fainter stars there was distinct data that in the atmospheres surrounding incandescent bodies, chemical compounds may already form and continue to exist.

The hypothesis on new stars was in no way contradicted by the spectral observations made of the two new stars of 1866 and 1876. The very bright continuous spectrum and the bright lines, which at the beginning only slightly exceeded its brilliancy, could not be well explained if one only supposes a violent eruption from the interior which again rendered the surface luminous, but were easily explained by the hypothesis that the quantity of light was considerably augmented through a simultaneous process of combustion. If this process was of short duration, then the continuous spectrum would quickly decrease in intensity down to a certain limit, while the bright lines in the spectrum, which resulted from the incandescent gases that have emanated in enormous quantities from the interior, would remain for some time.

The observations of the spectrum showed beyond doubt that the decrease in the light of the star was in connection with the cooling of its surface. The violet and blue parts decreased more rapidly in intensity than the other parts and the absorption bands which crossed the spectrum had gradually become darker and darker.

CHAPTER 10.

SPECTRA OF NEBULAE.

Observations on nebulae had proved difficult because they were very faintly luminous and this brightness cannot be increased by optical methods.

At the end of the 18th Century, Sir William Herschel, following a series of observations, suggested that the nature of nebulae to be:-

" ... a luminous matter accounting much better for it than clustering stars at a distance ...

If this matter is self-luminous, it seems more fit to produce a star by its condensation, than to depend on the star for its existence."

As the optical power of telescopes increased it was observed (140) that many nebulae could be resolved into countless stars and as a result many scientists thought that all nebulae could be resolved into stars. Nebulae could thus be thought of as existing star galaxies rather than the early stages of some evolutionary process.

Huggins, in 1864, observed the planetary nebula in Draco and saw a single bright line. The light thus seemed to be monochromatic and could not be extended any further. On passing the light through two prisms it remained as a single line having a width corresponding to that of the slit. Closer observation showed two other bright lines on the blue side.

Nebulae thus seemed to consist of luminous gas and hence to be quite different of stars which gave rise to

a different spectrum. Later observations showed up two lines of hydrogen together with element helium. Recent observations showed that the temperature of the nebulae was high, i.e. the molecules have motions equivalent to that of a high temperature. However, because of the great size of the nebulae, a fairly small number of luminous molecules could cause the state of brightness that was observed. Thus their mean temperature could be low corresponding to that of a gas in an early stage of condensation.

Some of the nebulae gave rise to an appearance of round or oval discs in the telescope. For this reason Sir William Herschel called them Planetary Nebulae. Many of this class were blue tinted with green which was rare amongst single stars and further they showed no signs of central condensation. Huggins' description of individual nebulae were as follows:-

DRACO, No.4373. Herschel Catalogue (Phil. Trans Part 1
1864. pp 1-138)

A short line of light perpendicular to the direction of dispersion was observed. Much of the light was monochromatic which after passing through the prism remained concentrated in a bright line. Further careful observation showed a more refrangible fainter line separated from the bright line by a dark interval. Beyond this again a very faint line was observed. The position of these lines was determined by the simultaneous comparison method (as previously explained). The strongest line coincided with nitrogen and occurred midway between b

and F of the solar spectrum. The faintest line agreed with the hydrogen line corresponding to F of Fraunhofer. The other bright line was very close to the barium line 2075. Two very faint spectra were observed, one on either side of the bright lines. These were probably due to some solid or liquid matter in the nucleus. The overall colour of the nebula being greenish blue.

TAURUS PONIATOWSKI, No.4390.

The spectrum was very similar to that of No.4373 except the nebula did not have a distinct nucleus.

CYGNUS, No.4514.

The same three bright lines were seen. Further a solar spectrum could be detected between D and G which was much stronger than that in 4373.

SAGITTARIUS, No.4510.

Similar to 4373, but with only two of the bright lines being well defined.

AQUARIUS, No.4628.

Three very sharp and distinct bright lines with a suspicion of a faint spectrum.

LYRA, No.4447.

The brightest of the three lines was easily observed but there was no indication of a spectrum. The bright line proved interesting as it consisted of two bright dots with an extremely faint line joining them.

From the above observations, together with many others, it was seen that nebulae could not be thought

of as collections of suns. They appeared to be quite distinct with their own unique form and structure. They seemed to consist of huge masses of luminous gas or vapour, for light of particular refrangibilities only is emitted from the gaseous state and this is the type of light emitted from nebulae.

Had they been mere clusters of stars then they would cause an apparent increase of brightness towards the centre in proportion to the thickness crossed by the visual rays. Further spectrum analysis (142) showed that nebulae had a simple structure shown by the three bright lines possibly indicating nitrogen, hydrogen and helium.

During 1865 the Great Nebulae in Orion was examined, when the light from the brightest parts of the nebula near the trapezium was resolved into three bright lines. These lines were similar to those of gaseous nebulae. When the four bright stars α , β , γ , δ Trapezii were examined a continuous spectrum was observed together with the three bright lines of the nebula (143). The positions in the continuous spectrum corresponding to the three bright lines of the nebula were observed but no dark absorption lines could be detected.

All parts of the nebula were brought in turn onto the slit but throughout the spectrum remained unchanged consisting of the three bright lines only. It thus seemed that the whole of the nebula emitted light which differed in intensity only as one moved across its surface.

The most powerful instruments available showed that

the brighter parts of the nebula Orion were a 'mass of stars'. Hence the light from this part of the nebula should be the combined effect of these many star points. However, this light having undergone spectrum analysis showed no sign of any continuous spectrum as is normally produced by all the brighter stars.

Thus the telescope detection of tiny closely associated pinpricks of light with a nebula could no longer be accepted as certain evidence that the object was formed from true stars. These luminous points seemed to be more dense portions of the total gaseous body since they had a similar structure to the fainter outer parts of the nebula which had failed to undergo further resolution.

All the nebulae which gave rise to a gaseous spectrum showed the same three bright lines. Thus nebulae appeared to possess a structure quite distinct from the order to which our sun and fixed stars are members. Had the gaseous substance represented the material from which stars were to be formed by condensation then the gaseous spectrum would be expected to show numerous groups of bright lines as frequent as the dark absorption lines in the spectra of stars.

Nebulae being extremely faint objects have been examined only so far as to show the general character of their spectra. Clusters and nebulae showed either a spectrum of one, two or three bright lines or showed an apparently continuous spectrum, i.e. the spectrum could not be resolved into bright lines (it was not possible to see if the spectrum was crossed by dark absorption

lines as is the solar spectrum).

The intensity of the brightest line in the spectra of the gaseous nebulae was greater than (generally) the intensity of light of the same refrangibility of the other types which furnished a continuous spectrum. This in turn could indicate a more intense source of heat and thus the gaseous spectra nebulae could be regarded as the hottest class.

Observations of nebulae with gaseous spectra.

No.2102.

One bright line between b and F of the solar spectrum, probably corresponding in position to the brightest lines of nitrogen. The two other bright lines were observed in 1865 together with a suspicion of a continuous spectrum.

No.4234.

Three bright lines were observed taking up positions similar to the bright lines of No.4373. (144)

Observations of nebulae giving continuous spectra.

No.1950.

Continuous spectrum being very faint at the red end.

No.4230.

Continuous spectrum ending sharply at the orange.

FURTHER OBSERVATIONS 1868.

At this time about seventy nebulae had been examined in detail (145). Approximately one third of them gave a bright line spectra. This was higher than one would have obtained if a greater series of observations had been taken since the nebulae chosen on characteristics which indicated a gaseous character. At this time the brightest of the three lines which coincided in position with the brightest lines of the nitrogen spectrum was present in all the nebulae which gave rise to a spectrum indicating a gaseous structure. Further, no nebula giving a bright line spectra showed any further lines on the brighter and less refrangible side of the common bright line to all gaseous nebulae.

GREAT NEBULA IN ORION.

It was observed that the coincidence of the line in the nebula with the brightest of the nitrogen lines was seen as accurately as before but this time more rigour was taken of the techniques used. The line in the nebula was narrower than the double nitrogen lines and it proved impossible to find any splitting of this line into two. The third line in the nebula was found to be perfectly coincident with the thin sharply defined line of hydrogen. The measurements were about four times more accurate than the previous observations and so gave a probability that the line in the nebula was due to luminous hydrogen.

Orion was further examined in 1872 using a new and much more powerful instrument. With this series of observations four lines were seen (146). The first line was seen to be narrow with well defined edges.

Further, it proved impossible to find a set of physical conditions with luminous nitrogen in which the line had the same characteristics with the single line of the nebula. However it was still considered that this line in the nebula was due to nitrogen.

The second line was found to be slightly less refrangible than a strong line in the barium spectrum. It was found to have a wavelength of λ 4957 on the Ångström scale and thus it might indicate the presence of iron. In the case of the third and fourth lines, they agreed in position with two lines in the hydrogen spectrum, that at F and the other line near G.

The spectrum of Orion was photographed in 1882. The plate showed a spectrum of bright lines together with a narrow continuous spectrum possibly due to stellar light.

The previous observations of 1872 showed four bright lines, (147), the brightest line λ 5005 being coincident with the less refrangible part of the double line in the nitrogen spectrum. The second line λ 4957 with the two other lines coincident with two of the hydrogen lines H β or F, and H γ near G. In the photographic plate these lines appeared faint but were measurable and in addition a relatively strong line in the ultra violet was shown of λ 3730. Due to the wide width of the slit it proved impossible to tell if this line was single or double or multiple. This line appeared to correspond to of the typical spectrum of white stars.

During 1889 Orion was again photographed but this time a plate was obtained using a narrow slit. This

plate not only showed a strong line at about λ 3730 but also another pair of lines on the less refrangible side of the strong line. There was also the continuous spectrum of two of the four bright stars of the Trapezium across which four groups of bright lines could be seen. Thus it seemed that these stars were physically connected with the gaseous matter of the nebula.

The first group consisted of six lines falling between λ 4116 and λ 4167. Beyond these there was a group of four lines a little beyond . The third faint group lay between λ 3896 and λ 3825. These same lines were seen in the adjoining nebula matter. Two further lines at λ 3709 and λ 3699 were also observed.

A photograph was obtained under very good weather conditions when the slit was very narrow. This plate appeared to be somewhat different from that taken in 1888 insofar as the previously conspicuous line at λ 3730 was not now observed. Two further pairs of lines were noticed in the more refrangible region.

Two faint bright lines were seen within the continuous spectra of the brighter stars of the Trapezium.

The Visible Spectrum.

The brightest line was coincident with the middle of the less refrangible line of the double line of nitrogen according to the observations of 1872. This nitrogen line was hereafter called N_1 by Huggins. Since N_1 was rather diffused, a better line for comparison was sought and a narrow line of lead was discovered which lay almost in the middle of N_1 .

During December 1872 a total of seven gaseous nebulae were examined using the lead line as comparison and, in all cases, no relative changes of position were discovered. The wavelength of the brightest line was taken after several comparisons as λ 5004.7.

The second line by comparison with a barium line and later an iron line was determined as λ 4957.0.

The third line by comparison with hydrogen and confirmed by photographs was determined as λ 4860.7.

The fourth line coincided with the line H δ which was confirmed by photographs and was determined as λ 4340.1.

It was next decided to compare the nebular lines directly with the spectrum of burning magnesium. The experiments were performed during March 1889. The relative positions of the two spectra are to be seen in the diagram.

The interpretation of the lines observed was discussed with great caution, as it was felt that many more photographs should be taken covering different parts of the nebula. Huggins felt that with some certainty that two of the lines were due to hydrogen. The fineness of the lines indicated a high temperature and a highly dispersed state. This, in turn, could indicate that the other substances may exist under high temperature conditions and be of a low vapour density.

When it came to the groups of lines which crossed the star spectra it was noted that the lines were strong and distinct and that some extended into the surrounding

nebular matter. No decision could be made at the time as to whether they were peculiar to the stars and the closely adjoining material or whether they would be found everywhere in the nebula or merely in certain parts. The first group showed, in general, a strong iron group whilst the position of the third group indicated the presence of the cyanogen group. On further checking it was felt that the nebula group began earlier by one strong line than the cyanogen group and presented a different character and thus the lines could well not be due to cyanogen.

Huggins suggested (1889) that, in general, nebulae stood near the beginning of an evolutionary cycle. They appeared to consist of gas at a high temperature in a state of dissociation probably arranged in order of vapour-density.

The nebulae would take second place in the evolution theory put forward by Croll⁽ⁱ⁾ whereby existing solid bodies are converted to gas of a very high temperature. Many of the nebulae gave the appearance of flat discs without condensation, and if it was assumed that they were gaseous in nature then the light emitted from the more distant parts would be in some extent absorbed by the intervening gas giving rise to an appearance of a luminous surface only.

Some of the nebulae possessed a very faint continuous spectrum which further examination could well show to consist of closely adjacent bright lines.

The plate taken in 1888 was re-examined by Liveing in 1894, who stated that there were indeed faint lines on both sides of the strongest line $\lambda 3727$. In the same year

(i) JAMES CROLL (1821-1890) SEE 'STELLAR EVOLUTION AND ITS RELATION TO GEOLOGICAL TIME'.
144.

Scheiner, Keeler and Hale all confirmed that the negative showed the presence of real lines.

The principal line in the spectrum of Orion had its position redetermined in 1890, using an improved instrument. The main improvements being new object-glasses by Sir Howard Grubb, together with a variable brightness pointer by Hilger. The new arrangement eliminated any sensible parallax effect from a change of position of a light source. For any movement of the source of light for comparison had the effect of pushing the light to one side, without the slit: hence if the comparison spectrum was seen then the light falling on the slit was always in the same direction relative to the optical axis of the telescope. (See later.)

For the nebular line a position of λ 5005.0 was recorded.

Further photographs of the Orion spectrum were obtained in March 1890. Two photographs were obtained covering approximately the same area as those taken in 1889. The new photographs showed the hydrogen lines at h and H to be most strongly marked when no trace of them could be detected with the previous photographs.

The new photographs further showed the first two lines of the ultra-violet series in the white stars described in 1879.

The line ζ at λ 3887.8 was strong whilst the next line η at λ 3834.5 was much more faint (149). There was some evidence of the line θ being present and it was believed that one or more of the other lines of the white star series may have made their appearance with a longer exposure. Further, the hydrogen lines were noticeably

stronger and broader on the plate as the Trapezium with its stars were approached.

A strong line was observed at λ 3868.

The strongest line observed in the photographic region was taken as at λ 3724 when the narrow slit was being used.

The background to the spectrum contained numerous faint lines, which seemed to be the same as observed in the earlier photographs.

A strong feature of the lines was their abruptly different intensities at different parts of their length giving rise to a blotchy appearance. The length of the slit took in a large angular extent of the nebula, and therefore included within it one or more of the brighter mottlings. These brighter blotches had sharply defined boundaries which indicated that different parts of the nebula were to some extent distinct.

The lines on the new photographs showed two very strong and sharply bounded blotches plus a third area slightly less well defined.

The brighter blotches seemed to indicate a different condition of the nebula on the two sides of the star spectra.

CHAPTER 11.

INSTRUMENTS. *

The direct vision spectroscope of Thollon was able to be modified so that it combined its excellent definition with a means of reducing to a minimum errors of adjustment within the workings of an automatic system. (150)

Two prisms were used, where one is fixed and which received light from a collimator by a reflecting prism and then transmitted the light in a plane perpendicular to the axis of the collimator to the second prism.

The second prism was moveable about an axis parallel to its edge and to the axis of the telescope. A right angled reflecting prism was attached to it, so that the light having crossed this prism twice passed the second time through the fixed prism and so by reflection into the telescope.

The design was intended to obtain considerable dispersion with minimal light loss together with good definition in all parts of the spectrum (151).

Previous work had already shown that one half-prism attached to the collimator with one face perpendicular to the axis together with another attached in a similar way to the telescope enabled a larger beam of light to be used (larger in proportion to the size of the face of the prism) than if one used a single prism with an angle equal to the sum of the angles of the two prisms.

Two half-prisms were attached to the collimator and telescope respectively and there were two whole prisms

* SEE (157)

between them. These were compound prisms, so as to obtain considerable dispersion without the loss of light involved in a very oblique incidence.

The prisms must be adjusted to give minimum deviation in order to obtain good definition or even to see the faint lines at the ends of the spectrum.

The collimator L was fixed to the table of the instrument so that the prolongation of the first face of the half-prism attached to it passed through the centre of the table; a broad arm E turned on an axis C at the centre of the table, carried the telescope T and a vernier. The two whole prisms were each carried by an arm moveable about the same axis C as the telescope. The plane through the edge of the first prism A and the axis C was made always to bisect the angle between the plane through the edge of B and the same axis and the plane which was the prolongation of the first face of the half-prism attached to the collimator. This was effected by two levers, one working on a pivot E fixed to the table, and the other working on pivot g fixed to the arm F which carried the prism B. These two levers had at their ends a common pivot f, which worked in a slot in the arm G which carried the prism A. The line CA thus always bisected the angle g C e. By similar levers attached to the arms E and G the line BC was made always to bisect the angle l C h. By this mechanism the prisms were always kept symmetrically arranged.

The linear spectrum produced by a star formed at the focus of the objective lens is too narrow for the observation of the dark lines. Thus the image of the star needs to be spread out, and further to be enlarged in one direction only so as to prevent loss of light. The most suitable arrangement was found to be the use of a cylindrical lens as first employed for this purpose by Fraunhofer. The cylindrical lens being plano-convex was placed within the focus of the objective lens and immediately in front of the slit of the collimator.

With reference to the diagram figures 1 and 2.

- (a) plano-convex cylindrical lens $f = 14''$;
- (d) slit, with over one half of it, a right angled prism (e) so placed as to reflect light from the mirror (f) through the slit;
- (g) achromatic collimating lens (T. Ross) so made that it received the whole of the light which diverged from the linear image of the star when this was brought exactly within the jaws of the slit;
- (h) two dispersing prisms with a refracting angle of 60° which were adjusted to the angle of minimum deviation for the ray D.

Considering the telescope part of the apparatus.

The mirror f received the light which was compared with that of the star spectrum and in turn reflected it upon the prism (e) in front of the slit (d). This light was usually obtained from an induction coil. The connections

of the coil system were so arranged so that the observer could make and break contact without removing his eye from the telescope. This was important since, by tilting the mirror (f) it was possible within limits to alter the position of the spectrum of the metal relative to that of the star. Thus the observer was able to have perfect correspondence in relative position in the instrument of the stellar spectrum and the spectrum to be compared with it.

Since stars emit very limited amounts of light it was important to spread out the spectrum to the smallest amount to permit easy measurements of the separation of the principal lines. Further, if a slit was to be used then it would have to be narrow and hence it would only allow a portion of light to enter the collimator and thus greatly increase the time required to obtain a photographic exposure.

Huggins decided to use a slit because it firstly gave a more pure spectrum, and secondly it enabled a second comparison spectrum to be formed on the same plate as the stars spectrum. The photographic plates employed were $1\frac{1}{2}$ " x $\frac{1}{2}$ " which took a photographic spectrum of about $\frac{1}{2}$ " between the lines G and P in the ultra violet. The definition was so good as to enable a low powered microscope to be used to observe about fourteen lines between the lines H and K. The apparatus in general gave a sufficiently defined separation of the parts of the spectrum with a moderate diminution only of the intensity of the stars light.

A compromise had to be reached on the width of the slit used. A very narrow slit which gave the best photographs of solar spectra tended to seriously diminish the light of the stars. On opening up the width of the slit to about $\frac{1}{350}$ " the solar lines were still well defined but the number of lines able to be counted between H and K was reduced to about seven.

It was most important to have a method of bringing the stars image easily and accurately onto any required part of the slit. Further, it was required to have a method of continuously observing the star's image when on the slit for the whole period of the exposure in order to rectify any motion of the telescope which could move the star's image off the slit.

A circular thin plate of highly polished silver was taken with a narrow opening in the centre slightly larger than the slit itself, ^{which} was fixed over the spectroscope slit. The plate acted as a plane mirror, and after a rough focussing of the telescope a bright image of the star could be seen on the plate. When artificial light was projected onto the plate, then the plate itself became visible and so the opening in the plate and the slit inside the opening could be observed at the same time as the image of the star as a bright spot upon it. Thus the star's image might be brought with accuracy on any part of the slit. Since the star's image was wider than the slit itself, it was possible to keep the star in view on the slit for the whole exposure time and to quickly correct any small movement of the

star's image from the required position on the slit.

The star's image was not a point and so its linear spectrum had a small breadth , but too small for the lines to be well seen. Once sufficient exposure had elapsed to allow the production of a linear spectrum then the image of the star was moved upon the slit in the direction of its length through the diameter of the star's image. The exposure was continued again for the same time as above and thus a photographic spectrum could be obtained of the required breadth by the union of two or more linear spectra.

The spectroscope described above was arranged to include the whole of the ultra-violet region of the light from stellar objects. (154).

An 18 inches aperture Cassegrain telescope was chosen mainly because it tended not to suffer from the chromatic aberrations of a refractor and also because it used Iceland spar for the prism and quartz for the lenses thus enabling the whole of the more refrangible part of the spectrum to be photographed.

This telescope had speculum metal mirrors of a very fine defining power and when first used between 1876 and 1879 it was linked with a small spectroscope whose slit was placed at the principal focus of the great speculum (the small convex speculum having been removed).

It was decided to attempt to use the slit jaw-plates as mirrors when a reflection of the luminous object together with the slit itself could both be observed. The early

experiments used polished silver and then thin silvered plates of quartz as the reflecting surface. Later on it was found that speculum metal could give a good reflecting surface together with the ability of providing a sharp edge for the slit. The first experiments involved having a hole in the great speculum through which the reflections were observed using a small telescope which stood in place of the normal eyepiece.

The above arrangement, however, soon showed up several disadvantages. Firstly, although the spectroscope was made as small as possible it was still larger than the hole in the speculum and so blocked out some of the light. Secondly, the adjustments to the spectroscope could only be performed at the top of the tube which proved to be inconvenient. Thirdly, changing the photographic plates proved difficult.

Furthermore the collimator had to be made very short due to the large ratio of the aperture to the focal length of the great speculum. Hence the spectroscope was restricted to having only one prism which resulted in either the quantity of light or the purity of the spectrum being sacrificed.

However it did have one advantage in that it did reduce the loss of light by reflection.

The instrument was now redesigned by restoring the Cassegrain telescope to its original form and with the collimator of the new spectroscope passing through a hole in the large speculum. The slit being placed within the telescope at the focal plane after reflection from the small convex speculum. This design was free from the disadvantages of the early arrangement but suffered from

the additional loss of light from reflection at the second speculum.

Fig. 9 shows the collimator within the telescope tube.

Fig.10 shows the remaining part of the spectroscope both outside and below the telescope tube.

Fig. 6 A rod was used to adjust the slit and behind the slit there was a shutter which closed the central half of the slit so as to protect the part of the plate on which the stars' spectrum falls when narrow comparison spectra are photographed through the outer parts of the slit, above and below the stars' spectrum.

When an observer looked into the diagonal eyepiece (see fig.10) the slit and a small field of stars were seen. The eyepiece by means of a clamp could be adjusted to the most useful observation position. The slit plates were so inclined as to reflect any light not passing through the slit to one side of the tube, where a prism arrangement returned it along the view tube at the side of the collimator. A series of achromatic lenses together with a suitable eyepiece gave rise to a well defined and bright view of the small field of stars upon the slit plates.

The arrangement for showing comparison spectra from sparks or flames is seen in fig.9.

An inner tube ending in a right angled reflecting prism could be moved through an outer tube until the reflecting prism came just in front of the slit. The

external light was then converged to a focus on the slit and then diverged slightly more than necessary to fill the collimator lens.

To give the required breadth to the star spectra the star's image was allowed to trail in the slit or a concave cylindrical lens could be used in place of the sliding diaphragm tube.

A method was required whereby the positions of lines observed in the spectrum of the corona could be recorded without the removal of the eye from the instrument. It was decided that this could be achieved by having a pointer within the eyepiece which moved across the spectrum using a quick motion screw. This device was found to be suitable for the rapid registration of spectra. (155)

The small telescope of the spectroscope was fixed and a pointer was placed at its focus which could be moved by a screw mechanism outside the telescope. The spectrum and pointer were viewed by an eyepiece so designed that any part of the spectrum could be brought into the centre of the field of view. A lever and card mechanism was in turn attached to the pointer.

It was found that ten to twelve Fraunhofer lines could be registered in fifteen seconds and that when the same lines were recorded five times in succession no discernible difference of position could be recorded.

REFERENCES.

1. SIR I. NEWTON 'Opticks', 4th Edition, London, 1730. Reprinted New York, Dover Books, (1952) p.72.
2. THOMAS MELVILLE 'Observations on Light and Colours', p.35.
Notes on the above:- Journal of the Royal Astronomical Society of Canada, Volume 8, (1914) pp 231-272.
3. W.H. WOLLASTON Philosophical Transactions of the Royal Society, Volume 75, (1785), pp 120 and 190.
4. W.H. FOX TALBOT Philosophical Magazine, 3rd Series, Volume 4, (1834) p 112.
5. W. SWAN Philosophical Transactions of the Royal Society of Edinburgh, Volume 21, (1857) p 411.
6. W.H. WOLLASTON Philosophical Transactions of the Royal Society, Volume 92, (1802), pp 378-380.
7. SIR WILLIAM HERSCHEL Philosophical Transactions of the Royal Society, Volume 90, (1800), p 255.
8. J. VON FRAUNHOFER Denkschriften Der Koniglichen Academie Der Wissenschaftler Zu Munchen, Band 5, (1814/1815) pp 193-226.

see also translation of the above
SIR DAVID BREWSTER Edinburgh Philosophical Journal, Volume 9, p 296 and Volume 10, p 26 (1823).
9. J. VON FRAUNHOFER Edinburgh Journal of Science, Volume 8, (1823) p 9 and p 220.
10. SIR DAVID BREWSTER Philosophical Transactions of the Royal Society of Edinburgh, Volume 9, (1822), p 435.

11. SIR J.F.W. HERSCHEL Philosophical Transactions of the Royal Society of Edinburgh, Volume 9, (1822), p 435.
12. SIR D. BREWSTER American Journal of Science, Volume 16, (1829), p 301.
13. SIR J.F.W. HERSCHEL Encyclopaedia Metropolitana, Volume 4, (1827), pp 409 and 433.
14. SIR D. BREWSTER British Association for the Advancement of Science, (1832), p 319.
15. SIR G.B. AIRY Philosophical Magazine, 3rd Series, Volume 2, (1833), p 423.
16. W.H. FOX TALBOT Philosophical Magazine, 3rd Series, Volume 6, (1834), p 114.
17. W.A. MILLER Philosophical Magazine, 3rd Series, Volume 27, (1845), pp 81-91.
18. I.A.M.F.X. COMTE Cours De Philosophie Positive Paris (1835)
and
L'Institute, Volume 3, pp 31-33.
19. J.W. DRAPER)
)
)
20. J.W. DRAPER)
)
)
21. J.B.L. FOUCAULT Philosophical Magazine, 4th Series, Volume 19, (1860), pp 193-197.
(G.G. Stokes, Translation.)
22. W.A. MILLER Philosophical Magazine, 4th Series, Volume 25, (1863), p 261.
23. J.C. DOPPLER Abhandlungen Der Kohln Böhmsch Gesellschaft Der Wissenschaftler, Band 2, (1841/1842), p 467.
24. H.L. FIZEAU Societe Philomathique De Paris, (Dec. 1848), p 81.

40. W.A. MILLER Philosophical Magazine, 3rd Series, Volume 27, (1845), pp 80-91.
41. SIR WILLIAM CROOKES Chemical News, Volume 5, May 18th, 1862, p 234.
42. G. KIRCHHOFF Philosophical Magazine, 4th Series, Volume 25, (1863), p 261.
43. A.J. ÅNGSTRÖM Philosophical Magazine, 4th Series, Volume 24, (1862), pp 1-11.
44. G.J. STONEY Proceedings of the Royal Society, Volume 17, (1868), pp 17-20.
45. G. KIRCHHOFF 'On the Solar Spectrum', Berlin Academy of Science, July 1861.
46. SIR J. NORMAN LOCKYER Proceedings of the Royal Society, Volume 15, (1866), p 256.
47. H. FAYE Comptes Rendus, Volume 49, (1859), pp 696-705.
48. SIR WILLIAM HUGGINS Philosophical Transactions of the Royal Society, Volume 148, (1868), p 529.
49. SIR J. NORMAN LOCKYER Monthly Notices of the Royal Astronomical Society, Volume 25, (1865), p 237.
50. SIR J. NORMAN LOCKYER Philosophical Transactions of the Royal Society, Volume 149, (1869), p 425.
51. J.W. HITTORF Philosophical Transactions of the Royal Society, Volume 145, (1865), pp 1-29.
52. E. FRANKLAND Proceedings of the Royal Institution, Volume 5, (1869), pp 419-423.
53. SIR J. NORMAN LOCKYER Proceedings of the Royal Society, Volume 17, (1869), p 288.

54. SIR J. NORMAN LOCKYER Nineteenth Century Review,
June 1897.
55. SIR WILLIAM HUGGINS Monthly Notices of the Royal
Astronomical Society, Volume 26,
(1866), p 260.
- see also Philosophical Transactions of the
Royal Society, Volume 148, (1868),
p 529.
56. SIR J. NORMAN LOCKYER Proceedings of the Royal Society,
Volume 15, (1866), p 256.
57. SIR WILLIAM HUGGINS Monthly Notices of the Royal
Astronomical Society, Volume 38,
(1868), p 88.
58. SIR WILLIAM HUGGINS Monthly Notices of the Royal
Astronomical Society, Volume 29,
(1868), p 4.
59. SIR WILLIAM HUGGINS Monthly Notices of the Royal
Astronomical Society, Volume 30,
(1869), p 36.
60. SIR WILLIAM HUGGINS Proceedings of the Royal Society,
Volume 39, (1885), p 108.
61. SIR WILLIAM HUGGINS Proceedings of the Royal Society,
Volume 30, (1869), p 20.
62. A. SCHUSTER Proceedings of the Royal Society,
Volume 35, (1883), pp 151-155.
63. S.P. LANGLEY American Journal of Science
(Silliman's) Third Series,
(Sept. 1884), p 163.
64. A. SCHUSTER Philosophical Transactions of the
Royal Society, (1884), pp 264-270.
65. SIR J. NORMAN LOCKYER Monthly Notices of the Royal
Astronomical Society, Volume 25,
(1865), p 237.
66. SIR J. NORMAN LOCKYER Proceedings of the Royal Society,
Volume 15, (1866), p 256.

67. SIR J. NORMAN LOCKYER Proceedings of the Royal Society, Volume 15, (1866), p 256.
68. SIR J. NORMAN LOCKYER Philosophical Transactions of the Royal Society, Volume 149, (1869), p 425.
69. D.F.J. ARAGO Annuaire Du Bureau Des Longitudes (1846), pp 271/372/477.
70. R. GRANT History of Physical Astronomy, London, (1852), p 400.
71. W. SWANN Transactions of the Royal Society of Edinburgh, Volume 20, Part 3 (1853), pp 462-464.
72. E. LIASIS L'Espace Celeste et la Nature Tropicale.
Notes by H. Faye Comptes Rendus, Volume 48, (1859), pp 159-174.
73. H. FAYE Comptes Rendus, Volume 48, (1859), p 163.
74. U.J.J. LE VERRIER Comptes Rendus, Volume 68, (Feb. 1869), pp 314-320.
75. BALFOUR STEWART See Philosophical Magazine, 4th Series, Volume 24, (1862), pp 302-305.
76. G.J. STONEY Monthly Notices of the Royal Astronomical Society, Volume 28, (1868), p 19.
77. SIR J. NORMAN LOCKYER Proceedings of the Royal Society, Volume 17, (1869), p 350.
78. SIR J. NORMAN LOCKYER Proceedings of the Royal Society, Volume 18, (1869), pp 74-118.
79. P.A. SECCHI Comptes Rendus, Volume 68, (1868), p 580 and Volume 109, (1869).
80. P.A. SECCHI Comptes Rendus, Volume 68, (1869), p 764.

81. SIR J. NORMAN LOCKYER Proceedings of the Royal Society,
Volume 18, (1870), p 354.
82. J.K.F. ZOLLNER Saxon Academy, 2nd June (1870).
83. C.A. YOUNG Nature, Volume 3, (1870), p 112.
84. L. RESPIGHI Reale Accademia Dei Lincei,
Volume 24, 4th Dec. (1870),
pp 62-112.
85. P.A. SECCHI Comptes Rendus, Volume 73,
(Oct. 2nd, 1871), pp 826-836.
86. C.A. YOUNG Journal of the Franklin Institute
No.524, (1869), p 141.
see also Nature, Volume 3, (1870), p 112.
87. C.A. YOUNG Nature, Volume 3, (1870), p 111.
88. C.A. YOUNG Nature, Volume 3, (1870), p 17.
89. C.A. YOUNG Nature, Volume 7, (Dec. 1872), p 109.
90. SIR J. NORMAN LOCKYER Proceedings of the Royal Society,
Volume 15, (1868), pp 128-131.
91. C.A. YOUNG Nature, Volume 3, (Dec. 1870),
p 110 et seq.
92. J.K.F. ZOLLNER Astronomische Nachrichten, Volume 74,
(1869), pp 269-272.
93. SIR W. HUGGINS Proceedings of the Royal Society,
Volume 17, (1869), p 302.
94. SIR J. NORMAN LOCKYER Proceedings of the Royal Society,
Volume 18, (1869), p 350.
95. SIR W. HUGGINS Proceedings of the Royal Society,
Volume 21, (1872), p 127.

96. SIR J.F.W. HERSCHEL Proceedings of the Royal Society,
Volume 17, (1869), p 508.
97. C.A. YOUNG Journal of the Franklin Institute,
No.550, (Nov. 1871), p 348.
98. SIR J. NORMAN LOCKYER Proceedings of the Royal Society,
Volume 21, (1872), p 105.
99. L. RESPIGHI Atti Degli Reale Accademia Dei Lincei,
5th Note (May 1872), Volume 23,
pp 53-70 and 156.
100. P. TACCHINI Comptes Rendus, Volume 76,
(March 1873), p 829.
101. H.C. VOGEL Astronomische Nachrichten,
Volume 82, (1873), pp 291-298.
102. G. LORENZONI Memorie Della Societa Degli
Spettroscopisti Italiani, Volume 1,
(1872), pp 7-16.
103. C.A. YOUNG American Journal of Science
(Silliman's), 3rd Series,
(Nov. 1872), p. 356 etc.
104. H.C. VOGEL Astronomische Nachrichten,
Volume 82, (1873), pp 291-298.
105. P.A. SECCHI Comptes Rendus, Volume 68,
(March 1869), p 580.
106. SIR J.F.W. HERSCHEL Proceedings of the Royal Society,
Volume 18, (1869), p 64.
107. C.A. YOUNG Nature, Volume 7, (Dec. 1872), p 109.
108. G.B. DONATI Monthly Notices of the Royal
Astronomical Society, Volume 25,
(1864), p 114.
109. SIR W. HUGGINS Proceedings of the Royal Society,
Volume 15, (1866), p 5.

110. SIR W. HUGGINS Proceedings of the Royal Society,
Volume 16, (1868), p 386.
111. SIR W. HUGGINS Philosophical Transactions of the
Royal Society, Volume 144, (1864),
p 154.
112. SIR W. HUGGINS Proceedings of the Royal Society,
Volume 20, (1871), p 45.
113. G.D. LIVEING Proceedings of the Royal Society,
Volume 20, (1871), p 494.
114. SIR J. NORMAN LOCKYER Proceedings of the Royal Society,
Volume 30, (1880), p 461.
115. SIR W. HUGGINS Proceedings of the Royal Society,
Volume 34, (1882), p 148.
116. SIR W. HUGGINS Proceedings of the Royal Society,
Volume 33, (1881), p 1.
117. SIR W. HUGGINS Proceedings of the Royal Society,
Volume 12, (1863), p 444.
118. SIR W. HUGGINS Philosophical Transactions of the
Royal Society, Volume 154, (1864),
pp 413-435.
119. P.A. SECCHI Monthly Notices of the Royal
Astronomical Society, Volume 25,
(1865), p 153.
120. G.B. DONATI Monthly Notices of the Royal
Astronomical Society, Volume 23,
(1863), p 100.
121. P.A. SECCHI British Association Report,
(1868), p 166.
122. C.P. SMYTH Speculum Hartwellianum (1860).
123. D.F.J. ARAGO (Smyth/Grant) Translation
Popular Astronomy, Volume 1, p 295.

124. SIR WILLIAM HUGGINS Philosophical Transactions of the Royal Society, Volume 154, (1864), p 428.
125. SIR HOWARD GRUBB
126. SIR WILLIAM HUGGINS Philosophical Transactions of the Royal Society, Volume 154, (1864), pp 427-429.
127. H.C. VOGEL Monatsbericht Der Koniglichen Academie Der Wissenschaftler Zu Berlin, (1879), pp 241-259.
128. SIR WILLIAM HUGGINS Philosophical Transactions of the Royal Society, Volume 158, (1868), p 529.
129. SIR WILLIAM HUGGINS Proceedings of the Royal Society, Volume 20, (1872), p 379.
130. H.C. VOGEL Monatsbericht Der Koniglichen Academie Der Wissenschaftler Zu Berlin, (1877), pp 104-142.
131. M.A. CORNU Nature, Volume 15, (Dec. 1876), p 158.
132. M.A. CORNU Comptes Rendus, Volume 83, (1876), p 1172.
133. SIR WILLIAM HUGGINS Proceedings of the Royal Society, Volume 46, (1888), p 134.
134. M.A. CORNU Journal De Physique, Volume 10, (1881), pp 5-17.
135. SIR W.N. HARTLEY Journal of the Chemical Society, Volume 39, (1881), p 57 and 111-129.
136. SIR WILLIAM HUGGINS Proceedings of the Royal Society, Volume 48, (1890), p 216.
137. SIR WILLIAM HUGGINS Comptes Rendus, Volume 60, (1867), p 292.

READING LIST.

- G. ABETTI The History of Astronomy,
London, 1954.
- F. CAJORI A History of Physics,
London, 1962.
- A.M. CLERKE History of Astronomy During the
Nineteenth Century, London, 1902.
4TH EDN.
- R. GRANT History of Physical Astronomy,
London, 1852.
- W. HUGGINS An Atlas of Representative
Stellar Spectra, London, 1899.
- W. HUGGINS Scientific Papers of Sir William
Huggins, London, 1909.
- C.D. LIVEING
 and Collected Papers on Spectroscopy,
Cambridge, 1915.
- J. DEWAR
- W. MCGUCKEN Nineteenth Century Spectroscopy,
London, 1970.
- A. PANNEKOEK A History of Astronomy,
London, 1961.
- THE ROYAL INSTITUTION
LIBRARY OF SCIENCE Astronomy, Volume 1, ~~BARKING~~
Essex, 1970.
- M. SUTTON Spectroscopy and the Chemists,
AMBIX, Volume 23 (1976) No.1
Cambridge, p 16 etc.

READING LIST (Continued)

- SIR W. CROOKES Presidential Address Report of
the British Association, (1886)
pp 558-576
- H. DINGLE "A Hundred Years of Spectroscopy"
The British Journal for the History
of Science, i (1962/63) p 199-216
- E. E. FOURNIER-D'ALBE Life of Sir William Crookes,
London, 1923
- A. J. MEADOWS Science and Controversy London, 1972
- J. C. POGGENDORFF Biographisch-Literarisches Handwörterbuch,
Leipzig (1898)
- H. E. ROSCOE Six Lectures on Spectrum Analysis
4th Ed.) London 1885.
- ROYAL SOCIETY Catalogue of Scientific Papers,
Volumes 1-19, (Cambridge) (1908)
- ROYAL SOCIETY Biographical Memoirs of Fellows,
London, 1955
- G. G. STOKES Mathematical and Physical Papers,
Cambridge, 5 volumes (1922)
- G. G. STOKES Memoirs to Cambridge Philosophical
Society, Cambridge (1900)
- DICTIONARY OF SCIENTIFIC BIOGRAPHY
- T. I. WILLIAMS A Biographical Dictionary of Scientists
(2nd Ed.) London 1974
- G. L'E TURNER "On the History of the Development of
Astrospectroscopy in Russia and the U.S.S.R.
(O.A. Melnikov)
Istorico-Astronomicheski Issledovniya
Volume 3, 1957

Positions upon Kirchhoff's scale of the principal points of a scale which expresses the lengths of the light-waves in air.

(N.B. Those positions which have a note of interrogation after them are doubtful, as they are too distant from rays measured by Angström to admit of a safe interpolation.)

Wave-lengths in eighth-metres, i. e. metres di- vided by 10 ⁸ .		Kirchhoff's arbitrary scale.	Wave-lengths in eighth-metres i. e. metres di- vided by 10 ⁸ .		Kirchhoff's arbitrary scale.
43	corresponds to	2873.1	44.30	"	2051.5
43.10	"	2855.0	45	"	2553.2?
43.20	"	2837.0	46	"	2423.0?
43.30	"	2819.0	47	"	2202.5?
43.40	"	2801.1	48	"	2104.0?
43.50	"	2783.4	48.50	"	2099.8
43.60	"	2768.0	48.60	"	2086.7
43.70	"	2748.8	48.70	"	2073.7
43.80	"	2732.0	48.80	"	2060.8
43.90	"	2715.7	48.90	"	2047.9
44	"	2699.8	49	"	2035.2
44.10	"	2683.7	49.10	"	2022.6
44.20	"	2667.6	49.20	"	2010.2

VOL. XVII.

C

ANGSTRÖM'S λ CHART

TABLE (continued).

Wave-lengths in eighth-metres, i. e. metres di- vided by 10 ⁸ .		Kirchhoff's arbitrary scale.	Wave-lengths in eighth-metres, i. e. metres di- vided by 10 ⁸ .		Kirchhoff's arbitrary scale.
40.30	corresponds to	1998.0	55	corresponds to	1309.0
40.40	"	1986.1	55.70	"	1248.4
40.50	"	1974.3	55.80	"	1240.2
40.60	"	1962.5	55.90	"	1232.0
40.70	"	1950.8	56	"	1223.8
50	"	1913.0?	56.10	"	1215.6
51	"	1782.0?	56.20	"	1207.4
51.60	"	1673.0	56.30	"	1199.3
51.70	"	1658.3	57	"	1144.0?
51.80	"	1644.3	58	"	1070.0?
51.90	"	1630.8	58.90	"	1009.7
52	"	1617.5	59	"	1003.0
52.10	"	1604.3	60	"	948.0?
52.20	"	1591.2	61	"	897.2
52.30	"	1578.3	61.10	"	891.9
52.40	"	1565.5	61.20	"	886.6
52.50	"	1552.8	61.30	"	881.3
52.60	"	1540.2	61.40	"	876.1
52.70	"	1527.9	61.50	"	870.9
52.80	"	1516.1	61.60	"	865.7
52.90	"	1504.8	61.70	"	860.6
53	"	1494.1	61.80	"	855.5
53.10	"	1483.8	61.90	"	850.5
53.20	"	1473.7	62	"	845.5
53.30	"	1464.0	63	"	800.0?
53.40	"	1454.4	64	"	758.5?
53.50	"	1445.6	65	"	719.1?
53.60	"	1436.1	66	"	682.3
53.70	"	1426.6	67	"	648.3?
53.80	"	1417.2	68	"	615.9?
53.90	"	1407.7	69	"	584.8
54	"	1398.3	70	"	555.8?
54.10	"	1389.0	71	"	528.4?
54.20	"	1379.7	72	"	502.4?
54.30	"	1370.5	73	"	477.7?
54.40	"	1361.2	74	"	453.8?
54.50	"	1352.1	75	"	430.3?
54.60	"	1343.3	76	"	406.9
54.70	"	1334.7	77	"	383.0?

Wave-lengths of 63 rays of the solar spectrum in \AA units, reduced from Angström's determinations.

Designation of ray.	Wave-lengths in eighth-metres.	Intervals between rays in tenth-metres.	Corresponding positions on Kirchhoff's arbitrary scale.	Darkness of ray, 6 being the darkest, and breadth of ray, G being very broad, according to Kirchhoff.	Remarks.
H ₂	39.36	36 -	Ca.
H ₁	40.07+	36 -	Ca.
	48 -	40+	Unknown; strong.
	66	18+	Fe; strong.
	75	0	Fe; strong.
h	41.04-	20 -	Fe; strong.
		43+	H; very strong. Lately ascertained to be a fourth Hydrogen line.
	47	82+	Double.
g	42.29+	24	Ca; double line.
	53+	9+	Fe.
	63 -	12	Fe.
	75 -	36 -	Fe.
G	43.10+	18 -	2854.4	6	Fe; winged.
	28	15	2821.9	6	Fe; winged; broad.
	43	43+	2796.2	6	H; winged; very broad.
	80+	23	2721.2	6	Fe; winged; very broad.
	44.08+	10	2686.4	6 f	Fe; winged.
f	18+	447	2670.0	6 e	Fe.
F	48.65+	10+	2080.0	6 g	H; winged.
	76 -	19+	2066.6	5 o; 5 c	Fe; double.
	95	27+	2041.7	6 b; 6 c	Fe; double.
	49.22+		2007.2	6 c	Fe.
	24+	2	2005.2	6 d	Fe; winged on one side.
c	61	37 -	1961.0	4	Fe; with wings of intensity 6.
b _a	51.72 -	211+	1655.6	6 e	Fe; Mg; winged on one side.
b ₂	73+	2 -	1653.7	6 b	Fe; Ni; winged on one side.
b ₁	77	4 -	1648.8	6 f	Mg; winged.
	88	11	1634.1	6 g	Mg; winged.
	96+	8+	1622.8	5 b, 5 c	Fe; double like E.
	52.37	46 -	1569.6	5 c	Fe.
	70	28	1527.7	5 c	Fe; Co.
E ₂	73+	3+	1523.7	6 c	Fe
E ₁	74+	1	1522.7	6 c	Fe, Ca. } Interval between E ₂ and E ₁ = 1.07 Xth-metres.
	87+	13	1508.6?	5 b	Fe.
	53.20	33 -	1473.9	5 b	Fe.
	28 -	8 -	1466.8	5 c	Fe.
	32 -	4	1463.0	5 c, 5 e	Fe; double line, closer than E.
	44	12+	1451.8	5 b, 5 c	Fe; double line like E.

TABLE (continued).

Designation of ray.	Wave-lengths in eighth-metres.	Intervals between rays in tenth-metres.	Corresponding positions on Kirchhoff's arbitrary scale.	Darkness of ray, 6 being the darkest, and breadth of ray, G being very broad, according to Kirchhoff.	Remarks.
	53.69+	25+	1428.2	5 b	Fe.
	71+	2	1425.4	5 b	Fe.
	74+	5	1423.0	5 b	Fe.
	76 -	1+	1421.5	6 c	Fe.
	54.08+	33 -	1390.9	5 d	Fe.
	10 -	1+	1389.4	6 c	Fe.
	28+	19 -	1372.6	5 b	Fe.
	34 -	5+	1367.0	6 d	Fe.
	49+	16 -	1352.7	5 b	Fe.
	51	1+	1351.1	5 b	Fe.
	54.60 -	9	1343.5	6 c	Fe.
	55.77 -	117	1242.6	6 c	Fe.
	91	14+	1231.3	5 d	Fe.
	99	8	1224.7	5 d	Ca.
	56.03 -	4 -	1221.6	5 d	Ca.
	97	4+	1217.8	5 d	Fe; Ca.
	20	13	1207.3	5 g	Fe.
D ₂	58.94+	274+	1006.8	6 b	Na } Interval between D ₂ and D ₁ = 6.03 Xth-metres.
D ₁	59.00+	6	1002.8	6 b	Na }
	61.05 -	20+	894.9	2 e	Ca.
	24 -	19	884.9	4 b	Ca. Co.
	39 -	15	877.0	4 c	Fe.
	43+	5 -	874.3	4 b	Ba.
	63+	20	863.9	5 b	Ca.
	71	8 -	860.2	3 d	Cn.
	92 -	21 -	849.7	3 c	Fe.
a	62.59	67+	A strong line caused by the earth's atmosphere.
C	65.68	309	694.1	6 c	H; winged.
B	68.75	307	502.7	6 c	Winged on one side.
A	76.12	737	404.1	6	Winged.

ANGSTRÖM'S λ CHART (SOLAR SPECTRUM)

YOUNG.
 BRIGHT LINE SPECTRA
 IN THE CHROMOSPHERE.
 1ST CATALOGUE

Ref. No.	Kirchhoff.	Angström.	Relative Frequency.	Relative Brightness.	Chemical Element.	Previous Observer.
1	534.5	7060.?	60	3		
2	654.5	6677.?	8	4		
3	C	6561.8	100	100	H.	L. J.
4	719.0	6495.7	2	2	Ba.	
5	734.0	6454.5	2	3		
6	743.?	6431.	2	2		
7	768.?	6370.	2	2		
8	816.8	6260.3	1	1	Ti.	
9	820.0	6253.2	1	2	Fe.	

YOUNG 1ST CATALOGUE (CHROMOSPHERIC LINES)

NOTE II.

Ref. No.	Kirchhoff.	Ångström.	Relative Frequency.	Relative Brightness.	Chemical Element.	Previous Observer.
10	874.2	6140.5	6	8	Ba.	L.
11	D ₁	5894.8	10	10	Na.	L.
12	D ₂	5889.0	10	10	Na.	L.
*13	1017.0	5871.1	100	75		L. J.
14	1274.3	5534.0	6	8	Ba.	R. L.
15	1281.5	5526.0	1	1	Fe.	
16	1343.5	5454.5	1	2	Fe.	
17	1351.3	5445.9	1	2	Fe. Ti.	
18	1363.1	5433.0	1	1	Fe.	
*19	1366.0	5430.0	2	3		
20	1372.0	5424.5	3	4	Ba.	L.
21	1378.5?	5418.0?	1	2	Ti.?	
*22	1382.5	5412.1	1	1		
23	1391.2	5403.0	2	2	Fe. Ti.	
24	1397.8	5396.2	1	2	Fe.	
25	1421.5	5370.4	1	2	Fe.	R.
26	1431.3	5360.6	2	2		R.?
27	1454.7	5332.0	2	2	Ti.	
28	1462.9	5327.7	1	3	Fe.	
29	1463.4	5327.2	1	3	Fe.	
30	1465.0?	5321.1	2	2		
	Corona line					
31	1474.1	5315.9	75	15	Fe.?	L.
32	1505.5	5283.1	5	4		
33	1515.5	5275.0	7	5		L. R.
34	E ₁	5269.5	1	3	Fe. Ca.	
35	E ₂	5268.5	1	2	Fe.	
36	1528.0	5265.5	3	2	Fe. Co.	L.
37	1561.0	5239.0	1	1	Fe.	
38	1564.1	5236.2	1	1		
39	1597.7	5233.5	2	2	Mn.	R.
40	1599.7	5232.0	1	2	Fe.	
41	1577.3	5226.0	1	2	Fe.	
42	1580.5?	5224.5	1	1	Ti.	
43	1601.5	5207.3	3	3	Cr. Fe.?	
44	1604.4	5205.3	3	3	Cr.	
45	1606.5	5203.7	3	3	Cr. Fe.?	
46	1609.3	5201.6	1	2	Fe.	
47	1611.5	5199.5	1	1		
48	1615.6	5197.0	3	2		L. R.
49	h ₁	5183.0	15	15	Mg.	L.
50	h ₂	5172.0	15	15	Mg.	L.
51	h ₃	5168.5	12	10	Ni.	L.
52	h ₄	5166.5	10	10	Mg.	L.
53	1673.9	5153.2	1	1	Na.	
54	1678.0	5150.1	1	2	Fe.	
55	1778.5	5077.8	1	1	Fe.	
56	1866.8	5017.5	2	3		R.

NOTE II.

Ref. No.	Kirchhoff.	Ångström.	Relative Frequency.	Relative Brightness.	Chemical Element.	Previous Observer.
57	1870.3	5015.?	2	2		R.
58	1989.5	4933.4	8	5	Ba.	L.
59	2001.5	4923.2	5	3	Fe.	R. L.
60	2003.2	4921.3	1	1		
61	2007.1	4918.1	3	3		L.
62	2031.0	4899.3	6	4	Ba.	L.
63	2051.5	4882.5	2	2		L.
64	F.	4860.6	100	75	Il.	J. L.
65	2358.5	4629.0	1	1	Ti.	
66	2419.3	4583.5	1	1		
67	2435.5	4571.4	1	1	Li.	
68	2444.0	4564.6	1	1		
69	2446.6	4563.1	1	2	Ti.	
70	2457.8	4555.0	1	1	Ti.	
71	2461.2	4553.3	3	3	Ba.	
72	2467.7	4548.7	1	3	Ti.	
73	2486.8	4535.2	1	1	Ti. Ca.?	
74	2489.5	4533.2	1	1	Fe.	
75	2490.6	4531.7	1	1	Ti.	
76	2502.5	4524.2	2	2	Ba.	
77	2505.8	4522.1	1	2	Ti.	
78	2537.3	4500.4	1	3	Ti.	
79	2553.?	4491.0?	1	1	Mn.?	
80	2555.?	4489.5?	1	1	Mn.?	
81	2566.5	4480.4	1	2	Mg.	L.
82	2581.5?	4471.4	75	8	A band rather than a line. †	
83	2585.5	4468.6	1	1	Ti.	
84	2625.0	4443.0	1	1	Ti.	
85	2670.0	4414.6	1	1	Fe. Mn.	
86	2686.7	4404.3	1	2	Fe.	
87	2705.0	4393.5	3	2	Ti.	
88	2719.?	4384.8	1	1	Ca.?	
89	2721.2	4382.7	1	2	Fe.	
90	2734.?	4372.1	1	1		
91	2737.?	4369.3?	1	1	Cr.	
92	2775.8	4352.0	1	1	Fe. Cr.	
93	2796.0	4340.0	100	50	Il.	L. J.
94	G.	4307.0	1	2	Fe. Ti. Ca.	
95	2870.0	4300.0	1	1	Ti.	
96		4297.5	1	1	Ti. Ca.	
97		4289.0	1	2	Cr.	
98		4274.5	1	2	Cr.	
99		4260.0	1	1	Fe.	
100		4245.2	1	1	Fe.	
101		4226.5	1	1	Ca.	
102		4215.5	1	2	Fe. Ca.	
103	A.	4101.2	100	20	Il.	R. L.

YOUNG'S SECOND CATALOGUE

TABLE showing the Number of Coincidences between the Bright Lines observed in the Spectrum of the Chromosphere, and those of the Spectra of the Chemical Elements.

				Unknown.	52	Total.
Fe. Ti. S _(w)	1					
" Ba. S _(w)	1	Ti. S _(w)	3	Fe.	64	110
" S _(w) Zn _(w)	1	" Ca.	2	Ti.	23	43
" Co. Ce.	1	" Mn	1	Ca.	10	29
" Ni. E _(w)	1	" Ce.	1	Ba.	8	13
Ca. Cr. Ce.	1	" Sr.	1	S _(w)	7	14
" Li. Zn.	1	" Zn.	1	Mn.	6	12
Ti. Ba. S _(w)	1	Ca. Cd.	1	Ce.	5	11
Ba. La. E _(w)	1	" Ce.	1	H.	4	4
Fe. Ca.	10	" Co.	1	Na.	4	6
" Ti.	9	" Cr.	1	Cr.	4	10
" Mn.	4	" Sr.	1	Mg.	3	4
" Cr.	3			Sr.	3	6
" Ni.	3	S _(w) E _(w)	1	Zn.	3	9
" Ba.	2	Mn. Zn.	1	E _(w)	2	9
" Zn.	2			Ni.	2	6
" E _(w)	2	Cr. E _(w)	1	Co.	1	5
				Cu.	1	2
" Ce.	1	Ce. Co.	1	La.	1	3
" Co.	1			Ru. Ir.	1	1
" Mg.	1	Na. Cu	1	Cd.		1
" Na.	1			Li.		1
" S _(w)	1					
" La.	1	lines marked with an *	14			

The numbers in the last column denote the whole number of times that the symbol of each element appears in the catalogue, either singly or combined with others.

YOUNG'S

SECOND CATALOGUE

No.	P.C.	K.	A.	F.	B.	E.
94	27	1454.7	5335.9	5	2	Tl. Zn(w)
95		1461.5	5329.1	5	4	
96	28	1462.8	5327.1	5	2	Fe.
97	29	1463.3	5327.6	5	2	Fe.
98		1464.8	5325.1	6	2	
99		1471.9*	5318.0	1	1	
100†	31†	1473.9	5315.9	90	50	Fe.? O(w)?
101		1476.8	5313.1	3	1	
102		1497.3	5292.0	1	1	Cu. Br(w)
103	32	1505.3	5283.4	20	10	Ti(w)
104	33†	1515.5	5275.0	30	15	
105	34	E ₁ 1522.7	5269.5	15	4	Fe. Ca.
106	35	E ₂ 1523.7	5268.5	12	3	Fe.
107	36†	1527.7	5265.8	10	4	Fe. Co.
108		1530.2	5263.3	1	1	Ca. Br(w)
109		1538.5*	5256.2	2	1	Sr.
110		1541.9	5254.1	1	2	Fe. Mn.
111		1547.7	5249.7	3	1	Fe. Z(w) Br(w)
112		1551.6	5246.3	3	1	Fe.
113	37	1561.0	5239.0	4	2	Fe.
114	38	1564.2	5236.3	4	2	
115	39†	1567.5	5233.6	10	8	Mn. Zn(w)
116	40	1569.6	5232.1	1	3	Fe.
117		1575.4	5227.5	1	1	Sr.?
118	41	1577.4	5226.2	10	3	Fe.
119		1578.1	5225.5	2	3	Sr. Br(w)
120	42	1580.1	5224.3	2	2	Ti.
121		1589.1	5216.5	2	1	Fe.
122		1590.7	5215.5	3	2	Fe.
123		1592.3	5214.4	2	1	Fe.
124		1597.9*	5210.5	1	1	
125		1599.9	5209.5	1	2	Ti.
126	43	1601.5	5207.6	10	6	Fe. Cr.
127	44	1604.4	5205.2	10	6	Cr. E(w)
128	45	1606.4	5203.7	10	6	Cr. Fe.
129	46	1609.2	5201.5	5	3	Fe.
130	47	1611.3	5199.7	4	2	S(w) E(w)
131		1613.9	5197.9	1	1	Fe.
132	48†	1615.6	5197.0	15	10	
133		1617.4	5195.0	1	1	Mn.
134		1618.9	5194.1	2	2	Fe.
135		1627.2	5188.2	10	5	Fe. Ca.
136		1628.2	5187.3	1	1	Ti.
137		1631.5	5185.1	5	2	Fe. Ti.
138	49†	b ₁ 1634.1	5183.0	50	30	Mg.
139	50†	b ₂ 1648.8	5172.0	50	35	Mg.
140	51†	b ₃ 1653.7	5168.3	40	30	Fe. Ni. Br(w)
141	52†	b ₄ 1655.6	5166.7	30	20	Fe. Mg.
142		1666.?	5160.?	1	1	
143		1671.5	5154.8	3	1	Na.
144	53	1673.7	5152.5	3	1	Na. Cu.?
145	54	1677.9	5150.1	2	2	Fe. Br(w)
146		1689.5	5142.2	1	2	S(w)

No.	P.C.	K.	A.	F.	B.	E.
147		1701.8	5133.0	1	1	Fe.
148		1704.7	5130.8	1	1	Fe.
149		1707.9	5128.6	1	1	Ti.
150		1710.7	5126.7	1	1	Fe. Ti.
151		1712.2	5125.5	1	2	
152†		1713.4	5124.4	1	1	Fe.
153		1715.2	5123.2	1	1	Fe.
154		1717.9	5121.0	1	1	Fe.
155		1719.4	5119.9	1	1	Ti.
156†		1727.3	5114.9	1	1	Ni.
157		1734.6	5108.8	2	2	Ti(w)
158		1737.7	5107.0	1	1	Fe.
159		1750.4	5098.1	1	1	Fe.
160		1752.8	5096.5	1	1	Fe. S(w)
161		1765.0*	5087.0	2	1	E(w)
162		1771.5	5083.5	1	1	Zn(w)
163	55	1778.5	5077.9	1	2	Fe.
164		1823.6	5047.8	2	2	Fe.? Zn(w)
165		1833.4	5041.2	2	2	Fe. Ca.
166		1834.3	5040.1	2	2	Fe.
167		1848.9	5030.1	4	3	S(w)
168		1856.9	5023.5	3	1	S(w)
169	56†	1867.1	5017.6	30	15	Fe. Ni.
170	57†	1870.6	5015.0	30	10	Ti(w)
171		1905.1	4993.3	2	1	Fe. N(w)
172†		c. 1961.0	4956.7	1	2	Fe.
173	58†	1989.5	4933.4	30	8	Ba.
174	59†	2001.6	4923.1	40	12	Fe. S(w) Zn(w)
175	60†	2003.2	4921.3	30	8	S(w)
176	61	2007.2	4918.2	20	3	Fe.
177		2016.0	4911.2	3	2	Zn(w)
178	62†	2031.1	4899.3	30	6	Ba. La. E(w)
179	63†	2052.5*	4882.9	10	4	Ce.
180		2067.8	4869.4	5	1	
181	64†	F 2080.0	4860.6	100	80	II.
182		2087.6	4854.7	5	2	Fe. Ni. E(w)
183		2094.0	4848.1	3	2	Ca. O(w)
184		2116.?	4826.5	1	1	
185		2121.2	4822.8	10	2	Mn.
186		2142.4	4804.4	3	1	Ti. S(w) O(w)
187		2171.5	4778.7	3	2	Co. N(w)
188		2229.1	4730.8	1	1	Fe.
189†		2251.3*	4712.5	2	2	Ce. O(w)
190		2309.5	4666.3	3	1	Fe. Ti.
191		2314.3	4663.3	2	1	
192		2323.0	4656.0	2	1	Ti.
193	65	2358.4	4629.0	15	8	Ti. N(w)
194		2359.5*	4628.2	2	1	Ce.
195		2360.7	4620.3	1	1	
196		2410.2	4589.4	1	1	
197		2412.8	4587.5	2	2	
198	66	2419.3	4583.2	15	6	
199		2429.5	4576.0	4	2	

No.	P.C.	K.	A.	F.	B.	E.
200	67	2435.5	4571.4	10	4	Ti.
201	68	2443.9	4564.8	10	3	
202	69	2446.6	4563.2	10	5	Ti.
203		2452.1	4559.5	8	2	
204		2454.1	4558.1	8	1	
205	70	2457.9	4555.3	10	5	Fe. Ti.
206	71	2461.2	4553.4	10	5	Ba.
207		2463.4	4551.8	1	1	Ti. S(w)
208	72	2467.6	4548.9	10	8	Ti.
209		2480.8	4539.2	2	1	Ce.
210	73	2486.6	4535.5	2	2	Ti. Ca.
211	74	2489.4	4533.2	5	5	Fe.
212		2490.5	4532.1	3	2	Ti. Ca.
213	76	2502.2	4524.4	3	2	Ba. Fe.
214	77	2505.6	4522.0	3	3	Ti. S(w)
215		2517.0	4514.0	2	1	
216		2518.4	4513.0	1	1	
217		2527.0	4506.0	2	1	
218	78	2537.1	4500.3	15	6	Ti.
219	79	2552.4	4490.9	20	8	Mn.
220	80	2555.0	4489.4	15	3	Fe. Mn.
221	81	2566.3	4480.9	5	2	Mg.
222+	S2+	f 2581.2	4471.2	100	25	Ce.
223	83	2585.4	4468.5	20	5	Ti. O(w)
224		2620.8	4446.3	1	1	Ti.
225	84	2625.2	4443.0	10	2	Ti.
226		2633.0	4436.7	1	1	Mn?
227		2639.6	4433.5	1	1	
228		2651.5	4426.0	2	3	
229		2653.2	4425.0	2	2	Ca.
230		2664.9	4418.0	2	1	O(w)
231		2665.9	4417.5	3	1	Ti.
232	85	2670.0	4414.7	1	1	Fe. Mn. O(w)
233		2680.0	4407.7	1	1	Fe. Ca.
234		2686.8	4404.2	1	1	Fe.
235		2696.0	4398.5	1	1	Ti. Ce. O(w)
236		2698.2	4396.5	1	2	
237	87	2702.5	4394.6	15	3	
238		2715.2	4388.5	1	1	Fe?
239	88	2718.5	4384.7	8	2	Ca. Ce.
240		2720.2	4383.5	1	1	
241	89	2721.6	4382.8	1	1	Fe. Cr.
242		2725.8	4380.4	1	1	
243		2728.0	4379.1	1	1	Ca.
244	90	2733.7	4375.5	5	3	Fe.
245	91	2736.9	4374.2	8	3	E(w)
246		2762.0	4359.1	1	1	Cr.
247	92	2775.7	4351.8	3	1	C.
248	93+	2795.7	4340.1	100	65	H.
249		2798.0	4338.2	10	2	Cr.
250		2805.4	4335.1	2	1	La.
251		2823.4	4324.0	1	2	
252		2830.7	4320.1	1	1	Ti. O(w)

No.	P.C.	K.	A.	F.	B.	E.
253		2843.0	4313.5	1	1	Ti.
254	94	G. 2854.2	4307.2	3	2	Ca. Fe.
255	95	2867.7	4302.1	3	2	Ca. Fe.
256	96	2874.2	4298.0	1	1	Ca. Fe.
257	97	2894.5	4289.4	1	1	Cr. Ca. Ce(w)
258	98	2928.5	4274.6	2	1	Cr. Ca.
259	99	8961.2	4260.0	2	1	Fe.
260	100	2996.2	4245.2	30	3	Fe.
261		3018.0	4235.5	30	5	Fe.
262		3022.8	4233.0	15	5	Fe. Ca.
263	101	3040.0	4226.3	3	3	Ca. Sr.
264	102	3061.8	4215.3	40	7	Ca. Sr.
265		3155.5	4178.8	1	1	
266		3187.0	4166.7	1	1	Ca.
267	103+	h. 3363.5	4101.2	100	50	H.
268		3431.0	4077.0	25	2	Ca.
269		3526.0	4045.0	3	2	Fe.
270		3703.3	3990.?	2	1	
271		3769.5	3970.?	2	1	Fe.
272+		H ₁ 3778.5	3967.9	75	3	Fe. Ca.
273		H ₂ 3882.5	3932.8	50	1	Fe. Ca.

NOTES.

- The position assigned to this line, first observed by Respighi (a fact of which I was ignorant when the Preliminary Catalogue was published), rests upon two series of micrometric measurements, referring it to four neighbouring dark lines—the probable error is about $\frac{1}{10}$ th of a division of Kirchhoff's scale.
- No. 6 in P.C. Position there given, 743?
- 16 and 17. Nos. 8 and 9 of P.C. Position given as 816.8 and 827.6, by a mistake in identifying lines upon the map.
- I have never myself seen this line reversed. Prof. Emerson, however, saw it several times. It was first reported by Rev. S. J. Perry, in *Nature*, vol. iii. p. 67.
- The position of this line has been independently determined by three series of micrometric comparisons with neighbouring lines. My result agrees exactly with that of Huggins.
- Erroneously given in P.C. as 1363.1, which line does not reverse, or at least was never seen reversed at Sherman.
- The principal line in the spectrum of the corona. The corresponding line in the spectrum of iron is feeble, and on several occasions when the neighbouring lines of iron (1463, &c.) have been greatly disturbed, this has wholly failed to sympathise. Hence I have marked the Fe with a ?. Watts indicates a strong line of oxygen at 5315 A.
- 152 and 156. Observed only on one day, but verified by Prof. Emerson.
- Called "little C" by Mr. Stoney.
- Given by Lockyer as K 2054. Its position is a little uncertain; it seems to coincide with neither of the dark lines at 2051 and 2054, but lies between them, a little nearer to 2051.
- Rather a band than a line.
- The position of this line, which, however, like 189, is rather a band,

"In the catalogue, the first column contains simply a reference number: a † refers to a note at the end of the catalogue.

"The numbers in the second column refer to the 'Preliminary Catalogue,' containing 103 lines, which was published a year ago in the *American Journal of Science*. In this column a † indicates that some other observer has anticipated me in the determination and publication of the line. As I have depended for my information almost solely upon the *Comptes Rendus* and the *Proceedings of the Royal Society* (which gave the observations of Lockyer, Janssen, Rayet, and Secchi), it is quite possible that some other lines ought to be marked in the same manner.

"The third column, headed K, gives the positions of the lines on Kirchhoff's scale, the numbers above G being derived from Thalén's continuation of Kirchhoff's maps. In this column an asterisk denotes that the map shows no corresponding dark line, a ? that the exact position, not the existence, of the line is for some reason slightly uncertain.

"The fourth column, headed A, gives the wave-length of the line in ten-millionths of a millimeter, according to Angström's atlas.

"The numbers in this and the preceding column were taken, not from the maps themselves, which present slight inaccuracies on account of the shrinking and swelling of the paper during the operation of printing, but from the numerical catalogues of Kirchhoff and Angström which accompany their respective atlases. In the Preliminary Catalogue the numbers were derived from the maps; hence some slight discrepancies in the tenths of division.

"The fifth column, marked F, contains a rough estimate of the percentage of frequency with which the lines were seen during the six weeks of observation; and the sixth column, B, a similar estimate of their maximum brightness compared with that of the hydrogen line C.

"The variations of brilliance, however, when the chromosphere was much disturbed, were so considerable and so sudden that no very great weight can be assigned to the numbers given. Nor is it to be inferred that lines which have in the table the same index of brightness were always equally bright. On certain occasions one set of lines would be particularly conspicuous; on others, another.

"With two or three exceptions, indicated in the notes, no lines have been catalogued which were not seen on at least two different days. In the few cases where lines observed only on one occasion have been admitted to the list, the observations were at the time carefully verified by my assistant, Prof. Emerson, so as to place their correctness beyond a doubt. Many other lines were 'glimpsed' at

one time and another, but not seen steadily enough or long enough to admit of satisfactory determination.

NOTE II.

"The last column of the catalogue contains the symbols of the chemical elements corresponding to the respective lines. The materials at my disposal are the maps of Kirchhoff and Angström, Thalén's map of the portion of the solar spectrum above G, and Watts' "Index of Spectra." Since the positions of the lines in the latter work are given only to the nearest unit of 'Angström's scale,' I have marked the coincidences indicated by it with a (w), considering them less certain than those shown by the maps."

Professor Young thus sums up his work:—

"In addition to the elements before demonstrated to exist in the chromosphere, the following seem to be pretty positively indicated—sulphur, cerium, and strontium; and the following with a somewhat less degree of probability, zinc, erbium and yttrium, lanthanum and didymium. There are some coincidences also with the spectra of oxygen, nitrogen, and bromine, but not enough, considering the total number of lines in the spectra of these elements, or of a character, to warrant any conclusion. One line points to the presence of iridium or ruthenium, and only three are known in the whole spectrum of these metals.

"No one, of course, can fail to be struck with the number of cases in which lines have associated with them the symbols of two or more elements. The coincidences are too many and too close to be all the result of accident, as for instance in the case of iron and calcium, or iron and titanium.

"Two explanations suggest themselves. The first, which seems rather the most probable, is that the metals operated upon by the observer who mapped their spectra were not absolutely pure—either the iron contained traces of calcium and titanium, or *vice versa*. If this supposition is excluded, then we seem to be driven to the conclusion that there is some such similarity between the molecules of the different metals as renders them susceptible of certain synchronous periods of vibrations—a resemblance, as regards the manner in which the molecules are built up out of the constituent atoms, sufficient to establish between them an important physical (and probably chemical) relationship.

"I have prefixed to the catalogue a table showing the number of lines of each substance, or combination of substances, observed in the chromosphere spectrum; omitting, however, oxygen, nitrogen, and bromine, since with one exception (line 230) neither of them ever stands alone, or accounts for any lines not otherwise explained."

Fig 1

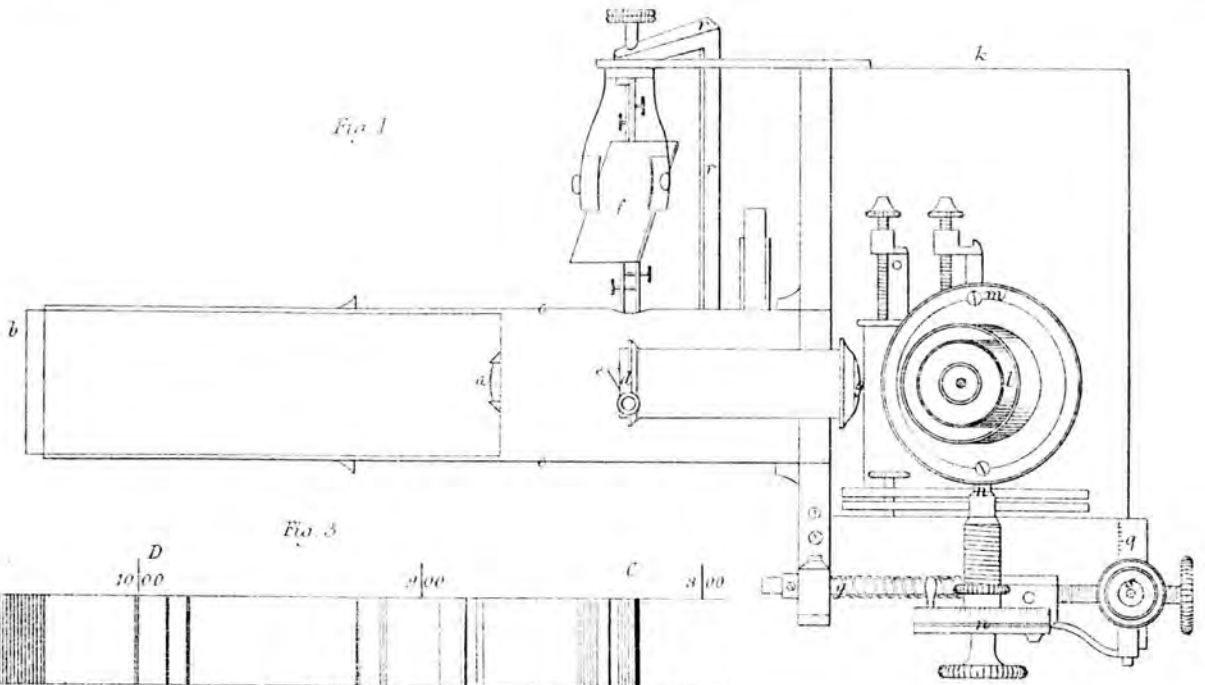

Fig 3

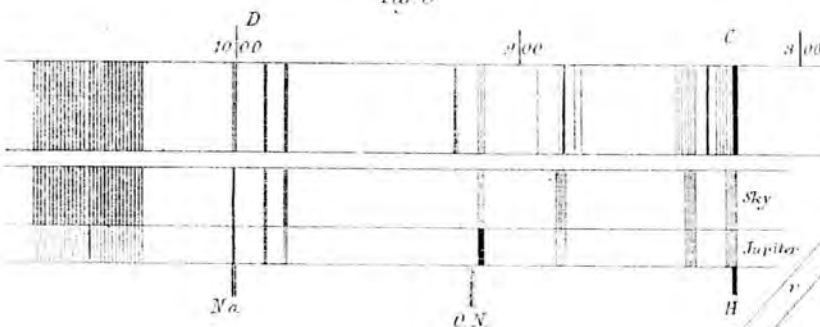

Fig 2

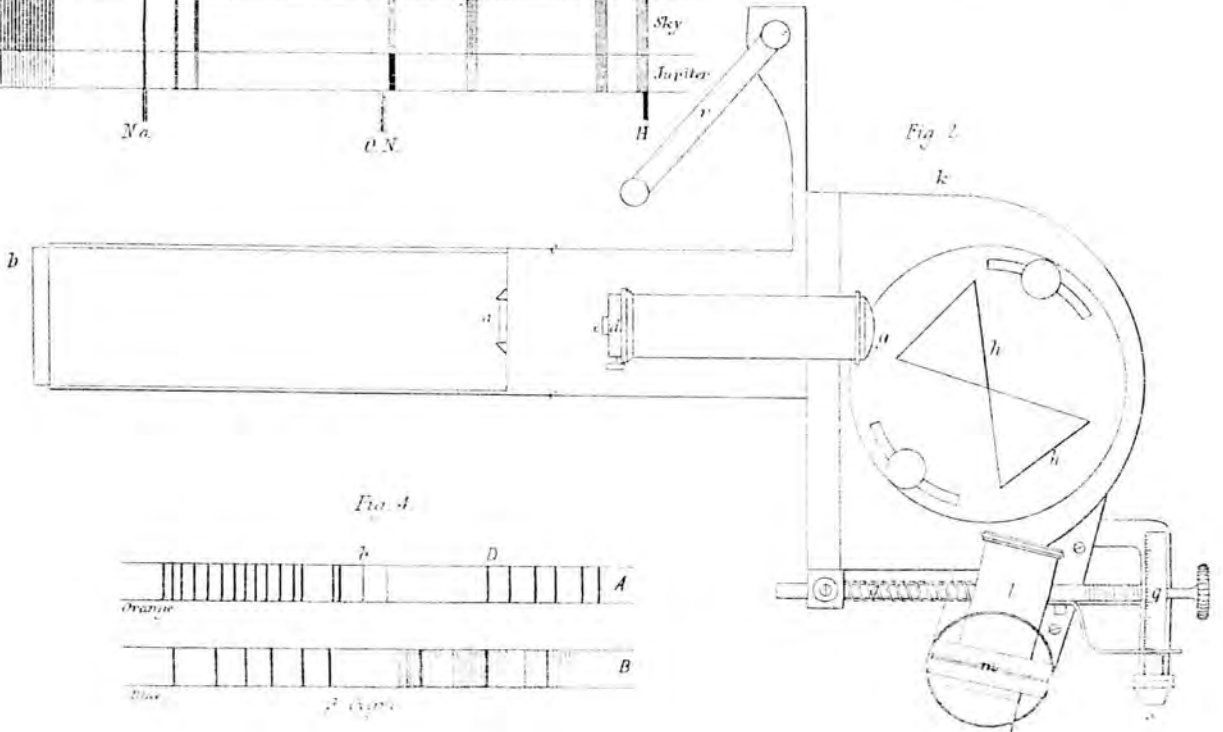
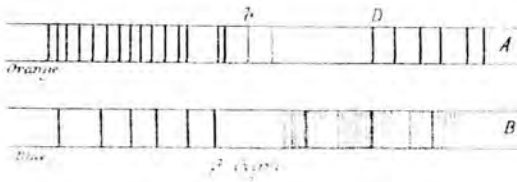
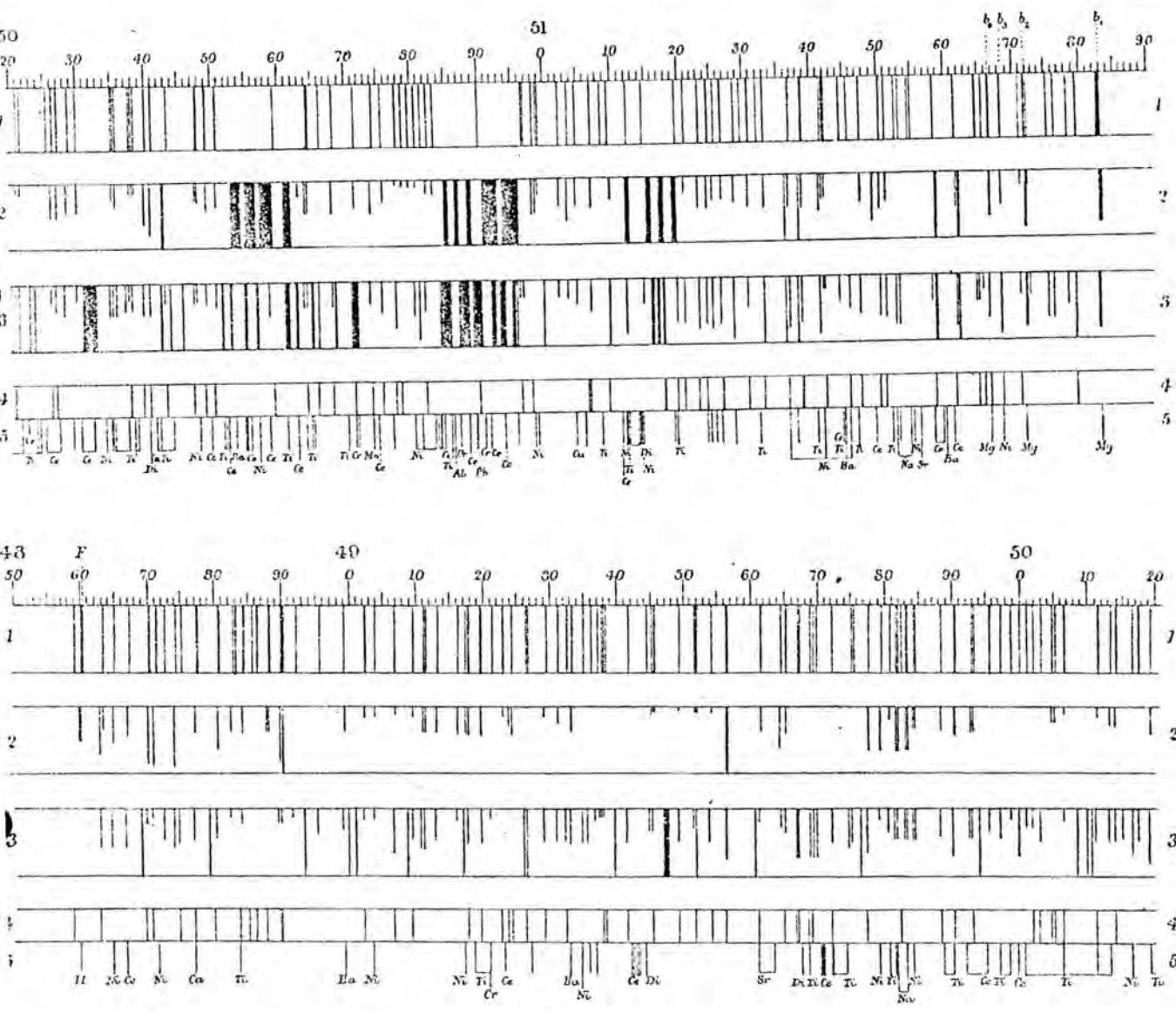

Fig 4



HUGGINS REF. 118



No. 1 is part of Ångström's Normal Solar Spectrum.

No. 2 gives the lines observed at Greenwich to be widened in Spot 436 and No. 3 those observed in Spot 614, the length of line representing the amount of widening, except when this was excessive when it is represented by the actual breadth drawn, Greenwich Obs. 1881.

No. 4 gives the lines of Iron and No. 5 those of some other metals as observed in the Arc.

DEWAR SUN-SPOTS & TERRESTRIAL ELEMENTS IN THE SUN

PHIL. MAG. SERIES 5, VOL. 16, (1883) PP 401 etc.

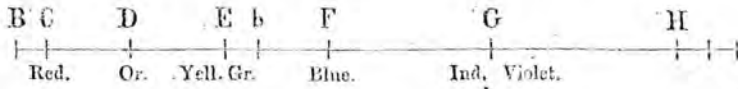

White Stars:—



Yellow Stars:—

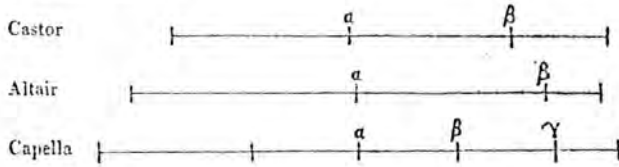

Orange Stars:—

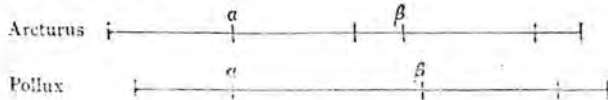

Red Stars:—

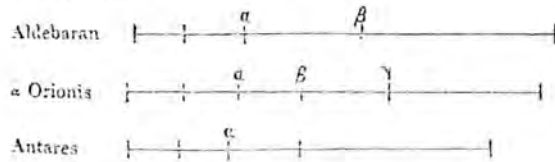

		(γ α)	(α β)	(β γ)	(γ ν)
Sirius	$\alpha = F \odot - 15''$	85' 40''	66' 37''	42' 27''	20' 17''
	α very fine, breadth 30''; β very fine, double, breadth 80''; γ as broad as α , faint.				
Vega	$\alpha = F \odot + 40''$	77' 15''	67' 56''	34' 55''	10' 18''
	α, β , very fine; α 40'', β 60'' broad; γ very broad, faint.				
Procyon	$\alpha = F \odot - 33''$	78' 55''	65' 30''	37' 1''	9' 32''
	α well seen, 15'' broad; β scarcely seen; γ ditto, rather broader than α .				
Regulus	$\alpha = F \odot - 60''$	68' 30''	66' 17''	30' 55''	—
	α very clear, 20'' broad; β seen at intervals.				
Fomalhaut	$\alpha = F \odot - 55''$	61' 44''	70' 36''	—	—
	α fine, 35'' broad.				
Castor	$\alpha = F \odot - 30''$	69' 43''	62' 4''	30' 9''	—
	α very fine, 40'' broad; β ditto, 60'' broad.				
Altair	$\alpha = F \odot + 5''$	73' 42''	66' 3''	24' 23''	—
	α fine, 20'' broad; β indistinct, faint, 40'' broad.				
Capella	$\alpha = F \odot - 2' 40''$	81' 1''	31' 55''	34' 35''	23' 36''
	α very thin, well observed; β, γ , scarcely visible, uncertain observation.				
Arcturus	$\alpha = F \odot - 29' 22''$	51' 25''	44' 27''	66' 23''	—
	α very thin, seen with trouble; β very difficult to be seen.				
Pollux	$\alpha = F \odot - 28' 42''$	47' 33''	45' 46''	68' 56''	—
	α very thin, seen with trouble; β very difficult to be seen.				

Prof. Donati, Memorie Astronomiche.

105

Aldebaran	$\alpha = F \odot - 22' 39''$	50' 39''	29' 40''	64' 17''	—
	α very fine, 30'' broad; β somewhat thinner than α , very fine.				
α Orionis	$\alpha = F \odot - 30' 35''$	50' 19''	17' 24''	16' 51''	57' 18''
	α very fine, 40'' broad; β very fine, 50'' broad; γ frothy, well seen.				
Antares	$\alpha = F \odot - 33' 28''$	47' 20''	18' 17''	65' 45''	—
	α fine, 30'' broad; β rather fine, 20'' broad.				

α Aurigæ.

Date.	Obs. Vel.	Earth's Vel.	Vel. of Star rel. to ☉.
1888 Oct. 6	- 3.5	-15.4	+11.9
22	+ 2.9	-13.0	+15.9
24	+ 3.8	-12.6	+16.4
25	+ 3.5	-12.4	+15.9
28	+ 3.8	-11.8	+15.6
Nov. 9	+ 9.2	- 8.9	+18.1
Dec. 1	+10.8	- 2.9	+13.7
13	+15.6	+ 0.7	+14.9
1889 Jan. 2	+20.2	+ 6.6	+13.6
Feb. 5	+30.8	+14.3	+16.5
May 6	+33.2	+17.0	+16.2
Sept. 15	- 3.6	-16.8	+13.2

α Tauri.

1888 Oct. 28	+18.1	- 9.5	+27.6
Nov. 10	+24.9	- 5.9	+30.8
Dec. 4	+30.6	+ 1.8	+28.8
1890 Jan. 9	+43.7	+12.3	+31.4

α Ophiuchi.

1888 Sept. 30	+27.6	+14.1	+13.5
1889 June 7	+ 9.7	- 1.0	+10.7

α Ursa Majoris.

1888 Nov. 7	-17.0	-11.9	- 5.1
9	-18.1	-11.9	- 6.2
1889 May 4	+ 5.2	+11.8	- 6.6
22	+ 3.4	+11.2	- 7.8

Date.	Obs. Vel. less Vel. of Translation.	Calc. Vel.	O.-O.
1889 April 21	-48.4	-53.5	+5.1
29	-54.3	-52.1	-2.2
May 1	+50.7	+52.6	-1.9
1890 April 4	- 6.5	-12.4	+5.9
9	-55.3	-56.2	+0.9
10	+ 6.0	+10.6	-4.6
11	+50.7	+56.2	-5.5
13	-57.6	-56.2	-1.4
15	+62.7	+56.2	+6.5
May 1	+53.5	+56.7	-3.2
4	- 3.7	- 1.8	-1.9
7	-61.3	-56.7	-4.6
8	- 0.5	- 1.4	+0.9
9	+63.2	+56.7	+6.5
17	+61.8	+56.7	+5.1
18	+ 6.0	+ 5.5	+0.5
23	-63.5	-56.2	-7.3
24	- 1.4	- 5.5	+4.1
25	+53.0	+56.2	-3.2
26	+ 5.1	+ 5.5	-0.4
27	-52.6	-56.2	+3.6
28	-12.9	- 8.8	-4.1
31	-56.2	-56.2	0.0
June 4	-49.8	-53.8	+6.0
1891 April 24	+ 3.2	+ 4.6	-1.4
27	+47.9	+45.2	+2.7
May 3	-58.1	-63.2	+5.1

INFLUENCE OF THE EARTH'S
MOTION ON THE DISPLACEMENT

H. C. VOGEL

ACCURACY OF THE METHOD
OF SYMMETRICAL SETTING

STAR VELOCITY

α Lyre.

	Obs. Vel.	Earth's Vel.	Star's Vel. rel. to ☉.
1888 Sept. 23	- 2.6	+ 8.6	-11.2
Nov. 11	- 1.7	+ 7.0	- 8.7
13	- 1.5	+ 6.8	- 8.3
1889 May 31	-10.7	- 4.8	- 5.9
June 6	- 9.9	- 4.0	- 5.9
Sept. 15	- 1.8	+ 8.1	- 9.9
Nov. 24	- 4.2	+ 5.7	- 9.9
25	- 6.7	+ 5.6	-12.3
26	- 7.2	+ 5.4	-12.6

α Canis Majoris.

1888 Dec. 13	-14.1	- 4.9	- 9.2
1890 Feb. 12	+ 0.8	+ 9.4	- 8.6
1891 Feb. 7	+ 0.1	+ 8.3	- 8.2
Mar. 21	+ 4.4	+13.8	- 9.4
22	+ 6.1	+13.9	- 7.8

ACCURACY OF COVERING
BY A STRIP

H X

152

SIR W. HUGGINS
 PROC. ROY. SOC., VOL. 20, (1872) P379

TABLE I.—STARS MOVING FROM SUN

Star.	Compared with	Apparent motion.	Earth's motion.	Motion from sun.
Sirius	H	26 to 36	-10 to 14	18 to 22
Betelgeux	Na	37	-15	22
Rigel	H	30	-15	15
Castor	H	40 to 45	-17	23 to 28
Regulus	H	30 to 35	-18	12 to 17
β Ursæ majoris	H			
γ " "	H			
δ " "	H	30	- 9 to 13	17 to 21
ϵ " "	H			
ζ " "	H			
β Leonis	H			
δ Leonis	H			
η Ursæ majoris	H			
α Virginis	H			
α Coronæ borealis	H			
Procyon	H			
Capella	H			
Aldebaran?	Mg			
γ Cassiopeiæ	H			

TABLE II.—STARS APPROACHING THE SUN

Star.	Compared with	Apparent motion.	Earth's motion.	Motion towards sun.
Arcturus	Mg	50	+ 5	55
Vega	H	40 to 50	+ 3'9	44 to 54
α Cygni	H	30	+ 9	39
Pollux	Mg	32	+ 17	49
α Ursæ majoris	Mg	35 to 50	+ 11	46 to 60
γ Leonis	Mg			
ϵ Boötis	Mg			
γ Cygni	H			
α Pegasi	H			
γ Pegasi?	H			
α Andromedæ	H			

SPECTRUM OF GREAT NEBULA IN ORION.

Photograph of 1888.

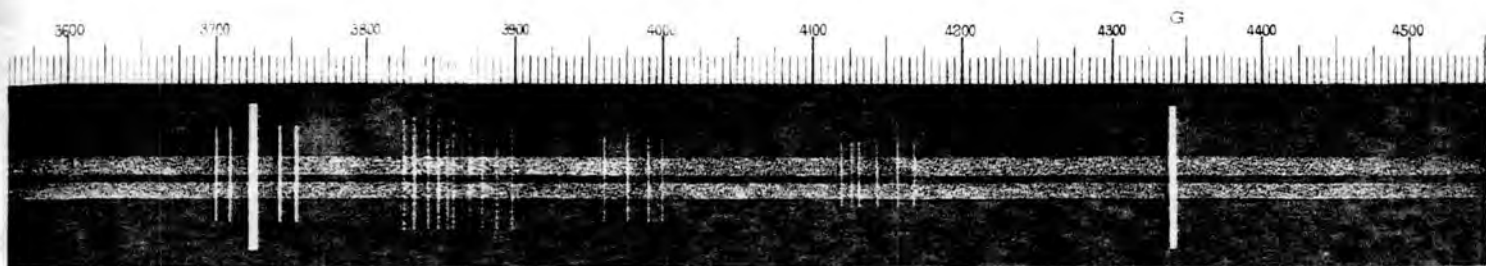

Visible Spectrum.

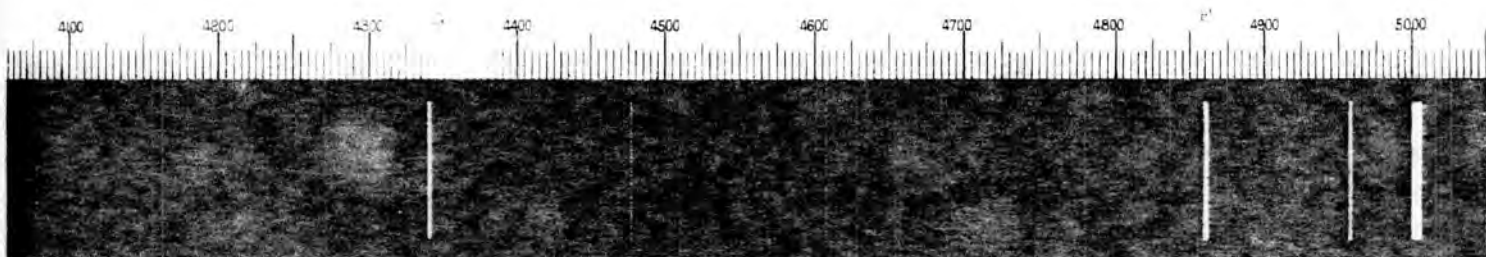

Photograph of 1889.

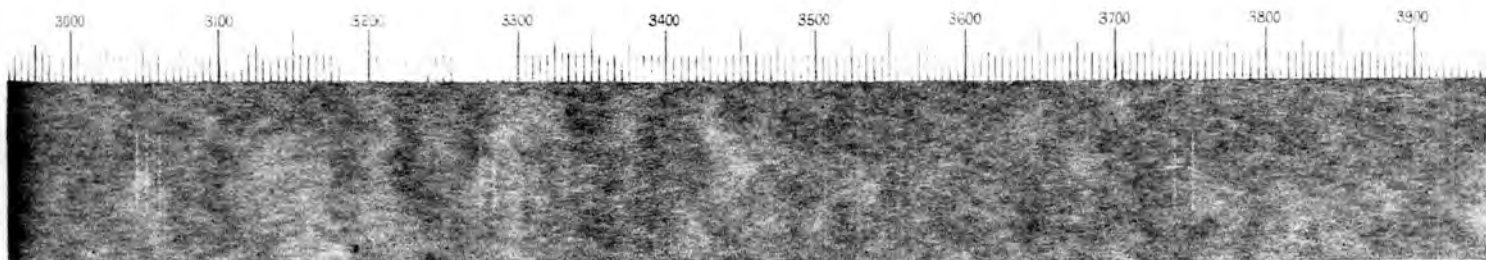

HUGGINS

TABLE OF STELLAR SPECTRA

Aldebaran.			α Orionis.		β Pegasi.	
822.5	H	1107	840	1139.5	896	
855.5		1112	860	1144	923	
872.5		1117.5	870	1145.5	1000	} Na
880		1143 ^d	881	1148	1002	
893.5		1158	887	1151	1014	
900		1164	890	1158.5	1165	
903.5		1171.5	899	1167	1220	
907.5		1178	911	1169.5	1276.5	
915		1187	918	Ca 1176.5	1291.5	} Mg
918	Ca	1192	920	1183.5	1297.5	
923	Hg	1202	929	1187	1300.5	
933	Ca	1210	933	Ca 1191.5	1350.5	
945.5	Sb	1224.5	936	1198	1392.5	
951.5		1240	946	1201.5	1425	
954.5		1241.5	966	1210	1515	
956		1250	968.5	1214	1732	
966.5	Sb	1252	976	1220.5	1835	
972.5		1269.5	983	1225		
976	Te	1272	992	1237		
982		1277	1000	1243		
986.5		1282	1002	} Na 1252	Fe	
993		1291.5	1010.5	1262		
1000	} Na	1297.5	1013	Ca 1269.5	Fe	
1002		1300.5	1030	1277	Bi	
1013	Ca	1314	1040	1280.5		
1023		1323	1050.5	1285.5		
1028		1328	1062	Bi 1291.5	} Mg	
1031		1351	1069.5	1297.5		
1036.5	Hg	1420	1079.5	1300.5		
1040		1442.5	1085.5	1303		
1044	Hg	1483	1090	1314	Bi	
1058			1091.5	1334		
1062	Bi		1099	1350		
1067	Te		1105	Ca 1356		
1076			1109.5	1361		
1086.5	Te		1116.5	1416		
1095			1123.5	1420	Fe	
1100			1132	1442.5	Fe	
1105	Ca		1135.5	1557		

HUGGINS

FIXED STAR SPECTRA

ARCTURUS

LINES

	W. L.		W. L.
H ₁	4340		as in solar spectrum.
	4325	}	doubtless the group G
	4307.5		clearly multiple.
	4289		
	4271		stronger.
	4252.5		
	4237.5		
	4227.5		
	4214		
	4201		
	4195		
	4185		thin.
	4176		
	4170		
	4150	}	probable group.
	4141		
	4132.5		thin rather.
	4112		
h	4099		
	4075		
	4064		
	W. L.		W. L.
	3815		3657.5
	3814.5		3641
	3810		3637.5
	3805		3625
	3798		3610
γ	3795		3602.5
	3789		3592.5
	3775		3585
	3762.5		3575
	3755		3560
ε	3745.5		3551
	3732.5		3515
ζ	3730		3507.5
η	3717.5		3504.5
θ	3707.5		3487
	3702.5		3482
	3690		3475
	3682.5		3467
	3672.5		3457
	3662.5		
	W. L.		W. L.
	4055		
	4045		
	4034		
	4040		
	3995		
	3980		
	3968	H ₁	
	3933	H ₂	
	3920		
	3905		
	3900		
	3887.5	α	
	3881		
	3870		
	3859		
	3856		
	3850		
	3838		
	3835		
	3832.5		
	3822.5	α	

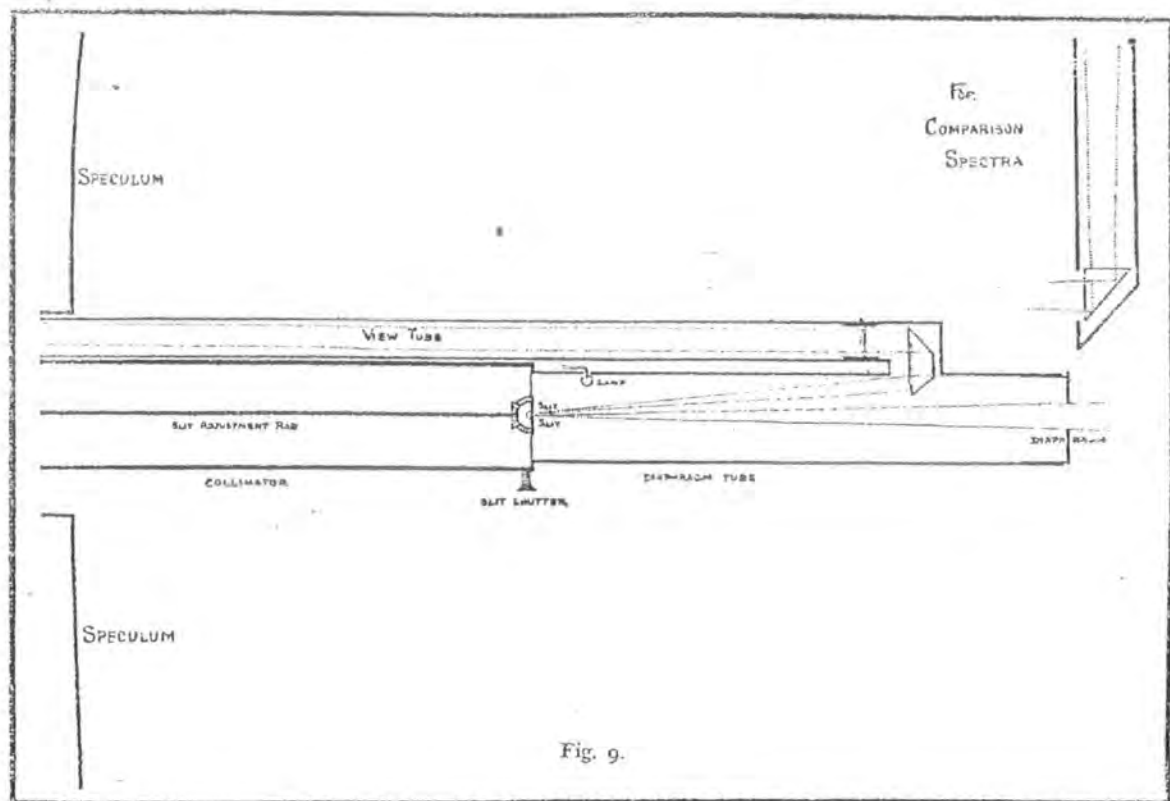

Fig. 9.

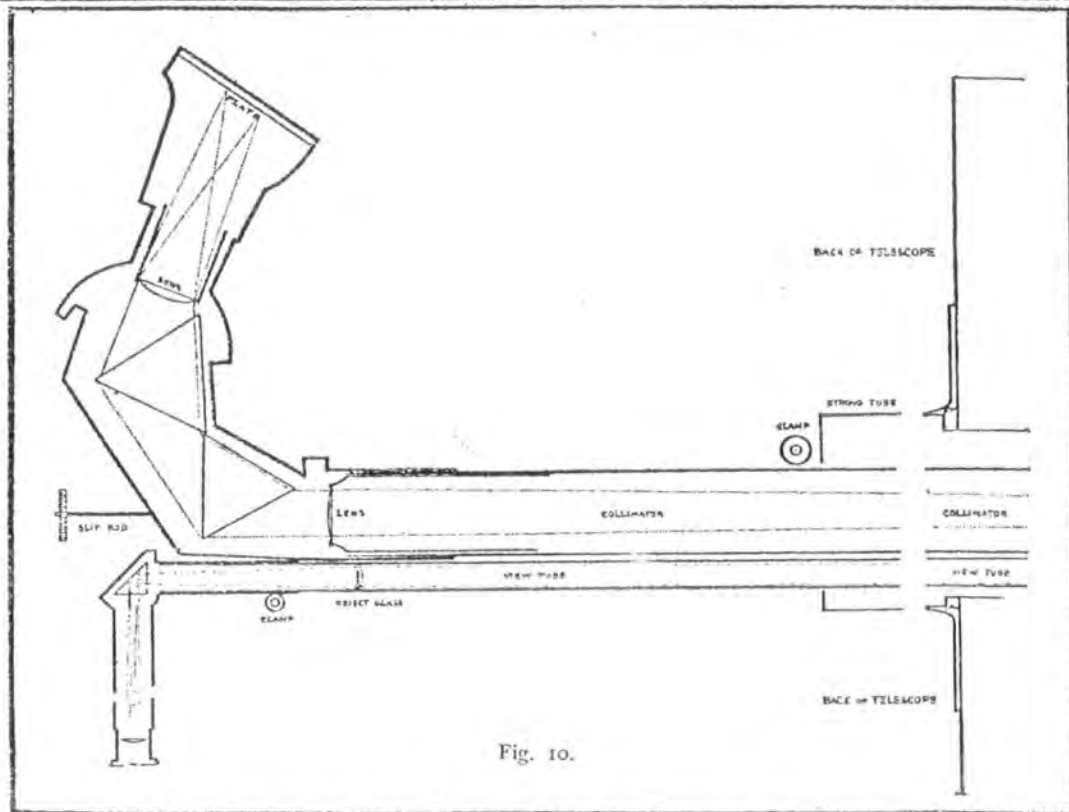
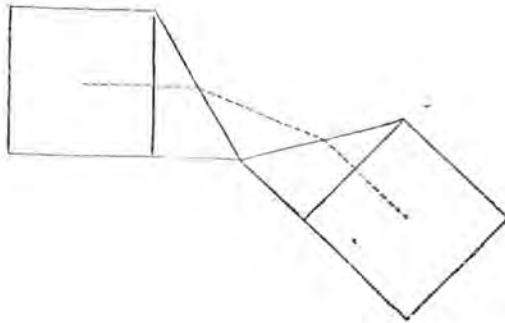

Fig. 10.

THE TULSE HILL ULTRA-VIOLET SPECTROSCOPE.

HUGGINS, ²³ ASTRO PHYS. JOURN., VOL (i) P359

No. 1.



No. 2.

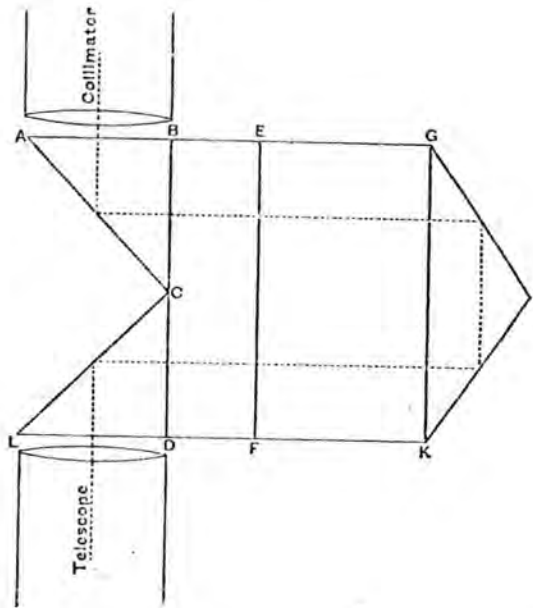

Diagram No. 2 (not in the original paper but given by Kayser, *Handbuch der Spectroscopie* i 521) shows the projection of the prisms on a plane through EF , the axis of the moveable part, perpendicular to the edges of the fixed reflecting prisms.

ABC and CLD fixed reflecting prisms.

$BEFD$ fixed refracting prism.

$EGKF$ moveable refracting prism.

GIK reflecting prism attached to $EGKF$.

The dotted line indicates the course of a ray of light through the instrument.

DEWAR ~ DIRECT VISION SPECTROSCOPE

Proc. Roy. Soc. Vol. 28 (1879) p 482

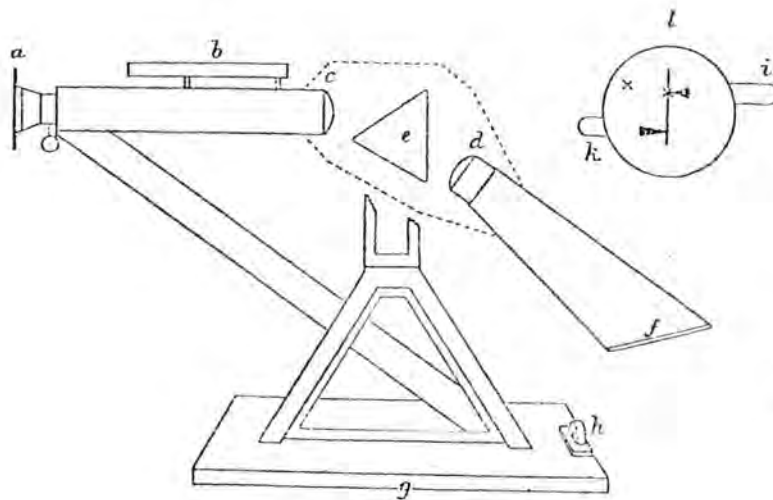

HUGGINS
REF. 152

- a. Slit plate.
- b. Tube for collimation.
- c, d. Quartz lenses.
- e. Prism of Iceland spar.
- f. Photographic plate.
- g. Bevelled edge.
- h. Screw for adjustment in focus of mirror.
- i, k. Shutters of slit.
- l. Silver plate with slit.

Fig. 6.

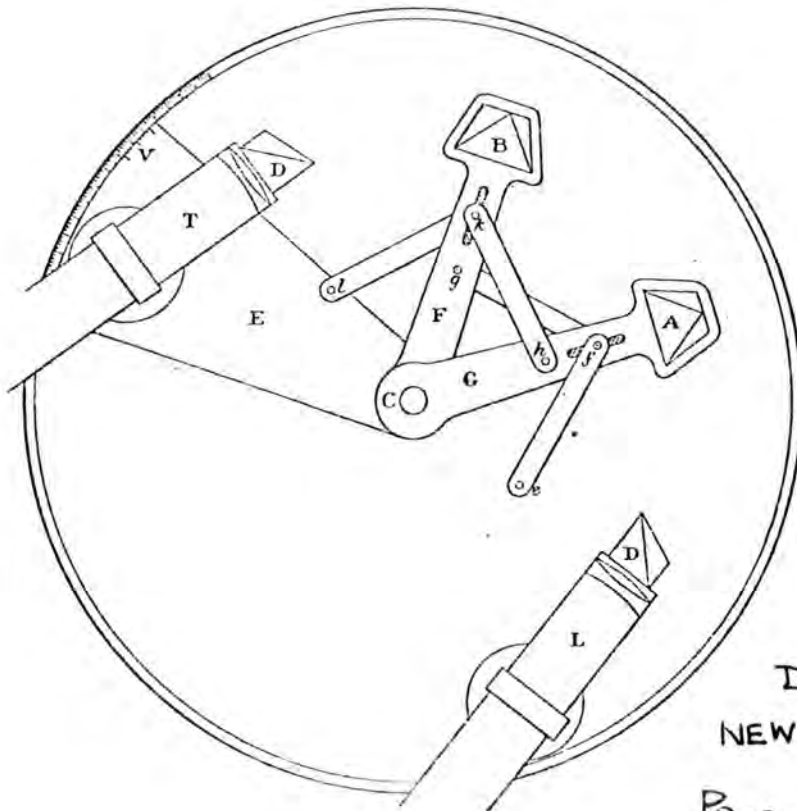
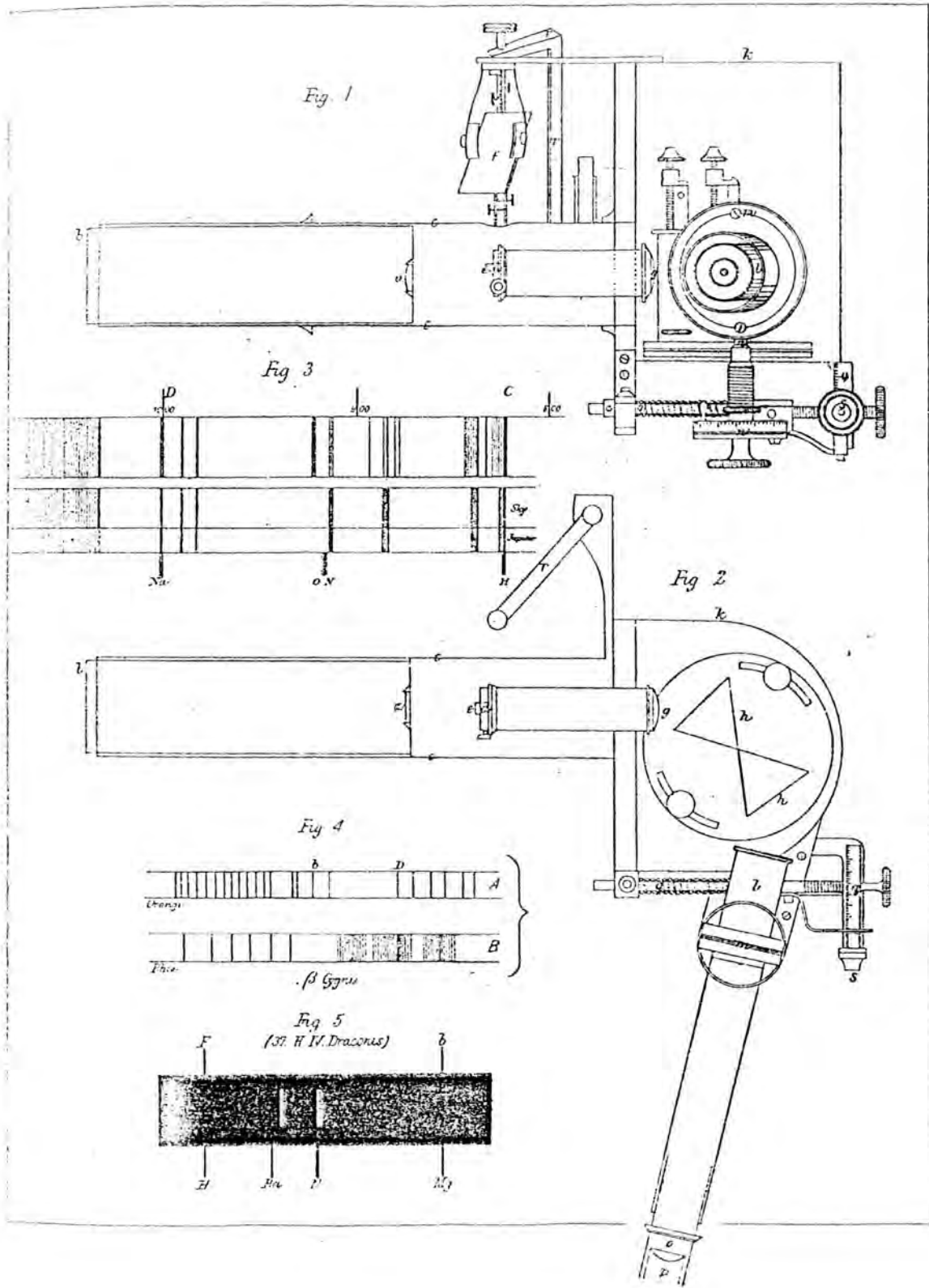
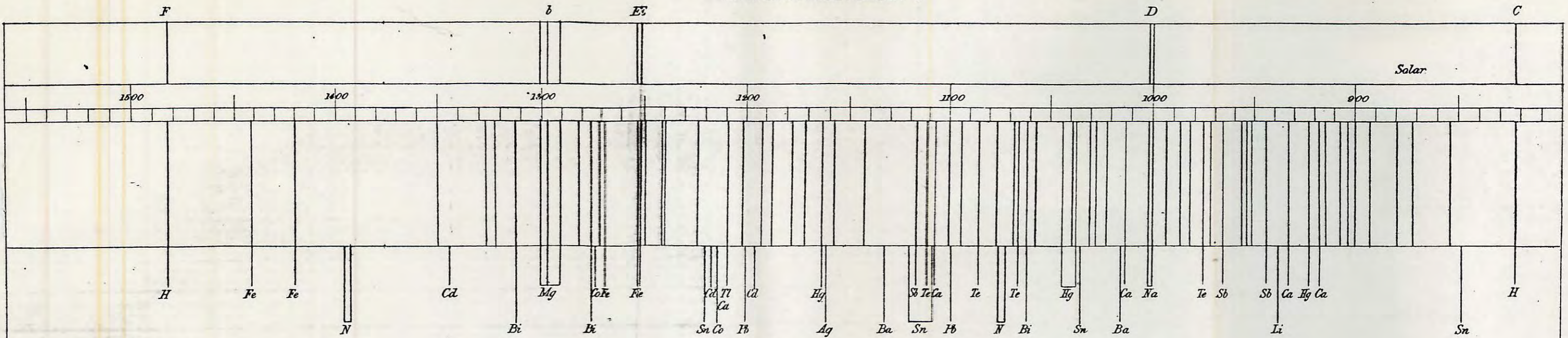

FIG. 3.

DEWAR —
NEW SPECTROSCOPE
PROC. CAMBRIDGE PHIL. SOC.
VOL. 3 PART 6 (1879) P260



ALDEBARAN.



α ORIONIS.

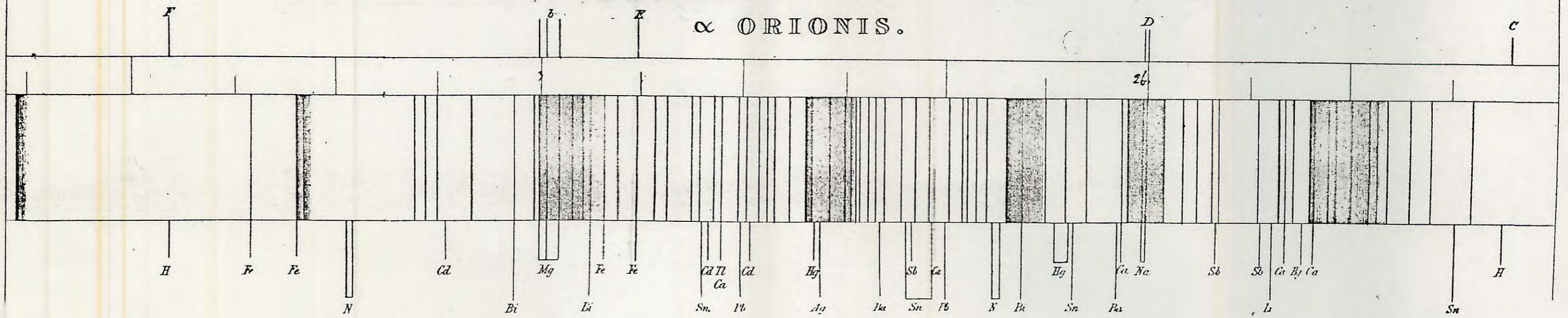

HUGGINS
 PHIL. TRANS. 1864

HUGGINS
STAR
SPECTRA.

