

Durham E-Theses

*The use of intertidal habitats by shorebird populations,
with special reference to grey plover (*Pluvialis
Squatarola*) and Curlew (*Numenius Arquata*)*

David John Townshend

How to cite:

Townshend, David John (1981) The use of intertidal habitats by shorebird populations, with special reference to grey plover (*Pluvialis Squatarola*) and Curlew (*Numenius Arquata*). Doctoral thesis, Durham University.

Use policy

The full-text may be used and/or reproduced, and given to third parties in any format or medium, without prior permission or charge, for personal research or study, educational, or not-for-profit purposes provided that:

- a full bibliographic reference is made to the original source
- a <https://etheses.durham.ac.uk/id/eprint/7598/> is made to the metadata record in Durham E-Theses
- the full-text is not changed in any way

The full-text must not be sold in any format or medium without the formal permission of the copyright holders.

Please consult the [full Durham E-Theses policy](#) for further details.

THE USE OF INTERTIDAL HABITATS BY SHOREBIRD
POPULATIONS, WITH SPECIAL REFERENCE TO GREY PLOVER
(PLUVIALIS SQUATAROLA) AND CURLEW (NUMENIUS ARQUATA)

DAVID JOHN TOWNSHEND, M. A. (Cantab.)
Department of Zoology, University of Durham.

The copyright of this thesis rests with the author.
No quotation from it should be published without
his prior written consent and information derived
from it should be acknowledged.

Being a thesis presented in candidature for the degree of
Doctor of Philosophy in the University of Durham.

March 1981.



To my wife, Gill

ABSTRACT

The use of intertidal habitats by Grey Plovers, Pluvialis squatarola, and Curlews, Numenius arquata, was studied on Seal Sands in the Tees estuary, north-east England during the three winters 1975-78. Birds were uniquely marked with combinations of colour rings to obtain information on the behaviour of individuals throughout and in successive winters.

Grey Plovers arrived on the estuary from July to February, giving rise to peak numbers in February, but left mainly in March and April. Thus periods of stay by individuals varied markedly. In contrast most Curlews arrived in late summer and left in spring. Consequently most individuals were present for similar periods, and the number on the estuary remained constant through the winter. However, the number of Curlews feeding on Seal Sands fell to a minimum in mid winter when some moved to feed on the fields. Both species showed a high percentage return rate to the estuary in successive winters.

During each tidal cycle individuals changed their feeding sites in predictable ways. For any one bird the pattern was constant over periods of several weeks or months, and sometimes repeated in successive winters. In both species, four basic patterns in use of space could be identified. These were distinguished by:

- i) whether one or more than one feeding site was used during a tidal cycle, and
- ii) whether or not a feeding site was defended. The strategy employed on a particular site could be predicted from two characteristics of that site: i) its period of exposure, and ii) the rate of drainage of the substrate. It is argued that these characteristics determine the availability of Nereis diversicolor, the main prey of both bird species on Seal Sands.

Simple models based on the supposed activity and depth distribution of Nereis on different sites explained much of the variety in use of space shown by individual Grey Plovers and Curlews both during a tidal cycle and during a winter. However the models were inadequate to explain the detailed components of foraging behaviour observed. Also, variability in the foraging responses to changes in Nereis availability was considerable, both between individuals and between days for the same individual; this raises doubts over the validity of studies based on "average" birds.

Curlews show marked sexual dimorphism in bill length. This influenced the pattern in use of space employed by individuals. Most long-billed birds remained on the mudflats all winter, but many short-billed individuals (i. e. males) fed upon the adjacent pastures, particularly in mid winter when Nereis was most likely to be buried out of reach of their bills.

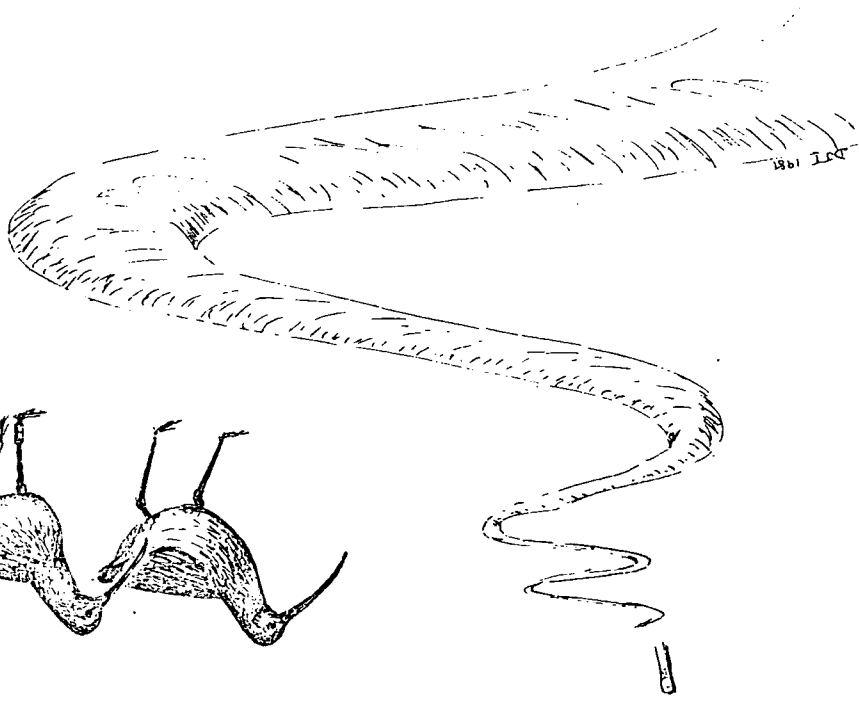
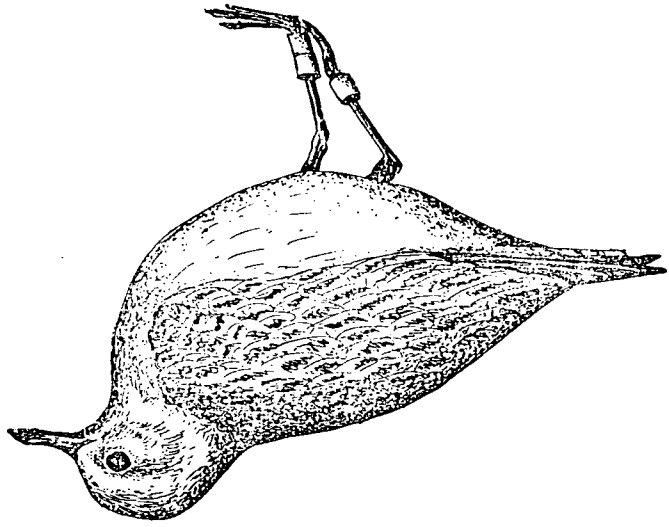

ACKNOWLEDGEMENTS

I wish particularly to thank my Supervisor, Dr. P. R. Evans for his guidance, encouragement and patience during both the fieldwork and the preparation of this thesis.

I am grateful to Professor D. Barker for permitting me the use of the facilities of the Department of Zoology.

I would like to thank my colleagues in the Shorebird Research Group, N. C. Davidson, P. J. Dugan, L. R. Goodyer and M. W. Pienkowski for their suggestions, stimulating discussions and practical assistance throughout the study.

I congratulate Mrs. C. Dowson on her skilful and accurate typing of the manuscript, and thank C. J. Pienkowski for translating a Russian paper.

The study was financed by a Natural Environment Research Council research studentship.

My special thanks go to my wife, Gill, to whom this thesis is dedicated, for her untiring encouragement and assistance during the many long hours of preparation of this thesis, even when the task seemed endless.

CONTENTS

	Page
<u>SECTION 1. INTRODUCTION</u>	
1. A Background to research	1
1. B The study area	5
<u>SECTION 2. DISTRIBUTION - POPULATIONS</u>	
2. A Methods of counting	11
2. B The use of Seal Sands by Grey Plovers	20
2. C The use of Seal Sands by Curlews	46
2. D The use of Seal Sands by Bar-tailed Godwits	70
<u>SECTION 3. DISTRIBUTION - INDIVIDUALS</u>	
PART I. THE USE OF TEESMOUTH AS A WINTERING SITE	
3. I. A Methods of capturing and marking	95
3. I. B The use of Teesmouth as a wintering site by individual Grey Plovers	98
3. I. C The use of Teesmouth as a wintering site by individual Curlews	116
3. I. D The use of Teesmouth as a wintering site by individual Bar-tailed Godwits	135
3. I. E Discussion	141
3. I. E. 1 Interrelationships between species on Seal Sands	141
3. I. E. 2 The position of Teesmouth in the migration systems of Western Europe and Africa	145
PART II. THE FEEDING SITES USED BY INDIVIDUAL BIRDS	
3. II. A The use of Seal Sands as a feeding area by individual Grey Plovers	153
3. II. A. 1 Low Water feeding sites of individual Grey Plovers	154
3. II. A. 2 Feeding sites used during the tidal cycle	187
3. II. A. 3 Feeding territories	209
3. II. B The use of Seal Sands as a feeding area by individual Curlews	239
3. II. B. 1 Low Water feeding sites of individual Curlews	239

	Page	
3. II. B. 2	Feeding sites used during the tidal cycle	272
3. II. B. 3	Feeding territories	288
3. II. B. 4	The use of Seal Sands by Curlews in relation to their bill lengths	308
3. II. C	The use of fields as feeding areas by Curlews	314
3. II. C. 1	Counts of Curlews feeding on the Brinefields	314
3. II. C. 2	The use of fields by marked Curlews	319
3. II. D	Discussion	336
3. II. D. 1	The advantages of winter territoriality to individual shorebirds	336
3. II. D. 2	Strategies in use of space during a tidal cycle in relation to prey behaviour	346
3. II. D. 3	Use of space during a winter in relation to prey behaviour	370
3. II. D. 4	Bill length in relation to Curlew use of space	381
3. II. D. 5	A comparison between Grey Plover and Curlew use of space during a winter	385

(Section 4. Part I. Removed at the request of the examiners.)

SECTION 4. PART II. THE FORAGING BEHAVIOUR OF GREY PLOVERS AND CURLEWS IN RELATION TO PREY BEHAVIOUR

4. II. A	Introduction	422
4. II. B	Grey Plover	422
4. II. C	Curlew	461
4. II. D	Summary and Discussion	499

SECTION 5. GENERAL DISCUSSION

5. A	Inter-individual variability and its consequences for winter feeding by birds	505
5. B	Winter territoriality	511
5. C	Interspecific competition	514
5. D	Future research into use of space by Grey Plovers and Curlews	517

	Page
REFERENCES	520
SUMMARY	532
APPENDIX 1	536
APPENDIX 2	541
APPENDIX 3	543
APPENDIX 4	548

SECTION 1

INTRODUCTION

1. A. BACKGROUND TO RESEARCH

This research project was begun as an attempt to answer some of the questions raised by the study of the effects upon shorebird populations of reclamation of intertidal land on Teesmouth. Because land at the highest tidal levels was reclaimed preferentially, the time for which mudflats were uncovered was reduced from 12 to 8 hours (Evans 1980). The average feeding time of some shorebird species during a daylight tidal cycle prior to reclamation exceeded the 8 hours available, e.g. Grey Plover, Pluvialis squatarola, $6\frac{1}{2}$ to 10 hours; Redshank, Tringa totanus, 9 to 10 hours; Dunlin, Calidris alpina, $9\frac{1}{2}$ to 11 hours (Goss-Custard et al. in prep.). Thus in cold weather, when energy requirements are highest and therefore feeding time longest, the time available for feeding should be insufficient for these birds to meet their food requirements. Reclamation should therefore have resulted in the complete loss of these species from the estuary.

However this did not occur. The number of Grey Plovers feeding on Seal Sands fell only slightly, presumably because many were able to meet their food requirements on the mudflats despite the reduced feeding time. This indicates that there was variation between individual Grey Plovers in the time they required to obtain their food on Seal Sands in each daylight tidal cycle: those requiring less than 8 hours stayed, those requiring more than 8 hours left or died.

As Grey Plovers vary rather little in size and therefore have similar energy requirements, the differences in feeding times are presumably a result

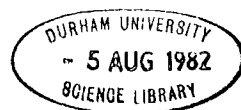

of some birds feeding faster than others. This would occur if, in any given area, some individuals were more efficient at capturing prey. To investigate this individual variation in foraging efficiency I marked individual Grey Plovers, Curlews, Numenius arquata and Bar-tailed Godwits, Limosa lapponica, with unique colour-ring combinations, thus permitting comparisons between individuals of a species and between visual foragers (Grey Plovers) and tactile foragers (Curlews and Bar-tailed Godwits).

However this colour-marking soon revealed that individuals within a species used the intertidal habitat in different ways, but that most individuals had regular patterns of behaviour. The observed variation in feeding times within a species could be a consequence of some individuals feeding on the areas with the highest densities of available prey, where a high feeding rate could be maintained, and others on areas of lower prey density. The extent and importance of this individual variation in use of space therefore became the major aspect of my study.

Individual variation in feeding behaviour - The variation in use of space between Grey Plovers could be a consequence of differences in age or sex, or due to differences in behaviour between individuals of the same age and sex. There is increasing evidence from studies on birds that, under a given set of environmental conditions, individuals within a population do show a variety of patterns of feeding behaviour, and that some, but not all, of the differences are age- or sex-related.

i) Age-related differences - Adults have been shown to have a higher foraging success (measured as the proportion of attempts to capture prey that are successful) than juveniles in [Ruddy] Turnstones, Arenaria interpres (Groves 1978) and also in several non-shore bird species, such as Brown Pelicans,

Pelecanus occidentalis (Orians 1969), Little Blue Herons, Florida caerulea (Recher and Recher 1969a) and Grey Herons, Ardea cinerea (Cook 1978a), Sandwich Terns, Sterna sandvicensis (Dunn 1972), Herring Gulls, Larus argentatus (Verbeek 1977), Glaucous-winged Gulls, Larus glaucescens (Searcy 1978) and Olivaceous Cormorants, Phalacrocorax olivaceus (Morrison *et al.* 1978). In Royal Terns, Sterna maxima, there is no difference in foraging success between adults and juveniles but adults have a higher capture rate because they dive more frequently (Buckley and Buckley 1974).

ii) Sex-related differences - Sexual dimorphism in size results in males and females taking different prey species in hawks (Storer 1966) and owls (Earhart and Johnson 1970), different sizes of the same prey species in Bar-tailed Godwits (Smith and Evans 1973), or feeding in different locations as in Bar-tailed Godwits (Smith and Evans 1973, Smith 1975), and woodpeckers (Hogstad 1976).

iii) Individual differences - Individual variation not correlated with age or sex differences has been demonstrated in the following aspects of feeding behaviour: in choice of prey type in Oystercatchers, Haematopus ostralegus (Heppleston 1971) and gulls (Harris 1965); in method of prey handling in Oystercatchers (Norton-Griffiths 1967); in choice of feeding location in Woodpigeons, Columba palumbus (Murton *et al.* 1966), Herring Gulls (Davis 1975) and Great Tits, Parus major (Partridge 1976); and in use of space in shorebirds (Recher and Recher 1969b, Goss-Custart 1970, Myers *et al.* 1979a), Golden-winged Sunbirds, Nectarinia reichenowi (Gill and Wolf 1975), Pied Wagtails, Motacilla alba (Davies 1976) and Tennessee Warblers, Vermivora peregrina (Tramer and Kemp 1979).

In addition to these examples of individual variation in feeding behaviour under given environmental conditions, investigations have revealed differences

in the responses of individuals to changes in environmental conditions in Sanderlings, Calidris alba (Myers et al. 1979b) and Pied Wagtails (Davies 1976).

Implications of individual variation in feeding behaviour - If some individuals are more successful at exploiting a food supply than other members of the population, by being more efficient at capturing prey at a high rate during the time available and/or at competing with others for food or space in which to feed, they should have a higher chance of survival in severe conditions. Also such differences in efficiency could explain why juvenile mortality, even after fledging, is higher than that of adults not only in shorebirds (Boyd 1962, Hilden 1978, Pienkowski 1980a) but also in most other birds, e.g. gulls (Olsson 1958, Coulson and White 1959, Flegg and Morgan 1976), skuas (Furness 1978), herons (Olsson 1958, Owen 1959, Kahl 1963, Mead et al. 1979) and owls (Olsson 1958, Southern 1970).

A second implication of individual variation in feeding behaviour is that, if individuals show different preferences e.g. for feeding location or prey type, intraspecific competition may be reduced. For example, it has been suggested that sexual dimorphism in size has evolved to reduce intraspecific competition for food in raptors (Reynolds 1972, Newton 1979), woodpeckers (Selander 1966, Hogstad 1978) and finches (Newton 1967).

Approach to research project - To determine the extent and importance of individual variation in shorebird feeding behaviour, I studied the use of space and foraging behaviour of individually-marked Grey Plovers, Curlews and, to a more limited extent, Bar-tailed Godwit under a variety of environmental conditions during 3 winters. Throughout the study I attempted to answer the question: "How does an individual bird use its habitat?" Firstly I determined the variety of patterns in use of space shown by individuals within each species. Both fidelity to an estuary and choice of feeding area(s) within the Tees estuary (in

particular on Seal Sands) were investigated. Subsequently I concentrated my studies on one visual forager (Grey Plover) and one tactile forager (Curlew), relating the observed variation in spacing behaviour to the food supply, in particular to variations in availability of the main prey species, Nereis diversicolor.

1.B. THE STUDY AREA

The study was carried out on the Tees estuary, north-east England ($54^{\circ}37' N$, $1^{\circ}12' W$) during the 3 winters 1975/76, 1976/77 and 1977/78. The estuary comprises a main shipping channel, with 2 intertidal areas (Seal Sands and North Gare Sands) to the north of it and one (Bran Sands) to the south (Fig. 1.1). To the north-west and west of the estuary lie extensive areas of rough pasture, of which Cowpen Marsh is the largest.

Most observations of shorebird behaviour were made on Seal Sands, the most productive area of mudflats (140 hectares) remaining on the estuary. The term Seal Sands as used in this study corresponds to the North Area of Evans *et al.* (1979) and Knights (1979). (A detailed description of the history of reclamation on the estuary is given by Knights (*op. cit.*)). Seal Sands, bounded on 3 sides by reclamation walls, comprises mudflats to the east enclosed by the slag mid-tide wall and, to the west, mudbanks beside Seaton Channel (Fig. 1.2). The 2 sets of mudbanks are separated by Central Channel which lies at a lower tidal level. Creeks form the boundary between the northern parts of Eastern Channel and Central Bank, and between the 2 distinct halves of Scalloped Mud. On the eastern half of Scalloped Mud, close to the East-West Reclamation Wall, lie a series of mussel scars favoured by birds roosting on the flood tide. Greatham Creek empties into the south-west corner of Seal Sands. The high levels of partially-treated human sewage in this outflow enrich the sediments of Seal Sands, and result in an infauna of high biomass density but

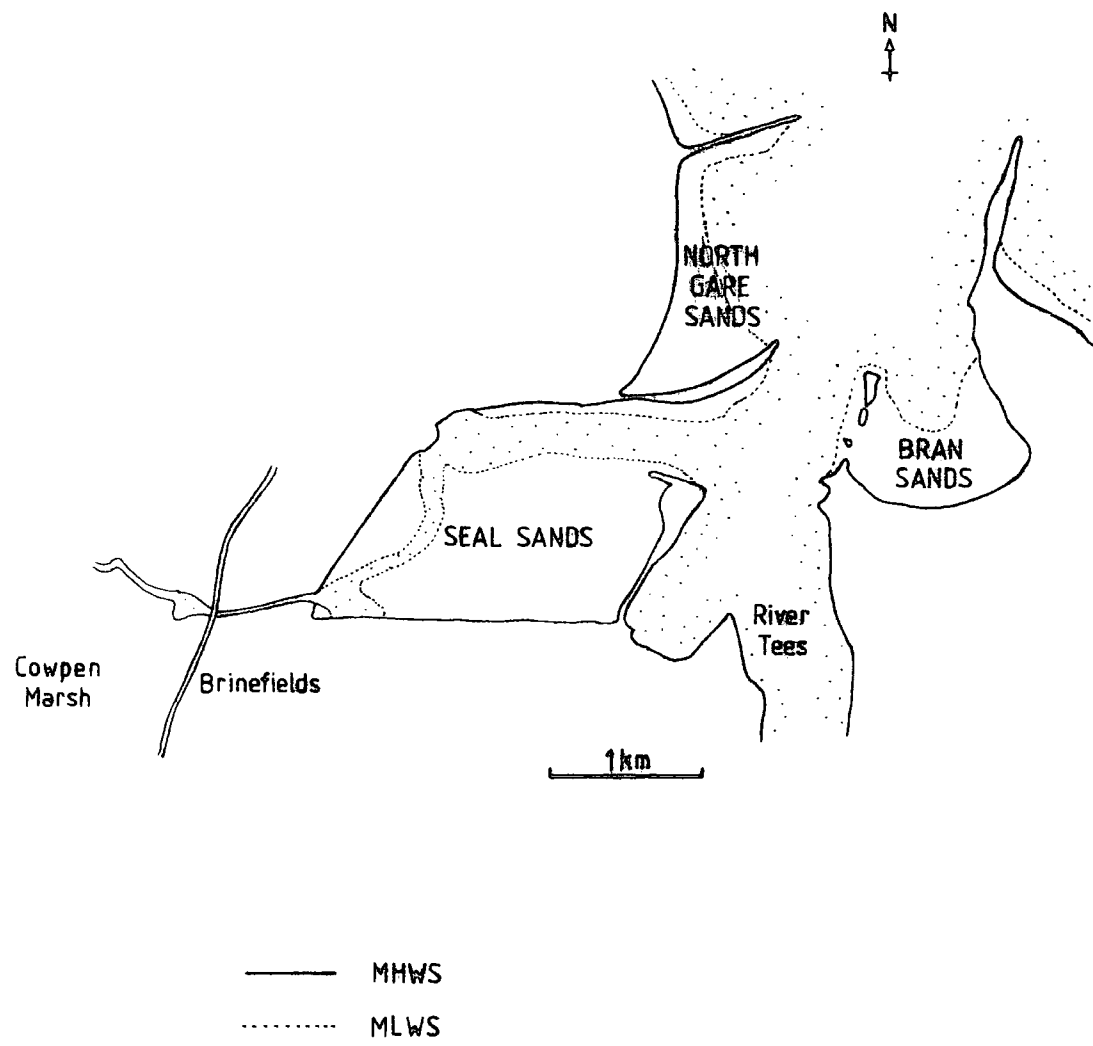

Figure 1.1 The intertidal areas on the Tees estuary.

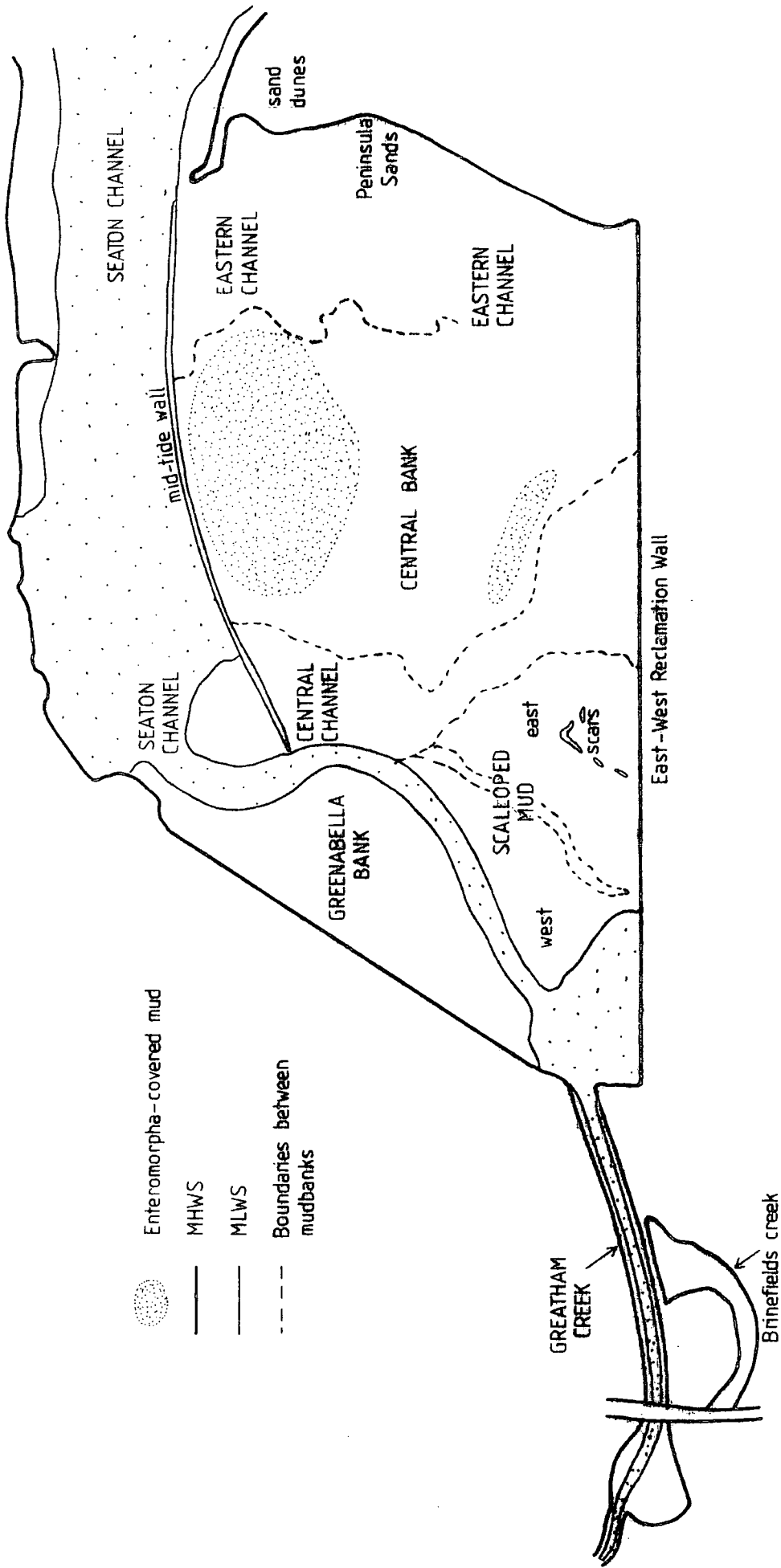

Figure 1.2 The intertidal mudflats of Seal Sands.

low species richness. Greatham Creek contains a small area of mudflats used by waders particularly for feeding at High Water in mid winter.

The sediment type varies across Seal Sands (Fig. 1.3). The Peninsula and parts of Central Bank and Eastern Channel consist primarily of sandy substrates, whereas the sediment elsewhere contains greater proportions of silt. The softest muds are found in the south-east corner of Seal Sands next to the East-West Reclamation Wall, on Central Channel, and on either side of Seaton Channel on Greenabella Bank and Scalloped Mud. On Greenabella Bank soft substrates surround a central ridge of firmer mud. During the summer the green algae Enteromorpha spp. cover large parts of the sandier areas of Central Bank. This gradually disappears during the autumn and winter. The presence of this film may reduce the rate of drying of the surface layers of sediment after exposure by the tide.

On most tides all the intertidal areas shown in Fig. 1.2 are exposed during the Low Water period, as most mudflats are at roughly the same (mid-) tidal level. At Low Water on extreme spring tides mudbanks at a very low tidal level are uncovered at the edges of Seaton Channel, particularly on Central Channel and Greenabella Bank. On extreme neap tides the northern part of Central Channel and the lower tidal levels of Greenabella Bank remain covered even at Low Water. As the tide ebbs the sand of the Peninsula is the first area to be exposed, followed by the highest parts of Central Bank and Scalloped Mud. The remaining mudflats are then exposed in quick succession due to the flatness of Seal Sands.

Seal Sands has a restricted invertebrate macrofauna with only 5 species occurring at levels of abundance that make them important items in the diets of shorebirds (Evans et al. 1979). The species are Nereis diversicolor, the only abundant large annelid and the main food of the larger waders, Hydrobia ulvae,

- A Sand
- B Firm sandy mud
- C Mud
- D Soft mud
- E Liquid mud

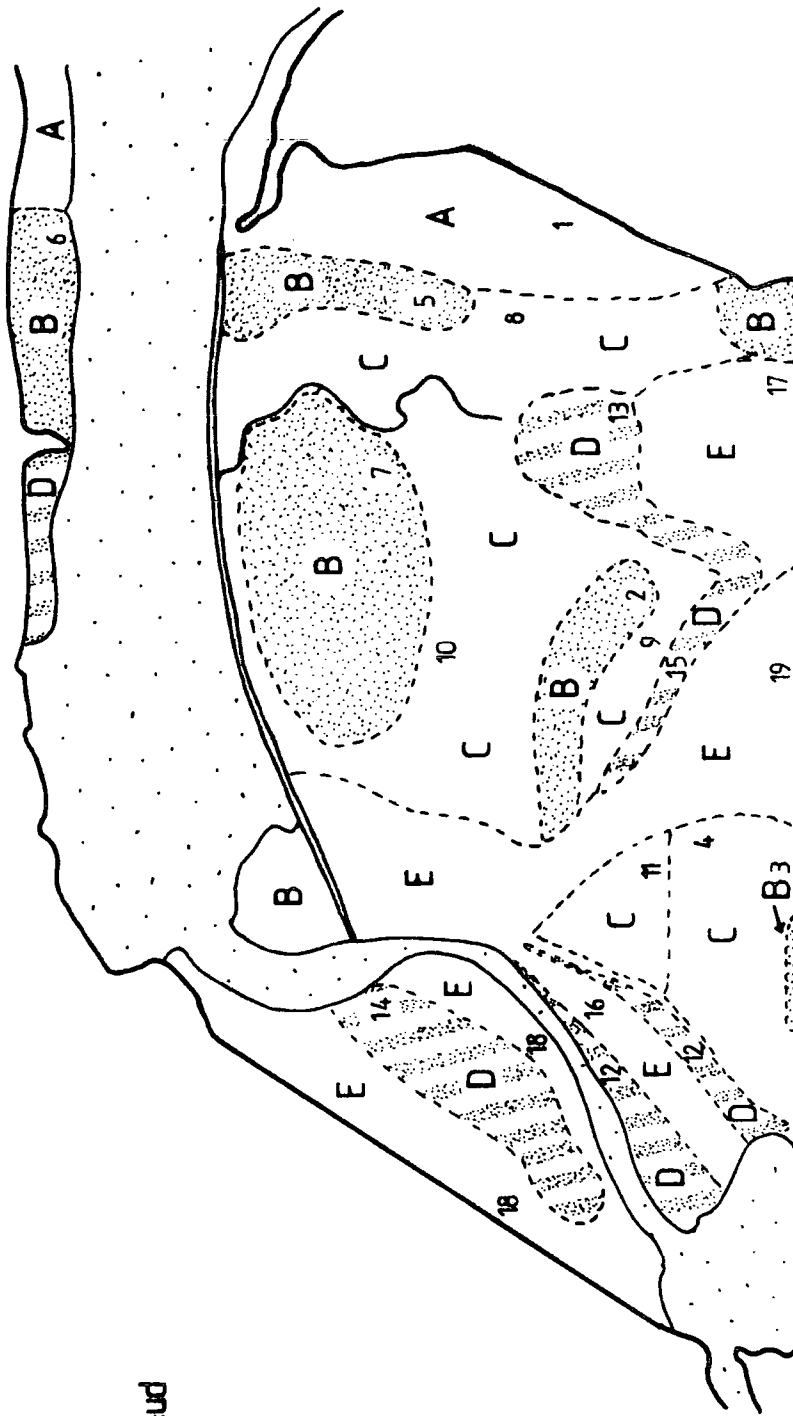

Figure 1.3 The sediment types on Seal Sands, during the period 1975-78.

Corophium volutator, Macoma balthica and Carcinus maenas. There is a very abundant meiofauna on Seal Sands, comprising small polychaetes, oligochaetes and nematodes (Grey 1976, Kendall 1979).

Seal Sands was the main intertidal feeding area on Teesmouth not only for the 3 study species, Grey Plover, Curlew and Bar-tailed Godwit, but also for substantial populations of Dunlin (Calidris alpina), Redshank (Tringa totanus) and Shelduck (Tadorna tadorna), and smaller numbers of Knot (Calidris canutus) and Ringed Plover (Charadrius hiaticula). During periods of snow Lapwings (Vanellus vanellus) and in particular Golden Plovers (Pluvialis apricaria) moved from the fields to the mudflats. Gulls used Seal Sands as a roost site through the winter, occasionally in many thousands.

Individuals of the 3 study species captured for colour-ringing were aged using the plumage characteristics described by Minton (1971). Ageing of Grey Plovers was also possible in the field, particularly in autumn. Juveniles and adults differed markedly not only in plumage but also in behaviour, the juveniles feeding in areas generally avoided by adults. Both Curlews and Bar-tailed Godwits show sexual dimorphism, the females being larger than the males (e.g. Witherby et al. 1945). The dimorphism is particularly marked in bill length, enabling both species to be sexed in the hand. In addition, some large females and small males could be sexed, from bill length, in the field (see also Smith and Evans 1973).

In the following Sections the term Godwit is synonymous with Bar-tailed Godwit as this was the only Limosa species using Teesmouth in large numbers.

SECTION 2

DISTRIBUTION - POPULATIONS

2.A. METHODS OF COUNTING

All counts and observations of birds were made using a 15-60 x 60 Swift Telemaster telescope or 10 x 50 binoculars. For much of the time a landrover was used as a mobile hide, as it allowed a much closer approach to the birds without causing disturbance, and permitted observations in all weather conditions. Birds on the more northern mudflats were occasionally observed at close range from a rubber dinghy.

2.A.1. Low Water Counts on Seal Sands

Counts of all birds present on Seal Sands at Low Water were made from fixed points on the surrounding reclamation walls (Fig. 2.1). When possible, counts were made at about weekly intervals on successive neap and spring tides to reveal any differences associated with the extent of habitat exposed at Low Water.

During 1976/77 and 1977/78, 5 areas of Seal Sands, namely Eastern Channel, Central Bank, Central Channel, Scalloped Mud and Greenabella Bank (Fig. 2.1) were counted separately from the positions indicated. The period of counting was usually confined to Low Water \pm 1 hour. During this period all the mud to be exposed on that tide was uncovered, and movement of birds was at a minimum.

In the summer of 1977 wooden posts 1 - 2 metres high were placed on a grid marking out 100 x 100 metre squares on the largest area of mudflats, Central Bank and Eastern Channel (Fig. 2.1). Each post was marked with

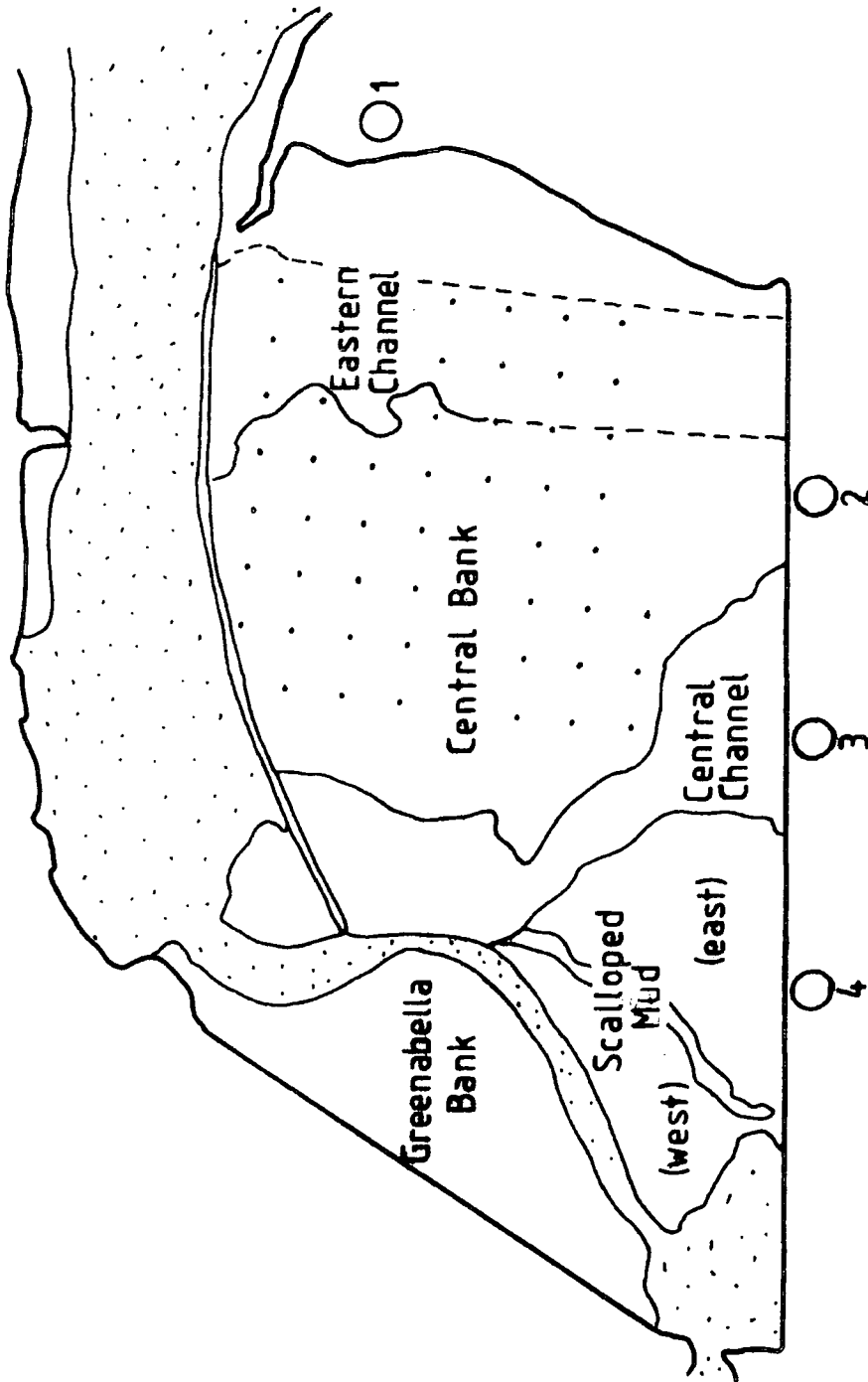

Figure 2.1 The four vantage points used for counting birds on Seal Sands at Low Water, the areas counted, and the grid on Central Bank.

two stripes of paint, the top colour indicating the vertical row of the grid and the bottom colour the horizontal row, as seen from the reclamation wall. It was thus possible to determine its exact position when seen through a telescope, even at a range of 1 km.

This grid enabled the total counts of Central Bank in 1977/78 to be subdivided. Although counts in strips running east-west across Central Bank would have been most valuable as each strip would then have contained points at a single tidal level, they were not practicable due to poor visibility of some sites from the Peninsula, the only suitable vantage point. Hence Central Bank was counted along north-south strips from the end of a line of posts, on the East-West Reclamation Wall (Fig. 2.2).

2.A.2. Problems and Errors in Low Water Counts

Certain difficulties were experienced during counting at Low Water.

(a) Access - A security fence prevented access to/from the eastern part of the East-West Reclamation Wall unless the gate had been unlocked by Philips Petroleum. If closed, there was a gap of 10-15 minutes whilst the landrover was driven round the petrochemical site to the other side of the fence, and during this time some movement of birds may have occurred, particularly of Curlew and Shelduck to/from Greenabella Bank and Central Bank. However, as the counts were usually conducted at or around Low Water such movement was likely to be small in relation to the number of birds present, and would have led to errors of at most 5 per cent.

(b) Weather - The accuracy of Low Water counts was much influenced by the prevailing weather conditions. Strong winds shook the telescope even when it was mounted inside the vehicle and poor visibility, caused by heat haze, mist, heavy rain or snow, made counting of the more distant areas difficult.

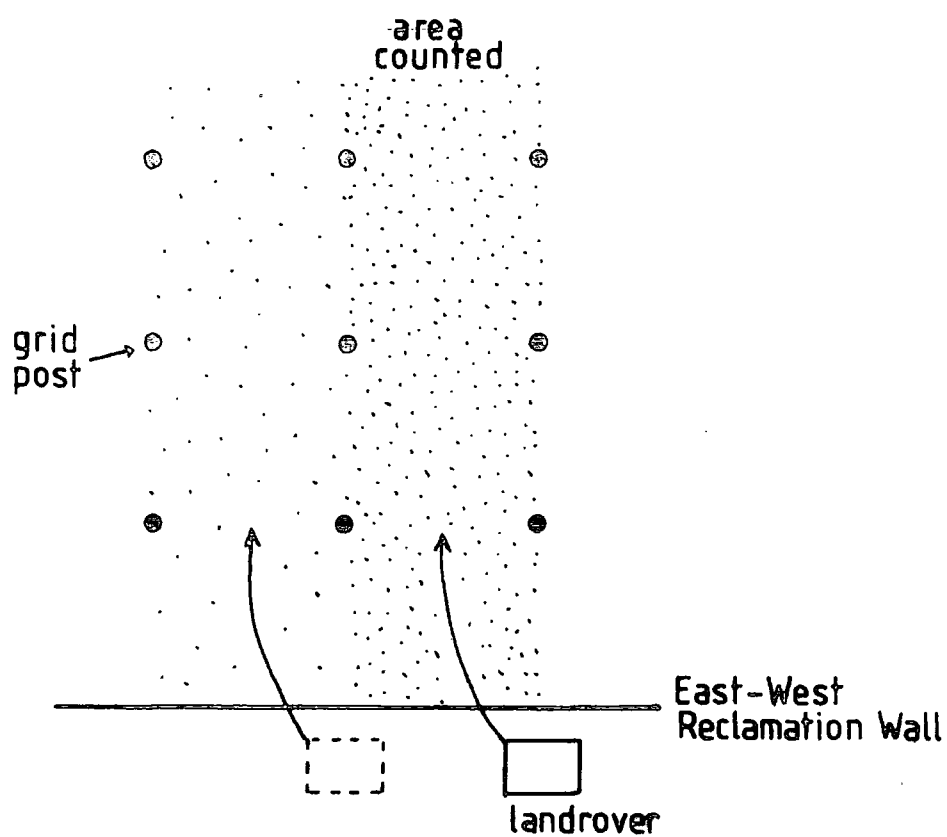

Figure 2.2 The method for counting birds on Central Bank at Low Water using the grid.

In such conditions, the number of birds present on the far parts of Central Bank were underestimated, whereas the counts of nearer areas such as Scalloped Mud and Eastern Channel were as reliable as in good weather.

An example is given in Table 2.1.

In strong winds and/or driving rain the behaviour of the birds changed, and this also influenced the counts. Some species, particularly Grey Plovers, tended to spend much more time feeding in creeks than on the open mud in such conditions, and all species tended to roost in creeks rather than on the exposed open mud. This led to further underestimation of numbers (Table 2.1).

Where counts were obviously depressed by poor weather they have been excluded from the data on seasonal changes in numbers, presented in the sections which follow.

(c) The identity of the counter - A series of counts in December 1977 revealed discrepancies between counters. The other counter, L. R. Goodyer, had less experience of the area and the behaviour of the birds than I had, and his totals were in all cases lower than mine. Therefore I have restricted the counts used in the discussion of mid-winter numbers to my own. However, for the months of July-August and again between late April and May I have used counts made by L. R. G. although they are probably underestimates, as they are the only ones available.

(d) Disturbance - Seal Sands is an area of intensive industrial development, and there was much activity on the reclaimed land adjacent to the mudflats. In the main this comprised movement of vehicles and people along the East-west Reclamation Wall, the Peninsula Wall and Sands, and occasionally along the eastern end of the mid-tide wall. Birdwatchers also caused disturbance on the sea-wall by Greenabella Bank, chiefly at weekends.

Table 2.1

The effects of weather conditions upon Low Water counts
of Grey Plovers on Seal Sands in December, 1977

Date	14th December	15th December	16th December
Wind Speed (kt.)	20 (high)	2 (low)	17 (high)
Visibility (km.)	22 (very good)	5 (moderate)	2.5 (poor)

<u>Section of Seal Sands</u>	<u>Counts</u>		
Eastern Channel	16**	20	10***
Central Bank	53	49	13*
Central Channel	0	2	0
Scalloped Mud	2	7	0
Greenabella Bank	7	14	28

Note: * Effect of Poor Visibility
 ** Effect of High Winds
 *** Effect of Poor Visibility and High Winds

This disturbance may result in considerable redistribution of the birds between potential feeding areas, but at Low Water most birds are sufficiently far from vehicle and public access to remain unaffected.

There is a considerable amount of air traffic over Seal Sands, consisting of light aircraft and helicopters, and, in certain wind conditions, of airliners coming in to land at Teesside airport. In late winter and spring 1978 there was a marked increase in the number of helicopter flights directly over Seal Sands up to a frequency of one per hour throughout the day. When these flights caused disturbance during a Low Water count, inaccuracies resulted from unknown numbers of birds flying off to areas already counted.

Frequent disturbance from aircraft may have contributed to the increased variability in numbers of Godwit feeding on Seal Sands during late winter and spring 1978, since this species is particularly sensitive to disturbance (see e.g. Furness, 1973).

2. A. 3. High Water Counts on the Estuary

Counts of Curlew, Godwit and Grey Plover were also made at roost sites, when Seal Sands was covered. High Water counts were confined to known roost sites on the north side of the estuary. Additional information concerning roost sites on the south side of the estuary was obtained from observations of birds flying across the river before High Water, and from sightings of these species made by D. M. Brearey whilst working on the coastal sands near South Gare.

Most High Water counts are minima as a complete check of all known roost sites was not carried out on every occasion. For example, Curlew and Godwit frequently roosted on an island on the south side of the main shipping channel of the Tees and were impossible to count there. Also, although the main roost sites for each species were known, subsidiary roosts consisting

of small numbers of birds may have remained undetected. Therefore High Water counts (which could include birds that feed in any part of the estuary) were used only when the numbers seen on roosts exceeded those counted at Low Water on Seal Sands.

Complete High Water counts were usually greater than Low Water counts. This was because:

- (a) During Low Water counts of Seal Sands, some birds were missed for reasons discussed in Section 2. A. 2. e.g. poor counting conditions. Therefore the number of birds actually feeding on Seal Sands at Low Water was often greater than the number counted. This is confirmed by counts made as the tide covered the mudflats. Numbers of each species, particularly of Grey Plovers, apparently increased on Seal Sands as the creeks and more distant areas of mud were covered and all birds present were forced into view. These increases were not due to birds flying into Seal Sands from other parts of the estuary. No more than 3 Godwits and 3 Grey Plovers were seen to fly in. Comparison of Low and High Water counts of Curlew is more difficult since many individuals feed on the fields at all stages of the tide and some move between the mudflats and the fields during the tidal cycle. This phenomenon will be discussed in more detail later.
- (b) As the roost sites are scattered around the estuary rather than restricted to sites adjacent to Seal Sands, they will include any individuals feeding elsewhere in the estuary and on the coast or the fields, as well as birds from Seal Sands. Curlews that have not been seen feeding on Seal Sands for several weeks, and are therefore field feeders, appear at High Water roosts.

Nevertheless, High and Low Water counts usually change in parallel during the winter.

2. A. 4. 'Birds of Estuaries' Counts

Once a month, a team of observers organised by the Teesmouth Bird Club check all known, accessible roost sites during a short period around High Water on a single day in order to determine the numbers of waders and waterfowl present on the estuary. This method has a distinct advantage over counts made by a single person in that movement of birds between roosts during the count should be negligible.

However, such counts are made on a date fixed in advance, to permit co-ordination with other estuaries. If bad weather or disturbance of roost sites occurs immediately before the count, unrepresentative and inaccurate data are recorded. Also short-term fluxes in numbers of birds are often not detected in monthly counts.

As the whole estuary is covered by 'Birds of Estuaries' counts, the totals recorded for each species should be higher than my High Water or Low Water counts. This is not always the case. Sometimes new roost sites, used only temporarily, have been missed. Also underestimates have been made when counting species which pack together tightly at roost. These species, e. g. Knot and Dunlin, are more effectively counted in flight or on feeding sites.

However 'Birds of Estuaries' counts have been used, when they exceeded my counts, to assess whether sudden changes in my Low Water or High Water counts are anomalies (produced by poor conditions) or are due to real changes in the numbers present on the estuary.

2. B. THE USE OF SEAL SANDS BY GREY PLOVERS

2. B. 1. Seasonal Changes in Numbers Feeding

The Low Water counts provide an index of the use made of Seal Sands for feeding by Grey Plovers. Changes in numbers during and between winters can be assessed, bearing in mind the reliability of counts, discussed above.

Frequent Low Water counts are available for the winters of 1976/77 and 1977/78 (Fig. 2.3). Numbers increased gradually from July to October. In 1976 many Grey Plovers, chiefly juveniles, arrived in late September-early October, with a peak of 185 birds feeding on Seal Sands at Low Water. In the following October many juveniles were again present, but no large population increase occurred. By the end of November in both years, most juveniles had left for other wintering grounds. (A flock of 20 Grey Plovers was seen to leave the estuary on 31st October 1977). However total Low Water numbers did not fall in November 1977 since incoming adults replaced juveniles on Seal Sands.

Despite the differences in the pattern of autumn passage in the two years, a steady population fed on Seal Sands in both years from late November until the marked population increases of January, a period of 6-7 weeks. However the level maintained during this period differed, being 40-50 birds in 1976/77, but around 90 in 1977/78. Thus the total number of Grey Plovers feeding on Seal Sands in December 1977 was 100 per cent greater than that in 1976.

In both winters the numbers were highest in February. The peak Low Water counts occurred on very similar dates, 8th February 1977 and 11th February 1978, both being preceded by a rapid increase in numbers. However this increase began 2 weeks earlier in winter 1976/77. Each increase coincided

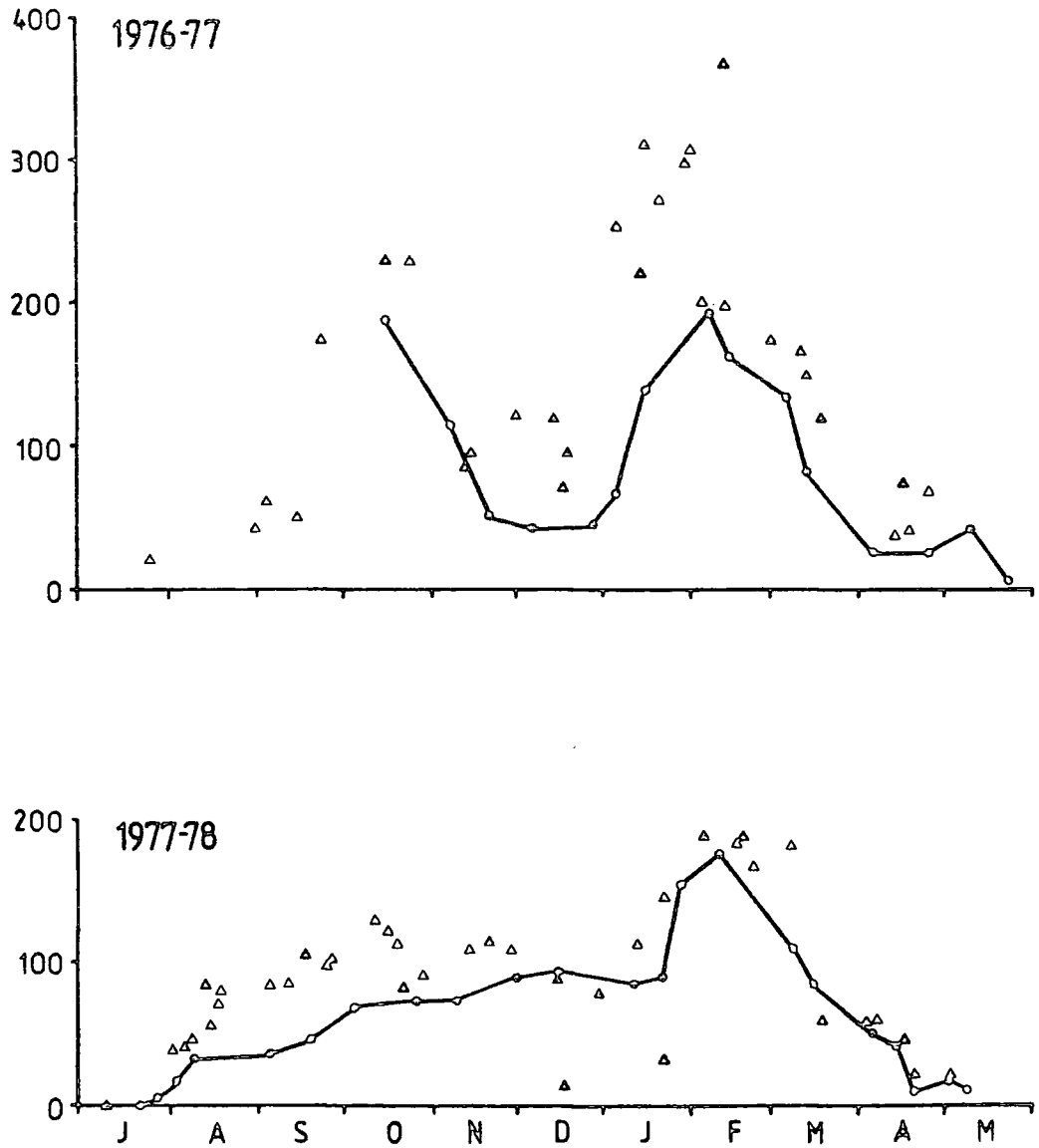

Figure 2.3 Counts of Grey Plovers in the winters of 1976/77 and 1977/78 on Seal Sands at Low Water (—○—) and on the north side of the Tees estuary at High Water (△). Also shown are the "Birds of Estuaries" counts (△).

with the onset of the coldest conditions of that winter (27th December 1976, and 14th January 1978).

Possibly the new arrivals are birds that have been forced off less suitable wintering grounds by cold weather and its depressive effects upon food availability (Pienkowski 1980b). However, very few birds feed along the Durham or North Yorkshire coasts (R. McAndrew, pers. comm.) so these large influxes cannot be explained purely by local movements.

An alternative explanation is that these birds are in fact on migration northwards to their breeding grounds, having left wintering grounds in southern Europe and Africa during December. In support of this, the peak in the small numbers feeding along the Durham coast coincides with the peak numbers on Seal Sands (R. McAndrew, pers. comm.). If Grey Plovers are moving northward in January and February, their stay on Seal Sands may be caused by the harsh conditions retarding their progress north, or simply coincident with them.

In both years the peak was followed by a steady decrease from mid-February to a level of 10-25 birds in April. During late April and May there was a further, small, passage of Grey Plovers, indicated by an increase in numbers and the appearance of birds in full summer plumage. Few of the wintering population acquired this plumage whilst on the estuary.

The total use made of Seal Sands by Grey Plovers was very similar in the two winters (bird-days November to March inclusive: 3,720 in 1976/77, and 3,820 in 1977/78).

My counts of birds at roost sites show general agreement with the population changes revealed by the Low Water counts, especially in 1977/78. In both years maximum High Water counts exceeded the Low Water counts, as expected (see Section 2. A. 3). However, the difference between High and Low

Water counts varied, and was larger during periods of influx, i. e. October, and January to March. This suggests that only a proportion of the arrivals fed on Seal Sands. The remaining birds, together with any displaced from Seal Sands by newcomers, must have fed in marginal habitats such as the coast. Such birds could have produced the increases in coastal numbers detected at this time. In February 1977 the large difference between High and Low Water counts decreased rapidly over a two-week period, suggesting that these "excess" birds soon left the estuary.

The 'Birds of Estuaries' (B. O. E.) counts for Teesmouth (see Fig. 2.3) show general agreement with my High Water counts, except in December 1977 and January 1978 when roosts were missed in the B. O. E. census.

'Birds of Estuaries' counts from previous years indicate October peaks in some years but not others. This may be due to influxes falling between two monthly counts, or to real differences between years. In five of the past six winters, a peak in Grey Plover numbers has been detected by B. O. E. counts in February suggesting that the Tees may be a regular 'refuelling site' on the northward migration.

2. B. 2. a. The distribution of birds on Seal Sands at Low Water

A general pattern of use of different areas of Seal Sands can be discerned at Low Water, the period of maximum exposure of the intertidal habitat (Figs. 2.4 and 2.5). This distribution was not maintained throughout the tidal cycle of exposure of Seal Sands, as will be discussed in Section 2. B. 3, nor did it remain constant throughout a winter (see Section 2. B. 2. b.).

Central Bank held the largest number of Grey Plovers on Seal Sands at Low Water (1976/77 \bar{x} 59.5, 1977/78 \bar{x} 58.0; see Table 2.2). This bank lies at the highest tidal level at which mud occurs, and is the largest area of

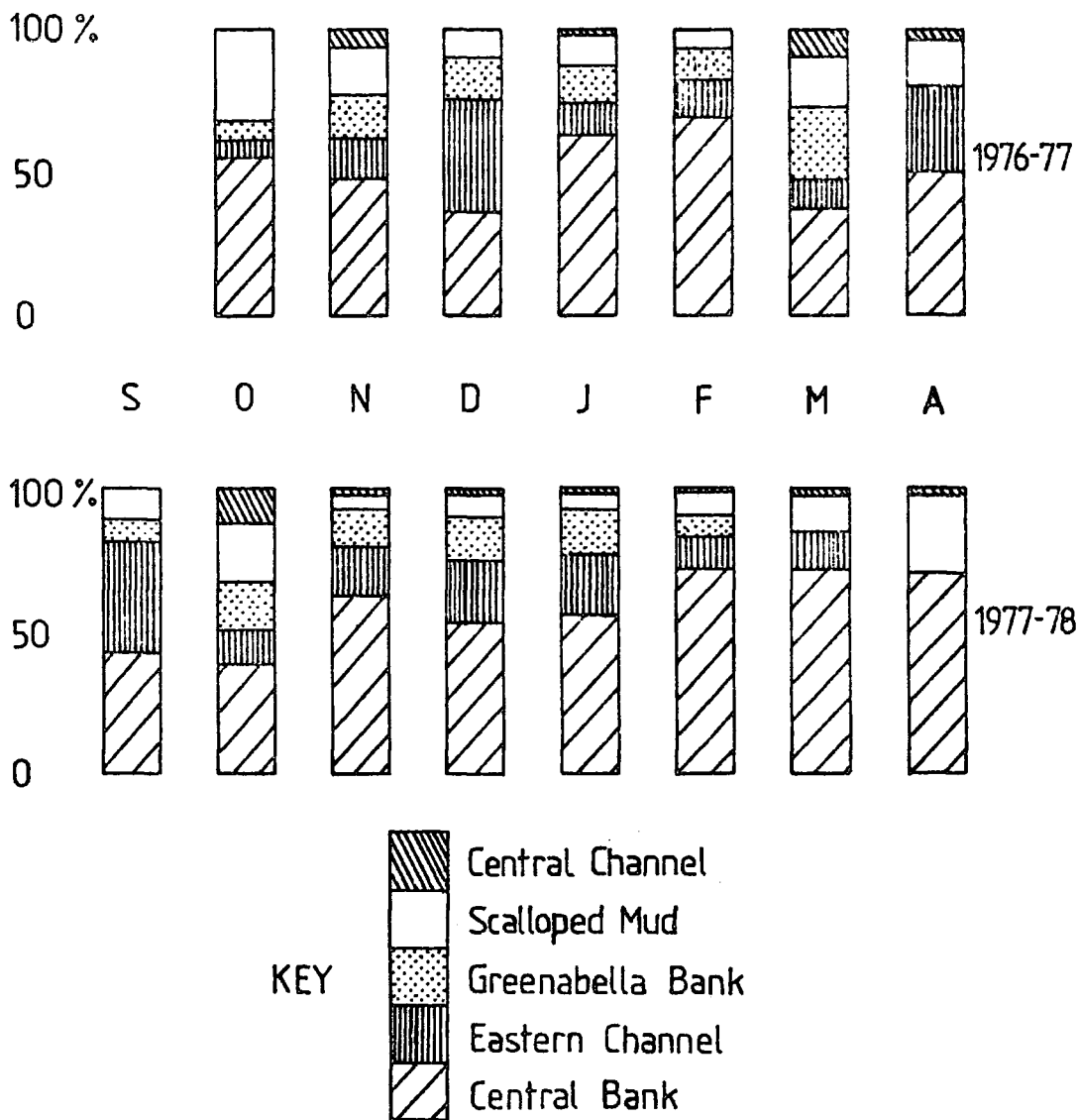

Figure 2.4 Typical examples for each month of the distribution of Grey Plovers between the different areas of Seal Sands at Low Water, in two winters. The counts for each area are shown as percentages of the total present on Seal Sands on that day.

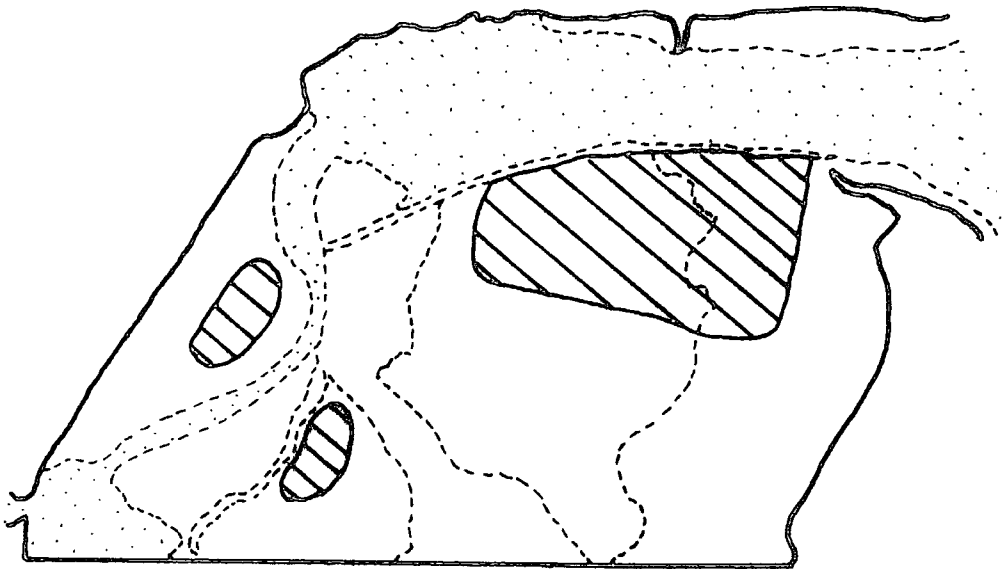

Figure 2.5 The main feeding areas used by Grey Plovers on Seal Sands at Low Water.

Table 2.2

Counts at Low Water of Grey Plovers on
Seal Sands in the months October to March

1976/77	<u>Number of counts</u>	<u>Mean</u>	<u>Standard Deviation</u>	<u>Coefficient of variation*</u>	<u>Mean as a percentage of the Seal Sands total</u>
Seal Sands total	11	109.2	56.5	0.52	100.0%
Central Bank	11	59.5	39.0	0.66	54.5%
Eastern Channel	16	15.9	3.9	0.25	14.6%
Scalloped Mud	12	14.8	15.7	1.06	13.6%
Greenabella Bank	12	15.5	11.6	0.75	14.2%
Central Channel	12	3.4	4.0	1.16	3.1%
1977/78					
Seal Sands total	11	97.9	34.6	0.35	100.0%
Central Bank total	12	58.0	33.9	0.58	59.2%
Eastern Channel	18	15.4	4.6	0.30	15.7%
Central Bank - eastern**	11	21.7	6.4	0.29	22.2%
Central Bank - middle	11	21.1	16.2	0.77	21.6%
Central Bank - western	11	32.1	18.4	0.57	32.8%
Scalloped Mud	15	9.9	6.4	0.64	10.1%
Greenabella Bank	14	10.9	7.8	0.72	11.1%
Central Channel	14	2.9	4.9	1.69	3.0%

* Coefficient of variation = $\frac{\text{Standard deviation}}{\text{Mean}}$

** Central Bank - eastern includes both the eastern part of Central Bank and Eastern Channel (see Fig. 2.8).

mud on Seal Sands. Although it constitutes 38 per cent of the total area of mud, it held between 50 and 60 per cent of the total Grey Plover population in the two winters. Most of the birds fed on the northern half of Central Bank, particularly on the large area of Enteromorpha-covered mud (see Section 1. B). Few birds fed on the softest muds near the East-West Reclamation wall (Table 2. 3).

The Eastern Channel held approximately 15 Grey Plovers each winter (1976/77 \bar{x} 15.9, 1977/78 \bar{x} 15.4) on an area of 22 hectares (16 per cent of the total area of mud). The distribution within the Eastern Channel at Low Water was similar to that on Central Bank, with most birds on the area furthest from the Reclamation Wall, fewer along the central section, and usually none on the softest muds near the Reclamation Wall. No Grey Plovers fed on the Peninsula Sands, although some fed on very sandy mud in the adjacent Eastern Channel.

Central Channel, which comprises 18 hectares of liquid mud (13 per cent of the total area of mud), was avoided by Grey Plovers. A maximum of 2 were present for most of the 1977/78 winter and 4 the previous winter. When present in the Central Channel, Grey Plovers generally fed close to the Central Bank and not near the tide edge.

The use of the other areas, Scalloped Mud and Greenabella Bank, was very variable, but each usually held less than 20 birds. Within each of these two areas Grey Plovers generally avoided the softest mud (which occurred at a lower tidal level) and fed upon the firmer mud such as the eastern half of Scalloped Mud and the ridge which runs along Greenabella Bank parallel to the sea wall (see Section 1. B).

On all areas Grey Plovers avoided the tide edge while feeding, and spread out across the mudflats, chiefly on areas of firmer mud, and rarely on

Table 2.3

Four Low Water counts of Grey Plovers showing
 their distribution between the northern, central
and southern sections of Central Bank

	A Central Bank - north	B Central Bank - central	C Central Bank - south
10. 11. 77.	11	5	2
13. 1. 78.	12	8	7
16. 2. 78.	20	24	10
16. 3. 78.	21	31	6

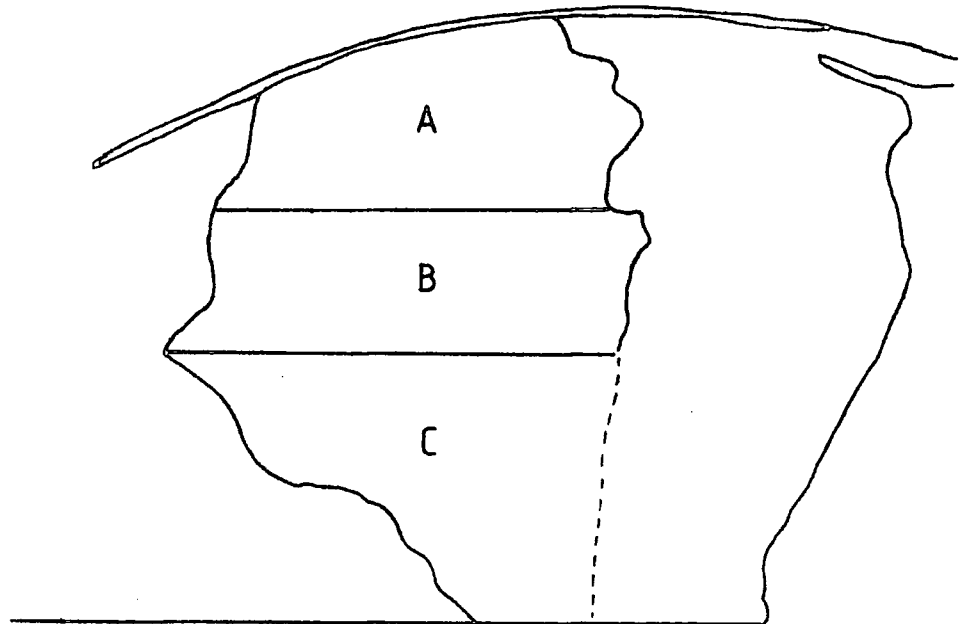

areas of liquid mud. They spent much time feeding in small creeks or along the sides of large creeks, in both cases apparently capturing prey present on the sloping sides of the creeks.

Differences in distribution between spring and neap tides - Grey Plover counts for successive neap and spring tides with similar Seal Sands totals (Appendix 1) were compared (Fig. 2.5a) to reveal any differences in distribution resulting from the differences in area exposed at Low Water on neaps and spring (see Section 1. B). (Comparing successive tides excluded any seasonal variation in the distribution.) Grey Plovers were relatively unaffected by the difference in area exposed on neaps and springs as they fed away from the tide edge mainly on Central Bank and Eastern Channel which were completely uncovered on every Low Water. As they avoided Central Channel no change in Low Water distribution occurred on extreme neaps. In 1977/78 the number of Grey Plovers on Greenabella Bank at Low Water was usually similar on neaps and springs. In 1976/77 there were more present on springs on 4 out of 5 occasions. As Grey Plovers generally avoided the lowest tidal levels and the tide edge, any increase in numbers on Greenabella Bank on springs must have been a response to the increased area of sparsely populated mud on the top of the mudbank. This increase was caused by most waders of other species moving to the lowest mudflats in Seaton Channel to feed. Exceptionally, Grey Plovers did feed on the lowest mudflats of Greenabella Bank at Low Water on an extreme spring tide, e.g. 10th December 1977 when 11 out of 13 Grey Plovers fed on open mud close to the tide edge. Even then they kept away from the flocks of Curlews and Godwits feeding at the water 's edge.

The counts for other sections of Seal Sands indicate that the Grey Plovers which fed on Greenabella Bank on spring tides in 1976/77 probably used Central Bank on neaps (Fig. 2.5a). In 1977/78 any such exchange appears to

Fig. 2.5a. Differences in the distribution of Grey Plovers on Seal Sands on spring and neap tides.

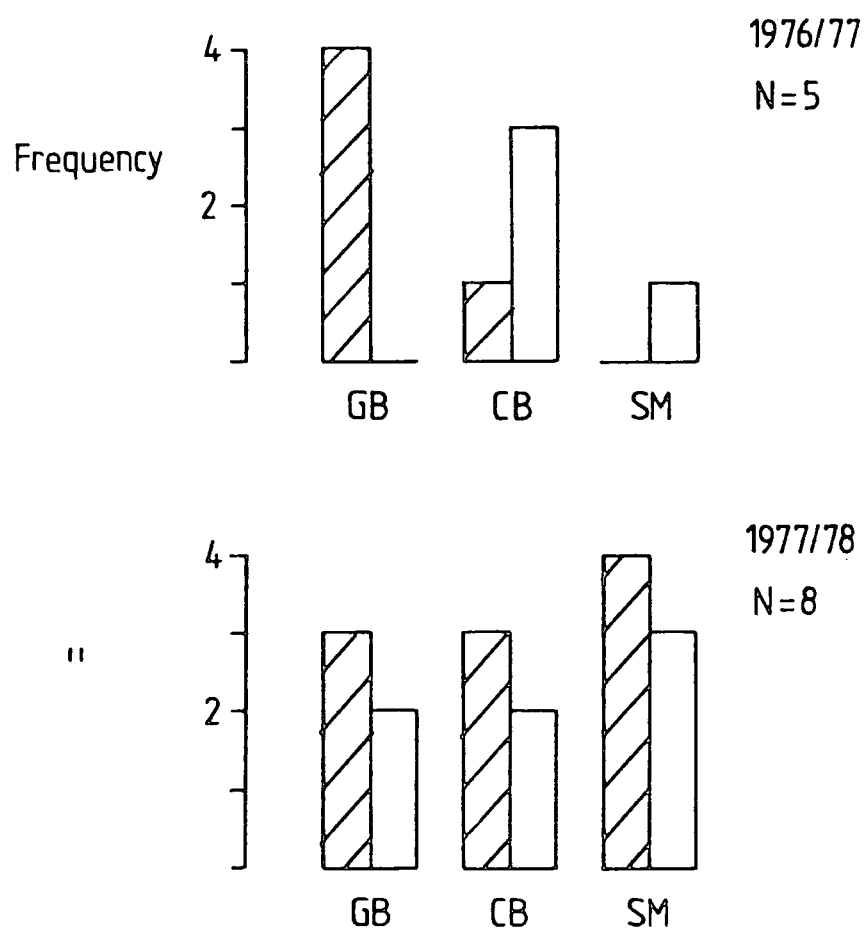

Key: Columns show the number of occasions on which:

 Spring count higher than neap.

 Neap count higher than spring

N = total number of spring/neap pairs.

Spring and neap counts differing by $< 10\%$ or < 3 birds were not considered different.

Abbreviations as on Table 3.19.

Full counts set out in Appendix 1.

have been between Greenabella Bank and the eastern half of Scalloped Mud.

2. B. 2. b. Seasonal changes in the Low Water distribution

Zwarts (1976) has shown that the distribution of Teal (Anas crecca) on intertidal mudflats is dependent upon population density, favoured areas being filled before sub-optimal sites are used. I therefore examined the distribution of feeding Grey Plovers on Seal Sands to determine whether it too was influenced by population density. The two winters 1976/77 and 1977/78 are treated separately as invertebrate prey distributions may have changed between the winters.

(i) Winter 1976/77 (Fig. 2.6 and Table 2.2) - With the arrival of Grey Plovers on Seal Sands in autumn, the first area to be filled to a ceiling was Eastern Channel. Numbers feeding there at Low Water increased to 15 - 20 ($\bar{x} = 15.9$) by October, and this level was maintained through the winter, with little variation (coefficient of variation (c.v.) = 0.25) until March when numbers fell due to emigration. Eastern Channel thus showed the characteristics of an optimal area in the sense used by Zwarts.

Although Grey Plovers fed in other areas of Seal Sands from September onwards, my counts did not reveal any comparable long-lasting plateaux in numbers throughout the winter. In contrast to the counts for Eastern Channel, those for Central Bank varied with the time of year (c.v. = 0.66), mirroring the total Seal Sands Low Water counts very closely. This would be expected of a sub-optimal site, used by surplus birds when the optimal site (Eastern Channel) is full. A ceiling may have been reached on Central Bank during population peaks, as similar numbers of Grey Plovers fed there in October and February despite marked differences in totals for the estuary as a whole (High Water counts, see Fig. 2.3).

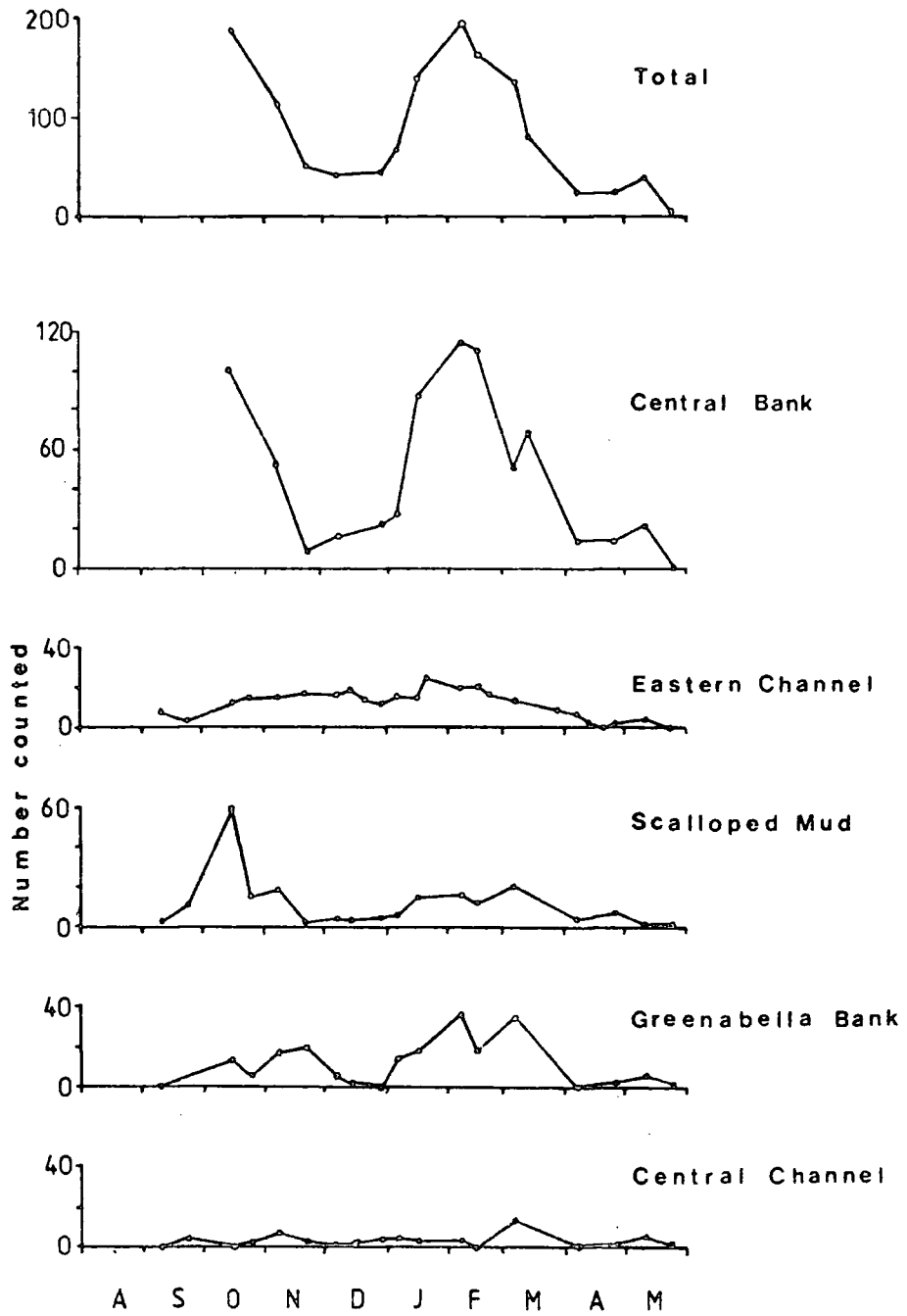

Fig. 2.6: Seasonal changes in the number of Grey Plovers feeding on the different areas of Seal Sands at Low Water during the winter of 1976/77.

Counts for Scalloped Mud ($\bar{x} = 14.8$) indicate that this is also a sub-optimal feeding site, at least for adult Grey Plovers. Changes in numbers generally paralleled those on the whole of Seal Sands, but during the mid-winter population peak a ceiling of 15 - 20 birds was quickly reached and maintained for a few weeks until the spring emigration. During the autumn peak a similar ceiling was reached. (The count on 16.10.76, which greatly exceeded this level may have been an anomaly produced by the recent arrival of a large flock of juvenile Grey Plovers on passage.) Scalloped Mud was certainly an area favoured by juvenile Grey Plovers in the autumn.

Numbers at Low Water in Central Channel remained very low through the winter ($\bar{x} = 3.4$) and any larger numbers observed were probably due to birds being displaced by disturbance on other areas of Seal Sands, especially Central Bank. Central Channel appears to be a very poor feeding site for Grey Plovers and was not used even at high Seal Sands population levels.

No seasonal pattern can be detected in the counts for Greenabella Bank. No ceiling was reached during the winter. A tendency for the counts to parallel changes in those for Seal Sands as a whole suggests that it is a sub-optimal area taking surplus birds at Low Water. Numbers there were also correlated with the height of the tide, more Grey Plovers feeding there on spring tides when an increased feeding area was available (see above).

(ii) Winter 1977/78 (Fig. 2.7 and Table 2.2) - As in 1976/77, Eastern Channel was a preferred feeding area for Grey Plovers, being filled in autumn to a ceiling of 15 - 20 birds which was maintained throughout the winter ($\bar{x} = 15.4$, c. v. = 0.30).

The 1977/78 counts for Central Bank were combined with those for Eastern Channel and then divided into 3 smaller sections, as indicated in

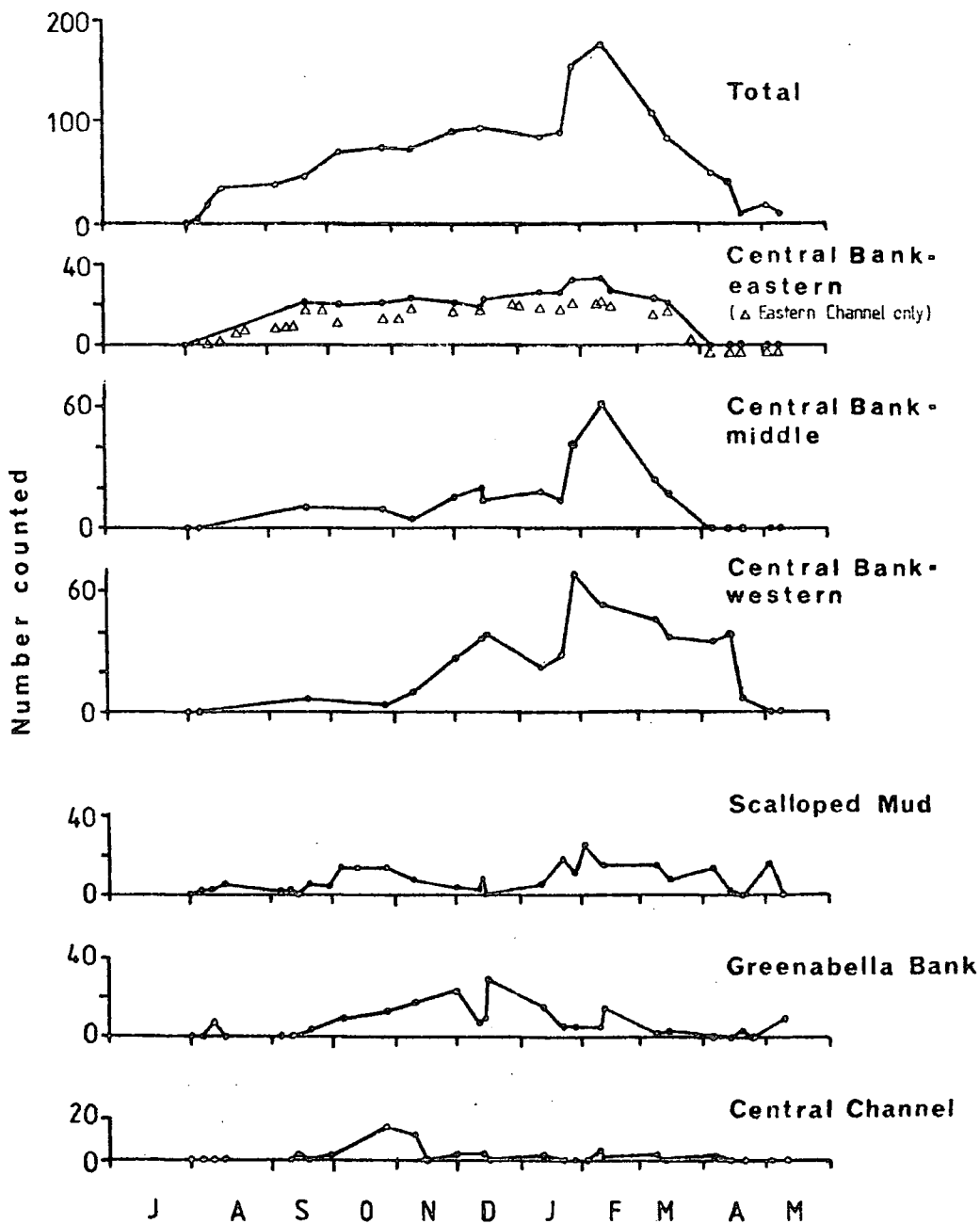

Figure 2.7 Seasonal changes in the number of Grey Plovers feeding on the different areas of Seal Sands at Low Water during the winter of 1977/78.

Fig. 2.8. This revealed that the preferred area for Grey Plovers extends westwards from Eastern Channel onto part of Central Bank. Counts for this area (Section 1 on Fig. 2.8) reached a ceiling of approximately 20 birds in autumn and remained level for most of the winter ($\bar{x} = 21.7$, c.v. = 0.29). The increase of up to 12 birds during the mid-winter population peak was due to Grey Plovers feeding in the softer muds of Eastern Channel and Central Bank nearer the Reclamation Wall. Similar behaviour was observed during the mid-winter peak of 1976/77. Thus the area preferred by the Grey Plovers and filled in autumn does not extend as far south as these softer muds, which are sub-optimal substrates used only when high numbers are present on Seal Sands. The softest muds adjacent to the East-West Reclamation Wall were not used at all, as in 1976/77.

Counts for the other sections of Central Bank paralleled those for the whole of Seal Sands, these sub-optimal areas taking surplus birds during population increases. No ceiling in numbers was reached. In spring the open mud in the western section (Section 3 in Fig. 2.8) became the main feeding site for up to 90 per cent of the Grey Plover population. Their concentration into this area may have been due to changes in prey availability and/or changes in social behaviour prior to migration.

As in 1976/77, a ceiling of 15 - 20 birds was maintained on Scalloped Mud during both the autumn passage of juveniles (which again favoured this area as a feeding site), and the mid-winter peak.

An analysis of all available counts for the two distinct halves of Scalloped Mud (Fig. 1.2) shows that in autumn the juveniles preferred the softer mud of the western half (Fig. 2.9). In contrast, during the mid-winter peak, few Grey Plovers fed there, and instead used the firmer, drier eastern area.

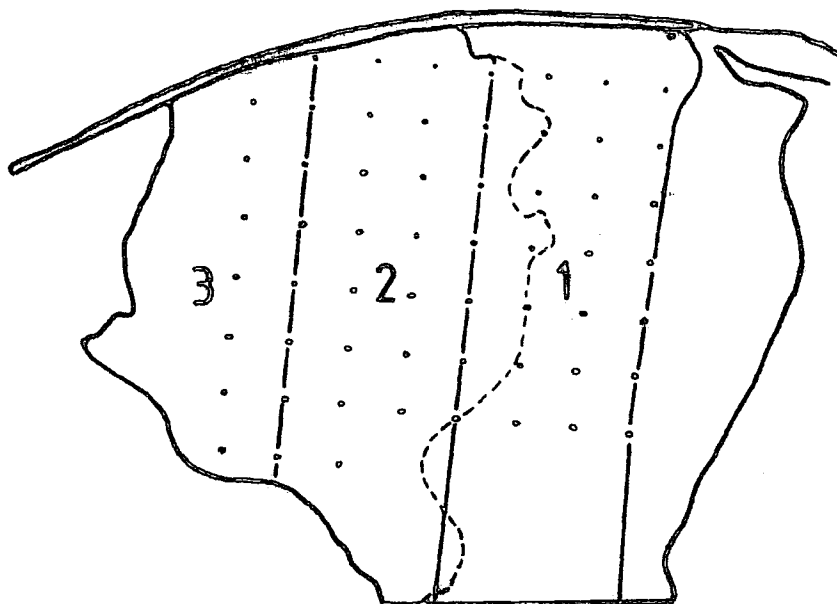

Figure 2.8 Subdivisions of Central Bank and Eastern Channel used for counting in the 1977/78 winter: 1. Central Bank - eastern
2. Central Bank - middle
3. Central Bank - western.

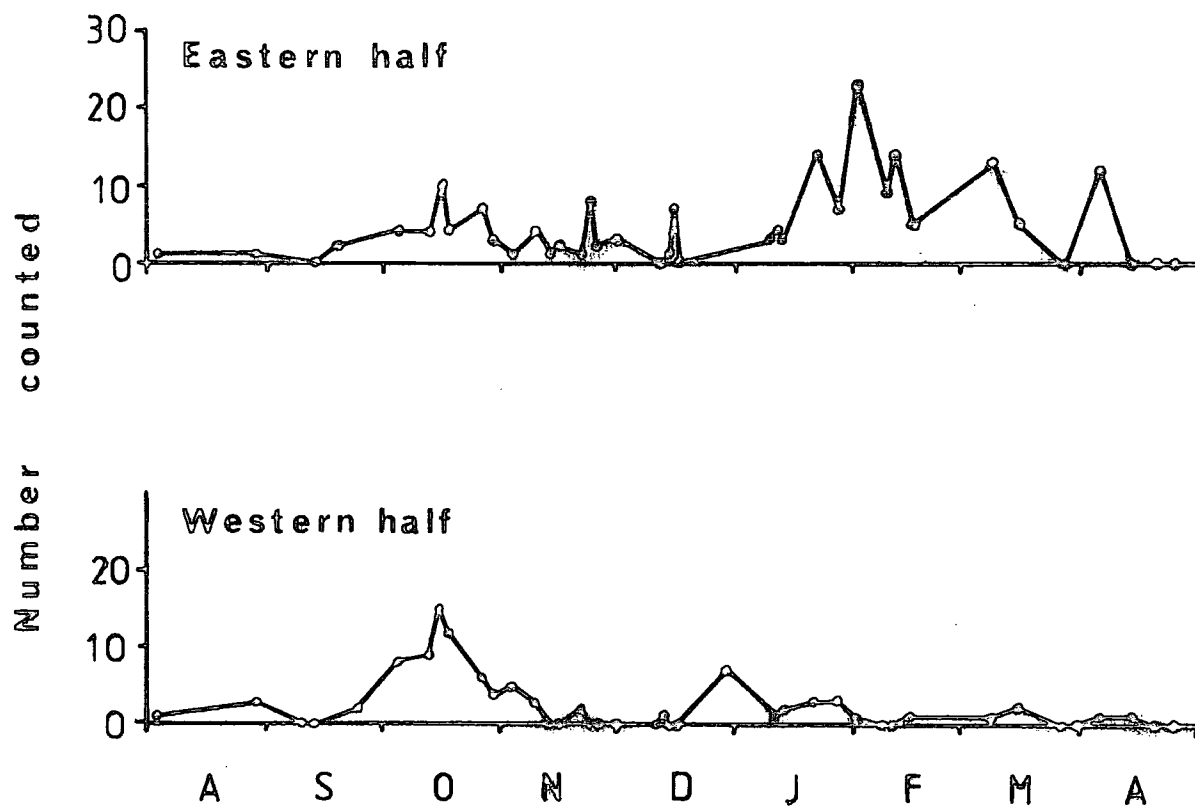

Figure 2.9

Low Water counts of Grey Plovers on the two halves of Scalped Mud during the winter of 1977/78.

The numbers feeding in Central Channel were even lower than in 1976/77 ($\bar{x} = 2.9$), except during the autumn passage of juveniles. No seasonal pattern in the counts for Greenabella Bank could be detected. Numbers increased in parallel with those for the whole of Seal Sands to reach a peak in December. There was then a marked decrease, and numbers rarely exceeded 5 after mid-January.

(iii) Conclusions - The distribution of Grey Plovers at Low Water on Seal Sands was similar in the two years studied and is dependent upon the total numbers of birds on Seal Sands. The preferred area, Eastern Channel and the eastern side of Central Bank, is filled in autumn. During peaks in the total Seal Sands population, sub-optimal areas (Scalloped Mud, the rest of Central Bank) receive surplus birds until they are filled. Areas of liquid mud such as the Central Channel are avoided by adult Grey Plovers even at high population levels. However juveniles in autumn show different preferences, feeding particularly on the areas of liquid mud on Scalloped Mud and Central Channel.

A few observations suggest that further subdivision of Central Bank counts might show that the northern Enteromorpha-covered mud (see Table 2.3, area A), is also a preferred feeding site for Grey Plovers, whereas the softer mudflats nearer the wall are used mainly during population peaks.

2. B. 3. Changes in Distribution During the Tidal Cycle (Fig. 2.10)

The distribution patterns described earlier refer to the Low Water period, when the maximum area of mud is exposed. Because of the topography of Seal Sands (described in Section 1. B), this area is exposed from approximately High Water + 5 to High Water + $7\frac{1}{2}$ hours, i. e. Low Water $\pm \sim 1$. Either side of this period, the mudflats are covered to a varying degree, thus affecting the distribution of the feeding birds. It is important to note that these patterns apply

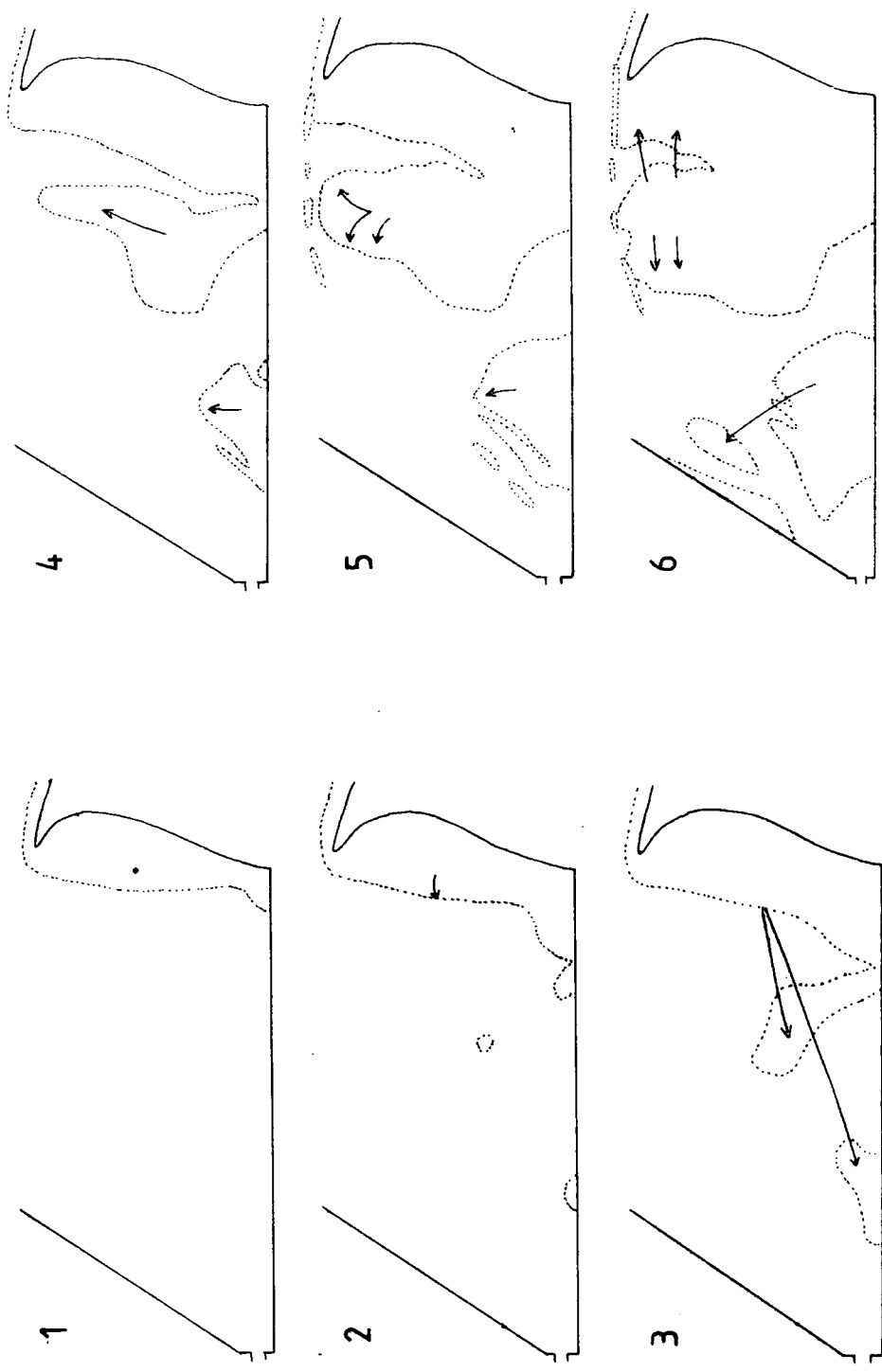

Figure 2.10 The main movements of Grey Plovers across Seal Sands as the tide ebbs.

only to the population as a whole. In later sections the different patterns shown by different individuals will be described in detail.

The patterns observed in 1976/77 and 1977/78 were as follows. As the tide ebbed, feeding areas along the eastern side of Eastern Channel were exposed first. Grey Plovers often fed on these areas, throughout the winter (Table 2.5). However, there were usually less than 20 birds feeding on any ebb tide. The Grey Plovers always fed behind the retreating tide edge if flocks of Knot and Dunlin were present and feeding there. They occasionally moved to feed at the tide edge itself, once the Knot and Dunlin had left Eastern Channel for the freshly uncovered parts of Central Bank and Scalloped Mud. In general, Grey Plovers did not fly to Central Bank and Scalloped Mud until 15 - 35 minutes after their first exposure. During this period the other shorebird species already on the mudflats followed the retreating tide edge, gradually leaving a sparsely populated area away from the tide. Only when such an area had been created did the main flock of Grey Plovers move onto the exposing mudflats (Fig. 2.10, stage 3).

As the ebbing tide gradually exposed Central Bank and Scalloped Mud, the Grey Plovers spread out, always on open mud rather than at the tide edge. On Central Bank many moved north as the flat northern half of Central Bank and the top of Eastern Channel became exposed ($\sim 1-1\frac{1}{2}$ hours after the first mud on Central Bank). Once uncovered this area held a large proportion of the total number of Grey Plovers on Seal Sands (as indicated earlier, in Section 2. B. 2. a). On most days on Scalloped Mud, up to 30 Grey Plovers fed first around the mussel scars, but left these once further areas had been exposed for some time and were relatively empty of birds (Fig. 2.10). (Many of these Grey Plovers left Scalloped Mud during the Low Water period, once lower mudflats had been uncovered.)

Table 2.5

The occurrence of ebb tide feeding
 along the Eastern Channel by Grey
Plovers during the winter of 1977/78

	Aug	Sept	Oct	Nov	Dec	Jan	Feb	Mar
Number of days on which the Eastern Channel tide edge checked for birds	1	2	3	2	2	3	2	2
Number of days on which feeding occurred	1	2	1	1	2	0	2	0

Movement of Grey Plovers to Greenabella Bank again occurred well after the first mud had appeared there and after the other shorebird species had followed the tide edge to its lowest position (Fig. 2.11).

A smaller percentage of the Grey Plovers present on Seal Sands fed on the flood than the ebb tide. Any that had finished feeding moved directly to the sandy ridge on Central Bank or to the mussel scars on Scalloped Mud where they washed and preened themselves. These birds moved to the scars before being pushed off their feeding area by the tide.

Those still feeding on lower mudflats, e.g. Eastern Channel, Greenabella Bank and the northern part of Central Bank, remained there until the incoming tide forced them to move to higher mudflats, (Fig. 2.11). These birds collected in distinct areas of Central Bank, and were finally forced onto the sandy ridge before flying off to roost. On Scalloped Mud the feeding Grey Plovers again remained on the lower areas, until pushed off by the tide towards the mussel scars which were their final refuge before flying to roost.

These tidal patterns of use were sometimes modified by:

(a) Weather - During periods of cold weather (e.g. 17.1.78, 17.2.78) movement of Grey Plovers to Central Bank and Scalloped Mud on the ebb tide occurred sooner, with less delay between first exposure and movement of the main flock. This indicates that foraging at/near the Eastern Channel tide edge did not provide food at a sufficiently high rate to meet their energy demands in cold weather.

On the incoming tide the Plovers tended to feed for longer, many still searching for prey on the last remaining mudflat even when surrounded by flocks of other waders. Also they tended to fly to the roost only when Seal Sands was completely covered.

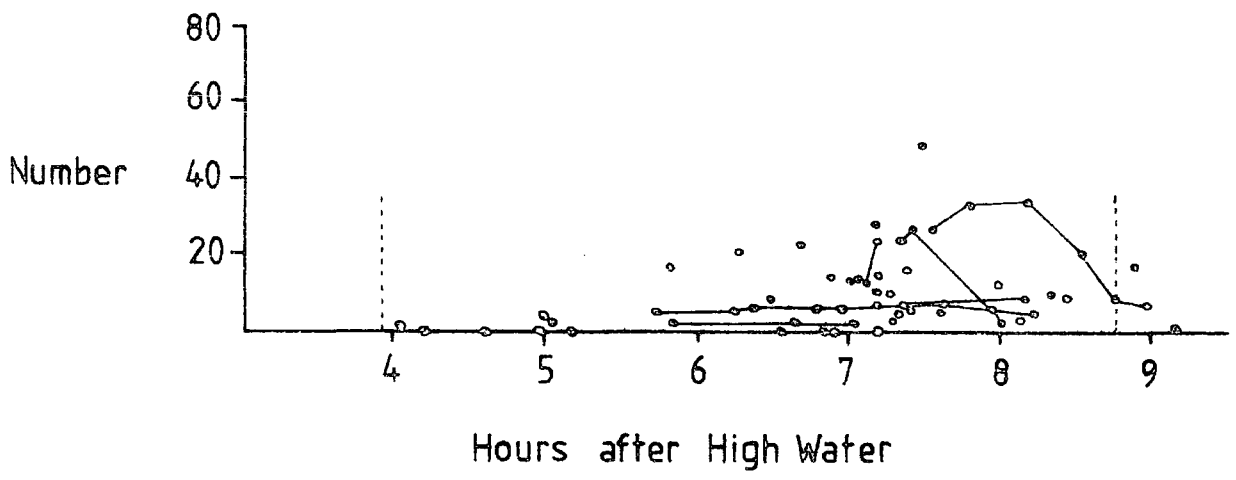

Figure 2.11 Counts of Grey Plovers on Greenabella Bank during the period of exposure, in the 1977/78 winter. Solid lines join counts made on the same day. The dotted lines indicate the mean times of emergence and submergence of Greenabella Bank.

(b) Season - In both years, Grey Plover numbers increased in September/October and January/February. During both these periods Grey Plovers were observed feeding in sites they did not use at other times of year. As the falling tide exposed Scalloped Mud, large numbers (maximum 99) fed on the mud between the mussel scars and mid-tide wall during the January/February peak (e.g. 13.2.77, 19.1.78, 3.2.78, 17.2.78 and especially 17.1.78). Even after lower areas of mudflat had been exposed, some Grey Plovers continued to feed close to the seawall, and similar feeding sites were used during the September/October peak. During the autumn peak in 1978 many more Grey Plovers fed along the Eastern Channel tide edge on the ebb tide. On 18th October 1977, 95 fed there, compared with a maximum count of 20 during the rest of the winter. These birds may have required this additional feeding due to either recent arrival on the estuary or imminent emigration.

From mid March 1978 until their departure from the estuary, many of the remaining Grey Plovers adopted a different foraging behaviour forming loose flocks, often with Dunlin. Rather than feeding in sparsely populated areas the Grey Plovers wandered as a flock around Seal Sands. Greenabella Bank, the lower parts of Scalloped Mud and Central Bank were the main areas visited, but no regular pattern of usage could be discerned.

(c) Disturbance - The choice of feeding area whilst the mudflats were exposing was also influenced by disturbance, both human and avian. Helicopter flights over Seal Sands and humans on the sea wall frequently redistributed the birds.

During mid-January and early February 1978 huge increases occurred in the number of gulls on the estuary, numbers being in excess of 10,000. These gulls tended to use Seal Sands as a roosting area, covering the Peninsula

during High Water and Central Bank at Low Water. Their physical presence alone hindered feeding along the Eastern Channel tide edge. If the gulls moved onto Central Bank as it became exposed, little sparsely populated mud was available for the Grey Plovers. The arrival of the Grey Plovers on Central Bank was therefore delayed until such mud became available to them, e. g. 15.1.78. It was during this period that Grey Plovers began using Scalloped Mud in large numbers (up to 100) as the tide ebbed, probably because Scalloped Mud remained free of gulls. Also up to 145 Grey Plovers moved onto Scalloped Mud rather than Central Bank as the incoming tide covered the lower mudflats. At Low Water on 13.1.78 and 15.1.78 unusually high numbers of Grey Plovers fed on Central Channel and the western part of Central Bank due to the gulls roosting further east on Central Bank.

When the fields were covered in deep snow in mid-February 1978 large numbers of Golden Plovers (up to 700) moved onto Seal Sands to feed. They fed on the sandy ridge of Central Bank, the first area exposed by the tide. Due to interspecific competition for space many Grey Plovers (up to 50) were unable to feed on Central Bank at this stage of the tidal cycle, and hence fed on Scalloped Mud instead. On Central Bank some individuals of both species of plover, which are of similar size, defended territories. As well as intra-specific exclusion by both species, Grey Plovers occasionally evicted Golden Plovers from their feeding sites. The majority of individuals of both species, however, relied on mutual avoidance to find a site free of plovers in which to feed. Some Grey Plovers fed on Scalloped Mud instead of Central Bank simply because of the large number of plovers present in their usual feeding site.

2.C. THE USE OF SEAL SANDS BY CURLEWS

2.C.1. Seasonal Changes in Numbers Feeding

Regular Low Water counts of Curlews on Seal Sands are available for the winters of 1976/77 and 1977/78 (Fig. 2.12). These counts show considerable variation even on successive days, particularly in mid winter, and therefore it is difficult to estimate the total use of Seal Sands through each winter in bird-days, a figure needed if the impact of Curlew on their foods is to be estimated. However, High Water counts made by myself and by the B. O. E. counters (when all the roosts were checked) indicated a fairly constant population on the whole estuary for much of the winter. In 1976/77 a level of 280 - 300 was maintained from late September (the earliest count available) until December. Following an increase in late December and January, numbers remained around 440 - 480 from February to mid-April. In 1977/78, after a passage of birds in July, 340 - 370 birds were present on the estuary from August until December. The few reliable counts for January-February suggest a decrease to 260 - 280. In early March, 400 - 420 birds were present, indicating an influx of Curlews during February. This level was maintained until emigration in mid April.

Short-term changes in the numbers of Curlews feeding on Seal Sands at Low Water must therefore have been due to a redistribution of feeding birds between Seal Sands and other feeding habitats on the estuary.

The only other large intertidal feeding site suitable for Curlews was Bran Sands, an area of sandflats on the south side of the estuary (Fig. 1.1) which supported very low densities of the larger invertebrates. Bran Sands used to support many hundred Curlew before pollution killed the invertebrates there in the early 1960s (Stead 1964). In 1977/78 no more than 23 Curlews were

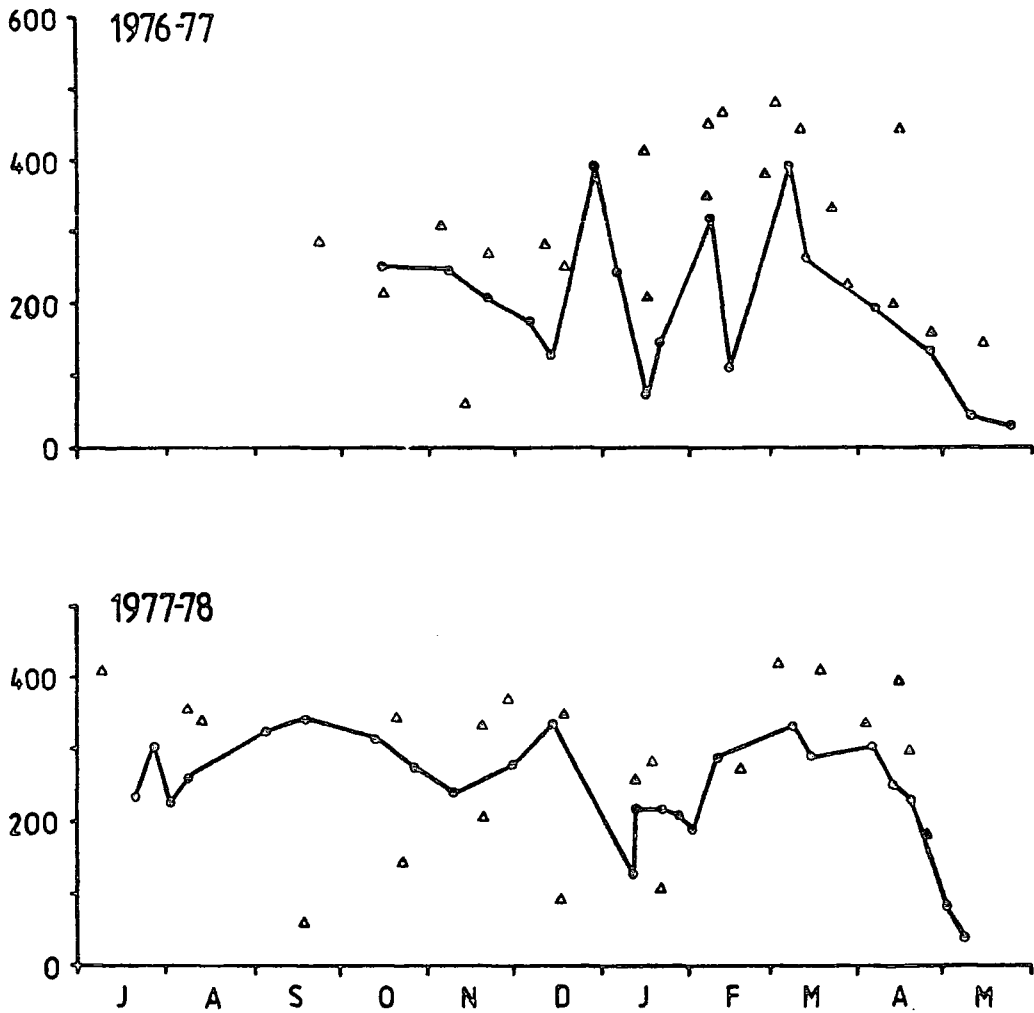

Figure 2.12

Counts of Curlews in the winters of 1976/77 and 1977/78 on Seal Sands at Low Water (—○—) and on the north side of the Tees estuary at High Water (△). Also shown are the "Birds of Estuaries" counts (△).

seen feeding there at Low Water until March (D. M. Brearey, pers. comm.), and changes in Low Water use of Bran Sands paralleled those for Seal Sands. Therefore movement between Seal Sands and Bran Sands cannot explain the marked day to day changes in Seal Sands Low Water counts.

Instead, these changes appear to be caused by the variable use of the other major feeding habitat for Curlews, the low-lying fields surrounding the north side of the estuary. It was not possible to find and count all the Curlews feeding on the fields, but groups of 10 - 40 were observed feeding on the few accessible pastures near Seal Sands.

The division of feeding Curlews between Seal Sands and the surrounding pastures seemed to be determined primarily by the weather conditions. When the pastures were frozen and/or covered with deep snow, e. g. on 29th December 1976, and 11th February 1978, Curlews were unable to feed on the fields and had to move onto Seal Sands to feed; hence the Low Water counts on the mudflats were high. If a rapid thaw follows a period of snow cover the fields become waterlogged, earthworms come to the surface and field feeding for the Curlews is extremely profitable. This occurred for example on 16th January 1977, producing a Low Water count on Seal Sands of only 73 Curlews (18 per cent of the total population on the estuary), compared with a peak of 395 (~100 per cent) during a period of heavy snow a fortnight earlier. Periods of rain produce feeding conditions similar to those during a rapid thaw, and Low Water counts on the intertidal areas are similarly reduced, e. g. 2nd February 1978. Finally, the extensive flooding of the pastures which followed the breaching of the sea walls on 11th January 1978 resulted in a Low Water count on Seal Sands next day of only 128 Curlews (50 per cent) due to the profitable feeding available on the fields.

Thus most short-term changes in numbers of Curlews feeding on Seal Sands at Low Water can be related to the relative profitability of the 2 main Curlew feeding areas. Long-term trends in Curlew numbers on Seal Sands are also correlated with the weather. After the passage period of July and August, the Low Water counts showed no marked variations from September to November (1976/77 coefficient of variation (c. v.) = 0.11, 1977/78 c. v. = 0.14), with 70 - 90 per cent of the estuary population feeding on Seal Sands. In both winters there was a gradual decrease in the number of Curlews feeding on Seal Sands from a September peak to the lowest Low Water counts which occurred in January. This paralleled the seasonal decrease in air temperature (see Fig. 3.19).

During mid winter, the Low Water numbers remained at 100 - 150 in 1976/77 and around 200 in 1977/78, unless extreme conditions of snow or flood markedly altered the relative profitability of the fields. In each winter, variation in Low Water numbers on Seal Sands was greatest during this period (see Fig. 2.12). It is not clear why the numbers varied much more during winter 1976/77, but it could be due to greater disturbance on the fields favoured by the Curlews.

In February the Low Water numbers increased to a spring peak which was maintained with reduced day to day variation (March-first half April, 1976/77 c. v. = 0.36, 1977/78 c. v. = 0.12) until emigration from the estuary in April. The numbers using Seal Sands at Low Water decreased from mid-March in 1976/77, whereas numbers remained steady until April in 1977/78. However, the B. O. E. counts for April 1977 and April 1978 suggest that the emigration from the estuary occurred during late April and May in both winters. So a clear seasonal pattern in the use of Seal Sands by Curlews underlies the short-term variations. It comprises an autumn peak, a decrease to a mid winter minimum and then a rise to a spring peak. A similar pattern was

detected in Curlew Low Water numbers on Seal Sands in the three winters 1973-76 (Evans, 1980).

B. O. E. counts for previous years show no consistent pattern (probably due to counting errors), but there is confirmation for the population increase in Spring.

2. C. 2. a. The distribution of birds on Seal Sands at Low Water

A general pattern in the dispersion of Curlews on Seal Sands at Low Water can be discerned (Fig. 2.13). The variations in this pattern due to tidal height, weather conditions, time of tidal cycle and time of year will be discussed in later sections.

Most Curlews fed at/near the tide edge, particularly on liquid mud. Therefore at Low Water they were concentrated on the mudbanks beside Seaton Channel, the lowest areas exposed (Fig. 2.14). The high counts for Greenabella Bank and Central Channel were due in part to Curlews feeding at high density at the Seaton Channel tide edge, particularly on spring tides (see below).

Greenabella Bank held the largest number of Curlews on Seal Sands at Low Water. The mean number for winter 1977/78 ($\bar{x} = 130.5$) was over 80 per cent higher than that in winter 1976/77 ($\bar{x} = 69.8$; see Table 2.6). With this large number in 1977/78, Greenabella Bank held 50 per cent of the total Seal Sands population at Low Water.

The number of Curlews feeding in Central Channel was similar in the two winters (1976/77 $\bar{x} = 41.7$, 1977/78 $\bar{x} = 53.4$), this constituting about 20 per cent of the total Low Water population. Thus 50 - 70 per cent of the Curlews on Seal Sands fed on Greenabella Bank and Central Channel.

Central Bank held a similar number of Curlews to Central Channel (1976/77 $\bar{x} = 50.7$, 1977/78 $\bar{x} = 45.9$) despite being three times as large an

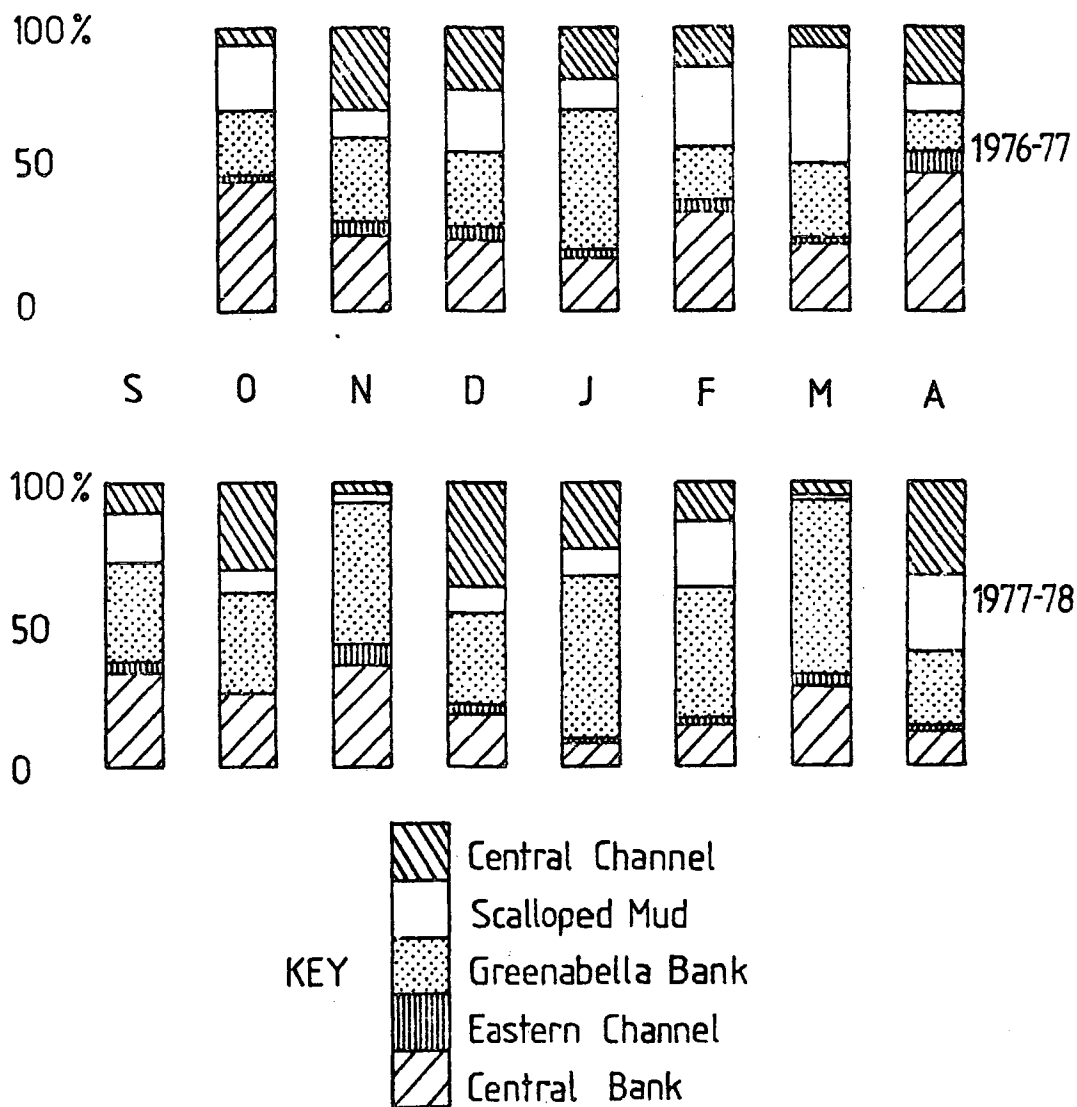

Figure 2.13

Typical examples for each month of the distribution of Curlews between the different areas of Seal Sands at Low Water, in two winters. The counts for each area are shown as percentages of the total present on Seal Sands on that day.

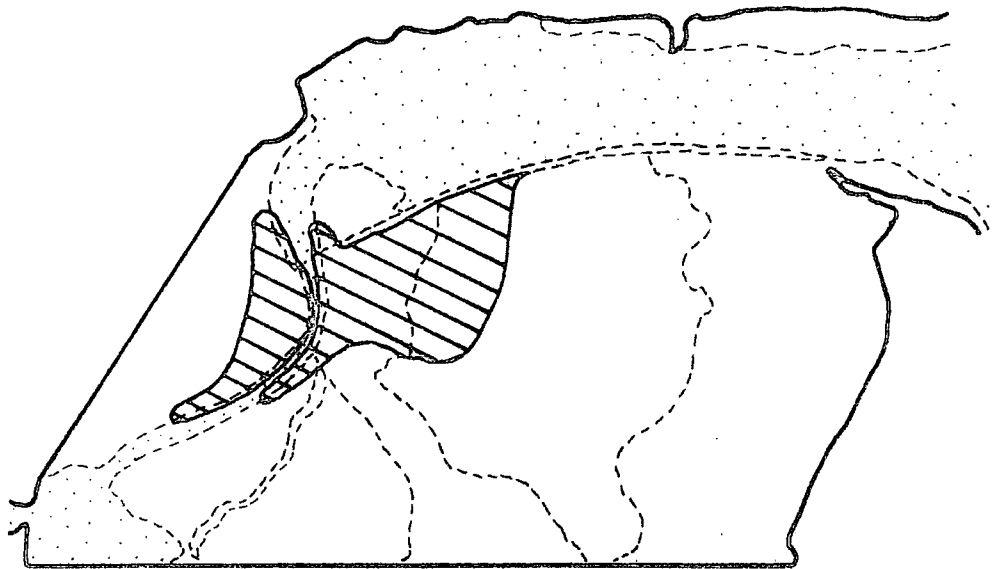

Figure 2.14 The main feeding areas used by Curlews on Seal Sands at Low Water.

Table 2.6

Counts at Low Water of Curlews on
Seal Sands in the months October to March

1976/77	<u>Number of counts</u>	<u>Mean</u>	<u>Standard Deviation</u>	<u>Coefficient of variation</u>	<u>Mean as a percentage of the Seal Sands total</u>
Seal Sands total	13	226.5	102.3	0.45	100.0%
Central Bank	13	50.7	37.9	0.75	22.4%
Eastern Channel	13	6.8	4.7	0.70	3.0%
Scalloped Mud	13	60.8	64.1	1.05	26.8%
Greenabella Bank	13	69.8	25.8	0.37	30.8%
Central Channel	12	41.7	20.9	0.50	18.4%
1977/78					
Seal Sands total	13	255.3	61.7	0.24	100.0%
Central Bank total	12	45.9	25.6	0.56	18.0%
Eastern Channel	17	7.8	3.4	0.44	3.1%
Central Bank - eastern	11	13.1	5.8	0.45	5.1%
Central Bank - middle	11	12.2	6.5	0.53	4.8%
Central Bank - western	11	26.0	17.2	0.66	10.2%
Scalloped Mud	14	31.5	18.7	0.59	12.3%
Greenabella Bank	15	130.5	29.7	0.23	51.1%
Central Channel	12	53.4	33.7	0.61	20.9%

area. In contrast to the Curlews on areas with a long tide edge at Low Water, those on Central Bank were spaced out on the open mud, particularly on the western side (Table 2.6, 1977/78 Central Bank counts). The few Curlews feeding in Eastern Channel at Low Water (1976/77 $\bar{x} = 6.8$, 1977/78 $\bar{x} = 7.8$) were also spread out on the exposed mud. Like the Grey Plovers they generally avoided the softest muds close to the Reclamation wall. Scalloped Mud was not a major feeding area for Curlews at Low Water. Curlews fed mainly on the softest mud of the western half and along the Seaton Channel tide edge. The northern tip of Scalloped Mud was a favourite roosting area for Curlews, and high counts on Scalloped Mud at Low Water were due to large numbers of Curlews roosting there, e.g. :

7. 3. 77. 151 Curlews on Scalloped Mud, 139 roosting, 12 feeding

6. 4. 78. 84 Curlews on Scalloped Mud, 62 roosting, 22 feeding.

Differences in distribution between spring and neap tides - The major changes in area of mud exposed on Seal Sands between spring and neap tides occur along Seaton Channel (see Section 1. B), i. e. in the centre of the main Low Water feeding area of Curlews. Changes in area of mud exposed would therefore be expected to affect the distribution of Curlews to a much greater extent than that of Grey Plovers. This was investigated by comparing counts for successive neap and spring tides with similar Seal Sands totals (Appendix 1).

1977/78 - The number of Curlews feeding at Low Water on Central Channel and Greenabella Bank was in general higher on the spring tides, whereas that on Central Bank was lower (Fig. 2.14a). Thus Curlews that fed on the lowest mudflats of Greenabella Bank and Central Channel on spring Low Waters probably fed on neaps on Central Bank, particularly on the western half:

Fig. 2.14a: Differences in the distribution of Curlews on Seal Sands on spring and neap tides, in two winters.

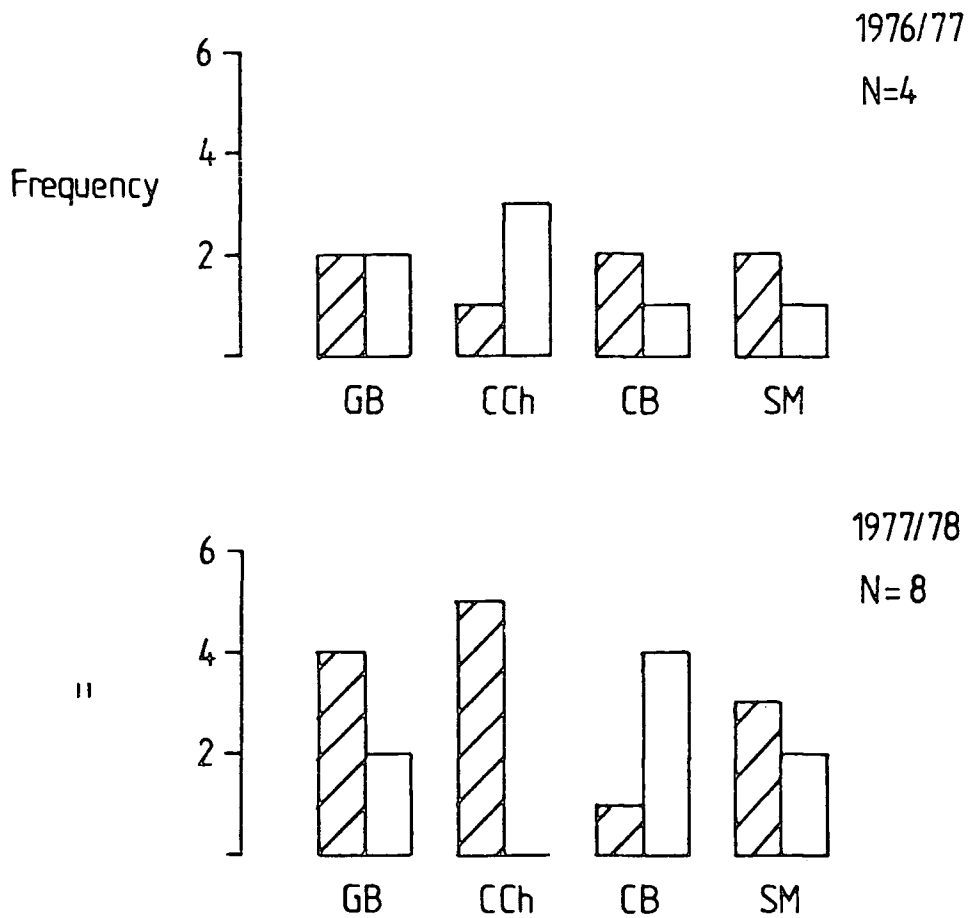

KEY: Columns show the number of occasions on which:

 Spring count higher than neap

 Neap count higher than spring

N = total number of spring/neap pairs.

Other details as on Fig. 2.5a.

5.10.77	Neap:	Central Bank western half	151,	eastern half	31		
13.10.77	Spring:	" "	" "	81	" "	1	
14. 4.78	Neap:	" "	" "	131	" "	1	
6. 4.78	Spring:	" "	" "	28	" "	8	

Even when the spring and neap counts for Greenabella Bank, and other areas, were similar, (e.g. 2.2.78/28.1.78, 16.2.78/11.2.78) the Low Water distribution of Curlews within areas changed. On springs a much greater proportion of the Curlews on Greenabella Bank and Central Channel fed at/near the tide edge:

9.3.78	Spring:	224 Curlews on Greenabella Bank and Central Channel,
		85 per cent at the tide edge
2.2.78	Neap:	122 Curlews on Greenabella Bank,
		22 per cent at the tide edge

The distribution of Curlews on Scalloped Mud also differed between neaps and springs. Although the eastern half of Scalloped Mud held a major roosting site for Curlews, the western half was used only by feeding birds. More birds fed on the western half on neap than on spring Low Waters (Fig 2.14b). On spring tides these birds probably fed on the lower mudbanks exposed along Seaton Channel.

1976/77 - Comparisons between neaps and springs were more difficult than in 1977/78 as the total number of Curlews on Seal Sands at Low Water varied so markedly. There are no consistent differences associated with the changes in area of mud exposed.

Fig. 2.14x Differences in the distribution of Curlews on the two halves of Scalloped Mud on spring and neap tides during the winter of 1977/78.

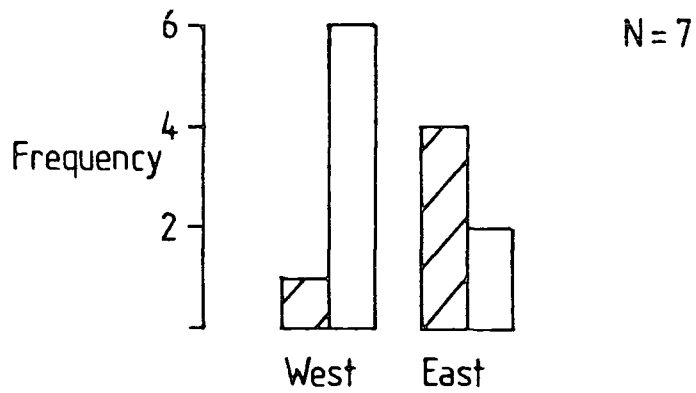

KEY: Columns show the number of occasions on which:

▨ Spring count higher than neap.

□ Neap count higher than spring.

N = total number of spring/neap pairs.

Other details as on Fig. 2.5a.

2. C. 2. b. Seasonal changes in the Low Water distribution

Seasonal changes in the distribution of feeding Curlews at Low Water can be detected despite the marked short-term changes in numbers described earlier (Section 2. C. 1). As there are differences in the Low Water distributions of the two winters (Section 2. C. 2. a), the changes during winter 1976/77 and winter 1977/78 will be discussed separately.

(i) Winter 1976/77 (Fig. 2.15 and Table 2.6) - There is no clear evidence of favoured areas being filled to a ceiling during autumn, and then remaining at a constant level until Curlews moved off to the fields later in the year. However as detailed counts were not made before October, such filling of favoured areas may have been missed.

Greenabella Bank held a reasonably constant number of Curlews throughout the winter ($\bar{x} = 69.8$, c. v. = 0.37). Numbers in December were 50 per cent lower than in other months. For the rest of the winter numbers generally remained around 60 - 90. The fairly constant, high number suggests that it was an area preferred by Curlews throughout the winter. The spring decrease for Greenabella Bank coincided with that for Seal Sands as a whole.

The counts for Central Channel were more variable (c. v. = 0.50) and no definite seasonal pattern is evident. Use of Central Channel was greatest in November-December and gradually fell during the rest of the winter. During Seal Sands population peaks there was a small increase in the numbers of Curlews on Central Channel. The changes in numbers on Central Channel and those on Greenabella Bank appear to be inversely related. The combined counts for Greenabella Bank and Central Channel (Fig. 2.16) show that a constant number of Curlews fed on these areas from November to March ($\bar{x} = 116.5$, c. v. = 0.25). This is due to many birds feeding indiscriminately on either side of Seaton Channel at Low Water. As the number of Curlews feeding on/near

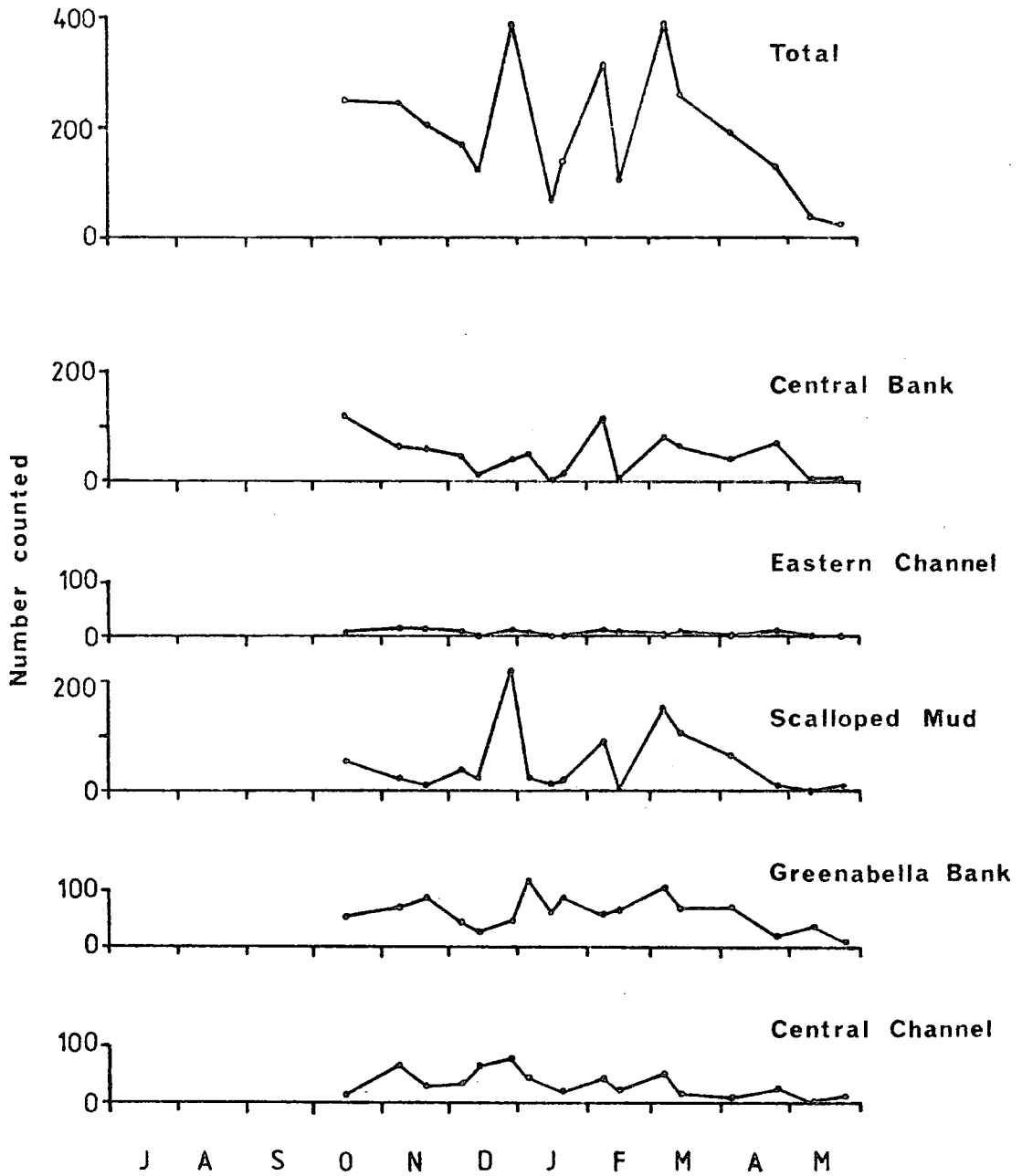

Figure 2.15

Seasonal changes in the number of Curlews feeding on the different areas of Seal Sands at Low Water during the winter of 1976/77.

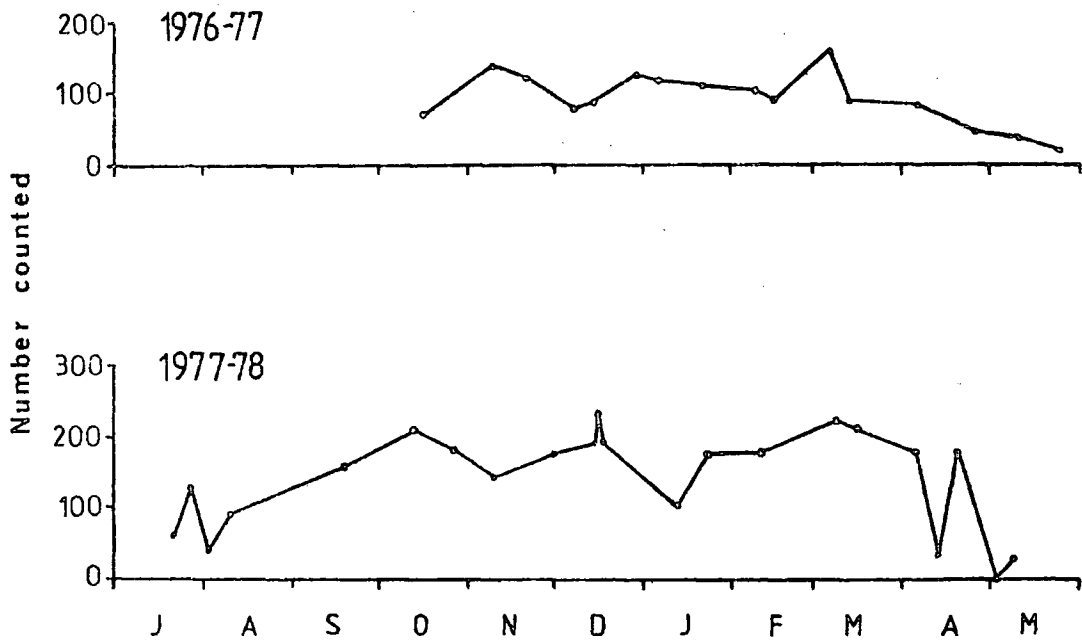

Figure 2.16

The total number of Curlews feeding on Greenabella Bank and Central Channel at Low Water, in two winters. For each winter the Low Water counts for Greenabella Bank and Central Channel are combined.

these tide edges remained constant through the winter, despite the changes in the total number on Seal Sands, this may be an area favoured by them.

Numbers on Central Bank varied with the time of year (c. v. = 0.75) and mirrored the total Seal Sands Low Water counts, with the lowest counts occurring in mid winter. However in October and again in April, Central Bank held a higher proportion of the Seal Sands Curlew population at Low Water, 45 - 50 per cent as compared with the mean for the winter of 22 per cent.

Eastern Channel held a very low number of Curlews throughout the winter ($\bar{x} = 6.8$). There were never more than 15 present at Low Water, but variation in numbers was still considerable (c. v. = 0.70). Although few birds fed on Eastern Channel, the changes in numbers were usually related to those on the whole of Seal Sands.

Numbers of Curlews on Scalloped Mud varied greatly (c. v. = 1.05) due to high counts produced by roosting flocks (see Section 2.C.2.a). Roosting flocks were larger during population peaks on Seal Sands so changes in Scalloped Mud counts paralleled those for the whole of Seal Sands. Excluding peak counts, 20 - 40 Curlews were present on Scalloped Mud at Low Water from November to January. Even these counts included some roosting birds. The increase during March and early April was probably produced by an increase in the number of Curlews roosting at Low Water in the milder weather.

(ii) Winter 1977/78 (Fig. 2.17 and Table 2.6) - Greenabella Bank was by far the most important feeding ground for Curlews at Low Water in 1977/78 ($\bar{x} = 130.5$). It held a very constant population through the winter (c. v. = 0.23). With the arrival of birds in July and August, Low Water numbers on Greenabella Bank rapidly increased showing this to be an area favoured by Curlews. A level of 100 - 140 birds was reached in September and maintained until December (mid-September to December $\bar{x} = 140.7$, c. v. = 0.27), thus paralleling the

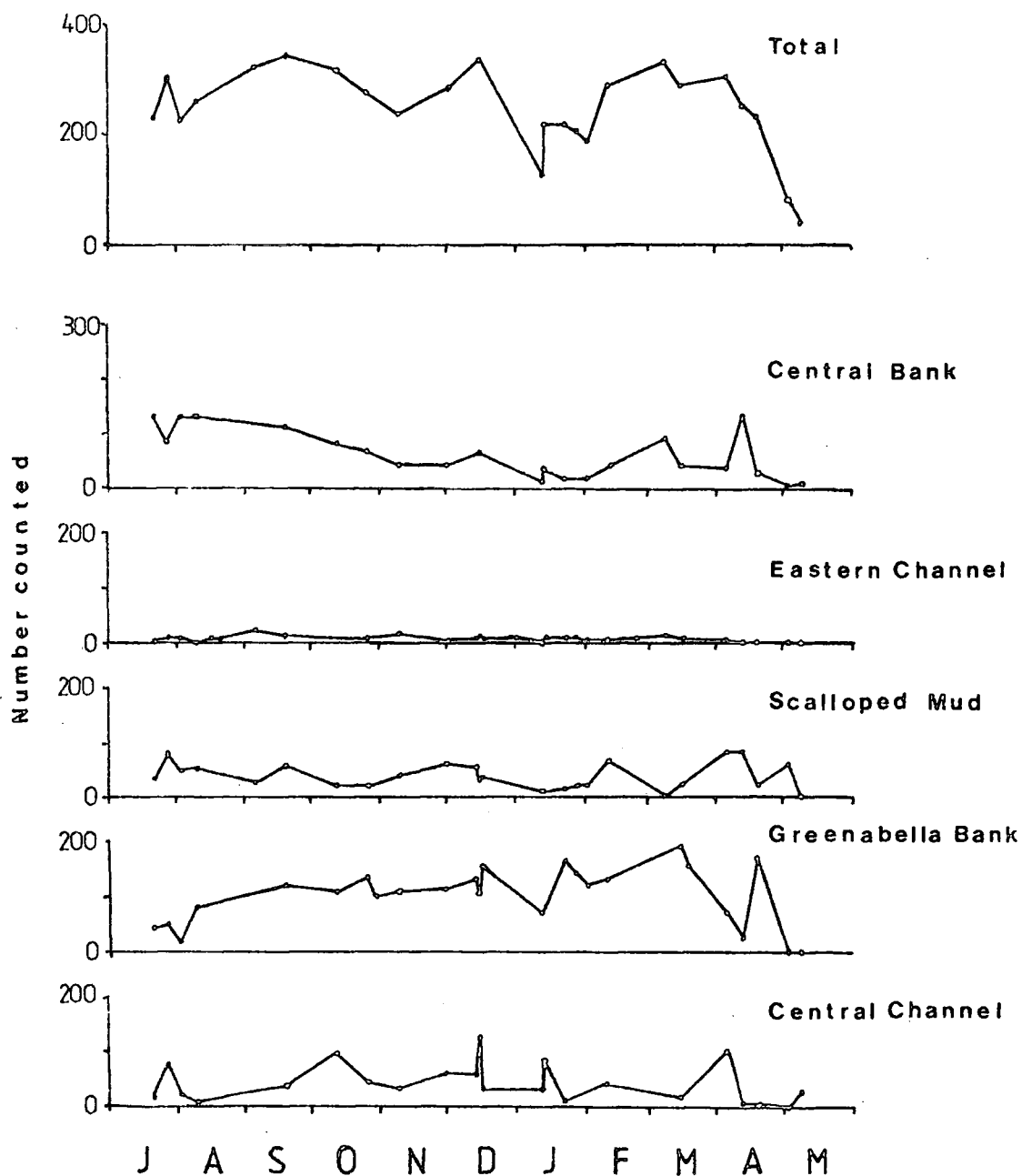

Figure 2.17 Seasonal changes in the number of Curlews feeding on the different areas of Seal Sands at Low Water during the winter of 1977/78.

increase for Seal Sands as a whole. However, in contrast to the Seal Sands counts, the March peak on Greenabella Bank was higher than the level there in September-December. The number of Curlews on Greenabella Bank varied more widely during emigration in April.

The numbers of Curlews feeding on Central Channel varied considerably through the winter (c. v. = 0.63). The counts were highest from October to December, and as in 1976/77 they gradually decreased to reach a minimum in spring. These counts again bear an inverse relation to those for Greenabella Bank. The combined counts for the two areas (Fig. 2.16) show that a constant number of Curlews fed on either Greenabella Bank or Central Channel from September until April. Therefore the profitability of feeding on Central Channel relative to Greenabella Bank presumably decreased during the winter. As in 1976/77, the tidal edges of Greenabella Bank and Central Channel may have constituted a favoured area for Curlews.

In contrast to the counts for 1976/77, the 1977/78 Central Bank counts do not bear a close resemblance to those for Seal Sands as a whole. Central Bank held around 120 Curlews from late July until late September. This constituted up to 55 per cent of the total Seal Sands population. Thus many of the first arrivals on Teesmouth after the breeding season stayed on Central Bank at Low Water. It is probable that Central Bank functioned more as a roosting site for these birds. After September, numbers fell steadily to a minimum of approximately 20 in January. A similar decrease occurred during winter 1976/77. Use of Central Bank in 1977/78 then increased during spring. Figure 2.18 shows that Curlews fed on all parts of Central Bank during the autumn peak, but in spring they were confined mainly to the western side.

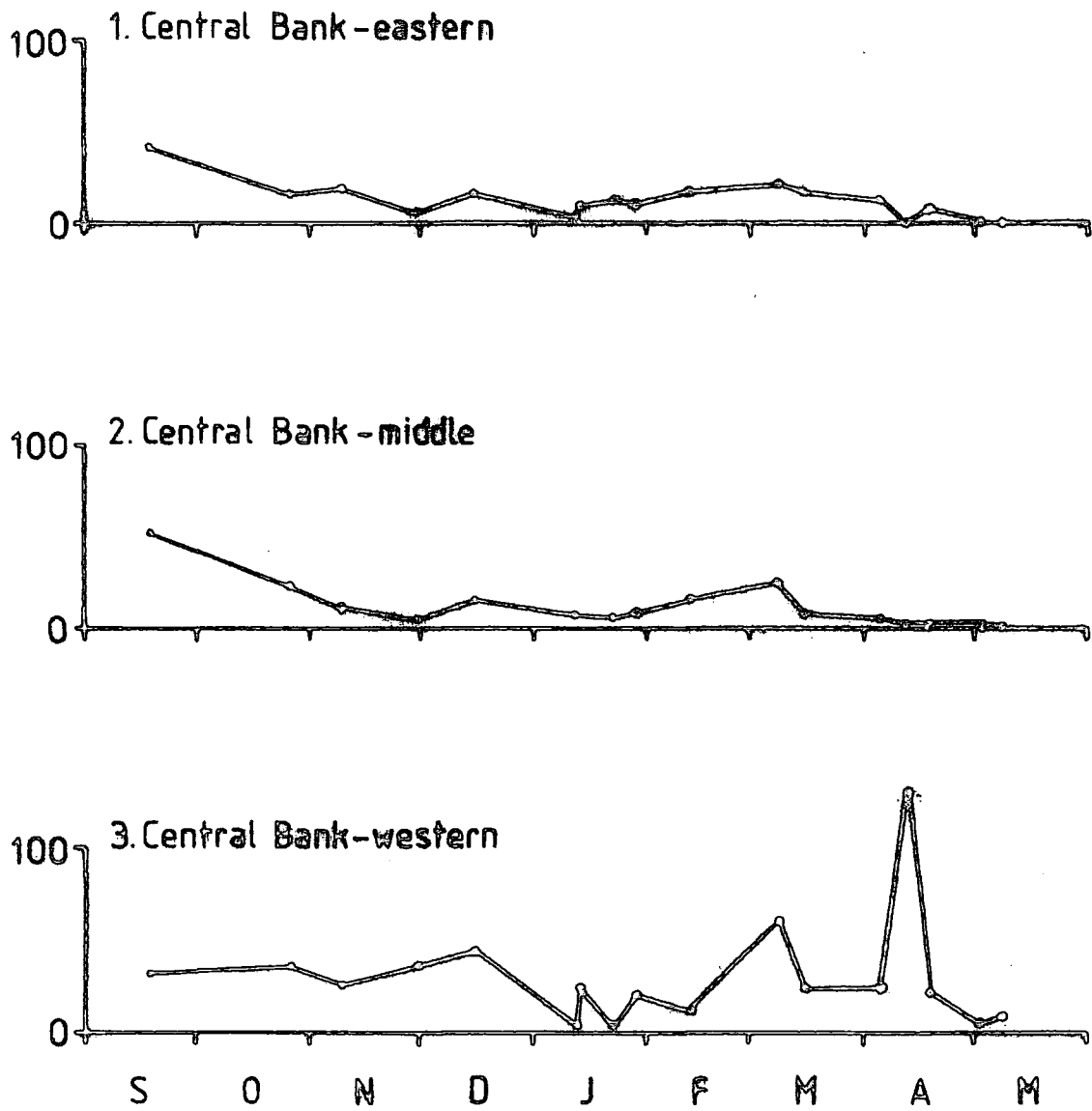

Figure 2. 18 Low Water counts of Curlews feeding on the three subdivisions of Central Bank - Eastern Channel (shown in Figure 2. 8) in the winter of 1977/78.

As in 1976/77, Eastern Channel held a low but variable number of Curlews ($\bar{x} = 7.8$, c. v. = 0.44). Numbers rose in August and September, paralleling the increase in the number on Seal Sands as a whole, and then gradually decreased to a minimum in January-February. Eastern Channel may have been filled to a ceiling in early autumn, with birds leaving subsequently going either to other mudflats or the fields.

Use of Scalloped Mud was less variable than in winter 1976/77 (1977/78 c. v. = 0.59) as few large roosts were present during the counting sessions. Numbers remained around 20 - 60 from August to December, and then decreased during January, paralleling the counts for the whole of Seal Sands. In spring numbers increased again, partly due to birds roosting on Scalloped Mud in large numbers, e.g. 62 out of the 84 Curlews present on 6th April 1978 were roosting. Regular observations of the activities of the Curlews on Scalloped Mud during winter 1977/78 revealed that on average 50 per cent of the Curlews present at Low Water were roosting, but that this varied markedly even between days (c. v. = 0.60). Therefore it is probable that the number of Curlews feeding on Scalloped Mud rarely exceeded 40 and was more commonly around 20.

(iii) Conclusions - The Low Water distribution of Curlews does not seem to be dependent upon the total number of Curlews on Seal Sands. The differences between the two winters are of degree rather than kind. Greenabella Bank was the main Low Water feeding area used throughout both winters, but Curlews also fed on Central Channel in the first half of the winter and on Central Bank in autumn and spring.

2.C.3. Changes in Distribution during the Tidal Cycle (Fig. 2.19)

The Curlews showed several patterns of movement as the tide ebbed and flowed. The patterns were constant through both winters, but the numbers of Curlews showing each pattern varied with the conditions. It must be stressed

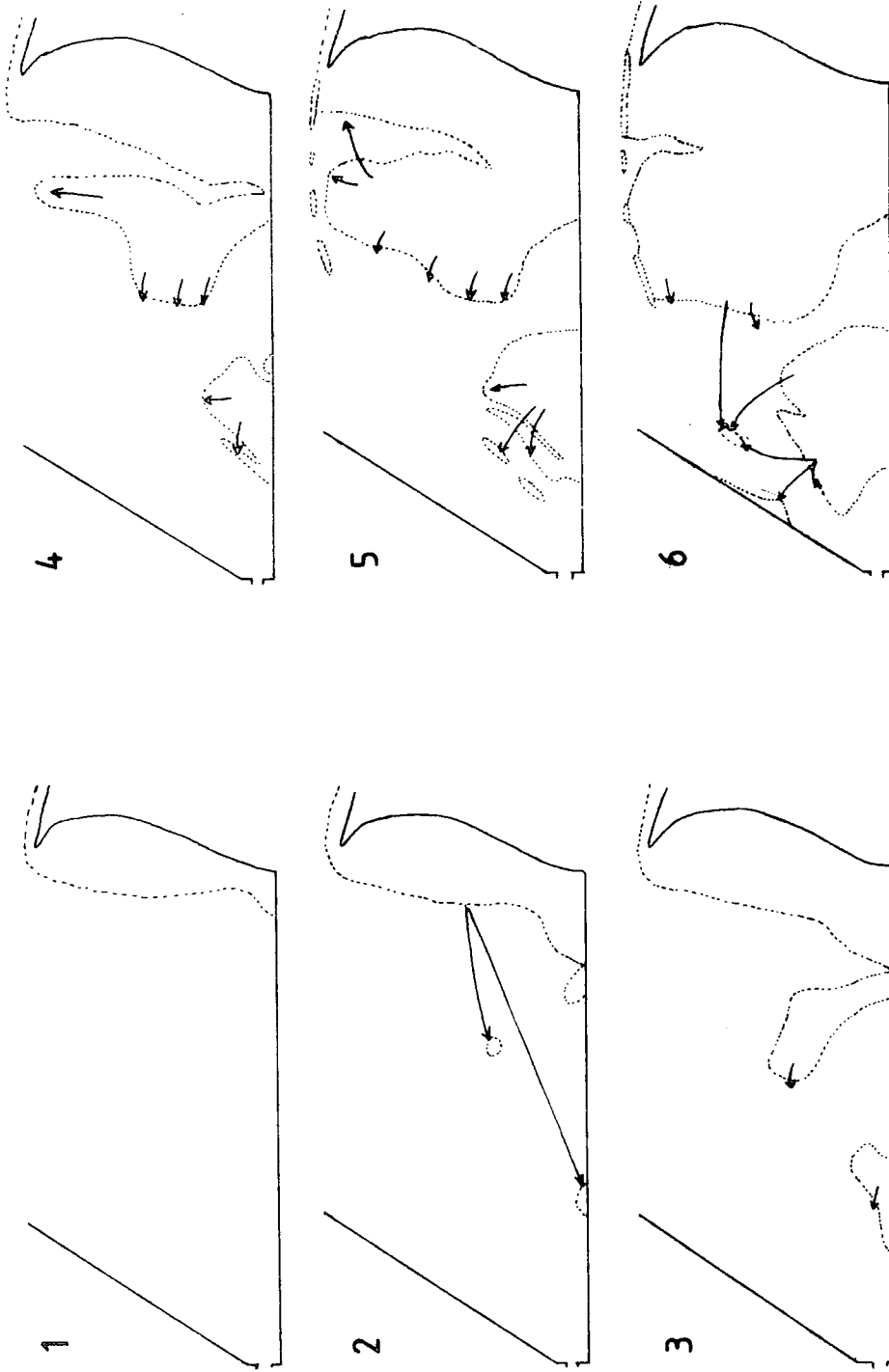

Figure 2.19 The main movements of Curlews across Seal Sands as the tide ebbs.

that these descriptions apply to the population as a whole. The different patterns of movement shown by different individuals will be described in detail in later chapters.

As the ebbing tide exposed the higher mudflats of Seal Sands some Curlews flew from their roosts to the freshly uncovered mud of Central Bank and Scalloped Mud and began feeding immediately. However many Curlews either remained on the roost for up to 2 hours after the first mud was exposed, or moved to the mudflats and then continued roosting there.

The feeding Curlews followed the retreating tide edge across the mudflats. On Central Bank the Curlews spread out, but movement was particularly in a north-westerly direction towards the western edge of Central Bank. This north-westerly movement continued across Central Channel as it became exposed. Similarly Curlews on Scalloped Mud gradually moved north-westwards, feeding at/near the tide edge and repeatedly moving onto newly exposed ridges on the western half of Scalloped mud (Fig. 2.19). The Curlews continued to feed on the furthest ridge and on the adjacent liquid mud of Scalloped Mud until Greenabella Bank became exposed. Then many of these birds, together with some from the Central Bank and Central Channel, flew over to feed on Greenabella Bank, especially at the tide edge. Individual birds that had been roosting as Seal Sands was uncovered joined this sequence of movements at various stages.

Even before Low Water some Curlews had stopped feeding, and begun to wash and preen, or roost. For this they either remained on the same mudflat, but moved away from the feeding birds near the tide edge, or they flew to one of the two main Curlew roosts on Seal Sands, on Scalloped Mud and on Central Bank.

After Low Water the number of Curlews on the two main roosts increased as more Curlews finished their feeding. However some Curlews flew directly to their High Water roost without using the roosts on Seal Sands. Those Curlews still feeding remained on the lower mudflats, moving up the shore with the incoming tide. When Greenabella Bank and Central Channel were covered, feeding Curlews returned to the western parts of Scalloped Mud and Central Bank, usually feeding at the tide edge.

As the tide covered Scalloped Mud and Central Bank the roosting birds moved to the highest areas of mudflats. Often the main Curlew flock left Seal Sands before the mudflats were covered.

These tidal patterns of use were modified by:

(a) Weather - During cold weather the Curlew population spent more of the tidal cycle feeding. This was achieved in 3 ways. Fewer birds roosted at Low Water, e.g. Scalloped Mud, Low Water:

13.1.78, midday air temperature 6°C , 61 Curlews present,
50 roosting

16.2.78, midday air temperature 2°C , 55 Curlews present,
23 roosting.

Secondly, movement from the roost(s) to the exposing mudflats was earlier and more synchronised, with most birds feeding immediately, e.g. Central Bank as the first mud was uncovered:

2.2.78, midday air temperature 4°C , first Curlew arrived 40 mins
after first mud exposed.

12.2.78, midday air temperature 1°C , many Curlews moved onto Central Bank
to feed as the first area was uncovered.

The chilling effect of a strong wind produced a similar effect even when the air temperature was not low:

20.11.78, midday air temperature 5°C , wind speed 17 - 20 kts ,
Curlews moved onto Central Bank to feed as the first area was uncovered.

Thirdly, in cold weather there was more feeding as the tide covered the mudflats, and the main movement of Curlews to the High Water roost occurred only as the last areas were covered, e.g. Central Bank as the tide covered the last area of mudflat:

24.2.78, midday air temperature 10°C , most of the Curlew left
Seal Sands 1 hour before the
mud was covered.

9.2.78, midday air temperature 1°C , Curlew flock left only when the
last mud was covered.

(b) Season - Some Curlews altered their pattern of movements during cold weather in March 1978. Up to 118 Curlews flew over to Greenabella Bank whilst it was still covered by the ebbing tide, and stood in the water waiting for it to appear. Once it began to be exposed by the tide, they immediately started feeding, e.g. 16.3.78, 13 minutes after exposure of the first part of Greenabella Bank 170 Curlews were feeding on it. However, 1 hour before Greenabella Bank was exposed, these Curlews had been roosting on Central Bank when they could have been feeding there. Therefore, it seems that the profitability of feeding on Central Bank during cold weather had decreased markedly by spring.

In mid-winter (e.g. 17.1.78, 31.1.78) Curlews were observed flying onto Seal Sands from inland. These were presumed to be birds that had been feeding on the fields surrounding Seal Sands. They arrived from Low Water onwards, and usually joined the Low Water roost on Scalloped Mud. However, during the very cold spell of weather in February 1978 some of these Curlews began feeding as soon as they arrived on Scalloped Mud.

(c) Disturbance - Curlews were very wary and moved considerable distances when disturbed. Therefore the presence of humans on the sea walls caused marked redistributions of Curlews. On the ebb tide human disturbance caused premature dispersion of Curlews from the vicinity of the East-West Reclamation Wall and the Peninsula. Air traffic also caused considerable redistribution at all stages of the tide.

The huge flocks of gulls present on Seal Sands during January-February 1978 had relatively little effect upon the Curlews at Low Water as the Curlews fed mainly near the tide edge whereas the gull flocks roosted on the open mud (and fed in the shipping channel or on the coast). However, on 31st January 1978, 25 of the Curlews on Central Bank were displaced by the gulls to feeding sites close to the East-West Reclamation Wall and in the adjacent Central Channel. The presence of the gulls caused more considerable redistribution of the Curlews on the Central Bank on the ebb and flood tides. During these periods the area of available mud was smaller than at Low Water, and Curlews on Central Bank were forced to move to the unoccupied liquid mud near the East-West Reclamation Wall, e.g. on 31.1.78, 15.1.78 and 22.1.78. They fed here in numbers only whilst the huge gull flocks were present on Seal Sands.

2. D. THE USE OF SEAL SANDS BY BAR-TAILED GODWITS

2. D. 1. Seasonal Changes in Numbers Feeding

The seasonal changes in Low Water numbers of Godwits on Seal Sands (Fig. 2.20) resemble those shown by Grey Plovers. Small numbers of non-breeding Godwits were present on the estuary throughout the summer of 1977. The autumn arrival of Godwits on Seal Sands began in August and reached a peak in September or October, when approximately 60 birds were present at Low Water in both years. Although the autumn peak in 1976/77 appears to have occurred one month later, the data are incomplete for that autumn.

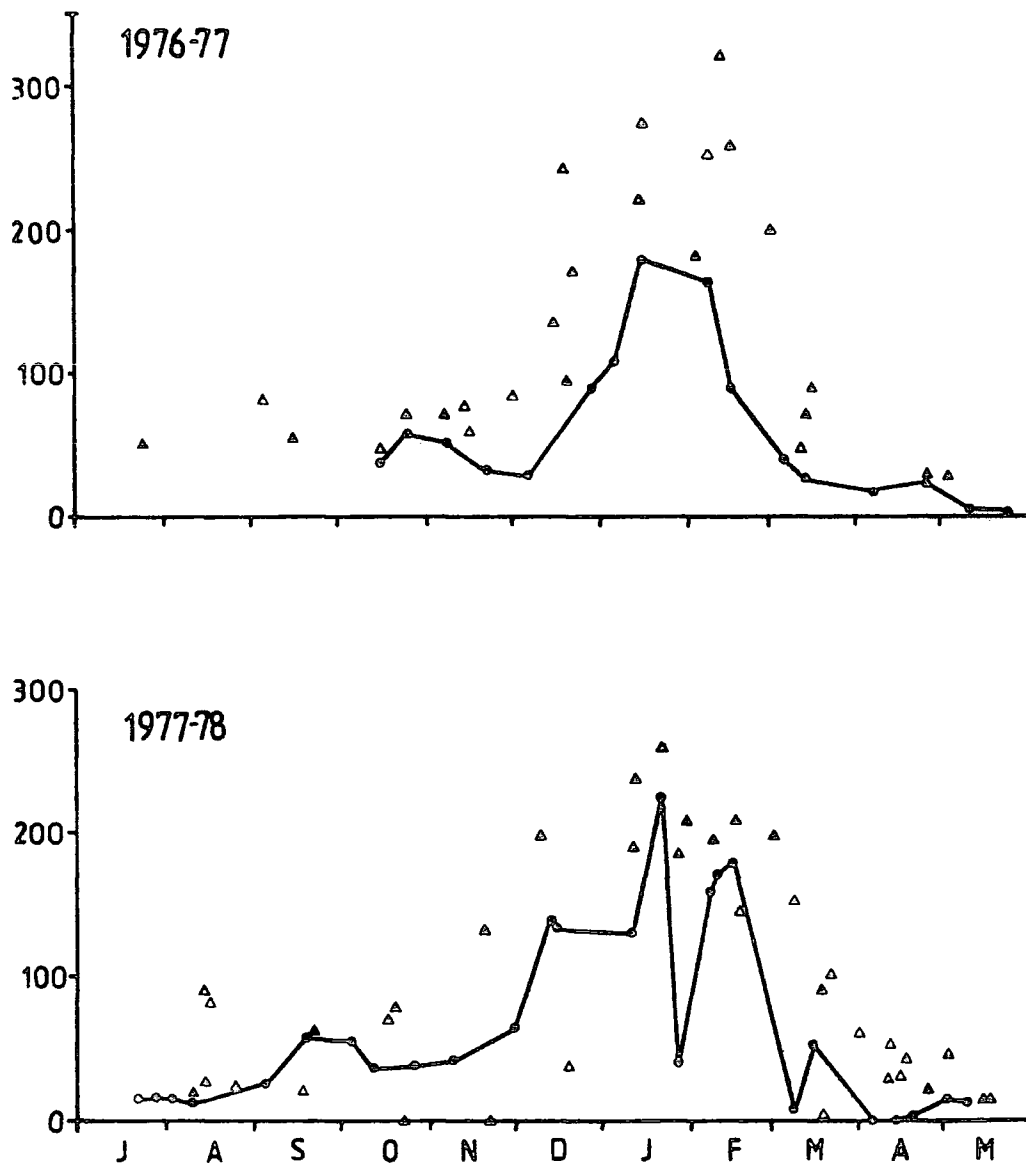

Figure 2.20

Counts of Bar-tailed Godwits in the winters of 1976/77 and 1977/78 on Seal Sands at Low Water (—○—) and on the north side of the Tees estuary at High Water (△). Also shown are the "Birds of Estuaries" counts (△).

Following the autumn peaks, there was a decrease in the Seal Sands population, particularly in 1976, before numbers increased to the winter maximum in mid-January. The peak Low Water counts occurred on similar dates, 16th January 1977 and 22nd January 1978. However for the two winters, the first Low Water count of at least 100 Godwit was reached on 6th January in winter 1976/77 but on 14th December in 1977/78. Thus the changes in Godwit numbers on Seal Sands in both autumn and winter appear to have taken place 3 - 4 weeks earlier in 1977/78 than in the preceding winter.*

The 1977/78 increase appeared to consist of two separate influxes, one in early December and one in mid-January. The second of these coincided with the beginning of the very cold spell of weather, as did the later stages of the mid winter influx in 1976/77. Like the Grey Plovers, Godwits arriving during cold weather may have been forced off less suitable wintering grounds, or be pausing on their spring migration north to their arctic breeding grounds.

In both years Low Water numbers fell rapidly during February and March, and by late April most Godwits had left Seal Sands. Because the build-up in winter 1977/78 occurred one month earlier, the total use made of Seal Sands by Godwits was nearly 20 per cent greater in winter 1977/78 than in the previous winter (bird-days between November-March inclusive 2,900 in 1976/77, and 3,550 in 1977/78). (The marked variation between Low Water counts from January to March 1978 will be discussed later.)

Counts made of Godwits at High Water roost sites show general agreement with the changes in Low Water counts. However, as the Godwits frequently roosted on inaccessible sites, especially in 1977/78, High Water counts may be underestimates of the numbers present on the estuary. Nevertheless, a swift passage of Godwits in August, not detected in the Low Water counts, is revealed

* The differences between the two winters could have been due to conditions at the point of departure.

by High Water counts made by myself and the Birds of Estuaries Survey. Also the High Water counts indicate that the mid winter numbers increased at least 3 weeks earlier on the estuary as a whole than on Seal Sands itself, although the increase in 1977 still began approximately one month before that in 1976. In contrast to the Low Water counts, there is no evidence of 2 separate influxes in the 1977/78 High Water Counts.

There was no sign of a drop in numbers roosting at High Water around the estuary following the autumn peak in numbers feeding on Seal Sands (at Low Water) in either winter, so the Low Water decrease must have been due to a redistribution of the Godwits on the estuary in October and November. Similarly, during the mid winter increases and the 1976/77 mid winter peak it appears that up to 80 - 90 Godwits must have fed elsewhere on the estuary or coast at Low Water. Up to 30 Godwits may have fed on Seal Sands beyond the mid-tide wall, particularly in 1976/77, and therefore been invisible from the normal observation points. Occasional checks revealed numbers rarely above 20 and usually below 10, so at least 50 Godwits (and probably 60 - 70) must have used feeding areas other than Seal Sands. Other feeding grounds known to be used by Godwits at Low Water are Bran Sands and the coastal sands south of the river mouth. Regular Low Water counts were not conducted on these sites, but observations by D. M. Brearey in 1977/78 suggest that Bran Sands was used by no more than 15 Godwits at Low Water until late January (Table 2.9). Probably no more than 20 birds fed on the coastal sands at Low Water during the winter. Therefore from October 1977 to late January 1978 up to 50 Godwits must have fed on unknown sites at Low Water.

Table 2.9Low Water counts of Bar-tailed Godwits
on Bran Sands during the 1977/78 winter

Month	Oct	Nov	Dec	Jan	Feb	Mar
Counts	0	0	8	0	16	63
	0	8		106	183	146
	0			24	0	
	0					
	3					

(Data from D. M. Brearey, pers. comm.)

From the end of January until March 1978, many more Godwits fed on Bran Sands, up to 183 being present at Low Water (Table 2.9). Numbers on Bran Sands varied markedly (0 - 183) even between successive days:

7th February 1978, 6¹/₂ hours after High Water 16 Godwit

8th February 1978, 6¹/₂ hours after High Water 183 Godwit

During this period the number of Godwits on Seal Sands at Low Water became more variable (see Fig. 2.20). Also the Godwits were more restless when on Seal Sands. On one occasion disturbance from a helicopter at Low Water caused the whole flock (over 150 birds) to fly across the river towards Bran Sands. On two occasions during this period, the Seal Sands Low Water counts coincided with counts made at Low Water on Bran Sands:

11th February 1978 Seal Sands 170, Bran Sands 0

9th March 1978 Seal Sands 8, Bran Sands 146

Clearly the same birds are using Seal Sands or Bran Sands at Low Water on different days. Thus it seems that Seal Sands was only marginally more profitable than Bran Sands as a feeding ground during early 1978. The Godwits made frequent use of both areas, and sometimes commuted between the two during a tidal cycle.

The B. O. E. counts for 1976/77 show general agreement with my High Water counts. The count for February 1977 which exceeded my High Water roost counts for that month may indicate a passage of Godwits through Teesmouth. The counts for 1977/78 rarely included the Godwit roost on the islands in the Tees and were usually considerable under-estimates of the true population on the estuary.

Despite the great variability between B. O. E. counts for previous years, a peak in January/February can be discerned in 5 of the past 6 winters.

Therefore the Godwits may be following the same pattern as the Grey Plovers, regularly using the Tees as a refuelling station on their northward migration each spring.

2. D. 2. a. The distribution of birds on Seal Sands at Low Water

Typical examples of the Low Water distribution of Godwits on Seal Sands are shown in Fig. 2.21. As the distribution in the two winters 1976/77 and 1977/78 is very different, each winter will be discussed separately. Variations in the dispersion within a winter and during a tidal cycle will be discussed in later sections.

(i) Winter 1976/77 - Central Bank ($\bar{x} = 39.6$; see Table 2.10) and Eastern Channel ($\bar{x} = 23.9$) were the main feeding areas for the Godwits (Fig. 2.22), together holding over 80 per cent of the total Seal Sands population at Low Water. On both areas the birds fed on the more northern parts, avoiding the liquid mud near the Reclamation Wall. Very few Godwits fed on the other areas of Seal Sands.

(ii) Winter 1977/78 - The Low Water dispersion of Godwits in 1977/78 was more variable than in the previous winter (see Fig. 2.21), so it is more difficult to discern a pattern of use. The use of Central Bank was similar in 1977/78 ($\bar{x} = 34.5$) to that in 1976/77. However very few Godwits fed on Eastern Channel in 1977/78 ($\bar{x} = 3.1$). This eastern side of Seal Sands was virtually unused by Godwits at Low Water as those present on Central Bank were confined mainly to the middle ($\bar{x} = 15.2$) and western ($\bar{x} = 19.8$) sections, avoiding the eastern side (Central Bank - eastern, including Eastern Channel, $\bar{x} = 5.1$).

Many more Godwits fed on Central Channel ($\bar{x} = 31.9$), and Greenabella Bank ($\bar{x} = 23.8$) in 1977/78. On both areas they fed mainly at the tide edge, with the Curlews, but areas of liquid mud were also used, particularly on Central

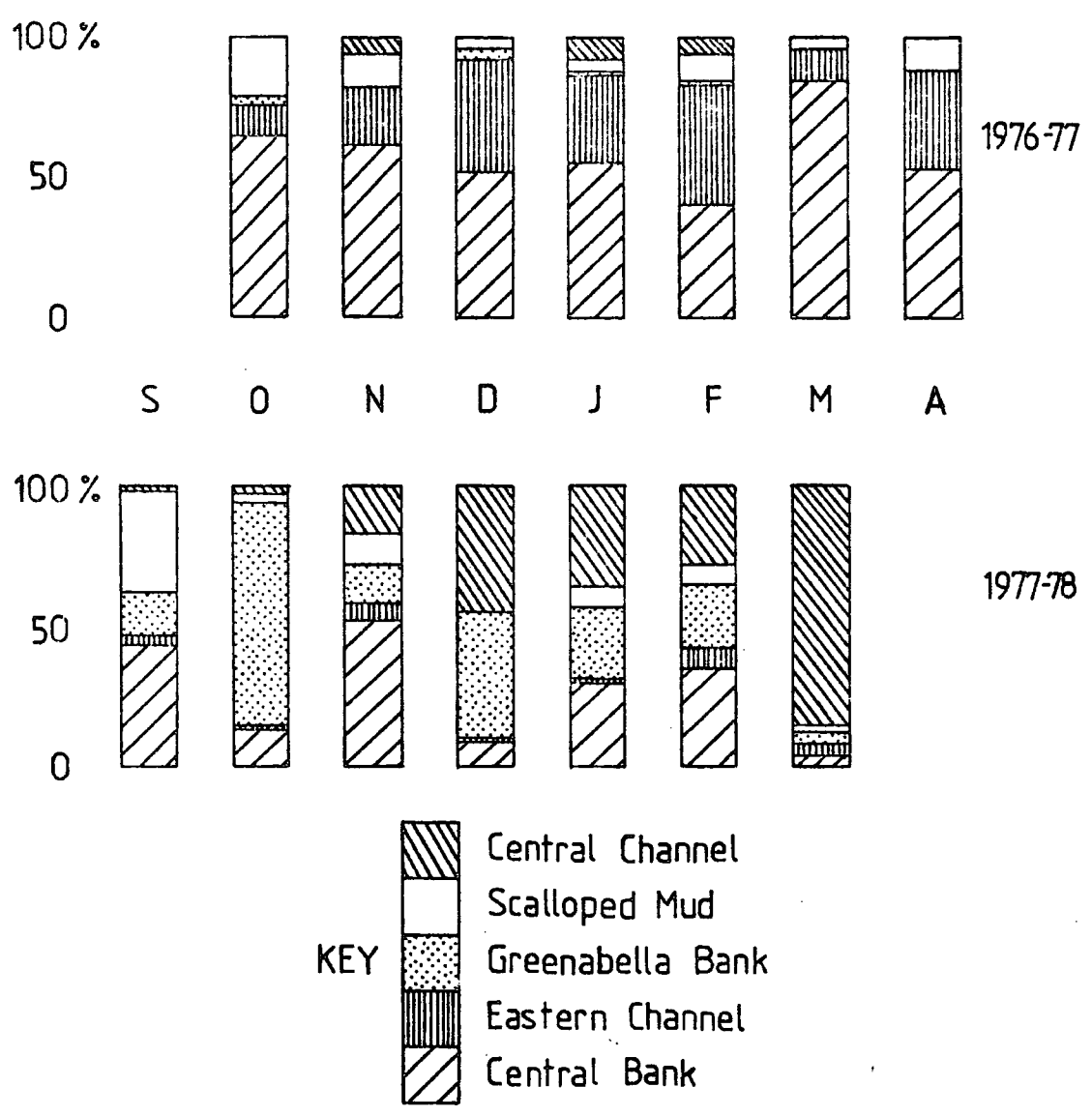

Figure 2. 21

Typical examples for each month of the distribution of Bar-tailed Godwits between the different areas of Seal Sands at Low Water, in two winters. The counts for each area are shown as percentages of the total present on Seal Sands on that day.

Table 2.10

Counts at Low Water of Bar-tailed Godwits on
Seal Sands in the months October to March

1976/77	<u>Number of counts</u>	<u>Mean</u>	<u>Standard Deviation</u>	<u>Coefficient of variation</u>	<u>Mean as a percentage of the Seal Sands total</u>
Seal Sands total	12	73.8	52.1	0.71	100.0%
Central Bank	12	39.6	31.3	0.79	53.7%
Eastern Channel	17	23.9	20.3	0.85	32.4%
Scalloped Mud	12	7.5	8.4	1.12	10.2%
Greenabella Bank	12	2.1	3.8	1.82	2.8%
Central Channel	15	6.1	7.5	1.23	8.3%
1977/78					
Seal Sands total	15	97.6	66.7	0.68	100.0%
Central Bank total	14	34.5	33.2	0.96	35.3%
Eastern Channel	17	3.1	4.4	1.42	3.2%
Central Bank - eastern	14	5.1	7.8	1.54	5.2%
Central Bank - middle	13	15.2	20.8	1.37	15.6%
Central Bank - western	13	19.8	15.7	0.79	20.3%
Scalloped Mud	15	9.7	19.1	1.97	9.9%
Greenabella Bank	16	23.8	21.2	0.89	24.4%
Central Channel	14	31.9	31.5	0.99	32.7%

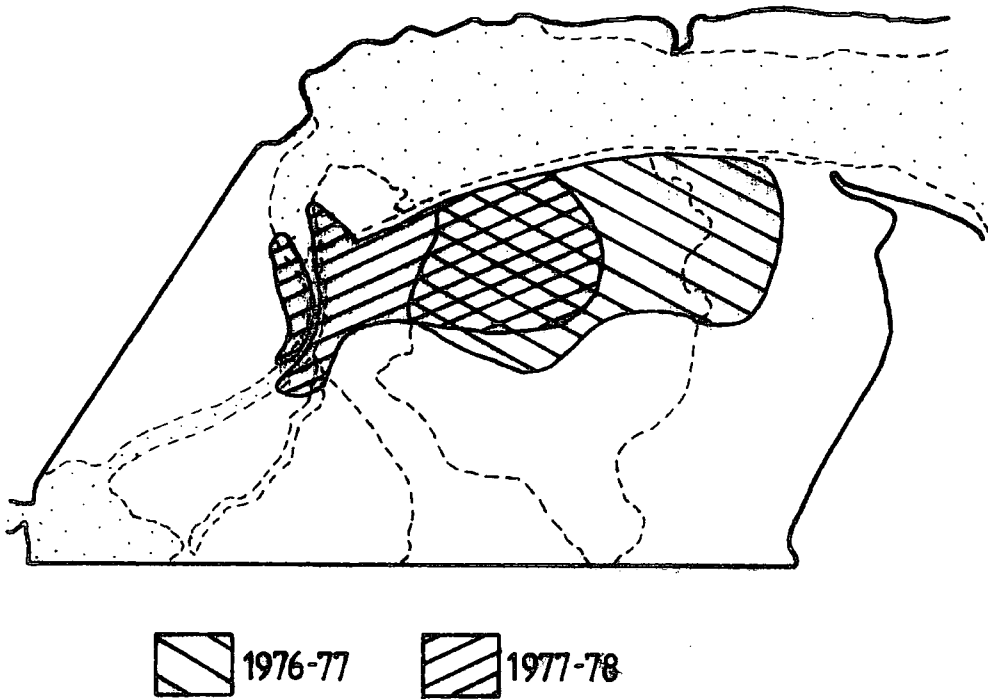

Figure 2.22

The main **feeding** areas used by Bar-tailed Godwits on Seal Sands at Low Water, in the winters of 1976/77 and 1977/78.

Channel (Fig. 2.22). As in 1976/77, Scalloped Mud held about 10 per cent of the population ($\bar{x} = 9.7$).

Differences in distribution between spring and neap tides

1976/77 - More Godwits fed on Eastern Channel on spring tides, whereas the other main feeding area, Central Bank, held an approximately constant proportion of the population (Fig. 2.22a). It is not known why Eastern Channel was preferred on spring Low Waters as there is no difference in area exposed compared with neaps.

1977/78 - The few comparable counts available (Fig. 2.22a) reveal the expected pattern - Godwits fed particularly on Greenabella Bank and Central Channel (on the lowest areas) on springs, and on Central Bank and Scalloped Mud on neaps when the lowest mud along Seaton Channel was not available.

2. D. 2. b. Seasonal changes in the Low Water distribution

Although the seasonal changes in numbers of Godwits and Grey Plovers feeding on Seal Sands at Low Water are similar, the Godwit counts do not provide evidence of the filling of optimal feeding areas as detected in the Grey Plover counts. Indeed counts for all areas are very variable (c.v. > 0.75 see Table 2.10).

(i) Winter 1976/77 (Fig. 2.23) - The changes in numbers on Central Bank paralleled those for the whole of Seal Sands, (except for one count in January during extreme weather conditions), so Central Bank held a constant proportion of the total on Seal Sands throughout the winter at all population densities.

The use of Eastern Channel was also related to the total number present on Seal Sands. However no autumn peak in numbers occurred in October-November, and the peak in February was reached after that on Central Bank and Seal Sands

Fig. 2.22a: Differences in the distribution of Bar-tailed Godwits on Seal Sands on spring and neap tides.

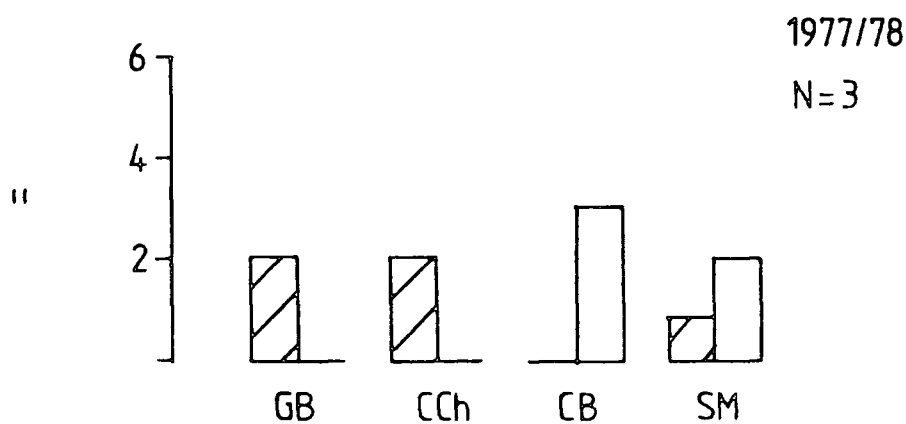
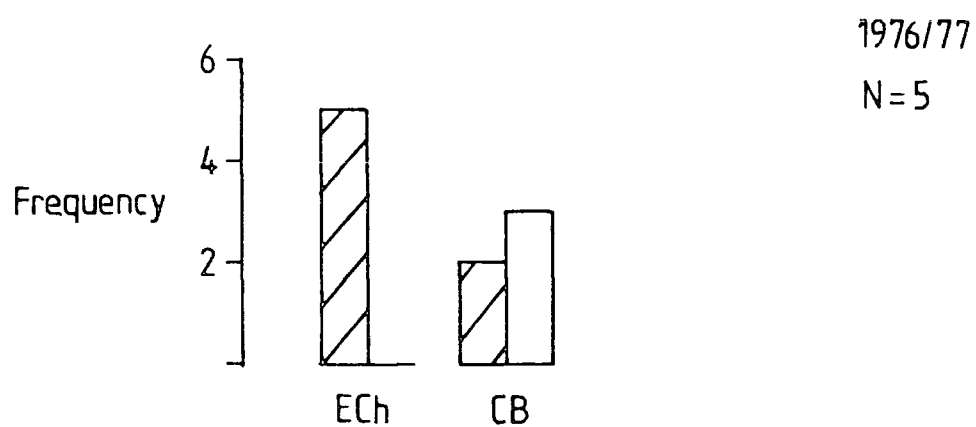

KEY: Columns show the number of occasions on which:

 Spring count higher than neap.

 Neap count higher than spring.

N = total number of spring/neap pairs.

Other details as on Fig. 2.5a.

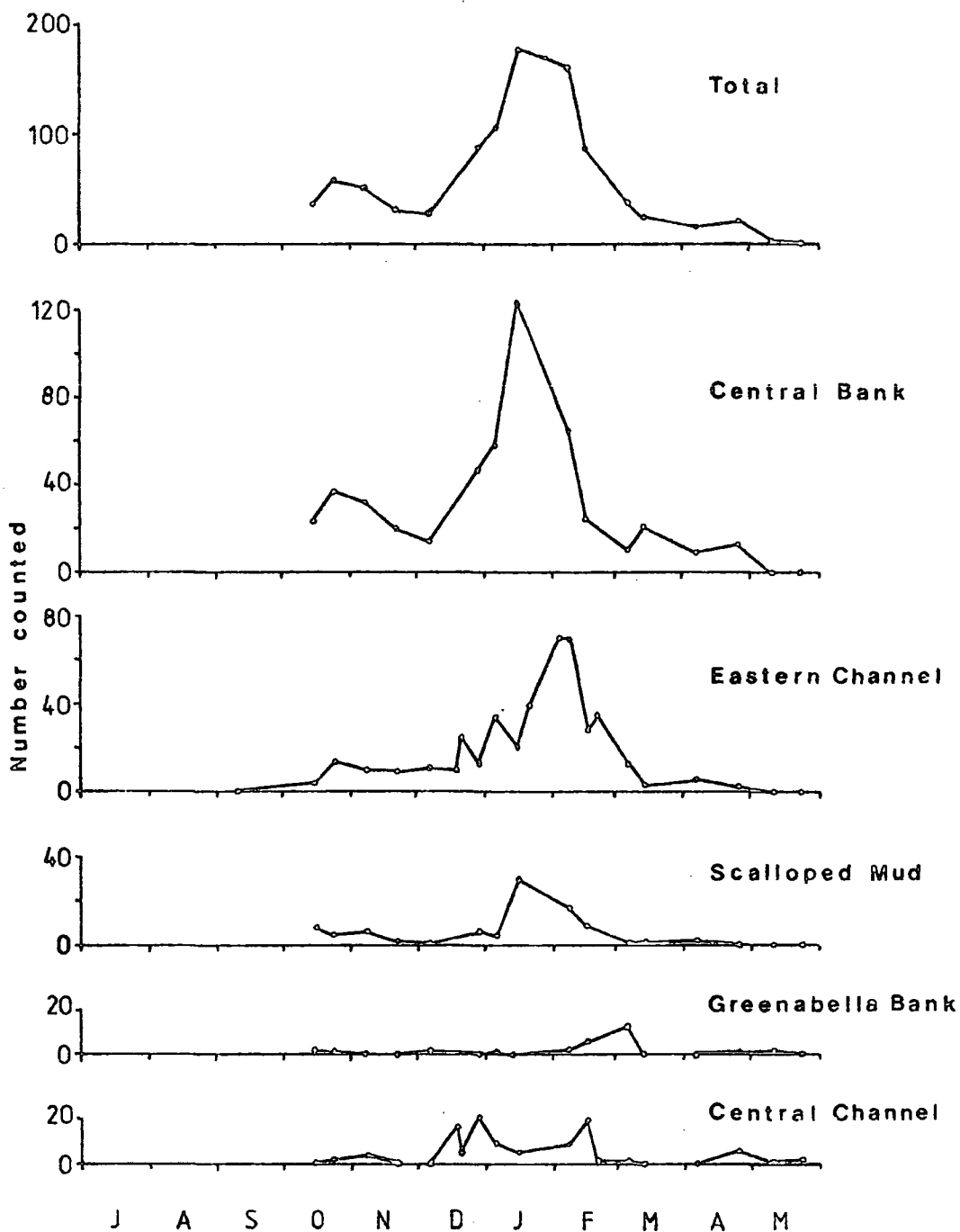

Figure 2.23 Seasonal changes in the number of Bar-tailed Godwits feeding on the different areas of Seal Sands at Low Water during the winter of 1976/77.

as a whole. The spring decrease matched that of the Seal Sands total.

Very few Godwits fed on Scalloped Mud at Low Water except during the mid winter peak in January and February. The increase in numbers on Scalloped Mud only occurred when the Seal Sands Low Water total exceeded 100. Thus Scalloped Mud seems to have been a sub-optimal area for Godwits, only used when the population density on Seal Sands was high.

Use of Central Channel at Low Water was also confined to peaks in Seal Sands numbers. Godwits only fed on Central Channel when the total on Seal Sands exceeded about 50. However there were never more than 21 on Central Channel, and numbers varied considerably, so Central Channel also appears to have been a sub-optimal feeding site for Godwit in winter 1976/77.

During the whole winter, numbers on Greenabella Bank at Low Water remained below 3 except for 2 counts in February-March. Thus Godwits seemed to avoid feeding on this mudflat even at high Seal Sands population densities.

(ii) Winter 1977/78 (Fig. 2.24) - As in 1976/77, the Central Bank counts in general resemble those for the whole of Seal Sands. However, due to the extremely variable choice of feeding areas shown by the Godwits from December to March, the agreement is not as close as in the previous winter. Nevertheless a roughly constant proportion of the Godwits present on Seal Sands fed on Central Bank, whatever the total on Seal Sands. When feeding on Central Bank, the Godwits avoided the softest mud near the East-West Reclamation Wall. They also avoided the eastern side of Central Bank and Eastern Channel (Fig. 2.25). These areas were only used during the peak in Seal Sands numbers (compare Fig. 2.24 and 2.25). Use of the middle section of Central Bank was also confined to the Seal Sands population peak in January-February. However during

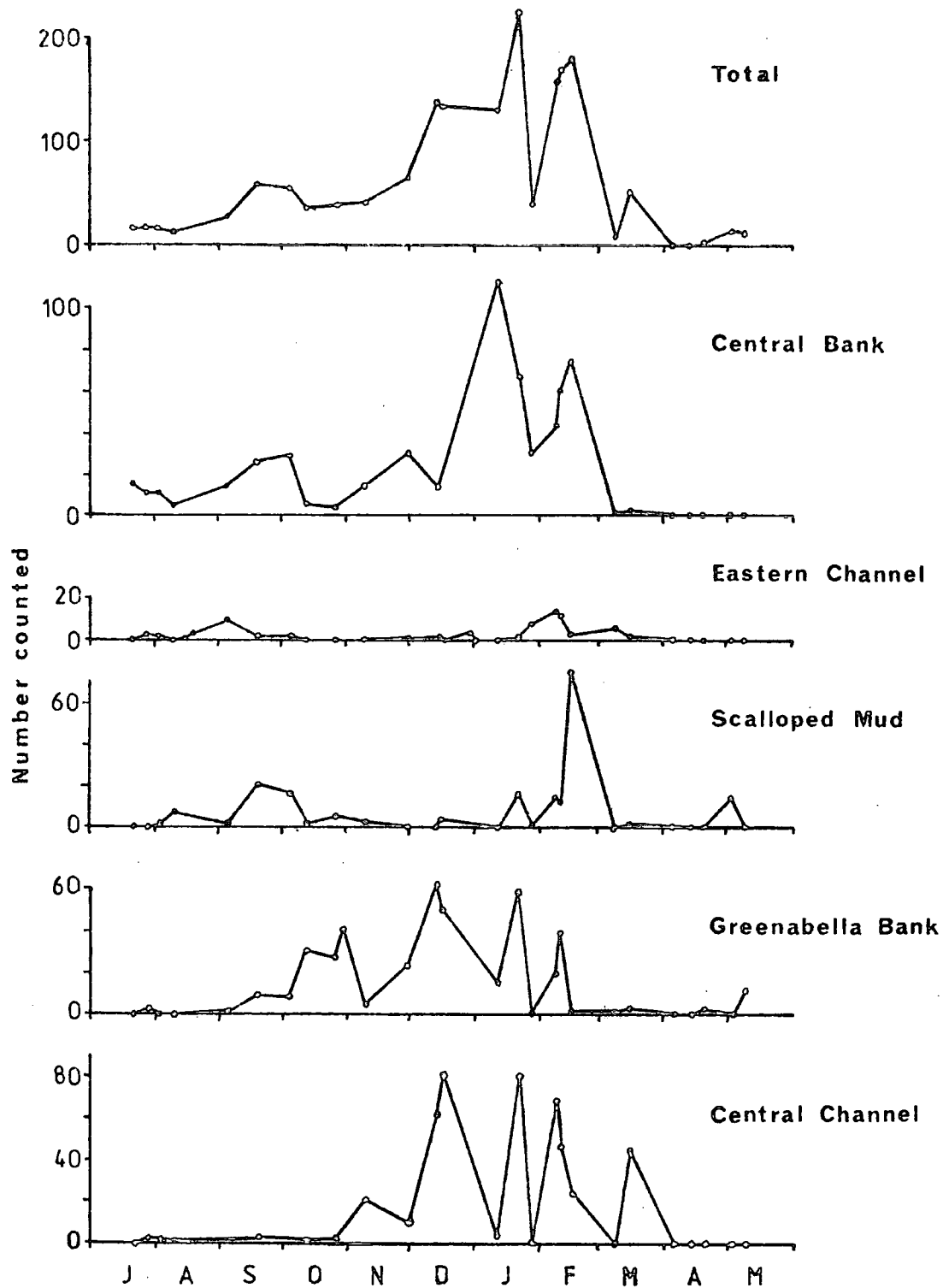

Figure 2.24

Seasonal changes in the number of Bar-tailed Godwits feeding on the different areas of Seal Sands at Low Water during the winter of 1977/78.

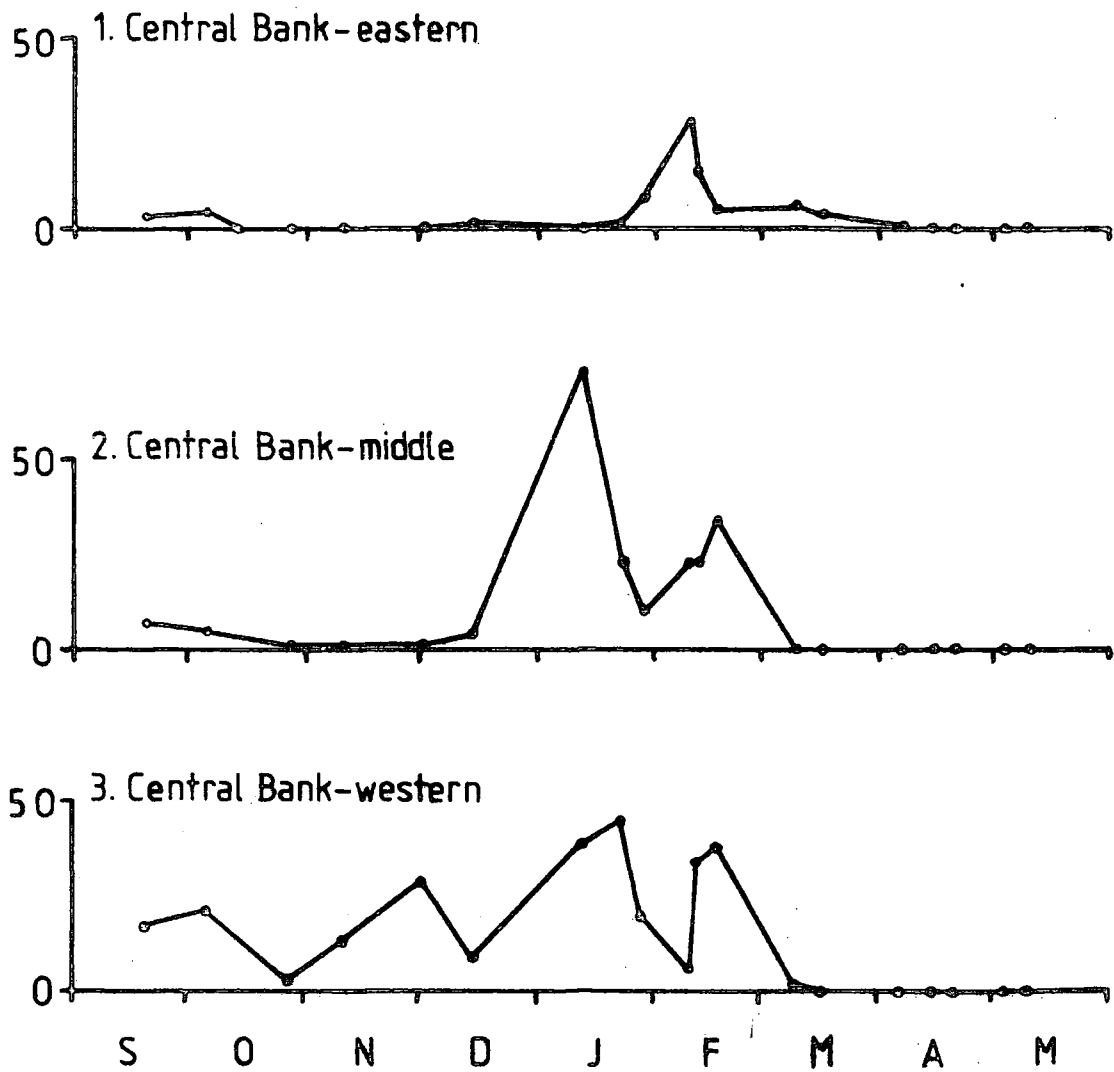

Figure 2.25

Low Water counts of Bar-tailed Godwits feeding on the three subdivisions of Central Bank - Eastern Channel (shown in Figure 2.8) in the winter of 1977/78.

this time more Godwit fed here than on the eastern section, and the numbers remained fairly constant (except for the count on 12.1.78, during extreme weather conditions - see below) (Fig. 2.25). In contrast Godwits fed on the western section of Central Bank at Low Water from September to February. The number present varied roughly in parallel with the counts for the whole of Central Bank, except that a ceiling was apparently reached when Seal Sands counts were at their highest, in January-February. Thus Godwits preferred to feed on the western side of Central Bank. When this was full they spread onto the middle section. When this was filled (in February 1978, Fig. 2.24) Godwits also fed in numbers at Low Water on the eastern section. It is not known how the Godwits achieved apparent density regulation on Central Bank, for they were not spaced out across the available mudflat and apparently suitable areas were often devoid of Godwits.

Scalloped Mud was an area favoured by Godwits in autumn, when changes in numbers matched those for the whole of Seal Sands. Subsequently it was not used at Low Water until the second midwinter influx in January. Numbers rarely exceeded 20 during this period. So as in 1976/77, Scalloped Mud was a sub-optimal Low Water feeding area for Godwits for much of the winter, only being used at peak Seal Sands numbers.

In marked contrast to winter 1976/77, Central Channel and Greenabella Bank together held over 50 per cent of the Seal Sands Low Water population in 1977/78. Use of both areas was extremely variable. Central Channel was favoured by Godwits in October, but subsequently both areas were used at Low Water, although Central Channel continued to support more Godwits than Greenabella Bank. Changes in numbers on the two areas combined (Fig. 2.26) generally paralleled those on Seal Sands as a whole, but few Godwits fed on

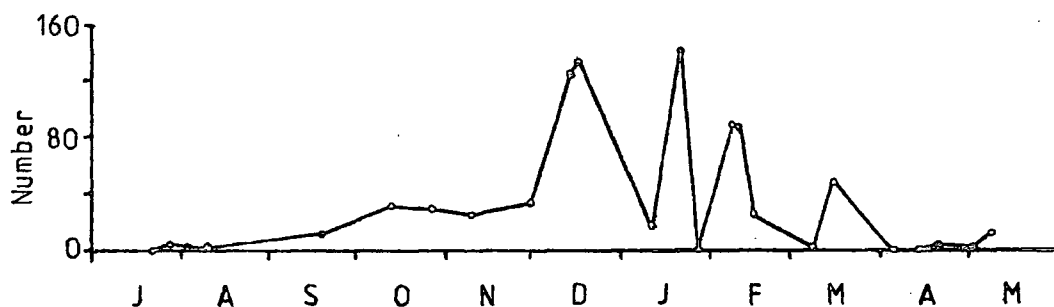

Figure 2.26

The total number of Bar-tailed Godwits feeding on Greenabella Bank and Central Channel at Low Water, in the 1977/78 winter. The Low Water counts for Greenabella Bank and Central Channel are combined.

Central Channel or Greenabella Bank during the autumn peak. Like the Curlews, Godwits did not discriminate between the sides of Seaton Channel when feeding at Low Water, at least in the short-term. Hence the combined counts for Central Channel and Greenabella Bank show less variation than the counts for individual areas (Fig. 2.24 and 2.26, e.g. 27.10.77 versus 10.11.77, 14.12.77 versus 16.12.77, 9.2.78 versus 11.2.78).

(iii) Conclusions - Godwits changed their Low Water feeding areas from Central Bank and Eastern Channel to Central Bank, Greenabella Bank and Central Channel between the two winters. No areas held a constant population through the winter. The favoured areas held numbers roughly in proportion with the total number on Seal Sands. The other areas were used only at times of high Seal Sands numbers.

2. D. 3. Changes in Distribution during the Tidal Cycle

Because the main feeding areas used by Godwits at Low Water were different in winter 1976/77 and winter 1977/78, the patterns of movement as the tide ebbed and flowed also differed. Therefore the changes in distribution during the tidal cycle for each winter will be discussed separately.

(i) Winter 1976/77 (Fig. 2.27) - As the tide uncovered feeding areas along the Eastern Channel some Godwits fed at the tide edge amongst the Knot and Dunlin. Frequently they fed in water up to ~5 cm deep. This reduced disturbance from the other waders which only fed at the actual water's edge, and also enabled the Godwits to capture prey as yet unavailable to the Knot, Dunlin and Grey Plover.

Godwits flew over to Central Bank as soon as it was exposed, and then followed the tide edge across the mudflat. As the area of exposed mud increased some Godwits stopped moving with the tide and began feeding on open mud.

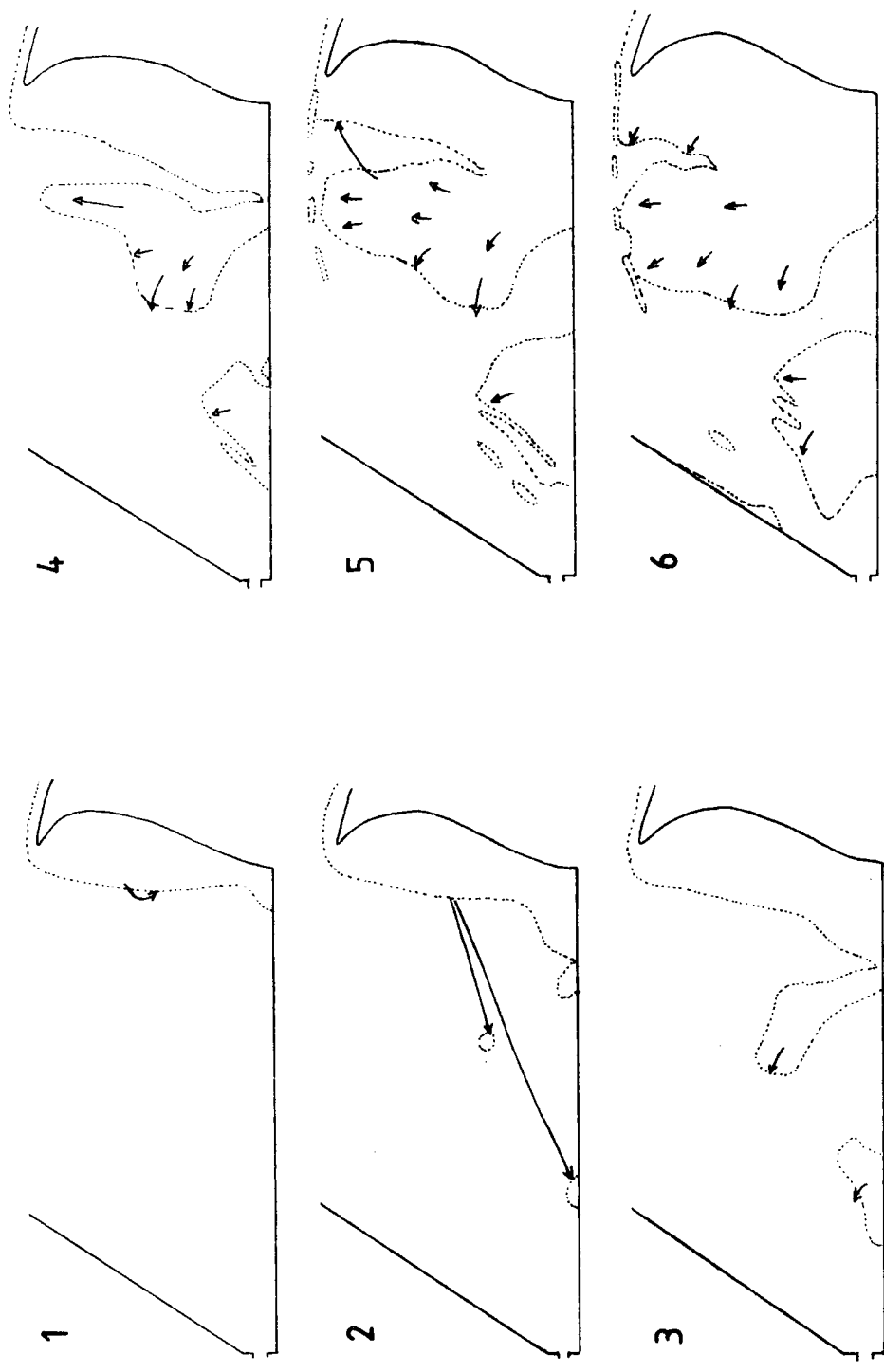

Figure 2.27 The main movements of Bar-tailed Godwits across Seal Sands as the tide ebbs, in the 1976/77 winter.

Others continued northwards with the tide, moving onto the flat northern half of Central Bank and the top of Eastern Channel. Consequently the majority of the Godwits on Seal Sands were spread across Central Bank and Eastern Channel by the time of Low Water. However a few Godwits moved north-westwards across Central Bank to feed in Central Channel, and others followed the tide across Scalloped Mud.

On the flood tide, those Godwits that had completed their feeding moved to the sandy ridge on Central Bank where they washed and preened beside the Grey Plovers. The Godwits that were still feeding on the lower mudflats, i. e. Eastern Channel and northern part of Central Bank, remained there until pushed off by the incoming tide. They then fed at the tide edge, moving up the shore with the tide until the feeding areas were covered.

(ii) Winter 1977/78 (Fig. 2.28) - During winter 1977/78 the patterns of movement shown by Godwits as the tide ebbed and flowed were similar to those of the Curlews because both species fed at/near the tide edge.

As in 1976/77 some Godwits fed along the Eastern Channel when the first feeding areas were exposed, often wading in deeper water than the other waders. As soon as Central Bank was exposed, Godwits flew over and began feeding there. They followed the tide edge particularly north-westwards, and many then moved onto Central Channel as it appeared. Scalloped Mud was used less than Central Bank by Godwits, but again the tide was followed down.

Unlike the Curlews, the Godwits did not fly over to Greenabella Bank immediately it became exposed, but continued feeding on Central Bank and in Central Channel until the lower parts of Greenabella Bank at the N. E. end were exposed. Then the Godwits distributed themselves on both sides of Seaton Channel at/near the tide edge (see Fig. 2.22).

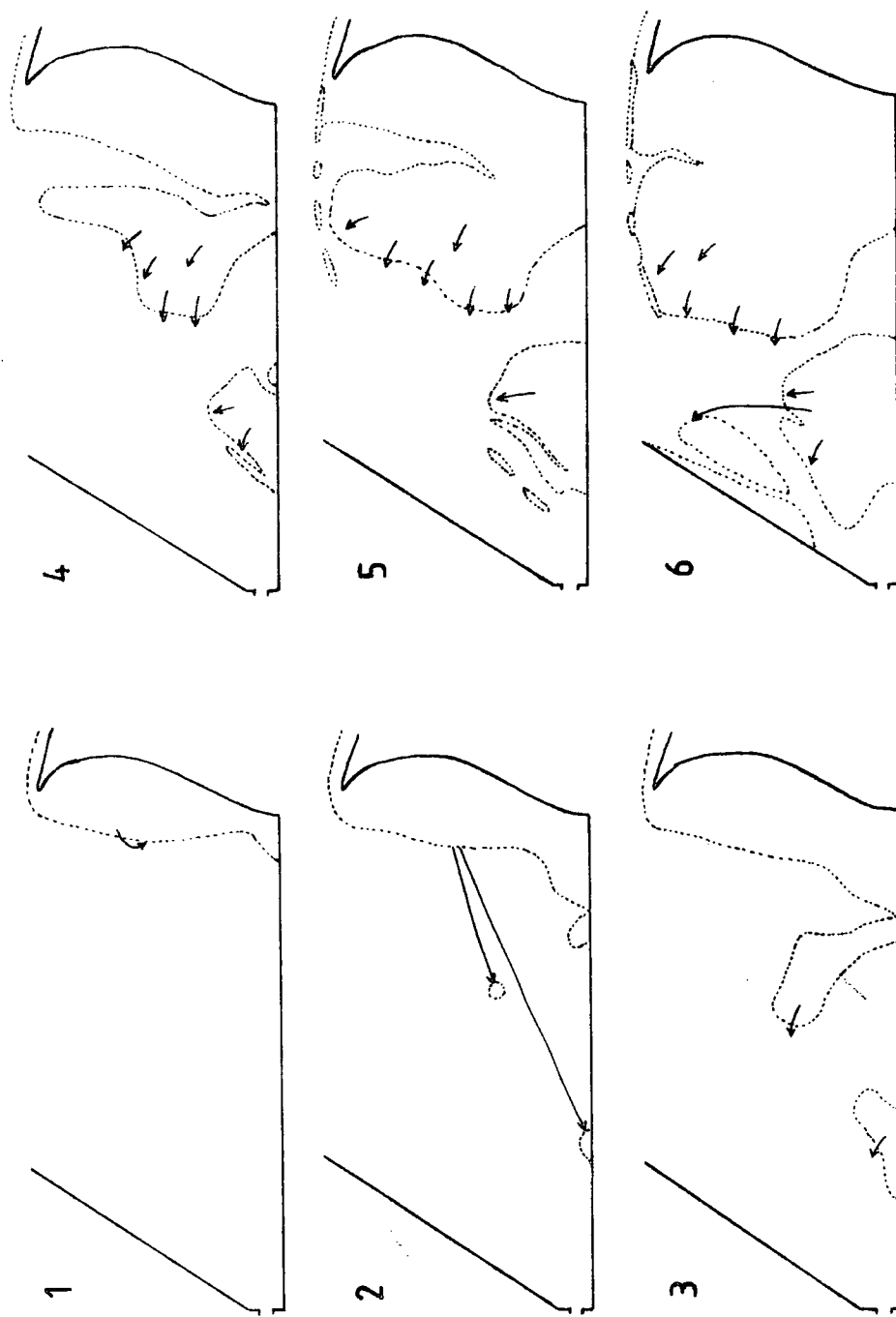

Figure 2.28 The main movements of Bar-tailed Godwits across Seal Sands as the tide ebbs, in the 1977/78 winter.

In contrast to the Curlews, few Godwits roosted at Low Water, but continued feeding on the lower areas of mud. As the tide covered Seal Sands, some Godwits joined the Curlew roosts on Scalloped Mud and especially Central Bank. Those that were still feeding moved up the shore with the tide, particularly in Central Channel and then onto Central Bank. Some Godwits remained until Seal Sands was covered, but others left when feeding areas were still available.

These tidal patterns of use were modified by:-

(a) Weather - In cold weather Godwits showed similar behaviour to the Grey Plovers and Curlews, more birds beginning to feed earlier and moving onto Central Bank as soon as it was exposed, e. g. 15.1.78.

Strong winds can decrease the foraging efficiency of shorebirds in several ways (Evans 1976). Onshore gales produce severe wave action that prevents Godwits from feeding at the tide edge (Evans and Smith 1975). In such conditions on Teesmouth on 12th January 1978, the movements of Godwits across Seal Sands as the tide ebbed were curtailed. Due to a N. E. gale blowing directly onto their main feeding areas on Central Channel and Greenabella Bank (see Fig. 2.22), most of the Godwits remained on Central Bank through the Low Water period. Numbers on both Central Channel and Greenabella Bank dropped from around 60 - 80 to less than 20, whereas the count for Central Bank was the highest during the whole winter (Fig. 2.24). The Godwits fed particularly in the pools on the sandy mud in the southern part of Central Bank. Because of the considerable drying effect of the wind on the open mud (Evans and Smith 1975), prey availability would have been higher in the pools than on the mud. Nevertheless the rate of food intake of the Godwits was probably much lower than the rate at the tide edge in normal conditions.

(b) Season - The use of Bran Sands by Godwits during January - March 1978 (see section 2. D. 1) was not confined to Low Water. Godwits fed on and moved to and from Bran Sands at all times during the period of exposure (e.g. Table 2.12), and on some days very few Godwits were present on Seal Sands throughout the tidal cycle. As one of the roosts favoured by Godwits during winter 1977/78 was adjacent to Bran Sands, Godwits frequently flew over to Bran Sands to feed on the flood tide, before or after Seal Sands was covered, and then moved onto the roost at High Water. On some occasions Godwits also fed on Bran Sands on the following ebb tide, before flying over to feed on Seal Sands at Low Water.

No counts for 1976/77 are available but feeding on Bran Sands is not a new behaviour confined to 1977/78 for 60 Godwits were seen feeding there on an ebb tide in October 1975.

(c) Disturbance - The air traffic over Seal Sands was the main disturbance for Godwits, particularly in early 1978. The disturbance resulted in considerable redistribution between areas on Seal Sands and also between Seal Sands and Bran Sands, e.g. 13.1.78. disturbance at Low Water

5 minutes later 35 Godwits on Seal Sands

2 hours later 137 Godwits on Seal Sands

At Low Water Godwits were little affected by the huge flocks of gulls present on Seal Sands during January and February 1978, as the gulls remained upon the open mud of Central Bank, away from the tide edge. However on 15th January 1978 the presence of the gulls on Central Bank as the tide ebbed forced the Godwits to feed with the Curlews on the liquid mud near to the East-West Reclamation Wall, an area normally avoided by Godwits.

Table 2.12Movement of Godwits between Seal Sands
and Bran Sands during a tidal cycle28.1.78. Numbers of Godwits on each site

<u>Hours after H. W.</u>	<u>H. W. roost near Seal Sands</u>	<u>Seal Sands</u>	<u>Bran Sands</u>
2	210	0	0
3-4	0	184	no count
6-7	0	39	131
8	0	3	159

(Counts for Bran Sands from D. M. Brearey, pers. comm.)

SECTION 3

DISTRIBUTION - INDIVIDUALS

PART I. THE USE OF TEESMOUTH AS A WINTERING SITE

3. I. A. METHODS OF CAPTURING AND MARKING

Grey Plovers, Curlews and Godwits were captured, marked with dye and individual combinations of colour rings, and then released. The feeding behaviour of individual birds could then be followed over long periods.

3. I. A. 1. Capturing

Birds were captured mainly with cannon nets, although mist nets and clap nets were also used. Almost all birds were caught at High Water when the number of sites used by roosting birds was limited. Attempts to catch birds on Seal Sands at Low Water were unsuccessful due to the large area of mudflat available to them, in relation to the size of the catching nets.

As most birds were caught at High Water roost sites, there was no direct selection for individuals feeding in particular sites - a problem inherent in catching at Low Water. I had hoped to ring a representative sample of the age and sex classes within the Teesmouth population of each species, but this proved impossible due to the difficulties in catching these shorebirds. Catches were infrequent, only 10 birds being ringed in the first winter, 1975/76, and opportunistic. As 75 per cent of the birds colour-ringed in this study were caught in 3 cannon net catches, they may be a biased sample of the total population on the estuary, in terms of age and moult. Pienkowski and Dick (1976) have shown that cannon netting results in preferential capture of adults in wing moult over juveniles and non-moulting adults, and suggested that waders in roosting flocks tend to segregate into groups differing in age and/or state of moult. It is also possible that birds from particular feeding sites group non-randomly within roosting flocks.

Thus, although individuals of different age, sex and state of moult were colour-ringed, the age composition and moult stages of the samples may not be representative of the population.

3. I. A. 2. Marking

(a) Rings - Individual birds were marked with a unique combination of colour rings on the legs. Each Grey Plover was given 3 colour rings, 1 on the left tarso-metatarsus, and 2 on the right. As Grey Plovers rarely feed in liquid mud or water, these rings were usually visible. However both Curlews and Godwits spend much of their time wading in liquid mud and water, thus covering rings placed on the tarso-metatarsus. Therefore nearly all Curlews and Godwits were given 3 additional colour rings above the "knee" joint (i. e. on the tibio-tarsus), repeating the combination below. These additional rings were less easy than the lower set to detect on roosting birds due to their proximity to the feathers, but permitted identification of birds wading in liquid mud or water.

Colour ringing was an effective method of marking for long-term observations. No birds lost their rings during the study, and the colours were easily identifiable on birds three years after ringing.

(b) Dyes - In addition to the colour rings on the legs, some birds of each species were dyed with Picric Acid (yellow) and/or Rhodamine B (bright pink) on the rump, tail and/or underbelly. The dye solution used to mark the birds comprised 1 per cent dye (dissolved in acetic acid), 59 per cent distilled water and 40 per cent ethanol, (as suggested by M. C. Perry, 1974, unpublished report). This was applied to the feathers with a paintbrush or cloth. After dyeing, the birds were placed in holding boxes until dry, and then released.

Although dyeing did not provide individual identification, it facilitated location of colour-ringed birds. Dyed birds were very obvious both on the ground

and in flight, even at long distances, so the feeding sites and movements of newly-marked individuals could be determined quite rapidly. Much longer periods of searching were required to find some ringed but un-dyed birds.

As Picric Acid is a permanent dye, dyed birds can be followed throughout a winter provided they retain the same plumage. However waders moult their body feathers twice a year, in spring and in autumn, so dyeing is an effective long-term marking technique only if applied just after a moult. As birds were captured through the winter and not just after moults, dyeing was mainly a short-term aid used in the initial determination of a bird's foraging movements.

(c) Problems in identification of marked birds - In reasonable light it was possible to identify most colour-ringed birds on firm open mud up to 400 m away. However this distance decreased to 200 m or less in mist, bad light, and heavy precipitation. Occasionally problems were caused by confusion between colours, or when the rings were obscured by mud adhering to them. Birds standing in creeks or liquid mud or water could only be identified when an upper set of colour rings was present and visible.

Similarly, birds dyed with Picric Acid could be located up to 800 m away in good light, but poor visibility reduced this distance markedly. In addition, the orangey hue produced by the low winter sun sometimes made it impossible to determine whether or not a distant bird was dyed.

When it was not possible to make a definite identification, no data were collected from that bird. However some individuals could be identified confidently even though some colour rings were obscured. Some birds regularly fed in a particular site, followed similar paths when foraging, and washed in the same ponds, each time they were observed. A few also showed characteristic plumage features, e. g. white wing coverts. Certain individuals in specific sites and with characteristic behaviour could therefore be identified even in

poor conditions. It should be stressed that this technique was used only when identification was absolutely definite, and that regular checks on the full ring combinations of such birds were made at other times.

3. I. B. THE USE OF TEESMOUTH AS A WINTERING SITE BY INDIVIDUAL GREY PLOVERS

3. I. B. 1. Numbers individually marked

During the 3 winters of the project, 44 Grey Plovers were caught (42 with cannon nets) and colour-ringed. Of these, 35 were also dyed. Most Grey Plovers were caught in the winter of 1976/77, particularly in one large catch of 26 in February 1977.

Approximately equal numbers of juveniles and adults were captured over the 3 winters. However there was seasonal variation in the composition of the catch (Table 3. 1). In October more juveniles were caught, but adults predominated in subsequent catches until February when juveniles and adults were caught in similar numbers. None of the Grey Plovers were in wing moult when captured. As the sexes are identical in Grey Plovers it is not possible to determine whether the proportion of males to females changed during a winter.

3. I. B. 2. Fidelity to Teesmouth in successive winters

Each winter, checks were made at about weekly intervals for the presence of colour-marked birds. Fidelity to Teesmouth in successive winters was studied in 43 marked Grey Plovers, as one of the colour-ringed individuals is known to have died during the winter in which it was ringed. Twenty-one (49 per cent) of the 43 surviving birds were seen on the estuary in the first winter following ringing (Table 3. 2). Fourteen of these returning individuals were ringed early in the study (in winters 1975/76 and 1976/77) and therefore provide data for return rates in subsequent winters (Table 3. 3; sightings for

Table 3.1

The ages of Grey Plovers captured during the three winters of the study

	O	N	D	J	F	Totals of each age class	Grand totals
1975/76	-	-	5A*	-	1J	1J 5A	6
1976/77	-	-	-	1A	13J 13A	13J 14A	27
1977/78	4J 1A	1J 2A	-	-	3A**	5J <u>6A</u> 19J 25A	<u>11</u> 44

Key: J = Juvenile
A = Adult

* 3 of birds caught in December 1975 are "suspected adults" as ageing uncertain.

** Catch comprised 5 adults (2 retraps).

Table 3.2

The return of colour-ringed Grey Plovers to Teesmouth
in subsequent winters in relation to the month of capture

	<u>Month of Capture</u>					<u>Totals</u>
	Oct	Nov	Dec	Jan	Feb	
1975/76 ringed	-	-	5	-	1	6
1976/77 returned	-	-	5	-	0	5
1977/78 returned	-	-	3	-	0	3
1978/79 returned	-	-	3	-	1	4
1976/77 ringed	-	-	-	1	26	27
1977/78 returned	-	-	-	0	9	9
1978/79 returned	-	-	-	0	17	17
1977/78 ringed	4*	3	-	-	3	10
1978/79 returned	2*	3	-	-	2	7

* One bird found dead soon after capture excluded from analysis.

Data for 1978/79 supplied by P. J. Dugan (pers. comm.).

Table 3.3

The fidelity of individually marked Grey Plovers to
Teesmouth in successive winters after ringing

1975/76	<u>Patterns of return to Teesmouth shown by individual Grey Plovers</u>			<u>No. of marked Grey Plovers showing each pattern</u>
	1976/77	1977/78	1978/79	
6 ringed				
R	/	/	/	3
R	/	/	X	0
R	/	X	X	2
R	X	X	/	1
	27 ringed			
	R	/	/	9
	R	/	X	0
	R	X	/	8
	R	X	X	10

R = winter in which bird colour-ringed.

/ = returned to Teesmouth in this winter.

X = not seen on Teesmouth in this winter.

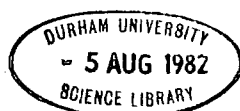

1978/79 from P. J. Dugan, pers. comm.). Their return rate between the first and second winter following ringing was 86 per cent (12 birds), and that between the second and third winter was 100 per cent (3 birds).

Birds caught in different months showed different degrees of fidelity to Teesmouth in successive winters. Those captured during October-December showed a high rate of return (83 per cent) in the first winter following capture (Table 3.2), and some have continued to return in every subsequent winter. Only 37 per cent of the Grey Plovers caught in February returned in the first winter after ringing. These individuals showed a 100 per cent return between the first and second winters, so their behaviour resembled that of the birds caught in October-December. More variable behaviour was shown by the 19 Grey Plovers caught in February that were not seen on Teesmouth in the first winter after ringing. Nine of them reappeared on the estuary in the second or third winter after ringing. Their return to Teesmouth after an absence of more than one year may have been related to the weather, as 4 of them appeared during the extremely cold conditions of January 1979.

The difference in behaviour observed between individuals captured in February is a function of age, juveniles showing a much lower rate of return in the winter following capture than adults (Table 3.4). Overall, 68 per cent of the adults but only 22 per cent of the juveniles returned to Teesmouth in the winter after being ringed.

Mortality rates are difficult to determine from the available data as not all surviving birds were seen each winter. However, minimum survival rates (i. e. survival and return) can be calculated. That for juveniles (56 per cent per annum) is clearly lower than that for adults (87 per cent). The maximum rate of adult mortality (13 per cent) is therefore considerably lower than the 34 - 42 per cent calculated by Boyd (1962) for other British species of plover.

Table 3.4

The effect of age at capture upon the return
rates of marked Grey Plovers

Age when caught	Juvenile					Adult				
	O	N	D	J	F	O	N	D	J	F
Month of capture										
Number caught	3	1	-	-	14	1	2	5	1	16
Number that returned in the next winter	1	1	-	-	2	1	2	5	0	9

Table 3.5

The month of arrival of marked Grey Plovers

Month of arrival	A	S	O	N	D	J	F
No. arriving 1976/77	-	2	-	2	-	1	-
No. arriving 1977/78	2	-	1	3	1	3	2
No arriving 1978/79	4	2	3	2	7	9	1

Data for 1978/79 from P. J. Dugan (pers. comm.)

3. I. B. 3. Period of stay on the estuary during a winter

All observations of marked Grey Plovers seen during the period August - May were recorded, so for each individual it is possible to determine the first day it was observed (termed the arrival date), the last day seen (termed the departure date), and whether or not the individual was present throughout the winter. Most marked Grey Plovers were seen at least 3 times per month when present on the estuary, and some up to 8 times (see Appendix 2). Also many birds fed in the same site for several weeks or months so regular checks could be made for particular individuals. Therefore the true dates of arrival of individuals probably do not differ from the dates of first sighting by more than a week. True departure dates in late March or early April are less reliably estimated as observations were made less frequently at that time. (This is taken into account in the interpretation of the data on departures.)

Of course it is not always possible to distinguish between true departures from the estuary and death. However as only one colour-ringed Grey Plover was found dead on the estuary, all except one of the other ringed birds were seen alive after ringing, and several individuals reappeared on Teesmouth after an absence of more than one year, it is presumed that the last day seen does relate to true departure from the estuary and not to death.

Arrival dates - Data are available for 5 marked Grey Plovers in winter 1976/77 and for 12 in 1977/78 (Table 3.5). P. J. Dugan has kindly supplied the arrival dates for these individuals during winter 1978/79 to permit further comparison between years. Arrival dates ranged from 16th August to 16th February, and were spread evenly through the winter. Thus the arrival of Grey Plovers on Teesmouth was not confined to the periods of marked population increase shown in Fig. 2.3. (The large number of arrivals in December - January, winter 1978/79, may have been correlated with the severe weather at that time.)

Individuals showed marked consistency between years. Twelve marked Grey Plovers returned for 2 or more winters, and each had a similar arrival date each year (Appendix 3). In no case did the arrival dates for an individual differ between years by more than 35 days, and 9 birds returned on a date within 2 weeks of their arrival in the previous year (Table 3.6).

Little information is available on the influence of age upon arrival date. The 2 second winter birds which returned to Teesmouth showed no clear difference in arrival dates between years. As no juveniles were ringed until after their arrival on Teesmouth, no arrival dates can be obtained for birds in their first winter.

Departure dates - Although Grey Plovers continued to arrive at Teesmouth through the winter, emigration was generally confined to the period February - April, with most birds leaving during March (Table 3.7). Last sighting dates of adult Grey Plovers were very similar in successive springs (Table 3.8). Considering the data up to winter 1977/78, in 16 of the 17 cases there was a difference of no more than 4 weeks, with 12 differing by no more than 14 days. The only bird which differed substantially from this pattern was not seen subsequently, so it may have died rather than emigrated.

The departure dates given for 1978/79 are considered less accurate estimates of the true dates of departure from the estuary as many more colour-ringed birds were being observed during this winter (P. J. Dugan, pers. comm.). Nevertheless, there is good agreement between years for individual birds even if they are not present on the estuary every winter (e.g. Y W/R, Y G/O, Y Y/Y). However, one bird (L W/R) appeared to show a major change in behaviour, leaving in February (the month it was ringed) in one

Table 3.6

Frequency distribution of the differences in the dates of first sighting of individual Grey Plovers in successive winters

	No. of days between arrival dates in successive winters					
	0-7	8-14	15-21	22-28	29-35	
1976/77 - 1977/78	0	1	2	0	0	3
1977/78 - 1978/79	4	4	1	1	2	12
	4	5	3	1	2	15

Data for 1978/79 from P. J. Dugan (pers. comm.)

Details of arrival dates set out in Appendix 3.

Table 3.7The month of departure of marked Grey Plovers

Month of departure	S	O	N	D	J	F	M	A	M
No. departing 75/76	-	-	-	-	-	-	3	3	-
No. departing 76/77	1	-	-	-	-	8	20	1	2
No. departing 77/78	-	1	2	-	-	1	12	6	-
No. departing 78/79	1	1	1	-	3	8	11	2	-

Data for 1978/79 from P. J. Dugan (pers. comm.)

Table 3.8

Frequency distribution of the differences in the dates of last sighting of individual Grey Plovers in successive winters

	No. of days between departure dates in successive winters							
	0-7	8-14	15-21	22-28	29-35	36-42	>42	
1975/76 - 1976/77	0	2	1	1	0	0	1	5
1976/77 - 1977/78	7	3	1	1	0	0	0	12
1977/78 - 1978/79	5	2	4	1	2	2	2	18
	12	7	6	3	2	2	3	35

Data for 1978/79 from P. J. Dugan (pers. comm.).

Details of departure dates set out in Appendix 3.

winter, but staying only briefly in September two winters later.

Individual Grey Plovers tended to emigrate from Teesmouth later when juvenile than in subsequent years (e.g. Y L/R, L W/L, see Appendix 3). However there was no difference in the mean spring departure date for juveniles and adults, at least for spring 1977 (juveniles \bar{x} = 17th March, S. D. = 23.2 days; adults \bar{x} = 7th March, S. D. = 15.9; $t = 1.41$, $P > 0.10$). Therefore juveniles and adults must have shown a similar range of departure dates in spring and any differences are only detectable at the individual level.

A few Grey Plovers disappeared from Teesmouth in autumn (Table 3.7). In total 6 individuals were involved, 3 adults and 3 juveniles. Only 2 (1 adult L W/R, 1 Juvenile Y O/O) were seen subsequently; it is not possible to tell whether the others emigrated or died. The juvenile Y O/O returned the following autumn, and it again left the estuary before mid-winter (Appendix 3), so it is not clear whether the differences in behaviour observed in autumn are due to differences in age or to variation between individuals.

Length of stay - As Grey Plovers arrived throughout the winter but left mainly in March, the lengths of stay for individual birds varied considerably (Fig. 3.1 and 3.2). Almost all marked adult birds remained on the estuary after their arrival until the time of the spring emigration. Therefore those that reached Teesmouth in August (B W/G, L W/L) stayed for over 200 days, whereas birds not arriving until February (O L/O, O R/W) were present for less than 50 days. The consistency between years shown by individual birds (Fig. 3.1) is a consequence of their regular arrival and departure dates, described earlier.

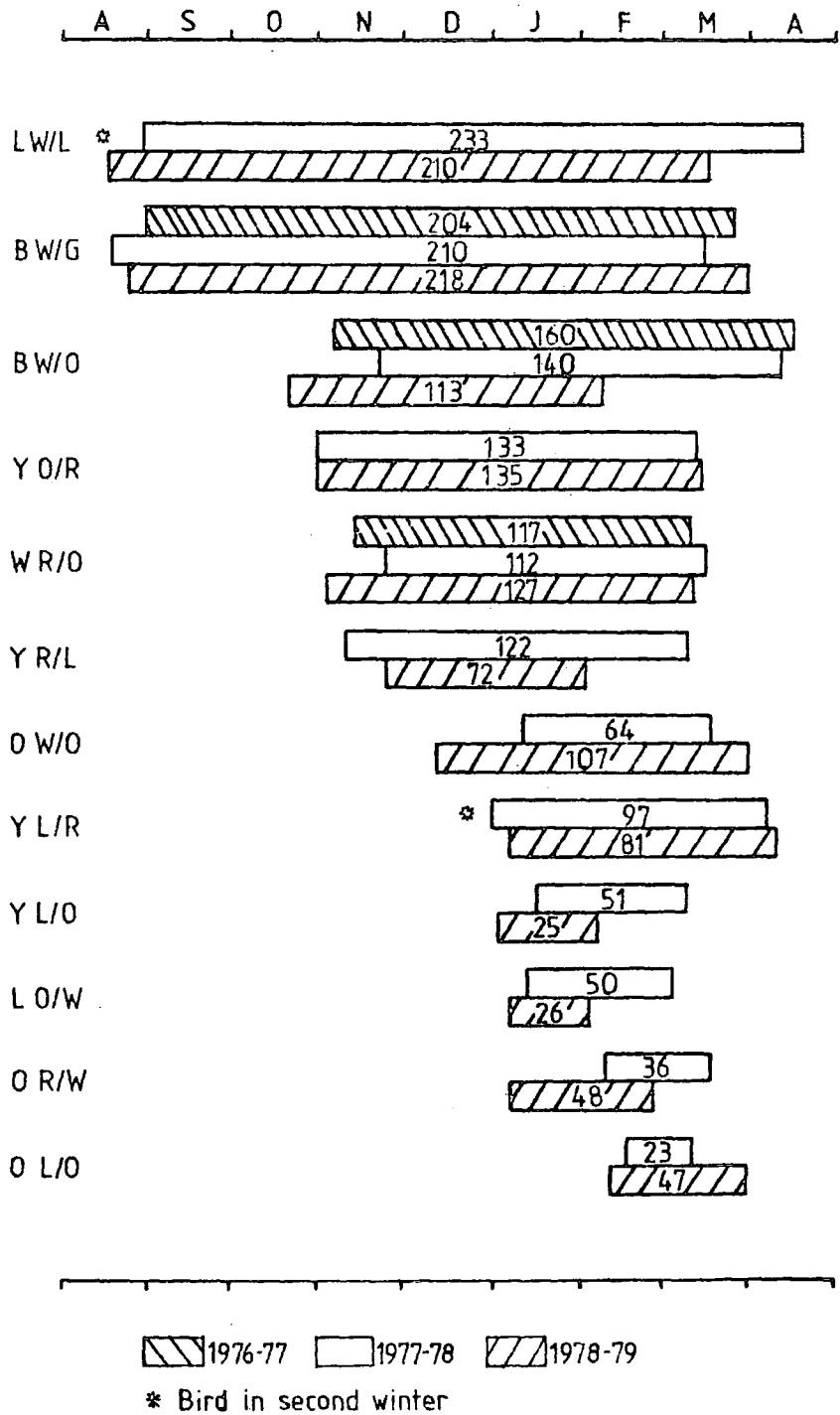

Figure 3.1 The length of stay on the Tees estuary of individually marked Grey Plovers in successive winters. Written in each bar is the number of days the individual was known to be present on the estuary. (Data for 1978/79 supplied by P. J. Dugan, pers. comm.)

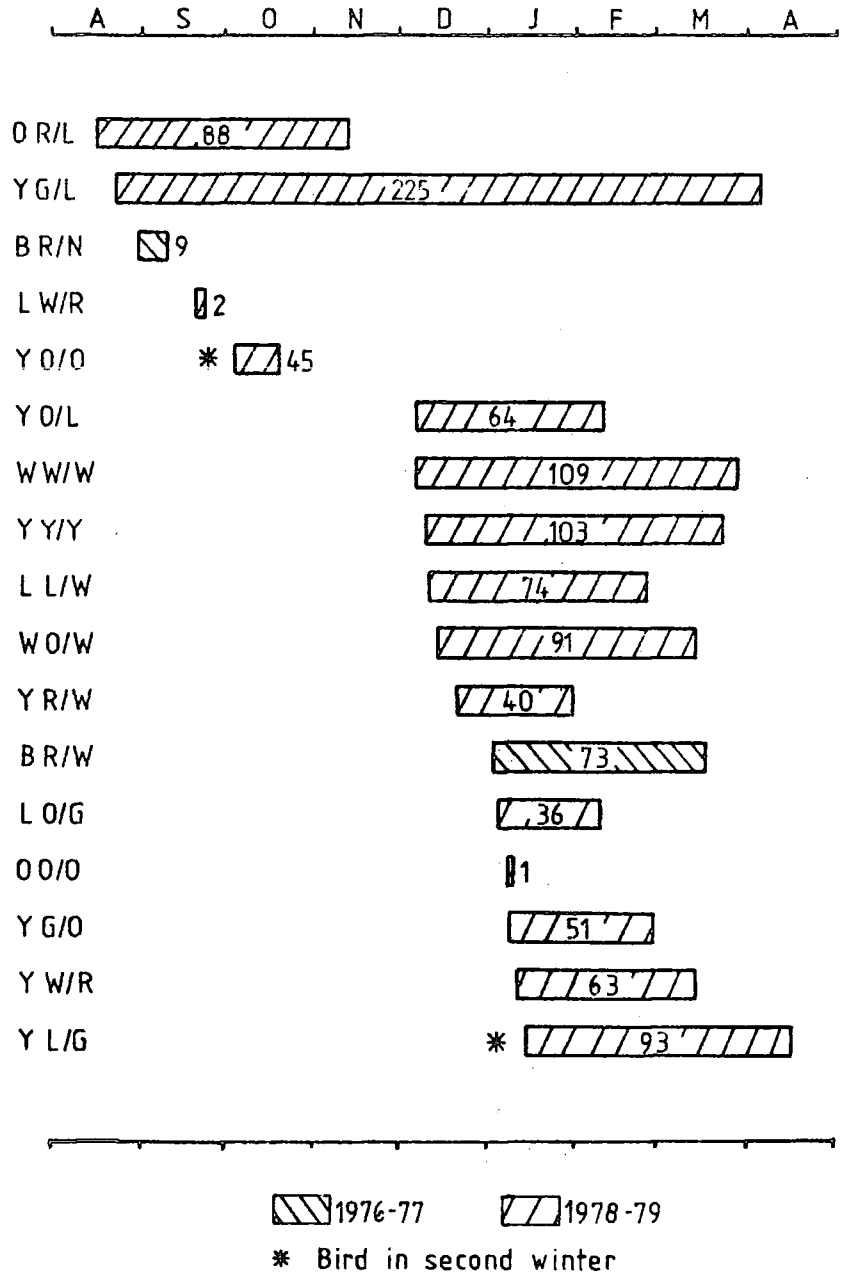

Figure 3.2

The length of stay on the Tees estuary of individually marked Grey Plovers seen for only one complete winter. Written in each bar is the number of days the individual was known to be present on the estuary. (Data for 1978/79 supplied by P. J. Dugan, pers. comm.)

The lengths of stay for the 4 known second-winter marked Grey Plovers showed no consistent clear-cut differences from those of the adults.

Birds captured during a winter provide further information even though the full period of stay on the estuary cannot be determined. All adults caught before February remained on the estuary until the February - April emigration period, whereas the juveniles captured in October left the estuary within a month. One of the latter birds (Y L/G) reappeared in February, 80 days after it had last been seen. It then remained on the estuary until April. This is the only proof to date of a Grey Plover of any age leaving the estuary and returning, during a single winter.

3. I. B. 4. Hypothesis for the use of Teesmouth by Grey Plovers (Fig. 3. 3)

The sightings of marked Grey Plovers described above can be combined with counts of Grey Plovers on the estuary (Section 2. B. 1 and Fig. 2. 3) to produce a more detailed hypothesis for the use of Teesmouth by Grey Plovers. I have referred to the arrival and departure of marked birds at Teesmouth as a whole rather than Seal Sands because I have used all the sightings of ringed birds, whether on the mudflats or the roost. Therefore I shall interpret the seasonal changes in High Water counts in the light of the data on individual birds. As the majority of Grey Plovers present on the estuary fed on Seal Sands, the pattern for Seal Sands would be similar to that described below.

The increase in numbers from July to September was due mainly to the arrival of adult birds in full summer plumage. Some first and second winter birds were also present. At least some of the adults (e. g. B W/G) and second winter birds (e. g. L W/L) remained on the estuary throughout the winter, although

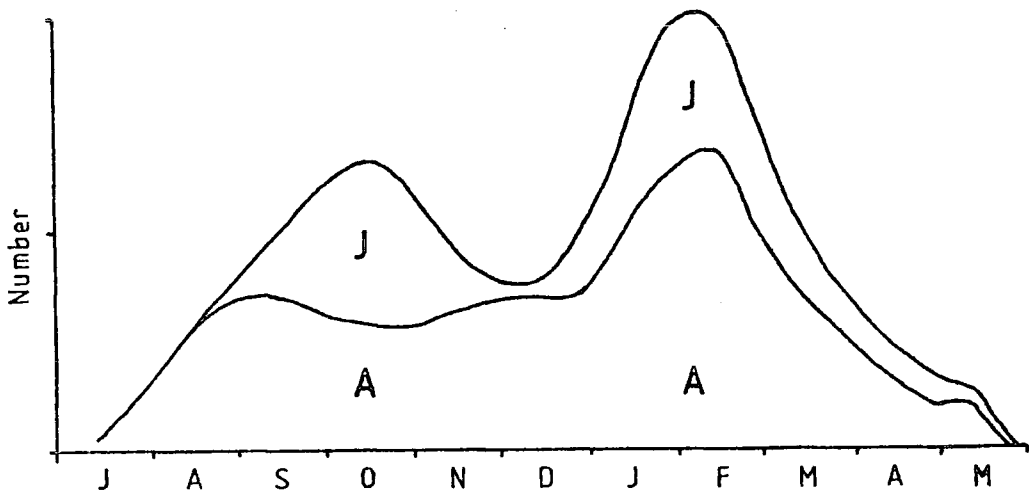

Figure 3.3

A generalised pattern for the use of the Tees estuary during a winter by adult (A) and juvenile (J) Grey Plovers.

other adults (L W/R) may have been on passage as they were present for less than 2 weeks.

The peak in October caused by the arrival of many juveniles and also some second winter birds (e. g. Y O/O, 1978/79) was followed by a decrease in numbers in late October and November as the juveniles (e. g. R W/R,* Y L/G, Y N/W,* Y O/O, 1977/78), some second winter birds (e. g. Y O/O, 1978/79) and some adults (e. g. O R/L,* 1978/79) left the estuary. The October 1976 peak was much larger presumably because more passage juveniles arrived at Teesmouth and/or that they stayed longer than in autumn 1977. The departure of the juveniles etc. coincided with the arrival of more adults at Teesmouth (e. g. W R/O, B W/O, Y O/R, Y R/L) and these adults also stayed until spring. On arrival one of these adults (W R/O) spent some time evicting a juvenile from a feeding site on Seal Sands. Therefore some of the juveniles (and perhaps also the older birds, e. g. O R/L)* may have left because they had been displaced from the better feeding areas by the newly arrived adults. However not all juveniles were forced out, as some fed in sites that adult Grey Plovers rarely used but still left the estuary in autumn.

In the winters 1976/77 and 1977/78 numbers were more or less constant by December, with no more marked birds appearing until the end of the month (Y L/R, adult). Very few juveniles were present on the estuary. In the winter of 1978/79 Grey Plovers apparently arrived throughout December (P. J. Dugan, pers. comm.). It is not known whether this was a consequence of the severe weather in that winter.

The large increase in numbers during January was due at least in part to the arrival of adults (e. g. L O/W, O W/O, Y L/O). By the time the numbers had reached a peak in February, many juveniles were also present. Adults continued to arrive in February (e. g. O L/O, O R/W), and one juvenile (Y L/G)

* These birds may have died rather than emigrated.

that had disappeared in autumn reappeared on Seal Sands. This influx of Grey Plovers included individuals, particularly amongst the juveniles, that did not return during the following winter. Therefore they are unlikely to be birds from local sub-optimal habitats (e. g. coast) moving into the estuary during the coldest conditions of the winter. Such local birds would be expected to repeat this movement each winter. Instead they could be birds pausing on their northward migration. If these migrants only pause when the weather is bad (and the January - February increases coincided with the coldest conditions of the winter in both 1976/77 and 1977/78), then different individuals will pause on Teesmouth in successive winters if the coldest weather occurs at a different time. In support of this, it is interesting to note that several Grey Plovers (e. g. Y G/O, L O/G, O O/O) not seen during winter 1977/78 were present in both 1976/77 and 1978/79, and the coldest conditions in these 2 winters occurred earlier than those in 1977/78.

In the second half of February numbers began to fall rapidly as both adults (e. g. 1977: L L/G, O R/W, Y R/W, Y N/O) and juveniles (e. g. 1977: L R/W, L W/R, L Y/N) left. Emigration of the rest of the Grey Plovers occurred in March and early April in both years. A few juveniles (e. g. L W/L, Y L/R) remained on the estuary. These were joined by adults in breeding plumage on passage, before all departed in May.

The consistency in arrival and departure dates for ringed individuals, which return to Teesmouth each winter, indicates that this pattern of use is likely to be similar each year.

This hypothesis for the use of Teesmouth by Grey Plovers is based upon and limited to observations on the 44 birds ringed during my study. As it is rarely possible to age Grey Plovers in the field, further data on the age

composition of the population can only be obtained by watching many more marked birds. This work is now in progress (P. J. Dugan, pers. comm.).

3. I. C. THE USE OF TEESMOUTH AS A WINTERING SITE BY INDIVIDUAL CURLEWS

3. I. C. 1. Numbers individually marked

A total of 82 Curlews were colour-ringed during the study, 72 also being dyed with Picric Acid. Cannon-netting was the main method of capture producing two large catches, in March (34 Curlews) and in August (38).

Although I wished to mark equal numbers of adults and juveniles, and males and females to determine differences in their feeding behaviours, this was not possible due to the difficulties in capturing the birds. Many more adults than juveniles were captured over the 3 winters (66 adults, 8 juveniles, 8 birds not aged). Juveniles constituted ~ 20 per cent of the catch in March, but none were caught in August (Table 3.9). All the adults caught in August were in wing moult.

Curlews are sexually dimorphic, the females being larger (e.g. Witherby et al. 1945, Bannerman 1961). The most clear-cut proportional difference between males and females is in the length of the bill. Estimates of the bill length (the chord from bill tip to feathers) dividing males from females vary (Prater et al. 1977, Elphick 1979, Bainbridge and Minton in preparation) depending in part upon the geographical origin of the birds. Therefore I have used bill lengths from my catches together with measurements from 14 skins of birds of known sex collected at Teesmouth to estimate the division between males and females for the Teesmouth population. All male skins had bills less than 126 mm (6 birds, range 103-125 mm) and all females greater than 132 mm (8 birds, range 133-156 mm). The measurements of adult Curlews captured for ringing show a division around 120-130 mm bill length

Table 3.9

The ages of Curlews captured
during the three winters of the study

	A	S	O	N	D	J	F	M	Totals
1975/76	-	-	-	-	4F	-	-	-	4
1976/77	-	-	1A 1J	1F	1F	-	-	27A 7J	38
1977/78	38A	-	-	2F	-	-	-	-	40

Key: F = Full-grown (not aged - may be juvenile or adult)

J = Juvenile

A = Adult

(Figs. 3.4 and 3.5). Therefore I have termed all birds with bill lengths less than 122 mm males, and all those with bills exceeding 129 mm females. Thus 5 birds with bill lengths of 123-128 mm (one adult excluded from Fig. 3.5 as no wing measurement) cannot be sexed with confidence.

Juvenile Curlews are believed to have completed bill growth by October (Bainbridge and Minton, in preparation). However the bill lengths of 7 juveniles caught on Teesmouth in March (\bar{x} = 118.9 mm, range = 105-137 mm, cf. 27 adults in the same catch \bar{x} = 124.4 mm, range 102-160 mm) indicate that this may not be so. It is interesting to note that 2 of the Curlews that could not be sexed by bill length were juveniles. Thus the division between males and females could be confused by the presence of juveniles with bills still undergoing active growth.

Wing length is another parameter that differs between the sexes, although with considerable overlap (Fig. 3.4). Any Teesmouth bird with a wing length (measured by the maximum length method, Evans 1964) shorter than 300 mm can be sexed a male and any exceeding 310 mm a female, a similar result to that obtained by Bainbridge and Minton (in preparation) on birds captured on the Wash.

Both sexes were present in every month that Curlews were ringed. The two big catches, in August and in March, contained a similar proportion of males (approximately 60 per cent) (August catch: 23 males, 13 females, 2 unsexed; March catch: 20 males, 12 females, 2 unsexed). The proportion of males to females in the March catch is unaltered if juveniles are excluded.

3. I. C. 2. Fidelity to Teesmouth in successive winters

Of the 82 Curlews caught in the three winters, 2 were found dead (one shot) during the winter of capture. Sixty-one (76 per cent) of the 80 remaining birds were seen on the estuary in the first winter following ringing

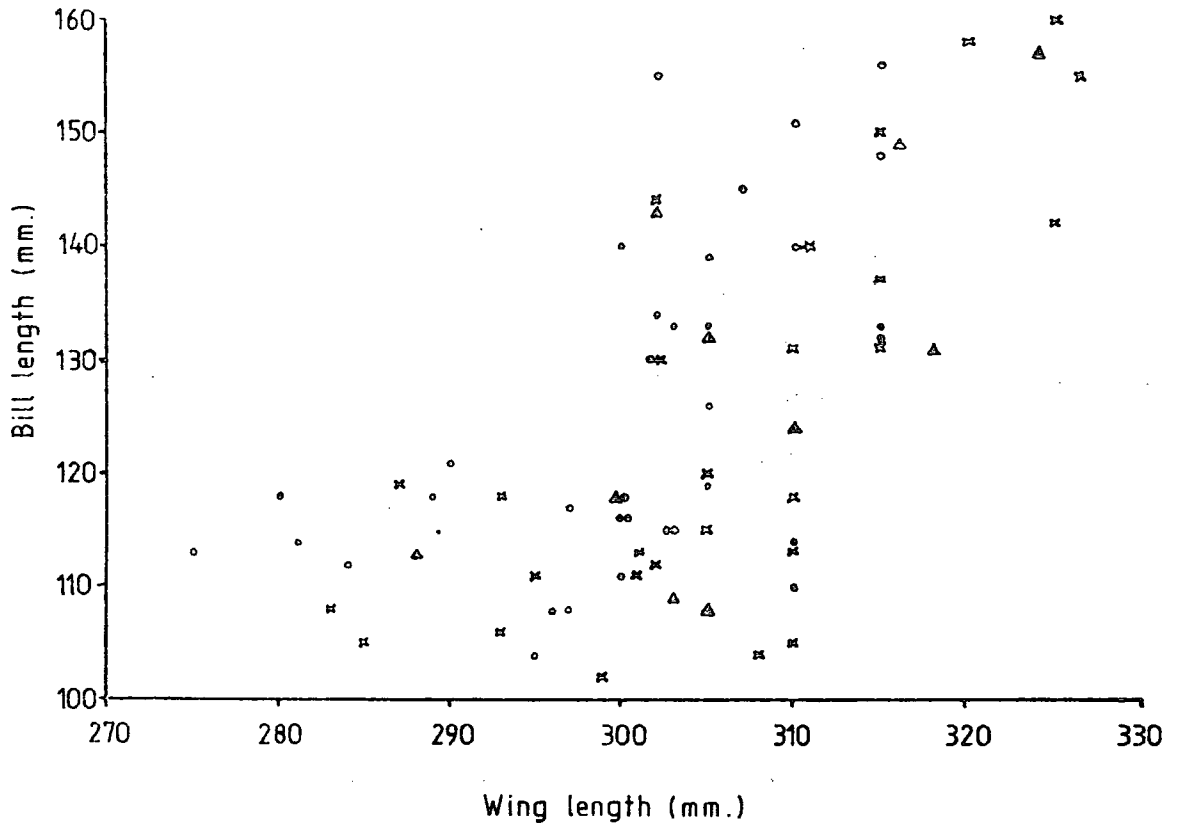

Figure 3.4 The relationship between the bill length and wing length of adult Curlews captured at Teesmouth.

(Key: x = birds caught in March 1977;
 o = birds caught in August 1977;
 Δ = birds caught in other months.)

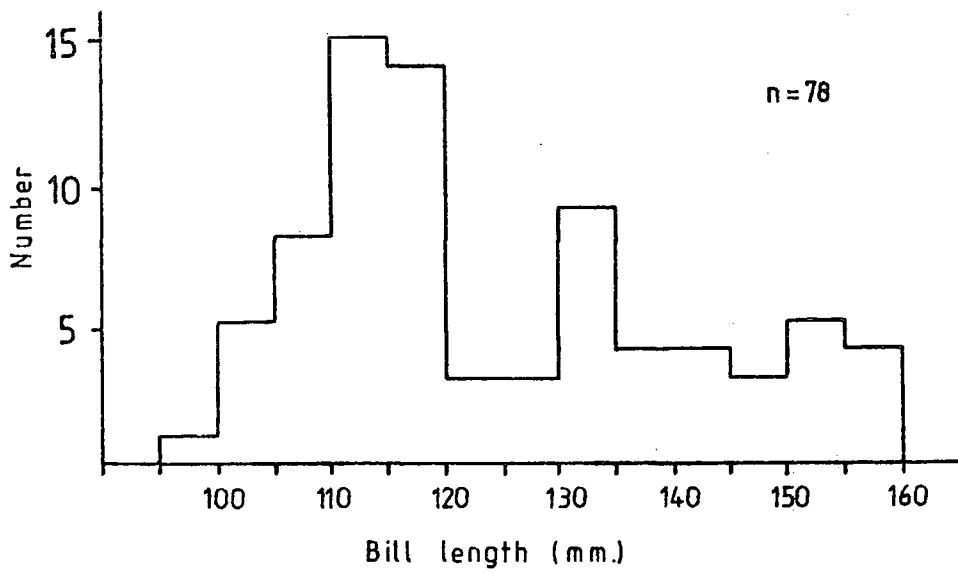

Figure 3.5 The frequency distribution of bill lengths of adult Curlews captured at Teesmouth.

(Table 3.10). The return rate between the first and second winters after marking was similar (81 per cent). (The extremely high rate of return between years shown in Table 3.10 (26 out of 27 birds returning) is due to 4 birds being seen in 1978/79, but not in the previous winter; see Table 3.11).

Adults and juveniles caught in 1976/77 had similar return rates in the following winter (70 per cent and 75 per cent respectively), and also in the second winter after ringing (81 per cent and 83 per cent respectively). There was little difference between the return rates of adult males and adult females, either in the winter following ringing (males 78 per cent, females 72 per cent) or in subsequent winters.

The return rate in the winter following ringing was not influenced by the month of capture. Birds caught in August and March had similar rates (return rate, August = 78 per cent, March = 71 per cent), and some of the birds caught in each of the other months also returned.

Mortality rates for each age class cannot be determined accurately as only 8 juveniles were ringed during the study. Seven of these were caught in March by which time most juvenile mortality will already have occurred. Between March and the following winter, mortality amongst the juveniles was just 12 per cent. Adult mortality between years was estimated to be 15 - 25 per cent, giving good agreement with the estimates of 25 per cent given by Boyd (1962), and 26 per cent given by Bainbridge and Minton (1978). Mortality in adult males and adult females was identical (approximately 20 per cent per annum).

3. I. C. 3. Period of stay on the estuary during a winter

Some marked Curlews fed on the fields surrounding Seal Sands during each winter, and were seen much less frequently than those which fed on the mudflats. Consequently arrival and departure dates were more difficult to determine for Curlews than for Grey Plovers, and are less reliable estimates of the true dates of arrival and departure.

Table 3.10The return of colour-ringed Curlews to
Teesmouth in successive winters

1975/76	4 ringed	-	-
1976/77	4 returned	38 ringed	-
1977/78	2 returned	27 returned	38 ringed*
1978/79	2 returned	26 returned	30 returned*

* 2 birds found dead during winter of capture excluded from analysis

(Sightings for 1978/79 from N. C. Davidson, L. R. Goodyer and F. L. Symonds).

Table 3.11

The fidelity of individually marked Curlews to Teesmouth
in successive winters after ringing

<u>Patterns of return to Teesmouth shown by individual Curlews</u>				<u>No. of Curlews showing each pattern</u>
1975/76	1976/77	1977/78	1978/79	
4 ringed				
R	✓	✓	✓	2
R	✓	X	X	2
38 ringed				
	R	✓	✓	22
	R	✓	X	5
	R	X	✓	4
	R	X	X	7

R = winter in which bird colour-ringed.

✓ = returned to Teesmouth in this winter.

X = not seen on Teesmouth in this winter.

Arrival dates - Most marked Curlews had returned to Teesmouth by October (Table 3.12). August is the main month for first sightings of marked Curlews. However data for July are few (especially in 1977) due to the difficulties of observation through the heat haze on the mudflats, so extensive immigration of marked birds may also have occurred in this month. (The apparent influx of marked Curlews in October - November 1978 was the result of greatly intensified searching for marked birds at that time.)

During the winters of 1976/77 and 1977/78, 5 marked Curlews were first seen in January. Four of these were males and 2 of them were known to be field feeders, so their appearance on Seal Sands was probably due to the fields becoming frozen rather than to their arrival on the estuary in January. Similarly the first sightings of 7 marked Curlews in January 1979 did not indicate an influx of birds into the estuary, but rather an increase in searching for ringed birds, particularly on the fields.

The true month of arrival on the estuary was not influenced by the sex of the birds. However age did affect the time of arrival. Three of the 5 Curlews in their second winter in 1977/78 (Y O/R, Y O/L, L W/R) arrived later than most of the adults (Table 3.13).

There was considerable consistency in the arrival dates of individual birds (Table 3.13), despite the change in observers and main areas searched during the winter of 1978/79. In twelve cases there is a difference of no more than 3 weeks. The major differences between years are anomalies caused by field feeding birds seen on the mudflats in autumn in one year but not until the fields were frozen in January in another (e.g. B W/O, L R/W).

Departure dates - During the 3 winters 1975/78 most marked Curlews left the estuary in March and April (Table 3.14). Some left in autumn, but it is difficult to separate these from birds that moved onto the fields and were not

Table 3.12The month of first sighting of marked Curlews

Month of arrival	J	A	S	O	N	D	J	F	M	A
No. arriving 1976/77	-	-	2	-	1	-	1	-	-	-
No. arriving 1977/78	-	14	6	4	1	-	4	-	-	-
No. arriving 1978/79	6	21	1	12	8	1	7	1	-	1

(Sightings for 1978/79 from N. C. Davidson, L. R. Goodyer and F. L. Symonds)

Table 3.13

Frequency distribution of the differences in the dates of
first sighting of individual Curlews in successive winters

	No. of days between arrival dates in successive winters							
	0-7	8-14	15-21	22-28	29-35	36-42	>42	
1976/77 - 1977/78	0	0	1	0	0	0	1	2
1977/78 - 1978/79	2	6	3	1	3	1	7	23
	2	6	4	1	3	1	8	25

Sightings after September 1978 supplied by N. C. Davidson, L. R. Goodyer and F. L. Symonds.

Details of arrival dates set out in Appendix 3.

Table 3.14The month of last sighting of marked Curlews

Month of departure	A	S	O	N	D	J	F	M	A	M
No. departing 1975/76	-	-	-	-	2	1	1	-	-	-
No. departing 1976/77	-	-	1	-	-	3	1	10	22	-
No. departing 1977/78	2	2	2	1	2	6	5	19	26	-
No. departing 1978/79	1	1	2	5	-	7	19	12	8	3

(Data for 1978/79 supplied by N. C. Davidson, L. R. Goodyer and F. L. Symonds)

seen again during the winter. Similarly, some of the last sightings in January and February were caused by field feeders moving onto the mudflats when the ground was frozen and then disappearing for the rest of the winter. Searching for marked birds during the winter of 1978/79 was less intensive, particularly after February, so departure dates for this winter have been excluded from the analysis.

There was no difference between adult males and females in the timing of emigration.

The consistency in apparent departure date for successive years varies between individuals (Table 3.15). Considering the data for the three winters 1975-78, 21 out of the 31 marked Curlews had departure dates in successive winters differing by less than one month, 15 by less than 2 weeks. Twenty-one individuals left during the March - April emigration period in 2 successive years. However some birds had departure dates that differed markedly between winters. For birds not seen subsequently (B R/O, O W/W, W Y/Y) this could be due to mortality rather than true departure. Other disparities between years (e.g. for Y G/W, L O/W) may have been a consequence of very irregular sightings of birds that were mainly field feeders.

Seven of the 8 juveniles marked in the winter of 1976/77 departed during the period of adult emigration. However as 4 of these juveniles were still present on the estuary in late April, further ringing may show that the peak in juvenile emigration occurs 1-2 weeks later than that of the adults. The information from the departure dates of individuals ringed as juveniles is equivocal. In their second winter 3 had departure dates differing from the previous spring by less than 8 days, but 2 were last seen 2 and 5 weeks earlier than when juveniles, and one apparently left 14 weeks later in its second winter.

Table 3.15

Frequency distribution of the differences in the dates of
last sighting of individual Curlews in successive winters

	No. of days between departure dates in successive winters							
	0-7	8-14	15-21	22-28	29-35	36-42	>42	
1975/76 - 1976/77	0	0	1	1	0	0	2	4
1976/77 - 1977/78	11	3	4	0	2	2	7	29
	11	3	5	1	2	2	9	33

Details of departure dates set out in Appendix 3.

Length of stay - Discussion is confined to the 2 winters of 1976/77 and 1977/78 as the 1978/79 departure dates are unreliable. Because most of the marked Curlews were first seen at Teesmouth between August and October (Table 3.12) and left in March or April (Table 3.14), most individuals stayed on the estuary for a similar length of time. Twenty of the 31 marked Curlews that returned during the winters 1976/77 and 1977/78 stayed for 185 - 250 days (Fig. 3.6a). The birds staying for 250 days were amongst the first to arrive in August and the last to emigrate in mid-April. Three birds that arrived later, in September and October, and left in March or April stayed for 140 - 170 days (Fig. 3.6b). Two ringed birds (O W/W and W Y/Y) which emigrated in spring one year but disappeared in autumn the next, may in fact have died rather than emigrated in autumn. Two marked Curlews returned to Teesmouth in both winters (Fig. 3.6a). One (B R/W) showed consistency between years but the other (B W/O) showed great variation as it was a field feeder and therefore rarely seen even though present on Teesmouth. Other short periods of stay were also due to field feeders appearing only irregularly during a winter.

3.1.C.4. Hypothesis for the use of Teesmouth by Curlews (Fig. 3.7)

The High Water counts for Teesmouth given in Section 2. C. I. (Fig. 2.12) indicated that the estuary held a fairly constant population for much of the winter. Sightings of marked Curlews give strong support to this suggestion.

August (possibly July) was the main month of arrival for adult Curlews of both sexes. These birds were probably collecting on Teesmouth to moult, after breeding locally, in Durham or Yorkshire (Evans 1966). The population comprised 60 per cent males. By October juveniles were also present. Some Curlews left the estuary in September and October, possibly moving west to winter. This departure coincided with the arrival of other individuals especially

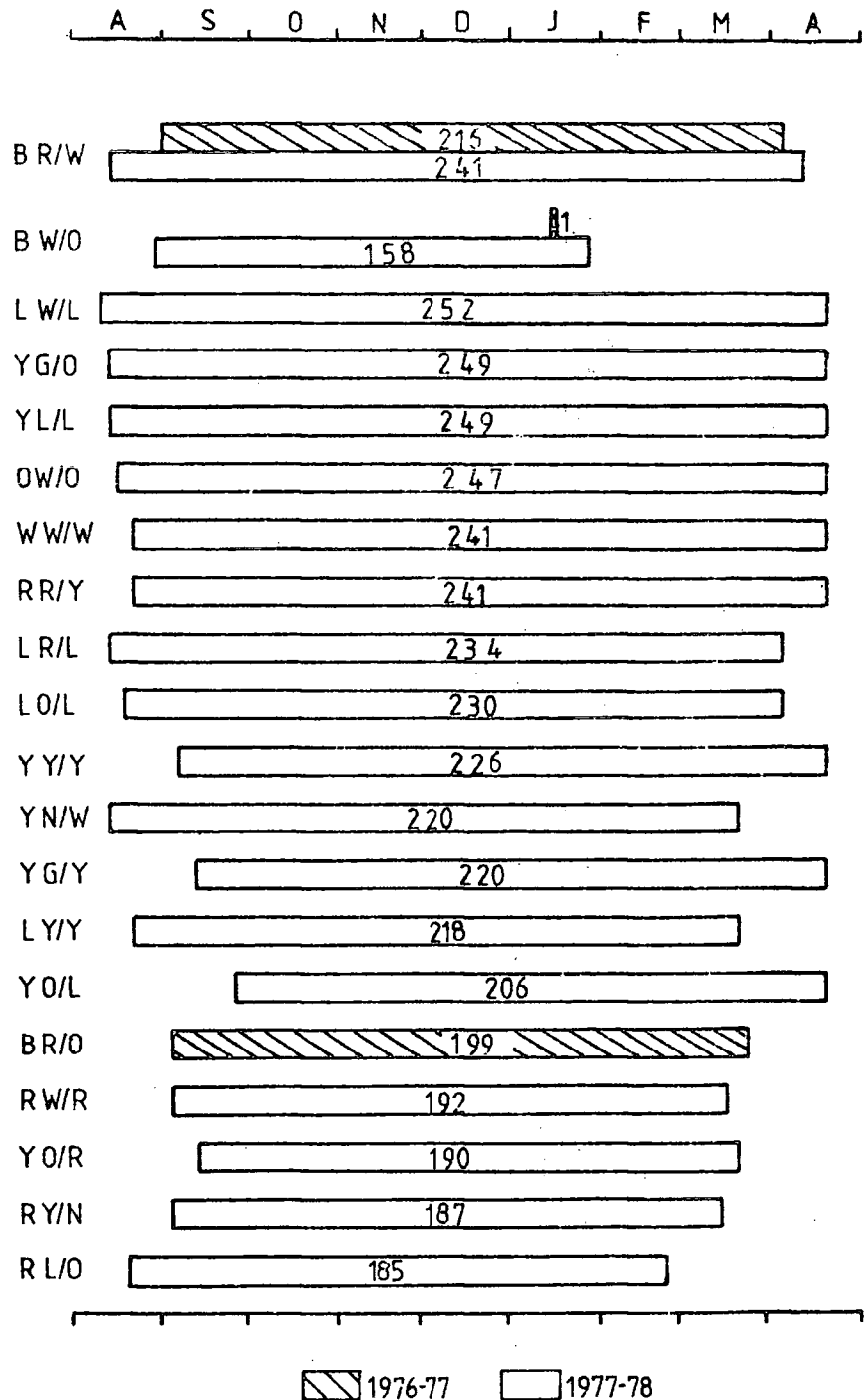

Figure 3.6 The length of stay on the Tees estuary of individually marked Curlews. Written in each bar is the number of days the individual was known to be present on the estuary.

(a) Birds present for at least 180 days.

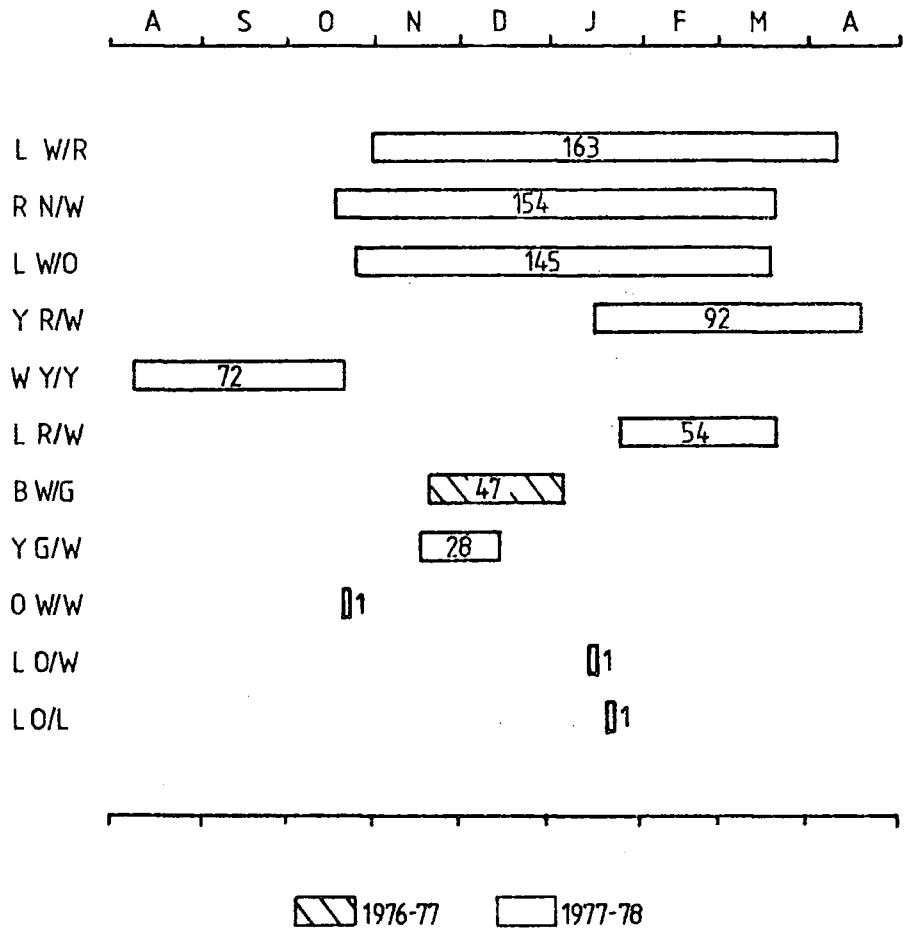

Figure 3.6 (cont..)

(b) Birds present for less than 180 days.

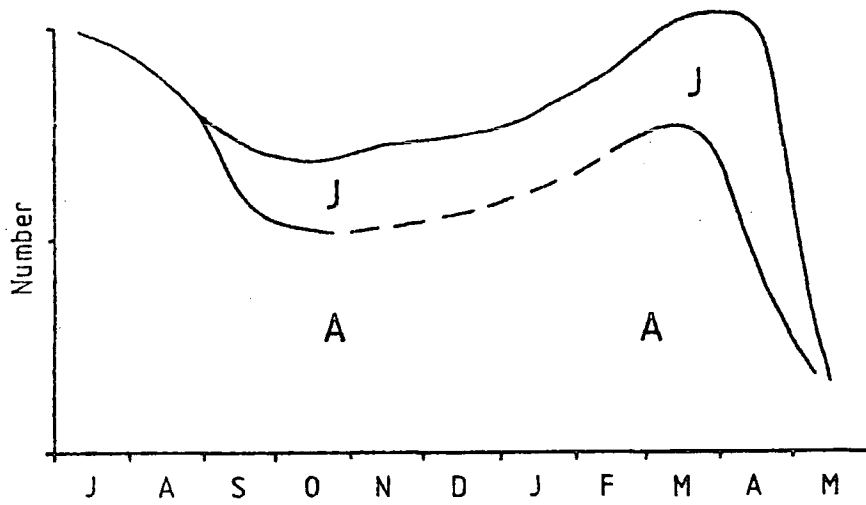

Figure 3.7 A generalised pattern for the use of the Tees estuary during a winter by adult (A) and juvenile (J) Curlews.

second winter birds, so the total number on the estuary remained constant. Ringing recoveries analysed by Evans (1966) indicate that these are birds from Fenno-Scandinavian breeding grounds. After October few new arrivals were seen on the estuary. Those birds that had already arrived on Teesmouth remained there, whether feeding on mudflats or fields, until spring.

The Teesmouth High Water counts (Fig. 2.12) indicate an increase in the population during January and/or February. Ringed birds both appeared and disappeared during this period, mainly because they were field feeders which were seen only irregularly. Thus the observations give no evidence of a mid winter influx. It is likely that any apparent increase in the number of Curlews on the estuary is caused by the movement of field feeding birds from more distant fields (up to 4 kms away) to the pastures adjacent to Seal Sands during January and February.

In March the population contained the same individuals as in autumn. Although adults made up 80 per cent of the catch, some juveniles were present. As in August, males constituted 60 per cent of the population. The sightings of marked birds give no evidence of an influx of Curlews in spring, so the peak in March - April may be due to birds moving from the fields to the mudflats prior to emigration.

Most marked Curlews left Teesmouth in March and April, matching the population decrease on the estuary. Adult males and females emigrated at the same time as the juveniles. As local Curlews return to their breeding grounds in late February and March, those still present in April are probably from continental breeding grounds (Evans 1966).

The majority of marked Curlews returned to Teesmouth and had similar arrival and departure dates in successive winters so it is likely that a similar pattern will occur each winter.

3. I. D. THE USE OF TEESMOUTH AS A WINTERING SITE
BY INDIVIDUAL BAR-TAILED GODWITS

3. I. D. 1. Numbers individually marked

Bar-tailed Godwits proved both difficult to catch, and difficult to observe because of their strong preference for inaccessible roost sites and for feeding at the tide edge and on the more distant mudflats of Seal Sands. Only 11 were ringed during the project, 8 in August 1977, so data on individual birds are limited, and refer mainly to the winter of 1977/78.

Adults and juveniles of both sexes were caught in August (Table 3.16). Juveniles were also present in October and April. Three of the 5 adults caught in August were in full summer plumage (2 males, 1 female), and 4 were in wing moult.

3. I. D. 2. Fidelity to Teesmouth in successive winters

Fidelity between winters was very high, with 9 out of the 11 Godwits returning to the estuary the year after being ringed (Table 3.17), (Data for 1978/79 from L. R. Goodyer, pers. comm.). The return rate for adults was 100 per cent, and that for juveniles 67 per cent. Birds returned regardless of the month of capture. One Godwit ringed as a juvenile has now spent 3 successive winters at Teesmouth. Another juvenile, which spent the winter of 1977/78 on Teesmouth but was not seen there the following winter, was observed on the Humber estuary (120 kms to the south) during February and March 1979 (M. Tasker, pers. comm.).

3. I. D. 3. Period of stay on the estuary during a winter

Arrival dates - 4 of the 5 adults caught in August 1977 returned in July 1978 when one male (W R/O) was again in full summer plumage. Later in the winter of 1978/79, the fifth adult and 2 of the juveniles were also seen on Teesmouth. The bird ringed as a juvenile in April was seen on the estuary once the following August. The juvenile caught in late October 1976 was the first seen the next

Table 3.16The ages of Bar-tailed Godwits
captured during the study

A	S	O	N	D	J	F	M	A
2J _♀	-	1J _♀	-	-	-	-	-	1J _♀
1J _♂	-	1J _♂	-	-	-	-	-	-
3A _♀	-	-	-	-	-	-	-	-
2A _♂	-	-	-	-	-	-	-	-

Key: J = Juvenile

A = Adult

Table 3.17

The return of colour-ringed Godwits to Teesmouth in
relation to the month of capture

	August		October	April
Number ringed	5A	3J	2J	1J
Number that returned the following winter	5	2	1	1

winter at the beginning of December. Therefore it arrived at least one month later in its second year than in its first.

Departure dates - Marked Godwits departed from Teesmouth either in autumn or spring (Table 3.18). Autumn departures occurred from August to November and included both adults and juveniles. The 3 females (2 adults, 1 juvenile) left before the juvenile male. In spring, most adults migrated in February, whereas the juveniles stayed up to 3 months longer. The females tended to emigrate slightly later than the males. Two marked Godwits, both females, changed their behaviour between their first and second winters on Teesmouth. One left in March when a juvenile, but one month earlier the following spring. The second individual left in August when a juvenile, but was still present in November in the following winter. One adult, also a female, changed its behaviour between years, leaving the estuary in October in one winter, but staying at least until January in the next.

Length of stay - Complete information on arrival and departure is available for only 2 marked Godwits. One was seen only once in August and was presumably a passage bird as it had been caught the previous spring when migrating Godwits were passing through Teesmouth. The other Godwit was present on the estuary for about 80 days after arriving in early December. In the previous winter, when a juvenile, this bird stayed for a minimum of 150 days. The minimum length of stay for the Godwits caught in August varied from 7 to 240 days, and was around 180 - 190 days for the adults that left in February.

3. I. D. 4. Hypothesis for the use of Teesmouth by Bar-tailed Godwits (Fig. 3.8)

As few Godwits were marked, relatively little information can be added to the discussion of seasonal changes in numbers of Godwits on the estuary (Section 2. D. 1).

Table 3.18The month of last sighting of marked Godwits

Month of departure		A	S	O	N	D	J	F	M	A	M
1976/77		-	-	-	1	-	-	-	1	-	1
1977/78		2	-	1	-	-	-	4	2	1	-
Juveniles	♂	-	-	-	1	-	-	-	1	-	-
	♀	1	-	-	-	-	-	-	1	1	1
Adults	♂	-	-	-	-	-	-	2	-	-	-
	♀	1	-	1	-	-	-	2	1	-	-

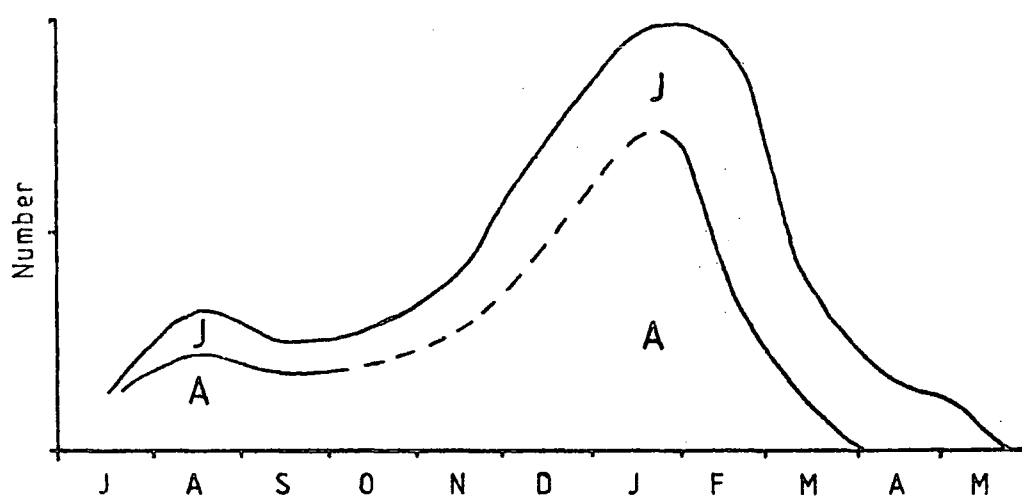

Figure 3.8 A generalised pattern for the use of the Tees estuary during a winter by adult (A) and juvenile (J) Bar-tailed Godwits.

Both adult and juvenile Godwits arrived during the autumn increase. The decrease that followed was due to the emigration of birds in both age groups.

The ringed birds gave no information on the nature of the increase in January and February (except that one second winter Godwit arrived in early December), but they do show that the decrease from this peak was started by the departure of adults. (The juveniles did not leave until March at the earliest.) In both age groups spring emigration of females was slightly behind that of males. It was more difficult to determine true departure dates in spring 1978 due to the increasing use of Bran Sands as both a feeding and roosting area. My estimated departure dates for marked Godwits may be earlier than their true emigration if they remained on Bran Sands (and were therefore not identified) throughout the tidal cycle. Nevertheless the basic sequence of events is probably unaltered.

3. I. E. DISCUSSION

3. I. E. 1. Interrelationships between species on Seal Sands

Thus far, each of the 3 species has been discussed in isolation. I shall now consider how the use of the estuary by one species may be influenced by that of other species.

As Nereis was the main prey of Curlews, Grey Plovers and Godwits,* some interspecific competition for space in which to feed on Seal Sands might have been expected, in addition to any competition for food that might have occurred. Some segregation of feeding areas was found between Grey Plovers and Curlews. Grey Plovers fed in areas with a low density of waders, not only at Low Water but also on the ebb and flood tides. Consequently there was little overlap between the main feeding areas of Grey Plovers (Fig. 2.5) and Curlews (Fig. 2.14) (as found also by Evans et al. 1979) as the latter fed in the high density areas.

* see Evans et al. 1979

The distribution of Avocets (Recurvirostra avocetta) and Black-headed Gulls (Larus ridibundus) have also been shown to be mutually exclusive (Zwarts 1974). No direct interactions were observed between Grey Plovers and Curlews, so the distribution patterns were probably a result of Grey Plovers avoiding areas with a high density of feeding birds. It is not clear whether Godwits competed for space with Grey Plovers and/or Curlews as they used similar areas to Grey Plovers in 1976/77 and also in 3 earlier winters (Evans et al. 1979) and to Curlews in 1977/78 (see below).

The changes in the total number of Curlews feeding on Seal Sands were inversely related to those of both Grey Plovers and Godwits during the 1976/77 and 1977/78 winters, and also in 1975/76, although not in the previous 3 winters (Evans 1980). This was due to the movement of Curlews to the fields coinciding with the arrival of Grey Plovers and Godwits on the estuary. These changes were believed not to be causally linked as, on each mudflat of Seal Sands, there were no inverse seasonal changes in the Curlew and Grey Plover or Godwit numbers. This contrasts with the Avocet/Black-headed Gull relationship described by Zwarts (1974). Also, although Godwits had an alternative feeding area, Bran Sands, the number feeding there at Low Water was independent of both Curlew numbers on Seal Sands, e.g.

11th February 1978, Bran Sands 0 Godwit;
Seal Sands 170 Godwit, 290 Curlew

9th March 1978, Bran Sands 146 Godwit;
Seal Sands 170 Godwit, 332 Curlew,

and the area of mudflat exposed in their main feeding area on Seal Sands, Seaton Channel:

23rd January 1978,	Bran Sands	106	Godwit,	intermediate tide
25th January 1978,	" "	24	"	spring tide
7th February 1978,	" "	16	"	intermediate tide
8th February 1978,	" "	183	"	spring tide
22nd February 1978,	" "	0	"	spring tide
2nd March 1978,	" "	63	"	neap tide
9th March 1978	" "	146	"	spring tide

Thus, although Grey Plovers show a general preference for areas with a low density of feeding waders, the seasonal changes in the numbers of all 3 species on each area of Seal Sands appear to be due to intraspecific factors (e.g. influxes into the estuary, filling of preferred areas) and/or to weather or disturbance, rather than to direct interspecific competition for space.

Very different behaviour occurred, however, following influxes of large numbers of species that normally do not use Seal Sands. The arrival of huge flocks of gulls in January 1978 caused a redistribution of Curlews, Godwits and Grey Plovers on the ebb and flood tides and of Grey Plovers also at Low Water. The arrival of a large flock of Golden Plovers also caused not only a redistribution of Grey Plovers but also an increase in the number of territories held by Grey Plovers, on the ebb and flood tides. Golden Plovers feed in a similar way to Grey Plovers, taking prey available at the surface, so their presence is likely to have a much greater depressive effect on prey capture by Grey Plovers than is the presence of the probing Curlews and Godwits.

The changes between winters in the main feeding areas used on Seal Sands give further evidence that in general only Grey Plovers suffered directly from interspecific competition for space. The most marked change during the study was that of the Godwit population from Eastern Channel to the Seaton Channel tide edge. The Curlew and Grey Plover populations did not show any

simultaneous changes of similar magnitude, so competition for feeding space with these species is unlikely to have been the cause. As the mean number of Curlews feeding on Greenabella Bank (including the Seaton Channel tide edge) at Low Water in 1977/78 was 80 per cent higher than in the previous winter, the increase in the number of Godwits there may have been a result of increased prey density on this area relative to Eastern Channel. The prey density along Seaton Channel may also have increased between years relative to that on other Godwit feeding areas on the estuary as in 1977/78 a greater proportion of the Godwits on the estuary fed on Seal Sands than in 1976/77 (see Fig. 2.20). As the number of Grey Plovers did not increase in parallel with the other 2 species, the absence of other waders must be a more important factor in the choice of feeding area than prey density. Data from previous winters (Knights 1979, Evans 1980) show that Grey Plovers have not changed their main Low Water feeding area since at least the 1972/73 winter, whereas Godwits have shown several major changes.

Data presented by Evans (1980) suggested that the numbers of shorebirds settling on the Tees estuary were determined before feeding conditions became most difficult, at least during mild and wet winters. Curlews followed a similar pattern during 1976/77 and 1977/78 to that in previous winters, with no arrivals in mid winter, so my data support Evans' hypothesis of numbers being adjusted in autumn. In contrast, however, the marked mid-winter increases in Grey Plovers and Godwits in both 1976/77 and 1977/78 seem to contradict the hypothesis. Despite this major difference between the 2 studies (discussed further below), Grey Plovers appeared to fill preferred areas first in autumn and Godwits used some, presumably sub-optimal, areas only during population peaks. This behaviour indicates that population density was adjusted in autumn, but only for the first part of the winter.

If adjustment occurred in the autumns of 1976 and 1977, why did the numbers increase in mid winter? One possible explanation is that those birds arriving late in the autumn find the optimal areas filled, and therefore move to another estuary, where the most profitable areas are not yet filled, to spend the winter. However, if birds migrating north along the coast of eastern England in January (see below) meet severe weather and are forced to stop at Teesmouth, they will have no better alternative than to find a feeding site on Seal Sands (and perhaps also on nearby coastal beaches), regardless of the number of birds already present.

3. I. E. 2. The position of Teesmouth in the migration systems of Western Europe and Africa

Using counts from other wintering grounds, the hypotheses for the use of Teesmouth by the 3 species can be discussed in the context of their migration patterns in the rest of Western Europe and Africa. Published counts for the following sites have been used: British estuaries as a whole ("Birds of Estuaries" counts) (Prater 1973, 1974a, 1976, 1977), the Wash (Prater 1974b), the Ribble (Smith and Greenhalgh 1977), Morecambe Bay (Wilson 1973), Morocco (Pienkowski 1972, 1975) and Mauritania (Dick 1975). I have also used counts for 3 sections of the Wadden Sea either recently published (Melfotte 1980) or in preparation (Smit in press, Busche in prep.). Discussion is concentrated upon the Wadden Sea and Wash counts due to their importance and to the knowledge of the movements of birds using these areas.

Although the winters in which counts were made differed between sites, it is assumed that the general pattern of migration is similar each winter so that comparisons between sites can be made. The marked fidelity to Teesmouth as a wintering site and the consistency in times of arrival and departure shown by colour-marked Grey Plovers, Curlews and Godwits indicate that the assumption is valid for individual birds. Strong fidelity to a wintering site is also shown by

Grey Plovers (Branson and Minton 1976) and Curlews (Bainbridge and Minton 1978) on the Wash.

The numbers of waders using Teesmouth are very small when compared with the populations on the other areas discussed. It must therefore be assumed that the changes on Teesmouth are representative of movements on a larger scale within the wintering range of each species.

Grey Plover (Fig. 3.9) - It is believed that all the Grey Plovers migrating through Western Europe come from the Siberian, and not the Canadian, breeding grounds (Branson and Minton 1976). Adult Grey Plovers in full breeding plumage begin arriving from the Siberian Arctic on Teesmouth, the Wash (Branson and Minton 1976) and the Wadden Sea (Boere 1976) in late July. It is not known whether those reaching Teesmouth flew directly from the breeding grounds (or Arctic coast) or paused to refuel on the Wadden Sea. Some of the adults reaching Teesmouth and the Wadden Sea, and most of those arriving at the Wash remain to moult into winter plumage. Some at Teesmouth and the Wash then remain for the winter, whereas the majority of those moulting on the Wadden Sea leave by November.

The main passage of juveniles through Teesmouth and the Wash begins in September and, at least on Teesmouth, reaches a peak in October. It is not known when juveniles arrive on and depart from the Wadden Sea.

In late October and November adults in winter plumage arrive at Teesmouth. They may have moulted on the Wadden Sea as numbers fell there in October/November (Fig. 3.9) once moulting had been completed or arrested (Boere 1976). Alternatively they could have moulted on the Wash, before moving northward to Teesmouth. Grey Plovers do leave the Wash between September and December (Fig. 3.9). Also, although a northward movement from the Wash to the Tees in late autumn has not been shown for Grey Plovers, it is known to

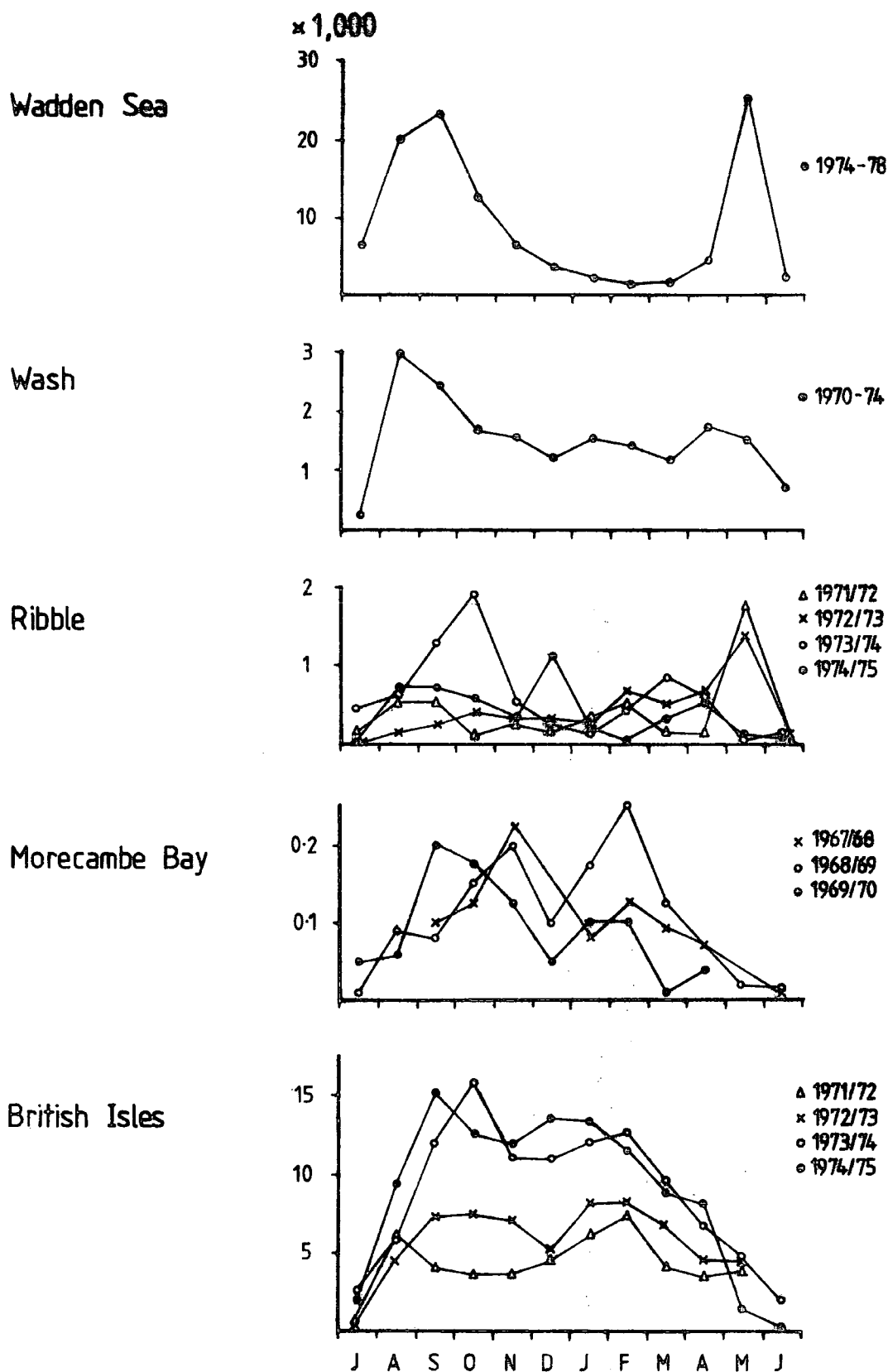

Figure 3.9

The seasonal changes in the number of Grey Plovers using four estuaries in Western Europe, and in the combined counts for the British estuaries. Data from Busche (in prep.), Meltote (1980), Prater (1973, 1974a, 1974b, 1976, 1977), Smit (in press), Smith and Greenhalgh (1977) and Wilson (1973). All axes are marked in thousands of birds.

occur in Dunlin, Knot and Sanderling (L. R. Goodyer, unpublished data), presumably after moult has been completed. Some Grey Plovers, therefore, may follow a similar pattern.

Many Grey Plovers migrate further south than the British Isles in autumn, reaching Morocco and Mauritania by September/October (Dick 1975, Pienkowski and Knight 1977). In Mauritania the juveniles arrive after the first adults (Dick 1975) and during the period when juveniles are known to leave Teesmouth, the Wash (Minton 1975) and probably the Wadden Sea.

In January/February both adult and juvenile Grey Plovers arrive on Teesmouth. Parallel increases occurred on the Wash, the Ribble, Morecambe Bay and in the B. O. E. total in at least some winters (Fig. 3.9), so it is likely that some Grey Plovers moved into Britain from elsewhere. There is no evidence from the Wadden Sea counts that they originated there. The other possible source is the large wintering population in West Africa. Unfortunately there are insufficient counts from this area to tell whether any Grey Plovers left in December/January.

Grey Plovers leave the Tees from late February to early April. Although they probably have sufficient reserves to fly direct to the breeding grounds or the Arctic coast (see Minton 1975), sightings in Schleswig Holstein in April of colour-marked Grey Plovers originally ringed on the Tees (G. Busche, T. Norgall, pers. comm.) suggest that they may pause on route. Later in the spring, in May, there is a major passage of Grey Plovers particularly through the Wadden Sea but also in some British west coast estuaries (e.g. the Ribble). Only a few passage birds use the Tees in May.

Curlew (Fig. 3.10) - Curlews wintering in different parts of the British Isles come from populations breeding in several parts of Europe, as detailed by Bainbridge and Minton (1978). In June and July adult Curlews move from

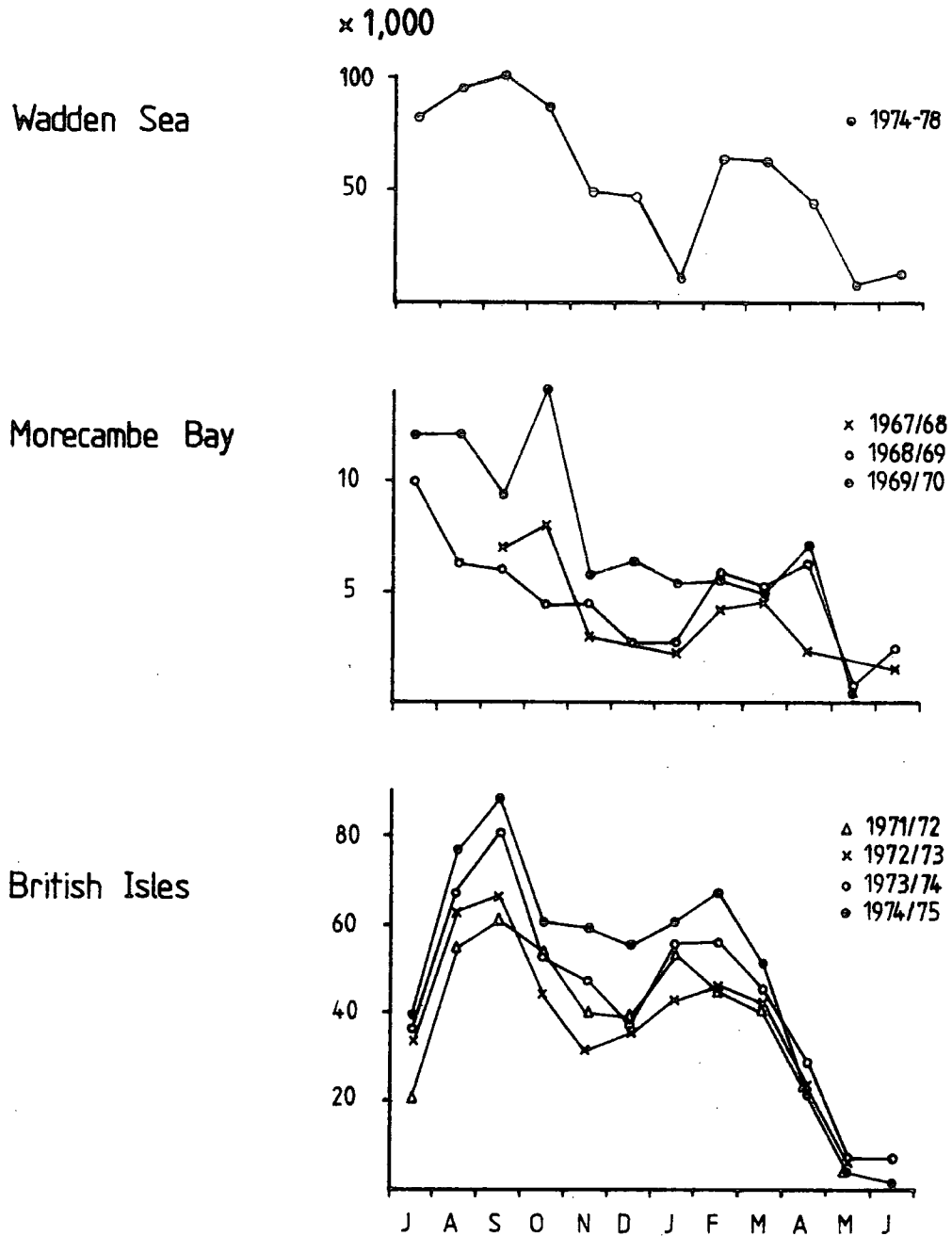

Figure 3.10

The seasonal changes in the number of Curlews using two estuaries in Western Europe, and in the combined counts for the British estuaries. Data from Busche (in prep.), Meltofte (1980), Prater (1973, 1974a, 1976, 1977), Smit (in press) and Wilson (1973). All axes are marked in thousands of birds.

their breeding grounds to intertidal areas in order to begin moulting. Most move to adjacent estuaries (e. g. Evans 1966, Wilson 1973, Boere 1976) but some European birds migrate to the Wash before commencing their moult (Bainbridge and Minton 1978). Many Curlews remain throughout the winter on the same estuary. However some westward movement occurs, and in September/October birds from Fenno-Scandinavia (Evans 1966, Wilson 1973) and the Wadden Sea (Boere 1976) reach British estuaries.

The counts for the Wadden Sea, the Ribble and Morecambe Bay, together with the B. O. E. counts, fall to a low level in November - January (Fig. 3.10), thus resembling the Tees counts. Although some migration may have occurred, it is probable that local movements from the mudflats to the fields, as demonstrated on the Tees, are the main cause of these decreases (L. Zwarts, pers. comm.).

The Curlews that left Teesmouth during March - April probably flew directly to continental breeding grounds. Those wintering on the Wadden Sea also moved to their breeding grounds in April. British breeding birds moved to the breeding areas in February - March, as detected in the counts from the west coast estuaries.

Godwit (Fig. 3.11) - The Bar-tailed Godwits which winter in Western Europe and Africa breed in the Siberian Arctic (Prater 1974a). The first adults in full summer plumage reach Teesmouth and also the Ribble, Morecambe Bay, the Wash and the Wadden Sea in July. It is not known whether the Teesmouth birds pause on the Wadden Sea on their migration from the breeding grounds. At least some of these early birds remain to moult into winter plumage. However others pass swiftly through the Wadden Sea on their way to West Africa (Boere 1976).

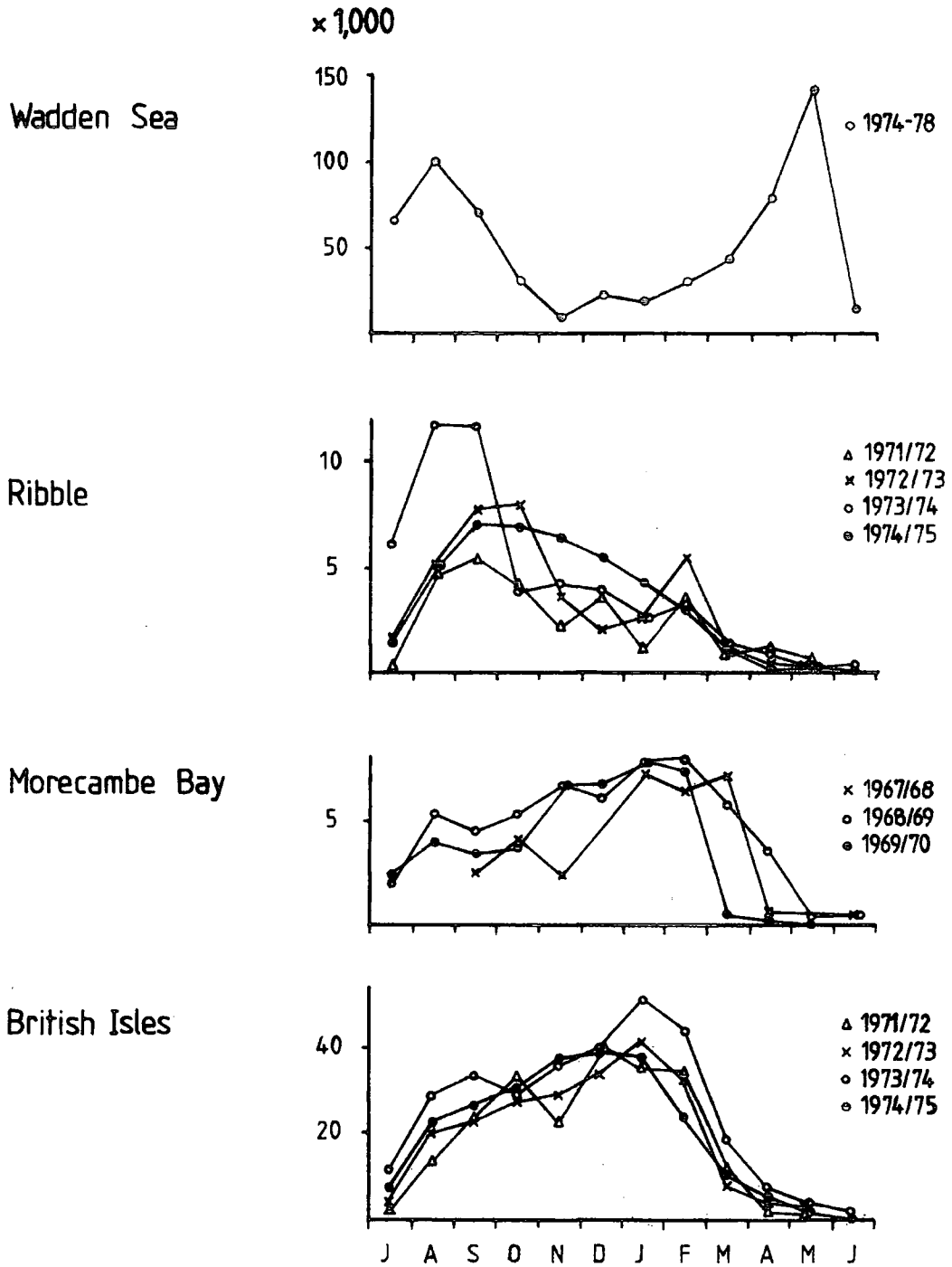

Figure 3.11

The seasonal changes in the number of Bar-tailed Godwits using three estuaries in Western Europe, and in the combined counts for the British estuaries. Data from Busche (in prep.), Meltofte (1980), Prater (1973, 1974a, 1976, 1977), Smit (in press), Smith and Greenhalgh (1977) and Wilson (1973). All axes are marked in thousands of birds.

Later in the autumn juveniles and adults in winter plumage arrive on British estuaries, the adults perhaps having moulted in the Wadden Sea or the Baltic.

The large numbers of Godwits arriving on the Tees in January/February do not appear to have come from the Wadden Sea as no decrease was recorded there. There was an increase in the counts for the Ribble (but not Morecambe Bay) and in the overall B. O. E. counts at this time, so the Godwits arriving on Teesmouth may, like the Grey Plovers, be moving north from West Africa after moulting there. It is known that over 200,000 Godwits migrate south to Mauritania in autumn (Dick 1975), and many passage birds in Morocco are in full breeding plumage (Pienkowski 1975). Unfortunately at present there are insufficient counts to show whether a December/January departure follows the moult.

The majority of Godwits on Teesmouth and on most British estuaries have left by the end of March (Prater 1974a). They may have paused on migration on the Wadden Sea (numbers on the Danish section increased in March) or flown directly to the Arctic.

In April/May adults, all in full breeding plumage, pass through Teesmouth, but not through the west coast estuaries. Their appearance coincides with the main passage through the Wadden Sea (Fig. 3.11). Prater (1974a) has suggested that these are birds that have wintered in West Africa. If so, it is possible that the southern wintering Godwits may follow one of two patterns of spring migration: a) migrating north in January and moulting into breeding plumage in Western Europe, or b) migrating in April/May, presumably after acquiring their breeding plumage.

PART II. THE FEEDING SITES USED BY INDIVIDUAL BIRDS

In this and future Sections only Grey Plovers and Curlews will be discussed as the data for marked Godwits are insufficient to draw reliable conclusions.

3. II. A THE USE OF SEAL SANDS AS A FEEDING AREA BY INDIVIDUAL GREY PLOVERS

The hypothesis set out in Section 3. I. B. 4. referred to the use of the whole of Teesmouth as a wintering area by individual Grey Plovers. More detailed observations of individual Grey Plovers have been made on Seal Sands, their main feeding area on the estuary. The Low Water counts for Seal Sands were generally lower than those made at High Water on the estuary as a whole (Fig. 2. 3). This difference was due in part to a few Grey Plovers feeding in sites other than Seal Sands, e.g. B R/W in the tidal Brinefields creek adjacent to Seal Sands and in part to a few feeding on parts of Seal Sands not always visible at Low Water, e.g. R Y/Y which, along with 3 other Grey Plovers, regularly fed on a small, inaccessible mudbank on the northern edge of Seaton Channel. Therefore the number of individuals discussed in this section on Seal Sands will be less than that included in the preceding section on Teesmouth.

The general pattern of use of Seal Sands by Grey Plovers was outlined in Section 2. B. However it is clear that individual birds can differ markedly in their behaviour (e.g. in arrival dates, Appendix 3). In this section therefore the feeding sites and patterns of movement of marked individuals on Seal Sands are described and contrasted with the general pattern detected for the whole population. On any mudflat, each marked Grey Plover (and Curlew) tended to forage within a restricted area of mud (whether or not that area was defended) - I have termed these restricted areas "feeding sites". A bird was

considered to have changed feeding site when there was no overlap between the old and new areas in which it foraged. The size of feeding sites varied between mudflats and individual birds.

3. II. A. 1. Low Water feeding sites of individual Grey Plovers

3. II. A. 1. a. Sites used

The feeding sites used by Grey Plovers, and by Curlews (Section 3. II. B. 1.) are classified first as areas within Seal Sands. These areas differed in 2 characteristics: tidal level and sediment type. Later, (in Section 3. II. D. 2.), it will be shown how these characteristics influence the distribution of feeding sites of both Grey Plovers and Curlews.

Low Water feeding sites were determined for 18 of the 22 marked Grey Plovers present on the estuary during the winter of 1977/78 (Fig. 3.12 and Table 3.19). During the winter, some individuals changed their Low Water feeding sites (see below), so the total number of feeding sites used by marked Grey Plovers exceeded the number of ringed birds observed feeding at Low Water. The Low Water feeding sites were distributed in approximately the same way as the sites used by the whole population (Table 3.20). It is not possible to carry out a 2x5 contingency table on ringed and unringed birds on each area due to the small numbers involved (see Table 3.20). However in 1977/78 there was no significant difference between ringed and unringed birds in their Low Water distribution between the eastern (Central Bank and Eastern Channel) and the western (Scalloped Mud, Greenabella Bank and Central Channel) halves of Seal Sands ($\chi^2 = 1.56$, 1 d.f., $p > 0.10$). Similarly there was no significant difference between the two halves in 1976/77 ($\chi^2 = 2.09$, 1 d.f., $p > 0.10$). Therefore, the ringed birds were representative of the population in their choice of feeding sites at Low Water.

Within each area of Seal Sands the distribution of marked Grey Plovers

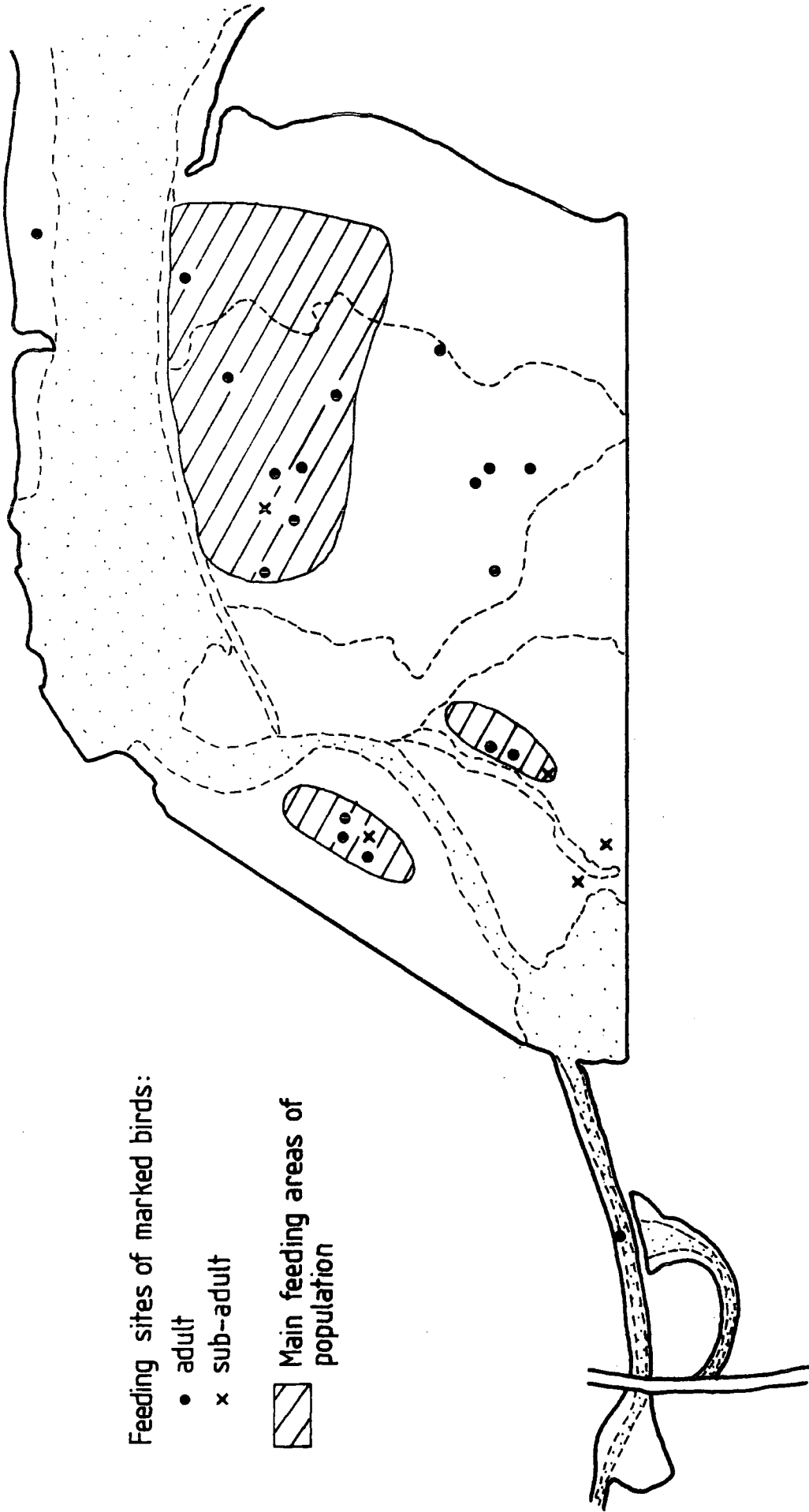

Figure 3.12 The distribution of marked Grey Plovers and the Grey Plover population on Seal Sands and adjacent sites at Low Water during the 1977/78 winter.

Table 3.19

The Low Water feeding sites used by marked Grey Plovers on Seal Sands

Number of marked birds present	Number whose L. W. feeding sites known	Number of L. W. feeding sites on sections of Seal Sands*				Number feeding on sites other than Seal Sands	Number with feeding sites unknown	
		CB	ECh	SM	GB			CCh
22	18	12	1	4	4	0	1	4
6	4	0	1	1	2	0	0	2
32	11	4	1	2	3	1	0	18

* Each figure refers to the number of marked birds which regularly fed on that area in that year.

Key: Abbreviations for this and subsequent tables:

B	Brinefields creek	CCh	Central Channel	GB _t	tide edge of GB
Bf	Brinefields field	ECh	Eastern Channel	GC	mud banks of Greatham Creek
CB	Central Bank	ECh _n	northern half of ECh	SCh	mud banks of Seaton Channel
CB _c	central section of CB	ECh _s	southern half of ECh	SM	Scalloped Mud
CB _n	northern section of CB	GB	Greenabella Bank	SM _e	eastern half of SM
CB _s	southern section of CB	GB _r	ridge of GB	SM _w	western half of SM

Table 3.20

The distribution of marked Grey Plovers
and the Grey Plover population on Seal Sands
at Low Water, in two winters

	<u>Section of Seal Sands</u>				
	<u>CB</u>	<u>ECh</u>	<u>SM</u>	<u>GB</u>	<u>CCh</u>
1977/78:					
Low Water feeding sites of marked Grey Plovers	12(57)	1(5)	4(19)	4(19)	0(0)
Low Water distribution of the Grey Plover population	58(60)	15(16)	10(10)	11(11)	3(3)
1976/77:					
Low Water feeding sites of marked Grey Plovers	4(37)	1 (9)	2(18)	3(27)	1(9)
Low Water distribution of the Grey Plover population	60(54)	16(15)	15(14)	16(15)	3(2)

Values are numbers, with approximate percentages in brackets.

Data for the Grey Plover population taken from Table 2.2.

Key for abbreviations given on Table 3.19.

on different substrates was also broadly similar to that of the whole population (Table 3.21). On Central Bank, most marked Grey Plovers fed on the Enteromorpha-covered firm sandy mud of Central Bank-north, favoured also by the unmarked birds. Marked birds used the sandy mud of Central Bank-south only for a short period in mid winter (see Section 3. II. A. 1. d. below); hence the data on Table 3.21 exaggerate its use by marked birds. On Greenabella Bank the marked Grey Plovers stayed on the firmer ridge and avoided the softest muds and the tide edge, as found for the whole population.

Sub-adults - Little information on the behaviour of sub-adult Grey Plovers could be collected, as Low Water feeding sites were determined for only 4 of the marked juveniles (3 in 1976/77, 1 in 1977/78) and 3 marked second winter birds (2 in 1977/78, 1 in 1978/79). These sub-adults fed with unmarked birds and were not using areas avoided by other Grey Plovers. However, they showed a preference for the western mudflats of Seal Sands: 3 of the 7 feeding sites were on the ridge of Greenabella Bank, and 2 on Scalloped Mud-east with only 2 on Central Bank. The distribution between "Central Bank and Eastern Channel" and "Scalloped Mud, Greenabella Bank and Central Channel" was significantly different from that of adult ringed birds in 1977/78 (the best estimate of distribution available) (exact probability test for 2x2 contingency table (Bailey 1959), $P = 5.60$ per cent). It is hoped that future studies will provide more information on the feeding sites used by sub-adult Grey Plovers.

3. II. A. 1. b. The use of 2 feeding sites during a Low Water period

Most marked Grey Plovers fed on a single site for the whole Low Water period. They moved to the Low Water site more or less as soon as it became exposed by the ebbing tide, and then stayed there until pushed off by the flood tide (see Section 3. II. A. 2. a. below). However a few marked Grey Plovers were seen to use 2 Low Water feeding sites during a single tidal cycle. (This excludes cases

Table 3.21

The distribution of Low Water feeding sites of marked birds and of the Grey Plover population within the areas of Seal Sands, in the 1977/78 winter

	<u>Feeding sites of marked birds</u>		<u>Feeding sites of the population</u>	
	number	percentage	number	percentage
Central Bank				
- north	6	50	16.0*	41
- central	2	17	17.0*	43
- south	4	33	6.3*	16
Eastern Channel				
- north	1	100	11.2**	81
- south	0	0	2.7**	19
Scalloped Mud				
- east	4	80	7.8***	80
- west	1	20	1.9***	20
Greenabella Bank				
- ridge	4	100	-	~90
- at/near tide edge	0	0	-	~10

Population figures derived from:

* Table 2. 3.

** 6 counts at Low Water.

*** 10 counts at Low Water.

where human disturbance clearly caused a change in feeding site.) Such birds followed one of 2 patterns: they either

1. moved from their ebb tide feeding site on the higher mudflats to an area at a lower tidal level; and then moved elsewhere later in the Low Water period, or
2. remained on the mudflats at high tidal level until well into the Low Water period, and then moved elsewhere. (They therefore moved from the high to the lower mudflats much later in the period of exposure than did the majority of Grey Plovers.)

It will be shown in Section 3, II, D, 2. that the proximate cause for the two types of movement during the Low Water period may differ from that for movements made during the ebb tide (see Section 3, II, A, 2. a. for details of ebb tide movements).

As these Grey Plovers returned to the higher mudflats on the flood tide they were utilising a feeding circuit incorporating 2 Low Water sites.

During the 3 winters of the study only 11 cases of this behaviour were documented, as opposed to well in excess of 200 of other behaviours, so it is clearly exceptional. Of the 11 cases, 6 were of individuals regularly using 2 Low Water sites, and 5 were single occurrences (Table 3.22).

Regular use of 2 Low Water sites - 3 birds (B W/G, L W/L, O W/W) remained on the higher mudflats (Scalloped Mud - east and Central Bank - south) well after suitable areas at lower tidal areas were exposed (i. e. type 2, above). Two of these (L W/L, O W/W) defended feeding territories on their sites on the higher mudflats. Presumably they remained on their territories for as long as it was profitable to do so during each period of exposure in order to maximise the short-term advantages of territoriality (see detailed discussion

Table 3.22.

The use of 2 feeding sites during a single Low Water period by marked Grey Plovers

Marked Grey Plover	Low Water		Tidal Time of Movement (hours after H.W)	Duration of Behaviour	
	1st Site	2nd Site		During Winter	Winter
<u>Regular Use</u>					
B W/G	SMe	GB	+5.5 - +7.5	At least Feb - emigration	1975/76
B W/O	?	GB	+5.5 - +7.5	At least Feb - emigration	1975/76
L W/L	SMe	GB	+5.0 - +6.5	November - March	1977/78
B R/W	B	GC	Any time	At least Feb - emigration	1975/76
O W/W	CBs	?	+6.5 - +7.5	March	1976/77
B W/O	CCh	SM _w	+5.5 - +7.5	January	1976/77
<u>Single Occurrences</u>					
Y O/R	ECh	CBs	+6.0	30th December	1977/78
B W/O	GB	CCh	+5.5	15th November	1976/77
Y O/R	SMe	GB	+5.0	17th January	1977/78
B W/O	SMe	GC	+4.5	19th December	1977/78
O W/O	SMe	SMe (different area)	+5.5	12th January	1977/78

Key: As on Table 3.19.

in Section 3. II. D. 1). Perhaps when unable to obtain prey at an adequate rate they moved to lower mudflats where food availability was higher (see Section 3. II. D). On some days L W/L was able to feed on its territory throughout the period of exposure and did not change site.

Two cases of regular use of 2 Low Water sites were caused by factors other than the tidal rhythm on Seal Sands. One marked bird (B W/O, 1976/77) fed on 2 sites during a transitional period which led to a permanent change in Low Water feeding site. Another (B R/W) fed in 2 sites adjacent to Seal Sands: the Brinefields creek, which has irregular variations in water level and Greatham Creek which contains mudbanks at a wide range of tidal levels. Its choice of feeding site may have been influenced by human disturbance on the 2 sites.

Single occurrences of use of 2 Low Water sites - 2 of the 5 cases (Y O/R 30.12.77, B W/O 15.11.76) involved movement between 2 sites at lower tidal levels (i. e. type 1. above). In 2 others (Y O/R 17.1.78, B W/O 19.12.77) the birds remained on the higher mudflats well after the lower areas were uncovered (i. e. type 2. above). The fifth bird (O W/O) fed on 2 sites on Scalloped Mud and also elsewhere on Seal Sands during a single Low Water period immediately following its arrival on the estuary. It may have been searching for a suitable feeding site on Seal Sands (see Section 3. II. A.3. d. below).

3. II. A. 1. c. Fidelity to a Low Water feeding site during a winter

The fidelity of Grey Plovers to a Low Water feeding site during a winter varied markedly between individuals. Some fed in one site throughout a winter, others changed site one or more times. In this section I shall show how the behaviour of a Grey Plover during a winter was related to its initial choice of Low Water feeding site. As seasonal changes in Low Water site and territorial

behaviour are interrelated, discussion of the possible causes for such changes will be held over until Section 3. II. A. 3. d.

Birds faithful to one feeding site - During the study only 3 marked Grey Plovers were known to have fed in the same site on Seal Sands at Low Water throughout a winter. This fidelity occurred only on sections of Seal Sands with firm or sandy mud. Two of these birds fed on the main Grey Plover Low Water feeding area on Central Bank - Eastern Channel, and the third on an area of similar substrate on the northern side of Seaton Channel. Both areas were at a mid tidal level. A fourth individual, which never fed on Seal Sands, was faithful to a Low Water feeding site on the slopes of the tidal Greatham Creek adjacent to the main mudflats, throughout its period of stay in the early months of 1977. This essentially linear habitat had different characteristics to those on Seal Sands, described above. It was composed of softer mud and, due to the steepness of the Creek banks, extended across both high and mid tidal levels. All 4 birds defended territories in their permanent Low Water feeding sites throughout their stay.

Birds that changed their Low Water feeding site - Nine marked birds were known to have changed feeding site during a winter, 5 in 1977/78, 3 in 1976/77, and 1 during 1975/76 (Table 3.23). The changes were not confined to one period, occurring both in November and from January to April, and were not associated with extreme spring and neap tides (c. f. Curlews, Section 3. II. B. 1. b). They were shown both by new arrivals to Seal Sands (e. g. W R/O 1976/77, O W/O 1977/78, Table 3.23) and by established individuals (e. g. B W/O 1976/77, L W/L 1977/78).

The behaviour of Grey Plovers feeding on the eastern and western halves of Seal Sands was very different (Table 3.24). All of the changes observed from November to February (when the average temperature was low or decreasing)

Table 3.23

Grey Plover: changes in Low Water feeding site during a winter by marked birds

Bird	First site	Date occupied	First move to	Date of move	Second move to	Date of move	Third move to	Date of move	Date of emigration
1977/78: Y R/L	CB _n	early Nov			No Change				early Mar
W R/O	ECh	late Nov			"				mid Mar
R Y/Y	SCh	before end Nov			"				late Mar
L W/L*	SM _w	early Sep	SM _e /GB	late Nov	wandering in flock	end Mar			mid Apr
Y O/R	SM _c	end Oct	GB	mid Nov	CB _s	early Feb	SIM _e	early Mar	mid Mar
O W/O	SM _e	mid Jan	CB _c	mid Jan					mid Mar
B W/O	GC	early Jan or earlier	GB	late Jan	SME	early Mar			mid Apr
O R/L	CB _n	before mid Nov	wandering in flock	early Apr					mid Apr
1976/77: B R/W	GC	early Jan			No Change				mid Mar
W R/O	GB	mid Nov	ECh	late Nov					early Mar
B W/O	CCh	mid Nov	SM _w	Jan					mid Apr
L L/G	B	before late Jan	CB _n	early Feb					early Feb
1975/76: W R/O	ECh	before mid Jan			No Change				early Apr
B W/O	GB	before mid Jan			"				late Mar
B R/W	B/GC	before early Mar			"				late Mar
B W/G	GB	before mid Jan	B	mid Feb	SM/GB?	early Apr			early Apr

Key for abbreviations given on Table 3.19.

* Known second winter bird.

Table 3.24

The changes in Low Water feeding sites in relation to the original feeding area on Seal Sands, shown by marked Grey Plovers during two winters

	Number present i. e. "at risk" of <u>changing</u>	Number known not to <u>change</u>	<u>Number that changed:</u>		
			a. Within that half of Seal Sands	b. To other half of Seal Sands	c. To wandering around whole of Seal Sands
1977/78					
Nov - Feb					
Eastern mudbanks	14	3	0	0	0
Western mudbanks	7	0	3	2	0
Mar - Apr					
Eastern mudbanks	9	3	0	1	1
Western mudbanks	4	0	1	0	1
1976/77					
Nov - Feb					
Eastern mudbanks	5	0	0	0	0
Western mudbanks	5	1	1	2	0
Mar - Apr					
Eastern mudbanks	5	0	0	0	0
Western mudbanks	6	2	0	0	0

Key: Eastern mudbanks = Central Bank, Eastern Channel and Seaton Channel

Western mudbanks = Central Channel, Scalloped Mud and Greenabella Bank,
+ adjacent sites (Greatham Creek and Brinefields)

involved individuals feeding initially on mudflats to the west of Central Bank. These birds usually moved from areas at higher tidal levels (e.g. Scalloped Mud) and marginal sites (e.g. the Brinefields creek) to Greenabella Bank or onto the eastern parts of Seal Sands. Only in March were movements away from the eastern mudbanks observed. Thus none of the marked birds feeding (and in most cases defending a site (see Section 3. II. A. 3)) on the main Low Water feeding area of Grey Plovers on Central Bank - Eastern Channel changed site until spring, if at all, whereas several of those feeding further west (where territoriality was infrequent) changed site at least once during the winter.

Although Low Water sightings of most Grey Plovers feeding on Central Bank-north were infrequent, the lack of sightings of these individuals elsewhere on Seal Sands at Low Water suggests that they continued to use the same or adjacent feeding sites throughout a winter.

3. II. A. 1. d. Choice of Low Water feeding site in relation to date of arrival

The Low Water distribution of Grey Plovers on Seal Sands indicated that certain areas (Eastern Channel and the northern section of Central Bank) were filled in autumn, with other areas being used when numbers were high (Section 2. B). It might be supposed that only the later arrivals used these other areas. Observations on marked Grey Plovers show the situation to be more complex.

Marked Grey Plovers arriving during August - October took up regular feeding areas not only on the favoured section of Central Bank but also on Scalloped Mud, Greenabella Bank and Central Bank - south. Therefore although the favoured areas were not yet filled, some Grey Plovers fed elsewhere on Seal Sands. Later arrivals, e.g. W R/O in November, were thus able to establish feeding sites in the favoured areas. This was even possible when the desired site was already occupied. When W R/O returned

to the estuary in late November 1977 it found another individual (believed to be a juvenile) feeding in the site in Eastern Channel that W R/O had used throughout the previous 2 winters. W R/O chased the other Grey Plover back and forth across the feeding site throughout the 20 minutes of observation. During this dispute the unmarked bird never flew off, indicating tenacity to the site. All the adjacent feeding sites were defended by other Grey Plovers, particularly when the disputing birds approached their boundaries. The end of the dispute was not observed. However 3 days later W R/O was the only Grey Plover in that site and it fed there at Low Water until spring.

In the 2 winters 1976/77 and 1977/78 a total of 7 marked Grey Plovers arrived in late December - February, well after the autumn arrival of adults and during a peak in the numbers on the estuary. Four of these fed on the southern half of Central Bank, i. e. away from the favoured northern section, and a fifth fed in a previously unoccupied site in the tidal part of Greatham Creek adjacent to Seal Sands. However the other 2 birds (Y L/O, Y L/R) acquired feeding sites in the middle of the favoured northern half of Central Bank, and remained there until spring. These 2 Grey Plovers may have either displaced or restricted the areas used by other individuals in order to feed in this area. (I have no observations to indicate what actually occurred.)

Sightings of marked Grey Plovers arriving in late December - February in the winter of 1978/79 (P. J. Dugan, pers. comm.) confirm the results of 1977/78. Low Water feeding sites were determined for 7 ringed birds. Two arriving in January fed in the softer mud in the southern half of Eastern Channel, and 2 fed in the central section of Central Bank, both areas lying to the south of the favoured areas. Another 2 mid-winter arrivals fed at Low Water on Greenabella Bank, another less favoured area. Only one of the late arrivals (Y L/O) managed to acquire a feeding site on a favoured area, Central Bank - north.

This bird thus repeated the behaviour it showed after a late arrival in the previous winter (see above).

Since some of the marked Grey Plovers arriving after November acquired feeding sites on the favoured areas, eviction of other individuals may have occurred. If colour-ringed birds had been evicted a change in their Low Water feeding area might have been detected. None of the seasonal changes in Low Water feeding sites of ringed birds described above can be related to such eviction, although insufficient details are available in some cases. Where full details are known, sites vacated by marked birds were not used by other individuals. However further, more detailed observations on marked birds are required to substantiate this.

3. II. A. 1. e. Fidelity to a Low Water feeding site between years

In this section I shall show that marked Grey Plovers tended to return to the same Low Water feeding site(s) in successive years. Those on the main Low Water feeding area of Grey Plovers were more faithful between years to their feeding site than were birds using other parts of Seal Sands at Low Water. Most changes in Low Water feeding site were due to the Grey Plover choosing an alternative feeding area. However, return to a specific site was sometimes prevented by the presence of another Grey Plover feeding there. The time of arrival of a bird on Seal Sands did not appear to affect its chances of returning to a site, as discussed above.

The fidelity of marked Grey Plovers to Low Water feeding sites between years is set out in Table 3.26. As some marked Grey Plovers changed their Low Water feeding site during a single winter, year-to-year comparisons have been made only between Low Water feeding sites used at similar dates. Overall, marked Grey Plovers tended to return to the same sections of Seal Sands to feed in successive years (20 cases) rather than changing their Low Water

Table 3.26

The fidelity of marked Grey Plovers to a Low Water feeding site between years

	<u>Number of birds returning to same area in second winter</u>	<u>Number returning to a different area</u>	<u>Number returning but feeding area unknown*</u>	<u>Number not returning to Seal Sands in second winter</u>
1975/76 - 1976/77				
ECh	1	0	0	0
GC	1	0	0	0
GB	0	1 (SM _w)	1	0
B	0	2 (GC;GB)	0	0
SM	0	0	1	0
1976/77 - 1977/78				
ECh	1	0	0	0
SM	2	0	0	0
GB	2	0	0	1
CB _s	2	0	0	1
CCh	0	1 (GC/GB)	0	0
CB _n	0	0	0	1
GC	0	0	0	1
B	0	0	0	1
1977/78 - 1978/79				
SCh	1	0	0	0
SM	2	0	2	0
CB _n	5	1 (ECh)	1	0
GB	3	1 (CB)	0	0
CB _s	0	1 (CB _n)	3	1
GC	0	1 (GB)	0	0
ECh	0	0	1	0

Key as on Table 3.19

Data for 1978/79 supplied by P.J. Dugan,(pers. comm.)

* Birds seen only on roosts or pre-roost gatherings, and not at Low Water.

feeding site (8 cases). However the Low Water feeding sites of some marked Grey Plovers, which are known to have returned to Seal Sands, were never found (Table 3.26). These may have changed site in the second winter. Therefore the number of changes observed may under-represent the actual number occurring.

The comparison between years was most complete for the winters 1976/77 and 1977/78. Low Water feeding areas for all marked Grey Plovers present in both winters were determined and only one bird changed site (during the parts of the winter for which comparisons are available) (Table 3.26). More changes were found in comparisons between other years. However it is not clear whether this was due to the less extensive observations resulting in incomplete information on the feeding areas used by individual birds. Certainly observations on these marked Grey Plovers were less frequent during 1978/79 (P. J. Dugan, pers. comm.).

The reasons for the changes could sometimes be identified. Disturbance by brine drilling operations prevented Grey Plovers from feeding on the Brinefields during much of the 1976/77 winter. On Seal Sands one marked bird apparently chose a poor feeding area in autumn 1976 and therefore did not return to it the following winter. (The area, Central Channel, was believed to be poor as it was generally avoided by Grey Plovers (see Section 2. B) and the marked bird actually stopped feeding there in January 1977.) It is not known why the other changes in Low Water feeding site occurred. The Grey Plovers may have been responding to changes between years in the prey distribution and/or density on Seal Sands. The behaviour of some marked Grey Plovers immediately after their arrival on Seal Sands indicates that they may have been sampling the different mudflats before choosing a Low Water feeding site (see Section 3. II. A.3. d, below). However there are no trends

to or away from particular mudflats in the observed changes in site between winters. Therefore gross changes in prey distribution do not seem to have occurred. Instead the Grey Plovers may have responded to changes at a much finer level.

Throughout the study birds feeding on the main Grey Plover feeding area (Eastern Channel and the northern part of Central Bank) and on Seaton Channel were faithful to those areas in the following winter (Table 3.26), there being only one sighting (in 1978/79) or a marked bird apparently changing between years. Thus marked birds on these areas were usually faithful to a site both throughout a winter (see Section 3. II. A. 1. c. above) and between winters. Site fidelity between years was also observed on other feeding areas on Seal Sands and also on Greatham Creek (Table 3.26). However only on Scalloped Mud was the frequency of returns to the same site as high as to the main Grey Plover feeding area.

Although many marked Grey Plovers attempted to return to the same feeding sites in successive winters, other Grey Plovers had sometimes acquired those sites. Two examples were observed. On Scalloped Mud in 1978/79 one individual (L W/L), although it returned to the same section of Seal Sands in August, was unable to use the identical feeding site close to the Reclamation Wall until January. This feeding site was occupied by another Grey Plover until January when the unmarked bird vacated the site (P. J. Dugan, pers. comm.). L W/L then moved into this site and fed there at Low Water until early spring (P. J. Dugan, pers. comm.). A marked bird (W R/O) which fed in Eastern Channel in successive winters had to evict another Grey Plover on arrival in autumn 1977 in order to regain its feeding site (see Section 3. II. A. 1. d. above). Therefore there may be a distinct advantage in occupying the same Low Water

feeding site in successive winters if the food resources are similar each year.

If it is advantageous to return to a site but some birds are prevented from doing so (e.g. L W/L, 1978/79) because the site has been acquired by another Grey Plover, it might be predicted that birds arriving late in the winter would be more likely to find their site occupied. This would be particularly true for Grey Plovers returning to those areas which were filled in autumn, Eastern Channel and Central Bank - north. Nevertheless 2 late arrivals regained sites on these areas (W R/O in late November, after evicting another Grey Plover; Y L/O in early January). For most marked Grey Plovers arriving in mid winter the likelihood of their Low Water feeding site being occupied was reduced as they took up feeding sites on the sparsely populated sections of Seal Sands away from the northern parts of Central Bank and Eastern Channel (see Section 3. II. A. 1. d. above). Individual birds showed marked consistency in arrival date between years (Table 3.6). Therefore each year they arrived when roughly similar areas of Seal Sands were full of Grey Plovers, and similar areas empty. The 3 marked Grey Plovers returning to Seal Sands in January - February during the winters of 1976/77 and 1977/78 all regained their feeding sites on sparsely populated areas (the southern part of Central Bank, and Greatham Creek).

Early arrival on Seal Sands did not ensure that a bird's Low Water feeding site would be unoccupied. Indeed L W/L, the only bird which appears to have been excluded from its site, arrived in August. Nevertheless early arrival and establishment of a site must reduce the chance of a bird finding its Low Water feeding site occupied, and would therefore appear to be advantageous.

Six Grey Plovers have been observed feeding at Low Water on Seal Sands in 3 or more years. In each case similar sites have been used in successive winters (Table 3.27). One individual (W R/O) fed in exactly the same site in

Table 3.27

The Low Water feeding sites of individually marked Grey Plovers
known to feed on Seal Sands in 3 or 4 successive winters

<u>Individual Grey Plover</u>	<u>Low Water feeding sites used</u>			
	1975/76	1976/77	1977/78	1978/79
W R/O	ECh	ECh	ECh	?
L W/L	-	GB	SM/GB	SM/GB
O L/O	-	CB _s	CB _s	CB _n
Y O/R	-	SM	SM/GB/CB _s	SM/GB
B W/G	GB/SM/B	GB	GB	CB/B
B W/O	GB	CCh/SM	GB/SM/GC	GB

Six other marked Grey Plovers also returned to Seal Sands in 3 successive winters but Low Water feeding sites were determined in only 1 or 2 winters.

Key as on Table 3.19.

Eastern Channel at Low Water more or less throughout 3 winters. Other individuals have been faithful to a Low Water site for two winters, but used a different site in either the preceding (L W/L) or the following winter (O L/O). A few individuals changed site at least once during a winter (e. g. B W/O), but were faithful between years to the western half of Seal Sands.

Four Grey Plovers marked and observed when juveniles were also seen feeding at Low Water on Seal Sands in subsequent winters. There was a marked tendency to feed in the same area(s) as in their first winter. Three again fed on Scalloped Mud and/or Greenabella Bank. The fourth bird fed on Central Bank when a juvenile and also in the subsequent winter, but was seen once in its third winter feeding in Eastern Channel (P. J. Dugan, pers. comm.), possibly indicating a change in feeding area. From these observations there is no strong evidence of juveniles feeding in certain areas and then moving to more favoured areas in subsequent winters.

3. II. A. 1. f. Summary

Marked Grey Plovers fed on all areas of Seal Sands at Low Water. As found for the population as a whole, more than half the Low Water feeding sites of marked birds were on the northern halves of Central Bank and Eastern Channel. However sub-adults showed a preference for Scalloped Mud and Greenabella Bank. The softest muds on Seal Sands were in general avoided by all Grey Plovers.

Individual birds regularly used the same Low Water site on the northern Central Bank and Eastern Channel for periods of several weeks or months. Seasonal changes in Low Water feeding site were more frequent amongst birds feeding on other areas of Seal Sands. Changes occurred in November and from January to April. The changes before March usually involved movements

from higher to lower tidal levels on the western half of Seal Sands, or to the eastern half of Seal Sands. Only in spring were movements away from the eastern half observed.

Favoured areas were filled during the autumn but some individuals chose to feed elsewhere on Seal Sands even before filling was completed. Most of the later arrivals fed in previously unoccupied areas, but some acquired sites on the well-populated areas. Displacement of individuals on preferred areas did occur.

Marked Grey Plovers tended to return to the same Low Water feeding site(s) in successive years. Those on the main Grey Plover Low Water feeding area were more faithful between years than those using other parts of Seal Sands. Marked birds were able to regain their Low Water feeding site even if they arrived in mid winter. (see Section 3. II. A. 1. e).

3. II. A. 2. Feeding sites used during the tidal cycle

The feeding sites described in the previous section were used during the Low Water period (i. e. approximately 1 hour either side of true Low Water) when the maximum area of mud is exposed. On either side of this period the overall distribution of the Grey Plover population changes with the ebb and flow of the tide (Section 2. B. 3). However individual birds showed several patterns of movement not revealed by the general changes in distribution discussed in Section 2. B.

3. II. A. 2. a. Sites used

Eastern Channel tide edge - As the tide falls, the first feeding area to be exposed is the sandy eastern edge of Eastern Channel. Prey density was much lower here than in the centre of Eastern Channel and on Scalloped Mud and Central Bank, during the winter of 1977/78 (Appendix 4). Therefore Grey Plovers would not have been expected to feed there under most conditions except if they were short of feeding time. However in conditions which lowered their rate of

prey capture (e.g. low temperature, strong winds) or increased their energy requirements (e.g. low temperature, strong winds, preparation for migration, recent arrival after migration) feeding along this part of Eastern Channel might have been expected to occur in order to increase the feeding time available.

The sightings of marked Grey Plovers feeding at/near the Eastern Channel tide edge on the ebb tide could be correlated only with certain of these conditions. Three marked juveniles fed along the Eastern Channel tide edge just before their emigration from the estuary in October - November 1977. These juvenile Grey Plovers may have been using this extra feeding time to build up fat reserves prior to migration. Alternatively their presence along Eastern Channel may have indicated difficulty in obtaining sufficient food on the main mudflats, this difficulty leading to emigration. In contrast there were no known cases where a marked bird fed along Eastern Channel on the ebb tide immediately following its arrival on the estuary, even though its energy requirements would then also be high.

There was no correlation between feeding by marked birds on the ebb tide on the Eastern Channel tide edge and periods of low temperature and/or strong winds. During 1977/78 Eastern Channel ebb tide feeding was observed amongst marked birds mainly from September to December (Table 3.28). It was shown by 9 of the 14 marked Grey Plovers present during August - December 1977 but by only 1 of the 19 present during January - April 1978, even though the worst weather and the peak in number of marked birds on the estuary both occurred in February.

Feeding along the edge of Eastern Channel on a falling tide was not influenced by the Low Water feeding area of the individual. It was shown by marked birds that fed at Low Water on all the feeding areas of Grey Plovers on Seal Sands, and by both territorial and non-territorial birds. No marked

Table 3.28

The occurrence amongst marked Grey Plovers
of feeding along the Eastern Channel tide edge
on the ebb tide during 1977/78

	A	S	O	N	D	J	F	M	Total
Number of days on which Eastern Channel tide edge checked for birds	1	2	3	2	2	3	2	2	17
Number of days on which marked Grey Plovers seen feeding there	0	2	1	1	2	0	1	0	7

Grey Plover regularly fed on the Eastern Channel tide edge on the ebb tide through the winter, and most individuals were seen feeding there only once or twice (Table 3.29). Therefore individual birds used the extra feeding time available on the ebb tide only on certain occasions, perhaps when they had difficulty meeting their energy requirements on the main mudflats.

Central Bank and Scalloped Mud - Before discussing the adaptiveness of the behaviour of marked Grey Plovers I shall outline again the movements of the population described in full in Section 2.B.3. The first large areas of mudflats to be exposed on the ebb tide are Central Bank and Scalloped Mud. The Grey Plovers flew over to these from their roosts, or from feeding sites along Eastern Channel, once an area of relatively unoccupied mud was available. Later in the tidal cycle the ebbing tide exposes the lower mudflats, Eastern Channel, Greenabella Bank, Central Channel and Seaton Channel, and the lower parts of Central Bank and Scalloped Mud. Many Grey Plovers moved to these mudflats once uncovered, although some remained on the higher mudflats.

On the ebb tide, when its Low Water feeding area is still covered, a Grey Plover must feed either on Scalloped Mud or Central Bank. It would be expected that, if prey density is more or less uniform over the exposed mudflats, an individual Grey Plover should feed at this stage on the tide on the area closest to its Low Water feeding site under most conditions. It would thereby minimise the distance it had to fly (thus saving time and energy) once the lower mudflats became exposed. The predicted routes are shown in Fig. 3.14.

This hypothesis was tested using the observations on marked Grey Plovers. Once the ebbing tide exposed the higher parts of Central Bank and Scalloped Mud marked Grey Plovers did indeed feed on both areas, in both 1976/77 and 1977/78. However, although some individuals used only one of these sites on the ebb tide throughout a winter, 67 per cent of those whose feeding sites were identified

Table 3.29

The frequency of feeding along the Eastern Channel
tide edge amongst marked Grey Plovers, during 3 winters

	<u>Number of marked Grey Plovers present on the estuary</u>	<u>Total number seen</u>	<u>Number seen once</u>	<u>Number seen twice</u>	<u>Number seen three times</u>
Ebb tide					
1977/78	22	9	3	5	1
1976/77	32	6	5	1	0
1975/76	6	1	1	0	0
Flood tide					
1977/78	22	2	2	0	0
1976/77	32	0	0	0	0
1975/76	6	0	0	0	0

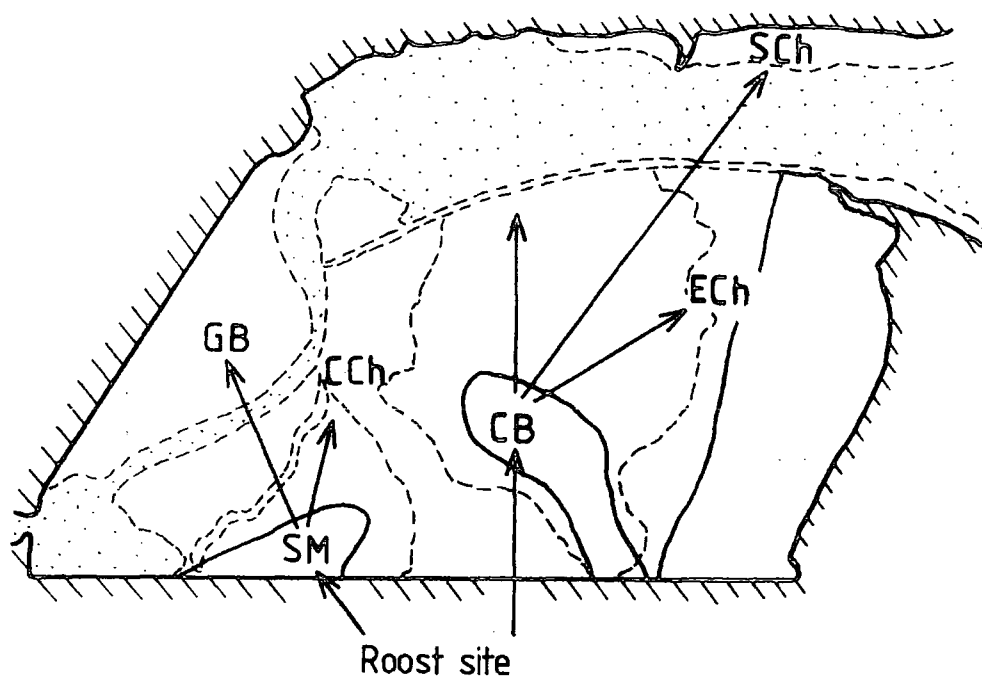

- Predicted movements between areas
 ○ First areas exposed by ebbing tide
 ○ Areas exposed at Low Water

CB Central Bank	GB Greenabella Bank
CCh Central Channel	SCh Seaton Channel
ECh Eastern Channel	SM Scalloped Mud

Figure 3.14 The predicted routes of Grey Plovers across Seal Sands on the ebb tide, if travel time and distance are to be minimised.

in 1977/78 and at least 37 per cent of those in 1976/77 (when fewer observations were possible) used both Central Bank and Scalloped Mud at some time (Table 3.30). Many individuals showed clear seasonal changes in their choice of feeding area on the ebb tide during the 1977/78 winter (see below). However no seasonal changes occurred between August and December 1977. During this period the predicted relationship between Low Water and ebb tide feeding sites was found to be true (Fig. 3.15). The ebb tide sites used by marked Grey Plovers feeding at Low Water on Scalloped Mud and Greenabella Bank were significantly different (exact probability test, $P = 4.76$ per cent) from those used by birds feeding at Low Water on Central Bank, Eastern Channel, and Seaton Channel. This applied both to birds moving to lower tidal levels (e.g. to Seaton Channel) and to those which continued to feed on higher areas of Scalloped Mud or Central Bank adjacent to the mudflats first exposed by the tide.

After December 1977 a greater variety of patterns of movement occurred on the ebb tide (Fig. 3.15). On at least some days individual Grey Plovers did not minimise the distance flown between feeding areas on Seal Sands. The reasons for this will be discussed below.

The data for the winter of 1976/77 show a similar relationship between Low Water and ebb tide feeding sites (Fig. 3.15). However the difference between the ebb tide sites used by marked Grey Plovers feeding at Low Water on "Scalloped Mud and Greenabella Bank" and those feeding at Low Water on "Central Bank, Eastern Channel and Seaton Channel" is significant only at the 10 per cent level (exact probability test, $P = 6.66$ per cent). Most of the observations refer to the period February to March, as few marked birds were available before February.

The data for autumn and winter 1976/77 and autumn 1977 therefore support the hypothesis that most Grey Plovers choose ebb tide feeding sites that minimise

Table 3.30

The feeding sites used by marked Grey
Plovers on the ebb tide during 2 winters

<u>Ebb tide feeding sites</u>	<u>Number of marked Grey Plovers</u>	
	1977/78	1976/77
Scalloped Mud	4	4
Central Bank	2	8
Scalloped Mud and Central Bank	12	7
Unknown	4	12
	—	—
	22	31
	—	—

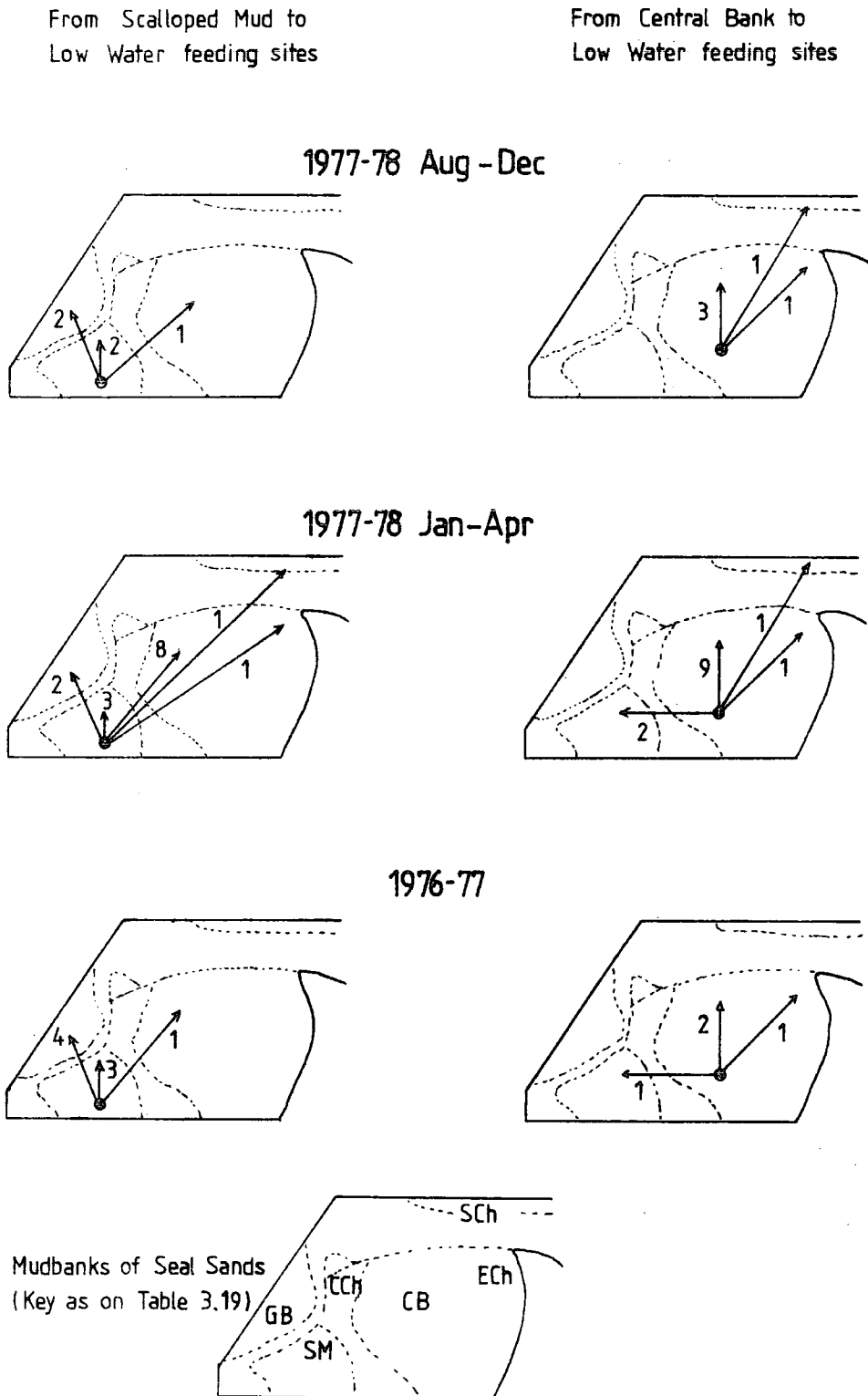

Figure 3.15 The movements of marked Grey Plovers between feeding sites on the ebb tide, during two winters.

their flying distances across the main mudflats of Seal Sands. Exceptions to this pattern were rare. However Grey Plovers did not choose an ebb tide feeding site specifically to minimise flying time between the High Water roost and the first feeding site used. This may have been because few roosts were available and human disturbance led to frequent changes in roost site, even during a single High Water period.

It was shown earlier in this Section (Fig. 3.12) that in 1977/78 6 marked Grey Plovers had Low Water feeding sites on the lower mudflats, i.e. Eastern Channel, Greenabella Bank, and Seaton Channel which were still covered when the higher parts of Scalloped Mud and Central Bank were first exposed. Eight others fed at Low Water on the lower parts of Central Bank. Nine birds fed at Low Water either on the highest parts of Scalloped Mud and Central Bank or on adjacent lower areas which could be reached simply by walking from these highest mudbanks. These birds had at the most a short walk from their ebb tide feeding site to that used at Low Water. In contrast those that moved to lower mudflats had to fly up to 1 kilometre between ebb tide and Low Water feeding sites. A return movement from the lower to the higher mudflats occurs on the flood tide (see below). Therefore I have termed the cycle of movements a feeding circuit, regardless of whether or not a bird retraces its path exactly on the flood tide.

The advantages of a feeding circuit - As the majority of marked Grey Plovers followed feeding circuits this behaviour would be expected to confer some advantages to the birds. Three possible advantages are:

1. If the Grey Plovers are spread out across the main mudflats at Low Water rather than being concentrated on the higher mudflats the density of feeding Grey Plovers will be reduced. An individual Grey Plover will then suffer fewer interactions with other Grey Plovers. (This will also enable some birds to continue feeding on the higher mudflats - see

Section 3. II. D. 2.)

2. The prey density may be higher on the lower mudflats.
3. Moving to lower mudflats may facilitate prey capture even if prey density does not vary across Seal Sands. The density of available prey (i. e. the number of prey per unit area available on the surface at any moment to be captured by the Grey Plover) on areas of similar prey density and similar substrate is believed to be higher in more recently exposed sites than on those exposed earlier in the tidal cycle (see 3. II. D. 2.). By moving to lower mudflats as they are exposed, a Grey Plover will presumably keep in areas where the activity of the prey is high.

Prey density on Seal Sands - The main invertebrate prey species on Seal Sands were sampled during the 1977/78 winter (pers. obs. (see Appendix 4) and P. J. Dugan, pers. comm.). Considering the feeding areas used by Grey Plovers, no major and consistent differences in the density of Nereis diversicolor (the main prey of Grey Plovers on Seal Sands during the study) were found between the higher mudflats (the southern parts of Central Bank and Scalloped Mud) and the areas exposed later in the tidal cycle (Greenabella Bank, Eastern Channel, Seaton Channel, Central Bank - north). Therefore the observed movements between feeding areas must be responses to differences in availability rather than absolute density.

Timing of movements between feeding areas - To maximise these proposed advantages the Grey Plovers should move to the lower feeding areas as soon as they become exposed. On the flood tide they should continue to feed on their Low Water sites until pushed off by the tide. Although the density of available worms on this site would have dropped during the Low Water period (see 3. II. D. 2.) it should still be higher than that on the higher mudflats (assuming prey density and substrate are similar).

The observed behaviour only partly supports the hypothesis. In all 3 winters the timing of the movement was determined by the Low Water feeding site used as detected in the movements of unmarked Grey Plovers (Section 2.B). Marked birds moved to Eastern Channel, Seaton Channel and Central Bank - north as soon as they were exposed by the tide. On both Eastern Channel and Central Bank - north Grey Plovers have been observed standing on tiny ridges of mud surrounded by shallow water waiting for the tide to uncover the rest of the mud. In contrast, movement to Greenabella Bank usually occurred sometime after the first mud had been exposed, and might be delayed until 2 hours later (see Section 3. II. A. 1. b above). This was particularly true of 2 marked birds during the winter of 1975/76, but also applied to other birds in the following winters. Behaviour on Scalloped Mud and Central Bank - south was more variable. Some individuals (e.g. L W/L, O L/O) moved immediately to their Low Water feeding sites as soon as they were exposed. Others, whose Low Water feeding sites changed quite frequently during the winter (e.g. Y O/R, Table 3.23 above), tended to move gradually from their feeding site on the ebb tide to the area used around Low Water.

On the flood tide the timing of the movement from a Low Water feeding site to the higher parts of Scalloped Mud or Central Bank was again determined by the Low Water site. Marked birds on Eastern Channel, the banks of Seaton Channel, the northern part of Central Bank and the southern part of Scalloped Mud all remained on their Low Water feeding site, whether feeding or roosting, until pushed off by the tide. However those on Greenabella Bank often flew over to Scalloped Mud (or to Central Bank) before the tide had covered all the available feeding areas on Greenabella Bank. These individuals frequently fed on Scalloped Mud as soon as they landed. Therefore they did not leave Greenabella Bank because they had completed their feeding. Perhaps feeding on Greenabella

Bank had become less profitable than on Scalloped Mud.

Clearly the behaviour of Grey Plovers feeding at Low Water on Greenabella Bank differs from that of birds elsewhere on Seal Sands. Large numbers of waders of other species fed at high density at/near the tide edge of Greenabella Bank (and also on Central Channel) on both ebb and flood tides (Section 2.). The other areas used by Grey Plovers at Low Water (northern Central Bank, Scalloped Mud, Eastern Channel, Seaton Channel) support fewer waders, are much flatter than Greenabella Bank and do not extend down to low tidal levels. The tide moves across them very swiftly and the waders feeding at the tide edge soon move off to other mudflats, particularly Greenabella Bank and Central Channel. Therefore crowding by other species of waders could be a problem to Grey Plovers only on Greenabella Bank.

It is known that Grey Plovers avoided mudflats with a high density of feeding birds (Section 2. B), probably because of the greatly increased disturbance of both the prey and of the searching of the Grey Plover (Section 3. II D. 2). On Greenabella Bank this disturbance presumably outweighed the advantage of the higher density of available prey there.

Choice of feeding site on the flood tide - The Grey Plovers feeding on the higher mudflats of Scalloped Mud and Central Bank at Low Water flew from there to their roost(s) when pushed off by the incoming tide. Those on the lower mudflats (e. g. Eastern Channel, Greenabella Bank) moved to either Central Bank or Scalloped Mud, where they fed (or roosted) until Seal Sands was covered by the tide. It would be expected that Grey Plovers which were still feeding should minimise the distance flown between mudflats, as on the ebb tide. The predicted routes on the incoming tide would thus be the reverse of those shown in Fig. 3.14.

Some marked Grey Plovers used only one of these 2 sites throughout a

winter (Table 3.31). However 50 per cent of the marked birds in 1977/78 and at least 24 per cent in 1976/77 (when fewer observations were possible) used both Central Bank and Scalloped Mud on the flood tide at some time during the winter. In many cases birds changed their flood tide feeding site during a winter, in association with changes in Low Water site (see next section). Even though seasonal changes occurred, the predicted relationship between Low Water and flood tide feeding sites was shown for two periods (Fig. 3.16). The flood tide feeding sites used by marked Grey Plovers feeding at Low Water on "Scalloped Mud and Central Bank" were significantly different from those used by birds feeding at Low Water on "Central Bank, Eastern Channel and Seaton Channel", during 1976/77 (exact probability test for 2 x 2 contingency table, $P = 1.52$ per cent) and January - April 1978 ($P = 2.86$ per cent), but not during August - December 1977 ($P = 7.40$ per cent).

Longer movements by marked Grey Plovers on the flood tide, from Scalloped Mud and Greenabella Bank to the higher parts Central Bank, were more frequent than expected (Fig. 3.16). On arriving on Central Bank these marked Grey Plovers resumed their feeding. Central Bank was the main collecting area for non-feeding Grey Plovers before going to roost. If the marked birds soon completed their feeding (this was not determined) the advantages of joining the main roost may have outweighed the disadvantage of the longer flight. Presence in the main roost must confer some advantages (possibly protection from predators) as non-feeding Grey Plovers also flew from Scalloped Mud to Central Bank on the flood tide.

Once Scalloped Mud and Central Bank were covered by the incoming tide, some Grey Plovers moved to the Peninsula Sands. However feeding along the nearby Eastern Channel tide edge was observed amongst marked Grey Plovers only twice during the study, during September 1978. Both of the birds involved,

Table 3.31

The feeding sites used by marked Grey Plovers
on the flood tide during 2 winters

<u>Ebb tide feeding sites</u>	<u>Number of marked Grey Plovers</u>	
	1977/78	1976/77
Scalloped Mud	0	4
Central Bank	9	9
Scalloped Mud and Central Bank	9	4
Unknown	4	14
	<u>22</u>	<u>31</u>

From Low Water feeding sites to Scalloped Mud

From Low Water feeding sites to Central Bank

1977-78 Aug-Dec

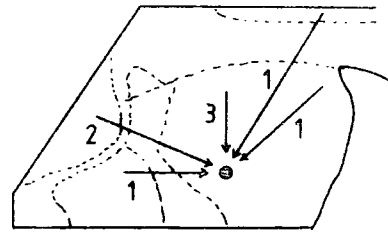
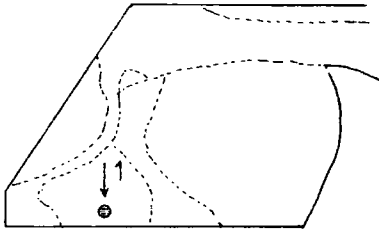

1977-78 Jan-Apr

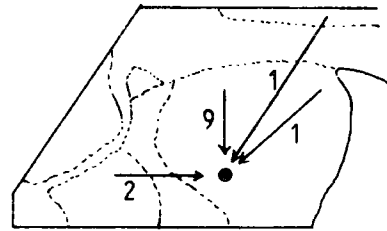
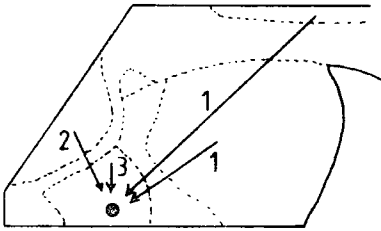

1976-77

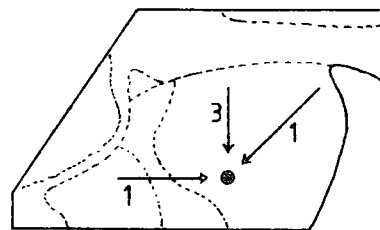
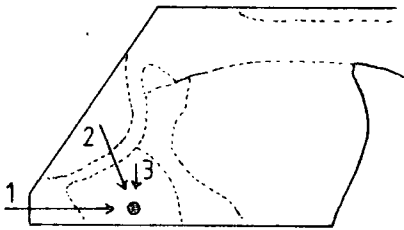

Mudbanks of Seal Sands
(Key as on Table 3.19)

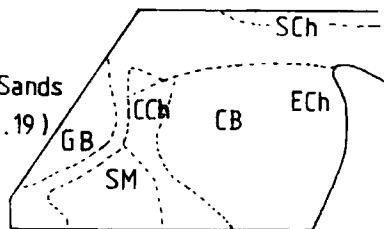

Figure 3.16

The movements of marked Grey Plovers between feeding sites on the flood tide, during two winters.

one second winter and one adult, stayed on the estuary for the rest of the winter.

3. II. A. 2. b. Seasonal changes in feeding sites used during the tidal cycle

Changes in feeding sites used on the ebb and flood tides were observed during both the 1976/77 and 1977/78 winters. Ebb and flood tide feeding sites changed more frequently than Low Water feeding sites. Some were long-term changes lasting weeks or months, whereas others occurred on only one or two days, the birds then reverting to their original feeding sites.

Long-term changes - it was shown in the last section that the feeding sites used on the ebb and flood tides were generally determined by those used at Low Water. Most marked Grey Plovers thereby reduced to a minimum the distance they travelled between feeding sites on Seal Sands. Some marked Grey Plovers changed their Low Water feeding site during a winter (see Section 3. II. A. 1. c. above). Therefore, if Grey Plovers attempt to minimise their travelling throughout the winter, predictions can be made of changes in ebb and flood tide feeding sites that should be associated with the changes at Low Water. For example, a bird changing its Low Water feeding site from Greenabella Bank to Eastern Channel (e.g. W R/O, 1976/77, Table 3.23) should feed on the ebb and flood tides on the higher mudflats of Central Bank instead of on Scalloped Mud. However if a Grey Plover changed to feed at Low Water on Greenabella Bank instead of on Scalloped Mud (e.g. Y O/R, 1977/78, Table 3.23) it should still feed on the higher parts of Scalloped Mud, as before, when Greenabella Bank is covered.

These predictions were tested on the marked Grey Plovers that changed their Low Water feeding sites during a winter (1 in 1975/76, 3 in 1976/77, 5 in 1977/78, Table 3.23). Information could be used from those marked birds for which the ebb and flood tide feeding sites used with each Low Water site had been

determined. From Tables 3.32 and 3.33 it can be seen that the majority of Low Water changes in Low Water feeding site were accompanied by the predicted changes at other stages of the tidal cycle, thus minimising the flying distance.

Although most Low Water site changes detected amongst the marked Grey Plovers during the study were accompanied by changes in ebb and flood tide feeding sites, additional, apparently permanent, changes on ebb and flood tides were also observed. In some cases the Low Water sites used by the marked bird were not determined. In others the birds were clearly flying further than the minimum distance between mudflats. On the ebb tide 4 such changes were observed during the 1977/78 winter and 1 in 1976/77; 4 of these 5 occurred between mid March and April. Of the changes in feeding site on the flood tide (5 in 1977/78, 2 in 1976/77) 3 occurred in April. On both ebb and flood tides in 1976/77 and on the flood tides in 1977/78 the changes were all from Scalloped Mud to Central Bank. Perhaps Grey Plovers had difficulty in capturing sufficient prey on Scalloped Mud in spring. However on the ebb tides birds changed in both directions in the spring of 1978. Possibly these changes in spring were due to a change in social organisation, caused for example by food shortage, patchy distribution of prey or imminent emigration. (These ideas will be discussed in more detail later in this Chapter (Section 3. II. A. 3. d)).

Short term changes - Although most Grey Plovers attempted to minimise their travelling between feeding sites on Seal Sands for much of the winter, under certain conditions this attempt was temporarily abandoned. By moving to lower mudflats Grey Plovers can feed in areas of high prey availability. By flying the shortest distance between mudflats they allow more time for feeding and keep down energetic costs. However if the rate of prey capture on the ebb tide mudflat which is closest to the Low Water site is markedly reduced (by disturbance) below that on other more distance mudflats, the advantage of minimising travel distance may be

Table 3.32

The relationship between predicted and observed changes in ebb and flood tide feeding sites amongst marked Grey Plovers, during 3 winters

Winter	Change in Low Water site	Number which changed	Time of Low Water change	Predicted change in ebb/flood tide site	Observed change in ebb tide site	Time of change on ebb	Observed change in flood tide site	Time of change on flood
1977/78	SMe → GB	1	mid Nov.	-	CB → SM/CB	late Nov.	SM → SM/CB	late Nov.
	SMw → SMe/GB	1	late Nov.	-	-	-	-	-
	GB → SMe	1	early Mar.	-	-	-	-	-
	GC → GB	1	late Jan.	-	-	-	-	-
	SMe/GB → wandering	1	end Mar.	SM → SM/CB	-	-	-	-
	CB → wandering	1	early Apr.	CB → SM/CB	-	-	CB → SM/CB	early Apr.
	SMe → CB	1	mid Jan.	SM → CB	SM → CB	mid Jan.	?	?
	GB → CB	1	early Feb.	SM → CB	SM → CB	early Feb.	-	-
	CB → SMe	1	early Mar.	CB → SM	CB → SM	mid Feb.	?	-
1976/77	SMw → GC/SMw	1	early Mar.	-	-	-	-	-
	GB → ECh	1	late Nov.	SM → CB	SM → CB	late Nov.	?	-
	B → CB	1	early Feb.	SM → CB	?	-	?	-
	CCh → SMw	1	Jan.	CB → SM	?	-	CB → SM	Jan - Feb.
1975/76	GB → B	1	mid Feb.	-	?	-	?	-
	B → SM/GB	1	early Apr.	-	?	-	?	-

Key as on Table 3.19.

Table 3.33

Grey Plover feeding sites: the correlation between changes at Low Water and changes on the ebb and flood tides, for marked Grey Plovers, during 3 winters

	<u>Total number of Low Water changes observed</u>	<u>Did the predicted changes in feeding site occur ?</u>					
		Ebb Tide			Flood Tide		
		Yes	No	Unknown	Yes	No	Unknown
1977/78	9	8	1	0	5	2	2
1976/77	4	2	0	2	2	0	2
1975/76	2	0	0	2	0	0	2

Note: During April 1978 the 2 marked birds which wandered around Seal Sands could have used either Scalloped Mud or Central Bank on the ebb and flood tides. If they were seen on just one of the areas they were still considered to have met the predictions as the observation period available before emigration was so short.

outweighed by the advantages of the alternative strategy: flying further than normal between ebb tide and Low Water feeding sites but thereby feeding on an area where a high rate of prey capture can be maintained.

Early in 1978, 2 situations occurred in which this alternative strategy was employed. In mid January many thousands of gulls that had arrived on the estuary began using Central Bank as a roosting area, throughout its period of exposure (see Section 2.B.3). During the 1977/78 winter a total of 12 marked Grey Plovers were known to have changed feeding site on the ebb tide. Eight of these did so whilst the gulls were present, changing from Central Bank to Scalloped Mud. These 8 Grey Plovers fed on Scalloped Mud on all the ebb tides when the gull flocks were roosting on Central Bank, even though none of them changed their Low Water feeding site. Clearly the advantage of feeding on a relatively sparsely populated mudflat where disturbance was infrequent outweighed the disadvantage of increased travelling time. On a few occasions the presence of the gulls on Central Bank on the ebb tide was sufficient to prevent many Grey Plovers from finding space in which to feed.

Changes in feeding area on the flood tide during this period were observed in only two marked Grey Plovers. This was probably because fewer Grey Plovers fed on the last areas of mudflat remaining exposed on the flood tide than on the first areas uncovered by the outgoing tide; hence the presence of large flocks of gulls had less effect upon Grey Plovers on the flood tide.

Once the gull flocks had moved away from Seal Sands in early February 1978, all but one of these marked Grey Plovers reverted to using Central Bank on the ebb tide. However in mid February 1978, 5 individuals again changed from feeding on Central Bank to using Scalloped Mud on the ebb tide. This was caused by the arrival on Seal Sands of large numbers of Golden Plovers which had been driven off the fields by heavy snow (see Section 2.B.3). The Golden

Plovers fed mainly on Central Bank on the ebb tide. Some marked Grey Plovers fed amongst the Golden Plovers on Central Bank. Therefore the energy gain from the two strategies, feeding on the densely populated Central Bank or flying to and from the sparsely populated Scalloped Mud, must have been similar.

3. II. A. 2. c. Fidelity between years to feeding sites used during the tidal cycle

Choice of feeding sites on the ebb and flood tides has been shown to be determined mainly by the Low Water feeding site used. Therefore fidelity to a Low Water feeding site between years should lead to fidelity in feeding sites used by an individual on the ebb and flood tides, except when increases in numbers of other birds force the Grey Plovers to change their behaviour. This was particularly true on the flood tide where 6 marked Grey Plovers used the same area in the winters of 1976/77 and 1977/78. Only one (B W/O) clearly changed between years, and these changes can be correlated with its changes in Low Water feeding site during and between winters. On the ebb tide 2 marked Grey Plovers used the same feeding sites through the winters of 1976/77 and 1977/78, and a further 5 visited both sites but fed mainly on the same one each winter. No major differences between the years were observed.

3. II. A. 2. d. Summary

Most marked Grey Plovers fed on several areas of Seal Sands during a tidal cycle. They did not feed regularly on the first feeding areas uncovered by the ebbing tide, along Eastern Channel, but once uncovered, both Central Bank and Scalloped Mud were used. The site used by an individual at mid-tide was determined by its Low Water feeding site. Individuals thus used feeding circuits which minimised their flying time and energy once feeding had started. Some marked Grey Plovers used Low Water feeding sites adjacent to the first areas on Central Bank and Scalloped Mud to be exposed by the tide. They did not

use feeding circuits but fed in the same site more or less through the tidal cycle.

Seasonal changes in feeding site on the ebbing tide occurred mainly from January to April. They were caused by changes in Low Water feeding site of the individual, or by the presence of other species of birds in large numbers on Central Bank.

On the flood tide both Central Bank and Scalloped Mud were used. The choice of site by an individual was again determined by its Low Water feeding site.

3. II. A. 3. Feeding territories

Interactions between unmarked Grey Plovers suggesting defence of a feeding area have been observed before this study both on Seal Sands (e.g. Knights 1979) and elsewhere (Michael 1935, Panov 1963, Burger, Hahn and Chase 1979, Myers, Connors and Pitelka 1979a, Myers and Myers 1979). However if birds are not individually marked it is impossible to distinguish between true defence of a fixed feeding area, i. e. territoriality, and defence of a mobile individual space around a bird (see Conder 1949). My observations on marked Grey Plovers revealed that both defence of individual space and true territoriality occurred on Seal Sands.

Defence of individual space - The individual space of a Grey Plover, which extended 2 - 3 metres from the bird, was rarely transgressed. In most situations, on areas where territoriality did not occur, feeding Grey Plovers maintained their spacing (usually at least 10 - 15 metres apart) by avoidance movements (see also Stinson 1977). However at high densities of feeding birds these movements were not effective in taking the Grey Plover into an unoccupied area of mud. It was on occasions when Grey Plovers were feeding at high densities that disputes over individual space were most frequent, as predicted

by Recher and Recher (1969b). Defence of individual space was most frequently observed on the ebbing tide (Table 3.34), especially just after the first mud was exposed. At this time most Grey Plovers were feeding, and uncovered feeding area was limited. Defence of individual space was rarely seen at Low Water when densities of feeding Grey Plovers were low due to the large area of mud exposed, or on the flood tide when many fewer Grey Plovers were feeding (Table 3.34). On the ebb tide interactions were most frequent during the mid winter peak population of Grey Plovers on Seal Sands in 1976/77 (see Fig. 2.3). Displacements occurred at a high rate also in January 1978 when more Grey Plovers than usual fed on Scalloped Mud on the ebb tide. Many of these Grey Plovers had moved from Central Bank because of the presence of the flocks of gulls there (see Section 2. B. 3).

Nevertheless the rate of disputes over individual space was usually very low, rarely exceeding 6 per bird per hour (Table 3.34). Interactions over individual space were brief, lasting less than 5 seconds. They occurred on any parts of Seal Sands where Grey Plovers fed at high densities. Defence of individual space was shown by non-territorial birds and also by birds feeding away from their territories. Individual birds change immediately from one form of spacing to another on moving between areas on Seal Sands.

Territoriality - True intraspecific territoriality, the defence of a fixed area of mudflat against conspecifics, could be distinguished from defence of individual space by the following characteristics. The territory holder fed in a more or less clearly defined area of mud, from which conspecifics were vigorously excluded by means of calls, displays and direct aggression. Disputes at the boundaries between adjacent territories sometimes lasted several minutes, e.g. length of disputes between Grey Plovers on Eastern Channel -

Table 3.34

Defence of individual space amongst feeding Grey Plovers:
the frequency of displacements amongst feeding marked
Grey Plovers that were not defending territories, during 1976/77

	S	O	N	D	J	F	M	A	M
<u>EBB TIDE</u>									
Number of minutes of observation on marked birds	13	0	71	0	19	38	225	43	0
Number of displace- ments observed	1	-	0	-	4	1	5	4	-
Rate of displace- ments per bird per hour	4.62	-	0	-	12.63	1.58	1.33	5.58	-
<u>LOW WATER</u>									
Number of minutes of observation on marked birds	0	0	15	51	10	32	87	0	0
Number of displace- ments observed	-	-	0	1	0	0	0	-	-
Rate of displace- ments per bird per hour	-	-	0	1.18	0	0	0	-	-
<u>FLOOD TIDE</u>									
Number of minutes of observation on marked birds	4	0	119	51	68	61	97	0	31
Number of displace- ments observed	0	-	0	0	1	0	0	-	1
Rate of displace- ments per bird per hour	0	-	0	0	0.88	0	0	-	1.94

Y O/R, 30.12.77, 8 mins.

W R/O, 24.11.77, 20 mins.

unmarked bird, 1.1.78, 30 mins.

However, as the territory holders become established, such disputes became shorter and occurred less frequently. In territories held for periods of weeks, the owner predictably fed on the site each time it was exposed at Low Water. It also roosted and preened within its territory. A territory holder swiftly returned to its territory following a disturbance. Territoriality on a mudflat results in Grey Plovers being rather evenly spaced. However Grey Plovers were also spaced evenly over areas in which no territories were held, by means of avoidance of each other rather than overt aggression towards each other. Thus detailed long-term observations of marked birds, as were possible in this study, must be made before the occurrence and extent of territoriality can be determined.

3. II. A. 3. a. Sites in which territoriality was observed (Fig. 3.17)

Grey Plovers held territories only on certain parts of Seal Sands (Table 3.35). In this section it will be shown that the spacing behaviour of Grey Plovers on an area can be predicted from the physical characteristics of the site.

1977/78 - Eastern Channel and the northern section of Central Bank (area A, Table 2.3) were the main sites used during 1977/78 (Table 3.35). The Seaton Channel mudbanks also held territorial Grey Plovers, but this is a very small site (< 4 hectares), and therefore a much less important feeding area in terms of the number of birds supported than Eastern Channel or Central Bank. In Eastern Channel territories were defended by marked individuals in both the northern and southern halves. Observations on the behaviour of unmarked Grey Plovers feeding in the rest of Eastern Channel indicated that territories were

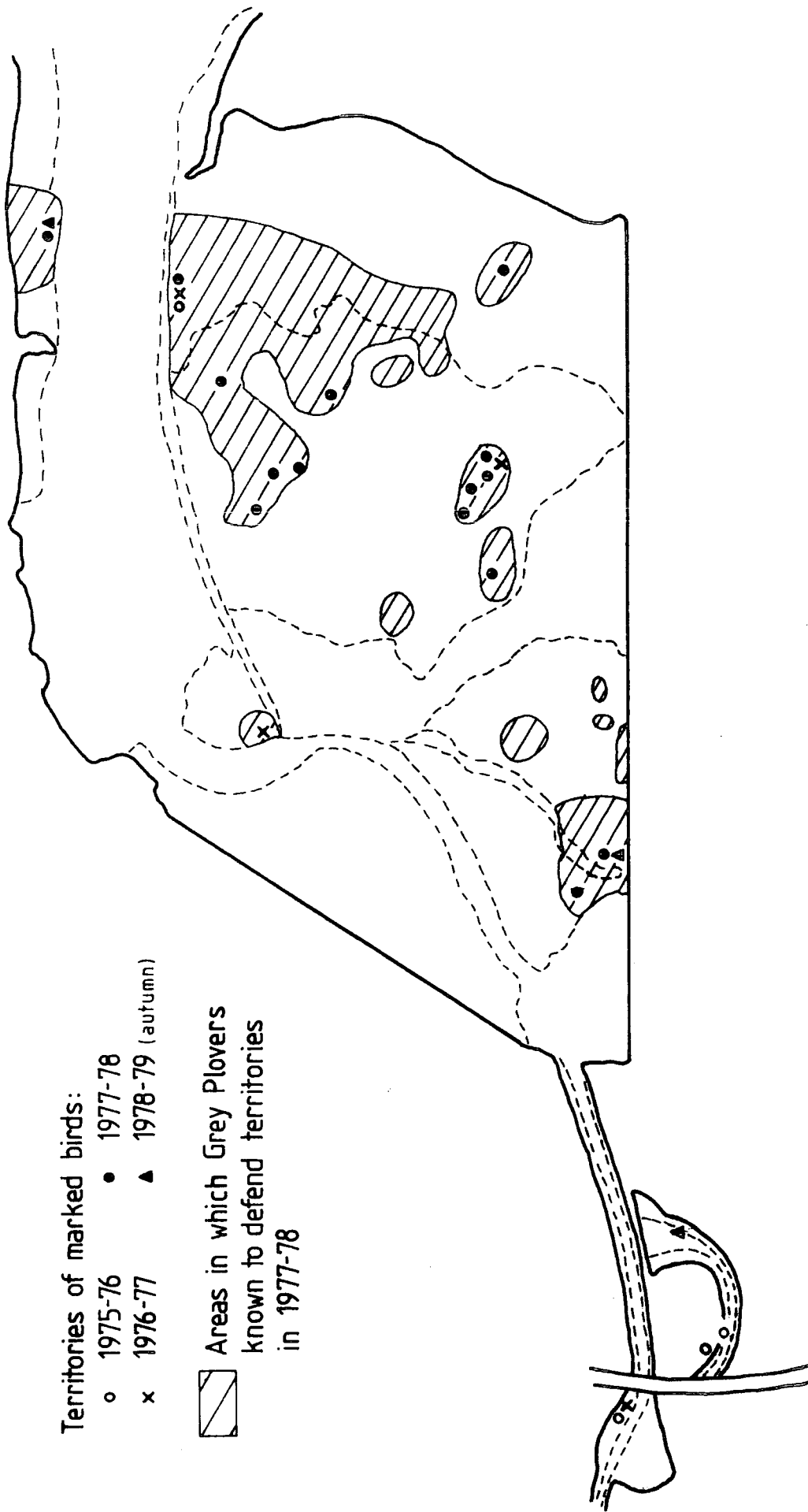

Fig. 3.17 The occurrence of territoriality amongst Grey Plovers on Seal Sands and adjacent sites.

Table 3.35

The occurrence of territoriality amongst marked Grey Plovers
on Seal Sands, during the 1977/78 winter

Section of Seal Sands	Total number of marked Grey Plovers observed	Marked Grey Plovers showing territoriality	
		Number	Percentage of total observed
Eastern Channel	2	2	100%
Seaton Channel	1	1	100%
Central Bank - north	7	4	57%
Central Bank - central	7	1	14%
Central Bank - south	19	5	26%
Scalloped Mud	15	1	7%
Greenabella Bank	5	0	0%
Central Channel	0	-	-
	—	—	—
Total	56	14	25%
	—	—	—

defended by all Grey Plovers feeding there. Only ~60 per cent of the marked Grey Plovers feeding on the northern section of Central Bank were known to defend territories. Others may have done so. The situation is uncertain because fewer observations were made there than on Eastern Channel, so that full details of the spacing behaviour employed on Central Bank were not obtained. Unmarked Grey Plovers feeding on the *Enteromorpha*-covered mud of the northern part of Central Bank were highly territorial, at least in February, so if some Grey Plovers were not defending territories they must have been feeding elsewhere on this northern section, e.g. on the softer mud to the west. Territories were defended by some individuals on the other sections of Central Bank, particularly on the eastern side next to Eastern Channel and on the sandy ridge nearer to the Reclamation Wall (see Fig. 3.17).

Grey Plovers very rarely held territories on areas of Seal Sands to the west of Central Bank, Scalloped Mud being the only area on which territoriality was observed. On Scalloped Mud one marked (L W/L) and several unmarked Grey Plovers defended feeding sites on the eastern half, close to the Reclamation Wall. L W/L Grey Plover was also the only marked Grey Plover to defend a territory on the softer mud of the western side of Scalloped Mud. Territoriality was never observed in any Grey Plovers, marked or unmarked, feeding on Greenabella Bank or Central Channel during the winter of 1977/78. The occurrence of territoriality amongst marked Grey Plovers on the eastern mudbanks (Eastern Channel, Central Bank, Seaton Channel) was significantly higher than on the western mudbanks (Scalloped Mud, Greenabella Bank, Central Channel) ($\chi^2 = 5.08$, 1 d.f., $P \approx 0.025$).

1975/76 and 1976/77 - The less extensive data for the 2 previous winters confirm the pattern described above. Marked Grey Plovers fed on all areas of Seal Sands but territorial behaviour was observed only on Eastern

Channel and on the northern and southern sections of Central Bank.

Territoriality was also shown by 3 marked Grey Plovers feeding on the muddy edges of the Brinefields pool, and by one on the banks of Greatham Creek. Two of these birds also defended territories elsewhere. In the winter of 1975/76, one Grey Plover defended a territory whilst on the Brinefields pasture at High Water. This bird fed non-territorially on Seal Sands at Low Water.

The main sites on Seal Sands in which territoriality occurred have common physical features. Eastern Channel, Seaton Channel mudbank and the northern and southern sections of Central Bank consist largely of firm mud or sandy mud. In general, the areas comprising softer substrates (Central Channel, Greenabella Bank, Scalloped Mud - west) did not support Grey Plover territories. All but one of the areas on which Grey Plovers regularly defended territories are uncovered for at least 5 hours each tidal cycle, being at high or mid tidal levels (Table 3.36). Thus territories were not defended close to the Low Water tide edge where the majority of other wader species preferred to feed. On Scalloped Mud in mid winter, territories were held on two substrate types: on sandy mud close to the Reclamation Wall, and on the firmer mud at the edges of deep creeks filled with liquid mud or water. These creek sides and also the edges of Seaton Channel, the Brinefields creek and Greatham Creek, are essentially linear habitats.

Sub-adults - The occurrence of territorial behaviour in the 3 age classes of marked Grey Plovers is shown in Table 3.37. Despite the small sample sizes it appears that territorial behaviour is less frequent in juveniles than in older birds. It is hoped that future studies will provide data to test this possibility.

Table 3.36

The periods of exposure of territories
regularly held by marked Grey Plovers

<u>Marked Grey Plovers</u>	<u>Section of Seal Sands on which territory held</u>	<u>Period of exposure (hours)</u>
L L/G	Central Bank - north	4.5
W R/O	Eastern Channel	5.5
Y L/R	Central Bank - north	5.5
Y L/O, O R/L	Central Bank - north	5.75
L W/L	Scalloped Mud - west	6
R Y/Y	Seaton Channel	6
L W/L	Scalloped Mud - east (creek)	6.25
Y R/L	Central Bank - north	6.25
O L/O	Central Bank - south	7.25
O W/W	Central Bank - south	7.5 - 8.5
B R/W	Greatham Creek	10 - 11.5

Table 3.37

The occurrence of territorial behaviour in 3 age classes
of marked Grey Plovers, during the winters 1975-78

	<u>Adults</u>	<u>Second winter birds</u>	<u>Juveniles</u>
Number whose Low Water feeding site known	27	2	4
Number (percentage) which showed territorial behaviour	17 (63%)	2 (100%)	1 (25%)

3. II. A. 3. b. Changes in territoriality during the tidal cycle

Grey Plovers were more likely to leave their territories during the tidal cycle if defending an area away from the main sites. Territories held on Eastern Channel and Central Bank - north were defended from first exposure by the ebbing tide until the Grey Plovers were pushed off their feeding sites by the flood tide, usually a period of 5-6 hours (Table 3.36). This was also true for territories on the western half of Scalloped Mud. In contrast territories on Scalloped Mud - east were sometimes abandoned at around the time of Low Water. This was due at least in part to the considerable human disturbance experienced by the Grey Plovers defending territories close to the seawall. When not in its territory adjacent to the Scalloped Mud reclamation wall the marked Grey Plover L W/L was usually observed on Greenabella Bank. This bird was never territorial on Greenabella Bank yet from late November always defended its feeding site when present on Scalloped Mud - east. Data for the central area of Central Bank are few, but indicate that territories there were defended for at least the major part of the period of exposure. Territorial behaviour on the southern section of Central Bank was more complex. One marked individual defended its territory on mud for the whole of the Low Water period in February, whereas others, on a much sandier substrate, did so either for a few minutes as the tide ebbed or flowed, or stayed until true Low Water and then left. Furthermore Grey Plover behaviour on this area changed with the season (see below). It is important to note that this southern area with its more complex territorial system is at a very high tidal level compared with most other areas with territories.

When Grey Plovers defended territories from the time of first exposure of the mud they had to tolerate initially a high density of waders of other species in their territories. These waders feeding at the tide edge

as it crossed their territory interfered with the Grey Plover's foraging. However most Grey Plover territories were held on very flat mudbanks (e.g. Central Bank, Eastern Channel) across which the tide ebbed very rapidly. Therefore any disturbance was of short duration. Similarly disturbance on the flood tide did not last for long.

Territorial defence on the sites adjacent to Seal Sands was complicated by the tidal rhythms in the Brinefields pool which were less regular than and not in phase with those on Seal Sands. Also most Grey Plovers that fed on the Brinefields used it when Seal Sands was covered by the tide. Therefore their defence of a territory on the Brinefields depended upon a) how long they needed to feed to supplement their intake in the rest of the tidal cycle, b) the tidal state of the Brinefields and c) the total number of Grey Plovers feeding there. One bird (B R/W) that in 1975/76 regularly fed at the edge of the Brinefields pool regardless of state of tide on Seal Sands always defended its territory when present. B R/W also defended a territory along Greatham Creek in 1975/76 and 1976/77, often for the whole period of exposure of the area.

Defence of 2 territories during a tidal cycle - Only 3 marked Grey Plovers were known to defend more than one territory during a tidal cycle. In the winter of 1975/76 one bird (B R/W) defended a feeding site on both Greatham Harbour and the Brinefields pool. Another individual (Y L/R) held a territory at Low Water on the northern section of Central Bank during its period of stay in 1977/78, and on one day in early February also defended a site on the sandy ridge of Central Bank - south on the flood tide. The third occasion concerned W R/O which temporarily defended a territory at the edge of the Brinefields pool at High Water in March 1976 in addition to the territory it

regularly held on Eastern Channel at Low Water. Thus B R/W was the only marked Grey Plover to defend 2 sites on a regular basis, and on Seal Sands such behaviour was extremely uncommon during the study.

3. II. A. 3. c. Seasonal changes in territorial behaviour
in relation to the Low Water feeding area used

In this section I shall show that some Grey Plovers changed their spacing behaviour between being territorial and non-territorial during a winter, whereas other individuals either maintained the same territory or remained non-territorial throughout. Then, in the following section, the possible causes of changes in territorial behaviour will be discussed.

The behaviour of individual birds could be predicted from the section of Seal Sands on which they fed (Table 3.38). During the winter of 1977/78, no seasonal changes in territorial behaviour were observed amongst marked Grey Plovers defending sites on the major area of Grey Plover territories (the northern parts of Central Bank and Eastern Channel) and on Seaton Channel until late March (Tables 3.38 and 3.39). In the previous 2 winters, marked birds defending territories in Eastern Channel and Greatham Creek were faithful to their territories throughout the winter (except for the period immediately following arrival on the estuary). Thus fidelity to a territory during a winter was highest on the areas of greatest fidelity to Low Water feeding sites (Section 3. II. A. 1. c).

In contrast seasonal changes, particularly from non-territorial to territorial behaviour, were shown by marked Grey Plovers feeding initially on the areas of Seal Sands with few regularly defended Grey Plover territories, i. e. the southern part of Central Bank, and Scalloped Mud (Tables 3.38 and 3.39). These changes occurred throughout the winter, and were frequently associated with changes in Low Water feeding site (see below).

Table 3.38

The occurrence of seasonal changes in territorial behaviour in relation to the Low Water feeding area used, amongst marked Grey Plovers on Seal Sands, during 1977/78

<u>Area of Seal Sands</u>	<u>Number of marked Grey Plovers showing territoriality</u>	<u>Number of marked Grey Plovers showing seasonal changes in territoriality</u>
Eastern Channel - north	1	0
Seaton Channel	1	0
Central Bank - north	4	1
Central Bank - central	1	0
Central Bank - south	5	4
Eastern Channel - south	1	1
Scalloped Mud - east	1	1
Scalloped Mud - west	1	1
Greenabella Bank	0	-
Central Channel	0	-

Grey Plover - territorial behaviour shown by marked birds during 3 winters

1977/78	Bird	Date of arrival on Seal Sands	First territory	Date occupied	Date abandoned if before emigration	Second territory	Date occupied	Date abandoned if before emigration	Date of emigration
	Y R/L	early Nov.	Cbn	early Nov					early Mar
	W R/O	late Nov	Ech	late Nov					mid Mar
	R Y/Y	before early Nov.	Sch	before end Nov.					late Mar
	Y L/O	mid Jan.	Cbn	before mid Feb.					early Mar.
	O L/O	mid Feb.	CBs	mid Feb.					mid Mar.
	Y L/R*	late Dec	Cbn	before mid Feb		CBs	mid Feb	mid Feb	early Apr
	L W/L*	late Aug	SMw	mid Oct		SMe	late Nov	late Mar	mid Apr
	O R/L	before mid Oct	Cbn	before mid Nov					mid Apr
	Y O/R	late Oct	Ech	late Dec					mid Mar
	L O/O	before early Feb	CBs	mid Feb					mid Feb
	L O/W	mid Jan	CBs	late Jan					early Mar
	O W/O	mid Jan	CBs	late Jan					mid Mar
	O R/W	early Feb	Cbc	mid Feb					mid Mar
1976/77	W R/O	mid Nov	Ech	late Nov					mid Mar
	B R/W	early Jan	GC	early Jan					mid Mar
	O W/W**	before mid Feb	CBs	early Mar					mid Mar
	L L/G	before late Jan	Cbn	early Feb					early Feb
1975/76	W R/O	before mid Dec	Ech	before mid Jan		B	early Mar	early Mar	early Apr
	B R/W	before mid Dec	B	before early Feb		GC	before early Mar		late Mar
	B W/G	before mid Dec	B	early Feb					early Apr
	B W/O	before mid Dec	Bf	mid Feb					late Mar

Details are given for all marked Grey Plovers that showed territorial behaviour during the study.

Key for abbreviations given on Table 3.19.

* known 2nd winter bird. ** known Juvenile.

Observations of territoriality amongst unmarked Grey Plovers during 1977/78 provide further evidence of this area-related difference in behaviour. Territories were defended throughout the winter by unmarked Grey Plovers feeding in the northern half of Eastern Channel (Fig. 3.18). In contrast, territorial defence on mudflats away from the main area of Grey Plover territories was observed only during peaks in the population, i. e. in autumn (Scalloped Mud - west) or in midwinter (Central Bank - south and central, Eastern Channel - south, and the open mudflats of Scalloped Mud - east). There was thus a general increase through the winter in the number of mudflats which held territorial Grey Plovers.

Marked birds that established exclusive feeding areas soon after their arrival on the estuary defended sites on certain areas of Seal Sands: the northern parts of Eastern Channel and Central Bank, and on firm (but not sandy) mud on the southern section of Central Bank, and also in Greatham Creek (Table 3.39). Marked birds that became territorial only after several weeks on Seal Sands chose to defend sites on different areas: Scalloped Mud and the sandy ridge on Central Bank - south (Table 3.39). Thus the physical features of the different sections of Seal Sands appear to influence not only the areas in which most territories are held and any changes during the tidal cycle, but also seasonal changes in territorial behaviour.

With this knowledge of seasonal changes in the occurrence of territorial behaviour on Seal Sands together with the counts of the Grey Plover population (Section 2.B), it is possible to estimate the number of Grey Plovers that defended territories in the autumn and in mid winter of 1977/78 (Table 3.39a). The proportion of 40 per cent of the population defending territories in both seasons may be an under-estimate, as the spacing behaviour of Grey Plovers on the northern half of Central Bank was not fully documented.

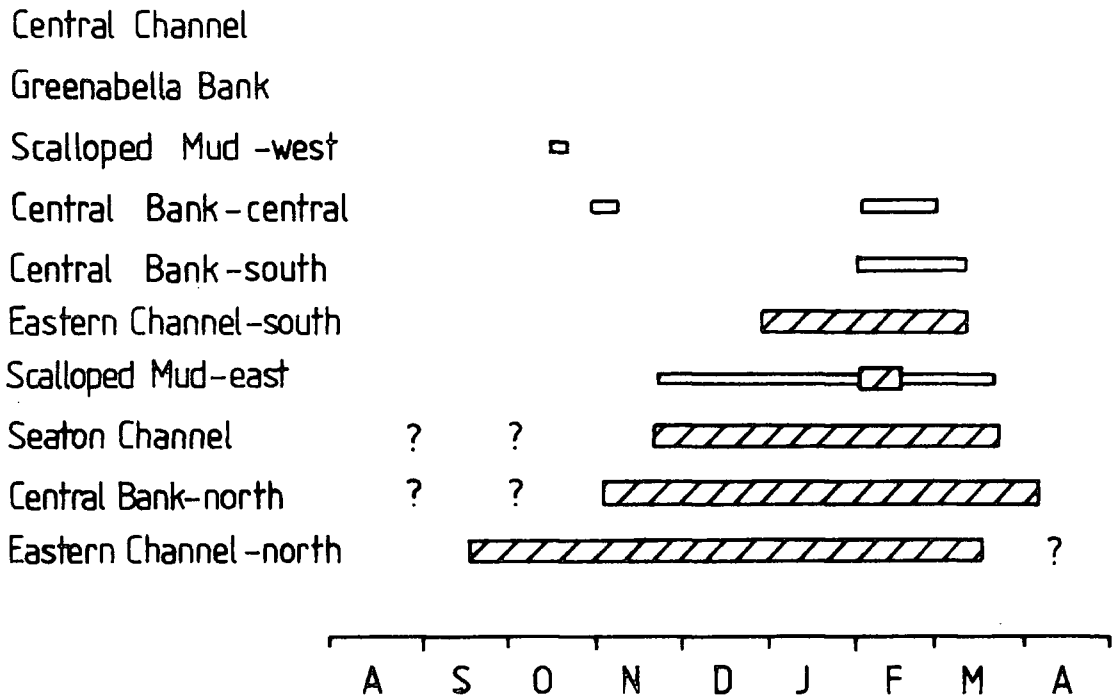



 Area \pm completely partitioned between territorial Grey Plovers
 Only a few of the Grey Plovers present were defending territories.

Figure 3.18 The seasonal occurrence of territoriality amongst Grey Plovers on areas of Seal Sands during the 1977/78 winter.

Table 3.39a

Estimates of the number of Grey Plovers defending
feeding sites on Seal Sands during autumn
and mid winter, 1977/78

	<u>November 1977</u>	<u>February 1978</u>
Eastern Channel	16	20
Seaton Channel	4	4
Central Bank - north	(12)*	(26)*
Central Bank - central	(0)*	(8)*
Central Bank - south	0	8
Scalloped Mud - east	2	5
Scalloped Mud - west	0	0
Greenabella Bank	0	0
Central Channel	0	0
	—	—
Total number of territorial Grey Plovers	34	71
Total population	90	177
Percentage of population showing territoriality	38%	40%

*The estimates for the more northerly sections of Central Bank
are probably too low - see text.

Only a few sub-adult birds were marked during the study, so differences between age classes cannot be identified convincingly. Both adults and sub-adults showed seasonal changes in territorial behaviour (Table 3.39). However, amongst the 8 marked Grey Plovers that defended permanent territories during 1977/78, only the 2 second winter individuals defended more than one territory on Seal Sands during the winter. This may indicate that they were having difficulty meeting their energy requirements when feeding on a single defended site. The ability to acquire and defend a permanent territory successfully, with benefits exceeding costs, may, therefore, be achieved only after at least 2 years of life.

3. II. A. 3. d. The causes of seasonal changes in use of space

Seasonal changes both in Low Water feeding site and in territorial behaviour were shown by marked Grey Plovers on Seal Sands. The discussion of the possible causes of changes in Low Water site were held over to this section because changes in site and in territoriality often occurred simultaneously. I shall now examine how the two are inter-linked, and then investigate why the changes occurred.

If a Grey Plover changes its use of space it has several possible choices:

- a) stay in the same site but change from territorial to non-territorial behaviour or vice versa
- b) abandon the first site; on the new site it may
 - i) retain the same behaviour, i. e. defend or not, or
 - ii) change behaviour.

Thus changes in site and behaviour could coincide. Table 3.40 shows that, during the study, 7 out of 20 seasonal changes in use of space by marked Grey Plovers at Low Water involved both a new site and a change in territorial behaviour - hence the combined discussion of causes presented below.

A Grey Plover could have changed its use of space for any of three main

Table 3.40

Changes in use of space observed amongst marked Grey Plovers
at Low Water on Seal Sands during the three winters 1975-78

		<u>Low Water Site</u>	
		Change	No change
<u>First site</u>	<u>Second site</u>	<hr/>	
No	No	9	-
Yes	Yes	0	-
<u>Site Defence</u>			
No	Yes	5	2
Yes	No	2	2
		<hr/>	

reasons. The first reason is that it was unable to obtain food fast enough with its original use of space. This would occur if the density of available prey (i. e. the number per unit area of prey animals accessible to the predator) became insufficient to enable the bird to capture prey at a fast enough rate to meet its daily requirements. This would be a consequence of any of the following:

- i) a poor feeding area (i. e. with a very low density of available prey) being chosen on arrival on Seal Sands.
- ii) falling temperatures and strong winds - falling temperatures reduce the availability of prey (see Section 3. II. D), strong winds impede the capture of prey (Townshend in Evans 1976, Dugan et al.1981), and both increase the energy requirements and therefore the required feeding rate of Grey Plovers (Evans 1976).
- iii) the absolute density of prey decreasing during the winter due to predation by the waders and/or other natural mortality.
- iv) an increase in the density of Grey Plovers feeding nearby - these would reduce the density of available prey by removing and/or disturbing prey which would otherwise be accessible at the mud surface. Additionally, avoidance movements (in which the bird moves away from nearby birds and into an empty area of mud) and disputes over individual space would be more frequent at high Grey Plover density, leading to a reduction in the time available for feeding. Increased avoidance and prey disturbance would also occur if the density of other species of shorebird in a feeding area increased. Increases in bird density on a feeding area might occur not only during influxes onto Seal Sands as a whole, but also when a fall in prey availability, for example due to falling temperatures, causes birds to concentrate into sites with relatively higher densities of available prey.

Faced with a marked decrease in the density of prey available at the surface of the mud, a Grey Plover should change its foraging behaviour in one of 2 ways:

- i) if previously non-territorial, it could reduce the disturbance and removal of accessible prey by defending its feeding site against conspecifics
- ii) if already territorial, or non-territorial in an area where prey availability has fallen too greatly to make it worth defending, the bird has no option but to change site. It could either move to an area elsewhere on Seal Sands with a higher density of available prey, or leave Seal Sands altogether.

The second main reason is that it could obtain food at a faster rate by a change in use of space, even though the density of available prey was adequate to enable it to meet its energy requirements without such a change, at that time.

Such changes "by choice" could occur:

- i) soon after a Grey Plover arrives on Seal Sands, if it samples the prey density in several areas before deciding on a suitable site and defence (or otherwise) of it. It would perhaps be particularly likely in juveniles which have no previous experience of feeding on these mudflats. During this period after arrival (in autumn or mid winter), a Grey Plover may change Low Water feeding site several times over a period of days or even hours.
- ii) as a direct response to a change in the profitability for feeding of one area, or net benefit of one type of territorial behaviour relative to that of another, during the winter. For example the relative profitability of a sheltered site would increase during strong winds (which increase energy requirements and impede prey capture).

- iii) A Grey Plover might change its use of space in autumn in anticipation of poor feeding conditions in mid winter. If the density of available prey is only just adequate in mild conditions, it might change site in autumn; if the food stocks will last all winter only if no more than one Grey Plover is removing prey, it might defend the site from early autumn. Either change would not be a direct response to feeding difficulties, but rather a long-term strategy to survive the winter.

The third main reason could be that it was excluded from the site by another Grey Plover. This could occur:

- i) when an individual starts defending a site previously used non-territorially by other Grey Plovers,
- ii) when a territorial Grey Plover is evicted from its defended site by another individual.

This discussion of possible reasons for seasonal changes in the use of space applies equally to changes shown by Curlews (Section 3. II. B. 3. d.).

I shall now explore the observed changes in use of space in the light of these possible explanations, dealing firstly with cases where a change in only Low Water site or territorial behaviour, but not both, occurred.

1. Change in Low Water site, always non-territorial - During the three winters 1975 - 78, there were 6 of these changes between November and February (Table 3.41). Four coincided with decreases in temperature - notably one with a marked decrease in mid November 1977 (midday air temperature dropped from 10-14^o to 4-6^oC, Fig. 3.19), and one with the coldest spell of the 1977-78 winter. In two of the four cases, the marked birds moved from higher to lower mudflats,

Table 3.41

Correlations between changes in use of space by marked Grey Plovers on Seal Sands during the 1975-78 winters and 5 possible causes

	Change in Low Water site, always non-territorial					O....F	Change in Low Water site and from non-territorial to territorial					Change in Low Water site, and from territorial to non-territorial
	N	D	J	F	M		A	N	D	J	F	
Number of changes observed	1	0	3	2	2	1	1	1	0	1	1	1
Correlations between changes and:												
a) Temperature decrease	1	-	2	1	-	-	-	1	-	-	-	1
b) Temperature increase	-	-	-	-	2	-	-	-	-	1	-	-
c) Recent arrival of individual	1	-	1	-	-	-	-	1	-	-	-	-
d) Influx of Grey Plovers into feeding area	-	-	-	-	-	1	1	-	-	-	-	-
e) Eflux of Grey Plovers from Seal Sands	-	-	-	-	2	-	-	1	-	-	-	1
Cause unknown	-	-	-	1	-	1	-	-	1	-	-	-

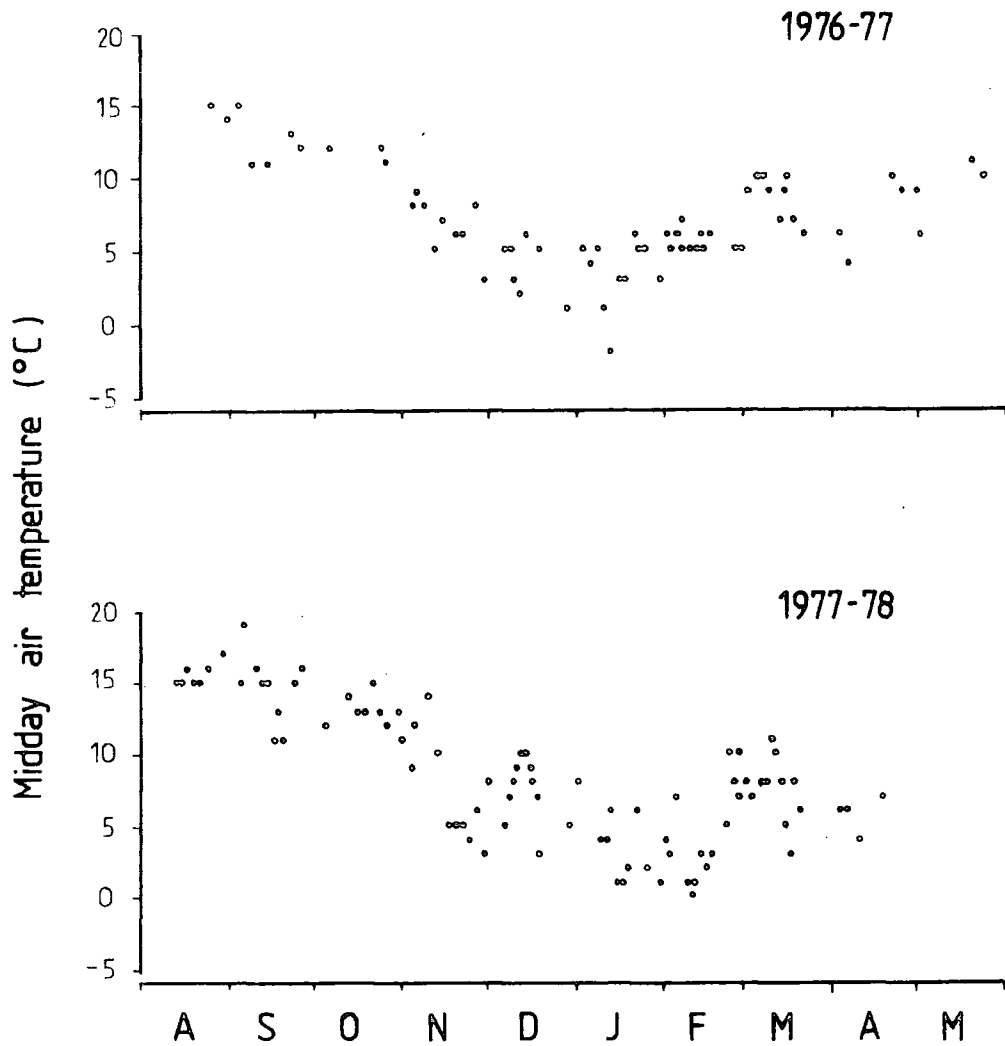

Figure 3.19 The midday air temperature on observation days during two winters. Data from the records of the Teesmouth coastguard station.

and in the third the individual moved from an area little used by Grey Plovers and where no nereids were captured, to an area where Nereis was the main prey.

Two marked Grey Plovers changed site soon after their arrival on the estuary (in November and January), with both birds feeding at first in small groups on Scalloped Mud-east. They may each have been forced to change after choosing a poor area (i. e. Scalloped Mud-east) on arrival, or may have changed by choice whilst sampling the prey density on different areas of Seal Sands. In none of the six cases before March was the change in site the result of competition for space with other Grey Plovers.

Three marked Grey Plovers changed site, always feeding non-territorially in March-April when absolute prey density would be lower than earlier in the winter but temperatures generally increasing. Two changes coincided with increasing temperatures after the cold spell of February 1978 (Fig. 3.19). Both birds began to feed on a higher mudflat (Scalloped Mud-east) throughout the period of exposure instead of moving to lower areas. This could have been a consequence of Scalloped Mud-east providing high enough densities of available prey only in warm conditions. There may also have been more space in which to feed on Scalloped Mud as a result of emigration of some Grey Plovers from Seal Sands during this period.

2. Change in Low Water site, both sites defended - No example of this behaviour was observed.

3. Change from non-territorial to territorial behaviour, same site - Two marked Grey Plovers began defending a site (on Scalloped Mud-west and the Brinefields Pool) at which they had previously been feeding non-territorially. In both cases the defence was temporary, lasting up to 3 days. Each case occurred when an exceptionally high density of Grey Plovers was feeding in the vicinity of

the marked bird, probably leading to increased prey disturbance and removal as described earlier. The temporary defence on Scalloped Mud-west in October (not only by the marked bird, but also by several unmarked individuals) coincided with the passage through the estuary of juvenile Grey Plovers which favoured this area of softer muds (see Section 2. B).

4. Change from territorial to non-territorial behaviour, same site - This occurred only at the end of the short-term territorial behaviour described above. When long-term territories were abandoned, a change in site also occurred (see below).

5. Change in Low Water site and from non-territorial to territorial behaviour - During the winters of 1975-78, 5 previously non-territorial marked birds moved to new sites and defended them. No common causes for the changes, which occurred at all times of winter, could be identified (Table 3.41). Two marked birds moved to new areas and began long-term defence in November, one (L W/L) after feeding non-territorially elsewhere since August, and the other (W R/O) only two weeks after its arrival on the estuary. W R/O returned to the territory it had occupied the previous winter. At first it fed non-territorially on Greenabella Bank, and perhaps sampled other areas of Seal Sands. However, it is more likely that it was either waiting for its territory to become vacant, or feeding non-territorially before evicting another Grey Plover in order to regain its territory (as it did in the following autumn). The movement of L W/L to a new, defended site coincided with a marked decrease in temperature, so the change may have been a direct response to the decreasing density of available prey and increased energy requirements.

The other 3 marked birds in this category defended their new sites for shorter periods (Y O/R, O W/W, L L/G, Table 3.39) and less is known of their preceding and/or subsequent behaviour.

6. Change in Low Water site and from territorial to non-territorial behaviour -

In spring 1978, 2 marked Grey Plovers (O R/L, L W/L), which had each defended a Low Water feeding site since autumn, abandoned their territories and fed instead in the loose flock of Grey Plovers and Dunlin wandering over Seal Sands. This change in behaviour was correlated with several possible causes. It followed the departure from the estuary of Knot, Godwit and many of the Grey Plovers and Dunlin (P. R. Evans, pers. comm.) and may, therefore, have been a response to the increase in the number of areas on Seal Sands where densities of all species of feeding waders were low. However there was also a decrease in temperature during this period (midday air temperature fell from 7-11^o to 4-6^oC, Fig. 3.19), and absolute prey densities must have been at their lowest as a result of predation through the winter, so the change of site may have occurred because of difficulties in maintaining the required food intake in the original site. As the change of site coincided with the chief spawning period of Nereis, (Evans et al. 1979), which come to the surface and are easily accessible to predators, their flocking behaviour may assist in finding patches of recently emerged Nereis. A final possibility is that the flocking was a consequence of increasing migratory restlessness and not related to feeding.

Conclusions - Overall, the factors most frequently correlated with seasonal changes in use of space were temperature changes (9 out of 18), particularly decreases (7 cases), and changes in Grey Plover density (7 out of 18). However the importance of these factors varied between the types of change that occurred. Changes in use of space by marked Grey Plovers were shown mainly by those which initially fed non-territorially (16 out of 18 cases). Movement to a new site where they continued to feed non-territorially was the most frequently observed change (9 out of 18 cases). When low temperatures made feeding difficult, the

birds moved to lower mudflats. Changes in the opposite direction occurred only in the warmer weather of spring. In contrast, when the density of Grey Plovers feeding nearby temporarily increased, marked birds began to defend their feeding sites for short periods, rather than change Low Water site. Temporary territoriality in response to an influx of Grey Plovers was also observed on the ebb and flood tides (see next section).

In at least some cases, movement to a new site and the start of territorial defence occurred together, when a long-term territory was established in autumn. Such long-term defence probably provides considerable advantages to the holder (see Section 3. II. D. 1), and long-term territories were sometimes taken up in autumn in anticipation of benefits accruing later. Long-term territories were never abandoned in winter, only in spring, and no specific cause could be identified.

3. II. A. 3. e. Seasonal changes in territoriality outside the Low Water period

It has been shown above that seasonal changes occur at Low Water feeding sites in the incidence of both permanent and temporary territoriality. However by combining discussion of changes in Low Water feeding site and in territorial behaviour not all cases of site defence are included. During the study, six marked Grey Plovers defended feeding sites only at times other than Low Water. In all but one case such defence lasted for less than a day.

Four marked birds each attempted to defend a feeding site on the high, sandy ridge of Central Bank-south during the very cold weather of January-February 1978. Three did so on the ebb tide and one as the tide flooded. At these times, the already high density of Grey Plovers would have been increased further because of the reduced area for feeding. On one occasion a marked Grey Plover also tried to exclude Golden Plovers which were present in very large numbers. These four attempts to defend sites on this ridge can be matched

exactly to the most severe weather conditions: heavy snow and the coldest mud and midday air temperatures recorded that winter. Thus the high energy requirements and likely reduced availability of prey caused by bad weather (see Section 3. II. D.), exacerbated by the high density of feeding plovers, led these birds to defend their feeding sites.

The other two cases of defence occurred at High Water. One bird (W R/O 1975/76) defended a site on a tidal creek on a single day when exceptionally high numbers of Grey Plovers were present along the creek. The other individual defended a site on pasture adjacent to the creek. This defence lasted from mid February until the bird emigrated in late March. Presumably it was unable to meet its energy requirements when feeding on Seal Sands at Low Water, perhaps because of the decreasing absolute density of prey there.

Combining these data with those for use of space at Low Water, we see that temporary site defence occurred most often when Grey Plover density was high (7 out of 8 cases) and temperatures low (4 out of 8).

3. II. A. 3. f. Changes in the territorial behaviour of individual Grey Plovers between years

As detailed observations of territoriality were confined mainly to winter 1977/78, comparisons between years are limited. Fourteen Grey Plovers returned to the estuary during the three years of my study. In the first year in which they were observed 2 were known to be juveniles. One of these (L W/L) is known to have been non-territorial when a juvenile, but the behaviour of the other (Y L/R) in its first winter is unknown. In the following winter (1977/78) both birds were territorial, and L W/L also defended the same territory during winter 1978/79 (P. J. Dugan, pers. comm.).

Amongst the 12 adults, 2 (W R/O, B R/W) regularly defended a territory at Low Water in the first winter in which they were observed. In the following

winter (1976/77) both defended the exact territory they had held the previous year. (B R/W fed solely in Greatham Creek in 1976/77 due to disturbance on the Brinefields.) W R/O held a territory in the same site during the winter of 1977/78, evicting another individual in order to do so. The other 2 marked Grey Plovers that defended territories on the Brinefields (but not on Seal Sands) during 1975/76, returned in the 2 following winters. They were not seen feeding on the Brinefields in either winter, and again showed no territorial behaviour on Seal Sands. Knowledge of the territorial behaviour of the other 8 adults in their year of ringing is sparse so comparisons between this and the following winter are difficult. However 2 individuals fed in identical sites in successive years and were definitely territorial in the second winter in which they were observed. Two others were non-territorial in the 1976/77 winter (when ringed) and for much of the following winter, each attempting to defend a territory on only one occasion in 1977/78. Of the remaining 4 birds, 3 showed territorial behaviour in the second winter of observation, and the fourth was probably non-territorial in both winters. In 1978/79 2 marked Grey Plovers, previously non-territorial in early 1977 and absent in 1977/78, defended territories, one in Eastern Channel and one at the edge of the Brinefields creek (P. J. Dugan, pers. comm.).

Thus no marked individuals feeding on Seal Sands changed from being territorial in one winter to non-territorial in the following winter. All individuals regularly showing territorial behaviour on certain sites in one winter did so in the same sites in subsequent winters. Of the Grey Plovers that did not defend any feeding sites in one winter, some fed in similar sites with similar behaviour in the following winter, whereas others changed feeding sites and became territorial. Therefore between years there is a gradual shift towards territoriality which parallels the trend detected in the seasonal changes in the occurrence of territoriality.

3. II. A. 3. g. Summary

At least 40 per cent of the Grey Plovers on Seal Sands during a winter defended feeding territories. Territories were held only on certain areas of Seal Sands. These areas share common physical features: they are at high or mid tidal levels, and consist largely of mud or firm sandy mud. Territories were held throughout the period of exposure on Eastern Channel and the northern part of Central Bank, but those on Scalloped Mud and the southern part of Central Bank were often deserted during the Low Water period. Territoriality amongst Grey Plovers occurred on Seal Sands throughout the winter, but was most frequent in January and February. The increase was due mainly to birds taking up territories on areas of Seal Sands that were previously undefended. Seasonal changes in use of space were correlated particularly with changes in temperature and in Grey Plover density.

Identical territories were defended by individuals in successive winters. Between years there was an increase in the occurrence of territoriality in the population of marked Grey Plovers.

3. II. B. THE USE OF SEAL SANDS AS A FEEDING AREA BY INDIVIDUAL CURLEWS

The counts of Curlews on the estuary (Section 2.C) and the sightings of marked individuals (Section 3. I. C, above) indicate that there is a fairly constant population of Curlews on and around the estuary for much of the winter. The behaviour of individuals on their main intertidal feeding area, Seal Sands, has been studied in more detail and will be described below. The use of the pastures adjacent to Seal Sands as a feeding area is closely linked to the use of Seal Sands itself, with some individuals feeding on both sites. The use of the pastures by Curlews will be discussed later, in Section 3. II. C.

3. II. B. 1. Low Water feeding sites of individual Curlews

3. II. B. 1. a. Sites used

Low Water feeding sites were determined for 49 of the 67 marked Curlews present on the estuary during the winter of 1977/78 (Fig. 3.20, Table 3.42). Unfortunately these sites were unrepresentative of the whole population (Table 3.43). The distributions of marked and unmarked Curlews were very significantly different ($\chi^2 = 67.35$, 4 d.f., $P \ll 0.001$). This arose from the relative ease of identification and observation of ringed birds on Scalloped Mud but difficulty in the identification of those at the tide edges of Greenabella Bank and Central Channel. However, within each section the distribution of marked birds on different substrates was similar to the distribution of all Curlews (e.g. Table 3.44), except on Central Channel (see below).

Many marked Curlews were seen on more than one site, and in general their behaviour was less predictable than that of the marked Grey Plovers, but more so than that of the marked Godwits (pers. obs.).

Scalloped Mud - 14 of the marked Curlews fed almost exclusively on the eastern half, and 9 on the western half, with only one being seen regularly on both.

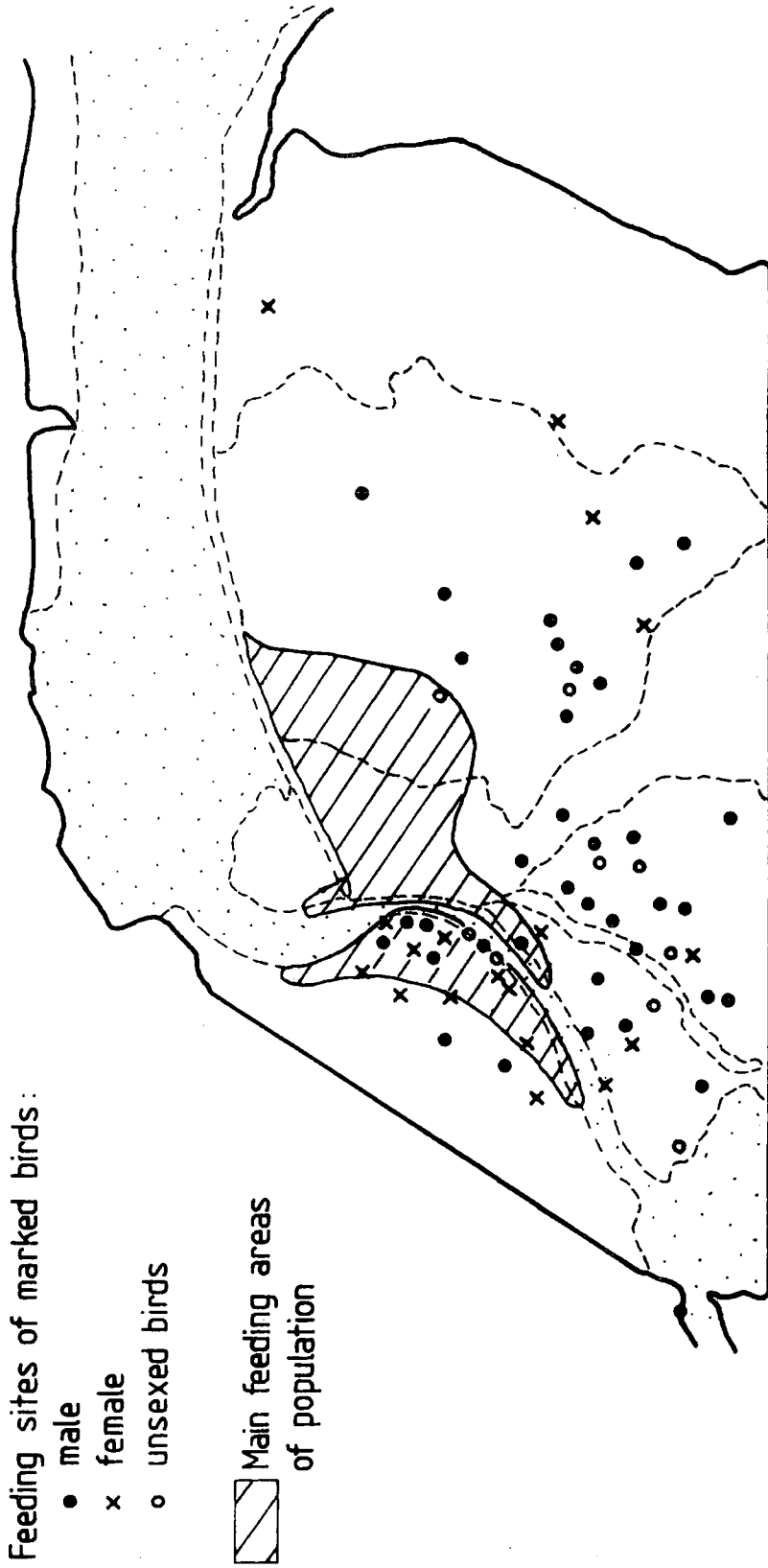

Figure 3.20 The distribution of marked Curlews and the Curlew population on Seal Sands at Low Water during the 1977/78 winter.

Table 3.42

The Low Water feeding sites used by marked Curlews on Seal Sands

	Number of marked birds present	Number whose Low Water feeding sites known	Number of Low Water feeding sites on sections of Seal Sands					Number feeding on sites other than Seal Sands	Number with feeding sites unknown
			CB	ECh	SM	GB	CCh		
1977/78	67	45	14	2	24	19	2	12	18
1975/76	4	2	1	0	0	0	1	0	2
1976/77	42	20	0	1	17	5	1	0	23

Table 3.43

The distribution of marked Curlews and the Curlew population
on Seal Sands at Low Water, in 2 winters

	<u>Sections of Seal Sands</u>				
	CB	ECh	SM	GB	CCh
<u>1977/78</u>					
Low Water feeding sites of marked Curlews	14(23%)	2(3%)	24(40%)	19(31%)	2(3%)
Low Water distribution of the Curlew population	46(17%)	8(3%)	32(12%)	131(48%)	53(20%)
<u>1976/77</u>					
Low Water feeding sites of marked Curlews	0(0%)	1(4%)	17(71%)	5(21%)	1(4%)
Low Water distribution of the Curlew population	51(22%)	7(3%)	61*(27%)	70(30%)	42(18%)

* includes some roosting birds (see text).

Values are numbers, with approximate percentages in brackets.

Data for the Curlew population taken from Table 2.6.

Key for abbreviations given on Table 3.19.

This distribution is very similar to that of the Curlew population on Scalloped Mud (Table 3.44). At Low Water the marked Curlews on the eastern half fed mainly on the open mud to the west and north of the mussel scars keeping away from the Reclamation Wall. Those feeding on the western half tended to be spaced out across the whole area, but the individuals that appeared only infrequently fed mainly on the liquid mud in the centre.

Greenabella Bank - Individual marked Curlews on Greenabella Bank tended to feed preferentially on either the open mud (7 birds) or at the tide edge (8 birds). Sightings of the other 4 birds that used Greenabella Bank at Low Water were insufficient to determine a preference. Although open-mud and tide-edge feeders were not differentiated during Low Water counts of the whole population on Greenabella Bank, Curlews fed on both open mud and tide edge in roughly similar numbers, except on extreme tides (see Section 2. B. 2. a).

Central Bank - On Central Bank most marked birds fed in the southern section (Table 3.44). This distribution reflects the preference shown for the southern section by the whole Curlew population (Tables 3.44 and 3.45) but under-represents birds on Central Bank - north. On the southern section the marked Curlews tended to feed on the softer muds, including the Enteromorpha-covered area, and rarely fed on the sandy ridge.

Eastern Channel - Only 2 marked Curlews were seen feeding in Eastern Channel during 1977/78, one in the northern half and one in softer mud in the southern half. These birds are representative of the whole population as unmarked Curlews fed throughout the length of Eastern Channel (except close to the Reclamation Wall).

Central Channel - The two marked Curlews seen in Central Channel at Low Water both fed on the liquid mud to the north-east of Scalloped Mud. Most of the rest of the Curlew population fed closer to Seaton Channel, either on the

Table 3.44

The distribution of Low Water feeding sites of marked birds and of the Curlew population within 2 areas of Seal Sands, in the 1977/78 winter

	<u>Feeding sites of marked birds</u>		<u>Feeding sites of the population</u>	
	number	percentage	number	percentage
Scalloped Mud				
- east	15	60 %	16.5*	56 %
- west	10	40 %	13.0*	44 %
Central Bank				
- north	1	7 %	8.3**	23 %
- central	3	21 %	7.3**	20 %
- south	10	72 %	20.8**	57 %

Population figures derived from:

* 11 counts at Low Water

** Table 3.45

Table 3.45

The distribution of the Curlew population on
three sections of Central Bank at Low Water
during the 1977/78 winter

	<u>A</u> Central Bank - north	<u>B</u> Central Bank - central	<u>C</u> Central Bank - south
10. 11. 77.	13	8	21
13. 1. 78.	6	2	26
16. 2. 78.	9	10	10
16. 3. 78.	5	9	26

Sections of Central Bank as shown on Table 2. 3.

liquid mud or at the tide edge. Therefore the marked birds were not representative of the total numbers of Curlews using Central Channel.

There is little information on the Low Water feeding sites used by marked Curlews in the two previous winters of 1975/76 and 1976/77, because, until March 1977, only 8 Curlews were colour-ringed. In 1976/77, the distribution of Low Water feeding sites of the marked birds on the whole of Seal Sands was unrepresentative of the whole Curlew population (Table 3.43). However within 3 sections, Eastern Channel, Scalloped Mud and Greenabella Bank, the marked Curlews and the Curlew population were believed to be distributed similarly in 1976/77 although there are insufficient data to show this.

Juveniles - It was difficult to investigate whether juveniles chose Low Water feeding sites which differed from those of adults during a winter as only 3 of the 8 ringed juveniles were seen on Seal Sands at Low Water, and these sightings were confined to March and April 1977. All 3 birds were observed at Low Water solely on Scalloped Mud, 2 on the western side and 1 on the eastern half. There are too few sightings to know whether this indicates a real preference of juveniles for Scalloped Mud.

3. II. B. 1. b. Fidelity to a Low Water feeding site during a winter

The fidelity of marked Curlews to a Low Water feeding site on Seal Sands during a winter varied between individuals, as in Grey Plovers. In this section I shall show that the behaviour of an individual Curlew during a winter was influenced by its original choice of Low Water feeding site. In Section 3. II. B. 1. d, the possible causes of changes in Low Water feeding site, and in territorial behaviour, will be discussed. The data refer in the main to the winter of 1977/78.

Birds faithful to one feeding site (Table 3.49) - During 1977/78 Curlews faithful to their Low Water feeding site throughout the winter were found only on

Table 3.49

Marked Curlews faithful to a single Low Water feeding site:
sightings of birds at Low Water during the winter of 1977/78

	A	S	O	N	D	J	F	M	A
R O/G	a ○	●●	●	●	●●		●●	●●	●●●d
G W/O	a	●●	●		●●●●		●●	●	●x d
Y W/R	a	●●	●	●●	●●●		●●●	●●	d
R O/O	a ○	●●●	●	●●	●●●●		●●●	●●d	
R W/R		a●●●				●	●●	●d	
W Y/Y	a●●●	●●	d						
W W/W	a □			□x		□		□□	d
Y G/Y		a □				□	x	□□	□□d
R O/R	a				□			□□	□d
R G/W	a					□	□	□	d
L O/G	a				□		□	□d	
R L/O	a		□	□	□	□		d	

Symbols represent the number of observation-days each month that individual Curlews were seen on the Low Water feeding areas on Seal Sands. All sightings of feeding at Low Water are shown.

Key: ○ = Central Bank - south
 □ = Greenabella Bank
 x = Scalloped Mud - west
 a = month in which first seen/ringed
 d = month in which last seen

Central Bank and Greenabella Bank. Six of the 10 marked Curlews seen feeding at Low Water on Central Bank - south did so throughout their period of stay. No changes in Low Water feeding site were observed on extreme tides. On Greenabella Bank 6 marked birds were faithful to their Low Water site for the whole winter. None of these birds was seen feeding anywhere else on Seal Sands at Low Water, except on 2 extreme neap Low tides when much of the lowest mud on Greenabella Bank remained covered. On the ebb and flood tides throughout the winter they used feeding sites consistent with the use of Greenabella Bank at Low Water (see below). Therefore although Low Water sightings of marked Curlews on Greenabella Bank were infrequent, these individuals did appear to feed almost exclusively on Greenabella Bank, throughout the winter.

In contrast to the Grey Plovers, Curlews were faithful to feeding areas at more than one tidal level (mid on Central Bank, mid and low on Greenabella Bank) and on a variety of substrates (mud and soft mud on Central Bank, soft and liquid muds on Greenabella Bank).

Birds that changed their Low Water feeding site (Table 3.50) Seasonal changes in Low Water feeding site within Seal Sands were detected amongst 10 marked Curlews during the winter of 1977/78. In general, feeding sites that were abandoned during the winter were on areas of Seal Sands at high or mid-tidal levels (Scalloped Mud, Eastern Channel), the marked birds moving to areas at lower tidal levels (usually Greenabella Bank) (Table 3.51). In addition, at least 9 moved from Seal Sands to feed on fields in mid-winter (see Section 3. II. C). Changes in Low Water feeding site occurred particularly from November to March, and were shown by both territorial and non-territorial individuals.

Differences in seasonal use were found not only between, but also within, areas. The number of marked Curlews feeding on the eastern half of Scalloped Mud

Table 3.50

Marked Curlews which changed their Low Water feeding site within Seal Sands during a winter:
sightings of birds at Low Water during the 1977/78 winter

Marked Curlew	A	S	O	N	D	J	F	M	A
Y N/W	a ▽▽	▽▽▽	▽▽	▽▽□▽▽	▽	▽□□□	□□▽▽	□□d	
Y W/O	a	▽▽	▽	▽	▽		▽	□	d
B R/W	a ⊗⊗	⊗⊗⊗		⊗⊗⊗	⊗⊗⊗		⊗	⊗BB	d
Y O/L		a		x	⊗⊗	xx	⊗	B	xxd
L R/L	a xx	xxxxxxx	xxxxxx	xx	xxxxx	xxx	xxx	xx	d
O W/O	a xx	xxxxxx	xxxxx	xxx	□xxx	xx□x	xx□xx	□x	□x□d
R G/O	a	xx	xx		xx	xx		xx	x d
R R/Y	a x	xxx	x	x			x	xx	xxd
W O/O	a Δ	Δ	□		□	⊗□	□		d
Y O/O	a	⊗	⊗□					□□	□d

Symbols represent the number of observation-days each month that individual Curlews were seen on the Low Water feeding areas on Seal Sands.

Key:	○	Central Bank - south
	⊗	Central Bank - central
	□	Greenabella Bank
	▽	Eastern Channel
	⊗	Scalloped Mud - east
	x	Scalloped Mud - west
	Δ	Central Channel
	B	Brinefields
	a	Month in which first seen/ringed
	d	Month in which last seen

Table 3.51

The occurrence of seasonal changes in Low Water feeding site amongst marked Curlews on different areas of Seal Sands, during the 1977/78 winter

	Number of marked birds which fed there regularly in autumn	Number which fed only there throughout their stay	Number which regularly used another feeding site (site used)	Number whose use of sites unknown
Eastern Channel	2	0	2 (GB)	0
Scalloped Mud - east	15	0	11 (GB, SM _w , B*)	4
Scalloped Mud - west	4	0	4 (GB)	0
Central Channel	2	0	1 (GB)	1
Central Bank - north	0	0	0	0
Central Bank - central	1	0	1 (GB)	0
Central Bank - south	6	6	0	0
Greenabella Bank	10	6	0	4

* 9 of the 11 birds moved to the fields. Key as on Table 3.19.

decreased from September to January (matching the seasonal decrease in temperature), whereas the number on the western half varied little through the winter (Table 3.52). Many of those on the latter defended long-term territories. Those feeding on the eastern part in autumn moved particularly to the fields in mid winter (Table 3.51) returning to Seal Sands only under exceptional weather conditions (see Section 3. II. C. 2. below).

3. II. B. 1. c. Fidelity to a Low Water feeding site between years

In this section I shall show that some marked Curlews on all the well studied areas used the same Low Water feeding site in successive years. The proportion of marked Curlews returning to the same Low Water feeding site between years was higher on Greenabella Bank and the southern section of Central Bank than on other sections of Seal Sands.

Several marked Curlews were observed in 2 or more winters. However, as observations in winters other than 1977/78 were less detailed and/or less extensive, comparisons are limited. The fidelity of marked Curlews to Low Water feeding sites between years is set out in Table 3.53. (As some birds changed their Low Water feeding site during a winter year-to-year comparisons are made only between sites used on similar dates.) Overall, marked Curlews tended to feed at Low Water on the same section of Seal Sands as in the previous winter (22 out of 35 cases).

Fidelity to a Low Water feeding site was most marked on the southern section of Central Bank. Four of the 6 birds which fed there throughout the 1977/78 winter were feeding in the same area in August 1978, and at least 2 continued to do so throughout the 1978/79 winter (N. C. Davidson, L. R. Goodyer, F. L. Symonds, pers. comm.). Fidelity was also high on Greenabella Bank. Thus marked birds on these 2 areas are usually faithful to a Low Water site not only throughout a winter (see Section 3. II. B. 1. c. above) but also between winters.

Table 3.52

The number of marked Curlews feeding
at Low Water on the 2 halves of Scalloped Mud
during the winter of 1977/78

	A	S	O	N	D	J	F	M	A
Eastern half	6	7	2	3	3	1	6	1	3
Western half	4	4	4	5	4	4	3	4	5

Table 3.53

The fidelity of marked Curlews to a Low Water feeding site between years

Number of 1976/77 marked Curlews

	<u>Feeding in same area at same time of year</u>	<u>Feeding in a different area</u>	<u>Feeding area on Seal Sands unknown</u>	<u>Did not return to Seal Sands</u>
1977/78				
ECh	1	0	0	0
SM _e	2	2 (CB;SM _w)	3	2
SM _w	4	3 (GB;GB;GB+GC)	0	3
GB	3	1 (SM _w /CB _s)	1	0
CCh	0	1 (GB)	0	0

Number of 1977/78 marked Curlews

1978/79				
ECh	0	0	2	0
CB _n	1	0	0	0
CB _c	0	1 (CCh)	2	0
CB _s	5	0	4	1
SM _e	1	2 (CB;CCh)	11	1
SM _w	2	1 (GB)	7	0
GB	3	1 (SM _w)	13	2
CCh	0	0	2	0

Key as on Table 3.19

Much of the data for 1978/79 supplied by N. C. Davidson, L. R. Goodyer and F. L. Symonds, (pers. comm.)

Some marked Curlews showed similar seasonal changes in Low Water feeding site in successive winters, thereby being "faithful" to more than one site during a winter. For example Y N/W fed on Eastern Channel and Greenabella Bank at similar times during the winters of 1976/77 and 1977/78. Also O W/O fed on both Greenabella Bank and Scalloped Mud during 1977/78 and 1978/79. However O W/O began feeding on Greenabella Bank much earlier than in 1978/79 (August) than in the previous winter (December).

Most of the marked Curlews which used different Low Water feeding sites in successive years were seen only occasionally. However one bird (B R/W) was observed in 4 successive winters during which it changed its Low Water feeding site several times (Table 3.54). It was first seen in autumn at the Low Water feeding site used in the previous spring, as were those birds that were faithful to a site both during and between winters. This indicates that there may be an advantage in returning to the same site in successive years, if the food supplies are similar each year. This advantage would be lost if the density of available prey on the site were too low to last the winter. This may have been the reason for B R/W leaving the eastern side of Scalloped Mud in late autumn 1977.

Many of the marked Curlews which fed in different Low Water sites in successive years changed between Greenabella Bank and the western half of Scalloped Mud (Table 3.53). In some cases (e.g. O W/O, B R/W, see above) real changes in Low Water feeding site between years did occur. In others the paucity of observations in winters other than 1977/78 prevent a distinction between temporary changes (for example because of gales hindering feeding at the Greenabella Bank tide edge) and permanent changes from being made. It is thought likely that further information on the sites used would lead to a reduction in the number of permanent changes between Greenabella Bank and the western part of Scalloped Mud from that estimated in Table 3.53.

Table 3.54

The Low Water feeding sites used by one marked Curlew
 (B R/W) on Seal Sands during 4 winters

	A	S	O	N	D	J	F	M	A
1975/76					r		CCh		
1976/77		a			GB	GB	GB	SM _e	d
1977/78	aSM _e	SM _e	SM _e	SM _e /CB _s	SM _e /CB _s	CB _s	CB _s	CB _s	d
1978/79	aCB _s								

Key:

- r = month in which bird colour-ringed
- a = month in which bird arrived on the estuary
- d = month in which bird emigrated
- CCh = Central Channel
- GB = Greenabella Bank
- SM_e = Eastern half of Scalloped Mud
- CB_s = Southern part of Central Bank

3. II. B. 1. d. Summary

At Low Water marked Curlews could be found on all the mudflats of Seal Sands. The majority fed on the softer muds at mid or low tidal levels, including the Low Water tide edge.

Fidelity to a Low Water feeding site during a winter was high amongst marked Curlews on Greenabella Bank and the southern section of Central Bank. Birds feeding in the autumn on other areas of Seal Sands changed Low Water site during the winter. They moved from the higher mudflats (Scalloped Mud, Central Bank, Eastern Channel) either to the lower mudflats (Greenabella Bank) or to the fields. The changes in Low Water feeding site were correlated with seasonal changes in temperature.

Fidelity to a Low Water feeding site between years was shown on all areas. It was highest amongst marked Curlews feeding on Greenabella Bank and the southern section of Central Bank. Thus the greatest fidelity to a Low Water site both during a winter and between years was found on the same areas of Seal Sands.

3. II. B. 2. Feeding sites used during the tidal cycle

Either side of the Low Water period, as the tide ebbed and flowed across the mudflats, the overall distribution of Curlews on Seal Sands changed (Section 2. C. 3). In this section I shall show that the ebb and flood tide feeding sites chosen by most marked Curlews were determined by their Low Water feeding site. Seasonal changes in ebb and flood tide feeding sites were correlated with changes in Low Water site.

3. II. B. 2. a. Sites used

Choice of feeding site on the ebbing tide - Most Curlews moved from their roost sites to Central Bank or Scalloped Mud on the ebbing tide before they began to feed. As described in detail in Section 2. C, they spread out across the mudflats following the retreating tide edge. Later in the tidal cycle the lower mudflats (Eastern Channel, Greenabella Bank and Central Channel) and

the lower parts of Central Bank and Scalloped Mud became exposed. Some Curlews continued feeding on the higher mudflats, but most flew over to the lower areas as soon as they were uncovered.

A Curlew that wishes to feed on the ebbing tide before its Low Water feeding area is exposed must do so either on Scalloped Mud or Central Bank. The hypothesis proposed for Grey Plovers (Section 3. II. A. 2. a.) applies also to Curlews, namely:

If prey density is more or less uniform over the exposed mudflats, an individual Curlew should feed on the ebbing tide on the area closest to its Low Water feeding site. By doing so it would minimise the distance it had to fly when the lower mudflats were exposed. The predicted routes for Curlews are shown in Fig. 3.23.

This hypothesis was examined with the data on marked Curlews collected during the winter of 1977/78. The less complete information for 1976/77 and 1978/79 was used to confirm the results for 1977/78. Marked birds fed on both Scalloped Mud and Central Bank in all 3 years (Table 3.55). Some individuals showed seasonal changes in their ebb tide feeding site (see below), hence the high number that used both areas within a winter. The predictions concerning the Low Water and ebbing tide feeding sites used in the 1977/78 winter were upheld (Fig. 3.24). The ebb tide sites used by the group of marked Curlews feeding at Low Water on "Scalloped Mud and Greenabella Bank" were significantly different (exact probability test for 2 x 2 contingency table $P \ll 0.001$ per cent) from those used by birds feeding at Low Water on "Central Bank, Eastern Channel and Central Channel". This applied both to birds which moved to lower tidal levels (e.g. Greenabella Bank) and to those staying on the highest areas of Scalloped Mud and Central Bank.

The incomplete data for the winters of 1976/77 and 1978/79 do not

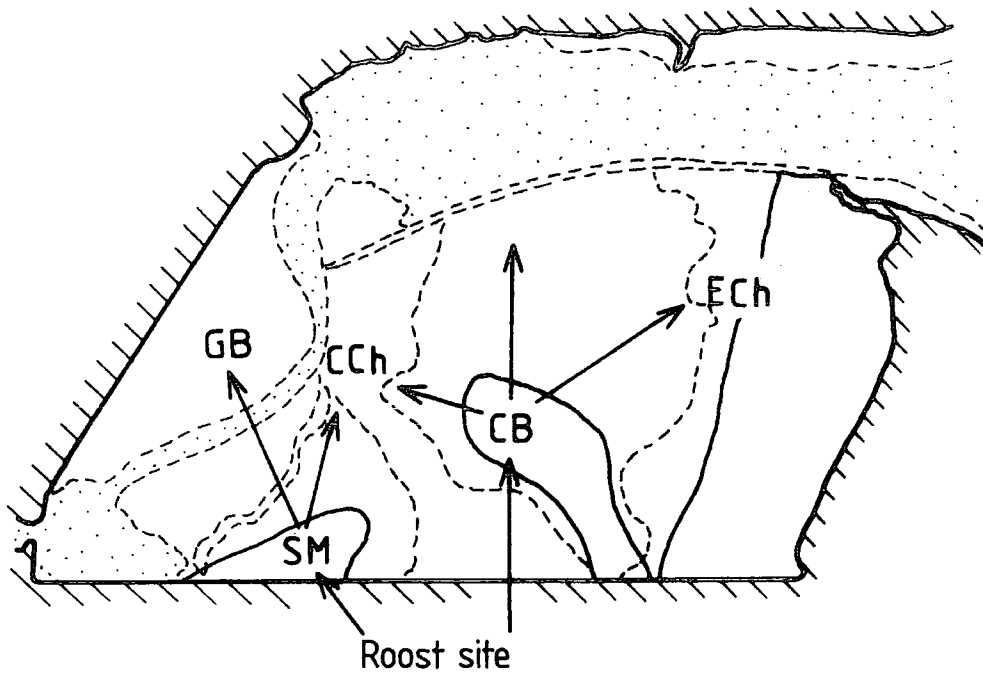

Key as on Fig. 3.14

Figure 3.23 The predicted routes of Curlews across Seal Sands on the ebb tide, if travel time and distance are to be minimised.

Table 3.55

The feeding sites used by marked Curlews
on the ebb tide, during 3 winters

<u>Ebb tide feeding sites</u>	<u>Number of Curlews</u>		
	1977/78	1976/77	1978/79
Scalloped Mud	21	12	8
Central Bank	9	1	15
Scalloped Mud and Central Bank	22	2	8
Unknown	17	27	27
	—	—	—
	69	42	58
	—	—	—

Date for 1978/79 from N. C. Davidson, L. R. Goodyer and
F. L. Symonds, pers. comm.

From Scalloped Mud to
Low Water feeding sites

From Central Bank to
Low Water feeding sites

1977-78

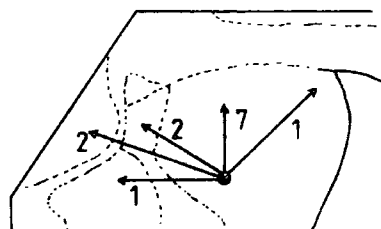
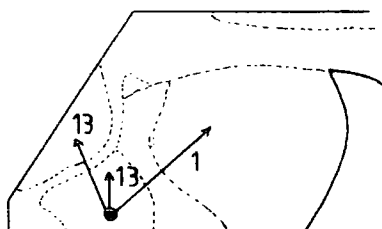

1976-77

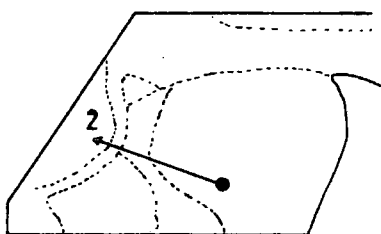
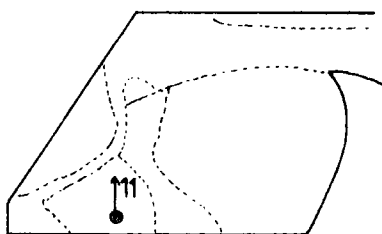

1978-79

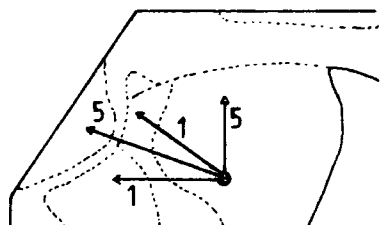
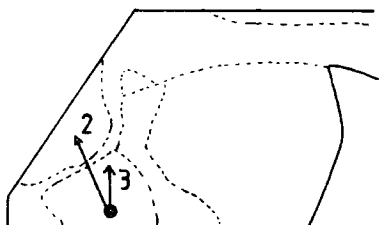

Mudbanks of Seal Sands
(Key as on Table 3.19)

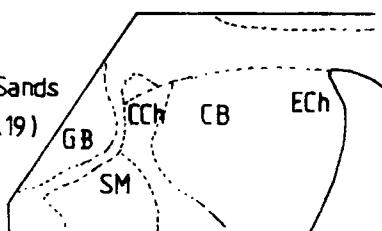

Figure 3.24

The movements of marked Curlews between feeding sites on the ebb tide, during three winters.

support the hypothesis (exact probability test, $P > 10$ per cent in both winters). This is due in part to the number of observations of marked Curlews which moved from Central Bank to Greenabella Bank during these winters. As Curlews feeding on Central Bank gradually moved north-westward across Central Bank and Central Channel with the retreating tide (Section 2. C. 3) the distance they had to fly to Greenabella Bank when it became exposed was not much greater than that from Scalloped Mud to Greenabella Bank (Fig. 2.19).

Once the lower mudflats on Seal Sands became exposed by the outgoing tide Curlews had a choice of areas on which to feed at Low Water. Some marked birds (27) fed at Low Water on the higher parts of Scalloped Mud and Central Bank, areas to which they could walk from their first ebb tide feeding site on the main mudflats. These birds therefore expended little energy in moving to their Low Water feeding site. The majority of marked Curlews (35 - an underestimate; see Section 3. II. B. 1. a) fed on the lower mudflats, particularly Greenabella Bank, and had to fly up to 1 kilometre between ebb tide and Low Water feeding sites. As they returned to the higher mudflats on the flood tide they, like the Grey Plovers, followed a "feeding circuit", as defined earlier. As the majority of marked Curlews followed feeding circuits this behaviour presumably resulted in considerable advantages that outweighed the costs of travelling:

1. they may have encountered higher prey densities on the lower mudflats.
2. since the availability of their main prey Nereis diversicolor is maximal at/near the tide edge (Vader 1964), by following it and thereby making a feeding circuit, most Curlews fed where the proportion of the prey that are available is at its maximum.

The absence of major differences in prey density between the higher and lower mudflats (Appendix 4) means that the observed movements between feeding areas are probably a response to differences in availability.

Timing of movements between feeding areas - To maximise the advantage, just detailed, the Curlews should move from the higher to the lower mudflats as they become exposed. They should then remain at/near the tide edge throughout the Low Water period and again on the flooding tide, only leaving when the particular mudflat is covered by the tide.

Most marked Curlews moved between feeding areas exactly as predicted and no delays, seen amongst the Grey Plovers, occurred. This applied not only to birds moving to the lower mudbanks, e.g. Greenabella Bank, but also to those walking to nearby Low Water sites on high mudflats. On the flooding tide the only marked Curlews that left before being pushed off by the tide were those that had finished feeding and flew over to roost on Scalloped Mud or Central Bank.

Choice of feeding site on the flooding tide - Those Curlews feeding on the higher mudflats at Low Water flew directly to their roosts when the incoming tide covered their feeding site. Those individuals that were pushed off the lower mudflats by the flooding tide and still wanted to feed moved either to Central Bank or Scalloped Mud. One would predict that, as on the ebb tide, these Curlews should minimise the distance flown between mudflats. Consequently the predicted routes are the reverse of those shown in Fig. 3.23.

Marked Curlews fed on both Central Bank and Scalloped Mud (Table 3.56) the area used being determined, as predicted, by the Low Water feeding site in all 3 winters (Fig. 3.25). The flood-tide feeding sites used by those marked Curlews feeding at Low Water on "Scalloped Mud and Greenabella Bank" were significantly different from those used by birds feeding at Low Water on "Central Bank, Eastern Channel and Central Channel" during both 1977/78

Table 3.56

The feeding sites used by marked Curlews
on the flood tide during 3 winters

<u>Flood tide feeding sites</u>	<u>Number of Curlews</u>		
	1977/78	1976/77	1978/79
Scalloped Mud	11	5	12
Central Bank	10	1	5
Scalloped Mud and Central Bank	15	0	1
Unknown	33	36	40
	69	42	58

Data for 1978/79 from N.C. Davidson, L.R. Goodyer and
F.L. Symonds, pers. comm.

From Low Water feeding sites to Scalloped Mud

From Low Water feeding sites to Central Bank

1977-78

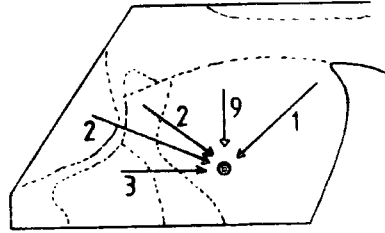
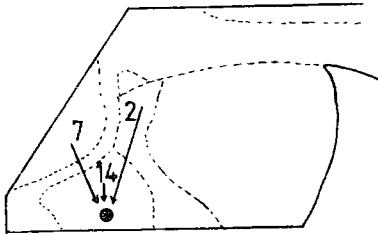

1976-77

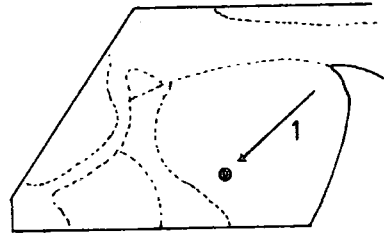
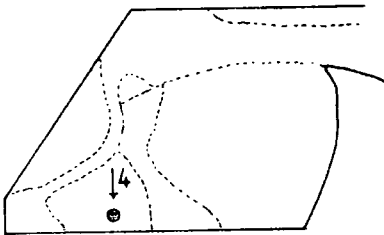

1978-79

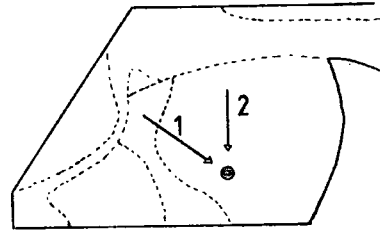
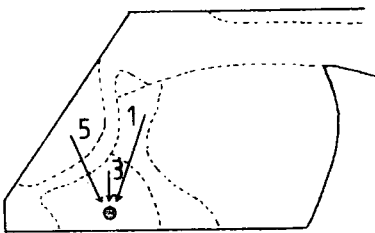

Mudbanks of Seal Sands
(Key as on Table 3.19)

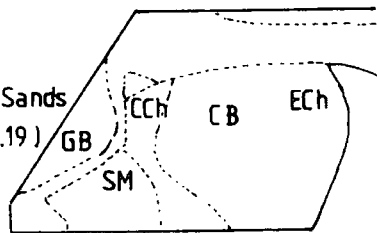

Figure 3.25

The movements of marked Curlews between feeding sites on the flood tide, during three winters.

($\chi^2 = 16.46$, 1 d.f., $P < 0.001$) and 1978/79 (exact probability test for 2 x 2 contingency table, $P = 1.82$ per cent), but the difference was not significant using the sparse 1976/77 data ($P = 20$ per cent).

Roosting on the flooding tide - A comparison between Tables 3.55 and 3.56 shows that, although the feeding sites of many marked Curlews were not identified on the ebb and flood tides, the number of 'unknowns' on the flood tide was considerably higher, constituting half the number of marked Curlews present on the estuary in 1977/78. It is believed that this arose because many Curlews that fed on Seal Sands at Low Water stopped feeding when the tide covered their Low Water site, so that, instead of feeding on the flood tide, they roosted then. Some stayed on Seal Sands (Scalloped Mud or Central Bank), others flew straight from their Low Water site to the High Water roost, e.g. B R/W from Greenabella Bank, 10th December 1976; Y N/W from Eastern Channel, 25th October 1977.

Support for this idea comes from sightings of marked Curlews on Seal Sands in 1977/78. Of the 33 marked birds for whom no flood tide feeding sites could be determined (Table 3.56) 18 were seen roosting on Seal Sands on the incoming tide, suggesting that they had fed on Seal Sands at Low Water. Indeed 12 of them were observed doing so. Presumably these birds had met their energy requirements in the earlier stages of the tidal cycle (unless they also fed elsewhere at High Water) and therefore did not need to feed on the flooding tide. Since 8 of these 12 marked birds fed at Low Water on Greenabella Bank (a significantly higher proportion than that for birds known to feed on Seal Sands at both Low Water and on the flooding tide ($\chi^2 = 4.01$, $P < 0.05$)), it may be that energy requirements can be satisfied more rapidly there than elsewhere on Seal Sands.

Feeding at the edge of Eastern Channel - Feeding by marked Curlews along the Eastern Channel tide edge or on the adjacent Peninsula Sands, the first areas to be uncovered by the ebbing tide, was observed only rarely. Eight individuals were involved, only one being seen there more than once during the winter (Y G/Y, seen twice). The occurrence of feeding there was not related to the Low Water feeding site used or to whether or not the individual defended a territory at Low Water.

The paucity of sightings of marked Curlews and the seasonal pattern of occurrence (Table 3.57) indicate that Eastern Channel is not important as an extra feeding site for Curlews at those times of tide when the main mudflats are covered, even during the coldest months. Furthermore, when feeding along Eastern Channel at this stage of the tide, the Curlews did not always feed at the tide edge, feeding instead on the open sandy mud nearby. The bouts of feeding were usually intermittent, the bird often stopping to preen or look around.

Feeding along Eastern Channel was related to the choice of roost site. Curlews were more likely to wait, and sometimes feed, along the Eastern Channel when their roost was on the Peninsula (on neap tides) or on the islands south of the main shipping channel of the river Tees.

On only one occasion did Curlews feed along the Eastern Channel tide edge when feeding conditions were difficult, namely on 17th January 1978 when 5 individuals were feeding. The midday air temperature on that day was very low (1° C).

Towards High Water feeding along the Eastern Channel tide edge was desultory and was observed on only 3 occasions, in August, October and November.

The proportion of females feeding along the Eastern Channel tide edge on both ebb (3 females, 3 males, 2 unsexed) and flood (2 females, 1 male) tides was greater than that in the ringed population as a whole. This contrasts with

Table 3.57

The occurrence amongst marked Curlews
of feeding along the Eastern Channel tide
edge on the ebb tide, during 1977/78

	A	S	O	N	D	J	F	M	Total
Number of days on which Eastern Channel tide edge checked for birds	1	2	3	2	2	3	2	2	17
Number of days on which marked Curlews seen feeding there	0	1	0	1	1	1	0	0	4

the almost complete absence of ringed females feeding on the fields at High Water during the study (see Section 3. II. C. 2. b) and may indicate a preference of females for feeding on intertidal substrates. Males appeared to gain extra feeding time by feeding on the fields (see Section 3. II. C. 2. b, below).

3. II. B. 2. b. Seasonal changes in feeding sites used during the tidal cycle

Changes in ebb and flood tide feeding sites of several marked Curlews were observed during the 1977/78 winter. Some changes were correlated with changes in Low Water feeding site, but the total number of changes on the ebb and flood tides were greater than of those at Low Water.

It was shown above that Curlews minimise their travelling between feeding sites on Seal Sands by choosing ebb/flood tide feeding areas closest to their Low Water feeding site (at least during 1977/78). If the relationship between Low Water and ebb/flood tide feeding sites is maintained throughout the winter, it is possible to predict changes in ebb and flood tide sites associated with changes in the site used at Low Water, as explained for Grey Plovers (Section 3. II. A. 2. b).

The predictions were examined with data from the marked Curlews known to have changed their Low Water feeding sites within Seal Sands (i. e. excluding birds which moved to the fields) during the 1977/78 winter (Table 3. 58). Observations on ebb and flood tide feeding sites were less frequent than those at Low Water so it is more difficult to determine if and when changes occurred. Nevertheless it is clear that the predictions were upheld on both ebb and flood tides for marked birds moving from Low Water sites on Scalloped Mud (Table 3. 58, first 3 categories). Birds that changed Low Water site from Central Bank - central, Eastern Channel or Central Channel (Table 3. 58) either showed no change on ebb or flood tides, or a change on just one of them.

Table 3.58

The relationship between predicted and observed changes in ebb and flood tide feeding sites amongst marked Curlews during the 1977/78 winter

Change in Low Water Site	Number of birds which changed	Time of Low Water change	Predicted change in ebb/flood tide site	Observed change in ebb tide site	Time of change on ebb	Observed change in flood tide site	Time of change on flood
SM _e → CB _s	1	Nov - Dec	SM → CB	SM → CB	Nov - Feb	SM → CB	Oct - Nov
SM _e ↔ SM _w	1	Nov - Apr	-	-	-	-	-
SM _w → GB	?4	Nov - Apr	-	-	-	-	-
CB _c → GB	1	Oct	CB → SM	CB → SM	Oct	?	-
ECh → GB	2	Nov	CB → SM	-	-	CB → SM	Jan
CCh → GB	1	Sep - Oct	CB → SM	SM → CB	Dec - Jan	-	-

Key for abbreviations given on Table 3.19.

Predictions can also be made for the 12 individuals which did not change their Low Water site during a winter (Table 3.49). If minimising travel as shown in Section 3. II. B. 2. a. above, these birds should continue to use the same ebb and flood tide feeding sites throughout their stay on Seal Sands. This was found for all 6 feeding on the southern section of Central Bank, with the exception of G W/O on 2 occasions. Once during the severe weather in February it fed on Scalloped Mud instead of Central Bank on the ebb tide, and once in mid April it fed on Scalloped Mud on the flood tide after feeding there at Low Water. On both occasions the change could be related to the likelihood of food shortage - due to reduced availability in February and to low absolute density in April. The 6 marked Curlews which fed at Low Water throughout the winter on Greenabella Bank were less predictable than the birds faithful to the southern part of Central Bank. On the ebb tide 4 were seen at least occasionally on Scalloped Mud or Central Bank on different days during the winter. Three were seen on Scalloped Mud or Central Bank on the flood tide. No seasonal trends could be detected in these observations. Changes were observed in the ebb and flood tide feeding sites of other marked Curlews, often those whose Low Water feeding sites had not been determined. Again no seasonal trends were apparent.

Through the winter no overall trend away from one ebb tide feeding site (Scalloped Mud or Central Bank) to the other (Central Bank or Scalloped Mud) was detected. It is therefore unlikely that the observed changes are a consequence of difficulty in obtaining sufficient food on either site. Some marked Curlews did choose their ebb and flood tide feeding sites in order to minimise their travelling between feeding sites. The failure of others to do so could have been due to:

- a) the distance travelled from Central Bank (or Central Channel) to Greenabella Bank being little further than that from Scalloped Mud to Greenabella Bank. If this is so, there would be no advantage in using only Scalloped Mud on the ebb and flood tides when feeding on Greenabella Bank at Low Water.
- b) factors other than distance between feeding sites influencing their choice of feeding area. For individuals that feed very little on the flood (and perhaps ebb) tide, proximity to the High Water roost may be a stronger influence on the choice between Scalloped Mud and Central Bank.

3. II. B. 2. c. Fidelity between years to feeding sites used during the tidal cycle

As choice of ebb and flood tide feeding sites was in general determined by the Low Water feeding site used, fidelity to a Low Water feeding site between years should result in fidelity on the ebb and flood tides. No exceptions to this expected pattern were observed.

3. II. B. 2. d. Summary

On the ebb tide marked Curlews began to feed either on Central Bank or Scalloped Mud. The feeding site chosen was determined by the Low Water feeding site used by the individual. Similarly birds feeding on the flood tide chose the site closest to their Low Water feeding site. In this way they minimised the distance flown between mudflats on Seal Sands.

The majority of marked Curlews followed feeding circuits, moving from the higher parts of Central Bank or Scalloped Mud to the lower mudflats (particularly Greenabella Bank) as they became exposed, and then returning to the higher areas on the flood tide. A few birds fed at Low Water on the higher parts of Scalloped Mud and Central Bank, so no feeding circuit was involved and very little energy used in moving between sites.

Many Curlews roosted on the flood tide, particularly those feeding at

Low Water on Greenabella Bank.

Feeding along the Eastern Channel tide edge before the main mudflats of Seal Sands became exposed was rarely seen and usually desultory. Its occurrence was related more to the roost site used at High Water than to adverse conditions under which extra feeding might be required.

During a winter, changes in Low Water feeding site were, in general, accompanied by changes in ebb and flood tide feeding site such that travel between sites on Seal Sands continued to be minimised. However, changes in ebb and flood tide feeding site were more frequent than changes in Low Water site.

No differences between the sexes were detected in the feeding sites used during the tidal cycle.

3. II. B. 3. Feeding territories

Both defence of individual space and true territoriality as defined earlier (Section 3. II. A. 3) were shown by Curlews feeding on Seal Sands. Disputes over individual space were rare (Table 3.59) as reported also by Goss-Custard (1970). They occurred most frequently at the tide edge where the nearest-neighbour distances between Curlews were smallest (Table 3.60). Transgression of individual space was much less frequent on the open mud well away from the tide edge where the density of feeding Curlews was much lower (Table 3.60). Interactions over individual space generally lasted less than 5 seconds.

True intraspecific territoriality was observed amongst the Curlews on Seal Sands throughout the winter of 1977/78. Observations in the previous winter, 1976/77, were confined mainly to Eastern Channel. Intraspecific territoriality in wintering Curlews has also been observed elsewhere in Great Britain (Goss-Custard, 1970) and in the Dutch Wadden Sea (Ens, 1979).

Table 3.59

Defence of individual space amongst feeding Curlews:
the frequency of displacements amongst feeding marked
Curlews that were not defending territories, during 1976/77

	N	D	J	F	M	A
<u>EBB TIDE</u>						
Number of minutes of observation on marked birds	0	25	3	0	0	7
Number of displacements observed	-	1	0	-	-	0
Rate of displacements per bird per hour	-	2.40	0	-	-	0
<u>LOW WATER</u>						
Number of minutes observation on marked birds	0	10	26	20	30	42
Number of displacements observed	-	0	0	0	0	0
Rate of displacements per bird per hour	-	0	0	0	0	0
<u>FLOOD TIDE</u>						
Number of minutes observation on marked birds	17	17	24	0	13	0
Number of displacements observed	1	0	0	-	0	-
Rate of displacements per bird per hour	3.53	0	0	-	0	-

Table 3.60

Nearest-neighbour distances between
Curlews feeding at the tide edge and on open mud

	<u>Section of Seal Sands</u>	<u>Date</u>	<u>Marked bird</u>	<u>Nearest-neighbour distance (metres)</u>
TIDE EDGE	Greenabella Bank	1. 12. 77	O W/O	1
	" "	26. 1. 78	R W/W	< 3
	" "	7. 3. 78	W W/W	< 1
OPEN MUD	Scalloped Mud	14. 2. 78	Y O/R	> 5
	Greenabella Bank	7. 3. 78	R Y/N	5 - 10

Territoriality in Curlews had the same characteristics as in Grey Plovers, namely that conspecifics were excluded by means of calls, displays and direct aggression. Boundary disputes between neighbouring territory holders were often lengthy, especially in autumn (Table 3.61). Whilst in possession of a territory, the owner predictably fed on the same site each time it was exposed at Low Water. It also roosted and preened in its territory.

3. II. B. 3. a. Sites in which territoriality was observed (Fig. 3.26)

In this section I shall show that Curlews held territories mainly on mudbanks at mid tidal levels. They often used softer substrates than territorial Grey Plovers.

During 1977/78, territoriality in Curlews was observed on only a few areas of Seal Sands, namely Eastern Channel, the southern section of Central Bank and Scalloped Mud (Table 3.62). In Eastern Channel, 2 territories were defended by marked Curlews, one in the northern part and one in the softer mud nearer the Reclamation Wall, close to Central Bank. Unmarked Curlews were also seen to defend territories along much of Eastern Channel, but not on the softest muds close to the Reclamation Wall. The Curlews that occasionally fed at Low Water on the very sandy mud of Eastern Channel and on the adjacent Peninsula Sands were not seen to defend territories.

On Central Bank territoriality amongst Curlews was observed only on the southern section. Four marked Curlews all defended sites mainly on the softer mud south of the sandy ridge. Few of the unmarked Curlews seen feeding there defended territories. On the more northern areas of Central Bank territorial behaviour may have been overlooked because of the distance of these areas from the observation points on the Reclamation Wall.

Territoriality amongst Curlews on Scalloped Mud was in the main confined to the western half. Here territories of marked and unmarked birds

Table 3.61

The duration of some disputes over
territorial boundaries between Curlews on Seal Sands

<u>Section of Seal Sands</u>	<u>Date</u>	<u>Marked bird</u>	<u>Duration of dispute (mins)</u>
Eastern Channel	27. 11. 76	Y N/W	8
" "	10. 12. 76	"	13
" "	17. 9. 77.	"	4
Scalloped Mud - west	10. 9. 77	L R/L	3
" " "	19. 9. 77	O W/O	8
" " "	24. 9. 77	R G/O	20
" " "	24. 9. 77	O W/O	7
" " "	24. 9. 77	L R/L	4
Central Bank - south	11. 4. 78	R O/G	6

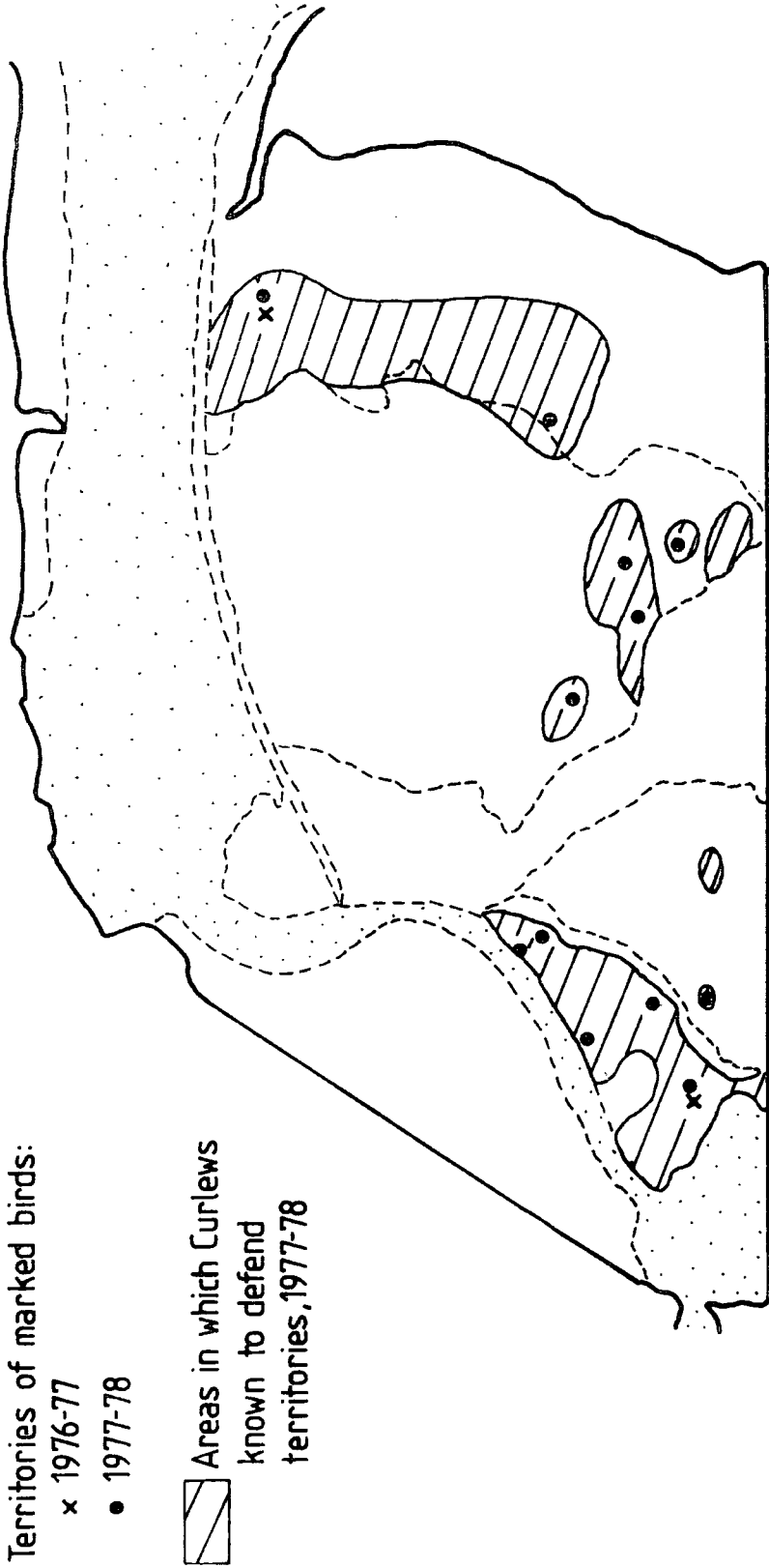

Figure 3.26 The occurrence of territoriality amongst Curlews on Seal Sands

Table 3.62

The occurrence of territoriality amongst Curlews on Seal Sands during the 1977/78 winter

<u>Section of Seal Sands</u>	<u>Total number observed</u>	<u>Marked Curlews</u>		<u>Unmarked Curlews (see key)</u>
		<u>Number showing territoriality</u>	<u>Territorial birds as percentage of total observed</u>	
Eastern Channel	2	2	100 %	***
Scalloped Mud - west	24	5	21 %	***
Scalloped Mud - east	37	1	3 %	**
Central Bank - south	27	4	15 %	**
Central Bank - central	11	0	0 %	*
Central Bank - north	4	0	0 %	*
Greenabella Bank	24	0	0 %	*
Central Channel	12	0	0 %	*
Total	141	12	9 %	

Key: Sightings of territorial defence amongst unmarked Curlews seen: *** frequently
 ** occasionally
 * never

abutted, almost the whole western mudbank being divided up into territories. Up to 10 feeding areas were defended there during the 1977/78 winter. On the eastern section only 3 Curlews (one marked) defended feeding sites, all temporarily.

Territoriality was never observed in either marked or unmarked Curlews feeding on Greenabella Bank or Central Channel during the winter of 1977/78.

Few observations were made upon the use of space by Curlews in other winters, but the data available for 1976/77 confirm the pattern described above. Three marked Curlews were seen to defend territories, one in the northern section of Eastern Channel and two on the western half on Scalloped Mud.

Thus, although the areas in which Curlews defended territories were not identical to those in which Grey Plover territories occurred, there was considerable overlap in the sections of Seal Sands used (compare Figs. 3.17 and 3.26). Both species defended territories on the same parts of Eastern Channel. Neither attempted to defend feeding sites on either Greenabella Bank or Central Channel, thus avoiding the areas of highest density of feeding waders (of all species) at Low Water.

Curlews also defended territories on softer muds than were used by Grey Plovers. This was particularly evident on Scalloped Mud where Curlews defended areas almost solely on the softer western half and Grey Plovers mainly on the eastern half. Similarly on the southern section of Central Bank, Curlews generally avoided the sandy ridge used by territorial Grey Plovers. Curlews fed only at very low density on the dry Enteromorpha-covered mud of Central Bank - north (Table 3.45), and limited observations did not detect any territorial behaviour. This contrasts markedly with the high incidence of territoriality amongst the many Grey Plovers that fed there.

On the areas used by both territorial Curlews and territorial Grey Plovers, i. e. Eastern Channel and parts of Scalloped Mud and Central Bank (Figs. 3.17 and 3.26) no direct interspecific competition for space was seen in over 50 hours of observations. No aggressive interactions over territorial boundaries between individuals of the 2 species were seen during the study. On Eastern Channel and Scalloped Mud - west there was evidence that at least some territories of Curlews overlapped in space with those of Grey Plovers. In these areas interspecific avoidance may have occurred. If so, the Grey Plover should not feed on the common ground when the Curlew was present, and vice versa. No measures of avoidance were made but it was clear that Grey Plovers and Curlews along Eastern Channel rarely fed together. The data discussed in Section 3. I. E. 1. indicate that Grey Plovers may avoid Curlews but Curlews are not influenced by Grey Plovers feeding nearby.

All the areas on which Curlews defended territories lie at mid tidal levels, being uncovered for $5\frac{1}{2}$ - $7\frac{1}{4}$ hours each tidal cycle (Table 3.63).

3. II. B. 3. b. Changes in territoriality during the tidal cycle

The 2 territorial marked Curlews on Eastern Channel and 2 of the 4 on Central Bank - south defended their territories throughout the period of exposure by the tide. Thus they arrived on the area on the ebb tide before other Curlews

Table 3.63

The periods of exposure of territories
regularly held by marked Curlews

<u>Marked Curlew</u>	<u>Section of Seal Sands on which territory held</u>	<u>Period of exposure (hours)</u>
Y N/W	Eastern Channel	5.5
Y W/O	Eastern Channel	5.5
R R/Y	Scalloped Mud - west	6
R G/O	Scalloped Mud - west	6.25
R O/O	Central Bank - south	6.25
O W/O	Scalloped Mud - west	7
L R/L	Scalloped Mud - west	7.25
R O/G	Central Bank - south	7.25

could begin feeding there and left only when pushed off by the incoming tide. Four of the 5 marked birds defending territories on the western half of Scalloped Mud also remained on their territories throughout the period of exposure on some days. However they showed seasonal changes in Low Water feeding site (see Section 3. II. B. 1. b. above) which resulted in seasonal changes between territorial and non-territorial behaviour in at least one bird (see below). Two of these marked Curlews abandoned their territories during the Low Water period, at least one feeding non-territorially along the tide edge of Greenabella Bank. Changes between territorial and non-territorial behaviour in other marked Curlews regularly defending territories on Seal Sands were also observed during the winter (see below).

Those marked Curlews with territories on the higher tidal levels of Scalloped Mud and Central Bank moved from their roost onto their feeding areas as soon as they were exposed. They very rarely fed on other areas before this time. In contrast Curlews with territories on lower mudflats exposed for shorter periods (i. e. those at the top of Table 3.63) followed feeding circuits. At least one of those defending a territory in Eastern Channel (Y N/W, at the lower, northern end) fed on Central Bank, acting non-territorially, until its territory was uncovered by the outgoing tide. Similarly it was seen to feed again on Central Bank (non-territorially) when the flood tide had covered its territory.

A feeding circuit was also employed by the marked Curlew (R R/Y) occupying the territory at the most northerly tip of the western half of Scalloped Mud. This territory was at a lower tidal level than those nearer to the seawall. R R/Y fed on the adjacent and higher tip of the eastern half of Scalloped Mud until $3\frac{1}{2}$ to 4 hours after High Water when its territory was

uncovered by the tide. On the flood tide R R/Y usually stopped feeding once its territory was covered, but once continued feeding on the eastern half of Scalloped Mud. Again it showed territorial behaviour only on its Low Water feeding site.

No marked Curlews defended more than one territory during a tidal cycle. This contrasts with the behaviour of some marked Grey Plovers (see Section 3. II. A. 3. b.).

Defence of an exclusive feeding area is energetically expensive in that intruders have to be evicted from the territory, at least until the boundaries are learnt and respected by other Curlews. Those territories on the higher tidal levels of Scalloped Mud and Central Bank (listed at the bottom of Table 3.63) were particularly subject to disturbance by other Curlews, since, when little of Seal Sands was exposed, feeding conspecifics were present at high density on the few uncovered mudflats.

3. II. B. 3. c. Seasonal changes in territorial behaviour in relation to the Low Water feeding area used

In this section I shall demonstrate that none of the marked Curlews defended a territory throughout their period of stay on the estuary. Each of the marked birds known to defend a feeding site changed between territorial and non-territorial behaviour during a winter. There was no overall change in the proportion of marked Curlews defending feeding sites, as during mid-winter territories were abandoned on some areas and established on others. No Curlews defended territories on more than one site during a winter.

Changes in the occurrence of territoriality were shown by all 12 marked Curlews seen defending feeding sites on Seal Sands during the winter of 1977/78 (Table 3.64). However the type of change that occurred was related to the Low Water feeding area used. Those territories held by marked Curlews on Eastern Channel and on Scalloped Mud - west were used in the autumn but were then abandoned for at least part of the mid-winter period (see below). In contrast territories on Central Bank - south were not taken up until December - January, and two were then defended until spring (Table 3.64). All 4 marked birds which took up territories on Central Bank had previously fed in the same area, non-territorially, from August or September.

There were also seasonal differences between birds on different areas in the time spent on the territory during a tidal cycle. The marked Curlews on Central Bank - south remained there throughout the period of exposure, both when territorial and non-territorial. The 2 on Eastern Channel changed in mid November from defence of their territories throughout the period of exposure to feeding non-territorially on Greenabella Bank when it was exposed and not using Eastern Channel at all. At least 2 of the marked Curlews on Scalloped Mud - west showed intermediate behaviour in mid winter. They remained on their territories throughout the Low Water period on some days; on others they left their territories around Low Water and fed elsewhere, at least one using Greenabella Bank (Table 3.64a).

Thus, although marked Curlews on both Eastern Channel and Scalloped Mud - west abandoned their territories during a winter, they behaved differently. The difference may have resulted from differences in the physical characteristics of the 2 sites. The territories on Eastern Channel were held on firmer, better-

Table 3.64

Seasonal changes in territoriality shown by the 12 marked Curlews defending feeding sites on Seal Sands during the winter of 1977/78

Marked Curlew	A	S	O	N	D	J	F	M	A
Y N/W	∇∇	∇∇∇	∇∇	∇∇-∇∇	-∇	∇---	--∇∇	---	
Y W/O		∇∇	∇	∇	-∇	-	∇	---	-
L R/L	xxx	xxxxxxxx	xxxxx	xxxxx	xxxxxxx	--- x-xx	-x-x -xx	---x xx-	x
R G/O		xx	xxxx		xxx	xxx-	-	xxxx	xx
R R/Y	xx	xxxx	xxxxxxx	xx	x	--	xx	xx-	xx
O W/O	xxxx	xxxx xxxx	xx-x xxx	xxx-x	---xxx	--x- x-x	-xx-xx	--xx--	-x-
R O/O⊙	○	○.	⊙⊙⊙	
R O/G	⊙.	...	⊙.	⊙.
Y W/R		⊙	○
G W/O		⊙..	⊙.
R W/N	x	-						-	
B W/O	..	x				-			
Number of birds showing territorial behaviour in each month	5	7	6	5	7	7	6	7	6

Symbols represent the number of observation-days each month when each individual known to be present/absent and territorial/non-territorial. All sightings are shown.

- Key:
- ∇ territory defended on Eastern Channel
 - x territory defended on Scalloped Mud
 - territory defended on Central Bank
 - ⊙ present on Scalloped Mud site but non-territorial
 - present on Central Bank site but non-territorial
 - absent from territory

Table 3.64a

The use of territories on the western half of Scalloped Mud
by 2 marked Curlews during 1977/78

	A	S	O	N	D	J	F	M	A
O W/O									
Number of days that O W/O remained on Scalloped Mud - west throughout the period of exposure	2	5	1	2	0	3	2	0	0
Number of days that O W/O was absent from or left Scalloped Mud - west at some time during the period of exposure	0	0	2	2	4	4	2	5	3
Number of days on which O W/O seen feeding on Greenabella Bank	0	0	0	0	1	1	1	1	2
L R/L									
Number of days that L R/L remained on Scalloped Mud - west throughout the period of exposure	2	6	5	3	2	3	1	1	-
Number of days that L R/L was absent from or left Scalloped Mud - west at some time during the period of exposure	0	0	0	0	1	5	3	4	-

drained mud than those on Scalloped Mud. Therefore the availability of prey probably fell more rapidly after exposure on Eastern Channel. The Eastern Channel sites were 0.5 kilometres from Greenabella Bank and exposed only a few minutes earlier. Those on Scalloped Mud - west were exposed 2 hours earlier than Greenabella Bank and were only 200 metres away. Therefore birds on the latter could not only feed on Greenabella Bank throughout its period of exposure but also use their territories for 4 hours on the ebb/flood tides - a possibility not available to the Curlews with territories on Eastern Channel. Furthermore the Scalloped Mud birds did not need to undertake long flights like those required to move between Eastern Channel and Greenabella Bank. The Curlews that originally defended areas on Eastern Channel fed only on Central Bank or Scalloped Mud when Greenabella Bank was covered, so it is presumed that these disadvantages made a feeding circuit incorporating Eastern Channel and Greenabella Bank relatively unprofitable.

Observations of territoriality in unmarked Curlews during 1977/78 (Fig. 3.27) emphasize the difference in behaviour of birds on the various sections of Seal Sands. In Eastern Channel the Curlews were spaced out as if defending territories from mid-August (when observations began) to April, and actual territorial defence was observed in every month from September to March. It is not known whether the same unmarked individuals defended the same sites throughout the winter, but it appeared that all the unmarked Curlews feeding on the Eastern Channel mudflats were territorial.

On Central Bank - south territoriality amongst unmarked Curlews was observed once in early November and then from February to April. However many Curlews, marked and unmarked, fed there non-territorially throughout the winter. This contrasts markedly with the spacing behaviour of Curlews on Eastern Channel.

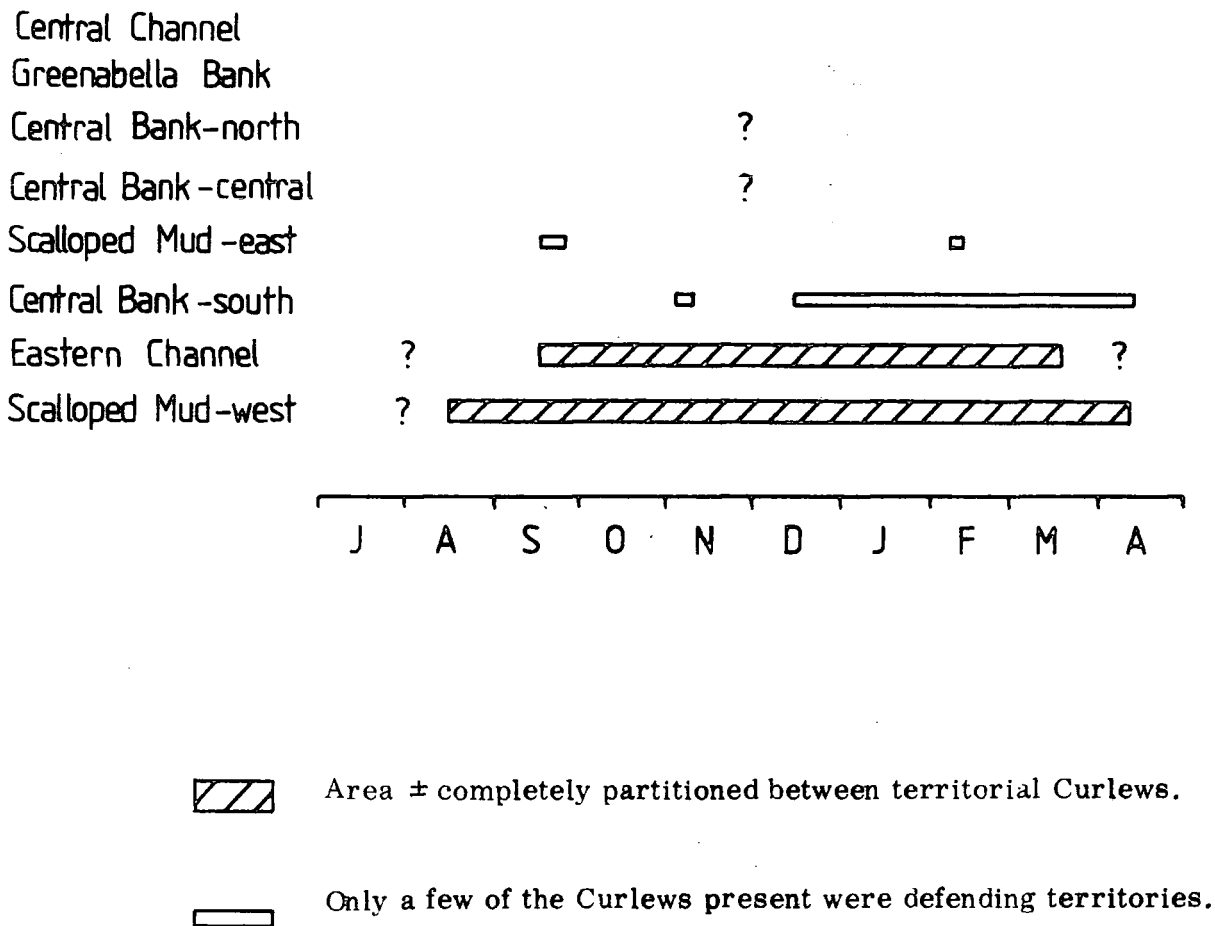

Figure 3.27 The seasonal occurrence of territoriality amongst Curlews on areas of Seal Sands during the 1977/78 winter.

Territoriality on Scalloped Mud - west was first observed in mid-August (when observations began) and continued throughout the winter until emigration in spring. Disputes over the position of territorial boundaries were particularly frequent during August and September.

Territoriality on Scalloped Mud - east was observed on only 3 days in September and one in February during the winter of 1977/78. On each occasion the defence of a feeding site was temporary, and no long-term territories were defended there.

There was no seasonal change in the number of marked Curlews defending feeding sites on Seal Sands (Table 3.64), due to the variety of changes between territorial and non-territorial behaviour described above. Using the data collected from marked Curlews and the population counts (Section 2. C) it is possible to estimate the total number of Curlews that defended territories on Seal Sands (Table 3.65). There was no significant difference between the proportions in November and February.

3. II. B. 3. d. The causes of seasonal changes in use of space

As for Grey Plovers, seasonal changes in Low Water feeding site and in territorial behaviour by Curlews sometimes occurred simultaneously. During the 1977/78 winter, 8 out of 22 seasonal changes in use of space at Low Water involved both a new site and a change in territorial behaviour (Table 3.66). The discussion of possible reasons for seasonal changes in use of space by Grey Plovers (section 3. II. A. 3. d) applies equally to Curlews, with one exception: the disturbance of prey near to the surface caused by a high density of waders may not depress seriously the density of prey available to a Curlew.

Table 3.65

Estimates of the number of Curlews defending feeding sites
on Seal Sands during autumn and mid-winter, 1977/78

	<u>November 1977</u>	<u>February 1978</u>
Eastern Channel	15	5
Central Bank - north	0	0
Central Bank - central	0	0
Central Bank - south	0	4
Scalloped Mud - east	0	0
Scalloped Mud - west	10	10
Greenabella Bank	0	0
Central Channel	0	0
	—	—
Total number of territorial Curlews	25	19
Total population	240	290
Percentage of population showing territoriality	11%	6%

The difference between November and February in the proportion of the population that is territorial is not significant ($\chi^2 = 2.59, p > 0.05$).

Table 3.66

Changes in use of space observed amongst marked Curlews
at Low Water on Seal Sands during the 1977/78 winter

		<u>Low Water Site</u>	
		Change	No change
<u>First site</u>	<u>Second site</u>	<hr/>	
No	No	4	-
Yes	Yes	0	-
No	Yes	5	6
Yes	No	3	4
		<hr/>	

1. Change in Low Water site, always non-territorial - Four marked Curlews showed this change in use of space during the 1977/78 winter. No cause common to all could be identified (Table 3.67). One change coincided with falling temperatures in autumn (Fig. 3.27a). The other three may have occurred directly in response to low prey density, on Central Channel and Central Bank-central in autumn and on Scalloped Mud-east in spring. Alternatively the autumn changes may have been in anticipation of feeding difficulties on the original sites later in the winter. Three birds moved to lower tidal levels, where prey availability was presumably higher; the fourth moved from an area avoided by most Curlews in mid-winter, probably because of very low prey availability.
2. Change in Low Water site, both sites defended - No marked Curlews showed this behaviour.
3. Changes from non-territorial to territorial behaviour, same site - Six cases were observed amongst Curlews during the 1977/78 winter. In 4 of the 6 examples defence was only temporary, lasting no more than a single Low Water period. One individual showed temporary defence on the same site twice, in January and again in April. Temporary site defence was correlated particularly with low temperatures and a high density of Curlews on the feeding area (Table 3.67). It was observed only on areas at higher tidal levels (Central Bank-south and Scalloped Mud-east).

Establishment of a longer-term territory on a date well after an individual had arrived on Seal Sands was not common, but was shown twice by marked Curlews. In one case it coincided with low temperatures in January. The other bird began defending in December, before the coldest weather. It may have changed its use of space in anticipation of more severe weather, or in response to the increased density of Curlews on its feeding area at that time. Both longer-term territories were defended on Central Bank-south.

Table 3.67

Correlations between changes in use of space by marked Curlews on Seal Sands during the 1977/78 winter and 6 possible causes

	Change in Low Water site, always non-territorial	O	N-D...A	S....D	J	F	M	A	A....D	J	F	Change in Low Water site and from non-territorial to territorial	Change in Low Water site, and from territorial to non-territorial
	2	1	1	1*	1	1	1*	1*	1*	1*	2*	1	2
	-	1	-	1	-	1	1	-	1	-	-	1	2
	-	-	-	-	-	-	-	-	-	-	2	-	-
	-	-	-	-	-	-	-	-	-	-	-	-	-
	-	-	-	1	1	-	1	1	1	-	-	-	-
	-	-	-	-	-	-	-	-	-	-	-	-	-
	-	-	-	-	-	-	-	-	1	1	-	-	-
	2	-	1	-	-	-	-	-	-	-	-	-	-

Number of changes observed

Correlations between changes and:

- a) Temperature decrease
- b) Temperature increase
- c) Recent arrival of individual
- d) Influx of Curlews into feeding area
- e) Eflux of Curlews from Seal Sands
- f) Gales

Cause unknown

* Defence only temporary

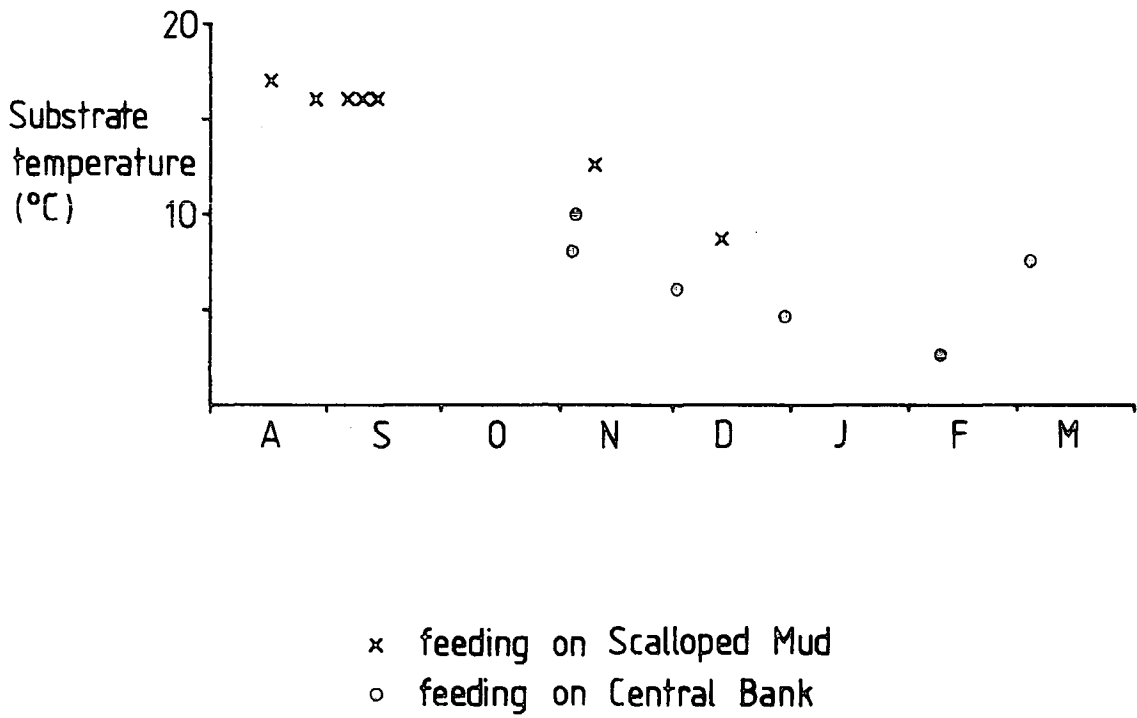

Figure 3.27a The changes in Low Water feeding site by one marked Curlew (B R/W) during the 1977/78 winter in relation to substrate temperature.

4. Change from territorial to non-territorial behaviour, same site -

This occurred only at the end of the four cases of temporary site defence described above. As for Grey Plovers, abandoning of long-term territories coincided with changes in Low Water site (see below).

5. Change in Low Water site and from non-territorial to territorial behaviour -

In each of the five cases, the defence was temporary and the new site abandoned soon after occupation. Three coincided with strong winds (up to 28 knots), the marked birds moving from the Greenabella Bank tide edge to open mud. Feeding at the tide edge would have been very difficult in such conditions, due to wave action (Evans, 1976). For one bird (in August), the task of finding an alternative feeding site would have been made more difficult by the high number of Curlews feeding on Seal Sands leading to potential competition for space. The other two birds (Y N/W, Y W/O) attempted to feed again temporarily in territories they had defended in autumn but abandoned in mid-winter (see below). They returned to their territories in late February, these changes in use of space coinciding with increasing temperatures (Fig. 3.27b). As the attempts were short-lived, presumably the prey density in spring was too low for profitable feeding there. In the previous winter (1976/77), one of these birds (Y N/W) behaved similarly but then remained in its re-occupied territory until emigration. This may indicate that prey density in spring was higher in 1976/77 than in 1977/78.

6. Changes in Low Water site and from territorial to non-territorial behaviour -

Three marked birds were known to have moved from one site which they had defended since their arrival on Seal Sands to another, undefended, site during 1977/78. One of these also did so in 1976/77. All four changes coincided with decreasing temperatures (Table 3.67, Fig. 3.27b). In each case the new, undefended, site was at the tide edge on Greenabella Bank. One of the abandoned

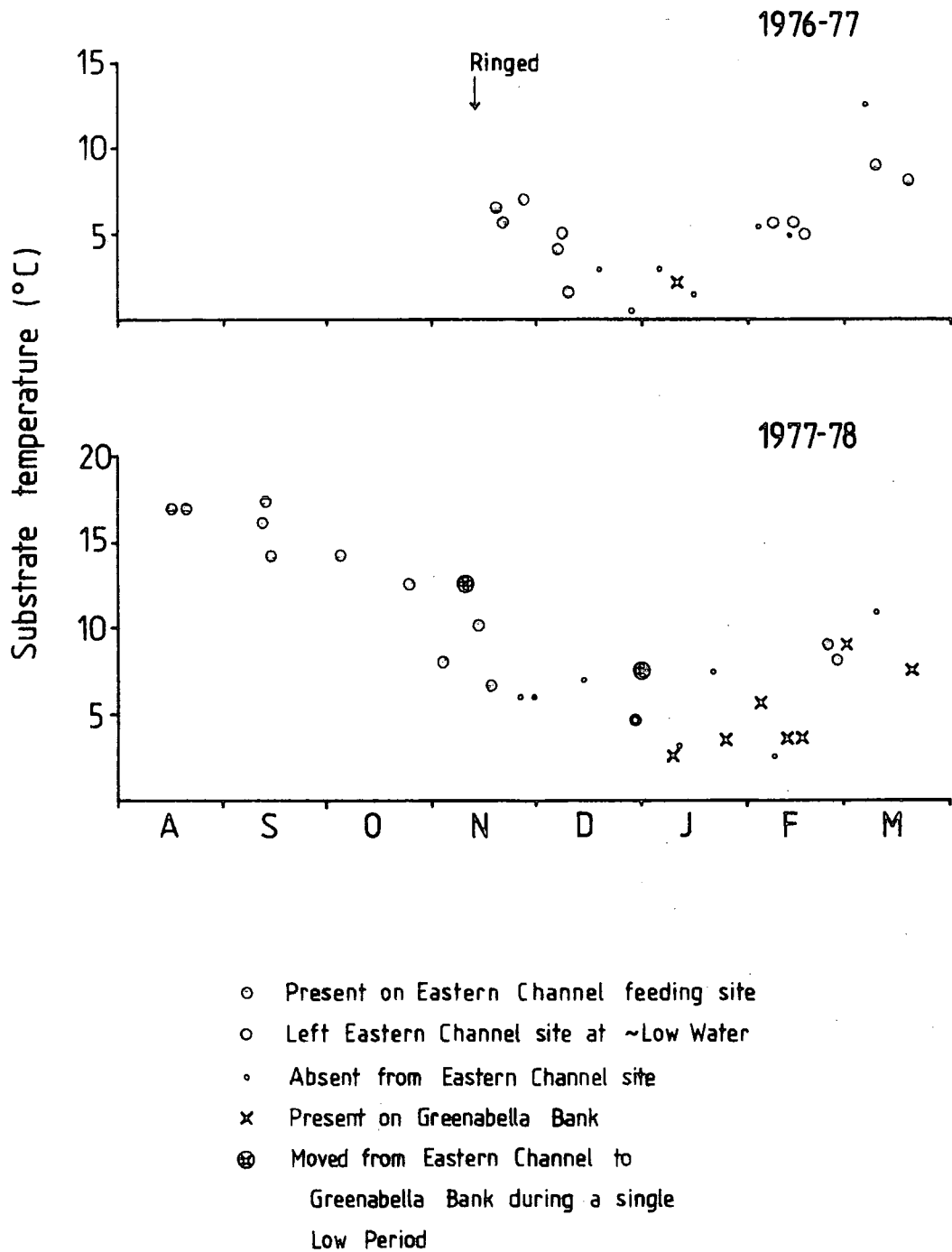

Figure 3.27b

The changes in Low Water feeding site by one marked Curlew (Y N/W) during two winters in relation to substrate temperature.

territories was on Scalloped Mud-west. Three other marked Curlews also abandoned territories there during the 1977/78 winter, but their new sites were unknown. Again the changes could be matched with colder weather. These Curlews on Scalloped Mud-west abandoned their territories on some days but not on others (see above). Detailed observations on two of them showed that their increasing use of alternative Low Water sites matched the seasonal decrease in temperature (Fig. 3.27c). However at low substrate temperatures (particularly below 3°C) the trend was reversed: perhaps when feeding conditions were difficult, they returned to patches of high prey density previously identified in their territories.

None of the marked Curlews discussed in this section was evicted from its territory by another Curlew.

Conclusions - Most seasonal changes in use of space by marked Curlews (10 out of 16) occurred during periods of temperature change, mainly decreases (8 cases), and/or during increases in Curlew density (6 out of 16). Several types of change occurred with similar frequency. Changes in Low Water site (mainly in autumn) by marked individuals that never defended feeding sites occurred probably because of difficulties, either present or future, in meeting food requirements. Temporary defence of a site, previously used non-territorially, was most likely when a high density of Curlews on a higher tidal level coincided with low temperature, i. e. when competition for food and/or space was high and feeding conditions difficult.

During a winter, long-term territories were both abandoned and established. Defended sites were abandoned when temperatures fell in late autumn, presumably reducing prey availability and increasing food requirements. In spring, return movements were sometimes attempted. On other areas, long-term territories were established on sites previously used non-territorially. This defence may have been a direct response to feeding difficulties caused by either cold weather or increased

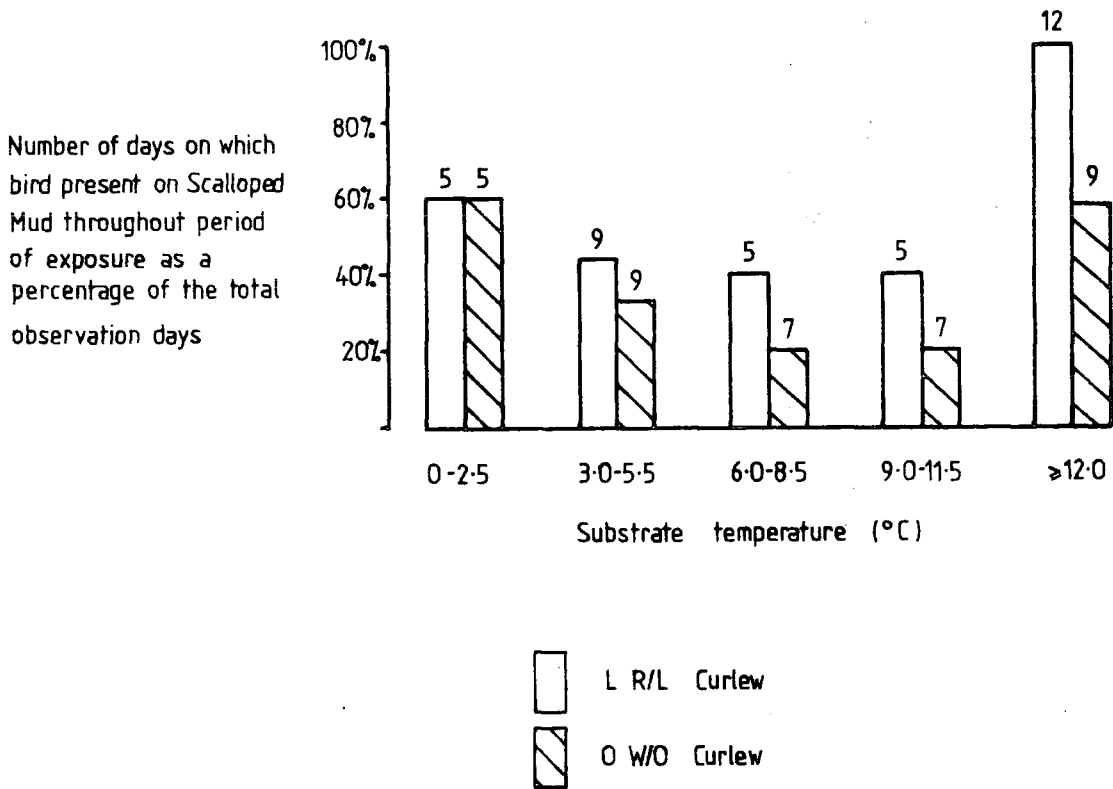

Figure 3.27c

The use of Scalloped Mud by two marked Curlews, during the 1977/78 winter, in relation to substrate temperature. The columns indicate the proportion of observation days on which they stayed on Scalloped Mud throughout the period of exposure. Sample sizes (total number of observation days) are shown above each column.

Curlew density. Thus, in Curlews, long-term territories may be established either in early autumn, in anticipation of future difficulties, or later in the winter in response to such difficult conditions.

3. II. B. 3. e. Changes in the territorial behaviour of individual Curlews between years

Comparisons between years can be made for only 3 ringed birds. Two of them (L R/L, O W/O) defended territories on the western half of Scalloped Mud in both 1976/77 and 1977/78. Each bird fed in the same site in the two winters and although full details of territorial boundaries were not determined in the spring of 1977 (between the dates of ringing and emigration) the areas defended seemed similar to those occupied in 1977/78.

More details are known of the behaviour of the third individual (Y N/W) which was observed on Eastern Channel during most of the winter of 1976/77 and all of the following winter. Again it used the same site in each winter, with only minor changes in the position of the boundaries of the territory. In both years it spent the mid winter period (during the worst weather conditions of each winter) feeding elsewhere but returned again in spring. However in 1976/77 it then continued to feed in its territory in Eastern Channel until emigration, whereas in the following year it soon reverted to its mid winter feeding sites where it did not show any territorial behaviour.

Data for other individuals are sparse but there is no indication of any marked Curlews changing their territorial behaviour between years.

Of the eleven Curlews seen defending feeding territories, only one (O W/O) was juvenile. O W/O continued to defend the same area when an adult.

3. II. B. 3. f. Summary

About 10 per cent of the Curlews present on Seal Sands during a winter defended territories. Territories were held only on certain areas of Seal Sands, generally

at mid tidal level. In autumn, most territories were defended throughout the period of exposure. Seasonal changes in territorial defence occurred in most individuals, but there was no significant overall change in the frequency of territoriality between autumn and winter. Both permanent and temporary changes in territorial behaviour were observed. Most changes in use of space were correlated with changes in temperature. Identical territories were defended by individual Curlews in successive winters.

3. II. B. 4. The use of Seal Sands by Curlews in relation to their bill lengths

3. II. B. 4. a. Low Water feeding sites

The length of the bill of an individual Curlew influenced its choice of Low Water feeding area. Once bill growth is complete (after the first winter) most Curlews can be sexed by bill length (see Section 3. I. C. 1). The distribution on Seal Sands in the winter of 1977/78 of adult marked Curlews whose bills were measured when full grown is shown in Table 3.67a. These marked Curlews were not distributed randomly with respect to bill length while feeding. Scalloped Mud and Central Bank held proportionately more males (i. e. shorter-billed birds) and Greenabella Bank more females (i. e. long-billed birds). Sightings of marked Curlews on Eastern Channel and Central Channel were too sparse to permit conclusions to be drawn. The proportion of males to females amongst the marked Curlews on the estuary during 1977/78 did not differ from that on any of Scalloped Mud, Central Bank and Greenabella Bank even at the 10 per cent level of significance. However the ratio of males to females on Greenabella Bank was significantly less than that on Scalloped Mud ($\chi^2 = 3.91$, 1 d. f. , $P \approx 0.05$).

Differences between the sexes are also apparent within areas. On the western half of Scalloped Mud, which consists largely of liquid mud, the proportion of marked males to females at Low Water (1.67 : 1) was similar to that for the ringed population (1.50 : 1, $P > 30$ per cent). In contrast, on the eastern half

Table 3.67a

The distribution of male and female adult marked Curlews on the Low Water feeding areas of Seal Sands during the 1977/78 winter

	<u>Number of males</u>	<u>Number of females</u>	<u>Number of birds that could not be sexed</u>
Total population of marked Curlews on the estuary	36(57%)	24(38%)	3(5%)
Low Water area:			
Central Bank	9	3	2
Scalloped Mud	15	4	2
Greenabella Bank	7	10	2
Eastern Channel	0	2	0
Central Channel	2	0	0
Scalloped Mud - western	5	3	0
- eastern	10	1	2

Adult birds whose bills were measured when juvenile, and therefore possibly not full-grown, are excluded.

which comprised firmer, better-drained mud, use was almost exclusively by males (Table 3.67a). The ratio of males to females on the eastern half, however, did not differ from that on the western half or from the ringed population as a whole at the 10 per cent significance level.

As a consequence of this distribution of males and females, and of the observed differences in site fidelity during a winter between Curlews on different areas of Seal Sands (Section 3. II. B. 1. b), there were differences between the sexes in their seasonal use of Low Water sites. During 1977/78, marked birds were faithful to Low Water feeding sites on two areas. On Central Bank-south (favoured by males) 4 of the 6 faithful Curlews were males. In contrast 5 of the 6 faithful to Greenabella Bank (used particularly by females) were females. During the winter, 5 marked Curlews were known to have changed their Low Water site to Greenabella Bank (Table 3.50), - unlike the faithful birds, only 2 of these were females.

In autumn, 2 areas of Seal Sands (Scalloped Mud - east and Central Bank - north) were used mainly by short-billed birds, females being almost absent (on Scalloped Mud - east, 1 out of 15 marked birds was female in autumn 1977; on Central Bank - north, 0 out of 4 were female in autumn 1977, and 1 out of 6 in August 1978). Both areas were almost completely abandoned at Low Water in mid winter (see above) the birds going either to mudflats at a lower tidal level or to the fields.

These data can be combined to produce a general pattern of winter use by male and female Curlews of the sections of Seal Sands at Low Water, as follows:

In autumn, although both sexes fed on all areas, females fed particularly on Greenabella Bank and Eastern Channel, whereas males were found especially on the drier areas, i. e. Central Bank - north and Scalloped Mud - east.

As the temperature decreased towards a mid-winter minimum, some birds on the higher mudflats moved to sites on the lower areas, especially Greenabella Bank.

The first changes occurred in October when males moved from Central Channel and Central Bank - north to Greenabella Bank. In November, females moved from Eastern Channel to Greenabella Bank. The changes shown by Curlews feeding at Low Water on Scalloped Mud continued over several months. Both males and females began to leave their feeding sites on the western half after Low Water from October to January. Movement from the eastern half to the fields began by October and continued through to December. (It will be shown in the following section (3. II.C.) that most birds that moved to the fields had short bills). Some Curlews remained on the same Low Water feeding area throughout the winter, notably females on Greenabella Bank and males on the southern section of Central Bank.

In spring, as the temperature increased, some return movements to feeding areas at higher tidal levels occurred, e.g. from Greenabella Bank to Eastern Channel in late February. However these changes were usually not permanent. In April a few of the field-feeding Curlews returned to feed on Seal Sands, but the autumn distribution of marked birds was not re-established.

3. II. B. 4. b. Feeding territories

In each section of Seal Sands in which territoriality occurred, the sex ratio amongst marked Curlews defending feeding sites was similar to that in the total population of marked birds (Table 3.67b). Thus, once Curlews have chosen a feeding site, there appears to be no difference in the frequency with which males and females become territorial. (It is not known whether the initial choice of site is influenced by a fore-knowledge of the territorial behaviour that will be required later in the winter).

During a winter, there were differences between the sexes in the defence of temporary and long-term territories. Each of the 5 temporary territories (3 on Central Bank - south, 2 on Scalloped Mud) was defended by a male. In contrast the

Table 3.67b

The sex ratio amongst marked Curlews defending territories on sections of Seal Sands and in the total marked population on these sections

Section of Seal Sands	Number of territorial Curlews			Sex ratio in marked population (from Table 3.67a)		
	males	females	unsexed birds	males	females	unsexed birds
Central Bank - south	3	1	0	6	3	1
Scalloped Mud - west	3	1	1	5	3	0
Scalloped Mud - east	1	0	0	10	1	2
Eastern Channel	0	2	0	0	2	0
Total	7	4	1			

No territories were defended by Curlews on other areas of Seal Sands.

proportion of males amongst the Curlews defending long-term territories (3 males, 4 females, 1 unsexed bird) was lower than that in the non-territorial marked population. (The difference was not significant perhaps because of the small numbers involved.)

Within areas, males and females showed similar changes (establishment or abandoning) in long-term defence, and most changes by both sexes were correlated with changes in temperature. However, females changed their territorial behaviour earlier in the winter than did males. Of four marked birds defending sites on the western half of Scalloped Mud, the 2 males did not feed away from their territories during the period of tidal exposure until December or late January, whereas the female and bird of intermediate bill length changed in November and December respectively. On Central Bank, the 3 males became territorial during very cold weather in January, or in spring when absolute food density was low, but the female began defending its feeding site earlier in the winter (December), possibly in anticipation of such conditions.

3. II. C. THE USE OF FIELDS AS FEEDING AREAS BY CURLEWS

Curlews wintering on the Tees estuary are known to feed on the low-lying fields surrounding the north side of the estuary at both High and Low Water (Pienkowski 1973, Knights 1979). Knights described birds feeding both on the mudflats and the fields, but also suspected that some fed solely on the fields. Therefore observations were made of Curlews on the fields to determine the importance of field feeding in the energy budget of individual birds through a winter.

3. II. C. 1. Counts of Curlews feeding on the Brinefields

Curlews were seen feeding on the fields on the north side of the estuary during all three winters, 1975-78. Although it was impossible to check all the fields for feeding Curlews, counts were made at frequent intervals on one easily accessible pasture used by the Curlews: the Brinefields. This site was known to be favoured by Curlews (Pienkowski 1973, Knights 1979). Invertebrate sampling and counts of Curlews on the main pastures around Seal Sands during the 1978/79 winter by Davidson (1980) indicate that the Brinefields is probably a typical feeding site for field-feeding Curlews. On most days with no disturbance the Brinefields are believed to have held approximately 10-30 per cent of the Curlews feeding on the fields. However the exact relationship between the number on the Brinefields and the total on the fields is unknown.

Curlews fed on the Brinefields at both Low and High Water (Fig. 3. 28). Thus the Brinefields may have been used both as an alternative (Low Water) and a supplementary (High Water) feeding area to the mudflats of Seal Sands.

3. II. C. 1. a. Low Water feeding

The Brinefields were used at Low Water mainly from December to March. The peak count occurred in different months in the three winters:

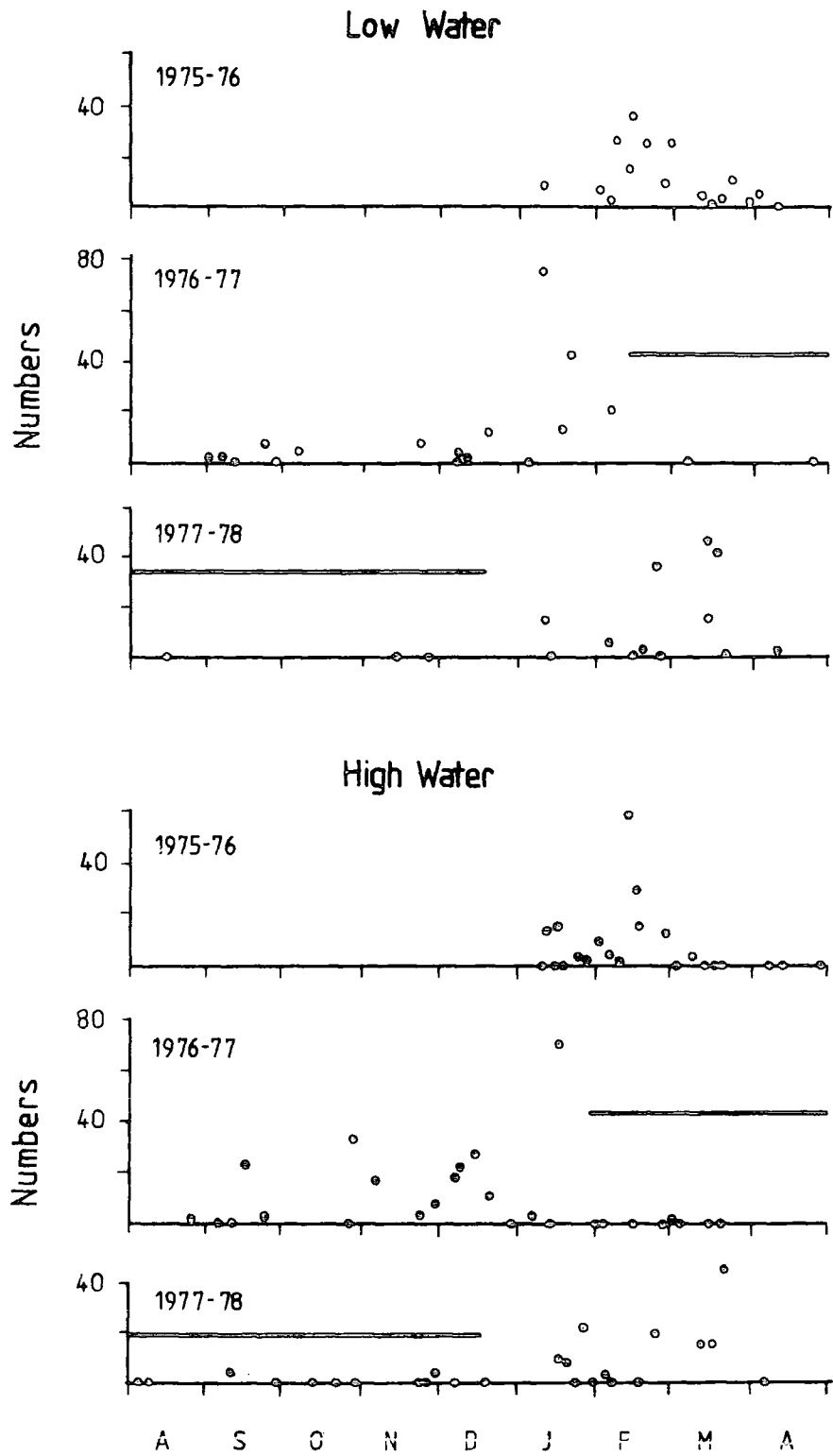

Figure 3.28

Counts of Curlews feeding on the Brinefields pasture at Low and High Water, during three winters. The horizontal bar indicates the period of disturbance. Counts commenced in January 1977.

February in the 1975/76 winter, January in 1976/77 and March in 1977/78.

In the winter of 1976/77 Curlews stopped using the Brinefields during February due to a major disturbance caused by drilling operations. This disturbance continued until the end of 1977, so very few Curlews fed on the Brinefields until January 1978. Presumably they fed instead on other pastures.

The Low Water counts of Curlews on Seal Sands have been interpreted in terms of the relative profitability of Seal Sands and the fields as Curlew feeding areas (Section 2. C). The use of the Brinefields can be interpreted similarly. The Brinefields were not used by many Curlews at Low Water until January when temperatures were low. Curlews then fed there at Low Water until the temperature increased in late February. In March 1978, the Brinefields continued to be a *regular* Low Water feeding area for Curlews. As more Curlews fed on Seal Sands at Low Water in 1977/78 than in 1976/77 (Section 2. C) or in 1975/76 (Evans 1980), the prey density on Seal Sands may have been reduced to a low level by March, making the fields, including the Brinefields, a more profitable feeding site for at least some Curlews.

The Brinefields Low Water counts can also be related to short-term changes in the weather conditions. In general no Curlews fed on the Brinefields when they were covered with snow. Thus they were absent in late January 1976, late January and mid February 1978, and late December-early January in the winter of 1976/77. However on 11th January 1976/77 a flock of over 70 Curlews fed on the frozen, snow-covered Brinefields for up to 2 hours around true Low Water. These Curlews flew there from Seal Sands and subsequently returned to the mudflats on the flood tide. As the temperature was very low (midday air temperature 1°C ; mud temperature at 5 cm depth 2°C) these birds were probably having more difficulty than usual obtaining their food requirements

on Seal Sands. Their movement to the Brinefields may therefore have been an attempt to increase their rate of food intake. Alternatively they may have been checking on the relative profitability of the two areas in case conditions became more difficult on Seal Sands.

3. II. C. 1. b. High Water feeding

The use of the Brinefields at High Water resembled that at Low Water in each year, with peak numbers at High Water and Low Water coinciding in February 1976, January 1977 and March 1978. Birds feeding on the Brinefields at High Water were presumably doing so to supplement their Low Water food intake (either on the fields or the mudflats). Thus peak numbers could indicate adverse weather conditions leading to increased energy requirements and/or difficulty in obtaining normal requirements due to a decrease in prey density. However Curlews occasionally took advantage of a superabundant food supply on the fields. Extensive flooding of the Brinefields due to a rapid thaw of deep snow occurred on 16th January 1977. This caused large numbers of earthworms to come to the surface of the pasture (described also by Edwards and Lofty 1977). At High Water 70 Curlews were feeding there even though the air temperature was not very low (3°C). Another 80 Curlews were present but roosting. Earlier in the day only 73 Curlews (out of a total on the estuary of around 400) had been present on Seal Sands at Low Water (Fig. 2.12), so it is likely that many Curlews (perhaps up to 200) fed on the Brinefields at Low Water also.

The ratio of males to females in flocks of Curlews feeding on the Brinefields was estimated during January - March 1978 (Table 3.68). At both High and Low Water every flock contained at least 80 per cent male (i. e. short-billed) birds.

Table 3.68

The sex of unmarked Curlews seen feeding on the Brinefields pasture

Date	State of Tide	Number of Curlews in flock	Composition of flock			Males as a percentage of total
			females	unsexed birds	males	
10.1.78.	LW	13	2	0	11	85
26.1.78	HW	18	0	2	16	89
23.2.78.	HW	10	2		8	80
16.3.78.	LW	16	0	0	16	100
19.3.78.	LW	39	3	0	36	92

3. II. C. 1. c. Summary

Curlews fed on the fields at both Low and High Water. Numbers were highest (at Low Water and High Water) in mid winter and spring, thus coinciding with the periods of relative food shortage on Seal Sands due to cold temperatures and low prey density respectively. The majority of Curlews feeding on the fields at all stages of the tide were males.

3. II. C. 2. The use of fields by marked Curlews

Checks were made for marked Curlews mainly on the Brinefields during 1976/77 and 1977/78, and on the Brinefields and parts of Cowpen Marsh in 1978/79 (N.C. Davidson, pers. comm.). A total of 28 marked Curlews were seen feeding on the fields around Seal Sands during the 3 winters 1976-79. Six individuals were seen there only at Low Water, 10 only at High Water and 12 fed on the fields at both Low and High Water. Eleven of the latter did so within a single winter. All but one of the field-feeding Curlews were also seen feeding on Seal Sands at some time. The pattern of use of the fields followed by each individual was related to its bill length, shorter-billed birds in general spending more time on the fields. The proportion of females on the fields was significantly lower than that on the mudflats (fields: 6 females in 44; mudflats: 10 females in 22 : $\chi^2 = 8.09$, 1 d.f., $P < 0.01$). Amongst the field feeders none of those which fed there at Low Water had bills greater than 130 mm, and longer-billed birds were seen there only at High Water.

Some individuals fed on the fields in successive years. Four of the 18 marked birds seen feeding at Low Water did so in two successive winters, as did 5 of the 22 birds that fed at High Water. Four other individuals were seen feeding on the fields at High Water in all three winters 1976-79. Overall some form of field feeding appeared to be a regular behaviour in at least 36 per cent of the total of marked individuals seen on the fields in all years.

No marked or unmarked Curlews were seen defending feeding sites on the fields at any time during the study.

3. II. C. 2. a. Low Water feeding on fields

Birds on the fields at Low Water were using the fields as an alternative feeding area to Seal Sands. Observations on marked birds give support to the hypothesis derived from the Brinefields counts (Fig. 3.28): that feeding on the fields is more profitable than feeding on Seal Sands for at least some Curlews during the period January-March (Table 3.69). The observations on marked birds also revealed that between 60 per cent and 100 per cent of those individuals seen feeding on the fields at Low Water also fed on Seal Sands at some time during that winter (Table 3.70). When on Seal Sands, Scalloped Mud appeared to be the major area used by these marked Curlews at all stages of the tide (Table 3.71). In 1977/78 the difference between the distribution on Scalloped Mud versus the rest of Seal Sands for Low Water field feeders (6 out of 9 on Scalloped Mud) and other marked Curlew (18 out of 52 on Scalloped Mud) was significant only at the 10 per cent level (exact probability test, $P = 8.50$ per cent). At other stages of the tide and in other years no significant preferences for Scalloped Mud could be detected.

Patterns of use - Birds using both the mudflats and the fields as Low Water feeding areas showed one of two patterns of use (Table 3.72):

1. Four individuals (3 in 1977/78, 1 in 1978/79) fed on Seal Sands at Low Water more or less throughout the winter, only using the fields at Low Water on one or a few days in one month. Even when feeding on the fields, i. e. in March 1978 and January 1979, they returned to feed on Seal Sands at Low Water a few days later. Immediately before moving onto the fields, all 4 birds had been feeding on Scalloped Mud at Low Water, 2 exclusively, and 2 also on Central Bank and in one case Greenabella Bank.

Table 3.69

The number of marked Curlews seen feeding on the
fields each month, during 3 winters

		A	S	O	N	D	J	F	M	A
Low Water	1976/77	0	0	0	0	0	0	0	0	0
	1977/78	0	0	0	0	0	1	0	11	0
	1978/79	0	0	0	1	0	8	6	?	?
High Water	1976/77	0	0	0	2	2	2	0	7	0
	1977/78	0	0	0	0	0	6	3	9	0
	1978/79	0	0	0	0	0	8	8	?	?

Counts in the 1978/79 winter (supplied by N. C. Davidson, L. R. Goodyer and F. L. Symonds) terminated at the end of February.

Table 3.70

The use of Seal Sands by field-feeding
marked Curlews, during 3 winters

		<u>Number seen feeding on Seal Sands</u>	<u>Number seen only roosting on Seal Sands</u>	<u>Number never seen on Seal Sands</u>
Low Water field feeders	1976-77	0	0	0
	1977-78	11	0	0
	1978-79	7	1	3
High Water field feeders	1976-77	5	3	1
	1977-78	10	1	1
	1978-79	13	1	2

(Data for 1978-79 supplied by N. C. Davidson, L. R. Goodyer and F. L. Symonds)

Table 3.71

The regular feeding areas on Seal Sands used by individual Curlews that also fed on the fields at Low Water during the same winter

	Section of Seal Sands				
	SM	CB	GB	CCh	ECh
Low Water					
1977/78	6	1	1	1	0
1978/79	1	0	0	0	0
Ebb tide					
1977/78	7	2			
1978/79	3	0			
Flood tide					
1977/78	6	1			
1978/79	1	0			

Abbreviations for the sections of Seal Sands as on Table 3.19.

Table 3.72

Feeding areas used by marked Curlews which have fed, during a single winter, on both the mudflats and the fields during the period of exposure of Seal Sands

		A	S	O	N	D	J	F	M	A
1. <u>Birds that fed on Seal Sands throughout the winter:</u>										
1977/78	B R/W	*	*	*	*	*	*	*	*F	*
	Y L/L	*	*	*	*	*	*	*	*F	
	Y O/L				*	*		*	F	*
1978/79	Y G/O	*			*	*	?F	*	*	
2. <u>Birds that left Seal Sands for mid winter:</u>										
1977/78	L Y/Y	*		*					F	
	G Y/Y	?	*	*					F	
	G O/W	*	?	*				*	*F	
	Y Y/Y		*	*	*				F	*
	Y G/O	*	*	*	*			*	*F	*
	L G/L	*	*	*	*			*	F	*
1978/79	L O/G	*						*F		
	L G/L	*					F	F		
	L Y/Y	*					F	F	?	
	L R/W	*					*	F	*	
	Y Y/Y	*			F			F		
	G R/W	?			*		F	*F	*	
3. <u>Birds which fit neither pattern:</u>										
1977/78	L W/O					*	F		F	
	R W/W					*	*		*F	

- Key: * Definite sighting(s), feeding on Seal Sands during this month.
 ? Possible sighting, feeding on Seal Sands during this month.
 F Definite sighting(s), feeding on the fields during the period of exposure of Seal Sands, during this month.

As the 3 marked Curlews in 1977/78 all fed on the fields at Low Water in mid March (Table 3.72) they may have been experiencing increasing difficulty in capturing worms on Seal Sands because of the low absolute density of prey. The use of the fields did not coincide with particularly low temperatures (Fig. 3.29 and Table 3.73) which might have reduced further the density of available prey, but did correlate with strong winds (Table 3.73). Presumably the strong winds so hindered the capture and handling of prey on Seal Sands that feeding on the fields became relatively more profitable. Feeding on the relatively sheltered fields would also have reduced heat loss and therefore energy requirements. The Curlew seen feeding on the fields at Low Water once in the following winter of 1978/79 did so during the strongest winds of that winter (Table 3.73) (N. C. Davidson, pers. comm.).

2. The alternative pattern, shown by the majority of field-feeding Curlews (6 in 1977/78, and 6 in 1978/79), was to feed on Seal Sands at Low Water in autumn and then, as the temperature dropped, to move to the fields and feed there at Low Water for most of the winter, only returning to Seal Sands in bad weather (deep snow, frozen ground) and/or in spring. (Sightings on the fields in 1977/78 were infrequent due to the disturbance on the Brinefields.) During 1977/78 the Curlews showing this pattern stopped feeding on Seal Sands in October or November (Table 3.72). The timing of movement to the fields in the following autumn is uncertain as fewer observations were made on Seal Sands in the 1978/79 winter. Six of the marked Curlews that left Seal Sands in autumn reappeared during January or February (G O/W, Y G/O, L G/L in 1977/78; L O/G, L R/W, G R/W in 1978/79). In each case the reappearance coincided with a period of very cold temperatures and heavy snowfall, conditions under which feeding on the pastures would be impossible. When temperatures

Table 3.73

Weather conditions on the days when marked Curlews fed on
the fields instead of their usual habitat, Seal Sands

	Individual Curlews	Midday air temperature (°C)	Seal Sands substrate temperature (°C)	Mean wind speed (knots)	Maximum speed of wind gusts (knots)
Field feeding at Low Water	16.3.78. B R/W Y L/L	5	5	19	34
	19.3.78. B R/W Y O/L	8	6	24	44
	19.1.79. Y G/O	-1	-	40	54
Field feeding at High Water	19.3.78. B R/W Y L/L	8	6	24	44
	21.3.78. Y L/L Y O/L	6	7.5	25	42

increased in March and April 6 of the 12 Curlews that had moved to the fields were seen feeding on Seal Sands again. Only two birds did not conform to either of the patterns described (Table 3.72).

The pattern of use of the fields as a Low Water feeding area was apparently related to bill length. Even though all 18 birds seen feeding on both Seal Sands and the fields at Low Water had bills less than 131 mm, the mean for the 4 individuals using Seal Sands throughout the winter (mean=118.3 mm, S. E.=4.52) was higher than that of the 12 known to leave Seal Sands for the mid-winter period (mean=114.6 mm, S. E.=2.23). Because of the small samples this difference is not significant ($t = 0.80$, $P > 0.10$).

Four individuals were observed feeding on both the fields and on Seal Sands at Low Water in two successive winters. Three showed a similar pattern of behaviour in both 1977/78 and 1978/79. In contrast the fourth (Y G/O) changed its behaviour from deserting Seal Sands in mid winter in 1977/78 to remaining on Seal Sands more or less all winter in 1978/79. The reason for this change is not known.

In 1978/79, 4 marked Curlews were seen feeding on the fields at Low Water but never on Seal Sands (Table 3.70). Each bird was seen only once feeding on the fields adjacent to Seal Sands at Low Water, and in each case this occurred during the severe weather of January 1979. As they were not seen on these fields at other times during the winter, despite frequent checking, they may have fed on fields further inland, only moving to the vicinity of the mudflats when the weather was bad. (Small flocks of Curlews have been seen feeding on fields up to 4 kilometres inland from Seal Sands during the winter.)

3. II. C. 2. b. High Water feeding on fields

Birds feeding on the fields at High Water were gaining feeding time additional to that available if feeding was confined to Seal Sands. Marked

Curlews used this additional feeding time from November to March (Table 3.69), the changes in numbers resembling those in the Brinefields counts (Fig. 3.28). Between 55 per cent and 80 per cent of these marked individuals also fed on Seal Sands at some time during the same winter (Table 3.70). Scalloped Mud was favoured at Low Water by the High Water field feeders (Table 3.74). In 1977/78 the proportion of the High Water feeders that fed on Scalloped Mud (6 out of 8) was significantly greater than that predicted from the distribution of the other marked Curlews (18 out of 53) (exact probability test, $P = 3.49$ per cent). The apparent preference for Scalloped Mud at other stages of the tide and in other years is not statistically significant and may be a consequence of the bias towards Scalloped Mud in the sightings of marked birds.

Patterns of use - The marked Curlews feeding on Seal Sands at Low Water and on the fields at High Water followed one of two patterns of use (Table 3.75):

1. Eight birds (5 in 1976/77, 3 in 1977/78) used High Water field feeding to supplement their food intake on Seal Sands. Seven were seen feeding on both Seal Sands at Low Water and the fields at High Water on the same day. Whilst on Seal Sands 4 fed only on Scalloped Mud, and 3 not only on Scalloped Mud but also Greenabella Bank and Central Bank (Table 3.74).

As supplementary feeding on the fields was shown by several birds in March, in both winters (Table 3.69), it may have been necessary for some birds when the absolute density of Nereis on Seal Sands had fallen to a low level. Alternatively the extra feeding may have been required to lay down fat reserves in preparation for migration. Supplementary feeding did not occur only when the temperature was low, and therefore energy requirements higher and Nereis less accessible, but did coincide with strong winds (Table 3.73).

Table 3.74

The regular feeding areas on Seal Sands
used by individual Curlews that also fed
on the fields at High Water during the same winter

		Section of Seal Sands				
		SM	CB	GB	CCh	ECh
Low Water	1976/77	4	0	1	0	0
	1977/78	6	1	1	0	0
	1978/79	0	1	0	0	0
Ebb tide	1976/77	4	0			
	1977/78	6	2			
	1978/79	2	1			
Flood tide	1976/77	1	0			
	1977/78	3	1			
	1978/79	0	0			

Abbreviations for the sections of Seal Sands as on Table 3.19.

Table 3.75

The relationship between feeding on Seal Sands when exposed and on the fields at High Water during a winter, for individual Curlews

		A	S	O	N	D	J	F	M	A
1. <u>Birds that fed on the fields at High Water in addition to Seal Sands when exposed:</u>										
1976/77	B R/W				F	*F	*F	*	*	
	L W/R							r	*F	
	O N/O							r	*F	*
	Y O/L							r	*F	*
	Y Y/Y							r	*F	
1977/78	B R/W	*	*	*	*	*	*	*	*F	*
	Y L/L	*	*	*	*	*	*	*	*F	
	Y O/L				*	*	*	*	F	*
2. <u>Birds that left Seal Sands for mid winter and were then seen feeding on the fields at High Water:</u>										
1977/78	B W/O	*	*				F			
	L Y/Y	*		*			F		F	
	Y Y/Y		*	*	*				F	*
	L G/L	*	*	*	*		F	*F	F	*
1978/79	Y Y/Y	*						F		
	L Y/Y	*						F		
	G R/O	*						F		
	Y W/O	*	*					F		
	L G/L	*						F		
	L W/R			*			F	*	*	
	L R/W	*		*			*	F	*	
	B R/W	*			*		F			
	G R/W	?			*		F	*F	*	
	G W/O			*	*		F	*		
	R G/Y				*		*F			
3. <u>Birds which fit neither pattern:</u>										
1977/78	R W/W					*	*		*F	
	L W/O					*	F			
	Y O/R						F	*F	F	
	Y L/L							*F	*	
1978/79	O O/O						*F	*		

2. Most Curlews (15 out of 28) seen feeding on the fields at High Water appeared to follow the alternative pattern of use (Table 3.75): moving from Seal Sands to the fields in late autumn (see above), and then feeding on the fields at both Low and High Water during mid winter and spring. Eight marked birds (3 in 1977/78, 5 in 1978/79) were seen feeding on the fields at both Low and High Water in the same winter (compare Tables 3.72 and 3.75). Two were seen doing so on a single day. Thus birds that moved to the fields probably fed throughout the day, abandoning the tidal cycle of feeding activity used in the autumn.

As observations in 1978/79 were confined mainly to the fields with only infrequent checks made on Seal Sands, there is a bias in the data favouring the second pattern of use. Some individuals described as having left Seal Sands may have fed there, undetected, for most/all of the winter.

Shorter-billed birds spent more of the winter feeding on the fields at High Water than did long-billed birds. The mean bill length of the 4 individuals that moved to the fields during 1977/78 ($\bar{x} = 110.0$ mm, S. E.=1.68) was smaller than that of the 3 birds that used the fields at High Water only infrequently ($\bar{x} = 122.7$ mm, S. E.=1.33). This large difference is not significant ($t = 1.86$, $P > 0.10$) due to the small samples.

Seven marked birds were seen feeding on the fields at High Water and on Seal Sands at Low Water in more than one winter. Three (L G/L, L Y/Y, Y Y/Y) behaved similarly in 1977/78 and 1978/79, as they did at Low Water (see above). Two apparently changed their behaviour to mid-winter field feeding in 1978/79 having fed almost solely on Seal Sands during the previous 1 or 2 winters. Two birds were not seen frequently enough to make year to year comparisons.

Nine marked Curlews were seen feeding on the fields at High Water but never on Seal Sands in the same winter (Table 3.70). Three were seen on the

fields from November to March and were believed to be purely field feeders, from autumn to spring. These birds had very short bills ($\bar{x} = 109.3$ mm, S. E. = 3.53). Observations on the other individuals were too sparse to tell if they followed the same pattern.

Four other birds seen on the fields at High Water (L W/O, Y O/R, Y L/L in 1977/78, O O/O in 1978/79; Table 3.75) also appear to be mainly field feeders, as they were only seen feeding on Seal Sands once or twice, usually during bad weather conditions. Thus they may also have fed almost exclusively on the fields from their arrival in autumn until emigration in spring. Their mean bill length was 117.3 mm.

3. II. C. 2. c. Summary and Discussion

Marked Curlews feeding on the low-lying fields around Seal Sands follow one of three basic patterns of behaviour during a winter. Some feed on Seal Sands at Low Water throughout the winter, only occasionally feeding on the fields. Others feed on the fields throughout the winter, and feed on Seal Sands only when field feeding is impossible due to deep snow and/or frozen ground. Yet others feed on Seal Sands in autumn, and perhaps also in spring, but move to the fields for the mid-winter period. These individuals may return to Seal Sands during this period if feeding on the fields becomes impossible. During mid winter the Seal Sands feeders and the field feeders may form two distinct groups. In January 1978 a large flock of Curlews (200-300) was disturbed from its High Water roost on saltmarsh beside Greatham Creek. All the birds flew off, but in two different directions. About 70 flew south-west onto the fields of Cowpen Marsh, whereas the rest flew east towards Seal Sands (and the adjacent roosts such as the Peninsula Sands). This separation suggests that the two groups behave very differently in mid winter.

It is believed that individual Curlews use the fields when their profitability changes relative to Seal Sands. Those individuals which feed on the fields only occasionally do so in spring (when absolute prey density on Seal Sands is low) and/or during strong winds (which greatly hinder prey capture and handling on the mudflats). The birds that use the fields for much of the winter move there from the mudflats as the temperature falls. They return only in deep snow/frozen ground when the profitability of the fields falls to zero, or in spring when the temperature rises again. Fewer return in spring than left in autumn presumably because of the much lower prey density on Seal Sands in spring.

The movement of Curlews to the fields as the temperature falls in autumn is believed to be due in part to a decrease in the accessibility of Nereis on the mudflats in winter (see 3.11.D.). However the movement is probably also a response to an increase in the availability of earthworms on the fields. On inland pastures most earthworms of all species are active and near to the surface in November and December (Evans and Guild 1947, Gerard 1967) following the autumn rains, so their availability to Curlews increases. During cold weather in mid winter, although earthworms on inland pastures burrow deep in the substrate and often become quiescent (Gerard 1967), those on the pastures adjacent to Seal Sands probably change depth very little. The earthworms were found only in the thin surface layer of soil and not in the underlying clay, and always on areas that generally remained above the water table (Davidson 1980). As a consequence most would have remained within reach of the Curlew's bill (N.C. Davidson, pers. comm.). Therefore, except when the ground was frozen or covered in deep snow, the availability of earthworms on the fields remained high throughout the winter.

However, although the increase in the availability of earthworms may encourage Curlews to move from the mudflats to the fields in autumn, it does

not explain why short-billed Curlews in general spend more time on the fields than longer-billed birds. In Section 4 it will be shown that this difference is a consequence of the greater difficulty that short-billed birds have in capturing Nereis on the mudflats in mid winter.

Curlews are known to feed in fields during the winter in many parts of Great Britain, and also in Europe (Ens 1979). The sites may be within a few kilometres of an estuary, e.g. on Morecambe Bay (Wilson 1973), the Humber (Tasker and Milsom 1979), the Wash (Bainbridge and Minton 1978), Lindisfarne (pers. obs.) and the Ribble (Smith and Greenhalgh 1977, and pers. obs.), or more than 20 km inland, e.g. Cheshire (Elphick 1979), western Ireland (Hibbert-Ware and Ruttledge 1944). In the coastal sites field feeding was observed either at High Water (Bainbridge and Minton 1978) or throughout the tidal cycle (Wilson 1973, Tasker and Milsom 1979) and movement between estuary and fields occurred. Further inland the Curlews generally confined their feeding to the fields (Hibbert-Ware and Ruttledge 1944, Elphick 1979).

A change in feeding area from mudflats to fields has been inferred from decreases in autumn in counts on the Wash and Morecambe Bay (Bainbridge and Minton 1978), although such a change is believed not to occur on the Humber estuary (Tasker and Milsom 1979). During periods of deep snow, few Curlews continued to feed on the fields in Cheshire (Elphick 1979) and on the Humber (Tasker and Milsom 1979), as on Teesmouth. The Curlews moved to the mudflats to feed.

A preponderance of males in flocks of Curlews feeding on pastures appears to be a widespread phenomenon as it has also been noted in Cheshire (Elphick 1979) and on the Wadden Sea (Ens 1979).

3. II. D. DISCUSSION

3. II. D. 1. The advantages of winter territoriality to individual shorebirds

Although it has been suggested in the past that winter territoriality in shorebirds is non-adaptive (Hamilton 1959), it is now generally agreed that non-breeding territories, like breeding territories (Brown 1964), are maintained only where and when the benefits of defence outweigh the costs incurred (Myers, Connors and Pitelka 1979a).

On Seal Sands, winter territoriality is shown by some Grey Plovers, Curlews and by Redshanks (which are known to defend territories under certain circumstances elsewhere (e.g. Goss-Custard 1970, 1976)) also, during the brief period spent on Seal Sands, by Golden Plovers (see Section 2. B. 3). It has never been observed in the other shorebird species present throughout the winter, Knot, Dunlin, Bar-tailed Godwit. Therefore the balance of the cost/benefit equation must vary between the species feeding on the mudflats of Seal Sands.

In all 4 species which show territorial behaviour on Seal Sands, not all individuals do so, as noted also by Ens (1979) for Curlew and Goss-Custard (1970) for Redshank. Grey Plovers and Curlews (and Golden Plovers) defend territories only on certain of their feeding areas. Similarly Redshank are territorial on only some of the mudflats, e.g. Eastern Channel, and Scalloped Mud and Central Bank adjacent to the seawall, but not for example at the tide edge (pers. obs.). Furthermore the proportion of the individuals of a species that defend feeding sites varies between parts of the mudflats (Tables 3.35 and 3.62). Territories are defended on more sections of Seal Sands as the winter progresses (Figs. 3.18 and 3.27). Also there are seasonal changes within areas in the incidence of territoriality amongst Curlews (e.g. Table 3.65). Thus the balance of the costs and benefits of territoriality for Grey Plovers, Curlews and probably

Redshanks on Seal Sands must vary both in space and time.

In their review of territoriality in non-breeding shorebirds, Myers et al. (1979a) established that defence of a feeding site has been recorded in many wintering areas and in many species. In each of 2 detailed studies, one in California, U.S.A. and one in Buenos Aires Province, Argentina, they illustrate that individuals of a species can be territorial in one habitat whereas other (conspecific) individuals in adjacent habitats are not. Thus many species include both territorial and non-territorial individuals. Similarly Burger, Hahn and Chase (1979) described Grey Plovers in New Jersey, U.S.A. defending feeding sites only on open mudflats and not on the adjacent beach, and Goss-Custard (1970) reported interactions between territorial Redshanks in many places on the narrow Ythan estuary, Scotland, but rarely on areas of wide mudflats. Thus the variety of spacing behaviours observed on Seal Sands is typical of shorebirds in several geographical regions. The Grey Plover is one of the most territorial of the shorebirds studied, behaving territorially in all the habitats in which it has been observed (Myers et al. 1979a) and, in the present study, including the highest proportion of individuals that defend feeding sites.

There are 2 points about winter territoriality in shorebirds that should be stressed:

- a) territoriality is widespread amongst shorebirds - therefore it must be adaptive (Myers et al. 1979a).
- b) there is great variation between species and between individuals of a species, both within and between habitats - therefore the balance of the costs and benefits of territoriality must vary.

In order to determine why territoriality occurs only under certain conditions,

the possible costs and benefits associated with the defence of a feeding site must be considered.

Costs - In excluding conspecifics from its feeding site a shorebird expends time and energy. It was shown earlier that disputes between territorial Grey Plovers can last up to 30 minutes (although this was exceptional). During such a dispute the neighbouring conspecific territory holders walked or ran back and forth along the boundary line between adjacent territories. This not only expends energy but also occupies time that could otherwise be spent feeding or watching out for approaching predators. It is not known how much time Grey Plovers and Curlews on Seal Sands spend on anti-predator behaviour. This behaviour is less important on Teesmouth than in California (Page and Whitacre 1975), as diurnal predators are very rare. During the study the only regularly-observed avian predator was a female Merlin (Falco columbarius), and this was seen to capture Dunlin but not larger shorebirds. Nevertheless the larger shorebirds still spent time looking out for predators, especially when the smaller birds were on alert.

It is unlikely that, on Teesmouth, marked seasonal changes in the time spent in anti-predator behaviour will occur during a winter. However the time required for feeding will vary. In severe weather a territorial bird could have difficulty meeting its energy requirements, which have increased because of the conditions, in the time remaining after defence. It may also have difficulty finding sufficient time for feeding as well as defence and anti-predator behaviour when daylength is short and High Water occurs around midday, since such conditions give minimal daylight feeding time. This assumes that day feeding is more important than night feeding (as suggested by Evans 1976, Goss-Custard et al. 1977), but this is now open to doubt, at least for Grey Plovers (P.J. Dugan, pers. comm.).

It has been shown that individuals amongst both the Grey Plover and the Curlew populations on Seal Sands change between territorial and non-territorial behaviour during a winter. This could be the result of seasonal changes in the cost of defence. It might be expected that the costs incurred in excluding conspecifics from a feeding site throughout a winter would remain approximately constant because potential intruders will always be present, (unless all birds become territorial: a situation which did not occur in any species on Seal Sands during the study). However costs might decrease because boundaries become "agreed" with identifiable neighbouring territory holders; this would result in fewer long disputes with neighbours. On the other hand the number of disputes might increase because of an increase in the frequency of intrusions into the territory during influxes of conspecifics into Seal Sands. This would lead to an increase in disputes with strange birds.

Most marked Grey Plovers with territories on Eastern Channel, Seaton Channel, Central Bank - north and Scalloped Mud - east defended their feeding sites from autumn to spring (Table 3.39). During this period they would have the opportunity to recognise their neighbours and a reduction in the frequency or duration of disputes could occur. Similarly territories on Scalloped Mud - west were defended by the same individual Curlews throughout the winter so recognition of neighbours was highly probable.

Some individual Grey Plovers and Curlews however changed their spacing behaviour on Seal Sands during a winter and even during a tidal cycle. As there is no clear evidence to show that the cost of territorial defence and the risk of predation changed markedly, it seems probable that the benefits must have varied over the same time periods.

Benefits - The duration of defence of a given site by both Grey Plovers and Curlews varied from less than 30 minutes during a single tidal cycle to

over 140 days (Fig. 3.30). I have too few observations to tell whether Grey Plovers and Curlews on Seal Sands show a continuum in duration of defence, as seen in Sanderlings in California (Myers et al. 1979a). Nevertheless, for the purposes of the discussion of the benefits of territoriality, 2 categories will be considered:

- a) the temporary defence of a site abandoned within, at most, a few days.
- b) the permanent defence of a feeding site for several months.

The possible advantages of territorial over non-territorial behaviour might be gained in the short and/or long term.

Short-term advantages - By excluding conspecifics, temporarily or permanently, a territory holder immediately gains the following advantages:

- i) it prevents conspecifics from removing any of the available prey, (i. e. the proportion of the prey animals present that can be captured by the predator at any one time); the territory holder is, therefore, the only bird of that species "competing" to remove the available prey from the site.
- ii) it reduces the physical disturbance to prey caused by waders walking across the mud - the waders will produce vibrations in the mud to which certain intertidal invertebrates (including Nereis) respond by rapidly moving from the surface down into their burrows (Vader 1964, Goss-Custard 1970, Ratcliffe 1979). Goss-Custard (1970) has demonstrated that a single wader walking across the mud reduces the frequency of visits to the surface made by the amphipod Corophium. The reduction will be greater when birds are feeding at high density, leading to a decrease in capture rate

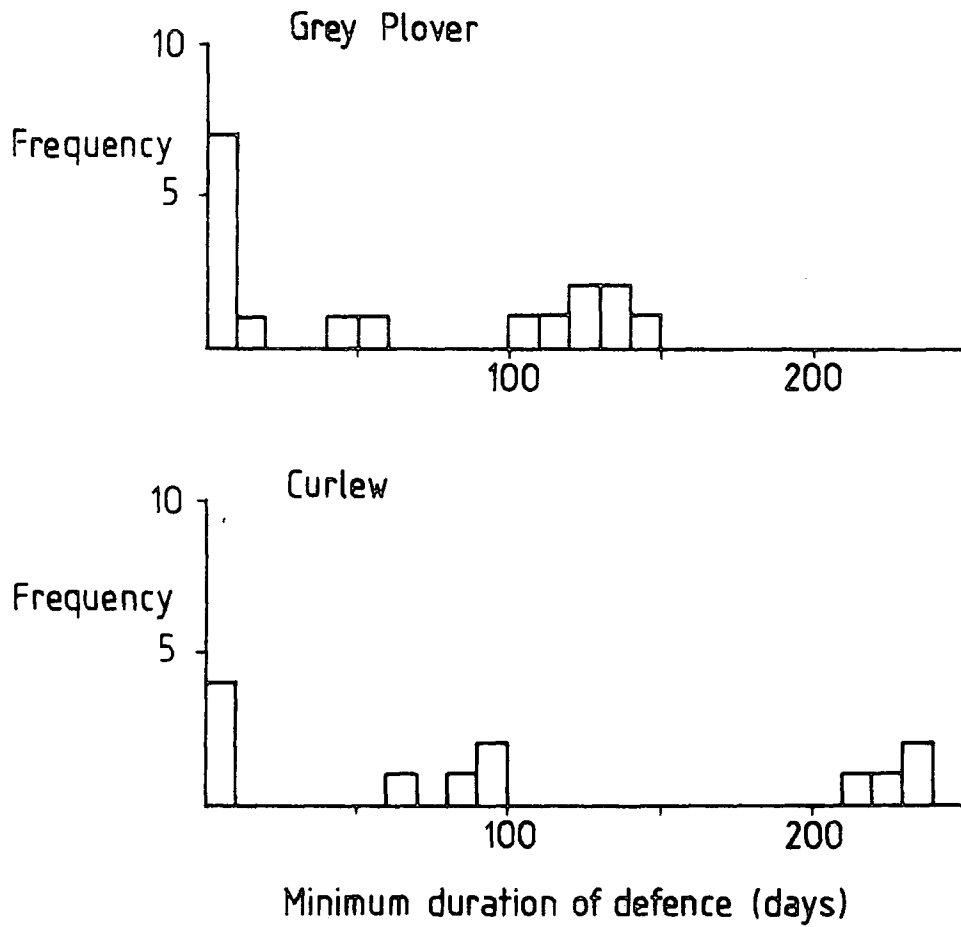

Figure 3.30

The minimum duration of defence of single feeding sites on Seal Sands by marked Grey Plovers (1976/77 and 1977/78) and marked Curlews (1977/78).

(Goss-Custard 1976). By defending a feeding site, the physical disturbance caused by conspecifics (but not by other species of wader) will be reduced to that caused by the territory holder.

This will result in an increase in the percentage of the worms present that are available to the territory holder. The increase would be most pronounced in waders capturing prey only at the surface of the mud, e.g. Grey Plovers feeding on Nereis, Redshank feeding on Corophium.

- iii) it eliminates interference and overlap of search paths with conspecifics - the territory holder no longer has to make adjustments to its search path to avoid nearby conspecifics.

These advantages would be reduced or even nullified if individuals of other species feed within the defended area and consume the same prey as the territory holder (see below).

Long-term advantages - By defending the same feeding site successfully for several months a bird can gain further, long-term advantages, not available to the short-term territory holder.

- i) If feeding conspecifics are excluded, the rate of decrease of absolute prey density on that site during a winter can be reduced, thereby preserving food stocks. (This assumes that Nereis worms (other than spat) are not mobile during a winter.)
- ii) The territory holder is able to acquire a knowledge of the micro-distribution of the prey within the feeding site. If there are patches of high density of prey animals, a predator can exploit them to the full only if no other predator (of the same or other species (see below)) is also feeding on the patches.

iii) By employing this knowledge, a territorial individual may be able to avoid visiting sites that it has recently depleted of prey, until the resource is renewed, e.g. by more prey animals becoming available to the predator. If several predators were removing prey from the same sites, none of them could accurately predict the availability in each and therefore could not avoid visiting some sites from which the available prey had just been removed. This advantage of territoriality is particularly important when only a small proportion of the food present is available to the predator at any one time, e.g. Sunbirds (Nectarinia) feeding on nectar, which is produced continually but at a very low rate (Gill and Wolf 1975), and Grey Plovers feeding on the few Nereis present at the surface of the mud at any moment. At least some of the territorial marked Grey Plovers on Seal Sands avoid feeding on recently-depleted patches by following "circuits" around their territories, returning to each spot after 10 - 30 minutes by which time more Nereis should have moved up to the mud surface. Pied Wagtails use river-edge territories in a similar way (Davies 1976). Such circuits were not detected amongst the territorial Curlews, possibly because the density of their available prey, Nereis, buried in the mud but within reach of their bill, is little depleted when a worm is removed by a predator.

The three advantages set out above are maximised if the territory holder is the only predator feeding in that site on the chosen prey. However in general neither Grey Plovers nor Curlews excluded any waders other than conspecifics from their territories. Territorial Grey Plovers often allowed Curlews, Bar-tailed

Godwits, Black-tailed Godwits (Limosa limosa), Redshanks, Dunlins, Knots and Ringed Plovers to feed in their sites. Indeed interspecific exclusion was never observed in territorial Curlews and only sporadically amongst territorial Grey Plovers. Grey Plovers were occasionally seen to evict both Golden Plovers and Ringed Plovers, i. e. species which also captured Nereis worms present at the surface of the mud. This general absence of interspecific exclusion contrasts with the behaviour of territorial Pied Wagtails which evicted intruding passerines from their feeding sites (Davies 1976). Perhaps these passerines were in more direct competition for the available food than were most waders on Seal Sands.

As waders of other species were usually ignored by the territory holder when feeding in a Grey Plover or Curlew territory, they could feed there without interruption. If eating Nereis (as did Curlews, Grey Plovers, Godwits, Redshanks, Golden Plovers and Ringed Plovers) the intruders would reduce both the short-term and the long-term advantages of territoriality to the holder outlined above. Even waders feeding on other prey could reduce the availability of Nereis by disturbance, and interfere with the search paths of the territory holder. For example one territorial marked Grey Plover on Scalloped Mud ran from a favoured spot to another part of its territory when a dense flock of Knot, feeding on Hydrobia, moved into its territory. It fed in the less preferred spot until the Knot flock had moved away.

Nevertheless, despite the disadvantages of excluding only conspecifics, both Grey Plovers and Curlews defended feeding sites successfully. Indeed some individuals of both species returned to the same territory in 2 or more successive winters. Therefore these disadvantages must be so reduced that territoriality remains an economically viable strategy. There are 2 ways in which interspecific intrusion is reduced:

1. Grey Plovers took up territories on those intertidal areas little used by other waders (with the exception of Bar-tailed Godwits on Eastern Channel in 1976/77) for most of the period of exposure. They did not attempt to defend sites on the mudflats most used by other waders, e.g. Greenabella Bank. Curlews also tended to defend territories only on areas away from the mudflats favoured by most waders at Low Water.

2. On some areas, particularly Eastern Channel, territories were held not only by all the Grey Plovers present but also by all the Curlews, and possibly the Redshanks too (though these were not individually marked). On the northern section of Eastern Channel the Grey Plover territories abutted so that no intruding Grey Plover could feed there. The Curlews were dispersed similarly, thus excluding non-territorial Curlews. Because of this exclusion of conspecifics by at least 2 species, the whole area held a very low density of birds for much of the period of exposure. Consequently prey availability was little depressed by the removal of available animals and disturbance, search paths were not interfered with and food stocks presumably lasted longer.

Thus Curlews and, in particular, Grey Plovers reduce the effects of other species upon prey availability and searching efficiency by defending sites in areas with a very low density of feeding birds.

One further long-term advantage to territory holders, not directly connected with food, is the knowledge of safe refuges from predators and from severe weather, particularly strong winds which increase heat loss (Evans 1976) and hinder the capture of food (Dugan *et al.* 1981).

Some individual Grey Plovers and Curlews return to the same territories in successive years. If the physical habitat remains unaltered and prey density and distribution are roughly similar each winter, these individuals could reap further

benefits from territoriality. They will know the parts of their territory which are likely to have a high density and/or availability of prey, which are sheltered from the wind, and which are safe refuges from predators. If neighbouring territory holders also return, the time spent determining boundaries could be much reduced. Thus more time will be available for feeding.

Having discussed the possible advantages of territoriality to waders on Seal Sands it must be stressed that not all individuals in either the Grey Plover or the Curlew population defended feeding sites. From the basic premise that territories are defended only when the benefits outweigh the costs, the following argument is proposed as a basis for the discussion below of Grey Plover and Curlew spacing behaviour and movements:

It is assumed that both Grey Plovers and Curlews on any area feed non-territorially if possible. Territories are defended only if the required capture rate cannot be maintained on that site without such defence. (The reason for a low or falling capture rate is irrelevant to the argument.) If the capture rate falls further the site is abandoned, either during each period of exposure (when the capture rate falls below the minimum required) or completely. Thus there are 3 stages involved:

- a) feed non-territorially in a site
- b) feed and defend a territory in that site
- c) abandon the site.

If the fall in capture rate is rapid, a bird may miss out the second stage and abandon the site immediately.

3. II. D. 2. Strategies in use of space during a tidal cycle in relation to prey behaviour

From the variety of strategies in use of space shown by Grey Plovers and by Curlews during a tidal cycle on Seal Sands, 4 basic patterns can be identified.

These differ in:

- a) whether one, or more than one, feeding site is used
- b) whether or not a territory is defended on one of the sites used.

Thus, the 4 basic patterns of use of space on Seal Sands are:

1. feed in one site throughout the period of exposure of Seal Sands,
2. feed in one site and defend a territory there,
3. follow a feeding circuit, feeding on several sites on Seal Sands at different times during the period of exposure, without defending any of these feeding sites,
4. follow a feeding circuit and defend a feeding site on just one (exceptionally two) of the mudflats visited.

Each individual in the Grey Plover population and in the Curlew population feeding on Seal Sands followed one of these 4 patterns during each tidal cycle. Individual birds changed their patterns of use of the habitat during a winter, but if they fed only on Seal Sands they always used one of these 4 options. There is a major difference between the 2 species in the proportions of the population following these patterns (Tables 3.76 and 3.77). The proportion of Grey Plovers defending feeding sites (38 - 40 per cent, and believed to be an underestimate (see Section 3. II. A. 3. c. above)) is significantly greater than the proportion of Curlews (6 - 11 per cent) both in November ($\chi^2 = 33.37$, 1 d.f., $P \ll 0.001$) and February ($\chi^2 = 79.59$, 1 d.f., $P \ll 0.001$). Other differences (e.g. the number following feeding circuits with a territory) are simply a consequence of the difference in the occurrence of territoriality. Similar proportions of the 2 populations follow feeding circuits (Grey Plovers 79 - 89 per cent, Curlews 75 - 79 per cent),

Table 3.76

Estimates for autumn and mid-winter, 1977/78, of the number of Grey Plovers following each pattern of use of space on the areas of Seal Sands

	NOVEMBER				FEBRUARY					
	Total present	1 site, not defended	1 site, defended	>1 site, not defended	>1 site, defended	Total present	1 site, not defended	1 site, defended	>1 site, not defended	>1 site, defended
Eastern Channel	16	0	0	0	16	20	0	0	0	20
Seaton Channel	4	0	0	0	4	4	0	0	0	4
Central Bank - north	21	0	0	9	12*	46	0	0	20	26*
Central Bank - central	9	0	0	9	0*	55	0	0	47	8*
Central Bank - south	4	4	0	0	0	23	15	8	0	0
Scalloped Mud - east	4	2	2	0	0	14	9	5	0	0
Scalloped Mud - west	2	2	0	0	0	0	0	0	0	0
Greenabella Bank	18	0	0	18	0	14	0	0	14	0
Central Channel	12	0	0	12	0	1	0	0	1	0
Total	90	8	2	48	32	177	24	13	82	58
% of total population	100%	9%	2%	53%	36%	100%	14%	7%	46%	33%

* Believed to underestimate (see Section 3. II. A. 3. c)

Table 3.77

Estimates for autumn and mid-winter, 1977/78, of the number of Curlews following each pattern of use of space on the areas of Seal Sands

	NOVEMBER					FEBRUARY				
	Total present	Use of space			Total present	Use of space				
		1 site, not defended	1 site, defended	> 1 site, not defended		1 site, not defended	1 site, defended	> 1 site, not defended		
Eastern Channel	15	0	0	0	15	5	0	0	0	5
Central Bank - north	13	0	0	13	0	14	0	0	14	0
Central Bank - central	8	0	0	8	0	16	0	0	16	0
Central Bank - south	21	21	0	0	0	16	12	4	0	0
Scalloped Mud - east	22	22	0	0	0	50	50	0	0	0
Scalloped Mud - west	16	1	6	5	4	16	1	6	5	4
Greenabella Bank	112	0	0	112	0	133	0	0	133	0
Central Channel	33	0	0	33	0	40	0	0	40	0
Total	240	44	6	171	19	290	63	10	208	9
% of total population	100%	18%	3%	71%	8%	100%	22%	3%	72%	3%

because the main Low Water feeding areas of both species are some distance from the first mudflats to be exposed.

Having identified the basic patterns in use of space shown by the 2 species, the question arises: "Why do different individual Grey Plovers (and different individual Curlews) follow different patterns in use of space?"

It has been shown above that the site(s) on which a Grey Plover or Curlew feeds influences its spacing behaviour (Sections 3. II. A. 3. and 3. II. B. 3) and movements (Sections 3. II. A. 2. and 3. II. B. 2). This variation in behaviour on different mudflats can be related to 2 physical characteristics in which the areas differed:

- a) tidal level
- b) substrate type.

Additionally, variations in prey density may have influenced the behaviours shown. The tidal levels and substrate types of the mudflats of Seal Sands are given in Table 3.78. The distribution of substrate types between the 3 tidal levels is not random, there being mainly sandy substrates at high tidal levels and very soft muds at the lowest tidal levels.

Grey Plover behaviour in relation to tidal level and substrate type

1. Grey Plovers fed at Low Water on high and mid tidal levels and avoided the low tidal levels (Table 3.79, 1).
2. They did not feed on either coarse sand or liquid mud (with a few exceptions), using only intermediate substrates (Table 3.79, 1).
3. Grey Plovers abandoned sandy sites at high tidal level during the period of exposure (Table 3.79, 1), moving to sites at lower tidal levels.

Table 3.78

The tidal level and substrate type of each mudflat on Seal Sands

<u>TIDAL LEVEL</u>	<u>SUBSTRATE TYPE</u>			
	<u>SAND</u>	<u>FIRM SANDY MUD</u>	<u>MUD</u>	
<u>HIGH</u>	1. Peninsula	2. Central Bank - south	4. Scalloped Mud - east	
		3. Scalloped Mud - east		
			8. Eastern Channel	12. Scalloped Mud - west
			9. Central Bank - south	13. Central Bank - central/ Eastern Channel
			10. Central Bank - central	14. Greenabella Bank - ridge
			11. Scalloped Mud - east	15. Central Bank - south
				16. Scalloped Mud - west
				17. Central Bank - south east/ Eastern Channel
				18. Greenabella Bank - lower and tide edge
				19. Central Channel

The numbers provide a cross-reference to Fig. 1.3 on which the position of each area on Seal Sands is shown.

Table 3.79

The use of space by Grey Plovers on Seal Sands in relation to the tidal level and substrate type of each mudflat

1) Low Water feeding areas

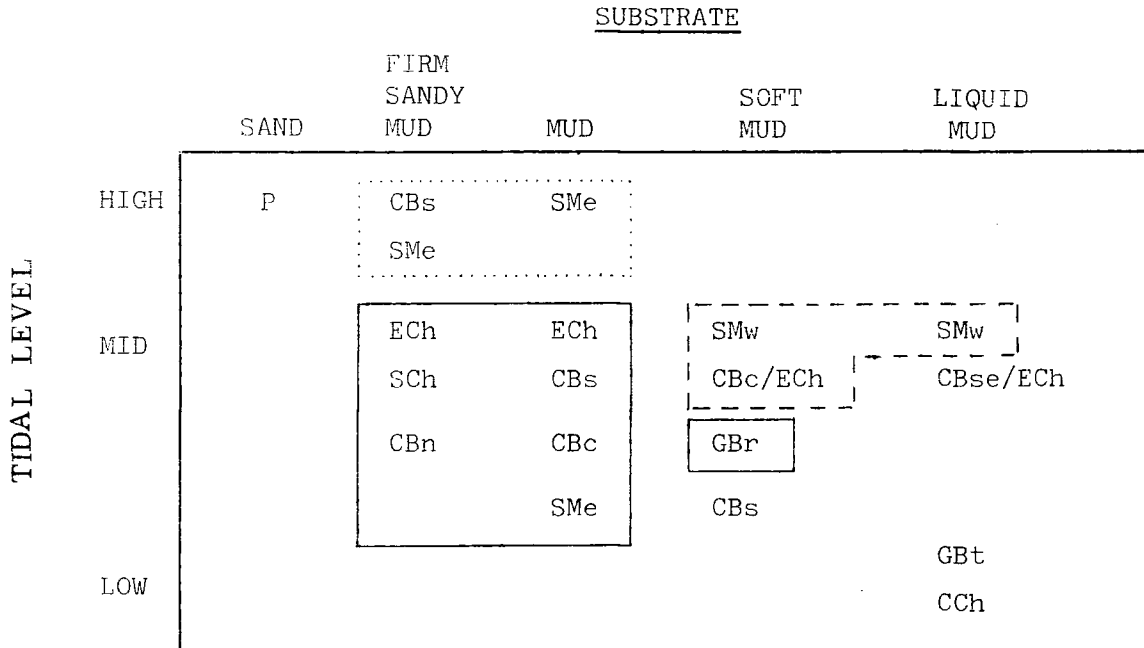

2) Areas in which territories defended

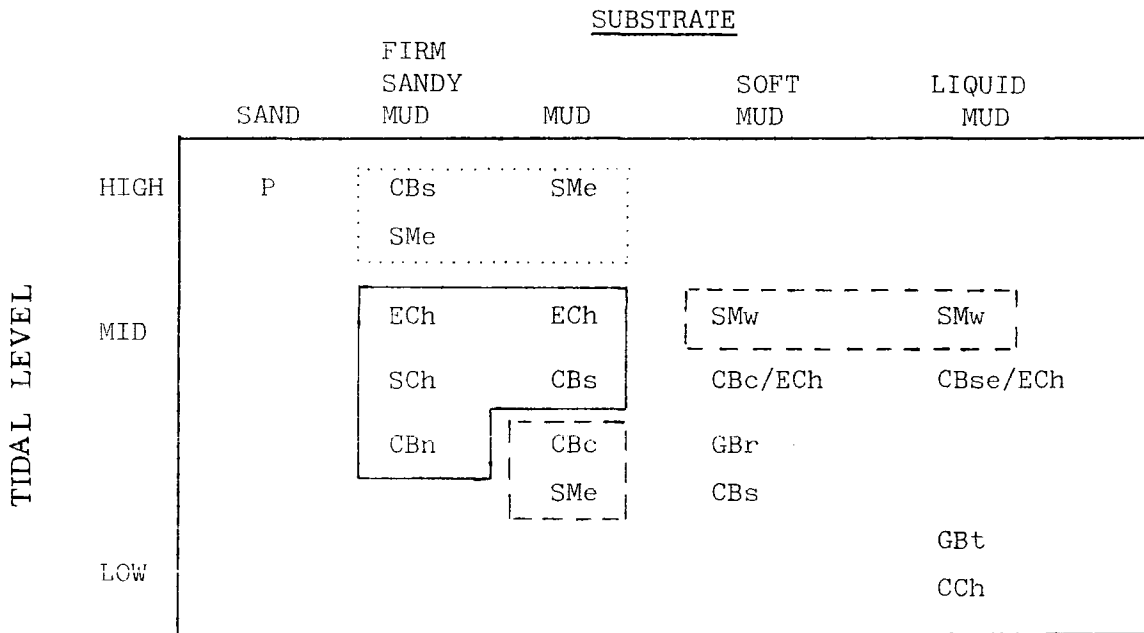

- Key:
- Main areas used for the whole period of exposure.
 - Other areas used for the whole period of exposure.
 - Other areas used for only part of the period of exposure.

The abbreviations refer to the areas listed on Table 3.78.

4. Territories were defended regularly at mid tidal levels on firm sandy mud and mud (but in general not on soft mud) (Table 3.79, 2). Occasionally they were defended on similar substrates at high tidal level. A common feature of sites on which territories were defended by Grey Plovers was that they were exposed for at least 5 hours each tidal cycle (Table 3.36).
5. Territories at mid tidal levels were defended throughout their period of exposure (Table 3.79, 2). Those at high tidal levels were defended for a short period only, after which the individual left the site.

Thus it is clear that substrate type and tidal level have a marked influence upon Grey Plover spacing behaviour and movements.

Curlew behaviour in relation to tidal level and substrate type

It will be shown here that the physical features of the mudflats of Seal Sands, which are, of course, the same for Curlews as for Grey Plovers, elicited somewhat different patterns of behaviour from Curlews.

1. Curlews fed at Low Water on all tidal levels (Table 3.80) although high tidal levels were used by only a few birds and only at certain times of year.
2. They fed mainly on the softer muds, including liquid mud, and at the tide edge.
3. Curlews abandoned sites at a high tidal level during the period of exposure (Table 3.80) moving to sites at lower tidal levels.
4. Territories were defended regularly on all the substrate types occurring at mid tidal level except firm sandy mud. Territories at a high tidal level were rare and temporary. All sites on which Curlews defended territories were exposed for at least 5 1/2 hours (Table 3.63).

Table 3.80

The use of space by Curlews on Seal Sands in relation to the tidal level and substrate type of each mudflat

1. Low Water feeding areas

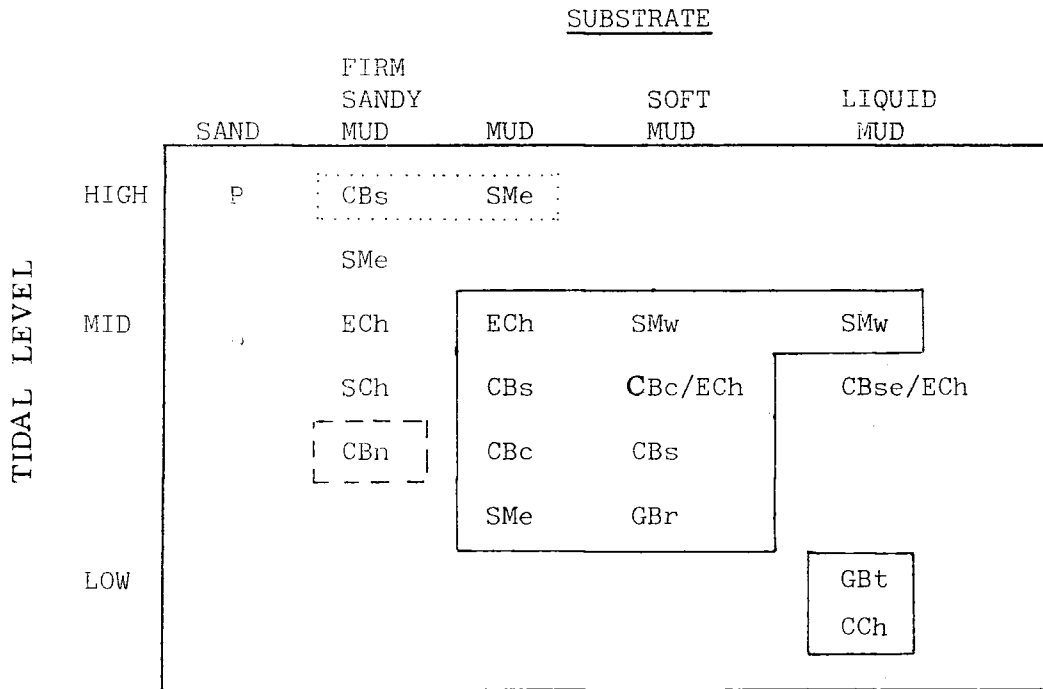

2. Areas in which territories defended

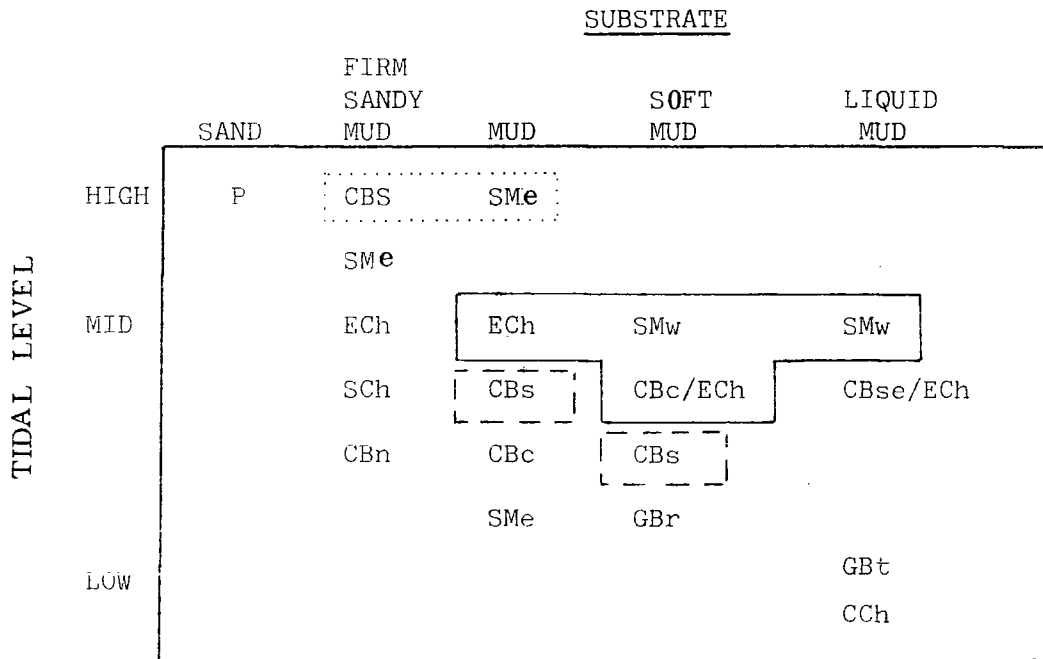

- Key:
- Main areas used for the whole period of exposure.
 - Other areas used for the whole period of exposure.
 - Other areas used for only part of the period of exposure.

The abbreviations refer to the areas listed on Table 3.78.

5. The territories at mid tidal level were defended throughout their period of exposure, at least in autumn.

Thus the behaviour of both Grey Plovers and Curlews differs between areas of Seal Sands with different physical features. (In Section 3. II. D.5. further comparison of the use of space by Grey Plovers and Curlews on Seal Sands, particularly under changing environmental conditions, will be made.)

The question then arises: "How can the tidal level and substrate type of the mudflats determine the spacing behaviour and movements of Grey Plovers and Curlews?"

The relationship between tidal level, substrate type and spacing behaviour

It is believed that tidal level and substrate type influence Grey Plover and Curlew behaviour by determining the level of the water table in the mud.

Period of exposure - After exposure by the ebbing tide, the mud dries out as the water drains away and the water table falls. In each tidal cycle, therefore, the water table in all areas at the same tidal level, i. e. areas uncovered at the same time, will fall for the same time period (from exposure to just before covering). Areas at a higher tidal level will be exposed for longer and therefore have longer to dry out; those at lower levels will have little time for the water to drain away (Fig. 3.31).

Curlews, by feeding particularly on the mudflats at low tidal level (including the tide edge where the water table is at the surface), used areas that had little time to dry out. In contrast Grey Plovers avoided the mudflats at low tidal level. They fed on high and mid tidal areas, where the water table fell below the surface during the period of exposure. Both species tended to abandon sandy areas at high tidal level (Central Bank - South, part of Scalloped Mud - east) which had a long period to dry out. Both species defended territories only on

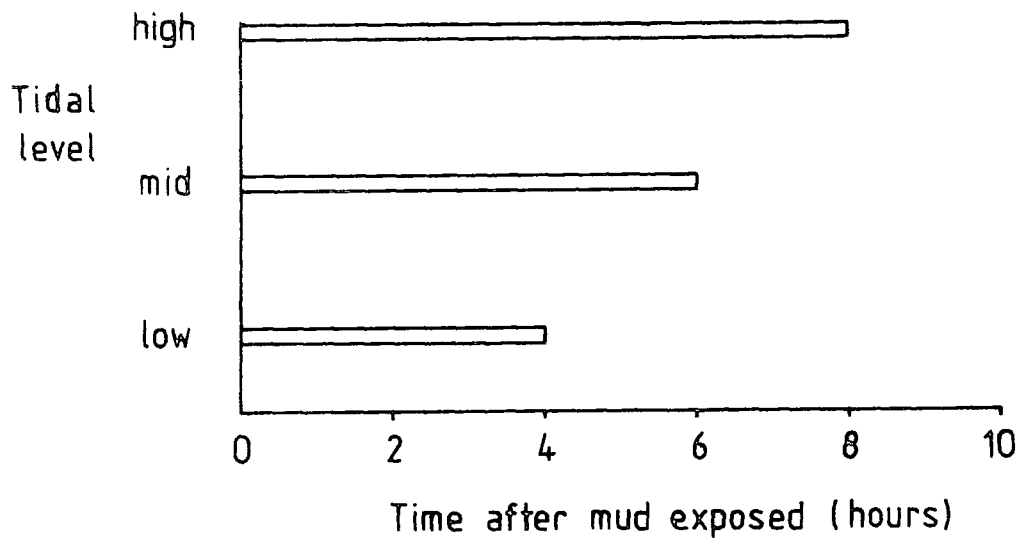

Figure 3.31 The approximate periods of exposure of mudflats at three tidal levels.

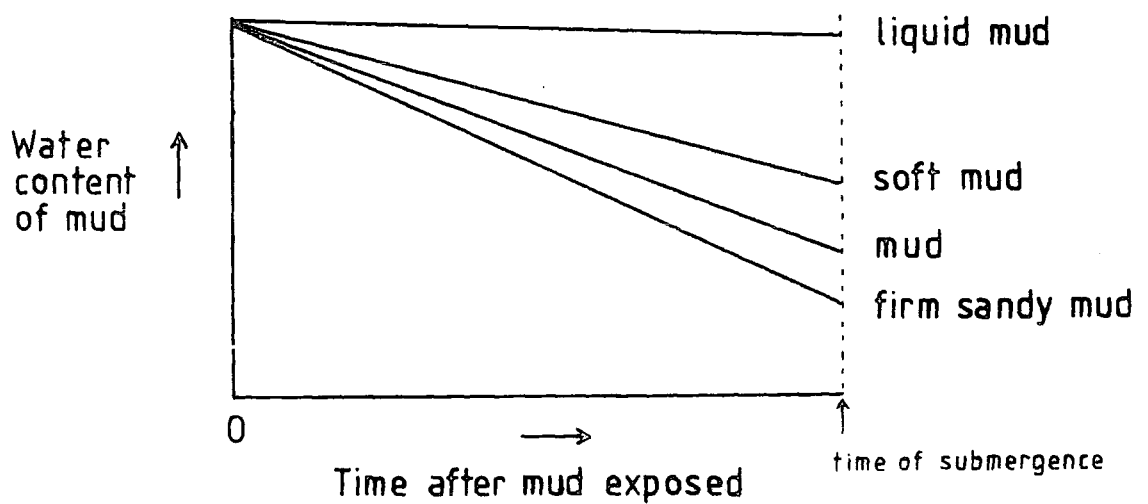

Figure 3.32 The rates of drying of four sediment types at the same tidal level.

mudflats at high and mid tidal levels, i. e. on areas where the water table fell well below the surface. Territories at a high tidal level, which had a long time to dry out, were abandoned during the period of exposure.

Thus the period of exposure of the mud influences the choice of feeding area of Grey Plovers and Curlews, but produces different responses in the 2 species. This single physical factor explains only some and not all of the variation observed in Grey Plover and Curlew use of habitat. It does not explain the variation in spacing behaviour seen on areas within one tidal level. This can instead be correlated with the substrate type and its effect upon the drainage of the mud.

Rate of fall of the water table - The type of sediment determines the rate of drainage of the mud. At any one tidal level the water table in a sandy substrate falls at a faster rate than on muddier (i. e. more silty) ones (Fig. 3.32).

Grey Plovers at mid tidal level (the only tidal level in which there is a wide range of substrates) fed non-territorially on soft mud (except for the juveniles in autumn) but defended feeding sites on firmer sandier substrates in which the water table falls more rapidly. Curlews defended feeding sites mainly on mud and soft mud, and not on sandier or siltier substrates, with the exception of the liquid mud of Scalloped Mud - west. Thus at mid tidal level Curlews defended territories on wetter substrates than Grey Plovers, but neither species defended sites on the wettest areas.

At high tidal levels territorial defence amongst Grey Plovers was more frequent on the sandy substrates than on the mud. The sandy sites were also abandoned earlier during the period of exposure.

Thus the drying out of the mud (both the period of drying and the rate of drainage) is an important determinant of the behaviour of Grey Plovers and Curlews feeding on the different mudflats of Seal Sands.

Prey behaviour

Why should the drying of the mud influence Grey Plover and Curlew use of space so markedly? I believe that it influences the availability of the main prey species, Nereis diversicolor, and in the following paragraphs I shall discuss how such a relationship could explain the observed behaviours during a tidal cycle. Although they feed on the same main prey, Grey Plovers and Curlews use contrastingly different methods of capture, and will, initially, be discussed separately.

Grey Plovers

Grey Plovers catch only prey coming to the surface of the mud (Pienkowski, 1980a), and are, therefore, influenced mainly by changes in prey activity. Direct observations of Nereis on the main Grey Plover feeding areas of Seal Sands during daylight did not provide any information on its behaviour because of the very low level of activity, visible to a human observer, at the surface. There is, therefore, no direct evidence as to whether its activity changes as the mud dries out. However it has been shown for another intertidal polychaete, Arenicola marina, at Lindisfarne, Northumberland, that the frequency of visits to the surface (in order to defaecate) decreases as the mud dries out after exposure (Smith, 1975). This decrease was observed at all tidal levels, but was most marked on drier sites in the later part of the period of exposure. Bar-tailed Godwits and Grey Plovers can capture the deep burrowing Arenicola only when it comes to the surface to defaecate (Evans, 1979). The decrease in the frequency of visits to the surface leads to decreased prey availability at the surface as the mud dries out. Therefore, if the waders maintain a constant searching effort on the same feeding site, they will experience a decreased rate of capture of Arenicola with time after exposure. As the use of space by Grey Plovers during a tidal cycle on Seal Sands is correlated with the drying of the mud on each area, it seems probable that Nereis diversicolor behaves

similarly to Arenicola, coming to the surface (to defaecate or feed) less frequently as the mud dries. (The rate of appearance at the surface can be termed the density of prey available per unit time.)

Curlews

Curlews feed chiefly by pacing across the substrate and probing into the mud for worms. They appear to locate areas of high Nereis density by sight, but within an area nereids are detected by touching the surface of the mud. They are then extracted by probing into the mud. Therefore, a Curlew can capture any worms in the mud down to the maximum depth it can reach with its probing bill. The density of worms within reach of a Curlew's bill is termed the density of accessible worms. It has been shown in both laboratory and field studies in the Netherlands that, for most of the Low Water period, Nereis diversicolor worms stay in their burrows at/below the level of the water table in the mud (Vader, 1964) (Fig. 3.33). As the behaviour of Curlews during a tidal cycle on Seal Sands is, like that of Grey Plovers, correlated with the drying of the mud, it seems very probable that nereids on Seal Sands respond to changes in water level in a similar way to those in the Netherlands.

From these hypotheses for the changes in activity and depth distribution of Nereis during a tidal cycle on Seal Sands, I shall now relate the use of space shown by Grey Plovers and Curlews to their foraging behaviour. Let us assume that both Grey Plovers and Curlews attempt to meet their energy requirements during a tidal cycle by capturing worms at a constant rate throughout the period of feeding and do not change the size they select. (Data to be presented in Section 4 show this to be a reasonable assumption.) So, for a Grey Plover to meet its requirements, there must be sufficient Nereis coming to the surface per unit time for it to maintain its required capture rate - i. e. the density of prey available per unit time \geq the

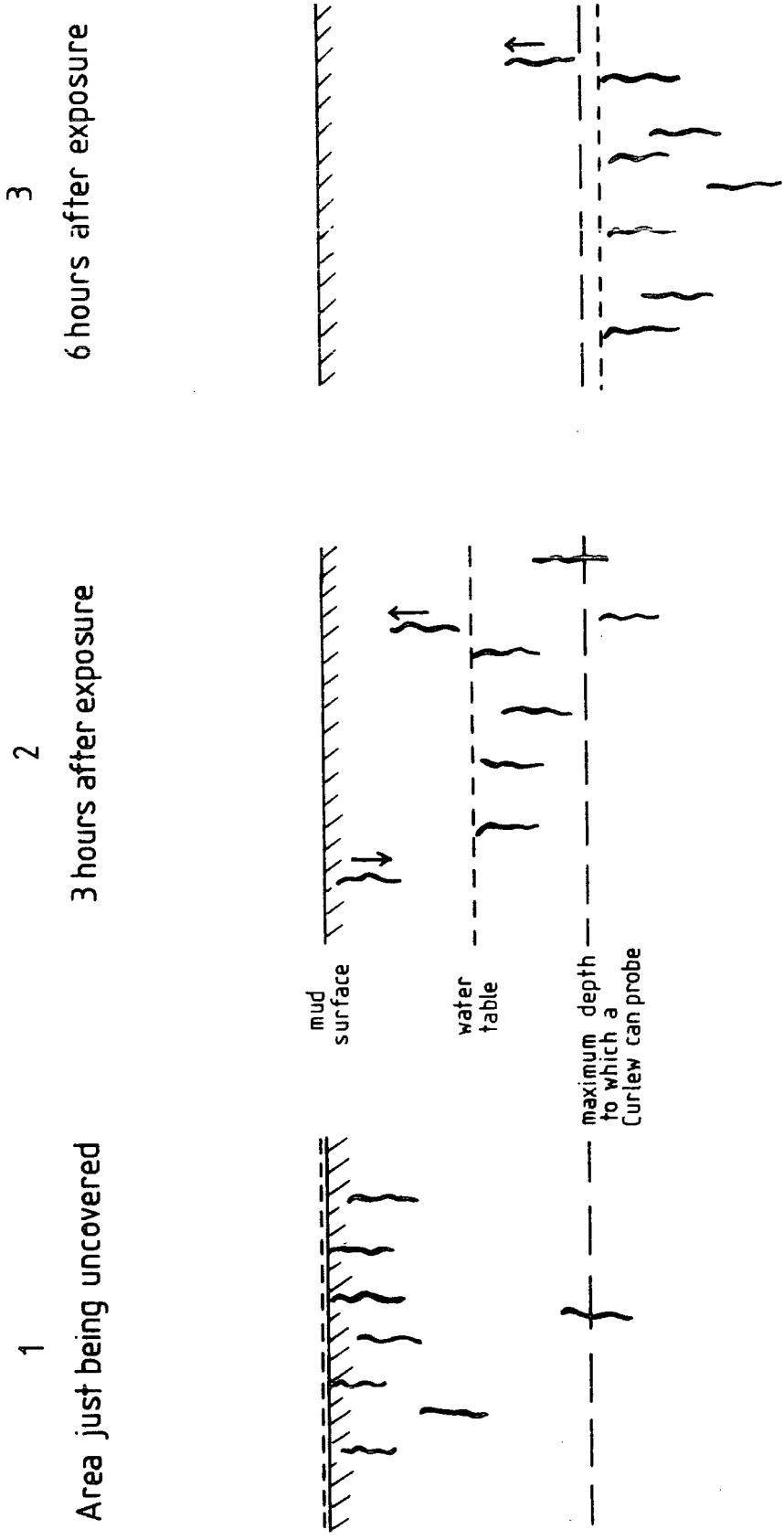

Figure 3.33 The depth distribution of *Nereis* worms at different stages of the tide. (Derived from information in Vader, 1964.)

threshold density of worms available per unit time. For Curlews, the density of accessible worms must similarly remain above the threshold density.

If Nereis behaves as proposed, as the mud dries out during the period of exposure, each feeding Curlew and Grey Plover will face a reduction in the density of prey accessible or available per minute. The rate of decrease will be fastest on sandy well-drained sites and slowest on liquid mud (Fig. 3.34). Thus Grey Plovers and Curlews abandoned sandy sites at high tidal level (Table 3.79 and 3.80) presumably because the density of available prey (Fig. 3.35, line C) fell below the threshold density (Fig. 3.35, line B). On lower and/or wetter areas, both species remained throughout the period of exposure presumably because the density of available prey remained above the threshold (Fig. 3.35, line A). On areas of drier mud at mid tidal level, this was generally possible only if a feeding site was defended. Site defence would immediately reduce the fall in prey activity during the period of exposure (Fig. 3.36). The territory holder would be the only member of that species a) removing available prey (for Grey Plovers, worms at the surface; for Curlews, worms within reach of the probing bill), and b) disturbing worms at/near the surface (see Section 3. II. D. 1). (The importance of disturbance of prey to Curlews depends upon the cues used to detect Nereis. Curlews may use visual/tactile cues of activity (e.g. vibrations, water currents) and/or tactile detection of the worm in its burrow. If the activity of the worm is important, exclusion of conspecifics will reduce disturbance and thereby increase detectability.)

Fig. 3.37(b) illustrates how defence of a feeding site can enable Grey Plovers and Curlews on soft mud and mud at high tidal levels (intersects A and B), and on mud and firm mud at mid tidal levels (C and D), to remain in those sites through the period of exposure. This would not be possible without territoriality (Fig. 3.37(a)). In contrast, birds on sandy areas at a high tidal level have to leave these areas during the period of exposure, even if the site is defended (Fig. 3.37(a) and (b), intersect E).

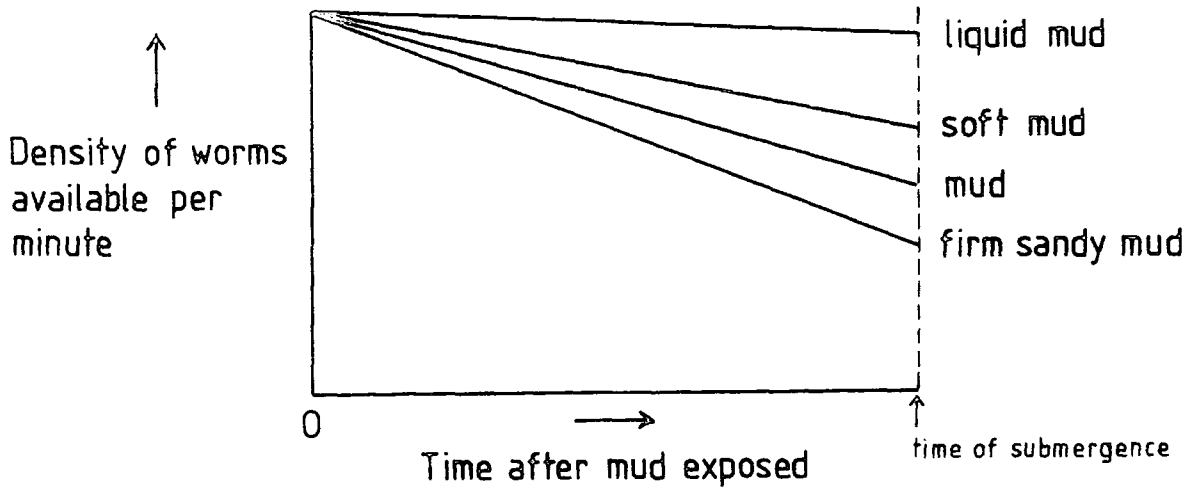

Figure 3.34 The predicted effect of substrate type upon the availability of *Nereis* to Grey Plovers, at a given tidal level.

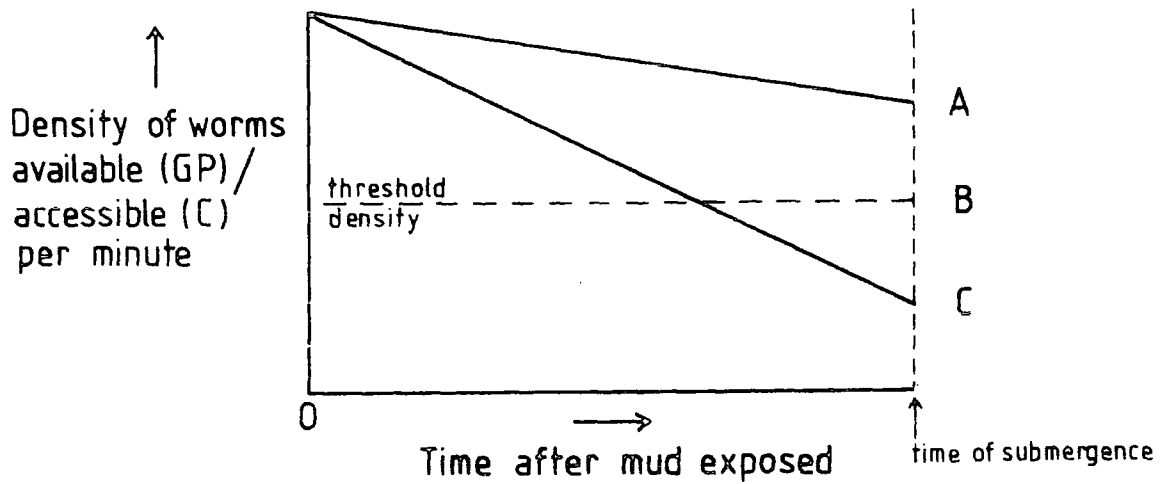

Figure 3.35 The possible relationships between the density of available prey and the requirements of a feeding Grey Plover or Curlew during the period of exposure of one site (see text).

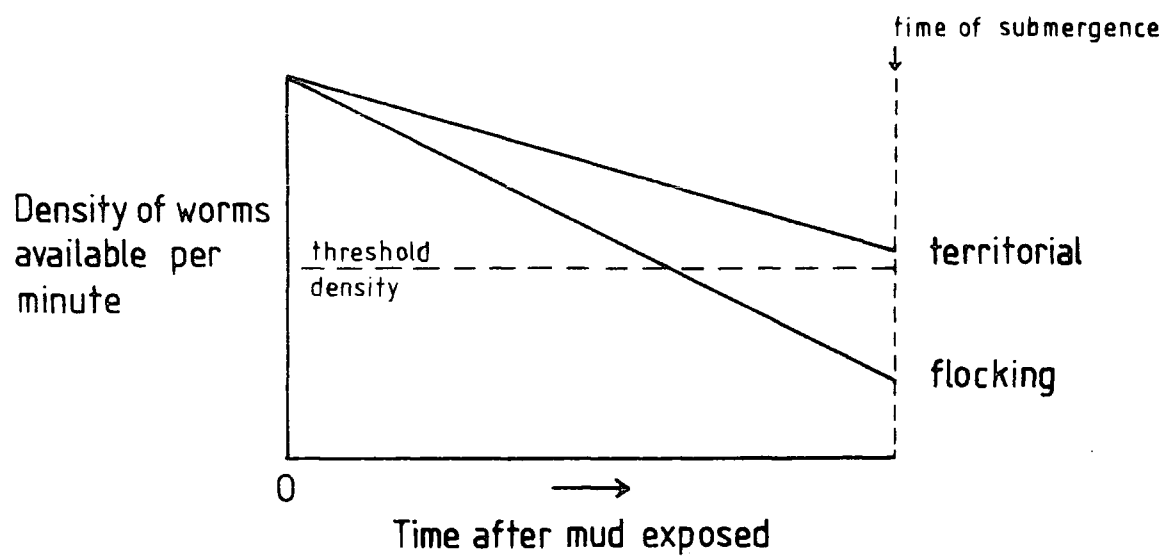

Figure 3.36

The predicted effect of territoriality upon the rate of decrease of prey availability at the site.

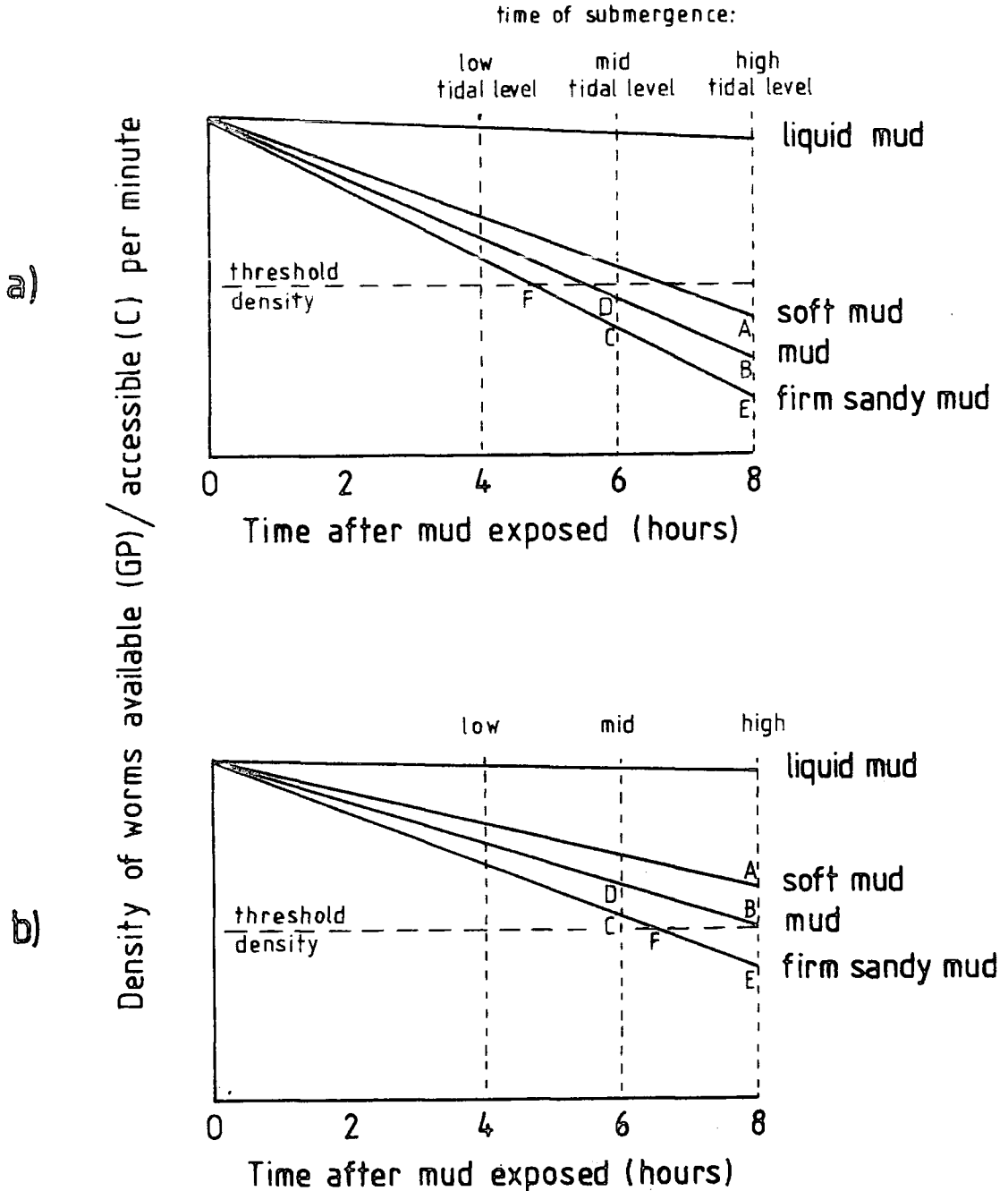

Figure 3.37

The predicted relationship between the density of available prey and the requirements of a feeding Grey Plover or Curlew on different substrates and tidal levels; a) without territoriality; b) when feeding sites are defended. The labelled intersects are discussed in the text.

The assumption that Nereis activity falls and depth increases during the period of exposure, enables predictions to be made of Grey Plover and Curlew use of space on different substrate - tidal level combinations (Tables 3. 81 and 3. 82). Although there are a few exceptions (see below), there is general agreement between predicted and observed behaviour. This supports the thesis that Nereis responds directly to the rate of drying of the substrate, and thereby directly determines Grey Plover and Curlew behaviour during a tidal cycle.

Exceptions: A. Grey Plovers

1. Avoidance of areas of liquid mud - Grey Plovers generally avoided areas of liquid mud even though the density of available prey should remain high there throughout the period of exposure (Fig. 3. 34). There must, therefore, be some disadvantage(s) to Grey Plovers that outweighs the advantage of the high density of available prey.

Possible disadvantages:

a) Interspecific effects - other waders of several species (e.g. Curlew - see Section 2. C) feed in large numbers at/near the tide edge on the areas of liquid mud, particularly those at low tidal level.

It has been shown above that the density of worms available per minute at the surface of the mud is reduced when several waders feed close together.

A high density of birds also leads to interference in search paths, particularly of species searching visually.

When the waders are of other species a Grey Plover cannot reduce these effects by defending a feeding site, as Grey Plovers exclude other species from their territories only very rarely (Section 3. II. D. 1). Therefore Grey Plovers may avoid feeding on areas of liquid mud because they are unable to maintain an adequate capture rate and cannot increase the rate by a change in use of space. In support of this idea, it is relevant to note that, occasionally at Low Waters of extreme spring tides a very few Grey Plovers did feed on the liquid mud

Table 3.81

Grey Plover: the predicted and observed use of space on the mudflats of Seal Sands in relation to tidal level and substrate type

		<u>PREDICTED</u>				<u>OBSERVED</u>			
		FIRM SANDY MUD		SOFT MUD	LIQUID MUD	FIRM SANDY MUD		SOFT MUD	LIQUID MUD
a) <u>Low Water feeding areas abandoned during the period of exposure</u>									
TIDAL LEVEL	HIGH	CBs	SMe			CBs	SMe		
		SMe				SMe			
		ECh	ECh	SMw	SMw	ECh	ECh	SMw	SMw
	MID	SCh	CBs	CBc/ECh	CBse/ECh	SCh	CBs	CBc/ECh	CBse/ECh
	CBn	CBc	GBr		CBn	CBc	GBr		
		SMe	CBs			SMe	CBs		
				GBt				GBt	
LOW				CCh				CCh	
b) <u>Low Water feeding areas used throughout the period of exposure, if defended</u>									
TIDAL LEVEL	HIGH	CBs	SMe			CBs	SMe		
		SMe				SMe			
		ECh	ECh	SMw	SMw	ECh	ECh	SMw	SMw
	MID	SCh	CBs	CBc/ECh	CBse/ECh	SCh	CBs	CBc/ECh	CBse/ECh
	CBn	CBc	GBr		CBn	CBc	GBr		
		SMe	CBs			SMe	CBs		
				GBt				GBt	
LOW				CCh				CCh	
c) <u>Low Water feeding areas used throughout the period of exposure, without defence</u>									
TIDAL LEVEL	HIGH	CBs	SMe			CBs	SMe		
		SMe				SMe			
		ECh	ECh	SMw	SMw	ECh	ECh	SMw	SMw
	MID	SCh	CBs	CBc/ECh	CBse/ECh	SCh	CBs	CBc/ECh	CBse/ECh
	CBn	CBc	GBr		CBn	CBc	GBr		
		SMe	CBs			SMe	CBs		
				GBt				GBt	
LOW				CCh				CCh	

Table 3.82

Curlew: the predicted and observed use of space on the mudflats of Seal Sands in relation to tidal level and substrate type

		<u>PREDICTED</u>				<u>OBSERVED</u>			
		FIRM SANDY MUD		SOFT MUD	LIQUID MUD	FIRM SANDY MUD		SOFT MUD	LIQUID MUD
TIDAL LEVEL	HIGH	CBs	SMe			CBs	SMe		
		SMe				SMe			
	MID	ECh	ECh	SMw	SMw	ECh	ECh	SMw	SMw
		SCh	CBs	CBc/ECh	CBse/ECh	SCh	CBs	CBc/ECh	CBse/ECh
	LOW	CBn	CBc	CBs		CBn	CBc	CBs	
			SMe	GBr			SMe	GBr	
				GBt				GBt	
				CCh				CCh	

(b) Low Water feeding areas used throughout the period of exposure, if defended

TIDAL LEVEL	HIGH	CBs	SMe			CBs	SMe		
		SMe				SMe			
	MID	ECh	ECh	SMw	SMw	ECh	ECh	SMw	SMw
		SCh	CBs	CBc/ECh	CBse/ECh	SCh	CBc/ECh	CBse/ECh	
	LOW	CBn	CBc	CBs		CBn	CBs	CBs	
			SMe	GBr			CBc	GBr	
				GBt				GBt	
				CCh				CCh	

(c) Low Water feeding areas used throughout the period of exposure, without defence

TIDAL LEVEL	HIGH	CBs	SMe			CBs	SMe		
		SMe				SMe			
	MID	ECh	ECh	SMw	SMw	ECh	ECh	SMw	SMw
		SCh	CBs	CBc/ECh	CBse/ECh	SCh	CBs	CBc/ECh	CBse/ECh
	LOW	CBn	CBc	CBs		CBn	CBc	GBr	
			SMe	GBr			SMe		
				GBt				GBt	
				CCh				CCh	

of the low tidal levels of Greenabella Bank (Section 2. B. 2. a). On these tides most waders moved down to the lowest exposed mud (an area that was rarely accessible and presumably had a high density of worms) leaving an area of sparsely populated liquid mud that the Grey Plovers could use.

- (b) Prey capture - it may be more difficult for Grey Plovers to capture worms on a liquid substrate.
- i) the Grey Plovers may have difficulty in detecting accessible worms. The cue to an accessible worm may be an outflow of water from the burrow, as is believed to be the case for plovers feeding on Notomastus latericeus (Pienkowski, 1980a). Such a cue may be impossible to detect when it appears in an area of liquid mud.

Reflections in the watery surface of liquid mud may interfere with detection by the Grey Plovers of cues or movements of the worms.

Grey Plovers nearly always seem to feed on drier ridges within an area (e.g. Eastern Channel) and along creek sides (e.g. Scalloped Mud) rather than in adjacent wetter areas.

There may also be an element of confusion caused by the high percentage of prey available on the surface of the liquid mud (where availability is always high (Fig. 3.34)), but this seems less likely.
 - ii) on liquid mud it may be difficult for a Grey Plover to accelerate when moving to capture a visible worm. Compared with firmer substrates, liquid mud will offer very little resistance to downward pressure by the Grey Plover's feet. Acceleration is a vital part of the Grey Plover capture technique (see above).
 - iii) on liquid mud it may be difficult to grasp the worm at the entrance to its burrow due to the lack of a firm substrate to press against.

2. Delayed movement between feeding areas - Grey Plovers following feeding circuits should move to the lower feeding areas as soon as they are exposed (Section 3. II. A. 2). The few Grey Plovers that moved from high to low feeding areas well after the latter became exposed (Section 3. II. A. 1. b.) were, therefore, apparently not optimising their use of the available feeding areas. There are 2 possible interpretations (not mutually exclusive) of this behaviour:

- (a) the Grey Plover moved from the higher area only if and when its capture rate fell to/below the minimum required to meet its energy requirements. Thus, in contrast to the majority of Grey Plovers following feeding circuits, it moved in response to, rather than in anticipation of, the density of available worms falling below the threshold. It appears that some Grey Plovers defend territories on sites that cannot always provide an adequate capture rate. One marked bird fed in its territory on the eastern half of Scalloped Mud throughout the period of exposure only on certain days, moving to lower mudflats after a few hours on other days.
- (b) a Grey Plover showing these delayed movements may be employing an alternative pattern of use to the majority of Grey Plovers. One of the possible advantages to Grey Plovers moving to lower mudflats was to feed in areas of lower Grey Plover density (Section 3. II. A. 2. a). Waders of other species also feed in the main on the lower areas. Consequently, once this movement has occurred, relatively unpopulated areas will be found at high tidal levels. A few Grey Plovers can continue to feed in these higher areas for several hours, even though prey availability is not high, instead of competing for space on the exposing lower mudflats.

B. Curlews

1. The occurrence of territoriality across Seal Sands - on two areas, the liquid mud of Scalloped Mud - west and the sandy mud at high tidal level on

Central Bank - south, territories were defended throughout the period of exposure. These areas appeared, respectively, too slow- and too fast-draining for such behaviour. These exceptions appear to be consequences of the spatial distribution of sediments on Seal Sands. It is believed that the distance across the area of mud/soft mud is, in both cases, less than the minimum diameter for a Curlew territory. Areas of adjacent sediment (liquid mud and sandy mud, respectively) were therefore defended to provide an adequate area in which to feed.

The high incidence of non-territoriality on Central Bank - south was also unexpected, as some of the sediments there are high and fast-draining. Most Curlews on Central Bank - south may avoid the need for a territory by feeding over a large area including a range of sediments, as are found in this part of Seal Sands (Fig. 1.3).

3. II. D. 3. Use of space during a winter in relation to prey behaviour

It has been argued above that the variety of patterns of use of space shown by Grey Plovers and Curlews during a tidal cycle are probably direct responses to changes in the availability of Nereis diversicolor. In this section I shall show how many of the changes in use of space occurring during a winter can similarly be explained in terms of direct responses by the birds to changes in prey availability, but on a seasonal basis.

It was shown in Sections 3. II. A. 3. d. and 3. II. B. 3. d. that the factors most frequently correlated with the observed seasonal changes in use of space by both Grey Plovers and Curlews were changes in weather and in the density of conspecifics feeding nearby. In particular, they abandoned Low Water feeding sites (Curlews also long-term territories) when the temperature fell, and temporarily defended their feeding sites when the density of conspecifics feeding nearby increased. The depressive effects of a high density of conspecifics upon the density of available prey

were discussed in Section 3. II, A, 3. d. Here, I shall consider the question: How could low temperatures promote changes in use of space?

Cold temperatures lead to increased energy requirements for the birds. They may also decrease prey availability. Although there are no direct observations of the activity and depth distribution of Nereis during a winter on Seal Sands, data from other sites and other species of polychaete indicate that Nereis availability probably decreased during the cold weather of mid winter. Decreases in activity with falling substrate temperature have been identified in two intertidal polychaetes occurring in north-east England, Arenicola marina (Smith, 1975) and Notomastus latericeus (Pienkowski, 1980a). Correlated with the decreased activity in Notomastus was a decrease in the rate of capture of Notomastus by Grey Plovers. Pienkowski (1980b) suggests that such behaviour at low substrate temperatures is probably typical of intertidal polychaetes. Thus it is probable that Nereis diversicolor on Seal Sands comes to the surface less frequently at lower substrate temperatures. Nereis also shows a seasonal rhythm in depth distribution, burrowing deepest in mid winter in Denmark (Muus, 1967). It is not known whether this increase in depth is a direct response to falling substrate temperature, as found for another polychaete in north-east England (Smith, 1975), or a rhythm independent of temperature. Comparable seasonal changes probably occur amongst the nereids on Seal Sands (although the actual depths may differ between the sites).

These supposed seasonal changes in Nereis activity and depth distribution on Seal Sands could explain the temperature-related changes in use of space shown by Grey Plovers and Curlews during a winter. If Nereis diversicolor comes to the surface less frequently at lower substrate temperatures, the density of prey available per minute for Grey Plovers at any chosen time after exposure of a feeding site will decrease as the temperature falls. Data given earlier support the hypothesis that, during a tidal cycle, the availability of Nereis also decreases

with time after exposure of the mud. At a lower temperature, therefore, the decrease in the proportion of worms available per minute will be parallel to, but lower than, that at a higher temperature (Fig. 3.38). If so, the density of worms available per minute may drop below the threshold needed by Grey Plovers, particularly on sites exposed for a long period during the tidal cycle (Fig. 3.38) and/or composed of fast-draining substrates, i. e. mud or firm sandy mud (Fig. 3.39).

If, as postulated, there is also a seasonal rhythm in depth distribution of Nereis on Seal Sands, the proportion of the worms within reach of a Curlew's bill on a particular site at a given time after exposure will decrease from autumn to mid winter, and then increase again in spring (Fig. 3.43). In mid winter, the density of accessible worms on some sites could fall below the threshold during the period of exposure (Fig. 3.40). As for Grey Plovers, this fall is most likely to occur on areas at higher tidal levels and/or comprising faster-draining substrates (Fig. 3.41).

As described in Section 3. II. A. 3. d. , a Grey Plover or Curlew that experiences such a fall below the threshold should attempt to increase the density of prey available to it, either by commencing defence of its feeding site, or by moving to a new site. For the density of available prey to remain above the threshold through the period of exposure, the new site should be at a lower tidal level and/or include a slower-draining substratum (see Figs. 3.38, 3.39, 3.40, 3.41).

The observed behaviour of marked Grey Plovers and Curlews can be analysed to test whether it fits these predictions. Five changes in use of space by Grey Plovers at Low Water during the period November-February coincided with falls in temperature (Table 3.41). Two abandoned sites on high or marginal mudflats and a third became territorial on a mid-tidal area of mud (Table 3.83). (A fourth fed upon small polychaetes but not nereids, so its behaviour is not directly relevant here.) Another four marked Grey Plovers that defended sites temporarily on Seal Sands on

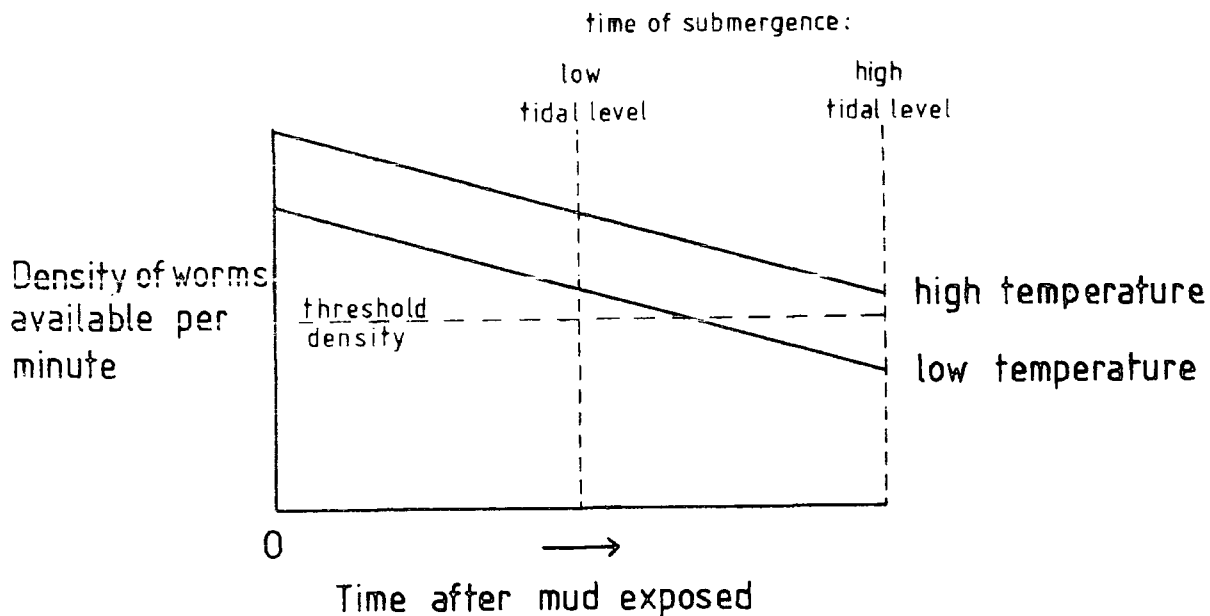

Figure 3.38 The predicted effect of low substrate temperature upon the availability of worms to Grey Plovers during a tidal cycle.

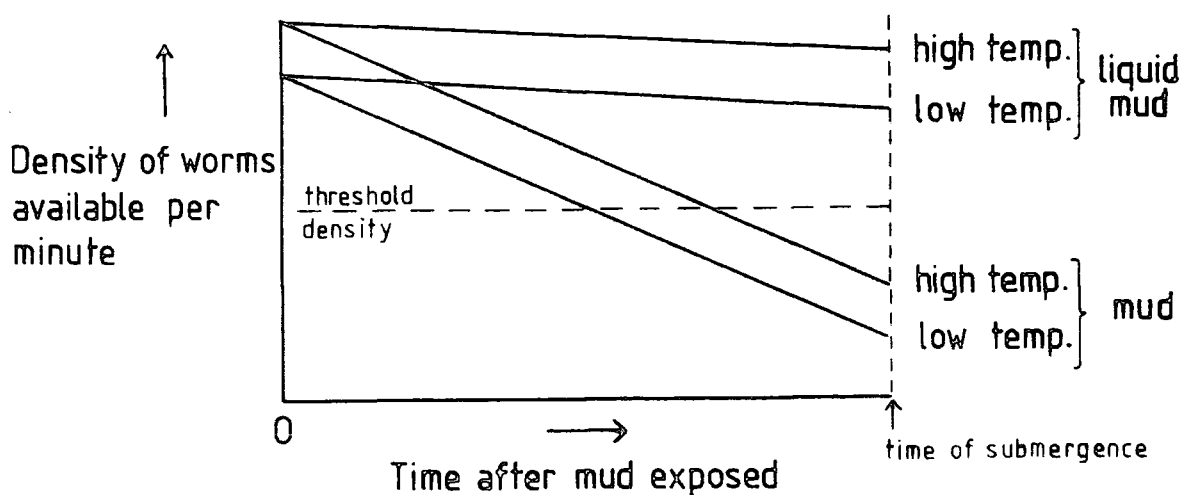

Figure 3.39 The predicted effect of low substrate temperature upon the availability of worms to Grey Plovers on two substrate types at a given tidal level.

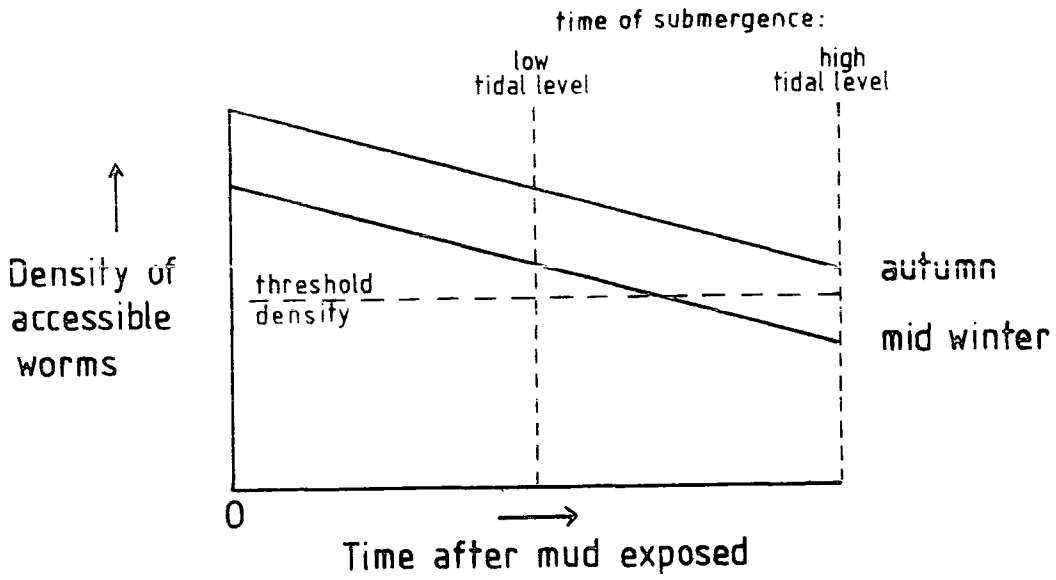

Figure 3.40

The effect of the seasonal change in Nereis depth upon the accessibility of Nereis to Curlews during a tidal cycle.

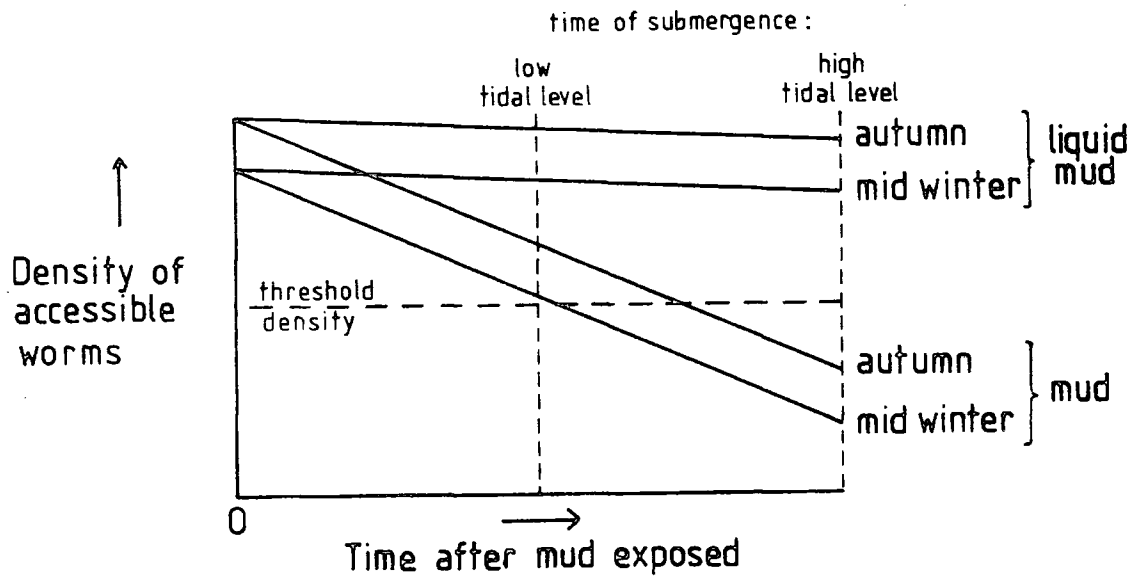

Figure 3.41

The effect of the seasonal change in Nereis depth upon the accessibility of Nereis to Curlews on two substrate types.

Table 3.83

Correlations between changes in Low Water feeding site by marked non-territorial Grey Plovers on Seal Sands, during the period November to February, and changes in temperature

	no. of marked Grey Plovers changing site	no. of changes correlated with falling temperatures	no. of these that changed to territorial defence	no. of remainder which changed between areas as predicted (see below)	no. which changed area again with increasing temperature
1977/78	5	4	1	2	2
1976/77	3	1	0	1	0
1975/76	1	0	-	-	-
	9	5*	1	3	2*

	1st site	2nd site as temperature fell	change as predicted?	3rd site as temperature rose	change as predicted?
1977/78	L W/L SM _w	SM _e (territorial)	✓		
	Y O/R SM _e	GB	✓		
	Y O/R GB	CB _s	x	SM _e	✓
	B W/O GC	GB	✓	SM _e	✓
1976/77	B W/O CCh(no nereids)	SM _w (nereids)	✓		

* Choice of feeding areas by birds that changed site:

Abbreviations as on Table 3.19.

the ebb/flood tides in cold weather (Section 3. II. A. 3. e) fed on a sandy ridge at high tidal level. Furthermore, 2 of the 3 birds which abandoned a site moved to a wetter mudflat at a lower tidal level, and 2 subsequently moved back to a high mudflat when the temperature rose again (Table 3. 83).

Six marked Curlews changed their use of space in mid winter (Table 3. 67) at a time when Nereis are believed to be least accessible. Five had been feeding on drier mudflats, four of them at mid tidal level and one at high tidal level. Two remained on the same site but became territorial, and three abandoned their sites and moved to a lower, wetter mudflat.

These data support the thesis that at least some changes in use of space by Grey Plovers and Curlews are direct responses to falls in prey availability at low temperature. When low temperatures coincide with an increase in density of feeding birds, difficulties in maintaining an adequate prey capture are aggravated. It is under such conditions that changes in use of space are most likely.

The behaviour of the Grey Plovers defending permanent feeding territories on Seal Sands would not have been predicted if Nereis availability does fall with temperature. Permanent territories were held mainly on mid tidal areas comprising mud or firm sandy mud, areas that were likely to have provided low availability of Nereis in cold weather. Yet none of the marked Grey Plovers feeding there abandoned their territories until March (Table 3. 39), even though the mud temperature in mid winter sometimes fell to 0.5°C . It appears that, on some mudflats, by excluding conspecifics from its feeding site and defending a site that is little used by other waders that feed on Nereis, a Grey Plover can maintain an adequate capture rate even during the coldest weather or mid winter. This may have been because the territory holder was the only Grey Plover removing worms from the territory and, therefore, the stocks were depleted only slowly, or because the absence of

conspecifics resulted in a) little reduction in the density of available prey during the period of exposure, and b) reduced interference in search paths.

Changes in use of space in spring may also be direct responses to falls in the density of available prey, but at this time the situation is more complex. Nereis activity should be higher in spring than in the cold weather of mid winter (Fig. 3.42). However, due to predation by waders and death, the absolute density of Nereis falls markedly through a winter and may be very low in spring (Evans et al. 1979). By then, even if the percentage of prey available is high, the density of prey available to Grey Plovers on any area may be as low as in mid winter (Fig. 3.42). With the proposed seasonal change in depth distribution of Nereis on Seal Sands, the density of worms accessible to Curlews in spring will also be low (Fig. 3.43). This could have two consequences: birds forced to change their use of space in mid winter in response to decreased availability of Nereis may not revert to their previous pattern of use in spring; and other individuals may be forced to change their behaviour in spring. The behaviour of marked Grey Plovers and Curlews gives some support to this argument. Two Grey Plovers and three Curlews changed their use of space in spring. Three of the changes coincided with falls in temperature which would have further decreased the already low density of available prey. Furthermore, of the 20 changes in use of space by Curlews in the autumn, only 5 were reversed in spring.

Summary - Simple hypotheses for changes in the activity and depth distribution of Nereis during a tidal cycle and during a winter account for much of the data on use of space by Grey Plovers and Curlews. It appears that Nereis activity is the major factor determining use of space by the visually-foraging Grey Plover, and Nereis depth distribution that determining use of space by the tactile-foraging Curlew.

The models proposed make 3 assumptions about the foraging behaviour of the 2 species:

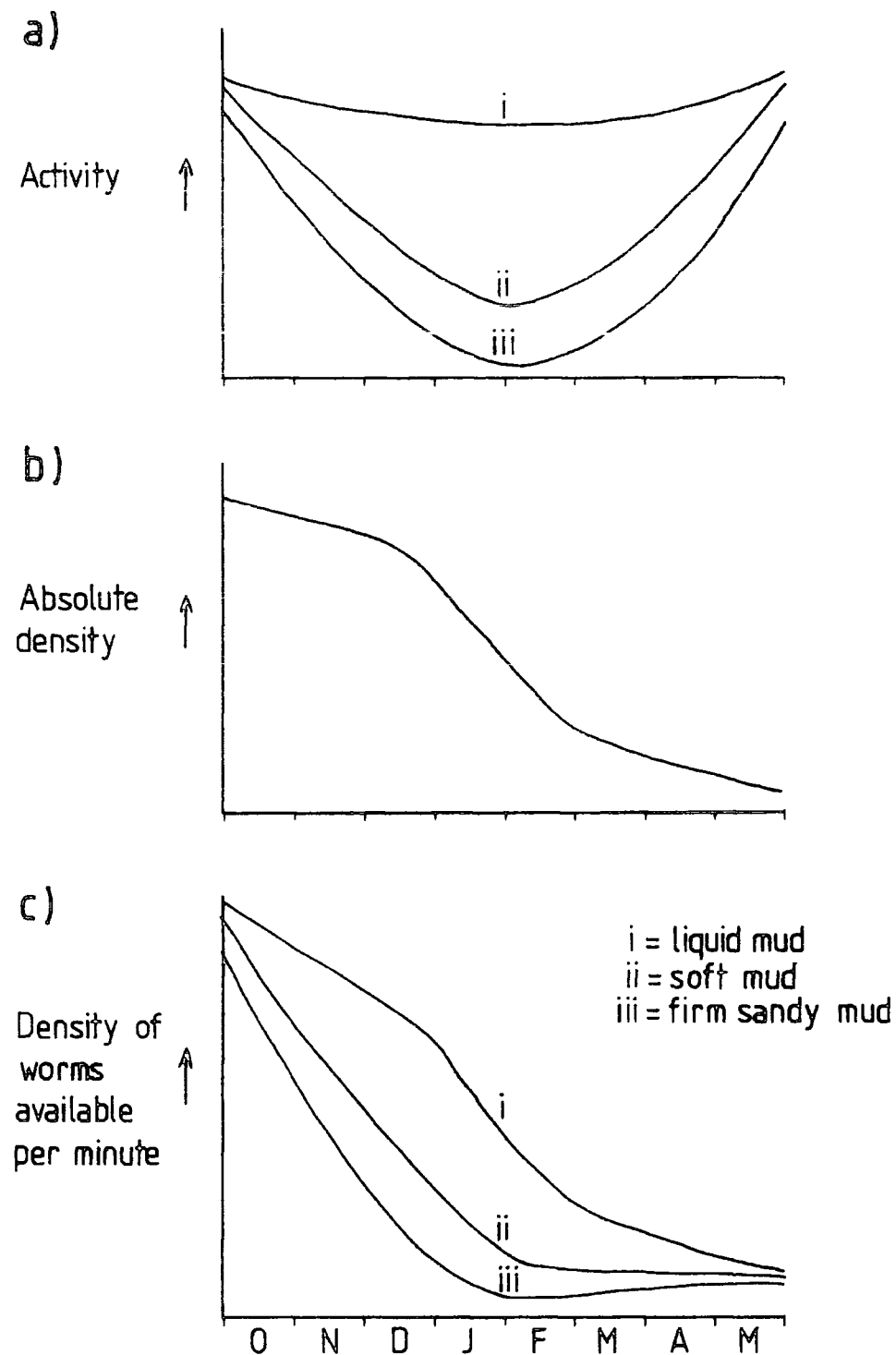

Figure 3.42 Seasonal changes in a) the activity of Nereis (assuming a minimum is reached in mid winter - see text), b) the absolute density of Nereis, and c) the density of Nereis available to Grey Plovers per minute (derived from a) and b)), on three different substrate types at a given time after exposure.

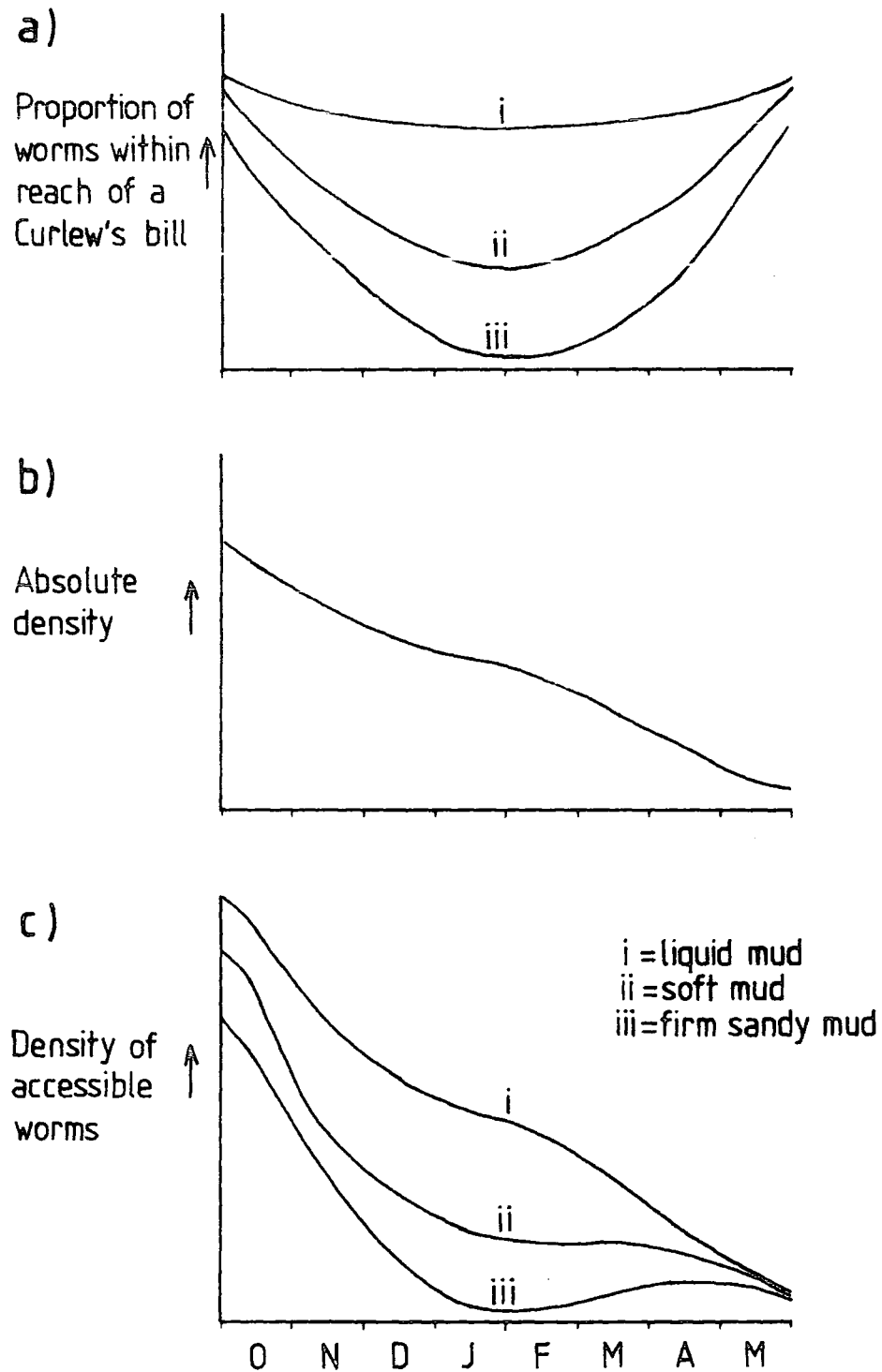

Figure 3.43 Seasonal changes in a) the proportion of worms within reach of a Curlew's bill, b) the absolute density of *Nereis*, and c) the density of *Nereis* accessible to Curlews (derived from a) and b), on three substrate types at a given time after exposure.

- a) worms are captured at a constant rate during the feeding period, if possible.
- b) there is no change in size selection.
- c) there is no change in search effort.

These assumptions are tested in Section 4. Two alternatives to the simple models employed above are:

1. A decreasing capture rate - birds might capture worms at a decreasing rate matching the decreasing availability/accessibility. By capturing at above the threshold rate early in the period of exposure and below it later on, a bird could capture sufficient worms during the whole tidal cycle to meet its energy requirements. However data to be presented in Section 4 suggest that both Grey Plovers and Curlews attempt to maintain a constant capture rate rather than a decreasing one.
2. An increase in energy requirements in cold weather - in cold weather birds need more food to maintain their energy balance. Even if prey availability remains constant Grey Plovers and Curlews may have difficulty meeting their higher energy requirements on some sites. This could lead to changes in use of space that are not a consequence of decreased Nereis activity or increased depth. From the data available it is not possible to distinguish between changes caused solely by increased energy requirements, and those due solely to decreased prey availability. It is probable that the observed changes are a consequence of their combined effects.

However, Nereis behaviour, although of major importance, is not the only factor affecting the choice of feeding areas and spacing behaviour of most Curlews and Grey Plovers. Intra- and interspecific interactions must also be considered. For example, the distribution of male Curlews on Seal Sands may be influenced by the feeding areas used by females (see Section 3. II. D. 4. below); and that of Grey Plovers is affected by the distribution of other feeding waders (see Section 3. II. D. 2 above).

3. II. D. 4. Bill length in relation to Curlew use of space

I have proposed above that Nereis on Seal Sands burrow deeper both during the period of exposure and also seasonally (deepest in mid winter), and shown that the observed behaviour of Curlews on different areas of Seal Sands supports this proposition. In this section I shall investigate whether the differences in use of space between male and female Curlews can also be explained in terms of responses to changes in prey depth distribution.

As females have longer bills than males (Section 3. I. C. 1), they can reach worms lying at a greater depth in the mud. Therefore, as Nereis burrow deeper with time after exposure of the site, and from autumn to mid winter, they should move out of reach of males first. On some sites the density of worms accessible to males may fall below the threshold under certain conditions whereas females can continue to capture worms at an adequate rate.

The use of the fields by Curlews of different bill lengths (Section 3. II. C.) fits with these predictions. Movement of Curlews from Seal Sands to the fields occurred during autumn when Nereis burying depth is believed to increase. The majority of Curlews feeding on the fields were males, and amongst these males the shorter-billed individuals spent more time during the winter feeding there. Birds with very short bills would be the first to experience difficulties capturing worms on Seal Sands as the worms burrowed deeper.

There is also evidence that males may have difficulty capturing prey fast enough on Seal Sands at other times of the year. Although the data are few, amongst the marked Curlews only males changed their use of space at Low Water during cold spells in mid winter and in spring, when absolute prey density was very low (Table 3.84). In 4 of the 5 cases, defence of a previously undefended feeding site occurred, usually temporarily. By this defence, these Curlews might reduce the disturbance and removal of the few Nereis close to the surface.

Table 3.84Timing of seasonal changes in Low Water use of space
by marked male and female Curlews during 1977/78

	Males	Females	Total
Autumn (Oct - Dec)	9	4	13
Cold spell in Jan - Feb	3	0	3
Spring (Mar - Apr)	2	0	2
	—	—	—
	14	4	18

There appear to be differences between the sexes in the timing of seasonal changes in use of space. No marked females changed their Low Water use of space after December (Table 3.84). This suggests that they chose a behaviour in anticipation of future feeding difficulties. Some females chose to occupy long-term territories, and thereby gained the long-term advantages detailed in Section 3. II. D. 1. Some males also defended such territories. In contrast, some of the males which remained on Seal Sands all winter became territorial for only short periods, when forced to by low prey accessibility (in cold weather) or low absolute prey density (in spring). Such behaviour could provide only short-term benefits (Section 3. II. D. 1). It is surprising that these males did not acquire long-term territories in autumn (and thereby preserve their food stocks, etc.) as it is they, rather than the longer-billed females, that are likely to experience difficulty in reaching worms in mid winter. Perhaps males are poor competitors (see below) and are often unable to acquire a suitable long-term territory. It must be noted, however, that the numbers in Table 3.84 are very small and the population contains an excess of males (Section 3. II. C. 1), so further observations are required to substantiate that a real difference in timing of seasonal changes between females and some males does exist.

It was shown in Section 3. II. B. 4. that seasonal changes in Low Water site and the occurrence of territoriality were consequences of the initial choice of Low Water feeding site. Surprisingly, the initial choice of site by the two sexes in autumn is apparently not determined simply by prey accessibility in relation to bill length. If it were, one would predict that males should in general choose wetter areas than females. There should be relatively few males on higher, sandier areas as the worms there should move beyond the reach of their bills during the period of exposure. In fact males fed particularly on higher, drier areas and females

especially on lower, wetter flats (Section 3. II. B. 4). There are four possible reasons for males feeding on such areas:

1. Females are better competitors - As the females are larger than the males they may be dominant to them. Dominance could result from either direct aggression, or avoidance by males or females. No sex-related biases in aggression or avoidance were observed, but avoidance in particular is difficult to identify. If females are dominant they may choose their feeding sites and the males have to use the remaining vacant areas.

All marked females on Seal Sands during August - December 1977 either fed regularly and non-territorially on Greenabella Bank, or defended regular feeding sites elsewhere on Seal Sands. They may therefore have had a choice of 2 equally good strategies in autumn. It is hypothesized that in autumn some males fed on Greenabella Bank, using the remaining space; the others had to feed elsewhere on Seal Sands, where the density of accessible prey was lower.

The behaviour of some males later in the winter (described above) suggests that they did not feed on the higher areas by choice, and were having difficulty capturing prey fast enough to meet their energy requirements. The movement of male but not female Curlews to the fields further supports the thesis that males have difficulty maintaining their capture rate on Seal Sands under certain conditions.

2. Males that will move to the fields use less favoured areas - It is not possible to tell whether male Curlews "know" in the autumn that they will later move to the fields. The fidelity of some individuals to the fields in successive winters (Section 3. II. C. 2) suggests that they may. As it appears that the density of accessible worms on the higher mudflats is adequate for Curlews in autumn but not in mid winter, males showing this behaviour would avoid competition with those Curlews taking up sites which will supply their energy requirements through the winter (e.g. on Greenabella Bank). Then, when feeding conditions become more

difficult with the seasonal decrease in temperature, these males could continue to avoid competition on the mudflats by moving to the fields rather than to Greenabella Bank.

3. Males are better at prey capture on drier areas - As the bills of male and female Curlews curve along the same arc (D. J. Townshend, unpublished data), because the male bill is shorter, it is also straighter. A shorter, straighter bill may be better for probing into firm substrates, e.g. fields and sandy substrates, than the longer, more curved female bill. The male bill is probably less likely to break when twisted. Thus the difference in bill length and shape may enable males to specialize in prey capture on firm substrates and females to be more adept at capturing worms in soft sediment.

No direct proof of this possible difference in niche utilization between the sexes is available. The distribution of males and females between the mudflats of Seal Sands, and between Seal Sands and the fields fit the hypothesis. However as some males on the mudflats experience difficulty in capturing worms fast enough in very cold conditions, their preference for higher rather than lower mudflats may be confined to mild weather.

4. Curlew behaviour is not determined by Nereis accessibility - The agreement between the hypothesis and the observed behaviour of Curlews described above makes this possibility unlikely.

3. II. D. 5. A comparison between Grey Plover and Curlew use of space during a winter

Grey Plovers show a similar range of fidelity to a Low Water feeding site during a winter, and similar causes and types of seasonal changes in use of space. However there were some differences in the timing of these changes and in the feeding areas involved. Many of the differences were a consequence of the difference methods of prey capture used by the two species (described in Section 3. II. D. 2).

Site fidelity - Amongst both the Grey Plover and Curlew populations, some individuals changed Low Water feeding site during a winter, whereas others fed throughout the winter on one site. Fidelity to a Low Water site was related, in both species, to the original choice of feeding site, being highest on their preferred feeding areas (i.e. those areas which held a high and constant number of that species throughout the winter). However the preferred feeding areas of the two species differed. Curlews concentrated on the areas of highest prey accessibility. Their method of prey capture was unaffected by the high density of waders feeding there. The areas preferred by Grey Plovers did not provide maximum prey availability, but had a low density of feeding waders. This, and the associated low level of disturbance, is required for the Grey Plover's method of prey capture to be successful (see above). From the small samples of colour-marked birds available, it is not possible to compare the proportion of individuals in each species that changed Low Water feeding site during a winter.

In both species, the majority of individuals fed in the same site, at a given time of year, in successive winters. Fidelity between years for both Grey Plovers and Curlews was highest on their preferred areas. For Curlews on other areas, limited data indicate that, where changes in feeding site occurred during a winter, a similar pattern of changes with similar timing was shown in successive winters by at least some individuals. There were too few data to show whether Grey Plovers also showed this pattern.

Seasonal changes in Low Water feeding site were often accompanied by changes in ebb and flood feeding sites. In this way, individuals of both species could continue using ebb and flood tide sites that minimised the distance flown between feeding sites, once feeding had started. However, the behaviour of some Grey Plovers was again sometimes influenced by the distribution of other feeding shorebirds. Some Grey Plovers changed feeding area on the ebb and flood tides

when large flocks of other species were present on their normal feeding areas. In contrast, Curlews were not affected. For the Grey Plovers, able to capture only those prey present at the surface, the decrease in disturbance of prey gained by this change outweighed the increased costs of the associated longer flight between mudflats. As the prey of Curlews do not immediately move out of reach when disturbed, Curlews are less affected by flocks of birds on the open mud. Furthermore, many Curlews did not begin feeding on the ebb tide until large areas of mud had been exposed and the density of birds consequently had decreased.

In autumn, some Grey Plovers and some Curlews defended feeding sites on certain areas of Seal Sands. Some individual Grey Plovers continued to defend a site during each Low Water period throughout the winter until emigration. No marked Curlews showed such fidelity, some abandoning territories in mid winter and others (on different areas) establishing them then. The number of areas on which at least some Grey Plovers showed territoriality increased during the winter, whereas the number for Curlews did not change. Also, the Grey Plover population on the estuary increased during the winter whereas the Curlew population was constant. In both species, the behaviour of each individual was influenced by the Low Water feeding site used: Grey Plovers on their preferred areas were faithful to their territories, whereas seasonal changes between non-territorial and territorial behaviour were shown only by individuals feeding on the less preferred areas; amongst the Curlews, the type of change (whether to or from defence of a feeding site) varied between areas.

The proportion of Grey Plovers defending feeding sites was greater than that of Curlews. It is believed that this is again a consequence of the Grey Plover's method of prey capture relying upon undisturbed prey animals. Thus it appears

that for Grey Plovers, but not for Curlews, the immediate benefits of defence are of major importance even to individuals defending long-term territories that may provide certain benefits only in the long-term.

The causes of seasonal changes in use of space - The possible causes of seasonal changes in use of space were detailed in Section 3. II. A. 3. d. Analysis of the data for marked Grey Plovers and Curlews showed that, despite differences in prey capture method, in both species the factors most frequently correlated with such changes were falling temperatures (which reduce prey availability and increase energy requirements) and increased density of conspecifics (which increases disturbance and removal of available prey). In many cases, particularly during severe weather in mid-winter, it was clear that the marked birds that changed behaviour were forced to do so because of difficulty in obtaining food fast enough with their original use of space. However, other changes by both species, particularly in autumn, probably occurred in anticipation of poor feeding conditions later in the winter.

Some Grey Plovers changed feeding site soon after their arrival on Seal Sands, whereas no such changes were observed amongst the marked Curlews. As most Curlews arrived during a short period in the autumn whereas Grey Plovers continued to arrive throughout the winter, changes amongst Curlews may have occurred but not been observed. Also as a larger proportion of Grey Plovers than Curlews defend feeding sites on Seal Sands, some newly-arrived Grey Plovers may have had difficulty finding a suitable, available feeding area. Others apparently either chose a poor area and were forced to change, or were sampling the available areas before choosing one.

Temporary territorial defence by both species occurred when prey availability fell and competition for food and/or space increased. However, only Curlews showed temporary site defence during gales. Gales make feeding at the tide edge very difficult, and would therefore affect Curlews, which feed at high

density at the tide edge, but not Grey Plovers as they tend to avoid the tide edge. Most Grey Plovers stop feeding during gales (Dugan et al. 1981).

The causes of changes in use of space by non-breeding individual Grey Plovers and Curlews under changing environmental conditions can be compared with those identified in two similar studies, one on another shorebird species, the Sanderling Calidris alba (Myers et al. 1979b) and one on a passerine species, the Pied Wagtail Motacilla alba (Davies, 1976). In all four species, individual variation in use of space occurred, with only a proportion of the population defending feeding sites.

Some Grey Plovers and Curlews on mudflats, Sanderlings on beaches and Pied Wagtails along river banks established territories in autumn and defended them for long periods during the winter, presumably because of the long-term advantages gained thereby. Such territories were sometimes abandoned during a winter, the birds moving to a new area to feed. Both Curlews and Pied Wagtails did so when feeding conditions on their territories deteriorated, i. e. they were probably forced to change due to food shortage. It was not possible to determine the cause of abandonment of territories by Grey Plovers in spring, but again food shortage may have been involved. In contrast, some Sanderlings abandoned territories when a superabundant food source appeared elsewhere, even though feeding conditions within the territory had not changed. Thus they were not forced to move, but changed their use of space because the benefits of feeding elsewhere were greater. Similar opportunistic behaviour was occasionally shown by Curlews and Pied Wagtails which changed feeding site in order to take advantage of a marked increase in prey availability caused by flooding of pastures.

Very short-term site defence was observed in all four species. Curlews and Grey Plovers showed this behaviour only when experiencing difficulty in capturing food fast enough in an undefended site, i. e. when forced to change behaviour.

This contrasts with the occurrence of temporary defence of feeding sites by Pied Wagtails. Individual wagtails within the flock that fed on partially flooded pasture defended feeding sites when the food temporarily became very clumped. Such defence appeared to be opportunistic, as these individuals fed non-territorially on the same site when the food became less clumped and therefore less dense. Presumably temporary defence was part of their tactics to maximise the benefits from the superabundant food source.

The differences in causes are probably a consequence of the predictability of the food sources of the different species. Opportunistic changes in use of space were most frequent where the food dispersion was subject to marked and sudden changes, i. e. in Sanderlings on beaches and Pied Wagtails in flocks on pastures. Where there is a predictable food supply, i. e. for Grey Plovers and Curlews on Seal Sands, and Pied Wagtails along river banks, long-term territories are often defended and changes in use of space occur only when forced by food shortage.

Ability to meet food requirements - By combining the information on individual birds with that on seasonal changes in the Low Water distribution on Seal Sands (detailed in Section 2), the ability of Grey Plovers and Curlews to meet their food requirements on areas of different substrate at different tidal levels can be compared. Throughout the winter, Grey Plovers tended to feed and defend territories on drier substrates and higher tidal levels than Curlews. The number of Grey Plovers on the areas at high tidal level reached a peak in mid winter, and that on the areas of firm sandy mud at mid tidal level remained constant from autumn to spring. Also, the majority of cases of temporary territorial behaviour amongst Grey Plovers coincided with the lowest temperatures of the winter. Most Grey Plovers, therefore, could probably maintain their required capture rate (albeit perhaps by defending their feeding site) on all areas, even though some areas may have been preferred to others.

In contrast, most Curlews abandoned areas at high level and certain areas of firm sandy mud at mid tidal level in mid winter. It appears, therefore, that they were unable to capture food at an adequate rate on these areas during the coldest parts of the winter. Also Curlews defended temporary territories under a wider range of temperatures than Grey Plovers. Only on softer substrates at mid and low tidal levels were Curlews able to feed in all conditions. On most areas where both Curlews and Grey Plovers defended territories at some time during the winter, as the temperature fell the Curlews were the first to change their use of space. Thus it appears that Curlews have more difficulty than Grey Plovers in maintaining an adequate capture rate, at least on the higher mudflats of Seal Sands, when feeding conditions are poor.

SECTION 4. PART I

This section has been removed at the
request of the examiners.

PART II. THE FORAGING BEHAVIOUR OF GREY PLOVERS
AND CURLEWS IN RELATION TO PREY BEHAVIOUR

4. II. A. INTRODUCTION

It is possible that most of the changes in use of space shown by Grey Plovers and by Curlews on Seal Sands could have been determined by changes in the activity and depth distribution (respectively) of Nereis diversicolor. I shall now investigate whether the data on Grey Plover and Curlew foraging behaviour collected during the study support this proposed causal relationship between invertebrate behaviour and shorebird behaviour.

4. II. B. GREY PLOVER

4. II. B. 1. Foraging behaviour during a tidal cycle

In preceding sections it was assumed that each Grey Plover attempts to maintain a constant rate of prey capture during its feeding period in each tidal cycle. It was argued that birds unable to maintain their capture rate should change their use of the habitat (either becoming territorial on the same site or moving to another site where an adequate capture rate could be achieved). Conversely, therefore, Grey Plovers that either began excluding conspecifics from a site or moved to a lower and/or wetter feeding site within a Low Water period should have shown a fall in capture rate before they changed. This fall could be either gradual, paralleling the gradual decrease in Nereis activity, or sudden, at the point when the gradually increasing effort to detect available prey (see below) fails to maintain the constant rate of capture. (To detect a sudden fall, measures of prey capture rate are required immediately before the bird changes its use of space; this was difficult to achieve in practice.)

a. Data collection

Data on the foraging behaviour of marked birds were collected during observation periods usually of 5 - 10 minutes length, but occasionally of up to 30 minutes. In each observation period the following data were recorded:

- i) the number of prey items swallowed
- ii) the identity and size of these prey items
- iii) the number of attempts to capture prey
- iv) the number of paces taken in each burst of running
(for Grey Plovers only).

Identification of prey species, and size estimation - The range of species of intertidal macro-invertebrates on Seal Sands is very small (Evans et al. 1979) so identification at close range was relatively simple. The size of the main prey species of Grey Plovers and Curlews, Nereis diversicolor, was estimated relative to the bill length of the bird extracting it. This method provided a relative measure of size sufficient for comparisons, for example between individual birds and between sites (but inadequate for a determination of absolute biomass intake).

Attempts to capture prey - For Grey Plovers each peck at the substrate, except those used to clean the bill, was considered to be an attempt to capture prey. For Curlews, which frequently made several probes at a single site, the number of attempts to capture prey was equated with the number of sites at which probes were made.

Difficulties in data collection -

- i) As, for the purposes of this part of the study, observations were made only on marked birds, on some occasions data on foraging had to be collected from birds up to 400 metres away.

During such long-distance observations some captures of
of small prey items were probably missed and size estimation
of worms seen to be captured was more difficult.

- ii) Estimation of the size of prey on easily observed sites was
made more complex by the following factors:
1. Worms were much easier to extract from liquid mud than
from sandy substrates, due to the greater purchase afforded
by sand for resistance by the worm. Consequently extraction
from sand took longer and involved greater stretching of the
worm. Therefore direct comparisons of prey sizes taken
cannot be made between sites of very different substrates.
 2. Worms hanging from the bill can be stretched markedly by
strong gusts of wind. As worm size is estimated during the
period between extraction and swallowing, data collected on
windy days will be biased towards larger sizes than on
calm days.
 3. Some worms break during extraction. For Grey Plovers,
which generally give up at a site if a worm breaks, no estimate
of the total length of the worm (for use in a study of size
selection) could be made. Curlews often persevere at the
site and extract all or most of the worm in pieces. It is
difficult to determine the original total length from pieces
but a minimum can be estimated.

Where possible, allowance is made for these difficulties in
data collection.

Minimum length of observation periods - Although some observation
periods lasted 30 minutes, others were curtailed by factors such as the

temporary disappearance of the bird, or cessation of feeding due to disturbance, preening, etc. An insufficient number of long observations (≥ 10 minutes) were made in some of the situations under study, so shorter periods have also been used in the analysis, e.g. of feeding rates prior to leaving a site. In order to determine the minimum length of observation that provides a reasonable estimate of the capture rate, observation periods on 6 marked Grey Plovers and 6 marked Curlews lasting 14 - 20 minutes were analysed. In each case the capture rates in 5 different periods of 1 minute were measured and a mean and standard deviation calculated from the 5 values. This was repeated for observations lasting 2 - 10 minutes. As the length of the observation was increased the standard deviation decreased (Fig. 4.13), levelling off for periods of ≥ 4 minutes for Grey Plovers and ≥ 5 minutes for Curlews. These were taken as the minimum lengths of observation periods for the 2 species. Shorter periods could not be taken as representative of a bird's foraging behaviour.

It must be pointed out, however, that long periods of observation also have disadvantages. A bird can move onto different substrates and across patches of high and low prey density, leading to increased variation in the foraging data.

b. Foraging behaviour of Grey Plovers that changed feeding site during a Low Water period

On 9 occasions during the study I measured the feeding rates of a marked Grey Plover that changed feeding site later in the Low Water period. Some individuals were observed on several days. In each case discussion is confined to observations of feeding on a single site no more than 30 metres across and comprising one substrate type at one tidal level.

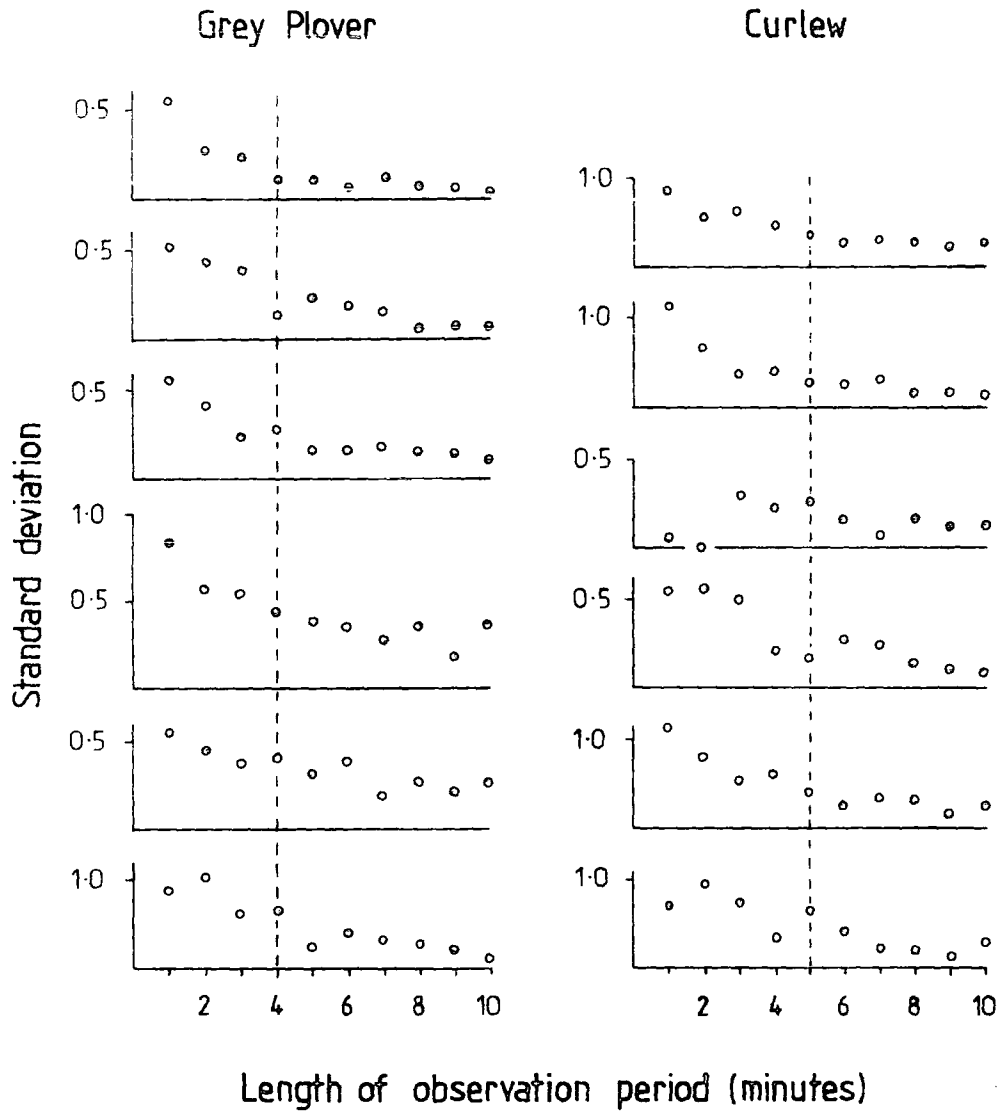

Figure 4.13 The determination of the minimum length of observation required to provide reasonable estimates of Grey Plover and Curlew capture rates. The minimum length for each species is indicated by a dashed line. Each graph refers to a different individual. (See text for details of the method.)

The rate of capture of worms -

i) Birds observed just before leaving (Fig. 4.14a) - the feeding rates of 4 birds were measured during the 15 minutes leading up to their departure. One (B W/G 1.4.76) showed a significant decrease in prey capture rate in the hour before it left the site (Table 4.10). This decrease was sudden rather than gradual. (Unfortunately no data are available to test whether the bird had previously been increasing its search effort to maintain its capture rate.) A second bird (Y O/R) left too early in the final observation period (after 3 minutes) to permit an accurate measure of its capture rate, but it appeared also to show a marked decrease in the hour before leaving.

No decrease in capture rate was shown by the other 2 marked birds, although in one case the final observation period was too brief to be an adequate measure. In both cases the feeding rate was extremely low throughout the time they fed on the site. They may therefore have left when the energetic costs of a further increase in search effort (see below) would have exceeded the resulting food intake.

ii) Birds observed some time before leaving (Fig. 4.14b) - Two birds (O W/W, L W/L 31.1.78) showed a fall in prey capture rate beginning $2\frac{1}{2}$ - 3 hours after the site was exposed. One fall was significant (at the 1 per cent level, Table 4.10) and sudden. The other (O W/W) was gradual and consequently the only difference significant at the 1 per cent level was between the peak and the final 2 values (see Table 4.10). The decrease in the 2 hours following the peak value fitted a straight line regression (correlation coefficient (r) = -0.883, $n = 5$, $P < 0.05$; slope significantly different from zero, $t = 3.27$, $P < 0.05$).

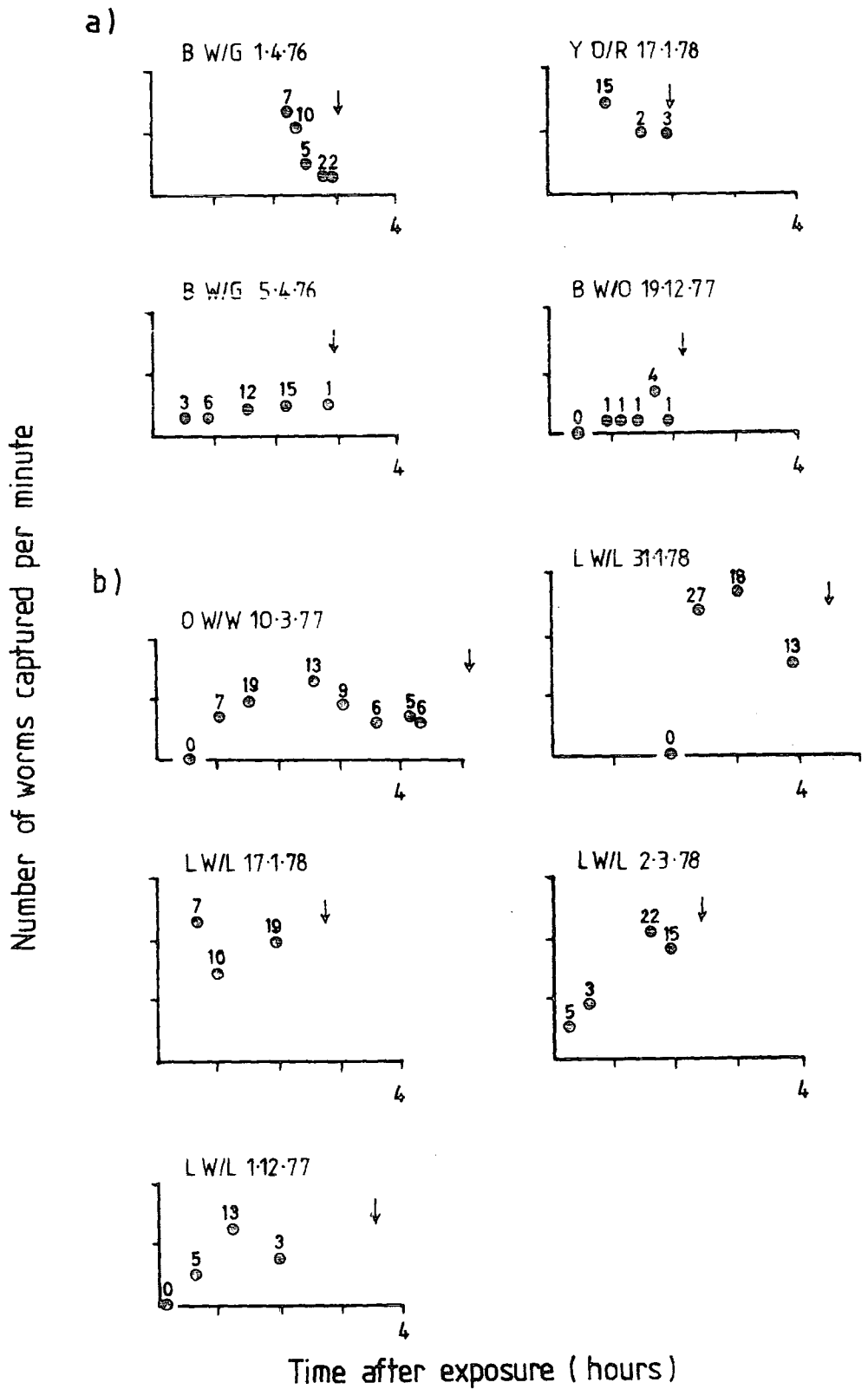

Figure 4.14

Changes in the rate of worm capture during the period of exposure, by marked Grey Plovers that changed feeding site:

a) four birds observed just before leaving,
 b) five birds observed some time before leaving.

Key: arrows indicate the time of leaving for each bird; the total number of worms taken during each observation period is shown above the point.

Table 4.10

Foraging behaviour of marked Grey Plovers that changed feeding site during a Low Water period:
 significance tests for decreases in the overall rate of worm capture

	Final Observation			Preceding Observations			Confidence Limits	
	Time before departure (mins)	Number of worms caught per minute (no. of mins. observation)	Time between these and final observations (hrs)	Number of observation periods	Mean number of worms caught per minute (total length of observations, mins)	Standard deviation	Level at which difference significant	Confidence limits at this level
a) Birds observed just before leaving:								
B W/G	0	0.29 (14)	1	2	1.26 (15)	0.205	1%	± 0.528
Y O/R	0	1.00 (5)	1	1	1.20 (10)	-		
b) Birds observed some time before leaving:								
L W/L	35	1.48 (10)	1	2	2.50 (19)	0.212	1%	± 0.546
O W/W	<60	0.66 (7 + 10) S.D. 0.078	2	1	1.30 (10) peak	-	1%	± 0.856

On the other 3 occasions included in this category (all L W/L) no marked decrease in capture rate was detected, the results being variable and therefore inconclusive.

Thus, in all, 4 of the 9 cases showed evidence of a decrease in capture rate prior to leaving a site, 3 sudden and 1 gradual. Whether a fall is sudden or gradual may be determined by the substrate on which the bird is feeding. The one gradual fall was shown by a marked bird feeding on a very sandy site on Central Bank - south, whereas all other observations, including the sudden decreases, were made on the muddier substrate (at a similar tidal level) of Scalloped Mud - east. Perhaps on Scalloped Mud the depressive effect of the decreasing activity of Nereis on capture rate can be overcome (e. g. by increased search effort, see below), at least for some time, whereas on the sandy mud of Central Bank - south the activity falls too rapidly for this to be possible.

The variety of behaviour shown by the marked birds on Scalloped Mud may be due in part to the weather conditions on the observation days. Two of the 3 falls in capture rate occurred during cold weather in January, and one in April when absolute prey density would be low. Thus the density of available prey would be low in each case. On another day in April (5th) the same bird as above (B W/G) showed no decrease in capture rate before leaving. However due to very strong winds (gusting up to 42 knots) on that day it had a very low capture rate throughout its feeding period - a rate similar to that shown just before it moved site on 1st April (Fig. 4. 14a). The density of available prey when it left was, therefore, probably at a similar level on the 2 days.

In 5 out of 9 cases of marked Grey Plovers being observed before they left a feeding site no decrease in capture rate with time after exposure was

detected. This cannot be explained simply in terms of the drying of the mud and the consequent decreasing activity of Nereis. In predicting the behaviour of Grey Plovers during a tidal cycle from changes in Nereis activity (Section 3.II.D.2) 3 assumptions were made. The behaviour of these 5 marked birds suggests that these assumptions may be invalid, as will now be discussed.

Assumption 1 - prey availability limits the rate of capture of worms:

As a fall in prey capture rate was shown by some marked Grey Plovers before they left Scalloped Mud and Central Bank, it is unlikely that the feeding rate of others (and even of the same bird on different days) feeding on the same area was independent of prey availability. It is more probable that the variety of behaviour observed was a consequence of individual variation in the birds' abilities to capture the available worms at an adequate rate.

Assumption 2 - there was no change in size selection of Nereis during the feeding period:

Grey Plovers feeding on an area where the availability of Nereis falls could maintain a constant rate of capture by selecting at first mainly large worms, and then, as the percentage of worms available falls, taking large and small worms in the proportions available at the surface of the mud. The decrease in selectivity may be gradual, paralleling the decreasing availability of worms, or sudden, involving a switch from selection to no selection (Fig. 4.15).

i) Birds which showed no decrease in overall capture rate (Fig. 4.16) -

one of the 5 (L W/L, 17.1.78) showed a significant decrease in the capture rate of large worms (i. e. worms \geq 3 bill lengths, equivalent to 90 mm estimated length) (Table 4.11). Two birds did not experience a decrease and the remaining 2 caught too few worms to make any conclusions.

ii) Birds which showed a decrease in overall capture rate (Fig. 4.17) -

all 4 showed a decrease in the number of large worms caught per minute

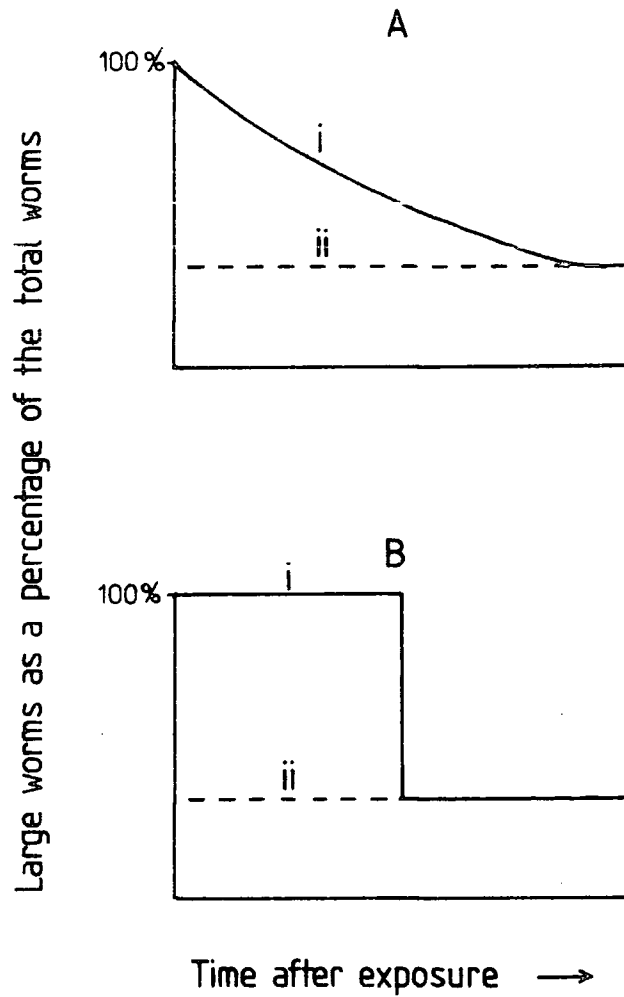

- i) large worms as a percentage of the total worms caught per minute.
- ii) large worms as a percentage of the total worms available to the predator.

Fig. 4.15

Two possible changes in size selectivity available to Grey Plovers and Curlews:

- A) a gradual decrease in selectivity,
- B) a sudden switch from selectivity to no selectivity.

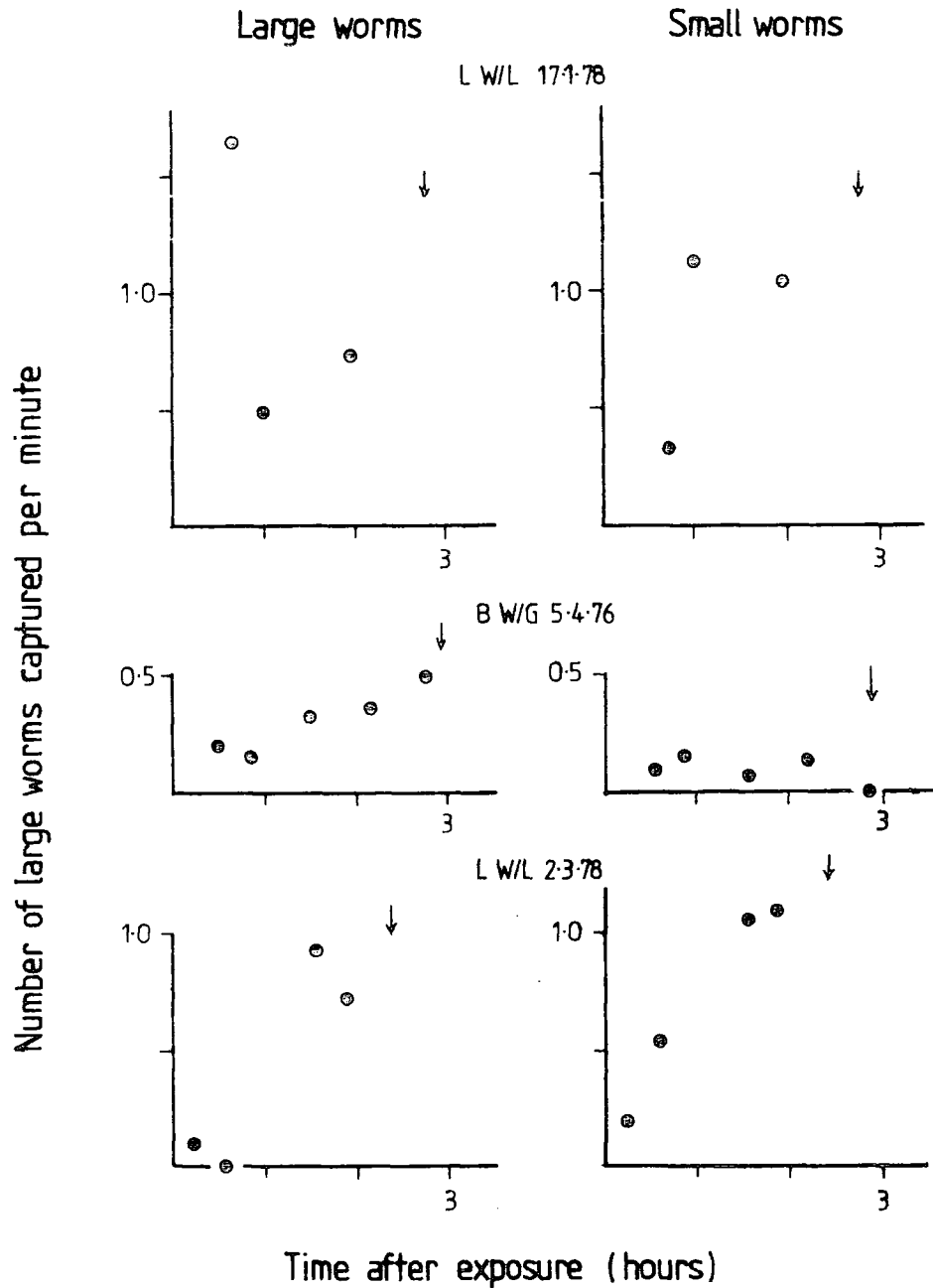

Figure 4.16 Changes in the rates of capture of large worms (≥ 90 mm estimated length) and small worms (< 90 mm estimated length) during the period of exposure: data for three marked Grey Plovers that showed no decrease in overall capture rate but did change site. These graphs are derived from the data presented in Figure 4.14.

Key: arrows indicate the time of leaving for each bird.

Table 4.11

Foraging behaviour of marked Grey Plovers that changed feeding site during a Low Water period:
 significance tests for decreases in the rate of capture of large worms

		<u>Final Observation</u>			<u>Preceding Observations</u>			<u>Confidence Limits</u>	
		Number of observation periods	Mean number of large worms caught per minute (total length of observations, mins)	Standard deviation	Number of observation periods	Mean number of large worms caught per minute (total length of observations, mins)	Standard deviation	Level at which difference significant	Confidence limits at this level
a) Birds which showed no decrease in overall capture rate:									
L W/L	17.1.78	2	0.60 (17)	0.17	1	1.63 (3)	-	1%	± 0.438
b) Birds which showed a decrease in overall capture rate:									
Y O/R	17.1.78	2	0.00 (5)	0.00	1	0.60 (10)	-		
L W/L	31.1.78	1	1.14 (10)	-	2	1.55 (19)	0.10	1%	± 0.255
B W/G	1.4.76	1	0.07 (14)	-	2	0.33 (25)	0.11	5%	± 0.216
O W/W	10.3.77	4	0.34 (37)	0.11	2	0.81	0.08	1%	± 0.289
						peak values			

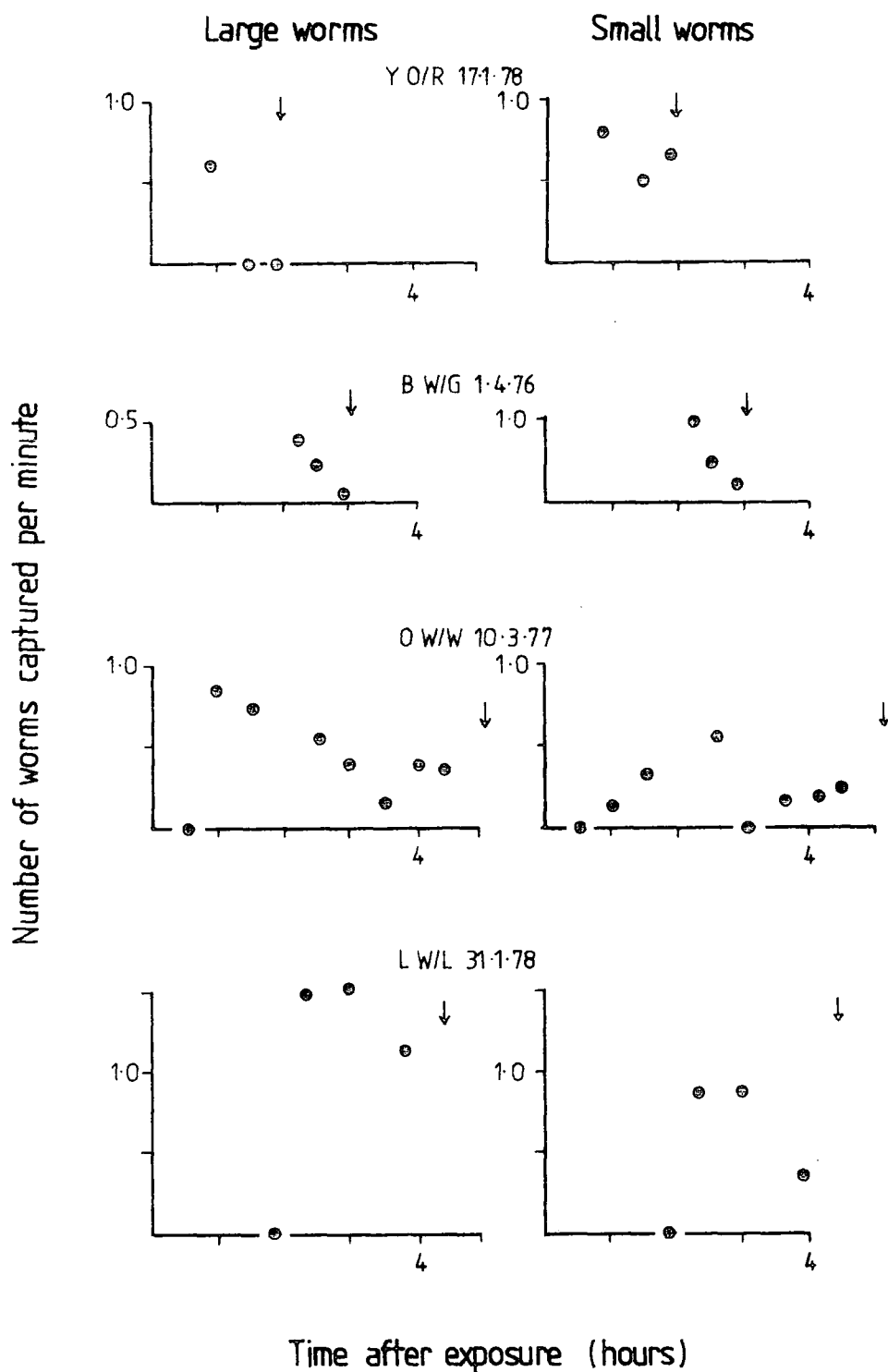

Figure 4.17 Changes in the rates of capture of large and small worms with time after exposure for four marked Grey Plovers which showed a decrease in overall capture rate before changing site. These graphs are derived from the data presented in Figure 4.14.

Key: arrows indicate the time of leaving for each bird.

with time after exposure of the site; 2 decreases were significant at the 1 per cent level and 1 at the 5 per cent level (Table 4.11).

As the decreases in overall capture rate and capture rate of large worms coincided in 4 cases, changes in size selectivity may not in fact occur. The decrease in the number of large worms caught per minute could be a consequence of increasing difficulty in capturing worms of all sizes. The decreases in the rates of capture of small worms (Fig. 4.17) show this to be true in 3 cases. However the limited data on the fourth bird (Y O/R, 17.1.78), and also the data for the individual that experienced a fall in the capture of large worms but not all worms (Fig. 4.16, L W/L, 17.1.78), showed real changes in size selectivity. Both prevented or reduced the fall in overall capture rate by a sudden increase in the proportion of small worms in the diet. As the 2 birds fed in the same creeks on Scalloped Mud at the same time on the same day the difference between them and the other 7 cases is probably significant. 17th January 1978 was the coldest day on which measures on birds changing feeding site were collected (mud temperature 2.5°C , midday air temperature 1°C). Changes in size selectivity, therefore, may be employed only when Nereis activity is very low. However, the data for Y O/R are inadequate for firm conclusions to be drawn.

In the majority of cases (5 out of 7) a decrease in sizes of worms selected did not occur. Thus in general Grey Plovers do not employ such changes to avoid or reduce a falling capture rate caused by the decreasing availability of Nereis.

Assumption 3 - there was no change in search effort during the feeding period:

A Grey Plover could maintain a constant capture rate of worms in the face of falling availability by increasing the effort made to capture worms. In

this study the parameter used to measure search effort in Grey Plovers was the area searched at each pause between runs. It is argued that, to maximise its chances of capturing prey, a Grey Plover should:

- a) search the smallest area required
- b) avoid overlap between areas searched

a) Size of area searched at each pause - Grey Plovers very rarely capture more than one worm from each area searched. Each bird should, therefore, search an area that contains at least one worm available at the surface.

However, as soon as the Grey Plover runs across the mud from its observation point to catch a worm it will create vibrations in the mud. These will cause nearby worms to retreat from the surface into their burrows (Vader 1964, Muus 1967, Ratcliffe 1979). In order to minimise disturbance the Grey Plover should run the shortest distance possible. Thus the area searched should be the smallest that supplies an adequate number of available worms.

b) Overlap between areas searched - if a Grey Plover is to run the shortest distance possible, each run after prey capture or attempted prey capture should take it to the far edge of the area just searched. A shorter run would reduce disturbance but it would then search some mud twice within a few seconds.

As the mud dries out with time after exposure fewer Nereis come to the surface per unit time. By increasing the area searched a Grey Plover could search an area containing the same number of Nereis at the surface, throughout the feeding period. It could thereby maintain a constant rate of worm capture despite the falling availability. (This assumes that it can capture Nereis from a large search area, often with a long run, or a small area with equal facility.)

No absolute measure of area searched during each pause could be obtained. Instead an estimate was derived from the number of paces taken in each burst of running. A mean value for the number of paces per burst of running (excluding any runs for purposes other than feeding, e.g. across creeks or moving off other birds) was obtained for each observation period, and it is these means that are plotted on Fig. 4.18. It is expected that any increase in area searched with time after exposure should be gradual, matching the gradual decrease in Nereis activity.

- i) Birds which showed no decrease in overall capture rate (Fig. 4.18a) - 3 of the 5 increased the area searched with time after exposure. In only one case was the increase significant even at the 10 per cent level (Table 4.12).
- ii) Birds which showed a decrease in overall capture rate (Fig. 4.18b) - all 3 for which data are available increased the area searched, one increase being significant at the 10 per cent level (Table 4.12).

The increases in area searched shown by some birds were very marked so it is believed that more extensive data would have increased the level of significance of the results. The marked bird feeding on Central Bank (O W/W) increased its search area more gradually than those on Scalloped Mud.

At least some Grey Plovers, therefore, prevent a fall in overall capture rate by increasing the area searched each pause. Two of the 3 marked birds doing so (B W/O, B W/G 5.4.76) had very low capture rates (Fig. 4.15) and the third (L W/L, 17.1.78) has been shown above to have been experiencing difficulties in capturing large worms fast enough. Other Grey Plovers were unable to avoid a fall in capture rate despite increasing the area searched.

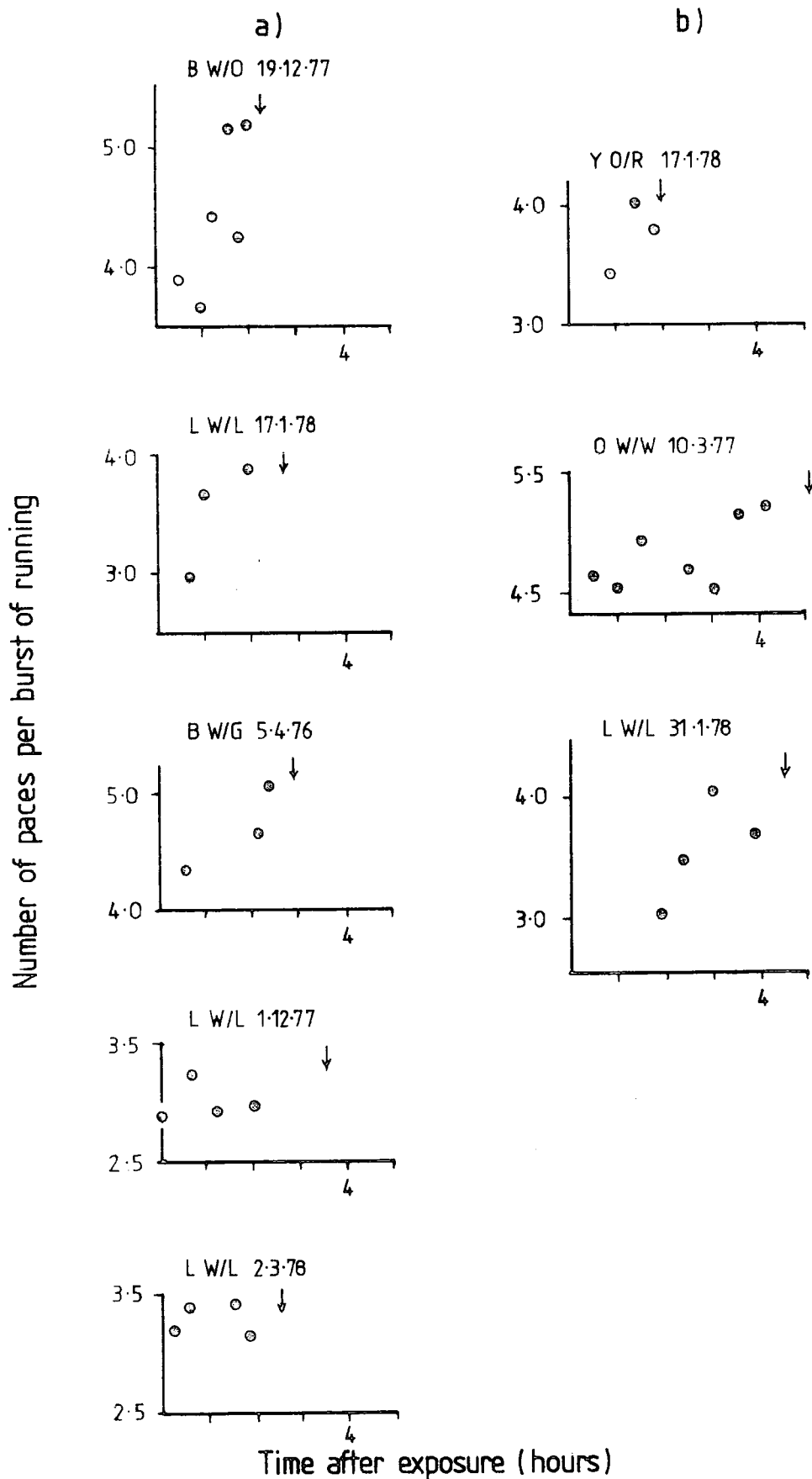

Figure 4.18 Area searched during each pause in relation to time after exposure of a site, for marked Grey Plovers which changed feeding site: a) five birds which showed no decrease in overall capture rate. b) three which showed a decrease in overall capture rate. Arrows indicate the time of leaving for each bird.

Table 4.12

Foraging behaviour of marked Grey Plovers that changed feeding site during a low water period:
 statistical parameters of the increases in area searched during each pause

		Number of points	Correlation coefficient	Significance of correlation (where $P \leq 0.10$)	Slope	Difference of slope from zero (where $P \leq 0.10$)
						t probability
a)	Birds which showed no decrease in overall capture rate:					
	B W/O	6	0.761	$P < 0.10$	0.950	2.35 $P < 0.10$
	L W/L	3	0.840		0.612	
	B W/G	3	0.920		0.312	
b)	Birds which showed a decrease in overall capture rate:					
	O/R	3	0.709		0.419	
	O W/W	7	0.670	$P = 0.10$	0.144	2.02 $P = 0.10$
	L W/L	4	0.686		0.340	

Conclusions - It is clear that the hypothesis presented in Section 3.II.D., that Grey Plover behaviour is determined only by the activity of Nereis, is much too simple a model to explain the variations observed in foraging behaviour. Although some birds experienced the predicted fall in overall capture rate of worms this fall was delayed, reduced or avoided by searching a larger area at each pause. In very cold weather when Nereis availability should have been very low, changes in sizes selected appear also to have been made in an attempt to maintain a constant capture rate.

c. Foraging behaviour of Grey Plovers that fed in one site throughout the period of exposure

From the preceding section it is clear that considerable periods of observation on the foraging behaviour of individual birds are required for meaningful analyses to be performed on the data. When studying birds that changed feeding site during a tidal cycle the period for which a bird can be observed in the site is, by definition, limited. However considerably longer periods of observations were made on individual Grey Plovers that remained in a single site throughout its period of exposure. These observations were analysed to identify whether any changes took place in those parameters discussed above, namely:

- 1) the rate of capture of worms
- 2) size of worms taken
- 3) the area searched during each pause.

1) The rate of capture of worms

The following changes in the overall capture rate are possible:

- a) no decrease, because
 - i) prey availability is not limiting the rate of capture, or
 - ii) the falling capture rate is avoided by a change in sizes selected or area searched.

- b) decrease - if a decrease occurs it is presumed that the capture rate does not fall below the threshold so the bird can continue feeding in that site (in contrast to those Grey Plovers that left a site during the Low Water period).

The effect on Grey Plover feeding rates of the incoming tide covering the mud indicates that prey availability does limit the rate of capture of worms on at least some territories. On all but the softest substrates, the mud dries out after exposure, resulting in a fall in the density of available worms. As the incoming tide covers the mud, the activity of Nereis increases rapidly and most worms come to the surface (Vader 1964); thus the density of available worms suddenly increases. If availability is limiting the rate of capture, this increase should lead to:

- i) an increase in capture rate, and/or
- ii) a decrease in area searched during each pause, if the capture rate had previously been maintained at a constant level by increasing the area searched.

Each of 6 marked Grey Plovers was observed feeding on a site both before and as it was flooded by the tide. In 5 periods of observation the arrival of the tide on the site led to a marked decrease in area searched each pause (Table 4.13). The capture rate increased in only two. Thus it appears that prey availability limits the rate of capture of worms, at least on the sandier substrates, i. e. on the main Grey Plover feeding areas: Central Bank - north, Eastern Channel (see Table 4.13).

If prey availability is limiting on these sites, the rate of capture should fall during the period of exposure of a site, unless the Grey Plover changes its foraging behaviour to avoid the fall. Changes in capture rate were studied in

Table 4.13

The rate of worm capture and area searched during each pause of marked Grey Plovers on Seal Sands, each feeding on one site both before and as the tide covered the mud

Date	Bird	Site	Time between observations (mins)	Rate of capture of worms, no./min., and (length of observation, mins.)		Area searched each pause, paces/burst, and (no. of bursts)	
				Open mud	Tide flooding	Open mud	Tide flooding
4. 2.77.	W R/O	ECh	23	0.67 (6)	1.11 (9)	5.98 (49)	4.89 (81)
12.12.77.	W R/O	ECh	45	0.52 (6)	1.50 (10)	4.20 (34)	4.67 (76)
28. 2.78.	Y L/O	CB _n	74	0.60 (5)	0 (2)	8.84 (32)	5.65 (17)
28. 2.78.	Y L/R	CB _n	71	2.40 (5)	0.67 (6)	7.57 (37)	6.50 (58)
22. 1.77.	B R/W	GC	35	1.25 (4)	0.50 (2)	7.7C (10)	5.57 (7)
12.12.77.	R Y/Y	SCh	127	--	--	4.3z (25)	3.59 (44)

Key for sites as on Table 3.19.

13 long periods of observation on individually-marked Grey Plovers, each lasting at least 2 hours. The rate of capture of worms decreased in only 2 cases (Fig. 4.19a); on both occasions the final value was outside the 99 per cent confidence limits of the mean of the other values. Both decreases were gradual rather than sudden, suggesting that the bird was unable to avoid the depressive effect of decreasing Nereis activity on capture rate. Despite the decreases no change in feeding site occurred so presumably the rate, when integrated over a certain time period, did not fall below the supposed threshold. As one bird (W R/O 13.1.77) caught no worms in a 5 minute spell, yet did not leave that site, it must have integrated its capture rate over more than 5 minutes before deciding whether or not to leave.

In 11 out of the 13 cases no decrease in capture rate was observed (Fig. 4.19b) even though prey availability was believed to be limiting the rate on the main Grey Plover feeding areas (see above). It seems probable that this was achieved by decreasing the size selectivity and/or increasing the search area during the period of exposure. This will now be investigated.

2) Size selectivity

i) Birds which showed no decrease in overall capture rate - the rate of capture of large worms decreased in 3 of the 11 cases (Fig. 4.20). In one case (R Y/Y) the decrease was sudden and marked (the final 2 values both lie outside the 99 per cent confidence limits of the mean of the peak values). The decrease shown by O L/O was very gradual, and that by L W/L (19.12.77) occurred very early in the period of exposure and is unlikely to have been due to a fall in the activity of large Nereis. In 2 cases (R Y/Y, O L/O) a real decrease in size selectivity occurred: the decrease in the capture rate of large worms was correlated with an increase in the

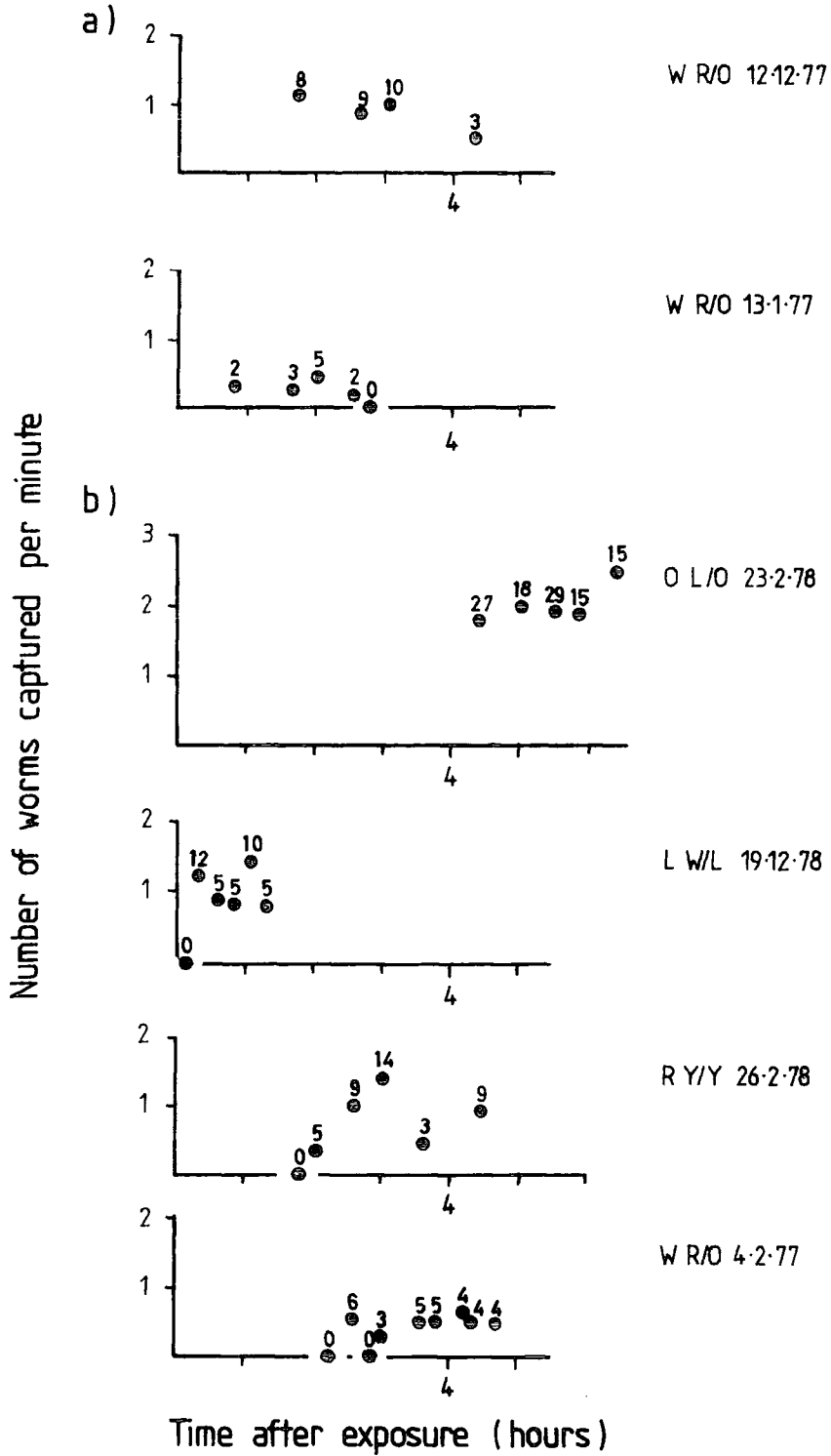

Figure 4.19 Changes in the rate of worm capture with time after exposure shown by thirteen marked Grey Plovers that fed in single sites throughout their periods of exposure; a) birds that showed a decrease, b) birds which showed no decrease.

Key: the total number of worms taken during each observation period is shown above the point.

b) contd.

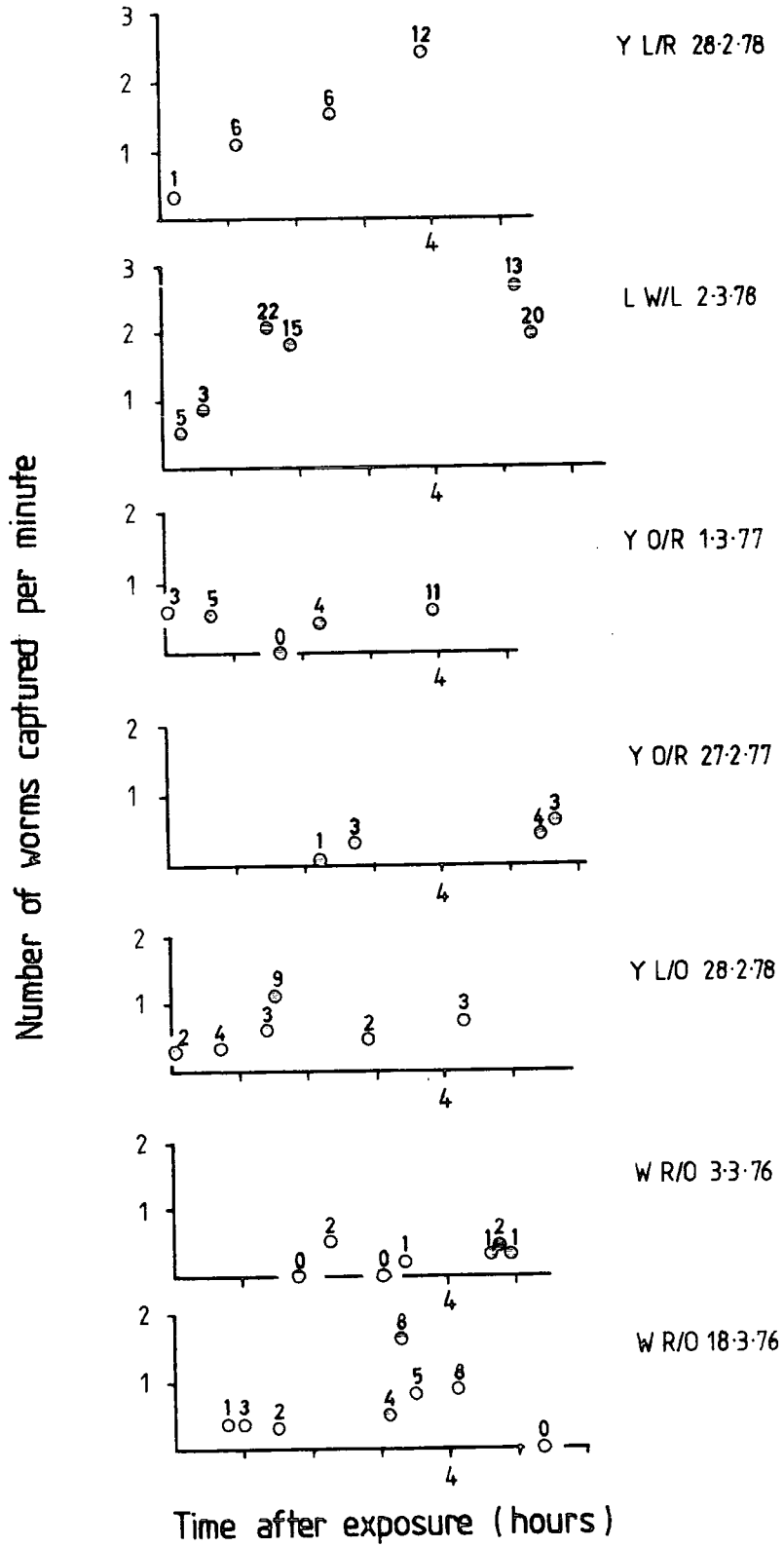

Figure 4.19 cont'd

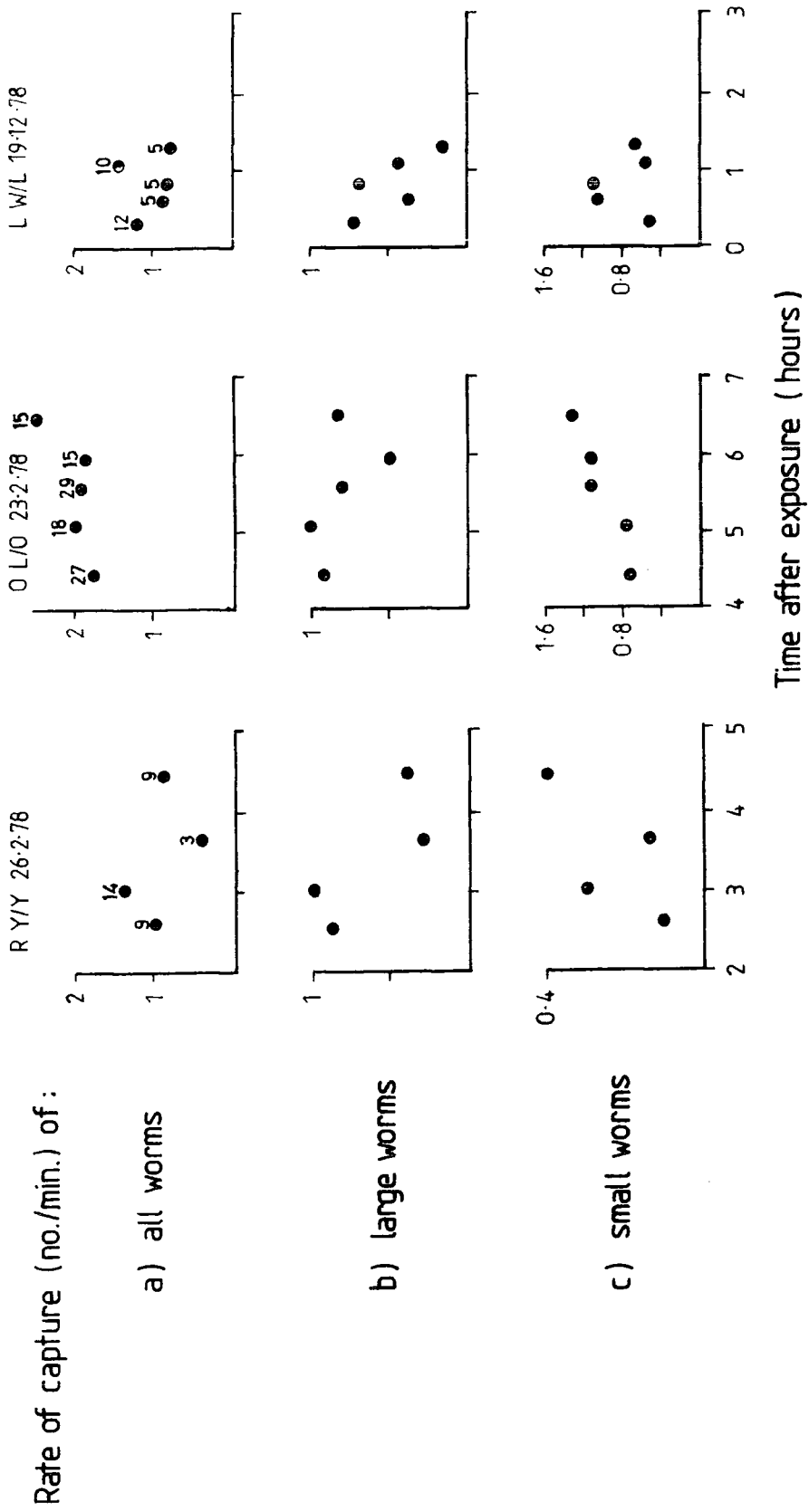

Figure 4.20 Changes in the rates of capture of a) all worms, b) only large worms and c) only small worms with time after exposure; data for three marked Grey Plovers each of which fed in a single site throughout its period of exposure. Key as on Figure 4.19.

capture rate of small worms (Fig. 4.20). Unlike the examples discussed earlier, this change in size selectivity did not occur on particularly cold days.

Two birds showed no decrease in the capture rate of large worms (Fig. 4.21a); and 6 caught too few worms for any conclusions to be drawn.

ii) Birds which showed a decrease in overall capture rate - one showed no decrease in the number of large worms caught per minute with time after exposure (Fig. 4.21b), and the other caught too few worms for conclusions to be drawn.

These results serve to emphasize the variability in behaviour both between individuals and between days for the same individual.

3) The area searched during each pause

i) Birds which showed no decrease in overall capture rate or capture rate of large worms (Fig. 4.22) - 6 of the 8 birds showed an increase in area searched during each pause, 3 increases being significant at the 10 per cent level (Table 4.14).

ii) Birds which showed no decrease in overall capture rate but a decrease in the capture rate of large worms (Fig. 4.23a) - 2 of the 3 increased their search area (both increases significant at the 10 per cent level, Table 4.14). The data for the third bird (O L/O), when combined with that collected from the same bird on the same site 9 days earlier in similar weather conditions, show that this bird also increased its search area with time after exposure (Fig. 4.23b).

iii) Birds which showed a decrease in overall capture rate (Fig. 4.23c) - both birds increased the area searched during each pause, one significantly (Table 4.14).

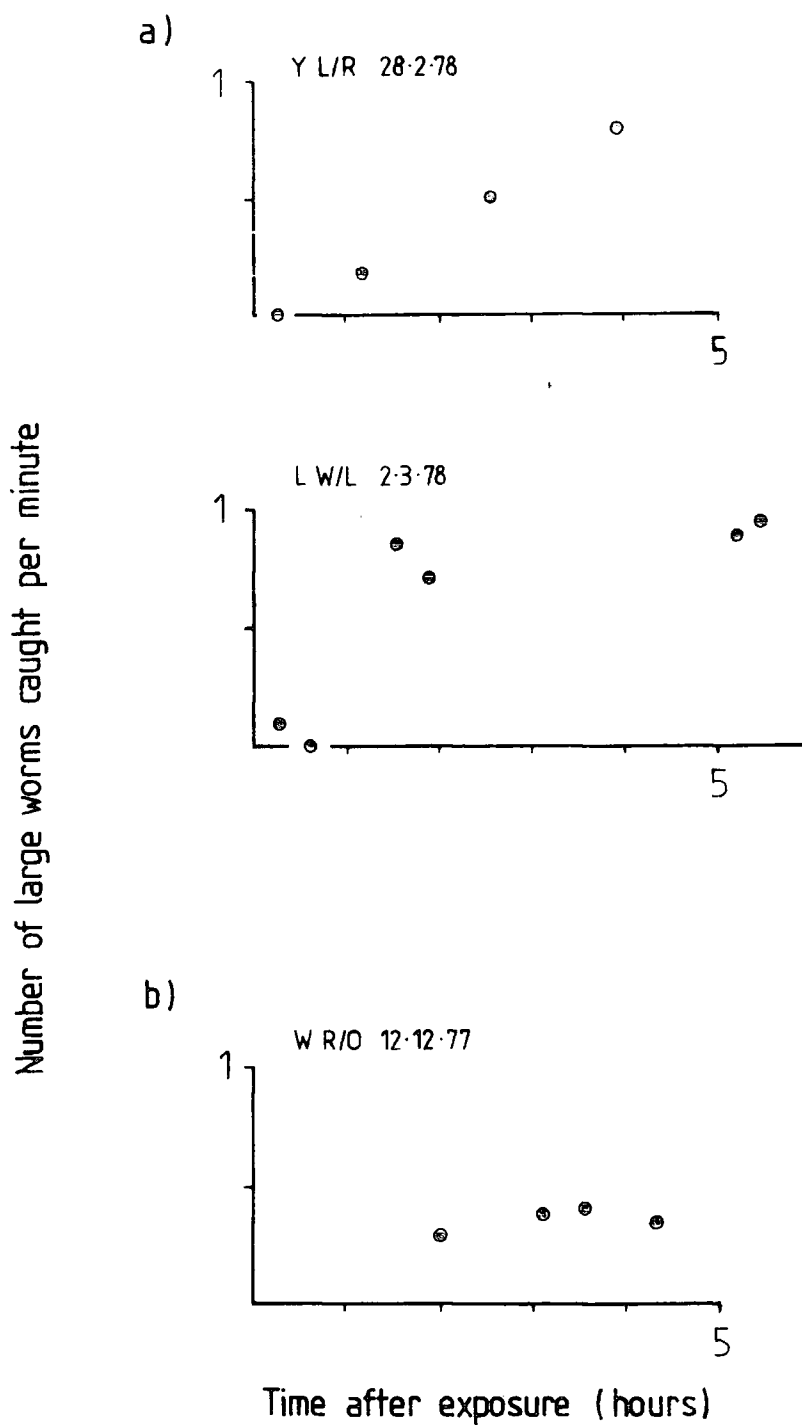

Figure 4.21 Changes in the rate of capture of large worms during the period of exposure: a) two marked Grey Plovers which showed no decrease in overall capture rate, and b) one which did show a decrease in overall capture rate. These graphs are derived from the data presented in Figure 4.19.

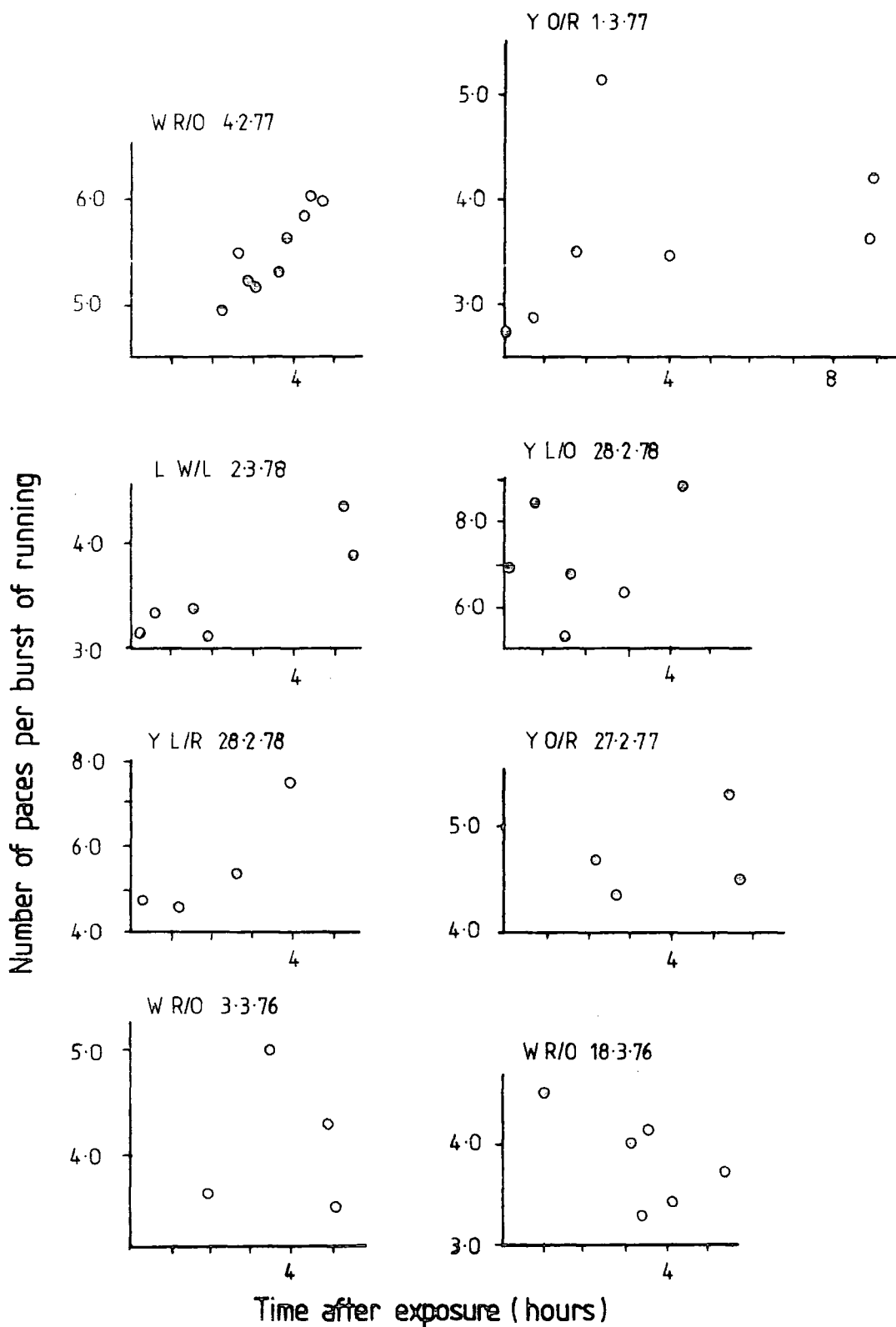

Figure 4.22 Area searched during each pause in relation to time after exposure of a site: eight marked Grey Plovers which showed no decrease in overall capture rate or capture rate of large worms.

Table 4.14

Foraging behaviour of marked Grey Plovers that fed on one site throughout the period of exposure: statistical parameters of the increases in area searched during each pause

Bird	Date	Site	Period of increase (hrs after High Water)	No. of points	Correlation coefficient	Significance of correlation (where $P \leq 0.10$)	Slope	Difference of slope from zero (where $P \leq 0.10$)
a) Birds which showed no decrease in overall capture rate or capture rate of large worms:								
W R/O	4. 2.77	ECh	5.5 - 8.5	9	0.895	$P \leq 0.001$	0.403	5.32 $P < 0.002$
L W/L	2. 3.78	SM _e	3.0 - 8.5	6	0.882	$P = 0.02$	0.137	3.74 $P = 0.02$
Y L/R	28. 2.78	CB _n	3.5 - 7.5	4	0.915	$P < 0.10$	0.787	3.21 $P < 0.10$
Y L/O	28. 2.78	CB _n	3.5 - 7.5	6	0.320		0.284	
Y O/R	27. 2.77	SM _e	4.0 - 7.5	4	0.463		0.106	
Y O/R	1. 3.77	SM _e	2.0 - 11.0	7	0.367		0.080	

b) Birds which showed no decrease in overall rate, but a decrease in capture rate of large worms:

R Y/Y	26. 2.78	SCh	5.0 - 8.0	6	0.801	$P < 0.10$	0.352	2.68 $P < 0.10$
L W/L	19.12.77	SM _e	3.5 - 5.0	6	0.754	$P < 0.10$	0.979	2.30 $P < 0.10$
O L/O	23. 2.78	CBs	7.5 - 9.5	5)	0.729	$P < 0.01$	0.172	3.37 $P < 0.01$
	4. 3.78	CBs	3.0 - 5.5	7)				

c) Birds which showed a decrease in overall capture rate:

W R/O	13. 1.77	ECh	4.5 - 6.5	5	0.968	$P < 0.01$	1.356	6.64 $P < 0.01$
W R/O	12.12.77	ECh	5.5 - 8.0	4	0.548		0.372	

Key for sites as on Table 3.19.

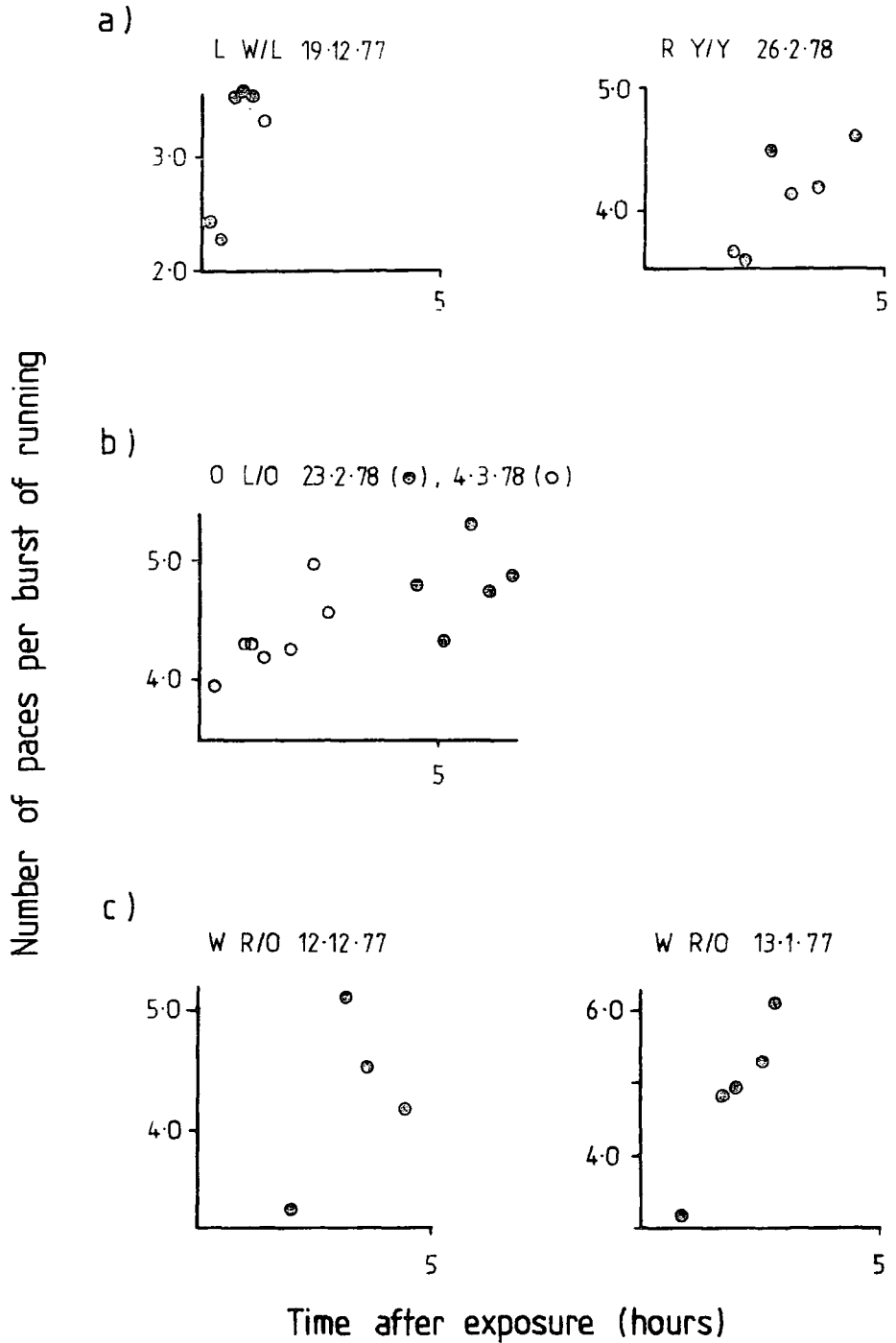

Figure 4.23 Area searched during each pause in relation to time after exposure of a site: a) and b) three marked Grey Plovers which showed no decrease in overall capture rate but a decrease in the capture rate of large worms (see text), c) two birds which showed a decrease in overall capture rate.

Overall 10 of the 13 birds showed an increase in area searched with time after exposure, 6 increases being significant at the 10 per cent level. The proportion showing a decrease in either overall capture rate or capture rate of large worms was much smaller. However data on search area were much easier to collect than those on worm capture rates as so few worms were caught per minute. More extensive observations may reveal decreases in the capture rates of all or only large worms during the period of exposure of a site.

Conclusions -

The results of the previous section are substantiated: most Grey Plovers avoid the predicted fall in capture rate caused by the falling activity of Nereis by increasing with time after exposure the area searched during each pause. The hypothesis used to predict Grey Plover foraging behaviour during a tidal cycle solely from the changes in activity of Nereis is therefore too simple.

There is great variability in the foraging behaviour of Grey Plovers both between individuals and between days for the same individual.

4. II. B. 2. Foraging behaviour during a winter

In Section 3. II. D. 3. it was shown that during a winter some Grey Plovers changed their use of habitat, probably in response to decreases in Nereis activity (caused by cold temperatures or an annual rhythm) and in Nereis density. It seems possible, therefore, that changes in Grey Plover foraging behaviour should occur in relation to the same factors. For example, in cold weather, when Nereis activity falls, the rate of capture of worms by a Grey Plover in a given site might be expected to fall. If it does not, it may be for one or both of the following reasons:

- a) a decrease in size selectivity
- b) an increase in area searched during each pause.

In this section I shall describe the behaviour of 2 birds seen feeding regularly in one site during one or more winter. It was hoped that the extensive observations on these 2 birds would provide a clearer pattern of the changes occurring during a winter than would infrequent observations on a larger number of marked birds. The 2 birds studied were W R/O on its Eastern Channel territory during the winters of 1975/76, 1976/77 and 1977/78, and L W/L on its territory on Scalloped Mud - east during the 1977/78 winter. Data for any observations of feeding within the territory were used for L W/L; for W R/O only data collected during High Water +6 - High Water +8 hours were analysed.

1. The rate of capture of worms (Fig. 4.24)

In each of the 3 winters, W R/O showed a decrease in the overall capture rate as the substrate temperature fell. During 1977/78 L W/L also showed such a decrease, although at low substrate temperatures the range of capture rates was much more variable. The reason for this is not known. At lower temperatures a Grey Plover's energy requirements are likely to be higher, even though food availability is lower. The occasional high capture rates at low temperature may have resulted from chance observations of the bird feeding on higher-than-average density patches of food within the territory. On other days, if no such patches were encountered during observation periods, the rate would have been low, limited by availability. Certainly, Grey Plover feeding territories did not contain uniform prey distributions.

2. Size selectivity (Figs. 4.25 and 4.26)

In addition to the fall in overall capture rate, each bird caught large worms less frequently at lower substrate temperatures, in each winter studied. Again L W/L showed greater variation than W R/O at low temperatures. Neither bird showed a decrease in sizes selected, however, as there were falls of similar

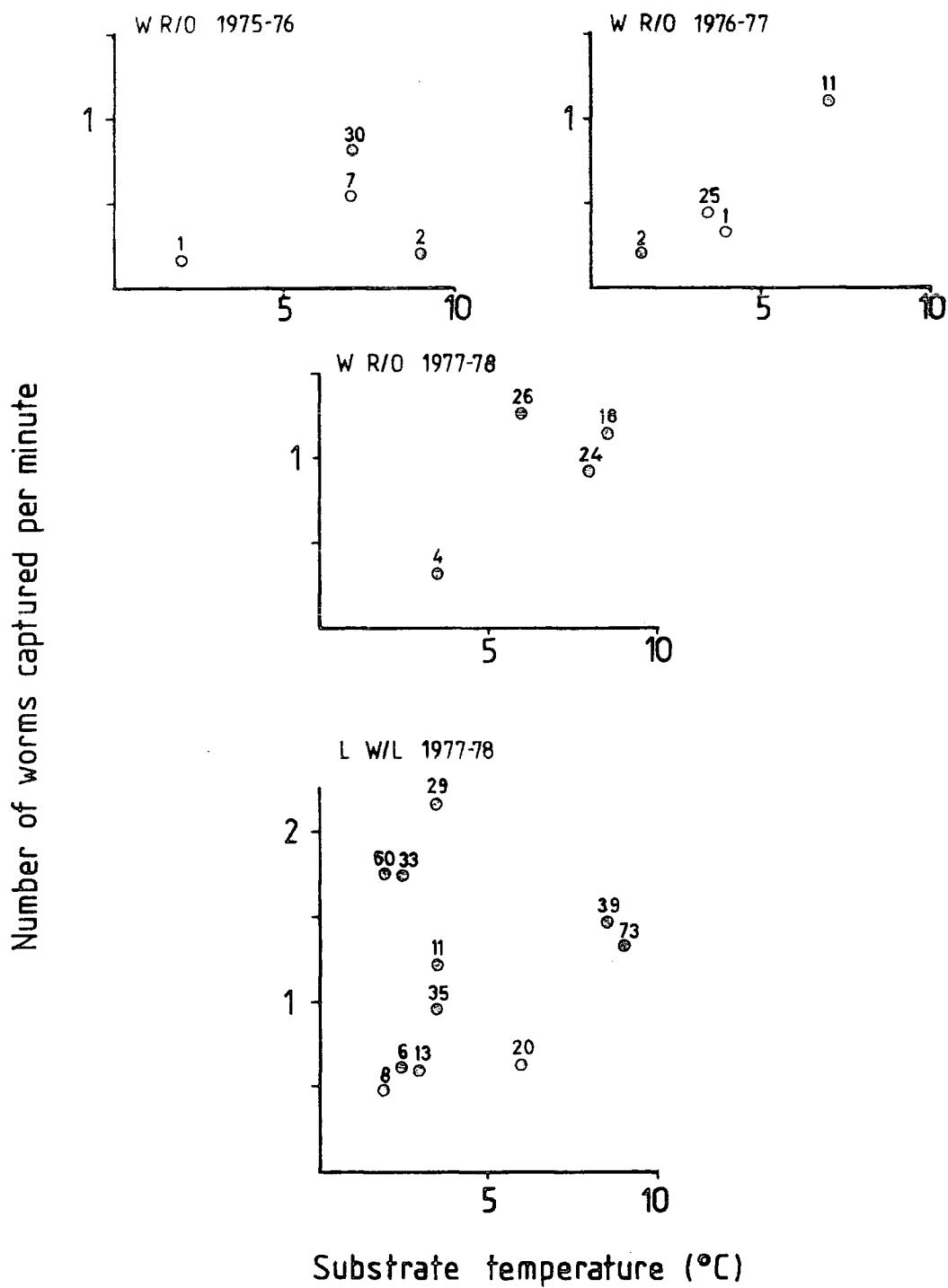

Figure 4.24 Rates of worm capture in relation to substrate temperature: data for two marked Grey Plovers. W R/O in three winters and L W/L in one winter. Key as on Figure 4.19.

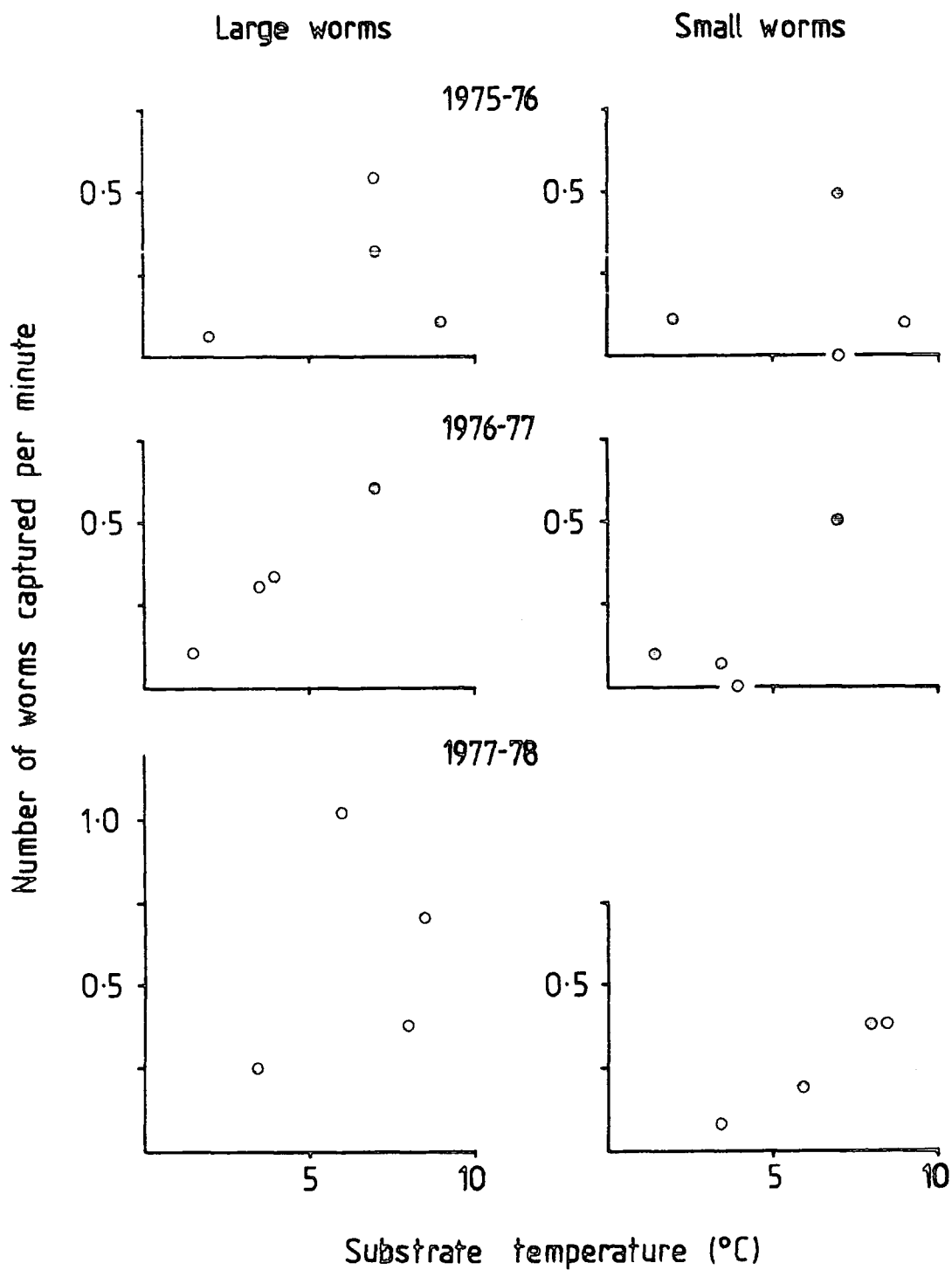

Figure 4.25 Rates of capture of large and small worms in relation to substrate temperature shown by one marked Grey Plover (W R/O) in three winters. These graphs are derived from the data presented in Figure 4.24.

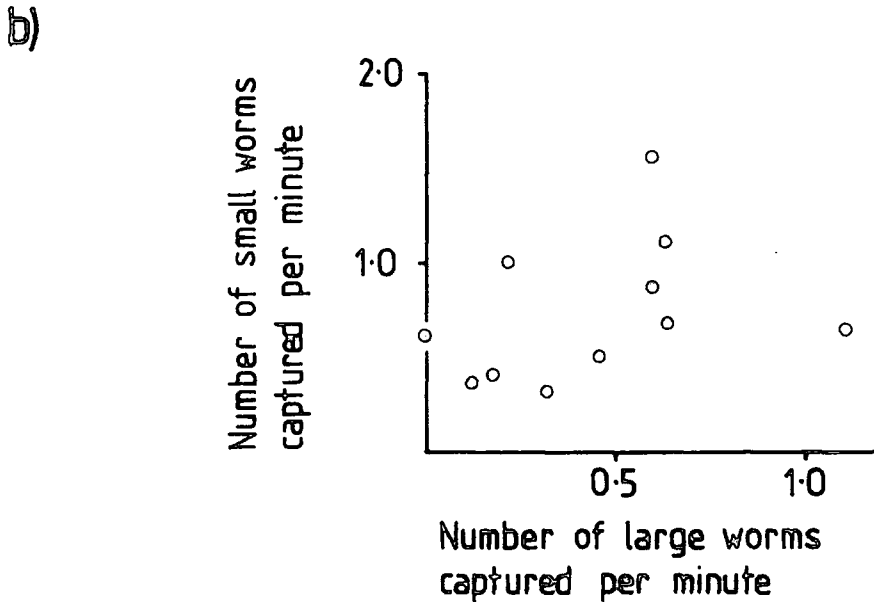
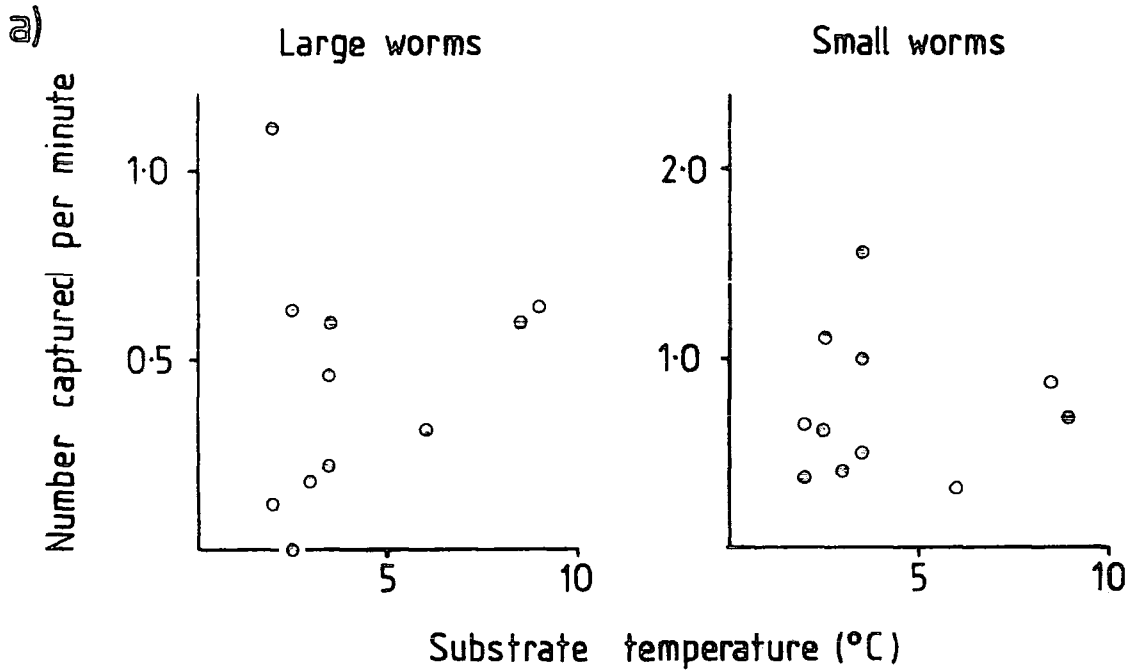

Figure 4.26 a) Rates of capture of large and small worms in relation to substrate temperature shown by one marked Grey Plover (L W/L) in one winter. These graphs are derived from the data presented in Figure 4.24.

b) The relationship between the rates of capture of small and large worms taken by this marked Grey Plover.

percentage in the capture rates of large and small worms with decreasing substrate temperature. The high variability in the data for L W/L does not hide an inverse relationship between the capture rates of large and small worms (Fig. 4.26b).

3. The area searched during each pause (Fig. 4.27)

In 2 winters (1976/77, 1977/78) W R/O increased the area searched during each pause as substrate temperature fell. L W/L showed a similar relationship.

When the data for W R/O over 3 winters are combined, a significant relationship between overall capture rate and substrate temperature is revealed (Fig. 4.28) ($r = 0.584$, $n = 12$, $P < 0.05$; slope significantly different from zero, $t = 2.27$, $P < 0.05$). The inverse relationship between area searched during each pause and substrate temperature (Fig. 4.28) was not significant even at the 10 per cent level for the combined data for 3 winters, but was significant when only the 1976/77 and 1977/78 data were used ($r = -0.692$, $n = 8$, $P < 0.10$; slope significantly different from zero, $t = 2.35$, $P < 0.10$). The reason for this difference is unknown, although it may be due in part to an improvement in data collection after the first winter.

Both capture rate and area searched also show a clear seasonal change, with the former reaching a minimum in January - February when area searched reaches a maximum (Fig. 4.28). As the coldest air and sea temperatures (and therefore substrate temperatures) occur on average in late January and early February, respectively, it is not possible to say whether the changes in the foraging parameters are caused by a direct decrease in Nereis activity in response to cold weather or to an annual decrease in activity, independent of actual changes in temperature, which reaches a minimum in mid winter.

Due to the variability in the data for L W/L, no seasonal pattern was apparent.

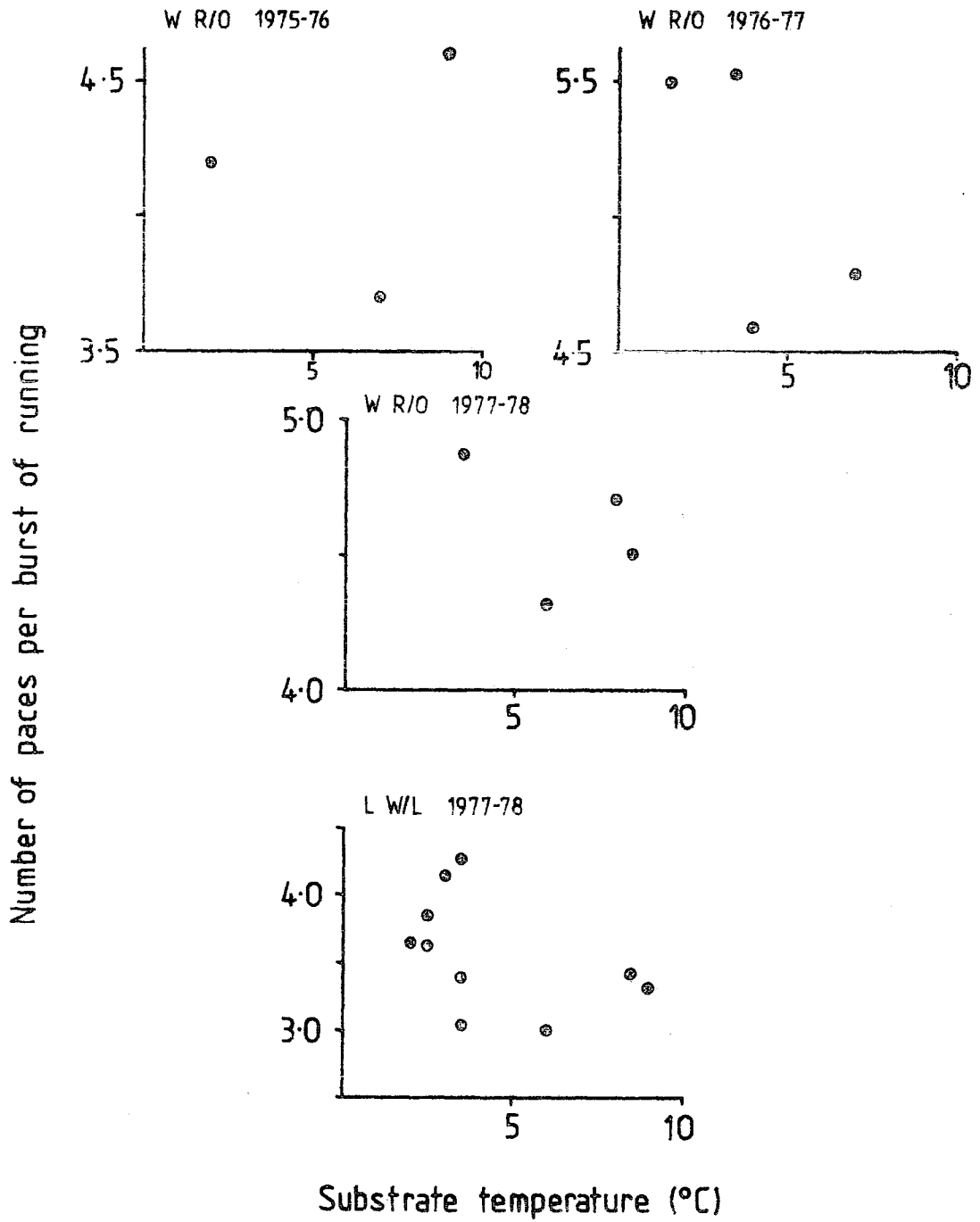
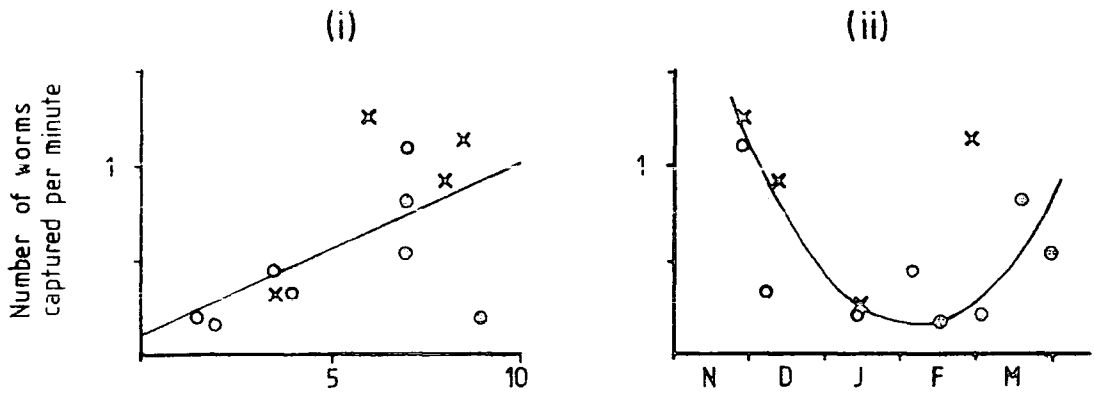

Figure 4.27

Area searched during each pause in relation to substrate temperature: data for two marked Grey Plovers. W R/O in three winters and L W/L in one winter.

a) Overall capture rate :



b) Area searched each pause :

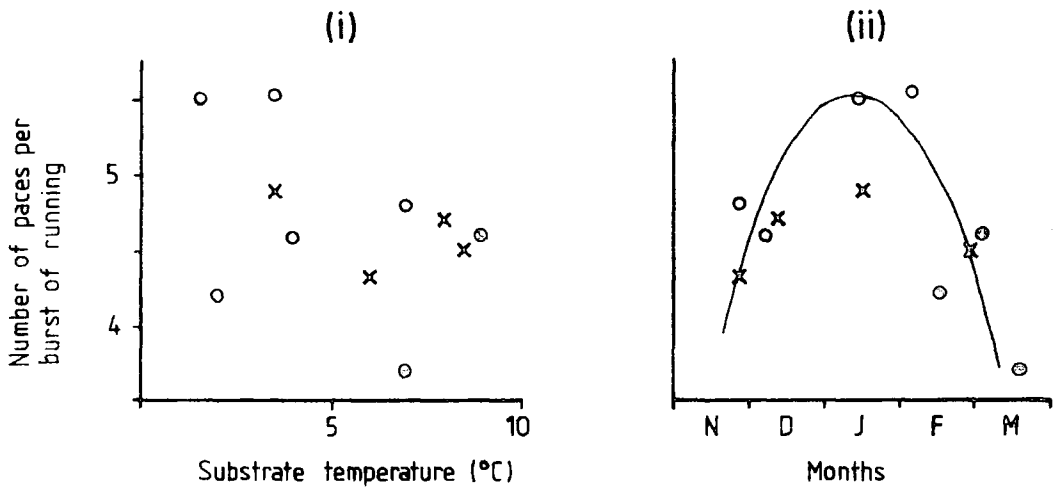

- 1975-76
- 1976-77
- × 1977-78

Figure 4.28 Changes in a) overall capture rate and b) area searched during each pause with substrate temperature and with season (curves fitted by eye) shown by one marked Grey Plover (W R/O) during three winters.

4. II. C. CURLEW

4. II. C. 1. Foraging behaviour during a tidal cycle

In Section 3.II.D.2, it was argued that, if each Curlew on Seal Sands attempts to maintain a constant prey capture rate during the time for which it feeds in each tidal cycle, but fails to do so, it should either become territorial on that site or change feeding site. It follows that Curlews showing either of these changes in habitat use should have experienced a falling prey capture rate before the change. As the fall is caused by the worms burrowing deeper, capture rate should suddenly drop at the time when the worms (of the size classes taken by Curlews) move out of reach of the Curlew's bill (as shown in Fig. 3.33, 3). (This assumes that worms of all size classes burrow at a similar rate.) No data are available on the foraging of marked Curlews just before they changed to territorial behaviour, but in the following section I shall discuss foraging behaviour before a change of feeding site.

a. Foraging behaviour of a Curlew that changed feeding site during the Low Water period

Only one colour-marked Curlew was observed for an extensive period (1 1/2 hours) before it changed feeding site. During this time the rate at which it caught worms, when foraging, fell (Fig. 4.29a) (the first value lies outside the 99 per cent confidence limits of the mean of the final two values). There are insufficient data to show whether the fall was sudden or gradual. This bird left the site during the final 8-minute observation period just after it had begun a boundary dispute with a neighbouring Curlew. Its departure at this time indicates that it was unable to maintain a capture rate adequate to meet its energy requirements if it spent any time in activities other than feeding. It moved to a mudflat at a lower tidal level where no territories are held by Curlews.

It was not possible to investigate whether a change occurred in the rate at

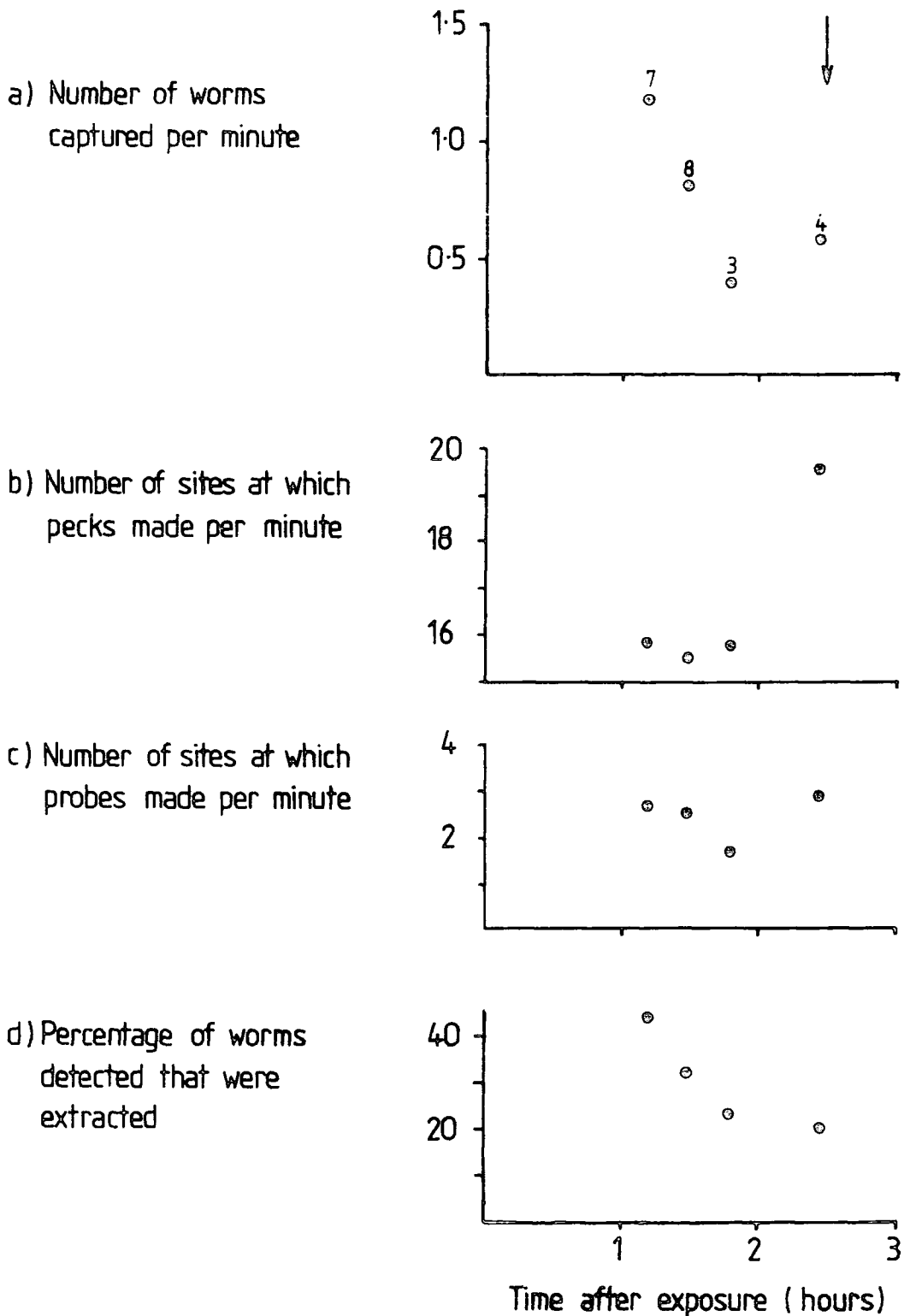

Figure 4.29 Changes in four foraging parameters of a marked Curlew (Y N/W) during a single Low Water period (1st January 1978): a) the rate of capture of all worms (total number of worms taken in each observation period shown above points), b) the search rate, c) the detection rate, and d) the percentage of worms detected that were extracted from the mud. The arrow indicates when the bird left the site.

which it captured large worms (i. e. worms \geq 100 mm estimated length), as too few were taken.

The decrease in overall capture rate was matched by an increased effort to detect prey. In Curlews the parameter used to measure search effort was the number of sites at which one or more pecks were made per minute. Pecks (i. e. touching the surface of the mud with the bill tip) are believed to be used to detect worms in the mud. A Curlew was considered to have detected a prey when the peck was followed by one or more probes into the mud. Thus the number of sites at which a Curlew detected prey is taken to equal the number of sites at which it probed into the mud. Thus:

search rate = the number of sites at which pecks made per minute

detection rate = the number of sites at which probes made per minute

capture rate = the number of worms caught per minute

By increasing the search rate (Fig. 4. 29b) (the final value lies outside the 99 per cent confidence limits of the mean of the other three values) this Curlew managed to detect worms at a similar rate in each observation period (Fig. 4. 29c). However it extracted from the mud a decreasing proportion of the worms detected (Fig. 4. 29d) (the first value lies outside the 99 per cent confident limits of the mean of the other three values), hence the decrease in the overall capture rate (Fig. 4. 29a). This suggests that this Curlew could detect worms in their burrows, even when the mud had dried considerably, but as the worms were burrowing deeper it could reach only a decreasing proportion of them.

As no other observations on marked Curlews changing their feeding sites during a tidal cycle are available, no confirmation of these results can be obtained directly. Instead I shall present data on Curlews that fed throughout the Low Water period in a single site to see whether they too experienced changes in the 3 parameters:

1. overall worm capture rate
2. sizes of worms selected
3. search effort

b. Foraging behaviour of Curlews that fed in one site throughout the period of exposure

On 7 occasions single marked Curlews were observed feeding in one site, for at least 2 hours during which the 3 parameters of foraging were measured at least 4 times. In each case the Curlew fed on a single substrate type throughout the observation period.

1) The rate of capture of worms

Only 2 birds showed a fall in overall capture rate with time after exposure of the feeding site (Fig. 4.30a). Both falls were gradual, and the differences between the first and last rates were not significant at the 10 per cent level. The other 5 birds either maintained or increased their capture rate (Fig. 4.30b). Prey availability does appear to be limiting the capture rate: the capture rate of individual Curlews on a given site increased markedly as the incoming tide covered the mud (Table 4.15). Therefore the absence of marked falls in the capture rate of Curlews feeding in one site during the period of exposure suggests that the Curlews are employing at least one of the following tactics:

- a) changing the sizes of worms selected
- b) increasing their search effort.

2) Size selectivity

- i) Birds which showed no decrease in overall capture rate (Fig. 4.31a) - in 4 of the 5 cases the number of large worms (≥ 100 mm estimated length) caught per minute fell with time after exposure. The fall was significant at the 5 per cent level in 3 cases (Table 4.16). All 4 birds maintained or

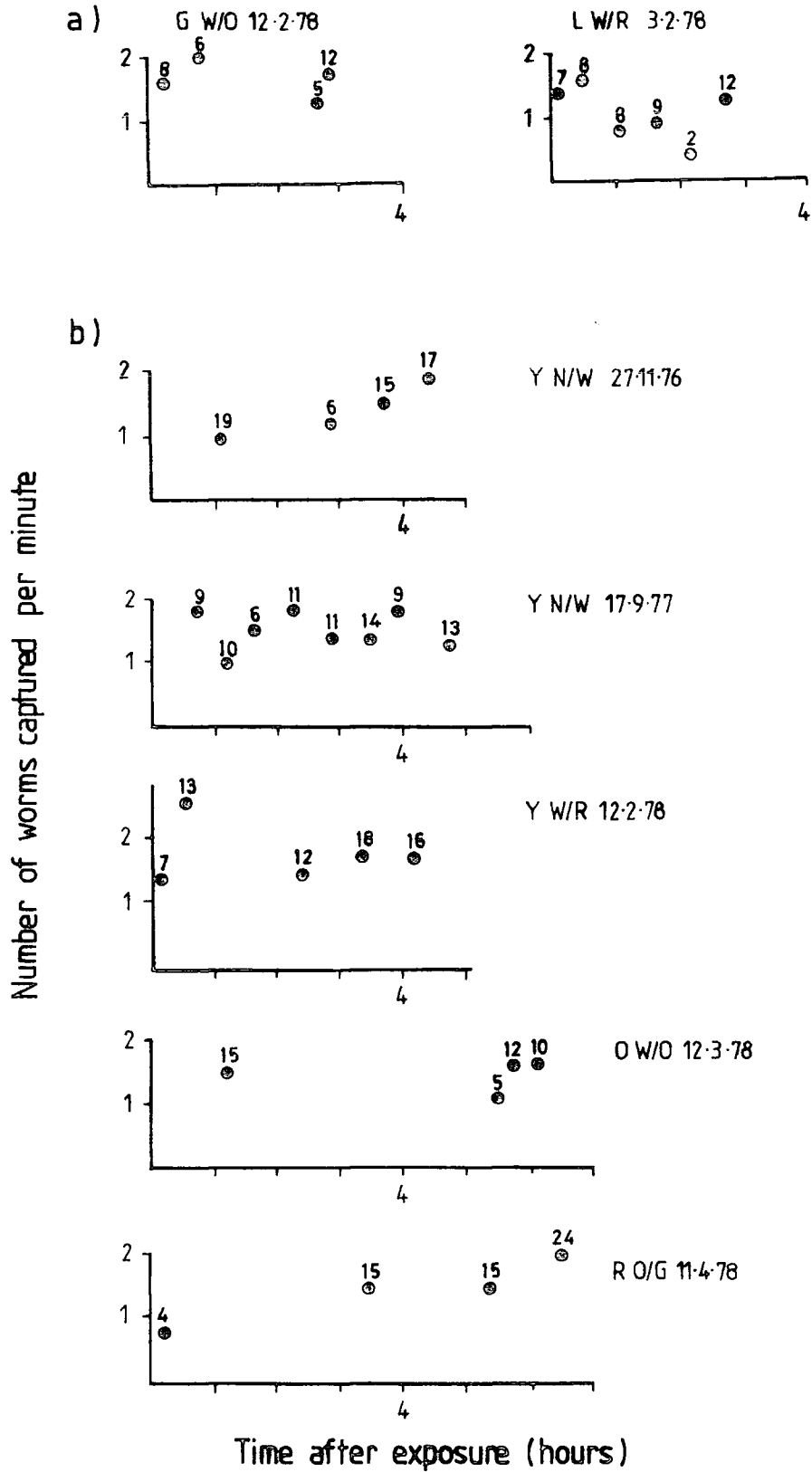

Figure 4.30 The rate of capture of worms in relation to time after exposure: a) two marked Curlews which showed a decrease, b) five which showed no decrease.

Table 4.15

The rate of worm capture of marked Curlews feeding on soft mud, Scalloped Mud - west, on the same site both before and as the tide covered the mud

Date	Bird	Time between observations (mins)	Rate of capture of worms, no./min., and (length of observation, mins)	
			Open mud	Tide flooding
29. 8.77	O W/O	11	1.44 (9)	2.40 (5)
10. 9.77	O W/O	22	1.17 (6)	2.40 (2)
10. 9.77	L R/L	72	0.78 (9)	2.20 (5)
19. 9.77	O W/O	30	1.00 (13)	3.50 (2)
24. 9.77	O W/O	86	1.00 (15)	1.00 (8)
1.12.77	O W/O	2	1.50 (2)	2.00 (13)
10. 1.78.	O W/O	2	1.78 (5)	1.56 (5)
12. 3.78	O W/O	1	1.49 (18)	3.33 (3)

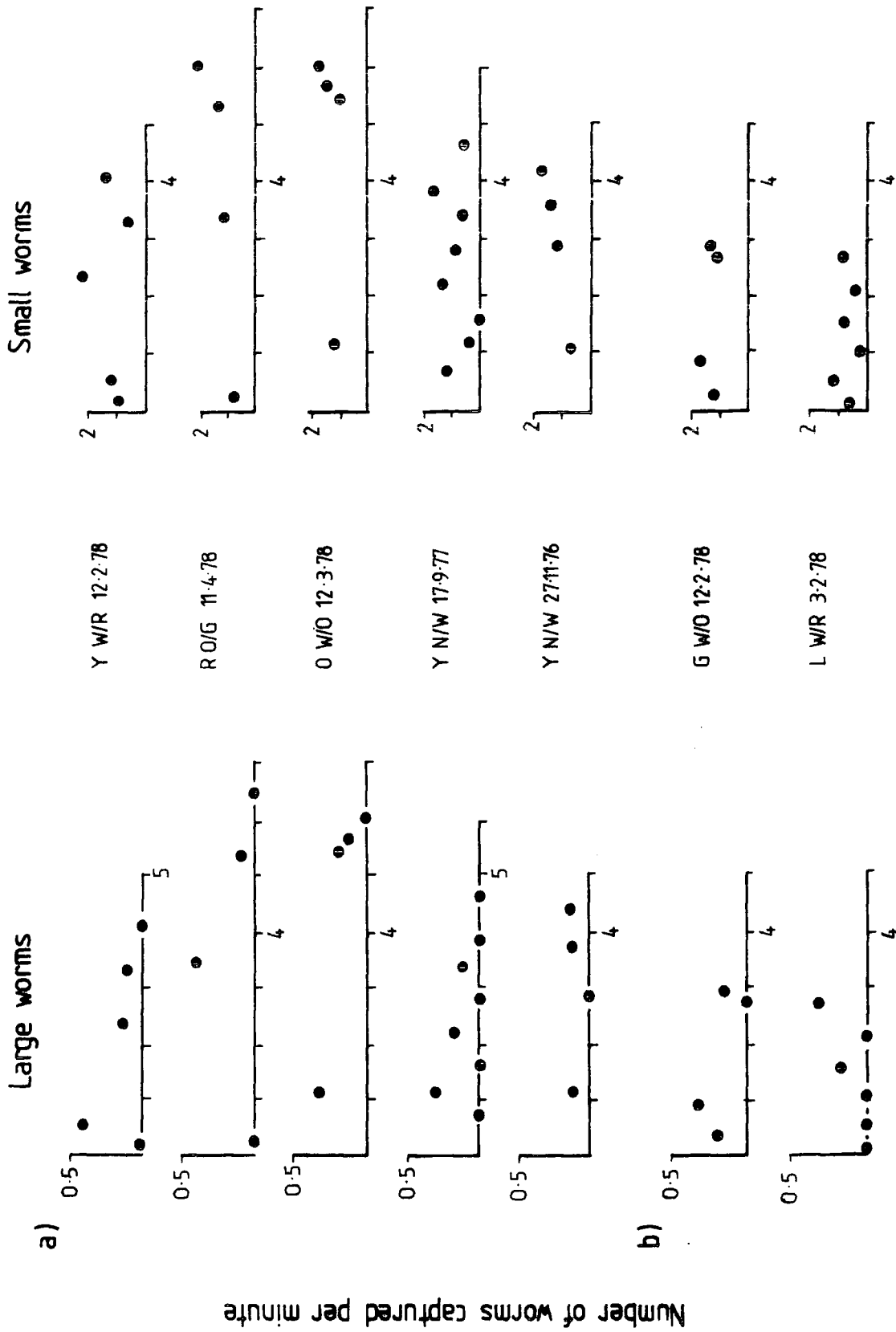

Figure 4.31 Rates of capture of large worms (> 100 mm estimated length) and small worms (< 100 mm estimated length) in relation to time after exposure: a) five marked Curlews which showed no decrease in overall capture rate, b) two which did show a decrease in overall capture rate. These graphs are derived from the data presented in Figure 4.30.

Table 4.16

Foraging behaviour of marked Curlews that fed in one site throughout the period of exposure:
 significance tests for decreases in the rate of capture of large worms

		<u>Final Observation</u>			<u>Preceding Observations</u>			<u>Confidence Limits</u>	
		Number of observation periods	Mean number of large worms caught per minute (total length of observations, mins)	Standard deviation	Number of observation periods	Mean number of large worms caught per minute (total length of observations, mins)	Standard deviation	Level at which difference significant	Confidence limits at this level
Y W/R	12.2.78	3	0.08 (27)	0.07	1	0.40 (5)	-	1%	± 0.180
R O/G	11.4.78	2	0.05 (22)	0.07	1	0.40 (10)	-	1%	± 0.183
O W/O	12.3.78	3	0.11 (23)	0.10	1	0.33 (10)	-	5%	± 0.202

Birds which showed no decrease in overall capture rate:

increased their capture rate of small worms (Fig. 4. 31a). Thus a real change in size selectivity must have occurred. The decreases in the capture rate of large worms were gradual so the change was of type A in Fig. 4. 15.

ii) Birds which showed a decrease in overall capture rate (Fig. 4. 31b) - only one of the 2 birds caught fewer large worms per minute as the mud dried out, but the fall was not significant at the 5 per cent level. This bird showed no change in size selectivity as its capture rate of small worms also fell slightly (Fig. 4. 31b).

As only 2 of the 7 marked Curlews showed a significant decrease in the capture rate of worms ≥ 75 mm estimated length and only one of them a decrease for worms of ≥ 50 mm, it appears that it is mainly the decreased accessibility of the largest worms, which burrow deepest in the mud (Muus 1967, Ratcliffe 1979), that affects the size range of worms taken by Curlews.

3) Search effort

i) Birds which showed no decrease in overall prey capture rate (Fig. 4. 32a) - 3 of the 5 showed an increase in the number of sites at which pecks were made per minute, a measure of search effort, with time after exposure. All 3 increases were significant at the 5 per cent level (Table 4. 17).

ii) Birds which showed a decrease in overall prey capture rate (Fig. 4. 32b) - the bird (G W/O) that had shown a fall in the number of large worms caught per minute, increased its search effort (an increase significant at the 1 per cent level (Table 4. 17)). The other bird did not show a change in search effort.

By increasing their search effort, 2 birds managed to at least maintain their detection rate, i. e. the number of sites at which prey were detected

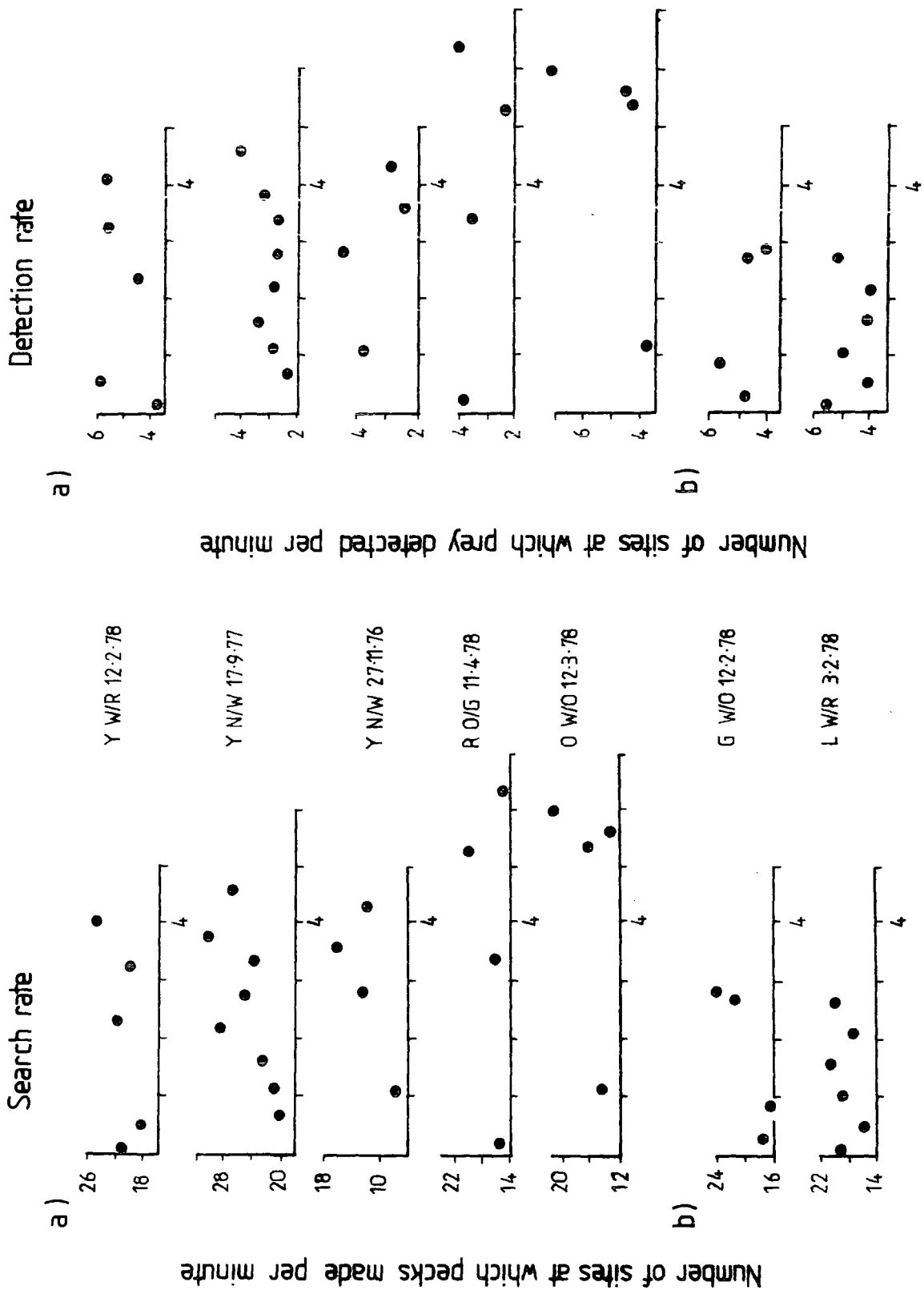

Figure 4.32 Changes in search rate and detection rate with time after exposure shown by marked Curlews:
 a) five birds which showed no decrease in overall prey capture rate, b) two birds which showed a decrease in overall prey capture rate.

Table 4.17

Foraging behaviour of marked Curlews that fed in one site throughout the period of exposure:
significance tests for increases in search effort

		<u>Final Observation</u>			<u>Preceding Observations</u>			<u>Confidence Limits</u>	
		Number of observation periods	Mean number of peck-sites per minute (total length of observations, mins)	Standard deviation	Number of observation periods	Mean number of peck-sites per minute (total length of observations, mins)	Standard deviation	Level at which difference significant	Confidence limits at this level
a)	Birds which showed no decrease in overall prey capture rate:								
	Y W/R	1	25.11 (9)	-	4	20.58 (28)	1.50	1%	+ - 3.86
	Y N/W	2	29.14 (15)	2.11	3	21.67 (19)	1.16	1%	+ - 2.99
	Y N/W	3	13.50 (24)	2.36	1	7.90 (20)	-	5%	+ - 4.63
b)	Birds which showed a decrease in overall prey capture rate:								
	G W/O	2	22.96 (11)	1.69	2	17.14 (8)	0.66	1%	+ - 1.70

per minute (Fig. 4.32). The other 2 detected worms less frequently as the mud dried out, despite their increased effort to find prey. Thus it is not clear whether (a) increases in search effort are shown by the Curlew population as a whole, and (b) such increases do enable Curlews to detect worms at a similar rate throughout the period of exposure.

Correlations between changes in foraging parameters - Of the 5 birds that showed no decrease in the overall capture rate of worms, 4 changed the sizes they took. Three of them also increased their search effort with time after exposure of the mud, 2 thus maintaining a constant rate of detection of prey. Thus it appears that at least some Curlews maintain their overall capture rate by increasing their search effort and reducing their selection of the larger size classes of worms.

The 2 marked Curlews that experienced a fall in overall capture rate showed different changes in the other parameters so no generalizations can be made.

Conclusions

The simple hypothesis relating Curlew foraging behaviour to the depth changes shown by Nereis during the tidal cycle is clearly inadequate to explain the full range of behaviour observed. Several Curlews avoided the predicted fall in overall capture rate via a decrease in size selectivity and/or an increase in the number of attempts made to detect prey.

There is great variability in the foraging behaviour of Curlews both between individuals and between days for the same individual.

4. II. C. 2. Foraging behaviour during a winter

Curlews have been shown to change Low Water feeding sites in a way that would be predicted if an increase in depth of their prey, Nereis, occurred in cold weather and/or in response to a seasonal rhythm (Section 3.II.D.3). Such changes in Nereis behaviour should also lead to changes in Curlew foraging behaviour under such conditions. In particular, in cold weather Curlews should have had difficulty capturing prey at an adequate rate to meet their energy requirements. In the following section I shall discuss data on marked Curlews, each of which fed regularly on a single site during a winter.

1. The rate of capture of worms

The direct association between low temperatures and a reduction in the rate of capture of worms is shown in Fig. 4.33 for a single bird which fed in the same site (open mud) on days of different temperatures during a 3-week period. (Seasonal changes in depth distribution or density of Nereis were thus excluded.) The fall was significant at the 5 per cent level (Table 4.18). This bird did not use the site between 10th December and February, a change that appeared to be a direct response to the effect of low temperatures upon its rate of capture of worms.

Extensive observations of 2 marked Curlews on the western half of Scalloped Mud between October and March also revealed falls in capture rate (significant at the 10 per cent level in each case (Table 4.18)) associated with low substrate temperatures, when feeding on open soft mud (Fig. 4.34). One bird (O W/O) showed a similar (but non-significant) decrease with falling temperature when feeding at the tide edge (on soft mud), and, when data for September are included, so did the other bird (L R/L). However on liquid mud no decrease in capture rate was shown by either L R/L (October - March data)

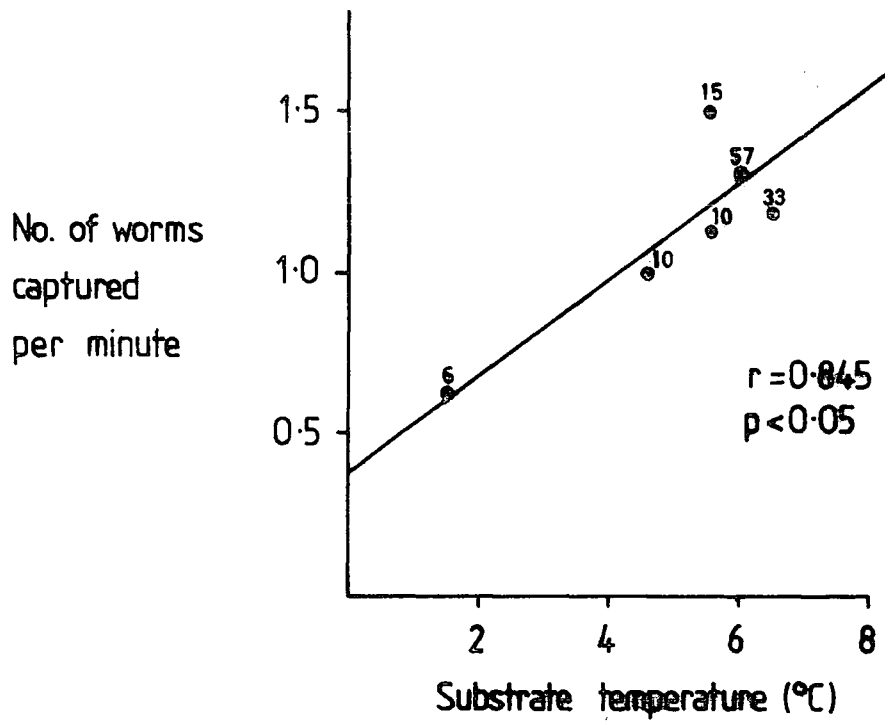

Figure 4.33 The relationship between the rate of worm capture and substrate temperature for one marked Curlew (Y N/W) during the period 20th November - 10th December 1976. Key as on Figure 4.19.

Table 4.18

Statistical parameters of changes in the rate of worm capture with changing substrate temperature shown by marked Curlews feeding on different substrate types

Y N/W	Site	Substrate	No. of points	Correlation coefficient	Significance of correlation (where $P \leq 0.10$)	Slope	Difference of slope from zero (where $P \leq 0.10$)
20.11.76-10.12.76.	ECh	mud	6	0.845	$P < 0.05$	0.143	3.16 $P < 0.05$
O W/O	SM _w	soft mud	8	0.677	$P < 0.10$	0.086	2.25 $P < 0.10$
L R/L	SM _w	soft mud	5	0.888	$P < 0.05$	0.149	3.35 $P < 0.05$
O W/O	SM _{wr}	tide edge	5	0.780		0.250	
L R/L	SM _w	tide edge	5	0.646		0.049	
O W/O	SM _{wr}	liquid mud	5	0.203		0.008	
L R/L	SM _w	liquid mud	6	-0.131		0.013	
R O/O	CB _s	mud	7	-0.497		0.056	
Y W/R	CB _s	mud	10	0.184		0.024	

Key for sites as on Table 3.19.

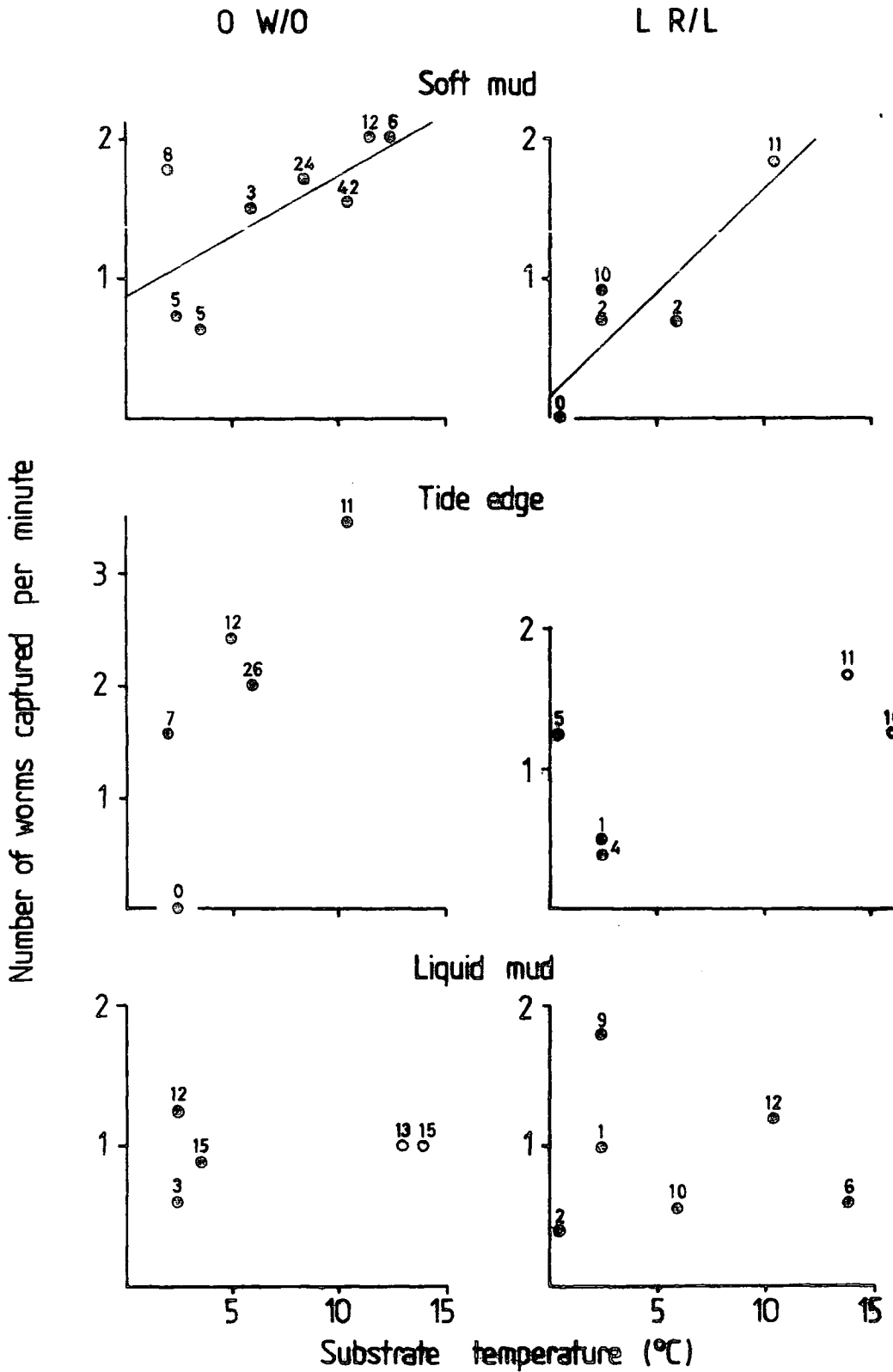

Figure 4.34

Rates of worm capture in relation to substrate temperature for two marked Curlews (O W/O, L R/L) each on soft mud, liquid mud and at the tide edge, during the 1977/78 winter (open circles, September; filled circles October to March). Key as on Figure 4.19.

or O W/O (September - March data) (Fig. 4.34 and Table 4.18).

In contrast to the data presented above, prey capture rates of 2 marked Curlews feeding on the southern part of Central Bank during October to March did not show the expected marked decreases in association with low substrate temperatures, one bird actually increasing its capture rate in such conditions (Fig. 4.35 and Table 4.18). As both these birds fed on mud or soft mud, and not on a liquid substrate, their capture rates should have fallen in cold weather, according to the simple hypothesis of changes in Nereis depth. As they did not, they may have been using either or both of the following tactics:

- a) changing the sizes of worms selected
- b) increasing their search effort.

2. Size selectivity

i) Birds which showed no decrease in overall capture rate - neither of the 2 marked birds on Central Bank showed a significant fall in the capture rate of large worms (≥ 100 mm estimated length for R O/O, ≥ 50 mm for Y W/R) with falling substrate temperature (Fig. 4.36). However one bird (R O/O) significantly increased the rate at which it caught small worms ($r = -0.943$, $n = 6$, $P < 0.01$; slope significantly different from zero, $t = 5.68$, $P < 0.01$). (By this means it produced the slight increase in overall capture rate shown in Fig. 4.41). This bird thus reduced the proportion of large worms in the diet at low temperatures (Fig. 4.36). The other bird (Y W/R) showed no significant changes in its selection of Nereis size classes with changes in temperature (Fig. 4.36). Unlike R O/O, it took very few worms of ≥ 100 mm estimated length at any temperature (see Section 4. II. C. 3). Worms of ≥ 100 mm estimated length may, therefore, move relatively deeper than smaller worms when the substrate temperature falls, as they do in mid winter (Muus 1967).

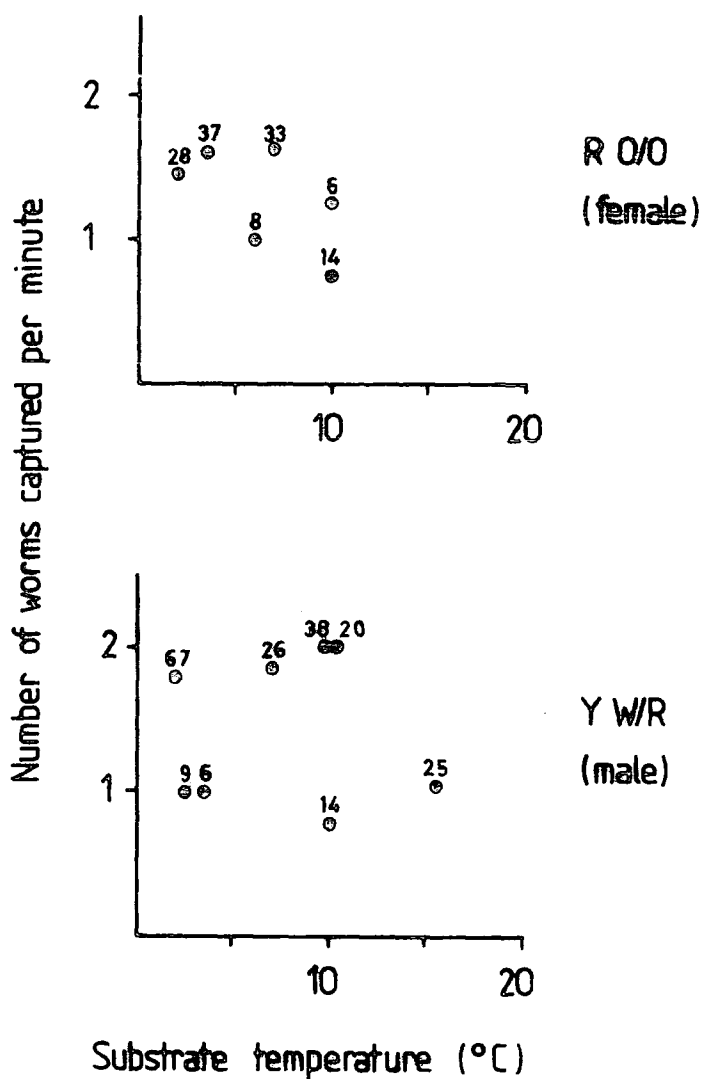

Figure 4.35

Rates of worm capture in relation to substrate temperature for two marked Curlews (R O/O, Y W/R) feeding on Central Bank - south during October to March, 1977/78. Key as on Figure 4.19.

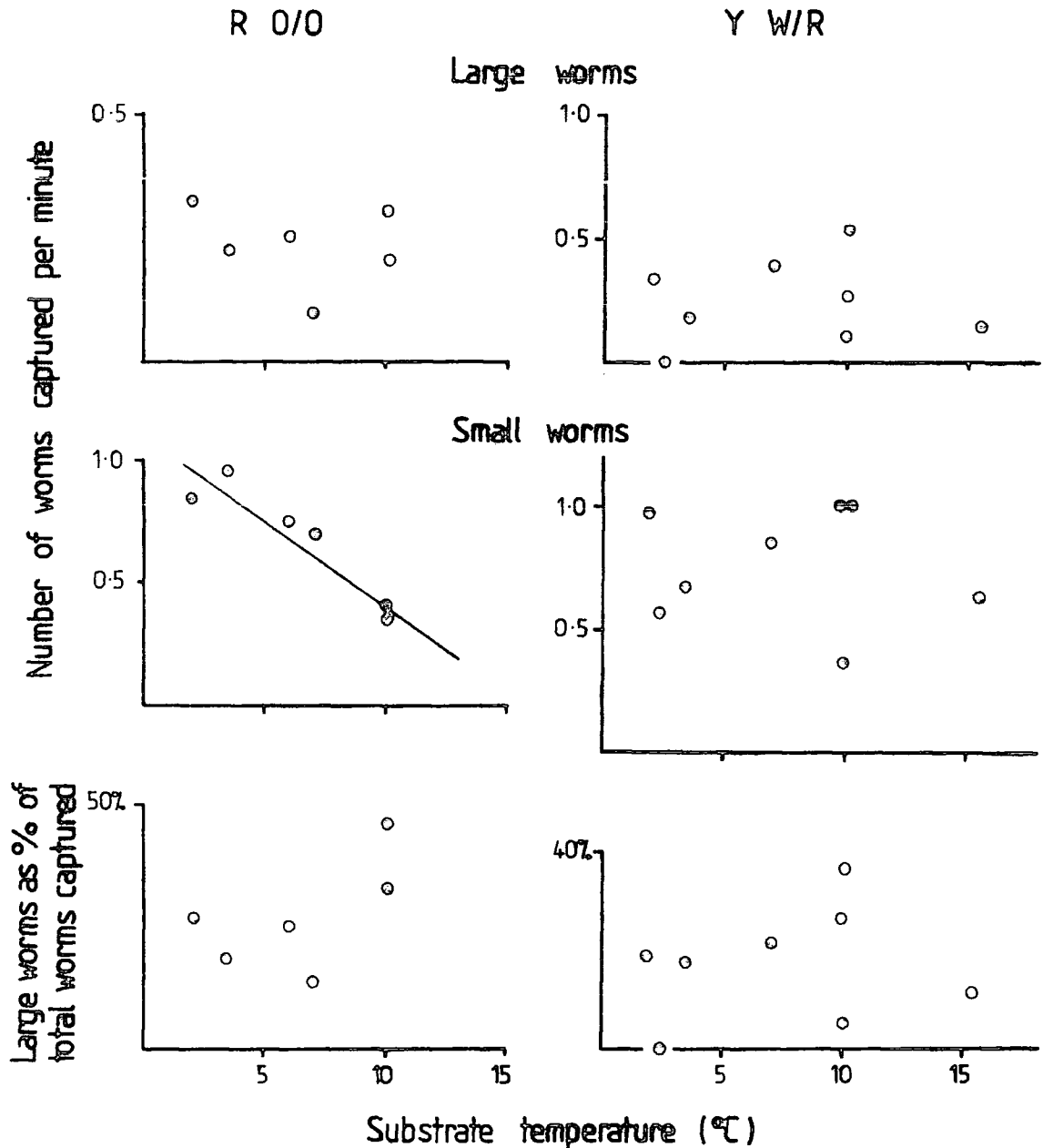

Figure 4.36

Capture rates of large worms (R O/O ≥ 100 mm, Y W/R ≥ 50 mm estimated length) and small worms (R O/O < 100 mm, Y W/R < 50 mm) and in the percentage of large worms in the diet in relation to substrate temperature; data for 2 Curlews (R O/O female, Y W/R male) feeding in the same area of Central Bank - south from October to March, 1977/78. These graphs are derived from the data presented in Figure 4.35.

The data on worm sizes for the other 2 birds which maintained a constant capture rate (O W/O and L R/L on liquid mud) are too few to draw conclusions.

ii) Birds which showed a decrease in overall capture rate (Figure 4.37) - none of the birds in this category showed evidence of a decrease in size selectivity with falling substrate temperature. In 3 cases (Y N/W, O W/O and L R/L on soft mud) the fall in overall capture rate was clearly due to difficulty in catching worms of all sizes. The data for O W/O and L R/L feeding at the tide edge show similar trends.

Thus some Curlews appear to capture large and small worms in the proportions available, at all temperatures. Others (e.g. R O/O above) reduce the proportion of larger worms in the diet when the temperature falls. This reduction could be achieved by rejecting some small worms when detected at high temperatures, but eating all worms detected at low temperatures, i. e. a real change in size selectivity.

When the substrate temperature fell, R O/O apparently caught more small worms per minute as well as maintaining the rate at which it caught large worms. The change in size selectivity alone could have produced this result only if availability did not change with substrate temperature. As the evidence presented above suggests that availability in fact falls with falling temperatures, it would be expected that R O/O increased its search effort in cold conditions to overcome the reduced prey availability. Changes in search effort with substrate temperature will now be discussed.

3. Search effort

The number of sites at which pecks were made per minute is used as a measure of search effort, as above.

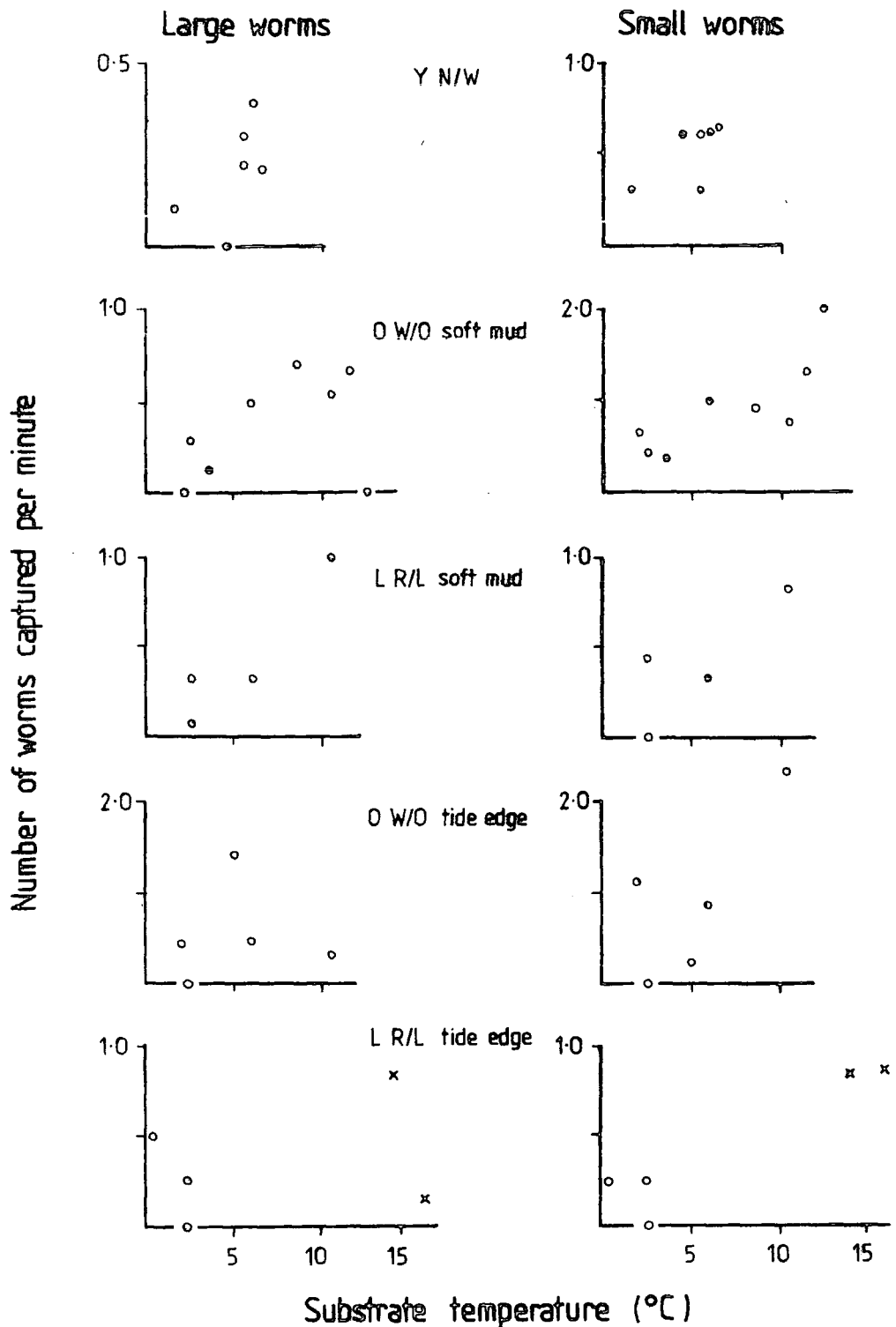

Figure 4.37

Capture rates of large worms (≥ 75 mm estimated length) and small worms (< 75 mm estimated length) in relation to substrate temperature shown by marked Curlews: data for three birds, two both on soft mud and at the tide edge (crosses, September; circles, October to March). These graphs are derived from the data presented in Figures 4.33 and 4.34.

i) Birds which showed no decrease in overall capture rate - the 2 which fed on Central Bank - south did not increase their search effort at low substrate temperatures (R O/O, Y W/R, Fig. 4. 38a). R O/O therefore appears to have increased its overall intake without searching for prey any faster.

In contrast the 2 birds which maintained their overall capture rate on liquid mud did increase their search effort when the temperature fell (Fig. 4. 38a), one significantly (Table 4. 19).

ii) Birds which showed a decrease in overall capture rate - 2 showed significant increases in search effort with falling temperature when feeding on soft mud (Fig. 4. 38b and Table 4. 19), and in 2 other cases the lowest measures of search effort occurred at the highest temperatures (Fig. 4. 38b). None of these birds had shown a change in size selectivity (see above) so their response to falling temperatures was to increase their search effort.

Thus these observations on foraging behaviour indicate the following:

1 marked Curlew (R O/O) avoided a fall in overall capture rate by decreasing its size selectivity; 2 others, feeding on liquid mud, did so by increasing their search effort; 5 marked birds feeding on mud or at the tide edge were unable to avoid a falling capture rate when they increased their search effort.

4. II. C. 3. Sex differences in foraging behaviour

In Section 3. II. C. it was shown that male and female Curlews employed different patterns of use of the mudflats within Seal Sands and the nearby fields. In this section I shall show that the movement of males, but not females, from Seal Sands to the fields in mid winter may result from the greater difficulty that the males experience in maintaining an adequate rate of prey capture on at least some mudflats of Seal Sands in severe weather.

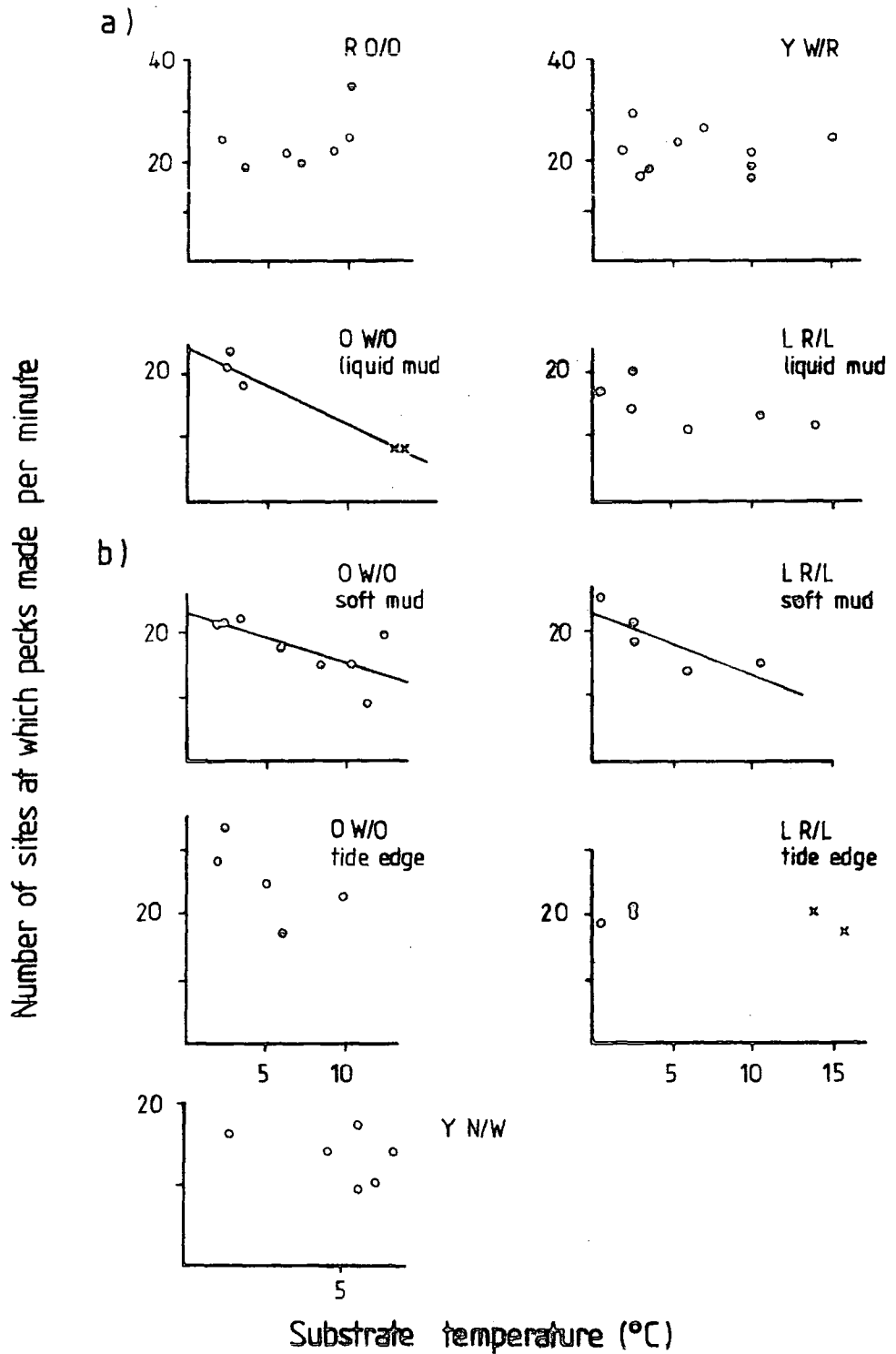

Figure 4.38

Search effort of marked Curlews in relation to substrate temperature: a) birds which showed no decrease in overall capture rate, b) birds which did show a decrease in overall capture rate (crosses, September; circles, October to March).

Table 4.19

Statistical parameters of changes in the search effort with changing substrate temperature shown by marked Curlews feeding on different substrate types

	Site	Substrate	No. of points	Correlation coefficient	Significance of correlation (where $P \leq 0.10$)	Slope	Difference of slope from zero (where $P \leq 0.10$)
a) Birds which showed no decrease in overall prey capture rate:							
R O/O	Oct - Mar	CBs mud	7	0.469			
Y W/R	Oct - Mar	CBs mud	10	-0.044			
O W/O	Sep - Mar	SM _w liquid mud	5	-0.977	$P < 0.01$	-1.160	7.95 $P < 0.01$
L R/L	Oct - Mar	SM _w liquid mud	6	-0.667			
b) Birds which showed a decrease in overall prey capture rate:							
O W/O	Oct - Mar	SM _w soft mud	8	-0.690	$P < 0.10$	-0.737	2.33 $P < 0.10$
L R/L	Oct - Mar	SM _w soft mud	5	-0.825	$P < 0.10$	-0.951	2.53 $P < 0.10$
Y N/W	20.11.76 - 10.12.76	ECh mud	6	-0.458			
O W/O	Oct - Mar	SM _w tide edge	5	-0.617			
L R/L	Sep - Mar	SM _w tide edge	5	-0.588			

Key for sites as on Table 3.19.

Much of the information discussed below concerns extensive observations of a male (Y W/R) and a female (R O/O) Curlew feeding near each other on the southern part of Central Bank during the 1977/78 winter. Because there is a marked difference in bill length between the 2 birds (male 114 mm, female 156 mm), any differences between the foraging abilities of short- and long-billed Curlews should be revealed by this analysis.

i) The rate of capture of worms

As females have longer bills and can therefore reach worms deeper in the mud, it might be expected that they could catch worms at a higher rate than males (assuming they capture worms of similar sizes). However for much of the winter this is found not to be the case. On 6 days during the 1977/78 winter (late September to mid March) observations were made on both R O/O and Y W/R, thus avoiding differences in behaviour due to variations in environmental conditions. On 5 occasions the male had the highest capture rate (Table 4.20 and Fig. 4.35). Data on other marked Curlews feeding on the same area (Table 4.20) show that the shorter-billed birds did not capture worms at a slower rate than the long-billed individuals.

The exception to this general pattern occurred at low substrate temperatures. Data presented in Section 4. II. C. 2. showed that the female (R O/O), but not the male (Y W/R), increased its capture rate when the temperature fell (Fig. 4.35). As birds require more food at lower temperatures, it is therefore likely that the male would be the first to have difficulty meeting its energy requirements during cold weather.

ii) The sizes of worms captured

Large Nereis tend to burrow deeper in the mud than smaller individuals (e.g. Muus 1967, Ratcliffe 1979). Therefore the longer-billed females should be able to reach more large worms than the males, especially during the low

Table 4.20

The rates of worm capture of male and female marked Curlews observed feeding on Central Bank - south on the same days during the 1977/78 winter

	Time of observation (hours after High Water)	R O/O ♀(156)	B R/W ?(124)	Y W/R ♂(114)	G W/O ♂(115)	R O/G ♂(112)	R W/R ♂(112)
26.	9.77	1.36 (11)		2.00 (10)	2.20 (10)		
5.11.	7.77	1.20 (5)		2.00 (19)		2.00 (9)	
5.11.	7.77		1.10 (10)			2.20 (10)	
15.12.	7.77	1.89 (9)		1.88 (8)	2.50 (10)		
15.12.	7.77	1.45 (11)		1.80 (5)			
15.	1.78	1.61 (23)		1.00 (6)			1.80 (5)
12.	2.78	1.50 (14)		1.68 (19)	1.75 (8)		
12.	2.78	1.40 (5)		1.84 (19)	1.55 (11)		
4.	3.78.		1.00 (10)		2.20 (5)		
4.	3.78	1.50 (2)	0.60 (5)		1.50 (10)		0.40 (5)
11.	3.78	0.70 (20)		0.74 (19)		0.95 (21)	

The figures given are the number of worms captured per minute, with duration of observation (minutes) in parentheses.

The sex and bill length (mm) of each bird are given at the top of each column.

substrate temperatures of mid winter when larger Nereis burrow deeper (Muus 1967). This was found to be true. On all 6 days when both R O/O and Y W/R were observed, the diet of the female included a higher percentage of worms of ≥ 50 mm estimated length than did that of the male (Fig. 4.39). The male rarely took the largest worms (≥ 100 mm estimated length) whereas these constituted up to 57 per cent of the worms taken by the female. Other short-billed birds feeding on this mudflat similarly took few of the largest worms (Table 4.21).

The percentage of large worms (≥ 100 mm estimated length) in the diet of the female (R O/O) decreased both seasonally (reaching a minimum in mid winter (Fig. 4.39)) and with falling substrate temperatures (Fig. 4.36). Thus it appears that, on this part of Central Bank, many of the largest worms which can be reached by females in autumn and spring move out of reach during the colder weather of mid winter. Few of the largest worms are within reach of males even at high temperatures. Unlike the female, the male (Y W/R) did not show a decrease in size selectivity with falling substrate temperature (Fig. 4.36).

iii) The rate of biomass intake

The male Curlew Y W/R did not capture more worms or more large worms in very cold weather (Figs. 4.35 and 4.36), so it is likely that it was unable to increase its rate of biomass intake to match its increased energy requirements caused by greater heat loss (see Evans 1976). In contrast the female increased the rate at which it caught small worms (Fig. 4.36). So its rate of biomass intake may indeed have increased at low temperatures. (Prey other than Nereis were taken by these birds extremely rarely. Hydrobia was the only other prey seen to be taken, but the intake rate exceeded 0.5 per minute on only 2 occasions.)

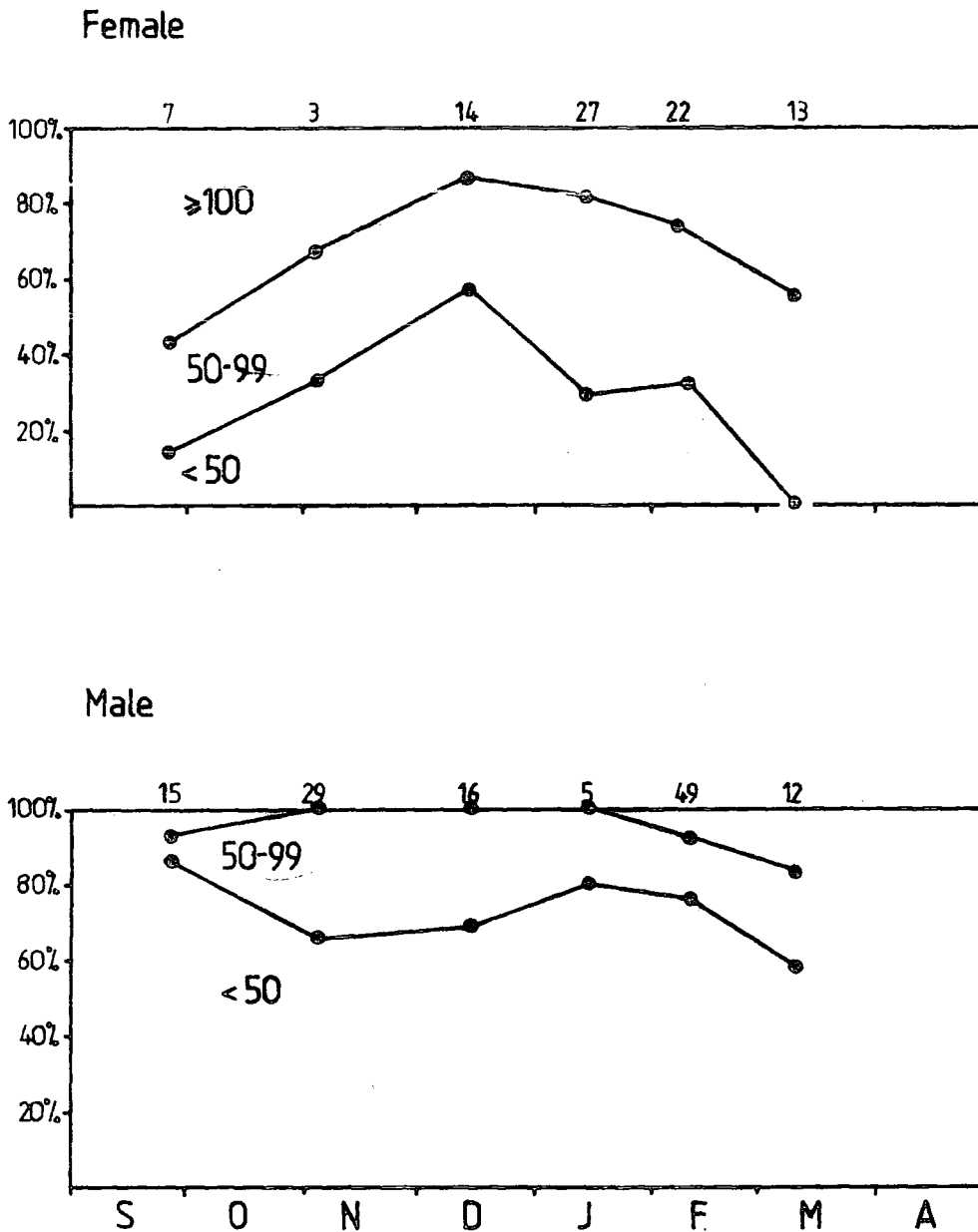

Figure 4. 39

A comparison of the sizes of worms taken by a marked female (R O/O) and a marked male (Y W/R) Curlew feeding on the same mudbank on the same days, during the 1977/78 winter. Worms (sample size shown above each observation day) divided into three classes: < 50 mm, 50 - 99 mm, > 100 mm estimated length.

Table 4.21

The sizes of worms taken by male and female marked Curlews observed feeding on Central Bank - south on the same days during the 1977/78 winter

	R O/O ♀(156)	B R/W ?(124)	Y W/R ♂(114)	G W/O ♂(115)	R O/G ♂(112)	R W/R ♂(112)
26. 9.77	1:2:4		13:1:1	16:4:1		
5.11.77	1:1:1	4:4:0	19:10:0		16:18:1	
15.12.77	8:4:2		11:5:0	0:1:0		
15. 1.78	8:14:5		4:1:0			1:3:0
12. 2.78	7:9:6		37:8:4	23:2:3		
4. 3.78	0:2:1	5:0:0		7:6:1		0:2:0
11. 3.78	0:7:6		7:3:2		5:12:0	
Totals	25:39:25	9:4:0	91:28:7	46:13:5	21:30:1	1:5:0

The figures given are the number of worms in each of 3 size categories (0 - 49 mm, 50 - 99 mm, \geq 100 mm) taken by the marked Curlews. Only whole worms of known length are included.

The sex and bill length (mm) of each bird are given at the top of each column.

Estimates of biomass intake were therefore made, using the information on Nereis worms captured, as follows:

- a) Worms captured whole during observations were separated into length classes as determined by comparison with the length of bill of each individual bird.
- b) The lengths of pieces of worms that were swallowed after being broken during extraction were estimated similarly.
- c) Worms extracted whole whose length could not be estimated were given a mean estimated length of 40 mm. It was usually possible to estimate the length of large worms. The mean estimated length used here is therefore the most frequently taken class of small (< 50 mm) worms.
- d) Each length estimate was converted to an estimate of dry weight using an empirical relationship between length and body weight derived by Ratcliffe (1979):

$$\log_{10} \text{ dry weight (mg)} = 3.072 \log_{10} \text{ head width (mm)} + 0.385$$

$$\text{where head width (mm)} = \frac{\text{body length (mm)} + 3.746}{30.292}$$

- e) The total estimated dry weight intake for each occasion was then calculated by multiplying the estimated dry weight for each size class of worm (including pieces and worms of unknown length) by the number in each class.
- f) A rate of dry weight intake was then calculated using the length of the observation period on each day.

This rate of dry weight intake is considered as an estimate of the true rate of biomass intake. (It must be stressed that a true biomass intake rate cannot be calculated from the data available.) Fig. 4.40 shows that the female

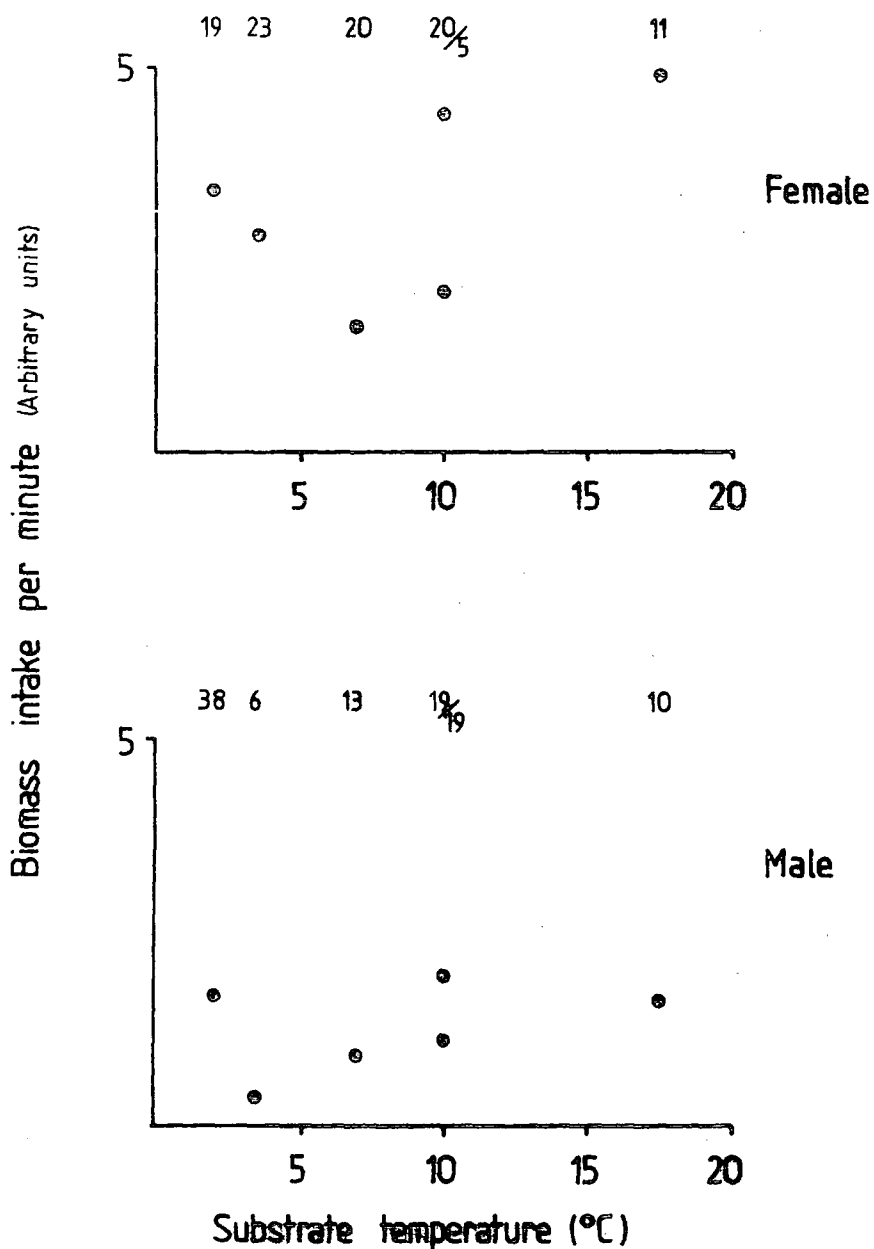

Figure 4.40

Estimated rates of biomass intake in relation to substrate temperature for a female (R O/O) and a male (Y W/R) Curlew which fed on the same mudbank during the 1977/78 winter. The biomass intake rates were measured for both birds on the same six days. The total length of observation (minutes) for each bird on each day is shown above each point.

had a considerably higher estimated biomass intake rate than the male on all 6 occasions. In both cases the rate of biomass intake was highest at high temperature but neither trend was significant at the 10 per cent level.

As male Curlews are smaller than females (Section 3. I. C. 1) they require less food per day. Standard metabolic rates for males and females were estimated using the equation for non-passerines in Lasiewski and Dawson (1967) (Table 4. 22). The ratio of male : female metabolic rates shows that males require about 12 per cent less food per day than females, a value resembling that calculated for the similarly sexually dimorphic Bar-tailed Godwit (Smith and Evans 1973).

The estimated biomass intake rate of the male Curlew on Central Bank was 33 - 55 per cent that of the female on 5 occasions, falling to 10 per cent in cold weather in January. This difference is considerably greater than expected on the basis of the size difference between males and females.

The estimates of intake assume that the male and female Curlews fed for the same period of time during the tidal cycle. In fact this was probably not so. Although the total time feeding was not measured on the observation days, the male bird roosted less often and for shorter periods than the female (Table 4. 23). It may therefore have fed for a greater percentage of the time available, thus reducing the difference between male and female estimated biomass intakes. Also it may have fed more at night. Nevertheless the difference between male and female values will probably still be greater than that based upon their size differences. The reason for this is not known, although the method of estimating biomass intake may have exaggerated the difference to some degree.

iv) The onset of territoriality in relation to biomass intake rate

During the 1977/78 winter, the minimum estimated biomass intake rate of the female (R O/O) occurred in December and that of the male (Y W/R) in

Table 4.22

The calculation of standard metabolic rates for
female and male Curlews

	Females	Males
Bill length (mm) of adults (see Section 3.I.C.1)	≥ 130	≤ 121
Mean body weight (Kg)	0.879	0.738
Standard error	0.016	0.010
Sample size	28	43
Difference between mean weights		16% lower
Standard metabolic rates (Kcal/24 hr)*	71.36	62.91
Difference between rates		12% lower

* Rates calculated using the equation for non-passerines
given in Lasiewski & Dawson (1967):

$$\log_{10} \text{ heat production (Kcal/24 hr) } =$$

$$\log_{10} 78.3 + 0.723 \log_{10} \text{ body weight (Kg) } + 0.068.$$

Table 4.23

The occurrence of roosting by the marked female (R O/O) and marked male (Y W/R) Curlews during the observation periods discussed in the text, and the duration of roost periods

	Female	Male
26. 9.77	+	
4.11.77	+	
5.11.77	+	+
20.11.77		
15.12.77	+	+
15. 1.78	+	
12. 2.78	+	+
11. 3.78	+	+

+ = day on which bird seen to roost during the period
3 - 8 hours after High Water.

	Female	Male
Duration of roosting periods (Minutes)	20	11
	5	6
	90	8
	30	1
	29	23

January (Fig. 4.41). In each case the minimum coincided with the first incidence of territorial behaviour that winter. Furthermore the male also defended a feeding site on Central Bank - south on one day in April and its biomass intake rate (calculated as above) was again extremely low (Fig. 4.41). These biomass intake rates refer only to periods of foraging, and exclude any time spent in other activities such as preening, looking out for predators or evicting other waders. The onset of territorial defence was therefore coincident, in each case, with increasing difficulty in capturing Nereis at an adequate rate.

As the estimated biomass intake rate of the male Curlew was extremely low on the 2 single days on which it defended a feeding site (one in cold weather in January and one in spring), such temporary exclusion may occur only when a bird is having extreme difficulty in capturing worms fast enough in the available time. It is interesting to note that temporary territories were defended only by males, and usually during periods of relative food shortage (Section 3. II. B.4). Presumably, when successful, the advantage of the increased percentage availability (see Section 3. II. D.1) outweighs the disadvantage of time spent defending the site, rather than feeding. As on both occasions the male Y W/R ceased defending the site later in the same tidal cycle, the change in behaviour did not increase its capture rate adequately. The high density of Curlews feeding nearby, and the resulting high rate of intrusions into the territory could have reduced feeding time for the male to an unacceptable level.

The female bird (R O/O) began excluding conspecifics from its feeding site in December, when the accessibility of Nereis was believed to be falling (see Section 3. II. D.3). It became territorial before its feeding rate fell to the very low level experienced by the male Y W/R. It may therefore have established an exclusive feeding site to avoid that possibility. This change in use of habitat in response to the general decrease in the accessibility of Nereis thus resembles

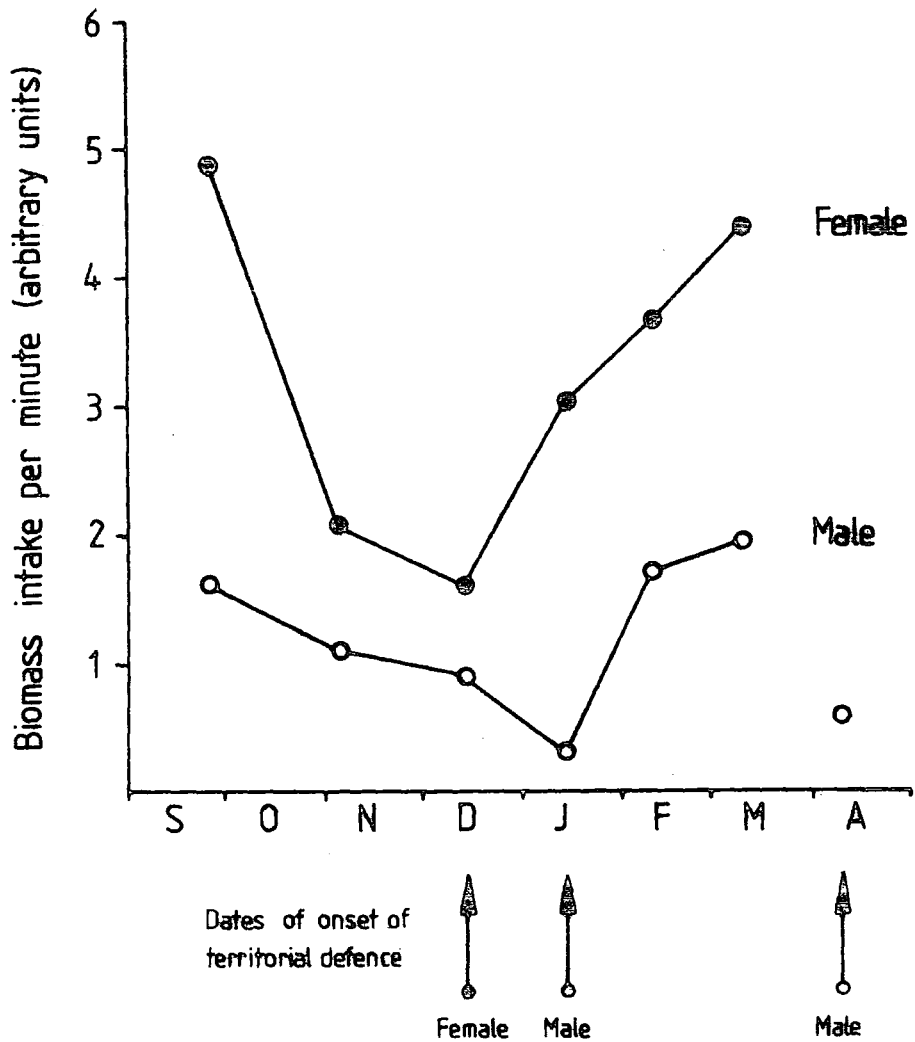

Figure 4.41

The onset of territoriality for a marked female (R O/O) and a marked male (Y W/R) Curlew in relation to their estimated rates of biomass intake. The Curlews fed on the same area of Central Bank - south during the 1977/78 winter.

the change shown by the female Curlew Y N/W which abandoned a Low Water feeding site (see Section 4. II. C. 2).

v) The use of the fields

In Section 3. II. C. it was shown that shorter-billed Curlews spent more time feeding on the fields surrounding Seal Sands at Low Water during the winter. The evidence presented above suggests that this use of habitat occurs because at least some males have difficulty meeting their energy requirements on Seal Sands during the coldest conditions of the winter. Feeding rates of male Curlews on Seal Sands support this thesis. The combined data on capture rates of all male Curlews observed feeding on the eastern half of Scalloped Mud are shown in Fig. 4.42. Although the capture rate of some males at low temperatures was similar to that of males in much warmer weather, others clearly experienced difficulty in capturing any worms during the coldest weather.

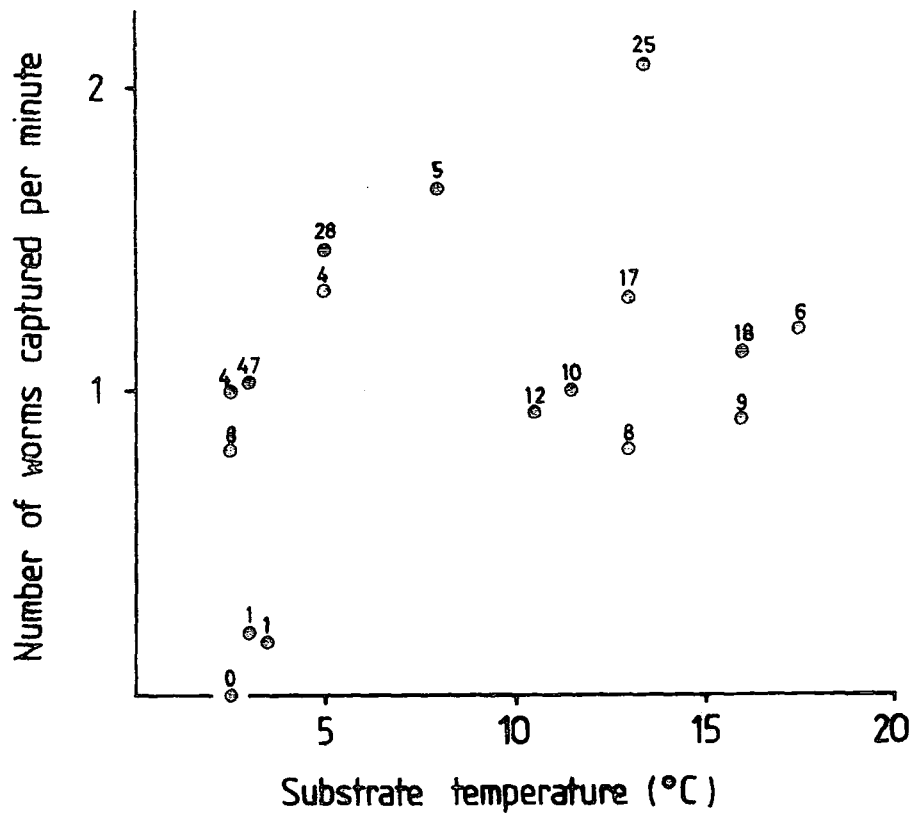

Figure 4.42

Capture rates of male Curlews feeding on Scalloped Mud - east in relation to substrate temperature. All measures of capture rate made during the 1977/78 winter are shown.

Key: the total number of worms taken by each individual is shown above each point.

4. II. D. SUMMARY AND DISCUSSION

The analysis of foraging behaviour presented above is based upon very small samples due to the limited data available. Consequently very low levels of significance were used in order to identify the trends in the parameters with changing conditions. The results can therefore be considered only as an indication of the responses of Grey Plovers and Curlews to changes in the availability of Nereis, and further work is required to substantiate the findings summarised below.

1. The observed foraging behaviour in relation to the proposed causal relationship between invertebrate behaviour and shorebird behaviour

The range of behaviours shown by foraging individuals of both species demonstrates that this relationship of changes in the activity and depth of Nereis causing changes in the foraging behaviour of Grey Plovers and Curlews (respectively) are too simple. Nevertheless it does provide a basis for interpreting the observed foraging behaviour.

During the periods of exposure of their feeding sites only 6 out of 22 (27 per cent) marked Grey Plovers and 3 out of 8 (38 per cent) marked Curlews experienced the expected fall in the overall prey capture rate as the mud dried out. Falls were more frequent amongst individuals that changed Low Water feeding site later in the tidal cycle (4 out of 9 Grey Plovers, 1 out of 1 Curlew) than those that remained in the same site throughout the period of exposure (2 out of 13 Grey Plovers, 2 out of 7 Curlews). Overall the majority of marked Grey Plovers and Curlews studied at least maintained their prey capture rate, even though the density of available worms appeared to limit their capture rate (see Tables 4.13 and 4.15) at least on firm substrates.

Two methods by which Grey Plovers and Curlews could avoid a fall in overall capture rate were investigated. A change from selection of large worms

to no size selection was shown by 4 out of 5 (80 per cent) Curlews but only 3 out of 8 (38 per cent) Grey Plovers for which data are available. (1 of the 5 Grey Plovers which showed a fall in overall capture rate also changed its size selectivity.) An increase in search effort was shown by 11 out of 13 (85 per cent) Grey Plovers and 3 out of 5 (60 per cent) Curlews that avoided a fall in overall capture rate. Amongst those that showed a fall in overall capture rate, 5 out of 5 (100 per cent) Grey Plovers and 2 out of 3 (67 per cent) Curlews also increased their search effort with time after exposure. Thus it appears that individuals of both species alter their foraging behaviour in an attempt to avoid a fall in the rate at which they capture worms. Most Grey Plovers usually do so by increasing their search effort, but Curlews do so particularly by a decrease in size selectivity as well as an increase in search effort. However it must be borne in mind that the data on search effort are more extensive. Further information on the sizes of worms taken may show changes in size selectivity to be important to a greater proportion of Grey Plovers.

During a winter a higher proportion of the marked individuals of both species experienced the expected seasonal fall in overall prey capture rate (4 out of 4 (100 per cent) Grey Plovers (including one bird in 3 winters) and 5 out of 9 (56 per cent) Curlews). Amongst the Curlews falls were observed on some but not all areas of mud, but not on liquid mud. Only one marked bird (a Curlew) decreased its size selectivity at low temperatures; it thereby avoided a fall in overall capture rate. Three out of 4 (75 per cent) Grey Plovers and 5 out of 9 (56 per cent) Curlews increased their search effort at low temperatures. By this means the 2 Curlews feeding on liquid mud avoided a fall in overall capture rate. The other Curlews and the Grey Plovers failed to avoid this fall despite their increased search effort.

2. The timing of changes in Low Water feeding site

During the Low Water period some Grey Plovers and Curlews changed feeding site. In at least some cases (4 out of 9 Grey Plovers, 1 out of 1 Curlew) the change coincided with a fall in the rate at which worms were caught. It has been assumed that a bird changes feeding site immediately the number of worms caught per minute falls below a threshold rate, but an alternative possibility exists. A bird might integrate its capture rate over a certain time period, e.g. the past hour, and move when the integrated value falls below the threshold. Therefore when it leaves, its instantaneous prey capture rate will be below the threshold level. If all individuals integrate over the same time period, regardless of the rate of decrease in their capture rate, the capture rate at the point of leaving of birds with a rapidly decreasing capture rate (Fig. 4.43, A) will be lower than that of birds with a slowly decreasing rate (Fig. 4.43, B). This integration might involve the rate of biomass intake rather than the rate of capture of prey items. It is not known what form of integration, if any, is employed by foraging shorebirds.

The method by which Grey Plovers and Curlews determine the moment at which they should abandon a Low Water feeding site does not affect the results presented above. My results are concerned only with changes in the foraging parameters, and not with actual capture rates. If integration occurred, the time period involved would markedly affect predictions of the actual capture rates or biomass intake rates at which birds should change site.

3. Curlew sexual dimorphism in relation to field feeding

Although males and females are distributed differently between the mudflats and the fields, it seems unlikely that the sexual dimorphism in Curlews has evolved to reduce intraspecific competition for food, as has been suggested for

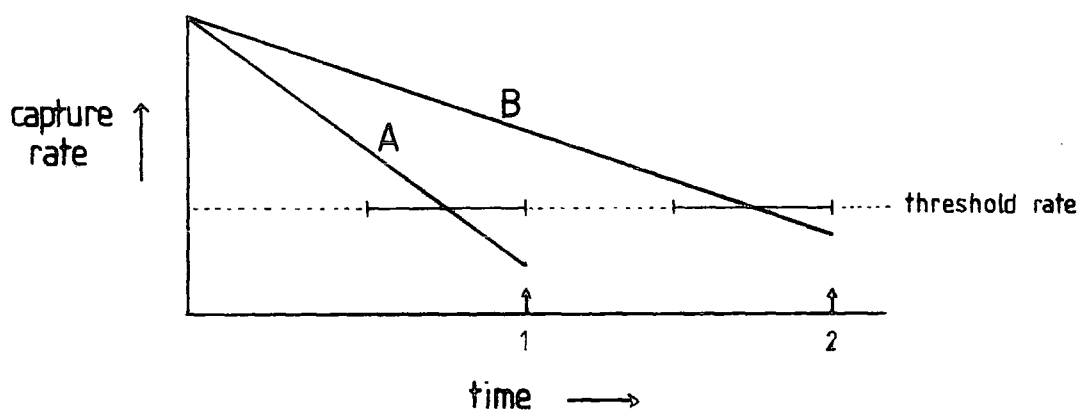

┌──────────┐ period of integration
 1 point of leaving of bird A
 2 " " " B

Figure 4.43

A model for integration of capture rate in which each individual bird integrates over the same time period. Bird A has a more rapidly decreasing capture rate, so at the point of leaving it will have a lower capture rate than bird B.

raptors (Reynolds 1972, Newton 1979), woodpeckers (Selander 1966, Hogstad 1978) and finches (Newton 1967), during the non-breeding season. The data on foraging indicate that the male Curlews moving to the fields do so because they are having difficulty capturing Nereis fast enough on the mudflats in cold weather, i. e. they are forced to move. Other males feed on the mudflats all winter. If the dimorphism in bill length gave the males an advantage on fields (with the shorter, straighter male bill perhaps better for probing into firm substrates (see Section 4. I. C. 3)) and females the advantage on mudflats (with the longer bill being more adept at capturing worms deep in soft sediment) all males should feed on the fields throughout their stay on the estuary, rather than just some doing so and only when conditions deteriorate on the mudflats.

4. Other factors influencing shorebird foraging behaviour

In addition to the changes in size selection and search effort shown by Curlews and Grey Plovers, other factors may conspire to cause the observed foraging behaviour to be more complex than that predicted by the hypotheses concerning Nereis activity and depth distribution. Three possibilities are listed below:

- a) Variations in substrate may occur on a much finer scale than discussed so far, e. g. within territories.
- b) Variations in prey density also occur on a fine-grained scale, resulting from variations in substrate, differential settlement of Nereis, and/or differential predation.
- c) Individual variation in foraging ability undoubtedly occurs within each species.

SECTION 5

GENERAL DISCUSSION

In this section I shall discuss, in a wider context, some of the main points arising from my study. I shall, however, confine the discussion of feeding behaviour to studies on birds, since their mobility enables them to respond rapidly and frequently to changes in environmental conditions such as weather, and in prey availability and prey dispersion (a feature not shared by other groups of animals, with the exception of some mammals).

5. A. INTER-INDIVIDUAL VARIABILITY AND ITS CONSEQUENCES FOR WINTER FEEDING BY BIRDS

5. A. 1. Variability in winter feeding behaviour between individuals

My observations of individually-marked Grey Plovers and Curlews revealed, within each species, a high degree of variability between individuals in several aspects of feeding behaviour. This was apparent not only in their use of habitat, e. g. choice of a particular mudflat, defence of a feeding site, or use of the fields, but also in their foraging behaviour, e. g. their responses to changes in prey availability. (Published examples of individual differences in aspects of feeding behaviour in other species of birds were given in the Introduction to this thesis - Section 1. A).

Because of this variability between individuals it is difficult to determine a general pattern of use of the wintering area by the Grey Plover (and the Curlew) population as a whole. Furthermore this variability raises doubts about the *interpretation* of the data on use of habitat obtained from studies of bird populations that have been based upon the concept of the "average bird" (e. g. Goss-Custard (1969), Heppleston (1971), Feare et al. (1974), Bryant and Leng (1975), Smith (1975),

Goss-Custard et al. (1977), Green (1978), Knights (1979), Pienkowski (1980a), Zwarts (in press). It is clear from my studies that the assumption that all individuals show similar behaviour is incorrect. Indeed the differences in feeding behaviour between individuals within a species have important consequences for the interpretation of data on feeding behaviour (see Section 5. A. 4. below).

5. A. 2. Consistency between years for individual birds

In marked contrast to this variation between individuals, there was remarkable consistency between years in much of the behaviour shown by each individual Grey Plover and Curlew. This consistency was evident in fidelity to the estuary, arrival and departure dates, choice of Low Water feeding site, occurrence of territorial behaviour, and in some cases in their response to changes in environmental conditions. It appears, therefore, that a predictive understanding of the population as a whole could be achieved despite the high degree of variability between individuals, but only if the pattern of use of habitat is determined for the majority of individuals present.

5. A. 3. Polymorphisms in winter feeding behaviour

As a consequence of individual birds showing different feeding behaviour but each individual being consistent between years, there is a regular polymorphism in use of habitat within both the Grey Plover and Curlew populations on the Tees estuary. At any one time some Grey Plovers defend feeding sites, whereas others feed in a loose flock; some male Curlews forage on the mudflats and others on the fields. Some Grey Plovers spend the whole non-breeding season on the Tees estuary, others only a few weeks.

This polymorphism in use of space is reminiscent of the phenomenon of partial migration (Lack, 1943-44) in which only some of the individuals within a breeding population emigrate, usually to a milder climate, for the winter. If one

behaviour, e.g. emigration, or territoriality, were always at a selective advantage such polymorphisms should not persist. However they can be maintained if the balance between selection pressures on the different behaviours varies with changing environmental conditions. For example, amongst populations showing partial migration, the advantage in mild winters lies with the resident individuals whereas in severe winters they will suffer higher mortality than the migratory birds. In a similar way, occasional severe winters interspersed amongst mild winters could maintain the polymorphism in use of space amongst Grey Plovers and Curlews on Seal Sands. Field feeding in Curlews would be selected against in severe winters when the ground would often be frozen, but favoured in mild winters because the fields would frequently be waterlogged forcing earthworms to the surface. Grey Plovers with long-term territories, perhaps at a disadvantage in mild winters due to the time and energy used in defence, might be more likely to survive severe winters because of their safeguarded stocks of food and resulting higher-than-average density of available prey.

In general the use of habitat by wintering birds has been little studied at the individual level. As the two comparable studies, on Sanderlings (Myers et al. 1979b) and on Pied Wagtails (Davies 1976), revealed variability between individuals similar to that in this study, polymorphisms in use of habitat may, in fact, be widespread within populations of birds in the non-breeding season.

5.A.4. Implications of inter-individual variability for studies of winter feeding behaviour

Intraspecific competition is strongest when all members of the population are competing for identical resources. The considerable inter-individual variability found within both the Grey Plover and the Curlew populations (and also in the Pied Wagtail population studied by Davies (1976) should therefore reduce competition between conspecifics for space in which to feed. For example,

juvenile Grey Plovers on Seal Sands feed particularly on softer sediments. As discussed in more detail below, this may be by choice, thereby reducing competition with the adults feeding on firmer substrates; alternatively the juveniles may be forced to feed there. Some male Curlews move to the fields to feed in mid winter, when feeding conditions on the mudflats are believed to be at their worst. Competition with other males (and also with the longer-billed females) on the mudflats is thus reduced. In autumn the males which will later move to the fields feed on the mudflats in areas which may be sub-optimal for Curlews (as they are abandoned in mid winter) - they may thus avoid competition with other Curlews even in autumn (see Section 3.E.D.4). Thus some intra-specific partitioning of resources may occur as a consequence of variability in use of space between individuals.

Variability between conspecific individuals also has important implications for investigations into interspecific competition for food resources and feeding space. The range of behaviours found within two species feeding on the same prey in the same area, e. g. Grey Plovers and Curlews on Seal Sands, makes it very difficult to determine the degree of overlap between the species. Simple partitioning of feeding space between Grey Plovers and Curlews on Seal Sands cannot occur due to the complexity of the patterns of use of space. It is likely that this applies more generally to bird populations in a variety of habitats, and this is an area of research that warrants increased emphasis.

5. A. 5. Sex- and Age-related differences in use of space

Inter-individual variation in feeding behaviour under a given set of environmental conditions can be a consequence of differences in age or sex. Examples of such age- or sex-related differences between individuals in other species of birds were listed in Section 1. A. In my study, variations in feeding behaviour were correlated with both age and sex differences.

The difference in choice of feeding habitat and rate of foraging in cold weather between male and female Curlews was clearly related to the difference in bill length between the sexes. Comparable sex-related differences correlated with sexual dimorphism in bill length have been shown in choice of feeding location and prey size selection by Bar-tailed Godwits (Smith and Evans 1973, Smith 1975) and choice of feeding location in, for example, woodpeckers (Hogstad 1976).

Age-related differences in feeding behaviour, in contrast, cannot be correlated with a simple morphological difference. Instead the tendency of juvenile Grey Plovers to feed away from the areas favoured by adults, and the lower frequency of territorial behaviour amongst juveniles than adults must be a consequence of differences in foraging ability between the age classes. A comparable difference in use of space has been described by Panov (1963), who noted that amongst migrating Grey Plovers on the Pacific coast of the Soviet Union adults, but never juveniles, defended feeding sites in autumn. The age-related difference in use of space seen on Seal Sands could be due to intra-specific competition, the adults excluding juveniles from the favoured areas. Dominance of adults over juveniles in aggressive interactions has been noted in Turnstones (Groves 1978), but the reverse was observed in Semipalmated Sandpipers, Calidris pusilla (Harrington and Groves 1977). Also adult Grey Herons were more successful than immatures in territorial conflicts (Cook 1978b).

Alternatively the juveniles may choose to feed in flocks in the areas less favoured by adults. On arrival on Seal Sands in autumn the juveniles will have fed on intertidal mudflats for only a few weeks in all and will therefore be inexperienced at capturing (intertidal) prey, as found for juveniles of other bird species, e.g. Turnstones (Groves 1978), Little Blue Herons (Recher and Recher 1969a), Brown Pelicans (Orians 1969), and Sandwich Terns (Dunn 1972). Consequently, to meet their energy requirements, the juvenile Grey Plovers will probably have to

forage for a greater part of the available feeding time than do adults, as found for juvenile Royal Terns (Buckley and Buckley 1974), Grey Herons (Cook 1978a) and Olivaceous Cormorants (Morrison et al. 1978) (but, on limited evidence, not for Turnstones (Groves 1978) or Sandwich Terns (Dunn 1972)). They may therefore be less able to afford the time and energy required to establish an exclusive feeding site.

By feeding in a flock instead, the juveniles will be able to overcome the disadvantage of not knowing the types of substrate associated with high prey availability or the directions from which predators are most likely to attack. Flocking should increase their chance of finding good feeding sites (Murton et al. 1971, Ward and Zahavi 1973). It may also result in earlier detection of predators (Powell 1974), thereby enabling them to forage faster (Silliman et al. 1977) and spend a greater proportion of the available time foraging (Powell 1974). However these latter effects may be of lesser importance on the Tees estuary due to the scarcity of avian predators (see Section 3. II. D. 1).

In contrast to the juveniles, the adult Grey Plovers will be experienced feeders and, as they show high fidelity to feeding sites on Seal Sands between years, they will have some knowledge of the variation in prey availability within their feeding sites. They can therefore spare the time required to acquire, or regain, and defend a feeding site. For adults, the long-term advantages of territoriality, e.g. preservation of food stocks, will outweigh the initial costs. For juveniles the initial costs are too great.

Further data are required to tell whether the age-related differences in use of space by Grey Plovers are due to intraspecific competition or to intraspecific differences in choice of feeding sites.

It is known that mortality amongst shorebirds decreases after the first year of life (Boyd 1962, Hildén 1978, Pienkowski 1980a, this study). From the

arguments presented above, the higher mortality of juvenile Grey Plovers could be a result of either

- a) competition for food or feeding sites between adults and juveniles, with the adults preventing some juveniles from obtaining enough food, or,
- b) the inability of juveniles to capture prey at an adequate rate.

Recher and Recher (1969a) believed that, in Little Blue Herons, the higher mortality amongst juveniles was simply due to their inefficiency at prey capture. In my study it was not possible to distinguish between the two causes.

5. B. WINTER TERRITORIALITY

5. B. 1. The role of winter territoriality in regulation of density

In Section 3. II. D. I discussed the possible costs and benefits involved in territoriality, arguing that winter feeding sites were defended only where the benefits outweighed the costs. I then showed how territoriality had a less depressive effect than flock feeding on prey availability on a site, and provided evidence that individual Grey Plovers and individual Curlews defend winter feeding sites to ensure an adequate prey capture rate. I concluded that a bird shows territorial behaviour only when it is of advantage to that individual.

However, although selected for at the individual level, territoriality can have consequences at the level of the population. By preventing other Grey Plovers (or Curlews) from settling in an area, territorial behaviour could play a role in regulation of density during the winter, analogous to the limiting effect of territories upon the breeding densities of many birds, e. g. Red Grouse, Lagopus L. scoticus (Watson 1967), Tawny Owls, Strix aluco (Southern 1970), Great Tits (Krebs 1971). Alternatively territorial behaviour might be a method of density assessment, resulting in the spacing out of individuals but imposing no limits on the density (Fretwell 1972, Davies 1978).

To my knowledge no discussion of the role of winter territoriality in regulation of density on areas away from the breeding grounds has yet been published. Comparisons are therefore not possible and I shall simply interpret my information on territorial behaviour in the context of the population changes on Seal Sands.

Grey Plovers - On Seal Sands the occurrence of territorial behaviour amongst Grey Plovers varied between mudflats, being most frequent on the northern parts of Eastern Channel and Central Bank (Section 3. II. A. 3). These were the first areas to be filled to a ceiling in autumn and then held a more or less constant population of Grey Plovers through the winter (Section 2. B. 2. b). They were therefore considered to be the optimal feeding areas for Grey Plovers on Seal Sands. As all the Grey Plovers resident in these areas were territorial, and intruding Grey Plovers were repeatedly driven out throughout the winter, territorial behaviour must have limited to some extent the number of Grey Plovers settling on these areas. It was not simply a method of density assessment leading to spacing out of the individuals.

However, on several areas of Seal Sands, e.g. Greenabella Bank, territoriality amongst Grey Plovers was almost or completely absent. Individuals which did not have a territory on the presumed optimal feeding areas could therefore have fed elsewhere within Seal Sands throughout the winter. Consequently territorial behaviour cannot in itself limit the population on Seal Sands as a whole. This contrasts with the effect of territoriality upon the breeding densities of Red Grouse, Tawny Owls and Great Tits where only those individuals with territories could attempt to obtain a mate and breed (Watson 1967, Southern 1970, Krebs 1971). On Seal Sands population density could be limited if, in addition to territorial behaviour on some areas, there was some mechanism of population regulation on non-territorial areas. The plateaux in the counts for Scalloped Mud

and western parts of Central Bank during population peaks on Seal Sands indicate that this might have occurred. Although there is at present no evidence of a behavioural mechanism for density regulation on non-territorial areas, a dominance hierarchy, in which the lowest individuals were unable to feed sufficiently quickly on that area, and therefore left, could limit the density.

As winter progressed the number of areas on which Grey Plovers defended feeding sites increased. This was due at least in part to new arrivals taking up territories. The number of possible territories could limit the number of Grey Plovers that can subsequently settle in an area, except if the territories are swamped by flocks of non-territorial individuals as observed in the Sanderling (Myers et al. 1979b). Thus the influence of territorial behaviour upon the population size on Seal Sands probably increased during a winter. However, as some earlier arrivals remained non-territorial throughout the winter despite there being areas apparently unoccupied and available for defence in early winter, the interrelationship between territorial behaviour and the numbers of birds that could be accommodated must be complex, and the relative advantages of territorial and non-territorial behaviour well balanced.

Curlews - Curlews on Seal Sands differed from the Grey Plovers in that a smaller proportion of the population was territorial and these birds defended sites on fewer areas of Seal Sands (Section 3. II. B. 3). Territories were taken up on some areas very early in the autumn, and intruding Curlews were subsequently evicted, so on these areas territorial behaviour probably limited the number of birds settling there. However, on most areas at least the majority of Curlews were non-territorial. If the overall population density on Seal Sands was limited by behavioural interactions, the behavioural mechanism operating on non-territorial areas (for which my observations provide no evidence) would be of considerably more importance than territoriality.

5.B.2. The absence of territoriality at high food availability

Throughout my discussions of territorial behaviour I have stressed that feeding sites were defended only when this was necessary to maintain an adequate prey capture rate on that site. It follows, therefore, that there should be no territoriality on areas of high prey availability, simply because the birds could meet their energy requirements there without it. This was also the interpretation adopted by Carpenter and MacMillen (1976) for the absence of defence amongst Hawaiian Honeycreepers, Vestiaria coccinea, when food was superabundant.

However Gill and Wolf (1975) argue from their observations on another nectarivorous species, the Golden-winged Sunbird, Nectarinia reichenowi, that at high nectar levels the costs of defence, due to high intruder pressure, exceed the energetic benefits. The importance of defence costs in determining whether a bird can successfully occupy a territory is also stressed by Myers et al. (1979b) for Sanderling.

From the data available I am unable to tell why Grey Plovers and Curlews on Seal Sands did not defend territories on areas of high prey availability.

5.C. INTERSPECIFIC COMPETITION

In an intertidal habitat many species of shorebird feed together, often eating the same prey. Lack (1944, 1945) predicted that there should be slight differences in ecology between coexisting species which prevent interspecific competition for resources. He argued that these differences are the result of interspecific competition that occurred in the past. However Zwarts (in press) has shown that competition between some species is still occurring and that this can determine the present habitat selection shown by shorebird species feeding on intertidal mudflats. On winter feeding grounds, interspecific competition might

be over food or space in which to feed. The Grey Plovers, Curlews and Bar-tailed Godwits on Seal Sands all fed mainly on the same prey species and the first two species showed a similar range of patterns of use of space. In this section I shall discuss whether these overlaps resulted in any interspecific competition, comparing my findings with those of Zwarts.

5.C.1. Competition for food

In the areas of Seal Sands where both Grey Plovers and Curlews fed, competition for food might have occurred. Although Grey Plovers were feeding on a different section of the Nereis population than the Curlews, because of their different methods of prey capture (3.II.D.2), the two species were removing prey from the same stocks. Even if, at any one time, only a proportion of the stocks were available, some reduction in the density of worms available to each species must have occurred.

Direct competition could be avoided if each species fed upon a different size class of prey. On Seal Sands, although Grey Plovers tended to capture fewer very large worms and more smaller ones than Curlews, there was much overlap in the sizes taken. So interspecific competition for food could occur. Zwarts (in press) similarly found that most species took Nereis of about the same size.

Even if the Grey Plovers on Seal Sands ate only the smaller size classes of Nereis and Curlews only the large ones, they would still be competing, indirectly, for food. The density of large Nereis (> 1 year old) in one winter would be determined by predation on the small Nereis (< 1 year old) by Grey Plovers (and other species such as Dunlin and Redshank) in the previous winter (Evans et al. 1979).

5.C.2. Competition for space

It was shown in Section 3.I.E. that some segregation of feeding areas occurred between Grey Plovers and Curlews on Seal Sands, with Grey Plovers

apparently avoiding areas with a high density of shorebirds. Grey Plovers also changed feeding area to avoid flocks of gulls and of Golden Plovers. Similar segregation between bird species on intertidal mudflats has been demonstrated by Zwarts (1974 and in press). It appears that the distribution of Grey Plovers is determined in part by their inability to compete for food when other birds are present at high density. This is believed to be a consequence of their method of prey capture (Pienkowski 1980a) which is most successful on mudflats with a low density of birds.

One method by which a bird can acquire space in which to feed is to defend a feeding site, and exclude from it all competing birds. As well as excluding conspecifics, territorial Grey Plovers on Seal Sands also evicted Golden Plovers and Ringed Plovers, both of which compete with Grey Plovers for those Nereis present at the surface of the mud. In contrast, territorial Grey Plovers did not evict Curlews or Bar-tailed Godwits even though they were eating Nereis and disturbing the prey. This contrasts with the behaviour of Reed Warblers, Acrocephalus scirpaceus, which defend bushes against any species of small bird as these would disturb its prey (Davies and Green 1976). Perhaps Curlews and Godwits are too large to be evicted by Grey Plovers; alternatively the resulting benefit may not outweigh the cost incurred. Territorial Curlews did not spend time and energy evicting Bar-tailed or Black-tailed Godwits, or Grey Plovers from their feeding sites even though all three species consume the same prey and all are smaller than Curlews (and can be displaced in aggressive interactions, e.g. Smith 1975). This suggests that the cost-benefit equation is the factor determining whether territoriality occurs amongst shorebirds as well as within a species. Interspecific territoriality on Seal Sands therefore occurs only between species which have similar ways of exploiting their food resources (as predicted by Orians and Willson 1964) and whose prey is available only at low density, i. e. the plovers.

Grey Plovers "deliberately" reduced the likelihood of intrusions from Curlews and Godwits by defending sites only on areas away from the mudflats favoured by most waders at Low Water (Section 3. II. D. 1). In addition, on some mudflats Grey Plovers and Curlews held overlapping territories, thereby gaining from each other's exclusion of conspecifics. Thus the absence of inter-specific competition for space between individual territorial Grey Plovers and Curlews reduces overall interspecific competition for space and/or food on that area.

5. D. FUTURE RESEARCH INTO USE OF SPACE BY GREY PLOVERS AND CURLEWS

In this section I shall outline some of the topics that could usefully be investigated in future research into the use of space by Grey Plovers and Curlews on Seal Sands. I shall concentrate upon Grey Plover behaviour as this shows the more marked polymorphism. The suggestions for future research assume that a greater proportion of the population, particularly amongst immature birds, can be individually marked.

I have suggested above that the polymorphisms in winter use of space could be maintained by differential selection in mild and severe winters. This could be investigated using long-term information on the survival rates of individuals following each strategy.

One of the main variables in the polymorphisms is whether or not a feeding site is defended. Permanent defence of a site can provide certain advantages in the long term, i. e. during a complete winter: preservation of food stocks and of the microdistribution of the prey, and the ability to predict prey availability in different parts of the territory. These advantages require that no other conspecifics feed in the site. I have shown that, in both Grey Plovers and Curlews, this occurs during the daylight hours. However both species feed at night to a greater or

lesser degree (Pienkowski 1973, Knights 1979, Dugan 1981) so territorial individuals should also defend their feeding sites at night. No information on night feeding could be collected from marked birds during my study.

I have argued that Grey Plovers reduce the effects of other species of wader upon prey availability and searching efficiency partly by defending sites in areas where individuals of other species are also territorial. This possible effect could be tested by measuring the predator pressure on two similar areas of mudflat, one with and one without Curlew territories.

My observations on Grey Plovers indicated that there may be differences in use of space between the age classes. More data are required to substantiate this. If the differences are real they could be due either to differential mortality of juveniles showing different patterns of use of space and/or to individual birds changing their use of space within and between winters. This could be investigated using the histories of marked Grey Plovers.

In November - December many adult Grey Plovers arrive on Seal Sands and many juveniles leave. It is not known whether they choose to leave or are displaced from the better feeding areas by the adults. Also it is not clear whether these juveniles move to poorer areas within Seal Sands or leave the estuary completely. If both strategies are followed the survival rates may differ. Some of these problems could be solved by detailed observations of marked juveniles and of their interactions with other Grey Plovers. Such observations might reveal how territorial behaviour develops in juvenile birds.

In addition to the role of territoriality in regulation of density, I suggested that some form of behaviour leading to regulation, possibly a dominance hierarchy, might occur on non-territorial areas. This possibility could be investigated particularly in relation to the regulation of numbers on Seal Sands as a whole.

The two most interesting areas of research specific to Curlew use of space are a) the difference between males and females, and b) the use of the fields as an alternative feeding habitat. Further studies on the foraging rates and total time spent feeding of male and female Curlews in a variety of environmental conditions are required to substantiate the sex-related differences in foraging revealed by my study. Measures should be made at night as well as by day as night feeding may be a method by which males increase their energy intake per twenty-four hours. Before comparisons of the relative advantages of feeding in the two habitats, fields and mudflats, can be made, the extent of night feeding in each must be identified.

Due to the biases in the age composition of birds caught for ringing, we have little information on a) the differences between adults and juveniles in use of space, and b) the amount of turnover in the Curlew population during a winter. Further ringing throughout the winter would help to fill these gaps in our knowledge.

REFERENCES

- Bailey, N. T. J. 1959. *Statistical Methods in Biology*. English Universities Press, London.
- Bainbridge, I. P. and Minton, C. D. T. 1978. The migration and mortality of the Curlew in Britain and Ireland. *Bird Study* 25: 39-50.
- Bainbridge, I. P. and Minton, C. D. T. in prep. Sexual dimorphism, sex ratios and moult of the Curlew.
- Bannerman, D. A. 1961. *The Birds of the British Isles*, Vol. IX. Oliver and Boyd, Edinburgh.
- Boere, G. C. 1976. The significance of the Dutch Waddensee in the annual life cycle of arctic, subarctic and boreal waders. Part 1. The function as a moulting area. *Ardea* 64: 210-291.
- Boyd, H. 1962. Mortality and fertility of European Charadrii. *Ibis* 104: 368-387.
- Branson, N. J. B. A. and Minton, C. D. T. 1976. Moults, measurements and migrations of the Grey Plover. *Bird Study* 23: 257-266.
- Brown, J. L. 1964. The evolution of diversity in avian territorial systems. *Wilson Bull.* 76: 160-169.
- Bryant, D. M. and Leng, J. 1975. Feeding distribution and behaviour of Shelduck in relation to food supply. *Wildfowl* 26: 20-30.
- Buckley, F. G. and Buckley, P. A. 1974. Comparative feeding ecology of wintering adult and juvenile Royal Terns (Aves: Laridae, Sterninae). *Ecology* 55: 1053-1063.
- Burger, J., Hahn, D. C. and Chase, J. 1979. Aggressive interactions in mixed-species flocks of migrating shorebirds. *Anim. Behav.* 27: 459-469.
- Busche, G. in prep. In Vogelbestände des Wattenmeeres von Schleswig-Holstein.

- Carpenter, F. L. and MacMillen, R. E. 1976. Threshold model of feeding territoriality and test with a Hawaiian Honeycreeper. *Science* 194: 639-642.
- Conder, P. J. 1949. Individual distance. *Ibis* 91: 649-655.
- Cook, D. C. 1978a. Foraging behaviour and food of Grey Herons, Ardea cinerea, on the Ythan estuary. *Bird Study* 25: 17-22.
- Cook, D. C. 1978b. Grey Herons, Ardea cinerea, holding feeding territories on the Ythan estuary. *Bird Study* 25: 11-16.
- Coulson, J. C. and White, E. 1959. The post-fledging mortality of the Kittiwake. *Bird Study* 6: 97-102.
- Davidson, N. C. 1980. Seal Sands Feasibility Study: An investigation into the possibility of developing alternative areas in compensation for the eventual loss of the remaining areas of Seal Sands, Teesmouth. Unpublished report to Cleveland County Council and the Nature Conservancy Council.
- Davies, N. B. 1976. Food, flocking and territorial behaviour of the pied wagtail, Motacilla alba yarrellii in winter. *J. Anim. Ecol.* 45: 235-253.
- Davies, N. B. 1978. Ecological questions about territorial behaviour. pp. 317-350 in Krebs, J. R. and Davies, N. B. (Eds.) *Behavioural Ecology: an evolutionary approach*. Blackwell Scientific Publications, Oxford.
- Davies, N. B. and Green, R. E. 1976. The development and ecological significance of feeding techniques in the reed warbler (Acrocephalus scirpaceus). *Anim. Behav.* 24: 213-229.
- Davis, J. W. F. 1975. Specialization in feeding location by Herring Gulls. *J. Anim. Ecol.* 44: 795-804.
- Dick, W. J. A. (Ed.) 1975. *Oxford and Cambridge Mauritanian Expedition 1973 Report*. Cambridge.

- Dugan, P.J. 1981. The importance of nocturnal foraging in shorebirds: a consequence of increased invertebrate prey activity. In Jones, N. V. and Wolff, W. J. (Eds.) *Feeding and Survival Strategies of Estuarine Organisms*. Plenum Publishing Co. Ltd., London.
- Dugan, P. J., Evans, P. R., Goodyer, L. R., and Davidson, N. C. 1981. Winter fat reserves in shorebirds: disturbance of regulated levels by severe weather conditions. *Ibis* 123: in press.
- Dunn, E. K. 1972. Effect of age on fishing ability of Sandwich Terns, *Sterna sand-*
vicensis. *Ibis* 114: 360-366.
- Earhart, C. M. and Johnson, N. K. 1970. Size dimorphism and food habits of North American owls. *Condor* 72: 251-264.
- Edwards, C. A. and Lofty, J. R. 1977. *Biology of Earthworms*. 2nd Ed. Chapman and Hall, London.
- Elphick, D. 1979. An inland flock of Curlews *Numenius arquata* in mid-Cheshire, England. *Wader Study Group Bull.* 26: 31-35.
- Ens, B. 1979. Territoriality in Curlews *Numenius arquata*. *Wader Study Group Bull.* 26: 28-29.
- Evans, A. C. and Guild, W. J. 1947. Studies on the relationships between earthworms and soil fertility. I. Biological studies in the field. *Ann. appl. Biol.* 34: 307-330.
- Evans, P. R. 1964. Wader measurements and wader migration. *Bird Study* 11: 23-38.
- Evans, P. R. 1966. Wader migration in north-east England. *Trans. nat. Hist. Soc. Northumb.* 16: 126-151.
- Evans, P. R. 1976. Energy balance and optimal foraging strategies in shorebirds: some implications for their distributions and movements in the non-breeding season. *Ardea* 64 : 117-139.

- Evans, P.R. 1979. Adaptations shown by foraging shorebirds to cyclical variations in the activity and availability of their intertidal invertebrate prey. pp. 357-366 in Naylor, E. and Hartnoll, R.G. (Eds.) *Cyclic Phenomena in Marine Plants and Animals*. Pergamon Press, Oxford.
- Evans, P.R. 1980. Reclamation of intertidal land: some effects on Shelduck and wader populations in the Tees estuary. *Proc. Int. Waterfowl Res. Bureau Symp. on Feeding Ecology*, Gwatt, Switzerland, September 1977. *Verh. orn. Ges. Bayern* 23: in press.
- Evans, P.R., Herdson, D.M., Knights, P.J. and Pienkowski, M.W. 1979. Short-term effects of reclamation of part of Seal Sands, Teesmouth, on wintering waders and Shelduck. I. Shorebird diets, invertebrate densities, and the impact of predation on the invertebrates. *Oecologia* 41: 183-206.
- Evans, P.R. and Smith, P.C. 1975. Studies of shorebirds at Lindisfarne, Northumberland. 2. Fat and pectoral muscle as indicators of body condition in the Bar-tailed Godwit. *Wildfowl* 26: 64-76.
- Feare, C.J., Dunnet, G.M. and Patterson, I.J. 1974. Ecological studies of the rook (Corvus frugilegus L.) in north-east Scotland. *J. Appl. Ecol.* 11: 867-896.
- Flegg, J.J.M. and Morgan, R.A. 1976. Mortality in British Gulls. *Ringing and Migration* 1: 65-74.
- Fretwell, S.D. 1972. *Populations in a Seasonal Environment*. Princeton University Press, Princeton.
- Furness, R.W. 1973. Roost selection by waders. *Scott. Birds* 7: 281-287.
- Furness, R.W. 1978. Movements and mortality rates of Great Skuas ringed in Scotland. *Bird Study* 25: 229-238.
- Gerard, B.M. 1967. Factors affecting earthworms in pastures. *J. Anim. Ecol.* 36: 307-330.

- Gill, F.B. and Wolf, L.L. 1975. Economics of feeding territoriality in the Golden-winged Sunbird. *Ecology* 56: 333-345.
- Goss-Custard, J.D. 1969. The winter feeding ecology of the Redshank Tringa totanus. *Ibis* 111: 338-356.
- Goss-Custard, J.D. 1970. Feeding dispersion in some overwintering wading birds. pp. 3-35 in Crook, J.H. (Ed.) *Social Behaviour in Birds and Mammals*. Academic Press, London.
- Goss-Custard, J.D. 1976. Variation in the dispersion of Redshank, Tringa totanus, on their winter feeding grounds. *Ibis* 118: 257-263.
- Goss-Custard, J.D., Evans, P.R., Knights, P.J. and Pienkowski, M.W. in prep. Short-term effects of reclamation of part of Seal Sands, Teesmouth on wintering waders and Shelduck. 2. Changes in ecology and foraging behaviour.
- Goss-Custard, J.D., Jenyon, R.A., Jones, R.E., Newbery, P.E. and Williams, R. le B. 1977. The ecology of the Wash. II. Seasonal variation in the feeding conditions of wading birds (Charadrii). *J. appl. Ecol.* 14: 701-719.
- Gray, J.S. 1976. The fauna of the polluted River Tees estuary. *Estuarine Coastal Marine Sci.* 4: 653-676.
- Green, R.H. 1978. Factors affecting the diet of farmland skylarks, Alauda arvensis. *J. Anim. Ecol.* 47: 913-928.
- Groves, S. 1978. Age-related differences in Ruddy Turnstone foraging and aggressive behaviour. *Auk* 95: 95-103.
- Hamilton, W.J. 1959. Aggressive behaviour in migrant Pectoral Sandpipers. *Condor* 61: 161-179.
- Harrington, B.A. and Groves, S. 1977. Aggression in foraging migrant Semipalmated Sandpipers. *Wilson Bull.* 89: 336-338.

- Harris, M. P. 1965. The food of some Larus gulls. *Ibis* 107: 43-53.
- Heppleston, P. B. 1971. The feeding ecology of Oystercatchers (Haematopus ostralegus L.) in winter in northern Scotland. *J. Anim. Ecol.* 40: 651-672.
- Hibbert-Ware, A. and Rutledge, R. F. 1944. A study of the inland food habits of the Common Curlew. *Brit. Birds* 38: 22-27.
- Hildén, O. 1978. Population dynamics in Temminck's stint, Calidris temminckii. *Oikos* 30: 17-28.
- Hogstad, O. 1976. Sexual dimorphism and divergence in winter foraging behaviour of Three-toed Woodpeckers, Picoides tridactylus. *Ibis* 118: 41-50.
- Hogstad, O. 1978. Sexual dimorphism in relation to winter foraging and territorial behaviour of the Three-toed Woodpecker Picoides tridactylus and three Dendrocopos species. *Ibis* 120: 198-203.
- Kahl, M. P. 1963. Mortality of Common Egrets and other herons. *Auk* 80: 295-300.
- Kendall, M. A. 1979. The stability of the deposit feeding community of a mud flat in the River Tees. *Estuarine Coastal Marine Sci.* 8: 15-22.
- Knights, P. J. 1979. Effects of changes in land use on some animal populations. Unpublished Ph. D. thesis, University of Durham, U. K.
- Krebs, J. R. 1971. Territory and breeding density in the great tit, Parus major L. *Ecology* 52: 2-22.
- Lack, D. 1943-44. The problem of partial migration. *Brit. Birds* 37: 122-130, 143-150.

- Lack, D. 1944. Ecological aspects of species-formation in Passerine birds.
Ibis 86: 260-286.
- Lack, D. 1945. The ecology of closely related species with special
reference to cormorant (Phalacrocorax carbo) and shag (P. aristotelis).
J. Anim. Ecol. 14: 12-16.
- Lasiewski, R. C. and Dawson, W. R. 1967. A re-examination of the relation
between standard metabolic rate and body weight in birds.
Condor 69: 13-23.
- Mead, C. J., North, P. M. and Watmough, B. R. 1979. The mortality of
British Grey Herons. *Bird Study* 26: 13-22.
- Meltofte, H. 1980. Wader counts in the Danish part of the Wadden Sea.
1974 - 1978. Fredningsstyrelsen (Danish with English summary).
- Michael, C. W. 1935. Feeding habits of the Black-bellied Plover in winter.
Condor 37: 169.
- Minton, C. D. T. 1971. Wader Ageing Guide. Wader Study Group, Tring.
- Minton, C. D. T. 1975. Waders of the Wash - Ringing and Biometric Studies.
Contribution to Wash Feasibility Study Report.
- Morrison, M. L., Slack, R. D. and Shanley, E. Jr. 1978. Age and foraging
ability relationships of Olivaceous Cormorants. *Wilson Bull.* 90:
414-422.
- Murton, R. K., Isaacson, A. J. and Westwood, N. J. 1966. The relationships
between wood-pigeons and their clover food supply and the mechanism
of population control. *J. appl. Ecol.* 3: 55-96.
- Murton, R. K., Isaacson, A. J. and Westwood, N. J. 1971. The significance of
gregarious feeding behaviour and adrenal stress in a population of
Wood-pigeons, Columba palumbus. *J. Zool., Lond.* 165: 53-84.

- Muus, B. J. 1967. The fauna of Danish estuaries and lagoons, distribution and ecology of dominating species in the shallow reaches of the mesohaline zone. *Meddr. Danm. Fisk. - og Havunders.* 5: 1-316.
- Myers, J. P., Connors, P. G. and Pitelka, F. A. 1979a. Territoriality in non-breeding shorebirds. *Studies in Avian Biology* No. 2: 231-246.
- Myers, J. P., Connors, P. G. and Pitelka, F. A. 1979b. Territory size in wintering Sanderlings: the effects of prey abundance and intruder density. *Auk* 96: 551-561.
- Myers, J. P. and Myers, L. P. 1979. Shorebirds of coastal Buenos Aires Province, Argentina. *Ibis* 121: 186-200.
- Newton, I. 1967. The adaptive radiation and feeding ecology of some British finches. *Ibis* 109: 33-98.
- Newton, I. 1979. *Population Ecology of Raptors.* T. and A. D. Poyser, Berkhamsted.
- Norton-Griffiths, M. 1967. Some ecological aspects of the feeding behaviour of the Oystercatcher Haematopus ostralegus on the Edible Mussel Mytilus edulis. *Ibis* 109: 412-424.
- Olsson, V. 1958. Dispersal, migration, longevity and death causes of Strix aluco, Buteo buteo, Ardea cinerea and Larus argentatus. *Acta Vertebratica* 1: 88-189.
- Orians, G. H. 1969. Age and hunting success in the Brown Pelican (Pelecanus occidentalis). *Anim. Behav.* 17: 316-319.
- Orians, G. H. and Willson, M. F. 1964. Interspecific territories of birds. *Ecology* 45: 736-745.
- Owen, D. F. 1959. Mortality of the Great Blue Heron as shown by banding recoveries. *Auk* 76: 464-470.

- Page, G. and Whitacre, D. F. 1975. Raptor predation on wintering shorebirds. *Condor* 77: 73-83.
- Panov, E. N. 1963. On territorial relationships of shorebirds during migration. *Ornithologiya* 6: 418-423.
- Partridge, L. 1976. Individual differences in feeding efficiencies and feeding preferences of captive great tits. *Anim. Behav.* 24: 230-240.
- Perry, M. C. 1974. Mobility of Canvasbacks wintering in Chesapeake Bay. Unpublished M. S.
- Pienkowski, M. W. (Ed.) 1972. University of East Anglia Expedition to Morocco 1971 Report. Norwich.
- Pienkowski, M. W. 1973. Feeding activities of wading birds and Shelducks at Teesmouth and some possible effects of further loss of habitat. Unpublished report to Coastal Ecology Research Station, Institute of Terrestrial Ecology.
- Pienkowski, M. W. (Ed.) 1975. Studies on coastal birds and wetlands in Morocco, 1972. Joint report of the University of East Anglia Expedition to Tarfaya Province, Morocco, 1972 and the Cambridge Sidi Moussa Expedition, 1972. Norwich.
- Pienkowski, M. W. 1980a. Aspects of the Ecology and Behaviour of Ringed and Grey Plovers, Charadrius hiaticula and Pluvialis squatarola. Unpublished Ph. D. thesis, University of Durham, U. K.
- Pienkowski, M. W. 1980b. Differences in habitat requirements and distribution patterns of plovers and sandpipers as investigated by studies of feeding behaviour. *Proc. Int. Waterfowl Res. Bureau Symp. on Feeding Ecology*, Gwatt, Switzerland, September 1977. *Verh. orn. Ges. Bayern* 23: in press.
- Pienkowski, M. W. and Dick, W. J. A. 1976. Some biases in cannon- and mist-netted samples of wader populations. *Ringing and Migration* 1: 105-107.

- Pienkowski, M. W. and Knight, P. J. 1977. La migration post-nuptiale des limicoles sur la côte atlantique du Maroc. *Alanda* 45: 165-190.
- Powell, G. V. N. 1974. Experimental analysis of the social value of flocking by Starlings (*Sturnus vulgaris*) in relation to predation and foraging. *Anim. Behav.* 22: 501-505.
- Prater, A. J. 1973. BTO/RSPB/WT Birds of Estuaries Enquiry. Report for 1971-72. Tring: British Trust for Ornithology.
- Prater, A. J. 1974a. Ditto, Report for 1972-73.
- Prater, A. J. 1974b. The Wader Population of the Wash. Contribution to Wash Feasibility Study Report.
- Prater, A. J. 1976. BTO/RSPB/WT. Birds of Estuaries Enquiry. Report for 1973-74. Tring: British Trust for Ornithology.
- Prater, A. J. 1977. Ditto, Report for 1974-75.
- Prater, A. J., Marchant, J. H. and Vuorinen, J. 1977. Guide to the Identification and Ageing of Holartic Waders. BTO Guide 17.
- Ratcliffe, P. J. 1979. An ecological study of the intertidal invertebrates of the Humber estuary. Unpublished Ph. D. thesis, University of Hull.
- Recher, H. F. and Recher, J. A. 1969a. Comparative foraging efficiency of adult and immature Little Blue Herons (*Florida caerulea*). *Anim. Behav.* 17: 320 - 322.
- Recher, H. F. and Recher, J. A. 1969b. Some aspects of the ecology of migrant shorebirds. II. Aggression. *Wilson Bull.* 81: 140-154.
- Reynolds, R. T. 1972. Sexual dimorphism in accipiter hawks: a new hypothesis. *Condor* 74: 191-197.
- Searcy, W. A. 1978. Foraging success in three age classes of Glaucous-winged Gulls. *Auk* 95: 586-588.

- Selander, R. K. 1966. Sexual dimorphism and differential niche utilization in birds. *Condor* 68: 113-151.
- Silliman, J., Mills, G.S. and Alden, S. 1977. Effect of flock size on foraging activity in wintering Sanderlings. *Wilson Bull.* 89: 434-438.
- Smit, C. in press. In Wolff, W.J. *Ecology of the Wadden Sea*. 3 vols. Balkema, Rotterdam.
- Smith, P. C. 1975. A study of the winter feeding ecology and behaviour of the Bar-tailed Godwit Limosa lapponica. Unpublished Ph. D. thesis, University of Durham, U. K.
- Smith, P. C. and Evans, P. R. 1973. Studies of shorebirds at Lindisfarne, Northumberland. 1. Feeding ecology and behaviour of the Bar-tailed Godwit. *Wildfowl* 24: 135-139.
- Smith, P. H. and Greenhalgh, M. E. 1977. A four-year census of wading birds on the Ribble Estuary, Lancashire/Merseyside. *Bird Study* 24: 243-258.
- Southern, H. N. 1970. The natural control of a population of Tawny owls (Strix aluco). *J. Zool., Lond.* 162: 197-285.
- Stead, P. J. 1964. The birds of Tees-side. *Trans. nat. Hist. Soc. Northumb.* 15: 1-58.
- Stinson, C. H. 1977. The spatial distribution of wintering Black-bellied Plovers. *Wilson Bull.* 89: 470-472.
- Storer, R. W. 1966. Sexual dimorphism and food habits in three North American accipiters. *Auk* 83: 423-436.
- Tasker, M. and Milsom, T. P. 1979. Birds of the Humber Estuary. Unpublished report to the Nature Conservancy Council.

- Tramer, E. J. and Kemp, T. R. 1979. Diet-correlated variations in social behaviour of wintering Tennessee Warblers. *Auk* 96: 186-187.
- Vader, W. J. M. 1964. A preliminary investigation into the reactions of the infauna of the tidal flats to tidal fluctuations in water level. *Neth. J. Sea Res.* 2: 189-222.
- Verbeek, N. A. M. 1977. Comparative feeding behaviour of immature and adult Herring Gulls. *Wilson Bull.* 89: 415-421.
- Ward, P. and Zahavi, A. 1973. The importance of certain assemblages of birds as "information-centres" for food-finding. *Ibis* 115: 517-534.
- Watson, A. 1967. Population control by territorial behaviour in Red Grouse. *Nature* 215: 1274-1275.
- Wilson, J. 1973. Wader populations of Morecambe Bay, Lancashire. *Bird Study* 20: 9-23.
- Witherby, H. F., Jourdain, F. C. R., Ticehurst, N. F. and Tucker, B. W. 1945. *The Handbook of British Birds, Vol. IV.* H. F. and G. Witherby, London.
- Zwarts, L. 1974. *Vogels van het brakke getijgebied.* Amsterdam.
- Zwarts, L. 1976. Density-related processes in feeding dispersion and feeding activity of Teal (Anas crecca). *Ardea* 64: 192-209.
- Zwarts, L. in press. Intra- and interspecific competition for space in estuarine bird species in a one-prey situation. *Proc. 17th Int. Orn. Cong.*

SUMMARY

In this section I shall summarise the major findings of my research.

1. The use of Teesmouth as a wintering site

Grey Plovers - The number of Grey Plovers on the estuary increased twice during the year, from July to October, and again from January to reach the peak for the winter in February. Adults arrived on the estuary from July to February; most remained until the main spring departure in March/April. The periods of stay of individual birds during a winter (excluding passage birds) thus varied from 20 to 230 days. Juveniles arrived mainly in September/October; many departed within a month. The mid-winter influx into the estuary comprised both adults and juveniles. Grey Plovers showed both a high percentage return rate, and consistency in arrival and departure dates, in successive years. Adults had higher rates of return than juveniles.

Seal Sands was the only major feeding area for Grey Plovers on the Tees estuary.

Curlews - The number of Curlews on the estuary changed little after the late summer arrival until the time of spring emigration. Most Curlews arrived on Teesmouth between July and October and left in March/April. Consequently most individual periods of stay on the estuary ranged from 140-250 days. Like Grey Plovers, Curlews also showed a high percentage return rate, and many individuals had similar arrival and departure dates, in successive years.

Most Curlews fed on Seal Sands in early autumn; some, almost solely males, moved to the fields as the temperature fell, so the number on Seal Sands fell to a minimum in mid winter. Movement between Seal Sands and the fields also occurred following snow, heavy rain, and flooding. A few Curlews fed on Bram Sands.

Bar-tailed Godwits - The number of Bar-tailed Godwits on the estuary reached two peaks during the autumn and winter, one in September/October and a larger one in mid January. Adults were present from July and juveniles chiefly from late August. Most adults left in February, but some juveniles stayed up to three months longer. Amongst the few colour-marked birds, fidelity to the estuary between winters was very high, especially of adults.

Bar-tailed Godwits fed not only on Seal Sands but also on the other large intertidal area, Bran Sands, especially from January to March.

2. The use of Seal Sands as a feeding area

At Low Water Grey Plovers fed mainly on the drier intertidal mudflats, avoiding softer muds more densely populated by other shorebirds (although in autumn juveniles favoured areas of very soft mud). Certain mudflats were filled in autumn and the number of Grey Plovers feeding there then changed little until spring. During peaks in the total Seal Sands population the number on other, presumably suboptimal, areas increased. Most Curlews fed at/near the tide edge, particularly on the softest muds. There was no clear evidence of certain areas being filled in autumn.

The fidelity of Grey Plovers and Curlews to a Low Water feeding site within Seal Sands during a winter varied markedly between individuals. Some individuals fed in the same site for periods of weeks or months, and often returned to that site in successive winters. The degree of fidelity varied between different parts of the mudflats, being greatest on the areas favoured by the population as a whole. Changes in Low Water feeding sites used by individuals occurred in both species more or less throughout the winter; most were correlated with changes in temperature.

Most colour-marked Grey Plovers and Curlews fed on several areas of

Seal Sands within a single tidal cycle, following "feeding circuits". The feeding areas used on the ebb and flood tides were highly correlated with the particular mudflats used at Low Water. Individual Grey Plovers and Curlews minimised the distance flown between areas on a circuit once feeding had begun. A few individuals of each species fed throughout the period of exposure on the higher parts of Seal Sands, and therefore did not follow feeding circuits. Seasonal changes in the areas used on the ebb and flood tides were also related to seasonal changes in Low Water feeding site, or, in the case of Grey Plovers, to the presence of other species of birds in large numbers on their usual site.

About 40 per cent of the Grey Plovers and 10 per cent of the Curlews defended feeding sites on Seal Sands. Sites were defended by Grey Plovers mainly on firm substrates at mid and high tidal levels, and by Curlews also at mid tidal levels but often on softer substrates than were used by territorial Grey Plovers. Both permanent and temporary territories were defended. Most Grey Plovers on the main feeding area used by the population defended permanent territories. Temporary defence of a feeding site occurred on other mudflats. Grey Plovers became territorial either on arrival on the estuary, or when there was an influx of Grey Plovers or a fall in the temperature - conditions under which defence of a feeding site increased prey availability. Curlews did not defend feeding sites on the main feeding area used by the population, but only on other mudflats. Some marked Curlews defended sites on arrival in autumn; these sites were abandoned, at least temporarily, in cold weather in mid winter when prey accessibility in those sites was very low. Other Curlews began defending sites (temporarily or permanently) when the temperature fell, in order to increase prey accessibility. Both Grey Plovers and Curlews returned to the same territories in successive years, thereby taking advantage of their knowledge of sheltered feeding sites, patches of higher prey availability and safe refuges from predators there.

3. The use of space in relation to prey behaviour

In both species four basic patterns in the use of space on Seal Sands could be identified. These were distinguished by

- i) whether one or more than one feeding site was used during a tidal cycle, and
- ii) whether or not a feeding site was defended.

Each individual in the Grey Plover and Curlew populations feeding on Seal Sands followed one of these patterns during each tidal cycle. The strategy employed on a particular feeding site could be predicted from two characteristics of that site:

- i) its period of exposure during each tidal cycle, and
- ii) the rate of drainage of the substrate.

These two characteristics determine the level and rate of change of the water table in the mud, which in turn influences the availability of Nereis diversicolor, the main prey species of Grey Plovers and Curlews on Seal Sands.

Because of their different methods of prey capture, Grey Plovers are influenced by changes in Nereis activity, and Curlews by changes in depth. Simple models based upon the supposed changes in activity and depth distribution explained much of the variety in use of space shown by individual Grey Plovers and Curlews respectively, both during a tidal cycle and during a winter. However studies of the foraging behaviour of individual Grey Plovers and Curlews have shown that the models proposed are inadequate to explain finer details of the relationship between predator behaviour and prey behaviour, and indicate that the predators change their foraging tactics in response to changes in prey activity and depth distribution.

Appendix 1

Low Water counts for three species on different areas of Seal Sands on spring and neap tides

Counts of Grey Plovers, Curlews and Bar-tailed Godwits on Seal Sands were made at Low Water on both spring and neap tides through the 1976/77 and 1977/78 winters. In the following tables, counts made on successive spring and neap tides with similar Seal Sands totals are paired to reveal any differences in distribution. These differences are discussed in Section 2.

Table i

Low Water counts of Grey Plovers on certain areas of
Seal Sands on Spring and Neap tides

<u>Date</u>	<u>Spring (S) or Neap (N) tide</u>	<u>Greenabella Bank</u>	<u>Central Bank</u>	<u>Scalloped Mud</u>	<u>Total for the whole of Seal Sands</u>
1976/77:					
14.12.76.	N	2	21	3	46
7.12.76.	S	6	15	4	41
29.12.76.	N	0	22	5	43
21.12.76.	S	11	11	3	42
29.12.76.	N	0	22	5	43
6. 1.77.	S	14	28	6	67
14. 3.77.	N	18	67	-	161
7. 3.77.	S	35	50	21	134
26. 4.77.	N	2	12	7	24
7. 4.77.	S	0	12	4	24
1977/78:					
5.10.77.	N	9	36	13	68
13.10.77.	S	11	26	13	66
1.12.77.	N	22	46	3	88
15.12.77.	S	14	49	7	92
22. 1.78.	N	5	49	17	87
12. 1.78.	S	13	46	5	82
2. 2.78.	N	2	109	24	144
28. 1.78.	S	5	115	10	154
2. 2.78.	N	2	109	24	144
11. 2.78.	S	14	125	14	174
16. 2.78.	N	8	54	6	87
9. 2.78.	S	5	65	9	102
16. 3.78.	N	2	58	7	82
9. 3.78.	S	0	76	14	106
14. 4.78.	N	1	38	0	39
6. 4.78.	S	0	34	13	48

Table ii

Low Water counts of Curlews on certain areas of
Seal Sands on Spring and Neap tides

<u>Date</u>	<u>Spring (S) or Neap (N) tide</u>	<u>Greena- bella Bank</u>	<u>Central Channel</u>	<u>Central Bank</u>	<u>Scalloped Mud</u>	<u>Total for the whole of Seal Sands</u>
1976/77:						
15. 11. 76.	N	73	19	43	27	177
7. 12. 76.	S	45	37	44	39	174
14. 12. 76.	N	29	57	13	25	125
21. 12. 76.	S	40	18	28	23	111
29. 12. 76.	N	47	81	39	218	395
6. 1. 77.	S	118	46	47	25	244
28. 3. 77.	N	103	26	62	14	210
7. 4. 77.	S	74	9	39	69	193
1977/78:						
5. 9. 77.	N	19	0	254	28	322
19. 9. 77.	S	121	38	112	58	342
5. 10. 77.	N	64	0	182	36	293
13. 10. 77.	S	111	97	82	24	315
22. 1. 78.	N	165	11	16	17	216
28. 1. 78	S	146	30		23	208
2. 2. 78	N	122	19	19	24	188
28. 1. 78.	S	146	30		23	208
16. 2. 78.	N	142	13	41	55	253
9. 2. 78.	S	52	89	33	58	239
16. 2. 78.	N	142	13	41	55	253
11. 2. 78.	S	133	44	42	66	290
16. 3. 78.	N	191	22	40	26	288
9. 3. 78.	S	224		92	3	332
14. 4. 78.	N	25	22	132	84	249
6. 4. 78.	S	73	107	36	84	306

Table iii

Low Water counts of Curlews on the two halves of
Scalloped Mud, on Neap or Spring tides in the 1977/78 winter

	Neap or Spring tide	<u>Scalloped Mud</u>		Total for the whole of <u>Seal Sands</u>
		<u>western half</u>	<u>eastern half</u>	
1. 12. 77.	N	38	24	283
15. 12. 77.	S	7	24	337
22. 1. 78.	N	15	2	216
28. 1. 78.	S	8	15	208
2. 2. 78.	N	4	20	188
28. 1. 78.	S	8	15	208
16. 2. 78.	N	20	35	253
9. 2. 78.	S	11	47	239
16. 2. 78.	N	20	35	253
11. 2. 78.	S	16	50	290
16. 3. 78.	N	8	18	288
9. 3. 78.	S	0	3	332
14. 4. 78.	N	39	45	249
6. 4. 78.	S	22	62	306

Table iv

Low Water counts of Bar-tailed Godwits on certain
areas of Seal Sands on Spring and Neap tides

	<u>Spring (S) or Neap (N) tide</u>	<u>Eastern Channel</u>	<u>Central Bank</u>			<u>Total for the whole of Seal Sands</u>
1976/77:						
16.10.76.	N	4	24			37
25.10.76.	S	13	37			57
29.12.76.	N	13	47			87
6. 1.77.	S	34	58			106
16. 1.77.	N	20	123			178
8. 2.77.	S	69	65			162
14. 3.77.	N	3	21			25
7. 3.77.	S	13	10			38
26. 4.77.	N	2	13			22
7. 4.77.	S	6	9			17
	<u>Spring (S) or Neap (N) tide</u>	<u>Greena- bella Bank</u>	<u>Central Channel</u>	<u>Central Bank</u>	<u>Scalloped Mud</u>	<u>Total for the whole of Seal Sands</u>
1977/78:						
5.10.77.	N	8	0	28	16	54
19. 9.77.	S	9	2	25	20	58
16. 2.78.	N	1	24	74	75	177
9. 2.78.	S	19	69	43	14	159
16. 2.78.	N	1	24	74	75	177
11. 2.78.	S	39	47	60	12	170

Appendix 2Sightings of colour-marked Grey Plovers

All sightings of colour-marked Grey Plovers on the Tees estuary were recorded. Table v shows the data for all marked Grey Plovers seen during the 1977/78 winter, together with the data for those ringed in 1975/76 which returned to the estuary in the 1976/77 winter. For each individual, every date on which it was seen on the estuary is marked (o); also shown are dates of ringing (x) and dates when birds were found dead (o). No checks for marked birds were made during late March in either winter.

Table v

Sightings of colour-marked Grey Plovers on the Tees estuary in two winters
(See text for details)

	A	S	O	N	D	J	F	M	A
1977-78									
B W/G	••	•••••	•••••	••••••••	•••••	••••••••	••••••••	••••••••	•••••
L O/O				•••••	••	••••••••	••••••••	••••••••	•••••
L O/W				••••••••	••••••••	••••••••	••••••••	••••••••	•••••
L W/L	•••••	•••••	••••••••	••••••••	••••••••	••••••••	••••••••	••••••••	•••••
L W/N			X•	••••••••	••••••••	••••••••	••••••••	••••••••	•••••
O L/O			••	••••••••	••••••••	••••••••	••••••••	••••••••	•••••
O R/L			••	••••••••	••••••••	••••••••	••••••••	••••••••	•••••
O R/W			••	••••••••	••••••••	••••••••	••••••••	••••••••	•••••
O W/O			••	••••••••	••••••••	••••••••	••••••••	••••••••	•••••
R Y/Y			••	X•••••••	••••••••	••••••••	••••••••	••••••••	•••••
R W/R			X•••••	••	••••••••	••••••••	••••••••	••••••••	•••••
W O/W			••	••••••••	••••••••	••••••••	••••••••	••••••••	•••••
W W/W			••	••••••••	••••••••	••••••••	••••••••	••••••••	•••••
Y L/G			••	X•••••••	••••••••	••••••••	••••••••	••••••••	•••••
Y L/R			••	••	••••••••	••••••••	••••••••	••••••••	•••••
Y N/W			••	••••••••	••••••••	••••••••	••••••••	••••••••	•••••
Y O/O			••	X•••••••	••••••••	••••••••	••••••••	••••••••	•••••
Y R/L			••	••••••••	••••••••	••••••••	••••••••	••••••••	•••••
1976-77									
BR/N	•••••								
B R/W				••	••••••••	••••••••	••••••••	••••••••	•••••
B W/G				••••••••	••••••••	••••••••	••••••••	••••••••	•••••
W R/O				••	••••••••	••••••••	••••••••	••••••••	•••••

Appendix 3

Arrival and departure dates of
individual Grey Plovers and Curlews

Tables vi - ix list the dates of first sighting (termed the arrival date) and last sighting (termed the departure date) of all individually marked Grey Plovers and Curlews that were present on the estuary for two or more winters.

Table vi

Comparison between arrival dates of all individual
Grey Plovers that returned in successive winters

<u>Individual Grey Plover</u>	<u>1976/77</u>	<u>1977/78</u>	<u>1978/79</u>
B W/G	1st Sept	17th Aug	24th Aug
B W/O	5th Nov	22nd Nov	20th Oct
W R/O	13th Nov	24th Nov	3rd Nov
L W/L	-	29th Aug*	16th Aug
Y O/R	-	31st Oct	31st Oct
Y R/L	-	10th Nov	24th Nov
Y L/R	-	30th Dec*	8th Jan
O W/O	-	12th Jan	13th Dec
L O/W	-	13th Jan	8th Jan
Y L/O	-	17th Jan	3rd Jan
O R/W	-	9th Feb	8th Jan
O L/O	-	16th Feb	11th Feb

* = second winter bird

Data for 1978/79 from P. J. Dugan (pers. comm.)

Table vii

Comparison between the departure dates of individually marked
Grey Plovers in successive winters

<u>Individual Grey Plover</u>	<u>1975/76</u>	<u>1976/77</u>	<u>1977/78</u>	<u>1978/79</u>
Y W/R	18th March*	-	-	14th March
B R/W	25th March	17th March	-	-
B W/O	25th March	14th April	11th April	10th Feb.
B R/N	1st April	10th Sept.	-	-
W R/O	1st April	10th March	16th March	11th March
B W/G	5th April	23rd March	15th March	30th March
Y R/W	-	14th Feb.	-	30th Jan.
L W/R	-	16th Feb. *	-	22nd Sept.
O R/W	-	27th Feb.	17th March	25th Feb.
Y O/L	-	3rd March	-	10th Feb.
O O/O	-	8th March*	-	8th Jan.
L O/W	-	8th March	4th March	3rd Feb.
Y G/O	-	10th March	-	27th Feb.
L L/W	-	14th March*	-	25th Feb.
Y R/L	-	14th March	9th March	4th Feb.
Y O/R	-	14th March	12th March	14th March
Y L/O	-	16th March	9th March	28th Jan.
L O/G	-	19th March*	-	9th Feb.
O L/O	-	19th March	11th March	30th March
O W/O	-	19th March	17th March	30th March
Y Y/Y	-	23rd March*	-	23rd March
Y L/R	-	2nd May*	6th April	30th March
L W/L	-	2nd May*	19th April	14th March
Y O/O	-	-	10th Nov. *	19th Oct.
W W/W	-	-	2nd March	27th March
W O/W	-	-	4th March	14th March
Y G/L	-	-	11th April	5th April
Y L/G	-	-	11th April*	17th April
OR/L	-	-	19th April	12th Nov.

Key * = known juvenile in winter marked.

Data for 1978/79 from P. J. Dugan (pers. comm.)

Table viii

Comparison between dates of first sighting of all
individual Curlews that returned in successive winters

Individual Curlew	<u>1976/77</u>	<u>1977/78</u>	<u>1978/79</u>
B R/W	1st Sept.	13th Aug.	24th Aug.
B W/O	13th Jan.	21st Aug.	16th Jan.
Y G/O	-	13th Aug.	10th July
L R/L	-	13th Aug.	18th Aug.
Y L/L	-	13th Aug.	24th Aug.
Y N/W	-	13th Aug.	18th Dec.
O W/O	-	15th Aug*	23rd Aug.
L O/O	-	17th Aug.	11th Jan.
W W/W	-	21st Aug.	10th July
L Y/Y	-	21st Aug.	23rd Aug.
R L/O	-	21st Aug.	8th Sept.
R R/Y	-	21st Aug.	8th Nov.
R W/R	-	5th Sept.	24th Aug.
R Y/N	-	5th Sept.	24th Aug.
Y Y/Y	-	6th Sept.	26th Aug.
Y G/Y	-	12th Sept.	31st Oct.
Y O/R	-	13th Sept. *	9th Oct.
Y O/L	-	26th Sept. *	24th Aug.
R N/W	-	18th Oct.	16th Nov.
L W/O	-	25th Oct.	9th Nov.
L W/R	-	30th Oct. *	9th Oct.
L O/W	-	17th Jan.	8th Aug.
L R/W	-	26th Jan*	26th Aug.

* = Bird in second winter

(Sightings after September 1978 supplied by N. C. Davidson,
L. R. Goodyer and F. L. Symonds)

Table ixComparison between the dates of last sighting of individually marked Curlews in successive winters

<u>Individual Curlew</u>	<u>1975/76</u>	<u>1976/77</u>	<u>1977/78</u>
B W/G	16th Dec.	6th Jan.	-
B W/O	"	13th Jan.	26th Jan.
B R/O	15th Jan.	23rd March	-
B R/W	1st Feb.	4th April	11th April
Y R/W	-	9th Jan. *	19th April
L O/L	-	2nd Feb.	22nd Jan.
W Y/Y	-	17th March	21st Oct.
R W/R	-	17th March	16th March
R N/W	-	17th March	21st March
Y N/W	-	19th March	21st March
L R/W	-	19th March *	21st March
L O/O	-	19th March	4th April
Y G/Y	-	19th March	19th April
Y L/L	-	19th March	19th April
Y G/W	-	4th April	15th Dec.
L W/O	-	4th April	19th March
Y Y/Y	-	4th April	19th April
L R/L	-	7th April	4th April
Y G/O	-	7th April	19th April
R L/O	-	23rd April	24th Feb.
Y O/L	-	23rd April *	19th April
W W/W	-	23rd April	19th April
O W/W	-	26th April	21st Oct.
L O/W	-	26th April	17th Jan.
R Y/N	-	26th April	11th March
Y O/R	-	26th April *	21st March
L W/R	-	26th April *	11th April
O W/O	-	26th April *	19th April
L W/L	-	26th April	19th April
R R/Y	-	26th April	19th April
L Y/Y	-	29th April	21st March

Key: * = known juvenile in winter marked.

Appendix 4

Sampling of Nereis abundance on areas of Seal Sands

Introduction

The invertebrate sampling described in this section was prompted by the observation that, as the tide ebbed, the majority of Grey Plovers and Curlews moved from the higher to the lower mudflats (Sections 3. II. A. 2. and 3. II. B. 2.). I wished to investigate whether this movement was due to Nereis diversicolor, their main prey species on Seal Sands, being more abundant on the lower than the upper mudflats.

An exhaustive survey by repeated collection of substrate, sieving and sorting was not carried out due to a) the disturbance of marked birds, which may have caused changes in feeding site and thus biased the results of the main project; and b) the difficulty of extracting the animals from the glutinous sediment found on much of Seal Sands. This method was therefore used on only a few occasions. The majority of measures of abundance were obtained by a method which did little damage to the mudflat. A visual estimate of the number of worms was obtained by counting the number of burrows in an area of mud. Alternative methods, using irritants to bring the worms up to the surface, were unsuccessful because the chemicals hardly penetrated the surface of the sediment.

The practicable sampling methods will be described below; the results of the sampling will then be considered in relation to the movement of birds across Seal Sands on the ebb tide.

Methods

1. Burrow counts: Open-ended aluminium cylinders (radius 10 cm, height 30 cm) were inserted into the sediment to a depth of approximately 5 cm (i. e. below the oxygenated layer). They were then inclined to break the sediment core at the

bottom edge of the cylinder, thus revealing a cross-section of the burrows in the mud. All large, oxygenated burrows were counted, and the total taken as an estimate of Nereis abundance. Several burrow counts were made at each site.

In taking a burrow count as an estimate of Nereis abundance, several assumptions were made. Firstly it was assumed that Nereis made only large burrows and that the small burrows were made only by Corophium. However this will probably have resulted in an under-estimate of the abundance of the smallest size classes of Nereis. Counts were made only of oxygenated burrows, i. e. those with light-coloured walls, as it was believed that these were the only burrows that were occupied during that tidal cycle.

It was assumed that each worm had a single burrow exit at the surface. However it is known that Nereis on mudflats have complex burrow systems, with each worm having several exits (Vader, 1964, and pers. obs.). The number of burrows in a cross-section of mud cannot therefore be equated with the number of worms in that core of sediment. However, there is no reason to believe that the relationship between the number of burrows and the number of Nereis varied greatly across Seal Sands. Burrow counts followed by hand-sorting of the sediment core revealed a predictable relationship between the two numbers ($r = 0.796$, $n = 20$, $P < 0.001$).

It must be stressed that this method gives only an estimate of abundance and does not indicate absolute density. It was adopted because it provided a swift and non-destructive method of estimating worm abundance on areas within Seal Sands.

2. Extraction of invertebrates from the substrate: Cores of sediment (radius 10 cm, depth approx. 12 cm) were collected by inserting an open-ended cylinder into the substrate and then digging out the filled cylinder. In the laboratory the invertebrates were extracted from the sediment in one of two ways:

- a) The invertebrates were sieved from the sediment using a jet of water. The sieve retained most Nereis, Hydrobia and Corophium, but some of the smallest size classes may have been lost.
- b) In a cold room at 8^o C, each core of sediment was placed in a plastic tub, covered with approximately one litre of seawater, stirred to spread the sediment, and left for three days. The seawater was then replaced with a concentrated salt solution (50 gm salt per litre of seawater) and left for two days. Throughout the five days, invertebrates came up to the surface and were removed and stored in alcohol. Sieving revealed that this method removed all the animals from the sediment within the five days. This method of extraction was developed by P. J. Dugan (pers. comm.).

The size of cores collected during this sampling was chosen to provide estimates of abundance of invertebrates living in the surface layers of mud, such as Corophium and Hydrobia. The sampling of Nereis was therefore confined to those individuals in the surface layers, and deep-burrowing worms would not have been collected.

Results

Burrow counts and extractions were carried out on various areas of Seal Sands during the 1977/78 winter. The estimates of abundance of Nereis are shown on Table X. For each day, all estimates for each area are combined to give a mean value. The results of sampling by burrow counts and by extraction are presented separately.

The results show that:

1. There were no major and consistent differences between estimates of abundance for the higher and the lower mudflats. For example, although on 7.2.78. the mean values of the burrow counts for Central Bank - west and for Greenabella Bank (areas at lower tidal levels) were both greater than that for Central Bank - south (high tidal level) (respectively, $t = 2.86$, 10 d.f., $P < 0.02$; $t = 3.09$, 29 d.f., $P < 0.01$), on 15.3.78. extraction methods showed that any differences between Central Bank - south (high tidal level) and Central Bank - north or Central Bank - west (both at lower tidal levels) were not significant at the 10 per cent level.

Thus there is evidence that the movement of Grey Plovers and Curlews from the higher to the lower mudflats on the ebb tide was not due to Nereis being more abundant on the lower areas.

2. The estimates of abundance for a single site varied considerably both during and between sampling occasions, indicating that the distribution of Nereis on Seal Sands was very patchy.
3. The abundance of Nereis on the Peninsula Sands and the sandy eastern edge of Eastern Channel was much lower than that on the rest of Eastern Channel and on the other areas of Seal Sands at high tidal level. On each

Table X : Estimates of abundance of *Nereis diversicolor* on areas of Seal Sands at high and lower tidal levels, obtained by two sampling methods. The mean values are followed by the sample size, in brackets, and the standard error of the mean

	HIGH TIDAL LEVEL			LOWER TIDAL LEVELS						
	P/ECh sands	SMe	CBs	ECh	SMw	C3n	CBW	CBc	GB	SCh
) Burrow counts (no. per cross-section)										
29.11.77		42.5 (4) 4.12								
8.12.77		24.7 (3) 8.74								
15.12.77	16.0 (2) 1.00			30.9 (9) 3.51						
1. 1.78	9.8 (4) 1.60			33.1 (22) 1.42						
7. 2.78		24.9 (8) 1.57					35.0 (4) 3.54		34.1 (23) 2.54	
26. 2.78										32.1 (36) 2.51
5. 3.78	6.6 (58) 0.76			20.6 (21) 2.44						
) Worm density (no. per m ²) in surface samples										
22. 9.77	340.0 (3) 212.0								127.0 (7) 47.9	
5.10.77										
16.12.77		1023.0(5) 174.2							952.0 (6) 228.5	
15. 3.78		817.0 (14) 174.9	980.0 (4) 381.3	660.0(5) 181.6	101.0 (3) 50.4	320.0 (9) 135.9	1128.0 (4) 370.8	37.0 (4) 37.6		

Abbreviations for areas as on Table 3.19.

of the three days when both parts of Eastern Channel were sampled by burrow counts, the mean for the mud at mid tidal level was significantly greater than that for the sand (15.12.77, $t = 4.08$, 9 d.f., $P < 0.01$; 1.1.78, $t = 10.93$, 24 d.f., $P < 0.001$; 5.3.78, $t = 5.48$, 77 d.f., $P < 0.001$). The means for Central Bank - south (7.2.78) and Scalloped Mud - east (29.11.77) (but not Scalloped Mud - east (8.12.77)) were significantly greater ($P < 0.01$) than those for the sand of Eastern Channel and the Peninsula.

Because of the much lower abundance of Nereis on the sandy eastern edge of Eastern Channel, Grey Plovers would not be expected to feed there under most conditions (see Section 3. II. A. 2).

Reference

- Vader, W. J. M. 1964. A preliminary investigation into the reactions of the infauna of the tidal flats to tidal fluctuations in water level. *Neth. J. Sea Res.* 2: 189-222.