

Durham E-Theses

*Morphology and physiology of horizontal cells in the retina of the perch (*perca fluviatilis.L.*)*

Thor Gunnarsson

How to cite:

Gunnarsson, Thor (1985) Morphology and physiology of horizontal cells in the retina of the perch (*perca fluviatilis.L.*). Doctoral thesis, Durham University.

Use policy

The full-text may be used and/or reproduced, and given to third parties in any format or medium, without prior permission or charge, for personal research or study, educational, or not-for-profit purposes provided that:

- a full bibliographic reference is made to the original source
- a <https://etheses.durham.ac.uk/id/eprint/7486/> is made to the metadata record in Durham E-Theses
- the full-text is not changed in any way

The full-text must not be sold in any format or medium without the formal permission of the copyright holders.

Please consult the [full Durham E-Theses policy](#) for further details.

MORPHOLOGY AND PHYSIOLOGY OF HORIZONTAL CELLS
IN THE RETINA OF THE PERCH (PERCA FLUVIATILIS,L.).

by

THOR GUNNARSSON, B.Sc.
(University of Iceland).

A thesis presented in candidature for the degree of
Doctor of Philosophy.

Department of Zoology, University of Durham.

The copyright of this thesis rests with the author.
No quotation from it should be published without
his prior written consent and information derived
from it should be acknowledged.



Durham, 1985.

-8. OCT 1986

Theris
1985/GUN

Thor Gunnarsson.

Morphology and physiology of horizontal cells
in the retina of the perch (*Perca fluviatilis*, L.).

ABSTRACT.

Horizontal cells of the perch retina were studied with morphological and physiological techniques. Three types of cone horizontal cells were observed in Golgi preparations and they were called H1, H2, and H3 type cells, according to their morphological characteristics. Analysis of cone-horizontal cell contacts revealed that H1 cells contact red sensitive twin cones and green sensitive single cones, H2 cells contact red sensitive twin cones exclusively, and H3 cells contact exclusively green sensitive single cones. Interconnections of cones by basal processes were also examined; single cone basal processes were found to contact twin cone pedicles, and twin cone basal processes to contact other twin cone pedicles.

The spectral sensitivity and spatial organization of horizontal cells were analysed by intracellular recordings. Two types of horizontal cell responses were observed; L-type responses that hyperpolarized to light stimuli of all wavelengths, and R/G C-type responses that depolarized to red and hyperpolarized to green stimuli. Correlation of anatomical and morphological results suggests that H1 and H2 cells generate L-type responses, and H3 cells generate R/G C-type responses. The R/G cells are hyperpolarized by signals from the green (P535₂) sensitive cones and depolarized by a far red (650-670 nm) mechanism. Compared with the red cone pigment (P615₂), the L-type horizontal cell spectral sensitivity curve is narrow and with maximum (650 nm) displaced towards the red end of the spectrum (a pseudopigment spectral sensitivity curve), suggesting that an antagonistic interaction occurs between the two cone types, generating the horizontal cell spectral sensitivity function.

DECLARATION:

THIS THESIS IS THE ORIGINAL WORK OF THE AUTHOR, EXCEPT WHERE DUE ACKNOWLEDGEMENT IS GIVEN IN THE TEXT, AND NO PART OF IT HAS PREVIOUSLY BEEN SUBMITTED FOR A DEGREE IN THIS OR ANY OTHER UNIVERSITY.

STATEMENT OF COPYRIGHT.

THE COPYRIGHT OF THIS THESIS RESTS WITH THE AUTHOR. NO QUOTATION FROM IT SHOULD BE PUBLISHED WITHOUT HIS PRIOR WRITTEN CONSENT AND INFORMATION DERIVED FROM IT SHOULD BE ACKNOWLEDGED.

ACKNOWLEDGEMENTS.

I am greatly indebted to Dr. D. Hyde for his encouragement and advice throughout the course to this study and also for his criticism of the manuscript of this dissertation.

My thanks are also due to Dr. J. Scott and to Dr. S. Fridriksson for their criticisms of this manuscript and for many valuable discussions.

My thanks are due to Mrs. C. Richardson for technical assistance with the histological research and my thanks go to Mr. A. Bowman and Mr. D. Hutchinson for their technical assistance.

I am very grateful to my wife for the invaluable assistance and support in preparing and typing this manuscript. My thanks are also due to Mrs. S. Laxdal for critically reviewing the manuscript and to my parents for their support.

I acknowledge the financial support of the Icelandic Government Loan Fund for finance during the course of this study.

C O N T E N T S:

	Page:
ABSTRACT	i
DECLARATION/STATEMENT OF COPYRIGHT	ii
ACKNOWLEDGEMENTS	iii
CONTENTS	iv
LIST OF FIGURES	ix
LIST OF PLATES	xi
LIST OF TABLES	xii
<u>INTRODUCTION.</u>	1
<u>Chapter 1. The structure of the fish (vertebrate) eye.</u>	2
1.1. General.	2
1.2. The retina.	3
1.2.1. The retinal epithelium.	3
1.2.2. The sensory retina.	5
1.3. Photoreceptors.	6
1.3.1. The outer segment.	7
1.3.2. The inner segment.	8
1.3.3. Visual pigments.	10
1.3.4. Cone types and cone arrangements. ...	14
1.3.5. Synaptic terminations, outer plexiform layer.	18
1.3.6. Photoreceptor interconnections.	20
1.4. Horizontal cells.	22
1.4.1. Teleosts.	23
1.4.2. Other vertebrates.	25
1.5. Other neurons of the retina.	28

	Page:
1.5.1. Bipolar cells.	28
1.5.2. Amacrine cells.	30
1.5.3. Interplexiform cells.	32
1.5.4. Ganglion cells.	32
<u>Chapter 2.</u> Physiology of the retina.	35
2.1. General.	35
2.2. Photoreceptors.	35
2.2.1. Transduction mechanisms.	38
2.2.2. Photoreceptor response properties. ..	39
2.2.3. Synaptic mechanisms.	43
2.2.4. Ionic properties.	45
2.3. Horizontal cells.	47
2.3.1. General.	47
2.3.2. L-type horizontal cells.	49
2.3.3. C-type horizontal cells.	52
2.3.4. Generation of horizontal cell responses.	56
2.3.5. Synaptic mechanisms.	59
2.3.5. Receptive field properties.	62
2.4. Other neurons.	65
2.4.1. Bipolar cells.	65
2.4.2. Amacrine cells.	68
2.4.3. Ganglion cells.	70
2.5. Behavioural studies.	73
2.6. The present study.	74

	Page:
<u>MATERIAL AND METHODS</u>	76
<u>Chapter 3. Morphological methods.</u>	77
3.1. Material.	77
3.2. Methods.	77
3.2.1. Isolation of the retina.	77
3.2.2. Golgi flat (whole) mount preparation.	78
3.2.3. Golgi thick sections.	79
3.2.4. Serial 1 μm sectioning and analysis.	80
 <u>Chapter 4. Physiological methods.</u>	 83
4.1. Preparation.	83
4.2. Microelectrodes.	84
4.3. Recordings.	84
4.4. Optics.	85
4.5. Calibrations.	87
 <u>RESULTS</u>	 90
<u>Chapter 5. Morphology of Golgi preparations.</u>	91
5.1. General observations.	91
5.2. H1-type horizontal cells.	92
5.3. H2-type horizontal cells.	95
5.4. H3-type horizontal cells.	97
5.5. Horizontal-receptor cell contact.	99
5.6. H1-cell contact.	99
5.7. H2-cell contact.	101
5.8. H3-cell contact.	102

	Page:
7.2. Horizontal cell axons.	197
7.3. Patterns of interconnections between cones and cone horizontal cells.	198
7.4. Photoreceptor interconnections.	203
<u>Chapter 8.</u> Intracellular recordings.	207
8.1. General observations.	207
8.2. L-type horizontal cells.	207
8.2.1. Spectral sensitivity.	210
8.3. C-type horizontal cells.	217
8.4. Spatial properties.	221
<u>Chapter 9.</u> General discussion and conclusion.	224
9.1. Correlation of the morphological and physiological results.	224
9.2. Generation of horizontal cell responses.	227
9.3. Pseudopigment spectral sensitivity.	230
<u>References.</u>	233

LIST OF FIGURES

	Page:
Figure 1.1.	10
Figure 1.2	11
Figure 1.3	12
Figure 4.1	89
Figure 6.1	142
Figure 6.2	143
Figure 6.3	144
Figure 6.4	145
Figure 6.5	146
Figure 6.6	147
Figure 6.7	148
Figure 6.8	149
Figure 6.9	153
Figure 6.10	154
Figure 6.11	155
Figure 6.12	156
Figure 6.13	157
Figure 6.14	158
Figure 6.15	159
Figure 6.16	160
Figure 6.17	165
Figure 6.18	166
Figure 6.19	167
Figure 6.20	168
Figure 6.21	169

	Page:
Figure 6.22	170
Figure 6.23	171
Figure 6.24	172
Figure 6.25	173
Figure 6.26	180
Figure 6.27	181
Figure 6.28	182
Figure 6.29	183
Figure 6.30	184
Figure 6.31	185
Figure 6.32	186
Figure 6.33	187
Figure 6.34	188
Figure 6.35	189
Figure 6.36	190
Figure 6.37	191
Figure 8.1	214
Figure 8.2	215
Figure 9.1	225
Figure 9.2	229

LIST OF PLATES

	Page:
KEY TO ABBREVIATIONS.	110
PLATE 1.	111
PLATE 2.	112
PLATE 3.	113
PLATE 4.	114
PLATE 5.	115
PLATE 6.	116
PLATE 7.	117
PLATE 8.	118
PLATE 9.	119
PLATE 10.	120
PLATE 11.	121
PLATE 12.	122
PLATE 13.	123
PLATE 14.	124
PLATE 15.	125
PLATE 16.	126
PLATE 17.	127
PLATE 18.	128
PLATE 19.	129
PLATE 20.	130
PLATE 21.	131
PLATE 22.	132
PLATE 23.	133
PLATE 24.	134
PLATE 25.	135

LIST OF TABLES

	Page:
TABLE 4.I.	88
TABLE 5.I.	108
TABLE 5.II.	109

INTRODUCTION.



Chapter 1.

The structure of the fish (vertebrate) eye.

1.1. General.

The vertebrate eye is a complex sense organ that does not differ significantly in structure between species. This implies that the basic functional principles are the same for the eyes of most vertebrates; light rays pass through the transparent interior to form a real inverted image of the external world at the back of the eye chamber.

The main structural components of the vertebrate eye are: i) the sclera, which forms the outer protective layer of the eyeball, ii) the cornea, through which the light rays enter the eye, iii) the lens, which, in fish, has a fixed (unchanging) spherical shape, iv) the choroid, a pigmented layer, lining the sclera inside the eye and contains many of the blood vessels which nourish the structures in the eyeball, v) vitreous humor, a transparent gelatinous substance which fills the eyeball behind the lens, and vi) the retina, a thin layer lining the interior of the eyeball next to the choroid. The inverted image is formed on the retina which contains the photo-receptors, together with the neurons involved in the first levels of synaptic processing.

Numerous excellent reviews on the structure and physiology of the retina have been published in the last decade (Cohen, 1972; Stell, 1972a; Daw, 1973; Rodieck, 1973; Kaneko, 1979; Witkovsky, 1980; Wheeler, 1982), therefore I will only deal in depth with those features of the retina which are of relevance to this study.

1.2. The retina.

The retina consists of two main parts: i) a single layer of columnar neuroepithelial cells, termed the retinal epithelium, and ii) the major part of the retina consisting of neurons and termed the sensory retina. The retina is a portion of the central nervous system, an ontogenic derivation of the forebrain. The essential function of the retina is to extract the visual information present in the inverted image. In general, a retinal response must be considered in terms of the timing, the spectral composition and the spatial extent of the stimulus. The responses of the photoreceptors are transformed by processing in the retina and transmitted, via the optic nerve, to the central nervous system as complex interactions between the temporal, spectral and spatial retinal pathways.

1.2.1. The retinal epithelium.

The retinal epithelium of the vertebrate eye is a single layer of cells which are interconnected by tight junctions. The basal surface (sclerad) of each cell is attached to Bruchs membrane, a layer of connective tissue which separates the choriocapillaries from the retinal epithelium. The apical surface of the retinal epithelium has many processes that extend vitread and surround the photoreceptor outer segments. In many vertebrates the retinal epithelium contains pigment granules, and therefore it is usually termed 'pigment epithelium'.

The pigment epithelium has a surprising variety of roles; a) apical processes provide a large area of contact with the outer segments and may thus play a mechanical role in the attachment of

the neural retina to the inside of the eye chamber (Rodieck, 1973); b) when pigmented, the melanin pigment granules absorb light not absorbed by photoreceptors and thus prevent reflection and light scatter which would blur the image and may actually reduce the amount of light absorbed by an outer segment; c) the epithelial cells contain phagosomes that remove the rod outer segment discs by phagocytosis (Young and Bok, 1969); d) interchange of metabolites, such as vitamin A which moves from the rods to the pigment epithelium during light adaptation and returns during dark adaptation (Dowling, 1960); e) pigment migration: in some lower vertebrates a change in illumination causes a migration of pigment granules within the apical processes of the retinal epithelium. In the dark adapted state the pigment is withdrawn from the apical processes between the receptor outer segments, thereby reducing its screening effect. The nature of the pigment migration mechanism is poorly understood.

The pigment epithelium responds electrically when light is absorbed in the rod outer segment (Brown and Wiesel, 1961; Schmidt and Steinberg, 1971). Intracellular recorded responses consist of a slow hyperpolarization which is graded with intensity and identical in time course to the C-wave of the electroretinogram and results from modulation of potassium ion concentration in the extracellular space by the activity of the photoreceptors.

1.2.2. The sensory retina.

In general, the sensory retina of all vertebrates studied contains five major classes of neurons; photoreceptors, horizontal cells, bipolar cells, amacrine cells and ganglion cells.

The retina is stratified into nuclear and synaptic layers. The cell bodies are arranged in three distinct nuclear layers and their synaptic interconnections are mainly confined to two 'synaptic' or 'plexiform' layers. Receptors, whose perikarya are in the outer nuclear layer (O.N.L.), make synaptic contact with both horizontal cells and bipolar cells in the outer plexiform layer (O.P.L.). The inner nuclear layer (I.N.L.) contains the perikarya of horizontal, bipolar and amacrine cells. The horizontal cells occupy the outer, or distal, part of the I.N.L. and the bipolar and amacrine cells occupy the inner, or proximal, part of the I.N.L. The inner plexiform layer (I.P.L.), which lies proximal to the I.N.L., contains processes of bipolar, amacrine and ganglion cells. The ganglion cells are the only cells that convey signals from the retina to the central nervous system and most of their cell bodies are in the ganglion cell layer, which lies proximal to the inner plexiform layer.

A recently described retinal element the "interplexiform cell" is located in the inner nuclear layer and extends its processes to both the inner and to the outer plexiform layers. The interplexiform cells may be thought of as either a major distinctive subdivision of amacrine cells or a sixth class of retinal cells (Ehinger and Falck, 1969; Boycott, Dowling, Fisher, Kolb and Laties, 1975; Dowling and Ehinger, 1975).

In general, each cell class is subdivided into two or more subclasses, with multiple parallel pathways through the visual system at each stage and complex interconnections within each synaptic layer.

In addition to neurons, the sensory retina contains glial cells, which resemble astrocytes in cytoplasmic detail. These columnar glial cells span the full thickness of the retina. The most frequent are the radially orientated Muller cells, which span the retina from the 'outer limiting membrane' (O.L.M.) to the 'inner limiting membrane' (I.L.M.). Their nuclei lie in the I.N.L. and are generally fusiform in shape. Their processes penetrate between all neurons and cover most of, though not all, their surface area. Electron microscopic studies have revealed that the glial cell processes occupy almost all the space between the retinal cells, so that there is almost no extracellular space in the sensory retina (Lasansky, 1965; Missotten, 1965b; Dowling and Boycott, 1966). Since glial cells contain glycogen their role in the retina is thought to be nutritive as well as structural.

1.3. Photoreceptors.

Vertebrate photoreceptors occur in a variety of shapes and sizes. The photoreceptor cell is bipolar in form, consisting of an outer segment, an inner segment, a cell perikaryon with the nucleus in the O.N.L. and a synaptic terminal in the O.P.L. The outer and inner segments extend above the retina and form a sheet at the back of the eye, with the outer segment buried in the apical processes of the retinal epithelium. Light normally enters the retina at the

vitreal surface, passing through its layers before reaching the photoreceptors.

Two broad classes of vertebrate photoreceptor have been distinguished; rods and cones, so named because of their structural appearance. Schultze (1866) noted the correlation of the cones and rods with day and night vision, respectively, and established the duplex nature of the vertebrate retina. Rods and cones can easily be distinguished by a number of special features in many vertebrates.

Typically, in teleosts (Engstrom, 1963b), both rods and cones are present and the two receptors are distinguishable on the basis of the shapes of the outer and inner segments. Rods have longer, cylindrical outer segments and more slender inner segments than cones which have a tapering outer segment and a flask-shaped inner segment. In other vertebrates, however, such as the lower fishes, amphibians, reptiles and diurnal birds, this distinction between rods and cones can be difficult to make because their morphological characteristics overlap considerably.

1.3.1. The outer segment.

Photoreceptor outer segments are elongated and consist of a stack of several hundred membranous discs. Each disc is a sac, apparently formed by ingrowth or infolding of the plasma membrane. The connections of the resultant sac to the membrane may be very narrow or absent in most rod sacs, but are generally persistent in cone sacs (Sjostrand, 1961; Cohen, 1963a). The photopigment molecules are incorporated in the discs and orientated so as to achieve maximal absorption of the light rays, which travel along the length of the

outer segment. The protein part of the photopigment is synthesized in the inner segment and transported to the outer segment. When the protein reaches the outer segment in rods, it becomes incorporated in the plasma membrane, which then forms the discs by invagination.

There is an apparently continuous formation and removal of rod discs by the pigment epithelium and, in frogs, the whole rod outer segment is renewed every 6-7 weeks (Young, 1967, 1969). Similar renewal of cone discs was not observed in frogs. In teleosts, some evidence suggests that cones shed their discs at any level from the side which is open to the extracellular space. The discs are shed in small portions but not discarded whole (for review see Cohen, 1972).

1.3.2. The inner segment.

Receptor inner segments are joined to the outer segments by narrow stalks which contain nine pairs of filaments or microtubules, similar to cilia except for the absence of a central pair of filaments (see Cohen, 1972 for review).

The inner segment is the metabolically active part of the cell and its distal part contains densely packed mitochondria and has been termed the ellipsoid (Walls, 1942).

In some fish, amphibia, birds and reptiles there is a region in the ellipsoid termed 'paraboloid' with many intracellular vacuoles which probably contain glycogen granules (Yamada, 1969; Cohen, 1963a). The region of the inner segment that lies between the ellipsoid (paraboloid) and the outer limiting membrane has been termed myoid. In some species the myoid is contractile (Ali, 1975; Couillard, 1975). A striking feature in many teleosts is the

opposing photomechanical responses to light by the rods and cones. When the retina is illuminated the cone myoids contract, bringing the outer segments closer to the external limiting membrane, simultaneously, the rod myoids elongate, thus burying the rod outer segments within the apical membranes of the pigment epithelium. In darkness these movements are reversed. It may be significant that photomechanical responses are well developed in teleosts in which pupillary movements are either absent or small but species with rapid and effective pupillary control have no photomechanical movements (Crescitelli, 1972).

The cell bodies of photoreceptors are in the outer nuclear layer. Cone nuclei in vertebrates are usually situated near the outer limiting membrane but rod nuclei always lie vitread to the cone nuclei. With the exception of a few displaced bipolar cells found in some species, the outer nuclear layer contains only the cell bodies of rods and cones.

1.3.3. Visual pigments.

The retina of the dark adapted eye has a reddish colour, which was first noticed by Muller (1851). Boll (1877) noted that this colour fades when the retina is exposed to light, now termed 'bleaching'. Kuhne (1878) was the first to extract the light sensitive substance, which he named rhodopsin. Its chemical structure remained a mystery for some time but Wald (1933, 1935) showed that this substance was based on Vitamin A.

The structure and chemistry of visual pigments have been reviewed from time to time (Dartnall, 1957; Morton, 1972; Rodieck,

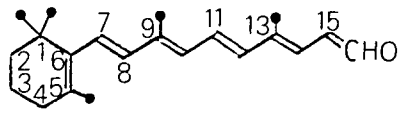

Retinal

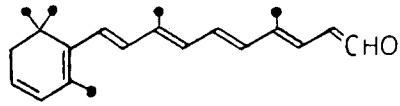

3-Dehydroretinal

Figure 1.1.a. The structure of retinal and 3-dehydroretinal.
(From Lythgoe, 1979).

all-trans
retinol11-cis
retinol

Figure 1.1.b. The isomeric configuration of retinol.
(From Lythgoe, 1979).

1973; Knowles and Dartnall, 1977) and only a very brief description will be given here.

The molecular basis of the interaction of the rod photopigment with light was established by Wald (1968). The visual pigments are chromoproteins consisting of a chromophoric group which is the aldehyde of vitamin A1 (retinal) or vitamin A2 (dehydroretinal) (Fig. 1.1.a), and are derived from β -carotene ingested in the food, these are joined to an opsin protein molecule and are called rhodopsin and porphyropsin respectively.

Retinal and 3-dehydroretinal exist in several isomeric forms, of which only two, 11-cis and all-trans are important in the visual process (Fig. 1.1.b).

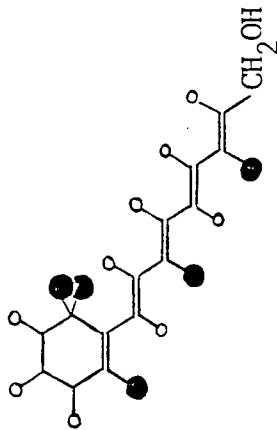
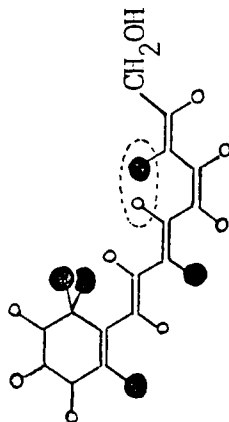
The initial stage of photoactivation appears to be the same in all vertebrates. Before a photon is absorbed, the chromophoric group is in the 11-cis configuration which fits into the opsin molecule in the disc membrane. On the absorption of a photon, the chromophoric group changes to the all-trans configuration and spontaneous detachment of the chromophoric group from the opsin molecule occurs.

The reaction:

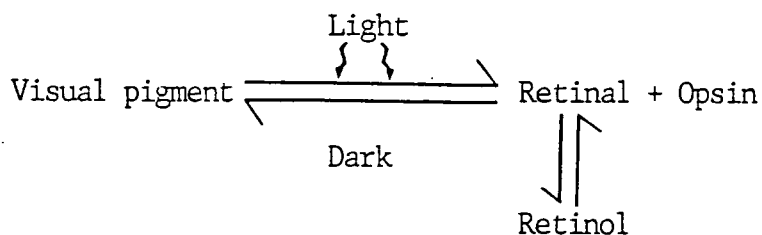

Figure 1.2. Simplified sequence of bleaching.

At the intermediate stage of transduction, coloured compounds called metarhodopsins are formed. The whole process is called

'bleaching'.

The regeneration of vertebrate rhodopsin is a chemical process and involves first the isomerization of the chromophore group back from the all-trans to 11-cis configuration followed by the spontaneous recombination of the opsin molecule with the chromophore to form the rhodopsin or porphyropsin molecule.

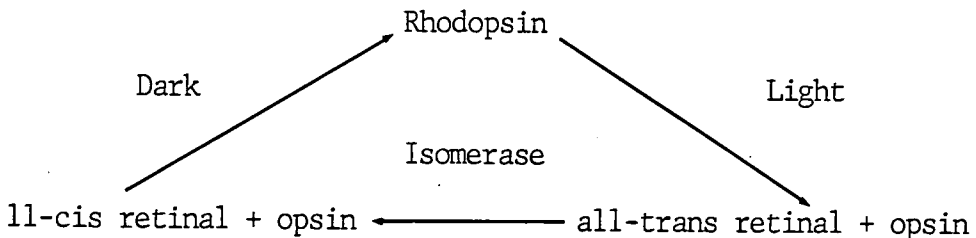

Figure 1.3. Showing the first steps in the isomerization cycle.

(From Wald, 1968).

There are two major factors that influence the spectral absorption of the visual pigment. The first is whether the chromophoric group is retinol (rhodopsin) or 3-dehydro-retinol (porphyropsin); the second is the detailed nature of the electronic linkage between the chromophore and the opsin. The longer-wave pigments in both series (A1, A2) have a narrower absorption spectra than the shorter-wave pigments (Harosi, 1976) a fact that Ebrey and Honig (1977) accounted for in their construction of nomograms for long-, intermediate- and short-wave rhodopsins and porphyropsin. The nomograms of Dartnall (1953) and Munz and Schwanzara (1967), however, were based on the assumption that the shape of the absorption spectra plotted on wavenumber ($1/\lambda$) scale is invariant.

In addition to the main absorption band (the α -band) there is

also the shorter-wavelength cis-peak (the β -band) and in the ultraviolet a strong protein absorption band (Shichi, Lewis, Irreverre and Stone, 1969). Absorption by the beta band is not physiologically significant for most visual pigments because the shorter wavelengths are cut off by the lens and vitreous body (Burkhardt, 1966; Witkovsky, 1968; Govardovskii and Zueva, 1974). However, the beta band may be significant for some vitamin A2 pigments, partly because vitamin A2 pigments absorb at longer wavelengths than vitamin A1 pigments, bringing at least part of the beta band above 400 nm, and partly because the beta band has a higher absorption in relation to the alpha band for vitamin A2 pigments (30-50%) than it does for vitamin A1 pigments (20-30%) (Goodeve, Lythgoe and Schneider, 1941; Wald, Brown and Smith, 1953; Bridges, 1967; Daw, 1973).

Porphyropsins are found primarily in freshwater fish retina but they are also found in some marine fishes and in amphibia (tadpoles) and are generally associated with the presence of a relatively large fraction of long wavelength light in the individual species environment. Some species have both rhodopsin and porphyropsin based photopigment (Dartnall, 1962; Bridges, 1965a, b, c; Schwanzara, 1967; Beatty, 1966; Allen, Loew and McFarland, 1982) and their ratio varies with a number of factors, such as temperature (Allen and McFarland, 1973; Cristy, 1976; Tsin and Beatty, 1977), season (Bridges and Yoshikami, 1970a), hormonal state (Munz and Swanson, 1965), ambient light (Bridges and Yoshikami, 1970b) and day length (Loew and Dartnall, 1976).

Porphyropsin absorption curves are similar to those of

rhodopsin but somewhat broader (Bridges, 1967; Munz and Schwanzara, 1967; Mooij and Berg, 1983). More importantly porphyropsins have an absorption peak that is shifted towards longer wavelengths, compared with its rhodopsin analogue and the shift is relatively greater for long (red) wavelength pigments than for those that peak at shorter (blue, green) wavelengths.

Classically, it is the solubilized (extracted) form of the visual pigment that has been used to study its spectral properties (Wald, 1935, 1968; Dartnall, 1957, 1962). Rod pigments are dominant in the extracts since cone pigments may contribute only 1% or less (Liebman, 1972). Studies of cone pigments have been hindered because of the difficulty of their extraction, possibly due to the particular lamellar organization. The visual pigments of rods and cones do not appear to differ fundamentally from each other (Dartnall, 1960). Microspectrophotometry (M.S.P.) has been applied to single photoreceptor outer segments to define the absorption spectra of single rods and cones alike (Liebman and Entine, 1964; Liebman, 1972).

1.3.4. Cone types and cone arrangements.

Cones of lower vertebrates are variable in structure and they may differ markedly in closely related species. Subsequently, many investigators were concerned with the form and cone arrangements in the teleostean retinas (Engstrom, 1963a ,b; Scholes, 1975; Stell and Lightfoot, 1975).

Cone types and cone arrangements of the Eurasian perch (Perca fluviatilis) have been investigated by a number of authors. Two types of cone photoreceptors in perch have been described: equal

double cones and single cones (Muller, 1856, 1872, 1874; Schulze, 1866, 1867; Friis, 1879; Krause, 1886; Eigenmann and Shafer, 1900; Greef, 1900; Wunder, 1925; Arey, 1928; Lyall, 1957; Engstrom, 1963b; Ahlbert, 1969). Morphologically double cones are classified as unequal, when they consist of a long and a short member (principal and accessory) and as equal (or twin) cones when both members are of equal size (Walls, 1942). Single cones are classified according to their general appearance, i.e. long or short singles, and by their position in the receptor mosaic, i.e. additional or central single cones (Engstrom, 1963b).

Several workers have suggested that the possession of double cones is related to sensitivity (Willmer, 1953; Lyall, 1957; O'Connell, 1963; Engstrom, 1963b) and is associated with vision in deep water. A supporting evidence has been found in the teleost species, *Sebastes diploproa*, which develops distinct cone patterns, with the loss of single cones, in association with permanent migration from the surface to deep water (Boehlert, 1978). Lythgoe (1979) concluded that double cones are associated with vision at the lowest light intensities.

The cones in perch, as in a number of other teleosts form a very regular square mosaic, which is made by four double cones with a single cone in the centre of the square (Lyall, 1957; Engstrom, 1963b; Ahlbert, 1969). A regular square mosaic is generally observed in the retinae of active, shallow-living teleosts, but a row pattern is observed in deep-living teleosts (Lyall, 1957; Engstrom, 1963b).

Interspecific comparison, correlating cone type and pattern with the behavior and ecology of teleosts, has suggested that

species with well developed patterns of single and double cones feed on fast moving prey, indicating that these patterns may improve perception of movement (Lyll, 1957), possibly providing a structural basis for high temporal and spatial resolution (Wagner, 1975). Double cones and poorly developed patterns, on the other hand, are associated with less acute vision in deep water (Boehlert, 1978).

Variations in cone density in the fish retina have been shown to depend on the main visual direction with the corresponding correlations between cone density and feeding habits (Vilter, 1947, 1950; Engstrom and Ahlbert, 1963; Ahlbert, 1969). Ahlbert (1969) found that in the perch retina the highest cone density was in a horizontal region towards the posterior part of the retina.

It had become clear among investigators using microspectrophotometry that there was some correlation between cone morphology and the spectral absorption of the visual pigment (Marks, 1965; Svaetichin, Negishi and Fatehchand, 1965; Liebman and Entine, 1968; Harosi and MacNichol, 1974). However, the correlation between cone structure and spectral absorption was first recognized by Scholes (1975) and he was the first to apply it to analysis of a chromatic pathway in the rudd retina (Scholes and Morris, 1973; Scholes, 1975). Using photographic densitometry, Scholes and Morris (1973) found the rudd to be trichromatic. The rudd has, however, turned out to be photochemically very complex since it contains A1/A2 mixture, but the results obtained by Scholes have been confirmed (Loew and Dartnall, 1976; Loew and Lythgoe, 1978). In the related goldfish six morphologically distinguishable cone types have been shown, by microspectrophotometry, to contain one of three

visual pigments with absorption maxima in the blue (455 nm), green (532 nm) and red (623 nm) region of the spectrum (Liebman and Entine, 1964; Marks, 1965; Harosi and MacNichol, 1974; Stell and Harosi, 1976).

In the perch (Perca fluviatilis), Loew and Lythgoe (1978) found, in their studies using microspectrophotometry, that both members of the equal double cone contain the same photopigment with an absorption maximum at 615 nm (red) and the single cone with an absorption maximum at 535 nm (green). Both are vitamin A₂ or porphyropsin. Recently Loew and Lythgoe (1978) and Levine, MacNichol, Kraft and Collins (1979) classified equal double cones as 'identical twins' if both members contained the same photopigments and as 'non-identical' if they did not.

Photochemically and structurally identified cone types can also be recognized by the position they occupy in the receptor mosaic (Marc and Sperling, 1976a, b). Correlation studies between pigment content and cone structure using microspectrophotometry in fish retina have revealed that, in general, the long wavelength (red) pigment is contained in long cones, i.e. long double and long single cones. The green photopigment is contained in the short double and long single cones and the blue pigment is contained in short single and in miniature short single cones. The cone shape within a given species may indicate the pigment content but there is not yet enough data to allow extrapolation from one species to another (Stell and Harosi, 1976; Loew and Lythgoe, 1978).

1.3.5. Synaptic terminations, outer plexiform layer.

There is a striking difference between the synaptic termination of rods and cones in fish, nocturnal birds and mammals. The cones have a flat conical (pyramidal) foot, called a pedicle, but the rods terminate in a much smaller rounded swelling called a spherule. From the photoreceptor terminals arise a number of fine processes called basal processes or telodendria, which ramify in the outer plexiform layer.

The terminals of rods and cones both contain small synaptic vesicles, of 30-60 nm in diameter. The synaptic vesicles in rod terminals are of uniform size and are more abundant than in cones (Evans, 1966).

It is generally believed that the synaptic vesicles contain the transmitter substance. It is not clear whether there is a change in size or number of these vesicles after periods of light and dark (Cohen, 1972), nor has the photoreceptor neurotransmitter been identified.

The receptor cytoplasm opposed to the tips of the invaginating processes has a ribbon-like structure, termed the synaptic ribbon (Sjostrand, 1953b). Cohen (1963a) showed that the synaptic ribbon is a penta-laminar structure in cross-section. It seems to be separated by a clear zone of 10-20 nm from the synaptic vesicles which surround the ribbon. The ribbon is separated from the cone cell membrane by a smaller electron-dense organelle called an arciform density (Ladman, 1958).

The function of the synaptic ribbon is unknown but similar structures have been described in the inner plexiform layer in

bipolar cells (Kidd, 1962; Dowling and Boycott, 1965, 1966) and in other receptors such as the hair cells of the cochlea (Smith and Sjostrand, 1961a, b), the vestibular apparatus (Flock, 1964) and the lateral line organ (Flock, 1965; Hama, 1965).

Rod spherules in most vertebrates have a single pit which contains the invaginating processes although there may be more than one synaptic ribbon. In some vertebrate classes rods terminate in a pedicle rather than in a spherule, which has a number of synaptic ribbons, and are not easily distinguished from the cone terminations (Cohen, 1963a; Evans, 1966; Dowling, 1968).

In mammalian cones there is a separate synaptic invagination for each synaptic ribbon (there may be as many as 30), which contains just the two horizontal processes in the lateral position, and one bipolar process in the central position, and is termed triad (Missotten, 1965b). In lower vertebrates the position is less clearly described but, in general, several ribbons share a common synaptic cavity occupied by numerous bipolar and horizontal cell processes (Pedler, 1965; Stell, 1967; Lasansky, 1971; Witkovsky, Shakib and Ripps, 1974; Scholes, 1975; Haesendonck and Missotten, 1979, 1984).

The definitive synaptic junctions with photoreceptors fall into two groups, superficial (basal) and invaginated. Superficial contacts have been observed on pedicle terminals in primates (Cohen, 1961; Dowling and Boycott, 1966). The situation is less clear in other vertebrates. Superficial contacts have been demonstrated in frogs (Dowling, 1968), in turtles (Lasansky, 1969) and in the mudpuppy (Dowling and Werblin, 1969), but Scholes (1975) did not

observe them in the fish retina. These contacts may be synaptic but neither side shows clear morphological specializations such as aggregation of synaptic vesicles.

1.3.6. Photoreceptor interconnections.

Photoreceptors contact one another at two sites i) along the inner segment (ellipsoid) and ii) at the level of the synaptic terminals.

The close membrane contact between inner segments of teleostean double cones is characterized by large areas of mutually opposed membranes, separated by a very regular cleft. Each cone contains a single flattened subsurface cisterna which has been described in a number of teleosts (Engstrom, 1963b; Stell, 1965; Berger, 1967; Ahlbert, 1973). Similar contacts have been described between rod and cone inner segments in goldfish (Stell, 1965) and rod to rod contact in humans (Uga, Nakao, Mimura and Ikui, 1970). Other special but non synaptic contacts have been described in other vertebrates (Cohen, 1963a, Pedler and Tilly, 1964; Locket, 1970a). Cohen (1963a) suggests that such close contact makes the cells an optical unit.

At the synaptic terminals, photoreceptors may contact one another in a variety of ways, to a variable degree of specialization. Mainly by two ways: a) Through simple membrane apposition, without evidence of any functional specialization and b) via basal processes (telodendria).

Membrane appositions have been described between receptor terminals in a number of vertebrates and generally without any

selectivity for receptor type (Nilson, 1964b; Cohen, 1965; Missotten, 1966; Dowling and Werblin, 1969; Sjostrand, 1969; Raviola and Gilula, 1973; Fain, Gold and Dowling, 1976). In some cases the membranes show an increase in electron density and may resemble gap junctions, which may mediate low resistance coupling between receptors (Witkovsky et al., 1974; Scholes, 1975; Nagy et al., 1979 as quoted by Stell, 1980).

It seems likely that these inter-receptor contacts have another function than physiological interaction because of their lack of selectivity for receptor type (Cohen, 1965; Missotten, 1965a; Dowling and Boycott, 1966; Scholes, 1975).

The horizontally orientated terminal filaments or telodendria are now usually termed 'basal processes'. Basal processes seem to be a universal feature of vertebrate synaptic terminals of cones and rods from most species, except for mammalian rods (Cajal, 1892; Polyak, 1941). Basal processes are small processes which extend laterally in the outer plexiform layer and their length and density vary according to species, retinal locus and, among lower vertebrates at least, to cone type (Cajal, 1892).

The basal processes (telodendria) in vertebrates are known to make contact with other processes of unknown origin (Lasansky, 1971) as well as other basal processes, with pedicles, and some may contact rods. These contacts are usually characterized by membrane apposition (Sjostrand, 1958, 1959, 1965; Cohen, 1964, 1965; Missotten, 1965a, b; Lasansky, 1971, 1972).

In addition, basal processes may also make contact with second-order cells, as has been observed in catfish (Sakai and Naka, 1983).

Some cone basal processes have been shown to enter the synaptic cavity of neighbouring cone pedicles in lower vertebrates, such as in turtle (Lasansky, 1972; Normann, Perlman, Kolb and Daly, 1984) and in teleosts (Scholes, 1975; Lockhardt and Stell, 1979). Scholes (1975) observed in the rudd that the pattern of interconnections via the invaginating basal processes is colour-coded; only chromatically different sets of cones invaginate one another. This has also been observed in goldfish (Lockhart and Stell, 1979).

1.4. Horizontal cells.

Heinrich Muller (1851, 1856) was first to describe horizontal cells, which he called the 'zwischenkornerschicht'. He noted two layers of horizontally oriented cells between the outer and inner nuclear layers. Subsequently a number of the early investigators described similar cells under various names. Since these cells appeared to have no axon they were considered to be supporting cells (Schiefferdecker, 1886). The horizontal cells have been described in most vertebrates, they are usually relatively large compared to other retinal cells, forming between one and four continuous but perforated layers proximal to the outer plexiform layer. Cajal (1892) observed with the Golgi method that horizontal cells had dendritic processes extending into the outer synaptic layer and he suggested that they contacted photoreceptors. Electron microscopic studies have demonstrated 'tight junctions' or 'gap junctions' between horizontal cells of the same type (Yamada and Ishikawa, 1965; O'Daly, 1967; Witkovsky and Stell, 1973; Lasansky, 1976; Witkovsky, Burkhardt and Nagy, 1979).

Cajal (1893) was in no doubt that teleost horizontal cells were neurons, while other workers (Villegas, 1960; Villegas and Villegas, 1963; Testa, 1966) claimed that they were either glia or morphological intermediates between glia and neurons (Svaetichin et al., 1965). It has been pointed out, a) that they lack nissl substance, which is normally a characteristic of neurons (Villegas, 1960; Villegas and Villegas, 1963; Yamada and Ishikawa, 1965; Stell, 1967), b) that they have a high content of glycogen (Parthe, 1967) and c) that they lack synaptic vesicles and membrane specializations characteristic of synaptic regions (Yamada and Ishikawa, 1965). Nevertheless, the ultrastructural relationship between horizontal cells and the photoreceptors and their physiological characteristics leave no doubt that they are neurons.

1.4.1. Teleosts.

Teleostean horizontal cells are connected either to rods or cones (Cajal, 1892; Stell 1967; Parthe, 1972; Wagner, 1978, Haesendonck and Missotten, 1979). Horizontal cells vary considerably in size and shape in different species of teleosts. Retinas which have a high proportion of rods tend to have more layers and larger cells than those which have a high proportion of cones (Cajal, 1892). The cells in the distal layer are usually small and polygonal, while those in the successive proximal layers are progressively larger and more stellate (Villegas and Villegas, 1963; Testa, 1966; Parthe, 1967, 1972; Stell and Lightfoot, 1975; Haesendonck and Missotten, 1979; Witkovsky et al., 1979). In retinas where the rods and cones are nearly equal in number, the horizontal cells are

reduced to a single layer (Engstrom, 1963a; Anctil, 1969; Stell, 1972). In the rod dominated retinas there are as many as four layers of horizontal cells and of the four layers, three appear to make contact with cones and one with rods (Parthe, 1972).

Stell and Lightfoot (1975) described three types of cone horizontal cells in goldfish. They were termed H1, H2 and H3 cells in order of increasing density of cone contacts. The particular synaptic contacts that each of the goldfish horizontal cell types makes with photoreceptors were evaluated by Stell and Lightfoot (1975) and chromatic input was characterized by correlating the cone pigment and photoreceptor morphology (Scholes, 1975). The H1 cells (external) contact all cone types, red, green and blue cones. The H2 cells (intermediate) make synaptic contact with green and blue cones, and H3 cells (internal) contact only blue cones. Similar methods, making use of the regular receptor mosaic in teleosts have been applied to reveal the connectivity pattern between cones and horizontal cells, such as in cichlids (Wagner, 1976), in the marine teleost, dragonet (Haesendonck and Missotten, 1979), and in pikeperch (Witkovsky et al., 1979).

Rod horizontal cells have been shown to occupy the third layer (of four) or the fourth layer depending on species (Stell, 1965; Parthe, 1972). However, in Callionymus lyra (dragonet) Haesendonck and Missotten (1979) describe a rod horizontal cell which occupies the external (distal) layer of the inner nuclear layer. The variety of horizontal cells in teleosts is great and therefore it is hardly meaningful to refer to the generalized teleost retina.

Horizontal cell axons: Cajal (1892) observed axons on the external and intermediate horizontal cells, but he did not observe an axon terminal. Investigators using the Golgi method have in some cases been unable to demonstrate axons on horizontal cells (Stell, 1967; Stell and Witkovsky 1973b), or have reported difficulty in locating these horizontal cell axons in teleosts (O'Daly, 1967; Parthe, 1967). Cajals 'internal horizontal cells' have never been shown to send processes into the outer synaptic layer and thus Stell (1967) did not consider them to be true horizontal cells. Yamada and Ishikawa (1965) and Stell (1967) failed to find evidence for a nucleus or a cell body in these cells. Stell (1975) designated them 'cylindrical processes' of the intermediate neuronal layer, a term which simply recognizes their observed form. Recently Weiler and Zettler (1979) showed the horizontal cells and their axons to be functional as well as structural units. Because of staining failure the axon is not always apparent on all cells, it seems likely that some horizontal cells lack an axon, in some cases, however, axons have been reported in the majority of cells (Parthe, 1972; Wagner, 1972; Stell, 1975; Haesendonck and Missotten, 1979). The lack of an axon has led some investigators to term them 'stellate amacrines' (Testa, 1966; Parthe, 1967), but these cells were later shown to be rod horizontal cells (Parthe, 1969, 1970, 1972; Stell and Laufer as quoted by Stell, 1972).

1.4.2. Other vertebrates.

Horizontal cells in elasmobranchs are known to be very large and to form at least two distinct layers (Yamada and Ishikawa,

1965). Stell and Witkovsky (1973b) reported three distinct types of horizontal cells which were segregated in distinctly separate layers in the smooth dogfish. The external and the intermediate horizontal cells make contact with rods. The internal (vitread) H-cells contact cones. Toyoda, Saito and Kondo (1978) reported three types of horizontal cells in the stingray retina, which apparently have receptor connections similar to the dogfish horizontal cells, except that the external horizontal cells receive input from both rods and cones. In general, the vertical sequence of horizontal cells which contact rods or cones in dogfish is inverted from that in teleosts.

In reptiles, Cajal (1892) distinguished two types of horizontal cells, a) brush-shaped cells, and b) stellate cells. He suggested that both made contact with cones but with different types. These two horizontal cell types have been described in the turtle retina by Lasansky (1971). However, in Golgi preparations of turtle retina Leeper (1978a, b) observed four types of horizontal cells which he termed H1, H2, H3 and H4. H1 is a stellate cell body (H1CB) with an axon and an axon terminal (H1AT), and both parts make contact with receptors as in mammals. Dendritic terminals of H1 cell bodies contact red and green cones while the axon terminal contacts only red cones and rods. He described H2, H3 and H4 cells as axonless stellate cells, the H2 cell made contact on green and blue, and the H3 on blue cones only, the H4 cell contacted only green sensitive accessory members of the double cones.

In the amphibian retina Cajal (1893) distinguished two types, outer and inner horizontal cells. Using intracellular injections of HRP (horseradish peroxidase) Lasansky (1978) only observed a single

type of horizontal cell containing an axon that makes contact with photoreceptors. The cell body and the axon terminal are separate functional units (Lasansky, 1978).

Two types of horizontal cells have been described in the bird retina (Mariani and Du Pree, 1977). A brush-shaped horizontal cell with an axon and its stellate axon terminal, both of which make contact with photoreceptors (Cajal, 1892; Gallego, Baron and Gayoso, 1975; Gallego, 1976; Mariani and Du Pree, 1977), and an axonless stellate horizontal cell (Mariani and Du Pree, 1977). The brush-shaped cell body and the axonless stellate cell contact cones but the axon terminal makes contact with rods or with rods and cones depending on species (Gallego, 1976; Mariani and Du Pree, 1977).

In non-primate mammals Cajal (1893) described two types of horizontal cells which he called outer and inner horizontal cells, these have been observed in the retina of mammals such as the ox, cat and rabbit and are termed type A and B cells (Gallego, 1971, 1976; Fisher and Boycott, 1974; Kolb, 1974; Boycott, Peichl and Wassle, 1978). Type A is a large axonless stellate cell (Fisher and Boycott, 1974; Kolb, 1974; Wassle, Peichl and Boycott, 1978, 1979; Kolb and Normann, 1982), and type B has an axon and resembles the HI cell in primates and makes contact with rods (Kolb, Mariani and Gallego, 1980; Dacheux and Raviola, 1981).

Initially the primate retina was said to contain only one horizontal cell type, termed the HI cell (Polyak, 1941; Kolb, 1970; Gallego, 1971; Boycott and Kolb, 1973; Ogden, 1974; Gallego and Sobrino, 1975). Recently, however, Kolb et al. (1980) described a second type of horizontal cell in the monkey retina, termed the HII

cell. Both the HI and the HII cell types have an axon and an axon terminal, and both cell parts make contact with photoreceptors as lateral elements of the ribbon synapse (Kolb et al., 1980). The cell bodies of both types make contact with cones, but the axon terminal of the HI cell contacts rods, in contrast to the axon terminal of the HII cell, which contacts cones (Kolb, 1970; Boycott and Kolb, 1973; Gallego and Sobrino, 1975; Gallego, 1976; Kolb et al., 1980).

1.5. Other neurons of the retina.

1.5.1. Bipolar cells.

The bipolar cells of the retina are neurons which make synaptic contacts in the inner and outer synaptic (plexiform) layers. The bipolar cells transfer information directly from photoreceptors to ganglion cells and these pathways, receptor > bipolar > ganglion cells, have been termed the direct-through pathways.

In fish, Cajal (1892) described two types of bipolar cells in the teleost retina, large and small, similar to what Schiefferdecker (1886) had noted in most other vertebrates. Cajal (1892, 1893) concluded that the large bipolars made synaptic contact with rod spherules whereas the small bipolar cells contacted cone pedicles. It has since been shown that the large bipolars also make contact with cones (Stell, 1967; Parthe, 1972; Scholes and Morris, 1973; Scholes, 1975; Stell, Ishida and Lightfoot, 1977; Ishida, Stell and Lightfoot, 1980).

Numerous morphological types of bipolar cells have since been identified in the fish retina (Haesendonck and Missotten, 1984; Parthe, 1972; Scholes, 1975; Stell, 1967, 1972, 1978).

Bipolar cells can be classified by the specific connections they make with rods and cones with selective or a combination of chromatic receptor types. Bipolar cells fall within one of the two major categories, mixed bipolars (MB) that make contact with both rods and cones, and pure cone bipolars (CB) which contact only cones (Scholes, 1975).

The type and location of synaptic terminations in the inner plexiform layer (IPL) has been directly correlated to the bipolar cells general response properties and is used as an additional means of classifying bipolar cell types. Functionally, bipolar cells have been classified as ON and OFF cells. A correlation between functionally and morphologically identified bipolar cells has shown that in cyprinids, OFF (hyperpolarizing) cells terminate in the distal sublamina (termed 'a'), while ON (depolarizing) cells terminate in the proximal sublamina (termed 'b'), of the inner plexiform layer. So that in addition to being classified morphologically as mixed bipolar (MB) or cone bipolar (CB) they are also classified in accordance with the sublamina (a or b) of the inner plexiform layer in which the dendritic tree ramifies (Famiglietti, Kaneko and Tachibana, 1977; Stell et al., 1977; Ishida et al., 1980). The inner plexiform layer in the non-mammalian retina is stratified and usually five or more strata have been observed (Cajal, 1892; Boycott and Dowling, 1969; Wagner, 1973a, b) and the simple classification into sublamina 'a' and 'b' may not always be clear (Haesendonck and Missotten, 1983).

Bipolar cells contact photoreceptor terminals over the extent of their dendritic fields and it has been suggested that the nature

of these contacts determines the bipolar cell's response properties (Stell, 1976; Stell et al., 1977; Saito, Kujiraoka and Yonaha, 1983; Sakai and Naka, 1983), however, other investigators found no correlation between the type of junction and bipolar cell response properties (Lasansky, 1978; Dacheux, 1982).

1.5.2. Amacrine cells.

The amacrine cell bodies lie in the most proximal part of the inner nuclear layer, with the exception of displaced varieties, and their processes extend into the inner plexiform (synaptic) layer. The word 'amacrine' (Cajal, 1892), which means no axon, is an appropriate term since the amacrine cells are characterized by having numerous identical processes. Cajal (1893) described two main types of amacrine cell, diffuse and stratified, which he found in all vertebrate classes. Stratified cells can be divided into 'unistratified', 'bistratified' or 'multistratified' cells depending on whether their processes ramify in the same planar level or in two or more levels of the inner plexiform layer. In addition to classifying amacrine cells by the disposition of their processes, Cajal further distinguished them in terms of size, position and shape of their cell body; the thickness, branching size of their fields and the form of their processes. This method of classifying amacrine cells is still used, characterizing each cell type by their dendritic morphology (i.e. field, size and branching pattern) and specific stratification levels (Boycott and Dowling, 1969; Kolb, 1982).

In teleosts several types of stratified amacrines have been described. In addition to the diffuse amacrine cells (Vrabec, 1966;

Testa, 1966; Parthe, 1967) displaced amacrines have been observed in fish, these are unistratified cells whose soma are in the same layer as their processes (Testa, 1966; Parthe, 1967; Chan and Naka, 1976). Similarly displaced amacrine cells have been observed in other vertebrates (Gallego, 1971; West, 1976; Hughes and Vaney, 1980; Perry, 1981).

A variable number of amacrine cells have been observed in most vertebrate retinas (see Stell, 1972 for review) and only generalizations can be made. A great number of morphologically different types of amacrine cells have been described for example in cat (>20) (Kolb and Nelson, 1981) and 27 different types have been described in turtle (Kolb, 1982).

A variety of contacts have been described between cells in the inner plexiform layer. The bipolar cell terminals contain a synaptic ribbon (Cohen, 1961) contacting a pair of postsynaptic processes, this has been termed 'dyad' (Dowling and Boycott, 1965a, b). In primates, one element of each dyad is contributed by a ganglion cell, the other by an amacrine cell. Other combinations have been observed, such as amacrine - bipolar (no ribbon), amacrine - amacrine and amacrine - ganglion cell contacts (Dowling and Boycott, 1965a, b, 1966, 1969). They suggested that the amacrine cells mediate lateral interactions which are responsible for the opponent surround functional receptive field of the ganglion cell (for full review see Stell, 1972; Wheeler, 1982).

1.5.3. Interplexiform cells.

The interplexiform cell was first observed and termed by Dowling and Ehinger (1975), using a histochemical technique (developed by Falck, Hillarp, Thieme and Torp, 1962), whereby amine-containing neurons can be selectively made to fluoresce throughout their cellular structure. They observed this neuron in goldfish and monkey retina. The interplexiform cells were occasionally stained with the Golgi method in cat, monkey and squirrel (Boycott et al., 1975), subsequently, Dowling, Ehinger and Hedden (1976) suggested the interplexiform cells to be a general feature of the vertebrate retina.

The interplexiform cell perikaryon is located among amacrine perikarya bodies in the inner nuclear layer, and extends processes into both plexiform layers. Following intravital injection of drugs, these cells were identified in an electron microscope, and their synaptic organization studied (Dowling and Ehinger, 1975; Dowling et al., 1976). In goldfish the interplexiform cell processes were reported to be pre- and post-synaptic to amacrine cells in the inner plexiform layer and pre-synaptic to bipolar and horizontal cells in the outer plexiform layer. These interplexiform cells appear to provide an intraretinal centrifugal pathway from the inner to the outer plexiform layer and use dopamine as a neurotransmitter.

1.5.4. Ganglion cells.

The proximal neural layer of the retina contains cells termed the ganglion cells. Their axons become fibers of the optic nerve and

their dendrites ramify in the inner plexiform layer where they are postsynaptic to amacrine cell processes and bipolar cell axon terminals. Ganglion cell perikarya usually lie in the ganglion cell layer, vitread to the inner plexiform layer. However, displaced ganglion cells may occur in the inner plexiform or in the amacrine cell layer. Cajal (1892) describes two main types of ganglion cells; diffuse and stratified. It was first shown in mammals by Gallego (1954) that the dendritic fields of ganglion cells are much smaller than the functional receptive fields. Gallego proposed that the direct bipolar-ganglion cell dendritic contact might determine only the properties of the centre of the receptive field, the periphery effect being mediated by some other neurons, probably amacrine cells.

Recent studies have correlated at least three morphological ganglion cell types in the carp with the general characteristics of their response properties (Famiglietti et al., 1977). ON ganglion cells terminate in sublamina 'b' of the inner plexiform layer as do ON bipolar cells. OFF ganglion cells and OFF bipolar cells ramify in sublamina 'a'. Individual ON-OFF ganglion cells make contacts in both sublamina of the inner plexiform layer. The cell bodies of the ON ganglion cells are much smaller than those of the OFF or the ON-OFF cells, which have relatively large cell bodies (Famiglietti et al., 1977). No correlations have yet been reported between a ganglion cell's spectral properties and its morphological characteristics.

Boycott and Dowling (1969) classified primate ganglion cells into five varieties, and recently Mariani (1982) describes a gan-

glion cell that contacts photoreceptors, which he termed 'biplexiform' cell. A great variety of ganglion cell types have been described in vertebrates but systematic and comprehensive investigations are lacking, with the exception of studies on the primate retina (Polyak, 1941, 1957; Boycott and Dowling, 1969; Stell, 1972; Rodieck, 1973). Recently Kolb, Nelson and Mariani (1981) describe 23 morphological types of ganglion cells in the cat retina and 21 in the turtle retina (Kolb, 1982), however, whether each of these cell types is a unique functional type is unknown.

Chapter 2.

Physiology of the retina.

2.1. General.

Photoreceptor, bipolar and ganglion cells form a through pathway for visual signals in the retina. The response properties of these retinal through pathways are modified in successive stages by interaction with horizontal and amacrine cells. Receptors provide direct input to both horizontal and bipolar cells. All visual signals reaching the inner plexiform layer must pass through bipolar cells, since only they terminate in both the inner and the outer plexiform layers. The information content at successive stages in this retinal through pathway is altered by interaction of the laterally orientated horizontal cells with the receptors and bipolar cells in the outer plexiform layer, and by interaction of amacrine cells with bipolar and ganglion cells in the inner nuclear layer.

2.2. Photoreceptors.

All vertebrate photoreceptors respond to illumination with a membrane hyperpolarization as has been shown in teleosts (Kaneko and Hashimoto, 1967; Tomita, Kaneko, Murakami and Pautler, 1967; Burkhardt, 1977), in reptiles (Toyoda, Nosaki and Tomita, 1969; Baylor and Fuortes, 1970; Baylor, Fuortes and O'Bryan, 1971; Baylor and Hodgkin, 1974), in amphibians (Bortoff, 1964; Werblin and Dowling, 1969; Fain and Dowling, 1973; Fain, 1975) and in mammals (Penn and Hagins, 1969; Nelson, Kolb, Famiglietti and Gouras, 1976).

The hyperpolarization is accompanied by an increase in membrane resistance in the outer segment, which suggests that the receptor

potential results from decreased conductance for an ionic process, having a more positive equilibrium potential than resting potential (Borton and Norton, 1967; Toyoda et al., 1969; Baylor and Fuortes, 1970; Werblin, 1975a). Intracellular recordings show that the transmembrane resting potential is -10 to -40 mV in the dark, depending upon species. Penn and Hagins (1969) demonstrated that a steady current flows from the inner segment into the outer segment in darkness and that this current is reduced by illumination. Furthermore, when the outer segment is broken away from the inner segment, the light response disappears (Yau, Lamb and Baylor, 1977), which is consistent with the conclusion drawn earlier (Penn and Hagins, 1969) that the inner segment is the source of the current.

The hyperpolarizing response to light is thought to result from the decrease of a selective sodium conductance in the outer segment (Arden and Ernst, 1969; Sillman, Ito and Tomita, 1969a, b; Yoshikami and Hagins, 1970; Korenbrot and Cone, 1972; Cervetto, 1973; Brown and Pinto, 1974). The amplitude of the photoreceptor response and the PIII component of the electroretinogram varies in direct linear proportion to the logarithm of the external sodium concentration (Sillman et al., 1969a, b). Similarly when extracellular sodium is replaced by lithium, choline or sucrose, the membrane hyperpolarizes and the light response is abolished (Cervetto, 1973; Brown and Pinto, 1974; Capovilla, Cervetto, Pasino and Torre, 1981). Recently Woodruff, Fain and Bastian (1982), demonstrated with labeled sodium that darkadapted retinas show higher sodium accumulation than lightadapted retinas which corresponds closely to the value of photoreceptor dark current.

In the rod, at least, the light activated change in membrane potential affects voltage dependent mechanisms which in turn contribute to the shaping of the receptor potential (Lasansky and Marchiafava, 1974; Schwartz, 1976; Fain, Quandt, Bastian and Gerschenfeld, 1978; Detwiler, Hodgkin and MacNaughton, 1978; Bader, MacLeish and Schwartz, 1979; Bader and Bertrand, 1984). Photoreceptor response to a bright flash shows an initial peak followed by a decay to a plateau (Fain, 1975). The factors responsible for the initial peak and the later plateau are complex. An inward current activated by hyperpolarization and carried by sodium and potassium ions, contributes to the decay of the initial peak to plateau value (Fain et al., 1977; Bader et al., 1982). It is not known whether cone membranes contain the same voltage-sensitive channels as do the rod membranes. Responses to bright flash show a sag back to depolarized plateau from an initial peak hyperpolarization suggesting that there is a voltage-gated current in cones (Attwell, Werblin and Wilson, 1982; Attwell, Werblin, Wilson and Wu, 1982). However, at least part of this results from a depolarizing feedback from horizontal cells to cones (Baylor et al., 1971; Simon, 1973; Attwell et al., 1982a, b) which rods appear to lack (Copenhagen and Owen, 1976; Attwell, Werblin, Wilson and Wu, 1983).

Penn and Hagins (1969) and Hagins, Penn and Yoshikami (1970) demonstrated an axial 'dark' voltage gradient in the interstitial space along the whole length of the receptor, with the synaptic region positive in respect to the outer segment tip. Upon illumination, the flow of current is reduced but the change never exceeds the dark current.

2.2.1. Transduction mechanisms.

Vertebrate photoreceptors contain an ion conductance mechanism whose properties are controlled by chemical events that are modulated by photon absorption. Because rhodopsin is situated as an integral membrane protein in lamellar disks not contiguous with the plasma membrane in rods, one or more light-regulated internal messengers must communicate between the disk membrane and the plasma membrane. The argument for cones is somewhat different, because, at least some of their disks are confluent with the extracellular fluid. However, photoactivation of a visual pigment molecule must result in the release of a substance, the internal transmitter, that affects a large number of conductance channels in cones (Cone, 1973). It has been argued that hundreds or thousands of internal transmitters are generated by isomerization of a single molecule (Yoshikami and Hagins, 1973; Baylor, Lamb and Yau, 1979; Baylor, Matthews and Yau, 1980). A substantial body of evidence supports the hypothesis that calcium is the messenger that affects rod sodium conductance decrease. The evidence includes the following facts; first, that elevated intracellular calcium activity decreases the sodium conductance (Yoshikami and Hagins, 1973) and hyperpolarizes the rod (Brown, Coles and Pinto, 1977), second, that illumination causes extrusion of calcium from rods into the extracellular space (Gold and Korenbrot, 1980; Yoshikami, George and Hagins, 1980) on a time scale with a rising phase that closely resembles the normal photocurrent (Yoshikami et al., 1980) and finally that light-stimulated release of calcium from calcium-loaded disks is

produced with the speed required by visual excitation (George and Hagins, 1983).

An alternative hypothesis was proposed after discovery of phosphodiesterase activity in rod outer segment. The cyclic nucleotide hypothesis (Hubbell and Bownds, 1979) states that photon absorption activates an endogenous enzyme system (Yee and Liebman, 1978; Liebman and Pugh, 1979), in which the enzyme would produce the transmitter and modify the permeability of the membrane. An increase in cyclic GMP by injection or by using phosphodiesterase inhibitor IBMX, resulted in the depolarization of the cell membrane and an increase in the light dependent permeability (Miller and Nichol, 1979). Capovilla, Cervetto and Torre (1983) suggested that phosphodiesterase activity controls the time course of light response in vertebrate rods. Changes in cyclic GMP may change the intracellular calcium ion concentration and thus indirectly influence the membrane permeability. Since the decrease in cyclic GMP is rapid and occurs over the same range of light intensities as the photoreceptor light responses and the light-dependent increase in calcium efflux from rods (Gold and Korenbrot, 1980), it is conceivable that the decrease in cyclic GMP is responsible for triggering a release of calcium ions during transduction (Woodruff and Fain, 1982).

2.2.2. Photoreceptor response properties.

The hyperpolarizing response to illumination is graded in amplitude and duration as a function of intensity of the stimulus (Tomita et al., 1967; Tomita, 1970; Burkhardt, 1977). The response

(V) versus light intensity (I) relationship follows a template function, according to the principle of univariance as was proposed by Naka and Rushton (1966). The isomerization of photopigment is solely a function of the number of quanta absorbed by the pigment and is independent of the wavelength of the incident illumination, as is shown by the following equation.

$$\frac{V}{V_{\max}} = \frac{I^n}{I^n + I_0^n}$$

where: V_{\max} = saturation response voltage, I_0 = value of I for which $V = 1/2 V_{\max}$ and n = an exponent usually close to 1.0.

The duration of rod and cone responses increases as a function of increasing stimulus intensity even after the response has reached its maximum amplitude (V_{\max}).

There are basic differences between responses of rods and cones. In general cones respond more rapidly than rods to both stimulus onset and cessation of stimulus, whereas rods recover slowly from their response to a stimulus irrespective of whether or when the stimulus is terminated.

Receptive field organization: The light response of the vertebrate photoreceptor depends not only on the photons effectively absorbed in its outer segment, but also on the illumination of the adjacent area of the retina. There are two types of interaction that modify the photoreceptor receptive field.

First, rods and cones do not function independently but are coupled through electrical junctions. The receptor potential shows spatial summation to illumination of areas which are much greater than their own cross-sectional area. For example, in turtle and in

pikeperch cones, Baylor et al. (1971) and Witkovsky et al. (1979) found spatial summation up to a radius of about 40 to 50 μm . Baylor et al. (1971) demonstrated by passing current through a cone that the spatial summation results from electrical coupling between cones. Gap junctions have been found between contiguous cones (Raviola and Gilula, 1973; Witkovsky et al., 1974; Fain et al., 1976; Witkovsky et al., 1979), and electrical coupling occurs only between cones of the same chromatic type (Baylor et al., 1971; Baylor and Hodgkin, 1973; Detwiler and Hodgkin, 1979). Spatial summation in rods is extensive in turtle and toad retinas and covers a much wider area than in cones (about 200 μm) and the electrical coupling is stronger (Fain, 1975; Fain, Gold and Dowling, 1975; Schwartz, 1975; Copenhagen and Owen, 1976). Up to 80% of the response recorded from one rod may be due to light absorption in neighbouring rods.

Second, illumination of surround areas results in a depolarizing component in the cone response waveform during the steady phase. Thus the receptive field of turtle cones has an antagonistic centre-surround organization (Baylor and Fuortes, 1970; Baylor et al., 1971). More recently, similar interactions have been found in gecko (Pinto and Pak, 1974a, b) and perch retinas (Burkhardt, 1977), so it seems probable that this receptive field organization is universal among vertebrates. The cell providing the depolarizing input had a time course, a wide area of spatial summation, and lacked prominent centre-surround organization characteristics that implicated the horizontal cell. Direct confirmation was provided by Baylor et al. (1971), by recording simultaneously from a horizontal

cell and a cone. They found that hyperpolarizing currents injected into the horizontal cell evoked graded depolarizations in the cone proportional to current strength. Therefore the lateral effect is thought to be mediated by horizontal cells through a reciprocal synapse (O'Bryan, 1973; Piccolino and Gerschenfeld, 1978, 1980). However, no chemical synapse of appropriate polarity has been described so that the morphological site of this synaptic transfer is uncertain.

The horizontal cell feedback has been shown to be colour specific (Fuortes, Schwartz and Simon, 1973; Burkhardt, 1977; Burkhardt and Hassin, 1978). For example, both red and green cones respond with a simple hyperpolarization to a small red spot of light, but both have a large delayed depolarization to a large red stimulus; green stimuli, however, produced only hyperpolarization.

Horizontal cell feedback to cones may play an important role in constructing the chromatic response properties of horizontal cells as proposed by Fuortes and Simon (1974). In turtle and in fish, each horizontal cell receives input from a corresponding type of cone: L-type from red sensitive cones, R/G type from green sensitive cones and B/G from blue sensitive cones. (For further description of the horizontal cell types see section 2.3. on horizontal cells). All cone types contact the L-type horizontal cells and thus the depolarizing response in R/G and B/G type horizontal cells may be mediated by feedback from the L-type horizontal cells to corresponding cones (Stell, Lightfoot, Wheeler and Leeper, 1975). However, Burkhardt and Hassin (1978) conclude that the colour-opponent properties of the chromatic horizontal cells originate from

antagonistic interactions generated in the postreceptor networks rather than on feedback to cones, since it does not depend upon spot size. In addition to the contribution of horizontal cells on the cone, response properties may be altered via cone to cone contacts through the invaginating basal processes (Scholes, 1975; Stell and Harosi, 1976; Norman et al., 1984).

In addition to the spatial summation and the centre-surround organization, a rod to cone interaction may be present (Attwell, Werblin, Wilson and Wu, 1983). The data from other species suggest that such a rod-cone interaction may play a role in chromatic information transfer (Fain, 1976; Nelson et al., 1976). Rod-cone system interactions have been demonstrated both functionally and anatomically (Stell, 1967; Fisher and Boycott, 1974; Fain, 1975; Scholes, 1975; Leeper, 1978b; Levine and Shefner, 1981) and may prove to be a basic phenomenon in all species.

2.2.3. Synaptic mechanisms.

Dendrites emitted by secondary neurons (bipolar and horizontal cells) come into close contact with the photoreceptor ribbon synapse, the presumed site of chemical synaptic transfer. It has been concluded from several pieces of evidence that photoreceptors release an excitatory (depolarizing) transmitter in the dark when the receptor is in a depolarized state (Trifonov, 1968). Trifonov (1968) found in the turtle retina, that an extrinsic transretinal current from the receptors to the vitreous evoked a depolarization of the horizontal cell; and a current in the opposite direction, a hyperpolarization. Trifonov assumed that the current acted presynap-

tically on photoreceptors; a vitreally directed positive current would therefore depolarize receptors, whereas current of the opposite direction hyperpolarized receptors. Depolarization of the receptor terminal by transretinal current has been shown to depolarize the horizontal cells in a graded manner (Byzov and Trifonov, 1968; Kaneko and Shimazaki, 1976). Trifonov (1968) concluded that, in the dark, the relatively depolarized receptor released a transmitter which, in turn, depolarized the horizontal cell and thus followed the general rule that transmitter release is increased by depolarization as in synaptic terminals of other neurons (Katz, 1969). Light hyperpolarizes the photoreceptor and thus reduces the transmitter release which causes corresponding changes in secondary neurons dependent on type (for example the L-type horizontal cells hyperpolarize (Trifonov, 1968)). The hypothesis that transmitter release from photoreceptors occurs in darkness is further supported by the finding that, interruption of the photoreceptor-to-horizontal cell transmission using either calcium free extracellular medium or adding calcium antagonists, results in hyperpolarization of the horizontal cell membrane and suppression of the light-evoked response (Dowling and Ripps, 1973; Cervetto and Piccolino, 1974; Kaneko and Shimazaki, 1975, 1976).

The photoreceptor transmitter is probably an acidic amino acid, either L-glutamate or L-aspartate (Murakami, Ohtsu and Ohtsuka, 1972; Dowling and Ripps, 1973; Kaneko and Shimazaki, 1976; Hedden and Dowling, 1978; Wu and Dowling, 1980; Ishida and Fain, 1981;

Miller, Slaughter and Dick, 1982). However, the neurotransmitter released by photoreceptors has yet to be unequivocally identified.

2.2.4. Ionic properties.

Photoreceptors contain voltage - dependent calcium channels (Fain, Ishida and Callery, 1983), which seem to behave like calcium channels in other systems. They do probably direct the release of the synaptic transmitter. A voltage change of the photoreceptor produces a change in the amplitude of the calcium current which is tonic or maintained, but it does not decline (inactivate) with time (Bader et al., 1982; Corey, Dubinsky and Schwartz, 1982) like the sodium current of the nerve (Hodgkin and Huxley, 1952). Photoreceptors have a large sodium permeability in darkness which contributes to their dark resting potential. The consequence of this depolarization is an increase in calcium entry and thus the release of a synaptic transmitter. Light decreases sodium permeability of the photoreceptor, and the membrane hyperpolarizes, reducing entry of calcium and thus the transmitter release (Fain, Ishida and Callery, 1983).

The conductance change produced in the cone membrane during feedback response elicited by the horizontal cells, appears to consist of two components, i) a transient spikelike response followed by, ii) a slower sustained component (O'Bryan, 1973).

The transient response is thought to be due to an increase in permeability of calcium (Piccolino and Gerschenfeld, 1978, 1980;

Gerschenfeld and Piccolino, 1980). Since light responses of horizontal cells are hyperpolarizing and associated with a decrease in conductance, it is likely that the release of transmitter from their processes might be similar to that observed in photoreceptors, i.e. a continuous release of transmitter in darkness which becomes reduced or suppressed by light (Trifanov, 1968; Dowling and Ripps, 1973; Cervetto and Piccolino, 1974; Kaneko and Shimazaki, 1975; Dacheux and Miller, 1976). Therefore, the L-type horizontal cell transmitter released in darkness would close calcium channels in the cone membrane.

Lasansky (1981) showed that sustained feedback response in cones of the tiger salamander is accompanied by an increase in chloride conductance. He proposed that the synaptic transmitter of horizontal cells produced a decrease in cone permeability for chloride, thus, light would reduce the flow of transmitter and allow chloride channels to reopen. However, Piccolino and Gerschenfeld (1980) have observed that the sustained component of feedback can be blocked by passing a hyperpolarizing current into cones, but hyperpolarization should enhance the change in membrane potential produced by an increase in chloride conductance. In an alternative hypothesis it has been suggested (Gerschenfeld and Piccolino, 1980; Gerschenfeld et al., 1980) that L-type horizontal cell transmitter released in darkness may increase the potassium or chloride conductance of the cone synaptic membrane, and thus tonically decrease the voltage dependent calcium conductance. The decrease of transmitter release during the L-type horizontal cell hyperpolarization by light would therefore decrease such cone potassium or chloride conductance

and consequently the calcium conductance would increase. This would explain both the production of the calcium spikes and the inhibition by hyperpolarization.

The limited available data obtained, bearing directly on the photoreceptor synapse in terms of the relation of light absorption to transmitter release, suggest that the photoreceptor synapse is exquisitely sensitive to small fluctuation in transmembrane voltage. It is probable that near the dark voltage of the cell, a small fluctuation in polarization level results in a large change of calcium entry and hence in transmitter release (Fain, 1977; Fain et al., 1977).

2.3. Horizontal cells.

2.3.1. General.

Horizontal cells respond to illumination with graded sustained responses that have a high degree of spatial summation. The horizontal cell response is of a large amplitude (10 to 50 mV), usually negative, superimposed on a negative resting potential (-10 to -50 mV), graded with light intensity and maintained for the duration of the light stimulus.

Horizontal cells respond with hyperpolarization to white light, but their response polarity to chromatic illumination depends on the wavelength of the incident light. According to their spectral response properties, horizontal cells are classified into two groups: first, the L-type horizontal cells which show hyperpolarizing responses to light stimuli of all wavelengths and second, the C-type horizontal cells. The C-type cells are further classified into the

biphasic C-type, that are hyperpolarized by short (blue-green) wavelengths and depolarized by long (red) wavelengths, and the triphasic C-type, that are hyperpolarized by monochromatic short (blue) and long (red) wavelengths and depolarized by intermediate (green) spectral stimuli. L-potentials are reported in all species, but C-potentials have only been observed in lower vertebrates. Before their origin had been determined, these responses were named 'S-potentials' as a tribute to Svaetichin (1953), who first described them in the fish retina. However, it was only after years of effort by a large number of researchers using intracellular staining techniques (Motokova, Oikawa and Tasaki, 1957; MacNichol and Svaetichin, 1958; Mitarai, 1958; Tomita, Murakami, Sato and Hashimoto, 1959; Oikawa, Ogawa and Motokova, 1959; Gouras, 1960; Mitarai, 1960; Svaetichin, Laufer, Mitarai et al., 1961) that it was conclusively demonstrated that these responses originated from horizontal cells (Werblin and Dowling, 1969; Kaneko, 1970, 1971b; Steinberg and Schmidt, 1970; Kaneko and Yamada, 1972; Matsumoto and Naka, 1972; Miller, Hashimoto, Saito and Tomita, 1973; Simon, 1973; Mitarai, Asano and Miyake, 1974; Hashimoto, Kato, Inokuchi, and Watanabe, 1976).

MacNichol and Svaetichin (1958) proposed that the function of L-potentials was to carry luminosity (brightness) information, therefore called L-unit, whereas the function of C-potential was to code colour and therefore termed chromaticity or C-unit (Svaetichin, 1956; MacNichol, MacPherson and Svaetichin, 1957; Svaetichin and MacNichol, 1958; MacNichol and Svaetichin, 1958). However, the terms 'luminosity' and 'colour' are generally not used since they are

considered prejudicial.

In teleosts four general horizontal cell types have been identified. There are three horizontal cell types which only receive input from cones: 1) the monophasic L-type, 2) biphasic C-type and 3) triphasic C-type cells. The fourth type of horizontal cells, receive input only from rods, and are termed 'rod' horizontal cells, but they are also monophasic L-type cells that hyperpolarize to light stimuli of all wavelengths (Laufer and Millan, 1970; Kaneko and Yamada, 1972; Mitarai et al., 1974; Weiler and Zettler, 1976).

2.3.2. L-type horizontal cells.

The L-type horizontal cells can be subdivided into a variety of subtypes based on their responses to monochromatic lights. Some results indicate that all L-units in a particular species of fish have approximately the same spectral response (MacNichol and Svaetichin, 1958), but others show that L-units in the same retina may have different spectral responses (Svaetichin, 1953, 1961; Motokova et al., 1957; Tamura and Niwa, 1967).

Under photopic conditions, the most commonly described L-units in cyprinids (goldfish and carp) have maximum spectral sensitivity about 620 nm or red sensitive L-cells (Tomita, 1965; Witkovsky, 1967; Kaneko, 1971b; Mitarai et al., 1974; Hashimoto et al., 1976; Yang, Tauchi and Kaneko, 1982, 1983). In addition to the red sensitive L-unit, Tamura and Niwa (1967) found, under photopic conditions, green- and blue sensitive L-cells. Laufer and Millan (1970) found under photopic conditions three L-units, a red-, green- and blue sensitive cells in the teleost Eugerres plumeri. Hashimoto and

Inokuchi (1981) found two separate L-units, L1 and L2, in the dace retina which peaked at 590 and 630 nm respectively. In the dichromatic pikeperch retina, Burkhardt and Hassin (1978) found two separate L-units that receive predominant input from orange cones (605 nm). The spectral sensitivity curves of these L-units were found to match the corresponding cone pigment's absorption spectra.

The spectral responses of L-units may have several submaxima in their action spectra (Svaetichin, 1956; Svaetichin and MacNichol, 1958; Tomita, Tosaka, Watanabe and Sato, 1958; Witkovsky, 1967). This indicates that at least two or more photoreceptor systems must contribute to their response (Orlov and Maksimova, 1965; Maksimova, Maksimov and Orlov, 1966; Naka and Rushton, 1966c; Witkovsky, 1967; Gouras, 1972; Yazulla, 1976; Yang et al., 1983). Witkovsky (1967) found, for example in carp, two peaks in L-units, a primary peak at 620 nm and a secondary peak at 665 nm, the latter more prominent at lower criterion response amplitudes. In L-units in the tench retina Naka and Rushton (1966c) also found two peaks, at 620 nm and at 680 nm, but when the action spectra of these units were determined in the presence of chromatic background an additional peak at 540 nm and possibly another in the blue region of the spectrum were uncovered. They concluded that L-units receive signals from four different cone mechanisms with peak sensitivities in the far red (680 nm), in red (620 nm), in green (540 nm) and in the blue (450 nm) part of the spectrum. The latter three mechanisms are probably related to photopigments identified in single cones of Cyprinidae fishes by microspectrophotometry (Liebman and Entine, 1964; Marks, 1965). However, no 680 nm cone pigment has been found microspectro-

photometrically. A steady red background not only decreases the cells' sensitivity to red light, but also considerably increases the cells' sensitivity to green light (Maksimova et al., 1966; Naka and Rushton, 1966c; Laufer and Negishi, 1978; Yang, et al., 1982, 1983). This indicates that the L-units receive inputs from both red- and green-sensitive cones. However, in contrast to these results, no change in the peak spectral sensitivity of the L-cells was observed under selective chromatic background adaptation in carp (Witkovsky, 1967), in pikeperch (Burkhardt and Hassin, 1978), and in dace retina (Hashimoto and Inokuchi, 1981).

The long wavelength shift of the red cone mechanism to 650-680 nm is now acknowledged to be 'pseudopigments', which are thought to be generated by interaction between signals derived from photoreceptors with different photopigments (Abramov, 1972; Sirovich and Abramov, 1977). Pseudopigments are characterized by having much narrower spectral sensitivity curves than the absorption curves of the corresponding hypothetical visual pigments. Pseudopigments have occasionally been observed in monophasic and regularly in biphasic and triphasic horizontal cells, and also in ganglion cells (Witkovsky, 1967; Spekrijse, Wagner, and Wolbarsht, 1972), and behaviourally, in perch (Cameron, 1982) and in rhesus monkey (Hartwerth and Sperling, 1971).

In turtles, the L-type horizontal cells have been shown to receive their major input from the red cones (Simon, 1973; Fuortes and Simon, 1974; Yazulla, 1976). However, as in teleosts, a green cone input to the L-units has been demonstrated (Fuortes, Schwartz and Simon, 1973). Using chromatic adaptation Yazulla (1976) found

that the red cone dominated L-units could be subdivided on the basis of receptor input, some receiving input only from red cones, others from red and green cones, or from all cones, red, green, and blue.

Under scotopic conditions rod driven L-type horizontal cells have been observed in various teleosts. The rod driven L-potentials are characterized by much slower rise and decay in timecourse, and by lower threshold sensitivity (by 2 to 4 log units) than their photopic counterparts (Witkovsky, 1967; Laufer and Millan, 1970; Kaneko and Yamada, 1972; Mitarai et al., 1974; Hashimoto et al., 1976). Most physiological observations in teleosts show that no Purkinje shift from a rod to cone pigment maximum occurs (Watanabe and Hashimoto, 1965; Witkovsky, 1967; Laufer and Millan, 1970; Hashimoto et al., 1976), which is in agreement with the anatomical observations that the teleostean horizontal cells are connected exclusively to either rods or cones (Cajal, 1892; Stell, 1967; Parthe, 1972; Haesendonck and Missotten, 1979).

In elasmobranchs and in the mammalian horizontal cells, a mixed rod and cone input (Purkinje shift) has been observed (Nelson et al., 1976; Toyoda et al., 1978; Bloomfield and Miller, 1982). This indicates that these horizontal cells are not physiologically devoted to either rods or cones exclusively, as implicated by their anatomical connections with photoreceptors (Stell and Witkovsky, 1973b; Kolb, 1974; Wassle et al., 1978; Dacheux and Raviola, 1981).

2.3.3. C-type horizontal cells.

The C-type horizontal cells are subdivided, on the basis of their response properties to monochromatic lights, into biphasic and

triphasic C-type horizontal cells. C-type horizontal cells have only been found in teleosts, elasmobranchs and turtles, but not in other vertebrate classes (Tomita, 1965; Miller et al., 1973; Toyoda et al., 1978).

Several varieties of the biphasic horizontal cells have been distinguished in terms of their spectral responses. In teleosts the most commonly described C-type horizontal cell is the dichromatic R/G-cell. It is depolarized by far red (650-680 nm) light and hyperpolarized by green (520-540 nm) light (Tomita, 1965; Naka and Rushton, 1966a; Witkovsky, 1967; Mitarai, et al., 1974; Kaneko, 1970, 1971b; Burkhardt and Hassin, 1978; Hashimoto and Inokuchi, 1981). Other varieties include cells that show a maximum depolarization in the green region of the spectrum and a maximum hyperpolarization in the blue region of the spectrum or a G/B type, and a depolarizing yellow and hyperpolarizing blue or a Y/B type (Motokova et al., 1957; MacNichol and Svaetichin, 1958; Naka and Rushton, 1966a, b; Mitarai et al., 1974). The triphasic C-type horizontal cells are hyperpolarized by red and blue light and depolarized by green light (Motokova et al., 1957; Naka and Rushton, 1966a, b; Tamura and Niwa, 1967; Mitarai et al., 1974).

If photoreceptors display univariance (Naka and Rushton, 1966a, b, c), the C-type horizontal cells must receive signals from more than one receptor type. The cone mechanism underlying the opposite polarity response in C-units has been isolated by selective chromatic adaptation (Naka and Rushton, 1966a, b; Witkovsky, 1967). They have shown that: 1) biphasic R/G cells receive inputs from the green and red cones although the far red mechanism might be

involved (for further information see section 2.3.4.), 2) the G/B cells receive inputs from the green and blue cones and 3) triphasic cells receive input from the red, green, and blue cones. When the contributions of each cone type were separated and measured, Naka and Rushton (1966a) found that the amplitude of the C-potential was equal to the sum of the opposing contribution of the cone types. Naka and Rushton (1966c) demonstrated that the biphasic cell's response to a red stimulus saturates independently of the intensity of a green stimulus applied simultaneously. The response of red cones or synaptic contacts between the red cones and horizontal cells must therefore reach saturation levels before their response combines with the response from the green cones at the horizontal cells. The pre-horizontal cell saturation of the red system may also contribute to the green enhancement in L-units under red background illumination (Witkovsky, 1967).

An important difference has been observed between depolarizing and hyperpolarizing S-potentials. Depolarizing potentials have a longer latency and a slower time course than hyperpolarizing ones (MacNichol and Svaetichin, 1958; Gouras, 1960; Spekrijse and Norton, 1970). When these two opposing potentials are approximately balanced, transient hyperpolarizing on-responses and depolarizing off-responses occur, suggesting that the depolarizing response may be mediated by one or more additional synapses (Gouras, 1972).

A number of investigators using intracellular dye injection have attempted to locate the characteristic S-potentials within horizontal cell layers in the retina. Kaneko (1970, 1971b) found in carp and goldfish that both L- and C-type cells originated in the

external and internal horizontal cell layers. Similarly, Mitarai et al. (1974) found L- and C-type cells to originate in either external or internal horizontal cell layers, although within the external layer C-units seemed to be below (vitread) the L-units. Hassin (1979) found in the pikeperch retina two types of L-units in H1 (external) and H2 (medial) proximal (vitread) to H1 and a C-type (H3) in yet more proximal position. Hashimoto et al. (1976) using procion yellow in carp retina found four layers, with L-type response in the external layer (layer I), the C-type in medial (layer II), both L- and C-type responses were found in the innermost layer (layer III), and the horizontal cells which were attributed to rod function formed another layer between layers II and III. Several authors (Kaneko and Yamada, 1972; Mitarai et al., 1974; Hashimoto et al., 1976) have located the origin of the scotopic L-potential in the carp retina to correspond to the intermediate horizontal cells of Cajal (1894, 1933).

In teleosts, unlike reptiles, birds and mammals, the horizontal cell axon terminals end deep in the inner nuclear layer and do not make contact with photoreceptors (see section 1.4). However, cyprinid axon terminals have the same general response properties as their corresponding cell body (Kaneko, 1970; Mitarai et al., 1974; Hashimoto et al., 1976). The teleostean cone horizontal cell responses are conducted non-decrementally and without spikes from cell body to axon (Stell, 1975; Weiler and Zettler, 1976, 1979). The only differences in the response properties of the axon compared to those of the cell body are that the amplitude is smaller, and that axons show larger spatial summation (Kaneko, 1970). The axon

terminals of turtle and mammalian horizontal cells have been shown to contact photoreceptors and respond independently of their corresponding cell body (Boycott and Dowling, 1969; Fisher and Boycott, 1974; Leeper, 1978). The functional role of the teleostean horizontal cell axon terminals is still unknown.

2.3.4. Generation of horizontal cell responses.

On the basis of cone and horizontal cell electrophysiology, the connections of various receptor and horizontal cell types were predicted, in fish by Gouras (1972), and in turtle by Fuortes and Simon (1974). They concluded that the responses of L-type as well as C-type horizontal cells could be explained by assuming that each horizontal cell type receives direct hyperpolarizing input primarily from only one chromatic cone type for which the latency is shortest, and makes indirect contacts via interneurons with the other cone types, with sign inversion (depolarization) and added delay at each stage. These cascading models emphasize the cones as interneurons and incorporate the horizontal cell feedback onto cones, as shown by Baylor et al. (1971). Thus the C-type horizontal cells receive hyperpolarizing input directly from only one cone mechanism and are depolarized when other cone mechanisms are stimulated. The depolarizing signal goes through additional synapses and is consequently more delayed than the hyperpolarizing signal (MacNichol and Svaetichin, 1958; Gouras, 1960; Spekreijse and Norton, 1970). It is difficult, however, to predict unequivocally the morphological interconnections which exist between horizontal and photoreceptor cells on the basis of spectral sensitivity data alone. For example,

Stell and Lightfoot (1975) have shown that goldfish horizontal cell responses, dependent on given cone system, may not be generated by immediate contact with those cones. In their correlation between the functionally identified versus the histologically identified cone horizontal cell types, the following relations were proposed. The histologically identified H1 cells were found to be the monophasic L-type cells receiving functional input mainly from red sensitive cones, but making contact with red, green and blue sensitive cones. The H2 cells, contacting the green and blue sensitive cones were found to be the biphasic R/G cells, and the H3 cells were found to be the triphasic G/RB cells, that receive functional input from all three chromatic classes of cones, but contact only the blue sensitive cones. These functional/histological correlations are also supported by data obtained from cells stained intracellularly after functional identification (Mitarai et al., 1974; Hashimoto et al., 1976).

Stell, Lightfoot, Wheeler and Leeper (1975) have proposed a functional model to account for the spectral properties of the three horizontal cell types. In their model each horizontal cell acts through feedback synapses upon the next cone type in sequence. The horizontal cells receive their input from cones through a horizontal cell synaptic process which occupies a central position in the synaptic ribbon complex of the cone photoreceptors, whereas the horizontal cell synaptic processes which terminate as lateral elements in the synaptic ribbon complex mediate the sign inverting feedback from horizontal cells to cones. In the proposed scheme, H1 cells receive direct input from the red sensitive cones and feedback

onto the H2 cells via the green cones. Subsequently, H2 cells receive direct input from the green sensitive cones and feedback onto the H3 cells via the blue cones. The proposed scheme is consistent with the difference in latencies of the horizontal cell response components reported by Spekreijse and Norton (1970). In general, the horizontal cell to cone feedback model accounts for a large proportion of both the histological and functional properties of cone horizontal cells, and pathways similar to these have also been proposed for the horizontal cells of turtle (Leeper, 1978b). Since these models emphasize the photoreceptors as interneurons in generating the colour opponency of the C-type horizontal cells, and account for the feedback from horizontal cells to receptors, the C-type horizontal cells should reflect the spatial and spectral properties of the feedback system.

The participation of the horizontal cell to cone synapses in the generation of the horizontal cell chromatic response patterns is still controversial. In its favor are: i) the observed functional horizontal cell to cone synapses in fish (Burkhardt and Hassin, 1978; Hedden and Dowling, 1978), ii) the blockage of synaptic transmission from monophasic horizontal cells, which are probably GABA-ergic (Marc, Stell, Bok and Lam, 1978; Lam, Su, Swain and Marc, 1979; Murakami, Shimoda, Nakatani et al., 1982a, b; Yazulla and Kleinschmidt, 1982), by GABA antagonist (Lam, Lasater and Naka, 1978) or GABA itself in excess (Murakami, Shimoda and Nakatani, 1978) and, iii) the absence of ultrastructural features characteristic of direct chemical transmission from H1 to H2 or H2 to H3 cells (Stell, 1976). In contradiction, the depolarising feedback component

in cones is not always observed. The spectral properties of the C-type cells are not dependent upon the spatial extent of the stimulus as in the feedback system since, using small spots which produce no detectable feedback from horizontal cells in cones, normal chromatic responses are recorded in horizontal cells (Burkhardt, 1977; Burkhardt and Hassin, 1978).

2.3.5. Synaptic mechanisms.

Horizontal cells have a resting potential of about the same magnitude as photoreceptors in darkness (Saito, Kondo and Toyoda, 1979; Ashmore and Falk, 1980; Ishida and Fain, 1981). The level of the horizontal cell membrane potential is produced primarily by the continuous release of the photoreceptor transmitter, and perhaps from interplexiform cell transmitters as well (Dowling and Ripps, 1973; Cervetto and Piccolino, 1974; Dacheux and Miller, 1976; Kaneko and Shimazaki, 1976; Dowling and Ehinger, 1978). The effect of the photoreceptor transmitter is to depolarize the horizontal cell membrane in darkness (see section 2.2.3). Bright light, which stops synaptic transmission from photoreceptors, or interrupting synaptic transmission by treating the retina with cobalt, hyperpolarizes horizontal cells and brings the membrane potential near to the potassium equilibrium potential (Kaneko and Shimazaki, 1975; Byzov and Trifonov, 1981). The membrane potential of hyperpolarized horizontal cells has been shown to follow closely the transmembrane potassium equilibrium potential (Byzov and Trifonov, 1981; Tachibana, 1981). Recent electrophysiological studies on isolated horizontal cells from goldfish retina have shown that they have a

prominent voltage dependent calcium conductance (Byzov and Trifonov, 1981; Johnston and Lam 1981; Tachibana, 1981). Voltage dependent sodium channels, tetrodotoxin (TTX) sensitive, have not been observed in goldfish horizontal cells (Byzov and Trifonov, 1981; Tachibana, 1981; Djamgoz and Stell, 1984). However, Shingai and Christiansen (1983a, b) found voltage dependent sodium channels (TTX-sensitive) in the catfish horizontal cells. These studies on the isolated teleostean horizontal cells have shown that the horizontal cell membranes are capable of generating 'slow' action potentials through voltage dependent calcium and/or sodium channels (Johnston and Lam, 1981; Shingai and Christensen, 1983 a, b). Other studies on isolated horizontal cells have shown that their action potentials are calcium dependent, but sodium independent (Johnston and Lam, 1981; Tachibana, 1981, 1983).

Glutamate, the presumptive photoreceptor transmitter, induces a long lasting depolarization in horizontal cells at low (μM) concentrations (Ishida and Fain, 1981; Dowling Lasater, Buskirk and Watling, 1983). Depolarization appears to be the result of an initial decrease in potassium conductance (Byzov and Trifonov, 1981), followed by an increase in calcium conductance (Dowling et al., 1983). However, Ishida et al. (1983, 1984) reported that the effect of L-glutamate on isolated horizontal cells is accompanied by a conductance increase which is sodium dependent, and Tachibana (1981) concluded that both sodium and calcium conductances contributed to horizontal cell membrane potential.

A number of studies have pointed to Gamma-aminobutyric acid (GABA) as the neurotransmitter of H1-type horizontal cells in

cyprinid and catfish retinas (Lam and Steinman, 1971; Lam, 1975; Marc et al., 1978; Murakami et al., 1978; Lam et al., 1978, 1979; Wu and Dowling, 1980). Horizontal cells have been shown to release GABA by means of a voltage-dependent but calcium independent transport system (Schwartz, 1982; Lam and Ayoub, 1983). It has also been demonstrated that GABA can be released from H1-type horizontal cells by L-glutamate and L-aspartate (Yazulla and Kleinschmidt, 1982). They suggest that the release of GABA occurs via sodium dependent, but calcium independent transport system.

Dopamine, at least in fish, is the presumptive neurotransmitter of the interplexiform cells which make synaptic contact with H1-type horizontal cells (Ehinger, Falck and Laties, 1969; Dowling and Ehinger, 1978). Dopamine has been reported to produce a decrease in the size of the receptive field of H1-type horizontal cells (Negishi and Drujan, 1978; Neyton, Piccolino and Gerschenfeld, 1982; Gerschenfeld, Neyton, Piccolino and Witkovsky, 1983) and thus reduce the lateral influence exerted by H1-type horizontal cells on red cones and bipolar cells (Negishi and Drujan, 1978; Hedden and Dowling, 1978). The effect of dopamine seems to be produced by a decrease in conductance of the gap junction between the horizontal cells (Piccolino, Neyton, Witkovsky and Gerschenfeld, 1982), which may arise from dopamine activation of adenylate cyclase (Wu and Dowling, 1980; Dowling and Watling, 1981; Watling and Dowling, 1981; Neyton et al., 1982; Teranishi, Kato and Nagishi, 1982). Dopamine, in virtually all parts of the brain, activates the enzyme adenylate cyclase causing substantial increase in intracellular cyclic AMP concentration (Iversen, 1975; Daly, 1977). The effect of dopamine is

mimicked by C-AMP, indicating that dopamine causes an increase in intracellular level of cyclic AMP in H1-type horizontal cells (Yazulla and Kleinschmidt, 1982), as demonstrated by Dowling et al. (1983).

The horizontal cells show a non-linear current/voltage relationship (Trifonov, Chailachian and Byzov, 1971, 1974; Byzov and Trifonov, 1973). The results of voltage clamp studies suggest that the horizontal cell light response is elicited by a resistance increase at the synaptic membrane that is obscured by a potential and time-dependent resistance decrease at the non-synaptic part of the cell membrane (Werblin, 1975b). Byzov and Trifonov (1981) propose that there are several ionic mechanisms underlying the nonlinearity of the horizontal cell membrane, depending mainly on potassium conductance changes and on voltage dependent calcium conductance. Tachibana (1983) concluded that the combination of one calcium current and three voltage dependent potassium currents contributed to the non-linear current voltage relationship of isolated horizontal cells.

2.3.6. Receptive field properties.

Receptive field of a retinal cell is defined as the retinal area over which light stimulation is able to elicit a response in a cell.

Horizontal cells have a large receptive field, particularly in the retinas of lower vertebrates, where the receptive field is much larger in area than the dendritic spread of a single horizontal cell (Naka and Rushton, 1967; Norton, Spekrijse, Wolbarsht and Wagner,

1968; Kaneko, 1971a). The large receptive field of the S-potential was noted by several authors (Tomita et al., 1958; Oikawa et al., 1959; Watanabe and Tosaka, 1959; Gouras, 1960; Naka and Rushton 1967; Norton et al., 1968). Naka and Rushton (1967), showed that it was current but not scattered light that generated the large receptive field of horizontal cells.

Electrical coupling between horizontal cells has been proposed to explain the long spread of potentials along the horizontal cell layer of the fish retina (Tomita, 1957; Naka and Rushton, 1967). The electrical coupling between horizontal cells has been confirmed by the morphological findings of electrical or low resistance 'gap' junctions between processes of adjacent horizontal cells, in fish (Yamada and Ishikawa, 1965; Kaneko, 1971a; Pinto and Pak, 1974a, b; Witkovsky et al., 1979), and in turtle (Borovyagin, 1966; Raviola, 1976). Kaneko (1971a) showed by current and procion yellow injection that the external horizontal cells of the dogfish are electrically coupled. The electrical responses and morphological properties of each horizontal cell type strongly suggest that only cells of same type are electrically coupled; i.e. monophasic cells are only coupled to other monophasic cells, biphasic to other biphasic cells, and triphasic to other triphasic cells, with no evidence of direct cross coupling between different cell types (Yamada and Ishikawa, 1965; Kaneko, 1971a; Lasansky, 1973; Simon, 1973; Byzov, 1975; Witkovsky et al., 1979).

Potential changes arising within the horizontal cell layer (S-space) propagate passively with an exponential distribution, according to a given space constant. In the cable theory the one

dimensional space constant is the distance at which the potential, spreading passively is decreased to $1/e(V_0)$, where V_0 = voltage at origin. The decrease in the amplitude of the response with increasing distance has the form of exponential decay; for example in tench, carp and in mudpuppy, the space constant was found to be about 0.25 mm, (Naka and Rushton, 1967; Werblin, 1970).

The spatial summation of the teleostian horizontal cells has been found to vary from 0.5 to several millimeters in extent (Naka and Rushton, 1967; Norton et al., 1968; Hassin, 1979). Furthermore the receptive fields of C-potentials appear to be about twice the size of those for L-potentials, in fish (Negishi and Sutija, 1969; Kaneko, 1970). However, in turtle the LI-type cells have receptive field diameters twice that of C- and LII-type cells (Simon, 1973; Saito, Miller and Tomita, 1974).

2.4. Other neurons.

2.4.1. Bipolar cells.

Bipolar cells respond to illumination by a slow potential (S-potential) as photoreceptors and horizontal cells, and their responses are characteristically graded with light intensity and maintained for the duration of the stimulus. Bipolar cells are characterized by having receptive fields consisting of antagonistic centre and surround organization (Werblin and Dowling, 1969; Kaneko, 1970). Stimulation of the surround produces a response which has a opposite polarity to that of a central stimulus (Werblin and Dowling, 1969; Kaneko, 1970; Toyoda, 1973; Schwartz, 1974; Richter and Simon, 1975). Functionally, bipolar cells are classified in on- and off-centre cells. On-centre cells are depolarized by a light spot presented to their receptive field centres, but respond with hyperpolarization to surround stimuli. On the other hand off-centre cells are hyperpolarized by a central stimulus, and depolarized by a surround stimuli (Werblin and Dowling, 1969; Kaneko, 1970).

A number of investigators have succeeded in recording intracellularly from fish bipolar cells (Kaneko and Hashimoto, 1969; Kaneko, 1970; Ashmore and Falk, 1977a, b; Toyoda, 1973; Naka and Ohtsuka, 1975). In general the centre of the receptive field is much more sensitive than the surround. For example, in goldfish, the centre of the bipolar cell receptive field is approximately 100 times more sensitive than the surround, i.e. 100 times more energy is required in the surround in order to produce a comparable response to that of a central response (Kaneko, 1973). Other investigators have found it necessary in some cases, to lightadapt the

receptive field centre before any response can be produced with a surround stimulation (Kaneko, 1973; Richter and Simon, 1974).

The spectral response properties of bipolar cells in fish have been described by a number of authors, and they have been classified into two types; non-colour coded and colour-coded bipolar cells by their spectral properties (Kaneko, 1973; Toyoda, 1973; Famiglietti et al., 1977; Mitarai, Soto and Takagi, 1978; Kaneko and Tachibana, 1981, 1983). The non-colour coded type receives input predominantly from red cones at the receptive field centre and surround. In colour coded cells the receptive field centre is usually dominated by red cones, while the green cones contribute to the surround. The colour-coded bipolar cells include double-colour opponent cells whose response polarity depends not only upon the wavelength of light, but in addition the response polarity was also found to depend on light intensity (Kaneko and Tachibana, 1981).

Almost all bipolar cells identified morphologically by intracellular dye injection are in the category of Cajal's large bipolar cells or mixed bipolar (M.B.) cells (Kaneko, 1973; Mitarai et al., 1978; Tachibana, 1978; Hashimoto, Inokuchi, Umino and Katagiri, 1980). It is likely that the sampling by intracellular recording strongly favours the larger cell types (M.B.s) which receive input primarily from red cones (Scholes, 1975; Stell et al., 1977). It is certain that bipolar cells do exist which contact predominantly green cones and others that contact predominantly blue cones (Scholes, 1975), but these cells are rare or absent in the sample of chromatic bipolar cells found using intracellular recordings.

Most evidence suggests that the central response is produced by

direct receptor-bipolar cell contacts whereas the bipolar cell's surround responses are provided by interneurons, presumably by horizontal cells. These conclusions are consistent with the observations that the size of functionally defined bipolar cell receptive field centres (100-200 μm) are proportional to the bipolar cell dendritic spreads in the outer plexiform layer (Kaneko, 1971b, 1973; Scholes, 1975, Stell et al., 1977). Naka (1972) presented the most direct evidence for horizontal to bipolar cell transfer in the catfish retina. Passing a depolarizing current into a L-type horizontal cell produced a bipolar cell response equivalent to that elicited by a centred spot of light. On hyperpolarizing the horizontal cell the bipolar cell's response was equivalent to that elicited by a surround stimulus. Recently, Toyoda and Kujiraoka (1982) demonstrated that passing hyperpolarizing current into horizontal cells of carp, irrespective of cell type, elicited a hyperpolarizing response in on-centre bipolar cells and a depolarizing response in off-centre bipolar cells, i.e. a response similar in polarity to that elicited by surround illumination. Essentially the same results had been reported previously for bipolar cells of the turtle retina (Marchiafava, 1978), and for off-centre bipolar cells of the carp retina (Trifonov and Byzov, 1977). There are two possible pathways by which this can be mediated. One is a direct synaptic pathway from horizontal cells to bipolar cells (Werblin and Dowling, 1969), and the other is an indirect one, involving a feedback pathway from horizontal cells to photoreceptors (Toyoda and Tonosaki, 1978). Direct synaptic contacts from horizontal cells to bipolars were first postulated to be responsible for centre surround organization

of bipolar cells (Werblin and Dowling, 1969), and direct contacts have been clearly identified in mammals (Fisher and Boycott, 1974) and in turtle (Kolb and Jill, 1982). Possible synaptic connections between dendrites of horizontal cells and bipolar cells have also been reported in some amphibians (Dowling and Werblin, 1969; Lasansky, 1973) and in catfish (Naka, 1976). Conventional synaptic structures between horizontal cells and bipolar cells have not been reported in cyprinids, but Stell (1978) reported occasional close contacts between dendrites of horizontal and bipolar cells, suggesting that it might be the site of unconventional synaptic contact. Some rod-driven bipolar cells have been shown to have a centre/surround organization (Fain, 1975, Saito, Kondo and Toyoda, 1981), but feedback from horizontal cells has not been demonstrated in rods and therefore the surround effect must be mediated by some other mechanism. However, the evidence for horizontal to bipolar cell synapses in fish is virtually non-existent. Thus, it seems likely that the feedback system from horizontal cell to cones is the source of the bipolar cell surround properties (Toyoda and Tonosaki, 1978; Wheeler, 1982; Fain et al., 1983). Presumably, the feedback would depolarize the receptor and increase its transmitter output, thereby antagonizing the central mechanism, which depends on a light induced reduction in receptor transmitter release. However, none of these possible pathways can be considered to be proved as yet.

2.4.2. Amacrine cells.

The response properties of two distinct physiological types of amacrine cell have been described in the teleost retina and termed

sustained and transient amacrine cells (Kaneko, 1973; Naka and Ohtsuka, 1975). One feature of the amacrine cells that is different from other peripheral neurons is that the amacrine cells show spike discharges, but these spikes are, however, atypical and are often abortive (Werblin and Dowling, 1969; Kaneko, 1970; Werblin, 1977). Most amacrine cells lack centre-surround organization, or have only rudimentary centre-surround responses (Kaneko, 1973; Mitarai et al., 1978).

Sustained amacrine cells respond with either a maintained hyperpolarization (off-amacrine) or depolarization (on-amacrine) to illumination and have been identified histologically (Chan and Naka, 1976). Transient amacrine cells, on the other hand, respond to illumination with a transient depolarization to both the onset and offset of the stimulus, and often produce spontaneous discharges superimposed on the transient on-off depolarizations (Kaneko and Hashimoto, 1969; Werblin and Dowling, 1969; Kaneko, 1970; Toyoda, Hashimoto and Ohtsu, 1973; Chan and Naka, 1976; Murakami and Shimoda, 1977).

Both the sustained and transient amacrine cells in goldfish respond differentially to spectral stimuli (Kaneko, 1973; Mitarai et al., 1978). The spectral response properties of sustained amacrines suggest that they receive direct input from colour coded bipolar cells (Mitarai et al., 1978). The transient amacrine cells are reported to show enhanced response to green light in presence of red background illumination, i.e. the same spectral properties as H-1 type horizontal cells and the surround of mixed bipolar cells (Kaneko, 1973). This suggests that the transient amacrines may

receive direct input from H1 horizontal cell axons (Naka, 1976, 1980).

Amacrine cells receive their synaptic input from bipolar cells and are known to be presynaptic to ganglion, bipolar and other amacrine cells (Dowling and Boycott, 1966; Dowling, 1968; Stell, 1972; Marc et al., 1978; Naka and Christensen, 1981). Famiglietti et al. (1977) showed that the axons of on-centre bipolar cells always reached the proximal portion of the inner plexiform layer (IPL), termed sublamina b. Dendrites of off-centre bipolar cells terminated at the distal portion of the IPL, termed sublamina a (see section 1.5). In the cyprinid retina, intracellular staining has revealed that the amacrine cell dendrites are also confined to the sublamina expected from their response polarities: on type to sublamina b, off type to sublamina a, and on-off type to both sublamina (Kaneko, 1973; Murakami and Shimoda, 1977; Kaneko, Nishimura, Tachibana et al., 1981). The primary role of amacrine cells is the formation of the on-off ganglion cell receptive field response properties (Werblin and Copenhagen, 1974; Miller and Dacheux, 1976a, b, c; Wheeler, 1982). Furthermore, it appears that amacrine cells form a network for the lateral transfer of information in the IPL (Naka and Christensen, 1981; Wheeler, 1982). For full review on the amacrine cell function see Witkovsky (1980) and Wheeler (1982).

2.4.3. Ganglion cells.

Ganglion cells are the only cells in the retina with a typical axon. The cell bodies are located in the innermost (proximal) part of the retina (see section 1.8). The ganglion cell axons form the

optic nerve, which conveys spike discharges (action potentials) to the higher visual centres. Ganglion cell responses are characterized by graded potentials with superimposed action potentials (spikes). Ganglion cells can be divided into three response categories; on, off, and on-off units (Hartline, 1938; Kuffler, 1953; Barlow, 1953).

On-units increase their firing rate to increased stimulus intensity. Off-units decrease their firing rate to an increase in stimulus intensity and typically produce a high rate of firing to a stimulus offset. On-off units have an increased rate of firing to both stimulus onset and offset. Ganglion cells have an antagonistic centre-surround receptive field organization, thus their surround response is opposite to that of the centre (Kuffler, 1953; Wagner, MacNichol and Wolbarsht, 1960; Svaetichin et al., 1965; Daw, 1968; Dowling and Ripps, 1970).

Naka (1977) demonstrated that on-ganglion cells receive input only from on-centre bipolar cells and off ganglion cells from off-centre bipolar cells. These results are consistent with the morphological observations that the on-centre bipolar and on ganglion cells terminate in sublamina b of the inner plexiform layer, and off-centre bipolar and off ganglion cells terminate in sublamina a, while the on-off ganglion cells ramify in both sublamina of the inner plexiform layer (Famiglietti et al., 1977), which suggests that they receive input from both on and off-centre bipolar cells. These findings suggest that the synaptic contacts between bipolar and ganglion cells are always sign conserving, or that the polarity of the response is maintained through the bipolar-ganglion cell

transmission. Physiological support for this hypothesis comes from the observation that depolarization of on-centre bipolar cells produces spikes in on-ganglion cells and depolarization of off bipolars produces spikes in off-ganglion cells (Baylor and Fettiplace, 1977; Naka, 1977). No cross-interaction was found between cells with different response polarity.

The ganglion cell receptive fields are complex and have been attributed directly to inputs from bipolar and amacrine cells. Kaneko (1973) found that the size of goldfish ganglion cell centre was comparable to the size of the total receptive field of a bipolar cell. The ganglion cell receptive field centre has been shown to consist of two components, generated by direct input from bipolar cells, an inner core and an outer core (Raynauld, 1975). Raynauld (1975) concluded that the inner core is generated by the sum of bipolar cell centres and the outer core is generated by the sum of bipolar cell surrounds (see Wheeler, 1982, for review). The ganglion cell surround (up to 6 mm in diameter) constitutes the sum of amacrine cell receptive fields (Daw, 1968).

Wagner et al. (1960, 1963) were first to describe colour opponent centre surround organization in ganglion cells in fish. Some ganglion cells have single colour receptive fields, some have double colour receptive fields, and some of the receptive fields are more complex (Witkovsky, 1965, 1967; Daw, 1968; Adams and Afandor, 1971; Beauchamp and Daw, 1972; Kaneko, 1973; Raynauld, 1975). The most commonly observed colour opponent cells are red and green sensitive, but ganglion cells also receive input from blue cones and from rods (Adams and Afandor, 1971; Beauchamp and Daw, 1972;

Spekreijse et al., 1972). A few units of colour coded ganglion cells have been found with a far red spectral sensitivity peaking at 650 to 680 nm, with a narrow spectral sensitivity curve (Witkovsky, 1967; Daw and Beauchamp, 1972). This is similar to the spectral sensitivity observed in horizontal cells, which is thought to be due to an inhibitory interaction between red and green cones (Witkovsky, 1967; Sirovich and Abramov, 1977; Gunnarsson and Hyde, 1982).

Movement sensitive units were first observed in the rabbit by Barlow and Hill (1963). They discovered a class of ganglion cells which had radically different response to moving stimuli from those with centre surround organization. These units exhibited a well defined vectorial axis, so that movement in one direction ('preferred'), produced a strong discharge, whereas movement in the opposite direction ('null') produced no response ('silent'). Similar movement sensitive ganglion cells have been described by a number of other investigators (Barlow, Hill and Levick, 1964; Werblin, 1970; Karwosky and Burkhardt, 1976). It has been suggested that the direction selectivity is due to laterally mediated transient suppression when the motion is in the 'null' direction (Barlow and Levick, 1965; Bishop, Coombs and Henry, 1971; Wyatt and Daw, 1975). For further review on-ganglion cell response properties see Levick (1972), Daw (1973), and Wheeler (1982).

2.5. Behavioural studies.

Behavioural studies on teleost colour vision have demonstrated that many of the fish studied possess colour vision. Spectral sensitivity curves of large variety have been derived by behavioural

methods (Powers and Easter, 1978a, b; Cameron, 1982). The maximum spectral sensitivity and the shape of the spectral sensitivity curves seem either to depend on the method of measurement or the experimental conditions or both. However, the behavioural studies have, in some cases, revealed the nature (i.e. dichromatic, trichromatic etc.) of the colour vision (Muntz and Northmore, 1970). Cameron (1982), measured photopic spectral sensitivity in the freshwater perch (Perca fluviatilis) using a behavioural technique and found it to be dichromatic with maximum spectral peaks in the green (530-560 nm) and the far red (660-680 nm).

2.6. The present study.

The aim of the present study is to examine in detail morphological and physiological characteristics of horizontal cells in the perch (Perca fluviatilis) retina.

The perch was chosen for this study for a number of reasons: First, the perch retina is characterized by a regular mosaic arrangement of different cone types (Engstrom, 1963b). Second, the perch has been shown to have two types of cones, double (twin) cones forming a square mosaic and single cones each situated in the center of the double cone square (Ahlbert, 1969). Third, microspectrophotometry has revealed that the double cones contain a red sensitive 615 nm photopigment, and the single cones a green sensitive 535 nm photopigment (Loew and Lythgoe, 1978). Fourth, the cone pedicles can easily be identified at the level of the outer plexiform layer (OPL), because of the regular mosaic pattern of cones, permitting identification of the connections between different cone horizontal

cells and specific cones.

In this study it was intended to i) identify and describe morphological characteristics of different types of perch horizontal cells in Golgi preparations, ii) characterize the chromatic inputs to cone horizontal cells by determining the connection pattern of Golgi impregnated cone horizontal cells with chromatically identified cones, using the light microscope, iii) characterize the different horizontal cell response properties by intracellular recordings, and iv) attempt to correlate their response properties with the chromatic inputs they receive from cones, in order to gain some insight into the processing of colour vision in the outer plexiform layer.

MATERIAL AND METHODS.

Chapter 3.

Morphological methods.

3.1. Material.

Experiments were carried out on retinas of the freshwater teleost fish perch (Perca fluviatilis L.). Fish were captured with nets and traps in the Hallington Reservoir in Northumberland, with permission from the Northumberland Water Authority. The fish were kept in 1000 liter aerated aquaria at 15°C, and were maintained on a diet of mealworms. The light and dark cycle was normally 9 hours dark and 15 hours light. Some fish were used shortly after capture, others were held and used many months later. All animals used measured between 15 and 25 cm.

3.2. Methods.

3.2.1. Isolation of the retina.

To facilitate the separation of the pigment epithelium from the retina the fish was dark adapted for at least 1½ hour. The fish was decapitated and one eye was carefully enucleated. After removing muscles from the scleral surface of the eye, a cut was made right round the equator using fine scissors. The front half of the eye was removed with the lens and discarded. The posterior eyecup was then placed in a cool Ringer solution. It was cut in half and the retina carefully shaken out of the eyecup in the Ringer solution. Most dissections were carried out under a dim white light, but a red light and a infra-red light were also occasionally used.

The Ringer solution used was a Kaneko-Carp Ringer of the following composition: 110 mM NaCl, 2.5 mM KCl, 10 mM CaCl₂ and 5

mM HEPES (N-2-hydroxyethyl piperazine N-2-ethanesulphonic acid) buffered to pH 7.4 with NaOH. 10 mM Glucose was used as a substrate.

3.2.2. Golgi flat (whole) mount preparation.

Approximately fifty eyes were used to obtain retinal flat mounts using a modification of Cajal's rapid-Golgi procedure (Stell and Witkovsky, 1973a). After the dark adapted retina had been isolated, several partial radial cuts were made so that the retina would lie flat. The retina was placed receptor side down on a microscope slide; covered by a perforated plastic film (cut from a Telfa pad). Covering the perch retina with filter paper was also tried but no useful impregnation was obtained that way. Several pieces of record cards were placed on top of the plastic film for mechanical support. The 'sandwich' was secured to a microscope slide with cotton thread. The fixation and staining was then completed in a Coplin jar.

The material was fixed and stained by procedures similar to those used by Stell and Lightfoot (1975) and Leeper (1978a). A number of combinations were tried but the following method gave the most consistent results.

Fixation: The retinas were immersed in a fixative containing 2.5% gluteraldehyde, 1% paraformaldehyde, 3% sucrose in 0.06 M sodium phosphate buffer at pH 7.3. Isolated retinas were fixed at room temperature, 22-24°C, for 15 minutes, and then at 8°C for 4 hours.

Golgi impregnation: The retinas were then washed briefly in a phosphate buffer and transferred to a mixture of 0.3 M potassium

dichromate (19 parts), and 4% osmium tetroxide (1 part), and left for 5 days at room temperature. The retinas were rinsed briefly with distilled water and then transferred to a 1% silver nitrate solution and left for 2 days in the dark. Finally the retinas and the film were removed together from the slide and excess crystals were removed from the surface of the retina using a fine brush. The preparations were examined for signs of useful impregnation; retinas showing successful impregnation were dehydrated in graded alcohols and mounted. Retinas showing little staining were returned for another cycle of osmium-dichromate and silver nitrate treatment.

Embedding: Those retinas that were successfully stained were mounted vitreal surface up on a glass slide under freshly made araldite and covered with a weighted polyethylene cover slip. The araldite mounted retinas were cured at 60°C for 36 hours. After this time the polyethylene cover slips were removed, and the retinas carefully examined. Selected areas with well stained and isolated cells were photographed and mapped. Selected cells were drawn (see section 3.2.4), these cells and the surrounding area of the flatmount were cut out and remounted on epon blocks for serial 1 μ m horizontal or vertical sectioning.

3.2.3. Golgi thick sections.

The material used for thick sections was fixed and stained as described previously (section 3.2.2). However, these had usually a slightly longer staining time, or in some cases a double impregnation. In common with all Golgi procedures there is a tendency for the tissue to darken and crystals to form on the surface. The

crystals could be brushed off to some extent but the inner segments of the photoreceptors tend to form a general dark background which often made the retina too dark to examine with trans-illumination. In these cases the material could not be examined as flat mounts. These darker retinas were divided into 4 or 5 pieces, usually by cuts radiating from the optic nerve and embedded in araldite (epoxy resin). The resin was cured for 36 hours.

Sectioning: Thick sections, 20 to 60 μm , were cut either vertically or horizontally in a sliding microtome with a steel blade. Cutting the sections was facilitated by heating the block face using the method described by West (1972). The sections were transferred in serial order and placed flat on a microslide. Mounted either in D.P.X. and covered with a thin glass coverslip, or in fresh araldite and covered with a lightly weighted polyethylene coverslip. Araldite mounted sections were cured overnight at 60°C. After the polyethylene cover had been removed, well impregnated cells were photographed and drawn (see section 3.2.4). Selected areas from the araldite mount were removed from the slide and remounted for further sectioning.

3.2.4. Serial 1 μm sectioning and analysis.

Selected cells from the flat mount retinas or from thick sections were further analysed by serial sectioning. Selected areas were removed using a fine (no. 11) scapel blade and were flatmounted with clear araldite on to a transparent capsule-shaped araldite block, and cured over night at 60°C. The mounted specimen was then trans-illuminated and viewed in a light microscope so that the

progress of subsequent trimming and sectioning could be followed.

Sectioning and staining techniques: The re-embedded block was mounted in the specimen holder of a microtome and the edges of the block face were trimmed smooth and parallel with a razor blade, so that sections would form a straight unbroken ribbon. Material was sectioned either horizontally or vertically on a Reichert OMU3 ultra-microtome using glass knives with tape boats.

For light microscopy the material was sectioned at approximately 1.0 μm . These sections were flattened in the knife boat using a heat pen. The sections were lifted, usually two to four at a time, from the tape boats either with a narrow glass strip cut from a glass coverslip, or with a round glass rod. The sections were then dried on a hot plate at 90°C. The sections were stained with toluidine blue for one to two minutes, washed briefly with distilled water and, after drying on the hot plate, they were mounted under a glass coverslip.

The stained serial 1.0 μm sections were examined and photographed using a Microfex UFX camera mounted on a Nikon Biological microscope (Optiphot), or a Zeiss Ultraphot microscope.

Material for electron microscopy was sectioned at approximately 0.1 μm . Ultrathin sections for electron microscopic studies were doubly stained, first with uranyl acetate, followed by lead citrate and subsequently examined and photographed with a Philips 400 T electron microscope.

Analysis: Golgi impregnated cells were readily identified in the 1 μm sections and their processes were traced through the series of sections to the cone pedicles. The identity of the cones was

established from their position in the photoreceptor mosaic.

In photomicrographs of cells from whole mounts, and from thick sections, only a limited number of terminals and dendrites could be seen in one focal plane. Therefore, in order to reconstruct the form of the whole cell, it was necessary to take serial photographs at different focal levels. By superimposing the pictures the form of the horizontal cell was reconstructed and drawn, and where the photoreceptor mosaic was visible the cone horizontal cell contacts could be identified.

Measurements of size and distance were made with the aid of an eye-piece graticule calibrated against a stage micrometer. All measurements were made under oil immersion using a Zeiss 100 x Planapochromatic objective at a total magnification of 2000 x. Measurements could be made with an accuracy of approximately $\pm 0.2 \mu\text{m}$.

Terminology: For convenience, visual pigments with absorption curves that peak in the red, green, or blue regions of the spectrum will be called red-, green-, and blue-absorbing visual pigments respectively. Cones which contain these visual pigments will be called red-, green-, and blue-sensitive cones, or simply, red, green, and blue cones.

Chapter 4.

Physiological methods.

4.1. Preparation.

The retina was isolated as described in section 3.2.1. The isolated retina was then placed on a piece of filter paper with the receptor side up and transferred to the recording chamber, which measures 5 cm in length, 3 cm in width and is 2 cm high. The retina was mounted on a small black perspex platform in the middle of the recording chamber. On each side of the platform was tissue paper soaked in fish Ringer perfusate (see section 3.2.1), to keep the retina moist and provide an electrical reference to the retina. Oxygenation and pH of 7.4 were maintained by supplying the retina with a steady flow of cool (10 to 15°C), moist gaseous mixture of 95% oxygen and 5% carbon dioxide, at the rate of 120 ml/min. In order to cool and moisten the gaseous mixture, it was led through a series of bottles containing cold water. The water was kept cool by standing the bottles on ice.

The recording chamber was mounted on a Peltier device cooling unit to control the temperature, this was in turn mounted on an X-Y micrometer driven base. During experiments the temperature of the recording chamber was kept at approximately 15°C.

The recording platform consisted of about 1m high concrete pillar on top of which was a 3 cm thick steel plate.

Recordings were made inside an electrically shielded light tight Faraday cage.

4.2. Microelectrodes.

The microelectrodes were pulled on a Livingstone-type, single stage microelectrode puller (Clark Electromedical-LPP2). The glass used was Borosilicate tubing 1.0 mm OD, 0.5 mm ID, with a glass fibre attached to bore.

The microelectrodes were filled with 4 M aqueous solution of potassium acetate. Microelectrodes which had resistance of 100-500 Megaohms were accepted, but usually their resistance was between 200 and 300 Megaohms. Microelectrode resistance was measured on the surface of the retina with a small D.C. current (0.1 nA).

4.3. Recordings.

Microelectrodes were advanced vertically onto the surface of the retina and the resistance of the microelectrodes was measured. Once on the surface, the microelectrodes were inserted into the retina in 1 μ m steps using a micromanipulator. Contact of the electrode with the retina was indicated by a shift in the steady potential, while impalement of neurons was indicated by a negative shift in voltage. Penetrations of horizontal cells, as all other retinal cells, was best accomplished by briefly bringing the electrode pre-amplifier into oscillation by increasing the capacity compensating feedback. This procedure for penetrating small cells has been used for some time by many workers, but the mechanism of penetration is not understood. Perhaps the electrical oscillation itself, or a resulting mechanical vibration allows the electrode to jump abruptly across the cell membrane (Baylor and Fuortes, 1970). Stable penetrations could only be made after the retina had been allowed to settle

down in the chamber for approximately 30 minutes. Within that time the movement of the retina was too great to allow any stable penetrations. After the retina had completely settled down, it was possible to hold any single cell for up to one hour or even more. In the experiments where responses to a series of light intensities and wavelengths were compared, it was necessary to have stable recordings up to 20 minutes long. Since the condition of the cell could change during the recording, a comparison of responses were made only when response amplitude and light sensitivity of the cell did not deteriorate notably. Fortunately the penetrations were usually quite stable, but the loss of a cell was typically abrupt.

The indifferent electrode was of uncoated silver as was the input wire connection to the microelectrode. Signals were recorded with high input impedance amplifier (Colburn & Schwartz). All electrical recordings were monitored on an oscilloscope (Tektronics 502A), and fed to a Vetter Model A, FM tape recorder (D.C.-300 HZ) for later evaluation and photography. All recordings were printed on a penwriter for analysis.

4.4. Optics.

The arrangement used is shown schematically in Figure 4.1. The light sources were two Tungsten Halogen lamps, of 70W and 24 volt, run with a constant current from a Coutant TC-500 power supply. The lamps were slightly underrun (25%) to extend their life and ensure greater stability of light output. In path 1. (Fig. 4.1.) the interference filters (IF) are B-40 Balzers, $\frac{1}{2}$ bandwidth (10-12 nm), they are seventeen in all and are placed on a moveable wheel. Their

range is from 704 to 388 nm in wavelength and collimated (parallel) light passes through them.

Shutters (SH) are driven by Stepping motors, which are controlled by a Digitimer, that also provided a trigger signal for the oscilloscope.

Mirror 1. (M1, Figure 4.1) is a half silver mirror, but mirrors 2 and 3 (M2 & M3) are front surface mirrors.

The stop B (path 1) is a calibrated aperture wheel providing concentric circular stimuli 0.1 to 5.0 mm in diameter, which was focused upon the retina. In order to align the small spots with the center receptive field of a cell, the spot was visually aligned over the electrode tip prior to retinal penetration. Sequential presentation of small spots of increasing diameter was used as the basis for area summation measurements, and to evaluate the extent of interaction between horizontal cells. For measurements of the 'space' constant a long (1-2 cm) and narrow (80 μm) bar (slit) of light was used. The light bar could be moved across the retina with a micro-manipulator. Using the slit has the advantage of reducing the complex two-dimensional syncytial networks in the retina (Naka, 1972) to a one-dimensional cable (Lamb, 1976).

Heat filters (Interference-type Balzers), which have a maximum absorption at wavelengths longer than 720 nm, were used to eliminate nonvisual irradiation.

Light intensity was controlled in path 1 by two neutral density Wedges (NDW1), Carbon-type (Optical and Electrical Coatings LTD) of 0-3 log unit range. Additionally, two fixed neutral density filters (Inconel-on-glass) of 1.6 log units were placed in the light path

while white light was used.

Path 2 was only used for background illumination. The spot size in path 2 remained fixed at 5.0 mm in diameter. The light intensity of the background was controlled by a neutral density wedge (NDW2) of three log unit range. To provide red background illumination a red Wratten filter no. 70. was used, with 80% transmission above 700 nm and 1 log attenuation at 605 nm and 2 log attenuation at 655 nm. This filter will be referred to as 'red (700 nm) background'. To provide blue background illumination a blue Wratten filter no. 47B was used, with peak transmission at 435 nm, half bandwidth of 405 to 465 nm, with an additional transmission beyond 750 nm of 1 log unit, which was largely filtered out with IR blocking filters. This filter will be referred to as 'blue (435 nm) background'.

4.5. Calibrations.

Calibrations, were made at the plane of the retina with a silicon Photodiode (UDT 10DF, United Detector Technology radiometric), which has a 1.0 cm detection area. The photodiode was stored in the dark and was only used for calibrations, which were made about once every three months. The detector's output was measured with a vacuum thermopile (Hilger Schwartz, 0.1003 Amp/watt), that has a response which is flat from 450 nm to 900 nm ($\pm 2\%$). A spectrophotometer (Pye-Unicam SP 1800) was used for calibrating all filters, except the neutral density wedges, which were calibrated in situ. Calibrations were made for each wavelength by measuring light intensity at approximately 0.25 LogI fixed steps on the neutral density wedges (NDW1 and NDW2).

Table 4.I.

The table illustrates the unattenuated light from the interference filters (452 to 704 nm and for Wratten filters no. 47B and no. 70), and shows the sequence of conversion of the detector output (in Amps.) to $\mu\text{W}/\text{cm}^2$ for four mm spot size ($1\mu\text{A}=10\mu\text{W}$ radiation), and the conversion of $\mu\text{W}/\text{cm}^2$ to photons/ $\mu\text{m}^2/\text{sec}$. Photon energy = $h\nu = hc/\lambda$, where h = Plancks constant (6.6608×10^{-34} JS); $c = 2.997 \times 10^8$ m/sec; and λ = wavelength. For example at 704 nm, $1\mu\text{W} = 3.52989 \times 10^4$ Photons/sec/ μm^2 .

Interference filters Wavelength	Detector output		Log photons/ $\mu\text{m}^2/\text{sec}$
	Ampere	$\mu\text{W}/\text{cm}^2$	
704 nm	0.552×10^{-6}	44.16	6.1928
687 nm	0.972×10^{-6}	77.76	6.4277
674 nm	1.580×10^{-6}	126.40	6.6298
651 nm	1.106×10^{-6}	88.48	6.4603
630 nm	0.852×10^{-6}	68.16	6.3325
608 nm	0.297×10^{-6}	23.76	5.8597
585 nm	$1,437 \times 10^{-6}$	115.00	6.5280
571 nm	0.724×10^{-6}	57.92	6.2195
550 nm	$0,767 \times 10^{-6}$	61.36	6.2280
526 nm	0.490×10^{-6}	39.20	6.0138
514 nm	0.270×10^{-6}	21.60	5.7547
493 nm	1.329×10^{-6}	106.32	6.4184
474 nm	0.265×10^{-6}	21.20	5.7010
452 nm	0.346×10^{-6}	27.68	5.7943
no 47B			
435 nm	1.304×10^{-5}	1.8391×10^3	6.0028
no 70			
700 nm	1.625×10^{-5}	2.2989×10^3	6.3065

Figure 4.1.

Path 1; 'LS1', light source; 'L1 to L4' lenses; 'SH1', shutter driven by Stepping motors; 'IF', interference filters; 'HF', heat filters to eliminate nonvisual irradiation; 'B', calibrated aperture wheel provides concentric circular stimuli, 0.1 to 5.0 mm in diameter; 'NDW1', two neutral density wedges of 0-3 log unit range each, to control light intensity. The mirrors, 'M1', a half silver mirror, and inside the Faraday cage a front surface mirror 'M2'; 'L5', a lens that focused the light spot on to the retina.

Path 2 was used for background illumination only; 'LS2', light source; 'L6 to L9', lenses; 'SH2', shutter; 'IF', interference filters, either a red Wratten filter no. 70 to provide red (700 nm) background illumination or a blue Wratten filter no 47B to provide blue (435 nm) background illumination; 'NDW2', a neutral density wedge of 3 log unit range; 'M3', a front surface mirror.

PATH 1

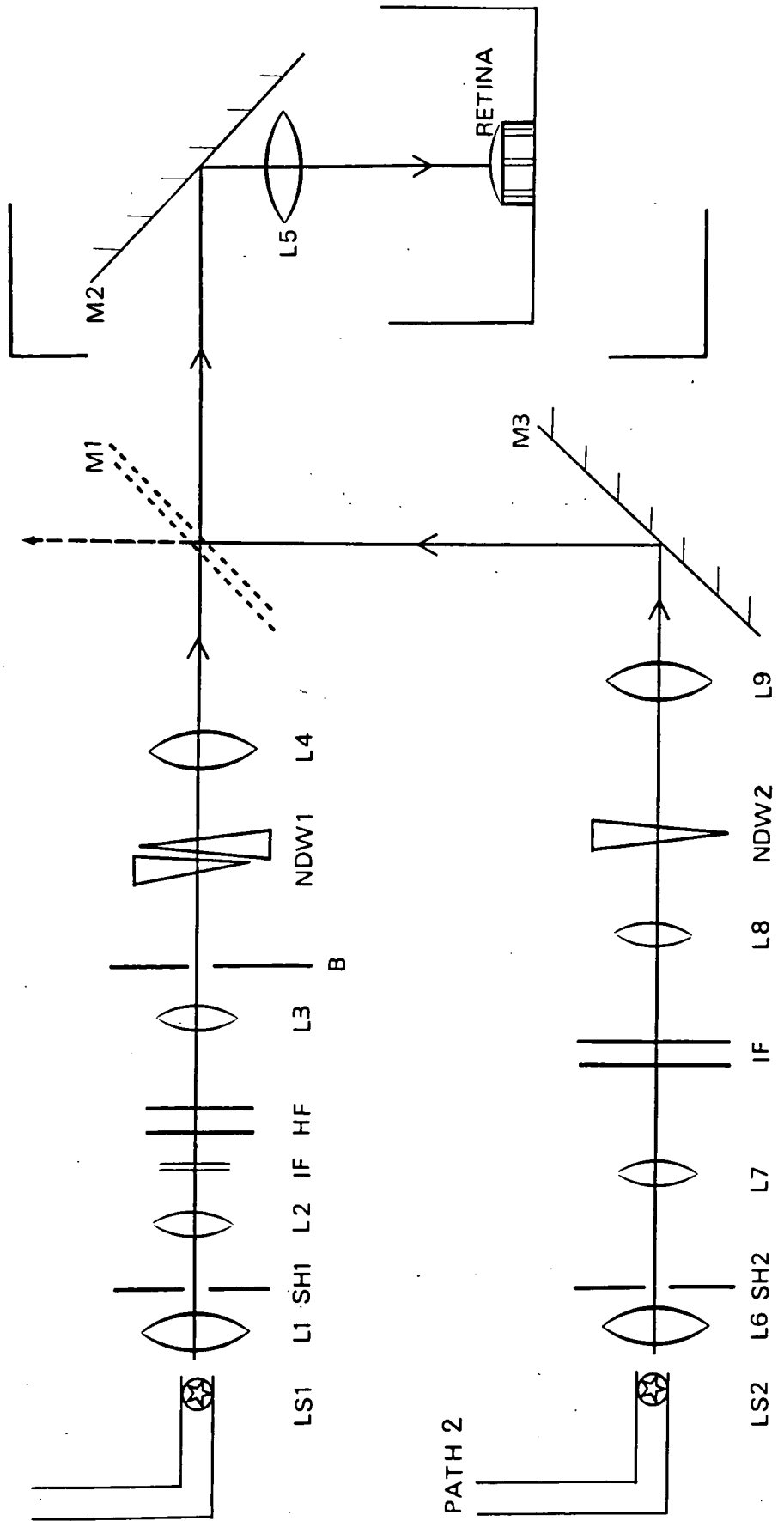

PATH 2

RESULTS.

Chapter 5.

Morphology of Golgi preparations.

5.1. General observations.

Following the Golgi impregnation and subsequent embedding of the perch retina (Chapter 3), the morphology of the horizontal cells was determined under the light microscope. In Golgi preparations of the perch retina three types of horizontal cells were observed which were seen to be segregated into separate layers. For convenience the cell types are here called H1, H2, and H3, on the basis of: a) increasing distance from the outer plexiform layer, b) increasing extent of dendritic spread, and c) the unique subset of receptor cell types contacted by members of each type of cell.

In addition to horizontal cells a number of other Golgi impregnated cell types were observed. Main emphasis was given to the outer plexiform and the inner nuclear layers. Two types of photoreceptors, rods and cones, were readily identified on their characteristic appearances. The cones were found to be of two types, equal double cones (twin-cones) and single cones. The cones form a very regular square mosaic, which is formed by four double cones with a single cone in the center of the square, here termed a 'mosaic unit'. These results are consistent with previous studies on cones and cone arrangements in the perch retina (Engstrom, 1963b; Ahlbert, 1969). A square mosaic, similar to the cone mosaic, was observed in the outer plexiform layer, formed by processes, some of which were found to be of bipolar cell origin. No attempt was made to classify Golgi impregnated bipolar cells or amacrine and ganglion cells.

It was always possible to distinguish between stained horizontal cells and the distal dendritic structures of bipolar cells on their characteristic appearances.

Measurements of the horizontal cells are given for comparison in Table 5.I. The selection of points for measurement, i.e. the narrowest part of a cell body or the definition of a "cell body", is somewhat arbitrary. No attempt was made to study and compare different retinal locations in a systematic way so that the differences between H1, H2, and H3 cells are not attributable to differences in retinal locations.

5.2. H1-type horizontal cells.

Thirty two Golgi impregnated H1-type horizontal cells, from the whole mounts and the 20 to 40 μm thick sections of the perch retina, were selected for further sectioning and morphological characterization. Only those cells were selected that showed successful staining and were reasonably isolated from other Golgi impregnated cells.

In horizontal view (Figs. 1-3, Plate 1) the H1-type horizontal cell is a compact stellate cell. The H1-type cell body measures approximately 15 μm in diameter (Table 5.I) and is about 5 μm thick. Typically, twelve to eighteen relatively short (5-10 μm), usually branched and gradually tapering dendrites, radiate from the cell body of the H1-cell and delimit the cell. The dendritic tree is often deeply indented (Figs. 1-3, Plate 1, and Fig. 4, Plate 2), and the boundaries of the dendritic field may vary from roughly four sided to circular in outline in the horizontal section. The dendritic spread is about 37 μm in diameter (Table 5.I). The H1-cell

may bear horizontally directed processes or filamentous appendages that measure about 0.5-1.0 μm in diameter and 1-5 μm in length and some may expand slightly at the tip (Figs. 1.b, 2.a, Plate 1, and Fig. 4, Plate 2).

One dendrite of the H1-cell usually gives rise to a slender axon 0.5 to 1.0 μm in diameter and usually 150 to 200 μm in length in well stained preparations (Figs. 3.a, b, Plate 1, and Fig. 4, Plate 2). The axon runs horizontally across the retina and descends towards the inner nuclear layer. The axon was occasionally observed to have a swelling but generally it appeared smooth and unbranched. It was not possible to identify any contacts of the axon. Not all stained H1-type horizontal cells were observed to possess an axon.

The H1-type horizontal cells form the distal (external, sclerad) layer of horizontal cells in the inner nuclear layer (I.N.L.) and lie proximal to the outer plexiform (synaptic) layer and the receptor terminals. Vertical sectioning of the H1-cells demonstrates that their cell bodies lie directly below the synaptic terminals of cone photoreceptors (Fig. 5, Plate 3), with dendrites arborizing laterally at the border of the inner nuclear layer and the outer plexiform layer.

From the sclerad (distal) surface of the cell body and dendrites, arise many short dendritic processes (Figs. 1, 2, Plate 1, and Fig. 5, Plate 3). These dendritic processes, which are usually unbranched, run radially and/or obliquely towards the receptor terminals. They are 0.5 to 1.0 μm in diameter and their length varies according to their position on the cell. They are shortest from the centre of the cell (Figs. 5.a, b, Plate 3) being 0.5 to 1.0

μm in length but the dendritic processes arising peripherally (Figs. 5.e, f, Plate 3) are somewhat longer, up to 5-10 μm in length. At their termination, at the level of the photoreceptor synaptic terminals, the dendritic processes clearly branch within the cone pedicle base to form what appears to be a cluster of small round endings about 0.5 μm or less in diameter (Figs. 5.a-f, Plate 3, and Fig. 28.f, Plate 11). However, fine details of the ultrastructure of terminal endings of the H1-cells are difficult to resolve in the light microscope.

H1-cells appear to be arranged in a regular square pattern which is best observed as the regular distance between the H1-cell nuclei (Fig. 33.d, Plate 15), with the centre of the cell body directly below a central single cone (Fig. 30, Plate 13). The distance between the centres of the H1-cells is the same as the distance between neighbouring single cones when measured in the same area and there is obviously one H1-cell per cone "mosaic unit", which consists of a square of four pairs of double cones with a central single cone. When the size of the dendritic spread (37 μm) is compared with the distance between the centres of adjacent H1-cells (which is approximately 20 μm), then it is obvious that there is a considerable overlap of H1-cells.

The appearance of the H1-cell is rather variable as the examples of the H1-cells (Figs. 1-3, Plate 1) show. It was concluded that the variation was due to differences in the reaction of H1-type cells to the Golgi staining procedure. In general, relatively few well impregnated H1-cells were found compared with the numbers of well impregnated H2 and H3-cells.

5.3. H2-type horizontal cells.

Eighty-six Golgi impregnated H2-type horizontal cells, from the whole mounts and the thick sections, were selected for morphological characterization and further sectioning.

In appearance, the outline of the Golgi impregnated H2-cell is similar to that of the H1-cell. However, it is easily distinguished from the H1-cell by its larger cell body, greater dendritic spread and the less compact appearance of its processes. In the horizontal plane, the H2-cell is, like the other perch horizontal cells, fundamentally a stellate cell, but, of the three types, it has the most cuboidal appearance (Figs. 6-8, Plate 4, and Fig. 9, Plate 5). The cell body of H2-horizontal cells is characteristically the largest of the three perch horizontal cells, with an area of approximately $30 \times 45 \mu\text{m}$ (Table 5.I). Typically, eight to fifteen, thick (up to $15 \mu\text{m}$ across), tapering and usually branched dendrites radiate from the cell body and delimit the cell (Figs. 6-8, Plate 4, and Fig. 9, Plate 5). The dendrites of the H2-cell sometimes appear to end in a thin, horizontally directed process or appendage (Fig. 8.b, Plate 4), these are 0.5 to $1.0 \mu\text{m}$ in diameter and with no expansion of the tip. The dendritic field is roughly circular in extent or occasionally elliptical. The diameter of the dendritic field of the H2-cell is typically about $100 \mu\text{m}$ (Table 5.I).

In favourable Golgi preparations (Figs. 7.a, b, Plate 4), both cells of a contiguous pair were positively identified as H2-cells. Their dendritic fields overlap partially and three dendrites appear contiguous. Four or five cones appear to be in mutual contact with the dendritic processes of both cells (Fig. 7.b, Plate 4). The

distance between the centres of the cell bodies is about 55-60 μm or about three mosaic units, which means that the number of H1-type per H2-type cells is about 9/1 (Figs. 33.b-d, Plate 15). The dimension of the dendritic spread, in combination with the separation of the cell bodies, shows that the overlap between the dendrites of adjacent H2-cells is much smaller than for the H1-cells.

Only rarely was it observed that H2-cells possessed an impregnated axon (Figs. 6.a, b, Plate 4). This axon is 1 to 2 μm in diameter and more than 100 μm long, it runs horizontally with a sinuous course and descends towards the inner nuclear layer. It appears smooth, unbranched and a terminal ending was not observed.

The H2-type horizontal cells form the intermediate layer of horizontal cells. They lie proximal to the H1 and distal to the H3 horizontal cells and to the bipolar cells (Figs. 13-15, Plate 6). However, the horizontal cell layers do overlap to some extent in perch, but they still remain clearly segregated into layers.

In vertical view the sclerad surface of the H2-cell is located 5 to 6 μm from the outer plexiform layer, and the cell body is maximally 8 to 10 μm thick (Figs. 10-12, Plate 6). From the sclerad (distal) surface of the H2-cell radiates an average of 34 dendritic processes. These dendritic processes are usually unbranched, about 1.0 to 1.5 μm in diameter and ascend radially for 5 to 8 μm towards the outer plexiform layer where they form terminal clusters (Figs. 10, 11, Plate 6). The terminal clusters of the H2-cell clearly invaginate the cone pedicle base as can be seen in vertical 1.0 μm sections (Figs. 12.a-c, Plate 6). The terminals themselves are clusters of small round endings about 0.5 μm in diameter, strung

together on finer processes (Figs. 12.a-c, Plate 6).

5.4. H3-type horizontal cells.

Fourty-six Golgi impregnated H3-type cells, from the whole mounts and the thick sections, were selected for further sectioning and morphological characterization.

The H3-type horizontal cells form the proximal layer of horizontal cells in the inner nuclear layer. In position they lie proximal to the H2-type horizontal cells and distal to the bipolar cell layer (Figs. 13-15, Plate 6).

The H3-cells are stellate cells with a relatively small cell body compared with their dendritic spread (Table 5.I). The cell body, which is often very difficult to define (Figs. 16-20, Plate 7, and Fig. 21, Plate 8), is usually elongated, measuring $16.6 \times 37.6 \mu\text{m}$ in area (Table 5.I). Typically, seven to ten, usually branched dendrites radiate horizontally and obliquely from the cell perikaryon. The dendrites are typically long and slender, cylindrical in cross-section and gradually tapering along their length. The dendritic field outline of the H3-type horizontal cell is typically elongated to fusiform in shape only occasionally circular (Figs. 16-20, Plate 7, and Fig. 21, Plate 8). The dimensions of the H3-cell dendritic field measure on average $104 \times 125 \mu\text{m}$ in diameter and thus this cell has the greatest dendritic field of the three perch horizontal cells (see Table 5.I).

In the flat-mount preparations and in $20 \mu\text{m}$ thick sections (Figs. 16-20, Plate 7) the Golgi-impregnated H3-type cell is easily distinguished from H1- and H2-type horizontal cells by the

characteristically long and slender appearance of the perikaryon and dendrites, and by the relatively few dendritic processes radiating from the sclerad surface.

Both cells in Figure 35 (Plate 17) of the contiguous pair were positively identified as H3-cells. The centre to centre distance between Golgi impregnated H3 pairs is 75 to 80 μm or approximately four mosaic units. Typically, one or two dendrites appear contiguous and two to three cones are in mutual contact with dendritic processes from both cells.

Only a few H3-type horizontal cells have been seen to possess an axon, an example of which is shown in Figure 23 (Plate 9). The axon arises from a dendrite and is similar in appearance to the H2-type axon. However, the H3 axon (Fig. 23, Plate 9) is clearly running obliquely in the horizontal cell layer, before disappearing from view. The axon does not make contact with photoreceptors, and an axon terminal was not observed.

In vertical view (Figs. 22-24, Plate 9) the H3-cell body is maximally about 6 to 7 μm in thickness and is at a distance of about 8 to 10 μm from the outer plexiform layer. The dendritic processes arising from the peripheral part of the cell usually run more obliquely towards the outer plexiform layer, compared with those arising from the cell centre which take a more direct course (Fig. 22, Plate 9). It is usual for the dendritic processes of the H3-cell to run for some distance tangentially in the outer plexiform layer before they terminate in a cone pedicle (Fig. 24.b, Plate 9). The terminal clusters of the H3-type cells appear similar to the H2-type terminal endings.

5.5. Horizontal-receptor cell contact.

Several examples of each type of Golgi impregnated horizontal cells from flat, whole-mounted perch retinas were serially sectioned in the horizontal plane at 1.0 μm thickness, and examined with a light microscope. The cones that contact the stained horizontal cells were identified by their position in the cone mosaic. The pattern of the horizontal cell terminals was also studied in 20 μm thick horizontal sections. In favourable 20 μm sections the plane of sectioning often separated the cell body from the terminal endings so that each could be observed in adjacent sections. In this way the pattern of termination of the dendritic processes was not obscured by the densely stained cell body and the terminal pattern could be compared with the photoreceptor mosaic. The results are summarized in Table 5.II.

5.6. H1-cell contact.

The pattern of dendritic processes arising from the H1-cell can be seen in favourable 20 μm sections (Figs. 25-27, Plate 10). From the pattern of the terminals seen in 20 μm horizontal sections it was difficult to be certain of the precise connections with cones, when compared with the mosaic of cone photoreceptor terminals. However, the best correspondence between H1-cell terminals and the cone mosaic requires that the H1-cell makes contact indiscriminately with all the cones within reach. This conclusion is supported by observations from vertical 1.0 μm sections through the H1-cell (Figs. 5.a-f, Plate 3), where the H1-cell terminals appear to invaginate all cone pedicles within reach. These results were verified

by analysis of horizontal 1 μm serial sections.

The numbers of cones contacted by the dendritic processes of H1-cells were counted in reconstructions of a total of 17 cells from 1 μm horizontal sections (Figs. 28.a-f, Plate 11, and Figs. 29.a-e, Plate 12). The mean numbers of double (red) and single (green) cones contacted by a single H1-cell were 13.5 (± 3.4) and 2.5 (± 0.5) respectively (Table 5.II). Figure 30 (Plate 13), shows an actual observation of the H1-cell contact pattern as revealed by reconstruction. Since, in some cases, the Golgi impregnated H1-cells were accompanied by other Golgi impregnated horizontal cells (Figs. 29.a-e, Plate 12), the total number of cones contacted by the H1-cell might be overestimated. There is, however, no doubt about the pattern of cone contacts by H1-cells, i.e. that they make contact with both double and single cones.

In 1.0 μm serial horizontal sections through the H1-cell (Figs. 28, Plate 11, and Figs. 29, Plate 12) the distal (sclerad) surface appears very rough, with an extensive plexus of appendages or processes. Most of the projections are 1 to 2 μm in length and 0.2 to 0.5 μm in diameter, and are radially directed into the outer plexiform layer. Fewer, usually longer, projections (some up to 10 μm) are horizontally directed. Some of the processes appear to expand into a knob or bulb at the tip (Fig. 29.d, Plate 12).

Most of these appendages appear to end within the outer plexiform layer, although other processes (e.g. Fig. 29.c-d, Plate 12), appear to extend and make contact with rods. However, an indication of a rod contact was observed only in two out of the seventeen H1-cells analysed. Furthermore, no rod connections were observed in

an analysis of six H1-cells, from 1.0 μm vertical sections (Figs. 5.a-f, Plate 3). It has not been possible to provide positive structural evidence for an exclusive rod horizontal cell interrelation in perch retina.

5.7. H2-cell contact.

The pattern of the H2-cell to cone connections was revealed in favourable 20 μm thick horizontal sections, where the Golgi impregnated H2-cell body and its radially arising dendritic processes are separated in adjacent sections (Figs. 31, 32, Plate 14). The sections containing the H2-cell terminals reveal in a striking way the selective pattern of connections made by the H2-cell. The terminals are arranged in a ring pattern, which matches the pattern of the double cone pedicles. The H2 horizontal cell therefore appears to be exclusively associated with double cones. This conclusion was verified by analysis of 1.0 μm serial sections of 52 Golgi impregnated H2-cells (Figs. 33, Plate 15).

Careful reconstruction of the pattern of innervation of the 52 H2-cells revealed that in no instance were any terminal processes of the H2-cell associated with single cones. All terminations were seen to be made in the terminal ending of double cones (Fig. 34, Plate 16). In addition to the previously mentioned cells, more than 60 positively identified H2-cells were examined. The number of double cones that an individual H2-cell invaginated varied between 28 and 40, or 34.2 (± 3.6) on average (Table 5.II). Not all the double cones within the dendritic field of an individual H2-cell were associated with the terminal endings of that cell (Fig. 34, Plate 16), but



there was no obvious pattern of selectivity between members of the double cones.

5.8. H3-cell contact.

The H3-type horizontal cell is the most distinctive horizontal cell in the flat mount preparations and in thick sections. The radially orientated dendritic processes are relatively few and long compared with those of H1- and H2-cells. Because of their length, they are therefore frequently separated from the cell body in 20 μm horizontal sections and usually all of the Golgi impregnated dendritic terminals can be seen (Figs. 35-36, Plate 17). In all cases the dendritic terminals form a fairly regular square or rhomboidal pattern which resembles the form and dimensions of the central single cone pattern. The H3-cells show, as the H2-cells, a high degree of selective connectivity. Data from reconstructions of 21 serially sectioned H3-cells at 1.0 μm (Figs. 37.a-f, Plate 18) and from 30 H3-cells from 20 μm horizontal sections showed (Fig. 38, Plate 19) that there was no exception to the single cone contacts. The number of single cones invaginated varied from 10 to 19, with 14.0 (± 2.7) on average (Table 5.II).

The terminal endings of the H3-cell were rather variable in shape, overall size and complexity. Those arising centrally from the cell body were usually more complex and larger than those arising peripherally from the dendrites (Fig. 35.b, Plate 17). It is not unusual for two dendritic terminals from the same cell to invaginate the same single cone pedicle. Usually all single cones are invaginated within the H3-cell dendritic field (Figs. 35, 36, Plate 17, and Fig. 38, Plate 19).

5.9. Light microscopy of Golgi-impregnated receptor terminals.

The two classes of photoreceptors are readily identified in the Golgi impregnated perch retina by their size and shape alone. Both rods and cones produce basal processes (telodendria), that ramify in the outer plexiform layer (Figs. 39.a, b, Plate 20).

With the Golgi method; silver chromate impregnation did not extend to the outer segment of the receptors. Most Golgi impregnated cones were only partially impregnated, typically, proximal to the nucleus and in some cases the inner segment was impregnated as well.

The rod was rarely found to be Golgi impregnated. The rod spherule which measures about 1.0 to 2.0 μm in diameter has few and short basal processes (Fig. 36.b, Plate 17). They appear a homogeneous population of similar dimensions, 1 to 3 μm in length and less than 0.5 μm in diameter. They were generally unbranched and are proximally directed towards the outer plexiform layer, and they have a terminal swelling or knob at their tip. They do not appear to invaginate other spherules or cone pedicles.

When the Golgi impregnated cone pedicles are viewed in the flat mount two types of pedicle can be identified by the structural characteristics of their basal processes (Figs. 40-43, Plate 21). One type has several long and relatively thick basal processes, in addition to shorter and finer processes (Figs. 40, 41, Plate 21), whereas the other type has only short and frequently branched processes (Figs. 42, 43, Plate 21). In the 20 μm horizontal sections the two types could be identified by their position in the receptor mosaic. The cone pedicle with only short processes was identified as a single cone (Figs. 44.a-c, Plate 22), and the pedicle with long

processes was identified as a double cone (Figs. 45.a-c, Plate 22).

5.10. Double cones.

The double cone pedicle is usually slightly larger than the single cone pedicle, with diameters of 8.0 to 8.5 μm and 7.5 to 8.0 μm , respectively. Each double cone pedicle forms processes which may be classified into 3 types according to their size. i) Long and relatively thick processes which are horizontally directed in the outer plexiform layer. They can reach 30 to 35 μm in length and 1.0 to 1.2 μm , in diameter. They are generally branched and have a terminal swelling at the tip. These processes have a tendency to course in a particular retinal direction. The double cone usually emits 2 to 3 such processes which run parallel and one in the opposite direction (Figs. 40, 41, Plate 21, and Figs. 45.a-c, Plate 22). ii) Intermediate long processes that are 0.5 to 0.8 μm in diameter and 10 to 15 μm in length. These are generally more frequently branched than the longer ones and they may have several knobs or swellings. iii) Short basal processes, are 0.1 to 0.3 μm in diameter and 1 to 5 μm in length, frequently branched, and have several terminal knobs. They often take a more proximal course towards the external horizontal cells (H1). However, the fine details are difficult to resolve in the light microscope because of their small size.

5.11. Single cones.

Each single pedicle emits two types of basal process (Figs. 42, 43, Plate 21, and Figs. 44.a-c, Plate 22). i) Short basal processes that are approximately 0.1 μm in diameter and 1 to 2 μm in length.

They appear very similar to the short processes of the double cone, being frequently branched and with several knobs. ii) Long basal processes that are 10 to 15 μm in length and approximately 0.5 μm in diameter. They are frequently branched with a large number of terminal swellings. Usually these processes do not extend outside the mosaic unit.

The basal processes usually course within the outer plexiform layer (Figs. 39.a, b, Plate 20) where they generally terminate 'blind' in the outer plexiform layer. However, a proportion of the longer processes both from the double and single cones leave the outer plexiform layer and invaginate other cone synaptic terminals. In the light microscopic examinations of the flat mount and 20 μm sections, it was not possible to establish the exact point of termination of the Golgi impregnated basal processes. The Golgi impregnated cones of both types were therefore selected for further sectioning in the horizontal plane at about 1.0 μm and counterstained with toluidine blue. The chromatic identity of the invaginated cones could readily be identified from their position within the receptor mosaic. The contacts of the basal processes that did not invaginate other cone pedicles could not be identified.

5.12. Invaginating basal processes.

Double cones: Analysis of eleven Golgi impregnated double cone basal processes from serial 1.0 μm horizontal sections revealed that they invaginate exclusively other double cone synaptic terminals (Figs. 46, 47, Plate 23). Each double cone invaginates 3 to 5 other double cones. Normally, any particular cone pedicle sends just one

process into each of the nearby pedicles, though occasionally two or three processes may be involved. Double cone processes showed a preference for cones which are in the same position in the mosaic, even though other adjacent cone pedicles were also invaginated, (Fig. 47, Plate 23).

Single cones: Reconstructions of nine single cones showed that they were likewise selective; they invaginated exclusively double cones (Figs. 48, 49, Plate 24). Basal processes from each single cone invaginated 6 to 8 double cones. Figures 47 and 49 (Plates 23 and 24) show actual reconstructions of invaginating basal processes of double and single cones respectively.

The invaginating basal processes do not penetrate the synaptic cavity as deeply as the dendritic processes of the horizontal cells.

5.13. Electron microscopy of Golgi-preparations.

Selected Golgi impregnated cells from 20 to 40 μm thick horizontal sections were sectioned further at 0.1 μm for electron microscopy. It had been observed with the light microscope that fixation and isolation of impregnated cells in this material was rather poor at the ultrastructural level. However, it was possible to confirm the results of the 1.0 μm serial sectioning of the interconnection of H2- and H3-type horizontal cells with double and single cones respectively, and it appears as if the processes of H2- and H3-cells occupy both central and lateral position at the synaptic ribbon complexes (Figs. 50, 51, Plate 25). In addition, membrane appositions, that resemble 'gap junctions' in other teleosts, were observed between adjacent horizontal cells. Reasonably isolated examples of

Golgi impregnated H1-type cells and cones could not be obtained for ultra thin sectioning, since the best material had already been used for 1.0 μm serial sectioning. Therefore electron microscopy of Golgi impregnated material was not attempted further.

In general the outer plexiform layer of the perch retina shows a lamellar organization in the electron microscope, which is composed primarily of photoreceptor terminals. Rod synaptic terminals are typical spherules and are readily identified from cones by their size (1 to 2 μm) and shape (Fig. 50, Plate 25). Cone synaptic terminals or pedicles measure 7 to 9 μm in diameter. The electron microscope reveals clearly the difference in size and complexity between the double and single cones. Both cone types have a common synaptic cavity, into which processes of horizontal and bipolar cells enter. The double cones contain up to eleven synaptic ribbons compared with seven or less in the single cone pedicles, and the rod spherules contain only one synaptic ribbon. The general organization of the ribbon synapses, i.e. dyad and triad organizations in cones and triad in rods were observed, and are fully consistent with earlier studies on the fish retina (Stell, 1967, 1976; Scholes, 1975; Haesendonck and Missotten, 1979).

Table 5.I.

Dimensions (in μm) of perch cone horizontal cells in flat mounts and thick sections.

	H1 (n=32)	H2 (n=86)	H3 (n=46)
Dendritic-field (dimensions)	35.9 x 38.1 μm	94.1 x 108.3 μm	104.3 x 125.6 μm
S.D.	(± 3.0) (± 3.2)	(± 5.2) (± 6.6)	(± 9.0) (± 10.5)
Cell body (dimensions)	13.8 x 17.2 μm	30.5 x 45.1 μm	16.6 x 37.6 μm
S.D.	(± 3.1) (± 3.7)	(± 5.2) (± 6.1)	(± 7.7) (± 9.0)

Measurements of cone horizontal cells in flat mounts and in 20 to 40 μm thick sections. Numbers are the mean and standard deviation (\pm S.D.) of n cells. Major and minor axes of dendritic field and cell body were measured.

Table 5.II.

Input patterns of reconstructed perch cone horizontal cells.

	Double cone	Single cone
H1-type horizontal cell (n=17)	13.5	2.5
S.D.	(±3.4)	(±0.5)
H2-type horizontal cell (n=112)	34.2	0.0
S.D.	(±3.6)	-
H3-type horizontal cell (n=51)	0.0	14.0
(S.D.)	-	(±2.7)

The numbers of cones contacted by horizontal cells reconstructed from serial 1.0 μm sections and 20 μm thick horizontal sections. The numbers given are the mean number of cones contacted by n cells and standard deviation (\pm S.D.) for n cells.

Key to abbreviations:

- Ap: Appendage (process).
Ax: Axon.
CB: Cell body.
Cbp: Cone basal process.
Cn: Cone nucleus.
Cp: Cone pedicle.
De: Dendrite.
Dp: Dendritic process.
Dc: Double cone (red).
H1: H1-type horizontal cell.
H1.N: H1-cell nucleus.
H2: H2-type horizontal cell.
H2.N: H2-cell nucleus.
H3: H3-type horizontal cell.
H3.N: H3-type nucleus.
INL: Inner nuclear layer.
OLM: Outer limiting membrane.
ONL: Outer nuclear layer.
OPL: Outer plexiform (synaptic) layer
PT: Photoreceptor terminal.
Rs: Rod spherule.
SC: Single cone (green).
Te: Terminal ending.

Plate 1.

Light micrographs of Golgi impregnated H1-type horizontal cells. Photographed at different focal planes, from 20 μm horizontal sections.

Figures 1.a and 1.b. H1-type (H1) horizontal cells photographed at the level of dendritic terminals, showing a part of the much larger H2-type (H2) horizontal cell. Note the numerous horizontally orientated processes or appendages radiating from the H1-cell. Note also the difference between the H1- and H2-terminal (Te) endings (arrow >).

Figures 2.a. and 2.b. H1-cell photographed at the level of its cell body (CB) and dendrites (De) and 2.b. showing the terminal endings of the dendritic processes (Dp).

Figure 3.a. and 3.b. Shows an H1-cell with a short axon (Ax). Note the silver-chromate precipitation randomly distributed all over the tissue in 2.a., 2.b., 3.a. and 3.b.

Abbreviations:

- AX: Axon.
- CB: Cell body.
- De: Dendrites.
- Dp: Dendritic processes.
- H1: H1-type horizontal cell.
- H2: H2-type horizontal cell.
- Te: Terminal ending.

Markers = 20 μm .

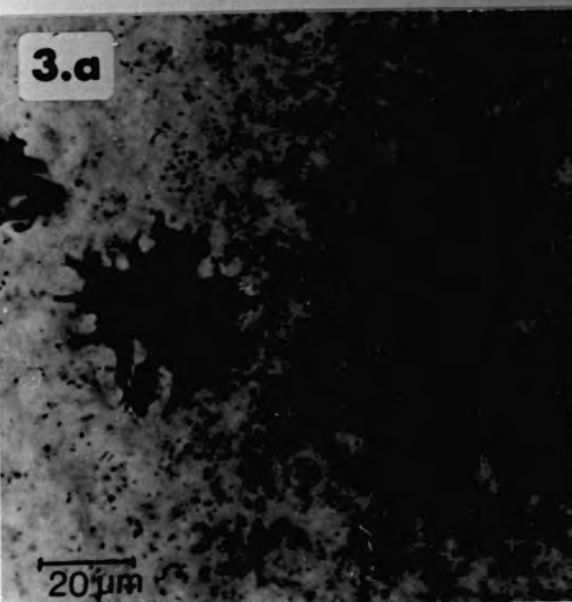
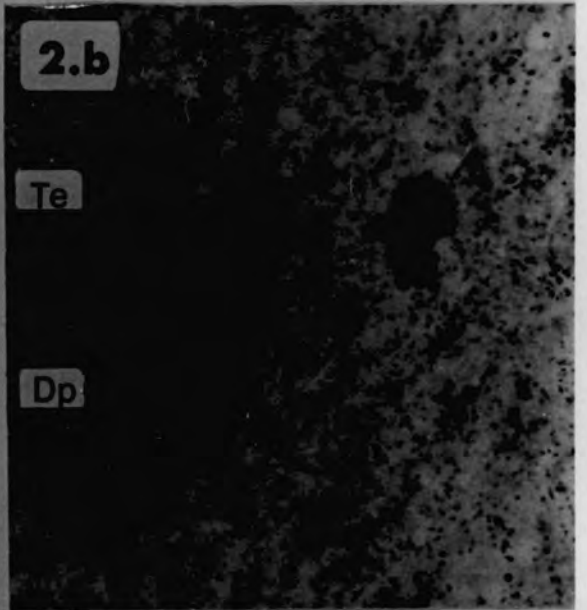
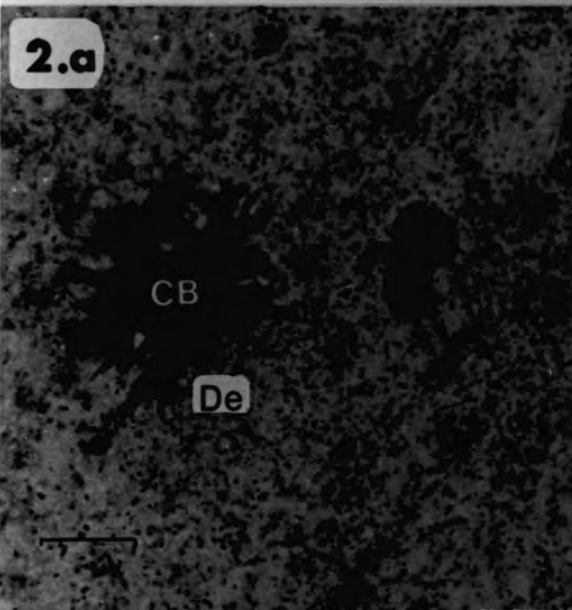
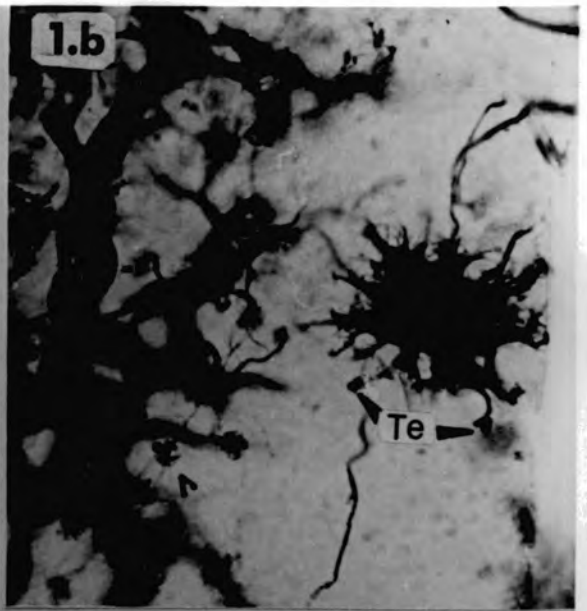
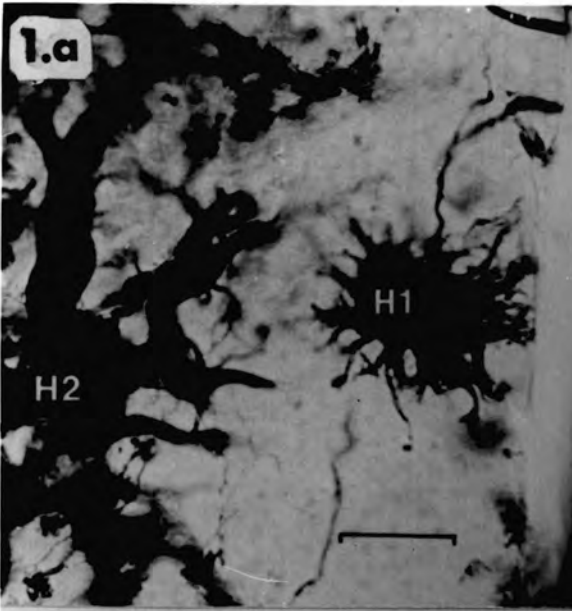

Plate 2.

Figure 4. H1-type horizontal cells, reconstructed from light micrographs of Golgi impregnated cells that were photographed serially at different focal planes (Section 3.2.4).

Abbreviations as for Plate 1.

Marker = 20 μ m.

FIGURE 4. H1

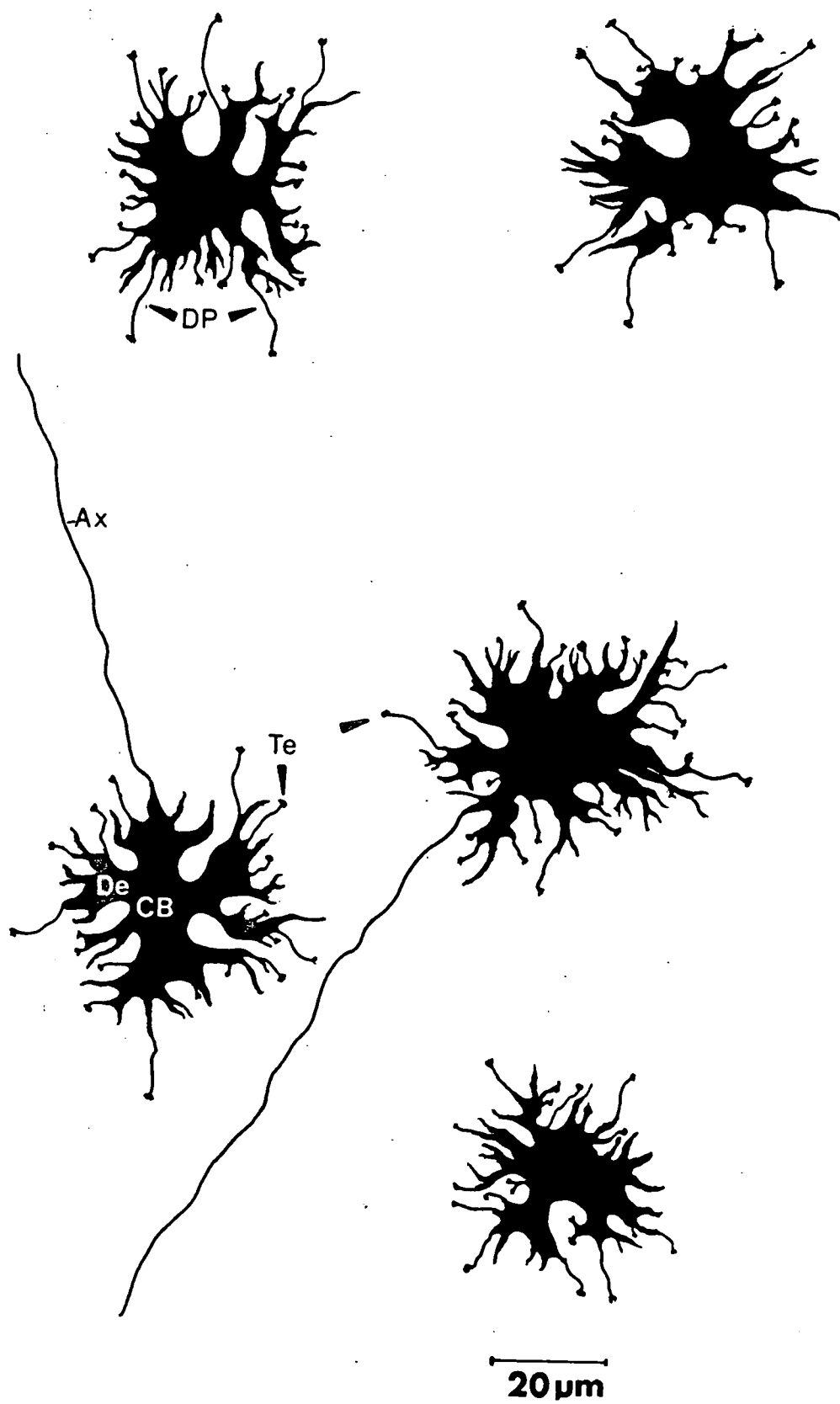

Plate 3.

Light micrographs of Golgi impregnated H1-type horizontal cell, serially sectioned vertically at 1.0 μm and counterstained with toluidine blue.

Figures 5.a., 5.b., 5.c., 5.d., 5.e. and 5.f. Showing the H1 cell nucleus (H1.N) 5b, dendrites (De) 5d, and terminal endings (Te) 5e, that clearly terminate inside cone pedicles. The H1-cell dendritic processes appear to invaginate all cone pedicles (Cp) within reach (5a, and 5e). Note the short distance between the cell perikaryon and the cone pedicle above its center as in 5.a. and 5.b. In 5.f. there are at least two fine processes or appendages visible which appear to end blind in the outer plexiform layer (arrow >). A part of the much larger H2-type cell body can be seen in 5c. A cone cell body can be seen in 5a with its nucleus (Cn) and its fine process terminating in a cone pedicle (Cp). Rod spherules can be seen in 5e, that are characteristically much smaller than the cone pedicles.

Abbreviations: Cn: Cone nucleus.

Cp: Cone pedicle.

H1.N: H1-cell nucleus.

H2: H2-type horizontal cell.

OLM: Outer limiting membrane.

ONL: Outer nuclear layer.

Rs: Rod spherule.

Other abbreviations as on previous plates.

Marker = 10 μm .

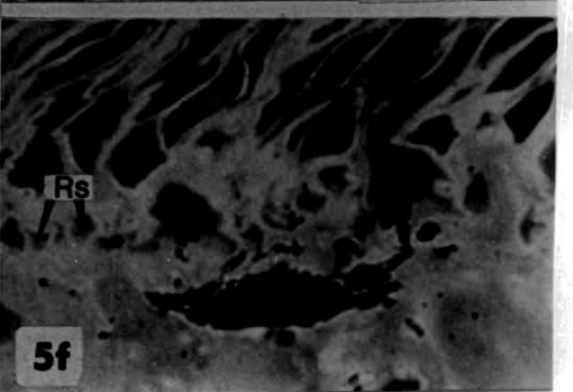
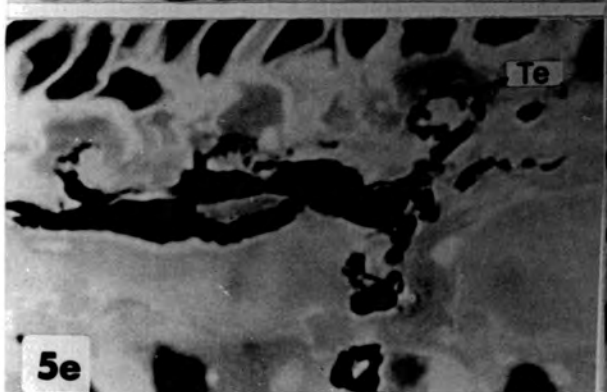
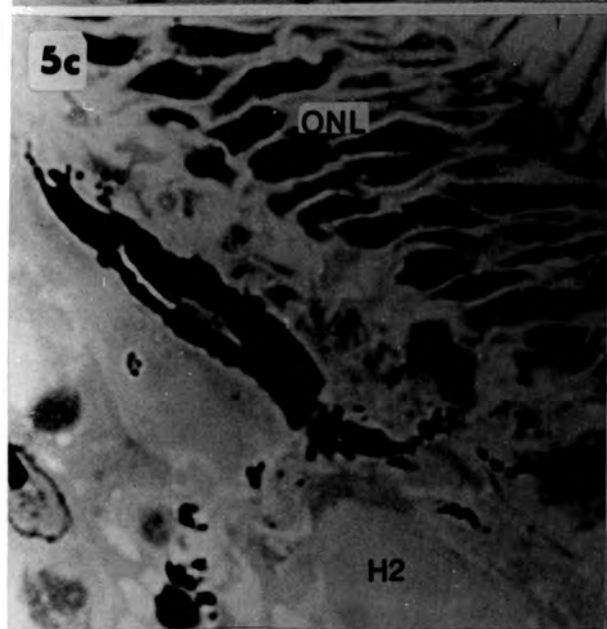
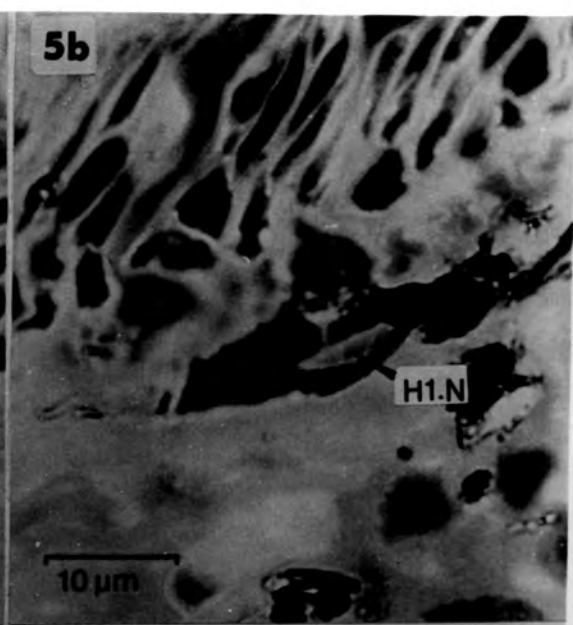
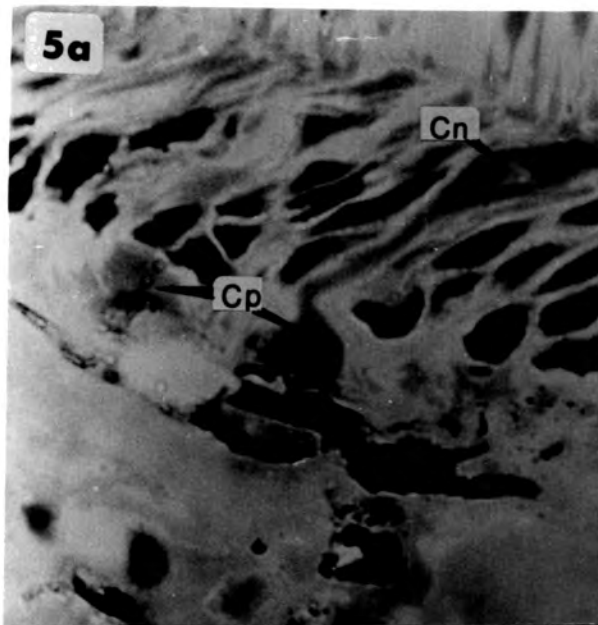

Plate 4.

Light micrographs of Golgi impregnated H2-type horizontal cells, from 20 μm horizontal sections, photographed at different focal planes.

Figures 6.a. and 6.b. Show an H2-cell with an axon (Ax), also showing dendritic processes (Dp).

Figures 7.a. and 7.b. Two contiguous Golgi impregnated H2 cells with three dendrites in continuity, and a H3 cell can be seen. In 7.b., at least two dendritic processes from each cell appear to invaginate the same cone pedicles. (arrow >)

Figures 8.a. and 8.b. Note the thin processes or appendages (Ap) coursing horizontally from some dendrites. (8a and b are not the same cell).

Abbreviations: Ap: appendage or process.

Other abbreviations as for previous plates.

Marker = 40 μm .

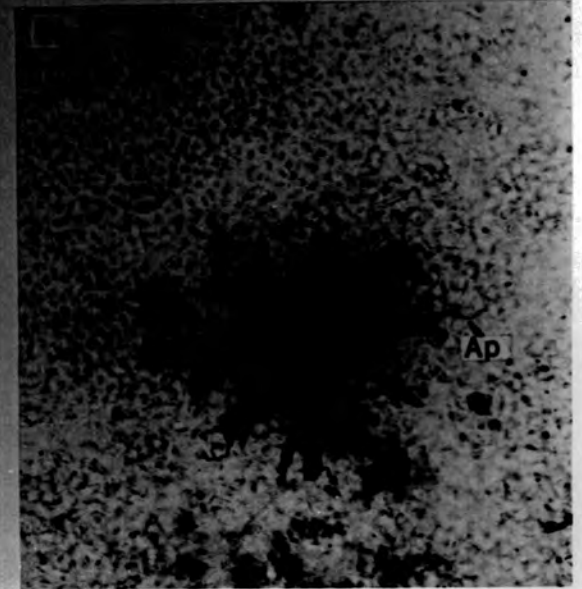
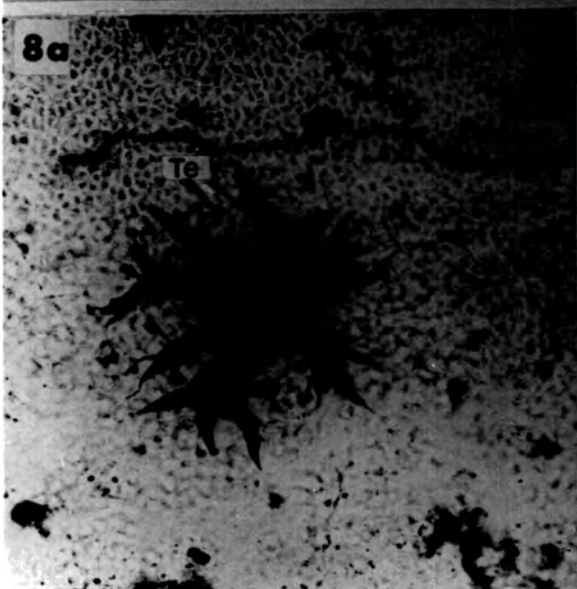
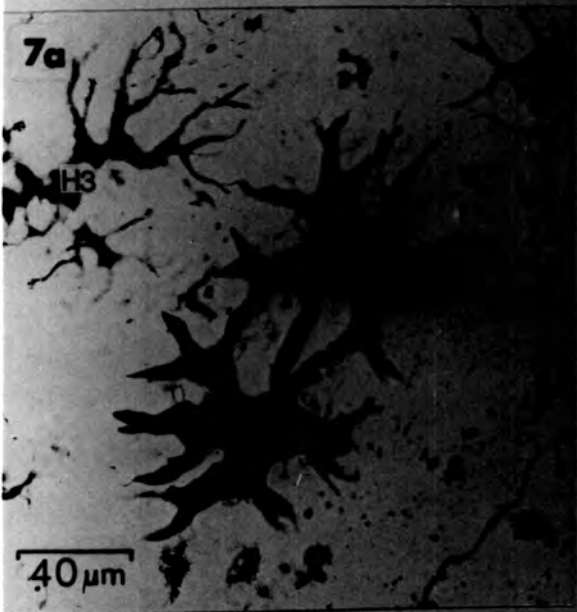
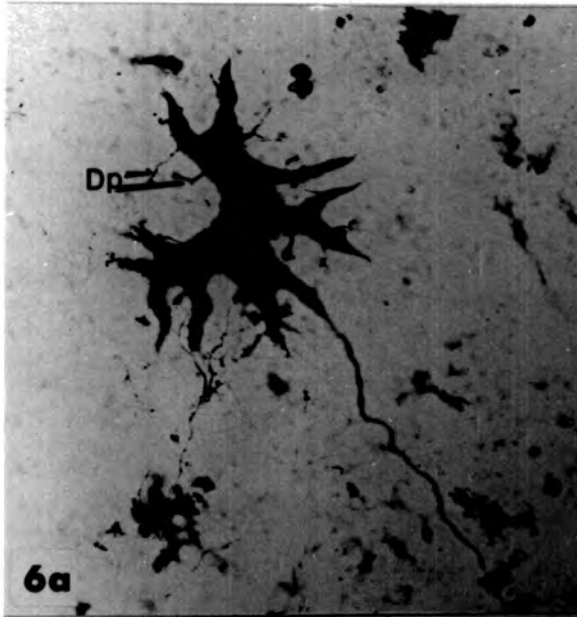

Plate 5.

Figure 9. H2-type horizontal cells reconstructed from light micrographs of Golgi impregnated cells that were photographed serially at different focal planes. The dendritic processes were usually unbranched, but occasionally branched processes were observed (arrow >).

Abbreviations as for previous plates.

Marker = 20 μ m.

FIGURE 9.H2.

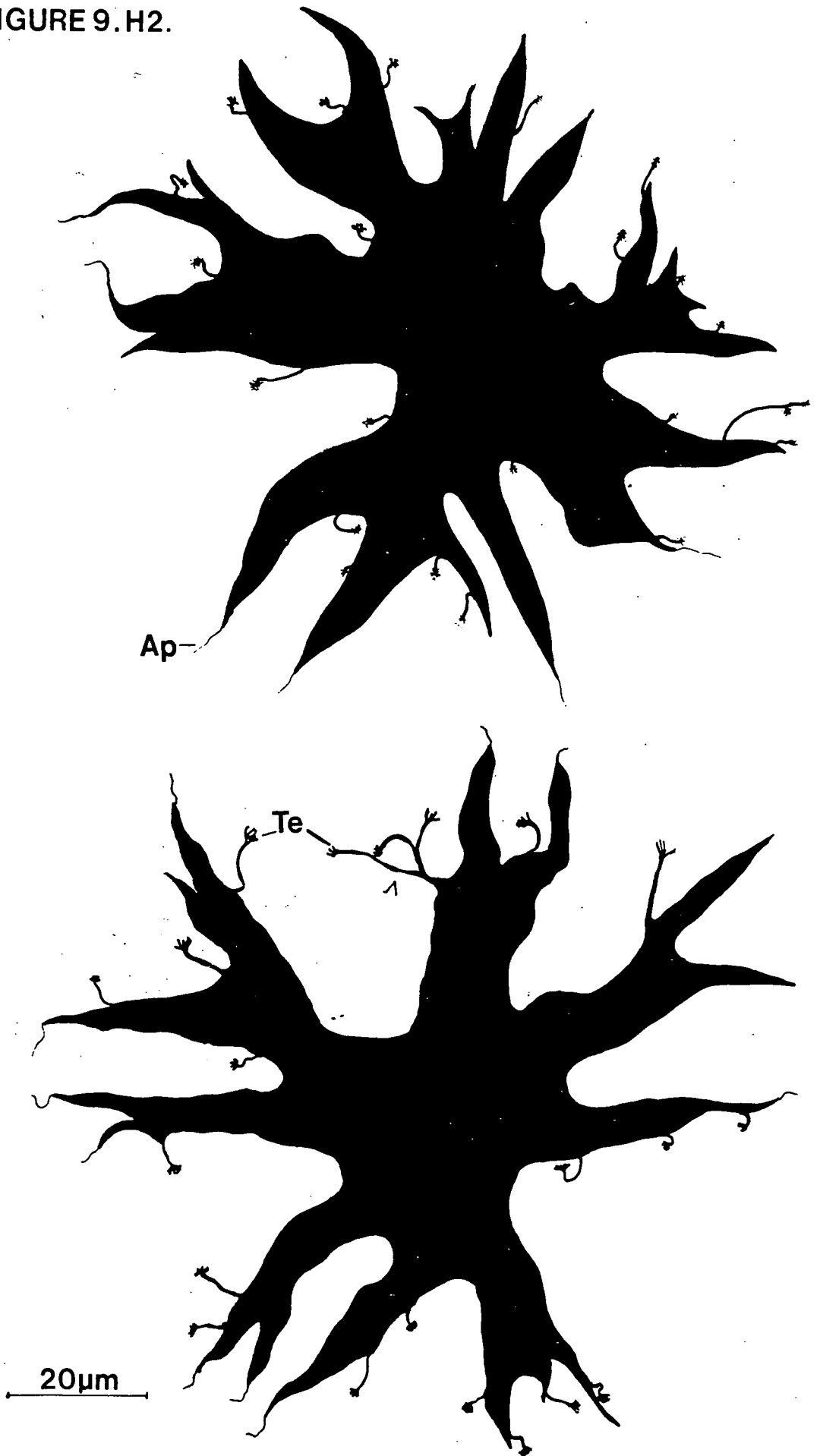

Plate 6.

Light micrographs of vertically sectioned, Golgi impregnated horizontal cells.

Figure 10.a. and 10.b. H2-type horizontal cell, sectioned vertically at 40 μm , photographed at two focal planes.

Marker = 30 μm .

Figure 11. H2-cell, from a vertical, 40 μm section.

Marker = 30 μm .

Figure 12.a., 12.b., and 12.c. H2-type horizontal cell sectioned vertically at 1.0 μm . Note the shape of the H2-cell terminal ending (Te) inside cone pedicles (Cp).

Marker = 5 μm .

Figure 13. H1-type horizontal cell, from vertical 40 μm sections.

Marker = 10 μm .

Figure 14. H2-type horizontal cell, from vertical 40 μm sections.

Marker = 10 μm .

Figure 15. H3-type horizontal cell, from vertical 40 μm sections.

The length of the horizontal cells dendritic processes indicates the relative distance from the outer plexiform layer (OPL) of the three perch horizontal cells.

Marker = 10 μm .

Abbreviations: OPL: Outer plexiform layer

H2.N: H2-cell nucleus.

H3: H3-type horizontal cell.

Other abbreviations as for previous plates.

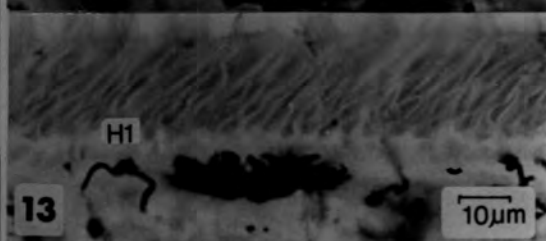
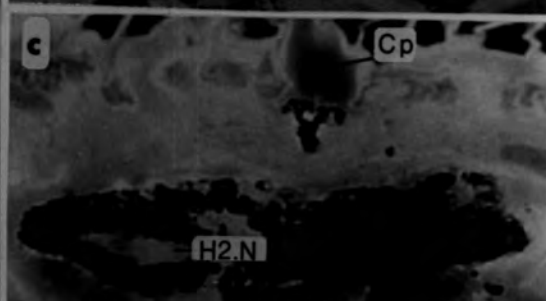
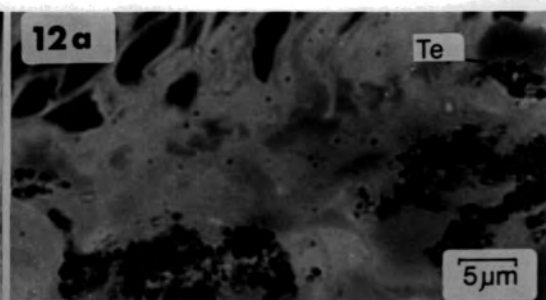
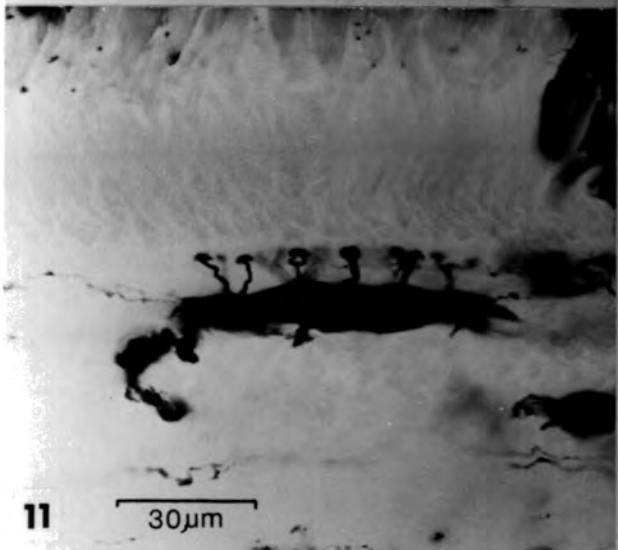
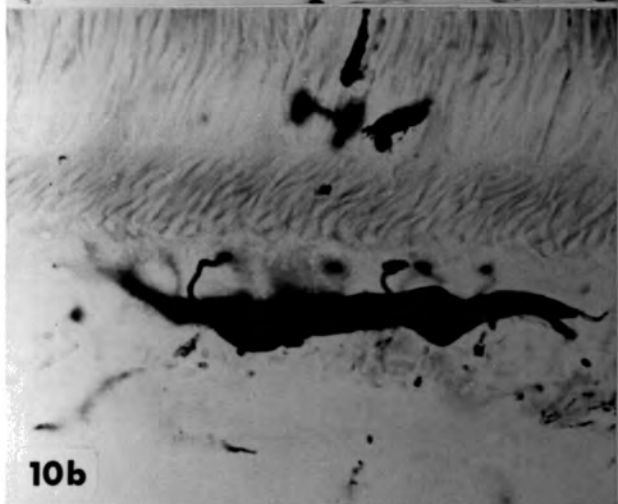
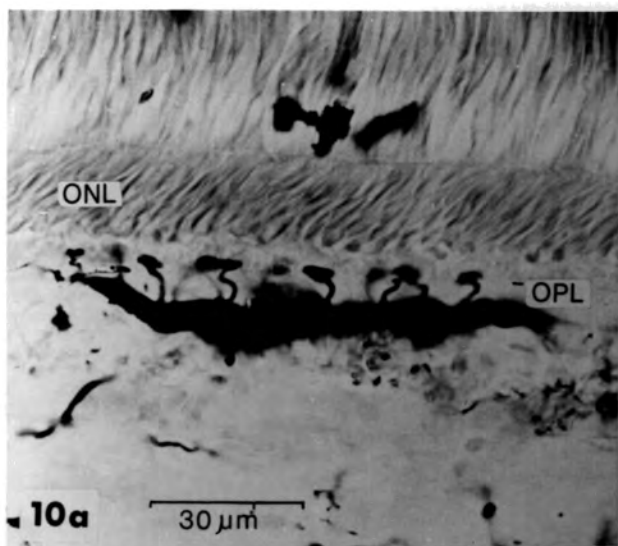

Plate 7.

Light micrographs of Golgi impregnated H3-type horizontal cells.

Figure 16. From a whole (flat) mount.

Marker = 40 μ m.

Figure 17. Two contiguous H3-type horizontal cells from the whole mount, two H2 cells can also be seen.

Marker = 40 μ m.

Figures 18. and 19. H3-type horizontal cells from 20 μ m thick horizontal sections, photographed in the plane of the cell body.

Marker = 60 μ m.

Figures 20.a. and 20.b. H3-cell photographed at two focal planes.

Fig. 20.a. at the level of the cell body, fig. 20.b. at the level of the dendritic processes.

Marker = 60 μ m.

Abbreviations as for previous plates.

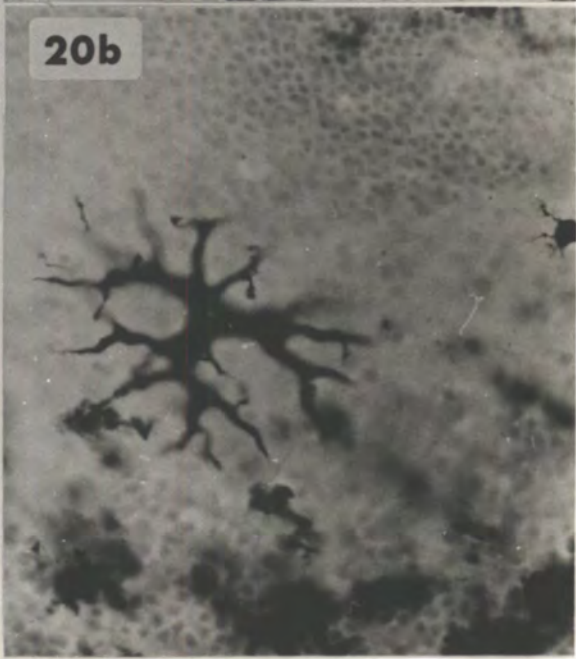
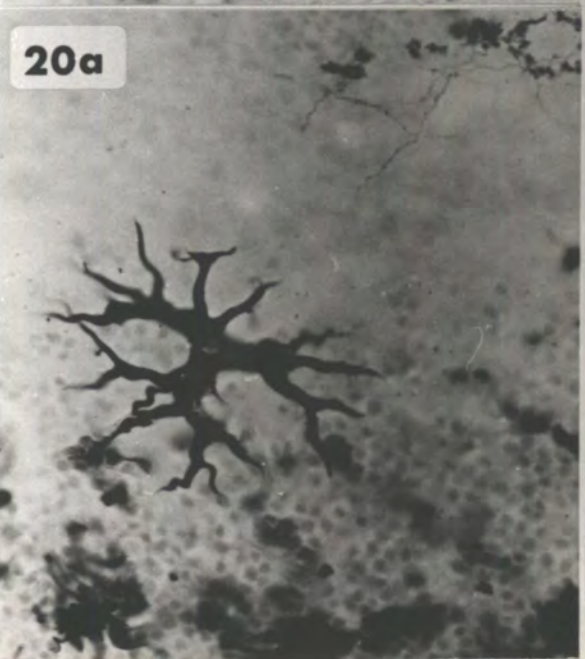
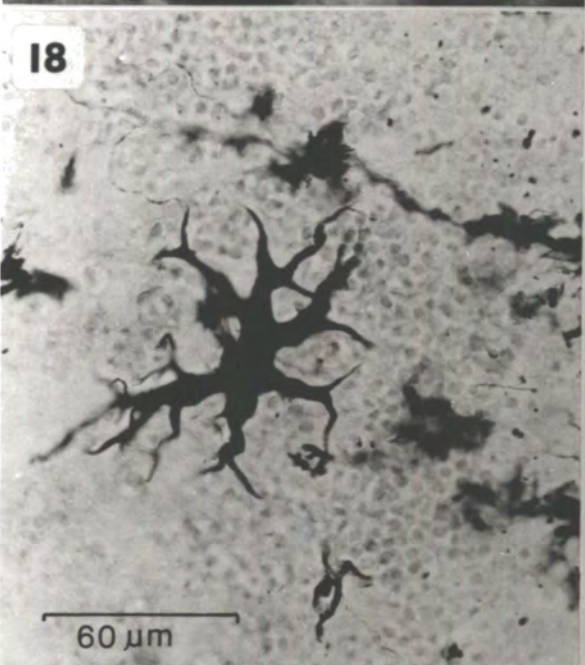
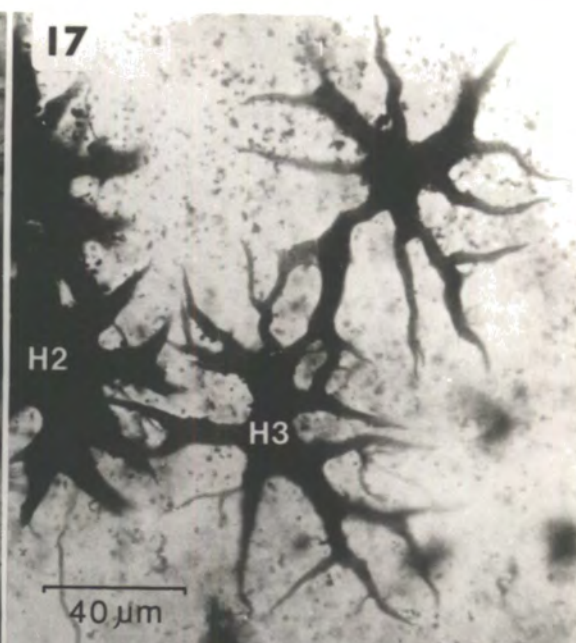
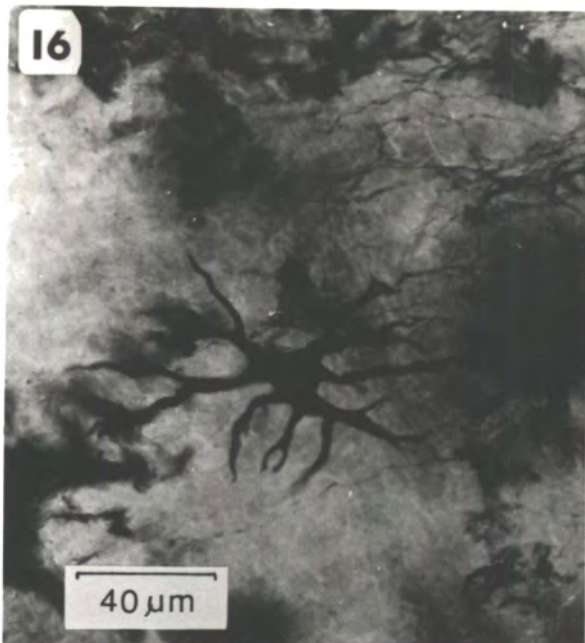

Plate 8.

Figure 21. H3-type horizontal cells reconstructed with the aid of serial focus photographs from 20 μm thick horizontal sections, showing dendritic processes (Dp) and terminal endings (Te). On most H3 cells two dendritic processes were seen to make contact with the same cone (arrows ►).

Abbreviations as for previous plates.

Marker = 20 μm .

FIGURE 21. H3.

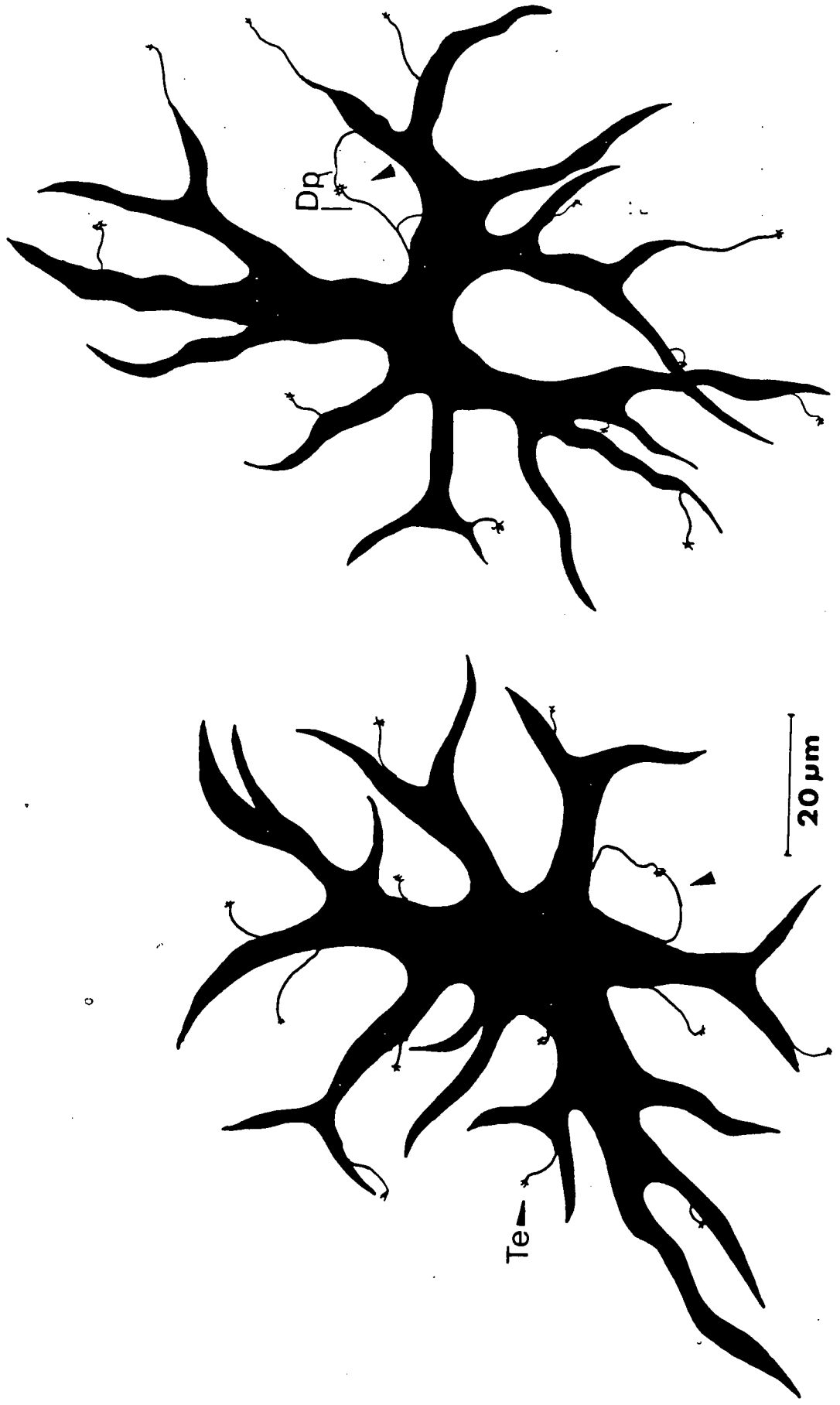

Plate 9.

Light micrographs of Golgi impregnated vertically sectioned H3-type horizontal cells.

Figure 22. H3-type cell, from 40 μm thick sections. Note that a part of a Golgi impregnated H2-cell is visible.

Marker = 40 μm .

Figure 23. Shows an H3-cell with an axon (Ax), from 40 μm thick section.

Marker = 40 μm .

Figure 24.a. and 24.b. From 1.0 μm vertical sections, counterstained with toluidine blue. Figure 24.a. Shows two dendritic processes that appear to invaginate the same cone pedicle. Note the 'knob' like endings on the terminal (Te). Figure 24.b. Shows an H3-cell dendritic process (Dp) coursing horizontally in the outer plexiform layer distal to an H1-cell, before invaginating the cone pedicle above the centre of the H1-cell. Note that an H2-cell can be seen between the H3 and H1 cells.

Marker = 5 μm .

Abbreviations as for previous plates.

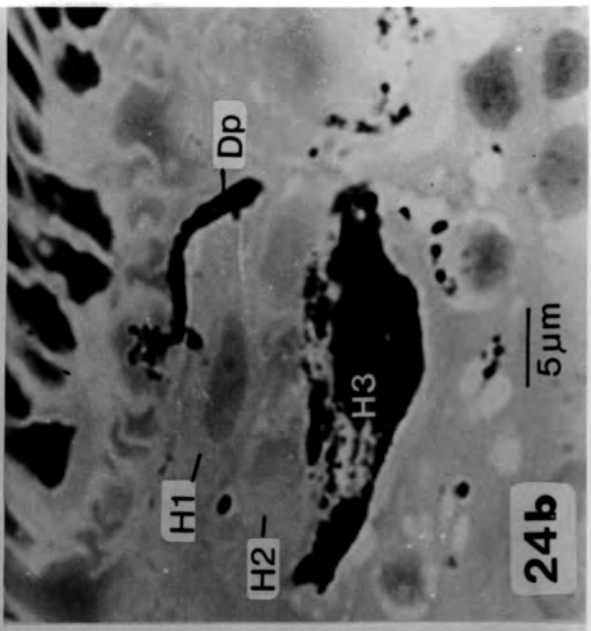
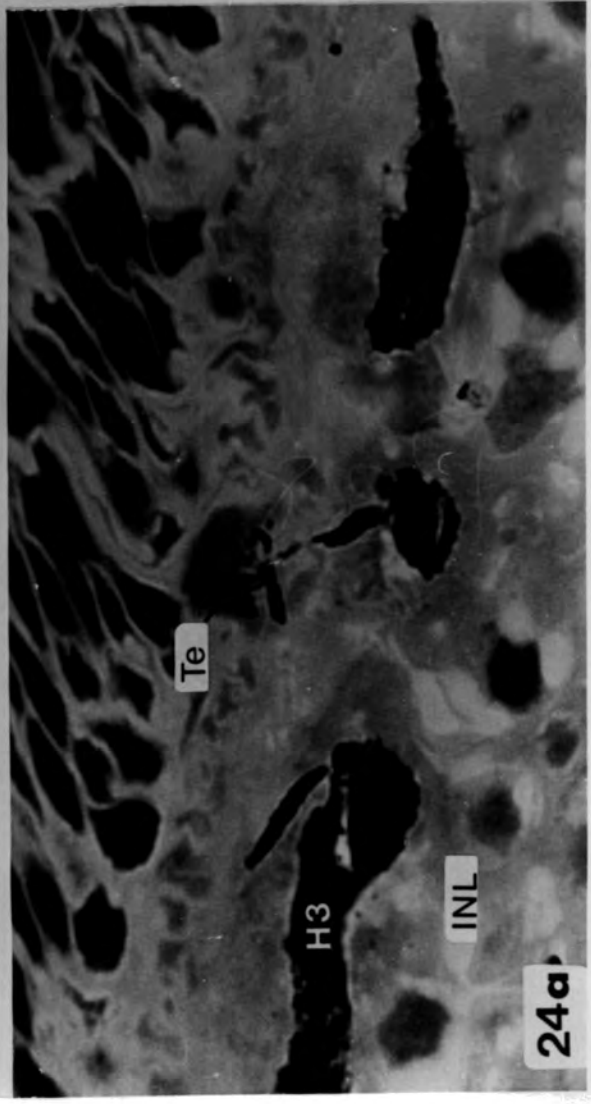
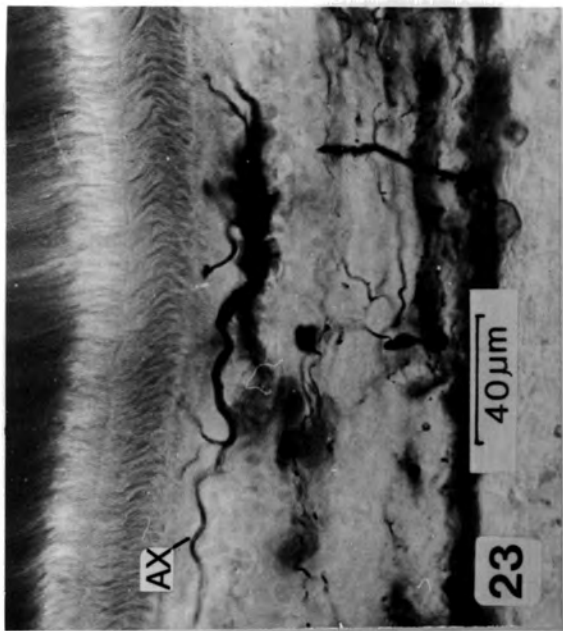
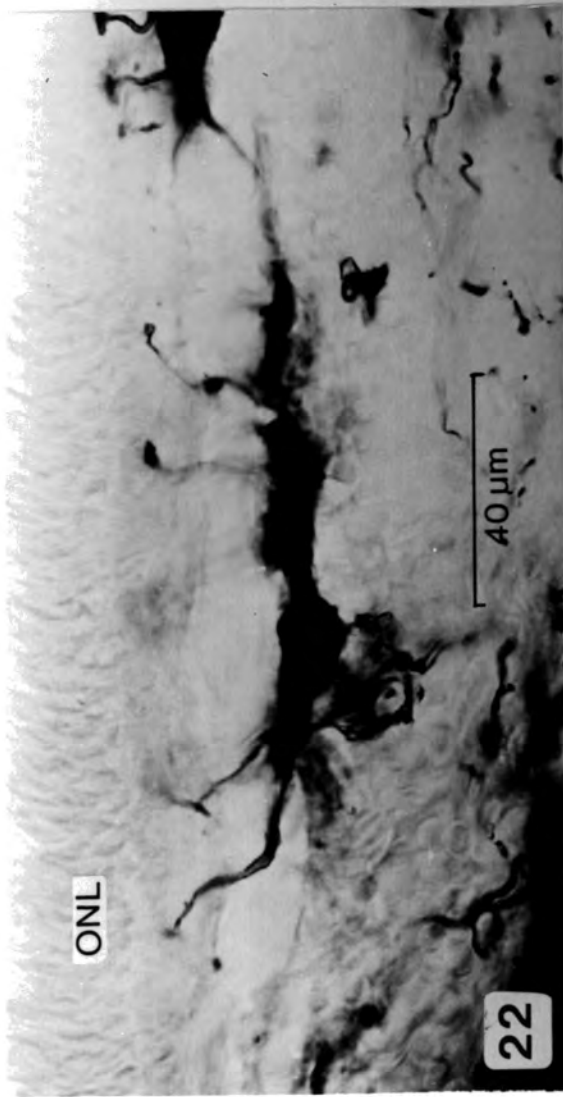

Plate 10.

Light micrographs of Golgi impregnated H1-type horizontal cells, from 20 μm horizontal sections where the cell body is separated from the terminal endings.

Figure 25.a. Shows the cell body.

Figure 25.b. Shows the terminal endings (Te) with part of the cell body, note the rough upper surface with a number of small processes or appendages (Ap).

Figure 26. Terminal endings from an H1-cell without cell body.

Figure 27. Same as fig. 26. Note that the receptor mosaic of double (Dc) and single cones (Sc) is clearly visible.

Abbreviations: Dc: double cone

Sc: single cone

Other abbreviations as for previous plates.

Marker = 10 μm .

25a

H1

10 μ m

25b

Te

Ap

26

Te

27

Dc

Sc

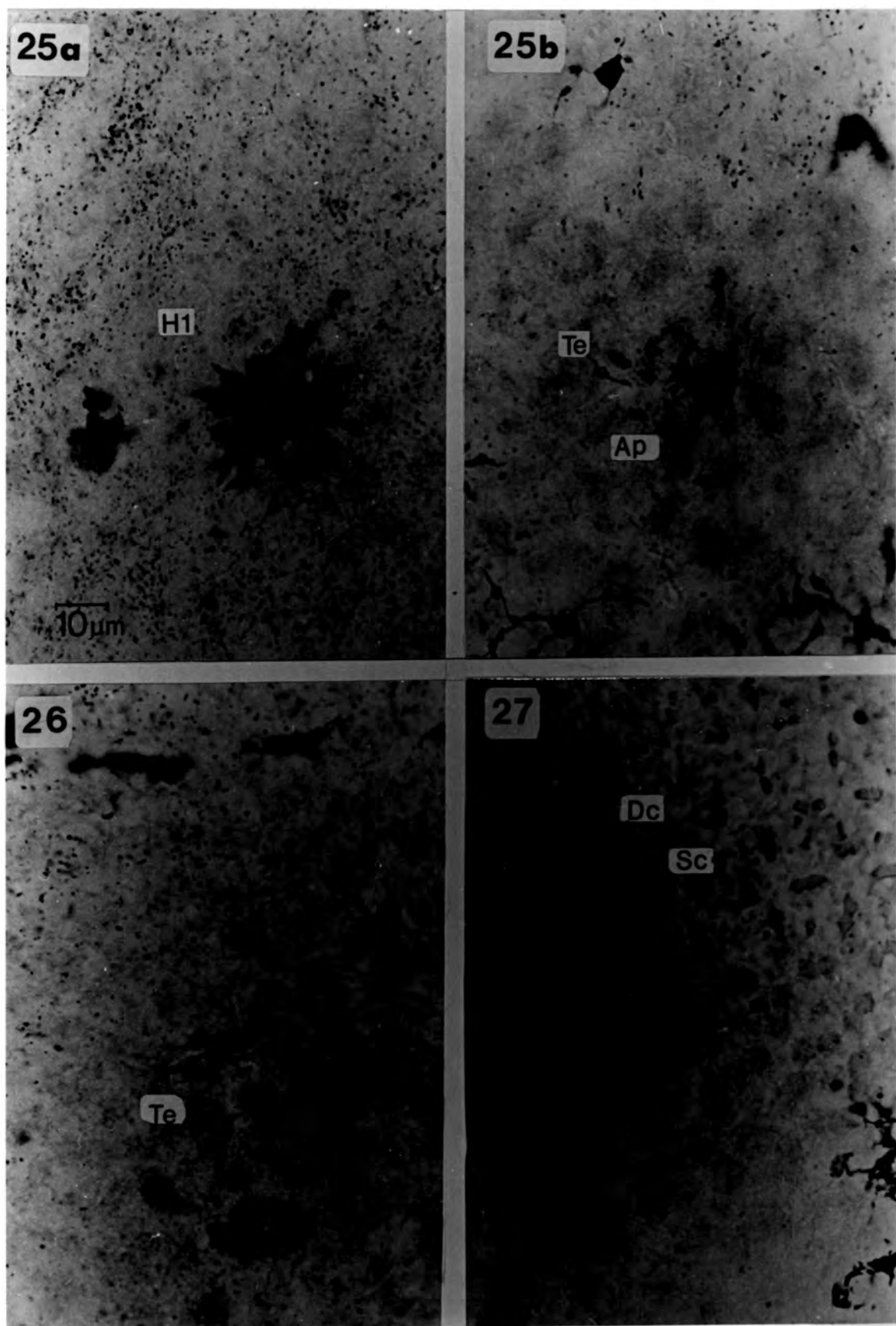

Plate 11.

Light micrographs of a Golgi impregnated H1-type horizontal cell, serially sectioned horizontally at 1.0 μm and counterstained with toluidine blue. Photographed under oil immersion at 100x magnification.

Figure 28.a. A section through the cell perikaryon.

Figure 28.b., 28.c. and 28.d. Showing a part of the cell body and invaginated cone pedicles, note the rod spherules (Rs).

Figure 28.e. and 28.f. Show sections through the plane of the cone pedicles and outer plexiform layer, note that the H1 cell clearly makes contact with both double (Dc) and single cones (Sc).

Abbreviations as on previous plates.

Marker = 5 μm .

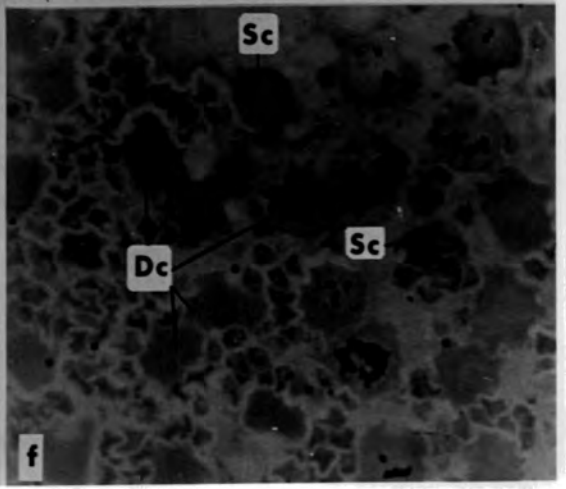
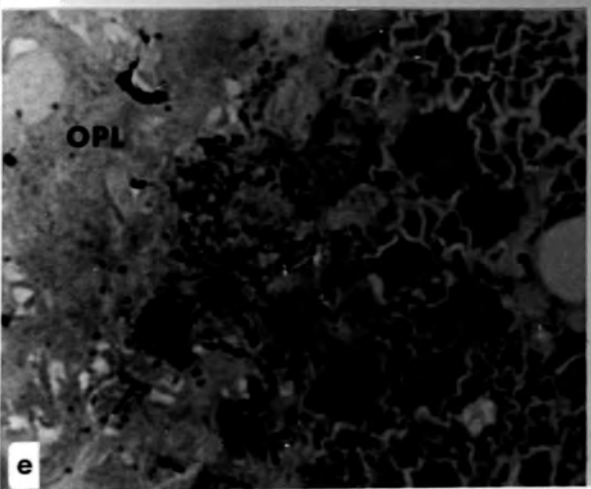
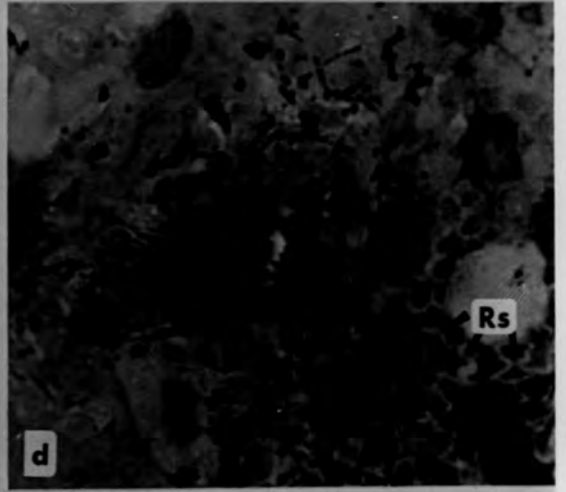
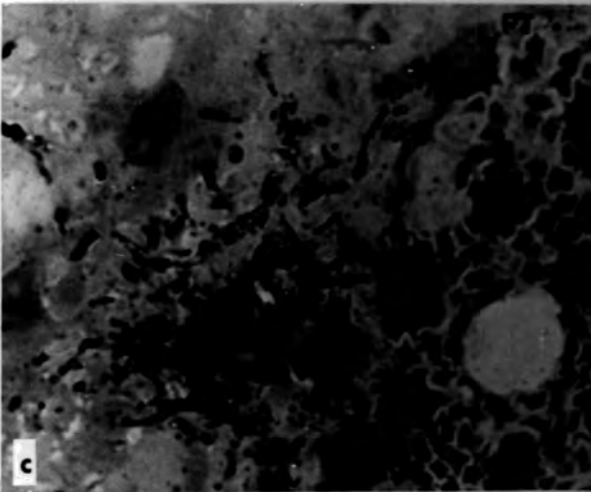
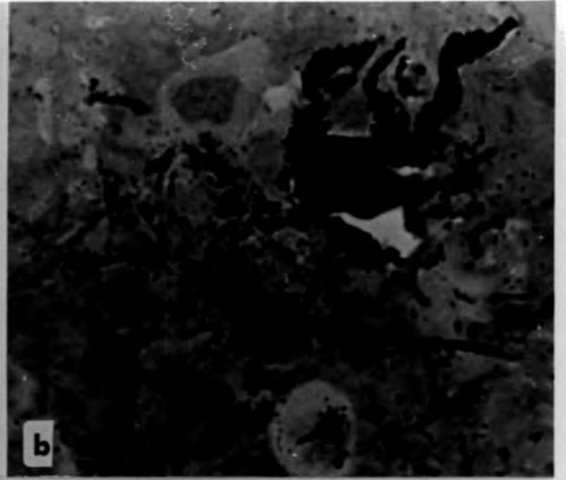
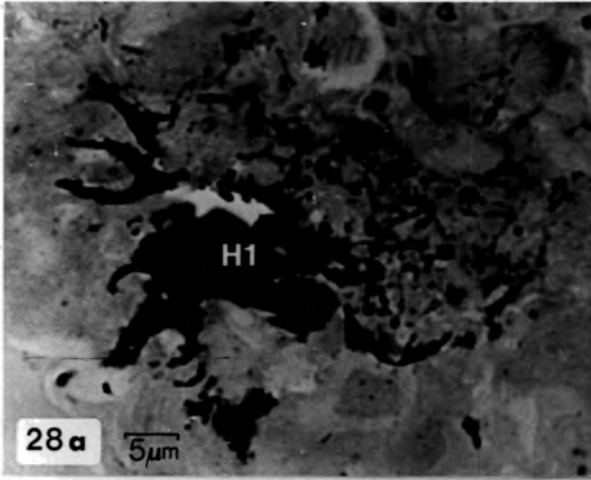

Plate 12.

Light micrographs of Golgi impregnated H1- and H2-type horizontal cells, serially sectioned horizontally at 1.0 μm and counter-stained with toluidine blue.

Figure 29.a. and 29.b. Show sections through the cell bodies of H1 and H2 cells. Note the regular distance between H1-cell nuclei that are visible around the Golgi impregnated cell in 29b.

Figures 29.c., 29.d. and 29.e. Show sections through the outer plexiform layer and the cone pedicles. Note the large number of Golgi impregnated appendages and processes above the H1-cell in 29.c, and that both double and single cones appear to be contacted by the H1 cell and rods as well, 29d. Some of the horizontally directed processes appear to end in a knob or a bulb at the tip 29d (arrow \rightarrow).

Abbreviations: PT: photoreceptor terminals.

Other abbreviations as on previous plates.

Marker = 10 μm .

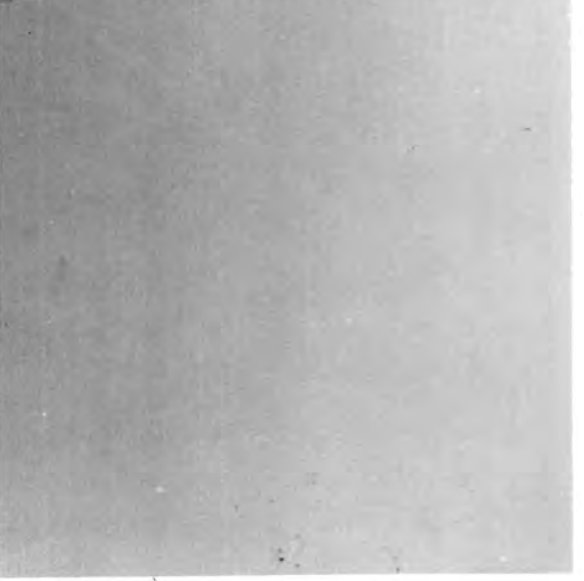
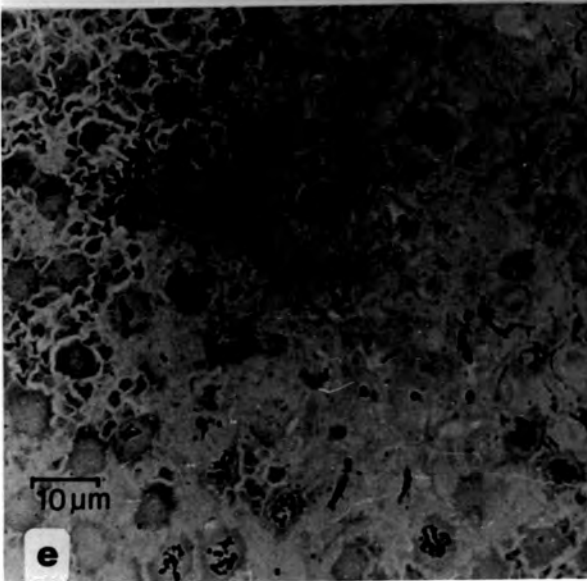
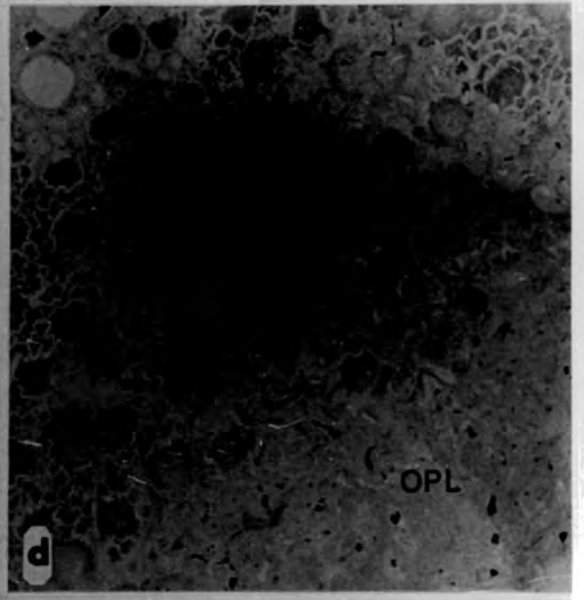
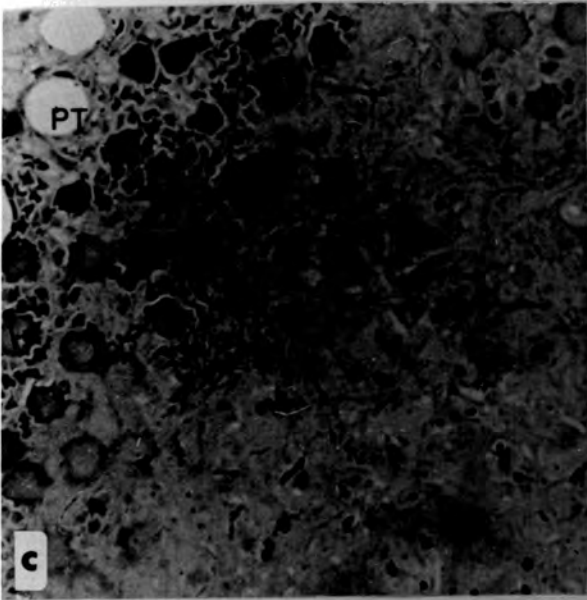
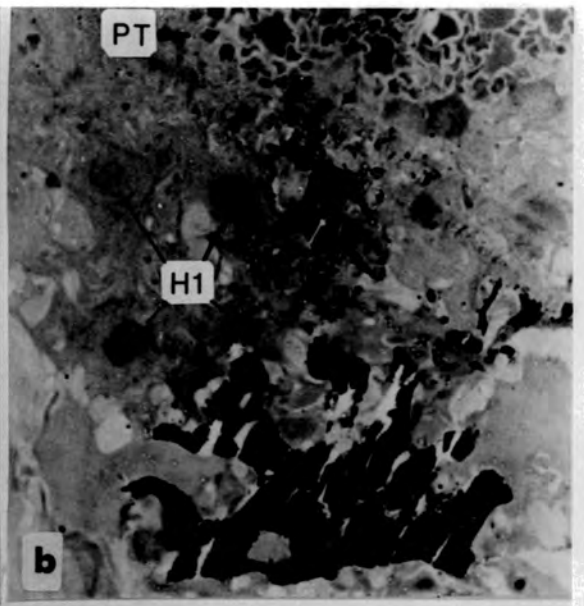
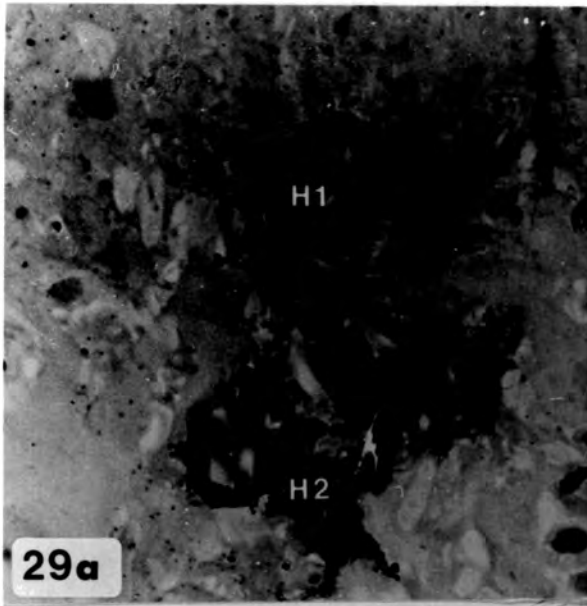

Plate 13.

Figure 30. Perch H1-type horizontal cell and its cone contacts.

Horizontal projections reconstructed from serial 1 μm horizontal sections. Outlines of the cell bodies are drawn. Cone pedicles are represented as circles. Double cones, 'oo', and single cones, 'o'. Filled circles, represent cones which are contacted, while open circles represent cones which were not contacted by the H1-cell. Note that the figure is not drawn to scale for clarity.

Abbreviations as on previous plates.

FIGURE 30 H1.

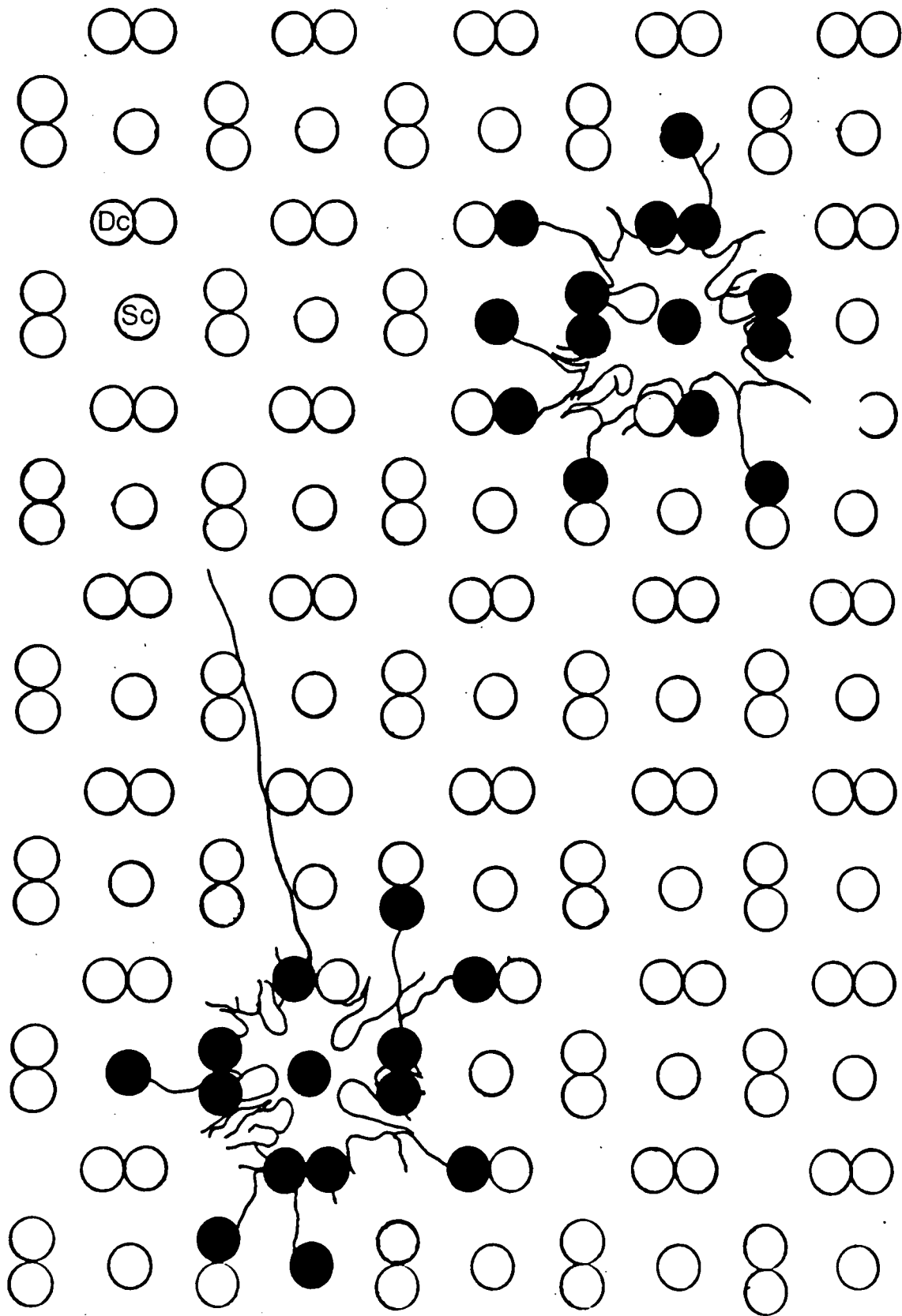

Plate 14.

Light micrographs of Golgi impregnated H2-type horizontal cells, from 20 μm horizontal sections where the cell body is separated from the terminal endings.

Figure 31.a. and 31.b. Adjacent sections of the same cell. Fig. 31.a. shows the cell body and 31.b. the terminal endings. Note that a part of the receptor mosaic is visible and that only the double cones appear impregnated.

Figure 32.a. and 32.b. Same as fig. 31. Fig. 32.a. shows the H2-cell body and 32.b. shows the terminal endings. Note that the terminal pattern forms a circle. Golgi impregnated cones with their basal processes (C.bp) can be seen.

Abbreviations: C.bp. = cone basal processes.

Other abbreviations as on previous plates.

Marker = 40 μm .

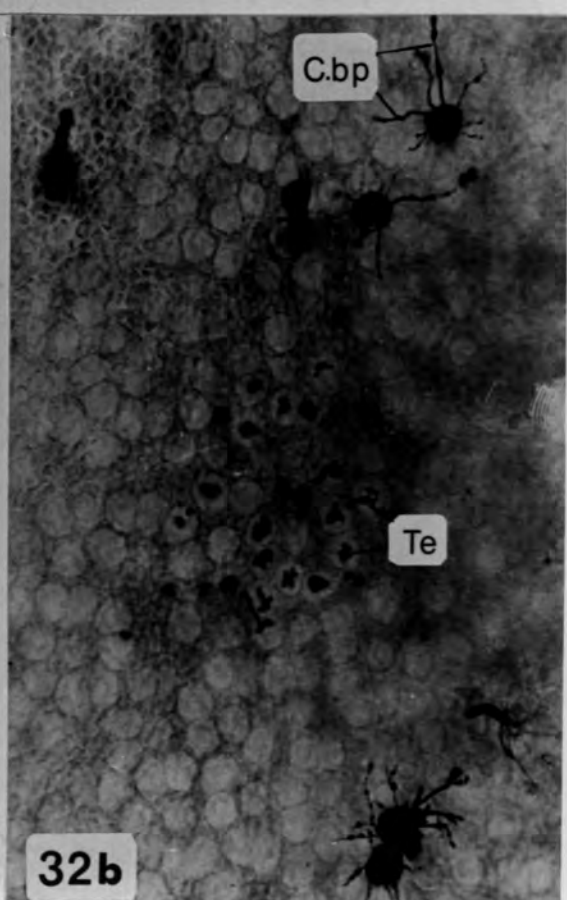
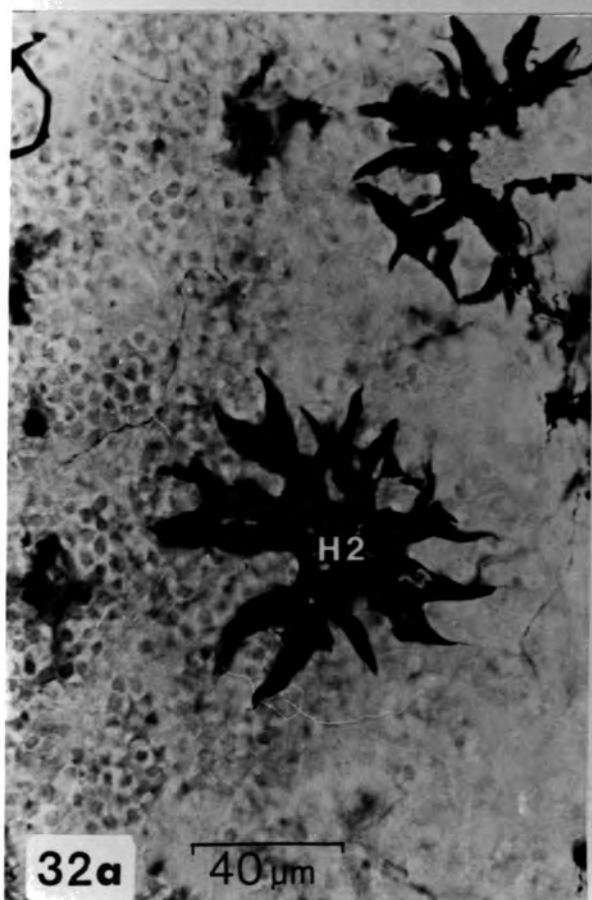
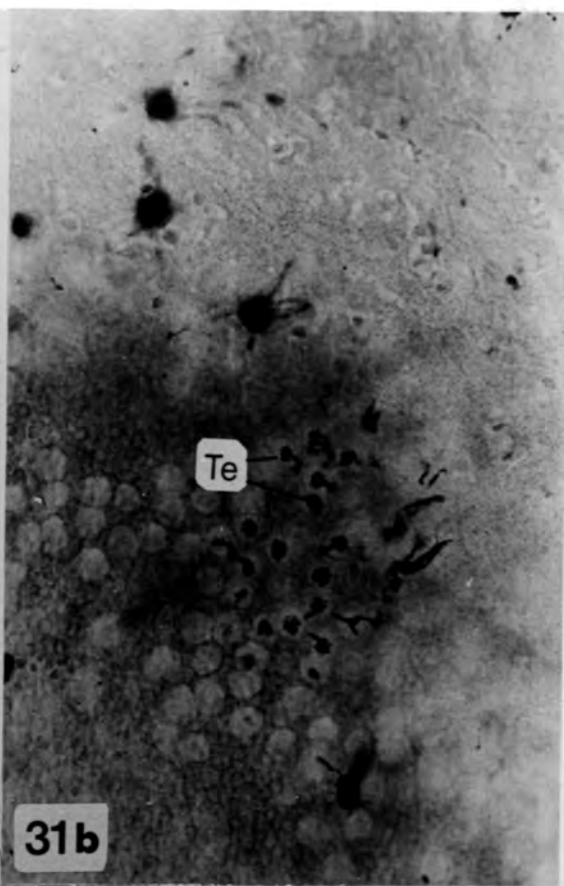
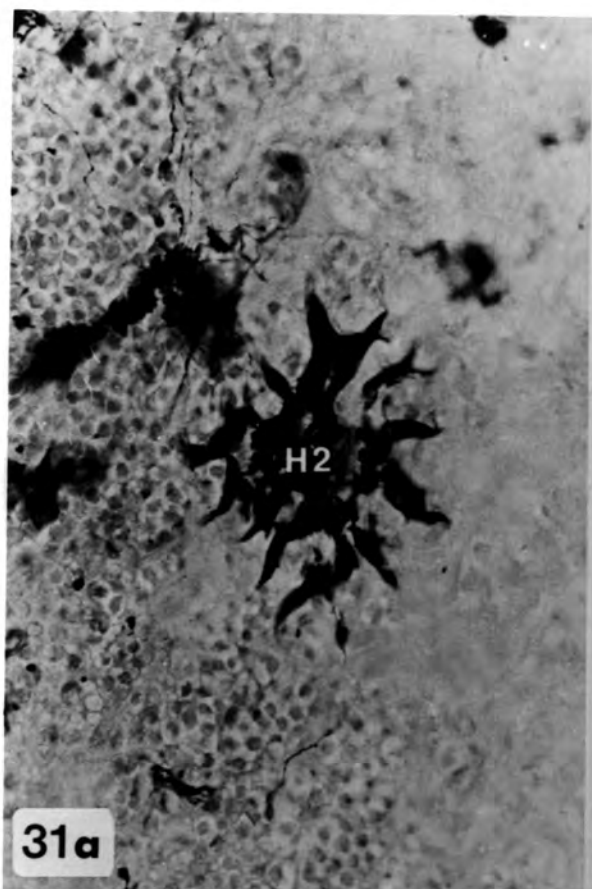

Plate 15.

Light micrographs of two Golgi impregnated H2-type horizontal cells, serially sectioned horizontally at 1.0 μm and counterstained with toluidine blue.

Figure 33.a. Shows the proximal parts of H2-cells at the level of H3-type horizontal cells and bipolar cells.

Figure 33.b. and 33.c. Photographed at the level of their cell bodies.

Figure 33.d. Photographed at the level of the H1-type horizontal cells. Note the regular space between H1-cell nuclei.

Figure 33.e. Shows the dendritic processes in the outer plexiform layer.

Figure 33.f. At the level of the cone terminals, showing clearly that the H2-cell contacts exclusively the double cones.

Abbreviations as for previous plates.

Marker = 20 μm .

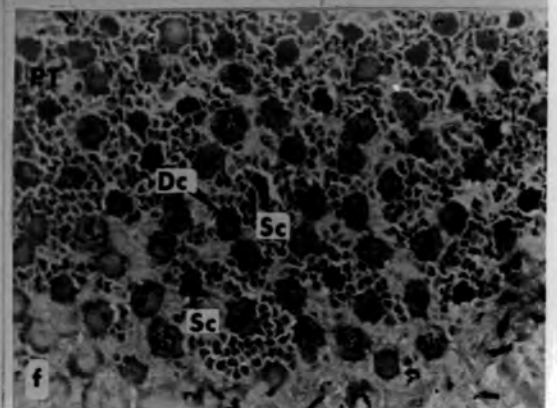
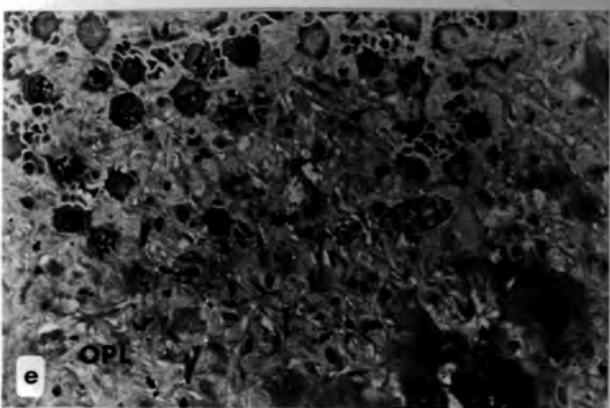
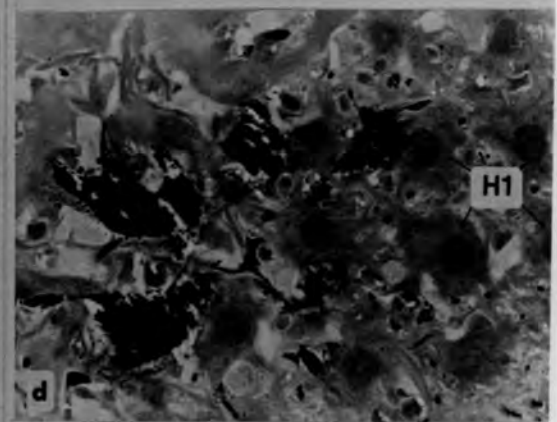
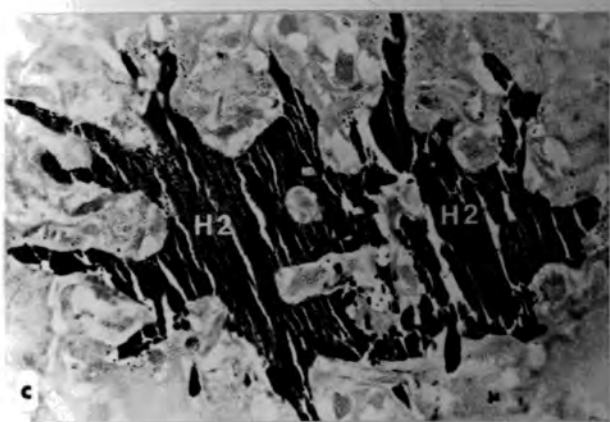
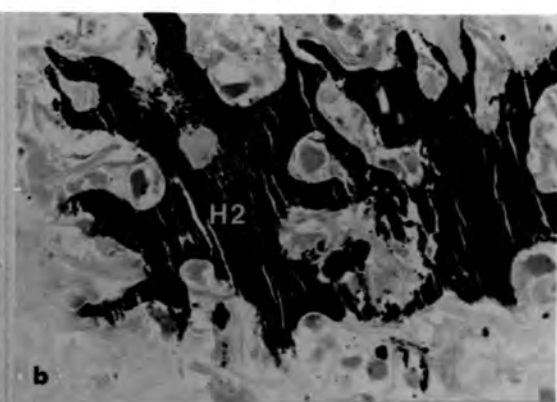
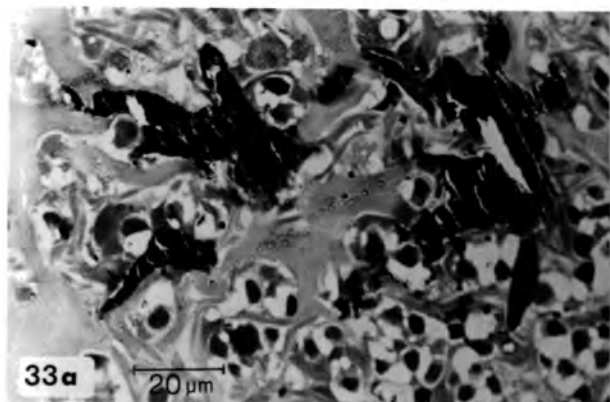

Plate 16.

Figure 34. Perch H2-type horizontal cell and its cone contacts.

Horizontal projection reconstructed from serial 1.0 μm horizontal sections. Outlines of the cell body are drawn. Cone pedicles are represented as circles (See Fig. 30, Plate 13). Filled circles represent cones which are contacted and open circles represent cones that were not contacted by the H2-cell. The figure is not drawn to scale.

FIGURE 34, H2.

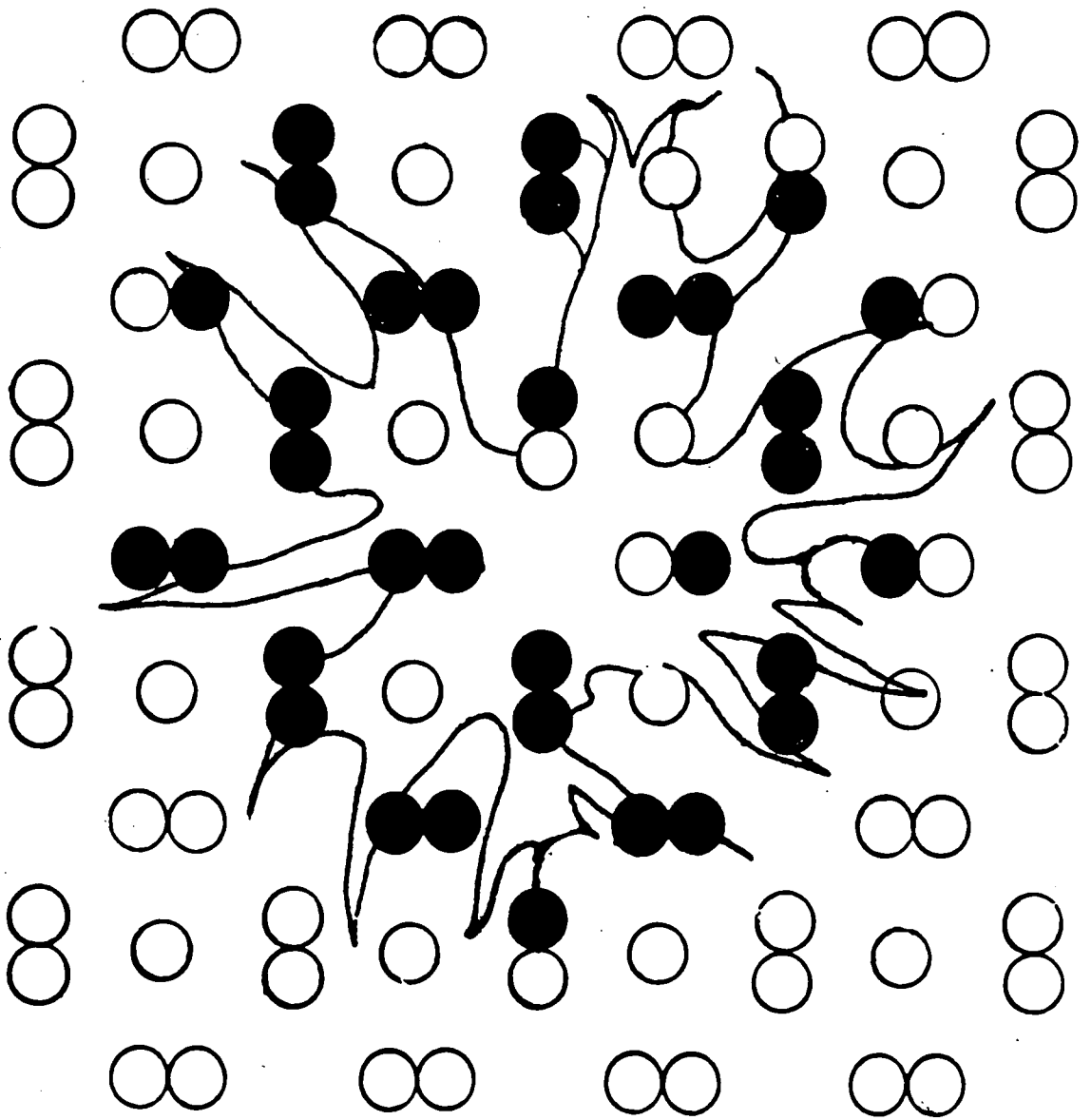

Plate 17.

Light micrographs of two Golgi impregnated H3-type horizontal cells, from 20 μm horizontal sections where the cell body is separated from the terminal endings and each can be observed in adjacent sections.

Figure 35.a. Two H3-type cell bodies simultaneously impregnated.

Note that two to three dendrites appear contiguous.

Figure 35.b. Their terminal endings. Note the regular square or rhombic pattern.

Figure 36.a. At the level of the H3-cell perikaryon.

Figure 36.b. Its terminal endings. Note the Golgi impregnated rod spherule (Rs).

Abbreviations as on previous plates.

Marker = 40 μm .

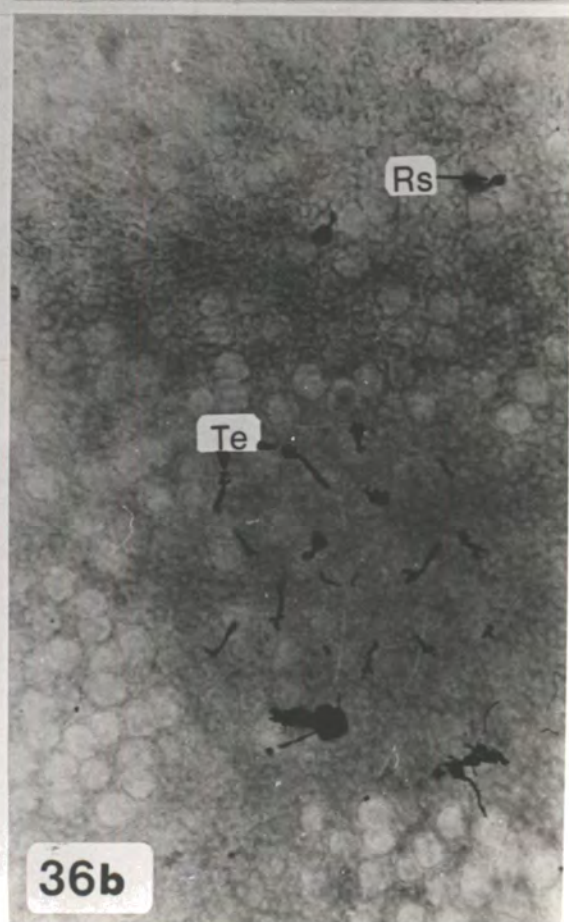
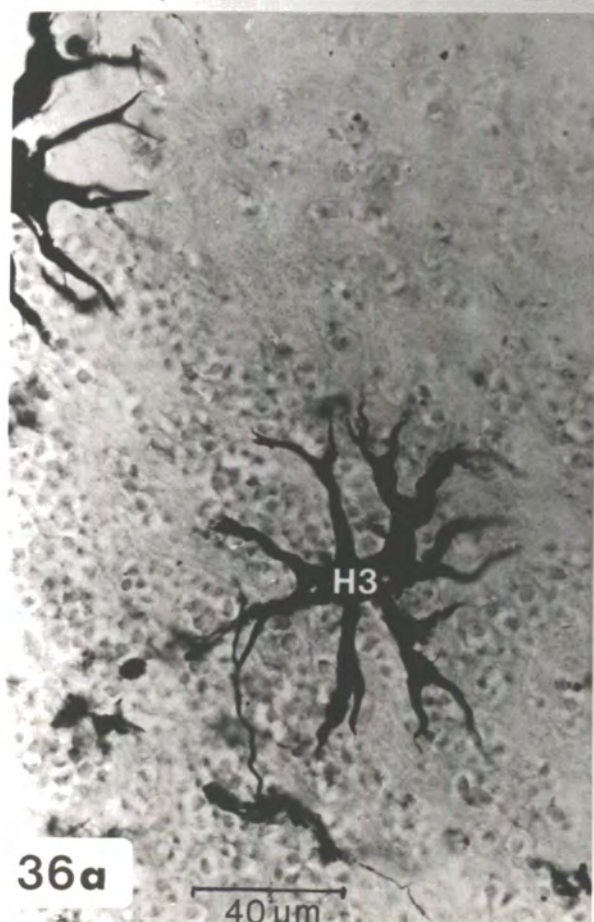
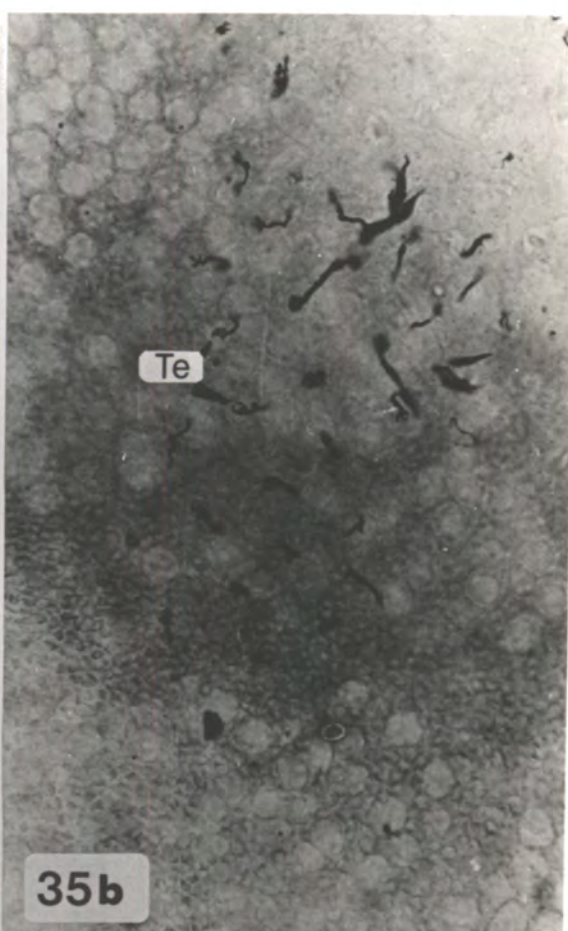
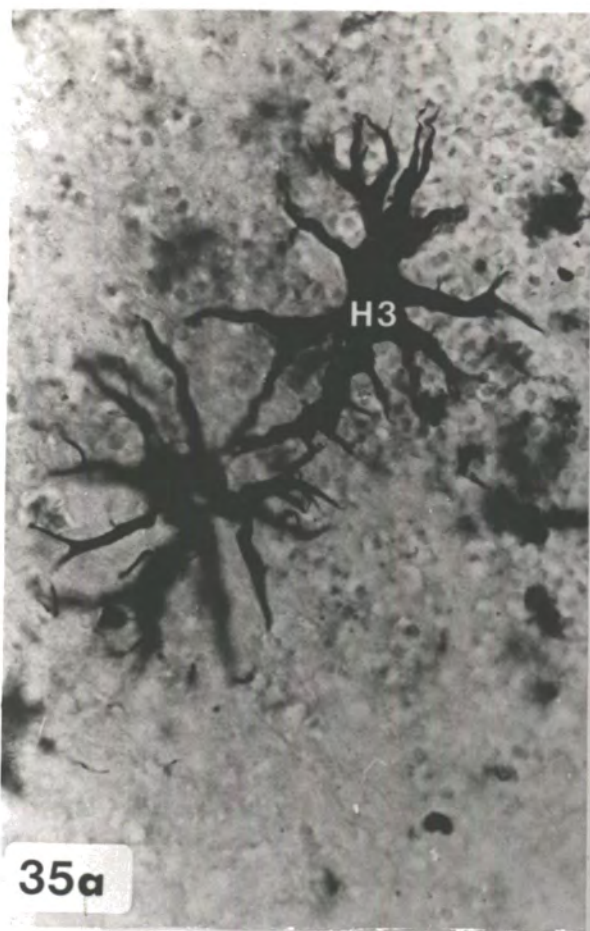

Plate 18.

Light micrographs of Golgi impregnated H3-type horizontal cells. Serial 1.0 μm horizontal sections, counterstained with toluidine blue. Figures 37.a. to 37.f. are in sequence from proximal to distal (sclerad).

Figure 37.a. The proximal part of the H3-cell showing the inner nuclear layer with the bipolar cell nuclei. Note that its nucleus is visible.

Figure 37.b. Section through the middle of its cell body with the nucleus (H3.N).

Figure 37.c. At the level of H2-cell bodies. Note the difference in size between the stained H3-cell body and H2-cell perikaryons around it, this indicates that there is an overlap between the H2 and H3-cell layers.

Figure 37.d. At the level of the H1-type horizontal cells, where only dendritic processes of the H3-cell are visible.

Figure 37.e. and 37.f. At the level of cone pedicles showing clearly that they exclusively contact central single cones.

Abbreviations: H3.N: H3-type horizontal cell nucleus.

Other abbreviations as for previous plates.

Marker = 20 μm .

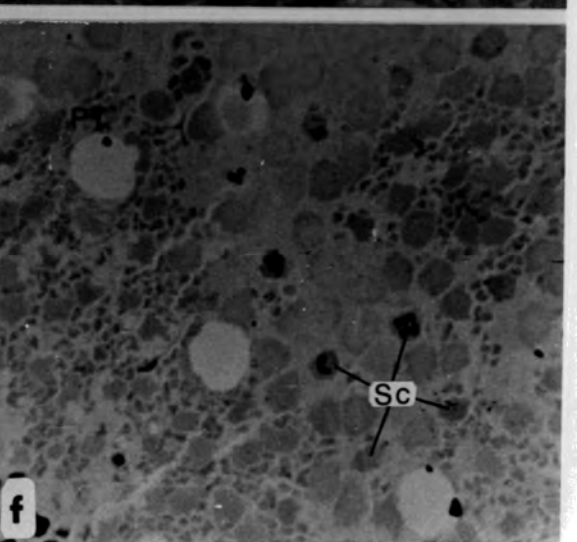
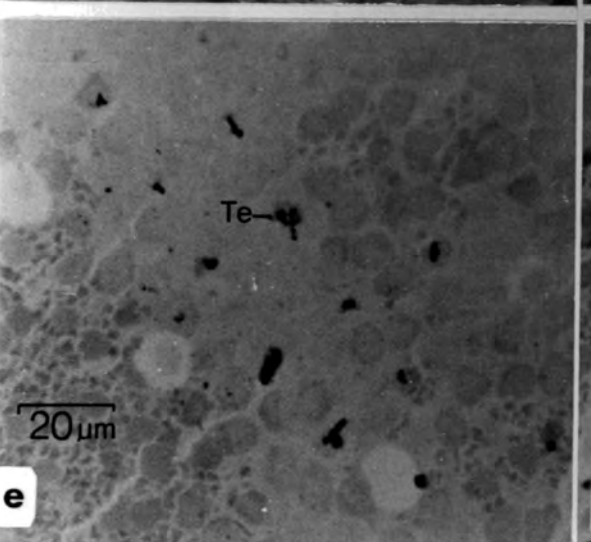
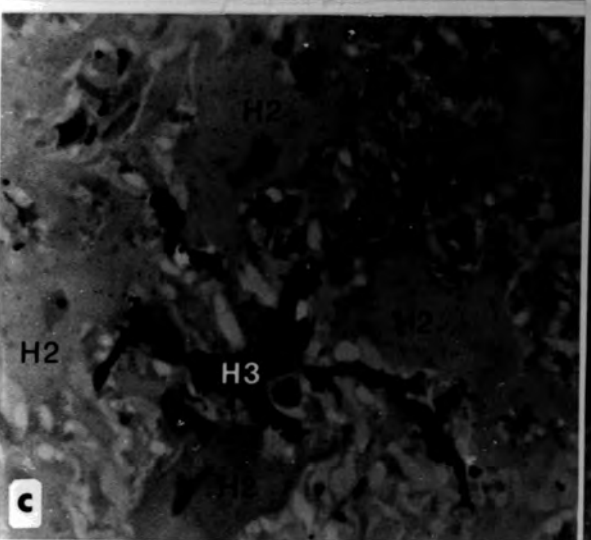
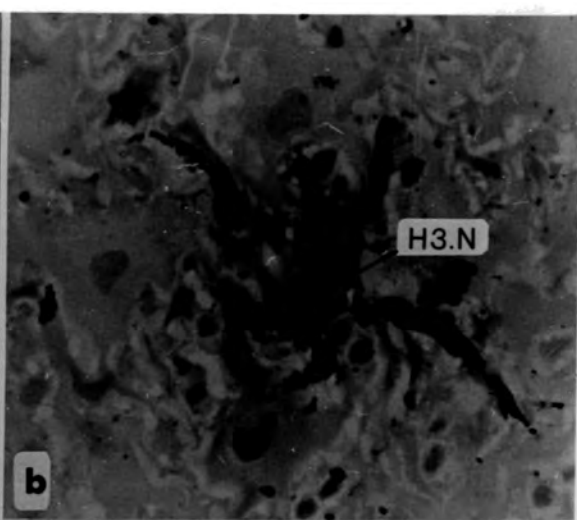
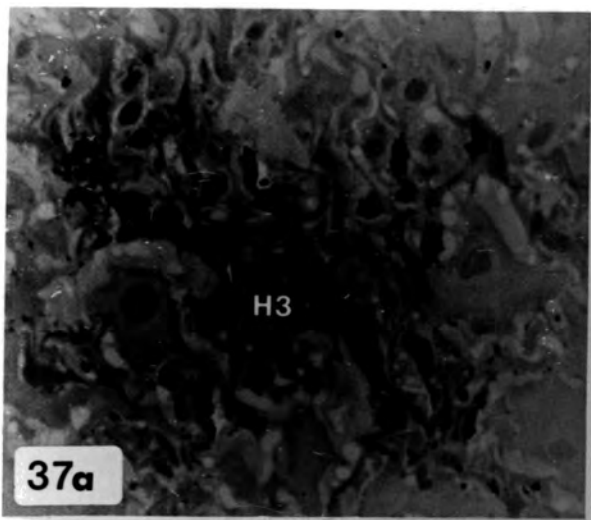

Plate 19.

Figure 38. Perch H3-type horizontal cell and its cone contacts.

Horizontal projection reconstructed from serial horizontal 1.0 μm sections. Outlines of the cell body are drawn. Note that the figure is not drawn to scale.

Representations as for Plates 13 and 16.

FIGURE 38, H3.

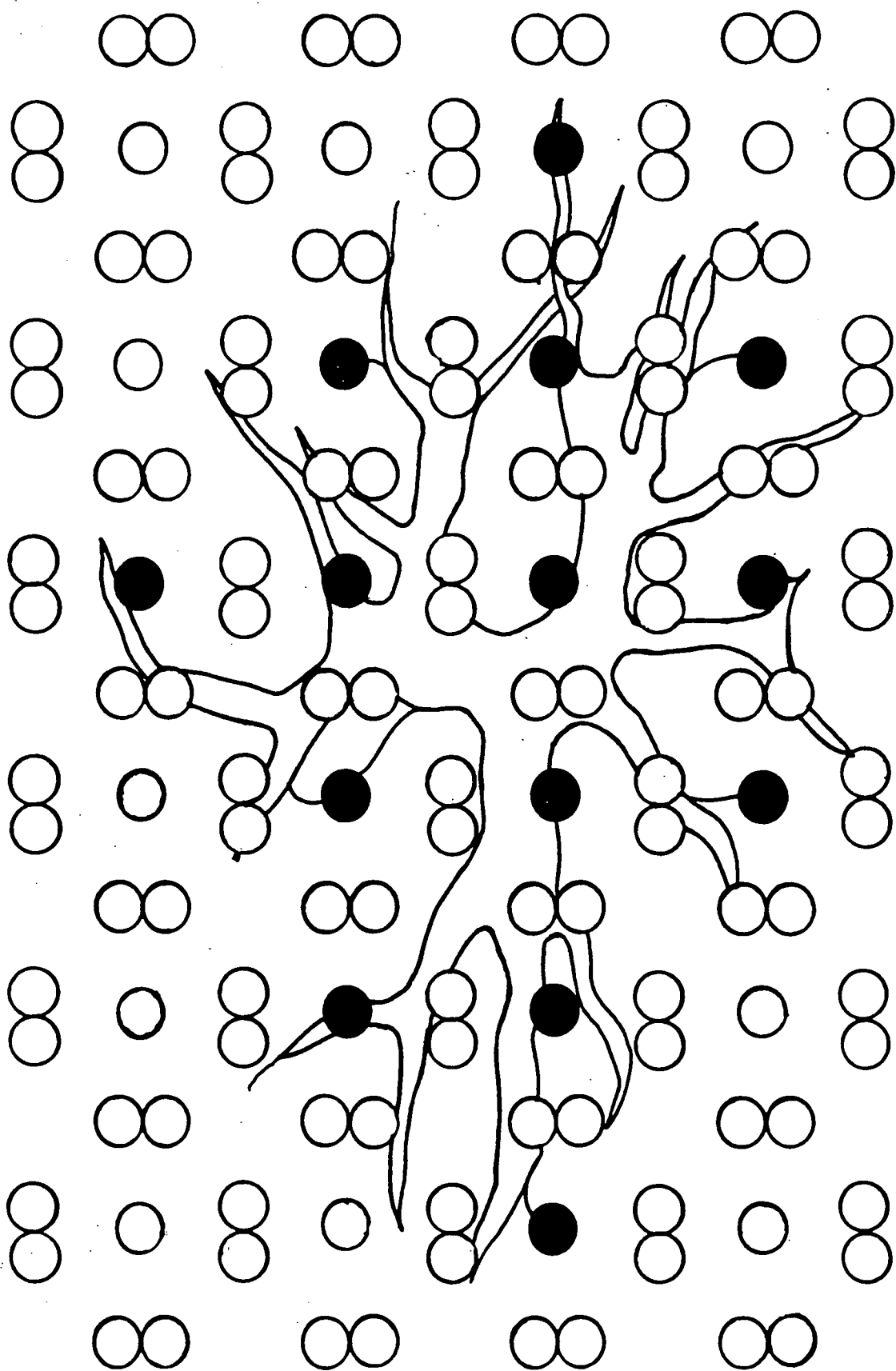

Plate 20.

Light micrographs of a Golgi impregnated cone. From vertical 40 μm thick sections photographed at different focal planes showing the basal processes.

Figure 39.a. Showing basal processes radiating horizontally in the outer plexiform layer. One appears to leave the outer plexiform layer and terminate at the plane of the cone pedicles, filled arrow (\blacktriangleright). While others end in the outer plexiform layer proximal to the cone pedicles, open arrow (\triangleright). Other basal processes have a more vertical direction (\triangleright).

Figure 39.b. Shows horizontally directed basal processes (arrow \blacktriangleright), which are shorter and thinner than those in fig. 39.a.

Marker = 10 μm .

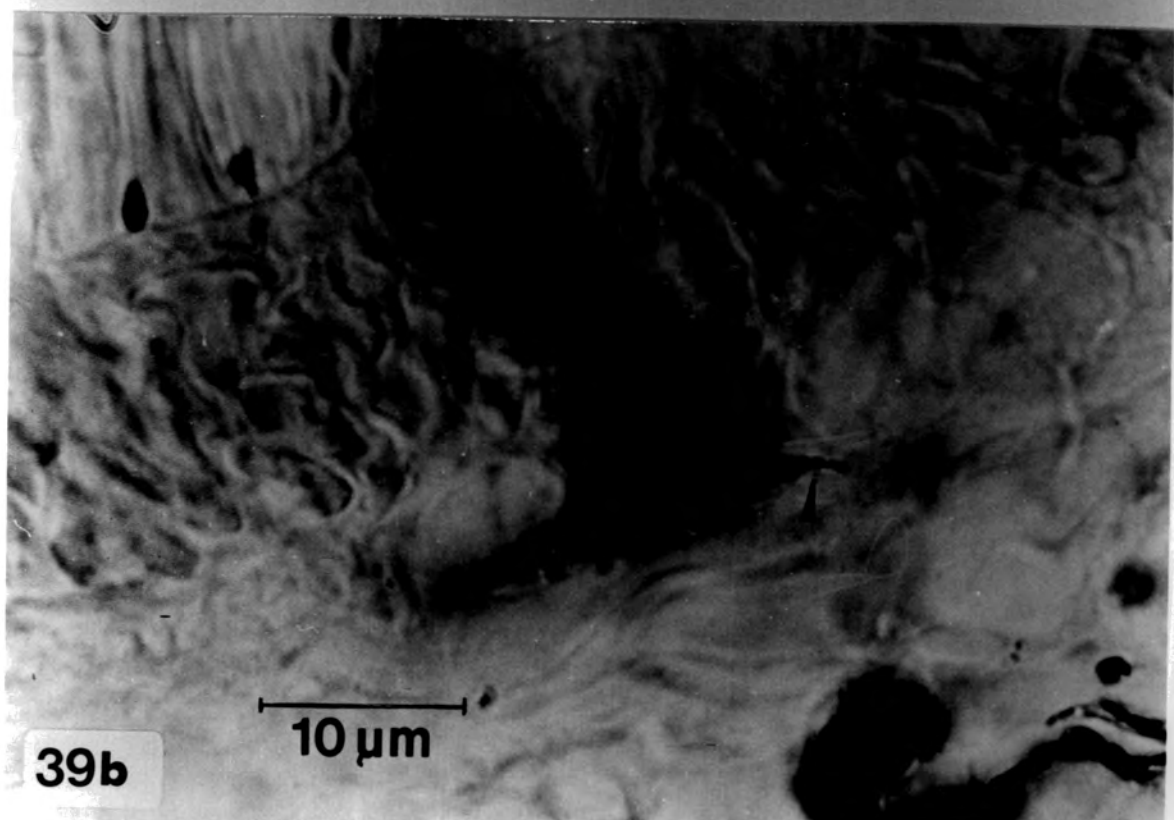
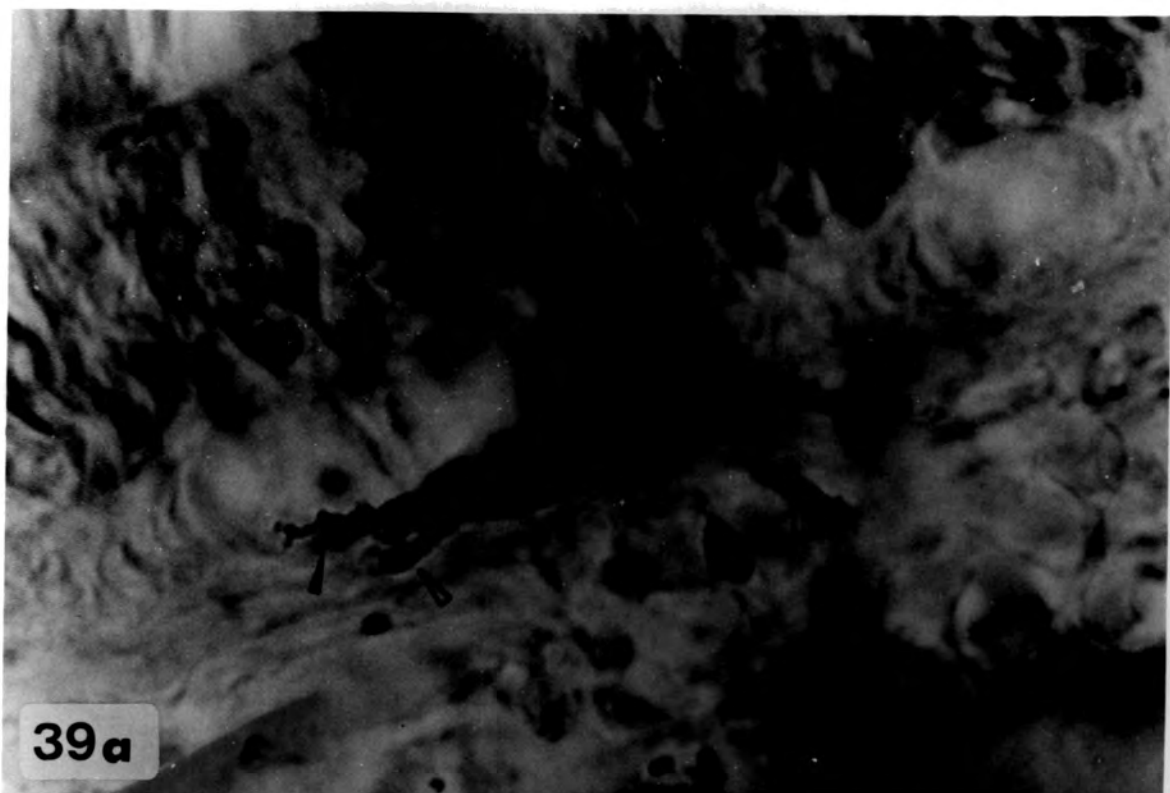

Plate 21.

Light micrographs of Golgi impregnated cones, photographed from the flat mount retina.

Figures 40. and 41. Cones with two types of basal processes, long and thick (filled arrows) on the one hand, and shorter and thinner ones (open arrows) on the other. These were identified as double cones.

Figures 42. and 43. Cones that in the flat mount appear to have a homogenous population of basal processes, all are of similar appearance with numerous knobs and of similar thickness and length. These were identified as single cones.

Marker = 20 μ m.

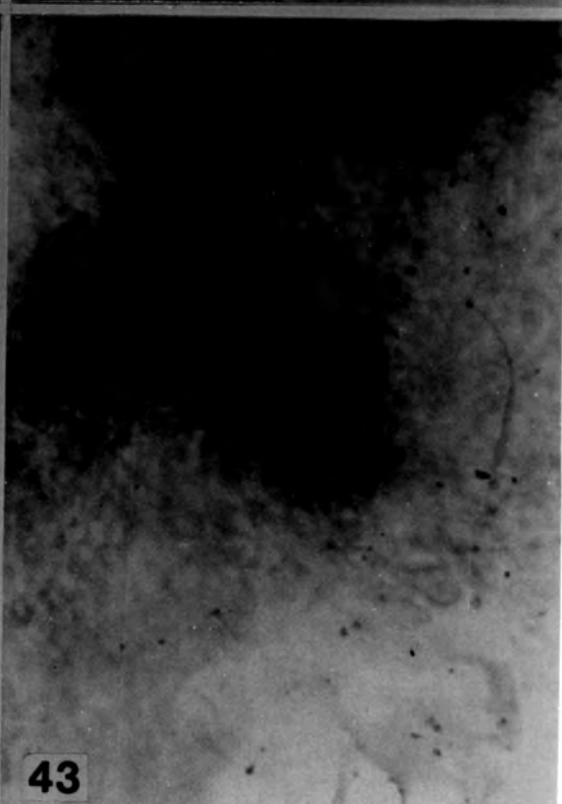
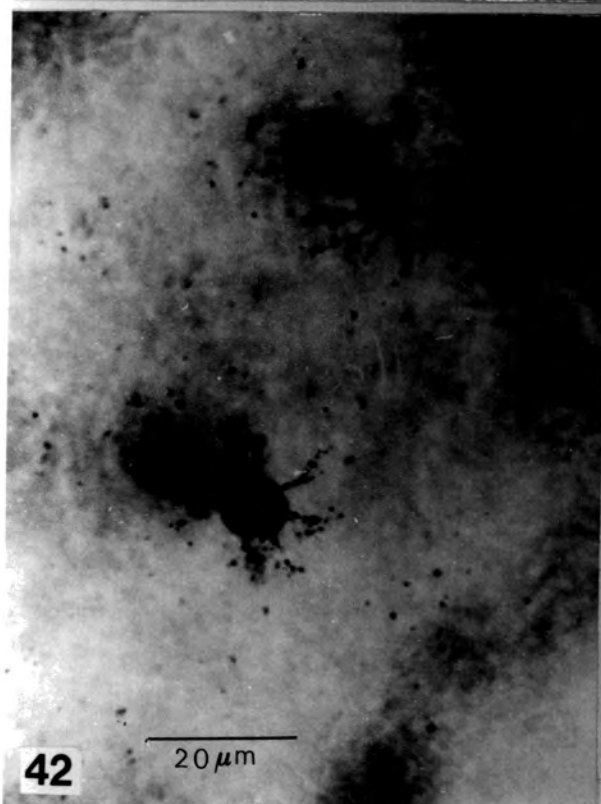
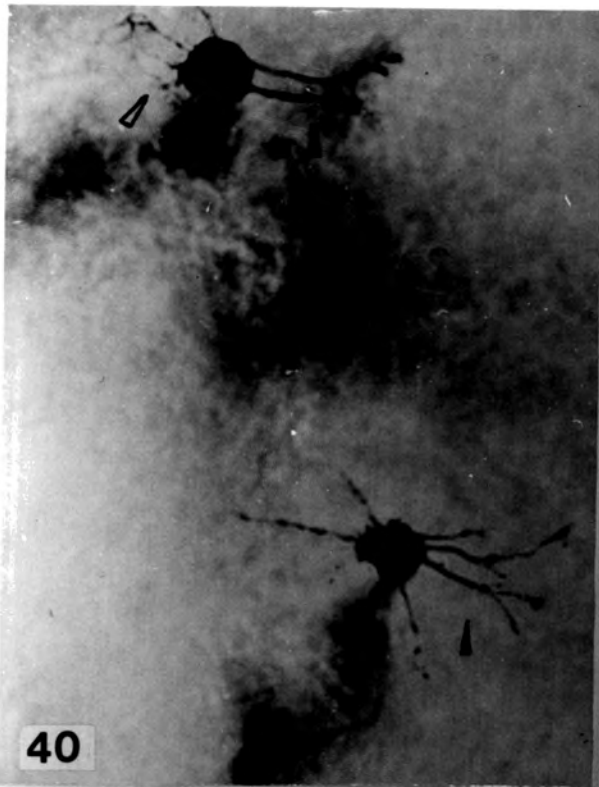

Plate 22.

Light micrographs of Golgi impregnated cones. From 20 μm thick horizontal sections, photographed at different focal planes.

Figures 44.a., 44.b. and 44.c. A single cone and its basal processes.

Figures 45.a., 45.b. and 45.c. A double cone and its basal processes.

Marker = 10 μm .

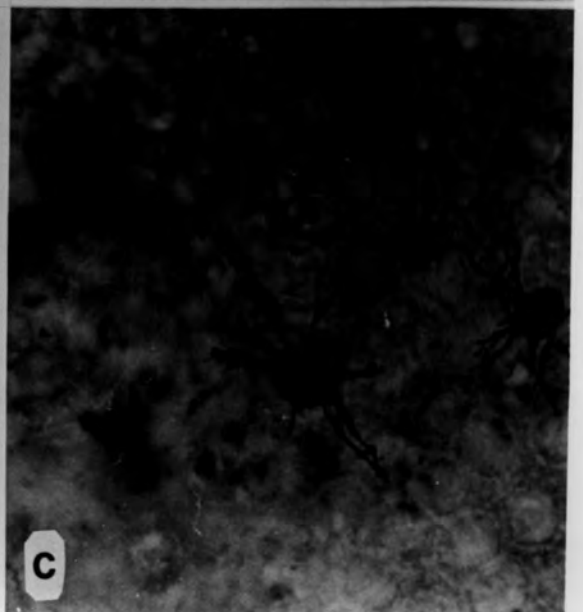
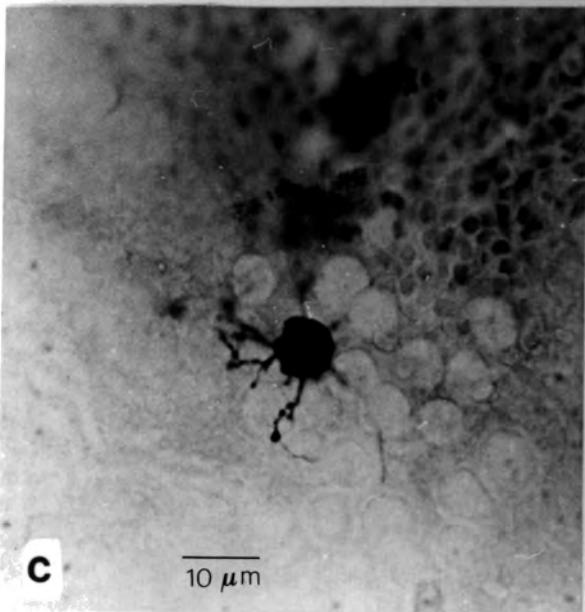
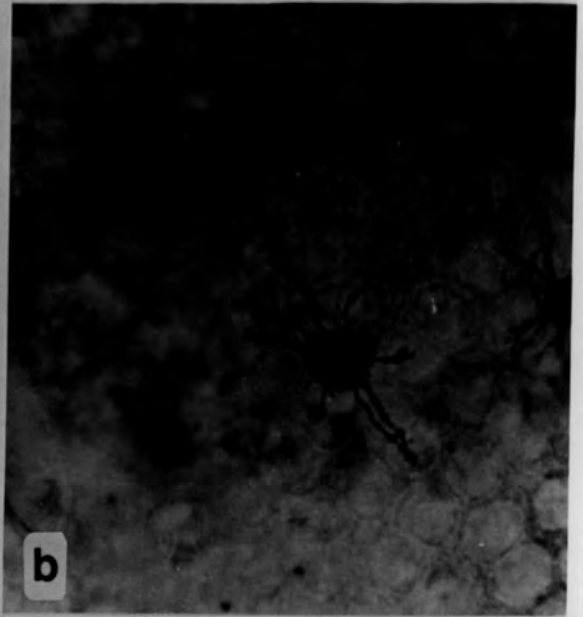
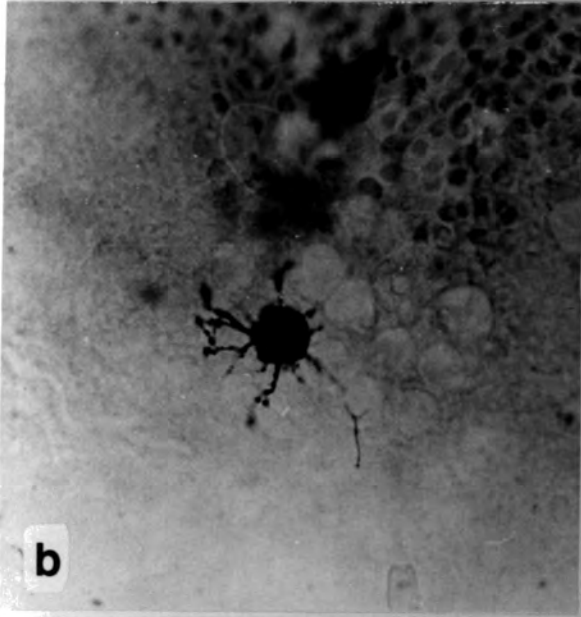
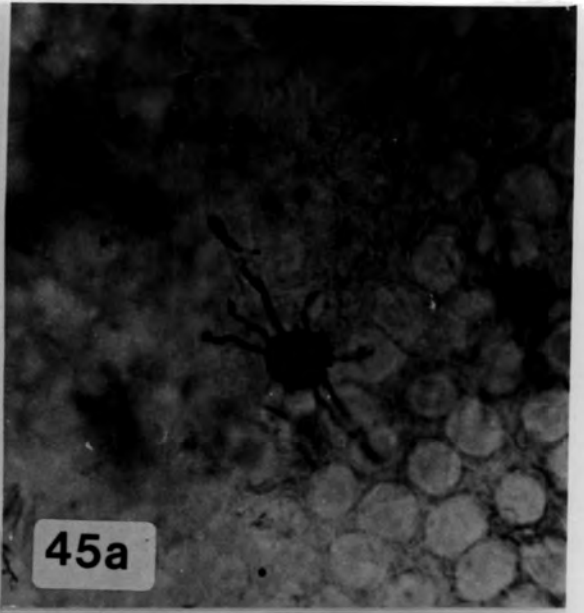
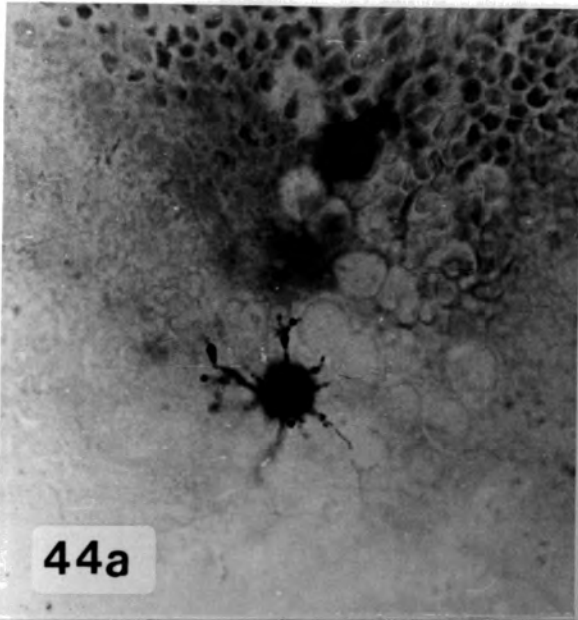

Plate 23.

Light micrographs of Golgi impregnated double cone. Serially sectioned horizontally at 1.0 μm and counterstained with toluidine blue.

Figure 46.a. Shows basal processes in the outer plexiform layer.

Figure 46.b., 46.c., and 46.d. Show invaginating basal processes. Note that the cone has a common aperture and that only other double cones appear invaginated.

Marker = 20 μm .

Figure 47. Pattern of cone-cone connections reconstructed from serial 1 μm sections. Invaginated cone pedicles are marked by a filled square, the Golgi impregnated cone pedicle is marked by a filled circle (\bullet), double cones (Dc) and single cones (Sc). The figure is not drawn to scale.

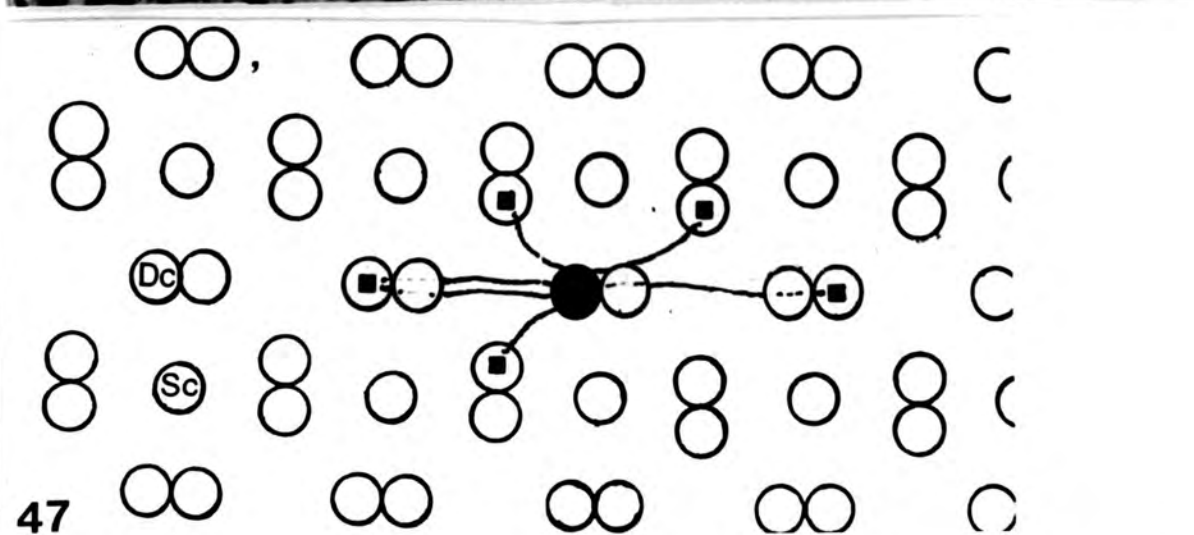
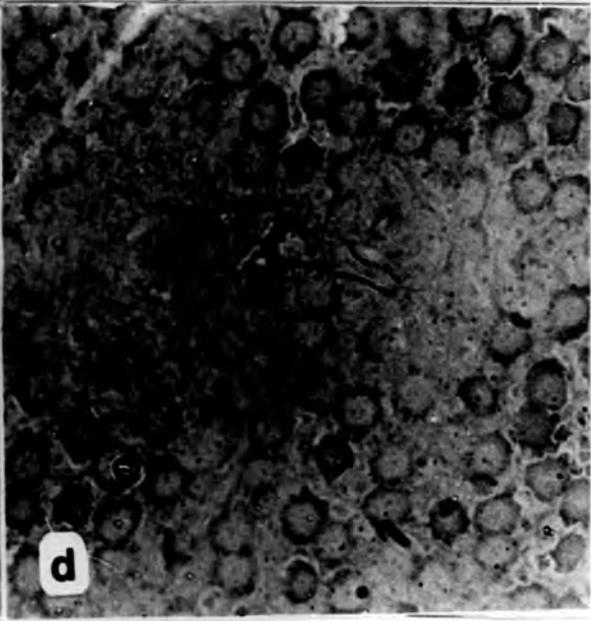
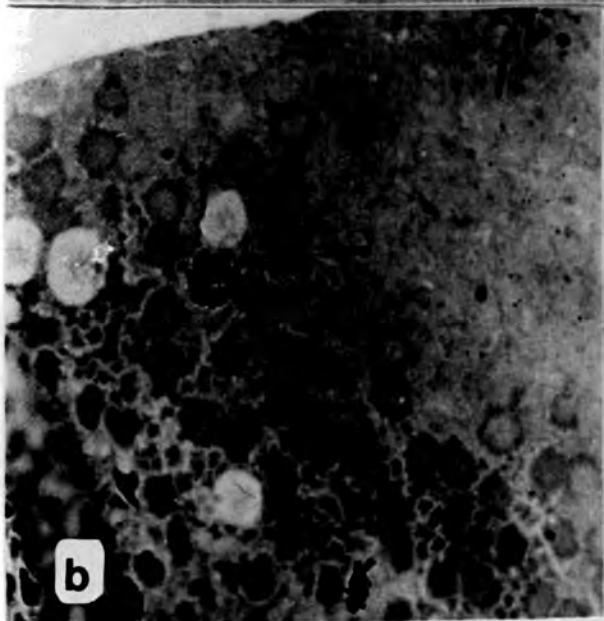
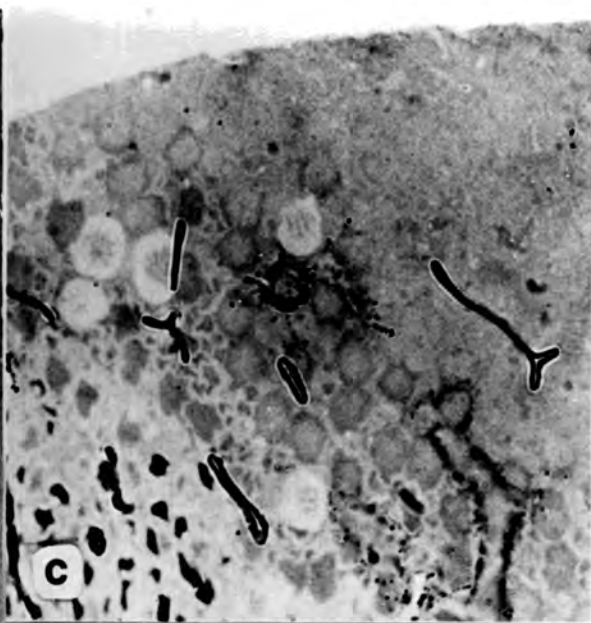
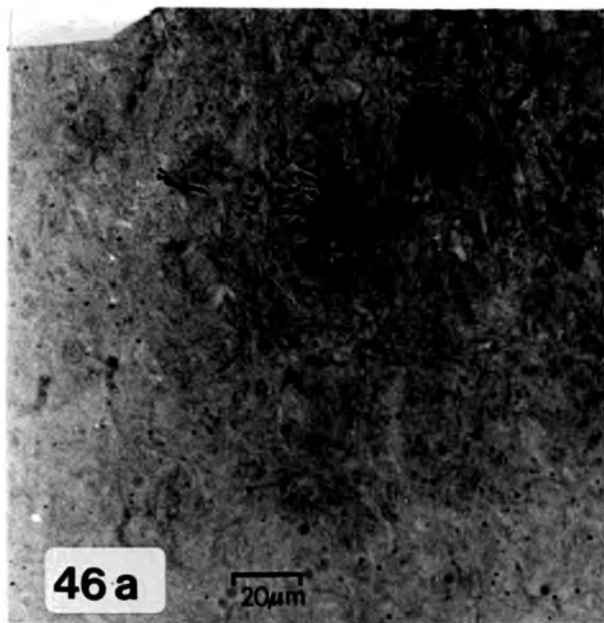

Plate 24.

Light micrographs of Golgi impregnated central single cone. Serially sectioned horizontally at 1.0 μm and counter-stained with toluidine blue.

Figures 48.a., 48.b., 48.c., and 48.d. Note that basal processes from the single cone can only be seen to invaginate double cones.

Marker 20 μm .

Figure 49. Pattern of cone-cone connections reconstructed from serial 1 μm horizontal sections. Invaginated cone pedicles are marked by a filled square, the Golgi impregnated cone pedicle is marked by a filled circle (●), double cones (Dc) and single cones (Sc).

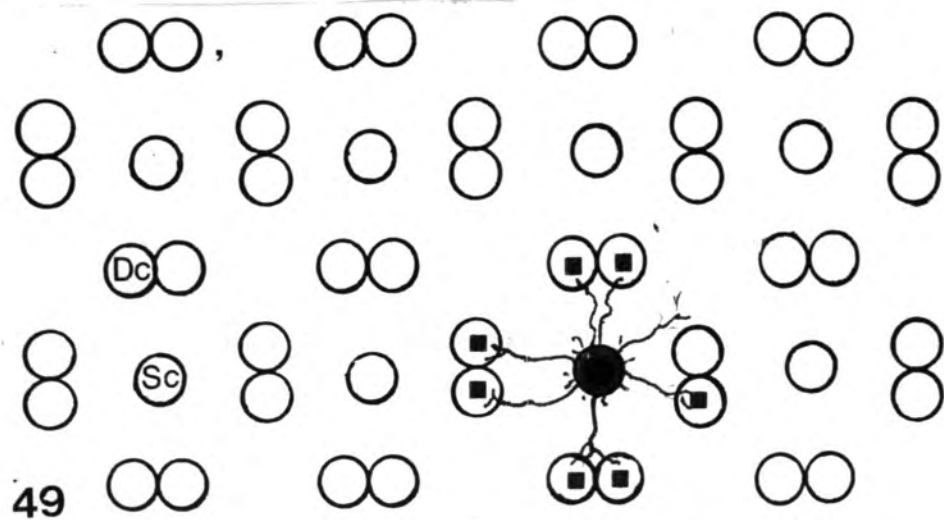
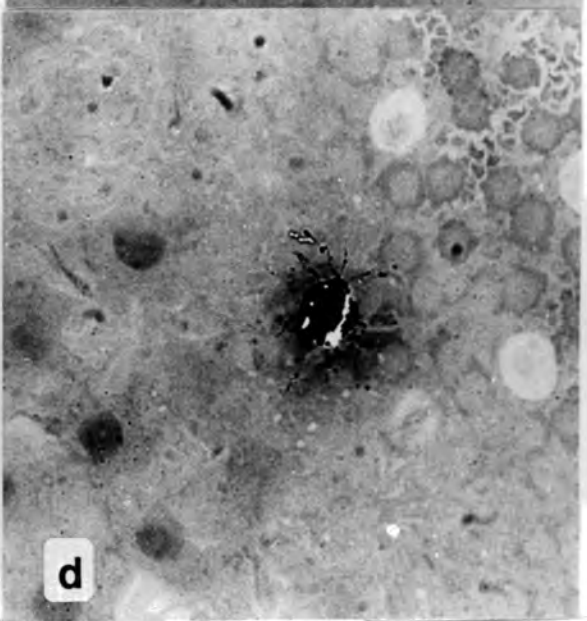
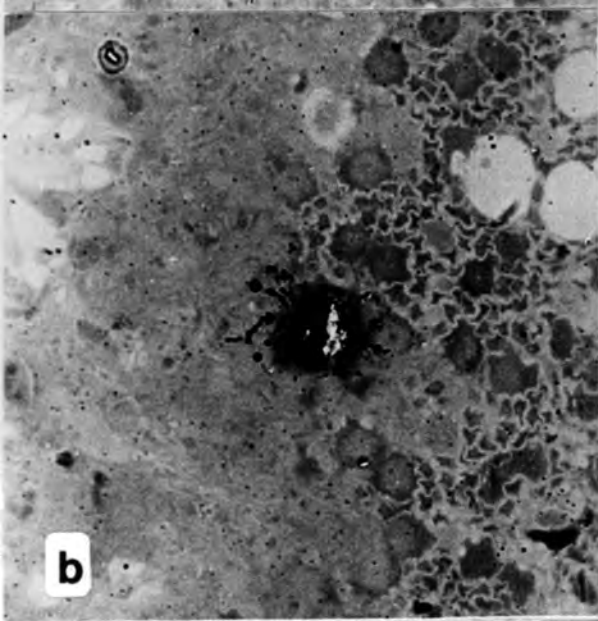
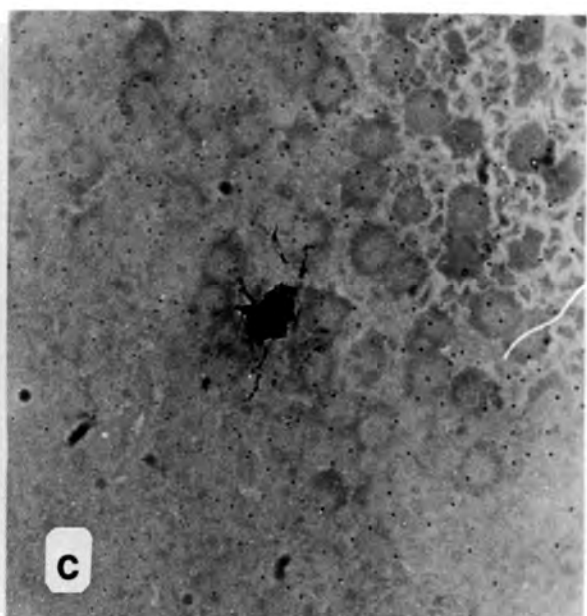
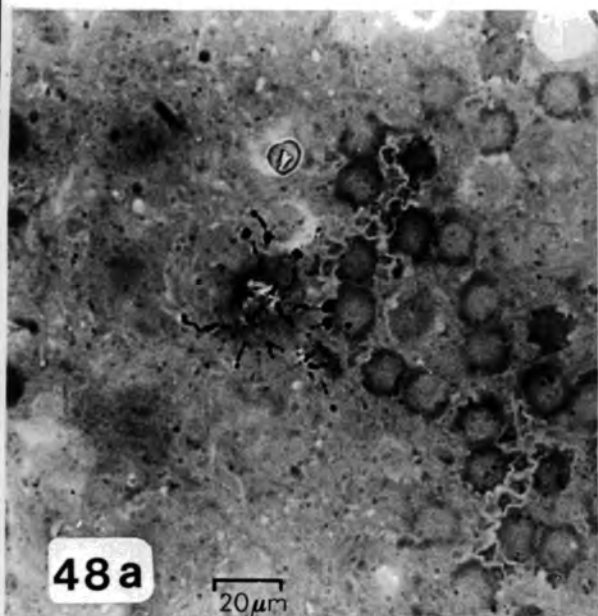

Plate 25.

Electron micrographs of ultrathin horizontal sections through photoreceptor terminals.

Figure 50. Shows the dendritic processes of Golgi impregnated H2-type horizontal cell. Note that terminations of the H2 cell contact only double cones (Dc), which surround a single cone.

Marker = 5 μm .

Figure 51. Dendritic termination of an H3-type horizontal cell, contacting a single cone (Sc).

Abbreviations as for previous plates.

Marker = 2 μm .

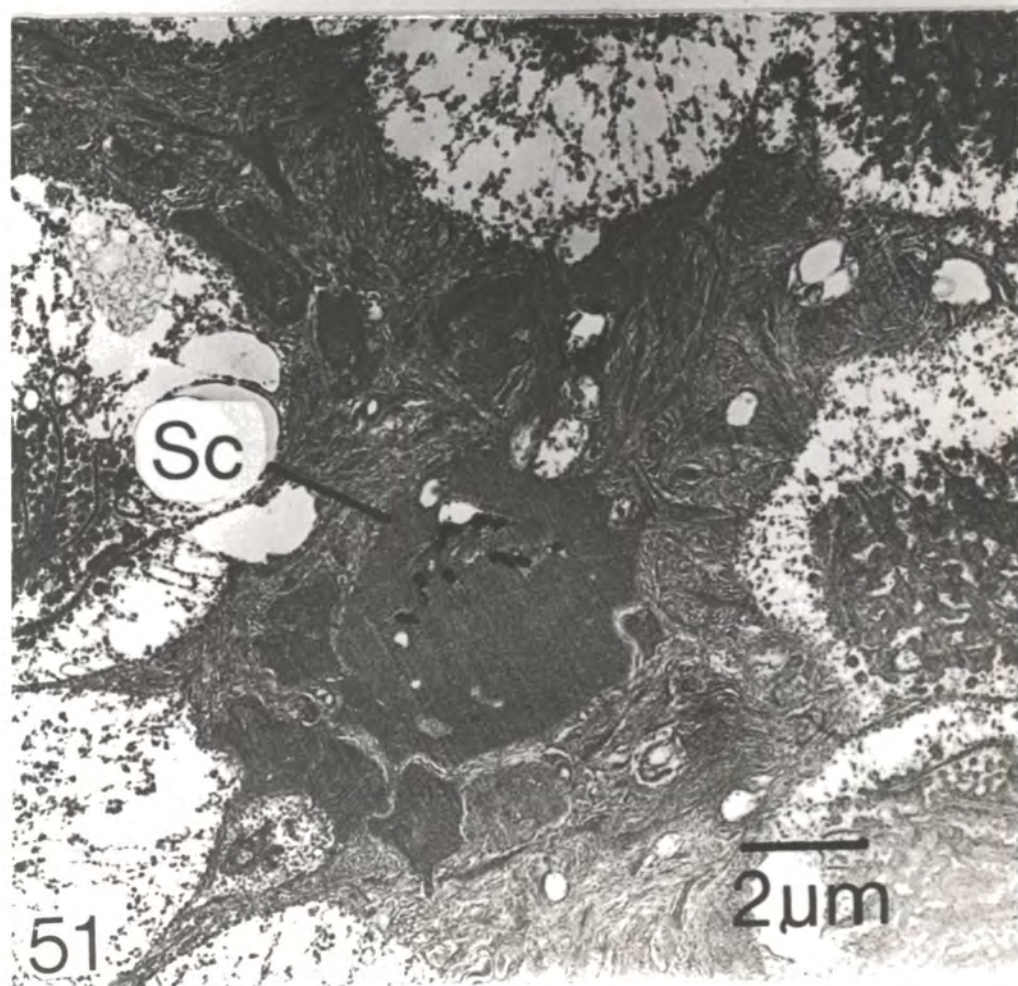
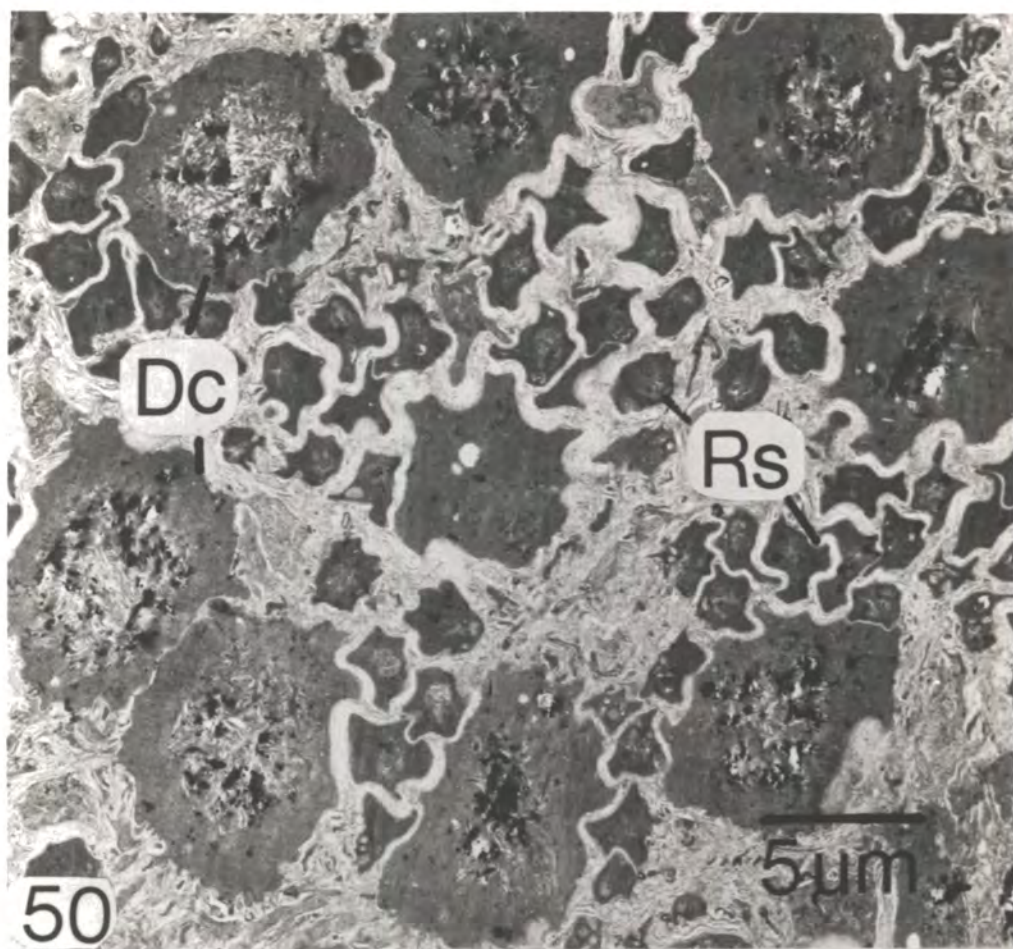

6.2.2. Receptive fields.

Receptive field size was determined by the dependence of response amplitude upon the diameter of a centred spot of light, flashed at constant intensity level. Figure 6.4 shows the relationship between peak amplitude and stimulus diameter when the intensity was selected so that the largest diameter stimulus would evoke a response of about half-maximum ($1/2V_{max}$) amplitude, and for comparison, showing the relationship when using higher intensities which evoked responses of approximately maximum amplitude (V_{max}) for a large diameter spot. No difference was observed between white or monochromatic red and green lights when compared as V/V_{max} for different amplitude responses (Fig. 6.5). The curve shows that this cell has a uniform receptive field of 5 mm in diameter. Similar results were obtained from 6 other L-type horizontal cells, which showed homogenous receptive field size, ranging from 4 to 5 mm.

The spread of potential along the conducting layer of cells is characterized by the space constant. In cable theory, the space constant is the distance over which the potential spreading passively, decreases to $1/e(V_0)$ (i.e. exponential), where V_0 = voltage at origin. In their work Naka and Rushton (1967) assumed that the system of horizontal cells behaves as a continuous two-dimensional network. However, Lamb (1976) showed, by using a long bar (slit) of light, that the complex two-dimensional voltage distribution was reduced to a single one-dimensional exponential, from which the space constant could easily be measured. Figure 6.6.a shows the L-type peak response plotted as a function of displacement of a long

narrow slit or bar of light. In figure 6.6b straight lines have been fitted to the points on the semilogarithmic plot to test the exponential decay as predicted by Lamb's (1976) model for low light intensities. The lines provide a reasonable fit to the points and correspond to a length constant of 250 μm . Increasing the light intensity by 0.5 log unit, caused a change in length constant from 250 μm to 385 μm or an increase of 35.1%.

6.2.3. Spectral response properties.

To light stimuli of all wavelengths, the response waveform of the L-type horizontal cell, in its timecourse, consists of a rapidly hyperpolarizing initial (rising) phase, to peak amplitude followed by a return to a less hyperpolarized level, here termed late phase or plateau (Figs. 1.a-c). The peak/plateau waveform is not observed at low amplitude responses and at maximum (saturating) amplitude (Figs. 1.a-c). At the termination of the flash, the membrane potential returned rapidly to the level observed prior to illumination (Fig. 1).

The response waveforms of the L-type cell of equal peak amplitude differ, when compared, according to the stimulus wavelength. The rapidly hyperpolarizing initial (rising) phase of the response, however, showed a similar time-course when responses of equal amplitude of different wavelengths were compared (Fig. 6.7). Figure 6.7 illustrates the initial phase of the response of a dark adapted L-type cell to various wavelengths of red and green lights of various amplitudes, with each pair of stimuli adjusted in intensity to elicit responses of equal amplitude. The late phase (plateau) of

the L-type response waveform, however, differed markedly when elicited by shorter (<550 nm) as opposed to longer (>600 nm) wavelength stimuli. Figure 6.8 shows superimposed responses of equal peak amplitude of a dark adapted L-type cell to red and green flashes. Responses to the 526 nm (green) flash have a less hyperpolarized late phase (plateau) than the responses to 651 nm (red) flash, and the latter is slightly slower in the returning phase than the response of the green-blue flash. For small amplitude responses (Fig. 6.8) the differences between red and green flashes are minimal and have a similar time-course and duration.

This dependence of response waveform on stimulus wavelength was observed in all cells studied, and may indicate that L-cells receive inputs from more than one type of photoreceptor.

Figure 6.1.

Superimposed response of L-type horizontal cell to 0.5 sec duration flashes of different intensities.

Figure 6.1.a. White light.

Figure 6.1.b. Monochromatic red (674 nm) light.

Figure 6.1.c. Monochromatic green (526 nm) light.

The light intensity was increased in approximately 0.25 log unit steps.

a.

White light

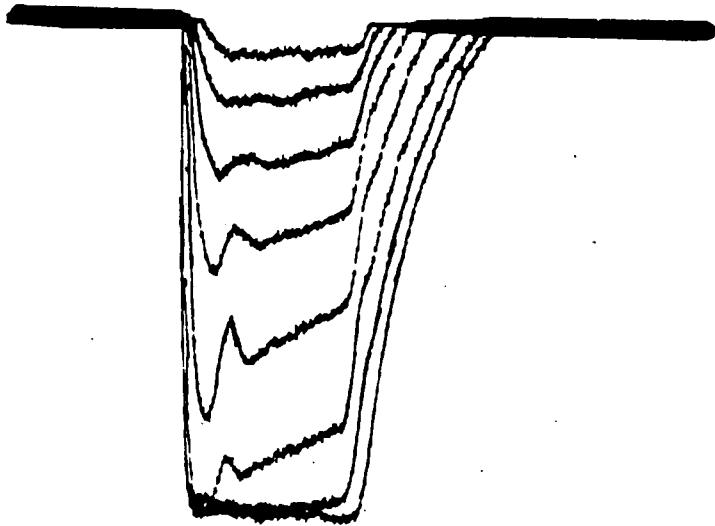

b.

Red, 674 nm

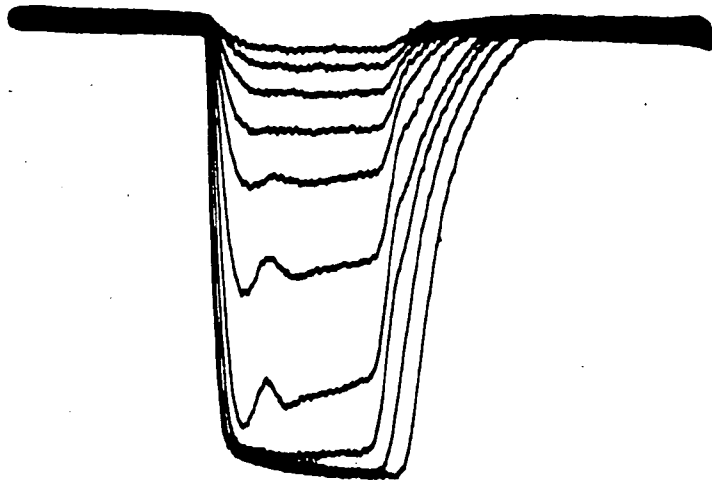

c.

Green, 526 nm

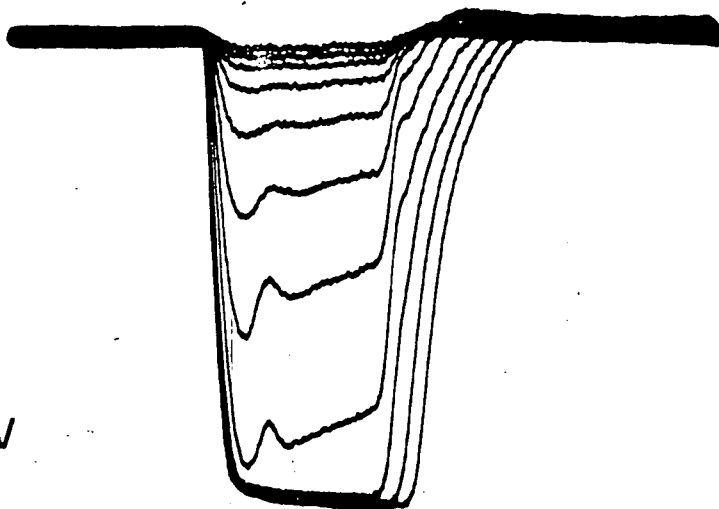

10 mV

0.5 sec

Figure 6.2.

The response amplitude of L-type horizontal cell plotted as a function of the logarithm of light intensity.

Figure 6.2.a. The figure shows linear relationships except at high and low amplitude.

Figure 6.2.b. Linear plot on double logarithmic scale reveals that the relationship is linear at low amplitude responses.

Stimulus white light of 5 mm spot diameter and 0.5 sec in duration.

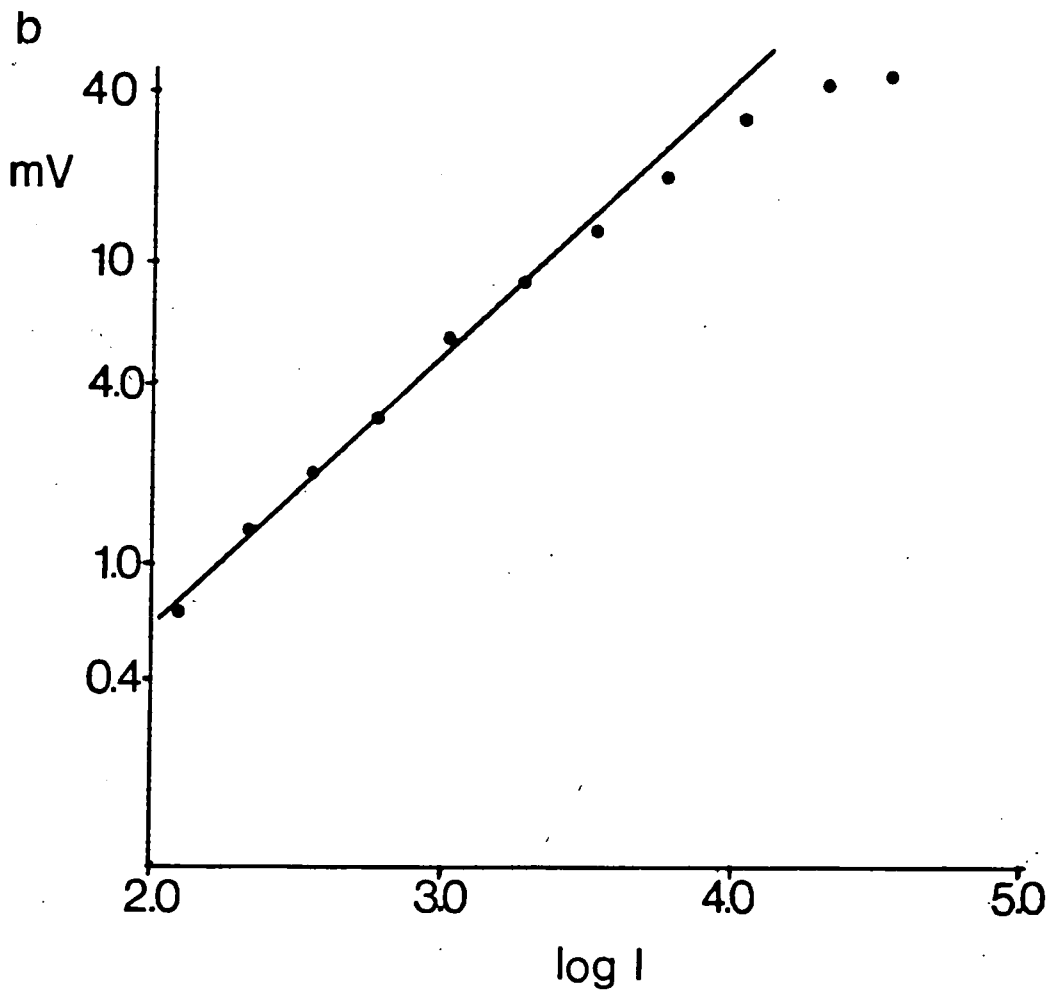
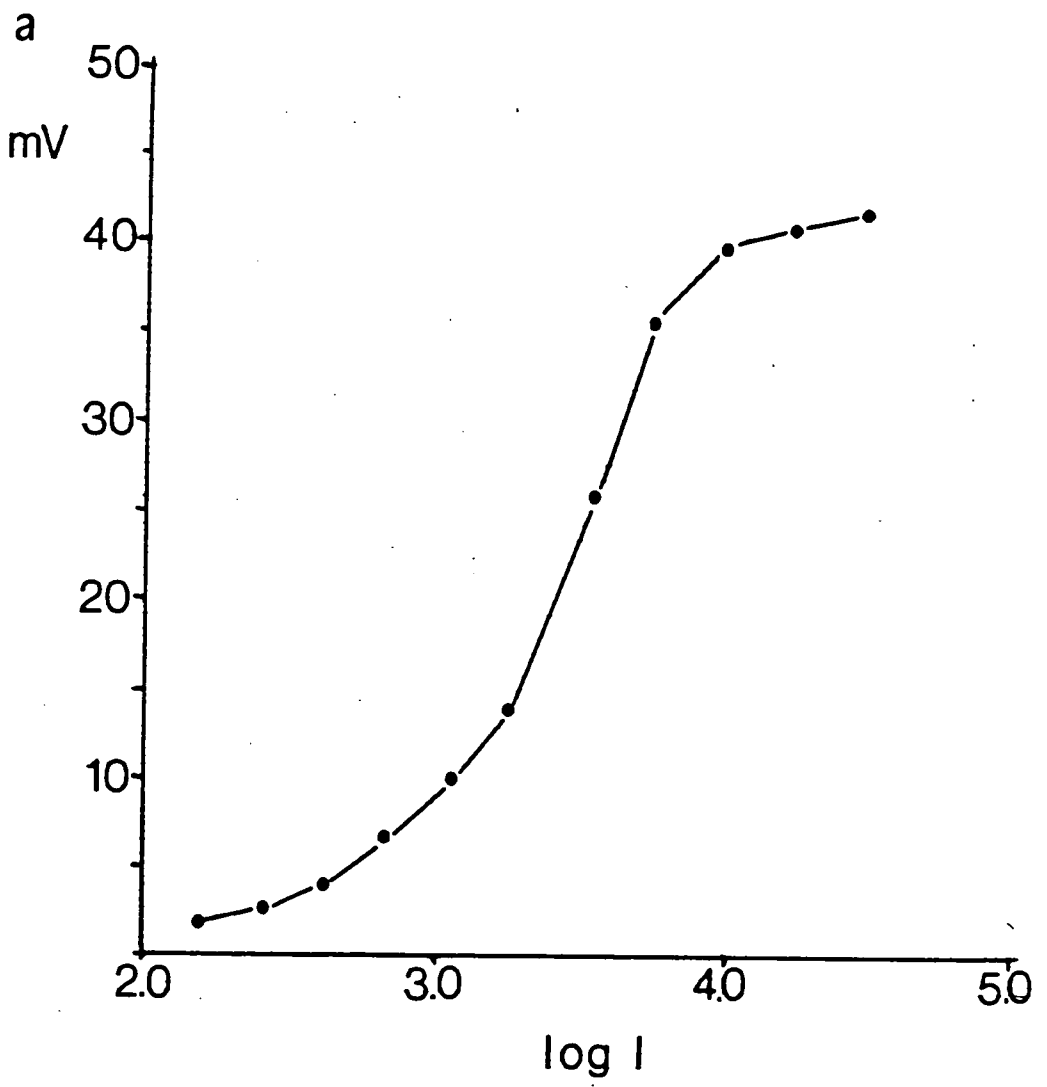

Figure 6.3.

Relation between relative amplitude of the L-type response and stimulus intensity. The smooth curve $V/V_{\max} = I^n / I^n + \sigma^n$ (where $n = 1.5$) (see text) gives the best visual fit of the L-type V-logI relationship.

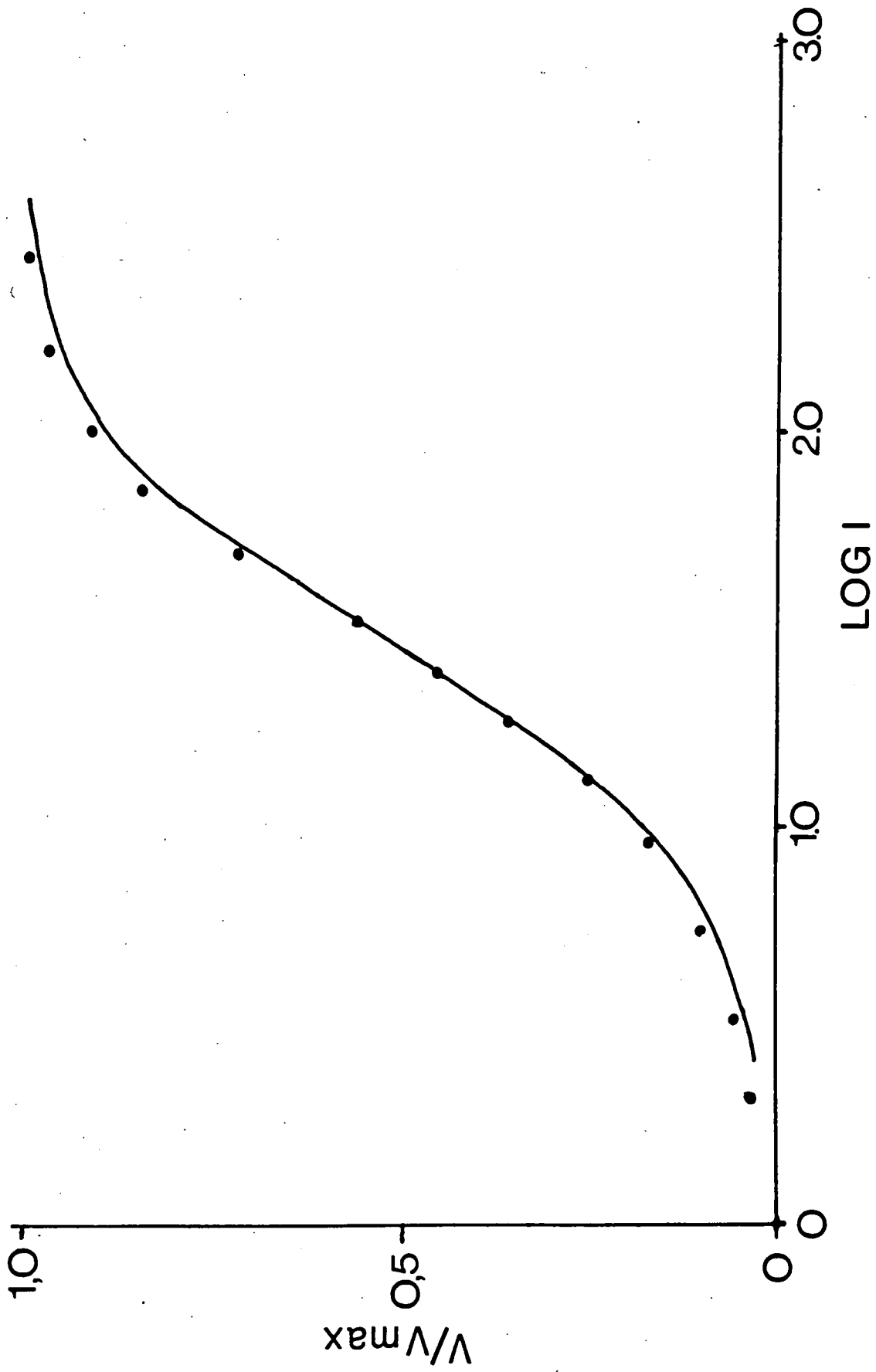

Figure 6.4.

Relation between response amplitude and stimulus diameter for L-type horizontal cells. Top, superimposed responses to white, red, 651 nm, and green, 550 nm flashes. Intensity for each stimulus was adjusted to evoke half maximum or $\frac{1}{2}V_{max}$ amplitude response, with a 5 mm spot diameter. Solid circles represent white light of maximum amplitude (V_{max}) for 5 mm spot diameter. See text for details.

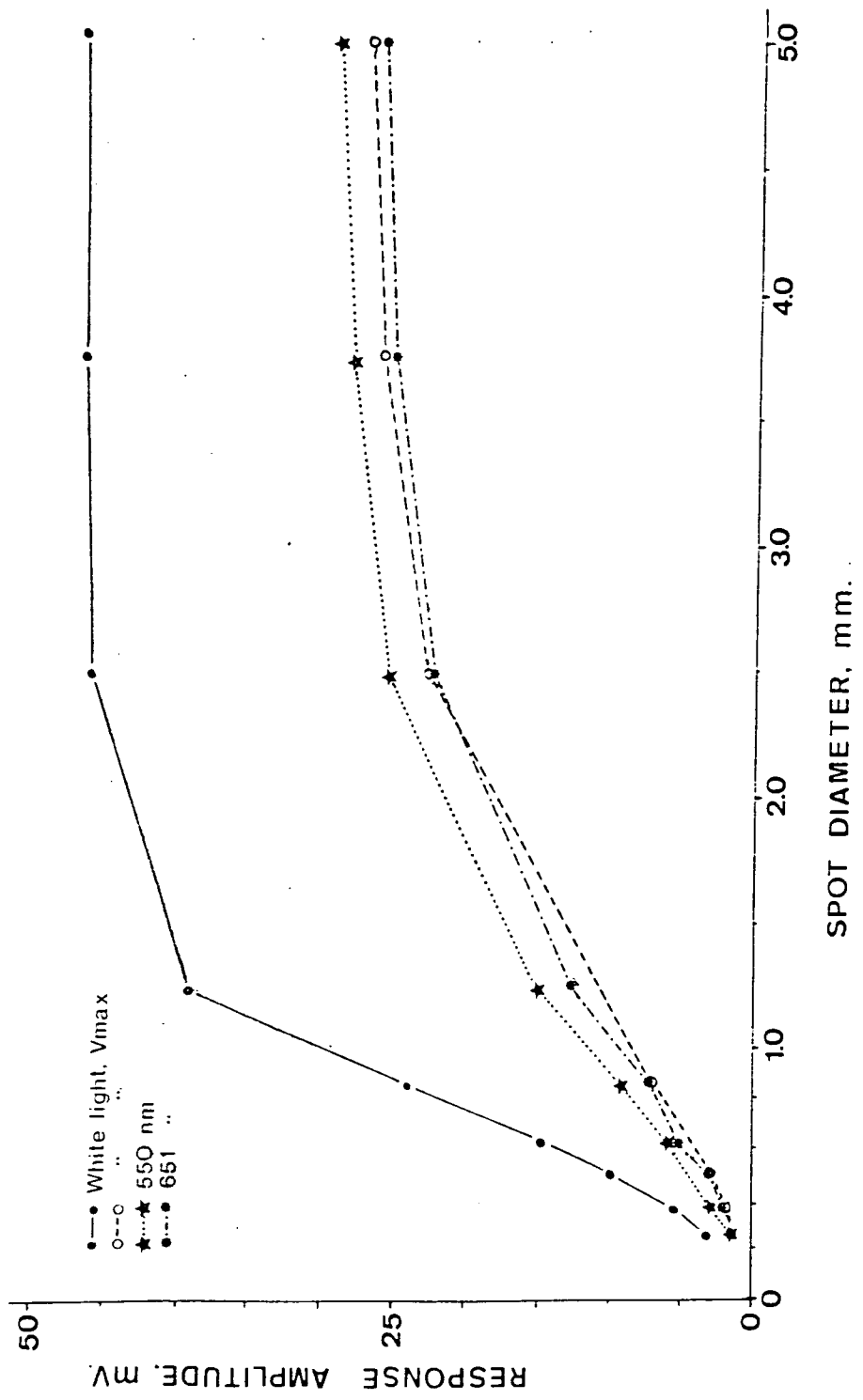
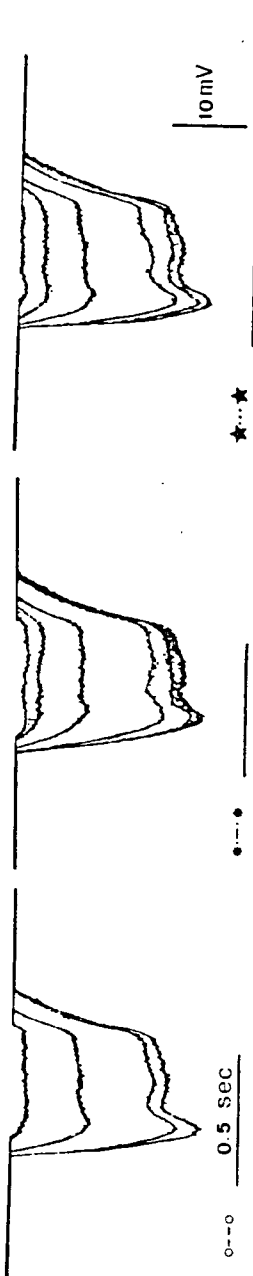

Figure 6.5.

The data from figure 6.4. plotted as a relative response amplitude against spot diameter. Smooth curve drawn by eye as best fit to points.

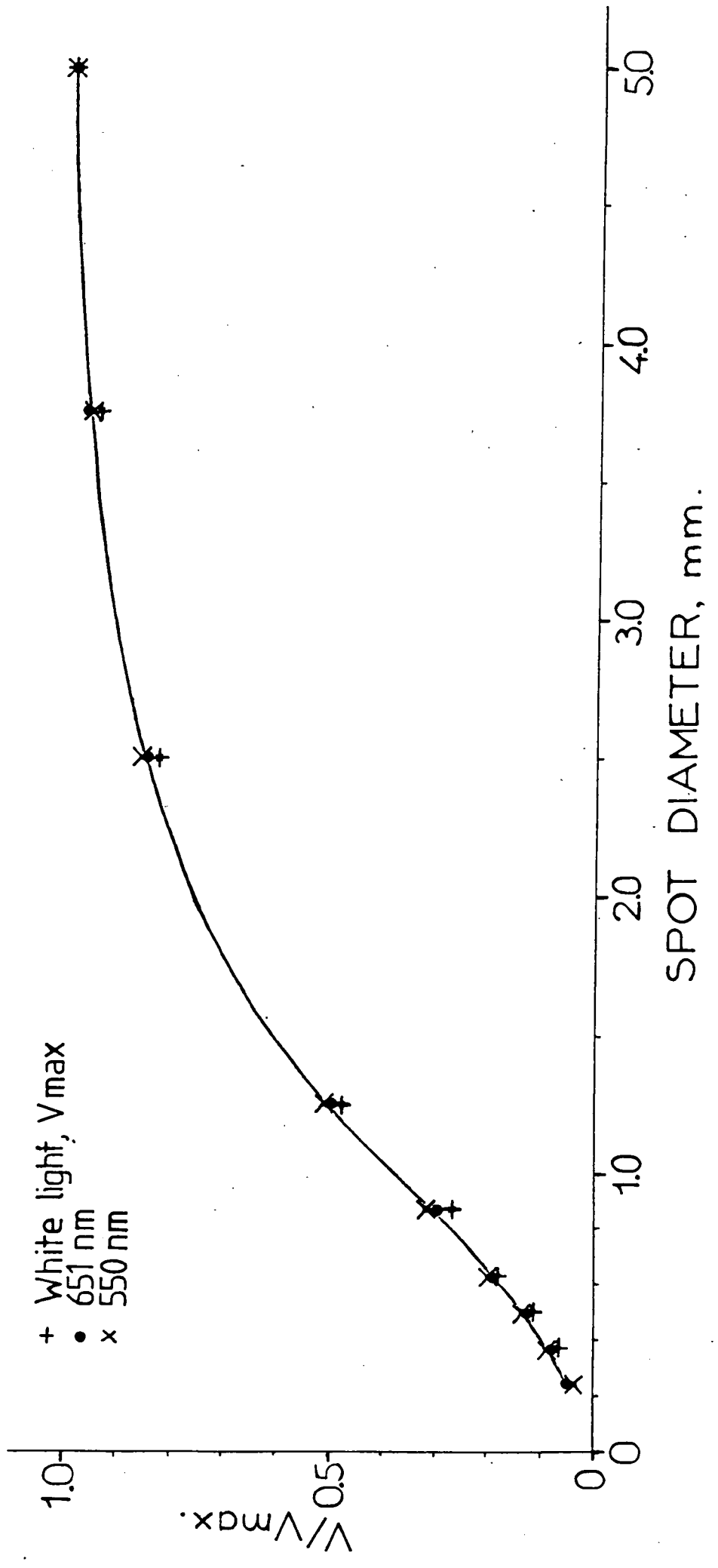

Figure 6.6.

Responses of L-type horizontal cell as a function of displacement of a narrow (80 μm) slit. Peak hyperpolarization is plotted a) linearly and b) logarithmically against slit position.

Figure 6.6.a. The broken top has been drawn by eye.

Figure 6.6.b. Straight lines have been drawn by eye to fit the points.

Flash delivered 2.0×10^2 photons μm^{-2} for white light of 0.5 sec in duration.

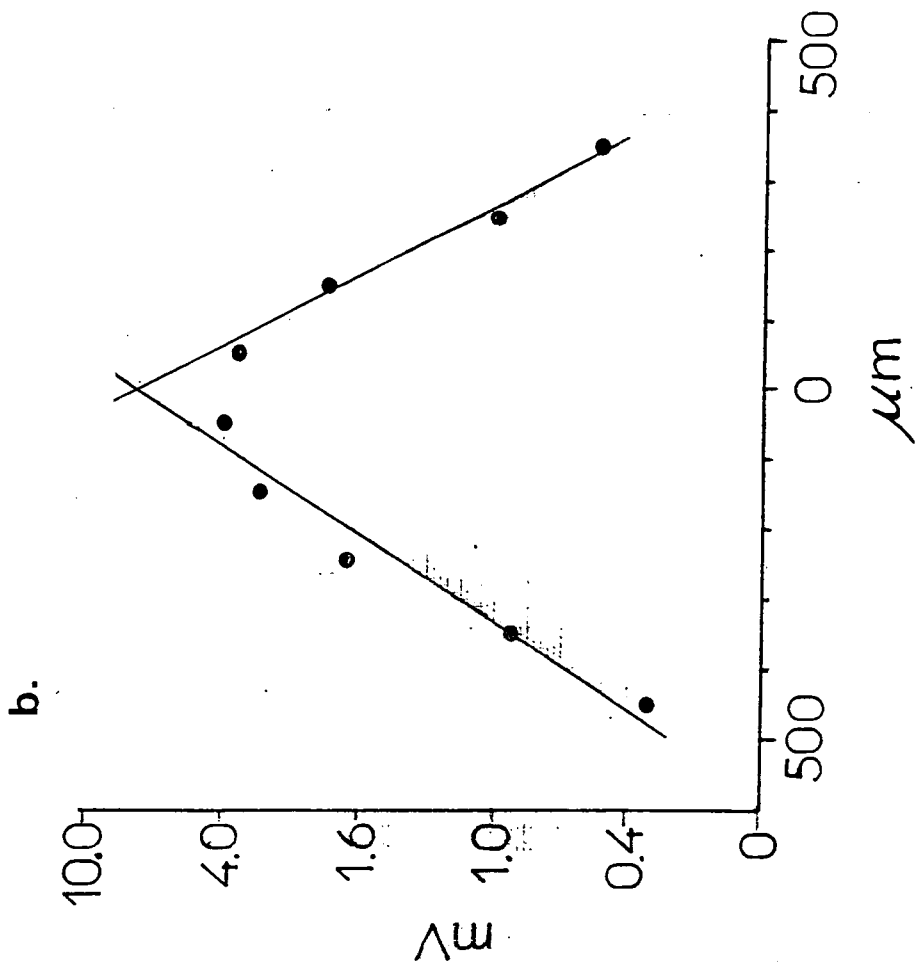
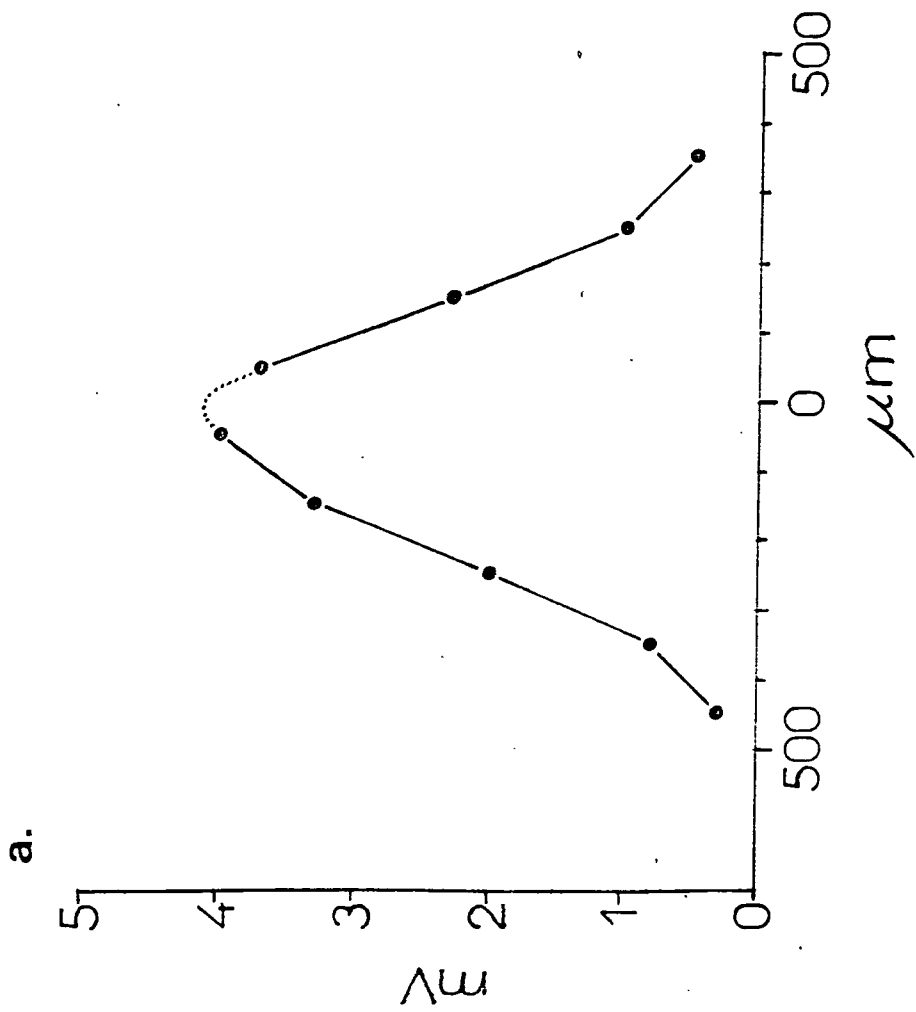
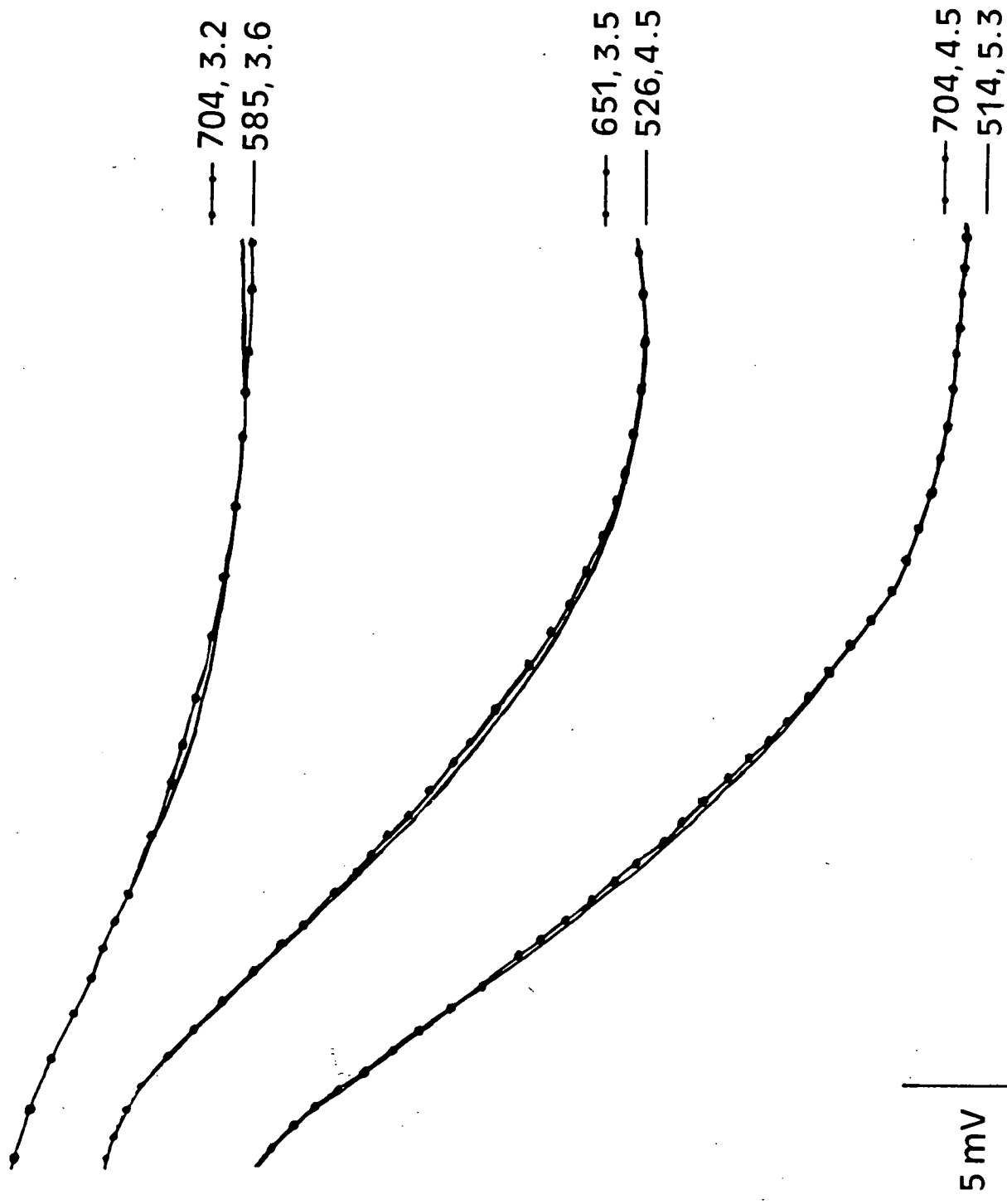

Figure 6.7.

Comparison of the rising phase of response waveforms to flashes of various wavelengths recorded from a dark adapted L-type horizontal cell. Stimuli were matched in intensity so as to elicit responses of equal amplitude. Top trace; response to 704 nm ($\log I = 3.2$) flash (dotted curve), and 585 nm ($\log I = 3.6$) flash (solid curve). Middle trace; responses to 651 nm ($\log I = 3.5$) flash (dotted curve), and 526 nm ($\log I = 4.5$) flash (solid curve). Bottom trace; responses to 704 nm ($\log I = 4.5$) flash (dotted curve) and 514 nm ($\log I = 5.3$) flash (solid curve).



5 mV
50 msec

Figure 6.8.

Comparison of response waveforms of a dark adapted L-type horizontal cell. Stimuli were varied in intensity so as to elicit responses of equal peak amplitude.

Figure 6.8.a. Shows responses to 687 nm ($\log I = 2.5$) and 526 nm ($\log I = 3.4$) flashes.

Figure 6.8.b. Shows responses to 651 nm ($\log I = 3.0$) flash (solid curve) and 514 nm ($\log I = 3.7$) flash (dotted curve).

Figure 6.8.c. Shows responses to 651 nm ($\log I = 3.3$) flash (solid curve) and 526 nm ($\log I = 4.3$) flash (dotted curve).

Figure 6.8.d. Shows responses to 651 nm ($\log I = 3.5$) flash (solid curve) and 493 nm ($\log I = 4.6$) flash (dotted curve).

a.

687+526 nm, 2.5+3.4

b.

514 nm, 3.7

651 nm, 3.0

c.

526 nm, 4.3

651 nm, 3.3

d.

493 nm, 4.6

651 nm, 3.5

5mV

250 msec

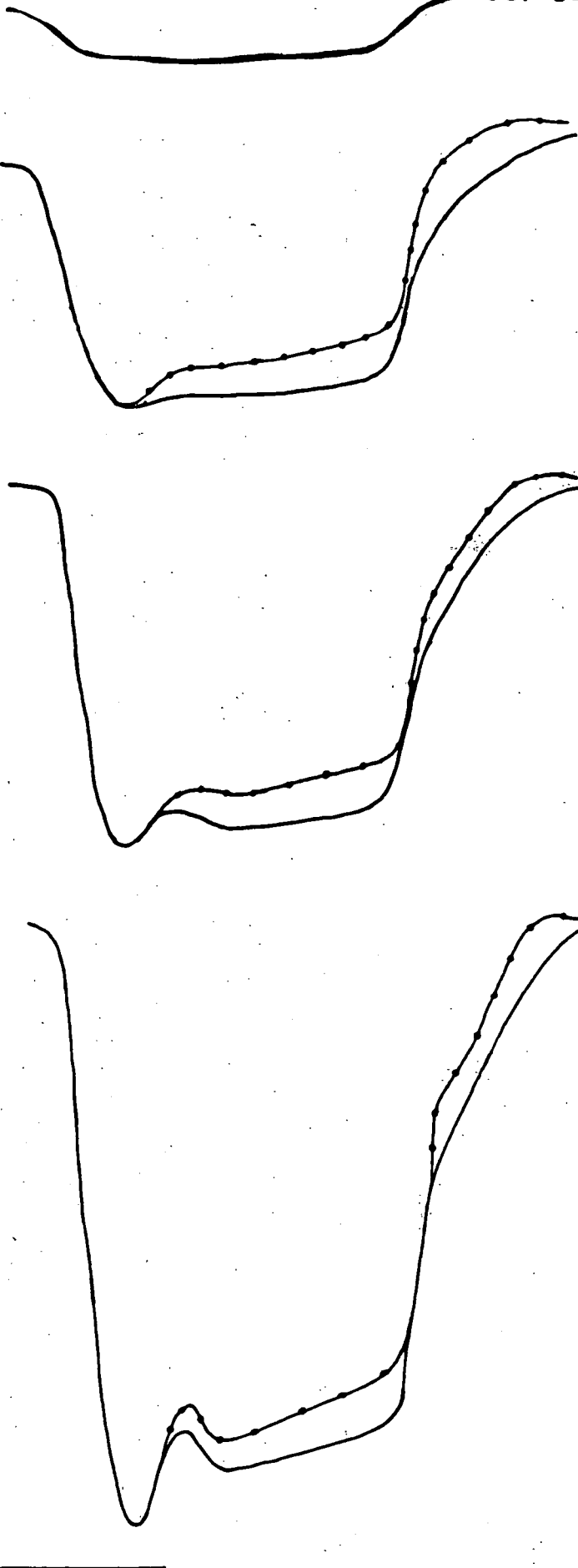

6.2.4. Spectral analysis.

The response amplitude, V , was measured electrophysiologically as a function of the logarithm of the stimulus intensity, I , for various wavelengths at approximately 20 nm intervals in the wavelength range from 450 nm to 704 nm. This was done in two ways: i) the wheels carrying the neutral density filters were rotated in steps from low to high intensity for each interference filter or, ii) the wheel carrying the interference filters was rotated from one wavelength to the next for each intensity level, the light intensity was then increased when all interference filters had been tested, and the procedure repeated for each light intensity level. Generally the first method was used, the second method being used occasionally for comparison.

Figure 6.9.a illustrates the V -log I relationship of an L-unit for a series of wavelengths from 704 nm to 514 nm, when the maximum amplitude (peak amplitude) of the response was measured. The L-type V -log I curves for different wavelengths are parallel (self-similar, Sirovich and Abramov, 1977) over the whole dynamic range of the response (Fig. 6.9.b). Furthermore, V -log I curves constructed for the initial (rising) phase (Fig. 6.10) and for the late (plateau) phase (Fig. 6.11) at 200 and 500 msec respectively, after the flash onset, were also found to be parallel. V -log I relationships were found to be parallel in thirty L-units studied for all wavelengths.

The L-type horizontal cell seems to respond according to the principle of univariance (Naka and Rushton, 1966a, b), which states that the signal from a photoreceptor depends only upon the rate at

which it is effectively absorbing quanta, it does not depend upon the associated wavelength. Thus, if an S-potential unit is driven by a single cone type, then the V-logI curves, generated in response to different monochromatic lights, should be self-similar (parallel) but shifted horizontally along the logI axis. In addition, the response waveform should be identical in shape to stimuli of all wavelengths.

The L-type horizontal cell in perch behaves as would be expected of a cell obeying univariance from the parallel V-logI curves and as does the similarity of the initial phase kinetics. However, the late phase deviates from the univariant response.

6.2.5. Spectral sensitivity curves.

Spectral sensitivity curves were constructed from the V-logI curves. The sensitivity was defined as the reciprocal of the light intensity giving rise to an arbitrarily determined criterion response amplitude and plotted as a function of wavelength to provide the spectral sensitivity curves. Usually two criterion amplitudes were chosen from the linear part of the V-logI curves at approximately $1/2$ ($1/2V_{max}$) and $1/3$ ($1/3V_{max}$) of maximum amplitude for comparison.

The spectral sensitivity curves of all L-type cells studied showed a maximum at 650 nm. A mean spectral sensitivity curve of 30 L-units was constructed for $1/2V_{max}$ criterion amplitude (Fig. 6.12). Comparison of spectral sensitivity curves constructed from different criteria amplitudes ($1/2V_{max}$ and $1/3V_{max}$) were identical, as expected from parallel V-logI curves (Fig. 6.13). Thus, the shape of

the spectral sensitivity curve did not vary with the amplitude of the criterion voltage. Figure 6.14 shows that the spectral sensitivity curves determined at the rising phase (200 msec), peak (250 msec), and plateau (500 msec) respectively, were almost identical over the entire spectral range. This is what can be expected from the univariant rising phase, but the observed differences in the late phase of the response did not appear to affect the shape of the spectral sensitivity curves.

The L-cell spectral sensitivity curve reached a maximum at a wavelength of 650 nm and is therefore shifted towards the long wavelength end of the spectrum when compared with the red cone photopigment (Fig. 6.15) which has a maximum absorption at a wavelength of 615 nm (Loew and Lythgoe, 1978). In addition, the shape of the L-type spectral sensitivity curve is narrow when compared with a hypothetical photopigment, constructed from Ebrey and Honig's (1978) monogram, of the same absorption peak (Fig. 6.16).

In perch only two types of cone photoreceptors have been observed (Engstrom, 1963; Ahlbert, 1969); double and single cones containing red and green absorbing photopigments (λ_{\max} 615 and 535 nm) respectively, as detected by microspectrophotometry (Loew and Lythgoe, 1978). It may be assumed that the L-type spectral sensitivity arises as the result of interaction between signals from the red sensitive double cone and the green sensitive single cone, since a photopigment with an absorption maximum at 650 nm has not been detected in the perch retina and the observation that the L-type spectral sensitivity curve is much narrower than a hypothetical photopigment.

Figure 6.9.

Relation between response amplitude and the logarithm of the light intensity (V-logI) curves of a dark adapted L-type cell. Response amplitudes were measured at peak amplitude, at approximately 250 msec after the flash onset.

Figure 6.9.a. V-logI curves for various wavelengths. Key: 1 = 704 nm; 2 = 687 nm; 3 = 674 nm; 4 = 651 nm; 5 = 630 nm; 6 = 608 nm, 7 = 585 nm; 8 = 571 nm; 9 = 550 nm; 10 = 526 nm; 11 = 514 nm. (The V-logI curves for 450 to 493 nm were omitted for clarity).

Figure 6.9.b. The V-logI curves from a) have been adjusted laterally to show their self-similarity.

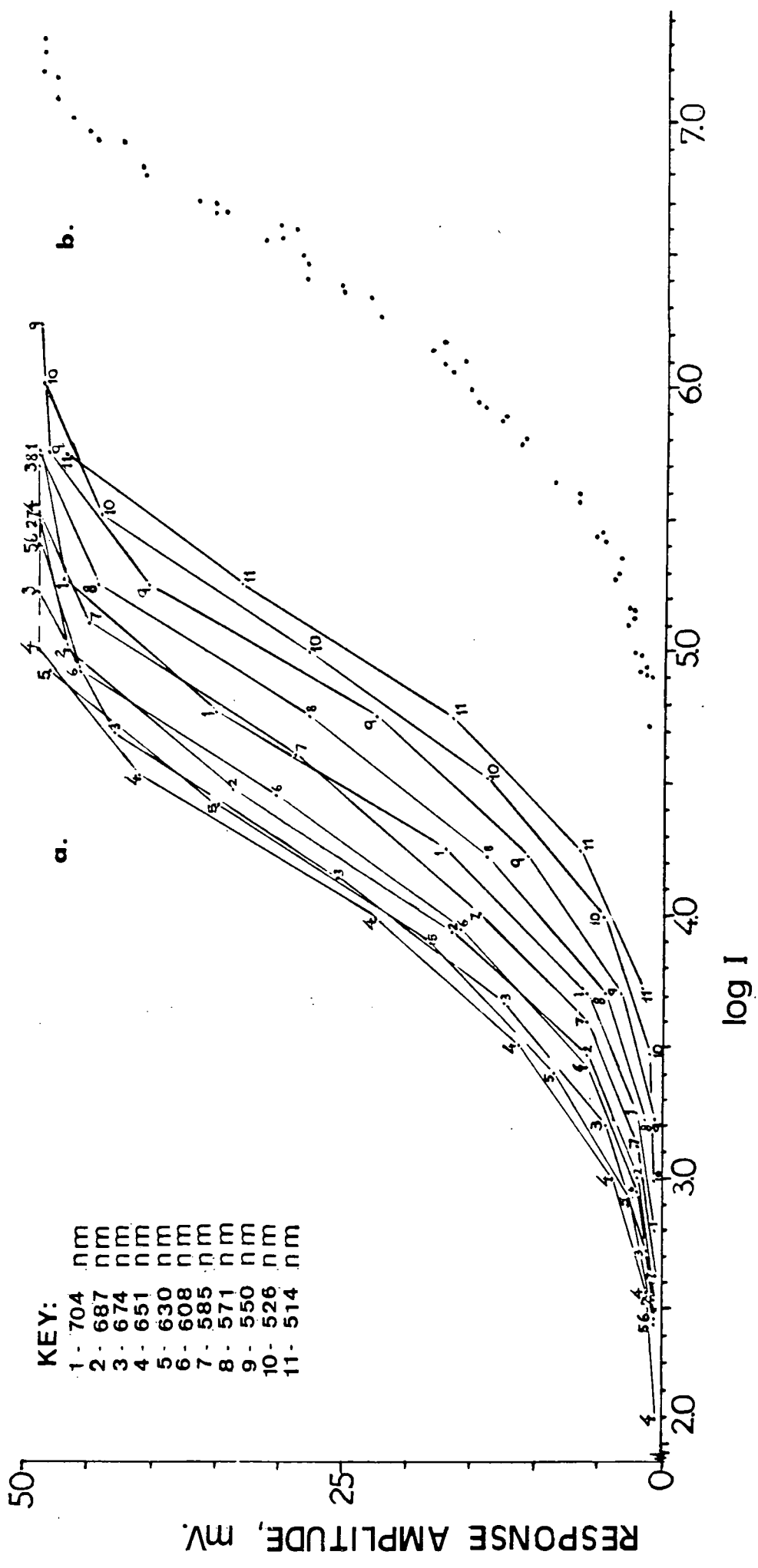

Figure 6.10.

V-logI curves of the L-type cell (the same as in figure 6.9) measured at the rising phase, at approximately 200 msec after the flash onset.

Figure 6.10.a. V-logI curves for various wavelengths. Key as in fig. 6.9.

Figure 6.10.b. The V-logI curves have been adjusted laterally to show their self-similarity.

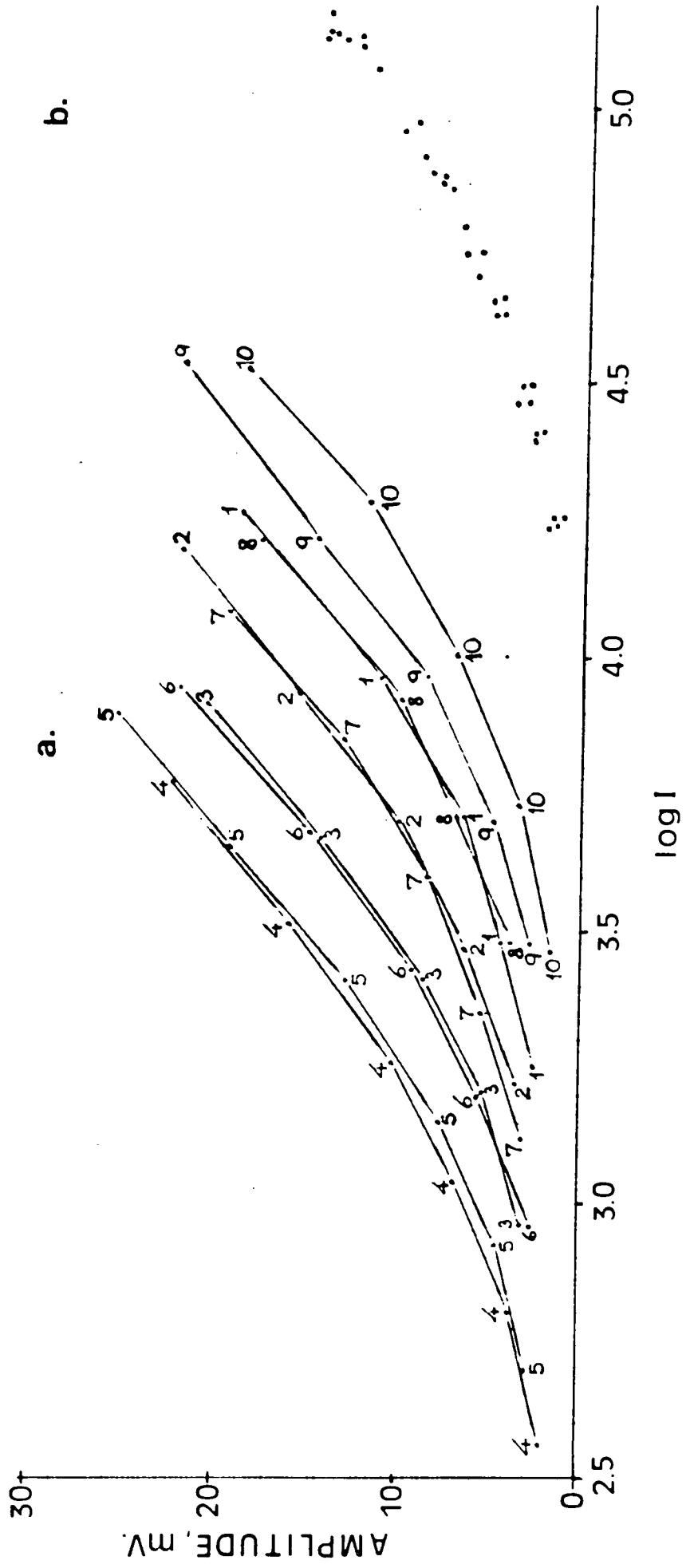

Figure 6.11.

V-logI curves of the L-type cell (the same as in figures 6.9 and 6.10) measured at the late phase (plateau), at approximately 500 msec after the flash onset.

Figure 6.11.a. V-logI curves for various wavelengths. Key as in fig. 6.9.

Figure 6.11.b. The V-logI curves have been adjusted laterally to show their self-similarity.

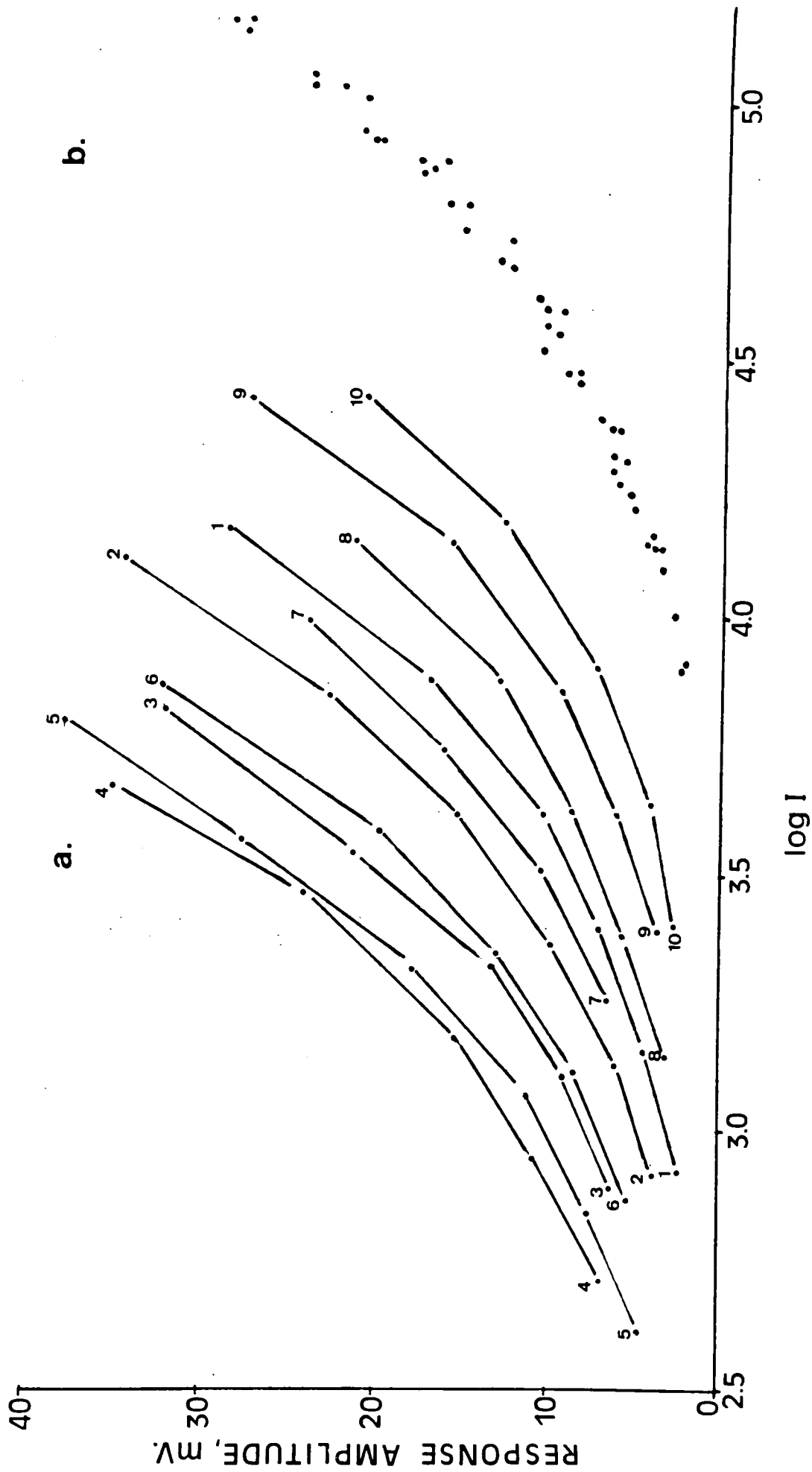

Figure 6.12.

Spectral sensitivity of dark adapted L-type horizontal cells. The circles are average values from 30 cells; vertical bars show the standard deviation of the mean. The curve is based on a criterion response of 50% maximum amplitude ($\frac{1}{2}V_{\max}$) from peak amplitude responses.

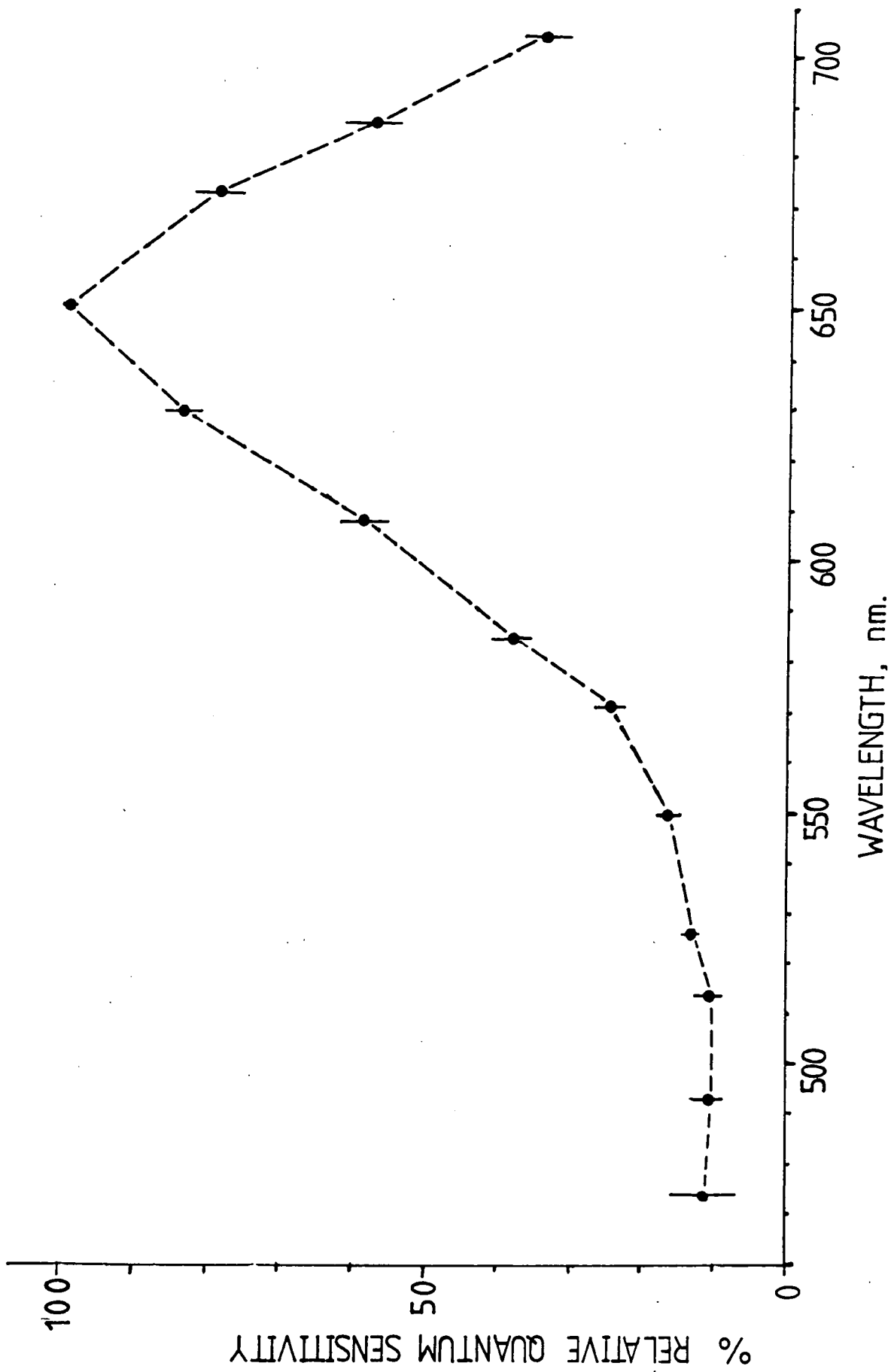

Figure 6.13.

Spectral sensitivity of dark adapted L-type horizontal cells comparing two criterion levels; crosses are $\frac{1}{2}V_{max}$ and open circles represent $\frac{1}{3}V_{max}$. The points are the average of 30 L-type cells, based on peak amplitude responses.

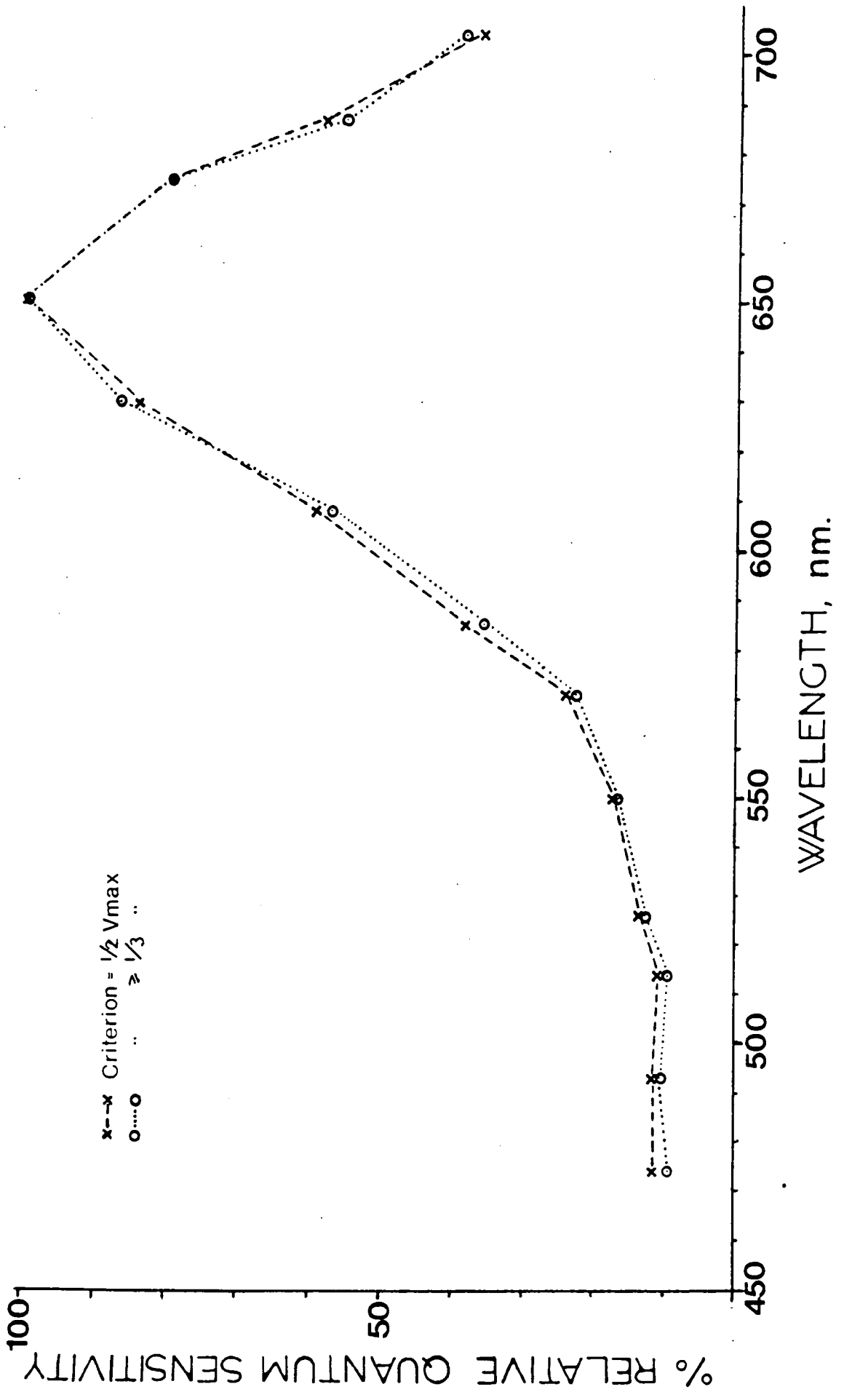

Figure 6.14.

Spectral sensitivity curves from a dark adapted L-type horizontal cell, determined at the initial phase (200 msec) open circles, peak (250 msec) (solid circles), and late phase (500 msec) (crosses). Criterion response $\frac{1}{2}$ maximum amplitude.

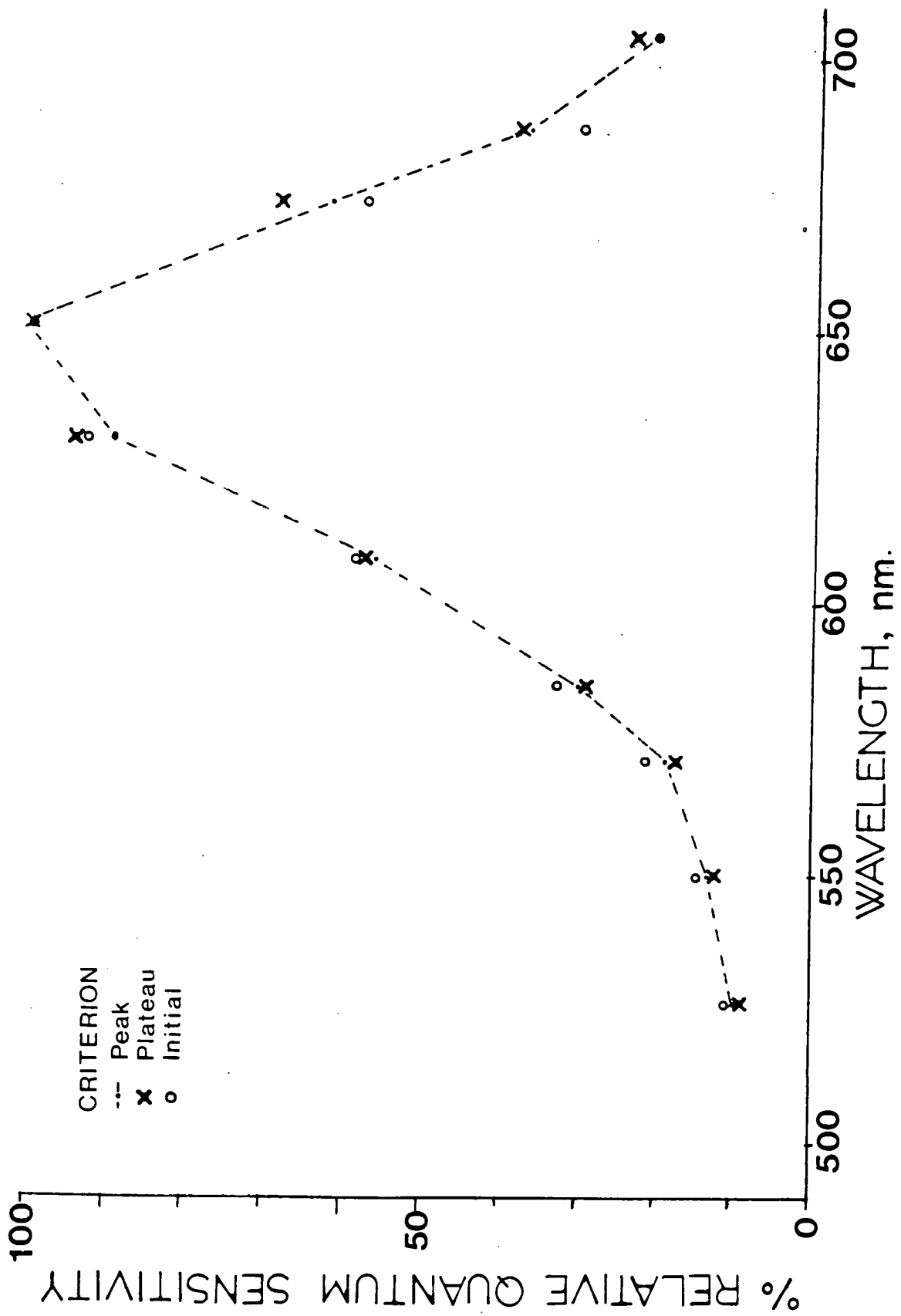

Figure 6.15.

Comparison of dark adapted L-type spectral sensitivity curve (open circles), with the absorption curve of perch red (P615₂) cone photopigment (solid line), from microspectrophotometry study by Loew and Lythgoe (1978), as printed by Lythgoe (1979).

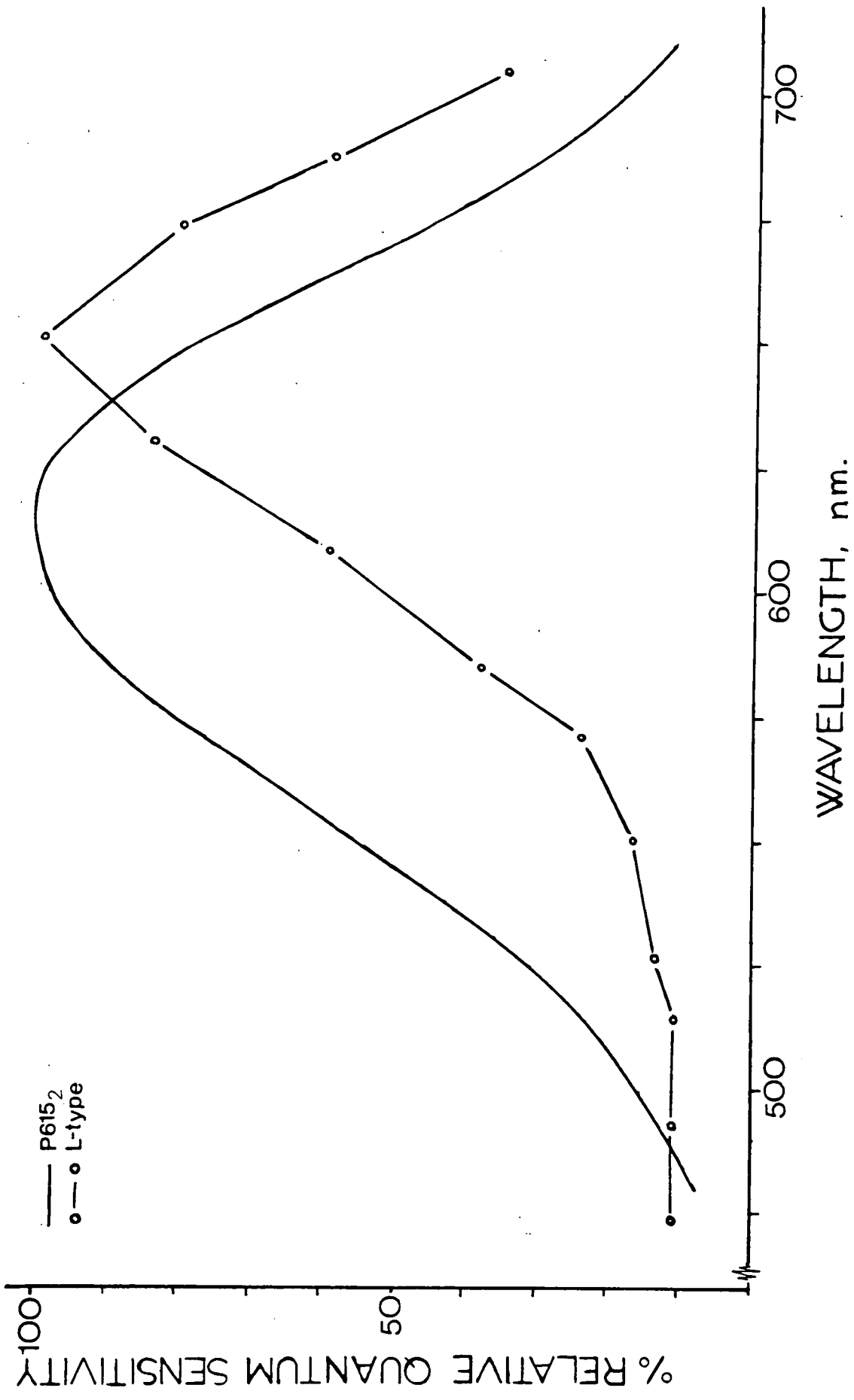
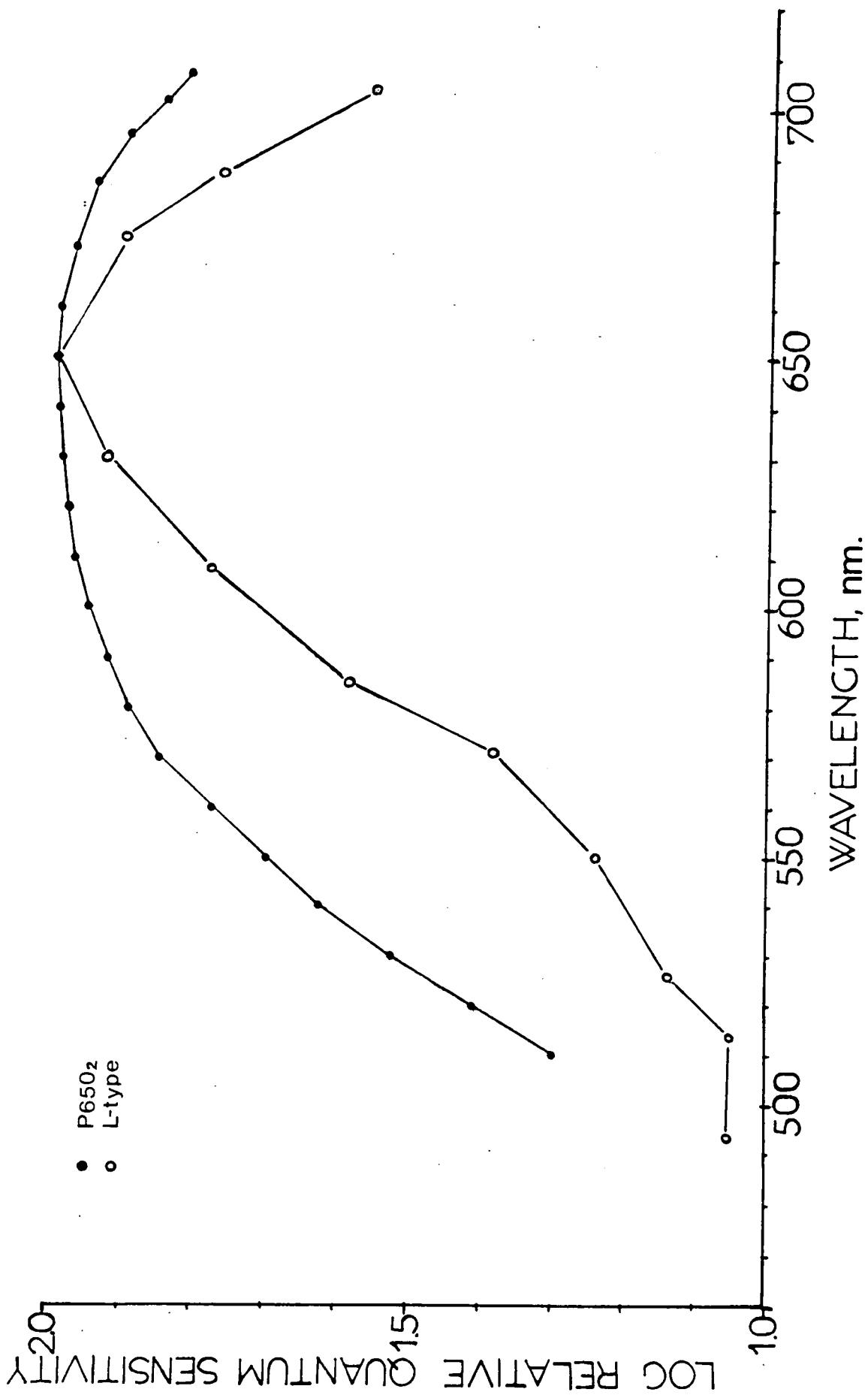

Figure 6.16.

Comparison of L-type cell spectral sensitivity curve (open circles) with a hypothetical pigment of the same max (650 nm) constructed from Ebrey & Honig (1977) nomogram (solid circles).



6.2.6. Effects of chromatic adaptation.

In order to test whether the unusual spectral sensitivity of the L-unit arises from the interaction of signals derived from two distinct photoreceptor types, the responses of the L-units were examined under chromatic background adaptation. If the spectral sensitivity of the L-unit results from an interaction between signals from the red and green sensitive cones then it would be expected that chromatic background adaptation would alter the balance of inputs to the L-unit, leading to a change in its spectral sensitivity. If, however, the L-cells respond as if they were driven by a single pigment ($\lambda_{\text{max}} = 650 \text{ nm}$), chromatic adaptation should not change the spectral sensitivity curve.

Figure 6.17 illustrates the time-course of changes in membrane potential of a representative L-type horizontal cell after exposing the retina to bright (saturating) background light ($\log I = 0$) which hyperpolarized the cell by 50 mV (V_{max}). Under steady background illumination the membrane potential showed a partial recovery of 40 mV after 30 minutes, reaching a steady level at 10 mV more negative than the membrane potential before the background onset (Fig. 6.17).

Figure 6.18 illustrates V-logI curves taken at various time periods after onset of the background illumination. The cell's maximum response amplitude continued to increase for 25 minutes (Fig. 6.18), qualitatively similar to the recovery of the resting potential. Figure 6.19 shows that the sensitivity, which was defined as a 3 mV response, has reached a steady level after 10 minutes. Comparison of the dark adapted response waveform with the light adapted waveform of equal amplitude (Fig. 6.20), reveals that the

light adapted response has a shorter latency (40 msec) and faster rising phase (100 msec faster to peak amplitude) than the dark adapted response of the same cell.

Under intense (saturating) background illumination the cell did not initially respond to additional illumination of any wavelength and, as a rule, the spectral sensitivity was measured after approximately 25 minutes of steady background to allow the cell to recover. Changes in response waveform depend not only on the intensity and the wavelength of the background light, but also on the intensity and wavelength of the test flash (Figs. 6.21.a-c). In the dark a small depolarization (1.0 mV) could be detected after the flash offset, i.e. overshoot from the resting potential or an off response, for blue-green lights of wavelengths shorter than 571 nm (Fig. 6.22a). Under a moderate ($\text{Log}I=5.22$) blue background illumination no depolarization (off response) can be detected (Fig. 6.21.a). On the other hand, the off response was enhanced to an amplitude of 3 mV under a moderate ($\text{Log}I=6.40$) red background (Fig. 6.21.b). Under an intense ($\text{Log}I=7.25$) red background the L-cell showed a depolarizing response to flashes of relatively low ($\text{Log}I=4.5$) light intensities (Fig. 6.21.c). Higher ($\text{Log}I=5.5$) light intensities produced a hyperpolarization with an off response (Fig. 6.21.c). In addition, under high intensity red background the depolarizing off response is enhanced, i.e. reaching further into the long wavelength part of the spectrum than when under a weaker red background (Figs. 6.21.b, c). The effect of chromatic background adaptation can also be seen on the change in peak/plateau ratio. In the dark the peak/plateau ratio is slightly higher (1.7) for

green-blue light than for red light (1.5) when equal amplitude (about $1/2V_{max}$) responses were compared. The effect of blue background was observed to reduce the peak/plateau ratio (Fig. 6.22.b), whereas the effect of red background (Fig. 6.22.c, d) was to increase the peak/plateau ratio. This effect of chromatic adaptation was observed for both red and green flashes. However these differences are small and no differences were observed in spectral sensitivity (Fig. 6.24).

The response under intense red background (Fig. 6.22.d) to red and green flashes consists of a hyperpolarizing initial transient followed by a depolarizing plateau and off transient. The response to the green (550 nm) flash (Fig. 6.22.d), however, the response polarity of the plateau phase was opposite to that of the green test flashes in the absence of background and with moderately intense background. These effects on the L-type response waveform appear to be caused by a green-driven antagonizing signal which, under strong red background, causes the small depolarization in the plateau phase for blue-green test flashes at lower light intensities and the 'off' response at higher light intensities (Figs. 6.21.c, and 6.22.d). These results may suggest that a green sensitive antagonizing signal, presumably from the green cones, is revealed in the L-type cell response under chromatic adaptation.

Figure 6.23 shows the L-cell spectral sensitivity when measured under steady red moderate and intense background illumination (peak transmission about 700 nm) and blue background illumination (peak transmission at 450 nm). Despite the observed differences in response waveforms the spectral sensitivity of the L-type was not

significantly changed by chromatic background adaptation of any light intensities (Fig. 6.24). This indicates that the L-type cells receive input primarily from the far red (650 nm) mechanism.

In experiments where a monochromatic stimuli of red and green lights was held at fixed intensity and chromatic background was increased in steps between test flashes (Fig. 6.25). In Figure 6.25.a the deep red (687 nm) flash is of fixed intensity, while the intensity of the blue (500 nm) background is increased in steps and in Figure 6.25.b the flash is green (526 nm) with a red (700 nm) background also increased in steps. In both cases the increase in steady light produced an increase in the steady hyperpolarization of the unit, which was associated with a reduction in response to the flash.

Figure 6.17.

Recovery of membrane potential of a L-type horizontal cell during the course of light adaptation, during exposure to saturating ($\log I = 5.89$) blue (435 nm) background illumination. Note that the membrane potential prior to the background onset was set at 0 mv.

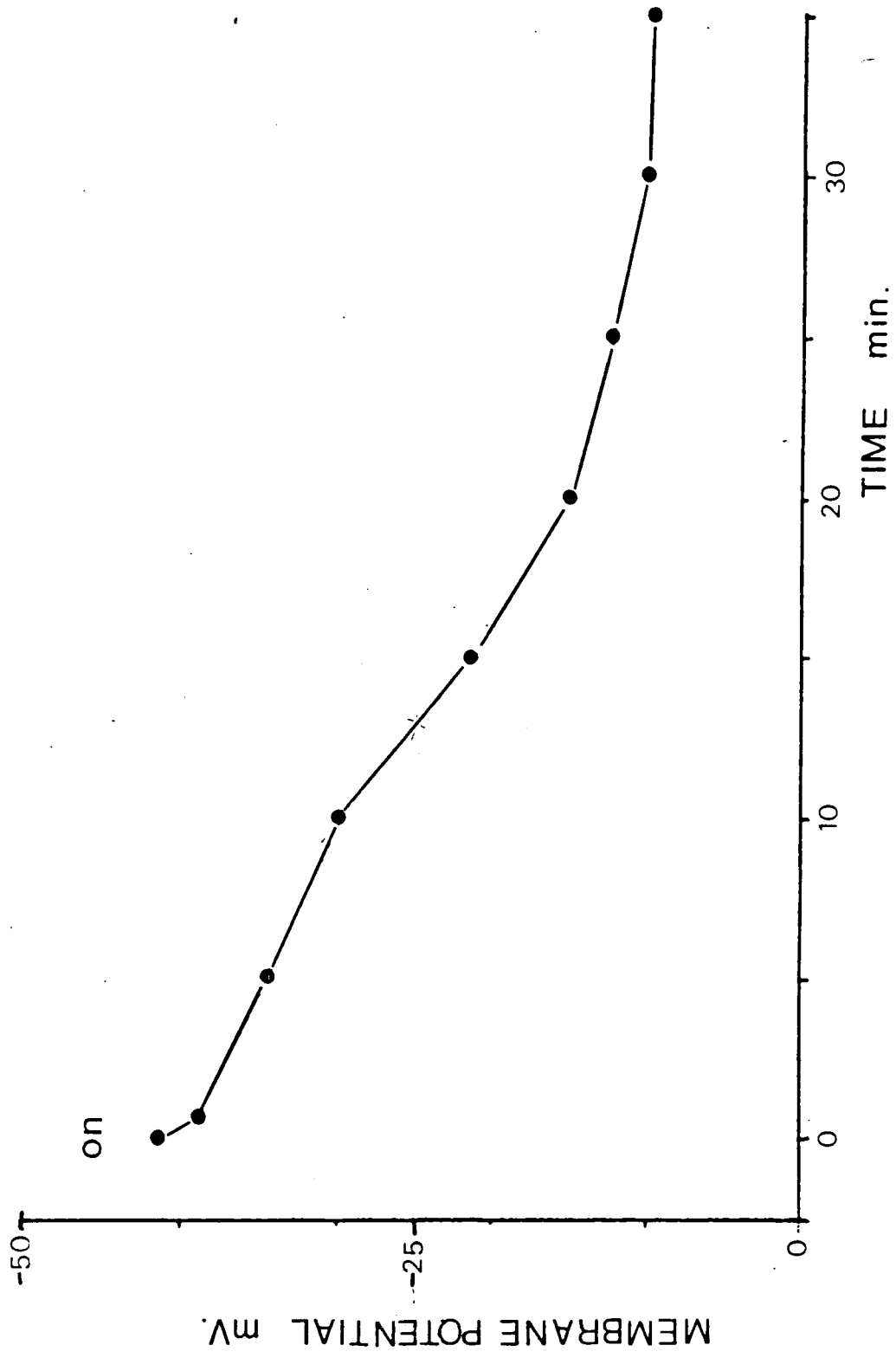

Figure 6.18.

V-logI curves for a L-type horizontal cell (the same as in fig. 6.17) before and after exposure to blue (435 nm) saturating background illumination. 1. dark adapted, 2. after 5 min of steady blue background, 3. after 10 min of blue background, 4. after 15 min of blue background and 5. after 20 min of blue background.

KEY
 1 dark adapted
 2 5 min. of blue background
 3 10 ..
 4 15 ..
 5 20 ..

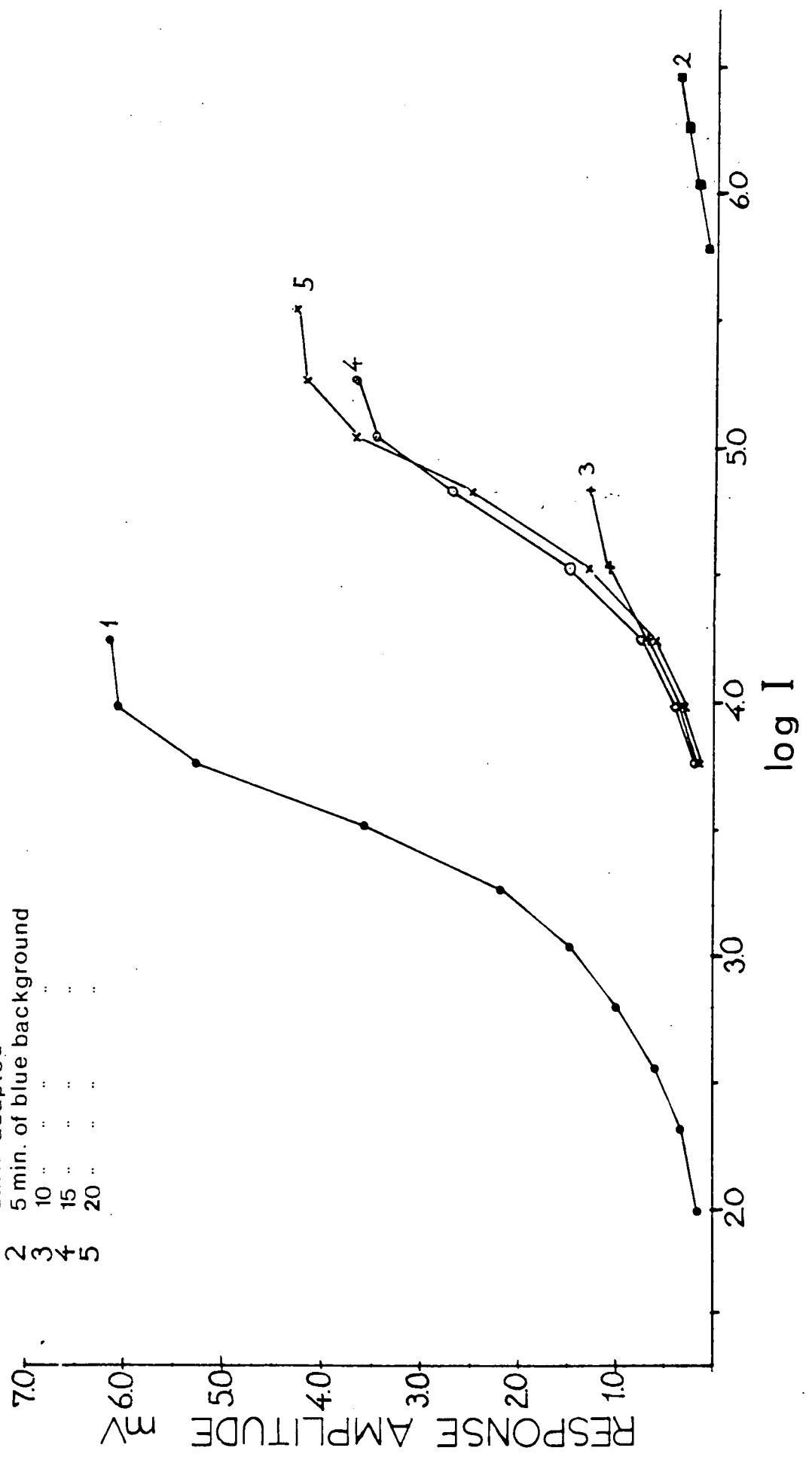

Figure 6.19.

Changes in sensitivity of the same cell as in figures 6.17 and 6.18. Sensitivity was defined as the intensity giving rise to a 3 mV response. Solid square represents the sensitivity in the dark (Da) and solid circles represent the sensitivity after exposure to the blue (435 nm) steady background.

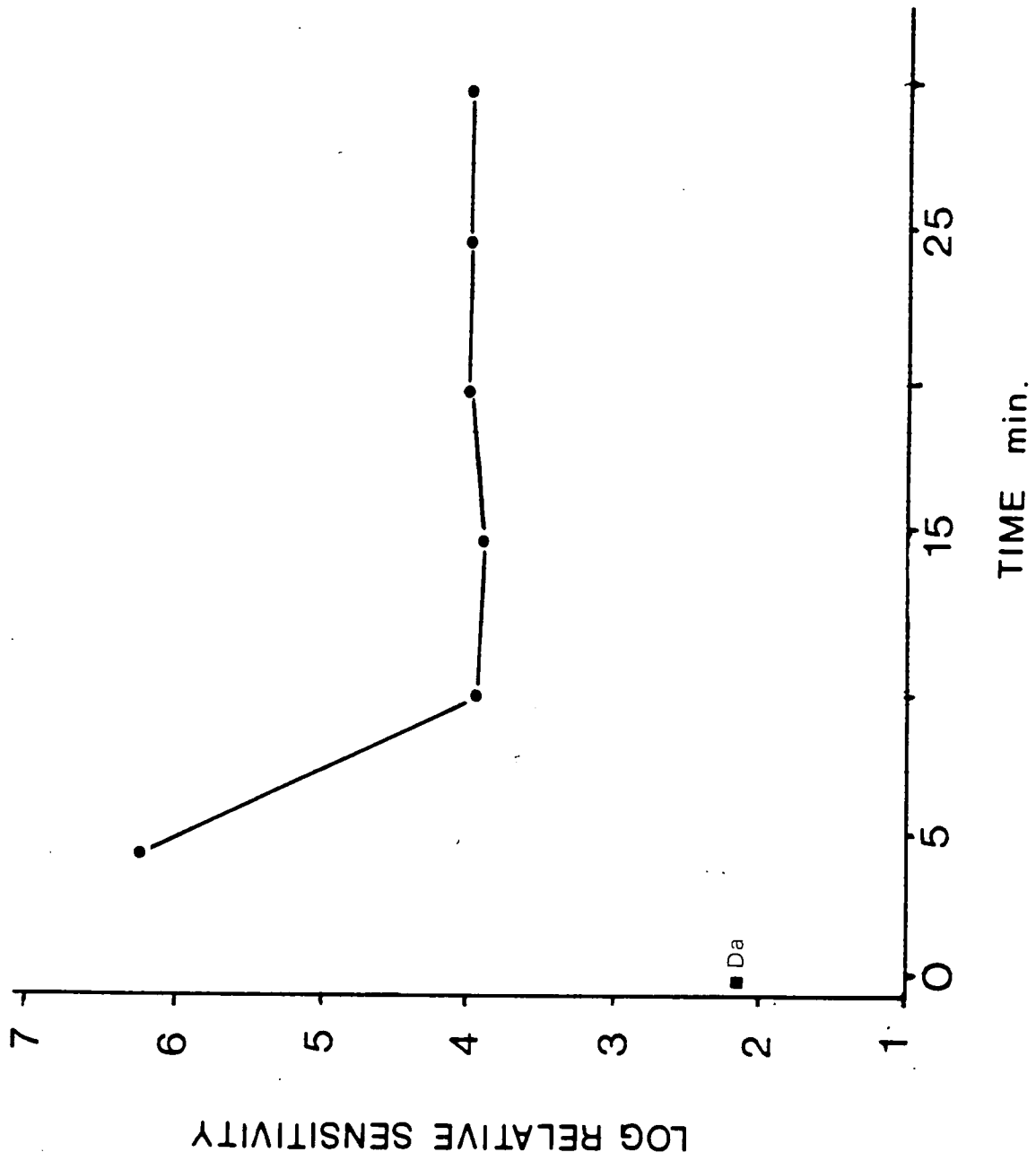
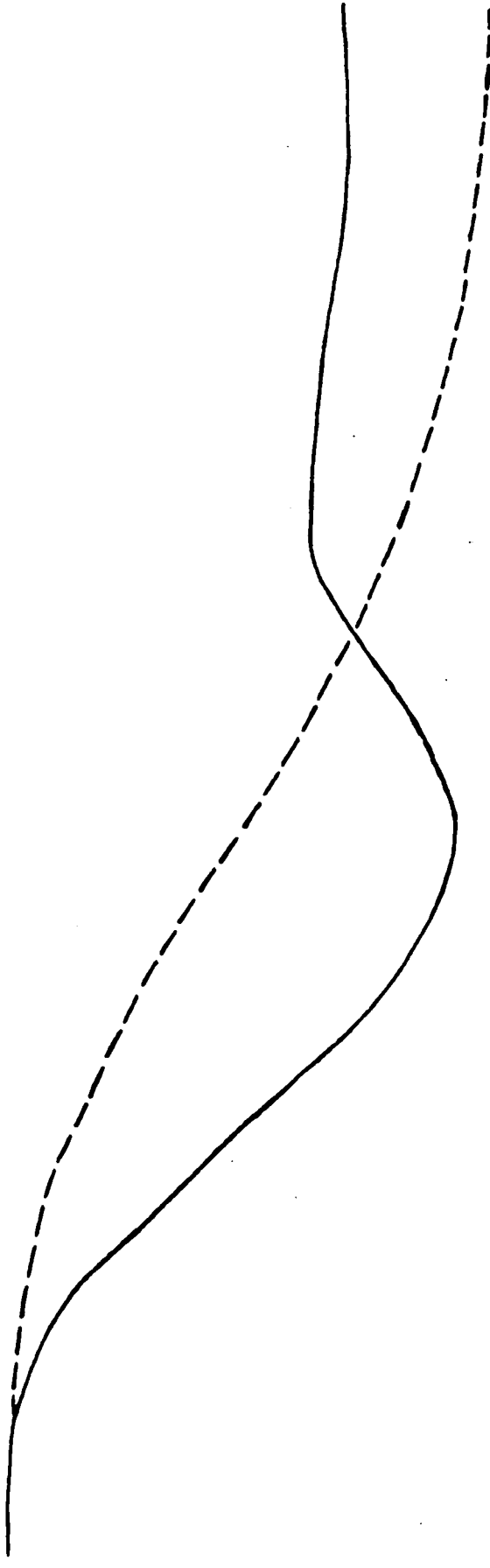

Figure 6.20.

Comparison of response waveforms of equal amplitude of an L-type horizontal cell (the same as on figs. 6.17 and 6.19) to a 651 nm flash; when dark adapted, broken line ($\log I = 3.26$), and solid line, after 15 min of blue (435 nm, $\log I = 5.89$) background.



--- Dark adapted
— Light

5 mV
50 msec

Figure 6.21.

Responses of a L-type horizontal cell to 608 nm (first row) and to 550 nm (second row) monochromatic flashes of increasing intensity. Showing the effects of superimposing the 608 nm and the 550 nm flashes upon different backgrounds.

Figure 6.21.a. Blue (435 nm) background ($\log I = 5.22$).

Figure 6.21.b. Red (700 nm) background ($\log I = 6.4$).

Figure 6.21.c. Strong red (700 nm) background ($\log I = 7.25$).

See text for details.

608 nm flash

550 nm flash

a. Blue Background

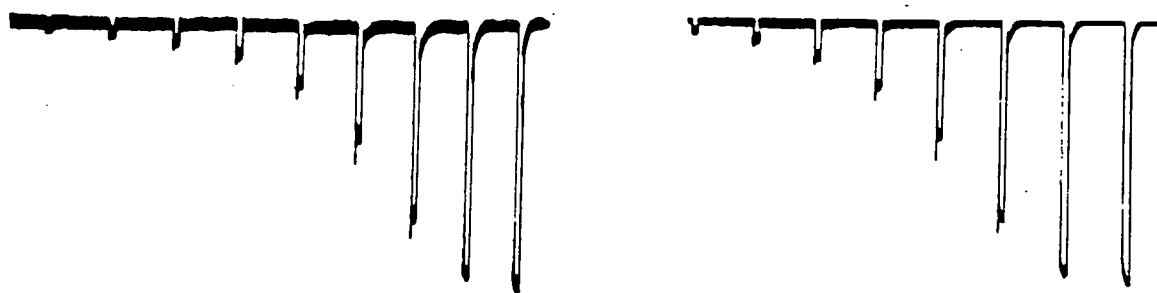

b. Red Background I

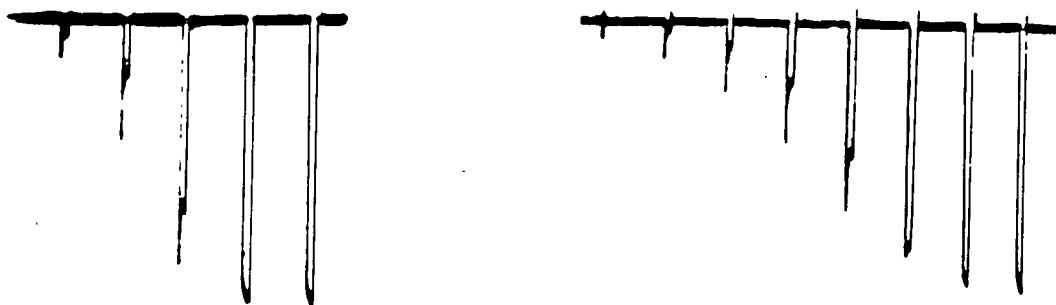

c. Red Background II



10mV |

0 1 2 log

Figure 6.22.

Superimposed responses of a L-type horizontal cell (the same as in figure 6.21) to monochromatic stimuli; 608 nm (first row) and 550 nm (second row) of increasing intensity, showing the effect of chromatic backgrounds on the response waveform.

Figure 6.22.a. Shows the dark adapted waveform.

Figure 6.22.b. A blue (435 nm) background ($\log I = 5.22$). Note the reduction in difference between the amplitude of the peak and the plateau.

Figure 6.22.c. A red (700 nm) background I ($\log I = 6.4$). Note here the increased difference in the amplitude of the peak and the plateau.

Figure 6.22.d. A red (700 nm) background II ($\log I = 7.25$). Note the depolarizing response at lower intensities for the 550 nm flash (second row) and the large 'off' response for the 608 nm flash.

(Note that the increase in light intensity is not always the same, i.e. 0.5 log steps were used in 'c and d' (608 nm) and in 'a' (550 nm), in all others 0.25 log steps were used).

608 nm flash

550 nm flash

a. Dark adapted

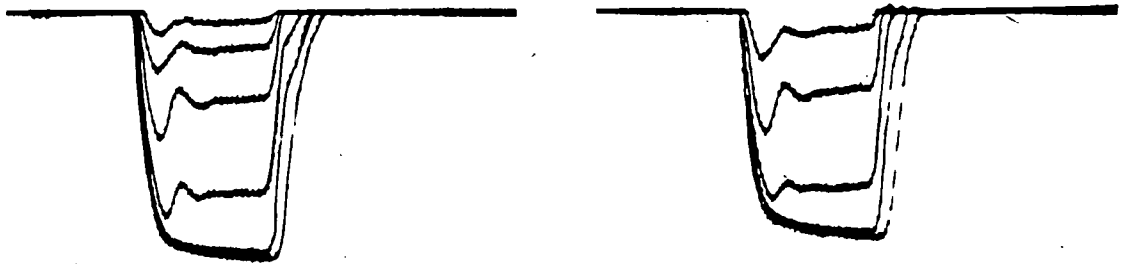

b. Blue Background

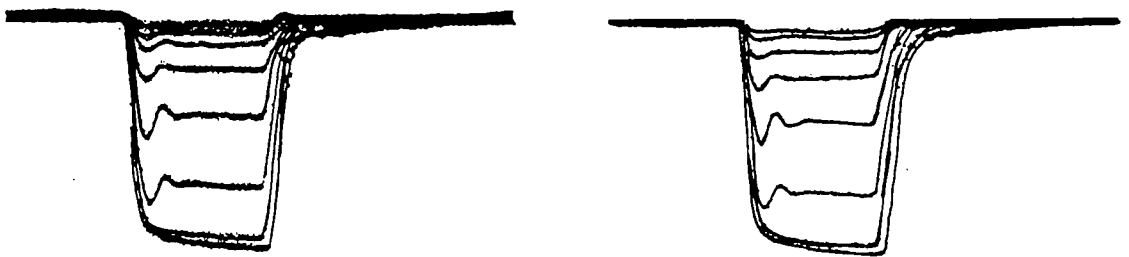

c. Red Background I

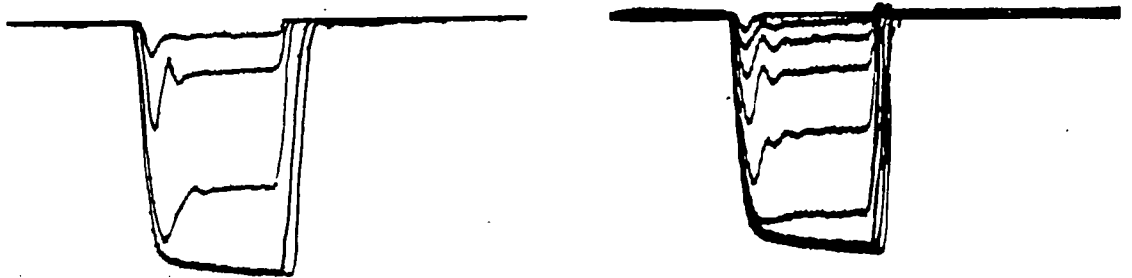

d. Red Background II

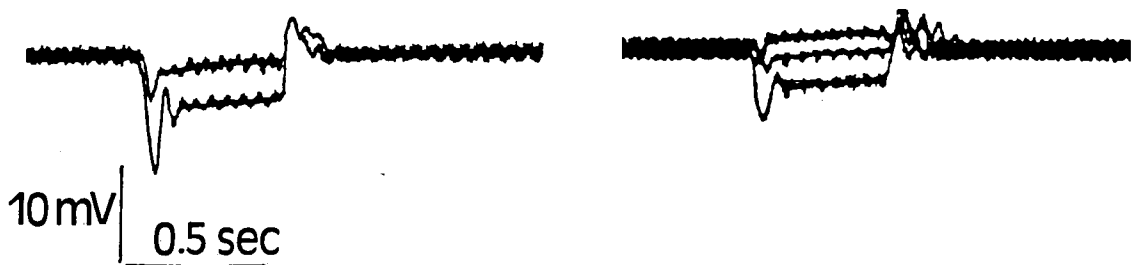

Figure 6.23.

Spectral sensitivity curves of an L-type horizontal cell, dark adapted (solid circles) and under chromatic background adaptation, crosses represent blue (435 nm) background ($\log I = 5.22$). Pluses (+) represent red (700 nm) background, 1. ($\log I = 6.4$) and open circles represent the red (700 nm) background, 2. ($\log I = 7.25$) criterion response was $\frac{1}{2}V_{\max}$.

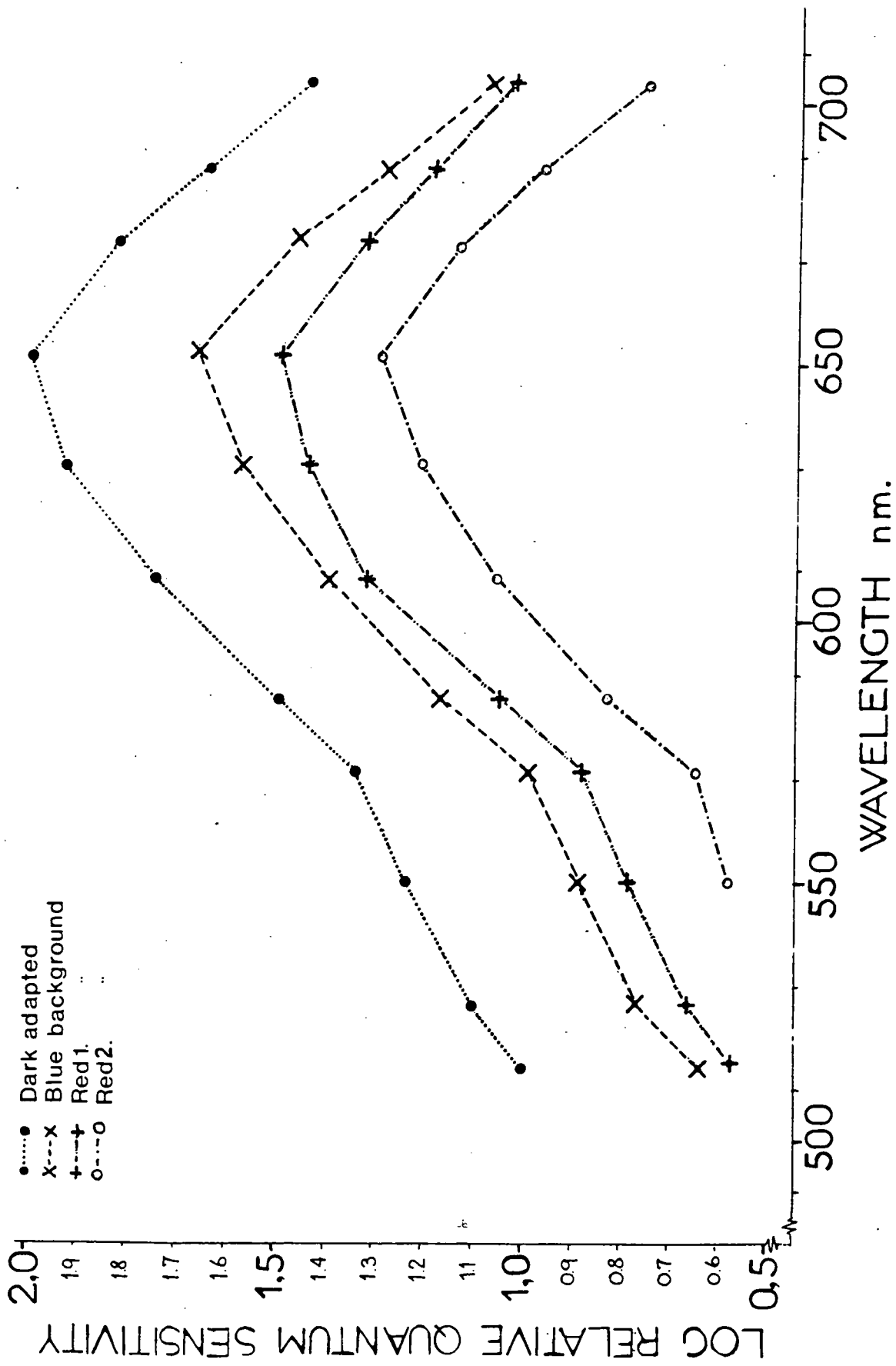

Figure 6.24.

Comparison of spectral sensitivity curves of a L-type horizontal cell (the same as in fig. 6.21) when dark adapted (solid circles), blue (435 nm) background (crosses) ($\log I = 5.22$) and red (700 nm) background (open circles) ($\log I = 7.25$). Spectral sensitivity curves were measured approximately 20 min after the onset of background illumination to allow the cell to recover.

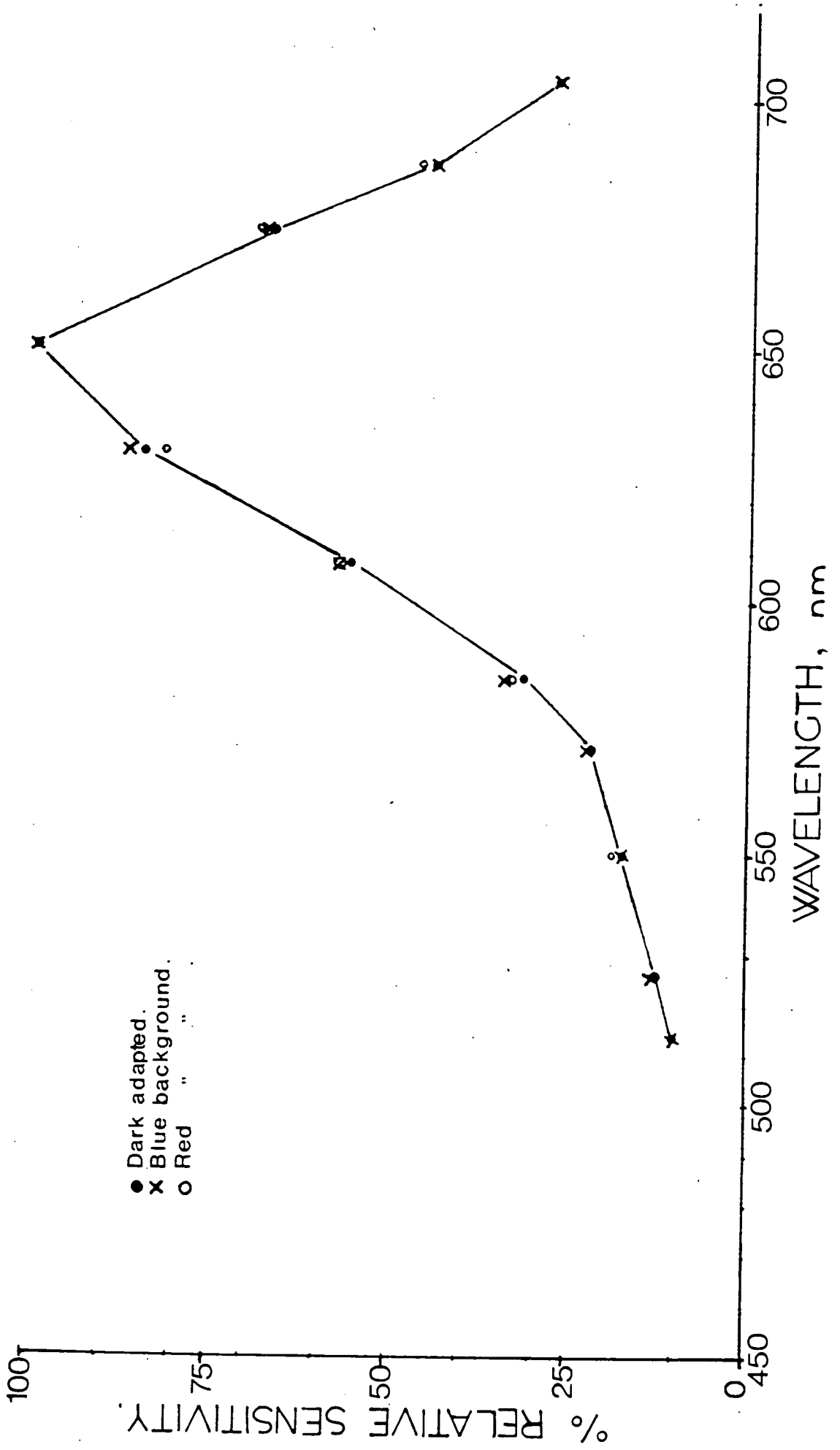

Figure 6.25.

Shows responses of a L-type cell to flashes of steady intensity, while background illumination was increased in 0.5 logI steps (arrows).

Figure 6.25.a. The flash 493 nm of steady intensity ($\log I = 5.1$) superimposed on red (700 nm) background of increasing intensity.

Figure 6.25.b. The steady 687 nm flash ($\log I = 4.77$) was superimposed on an increasing blue (435 nm) background.

a. ✓ Red background (700 nm) &

493 nm flash.

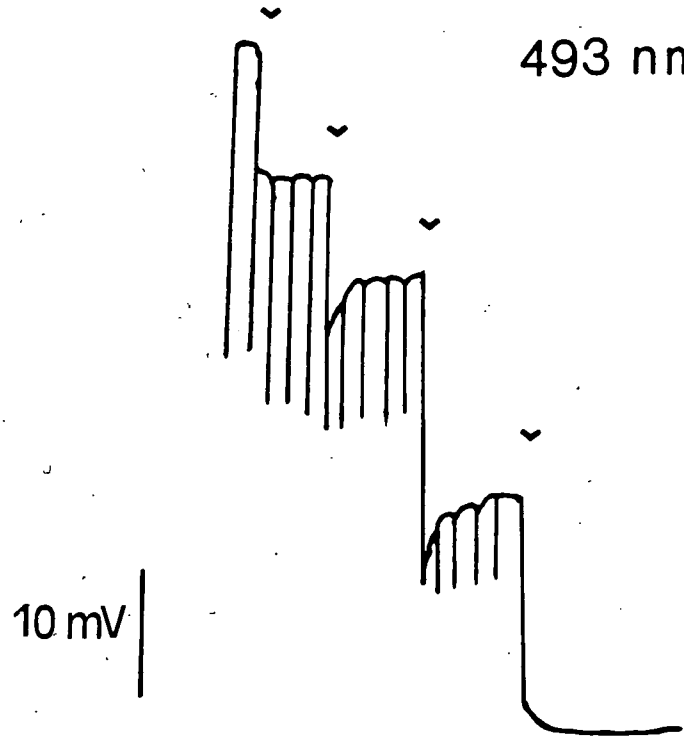

b. ✓ Blue background (435 nm) &

687 nm flash.

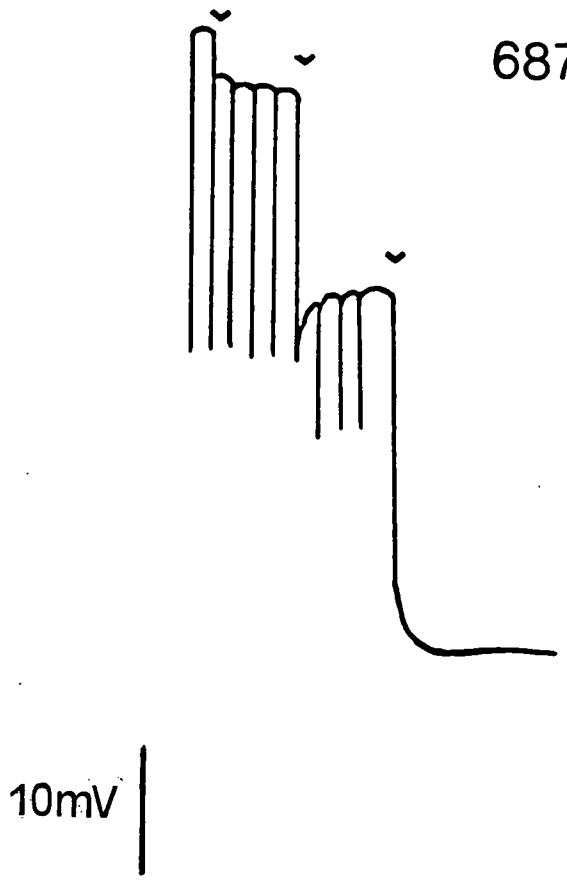

6.3. Properties of C-type horizontal cells.

6.3.1. General observations.

Intracellular recordings from the C-type horizontal cells in perch were always obtained proximal to the L-type horizontal cells, which suggests that the C-type cells comprise the most proximal layer of horizontal cells. In general it was more difficult to penetrate and more difficult to obtain stable intracellular recordings from C-type cells than from L-units.

All the C-type cells tested depolarized to red (704 nm) test light and hyperpolarized to green (526 nm) test light (R/G-cell) (Fig. 6.26). The depolarizing and hyperpolarizing responses were superimposed on negative resting potentials, usually -25 to -35 mV, and were sustained, lasting for the duration of the stimulus. Both hyperpolarizing and depolarizing responses were graded with light intensity. However, responses to intermediate wavelengths show complex biphasic waveforms. The neutral point of the C-potential shifts as a function of the relative amplitudes of hyperpolarizing and depolarizing components and the intensity of the light, i.e. depolarizing for lower light intensities (Fig. 6.26) and hyperpolarizing for higher light intensities. The depolarization usually occurred before the hyperpolarization and with increasing hyperpolarization the depolarizing component was reduced in amplitude. The stimuli, when neutral, caused no net hyperpolarization or depolarization, the response consists of transient responses to both stimulus onset and cessation.

6.3.2. Spatial properties.

The C-type cell has a large uniform receptive field, with no centre-surround organization. Figure 6.27 shows the dependence of response amplitude on spot diameter for red (704 nm) and green (550 nm) test flashes. The constant light intensity was adjusted for the largest diameter spot to give half maximum ($1/2V_{max}$) amplitude response. The polarity of the response is not dependent on spot diameter, since the response amplitude increased with increased stimulus diameter both for the depolarizing and the hyperpolarizing components (Figs. 6.27.a, b). The C-type receptive field size ranges from 3 to 5 mm in diameter, depending on cell (Fig 6.28).

6.3.3. Wavelength dependent responses.

At 704 nm the response function is a monophasic depolarization for all intensities tested (Fig. 6.26.a), whereas at 687 nm (Fig. 6.29.a) and 651 nm (Fig. 6.26.b) the response function is monophasic for less than 2 log units above threshold. At higher intensities the depolarizing response becomes increasingly antagonized by the hyperpolarizing response which, when large enough, results in a complex biphasic response. At 630 nm (Fig 6.29.b) the depolarization is reduced to a on transient and is observed only at lower light intensities, just above threshold, but at higher light intensities the cell hyperpolarized. At shorter wavelengths, however, only monophasic hyperpolarizations were observed (Fig. 6.26.c).

In general, the maximum response amplitude of the hyperpolarizing mechanism exceeded the maximum depolarizing response amplitude by a

factor of 2 to 5. However, the R/G cells were variable and in a few extreme cases, R/G-cells were observed which showed very weak depolarizing responses and could be mistaken for green-sensitive L-type cells.

6.3.4. Spectral sensitivity.

Spectral sensitivity curves and V-logI curves were constructed for C-type horizontal cells by the same method as was described in section 6.2. The V-logI curves for the hyperpolarizing and depolarizing responses were not parallel and the same fixed template would not describe them all (Figs. 6.30.a, b). However, at wavelengths shorter than 600 nm the V-logI curves for the hyperpolarizing responses showed a reasonable agreement with the fixed template constructed from the equation:

$$V/V_{\max} = I^n / I^n + \sigma^n, \text{ where } n=1, \text{ (Naka and Rushton, 1966a)}$$

(Fig. 6.31).

Figure 6.32 shows the mean spectral sensitivity for eleven dark adapted R/G type horizontal cells. The spectral sensitivity of the hyperpolarizing responses were constructed from half maximum amplitude ($1/2V_{\max}$), and the spectral sensitivity curve for the depolarizing component was constructed for low amplitude response, or were the V-logI curves were reasonably parallel. The spectral sensitivity curve of the hyperpolarizing response was maximally sensitive around 530 nm, whereas the depolarizing response was maximally sensitive at 670 nm. However, the shape of the R/G cell spectral sensitivity curves will be dependent upon chosen criterion level for their con-

struction (Fig. 6.30). This indicates that the C-type cell receive input from more than one cone mechanism.

The C-type cell spectral sensitivity curve of the hyperpolarizing response shows a reasonable fit with the absorption curve of the λ_{\max} 535 nm hypothetical pigment from Ebrey and Honig's (1977) nomogram (Fig. 6.33). This indicates that the hyperpolarizing component of the C-type response receives input from the green (535 nm) sensitive single cones. The depolarizing component may be driven by the red (615 nm) sensitive cones and the resulting spectral sensitivity curves arise from the antagonistic interaction between signals from the two cone types in the C-type horizontal cell, or it may receive input from the far red cone mechanism.

6.3.5. Effects of chromatic adaptation.

If the assumption that the C-type cell is driven by the red depolarizing and green hyperpolarizing cone mechanisms, it should be possible to isolate each mechanism by selective chromatic adaptation. Red background should suppress the red sensitive depolarizing component and the effect of the red depolarizing mechanism should be selectively reduced, isolating the effect of the green cone on the cell. Blue background should have the opposite effect, of enhancing the depolarizing component of the cell and suppressing the hyperpolarizing component. Figures 6.34.b, c, show the effect of two intensity levels ($\text{Log}I=4.8$ and 5.2) of red background adaptation, compared with the dark adapted cell before (Fig.6.34.a) and after background illumination (Fig 6.34.d). As expected, the effect

of a red background adaptation is to suppress the depolarizing mechanism, whereas the hyperpolarizing mechanism showed an increase in amplitude.

Under red background adaptation the peak of the action spectra curve of the hyperpolarizing response was not clearly altered from the dark adapted spectral sensitivity (Fig. 6.35). The action spectrum of the R/G cell under red background illumination is slightly broader than the dark adapted curve (Fig. 6.35). Similar results were obtained for five R/G cells under red background adaptation. Spectral sensitivity curves of R/G cells with very weak red depolarizing input or those that had been exposed to strong red background showed reasonable agreement with the green cone (P535₂) pigment absorption curve (Fig. 6.36).

Blue background adaptation had the opposite effect to red background adaptation, it enhanced the depolarizing component and suppressed the hyperpolarizing mechanism. Under blue background adaptation the action spectrum of the depolarizing component is shifted in maximum sensitivity from 670 nm to 650 nm (Fig. 6.36), it also has a narrow spectral sensitivity curve.

The perch R/G C-type horizontal cells appear to receive input from two sources; they are hyperpolarized by the green sensitive single cones and depolarized by the far red 650 nm cone mechanism. Comparison of spectral sensitivity curves of the depolarizing component of the R/G cell with a L-type cell, both under blue background adaptation, shows that their spectral sensitivity curves were very similar (Fig 6.37). This may indicate that the depolarizing

component of the R/G cell receives their input from the same source as the L-type cells, but not directly from the red (615 nm) sensitive cones.

Figure 6.26.

Superimposed responses of a R/G-type horizontal cell to monochromatic flashes.

Figure 6.26.a. Responses to 704 nm flashes.

Figure 6.26.b. Responses to 651 nm flashes.

Figure 6.26.c. Responses to 526 nm flashes.

The light intensity was increased in approximately 0.5 log unit steps for all flashes. The numbers (1-8) indicate increasing intensity

Fig. 6.26b.

a. 704 nm

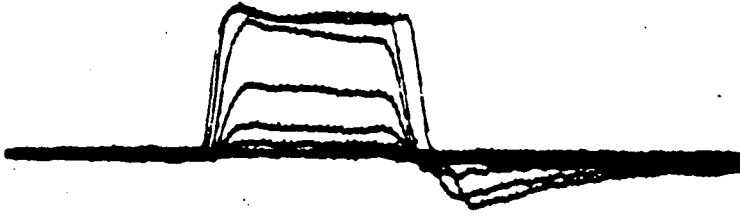

b. 651 nm

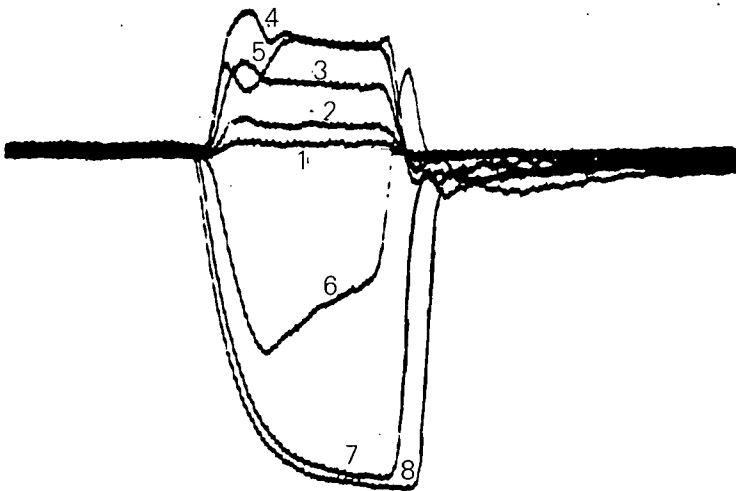

c. 526 nm

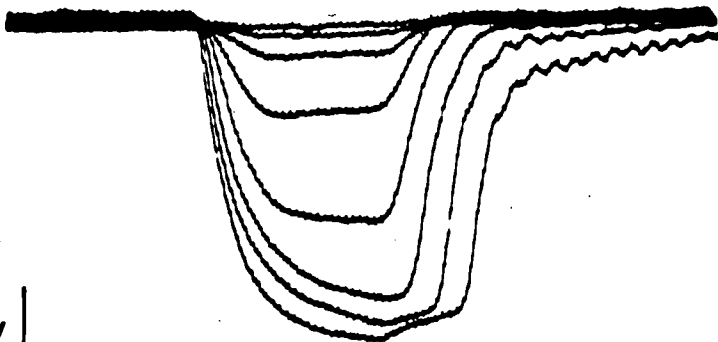

10 mV | 0.5 sec

Figure 6.27.

Relation between response amplitude and stimulus diameter for a R/G-type horizontal cell.

Figure 6.27.a. A red 704 nm flash.

Figure 6.27.b. A green 550 nm flash.

Note that the light intensity was adjusted to elicit half maximum amplitude ($\frac{1}{2}V_{\max}$) for the largest spot size of 5 mm in diameter. The flash duration was 0.5 sec.

a. 704 nm



0,5 sec

b. 550 nm



10 mV



Figure 6.28.

Response amplitude versus spot diameter.

The data from Fig. 6.27 plotted as a relative response amplitude against stimulus diameter where solid squares represent 704 nm, or the depolarizing component, and a solid circle represents 550 nm, or the hyperpolarizing component.

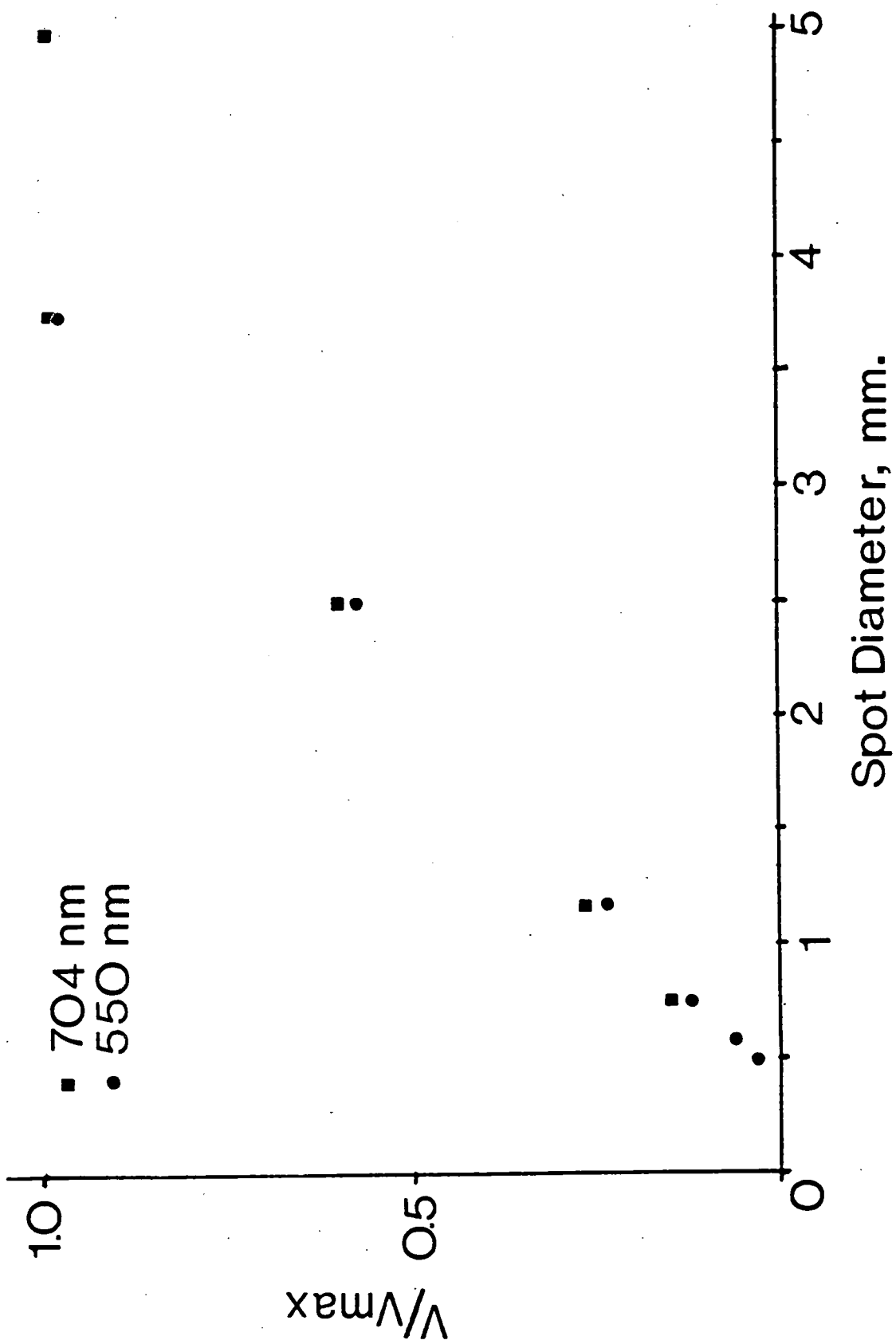

Figure 6.29.

Superimposed responses of a R/G type horizontal cell to monochromatic flashes.

Figure 6.29.a. Responses to 687 nm flash were depolarizing, except generating a biphasic waveform at maximum amplitude.

Figure 6.29.b. Responses to 630 nm, flash. The cell depolarizes only to flashes just above threshold, while intermediate intensities generate complex waveforms, and at higher light intensities the cell hyperpolarizes.

The flash delivered was of 0.5 seconds in duration. The light intensity was increased in approximately 0.5 log units steps as indicated by the numbers (1.. 7).

a. 687 nm

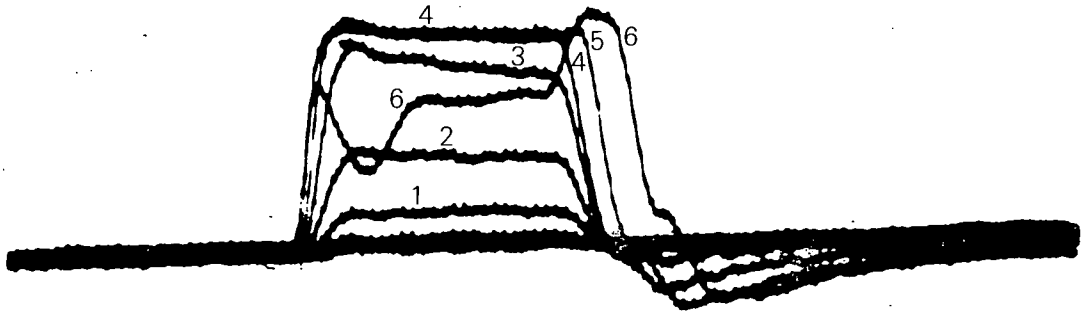

b. 630 nm

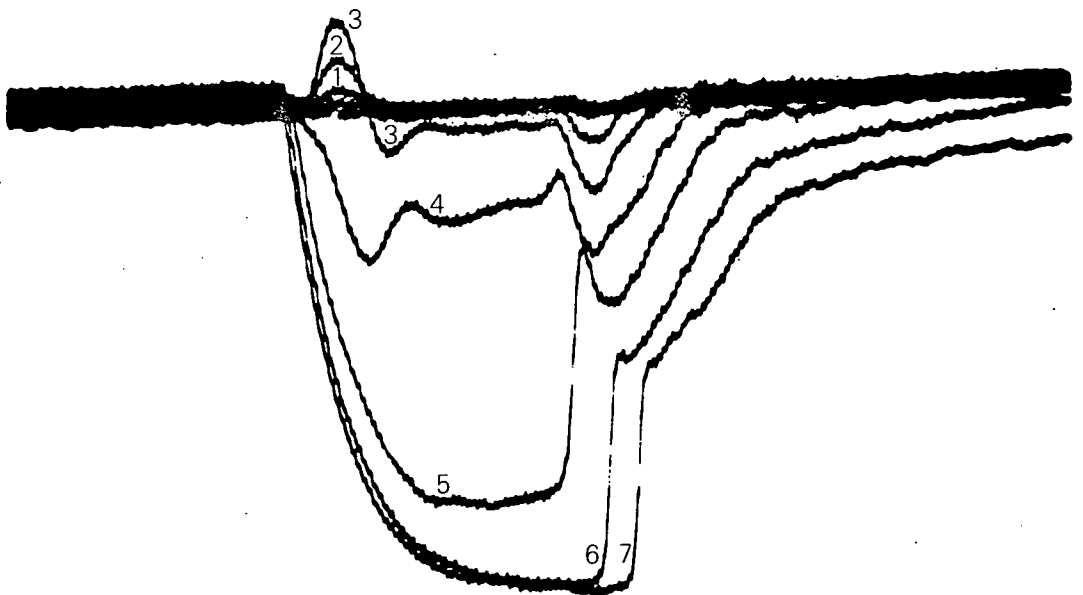

10 mV

0.5 sec

Figure 6.30.

Relation between response amplitude and the logarithm of the light intensity (V-logI curves) of a dark adapted R/G cell. Response amplitudes were measured at peak response.

Figure 6.30.a. V-logI curves for various wavelengths of the hyperpolarizing component. The wavelengths of the monochromatic flashes used are indicated in the figure.

Figure 6.30.b. V-logI curves of the depolarizing response. The wavelengths of the monochromatic flashes used are indicated in the figure.

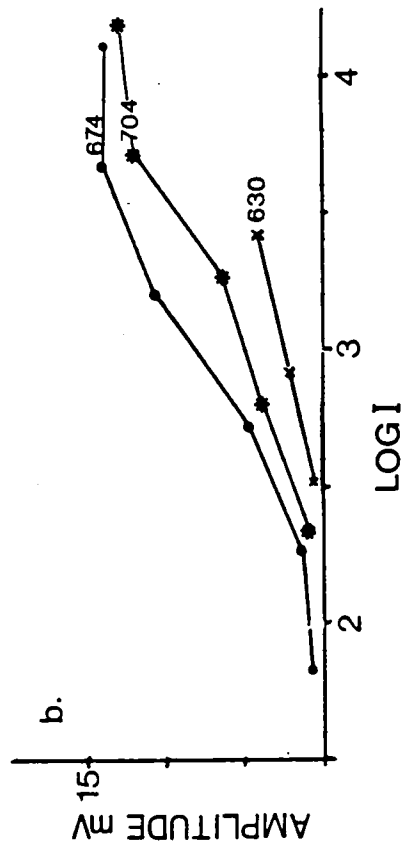
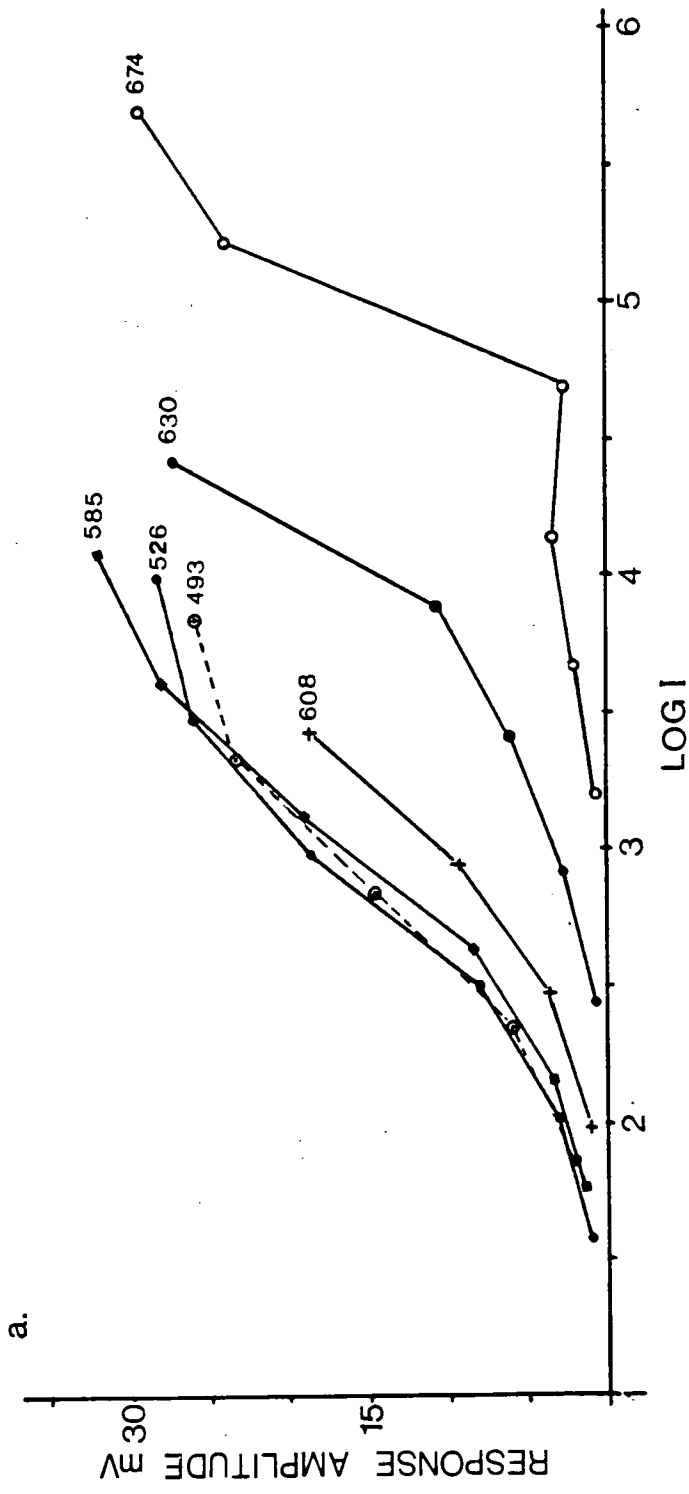

Figure 6.31.

Relation between relative amplitude of the R/G-type response and the logarithms of stimulus intensity of 550 nm flashes (open circles). The smooth curve is drawn from the equation

$$V/\max = I^n / I^n + \sigma^n, \text{ where } n = 1.$$

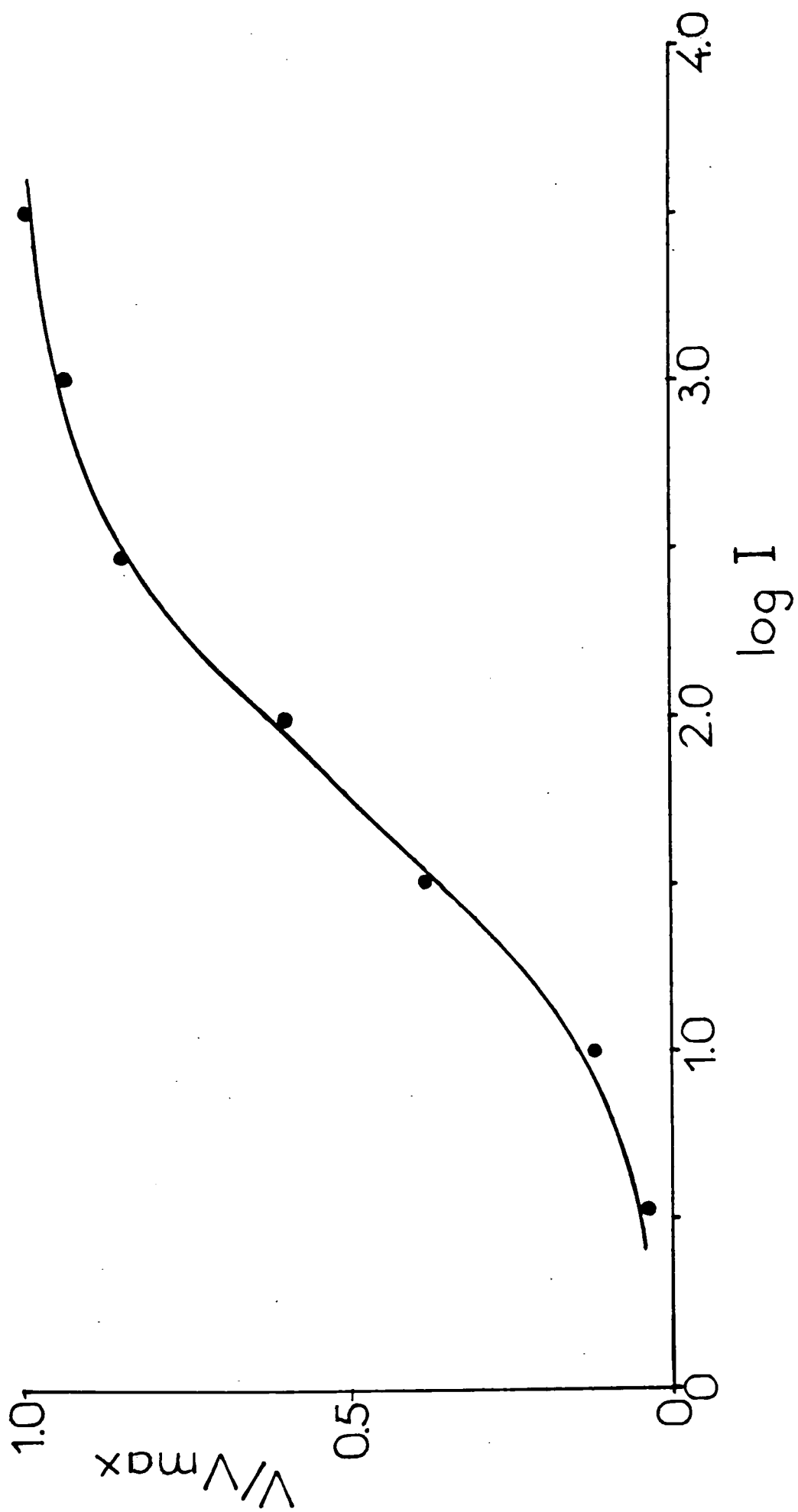

Figure 6.32.

Spectral sensitivity of dark adapted R/G-type horizontal cells. The curves are an average of eleven cells. 'H' with (solid circles) represent the hyperpolarizing component, and 'D' with (x) represent the depolarizing component. The hyperpolarizing curve is based on a criterion response of half maximum amplitude ($\frac{1}{2}V_{max}$), but the depolarizing response for approximately 1/3 of maximum amplitude ($\frac{1}{3}V_{max}$). Vertical bars show the standard deviation of the mean.

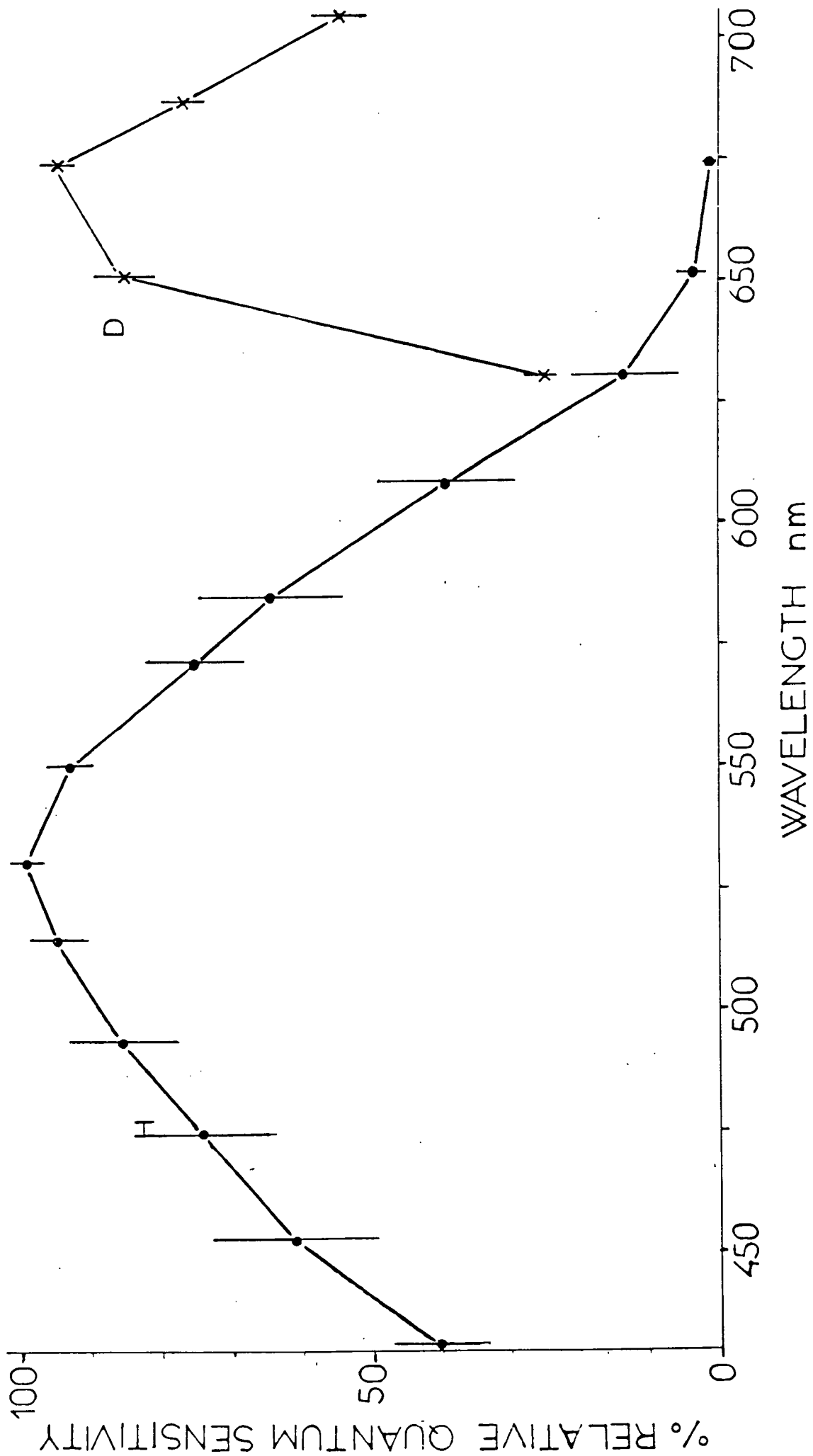

Figure 6.33.

Spectral sensitivity curves of the hyperpolarizing component from the dark adapted R/G cell (solid squares) compared with a 535 nm hypothetical pigment (porphyropsin) (solid circles), constructed from Ebrey and Honig's (1977) nomogram.

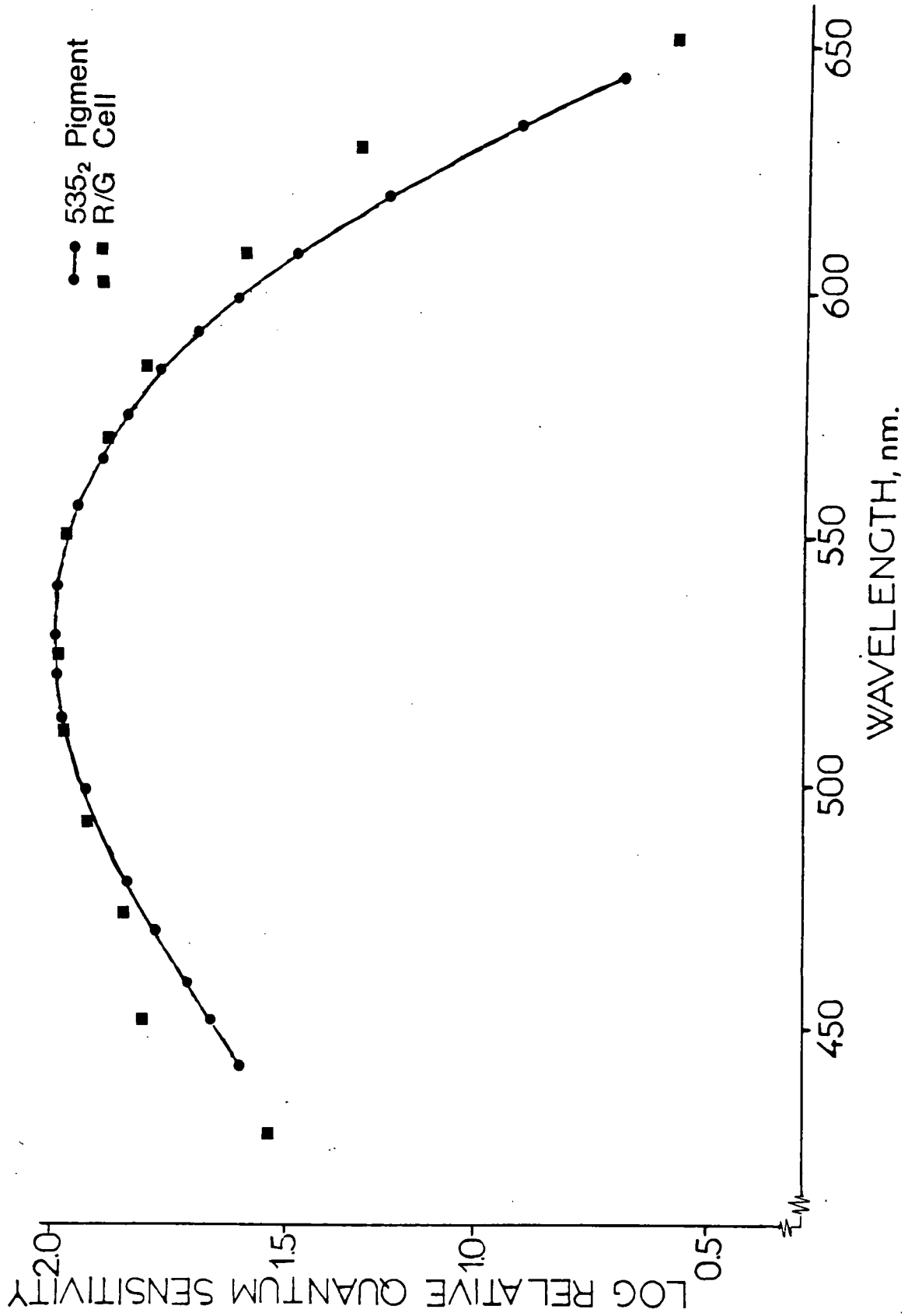

Figure 6.34.

Responses from R/G cell on a stationary time base. In each row the flash was of monochromatic light as indicated. Lateral shift of records shows its relative log intensity (see scale below (Fig. 6.34.d)).

Figure 6.34.a. The cell is dark-adapted.

Figure 6.34.b. Under red (700 nm) background ($\text{LogI} = 4.8$).

Figure 6.34.c. Under a more intense red (700 nm) background ($\text{LogI} = 5.2$).

Figure 6.34.d. The same cell dark adapted after using the two levels of red background adaptation. Note that the depolarizing response has almost been abolished.

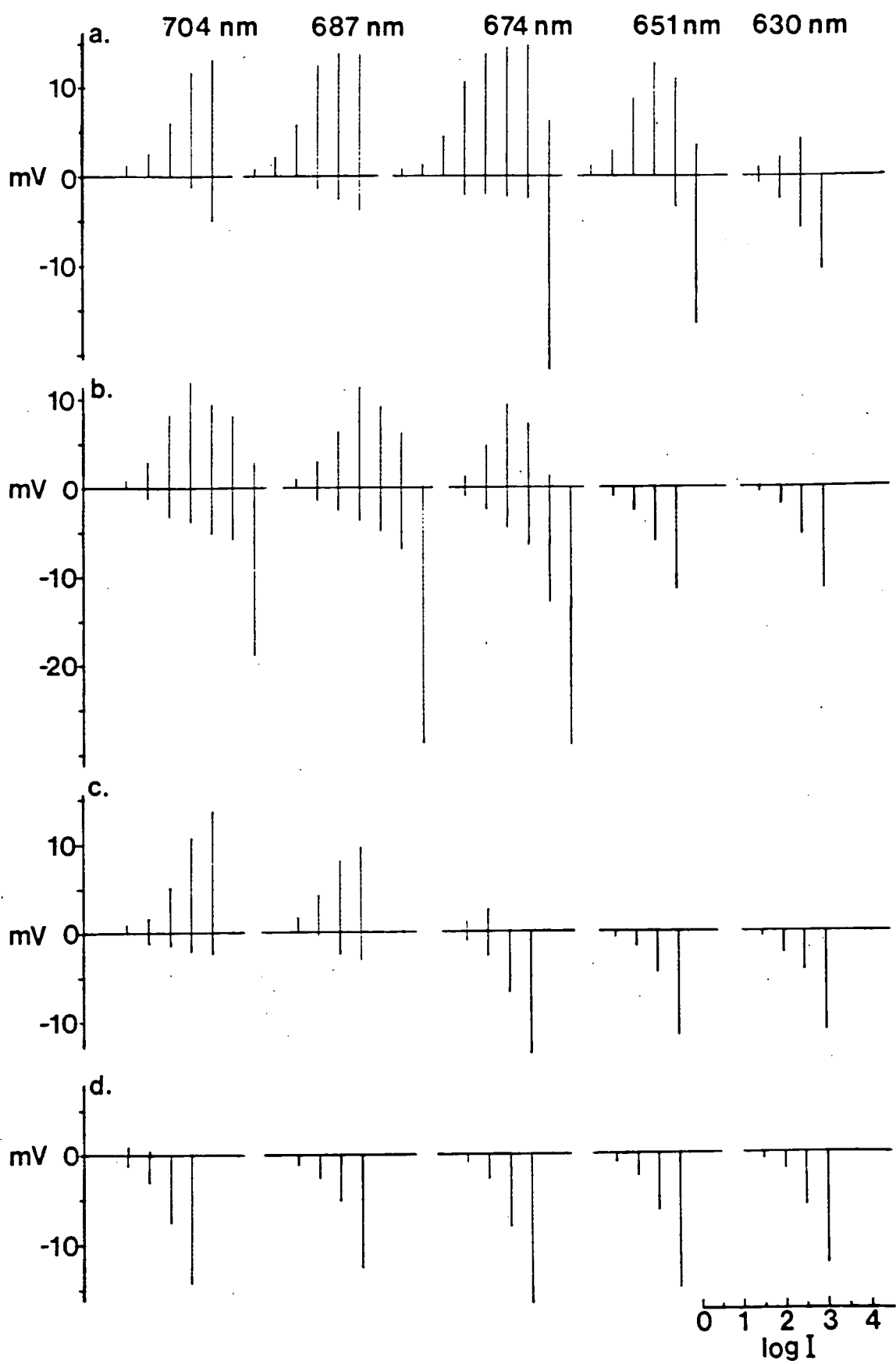

Figure 6.35.

Spectral sensitivity curves of an R/G-type horizontal cell; dark adapted (solid squares) and under red (700 nm) background (LogI = 4.8) (solid circle). D and H represent the depolarizing and hyperpolarizing components respectively.

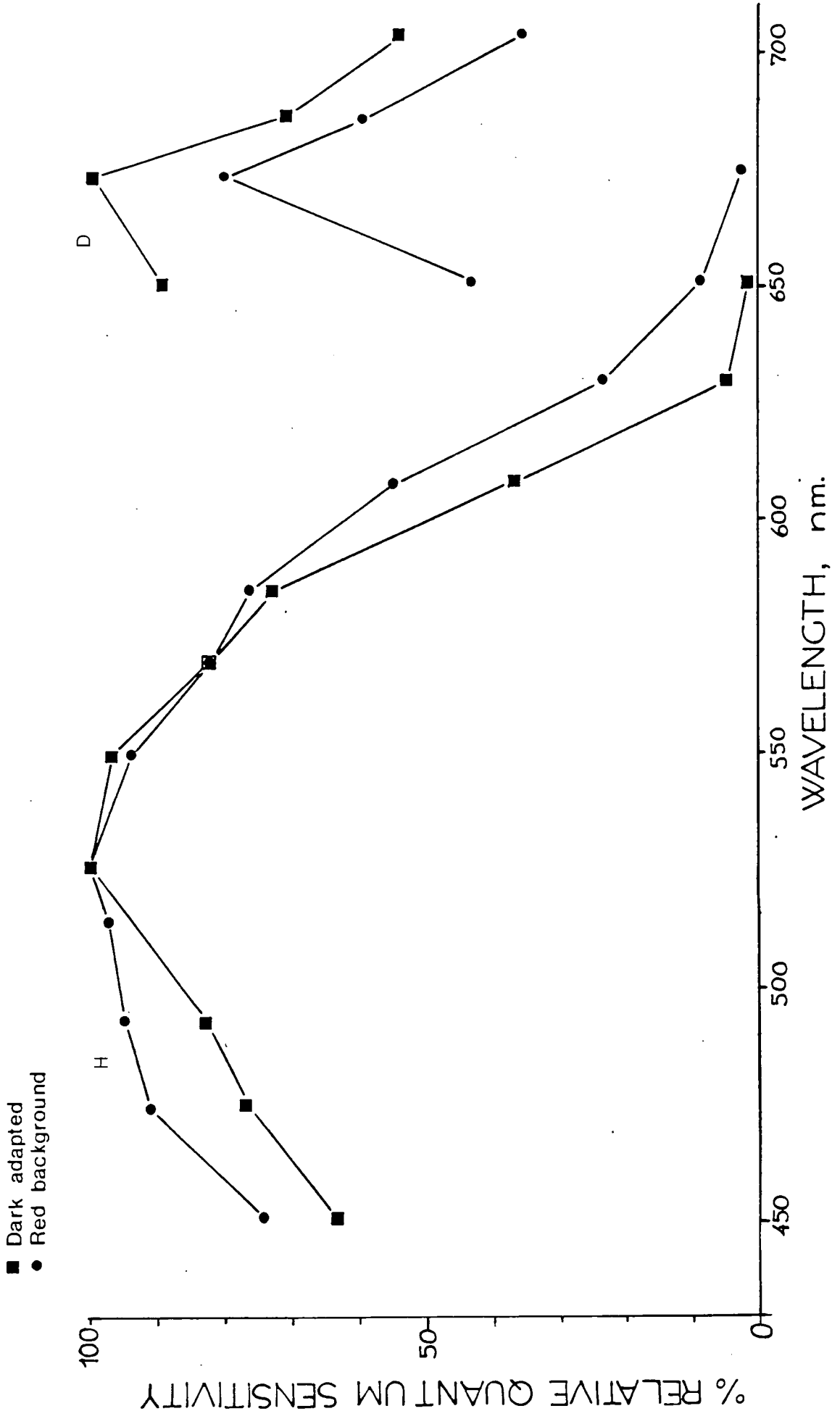

Figure 6.36.

Spectral sensitivity curves of the hyperpolarizing component of a dark adapted R/G cell (solid circles) which showed a very weak depolarizing component. Solid squares are 535 nm photopigment from Ebrey and Honig's (1977) nomogram. Astrix represents the depolarizing component of the dark adapted R/G cell, and open circles represent the depolarizing component under blue (435 nm) ($\text{LogI} = 5.1$) background adaptation.

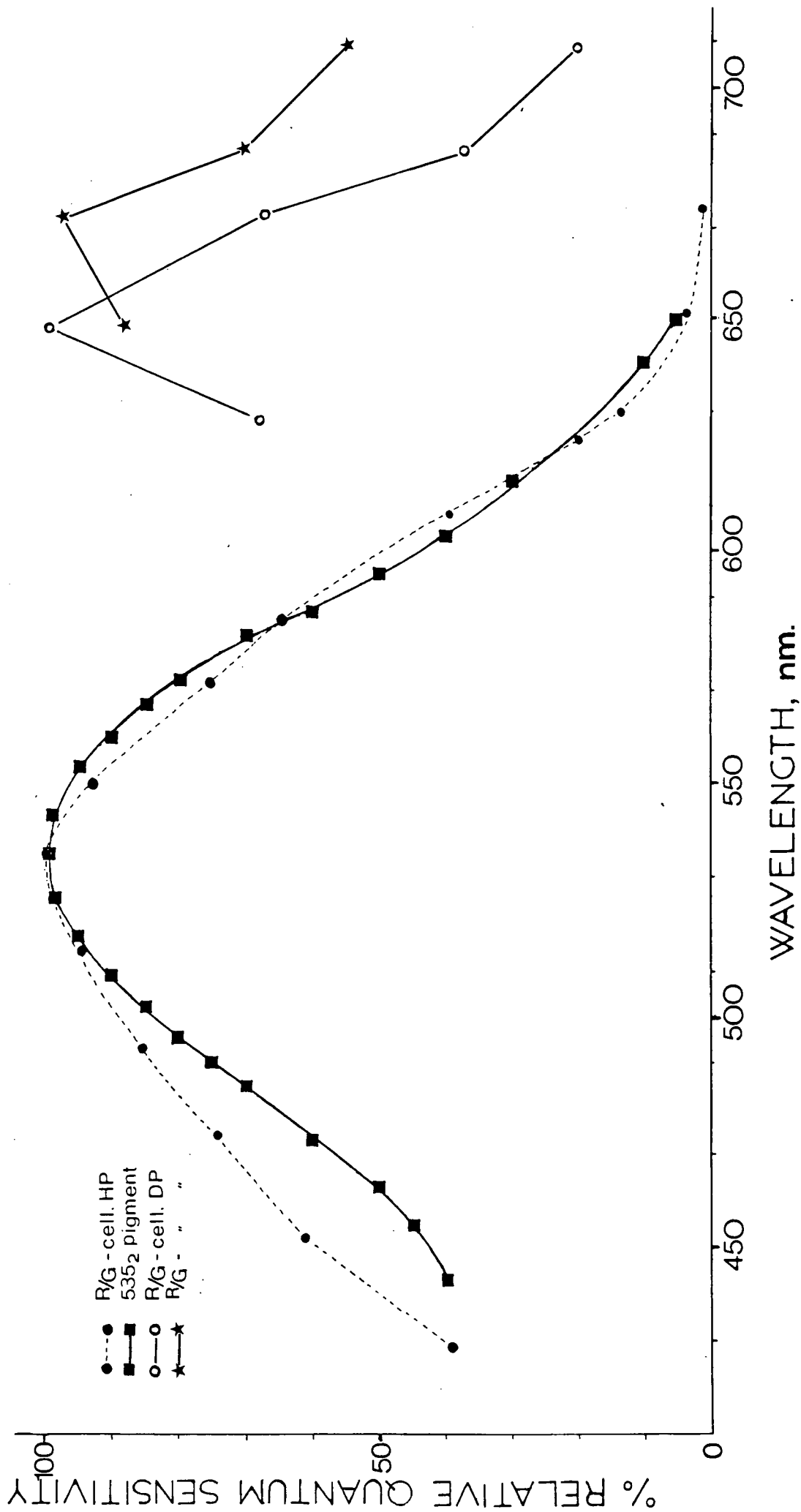
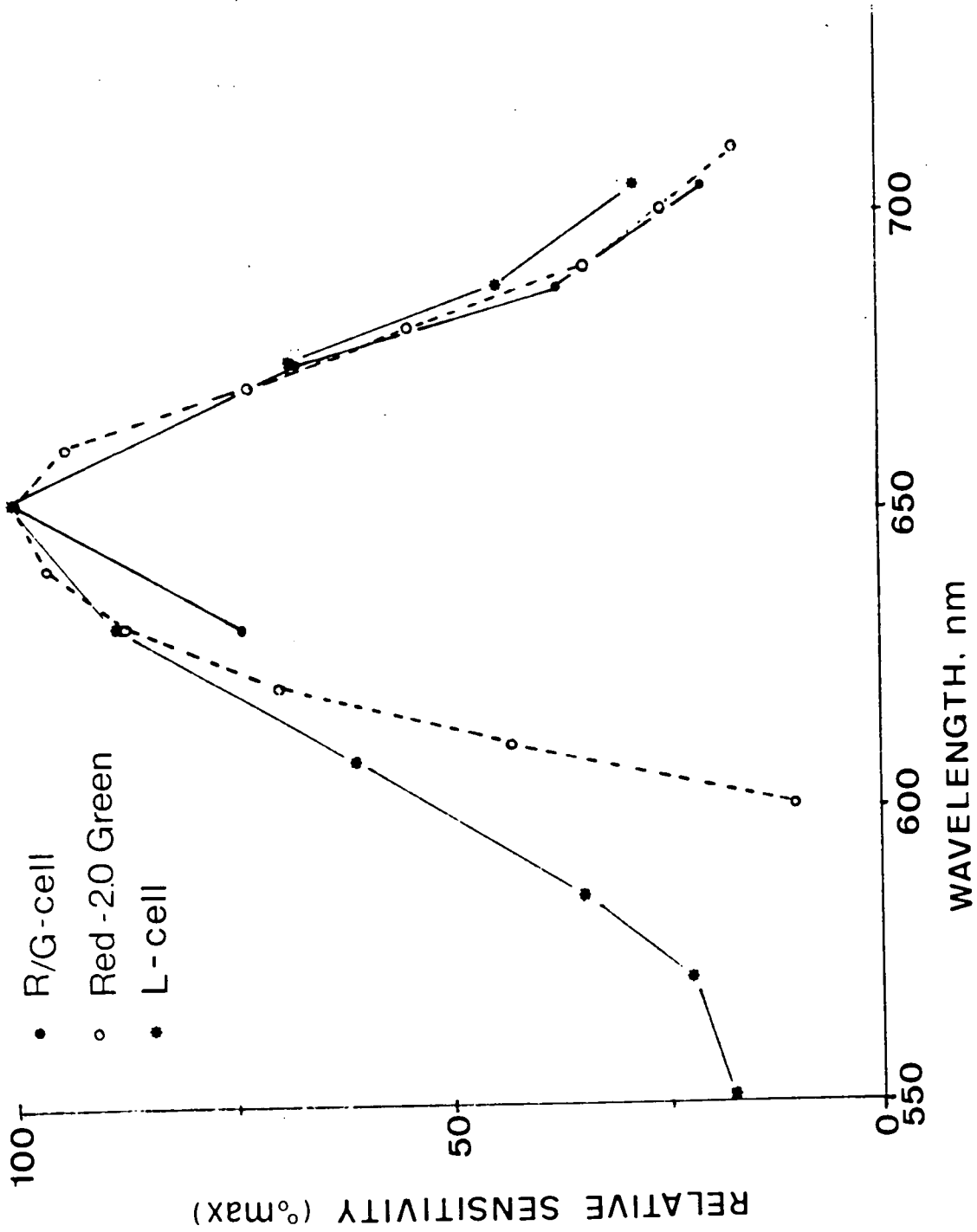

Figure 6.37.

Comparison of the spectral sensitivity curve of the depolarizing component of a R/G cell (●) (same as in Fig. 6.36) with a L-type spectral sensitivity curve (*) under blue background adaptation (same as in Fig. 6.22). The broken line (open circles) represents a curve calculated from red (615 nm) and green (535 nm) pigment curves, when the green (535 nm) pigment was weighted two times more than the red (615 nm) pigment and then summed.



DISCUSSION.

Chapter 7.

Morphology.

7.1 Horizontal cells.

Horizontal cells in teleosts have been classified on morphological grounds into two main types, rod and cone horizontal cells (Cajal, 1892; Stell, 1964, 1967; Parthe, 1972). The present study has demonstrated three morphological types of cone horizontal cells in the perch (Perca fluviatilis L.) retina. These three types of horizontal cells from distal H1 to proximal H2 and H3 become progressively larger and more stellate, as is commonly found in other teleost retinas containing a high proportion of rods (Cajal, 1892; Villegas and Villegas, 1963; Testa, 1966; Stell, 1967; Parthe, 1969, 1972; Naka and Carraway, 1975; Witkovsky et al., 1979).

The three types of cone horizontal cell have been observed to be segregated in separate layers as in a number of teleost species (Parthe, 1972), in goldfish (Stell and Lightfoot, 1975), in Callionymus lyra (Haesendonck and Missotten, 1979), and in pikeperch (Witkovsky et al., 1979; Hassin, 1979). This is in contrast with several teleostean genera in which the horizontal cells are clearly segregated into four layers (Testa, 1966; Parthe, 1972; Stell and Lightfoot, 1975; Haesendonck and Missotten, 1979), with three layers contacting only cones and one layer only rods. In perch only three layers were observed, all contacting cones. Rod horizontal cells were not observed. The retina of the related pikeperch (Hassin, 1979; Witkovsky et al., 1979) also has only three layers of cone

horizontal cells. In this species rod horizontal cells were not observed.

Electron microscopical observations of rod spherules in the perch indicate the presence of horizontal cell dendritic process in their ultrastructure. It is possible that the rod horizontal cell exists in perch, but its perikaryon could be intermingled among the cone horizontal cells. One of the drawbacks of the Golgi method is the capriciousness of impregnation; it may be difficult to demonstrate a cell type when it has not been impregnated. If the impregnation is incomplete, which is not always obvious, it may result in failure to visualize some cell processes (Stell, 1972). The rare observation that the perch H1 cell made contact with rod spherules is thought to be a staining artifact, since these dendritic processes that appeared to contact rods could not be traced to the H1 cell. Some results suggest, however, that the teleostean horizontal cells are not as exclusively segregated to rods and cones as the anatomical results indicate. For example, Laufer and Millan (1970) found on physiological grounds that some horizontal cells of the teleost Eugerres plumieri received both rod and cone input. Among elasmobranchs, Toyoda et al. (1978) found in the stingray retina that the external horizontal cell receives a mixed rod and cone input, but in the smooth dogfish retina the horizontal cells appeared to contact either rods or cones, but not both (Stell and Witkovsky, 1973b).

In general, the perch horizontal cells bear a close anatomical resemblance to the horizontal cells of the related pikeperch

(Hassin, 1979; Witkovsky et al., 1979) in their size and form, i.e. dendritic spread and thickness. In addition, there is obviously an anatomical similarity between the perch and pikeperch H1, H2 and H3 cells with the Golgi impregnated cone horizontal cells in the teleost Eugerres plumeri (Parthe, 1972). The cone horizontal cell types in perch resemble the cone horizontal cells in cyprinids in having increasing dendritic spread and decreasing density of cone contacts with increasing distance from the outer plexiform layer. In cyprinids, the H1 (external) cell has characteristically the largest cell body (Parthe, 1972; Stell and Lightfoot, 1975), whereas in perch the H2 (medial) cell has the largest cell body. In addition, the cone horizontal cells in perch are more clearly segregated in vertical layers than in cyprinids.

Horizontal cells make gap junctions with other horizontal cells of the same type at the lateral face of the perikaryon and between dendrites in teleosts (Stell, 1972). In the electron microscope, structural features which corresponded well with gap junctions described between horizontal cells in other vertebrates (Yamada and Ishikawa, 1965; Witkovsky and Dowling, 1969; Stell, 1972; Witkovsky and Stell, 1973; Lasansky, 1976; Witkovsky et al., 1979), were observed between adjacent horizontal cells in perch. There is good evidence that such intracellular junctions provide channels of enhanced ionic permeability through which horizontal cells are electrically coupled, generating their large uniform receptive field properties (Kaneko, 1971; Witkovsky et al., 1979).

The perch H1-type horizontal cells are very regularly spaced,

and it was observed that the horizontal distance between H1 cell nuclei was the same as that between adjacent single cones. When the H1 cell dendritic arborization were determined with respect to the photoreceptor mosaic, the H1 cell bodies were always situated exactly under a single cone, as suggested in earlier studies on the perch retina (Ahlbert, 1969). This pattern has also been observed in other teleosts with a regular square receptor mosaic (Engstrom, 1963b; Testa, 1966; Wagner, 1976; Haesendonck and Missotten, 1979).

7.2. Horizontal cell axons.

All three types of cone horizontal cell were observed to possess a short axon. An axon was only rarely observed on H2- and H3-types, but occurred frequently on the H1-type horizontal cells. The horizontal cell axons, as in other teleosts, were observed to be up to several hundred microns in length and descend gradually to the inner nuclear layer (Cajal, 1892; Parthe, 1972; Wagner, 1972; Haesendonck and Missotten, 1979), where they terminate abruptly. They were never observed to terminate in an fusiform axon terminal as described in cyprinids (Stell, 1975; Weiler, 1978), which may possibly be due to a staining failure (Stell, 1975).

In addition to the horizontal cell axons, 'free axons', that did not appear to be attached to any cell bodies in the inner nuclear layer were frequently observed. Similar free axons have been reported in the pike perch (Witkovsky et al., 1979). It is possible that these structures are impregnated axons of horizontal cells, but the corresponding cell bodies were not impregnated.

The axon and the axon terminal do not make contact with receptors in teleosts (Cajal, 1892; Stell, 1975; Weiler, 1977; Weiler and Zettler, 1979) unlike those of other vertebrates as in the turtle (Leeper, 1978a) and in mammals (Dowling, Brown, and Major, 1966; Gallego, 1971; Fisher and Boycott, 1974; Ogden, 1974), in which the axon terminal makes contact with receptors.

The teleostian horizontal cell bodies and their axon terminals have been shown to have remarkably similar electrophysiological and pharmacological properties (Kaneko, 1970; Lam and Steinman, 1971; Marmarelis and Naka, 1973; Weiler and Zettler, 1979).

Yamada and Ishikawa (1965) and Weiler and Zettler (1979) re-

ported that the fusiform elements contain large numbers of microtubules and that they make 'close membrane appositions' with one another. Kaneko (1970) and Marmarelis and Naka (1973) further observed that the axon terminals are electrically coupled as the horizontal cell bodies. It has been shown that the axon terminals show the same patterns of chromatic organization as the corresponding cell bodies, which suggest that the axon terminals are electrically coupled selectively only to others of the same type (Kaneko, 1970; Stell, 1975; Hassin, 1979; Weiler and Zettler, 1979). Comparison of the potential amplitudes in horizontal cell soma and its axon terminal shows that the conduction from the cell body to the axon terminal is non-decremental (Weiler and Zettler, 1979).

The functional significance of axon terminals and the intraretinal neurons they may contact has not been determined.

Naka (1977) suggests that horizontal cells may make direct contact with amacrine cells, since the axon descends to the amacrine cell layer, which would at least make a possible candidate for such connections.

7.3. Patterns of interconnections between cones and cone horizontal cells.

Two types of cones were observed; equal double (twin) cones and single cones. The double cones form a regular square mosaic with a single cone in the centre of each square. The ratio of twin/single cones was 2/1, as was previously reported by Engstrom (1963) and Ahlbert (1969). Exceptions from the square cone mosaic were very rarely observed, and did not effect the analysis of the cone-horizontal cell connections. Ahlbert (1969), in her study of perch

cones and cone arrangements, only rarely observed irregularities from the square mosaic. She observed irregular mosaic around the optic nerve where triple cones have been found, and also a row pattern in ora serrata (Ahlbert, 1969). In addition, Ahlbert (1969) observed a few single cones at the corners of the squares, which were only distinguishable from the central single cone by their position in the mosaic, and occasional single cones, which from their size and position in the mosaic, probably represented half a double cone.

Loew and Lythgoe (1978) presented evidence from microspectrophotometry which revealed that both members of the twin cones contain the same red absorbing photopigment based on vitamin A2 (dehydroretinal) with maximum spectral absorbance at 615 nm. The two members of these double cones are thus indistinguishable on the basis of morphology and pigment content and were thus termed 'identical twin' cones (Loew and Lythgoe, 1978). The central single cone contains green absorbing photopigment (dehydroretinal) with maximum absorbance at the wavelength of 535 nm. From the correlation between the cone structure and pigment content it is therefore reasonable to conclude that the perch is in fact dichromatic. This conclusion is supported by Camerons (1982) behavioral studies on perch (Perca fluviatilis).

It would seem unlikely that short wavelength light is of significance in the function of the perch retina. Not only are the blue cone photoreceptors absent in perch retina, but in addition, the combined absorption properties of its yellow cornea and the lens, should cut off all blue light from reaching the retina. The

perch cornea absorbs maximally at 460 nm, with minimal absorption at longer wavelengths than 550 nm (Cameron, 1982). The unpigmented lens in perch, as in many freshwater fishes, absorbs maximally at shorter wavelengths than 400 nm (Cameron, 1982).

Analysis based on 1 μm serial sections and on 20 μm horizontal sections of Golgi preparations shows that in perch the H1 cells contact all cones within their dendritic field, i.e. both double and central single cones. The H2 cells contact double cones exclusively and H3 cells contact central single cones exclusively. Thus in perch as in other teleosts, where cone-horizontal cell receptor contacts have been analysed, the general rule seems to be that the H1 or the external (sclerad) horizontal cell contacts all types of cones, with the H2 and H3 becoming more selective and contacting fewer types of cones, as for example in goldfish (Stell and Lightfoot, 1975); in pikeperch (Witkovsky et al., 1979) and in *Callionymus* (Haesendonck and Missotten, 1979). This pattern had previously been noticed by the distribution of horizontal cell dendrites in teleosts (Parthe, 1972).

From the specific connections of the different classes of horizontal cells with the cones, identified by their position in the mosaic, it should be possible to make a prediction of the spectral characteristics of each type of horizontal cell. Thus for the perch retina studied here it is concluded that the colour coded cone inputs is as follows: H1 receive input from red and green cones; H2 receive input from red cones; and H3 cells receive input from green sensitive cones. However, a number of investigators have shown that the response properties of horizontal cells do not correspond with

the cone-horizontal cell contact pattern. Stell and Lightfoot (1975) suggested a correlation between functionally identified versus histologically identified horizontal cells in the cyprinid retina. Based on such predictions as the percentage of cell types recorded in electrophysiological studies versus the cell body size, and the sequence in which the horizontal cell types were encountered when penetrating the retina from the receptor side. They concluded that the H1 type cells were monophasic (L-type) receiving functional input mainly from red sensitive cones, although contacting red green and blue sensitive cones. The H2 type were biphasic (C-type) receiving input from red and green cones, but making contact with green and blue cones and H3 type cells were triphasic (C-type) receiving input from all three cones, but contacting only blue sensitive cones. Their conclusions were later confirmed by functional/histological identification after dye injection experiments (Mitarai et al., 1974; Hashimoto et al., 1976; Weiler and Wagner, 1984).

Based on studies of connectivity of cones and cone horizontal cells in the goldfish Stell et al. (1975) proposed a functional polarization of the horizontal cell processes with respect to their localization in the ribbon synapse. According to this model, only central processes are postsynaptic, whereas lateral processes are presynaptic and thus mediate the feedback from horizontal cells to cones. Thus, H1 cells receive direct input from red cones and feedback (sign inverting synapses) via the green cones and hence onto the H2 cells. Subsequently, H2 cells receive direct input from green cones and feedback onto the H3 cells via the blue cones.

A correlation between histologically identified versus functionally identified horizontal cells in the turtle retina (Leeper, 1978), showed that the L-type cells (red sensitive) contacted red and green receptors, biphasic C-type (red/green sensitive) contacted green and blue receptors, and triphasic C-type (red, green, and blue sensitive) contacted only blue cones. Thus showing a similar contact pattern as goldfish horizontal cells. The contact pattern of Golgi impregnated cone horizontal cells in the dichromatic pikeperch (Witkovsky et al., 1979) appears similar to the contact pattern of the perch horizontal cells. As in perch the pikeperch H1 horizontal cells contact both twin (red) and single (green) cones and the H3 cells contact single cones exclusively. The pikeperch H2 cells were reported to make contact with single cones, although they predominantly contacted twin cones. In contrast with the H2 cell of perch which exclusively contacts double cones. Subsequent functional identification by intracellular dye injections revealed that the H1 and H2 cells in pikeperch were red sensitive L-type cells and the H3 cells were biphasic red/green sensitive C-type cells (Hassin, 1979).

Based on the connectivity pattern of perch horizontal cell types with red and green cones and considering the evidence from goldfish, turtle, and pikeperch, it should be possible to make a predictive model of the spectral characteristics of each type of perch horizontal cell. It is concluded that the H1 cells are red sensitive L-type cells, the H2 cells are also red sensitive L-type cells, and H3 cells are red/green (R/G) sensitive C-type cells.

The H1 cell in perch contacts both red and green cones as the

H1 cell in pikeperch (Witkovsky et al., 1979) and H1-cell body (H1CB) in turtle (Leeper, 1978), both of which have been shown to be red sensitive L-type cells (Leeper, 1978; Hassin, 1979). It is concluded in the perch retina that the contact of the H1 cell with the green sensitive single cone probably represents a feedback pathway. The H2 cell in perch makes contacts exclusively with the red sensitive double cones, and is therefore most likely a red sensitive L-type cell. A horizontal cell making exclusive contacts with red cones has not been reported in other species. The H3 cell in perch which exclusively contacts green sensitive single cones as does the H3 cell in pikeperch (Witkovsky et al., 1979), which has been shown to be a R/G cell (Hassin, 1979). According to the Stell and Lightfoot (1975) and Stell et al. (1975) model, the generation of R/G responses in H3 type cells in perch can be explained by direct input from green sensitive cones and a red depolarizing response produced indirectly through H1 L-type cells via feedback onto the green cones.

7.4. Photoreceptor interconnections.

Analysis of invaginating basal processes in 1 μm serial sections through Golgi impregnated cone pedicles suggest that the invaginating basal processes are highly selective according to cone

type. The pattern of interconnections of the central single cone (green sensitive) basal processes were found to be colour coded, invaginating exclusively the twin cones (red sensitive) around them in the cone mosaic. They were never observed to make contact with double cone pedicles outside their mosaic unit, or with other single cones. Basal processes from the red sensitive twin cones in perch were found to be non-colour coded, since they invaginated only other twin cones and were never observed to invaginate the green sensitive single cones. In other teleosts, the pattern of interconnections via the invaginating basal processes are colour coded, since they have been demonstrated only to invaginate chromatically different sets of cones (Scholes, 1975; Lockhart and Stell, 1979). This is in agreement with the colour coded pattern of the green cone basal processes in perch, but in contradiction with the non-colour coded pattern of perch red cone basal processes. In rudd (Scholes, 1975) the pattern is green into red, red into green and blue into green sensitive cones. In goldfish, Lockhart and Stell (1979) find a similar pattern, with the addition of red and green into the blue sensitive cones.

Invaginating basal processes in perch appear to make relatively shallow invaginations compared with the horizontal cell dendritic processes, as observed in the light microscope. This may indicate that the invaginating basal processes do not make direct contact with the ribbon synapse, and may correspond with other reports where they are reported to approach the ribbon synapse and make extensive, although apparently unspecialized, contact with both the cone pedicle and its horizontal cell processes (Lasansky, 1971; Scholes,

1976; Lockhardt and Stell, 1979). It is not known whether the invaginating basal processes are post or presynaptic, and in the absence of physiological data it is difficult to know whether the green cone is acting upon the red cone or vice versa.

The colour coded pattern of interconnections via basal processes suggests that they may play a role in colour opponent processing as suggested by Scholes (1975). The fact, however, that the cone pigment spectra and physiological action spectra agree closely in cyprinids (Tomita et al., 1967; Stell and Harosi, 1976) and in pikeperch (Burkhardt, Hassin, Levine, and MacNichol, 1980), suggests that cones themselves are not influenced strongly by antagonistic interactions from other cone types in these species. Therefore, it is logical that the cones act through their invaginating telodendria upon horizontal cell processes in the pedicle, rather than upon the invaginated cone pedicle (Lasansky, 1971; Stell, 1980).

In turtle retina, coupling between neighbouring cones has been demonstrated by current injection techniques (Baylor et al., 1971; O'Bryan, 1973) and gap junctions have been observed between their terminals (Lasansky, 1972; Raviola and Gilula, 1973). In addition, anatomical and physiological results from the salamander retina indicate that rods and cones may be electrically coupled (Gold and Dowling, 1979; Attwell et al., 1983).

The small areas of summation reported on cones in pikeperch (Burkhardt, 1977) and turtle (Baylor et al., 1971), as well as rods in toad (Fain et al., 1976) and turtle (Copenhagen and Owen, 1976) show that some receptors are coupled summatively.

The fact that the cone pigment spectra and the physiological

action spectra agree closely, suggests that the summative interactions, presumably via gap junctions, are limited to cones of the same spectral type (Baylor et al., 1971; Baylor and Hodgkin, 1973; Fuortes and Schwartz et al., 1973; Burkhardt, 1977; Detwiler and Hodgkin, 1979; Witkovsky et al., 1979). Gap junctions which may mediate a low-resistance coupling between receptors with the selectivity required have not been demonstrated. It has been suggested, however, that the receptor basal processes which have been shown to make membrane appositions with similar processes, (Witkovsky et al., 1974) might represent such a selective pathway (Scholes, 1975; Stell, 1980). It has been suggested (Fain and Dowling, 1973) that coupling of homologous pairs of photoreceptors may increase the light evoked changes in synaptic transmissions in very dim light, while exerting little or no effect in brighter light.

Chapter 8.

Intracellular recordings.

8.1. General observations.

The present study has demonstrated two types of horizontal cell recordings in the perch retina. Based on easily recognised physiological response characteristics, they were classified into L-type (monophasic) and C-type (biphasic) responses. The L-type cells hyperpolarized to light stimuli of all wavelengths, maximally sensitive at 650 nm. The C-type (R/G) cells hyperpolarized to light stimuli of short (blue-green) wavelengths, maximally sensitive at 535 nm, and depolarized to long (far red) wavelengths, maximally sensitive at 650-680 nm. The results described suggest that the spectral organization of the perch retina is complex, since the spectral sensitivity of the L-type cell and depolarizing component of the R/G cell are clear examples of horizontal cells with pseudopigment spectral sensitivity curves. These narrow, far red spectral sensitivity curves were first observed by Naka and Rushton (1966a, c) in teleostean horizontal cells. It has been suggested that these unusual spectral sensitivity curves are the result of interaction among responses derived from two or more directly measured photopigments (Sirovich and Abramov, 1977).

8.2. L-type horizontal cells.

In agreement with previous reports on teleost L-type horizontal cells (Svaetichin and MacNichol, 1958; Tomita, 1965; Naka and Rushton, 1966c; Burkhardt and Hassin, 1978), the L-type horizontal cell in perch hyperpolarized in response to flashes at all wavelengths, and the response amplitude showed a graded increase with increasing light intensity, having a dynamic range of about 2.5 logI units.

Photoreceptors, normally depolarized and releasing transmitter in darkness, hyperpolarize under the action of light and, the release of transmitter reduced or turned off depending on the intensity of the light stimulus. The action of the photoreceptor (excitatory) transmitter is to depolarize the L-type horizontal cells in darkness and therefore they hyperpolarize as a result of reduced transmitter release (Byzov and Trifonov, 1968; Trifonov, 1968). The relationship between light energy and response amplitude in the L-type cells in perch could be described by the hyperbolic tangent function for a single cone mechanism: $V/V_{\max} = I^n / I^n + \sigma^n$ (Naka and Rushton, 1966a, b, c) with an exponent (n) of about 1.5. Thus the L-type cells have a dynamic range of about 2.5 logI units (Fig. 6.3). The L-type cells in perch have significantly smaller dynamic range than the R/G cells in perch (see Fig. 6.31), cones and horizontal cells in turtle (Baylor and Hodgkin 1973; Yazulla 1976) and in fish (Burkhardt 1977; Burkhardt and Hassin 1978). The V-logI curves of these cells could be fit by a hyperbolic tangent function with an exponent 1.0, having a dynamic range of about 3.5 logI units.

The response waveform of the perch L-type horizontal cells showed initial peak to later plateau or transient on responses. The transient on responses were observed for all wavelengths and were most prominent at intermediate response amplitudes. Thus the perch L-type response waveform is similar to that of the related pikeperch (Burkhardt and Hassin, 1978) and of turtle (Gerschenfeld et al., 1980). These L-type cells are contrasted by the more complex L-type cells which show wavelength dependent response waveforms, as in turtle (Fuortes et al., 1973; Fuortes and Simon, 1974; Yazulla, 1976) and in cyprinids (Yang et al., 1982, 1983; Gutierrez, Neely, and Salinas, 1983).

The mechanisms for the generation of the transient on responses

are uncertain. In perch, there are some indications that the transient on responses may be dependent upon stimulus diameter (see Fig. 6.4). However, the observed effect of smaller (>2.0 mm) stimulus diameters (Fig. 6.4) may result from decreasing response amplitude since the transient is reduced by small (> 10.0 mv) response amplitudes (Fig. 6.1). Burkhardt and Hassin (1978) demonstrated in the pikeperch retina that the transient on responses were eliminated when smaller spot stimulus diameters than 1-2 mm were used. Since large stimulus diameters are also necessary to evoke the feedback from horizontal cells to cones (Baylor et al., 1971, Burkhardt, 1977), the transient on responses might be the consequence of the horizontal cell to cones feedback as suggested by Burkhardt and Hassin (1978). However, the voltage dependent conductance changes in the nonsynaptic part of the horizontal cell membrane (Werblin, 1975b; Byzov and Trifonov, 1981; Tachibana, 1983) can not be excluded from attributing to the generation of the transient on responses. Recently, Teranishi, Negishi and Kato (1984) observed an increase in the transient responses in dopamine treated carp retinas, and Gutierrez et al. (1984) showed that by treating the carp retina with dopamine blockers (haloperidol and 6-hydroxy dopamine) the transient on response was selectively eliminated. These results suggest that dopaminergic interplexiform cells may contribute to the the generation of the transient on response, since dopaminergic interplexiform cells are known to be presynaptic to external horizontal cells and bipolar cells in the perch and carp retinas (Ehinger et al., 1969). Application of dopamine on fish horizontal cells (L-type) results in depolarization of the membrane potential and reduction of the response to illumination (Dowling et al., 1976), decreasing the lateral spread of the L-type response, but increasing its amplitude to central

stimulation (Negeshi and Drujan, 1979; Teranishi et al., 1984). However, the present observations do not rule out any of these mechanisms. It is not known what part the interplexiform cells play in shaping the spectral responses of horizontal cells.

8.2.1. Spectral sensitivity.

The spectral sensitivity of the L-unit in the perch retina peaks at 650 nm and does not correspond with the 615 nm red (twin) cone photopigment, which has been identified by microspectrophotometry (Loew and Lythgoe, 1978). In addition, the spectral sensitivity curve of the L-type horizontal cell is narrow compared with a hypothetical photopigment of the same maximum.

The L-type cells in perch appear to receive their predominant input from one spectral class of cone mechanism peaking at 650 nm, since their spectral sensitivity does not change under selective chromatic adaptation and that their V-logI curves are parallel. Comparison of the L-type response waveform revealed wavelength dependent differences in the late phase (plateau), which might indicate that the L-unit receives input from more than one chromatic class of receptors. However, the V-logI curves constructed from different time periods after flash onset are linear and could be described by the same fixed template, and the spectral sensitivity curves constructed for different phases of the response were almost identical in shape. This suggests that the L-units receive input from a single photopigment peaking at 650 nm, and that the chromatic interactions leading to the generation of pseudopigment does not occur at the level of the L-type horizontal cells.

The L-type cells in perch show similar response properties as the L-type cells in pikeperch (Burkhardt and Hassin, 1978), in Eugeser

(Laufer and Millan, 1970), and in turtle (Yazulla, 1976), since the L-type cells in these species show similar response waveforms to stimuli of different wavelengths, with parallel V-logI curves and are not selectively adapted by chromatic background, and thus seem to receive a predominant input from a single cone type. However, there is one fundamental difference when these L-type cells are compared with those of perch, as the spectral sensitivity curves of these L-type cells correspond with the absorption curves of their cone photopigments, whereas the L-type cells in perch do not. These L-type cells are in contrast with the more complex L-type cells in cyprinids and in turtle where the experimental evidence strongly suggests that the L-type horizontal cells receive input from at least two chromatic classes of cones (Gouras, 1972). These cells show wavelength dependent waveforms and have action spectra which are strongly dependent upon the response amplitude, i.e. V-logI curves are not parallel (Fuortes et al., 1973; Fuortes and Simon, 1974; Yazulla, 1976; Yang et al., 1982, 1983), and are also dependent upon chromatic adaptation (Naka and Rushton, 1966c). In addition, in the L-type cells which have been shown to receive input from more than one class of cones, a red background not only decreases the cell's sensitivity to red light, but also considerably increases the cell's sensitivity to green light (Naka and Rushton, 1966c; Laufer and Negishi, 1978; Yang et al., 1982, 1983). This effect was not observed in perch, and thus further supports the conclusion that the L-type cells in perch only receive input from the 650 nm cone mechanism.

Naka and Rushton (1966c) in tench and Witkovsky (1967) in carp reported that the L-units had two peaks, a primary peak at 620 nm, and a secondary peak at 680 and 665 nm respectively. Naka and Rushton (1966c), who determined the L-unit's action spectra under chromatic

background, concluded that the L-unit's in tench receive signals from 680, 620, 540 nm and possibly from 450 nm as well. The latter three mechanisms correspond with the three cone photopigments identified in cyprinids (Liebman and Entine, 1964; Marks, 1965), but despite intensive microspectrophotometrical studies on the cones in these species (Harosi, 1976; Stell and Harosi, 1976; Loew and Lythgoe, 1978), the far-red 680 pigment has yet to be observed. Despite the mismatches between physiological and microspectrophotometrical results, the pseudopigments were accepted as being related to single, but unusual pigment, because they obeyed the generally accepted criteria for identifying responses driven by a single cone, such as that the V-logI curves for various wavelengths are parallel and/or the relative spectral sensitivity curves are unchanged under chromatic adaptation (Naka and Rushton, 1966a, c).

Preliminary calculations in which signals derived from the red (615 nm) and green (535 nm) sensitive cones, were given opposite signs and then summed, and the signal from the green cone is weighted two times more than the signal from the red cones. The calculated action spectra gives a 650 nm peak and corresponding with the red end of the horizontal cell spectral sensitivity curves. However, this method is inadequate to describe the possible interaction between the red and green cones, since the calculated curve deviates from the experimentally obtained horizontal cell spectral sensitivity curves at shorter wavelengths (Fig. 6.37).

Sirovich and Abramov (1977) proposed that these unusual pigments are the result of interaction between responses derived from two or more photoreceptors with different photopigments. Their proposed interaction is on the form:

$$S(V) = \left[\sum_{i=1}^N \beta_i A_i^p (V - V_i) \right]^{1/p}$$

where $S(V)$ = (spectral) sensitivity function, β = the weighting function, $A(V)$ = the absorption function of the contributing photopigments, and p = an exponent.

In this equation there are two unknowns; the exponent p and the weighting function, $\beta(\sigma)$ which incorporates information about the number of photopigments and their \max (Sirovich and Abramov, 1977).

The L-type horizontal cell in perch has parallel V-LogI curves as predicted by Sirovich and Abramov's model. For a solution of this equation, the two known cone photopigments in perch, the red P615 and green P535 absorption curves from the microspectrophotometric study on perch cones (from Loew and Lythgoe, 1978), were chosen as the absorption function $A(V)$. The weighting factor was found to be = 1.63, when the red pigment absorption curve was displaced to show asymptotic agreement at long wavelengths with the spectral sensitivity curves of perch L-type cells (Fig. 8.1).

The best correspondence is obtained (by the method of Sirovich and Abramov, 1977), according to the equation:

$$S = 1.63 \left[R_{(615)}^{0.5} - 0.4G_{(535)}^{0.5} \right]^2 \quad (\text{Fig. 8.2}).$$

The calculated curve gives a reasonable fit with the L-type spectral sensitivity curve, suggesting that an interaction, of the form proposed by Sirovich and Abramov (1977), occurs between the red and green cones in perch and generates the L-type pseudopigment spectral sensitivity.

The depolarizing signal observed under the intense red background adaption suggests that an antagonizing signal, presumably from the green cones, is observed in the L-type horizontal cell response waveforms. However, since the depolarization is not observed immediately after the onset of the red background and that the L-cell's spectral sensitivity remains unchanged under chromatic

Figure 8.1.

Perch photopigments, the green 535 nm and the red 615 nm, from a microspectrophotometric study by Loew and Lythgoe (from Lythgoe, 1979) and the L-type horizontal cell spectral sensitivity curve, where the pigment absorption curve is displaced ($\times 1.61$), to show asymptotic agreement at long wavelengths with L-type spectral curve.

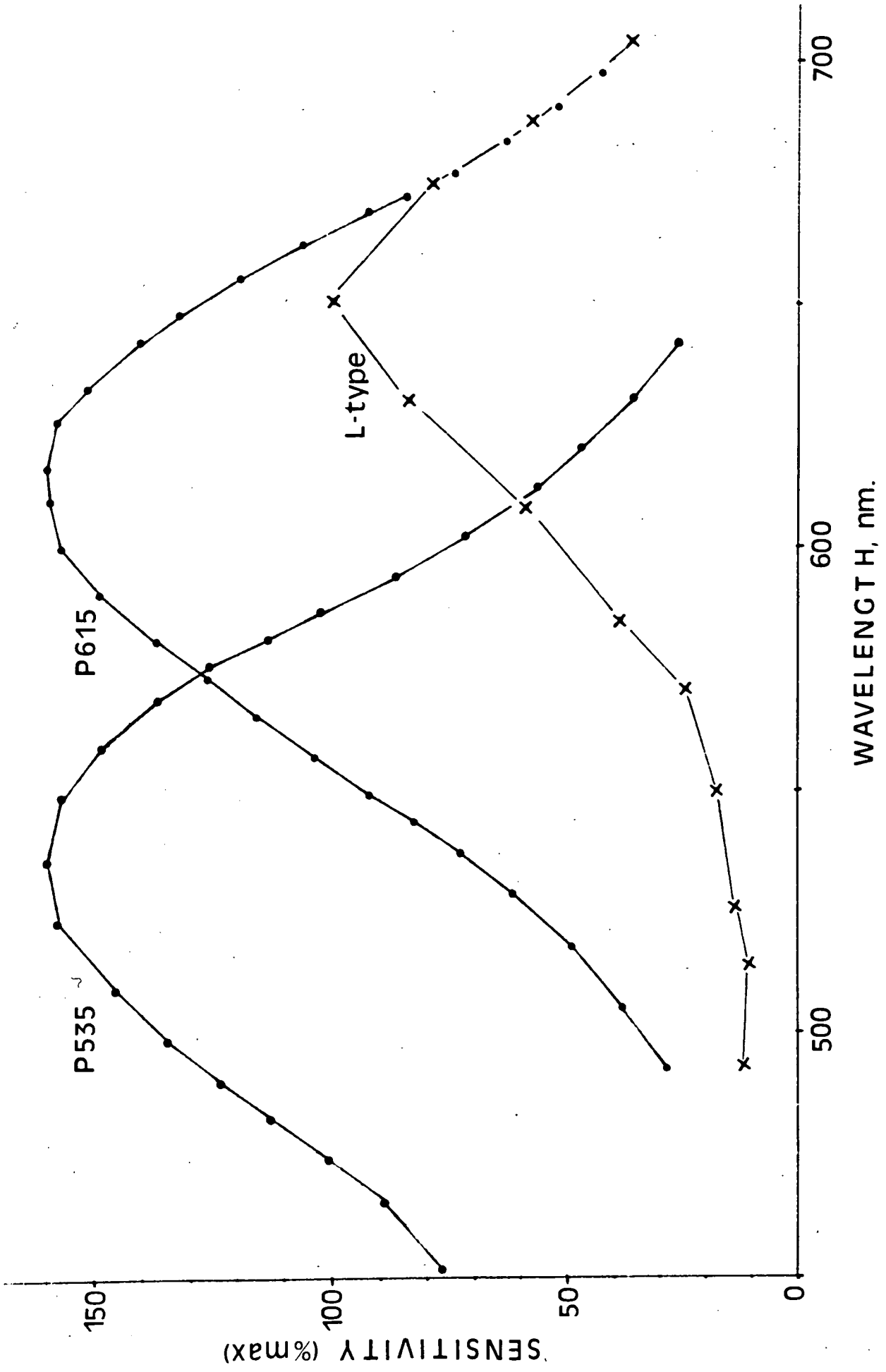
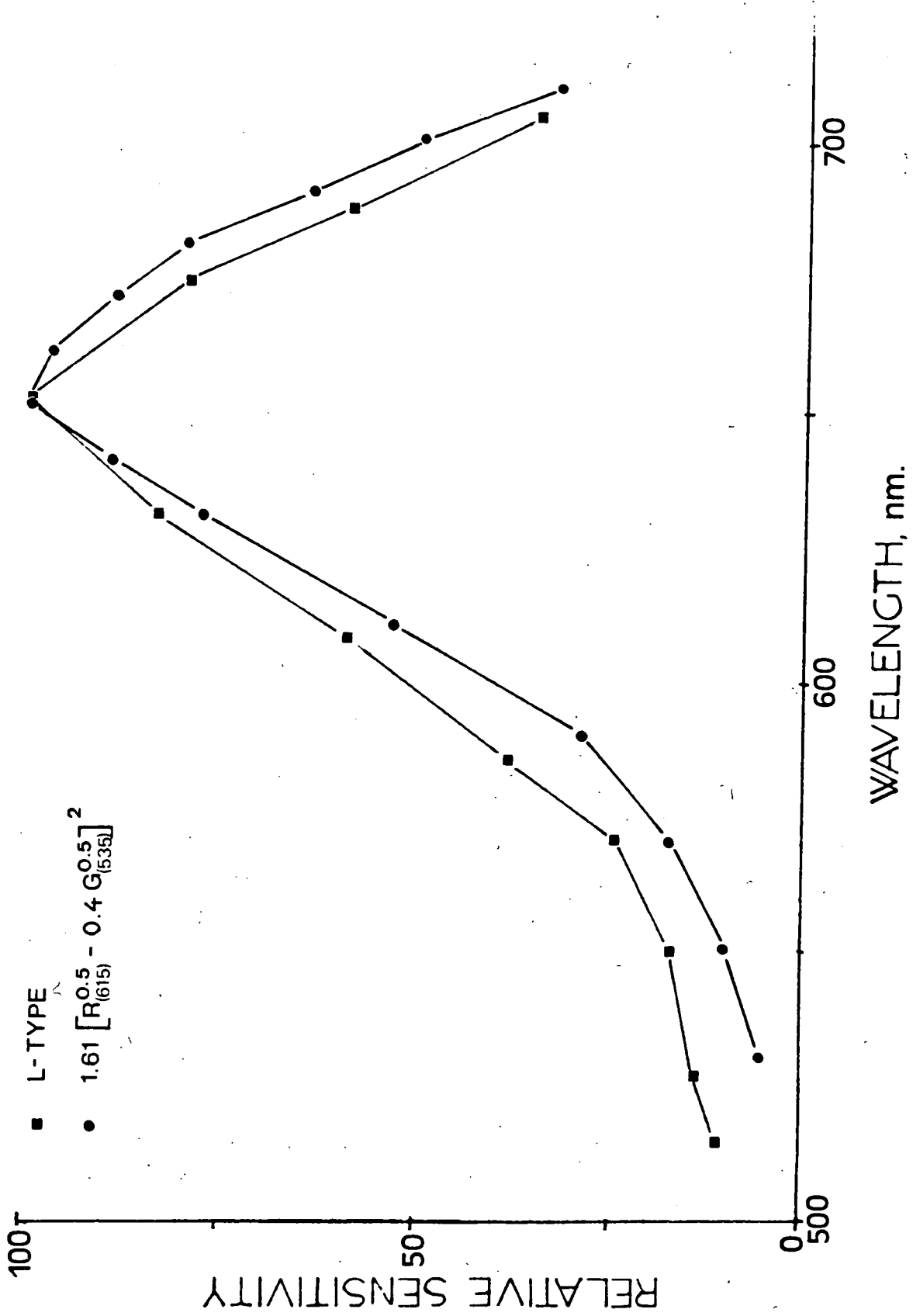

Figure 8.2.

Spectral sensitivity of a pseudopigment with a maximum at 650 nm, constructed according to the equation described in the text.

The relationship (solid circles),

$1.61 [R_{(615_2)}^{0.5} - 0.4G_{(535_2)}^{0.5}]^2$ (Sirovich and Abramov, 1977). Where 'R' is the 615 nm (red pigment) and G is the 535 nm (green pigment), the same as shown in fig. 8.1, and compared with the mean spectral sensitivity of L-type horizontal cells.



adaptation, this may indicate that the antagonizing signal is not acting directly upon the L-cell but presynaptic to the L-cell. It is unlikely that the depolarizing response can result from contamination of responses from neighbouring C-type cells, since the R/G C-type cells hyperpolarize to green wavelengths. Input from rods is unlikely since rods are supposedly not functioning under these conditions.

Under chromatic adaptation of both red and green background lights the spectral properties of the L-type horizontal cells remain unchanged, but only the absolute sensitivity is changed (Figs 6.18 and 6.23). Thus the cones not only interact to generate the pseudopigment spectral sensitivity but also by light adapting one cone type leads to simultaneous adaptation of the other cone type, since the relative contribution of the two cone types to the generation of the pseudopigment is independent of the adapting light. Since adaptation occurs mostly in the photoreceptors it must occur before or at the combination (pseudopigment) stages, but not after as Sirovish and Abramov (1977) proposed.

Depolarizing responses in monophasic horizontal cells have been reported in goldfish horizontal cells, presumably from the green sensitive cones (Tauchi, Yang, and Kaneko, 1984), but the L-type cells in goldfish show wavelength dependent responses and receive an input from the green cones, although receiving predominant input from the red (625 nm) sensitive cones (Yang et al., 1983). Depolarizing responses in L-type cells have also been reported as a result of interaction of receptive field centre and surround in the turtle (Piccolino, Neyton, and Gerschenfeld, 1981) and in larval tiger salamander (Lasansky and Vallegra, 1975).

The present observations are not sufficient to identify the underlying mechanisms, and only speculations can be made, which need

further study. However, it seems possible that the depolarization recorded arises as an interaction between the red and green cones, which by specific interaction generate the far red (650 nm) spectral sensitivity of the L-cell. If this interaction takes place between the cones, then it could be expected that the red cone spectral sensitivity was shifted to 650 nm as well. However, since it was not possible to obtain the cone spectral sensitivity, this assumption cannot be tested.

In the trichromatic cyprinid's retina, far red pseudopigment spectral sensitivity has been observed in horizontal cells (Naka and Rushton, 1966a; Witkovsky, 1967), and in ganglion cells (Daw and Beuchamp, 1972; Spekrijse et al., 1972). However, there is a good correlation between the cone action spectral sensitivity (Tomita, 1967) and the cone pigment spectra (Stell and Harosi, 1976) in cyprinids, suggesting that the pseudopigment spectral sensitivity functions are generated in the postreceptoral network, rather than by direct cone to cone interactions. Whether this assumption holds for perch is not known, but the L-type horizontal cells in perch are unusual, however, since they have this far-red pseudopigment spectral sensitivity that in most respects follows the principle of univariance.

8.3. C-type horizontal cells.

All the C-type horizontal cells observed in perch were red/ green (R/G) sensitive C-type cells, that hyperpolarized to green 550 nm and depolarized to red 670 nm test stimuli. The action spectra and the complex biphasic response waveform of perch R/G cells, where the neutral point shifts as a function of the relative amplitude of hyperpolarizing and depolarizing components and of stimulus intensity

are characteristic for R/G cells in other species (Svaetichin and MacNichol, 1958; Naka and Rushton, 1966a; Witkovsky, 1967; Burkhardt and Hassin, 1978).

The hyperpolarizing component of the R/G cell, maximally sensitive at 535 nm, corresponded with the perch green (P535) single cone photopigment. The V-logI curves were parallel at shorter wavelengths than 600 nm, where the depolarizing component did not affect the hyperpolarizing component, and selective chromatic adaptation did not change the maximum sensitivity of the hyperpolarizing component. This suggests that the hyperpolarizing component results from a direct input from the green sensitive single cones.

The depolarizing component of perch R/G cells in the absence of adapting background, shows good correlation with previous reports on teleostean R/G cells with maximum sensitivity at 670 nm and a narrow spectral sensitivity curve (Naka and Rushton, 1966a; Witkovsky, 1967; Burkhardt and Hassin, 1978). However, under intense monochromatic blue background adaptation the maximum sensitivity was shifted to 650 nm, and corresponding with the L-type maximum sensitivity and with a similar shaped spectral sensitivity curve. This may indicate that the depolarizing component of the R/G cell receives input from the 650 nm red cone mechanism as the L-type cells, either directly or indirectly from the L-type cells. In other teleosts the depolarizing component of the R/G cells did not show a significant change in spectral sensitivity under monochromatic adaptation (Naka and Rushton 1966a; Witkovsky, 1967; Burkhardt and Hassin, 1978). Thus the R/G cell in perch may not correspond to the simple scheme of one receptor type opposing another as proposed for R/G cells in other teleosts (MacNichol and Svaetichin, 1958; Tomita, 1963; Naka and Rushton, 1966a; Spekrijse and Norton, 1970; Burkhardt and Hassin, 1978), since

the R/G cell in perch appears to receive input from the green (535 nm) sensitive cones and from the red (650 nm) sensitive cone mechanism.

It has been reported that the C-type horizontal cell depolarizing response has a longer latency and a slower time course than the cell hyperpolarizing response in teleosts (MacNichol and Svaetichin, 1958; and Gouras, 1960). Spekrijse and Norton (1970) measured the chromatic response latencies using sinusodally modulated stimuli and confirmed MacNichol's and Svaetichin's (1958) conclusion. They found that the shortest wavelength component, i.e. green hyperpolarizing in biphasic cells, had a latency of 25 msec; with 50 msec for the red depolarizing component in the biphasic R/G cell. This data has been interpreted to indicate that the biphasic cells make direct contact with the green cone system for which the latency is shortest and make indirect contact through interneurons with the red cone system and is thus consequently more delayed (Gouras, 1972).

The feedback from horizontal cells to cones, observed in turtle (Baylor et al., 1971) and in fish (Burkhardt, 1977), has been proposed to account for the generation of colour opponent properties of C-type cells (Gouras, 1972; Fuortes and Simon, 1974; Stell et al., 1975; Leeper, 1978b). These models (Stell et al., 1975; Leeper, 1978b) account for the known chromatic inputs to H2 biphasic R/G cells and H3 triphasic cells from cone systems with which they make no contact, and for the difference in latencies of the C-type horizontal cell response components (Spekrijse and Norton, 1970). Further evidence for feedback mechanism comes from the temporal frequency analysis of photoreceptor and horizontal cell photoresponses in carp and in catfish retinas (Fukurotani, Hara and Oomura, 1975; Lasater, 1982), and from ultrastructural analysis of HRP injected H1-type horizontal cell processes in carp (Weiler and Wagner, 1984). However, since these

models emphasize the photoreceptors as interneurons in generation of the colour opponency of C-type horizontal cells and account for the colour specific horizontal cell-to-receptor feedback, the C-type horizontal cells should reflect the spectral and spatial properties of the feedback system.

The horizontal cell feedback to green cones has been shown to be produced by a large red stimuli, but not by green stimuli or a small red stimulus, in turtle (Fuortes et al., 1973; Fuortes and Simon, 1974) and in fish (Burkhardt, 1977; Burkhardt and Hassin, 1978). In perch the colour opponent properties of the R/G cells were not dependent upon the spatial extent of the stimulus. As in perch, previous studies on carp and pikeperch show that the colour opponent properties of C-cells were detectable with small spots which do not significantly initiate horizontal cell feedback to cones (Norton et al., 1968; Hashimoto et al., 1976; Burkhardt and Hassin, 1978). Thus the present results may suggest that the horizontal cell feedback to cones is not essential for generating colour opponent responses in perch R/G cells. Furthermore, in these and many other reports, the C-potentials have been routinely recorded from the isolated fish retina where the horizontal cell feedback could not be detected (Burkhardt, 1977).

There is considerable evidence that the H1-type (L-cell) horizontal cells in the cyprinid retina, may use gamma-aminobutyric acid (GABA) as neurotransmitter, since these cells synthesize and accumulate GABA (Lam and Steinman, 1971; Lam, 1977; Marc et al., 1978; Lam et al., 1979). In two recent physiological studies on carp Murakami et al. (1982a, b), intracellular recordings from cones and horizontal cells, provided strong evidence supporting the idea that GABA is the neurotransmitter involved in the feedback system. Blocking the GABA pathway abolishes the depolarizing response of C-type cells.

However, the release of GABA must be assumed to occur in a non-vesicular way, since synaptic vesicles are rarely found in the cytoplasm of the horizontal cell terminals (Weiler and Wagner, 1984). Recently, calcium independent release of GABA has been demonstrated in isolated carp horizontal cells (Ayoub and Lam, 1984), which may suggest a non-vesicular release of GABA. These findings suggests that the R/G cell may receive its red component through the L-type horizontal cells, but whether the pathway includes the green cone as an interneuron or just a simple post-receptor circuitry like that proposed by Naka and Rushton (1966b) has yet to be decided.

8.4. Spatial properties.

A distinctive feature of all perch horizontal cells was their large area summation, as in other teleosts (Tomita, 1965; Naka and Rushton, 1967; Norton et al., 1968; Kaneko, 1970, 1971a; Hassin, 1979) and in turtle (Lamb, 1976). The result of this study shows that the receptive fields of the L-type cells were about 4 to 5 mm in diameter and 3 to 5 mm for the C-type cells, which far exceed the physical dimensions of dendritic processes radiating from the horizontal cells, measuring about 100 μm in diameter. The area summation in perch horizontal cells are similar to those in other teleosts ranging from 0.5 to several mm in extent. In perch the L- and C-type cells have similar receptive fields as in pikeperch (Burkhardt and Hassin, 1978; Hassin, 1979), but in other teleosts the C-type cells have been reported to have larger receptive fields than the L-type cells (Negishi and Sutija, 1969; Kaneko, 1970).

The large receptive fields of horizontal cells implies that signals from peripheral photoreceptor contribute to the spatial summation transmitted to the centre via interactions between neighbouring horizontal cell bodies of the same type. The spatial summation is probably mediated by a low resistance coupling between neighbouring horizontal cells (Kaneko, 1971a). Low resistance coupling among cells has been attributed to nexuses or gap junctions (Bennett, 1966). In the electron microscope, gap junctions are widely found between contiguous horizontal cells (Yamada and Ishikawa, 1965; Witkovsky and Stell, 1973; Witkovsky et al., 1979). Electrical coupling through gap junctions do probably mediate such lateral interaction in perch as in other vertebrates (Yamada and Ishikawa, 1965; Naka and Rushton, 1967; Kaneko, 1971a; Lasansky, 1973; Witkovsky et al., 1979). The electrical coupling between horizontal cells is limited to horizontal cells of the same spectral response properties, with no evidence of direct cross-coupling between different types (Kaneko, 1971a). In general, the perch horizontal cells appear to correspond well with previous investigations on horizontal cell receptive field properties in other teleosts, with a large uniform receptive field, which is probably mediated by low resistance gap junctions between horizontal cells of each type.

Measurements of the space constant with a long and narrow bar of light, showed an exponential decay as observed in other species (Naka and Rushton, 1967; Lamb, 1976). The space constant was found to be about 250 μm as in cyprinids (Naka and Rushton, 1967) and mudpuppy (Werblin, 1970). However, the space constant in perch was found to depend upon light intensity, which may result either from

an increase in membrane resistance or from light scattering, as suggested by Lamb (1976). In general the space constant seems to depend on the method used to measure it, such as light spot, light bar or current injection (Lamb, 1976; Byzov and Shura-Bura, 1983).

Chapter 9.

General discussion and conclusion.

9.1. Correlation of the morphological and physiological results.

Three types of cone horizontal cells have been identified in this study of Golgi impregnated perch retina. It has been mentioned earlier (Section 7.1) that each cell type forms a layer of cells distinctly separated from the other layers. The distal layer of horizontal cells consists of H1-type cells which contact both the red sensitive twin cones and the green sensitive single cones. The intermediate layer of cells consists of H2-type cells which contact the red sensitive twin cones exclusively. The proximal layer consists of H3-type cells which contact the green sensitive single cones exclusively. (For summary see Fig. 9.1).

In this study two main types of horizontal cell responses were observed by intracellular recordings, monophasic L-type and biphasic (R/G) C-type responses as was described previously (Section 8.2-3). The L-type responses were always observed distal to the C-type responses. In addition, it was noted that two L-type cells were often penetrated in sequence distal to the C-type cells. The sequence of responses observed in this study corresponds in many respects with the characteristic sequence observed in other species. Among cyprinids for example, in which cellular organization and function have been correlated and where the layering is evident, the C-type cells are generally found to be proximal to the L-type cells (Mitarai et al., 1974; Stell and Lightfoot, 1975; Hashimoto et al., 1976), which was consistent with the order in which these responses were encountered when penetrating the retina from the receptor side

Figure 9.1.

Summary diagrammatic reconstruction of perch cones and horizontal cells. Showing the interconnections of cones and horizontal cells, including the invaginating basal processes. RD, red double cones; GS, green single cones; ONL, outer nuclear layer; OPL, outer plexiform layer; H1, H2, and H3, H1-type, H2-type, and H3-type horizontal cells; H1P, H2P, H3P, H1-, H2-, H3-type dendritic processes; GIBP, green (single) cone invaginating basal process; RIBP, red (double) cone invaginating basal process.

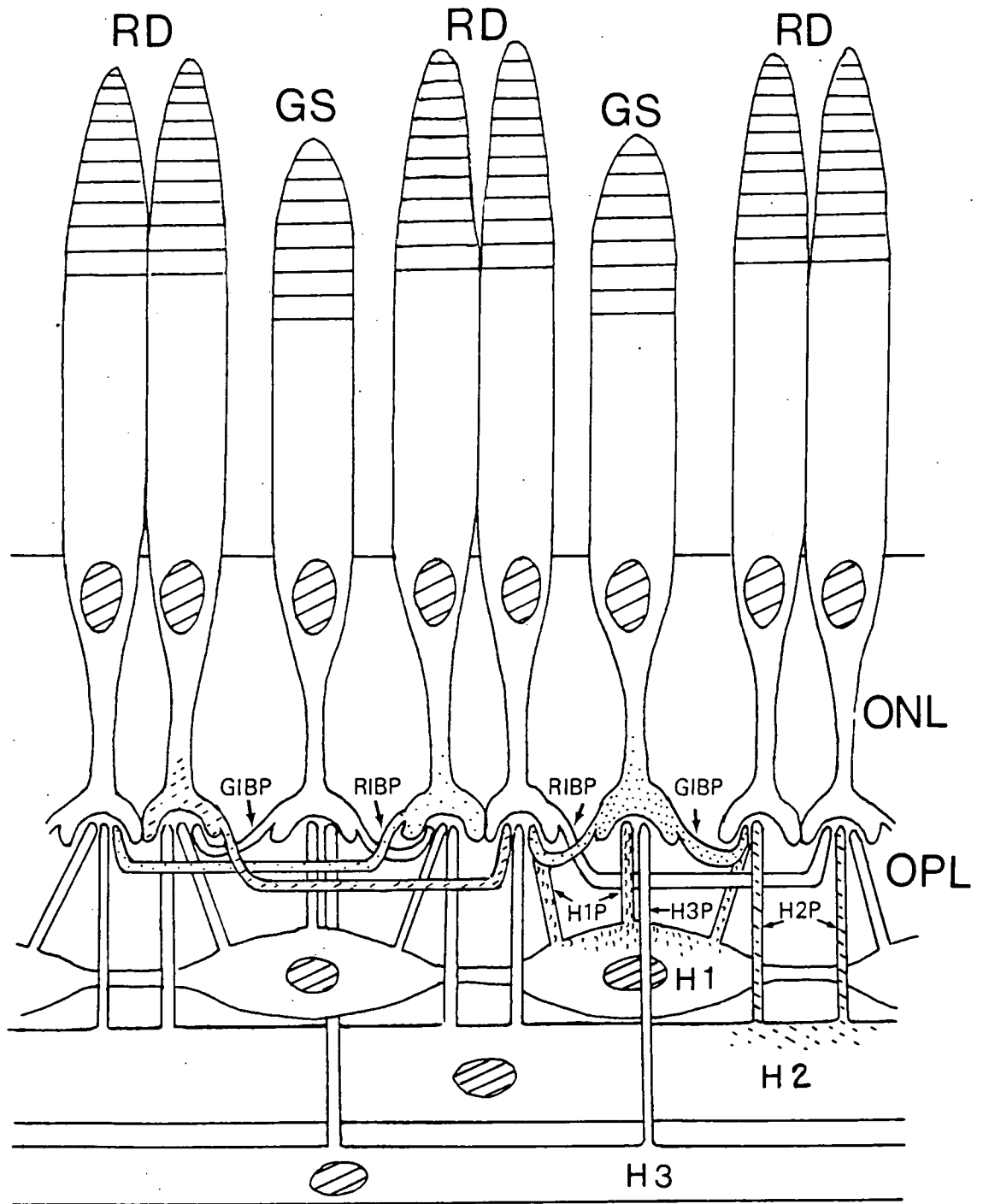

(Orlov and Maksimova, 1965; Witkovsky, 1967). In pikeperch, Burkhardt and Hassin (1978) made recordings from two L-type cells in succession distal to the C-type cells, later, Hassin (1979) using intracellular staining technique found that the two distal layers, H1 and H2 cell layers, gave L-type responses and the proximal layer, H3 cell layer, gave C-type responses which was consistent with the order in which these responses had been encountered and thus confirmed the previous results. This suggests that the sequence in which the cell types are encountered when penetrating the retina can be a reliable indication of the order in which the cell types are arranged in the retina.

According to the observed connection pattern of the three perch horizontal cell types with cones and on the sequence in which the L- and C-type cells were encountered when penetrating the retina in this study, and on correlation with functionally/histologically identified horizontal cells in other species (Section 7.3), the following relations are proposed: The histologically identified H1 and H2 cells generate monophasic L-type responses and H3 cells generate R/G C-type responses.

The primary distinction between perch and pikeperch retinas and other teleostean retinas is the possession of two layers of cone related L-type cells with clearly detectable nuclei. This may reflect differences in habitat or behavioural patterns or both and it may be a characteristic of the percidae family.

9.2. Generation of horizontal cell responses.

The H1-type cells in perch which contact both red and green cones probably generate red sensitive L-type responses. They correspond thus with the contact pattern of H1 L-type cells in pikeperch (Hassin, 1979; Witkovsky et al., 1979), and the L-type cells (H1CB) in turtle (Leeper, 1978). The H2-type cells in perch which contact red cones exclusively would therefore be expected to be L-type cells receiving input only from red sensitive cones. The H2 cell in perch has a similar connection pattern to the H1AT L-type in turtle (Leeper, 1978). While the H1 and H2 cells in perch differ in the contacts they make with cones, no difference was observed in spectral sensitivity in recordings from sequentially encountered L-type cells in the same penetration. Both cell types have the same maximum spectral sensitivity and no wavelength dependent differences in the response waveforms were observed. According to this evidence and the fact that the H1 cell contacts both red and green cones and the H2 cell only red cones, it seems likely that the sites of the H1 cell synapses on green cones may be involved mainly with L-type horizontal cell feedback onto green cones.

The H3 cells make contact only with the green sensitive single cones and are probably R/G C-type cells, since they have exactly the same contact pattern as R/G cells in pikeperch (Hassin, 1979; Witkovsky, et al., 1979), and similar contact pattern to R/G cells in goldfish and in turtle, which contact green and blue sensitive cones (Stell and Lightfoot, 1975; Leeper, 1978). Generation of R/G responses in H3 cells is explained by direct hyperpolarizing input from the green sensitive single cones. The depolarizing input must

therefore be mediated by an indirect pathway, probably through the H1 L-type cells. It remains uncertain, however, whether the depolarization of R/G cells to red light is produced by synaptic contact directly from L-type cells onto H3 cells, or by H1 cell feedback onto green cones.

Given the connectivity pattern of the three types of cone horizontal cells (H1, H2, and H3) and assuming the presence of a sign-inverting feedback mechanism from horizontal cells to cones, which may be a general feature, this concept readily explains the generation of the opponent colour responses in horizontal cells. A key feature appears to be a cascading system of interneurons, in which the cell type producing the monophasic responses (H1) receives a direct input from red sensitive cones and communicates its response to the biphasic cell type, probably by feedback onto the green cones (Fig. 9.2). However, as has been mentioned previously (Section 8.2.1) the spectral sensitivity of perch L-type horizontal cells differs markedly from those of other teleosts.

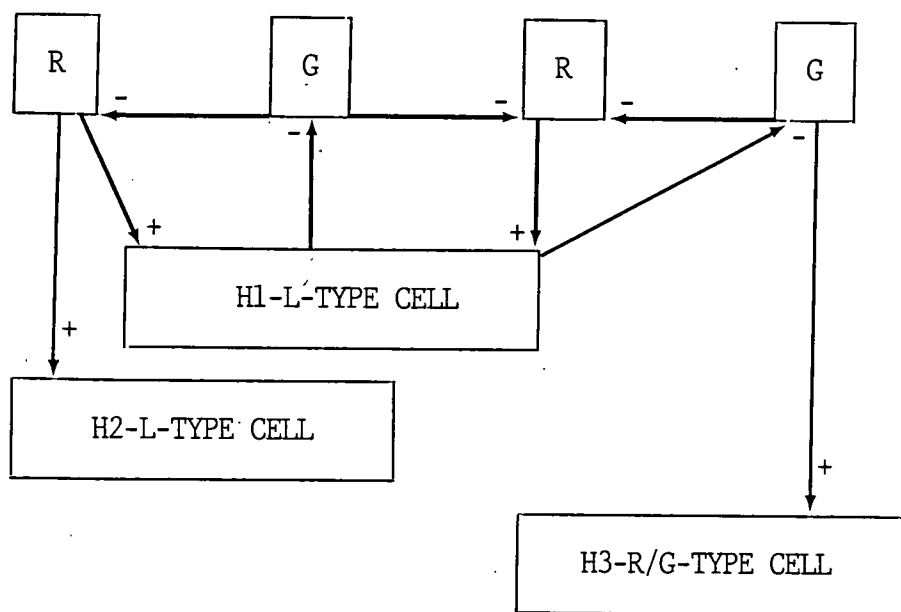

Figure 9.2.

Diagrammatic summary of the interconnections between horizontal and receptor cells in the perch retina, including a model for the pathways involved in the generation of horizontal cell responses and pseudopigment spectral sensitivity. R, red double cones; G, green sensitive single cones; "+", sign-conserving synapse; "-", inverting synapse.

9.3. Pseudopigment spectral sensitivity.

As has been previously demonstrated in this study (see section 8.2.1), by the method of Sirovich and Abramov (1977), the L-type pseudospectral sensitivity can possibly be generated by an antagonistic interaction between the red and green sensitive cones. The question arises as to the site of this interaction and the anatomical pathway through which this interaction is mediated. Since the L-type horizontal cells respond as if they receive input primarily from a single 650 nm pigment, it is likely that the antagonistic interaction between the two colour channels is mediated at some level peripheral to the site at which the responses are measured. Furthermore, the depolarizing signal observed in the horizontal cells under intense red background does not appear to be mediated directly on the L-cell but rather to be a postsynaptic interaction, and since the horizontal cells are connected directly to the cones, this interaction probably occurs directly between the red (R) and green (G) cones (Fig. 9.2).

The invaginating basal processes seem to be the anatomical pathway through which such an interaction might occur (see Fig. 9.1). Inhibitory actions of the green cone basal processes onto the red cone pedicles may generate the pseudospectral sensitivity observed in perch horizontal cells (Fig. 9.2). It could be expected that if the cones themselves directly interact in such a way to generate the 650 nm spectral sensitivity in perch, this spectral sensitivity should be observed without exception elsewhere in the visual pathway, but not the red 615 nm pigment. The behavioural measurements on perch (Cameron, 1982) may support such a conclusion,

as behavioural spectral sensitivity curves are in a very good qualitative agreement with the L-type cell 650 nm spectral sensitivity measured physiologically in this study, and a spectral sensitivity corresponding with the 615 nm red cone photopigment was not observed. It was noted earlier (Section 7.4) that the colour opponent system of cone basal processes of other teleosts (Scholes, 1975; Stell, 1980) are unlikely to mediate direct cone to cone antagonistic interactions, since the physiological action spectra and behavioural measurements fit closely with the pigment spectra (Naka and Rushton, 1966c; Muntz and Northmore, 1971; Spekreijse et al., 1972). Therefore Stell (1980) suggested that the basal processes acted on the horizontal cell processes, rather than on the cone pedicles. However, ultrastructural details of the basal processes interconnections are still too poorly known for evaluation of this hypothesis, and in the absence of intracellular recordings from perch cones and other retinal neurons, it is difficult to determine the site of interaction between the colour channels and must await further investigation.

Loew and Lythgoe (1978) suggested that generation of pseudo-spectral sensitivity or 'ghost cones' with their narrow spectral sensitivity curves and spectral sensitivity displaced to longer wavelengths are particularly suitable for detection of contrast. McFarland and Munz (1975a) have showed that detection of contrast is best achieved by possession of at least two cone photopigments, one 'matched' to the wavelength of maximum background radiance and one 'offset' from that wavelength. The spectral bandwidth of light available in fresh water is narrower than on land due to selective

absorption of natural water. As light travels through the water column its long wavelength components are gradually absorbed and its short wavelength components are selectively absorbed by the breakdown products of chlorophyll (yellow substances) narrowing the background light, leaving the midspectrum green light to be transmitted. Due to the selective absorption of water, the distance of an object is critical for its detection. A distant object and an object in deep water have the same spectral distribution as the background light. In this case, a receptor having a spectral sensitivity matched to the spectral radiance of the water background, as the perch green (535 nm) sensitive cone, will be best for detection of contrast. On the other hand, the spectrum of a bright object, at short distances at least, in moderate or shallow water is broader than that of the background. Thus for a visual mechanism spectrally offset from the background light, the background would appear relatively dark compared with the object (Munz and McFarland, 1977). A pseudopigment spectral sensitivity which is narrow and displaced to longer wavelengths as in perch, would therefore be an efficient contrast detector.

The perch which is sensitive to green 535 nm and far red 650 nm light, therefore, has the opportunity to employ a wavelength selective visual mechanism, both for optimal detection of objects and for discrimination of objects against background, in its struggle for survival.

REFERENCES.

- ABRAMOV, I. (1972). Retinal mechanisms of colour vision. In Handbook of sensory physiology. VII/2. Physiology of photoreceptor organs, (ed. by Fuortes, M.G.F.), 567-608.
- ADAMS, A. J. and AFANDOR, A. J. (1971). Ganglion cell receptive field organization at different levels of light adaptation. Am. J. Optom. and Arch. Am. Acad. Optom., 48, 889-896.
- AHLBERT, I. B. (1969). The organization of the cone cells in the retinae of four teleosts with different feeding habits (Perca fluviatilis L., Lucioperca lucioperca L., Acerina cernua L. and Coregonus albua L.). Arkiv for Zoologi, Band 22, II, 445-481.
- AHLBERT, I. B. (1973). Ontogeny of double cones in the retina of perch fry (Perca fluviatilis, Teleostei). Acta Zoologica, 54, 241-254.
- Ali, M. A. (1975). Retinomotor responses. In Vision in fishes (ed. by Ali, M.A.), 313-356. Plenum, New York, NY.
- ALLEN, D. M., LOEW, E. R. and McFARLAND, W. N. (1982). Seasonal change in the amount of visual pigment in the retina of fish. Canadian J. of Zool., 60, 3, 281-287.
- ALLEN, D. M. and McFARLAND, W. N. (1973). The effect of temperature on rhodopsin-porphyrin ratios in fish. Vision Res., 13, 1303-1309.
- ANCTIL, M. (1969). Structure de la retine chez quelques teleosteens marins du plateau continental. J. Fish. Res. Bd. Canada, 26, 597-628.
- ARDEN, G. B. and ERNST, W. (1969). Mechanism of current production found in pigeon cones but not in pigeon or rat rods. Nature (Lond.), 223, 528-531.
- AREY, L. B. (1928). Visual cells and retinal pigments. In Special Cytology, section 25, (ed. by Cowdry), 2, 887-926. Paul B. Hoeber Inc., New York.
- ASHMORE, J. F. and FALK, G. (1977a). Fluctuations in retinal bipolar cell responses to dim light flashes. J. Physiol. (Lond.), 269, 27-28.
- ASHMORE, J. F. and FALK, G. (1977b). Dark noise in retinal bipolar cells and stability of rhodopsin in rods. Nature (Lond.), 270, 69-71.
- ASHMORE, J. F. and FALK, G. (1980). Responses of rod bipolar cells in the dark-adapted retina of the dogfish, Scyliorhinus canula. J. Physiol., 300, 115-150.
- ATTWELL, D., WERBLIN, F. S. and WILSON, M. (1982a). The properties of single cones isolated from the tiger salamander retina. J. Physiol., 328, 259-283.

- ATTWELL, D., WERBLIN, F. S., WILSON, M. and Wu, S. (1982b). Rod-cone and cone-cone coupling in the retina of the tiger salamander. J. Physiol., 328, 33-34.
- ATTWELL, D., WERBLIN, F. S., WILSON, M. and WU, S. M. (1983). Sign reversing pathway from rods to double and single cones in the retina of the tiger salamander. J. Physiol., 336, 313-333.
- AYOUB, G, S. and LAM, D, M, K. (1984). The release of γ -aminobutyric acid from horizontal cells of the goldfish retina. J. Physiol., 355, 191-214.
- BADER, C. R. and BERTRAND, D. (1984). Ionic currents activated by voltage and by intracellular calcium: a voltage clamp study in solitary vertebrate photoreceptors. In Photoreceptors (Ed. by Borsellino, A. and Cervetto, L.). Plenum Press, New York & London. 177-200.
- BADER, C. R., BERTRAND, D. and SCHWARTZ, E. A. (1982). Voltage-activated and calcium-activated currents studied in solitary rod inner segments from the salamander retina. J. Physiol., 331, 253-284.
- BADER, C. R., MACLEISH, P. R., and SCHWARZ, E. A. (1979). A voltage-clamp study of the light response in solitary rods of the tiger salamander. J. Physiol., 296, 1-26.
- BARLOW, H.B. (1953). Summation and inhibition in the frog's retina. J. Physiol., 119, 69-88.
- BARLOW, H. B. and HILL, R. M. (1963). Selective sensitivity to direction of movement in ganglion cells of the rabbit retina. Science, 139, 412-414.
- BARLOW, H. B., HILL, R. M. and LEVICK, W. R. (1964). Retinal ganglion cells responding to direction and speed of image motion in the rabbit. J. Physiol. Lond., 173, 377-407.
- BARLOW, H. B. and LEVICK, W. R. (1965). The mechanism of directionally selective units in rabbit's retina. J. Physiol., 178, 477-504.
- BAYLOR, D.A. and FETTIPLACE, R. (1977). Kinetics of synaptic transfer from receptors to ganglion cells in turtle retina. J. Physiol., 271, 425-448.
- BAYLOR, D. A. and FUORTES, M. G. F. (1970). Electrical responses of single cones in the retina of the turtle. J. Physiol., 207, 77-92.
- BAYLOR, D. A., FUORTES, M. G. F. and O'BRYAN, P. M. (1971). Receptive fields of cones in the retina of the turtle. J. Physiol., (Lond.) 214, 265-294.
- BAYLOR, D. A. and HODGKIN, A. L. (1973). Detection and resolution of visual stimuli by turtle photoreceptors. J. Physiol., Lond., 234, 163-198.

- BAYLOR, D. A. and HODGKIN, A. L. (1974). Changes in the time scale and sensitivity in turtle photoreceptors. J. Physiol., 242, 729-758.
- BAYLOR, D. A., LAMB, T. D. and YAU, K. W. (1979). Responses of retinal rods to single photons. J. Physiol., 288, 613-634.
- BAYLOR, D. A., MATTHEWS, G. and YAU, K. W. (1980). Two components of electrical dark noise in toad retinal rod outer segments. J. Physiol., 309, 591-612.
- BEATTY, D. D. (1966). A study of the succession of visual pigments in the pacific salmon (*Oncorhynchus*). Can. J. Zool., 44, 429-455.
- BEAUCHAMP, R. D. and DAW, N. W. (1972). Rod and cone input to single goldfish optic nerve fibers. Vision Res., 12, 1201-1212.
- BENNETT, M. V. L. (1966). Physiology of electrical junctions. Ann. N.Y. Acad. Sci., 137, 509.
- BERGER, E. R. (1967). Subsurface membranes in paired cone photoreceptor inner segments of adult and neonatal, *Lebistes* retinae. J. Ultrastructure. Res., 17, 220-232.
- BISHOP, P. O., COOMBS, J. S. and HENRY, G. H. (1971). Interaction effects of visual contours on the discharge frequency of single striate neurones. J. Physiol., 219, 659-687.
- BLOOMFIELD, S. A. and MILLER, R. F. (1982). A physiological and morphological study of the horizontal cell types of the rabbit retina. J. Comp. Neurol., 208, 288-303.
- BOEHERT, G. W. (1978). Intraspecific evidence on the function of single and double cones in the teleost retina. Science, N. Y., 202, 309-311.
- BOLL, F. (1877). Zur Anatomie und Physiologie der Retina. Arch. Anat. Physiol., 4-35.
- BOROVYAGIN, V. L. (1966). English translation: Submicroscopic morphology and structural connexion of the receptor and horizontal cells of the retina of a number of lower vertebrates. Biophysics, 11, 930-940.
- BORTOFF, A. (1964). Localization of slow potential responses in the *Necturus* retina. Vision Res., 4, 627-636.
- BORTON, A. and NORTON, A. L. (1967). An electrical model of the vertebrate photoreceptor cell. Vision Res., 7, 253-263.
- BOYCOTT, B. B. and DOWLING, J. E. (1969). Organization of the primate retina: Light microscopy. Phil. Trans. Roy. Soc. (Lond.) B., 255, 109-184.

- BOYCOTT, B. B., DOWLING, J. E., FISHER, S. K., KOLB, H. and LATIES, E. M. (1975). Interplexiform cells of the mammalian retina and their comparison with catecholamine containing cells. Proc. Roy. Soc. (Lond.) B, 191, 353-368.
- BOYCOTT, B. B. and KOLB, H. (1973). The horizontal cells of the rhesus monkey retina. J. Comp. Neurol., 148, 115-140.
- BOYCOTT, B. B., PEICHL, L. and WASSLE, H. (1978). Morphological types of horizontal cells in the retina of the domestic cat. Proc. R. Soc. (Lond.) B, 203, 229-245.
- BRIDGES, C. D. B. (1965a). The grouping of fish visual pigments about preferred positions in the spectrum. Vision Res., 5, 223-238.
- BRIDGES, C. D. B. (1965b). Variability and relationships of fish visual pigments. Vision Res., 5, 239-251.
- BRIDGES, C. D. B. (1965c). Visual pigments in a fish exposed to different light-environments. Nature, 206, 1161-1162.
- BRIDGES, C. D. B. (1967). Spectroscopic properties of porphyropsin. Vision Res., 7, 349-369.
- BRIDGES, C. D. B. (1969). Yellow corneas in fishes. Vision Res., 9, 435-436.
- BRIDGES, C. D. B. and YOSHIKAMI, S. (1970a). The rhodopsin-porphyrpsin system in freshwater fishes. 1. Effects of age and photic environments. Vision Res., 10, 1315-1322.
- BRIDGES, C. D. B. and YOSHIKAMI, S. (1970b). The rhodopsin-porphyrpsin system in freshwater fishes. 2. Turnover and interconversion of visual pigment prosthetic groups in light and darkness: Role of pigment epithelium. Vision Res., 10, 1333-1345.
- BROWN, J. E., COLES, J. A. and PINTO, L. H. (1977). Effect of injection of calcium and EGTA into the outer segments of retinal rods of *Bufo Marinus*. J. Physiol. (Lond.), 269, 707-722.
- BROWN, J. E. and PINTO, L. H. (1974). Ionic mechanism for the photoreceptor potential of the retina of *Bufo marinus*. J. Physiol. (Lond.), 236, 575-591.
- BROWN, K. T. and WIESEL, T. N. (1961). Analysis of the intra-retinal electroretinogram in the intact cat eye. J. Physiol., 158, 229-256.
- BURKHARDT, D. A. (1966). The goldfish electroretinogram relation between photopic spectral sensitivety functions and cone action spectra. Vision Res., 6, 517-532.
- BURKHARDT, D. A. (1977). Responses and receptive-field organization of cones in perch retinas. J. Neurophysiol., 40, 53-62.
- BURKHARDT, D. A. and HASSIN, G. (1978). Influences of cones upon chromatic- and luminosity-type horizontal cells in pikeperch retinas. J. Physiol., 281, 125-137.

- BURKHARDT, D. A., HASSIN, G., LEVINE, J. S. and MacNICHOL, E. F., Jr. (1980). Electrical responses and photopigments of twin cones in the retina of the walleye. J. Physiol., 309, 215-228.
- BYZOV, A. L. (1975) Interaction between horizontal cells of turtle retina. Neurophysiol., 7, 279-286.
- BYZOV, A. L. and SHURA-BURA, T. M. (1983). Spread of potentials along the network of horizontal cells in the retina of the turtle. Vision Res., 23, 4, 389-397.
- BYZOV, A. L. and TRIFONOV, Y. A. (1968). The response to electric stimulation of horizontal cells in the carp retina. Vision Res., 8, 817-822.
- BYZOV, A. L. and TRIFONOV, Y. A. (1973). Electrical properties of subsynaptic and nonsynaptic membranes of horizontal cells in turtle retina. Neurophysiology, 5, 423-431.
- BYZOV, A. L. and TRIFONOV, Y. A. (1981). Ionic mechanisms underlying the nonlinearity of horizontal cell membrane. Vision Res., 21, 1573-1578.
- CAJAL, S. R. y (1892). La retine des vertebres. Cellule. 9. (Trans. by Thorpe, S. A. & Glickstein, M.). In The structure of the retina. Springfield, Ill. Thomas.
- CAJAL, S. R. y. (1893). Laretine des vertebrates. La Cellule, 9, 17-25.
- CAJAL, S. R. y (1933). La retine des vertebres. Trav. Lab. Rech. Biol. Univ. Madrid., 28 (appendice), 1: 144. Translation published by Thomas. C. C., Springfield, Illinois, and of Cajal, 1933, by Mogueire, D. and Rodieck, R. W. In The Vertebrae Retina.
- CAMERON, N. F. (1982). The photopic spectral sensitivity of a dichromatic teleost fish (Perca fluviatilis). Vision Res. Vol. 22, 1341-1348.
- CAPOVILLA, M., CERVETTO, L., PASINO, E. and TORRE, V. (1981). The sodium current underlying the voltage response of toad rods. J. Physiol., 317, 223-242.
- CAPOVILLA, M., CERVETTO, L. and TORRE, V. (1983). The effect of phosphodiesterase inhibitors on the electrical activity of toad rods. J. Physiol., 343, 277-294.
- CERVETTO, L. (1973). Influence of sodium, potassium and chloride ions on the intracellular responses of turtle photoreceptor. Nature, 241, 401-403.
- CERVETTO, L. and PICCOLINO, M. (1974). Synaptic transmission between photoreceptors and horizontal cells in the turtle retina. Science, (N.Y.) 183, 417-419.
- CHAN, R. Y. and NAKA, K.-I. (1976). The amacrine cell. Vision Res., 16, 1119-1129.

- COHEN, A. I. (1961). The fine structure of the extrafoveal receptors of the Rhesus monkey, Exp. Eye. Res., 1, 128-136.
- COHEN, A. I. (1963a). Vertebrate retinal cells and their organization. Biol. Rev., 38, 427-459.
- COHEN, A. I. (1963b). The fine structure of the visual receptors of the pigeon. Exp. Eye. Res., 2, 88-97.
- COHEN, A. I. (1964). Some observations on the fine structure of the retinal receptors of the American gray squirrel. Invest. Ophthalm., 3, 198-216.
- COHEN, A. I. (1965). Some electron microscopic observations on interreceptor contacts in the human and macaque retina. J. Anat., Lond., 99, 595-610.
- COHEN, A. I. (1972). Rods and Cones. In Handbook of Sensory Physiology, VII/2, Physiology of Photoreceptor Organs, ed. by Fuortes, M. G. F., 63-110.
- CONE, R. A. (1973). The internal transmitter model for visual excitation: some quantitative implications. In Biochemistry and Physiology of visual Pigments. 275. Springer, Berlin.
- COPENHAGEN, D. R. and OWEN, W. G. (1976). Functional characteristics of lateral interactions between rods in the retina of the snapping turtle. J. Physiol., Lond., 259, 251-282.
- COREY, D. P., DUBINSKY, J. and SCHWARTZ, E. A. (1982). The calcium current of rod-photoreceptor inner segments recorded with a whole-cell patch clamp. Neurosci. Abstr., 8, 944.
- COUILLARD, P. (1975). Approaches to the study of contractility in the rods and cones. In Vision in Fishes, ed. by Ali, M. A., 357-368. Plenum, New York, NY.
- CRESCITELLI, F. (1972). The visual cells and visual pigments of the vertebrate eye. In Handb. of Sens. Physiol., ed. by Dartnall, H. J. A., Berlin, Springer, VII/1. Photochem. of Vision, 245-363.
- CRISTY, M. (1976). Effects of temperature and light intensity on the visual pigments of rainbow trout. Vision Res., 16, 1225-1228.
- DACHEUX, R. F. (1982). Connections of the small bipolar cells with the photoreceptors in the turtle. An electron microscope study of Golgi-impregnated Gold toned retinas. J. comp. Neurol., 205, 55-62.
- DACHEUX, R. F. and MILLER, R. F. (1976). Photoreceptor-bipolar cell transmission in the perfused retina eyecup of the mudpuppy. Science, 191, 963-964.
- DACHEUX, R. F. and RAVIOLA, E. (1981). Anatomy of physiologically identified horizontal cells in the rabbit retina. Invest. Ophthalm. visual Sci., ARVO suppl., 202.

- DALY, J. M. (1977). In Cyclic Nucleotides in the Nervous System. Plenum Press, New York.
- DARTNALL, H. J. A. (1953). The interpretation of spectral sensitivity curves. Br. med. Bull. 9., 24-30.
- DARTNALL, H. J. A. (1957). The visual pigments. London: Methuen.
- DARTNALL, H. J. A. (1960). Visual pigments from a pure-cone retina. Nature. 188, 475-479.
- DARTNALL, H. J. A. (1962). The photobiology of visual processes. In The Eye, Vol. 2., ed. by Davson, H., 321-533. New York, Academic Press.
- DAW, N. W. (1968). Colour-coded ganglion cells in the goldfish retina: extension of their receptive fields by means of new stimuli. J. Physiol. (Lond.), 197, 567-59.
- DAW, N. W. (1973). Neurophysiology of color vision. Physiol. Rev., 53, 3, 571-611.
- DAW, N. W. and BEAUCHAMP, R. D. (1972). Unusual units in the goldfish optic nerve. Vision Res., 12, 1849-1856.
- DETWILER, P. B. and HODGKIN, A. L. (1979). Electrical coupling between cones in turtle retina. J. Physiol., 291, 75-100.
- DETWILER, P. B., HODGKIN, A. L. and McNAUGHTON, P. A. (1978). A surprising property of electrical spread in two network of rods in the turtle retina. Nature, 274, 562-565.
- DJAMGOZ, M. B. A. and STELL, W. K. (1984). Tetrodotoxin does not block the axonal transmission of S-potentials in goldfish retina. Neurosc. Letters, 49, 233-238.
- DOWLING, J. E. (1960). Chemistry of visual adaptation in the rat. Nature, 188, 114-118.
- DOWLING, J. E. (1968). Synaptic organization of the frog retina: An electron microscopic analysis comparing the retinas of frogs and primates. Proc. Roy. Soc. B., 170, 205-228.
- DOWLING, J. E. and BOYCOTT, B. B. (1965a). Neural connections of the retina: Fine structure of the inner plexiform layer. Cold Spring Harb. Symp. Quant. Biol., 30, 393-402.
- DOWLING, J. E. and BOYCOTT, B. B. (1965b). Neural connections of the primate retina. In: The structure of the eye, II, 55-68. Rohen, J. (Ed.)
- DOWLING, J. E. and BOYCOTT, B. B. (1966). Organization of the primate retina: Electron microscopy. Proc. Roy. Soc. B., 166, 80-111.

- DOWLING, J. E. and BOYCOTT, B. B. (1969). Retinal ganglion cells: A correlation of anatomical and physiological approaches. In The retina: Morphology, function and clinical characteristics, ed. by STRAATSMA, B. R., HALL, M. O., ALLEN, R. A., CRESCITELLI, F. UCLA Forum in medical sciences no. 8, 31-62. Berkley-Los Angeles: University of California Press.
- DOWLING, J. E., BROWN, J. E. and MAJOR, D. (1966). Synapses of horizontal cells in rabbit and cat retinas. Science, 153, 1639-1641.
- DOWLING, J. E. and EHINGER, B. (1975). Synaptic organization of the amine-containing interplexiform cells of the goldfish and cebus monkey retina. Science, 188, 270-273.
- DOWLING, J. E. and EHINGER, B. (1978). The interplexiform cell system. I. Synapses of the dopaminergic neurons of the goldfish retina. Proc. R. Soc. Lond. B, 201, 7-26.
- DOWLING, J. E., EHINGER, B. and HEDDEN, W. L. (1976). The interplexiform cell: A new type of retinal neuron. Invest. Ophthalmol., 15, 916-926.
- DOWLING, J. E., LASATER, E. M., BUSHKIRK, R. and WATLING, J. (1983). Pharmacological properties of isolated fish horizontal cells. Vision Res., 23, No.4, 421-432.
- DOWLING, J. E. and RIPPS, H. (1970). Visual adaptation in the retina of the skate. J. gen. Physiol., 56, 491-520.
- DOWLING, J. E. and RIPPS, H. (1973). Effect of magnesium on horizontal cell activity in the skate retina. Nature, 242, 101-103.
- DOWLING, J. E. and WATLING, K. J. (1981). Dopaminergic mechanisms in the teleost retina. II. Factors affecting the accumulation of cyclic AMP in pieces of intact carp retina. J. Neurochem., 36, 569-579.
- DOWLING, J. E. and WERBLIN, F. S. (1969). Organization of retina of the mudpuppy, Necturus maculosus. I. Synaptic structure. J. Neurophysiol. 32, 315-338.
- EBREY, T. G. and HONIG, B. (1977). New wavelength dependent visual pigment nomograms. Vision Res., 17, 147-151.
- EHINGER, B. and FALCK, B. (1969). Adrenergic retinal neurons of some new world monkeys. Z. Zellforsch., 100, 364-375.
- EHINGER, B., FALCK, B. and LATIES, A. M. (1969). Adrenergic neurons in teleost retina. Z. Zellforsch., 97, 285-297.
- EIGENMANN, C. H. and SHAFER, G. D. (1900). The mosaic of single and twin cones in the retina of fishes. Amer. Nat., 34, 109-118.
- ENGSTROM, K. (1963a). Structure, organization and ultrastructure of the visual cells in the teleost family Labridae. Acta Zool., 44, 1-41.

- ENGSTROM, K. (1963b). Cone types and cone arrangements in the teleost retinae. Acta Zool. (Stockholm) 44, 179-243.
- ENGSTROM, K. and AHLBERT, I. (1963). Cone types and cone arrangements in the retina of some flatfishes. Acta Zool., 44, 119-129.
- EVANS, E. M. (1966). On the ultrastructure of the synaptic region of visual receptors in certain vertebrates. Z. Zellforsch., 71, 499-516.
- FAIN, G. L. (1975). Quantum sensitivity of rods in the toad retina. Science, N.Y., 187, 838-841.
- FAIN, G. L. (1976). Sensitivity of toad rods: dependence on wavelength and background illumination. J. Physiol. (Lond.), 261, 71-101.
- FAIN, G. L. (1977). The threshold signal of photoreceptors. In: Vertebrate Photoreception, ed. by Barlow, H. B. and Fatt, P., 305-323. Academic Press, New York.
- FAIN, G. L. and DOWLING, J. E. (1973). Intra cellular recordings from single rods and cones in the mudpuppy retina. Science, N.Y., 180, 1178-1181.
- FAIN, G. L., GOLD, G. H. and DOWLING, J. E. (1976). Receptor coupling in the toad retina. Cold Spring Harbor Symposia, Quant. Biol., 40, 546-561.
- FAIN, G. L., GRANADA, A. M. and MAXWELL, J. H. (1977). The voltage signal of photoreceptors at the visual threshold. Nature, 265, 181-183.
- FAIN, G. L., ISHIDA, A. T. and CALLERY, S. (1983). Mechanisms of synaptic transmission in the retina. Vision Res., 23, 11, 1239-1249.
- FAIN, G. L. and LISMAN, J. E. (1981). Membrane conductances of photoreceptors. Prog. Biophys. Mol. Biol., 37, 91-148.
- FAIN, G. L., QUANDT, F. N., BASTIAN, B. L. and GERSCHENFELD, H. M. (1978). Contribution of a cesium-sensitive conductance increase to the rod photoresponse. Nature (Lond.), 272, 467-469.
- FALCK, B., HILLARP, N.-A., THIEME, G. and TORP, A. (1962). Fluorescence of catecholamines and related compounds condensed with formaldehyde. J. Histochem. Cytochem., 10, 348-354.
- FAMIGLIETTI, E. V. Jr., KANEKO, A. and TACHIBANA, M. (1977). Neural architecture of 'On' and 'Off' pathways to ganglion cells in carp retina. Science, 198, 1267-1269.
- FISHER, S. K. and BOYCOTT, B. B. (1974). Synaptic connexions made by horizontal cells within the outer plexiform layer of the retina of the cat and rabbit. Proc. Roy. Soc. (Lond.) B., 186, 317-331.

- FLOCK, A. (1964). Structure of the macula utriculi with special reference to directional interplay of sensory responses as revealed by morphological polarization. J. Cell. Biol., 22, 413-431.
- FLOCK, A. (1965). Electron microscopic and electrophysiological studies on the lateral line canal organ. Acta Oto-Lar. Suppl., 199, 1-90.
- FRIIS, G. (1879). In Fiskeoiet. Kobenhamn.
- FUORTES, M. G. F., SCHWARTZ, E. A. and SIMON, E. J. (1973). Colour dependence of cone responses in turtle retinas. J. Physiol. (Lond.), 234, 199-216.
- FUORTES, M. G. F. and SIMON, E. J. (1974). Interactions leading to horizontal cell responses in the turtle retina. J. Physiol. (Lond.), 240, 177-198.
- FUKUROTANI, K., HARA, K. I. AND OOMURA, Y. (1975). Dynamic character of the receptive field of L-cells in the carp retina. Vision Res., 15, 1403-1405.
- GALLEGO, A. (1954). Conexiones transversales retinianas. An. Inst. Farmacol. esp., 3, 31-39.
- GALLEGO, A. (1971). Horizontal and amacrine cells in the mammal's retina. Vision Res., ed. by T. Shipley and J.E. Dowling, 11 (suppl.3), 30-50.
- GALLEGO, A. (1976). Comparative study of the horizontal cells in the vertebrate retina: Mammals and birds. In Neural Principles in Vision, Eds. F.Zettler and R. Wieler, Berlin: Springer-Verlag, 22-62.
- GALLEGO, A., BARON, M. and GAYOSO, M. (1975). Horizontal cells of the avian retina. Vision Res., 15, 1029-1030.
- GALLEGO, A. and SOBRINO, J. A. (1975). Short axon horizontal cells of the monkey's retina. Vision Res., 15, 747-748.
- GEORGE, J. S. and HAGINS, W. A. (1983). Control of Ca^{+2} in rod outer segment disks by light and cyclic GMP. Nature (Lond.), 303, 344-348.
- GERSCHENFELD, H. M., NEYTON, J., PICCOLINO, M. and WITKOVSKY, P. (1983). L-horizontal cells of the turtle; network organization and coupling modulation. Biomed. Res. In press.
- GERSCHENFELD, H. M. and PICCOLINO, M. (1980). Sustained feedback effects of L-horizontal cells on turtle cones. Proc. R. Soc. (Lond.) B., 206, 465-480.
- GERSCHENFELD, H. M., PICCOLINO, M. and NEYTON, J. (1980). FEED-back modulation of cone synapses by L-horizontal cells of the turtle retina. J. Exp. Biol., 89, 177-192.

- GOLD, G. H. and DOWLING, J. E. (1979). Photoreceptor coupling in retina of the toad, Bufo marinus. II. Physiology. J. Neurophysiol., 42, 311-328.
- GOLD, G. H. and KORENBROT, J. I. (1980). Light-induced calcium release by intact retinal rods. Proc. natn. Acad. Sci. U.S.A., 77, 5557-5561.
- GOODEVE, G. F., LYTHGOE, R. J. and SCHNEIDER, E. E. (1941). The photosensitivity of visual purple solutions and the scotopic sensitivity of the eye in the ultraviolet. Proc. Roy. Soc. (Lond.), Ser. B., 130, 380-395.
- GOURAS, P. (1960). Graded potentials of bream retina. J. Physiol. (Lond.), 152, 487-505.
- GOURAS, P. (1972). S-potentials. In Handbook of Sensory Physiology of Photoreceptor organs (ed. by Fuortes, M.G.F.), Chap. 13, 513-529.
- GOVARDOVSKY, V. I. and ZUEVA, L. V. (1974). Spectral sensitivity of the frog eye in the ultraviolet and visible region. Vision res., 14, 1317-1322.
- GREEF, R. (1900). Die mikroskopische Anatomie des Sehnerven und der Netzhaut. Handbuch d. ges. Augenheilkunde, ed. by Graefe Saemisch, 2nd ed., 1-212, Leipzig.
- GUNNARSSON, T. and HYDE, D. (1982). Pseudopigment spectral sensitivity of an L-type horizontal cell in the retina of Perca fluviatilis, L. J. Physiol., 325, 78p.
- GUTIERREZ, O., NEELY, A. and SALINAS, R. (1983). The horizontal system of the carp retina. Transients reveal chromatic influences on L-units with participation of interplexiform cells. Arch. Biol. Med. Exp., 16, 271-281.
- HAESSENDONCK, E. van and MISSOTTEN, L. (1979). Synaptic contacts of the Horizontal cells in the retina of the Marine Teleost, Callionymus lyra L.. J. Comp. Neurol., 184, 1.
- HAESSENDONCK, E. van and MISSOTTEN, L. (1983). Inter bipolar contacts in the dorsal inner plexiform layer in the retina of Callionymus lyra L. J. Ultrastruc. Res., 83, 303-311.
- HAESSENDONCK, E. van and MISSOTTEN, L. (1984). Synaptic contacts between bipolar and photoreceptor cells in the retina of Callionymus lyra L.. J. Comp. Neur., 223, 387-399.
- HAGINS, W. A., PENN, R. D. and YOSHIKAMI, S. V. (1970). Dark current and photocurrent in retinal rods. Biophys. J., 10, 380-412.
- HAM, W. T., MUELLER, H. A. and SLINEY, D. H. (1976). Retinal sensitivity to damage from short wavelength light. Nature (Lond.), 260, 153-154.
- HAMA, K. (1965). Some observations on the fine structure of the lateral line organ of the Japanese sea eel, Lyncozymba nystromi. J. Cell Biol., 24, 193-210.

- HAROSI, F. I. (1976). Spectral relations of cone pigments in goldfish. J. Gen. Physiol., 68, 65-80.
- HAROSI, F. I. and MacNICHOL, E. F., Jr. (1974). Visual pigments of goldfish cones. Spectral properties and dichromism. J. Gen. Physiol., 63, 279-304.
- HARTLINE, H. K. (1938). The response of single optic nerve fibers of the vertebrate eye to illumination of the retina. Amer. J. Physiol., 121, 400-415.
- HARTWERTH, R. S. and SPERLING, H. G. (1971). Prolonged color blindness induced by intense spectral lights in rhesus monkeys. Science 174, 520-523.
- HASHIMOTO, Y., KATO, A., INOKUCHI, M. and WATANABE, K. (1976). Re-examination of horizontal cells in the carp retina with procion yellow electrode. Vision Res., 16, 25-29.
- HASHIMOTO, Y., INOKUCHI, M., UMINO, O. and KATAGIRI, Y. (1980). Bipolar, amacrine and I.P. cells in the dace retina: Physiology and morphology (abstract). J. Physiol. Soc. Japan, 42, 292.
- HASHIMOTO, Y. and INOKUCHI, M. (1981). Characteristics of second order neurons in the dace retina: Physiological and morphological studies. Vision Res., 21, 1541- 1550.
- HASSIN, G. (1979). Pikeperch horizontal cells identified by intracellular staining. J. Comp. Neur., 186, 529-540.
- HEDDEN, W. L. Jr. and DOWLING, J. E. (1978). The interplexiform cell system. II. Effects of dopamine on goldfish retinal neurones. Proc. R. Soc. (Lond.) B., 201, 27-55.
- HIBBARD, E. (1971). Grid patterns in the retinal organization of the cichlid fish Astronotus ocellatus. Exp. Eye. Res., 12, 175-180.
- HODGKIN, A. L., and HUXELEY, A. F. (1952). The components of membrane conductance in the giant axon of Loligo. J. Physiol., 116, 473-496.
- HUBBELL, W. L. and BOWNS, M. D. (1979). Visual transduction in vertebrate photoreceptors. Annu. R. Neurosci., 2, 17-84.
- HUGHES, A. and VANEY, D. I. (1980). Coronate cells: displaced amacrines of the rabbit retina?. J. Comp. Neurol., 189, 169-189.
- ISHIDA, A. T. and FAIN, G. L. (1981). D-aspartate potentiates the effects of L-glutamate on horizontal cell in goldfish retina. Proc. natn. Acad. Sci. U.S.A., 78, 5890-5894.
- ISHIDA, A. T., KANEKO, A. and TACHIBANA, M. (1983). Solitary horizontal cells in culture.- II. A new tool for examining effects of photoreceptor neurotransmitter candidates. Vision Res., 23, 11, 1217-1220.

- ISHIDA, A. T., KANEKO, A. and TACHIBANA, M. (1984). Responses of solitary retinal horizontal cells from *Carassius auratus* to L-glutamate and related amino acids. J. Physiol., 348, 255-270.
- ISHIDA, A. T., STELL, W. K. and LIGHTFOOT, D. O. (1980). Rod and cone inputsto bipolar cells in goldfish retina. J. Comp. Neurol., 191, 315-335.
- IVERSEN, L. L. (1975). Dopamine receptors in the brain. Science 188, 1084-1089.
- JOHNSTON, D. and LAM, D. M. K. (1981). Regenerative and passive membrane properties of isolated horizontal cells from a teleost retina. Nature, (Lond.) 292, 451-454.
- KANEKO, A. (1970). Physiological and morphological identification of horizontal, bipolar and amacrine cells in goldfish retina. J. Physiol., 207, 623-633.
- KANEKO, A. (1971a). Electrical connexions between horizontal cells in the dogfish retina. J. Physiol. (Lond.), 213, 95-105.
- KANEKO, A. (1971b). Physiological studies of single retinal cells and their morphological identification. Vision Res. Suppl., 3, 17-26.
- KANEKO, A. (1973). Receptive field organization of bipolar and amacrine cells in the goldfish retina. J. Physiol., 235, 133-153.
- KANEKO, A. (1979). Physiology of the retina. Ann. Rev. Neurosci., 2, 169-191.
- KANEKO, A. and HASHIMOTO, H. (1967). Recording site of the single cone response determined by electrode marking technique. Vision Res., 7, 847-851.
- KANEKO, A. and HASHIMOTO, H. (1969). Electrophysiological study of single neurons in the inner nuclear layer of the carp retina. Vision Res., 9, 37-55.
- KANEKO, A., NISHIMURA, Y., TACHIBANA, M., TAUCHI, M. and SHIMAI, K. (1981). Physiological and morphological studies of signal pathways in the carp retina. Vision Res., 21, No. 11, 1519-1526.
- KANEKO, A. and SHIMAZAKI, H. (1975). Effects of external ions on the synaptic transmission from photoreceptors to horizontal cells in the carp retina. J. Physiol., 252, 509-522.
- KANEKO, A. and SHIMAZAKI, H. (1976). Synaptic transmission from photoreceptors to bipolar and horizontal cells in the carp retina. Cold Spring Harb. Symp. quant. Biol. 40, 537-546.
- KANEKO, A. and TACHIBANA, M. (1981). Retinal bipolar cells with double colour-opponent receptive fields. Nature, 293, 5829, 220-222.

- KANEKO, A. and TACHIBANA, M. (1983). Double colour-opponent receptive fields of carp bipolar cells. Vision Res., 23, No. 4, 281-388.
- KANEKO, A. and YAMADA, M. (1972). S-potentials in the darkadapted retina of the carp. J. Physiol., 227, 261-273.
- KARWOSKY, C. J. and BURKHARDT, D. A. (1976). Ganglion cell responses of the mudpuppy retina to flashing and moving stimuli. Vision Res., 16, 1483-1495.
- KATZ, B. (1969). The release of neural transmitter substances. Liverpool: Liverpool University Press.
- KENNEDY, D. and MILKMAN, R. D. (1956). Selective light absorption by the lenses of lower vertebrates and its influence on spectral sensitivity. Biol. Bull., 111, 375-386.
- KIDD, M. (1962). Electron microscopy of the inner plexiform layer of the retina in the cat and the pigeon. J. Anat., 96, 179-187.
- KNOWLES, A. and DARTNALL, H. J. A. (1977). Photobiology of Vision. In The Eye, IIB, 1-689 (ed. by H. Davson). Academic Press, London.
- KOLB, H. (1970). Organization of the outer plexiform layer of the primate retina: electron microscopy of Golgi-impregnated cells. Phil. Trans. R. Soc. (Lond.) B., 258, 261-283.
- KOLB, H. (1974). The connection between horizontal cells and photoreceptors in the retina of the cat: electron microscopy of Golgi preparations. J. Comp. Neurol., 155, 1-14.
- KOLB, H. (1982). The morphology of the bipolar cells, Amacrine cells and Ganglion cells in the retina of the turtle, *Pseudemys scripta elegans*. Phil. Trans. R. Soc. (Lond.) B., 298, 355-393.
- KOLB, H. and JILL, J. (1982). Electron microscopy of the outer plexiform layer of the turtle retina. Abs. Int. Cong. Eye Res., 5, 27.
- KOLB, H., MARIANI, A. and GALLEG0, A. (1980). A second type of horizontal cell in the monkey retina. J. Comp. Neurol., 189, 31-44.
- KOLB, H. and NELSON, R. (1981). Amacrine cells of the cat retina. Vision Res., 21, 1625-1633.
- KOLB, H., NELSON, R. and MARIANI, A. (1981). Amacrine cells, bipolar cells and ganglion cells of the cat retina: or Golgi study. Vision Res., 21, 1081-1114.
- KOLB, H. and NORMANN, A. N. (1982). A-type horizontal cells of the superior edge of the linear visual streak of the rabbit retina have orientated, elongated dendritic trees. Vision Res., 22, 905-916.

- KORENBROT, J. I. and CONE, R. A. (1972). Dark ionic flux and the effects of light in isolated rod outer segments. J. Gen. Physiol., 60, 20.
- KRAUSE, W. (1886). Die Retina. II. Die Retina der Fische. Intern Monatsschr. f. Anat. Hist. 3, 8-38, 41-73.
- KUFFLER, S. W. (1953). Discharge patterns and functional organization of mammalian retina. J. Neurophysiol., 16, 37-68.
- KUHNE, W. (1878). On the photochemistry of the retina and on Visual purple (ed. with notes by Foster, M.). MacMillan: London.
- LAM, D. M.-K. (1975). Biosynthesis of gamma-amino-butyric acid by isolated axons of cone horizontal cells in the goldfish retina. Nature, 254, 345-347.
- LAM, D. M.-K. (1977). Physiological and biochemical studies of identified cells in the vertebrate retina. In Biochemistry of characterized neurons, ed. by Osborne, N. N., 239-269. Oxford, Pergamon Press.
- LAM, D. M.-K. and AYOUB, G. S. (1983). Biochemical and biophysical studies of isolated horizontal cells from the teleost retina. Vision Res., 23, 433-444.
- LAM, D. M.-K., LASATER, E. M. and NAKA, K.-I. (1978). γ -Aminobutyric acid: a neurotransmitter candidate for cone horizontal cells of the catfish retina. Proc. natn. Acad. Sci., 75, 6310-6313.
- LAM, D. M.-K. and STEINMANN, L. (1971). The uptake of [γ - 3 H] amino-butyric acid in the goldfish retina. Proc. Natn. Acad. Sci. U.S.A., 68, 2777-2781.
- LAM, D. M.-K., SU, Y. Y. T., SWAIN, L., MARC, R. E., BRANDON, C. and WU, J. Y. (1979). Immunocytochemical localization of L-glutamic acid decarboxylase in the goldfish retina. Nature, 278, 565-567.
- LAMB, T. D. (1976). Spatial properties of horizontal cell responses in the turtle retina. J. Physiol. (Lond.), 263, 239-255.
- LASANSKY, A. (1965). Functional implications of structural findings in retinal glial cells. In Biology of neuroglia, ed. by DeRobertis, E. D. P. and Carrea, R. Amsterdam, Elsevier. Progr. Brain Res., 15, 48-72.

- LASANSKY, A. (1969). Basal junctions at synaptic endings of turtle visual cells. J. Cell Biol., 40, 577.
- LASANSKY, A. (1971). Synaptic organisation of cone cells in the turtle retina. Phil. Trans. Roy. Soc. B, 262, 365-381.
- LASANSKY, A. (1972). Cell junctions at the outer synaptic layer of the retina. Invest. Ophthalmol., 11, 265-274.
- LASANSKY, A. (1973). Organization of the outer synaptic layer in the retina of the larval tiger salamander. Phil. Trans. R. Soc. B., 265, 471-489.
- LASANSKY, A. (1976). Interactions between horizontal cells of the salamander retina. Invest. Ophthalmol., 15, 809.
- LASANSKY, A. (1978). Contacts between receptors and electrophysiologically identified neurons in the retina of the larval tiger salamander. J. Physiol. (Lond.), 258, 531-542.
- LASANSKY, A. (1981). Synaptic action mediating cone responses to annular illumination in the retina of the larval tiger salamander. J. Physiol., 310, 205-214.
- LASANSKY, A. and MARCHIAFAVA, P. L. (1974). Light induced resistance changes in retinal rods and cones of the tiger salamander. J. Physiol., 236, 171-191.
- LASANSKY, A. and VALLEGRA, S. (1975). Horizontal cell responses in the retina of the larval tiger salamander. J. Physiol. (Lond.), 251, 145-165.
- LASATER, E. M. (1982). A white noise analysis of responses and receptive fields of catfish cones. J. Neurophysiol., 47, 1057-1068.
- LASATER, E. M. and DOWLING, J. E. (1982). Carp horizontal cells in culture respond selectively to L-glutamate and its agonists. Proc. natn. Acad. Sci. U.S.A., 79, 936-940.
- LAUFER, M. and MILLAN, E. (1970). Spectral analysis of L-type S-potentials and their relation to photopigment absorption in fish (Eugerres plumieri) retina. Vision Res., 10, 237-251.
- LAUFER, M. and NEGISHI, K. (1978). Enhancement of hyperpolarizing S-potentials by surround illumination in a teleost retina. Vision Res., 18, 1005-1011.
- LEEPER, H. F. (1978a). Horizontal Cells of the Turtle Retina. I. Light Microscopy of Golgi Preparations. J. Comp. Neurol., 182, 777-794.

- LEEPER, H. F. (1978b). Horizontal cells of the Turtle Retina. II. analysis of Interconnections Between Photoreceptor Cells and Horizontal Cells by Light Microscopy. J. Comp. Neurol., 182, 795-810.
- LEVICK, W. R. (1972). Receptive fields of retinal ganglion cells. In Handbook of sensory physiology, vol. VII/2, ed. by Fuortes, M. G. F., Physiology of photoreceptor organs. Springer, Berlin-Heidelberg, New York.
- LEVINE, J. S., MacNICHOL, E. F., Jr., KRAFT, T. Q. and COLLINS, B. A. (1979). Intraretinal distribution of cone pigments in certain teleosts. Science, N.Y., 204, 523-526.
- LEVINE, M. W. and SHEFNER, J. M. (1981). Distance-dependent interactions between the rod and the cone systems in Goldfish retina. Exp., Brain Res., 44, 353-361.
- LIEBMAN, P. A. (1972). Microspectrophotometry of photoreceptors. In Handbook of Sensory Physiology, VII/1, Photochemistry of Vision (ed. by Dartnall, H.J.A.), 481-528. Springer, Berlin.
- LIEBMAN, P. A. and ENTINE, G. (1964). Sensitive low-light level microspectrophotometer: detection of photosensitive pigments of retinal cones. J. Opt. Soc. Am., 54, 1451-1459.
- LIEBMAN, P. A. and ENTINE, G. (1968). Visual pigments of frog and tadpole (Rana pipiens). Vision Res., 8, 761-775.
- LIEBMAN, P. A. and PUGH, E. N., Jr. (1979). The control of phosphodiesterase in rod dish membranes; Kinetics, possible mechanisms and significance for vision. Vision Res., 19, 375-380.
- LOCKET, N. A. (1970). Retinal structure in deep-sea fish, Sternophyx deaphana, Hermann. Exp. Eye. Res., 9, 22-27.
- LOCKET, N. A. (1972). The reflection structure in the iridescent cornea of the serranid teleost, Nemanthias carberryi. Proc. R. Soc. B., 182, 249-254.
- LOCKHART, M. and STELL, W. K. (1979). Invaginating telodendria: a pathway for color-specific interconnections between goldfish cones. Invest. Ophthalmol., Visual Sci., Suppl. April, 1979, 82.
- LOEW, E. R. and DARTNALL, H. J. A. (1976). Vitamin A1/A2-based visual pigment mixtures in cones of the rudd. Vision Res., 16, 891-896.
- LOEW, E. R. and LYTHGOE, J. N. (1978). The ecology of cone pigments in teleost fishes. Vision Res., 18, 715-722.
- LYALL, A. H. (1957). Cone arrangements in teleost retinae. Quart. J. Micr. Sci., 98, part 2, 189-201.

- LYTHGOE, J. N. (1971). Iridescent corneas in fishes. Nature (Lond.), 233, 205-207.
- LYTHGOE, J. N. (1975). The structure and phylogeny of iridescent corneas in fishes. In Vision in Fishes, ed. by Ali, M. A., 253-262. Plenum Press, New York.
- LYTHGOE, J. N. (1979). The Ecology of Vision. Clarendon Press. Oxford.
- MacNICHOL, E. F. jr., MacPHERSON, L. and SVAETICHIN, G. (1957). Studies on spectral response curves from the fish retina. No. 39, Natl. Physiol. Lab., Teddington.
- MacNICHOL, E. F. and SVAETICHIN, G. (1958). Electric responses from the isolated retina of fishes. Amer. J. Ophtal., 46, 26-46.
- MAKSIMOVA, E. M., MAKSIMOV, V. V. and ORLOV, O. Y. (1966). Intensified interaction between signals of receptors in cells that are sources of S-potentials. Biofizika, 11, 472-477.
- MARC, R. E. and SPERLING, H. G. (1976a). Colour receptor identities of goldfish cones. Science, 191, 487-489.
- MARC, R. E. and SPERLING, H. G. (1976b). The chromatic organization of the goldfish cone mosaic. Vision Res., 16, 1211-1224.
- MARC, R. E., STELL, W. K., BOK, D. and LAM, D. M. (1978). GABA-ergic pathways in the goldfish retina. J. comp. Neurol., 182, 221-244.
- MARCHIAFAVA, P. L. (1978). Horizontal cells influence membrane potential of bipolar cells in the retina of the turtle. Nature (Lond.), 275, 141-142.
- MARIANI, A. P. (1982). Biplexiform cells: Ganglion cells of the primate retina that contact photoreceptors. Science, 216, 1134-1136.
- MARIANI, A. P. and LEURE DU PREE, A. E. (1977). Horizontal cells of the Pigeon retina. J. Comp. Neurol., 175, 13-26.
- MARKS, W. B. (1965). Visual pigments of single goldfish cones. J. Physiol. Lond., 178, 14-32.
- MARMARELIS, P. Z. and NAKA, K.-I. (1973). Spatial distribution of potential in a flat cell. Application to the catfish horizontal cell layers. Biophys. J., 12, 1515-1532.
- MATSUMOTO, N. and NAKA, K.-I. (1972). Identification of intracellular responses in the frog retina. Brain Res., 42, 59-71.
- McFARLAND, W. N. and MUNZ, F. W. (1975). The photic environment of clear tropical seas during the day. Vision Res., 15, 1063-1070.

- MILLER, R. F. and DACHEUX, R. F. (1976a). Synaptic organization and ionic basis of on and off channels in the mudpuppy retina. I. Intracellular analysis of chloride-sensitive electrogenic properties of receptors, horizontal cells, bipolar cells, and amacrine cells. J. gen. Physiol., 67, 639-659.
- MILLER, R. F. and DACHEUX, R. F. (1976b). Synaptic organization and ionic basis of on and off channels in the mudpuppy retina. II. Chloride-dependent ganglion cell mechanisms. J. gen. Physiol., 67, 661-678.
- MILLER, R. F. and DACHEUX, R. F. (1976c). Synaptic organization and ionic basis of on and off channels in the mudpuppy retina. III. A model of ganglion cell receptive field organization based on chloride-free experiments. J. gen. Physiol., 67, 679-690.
- MILLER, W. H., HASHIMOTO, Y., SAITO, T. and TOMITA, T. (1973). Physiological and morphological identification of L- and C-type S-potentials in the turtle retina. Vision Res., 13, 443-447.
- MILLER, W. H. and NICHOL, G. D. (1979). Evidence that cyclic GMP regulates membrane potential in rod photoreceptors. Nature (Lond.) 280, 64-66.
- MILLER, R. F., SLAUGHTER, M. M. and DICK, E. (1982). Excitatory, inhibitory and peptidergic pathways in the mudpuppy retina. In Neurotransmitter Interaction and Compartmentation (ed. by Bradford, H.F.), 735-759. Plenum, New York.
- MISSOTTEN, L. (1965a). The ultrastructure of the human retina. Bruxelles: Arscia Uitgaven.
- MISSOTTEN, L. (1965b). The synapses in the human retina. In The structure of the eye, 2, Symposium, Ed. Rohen, J. W., 17-28. Stuttgart: Schattauer-Verlag.
- MITARAI, G. (1958). The origin of the so-called cone action potential. Proc. Jap. Acad. 34, 299-314.
- MITARAI, G. (1960). Determination of ultramicroelectrode tip position in the retina in relation to S-potential. J. Gen. Physiol. 43, 2, 94-99.
- MITARAI, G., ASANO, T. and MIYAKE, Y. (1974). Identification of five types of S-potential and their corresponding generating sites in the horizontal cells of the carp retina. Jap. J. Ophthal., 18, 161-176.
- MITARAI, G., SOTO, T. and TAKAGI, S. (1978). Receptive field arrangement of colour-opponent bipolar and amacrine cells in the carp retina. Sensory Proc., 2, 375-382.
- MOOIJ, J. E. M. and BERG, T. J. T. P. (1983). The spectral shape of A2 visual pigments. Vision Res., 23, 7, 701-705.

- MORELAND, J. D. and LYTHGOE, J. M. (1968). Yellow corneas in fishes. Vision Res., 8, 1377-1380.
- MORTON, R. A. (1972). The chemistry of the visual pigments. In Handbook of sensory physiology, VIII/1, ed. by Dartnall, H. J. A. 33-68. Springer Verlag, Berlin.
- MOTOKAWA, K., OIKAWA, T. and TASAKI, K. (1975). Receptor potential of vertebrate retina. J. Neurophysiol., 20, 186-199.
- MULLER, H. (1851). Zur Histologie der Netzhaut. Z. wiss. Zool., 3, 234-237.
- MULLER, H. (1856). Anatomisch-physiologische Untersuchungen uber die Retina bei Menschen und Wirbelthieren. Z. wiss. Zool., 8, 1-122.
- MULLER, H. (1872). Gesammelte und hinterlassene Schriften zur Anatomie und Physiologie des Auges. Leipzig.
- MULLER, W. (1874). Uber die Stammesentwicklung des Sehorganes der Wirbeltiere. Festgabe an Carl Ludwig. Fol. II. Heft.
- MUNTZ, W. R. A. (1972). Inert absorbing and reflecting pigments. In Handbook of Sensory Physiol. VII/1. Photochemistry of Vision, ed. by Dartnall, H. J. A. Springer-Verlag, Berlin.
- MUNTZ, W. R. A. (1973). Yellow filters and the absorption of light by the visual pigments of some amazonian fishes. Vision Res., 13, 2235-2254.
- MUNTZ, W. R. A. (1982). Visual adaptations to different light environments in Amazonian fishes. Rev. Can. Biol. Experiment., 41, 1, 35-46.
- MUNTZ, W. R. A. and NORTHMORE, D. P. M. (1970). Vision and visual pigments in a fish, Scardinius erythrophthalmus (the Rudd). Vision Res., 10, 251-289.
- MUNTZ, F. W. and SWANSON, R. I. (1965). Thyroxine-induced changes in the proportions of visual pigments. Am. Zool., 5, 683.
- MUNZ, F. W. and McFARLAND, W. N. (1977). Evolutionary adaptation of fishes to the photic environment. In Handbook of sensory Physiol., ed. by Crescitelly, F., VII/5. 193-274.
- MUNZ, F. W. and SCHWANZARA, S. A. (1967). A nomogram for retinene-based visual pigments. Vision Res., 7, 111-120.
- MURAKAMI, M., OHTSU, K. and OHTSUKA, T. (1972). Effects of chemicals on receptors and horizontal cells in the retina. J. Physiol. Lond., 227, 899-913..

- MURAKAMI, M. and SHIMODA, Y. (1977). Identification of amacrine and ganglion cells in the carp retina. J. Physiol. Lond., 264, 801-818.
- MURAKAMI, M., SHIMODA, Y. and NAKATANI, K. (1978). Effects of GABA on neuronal activities in the distal retina of the carp. Sensory Processes, 2, 334-338.
- MURAKAMI, M., SHIMODA, Y., NAKATANI, K., MIYACHI, E. and WATANABE, S. (1982a). GABA-Mediated negative feedback from horizontal cells to cones in carp retina. Jap. J. Physiol., 32, 911-926.
- MURAKAMI, M., SHIMODA, Y., NAKATANI, K., MIYACHI, E. and WATANABE, S. (1982b). GABA-Mediated negative feedback and color opponency in carp retina. Jap. J. Physiol., 32, 927-935.
- NAKA, K.-I. (1972). The horizontal cells. Vision Res., 12, 573-588.
- NAKA, K.-I. (1976). Neuronal circuitry in the catfish retina. Invest. Ophthalmol., 15, 926-935.
- NAKA, K.-I. (1977). Functional organization of catfish retina. J. Neurophysiol., 40, 26-43.
- NAKA, K.-I. (1980). A class of catfish amacrine cells responds preferentially to objects which move vertically. Vision Res., 20, 961-965.
- NAKA, K.-I. and CARAWAY, N. R. G. (1975). Morphological and functional identification of the catfish retinas neurons. I. Classical morphology. J. Neurophysiol., 38, 53-71.
- NAKA, K.-I. and CHRISTENSEN, B. N. (1981). Direct electrical connections between transient amacrine cells in the catfish retina. Science, 214, 462-464.
- NAKA, K.-I. and OHTSUKA, T. (1975). Morphological and functional identification of the catfish retinal neurons. II. Morphological identification. J. Neurophysiol., 38, 72-91.
- NAKA, K.-I. and RUSHTON, W. A. H. (1966a). S-potentials from colour units in the retina of fish (Cyprinidae). J. Physiol., 185, 536-555.
- NAKA, K.-I. and RUSHTON, W. A. H. (1966b). An attempt to analyse colour perception by electrophysiology. J. Physiol., 185, 556-586.
- NAKA, K.-I. and RUSHTON, W. A. H. (1966c). S-potential from luminosity units in the retina of fish (Cyprinidae). J. Physiol., 185, 587-599.
- NAKA, K.-I. and RUSHTON, W. A. H. (1967). The generation and spread of S-potentials in fish (Cyprinidae). J. Physiol., 192, 437-461.

- NEGISHI, K and DRUJAN, B. D. (1978). Effects of catecholamines on the horizontal cell membrane potential of the fish retina. Sensory Proc. 2, 388-395.
- NEGISHI, K and DRUJAN, B. D. (1978). Effects of some amino acids on horizontal cells in the fish retina. J. Neurosci. Res., 4, 351-363.
- NEGISHI, K. and SUTIJA, V. (1969). Lateral spread of light-induced potentials along different cell layers in the teleost retina. Vision Res., 9, 881-893.
- NELSON, R., KOLB, H., FAMIGLIETTI, E. V. Jr. and GOURAS, P. (1976). Neural responses in the rod and cone systems of the cat retina; intracellular records and procion stains. Invest. Ophthalmol., 15, 946-953.
- NEYTON, J., PICCOLINO, M. and GERSCHENFELD, H. M. (1982). Dopamine (DA) and drugs that increase intracellular cyclic AMP decrease junctional communication between L-horizontal cells. Soc. Neurosci. Abstr., 8, 132.
- NILSSON, S. E. G. (1964). Interreceptor contacts in the retina of the frog (Rana pipiens). J. Ultrastruct. Res., 11, 147-165.
- NORMANN, R. A., PERLMAN, I., KOLB, H. P. and DALY, S. J. (1984). Direct excitatory interactions between cones of different spectral types in the turtle retina. Science, 224, 625-627.
- NORTON, A.L., SPEKREIJSE, H., WOLBARSH, M.L. and WAGNER, H.G. (1968). Receptive field organization of the S-potential. Science, N.Y., 160, 1021-1022.
- OBRYAN, P. M. (1973). Properties of the depolarizing synaptic potential evoked by peripheral illumination in cones of the turtle retina. J. Physiol. Lond., 235, 207-223.
- O'CONNELL, C. P. (1963). The structure of the eye of Scardinops caerulea, Engraulis mordax, and four other pelagic marine teleosts. J. Morph., 113, 2, 287-330.
- O'DALY, J. A. (1967). ATPase activity at the functional contacts between retinal cells which produce S-potential. Nature, Lond., 216, 1329-1331.
- OGDEN, T. E. (1974). The morphology of retinal neurons of the owl monkey aotes. J. Comp. Neurol., 153, 399-428.
- OIKAWA, T., OGAWA, T. and MOTOKOWA, K. (1959). Origin of the so-called cone action potential. J. Neurophysiol., 22, 102-111.

- ORLOV, O. Y. and MAKSIMOVA, E. M. (1965). S-potential sources as excitation pools. Vision Res., 5, 573-582.
- PARTHE, V. (1967). Celulas horizontales y amacrinas de la retina. Acta Cient. Venezolana, Suppl., 3, 240-249.
- PARTHE, V. (1972). Horizontal, bipolar and oligopolar cells in the teleost retina. Vision Res., 12, 395-406.
- PEDLER, C. (1965). Ultrastructural variations in the photoreceptors of the macaque. Exp. Eye Res., 4, 370-373.
- PEDLER, C. and TILLY, R. (1964). The nature of the gecko visual cell. A light and electron microscopic study. Vision Res., 4, 499-510.
- PENN, R. D. and HAGINS, W. A. (1969). Signal transmission along retinal rods and the origin of the electroretinographic a-wave. Nature, Lond., 223, 201-205.
- PICCOLINO, M. and GERSCHENFELD, H. M. (1978). Activation of a regenerative calcium conductance in turtle cones by peripheral stimulation. Proc. R. Soc. Lond. B., 201, 309-315.
- PICCOLINO, M. and GERSCHENFELD, H. M. (1980). Characteristics and ionic processes involved in feedback spikes of turtle cones. Proc. R. Soc. Lond. B., 206, 439-463.
- PICCOLINO, M. NEYTON, J. and GERSCHENFELD, H. (1981). Center-surround antagonistic organization in small-field luminosity horizontal cells of turtle retina. J. Neurophysiol., 45, 363-375.
- PICCOLINO, M., NEYTON, J., WITKOVSKY, P. and GERSCHENFELD, H. M. (1982). Gamma-amino butyric acid antagonists decrease junctional communication between L-horizontal cells of the retina. Proc. Natu. Acad. Sci. U.S.A., 79, 3671-3675.
- PINTO, L. H. and PAK, W. L. (1974a). Light-induced changes in photoreceptor membrane resistance and potential in gecko retinas. I. Preparations treated to reduce lateral interactions. J. Gen. Physiol., 64, 26-48.
- PINTO, L. H. and PAK, W. L. (1974b). Light-induced changes in photoreceptor membrane resistance and potential in gecko retinas. II. Preparations with active lateral interactions. J. Gen. Physiol., 64, 49-69.
- POLYAK, S. L. (1941). The retina. Chicago: Chicago University Press.
- POLYAK, S., (1957). The Vertebrate Visual System. Univ. of Chicago Press, Chicago., 207-287.

- POWERS, M. K. and EASTER, S. S. (1978a). Absolute visual sensitivity of the goldfish. Vision Res., 18, 1137-1148.
- POWERS, M. K. and EASTER, S. S. (1978b). Wavelength discrimination by the goldfish near absolute visual threshold. Vision Res., 18, 1149-1154.
- RAVIOLA, E. (1976). Intercellular junctions in the outer plexiform layer of the retina. Invest. Ophthalmol., 15, 881-895.
- RAVIOLA, E. and GILULA, B. N. (1973). Gap junctions between photoreceptor cells in the vertebrate retina. Proc. Natn. Acad. Sci. U.S.A., 70, 1677-1681.
- RAYNAULD, J.-P. (1975). A module for the ganglionic receptive field organization. In Vision In Fishes ed. by Ali, M. A., 91-98. Plenum, New York, N.Y.
- RICHTER, A. and SIMON, E. J. (1974). Electrical responses of double cones in the turtle retina. J. Physiol., 242, 673-683.
- RICHTER, A. and SIMON, E. J. (1975). Properties of centre-hyperpolarizing, red-sensitive bipolar cells in the turtle retina. J. Physiol. Lond., 248, 317-334.
- RIPPS, H. and WEALE, R. A. (1976). The visual stimulus. In The eye, Ila, ed. by H. Dawson, 43-99. Academic Press, New York.
- RODIECK, R. W. (1973). The vertebrate retina. W. H. Freeman, San Francisco.
- ROWE, J. S. and RUDDOCK, K. H. (1982). Depolarization of retinal horizontal cells by excitatory amino acid neurotransmitter agonists. Neurosc. Lett. 30, 257-262.
- SAITO, T., KONDO, H. and TOYODA, J.-I. (1979). Ionic mechanisms of two types of ON-center bipolar cells in the carp retina. I. The responses to central illumination. J. Gen. Physiol., 73, 73-90.
- SAITO, T., KONDO, H. and TOYODA, J.-I. (1981). Ionic mechanisms of two types of ON-center bipolar cells in the carp retina. II. The responses to annular illumination. J. Gen. Physiol., 78, 569-589.
- SAITO, T., KUJIRAOKA, T. and YONAHARA, T. (1983). Connections between photoreceptors and horseradish peroxidase-injected bipolar cells in the carp retina. Vision Res., 23, 353-362.
- SAITO, T., MILLER, W. H. and TOMITA, T. (1974). C- and L-type horizontal cells in the turtle retina. Vision Res., 14, 119-123.
- SAKAI, H. and NAKA, K.-I. (1983). Synaptic organization involving receptor, horizontal and ON- and OFF-center bipolar cells in catfish retina. Vision Res., 23, 339-351.
- SCHIEFFERDECHER, P. (1886). Studien zur vergleichenden Histologie der Retina. Arch. Mikr. Anat., 28, 305-396.

- SCHIEFFERDECHER, P. (1887). Über das Fischauge. Anat. Anz., 2, 381-382.
- SCHMIDT, R. and STEINBERG, R. H. (1971). Rod-dependent intracellular responses to light recorded from the pigment epithelium of the cat retina. J. Physiol., 217, 71-91.
- SCHOLES, J. H. (1975). Colour receptors and their synaptic connections in the retina of a cyprinid fish. Phil. Trans. B., 270, 61-118.
- SCHOLES, J. H. (1976). Neuronal connections and cellular arrangement in the fish retina. In Neural principles in vision. ed. by Zettler, F. and Weiler, R. 63-93. Springer-Verlag, Berlin, Heidelberg.
- SCHOLES, J. H. and MORRIS, J. (1973). Receptor-bipolar connectivity patterns in fish retina. Nature, Lond., 241, 52-54.
- SCHULTZE, M. (1866). Zur anatomie und physiologie der Retina. Arch. Mikroskop. Anat., 2, 175-286.
- SCHULTZE, M. (1867). Über Stabchen und Zapfen der Netzhaut. Arch. mikrosk. Anat. Bd., 3, 215-247.
- SCHWANZARA, S. A. (1967). The visual pigments of freshwater fishes. Vision Res., 7, 121-148.
- SCHWARTZ, E. A. (1975). Rod-rod interaction in the retina of the turtle. J. Physiol. Lond., 246, 617-638.
- SCHWARTZ, E. A. (1976). Electrical properties of the rod syncytium in the retina of the turtle. J. Physiol., 257, 379-406.
- SCHWARTZ, E. A. (1982). Calcium-independent release of GABA from isolated horizontal cells of the toad retina. J. Physiol. (Lond.), 323, 211-227.
- SHICHI, H., LEWIS, M. S., IRREVERRE, F. and STONE, A. L. (1969). Biochemistry of visual pigments I: Purification and properties of bovine rhodopsin. J. Biol. Chem., 244, 529-536.
- SHIELLS, R. A., FALK, G. and NAGHSHINEH, S. (1981). Action of glutamate and aspartate analogues on rod horizontal and bipolar cells. Nature, 294, 592-594.
- SHINGAI, R. and CHRISTIANSEN, B. N. (1983a). Voltage clamp studies in isolated horizontal cells. A.R.V.O. Abstracts, 179.
- SHINGAI, R. and CHRISTIANSEN, B. N. (1983b). Sodium and calcium currents measured in isolated catfish horizontal cells under voltage clamp. Neurosci., 10, 893-897.
- SILLMAN, A. J., ITO, H. and TOMITA, T. (1969a). Studies on the mass receptor of the isolated frog retina. I. General properties of the response. Vision Res., 9, 1435-1442.

- SILLMAN, A. J., ITO, H. and TOMITA, T. (1969b). Studies on the mass receptor potential of the isolated frog retina. II. On the basis of the ionic mechanism. Vision Res., 9, 1443-1451.
- SIMON, E. J. (1973). Two types of luminosity horizontal cells in the retina of the turtle. J. Physiol., 230, 199-212.
- SIROVICH, L. and ABRAMOV, I. (1977). Photopigments and pseudopigments. Vision Res., 17, 5-16.
- SJOSTRAND, F. S. (1953). The ultrastructure of the inner segment of the retinal rods of the guinea pig eye as revealed by electron microscopy. J. Cell. Comp. Physiol., 42, 45-70.
- SJOSTRAND, F. S. (1958). Ultrastructure of retinal rod synapses of the guinea pig eye as revealed by three-dimensional reconstructions from serial sections. J. Ultrastr. Res., 2, 122-170.
- SJOSTRAND, F. S. (1959). The ultrastructure of the retinal receptors of the vertebrate eye. Ergeb. Biol., 21, 128-160.
- SJOSTRAND, F. S. (1961). Electron microscopy of the retina. In: The structure of the eye. New York. Academic Press.
- SJOSTRAND, F. S. (1965). The synaptology of the retina. In Colour Vision, 110-144. Ciba Foundation Symposium. London: Churchill.
- SJOSTRAND, F. S. (1969). The outer plexiform layer and the neural organization of the retina. In The retina: Morphology, function and clinical characteristics. U.C.L.A. forum in medical sciences, 8, 63-100, ed. by Straatsma, B. R., Hall, M. D., Allen, R. A. and Crescitelli, F. Berkeley and Los Angeles: University of California Press.
- SMITH, C. A. and SJOSTRAND, F. S. (1961a). A synaptic structure in the hair cells of the guinea pig cochlea. J. Ultrastructure Res., 5, 184-192.
- SMITH, C. A. and SJOSTRAND, F. S. (1961b). Structure of the nerve endings on the external hair cells of the guinea pig cochlea as studied by serial sections. J. Ultrastructure Res., 5, 523-556.
- SPEKREIJSE, H. and NORTON, A. L. (1970). The dynamic characteristics of color-coded S-potentials. J. Gen. Physiol., 56, 1-15.
- SPEKREIJSE, H., WAGNER, H. G. and WOLBARSHT, M. L. (1972). Spectral and spatial coding of ganglion cell responses in goldfish retina. J. Neurophysiol., 35, 73-85.
- STEINBERG, R. H. and SCHMIDT, R. (1970). Identification of horizontal cells as S-potential generators in the cat retina by intracellular dye injection. Vision Res., 10, 817-820.
- STELL, W. K. (1965). Observations on some ultrastructural characteristics of goldfish cones. Amer. Zool., 5, 435.

- STELL, W. K. (1967). The structure and relationship of horizontal cells and photoreceptor-bipolar synaptic complexes in goldfish retina. Amer. J. Anat., 121, 401-423.
- STELL, W. K. (1972). The morphological organization of the vertebrate retina. In The Handbook of Sensory Physiology, VII/1. B, Physiology of Photoreceptor Organs, Chapter 3., 111-213. Ed. by Fuortes, M. G. F. Springer, New York, N.Y.
- STELL, W. K. (1975). Horizontal cell axons and terminals in goldfish retina. J. Comp. Neurol., 159, 503-520.
- STELL, W. K. (1976). Functional polarization of horizontal cell dendrites in goldfish retina. Invest. Ophthalmol., 15, 895-908.
- STELL, W. K. (1978). Inputs to bipolar cell dendrites in goldfish retina. Sensory Proc., 2, 339-349.
- STELL, W. K. (1980). Photoreceptor-specific synaptic pathways in goldfish retina: a world of colour, a wealth of connections. In Colour Vision Deficiencies, V; Chapter 1. Ed. by Verrlest, G.
- STELL, W. K. and HAROSI, F. I. (1976). Cone structure and visual pigment content in the retina of the goldfish. Vision Res., 16, 647-657.
- STELL, W. K., ISHIDA, A. T. and LIGHTFOOT, D. O. (1977). Structural basis for ON and OFF-center responses in retinal bipolar cells. Science, 198, 1269-1271.
- STELL, W. K. and LIGHTFOOT, D. O. (1975). Color-specific interconnections of cones and horizontal cells in the retina of the goldfish. J. Comp. Neur., 159, 473-502.
- STELL, W. K., LIGHTFOOT, D. O., WHEELER, T. G. and LEEPER, H. F. (1975). Goldfish retina: Functional polarization of cone horizontal cell dendrites and synapses. Science, 190, 989-990.
- STELL, W. K. and WITKOVSKY, P. (1973a). Retinal structure in the smooth dogfish, Mustelus canis: general description and light microscopy of giant ganglion cells. J. Comp. Neurol., 148, 1-32, (XV-D).
- STELL, W. K. and WITKOVSKY, P. (1973b). Retinal structure in the smooth dogfish, Mustelus canis: Light microscopy of photoreceptor and horizontal cells. J. Comp. Neurol., 148, 33-45.
- SVAETICHIN, G. (1953). The cone action potential. Acta physiol. Scand., 29 (Suppl. 106), 565-600.
- SVAETICHIN, G. (1956). Spectral response curves of single cones. Acta physiol. Scand., 39 (Suppl. 134), 18-46.
- SVAETICHIN, G. (1961). Origin of the R-potential in the mammalian retina, in the Visual System. In Neurophysiology and Psychophysics, ed. by Jung, R. and Kornhuber, H., 61-64. Berlin-Göttingen-Heidelberg: Springer.

- SVAETICHIN, G., LAUFER, M., MITARAI, G., FATEHCHAND, R., VALLECALLE, E. and VILLEGAS, J. (1961). Glial control of neuronal networks and receptors. In: The Visual System: Neurophysiology and Psychophysics. (ed. by R. Jung and H. Kornhuber), 445-456. Springer-Verlag, Berlin.
- SVAETICHIN, G. and MacNICHOL, E. F., Jr. (1958). Retinal mechanisms for chromatic and achromatic vision. Ann. N.Y. Acad. Sci., 74, 385-404.
- SVAETICHIN, G., NEGISHI, K. and FATEHCHAND, R. (1965). Cellular mechanisms of the young-hering visual system. In Colour Vision. Ciba Foundation Symposium (ed. by de Reuck, A.V.S. and Knight, J. Little, Brown & Co. Boston, 178-207.
- TACHIBANA, M. (1978). Signal pathways in the carp retina. 1. Rod and cone pathways. J. Keio Med. Soc., 55, 477-492.
- TACHIBANA, M. (1981). Membrane properties of solitary horizontal cells isolated from goldfish retina. J. Physiol. Lond., 321, 141-161.
- TACHIBANA, M. (1983). Ionic currents of solitary horizontal cells isolated from goldfish retina. J. Physiol. Lond., 345, 329-351
- TAMURA, T and NIWA, H. (1967). Spectral sensitivity and color vision of fish as indicated by S-potential. Comp. Biochem. Physiol., 22, 745-754.
- TAUCHI, M., YANG, X. and KANEKO, A. (1984). Depolarizing responses of L-type external horizontal cells in the goldfish retina under intense chromatic background. Vision Res., 24, 867-870.
- TERANISHI, T., KATO, S. and NEGISHI, K. (1982). Lateral spread of S-potential components in the carp retina. Exp. Eye Res., 34, 389-399.
- TERANISHI, T., NEGISHI, K. and KATO, S. (1984). Regulatory effect of dopamine on spatial properties of horizontal cells in carp retina. J. Neurosci., 4, 1271-1280.
- TESTA, A. S. (1966). Morphological studies on the horizontal and amacrine cells of the teleost retina. Vision Res., 6, 51-59.
- TOMITA, T. (1957). A study on the origin of intraretinal action potential of the cyprinid fish by means of pencil-type microelectrode. Jap. J. Physiol., 7, 80-85.
- TOMITA, T. (1965). Electrophysiological study of the mechanisms subserving color coding in the fish retina. Cold Spr. Harb. Symp. Quant. Biol., 30, 559-566.
- TOMITA, T. (1970). Electrical activity of vertebrate photoreceptors. Quart. Rev. Biophys., 3, 179-222.

- TOMITA, T., KANEKO, A., MURAKAMI, M. and PAUTLER, E. L. (1967). Spectral response curves of single cones in the carp. Vision Res., 7, 519-531.
- TOMITA, T., MURAKAMI, M., SATO, Y. and HASHIMOTO, Y. (1959). Further study on the origin of the so-called cone action potential (S-potential). Its histological determination. Jap. J. Physiol., 9, 63-68.
- TOMITA, T., TOSAKA, T., WATANABE, K. and SATO, Y. (1958). The fish ERG in response to different types of illumination. Jap. J. Physiol., 8, 41-50.
- TOYODA, J.-I. (1973). Membrane resistance changes underlying the bipolar cell response in the carp retina. Vision Res., 13, 283-294.
- TOYODA, J.-I., HASHIMOTO, H. and OHTSU, K. (1973). Bipolar-amacrine transmission in the carp retina. Vision Res., 13, 295-307.
- TOYODA, J.-I. and KUJIRAOKA, T. (1982). Analysis of bipolar cell responses elicited by polarization of horizontal cells. J. Gen. Physiol., 79, 131-145.
- TOYODA, J.-I., NOSAKI, H. and TOMITA, T. (1969). Light induced resistance changes in single photoreceptors of *Necturus* and *Gecko*. Vision Res., 13, 283-294.
- TOYODA, J.-I., SAITO, T. and KONDO, H. (1978). Three types of horizontal cells in the stingray retina: Their morphology and physiology. J. Comp. Neur., 179, 569-580.
- TOYODA, J.-I. and TONOSAKI, K. (1978). Effect of polarisation of horizontal cells on the On-centre bipolar cell of carp retina. Nature. Lond., 276, 399-400.
- TRIFONOV, Y. A. (1968). Study of synaptic transmission between the photoreceptor and the horizontal cell using electrical stimulation of the retina. Biofizika, 13, 809-817.
- TRIFONOV, Y. A. and BYZOV, A. L. (1977). Interaction in photoreceptor synapses revealed in experiments with polarization of horizontal cells. In Vertebrate Photoreception, ed. by Barlow, H. B. and Fatt, P. Academic Press. Inc. Lond., 251-263.
- TRIFONOV, Y. A., BYZOV, A. L. and CHAILAHIAN, L. M. (1974). Electrical properties of subsynaptic and nonsynaptic membranes of horizontal cells in fish retina. Vision Res., 14, 229-241.
- TRIFONOV, Y. A., CHAILACHIAN, L. M. and BYZOV, A. L. (1971). An investigation of the origin of electrical responses of horizontal cells in fish retina. Neurophysiology, 3, 89-98.
- TSIN, A. T. C. and BEATTY, D. D. (1977). Visual pigment changes in rainbow trout in response to temperature. Science, 195, 1358-1360.

- UGA, S., NAKAO, F., MIMURA, M. and IKUI, H. (1970). Some new findings on the fine structure of the human photoreceptor cells. J. Electr. Micr., 19, 71-84.
- VILLEGAS, G. M. (1960). Electron microscopic study of the vertebrate retina. J. Gen. Physiol., 43, 15-43.
- VILLEGAS, G. M. and VILLEGAS, R. (1963). Neuron-glia relationship in the bipolar cell layer of the fish retina. J. Ultrastr. Res., 8, 89-106.
- VILTER, V. (1947). Dissociation spatiale des cones des batonnets dans la retine du callionyme et ses relations avec l'architectonique neuronale de l'appareil visuel. C. R. Seanc. Soc. Biol., 141, 346-348.
- VILTER, V. (1950). Adaptation biologique de l'appareil visuel et les structures retiniennes de la sardine. C. R. Seanc. Soc. Biol., 144, 200-203.
- VRABEC, F. (1966). A new finding in the retina of a marine teleost, Callionymus lyra L. Folia Morphol. (Warsawa), XIV, 143-147.
- WAGNER, H. J. (1972). Vergleichende Untersuchungen uber das Muster der sehzellen und Horizontalen in der Teleostier Retina (Pisces). Z. Morph. Tiere, 72, 77-130.
- WAGNER, H. J. (1973a). Die nervosen Netzhautelemente von Nannacara anomala (Cichlidae, Teleostei). I. Darstellung durch silberimpregnation. Z. Zellforsch., 137, 63-86.
- WAGNER, H. J. (1973b). Die nervosen Netzhautelemente von Nannacara anomala (Cichlidae, Teleostei). II. Quantitative Verteilung. Z. Zellforsch., 137, 87-95.
- WAGNER, H. J. (1975). Comparative analysis of the patterns of receptor and horizontal cells in teleost fishes. In: Vision in fishes. New approaches in research. New York.: Plenum.
- WAGNER, H. J. (1976). The connectivity of cones and cone horizontal cells in a mosaic type teleost retina. Cell. Tiss. Res., 175, 85-100.
- WAGNER, H. J. (1978). Cell types and connectivity patterns in mosaic retinas. Adv. Anat. Embryol., 55/3.
- WAGNER, H. G., MacNICHOL, E. F., jr. and WOLBARSH, M. L., (1960). The response properties of single ganglion cells in the goldfish retina. J. Gen., Physiol., 43, Suppl.2, 45-62.
- WAGNER, H. G., MacNICHOL, E. F., jr and WOLBARSH, M. L., (1963). Functional basis for 'ON'-center and 'OFF'-center receptive fields in the retina. J. opt. soc. Amer., 53, 66-70.
- WALD, G. (1933). Vitamin A in the retina. Nature, 132, 316-317.

- WALD, G. (1935). Vitamin A in eye tissues. J. Gen. Physiol., 18, 905-915.
- WALD, G. (1968). The molecular basis of visual excitation. Nature, 219, 800-807.
- WALD, G., BROWN, P. K. and SMITH, P. H. (1953). Cyanopsin, a new cone pigment of vision. Science, 118, 505-508.
- WALLS, G. L. (1942). The vertebrate eye, and its adaptive radiation. Bloomfield Hills, Michigan: Cranbrook Institute of Science. Reprinted. New York - London: Hafner.
- WALLS, G. L. and JUDD, H. D. (1933). The intra-ocular colour filters of vertebrates. Br. J. Ophthalmol., 17, 641-675 & 705-725.
- WASSLE, H., PEICHL, L. and BOYCOTT, B. B. (1978). Topography of horizontal cells in the retina of the domestic cat. Proc. R. Soc. (Lond.), B., 203, 269-291.
- WASSLE, H., PEICHL, L. and BOYCOTT, B. B. (1979). Quantification of horizontal cells in the domestic cat retina. In Development and chemical Specificity of Neurons. Progress in Brain Research, (ed. by Cuenod, M., Kreutzberg, G. W. and Bloom, F. E.), 51. Elsevier North, Amsterdam, Holland.
- WATANABE, K. and HASHIMOTO, Y. (1965). S-potential in light and dark adaptation in the live carp. Abstr. XXIII. Intern. Cong. Physiol. Sc. Tokyo.
- WATANABE, K. and TOSAKA, T. (1959). Functional organization of the cyprinid fish retina as revealed by discriminative responses to spectral illumination. Jap. J. Physiol., 9, 81-93.
- WATLING, K. J. and DOWLING, J. E. (1981). Dopaminergic mechanisms in the teleost retina. I. Dopamine-sensitive adenylate cyclase in homogenates of carp retina; effects of agonists, antagonists and ergots. J. Neurochem. 36, 559-568.
- WEILER, R. (1978). Horizontal cells of the carp retina: Golgi impregnation and Procion Yellow injection. Cell Tissue Res., 195, 515-516.
- WEILER, R. and WAGNER, H. J. (1984). Light-dependent change of cone-horizontal cell interactions in carp retina. Brain Res., 298, 1-9.
- WEILER, R. and ZETTLER, F. (1976). Electrophysiological and Histological studies of the carp retina. In Neural principles in Vision (ed. by Weiler, R. and Zettler, F.), 111-120.
- WEILER, R. and ZETTLER, F. (1979). The axon-bearing horizontal cells in the teleost retina are functional as well as structural units. Vision Res., 19, 1261.

- WERBLIN, F. S. (1970). Responses of retinal cells to moving spots: Intracellular recording in Necturus maculosus. J. Neurophysiol., 33, 342-350.
- WERBLIN, F. S. (1975a). Regenerative hyperpolarization in rods. J. Physiol., 244, 53-81.
- WERBLIN, F. S., (1975b). Anomalous rectification in horizontal cells. J. Physiol., 244, 639-657.
- WERBLIN, F. S. (1977). Regenerative amacrine cell depolarization and formation of 'ON-OFF' ganglion cell responses. J. Physiol., 264, 767-785.
- WERBLIN, F. S. and COPENHAGEN, D. R. (1974). Control of retinal sensitivity lateral interactions at the inner plexiform layer. J. Gen. Physiol., 63, 88-110.
- WERBLIN, F. S. and DOWLING, J. E. (1969). Organization of the retina of the mudpuppy, Necturus maculosus. II. Intracellular recordings. J. Neurophysiol., 32, 339-355.
- WEST, R. W. (1972). Superficial warming of epoxy blocks for cutting 25-150 μm sections to be sectioned in the 40-90 nm range, Stain Technol., 47, 201-204.
- WEST, R. W. (1976). Light and electron microscopy of the ground squirrel retina: functional considerations. J. Comp. Neurol., 168, 355-378.
- WHEELER, T. G. (1982). Color vision and retinal chromatic information processing in teleost; a review. Brain Res. Rev., 4, 177-235.
- WILLMER, E. N. (1953). Determining factors in the evolution of the retina in vertebrates. Symp. Soc. Exp. Biol., 7, 377-394.
- WITKOVSKY, P. (1965). The spectral sensitivity of retinal ganglion cells in the carp. Vision Res., 5, 603-614.
- WITKOVSKY, P. (1967). A comparison of ganglion cell and S-potential response properties in carp retina. J. Neurophysiol., 30, 546-561.
- WITKOVSKY, P. (1968). The effect of chromatic adaptation on color sensitivity of the carp electroretinogram. Vision Res., 8, 823-837.
- WITKOVSKY, P. (1980). Excitation and adaptation in the vertebrate retina. Current topics in eye research, 2, 1-66.
- WITKOVSKY, P., BURKHARDT, D. A. and NAGY, A. D. (1979). Synaptic connections linking cones and horizontal cells in the retina of the pikeperch (Stizostedion vitreum). J. Comp. Neurol., 186, 541-560.

- WITKOVSKY, P., SHAKIB, M. and RIPPS, H. (1974). Interreceptorial junctions in the teleost retina. Invest. Ophthalm., 13, 996-1009.
- WITKOVSKY, P. and STELL, W. K. (1973). Retinal structure in the smooth dogfish *Mustelus canis*: Electron microscopy of serially sectioned bipolar cell synaptic terminals. J. Comp. Neur., 150, 146-168.
- WOODRUFF, M. L. and FAIN, G. L. (1982). Calcium dependent changes in cyclic GMP levels are not correlated with opening and closing of the light dependent permeability of Toad photoreceptors. J. Gen. Physiol., 80, 537-556.
- WOODRUFF, M. L., FAIN, G. L. and BASTIAN, B. L. (1982). Light dependent ion influx into Toad photoreceptors. J. Gen. Physiol., 80, 4, 517-536.
- WU, S. M. and DOWLING, J. E. (1980). Effects of GABA and glycine on the distal cells of the Cyprinid retina. Brain Res., 199, 401-414.
- WUNDER, W. (1925). Physiologisch-vergleichend anatomische Untersuchungen an der Knochenfischnetzhaute. Z. Vergl. Physiol., 3, 1-61.
- WYATT, H. Y. and DAW, N. W. (1975). Directionally sensitive ganglion cells in the rabbit retina. Specificity for stimulus direction, size and speed. J. Neurophysiol., 38, 613-626.
- YAMADA, E. (1969). The fine structure of the paraboloid of the turtle retina as revealed by electron microscopy. Anat. Rec. 136, 352.
- YAMADA, E. and ISHIKAWA, T. (1965). The fine structure of the horizontal cells in some vertebrate retinae. Cold. Spr. Harb. Sympos. Quant. Biol., 30, 383-392.
- YANG, X.-L., TAUCHI, M. and KANEKO, A. (1982). Quantitative analysis of photoreceptor inputs to external horizontal cells in the goldfish retina. Jap. J. Physiol., 32, 399-420.
- YANG, X.-L., TAUCHI, M. and KANEKO, A. (1983). Convergence of signals from red-sensitive and green-sensitive cones onto L-type external horizontal cells of the goldfish retina. Vision Res., 23, 371-380.
- YAU, K. W., LAMB, T. D. and BAYLOR, D. A. (1977). Light-induced fluctuations in membrane current of single toad rod outer segments. Nature, Lond., 269, 78-80.
- YAZULLA, S. (1976). Cone input to horizontal cells in the turtle retina. Vision Res., 16, 727-735.
- YAZULLA, S. and KLEINSCHMIDT, J., (1982). Dopamine blocks carrier-mediated release of GABA from retinal horizontal cells. Brain Res., 233, 211-215.

- YEE, R. and LIEBMAN, P. A. (1978). Light-activated phosphodiesterase of the rod outer segment: kinetics and parameters of activation and deactivation. J. Biol. Chem., 253, 8902-8909.
- YOSHIKAMI, S., GEORGE, J. S. and HAGINS, W. A. (1980). Light-induced calcium fluxes from outer segment layer of vertebrate retinas. Nature, 286, 395-398.
- YOSHIKAMI, S. and HAGINS, W. A. (1970). Ionic basis of dark current and photocurrent in retinal rods. Abstr. 14th Ann. Meet. Biophys. Soc., WPM-13.
- YOSHIKAMI, S. and HAGINS, W. A. (1973). Control of the dark current in Vertebrate rods and cones. In Biochemistry and Physiology of Visual Pigments, edited by Langer, H., 245-255. Springer, New York.
- YOUNG, R. W. (1967). The renewal of photoreceptor cell outer segments. J. Cell Biol., 33, 61-72.
- YOUNG, R. W. (1969). The organization of vertebrate photoreceptor cells. In The Retina. Morphology, Function and Clinical Characteristics (ed. by Straatsma, B.R.; Hall, M. O.; Allen, R. A. and Crescitelli, F.). UCLA Forum Med. Sci. 8, Univ. of Calif. Press. Los Angeles.
- YOUNG, R. W. and BOK, D. (1969). Participation of the retinal pigment epithelium in the rod outer segment renewal process. J. Cell. Biol., 42, 392-403.

