

## Durham E-Theses

---

### *The school guidance services in Malaysia*

Rabae BT. MD. Hashim

#### How to cite:

---

Hashim, Rabae BT. MD. (1985) The school guidance services in Malaysia. Masters thesis, Durham University.

#### Use policy

---

The full-text may be used and/or reproduced, and given to third parties in any format or medium, without prior permission or charge, for personal research or study, educational, or not-for-profit purposes provided that:

- a full bibliographic reference is made to the original source
- a <https://etheses.durham.ac.uk/id/eprint/7388/> is made to the metadata record in Durham E-Theses
- the full-text is not changed in any way

The full-text must not be sold in any format or medium without the formal permission of the copyright holders.

Please consult the [full Durham E-Theses policy](#) for further details.

THE SCHOOL GUIDANCE SERVICES  
IN MALAYSIA

RABAE BT. MD. HASHIM, B.A. Honours (Malaya), Dip. Ed.

The copyright of this thesis rests with the author.  
No quotation from it should be published without  
his prior written consent and information derived  
from it should be acknowledged.

A thesis submitted for the Degree of Master of Arts (Ed.) to the  
School of Education, University of Durham.

July 1985



12 JUN 1986

ABSTRACTThe School Guidance Services in Malaysia

by

Rabae bt. Md. Hashim

This study is concerned with the aims, the achievements and the development of guidance and counselling services in Malaysian secondary schools. It also traces the historical development of guidance and counselling in America and Britain (for its predominant influence on the educational system of Malaysia), in the hope of finding the approaches most suitable for the multi-racial - multi-religious - multi-cultural societies of Malaysia. Two case studies are included in this study in the hope of illuminating the general literature findings on the existing services.

The study is divided into 5 chapters, besides the Introduction. The general pattern of chapters consists of Historical Development of Guidance and Counselling in United States of America, Britain and Malaysia; Guidance and Counselling Towards National Unity, The Achievements of Guidance and Counselling in Malaysia - Two Case Studies, Future Development and Conclusion.

Thus, this study hopes to unveil some of the issues that could facilitate the growth of guidance and counselling in schools as a means of achieving the goals of Malaysian education.

July 1985

Statement of Copyright

The copyright of this thesis rests with the author. No quotation from it should be published without her prior written consent and information derived from it should be acknowledged.

Note - Discrimination between the sexes

In this study, it is impracticable to eliminate completely the use of genders and retain a fluent and readable text. The reader is therefore asked to accept that no deliberate distinction between the sexes is implied.

ACKNOWLEDGEMENTS

I would like to express my gratitude to the Ministry of Education, Malaysia, for allowing me to distribute questionnaire used for this study to two secondary schools in Perlis and in particular to the Education Department of Perlis, the Principals and the guidance teachers of the schools concerned who co-operated so fully with my questionnaire. I would also like to thank the pupils of both schools and their parents who took part in the survey.

I wish to place on record my sincere appreciation to the late Mr. B. B. Hartop who supervised the initial stage of my work. At the same time I wish to express my special thanks to my present supervisor, Mr. J. B. McGuiness for his interest, support and advice in the production of this thesis. I also wish to acknowledge Miss A. Saunders for the assistance rendered to me in reading the draft of this thesis.

Last but not least to my husband, Othman Mohd Yatim who has been very understanding, patient and supportive all along and to my daughter, Nurulhudda who has taught me much about life.

To all may I say many thanks.

CONTENTS

	Page
Abstract	i
Statement of Copyright	ii
Note - Discrimination between the sexes	iii
Acknowledgements	iv
Lists of Maps	vi
List of Figures	vi
List of Tables	vi
Brief References	vii
Introduction	1
Summary of Argument	9
1. Chapter One: Historical Development of Guidance and Counselling:	13
A - United States of America	14
B - Britain	24
C - Malaysia	78
2. Chapter Two: Guidance and Counselling Towards National Unity	124
3. Chapter Three: The Achievements of Guidance and Counselling in Malaysia: Two Case Studies	175
4. Chapter Four: Future Development	251
5. Chapter Five: Conclusion	292
6. Bibliography	298
7. Appendices:	
Appendix 1 - Samples of questionnaire distributed to key personnel in case studies	319
Appendix 2 - Responses gathered from the questionnaire in the two case studies	378

List of Maps

Plate 1	Map 1	Peninsular Malaysia	ix
	Map 2	Sabah and Sarawak	ix

List of Figures

Fig. 1	Stages of Development in Guidance (and Counselling) in United States of America	43
Fig. 2	Guidance and Counselling in Britain (Influences on Development)	77
Fig. 3	Educational Patterns of Malaysia	88
Fig. 4	The Administrative Structure of Ministry of Education, Malaysia	90
Fig. 5	The Historical Development of Malaysian Education	98
Fig. 6	The Structure of Educational System of Malaysia	99
Fig. 7	The Historical Development of Guidance and Counselling Services in Malaysia	119
Fig. 8	The Objectives of the Mahathir Report	161

List of Tables

Table 1	Reasons for Seeking Guidance Teacher's Advice	194
Table 2	Outcome of Meetings with Guidance Teacher	194
Table 3	Relationship of the Principall with his staff, His Pupils, Their Parents and Society around him	198

Table 4	Relationship of the Principal 2 with his staff, His Pupils, Their Parents and Society around him	200
Table 5	Relationship of the Guidance Teacher in School 1	204
Table 6	Relationship of the Guidance Teacher in School 2	204
Table 7	Relationship of the Pupils from Both Schools with their Guidance Teachers, Teachers, Peer Groups, Parents and Others	209
Table 8	Relationship of the Parents with the Principals, the Teachers, their Son or Daughter and Society	211
Table 9	Parental Visits to School	212
Table 10	Occasions for Parental Visits to School	213
Table 11	Problems Faced by Pupils in Their Daily Life	217
Table 12	Problems Faced by Pupils in School	219
Table 13	Pupils' Sources of Help in Solving their Problems	224
Table 14	Parents' Views on Pupils' Source of Help	226
Table 15	Number of Guidance Teachers That Received Special Training on 1.2.1983.	269
Table 16	The Supply and Demand of Guidance Teachers 1983-1985	270
Table 17	Number of Guidance Teachers based on State, Sex and Ethnic Group, 1983.	271

Brief References

The following abbreviations are used in the text:

ARAVEG -	Asian Regional Association of Vocational and Educational Guidance
D.E.S. -	Department of Education and Science
H.S.C. -	Higher School Certificate
L.C.E. -	Lower Certificate of Examination
L.E.A. -	Local Education Authority
MARA -	<u>Majlis Amanah Rakyat</u>
MAVOGA -	Malaysian Vocational Guidance Association
M.C.E. -	Malaysia Certificate of Examination
M.E.S.T.I. -	Ministry of Education Staff Training Institute
M.S.S.E.E. -	Malaysian Secondary School Entrance Examination
S.P.M. -	<u>Sijil Pelajaran Malaysia</u>
S.R.P. -	<u>Sijil Rendah Pelajaran</u>
S.T.P. -	<u>Sijil Tinggi Persekolahan (Pelajaran)</u>
U.K.M. -	<u>Universiti Kebangsaan Malaysia</u>
UNESCO -	United Nations Educational Scientific and Cultural Organisation
U.P.M. -	<u>Universiti Pertanian Malaysia</u>
U.S.M. -	<u>Universiti Sains Malaysia</u>

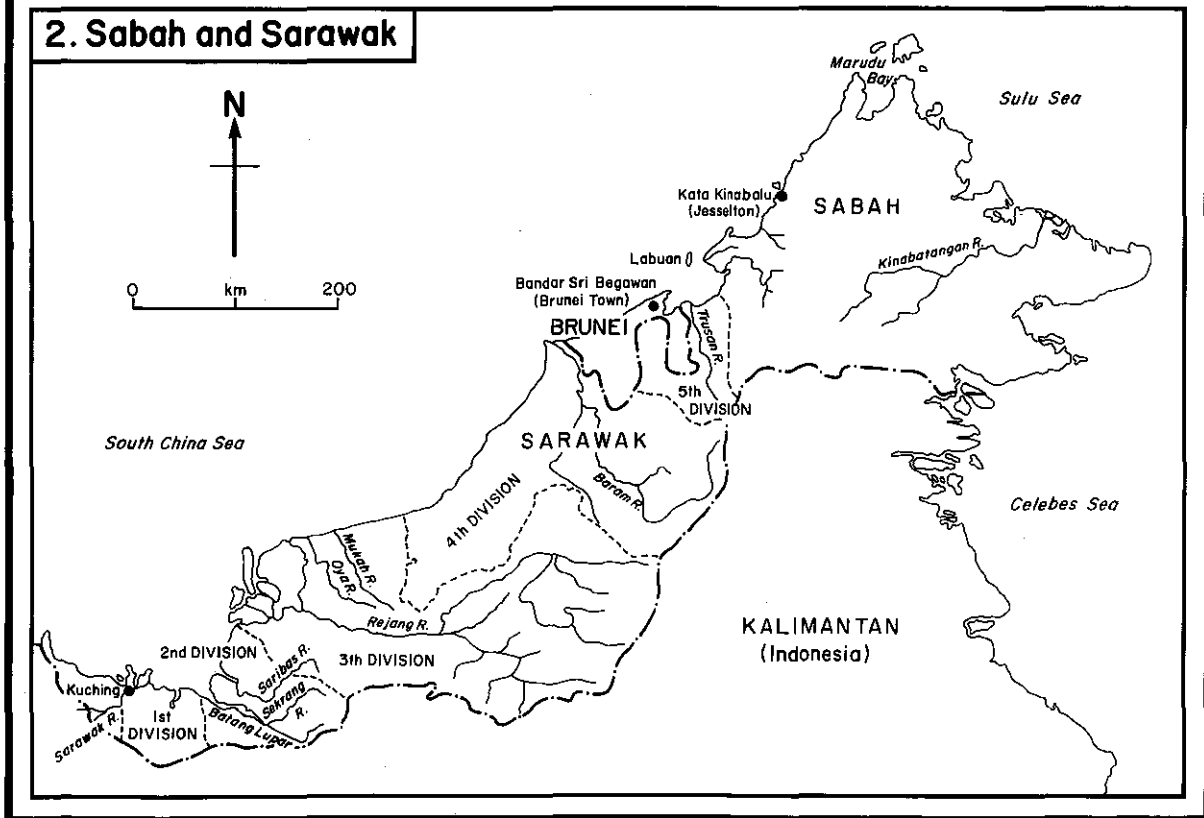
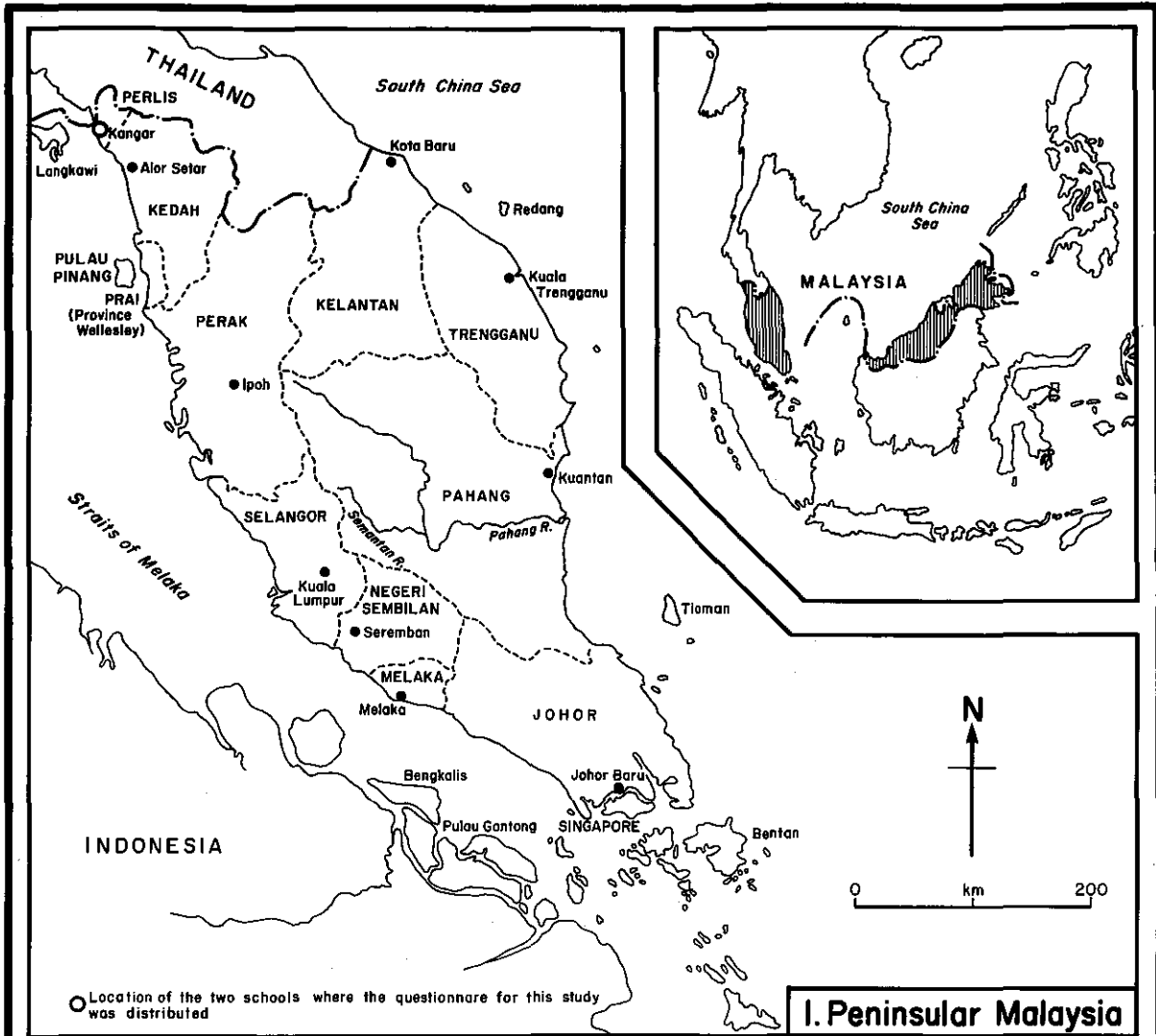

## INTRODUCTION

Since the terminology for guidance and counselling is still imprecise and since its usage has varied widely between and within countries, it would be most appropriate to use for the purposes of this thesis the basic definition given by UNESCO<sup>1</sup> (January 1983, p.3) which defined guidance as "the process of assisting individuals to make effective choices and transitions relating to their education, their work career and their life-style". This embraces a range of helping strategies, information, assessment, advice, teaching, counselling and enabling<sup>2</sup> (cf. Watts 1981). Such activities could be carried out either on a one-to-one or a group basis.

The UNESCO document also states that in some countries, the term 'guidance' is extended to include choices and transition relating to personal areas of people's lives, including relationships, social and psychological problems. In others, it is used mainly in relation to educational and vocational choices. Thus, educational guidance is defined as "the process of assisting the individuals to choose and successfully complete programmes of education suited to their talents and interests, taking into account prior educational achievement and any future job or career plans they may have", whilst vocational guidance is defined as "the process of assisting individuals to choose and enter an occupation suited to their talents and interests, for personal satisfaction and for the benefit of society (UNESCO 1983). Similarly, some countries use the terms 'career(s)



guidance' or 'occupational guidance' as synonyms for 'vocational guidance' (as in the case of Malaysia), while others use them with a slightly different meaning. For instance, 'career(s) guidance' is sometimes used as a broader term embracing guidance on the interaction between people's work, education and other roles.

The emergence of guidance and counselling as a specialised field of educational activity can be said to be of relatively recent origin (Craft & Lytton 1974; Daws 1976). More specifically, as a universal twentieth century phenomenon, it can be said that the guidance movement seems to have been brought to the fore in response to a number of discrete socio-economic and political factors experienced by the western countries, especially the United States of America, in their normal process of developmental growth (Craft & Lytton 1974; Daws 1976, passim). The view is further supported by Roger A. Aubrey in his article published by the Personnel and Guidance Journal (February 1977). He says that "guidance arose in the dawning 20th century as one of several movements answering the upheaval and turmoil created by the 19th century Industrial Revolution".

In studying the universal trends and the development in the field, a number of contributing factors may be highlighted. Foremost among these was the Industrial Revolution and its results which brought about a host of changes in the world of work with the majority of the population moving away from agricultural work to the manufacturing work, with fewer and fewer agricultural

workers supplying the food needs of the masses (Hopson and Scally 1981). Such changes created many complexities for the individuals in relation to vocational choices and job placement as well as problems relating to training in the range of skills required (Hopson and Scally 1981). These issues in turn caused subsequent repercussions on the existing patterns of family structure and inter-personal relationships which called for personal adjustment (Craft 1974; Daws 1976). In other words, the emergence of the guidance movement was initially provoked by conditions which resulted in personal anguish for hundreds of thousands of people in their daily life.

The Industrial Revolution also saw the gradual extension of schooling from selected and usually privileged groups to the mass of the population (Watts 1983). Gradually formal education was recognised as having an unlimited potential for national growth and solidarity, both by developing countries as well as by the more industrialised nations (UNESCO January 1983; Leona Tyler 1961; Craft 1974) in developing and utilizing talents and human resources. The growing school population began to expand tremendously and there emerged an increasing emphasis on the quality of education (Watts 1983). As indicated by Miller (1965), that a higher level of education was necessary for workers due to the automation of the system of production. Watts (1983) also mentioned that education has a close relationship with the world of work. Societies expect schools to develop in young people the knowledge, attitudes and skills which will enable them

to contribute to the economy. Young people and their parents, too, expect schools to help them enter a worthwhile job (ibid).

Furthermore, as mass or public education became universally popular and the school-leaving age began to increase progressively in many countries, (which according to Watts (1983, p. 2) was partly in response to arguments about the upgrading of skills, requirements of jobs and the need for the country to utilize more fully its human resources and talents) new demands in courses offered within the school as well as new teaching approaches which arose to cater for the heterogenous school population. All this coinciding with the knowledge explosion of the twentieth century gave rise to more educational options. (Sarojini Menon June 1975). The students, on the other hand needed assistance in making use of the expanded opportunities open to them (Miller 1965).

The guidance movement was said to have begun in the United States of America, in the early twentieth century during which a great knowledge explosion took place and great social changes occurred among the young people in the west, especially in America. As Daws (1976, p. 6) pointed out: "great social changes have occurred in the world of young people and in their relationship with their elders. They no longer wish to become miniature copies of their parents, striving to become like them and absorbing their values with little strain in their adolescence period" (cf. also Tibble T.W., Adults and Adolescents, UNESCO - NEF, 1964). They became more individualistic and were dedicated to the

defence of their individuality. Daws (1976, p. 6) again pointed out, "For the first time the young found a cultural identity of their own and adolescence ceased to be merely a grim transition, a waiting room for adulthood in which the young tentatively tried on the trappings and the manners of their parents as far as they were allowed". Thus, a tolerant society, where for the first time the young are expected to develop a cultural identity of their own, has been born. The individualistic society was more of a "live-and-let-live society" and a "you-do-your-thing-and-let-me-do-mine society" (Daws 1976).

The dramatic changes in life-style which are seen so clearly in developed countries such as the U.S.A. and Britain, particularly during the early years of this century, have their reflections in the current situation facing the developing countries. In Malaysia,<sup>3</sup> for instance, the rapid changes bring a host of side effects. Traditional eastern values are being replaced by those of the beneficiaries of development and modernisation. This is not what the leaders of developing countries seek, for as stated by the Prime Minister of Malaysia, Datuk Seri Dr. Mahathir Mohamed in the twenty-third National Day Speech, "Development need not be accompanied by moral decay. The Japanese have managed to retain much of their value system which has prevented their going the way of western society. Similarly, Malaysia can retain and foster the kind of values, both spiritual and material, which keep away the process of decay". (The New Straits Times, Malaysia, 31st August, 1980).

It was with this view in mind that the Deputy Prime

Minister, Datuk Musa Hitam, who was then the Minister of Education, stressed in his speech the importance of providing counselling services to the pupils "in view of the country's rapid development in various fields" (The New Straits Times, Malaysia, September 1979). He also said that following those developments, new problems had crept into the life of school pupils and most of these problems were beyond the pupils' abilities to handle, making them susceptible to bad influences.

His views were further supported by the Director General of Education, Tan Sri Haji Murad bin Mohamad Noor (The New Straits Times, Malaysia, 25 September 1980), who said, "Current factors such as both parents working, a big increase in the school-going population and fast development in various fields putting pressure on pupils, the relationship between pupil and teacher and even between pupils and parents has become very impersonal. This has resulted in a general drop in discipline in schools ...". Effective and concrete measures for the preservation of cultural continuity and the attaining of appropriate maturity of the young have to be found if the country is to progress and to achieve its expected goals as a developing nation.

Hence, guidance and counselling is seen as a counter-balance in the Malaysian educational system which at present tends to be formal, monolithic and unable to pay much attention to individual differences (Watts 1978). Guidance<sup>4</sup> is becoming not merely a desirable but an essential and integral part of the education system. The main objectives of that system are not only the development of

manpower resources but also the development of a well-rounded personality. This involves catering for the aesthetic, moral and intellectual needs of every individual in order that he becomes a happy and useful member of the society (Educational Planning and Research Division or EPRD, Kementerian Pelajaran Malaysia or Ministry of Education of Malaysia).<sup>5</sup>

NOTES

1. UNESCO, Division of Structures, Contents, Methods and Techniques of Education, Guidance and Counselling : UNESCO's Programmes and Suggestions For Future Actions, January 1983, Paris ED-83/WS/1-Rev.
2. Adopted from Watts, A.G., 'Counselling Needs of Youth and Adults', Bulletin of International Associations of Educational and Vocational Guidance, pp. 19-20, 37/1981.
3. MALAYSIA refers to states in Peninsular Malaysia, Sabah and Sarawak (See Map).
4. The school guidance services in Malaysia comprises of personal-social guidance, educational guidance, vocational or careers guidance and drug abuse prevention programmes (cf. Guidance in Schools 1971 by the Ministry of Education, Malaysia - later referred to in the text as Guidance in Schools 1971, and Iyer 1975). However, in recent years the term "personal-social guidance" has been changed to "counselling" and the guidance services in schools is currently being referred to as the guidance and counselling services in schools (as used in this text).
5. For convenience, the term 'Ministry of Education of Malaysia' will be widely used in this text in place of Kementerian Pelajaran Malaysia. In fact, the latter is the translation of the former.

## SUMMARY OF ARGUMENT

### 1.1 Scope of the Study

This study proposes to examine the aims, the achievements and the development of guidance and counselling services in Malaysian Secondary Schools by referring to three major sources of data:

- (i) Governmental or official publications ) Research literature and
- (ii) Non-governmental literature ) documentation
- (iii) Information elicited from questionnaires distributed to two specific secondary schools in the state of Perlis, Malaysia.

The data on available research literature and documentation will be used to analyse and critically comment on the following topics:

- a) Definitions and description of guidance and counselling
- b) The evidence of need for guidance and counselling
- c) The origins, current state and potential of guidance and counselling

Then, a specific comparison of the perceptions of the major participants of two school guidance services in Malaysia will be made to illuminate the general literature findings (cf. Chapter 3). Finally, general conclusions will be drawn from both sources.

### 1.2 Chapter One : Historical Development

In this chapter attempts will be made to trace the historical developments or background of guidance and counselling as used in the West, with special reference to the

United States of America, its country of origin. The origins of guidance and counselling services in Britain will also be examined, given that Britain had, and still has, very strong influence on the Malaysian educational system. Paying particular attention to the system of education in Malaysia, this chapter attempts to examine the rationale which assumes the need for guidance and counselling in Malaysian schools as well as its historical development in Malaysia. In this way, it may be possible to observe a number of key similarities in the developmental pattern of guidance and counselling in the three countries.

### 1.3 Chapter Two : Guidance Counselling Towards National Unity

The working definition of guidance and counselling given at the beginning of the introduction will be further analysed and developed in detail in this chapter. As the core of this study is on Guidance and Counselling Services in Malaysian Secondary Schools, attempts will be made to examine the aims of education in Malaysia (Education Towards Unity and Towards Development of Manpower Resources) and to consider how guidance and counselling services can assist in achieving these goals. For further understanding of the Malaysian situations, attempts will also be made to trace the historical background of the multi-racial society in Malaysia, the importance of unity in nation building and how guidance and counselling can be used as one of the means of contributing to the solution of the existing social problems. The aims of guidance and counselling will be further discussed in the Malaysian context.

1.4 Chapter Three : The Achievements of Guidance and Counselling in Malaysia : Two Case Studies

In this chapter, attempts will be made to examine and evaluate the extent and quality of guidance services currently offered by schools in the country by comparing the field data collected in two secondary schools in Perlis with the official data from the Ministry of Education of Malaysia and from other reliable published materials. The application of the findings will then be used to examine to what extent the stated aims of guidance and counselling mentioned in the previous chapter have so far been achieved in the two schools.

1.5 Chapter Four : Future Development

Further development of guidance and counselling services in Malaysia will be critically examined in this chapter. Discussions will also be made on the Ministry of Education's long-term future projects to improve the present situations, based on interviews with officials from the Ministry of Education and other government publications. Attempts will also be made to examine the cultural issue of how far permissive aspects of counselling can be allowed to be practised in Malaysian schools. Some suggestions (recommendations) will be forwarded for the improvement of guidance and counselling services in Malaysia so that our future generation might become mature and responsible adults who will be great assets to the nation.

1.6 Conclusion

1.7 Appendices

1.7.1 Appendix 1 consists of samples of questionnaire distributed to key personnel (the Principal, Guidance teachers, the pupils and their parents) in the two secondary schools in Perlis. It was designed to ascertain:

- a) the schools' acceptance of the guidance and counselling services for their pupils;
- b) the extent to which the guidance and counselling have been carried out in the schools;
- c) the extent to which guidance and counselling is seen as a means of facilitating solutions of the existing problems of the secondary school pupils by correlating the perceptions of different groups of people involved in the survey.

1.7.2 Appendix 2 consists of responses from the questionnaire.

CHAPTER ONEHISTORICAL DEVELOPMENT OF GUIDANCE AND COUNSELLING

As has been said earlier, the guidance movement began in America and later spread its wings to other parts of the world. This chapter attempts to trace the historical development of guidance and counselling not only in America (its country of origin) but also because of its influence during the 19th and early 20th centuries in Britain and in Malaysia (the focus of this study).

By considering these three analyses side by side it will be possible to observe a number of key similarities in the developmental pattern of national guidance services: to begin with the United States of America.

## A. THE UNITED STATES OF AMERICA

### A.1 Introduction

According to Wrenn (1962), "Guidance in school is an American phenomenon. No other country in the world devotes so much attention to the child as an individual - and to assisting children in the decisions they must make as they grow up" (p. 1). Schools in the United States are not only concerned with the transmission of cultural heritages and with the socialisation of the child, but with additional emphasis on the individual and on his needs and desires as well. Thus school counselling is said to be part of the response to the Americans' most deeply rooted traditions, based on what the anthropologist E. Adamson Hoelsel spelled out as the combination of four values which dominate the American way of life (cf. Wrenn 1962):

- A.1.1 The notion of progress - whereby material and social conditions are constantly improvable.
- A.1.2 A rational universe - generally prefer to apply the scientific method than to rely on chance or mysticism.
- A.1.3 Equal opportunity - whereby each person should have the opportunity to exercise his special abilities in a manner that is personally satisfying and socially useful - resulting in the ideal of universal education, a distrust of authority, a fluid status system and an intense drive to "succeed".
- A.1.4 Looking ahead - the American value system is future-oriented - striving towards the Golden Age.

These values affect the entire philosophy and practice

of the American educational system, which, according to Patterson (1962) form the basis for the philosophy of the guidance and counselling programmes of the school. As such the nature of counselling and personnel services in the school is very closely related to the kind of educational system that America has.

#### A.2 The Origin of Guidance and Counselling in the United States of America

Guidance<sup>1</sup> arose in the early years of the 20th century as one of the several movements answering the upheaval and turmoil created by the 19th century Industrial Revolution (Aubrey, 1977). Why should guidance have evolved in America?

Shertzer and Stone (1976) believed that guidance might have taken root in America because of the emphasis the American society placed upon the individual. Brewer, in History of Vocational Guidance (1942), advanced four conditions in American society that were responsible for the growth of guidance: division of labour, growth of technology, democratic government and extension of vocational education (cf. Shertzer and Stone, 1976). A definitive history of guidance has yet to be written. This was due to the fact that the precipitating events of its origin and the major influences upon its development did not fall into neat chronological division. Therefore, Shertzer and Stone (1976) tried to describe the brief history of guidance by dividing it into two main periods, i.e., its origin and early years (early 1900s) and the period of

greatest ascendancy (1958-1970). The intermediate years (1920-1958) had been left unattended.

However, Roger F. Aubrey, in an article published in the Personnel and Guidance Journal, February 1977, divided the history of guidance and counselling into four major periods namely:

- A.2.1 beginning of guidance in industrial centres (1898-1910)
- A.2.2 major breakthrough and expansion period (1950s)
- A.2.3 the promise of guidance and counselling for all (1960s)
- A.2.4 guidance in the 1970s and beyond.

The information of this author will be extensively used in this part of the study.

A.2.1 Beginning of Guidance in Industrial Areas (Early 1900s)

According to Shertzer and Stone (1976), the early 1900s formed "an entity that bears upon the early calendar of guidance" (p. 42). They considered it as the period in which social consciousness was prevalent in journalism, literature and art. Besides, picturing or portraying the current events in American life, journalists, novelists and poets also forwarded many eloquent protests against social injustices and economic maladjustments. Demands for reform, for experimentation and for setting new goals arose, and people awoke to the fact that the old rural America was passing away.

As a result, numerous charitable, humane and philanthropic

societies were established and organised in the hope of removing the fundamental causes of poverty and crime. A nationwide effort was also begun to protect children from the worst abuses of child labour, to provide education for children and youth (adolescents) and to protect their health and morals. Through such efforts, organised guidance services came into being (Shertzer and Stone, 1976).

Aubrey (1977) traced the beginnings of guidance in industrial centres as occurring during the period between 1898-1910. According to him, it was indeed a time of change especially in the fast developing industrial cities (centres) of the midwest and eastern seaboard such as Chicago, Detroit, Boston and New York. The industrial expansion brought many social problems and anguishes. Many newly arrived immigrants, out of work farmers, Southerners seeking northern prosperity, and young people bored with rural and small town life came to these industrial cities, hoping to get a better life there. Unfortunately, those drawn to these metropolitan areas rarely found the 'good life' (Aubrey 1977, cf. Daws 1968 and 1972). It was more likely that in the large cities, their miseries and insecurities were increased. Under such circumstances, many spiritual men and women, aware of the many social problems, tried to eradicate them and through their efforts, organised guidance services emerged (cf. Shertzer and Stone 1976).

In other words, the injustice and suffering brought by massive technological change had secured the early destiny of guidance whose primary targets were children and adolescents. Schools (in this case the public schools)

were selected to serve as agents for rectifying the existing ills of the society. Who could be better attended than "the greatest armies of child labourers who were leaving the public schools to become wage earners under unfavourable conditions"? (Miller 1964, p.7). This view was shared by Daws (1972, p.9) who said that, "the social patterns of industrialisation had become sufficiently familiar and disquieting to emphasise the need for preparation of young people for the adult working world, for them to meet its demands, and survive with reasonable profits and contentment".

Thus, in the early 20th century, the institution most profoundly influenced by guidance was the public school system. Guidance began in American public schools much like any other subjects. Initially, it was viewed as something that could be taught by a teacher to a large number of students in a classroom setting. Later, guidance was seen as a learning experience enhancing the existing curriculum by specifically addressing areas and topics that have since been ignored or neglected (Aubrey, 1977 and 1982).

There were two early forces in the growth of guidance in public schools. The first guidance movement, known as vocational guidance began at the turn of the 20th century in response to industrialisation and changing pattern in American society, and educational practice. It continued to play a critical role in influencing guidance practice in public schools until the 1940s. The second movement began in the 1920s. It was called "educational guidance" (Aubrey 1982).

#### A.2.1.1 Emergence of Vocational Guidance in Education

The history of vocational guidance movement has been exceptionally well covered by Borrow (1964) and others (Barry and Wolf 1962; Brewer 1942; Super 1955; Williamson 1964). According to Aubrey (1982), most writers agree that the early beginnings of vocational guidance in schools arose from a concern for individuals "who had moved from rural to urban settings or had been victimized by child labour abuses, and it grew out of a general concern for the job satisfaction of American workers" (McDaniels 1974, p. 252).

The growth of vocational guidance in schools was regarded as an uphill battle by Aubrey (1977). Its introduction and implementation in urban schools (where the services were most required) were indeed slow but steady. In fact, the first university course in vocational guidance was offered at Harvard College in 1911 by Parsons' successor at the Vocation Bureau, Meyer Bloomfield.

There were a number of forces combined to offset the apathy and opposition to vocational guidance in the first two decades of this century. The greatest support came from the social reform movement, in the early 1900s. Both used the issues of the growing exploitation and misuse of human beings (human suffering) as a means of pricking the conscience of the public, especially legislators who were forced to be responsive to the persistent and ceaseless cries of social reformers (Aubrey 1977). As a consequence, Congress passed the Smith-Hughes Act, a landmark for secondary school vocational education and teacher training in 1917. This legislation was further strengthened by

succeeding legislations such as the George-Reed Act in 1929, the George-Ellzey Act of 1934 and the George-Dean Act of 1936. All these combined to subsidize and support vocational education as a legitimate enterprise of the public schools (Aubrey 1977).

Besides that, vocational guidance was also stimulated by changing patterns of industrialisation (Aubrey 1977). As business and industry grew, there arose the need for a more intelligent and diversified working force (especially the highly skilled members of it) which could only be provided by the schools and their prevailing curriculum. In response, the schools had to keep students longer than they had previously (cf. Watts 1983 and Daws 1972). As the number of children and adolescents attending the public schools continued to increase, the schools were forced to change time-honoured customs and traditions. Many educators were caught unprepared and reluctant to extend mass education beyond elementary schools, but the founders of vocational guidance did not find the prospect frightening. This was due to the fact that the early vocational guidance movement's (until today) primary interests were in the individual and in the preparation of that individual for life in a fluid and ever changing environment (Aubrey 1977 and 1982).

However, the early vocational guidance movement (before 1915) was said to be "largely devoid of philosophical or psychological underpinnings" (Aubrey 1977, p. 290). According to Aubrey (1977), the Parsonian model of vocational choice was based on simple logic and common sense and relied

predominantly on observational and data gathering skills. Its inclusion in the public schools was defended on the basis of economic and humanitarian conditions outside the school. With the exception of Jesse Davis and a few others, vocational guidance was not associated with the process of education, nor was it viewed as a means of contributing to the development of the individual through a process of extending over a number of years. The vital link between vocational choice and personal development would have a hiatus and only emerge much later with the work of such people as Super (1942), Ginzberg (1951), Roe (1956), Tiedeman (1958) and others (cf. Aubrey 1977).

The lack of strong philosophical or psychological support was, however, being filled by the growing enchantment of guidance with psychometrics (Aubrey 1977 and 1982). In time, this merger of vocational guidance and psychometrics would set in motion a psychological foundation based on testing and individual pupil analysis.<sup>2</sup> Testing and later adoption of trait-factor psychology gave the vocational guidance movement respectability, credentials and a firm foothold in public institutions. Unfortunately, most of the tools adopted by vocational guidance did not fulfill the hopes and aspirations of its early founders in aiding individuals to arrive at greater self-determination and human dignity (Aubrey 1977. 1982).

#### A.2.1.2 Emergence of Educational Guidance

According to Aubrey (1982), the term 'educational guidance' has two distinct meanings:

- a) Educational guidance can refer to help given to students in selecting courses, adjusting to school, orientating themselves to new surroundings and deciding on courses of action on completion of schooling.
- b) Educational guidance is said to be much broader and more intimately related to the total process of education and character building, i.e., as a pervasive force in the curriculum and instructional process itself. In this sense, guidance encompasses and embodies a set of objectives, methods and experiences within the total educative process (cf. Aubrey 1982).

Educational guidance was first described as an educational activity by Truman L. Kelly whereby he advocated this activity as an essential process in helping students to make choices about courses of study and school adjustment problems (cf. Aubrey 1982). The form of educational guidance proclaimed by Kelly owed its origin to vocational guidance. In fact, this "new" vocational guidance emerged out of a need to redefine guidance as not simply an activity appropriate for occupational considerations but also for all educational experiences of the students. In other words the concern of the early advocates of educational guidance was for a broadening of a student's horizon through guidance (Aubrey 1982).

However, educational guidance was not always seen as promoting new views or prospects for students. In many circumstances, educational guidance was introduced in schools as a process to help in the distribution and adjustment of pupils. It was meant to remedy a number of problems

involving students that called for attention beyond that available in most schools. This definition of guidance was first introduced by Proctor (1925) in the 1920s and by the depression years of the 1930s, it competed with vocational guidance for popularity (cf. Aubrey 1982).

Another form of educational guidance also began to take form in the 1920s and was fully articulated in the early 1930s. Unlike the distributive and adjustive version of guidance, this movement viewed guidance as "neither adjusting nor suggesting, neither conditioning nor controlling, neither directing nor taking responsibility for anyone ... the work we do in schools may be described as helping children to understand, organise, extend and improve their individual and cooperative activities ... [This] means guidance". (Brewer 1932, p. 2.).

By expanding the guidance base to include all endeavours engaged in by students, Brewer drastically challenged the previous foundation of guidance whose primary concern was with the choices and decisions of young people regarding the world of work and vocations. Instead he opened up the entire spectrum of education and human development to guidance, (Aubrey 1982). As a consequence of this refocus, a new model for vocational guidance was established. In addition to that, it also laid the foundation for a theory of guidance intervention which would be linked directly to the process of education.

### A.2.1.3 Early Pioneers of Guidance

#### (i) Jesse B. Davies

Among the early pioneers of guidance were Jesse B. Davis and Frank Parsons. Educational historians attributed Jesse B. Davis the first effort to systematize guidance into the accepted school curriculum (Brewer 1942, Miller 1961, Aubrey 1977 and 1982). As a school administrator in the growing industrial city of Detroit between 1898 - 1907, Davis was concerned by the vocational problems and social differences of his students. As pointed out by Matthewson (1962, p. 72), and later by Shertzer and Stone (1976, p. 42), "Jesse B. Davis, while serving as eleventh-grade principal (1898-1907) spent most of his time actively counselling boys and girls." He then, carried this concern with him when he accepted the principalship of Grand Rapids, Michigan High School in 1907 and decided to create a guidance curriculum. Davis, therefore, selected English composition as the area best suited to what he termed as "vocational and moral guidance" and one English period per week was set aside for this lesson (Aubrey 1977 and 1982; Shertzer and Stone 1976). For Davis (1914 p. 17), the definition and objectives of guidance at this time were nothing less than the "pupil's better understanding of his own character, it means an awakening of the moral consciousness that will lead him to emulate the character of the good and the great who have gone before; it means a conception of himself as a social being in some future occupation, and from this viewpoint the appreciation of his duty and obligation towards his business associates, towards his

neighbours, and towards the law" (cf. Aubrey 1977).

According to Aubrey (1977) the words and work of Jesse Davis were those of an ambitious and inspired reformer. He is best understood not in the narrow frame of vocational guidance, but rather in the broad perspective of the progressivism in American education which was started by Horace Mann and was perfected by John Dewey and his followers in the Progressive Education Association. Aubrey (1977) further stressed that although the school counsellor was described "as the most characteristic child of the progressive movement" (Lawrence Cremin 1965, p. 5), the compliment was more symbolic than true. It was what counsellors represented, not what they delivered, that elevated them in the eyes of the progressives. They believed that guidance could embody the aims and ideals of American progressivism.

(ii) Frank Parsons

Coincidentally with the early work of Jesse Davis in the industrial midwest, another guidance pioneer arose, in an industrial complex on the eastern seaboard (Aubrey 1977 and 1982). Frank Parsons, often referred to as the "Father of Guidance" did not begin his career in the public schools. Instead, he began as an engineer and later became a social worker at an independent agency called the Breadwinner's Institute, Boston. (Patterson 1962). He was heavily influenced by the philanthropic example of Jane Addams in Chicago. This influence was early reflected by Parsons' work in establishing a settlement house in Boston for young adults

already employed in industry or in need of employment. (Aubrey 1977 and 1982).

Although the early work of Parsons was focussed on out-of-school young people, his hopes centred on a time when vocational guidance would "become part of the public school system in every community" (Lasch 1965, p. 157, cf. Aubrey 1977). To accomplish this, Parsons established the Vocational Bureau in Civil Service House in Boston in 1908 to provide services to school-leavers and out-of-school youths (Patterson 1962).<sup>2</sup> According to Shertzer and Stone (1976), Parsons was concerned that individuals understood their strength and weaknesses and used this knowledge in choosing among vocational opportunities. The founding of the Vocation Bureau was regarded as a major breakthrough because it represented the first "institutionalization of vocational guidance" (Ginzberg 1971, p. 23 and cf. Aubrey 1977). A year later, Parsons' volume on Choosing a Vocation (1909) was published (just after his death). His ideas in the book led to the establishment of vocational guidance departments in a number of the best school systems in the U.S.A. (Brewer 1942 and cf. Shertzer and Stone 1976).

In 1910, Parsons' contribution to guidance was recognized when Boston was selected as the site for the first National Conference on Vocational Guidance. This conference later resulted in the official founding of the National Vocational Guidance Association (NVGA) in 1913 in Grand Rapids, Michigan. The link between the pioneer work of Jesse Davis and Frank Parsons was obvious and their early achievements led to the first publication of the

later NVGA journal, the Vocational Guidance Bulletin in 1915, which eventually became the Personnel and Guidance Journal of today. (Aubrey 1977 and Patterson 1962). The journal highlighted the emerging profession's problems and aspirations (Shertzer and Stone, 1976).

#### A.2.1.4 Other Developments

The work of Davis and Parsons was also emulated by many persons with a similar interest in social reforms and the uncurbed exploitation of young people. For instance, vocational guidance entered the New York schools (as early as 1906) led by a school principal Eli Weaver, who had written a booklet called Choosing A Career. (Aubrey, 1977). Eli Weaver sought to assist the great army of child labourers who were leaving the schools in New York City under unfavourable conditions. Simultaneously, other pioneer guidance programmes and organisations also began to operate in Salt Lake City, Utah; Lincoln, Nebraska and Oakland, California and continued to spread throughout America. This extension of the guidance movement was very much attributed to the founding of the National Vocational Guidance Association (NVGA) in 1913. With the increase of NVGA's membership, the diversity of the members' interests and the increased psychological understanding of the individual led the NVGA to combine with other personal organisations thus leading to the formation of the present national organisation, The American Personnel and Guidance Association (APGA) in July 1952.

#### A.2.1.5 Counselling

When guidance was first recognised as a legitimate educational endeavour of the 20th century, little mention was made of counselling as a helping technique during its first three decades. The concept of counselling as a psychological process only appeared after the publication of a Workbook in Vocations by Proctor, Benefield and Wrenn in 1931. Nevertheless, a cursory reading of Parsons (1909), Bloomfield (1915) or Kitson (1915) revealed traces of what was later to be called counselling. Further, counselling as a psychological process was apparent in much of the legacy of the early mental health movement, the work of G. Stanley Hall and his disciples in the child-study movement, the introduction of psychoanalysis to America in 1909 by Freud's lectures at Clark University, and in the application of psychometrics following World War I (Aubrey, 1977).

The early inception of counselling was highly dependent on the existing scheme of guidance. As such, counselling was viewed simply and solely as an injunct technique in accomplishing limited vocational guidance outcomes. The application of this method was labelled as trait and factor counselling (Williamson 1965 and Munsterberg 1913; cf. Aubrey 1977). Later, the counselling model that evolved from the trait and factor approach came to be known as directive or counsellor-centred. As a result the counsellor was seen as the key figure in the counselling process and would take the responsibility for leading the counsellee into areas and directions most helpful to the counsellee. This dominant trait and factor approach to counselling began to

decline in the early 1940s and its inadequacy had been pointed out in the late 1930s by a number of clinical psychologists, social psychologists and psychotherapists (Allport 1937, Freud 1937, Horney 1937, Kardiner 1939, Murray 1938, Sherif 1936 and Warner 1937 - cf. Aubrey, 1977).

#### A.2.2 Major Breakthrough and Expansion Period (1940s to 1950s)

Freedom and self-determination was said to be the major factor in changing the direction of guidance and counselling in the 1940s with Carl Rogers as the prime mover (Aubrey, 1977). In fact, Rogers is regarded as the most profound single influence in changing the course and direction of the entire counselling movement in the mid and late 1940s (1939 1951, 1954, 1961). The eventual influence of the work of Rogers and his followers was so enveloping and unquestioned that Super (1964) felt the influence inimical to the profession as a whole. For Super, guidance theory at that time was simply too weak to integrate the theory and findings of Rogers without a resultant band wagon (cf. Aubrey 1982). In spite of the uproar caused by Roger's revolutionary approach, client-centred counselling prospered in the 1950s where testing was to some extent replaced by counselling as the key guidance function. The few years that followed saw how counselling became so imminent that it would compete and contend with guidance regarding the use of counsellors' time, the literature pertaining to the practice of guidance and counselling, and the overall purpose of guidance. Guidance suddenly disappeared as a major consideration in the bulk of the literature and had been replaced by a decade or more of

concentration on counselling (Aubrey 1977 and 1982).

#### A.2.2.1 Further Developments

##### a) From Vocational Choice (Guidance) to Career Development

The loss of interest in guidance in the 1950s was however, not totally replaced by counselling (Aubrey 1977). Instead, a number of advances in development psychology, learning theory, psychiatry and sociology (Erikson 1950, Havighurst 1952, Hollingshead 1949, Inhelder and Piaget 1958, Lynd and Lynd 1954, Piaget 1952, Riesman 1950, Sullivan 1953, Warner, Meeker and Ells 1955, White 1953) paved the way for significant gains in guidance theory and philosophy. As a result of Super's pioneer work (Super, 1953, 1955, 1956 and 1957), vocational guidance was transformed into career development. This dramatic change was enhanced by the addition of self concept theory (Combs and Snygg 1949) and was further aided by the work of several other career developmental theorists (Bordin, Nachman and Segal 1963; Ginzberg et. al. 1951; Holland 1959; Roe 1956; Tiedeman and Field 1965).

##### b) Developmental Guidance

Unlike the passage from vocational to career guidance (development), developmental guidance was said to be without precursor and eager audience (Aubrey 1982). The justification for its existence would rest primarily on the hopes and ambitions of its originators, not on societal or economic grounds. As such, it did not inherit any of the attachment to the earlier guidance theories. It also sought to utilize the latest advancements in the social and behavioural

sciences as applied to education and human development (cf. Aubrey 1982).

The origin of developmental guidance in schools is traceable to Robert Mathewson (1949, 1962). The key concept of development as the guiding principle in organising and implementing programmes of school guidance had already been stressed by Mathewson even prior to some writings of Erikson (1950); Havighurst (1952), Piaget (1952) and others (cf. Shertzer and Stone 1976; Aubrey 1982). Mathewson (1949) wrote that, "As an important phase of education, the guidance process moves with the individual in a developmental sequence up to the age of maturity, helping him gain in self-understanding as well as perspective on his surroundings" (p. 29). Later, he refined and expanded this notion of guidance as a process involved in monitoring and aiding human development. The work of Mathewson was expanded in the 1960s and 1970s by Kehas (1968, 1970, 1973), Mosher and Sprinthall (1971), Shoben (1965), and Tiedeman and Field (1965).

#### A.2.2.2

With the expansion in scope and purpose of guidance and counselling in the early 1950s, a professional organisation was needed to unify the diverse concern of counsellors and to bring together the range of groups operating under the guidance umbrella (Aubrey 1977). Therefore, in July 1952, three major existing associations of Guidance Supervisors and Counsellor Trainees (now ACES), American College Personnel Association and the National Vocational

Guidance Association (NVGA) merged to form the American Personnel and Guidance Association (APGA).

Judging from the above examination, one could see that the 1950s had a profound impact on counsellors. This period did not only produce major breakthroughs in theory, research, practice and a professional organisation, it also saw a number of national and worldwide events that shaped the future of counsellors (Aubrey 1977). In particular, major changes in guidance and counselling occurred, following the reaction of the American public to the launching of Russian Sputnik I in 1958. This incident, together with the Report of James Conant (1959) on the state of American Schools brought about the National Defense Education Act of 1958 (Aubrey 1977). The impacts of such occurrences were felt in the 1960s.

#### A.2.3 The Promising Period of Guidance and Counselling For All (1960s)

The 1960s were regarded by Shertzer and Stone (1976) as "a time of ascendance for guidance" in the U.S.A. The federal government's support, together with the prevailing mood or social conditions of that decade, had great impact upon its remarkable expansion in numbers, practices and preparation. According to them (Shertzer and Stone 1976), there were two prominent themes in the 1960s that could be identified as important contributing factors to the rapid development of guidance.

The first theme was the pervasive play of the forces of depersonalisation during that period. The quest for

identity and its related themes were much in evidence in contemporary guidance models such as guidance as a constellation of services (Hoyt 1962, cf. Shertzer and Stone 1976, pp. 67-69), developmental guidance (Little and Chapman 1955, Peters and Farwell 1967 and Mathewson 1962 - cf. Shertzer and Stone 1976, pp. 69-71), guidance as the science of purposeful action (Tiedeman and Field 1962, ibid.) and guidance as psychological or 'affective' education (cf. Shertzer and Stone, 1976, pp. 76-81).

The second theme was the result of two remarkable shifts that occurred in the concept of education, i.e., education as national defence (in the late 1950s and early 1960s) and education viewed and used as the vehicle or tool in reconstructing society (middle of the 1960s) (cf. Shertzer and Stone 1976, pp. 44 and 73-74; also refer to p.160). These two major changes in conceptualizing education "served as a backdrop for expanded guidance programme and personnel" (Shertzer and Stone 1976, p. 44). Thus, the decade brought tremendous expansion in the number of counsellors employed not only in educational institutions but also elsewhere.

The views put forward by Shertzer and Stone (1976) were shared by Merville C. Shaw (1973, p. 23) who said that two rough lines of demarcation could be drawn in the guidance history, i.e. at the end of World War II and around 1958 when the National Defence Education Act was passed by the Congress (ibid.). Since then, the number of counsellors had quadrupled and the ratio of counsellors to students had decreased from 960 in 1958-1959 to one to 45

by 1966-1967 (Shertzer and Stone, 1976, p. 120). The number of universities and counsellor-educators engaged in the training of counsellors also showed tremendous gains during this period. There was also marked increase in the number of groups wishing to learn about the self (sensitive groups, T-groups, encounter groups). Counsellor Peers' and support personnel were initiated and tried out in many educational and non-educational settings (Shertzer and Stone 1976, p. 44). In addition to that, the first computer-based guidance prototype was developed in 1965 and curriculum experiences were designed to facilitate psychological and career education.

To Aubrey (1977) the 1960s were regarded as a promising era for guidance and counselling. The rapid increase in the number of practising counsellors and those in training led many to believe that the profession was entering an era when guidance and counselling could be available to all. He also added that the infusion of self-concept theory and numerous variations by stage theorists on life as a series of developmental milestones, extended the audience and aspirations of the profession (Aubrey 1977). This belief was clearly articulated in the early 1960s by the publication of the APGA sponsored, The Counsellor in a Changing World, written by Gilbert Wrenn (1962).

However, according to him, the help extended to guidance and counselling through the behavioural sciences and other areas was not fully utilized in the 1960s. There was still a need for unifying principles and common objectives to join together the wide array of individuals who

called themselves counsellors.

Guidance and counselling in the 1960s faced a number of serious questions and challenges (Aubrey 1977; Shertzer and Stone 1976). One of the problems confronting the profession was centred on identifying appropriate recipients of counselling. Should it deal exclusively with the normal developmental concerns of individuals or should it tend to the psychological problems of a smaller and needier portion of the population? The second problem was related to methodology. Numerous competing counselling methodologies were presented to counsellors especially in the late 1960s, such as behavioural counselling, existential counselling, reciprocal inhibition, reality therapy, gestalt therapy, rational emotive therapy, Carkhuffian beginnings and various other psychoanalytic adaptations (Aubrey 1977 and Shertzer and Stone 1976). All of these gave rise to identity confusion.

Besides that, examination of earlier literature indicated that guidance (vocational as well as educational guidance), since its early beginning has always accorded a large part in the process of individual growth and development to the schools and teachers. It has not, to some extent, been so with counselling. Commencing with the advent of counselling psychology as a distinct speciality, those in this area have increasingly alienated themselves from the mainstream of education and a partnership with teachers (cf. Aubrey 1982).

The final problem facing counsellors as they confronted the 1970s was one of overall destination and direction (ibid.).

#### A.2.4 Guidance in the 1970s and Beyond

The early 1970s had brought pressures for accountability and accreditation. Many school districts were caught in a severe financial crunch and in some cases, had released teachers and counsellors. Consequently, counsellors increasingly became concerned about interpreting the merits of work to their various sponsors and clients (Shertzer and Stone 1976, Aubrey 1977). As such the quest of the profession, as in the 1960s, for a comprehensive and unifying system seemed to decrease. In other words, the 70s would see the decline of the Great Society (Aubrey 1977).

Another prominent issue during the 1970-1975 period was the focus on career education and the counsellors role in it. As a consequence, career development materials and activities were designed by practicing counsellors; counsellor educational institutions, and other community agencies. In addition, financial support at federal, state and local governmental levels was being given to career development and skill-building experiences and activities (Shertzer and Stone 1976). Therefore, highly competent professionals or counsellors were required.

The importance and trend of career guidance in the 1980s can be summarised by the statement made by Dr. Gary R. Waltz (1979), who said that "Career guidance has an unrealized potential to be responsive to the needs and interests of all people of all ages and from all walks of life". It is indeed a contemporary social invention which offers the strong probability of being a viable response to many of our educational and social problems.

As guidance enters the 1980s, the proliferation of counselling approaches continues, and so do their differences. Instead of striving for some unifying principles or common conceptual framework, the profession of school guidance and counselling has split into camps catering on technique and outcome (cf. Aubrey 1982).

An issue additional to the problems identified above is the extent to which counselling might be used to lubricate the operation of an unjust or insensitive society - in other words the conflict between counsellors' responsibility to society and their responsibility to individual clients.

### A.3 Some Aspects of Guidance in the United States Today

#### A.3.1

According to Arbuckle (1963), one of the main influences on guidance today was the publication of The American High School by J.B. Conant in 1959, along with the 1958 Defence Act. Among other proposals suggested by Conant are:

- (i) that there should be a full time counsellor for every 250-300 pupils in high school;
- (ii) that while these counsellors should have had experience as teachers they should work full time in their guidance role;
- (iii) that they should be familiar with the use of psychometric tests in general and
- (iv) they should keep in touch with parents as well as pupils;
- (v) that counselling ought properly to start in the elementary (primary) schools;
- (vi) that there should be a close continuity between counselling programmes at different levels.

As a result, changes rapidly took place and by 1966-67 the ratio had fallen from 1:960 (at the time Conant's work was published, i.e., 1958-59) to 1:450 (Wrenn 1966, cf. Shertzer and Stone, 1971, p.120). The number of universities and counsellor educators engaged in the training of counsellors also show tremendous increase during this period.

#### A.3.2

The prevailing social and cultural factors of the times had a great impact not only on the number of trained counsellors but also on guidance concepts and functions which began to change as a new psychology of learning was discovered. Guidance was no longer regarded as concerned purely with vocational pursuits (based on trait and factor approaches), but rather with all the developmental problems of youth (Shertzer and Stone 1976; Merville Shaw 1973). For instance, with the propagation of the new psychology of learning, which advocated the 'child-centred' emphasis of Rogers (1940s), there emerged a growing concern in relation to the role of education in assisting with the total development of the child and meeting, not only its academic, but also its emotional and social needs, e.g. including developmental, career, and personal development needs.

In other words, guidance within education represents society's expression of concern for the individual - for his needs and desires (Shertzer and Stone 1976, Wrenn 1962). Its contribution includes bringing to the students

increased understanding of the educational, vocational and social information needed to make wise choices. It also utilises psychological and sociological data for teachers and counsellors in understanding each pupil as an individual, clarifying and assisting in learning tasks and in helping individuals understand themselves and their world as well as make appropriate adjustments and choices along the way.

### A.3.3. Role Conflicts

Within education, counsellors are individuals who are not expected to act as judges or evaluators. They are not responsible, as teachers are for seeing that children (pupils) meet certain standards of achievement in given areas. According to Hamblin (1981) the role of the counsellor is amorphous and no clear expectations exist. As such, there is a great tendency for conflicts, because of the very nature of the skills which were listed by him as:

- (i) the power of realistic adaptation,
- (ii) the possession of intellectual flexibility,
- (iii) the maintenance of effective and consistent communication,
- (iv) sensibility and skill in noting low level signals.

In other words, three core dimensions of counselling - the ability to empathize, unconditional positive regard and genuineness must exist to ensure the effectiveness of a counselling relationship (which will be further discussed in Chapter 2 - cf. McGuiness, 1982).

The nature of skills mentioned above stress self-knowledge of the counsellor and are likely to remove any

comfortable confidence of his own adequacy. Considering the wide range of skills necessary in efficient counselling within the school situation, the counsellor is likely to feel himself under threat and in a state of considerable stress especially when the expectations of others are ambiguous. In addition, many of his colleagues may view the counsellor with suspicion. For instance, career masters and educational welfare officers often assume unjustifiably that he is a rival who is taking away their work. Heads and administrators fail to appreciate the nature of his work, whilst many of his colleagues see counselling as a soft option and a retreat from the real work of the classroom (Hamblin, 1981). Fortunately such reactions are diminishing as the trained counsellor is often aware of his dependence upon his colleagues and those trained in line with the active model (such as pastoral care in Britain), consider it as imperative for them to be the full, integrated members of the staff. The fears mentioned earlier must be treated with care and respect even though they may reflect rigidity, a sense of threat or a lack of knowledge in those voicing them. Therefore, the counsellor must explain clearly what he is doing. He must also provide his colleagues with relevant information which does not break confidentiality and which is helpful to the pupil. The best remedy, according to Hamblin (1981) is the gradual involvement of such critics in counselling.

Another subtle type of role stress (ibid.) comes from the fact that some school counsellors often have to interact with their clients (pupils) as teachers as well as

counsellors, i.e. the dual role of the teacher/counsellor (School Council 1967, Taylor 1971; Hamblin 1981). In this situation, the counsellor may find himself in an impossible position, because he may have to punish the person whom he is counselling. It has also been claimed that it may be extremely difficult for a pupil to be open and honest with someone who has an authority relationship with him in another situation. The research by Moore and Fuller (1967) showed that pupils tend on the average to discriminate between the counsellor in the teaching situation and in the counselling one, making appropriate adjustments. Eventually, the pupils will learn to accept the situation as important learning experiences which aid their growth. In fact, there are many real gains from teaching the pupils, because it enables the trained counsellor to know them better. Teaching experiences with them, provide him with the chance of strengthening his self picture and providing unobtrusive support. The classroom experience in general, provides valuable material for the counselling sessions that follow (Arbuckle 1950; Patterson 1962; Taylor 1971 and Hamblin 1981).

#### A.3.4

Another development that has appeared in recent years is the reaffirmation that essential guidance and counselling services are conducted by every professional staff member, instead of only by the school counsellor (Shertzer and Stone 1976 and Aubrey 1977). Besides which, guidance and counselling is no longer restricted to the

later years of secondary school, but is now being provided for pupils at all educational levels, i.e. from kindergarten to institutions of higher learning (Shertzer and Stone 1976; Anne Jones 1977; Daws 1980 and Bolger 1982).

#### A.4 Conclusion

Thus, we can see that the literature suggests that in the U.S.A. between 1900-1984, several major strands form a complex weave which we refer to in general as "guidance", (see Fig. 1). The early concerns about young workers and vocational choice quickly developed into a range of responses to broader personal issues. At the same time as the focus of attention moved from the vocational and educational to the personal, techniques also developed - from the initial trait and factor approaches of Parsons and Davis to the client-centredness of Rogers and the developmental analysis of Ginzberg and Super. It is this rich inheritance that counsellors beyond the U.S.A. in the 1980s have to adapt to the particular needs of their own country - preserving the useful and changing theme elements which do not meet their specific needs.

Fig. 1

Stages of Development in Guidance (and Counselling) in the U.S.A.

Trait and Factor 1908  
(Counsellor focus)  
Parsons and Davis

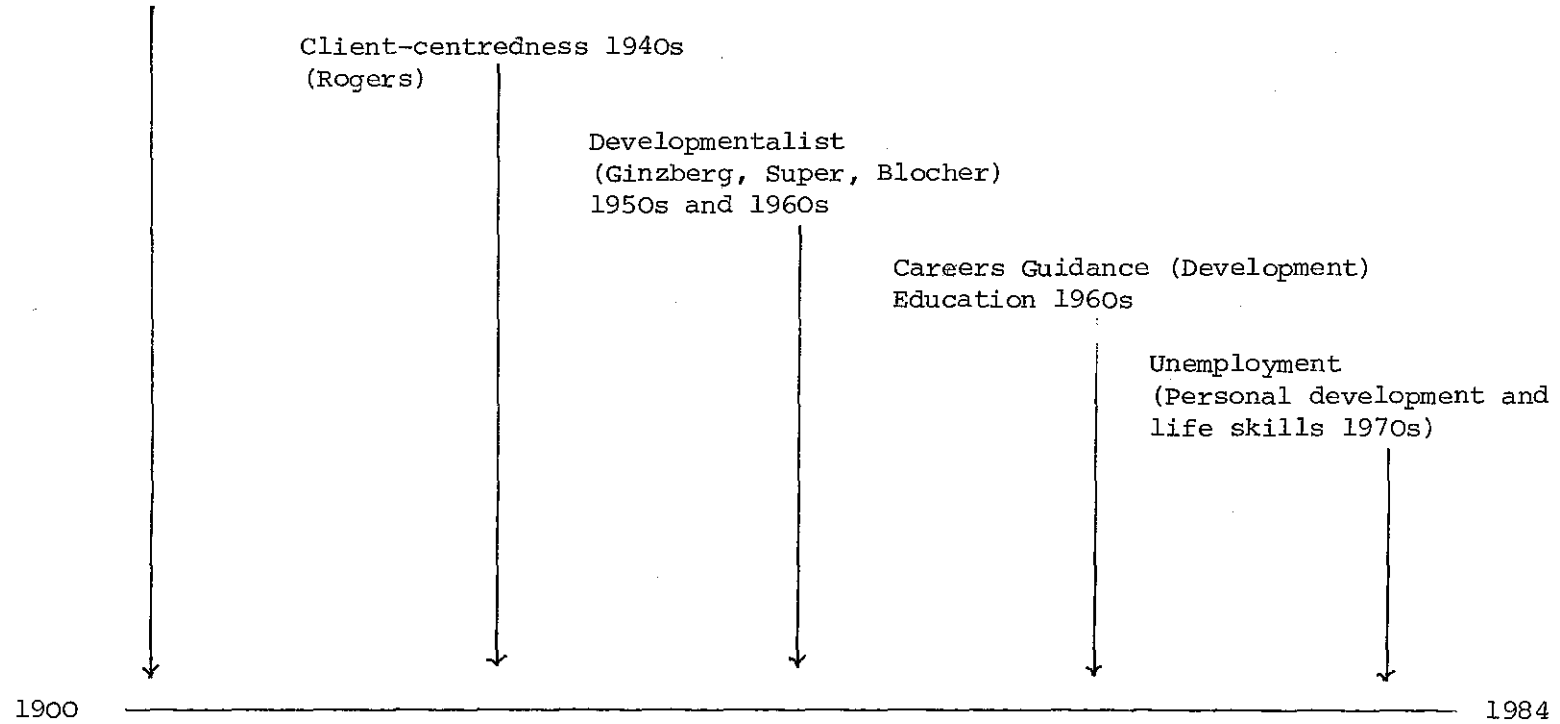

## B GREAT BRITAIN

### B.1 Introduction

If the U.S.A. can be regarded as the cradle of guidance and counselling, then Britain might be viewed as one of several important environments within which the baby grew up. Britain's guidance service also has a particular importance for this study, given British educational influence in Malaysia for many years.

Earlier we have seen how guidance, as an articulated movement started in the U.S.A. in the early years of this century and later firmly and permanently established itself in the American school system in the form of educational and vocational guidance. With the establishment of the National Vocational Guidance Association in 1913, there began vigorous and successful promotion of guidance services in education as well as in industry and service agencies. The post depression years, the immediate post-war period and the post-Sputnik period have each seen a most remarkable extension of these beginnings so that the word guidance in the U.S.A. has a much wider connotation than vocational guidance as used in those early days or as used today in Britain (Hughes 1971).

How then has the development of guidance and counselling arisen in British schools? What social needs is it designed to meet? What are the factors that influenced its development?

## B.2 The Rationale for the Development of Guidance in Britain

Broadly speaking, there seem to be three main recognisable ways in which the word has been deployed in Britain. In each of these the word guidance is accompanied by another word which restricts its actual meaning within relatively narrow limits. Though there is some overlap between the activities or operations referred to by these usages, the three areas are still regarded as quite distinct (Hughes 1971). They are vocational guidance, educational guidance and personal guidance or counselling.

### B.2.1 Vocational guidance

Vocational guidance in Britain by comparison is not only a much later development but in addition it has not been robust enough to establish firm roots within the school system before 1960s (Hughes 1971, Daws 1976). Its general concepts and aims which appeared in America at the beginning of the century are now broadly familiar in Britain through the work of the Youth Employment Service. This Youth Employment Service was established after the Second World War. It developed not from the school base but from the special departments for juveniles set up under the Board of Trade in 1909 and from juvenile employment bureaux set up by local educational authorities under the Board of Education in 1910. It became the principal source of vocational guidance for young people (besides the less formally organised type of help from careers teachers within the school). In fact, according to Hughes (1971),

the Youth Employment Service is probably the most readily recognisable of the three areas of guidance, though its purpose is still frequently envisaged as some ill-defined process of job information and advice given to pupils in their last year at school. This system of vocational guidance is a national one, provided under the Central Youth Employment Executive on which the Ministry of Labour, the Department of Education and Science and the Scottish Education Department are represented. Many local education authorities (L.E.A.) have been closely identified with this service through their Youth Employment officers, who interview and advise pupils on the world of work.

Despite the many efforts to provide vocational guidance for all school-leavers, the Y.E.S. has not been able to provide anything but a superficial version of the vocational guidance service for young people. The aspects of vocational guidance as the process of assisting individuals to 'choose' and to 'prepare for' an occupation while they are in secondary schools (as in the case of American pupils) has almost been neglected. The nearest approximation to a service of this kind has been the institution of "career teacher" - a recognised term since 1932.<sup>3</sup> With few exceptions, however, the form of service offered by the career teacher is a little more than casual, amateurish advice based on his general knowledge and experience backed up by pamphlets and other material collected on an informal and systematic basis. This role was such a peripheral one that, as Daws pointed out in his lecture of 1969, on the occasion of the founding of the National Association of

Career Teachers, there was no mention of it in the 1940s and 1950s. It was only as late as 1963 that the term careers teacher rather than careers master was used in an official document (Daws 1969, cf. Hughes 1971).

#### B.2.2 Personal Guidance

In the process of growing up, school children and adolescents undergo many developmental difficulties which demand or call for more skill, special training, detachment and time than the class teacher can give (Hughes 1971, Wall 1977). Moreover, statistical estimates also indicate that there is a considerable number of children who display more or less serious maladjustments which call for some kind of psychological treatment that teachers and schools cannot undertake unaided. Recognition of these needs had led many Western countries, including Britain, to develop some kinds of psychological services either in the education system itself or in relation to the social or medical service. The original motive behind the establishment of such services was that of treating the more serious forms of maladjustment in children as though they were diseases. Many child guidance clinics appeared in 1930s, concentrating upon problems mainly in the psychiatric field, withdrawing cases from schools and thus leaving almost untouched the pressing questions affecting the healthy mental and emotional growth of the majority of children. Other types of service have also grown up within the education system itself, whereby an educational psychologist is

attached to a school, or groups of schools and acts as adviser to his teaching colleagues on such matters as educational guidance, problems of methods and difficult individual cases (Wall 1977).

Earlier, Hughes (1971) mentioned that both mental testing and the idea of a Child Guidance Clinic, contrary to the notions publicised in some popular books, originated in Britain at the end of the last century (cf. Barbury 1945). As the movement gathered momentum, greater needs for specialised knowledge and expertise to cope with more serious problems of backwardness maladjustment among the school pupils was felt. Suggestions were made for expanded schemes of guidance to include every school pupil - such as:

- (i) cultural or economically disadvantaged pupils
- (ii) physically different pupils
- (iii) pupils undergoing transition from primary to secondary school

and (iv) pupils (adolescent) who faced vocational, emotional or educational problems.

(cf. Wall 1977, McGuinness 1982)

However, until the end of the Second World War, child guidance was mainly concerned with pupils who were mentally subnormal - the feeble-minded, the dull and backward, the delinquent and the neurotic (Burt 1955, cf. Hughes 1971). In other words, 'Child Guidance' as pointed out by a British psychologist is now commonly used to mean remedial education and psychological treatment. Guidance

in this combination denotes a way of dealing with rather specialised problems, by experts using specialised techniques (Ben Morris 1955).

This is where the counsellor acting as a facilitator whose concern is with the individual, regardless of background fits in. He is also a source of guidance, information and a source of skilled help where stresses associated with social mobility (among other things) arise. The concern Great Britain feels for the underprivileged and the special problems of 'educational priority areas' resulted in the appointment of school counsellors, school social workers, teacher/social worker and other similar specialists whose function is largely personal counselling and contact with parents and neighbourhood welfare agencies.

### B.2.3. Educational Guidance

It is used to signify the use of tests and measurements, particularly in the grouping of children according to their abilities and attainments. Though guidance is concentrated in the sense of educational measurements, it also deals with the relevance of this in a variety of contexts, for example, in advising the head with regard to the allocation of pupils to sets, biased courses, the diagnosis and remedial treatment of the backward, retarded and maladjusted pupils and the practice of vocational guidance. In practice, however, guidance is identified as a rather episodic matter concerned with the grouping or streaming of children within schools or of allocating

them to a different school or courses at entry to secondary education.

Wiseman (1964) mentions that with the exception of an occasional enterprising psychologist the use of tests in Britain has been virtually restricted to the 11-plus selection procedure and to the assessment of individual children referred for some special reasons. The need for an adequate system of tests in the secondary school that would give more weight to identification of talent and aptitudes and the tailoring of courses to particular pattern and profiles of abilities leading up to a sound basic system of vocational guidance at the end of the secondary school course was repeatedly stressed by many writers during the twenties, thirties, fifties and sixties. Therefore guidance before 1960s in Britain was said to have been equated with measuring and recording in the accompanying technology, rather than with the process of guidance itself (Hughes 1971).

The first major attempt in British writing to discuss guidance in broader terms (as used in U.S.A. and many other countries) was made in The Yearbook of Education 1955. This volume, i.e. the third under the joint editorial responsibility of the University of London Institute of Education and Columbia University, was devoted to the theme of "Guidance". The American contributions, when compared with the British showed marked differences in practice and approach of guidance between the two countries. Even though Britain was said to be the original home of the child study movement and educationists as well as

educational psychologists including Cyril Burt and others had, for many years advocated a much more broadly based system of guidance, in practice, it was still used in a restricted way in the fifties in Britain (Hughes 1971).

Since the early 1960s a noticeable change of position has occurred in Britain moving towards a wider view of guidance, and towards more organised methods of coping with the task involved. This change is linked with the developing awareness and understanding of the need for a broader conception of the role of the school and the role of the teacher in the personal development of a child. Such changes are reflected in publications by official bodies in which a changing attitude and terminology can be detected (Hughes 1971).

The first specific reference to school counselling in an official government paper was in the Newsom Report (1963) which stated that "in large schools, it may not be fanciful to look forward to a stage where there is a full-time Counsellor available to advise the pupils throughout their school course and to prepare them for going out into the world" (para. 233.3). In addition, the appearance of a pamphlet by the National Foundation for Educational Research on the burning issues of selection at 11-plus was one of the first indications of the newly emerging use of the terms guidance and counselling. The Foundation not only regarded guidance as a basic part of the task of all teachers but also emphasised the necessity of training some teachers as specialists in dealing with the more scientific aspects of guidance and counselling (cf. Hughes 1971).

Some of the recent studies indicate that streaming or early grouping of children into distinct and separate routeways through the primary and secondary school can lead to a polarisation of abilities and attitudes, and perhaps to a needless depression of the self concept for a majority of children (Douglas 1964, Hargreaves 1967, cf. Craft 1974). This was further complicated by the abandonment of selection at eleven plus to the age of thirteen, fourteen or fifteen years in the tripartite system and once the eleven plus decision had been replaced by one involving a far more extended form of assessment, the need for skilled guidance and counselling became urgent. Then, when the tripartite system had been superseded by a pattern of larger comprehensive schools with more differentiated curricula and with more flexible groupings, the need for educational guidance and for personal counselling followed automatically (Flann Campbell 1956, Half Our Future 1963 and Craft 1974). Here the school counsellor could provide what had been known as 'globality of concern', i.e. an all round view of the whole child (Craft 1974, Daws 1976). As schools became larger and organisationally more complex this became increasingly important as did the need for someone to co-ordinate the efforts of the teaching staff and of outside welfare specialists in case of need (Craft 1972 and 1974, Daws 1976, McGuinness 1982).

### B.3 The Origin of Guidance and Counselling in Britain

There are numerous alternative views on how and why guidance and counselling has arisen in British schools. Some of them will be discussed below.

B.3.1 According to Daws (1976), "School counselling had two contrasting parents: vocational guidance and mental health. Vocational guidance sired the courses, getting them funded and founded, but the mental health movement, considerably aided by transatlantic obstetrics, provided their eventual shape and spirit ..." (pp.13-14).

#### B.3.1.a) Vocational Guidance

The origin of vocational guidance in Britain could be traced back to the early 1960s, where a social worker Hans Hoxter tried to convince the Gulbenkian Foundation of Britain's need for more adequate educational and vocational guidance for secondary school pupils and for students in the tertiary of education (Daws 1976). At that time, he was Principal Youth Employment Officer from East Ham. Armed with Gulbenkian reassurances of interest in financing the research proposal and training schemes Hoxter travelled round the country to stir interest and the consciences of professors of education and psychology in "educational counselling and vocational guidance". His endless initiatives resulted in acceleration in schools, more ambitious careers guidance, careers education and the establishment of school and college counselling (Daws 1976).

At the time when Professor W.A.C. Stewart was writing a book on English education innovation with Philip McCann as co-author in 1962, Hans Hoxter paid him a visit at Keele to persuade him to mount a training programme for teachers in educational counselling so that the professional aid available to secondary school pupils might be gradually increased. Eventually, the University of Keele began its first course in educational guidance and counselling for experienced secondary school teachers in 1965. The introduction of this one-year full-time training programme startled the educational world. It was initially conceived as a course in guidance with an emphasis on educational and vocational guidance of the more traditional sort that was based on good record-keeping, interviews and psychological tests, to gain further information and other assessment skills (Daws 1976). The term 'educational guidance' was dropped before the end of the second year as a result of Gilbert Wrenn's<sup>4</sup> persuasiveness (i.e. suggestion made by Daws 1976) - Gilbert Wrenn was one of the two pioneering visitors sent by the Fulbright Commission to help with the start of this new venture. The other visitor was Gilbert Moore who was sent to Reading. Matters of mental health and of general personal growth of children (including the educational and vocational developmental tasks that confronted young people) became the basic broad platform of the Keele course along with training in the skills of counselling. In recent years techniques of behavioural counselling and group work were added to the course.

Simultaneously, an 'educational guidance course' (now known as 'educational guidance and counselling in schools') was begun at the University of Reading. Unlike Keele, its formation was neither being influenced by NAMH nor Hans Hoxter. According to Professor C.H. Dobinson (the man responsible for conceiving the course), he was very much influenced by Jean Beaussier, a Parisian specialist in vocational guidance as well as being impressed by American guidance practice that he had observed on his visits to America (Daws 1976). Later, the generosity of the Fulbright Commission had enabled Dobinson to invite Gilbert Moore, an American Counselling scholar from Buffalo, to Reading for a year. Therefore with the help of Moore and another educational psychologist, Dean Juniper, a strong educational and vocational diploma course was created at Reading with some emphasis on mental testing and practical aspects of counselling (Jackson & Juniper 1971, cf. Daws 1976). A similar course was offered for overseas students. Reading's contribution through in-service training to the professional development of the mental health movement in education, schools and colleges has been and continues to be considerable.

Following the founding of the initial course, Hoxter began his series of 'Round Tables'. The first was held in Neuchatel in January 1966, followed by others in Salzburg (1967), Turin (1968), The Hague (1970), Paris (1972), and Cambridge, England (1974). He initially called it the International Round Table of Educational Counselling and Vocational Guidance (IRTECVG) but the title was

changed in 1971 to the International Round Table for the Advancement of Counselling (IRTAC). The change of title was significant. It reflected the emphases of concern that have changed since the initial conceptions.

Courses that began later benefited from the experience of the Keele and Reading early courses. However, the nature of these courses varied from one to another. For instance, the Exeter course which began in 1966 was an initiative independent of NAMH influence. It developed, under the direction of Hugh Lytton, 'an educational psychologist of a strongly Rogerian persuasion' was a 'purer' counselling course than either Reading's or Keele's. The Swansea course which began in 1969, was least influenced by American models (Daws 1976). It was very much influenced by Douglas Hamblin who sees the counsellor as a team leader and co-ordinator of all the school's pastoral and guidance effort. Though the course places great importance on sensitivity to others, the ability to make an effective relationship and the basic skills of interviewing as in other courses, it reflects an indigenous British educational conception of school counselling (Daws 1976, see also Hamblin 1974).

Two other early courses were the course in health education (whose counselling component was introduced and developed in 1970s) at the Birmingham College of Education in 1965 and the diploma in educational guidance course at the University of Manchester which began in 1966. In 1969, Keele added a student counselling option to its course and the movement spread from the secondary to the

tertiary field when Aston, too, began a student counselling course in 1971. By 1976, there were around ten institutions (colleges and universities) offering courses and training in guidance and counselling for teachers (Daws 1976).

The same movement is about to begin in the primary school in which counselling will be offered to anxious parents as well as to pupils (Lawrence 1973, Daws 1976 and 1980). It is related to the common knowledge that a favourable family background (particularly during the pre-school years) has an important influence on satisfactory emotional development as well as on the development of specific intellectual skills such as language, visual and auditory perception and hand-eye condition. In spite of that, many remedial programmes tend to ignore the possible effects of unsatisfactory emotional development. Lawrence (1973)<sup>5</sup>, on the other hand, believes that it is possible to improve a child's image and ultimately his reading attainment by a systematic individual counselling. He regards this system as a practical method of helping the retarded reader through four helping hierarchy i.e. by non-professional people, by the teachers themselves, by highly trained school counsellor and by the educational psychologist. However, a child showing what is described as psychotic behaviour will have to be referred (or helped) to the Child Guidance Team where the psychiatrist will be most involved (Lawrence 1973).

Recently, in 1980, about twenty courses of training in counselling are available in this country on either

a one-year full-time or two-year part-time basis. Besides providing the interpersonal relationship skills of counselling, these courses aim to develop a diagnostic eye and sensitivity in reading the behaviour of people and to give skills in providing the ground work for adolescent development, mental health and the other essential components of guidance (Daws 1980). Reservations expressed in the U.S.A. (Cicourel and Kitsuse 1963) were echoed in the United Kingdom by J. Richardson (1979).

Although most of the teachers viewed the emergence of guidance and counselling movement in the mid-1960s with mistrust, because of its values, practices and objectives which were so different from what they were familiar with, there were a substantial and quietly influential minority of teachers who had recognised the need for more systematic help to be given to pupils in their personal development, especially to those who appeared troubled or distressed (Daws 1976). They recognised that the traditional panaceas and formulae the old had given to the young were no longer sound recipes for survival, let alone personal fulfillment in the world of rapid change (ibid., Craft 1974). As such, many teachers and head teachers turned to guidance and counselling movement for fresh approach to the development of personal and social competences among children.

#### B.3.1.b) Mental Health Movement

The origin of school counselling could also be traced in the mental health movement (Daws 1976). The mental

health movement owes its progress to the initiative taken by the late Lord Feversham at the beginning of the sixties when he reminded the National Association for Mental Health of its neglect in the field of preventive medicine. As the then President, he also set up a small working party to consider the appropriate contribution the Association might take to preventive mental health. Therefore, N.A.M.H. set out to consider what recommendations could be made to improve the caring and the protective aspects of the school, to identify the elements in the school as an institution that were unacceptable and stressful to children and to suggest the new ways the school might contribute to establishing and promoting personal competence and mental health in children.

Among the steps taken by N.A.M.H. were the holding of seminars in Bristol in September 1963 called the 'Seminar on Counselling Services in Schools' and in York in July 1966 i.e. at the end of the first year courses at Keele and Reading. The first seminar envisaged a counsellor (who might have a basic training as a doctor, a social worker or a teacher) as dealing with the second level himself, co-operating with the school psychological service and the clinics in helping children with problems at the third level (Daws 1976). The second seminar sought an understanding of the nature of counselling as a professional activity, its purposes, and how it should fit in with the rest of the school's activities.

N.A.M.H.'s next venture was to set up a working party in 1967, to work out a prescription for school counselling for the guidance of I.E.A.s, heads of schools and institutions that were running or contemplating setting up of training courses. A policy document on the subject was published three years later (N.A.M.H. 1970, Daws 1976).

The people who were involved in the mental health movement in school were those teachers who had recognised and questioned the limitations of the older traditions with regard to elementary education (Daws 1976, McGuinness 1982). As a result of this, i.e. a new consciousness of mental health responsibility, a number of discrete developments have taken place such as the emergence of specialised guidance roles and more effective pastoral care organisational structures such as house and year systems (Moore 1970, Anne Jones 1977). The mental health movement also sees counselling as a supplement to school mental health or social welfare services rather than a booster to the economic health of the nation, even though the two aspects are closely linked (Anne Jones 1977). Thus, under the umbrella of the mental health movement, many schemes for education in personal relationships comes into being. Some of these schemes are run by the Marriage Guidance Council and by teachers who undertake the task after receiving training from the Marriage Guidance Council (ibid.).

B.4 Factors that Motivate the Development of Guidance and Counselling in Britain

The development of counselling is part of the development of a 'personal service society', growing out of the decay of religion and its replacement by a faith in technology and the perfectibility of man (Halmos 1979). Bolger (1982) on the other hand considers the development of counselling in Britain as parallels to the development of the welfare state. It seems to have a close relationship with the modern development of medical services and the growth of progressive education. He further mentions that the two forces at work in counselling are the growing awareness and the expectations towards 'the quality of life'.

Indeed, the factors that motivate the development of guidance and counselling in Britain are many. Craft (1974), for instance, suggests three important factors that influence its emergence namely societal needs, political ideology and economy. He argues that societal pressures, and most significantly the influence of a changing political ideology alongside Britain's post-war economic pre-occupations, are closely associated with the arrival of guidance and counselling in British schools (cf. Cicourel and Kitsuse 1963).

After World War II Western society, including Britain, has moved from a relatively static state into an era of economic and social change unprecedented in its history. In other words, it has entered a stage of advanced industrial development, characterised by a number of

features which are creating a new 'technological' society (Hughes 1971, cf. Craft 1974). As such, it becomes anxiety prone by virtue of its predominantly urban nature, its rapid rate of social change, its cultural pluralism (i.e. the variety of moral codes it manifests), the decline of the large, extended family, the increased rate of geographical mobility, the influence of mass media and so on (Craft 1974). Therefore, the appointment of counsellors could be regarded as a kind of psycho-therapeutic response to acute social needs of the people during this period of advanced industrialisation. However, the relationship of educational change to wider social structure is always an extremely complex one and simple explanations are rarely possible (Craft 1974). In addition, the meagre literature on the introduction of guidance and counselling into British schools does not help much in making the societal analysis. Daws (1967) moved a little in this direction when he referred to the 'continuity of concern' which the counsellor would represent when there was a high teacher turnover (cf. Craft 1974).

The subject of social changes was again brought up by Daws in his later book called "Early Days" (1976) while tracing the origin or rise of guidance and counselling in English secondary schools. Daws regarded this as a phenomenon of the mid-sixties. During that time, great social changes had occurred, especially in the world of young people and in their relationship with their elders. Many teachers were not happy at the abrupt or

sudden appearance of guidance and counselling (school counselling as it is referred to by Daws 1967, 1980). They had reacted unfavourably to the notion of counselling which they saw as an undesirable American practice their schools could do well without. Their attitudes, however, began to change with the emergence of the comprehensive schools whose size magnified greatly the task of controlling pupils and of getting to know them with any degree of intimacy. Traditional modes of guidance and pastoral care were unable to function well in this new setting. Therefore, many head teachers turned hopefully to counselling as a more professional and fresh approach to pastoral care responsibilities to supplement the school resources (Daws 1967 & 1980; Craft 1974, McGuinness 1982). Another factor was the growing aspiration evident in many secondary schools to adopt more ambitious approaches to the development of personal and social competence in children, as advocated by the Newsom Report which appeared in 1963.

Craft (1974) further mentioned that the growth of an egalitarian political ideology in Britain during the post-war period (well beyond 1945), which turned Britain into a welfare state, also had great influence on the development of guidance and counselling in British schools (cf. Daws 1976). Great emphasis was placed on the extension of individual freedom through intervention of the state - a socialist ethic. As a consequence, educational opportunities were enlarged and basic rights to health, housing and employment were implemented. There

was also an increased demand for extended education and a greater participation by working class children in selective secondary education. All this reflected the prevailing political ideology of the post-war Britain. The sequence of reports from the Central Advisory Council (Early Leaving 1954, 'Crowther' 1959, 'Newsom' 1963, 'Plowden' 1967), the 'Robbins Report' (1963) and the successive sociological enquiries (e.g. Mays 1962, Douglas 1964, Bernstein 1965) which illustrated the variations in life-chance between children at different social levels had acted as both the cause and effect of the continuing concern to democratise Britain's educational system (Craft 1974).

There was also suggestion by Craft (1974) that while the educational system clearly interacted with the prevailing political ideology, it also interacted with the economy. In fact, he regarded the continuing economic crisis as the second most important influence on the development of guidance and counselling in British schools, next to the egalitarian political ideology in post-war years. There were anxieties about the waste of talent as a result of unsupportive background and waste of talent through streaming in the primary school, rigid selection at eleven-plus, deterioration in the grammar school and early leaving (cf. Flann Campbell 1956, Half Our Future 1963, ibid.). The under-representation of working class (especially lower-working class) children in selective secondary and higher education raised an awareness of the need to involve parents, to raise aspirations and reduce

under-achievement, to improve teaching techniques and the structure of the curriculum and thus inducing educational productivity (Anne Sharrock 1980 and A.G. Watts 1978).

The above literature suggests that Craft was not the only one who linked societal pressures, political ideology and economic preoccupation with the arrival of guidance and counselling in British schools. His views were foreshadowed by Leona Tyler (1961) on the need for guidance and counselling in the United States by saying, "It is the combination of an extremely diversified industrial society with democratic ideals that makes counselling necessary." These twin forces, economy and ideology, are often cited as the dynamic behind educational expansion in both developed and under-developed societies including Malaysia (Bereday 1969, Craft 1970, cf. Craft 1974, Ibrahim Saad 1982, cf. Mahathir Report 1979).

## B.5 Other Factors that Influenced the Development of Guidance and Counselling in Britain

### B.5.1 Educational Psychologists

It is interesting to note that a number of educational psychologists, particularly Grace Rawlings and George Robb have maintained close interest and support for the idea of school counselling. In fact, many of the early pioneers of school counselling in Britain are the same as those of the School Psychological Service, which include Francis Galton, James Sully, William McDougal and Cyril Burt. School counsellors have been welcomed by many psychologists

(as suggested by the Summerfield Report) as a realistic and appropriate alternative provision to supplement their work with the troubled and disturbed and with those teachers who have to face them (cf. Summerfield Report 1968, p.27).

This welcome reflects the mental health origins of the school counselling movement and has been a significant factor in securing for counselling a mental health orientation in schools (Daws 1976, cf. Summerfield Report 1968). Thus the school counsellor's most congenial ally is the educational psychologist and community social worker rather than the careers officers.

#### B.5.2 American Scholars and their Counselling Techniques

According to Daws (1976), the American scholars, especially Wrenn and Moore, have exerted a considerable influence upon the teachers of counselling as well as upon its students in Britain. For instance, Moore brought the basic techniques of counselling, together with values and objective of developmental counselling. He also brought particularly a concern for the development and co-ordination of specialised guidance roles within the school, all of which are still being practised in Britain (Daws 1976). Without the generosity of Fulbright US-UK Educational Commission and the authoritative influence of these two earlier scholars, the establishment of the presently accepted principles and practices of counselling would have taken a much longer period (ibid.). In fact, the American ideas, especially the client-centred approach of

Carl Rogers, have been the main determinants of the philosophies and the objectives of the present training courses in Britain (Daws 1976).

### B.5.3 The Guidance-Oriented Curriculum

In addition to the above factors, there is also an increasingly effective co-operation between schools and external helping agencies such as school psychological service, the education welfare service, the child guidance clinics, the careers service and social services (Daws 1976 and Anne Jones 1977). Unlike America, however, not every secondary school in Britain appoints a full-time counsellor who could devote his or her time and skills to guidance responsibilities (School Council 1967, Anne Jones 1977). In spite of that, there exists in the vast majority of secondary schools a systematic, structural and organised pastoral care system with specific tasks to do. These tasks are in addition to the day to day care and discipline, smoothing the transition from primary to secondary school, providing guidance for subject choices, offering careers advice and preparing for the transition from school to work (Anne Jones 1977, Daws 1980).

Increasingly, classroom time is being found for personal and social education and teachers are turning their attention to the development of systematic curricula in the areas of sex and health education, moral education, social education as well as careers education, in the hope that such 'guidance-oriented curriculum' would enable the teachers to help children in their personal as well as

their academic growth (Daws 1976, McGuiness 1982). What is meant by a guidance-oriented curriculum? How can it be implemented?

The Inspectorate's survey of secondary education (1979) observed that "in general, schools placed much greater emphasis on fostering the personal development of their pupils through pastoral care than through their curriculum". The survey also recommended that three-quarters of the schools surveyed should give more detailed attention to the ways in which the curriculum could serve the pupils' needs in the area of personal development (McGuiness 1982). According to McGuiness the Inspectorate's survey were recommending a "guidance-oriented curriculum" (*ibid.*). Earlier, the Inspectorate's working paper "Curriculum 11-16 (1977) emphasized the crucial nature of full staff involvement in pastoral care. It argued that social objectives "must be realized through the nature of the personal relationships in the classroom ... and through the daily example of all the adults with whom the pupils are in contact" (Curriculum 11-16, 1977 and cf. McGuiness 1982). The acceptance of this role and the structuring of a child's school experience to accommodate it are regarded by McGuiness (1982, p.9) as "the first vital step in a preventive approach to guidance" or guidance-oriented curriculum. If the school were to undertake successfully the task of helping its pupils "learn to be adults" as stated by the Warnock Report on Special Education (1978), it "must broaden its view of the child beyond the narrow confines of academic potential to include the full range

of their developmental potential" (McGuinness 1982, p.11). Thus, a well balanced curriculum should contain deliberately constructed strategies to develop academic and socio-emotional competence of its pupils, as indicated by studies like those of Hargreaves 1967 and Lawrence 1973 (cf. McGuinness 1982). How can this guidance-focused curriculum be achieved? According to McGuinness (1982), although "Ethically and pedagogically a guidance-focused curriculum is desirable, from a practical point of view it is not possible", since it is not easy to change a structured curriculum. He therefore, suggested that academic and guidance teams should be integrated at the planning stage. This could be done by setting up a structure which involved regular contact and evaluation of both areas of the school's work. The teacher's attitudes and values which govern their performance in schools are also important determining factors. Equally important is the nature of the pupils who need help (McGuinness 1982).

Why do the schools need to have guidance-oriented curriculum? Before going any further, let us examine briefly the aims or purposes of education in Britain. When Britain introduced its free education service in 1870, there were two major concerns of its planners: (a) that it should help to supply a basically educated workforce for the then current industrial expansion and (b) that it should ensure that this newly literate working class would not use its new skills for mischief (cf. McGuinness 1982, Watts - Employment, Youth and Work 1983). In other words schools were meant to prepare pupils for work without

unduly awakening political and social aspirations (ibid. and Wong and Ee, 1975).

The early historical context or issues on universal education continues to influence British educational settings. Present day schools in Britain as well as in Malaysia are still largely influenced by the two foci: work and obedience, both of which have given rise to many problems for the educators as a result of the changes in the context within which the schools now operate (McGuinness 1982). Looking back at the rise of guidance and counselling in Britain (which was discussed earlier) the prevailing egalitarian political ideology was said to give rise to the egalitarian education policy which was more concerned with the individual than with any benefit the state might derive incidently (Craft 1974).

However, when we considered guidance and counselling as being possibly related to economic factors, it might imply that the benefit of the state was the prime aim and that of the individual was more incidental (ibid.). This could be seen in the 'Crowther Report' (1959) which regarded the two purposes of education as a basic human right and social service for which the state must assume responsibility and as an investment. These purposes varied in emphasis over the years and had given rise to a conflict of views over their importance. Later, the "Robbins Report" (1963) seemed to find a way out of this apparent dilemma by considering that education is clearly an investment in a nation's future. The Committee observed that "the goal is not productivity as such but the good life that

productivity makes possible (op.cit. para. 621 - cf. Craft 1974). According to McGuiness (1982), the work ethic and economic need are no longer realistic motivators for present day children in school. The 1980s represents the beginning of a period of long term, structural unemployment (Sherman & Jenkins 1979, Merritt 1982) and the period of challenge to social order or authority. The alternative motivation can only be found in "human" schools which develop life skills in an atmosphere of respect for all (McGuiness 1982). Hopson and Scally (1981) clearly outlined the future implications for education whereby "people will need to be trained in how to cope with unemployment psychologically will need job-hunting skills, self-marketing skills, knowledge of how to get information on retraining opportunities, government grants, and schemes and further and higher education options" (p.9).

In future, the nation's task is to ensure that people have a good general education which will help them to prepare for the concept of life roles that differ from the ones of twenty years ago. The other task where work is available, is to help young people get the job most suited to them. Besides that, both sexes need the "skills of adaptability" as well as "wedded to the notion that non-work roles will have to provide a major slice of their life satisfaction, knowing that education is a life-long process. On the other hand, they need to be aware that sometimes they will not have jobs ..." (Hopson & Scally 1981, p.13). What implications will these issues have on the curriculum of our school? How is it to be taught?

Watts (1978) also asked fundamental questions about a school curriculum based on the work ethic. What value has it when increasingly there is going to be less work? To Watts (1983) education has a close relationship with the world of work.

According to McGuinness (1982), the answer to the problems could be found by looking carefully at the nature of change in schools. There was a need to develop a system in schools for managing change that facilitated consensus and encouraged a contribution to the change from all concerned. If a degree of consensus about the direction of education in British schools could be formulated and arrived at, then change would be possible. In other words, schools need to direct their minds to analysing the curriculum for "our pupils", a process which will require involvement from all members of the staff (cf. Curriculum 11-16, 1977).

Presently (in 1980s) there are about one hundred schools in England and Wales that have a designated full-time counsellor who devotes the bulk of his or her time to guidance responsibilities (Daws 1980). Part of their work may include spending time in the classroom, teaching aspects of personal and social education or providing remedial education. There are more than one thousand teachers, trained in counselling and in part-time guidance roles such as career teacher, remedial teacher, head of middle school, co-ordinator of pastoral care, head of guidance, tutor to sixth form or head of house or year systems (ibid.). Besides that, quite a number of teachers have acquired some

skill and understanding of guidance and counselling from short courses provided by D.E.S., local authorities and many institutions of higher education (Daws 1980).

#### B.6 Reflections on the Innovations

Daws (1980) further mentioned that changes are evident in numerous secondary schools in Britain which can be ascribed in part to the influence of counselling. One of them is that there is much more widespread appreciation of the difference between a child's problem and an institutional problem by the teachers. Counselling also brought about "an appreciation that knowing a child from the inside and knowing him from the outside are two quite different kinds of knowledge, requiring different kinds of information obtained in quite distinct ways" (Daws 1980, p.255). Such views of the child can only be acquired through intimacy of relationship and may usefully be complementary to one another. Counselling also brought back into education an enhanced awareness of the importance of the relationship that a teacher establishes with his pupils, collectively and individually, in determining the effectiveness of his teaching i.e. through the pupils' achievements. As a consequence, classroom styles are becoming less rigid and stereotyped, more flexible, more open and empathic than formerly (Daws 1980).

With the continued development of these trends in the 1980s and the spread of counselling to primary schools (in which counselling is offered to anxious parents rather than to pupils) it is hoped that a new dimension to the

eternal challenge of building effective bridges between the generations could be achieved through counselling.

The present model of the counsellor as trained in various university courses in Britain is largely based on the American university concept of the counsellor who is expected to combine the three strands of counselling namely vocational, educational and personal-social counselling (Lytton 1974). However, this need not be the final model. It is only useful at the time when a new concept is being introduced, that is, before the actual form or trend is formulated to suit the British culture. Even if one examines the situation in America and later looks at the different types of social agencies available in this country, doubts begin to arise concerning the alignment of functions between the different helping professions. They centre on the combination of educational-vocational and personal-social counselling functions in the same person and on the piecemeal growth of separate disciplines, all of which deals in some degree with personal-social counselling (Lytton 1974).

Lytton (1974) further added that the 'Holy Trinity' of counselling - educational, vocational and personal - only exists more in theory than in practice in the United States. In reality, the American school counsellors hardly ever combine the three functions. They are most heavily involved in educational guidance, that is, helping the pupil find the right combination of courses at school or choose the appropriate university (Lytton 1974 and cf. L. Tyler 1961, P. Halmos 1979). In fact, "the interaction

between the counsellor and pupil on educational choices will usually be of a routine character and will be kept at a mundane level" (Lytton 1974, p.165). Very rarely will such an encounter provide an opportunity for branching out into more deeply personal exploration (ibid.). Unlike Britain, the duality of the school counsellor role is seen as an inhibiting factor by many American students who perceive the two roles as contradictory, one detracting from the other (cf. Lytton 1968, 1974 and School Council 1967).

The number of full-time counsellors in Britain is still small. In America, for instance, by 1974, there were already about 30,000 full-time counsellors in schools (Lytton 1974), whereas in Britain there were only one hundred schools in England and Wales that have a designated full-time counsellor in 1980 (Daws 1980). The rest are the teachers who carry out the guidance and pastoral care duties as part-timers or as career teachers. The reasons for the differences are many. Among them are the fact that counselling in America has become part of the pattern of the manifold educational choices. The complexity of the American school system makes it necessary for a selected teacher to assume responsibility for guiding the student through the multiplicity of choices (Wrenn 1962, Lytton 1974).

On the contrary the school structure in Britain allows fewer educational choices and therefore less degree of specialisation of functions in counselling is required. Besides that, most of the people involved still lack special training or skills in this field. There was also

resistance to the introduction of professional skilled help in school, which was based on the fear that it would lead to a restriction of the activity, a diminution of the status of teachers (Lytton 1974, McGuinness 1982).

#### B.7. Conclusion

The complexities of the development of guidance and counselling in the United Kingdom have led to a variegated pattern of current practice. It is difficult to speak of guidance and counselling as one entity in the United Kingdom since the approach to it varies so greatly from region to region, over school to school. Fig. 2 indicates the numerous influences on practice - the extent of each influence varies according to local conditions (e.g. high unemployment), individual teacher philosophy (e.g. commitment to child-centred education) and so on. The task for Malaysia is to look carefully at this practice, selecting even more carefully those aspects which best facilitate the aim of Malaysian education.

Guidance and Counselling in Great Britain

Influences on Development

Historical	Structural	Theoretical	Date
1. U.S.A.	Out-of-School	Mental Health	1900
2. Industrialisation	In-school Specialists	Careers	1960's
3. Unemployment	Whole-school Commitment	Developmental Remedial Curriculum-based Egalitarianism Secularisation of Society	1970's    1984

Fig: 2

## C MALAYSIA

### C.1 Introduction

As mentioned in the introduction, social changes have taken place not only in western societies but in Malaysian society too. These changes have unavoidably affected the school as an important educational institution whose task is to create the "required values for future generation". (The Guidance and Counselling Unit, Ministry of Education, 1983.) The situation in schools became more complex. As academic certificates became a prerequisite of entry to any job in the modern sector, society expected the pupils to excel in many public examinations. This process continues to the present day and has led to the examination-oriented system of education in Malaysia. The examinations in schools are not only used as a means to diagnose weaknesses and to carry out remedial work, but also most importantly as a criterion in making critical decisions on each child's future at school and later in the world of work (ibid., cf. Watts 1981).

Furthermore, education is said to have "a close relationship with the world of work" Watts (1983, p.2). Societies expect schools to develop in the young people the knowledge, attitudes and skills which will enable them to contribute to the economy. Young people and their parents, too, expect schools to help them enter a profitable job. In the eagerness to get high percentage results, the academic teacher could no longer focus his main role as an "educator" but more on the role of

"transmitter of knowledge" (Guidance and Counselling Unit, 1983), thus neglecting the socio-physical aspects of the child's development. This is probably the reason why we require a "specialised personnel" to fill in the gap. As such, how and where do the roles of guidance and counselling fit in?

## C.2 The System of Education in Malaysia

Before further discussions on the needs and the functions of guidance and counselling services in Malaysia, it is pertinent to study the system of education that exist in the country. For the purpose of our study, the system of education in Malaysia will be discussed in four stages:

- C.2.1 Before the British Period (before 1870's)
- C.2.2 The British Period (1870's-1941)
- C.2.3 Post-war Re-construction
- C.2.4 The Formation of Malaysia in 1963 or since 1963.

### C.2.1 Before the British Period (before 1870's)

Before the coming of the British, a traditional form of education was already in existence in Malaya whereby knowledge and skills were not only handed down from parents to their children but also by means of religious schools. These religious schools fall into three categories: the Koran or surau schools, the sekolah pondok (hut schools) and the madrrasah schools (Cheeseman 1955 and Yegar 1984).

The Koran or surau schools were those run privately in the village mosque or surau (place of worship, smaller than the mosque), teaching the Koran and Islam.<sup>7</sup> They were purely religious in character and distinct from the vernacular-secular government schools introduced by the British. Promising pupils would be sent to a higher school, either sekolah pondok or madrasah school in charge of some well-known Muslim religious teacher, perhaps a Malay with years of study in Arabia or Egypt, or both, perhaps a teacher from Sumatra, India or Arabia (Yegar 1984). The sekolah pondok or hut schools were private Islamic schools usually established by a religious teacher, offering a regular course of Islamic studies from two to five years. The pupils came from different parts of the country. They then would live in a cluster of small huts built in or around 'their school's compound', which explains how the school obtained its name.

The madrasah schools were more advanced Islamic schools teaching in Arabic. They were originally run by private organisation or by the teachers themselves. Since independence, most of these schools are now gradually being taken over by the State Religious Affairs Department or being frequently assisted by the government. As such, their names have been changed to Sekolah Agama or Sekolah Arab (Religious or Arabic Schools). Under the current situation, the pupils are being exposed to the same curriculum as in other national schools, besides the teaching of Arabic language and other religious knowledge. In fact, it has been the policy of the government of

Malaysia to absorb all schools in the country to be placed under the common system of education.

### C.2.2 The British Period (1870's-1941)

At the beginning of the British rule in Malaya, a more formal and secular form of education was introduced by the British to suit their requirement in ruling the country (Wong and Ee 1975). Many schools were opened for the three major ethnic groups in Malaya - Malays, Chinese and Indians, giving rise to two types of schools namely the vernacular and the English medium schools (ibid, Andaya 1982).

C.2.2.1 Many controversial issues have been raised on the educational policy of the British in Malaya at that time. According to the British Government reports in 1854 and 1857 (Chelliah, 1960), it was stressed that the primary objective of the government was to provide elementary education in the vernacular and that the government as the guardian of natives rights and customs felt that the indigenous population in the rural districts had first claims. It is worth noting that free, universal elementary education did not appear in Britain until 1870 (McGuinness 1982).

C.2.2.2 The purpose of education for the indigenous population, however, had been subject to many criticisms for it was not meant for them to get any basic skills and knowledge to develop themselves but "to make the sons of

the fishermen and farmers become better fishermen and farmers than their fathers are..." (Cheeseman 1955, Roff 1967). On the other hand, the English medium schools were meant to produce intelligent, diligent and honest servants to work for the company (British East India Company) and the British government. Private enterprise was encouraged by the government of that period which pointed out that the government could not possibly provide the means for educating the whole country (Chelliah 1960).

C.2.2.3 As a result, three parallel systems of schooling existed in the country i.e. one vernacular for the Malays who predominated the rural areas and which was established and maintained by the government; Chinese and Tamil vernacular which was set up by their respective communities or employers (Tamil vernacular) and English schools maintained by the government which provided a westernised education taught primarily in English for the mixed urban population (Wong and Ee 1975). The various vernacular school systems had tended generally to emphasize disparate and often opposing goals (Ginsburg and Roberts 1958). The Malay schools were designed to instill a strong Moslem and Malay consciousness, the Chinese to perpetuate Chinese culture and to establish pupils firmly in that culture, and the Indians to provide a basically Indian background for displaced Indian students, while the mission schools tended to view their goal as the propagation of Christian virtues and Western

cultural values (ibid.). Thus, few schools, if any, until 1950s viewed their goals as the creation of a unified Malayan society comprising all the various ethnic, linguistic and cultural groups.

C.2.2.4 According to Wong and Ee (1975), a recent study showed that there were two contradictory tendencies in the British approach to Malay education (Loh 1970). One of them was that there was a humanitarian element which saw that an influx of foreign immigrants (Chinese and Indian) made it desirable that the indigenous community should be educated to protect itself. The other element was the fear that an English education might uproot the British rule in Malaya. This reflected fears expressed in the mid-19th century in Britain about the dangers of educating the working class (McGuinness 1982 & 1983).

During the British period, certain prime factors such as political, religious and racial backgrounds, private enterprise, geographical and economic issues played important roles in influencing Malayan education (Wong and Ee 1975, Ginsburg and Roberts 1958). Private enterprise also contributed to the shaping of the educational pattern and was also responsible for the early beginning of organised education which was later taken over by the government. The curriculum also reflected the economic trend of the period and the main purpose of the syllabus was to teach children reading and writing English, as well as arithmetic with the intention

of giving just the sort of knowledge that would enable them to find jobs.

### C.2.3 Post-War Education Re-Construction (1945-1962)

As stated earlier, the main weakness of the pre-war educational system was the division of children in separate type of schools which seemed to foster communalism. It was then felt that a common Malayan outlook was necessary if self-government were to succeed and that this was not possible if the children were educated separately. Hence, a re-organisation of the system was necessary, including the content of the curriculum to be taught in the schools. So, for example, H. Davies in his article "Needs of Liberated Malaya" stressed the importance of 'a unified system of education' (The Times Educational Supplement, London, 1946; cf. Wong and Ee, 1975).

C.2.3.1 Among the major reports that help to determine the present national education policy are:-

- (i) Report of Central Advisory Committee on Education  
1949
- (ii) Report of the Committee on Malaysian Education or Barnes Report, 1951
- (iii) Report of a Mission invited by the Federation Government to study the problems of the Education of Chinese in Malaya, 1951
- (iv) The Fenn-Wu Report, 1951
- (v) Report on the Barnes Report on Malay Education and the Fenn-Wu Report on Chinese Education, 1951

- (vi) Report of the Special Committee to consider ways and means of implementing the policy outlined in Education Ordinance, 1952, Sessional Paper No.67 of 1954
- \* (vii) Report of the Education Committee, 1956 or commonly known as the Razak Report
- \* (viii) Report of the Education Review Committee, 1960 or the Rahman Talib Report
- \* (ix) Report of Cabinet Committee on Education Policy or the Mahathir Report, 1979.

(Note: The three last reports are the most frequently mentioned and referred to in relation to education in Malaysia.)

In 1949, a Central Advisory Committee on Education was set up to advise the government on general policy and wide principles to be followed in education (Report on Education 1949, cf. Wong and Ee 1975).

In 1950, the Barnes Committee was set up 'to enquire into the adequacy or otherwise of the educational facilities available for Malays'. The committee recommended that primary schooling should be structured in a planned way, build a common nationality and that it should be organised on a new inter-racial basis and secondly that separate vernacular schools for the several racial communities should be abolished and be replaced by a single type of primary school common to all - the National School whose important feature was that it should be bilingual (Report of the Committee on Malay Education 1951, cf. Wong and Ee 1975).

In 1951, a second committee was appointed by the British High Commissioner, Sir Henry Gurney to investigate Chinese education in Malaya and two outside consultants were invited to make a preliminary survey of the whole field of Chinese education. They then produced a report called the Fenn-Wu Report. The report was sympathetic towards Chinese vernacular schooling and the main text tried to show how vernacular schools could contribute effectively towards building up a Malayan citizenship and fostering national consciousness. Both Dr. Fenn and Dr. Wu argued that an answer to the problem of diverse language must be sought, not in historical analysis (as in the case of Barnes Report), but in the collective wisdom and consent of the people of Malaya (Report of a Mission invited by the Federation Government to study the problems of the Education of Chinese in Malaya, 1951; cf. Wong and Ee 1975).

As a result of the above reports whose major issues were the formation of the National Schools and the use of English and Malay as the medium of instruction (Report on the Barnes Report on Malay Education and the Fenn-Wu Report on Chinese Education, 1951; cf. Wong and Ee 1975), legislation was passed in 1952 i.e. the Education Ordinance 1952, which laid down the National Schools as the pattern; Tamil and Chinese as a third language, rejecting the Indian and Chinese vernacular schools as part of the national system. Soon after that, it became apparent that it was regarded as an expansive scheme, due to lack of finance, which had obviously been overlooked by the legislators.

C.2.3.2 When the Alliance Government took office in 1955, it singled out education as one of the most important matters that had to be dealt with before the country achieved its independence. Thus 15 members of the Legislative Council, headed by the Minister of Education, Dato Abdul Razak and Dato Hussein were commissioned, "to examine the present education policy of the Federation of Malaya and to recommend any alterations or adaptations that are necessary with a view to establishing a national system of education ..." (Report of the Education Committee 1956 p.1). This report, commonly known as the Razak Report was unanimously adopted by the Legislative Council and the idea of the 'national school' as advocated by the Barnes Commission was abandoned and thus children would continue to receive their primary education in separate vernacular schools (cf. Fig. 3). Malay was to be a compulsory subject in all schools since it was the national language. To ensure its effectiveness, a knowledge of Malay would be required for admission to all secondary schools supported wholly, or in part, from public funds and for entry into government service. English was also compulsory due to its utilitarian value as an international language, while Chinese and Tamil would be taught in primary schools where parents of at least 15 children requested it (Wong and Ee 1975). In the secondary schools, the medium of instruction would be English or Chinese. Later, a start had been made in 1958 to provide secondary education in the Malay medium by attaching classes for this purpose to former government

Figure 3 EDUCATIONAL PATTERNS MALAYSIA

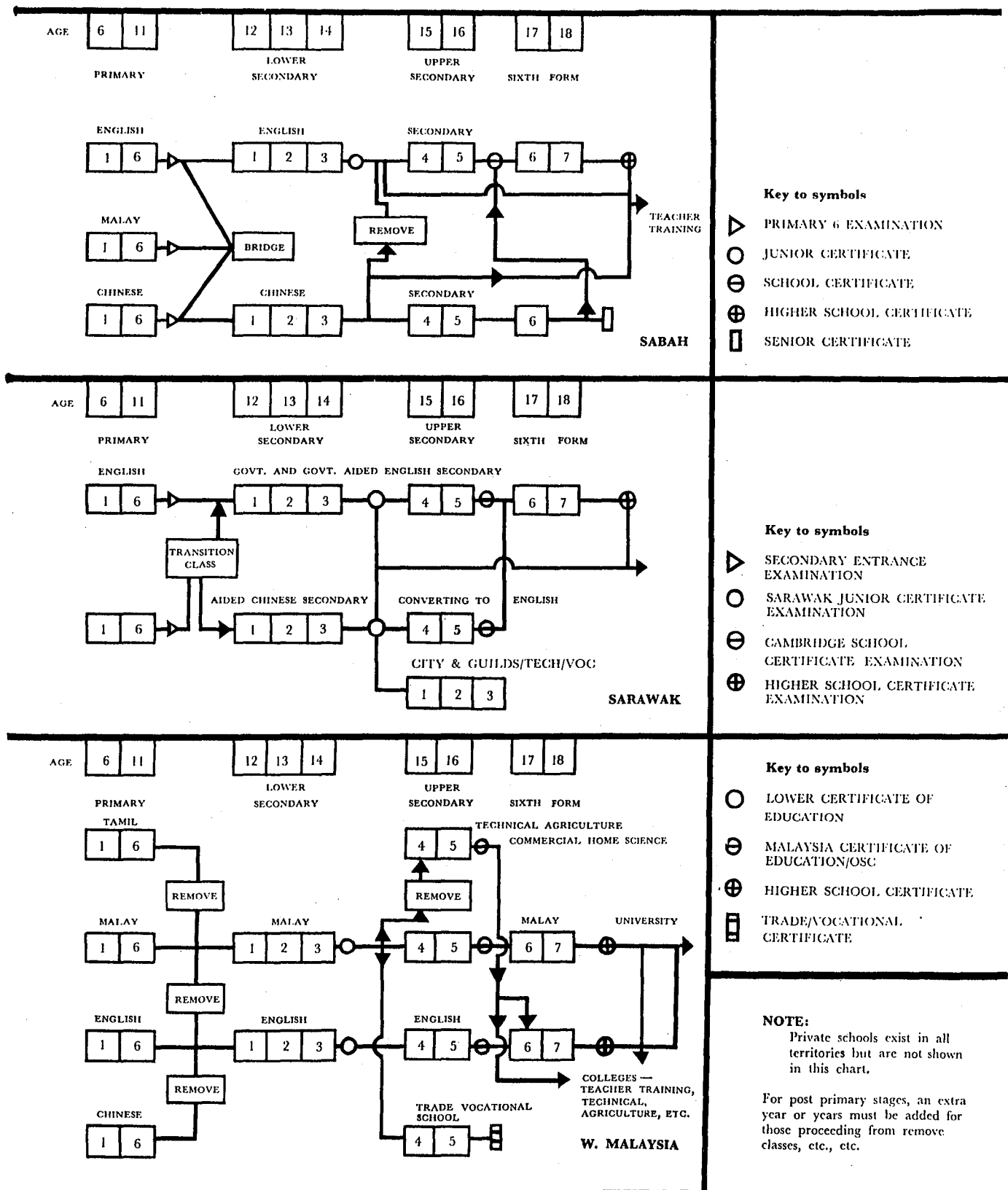

English schools. The fulfilment of the pledge by the government to use Malay as the medium of instruction in the university by 1967 was realized when the first batch of students from the Malay-medium secondary classes entered the University of Malaya and received instruction in Malay in 1965.

### C.3.3 After Independence - 1957

#### C.3.3.1 The Administrative Structure

When Malaya gained its independence from the British in 1957, the first major task taken by the Alliance Government as the first national government was to reorganise the structure and organisation of educational administration in Malaysia (as shown in Fig.4 ). It is patterned on the political and administrative systems of the country and may be examined at three levels i.e. federal, state and school which are represented by the Ministry of Education, the state education department and the schools (Ministry of Education cf. Wong and Ee 1975).

The Federal Constitution states that education is the responsibility of the Federal Government (see item 13 of the Ninth Schedule of the Constitution). Under the Inter-Governmental Agreement on the Formation of Malaysia, however, it was agreed that the policy and administration of education in Sabah and Sarawak should for a transitional period be undisturbed and remain under the control of the respective state governments, subject to the financial control of the Central Government (ibid.).

Fig. 4 THE ADMINISTRATIVE STRUCTURE OF MINISTRY OF EDUCATION, MALAYSIA, 1974

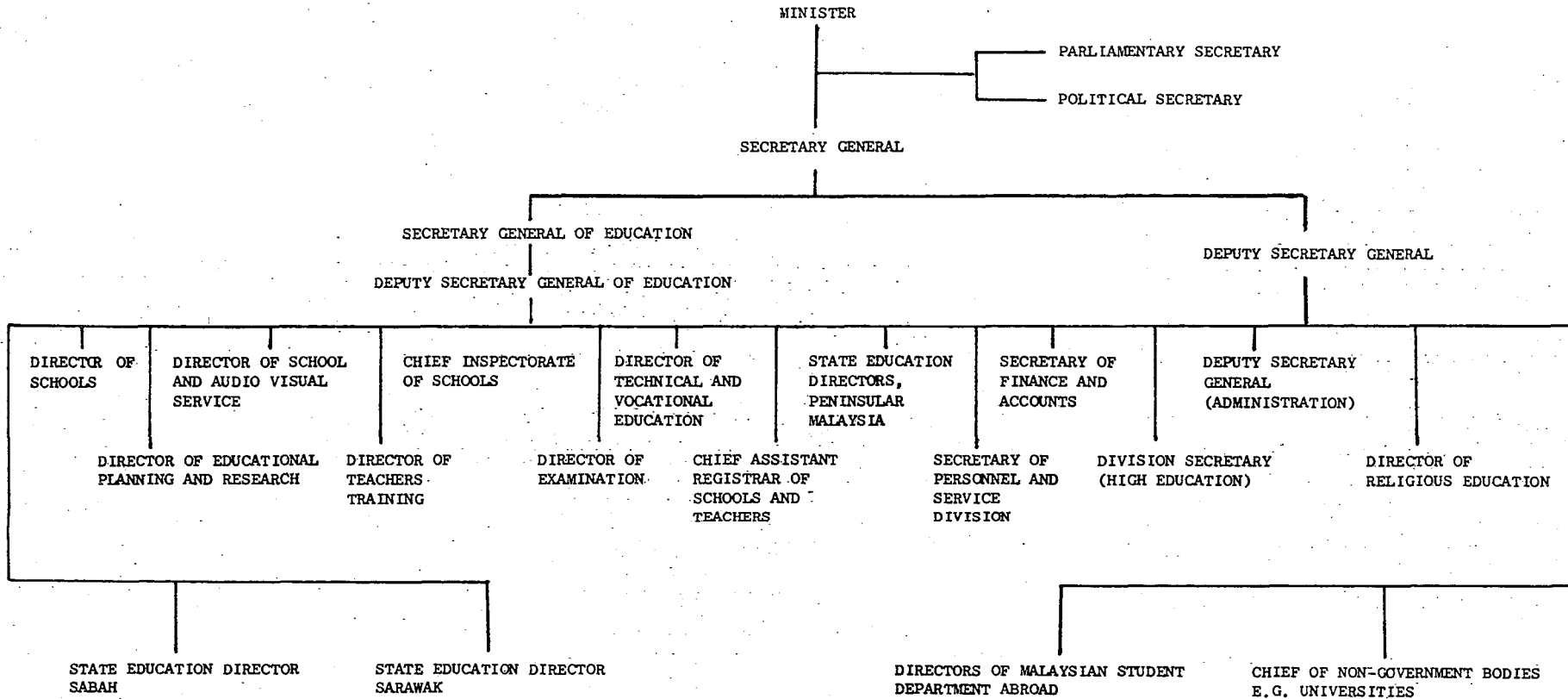

Source: ADMINISTRATIVE DIVISION, MINISTRY OF EDUCATION, NUALA LUMPUR, 1976.

Therefore, a national educational system of education as well as the national educational policy called Dasar Pelajaran Kebangsaan, which were established on the basis of the recommendation by the Razak Education Committee of 1956, and legislated for in the Education Ordinance of 1957.

Then, in 1960, the Razak Report was reviewed by the Education Review Committee which produced the Rahman Talib Report which was later formulated into the Education Act of 1961. The Rahman Talib Report recommended that primary education in all fully assisted schools (i.e. English, Chinese, Tamil and Malay) should be free to all. (Before this, primary education in all national primary schools, whose medium of instruction was Malay, had been free - a significant achievement measured against the target specified in the Karachi Plan which proposed that the objectives of free and compulsory education should be attained by 1980).

A series of 'crash programmes' to build more schools, provide more teachers and educational facilities were thus undertaken by the government of Malaya to ensure that all children in the country received at least seven years of education.

Under our system, curricula, syllabuses and examinations, for example, are uniform throughout the schools and colleges, and are prescribed by the Ministry of Education. Nevertheless, this uniformity does not amount to complete bureaucratic control. Within the broad lines of uniformity there is a certain measure of flexibility.

For instance, the headmasters or principals of schools are free, in consultation with their teachers, to plan their own timetables and schemes of work so long as the former meets the minimum conditions prescribed, and they are free to choose text books as well as teaching methods they consider desirable for their own schools. This centralization of educational administration is regarded by the government as a necessity to build a nation out of the diverse elements of race, language, culture and religion - a purpose that has been formulated in the educational policy set out in the Education Act, 1961.

C.4 After the Formation of Malaysia in 1963 or Since  
1963

C.4.1 The formation of Malaysia in 1963 has brought on more educational problems to the Central Government at Kuala Lumpur (Wong and Ee, 1975), especially the task of providing education (both primary and secondary) to an increasing and large school population in each of the four component states. As a new nation, Malaysia has to face many educational challenges to enable it to survive politically, economically and socially. As we have seen, in the case of primary education, the government had to make more provisions for free primary education as suggested by the Rahman Talib Report of 1960. Therefore, a series of 'crash programmes' to build new classrooms and provide teachers and other educational facilities had to be carried out by the Ministry of Education.

C.4.2 The government also faced and still faces mounting pressures for a substantial expansion and diversification of secondary education (Wong and Ee 1975). For instance, in 1963, an educational committee was appointed to review the Malaysian Secondary School Continuation System and the possible abolition of the Secondary School Entrance Examination (MSSEE) (*ibid.*) With the approval of the Malaysian Cabinet in 1964, the Standard Six primary pupils were automatically promoted to secondary school - Form One, beginning from 1965.

C.4.3 The decision to abolish the Secondary School Entrance Examination (MSSEE) was regarded as a bold and very welcome step towards education of the young (Wong and Ee 1975). Under this new system, pupils enjoy automatic promotion for eight or nine years if they enter remove classes (cf. Fig. 3) i.e. six years of primary education and three years of lower secondary education. Thus every pupil is assured of 8-9 years of schooling, without the hovering threat of the 11-plus examination whereas previously, only about 30-35 percent (1/3 of them) of the candidates managed to proceed to secondary schools. In addition, the new system also helps to reduce the social problems of pupils leaving schools too early and without any prospect of getting employment (Wong and Ee 1975, Ibrahim Saad 1975, Watts 1978).

C.4.4 In the secondary schools, pupils receive a three-year comprehensive and pre-vocational education to help them find and develop their own aptitudes and interests as well as the type of education - academic or vocational - to suit their particular needs. Under the present system, all pupils are required to study two broad groups of subjects namely the 'core' subjects, which are all compulsory and the 'elective' subjects, of which they choose one or two. One drawback of the system is that with automatic promotion, there is bound to be a lowering of standards and easy-going attitudes on the part of some teachers and pupils.

In order to facilitate the smooth-running of the system, educational guidance and counselling is provided for the pupils together with the maintenance of cumulative record cards showing a pupil's scholastic progress as well as his physical, social and intellectual development from the time he enters primary school to the time he has to choose or be guided to choose the subjects which will determine his future career.

In addition to that, the parents too are becoming increasingly aware of the importance of education to their daughters as well as to their sons. Therefore, the government has to take this into account in the overall educational and economic plans of the country (Wong and Ee 1975, Perkhidmatan Panduan Di Sekolah-Sekolah 1966).

C.4.5 Facilities - consequently, many educational facilities have been provided by the Malaysian Government

for the rural population of Peninsula Malaysia, Sabah and Sarawak to meet the educational demands there. This included new buildings, educational equipment and books, in-service courses to improve the teaching standards in Malay schools, posting of more trained teachers to Malay primary and secondary schools, the setting up of more Malay secondary schools in rural areas and the provision of hostels for pupils living in rural areas, the setting up of pre-university classes and an increase in the number of scholarships for lower and upper secondary pupils (The New Straits Times, 25 December 1963). The facilities were provided mainly to remedy the educational imbalance between the urban and rural areas i.e. between the 'haves' and the 'have-nots' so that social stability and justice might prevail in the country.

C.4.6 As mentioned earlier, one of the main objectives of education in Malaysia is to promote unity among the various ethnic groups. As such, the Malaysian system of education demands conformity to requirements that will ensure uniform progress towards established standards in all schools (Wong and Ee 1975). The elimination of vernacular education which was based purely on racial and linguistic lines does not mean that the pupil has to sacrifice his own culture and literature in as much as the continue to study vernacular languages and literature in the national education system. Thus that system does not hinder the promotion of individual cultures (ibid).

C.4.7 There are three basic concepts from which the national educational system evolves namely a common content syllabus, a common language (i.e. Malay Language - the National Language of Malaysia) and common public examinations, all of which were recommended by the Razak Report of 1956 and the Rahman Talib Report of 1960, which later formed the basis for our National Education Policy (Dasar Pelajaran Kebangsaan). They have played and will continue to play a vital role in the evolution of national consciousness (based on Malaysian orientation) and the promise of a future for our children, irrespective of their racial origins. They seek to give them equal opportunity in employment prospects and the means to be "full" citizens of Malaysia.

C.4.8 Even after more than twenty years of independence the main objectives of education in Malaysia still remain unchanged i.e. to provide the skilled and semi-skilled manpower resources and to create a united, well-disciplined and skilled society as clearly stated by the Report of Cabinet Committee on Education Policy or known as the Mahathir Report (Ministry of Education 1979). This report tries to examine ways and means of achieving the two stated objectives of education smoothly and effectively (The Mahathir Report, 1979). Further discussions on the report will be made in the following chapter.

C.4.9 Thus, the history of education in Malaysia is marked by three distinct stages of developments:

- a) the British Period of early education patterned on the lines of the English education system when Malaya, Singapore, Sabah (North Borneo) and Sarawak came under the British rule (Figs 5) and 6).
- b) the period of post-war re-construction, during which education in each of the four territories underwent a thorough overhaul, largely due to the changes in the political scenes in South-east Asia in general and in the four territories in particular (ibid).
- c) the period of educational challenge since the establishment of Malaysia in 1963 (ibid).

Malaysia, as a nation of diversified ethnic population is aware of the challenge she has to face and how important it is for her to achieve a unified Malaysia through a uniform or common educational system. In a country like Malaysia there is always the danger of using education as a pawn in the political game. This fear was once expressed by the former Chief Education Adviser, the late Encik Aminuddin bin Baki. He warned the country against it when he urged all political, cultural and communal groups in Malaysia to call a truce on education for the sake of the rising generation:

"I viewed with concern the different roads trodden at present by the Malaysian States. They were so, because they were formulated through bargaining and compromises arising out of nationalistic and chauvanistic demands, the circumstances of the time and the dictates of the moment. Even today, despite these compromises, we still find education not fully resolved and settled but daily become a matter of public controversy, a delicate and explosive political issue and not unknown to have been a gamble and determinant of many elections ... it is my earnest

Fig. 5 The Structure of Educational System of Malaysia

HISTORICAL EVENTS	INFLUENCES ON STRUCTURE	DATE
1. Before the British, each state of Malaya was ruled by their respective rulers.	No formal, modern education except the religious form of education i.e. <u>Sekolah Pondok</u> , <u>Madrasah</u> or <u>Koran</u> Schools - privately run by Moslem religious teachers and institutions.	1800's
2. British Influences or Intervention in the a) Straits Settlements b) Federated Malay States (FMS) c) Un-Federated Malay States (UFMS)	i) Introduction of formal education for each major ethnic group through vernacular schools and English schools. Malay Schools established by government Chinese Schools - privately established Indian Schools - estate employers English Schools - Christian missionary and government. ii) Education to help the British rule Malaya. iii) Education for the preservation of separate ethnic cultures, customs and religions - giving rise to disunited population and communal problems.	1870's
3. Post War Years - Japanese Occupation - Malayan Union - Federation of Malaya - The Razak Report of 1956	i) Rise of nationalism in South-East Asia ii) Struggle for Independence iii) Re-organisation of Educational System into one national system (for the purpose of unity) through - language - malaynization - university education	1940's
4. Independence - 1957		1957
The Rahman Talib Report - 1960	i) Free education for all assisted schools ii) Introduction of National Education System and National Education Policy	
Formation of Malaysia	Malaya's system of education was extended to Sabah and Sarawak	1963
The Mahathir Report - 1979	Education for Manpower Needs and for Unity	1985

Fig. 6 The Historical Development of Malaysian Education

DATE	HISTORICAL EVENTS	EDUCATIONAL DEVELOPMENT
1. 1800-1870	Each State in the Malay Peninsula was ruled by its own ruler (Sultan). Starting from acquisition of Penang 1786, gradually all states were taken over by the British 1826 - Formation of Straits Settlement	i) There was no formal, modern education except for the Islamic Religious education provided by Moslem religious teachers and private institution. ii) Initially, primary education was introduced in the Straits Settlement by missionary bodies and later by the British government.
2. 1870-1941	1874 - marked the Beginning of British Intervention in the Malay States - Treaty of Pangkor. 1896 - Formation of Federated Malay States and the remaining states were called the Un-Federated Malay States	i) Education expanded to other Federated Malay States and later to the Un-Federated Malay States Form of Education - a) Vernacular Schools (Malay, Chinese and Indian Schools) b) English Schools - established by missionary bodies and later by government.
3. 1941-1945	Period of Japanese Occupation of Malaya	The Japanese tried to introduce the Japanese System of Education - failed.
4. 1945-1962  1946  1948  1957	Post-War Educational re-Construction  i) Introduction of Malayan Union Concept 1946 - failed  ii) Formation of Federation of Malaya Note: the 1940s saw the rise of nationalism.  Malaya's Independence	i) The setting up of various committees to look into education matters and thus giving rise to a series of reports (cf. 13.3.1) that determine the education policy of Malaya. ii) Efforts towards nationalisation of schools and the educational system. iii) The establishment of National Educational System and National Educational Policy - 1960. Problems - nationalism - malayanization - language for unity - university education
5. 1963-1984	Formation of Malaysia in 1963  The Mahathir Report of 1979	The different systems of education for Peninsular Malaysia, Sabah and Sarawak are gradually being changed into the National System of Education for Malaysia  - Universal education and Manpower needs - Education for unity.

hope that all groups of the country ... will call a truce on education and to regard matters concerning the education of the rising generation as sacred in the same spirit and neutral manner as we have regarded such matters as religion by keeping it away from bickering and controversy" (cf. The New Straits Times, 18 June 1964).

C.5 The Rationale or the Need for Guidance and Counselling Services in Malaysian Schools

C.5.1 Definition

According to the book called 'Guidance in Schools', prepared by The Education Planning and Research Division, Ministry of Education (1971), guidance is regarded as "a pre-requisite in the educational system of Malaysia". It defines guidance as follows: "Guidance is the systematic professional process of helping the individual through educative and interpretative procedures to gain a better understanding of his own characteristics and potentialities and to relate himself more satisfactorily to social requirements and opportunities in accord with social and moral values", whereas: "Counselling is a learning-oriented process, carried on in a single, one to one social environment in which a counsellor, professionally competent in relevant psychological skills and knowledge, seeks to assist the client by methods appropriate to the latter's needs and within the context of the total personal programme, to learn more about himself, to learn how to put such understanding into effect in relation to more clearly perceived, realistically defined goals to the end that the client may become a happier and more productive member of his society".

One can see from the above two definitions that:

- a) the processes are concerned with client not patient,
- b) both emphasize learning theory at cognitive, intellectual and rational levels,
- c) both work through the assessment and appraisal of human traits for educational-vocational-social living, and
- d) both cast a balance sheet to aid the clients to contribute to, and to take the most from living in society.

The book "Guidance in Schools" (1971) also suggests that there are three main reasons why guidance and counselling services are regarded as 'a pre-requisite' of our educational system:-

- (i) The existence of "culturally disadvantaged" and "physically different" children.
- (ii) The Adjustmental problems of secondary school children.
- (iii) The Adolescent Culture.

C.5.1 (i) The existence of "culturally disadvantaged" and "physically different" children has been a cause for concern among educationists and officials from the Ministry of Education. The "culturally disadvantaged" children from parents of the lower socio-economic groups who experience emotional and cognitive difficulties when they attend school - a middle class institution, with future oriented rewards and goals. As a result, they do not adjust easily



to the school culture and become potential dropouts either at the end of their primary education or at the end of lower secondary education (ibid., Ibrahim Saad (Ed.) 1982).

The "physically different" children on the other hand are those with uncorrected deficiencies such as visual and auditory deficiencies and those with difficulties of a neurological nature. If these deficiencies are not detected, diagnosed and treated early, their physical handicaps might eventually affect their self concept and adversely affect their motivation to learn (Guidance in Schools 1971, Ibrahim Saad (Ed.) 1982 and Lawrence 1973). Until presently, there is no official figure on the number of school children who are unable to read after three or six years of schooling. However a research carried out by the School Division, Ministry of Education in 1967-1970 indicated that 15% of the school population from 2,636 schools involved in the study were slow learners. They included those with deficiencies resulting from social, economic, cultural, emotional and other related factors. In fact, those pupils who failed very badly in most of the school tests are regarded as murid-murid lembam or slow learners (Working Paper of School Division, Ministry of Education 1974).

C.5.1 (ii) Adjustmental problems of secondary school children also call for the need to have guidance and counselling services in the secondary schools to help the children who have just completed their primary edu-

cation to adjust or readjust themselves to the secondary school with its larger building, departmentalized organisation and different code of rules and regulations (Guidance in Schools 1971 and Ibrahim Saad 1982).

The need for an organised guidance and counselling service was particularly marked from as early as 1964. Before 1964, under the old system of education, the primary school pupils had to take the Malayan Secondary School Entrance Examination (MSSEE) before continuing their secondary education. Only those who passed this examination could enter the secondary schools. However, this Standard Six Examination was abolished in 1964 and from 1965 onwards Standard Six primary pupils are automatically promoted to secondary Form One (cf. p. 92). This automatic promotion year by year of pupils from Standard I right up to Form Three means that pupils in the Lower Secondary School ranged widely in their abilities, aptitudes and interests.

Under the present education system, there are two public examinations in the primary school. One is at Standard Three which is called the Diagnostic Test and the other is at Standard Five, called the Assessment Examination. Remedial work is then carried out when the children's weaknesses have been discovered through these examinations. For instance, in the case of wide differences in intelligence among the pupils of the former grammar schools and Secondary Modern Schools in Britain, the headmasters and the headmistresses evolved the devices of 'streaming', 'setting' and 'banding' the

pupils in the first year or subsequent year on the basis of the Common Entrance Examination - but this practice varied from one school to another (Eleven Plus 1956, Postlethwaite and Denton 1978) and has managed greatly in the post-comprehensive era.

C.5.1 (iii) The Adolescent Culture. The pupils joining the secondary school are just entering the period of early adolescence (12+ years of age). According to Coleman (1980), adolescence is universally acknowledged to be a critical phase in human development which has received relatively little attention from psychologists or other social scientists of the past. This situation is gradually being remedied in recent years due to the availability of an increasingly large body of research and the growing awareness that events in the first five years of life are not the only events which have fundamental implications for later development. Experiences during other critical phases of development, especially during adolescence, have been recognised as being equally important to adult development and the health of the society in general. Coleman (1980) presented different aspects of growth and change which together made up the adolescent experience, among which the physical development (associated with puberty and growth spurt), the cognitive development (changes in intellectual function - towards independence and action) and the self-concept development.

Indeed, adolescence is a time of change and doubt. Even though recent research indicates a major divergence of opinion about the degree of cultural discontinuity between adolescence and adulthood, the generation gap between adolescent and adult (as emphasized by Erikson, Piaget, Coleman and Sherif), most seem to agree that it is a developmental process, which sees the transformation of the child into the adult (cf. McGuinness 1982, Coleman 1980). Erikson's (1968) comments on adolescence is in relation to 'identity crisis' whereby he believes that the search for identity becomes especially acute at this stage due to a number of factors (cf. Coleman 1980). Brammer and Shostrom (1968) on the other hand, refer to growth as an "integrative and disintegrative process". According to them, before an adult patterns can become operative, childhood pattern must be disrupted (cf. McGuinness 1982).

For practical and educational purposes, Wall (1977) considers adolescence as a psycho-social interaction, regards it as a cultural and individual phenomena, as a process of adjustment and learning towards a goal - adult status. If the goal is easy to attain, the process will be short and free from stress but if it is a complex one, then the process will be long and very stressful.

How can such situations be applied in the Malaysian context?

The complexity of adolescent culture (referred to as the other reason for the guidance and counselling services by the Ministry of Education in Guidance in

Schools 1971) also creates certain specific problems for the secondary school pupils to which guidance provision can expand. At this stage, the pupils (adolescents) undergo physical changes that transform them from childhood to adulthood or from puberty to maturity (Shertzer & Stone 1976). The age at which the onset of puberty takes place also differs from one pupil to another and the physiological changes vary from one to another. Besides that, the adolescents also experience conflicts of emotion and have to learn how to handle the heightened emotionality. This learning is not catered for in the traditional academic classroom; guidance services are intended to respond to that need.

Adolescence is also a period when young people have to strive for personal independence. This struggle for independence often makes them brash and challenging in their social action. Therefore, at this stage they need encouragement and understanding from adults, rather than criticism, to enable them to adjust to the adult world (Guidance in Schools 1971). This view was supported by Shertzer and Stone (1976) by saying that adolescence also includes searching for emotional, social and economic independence. It is the time for individuals to utilize at a more mature and complex level the ability to give as well as to receive and to communicate with others and to trust them, and to learn what is harmful and what is good for themselves and others (ibid.). It is indeed "a time/period for integrating one's features of self-development" (McCandless and Evans, 1973; cf. Shertzer and

Stone 1976). Erickson referred to this period as identity diffusion or role confusion (Erickson, 1950, cf. Shertzer and Stone 1976). The adolescent's status, therefore, is marginal, it is neither that of a child from which he is emancipated nor that of the adult for which he is unprepared (Stone and Church 1973).

Under such conditions, the adolescent secondary pupils might find it difficult to cope with the emotional and social pressures of their daily life. This could result in the decline of their school performance and they might become potential dropouts at the end of the lower secondary education. This is not a specifically Malaysian problem. Such situations were also found among the Newsom Children (cf. Newsom Children, Half Our Future, 1963, p.15) whose discontent was said to be "related to the restiveness of adolescence which affects all young people in some degree. But others, as well as the pupils, are not happy about the situation ...". The survey also suggested that "linguistic inadequacy, disadvantages in social and physical background, and poor attainment in school, are closely associated ..." (ibid.). Appropriate steps should therefore be taken to help them, especially by the guidance teacher concerned and as such guidance and counselling services are viewed by the Ministry of Education as a tool to help these pupils overcome their problems (The Ministry of Education, cf. EPRD and The Guidance and Counselling Division 1966, 1971, 1982 and Half Our Future 1963).

The guidance teacher or the school counsellor could shoulder the responsibility of exploring the reasons for 'dropout' despite the fact that education is free and promotion automatic. Knowing some of the reasons for the dropout would help the school guidance teacher or counsellor find ways and means of avoiding the same incident from happening to other pupils while they are in the secondary schools. This view is shared by G. Krishna Iyer, Assistant Director (Educational and Vocational Guidance Unit) in his article published in the journal on guidance by MAVOGA. He said that "the need for guidance services was underlined by the incidence of dropout..." (MAVOGA, June 1975). The dropouts from the Lower Certificate Examination, in particular, after only three years of secondary education are those most particularly in need of help (Guidance in Schools, 1971). They normally need information about apprenticeship schemes, training schemes and some form of objective assessment to discover their special aptitudes.

In the lower secondary forms, the public examinations act as an instrument for making decisions regarding the selection of pupils to either arts, science, commercial and vocational or technical streaming. For instance the Lower Certificate of Education Examination (L.C.E.) which is presently known as Sijil Rendah Pelajaran (S.R.P.) held at the end of the third year of lower secondary schooling, serves as a decision making for the placement of students (pupils) at the upper secondary forms (Form 4 to Form 6). In Form Four, the pupils are streamed

according to their inclination for Science, Arts, Vocational or Technical Studies (Ministry of Education).

It is at this stage, in particular that some children face difficulties in their studies especially in their choice of subjects or 'stream' of study. Although they are being streamed according to their performances in the SRP or LCE examination, there are some students who lack confidence and courage in the streams chosen for them which they may have neither interest nor aptitude as suggested by A.G. Watts (UNESCO, July 1978) concerning the bumiputera (indigenous population) who have been channelled into science and technology despite their moderate or lower passes in the science subjects. As a result, they want to withdraw from the 'stream' offered but the matter are only being considered by the Ministry of Education or the State Education Department if the pupils actively protest and often not even then (ibid.).

In additon to that, many pupils from rural areas, with their dogmatic view that science is a difficult subject do not wish to join the science stream, as encouraged by the government. They are not confident that they can actually do science subjects, though their selection depends on the high performances in Mathematics and Science in their SRP or LCE examination. (The New Straits Times, Malaysia, 1980). It is therefore necessary to have a school counsellor (guidance teacher) who can help them create a realistic picture, give them advice and encourage them to make their own decisions as to what may be best for them.

Until recently, Malaysia, like many other developing countries experienced a shortage of skilled and qualified manpower especially in the field of science and technology, for during colonial era all key posts were in the hands of expatriates (Ibrahim Saad (Ed.) 1982; cf. Andaya 1982, Wong and Ee 1975). As a result, much emphasis has been placed by the government on the science and technological subjects. School children are therefore encouraged to take up these subjects with the promise of high material regards later in life (Watts 1978). This caused many parents to insist that their children pursue a certain course of study, particularly the science subjects, without taking into account their particular interests and abilities. There are also cases where parents, especially the successful businessmen and other professionals insist or force their children to follow their footsteps in choosing a particular career or occupation. In such cases the guidance teachers have to exercise tact, consult both parents and pupils and provide suitable guidance (Guidance in Schools 1971).

However, with the expansion of educational facilities, the number of pupils in each class has steadily increased over the year (Watts 1978; The New Straits Times, Malaysia, 1980; Wong and Ee 1975). Many classes have 40-45 pupils and in primary schools classes stretching even up to more than 45 pupils (ibid.). In such a large class, the relationship between the pupils and their teacher becomes too impersonal and the teacher often finds it well nigh impossible to provide individual assistance and attention

to all pupils in his or her charge. It is hoped that the presence of a qualified guidance teacher could help in alleviating some of these problems.

The secondary pupils find that sooner or later, depending upon when they leave school, they have to give serious thought to the question of vocation. As mentioned earlier in this chapter, the dropouts of the Lower Certificate Examination are those that require whatever help the guidance teacher could offer, whether to continue their education in the private schools (if they are not accepted in the government schools) or seek employment of which they have very little skills or knowledge. On the other hand, those who managed to continue their education have also to decide what they are going to do in the near future, as in the case of Form Five pupils who have to sit for another public examination called Sijil Pelajaran Malaysia (SPM) or Malaysian Certificate of Education Examination at the end of the year. Although career education forms one-third of the fifth-year civic syllabus (Watts, UNESCO 1978), proper and precise advice or assistance from the guidance and counselling teacher would be useful in helping them to make their own decision whether to continue their studies and enter colleges or universities, or to look for jobs. This dilemma is usually faced by those pupils who come from poor family background or lower income group families that require them to work in order to support their families. Thus, it is the teacher's duty to understand their problems and help them to develop flexibility in modifying their choice of careers as well as making other personal and social adjustments.

C.6        The Historical Development of Guidance and  
                 Counselling in Malaysia

C.6.1      Introduction

In tracing the origin of guidance and counselling in Malaysia, I have referred to a number of official publications of the Ministry of Education and the seminar papers by Haji Abdul Latif bin Mohd Ali<sup>9</sup>, Head of Guidance and Counselling Unit, Ministry of Education, from which much of the information concerning the early guidance and counselling in Malaysia is drawn.

C.6.2      Earlier References to Guidance

(1) The interest in career guidance in Malaya (the name used before the formation of Malaysia in 1963) could be traced as early as 1939 when the Department of Education of the Straits Settlement and Federated Malay states, published a book called "Career Guidance in Malaya for Parents, Teachers and Pupils". This book has documented a series of job opportunities in the government services (Perkhidmatan Panduan di Sekolah-Sekolah, 1966). The interest in career guidance faded out (declined) when the Second World War broke out and Malaya was occupied by the Japanese. However, after Malaya achieved its independence in 1957, various voluntary bodies such as Rotary Clubs and other government as well as semi-government bodies such as the Ministry of Education, Radio Malaya or Radio Malaysia (i.e. after formation of Malaysia in 1963) and the Armforces Service Recruitment Units rekindled the interests in career guidance (ibid.).

(2) In 1959 the Ministry of Labour had established the Youth Career Service in various Labour Offices throughout the country and in 1961, a small booklet on "Training Opportunities in Federation of Malaya" was published by the same ministry (Perkhidmatan Panduan di Sekolah-Sekolah 1966).

C.6.3. The History of Guidance and Counselling in Schools and Other Educational Institutions

C.6.3.1 In 1960, a circular on Career Guidance was issued by the Ministry of Education stating the importance of career or vocational guidance in primary and secondary schools and the need for career teachers, together with the suggestions as to how this aspects of school work could efficiently be carried out in helping the secondary school students. This marks the beginning of the systematic planning and implementation of guidance services in Malaysian schools.

C.6.3.2 In order to start the guidance and counselling services in schools, the Ministry of Education of Malaysia, following the recommendation by UNESCO Commission, managed to obtain assistance from the Colombo Plan<sup>10</sup> (a Commonwealth technical aid programme) which sent a consultant, R.K. MacKenzie from Canada to be attached to the Ministry from 1962-1963. His main duty was to train local staff in guidance and counselling. Thus a group of Pengelola Sekolah-Sekolah (School Organisers) and their Assistants

were given a six-month training programme at the Specialist Teachers Training Institute. This "kumpulan kaji" or study group consisted of eleven Organisers/Assistant Organisers of School from various states and the Headquarters at the Ministry and carried their study from January to June 1963 (Perkhidmatan Panduan di Sekolah-Sekolah 1966). This group had successfully prepared and distributed handouts on guidance and two books called "Perkhidmatan Panduan Di Sekolah-Sekolah", published by Dewan Bahasa dan Pustaka in 1966 and "Guidance Services in Schools", published in 1968 (besides that, a section called Educational and Vocational Guidance Unit was established in EPRD, Ministry of Education in 1963).

C.6.3.3 In 1964, another circular (SP.K.P. 5209/35/4) was issued by the Ministry of Education stating that "it is suggested that every school - primary/secondary must appoint a guidance teacher". It means that the Ministry of Education had, in principle (as a policy) started the guidance services in schools in 1964.

C.6.3.4 In 1968, an officer was specially appointed to head the Educational and Vocational Unit by the Ministry of Education. At first, this unit was placed under the Educational Planning and Research Division (EPRD) but in 1973, it was moved to the School Division, Ministry of Education.

C.6.3.5 In 1969, with the help from UNICEF, the first systematic six-day in-service training course was held for 275 teachers. This training, which took place during 1969-1972 was carried out through the joint-funding of UNICEF and the Ministry of Education. As stated earlier, the Ministry of Education obtained expertise via the Colombo Plan and financial aid from UNICEF which contributed M\$9,970,000 or £3,320 to the Ministry for the purpose of carrying out in-service training courses, organising seminars and workshops and preparing and publishing pamphlets and guidance books for the schools. However, after 1972, the financing of these services was borne by our own government (Hj. Abd. Latiff b. Mohd. Ali 1982). In 1969 Vocational Guidance Unit was established at MARA Institute of Technology (I.T.M.).

C.6.3.6 In the meantime, senior officers of the Ministry of Education were sent overseas to acquire full-time training and all secondary schools were directed to appoint a suitable teacher as the guidance teacher. By 1975, there was on the average at least one teacher trained to discharge guidance duties in each of the secondary schools (ibid.).

C.6.3.7 From 1970 onwards the post of Regional Guidance Officer was created in 6 states and at present, there is at least one Regional Guidance Officer to supervise the implementation of guidance services in every state (ibid.). The officer's duty is to administer, to supervise, to co-

ordinate counselling activities in schools and to organise follow up activities and workshops on guidance and counselling. He becomes the link between the Ministry of Education and guidance services in schools.

C.6.3.8 Training. By now, guidance and counselling has become an important phenomena in the Malaysian educational setting. Concrete measures are now being undertaken to train more teachers to carry out the guidance and counselling work in schools as "guru bimbingan" or guidance teachers.

One of the measures to overcome the shortage of trained guidance teachers was to organise a full-time one-year training course in guidance and counselling at the Specialist Teachers Training Institute, Kuala Lumpur starting from 1980. Those teachers who receive this training will in turn help train others at state level on a long term basis. Apart from the on-going training programmes or basic in-service courses organised by the Ministry of Education's Guidance and Counselling Unit, guidance teachers also attend seminars and workshops organised on a state basis.

Furthermore, courses for counsellors are also being conducted at institutions of higher learning. For instance, the National University of Malaysia (U.K.M.) is offering a diploma course in guidance and counselling starting from 1980. The Agriculture University of Malaysia is also starting a degree course in this field, while University of Malaya is offering a selective subject on guidance and

counselling to those students who are undergoing the Diploma in Education course.

Though these guidance teachers have been given some form of training in guidance and counselling many educationists feel that the training courses available now are inadequate. Up to 1980, there were 3.1 million pupils and 114,500 teachers in Malaysia (Fourth Malaysia Plan 1981-1985). In addition, through various in-service courses, carried out since 1969, there were a total of 3,451 guidance teachers (more precisely career teachers) in Malaysia in 1980 (The New Straits Times, Malaysia 1980). However, the number of teachers who have been trained in the field is extremely small (cf. Chapter 4 p. 272 ). Thus, only a very modest beginning has been made with regard to the establishment of an adequate guidance services in the schools.

At the beginning, the emphasis was on career guidance (as was initially the case in the U.S.A. and U.K. cf. p. 44 ), but the year 1968 marked the beginning of a service system called educational guidance, vocational guidance, health guidance and personal guidance (Perkhidmatan Panduan di Sekolah-Sekolah, 1966). Later the Report of the Committee of Officials appointed by the Cabinet to examine the recommendations of the dropout study, December 1973, suggested that the overall guidance in schools entails the following elements:

- a) personal-social guidance
- b) educational guidance
- c) vocational or careers guidance

- d) drug abuse preventive programme  
(cf. Guidance in Schools 1971).

C.6.3.9 Several other Ministries and private voluntary organisations such as the Ministry of Labour and Manpower, the Guidance Bureau of the Ministry of Culture, Youth and Sports, and the Malaysian Vocational Guidance Association also help to train personnel (besides offering services) in guidance and counselling (Hj. Abd. Latif b. Mohd Ali, 1983). Another important development in this field is the formation of the Association of Counsellors of Malaysia. This Association aims at improving and maintaining the quality of guidance and counselling in the country. It also aims to ensure that there are high professional ethics and standards of counsellors in Malaysia (The New Straits Times, 1980).

Such, then, are the various historical backgrounds of guidance and counselling in the U.S.A., Great Britain and Malaysia. As can be seen each country has followed a similar developmental process, from a social, natural concern with manpower and careers guidance, to a more individual concern for personal and educational development. Thus, the Malaysian case reflects the strong training influence of practitioners from the U.S.A. and the U.K.

In the following chapter I shall try to analyse the way in which guidance and counselling is perceived by experts via the literature on that topic, its aims, objectives and functions and relate it to the situation in Malaysia.

Fig. 7      The Historical Development of Guidance and  
Counselling Services in Malaysia

YEAR	EVENTS
1. 1939	Early traces of interest in career guidance in Malaysia.
2. 1959	Youth Career Service was established in various Labour Office.
3. 1960	A circular on career guidance was issued by the Ministry of Education - thus marking the beginning of the systematic planning and implementation of guidance services in Malaysia.
4. 1963	A six-month training course on guidance and counselling was carried out from January to June 1963 at S.T.T.I.
5. 1964	Circular (SP. K.P. 5209/35/(4)) was issued by the Ministry of Education.
6. 1965	Assessment Examination (MSSEE) to enter secondary school was abolished - thus giving rise to greater needs for guidance services in secondary schools.
7. 1966	The Vocational Counselling Services was started by the Ministry of Labour (UNESCO Bulletin 1966). 1966 also marked the starting of school guidance and counselling services in Malaysian secondary school.
8. 1968	An officer was appointed to head the Educational and Vocational Unit by the Ministry of Education. The Ministry of Education instructed all schools in the country to appoint guidance teachers - the emphasis of the work was on vocational counselling. 1st September 1968 - A circular (S.K.K.P.5209/30/(1)) was sent to all States Education Officers to instruct the headmasters to provide a number of basic facilities for guidance work in the School.
9. 1969	A six-day introductory in-service training course for guidance teachers was started for the first time in Maktab Perguruan Persekutuan, Pulau Pinang - organised by the Ministry of Education. It was attended by 275 guidance teachers. From that year onwards it has been carried out annually during the school vacation (April, August and December).  Vocational Guidance Services in institution of higher learning was first started by MARA - offer professional service to its students and their parents.

Fig. 7 cont.

YEAR	EVENTS
10. 1970	<p>Six new posts of <u>Pengelola Daerah Panduan Pelajaran dan Kerjaya</u> (District Supervisors on Educational and Vocational Counselling) were created.</p> <p>October - a seminar on guidance and counselling was held at Sekolah Menengah Bukit Bintang, Petaling Jaya - jointly organised by the Bukit Bintang Secondary School, Petaling Jaya and the Ministry of Education.</p> <p>In the same year, a study (research) on the progress of guidance services in Secondary Education was made.</p>
11. 1972	<p>The UNICEF Trust Funds was stopped.</p>
12. 1973	<p>The Educational and Vocational Guidance Unit has been moved from EPRD to School Division - a new development.</p>
13. 1974	<p>A new officer was elected as <u>Ketua Penolong Pengarah</u> (Deputy Director) of the Unit (UPPK) on December 1974.</p>
14. 1980	<p>Specialist Teachers Training Institute (S.T.T.I./MPIK) started organising a one-year guidance and counselling course.</p> <p>Formation of the Association of Counsellors of Malaysia.</p> <p>Universiti Kebangsaan Malaysia or UKM (The National University of Malaysia) started a course in Diploma in Counselling (Psychology) for guidance teachers from all over Peninsular Malaysia.</p>
15. 1981	<p>Another Special Duty Officer was recruited to supervise the attempt to prevent Drug-Abuse among the pupils in the schools.</p>

NOTES

1. Guidance services were offered in some schools as early as 1895, notably by George Merrill in California, Jesse B. Davis in Michigan and Eli Weaver in New York City. The first public school department was apparently the Vocational Information Department established in Boston 1913.
2. World War I stimulated the vocational guidance movement by spurring the development of test and testing. Donald G. Paterson of the University of Minnesota was one of the pioneers and important contributors of the vocational testing movement. The movement began with the publishing of his article, (The vocational testing movement, J. Personnel Res., 1922, 1, 295-305) and continued through the 1920s and 1930s with the development of the Minnesota Employment Mechanical Ability Tests and the Minnesota Employment Stabilization Institute (cf. C.H. Patterson 1962).
3. In his lecture on the occasion of the founding of the National Association of Careers Teachers in 1969, Daws (1969) pointed out that the term "careers masters" had been a recognised term since 1932.
4. Gilbert Wrenn was a distinguished American counselling theorist who was in touch with Campbell Stewart and who eventually came to Keele in September 1965 as the first Fullbright scholar - a Rogerian.

5. Lawrence (1973), an educational psychologist who made a study on the remedial situation of the retarded readers by focussing on the child's self-image, especially where the child already possesses the basic skills and has made a start with reading but is making no progress.
6. Malaysia was formed in 1963. Before, it was known as Federation of Malaya or commonly known as Malaya which comprises of 11 states (Perlis, Kedah, Pulau Pinang, Perak, Selangor, Negeri Sembilan, Melaka, Johor, Kelantan, Trengganu and Pahang). When Malaysia was formed, three more states (Singapore, Sabah and Sarawak) joined Malaysia. However, Singapore left Malaysia in 1965 and now is an independent republic.
7. At present, such schools (classes) are being held in the evening at the mosque for rudimentary religious training of both students and adults.
8. The government secondary schools comprise the normal academic secondary schools (including Full Boarding Secondary Schools and Science Secondary Schools), Vocational Secondary Schools, Technical Secondary Schools and Religious National Type Secondary Schools.
9. I wish to thank Haji Abdul Latiff bin Mohd. Ali for his cooperation and assistance especially in bringing to my attention the previous seminars organised in

Malaysia and for supplying me with some of the papers presented.

10. Colombo Plan is a Commonwealth body which gives technical, educational, agricultural and cultural aids to members of Commonwealth countries. Commonwealth is an organisation consisting of all independent states of former British Colonies.
  
11. Guru Bimbingan or guidance teachers are teachers who carry out guidance and counselling work in schools beginning from 1980. They usually have professional training and abilities in guidance and counselling for at least one year at Specialist Teachers Training Institute (MPIK) or National University of Malaysia (UKM) or in-service course during the school holidays term I-III 1982 or a diploma or a degree in guidance and counselling from local or foreign universities.

CHAPTER TWOGUIDANCE AND COUNSELLING  
TOWARDS NATIONAL UNITY2.1 Introduction

It has been mentioned earlier ( p. 1 ) that the terminology for guidance and counselling is still imprecise and its usage varies widely between and within countries (U.N.E.S.C.O. 1978). In fact, an examination of the plethora of books and articles written on the subject indicates that different authors use them in a variety of ways, to convey their opinions and biases on the subject. Therefore, the first part of this chapter will be devoted to outlining the numerous definitions and usages, and will draw out the major constraints affecting positions on the issues from this wide literature; and later, the chapter will consider these issues in relation to the Malaysian situation. Further discussions will also be made on how guidance and counselling could be used as one means of helping to establish a harmonious and unified Malaysian society.

2.2. What is Guidance?

2.2.1 Guidance has been defined in many ways. Indeed, a major criticism, past and present, is that the word "guidance" has been rendered relatively meaningless by the variety of ways in which it is used. For many individuals including parents, many teachers and other educationists

who do not claim it as part of their occupational expertise, its meaning when taken at face value is derived from its root word "to guide", which means to direct, pilot, manage or steer. Most individuals often view the counsellor as the person who directs or steers children into or away from certain occupational or educational endeavours (Shertzer and Stone 1976). Such views did not only exist in the U.S.A. when the guidance services were first introduced, they were also reflected in Britain (Daws 1976; Lytton 1974) as well as in Malaysia in the sixties (Perkhidmatan Panduan di Sekolah 1966 and Guidance in Schools 1971, Ministry of Education).

2.2.2 A different view suggests that guidance has also been used to represent the confluence of social pressures, inter-disciplinary insights about human behaviour and its dynamics, concerns for maximum use of human resources and demands for depersonalisation in an increasingly complex and depersonalised society. For these reasons, the term "guidance" is variously used to represent a concept, a philosophy, and a label for the services which implement the philosophy (Herr and Cramer 1972).

For instance, Hoyt (1962, p. 692) defines guidance as "the part of pupil personal services - and therefore of elementary and secondary education - aimed at maximal development of individual potentialities through devoting school-wide assistance to youth in the personal problems, choices and decisions each must face as he moves towards authority". He emphasizes the opportunities that classroom teachers have for guidance and does not want them relegated to passive

or minor roles in school guidance programmes. He also believes that guidance will be successful only if its goals are integrated within the context of the educational objectives set forth by the school. In this context, guidance has also been seen as the professional use of a science of purposeful action within the specific structure of education (Tiedeman and Field 1962).

Here, the main focus of guidance is upon youth and their future. It is therefore assumed that individuals who understand themselves would become more effective, more productive and happier human beings. Through guidance, individuals can achieve great awareness of who they are and who they can become. As maintained by Rogers (1962), that the purpose of most of the helping professions, including development, the psychological growth is towards a socialised maturity of its clients.

2.2.3 Arbuckle (1966), Peters and Farwell (1967) and others have attempted to clarify the usage of the term by pointing out the distinctions implicit in the word "guidance" being used as a concept (mental image), as an educational construct (intellectual synthesis) and as an educational service. As a concept, guidance denotes the utilization of a point of view in order to help an individual. As an educational construct, it refers to the provision of experiences that help pupils to understand themselves. As a service, it refers to procedures and processes organised to achieve a helping relationship (Arbuckle 1966; Peters and Farwell 1967, cf. Shertzer and Stone 1976). Due to

the many definitions of guidance, Shertzer and Stone (1976) choose to use a general definition of guidance as "the process of helping individuals to understand themselves and their world" (p. 38).

2.2.4 However, the above definitions of guidance may not be applicable to every country whose conditions differ from that of America. In Britain, for example, until recently, "guidance" has been used in a restricted sense in educational circles (Hughes 1971). Broadly speaking, there seem to be three main recognisable ways in which the word has been deployed. In each of these, the word guidance is accompanied by another word which restricts its actual meaning within relatively narrow limits. Though there is some overlap between the activities or operations referred to by these usages, the three areas are still regarded as quite distinct. The three generally accepted aspects or components of guidance and counselling are educational guidance, vocational guidance and personal guidance or counselling (Hughes 1971; Craft 1974; and cf. Perkhidmatan Panduan di Sekolah 1966 and Guidance in Schools 1971).

2.2.4(a) According to Craft (1974), educational guidance involves giving advice to pupils, parents and teachers on the choice of courses. The advice given is based on a variety of objective and impressionistic data such as test scores, teachers' assessments over a period, classroom performance, emotional adjustment and level of aspirations.

2.2.4(b) Vocational guidance involves a continuous and careful assessment of the interests, aptitude and potential of a person over a period, using a variety of sources of data. Together with educational guidance, (and in the light of the likely career opportunities, and of the help of the Youth Employment or Careers Officer), it is perhaps an advance on traditional careers work in schools<sup>1</sup> (cf. Craft 1974).

2.2.4(c) Personal guidance or counselling is related not only to educational and vocational guidance, but it is also concerned with emotional disturbances and behaviour problems. (Craft 1976; Guidance in Schools, Malaysia, 1966 and 1971). According to this wide definition of personal counselling, it is to help develop a pupil as a whole - mentally, physically and emotionally. With a pupil who has developed as a whole person, the counsellor would face little difficulty in his concern to develop the pupil's own capacity for decision-making, which is an important area of human growth and development. However, this third element of guidance will be discussed in greater detail in the following section.

2.2.5 In Malaysia, guidance is defined as "the systematic professional process of helping the individual through educative and interpretative procedures to gain a better understanding of his own characteristics and potentials, and to relate himself more satisfactorily to social requirements and opportunities in accord with social and moral values", (Guidance in Schools 1971, p. 1). From the above

definition, one could see that the overall guidance services in schools consists of the following elements (cf. Iyer 1975):

- (i) Personal social guidance - the help provided to individual pupils with regard to learning difficulties, behavioural problems, interpersonal relationships, such that the pupils learn to adjust and orient themselves to the school environment.
- (ii) Educational guidance - the help provided to individual pupils regarding the choice of electives and educational institutions such that pupils make wise choices with full understanding of these choices.
- (iii) Vocational guidance - the help provided to individual pupils through dissemination of occupational information, testing of interests, evaluation of abilities, organisation of visits to places of employment/training, job experience etc. such that pupils make rational career choice and carry out appropriate behaviour leading to the world of work.
- (iv) Drug Abuse/Development Programmes - the activities organised to educate pupils of the danger of drug abuse, bring about appropriate referral procedures to help any pupils who might have experimented with drugs. It further entails guidance and counselling aimed at helping pupils acquire desirable attitudes and behaviour in their day to day living, both at present and for the future (Iyer 1975).

In the light of the seriousness of drug abuse problems in Malaysia, Drug Abuse Prevention Education was introduced by the government to combat them. According to G. Krishna

Iyer (1977), an Assistant Director of Schools (Educational and Vocational Guidance), it is a process of creating awareness about the underlying causes of the drug abuse problem in order to generate individual, group and community involvement in formulating social action programmes to prevent drug abuse. The aim of this programme is to make use of various methods and approaches which will positively influence individuals, groups and the community at the cognitive, affective and psychomotor level, or, in other words, knowledge, attitudes and practice (also refer to Mencegah Salah Guna Dadah Melalui Kaunseling or Prevention of Drug Abuse Through Counselling 1983, and Berita Minggu 3 June 1984).

#### 2.2.6 Crisis Counselling

In recent years, another form of helping service has emerged in response to the needs of people involved in personal crises, such as drug problems, suicide, sex, rape, pregnancy, marital stress, depression and so on. This form of service owes its beginning (of an understanding of crisis work) to the pioneering work of Lindemann (1944) on bereavement reactions of families victimized by the Coconut Grove Nightclub fire (cf. Shertzer and Stone 1976). Later, his work was extended by Caplan (1961 and 1964) into a comprehensive and systematic presentation of crisis theory and practice. According to Caplan (1961, p. 18), "Crisis is a state provoked when a person faces an obstacle to important life goals that is for a time mountable through the utilization of customary methods of problem solving", (cf. Shertzer and Stone 1976). Among the fundamental

aspects of crisis are: (cf. ibid.):

- a) a crisis is of limited duration
- b) a crisis is essentially an interaction between the person and the hazard or the situation involving such factors as individual strengths, supports, and the intensity or the severity of the hazard as experienced by the individual
- c) a crisis produces deviation from normal behaviour patterns
- d) a crisis is assumed to be reversible and can serve as a means for positive growth.

According to Schneidman (1973) crisis intervention practices should restore individuals to their "pretraumatic level of overt functioning" (p. 9). The focus is upon the immediate cause of the anxiety rather than the underlying or primary cause. The helper or counsellor may consider the crisis from one or a combination of dimensions: stages of tension, impact-recoil phases, differing etiological process and/or levels of frustrations, (Shertzer and Stone 1976). McCord and Packwood (1971) report that crisis centres are found in every state in the United States (especially California), but most of them are clustered in metropolitan areas. They offer all kinds of services, particularly telephone listening and/or counselling (cf. Shertzer and Stone 1976; Su Bee Yan 1981).

Vaughan (1970), however, described vocational guidance given during the last year or sometimes even the last term of school life as crisis counselling, a term also used by him to describe any last minute attempt at guidance. The suitability of using such methods in counselling is questioned

by many, despite the argument by some career teachers that short, concentrated periods of advice to pupils just before they leave are the best solution in combatting the circumstances where little time is available for organising a complex guidance scheme.

#### 2.2.7 The Concept of Guidance as a Developmental Process

Unlike crisis counselling which offers services to the members of the community that are undergoing personal crisis, the concept of guidance as a developmental process stresses help to all students in all areas of their vocational, educational and personal-social experiences at all stages of their lives, (cf. Chapter 1, p.31). It is a relatively new concept which according to Mathewson (1962), identifies and stresses the centrality of choice making in educational, vocational and personal areas. As such, developmental guidance has been defined as having as its prime concern, the positive growth of all maturing students which involves team-work among classroom teachers, school counsellors and administrators, (Shertzer and Stone 1976). It is a cumulative, (concerned with long term growth), comprehensive and interpretive process which is directed towards the achievement of personal adequacy and effectiveness through self-knowledge, the awareness of one's surroundings, a thorough mastery of the relationship between self and environment and an understanding of personal and social values. In other words, the focus of developmental guidance lies in assisting the individual to evaluate self and personal experiences through contact with the counsellor

so that they can develop their capacities to the fullest extent for personal and societal benefit (cf. American School Counsellor Association Position Statements, 1983). This concern for the individual is based on the assumption that all individuals need guidance throughout their lives and the best way to do this is through team work or group work, which is generally described in Britain as pastoral care, (cf. Craft 1974; Best, Jarvis and Ribbins 1977; McGuinness 1977 and 1982).

Thus the overview of the literature suggests a number of major constraints in the term guidance:

- a) Beneficiary - Guidance has been used as a means of achieving several goals of the state as well as for the personal development of an individual.
- b) Content - it covers Educational Guidance, Vocational Guidance and Personal Guidance or Counselling.
- c) Focus - on crisis as well as developmental guidance. However, history suggests that there has been a move from state, vocational and crisis counselling to the individual, personal and developmental counselling.

### 2.3. What is Counselling?

#### 2.3.1 Introduction

As has been indicated towards the end of the previous section, guidance tends to move progressively towards a more individual, personal and developmental view of helping. At this point, in defining guidance it is often difficult to distinguish it from counselling.

As with guidance, the term "counselling" means so many different things to so many different people. It has been used in America as a synonym for psychotherapy as well as to indicate one aspect of vocational and educational guidance. Until recently, the term "counselling" has replaced the term "guidance" since guidance, as Blocher says, has been thought to be more appropriate to missiles than men, and he suggests that counselling is a more respectable term (for counsellor is a recognised professional figure in America, but less so in Britain).

2.3.2. The dictionary definition for counselling - 'to advise, recommend' - has been rejected by almost all counsellors (Lytton 1974). Most would accept a broader definition that relates counselling to the process of communication. Therefore, Carl Rogers' definition of psychotherapy as 'good communication within and between men' might be taken to apply to counselling in its widest sense (Lytton 1974).

2.3.3. According to Prof. Halmos (1979) the term 'counselling' has been used in a narrower sense in the clinical and welfare literature, especially in the United States. It has been taken to mean "a comparatively brief period of meeting - possibly only one meeting - during which a professional worker tries to help a client to sort out his educational, vocational and adjustment problems by discussion, clarification, advice and possibly also by referral to agencies which may give material or administrative help of some kind" (p. 2).

2.3.4. Patterson (1967, cf. Lytton 1974, p. 36), however, defines counselling or psychotherapy as "the relationship, and the process developing out of the relationship between an individual or individuals who are not functioning adequately or up to their potential, and who face problems which they feel unable to resolve alone, and (which) a trained professional who provides the kind of relationship in which the individual is able to change in ways which lead to the development of his potentials and ability to resolve his problems". This definition clearly stresses the malfunctioning of the individual which the counsellor seeks to redress, although this does not imply crisis counselling for a few selected individuals only, since obviously no one ever functions completely adequately in every respect. The emphasis here is seen to be on change in behaviour, and furthermore counselling is equated with psychotherapy (cf. Lytton 1974).

On the other hand, the British Association for Counselling (B.A.C.) has been very cautious in their attempt to formulate a definition of counselling (Bolger 1982). According to BAC, "People become engaged in counselling when a person, occupying regularly or temporarily the role of counsellor offers or agrees explicitly to offer time, attention and respect to another person or persons temporarily in the role of client. The task of counselling is to give the client an opportunity to explore, discover and clarify ways of living more resourcefully and toward greater well-being". In this definition, the word 'counselling' is used to denote a task and what is involved in the offering of

counselling as a service.

Having examined the above definitions one could see how varied the term "counselling" is to many different people, depending on their approaches towards counselling (cf. Chapter 1, p. 28). For the purpose of this study, a generally accepted definition of counselling will be used, i.e. Counselling is a relationship in which tested techniques are used to help people become more competent, happier, and more satisfied in their lives (cf. McGuiness 1982).

Therefore, the word counselling refers to:

2.3.4.1 A Relationship

2.3.4.2 A Process

2.3.4.3 A Technique

2.3.4.1 A Relationship

Pepinsky (1954) defines the relationship "as a hypothetical construct to designate the inferred affective character of the observable interaction between two individuals" (p. 171). According to Brammar and Shostrom (1968), the above definition of the 'relationship' refers to the affective or emotional elements of the interaction which can only be inferred from observation of client behaviour. They feel that a description of the relationship should include additional dimensions such as uniqueness-commonality, objectivity-subjectivity, cognitive-conotive, ambiguity-clarity, responsibility and ethical dimensions (cf. Brammer and Shostrom 1968).

Brammer and Shostrom (1968) consider all major approaches to counselling to be effective, but whichever method or

technique is selected, the quality of the relationship between the counsellor and the client is crucial (cf. Patterson 1962). The counsellor therefore, may develop any varying style and technique best suited to his own personalities and his estimates of his client's need.

Truax and Carkhuff (1967), and Rogers (1957) identify 3 "core dimensions" or "core conditions" in the relationship - the presence or absence of which will lead to effective counselling or otherwise. (Patterson 1978 and McGuiness 1982). The core dimensions are:

- (i) Emphatic Understanding/The ability to empathize - an ability to allow oneself as counsellor to experience or merge with the experience of the client, reflecting on that experience while suspending one's own judgements, and communicating this to the client. It involves an ability to be where the client is, without becoming tangled in the rigid perceptions that the client brings to the relationship (cf. McGuiness 1982).
- (ii) Unconditional positive regard (U.P.R. or non possessive warmth) - an ability to communicate to the client a level of human warmth, commitment to help, willingness to try to understand, which indicates a clear statement that the client is highly valued by the counsellor (ibid.).
- (iii) Genuineness - the ability to establish a relationship with the client in which there is no, or minimal, conflict between one's total experience and awareness, and one's overt communication with the client. The relationship should be characterised by honesty and

openness, rather than exploitation and manipulation (ibid.). (Carkhuff and Berenson (1977) mention Concreteness as a 4th core dimension).

#### 2.3.4.2 A Process

To regard counselling as a relationship tells part of the problem. People come to the counsellors because they see them as a source of help - the helping profession. Thus, counselling can also be analysed as a process which moves from the cry for help to the eventual supply of help in alleviating the dysfunction - i.e., people seek counselling because they feel incompetent, unhappy and dissatisfied. The process of counselling takes place in three basic phases (cf. Brammer and Shostrom 1968; Carkhuff and Berenson 1977):

- a) Exploitation - It is a phase in which the client is helped to view himself and his difficulties less rigidly, by loosening blocks that prevent influential perceptions from being examined (cf. McGuiness 1982).
- b) Understanding - a phase in which the client is helped to structure his new, less rigid, more open perceptions of reality in a way that gives him greater control over himself and his environment (ibid.).
- c) Action - a phase in which specific plans to expand his coping repertoire are developed so that functioning is increased (ibid.).

These three phases do not necessarily follow a rigid chronological sequence. Overlap between them is to be expected so that exploration and understanding will develop

together and plans for action will exist in embryo form while understanding is growing (ibid.).

#### 2.3.4.3 Techniques

Counselling also involves the ability on the part of the counsellor to select and use a wide range of techniques appropriate to the clients, the phase reached in counselling and the personal philosophy of the counsellor. The counsellor has a wide range of counselling approaches which he could choose from (cf. McGuinness 1982). For instance:

Exploration - can be facilitated by Rogierian

Understanding - can be facilitated by Gestalt

Action - Behavioural - Talent - matching model.

As with guidance, counselling, despite its complicated literature, presents us with a number of key constraints. All writers for example accept the importance of the quality of the relationship in achieving effective counselling. The precise nature of that relationship and the communication within it has been the subject of much research (Truax and Carkhuff, Rogers, Carkhuff and Berenson). Further, counselling practitioners divide on the importance of past experience, as opposed to present experience in dealing with problems, and on the influence of feelings as opposed to behaviours in seeking more effective functioning.

#### 2.4. Common Roles or Functions of the Counsellor

If we examine the literature on guidance and counselling, we are likely to find that almost all of them stated or mentioned that the counsellor's function is

related to remedial (preventive) aspects, i.e. to overcome or to solve problems so that the individual whose development was obstructed by certain obstacles, could be developed, (cf. A.S.C.A. Role Statement 1983). Are these the only functions of the counsellors?

According to Daws ( cf. Dennis Child 1977), since the beginning of the school counselling in Britain, in the mid-sixties, there had been strong emphasis on the purpose of guidance and counselling as "the prevention of breakdown rather than the rescue of those who are already casualties" (p. 381). It is intended to serve the normally occurring need of all children and not the psychotherapeutic needs of a disturbed, unhappy few (*ibid.*). In fact school counselling is considered as a potentially valuable contribution to the protection of the mental health of all children (NAMH 1970, Daws 1977, cf. Dennis Child 1977). In Britain it is being carried out through pastoral care, (cf. McGuiness 1982), while in Malaysia it is being channelled through the school guidance and counselling services. (Amer Awang 1983).

To begin with, all children undergo many developmental stages (Piaget 1952, Erikson 1965). In the course of their development, they are confronted with a series of challenges and transition points which they must adjust to, master, or come to terms to. For instance, all children experience the rapid physical changes of puberty and must come to terms with their dawning sexuality. As they move through adolescence, they have to undergo a changing relationship with adults and authority, including parents

and have to find their own identity to enable them to face and accept what the world has imposed on them (Daws 1977). The counsellor, who has considerable understanding of the developmental hurdles that lie before adolescents, should be able to help them cope with these hurdles and to grow into strong mature personalities that can withstand life's pressures. This pupil-focussed preventive work has three levels (in increasing order of strength), i.e. -

- a) the deviant and the distressed,
- b) vulnerable children
- c) all children.

However, very few counsellors go beyond the first stage except to be involved in educational and vocational guidance (Daws 1977, Amer Awang 1983 and Hj. Abdul Latif b. Mohd Ali 1983).

More often than not, the counsellor finds that he has to deal with crisis counselling, which occupies most of his time. He may be asked to 'deal with' the most disturbed children in the school on the grounds that this is where the greatest need lies, and that his training fits him better than anyone in the school to understand and help them. In this case, the counsellor may therefore undertake supportive work with such children, working in close collaboration with the specialists, psychomedical services or other outside agencies and also with parents. Such work can only be termed preventive, on the grounds that a potentially difficult situation should at least be prevented from becoming unendurable.

Another kind of role that the counsellor may find

himself being pushed into is dealing with all the school's misfits (indiscipline situations) such as the truants, the persistently violent, the anti-authority nonconformists, the underachievers and poorly motivated pupils whose behaviour is institutionally and socially unacceptable. (Daws 1977). Most counsellors will resist such responsibilities for two obvious reasons. One of them is that they see themselves as identifying and responding primarily to children's needs and problems and only secondary to those of the school. The other reason is that by doing or taking the task, the pupils may perceive the counsellor as another arm of the school's process. As such the counsellor's remedial work may be affected even though it is evident that the disapproved behaviour is often a symptom of excessive strain and disturbance on the part of the pupils concerned.

According to Daws (1977) the commonest role of the counsellor is as prophylaxis. In this case, the counsellor attempts to identify, with the help of his colleagues, all cases of distress and disturbance in the school. The more serious cases are referred to the specialist agencies while the rest are helped in the school by himself or a colleague. The preventive element here lies in the assumption that most psychiatric disturbance begins in small remediable ways and can be prevented by vigilant early detection and helpful intervention in what is regarded as crisis counselling (cf. p. 130). Such work will require a teaching or group guidance approach rather than individual counselling, though counselling will be an invaluable support service, (Daws 1977).

However, this prophylactic mental health services in education need not focus upon the pupils. The counsellor can choose instead to focus upon environmental inadequacies and stresses, intending to remedy the former and alleviate the latter (Daws 1977). Such contextual or environment-focussed prevention work are covered in two main areas: the school and the home. Here, too, what is done by the counsellor is frequently remedial rather than preventive, i.e. help for an irascible teacher or intervention in a disturbed family.

Another common counsellor role is centred upon careers work (educational and vocational guidance). It provides a very partial and fragmentary expression of the purposes of development counselling which according to Daws (1977) seemed to fit best the preventive and protective spirit of school counselling. (cf. Wrenn 1962 and Tyler 1961). Therefore, in helping pupils to make wide educational and occupational choices, the counsellor is said to have prevented some potentially serious cases of maladjustment and personal misery. However, because of the narrowness of its focus of concern it does not carry a very strong expression of preventive principle.

Despite the emphasis that has been consistently put upon the preventive as distinct from the remedial character of school counselling by originators, theoreticians, trainers and practitioners, only secondary attentiveness to the processes and objectives of prevention in the common counselling roles have emerged. This is partly the result of counsellors being a scarce resource (refer to Chapter 1, p.75)

because to indentify and respond to all the personal developmental needs of children would require thousands of counsellors.

Consequently, the strongest impression of the preventive principle in secondary school work is that devoted to the personal and social education of all pupils. Such work genuinely attempts to anticipate the developmental needs of all children. It covers such areas as health and sex education, moral education and personal relationships, social education, careers education and so on. It requires a team of suitable teachers, curriculum planning and a share of the timetable. It also implies a considerable opportunity and responsibility for the counsellor, who can help his colleagues appreciate the mental health objective of such work and the ways in which they can be most effectively achieved, i.e. through group work. According to Daws (1977), "it would be a pity if the gap between the counsellor's prophylactic image and the realities of his work was allowed to retard rather than enhance the rate of progress in developing a positive educational programme to give all children sound foundations of their mental health", (p. 386).

With regard to Malaysia, Dr. Amer Awang (1983) said that the majority of Malaysian counsellors pay particular attention to remedial work, while preventive and developmental aspects have not been fully exploited. Such a situation exists due to the environmental focus arising from the miscellaneous problems that exist in the country. As a result, efforts have to be geared at solving these problems (ref. Chapter 1, p.107). He further stressed

that preventive and developmental aspects should not be neglected because the client would not be satisfied through problem-solving alone. He may want to know how to prevent the problem from recurring and want to face his future with confidence.

The preventive aspect of guidance and counselling that is receiving most attention in recent years is the drug abuse prevention or programmes in schools (cf. p. 129). The concern for the increase of drug abuse problems is so great that the Malaysian government has proclaimed that drug abuse is the current major enemy of this country, besides communism (as the second enemy). A special Anti-Drug Committee in the National Security Council had been established to formulate (plan) as well as to carry out preventive measures regarding this problem. The Ministry of Education was given the task of carrying out drug preventive educational programmes, particularly among the pupils in fully assisted government schools throughout the country. In 1981, a Special Drug Officer was appointed to supervise the programme and a State Special Officer (Drug) was also recruited in every state to help combat the drug abuse problems (Guidance and Counselling Unit Newsletter, 1984).

## 2.5 Distinction between Guidance, Counselling and Psychotherapy

According to Shertzer and Stone (1976), attempts to differentiate the term guidance, counselling and psychotherapy have so far not met any notable degree of success. As may be concluded from the previous sections, this could be the consequence of the fact that they are not discrete

entities but positions on a complex matrix of helping. Precise differentiation is not possible, overlap is inevitable, but differences in emphasis in practice can be usefully observed. Many counselling practitioners and many psychotherapists believe that there is not much distinction among the terms, particularly between counselling and psychotherapy, and that they should be used interchangeably. Others think that distinctions must be made because of the differences in their preparation programmes.

However, many agree that guidance, counselling and psychotherapy have more common elements than differences. For instance, all of them have common bases, i.e. a helping relationship that seeks to assist the individual in attaining self-direction. The distinctions among them seem to "appear forced or contrived and theoretical rather than qualitative and practical in nature" (Shertzer and Stone 1976, p. 163, also refer to Lewis 1970; Bordin 1955; Balogh 1961; Patterson 1973 and Arbuckle 1970). Both the distinctions and the commonalities need to be borne in mind during any analysis of guidance and counselling services.

## 2.6 The Application of Guidance and Counselling in Malaysian Schools

Having defined and explored the numerous meanings and usage of guidance and counselling, as put forward by various well-known writers and personalities in this field, the next step will be to consider in detail the application of guidance and counselling services in Malaysia and the contributions that guidance and counselling can make to the multi-cultural Malaysian society. Two key questions emerge:

How are guidance and counselling related to the Malaysian educational system, and, perhaps more importantly, how can guidance and counselling help Malaysia achieve one of its prime goals in education, i.e. education towards unity?

Before going any further, let us consider a number of factors that influence the present educational system of Malaysia:

- (i) The Political Background
- (ii) The Racial and Religious Factors (The Rise of the Multi-racial Society)
- (iii) The Geographical and Economic Factor
- (iv) The Cultural Factor

(i) The Political Background

The end of the 18th century saw the coming of the British to Malaya. During that period, the British East India Company had the monopoly of trade in the East. It was maintained solely for commerce, but, indirectly, it was a means whereby Britain extended her influence and control of the countries where the Company had established trading posts (Wong & Ee 1975). In other words the flag followed trade.

Due to its strategic position on the trade route between India and China, Malaya was considered by the East India Company to be suitable for providing a port-of-call base for re-fuelling and defence of its interest in the East. At first Penang seemed to be the answer to their problems. After the acquisition of Penang in 1786, the British moved into the Straits of Malacca, looking for another place where the ships might shelter (Wong & Ee 1975). The result was the

occupation of Singapore as the British entrepot on 29 January 1819.

The signing of the Anglo-Dutch Treaty in 1824 more or less settled the spheres of contention between the British and the Dutch, the latter confining their interests in Indonesian waters and leaving the English to extend their influence in India and the Malay Peninsula. Malacca, which was then under the Dutch, was exchanged for Bencoolen, a British outpost in Java. In 1826, Singapore, Malacca, Penang and Province Wellesley (now part of Penang) were formed into a single administrative unit called the Straits Settlement which remained under the control of British authorities in India until 1867, when it was transferred to the Colonial Office in London. It was to become the base whence British influence was gradually extended throughout the Malay Peninsula (Andaya 1982).

By this time, the political conditions in the Malay states of Perak, Selangor, Pahang and Negeri Sembilan were ripe enough to invite British intervention (Wong & Ee 1975; Andaya 1982). Thus, in 1874, The Pangkor Treaty was signed and a British resident was appointed in Perak, marking the beginning of British intervention in the Malay states. Gradually, the British extended their control to the rest of the Peninsula. By 1919, the entire Malay Peninsula had come under some kind of British control.

Once the British had succeeded in becoming the paramount power in the Malay Peninsula, they continued a policy of 'conciliation' with the Malay rulers and of 'minimum interference' with the Malay peasantry. At the same time

they helped to maintain law and order in the country so that British commercial interests would be able to exploit the area's wealth. Towards this end, the British created political and administrative machinery to mobilise the resources of the country (Roff 1967; Andaya 1982). As a consequence, Malaya had been transformed from an economy based principally on subsistence agriculture and regional trade to one oriented to export commodities of great value in the world market, such as rubber, tin and palm oil. The colonial government harnessed its every resource, from education to government administration, to assure the financial success of its export economy (Andaya 1982).

On the 18th December 1941 Malaya was invaded by the Japanese who continued to rule the country until 15th August 1945 after which Malaya once again came under British rule. On their return to Malaya, the British tried to incorporate the Federated Malay States (Perak, Pahang, Selangor and Negeri Sembilan), Unfederated Malay States (Perlis, Kedah, Kelantan, Johor and Trengganu), Penang and Melaka into a Malayan Union, leaving Singapore a separate crown colony. The Malayan Union was regarded by the British as a necessary step towards the granting of independence to a united nation in which each group would have equal rights (cf. Andaya 1982). The plan met strong opposition from the Malay population. Initially the British government refused to withdraw the Malayan Union plan. However, when the Malayan Union was inaugurated on 1st April 1946, the opposition was so great and effective that the plan was never brought into effect. It was finally revoked in its entirety after 1st February 1948

when the Federation of Malaya was created. As a result, a strong unitary central government was established with legislative powers but the states were assured jurisdiction over certain important fields (Roff 1967; Andaya 1982).

In April 1949, the British Parliament made a commitment to Malaya's independence and preparations were then made towards this goal. Besides that, the British government was also confronted with the Malayan Communist Party's (MCP) insurgency in Malaya which forced it to proclaim a State of Emergency throughout Malaya on 1st June 1948. This State of Emergency was to last until 31 July 1960. It revealed some of the serious ethnic divisions existing within the community since the majority of the members of the MCP were Chinese. Even though the communist was no longer regarded as the prime threat to this country, the communal threat remained, a legacy of colonial rule, which would determine the survival or eventual demise of the new nation.

(ii) The Racial and Religious Factor

(The Rise of the Multi-Racial Society)

The latest census indicates that Malaysia has a population of 14.2 million (Peninsula Malaysia - 11.8 millions, Sarawak and Sabah - 2.4 millions). According to the census (1980), the population of Malaysia comprises 53.9% Malays and other bumiputras (indigenous people), 34.9% Chinese, 10.5% Indians and other minor ethnic group 0.7%.

How did such a multi-racial (plural/multi-ethnic) society come into existence?

Many thousands of years ago, waves of migrants moved

into the Malay Peninsula and made it their home. According to Ginsberg and Roberts (1958), attempts to identify the indigenous inhabitants of Malaya have been, on the whole, inconclusive (cf. Andaya 1982). Anthropologists tend to distinguish them into four types - the Negrito (Semang), the Senoi (Sakai), the proto-Malays (Jakun) and the Deutro-Malays (the 'Malays' of the present day). According to Wong and Ee (1975), the first known civilised inhabitants were the Malays. The majority of them are found in rural areas and along the coast of Peninsular Malaysia.

Even though contacts between the Malays and other races, especially the Indians and the Chinese, existed long before the coming of the Europeans (the Portugese, the Dutch and later the British), only a small number of them actually settled in Malaya during the early time (Ginsberg and Roberts 1958). Most of them, particularly the Chinese, tended to confine their interests to trade rather than to settlement or cultural infiltrations until the nineteenth century (Winstedt 1935; Ginsberg and Roberts 1958). However, the coming of the British and their colonization of Malaya brought about an influx of Chinese and Indian immigrants to this country.

Wong and Ee (1975) also mentioned that the Chinese immigrants came to Malaya in two phases. The first was when emigration from China was punishable by death. As a result, these immigrants had to cut themselves off completely from China. Since very few women undertook this hazardous course, many of this earlier group of immigrants married Malay women and in the course of time ceased to write or speak Chinese.

These Babas and Nyonyas, as they were called, were found mainly in Penang and Malacca. They spoke a kind of bazaar Malay, assimilated a few Malay customs and habits and looked upon these states as their home. Under the British rule, they pledged allegiance to the King of England.

The second phase came at the end of the nineteenth century when China abolished her laws forbidding emigration (ibid.). As such, an increasing number of women were able to come to Malaya. With this influx, there was a large increase of Chinese children born in this country. Most of them went to private vernacular schools established by the immigrants themselves (cf. Purcell, 1967; Chapter 1, p. 82). Most of these Chinese lived and worked in the tin mining areas and in large towns.

It was also mentioned earlier that the Indians' connection with Malaya dated back to the early centuries of our era when there had been regular trading between both countries. Therefore, when the East India Company established settlements in Penang, Malacca and Singapore, which were governed from Bengal (India), it was natural that there should be a considerable Indian element in the population there. Then, in the later part of the nineteenth century, many south Indians were recruited to work in the rubber estates owned by the British. They were also employed as labourers for road and railway constructions.

The influx of Chinese and Indian immigrants to Malaya was encouraged by the British colonial government through its unrestricted immigration policy. They provided

the much needed labour in the tin mining industry as well as the rubber industry, respectively. This gave rise to the plural or multi-racial which exists in Malaya today.<sup>2</sup> These diversified groups later created many formidable educational problems (as mentioned in the previous chapter, p. 97) to the present Malaysian government.

Furthermore, each of these races (ethnic groups) has a different dialect (language), customs and religions. The Malays are bound by the common tie of Malay language and Islam which is the official religion of Malaysia. In fact, the constitution of Malaysia also defines a Malay as one who among other things professes the religion of Islam. Some Chinese are Moslems but the majority are Buddhists, Confucianists, Taoists and Christians. According to Wong and Ee (1975), they have always been regarded as very tolerant in religious matters and many of them profess to reconcile all religions, (cf. Andaya 1982). The Indians are mostly Hindus and some are Moslems (of Pakistani origin) and Christians. Although it has been stated in the Malaysian constitution that the official religion is Islam, there is religious freedom in the country, whereby everybody is allowed to practice their chosen faith.

Due to these ethnic and religious differences, language is seen as an important means of linking the nation together. That is why Bahasa Malaysia (Malay language or the language of the indigenous) has been made the national language of the country and has become the medium of instruction in all schools and institutions of higher learning (cf. Chapter 1, p. 89).

However, it is an undeniable fact that the racial problem in this country has not yet been solved in spite of the passage of a quarter-century since independence. Racial consciousness still lingers in its various manifestations and certain issues can still stir up feelings that are essentially racial. Nevertheless, the character of the problem has altered. The gap in perception amongst different races has narrowed down considerably (The New Straits Times, 1983), due to the various developments that are taking place in the country. The three principle races of Malaysia are gradually moving towards a point of convergence.

(iii) The Geographical and Economic Factor

During the colonial phase, the ethnic groups of Malaya were very much divided by their geographical and occupational preferences. In other words, different groups concentrated in different occupations. This has been contributed to the fact that each ethnic-group has different levels of educational achievements and the economic status (Andaya 1982). The Chinese concentrated on tin-mining, while the Indians formed the labour force for rubber-cultivation and stayed in the rubber estates. Directly and indirectly, rubber and tin have contributed to the growth of town, schools, ports and communications, (ibid.). This has given more opportunities to the Chinese and Indian children to gain a more adequate education than the Malay children whose parents are mostly involved in cultivation on their small farms and in fishing along the coast.<sup>3)</sup> (cf. Chapter 1, pp. 81-82).

Though the Malaysians still have different preferences in jobs for their children, situations have changed. Education has opened up various opportunities for their children to engage in and better their life. Malay parents, even those who stay in rural areas, encourage their children to pursue the highest possible qualifications and preferably to enter the Civil Service. This is one of the reasons why a high proportion of Malays work in the Civil Service, ignoring, or being less motivated towards professional jobs or jobs in the private sector which promise higher income. Most Chinese parents, generally speaking, encourage their children to choose lucrative jobs in the private sector, while the Indians try to persuade their children to enter the medical, legal and educational profession (Wong and Ee 1975).

The government of Malaysia realises that the least fortunate ethnic group (at least where the distribution of wealth is concerned) is the Malays. It, therefore, has targeted that by 1990, at least 30% of the total commercial and industrial activities of the country in all categories and scales of operation to be in the Malay hand (Fourth Malaysia Plan, 1981-1985). Through these efforts the government hopes to reduce imbalances among racial groups which could invite disunity in the country. Past experiences, especially the May 13, 1969 incident, provided a good lesson to the country.<sup>4</sup> The racial clashes between the "have-nots" (mostly the Malays) and the "haves" (practically the Chinese), was due to the wide economic gap between the races in the country, which is clearly demonstrated as follows:

"the May 13th incident showed clearly that economic policies and programmes geared mainly to increasing the growth of the economy would not meet the needs of the nation. It demonstrated that any development effort that did not deal sufficiently with the needs of the poor and the imbalances among racial groups would lead to growth without equity and result in a nation divided between those who share in the benefits of growth and those who do not, in short a nation divided and compartmentalised. The trauma of the incident, therefore, led to a critical evaluation of past policies and approaches, out of which the National Ideology was formulated as a basis for National Unity." (Fourth Malaysia Plan, 1981-1985, pp. 1-2)

Current government policy seeks for improved racial harmony and integration, respect for one another, and tolerance and understanding between the individuals in the country regardless of their origin. This policy is in accordance with the concept of the "Rukunegara"<sup>5</sup> of Malaysia (Articles of Faith of the State).

Consequently with the New Economic Policy as a guide, teachers, especially the guidance teachers, should try their best, when the opportunity exists, to divert the biased evaluation of the professions that has been planted in Malay children. More information and guidelines should be given to them so that they become interested in lucrative jobs in the private sector or enter professions, preferably the profession of doctors, engineers, accountants and other high take-home income professions.

(iv) The Cultural Factor

Superimposed on the physical diversity of race and the varieties of language, there is also the cultural diversity. The present Malay culture, though based on its indigenous past, has been moulded by Hindu influences from

India and by Islamic influences from the Arab world. The Chinese, too, have brought to Malaysia their own distinctive culture with its amalgam of Confucianism, Taoist and Mahayana Buddhist elements, while from India, Pakistan and Ceylon the immigrants have brought Hinduism, Islam and Hinayana Buddhist elements (Wong and Ee 1975). In Sabah and Sarawak, the indigenous have preserved their own cultures. In addition, the western world has also contributed its share to the cultural and religious heritage of Malaysia through its association with this area over the past five centuries and the pervasive influence of the mass media (ibid.).

## 2.7 Education Towards National Unity

As described earlier, the two main objectives of education in Malaysia are to fulfill the manpower need of the country and to establish a united, well disciplined and skilled society. These objectives have remained unchanged ever since the time Malaya achieved its independence 27 years ago (1957).

In other words, education is still being regarded as a means of contributing to the unity of the ethnic groups in the country. As such, a national system of education acceptable to all is necessary. As indicated by Wong and Ee (1975) that "The whole body politic of Malaysia depends on successfully unifying the various racial groups of the country to form one nationality, and to create a Malaysian consciousness among the various races living in the country, a need which has become more urgent because of the increase of racial groups since the inclusion of the Borneo

territories in the new Federation" (pp. 104-105).

Encik Aminuddin bin Baki, the predecessor to the present Chief Education Adviser of Malaysia supported the view that the national system of education has to be flexible to allow for special conditions that exist in each territory (ethnic group), but the underlying structure should be common to all the three territories (ethnic groups). He pointed out that :

"To allow education policies, practices, and school curricula in the component States to go their separate ways is not consistent with the future of the nation. The earlier the different systems and policies are unified the sooner the much desired integration will be achieved. Any delay in the implementation of an education policy or practice means not a delay in terms of one or two years, but a delay of generation." (The New Straits Times, Malaysia 1964.)

Through a national system of education, where Bahasa Malaysia is used as the medium of instruction in the schools, directly or indirectly the system should help to unite the people socially and culturally. As suggested by Millins (1966) that sound language teaching should be closely linked with an understanding of the social and cultural factors as they affect individual children.

In a country like Malaysia, where the people are from different ethnic groups, have different religions, value-systems, cultures, languages, and are of different levels of economic status, the feelings of dissatisfaction and disagreement among groups of different origins, can easily erupt into serious disturbances. The May 13th incident (cf. Chapter 1, p. 95) is an example of dissatisfaction between the "haves" and the "have nots". Recurrences of such clashes will take much energy and time to

prevent or to mitigate. However, it is reassuring to note that such efforts may well be worthwhile. As remarked by Mannheim (1962) that important achievements in the elimination of conflicts would be accomplished if the democratic society were willing to invest more energy and time in mitigation of race and group hatred as the totalitarian societies did in fostering it.

In a multi-cultural or plural society like Malaysia, consensus among different groups is always problematic. Improved education could contribute to preventing inter-racial clashes and generate an atmosphere conducive to consensus and integration. As explained by Moorish (1981): "We are now living in the midst of an evolving multi-cultural society, in which consensus becomes increasingly problematic and integration a question of organised planning. Education must surely have something to offer in the amelioration of inter-racial clash and strife" (p. 33).

The question of a "national culture" is another problematic issue in the politics of the country (Ibrahim Saad 1982). This is true when it comes to the question, "whose culture should be of significance in the country?". There is no restriction to the practice of individual culture in the country, and there is always a tendency to disregard other cultures. In a democratic country like Malaysia, it is essential, for the members of society, to respect all groups and their way of life. The respect towards other cultures can best be developed through the knowledge and understanding that can be gained through education. In fact, the study on the cultures of Malaysia

has been absorbed in the normal school curriculum. Eventually, a true Malaysian culture might develop. As maintained by Clarke (1948) that a true culture would emerge from the common life and experience of a healthy society; a common purpose of that society would define itself and this should be heeded both within the school and outside. He further stressed that the content of education should be relevant to this common purpose, and the teachers chosen should be its especially sensitive representatives. In addition there should be a deliberate training in education for 'citizen consciousness'. In other words, education in school could, not only help a 'true culture' to emerge, but it is also a training for 'citizen consciousness' which is vital in the national unity of a country (cf. Chapter, 1, p. 96).

From the above discussion, it is evident that 'education' in general and guidance specifically can play a vital role in removing some stumbling-blocks to national unity. Education could be developed as a vehicle for contributing to unity in that its role could be further integrated with the objectives of the Mahathir Report (See Fig. 8) which still present the two major objectives or goals of education in Malaysia:

- a) to fulfill the manpower needs of the country (p. 1)
- b) to establish a united, well disciplined and skilled society (Mahathir Report, cf. Fourth Malaysia Plan, 1981-1985).

Fig. : 8

THE OBJECTIVES OF THE MAHATHIR REPORT

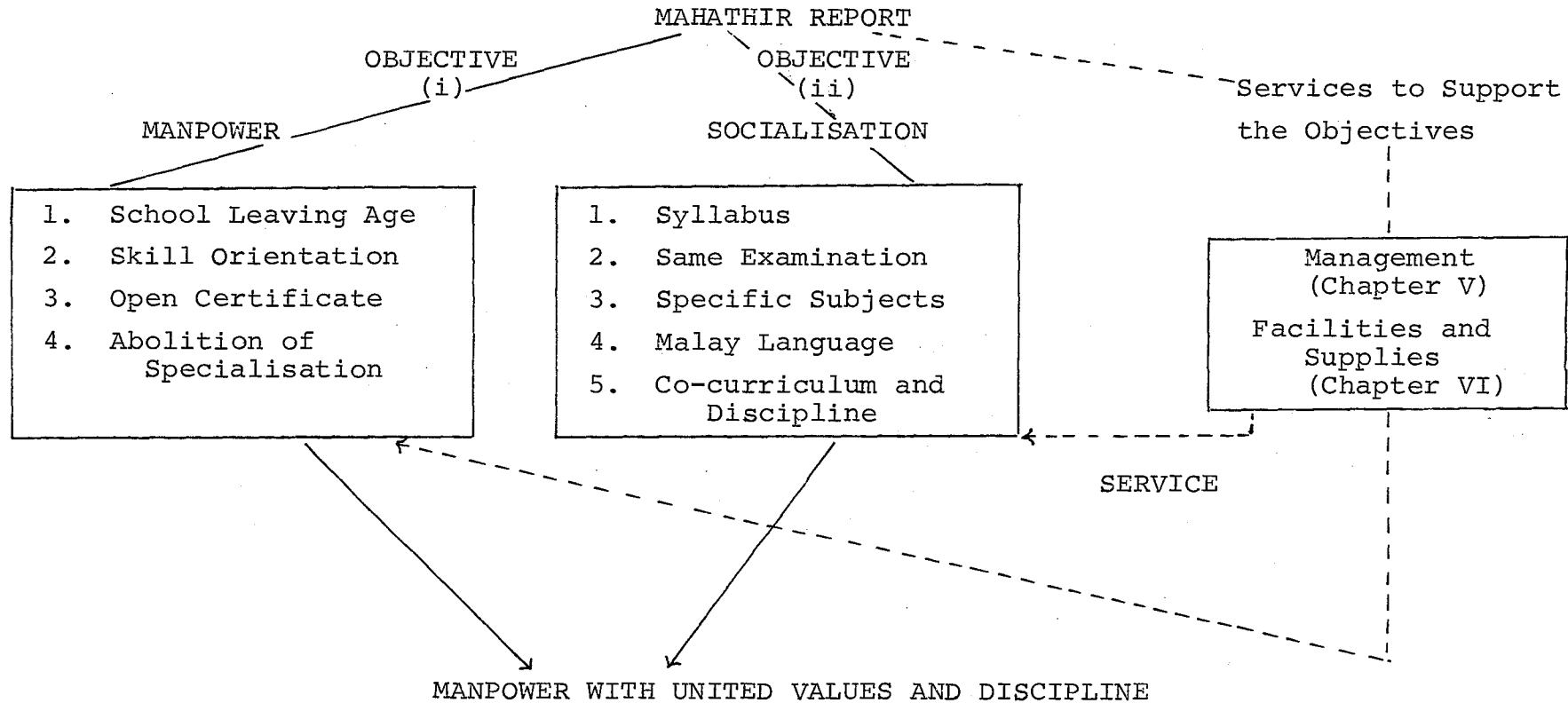

Source : Ibrahim Saad (Ed.) Isu Pendidikan di Malaysia, Kuala Lumpur: Dewan Bahasa dan Pustaka, Kementerian Pelajaran Malaysia, 1982

In the broadest terms these objectives involved:

- a) Educational and Vocational Guidance, and
- b) Personal Guidance.

Careful thought will have to be given to the methods by which these aims are pursued, given the analysis of the nature of guidance and counselling on pp.124-146. A balance between the needs, the rights and the responsibilities of both the state and the individual needs to be achieved.

Actually, investment in human capital, i.e. objective (a) is one of the 'new' concepts in education that developed during the Industrial Revolution. Since then, the concept has been used in a more 'sophisticated' and organised form to meet the long term goals and needs of a growing nation, (Watts 1983 and Menon 1975) through what has been referred to as 'vocational' or 'career guidance'. The second objective (b) could be regarded as a socialisation objective that is aimed at transmitting, absorbing and stabilising cultural values in the society by means of educational processes. In order to achieve this goal, schools have been established (cf. Watts 1983). With regard to education in a developing country like Malaysia, both objectives are inter-related and should therefore be tackled and solved simultaneously. Thus, the Mahathir Report is aimed at fulfilling these objectives.

## 2.8 The Mahathir Report

The Mahathir Report or the Report of Cabinet Committee on Education Policy was published in 1979, named after the Prime Minister of Malaysia, Dr. Mahathir bin Mohamed, the

then Minister of Education. For the purpose of this study, the report will be examined under two main headings:

2.8.1-I Education and Manpower Needs

2.8.2-II Education and National Unity

2.8.1-I Education and Manpower Needs

According to the Mahathir Report, too much wastage has been occurring in education. Firstly, the wastage is said to have been attributed to the large number of pupils who drop out from schools at a very early age (ref. p. 107). Secondly, the scope of education in Malaysia is too specific, leaving no room for free flow or mobility of manpower from one sector to another to occur. It resulted from the early specialisation in schools, i.e. from Form 4 onwards (ref. Chapter 1, p. 109).

In order to overcome this wastage, the Mahathir Report offers a number of suggestions which can be summarised as follows:

A) Wastage due to drop-outs

A.1 It suggests that the school leaving age is to be increased from 9 to 11 years (i.e. from Standard 1 to Standard 6 and Form 1 to Form 5). As such, 'forced drop-outs' due to examination failures may perhaps be avoided.

A.2 The orientation of the primary school curriculum will be towards specialisation as well as basic education.

Remedial education will be provided to the under-achieved pupils. Presently, due to the close relationship between age and form or class, promotion of the pupils from year to year is automatic. According to the report, the step

taken to retain these under-achievers is based on the principle of education (p. 19). It further stresses that the level of children's achievement is not based on age but on other variables as well. As such, children of the same age need not necessarily have the same level of achievement, as expected presently, e.g. an eleven year old is presumed to have the achievement of a Standard Five pupil.

## B) Wastage due to specialisation

### B.1 Abolition of specialisation

The report makes strong recommendation that particular attention or emphasis should be given to general education because "the present upper secondary education has no relation to occupation" (p. 37). Therefore, specialisation areas or streams such as arts and technical sciences will be abolished. Only academic and vocational streams will be offered to the pupils (p. 107). In other words, the science stream pupils will be exposed to arts subjects (p. 44) and the pupils in the academic stream will also be exposed to the technical and vocational subjects (p. 28). It is hoped that this so-called 'liberal' education could provide better opportunities for these pupils in getting jobs when they leave schools. It could also encourage free flow or mobility of manpower from one sector to another.

### B.2 Abolition of Achievement through Grades

The overall achievement through grades in Sijil Pelajaran Malaysia (S.P.M.) and Sijil Rendah Pelajaran (S.R.P.) would be abolished in the near future (pp. 30, 39). By adopting this

step, it is hoped that the manpower resources could be utilised to its maximum. For instance, pupils who pass two or three subjects will be able to compete for jobs even though their grades are very low; unlike the present situation where their chances are practically nil because they do not possess any certificate.

#### 2.8.1-II Education and National Unity

As mentioned earlier, the second objective of the Mahathir Report is to establish a united, disciplined and skilled society. However, it should be noted that the suggestions put forward by this report, regarding the above matter are almost synonymous to the Razak Report of 1956.

They are as follows:

##### a) Common syllabus

The Mahathir Report has gone a step further than the Razak Report by making it compulsory for the private schools to use the same syllabus as in the government schools, (p. 113). The Razak Report only mentioned the government schools and the government aided schools. Consequently, those in the schools involved will have to sit for the same examinations, i.e. Sijil Rendah Pelajaran (S.R.P.) and Sijil Pelajaran Malaysia (S.P.M.) (p. 69), which are in Bahasa Malaysia (Malay language).

However, doubts arise from the term 'private' schools - whether it includes the Chinese Secondary schools since all the pupils in those schools are taught in Mandarin (Chinese language), while the two examinations mentioned earlier are only set in Bahasa Malaysia (Malay language).

## b) Common Examination

Besides the two public examinations mentioned above, the government plans to control various examinations that are being carried out in this country. This is based on the argument that if everyone is allowed to take any examination they wish to, there is no point in having a common syllabus.

## c) Other subjects

Islamic Religious Studies will be made a compulsory subject for Moslem pupils in the public examinations (p. 71) and the case of moral and ethical education for the non-Moslems (p. 72). Other subjects such as Civics, local-focussed History and Geography will also be made compulsory in the hope that positive attitudes towards the nation could be established through the knowledge acquired from these subjects.

d) The Status of Bahasa Malaysia

The Mahathir Report recognises Bahasa Malaysia, our national language, as the language for unity but its importance as a subject is not as it used to be. It is still a necessary examination subject but it is not necessary to pass. The fall from grace of Bahasa Malaysia is based on the assumption that by 1983, all entries to the local universities will be from the Malay medium. They are expected to be able to converse and write in Malay language since all subjects are taught in the national language.

## e) Co-curriculum and Discipline

The main aims of co-curriculum is to establish esprit de corps while discipline is to develop loyalty towards the nation (p. 119). It is being regarded as a socialisation

attempt to produce the required citizens of the country.

Much criticism has been made of the Mahathir Report, especially in relation to the use and emphasis on certain subjects such as Languages, Civics, Religious knowledge, History and so on that are considered as necessary subjects for socialising the pupils towards unity, (Ibrahim Saad 1980). Without doubt, manpower resources could be built through a well-planned educational system, but whether a united and disciplined society could be established, together with it, is rather difficult to predict. To what extent the Report succeeds in establishing a united, disciplined and skilled society remains to be seen. But one cannot belittle the impact that this report has and will continue to do so on the Malaysian educational system. As its views are projected towards the establishment of a "new" society through education, one could not but accept its impact on the school guidance services (including counselling) which also contribute towards unity.

Thus, how can guidance and counselling help Malaysians in achieving their goals?

## 2.9 Guidance and Counselling towards Unity

As mentioned earlier, education could be a 'vehicle' towards unity. For this reason, the aims of education have been directed to meet both the needs of the individual and the Malaysian society (Hussein Onn 1971). Equally important, education can help an individual to understand the basis of the Malaysian society which in turn will induce him to become committed to the society's welfare and to

the restructuring of the multi-racial society.

Furthermore, the necessity of the opportunity for successful achievement in formal education for every individual, is undeniable, if unity is one of the main targets in the country. It is hoped that the gap between the 'haves' and the 'have nots' could be eradicated through education (Dasar Pelajaran Kebangsaan or National Education Policy). The question posed by the society is, "How can we ensure that majority, if not all, school children do not only perform well in their studies but also are not lacking in the development of a rounded personality?"

It is in this respect that guidance and counselling can play a vital role in helping to meet the goal. This view of the role of guidance is supported by the statements of the Ministry of Education of Malaysia that guidance is related to "the perpetuation and enhancement of the democratic way of life", and "the development of a well-rounded personality by catering for the aesthetic, moral, physical and intellectual needs of every individual in order that he becomes a happy and useful member of society" (EPRD 1968, cf. Menon 1975). Through guidance and counselling, both individually and in the classroom, the counsellor (in this case, the guidance teacher) can assist individuals to the realisation of the importance of education in terms of national unity.

According to Wall (UNESCO 1977), "wise educational guidance, at least from the age of 11 onwards, is the essence of a constructive education for adolescents; but it must be a guidance conceived in terms much broader than those

currently in use" (p. 89). This general form of guidance is inherent in any system which provides alternatives, as in the case of Malaysia where particular curricula leads to particular certificates. These certificates then are themselves required for entry to many occupations, the choice of a course or school implies crude vocational choice. Wall (1977) regards this process as not one of guidance but of selection. It means that certain arbitrary demands are set up to which the child must conform. For example, the rigidity of the Malaysian education system which limits the options available to its pupils, often forces a pupil to enter a particular "stream" which prevents him from taking subjects best suited to his needs, interests and aptitudes. This can seriously affect his academic performance. It often means failure in examination which, for many is tantamount to failure in life (cf. Watts 1978, Ibrahim Saad 1980). Indirectly, such occurrences could hinder the government's efforts to promote unity through education.

Wall (1977) further mentions that guidance implies more, that allowing education to play a constructive part in the healthy mental and development of adolescents who change and develop especially in the first half of their teens. Therefore, guidance and counselling personnel could play an important and active role in helping an individual to achieve his developmental goals before he reaches adulthood. Moreover, at different stages of growth, environmental influence have varying degrees of importance in shaping the intellectual life of the adolescents. Hence, "guidance must be

cummulative and continuous and at the same time must take account of the temperamental, personal, familial and environmental factors as well as of such more readily measurable variables as general and specific abilities and declared interests" (Wall 1977, p. 90).

Therefore, those who undertake such guidance (guidance teachers) must also deeply understand the ways in which family background tend to determine choices (Sharrock 1980; cf. Chapter 1, p.110). They must accept the responsibility for interpreting their study to the family, the adolescents themselves and to the school. In other words, they could fulfill a dynamic as well as a diagnostic role and endeavouring actively to bring about the best possible adjustment between parental attitudes, the child's capacities and the legitimate demands or goals of education. (Wall 1977, also refer to Guidance in Schools 1971).

For Malaysia (whose professional endeavours in the field of guidance is still in its infancy stage), both the inherent problems pertaining to the nature of guidance and counselling as a helping service as well as the problems of accommodating and assimilating innovative ideas on the traditional, indigenous structure, have indeed imposed many challenges. (Menon 1975). Even though the theory of individual differences is much subscribed to in the official statements of educational goals and in the rhetoric of the guidance philosophy which sees the guidance function in terms of "the assistance given to individuals in making intelligent choices and adjustments" (EPRD 1968,

cf. Menon 1975), the situation is not without discrepancies and contradictions. For instance, Malaysian schools are still very much subject-centred and content-oriented (Menon 1975; Watts 1978 and Ibrahim Saad 1982). It implies that the role of affect and emotional learnings necessary in fostering a balanced development of the individual is somewhat lost in sight.

Furthermore, Wall (1977) insists that "the role of the school in adolescence is as the interpreter to boys and girls of the world into which they are growing" (p. 90). Culture or the process of socialisation will at best be acquired only superficially if the deeper needs of the personality are not met. No matter how a school is organised, and whether or not it seeks to confine to the cultivation of the intellect or to the training of labour force, its influence on the emotional life of its pupils is very great. It is indeed a system of human relationships set up by and reflecting on outside social and economic system (Wall 1977).

In developed as well as in developing societies or countries, for an increasing number of adolescents, the school is the only means through which they may begin to acquire the deeper emotional education which will shape the whole of their adult character. Thus, the trusted teacher, particularly the guidance teacher, who is sensitively aware of the needs of his pupils can, both in the classroom and outside school hours do much to help the young pupils find for themselves the answers to the many questions which vex their growing minds. By helping his pupils to meet their developmental needs, to accept emotionally the world in

which they live, to solve or to hold temporarily in suspense problems with which their growth confronts them, the teacher can in fact liberate their energy, justify in their eyes the values of the studies which he advocates. In addition to this, he can, through the organisation and the climate of the school itself, expose them to a critical understanding of the achievements of society and of its shortcomings. In this way, he is paving ways for them to seek change in constructive ways, not only for their own benefit but for their society as well. (Wall 1977).

Thus, a well-trained guidance teacher would be able to provide effective guidance programmes in the school to meet the needs of his pupils. With an effective guidance programme in the school, the pupils will be better informed and prepared for entry into the competitive labour force and will also be aware of the technical and social needs of the country. Besides that, personal guidance or counselling can help the pupils understand themselves and the society around them. Such an understanding will enable them to formulate positive "social attitudes" towards others which are necessary for social integration.

NOTES

1. Besides vocational guidance, terms such as vocational counselling, careers guidance and careers counselling are also being used in relation to jobs and adult life (i.e. jobs, family and leisure). These terms are much debated in Britain of the 1980s with its high level of unemployment. A full discussion of the issues can be found in Watts et al. (1981).
2. For more about this subject, see Pluralism in Malaysia - Myth and Reality, by J.A. Nagata (Ed.), 1975.
3. The majority of the Malays are farmers engaged in a largely subsistence agricultural economy based on rice - wet rice cultivated in irrigated or flooded fields and to a much lesser extent, dry rice grown in shifting patches on cleared hill slopes. On both sides of the peninsula, especially on the east coast, many made a living from fishing in the sea or estuaries (cf. Roff 1967).
4. For further detailed account of the events of 1969 itself, there is the official report published by the National Operations Council entitled The May 13th Tragedy (Kuala Lumpur 1969). It describes the background of the riots themselves, and then discusses the future direction of the nation. Goh Cheng Teik, The May 13th Incident and Democracy in Malaysia

(Kuala Lumpur, 1971) provides a political analysis of the reasons for the outbreak of violence; whereas Mahathir b. Mohamed, The Malay Dilemma (Singapore 1970) attempts to see a deeper cultural basis for the disharmony between the Chinese and Malays in the society.

5. Rukunegara (Articles of Faith of the State) was the new national ideology formulated after the May 13th Tragedy.

Its five principles are:

Belief in God

Loyalty to the King and Country

Upholding the Constitution

Rule of Law

Good Behaviour and Morality

## CHAPTER THREE

A SURVEY OF THE SCHOOL GUIDANCE AND COUNSELLING SERVICES  
IN TWO MALAYSIAN SECONDARY SCHOOLS

1. PURPOSE AND DESCRIPTION OF THE SURVEY

The main purpose of this survey is to try:

- a) to examine and evaluate the extent and quality of guidance services in two secondary schools in the state of Perlis, Malaysia.
- b) to check whether the national aims of guidance and counselling services have been achieved in these schools.
- c) to correlate the Principals', the Guidance Teachers' (School Counsellors), the Pupils' and Parents' perceptions of the said service.

Questionnaires designated Form A, Form B, Form C and Form D were distributed to 2 Principals, 2 Guidance Teachers, 200 pupils and 200 parents of the pupils of the two schools (called School 1 and School 2), respectively, during the first week of June 1984. Thus a fairly substantial range of evidence was gathered from their returns and will be analysed as follows.

2. METHOD OF COLLATION

The method of presenting this complex matter of data seeks to focus on topics and issues rather than groups of respondents. In this way, guidance issues can be illuminated by the several different perspectives of the various groups of respondents.

The data generated by this survey has two methodological limitations:

- a) It examines only two schools, so that statistical analysis of the data is not possible.
- b) It elicits the school personnel's perceptions of what is happening, and these perceptions need to be viewed as potentially selective or biased.

Given these reservations, we are still able to draw inferences based on this size of sample using a case study model. The possibility of respondent bias, still leaves us with important data on how those people involved in two guidance services view it. Illuminative and case study approaches to research are important hypothesis generators - hopefully a larger study with a statistically significant sample may later be constructed using hypothesis generated by this study.

A summary profile of the four groups of respondents is given below.

### 3. EVIDENCE COLLATION

Evidence gathered from the data will be examined and analysed under the following headings and sub-headings:

- 3.1 Particulars of the schools
- 3.2 Particulars of the Guidance Teachers
- 3.3 Particulars of the Pupils
- 3.4 Particulars of the Parents
- 3.5 Extent of Guidance Services
  - a) Qualification of the Guidance Teachers
  - b) Time Allocation

- c) Facilities
- d) Skills
- 3.6 Quality of Guidance Services
- 3.7 Relationship of the Principals and the Guidance Teachers with the Pupils and their Parents and vice-versa.
- 3.8 Types of Problems
- 3.9
  - a) Context of Problem Solving
  - b) Decisions on the Selection of Subjects the Pupils wish to pursue
- 3.10 Other Related Matters (Guidance and the School Curriculum)
- 3.11 Evaluation
- 3.1 Particulars of the Schools (Form A - Section A Questions 1-8)

#### School 1

School 1 was established in 1948 as the first English speaking secondary school in the state of Perlis. It is therefore regarded as an urban school (location according to the Ministry of Education classification).

It is a mixed or co-education school, comprising 1192 pupils (49.66% are boys and 50.34% are girls) from four major ethnic groups, namely the Malays (92.62%), the Chinese (5.2%), the Indians (1.93%) and other minority groups (0.25%) (Ref: Form A, Qn 6(a) and 6(b)). Due to the inadequate number of classrooms, the school has morning and afternoon sessions. The number of teachers in the school is 79 (i.e. 78.48% Malay teachers, 18.99% Chinese,

1.27% Indian and another 1.27% other race - Ref: Form A, Sect. A, Qn 7). The Principal of the school is a Malay and he has been in the school since July 1982.

### School 2

School 2 was established in 1965. It is situated about 2 miles from Kangar and according to the classification made by the Ministry of Education, it is regarded as a rural school (Note: all secondary schools in Perlis are situated within 10 miles radius from Kangar). As in School 1, School 2 is a mixed school with only 992 pupils (52.62% are boys and 47.38% are girls) from four major ethnic groups (94.67% Malays, 3.13% Chinese, 1.92% Indians and 0.3% other races - Ref: Form A, Qn. 6(a) and 6(b)). Teaching is being carried out during the morning only and the number of teachers in the school is 48 (89.58% are Malays and 10.42% are Chinese - Form A, Qn. 7). The Principal is a Malay man.

When one compares the two schools, one will notice that School 1, being the oldest and the biggest secondary school in Perlis, has undoubtedly better facilities (that are reflected in the composition of the school's guidance services) than in School 2 whose guidance services seem to be inferior to that of School 1, based on the number of pupils that sought the service (Forms B, Section C, Qn. 9 and 10). (N.B. Both schools are now regarded as national secondary schools with Malay Language (Bahasa Malaysia) as the medium of instruction - cf. Chapter 1.)

### 3.2 Particulars of Guidance Teacher (Form B, Qn. 1-6)

The term 'Guidance Teacher' is used by the Ministry of Education to describe the teachers who perform guidance and counselling work in primary as well as secondary schools. They must have professional training and specialisation of at least a year in guidance and counselling at Specialist Teachers Training College (M.P.I.K.) or through in-service courses during I-III term vacation (which was started in 1982). Most favourably is the guidance teacher who has a diploma or a degree in guidance and counselling at local as well as foreign universities (Ministry of Education, 1983).

Both School 1 and School 2 have a qualified guidance teacher. Guidance teacher of School 1 has been carrying out his duties as guidance teacher since 1982 with the help of 2 female assistants (teachers). The guidance teacher of School 2 has been a guidance teacher since 1974 i.e. about 10 years ago. In 1981, he attended the Diploma in Counselling course at the National University of Malaysia (UKM) i.e. at the same time as the guidance teacher of School 1. Therefore, both teachers have the same qualifications and hold a Diploma in Counselling in 1981 (Form B, Section B, Qn. 2, 3 and 4).

### 3.3 Particulars of the Pupils (Form C)

#### School 1

As mentioned earlier, 100 questionnaires (Form C) were randomly distributed to the Form 5 pupils of the School 1 by the guidance teacher but only 92 questionnaires were

completed and returned. Out of the 92 pupils who responded to the questionnaire, 82 of them were Malays, 7 Chinese and 3 Indians at the ratio of 89%:7.6%:3.3% which could be regarded as the mirror of the overall or approximate ratio of the pupils in the school. The same indication also applies to School 2 since both schools and the whole state for that matter, are situated in the 'Malay' area and vice versa if the schools were situated in the big towns and cities like Kuala Lumpur, Ipoh and Penang where the major population comprises of Chinese, followed by the Malays and the Indians (as discussed in the previous chapters).

The number of pupils involved in this survey reflects the over all ratios in the racial or ethnical composition of the pupils in the school. Most of them are 16 years of age (Form C, Section A, Qn. 3 and 4) and about 45.7% of them have been in the school for 5 years i.e. from Form 1-Form 5. The remaining number i.e. about 2.17-16.3% have been in the school between 1-4 years (Form C, Section A, Qn. 7). The difference in the number of years studied by the pupil is due to the different in-takes of the pupils from other feeding schools in the state. Only the 'cream' of the schools were chosen by the State Education Department to study in School 1. This could be further explained by examining the pupils' reasons for studying in the school (Form C, Section A, Qn. 9), which showed that 83.7% of the pupils were sent by the government to the School 1, 52.17% for the facilities available there and only 28.26% due to parental wish for their children to study in what is con-

sidered to be the best school in the state. Thus most of the pupils like studying in the school (93.5% - Form C, Section A, Qn. 8).

### School 2

As in the case of School 1, 100 questionnaires (Form C) were randomly distributed to 100 Form Five pupils of School 2. Unfortunately, only 58 questionnaires were returned, some of which were incomplete. Out of 58 pupils who responded to the questionnaires, 48 of them were Malays, 9 Chinese and one from a minority group at the ratio of 82.76%:15.52%:1.74%. Their age ranges from 16 years (56.9%) to 17 years (37.9%) and 18 years (5.2%) (Ref: Form C, Section A, Qn. 4 and 5).

About 53.5% of the pupils have been in the school for about a year or so (probably after getting their Lower Certificate of Examination (S.R.P.) results which enable them to join Form 4 in the School 2). That explains why 82.8% of them said that the government sent them to the school and another 31% said that they studied there because it was near to their home as well as because of the facilities available there (31%) (Form C, Section A, Qn. 6, 7 and 9). As such, only about 56.9% of these pupils said that they like studying in the school and about 36.2% felt uncertain about the issue.

The data mentioned above indicates that most of the pupils in School 1 have been chosen and sent by the government (through State Education Department) from various 'feeding' schools throughout the state of Perlis after they have completed their Standard Six. This in-take has been

further confirmed by the official from the Education Department who stresses that the pupils of School 1 rarely give the department and the school in particular any problems since they are the 'cream' of the state and are very much interested in their studies. On the other hand, the data from School 2 indicates that majority of the Form 5 pupils there only joined the school after the Lower Certificate Examination (S.R.P.). In addition, the racial differences of the pupils and the teachers in both schools is very much related to the ratio of the population of the state of Perlis.

#### 3.4 Particulars of Parents (Form D, Section A, Qn. 1-3)

100 questionnaires (Form D) had been distributed to 100 Form 5 pupils of both schools with the instruction that they were to pass on the questionnaires to their respective parents. In School 1, 92 parents responded to the questionnaires, comprising 88% fathers, 9.8% mothers and 3.3% guardians. In School 2, from 61 parents who answered the questionnaires, 83.6% are fathers, 11.5% are mothers and 4.9% are guardians. They are from all walks of life including farmers, labourers (including other lower income group workers), government officers, teachers, housewives, businessmen, fishermen and others. Most of them have between 2-6 children who are still in schooling age (Form D, Section A, Qn. 1-3).

The response from the parents, particularly in School 2 is not very encouraging and it is therefore difficult to comprehend their attitudes, values and feelings towards

guidance and counselling services in the school. This lack of response could be related to their attitudes towards guidance and counselling as well as towards education in general (as suggested by the two principals) or it could be that some of the questionnaires did not reach them at all.

Having looked at the particulars of the people involved in the survey, the next step will be to examine the extent of guidance services in these schools.

### 3.5 Extent of Guidance Services

In the Report of the Committee of Officials appointed by the Cabinet to examine the Recommendations of the Dropout Study (December 1973, p.36) states that "It is the responsibilities of the Ministry of Education to provide adequate training of personnel and also to provide support to the personnel in schools in terms of fund, time and physical amenities ...".

To what extent have these provisions influenced the effectiveness of the guidance services in School 1 and School 2?

The extent of guidance services in the two schools will be examined under the following sub-headings:

- a) Qualification of Guidance Teachers
- b) Time Allocation
- c) Facilities - (i) Physical Amenities  
(ii) Financial Aid
- d) Skills
- e) Services Provided.

a) Qualification of Guidance Teachers

According to the Principals of Schools 1 and 2, both the guidance teachers of their schools have been appointed by them after receiving instruction from the Ministry of Education (Form A, Section B, Qn. 3). The necessary qualifications of a guidance teacher are:

- (i) he or she must be a qualified teacher i.e. a university graduate of D category
- (ii) have obtained a Diploma in Counselling at the National University of Malaysia (U.K.M.) or other universities
- or (iii) have professional training and specialisation (practice) for at least a year or must at least have attended the counselling course at Specialist Teachers Training Institute/College (M.P.I.K.) or in-service course during the I, II, and III terms vacation starting from 1982
- or (iv) a degree in guidance and counselling from local universities -- U.K.M. and U.P.M. (Agriculture University of Malaya) or foreign universities (Form A, Section B, Qn. 4 and Form B, Section A, Qn. 4; cf. Guidance and Counselling Unit, March 1983).

Besides that factors like age, marital status, personalities and interest in guidance and counselling are also being considered before an academic teacher is elected as guidance teacher (cf. Form A, Section B, Qn. 4).

b) Time Allocation

When the guidance services (recently known as educational and vocational guidance) were introduced in schools in 1964 (Ref: Surat Pekeliling (circular) K.P.5209/35/(4)), it was recommended that each primary and secondary school should appoint a guidance teacher and by 1968, another circular was sent to the States Education Departments authorising the Principals to provide basic amenities to facilitate effective guidance and periodic evaluation of guidance in the school such as a good and suitable place for the guidance and vocational teacher to carry out his duties effectively (smoothly) (Ref: Surat Pekeliling (circular) K.P.5209/30/(13), September 1968 and Surat Pekeliling Iktisas or Academic Circular No. 5/1976). The circular also states that, "in trying to facilitate effective guidance, it has been proposed that these teachers should do about 25 periods of classroom teaching per week", (as against the usual 30 periods or so) and should be exempted from extra-curricular activities (Watts, 1978 and Guidance and Counselling Unit, 1983). Thus the guidance teacher is expected to carry out guidance work during some teaching periods set-aside for it or during his or her free periods (ibid., cf. Form A, Section B, Qn. 7).

However, the time-table allocation for each guidance teacher very much depends on the school Principal's discretion. If the school has excess or a sufficient supply of teachers, he might consider giving the guidance teacher less teaching periods as in the case of School 1, whereby the guidance teacher has been allocated 12 periods

of Form 3, 4, and 5 Civics (Tatarakyat) with many free periods for guidance sessions with his pupils (Form A, Section B, Qn. 7 and Form B, Section B, Qn. 7, 8, 13, 14 and 15). The guidance teacher, therefore, spends about 2 hours (approximately 3 periods) per day for guidance sessions and he normally spends about 1½-2 hours (less than 3 periods) for counselling the problemmed pupils (Form B, Section B, Qn. 9(a) and (b); also Qn. 10). Consequently, he is happy with his present timetable arrangement (Form B, Section B, Qn. 17). This is supported by the Principal who feels that the number of teaching periods for the guidance teacher should be between 12-18 periods per week because the 'extra free period' allocated for him are really meant for guidance work (Form A, Section B, Qn. 10).

The School 2, on the other hand, has allocated specific time-table for guidance and counselling work (which has been regarded as a subject - guidance and counselling) i.e. 4 periods or 160 minutes per week. The guidance teacher in School 2, thus spends more than 2 hours for guidance sessions i.e. about 7 or 8 periods per week and 1½-2 hours for counselling sessions per week i.e. about 4 or 5 periods per week (Form B, Section B, Qn. 7-10). In addition to that, the guidance teacher has 21 more periods for teaching 3 classes of Form 4 and Form 5 Malay Language and 2 classes of Form 2 History, thus giving him a total of 25 teaching periods per week (including 4 periods allocated for guidance and counselling) (Ref: Form A, Section B, Qn. 13, 14 and 15).

When one compares the time-table allocation for guidance teachers of both schools, one could see that the guidance teacher in School 1 has more time to spend on his guidance and counselling work than the guidance teacher in School 2 (ibid.). Besides the "free" periods that have been specially allocated for him to carry out his guidance work, he could use his normal teaching periods (Civics) for 'guiding' and counselling his pupils especially those in Form 5 whose Civics syllabus incidently also covers subject on career education. However, it is also important to note that although Civics is a compulsory subject, it is not examined and it therefore tends to be regarded as a 'light-weight' subject (Watts, UNESCO, 1978). As such, the guidance teacher of School 1 is able to 'guide' or 'counsel' more pupils i.e. 4-5 pupils per week (often on educational and vocational guidance and only sometimes on personal counselling) than the guidance teacher of School 2 who is only able to see only 2-3 pupils per week (for personal counselling, educational and vocational guidance) (Form B, Section C, Qn. 9 and 10). That explains why the guidance teacher of School 1 seems to be happy and satisfied with his present time-table but not so in the case of guidance teacher of School 2 (Form B, Section B, Qn. 15 and 16).

On the other hand, the guidance teacher in School 2 could only render his services to the needy pupils during the 4 periods allocated for guidance and counselling per week and wherever possible, during his own 'normal' free period. Moreover, the subjects he teaches are considered

as 'heavy' subjects especially the Malay Language which is a compulsory subject in the public examinations. Therefore, he is not very much in favour of his present timetable arrangement. According to him, 8 periods should be set aside for guidance and counselling sessions and 15 periods for normal teaching sessions for a guidance teacher (Form B, Section B, Qn. 17 and 18). The Principal of School 2, however, thought that the present arrangement is suitable for the guidance and counselling work in his school (Form A, Section B, Qn. 10).

There are indications that the impacts of the timetable allocation are not only felt by the guidance teachers but also by the pupils. This is reflected by the number of pupils who seek the service. For instance, more pupils sought guidance and counselling services in School 1 than in School 2 i.e. 27.2% in School 1 and 17.2% in School 2 (Form C, Section B, Qn. 2 and 3). Moreover, some of the pupils in both schools thought that more time should be given to the guidance teachers to enable them to carry out their functions effectively. With more time in hand, closer rapport could be established between the pupils and their guidance teachers which in turn would further facilitate guidance and counselling work (Form C, Section E, Qn. 9).

The difference in number of pupils who sought guidance and counselling services in the two schools might have some connection with the length of time the guidance teacher was able to spend with them. Since the guidance teacher in School 1 has less teaching periods than his counterpart

in School 2, more pupils could have access to the service.

From the answers given by the Principals, there appears to be a difference in opinions and attitudes towards the length of time that should be allocated for the guidance and counselling work. The fact that more time has been allocated for it in School 1 seems to indicate that the Principal there recognises the importance of time factor in facilitating the guidance services in the school and has done his best to accommodate them. Although the Principal of School 2 appears to have great expectations from the guidance services, the present conditions in his school such as low level of staffing, teachers with wrong options and the large school population have prevented him from providing 'generous facilities' as in School 1. He could only comply to the minimum guidelines or suggestions of the Ministry of Education with regards to the provision of the facilities for the school guidance and counselling services (cf. circulars 1967, 1968 and 1976).

However, another amendment had been made to the Administrative Circular No. 3/1967 in 1983 which suggested that "In order to obtain maximum objectives from guidance services, the teaching load for guidance teacher should be 12 periods per week. Other periods should be devoted to guidance work ... ". This "relaxation" is only given to comprehensive secondary schools, vocational and technical secondary schools only. It will be carried out in three phases i.e. from 1983, 1984 and 1985 (Guidance and Counselling Unit, March 1983). This indicates that the Ministry of Education too has realised the importance of sufficient

time in facilitating guidance work (Berita Bimbingan dan Kaunseling, 1983).

c) Facilities

(i) Physical Amenities

The Ministry of Education has instructed the Principals of every school in the country to provide a suitable place (room) for guidance services (Circular S.K.K.P. 5209/35/(4)). Therefore School 1 has provided what the guidance teacher called as 'a special and well-furnished' room for guidance work. It has been furnished with facilities like file cabinet, fan, table and chairs, file, tape-recorder and career literature which are openly displayed on the notice board as well as being kept for reference in the school library and the counselling room (Form B, Section C, Qn. 25). Although the same facilities are being provided in School 2, they are very modest in nature (Ref: Form A, Section B, Qn. 14 and 15; Form B, Section B, Qn. 25 and 26; and also Form C, Section B, Qn. 4 and 5).

Such statements indicate that School 1, being the oldest, the biggest and the most established secondary school in the state, has better facilities in many aspects compared to other schools in the state including School 2. Majority of the pupils who study there are being regarded by the general public as the 'cream' of the state and naturally special attention has been given to the school by the State Education Department which is situated beside it. Given the choice, most parents in the state, would like their children to study there. All this, indirectly

has some impact on the pupil's performance in the school and on its guidance services.

On the other hand, the pupils in School 2 are not as fortunate as those in School 1. In fact, a number of pupils in School 2 mentioned that they have to study under the hot and humid conditions, with no overhead fans to cool them. They also complain that much of their time has been wasted on walking towards their science laboratories which are situated far from their classrooms (Form C, Section D, Qn. 1 and 2). Even the Principal of School 2 has indirectly revealed the inadequate and unsatisfactory conditions that exist in his school. He is not particularly happy with some of the teachers' options which are not suitable to his pupils' needs and as such could affect their performance in the school.

(ii) Financial Aid

With regards to financial aid, both the Principal and the guidance teacher of School 1 admitted that a small amount of money (less than M \$1,000.00 or approximately £345) had been allocated yearly to cater for guidance expenditure (Form A, Section B, Qn. 17 and Form B, Section B, Qn. 28 and 29). In School 2, however, the Principal mentioned that his school also provided financial aid towards guidance services but this was refuted by the guidance teacher (ibid.). A possible explanation for this matter is that the school might (probably) have used the money to buy career literature and for other resources without telling (informing) the guidance teacher about them.

Based on the above information, one could say that both School 1 and School 2 have provided sufficient facilities to create suitable environment for guidance and counselling work, even though School 1 commits more resources than School 2. The consequences for the pupils/parents will be discussed later (cf. 6 below).

d) Skills

Both schools have at least one 'qualified' and specially elected guidance teacher (cf. 3.2 p.179 and 3.5 (a) - Qualifications of Guidance Teachers) who possess not only the required qualification (as stated by the Ministry of Education) but also a few years experience in guidance and counselling work.

Initially their roles were mainly concerned with educational and career guidance services as stated in S.K.K.P. 5209/35(4), 1964 called Administrative Circular on the Roles (Duties) of Guidance Teachers in Primary and Secondary Schools. The circular listed 11 duties of the guidance teachers in primary schools and 14 duties of guidance teachers in secondary schools. Later, the 1967 circular extended their duties into areas such as personal counselling and relations with parents and also on major programmes as well as on social and moral education (Iyer, 1975).

The survey indicates that both School 1 and School 2 practice educational and career guidance as well as personal counselling (Form B, Section C, Qn. 10, Form C, Section E, Qn. 3 and Form D, Section B, Qn. 2). Unfortun-

ately, not many teachers, pupils and parents really make full use of the available services, may be due to their own ignorance of the services, the lack of information on the functions of guidance and counselling to the pupils or their attitudes towards the services in general, which will be examined and discussed in the later part of this chapter (cf. 7 Relationship).

e) Services provided

It was mentioned earlier (ref. p. 180) that 92 pupils responded to the questionnaire in School 1 but it was found that only 27.17%-34.78% of them had really made use of the service. In School 2, the number of pupils who returned the questionnaire was 58. Out of that, only 17.24%-32.76% had sought the service of the guidance teacher. The number of meetings that they had with the guidance teachers varied from one pupil to another, depending on the nature and degree of their problems (Form C, Section E , Qn. 3).

The main reason for seeking the guidance and counselling services is to get more information on present careers and trainings. Other reasons (in order of importance) are to get his advice before making any final decisions regarding studies, to get advice on personal problems, after being referred to by the school due to misbehaviour and to discuss family problems (Form C, Section E Qn 3 ) as indicated in the Table 1 below.

Table: 1 Reasons for Seeking Guidance Teacher's Advice

Reasons for seeking advice	School 1 %	School 2 %
a) after being referred by school due to misbehaviour	18	1.7
b) to discuss family problems	2.18	-
c) to discuss drug problems	-	-
d) to get advice on personal problems	14.13	15.5
e) to get more information on present careers and training	27	29.3
f) to get advice before making any decisions regarding (future) studies	10.9	25.9

As these pupils are in Form Five and are approaching the end of school life, naturally they would wish to get advice on future careers, trainings and prospects of pursuing higher education which could well be provided by the guidance teacher.

The outcome or results of such meetings could be examined below:

Table: 2 Outcome of Meetings with Guidance Teacher

Outcome of Meetings	School 1 %	School 2 %
a) helped to overcome the existing problem	15.2	27.6
b) made the pupil see pros. and cons. of past behaviour	2.8	5.2
c) made the pupil realise his mistake	4.4	8.6
d) obtained information on future career	27.0	27.6
e) made pupil regain his self confidence	16.3	20.7
f) none that could think of	2.18	6.9

In spite of the shortcomings, there are strong indications that the guidance teachers have so far been able to perform the functions that are expected of them especially the guidance teacher of School 1 who said that he rarely sought outside help except on vocational guidance (Form B, Section E, Qn. 1 and 2). On the other hand, the guidance teacher of School 2 often sought outside help especially when dealing with drug-taking offenders which fortunately are not many and are not among the pupils mentioned in this study (Form B, Section E, Qn. 3 and 4). Both have the expertise and training to carry out their duties effectively (Section E, Qn. 2). It is however understandable why the guidance teacher of School 2 has to seek outside help because when dealing with drug addiction, he requires not only expertise but also time and dedication.

The above literature suggests that both schools have made great efforts in providing the necessary conditions for the smooth-running of the guidance and counselling programmes in the two schools. However, these provisions can still be regarded as being somewhat basic.

### 3.6 Quality of Guidance Services

There are 3 types of record cards used in most Malaysian schools namely Cumulative Card 001 (School record), Cumulative Card 002 (Confidential record) and Pupils' Progress Report Card. The use of these cards is regarded by the Ministry of Education and the schools as a systematic approach towards providing comprehensive

information and serves as a guide both to parents and teachers. They provide data that reveals the special needs of pupils as they progress towards adolescence (Guidance in Schools 1971).

Both School 1 and School 2 have the 3 types of record cards mentioned above (Form A, Section C, Qn. 1 and 2). According to the Principals, the particulars of the pupils are collected by their respective form teachers who later fill the record cards provided by the schools. The actual mechanics of filling these cards is based on "Instruction for the Use of Cumulative Record Cards No. 001 and 002" which was given by the Ministry. In fact, there is no specification on how many times these cards are to be filled in one year, depending on the circumstances (Form A, Section C, Qn. 3, 4, 5 and 6). However, the Principals of both schools maintain that these record cards are reviewed and revised annually. Each entry is dated and signed by the teacher who filled it. On completion, the records are being put in the cabinets which are securely locked all the time.

These records are permanent and are kept up to date by the school from the primary school level. They also provided the pupil's educational history with information about their school achievements, attendance, health, test scores and other pertinent data. These cumulative records form a continuous report of each pupil by different teachers and they give only the rational basis for real understanding of the growth of individual - physically, socially, intellectually and emotionally, which McGuinness (1982) described as "the key feature of

guidance" (p. 48). They also form the basis for reports to parents, to schools and colleges and to prospective employers. In addition, the information and data obtained can contribute towards planning more effective instruction and in selecting and organising educational procedures and facilities (cf. Guidance in Schools 1971 and McGuinness 1982).

In School 1, these cards are available for professional consultation for all members of the staff and for parents' consultation (if necessary). Whenever the necessity arises, they are also accessible to the pupils.<sup>1</sup> In School 2, the records are available for professional consultation for the members of the staff and outside agencies (e.g. in the case of drug addicts) and also for parents' consultation but not accessible to the pupils (Form A, Section C, Qn. 8 and 9).

Unlike Britain, the issues on what the records should contain, who should have access to them and to what extent the law should be specifically involved (cf. McGuinness 1981 and 1982) have seldom been given serious thought. However, on the issue of confidentiality, there are strong indications that most of the staff are fully aware of their responsibilities regarding the record cards i.e. based on the views given by the Principals and the guidance teachers of both schools. According to them, about 50% of the teachers are aware of the importance of confidentiality of the records which are regarded as an important source of information regarding their pupils for future references (Form A, Section C, Qn. 10 and Form B, Section C, Qn. 5, 6 and 7).

Their importance is both recognised by the two guidance teachers who sometimes make use of them for referral purposes while carrying out their duties (roles) as guidance teachers (School 1 - sometimes but School 2 - more often, ibid.). Besides that, the guidance teachers are recommended to use anecdotal records to appraise their pupils' behaviour (Guidance in Schools 1971).

3.7 Relationship of the Principal with His Staff, His Pupils, Their Parents and Society Around Him and vice versa

3.7.1 a) Relationship of the Principal with his Staff

Table: 3

Relationship of the Principal 1 with His Staff, His Pupils, Their Parents and Society Around Him.

With	Poor (1)	Fair (2)	Satis- factory (3)	Good (4)	Very Good (5)
a) Teacher			✓		
b) Guidance Teacher			✓		
c) Parents			✓		
d) Pupils			✓		
e) Society			✓		
f) Among Teachers			✓		

According to the Principal of School 1, his relationship with his staff (including teachers and guidance teacher) is very satisfactory (Form A, Section C, Qn. 24 - cf. Table 3 ).

The only problems he has with his teaching staff are that some of the teachers, for some reason or another, are not happy with the recognition (appreciation) given by the society and the government of the services and sacrifices rendered by them and that many teachers are discontented with the attitudes of the present day parents who they considered as generally self-centred (Form A, Section D, Qn. 1).

With regards to these problems, he mentions that he always requests and advises the teachers to give sincere contributions regardless of the sympathy from others i.e. government and the public. He also encourages them to improve their position e.g. through further studies and so on (Form A, Section D, Qn. 2). In short, he does not face many serious problems from the teachers that could mar his relationship with them. According to him, the relationship among the teachers in his school is satisfactory.

His relationship with the guidance teacher of his school appears to be a good one too. The Principal seems to be satisfied with the guidance work in the school and has often given the teacher not only moral support but also financial aid to enable him to carry out his duties effectively (Form A, Section B, Qn. 17 and Form A, Section E, Qn. 11).

School 2

Table: 4

Relationship of the Principal 2 with His Staff, His Pupils,  
Their Parents and Society Around Him.

With	Poor (1)	Fair (2)	Satis- factory (3)	Good (4)	Very Good (5)
a) Teachers				✓	
b) Guidance Teacher				✓	
c) Parents				✓	
d) Pupils			✓		
e) Society			✓		
f) Among Teachers			✓		

The Principal of School 2 describes his relationship with his staff as generally good and satisfactory. The same applies to the relationship between members of his staff (Form A, Section C, Qn. 24). However, he is not very happy with some of the teachers' options and the teaching techniques used by them which he thinks are not suitable to the needs of the pupils in the school. Consequently, this might instigate strained relationship between him and the teachers concerned. For instance, in the case of the guidance teacher's roles in the school, the Principal thinks that the guidance teacher is not active enough in carrying out his guidance duties (Form A, Section D, Qn. 1 and 2). As mentioned earlier (cf. 3.5 (b) - Time allocation), the Principal's expectations from the

guidance and counselling services are great but he does not give the guidance teacher enough time and other considerations as in School 1, to enable the guidance teacher to carry out his duties well. Anyway, according to the Principal, he tries to overcome these problems through informal discussions with the teachers concerned.

3.7.1 b) Relationship of the Principal with His Pupils  
School 1

Being a Principal of a big school, who is normally busy with administrative duties, his contact with the pupils in the school is very informal except with extreme or outstanding cases which require his special attention. Whatever the situation, his relationship with his pupils can generally be regarded as satisfactory since there is no indication of misunderstandings or hard-feelings between them.

From the pupils' point of view, it is difficult indeed to trace the existing relationship between the pupils and their Principals (including Principal in School 2). This is probably due to the hierarchical position of the Principals which hinders normal interaction between them. Generally, the pupils regard their relationship with their Principal as fair (Form C, Section C, Qn. 10).

School 2

The Principal of School 2 is very concerned about the discipline situations in his school, which in many ways brought him into frequent contacts with the pupils

of his school. Interestingly, Best, Jarvis and Ribbins (1977) describe an early stage of guidance in the U.K. in which the focus is disciplinary rather than person-centred and developmental. It may be that School 2 is still at this earlier stage in developing its guidance system, and that in time greater account will be taken of the preventive potential of developmentally focussed school guidance.

Even though the Principal says that his relationship with his pupils is satisfactory, there is strong indication that the situation might not be as it appeared to be (cf. 3.7.1 Table 4 , Relationship of the pupils, p. 200 ).

### 3.7.1 c) Relationship of the Principal with the Parents and Society

#### School 1

It is very difficult indeed, to verify the extent of the relationship between the Principal and the parents because according to him, only a small percentage (less than 50%) of the parents really come to see him or visit the school (cf. Evidence in linking Home and School 1980). Their number is far from satisfactory (Form A, Section C, Qn. 25 and 26; also refer to Table 9 ).

According to the Principal of School 1, this unsatisfactory parental attendance may be attributed to the attitudes of the present day parents who are not very concerned about their children's education and they expect the school to solve all the problems faced by their

children especially those pertaining to educational and vocational problems. In other words, they regard it as the duty of the school and the teachers to educate their children (From A, Section C, Qn. 27). Whatever the situation, the Principal of School 1 states that he does not face many problems from any of the people mentioned earlier, which he cannot handle. As such, he is happy with his work in the school.

### School 2

The Principal of School 2, like his counterpart in School 1, also complains that the percentage of the parents attending the school occasions is always less than 50%. To remedy this situation he tries to make regular appeals for parental participation through their children (Form A, Section C, Qn. 25 and 26). However, he does not elaborate why their attendance is so unsatisfactory.

### 3.7.2 Relationship of the Guidance Teachers with the Principals, Other Teachers (Colleagues), Pupils and Their Parents

#### 3.7.2 a) Relationship of the Guidance Teachers with the Principals and other Teachers

Table: 5 Relationship of Guidance Teacher in School 1

Relationship with:	Poor (1)	Fair (2)	Satis- factory (3)	Good (4)	Very Good (5)
a) Principal					✓
b) Other Teachers				✓	
c) Your Assistant				✓	
d) Pupils					✓
e) Society (Parents)				✓	
f) Others				✓	

Table: 6 Relationship of Guidance Teacher in School 2

Relationship with:	Poor (1)	Fair (2)	Satis- factory (3)	Good (4)	Very Good (5)
a) Principal				✓	
b) Other Teachers				✓	
c) Your Assistants				✓	
d) Pupils				✓	
e) Society (Parents)			✓		
f) Others					

School 1

The guidance teacher of School 1 confirms the Principal's statement by saying that he has good relationships with everybody especially with the Principal (Form B, Section C, Qn. 16). He often gets moral support as well as practical support, in terms of financial aid and other guidance facilities from the Principal. He also mentions that the Principal is also very understanding and always respects any decisions made by him in relation to guidance and counselling matters (Form B, Section E, Qn. 11 and 12).

Although he is said to have satisfactory relationships with his colleagues, the guidance teacher is not very satisfied with the co-operation and support he is getting from some of them, whom he says seems to have negative attitudes towards guidance services in general (Form B, Section D, Qn. 2e). He suggested that all teachers in the school should be told of the heavy responsibilities the guidance teacher has towards the school and particularly towards the pupils in the school, so that they do not complain or grudge when the guidance teacher gets a time-table under 15 periods per week. He further stressed that in order to avoid crisis and duplication of roles, there should be co-ordination between the guidance teacher and the discipline teacher (Form B, Section E, Qn. 9).

School 2

The guidance teacher of School 2 says that he has

a good and satisfactory relationship with those around him including the Principal and all his colleagues. In spite of that, unlike his counterpart in School 1, the guidance teacher here faces quite a number of problems while doing the guidance and counselling work. For instance, as the Principal is very concerned about the discipline problems in the school, the guidance teacher finds himself being entrusted to help solve the problems. There is indication that both he and the Principal have different views on how to solve them, especially when the Principal expects to get quick results out of guidance work despite offering less time for it than the Principal in School 1 (Form B, Section D, Qn. 2).

3.7.2      b) Relationship of the Guidance Teacher with  
The Pupils

School 1

According to the guidance teacher of School 1, the relationship between him and the pupils in the school is very good (Form B, Section C, Qn. 16). What he means is that he never has any trouble from them and whenever necessary they will approach him for guidance or counselling.

The data collected from the pupils, however, indicates (in a few isolated cases) that the pupils are very self-conscious of their inadequacies but are afraid to seek help from the guidance teacher for fear of being ridiculed or laughed at. Basic trust, in most cases, does not seem to exist between them. Moreover, the

common attitudes towards the teacher as the transmitter of knowledge will prevent the pupils from expressing their inner most fears and feelings to the teacher especially the guidance teacher who does not teach in the class.

### School 2

The guidance teacher of School 2 expresses his concern by saying that although his relationship with the pupils of his school is generally good, many still do not understand the actual aims of guidance and counselling and have not come forward to seek his assistance. He also feels that many parents too do not know about the functions of guidance and counselling in schools. The guidance teacher, however, appears to be happy in whatever work he is doing especially with the knowledge that he is able to help the needy pupils understand their problems before asking or guiding them to try and solve their problems themselves (Form B, Section E, Qn. 13 and 14).

### Comments on the Relationship between Guidance Teachers and Pupils

Even though both the Guidance Teachers said that their relationship with the pupils was good or satisfactory, the number of pupils who sought the guidance and counselling services was comparatively small. The reasons for seeking the service were mainly to get information on future careers and trainings (27% in School 1 and 29.3% in School 2), to

get advice before making any decisions regarding studies i.e. educational guidance (10.9% in School 1 and 25.9% in School 2) and to get advice on personal problems or counselling (14.1% in School 1 and 15.5% in School 2 - Ref: Form C, Section E, Qn. 3; also refer to Form B, Section D, Qn. 5(a) and Table 1, page 194 ).

According to the pupils that made use of the services, their meetings with the guidance teacher were very useful indeed. Those meetings did not only supply them with information on future careers and trainings but most importantly they help them regain their self-confidence as well as help them overcome their problems (Form C, Sections E, Qn. 4). Therefore, most of the pupils agreed that guidance and counselling services could be used as a means of helping them overcome their problems (Form C, Section E, Qn. 5).

### 3.7.2 c) Relationship of the Guidance Teachers and The Parents of the Pupils in Both Schools

The relationship between the guidance teachers of both schools and their pupils' parents (as in the case of the Principals' relationship with them refer to p.200 ) is very difficult to assess. This is due to infrequent contact between them, despite the call for parents' involvement in various school activities. On the whole both parties regard their relationship as quite good and satisfactory (cf. Tables 5, 6 and Table 8 ).

Table: 7

Relationship of the Pupils from Both Schools with their  
Guidance Teachers, Teachers, Peer Groups and Parents

Relationship with:		Poor 1	Fair 2	S'tory 3	Good 4	V.Good 5
a) Principal	Sch 1	15.2	28.0	16.0	13.0	2.0
	2	15.5	25.7	12.1	12.1	3.5
b) Teachers	Sch 1	3.3	29.3	31.5	27.2	7.6
	2	13.8	31.0	19.0	28.0	8.6
c) G. Teacher	Sch 1	2.0	19.0	28.0	37.0	14.0
	2	7.0	24.0	17.2	34.5	12.1
d) Peer Groups	Sch 1	1.0	5.4	25.0	37.0	31.5
	2	3.5	10.3	22.4	38.0	25.7
e) Parents	Sch 1	-	4.4	8.7	21.7	65.2
	2	-	5.2	7.0	15.5	74.1
f) Others	Sch 1	1.0	15.2	19.0	8.7	8.7
	2	1.7	13.8	7.0	20.7	24.0

3.7.3 Relationship of the Pupils of Both Schools with their Principal, their Guidance Teachers, other teachers and their own Parents

The data from Table 7 suggests that the relationship between the pupils in both schools and their teachers, including guidance teachers ranged between fair and good. Only a few of them (less than 10%) mentioned that they have not been able to get along with certain subject teachers. Such unfortunate incidences could result in unnecessary drawback in their studies.

Under such conditions, the pupils would have to turn to other people for help or assistance (Form C, Section E, Qn. 1). Their relationship with their guidance teacher and peer group is said to be quite good. Most of the pupils (i.e. between 65-75% of them) claim to have very good relationship with their parents, except for a few isolated cases who says that their parents are not very understanding of the problems faced by them as adolescents (cf. Chapter 1, p. 111).

3.7.4 Relationship of the Parents with the Principals, the Teachers and their Own Sons or Daughters.

The relationship between the parents of the Form Five pupils of both schools and their Principals could be regarded as fair (41.3% in School 1 and 24.6% in School 2) and another 24.6% considers it as good (in School 2). The same grading applies to their relationship with the teachers

Table: 8

Relationship of the Parents with the Principals, the Teachers,  
Their own Son or Daughter and Society

		Poor 1	Fair 2	S'tory 3	Good 4	V.Good 5
a) Principal	Sch 1	21.7	41.3	17.4	14.0	5.4
	2	23.0	24.6	19.7	24.6	3.3
b) Teachers (Including guid- ance Teachers)	Sch 1	13.0	39.0	26.1	19.0	1.0
	2	14.8	32.8	16.4	24.6	4.9
c) Son/Daughter	Sch 1	-	1.0	12.0	16.0	57.6
	2	-	3.3	11.5	24.6	57.4
d) His/Her Friends	Sch 1	-	21.7	30.4	41.3	6.5
	2	1.6	24.6	16.4	41.0	13.1
e) Society around you.	Sch 1	-	1.0	25.0	57.6	16.0
	2	1.6	6.6	24.6	41.0	24.6

which is fair (39% in School 1 and 32.8% in School 2). Most of the parents claim to have very good relationship with their Form Five sons or daughters (57.6% in School 1 and 57.4% in School 2). They consider their relationship with their sons' or daughters' friends and society around them as good i.e. between 41-57.6% in both schools (cf. Form D, Section C, Qn. 10 and Table 8 ).

Table: 9                      Parental Visits to School

Number of visits to school	% School 1	% School 2
1) more than 3 times per year	4.4	3.3
2) 3 times per year	1.0	3.3
3) twice a year	3.3	1.6
4) once a year	5.4	6.6
5) only whenever necessary	51.1	63.9
6) never	37.0	21.3

After examining the Table 9 on the frequency of the visits made by parents to their children's schools, i.e. only whenever necessary (51.1% in School 1, and 63.9% in School 2), never visit (37% in School 1 and 21.3% in School 2 - cf. Form D, Section B, Qn. 3), one finds it difficult to determine the actual nature of their relationship with the school (cf. 3.6 (a) and (b)). Most of those visits were made after being requested by the schools (68.5% in School 1, 73.8% in School 2) or when necessity arise (58.7% in School 1 and 65.6% in School 2) or to attend Parents' Day (54.4% in School 1 and 41% in

in School 2) or P.T.A. meetings (22.8% in School 1 and 49.9% in School 2 - Ref: Form D, Section C, Qn. 5; see Table 10 below).

Table: 10

Occasions for Parental Visits to Schools

Occasions	School 1 %	School 2 %
(i) P.T.A. Meetings	22.8	45.9
(ii) Exhibition Day	15.2	14.8
(iii) Parents Day or Speech Day	55.4	41.0
(iv) Sports Day	13.0	9.8
(v) On Request by the School	68.5	73.8
(vi) When necessity arise	58.7	65.6

It was mentioned earlier (cf. 3.7 (c), p. 202 ) that parental attendance on all occasions was very unsatisfactory in both schools i.e. less than 50% (Form A, Section C, Qn. 25, 26 and 27). This was further confirmed by the guidance teachers of these schools who said that parents rarely pay any visit to the school (Form B, Section C, Qn. 17 and 18). Moreover, the guidance teacher of School 1 feels that the pupils whose parents rarely or never visit the school are capable of taking care of themselves. His view is shared by his counterpart in School 2 who implies that pupils whose parents do not come to school have either less problems in the school or daily life or would not like to seek help from the guidance teacher and thus are capable of taking

care of themselves (Form B, Section C, Qn. 19).

Even though most parents seem to have very good relationship with their children, they seldom help their children do their school work i.e. whenever necessary only. In fact, about 24-36% of the parents said that they never help their children in their school work (Form D, Section C, Qn. 9 and Form C, Section C, Qn. 9) may be because they are either too busy or in many cases lack the knowledge to do so (not all are highly educated) (cf. Particulars of Parents, Form D, Section A, Qn. 1-3).

### 3.8 Types of Problems as faced by the Principals, the guidance teachers, the pupils and their parents

#### 3.8.1 Problems faced by the Principals

School 1: According to the Principal of School 1, he does not encounter many problems since he took up his present post as the Principal of the school. One of them is concerning the teachers' discontentment towards the society and the government. Some teachers are not happy with the recognition given by the society and the government of the services and sacrifices rendered by them. In addition to that, the teachers are indignant of the attitudes of the present day parents whom they regard as generally self-centred.

The other problem is concerning discipline. However, the disciplinary problems among his pupils are not very serious, mostly domestic in nature such as parents divorced, parents spoiling their children with unnecessary attention and negative parents attitudes towards their

children's education - i.e. leaving everything to their teachers. The Principal's view has been supported by the guidance teacher who says that the problems faced by the school are very few indeed, such as truancy (15%), discipline offenders (25%) and others (15%) (Form B, Section D, Qn. 2).

School 2: The main problem faced by the Principal of School 2 is concerning discipline such as truancy, smoking, destruction of school properties, misuse of toilets, thefts and so on. This is confirmed by the guidance teacher of the school who states that among the problems faced by the pupils are personal problems (70%), drug taking (50%) and other problems of educational and social in nature. Besides that, the Principal indicates that he is faced with the problem of getting the 'right' teachers for the 'right' subjects. At present, some of the teachers' options and their teaching techniques are considered by the Principal as very unsuitable to his pupils. The Principal is also very concerned about the lack of interest shown by parents regarding the school's activities. This is portrayed by their low attendance on all important school occasions which is always less than 50%.

### 3.8.2 Problems Faced by the Guidance Teachers

School 1: The guidance teacher of School 1 indicates that he does not face many obstacles while carrying out his duties as the guidance teacher. In spite of the much publicity and information on guidance and counselling in the school, some of the teachers still have negative

attitudes towards the functions and capabilities of the guidance teacher. As such, he is occasionally confronted with the lack of co-operation from these teachers, especially those with heavy timetables (cf. pp. 185-190) on time allocation). There is no indication from the data that the guidance teacher ever face any serious problems in dealing with his pupils (clients). This explains why he is said to be happy and contented with his work.

School 2: The guidance teacher of School 2 also complains about the lack of co-operation from some of his colleagues in the school, who do not fully understand the functions and the importance of guidance and counselling to the pupils. Other problems faced by the guidance teacher are lack of sufficient time for guidance work, heavy timetable and negative student attitudes towards guidance and counselling services in the school. Although the guidance teacher does not mention it, there is strong indication (Form A, Section E, 11 and 14) that he sometimes faces conflicts of roles as disciplinarian and guidance teacher (cf. p. 206). As the Principal is very concerned about the discipline problems in the school, the guidance teacher is expected to assist him in eradicating these problems.

### 3.8.3 Problems Faced by the Pupils (Both Schools)

For the purpose of this study, the problems faced by the pupils in both schools will be examined under two sub-headings:

- a) Problems in Daily Life.

Table: 11

Problems Faced by Pupils in Their Daily Life

Type of Problems (%)	1 Most of the Time %		2 Often %		3 Sometimes %		4 Seldom %		5 Never %	
	Sch 1	Sch 2	Sch 1	Sch 2	Sch 1	Sch 2	Sch 1	Sch 2	Sch 1	Sch 2
a) Studies	-	-	37.0	34.5	54.0	55.0	-	-	-	-
b) Family	-	-	4.4	3.5	33.0	53.5	45.0	28.0	17.4	13.8
c) Health	-	-	5.4	8.6	50.0	50.0	37.0	38.0	4.4	5.2
d) Peer Group	2.0	1.7	4.4	3.5	47.0	34.5	39.0	44.8	5.4	12.1
e) Financial	2.0	-	16.0	17.2	56.0	43.0	19.0	28.0	3.3	8.6
f) Drug Abuse	-	-	-	-	-	-	-	3.5	94.0	89.7
g) Other Problems	1.0	-	4.4	5.2	8.7	7.0	-	3.5	7.6	12.1

## b) Problems in School.

a) Problems in Daily Life

The problems faced by pupils of both schools in their daily life can be categorised into studies, family, health, peer groups, financial matters or situations and other problems such as personal problems, religious problems and environmental problems (See Table 11 - reference Form C, Section D, Qn. 1).

The data in Table 11 indicates that most of the pupils appear not to face many serious problems in their daily life - only sometimes. Among the problems (in order of importance) are studies, financial, health, peer groups and family but none of the pupils who answered the questionnaire ever get involved in the drug abuse problems (ibid. - cf. p. 217 ). Problems in relation to studies tops the list. Such finding is not unexpected as the main concerns of these adolescents are passing examination and obtaining an education which will enable them to secure jobs.

b) Problems in School

As this study is more concerned about the situations in the school, it is considered most appropriate to look into the nature of the problems faced by the pupils in both schools i.e. regarding their studies (See Table 12 - Form C, Section D., Qn. 2).

The problems faced by the pupils vary from one pupil to another, but from the data collected one could

Table: 12

Problems Faced by Pupils in School

Nature of Problem in School Studies %	1 Most of the Time %		2 Often %		3 Sometimes %		4 Seldom %		5 Never %	
	Sch 1	Sch 2	Sch 1	Sch 2	Sch 1	Sch 2	Sch 1	Sch 2	Sch 1	Sch 2
a) Difficulty in understanding	3.3	3.5	31.5	41.4	59.8	51.7	2.0	1.7	1.0	-
b) Lack of interest	2.0	-	13.0	8.6	42.0	19.0	19.0	29.0	16.0	34.5
c) Unable to get along with teachers	1.0	-	-	-	28.0	15.5	28.0	28.0	34.8	51.7
d) Language problems	1.0	5.2	14.0	20.7	35.9	43.0	22.8	10.3	12.0	12.2
e) Too much school work	2.0	8.6	19.6	17.2	52.2	42.3	12.0	12.1	4.4	7.0
f) Other problems	-	-	1.0	5.2	6.5	17.2	4.4	8.6	15.2	13.8

say that the main ones are difficulty in understanding certain subjects, especially science subjects like Physics and Biology and other subjects such as Mathematics and Geography (about 30-60%). A few of them, though, indicate that for one reason or another, they could not get along with one or two teachers in the school.

In addition, about 40-60% of the pupils from both schools experience language problems, especially English Language and Malay Language (for non-Malays) and more than 50% of the pupils complain that they normally have too much school work both at home and in school. Other problems are strict discipline, teachers who do not understand their pupils' problems, favouritism between teachers and pupils and many others.

Their claims are supported by their parents (Form D, Section D, Qn. 1 and 2). According to the parents, about 75% of their children (in both schools) complain about their difficulties in understanding certain subjects, about 30-40% complain about language problems and about 30-43% of them complain about lack of interest in certain subjects they have to study (compulsory or core subjects).

The findings of the survey suggest that the major problem faced by these Form Five pupils from both schools are educational problems or problems related to school work. It was found that many of them found difficulty in understanding certain subjects, while others said that they often have too much school work to do in certain subjects. This could be attributed to overcrowded syllabus and curriculum. Some of them also indicated that they had not

been able to do well in their studies due to their lack of interest in certain subjects. They also complained about not spending enough time in their studies, worrying about examinations and marks and not knowing how to study effectively. Some of these problems may not only reflect the difficulties these adolescents are having with their studies but could also indicate their psychological problems (which most of them refused to mention or talk about). Whatever the reasons, they indicate the need for guidance and counselling in schools.

#### 3.8.4 Problems Faced by the Parents (Both Schools)

Very little is known about the problems faced by the parents of the pupils from both schools since the questionnaire distributed to them only touches on matters pertaining to their children and the guidance and counselling services in their children's schools. However, the data collected manages to reveal that most of the parents have very limited knowledge on guidance and counselling services in their children's schools. Therefore, it is difficult for them to give definite opinions on the subject which they know very little. In addition to that, majority of them are from the lower income group who are either not well-educated, too busy with their work or too over-dependent on the school to provide proper education for their children.

#### 3.9 Context of Problem Solving

In the previous section, attempts have been made to

identify the problems faced by the two Principals, the guidance teachers, the pupils and their parents. This section will try to examine the various approaches used by them to solve their individual problems.

### 3.9.1 The Principals

The Principal of School 1 tries to appease his staff's discontentment by requesting them to give sincere contribution towards educating their pupils regardless of the sympathy from others. He also encourages the teachers to improve their position, for instance, through further studies.

The Principal of School 2 tries to solve his problem of getting teachers with the 'right' option by requesting help and co-operation from the State Education Department. Informal discussions are also being held with the teachers whose teaching techniques he does not approve of.

With regard to disciplinary problems, the Principals of both schools indicate that they sometimes dealt with the problems themselves, especially the most serious ones. At other times, they delegate the task to either the senior assistants, discipline teachers (often) and guidance teachers (particularly in School 2). However, corporal punishment is rarely being carried out in front of the respective classroom (Form A, Section E, Qn. 1, 2 and 3).

Besides that, the Principals of both schools try to encourage parents' participation through their children. For instance, children are requested to persuade their parents to attend all school functions such as Open Day

for Parents (Parents' Day), the Exhibition Day, the Sports Day and the Parent-Teachers Association Meetings whereby parents could meet the teachers and discuss about their children's progress.

### 3.9.2 The Guidance Teachers

Both the guidance teachers try to gain support and co-operation from their colleagues by enlightening them with the knowledge on guidance and counselling through informal conversation, discussions or formal talks (to the pupils as well). Their effort is further facilitated by the availability of circulars, brochures or pamphlets and publications by the Ministry of Education and other interested parties.

The guidance teacher of School 2 is still trying to get less teaching periods (as his counter-part in School 1) to enable him to devote more time to the guidance and counselling work.

### 3.9.3 The Pupils

a) Personal Problems - With regard to personal problems, there is strong indication that whenever the pupils (from both schools) face any problems, the first person they turn to for help are their parents and sometimes close friends and close members of their family (Form C, Section E, Qn. 1 - See Table 13 ).

The data reveals that not many pupils would seek their teacher's help, including the guidance teachers, except on matters pertaining to their studies and future

Table: 13 Pupils' Sources of Help in Solving their Problems

Seek Help from (%)	Most of the time		Often		Sometimes		Seldom		Never	
	Sch 1	Sch 2	Sch 1	Sch 2	Sch 1	Sch 2	Sch 1	Sch 2	Sch 1	Sch 2
a) Parents	9.8	41.4	34.8	29.0	26.1	19.0	13.0	7.0	5.4	1.7
b) Close relatives (members of family)	2.0	5.2	19.0	22.4	38.0	43.0	23.9	15.5	13.0	13.8
c) Friends	9.8	-	21.7	24.0	38.0	51.7	21.7	15.5	3.3	8.6
d) Form teacher	1.0	1.7	3.3	5.2	15.2	29.0	27.2	36.2	45.0	28.0
e) Subject teacher	1.0	3.5	3.3	10.3	28.0	41.4	21.7	17.2	37.0	25.7
f) Guidance teacher	1.0	3.5	5.4	1.7	26.1	22.4	30.4	29.0	30.4	38.0
g) Elders	1.0	-	4.4	10.3	33.0	32.8	29.3	20.7	26.1	32.8
h) Welfare Officer	-	-	-	-	1.0	1.7	1.0	10.3	89.0	86.2
i) Local Policeman	-	-	-	-	1.0	3.5	7.6	12.1	81.5	81.0
j) Others	3.3	-	2.0	3.5	2.0	1.7	3.3	5.2	26.1	39.7

careers (cf. p. 194). This is further supported by their parents who claim that their children would normally tell them their problems (Form D, Section E, Qn. 1), which suggests the closeness of their relationship with their children. According to the information supplied by the parents, (Questionnaire for the parents were mostly filed by fathers), whenever the children face any difficulties, they would seek assistance (in order of importance) from their mothers (72.2% in School 1 and 65.6% in School 2) their sisters (52.2% in School 1 and 47.5% in School 2), their friends (62% in School 1 and 54.1% in School 2) and close members of the family (41.3% in School 1 and 50.8% in School 2) (see Table 14 ). However, a small percentage of the pupils (less than 10%) confessed that they were unable to discuss certain problems at home or that they felt nobody understood them. This inability to communicate may be due to the generation gap between them (as adolescents) and their parents or the distance which Asian families sometimes deliberately keep between them and their children. All this intensified the need for guidance and counselling in schools.

### 3.10 Decisions on the Selection of Subjects the Pupils

#### Wish to Pursue

For the purpose of instruction, all schools in Malaysia are organised along vertical and horizontal lines (cf. Moore 1970). That is to say, pupils are graded vertically according to their chronological age and they progress upwards by one grade each year (Wong and Ee 1975). In each year,

Table: 14

Parents' Views on Pupils' Sources of Help

Seek Help From (%)	School 1	School 2
a) His/Her Mother	77.2%	65.6%
b) His/Her Father	21.2	27.9
c) His/Her Sister	52.2	47.5
d) His/Her Brother	37.0	37.7
e) Friends	62.0	54.1
f) Teachers	12.0	23.0
g) Close members of the family	41.3	50.8
h) Others	3.3	4.9

pupils are expected to gain a certain amount of knowledge, a certain area of study or a specific number of units where a subject is programmed according to progressive levels of difficulty. To alleviate the problem of individual differences among the pupils in any one grade, a horizontal organisation is also resorted to in our schools, where pupils are 'streamed' according to their general ability until they reach the lower secondary schools where streaming is partly based on general ability and partly on the aptitudes of pupils on specific subjects (Wong and Ee 1975).

### 3.10.1 Time and Method of Selecting the Subjects

In the case of both School 1 and School 2, the selection of subjects for each stream takes place when the pupils are in Form 1, Form 3, Form 4 and Form 6 (Form A, Section C, Qn. 17). According to the two Principals, sometimes the pupils are allowed to make their own decisions regarding the 'elective' subjects they wish to pursue (Form A, Section C, Qn. 18), but generally they have to abide to the rulings or regulations made by the Ministry of Education regarding the compulsory or 'core' subjects they have to take. At the end of third year of their secondary education, the pupils have to sit for an examination called Lower Certificate of Education Examination (L.C.E./S.R.P.), after which they will be streamed to science, arts, technical or commercial (vocational) streams. The streaming is mainly done by the Ministry of Education with the help of the State Education Department. Therefore, according to Watts (UNESCO 1978) these decisions tend to be based heavily on

examination results rather than on the personal predilections of the pupils themselves, the latter are taken into account only if the pupils actively protest. Later, further public examinations, called Malaysia Certificate of Examination (M.C.E.) or Sijil Pelajaran Malaysia (S.P.M.) are held at the end of the fifth year, to determine who will go on to the Sixth-Form schools, to colleges of further education or to teachers training colleges and finally there are examinations at the end of the two-year Sixth-Form course, called Higher School Certificate Examination (H.S.C.) or Peperiksaan Sijil Tinggi Persekolahan (S.T.P.), to determine who will go to the universities.

### 3.10.2 Decision on Selection of Subjects

According to the Principal of School 1, his school sometimes does not only allow the pupils to make decisions but also consults the guidance teacher regarding the selection of subjects for its pupils. Sometimes the pupils themselves (less than 10%) sought his advice on the matter (Form A, Section C, Qn. 17, 18 and 19). The guidance teacher of School 1 confirmed the claim by saying that the pupils often sought his help (about 75%) before making any final decisions on the selection of subjects they wish to study (Form B, Section C, Qn. 11, 12 and 13).

The survey on School 2 indicates that the Principal there "sometimes" (between 2-3 on rating scale) allows his pupils to make their own decisions regarding the selection of subjects that they wish to pursue. He rarely consults the guidance teacher on the matter (Form A, Section C,

Qn. 17, 18 and 19). However, the pupils 'sometimes' approached him for advice on the issue (less than 10%). The guidance teacher of School 2 reveals that the head never consults him on the selection of subjects for the pupils and only about 10-25% of them really sought his advice before any final decisions were made (Form B, Section C, Qn. 11, 12 and 13).

About 81.5% of the pupils in School 1 said that most of the time they were allowed to make their own decisions on the subjects they wished to study, whereas in School 2, only about 17.2% said that they were ever allowed to have any say on the matter and about 17.2% said that they were never given the opportunity to do so. However, both schools allow them to make their own decisions on matters like choosing the class monitor, deciding or choosing the school societies or clubs they wish to join, taking up games or sports they like and selecting the committee members of clubs or societies except on choosing the school prefects which are made by the teachers and the school heads (Form C, Section C, Qn. 3, 4, 5 and 6).

### 3.10.3 Request for Parents' Opinion

It has been found that 80.4% and 67.2% of parents from School 1 and School 2 respectively said that they had never been consulted by the schools regarding the selection of subjects for their children (Form D, Section C, Qn. 3 and 4). The reasons for such incidences could be interpreted in many ways:-

- (i) Firstly, one could ask, how could the school

consult the parents when they themselves seldom visited the school to enquire about their children's progress or to attend the schools' functions? (cf. 3.7 - Relationship and Form D, Section B, Qn. 3 and Section C, Qn. 5).

(ii) Secondly, as stated earlier, though the pupils are sometimes allowed to make their own decisions on the selections of subjects they wish to study, they have to abide to the rules and regulations made by the Ministry of Education who has the final say on the matter. The survey in School 2 revealed that about 41.38% of the pupils said that the selection was done by the State Education Department (under the supervision of the Ministry of Education) and another 29% said that the decisions were made by the Principal himself (Form C, Section C, Qn. 3 and 4). As such, about 36.2% said that they were never allowed to make any decision on the matter, while another 22.4% said not sure (ibid.).

(iii) Thirdly, the head and the teachers' attitudes towards the parents. For instance the Principal of School 1 suggested that the poor attendance of parents at various school occasions was due to the attitudes of the present day parents who were not very concerned about their children's education ... (cf. 3.7 - Relationship - Form A, Section C, Qn. 25, 26 and 27). This view is also shared by many teachers, headmasters and education authorities who are concerned with the increasing lack of interest shown by parents in their children's progress and activities in the school. Of course, not all parents fail to show interest in their children's school activities. There are many who

sacrifice time and give a lot of services to the school. This level of interest shown by parents as figured by Douglas in The Home and The School 1964 and later mentioned by Sharrock (1980) was assessed partly on the teachers judgement and partly on the number of times each parent visited the school to discuss their children's progress with the head or class teacher and they might not be entirely correct. Maybe the link between home and school merits further detailed analysis and planning by the organisers of guidance services in Malaysian secondary schools. The research cited above suggests that such links would be a potent or powerful addition to guidance provision.<sup>2</sup>

#### 3.11.4 Other Related Matters (Guidance and the School Curriculum)

##### a) Impact of School Curriculum on Career Destination

The Malaysian school curriculum has very strong impact on career destinations, as suggested by A.G. Watts (1978) that it is mediated through the length of time the pupil (student) stays within the school system and through formal public examination. For instance, a survey published in the Murad Committee (1975) indicated that only 64% of the heads of households in Peninsular Malaysia with no formal education were in employment whereas 93% of those who had stayed until Form IV or higher had jobs. In addition, 83% of those without formal education were in slightly skilled and unskilled jobs whereas only 1% of those with Form IV or higher qualification were in such jobs (Murad Committee 1975, tables 3-4; Watts, 1978).

b) Selection of Subjects

Thus the pupils are expected to complete the six-years primary education and later proceed to secondary Form One (From 1965 onwards, the Malayan Secondary School Entrance Examination or M.S.S.E.E. was abolished and the primary pupils were automatically promoted to Form One - cf. Iyer 1975, Wong and Ee 1975). In the secondary schools, pupils receive a three year comprehensive and pre-vocational education to help them find their own aptitudes and interests and the type of education - academic or otherwise - to suit their particular needs (ibid.). Under this system, all pupils will study two broad groups of subjects namely the 'core' subjects, all of which are compulsory and the 'elective' subjects from which the pupils choose one or two. Besides that, the educational guidance and counselling was also introduced in Schools (cf. Chapter 1), together with cumulative record cards which showed the pupils scholastic progress as well as his physical, social and intellectual development from the time he enters a primary school to the time he has to choose or be guided into choosing the subjects which will determine his future careers in later years (Wong and Ee 1975).

c) Public Examination

Starting from the third year of the secondary school, the school curriculum's influence is seen mediated through formal public examinations. Much emphasis has been placed on these examinations which are regarded as a significant factor in determining life-chances of the pupils. The survey

on the two schools confirmed it for examinations were regarded or were seen by the heads as very important criterias in the pupils' life (Form A, Section C, Qn. 13).

### 3.12 Evaluation

After going through the evidence collation obtained from the return of the questionnaires distributed in the School 1 and School 2, it is now appropriate to proceed to the next purpose of the survey namely to check the extent to which the aims of guidance and counselling services have been achieved in these schools. In other words, how effective has the guidance and counselling services been to the pupils and the school in general.

Although evaluation of guidance services is frequently recommended in the literature (Shertzer and Stone 1976, Shaw 1973, HMI Aspects of Secondary Education 1980) there is very little of a procedural nature written. McGuinness (1982) suggests 10 key evaluative indicators, which will be used in this section to draw recommendations for Malaysian secondary schools for the data.

The key issues are:

1. Is the curriculum designed, constructed, implemented and monitored to ensure that all the full range of potential for all pupils is being met?

a) It was mentioned earlier (Chapter 2 p. 160 ) that education in Malaysia is aimed at fulfilling not only the needs of an individual pupil but also the needs of the Malaysian society. As such, the curriculum has been designed, constructed, implemented and monitored to

ensure that the above aims are being achieved. Therefore, the guidance services was introduced to the schools in 1964 (circular 1964). Initially, the main concern was on educational and vocational guidance but it was later extended into areas such as personal counselling and relations with parents (circular 1967). Since then, major responsibilities for drug education and social and moral education have also been added (Iyer 1975 and Watts 1978). The survey of both schools indicates that such services (commonly known in Britain as pastoral care) is being carried out by the guidance teachers who have been appointed by their respective principals. These guidance teachers are actually the academic teachers who are required to teach certain subjects and carry out their guidance work during their free time (School 1) or at certain time allocated to them, with the co-operation and assistance from the Principals and other teachers (Form B, Section C, Qn. 10, Form C, Section E, Qn. 3 and Form D, Section B, Qn. 2).

b) The school's examination policy - Examinations play important role in the Malaysian school system and as such, much efforts have been made by both schools to ensure that their pupils perform well in their examinations (cf. Wall 1976, Menon 1975, Form A, Section C, Qn. 15, 16). Extra classes as well as remedial classes are being organised for those who would be sitting for any important public examination - S.R.P., S.P.M. or S.T.P.

c) Hidden curriculum. Pupils who perform well are rewarded by the schools while the less able are given remedial classes.

d) Teaching methods - have never been discussed and seen as private. However the Principal of School 2 mentions that he is not very happy about some of the teachers' methods of teaching the pupils, may be attributed to the fact that some teachers are asked to teach the subjects they do not specialise in.

e) Educational guidance. Option choices are being made by the pupils based on their interest and their performances in their previous tests or examinations. Both guidance teachers said that sometimes the pupils would seek their advice on the matter personally or through their form teachers. However the option choices are very limited and have to follow the guidelines given by the Ministry of Education (cf. Wong and Ee 1975).

f) School grouping policy or streaming. The guidance teachers are expected to give 'guidance' to those pupils who face difficulties in deciding the stream they would like to be in.

2. Is every pupil in the school known? Are they individualized on the basis of sound, up to date, factual information?

a) Data on the pupils of both schools is collected by their form teachers. The pupils are required to fill in their personal particulars on a special form

provided by the school. The forms are then assembled, checked and the information on them would be transferred to the class register and two other record cards (Cummulative Cards 001 and 003). The cards are stored in a strong-locked cabinet placed either in the staffroom or in the school's office.

They provide data that reveals the special needs of pupils as they progress towards adolescence which serve as guides to parents and teachers especially the guidance teachers who sometimes use them as a source of reference while carrying out their duties as guidance teachers (Form B, Section C, Qn. 4, 5, 6 and 7). However, there is a tendency to overlook children who are quiet and are less likely to create trouble.

b) The informal data collection is undertaken by the form teachers, based on their knowledge and observation of the pupils inside and outside the classroom. However, there is no indication about the formal data collection other than the one mentioned above in both schools.

c) There is no indication about the existence of case conference in both school, perhaps only informal staffroom charts. Outside agencies are sometimes being referred to by the schools, especially in relation to drug abuse cases in School 2.

d) Parents and outside agencies are rarely asked to help in assembling an appropriate data base for educational decision making because all information are obtained from the pupils.

e) As mentioned earlier, form teachers have been given a specific responsibility in assembling the data on their pupils. The data collection is usually being carried out during the first week of the first term i.e. before the normal lessons commence.

3. Is the record system of the school assembled on the basis of evidence, not opinion? Is it systematically reviewed and is access open to all who are concerned with the education of the children?

a) Both schools have 2 types of records called Cumulative Card 001 and Cumulative Card 003, Pupil Progress Report Card and the Class Register as required by the Ministry of Education (Form A, Section C, Qn. 1 and 2). These records are factual and are being reviewed on an annual basis by the respective form teachers. In fact, it is regarded as the duty of the form teacher to collect personal data of their pupils, to fill the record cards in a systematic way and put them into safe-keeping of the school, under the close supervision of the Principal and the guidance teacher.

b) The records are kept securely but available for professional consultation by all members of staff and appropriate outside agencies. According to the Principal of School 1, the pupils are sometimes allowed to consult their records, i.e. whenever necessary.

c) The staff are aware of their responsibilities vis-a-vis records (with written instruction or circular from the Ministry of Education). However, some teachers are not happy with the present record system whereby most of the data has to be repeatedly filled in all the cards. This becomes an additional burden to the already over-worked teachers.

d) A certain measure of confidentiality regarding the records also exist in both school but the degree of confidentiality there is not absolute and apparent as in the United States of America and the United Kingdom (cf. McGuiness 1982).

e) All entries on the record cards are dated and signed by the teachers concerned.

f) So far, no serious discussions of parental rights of access to record cards has taken place in any of the schools.

4. Are staff attitudes towards guidance and counselling services positive?

a) Generally the teachers have positive attitudes towards the service especially the Principals. However, some of the academic teachers are not satisfied when the guidance teachers are given less teaching periods.

b) There is strong indication that some of the teachers in both schools have not been very co-operative in the implementation of the guidance and counselling services in the schools. According to the guidance

teachers, it may be due to their misunderstanding about the importance and functions of the service to the pupils.

c) The pupils of both schools are very much in favour of the service which they consider as one of the means of helping them to solve their current problems.

5. Is counselling expertise available for those in the school who need and want it?

a) Both schools have a trained guidance teacher (counsellor) who has attended courses designed to develop paraprofessional counselling skills (i.e. each has a Diploma in Counselling).

b) Each state has a Regional Counselling (Guidance) Officer who is always available for referral outside the school (ref. p. 115 ).

c) Both schools recognise the needs for the school guidance and counselling services and have provided the necessary facilities for the service (as required by the Ministry of Education).

d) Both the Principals are planning to send more members of their staff for training in guidance and counselling skills to help facilitate the smooth running of the services in the school.

6. Do decision-making skills appear as a skill objective in curriculum planning? Is appropriate information available as a basis for sound decision making?

a) With regard to decision making, the pupils in both

schools are sometimes allowed to make their own decision on the 'elective' subjects they wish to pursue. Other aspects of school organisation that allow pupils to participate in decision making are on matters like choosing the class or form monitor, deciding on which school societies (extra-curricular activities) they wish to join, taking up games or sports and choosing the committee members of their clubs or societies, except in selecting the school prefects (which is carried out by the Principals and the teachers).

b) Among the techniques used in the classroom to develop skills in problem solving, decision making and value selection are by holding classroom debates, discussions, groupwork and role play situations which require full participation from all of the pupils. Furthermore, subjects like Communicational English and Bahasa Malaysia (written as well as oral Malay language) provide opportunities for the pupils to converse and develop skills in problem-solving and decision making.

c) The teaching methods in schools generally aim at encouraging initiatives and independence of the pupils but there are cases where they promote passive and accepting attitudes among the school pupils.

d) Both schools are able to provide sound up-to-date information on jobs, further and higher education opportunities and leisure possibilities to their pupils with the help of the career literature available

in the library and the guidance teacher's room (including the pin-up information on the notice board).

7. Is there a clear definition of areas of responsibility in the school, a clear statement of roles?

a) It has been found that a list of specific tasks is allotted to each member of the staff at the beginning of the year to ensure that everyone gets a fair share of responsibilities in the schools.

b) There are indications in both schools that the vital role of the form teacher as 'contact adult' have been recognised by including that teacher in all decision making related to the children in his care.

8. Does the school have a time-tabled tutorial or pastoral period?

a) As the schools in Malaysia do not practice pastoral care, there is no specific syllabus of areas to be covered during a regular pastoral period. The school guidance and counselling services is provided in the schools during the guidance teacher's free period (School 1) and during the special period allocated for it (School 2).

b) There is no set syllabus for the service.

9. Does the school have clear communication lines with appropriate outside agencies? Can it be claimed that there is a mutual respect between school and local

outside agencies?

- a) Both schools possess a list of locally available referral agencies with a telephone number and a contact person. The list is available to all staff especially those responsible for making external referral (whenever necessary).
- b) According to the Principals and the guidance teachers of School 1 and School 2, representatives of outside agencies would be invited to consult and contribute to the records when appropriate.
- c) It is found that representatives of outside agencies are sometimes invited to case conferences when appropriate, for instance in cases of drug abuse (in School 2).

10. What percentage of the parent body is involved in the school's work?

- a) There is no indication that all parents are contacted at the beginning of a child's school career in both schools.
- b) Parents are invited to school on Parents' Day, Speech and Prize-Giving Day, Sports Day, Parent-Teachers Meeting and whenever the necessity arise (applicable to both schools - cf. Form A and Form D).
- c) Sometimes the parents are invited to meet staff socially but the response is very unsatisfactory (cf. Form A and Form B).
- d) There is no set policy to help children whose parents gave clear evidence that they place little

value to school. However, evidences from the Principals and the guidance teachers of both schools indicate that though they are aware and are very concerned about the situation, there is very little they could do to eradicate it. It is the society that has to be re-educated.

e) The level of interest shown by parents was assessed partly from the head teachers and other teachers' judgements and partly from the number of times each parent visited the schools to discuss their children's progress with the head or class teacher (cf. Relationship p. 211 ; Wall 1977; Anne Sharrock 1980).<sup>2</sup>

### 3.13 General Statements (Findings from the Evaluation)

1. Both schools are very much examination-oriented where the stress is more on getting good examination results than the total development of the pupil.
2. Both schools have their own factual and systematic data source. However confidentiality is not absolute.
3. Guidance and counselling services have generally been accepted by the staff. Only a small percentage of the teachers are not willing to co-operate with the guidance teachers. This could be attributed to conflicts of roles or the lack of knowledge on the subject.
4. Both schools have the expertise in guidance and counselling work but there is still a need for more trained guidance teachers to ensure that the service could be extended to all the pupils (not only for the selected few).
5. The pupils are allowed and encouraged to make their own

decisions on matters pertaining to their lessons and daily activities except on administrative matters of the school and regulations circulated by the Ministry of Education.

6. Teachers especially the guidance teachers are expected to be 'adult contact' between the school and the parents.
7. Both schools have provided guidance and counselling facilities as requested by the Ministry of Education.
8. There is close co-operation between the guidance teachers in both schools, as internal agencies and outside agencies such as Guidance Regional Officer and local psychiatrist or doctor. Whenever necessary, these outside agencies would be allowed to consult the records of the pupils kept by the school.
9. The parents' involvement in their children's school life is very minimal. Much encouragement and persuasion are needed to remedy the present teacher-parent relationship.
10. The guidance and counselling work in both schools should not only be concerned about the emotional states of the learner for the sake of his academic achievement but also for the sake of his mental health.

### 3.14 Conclusion (Based on the survey)

#### 1. Extent of Guidance and Counselling Services

a) Even though guidance and counselling services (especially the guidance services) have been introduced to Malaysian schools about 20 years ago (cf. Chapter 1, p. 113), their concepts and functions have not been fully understood

and utilised by those concerned, Many pupils in both schools are still unaware of the importance of guidance and counselling to them and have not made full use of the services that are available in their schools. So do some of the teachers who expect to get quick (immediate) results from the guidance and counselling work, without realizing that it is more towards a preparation for the development of individuals (pupils) for life in the society (cf. Chapter 1, p 31 and Chapter 2 p. 125 ). The parents are no exceptions with regards to this matter. In fact, the survey indicates that many of them are only vaguely aware of the services available in the school.

b) There is strong indication that the guidance teachers (especially in School 2) are expected to deal with matters not solely related (belonged) to guidance but to the school as a whole (cf. role conflict, Chapter 1, pp. 39-41). This suggests that the role of the teacher who is elected to be guidance teacher need to be made explicit and differentiated from that of any other teachers. If this difference is not fully acknowledged, there will be role conflict (ibid.) and the guidance teacher will not be able to carry out his duties well. Instead, he will be forced to become involved in matters that are not essentially guidance matters but are rather a school's responsibility. Thus it is necessary for all school staff to have a clear understanding of the nature and functions of guidance (cf. Chapter 2 pp. 124-133 )

c) One of the ways of doing this is through the teacher's training programmes that should include a coun-

selling element which could deepen the teacher's knowledge of himself as a person and foster his skills in the interpersonal relationship. In this way, the teacher-trainee will not only be provided with teaching techniques but also with counselling 'know-how'. The other ways are to organise seminars and workshop on guidance and counselling and to invite qualified counsellors from institutions of higher learning to give talks on the subject to the teachers as well as to the pupils.

d) The amount of time allocated for guidance and counselling work has undoubtedly some impact not only on the performance of the guidance teacher but also on the pupils themselves because it is quite impossible for him to see more pupils in a very limited period without jeopardising his other duties as academic teacher (cf. Time allocation, pp.185-190. However, informal contact between the guidance teacher and his pupils could still be established through the Career and Guidance Club of which he is the adviser (cf. Form B and Form C, Section E, Qn. 2). This club normally organises activities such as exhibition on careers and trainings, field trips to places of employment and group discussions which include group counselling and peer counselling (Form C, Section E, Qn. 6, 7 and 8 cf. Berita Bimbingan 1983 and 1984; Shertzer and Stone 1976). In fact, quite a number of pupils involved in the survey had mentioned that such contacts had enabled them to mix and get to know their guidance teacher better in such an informal atmosphere.

e) Considering the fact that guidance work is only a 'part-time' job done by the academic teacher, one could not but sympathise with him for having to face many problems resulting from the insufficient time which is further exacerbated by the sheer profusion of tasks he is expected to perform (Circulars 1964, 1967 and 1968; Watts 1978 and Iyer 1975). A full-time guidance teacher or school counsellor could be the answer to these problems. In fact, the government is still looking into the possibility of employing a full-time guidance teacher in the schools (cf. Hj. Abdul Latiff 1983).

## 2. Quality of the Service

a) Although both schools have their own data source (records) on their pupils, the question of what the records should contain, who should have access to them and to what extent the law should be specifically involved in the issue, as stated by McGuiness (1982) have not been a major issue in the Malaysian educational system. As such, the extent of confidentiality of the pupils' records is difficult to determine, and no survey has ever been made on the issue as in Britain and the United States of America. This might cause the pupils to be wary of their guidance teachers and thus prevent them from confiding in these teachers whenever they have any personal-psychological problems.

b) The importance of parental involvement and responsibilities can be summed up by saying that there is rarely a case of a child going astray when the parent is closely in touch with the school (cf. John Pillai 1980).<sup>3</sup> However,

the schools are very concerned with the increasing lack of interest shown by parents in their children's progress and activities in the schools. Serious thought and action are necessary to remedy the situation.

c) What behavioural evidence is there in terms of pupils' performances that guidance is providing effects? (McGuinness 1982). In order to answer this question, one has to refer back to the information gathered in the survey such as the number of pupils who sought the service of their guidance teachers, their problems, their efforts to solve these problems, their relationship with their Principals, guidance teachers, peer groups and parents, and also their attitudes as well as suggestion on the guidance and counselling services in their schools. The survey indicates that they have to a certain degree managed to overcome their problems with the help of guidance teachers but the extent of success, or effectiveness of such services are difficult to forecast, and require further exploration (Form C, Section E, Qn. 4 and 5). Most of the pupils involved in the survey agreed that guidance and counselling is indeed a useful means of helping the pupils face and overcome their developmental problems, a view which was shared by the parents (Form D, Section E, Qn. 5). They offered many invaluable suggestions on how guidance and counselling services could be carried out more effectively in their schools.

d) Efforts should therefore be made to give more information to the society (in general) and to the teachers (in particular) on the importance of guidance and

counselling services in schools by preparing and distributing small pamphlets on the subject as well as holding talks to the Principals, the teachers and members of the public. In addition, the guidance teachers should try to demonstrate recognisable counsellor skills that could give actual or sufficient impact on the recipients and could be regarded as a great contribution to the educational system.

There is then, evidence from the literature (Herr 1976) on the United Kingdom and the United States of America guidance, and from this investigation which suggests that it is very difficult to assess how far counselling works, or to assess the effectiveness of counsellor education. What is important is that many improvements have been made in counselling and in counsellor education since its' emergence in the early 20th century, and that it will continue to be useful to many people including the school population.

NOTES

1. Although the Principal of School 1 stated that the record cards in the schools were available for pupils' consultation (Form A, Section C, Qn. 9 and 10), he might be referring to them in general only because based on my own personal experience in S.M.J.K. Confucian, Kuala Lumpur (1975-1982), there rarely had been cases where confidential records (Card 002) were intentionally exposed to the pupils.
  
2. The importance of the link between school and home has long been acknowledged in Malaysia. Unfortunately, not many studies have been made on the subject as in Britain where most of major studies were carried out after the Second World War (cf. Anne Sharrock, Chapter 6 in Linking Home and School 1980).
  
3. See Educational Times, The New Straits Times, Malaysia, 1980.

CHAPTER FOURFUTURE DEVELOPMENT

In the previous chapters, I have traced the past and the present development of guidance and counselling services in Malaysia and the roles it is expected to play in helping to achieve the goals of Malaysian education. This chapter will, then, try to examine critically the possible future development of guidance and counselling services in the country. Discussions will also be made on the Ministry of Education's long-term future projects to improve the quality of the service in Malaysian schools. In addition I shall try to examine the cultural issues of how far permissive aspects of counselling can be allowed to be practiced in Malaysian schools.

#### 4.1 The Development of Counselling discipline in Malaysia

As mentioned earlier, the history of guidance and counselling in Malaysia is very much related to the history of education in this country whereby guidance and counselling is focussed in schools and other educational institutions. As such, it has been developed academically and professionally under the surveillance of the guidance unit, Ministry of Education, Malaysia.

Consequently, counselling as an elective subject has long been introduced at the Faculty of Education, University of Malaya. It is being offered to those students taking Diploma in Education. (In fact, guidance and counselling has been included at all Teachers' Training Colleges.) In the National University of Malaysia (U.K.M.), the guidance and counselling subject is called Guidance and Advisory. It is also an elective subject. Besides that, the Psychology Department of the same university also offers a course in guidance and counselling to students in their Honour Years, starting from sessions 1975/76. Later in the middle of 1980, a Diploma in Counselling was started by the Psychology Department, National University of Malaysia (U.K.M.). The intakes are the guidance teachers from all over the Peninsular Malaysia. Its aim is to train the current guidance teachers based on integration mode and competency based (Department of Psychology, 1983).

Recently (1983), the Agriculture University of Malaysia has started a course in counselling at degree level. In addition to that, three universities are now offering a Masters Degree in Education with specialisation in

Guidance and Counselling. They are the University Science of Malaysia, University of Malaya and Agriculture University of Malaysia, and the National University is planning to do the same in the near future. At college level, the Specialist Teacher Training Institute (M.P.I.K.) (apart from the in-service courses by the Guidance Unit) has organised a one-year full-time Guidance and Counselling course at Certificate level from 1980. Besides that, other teachers' training colleges also offer a training programme that is compulsory for all teacher-trainees, which cover over a period of 3 years, starting from 1981.

#### 4.2 Counselling Services to the Society

##### 4.2.1 The Befrienders

'The Befrienders' was originally a service project of The Church's Counselling Centre that was founded and registered in 1971. However, this unit is now free to practice counselling from the church organisation. 'The Befrienders' unit began to operate the Telephone Counselling Service in 1971, following a suggestion by a group of 14 Befrienders members, to help members of the public who are facing problems pertaining to either emotional, mental or social pressures. This suggestion was very much supported by Professor Tan and Professor Teoh and other Consultant Psychiatrists from the Department of Medical Psychology, University of Malaya. They help this unit in giving training courses for its members, case studies and talks on counselling projects.

Then, on November, 8, 1974, the counselling centres of 'The Befrienders' was officially opened by the Minister of Social and Welfare Services and thus marking a new recognition era for 'The Befrienders' whose main aims are to offer counselling services to the society and to give talks, seminars and discussions on guidance and counselling.

The members of 'The Befrienders' come from all levels in the society around Kuala Lumpur and Petaling Jaya, such as housewives, nurses, doctors, lawyers, teachers and clergymen. The service they offer is voluntary. Before they are allowed to carry out counselling, they have to undergo a 10 weeks training. Generally, the counselling service of 'The Befrienders' "cater fundamentally for the late adolescent and young adult population who were sophisticated enough to utilize the telephone as a means of help". (Annual Statistical Report, Befrienders' Case Register, 1977, cf. Su Bee Yan, 1981). Nowadays, 'The Befrienders' have expanded its activities by co-operating with other organisations, universities, Social and Welfare Service, Narcotic Bureau and churches.

#### 4.2.2 The Guidance Clinic

The first Child and Adolescent Guidance Clinic was established in Ipoh in the early 1980s by a team from Hospital Bahagia (Mental Hospital), Ulu Kinta, Perak, comprising a consultant psychiatrist, a clinical psychologist and a clinical specialist. The need for such special clinics is rising because of the increasing psychological problems faced by many teenagers nowadays. This particular

clinic is in a non-hospital environment that is easily accessible by all concerned. The clinic provides a part-time service on every Tuesday and Thursday afternoons. It takes in an average of four "patients" by appointment at each session, all referrals from schools, hospitals, general practitioners and social welfare officers. Unfortunately, due to the limitations of time, staff and financial resources, only a limited number of cases has been treated since it started operating. Eighty percent of the cases are aged between 6 and 15 years, a crucial period in a person's life during which he is awakened to the trials and tribulations of growing up (The New Straits Times, 1981).

One way of helping the children is through 'play therapy', first introduced in the U.S.A. by a child psychoanalyst, Melanie Klein. Through this method, the child's behaviour is observed during play; where attention is focussed on how he relates with other children, his physical co-ordination and the play material he chooses. In addition, the staff also talk to parents to gather further insight into the child's problems. Counselling also plays an important part in this clinic, which leads to a better understanding of the problems confronting the child. The staff also work in close co-operation with the children's teachers, and where necessary, involve them in the therapy.

#### 4.2.3 Malaysian Vocational Guidance Association (MAVOGA)

The Malaysian Vocational Guidance Association, or commonly known as MAVOGA, is a voluntary service organisation, national in scope, dedicated to the advancement of

Vocational Guidance Association in Malaysia (History of MAVOGA, 1980).

MAVOGA had been inaugurated in December, 1973. It had its origin in the Selangor Vocational Guidance Association. It was initiated by Rotary Club members in 1966 to help to meet the growing need for Vocational Guidance Services to Secondary School Students and School Leavers. In recent years, concerned individuals and organisations in both the public and private sectors have contributed their time and efforts to the National aim of improving and expanding guidance services throughout the country. Today, MAVOGA's membership includes representatives from major corporations in business and industry, students, educators, civic leaders and public administrators.

The main objectives of MAVOGA (to quote a few) are listed in its constitutions which include:

- (i) to study and divert attention to Vocational Guidance problems and to strive towards their solution, in order to contribute to national unity, progress and development in accordance with the tenets of the Rukunegara;
- (ii) to encourage, undertake, sponsor and/or fund research and study in Vocational Guidance, with special emphasis to its problems and needs in Malaysia, whether on its own or in association with any other legally constituted body, government or otherwise;
- (iii) to promote the recruitment, training and deployment of Vocational Guidance workers to recognised national or international standards of proficiency, attainment and operation (cf. History of Mavoga, 1980).

#### 4.3 Towards Professional Counselling Services in Malaysia

(The Roles of MAVOGA, PERKAMA and the Psychology Association of Malaysia)

4.3.1. Counselling, as a profession, is a new development in Malaysia, which began to exist only in the 1960s. Even though there are a number of people who obtained training in the field of counselling before the end of the 1960s, either through planned effort by the Ministry of Education as well as privately, the posts of counsellors are indeed very few. The Mara Institute of Technology was the first institution of higher education in Malaysia to introduce Counselling services to its students in 1968. This Vocational Guidance Unit of MARA (officially established in 1969), presently known as the Career and Counselling Centre is staffed by 12 full-time counsellors (the largest in the country). The Centre offers a Comprehensive Counselling Service ranging from Personal Counselling and Career Counselling to Job Placement, not only to the students but also to their parents (Fawziah Elyas 1980).

4.3.2. Beginning from 1970, i.e., after the Mei 13 incident of 1969 and the student unrest in the campus, the government had taken the initiative to offer a better service towards the welfare of the university students. As such, the posts of counsellors have been introduced under the supervision of the Vice-Chancellor in charge of Student Welfare in all universities. At this stage, the roles of

these counsellors were very indefinite (vague) and they varied from one university to another. This was due to:

- (i) roles and scope of the post was very ambiguous not only to the student, but also to the administrators and other academicians;
- (ii) some of the counsellors did not have proper professional training;
- (iii) the counsellor's status in the administrative hierarchy had more or less complicated his roles as a counsellor to the students and academicians.

4.3.3. However, by the late 1970s, most of the counsellors in institutions of higher learning became more prepared, experienced and conscious of their own roles and identity towards the students. This change generated from the knowledge and expertise obtained on their return from overseas, as well as from seminars organised by many voluntary bodies such as Selangor Vocational Guidance Association and many other workshops organised by those interested in guidance and counselling.

4.3.4 Besides that, courses in guidance and counselling have also been offered by these institutions of higher learning to the potential (future) teachers and students. In addition, the Ministry of Education has also organised in-service courses to guidance teachers as an attempt to prepare these teachers in their new roles as the schools' guidance teachers (cf. pp. 273-274).

With this progress and fast development in guidance

and counselling in Malaysia, many trained counsellors began to feel the need to improve their services. One of the ways is to move towards professionalism in counselling (cf. Shertzer and Stone 1977).

4.3.5 However, it is pertinent to note that in Malaysia, the terms 'counsellor' and 'counselling' are still being discussed not only among members of the public, but also among those involved in giving the counselling services. At present, the service is being offered by the schools' guidance teachers, counsellor-administrators in institutions of higher learning, voluntary workers in many voluntary organisations and churches, welfare officers of rehabilitation centres and personnel officers in various industries. Thus, many questions arise, for example - what is counselling and who should be involved in carrying out the counselling functions? What code of ethics should be followed by those involved in counselling?

4.3.6 In their effort towards professionalism, a group of counsellors and those interested in counselling had formed an association called Persatuan Kaunselor Malaysia (PERKAMA or The Counsellor Association of Malaysia) in 1979. Its aims are:

- (i) to upgrade the professional counselling practice (quite similar to that of MAVOGA, cf. p. 256);
- (ii) to encourage and assist in researches in counselling;
- (iii) to improve further expansion of knowledge, understanding and acceptance of counselling in the context

- of multi-cultural Malaysia;
- (iv) to promote and preserve the professional ethical standard of counselling;
  - (v) to encourage the development of identity, harmony and co-operation among the members from various disciplines and to share their information and experience.

The membership of this association is open to all members from various disciplines but strangely they need not be those who are directly involved in counselling work. Unlike those associations like the American Personnel Guidance Association and the American School Counsellor Association, to name a few, whose memberships are only limited to those qualified in the specific professional field.

4.3.7 Besides PERKAMA and MAVOGA whose members are interested in counselling, those interested in psychology established their own association called The Psychology Association of Malaysia whose aims are:

- (i) to introduce psychology as a discipline that facilitates mental health of the society;
- (ii) to explore and to improve further the various aspects of psychology through research, education, instillation, development and formulation of guidelines on interpretation and practices of research results, investigation, code of ethics and other matters related to the psychology discipline in Malaysia. (cf. Department of Psychology, UKM, 1981).

4.3.8 Thus with the emergence of professionalism in the field of counselling in Malaysia, there is a tendency for other related fields, for instance, psychology, to flourish since the psychology discipline forms a basis for practical guidance. The interest in counselling as a field that facilitates the solution of individual and social problems in Malaysia will initiate the counsellors and psychologists to enhance the quality of their professionalism so that the mistrust of the society towards this profession can be eradicated.

4.4. Status and Importance of Educational and Vocational Guidance and Counselling in Schools at Present and in the Future

4.4.1 It is pertinent to note that the name of the service itself suggests the nature of the service that has been offered to the school pupils. Since its introduction, the emphasis was on Educational Guidance - a service meant to help or guide the pupils especially in their selection of subjects, before the streaming of pupils to arts and science streams were undertaken by the Ministry of Education (cf. Chapter 1, p.109). The need for this kind of service was intensified with the abolishment of Standard Six Examination leading to secondary schools which had resulted in the great increase of Form I pupils in the secondary schools. Furthermore, when the vocational and technical schools were established, the Ministry found that the pupils had to be given some form of guidance to enable them to enter these schools.

4.4.2 On the other hand, the emphasis on Vocational Guidance could be traced back to the 1960s (cf. Chapter 1, p.113). However, the distribution of information on training and job opportunities by the government as well as in the private sector was very disorganised, as though it was done in an adhoc manner. One of the activities that has been carried out in schools, pertaining to careers service, is to hold talks on careers opportunities either by relevant personnel that have been invited to the school or by the guidance teachers themselves. Besides that, the schools are also encouraged to organise visits to various training or job centres. Through this experience the pupils will gain first hand knowledge on the nature of training or jobs available in their area or country.

4.4.3 It is also important to note that the emphasis on various aspects of guidance services differs in the various types of school. Thus, for instance, in the Vocational and Technical schools the emphasis is in terms of vocational guidance and jobs placement. In the Residential Schools, there is a greater need, and hence stress is on helping pupils to adjust, integrate and steadily plan in terms of their educational and future career. On the other hand, in the Day Schools, depending on their locality, socio-economic grouping of pupils and related factors, the guidance service has to encompass personal-social guidance, educational guidance, vocational guidance and a programme directed towards attitude formation and drug abuse prevention.

4.4.4 Even though the school guidance services was named Educational and Vocational Guidance, it does not mean that Counselling Services has been totally neglected or left out entirely. The counselling aspects are still being included in all training organised by the Ministry of Education, either in theory, techniques or practical. The main difficulty arises when it comes to practicing the techniques of counselling in schools. In fact, it has been found that it is quite impossible for the guidance teachers whose exposure to practical counselling is only in terms of 5 hours lectures in their in-service training (i.e., 1 hour on theory, 2 hours on techniques and another 2 hours on practical), to carry out counselling effectively (cf. Hj. Abd. Latiff 1981). This inadequacy in training has given rise to much concern, not only among the officials from the Ministry of Education, but also from other counselling personnels, educationists and the teachers concerned. Without proper professional training, it is feared that such 'half-baked' counselling might increase the problems rather than solving them. In spite of this weakness counselling is still considered a necessity in the schools, in the light of the fact that it is not a new concept in our Malaysian society. The concepts 'advice' or 'guide' for instance, have been present in our culture even before the introduction of counselling in Malaysia. The main drawback faced by us is that we are still lacking in the number of qualified personnel who specialised in counselling as a profession.

4.4.5 Ideally, guidance and counselling should be the function of a full-time School Counsellor. In Malaysian secondary schools this is not at present attainable, partly because there is still a current shortage of teachers. If guidance teachers were deployed as full-time guidance personnel, this shortage would be further aggravated (Iyer 1975). In the school setting, therefore, the guidance teacher discharges both guidance duties as well as academic teaching. The guidance teacher is allotted a lighter teaching load, is exempted from some extra-curricular duties, and insofar as is possible, is given teaching duties inclusive of Civics (cf. Chapter 3, p 185). Thus, the guidance teacher could make use of part of the Civics teaching as a means for group guidance, attitude formation, and informal discussions on concerns and problems of pupils.

4.4.6 On the whole, the guidance and counselling services is gradually being recognised as an essential supportive service in the schools. Headmasters in recent years have recognised the need for this service, partly through attending guidance and counselling in-service courses and/or attending courses tailored for educational administrators (organised by M.E.S.T.I.)<sup>1</sup> or through study tours to other countries in which guidance is an essential component of the education system (e.g., Indonesia and Phillipines, cf. ARAVEG, 1980).<sup>2</sup> Recognition by headmasters on the importance of guidance and counselling is also shown by the fact that in many schools the head teachers have deployed more teachers to guidance functions as the enrollment of their

schools increased.

The guidance teachers themselves are conscious of the need to exchange ideas, up-date their knowledge and improve the services they are at present providing. This has prompted groups of them to form state guidance teachers' associations (cf. Iyer 1975; Berita Bimbingan dan Kaunseling 1983 and 1984).

#### 4.5 Future Development

According to Haji Abdul Latif (1981, 1983), the Head of Guidance and Counselling Unit, Ministry of Education, the nature of the existing guidance services in Malaysian schools is gradually being changed to Guidance and Counselling services. More emphasis will be placed on counselling services either on individual or group counselling. In fact, there has been strong suggestions from the Ministry, as well as from other counselling personnel, for further involvement or emphasis on Group Counselling, whereby much time could be saved, than in Individual Counselling.

In the light of the problems faced by the government, due to the increase of drug taking among the pupils, drug counselling will also be emphasized in schools (cf. Iyer 1979). Such a form of counselling will definitely require very highly skilled personnel, which our schools are still lacking.

Therefore, the government will not only be organising more in-service training, but will also be sending more officers and guidance teachers to be trained in this important field in our local universities as well as overseas.

This, however, does not mean that the personal, emotional, social and career aspects of guidance and counselling will be neglected. Further plans have been made to counter the discipline problems of the increasing school population, such as truancy, having long hair, smoking, fighting, stealing and so forth.

As the need for guidance and counselling is becoming greater, the Guidance and Counselling Unit of the Ministry of Education has been empowered the responsibility of organising the short as well as the long term projects on guidance and counselling in schools, some of which will be discussed under the following sub-headings:

- 4.5 (a) The Status of Guidance Teachers and Counsellors;
- 4.5 (b) The Supply and Utilization of Guidance Teachers and Counsellors;
- 4.5 (c) Training of Guidance Teachers;
- 4.5 (d) Qualification.

4.5 (a) The Status of Guidance Teachers and Counsellors

As mentioned earlier, the status of the guidance teachers is no better than the other academic teachers, since the position they are holding is not considered as a new post. In fact, they have been burdened or given further duties to carry out guidance and counselling work. The situation will continue until the time when the government will consider it necessary to establish the academic post of a School Counsellor, which, according to Hj. Abdul Latif (1981 and 1982), will take place in the near future. The possibility of achieving this goal is very encouraging and it is based upon statements made by various people including

the Minister of Education, Senior Officer of the Ministry of Education, organisations on counselling, teachers, and many others.

The most important declarations or affirmations that have been made are:

- (i) The Report of the Cabinet Committee on the Implementation of Educational Policy (1979) had recognised that the guidance and careers service "must be carried out in full" with emphasis on guidance activities (i.e. not necessarily to be on guidance and careers only). This implies the seriousness of the government's intention towards the future development of guidance and counselling in schools.
- (ii) The Educational Planning and Research Division, an important component of the Ministry of Education had recognised the necessity of allotting not more than 12 periods per week to the guidance teachers, to enable them to concentrate on guidance work during their 'free' periods (cf. KP(PP)0050/119 (58)). The implementation of this recommendation has been carried out in three phases - 1983, 1984 and 1985. During the three periods, efforts have been made to ensure that all comprehensive secondary schools, vocational as well as technical schools get at least one guidance teacher (the larger the school population, the more guidance teachers are required).
- (iii) There had been calls (suggestions) that one way of reducing the indiscipline problems in schools is by up-grading the educational and vocational guidance

services (including counselling) in schools (e.g. Seminars on Discipline and mass media such as radio, television, newspapers and magazines). Many felt that a full-time counsellor (school counsellor) should be placed in schools to facilitate effective service in guidance and counselling.

- (iv) As the Drug-Abuse Incidents are on the increase among the school pupils lately, the Executive Action Unit (Unit Bertindak Eksekutif) had instructed the Ministry of Education to request for special funds to enable the Ministry (The Guidance and Counselling Unit) to elect a 'Special Officer' to supervise the drug-prevention programme in secondary schools. This incidence indicates that Guidance and Counselling will continue to play a vital role in education (cf. Hj. Abdul Latif 1983).

#### 4.5 (b) The Supply and Utilization of Guidance Teachers

In spite of the various training programmes undertaken by the Ministry of Education (through the Guidance and Counselling Unit, local universities, colleges) and other interested bodies and personnels, the shortage of guidance teachers is still felt throughout the country (as shown in the Tables 15, 16, and 17 below).

TABLE 15

Number of Guidance Teachers that Received Special Training on 1.2.1983

Type of Training	Year				
	1980	1981	1982	1983	Total
1. Certificate in Guidance and Counselling, MPIK, Cheras	19	20	40	40	119
2. Diploma in Guidance and Counselling, University Kebangsaan Malaysia (UKM)	39	47	36	25	147
3. Certificate in Guidance and Counselling. Term Vacation Course I-III	-	-	183	-	183
	58	57	259	65	449

Source : The Guidance & Counselling Unit, Ministry of Education.

TABLE 16

The Supply and Demand of Guidance Teachers 1983-1985

Implement- ation	Demand			Supply	Shortage			Cummulative Shortage
	Number of Guidance Teachers based on the Size of School	Increase of Secondary School	Number of Demand		Total nos. of Guidance Teachers Required	Attrition	Total no. of Shortage	
Phase I 1983	1093	-	1093	384	709	91*	800	800
Phase II 1984	797	11	808	80**	728	29	757	1557
Phase III 1985	407	19	426	480***	-54	37	-17	1540
Total :	2297	30	2327	944	1383	157	1540	-

Source : The Guidance & Counselling Unit.

- Note : \*
- \* The number includes those involved in promotion, transfer to Department of Education/other Divisions in the Ministry of Education and further studies.
  - \*\* 40 teachers are undergoing a one-year course at MPIK, Cheras while approximately 40 teachers will be taking the course in Diploma of Guidance and Counselling, UKM, Bangi for 1983/84 session.
  - \*\*\* the rough estimates of those who will be undergoing Term Vacation Course while others (80) will be following a course at MPIK and UKM.

## Number of Guidance Teachers based on State, Sex and Ethnic Group 1983

State	Sex		Race				Total
	Male	Female	B	C	I	O	
Perlis	9	1	10				10
Kedah	23	5	27		1		28
Pulau Pinang	12	7	14	4	1		19
Perak	29	14	39	2	2		43
W. Persekutuan	1	15	6	6	4		16
Selangor	14	9	21		2		23
N. Sembilan	15	12	22	3	2		27
Melaka	10	3	9	4			13
Johor	24	12	33	2	1		36
Pahang	24	9	29	4			33
Trengganu	14		14				14
Kelantan	23	5	26	2			28
Sarawak	2		2				2
Sabah	1		1				-
TOTAL	201	92	253	27	23		293

B = Bumiputera (Indigenous People)  
C = Chinese

I = Indian  
O = Others

Source : Guidance and Counselling Unit

The above table shows that the average number of guidance teachers required for the implementation of the Amendment to Administrative Circular No. 3/67 is 2,327 guidance teachers. The shortage of guidance teachers for the whole country is as follows :

Phase I (1983)	=	800
Phase II (1984)	=	757
Phase III (1985)	=	-17
Total shortage	=	1540 guidance teachers

Table 3 shows great imbalance between the number of male and female guidance teachers, i.e. 68.6% are male teachers compared to 31.3% of female guidance teachers. The ethnical distribution of guidance teachers is also very unsatisfactory whereby 86.3% of the current guidance teachers are bumiputeras (indigenous people). It is therefore necessary to narrow down the imbalances between two sexes and ethnic divisions. The survey made by the Guidance and Counselling Unit also indicates that about 1,000 guidance teachers who are deploying guidance and counselling services throughout Malaysia have not received any special course or training in guidance and counselling. The only exposure to the subject was through a 6 days introductory course organised by the Ministry of Education. Under such conditions, it is impossible for them to carry out their functions effectively. This will bring us to the subject of 'Training of Guidance Teachers and Counsellors'.

#### 4.5.(c) Training of Guidance Teachers and Counsellors

c.1 Since the introduction of guidance services to schools in 1966, the Ministry of Education has organised a series of in-service courses (besides seminars and workshops) to train guidance teachers throughout the country in guidance and counselling.

c.2 In 1980, for the first time, 19 Category C1 and C2 teachers had undergone a one year full-time course in guidance and counselling at Specialist Teachers Training Institute (MPIK), and 20 more teachers were being trained in the following year (1981).

The Department of Psychology at the National University of Malaysia (UKM) had trained 39 guidance teachers of Category D1 and D2 in Diploma in Psychology (Counselling) during the 1981/82 sessions.

c.3 The problem of training - Training poses a problem because the Teachers Training Division that organises the course is still short of teaching staff. For instance, in 1981 there were only two guidance and counselling lecturers at the Specialist Teachers Training Institute (M.P.I.K.). Outside lecturers have to be acquired to help the running of the guidance and counselling course. In order to overcome this problem, the Ministry of Education plans to recruit a number of 39 Category D1 and D2 teachers who are undergoing the Diploma in Psychology (Counselling) at UKM to be lecturers of MPIK and other teachers' training colleges. In this way, more trainees could be trained, which in turn will speed up or increase the number of trained (probably full-time) guidance teachers or school counsellors.

c.4 In fulfilling further needs of full-time guidance teachers or school counsellors, the government (Ministry of Education) might consider sending more teachers to be trained and obtain a First Degree in Counselling at the Agriculture University of Malaysia. With regard to such a programme, the Training and Scholarship Division of the Ministry of Education will continue to offer scholarships to Educational Service Officers (teachers) who wish to further their studies at post-graduate level in Guidance and Counselling at the local, as well as overseas, universities. This group will one day be 'reference-experts' in the Ministry of Education and the State Education Department (Hj. Abdul Latif 1981).

Thus, it was estimated that by the end of 1981, 79 teachers, who obtained full-time training would qualify to be 'school counsellors' in schools (ibid.). If everything goes well, in 5 or 6 years' time the needs for full-time school counsellors could be fulfilled.

c.5 Guidance Teachers in Primary Schools

The Ministry of Education also realises the need to train primary school teachers as guidance teachers. The aim of this training is to assist them in making the other teachers realise the importance of supervising the primary school pupils as individuals, not only on the physical and mental aspects, but also on the development of their spiritual aspects. These primary school guidance teachers are expected to co-operate with the Health Teacher, the Special Education Teacher as well as other academic teachers.

The nature of training of these primary school

guidance teachers is quite different from the one given to the secondary school teachers. Each school is required to select 3 teachers from the school who will be attending the course together, including a principal or his deputy, and 2 guidance teachers (one man and one woman). The participation of the school's head is considered as a necessity considering that the success or failure of the service in his school lies in his hands. The same principle is also being used in the training of guidance teachers in the secondary schools.

c.6 The exposure to the philosophy, concepts and objectives of the Educational and Career Guidance has also been extended to the Hostel teachers, Principals (through courses at M.E.S.T.I.), and Religious Teachers. The Educational Planning Committee has recognised the need to give adequate training in guidance and counselling to the Religious Teachers in the secondary schools. This will enable them to establish a closer rapport (relationship) with the pupils in their effort to give whatever assistance they could offer from the religious point of view. As a consequence of such training, it has been found that the Principals who attended the course are more helpful and sympathetic towards the guidance teachers, either in giving them less teaching periods or supplying the necessary facilities for guidance and counselling work.

However, the implementation of guidance and counselling is still at a very initial stage. The effectiveness of the services very much depends on several conditions such as the existence of a trained guidance teacher, time

allocated and most importantly, physical as well as moral support from the administrators, teachers and pupils in the school.

c.7 Based on the above training schemes, the Ministry of Education will have to accept 4 categories of qualifications.

The 4 categories of Qualifications are at:

- |       |                         |   |            |
|-------|-------------------------|---|------------|
| (i)   | Certificate level       | - | Group I    |
| (ii)  | First degree level      | ) |            |
|       |                         | ) | - Group II |
| (iii) | Diploma level           | ) |            |
| (iv)  | Post-graduate level     |   |            |
|       | (M.A./M.Sc. and others) | - | Group III  |

#### 4.5.(d) Qualification

Since the qualification of the guidance teachers varies as a result of different academic qualifications (categories of teachers), and training in guidance and counselling (and thus giving rise to three different groups), it is therefore necessary for the Ministry of Education to plan ahead regarding their posts and status. Without proper planning, it is feared that dissatisfaction might occur among the future Student Counsellors (School Counsellors). If this happens, the profession of the counsellors might be jeopardized. The government then is relying on a professional body like "PERKAMA" (The Counsellors Association of Malaysia) to produce some kind of future guidelines on the nature of training that must be undertaken by anyone who wishes to be a Student Counsellor or a School Counsellor.

Besides that, some thought would also have to be given to the position based on Post, Salaries and Promotion among

the future Student or School Counsellors. This is to prevent these qualified personnel from leaving this much needed profession because they are unable to get promotion opportunities in the same field. Another scheme has to be considered to enable:

d.1 Student Counsellors in schools to get promotion opportunities in the same field, either as District or State Guidance Officers, or as Guidance Officers at Ministry level.

d.2 Student Counsellors will also be given from time to time further training in other important aspects of guidance and counselling that have not yet been developed, such as in the fields of research on guidance and counselling, tests and measurement, careers, drug counselling, job placement, student psychology and so forth.

Consequently, the future development of guidance counselling in schools very much depends on factors like:

- (i) the urgent needs of the schools and the nation as a whole, e.g. drug taking/abuse in schools and the increase of indiscipline incidents in schools;
- (ii) the impact that guidance and counselling has on the major decision makers, resulting from the pressures of the organisation and counselling personnel who are directly involved in this field;
- (iii) other factors such as personnel and financial provisions.

Therefore, there is a need for moral support and ongoing exchange of views, not only on counsellor training, but also on the co-ordination of counsellor output.

Moreover, as the attitudes and values towards the service are very relative, it is important that the guidance and counselling practitioners or professionals demonstrate recognisable counsellor skills as having sufficient impact and making a unique contribution to the individuals and society, in general. In this way, its credibility and professional status can be realised. Thus, the need for further development of this field (including the creation of new posts) could be justified.

We have examined the needs and the nature of future development in the field of guidance and counselling in Malaysia based on official reports from the Ministry of Education (Guidance and Counselling Unit), and other counselling personnel. The next step will be to examine the extent to which permissive aspects of counselling can be practiced in Malaysia.

#### 4.6 The Extent of Counselling in Malaysian Situation

Since the beginning of this century, the guidance and counselling movement has undergone tremendous changes. Its entry and development in South-East Asia, particularly in Malaysia, has given rise to many reactions. Some believe that such foreign or alien concept could never survive in the society that already possesses its own life concepts and way of life, while others take the 'wait and see' attitude. On the other hand, there are people who believe that this concept, if properly utilized, could offer a meaningful and effective service to the society and nation as a whole.

Presently, the concept and the service derived from guidance and counselling have become a reality that is very fast developing. The ever increasing support from the government has made it possible for the service to be extended to the pupils (students) and youth as a means of helping them to solve their problems. In the midst of this, there emerges another group, whose commitment to the service is equally important (locally known as religious counsellors). They begin to query: "Does Guidance and Counselling only come from the West?"; "Will we be able to assimilate our cultural values to guidance and counselling and thus make it more effective?"; "What sort of local colouring would make it more meaningful to our Malaysian society?".

This group strongly calls for re-examination of what we borrow from outside and calls for the evaluation of what we already have. This group of guidance personnel, who are mostly Moslems, tries to find ways and alternatives to what they know (learn) and what they actually practiced (Hamzah B. Mohamad, 1983). The question often forwarded by them is on the suitability of the theories that have been formulated in the West for the Western societies, for us in our unique situation based on the Eastern philosophy and culture (cf. Pande 1968 and Kinzie 1972).

Basically, this group does not question the objectives of guidance and counselling but more specifically considers the methodological approaches and principles underlying it, which according to them is very un-Islamic. Therefore, they argue that it must be carefully scrutinized so that

certain negative aspects of it do not have adverse effects on our young generation.

However, Dr. Mat Saat Baki, a local clinical psychologist of UKM, believes that "counselling that has been re-adjusted (modified) could be used in Malaysia". He further stresses that the re-adjustment is subject to the ability of the counsellor to understand and overcome the problems that exist in counselling (Mat Saat Baki 1983).

The problems and limitations in guidance and counselling will be examined under two sub-headings as follows:

- 4.7            Problems and limitation of Guidance and Counselling in Schools
- 4.8            Problems and Limitations of Counselling (in general, i.e. including Counselling for Mental Health)

4.7            Problems and Limitations of Guidance and Counselling in Schools

Even though the Educational and Careers Guidance Services was introduced in schools nearly 20 years ago, its concrete results are yet to be seen. This was due to factors like :

- 4.7.1        Lack of expertise. Wrenn (1966) stated that a School Counsellor is a skilled person who had a great knowledge of young people. Such qualities of guidance teachers are indeed very rare in our school situations, which can be attributed to the inadequacy and the unsuitability of training provided to them since 1966. The majority of them have been exposed to in-service programmes of short duration, ranging from a week to ten days, organised by the Ministry of Education. Such programmes have limited

impact on counsellors' attitudes and behaviour and ultimately counsellors are thrown on their own resources.

4.7.2 The appointment of a full-time school counsellor is still at 'thinking' level (Hj. Abdul Latif 1981). At the moment, the academic teachers are doing the guidance work as additional duties. The amount of guidance work carried out very much depends on the length of time allotted, physical support (facilities and place or room) as well as moral and financial support. (Financial support for guidance activities has in fact been approved by the Treasury since 1982 - cf. Hj. Abdul Latif 1983).

According to the Career Guidance Teachers who participated in the study conducted by the Selangor Vocational Guidance Association between 1st June and 20th July, 1973 in the States-Selangor and Pahang, there are four major problem areas in secondary school career guidance work:

1. Career Teachers' lack of time for guidance work
2. Negative student attitudes (59%)
3. Need for more current vocational information (55%)
4. Need for teacher training in Career Guidance methods or techniques (49%).

The problems mentioned above are often inter-related (cf. Chapter 3, pp. 215-216).

4.7.3 The actual position of the school counsellor in Malaysia is still very vague and subject to many speculations. One of the questions that arises is whether the school counsellor could or should be regarded as an integrated

part in the process of education as a whole, as in Indonesia (ARAVEG, 1980) and countries like America and Britain? Do the pupils view the counsellor as a meaningful individual in educational term as equivalent to a subject teacher, or do they view the counsellor as an assistant, a supplementary, or as an important personnel in their school's activities? Such questions require further detailed investigation.

4.7.4 Counselling as a helping process is still a newly introduced concept in our country. It carries various meanings and interpretation to common people. As a consequence, much criticism has been aimed at counselling as an effective means of "changing human behaviour" causing some kind of doubt and mistrust among certain sectors of the society.

4.7.5 At present, the number of guidance teachers who received a 5½ days training is 3,000 from the secondary schools, and another 480 teachers from the primary schools (Hj. Abd. Latif, 1983). Unfortunately, a study by the Ministry of Education in 1979, indicates that from the above figure, only about 700 teachers are still carrying out their duties as guidance teachers in their schools (ibid.). It shows that many of these guidance teachers, especially those in secondary schools have left the service for various reasons such as promotion, change in post, transfer to other schools, or they are no longer interested in becoming guidance teachers. All this has in one way or another

affected the Ministry's effort to provide more qualified personnel in this field.

4.7.5 The size and rigidity of the Malaysian educational system, to which guidance is seen as a counterbalance is regarded by Watts (1978) as an obstacle to the implementation of effective guidance. According to him, "the system tends to be formal, monolithic, and unable to pay much attention to the individual differences" (p. 108). In fact, Watts' view on this matter was mentioned earlier by Sarojini Menon (1975). She said that "Malaysian schools are still very much subject-centred and content-oriented", which implies that the need for emotional learning and development so necessary in fostering a balanced development of the individual, is somewhat lost sight of. She further added that highly centralised and prescribed curricula also tend to concentrate on and emphasise a teacher-centred approach. This raises the question of the relevance of learning as perceived by the pupils for whom the rigid examination system also creates many attendant pressures and anxieties rather than alleviating them. Although the Ministry of Education has asserted clearly "the democratic principle that it is the duty and the right of every individual to choose his own way of life, in so far as his choice does not interfere with the rights of others" (Ministry of Education 1970), this principle is not widely accepted in practice (Watts 1978). In addition, there are also other cultural factors which make guidance and particularly counselling-oriented approaches to guidance, difficult to implement (ibid.).

4.7.6. At present, the family still plays a very influential role in determining a person's goal in life. For instance, parental advice (and in some cases close family relatives') is sought on matters of importance, such as selection of jobs and marriage. (This act is traditionally an important part of the Asian social structure.) The pay and status of the job entered by the pupil (student) is regarded as affecting the status of the family as a whole. Since the public pension scheme only covers government employees, most parents, especially the Malays, would encourage their children to get a secure, pensionable job in the government service. As the parents' own future depends upon this, therefore, it is thought that they too have the right to influence, and even determine, the pupil's (student's) career.

Under such a situation, Watts (1978), feared that the predominantly client-centred approach to guidance, which seems to have been adopted by many guidance teachers and counsellors, would be in danger of consigning guidance permanently to a marginal and ineffectual role. Major structural changes would seem to be desirable, both in education and in the operation of the labour market before such guidance is likely to be truly effective (ibid.).

#### 4.8 Problems and Limitations in Counselling (in general)

4.8.1. The Different Views on Concept of Mental Health and Illness in Malaysian society.

Each ethnic group in Malaysia has different views on

the concept of mental health and illness. For instance, the concept of mental health to the Malays comprises a 'clean' life (self) concept in accordance with the teaching of Islam, submission to social norms and traditional values and preservation of spiritual strength (cf. Mat Saat Baki 1983; Kinzie 1972). To be healthy means that a person must be physically, mentally, socially and spiritually fit. Mental illness on the other hand, is regarded not only in a physical sense but also has implication on individual and societal attitudes towards the patient. Precisely, illness is associated with the physical weaknesses, social and spiritual handicap and fate from God. In other words, sickness, whether mental or physical, is always being related to the medical, magical and religious. Such differences have to be taken into consideration in counselling.

4.8.2 The counselling techniques that have been formulated and expanded in the West, emphasize social autonomy whereby an individual is helped to establish stability in life and integration with society through self-reflective method and critical re-evaluation of his relationship with environment and culture (Kinzie 1972). Some of these techniques may not be applicable to Malaysian society.

For example, counselling as practiced in Western countries gives more emphasis to the individual treatment and it thus limits the involvement or the participation of the family in counselling. In Malaysia, the group treatment (in case of psychotherapy or clinical counselling) is preferable where all members of the family will be present (cf. Mat Saat Baki 1983). In this way, the patient or

client will not feel alone or neglected in his suffering. In fact, the individual normally feels that his family has the right to be involved in the treatment.

4.8.3 Presently, most of the knowledge and methods in counselling are based on the attitudes and orientation of the people in the West. This is due to the fact that most of our counsellors are being trained in the West and the reading material for reference are also imported from there. As a consequence, their values and attitudes are directly being absorbed in counselling. These values may not be suitable for our Asian societies.

Besides which, the counsellors who were being trained in the West might face problems in re-adjusting themselves to their own societies. They might feel 'divorced' from their own society because what they understood and wished to practice might not be concurrent to the spiritual development of the society. In addition, they might not be able to carry out the academic training obtained overseas which may not be related to the needs of the local people (cf. Mat Saat Baki 1983). For example, the local people mostly would not accept the counselling approach towards psychopathology and its implication towards psychotherapy. Most of them often think that counselling or any spiritual treatment is only meant for psychotics and not for those who are facing serious problems in their daily life. This means that they rarely require or appear willing to undergo intensive counselling or spiritual treatment (Mat Saat Baki 1983; Kinzie 1972).

#### 4.9 Recommendations

4.9.1 A centre for guidance and counselling should be established in every school, district or state. At present only 2 or 3 schools in the state (known as sample schools) have such a centre whereby all information, particularly on careers could be collected and processed for the pupils that require them. It should be established based on the close co-operation and co-ordination between the Ministry of Education, Ministry of Youth and Culture, Ministry of Labour and Manpower Resources, The Malaysian Vocational Guidance Association (MAVOGA), statutory bodies and private sectors.

4.9.2 A complete and up-dated list of training programme on Career Planning should also be prepared and given to the pupils at the end of their schooling (i.e. before they leave schools), regardless of whether they wish to further their studies or to find jobs.

4.9.3 Efforts should be made by the Ministry of Labour and Manpower Resources to publish current labour market information; projection of future job demands; informational pamphlets on new positions in the industrial sector; and information on job training opportunities and higher education.

4.9.4 Placement service, i.e. a programme to help pupils find jobs with the help of job centres. Such service could help pupils to get jobs in industries that are fast developing in their areas or the country as a whole.

4.9.5 Effective training of guidance methods is the most critical need of the guidance teachers due to its inter-relationship with the other major guidance problems. Without proper training, even the simplest tasks may seem difficult. Effective training gives Career Teachers confidence in using basic guidance techniques, and also increases their ability to use their own ingenuity in dealing with a variety of difficult situations in guidance work. Therefore, the government should:

- a) increase efforts and funding to provide guidance training to guidance teachers who have not yet received this training;
- b) increase allocation of funds to hire and train additional personnel qualified to conduct guidance training;
- c) continue efforts to upgrade the effectiveness of a guidance training programme. The programme needs to analyse the question of counsellor roles and functions, expectations, counsellor image as well as philosophy, attitudes and skills;
- d) careful screening and selection of teachers for guidance work to ensure that only those who have real inclination, or possess observed abilities, are chosen.
- e) More workshops and seminars should be organised which would include some practicum of role-playing experience to enable the guidance teachers and counsellors gain more knowledge from the experiences which they could share with each other. In addition the guidance

teachers should be given the opportunity to practice the newly acquired counselling techniques in a supervised situation.

4.9.6 More multi-racial guidance teachers should be appointed in schools. At the moment, the majority of the guidance teachers are Malays (see p. 271) so that there exists a balance in their numbers to the actual school population. Besides that, more female guidance teachers should also be appointed to enable them to assist the girls in facing their adolescence problems besides the educational and vocational problems.

4.9.7 The pupils should be exposed to vocational guidance/counselling as early as possible, i.e. not necessarily to wait for the time they are about to leave school. Among the pupils who should be given the priority are as follows:

- (i) those who have been identified as experiencing a deficit in vocational development;
- (ii) those that come from remote or slum areas;
- (iii) those early school leavers;
- (iv) those who choose to work at an early age;
- (v) those from low socio-economic background;
- (vi) those who are about the complete SRP/SPM/STPM examinations.

From the above literature, we could see how involved the government is (through the Guidance and Counselling Unit, Ministry of Education) in the implementation and the future planning of the guidance and counselling services in schools

throughout the country. Without the support, financially and morally, from the government, guidance and counselling would not have flourished and become an increasingly important service towards the society and the school pupils in particular. The roles and support from other outside agencies and private organisations towards the development of the service are by no means small. With the increase in numbers of trained guidance and counselling personnel in this country, it is therefore hoped that a mentally healthy and unified society could be established in Malaysia.

## NOTES

1. M.E.S.T.I. stands for Ministry of Education Staff Training Institute.
  
2. ARAVEG 1980. ARAVEG is the short form of Asian Regional Association for Vocational and Educational Guidance. On 9th-12th September 1980, the 4th ARAVEG Conference and General Assembly was held in Kuala Lumpur, Malaysia, during which a number of working papers had been presented.

CHAPTER FIVECONCLUSION

The foregoing chapters have shown that the guidance and counselling services in Malaysia are still at a very initial stage, despite the fact that they have been introduced into the Malaysian educational system about 20 years ago. We have also seen how they have developed from the concern for suitable career opportunities to the developmental needs of the individual pupil as well as the state (McGuinness 1982, Haji Abdul Latif 1982 and 1983). Many have seen it as a means of achieving the educational goals of Malaysia, i.e. as a means to unify the multi-racial population of Malaysia.

At the beginning of this study (Chapter 1, p. 15), we have seen how guidance and counselling emerged and had taken roots in the middle-class American society. Much literature has been written and published on the concepts, theories and techniques of guidance and counselling, most of which are in relation to the western societies. Are all of them applicable to the Malaysian situation? How can they be effectively carried out in Malaysia, whose population is multi-racial? (cf. Chapter 2, p. 146). Do we need to have our own guidance and counselling concepts to suit our multiple needs? Is there a possibility of choosing a range of specific issues for further study and later using them in our own context?

Before answering the above questions, let us first examine why guidance and counselling has not been adequately

developed in Malaysia, compared to its development in the United States and particularly in Britain in the 1960s. According to Soliman (1984), there are four factors that contribute to the slow development of counselling (including guidance) in the Third World. They are as follows:

- 1) In developing countries, counselling may be performed by institutions other than those (professional counsellor) which offer counselling services in developed countries.
- 2) Counselling assumes availability of options which are very limited in the developing countries. In addition to that, placement, selection and employment are influenced by factors which may be unrelated to the individual merit (cf. Watts 1978).
- 3) Political powers influence professional practice in developing countries.
- 4) Slow programme development and education of professionals.

The above factors have to a certain extent affected the development of guidance and counselling in Malaysia. For instance, family, as an institution in the society is still regarded as an important source which provides caring, support and advice for its members (cf. Chapter 3, p.224 and Chapter 4, p.284 ). However there are indications from the survey as well as from the literature that as the Malaysian society undergoes social change, the family could no longer become effective in counselling. As a result, adolescents begin to look for other sources of assistance. However, this does not mean that the counselling function

of the family is no longer required. What needs to be emphasised here is that in developing countries like Malaysia, counselling by the family cannot replace professional counselling for at least two reasons:

a) Family members are close to each other and are actively involved in each other's affairs. As such, attempts will undoubtedly be made to influence rather than to facilitate the other's development as an individual. The counsellor, on the other hand, is "not emotionally involved as a parent, nor is he charged, as is a teacher, with seeing that a student meets a certain standard of intelligent growth in a given field" (Wrenn 1962, p. 3).

b) Guidance and counselling require special knowledge and skills which will enable the counsellor to help a person identify his potentials and facilitate his development. Therefore, attempts have to be made to find ways of adapting and adjusting the models of counselling that have grown out of the Western experience. This adjustment must take into account the unique world of the people that the counsellors wish to serve (cf. Kenzie 1972; Pande 1968).

As this study is more like a historical and conceptual clearing of the ground for effective guidance and counselling services in Malaysia, a full terrain detailed study on the subject is essential especially on matters pertaining to the cultural conflicts that exist in the society, testings in counselling and the needs of the individual versus state. We have seen how guidance and counselling in the United States is geared towards autonomy and self-help and in the United Kingdom as a form of caring for the weak or

those that need help (pastoral care). In Malaysia, the practice of guidance and counselling services is not without obstacles. For instance, the introduction of the theories and concepts of guidance and counselling from the West has given rise to many controversial issues.

One of the major issues that has often been forwarded by our guidance and counselling personnel is on the suitability of these theories and concepts that have been formulated in the West for the Western people for us in our unique situations based on the Eastern philosophy and culture. For example, guidance, in a generic sense, is a process to help an individual help himself. The concepts involved are a) guidance is a process, b) guidance is a form of help, and c) guidance is aimed at self reliance (independence). The three concepts stress on the importance of the individual, his right of making a choice (autonomy) and the nature of help that should be given to him (techniques). The extent of guidance and counselling services provided very much depends on how far the client can express his inner feelings to the counsellor. In other words, counselling can only be successful, if the client is willing to talk. A Malaysian pupil, for instance, normally faces problems in expressing himself due to the attitudes and cultural factors which expect the client to accept the explanation or answers from the counsellor. Pupils living in towns are, however, more ready to talk than those staying in the rural areas. (Yunus Md. Noor 1982).

With regard to self reliance (independence) most of our pupils still rely on their elder's choice or advice

before making any important decisions such as the choice of schools, vocation and even to a certain extent, the choice of their own life partners. Even in their normal life, they seldom make or are given the chance of making definite decisions. The individuality as practised in the West is difficult to maintain due to strong parental or family influence. Although it restricts self-reliance, such overdependence encourages co-operation and unity among all members of the family.

Besides that, the use of methodological approaches and principles of guidance and counselling (including psychology) also cause grave concerns among many Moslem counsellors. According to them, these approaches and principles are not in accordance with the teaching of Islam (i.e. psychology versus theology), and therefore must be carefully scrutinized and modified so that their negative aspects do not cause adverse effects on our young generation. Indeed, this is hardly a surprising issue since Halmos (1979), himself agreed that the development of counselling is part of the development of a 'personal service society', growing out of the decay of religion and its replacement by a faith in technology and the perfectibility of man.

In considering the emergence, development and continuation of guidance and counselling in Malaysia, issues emerge from the study which suggest that the philosophy of guidance and counselling in Malaysian society needs to:

- a) Assure confidentiality between counsellor and client,
- b) Take account of the different emphasis between the West, which advocates self-reliance, as opposed to

the East which values the community and family as a support system.

- c) Consider the relevance of the curriculum. The needs of the West differ from those of Malaysia and this has to be taken into account.
- d) Suitability of the techniques must be guaranteed or assured.
- e) Consider the spiritual values embedded within the Malaysian religious tradition.

In addition to the above factors, it is also important to look at the theory of practice and to understand problems encountered within the multi-religious, the multi-racial and the multi-cultural society of Malaysia, which should be considered when building a theory and concepts more suited to Malaysian society. To ground theory in practice would allow theory to respond to the unique situation found within Malaysian culture and society. More research, writing, publications and formulation of new theories suitable to our cultural context should be undertaken. Furthermore, the guidance teacher should be equipped with concrete knowledge on testing, evaluation and practice in administering and organising tests in counselling. All this could facilitate the growth or development of guidance and counselling as a means of achieving the goals of Malaysian education.

BIBLIOGRAPHY

- ABDUL LATIF  
B. MOHD ALI, HAJI
- : 'Masa Depan Bimbingan dan Kaunseling Di Sekolah' or 'The Future of Guidance and Counselling in School', Seminar paper presented to Seminar on Psychology and Society II, Universiti Kebangsaan Malaysia (UKM), 20-23 April, 1981 (Unpublished).
  - : 'Peranan Kaunselor Sekolah' or 'The Role of School Counsellor', Seminar paper presented to Seminar on Counselling II, UKM, 1982 (Unpublished).
  - : 'Kaunseling dalam Pendidikan Menengah' or 'Counselling in Secondary Education', Paper presented to Konvensyen Kaunseling I, Universiti Sains Malaysia (USM), Pulau Pinang, 19-23 April, 1983 (Unpublished).
- ALLPORT, G.W.
- : Personality : A Psychological Interpretation, New York: Holt, 1937
- AMER AWANG
- : 'Bimbingan dan Kaunseling untuk Kesejahteraan Masyarakat', paper presented to Konvensyen Kaunseling I, Universiti Sains Malaysia (USM), Pulau Pinang, 19-23 April, 1983 (Unpublished).
- AMERICAN SCHOOL  
COUNSELLOR ASSOCIATION  
(ASCA)
- : Position Statements, Falls Church, Virginia, 1983
- ANDAYA, BARBARA W.,  
and LEONARD, Y.
- : A History of Malaysia, London and Basingstoke: The Macmillan Press Ltd., 1982
- ANNUAL STATISTICAL  
REPORT
- : Befrienders Case Register, Kuala Lumpur, 1977
- ARBUCKLE, D.S.
- : Teacher Counselling, Cambridge, Mass.: Addison-Wesley, 1950.
  - : The Role of counsellors and counselling in 1962, in Boy, A.V. and Pine, G.J., Client-centred Counselling in the Secondary School, Boston: Houghton Mifflin, 1963, pp. 260-275.
  - : Pupil Personnel Services in the Modern School, Boston: Allyn and Bacon, Inc., 1966.

- : Counselling and Psychotherapy : an Overview, New York: McGraw-Hill, 1967
- : Counselling : Philosophy, Theory and Practice (Second Edition), Boston: Allyn and Bacon, Inc., 1970
- AUBREY, R.F.
- : 'Historical Developments of Guidance and Counselling and Implications for the Future', Personnel and Guidance Journal, 55 (6), February 1977, pp. 288-295.
- : 'A House Divided' - Guidance and Counselling in 20th Century America, Personnel and Guidance Journal, 61(4), December 1982, pp. 198-204.
- BARBURY, W.M. et al.
- : An Introduction to Child Guidance, London: Macmillan, 1945
- BARRY, R. and WOLF, B.
- : 'A History of the Guidance-personnel Movement in Education', unpublished doctoral thesis, Columbia University, 1955, cited in Aubrey, R.F., A House Undivided : Guidance and Counselling in 20th Century America, The Personnel and Guidance Journal, 1982, pp. 192-204.
- : Epitaph for vocational guidance, New York: Bureau of Publications, Teachers College, Columbia University, 1962.
- BEREDAY, G.Z.F. (Ed.)
- : Essays on World Education : the crisis of supply and demand, London: Oxford University Press, 1969
- BERITA MINGGU, KUALA LUMPUR, MALAYSIA
- : 'Menagih Dadah Puncanya Perlu Dicari', Berita Minggu, 3 June, 1984
- BERNSTEIN, B.
- : 'A Socio-Linguistic Approach to Social Learning', in Penguin Survey of the Social Services, London: Penguin Books, 1965
- BEST, R.E., et al.
- : Education and Care, London: Heinemann, 1970
- : Pastoral care : Concept & Process, British Journal of Educational Studies, Vol. XXV, No. 2, June, 1977, pp. 124-135.
- BLOCHER, D.H.
- : Developmental Counselling, (Second Edition), New York: Ronald Press, 1974.

- BLOOMFIELD, M. : The Vocational Guidance of Youth, Boston: Houghton Mifflin Company, 1911.
- : Readings in Vocational Guidance, Boston: Ginn, 1915.
- BOLGER, A.W. (ed.) : Counselling in Britain - A Reader, London: Batsford Academic & Educational Ltd., 1982.
- BORDIN, E.S. : Psychological Counselling, New York: Appleton-Century-Crofts, Inc., 1955.
- BORDIN, E.S. et al. : An articulated framework for vocational development, Journal of Counselling Psychology, 10, 1963, pp. 107-117.
- BORROW, H. : Milestones : A chronology of notable events in the history of vocational guidance, in H. Borrow (Ed.), Man in a World of Work, Boston: Houghton Mifflin, 1964.
- BRAMMER, L.M., and SHOSTROM, E.L. : Therapeutic Psychology : Fundamentals of Actualization Counselling and Psychotherapy, (2nd Ed.), New Jersey: Prentice-Hall, Inc., 1968.
- BREWER, J.M. : Education as Guidance, New York: Macmillan, 1932.
- : History of Vocational Guidance, New York: Harper and Brothers, 1942.
- BUCHHEIMER, A., and BALOGH, S.C. : The Counselling Relationship, Chicago: Science Research Associates, Inc., 1961.
- BURT, C. : The Yearbook of Education 1955 (Eds. Hall, R.K., and Lauwerys, J.A.), London: Evans Bros. Ltd., 1955.
- CAMPBELL, FLANN : Eleven-Plus & All That - The Grammar School in a Changing Society, London: Watts, 1956.
- CAPLAN, G. : An Approach to Community Mental Health, New York: Grune & Stratton, Inc., 1961.
- : Principles of Preventive Psychiatry, New York: Basic Books, Inc., 1964.
- CARKUFF, R.R., and BERENSON, B.G. : Beyond Counselling and Therapy, 2nd Edition, New York : Holt, Rinehart and Winston, 1977.

- CENTRAL ADVISORY COUNCIL: Early Leaving, London: HMSO, 1954.  
 FOR EDUCATION  
 (ENGLAND) : 15 to 18 ('Crowther Report'), London: HMSO, 1959.
- : Half our Future ('Newsom Report'), London: HMSO, 1963, (see also 'Newsom Report').
- : Children and their Primary Schools ('Plowden Report'), London: HMSO, 1967.
- CHEESEMAN, H.R. : 'Compulsory Education in Malaya', Education in Malaya, Kuala Lumpur: Government Printers, 1948.
- : 'Education in Malaya', The Malayan Historical Journal, Vol. 2, (No. 1), July 1955.
- CHELLIAH, D.D. : A Short History of Educational Policy in the Straits Settlements, Singapore: G.H. Kiat, 1960 (reprint).
- CHILD, D. : Readings in Psychology for the Teacher, London: Holt, Rinehart and Winston Ltd., 1977.
- CICOUREL, A.V., and KITSUSE, J.I. : The Educational Decision Makers, New York: Bobbs-Merril, 1963.
- CLARKE, F. : Freedom in the Educative Society, London: University of London Press, 1948.
- COLEMAN, J.C. : The Adolescent Society, New York Free Press, 1961.
- : Relationship in Adolescence, London and Boston: Routledge and Kegan Paul, 1974.
- : The Nature of Adolescence, London: Methuen & Co. Ltd., 1980 (Reprinted 1982).
- COMBS, A., and SNYGG, D. : Individual Behaviour, New York: Harper, 1949.
- CONANT, J.B. : The American high school today, New York: McGraw-Hill, 1959.
- : Slums and suburbs, New York: McGraw-Hill, 1961.
- CRAFT, M. (Ed.) : Family Class and Education - a Reader, London: Longman, 1970.

- : 'The School Welfare Team' in Craft, M. et al. (Eds), Linking Home and School, London: Longman (Second Edition), 1972.
- CRAFT, M. et al. (Eds.): Linking Home and School, (Second Edition), London: Longman, 1972, (originally published in 1967).
- : Linking Home and School - A New Review, (Third Edition), London: Harper and Row Publisher, 1980.
- CRAFT, M. and LYTTON, H. (Eds.): Guidance and Counselling in British Schools - A Discussion of Current Issues, (Second Edition), London: Edward Arnold Ltd., 1974.
- CREMIN, L.A. : The progressive heritage of the guidance movement, in R.L. Mosher, R.F. Carle, and C.D. Kehas (Eds.), Guidance : An Examination, New York: Harcourt, Brace and World, 1965.
- CROWTHER REPORT, THE : 15 to 18 : A Report by the Central Advisory Council Education (England), London: HMSO, Vol. 1 : Report, 1959 Vol. 2 : Report, 1960.
- CURRICULUM 11-16 : Working papers by H.M. Inspectorate: A contribution to current debate, D.E.S., HMSO, December, 1977, (see also D.E.S., 1977).
- CURRICULUM 11-16 : A Review of Progress, HMSO, 1981.
- CURRY, W.B. : 'A Pioneer of Education', by J.W. Tibble- The first W.B. Curry Lecture delivered in the University of Exeter on 16 October 1967, University of Exeter.
- DAVIS, J. : Vocational and Moral Guidance, Boston: Ginn, 1914.
- DAVIS, H.V. : 'The Cradle of Vocational Guidance', Vocational Guidance Quarterly, 11(1), Autumn 1962, pp. 4-6.
- DAWS, P.D. : 'The Guidance Team in the Secondary School', Bulletin of British Psychological Society, 21, 71, 1968, p. 129.
- : A Good Start in Life, Cambridge: CRAC, (first published in 1968 and reprinted in 1972).

- : Careers Bulletin, Central Youth Employment Executive, Autumn 1969.
- : Early Days - A Personal Review of the Beginning of Counselling in English Education during the Decade 1964-1974, Cambridge:Careers Research Advisory Council, Hobson Press Ltd., 1976.
- : Mental Health and Education : Counselling and Prophylaxis, in Dennis Child Readings in Psychology for the Teacher, London: Holt, Rinehart and Winston Ltd., 1977, pp. 380-386.
- : The School Counsellor, Linking Home and School, (3rd Edition), London: Harper & Row Publishers, 1980, pp. 244-256.

DEPARTMENT OF  
EDUCATION AND SCIENCE  
(D.E.S.)

- : Careers Guidance in Schools, D.E.S. Pamphlet No. 48, London: HMSO, 1965.
- : Careers Education in Secondary Schools, Education Survey 18, Department of Education and Science, London: HMSO, 1973.
- : Curriculum 11-16, HMSO, 1977.
- : Education in Schools : A consultative document, Cmnd 6869, HMSO, 1977.
- : Aspects of Secondary Education in England - A Survey by H.M. Inspectorate of Schools, London: HMSO, 1979.
- : A View of the Curriculum, HMSO, 1980.
- : The School Curriculum, HMSO, 1981.

DEPARTMENT OF EDUCATION:  
OF THE STRAITS SETTLE-  
MENT AND FEDERATED  
MALAY STATES

Career Guidance in Malaya for Parents, Teachers and Pupils, Kuala Lumpur: Government Printers, 1939.

DOUGLAS, J.W.B.

- : The Home and the School, London: MacGibbon & Kee, 1964.

ERIKSON, E.H.

- : Childhood and Society, New York: W.W. Norton, 1950
- : Identity and the Life Cycle, Psychological Issues, Monograph I, New York: International University Press, 1959.

- : Childhood and Society, Harmondsworth: Penguin, 1965.
- : Identity : Youth and Crisis, London: Faber and Faber, 1968.
- FAWZIAH ELYAS, PUAN : Bumiputra Development Training Programme - A Malaysian Experience, MARA Institute of Technology, Paper presented to 4th ARAVEG Conference & General Assembly, Kuala Lumpur, 9-12 September, 1980 (Unpublished).
- FLETCHER, ANNE : Guidance in Schools, Aberdeen: Aberdeen University Press, 1980.
- FREUD, A. : The Ego and the Mechanisms of Defense, London: Hogarth Press, 1937.
- GINSBERG, N.S. and ROBERTS, C.F. : Malaya, Seattle: University of Washington Press, 1958.
- GINZBERG, E. et al. : Occupational choice : An approach to a general theory, New York: Columbia University Press, 1951.
- GINZBERG, E. : Career Guidance, New York: McGraw-Hill, 1971.
- HAJI HAMDAN B. SHEIKH TAHIR : Pendidikan Hari Ini dan Hari Esok (Education - Today and Tomorrow), Kuala Lumpur: Dewan Bahasa dan Pustaka (DBP), 1975.
- HALL, R.K. and LAUWERYS, J.A. (Eds.) : The Yearbook of Education, London: Evans Bros. Ltd., 1955.
- HALMOS, P. : The Faith of the Counsellors, (2nd Edition), London: Constable, reprinted, 1979.
- HAMBLIN, D.H. : The Teacher and Pastoral Care, Oxford: Basil Blackwell, 1978.
- : The Teacher and Counselling, Oxford: Basil Blackwell, (First Published 1974, Reprinted 1981).
- HAMZAH S. MOHAMAD : 'Bimbingan dan Kaunseling Dari Sudut Pandangan Islam' (Guidance and Counselling from the Islamic point of View), Paper presented to the Konvensyen Kaunseling I, Universiti Sains Malaysia (USM), Pulau Pinang, 19-23 April, 1983. (Unpublished).

- HARGREAVES, D.H. : Social Relations in a Secondary School, London: Routledge & Kegan Paul, 1967.
- HAVIGHURST, R.J. : Developmental tasks and education, New York: Longman , Green, 1952.
- HENG-KENG CHIAM : 'The Role of Guidance and Counselling in Educational Development', Suara Pendidik, Vol. 5, No. 2, June 1979, pp. 14-25.
- HERR, E.L. : Does Counselling Work? Pennsylvania: Pennsylvania State University, 1976.
- HERR, E.L., and CRAMER, S.H. : Vocational Guidance and Career Development in the Schools : Toward a Systems Approach, Boston: Houghton Mifflin Co., 1972.
- HOLLAND, J.L. : A theory of vocational choice, Journal of Counselling Psychology, 6, 1959, pp. 35-45.
- HOLLINSHEAD, A.B. : Elmtown's youth, New York: John Wiley, 1949.
- HOPSON, B., and SCALLY, M. : Life skills Teaching, London: McGraw Hill Book Co. (U.K.), 1981.
- HORNEY, K. : The Neurotic Personality in Our Time, New York: Norton, 1937.
- HOYT, K.B. : 'Guidance : A Constellation of Service', Personnel and Guidance Journal 40, April 1962, pp. 690-697.
- HUGHES, P.M. : Guidance and Counselling in Schools - A Response to Change, Oxford: Pergamon Press, 1971.
- HUSSEIN ONN : Education in Malaysia, Kuala Lumpur: Jabatan Penerangan Malaysia, Government Printers, 1971.
- IBRAHIM SAAD (Ed.) : Isu Pendidikan Di Malaysia, Kuala Lumpur: Dewan Bahasa dan Pustaka, Kementerian Pelajaran Malaysia, 1982.
- INHELDER, B., and PIAGET, J. : The Growth of Logical Thinking from Childhood to Adolescence, New York: Basic Books, 1958.
- IYER, G.K. : Guidance Services - Its Current Status in Schools, Jernal Panduan MAVOGA, Vol. 1, No. 1, June 1975, pp. 21-24.

- : Educational Components of Drug Abuse Prevention, Jernal Panduan MAVOGA, Vol. 1, No. 2, December 1977, pp. 39-42.
- : Suitable Approaches for Drug Abuse Prevention Amongst Youth, Jernal Panduan MAVOGA, Vol. 1, No. 3, June 1979, pp. 21-29.
- JACKSON, R. and JUNIPER, D. : Manual of Educational Guidance, London: Holt, Rinehart and Winston, 1971.
- JENKINS, C. and SHERMAN, B. : The Collapse of Work, London: Eyre Methuen Ltd., 1979.
- JONES, ANNE : Counselling Adolescents in Schools, London: Kogan Page (First published in 1977, paperback edition in 1979).
- KARDINER, A. : The Individual and His Society, New York: Columbia University Press, 1939.
- KEHAS, C.D. : Guidance in Education : An examination of the Interplay between definition and structure, in V.F. Calia & D.B. Wall (Eds.), Pupil Personnel Administration, Springfield, Ill., Charles C. Thomas, 1968.
- : Toward a Redefinition of education : A New Framework of counselling for Counselling in Education, in B. Shertzer and S.C. Stone (Eds.), Introduction to Guidance : Selected Readings, Boston: Houghton Mifflin, 1970.
- : Guidance and the process of schooling : Curriculum and career education, School Counsellor, 21, 1973, pp. 103-113.
- KELLY, T.L. : Educational Guidance. Unpublished doctoral thesis, Columbia University Teachers College, 1946, cited in R.F. Aubrey A House Divided: Guidance and Counselling in 20th Century America, The Personnel and Guidance Journal, Vol. 61, No. 4, December 1982, pp. 198-204.
- KEMENTERIAN PELAJARAN MALAYSIA : See Ministry of Education, Malaysia.

- KINZIE, J. : 'Cross-cultural Psychotherapy : The Malaysian Experience', American Journal of Psychotherapy, Vol. 26, 1972, pp. 220-231.
- KITSON, H.D. : Suggestions Towards a Tenable Theory of Vocational Guidance, in Meyer Bloomfield (Ed.), Readings in Vocational Guidance, Boston: Ginn, 1915.
- LASCH, C. : The New Radicalism in America, New York: Vintage Books, 1965.
- LAWRENCE, D. : Improved Reading Through Counselling, London: Ward Lock, 1973.
- LEWIS, E.C. : The Psychology of Counselling, New York: Holt, Rinehart and Winston, Inc., 1970.
- LINDEMANN, E. : 'Symptomatology and Management of Acute Grief', American Journal of Psychiatry 101, (September 1944), pp. 141-148.
- LITTLE, W., and CHAPMAN, A.L. : Developmental Guidance in the Secondary School, New York: McGraw-Hill Book Company, 1955.
- LOH ENGGKIAT : A Critical Evaluation of the Curriculum for Elementary School in Malaysia, Majalah Pendidikan, (Proceeding of the Conference on Current Development and New Emphasis in School Curricula), Vol. 1, No. 1, Fakulti Pendidikan, Universiti Malaya, Kuala Lumpur, 1965.
- LYND, R.S., and H.M. : Middletown, New York: Harcourt Brace, 1954.
- LYTTON, H. : School Counselling and Counsellor Education in the United States, London: NFER, 1968.
- MALAYSIA : Fourth Malaysia Plan 1981-1985, Kuala Lumpur: Jabatan Cetak Kerajaan, 1981.
- MANNHEIM, K., and STEWART, W.A.C. : An Introduction to the Sociology of Education, New York: Routledge and Kegan Paul, 1962.
- MAT SAAT BIN MOHAMED BAKI : 'Kaunseling dan Kesihatan Jiwa', (Counselling and Mental Health), Paper presented to Konvensyen Kaunseling I, Universiti Sains Malaysia (USM), Pulau Pinang, 19-23 April 1983. (Unpublished).

- MATHEWSON, R.H. : Guidance Policy and Practice, (Second Edition), New York: Harper & Brothers, 1962, (1st Edition 1949).
- MAVOGA : History of MAVOGA, Kuala Lumpur, 1980.
- MAVOGA : Suara MAVOGA, Special Issue, Kuala Lumpur: 1982.
- MAYS, J.B. : Education and the Urban Child, Liverpool University Press, 1962.
- MENON, SAROJINI : Guidance and Counselling - An Overview, Jernal Panduan MAVOGA, Vol. 1, No. 1, June 1975, pp. 32-37.
- MERRITT, G. : World out of Work, London: Collins, 1982.
- MILLER, C.H. : Foundations of Guidance, New York: Harper and Bros., 1961 (Second Edition 1971).
- MILLER, C.H. : Vocational guidance in the perspective of cultural change, in H. Borrow, (Ed.), Man in a World of Work, Boston: Houghton Mifflin, 1964.
- MILLER, C.H. : Guidance Services - An Introduction, New York: Harper and Row, 1965.
- MILLINS, P.K. : 'The Preparation of Teacher', in Towards a Multi-racial Society, New York: McGraw-Hill, 1966.
- MINISTRY OF EDUCATION, MALAYSIA (KEMENTERIAN PELAJARAN MALAYSIA) : Perkhidmatan Panduan Di Sekolah, Kementerian Pelajaran Malaysia, Kuala Lumpur: Dewan Bahasa dan Pustaka, 1966.
- MINISTRY OF EDUCATION, MALAYSIA (KEMENTERIAN PELAJARAN MALAYSIA) : E.P.R.D. (Educational Planning and Research Division) Report, Kementerian Pelajaran Malaysia, Kuala Lumpur, 1968.
- MINISTRY OF EDUCATION, MALAYSIA (KEMENTERIAN PELAJARAN MALAYSIA) : Guidance in Schools - prepared by The Educational Planning and Research Division, Ministry of Education Malaysia, Kuala Lumpur, 1971.
- MINISTRY OF EDUCATION, MALAYSIA (KEMENTERIAN PELAJARAN MALAYSIA) : Education in Malaysia, Kuala Lumpur: Ministry of Education, 1970.
- MINISTRY OF EDUCATION, MALAYSIA (KEMENTERIAN PELAJARAN MALAYSIA) : Educational Statistics of Malaysia, The Educational Planning and Research Division, Ministry of Education, Kuala Lumpur: Dewan Bahasa dan Pustaka, 1971.

- : Sukatan Pelajaran Bimbingan dan Kaunseling - Kursus Perguruan Khas (Kursus Tambahan Satu Tahun), Bahagian Pendidikan Guru, Kementerian Pelajaran Malaysia, 1981.
  - : General Guide to Discipline in Schools, Ministry of Education Malaysia, Kuala Lumpur: Adabi, 1981.
  - : What is counselling? (Apa itu Kaunseling), Unit Bimbingan dan Kaunseling, Bahagian Sekolah-Sekolah, Kementerian Pelajaran Malaysia, Kuala Lumpur, 1982.
  - : Mencegah Salah Guna Dadah Melalui Kaunseling, Unit Bimbingan dan Kaunseling, Kementerian Pelajaran, Kuala Lumpur: Percetakan Dewan Bahasa dan Pustaka, 1983.
  - : Bekalan dan Utilizasi Guru-Guru Bimbingan Di Sekolah-Sekolah Menengah-Satu Tinjauan Awal, Unit Bimbingan dan Kaunseling, Bahagian Sekolah-Sekolah, Kementerian Pelajaran Malaysia, Kuala Lumpur, March 1983.
  - : Berita Bimbingan dan Kaunseling, Kuala Lumpur, Vol. 2, No. 1, Mei 1983.
  - : Berita Bimbingan dan Kaunseling, Kuala Lumpur, Vol. 3, No. 1, Mei 1984 and Vol. 3, No. 2, October 1984.
- MOORE, B.M.
- : Guidance in Comprehensive Schools : A Study of Five Systems, London: NFER, 1970.
- MOORE, G.D., and FULLER, J.A.
- : 'School Counselling : A Survey of the Roles of Counsellors who qualified in Reading in 1966', Guidance Unit, Institute of Education, University of Reading, 1967.
- MORRIS, B.M.
- : 'Guidance as a concept of educational philosophy in HALL and LAUWERYS (eds.), The Year Book of Education, 1955, London: Evans Bros.
  - : Objectives and Perspectives in Education - Studies in Educational Theory, London: Routledge and Kegan Paul Ltd., 1972.

- MOORISH, I. : The Background of Immigrant Children, London: Allen & Unwin, 1971.
- MOORISH, I. : The Sociology of Education : An Introduction, (Second Edition), London: George Allen and Unwin, 1981.
- MOSHER, R.L., and SPRINTHALL, N.A. : Psychological Education : A means to promote personal development during adolescence, Counselling Psychologist, 2(4), 1971, pp. 3-82.
- MUNSTERBERG, H. : Psychology and industrial Efficiency, Boston: Houghton Mifflin, 1913.
- MURAD COMMITTEE : Kajian Keciciran (dropout study, Kuala Lumpur: Ministry of Education Malaysia, 1975.
- MURGATROYD, S. : Helping the Troubled Child, London: Harper & Row, 1980.
- MURGATROYD, S.J., and BOORER, D.R. : Personality & Learning : A Select Annotated Bibliography, Caerphilly: MTM Publishing House, Wales, 1973.
- MURGATROYD, S, and REDMUND, M. : Collaborative Adult Education Counselling Model and Practices, London: Harper & Row, 1978.
- MURGATROYD et al. : Coping with Crisis : Understanding and Helping People in Need, London: Harper & Row, 1982.
- MURRAY, H.A. : Explorations in Personality, New York: Oxford University Press, 1938.
- MCCANDLESS, B.R., and EVANS, E.D. : Children and Youth, Hinsdale, Ill.: The Dryden Press, 1973.
- MCCORD, J.B. and PACKWOOD, W.T. : 'Crisis Centres and Hotlines : A Survey', Personnel and Guidance Journal 51 (June 1971), pp. 723-728.
- MCDANIELS, C. : NVGA : Past, present and future, Vocational Guidance Quarterly, 22, 1974, pp. 252-254.
- MCGUINNESS, J.B. : Towards a Rationale for Group Counselling in the Secondary School, (unpublished M.Ed. dissertation), University of Durham, 1977.
- MCGUINNESS, J.B. : ACE Information Sheet, "WHERE", No. 173, November/December 1981, pp. 11-14.

- : Planned Pastoral Care, London: McGraw-Hill Book Company (UK) Limited, 1982.
- : 'Secondary Education for All?', Sacred Cow in Education - Essays in Reassessment, (Edited by F. Coffield & R. Goodings, Edinburgh University Press for the University of Durham), 1983.
- NATIONAL ASSOCIATION FOR MENTAL HEALTH (N.A.M.H.) : School Counselling : a Report of a Working Party, London: NAMH, 1970
- NELSON-JONES, R. : The Theory and Practice of Counselling Psychology, London: Holt, Rinehart and Winston, 1982.
- NEWSOM REPORT, THE : Half Our Future, A Report of the Central Advisory Council for Education (England), Ministry of Education, HMSO, 1963.
- OANA, K. : Opportunities in Counselling and Guidance VGM, Career Horizon, Illinois: Skokie, 1979.
- OPPENHEIM, A.N. : Questionnaire Design and Attitude Measurement, London: Heinemann, 1966.
- OSMAN MOHAMAD : Research Report on 'Career Programmes For Entering Students in Univisiti Sains Malaysia', (USM), 4th ARAVEG Conference & General Assembly, Kuala Lumpur, Malaysia, 1980.
- PANDE, S.K. : The Mystique of "Western" Psychotherapy: An Eastern Interpretation, The Journal of Nervous and Mental Disease, Vol. 146, No. 6, June 1968, pp. 425-432.
- PARKER, CLYDE A. (Ed.) : Counselling Theories & Counsellor Education (Ed.), Boston, Mass.: Houghton Mifflin, 1968.
- PARSONS, F. : Choosing a Vocation, Boston: Houghton Mifflin, 1909.
- PATTERSON, C.H. : Counselling and Guidance in Schools, New York: Harper & Row, Publishers Inc., 1962.
- : The Counsellor in the School : Selected Readings, New York: McGraw-Hill, 1967a.

- : Psychotherapy in the School. In D.S. Arbuckle (Ed.), Counselling and Psychotherapy : An Overview, New York: McGraw-Hill, 1967b.
- : An Introduction to Counselling in the School, London: Harper and Row, 1971.
- : Theories of Counselling and Psychotherapy, London: Harper and Row, (2nd Edition), 1973.
- : 'Cross-cultural or intercultural counselling or psychotherapy', International Journal For The Advancement of Counselling, Vol. I, Part 3, 1978, pp. 231-247.
- PEPINSKY, H.B., and PEPINSKY, P.N. : Counselling Theory and Practice, New York: Ronald, 1954.
- PETERS, H.J., and FARWELL, G. : Guidance : A Developmental Approach, (2nd Edition), Chicago: Rand McNally & Company, 1967.
- PIAGET, J. : The origins of Intelligence in Children, New York: International Universities Press, 1952.
- PLOWDEN REPORT, THE : Children and Their Primary Schools, HMSO, 1967.  
(also see Central Advisory Council)
- POSTLETHWAITE, K, and DENTON, C. : Streams for the Future?, Pubansco, 1978.
- PRINGLE, M.K. : The Needs of Children, Hutchinson of London, 1975.
- PROCTOR, W.M. : Educational and Vocational Guidance, Boston: Houghton Mifflin, 1925.
- PROCTOR, W.M. et al. : Workbook in Vocations, Boston: Houghton Mifflin, 1931.
- PURCELL, V. : The Chinese in Malaya, London: Oxford University Press, (Reprint), 1967.
- RADIN SOENARNO : 'Malay Nationalism, 1896-1941', Journal of Southeast Asian History (J.S.E.A.H.), Vol. 1, No. 1, Singapore: March 1960.
- REPORTS (MALAYSIA) : Report of Central Advisory Committee on Education, Kuala Lumpur: Government Printers, 1949.

- : Report of the Committee on Malay Education or the Barnes Report, Kuala Lumpur: Government Printers, 1951.
- : Report of a Mission invited by the Federation Government to study the problems of the Education of Chinese in Malaya, Kuala Lumpur: Government Printers, 1951.
- : The Fenn-Wu Report, Kuala Lumpur: Government Printers, 1951.
- : Report on the Barnes Report on Malay Education and the Fenn-Wu Report on Chinese Education, Kuala Lumpur: Government Printers, 1951.
- : Report of the Special Committee to Consider Ways and Means of implementing the Policy Outlined in Education Ordinance, 1952, Sessional Paper No. 67 of 1954, Kuala Lumpur: Government Printers, 1954.
- : Report of the Education Committee (Razak Report), Ministry of Education, Kuala Lumpur: Government Printers, 1956.
- : Report of the Education Review Committee (Rahman Talib Report), Ministry of Education, Kuala Lumpur: Government Printers, 1960.
- : Report on Technical and Vocational Education, Ministry of Education, Kuala Lumpur: Government Printers, 1974.
- : Report of the Committee of Officials appointed to examine the Recommendations of the Dropout Study, Ministry of Education, Kuala Lumpur: Government Printers, December 1973.
- : Laporan Jawatankuasa Kabinet Mengkaji Perlaksanaan Dasar Pelajaran (Report of Cabinet Committee on Education Policy or Mahathir Report), Kementerian Pelajaran Malaysia, Kuala Lumpur: Dewan Bahasa dan Pustaka, 1979.
- : Laporan Tahunan Unit Panduan Pelajaran dan Kerjaya (Annual Report of The Educational Guidance and Careers Unit), School Division, Ministry of Education of Malaysia, Kuala Lumpur, 1982.

- : Report of the Department of Psychology, National University of Malaysia (UKM), Malaysia, 1981.
- : Report of the Department of Psychology, National University of Malaysia (UKM), Malaysia, 1983.
- RICHARDSON, E. : The Environment of Learning, London: Thomas Nelson & Sons Ltd., 1967.
- RICHARDSON, J. : 'Objections to Personal Counselling in Schools', British Journal of Guidance and Counselling, January, 1979, pp. 129-143.
- RIESMAN, D. : The Lonely Crowd, New Haven: Yale University, 1950.
- ROE, A. : The Psychology of Occupations, New York: John Wiley, 1956.
- ROBBINS REPORT, THE : Higher Education, London: HMSO, 1963.
- ROFF, W.R. : The Origins of Malay Nationalism, Kuala Lumpur: University of Malaya Press, 1967.
- ROGERS, C.R. : Counselling and Psychotherapy, Boston: Houghton Mifflin, 1939.
- : Client-centred Therapy, Boston: Houghton Mifflin, 1951, (Reprinted in paperback Eds., London: Constable, 1978).
- : 'The Necessary and Sufficient Conditions of Therapeutic Personality Change', Journal of Consulting Psychology 21, (April 1957), pp. 95-103.
- : On Becoming a Person, Boston: Houghton Mifflin, 1961, (Reprinted in paperback Ed., London: Constable, 1967).
- ROGERS, C.R., and DYMOND, R.F. (Ed.) : Psychotherapy and Personality Change, Chicago: University of Chicago Press, 1954.
- SCHNEIDMAN, E. : 'Crisis Intervention : Some Thoughts and Perspectives', in Gerald A. Specter and William L. Claiborn (eds.), Crisis Intervention, New York: Behavioural Publication, 1973.

- SCHOOL COUNCIL : Counselling in Schools - A Study of the present situation in Great Britain, Working Paper No. 15, London: HMSO, 1967.
- SHARROCK, ANNE : Research on Home-School Relations, Linking Home and School - A New Review, (3rd Edition) by Craft, M. et al. London: Harper and Row Publisher, 1980).
- SHAW, M.C. : School Guidance System, Boston: Houghton Mifflin, 1973.
- SHERIF, M. : The Psychology of Social Norms, New York: Harper, 1936.
- SHERMAN, B., and JENKINS, C. : The Collapse of Work, London: Eyre Methuen Ltd., 1979.
- SHERTZER, B., and STONE, S. : Fundamentals of Guidance (Second Edition), Boston: Houghton Mifflin Company, 1971, (Third Edition 1976).
- SHOBEN, R.J. : Guidance : Remedial Function or Social Reconstruction?, in R.L. Mosher, R.F. Carle & C.D. Kehas (Eds.), Guidance : An Examination, New York: Harcourt, Brace and World, 1965.
- SOLIMAN, ABDALLA M. : 'Why is Counselling Developing Slowly in Developing Countries?', Internationally Speaking, APGA International Relations Committee, Spring 1984.
- STONE, L.J., and CHURCH J. : 'Childhood and Adolescence', New York: Random House, 1973.
- SU BEE YAN : 'The Befrienders', Seminar Papers presented to Seminar on Psychology and Society II, Universiti Kebangsaan Malaysia (UKM), 20-23 April, 1981, (Unpublished).
- SULLIVAN, H.S. : The Interpersonal Theory of Psychiatry, New York: W.W. Norton, 1953.
- SUMMERFIELD REPORT, THE : Psychologists in Education Services, HMSO, 1968.
- SUPER, D.E. : The Dynamics of Vocational Development, New York: Harper and Brothers, 1942.
- : A Theory of Vocational Development, American Psychologist, 8, 1953, pp. 185-190.

- : Transition : From Vocational Guidance to Counselling Psychology, Journal of Counselling Psychology, 2, 1955, pp. 3-9.
  - : Vocational Development : The Process of Compromise or Synthesis, Journal of Counselling Psychology, 3, 1956, pp. 249-253.
  - : The Psychology of Careers, New York: Harper and Row, 1957.
  - : Guidance in American Education : Its Status and its future, in G. Landy and P.A. Perry (Eds.), Guidance in American Education, Cambridge, Mass.: Harvard University Press, 1964.
- TAYLOR, H.J.F.
- : School Counselling, Basingstoke and London: MacMillan Education Ltd., 1971.
- THE NEW STRAITS TIMES, (MALAYSIA)
- : The New Straits Times, Kuala Lumpur: Malaysia, 18 June 1964.
  - : The New Straits Times, Kuala Lumpur: September, 1979.
  - : The New Straits Times, Kuala Lumpur: Malaysia, 15 June 1980.
  - : The New Straits Times, Kuala Lumpur: Malaysia, 31 August 1980.
  - : The New Straits Times, Kuala Lumpur: Malaysia, 25 September 1980.
  - : The New Straits Times, Kuala Lumpur: Malaysia, 5 October 1980.
  - : The New Straits Times, Kuala Lumpur: Malaysia, 2 September 1981.
  - : The New Straits Times, Kuala Lumpur: Malaysia, 16 September 1983.
- THE TIMES EDUCATIONAL SUPPLEMENT
- : London: 23 March 1946.
- TIBBLE, J.W.
- : Adults and Adolescents - Group Discussions on Relationships and Problems of Communication, UNESCO/NEF, 1964.

- TIEDEMAN, D.V., et al. : Position choices and careers : Elements of a theory, Harvard Studies Career Development, No. 8, Cambridge: Harvard University School of Education, 1958.
- TIEDEMAN, D.V., and FIELD, F.L. : Guidance : The Science of Purposeful Action Applied Through Education, in R.L. Mosher, R.F. Clarke, & C.D. Kehas (Eds.), Guidance : An Examination, New York: Harcourt, Brace and World, 1965, pp. 192-213, (Originally published in Harvard Educational Review 32, Fall 1962).
- TRUAX, C.B., and CARKHUFF, R.R. : Toward Effective Counselling and Psychotherapy, Chicago: Aldine, 1967.
- TYLER, L.E. : The work of the Counsellor, New York: Appleton-Century-Crofts, 1961.
- UNESCO : Division of Structures, Content, Methods and Techniques of Education, Guidance and Counselling : UNESCO's Programmes and Suggestions for Future Actions, Paris: UNESCO, January, 1983.
- VAUGHAN, T.D. : Education and Vocational Guidance Today, London: Routledge and Kegan Paul Ltd., 1970.
- WALL, W.D. : Constructive Education for Adolescents, UNESCO, London: Harrap & Co. Ltd., 1977.
- WALTZ, G.R. : Emerging Issues and Priorities in Career Guidance For the 1980s, University of Michigan, 1979.
- WARNER, W.L. : The society, the individual and his mental disorders, American Journal of Psychiatry, 94, 1937, pp. 275-284.
- WARNER, W.L. et al. : Social class in America, Chicago: Science Research, 1955.
- WARNOCK REPORT : Meeting Special Educational Needs, HMSO, 1978.
- WATTS, A.G. : 'The Interaction between Careers Guidance and the School Curriculum in Malaysia', in Guidance and the School Curriculum, Paris: UNESCO, 1978, pp. 104-114.

- : Counselling Needs of Youth and Adults, Bulletin of International Association of Educational and Vocational Guidance, 37, 1981, pp. 19-20.
- : Education, Unemployment and the Future of Work, Milton Keynes: Open University Press, 1983.
- WATTS, A.G., et al. : Career Development in Britain - Some Contributions to Theory and Practice, Cambridge: CRAC, 1981.
- WHITE, R.W. : Lives in progress, New York: Dryden Press, 1953.
- WILLIAMSON, E.G. : An Historical Perspective on the vocational guidance movement, Personnel and Guidance Journal, 42, 1964, pp. 854-859.
- : Vocational Counselling, New York: McGraw-Hill, 1965.
- WINSTEDT, R.O. : A History of Malaya, London: Luzac & Co., 1935.
- WISEMAN, S. : Education and Environment, Manchester: Manchester University Press, 1964.
- WONG, H.K.F., and EE, T.H. : Education in Malaysia, (2nd Edition), Kuala Lumpur: Heinemann Educational Books (Asia) Ltd., 1975.
- WRENN, C.G. : The Counsellor in a Changing World, Washington, D.C.: APGA, 1962, (Sixth Printing in 1966).
- : The World of the Contemporary Counsellors, Boston: Houghton Mifflin Company, 1973.
- YEGAR, M. : The Development of Islamic Institutional Structure in Malaya, 1874-1941; The Impact of British Administrative Reforms, in Islam in Asia, Vol. II, (Eds.) Raphael Israeli and Anthony H. Johns, Jerusalem: The Magnes Press, 1984.
- YUNUS MOHD. NOR : 'Ke Arah Pembentukan Falsafah Kaunselling di Malaysia', or 'Towards Formulation of Counselling Philosophy in Malaysia', Paper presented to Seminar on Psychology and Society II, Universiti Kebangsaan Malaysia (UKM), 20-23 April, 1981 (Unpublished)

1.7 Appendix 1School Guidance Services in Malaysia

The questionnaire was divided into four separate groups called Form A, Form B, Form C and Form D. Each of them was distributed to the Principals, the guidance teachers, the pupils and their parents respectively.

**BORANG A**  
**(FORM A)**

Soal-selidik ini untuk diisi oleh Guru Besar  
(This questionnaire is to be answered by the Principal)

**BIMBINGAN DAN KAUNSELING DI SEKOLAH-SEKOLAH MENENGGAN DI MALAYSIA**  
**(GUIDANCE AND COUNSELLING IN MALAYSIAN SECONDARY SCHOOLS)**

Nota: Segala maklumat dalam kajian ini akan dianggap rahsia dan nama Sekolah atau orang yang berkenaan tidak akan diidentifikasi atau disebut dalam analisa data yang muktamad.

Note: (The information in this survey is confidential and no school or person will be identified or mentioned in the final analysis of data).

**BAHAGIAN A** - **SEKOLAH**  
**(SECTION S)** (SCHOOL)

1. Nama sekolah: .....  
(Name of Secondary School):

2. Tahun didirikan: .....  
(Year established)

3. Lokasi mengikut klasifikasi Kementerian Pelajaran:  
(Location according to Ministry of Education's classification):

Bandar/Pekan  
(Urban)

Luar Bandar  
(Rural)



4. Jenis Sekolah:  
(Type of School):

Lelaki  
(Boys)

Perempuan  
(Girls)

Campuran  
(Mixed)

Berasrama  
(Boarding)

5. Sesi Mengajar:  
(Teaching Session)

Pagi  
(Morning)

or

Pagi & Petang  
(Morning & Afternoon)

Bilangan Kakitangan dan Murid-Murid pada: ..... (Tarikh)  
(Staff and Pupils as on ..... (date))

6. Bilangan Murid-Murid:  
(Number of Pupils):

a) Komposisi Jantina  
(Sexual Composition)

Lelaki (Boys)	Perempuan (Girls)	Jumlah (Total)

b) Komposisi Keturunan:  
(Ethnic Composition):

Melayu Malays	China Chinese	India Indians	Lain-lain Others	Jumlah Total

7. Bilangan Guru-Guru mengikut keturunan:  
(Number of Teachers by Ethnicity):

Lelaki (Men)				Perempuan (Women)				Jumlah (Total)			
M	C	I	O	M	C	I	O	M	C	I	O

Nota: M = Malays C = Chinese I = Indian O = Others

8. Guru Besar: .....  
(Principal:)

a) Jantina (Sex): .....

b) Bangsa (Race): .....

c) Sejak bila tuan/puan menjadi Guru Besar sekolah ini?  
(How long have you been the Principal of this school?)  
.....

**BAHAGIAN B - KEMUDAHAN PERKHIDMATAN BIMBINGAN**  
**(SECTION B) - (EXTENT OF GUIDANCE SERVICES)**

1. Adakah pihak sekolah ini menyediakan sebarang bentuk perkhidmatan bimbingan dan kaunselling kepada murid-murid?  
 (Does the school provide any form of guidance and counselling services to its pupils?)

Ya/Yes  
 Tidak/No

2. Jika 'Ya':  
 (If 'Yes'):

a) Sejak bilakah perkhidmatan-perkhidmatan ini dimulakan di sekolah ini?  
 (When was these services first started in this school?):

b) Berapa orang gurukah yang dilantik sebagai guru bimbingan di sekolah ini?  
 (How many teachers are appointed as guidance teachers in the school?):

Lelaki (Men)	Perempuan (Women)	Jumlah (Total)

3. Siapakah yang melantik guru-guru bimbingan ini?  
 (Who appoint these guidance teachers?)

4. Bagaimanakah mereka dilantik? Sila nyatakan kriteria-kriteria yang diambil kira dalam pemilihan guru-guru bimbingan.  
 (How are they appointed? Please state the criterias used in the selection of the guidance teachers)

5. Berapa orangkah di antara guru-guru tersebut yang menghadiri kursus bimbingan dan kaunselling?  
 (How many of these teachers attended guidance and counselling course?):

Lelaki (Men)	Perempuan (Women)	Jumlah (Total)

6. Sila beri butir-butir lanjut mengenai kursus tersebut  
 (Misalnya: apa, dimana, bila dan sebagainya)  
 (Please give details of the course (e.g. what, where and when):

7. Jadual waktu/Timetable

Adakah pihak sekolah menetapkan jadual waktu tertentu bagi kerja-kerja bimbingan dan kaunseling?  
(Does the school allocate specific timetable for guidance and counselling work?)

Ya/Yes

Tidak/No

b) Jika 'Ya' berapa waktu (jam) seminggu diperuntukkan bagi sesi bimbingan?  
(If 'Yes' how many periods (hours) per week is being allocated for guidance sessions?)

.....

c) Jika 'Tidak' bilakah masanya khidmat bimbingan itu dijalankan oleh Guru Bimbingan?  
(If 'No' when does the Guidance Teacher help or guide his clients or pupils?)

.....

8. a) Adakah pihak sekolah menetapkan jadual waktu tertentu bagi kerja-kerja kaunseling?  
(Does the school allocate specific time table for guidance work?)

Ya/Yes

Tidak/No

b) Jika 'Ya' berapa waktu (jam) seminggu diperuntukkan bagi sesi kaunseling?  
(If 'Yes' how many periods (hours) per week is being allocated for counselling sessions?)

.....

c) Jika 'Tidak' bilakah masanya Khidmat kaunseling itu dijalankan oleh Guru Bimbingan?  
(If 'No' when does the Guidance Teacher counsel his clients or pupils?)

.....

.....

9. Adakah masa yang diperuntukkan bagi kerja-kerja bimbingan dan kaunseling itu dianggap sebagai sebahagian daripada masa mengajar biasa bagi guru bimbingan?  
(Is the time allocated for guidance and counselling work is considered as part of the normal teaching periods for the guidance teacher?)

Ya/Yes

Tidak/No



Tandakan (✓) dalam kotak-kotak yang difikirkan sesuai  
 (Please tick (✓) in as many boxes as you think appropriate)

15. Adakah bahan-bahan penerbitan mengenai kerjaya:  
 (Are careers publications:)

- a) dipamerkan dengan jelas dipapankenyataan?  
 (openly displayed on the notice board?)
- b) boleh dipinjam oleh murid-murid?  
 (available for borrowing?)
- c) terdapat dalam perpustakaan sekolah?  
 (available in the school library?)
- d) hanya terdapat dalam bilik kaunselling?  
 (only available in the counselling room?)
- e) dilengkapi dengan bahan penerangan yang di  
 sediakan sendiri?  
 (supplemented by locally prepared information  
 sheets?)

Tandakan (✓) dalam seberapa banyak kotak yang difikirkan sesuai.  
 (Please tick (✓) in as many boxes as you think appropriate)

16. Adakah pehak sekolah memberi bantuan kewangan tahunan untuk mem-  
 beli alat-alat bantuan bimbingan?  
 (Does the school provide annual fund for guidance aids?)

Ya/Yes

Tidak/No

17. Jika 'Ya' adakah jumlah bantuan itu:  
 (If 'Yes' is the sum)

- a) kurang daripada \$1,000  
 (less than \$1,000)
- b) antara \$1,000 - \$2,000  
 (between \$1,000 - \$2,000)
- c) antara \$2,000 - \$3,000  
 (between \$2,000 - \$3,000)
- d) antara \$3,000 - \$5,000  
 (between \$3,000 - \$5,000)
- e) lebih daripada \$5,000  
 more than \$5,000

Tandakan ( / ) ditempat yang difikirkan sesuai  
 (Please tick in the appropriate box)

BAHAGIAN C  
(SECTION C)

KEMAJUAN PERKHIDMATAN BIMBINGAN  
QUALITY OF GUIDANCE SERVICES

1. Adakah pehak sekolah menyimpan rekod-rekod mengenai seseorang murid?

(Are there records on each pupil kept by the school?)

Ya/Yes

Tidak/No

2. Jika 'Ya' adakah pehak sekolah menggunakan rekod-rekod atau kad-kad rekod seperti:

(If 'Yes' does the school use records or record cards such as):

a) Kad rekod persekolahan atau rekod himpunan 001  
(school record card or cumulative record card 001)

b) Kad rekod sulit atau rekod himpunan 002  
(confidential record card or cumulative record card 002)

c) kad atau buku lapuran kemajuan murid  
(pupil's report card)

d) lain-lain (others) -  
sila jelaskan (specify) .....

3. Bagaimanakah data-data/butir-butir mengenai seseorang murid itu dikumpul?

(How is the data collected?)

.....  
.....  
.....  
.....  
.....

4. Siapakah yang mengumpul data-data tersebut?  
(Who collected the data?)

a) guru tingkatan/Form teacher

b) ketua darjah/class monitor

c) kerani sekolah/school clerk

d) lain-lain (jelaskan)/others (please specify) .....

Tandakan (✓) dalam kotak yang berkenaan.  
(Please tick (✓) in the appropriate box).

5. Siapakah yang ditugaskan mengisi rekod-rekod itu?  
(Who filled in the record cards?)

a) guru tingkatan/form teacher

b) ketua darjah /class monitor

c) murid sendiri / pupil himself

d) kerani sekolah / school clerk

e) lain (jelaskan) / other (please specify)

Tandakan (✓) dalam kotak yang berkenaan  
(Please tick (✓) in the appropriate box)

6. Berapa kalikah kad-kad rekod ini diisi dalam setahun?  
(How many times are these record cards filled in one year?)

.....

7. Adakah kad-kad rekod ini disemak dan dikaji setiap tahun?  
(Are the record cards reviewed and revised on annual basis?)

Ya/Yes

Tidak/No

8. Adakah pihak sekolah menyediakan tempat khas bagi menyimpan kad-kad tersebut?

(Is there a special place for keeping these cards?)

Ya/Yes

Tidak/No

9. Jika 'Ya': If 'Yes'

a) Adakah kad-kad itu disimpan ditempat yang berkunci setiap masa? (Are they (records cards) being kept securely locked all the time?)

b) Adakah kad-kad itu boleh disemak oleh semua kakitangan sekolah (guru-guru) - (Are they available for professional consultation for all members of staff?)

c) Adakah kad-kad itu boleh dilihat secara professional oleh agensi-agensi luar yang berkenaan. (Are they available for professional consultation for appropriate outside agencies?)

d) Adakah kad-kad itu boleh dilihat (disemak) oleh murid-murid? (accessible to the students?)

e) Adakah kad-kad itu boleh disemak oleh ibu bapa murid-murid? (are they available for the parent's consultation?)

Tandakan (✓) dalam seberapa banyak kotak yang sesuai.  
(Please tick (✓) in as many boxes as you think appropriate).

10. Adakah kakitangan sekolah (staff) sedar dengan sepenuhnya akan tanggungjawab mereka berhubung dengan kad-kad yang dianggap sulit ini?

(Are the staff fully aware of their responsibilities regarding the confidentiality of these records?)

Sila letakkan diri tuam/uan pada sekel(scale) yang disediakan di bawah dan tandakan (x) pada tempat yang difikirkan sesuai.  
(Place yourself on the following scale below and mark (x) in the place where you think appropriate).

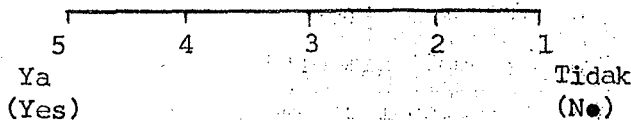

11. Adakah semua kemasukan butiran rekod ditandatangani dan bertarikh?  
(Are record entries initialed and dated?)

Ya/Yes	<input type="checkbox"/>
Tidak/No	<input type="checkbox"/>

12. Berapa kalikah pihak sekolah ini mengadakan peperiksaan dalam setahun?  
(How many times does the school hold its examination per year?)

- a) sekali dalam setahun/once a year
- b) 2 kali /twice a year
- c) 3 kali /three times
- d) setiap bulan /every month
- e) lain (jelaskan /other (specify)

<input type="checkbox"/>
<input type="checkbox"/>
<input type="checkbox"/>
<input type="checkbox"/>
<input type="checkbox"/>

Tandakan (✓) dalam kotak yang berkenaan  
(Please tick (✓) in the appropriate box.)

13. Apakah tujuan-tujuan mengadakan peperiksaan sekolah?  
(What are the aims of the school examinations?)

.....

.....

.....

.....

.....

.....

14. Adakah pihak sekolah berpuashati dengan keputusan-keputusan peperiksaan yang dicapai oleh murid-murid?  
(Is the school satisfied with the examination results of its pupils?)

Ya/Yes	<input type="checkbox"/>
Tidak/No	<input type="checkbox"/>

15. Jika 'Tidak', apakah langkah-langkah yang diambil oleh pihak sekolah untuk memperbaiki pencapaian murid-murid?  
(If 'No' what steps does the school take to improve the performance of its pupils?)

.....

.....

.....

.....

.....

16. Apakah pertolongan yang diberi oleh guru bimbingan untuk membantu murid-murid memperoleh pencapaian yang lebih baik dalam peperiksaan?  
 (What services does the guidance teacher give to help the pupils achieve better examination performance?)

.....  
 .....  
 .....  
 .....  
 .....  
 .....  
 .....

17. Bilakah pemilihan mata pelajaran bagi sesuatu jurusan dilakukan?  
 Tandakan (✓) pada kotak yang berkenaan.  
 (When do the selection of subjects for each stream take place?  
 Please tick (✓) in the appropriate box).

Form 1	<input type="checkbox"/>
Form 2	<input type="checkbox"/>
Form 3	<input type="checkbox"/>
Form 4	<input type="checkbox"/>
Form 5	<input type="checkbox"/>
Form 6	<input type="checkbox"/>

18. Adakah murid-murid dibenarkan membuat pemilihan sendiri berhubung dengan pemilihan mata pelajaran yang ingin mereka ikuti?  
 (Are the pupils allowed to make their own decisions regarding the selection of subjects they wish to pursue?)

5	4	3	2	1
Selalu (Often)	Kadang-kadang (Sometimes)			Tidak pernah (Never)

Tandakan (x) ditempat yang sesuai pada sekel di atas.  
 (Mark (x) where you think appropriate on the above scale)

19. Adakah pihak sekolah meminta nasihat (pandangan) guru bimbingan sebelum pemilihan mata pelajaran bagi sesuatu jurusan yang hendak diikuti oleh seseorang murid?

(Does the school consult the guidance teacher before making the decision on the selection of subjects that the pupils wish to pursue?)

Tandakan (x) ditempat yang sesuai pada sekel (scale) di bawah  
 (Mark (x) where you think appropriate on the scale).

5	4	3	2	1
Selalu (Often)	Kadang-Kadang (Sometimes)			Tidak pernah (Never)



24. Bagaimanakah hubungan antara:  
How is the relationship between):

	S.Baik V.Good	Baik Good	Memuaskan Satisfactory	Sederhana Fair	Tak Po
a) Guru Besar-Guru-guru (Principal - Teachers)					
b) Guru Besar-Guru Bimbingan (Principal -Guidance Teacher)					
c) Guru Besar - Iubapa (Principal - Parents)					
d) Guru Besar - Murid-murid (Principal - Pupils)					
e) Guru Besar - Masyarakat di luar sekolah (Principal - Society outside school)					
f) Sesama Guru - (Among Teachers)					

Tandakan (✓) pada kotak-kotak yang difikirkan sesuai  
(Please tick (✓) in the boxes where you think appropriate)

25. Dalam keadaan-keadaan yang manakah yang membawa ibu bapa murid-murid  
datang ke sekolah?  
(On what occasions/incidents do the parents of the pupils come to  
school?)

- i) .....
- ii) .....
- iii) .....
- iv) .....
- v) .....

26. Adakah tuan/puan berpuashati dengan bilangan ibu bapa yang datang itu?  
(Are you satisfied with the number of parents who come to school on  
the above occasions/incidents?)

- Amat Berpuashati/Very satisfied
- Puashati / Satisfied
- Sederhana / Fair
- Kurang memuaskan/Unsatisfactory
- Amat Kurang memuaskan/Very Unsatisfactory

Tandakan (✓) dalam kotak yang difikirkan sesuai  
(Please tick (✓) in the box where you think appropriate)

27. Jika 'kurang memuaskan', kenapa demikian?  
(If 'unsatisfactory), why is it so?)

- .....
- .....
- .....
- .....
- .....

28. Apakah langkah-langkah yang diambil oleh pihak sekolah bagi menggalakan penglibatan ibu bapa di sekolah?  
(What does the school do to encourage the parent's participation in the school?)

.....

.....

.....

.....

.....

.....

.....

.....

BAHAGIAN D - BENTUK/JENIS MASALAH  
(SECTION D - THE NATURE/TYPE OF PROBLEMS)

1. Apakah masalah-masalah yang biasa tuan/puan hadapi berhubung dengan tenaga pengajar di sekolah ini?  
(What are the common problems you have with your teaching staff?)

.....  
.....  
.....  
.....  
.....  
.....

2. Bagaimanakah tuan/puan mengatasi masalah-masalah tersebut?  
(How do you overcome these problems?)

.....  
.....  
.....  
.....  
.....  
.....

3. Adakah pihak sekolah menghadapi masalah-masalah disiplin dikalangan murid-murid?  
(Does the school have disciplinary problems among its pupils?)

Selalu/Most of the time

Kadang-kadang/Sometimes

Jarang-jarang/Seldom

Tidak pernah/Never

Tandakan (✓) ditempat yang difikirkan sesuai  
(Please tick (✓) where you think appropriate.)

4. Sekiranya terdapat masalah tersebut, sila nyatakan masalah-masalah itu (yang utama) secara ringkas.  
(If the school face such problems; please state briefly):

- a) .....
- b) .....
- c) .....
- d) .....
- e) .....



6. Adakah sekolah ini menghadapi masalah penagihan dadah?  
(Does the school face drug addict problems?)

Ya/Yes

Tidak/No

7. Jika 'Ya' bagaimana pihak sekolah cuba mengatasi masalah ini?  
(If 'yes' how does the school cope with these problems?)

.....  
.....  
.....  
.....  
.....

8. Adakah pihak sekolah mempunyai jawatankuasa menentang dadah?  
(Does the school have an anti-drug committee to deal with drug problems?)

Ya/Yes

Tidak/No

9. Adakah pihak Jabatan Pelajaran Negeri bekerjasama dengan sekolah dalam menghapuskan masalah dadah ini?  
(Does the State Education Department liaise with the school in preventing drug problems?)

Ya/Yes

Tidak/No

10. Berapa kalikah Pegawai Bimbingan dan Kaunseling daripada Jabatan Pelajaran melawat sekolah ini dalam setahun?  
(How often does the guidance and Counselling Officer from Education Department visit the school per year?)

.....

11. Apakah pendapat tuan/puan tentang perkhidmatan bimbingan dan kaunseling di sekolah ini sekarang?  
(What do you think of the present guidance and counselling services in the school?)

.....  
.....  
.....  
.....  
.....  
.....  
.....



BORANG B

Soal-selidik ini untuk diisi oleh Guru Bimbingan  
(This questionnaire is to be answered by the guidance Teacher)

BIMBINGAN DAN KAUNSELING DI SEKOLAH-SEKOLAH MENENGAH DI MALAYSIA  
GUIDANCE AND COUNSELLING IN MALAYSIAN SECONDARY SCHOOLS

Nota: Segala maklumat dalam kajian ini akan dianggap rahsia dan nama sekolah atau orang yang berkenaan tidak akan diidentifikasi atau disebut dalam analisa data yang muktamad.

Note: (The information in this survey is confidential and no school or person will be identified or mentioned in the final analysis of data)

BAHAGIAN A - SEKOLAH  
(SECTION A - SCHOOL)

Butir-butir mengenai Guru Bimbingan  
(Particulars of Guidance Teacher)

1. Nama Guru:.....  
(Name of Teacher)
2. Nama Sekolah: .....  
(Name of the School):
3. Jantina: .....  
(Sex)
4. Kelulusan (Qualification):
  - a) Kelulusan akademik tertinggi:.....  
(Highest academic qualification)
  - b) Kelulusan professional tertinggi:.....  
(Highest professional qualification)
5. Tarikh perlantikan sebagai guru terlatih:.....  
(Date of first appointment as qualified teacher)
6. Sejak bilakah tuan/puan dilantik sebagai Guru Bimbingan?.....  
(When were you appointed as the guidance Teacher?)

BAGIAN B - KEMUDAHAN PERKHIDMATAN BIMBINGAN  
(SECTION B - EXTENT OF GUIDANCE SERVICES)

1. Pernahkah tuan/puan mengikuti sebarang kursus bimbingan dan kaunseling?  
 (Have you attended any guidance course?)

Ya/Yes

Tidak/No

2. Jika 'Ya' sila berikan keterangan-keterangan lanjut mengenai kursus tersebut (Misalnya - jenis kursus, penganjurnya, di mana dan bila)  
 (If 'Yes' please give details of the course (e.g. type of course, organiser, where and when))

.....

.....

.....

.....

.....

.....

.....

3. Adakah tuan/puan seorang sahaja yang menjadi guru bimbingan di sekolah ini?  
 (Are you the only guidance teacher in the school?)

Ya/Yes

Tidak/No

4. Jika 'Ya' berapa orang gurukah yang dilantik membantu tuan/puan?  
 (If 'Yes' how many assistants do you have?)

Bilangan Pembantu  
 (No. of Assistants)

Lelaki (Male)	Perempuan (Female)	Jumlah (Total)

5. Adakah mereka menyertai sebarang kursus bimbingan?  
 (Have they attended any guidance course?)

Ya/Yes

Tidak/No

6. Jika 'Ya' sila berikan keterangan lanjut mengenai kursus itu?  
 (If 'Yes' please give details of the course)

.....

.....

.....

.....

.....

Jadual waktu (time-table)

7. Adakah pihak sekolah menetapkan jadual-waktu tertentu bagi kerja-kerja bimbingan dan kaunseling?  
 (Does the school allocate specific time-table for guidance and counselling work?)

Ya/Yes	<input type="checkbox"/>
Tidak/No	<input type="checkbox"/>

8. a) Jika 'Ya', adakah jadual-waktu itu:  
 (If 'Yes' is the time-table):

- a) disediakan berasingan bagi khidmat bimbingan?  
 (Prepared separately for guidance services)
- b) disediakan berasingan bagi khidmat kaunseling?  
 (prepared separately for counselling services?)
- c) disediakan sebagai satu komponen mata pelajaran bimbingan dan kaunseling  
 prepared as a subject-guidance and counselling)
- d) disediakan sebagai sebahagian daripada mata pelajaran lain (sila jelaskan namanya.....)  
 (prepared as part of another subject - please specify .....

<input type="checkbox"/>
<input type="checkbox"/>
<input type="checkbox"/>
<input type="checkbox"/>

- b) Jika 'Tidak' bilakah masanya tuan/puan memberi bimbingan dan kaunseling kepada murid-murid?  
 (If 'No' when do you carry out guidance and counselling work?)
- (i) bimbingan (guidance) .....
  - (ii) kaunseling (counselling).....

9. a) Berapa lamakah masa (jam dalam sehari) yang tuan atau puan gunakan untuk sesi bimbingan?  
 (How much time (hours per day) do you spend on guidance sessions?)

- a) lebih dari 2 jam (more than 2 hours)
- b) 2 jam (2 hours)
- c) 1½ - 2 jam (1½ - 2 hours)
- d) 1 - 1½ jam (1 - 1½ hours)
- e) 0 - ½ jam (0 - ½ hour)
- f) tidak tentu (indefinite time)

<input type="checkbox"/>
<input type="checkbox"/>
<input type="checkbox"/>
<input type="checkbox"/>
<input type="checkbox"/>
<input type="checkbox"/>

- b) Berapakah jumlah waktu mengajar (teaching periods) yang digunakan untuk sesi bimbingan?  
 (How many teaching periods per week are being used for guidance sessions?)

Untuk jawapannya, sila tandakan (x) pada sekel (scale) yang disediakan di bawah.  
 (For the answer, please mark (x) on the prepared scale below):

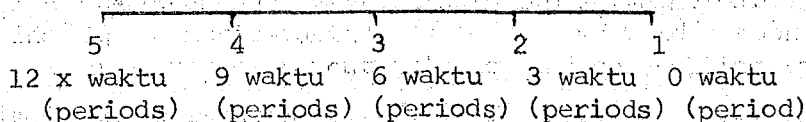

1 waktu (period) = ..... minit (minutes)

10. a) Berapa lamakah masa (jam dalam sehari) yang tuan atau puan gunakan untuk sesi kaunseling?  
 (How much time (hours per day) do you spend on counselling sessions?)

- a) lebih dari 2 jam /more than 2 hours
- b) 2 jam/hours
- c) 1½ - 2 jam/hours
- d) 1 - 1½ jam/hour
- e) 0 - ½ jam/hour
- f) tidak tentu/indefinite time

b) Berapakah jumlah waktu mengajar (teaching periods) yang digunakan untuk sesi kaunseling?  
 (How many teaching periods per week are being used for counselling sessions?)

Untuk jawapannya sila tandakan (x) pada sekel (scale) yang disediakan di bawah:

(For the answer, please mark (x) on the prepared scale below):

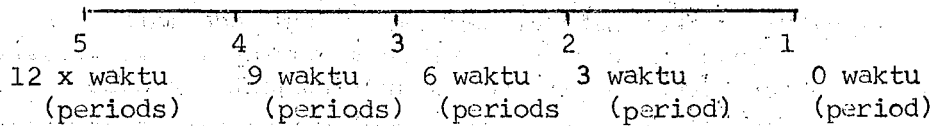

Perhatian (Note)

Sekiranya khidmat bimbingan dan kaunseling dijadikan sebahagian daripada mata pelajaran lain, sila jawab soalan-soal berikut (soalan-soalan 11 dan 12)  
 (If the guidance and counselling services are considered as part of another subject, please answer the following questions 11 and 12)

11. Apakah nama mata pelajaran yang merangkumi khidmat bimbingan dan kaunseling?  
 (Please state the subject that includes guidance and counselling services)

.....

12. Berapakah jumlah waktu mengajar (teaching periods) bagi mata pelajaran ini dalam seminggu?  
 (How many teaching periods are being allocated for this subjects per week?)

.....

13. Berapakah jumlah masa mengajar yang ditetapkan bagi tuan/puan untuk satu minggu?  
 (How many teaching periods do you have per week?)

.....waktu (periods)

14. Adakah masa yang disediakan untuk khidmat bimbingan dianggap sebahagian daripada masa mengajar biasa?  
 (Is the time allocated for counselling considered as part of your normal teaching periods?)

Ya/Yes

Tidak/No

15. Apakah mata pelajaran-mata pelajaran yang tuan/puan ajar?  
 (What subjects do you teach?)

Mata Pelajaran (Subjects)	Tingkatan (Forms)	Jumlah (Total)

16. Adakah tuan/puan bersetuju (berpuashati) dengan penetapan masa mengajar dan masa bimbingan yang ada sekarang?  
 (Are you in favour of the present teaching and counselling arrangement?)

Ya/Yes

Tidak/No

17. Jika 'Tidak' berapakah jumlah waktu (periods) dalam seminggu yang tuan/puan fikir sesuai bagi:  
 (If 'No' how many periods per week do you think is suitable for:)

- a) sesi bimbingan/guidance sessions .....waktu
- b) sesi mengajar bagi seorang guru bimbingan.....waktu  
 (normal teaching sessions for a guidance teacher) (periods)

18. Adakah suatu syllabus khas bagi bimbingan?  
 (Is there a specific syllabus for guidance?)

Ya/Yes

Tidak/No

19. Jika 'Ya' apa pendapat tuan/puan mengenainya?  
 (If 'Yes' what do you think of it?)

.....

.....

.....

.....

20. Jika 'Tidak' apakah garis panduan tuan/puan bagi kerja-kerja bimbingan?  
 (If 'No' what is your guide line for guidance work?)

.....

.....

.....

.....

21. Adakah sekolah ini mempunyai jawatankuasa/komiti kurikulum (Lembaga atau jawatankuasa akademik)? (Does the school have a curriculum committee/academic board?)

Ya/Yes

Tidak/No

22. Jika 'Ya' adakah tuan/puan sebagai seorang guru bimbingan menganggotai jawatankuasa ini? (If 'Yes' are you as the guidance teacher included in the committee?)

Ya/Yes

Tidak/No

23. Jika jawapan bagi soalan 17 ialah 'Tidak' mengapa agaknya tuan/puan tidak dimasukkan dalam jawatankuasa itu? (If the answer to question 17 is 'No', why is it that you are not included in the committee?)

.....  
.....  
.....  
.....

24. Kemudahan-kemudahan/Facilities. Adakah disediakan sebuah bilik khas bagi bimbingan dan kaunseling? (Is there a special room for guidance and counselling?)

Ya/Yes

Tidak/No

25. Adakah kemudahan-kemudahan berikut terdapat dalam bilik bimbingan dan kaunseling? (Are the following facilities available in the guidance and counselling room?)

- a) Telefon (telephone)
- b) Kabinet-fail(file cabinet)
- c) Kipas angin(fan)
- d) meja & kerusi (table & chairs)
- e) sofa
- f) Fail (file)
- g) alat perakam (tape recorder)
- h) lain-lain (others) (jelaskan/specify)

Tandakan (✓) dalam kotak-kotak yang difikirkan sesuai (Please tick (✓) in as many boxes as you think appropriate)

26. Adakah bahan-bahan penerbitan mengenai kerjaya:  
(Are careers publications):

- a) dipamerkan dengan jelas dipapan kenyataan?  
(openly displayed on the notice board?)
- b) boleh dipinjam oleh murid-murid?  
(available for borrowing?)
- c) terdapat dalam perpustakaan sekolah?  
(available in the school library?)
- d) hanya terdapat dalam bilik kaunseling?  
(only available in counselling room?)
- e) dilengkapi dengan bahan penerangan yang disediakan sendiri?  
supplemented by locally prepared information sheets

Tandakan (✓) dalam kotak-kotak yang difikirkan sesuai.  
(Please tick (✓) in as many boxes as you think appropriate)

27. Adakah alat-alat bantuan bimbingan berikut disediakan oleh pihak sekolah? Sila tandakan (✓) dalam kotak-kotak yang disediakan sekiranya alat-alat berikut digunakan.

(Are there any of these guidance aids in the school?  
Please tick (✓) in the boxes provided if use is made of:)

- a) radio
- b) television
- c) slides
- d) video-tapes
- e) tape-recorder
- f) pelbagai bahan penerbitan atau bacaan  
(various forms of publication or reading materials)

28. Adakah pihak sekolah memberi bantuan kewangan tahunan untuk membeli alat-alat bantuan bimbingan?

(Does the school provide annual fund for guidance aids?)

Ya/Yes

Tidak/No

29. Jika 'Ya' adakah jumlah bantuan itu:  
(If 'Yes' is the sum):

- a) kurang daripada \$1,000  
(less than \$1,000)
- b) antara (between) \$1,000-\$2,000
- c) antara (between) \$2,000-\$3,000
- d) antara (between) \$3,000-\$5,000
- e) lebih daripada (more than) \$5,000

BAHAGIAN C - KEMAJUAN PERKHIDMATAN BIMBINGAN  
(SECTION C - QUALITY OF GUIDANCE SERVICES)

1. Adakah pehak sekolah menyimpan rekod-rekod mengenai seseorang murid?  
 (Are there records on each pupil kept by the school?)

Ya/Yes	
Tidak/No	

2. Jika 'Ya' adakah pehak sekolah menggunakan rekod-rekod atau kad-kad rekod seperti:

(If 'Yes' does the school use records or record cards such as):

- |  |  |
|--|--|
| a) kad-kad persekolahan atau rekod himpunan 001<br>(school record card or cumulative record card 001)  |  |
| b) kad rekod sulit atau rekod himpunan 002<br>(confidential record card or cumulative record card 002) |  |
| c) kad atau buku lapuran kemajuan murid<br>(pupil's report card)                                       |  |
| d) lain-lain kad (others) -<br>sila jelaskan (specify) .....   |  |

3. Adakah kad-kad/rekod-rekod itu:  
 (Are those cards/records):

- |   |  |
|---|--|
| a) disimpan ditempat yang berkunci setiap masa?<br>(kept securely locked all the time?)   |  |
| b) boleh disemak oleh semua tenaga pengajar di sekolah?<br>(available for professional consultation for all members of staff?)                              |  |
| c) boleh dilihat secara professional oleh agensi-agensi luar yang berkenaan?<br>(available for professional consultation for appropriate outside agencies?) |  |
| d) boleh dilihat oleh murid-murid<br>(accessible to the students)   |  |
| e) boleh disemak oleh ibu bapa murid?<br>(available for parent's consultation?)   |  |
| f) dianggap sebagai bahan sulit?<br>(treated with strictest confidentiality?)   |  |

Tandakan (✓) dalam seberapa banyak kotak yang sesuai  
 (Please tick (✓) in as many boxes as you think appropriate)

Dalam beberapa soalan berikut tuan/puan diminta meletakkan diri pada suatu sekala (scale)

In some of the following questions you will be asked to position yourself on a scale.

Contohnya: Saya suka mendengar radio

Example :

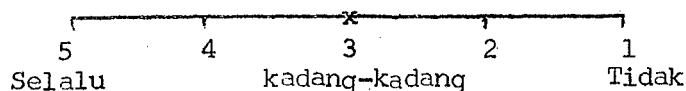

Tanda x menunjukkan pendapat/kedudukan tuan/puan pada sekala (scale) itu  
 The x indicates your position on that scale.

4. Adakah tuan/puan pernah menggunakan rekod-rekod murid?  
(Do you make use of the pupils record cards?)

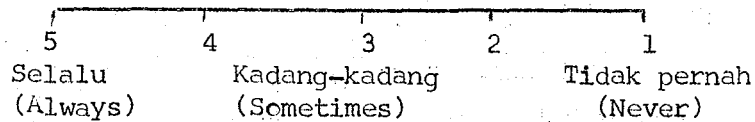

Tandakan x ditempat yang sesuai  
(Mark x where you think appropriate)

5. Pada pendapat tuan/puan, bagaimanakah penilaian guru-guru lain terhadap rekod-rekod murid ini?  
(In your opinion, how do other teachers value the pupils record cards?)

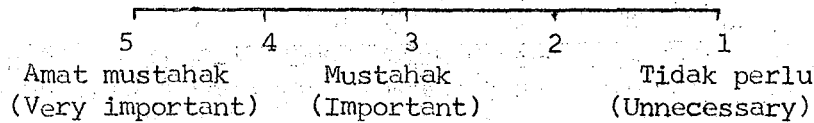

Tandakan x ditempat yang sesuai  
(Mark x where you think appropriate)

6. Bagaimana pula penilaian tuan/puan (sebagai guru bimbingan) terhadap rekod-rekod murid-murid ini?  
(How do you (as guidance teacher) value these record cards?)

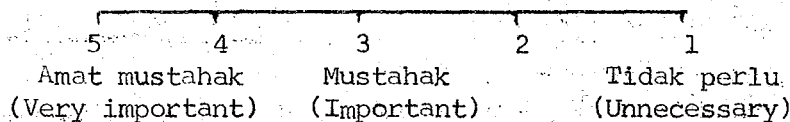

Tandakan x ditempat yang sesuai  
(Mark x where you think appropriate)

7. Berapa peratuskah kakitangan sekolah (staff) yang sedar dengan sepenuhnya akan tanggungjawab mereka berhubung dengan kad-kad yang dianggap sulit ini?  
(What proportion of the members of the staff are fully aware of their responsibilities regarding these record cards?)

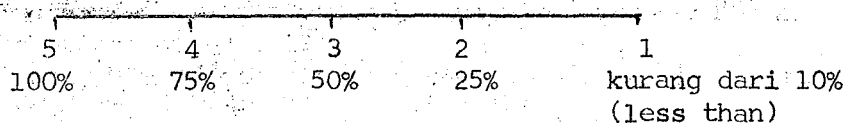

Tandakan x ditempat yang sesuai  
(Mark x where you think appropriate)

8. Berapa peratuskah jumlah murid-murid di sekolah tuan/puan yang tahu tentang khidmat bimbingan dan kaunseling yang ada di sekolah?  
(What percentage of the pupils in your school know the existence of guidance and counselling services in the school?)

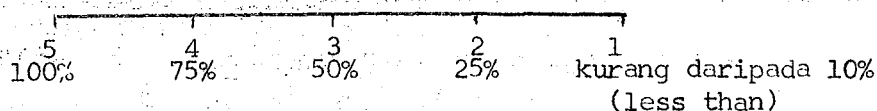

Tandakan x ditempat yang difikirkan sesuai  
(Mark x where you think appropriate)

9. Nyatakan bilangan murid-murid yang meminta atau menggunakan perkhidmatan bimbingan dan kaunseling pada setiap minggu.  
(State the number of pupils who seeked guidance and counselling services per week.)

5                      4                      3                      2                      1  
 12 orang      9 orang      6 orang      3 orang      1 orang  
 atau lebih      (pupils)      (pupils)      (pupils)      (pupil)  
 (more pupils)

Tandakan x ditempat yang difikirkan sesuai  
(Mark x where you think appropriate)

10. Di antara 3 jenis bimbingan dan kaunseling yang dipraktikkan di sekolah, jenis perkhidmatan yang manakah yang kerap diminta atau digunakan oleh murid-murid?  
(Among the 3 types of guidance and counselling practical in the school which form of service is most often seeked by the pupils?)

	5	4	3	2	1
	Selalu (Often)	Kadang-kadang (Sometimes)	Tidak pernah (Never)		
a) kaunseling persendirian/kendiri (Personal Counselling)					
b) Bimbingan Pelajaran (Educational guidance)					
c) Bimbingan Vokasional/Kerjaya (Vocational guidance)					

- a) kaunseling persendirian/kendiri  
(Personal Counselling)
- b) Bimbingan Pelajaran  
(Educational guidance)
- c) Bimbingan Vokasional/Kerjaya  
(Vocational guidance)

Tandakan (✓) ditempat yang difikirkan sesuai  
(Mark x where you think appropriate)

11. Adakah pihak sekolah meminta nasihat (pandangan) guru bimbingan sebelum pemilihan mata pelajaran bagi sesuatu jurusan yang hendak diikuti oleh murid-murid dibuat?  
(Does the school consult the guidance teacher before making the decision on the selection of subjects that the pupils wish to pursue?)

5                      4                      3                      2                      1  
 Selalu                      Kadang-kadang                      Tidak pernah  
 (Often)                      (Sometimes)                      (Never)

Tandakan (x) ditempat yang sesuai pada sekala (scale) di atas  
(Mark (x) where you think appropriate on the above scale)

12. Adakah murid-murid pernah meminta nasihat tuan/puan sebelum membuat pemilihan mata pelajaran yang ingin mereka ikuti?  
(Do the pupils seek your advice before making any decision on the selection of subjects they wish to study?)

5                      4                      3                      2                      1  
 Selalu                      Kadang-kadang                      Tidak pernah  
 (Often)                      (Sometimes)                      (Never)

Tandakan x ditempat yang sesuai pada sekala (scale) di atas  
(Mark x where you think appropriate on the scale)

13. Sila nyatakan peratusan murid-murid yang meminta bantuan tuan/puan berhubung dengan perkara di atas (pemilihan mata pelajaran bagi sesuatu jurusan)  
 (Please state the percentage of pupils who consult you on the above matter (selection of subjects for certain stream)

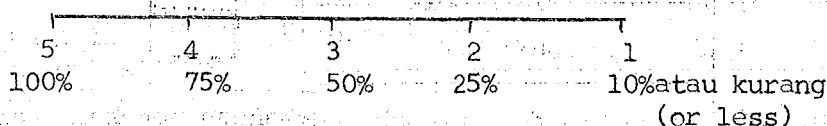

Tandakan x ditempat yang sesuai pada sekala (scale) di atas.  
 (Mark x where you think appropriate on the scale)

14. Adakah perlu mengadakan program kerjaya yang khas untuk murid-murid yang mempunyai kebolehan yang berbeza di sekolah anda?  
 (Is there a necessity to have a special career programme for pupils of different abilities in your school?)

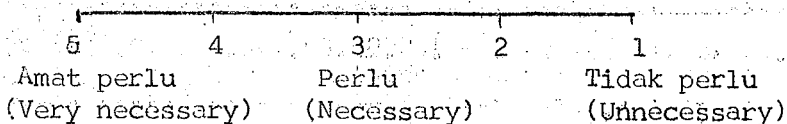

Tandakan x ditempat yang sesuai pada sekala (scale) di atas  
 (Mark x where you think appropriate on the scale)

15. Adakah implikasi perubahan kurikulum dibincangkan dengan:

- a) Murid/Pupil
- b) Ibu bapa/Parents
- c) Kedua-duanya/both

Tandakan (✓) di dalam kotak yang berkenaan  
 (Please tick (✓) where appropriate)

16. Bagaimanakah hubungan anda dengan:  
 (How is your relationship with):

	5 Amat baik (V.good)	4 Baik (Good)	3 Memuaskan Satisfac- tory)	2 Sederhana (fair)	1 Kurang Poor)
a) Guru Besar (Principal)					
b) Guru-guru lain (Other teachers)					
c) Pembantu-pembantu anda (Your assistants)					
d) Murid-murid (Pupils)					
e) Masyarakat luar sekolah (Society outside school)					
f) Lain-lain (jelaskan) Others (specify)					

Tandakan (✓) ditempat yang anda fikirkan sesuai  
 (Please tick (✓) where you think appropriate)

17. Adakah ibubapa murid-murid selalu datang ke sekolah?  
(Do the parents come to school?)

- a) Selalu Often
- b) Kadang-kadang/Sometimes
- c) Sekali sekala/rarely
- d) tidak pernah/never

18. Sila nyatakan sebab-sebab kedatangan mereka  
(Please state the reasons for their visits)

.....

.....

.....

.....

.....

.....

.....

19. Adakah murid-murid yang ibubapanya tidak datang ke sekolah:  
(Do the pupils whose parents do not come to school):

- a) mempunyai lebih banyak masalah di sekolah?  
(have more problems in school?)
- b) mempunyai masalah yang berkurangan di sekolah  
(have less problems in school?)
- c) meminta bantuan daripada guru bimbingan?  
(seek help from the guidance teacher?)
- d) tidak pernah meminta bantuan daripada guru bimbingan  
(never seek help from the guidance teacher)
- e) lebih pandai berdikari  
(are more capable of taking care of themselves)

Tandakan (✓) ditempat yang difikirkan sesuai  
Please tick (✓) where you think appropriate.

BAHAGIAN D - BENTUK/JENIS MASALAH  
(SECTION D - NATURE/TYPE OF PROBLEMS)

1. Adakah tuan/puan menghadapi banyak masalah semasa menjalankan tugas-tugas bimbingan dan kaunseling?  
 (Do you face many problems while doing the guidance and counselling work?)  
 Tandakan (x) ditempat yang sesuai pada sekala (scale) di bawah:  
 (Mark (x) in the place where you think appropriate)

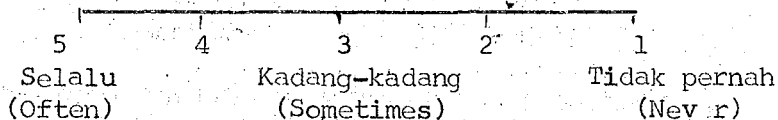

2. Jika jawapan 'Selalu' atau 'Kadang-kadang', apakah masalah-masalah itu berhubung dengan:  
 (If 'Often' or 'Sometimes', what are your problems with regards to:)

a) Guru Besar (Principal): .....

.....  
 .....  
 .....  
 .....

b) Kakitangan Sekolah (Members of staff): .....

.....  
 .....  
 .....

c) Murid-Murid/Clients/Pupils in the school):.....

.....  
 .....  
 .....

d) Ibu bapa murid/parents of Client/Pupil):.....

.....  
 .....  
 .....

e) Lain-lain masalah (jelaskan)

(Other problems (specify): .....

.....  
 .....  
 .....  
 .....

3. Adakah kes-kes kurang disiplin dirujuk/dihantar oleh pihak sekolah bagi bimbingan atau kaunseling?  
 (Are the disciplinary cases being referred to you for guidance and counselling?)  
 Tandakan(x) ditempat yang sesuai pada sekala(scale) di bawah  
 (Mark (x) in the place where you think appropriate)

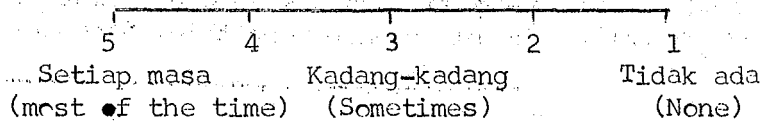

4. a) Jika 'setiap masa' atau 'kadang-kadang' masalah-masalah biasa yang dirujuk kepada tuan/puan ialah:  
 (If 'most of the time' or 'sometimes', the common problems referred to you are):

	Peratusannya (Percentage)
i) .....	
ii) .....	
iii) .....	
iv) .....	
v) .....	

- b) Sila terangkan dengan ringkas tindakan yang diambil untuk mengatasi masalah-masalah itu.  
 (Please state briefly how you dealt with these problems):

- i) .....
- ii) .....
- iii) .....
- iv) .....
- v) .....
- vi) .....
- vii) .....
- viii) .....

5. a) Selain daripada masalah-masalah yang disebutkan di atas, apakah masalah-masalah lain yang tuan/puan temui semasa menjalankan tugas-tugas harian?  
 (Besides the above problems what other problems do you dealt with in your daily work?)

- i) .....
- ii) .....
- iii) .....
- iv) .....
- v) .....
- vi) .....

BAHAGIAN E - KONTEKS PENYELESAIAN MASALAH  
(SECTION E - CONTEXT OF PROBLEM SOLVING)

1. Adakah tuan/puan meminta bantuan luar bila berdepan dengan masalah kaunseling yang besar tentang:  
 (When facing acute counselling problems, do you seek assistance for

- a) kaunseling sendiri/personal counselling
- b) bimbingan pelajaran/educational guidance
- c) bimbingan kerjaya/vocational guidance
- d) ketiga-tiganya sekali/all the three of them

Sila tandakan (✓) seberapa banyak jawapan yang sesuai  
 (Please tick (✓) as many as you think appropriate)

2. Kepada siapakah tuan/puan merujuk/meminta bantuan kendirian tentang bimbingan dan kaunseling di luar sekolah?  
 (Whom do you referred to for counselling expertise outside the school?)

- a) Pegawai Bimbingan dan kaunseling (guidance and counselling officer)
- b) pegawai kebajikan masyarakat (welfare officer)
- c) doktor tempatan (local doctor)
- d) pakar sakit jiwa tempatan (local psychiatrists)
- e) Polis (Police)

	Selalu (Often)	Kadang-kadang (Sometimes)	Tidak pernah (Never)
a)			
b)			
c)			
d)			
e)			

Tandakan (✓) dalam kotak-kotak yang difikirkan sesuai  
 (Please tick (✓) where you think appropriate)

3. Adakah di antara murid-murid yang datang berjumpa dan meminta bantuan tuan/puan itu mengalami masalah penagihan dadah?  
 (Are there drug problem cases among the pupils who seek your assistance?)

Ya/Yes

Tidak/No

4. Jika 'Ya' berapa peratuskah di antara murid-murid tersebut terlibat dalam masalah ini?  
 If 'Yes' what percentage of pupils are involved in this problem?

- a) 50%
- b) 25 - 50%
- c) 5 - 20%
- d) cuma satu atau 2 kes sahaja/only a few cases
- e) Tiada/None

Tandakan (✓) ditempat yang sesuai  
 (Please tick (✓) where appropriate)

b) Sila terangkan dengan ringkas tindakan yang diambil bila berdepani dengan masalah-masalah tersebut.

(Please state briefly how you dealt with these problems):-

- i) .....
- ii) .....
- iii) .....
- iv) .....
- v) .....
- vi) .....

5. Jika seseorang murid itu didapati terlibat dalam masalah penagihan dadah, apakah tindakan tuan/puan sebagai seorang guru bimbingan? (If you found out that one of your students is involved in drug addiction, what actions will you take as a guidance teacher?)

- a) kaunsel murid tersebut (counsel the pupil)
- b) hubungi ibu bapanya (contact his/her parents)
- c) melapurkan hal itu pada polis (report the matter to the police)
- d) menghantar murid tersebut ke pusat pemulihan dadah (send the pupil to re-habilitation centre)
- e) mencadangkan pukulan didepan semua murid. (recommend public canning)
- f) lain-lain tindakan (jelaskan) (Other actions) (specify)

Selalu (Often)	Kadang-Kadang (Sometimes)	Tidak pe (Never)

Tandakan (✓) seberapa banyak jawapan yang difikirkan sesuai  
Please tick (✓) as many answers as you think appropriate)

6. Adakah sekolah ini mempunyai Kelas Bimbingan dan Kerjaya? (Is there a Career and Guidance Club in the school?)

Ya/Yes

Tidak/No

7. Jika 'Ya' apakah aktiviti-aktiviti anjuran persatuan ini? (If 'Yes' what are the activities organised by the club?)

- i) .....
- ii) .....
- iii) .....
- iv) .....
- v) .....

8. Apakah faedah-faedah yang boleh didapati oleh murid-murid daripada persatuan (kelab) ini? (What benefits can the pupils get from the club?)

.....

.....

.....

.....

.....

.....

9. Adakah tuan/puan mendapat sokongan moral (emosi) daripada Guru Besar terhadap kerja-kerja bimbingan yang anda lakukan?  
 (Do you get moral (emotional) support for your work from the Principal?)

Ya/Yes

Tidak/No

10. Adakah tuan/puan mendapat sokongan praktikal (kewangan dan sebagainya) daripada Guru Besar?  
 (Do you get practical support for your work from the Principal?)

Ya/Yes

Tidak/No

11. Jika 'Ya' bagi soalan 10, apakah sokongan praktikal yang tuan/puan perolehi daripada Guru Besar?  
 (If 'Yes' to question 10, what practical support did you get from the Principal?)

.....

.....

.....

.....

.....

.....

.....

12. Bagaimanakah anggapan tuan/puan terhadap khidmat bimbingan dan kaunseling?

(How do you regard guidance and counselling?)

Adakah:

(Is it):

a) untuk berkhidmat pada sekolah sebagai sebuah institusi?  
 (to serve the school as an institution?)

b) untuk memberi perkhidmatan pada murid-murid  
 (to serve the pupils)

c) kedua-duanya (both)

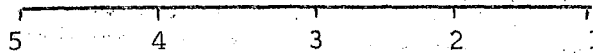

(a) Sekolah (c) Kedua-duanya (b) Murid-murid  
 (school) (Both) (Pupils)

Tandakan (x) ditempat yang sesuai pada sekala (scale) di atas  
 (Mark (x) where appropriate on the above scale)

13. Adakah tuan/puan suka dilantik sebagai seorang Guru bimbingan?  
 (Do you like being selected or appointed as a guidance teacher?)

Ya/Yes

Tidak/No

14. Jika 'Ya' diharap tuan/puan tidak keberatan menerangkan kenapa?  
(If 'Yes' would you mind telling why?)

.....  
.....  
.....  
.....  
.....

15. Jika 'Tidak' diharap tuan/puan tidak keberatan menjelaskan sebab-sebabnya?  
(If 'No' would you mind telling why?)

.....  
.....  
.....  
.....  
.....

16. Apakah pendapat tuan/puan tentang perkhidmatan bimbingan dan kaunseling di sekolah ini sekarang?  
(What do you think of the present guidance and counselling services in the school?)

.....  
.....  
.....  
.....  
.....

17. Apakah pendapat tuan/puan tentang perkhidmatan bimbingan dan kaunseling di sekolah-sekolah di seluruh Malaysia?  
(What do you think of the present guidance and counselling services available in schools throughout Malaysia?)

.....  
.....  
.....  
.....  
.....

18. Apakah kemudahan-kemudahan lain yang ingin tuan/puan perolehi untuk memperbaiki perkhidmatan ini di sekolah anda?  
(What other facilities would you like to have to improve these services in your school?)

.....  
.....  
.....  
.....  
.....



Identification Code - - -  
Record -

1-3  
4

BORANG C  
(FORM C)

Soal selidik ini untuk diisi oleh Murid  
(This questionnaire is to be answered by the Pupil)

BIMBINGAN DAN KAUNSELING DI SEKOLAH-SEKOLAH MENENGAH DI MALAYSIA  
(GUIDANCE AND COUNSELLING IN MALAYSIAN SECONDARY SCHOOLS)

Nota: Segala maklumat dalam kajian ini akan dianggap rahsia dan nama Sekolah atau orang yang berkenaan tidak akan diidentifikasi atau disebut dalam analisa yang muktamat.

Note: (The information in this survey is confidential and no school or person will be identified or mentioned in the final analysis of data).

BAHAGIAN A - BUTIR-BUTIR MENGENAI MURID  
(SECTION A - PARTICULARS OF PUPIL)

1. Dimanakah anda bersekolah? Tandakan (✓)  
(Which school do you attend? Please tick)
 

1	
2	

 a) Sek. Menengah Derma, Kangar, Perlis - Sekolah (School) 1:  
 b) Sek. Menengah Syed. Hassan, Kangar, Perlis-Sekolah(school) 2:
 5
  
2. Jantina:  
(What sex are you?)
 

1	
2	

 Lelaki (Boy)  
Perempuan (Girl)
 6
  
3. Bangsa:  
(Which ethnic group do you belong to?)
 

1	
2	
3	
4	

 Melayu (Malay)  
China (Chinese)  
India (Indian)  
Lain-lain (Others)
 7
  
4. Umur (pada lhb. Januari)  
Age (in years on January 1st)
 

7	
8	
9	

8-9
  
5. Tingkatan (contoh: 5=Tingkatan 5; S=Sains; A=Sastera 5 S 1)  
(Form (e.g. 5= Form 5; S = Science; A = Arts. 5 S 1)
 

5	
S	
1	

10-12
  
6. Adakah anda selamanya belajar di sekolah ini? Ya (Yes)  
(Have you always been in this school? Tidak (No)
 

1	
2	

13
  
7. Jika jawapan bagi soalan 6 ialah 'Tidak', sudah berapa lamakah anda bersekolah di sekolah ini?  
(If the answer to Question 6 is 'No', how many years have you been in the school?)
 

14	
15	

14-15

8. Sila nyatakan pendapat anda mengenai kenyataan ini:  
 "Saya suka belajar di sekolah ini"  
 (Please state your opinion on this statement):  
 "I like studying in this school"

- a) amat tidak setuju (strongly disagree)  
 b) tidak setuju (disagree)  
 c) setuju (agree)  
 d) amat setuju (strongly agree)  
 e) kurang pasti (not sure)

1	
2	
3	
4	
5	

16

Tandakan (✓) jawapan yang difikirkan sesuai  
 (Please tick where appropriate)

9. Adakah anda belajar di sekolah ini kerana:  
 (Do you study in this school because:)

- a) ianya berhampiran dengan rumah anda  
 (it is near your house?)  
 b) ia satu-satunya sekolah di kawasan itu?  
 (it is the only school in the area?)  
 c) kerajaan menghantar anda ke sini?  
 (government sent you here?)  
 d) ibubapa anda mahukan anda belajar di sini?  
 (your parents wish you to study here?)  
 e) kemudahan-kemudahan yang terdapat di sekolah ini?  
 (the facilities available in the school?)  
 f) kebanyakan kawan-kawan anda bersekolah di sini  
 (most of your friends study here?)

17

18

19

20

21

22

Sila tandakan (✓) seberapa banyak jawapan yang difikirkan sesuai  
 (Please tick as many as you think appropriate)

BAHAGIAN B - KEMUDAHAN PERKHIDMATAN BIMBINGAN  
(SECTION B - EXTENT OF GUIDANCE SERVICES)

1. Tahukah anda yang sekolah anda ada menyediakan perkhidmatan bimbingan dan kaunseling untuk murid-muridnya?  
 (Do you know that your school provides guidance and counselling services to its pupils?)
- Ya (Yes) 

1	
2	

 23
- Tidak (No) 

1	
2	
2. Pernahkah anda menggunakan perkhidmatan yang disediakan itu?  
 (Have you ever used the services provided?)
- Ya (Yes) 

1	
2	

 24
- Tidak (No) 

1	
2	
3. Jika 'Ya' berapa kalikah anda mengadakan pertemuan dengan guru bimbingan anda itu?  
 (If 'Yes' how many meetings did you have with your guidance teacher?)
- Sekali (Once) 

1	
2	
3	
4	
5	
6	

 25
- Dua kali (twice)
- 3 kali (3 times)
- 4 kali (4 times)
- 5 kali (5 times)
- lebih daripada 5 kali  
(more than 5 times)
4. Antara kemudahan-kemudahan yang terdapat dalam bilik kaunseling ialah:  
 (Among the facilities available in the counselling room are:)
- a) telefon (telephone) 

 26
- b) kabinet fail (file cabinet) 

 27
- c) sofa, meja dan kerusi (sofa, table and chairs) 

 28
- d) alat perakam (tape recorder) 

 29
- e) bahan bacaan kerjaya (career literature) 

 30
- f) kipas angin (fan) 

 31
- Tandakan (✓) seberapa banyak jawapan yang difikirkan sesuai.  
 (Please tick (✓) as many as you think appropriate)

5. Adakah bahan-bahan penerbitan mengenai Kerjaya:  
(Are careers publications:)

a) dipamerkan dengan jelas dipapan kenyataan?  
(openly displayed on the notice board?)

--

32

b) boleh dipinjam oleh murid-murid?  
(available for borrowing?)

--

33

c) terdapat dalam perpustakaan sekolah?  
(available in the school library?)

--

34

d) hanya terdapat dalam bilik kaunseling?  
(only available in the counselling room?)

--

35

e) dilengkapi dengan bahan-bahan penerangan yang disediakan sendiri.  
(supplemented by locally prepared information sheets)

--

36

Sila tandakan (✓) seberapa banyak jawapan yang difikirkan sesuai.  
(Please tick as many as you think appropriate)

6. Adakah anda selalu menggunakan kemudahan-kemudahan yang disediakan oleh Bahagian Bimbingan dan kaunseling di sekolah anda?  
(How often do you make use of the facilities provided by the guidance and counselling section of your school?)

Selalu (always)

1	
---	--

37

Kadang-kadang (Sometimes)

2	
---	--

Bila perlu (when necessary)

3	
---	--

Kurang pasti (uncertain)

4	
---	--

Tidak pernah (never)

5	
---	--

BAHAGIAN C - KEMAJUAN PERKHIDMATAN BIMBINGAN  
(SECTION C - QUALITY OF GUIDANCE SERVICES)

1. Berapa kalikah anda dibenarkan (dikehendaki) membawa pulang kad Laporan Kemajuan anda untuk ditunjukkan kepada ibu bapa anda?  
 (How many times were you allowed (required) to take home your Progress Report Card for your parents to see?)

Tidak pernah (never)

Sekali dalam setahun (once a year)

Dua kali setahun (Twice a year)

Tiga kali setahun (Three time per year)

Tidak lebih daripada sekali dalam sebulan  
 (not more than once a month)

1	
2	
3	
4	
5	

38

2. Selain daripada Kad Laporan Kemajuan adakah anda dibenarkan melihat kad-kad rekod sendiri yang disimpan oleh pihak sekolah?  
 (Besides the Report Card, were you allowed to see your other personal record cards kept by the school?)

Ya (Yes)

Tidak (No)

1	
2	

39

3. Adakah pihak sekolah membenarkan anda membuat keputusan sendiri berhubung dengan pemilihan mata pelajaran dalam sesuatu jurusan yang anda ingin ikuti?  
 (Does the school allow you to make your own decisions regarding the selection of subjects you wish to pursue in a stream?)

Setiap masa (most of the time)

kurang pasti (not sure)

Kadang-kadang (Sometimes)

Sekali (Once)

Tidak pernah (Never)

1	
2	
3	
4	
5	

40

4. Jika jawapannya 'Tidak pernah' siapakah yang membuat pemilihan itu?  
 (If 'Never' who made the selection?)

Guru Besar (Principal)

Guru Tingkatan (Form Teacher)

Ibu bapa (Parents)

Jabatan Pelajaran (Education Department)

Guru Bimbingan (Guidance Teacher)

41

42

43

44

45

Tandakan (✓) seberapa banyak jawapan yang sesuai  
 (Please tick as many as you think appropriate)

5. Adakah pihak sekolah membenarkan anda memilih mata pelajaran vokasional yang anda ingin pelajari?  
 (Does the school allow you to choose the vocational subjects you wish to study?)

Ya (Yes)

Tidak (No)

1	
2	

46

6. Selain daripada yang disebutkan dalam soalan-soalan 3 dan 5, adakah pihak sekolah membenarkan anda membuat keputusan sendiri dalam:  
 (Besides those mentioned in questions 3 and 5, does the school allow you to make your own decisions in:)

- a) pemilihan Ketua darjah (choosing the class monitor?)  47
- b) memilih pertubuhan sekolah atau kelab yang ingin diceburi (deciding which school societies or clubs you wish to join?)  48
- c) pemilihan pengawas-pengawas sekolah? (choosing the school prefects?)  49
- d) memilih jenis permainan/sukan yang ingin diceburi? (taking up games/sports?)  50
- e) pemilihan ahli jawatankuasa kelab atau pertubuhan? (choosing the committee members of clubs or societies?)  51

Tandakan (✓) berapa banyak jawapan yang sesuai  
 (Please tick as many as you think appropriate)

7. Dalam keadaan-keadaan yang bagaimanakah anda dibenarkan membuat keputusan sendiri dalam rumah (keluarga) anda?  
 (In what instances were you being allowed to make your own decisions in your house (family)?)

- a) dalam memilih kawan-kawan anda (in choosing your own friends)  52
- b) dalam membelanjakan wang saku anda (in spending your own pocket money)  53
- c) tentang bagaimana hendak menggunakan masa lapang anda (on how to spend your own free time)  54
- d) dalam memilih kerjaya sendiri (in choosing your own career)  55
- e) dalam jenis permainan yang ingin anda ceburi (in the types of games you wish to play)  56
- f) dalam memasuki pertubuhan/kelab yang anda minati (in joining the societies/clubs you are interested in)  57

Tandakan (✓) seberapa banyak jawapan yang sesuai  
 (Please tick as many as you think appropriate)

8. Pernahkah anda diberitahu tentang kesan (implikasi perubahan kurikulum atau sukatan pelajaran oleh orang-orang berikut?  
 (Have you ever been told about the implications of curriculum changes by any of these people?)

- a) guru tingkatan anda (your form teacher)  58
- b) guru bimbingan anda (your guidance teacher)  59
- c) guru mata pelajaran anda (your subject teacher)  60
- d) kawan-kawan anda (your friends)  61
- e) ibu bapa anda (your parents)  62
- f) lain-lain orang jelaskan (Other person - specify)  63

Tandakan (✓) seberapa banyak jawapan yang sesuai  
 (Please tick as many as you think appropriate)

9. Adakah ibu bapa anda selalu membantu anda membuat kerja-kerja harian sekolah anda?  
 (How much help do your parents give in your daily school work?)

- a) setiap masa (all the time)
- b) bilamana mereka lapang (whenever he/she is free)
- c) bila perlu (whenever necessary)
- d) kadang-kadang (sometimes)
- e) tidak pernah (never)

1	
2	
3	
4	
5	

64

Tandakan (✓) ditempat yang difikirkan sesuai  
 (Please tick where you think appropriate)

10. Bagaimanakah perhubungan anda dengan:  
 (How is your relationship with:)

Sila gunakan kod-kod berikut untuk jawapannya:  
 Please use the following codes for the answers:

kurang baik = 1; Sederhana = 2; Memuaskan=3; Baik=4, Amat Baik = 5  
 (Poor) (Fair) (Satisfactory) (Good) (Very good)

- a) Guru Besar (Principal)
- b) Guru-Guru (teachers)
- c) Guru bimbingan (guidance teacher)
- d) Teman-teman sebaya (peer group)
- e) Ibu bapa (parents)
- f) Lain-lain orang - jelaskan .....
- (Others - specify)

65  
66  
67  
68  
69  
70

1. Berikut adalah beberapa masalah-masalah yang mungkin dihadapi oleh murid-murid dalam kehidupan harian mereka. Adakah anda juga menghadapi masalah-masalah begini?

(Here are some of the problems likely to be faced by pupils in their daily life. Do you face any of these problems?)

Sila gunakan kod-kod berikut untuk jawapannya:

(Please use the following codes for the answers:)

- Setiap masa (most of the time) = 1
- Selalu (Often) = 2
- Kadang-kadang (Sometimes) = 3
- Jarang sekali (seldom) = 4
- Tidak pernah (Never) = 5

- a) berhubung dengan pelajaran (concerning studies) \_\_\_\_\_ 71
- b) berhubung dengan keluarga (concerning family) \_\_\_\_\_ 72
- c) berhubung dengan kesihatan (concerning health) \_\_\_\_\_ 73
- d) berhubung dengan teman sebaya (concerning peer group) \_\_\_\_\_ 74
- e) berhubung dengan keadaan kewangan (concerning financial situation) \_\_\_\_\_ 75
- f) berhubung dengan pengambilan dadah (concerning drug abuse) \_\_\_\_\_ 76
- g) lain-lain masalah - jelaskan .....  
 (other problems - specify) ..... \_\_\_\_\_ 77

Berikut adalah beberapa masalah berhubung dengan pelajaran di sekolah. Pernahkah anda mengalaminya).

(Here are some of the problems regarding studies (in school)

Have you ever faced these problems?

Perhatian: sila gunakan kod-kod berikut untuk jawapannya

(Note: Please use the following codes for the answers:)

- Setiap masa (most of the time) = 1
- Selalu (Often) = 2
- Kadang-kadang (Sometimes) = 3
- Jarang sekali (seldom) = 4
- Tidak Pernah (Never) = 5

2. Masalah-masalah (Problems)

- a) menghadapi masalah memahami mata pelajaran tertentu (jelaskan: .....  
 (experience difficulties in understanding certain subject - specify) \_\_\_\_\_ 78
- b) kurang berminat dalam mata pelajaran tertentu jelaskan .....  
 (lack of interest in certain subjects - specify) \_\_\_\_\_ 79
- c) tidak sefahaman dengan guru tertentu (cannot get along with certain teacher) \_\_\_\_\_ 80
- d) mengalami masalah dalam mempelajari bahasa jelaskan: .....  
 (face problems in learning language - specify) \_\_\_\_\_ 81
- e) terlalu banyak kerja sekolah yang mesti dibuat (too much school work to cope with) \_\_\_\_\_ 82
- f) lain-lain masalah (jelaskan - lihat dibawah) (other problems - specify - see below) \_\_\_\_\_ 83

Perhatian (note): Sila tambah atau sebutkan masalah-masalah lain yang mungkin anda hadapi tetapi tidak disebut di atas.

.....  
 .....  
 .....  
 .....

84-85

3. Di bawah ini terdapat beberapa masalah keluarga yang sering terjadi dalam masyarakat moden sekarang ini. Sila tandakan (✓) seberapa banyak jawapan yang difikirkan sesuai sekiranya anda juga mengalaminya.

(Here are some of the family problems found in our modern society. Please tick as many as you think appropriate if you face any of them).

a) ibu bapa yang sering bergaduh (bertengkar)  
 (quarelling parents)

--

86

b) ibu bapa yang terlalu sebak  
 (busy working parents)

--

87

c) ibu bapa yang telah bercerai  
 (parents divorced)

--

88

d) keluarga sangat miskin  
 (very poor family)

--

89

e) tidak tinggal bersama ibu bapa  
 (not staying with parents)

--

90

f) ibu bapa terlalu mengongkong  
 (very rigid parents)

--

91

g) lain-lain sebab (jelaskan) .....  
 (Other reasons - specify) .....

--

92

4. Pernahkah anda terlibat dalam masalah penagihan dadah?  
 (Have you ever been involved in drug taking problems?)

Ya (Yes)

1	
---	--

93

Tidak (No)

2	
---	--

5. Adakah di antara kawan-kawan anda juga turut terlibat dalam masalah penagihan dadah?

(Do any of your friends are involved in the drug taking problems too)

Ya (Yes)

1	
---	--

94

Tidak (No)

2	
---	--

6. Apakah jenis dadah yang biasa diambil oleh murid-murid sekolah?  
 (What type of drugs are normally being taken by the students?)

a) ganja (opium)

1	
---	--

95

b) heroin

2	
---	--

c) marijuana

3	
---	--

d) LSD

4	
---	--

e) lain-lain (sila jelaskan).....  
 (Others - please specify)

5	
---	--

7. Bagaimanakah seseorang murid sekolah itu boleh terlibat dalam masalah penagihan (pengambilan) dadah? Adakah:  
 (How does a school pupil become involved in drug taking? Is it:)

- |  |  |  |     |
|--|--|--|-----|
| a) kerana dipengaruhi oleh kawan-kawan<br>(because of the influence of friends)                          |  |  | 96  |
| b) kerana kecewa<br>(because of frustrations)  |  |  | 97  |
| c) kerana terlalu banyak tekanan atau masalah keluarga<br>(because too much pressure or family problems) |  |  | 98  |
| d) kerana ingin mencuba<br>(curious to try)  |  |  | 99  |
| e) lain-lain sebab - sebutkan .....<br>(other reasons - specify) .....                                   |  |  | 100 |

Tandakan (✓) seberapa banyak jawapan yang difikirkan sesuai  
 (Tick as many as you think appropriate)

BAHAGIAN E - KONTEKS PENYELESAIAN MASALAH  
(SECTION E - CONTEXT OF PROBLEM SOLVING)

1. Kepada siapakah anda mengadu (meminta nasihat) apabila berdepan dengan sesuatu masalah atau kesukaran?  
(Whenever you are in a difficulty, who do you turn to?)  
Sila gunakan kod-kod berikut untuk jawapannya:  
(Please use the following codes for the answers:)

- setiap masa (most of the time) = 1
- selalu (often) = 2
- Kadang-kadang (sometimes) = 3
- Jarang sekali (seldom) = 4
- Tidak pernah (never) = 5

- a) ibu bapa anda (your parents) \_\_\_\_\_ 5
- b) keluarga yang rapat (your close relatives) \_\_\_\_\_ 6
- c) kawan-kawan anda (your friends) \_\_\_\_\_ 7
- d) guru tingkatan anda (your form teacher) \_\_\_\_\_ 8
- e) guru mata pelajaran anda (your subject teacher) \_\_\_\_\_ 9
- f) guru bimbingan (guidance teacher) \_\_\_\_\_ 10
- g) orang tua-tua (your elders) \_\_\_\_\_ 11
- h) pegawai kebajikan masyarakat (welfare officer) \_\_\_\_\_ 12
- i) anggota polis (local policeman) \_\_\_\_\_ 13
- j) lain-lain orang (others) - jelaskan (specify) ..... \_\_\_\_\_ 14
- .....

2. Pernahkah anda pergi mendapatkan bantuan atau nasihat dari guru bimbingan di sekolah anda?

Ya (Yes)	1		15
Tidak (No)	2		

3. Jika 'Ya' mengapakah anda menemuinya? Adakah kerana:  
(If 'Yes' why did you see him? Is it because:)

- a) anda dirujuk oleh pihak sekolah akibat kesalahan kurang disiplin yang anda lakukan?  
(you have been referred by the school to see him due to your misbehavior in the school?) \_\_\_\_\_ 16
- b) anda mempunyai masalah keluarga yang ingin anda bincangkan dengannya?  
(you have family problems to discuss with him?) \_\_\_\_\_ 17
- c) anda terlibat dalam masalah dadah  
(you have been involved in drug problems) \_\_\_\_\_ 18
- d) anda memerlukan nasihatnya mengenai masalah personal anda.  
(you need his advice on your personal problems) \_\_\_\_\_ 19
- e) anda ingin memperolehi keterangan lanjut mengenai kerjaya dan kemudahan latihan yang ada  
(you wish to get more information on present careers and trainings that are available) \_\_\_\_\_ 20

- f) anda memerlukan pandangan atau nasihatnya sebelum mengambil keputusan berhubung dengan pelajaran anda.  21  
(you need his advice before making any decision regarding your studies).

Sila tandakan (✓) seberapa banyak jawapan yang difikirkan sesuai.  
(Please tick as many as you think appropriate)

Sekiranya 'Tidak' sila terus menjawab soalan 5  
(If 'No', please proceed to Question 5)

4. Apakah hasil (keputusan) pertemuan-pertemuan itu?  
(What were the outcome (results) of those meetings?)
- a) dia menolong anda mengatasi masalah yang dihadapi  
(he helped you overcome your problems)  22
- b) dia menunjukkan pada anda akan buruk baiknya kelakuan  
(he made you see the pros and cons of your past behaviour)  23
- c) dia membuat anda menyedari kesalahan-kesalahan anda  
(he made you realised your mistakes)  24
- d) anda memperolehi banyak penerangan mengenai kerjaya yang ingin anda ceburi.  
(you obtained information on the career you would like to pursue)  25
- e) dia menghidupkan semula kepercayaan anda pada kebolehan sendiri.  
(he made you regain your self-confidence)  26
- f) tiada yang dapat anda fikirkan  
(none that you could think of)  27
- Sila tandakan (✓) seberapa banyak jawapan yang difikirkan sesuai.  
(Please tick as many as you think appropriate).

5. Dengan tidak mengambilkira samada anda pernah menggunakan khidmat bimbingan dan kaunseling, setujukah anda jika dikatakan yang khidmat bimbingan dan kaunseling di sekolah adalah satu cara yang berfaedah untuk membantu murid-murid mengatasi masalah-masalah yang sedang mereka hadapi.

(Regardless of whether you have used the school guidance and counselling services, would you agree if one says that the school guidance and counselling services is a useful means of helping the school pupils overcome their problems).

Sila tandakan (✓) jawapan yang difikirkan sesuai.  
(Please tick where you think appropriate)

- a) amat tidak setuju (strongly disagree)  28
- b) tidak setuju (disagree)
- c) amat bersetuju (strongly agree)
- d) setuju (agree)
- e) kurang pasti (not sure)

6. Adakah anda menjadi ahli Kelab Bimbingan dan Kerjaya?  
Are you a member of Career and Guidance Club?

Ya (yes)

Tidak (No)

1	<input type="checkbox"/>
2	<input type="checkbox"/>

29

**BORANG D**  
**(FORM D)**

Soal selidik ini untuk diisi oleh Ibu bapa Murid  
(This questionnaire is to be answered by the Parent)

**BIMBINGAN DAN KAUNSELING DI SEKOLAH-SEKOLAH MENENGAH DI MALAYSIA**  
**(GUIDANCE AND COUNSELLING IN MALAYSIAN SECONDARY SCHOOLS)**

Nota : Segala maklumat dalam kajian ini akan dianggap rahsia dan nama sekolah atau orang yang berkenaan tidak akan diidentifikasi atau disebut dalam analisa data yang muktamad.

Note : (The information in this survey is confidential and no school or person will be identified or mentioned in the final analysis of data)

**BAHAGIAN A - BUTIR-BUTIR MENGENAI IBU BAPA**  
**(SECTION A - PARTICULARS OF PARENT)**

1. a) Hubungan dengan murid  
(Relationship with the pupil:

Bapa (Father)

Ibu (Mother)

Penjaga (Guardian)

1	
2	
3	

5

b) Pekerjaan: .....  
Occupation

6

2. Berapa orangkah anak tuan/puan?  
(How many children do you have?)

Anak Lelaki (Sons)	Anak Perempuan (Daughters)	Jumlah (Total)

- -

7-8

3. Berapa orangkah anak-anak tuan/puan masih menuntut?  
(How many of your children are still in schools?)

Anak Lelaki (Sons)	Anak Perempuan (Daughters)	Jumlah (Total)

- -

9-10

**BAHAGIAN B - KEMUDAHAN PERKHIDMATAN BIMBINGAN**  
**(SECTION B - EXTENT OF GUIDANCE SERVICES)**

1. Tahukah tuan/puan yang sekolah anak tuan/puan ada menyediakan perkhidmatan bimbingan untuk murid-muridnya?  
 (Do you know that your children's school provide guidance services to its pupils?)

Ya/Yes	1		11
Tidak/No	2		

2. Setahu tuan/puan pernahkan anak tuan/puan meminta bantuan guru bimbingan apabila mereka menghadapi sebarang masalah berhubung dengan:  
 (In your knowledge, have your son/daughter ever seeked the guidance teacher's assistance whenever they have any problems regarding:)

- |  |  |    |
|--|--|----|
| a) masalah peribadi/personal problems                          |  | 12 |
| b) masalah pelajaran/educational problems                      |  | 13 |
| c) masalah kerjaya/vocational problems                         |  | 14 |
| d) lain-lain masalah (jelaskan)/other problems (specify) ..... |  | 15 |

Tandakan (✓) seberapa banyak jawapan yang difikirkan sesuai  
 (Please tick as many as you think appropriate)

3. Selalukah tuan/puan pergi ke sekolah anak tuan/puan untuk bertanyakan/berbincang mengenai kemajuan pelajaran mereka di sekolah?  
 (How often did you go to your son's or daughter's school to enquire about their progress in school?)

- |  |   |  |    |
|--|---|--|----|
| a) lebih daripada tiga kali setahun (more than three times per year) | 1 |  | 16 |
| b) tiga kali setahun (three times per year)                          | 2 |  |    |
| c) dua kali setahun (twice a year)                                   | 3 |  |    |
| d) sekali dalam setahun (once a year)                                | 4 |  |    |
| e) bila diperlukan sahaja (only whenever necessary)                  | 5 |  |    |
| f) tidak pernah (never)  | 6 |  |    |

Tandakan (✓) ditempat yang sesuai  
 (Please tick (✓) where appropriate)

BAHAGIAN C - KEMAJUAN PERKHIDMATAN BIMBINGAN  
(SECTION C - QUALITY OF GUIDANCE SERVICES)

1. Berapa kalikah anak tuan/puan membawa pulang dan menunjukkan kad kemajuannya kepada tuan/puan?

How many times did your son or daughter bring home his or her Record or Progress Card for you to see?

- a) Setiap bulan/Every month  
 b) Tiga kali setahun/Three times per year  
 c) Dua kali setahun/ Twice a year  
 d) Sekali dalam setahun/Once a year  
 e) Tidak pernah/ Never

1	
2	
3	
4	
5	

17

Tandakan (✓) ditempat yang sesuai  
 (Please tick (✓) where you think appropriate)

2. Adakah pihak sekolah meminta pendapat tuan/puan berhubung dengan pemilihan mata pelajaran anak anda dalam sesuatu jurusan?

(Were you being consulted regarding the selection of subjects in each stream for your son or daughter?)

- a) selalu (often)  
 b) kurang pasti (not sure)  
 c) Kadang-kadang (Sometimes)  
 d) Sekali (Once)  
 e) Tidak pernah (Never)

1	
2	
3	
4	
5	

18

3. Pernahkah pihak sekolah berbincang dengan tuan/puan berhubung dengan implikasi perubahan kurikulum (sukatan pelajaran) ke atas anak tuan/puan dengan tuan/puan.

(Does the school ever discuss the implication of curriculum changes on your son/daughter with you?)

Ya/Yes

1	
2	

Tidak/No

19

4. Pernahkah tuan/puan membincangkan mengenai kerjaya yang boleh di ceburi oleh anak tuan/puan dengan:

(Have you ever discussed about your children's prospective career with:)

- a) guru tingkatan mereka (their form teacher)  
 b) guru bimbingan (guidance teacher)  
 c) anak-anak anda sendiri (your own children)  
 d) anggota keluarga anda (members of your family)  
 e) kawan-kawan anda (your friends)  
 f) tidak pernah (never)

20

21

22

23

24

25

Tandakan (✓) seberapa banyak jawapan yang sesuai  
 (Please tick (✓) as many as you think appropriate)

5. Dalam keadaan-keadaan yang bagaimanakah tuan/puan pergi ke sekolah anak tuan/puan dan bertemu dengan guru-guru mereka?

(In what condition did you go to your children's school and meet their teachers?)

- a) Perjumpaan P.T.A. (P.T.A. Meetings) 

--
- b) Hari Pamiran (Exhibition Day) 

--
- c) Hari Ibu bapa (Parents' Day) 

--
- d) Hari Sukan (Sports Day) 

--
- e) bila diminta oleh pihak sekolah (on request by the school) 

--
- f) bila keadaan memerlukannya (when necessity arise) 

--

26  
27  
28  
29  
30  
31

Tandakan (✓) seberapa banyak jawapan yang sesuai  
(Please tick (✓) as many as you think appropriate)

6. Siapakah yang patut menentukan kerjaya seseorang murid (anak)?  
(Who do you think should determine the pupil's career?)

- a) ibu bapanya/his parents 

1	
---	--
- b) guru-gurunya/his teachers 

2	
---	--
- c) murid itu sendiri/the pupil himself 

3	
---	--
- d) lain-lain (jelaskan)/others (specify) ..... 

4	
---	--

32

7. Adakah tuan/puan ingin anak-anak tuan/puan:

- a) mengikut jejak langkah anda dalam memilih kerjaya  
(to follow your footsteps in choosing a career) 

1	
---	--
- b) memilih kerjaya yang mereka ingini  
(to have freedom in choosing their own career) 

2	
---	--
- c) mengikut nasihat anda dalam memilih kerjaya  
to follow your advice on the choice of a career) 

3	
---	--

33

Tandakan (✓) jawapan yang sesuai  
(Please tick (✓) the appropriate answer.)

8. Pada fikiran tuan/puan adakah perkhidmatan bimbingan dan kaunseling di sekolah mendatangkan faedah kepada anak-anak tuan/puan  
(Do you think guidance and counselling services in the school is useful to your children?)

- Ya/Yes 

1	
---	--
- Tidak/No 

2	
---	--
- Tidak tahu/Don't know 

3	
---	--

34

9. Selalukah tuan/puan membantu anak-anak tuan/puan membuat kerja sekolah mereka?  
(How often do you help your children in doing their school work?)

- a) setiap masa/all the time 

1	
---	--
- b) semasa lapang/whenever free 

2	
---	--
- c) bila diperlukan/whenever necessary 

3	
---	--
- d) kadang-kadang/sometimes 

4	
---	--
- e) tidak pernah/never 

5	
---	--

35

10. Bagaimanakah hubungan tuan/puan dengan:  
(How is your relationship with:)

- |  |       |    |
|--|-------|----|
| a) Guru Besar/(Principal)                                | _____ | 36 |
| b) Guru-guru/(Teachers)                                  | _____ | 37 |
| c) Anak anda/(your son or daughter)                      | _____ | 38 |
| d) Rakan-rakan anak anda/(your son or daughter's friend) | _____ | 39 |
| e) masyarakat sekeliling<br>(society around you)         | _____ | 40 |

Sila gunakan kod-kod ini untuk jawapannya  
(Use the following codes for the answers)

Lemah (Poor) 1; Sederhana (Fair) 2; Memuaskan (Satisfactory) 3;

Baik (good) 4; Amat Baik (Very good) 5

BAHAGIAN D - BENTUK/JENIS MASALAH  
(SECTION D - NATURE/TYPE OF PROBLEMS)

1. Berikut adalah beberapa masalah-masalah yang sering dihadapi oleh murid-murid sekolah. Adakah anak tuan/puan juga menghadapi masalah-masalah tersebut?

(Here are some of the problems normally faced by the school pupils. Does your son/daughter face these problem too?)

Sila gunakan kod-kod berikut untuk jawapannya:  
 Please use the following codes for the answers:

Lemah (Poor) 1; Sederhana (Fair) 2; Memuaskan (Satisfactory) 3;  
 Baik (good) 4; Amat Baik (Very good) 5;

- a) berkaitan pelajaran/concerning studies \_\_\_\_\_ 41
- b) berkaitan keluarga/concerning family \_\_\_\_\_ 42
- c) berkaitan teman sebaya/concerning peer groups \_\_\_\_\_ 43
- d) berkaitan kesihatan/concerning health \_\_\_\_\_ 44
- e) berkaitan keadaan kewangan/concerning financial situation) \_\_\_\_\_ 45
- f) lain-lain masalah/other problems (jelaskan/ specify) \_\_\_\_\_ 46
- .....

2. Pernahkah anak tuan/puan mengadu mengenai:  
 (Did your son/daughter ever complain about:)

- a) kesusahannya memahami mata pelajaran tertentu (his difficulties in understanding certain subjects) 

--

 47
- b) kurang berminat dalam mata pelajaran tertentu (lack of interest in certain subjects) 

--

 48
- c) ketidak-upayanya menyesuaikan diri dengan seorang guru (his inability to get along with any teacher) 

--

 49
- d) masalahnya dalam mempelajari sesuatu bahasa (jelaskan) (his problems in learning a language - specify) 

--

 50
- e) lain-lain masalah (jelaskan) (other problems (specify) ..... 

--

 51

Tandakan (✓) seberapa banyak jawapan yang sesuai  
 (Please tick (✓) as many as you think appropriate

BAHAGIAN E - KONTEKS MENYELESAIKAN MASALAH  
(SECTION E - CONTEXT OF PROBLEM SOLVING)

1. Pernahkah anak tuan/puan menceritakan masalah-masalahnya kepada anda?  
 (Did your son or daughter tell (talk to) on about their problems?)
- |   |  |
|---|--|
| 1 |  |
| 2 |  |
| 3 |  |
| 4 |  |
| 5 |  |
- a) setiap masa (most of the time) 52  
 b) selalu (often)  
 c) kadang-kadang (sometimes)  
 d) jarang sekali (seldom)  
 e) tidak pernah (never)  
 Tandakan (✓) ditempat yang difikirkan sesuai  
 (Please tick where you think appropriate)
2. Selain daripada tuan/puan, kepada siapakah lagi anak tuan/puan menceritakan masalahnya?  
 (Besides you, who did your son/daughter turn to for help?)
- |  |
|--|
|  |
|  |
|  |
|  |
|  |
|  |
|  |
|  |
|  |
- a) ibunya (his/her mother) 53  
 b) bapanya (his/her father) 54  
 c) kakak-kakaknya (his/her sister) 55  
 d) abang-abang (his brother) 56  
 e) kawan-kawan (friends) 57  
 f) guru-guru (teachers) 58  
 g) anggota keluarga yang rapat (close members of the family) 59  
 h) orang lain - jelaskan .....  
 (Others - specify).....  
 Tandakan (✓) seberapa banyak jawapan yang difikirkan sesuai  
 (Please tick as many as you think appropriate)
3. Apakah pendapat tuan/puan berhubung dengan keadaan disiplin yang terdapat di sekolah tuan/puan itu  
 (What do you think of the present discipline situation in your son's/daughter's school?)
- |   |  |
|---|--|
| 1 |  |
| 2 |  |
| 3 |  |
| 4 |  |
| 5 |  |
- a) amat memuaskan (very satisfactory) 60  
 b) memuaskan (satisfactory)  
 c) terkawal (under controlled)  
 d) tidak memuaskan (not satisfactory)  
 e) amat buruk (very bad)
4. Sila nyatakan tiga langkah yang tuan/puan fikirkan sesuai untuk mengatasi atau mengurangkan masalah-masalah kurang disiplin disekolah.  
 (Please state three ways how the school could overcome or reduce its disciplinary problems)
- (i) ..... 61  
 (ii) ..... 62  
 (iii) ..... 63



1.8 Appendix 2 Responses gathered from the QuestionnaireFORM 'A' (Answered by the Principals)

<u>Question</u>	<u>PRINCIPAL OF SCHOOL 1</u>	<u>PRINCIPAL OF SCHOOL 2</u>
<u>SECTION A - Particulars of the Schools</u>		
1	Name -	-
2	1948	1965
3	Urban School	Rural School
4	Mixed School	Mixed School
5	Morning and Afternoon Sessions	Morning Session
6a)	Pupils - 1192	992
b)	Malays Chinese Indians Others	Malays Chinese Indians Others
7.	Teachers - 79	Teachers - 48
8	-	-
<u>SECTION B - Extent of Guidance Services</u>		
1	Yes	Yes
2a)	-	a) 1975
b)	1 teacher	b) 1 teacher
3	Principal	Principal
4(i)	holding a certificate or a Diploma in Counselling or at least have attended the counselling course	(i) - same -
(ii)	age factor and must be married	(ii) the teacher must be interested in the subject
(iii)	must have certain characteristics, e.g. patient and must be interested in the subject	
5	one teacher	one teacher
6	A Diploma course in Counselling at National University of Malaysia in 1981/82. This course was provided for	- same -

guidance teachers only.  
 - Qualifications required -  
 must be a university graduate  
 (i.e. Category D1 or D2  
 teacher)

7a)	No	a) Yes
b)	-	b) 4 periods (160 minutes)
c)	during free periods	
8	No (as above, i.e. Qn. 7)	a) No
		b) -
		c) whenever necessary
9	Yes	Yes
10	Between 12-18 periods/week	25 periods including (7b)
11	Yes	Yes
12a)	No	a) Yes
b)	For the time being. It is unnecessary.	b) -
13	Yes	Yes
14	Facilities - answers (b-g)	Facilities - answers (b to f and h)
15	Publications: a, b, c and e	Publications: a and c
16	Yes	Yes
17	A	A

SECTION C - Quality of Guidance Services

1	Yes	Yes
2	a, b, c	a, b, c, d
3	The pupils filled in the required information in the prepared form and handed them to their respective form teachers	- same -
4	a - form teacher	a - form teacher
5	a - form teacher	a - form teacher
6	depends on circumstances	-
7	Yes	Yes
8	Yes	Yes
9	a, b, d, e	a, c, e

10	Rating No. 3	Rating No. 3
11	No	Yes
12	E (six times)	C (3 times)
13(i)	assessment purposes	(i) diagnostic purposes
(ii)	for selection purposes	(ii) -
14	Yes	No
15	-	(i) by improving the teaching - learning processes based on normal timetable
		(ii) introducing extra classes
		(iii) by asking the parents to co-operate in supervising their children's work at home
16(i)	to give advice on how to study	(i) to explain about the selection of certain subjects
(ii)	to provide guidance services on how to overcome their personal problems	(ii) to explain the learning techniques
(iii)	to advise pupils on future careers	
17	Form 1, 4 and 6	Form 1, 3, 4 and 6
18	3	3
19	3	3
20	3	2
21	Rating 1 - i.e. less than 10%	- same -
22	not applicable in this school	Rating 2 - sometimes -
23	No	Yes
24	All satisfactory	a, b, c - good d, e, f - satisfactory

- |       |  |   |
|-------|--|---|
| 25    | Reasons for parental visits;   | Reasons:  |
| (i)   | to seek the school's help  | (i) to attend Speech Day and Prize Giving Day   |
| (ii)  | to report about their children e.g. sickness, etc.   | (ii) to attend Annual Parent-Teachers Association (P.T.A.) Meetings   |
| (iii) | to request for a place in the school   | (iii) when requested by the Principal (concerning their children)   |
| (iv)  | at the request by the school regarding their children's affairs  |   |
| 26    | Unsatisfactory   | - same -  |
| 27    | Not satisfied with the attitudes of the present day parents who are not very concerned about their children's education. They expect the school to solve all the problems faced by the pupils, i.e. regarded it as the duty of the school. | Not satisfied with the percentage of attendance by the parents on every school occasion, i.e. always less than 50%. |
| 28    | Attempts to encourage parental co-operation are :  |   |
| (i)   | Open Day for Parents   | (i) to appeal for parents' participation through their children   |
| (ii)  | to extend the guidance and counselling services to the parents   |   |
| (iii) | the School Speech Day  |   |

SECTION D : Nature or Type of Problems

- |      |  |  |
|------|--|--|
| 1(i) | Some teachers are not happy with the recognition (appreciation) given by the government of the services and sacrifices rendered by them. | (i) unsuitable teachers' options               |
|      |  | (ii) the teaching techniques of some teachers. |
| (ii) | Many teachers are discontented with the attitudes of the present day parents who are generally self-centred.                             |  |

- |       |  |       |  |
|-------|--|-------|--|
| 2(i)  | always ask (request) the teachers to give sincere contribution regardless of the sympathy from other people. | (i)   | Regarding the teachers' option -<br>try to obtain help or co-operation from the State Education Department |
| (ii)  | always encourage the teachers to improve their position e.g. by going for further studies.                   | (ii)  | Regarding the teaching techniques - by holding informal discussions with the teachers concerned.           |
| 3     | Sometimes  | -     | same -   |
| 4     | Problems faced by the School :   |       |  |
| (i)   | Problems arising from the pupils who faced domestic problems, e.g. parents divorced etc.                     | (i)   | pupils' truancy from classes   |
| (ii)  | Parents spoiling their children.   | (ii)  | smoking among the pupils   |
| (iii) | the groups of parents who never pay particular attention towards their children's education.                 | (iii) | destruction of school properties, e.g. tables, chairs, softboard etc.                                      |
|       |  | (iv)  | misuse of toilets.   |
|       |  | (v)   | theft (stealing).  |

SECTION E : Context of Problem Solving

- |     |                               |  |
|-----|-------------------------------|--|
| 1   | Sometimes - Rating No. 3      | Rating No. 6.  |
| 2a) | never                         | a) never   |
| b)  | sometimes                     | b) sometimes   |
| c)  | often                         | c) often   |
| d)  | often                         | d) sometimes   |
| e)  | never                         | e) never   |
| 3   | No                            | Yes (in the classroom)   |
| 4   | -                             | smoking and truancy from class   |
| 5   | e - i.e. once a month         | d - 2-5 times per month  |
| 6   | No                            | Yes  |
| 7   | -                             | Counselling  |
| 8   | No                            | No   |
| 9   | Yes                           | Yes  |
| 10  | 5 or 6 times                  | 3-4 times  |
| 11  | Good and satisfactory service | Not satisfied with the counselling services being carried out - despite the fact that the school is lucky enough to have a trained counselling teacher. In many cases, the Principal knew the problems before the guidance teacher and later referred them to the guidance teacher |

- |    |   |  |
|----|---|--|
| 12 | Not very effective because it was not equipped with many essential elements, e.g. not enough trained guidance teachers etc.   | The guidance and counselling services should be further equipped.        |
| 13 | Both - Rating No. 3   | Both - Rating No. 4  |
| 14 | Suggestions:  | Suggestions :  |
|    | (i) the service should be expanded by establishing a foster child system where the teachers could become mother or father to the pupils. In this way the teachers could help the guidance teacher solve many problems | Encourage the guidance teacher to be more active and full of initiative. |
|    | (ii) it is necessary to provide guidance and counselling services to the parents.   |  |

## FORM 'B' (Answered by the Guidance Teachers)

<u>Question</u>	<u>GUIDANCE TEACHER OF SCHOOL 1</u>	<u>GUIDANCE TEACHER OF SCHOOL 2</u>
-----------------	-------------------------------------	-------------------------------------

SECTION A - Particulars of the Guidance Teachers

1	Name -	-
2	School -	-
3	Male	Male
4a)	B.A. (Honours)	a) B.A. (Honours)
b)	Diploma in Education	b) Teacher's Certificate in Education
c)	Diploma in Counselling	c) Diploma in Counselling
5	1.7.1979	1.1.1960
6	Since 1982	Since 1974

SECTION B - Extent of Guidance Services

1	Yes	Yes
2	Diploma in Counselling at National University of Malaysia - organised by the NUM or UKM and Ministry of Education	- same -
3	No	Yes
4	2 women teachers as assistants	- none -
5	No	-
6	-	-
7	Yes	Yes
8	A	C
9a)	b - 2 hours	a) a - more than 2 hours
b)	120 minutes i.e. at 3 rating	b) approximately 7½ periods i.e. between 3-4 rating
10a)	c	a) c
b)	Rating No. 2 i.e. 3 periods	b) Rating No.2-3 i.e. 4½ periods

11	-	-
12	-	-
13	12 teaching periods	21 teaching periods (plus 4 more periods for guidance and counselling sessions)
14	No	Yes
15	Civics	Malay Language and History
16	Yes	No
17	-	a) 8                      b) 15 periods
18	No	No
19	-	-
20	Normally work related to guidance and counselling is being carried out in the guidance teacher's room provided and lavishly furnished by the school	Depends on the pupils' problems and the current situations
21	Yes	Yes
22	No	Yes
23	- no answer -	-
24	Yes	Yes
25	b, c, d, f, g, h (a well furnished room)	b, c, d, f (a very modest provision)
26	a, d and e	b, c, d and e
27	a, b and e	a, c and e
28	Yes	No
29	A	-

SECTION C - Quality of Guidance Services

1	Yes	Yes
2	a	a
3	a and f	a, b and f
4	Rating No. 3 - sometimes	Rating between 4-5

5	Rating No. 3 - important	Rating between 2-3
6	Rating No. 3 - important	Rating between 3-4
7	Rating No. 3 - 50%	Rating between 3-4 (50-75%)
8	Rating between 3-4 i.e. 50-75%	Rating between 2-3 i.e. 25-50%
9	Rating between 4-5 i.e. 9 to 12 pupils or more	Rating between 2-3 i.e. 3 to 6 pupils
10	a - 3 b - 5 c - 5	a - 3 b - 3 c - 3
11	3 - sometimes	between 1-2 rating
12	Rating between 4-5	Rating between 3-4
13	Rating No. 4 i.e. 75%	Rating between 1-2 i.e. 10-25%
14	Rating No. 3 - necessary	- same -
15	b - parents	no answer
16	Relationship: a - 5 b - 4 c - 4 d - 5 e - 4 f - 4	Relationship: a - 4 b - 4 c - 4 d - 4 e - 3 f - none
17	b - sometimes	c - rarely
18	Reasons for parental visits:- To discuss the pupils' problems concerning: (i) financial (ii) selection and transfer of school (iii) their children's progress (iv) further studies	(i) regarding their children's problems (ii) to request for educational as well as financial help after being requested by the school (iii) after being requested by the school
19	e	b and d

SECTION D - Nature or Type of Problems

1	Approximately 3 - sometimes	Rating No. 3 - sometimes
2	a to d) - no reply	a) Principal is more concerned about discipline

e) - Some of the teachers in this school often have negative attitudes toward guidance teacher (i.e. lack of co-operation from other teachers)

b) Many members of the staff do not understand about the counselling process because its result (effectiveness) is rather slow.

c) Pupils do not understand the functions of counselling

d) The parents also do not know much about counselling

e) - No reply

3 Rating No. 4

Rating No. 2

4a) (i) truancy 15%  
(ii) discipline offenders 25%  
(iii) others 15%

a) (i) Drug taking 50%  
(ii) personal problems 70%  
(iii) vocational 1%

5b) (i) none  
(I am very happy with my work)

b) (i) educational problems  
(ii) social problems (no further elaboration)

#### SECTION E - Context of Problem Solving

1 c - vocational guidance

d - all the three of them

2 a - sometimes

a - often  
b - sometimes  
c - sometimes  
d - never  
e - sometimes

3 No

Yes

4 a) -  
b) -

a) d - only a few cases  
b) (i) give advice  
(ii) call their parents

5 a - often

a - often  
b - sometimes  
c - never  
d - never  
e - -  
f - -

6 No

No

7 -

-

8 (i) obtain more information on career or vocation

- no reply -

	(ii) obtain information from career library	
	(iii) to increase their academic interest	
	(iv) -	
9	Yes	Yes
10	Yes	No
11	He gave financial support as well as guidance facilities. In addition "the Principal was very understanding and abide whatever decisions made by me".	-
12	Rating 3 i.e. c or both	- same -
13	Yes	Yes
14	"I am very interested in carrying out my duties as guidance teacher".	"Enable me to help the pupils (fully) understand their problems".
15	-	-
16	It should be extended to all schools in rural as well as urban areas.	Still not very satisfied with the present guidance and counselling services in the school. Many teachers and pupils do not understand its objectives and functions.
17	The services do not get enough attention from the Ministry of Education and from the Principals.	
18	"Up to now, I do not need anymore facilities".	"I hope to get less (lighter) teaching periods".
19	Suggestions: (i) All teachers in the school should be given explanation and information on guidance and counselling services in schools  (ii) There should be co-ordination between the guidance teacher's duties with that of the discipline teacher. Without this co-	Suggestions: (i) The Ministry of Education should regard (consider) guidance and counselling services as an important aspect of education.  (ii) Guidance teacher should be exempted (excluded) from teaching duties.

ordination, resentment will always occur between them.

(iii) Other teachers should be told that the duties of a counsellor are very difficult or heavy and they should not complain (grumble) if the guidance teacher is given a time-table below 15 periods

FORM 'C'

(Answered by the Pupils)

<u>Question</u>	<u>PUPILS OF SCHOOL 1</u>	<u>PUPILS OF SCHOOL 2</u>
<u>SECTION A - Particulars of Pupils</u>		
1	School 1	School 2
2	Male 45 Female 47 Total = 92	Male 32 Female 26 Total = 58
3	Ethnic group Malays - 82 Chinese - 7 Indians - 3 Others - -	Ethnic group Malays - 48 Chinese - 9 Indians - - Others - 1
4	Age: 16+ 87 pupils 17 4 pupils 18 1 pupil	Age: 16+ 33 pupils 17 22 pupils 18 3 pupils
5	Form: 5 Science - 83 5 Arts - 9	Form: 5 Science - 39 5 Arts - 18
6	No - 39 pupils Yes - 53 pupils	No - 51 pupils Yes - 7 pupils
7	1 year - 10 pupils 2 years - 15 pupils 3 years - 4 pupils 4 years - 2 pupils 5 years+ - 42 pupils	1 year - 31 pupils 2 years - 3 pupils 3 years - 1 pupil 4 years - 12 pupils 5 years+ - 1 pupil
8	a - 1 pupil b - none c - 52 pupils d - 34 pupils e - 5 pupils	a - 1 pupil b - 3 pupils c - 25 pupils d - 8 pupils e - 21 pupils
9	Reasons for studying in the schools a - 8 pupils b - none c - 77 pupils d - 26 pupils e - 48 pupils f - 13 pupils	a - 18 pupils b - 2 pupils c - 48 pupils d - 6 pupils e - 18 pupils f - 10 pupils
<u>SECTION B - Extent of Guidance Services</u>		
1	Yes - 92 pupils	Yes - 52 pupils No - 6 pupils

2	Yes - 25 pupils No - 64 pupils No Reply - 3 pupils	Yes - 10 pupils No - 48 pupils
3	Once - 12 or 44% Twice - 4 or 20% 3 times - 3 or 12% 4 times - - 5 times - - More than 5 times - 6 or 24%	Once - 2 or 20% Twice - 3 or 30% 3 times - 3 or 30% 4 times - - 5 times - 1 or 10% More than 5 times - 1 or 10%
4	Facilities a) 4 pupils b) 51 pupils c) 84 pupils d) 32 pupils e) 87 pupils f) 86 pupils	Facilities a) 9 pupils b) 45 pupils c) 49 pupils d) 14 pupils e) 48 pupils f) 52 pupils
5	Career Publications: a) 46 pupils b) 11 pupils c) 11 pupils d) 61 pupils e) 42 pupils	Career Publications: a) 37 pupils b) 33 pupils c) 34 pupils d) 18 pupils e) 21 pupils
6	Frequency of using the available facilities: Always - 3 pupils Sometimes - 29 pupils When necessary - 41 pupils Uncertain - 6 pupils Never - 10 pupils	Frequency of using the available facilities: Always - 3 pupils Sometimes - 9 pupils When necessary - 23 pupils Uncertain - 8 pupils Never - 16 pupils

### SECTION C - Quality of Guidance Services

1	Never - Once a year - Twice a year - 14 pupils Three times a year - 75 pupils Not more than once a month - 5 pupils	Never - 2 pupils Once a year - 1 pupil Twice a year - 2 pupils Three times a year - 26 pupils Not more than once a month - 27 pupils
2	Yes - 4 pupils No - 86 pupils	Yes - 5 pupils No - 53 pupils
3	Selection of subjects Most of the time - 57 pupils Not sure - 16 pupils Sometimes - 3 pupils Once - 12 pupils Never - 2 pupils	Selection of subjects Most of the time - 10 pupils Not sure - 13 pupils Sometimes - 9 pupils Once - 4 pupils Never - 21 pupils
4	a - Principal d - Education Department	a - Principal b - Education Department

5	Yes - 23 No - 47	Yes - 20 No - 35
6	a - 84 b - 86 c - 4 d - 84 e - 83	a - 57 b - 58 c - 6 d - 47 e - 54
7	a - 70 b - 65 c - 82 d - 83 e - 84 f - 81	a - 47 b - 41 c - 52 d - 53 e - 55 f - 55
8	a - 41 b - 29 c - 37 d - 14 e - 16 f - 4	a - 52 b - 18 c - 51 d - 24 e - 11 f - 7
9	Help from parents: a) all the time b) whenever she/he is free c) whenever necessary d) sometimes e) never	1. a) - 5 b) - 3 c) - 14 d) - 17 e) - 21
10	Relationship of pupils with: a) Principal - Fair b) Teachers - Fair-Good c) G. Teachers - Good d) Peer Group - Good e) Parents - Good f) Others - Satisfactory  (cf. Table: 7 p. 209)	a) Principal - Fair b) Teachers - Fair c) G. Teachers - Good d) Peer Group - Good e) Parents - Good f) Others - Good  (cf. Table: 7 p. 209 )

#### SECTION D - Nature or Type of Problems

1	(i) Financial Situation - sometimes (56%) (ii) Studies - sometimes (54%) (iii) Health - sometimes (50%) (iv) Peer group - sometimes (47%) (v) Family - seldom (45%) (vi) Other problems - strict discipline - personal problems - religious problems etc. - unsuitable environment for studying purposes  (cf. Table: 11 p. 217 )	(i) Studies - Sometimes (55%) (ii) Family - sometimes (53.5%) (iii) Health - sometimes (50%) (iv) Financial situation - some- times (43%) (v) Peer group - seldom (44.8%) (vi) Other problems - personal problems - transport problem to school - sleepy during lessons
---	--	--

- 2 In case of difficulties, they would turn to:
- |                                      |                             |
|--------------------------------------|-----------------------------|
| a) Parents - often (34.8%)           | a) Most of the time (41.4%) |
| b) Close relatives - sometimes (38%) | b) Sometimes (43%)          |
| c) Friends - sometimes (38%)         | c) Sometimes (51.7%)        |
| d) Form teacher - seldom (45%)       | d) Seldom (36.2%)           |
| e) Subject teacher - never (37%)     | e) Sometimes (41.4%)        |
| f) Guidance teacher - seldom (30.4%) | f) Never (38%)              |
| g) Your elders - sometimes (33%)     | g) Sometimes/never (32.8%)  |
| h) Welfare officer - never (89%)     | h) Never (50%)              |
| i) Local policeman - never (81.5%)   | i) Never (81%)              |
| j) Others - never (26.1%)            | j) Never (39.7%)            |
- (cf. Table: 13 p. 224 )

- |   |              |              |
|---|--------------|--------------|
| 3 | a) 3 pupils  | a) 5 pupils  |
|   | b) 4 pupils  | b) 11 pupils |
|   | c) 1 pupil   | c) 4 pupils  |
|   | d) 2 pupils  | d) 4 pupils  |
|   | e) 5 pupils  | e) 6 pupils  |
|   | f) 6 pupils  | f) 2 pupils  |
|   | g) 11 pupils | g) 8 pupils  |

- |   |                |                |
|---|----------------|----------------|
| 4 | Yes -          | Yes -          |
|   | No - 92 pupils | No - 54 pupils |

- |   |                |                |
|---|----------------|----------------|
| 5 | Yes - 2 pupils | Yes - 2 pupils |
|   | No - 88 pupils | No - 51 pupils |

- |   |                  |         |
|---|------------------|---------|
| 6 | a) Opium - 25    | a) - 34 |
|   | b) Heroin - 7    | b) - 4  |
|   | c) Marijuana - 4 | c) - 2  |
|   | d) LSD - 4       | d) - 2  |
|   | e) Others - 5    | e) - 2  |

- |   |                |                |
|---|----------------|----------------|
| 7 | a) - 82 pupils | a) - 55 pupils |
|   | b) - 77 pupils | b) - 46 pupils |
|   | c) - 78 pupils | c) - 48 pupils |
|   | d) - 78 pupils | d) - 55 pupils |
|   | e) - 16 pupils | e) - 11 pupils |

SECTION E - Context of Problem Solving

- |   |                           |                           |
|---|---------------------------|---------------------------|
| 1 | Refer to Table: 13 p. 224 | Refer to Table: 13 p. 224 |
| 2 | Yes - 32 pupils           | Yes - 19 pupils           |
|   | No - 59 pupils            | No - 39 pupils            |
| 3 | a) 2 pupils               | a) -                      |
|   | b) 2 pupils               | b) -                      |

- |   |   |               |
|---|---|---------------|
|   | c) - pupils   | c) -          |
|   | d) 13 pupils  | d) 9          |
|   | e) 25 pupils  | e) 17         |
|   | f) 10 pupils  | f) 15         |
| 4 | a) 14 pupils  | a) 16 pupils  |
|   | b) 2 pupils   | b) 3 pupils   |
|   | c) 4 pupils   | c) 5 pupils   |
|   | d) 25 pupils  | d) 16 pupils  |
|   | e) 15 pupils  | e) 12 pupils  |
|   | f) 2 pupils   | f) 4 pupils   |
| 5 | a) 2 pupils   | a) 3 pupils   |
|   | b) -  | b) 1 pupil    |
|   | c) 36 pupils  | c) 19 pupils  |
|   | d) 38 pupils  | d) 25 pupils  |
|   | e) 5 pupils   | e) 9 pupils   |
| 6 | Yes 55 pupils   | Yes 13 pupils |
|   | No 29 pupils  | No 43 pupils  |
| 7 | Among the activities of the career and guidance club are:   |               |
|   | (i) organise talks and speeches on career opportunities   |               |
|   | (ii) organise career projects and exhibitions   |               |
|   | (iii) hold discussions on careers and education   |               |
|   | (iv) group counselling  |               |
|   | (v) film shows  |               |
| 8 | Benefits derived from the club are:   |               |
|   | (i) able to make new friends  |               |
|   | (ii) encourage interaction and better relationship between the pupils and their guidance teachers |               |
|   | (iii) a useful means of filling free time   |               |
|   | (iv) to instill discipline and self-confidence  |               |
| 9 | Suggestions   |               |
|   | (As discussed in Chapter 3, pp. 287-290 )   |               |

FORM 'D' (Answered by the Parents)

Question PARENTS OF PUPILS IN SCHOOL 1 PARENTS OF PUPILS IN SCHOOL 2

SECTION A - Particulars of Parents :

1a)	Fathers : 81 )	Fathers : 51 )
	Mothers : 9 ) 92 Parents	Mothers : 7 ) 61 Parents
	Guardians : 3 )	Guardians : 3 )

b) Occupation : Farmers,  
government officers,  
teachers, businessmen etc.

2 Number of children  
between 2 - 5 - same -

3 Schooling children  
between 1 - 3 - same -

SECTION B - Extent of Guidance Services

1	Yes : 75 parents	Yes : 39 parents
	No : 18 parents	No : 22 parents

2a)	9	a)	4
b)	29	b)	36
c)	26	c)	14
d)	3	d)	1

(Note : Very few parents answered this question in both schools)

3 Visits to schools :

a)	more than 3 times/year	2	a)	2
b)	3 times/year	1	b)	2
c)	twice/year	3	c)	1
d)	once a year	5	d)	4
e)	only whenever necessary	47	e)	38
f)	never	34	f)	13

SECTION C - Quality of Guidance Services

1a)	72 parents	a)	14 parents
b)	16 "	b)	40 "
c)	-	c)	3 "
d)	2 "	d)	-
e)	2 "	e)	3 "

2 Opinion

a)	Often	3	a)	-
b)	not sure	9	b)	12
c)	sometimes	5	c)	6
d)	once	1	d)	-
e)	never	74	e)	41

3	Yes : 8 parents No : 83 "	Yes : 13 No : 46
4a)	3	a) 6
b)	4	b) 3
c)	63	c) 43
d)	51	d) 34
e)	3	e) 18
f)	19	f) 12
5a)	21	a) 28
b)	14	b) 9
c)	51	c) 25
d)	12	d) 6
e)	63	e) 45
f)	54	f) 40
6a)	10	a) 15
b)	8	b) 11
c)	86	c) 52
d)	2	d) 1
7a)	1 parent or 1.09%	a) 2 or 3.3%
b)	85 " 92.4%	b) 55 90.2%
c)	17 18.5%	c) 13 21.3%
8	Yes 80 parents or 87% No 1 " 1.1% Don't know 12 " 13%	Yes 50 parents or 82% No - - Don't know 10 " 16.4%
9a)	1 parent or 1%	a) 2 parents or 3.3%
b)	4 " 4.4%	b) 6 " 9.8%
c)	40 " 43.5%	c) 22 " 36.1%
d)	15 " 16%	d) 9 " 14.8%
e)	33 " 35.5%	e) 22 " 36.1%
10	Relationship with :	
a)	Principal - Fair	a) Fair - Good
b)	Teachers - Fair	b) Fair
c)	Son/Daughter - Very good	c) Very good
d)	Son's/Daughter's Friends - Good	d) Good
e)	Society - Good	e) Good
	(cf. Table : 8 p. 211)	

SECTION D - Nature or Type of Problems

1	Problems:	Problems :
(i)	Studies	(i) Studies
(ii)	Health	(ii) Financial situation
(iii)	Peer groups	(iii) Health
(iv)	Financial situation	(iv) Peer groups

## 2 Complaints

a)	75%	a)	72.1%
b)	28%	b)	42.6%
c)	15%	c)	26.2%
d)	28%	d)	47.5%
e)	5%	e)	6.6%

SECTION E - Context of Problem Solving

1a)	4.4%	a)	9.8%
b)	16%	b)	23%
c)	62%	c)	55.7%
d)	16%	d)	8.2%
e)		e)	3.3%

2a)	77.2%	a)	65%
b)	21.2%	b)	27.9%
c)	52.2%	c)	47.5%
d)	37%	d)	37.7%
e)	62%	e)	54.1%
f)	12%	f)	23%
g)	41.3%	g)	31%
h)	3.3%	h)	3%

3a)	19.6%	a)	17.2%
b)	57.6%	b)	32.8%
c)	19.6%	c)	36.2%
d)	3.3%	d)	19%
e)	-	e)	-

## 4 Suggestions

(As discussed in Chapter 3, pp. 287-290 )

