

Durham E-Theses

The integrity of serial data highway systems

D. Cowan

How to cite:

Cowan, D. (1983) The integrity of serial data highway systems. Doctoral thesis, Durham University.

Use policy

The full-text may be used and/or reproduced, and given to third parties in any format or medium, without prior permission or charge, for personal research or study, educational, or not-for-profit purposes provided that:

- a full bibliographic reference is made to the original source
- a <https://etheses.durham.ac.uk/id/eprint/7253/> is made to the metadata record in Durham E-Theses
- the full-text is not changed in any way

The full-text must not be sold in any format or medium without the formal permission of the copyright holders.

Please consult the [full Durham E-Theses policy](#) for further details.

The copyright of this thesis rests with the author.
No quotation from it should be published without
his prior written consent and information derived
from it should be acknowledged.

The Integrity of Serial Data Highway Systems

by

D.Cowan, B.Sc.

A thesis submitted for the degree of Doctor of Philosophy
in the University of Durham, 1983.



30. JUL 1984

Presio
1983/COW

The Integrity of Serial Data Highway Systems

D.Cowan

Abstract

The Admiralty Surface Weapons Establishment (ASWE) have developed a Local Area Network System. This thesis describes the development of a replacement for this LAN system, based around 16 bit microprocessor hosts, as opposed to the minicomputers currently used. This change gave a substantial reduction in size, and allowed the new system to be installed on a ship and tested under operational conditions. Analysis of the data collected during the tests gave performance information on the ASWE system. The performance of this LAN is compared to that of other leading types of LAN. The design of a portable network controller/ monitor unit is presented, which may be manufactured as a standard controller for the ASWE Serial Highway.

Acknowledgements

I wish to express my thanks primarily to Dr. C.T. Spracklen for his assistance during the course of this project. In addition, the advice of Mr. D.J. Dwyer and Dr. D.R. Isaac was much appreciated. Thanks are also due to the departmental technicians who provided valuable technical help on many occasions. The staff of XCC Division, ASWE, assisted in many ways during the course of my research, and they continually tolerated the disruption to their normal work which Dr. Spracklen and myself seemed to bring to them.

I am particularly grateful to the Ministry of Defence who funded this project.

Contents

Glossary of Terms

Chapter 1 Introduction

- 1.1 Local Area Networks
 - 1.1:1 Ring Topology
 - 1.1:2 Linear Topology
- 1.2 The Choice of LAN Architecture
- 1.3 Conclusion

Chapter 2 The A.S.W.E. Serial Highway

- 2.1 Introduction
- 2.2 Signalling Conventions
- 2.3 Message Protocols
 - 2.3:1 Control Messages
 - 2.3:2 Information Messages
 - 2.3:3 Message Fields
 - 2.3:4 The Error Recovery Scheme
- 2.4 Front-end Processors
- 2.5 Transceiver
- 2.6 Host Interface
- 2.7 Microcode Cross-Assembler & ASH Simulator
- 2.8 ASH Terminal Unit
 - 2.8:1 Software Tables
 - 2.8:2 Host Control of Highway Terminal Unit
- 2.9 Highway Controller Unit
 - 2.9:1 Software Tables
 - 2.9:2 Host Control of Highway Controller Unit
- 2.10 ASH Configuration
 - 2.10:1 Single Controller/ Twin Highway Cables
 - 2.10:2 Twin Controller/ Twin Highway Cables
 - 2.10:3 Cable Configuration
- 2.11 Conclusion

Chapter 3 Computer Systems

- 3.1 Introduction
- 3.2 The DEC PDP11/34 and Unix.
 - 3.2:1 The Implementation of BCPL and Coral
 - 3.2:2 ASH Software Packages
- 3.3 The Data General Nova-3 and RDOS
- 3.4 The Motorola MC6809 Development System
- 3.5 The Motorola MC68000 Single Board Computer
 - 3.5:1 An Upgrade of the On-board Memory
- 3.6 Additional Peripherals and Software
 - 3.6:1 Pro-Log Prom Programmer
 - 3.6:2 Computer Communications Software
- 3.7 DMA Interface
- 3.8 Conclusion

Chapter 4 SIXTH

- 4.1 Introduction
- 4.2 SIXTH Design Philosophy
- 4.3 System Kernel
- 4.4 System Dictionary
- 4.5 Conclusion

Chapter 5 The Portable Highway Controller

- 5.1 Introduction
- 5.2 Portable Controller Hardware
- 5.3 Controller Software
 - 5.3:1 Design of SIXTH Programs
 - 5.3:2 The Use and Upgrading of Controller Software
- 5.4 Testing the Portable Controller
- 5.5 Conclusion

Chapter 6 The ASH Ship Trials

- 6.1 Introduction
- 6.2 Test Hardware
 - 6.2:1 MC6809 Monitoring Unit
 - 6.2:2 MC68000 Highway Terminal Units
- 6.3 Ship Trial Software
 - 6.3:1 Design Concept
 - 6.3:2 Block Message Soak Test
 - 6.3:3 Short Message Soak Test
 - 6.3:4 Test Control Software
 - 6.3:5 Test Report Software
 - 6.3:6 Test Monitoring
- 6.4 Test Results
 - 6.4:1 Analysis Techniques
 - 6.4:2 Discussion of Results
- 6.5 Conclusion

Chapter 7 LAN Technology

- 7.1 Introduction
- 7.2 Review of Basic LAN Technology
- 7.3 Improvements to the Basic LANs
 - 7.3:1 Ring LANs
 - 7.3:2 Decentralised Control Linear Bus LANs
 - 7.3:3 Centralised Control Linear Bus LANs
- 7.4 A Second Generation ASH
- 7.5 Conclusion

Chapter 8 Conclusion

Bibliography

- Appendix A** Program listings
- Appendix B** An Upgrade of On-Board Memory
- Appendix C** DMA Interface Circuit Diagrams
- Appendix D** Portable Highway Controller User Commands
- Appendix E** Graphs of ASH Test Results

Glossary of Terms

ACIA	Asynchronous Communications Interface Adaptor
ALU	Arithmetic Logic Unit
ASCII	American Standard Code for Information Interchange
ASH	ASWE Serial Highway
ASWE	Admiralty Surface Weapons Establishment
CMOS	Complimentary Metal-on-Silicon
CPU	Central Processor Unit
CSMA	Carrier Sense Multiple Access
DMA	Direct Memory Access
DS	DO Stack
EPROM	Erasable Programable Read-only-Memory
FEP	Front End Processor
FIFO	First In First Out
I/O	Input/ Output
LAN	Local Area Network
LCD	Liquid Crystal Display
LED	Light Emitting Diode
MS	Machine Stack
OS	Operand Stack
PIA	Parallel Interface Adaptor
PROM	Programable Read-only-Memory
RAM	Random Access Memory
VDU	Visual Display Unit

Chapter 1

Introduction

1.1 Local Area Networks

In recent years the trend towards mainframe computers of ever increasing complexity has been overtaken by the use of distributed computer systems, in an attempt to provide greater speed and flexibility of computing power. This has been aided by the greatly reduced costs of computer hardware, and by the ease of application of modern block structured programming languages to multiprocessor systems. These systems normally fall into one of two categories, loosely coupled and tightly coupled systems. In the former, communications between the elements of the system take place at a very much higher rate than in the latter. Tightly coupled systems can have a communication rate of up to 200Mbits/ sec, whilst most loosely coupled systems have a maximum transmission rate of approximately 20Mbits/ sec. The difference in transmission speeds is due to the differing demands placed on the communication system by the elements in the network. Normally, the elements in a tightly coupled system are interdependant and would be unable to function satisfactorily if one element was malfunctioning. Array processor systems and multi-ALU systems fall into this category. Loosely coupled systems normally consist of units which are able to function satisfactorily by themselves, and communication between the elements is normally via data messages rather than machine level instructions as in the tightly coupled systems. The decrease in the transmission rate allows different transmission media to be used, and many loosely coupled systems use serial transmission lines. There is a large range of possible interconnection systems for these two types of distributed computing systems. However, they fall roughly into three categories; point to point, interconnecting bus, and network. In addition, combinations of the three types also occur.



In the past, point to point systems have been used to a great extent because they were the easiest and least expensive to implement. In a point to point system, a dedicated communication path exists between every element in the system. This necessitates a large amount of wiring between elements, but has the great advantage that the receiving unit has an inherent physical address; no additional software is required to generate the address or, in the receiver, to decode the address. However, greater importance is now placed upon the ability to reconfigure a communication system to incorporate new elements, and in a point to point communications system this necessitates expensive and complex rewiring. Thus point to point systems have largely been replaced by some form of shared communications system.

A communication network is a collection of shared communications paths and devices interconnected so at least one pair of devices has more than two simultaneous path possibilities. The most common of the network systems have computers as devices and telephone landlines as communications paths. Examples of these are ARPANET [1,2] and OCTOPUS [3]. Networks are characterised by their topology, protocols, communications disciplines and geographical extent. Networks which communicate over longer distances than 1km, such as ARPANET, are known as long-haul networks, whilst those which work over shorter distances, such as the Xerox FIBERNET [4], are known as short-haul networks. The most common topologies used are the mesh and star, shown in Figure 1.1a. The protocols implemented depend upon both the topology and communication discipline used, however they can usually be subdivided into transport protocols, routing and flow protocols and user level protocols. The communications disciplines used are circuit switching, message switching and packet switching. Our telephone

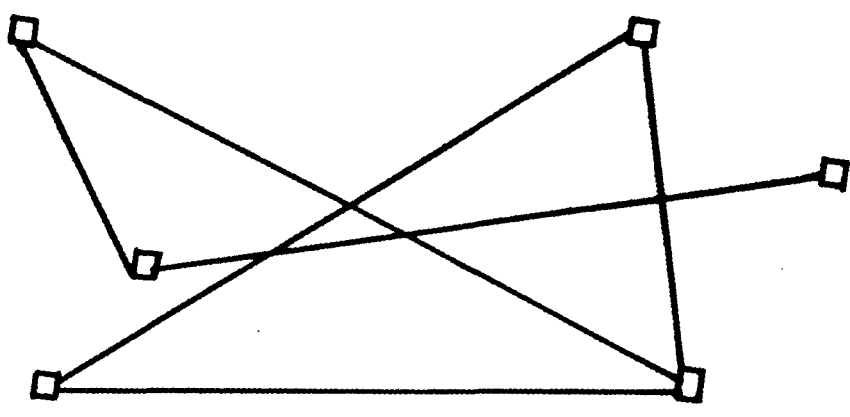

Mesh

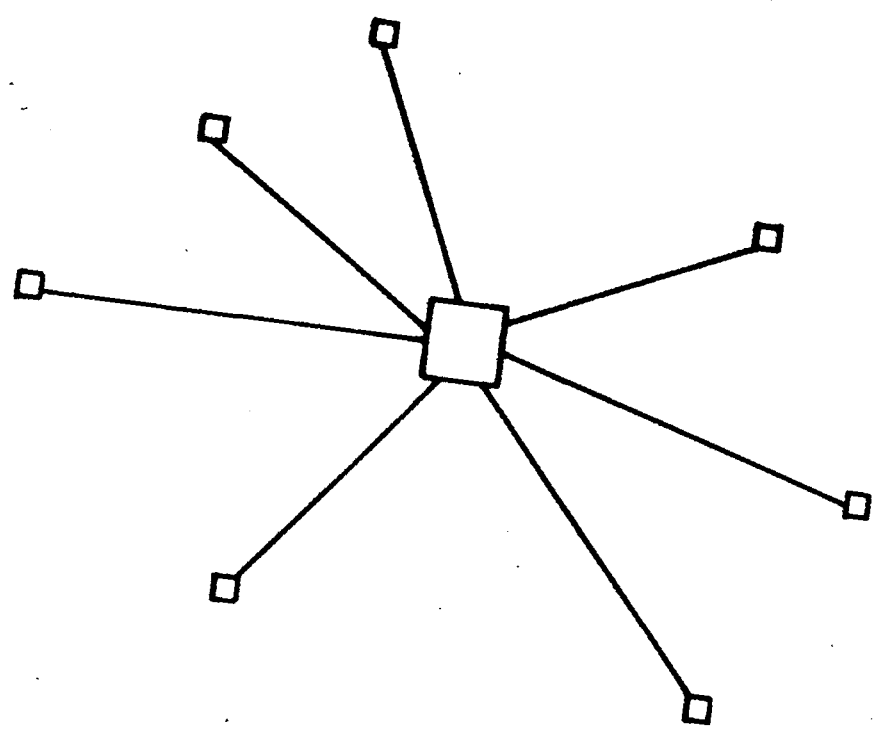

Star

Figure 1.1a Common Networks

system employs circuit switching; a complete circuit must be established between caller and the listening station otherwise the caller hears an engaged signal. Packet switching is employed by ARPANET and most short-haul networks. Messages are segmented into fixed length packets which are only reconstructed at the destination node. Intermediate nodes retransmit packets as received, but certain systems may perform error detection and correction. The distinction between packet switching and message switching is less obvious in certain configurations of local networks.

The pure star topology employed by FIBERNET type systems does not strictly fit the category of a network because of the lack of simultaneous paths.

A data bus is a shared communication path joining many devices with only one path between any two devices. Examples of such systems include MIL-STD 1553B [5], the Cambridge Data Ring [6], and ETHERNET [7,8]. One of the advantages of a data bus system over a point to point system is the ease of reconfiguration to support additional devices. However the data bus system has the disadvantage of the requirement for software addresses for every device, and the complicated protocols and decoding necessary to support this type of addressing.

The term 'Local Area Network' (LAN) is now used to describe short haul networks and data bus systems. The systems upon which most work is currently being undertaken are data bus systems. The most used topologies are ring, redundant ring, linear and redundant linear. The addition of redundancy gives protection against the failure of the transmission media.

Regardless of its topology, a data bus can be active or passive; an active bus is one with signal regeneration at each node,

whilst a passive one has no regeneration in the system.

1.1:1 Ring Topology

The topology of a typical ring network is detailed in Figure 1.1:1a. Each unit acts as a repeater on the ring and the LAN normally uses some form of token passing message handling system. A ring network utilises an active data bus. In such a system, single or multiple tokens are continually circulating round the ring. If a unit wishes to transmit a message it waits until it receives this token. It then transmits its message and appends the token to the end of the message. The unit to which the message is addressed takes a copy of the message and also regenerates it and the token in the same manner as the intermediate units. The removal of the message from the ring is left to the unit which originated the message. Although the ring type network theoretically has the advantage of completely decentralised control, in practice there must be a master station which inserts the tokens onto the ring and monitors its activity to ensure that there is always a token present.

The 'Cambridge Ring' LAN is a variation of the ring network. It uses token passing in the form of a 'Message Slot' format. The master unit initially sets up a message structure on the ring consisting of a number of message slots each preceded by a header to indicate whether the slot is empty or full. A unit wishing to transmit a message merely waits until an empty slot arrives, and it then fills the slot and alters the header accordingly. Again, removal of the message is left to the transmitting unit. Unfortunately, this means that the master unit in the ring must set up the message slots, and must then maintain them against the possibility of corruption by noise. Thus the

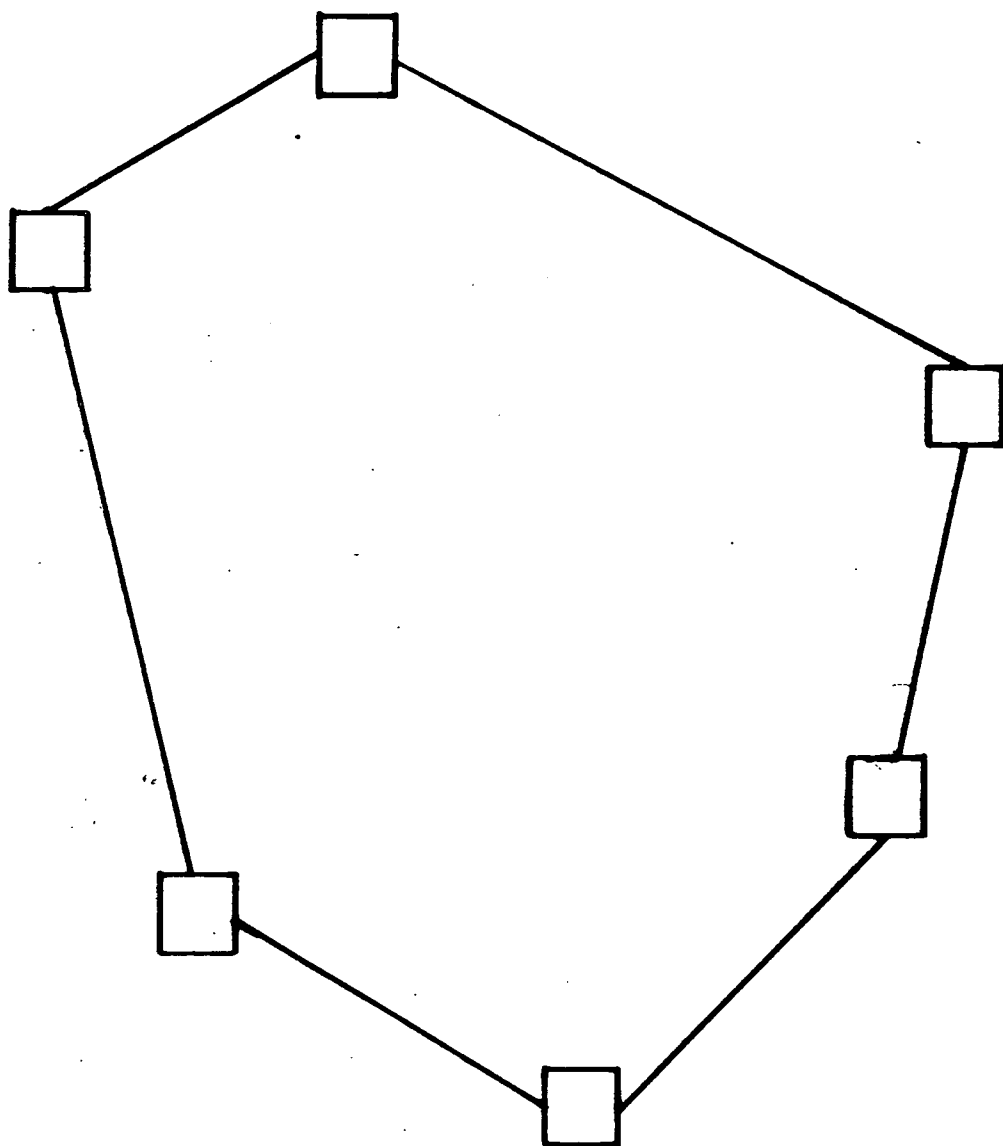

Figure 11:1a Ring Topology

advantages of decentralised control presented by the ring concept have been lost. In addition, since each unit on the ring is an active repeater, the failure of any one of these units can cause one section of the LAN to be isolated. This can be overcome by the use of more than one cable, (redundant ring topology) and by transmitting messages around each of the cables in different directions.

1.1:2 Linear Topology

The final class of LAN architecture is the one which is currently the most used. The topology of a linear bus LAN can be seen in Figure 1.1:2a. There are several message handling systems for such an architecture, but they fall into one of two classes; asynchronous and synchronous.

The ALOHA [9,10] system is an example of an early asynchronous LAN. If a unit wished to transmit a message it transmitted it immediately. It then waited for an acknowledgement of reception from the unit to which it had addressed the message. If the acknowledgement was not received, it assumed that the message had not been received, possibly due to the simultaneous transmission of a message by another unit. It then retransmitted the message after a random time interval, to ensure that the same clash did not occur again. However, as the load increased, the number of clashes also increased, and this meant that the maximum channel utilisation of a pure Aloha system was approximately 18 percent [8]. The addition of rudimentary coordination between units increased this utilisation. A series of synchronisation pulses were transmitted on the bus and units were only allowed to transmit messages immediately after the pulse. This increased the possible channel utilisation to 36 percent. An extension to the pure Aloha technique is the Carrier Sense Multiple Access with Collision

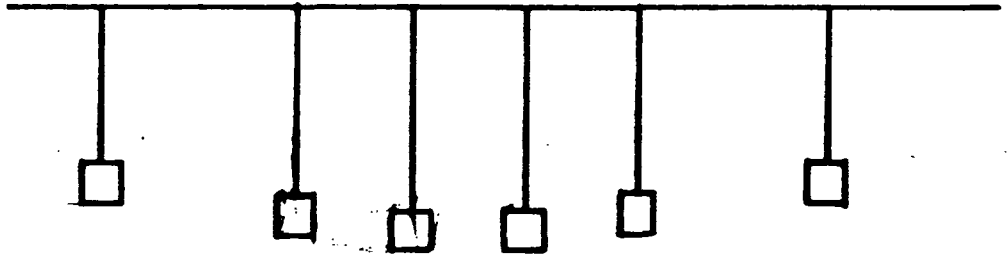

**Passive
Linear Bus**



**Active
Linear Bus**

Figure 11:2a Linear Bus Topology

Detect (CSMA/CD) system used in such LANs as Ethernet. In this system, all units monitor the activity on the bus before transmitting their messages. If the channel is free, a unit may transmit its message. If two (or more) units start transmission at the same time they can detect this clash by monitoring the activity on the channel. They immediately cease transmitting their message. The units then retransmit after a random time, to protect against repeated clashes. This system is efficient under conditions of low loading, however as the loading increases so too does the message delivery time. Channel utilisation in the Ethernet system can reach 98 percent [8].

Synchronous bus LANs have a controller which supervises the transmission of messages by the units on the bus. However, the throughput of the master unit does not determine the throughput of the network, as in the star LAN, because the master does not perform a 'receive and repeat' function. There are several type of synchronous bus control, but two of the more common types are :- round robin and polled systems. In the round robin system, each unit has a list of the order in which the units are to transmit held in its memory. The bus master transmits a message which says 'Next please' and the units consult their list to determine whether or not they are the next one on the list. The relevant unit then transmits a message if it wishes. Then the cycle is repeated. Synchronisation between the units must be achieved initially, to ensure that they are all at the same positions in their lists.

The second type of synchronous bus control commonly used is a polled system. In this system, the bus master explicitly polls each unit in turn. The unit may respond either with a message, or with an acknowledgement to show that it is still connected and functioning. This has the advantage of rigid control over message transmission by

the master. It allows a priority system to be implemented by polling a particular unit more often than the others.

Unfortunately, the synchronous bus LANs must have a control unit, and to protect against failure of this unit multiple controllers are normally used. Synchronous LANs do have the advantage of a lower message delivery time than the asynchronous systems when under high loading. Additionally, by using the bus controllers to maintain an error recovery scheme, they can offer guaranteed error free delivery of messages with fewer overheads than in the asynchronous systems.

However, this type of system does include certain overheads due to the poll messages which are not present in an asynchronous system. Careful design is needed to keep these overheads as low as possible. The major advantage of linear LANs over ring LANs, is that by careful choice of the signalling scheme and media used for the bus, it is possible to make it passive.

1.2 The Choice of LAN

Whilst there are many different LANs, there is no one type which is 'the best'. Each type has different characteristics which make it suitable for certain applications but completely unsuitable for others. In general, a careful assessment of the situation must be made before the choice of LAN for a particular application can be made. After such an assessment, the Admiralty Surface Weapons Establishment (ASWE) set down the design for their LAN, which is known as the ASH (ASWE Serial Highway) [11].

For many years, the Royal Navy have used large mainframe computers in their ships. These computers monitor the ships' surroundings with the aid of the radar systems, and provide target extraction and identification facilities to the officers in charge of the ships' operation. In addition, the computer provides automatic control over the various weapons systems used on board ship. As the years have advanced, the complexity and number of the radar systems, the displays, and the weaponry, have increased dramatically. This has led to two distinct problems in the modern naval ship. Firstly, the performance of the ship is very seriously affected if the computer ceases to function. Secondly, the amount of cabling necessary to route all of the control and monitoring functions to the master computer is immense. The adoption of distributed control using a local area network system will solve both of these problems. Every sub-system on board the ship, such as the radar, the gun-turrets, the missile launchers, the status displays etc; will contain a mini or micro computer. They will all be linked together via a local area network. The only cabling necessary for such a system will be the local wiring from the distributed processors to their subsystems, and the LAN

cabling, which will consist of several redundant highway cables. Each sub-system could then be factory tested with its local processor in full control.

The LAN used in such a system would have to have the following characteristics.

- 1) A very high resilience to individual element failure.
- 2) Guaranteed error free message delivery.
- 3) A simple, easily available highway cable/ connector to allow simple maintenance and repair.
- 4) A maximum cable length of 300 metres (due to length of ship).
- 5) Ease of alteration and reconfiguration.

It was decided that it would be very difficult to attain the necessary message throughput and overall system reliability needed by using a ring bus or star network. This meant the choice of a linear bus architecture. The need for guaranteed error free message delivery, and the knowledge that the bus was to be operated under a fairly high loading at all times dictated the choice of a poll-response system. Unfortunately, this type of system suffers from the obvious setback of centralised control, however the ASH was designed include multiple redundant controllers to alleviate this problem. In addition, the use of a passive highway, implemented using a screened twisted pair, allows the maximum cable length of 300 metres to be achieved without the use of repeaters. The signalling system chosen, a variant of Manchester coding known as Bifrequency Code (section 2.2) allows the cables to be connected without the need for any checks on polarity. The choice of NATO standard cable and connectors allowed the LAN to be simply and easily installed.

Unfortunately for ASWE, such an LAN was not available, so it was necessary to design their own. Great emphasis was placed on the need for simplicity of the host computer to LAN sub-system software interface. This led to the adoption (section 2.1) of a table driven interface between the LAN and its host computer, using an area of shared memory.

1.3 Conclusion

Local area network technology has advanced as the need has arisen for efficient communications between units in a loosely coupled distributed computing system. In such systems, a serial cable is normally used as the transmission media, and by a careful choice of signalling conventions, data rates up to 20Mbits/ sec can be achieved. Several possible topologies exist for LANs, each one suited to a different application. In many instances, distributed computing systems communicating via LANs have replaced single mainframes. This replacement was prompted by the need for greater overall system reliability, and the greater availability of mini and micro computers in recent years. In addition, the introduction of the software addressing used in LANs, in preference to the implicit hardware addressing used in earlier point to point systems, has greatly reduced the hardware changes necessary to reconfigure the system. In order to increase the reliability of the LANs, multiple redundancy is used for critical components and cabling. Careful choice of highway architecture allows a guaranteed error free message delivery, which may be critical in certain applications. ASWE have designed an LAN system for use in a future generation of naval ships and their choice of architecture gives the best performance in the naval environment with which they are concerned.

Chapter 2

The A.S.W.E Serial Highway

2.1 Introduction

The ASH was designed as a response to the needs of ASWE for a high speed local area network with guaranteed error free message delivery and a very high system reliability. Its specifications are laid out in Defence Standard 00/19 [11]. The network is of the poll-response linear bus type. In order to increase system reliability, there is a possibility of a multiple redundant highway cable and/or highway controller configuration. The line signalling and message protocols are handled by dedicated bit-slice front-end processors (FEPs), using AMD 2901 four bit wide devices. These processors are connected to the serial highway cable via transceivers, and to the host processors by specialised Direct Memory Access (DMA) interfaces. The host processor controls the communications processor by means of a set of tables in an area of shared memory. All messages sent on the highway may be put into one of two categories:- control and information messages. The information messages may be further divided into two types; short messages and block messages.

2.2 Signalling Conventions

The line signalling is performed using a variant of Manchester Code known as Bifrequency Code. The signalling rate is 3Mbits/sec. The valid signals are shown in Figure 2.2a. There are also two signalling violations defined as part of the specification, one to signal End of Message (EOM) and the other to signal End of Invalid Message (EOIM). These violations are shown in Figure 2.2b. The signal levels are detailed in Figure 2.2c. Since the highway is a passive linear bus,

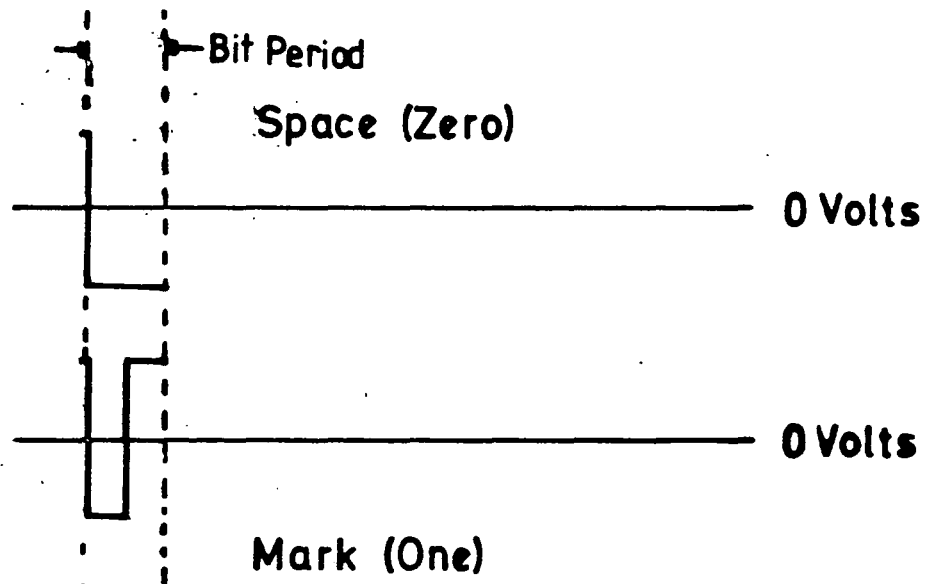

Figure 2.2a

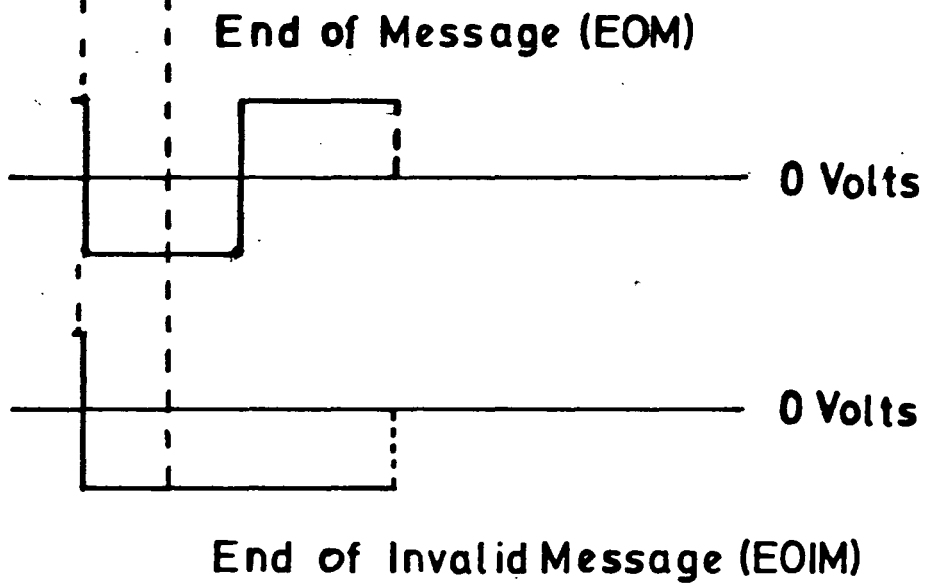

Figure 2.2b

these signal levels are subject to considerable degradation when a large number of units are connected, and/ or a long cable is used. The maximum level of degradation permitted is shown in Figure 2.2c. Error recovery is performed by the retransmission of incorrect messages.

2.3 Message Protocols

2.3:1 Control Messages

There are four types of control messages whose function is to maintain the poll and response scheme and to manage the error recovery system. The format of these messages may be seen in Figure 2.3:1a.

1) Permission to transmit (PTT): This message is issued by the highway controller and it gives a terminal specified by the DST field permission to use the highway.

2) Nothing to Transmit (NTT): This message is issued by a terminal in response to a PTT. The NAK field is used by the highway controller in the error recovery system.

3) Repeat Message (RM): This message is issued by the highway controller when a terminal unit indicates that a message has been missed. It takes the format of the class of information message of which it is a repeat, except that byte 2 is equal to byte 4.

4) Null Repeat Message (NRM): This message is issued by the highway controller when it is unable to obtain a valid response from a terminal, or when the controller does not have an error free copy of the message to retransmit.

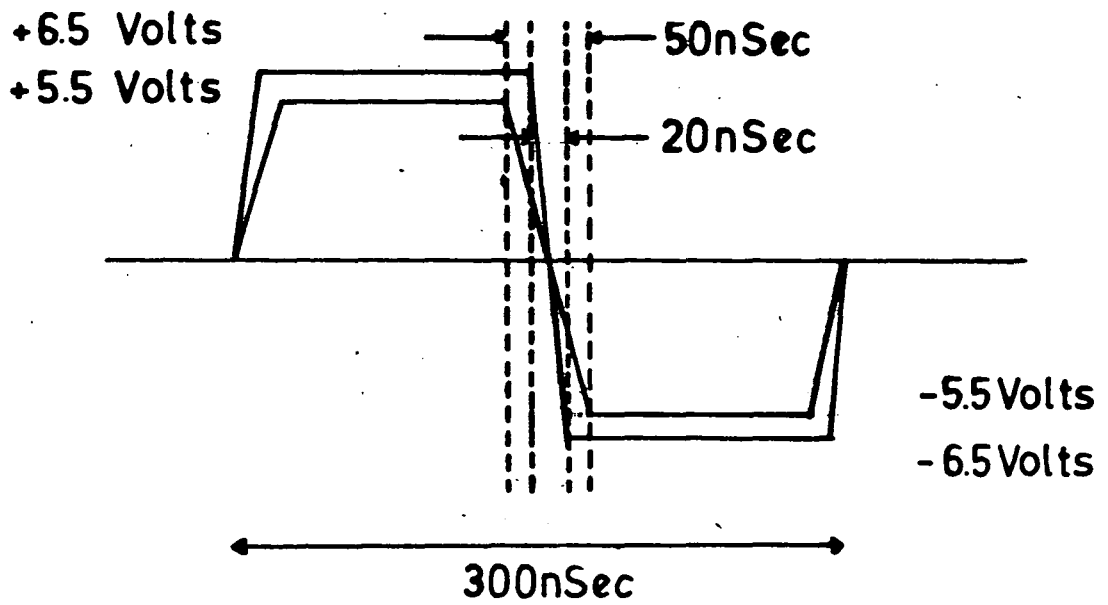

Signal Levels at Transmitter



Maximum Signal Degradation

Figure 2.2c

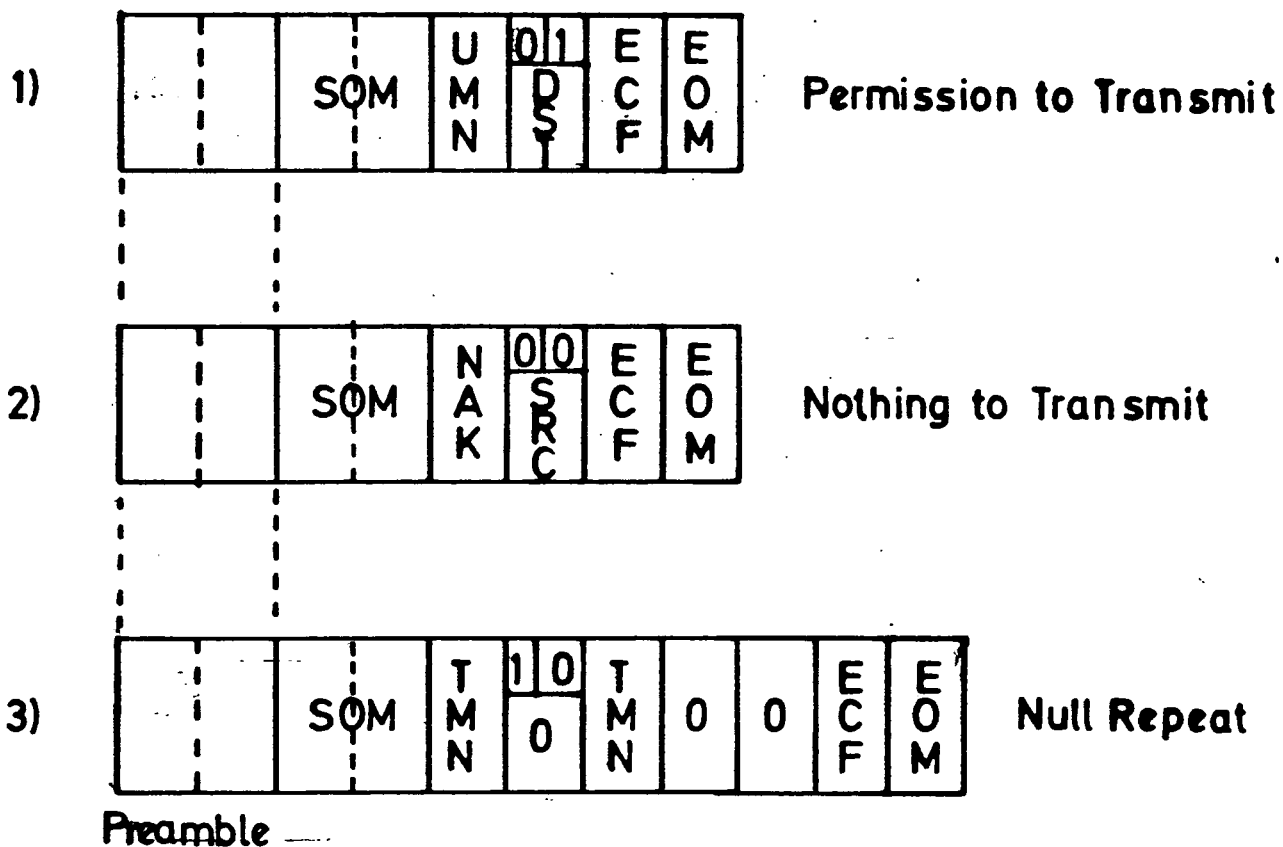

Control Message Formats

Figure 2.31a

2.3:2 Information Messages

These messages are used to pass information between the highway units. There are two classes of message, a data message and a block message.

1) **Data Message:** This may either be directed to a particular terminal unit, in which case it is termed a Point to Point Data Message, or it may be a Broadcast Data Message. The format of each type of message is shown in Figure 2.3:2a. In each case the length of the message may be in the range 2-31 words inclusive.

2) **Block Message:** A Block message transmission is made up of two types of messages, a Sub-Block Message and a Block Residue Message. The length of the former is 33 words, whilst the latter may be in the range 2-33 words inclusive.

2.3:3 Message Fields

The first byte of a message to be transmitted is defined to be byte 0 and subsequent bytes as byte 1, byte 2 etc. The first bit of each byte is defined to be bit 0. As can be seen in Figures 2.3:1a and 2.3:2a, there are several different fields within the messages. The function of each is as follows

1) **Preamble:** This is an optional series of ones which is used to obtain hardware synchronisation between transmitter and receiver.

Broadcast Message

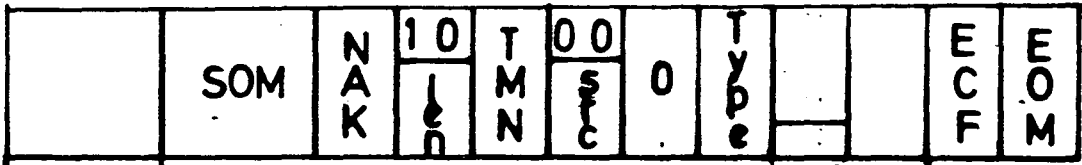

1)

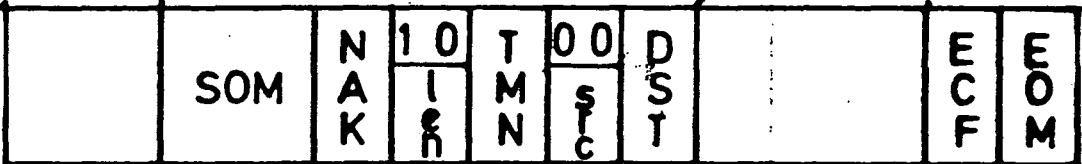

Point to Point Message

Block Residue Message

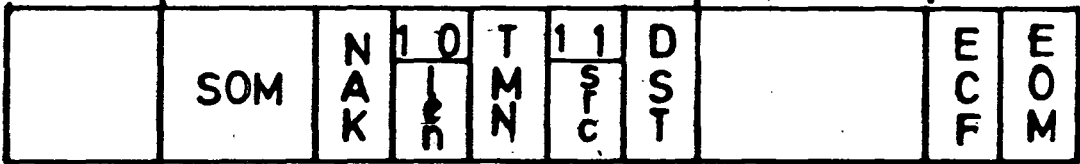

2)

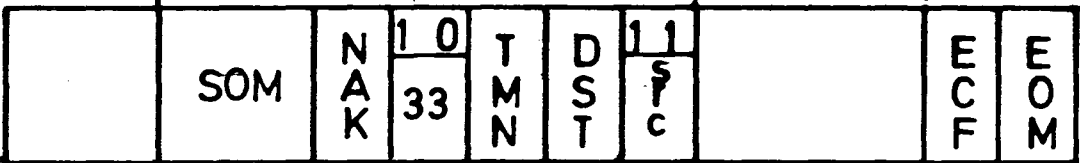

Sub-Block Message

Preamble

User Data Area

Information Message Formats

Figure 2.32a

2) Start of Message: This field consists of two bytes (0 & 1) which consist of fourteen ones and two zeros.

3) Error Check Field: The error check field occupies the last byte of every message and in a message of length 'n' is the modulo 256 sum of bytes 2 to n inclusive.

4) Use Message Number (UMN)

 Transmit Message Number (TMN)

 Not Acknowledge (NAK)

 These fields are used in the error recovery scheme. The UMN is issued by the highway controller as part of any message transmitted by it. The TMN and NAK fields are issued by the terminal units.

5) Type Field (MTB): The type field is set by a transmitting unit, and allows selection by the receiving unit of the types of messages to be received. Messages with an unwanted type are discarded by the receiving unit.

6) Source Field (SRC): This field is set by the transmitting unit to the units highway number (in the range 0-63).

7) Destination Field (DST): This is set by the transmitting unit in a point to point transmission and causes the message to be discarded by all units apart from the one whose highway number matches the DST field.

8) Length Field : This field corresponds to the number of sixteen bit words in the message between byte 4 and the Error Check Field (exclusive).

9) End of Message (EOM), End of Invalid Message (EOIM) : These fields occur after the Error Check Field. The EOM is used after an otherwise valid message, whilst the EOIM is used after a message during the transmission of which some error occurred (such as buffer overrun/underrun).

2.3.4 The Error Recovery System

Error recovery is performed by a system of error detection and retransmission of messages. All data messages are assigned a 'message number'. This number is assigned by the highway controller when it polls the terminals, and is held in the UMN field of the poll message. When the terminal responds to a poll from the controller with a data message, it inserts this number into the TMN field of the message. As terminals receive messages, they maintain a count of the highest TMN received in contiguous sequence. Any break in the sequence indicates the loss of a message. In this case, when the terminal responds to a controller poll, it responds with a 'nothing to transmit'. The controller will then be able to determine that the TMN sent by the terminal (contained within the NAK field) does not match its UMN, and the terminal therefore needs to have some messages repeated to it. The controller maintains a buffer of the 256 most recent messages it has received and is able to retransmit the message to the terminal from this store. The terminal should then respond with the correct TMN. A terminal unit which cannot be correctly updated will have the 'NAK

'stuck' status flag set (section 2.9:2). Should the controller receive a message in error, it will repoll the terminal up to four times before it is locked out of the polling sequence with the 'NR' status bit set (section 2.9:2).

2.4 Front-End Processors

The block diagram of this circuit may be seen in Figure 2.4a. The processor is based on two four bit wide microprocessors (AMD2901s) [12,13]. These are very high speed bipolar microprocessors, of a type known as 'bit-slice'. They are designed in such a manner that they may be cascaded together in parallel to obtain the desired word length. In this system, the use of two of these parts gives a word length of eight bits. The block diagram of an AM2901 is shown in Figure 2.4b. It consists of a two port RAM, a high-speed ALU and associated shifting, decoding and multiplexing circuitry. It is controlled by means of an externally generated instruction word, which is nine bits wide. Three of these bits select the ALU source operands, three the desired ALU function and the remaining three the destination register.

This instruction field of nine bits is obtained from a microcode store, the full size of which is 512 words by 32 bits. The fields in a single microcode word are shown in Figure 2.4c. Additional fields are used to select external registers which may be either read (Field A) or write (Field B) registers, and to supply a constant input to the 2901s when selected (Literal Field). The microcode store is addressed by a simple program counter which itself may be selected as an external write register by the 2901s, allowing unconditional branching. Conditional instruction skipping is implemented by using four of the microcode bits which select the desired 'skip flag', the state of which determines the subsequent state of the least significant microcode address bit.

There is also a FIFO buffer on the processor card. This is seen as an external register pair by the 2901s, a write only and a read only

2901 Board

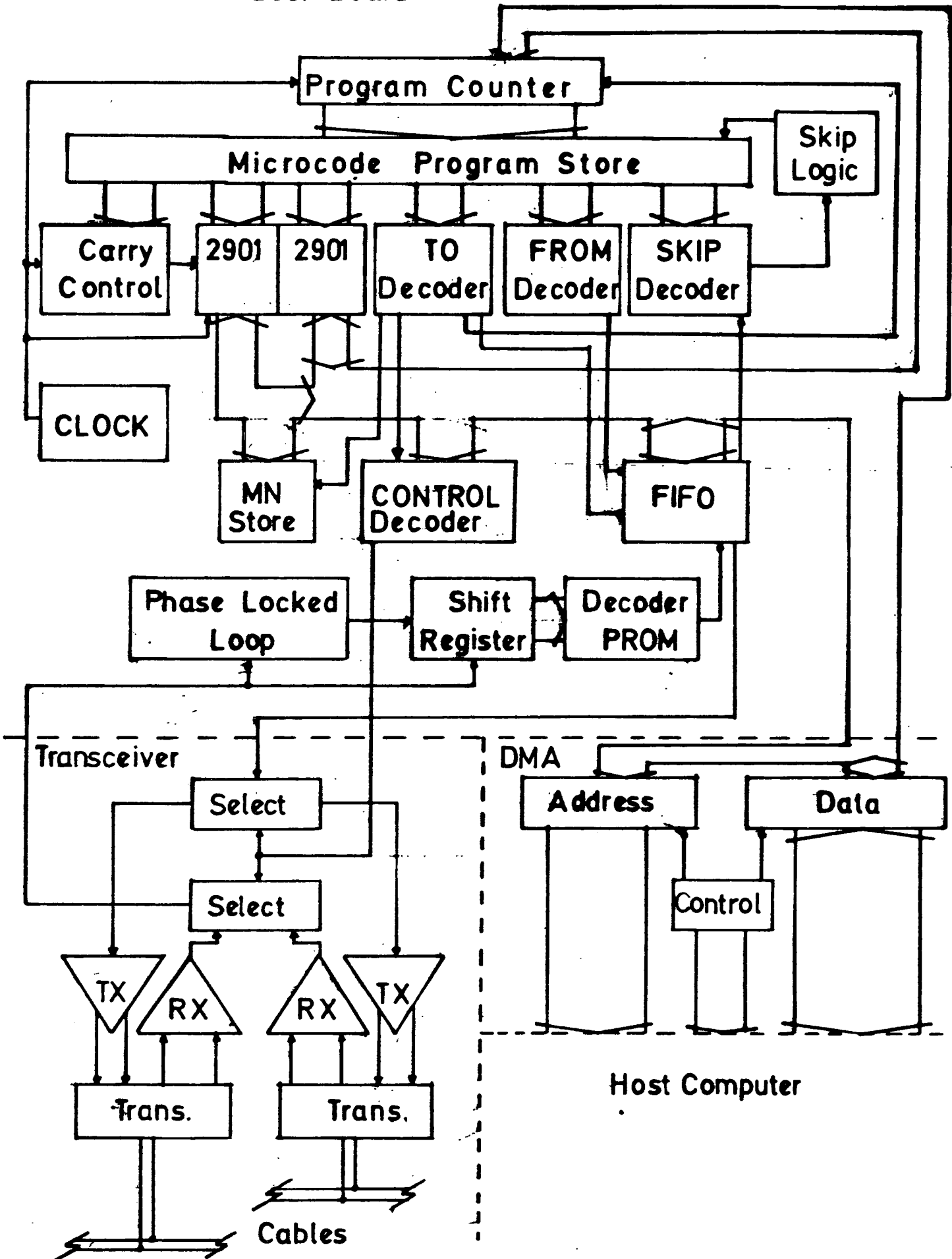

Figure 2.4a ASH Communications Processor

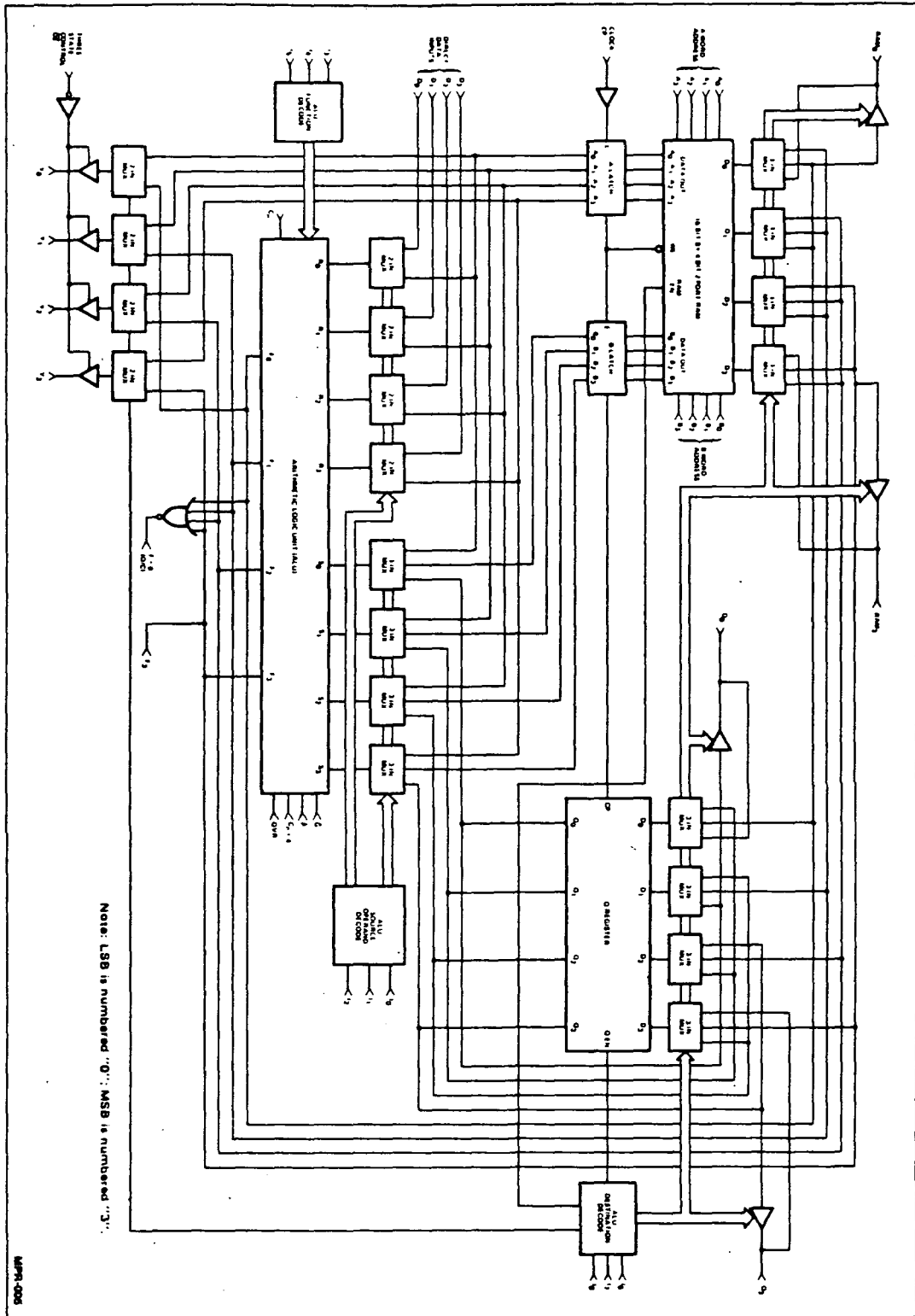

Figure 2.4b.

Block Diagram of 2901

2901 Microcode Format

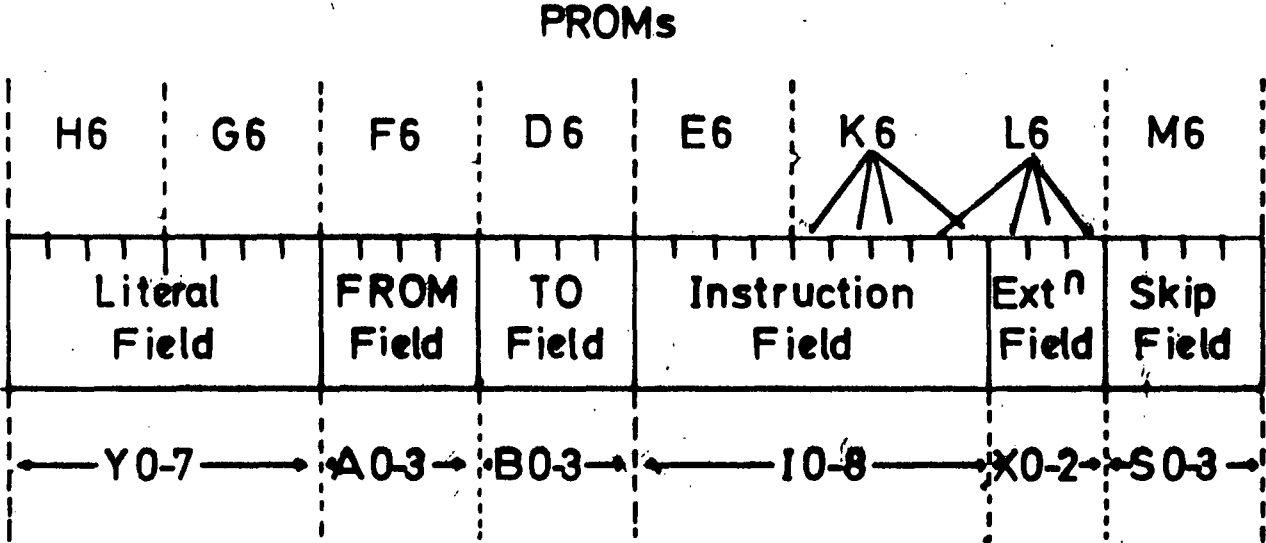

Figure 2.4c

register. The FIFO status flags are connected as skip flags to the skip logic. Also present on the processor card is a control signal decoder, accessed as an external write only register, which is used to supply control signals to various parts of the system.

The input to the FIFO buffer from the transceiver card is decoded from a bifrequency signal to a serial TTL compatible bit stream with the use of a decoding PROM. Initial synchronisation between the decoder and the received signal is achieved with a tracking phase locked loop. The output from the FIFO to the transceiver is a bit stream which is encoded to a bifrequency signal on the transceiver board.

Also included in the encoding/ decoding/ buffering section of the processor board is a hardware interlock which restricts the maximum length of continuous transmission to approximately 220us.

2.5 Transceiver

The transceiver board contains two sets of transmitters and receivers to support a dual redundant highway system. It can be expanded to a triple redundant system by adding a third transceiver on the board. Outgoing messages are transmitted on all cables, but messages are received on only one cable at a time. The cable to be used is selected from the processor board by the use of control signals and external registers.

The receiver is of the zero crossing detection type, and was designed to be tolerant of the type of signal degradation previously mentioned (Section 2.2). The transmitter encodes the serial bit stream from the FIFO buffers on the processor board into bifrequency code. It

should be noted that one of the control signals (C5) is used in order to send an EOM since this is a coding violation and would therefore be unobtainable by merely sending data to the FIFOs, as would happen during a normal transmission.

2.6 Host Interface

This board allows the 2901 processor card to read and write to the host computers memory. A write transfer is initiated by the 2901 writing two bytes of data, the most significant byte and then the least significant byte, onto latches on the interface board. These latches appear as external write only registers to the 2901s. A read transfer is initiated by the selection of a control flag (C1) by the 2901 board. In each case, the address has been previously set up by the 2901 board. The address is written into counters on the interface board (which auto-increment after each transfer). The successful conclusion of a transfer can be detected by the 2901 board by monitoring the relevant 'skip' flags (S3 & S5).

Additional control over the highway sub-system by the host processor is obtained either by writing to a memory-mapped control register on the interface board, or by using bus control lines (depending upon the method most suited to the host computer's architecture). The host computer controls the FEP with the aid of a set of latches in the interface. The first latch either enables or disables the FEPs ability to interrupt the host computer when it strobes its 't6' line. The second latch sets the start/stop skip flag to the FEP (S4). The third control from the host performs a direct reset of the FEP by pulsing its 'RESET' line.

2.7 Microcode Cross Assembler and ASH Simulator

In order to program the front-end processors, a custom cross-assembler was written [14]. This allowed the microcode instructions to be written in terms of user selectable register names (allowing greater program readability) and register operations. The output of this cross-assembler was a file of microcode suitable for programming the microcode store (in PROM). Samples of this microcode may be seen in Figure 2.7a.

Also, in order to test the correct operation of the microcode without resorting to repeated programming of PROMs, an ASH simulator was written [15]. This took as its input the file of assembled microcode previously mentioned, and by use of a comprehensive set of monitoring instructions, either a single or multi-step simulation of the entire ASH could be achieved. Whilst this did not allow any measure of the real time performance of the system, it did allow substantial debugging of the microcode at a lower level.

2.8 ASH Terminal Unit

2.8:1 Software Tables

Communication between the host computer and the front-end processor is maintained via a set of software tables. A PROM is included as a set of read only registers on the 2901 board pre-programmed with a set of system constants. In the case of the terminal units, only two constants are used, the terminals' Highway Number (in the range 1-63) and the address of the start of the primary table in the area of shared memory. The host computer must be pre-programmed with the address of this table. The format of the primary table may be

```

366 B70 0809037010      posn=[tatte
367 B71 BA00137010      a:lsa=#08 / receive error
368 B80 0A09037010      nullr:  a:lsa=#0a / null repeat
369 B81 BA00137010      branch cntrl
370 B90 0709037011      messs:  a:lsa=#07 , skip / data message
371 B91 0909037010      rrtms:  a:lsa=#09 / repeat
372 BA0 006A107030      cntrl:  msa=start+0
373 BA1 000F137010      cntrl=#00
          *even
374 B80 BR00137015      cntrl:  branch cntrl2 , sdnr
375 B81 0009101030      lsa=0+a
376 B80 002F307130      temp5=msdo+0
377 B81 0010007100      a=lsdo+0+1
378 B80 008C104020      msdi=0+temp5*cp
379 B81 000R101030      lsdi=0+a
          *even
380 B80 BE00137013      cntrl:  branch cntrl3,sdnac
381 B81 BE1 00C0104030      t0=0+posn
          /
          /
          / wait
          /:*****
          /this allows time after a repeat for the terminal tables to be
          /handled and for necessary message number updates
          /
382 B80 0032022130      wait1:  a=umr-nackn-1 / number of updates
383 B81 20C0005130      a=#20+a
384 C00 000001113F      wait2:  a=0_a-1 , szero
385 C01 C000137010      branch wait2
386 C10 C30C337110      wait3:  posn=[seal
387 C11 040014611F      0=#04 and flag1 , szero / no skip if null rpt
388 C20 BR00137011      branch nullr
389 C21 B900137011      branch rrtms
          /
          /
          /repeat sequence (sea)
          /*****
          /
          /
          / entered after a repeat from wait via cntrl
          / repeat sequence must not be entered after no response.
          / the value of 'tries' should allow time for software to clear a
          / buffer if thats why nak is stuck. if the nm store is
          / broken the number of tries will be used up and the terminal
          /
          / will be locked out.
          /
          *even
390 C30 200014611F      seal:  0=#20 and flag1 , szero / no skip if no response
391 C31 0A00137011      branch stab1
392 C40 010014611F      0=#01 and flag1 , szero / no skip if in sea
393 C41 2100137011      branch trtt1
394 C50 0100336110      flag1=#01 ior flag1 / set in sea
395 C51 0029314130      onak=0_nackn-1
396 C60 00E7307130      rpt=tries+0
397 C61 2100137011      branch trtt1
          /
          /
          /timtx message output (timtx)
          /*****
          /
          /this is entered from trtt when the timtx available bit is set.
          /
398 C70 C500037110      timtx:1 a=#c5 / length
399 C71 000F137010      cntrl=#00
400 C80 003F304130      temp9=0+umr / retain umr
401 C81 0003337110      umr=#00
402 C90 CA0C337110      posn=[timtx2
403 C91 AF00137010      branch star1
          *even
404 CA0 00F3304130      timtx:2 umr=0+temp9 / reset umr
405 CA1 050D337110      word=#05
406 CB0 0400037110      a=#04
407 CB1 00EE330110      flag3=flag3 ior a
408 CC0 AB00137011      branch chff3
          /
          /after time is output
          /
409 CC1 0809137010      timtx:3 lsa=#0b
410 CD0 000C137010      msdi=#00
411 CD1 000B137010      lsdi=#00
412 CE0 ER00037110      a=#eb
413 CE1 C0EF340110      flag3=flag3 and a / clear time output flag
          *even
414 CF0 CF00137013      timtx:4 branch timtx4 , sdnac
          / delay to allow terminal to handle time msg
415 CF1 000000110F      a=0+a+1 , szero
416 D00 CF00137011      branch timtx4
417 D01 FF00137010      branch patch?

```

Figure 2.7a

		Address	
In Interrupt Mask	No. of In Buffers	0	
Input Position		1	
Input Table Location		2	
Out Interrupt Mask	No. of Out Buffers	3	
Output Position		4	
Output Table Location		5	
Message Type Table		6 ↓ 37	
Highway Number		38	
Receive Error Counter		39	
Data Starvation Counter		40	
Retransmission Counter		41	
Buffer Overflow Counter		42	
In Data Available	In Transfer Fail	In Res. Length	43
In Block Source			44
In Sub-Block Total	In Sub-Blocks Recvd.		45
In Block Start Address			46
Out Data Available	Out Block Error	Out Res. Length	47
Out Block Destination			48
Out Sub-Block Total	Out Sub-Blocks Tx'd		49
Out Block Start Address			50

Figure 2.8:1a Terminal Primary Table

seen in Figure 2.8:1a. As can be seen, the locations and characteristics of all the other tables and terminal unit functions are held in the primary table. They are as follows:-

1) In Interrupt Mask: This mask is set by the host and is used by the front-end processor to determine whether to interrupt the host at input buffer wrap-around.

2) Number of In Buffers: This field is preset by the host (in the range 1-64) and sets the number of buffers in the input queue.

3) Input Position: This field is used by the front-end processor to indicate the location of the next free Input Buffer. It must not be altered by the host during normal operation.

4) Input Table Location: This field is preset to the word address of the start of the first Input Buffer by the host computer.

5) Out Interrupt Mask: This field is set by the host and is used by the FEP to determine whether to interrupt the host on output buffer wrap-around.

6) Number of Out Buffers: This field is preset by the host (in range 1-64)

7) Output Position: This field is maintained by the FEP and contains the index number of the next free output buffer. It must not be altered by the host.

8) Output Table Location: This is preset by the host to point to the start of the first output buffer.

9) Message Type Table: This field is set by the host to indicate to the FEP which message types it wishes to accept and which to reject. The field is 512 bits long (64 bytes), each bit corresponding to a particular message type.

10) Highway Number: This field is set by the FEP and corresponds to the highway number contained in its PROM.

11) Receive Error Counter: This field is maintained by the FEP and corresponds to the number of errors detected in incoming messages.

12) Data Starvation Counter: This field is maintained by the FEP and is incremented every time the FEP is unable to obtain data from/transfer data to its host sufficiently rapidly to maintain input/output of a message.

13) Retransmission Counter: This field is maintained by the FEP and is incremented every time the highway controller requests a message repeat.

14) Buffer Overflow Counter: This field is maintained by the FEP and is incremented by one every time an overflow of input buffers occurs.

Fields Relating to Block Transfer

15) In/Out Block Start Address: Preset by the host.

16) In/Out Sub-Block Total: Preset by the host to the number of 32-word sub-blocks expected to be transferred.

17) In/Out Residue Length: Preset by the host to indicate the expected number of words in the block residue message.

18) In Block Source: Preset by the host to indicate the terminal node from which the transfer is expected.

19) Out Block Destination: Preset by the host to indicate the destination of the block transfer.

20) In Sub Blocks Received: Set by the FEP to the number of Sub Blocks actually received.

21) In Transfer Fail: Set by the FEP to 127 if the transfer fails for any reason.

22) In Data Available: This field is set to zero by the host when it has preset all of the other fields relating to the block transfer to indicate that the transfer may go ahead. It may not subsequently be updated by the host until it has been set to one by the FEP to indicate that the transfer has been completed.

23) Out Sub Blocks Transmitted: This field is maintained by the FEP to indicate the number of sub blocks actually transmitted.

24) Out Block Error: This field is set to 127 by the FEP if the Out Residue Length is greater than 32 (i.e. an error has occurred).

25) Out Block Available: This field is set to one by the host when it has preset all of the other relevant fields. It may not subsequently be altered by the host until it has been set to zero by the FEP to indicate the conclusion of the transfer.

In and Out Table

These two tables have a similar structure which can be seen in Figure 2.8:1b. The 'Source' field has the same use and meaning as byte 5 (SRC) of an information message. The 'Destination' field has the same meaning as byte 6 of an information message. The 'Message Type' field is equivalent to the MTB (byte 7) together with the MTB extension bit (byte 8 bit 0) of a broadcast message. 'Buffer Length' when non-zero, indicates that the buffer contains valid information. When the information is either sent by the FEP (output buffer) or processed by the host (input buffer) this field should be set to zero to indicate that the buffer is free. The data area takes up the remainder of the buffer as determined from the Buffer Length field.

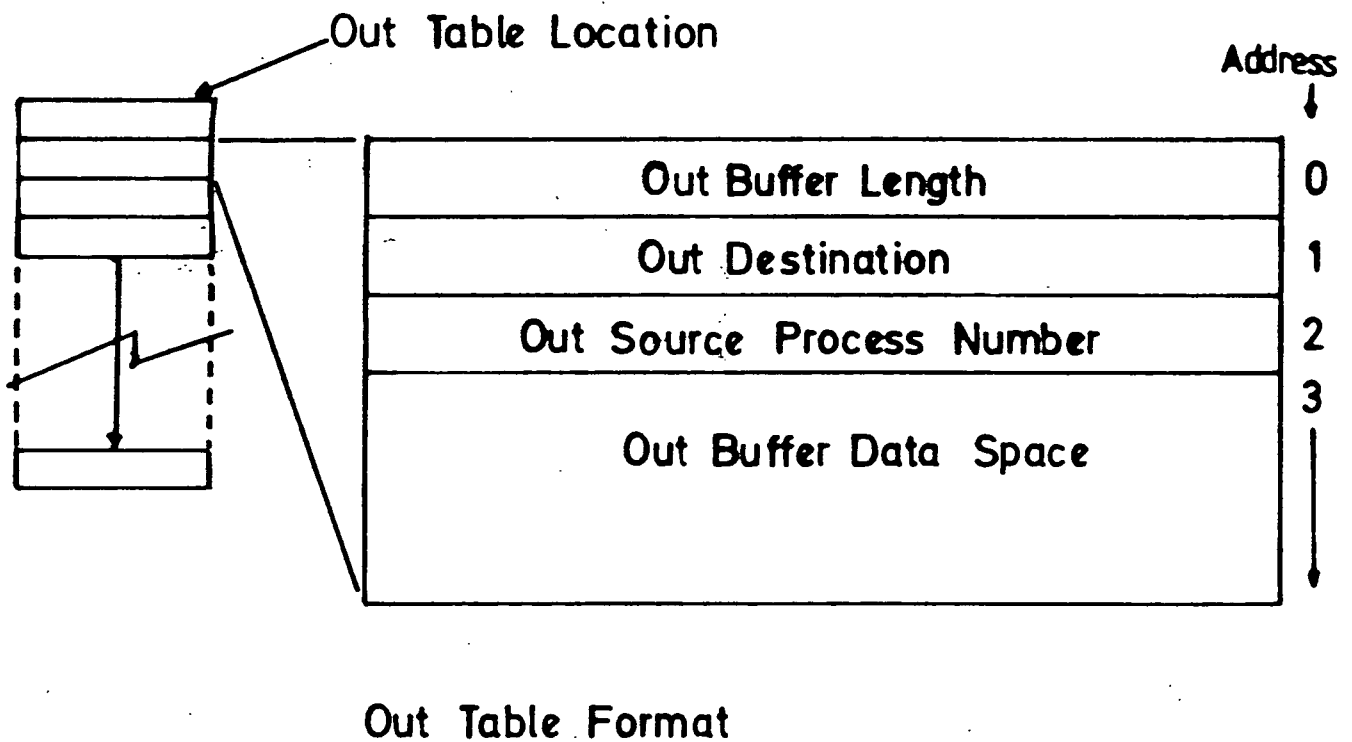
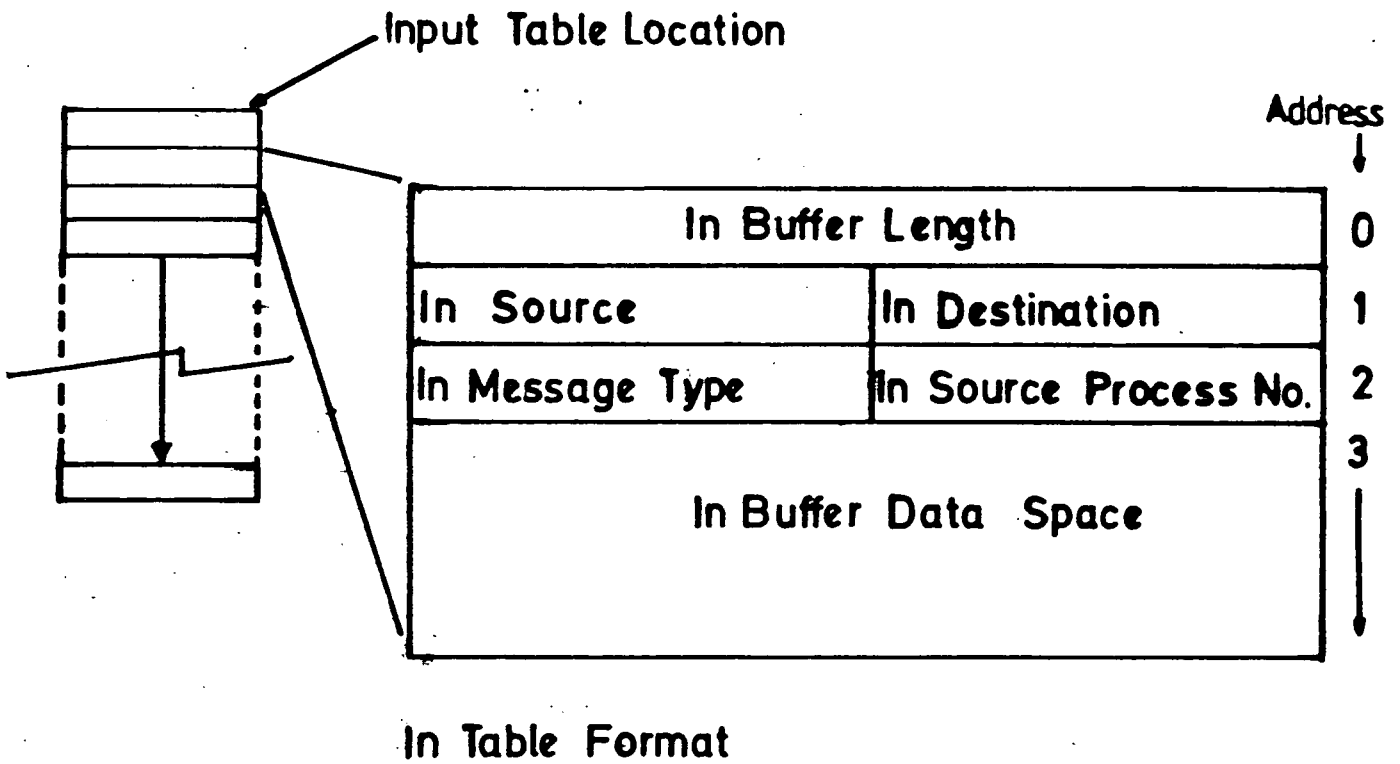

Figure 2.8.1b

2.8.2 Host Control of ASH Terminal Unit

There are three additional controls from the host computer to the host processor not included in the tables. They are provided by using some form of programmed output instruction. These are reset, start/ stop and interrupt enable/disable. To perform an orderly startup of the ASH terminal unit, the host must first reset the unit. The ASH will now be awaiting commands. Next the host must tell the ASH to 'stop'. The host computer should then set up the primary and secondary tables, and then start the ASH unit. Subsequently all communication is via the software tables. To send a message, the host computer must determine the location of the next free output buffer. It then sets up all of the fields in this buffer, with the buffer length field being set up last, as this is the indication to the FEP that the buffer is complete and ready to be sent. When it has been sent the FEP will clear the buffer length field.

Message reception is transparent to the host computer, all it must do is to check the input buffers for a buffer with a non-zero buffer length field, indicating that a valid message has been received. It must then clear the message length field (after having copied the message elsewhere) to indicate that the buffer is again available.

Block message transmission is more complex, and requires a higher level of intervention by the host computers. The Block Receive fields in the destination unit must also be correctly set up before the transfer can go ahead. Therefore information about the impending block transfer must be exchanged between the transmitting and receiving units before the transfer can go ahead. This exchange is user dependant, the only constraints being that the number of Sub Blocks and Block Residue Fields set up in the tables of both the transmitting and the receiving units are identical.

2.9 Highway Controller Unit

2.9:1 Software Tables

In the highway controller communication between the front-end processor and its host is via a set of software tables [16]. The address of the 'primary table' is known to both, it being pre-programmed into the FEPs on-board PROM. In addition, there are four secondary tables, whose addresses must be set up by the host computer. These tables are as follows:-

- 1) Polling Table. This table, of length 64 bytes, is the list of terminals which the highway controller is to poll. The 'Pointer to the Polling Table' (primary table address two) may only be altered by the host when the FEP is halted.
- 2) Buffer Store. The pointer to this table is held in primary table address three, and is set up by the host computer prior to activation of the FEP. Any subsequent alteration will be ignored by the FEP. The 'Buffer Store' consists of 256 contiguous buffers each of length 34 words. It is used as a circular buffer which contains the last 256 transmitted information messages.
- 3) Size Store. The pointer to this table is held in primary table address four. Again, it is set up by the host computer prior to initial activation of the FEP and any subsequent alteration will be ignored. The store consists of 256 words, and is used by the FEP as a record of the length of the messages held in the buffer store.
- 4) Status Table. The pointer to this table is held in primary table

address five, and is set up by the host computer prior to activation of the FEP. Any subsequent alteration will be ignored. The status table is maintained by the FEP as a record of the status of each terminal which is being polled. The table is 64 words in length.

The format of the primary table can be seen in Figure 2.9:1a. In addition to the four pointers detailed above, there are several other fields in the primary table, whose function is as follows:-

1) Controller Terminal Unit Status Word (CTUSW). Primary table address zero. This field contains bits which are set to indicate the current status of the highway controller.

a) Bit zero is set to one when the FEP has been stopped by a channel control command (Section 2.9:2), and is cleared to zero when the controller is restarted.

b) Bit one is set to one when the controller is active and to zero when it is passive (Section 2.10).

c) Bit two is set to one when the controller has overridden a 'Go Passive' command (Section 2.9:2), and cleared within 20 milliseconds of the 'Go Passive' command being cleared, or when the unit does go passive.

d) Bit three is set to one if the controller is active and detects contention for control of the highway (Section 2.10). It is cleared when the controller next assumes active status.

Controller Terminal Unit Status Word	0
Controller Terminal Unit Control Word	1
Pointer to Polling Table	2
Pointer to Buffer Store	3
Pointer to Size Store	4
Pointer to Status Table	5
Self Test Scratchpad	6
	7
Receive Error Counter	8
Repeat Counter	9
Null Repeat Counter	10
Out Time Available	11
Out Time	12
	16
In Time Available	17
In Time	18
	22

Figure 2.9:1a

Controller Primary Table

e) Bits eight to fifteen inclusive are set if the FEP detects a failure of the interface to the host computer.

2) Controller Terminal Unit Control Word (CTUCW). Primary table address one. This field is used by the host computer to control the activities of the FEP, in addition to the channel control commands normally used (Section 2.9).

a) When bit zero is set to one an active controller will assume the passive state (A Go Passive command).

b) Bits two and three are used by the host to select the highway cables on which the controller transmits. If the field is set to zero the controller will transmit on all cables. If the field is set to one, two or three, the controller shall transmit on only the selected cable.(n.b in the current implementation, only cables one and two are fitted, selection of cable three causes the controller to cease transmission on either cable).

3) Monitoring Counters. These are contained in primary table addresses eight to ten.

a) Receive Error Counter. Primary table address eight. This counter is incremented when an error is detected in a received message.

b) Repeat Counter. Primary table address nine. This field is incremented when the controller sends a repeat message.

c) Null Repeat Counter. Primary table address ten. This field is incremented when the controller sends a Null Repeat Message.

4) Time Fields. These fields are held in primary table addresses eleven to twenty-two. The time fields are sent by the currently active controller, and provide the complete time including year, month, day, hour, minute, second, tenths of seconds and one hundredths of seconds fields. The 'In Time' fields are used when the controller is passive to store any time message received from the active highway controller, while the 'Out Time' fields are used by the host processor to send a time message onto the highway when the controller is active.

a) Out Time Available. Bit fifteen, primary table address eleven. This field is set to one by the host computer of an active controller to indicate that the contents of the Out Time Fields are ready to be transmitted. It is cleared to zero by the FEP after the time message has been sent.

b) Out Time. Primary table addresses eleven to sixteen. This field is set by the host computer, the format of the complete field is shown in Figure 2.9:1b.

c) In Time Available. Bit fifteen, primary table address seventeen. This field is set by a passive controller after it has received a time message, and has updated the 'In Time' fields. The host may clear 'In Time Available' if it wishes to receive another 'In Time'.

d) In Time. Primary table address eighteen to twenty-two. The format of this field is also shown in Figure 2.9:1b.

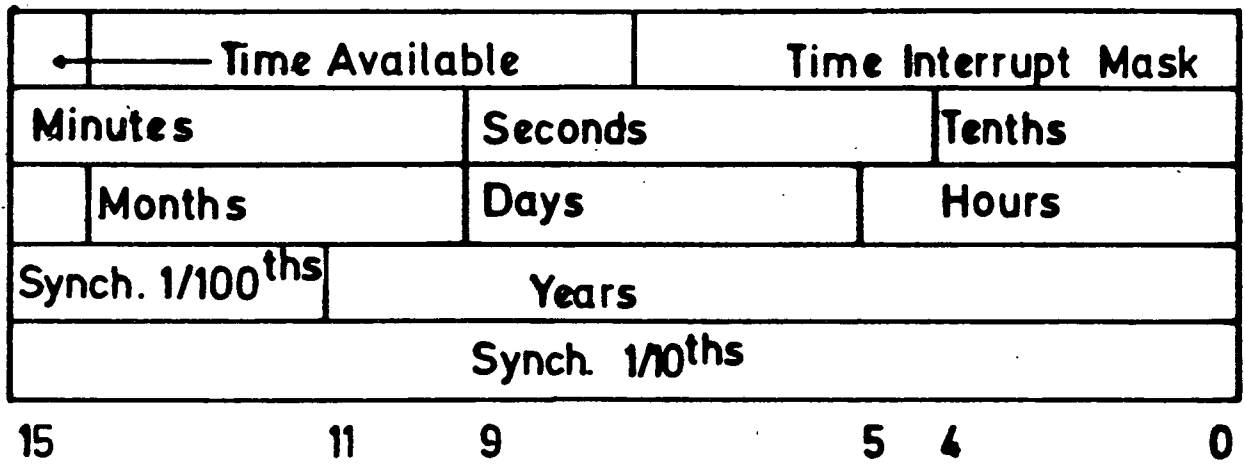

Format of In/Out Time Fields

Figure 2.9.1b

2.9:2 Host Control of Highway Controller Unit

The host computer has control of the controller unit (and therefore the operation of the highway) at three distinct levels. Firstly, it may use the channel control system to start, stop and reset the controller. Secondly, it may use the CTUCW to issue a 'Go Passive' command, or to change the cable used. Lastly, it may alter the tables, but this last control method must be used with caution, as an incorrect alteration can bring the controller, and possibly the entire highway, to a standstill.

The first type of control is used when the FEP is originally switched on. The hardware of the interface card assures that the FEP will be in its halted state immediately after the power is switched on. The tables must be set up by the host computer, and then the FEP may be started using the channel control system. The second control method may be used by the host at any time, and affects the operation of the highway as a whole. The last method of control may be used to add terminals to the polling table, or take them out of the polling table or reset terminals which have been locked out of the polling sequence. This lockout occurs under conditions detailed in section 2.3:3. The status of each terminal may be determined from the relevant status table entry. Each status table entry has several fields (Figure 2.9:2a) they are as follows:-

a) Information Message Monitor. Bits 0 to 7. This field is incremented by one for every information message sent by the terminal, and decremented by sixteen for each NTT message sent.

b) Error Monitor. Bits 8 to 13. This field is incremented by sixteen for each message received which included an error and decremented by

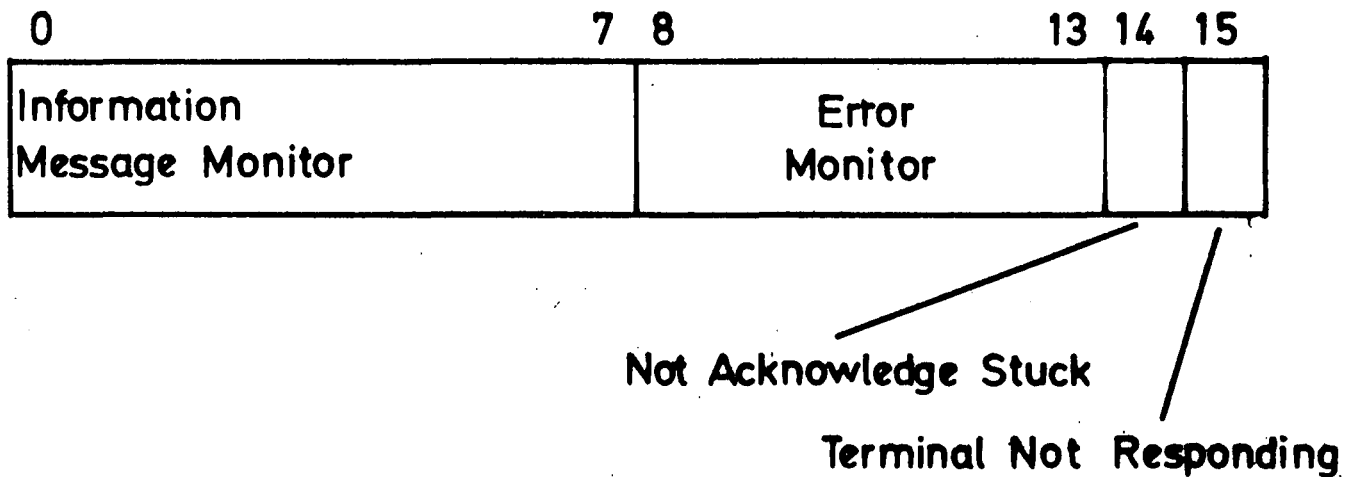

Controller Status Table Entry

Figure 2.9:2a

one for each error free message received.

c) Not Acknowledge Stuck. Bit 14. This bit is set if after four attempts a terminal still does not acknowledge receipt of the repeated message.

d) Terminal Not Responding. Bit 15. This bit is set if after four attempts, a reponse cannot be obtained.

If either bits fourteen or fifteen of the status word for a particular terminal are set, the FEP will stop polling the terminal unit. In this circumstance the terminal unit in question is said to be 'locked-out'. If a terminal has been locked out of the polling sequence, or is to be started up initially, it will be out of synchronisation with the rest of the highway. In order to reset a terminal in these circumstances, the controller must send it a reset message, and then recommence normal polling. The decision to send a reset message must be made by the host computer, based on either the status of a terminal as determined from the status table (i.e. locked out, NAK stuck or running) or by external operator intervention (i.e. adding terminals to the polling table). In order to send a reset message, bit fifteen of the relevant polling table entry must be set, and then cleared to return the polling sequence to normal. This obviously involves changes to the polling table. Changes may not be made to a polling table which is currently being used by the FEP, so they must be made as follows:-

- 1) Set up a new polling table at a different address to the current one, with the necessary alterations (additional terminals, reset bits set, etc.).
- 2) Set the channel control to 'Stop'.
- 3) Wait for the CTUSW stop bit to be set, indicating that the controller has finished a pass of the current polling table.
- 4) Change the polling table pointer (primary table address two) to point to the new polling table.
- 5) Set the channel control to 'Go'.

In order to satisfy the timing restrictions concerned with the takeover of an inactive highway by a previously passive controller (Section 2.10:2) the time between the controller setting the CTUSW stop bit, and the host setting the channel control to 'go' must be no more than fifty microseconds.

Thus to reset a terminal, this procedure must be performed twice, once to cause the controller to issue the reset message, and again to return polling to normal.

2.10 ASH Configuration

2.10:1 Single Controller/ Twin Highway Cables

The configuration shown in Figure 2.10:1a can include up to sixty-four terminals and one highway controller. These units are connected to a pair of twin screened cables which may each be up to three hundred metres in length. The pair of cables provide dual redundancy of the cabling where all units (apart from the controller, see Section 2.9:1) transmit on both cables and receive on one. The cable which is used for reception is decided by the FEP in each unit, on the basis of the cable with the highest number of error free messages received. The ASH was designed in an attempt to maximise the reliability of a network system and to minimise the possibility of overall system failure due to the failure of a single unit. Thus this particular configuration is not a good design since the failure of the highway controller can cause total system failure. The reliability of the system may be significantly increased by the inclusion of multiple controllers. In principle the scheme used for twin cable redundancy can easily be extended to include a greater number of redundant cables.

2.10:2 Twin Controller/ Twin Highway Cables

The configuration shown in Figure 2.10:2a is the one normally used at A.S.W.E. It is similar to that detailed in section 2.10:1, however there may only be up to sixty-three terminals and there are two controllers. In normal highway operation there will be one active and one passive controller. An active controller is one which is

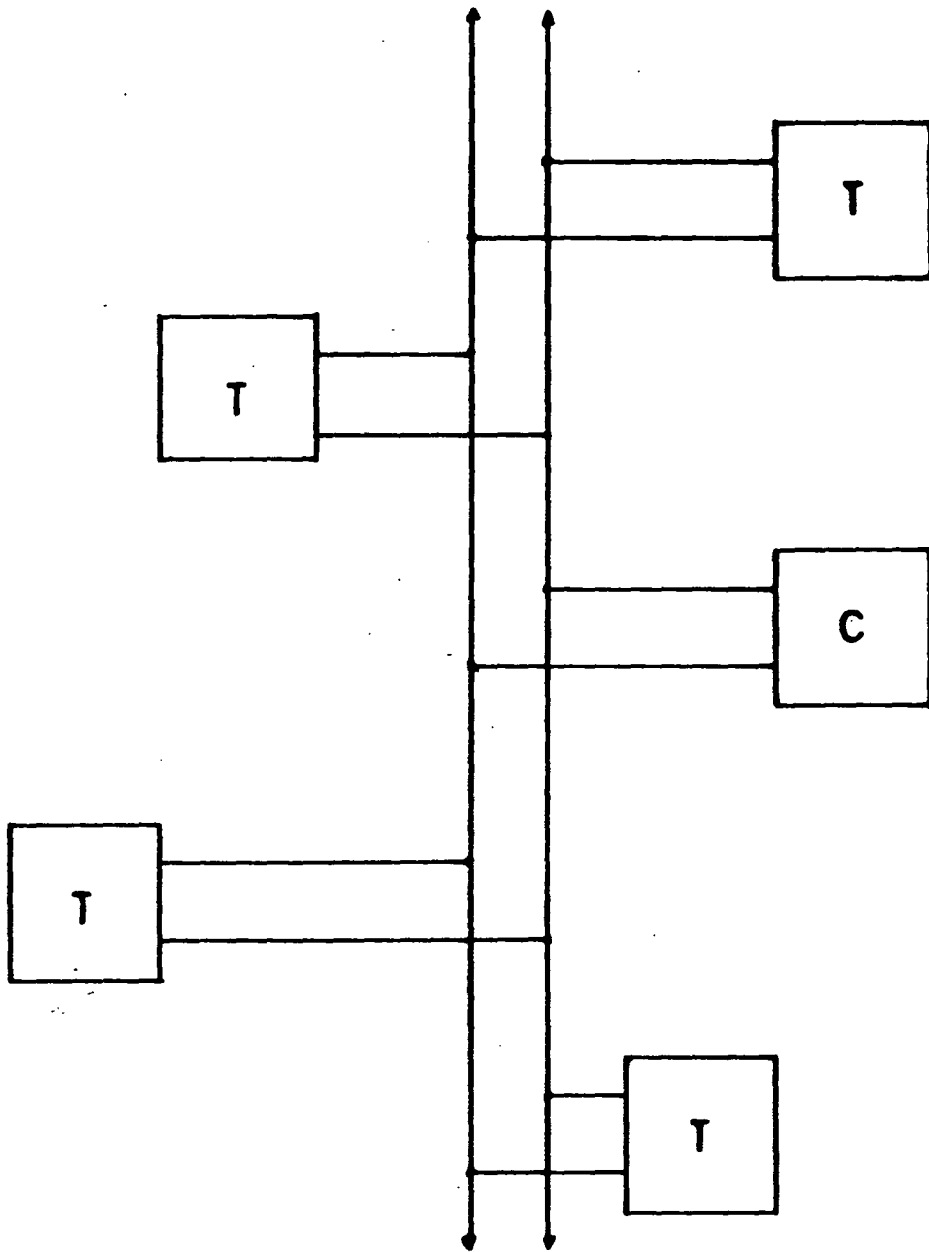

T Terminal Unit
C Controller

Single Controller - Multiple Cable

Figure 2.10.1a

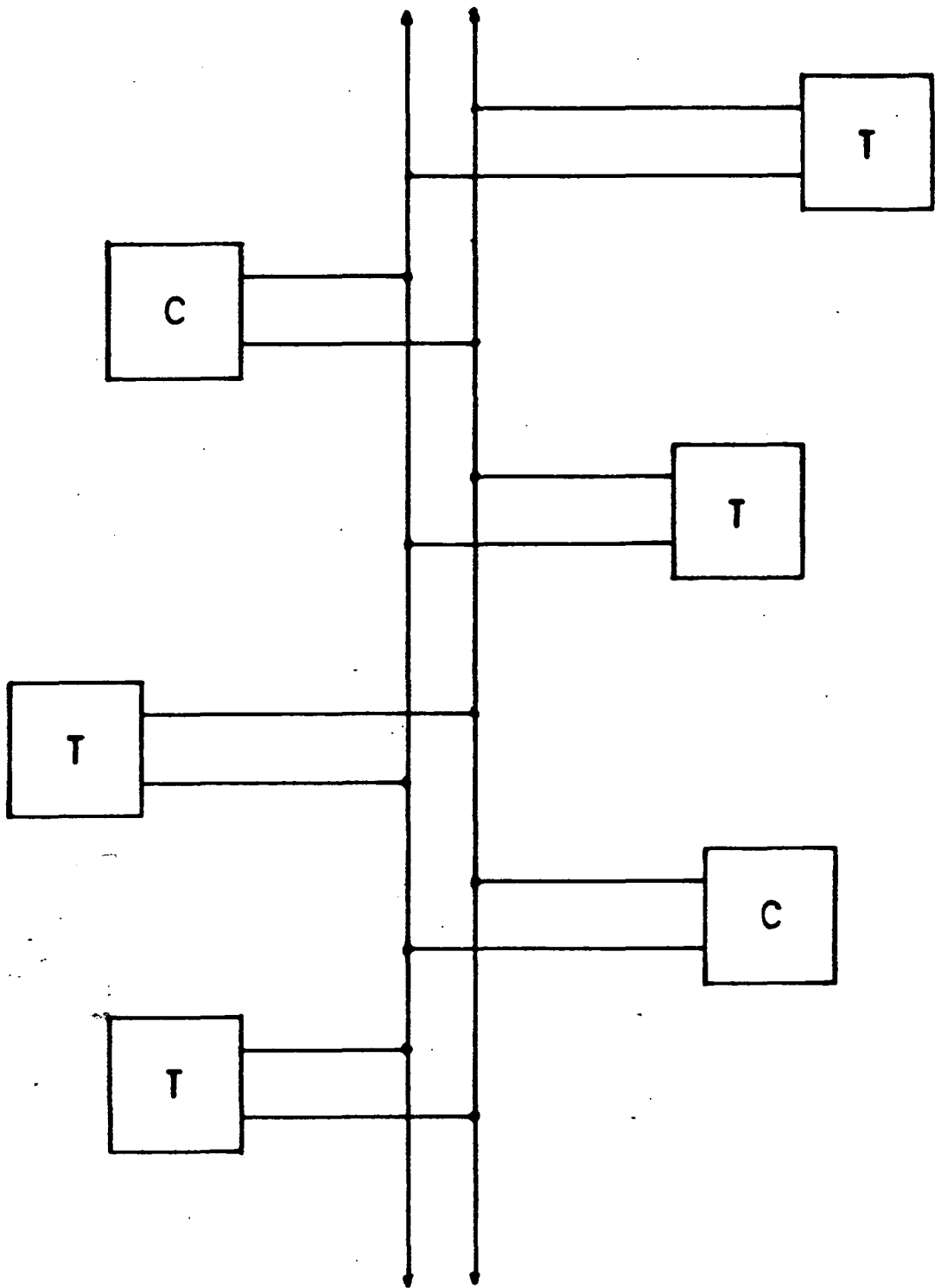

C Controller
T Terminal

Figure 210:2a Twin Controller-Twin Cable

running as normal, while a passive controller is one which is running but is merely performing checks on the operation of the highway so that it is able to take over control should it become necessary.

The two controllers operate in what may be likened to a Carrier Sense system. If the passive controller detects a lack of any activity on either highway for 3 milliseconds it attempts to take over control of the highway. If an active controller detects any activity on the highway within the five milliseconds before the start of transmission it will assume a passive status. The active controller polls the passive one (Highway Number zero) and the passive terminal responds with an NTT message. The active highway controller cannot lock the passive one out of the polling sequence for any reason. If at any time an active controller detects contention for the highway (as a result of inspecting the highway immediately prior to outputting a message) it will change cables and wait for approximately ten to fifteen microseconds. If this second highway is still active, the controller will record a contention by setting the CTUSW contention bit (Bit 3) and assume a passive state. When a previously passive controller assumes control of the highway system, it must first reset all of the terminal units. It does this because it is almost impossible to maintain a complete duplicate of the status and message information held within the previously active controller, and without this information it is impossible to restart the polling and error recovery system where the other left off. Using this method, the only major loss is of the message backup store which implies that should one of the terminals have 'lost' a message and have been awaiting a retransmission, this message will be permanently lost.

2.10:3 Cable Configuration

Due to the inherent problems of obtaining a reliable 'T' connection to a screened twisted pair, the actual configuration of the ASH is as detailed in Figure 2.10:3a. The highway cabling is split at each terminal unit, or highway controller, and the 'T' connection is formed internally.

In addition to the 'T' configurations previously described, the specifications include details for a 'Spur Connection' which is as yet not implemented. This will consist of an active repeater which will act as a gateway between two serial highways, each up to 300 metres in length. This configuration is illustrated in Figure 2.10:3b.

2.11 Conclusion

The ASH has been designed with two principle aims, firstly that the system should be as reliable as possible and secondly that the host processor should have as little processing to do as possible in order to send messages on the highway. These have been satisfied by the provision of multiply redundant system elements such as cables and controllers, and by the choice of a memory table driven FEP/ host software interface. In addition, by careful choice of FEP hardware interface design it was possible to allow the units to be interfaced to a wide variety of computers with a minimum of hardware changes.

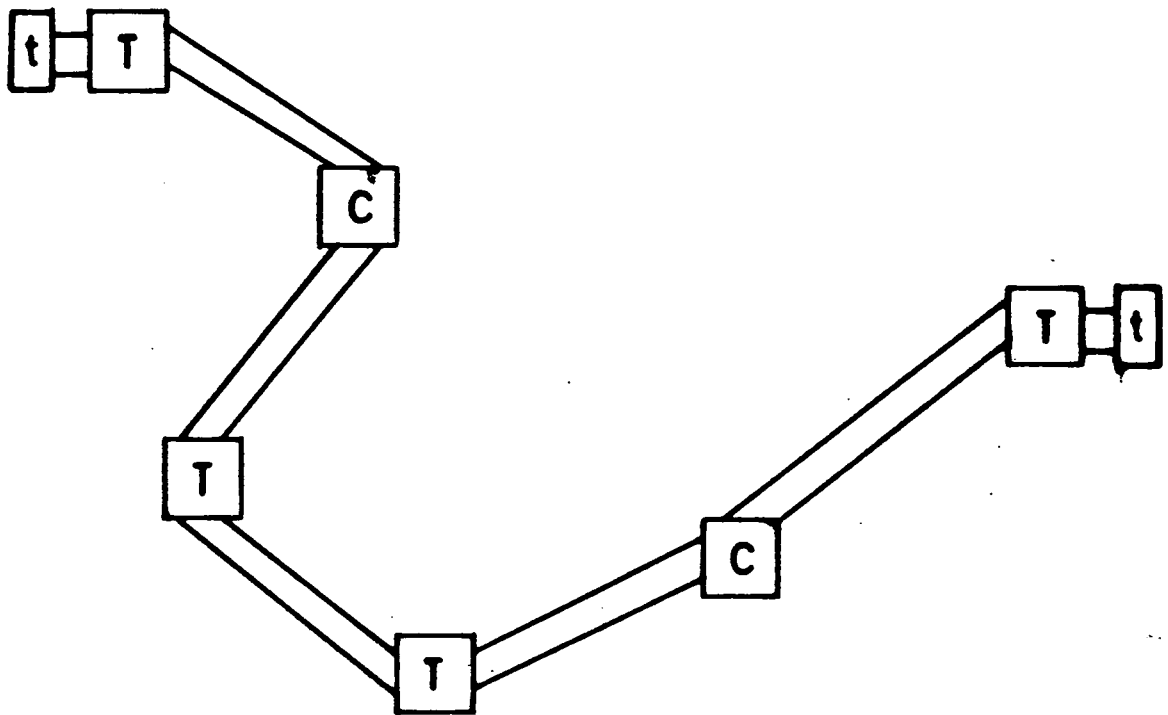

Figure 2.10:3a Actual ASH Configuration

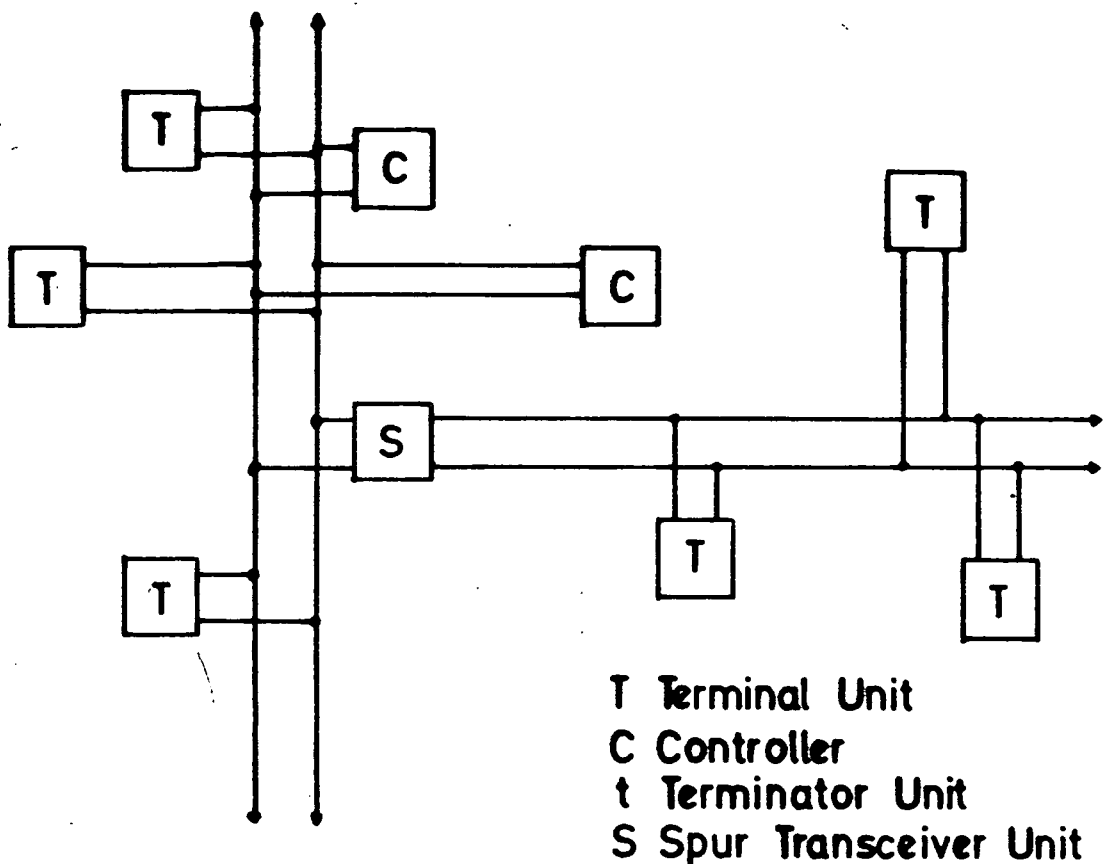

Figure 2.10:3b Spur ASH Configuration

Chapter 3

Computer Systems

3.1 Introduction

In the course of this research it was necessary to use a selection of different computer systems. Initially, a DEC PDP11/34 minicomputer was used to implement some high level support software. The machine was a Durham Computer Department general purpose machine, and operated with the UNIX operating system, which was written by Bell Laboratories in the U.S.A. It was necessary to implement certain programs on this machine which had previously been in use on a Ferranti Argus 700S minicomputer at A.S.W.E. In order to install this software it was necessary to first implement a Coral compiler on the DEC machine, since the great majority of Military software is written in Coral, and these packages were no exception.

In the course of writing software support for the Motorola MC68000 microprocessor, which was the principle microprocessor used in this project, a cross-assembler was produced on a Data General NOVA-3 which operated under RDOS. This machine was chosen for the task, in preference to the DEC, because it was more readily accessible and was used less. Also used in the development of the MC68000 software was a Motorola MC6809 development system using the SSB (Smoke Signal Broadcasting) DOS69 operating system. This was used to a greater extent as the project progressed as all of the software written in SIXTH for the MC68000s (Chapter 4) was written and edited on this system.

3.2 The DEC PDP11/34 and UNIX

Durham University Computing Department owns a DEC PDP11/34 which it maintains as a general service machine. It comprises a fully expanded system with 256kbytes of memory, two 5Mbyte front loading disk units (RK05), a single 10Mbyte top-loader, a dual eight inch floppy disk unit, a lineprinter, and approximately ten VDUs. It runs under UNIX version six [17], which was until recently the newest of Bell Laboratories UNIX operating systems (version seven is now available). UNIX is a user friendly operating system which has been long favoured in universities and has recently been more widely accepted. It offers programmers very easy software accessibility to system devices and files, and since most of the system software is written in a high level language known as 'c', it is considerably easier to understand than most other operating systems (which are normally written in assembler) making it ideal for teaching. It was decided that this machine should be used, firstly due to the ease of access, and secondly due to the ease of programming for file and device input/ output, since it was known from an early stage that it would be necessary to write such software.

3.2.1 The Implementation of BCPL and CORAL

As has been explained, due to the fact that the majority of Military software is written in Coral, it was necessary to install a Coral compiler at Durham. It was not possible to obtain a Coral compiler to run under the Unix operating system, so a more indirect method had to be followed.

A version of Coral [18,19], written in BCPL, and a BCPL compiler, were available. The BCPL compiler and the Coral compiler were designed to run under RT11 (DECs standard single user operating system for the PDP11 series), but a careful comparison of UNIX and RT11 showed that the main differences between them lay in the input/ output (I/O) system and in the assembler language used. However, UNIX already had an RT11 MACRO assembler [20] installed (MACRO is the standard RT11 assembler language) so it was only necessary to alter the I/O routines in order to transport the BCPL compiler to UNIX. This was because an assembler version of the BCPL compiler had been obtained, comprising the sections detailed in Figure 3.2:1a. The only operating system dependant section was the I/O section which was the compiler to operating system interface. It handled file and device I/O and memory allocation, and was identical to the one used in the Coral compiler. This assembler version of the BCPL compiler was a simple version, with just enough complexity to allow compilation of the version of BCPL written in BCPL. When this second, more complex version had been compiled, it was then possible to use this new compiler to compile the Coral compiler. This process is known as bootstrapping.

The difference between the two operating systems is the level at which the user interfaces to devices. In the case of UNIX, a device is handled in a similar manner to a file, whilst in the case of RT11, a device must be handled in a completely different manner, leading to a much more complex I/O system for the BCPL and CORAL compilers under RT11.

In the absence of any formalised test suite for the BCPL compiler, it was felt that a program of the complexity of the CORAL compiler would be a sufficient operational test. Similarly, the software packages written in CORAL and transported from the A.S.W.E. Ferranti

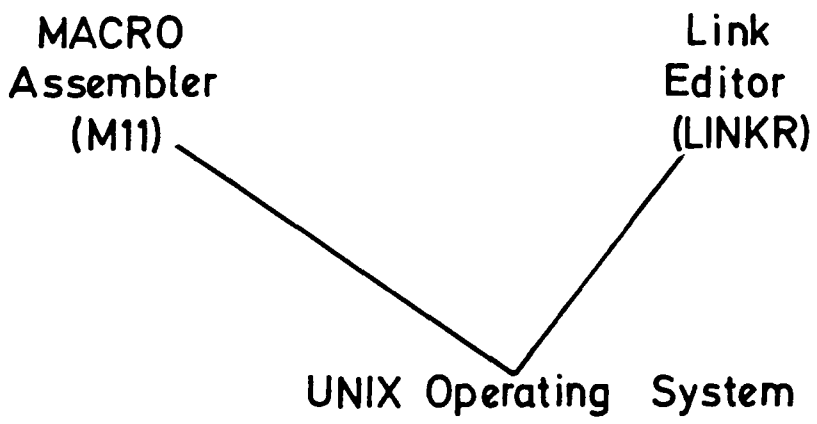
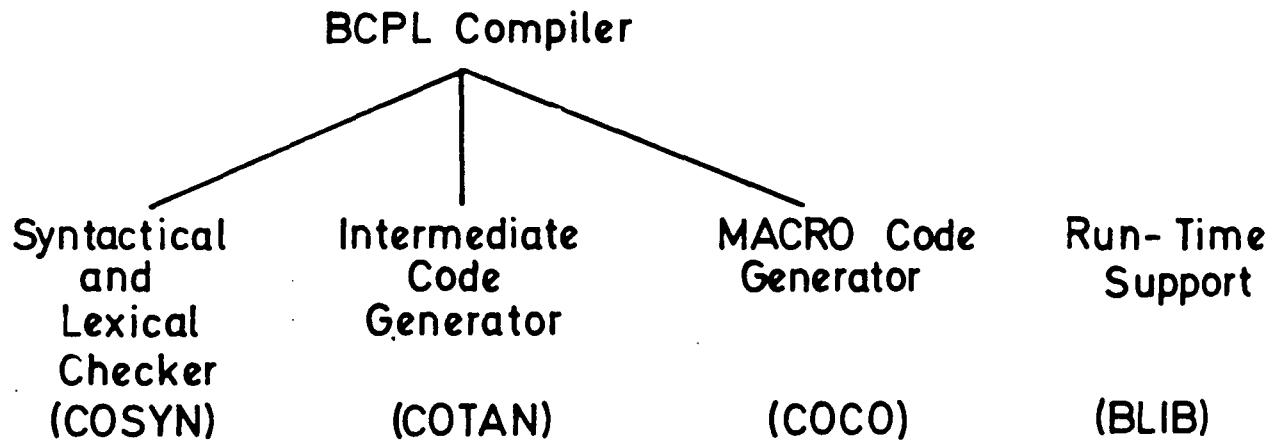

Figure 3.2:1a BCPL Compiler

Argus running CORAL were decided to be a sufficient operational test of the CORAL compiler.

3.2:2 ASH Software Packages

A.S.W.E. had commissioned the writing of two extensive software support packages for the development of the ASH software. The first was a cross-assembler for the microcode for the FEPs [14], and the second was a simulator [15] for the entire highway which was used to test the microcode before its installation in the actual system.

The cross-assembler was a two pass assembler which accepted as input a file of text and produced as output a binary file in a format suitable to be used to program a PROM programmer for the microcode PROMs, and a text file which contained a full assembler listing. The input file contained lines of instructions, each one of which corresponded to a word of microcode. Thus the maximum program length was 512 instructions, corresponding to the full depth of the microcode store. The hardware configuration of the FEPs, as detailed in section 2.4, includes sixteen internal ALU registers (named r0-F), sixteen external read-only registers (named f0-F), and sixteen external write-only registers (named t0-F). These registers may be assigned names using the assembler. This greatly increases the source program readability. The possible combinations of source, destination and internal registers with ALU instructions, are defined by the hardware design, and the program is checked against the allowable combinations by the cross-assembler. The combinations are detailed in Cambridge Consultants cross-assembler manual [14].

At ASWE this program was compiled in one section.

Unfortunately, owing to the inherent limitations of a DEC PDP11/34 and UNIX, the maximum size of a user program is limited to approximately 48kbytes of machine code. Due to the design of the CORAL compiler, the maximum size of a CORAL program which could be compiled in a single segment was approximately four hundred lines. This meant that the cross-assembler had to be segmented into three parts to allow it to be compiled. After this stage had been successfully accomplished, the compiled program was linked with its run-time package (the same one as was used by the compilers) to produce the complete assembler.

The ASH simulator is a very much more complex program. It allows complete simulation of the operation of the highway system. As an input it accepted the file of microcode produced by the cross-assembler, and a list of the allocation of external ALU registers (i.e. 'FIFO read' register equals f6, 'skip if FIFO full' equals sD etc) representing the actual hardware configuration. Then, the configuration of the highway, i.e. the number of terminals and controllers was input. Lastly, a set of monitor points were entered, which governed which simulated registers were printed out during the monitoring. Now the simulation could be started. The program simulated the exact function of the bit slice processors and all of the hardware, with the proviso that messages transmitted from a terminal or controller were merely 'injected' into the simulated FIFOs at all of the other units, i.e. the physical medium of the highway cabling and its transceivers was not simulated. It was possible either to simulate the highway operation in single step mode- corresponding to the execution of a single microcode word in each unit, or in run mode, where execution continued for a preset maximum number of microcode instructions. Alternatively, by using a comprehensive break point monitor, it was possible to cause a break from the run mode into

normal monitoring mode at the occurrence of any condition which had previously been selected as a break point (or any combination of multiple conditions). A full macro-executive allowed complicated break, monitor and restart functions to be established.

Due to the extreme complexity of this program, and the fact that it was simulating several highway units at the same time, it was extremely slow when in operation (a simulation of approximately 100 microseconds of highway activity could take as much as half an hour). Also, the program was very large, and in order to compile it under the CORAL on the PDP11/34 it was necessary to segment it into eleven parts. In addition, much of the monitoring section of the program had to be rewritten to compensate for the difference between the Ferranti single user operating system, and UNIX. This was due to the fact that on the Ferranti machine the monitoring was performed on a printer which was used only for that purpose, whilst this was not possible under UNIX because the printer was a shared resource. To compensate for this, a spooling program was included which saved the output for later printing, and the monitoring could also be performed on the VDU.

3.3 The Data General Nova 3 and RDOS

The Department of Applied Physics owns a Nova-3 which runs RDOS- the standard Data General single user operating system [21,22]. Its configuration is as follows:- Nova-3 CPU, 64kbytes memory, 10Mbyte top loading disk unit, VDU, printer and twin eight inch floppy disk unit. RDOS supports a BASIC interpreter, PASCAL compiler and a Nova-3 assembler, as well as a SIXTH interpreter/compiler which was written at Durham.

This machine was used to write a cross-assembler for the Motorola MC68000, because it was initially impossible to obtain one from Motorola which would be suitable for use at Durham. The cross-assembler was written in Nova assembler, and did not include all of the assembler language options possible with the MC68000 due to the extreme complexity of the assembler program that would be necessary. Instead, a simple assembler was produced, to which additional assembler instructions were added when needed.

3.4 The Motorola MC6809 Development System

The Motorola MC6809 [23] is one of the most advanced of the eight bit microprocessors currently available. It is similar in architecture to the earlier MC6800, however it offers the major advantage of a much enlarged instruction set and an additional stack pointer. The additions to the instruction set consist of several new addressing modes, including indirect addressing, which greatly increases the programming flexibility available to the user.

The development system used at Durham University is based around a SWTPc (South-west Technical Products Corp.) CPU board which

is housed in an MSI (Midwest Scientific Instruments) chassis [24]. It includes 48kbytes of RAM, a debug monitor (MON09), three serial ports and a triple five inch floppy disk drive unit with disk controller. The system runs under the operating system DOS69 [25], which is produced by SSB (Smoke Signal Broadcasting). This operating system offers all of the basic disk file utilities and a resident assembler and BASIC interpreter. It is an update of the earlier DOS68, written by SSB for the MC6800, and most of it was merely reassembled into MC6809 machine code from the original MC6800 assembler language source, since the MC6800 assembler mnemonics are a subset of those used on the MC6809. This shortcut taken by SSB to obtain an operating system for the MC6809 means that it is no more efficient than the earlier MC6800 version, since it does not take advantage of the additional facilities offered by the MC6809.

The development system has many additional unused connections, both to the main synchronous bus (SS-50C), and to a memory mapped I/O section (SS-30 bus). This allows the speedy addition of user built boards to the system.

3.5 The Motorola MC68000 Single Board Computer

Motorola produces a single board computer, the MEX68KDM [26] a diagram of which can be seen in Figure 3.5a. This microcomputer has an MC68000 as the processor, and many additional components enabling the board to be used in a wide variety of applications.

The MC68000 is Motorola's sixteen bit microprocessor [27,28]. Externally, it has twenty four address lines, sixteen data lines, and control lines for asynchronous and synchronous bus interfaces. Internally, it has a thirty-two bit architecture, in that it has seven

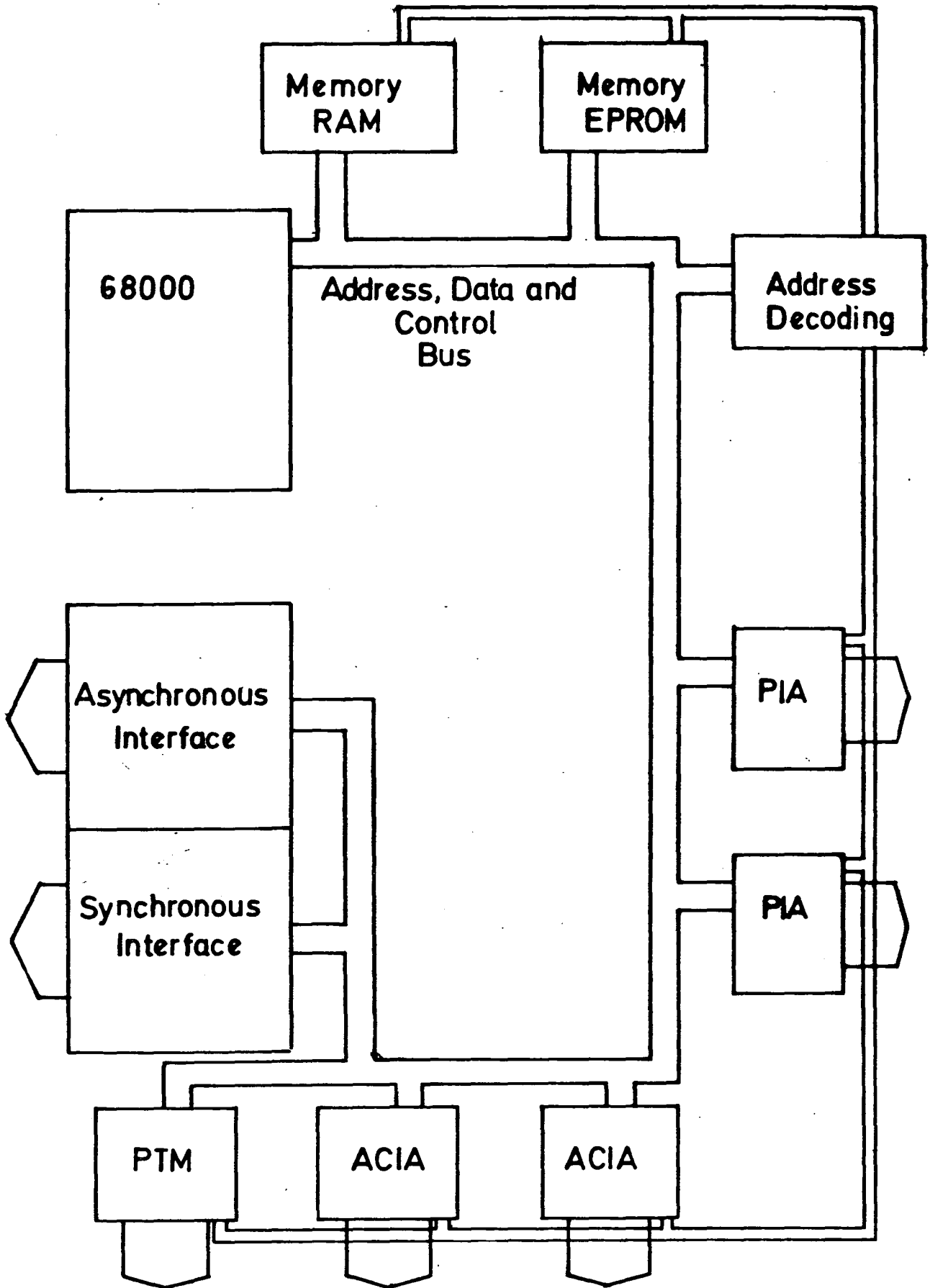

Figure 3.5a MEX68KDM Block Diagram

data registers, seven address registers and two stack pointers, all of which are thirty-two bits in length. The interrupt system is a multi-level one, having seven different priorities, selected by the use of three interrupt line connections to the processor. All but the highest priority interrupt may be masked out by the use of the appropriate instruction. The MC68000 also includes a bus arbitration section, which allows it to be used in multiprocessor systems with a shared bus. The design of the component allows it to be easily interfaced to all of the MC6800 family of peripheral chips [29], which only have an eight bit data bus, as well as the MC68000 family of peripherals which have a sixteen bit data bus (very few of these new peripheral chips are yet available).

The single board computer also includes 32Kbytes of dynamic RAM, two parallel ports (MC6821), two serial ports (MC6850), a programmable timer (MC6840), a very powerful debug monitor called MACSBUG (held in four 16kbit EPROMS) and additional sockets for a further four EPROMS (which may be 16,32 or 64kbit devices). The monitor provides a full trace/ debug facility for user programs, using the 'trace' mode which is designed into the MC68000 chip. In addition it allows programs to be loaded into RAM using 'S-record' format from an external device via one of the serial ports. Motorola have defined the format of 'S-records' and these are used extensively to allow the serial transfer of data. Initially they were used in paper tape systems as they incorporate parity checks and record length checks.

In addition, the board is provided with external connections (via edge connectors) for the two parallel ports, the programmable timer inputs, two sets of RS-232 serial connections, and a full set of synchronous bus signals designed to be compatible with the EXORCISER development system (Motorola's MC6800 development system). Lastly, the

board also has external asynchronous bus connections, allowing an external device to gain access to the on-board memory/ peripherals, or for the MC68000 to gain a similar access to an external devices memory/ peripherals.

3.5:1 An Upgrade of the On-Board Memory

Although the MC68000 single board computer already included a RAM area of 32kbytes, it was found (section 5.2) to be necessary to expand this RAM area for certain applications. The normal method advocated by Motorola was to plug the MC68000 board into an EXORCISER chassis and plug in standard Motorola RAM modules as needed. However, a closer examination of the circuitry of the MC68000 board showed that with a very few hardware alterations it was possible to upgrade the board to 128kbytes of RAM (Appendix B). This was possible due to the similarity between 64Kbit RAM chips and 16Kbit RAM chips. The pinout of these chips can be seen in Figure 3.5:1a. The 64Kbit component has an additional address line, and has only a single supply rail, in contrast with the twin supply rails used on the 16Kbit device. This meant that the memory could be upgraded by merely adding a two-into-one multiplexor, and rewiring the supplies. Extensive testing of the expanded memory, using a psuedo-random memory test routine, showed it to function correctly.

In addition to the RAM expansion, by reprogramming the MACSBUG monitor into two 32Kbit EPROMs, space was made available for up to 24Kbytes of user program in EPROM. This was necessary due to the requirement (sections 5.1,6.1) that the user programs should be held in non-volatile storage to allow an ordered program restart after a power failure.

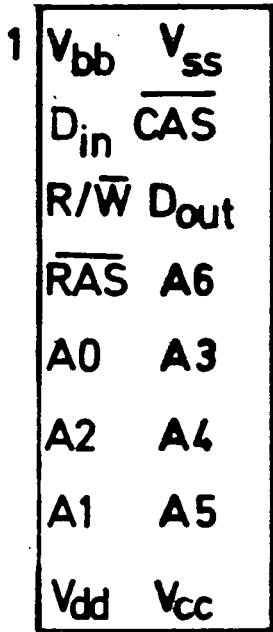

16Kbit RAM
(MCM4116)

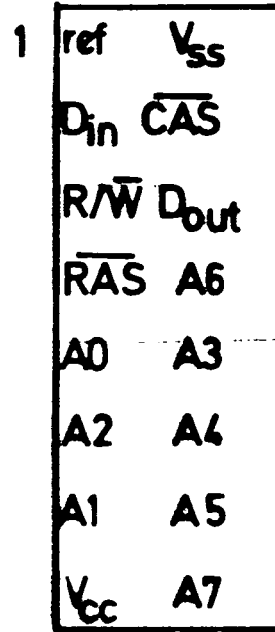

64Kbit RAM
(HM4864)

Figure 3.5.1a

3.6 Additional Peripherals and Software

In addition to the computer systems already mentioned there were many additional pieces of equipment and software used, the most important of which are detailed below.

3.6:1 Pro-Log PROM Programmer

Many different types of programmable memories were used throughout the project. Firstly, in the FEP there were three different types of fusible link PROMs. In addition, on the MC68000 board, three different types of EPROM, and another type of fusible link PROM were used. This meant that it was necessary to use a 'multi-function' PROM programmer. This type of programmer is able to program a wide variety of different devices either by the use of multiple driving programs stored internally, or by the selection by the user of the correct 'pinout module' and 'configuration module' (this last was merely a PROM which held the correct driving program to be able to program the desired type of PROM). The first type of programmer is very expensive, and on this basis it was decided to purchase the second type. A Pro-Log M920 programmer was purchased, along with two 'Generic Family Modules', four 'pinout modules' and five 'configuration modules'. This enabled any one of the seven PROMs/ EPROMs to be programmed, and many others in addition. The programmer could either be connected to a teletype/ VDU via a serial link, or to a computer system via a parallel link.

For reasons of speed, it was decided to connect the programmer to the MC6809 development system via the parallel link and a parallel port on the development system. This port was in the form of a MC6821 PIA (Parallel Interface Adaptor) plugged into the I/O area mentioned

in section 3.4.

A program was then written in assembler to control the programmer. A listing can be seen in Appendix A. This could be used to program the PROM with a microcode program already loaded into memory (by the operating system) and was also able to load the microcode programs into memory itself and subsequently to program the PROMs. Lastly, it was possible to use a 'modify' mode to perform a single location read or write into the PROM.

3.6.2 Computer Communications Software

To allow microcode which had been assembled on the DEC PDP11/34 to be programmed into the fusible link PROMs on the MC6809 system, it was necessary to write programs to allow communication between the two computers. They were separated by some considerable distance and the connection used between them was a 25mA current loop. The communications software composed the data to be transmitted into blocks of a preset length and included an error check field as part of the message to be transmitted. On reception at the MC6809 system, the message was checked for errors (by using the error check field) and if any error was detected the message was retransmitted by the DEC system.

A similar communications package was written for the transfer of data between the NOVA-3 and the MC6809. This allowed MC68000 programs which had been written and assembled on the NOVA-3 to be transferred to floppy disk on the MC6809, and subsequently either to be programmed into EPROM or down line loaded into the MC68000 boards. The program used on the MC6809 system was nearly identical in each

case, the only difference being in the commands which had to be sent to the 'other end' of the communication link. The function of the programs on the PDP and NOVA was identical, however the DEC program was written in 'c' and the NOVA program in assembler.

3.7 DMA Interface

As detailed in section 2.6 communication between the host computer and the FEP was by means of a specialised interface. This provided for communication on two levels. Firstly a high speed DMA interface, and secondly an interface by which the host could control the FEP using some form of programmed output. At the start of this project, a version of the interface had been designed for a Ferranti Argus, a Locus 16 and a Konsberg S500. It was necessary to design a new interface for any other computer used at Durham. The first design produced was for a Motorola MC68000 interface. The circuit diagram can be seen in Appendix C. The new interface design differed from the original ASWE designs because it used more LSI parts, as these were not available at the time the ASWE interfaces were designed. This resulted in a decreased chip count and therefore a smaller overall size. The DMA section of this interface was designed to satisfy the timing requirements of both the MC68000 processor and of the FEP, as set down in their relevant specifications. Unfortunately, these specifications proved to differ from the actual physical attributes of the processors, and considerable time was taken in attempting to debug this interface. It makes use of the bus arbitration section of the MC68000 processor by requesting access to the asynchronous bus on the MC68000 board when the FEP indicates that it wishes to perform a

memory transfer. This causes the MC68000 to halt at the end of the bus cycle currently being executed, and to pass control to the interface. The interface then completes the FEP's transfer and returns control to the MC68000.

The program control section of the interface is accomplished by partially decoding the address bus of the MC68000. If a write operation by the MC68000 is detected to an address preset by a set of switches on the interface, then the data being written to the address is decoded and latched to obtain the control signals for the FEP board. The signals are specified in section 2.6.

3.8 Conclusion

Several different computer systems were used, each for the task to which it was best suited, or most readily available. The DEC PDP11/34 was used primarily for 'high-level' program development, whilst the Nova-3 was used because access to it was virtually without restriction. The Nova-3 was used only to write assembler programs for the MC68000 system. The MC6809 development system was used for a wide variety of purposes:- to write SIXTH programs for the MC68000, to drive the PROM programmer, and as a monitor station and bulk storage unit (section 6.2:1). Lastly, the MC68000 was the workhorse of the project, being used in all of the ASH units built at Durham. In certain applications, its normal quota of 32Kbytes of on-board RAM was expanded to 128Kbytes. The design of the board gave great ease of interfacing to external systems, either under programmed I/O via parallel or serial ports, or under DMA control via a synchronous or asynchronous bus. An asynchronous interface was designed to connect the MC68000 boards to the ASH front end processors.

Chapter 4

SIXTH

4.1 Introduction

FORTH was written by C.H. Moore at Palo Alto Laboratory [30,31] to run on a DEC PDP 8. It was designed to allow a large number of tasks to be simultaneously memory resident. At the time at which it was written, memory was very expensive and the PDP 8 had only 12k words of RAM. FORTH optimised its use of memory at the expense of execution speed, to gain maximum possible resource utilisation. The PDP 8 was used to control and monitor a radio telescope. FORTH creates an environment in which complex interface driving software can be easily debugged and tested and so was well suited to that application.

SIXTH is a second generation FORTH which was designed at Durham University specifically for use with modern microcomputer systems. In these systems, memory is readily and cheaply available, as are a wide variety of microcomputer systems, and SIXTH has therefore been optimised for ease of implementation and transportation, rather than for super-efficient memory use. The SIXTH used on the MC68000 systems was specifically designed and written for this research project. Similar SIXTH systems have been written for a number of different systems, both minicomputer and microcomputer based.

4.2 SIXTH Design Philosophy

SIXTH is a stack based language. This gives rise to a notation throughout the system which is primarily 'backwards'. This includes reverse Polish notation for arithmetic functions. In addition, language constructs which are used in other languages (such as IF... THEN... ELSE....) appear in slightly strange format (i.e IF... ELSE.... THEN...).

The system uses SIXTH language words, which are known as definitions. These are held as a 'linked list' in memory. This list is known as the dictionary. Each definition is preceded by a header whose format is shown in Figure 4.2a. It consists; the name of the definition as a string truncated to the first four characters, the total length of the name string and a link address to the previous definition heading. The operating system maintains a pointer to the last definition in the dictionary. To search for a definition in the list, it is searched backwards by starting at the last definition (to which the system holds a pointer). If this is not the desired definition, the pointer to the next one is extracted from its header and the previous definition is then checked. This will continue until the last definition in the linked list (which is the first routine defined in the kernel) is reached. This last definition has its link address pointer set to zero. SIXTH recognises this as being the last definition, and if this stage is reached it implies that the definition was not in the dictionary. SIXTH normally operates from a VDU in interpretative mode. Alternatively it may operate from a file held on some bulk storage medium to 'RELOAD' large sections of program which would be too laborious to retype from the VDU.

In its interpretive mode, character entry is handled on a line-by-line basis by a buffer routine which also provides keyboard handling (i.e. backspace, prompts etc.). The line is parsed into character strings separated by spaces and terminated by a carriage return. SIXTH then attempts to interpret these strings as either numbers or previously defined SIXTH routines. If the string is a number, it is placed on the operand stack, otherwise the string is checked with the dictionary to see if it has been previously defined. If it matches a previous definition, this definition is executed. If it does not, an error is flagged. From this interpretive mode, new definitions may be

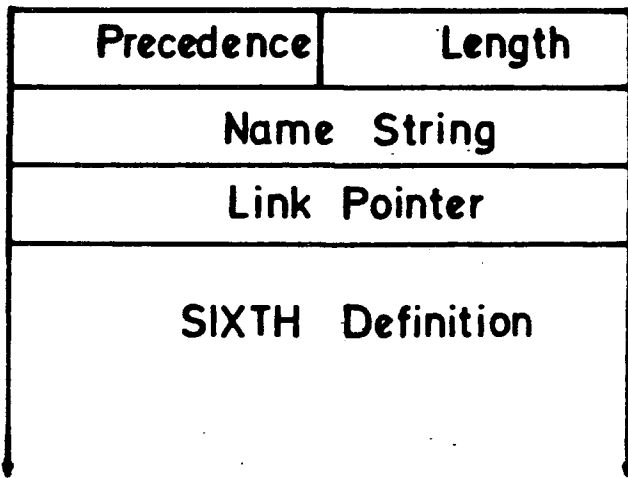

Figure 4.2a SIXTH Header Format

added to the dictionary by placing SIXTH into compile mode (using the definition ':' to start compilation and ';' to terminate it). In compile mode, any valid keyboard entry is compiled onto the end of the dictionary in the same format as previous definitions. After exit from the compile mode, this new definition may be executed from the keyboard in the same way as the old definitions. Thus any definition may either be executed from the keyboard or from within a definition, or may be compiled into a new definition. Additional SIXTH keywords cause the system to accept input from an alternative source to the keyboard. In some systems this would be a resident disk unit, but in the MC68000 system it was the serial link with the MC6809 development system. This allows the loading of the linked dictionary from the bulk storage device.

A normal SIXTH system comprises three parts; firstly the system kernel which is written in assembler, and incorporates all of the basic system routines such as I/O routines, terminal handler, interpreter/ compiler and number handler. The second part is the system dictionary which includes all of the high level routines such as conditional statements, loops, string handling, system utilities, and assembler if included in the implementation. The assembler was not included in the MC68000 implementation of SIXTH because of its great complexity. The final part of SIXTH is the user program section. The second and third sections are written in SIXTH.

The system as implemented on the MC68000 includes three stacks, the operand stack, the 'DO' stack and the machine stack. The first is the primary SIXTH stack which is used for parameter passing between routines and for keyboard interpreting. The second is only used in the 'DO..... LOOP' construct, and is used to stack loop parameters. The final stack is used to retain the return addresses from subroutine calls. The MC68000 processor has seven data registers and seven

address registers. The stacks are implemented using three of the address registers.

4.3 System Kernel

As explained, the system kernel was written in assembler and performed all of the basic SIXTH functions. A listing can be found in Appendix A. In all of the routines apart from the first two (CHIN, CHOUT) all parameters are passed on the operand stack, allowing all of these routines to be used by any SIXTH programs.

In the explanations of the routines that follow, the abbreviations 'D0-7' are used to represent data registers zero to seven, 'A0-7' for address registers zero to seven, 'MS' for machine stack, 'OS' for operand stack and 'DS' for the 'DO' stack. The current system I/O port may be either of the two ACIAs on the MC68000 board, and is selected by the value of the address in the location named 'PORT'.

CHIN Reads one character from the system port into D0.

CHOUT Writes one character from D0 to the system port.

BUFFER Used when A VDU is connected to the system port. It prompts the operator for characters and then buffers a line which is terminated by a carriage return. It also sets up the parameters for **WORD**.

CRLF Sends a carriage return/ linefeed pair to the system port.

WORD Parses the line buffer produced by **BUFFER** to set pointers to the beginning and end of the next word in the buffer. Sets the **LAST** flag if the end of the line has been reached.

FIND This is the dictionary search routine. It takes the word parsed by **WORD** and searches the dictionary for it. The address of the definition is placed on the OS if it was found, or zero is placed on the stack if it was not found.

PUSH Pushes the contents of D0 onto the OS.

POP Pops the top word of the OS into D0.

STK Pushes the contents of D0 onto the DS.

UNST Pops the top word of the DS into D0.

NUMBER This is the number crunching routine. It attempts to assemble the ascii word parsed by **WORD** into a binary number, in the base indicated by **RDX**. It then places this number on the OS.

RESTART This routine performs a system restart by resetting all of the **SIXTH** system variables.

: This routine puts **SIXTH** into compile mode. It also puts the new header onto the end of the linked list.

EXECUTE This routine is used after an attempt has been made to **FIND** the word. If the attempt succeeded, then the word is either executed or compiled, depending upon whether the system is in compile or execute mode. If the attempt failed, **EXECUTE** calls **NUMBER** in case the word is a number. If it is a number it is either left on the OS or compiled into the dictionary depending upon the machine state. Finally, if the word is neither, **EXECUTE** flags an error condition.

TYPE The length and address of a string to be output are taken from the OS and used to output the string to the system port.

TITLE Displays the **SIXTH** banner.

; This routine ends compile mode and finishes the new dictionary entry. Anything entered between **:** and **;** is compiled into the dictionary.

CONSTANT Assembles a number into the dictionary from the OS as a complete new dictionary entry. When the new definition is executed, it will put this number onto the OS.

INTEGER Assembles a number from the OS into the definition currently being compiled. When this definition is subsequently executed, this number will be placed on to the OS.

VARIABLE When executed it allocates space for a variable in the new definition currently being compiled, in addition it inserts machine code into the current definition. When the new definition is subsequently executed, this machine code causes the address of the variable space to be placed on the OS.

LOAD Resets the current system port to be the second ACIA connected to the MC6809 system and reads in one line of text into the line buffer.

OPEN This routine sends a command to the MC6809 system via the second ACIA which causes the MC6809 to open the SIXTH dictionary file.

RELOAD This routine sets the reload flag, thus putting SIXTH into reload mode.

IMMEDIATE If this word is compiled into a new definition, it causes the precedence bit (which is part of the header of each definition) to be set to one. This means that when this definition is subsequently included in a new definition, it will be executed rather than compiled, as is normal.

TO Sends the character on the OS to the system port using **CHOUT**.

DISSECT Dissects a binary number on the OS into ASCII characters, and a which it replaces on the stack.

Uses **DISSECT** to output a number in ASCII to the system port which corresponds to the number which was on the OS, expressed to the current base.

ASMB Puts a number from the OS into the dictionary.

@B, @W, @L These read a byte, a word or a long word from the address held on the OS and place the result on the OS.

!B, !W, !L These write a byte, word or a long word held on the OS into the address also held on the OS.

+, -, *, / These perform the relevant arithmetic operations on numbers already on the OS and place the result back on the OS.

LEFT This routine shifts the number on the OS left by the number of places held on the OS.

SWAP This swaps the top two numbers on the stack.

The interpret loop is the master routine for the SIXTH interpreter/ compiler. Its operation is illustrated in Figure 4.3a, and is fairly straightforward. It calls either **BUFFER** or **LOAD** depending upon the state of the reload flag. It then calls **WORD**, **FIND**, **EXECUTE** until such time as the end of the line is reached (which is indicated by the **LAST** flag, set by **WORD**), when it loops back again.

The use of **SIXTH** is best illustrated by example.

At the simplest level, the line:-

4 2 *

places two numbers on the OS, takes them both off the stack, multiplies them together and places the result back on the OS. The line:-

: SUM 4 2 * ;

compiles a new definition named 'SUM' onto the end of the dictionary, which may then be executed, by using the line:-

SUM

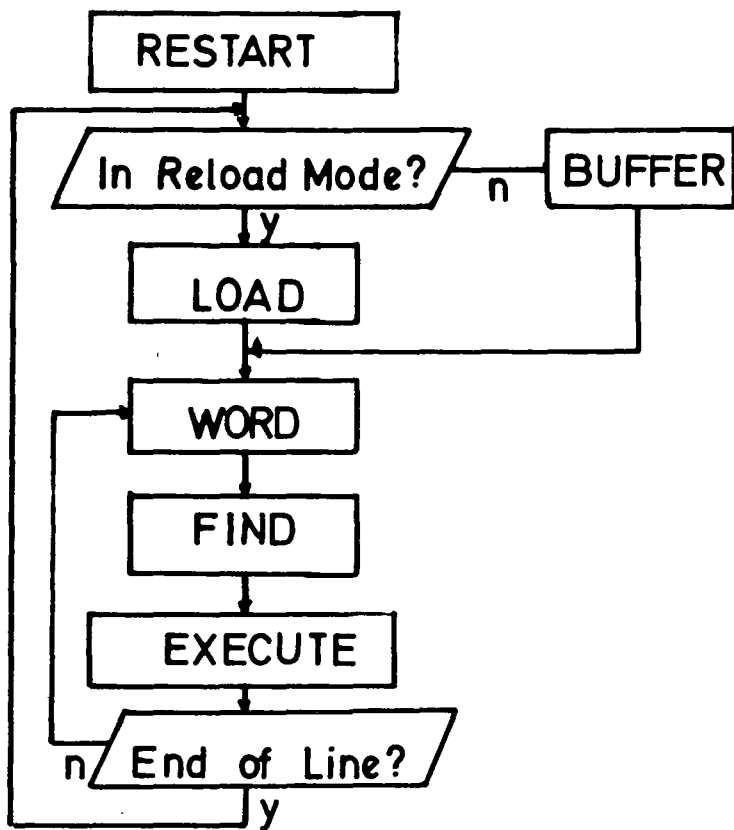

Figure 4.3a SIXTH Interpret Loop

This will perform the same operations as above. The line:-

```
10 CONSTANT FRED
```

creates a new definition which when executed places 10 on the OS. The line:-

```
10 : FRED INTEGER ;
```

has a similar effect. The memory manipulation commands are straightforward, the line:-

```
2 100 !W 300 @W
```

will store the number 2 at location 100, and will then read a word from address 300. The three operation types, byte, word and long word correspond to the modes for memory manipulation available on the MC68000 processor, which are 8,16 or 32 bits in length respectively. The lines:-

```
: THING VARIABLE ;
```

```
12 THING !W
```

```
THING @W
```

create a new definition called THING, stores the number twelve in the variable space thus allocated, and reads the contents of this variable space onto the OS.

Finally, the SIXTH dictionary may be reloaded by using the commands:-

```
OPEN
```

```
RELOAD
```

which open the SIXTH dictionary file on the MC6809 and reload the dictionary, by placing the system into the reload mode (the reload flag is set). The system is returned to normal operation by the inclusion of a 'RESTART' at the end of the dictionary file on the MC6809, which causes all of the SIXTH system variables to be reset, including the reload flag. SIXTH may be operated in any number base,

as defined by the contents of the location 'RDX'. The base used only affects the ASCII representation of numbers at the VDU. The internal representation of numbers is always in binary form.

4.4 SIXTH Dictionary

As described, this is held on the MC6809 system in the form of an ASCII file which was written and edited using the standard DOS69 text editing system. A listing of the dictionary may be found in Appendix A. Although it was impossible to include a full 'in-line' MC68000 assembler in the dictionary, several assembler instructions were needed to complete the dictionary. These may be found near the beginning of the dictionary. It should also be noted that although a comment construct is defined using '(' and ')' as delimiters, this new definition occurs some way down the dictionary, so the initial section is uncommented. Several of the main higher level SIXTH constructs are detailed below.

... DO ... LOOP

This is used in the normal manner, apart from the fact that it may be used only when SIXTH is in compile mode, and the loop limits must be entered in reverse, due to the stack orientation of SIXTH. i.e. a valid statement would be:-

```
      : TEST 10 0 DO I . LOOP ;
```

the 'T' routine places the current value of the loop counter on the OS. **STOP** may be used to abort the loop.

BEGIN END

This is the infinite loop construct and may be aborted by the use of **QUIT**.

... IF ... ELSE ... THEN ...

This is the conditional branch construct and may be used with the conditions =<, >=, =, >, <. A valid use would be as follows:-

```
: TEST < IF . DROP ELSE DROP . THEN ;
```

```
4 2 TEST
```

the definition TEST would then print out the lesser of two numbers on the stack, in this case it would print out '2'. Note that the construct may be used without ELSE, but IF and THEN must always be used together.

STRING

ARRAY allocates an array space within the current definition and also compiles machine code into the current definition to handle this array space a run time. **STRING** merely fills this array with the specified string. e.g. : SAYING STRING "The quick brown fox" ; creates an array filled with the specified string, whilst the command:-

```
SAYING TYPE
```

causes the size and length of this array to be placed on the OS, and TYPE then uses these parameters to type out the string. Several utilities are included, the more often used are:- **KEEP**, which is used to protect the dictionary against inadvertant deletion, **FORGET**, which is used to delete unwanted dictionary definitions and **WHAT**, which is used to list out the dictionary contents.

Finally, **COMPILE** is used to compile user programs from a file on the MC6809 which is specified by the operator thus:-

```
COMPILE FRED
```

This user file, which is held on the MC6809, must be terminated with a **%ENDFILE**.

4.5 Conclusion

A SIXTH interpreter/ compiler was written at Durham for the MC68000 single board computers which was capable of handling a VDU and accepting input, via a serial link, from the MC6809 development system which was used as a program development station. This allowed programs to be tested interactively from the VDU and then stored on floppy disk on the MC6809 system for subsequent recompilation. The SIXTH system was written in three parts, a kernel in assembler, and the dictionary and user programs in SIXTH. The design concepts differed from the FORTH language upon which SIXTH was based, in that memory use is no longer minimised at the expense of program execution speed. This was possible due to the current low cost and easy availability of semiconductor RAM as compared to the time at which FORTH was written.

Chapter 5

The Portable Highway Controller

5.1 Introduction

The portable highway controller was developed at Durham as part of the Durham University version of the ASH system [32]. As explained previously, the Ferranti Argus minicomputers used as hosts to the ASH system at ASWE could not be used at Durham, and instead Motorola MC68000 single board computers were used. Initially all software for both the highway controllers and the terminal units was stored in volatile memory on the MC68000 boards, and a system restart involved reloading all of the programs from the MC6809 development system. Subsequently, the programs were loaded into EPROM and a restart could take place without any intervention from the MC6809.

When the complete system was demonstrated to ASWE, it became apparent that an MC68000 hosted highway controller could perform all of the tasks which had been previously performed by a Ferranti Argus 700F minicomputer, at a much lower cost and in a much more compact form.

On this basis, a draft specification for a portable highway controller was set out whose main requirements were as follows:-

- 1) The unit should be entirely self-contained, should include some form of highway status display, and a keyboard of some sort to allow the operator to manually alter the highway controller operation.

- 2) The unit should be completely failsafe i.e. it should be able to restart automatically after a power failure, and important system parameters should be battery backed up, such as the system clock.

3) The operator should have as much (or more) control over highway controller operation as in the Ferranti Argus 700F system, and the display contained in the unit should provide all of the status information necessary for full monitoring of the network.

Several units have been developed at Durham which satisfy these requirements, and after extensive evaluation and testing of these units at ASWE, it has been decided to commission a commercial version for future use.

5.2 Portable Controller Hardware

The hardware used in the portable highway controller is an upgrade of that used in the standard Durham University terminal unit. The basic ASH hardware is as detailed in section 2.4-2.6, with the addition of an extra page (512 by 32) of microcode store. This is a standard ASWE alteration for the ASH systems which include dual controllers, as it was found to be impossible to include all of the necessary software in only one page of microcode store. The desired page is selected with the aid of a 'page register' which appears as a write only register to the 2901. In order to change page, the 2901 must write the desired page number into the register. Program execution will then continue at the same instruction address on the newly selected page.

The other hardware included in the unit was the Motorola MC68000 board with its on-board RAM expanded to 128kbytes (section 3.5:1). A CMOS clock chip (National Semiconductor MM58174) and 3V rechargeable battery were included to provide a battery backed-up system clock. The requirement for full monitoring capability was more difficult to

satisfy in the limited space available. Several different types of display were looked into including plasma panels, LED displays and LCD displays. The LCD display was finally chosen on the grounds of availability, compactness, low cost and ease of connection. In addition, LCD displays need only a single 5V power supply, and the unit chosen, a FELTEC 128 character display (4 rows of 32 characters) was available in a low power version which had a power consumption of only 25mW [33]. The keyboard used in the Durham versions was a hexadecimal keypad (Radiospares) however ASWE intend to have a custom keypad designed for them.

Finally, the units contained a fully stabilised four rail power supply, which could run from 240,220,120,110 volts at 50/60Hz. The five volt rail was protected with a crowbar unit to provide the unit with some protection against power supply failure. The power supply design included mains filters and sufficient 'backing voltage' margins, to ensure that the power rails remained stable even when operating with ship-borne power supplies and their occasional lack of regulation. The external case was designed to enable the unit to be either free standing or to be mounted in a nineteen inch rack. A cooling fan and vents were provided at the rear so that the unit could be mounted in the middle of a stack of equipment.

5.3 Controller Software

5.3:1 Design of SIXTH Programs

The highway controller software had to perform several separate types of functions which were as follows; firstly to allow the operator to control the function of the highway controller (and therefore of the highway system) via the keypad. Secondly, to provide continuous monitoring of any system feature which the operator wished to inspect (see section 5.3:2). Thirdly, the software had to provide a 'highway maintenance' function to automatically send out time messages, attempt to restart locked-out terminals, etc. Lastly, routines had to be included in the software to provide for orderly power-up restart of the controller and the highway system. The complete program listing may be seen in Appendix A. This SIXTH program is compiled onto the end of a standard SIXTH kernel and dictionary.

The first function is accomplished with an interrupt driven circular buffer routine to allow 'type-ahead' on the keypad (Figure 5.3:1a). Each operator command is a two character code, using the 'F' key as the equivalent of a 'carriage return' key. These commands fall into three groups (section 5.3:2), those that alter the status information which is being displayed, those which alter the operation of the controller, and those which alter the operation of the highway system. The codes generated by the hex keypad and associated circuitry are processed by the software to produce two character ascii commands which may be handled by the SIXTH buffer routine as though they had been originally entered in ascii. As mentioned 'F' is equivalent to 'carriage return' which is the SIXTH line terminator (section 4.3).

Interrupt Handler

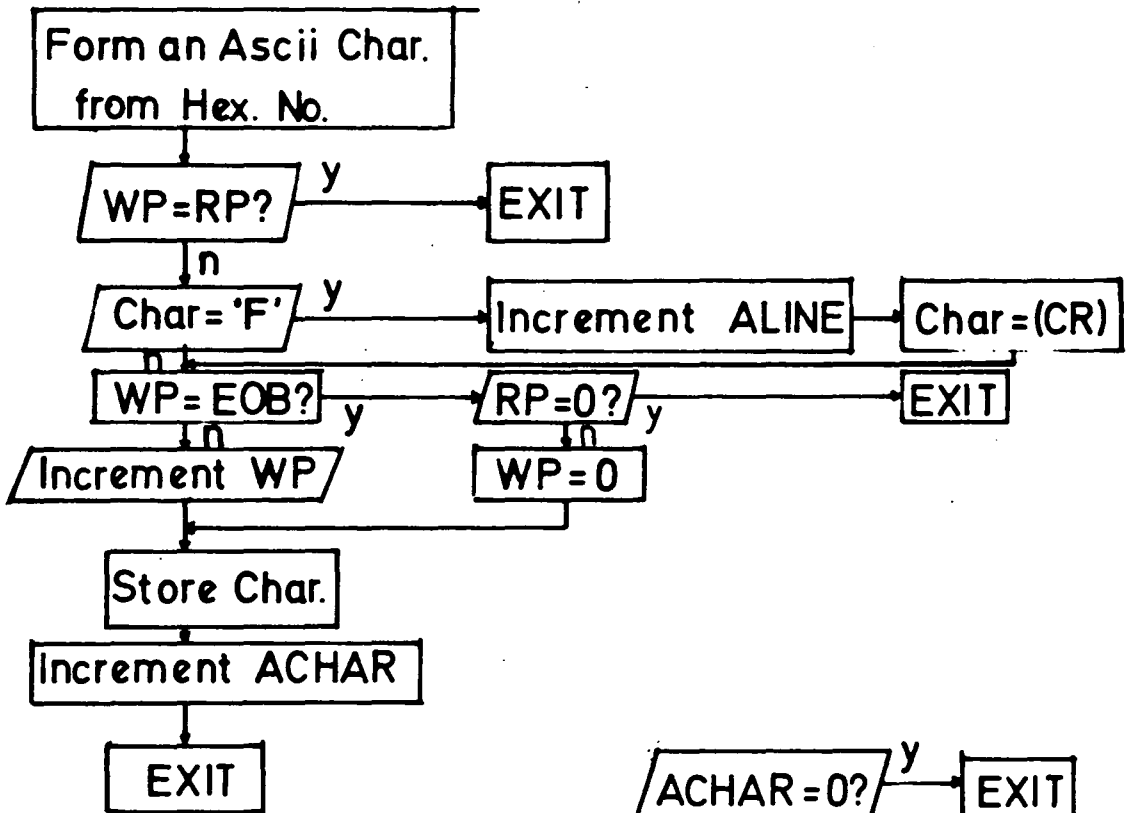

WP - Write Pointer
 RP - Read Pointer
 EOB - End of Buffer

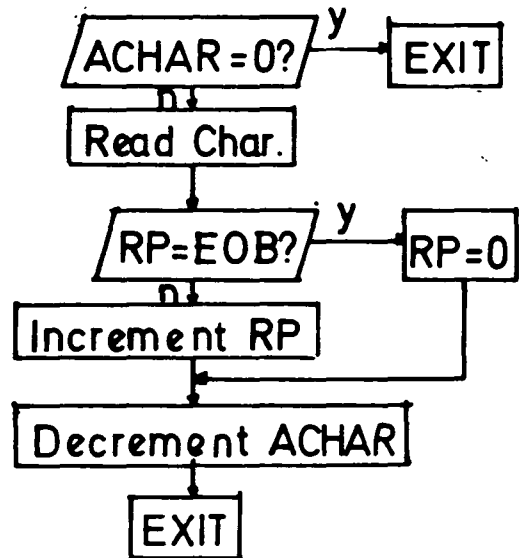

Programmed Character Read Routine

Figure 5.3:1a Keypad Service Routines

The first two types of commands may be carried out without any interaction with the highway controller FEP, however as explained previously (section 2.9:2), in order to alter highway operation, the controller must first be halted, and then restarted. An optimised routine was written for this function whose overall function is to swap the current polling table with an alternative one. The section of the routine executed with the controller halted has been minimised to keep within the time constraints mentioned in section 2.9:2.

The monitoring task is performed continuously, and is halted only when the operator is using the keypad (Figure 5.3:1b). At such times, the current monitoring cycle is completed, and then the display is cleared and used to echo characters to the operator and to prompt for the necessary entries. At the conclusion of that particular command entry, normal monitoring is resumed. The monitoring is normally in the form of a menu of controller status information taken from the various tables (section 2.9:1). This will only change should any of the various counters be updated by the FEP. The menu system is also used to display the terminal status information as extracted from the status tables, however the status information on multiple terminal units is displayed in rotation.

The highway maintenance function is invisible to the operator, and occurs at regular predefined intervals. The real-time clock chip is used to provide an interrupt once every five seconds. This prompts the MC68000 to set up a new time message in the 'out-time' space. The status of each terminal in the polling table is also checked, and should there be any terminals locked out, the MC68000 attempts to have them restarted, using the procedure detailed in section 2.9:2. Additionally, when the controller is passive instead of active, the interrupt routine will update the real-time clock, should an 'In-time'

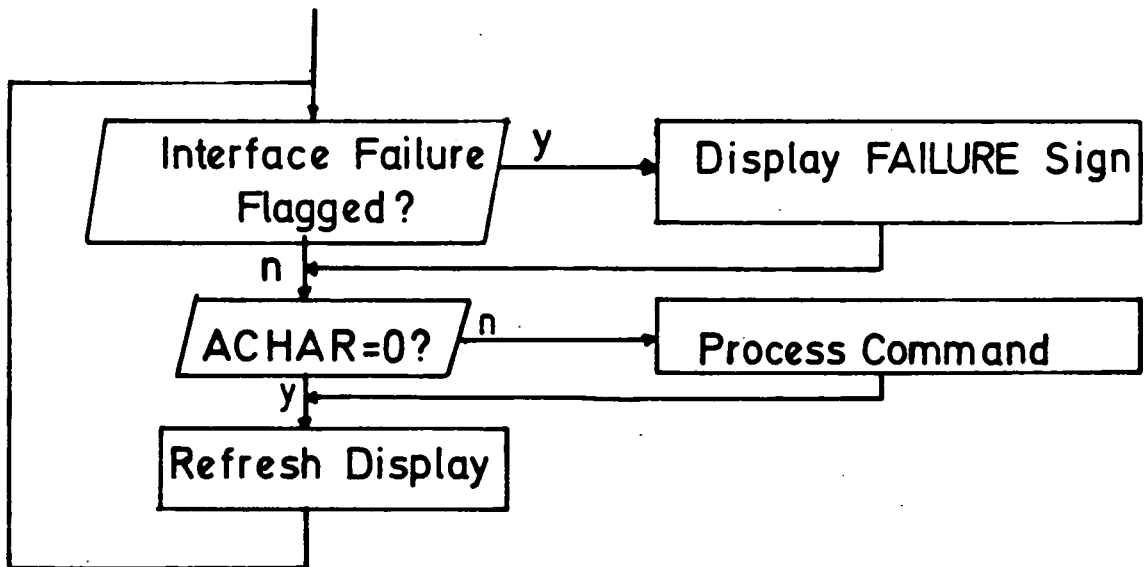

Figure 5.3:2b HWC Monitoring Routine

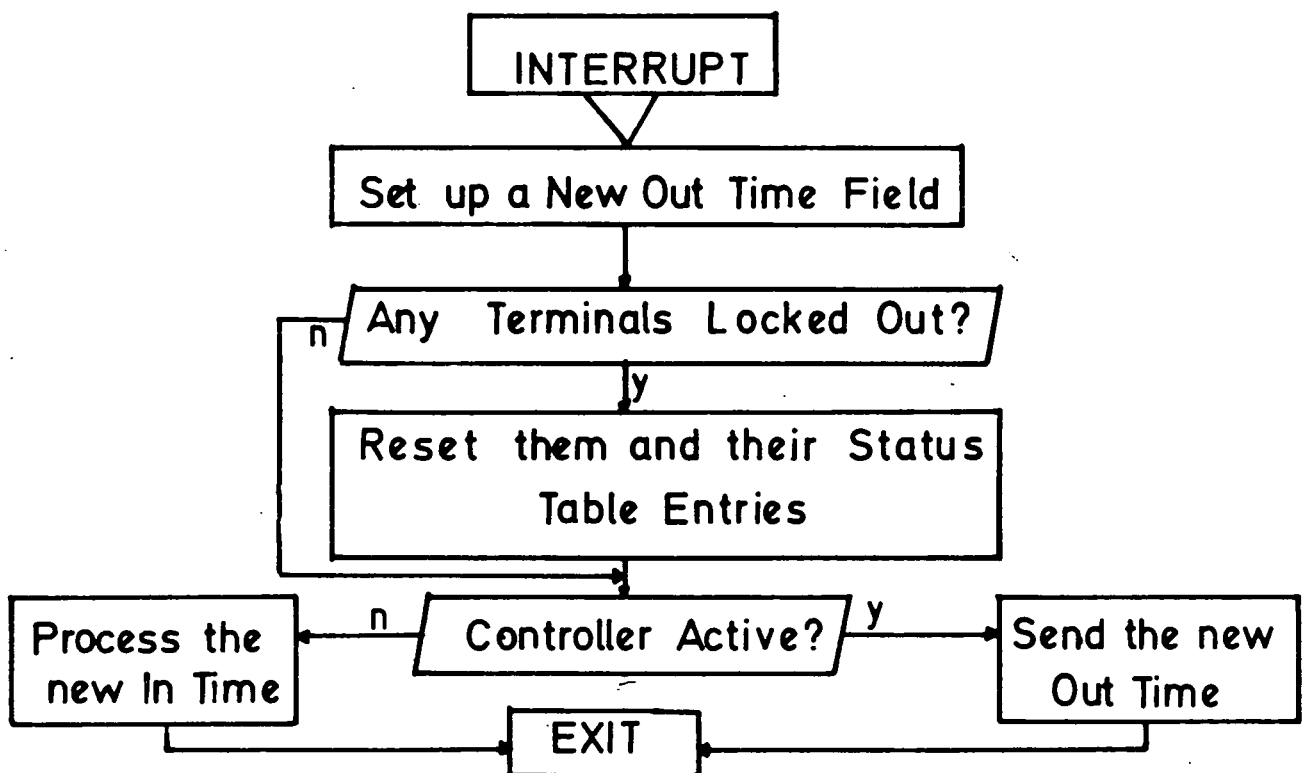

Figure 5.3:1b HWC Maintenance Routine

message have been recieved from the active controller.

The system chosen for the power-up software was as detailed in Figure 5.3:1c. A 'map' of the contents of the RAM immediately after loading SIXTH and compiling all of the controller programs was taken using the MACSBUG monitor. This map was transferred onto disk on the MC6809 system. In addition, a map of the SIXTH variable space was made, and a small supervisory program was assembled on the NOVA-3, and loaded onto disk on the MC6809. These various sections were programmed into the EPROMs as detailed in Figure 5.3:1d. At power-up, the MC68000 board generates a reset pulse. At reset, the MC68000 picks up the reset address from memory locations \$00000-\$00004, which are decoded into the EPROM address space. This address was set to point to the supervisory program, which then proceeded to copy the EPROM contents into the RAM space. After this copy was completed, control was passed to the SIXTH reset routine. This routine reset and halted the controller and set up the software tables to a predetermined default (currently to poll terminal numbers 0-16). The controller was then started, and control passed to the normal SIXTH program loop.

This method of restarting is very wasteful of memory space, because there are two copies of the entire SIXTH program when the unit is running correctly, and one copy is only ever used at reset time. An alternative would be to run the MC68000 from SIXTH programs stored in EPROM. This would give a great saving in memory, but would give rise to two other problems. Firstly, the access time for the EPROMs was considerably longer than for the RAM, thus programs would run slower than from RAM. Secondly, the SIXTH used on the MC68000 was designed to be run from RAM, and would have had to be considerably rewritten to allow it to be run from EPROM. Also, it was not relocatable and this would have led to addressing problems. The restart method chosen had

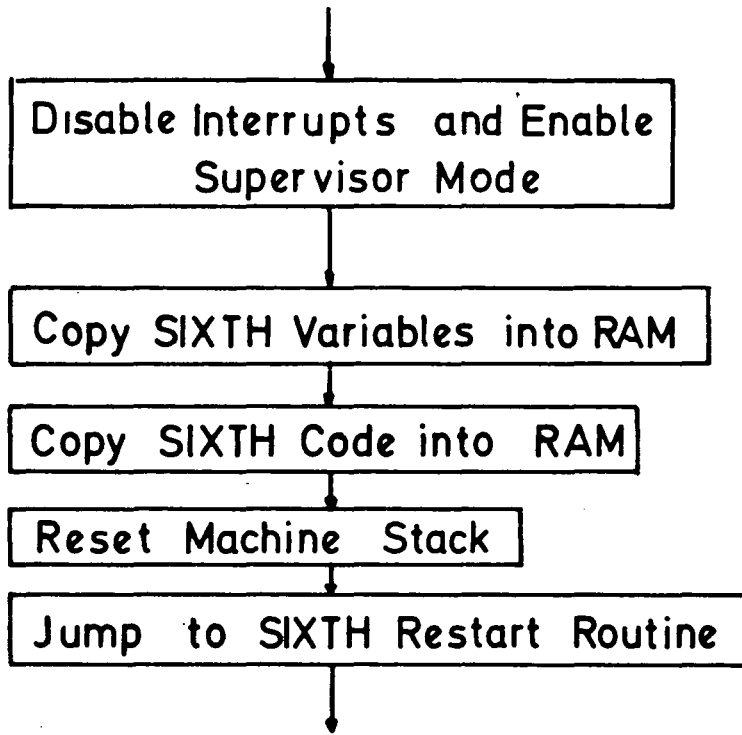

Figure 5.3:1c Power-up Software

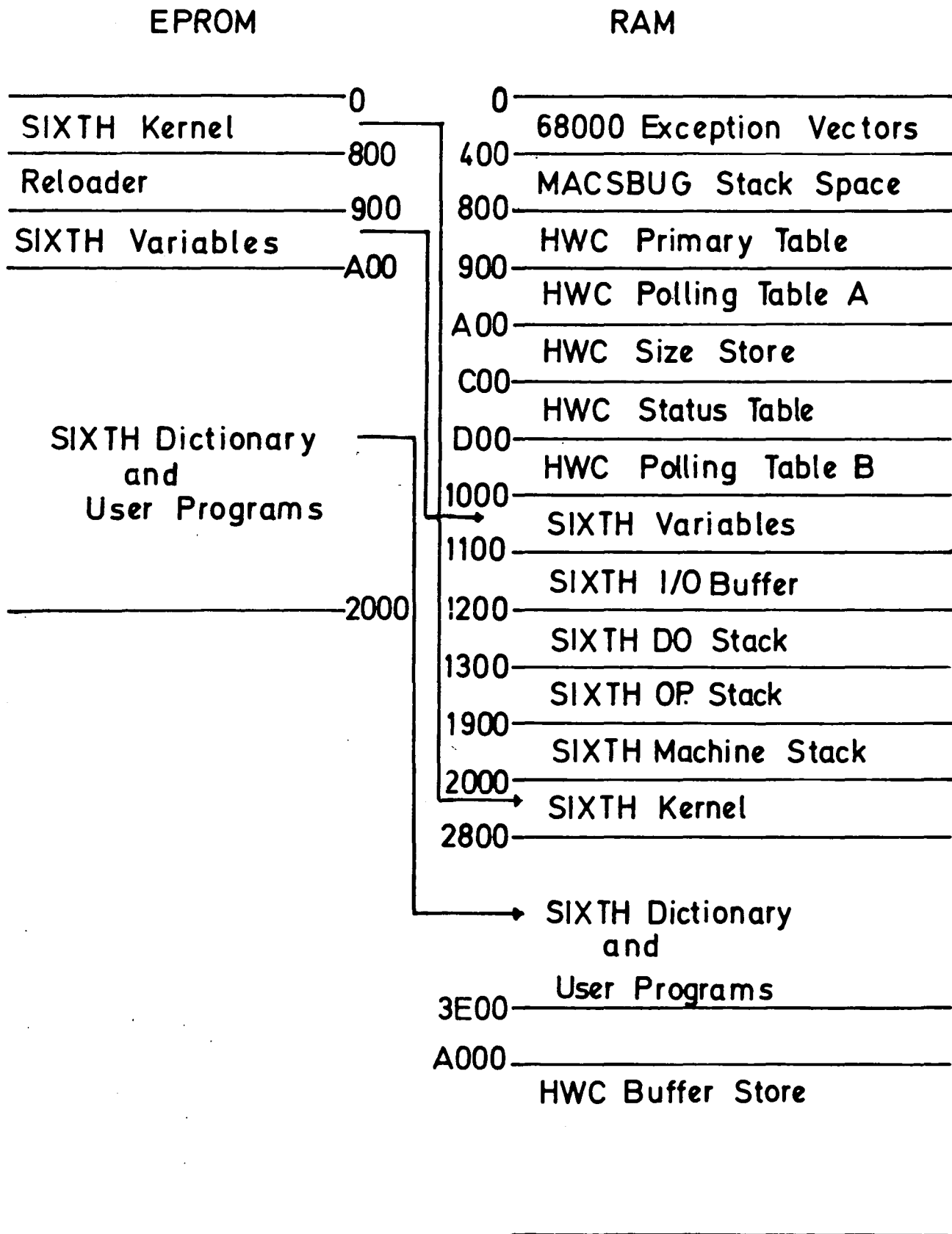

Figure 5.3:1d EPROM to RAM Map

the considerable advantage that to implement it, the standard MC68000 board needed only to have the restart vector changed (necessitating the changing of one EPROM) and to have the SIXTH EPROMs plugged in. In all other respects it was identical to the MC68000s in the terminal units, allowing complete interchangeability of hardware, and the great majority of software.

5.3.2 The Use and Upgrading of the Controller Software

The user commands are detailed in Appendix D. Unless the operator explicitly commands the controller's FEP to start, stop or reset (commands C1, C2, C3) it will continue to maintain normal highway signalling. In addition, the command 'AAA' causes termination of the normal mode of operation of the MC68000, and returns program control to the SIXTH interpret loop (section 4.3). This allows a VDU to be used as the I/O device. By this means, the operator may debug the software whilst the controller FEP is still in operation. Additional SIXTH routines may be added to those already present in RAM by compiling them from the MC6809 system or from the VDU. When these routines have been debugged and tested they may then be added to the normal controller program by reprogramming the EPROMs with the additional routines.

5.4 Testing the Portable Highway Controller

After the software for the controller had been written and debugged to the stage at which it would compile, it was necessary to devise some method of testing the many routines and the interactions between them. The routines concerned with monitoring the software

tables and with altering the tables were tested interactively by causing SIXTH to respond to both the keypad and the VDU simultaneously. Thus the VDU could be used to check that the flat-panel display was correctly displaying the contents of the software tables, and that the keypad was performing the correct changes.

The sections of the user program which proved most difficult to debug were those which had to interact with the FEP and those which performed the restart function. The former routines had to be tested with the aid of a Logic Analyser (Hewlett-Packard 1615A) while the controller was connected to the complete ASH system, to ensure that none of the rigid time constraints were violated. The latter routines were difficult to debug due to the fact that in their final form they 'bootstrap' a copy of the user program into RAM, and program control is passed to routines within this bootstrapped program. Thus if there is any mistake in the copy section of the routines, a complete processor crash could occur. The debug monitor, MACSBUG, was used to debug these routines as far as possible, however when the stage was reached at which the user routines were performing (or attempting to perform) the entire restart, this was no longer possible because MACSBUG was not initialised after the power-up, and could not function correctly. The final debugging had to be carried out with the aid of the logic analyser.

After performing all the tests possible on the unit's stand-alone function, it was necessary to test it while connected to the highway system. These tests were first carried out at Durham, with the controller connected to a system comprising six terminal units, and then at ASWE, with the controller connected to a system comprising seven terminal units and an additional controller. The controller was tested whilst the highway systems were performing soak tests (see

section 6.1). Terminal units were stopped and then started again, to ensure that the controller software was capable of automatically resetting terminal units. In the ASWE system, a second controller was used to check the operation of the portable controller in both active and passive modes. Extensive testing, over weeks of continuous use, necessitated minor alterations to the software which were mainly concerned with the MC68000/ operator software interface rather than the MC68000/ FEP software interface.

The final test of the portable controller was the ship trial (section 7) during which its operation in a hostile environment was fully tested.

5.6 Conclusion

A highway controller was designed and constructed at Durham as part of the ASH system built there. Interest was expressed by ASWE in the concept of a self-contained portable replacement for their Argus 700F based highway controllers. A set of requirements for such a unit was laid out, and a portable highway controller was designed at Durham to satisfy their requirements. The unit included a keypad and flat-panel liquid crystal display to allow operator control and monitoring. The software, which was written in SIXTH, performed all the functions necessary to supervise the FEP and to maintain correct highway operation. In addition, the unit was 'plug-in and go', in that it held the software in EPROM and could perform an auto-restart of itself and the highway system after a power failure. Extensive testing of the unit both at Durham and at ASWE has produced a proven design which may be manufactured in quantity.

Chapter 6

ASH Ship Trials

6.1 Introduction

The ASH is a highway system which is primarily intended for use on board ships in the late 1980s and 1990s. In addition it may be used as a high speed office LAN within certain MOD establishments. Although it had been extensively tested in a screened computer room environment within ASWE, it had never been tested on board a ship. This was due to the physical size of the ASH when based on a 'commercial' Ferranti Argus. Later systems will be based on the military Argus, which is a much smaller unit.

ASWE realised that it would be possible to test their LAN system using the Durham version, based around the small MC68000 single board computers. A test system using only the ASH for inter-system communication was proposed, because of the restrictions on access to several of the compartments in which the terminal units were placed. This system was designed and tested at Durham, and a monitoring unit based around the MC6809 development system was also included to provide a performance record on floppy disk, rather than on lineprinter paper, as was normal practice at ASWE.

The complete system was installed on board H.M.S. Londonderry, and ran continuously for six days, collecting some 3Mbytes of data concerning the operation of the highway. After the trials, extensive data analysis allowed a comparison between the operation of the highway as observed over the week on board the ship, with the operation of the highway as observed over similar periods at Durham and ASWE.

6.2 Test Hardware

6.2:1 MC6809 Monitoring Unit

Due to the inaccessibility of several of the highway terminal units and the difficulty in handling large amounts of computer printout in the small available space on board ship, it was decided at an early stage that the performance data collected from the test system should be in the form of records on floppy disk which could be printed out or analysed at a later date. A suite of monitoring programs (section 6.3:5) was incorporated into the software in each terminal unit. This software caused the reports from every terminal unit to be sent via the highway to one particular terminal unit, the master unit. This unit was situated in the Fixed Trials Office (F.T.O), and was accessible to the operators. It was connected to the MC6809 development system via a 9600 baud RS232 serial link, and software in the master unit and the MC6809 periodically updated the MC6809 disks. The hardware involved in the MC6809 system included the standard development system already described, with the addition of a serial port for connection to the master terminal unit. The MC6809 system was connected to a dedicated ships supply for the F.T.O. whose regulation was considerably better than that of the normal ships supply. This alternative supply was chosen because of the difficulty of providing adequate protection against disk corruption in the event of severe (but normal on standard ships supply) voltage fluctuations.

6.2:2 MC68000 Highway Terminal Units

An important consideration in the design and implementation of the hardware and software for the ASH ship trials, was that the software used in the terminal units which were not in the F.T.O. (slave units) should be held in non-volatile storage, and should have no need for local operator intervention. Thus the slave unit's hardware differed from that already described (section 3.5) only in the addition of four EPROMs which held the test software. The units were mounted securely to some part of the ships fittings to avoid damage in rough weather. The only connections necessary were to the ships standard 110volt/ 60Hz supply, and to the highway cabling. The layout of the units and cables in the test is shown diagrammatically in Figure 6.2:2a. In addition, a small hand held battery V.D.U. (G.R. Electronics) was used during the initial installation, to check on the correct local operation of each unit, before they were tested using the ASH.

6.3 Ship Trial Software

6.3:1 Design Concept

The terminal unit software necessary for the ship trials had to perform three specific functions. Firstly, the operator had to be able to control the actions of the remote (slave) terminal units from the master terminal unit. This involved the remote starting and stopping of test software, and the resetting of tables etc. Secondly, the master unit had to perform as a monitor/ information gatherer for status and performance data being sent from all of the slave units,

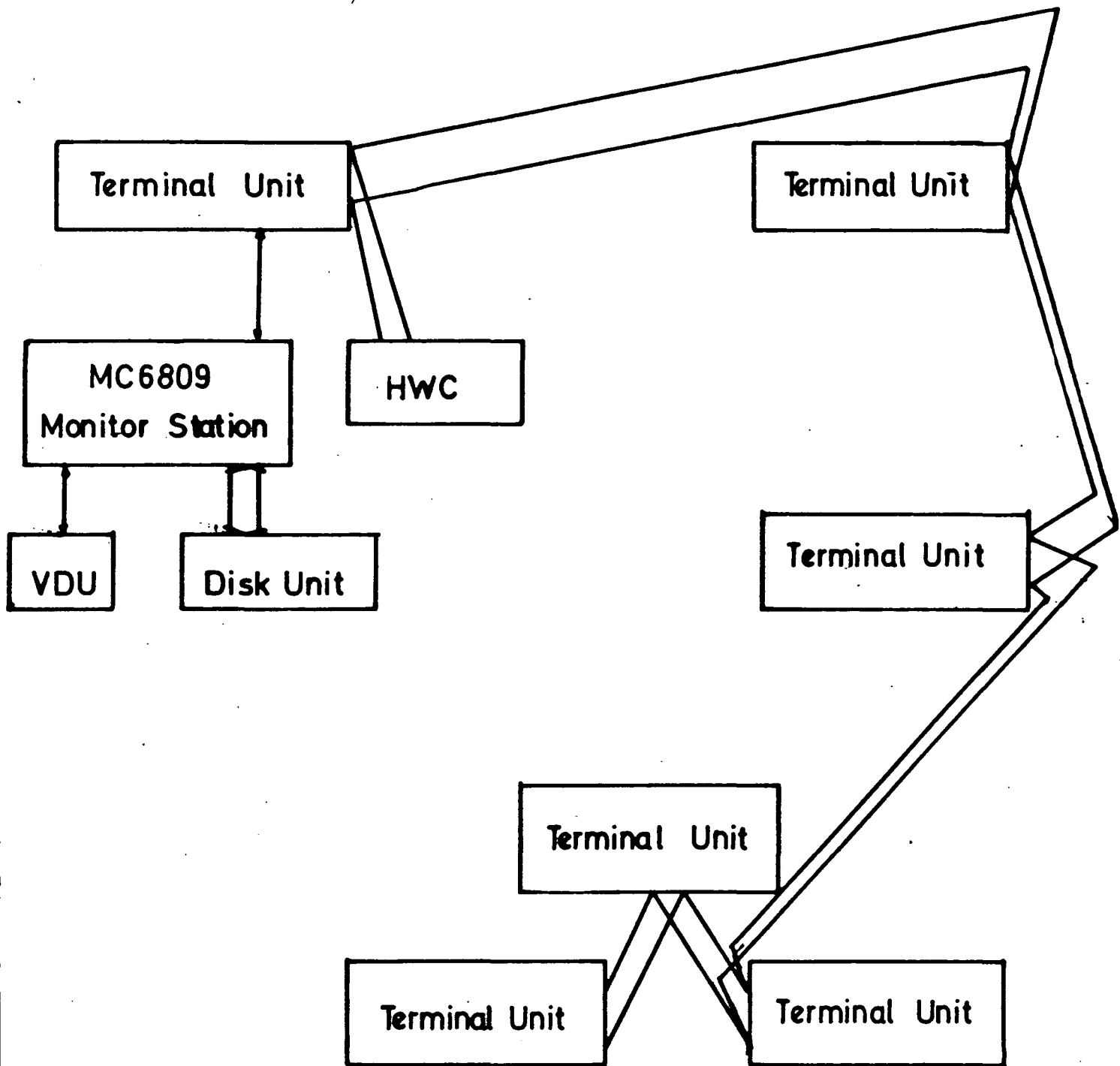

Figure 6.2:2a Schematic of ASH Ship Trial

and subsequently pass this data on to the MC6809 system which was acting as a bulk storage unit. Lastly, all of the units had to participate in soak tests of the highway, at the same time as the other two functions were being performed.

In addition to these functional requirements, the software suite had to be capable of restarting after a power failure in any of the slave units, and in the event of a highway signalling failure each slave unit had to be capable of returning the status of itself and its FEP to a level at which it could again receive messages from the highway. Full listings for the soak test software can be found in Appendix A.

This set of requirements necessitated some fairly complex programming, and meant that it was necessary to construct an operating environment in the MC68000 systems which was akin to that in a multi-tasking system. Indeed, at one point the design of such a system was considered as a possible solution to the programming problem, however time restraints and a long term hardware failure in the NOVA-3 (which would have had to be used to produce the new multi-tasking kernel) caused this approach to be abandoned. Instead, the multi-tasking environment was emulated with the aid of the multi-level interrupt system which is a feature of the MC68000 micro-processor.

6.3:2 Block Message Soak Test

The principle behind the Block Message Soak Test (BMST) was as follows. One terminal unit (in the case of these trials, the master unit) transmitted a broadcast block message of a predetermined length onto the highway. This message was composed of words of data which were cyclically generated from a stored generator word (Figure

Message 'N' :- $GW=N$

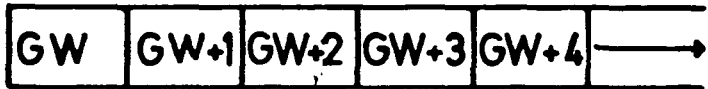

Message 'N+1' :- New $GW = \text{Previous } GW \text{ plus } 1$

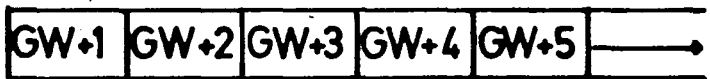

GW-Generator Word

Figure 6.32a Block Message Generation

6.3:2a). Thus the first word in any transmitted test block was the generator word. This generator word was incremented by one after each block was transmitted. At the receiving units, in this case the slave units, the content of each received block was compared with the expected content, again by the use of a generator word. This allowed the receivers to check each word of each block for correct content. The generator word was initialised to zero at the start of the test, in both the receivers and the transmitter. Thereafter, the generator was updated only after reception of a message(at the receivers), or after transmission (at the transmitter). If a receiver detected a message out of sequence (e.g every data word was a constant value greater or less than expected) it would make a record of the fact, and store the first word of data in the out of sequence block as its new generator word, to get into synchronisation with the transmitter again. Also, if any error was detected, this was noted and a report transmitted (section 6.3:4). This type of test had been in common use at ASWE for a considerable length of time. However, at ASWE, the system used to determine block message transmission frequency is purely empirical, a transmission rate is chosen by the operator based on past experience of rates which are suitable. The slowest piece of processing in the test is that which occurs in the receiver when it analyses the received block of data. Thus if a transmission rate is chosen which is slightly too fast, an overrun will occur at the receiver. On occasions this overrun may take several hours to occur, and cause a BMST to be aborted after several hours of results have been collected.

As an alternative to this scheme, a system of handshaking between the slave units and the master unit was adopted for the sea trials. This system involved the use of control messages (section

6.3:4) issued by each slave unit after a block had been analysed, and the unit had set up the 'In Block' (section 2.3) fields ready to receive the next block. This system allowed the highest possible data throughput, with no risk of overrun at the receiving units. However, it did mean that the failure of one slave unit would cause the test to stop because it would no longer be transmitting its handshaking messages. The master unit waited for such a message from every slave before transmitting the next test block of data. Unfortunately, although this could be overcome by operator intervention at the master unit, the slave units would still be in the middle of a BMST and normal control messages sent via the highway would be ignored. To overcome this problem a timed restart sequence was implemented in each of the slave units to cause the BMST to be abandoned if there was no highway soak test activity for more than five minutes at a time. A flow diagram of the BMST can be seen in Figure 6.3:2b.

After extensive testing of the software, firstly in a single MC68000 system, and then on the complete highway system, it was decided that the sections of SIXTH program which generated and checked the test blocks of data could be usefully replaced by assembler routines, in order to speed the throughput of the test. Unfortunately, owing to the extreme complexity of the MC68000 assembler language, it was not possible to include an in-line assembler in the SIXTH system, (section 4.4) as is possible in other SIXTH systems. Instead, the assembler routines were written and assembled on the NOVA-3, and included in the SIXTH program as machine code. This alteration to the soak test improved the test throughput by an order of magnitude. The improvement was due to careful design of the assembler routines to avoid the inefficiency inherent in the use of subroutine threaded code.

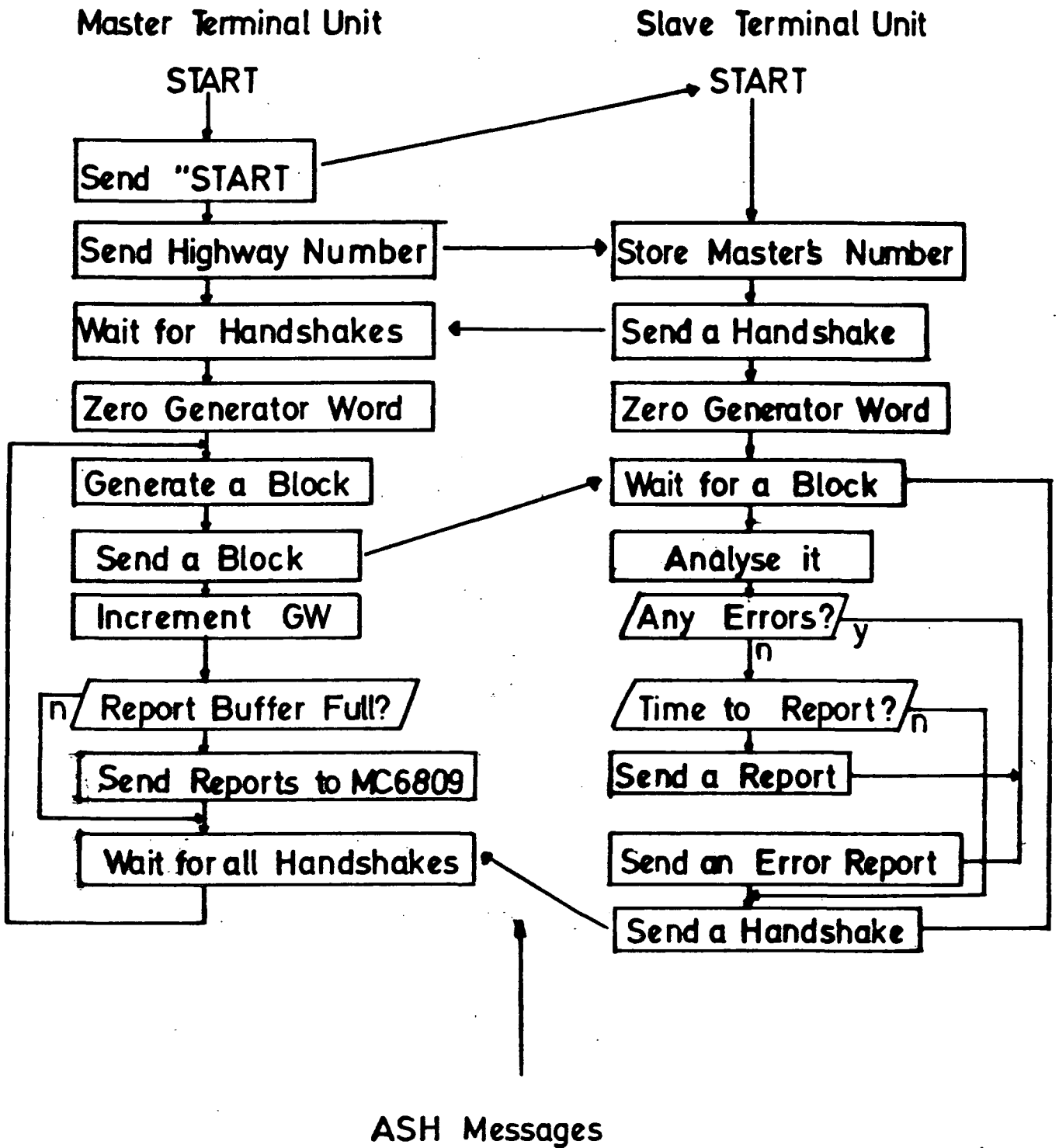

Figure 6.3:2b BMST Flow Diagram

6.3:3 Short Message Soak Test

The mechanism used to govern the frequency of the short message soak tests (SMST) at ASWE is again largely empirical. The operator specifies the transmission rate of test messages at each terminal in turn, and then instructs each unit to start the test. The latter operation is particularly ad hoc, since it is impossible to start all units simultaneously because the operator has to press a key on a VDU to start each unit and normally is unable to perform this operation on more than two units at a time. The problems encountered in the BMST concerning overrun also occur in the SMST. It was thus decided to use an entirely different system in the Durham SMST.

The requirements for a SMST are that every terminal in the test should transmit and receive messages to/ from every other terminal in the test. There should be no 'transmitter' as in the BMST, rather every unit should generate its own test messages. Two schemes are possible to perform this test. In the first, each unit transmits and receives broadcast block messages, and in the second each terminal transmits and receives point-to-point messages. In the first scheme handshaking would have to be performed in much the same way as for the BMST; i.e. a test message could not be transmitted unless a handshake message had been received from all of the units expected to receive the message. This could cause the same lockout problems as described in the BMST. Alternatively, the second method allows a considerably more elegant solution. If test message transmission is restricted to a point-to-point exchange with the unit from which a message has just been received then this overcomes the lockout problem. If a unit ceases to run the test then all that will happen is that no further messages will be received from it by any other unit, and thus no

further messages will be transitted to it by any of the units. In addition this solution makes more efficient use of the ASH since there is no necessity to transmit handshake messages.

Unfortunately, as with all elegant solutions, several difficulties were encountered with the second scheme, which was the one used in the Durham SMST. Firstly, the scheme used to maintain the generator word in the BMST would be very difficult to use because messages transmitted from a particular unit are no longer received by all other units, but by one unit only. Thus if there were five units in the test, unit 'A' would receive approximately one in four of the messages transmitted by unit 'B', and these messages need not necessarily be spaced apart by regular intervals of four messages. This meant that a different scheme was needed to inform the recipient of a test message of the value of the generator word. Fortunately, the ASH protocols include provision for a 'message type' word of length nine bits, allowing up to 512 different message types to be specified. The test control messages were using several of the message types between 0 and 255 (section 6.3:4) and the message types 256-511 were set aside to specify generator bytes, as opposed to generator words. This meant that the least significant eight bits of the MTB in a short message test message were initialised by the transmitter to the generator byte used, and were used by the receiver to check the content of the recieved message.

Another problem of the chosen SMST handshaking system was the increased complexity of the initial stages of the test. The complete block diagram of the test is illustrated in Figure 6.3:3a. Since each unit will only transmit a message to a terminal it has first received a message from, the startup section of test must perform two functions. Initially, every unit in the test must broadcast a message

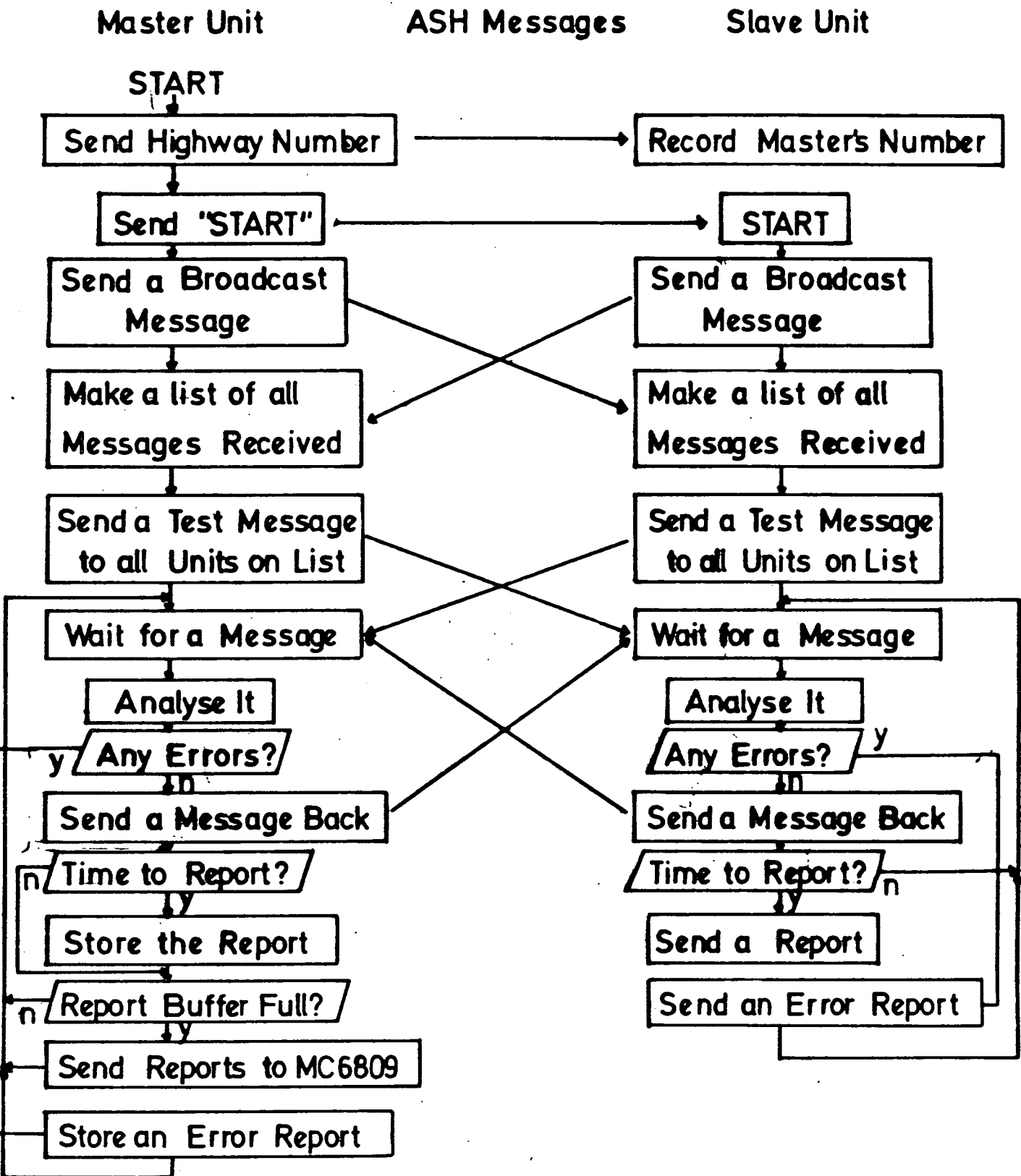

Figure 6.3:3a SMST Flow Diagram

to inform all of the other units that it is present and ready to participate in the test. Secondly, each unit must store a list of the terminals which broadcast to it in this manner, and subsequently issue one test message to each of the units in this list. After this has been performed the test may proceed as previously described, since all the terminals in the test should now have received one message from every other unit in the test.

A final problem with this test is that the timeout system used in the BMST will not function correctly, since if one unit stops the others will continue to operate. To overcome this problem an additional control message was added (section 6.3:4) which when transmitted by any unit on the highway caused all the other units to abort the SMST.

6.3:4 Test Control Software

As previously described, it was necessary to provide some means whereby a master unit could maintain control over the other slave units in the tests via the ASH. Several methods were tested, but the method finally chosen had the advantage of simplicity of programming over the other possibilities.

As described in section 4.3, SIXTH makes use of a line buffer which is normally updated from the VDU or from the routine used to perform a RELOAD. It was decided that the simplest possible method of 'remote' control by a master unit over the slave units would be to provide some mechanism in the slave's SIXTH program which would allow the master unit to send a SIXTH command line via the ASH which would then subsequently be interpreted in the normal (section 4.3) way by the SIXTH kernel. This routine consists of two parts, the routines

which allow a command to be sent from the master unit and the routines which process the command in the slave unit. The former routine is very simple and merely sets up an output buffer in the FEP buffer space which contains a SIXTH command line. The routine at the receiver is much more complex, and uses an interrupt service routine, driven by the Programmeable Timer Unit (PTM) at intervals of one second. This interrupt service routine checks the state of the receiver's input buffers. Should a message have been received in the previous interval of one second the service routine determines whether or not it is a control message. This is determined by examination of the message type. Types 0-255 were defined to be available as control messages. Currently there are only three types defined. One of these types is used in the test handshaking scheme, the second in the status and error report scheme, and the third is used to pass control messages to the SIXTH interpreter. The reception of any one of these three valid control messages causes SIXTH to stack the current machine state and process the command message. Upon completion of this processing the machine's previous state is unstacked and execution continues from the point at which it was halted. Thus, as long as a user program does not mask out the PTM interrupts, this scheme will operate invisibly during execution of any program, or whilst SIXTH is awaiting commands from the VDU. Alternatively, the section of the routine which performs the checking and processing of the command messages may be explicitly executed by the user at any time.

Thus to start a test running in a slave unit, the master merely has to send a command via the ASH which is identical to the command that an operator would use to start the test (were there a VDU connected to the slave unit). Thus sending the command 'SSRUN' via the ASH would start the SMST, as would typing the command 'SSRUN' onto a

VDU connected to the slave unit.

Once started, the SMST disables interrupts and executes the command message processing routine periodically to check whether a relevant command has been sent. The abort command, which may be issued by the master unit (SABORT), sets a 'halt' flag in the slave's memory and this is also checked periodically. Should the flag be set, the test is abandoned.

6.3:5 Test Report Software

In order to monitor the activity of the highway during both the BMST and the SMST, and to gather any information concerning errors occurring during these tests, reports were issued by each terminal. These reports were received and buffered by the master terminal. A report buffer was maintained in the master unit's memory for each of the slave units. When any one of the buffers was more than 75% full, a message was sent by the master unit to the MC6809 development system, via an RS232 link, requesting the use of floppy disk storage. When a response was obtained from the MC6809 system the relevant buffer was transmitted down the RS232 link. Then the MC6809 system wrote it onto floppy disk. During the BMST, the master unit was not participating in the soak test, thus test reports were only issued from the slave units. However, during the SMST all of the units, including the master, were participating in the test and test reports were issued by all of the units. The report software was in three distinct sections; the issuing section (in all units), the receiving section (in the master unit) and the storage section (in the MC6809 system). Flow diagrams for each software section may be seen in Figure 6.3:5a.

The issuing section could issue two types of reports. The standard type, whose format may be seen in Figure 6.3:5b, and a special error report, whose format may be seen in Figure 6.3:5c. The standard report was issued periodically after a preset number of soak test cycles. It included information on the total number of errors detected by the FEP, the total number undetected by the FEP, the total number of messages received, and in the BMST, the number of messages received out of sequence. During the SMST separate counters were maintained for the number of messages received from each unit in the test, whereas only one such counter was used during the BMST because only one unit was transmitting.

Issuing Section

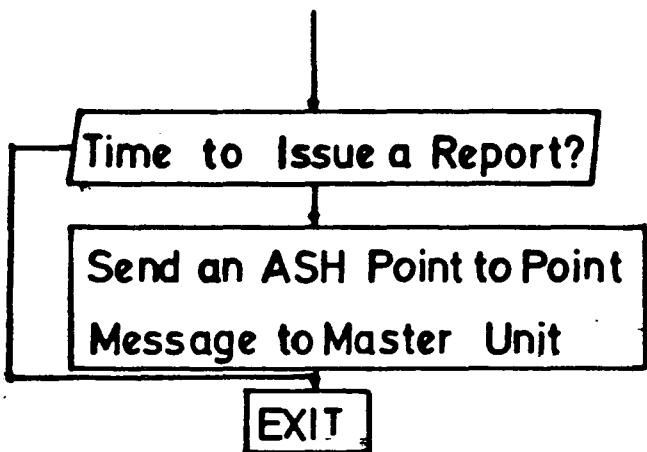

Receiving Section

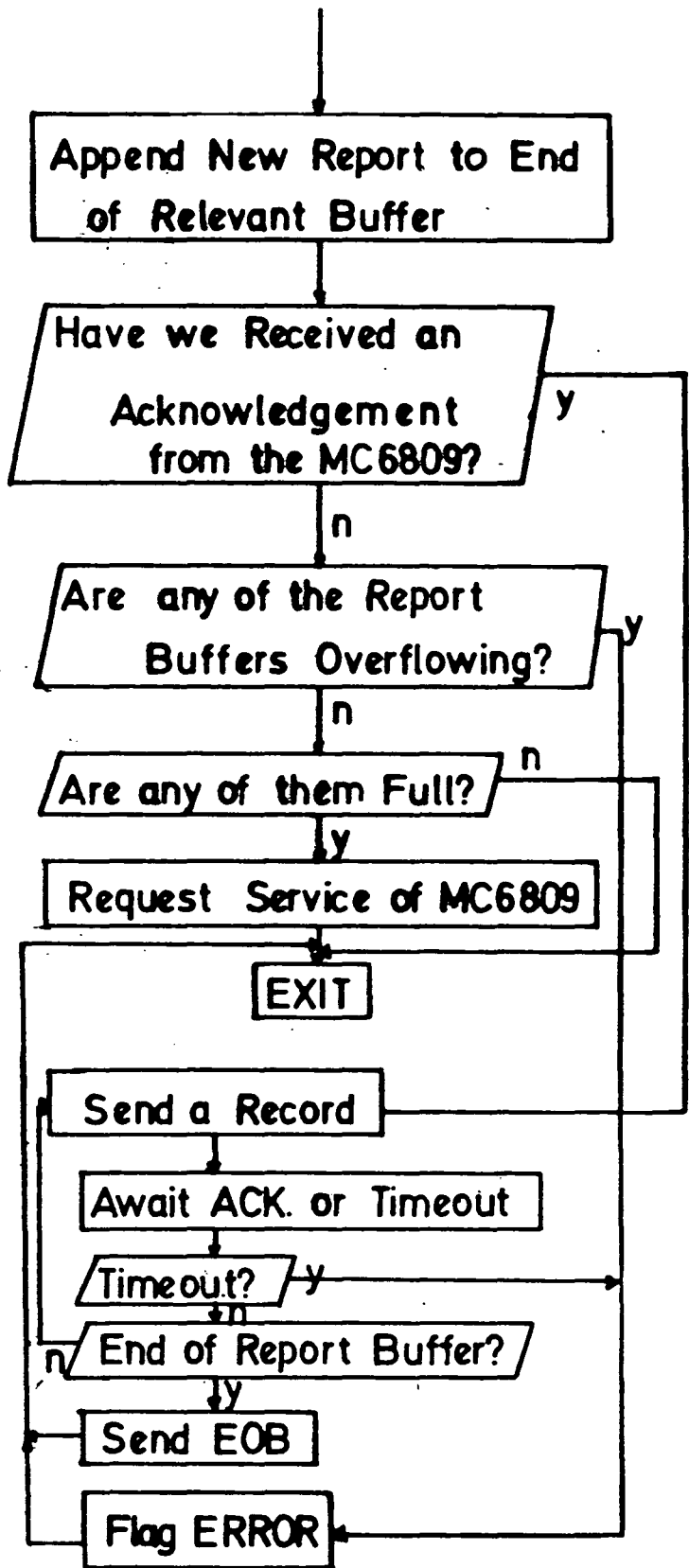

Storage Section

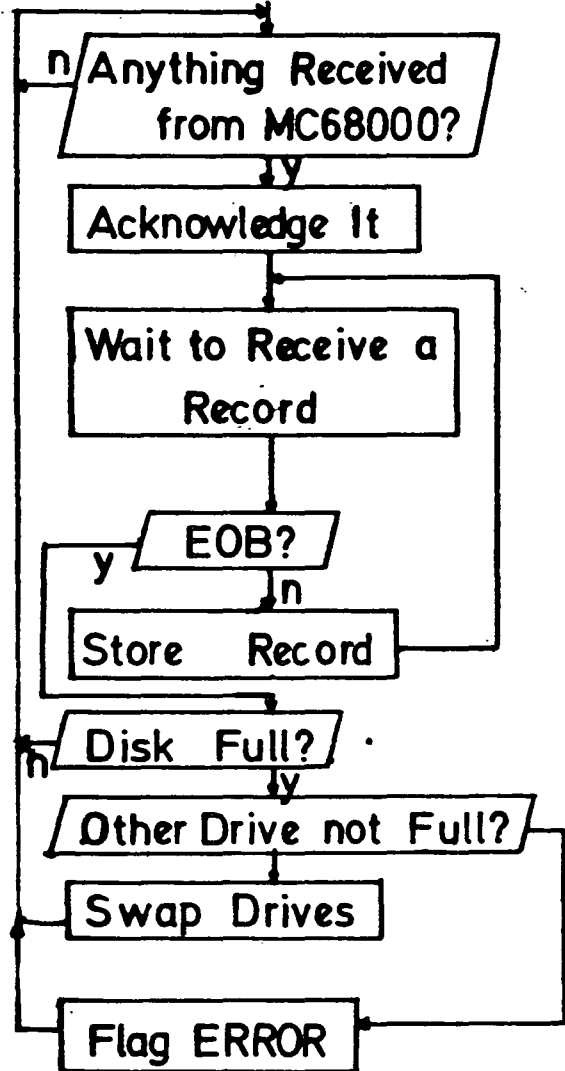
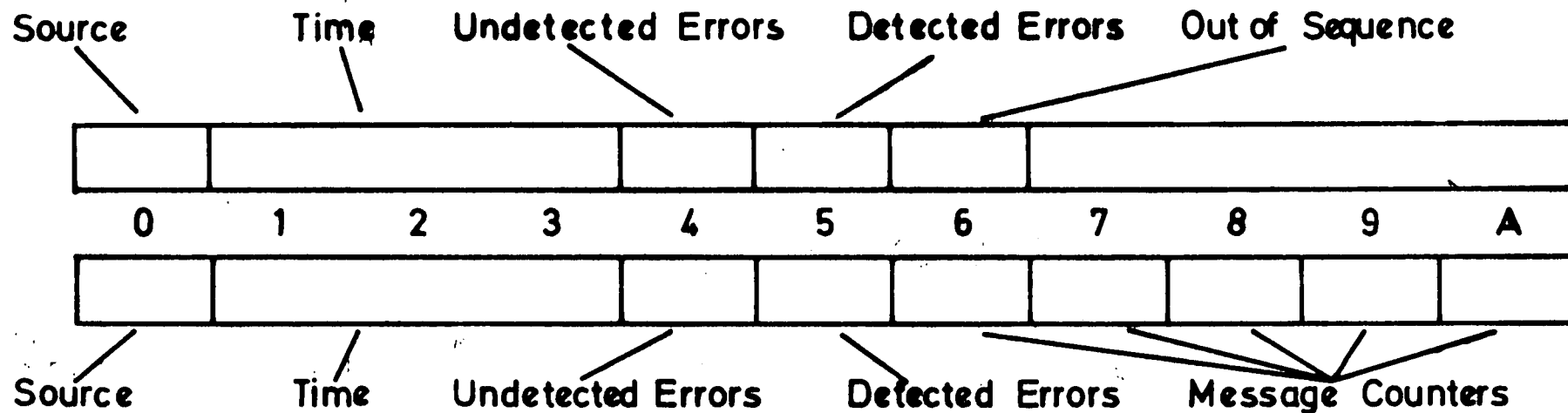

Figure 6.3:5a ASH Test Monitoring and Report Software

BMST Report Format



SMST Report Format

Figure 6.35b

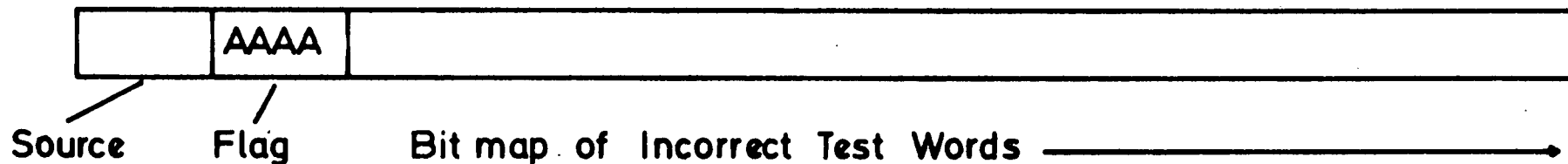

Error Report Format

Figure 6.3:5c

The second report type was issued immediately after an error was detected by the soak test software which had not been detected by the FEP. The ASH should be a guaranteed error free message delivery system, thus if the soak test software found an undetected error it implied that there had been a breakdown in the error detection system. The error report consisted of a count of the number of errors which were detected by the software, and a map of the bits which had been in error in each of the incorrect bytes of received data. This bit map could be analysed at some other time to discover in what way the error detection scheme had broken down, and how it could be improved upon to eliminate such errors.

The second section of the report software, the receiving section, was part of the interrupt service routine described in section 6.3:4. Report messages had a 'message type' of 1. If the interrupt routine in the master unit detected a 'type 1' message it would then check the message to determine the source, and store the message at the end of the relevant buffer. A further routine, which was executed periodically during the test, checked the buffers, and if any of them were more than 75% full, initiated the section of the program which transferred the buffer of reports to the MC6809 and reset the buffer pointers. This section of program was very simple, it merely sent a request to the MC6809 system to be serviced. When this request was acknowledged, the reports in the relevant buffer were sent to the MC6809 one report at a time. After the MC6809 had processed each report it issued an acknowledgement which caused the master unit to transmit the next report. If the MC6809 hung up for any reason the master unit would eventually time-out and signal a buffer overrun error to the operator.

During the SMST, when the master unit was also issueing

reports, these were entered directly into the relevant buffer in the master unit, rather than being sent on the ASH. That buffer was then treated in a similar manner to the slaves' buffers by the sections of program which checked for 'buffer full' and sent the reports to the MC6809 system.

The final piece of the report software was the section running on the MC6809 system. This program was written in assembler and performed three functions. Firstly it maintained the link with the master unit, waiting for any requests for communication to be issued. Secondly, when one of these requests was received it acknowledged it, and then proceeded to receive the report buffer as detailed above. During the reception of the buffers, they were stored in memory and after the entire buffer had been received they were written to disk, in order to keep the time which the master unit was 'communicating' with the MC6809 down to a minimum. This was necessary because during that time the master unit was no longer participating in the soak test. Finally, the MC6809 program performed monitoring and maintenance functions. The program checked the disks, and was able to swap to another disk unit when the previous one was full. If there was not an empty disk available, the program would flag the operator to change the disk. A small degree of monitoring of the reports being stored was also possible, in the form of a display of the most recently received reports from each of the units in the test. This could be called up by the operator from a VDU connected to the MC6809 system.

6.4 Test Results

6.4:1 Analysis Techniques

As previously described, the results from the sea trials were collected onto floppy disks at the MC6809 monitoring station. This process continued for the almost the entire week of the sea trials. The tests were only stopped in order to change between the block message and short message tests. This resulted in the collection of some 3Mbytes of data which had to be processed and analysed. In order to provide some control data for the experiment, the tests were also run in the laboratory at Durham University. Also, in order to have some data on the conditions in which the units were operating, the technical staff on board ship filled in detailed logs if there was any change in the status of electrical equipment, e.g. convertors or generators switched on or off. It had been suggested that the units which were operating in the more electrically 'noisy' environments, would be subject to a greater number of receive errors. For the purpose of the trials, the units were numbered as follows:-

- 0) FTO- Fixed Trials Office-Deck 1
- 1) CCR(H.P)- H.F. Transmitter- Deck 2
- 2) CRO- Radar- Deck 2
- 3) OPS- Deck 1
- 4) CMR- Conversion Machinery Room- Deck 3

The data which was collected during the sea trials was processed in two different ways. Firstly it was checked for the occurrence of undetected errors, and secondly for the occurrence of detected errors. Then graphs were plotted of the log error rate against the time for

each terminal.

The task of analysis was performed by an MC6800 system which was running BASIC. The trial records were read in off the floppy disks with the aid of a small section of assembler code. Then the error rate was calculated over a certain integration period, which could be preset by the user. Finally, the MC6800 plotted the results on an HP flat-bed plotter.

6.4:2 Discussion of Results

With such an enormous amount of data to be analysed, it became immediately obvious that it would be impossible to plot graphs which covered the reports from all of terminals for the complete trial. Instead, graphs were plotted for a certain time period for all of the terminals in an attempt to relate their physical environment to the error rate which occurred at that terminal. Then it was hoped that some of the data collected on the ship machinery logs could be used to explain any fluctuations in error rates.

The first thing which was discovered was that no errors occurred which were undetected by the ASH hardware during the entire length of the trials. This meant that no further analysis of that particular type of error was necessary.

Next the detected error rate was analysed. A selection of graphs can be seen in Appendix E. Graphs 1-5 show an analysis of the log error rate for the first six hours of the trials. During this period the ship was preparing to leave port. Each point plotted on these graphs represents one minute of data. It can be seen at this point that there is a very close correlation between the error rates

in graphs 1,3 & 4, whereas the graph for the terminal in the CMR room (graph 5, number (4)) appears quite different. This difference implies that the errors were induced directly into this terminal unit rather than onto the highway cable itself, otherwise the error rates would be identical at all of the terminal units. The physical positioning of this unit would support this theory, since the CMR was the only compartment on Deck 3 which had a terminal unit in it. It was definitely the most severe environment since it contained approximately eight high powered rotary convertors. The results detailed in graph 6 also support this theory. These are the error rates for the unit in the F.T.O. which was a shielded test office, with its own stabilised A.C. supply. As can be seen, the error rates for this unit are lower by more than an order of magnitude.

Additional series of results are shown in graphs 7-11, 12-16, and 17-21. These graphs all show a consistency of error rates for the remote units of approximately 1 part in 10^5 , and for unit 0 of between 1 part in 10^6 and 1 part in 10^7 .

The conclusion which must be drawn from these results is that the highway cabling is virtually unaffected by the environment in which it is placed. Any fluctuation in the error rate between different terminal units is caused by the environment in which that particular unit is situated. This change may either be due to the quality of the supply to the unit, or to direct electromagnetic pickup within the unit. Also, after a comparison with the machinery logs, there appeared to be no direct correlation between changes in the state of the machinery and the error rates. The machinery in the C.M.R. was running continuously thus there were no changes in that compartment which would affect the error rate of that terminal unit.

As additional evidence to support this conclusion, graph 22

presents remote terminal tests carried out in a control experiment at Durham. In this environment, it can be seen that the error rate is very similar to that measured in the F.T.O. on board the ship.

6.5 Conclusion

A software environment suitable for running tests on board a ship was designed and implemented. Hardware was constructed and installed aboard the ship in four remote compartments, and a test office. The highway was tested continuously for a week, and a large volume of data was collected. After detailed analysis of the test results, two major conclusions were reached. Firstly, the protocols implemented in the ASH were capable of preventing any undetected errors being passed on to the computer system to which the terminal units were connected. Secondly, there was a level of background noise causing an error rate of approximately 1 part in 10^6 , but depending upon the environment in which the terminal unit was placed, the error rate could increase by a factor of ten.

Based on these conclusions, it can be recommended that the exact source of this increased error rate is determined. Since great care had been taken in the design of the power supplies for the terminal units, and they had been tested in the laboratory under severe conditions of simulated supply fluctuation, it can be reasonably assumed that the increase in error rates was due to interference with the internal circuitry of the terminal units. If this could be proved to be the case, possible greater attention to screening of the unit as a whole, or certain sections of the circuitry in particular, might alleviate the problem.

Chapter 7

LAN Technology

7.1 Introduction

Many research centres are currently attempting to increase the performance of the basic types of LAN by the introduction of new techniques and the mingling of different LAN technologies. Each basic type of LAN has its advantages and disadvantages, and by careful redesign it is possible to reduce the disadvantages of each type to a minimum. The ASWE Serial Highway was designed after careful consideration of the network technologies available at that time. It has now reached a stage of development at which any advance in its performance may have to be achieved by a radical change in its design. It is possible that several of its most serious limitations may have been overcome elsewhere in the research being performed into LANs. Specifically, the areas which are of most interest are the necessity for centralised control, the survivability of the ASH after damage, and the system throughput under normal and abnormal loads and constraints.

However, in the case of the ASH a necessary constraint on any system modifications is that they should still conform as closely as possible to the specifications [11]. For example, although system throughput could be increased dramatically by a change in transmission media from a twisted pair to fibre optic cables, this would mean a radical and undesirable change to the specifications. Alternatively, the provision of a more flexible system of redundant controllers, or possibly the use of decentralised control, need not involve a radical change of specification.

A review of much of the work which has been performed on improving LAN performance has been carried out, and an attempt has been made to relate this to the current ASH. Suggestions are made for system redesign which attempt to conform as much as possible to the

current specifications.

7.2 Review of Basic LAN Characteristics

The basic operation and characteristics of the common LAN architectures was discussed in section 1. The architectures fall approximately into two classes, ring and linear bus. The ring systems theoretically have the advantage of completely decentralised control, however their system of signal regeneration at every node, and the single ring cable normally used, mean that the system is vulnerable to the failure of single nodes or cables. The ring systems may be categorised into three types; the Pierce Loop, the Newhall Loop, and the Delay Insertion Loop.

A Pierce Loop consists of fixed length message time slots circulating around a loop, which fill the loop length. Examples of this type are the original Pierce Loop [34], and the Cambridge Ring [6]. A ring monitor/ control node must be included in this system to maintain the message slots. This type of system can accommodate multiple simultaneous users.

A Newhall Loop serves only one user at a time, who passes a 'bus available' token when its message transfer is complete. Examples of this are the original Newhall Loop [35], and the NPGS ring. Once again, a master node must monitor the ring to ensure that a token is circulating.

Each node in a delay-insertion ring system contains two shift registers. One is permanently connected to the incoming signal, and the other is used to accommodate user messages. When a message has been placed in the second register by the user, the node awaits a clear space on the ring. When this occurs, the user message is clocked out onto the ring. If an incoming message should be received during the

time the message is being clocked onto the ring, it is shifted into the first register, and clocked out onto the ring at the end of the user message. The nodes are responsible for the removal of their messages when they have circulated around the ring. A monitor/ control unit is not necessary in this type of system. An example of this is the DLCN ring [37].

A comparison of the three types of basic ring system [38] shows that although a Pierce loop allows simultaneous users, a small ring size restricts the number of time slots available, thus restricting the number of simultaneous users. A Newhall loop is superior to a Pierce loop at high mean message arrival rates on small rings. A delay insertion loop allows simultaneous users. However an elaborate protocol may be needed to handle real-time data due to the unpredictable message delays caused by intervening nodes transmitting to the bus. Of the three, only the delay insertion loop has no requirement for a master node at some point on the ring.

Simulations of the performance of the Cambridge ring system [39,40] have shown it to perform well under conditions of low load. However, an increase in the number of nodes on the ring can seriously degrade its handling of real time messages due to the time taken for the signal regeneration at each node. Under conditions of heavy loading the message transmission delay increased towards a guaranteed maximum value. The standard Cambridge ring system uses 38 bit packets, of which a maximum of 16 may be used for data. Thus there is a minimum inherent overhead of 58 percent in the system.

Linear Bus LANs may be divided into two more general classes, synchronous and asynchronous. The former requires some form centralised control function, whilst the latter uses completely decentralised control. A system which uses decentralised control has a

very high reliability, however at high bus loading the mean message arrival times will be significantly higher than in the centralised control system, due to the bus arbitration techniques used. As already described, the ETHERNET [8] system is an example of a CSMA-CD LAN (Carrier Sense Multiple Access with Collision Detect) in which bus control is achieved by a system of collision detection and random retransmission. In such a system bus utilisation can reach 98 percent under heavy loading [8] using data packets of length 512 bytes or longer. Approximately 21 percent of this traffic is ETHERNET overheads such as packet headers, implying that under these conditions of very high load, useful bus utilisation can exceed 75 percent. However if the size of the packets is reduced whilst maintaining the bus loading, channel utilisation drops dramatically due to the increased number of collisions. If a packet length of 64 bytes is used, utilisation drops to approximately 80 percent, giving a useful bus utilisation of approximately 63 percent. Simulation suggests [39,40] that for the long packets, message transmission delay times can increase by a factor of ten (as compared to low loading), whilst for short packets, the delay can increase by factor of 50. Additionally, there is no error recovery scheme inherent in the design of ETHERNET, thus any additional error recovery messages included in the basic protocol would reduce the utilisation still further.

The ASWE Serial Highway uses a centralised controller. The polling scheme, which is in operation at all times, polls every terminal in turn and represents a constant overhead. A controller poll consists of 7 bytes, as does a Nothing to Transmit response from a terminal. A typical message from a terminal with some data content has a length in the range 12-72 inclusive, and includes 12 bytes of control information. Under conditions of maximum loading, where every

transmission from a terminal is a maximum length information message, the effective channel utilisation is approximately 76 percent. This decreases as the load decreases to 50 percent useful utilisation at 31 percent loading. There are two major advantages of this system; firstly, the message transmission delay time at high loading is increased by only a factor of six as compared to the low loading situation (for a maximal system consisting 64 terminal units). Secondly, an error recovery scheme is included in the message protocols, and this scheme only necessitates additional bus traffic if an error is detected. In this system, the controller maintains the recovery scheme, and a message backup store is not needed in every transmitting node, as would be the case if a standard ETHERNET system was to include error recovery.

7.3 Improvements to the Basic LAN Technologies

7.3.1 Ring LANs

A great deal of research has been carried out on several areas of the ring LAN technology in an attempt to eradicate some of the more obvious disadvantages. The first of these areas concerns the problems of ring failure due to the malfunction of a ring node or interelement cable. The Litton-DPS system [41] is designed for military applications and incorporates dual redundancy of the ring cabling to decrease the systems' vulnerability. Two cables connect every node on the ring. The primary loop is used for data, whilst the second is used for backup. The bus controller, which may be any unit on the bus, continually monitors bus operation for abnormal conditions. A backup bus controller is also assigned, whose task is to monitor both the bus and the bus controller, and to assume control when it determines that the normal controller has failed. An idle pattern is continually

transmitted on the backup ring to enable its status to be monitored. The failure of any node is easily detected, and those nodes adjacent to the failed node can automatically switch that node out of the ring (Figure 7.3:1a). It is based on a Newhall ring system. The bus controller provides clock synchronisation for the ring, and maintains the 'Go Ahead' token. If more than one node or cable failure occurs, the ring can still function as two or more separate smaller rings, since the bus controller function may be dynamically reassigned. The system is implemented using advanced high speed processors and the current transmission rate of 20mbits/ sec can be increased by the replacement of the coaxial cable bus with a fibre-optic bus, with no change to the ring protocols.

The Litton-DPS system has approached the problems of ring vulnerability with the addition of a more complex communications processor at every node. As a possible alternative, work performed at MIT [42] suggests a much simpler alternative using a 'Star-Shaped Ring Network'. In a normal Cambridge ring system, the electronic failure of a node is protected against by providing a bypass relay which will connect the input cable to the output cable should the node fail to maintain a signal 'I am functioning correctly'. Unfortunately, should this signal be maintained if the node is not functioning correctly, the bypass relay cannot be activated, and the ring will be rendered unusable. This will then necessitate the local testing of every node to attempt to discover the unit which is malfunctioning. The work performed at MIT recommends the inclusion of a 'wire centre' to which all of the cables are routed, as shown in Figure 7.3:1b. The bypass relays are re-sited at the wire centre and the cabling to every node consists of two ring cables (input and output) and the 'I am functioning' signal. This signal is monitored by the wire centre, as

LITTON-DPS System

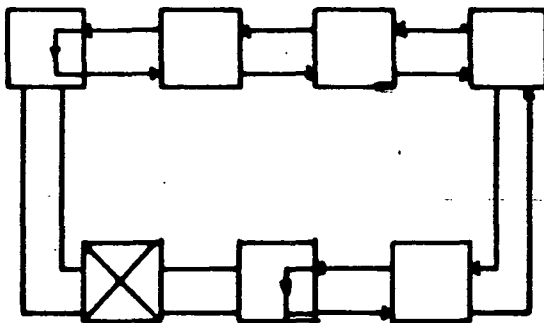
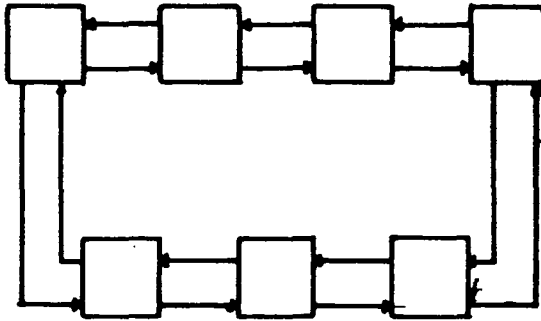

Dual Ring allows automatic reconfiguration
in the event of the failure of a
node.

Figure 7.31a

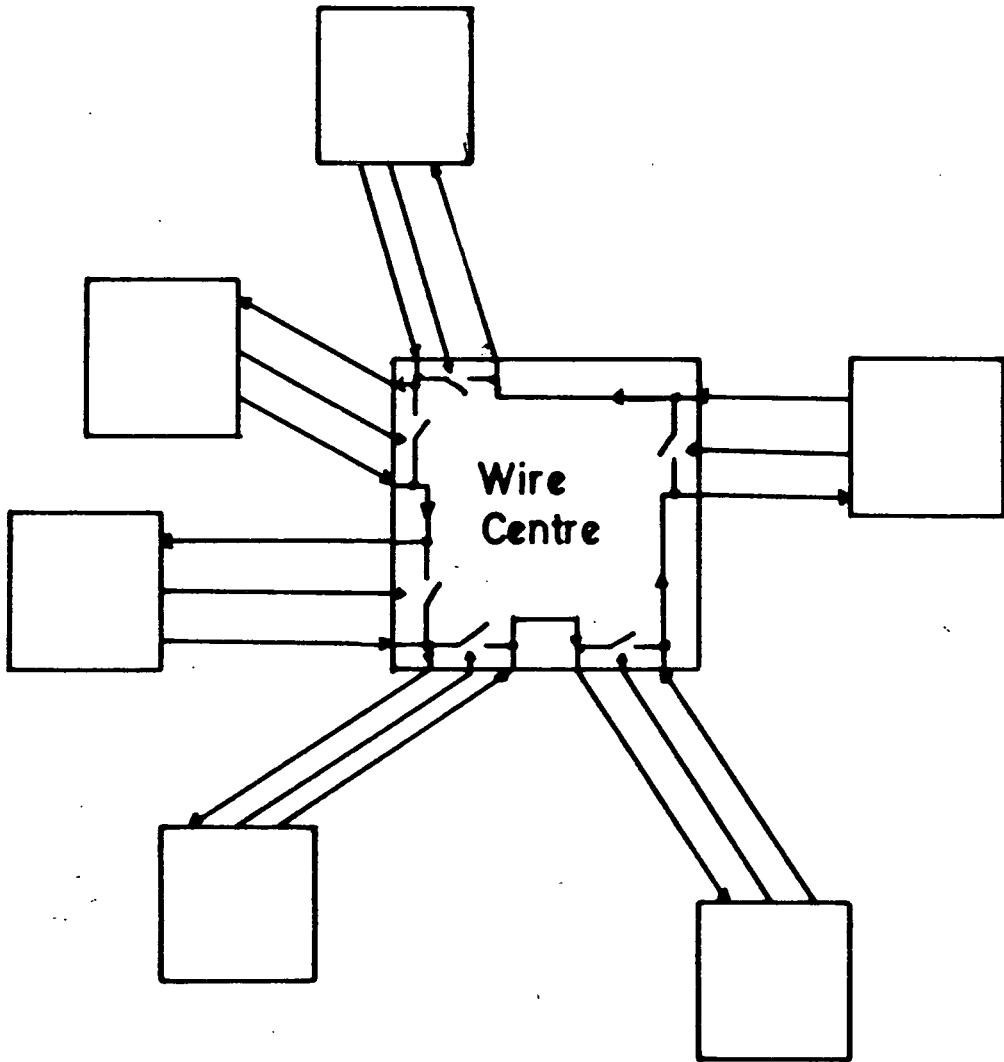

Star Shaped Ring LAN System

Figure 7.3.1b

is the activity on the ring cables. A failure of the signal, or abnormal activity (or lack of activity) on the cables from any node result in the bypass relay being activated. This scheme also allows greater ease of reconfiguration, since there is no need to break the ring to add further nodes. An additional cable need only be connected into the wire centre, and when the node is operational, the relevant bypass relay will be deactivated.

As mentioned, the first approach involves a far more complex communications processor in every node. The second approach is simpler, but more vulnerable since damage or malfunction in the wire centre could cause complete ring failure.

An additional problem in any ring system is that it is impossible to incorporate any type of priority access scheme. This is due to the round robin token passing system which is inherent in a ring network, and in certain applications is a serious drawback.

7.3.2 Decentralised Control Linear Bus LANs

ETHERNET has many advantages over a ring system because of its passive bus construction. Its overall bus utilisation and message transmission delay degradation at high loading cannot be significantly improved while still using the original CSMA-CD principles. However, priority access can be included into the ETHERNET system [43]. This allows important information to be transmitted with less delay at times of high bus loading. This priority system functions as follows; each packet is preceded by a preamble signal of length corresponding to its priority. A packet of the lowest priority has no preamble signal. When the channel is busy, a station wanting to transmit a packet waits until the channel becomes idle. When a collision is detected during transmission, the station does not stop transmitting

the packet if the collision is within its preamble period. When the collision becomes undetected during its preamble, the station continues to transmit the packet. This case means that the other packets had priority levels lower than that of its packet. When the station detects collision during the transmission of its packet, it aborts the packet and retransmits it after some random delay. This corresponds to the case when the other packets' priority was higher than that of its packet. In a system using two priority levels, when the ratio of the traffic of the higher level packet to the total traffic is small (less than 20 percent) the higher level packet is nearly always successfully transmitted after only one trial, even under heavy loading [43].

Motorola have devised a system [44] in which the round-robin polling scheme described in section 1.1:2 has been implemented using completely decentralised control. In normal operation, each node sounds-off in sequence by sending a packet which identifies it as the current user of the channel. All other nodes hear these sound-off packets and synchronise to them. Each node finds its place in the sequence when it is time to sieze the channel. If a node has information to transmit, it sends the data immediately after its sound-off packet, up to a predefined time limit. All other nodes monitor the channel, and can determine when it has finished occupying the channel so that the following user may proceed.

When a user node fails, the other users detect the failure by sensing that the channel has been idle longer than the prescribed waiting time. When this happens, all nodes know who is the next expected user, and update their 'next expected user' counters accordingly. Although the sound-off packets contribute to the system overheads, they do contain message source information which may

therefore be omitted from the information packet. New nodes may be added by updating the user lists at each node.

This system does not need a centralised controller, however one or more of the nodes must have the ability to cause the other nodes to alter their user lists. Since this system is essentially a message slot system, the choice of maximum information packet length will dictate the message transmission delay. A priority scheme cannot be implemented in this system due to the round-robin nature of the access scheme.

In conclusion, in ETHERNET systems, although overall message transmission delay times may be seriously degraded by high bus loading, a great improvement may be achieved for a small percentage of the traffic by the inclusion of a system of message priorities. A sound-off scheme can successfully be used to decrease this delay time under high loading, however a priority system cannot be implemented. ETHERNET is most efficient under light loading, when very few collisions occur, whilst the sound-off scheme, which is similar in effect to an LAN system with a polling mechanism, is more efficient at higher loadings.

7.3.2 Centralised Control Linear Bus LANs

A system designed by Sperry Univac for the Canadian Government utilises multiple bus cabling and reassignable centralised bus control [45]. This system is part of SHINPADS (SHipboard INtegrated Processing And Display System). The key areas of interest in the development of this bus system were bus access time, and transmission system reconfiguration time. There are several bus cables, of which two are used at any time. One is the control channel, the other is the data channel. The former is used solely for the purpose of system control

and reconfiguration, whilst the latter is reserved entirely for message traffic. Bus arbitration is carried out on the control channel, with the net result being a controlled allocation of the other channel for the purpose of sending data. This allows 'pipeline' levels of performance to be achieved on the data channel. Any of the available channels may be used as a control or data channel. The arbitration is carried out by a reassignable bus controller. Each node includes a control processor which can function either as a normal bus node, or as a bus master and bus node. The node assigned to be bus master polls the other nodes and determines their data channel usage requirements. It then dispatches the authority to transmit on the data channel to the node with the highest priority. The node priorities and the frequency of polling of nodes relative to others are under user control. Requests for the use of the data channel fall into one of two categories; immediate and normal. In the immediate mode, the relevant node is given immediate access to the data channel at the end of the current transmission, providing there are no other immediate requests in the controllers queues. In this case the new request is added to the end of the queue. Normal requests are queued according to the priority of the requesting node. The terminal nodes continually monitor the control channel for activity. If no activity is detected for more than a certain period, the activity on all other channels is monitored for normal control activity. Should this be detected, a systematic change of active control channels will take place in the terminal node. If no activity is detected on any channels, then the bus controller function must be reassigned to one of the other nodes. Currently, this reassignment is directed by the user, who may either direct the node to which he is connected to assume bus control, or may direct another node to assume bus control.

In a polled linear bus system, the overheads due to the poll-response system cause great inefficiency under conditions of light loading. As a possible solution to this problem, an adaptive polling technique has recently been proposed [46,47]. The essence of this technique, which has been designated probing, is to poll groups of terminals rather than individual units. If a member of a group of terminals being probed has a message to transmit, it responds in the affirmative by transmitting on the bus. Upon receiving a positive response to a probe, the controller splits the group into two sub-groups and probes each in turn. This process continues until the relevant terminal is isolated. This type of polling system is essentially a tree search. The best system performance may be obtained by dynamically varying the size of the group being polled, according to the probability of a terminal having a message. Thus at times of high loading, the polling system would be similar to that in a pure polling system, whilst in times of light loading, large groups would be polled. Compared to the conventional polling system, this system will offer substantially improved message transmission delay times at light loadings, and similar delays at heavy loadings.

In conclusion, it can be said that in conditions of high loading, the centralised control bus systems are superior in performance to the decentralised systems. It is very easy to add a priority polling scheme because the controller has complete control over the allocation of bus access. New terminals may be added to the polling system by merely causing the controller to add another terminal to its polling scheme. Unfortunately, the pure polling scheme becomes inefficient when used on a bus with a large number of terminals, and the probing technique described improves the performance of a polled system when there is a large probability that few of the units will have a message to transmit. Due to the fact that

a central controller is used, care must be taken in providing a mechanism for this function to be reassigned after equipment failure. Complete network failure will result should this function not be reassigned.

7.4 A Second Generation ASWE Serial Highway

It has become obvious during this review of different systems that when faced with similar criteria for the choice of LAN technology, different research groups have made different choices of LAN technology. In general it would appear that when a decision is made to seek an LAN with better characteristics than available from the one currently in use, most groups chose to upgrade their current system, rather than to switch technologies.

In the case of the ASH, it would appear that the original aims of the system designers cannot be fulfilled by a radical technology change. A ring system could not offer the system survivability offered by the passive linear bus. It is interesting to note that the Litton-DPS system [41] is being developed for the same type of military applications as the ASH, however its designers consider that it is suitable for this environment. The addition of the second ring cable allows single node or cable failure, however if more failures occur the ring will be segmented into several sections. This is clearly undesirable, when in a linear bus system it would be possible to include a higher level of cable redundancy to protect against a greater number of cable failures.

The CSMA-CD systems offer an attractive alternative to the polled system currently used. However, the uncertainty in message transmission delay times would be a serious problem in a LAN system

primarily concerned with real time data. Additionally, a priority system is essential for the transmission of critical data in military applications. The priority ETHERNET system described would be a possible alternative to the polled system currently being used. It offers the advantage of completely decentralised control and is the best alternative of the asynchronous linear systems.

It is, however, a requirement that the original ASH specification be conformed to as much as is possible. The areas of interest in a second generation ASH are; decentralisation of control function, and decreasing the polling scheme overheads on the bus. A possible solution to the latter is the probing scheme described. The addition of grouping protocols related to the terminal units 'Highway Number' would allow this system to function and necessitate very little change to the basic specification. However, the combination of the probing technique and the SHINPADS serial data bus techniques would provide a very powerful second generation technique. If a probing scheme was used on the control channel it would reduce the data channel access time due to the normal polling system overheads. Also, since the control and data channels are being operated in parallel, a great increase in message throughput could be achieved.

In the current ASH system, the highway controller is entirely separate, in both hardware and software, from the computers to which the terminal units are connected. Any change in the polling list or polling priorities must be originated by the computer which is host to the highway controller. Adoption of the system suggested above would allow such alterations to be originated from elsewhere in the system, because the controller function would be incorporated into the terminal nodes and its tables could be altered by appropriate instructions to its co-resident terminal node. The controller function

would be duplicated at all the nodes, however only one controller would be active at any time. If that controller should fail, its function could be taken over by another node, possibly on the basis of 'highway number' or possibly by contention access. The present system of error recovery could still be maintained, as could the present protocol system. The control messages would be transmitted on the control bus and the information messages on the data bus. Without the inclusion of the probing scheme or any protocol changes, this would mean that the throughput could be increased dramatically for low loads. By the addition to the protocols of a control message from the terminal units saying 'Yes I have something to transmit' and a message from the controller saying 'Proceed', the throughput under all loading conditions could be improved, due to the fact that while the data bus was in use, the controller could continue its polling cycle until it found a terminal with something to transmit. It would then wait until the current data bus user had completed its transmission, and signal to the relevant terminal node that it could proceed.

This design change would necessitate a large change in the hardware of the interface. However, several of the inherent problems in the current ASH would be removed, and the survivability of the LAN system would be greatly increased.

7.5 Conclusion

This section has described in detail various alternative approaches to improving the characteristics of the basic LANs; the ring systems, the decentralised control linear bus systems, and the centralised control linear bus systems. Several of the techniques used are now implemented in working systems, whilst others are still at the simulation stage. It has become obvious that the mingling of different LAN technologies gives a significant improvement as compared to the original systems. A second generation ASWE Serial Highway system has been considered, in which the original specifications are conformed to as closely as possible, and the original design criteria are used in the selection of new techniques. A system based upon a twin channel centralised control system was chosen as the most attractive possibility. This type of system offers a greater system throughput under all loading conditions by operating the control and data channels in parallel. The addition of a completely reassignable controller function, by incorporating the controller function into each of the terminal units, would give a great increase in survivability. An adaptive polling technique, known as probing, is discussed, and it is suggested that its inclusion in the second generation ASH, while necessitating some message format changes, would give an even greater improvement in the low loading message transmission delay time.

Chapter 8

Conclusion

Distributed computing systems fall into two categories, loosely and tightly coupled. The loosely coupled systems normally communicate via a serial cable, and are known as Local Area Networks. These distributed systems are used as replacements for large single mainframes, as the distribution of hardware and software greatly improves the systems' survivability and eases the initial testing. Most LAN systems currently under development fall into one of two categories, ring or linear bus.

ASWE have developed their own LAN for naval applications in the late 1980s and 1990s. It is based on a linear bus LAN with a central controller. The addition of redundancy of the controller function and the cabling gives greater system survivability. This system has been used as a laboratory test bed for some time, and the basic principles of operation have been well proved. It is implemented using high speed bipolar bit-slice microprocessors in dedicated front-end processors. These FEPs communicate with their minicomputer hosts via an area of shared memory.

There are several alternative LAN technologies available. Ring LANs are most suited to office applications using short rings, where the delays introduced by signal regeneration at every node are not significant, owing to the non real-time nature of the messages. Also, the ring LANs are very vulnerable to cable or node failure, and if they are to be used in military applications great care must be taken over the provision of redundant signal paths to protect the integrity of the system. Although this type of LAN theoretically has the advantage of completely distributed control, in practice most of the common systems have a monitor/ control station to supervise the LANs

activity.

Linear bus LANs are more suited to military applications than ring LANs due to the possibility of using a passive bus (no signal regeneration at nodes). There are two possible types of linear bus LANs, those with decentralised control, such as ETHERNET, and those with centralised control, such as the ASH. The former has greater survivability, whilst the latter performs better in conditions of high bus loading.

This thesis has described the replacement of the minicomputer hosts normally used with the ASH by microcomputer hosts based around Motorola's MC68000 16bit microprocessor. This replacement gave an enormous reduction in size, allowing the new system to be installed on board a ship. Tests were performed on the integrity of this system whilst the ship was performing normal manoeuvres. Analysis of these results has given the first performance data on the ASH system when used in the environment for which it was designed. It performed perfectly at all-times, and there was no indication that any of the error protection systems currently employed would need to be changed.

As part of this system, a portable highway controller was developed. This aroused considerable interest within ASWE, as it was able to perform all of the functions which are currently performed by a highway controller FEP with a Ferranti Argus host, at a fraction of the current cost and size. Separate trials of this unit have been performed at ASWE, over long periods of time (months). These have indicated that the unit performs to its specifications, and a new controller unit may be manufactured based upon the highway controller designed and built at Durham.

A review of work currently being performed in the LAN field has been carried out. The shortcomings of each type of LAN system are

being reduced by mingling the different technologies. It is suggested that a combination of two of the 'new generation' LAN systems with the ASH, would give substantial performance increases, with the need for minimal specification changes. This new system would have multiple redundant linear buses, and would use two simultaneously. One channel would be used for control information and the other for data. This would allow 'pipeline' levels of performance to be achieved on the data channel.

To conclude, LAN technology has advanced alongside the ever increasing demands for greater speed, reconfigurability and survivability of distributed computing systems. However, as these demands grow ever greater and more difficult to realise, it is necessary to make modifications to the basic LAN technology. In order to further improve the ASWE Serial Highway system, it will be necessary to perform substantial changes in the basic system. The ASH is now ten years old, and very few of the other LAN systems have survived that length of time without major alterations.

Notes on publications by the author:-

"Boost μ P-board memory capacity with simple hardware changes"

D. Cowan, EDI, 29th October 1981, pp 197-198.

Bibliography

- [1] F.G. Heart et al "The Interface Message Processor for the ARPA Computer Network" AFIPS Conf. Proc. SJCC 36, June 1970.
- [2] H. Frank, I.T. Frisch, W.S. Chou "Topological Considerations in the Design of the ARPA Computer Network" AFIPS Conf. Proc. SJCC 36, June 1970.
- [3] D.J. Farber "Networks: An Introduction" Datamation, April 1972, pp 36-39.
- [4] E.G. Rawson, R.M. Metcalfe "FIBERNET: Multimode Optical Fibers for Local Computer Networks" IEEE Trans. Comm. 26, 7 (July 1978) pp 983-990.
- [5] MIL-STD-1553B, 21 September 1978 (Aircraft Internal Time Division Command/ Response Multiplex Data Bus, DoD, Washington, D.C.)
- [6] K. Lunn, K.H. Bennett "Message Transport on the Cambridge Ring- a Simulation", Software-practical and experimental (GB), Vol 11, part 7, 1981, pp 711-716.
- [7] R.M. Metcalfe, D.R. Boggs "Ethernet: Distributed Packet Switching for Local Computer Networks", Comm. ACM. 19, 7 July 1979.
- [8] J.F. Shoch, J.A. Hupp "Measured Performance of an Ethernet Local Area Network" Comm. ACM 23, December 1980.
- [9] N.Abramson "The ALOHA System- another alternative for computer communications" Proc. 1977 Fall Joint Comp. Conf. 37, AFIPS Press pp 281-285.

- [10] N.Abramson "The Throughput of Packet Switching Broadcasting Channels" IEEE Trans. Comm. 25, Jan 1977, pp 117-128.
- [11] Defence Standard 00-19/ Issue 1, Ministry of Defence, 19th January 1981.
- [12] "The AMD2900 Family Data Book" AMD, 1979.
- [13] J. Mick, J. Brick "Bit-Slice Microprocessor Design", McGraw-Hill, 1980.
- [14] R.D. Weatherby "Mini Link X2901 Cross Assembler" Cambridge Consultants Ltd. report, December 1976.
- [15] C.T. Spracklen "Durham University-ASWE Minilink Simulator" Durham University report, August 1978.
- [16] M.Stainsby "Specification of the Software Interface to the Highway Controller (Version 6), Draft 3, 2nd May 1980, ASWE report.
- [17] D.M. Ritchie, K.Thompson "The Unix Time Sharing System" Comm. ACM 17, July 1974, pp 365-375.
- [18] K.L. Hunt, R.J. Firth "Guide to Coral-66 on the PDP11-45" RMCS, February 1976.
- [19] "Official Definition of CORAL 66" Ministry of Technology, HMSO, 1970.

- [20] "RT-11 System Reference Manual" Digital Equipment Corp. 1976.
- [21] "NOVA Line Computers" Data General, 1979.
- [22] "Real Time Disk Operating System (RDOS) Reference Manual" Data General, 1979.
- [23] "MC6809 Preliminary Programming Manual" Motorola Inc. 1979.
- [24] "The MSI 6800 Computer System" Midwest Scientific Instruments Inc. 1977.
- [25] "DOS-69" Smoke Signal Broadcasting, 1980.
- [26] "MC68000 Design Module, Users Guide" Motorola Inc. 1979.
- [27] "MC68000, 16-Bit Microprocessor, Users Manual" Motorola Inc. 1979
- [28] G. Kane, D. Hawkins, L. Leventhal "68000 Assembly Language Programming" OSBORNE/ McGraw-Hill, 1981.
- [29] "Microcomputer Components" Motorola Inc. 1979.
- [30] C.H. Moore "Forth: A New Way to Program a Minicomputer" Astron. Astrophys. Supp. 15, pp497-511 1974.
- [31] E.D. Rather "Forth: A Fresh Approach to Programming" Forth Inc. 1977.

- [32] D. Cowan, C.T. Spracklen "Annual Report, 1981" Durham University, 1981.
- [33] "Feltec LCD Display" Feltec, 1981.
- [34] J.R. Pierce "Network for Block Switching of Data" BSTJ 51, 6, July-August 1972.
- [35] W.D. Farmer, E.E. Newhall "An Experimental Distributed Switching System to Handle Bursty Computer Traffic" Proc. ACM Symp. on Problems in the Organisation of Data Comms. October 1969, pp 1-34.
- [36] E.R. Hafner et al "A Digital Loop Communications System" IEEE Trans. Comm. 23 June 1974, pp 877-881.
- [37] A.B. Gojko et al "A Performance Study of the Distributed Loop Computer Network (DLCN)" Proc. Comp. Networking Symposium, NBS 15. December 1977.
- [38] P.A. Willis "Data Buses and Distributed Data Processing in U.S. Navy Ships" Naval Surface Weapons Center/ Dahlgren, Spetember 1981.
- [39] G.S. Blair "A Performance Study of the Cambridge Ring" Computer Networks, 6 (1982) pp 13-20.

- [40] M.V. Wilkes, D.J. Wheeler "The Cambridge Digital Communications Ring" Local Area Comms. Network Symp. Boston May 1979.
- [41] R. Mauriello "A Distributed Processing System for Military Applications" Computer Design, Sept-Nov 1980.
- [42] J.H. Slatzer, K.T. Pogan "A Star-Shaped Ring Network with High Maintainability" Comp. Networks 4, 1980, pp 239-244.
- [43] I. Iida et al "Random Access Packet Switched Local Computer Network with Priority Function" IEEE Telecomms. Conf. 30 Nov 1980, pp 37.41-6.
- [44] D.Scavezze "Nodes Sound-Off to Control Access to Local Network" Electronics (USA) 1981, 54, 12, pp 176-181.
- [45] S.C. Andersen "A Serial Data Bus Control Method" Comp. Networks 3, 1979, pp 361-372.
- [46] J.F. Hayes "An Adaptive Technique for Local Distribution" IEEE Trans. Comm. 26, Aug 1978, pp 1178-1186.
- [47] J.F. Hayes "Local Distribution in Computer Communications" IEEE Comms.

- [48] A.K. Agrawal, V.V. Vadakan "Jet Propulsion Local Area Network (JPLAN)" 2nd Conf. on Dist. Comp. Systems. Paris, 8th April 1981, pp 360-368.
- [49] M.A. Dineson "Broadband Local Area Networks Enhance Communication Design" EDN, 1981, 26, 5, pp 77-85.
- [50] D.D. Clark et al "An Introduction to Local Area Networks" Proc. IEEE, 66, 11th November 1978, pp 1497-1517.
- [51] A.K. Mok, S.A. Ward "Distributed Broadcast Channel Access" Comp. Networks, 3, 1979, pp 327-335.
- [52] W.B. Watson "Simulation Study of the Traffic Dependant Performance of a Prioritised CSMA Braodcast Network" Comp. Networks, 3, 1979, pp 427-434.
- [53] S.S. Lam "A Carrier Sense Multiple Access Protocol for Local Area Networks" Comp. Networks, 4, 1980, pp 21-32.
- [54] F.A. Tobagi, V.B. Hunt "Performance Analysis of Carrier Sense Multiple Access with Collision Detect" Comp. Networks, 4, 1980, pp 245-259.

- [55] J.F. Shoch "Carrying Voice Traffic Through an ETHERNET Local Network- A General Overview" Int. Workshop on Local Area Comp. Networks, Zurich, Aug 1980.
- [56] J.F. Shoch "An Annotated Bibliography on Local Computer Networks" XEROX, Palo Alto, 1980.
- [57] T.D. Wells, M.G. Stainsby "ADNET: An Experimental Information Distribution System" ASWE, XCC, October 1978.



APPENDIX A
Program Listings

```

0443
0444
0445      *CHEKL*
0446      *CHECK FOR FLAG IN A REGISTER LOW*
0447
0448 015E J4 12      CHEKL PSHS A,X
0449 0140 8E F538      LDX  @PIA
0450 0163 A5 02      BITA  DRB,X
0451 0165 27 04 016B      BEQ  CHKLR
0452 0167 1A 01      SEC
0453 0169 20 02 016D      BRA  CHKLR2
0454 016B 1C FE      CHKLR ANDCC @0FE CLC
0455 016D 35 92      CHKLR2 PULS A,X,PC
0456
0457      *CHEKH*
0458      * CHECKS FOR FLAG HIGH *
0459
0460 016F J4 12      CHEKH PSHS A,X
0461 0171 8E F538      LDX  @PIA
0462 0174 A5 02      BITA  DRB,X
0463 0176 26 04 017C      BNE  CHKHR
0464 0178 1A 01      SEC
0465 017A 20 02 017E      BRA  CHKHR2
0466 017C 1C FE      CHKHR ANDCC @0FE
0467 017E 35 92      CHKHR2 PULS A,X,PC
0468
0469
0470      *LSET*
0471      * SETS THE APPROPRIATE FLAG LOW*
0472
0473 0180 J4 10      LSET  PSHS X
0474 0182 8E F538      LDX  @PIA
0475 0185 43          COMA
0476 0184 A4 02      ANDA  DRB,X
0477 0188 A7 02      STA  DRB,X
0478 018A 35 90      PULS  X,PC
0479
0480      *HSET*
0481      *SETS APPROPRIATE FLAG HIGH*
0482
0483 018C J4 10      HSET  PSHS X
0484 018E 8E F538      LDX  @PIA
0485 0191 AA 02      ORA  DRB,X
0486 0193 A7 02      STA  DRB,X
0487 0195 35 90      PULS  X,PC
0488
0489      *AWRITE*
0490      *WRITE TO PROM PROGRAMMER *
0491
0492
0493 0197 9D 82      AWRITE JSR  ADDR5
0494 0199 25 20 01BB      BCS  WERR1
0495 019B BD 0102      JSR  GETTB
0496 019E BC 05F7      AWRTE1 CMPX DTBEND
0497 01A1 2E 17 01BA      BGT  AWRTE2
0498 01A3 A4 80      LDA  ,X+
0499 01A5 B4 04A5      ANDA  MASK

```

```

00500 01A8 BD 0265      JSR  DWRITE
00501 01AB 24 F1 019E      BCC  AWRTE1
00502 01AD 34 10      PSHS  X
00503 01AF 30 8D 0312      LEAX STR9,PCR
00504 01B3 BD D2A6      JSR  ZOUTST
00505 01B6 35 10      PULS  X
00506 01B8 20 E4 019E      BRA  AWRTE1
00507 01BA 39          AWRTE2 RTS
00508 01BB 30 8D 02BB WERR1 LEAX STR6,PCR
00509 01BF BD D2A6      JSR  ZOUTST
00510 01C2 39          RTS
00511
00512      *ALOAD*
00513      *LOAD A BINARY DISK FILE INTO THE DATA TABLE*
00514
00515
00516 01C3 30 8D 0312      ALOAD LEAX STR10,PCR FILE NAME QUIZ
00517 01C7 BD D2A6      JSR  ZOUTST
00518 01CA BD D2B5      JSR  ZLINEI
00519 01CD BD D2BB      JSR  ZPEEK LOOK AT NEXT CHAR
00520 01D0 81 0D      CMPA  @CR CR?
00521 01D2 27 1A 01EE      BEQ  LOAD1 IF YES JUST CONTINUE FROM OL
00522 01D4 BD D783      JSR  CDFM JUST TO BE SAFE
00523 01D7 30 8D 041E      LEAX RFCB,PCR
00524 01DB BD D291      JSR  ZFLSPC
00525 01DE 86 04      LDA  @Q504R SET FOR READ
00526 01E0 A7 84      STA  XFC,X
00527 01E2 BD D786      JSR  DFM GO OPEN IT
00528 01E5 27 07 01EE      BEQ  LOAD1 OK SO BRA
00529 01E7 BD D2A9      JSR  ZTYPDE
00530 01EA BD D783      JSR  CDFM
00531 01ED 39          RTS
00532 01EE 86 05      LOAD1 LDA  @Q5READ
00533 01F0 A7 84      STA  XFC,X
00534 01F2 17 FF0D 0102      LB5R  GETTB
00535 01F5 1F 12      TFR  X,Y
00536 01F7 30 8D 0317      LEAX STR12,PCR SIZE QUIZ
00537 01F8 BD D2A6      JSR  ZOUTST PUT IT
00538 01FE BD D2B5      JSR  ZLINEI REPLY
00539 0201 BD D2A0      JSR  ZGETHN TRANSLATE
00540 0204 5D          TSTB
00541 0205 27 0B 0212      BEQ  LOAD7 NO REPLY SO CONTINUE
00542 0207 1F 20      TFR  Y,D DATA TABLE BASE
00543 0209 BF 05F7      STX  DTBEND OOPS
00544 020C F3 05F7      ADDD DTBEND NEW END
00545 020F FD 05F7      STD  DTBEND SAVE IT
00546 0212 BE 05F9      LOAD7 LDX  @RFCB
00547 0215 BD D786      LOAD6 JSR  DFM
00548 0218 26 13 022D      BNE  LOAD2
00549 021A 81 FF      CMPA  @0FF
00550 021C 26 F7 0215      BNE  LOAD6
00551 021E 10BC 05F7      LOAD4 CMPY DTBEND END OF TABLE?
00552 0222 2E 13 0237      BGT  LOAD3
00553 0224 BD D786      JSR  DFM READ ANOTHER CHAR
00554 0227 26 04 022D      BNE  LOAD2
00555 0229 A7 A0      STA  0,Y+ AND STORE IT
00556 022B 20 F1 021E      BRA  LOAD4

```

```

00333 0092 26 04 0098 BNE COM4
00334 0094 8E 01C3 LDX #ALOAD
00335 0097 39 RTS
00336 0098 81 4D COM4 CMPA #MODIFY
00337 009A 26 04 00A0 BNE COM5
00338 009C 8E 0360 LDX #AMOD
00339 009F 39 RTS
00340 00A0 81 53 COM5 CMPA #SIZE
00341 00A2 26 04 00A8 BNE COM6
00342 00A4 8E 02F7 LDX #ASIZE
00343 00A7 39 RTS
00344 00A8 81 45 COM6 CMPA #MONIT
00345 00AA 26 A9 0055 BNE GETCM
00346 00AC 8D D783 JSR CDFM
00347 00AF 7E FC57 JMP AMONIT
00348
00349
00350
00351 *ADDR5*
00352 *INTERPRETS START AND END ADDRESS*
00353 *AND SETS UP PROGRAMMER ACCORDINGLY*
00354 *CARRY SET IF ERRO OCCURS*
00355
00356
00357
00358 00B2 17 0183 0238 ADDR5 LBSR PRINT INITIALISE THE PROGRAMMER
00359 00B5 86 01 LDA #ADD
00360 00B7 17 00A4 015E ADDR51 LBSR CHEK1 CHECK FOR ADDRESS LOW
00361 00BA 25 FB 00B7 BCS ADDR51 IF CARRY SET THEN ADDRESS HI
00362 00BC 86 10 LDA #MODE
00363 00BE 17 00BF 0180 LBSR LSET SET MODE LOW
00364 00C1 30 8D 0368 LEAX STR1,PCR
00365 00C5 8D D2A6 JSR ZOUTST SEND LOW ADDRESS QUIZ
00366 00C8 8D D2B5 JSR ZLINEI AND RECEIVE IT
00367 00CB 8D D2A0 JSR ZGETHN MAKE IT INTO HEX ADDRESS IN
00368 00CE 5D TSTB IF ZERO NO HEX ADDRESS
00369 00CF 26 03 00D4 BNE ADDR52
00370 00D1 8E 0000 LDX #000000 SO LOAD DEFAULT
00371 00D4 17 01DE 02B5 ADDR52 LBSR WRITEA WRITE BOTTOM ADDRESS TO PROG
00372 00D7 AF 8D 05C6 STX BOT,PCR
00373 00DB 30 8D 0368 LEAX STR2,PCR
00374 00DF 8D D2A6 JSR ZOUTST
00375 00E2 8D D2B5 JSR ZLINEI
00376 00E5 8D D2A0 JSR ZGETHN TOP ADDRESS
00377 00E8 5D TSTB
00378 00E9 26 03 00EE BNE ADDR53
00379 00EB 8E 06A3 LDX HIGH
00380 00EE 17 01C4 02B5 ADDR53 LBSR WRITEA
00381 00F1 25 0C 00FF BCS ADDER1
00382 00F3 AF 8D 05A8 STX TOP,PCR
00383 00F7 86 01 ADDR54 LDA #ADD
***WARNING 001--00000
00384 00F9 17 0073 016F LBSR CMENH
00385 00FC 25 F9 00F7 BCS ADDR54 CHECK FOR ADDRESS HIGH
00386 00FE 39 RTS
00387 00FF 1A 01 ADDER1 SEC
00388 0101 39 RTS

```

```

00389
00390
00391
00392 *GETTB*
00393 *GET THE DATA TABLE BASE*
00394 *ALSO SETS TABLE TOP TO BASE ADDRESS PLUS 512 *
00395
00396
00397 0102 30 8D 0355 GETTB LEAX STR3,PCR TABLE B5E QUIZ
00398 0106 8D D2A6 JSR ZOUTST
00399 0109 8D D2B5 JSR ZLINEI
00400 010C 8D D2A0 JSR ZGETHN
00401 010F 5D TSTB
00402 0110 26 03 0115 BNE GETTB1
00403 0112 8E 06A9 LDX #DTABLE
00404 0115 FC 069F GETTB1 LDB TOP
00405 0118 B3 06A1 SUBD BOT
00406 011B FD 05F7 STD DTBEND
00407 011E 1F 10 TFR X,D
00408 0120 F3 05F7 ADD DTBEND
00409 0123 FD 05F7 STD DTBEND NOW WE HAVE THE ABSOLUTE EN
00410 0126 39 RTS
00411
00412
00413
00414
00415 *AREAD*
00416 *READS IN A TABLE FULL OF DATA*
00417 *OR UNTIL THE PROGRAMMER CLAMS UP*
00418
00419
00420
****WARNING 001--00384
00421 0127 17 FF88 00B2 AREAD LBSR ADDR5
00422 012A 25 29 0155 BCS AERR1
00423 012C 17 0114 0243 LBSR SREAD
00424 012F 86 40 LDA #READW
****WARNING 001--00421
00425 0131 17 0058 018C LBSR HSET SELECT READ
00426 0134 86 10 LDA #MODE
00427 0136 8D 54 018C BSR HSET SET MODE HIGH FOR READ
00428 0138 8D C8 0102 BSR GETTB GO GET TABLE ADDRESS
00429 013A BC 05F7 AREAD1 CPX DTBEND
00430 013D 2E 0A 0149 BGT AREAD2
00431 013F 17 0196 02D8 LBSR DREAD READ A BYTE
00432 0142 F4 06A5 ANDB MASK
00433 0145 E7 80 STB ,X+
00434 0147 20 F1 013A BRA AREAD1
00435 0149 17 0108 0254 AREAD2 LBSR SWRITE
00436 014C 86 40 LDA #READW
****WARNING 001--00425
00437 014E 17 002F 0180 LBSR LSET
00438 0151 17 0100 0254 LBSR SWRITE SELECT WRITE
00439 0154 39 RTS
00440 0155 30 8D 031E AERR1 LEAX STR4,PCR
00441 0159 8D D2A6 JSR ZOUTST
00442 015C 20 EB 0149 BRA AREAD2

```

```

00220
00221      F538      PIA      EQU      *F538
00222      0001      CRA      EQU      1
00223      0003      CRB      EQU      3
00224      0000      DRA      EQU      0
00225      0002      DRB      EQU      2
00226      00FB      NDDR      EQU      %11111011
00227      0004      DATA     EQU      %00000100
00228      00FF      AWR2      EQU      *FF
00229      0000      ARD      EQU      *00
00230      0078      BREG      EQU      %01111000
00231      0001      ADD      EQU      *01
00232      0002      ERROR     EQU      *02
00233      0004      RES      EQU      *04
00234      0008      TRANS     EQU      *08
00235      0010      MODE      EQU      *10
00236      0020      INTER     EQU      *20
00237      0040      READW     EQU      *40
00238      0057      WRITE     EQU      'W
00239      0051      QUIT      EQU      'Q
00240      0052      READ      EQU      'R
00241      004C      LOAD      EQU      'L
00242      004D      MODIFY    EQU      'M
00243      0053      SIZE      EQU      'S
00244      0045      MONIT     EQU      'E
00245      FC57      AMONIT    EQU      *FC57
00246
00247
00248      0000
00249      0000 10CE D200      MAIN  LDS      *D200
00250      0004 BD 0033      JSR      PIAIN
00251      0007 BE 0000      LDX      *00000
00252      000A BF 06A1      STX      BOT
00253      000D BE 01FF      LDX      *001FF
00254      0010 BF 049F      STX      TOP
00255      0013 BF 06A3      STX      HIGH
00256      0014 BF 05F7      STX      DTBEND
00257      0019 B4 03      LDA      *03
00258      001B B7 06A6      STA      AFIELD
00259      001E B4 0F      LDA      *0F
00260      0020 B7 06A5      STA      MASK          DEFAULTS
00261      0023 BD 0055      MAIN1 JSR      GETCM
00262      0024 108E 002E      LDY      *MAIN2
00263      002A 34 20      PSHS     Y
00264      002C 1F 15      TFR      X,PC
00265      002E 17 0324 0355 MAIN2 LBSR     DELAY
00266      0031 20 F0 0023      BRA      MAIN1
00267
00268
00269
00270
00271      *PIAIN *
00272      *INITIALISES THE PIA AS FOLLOWS *
00273      *A SIDE ALL OUTPUTS *
00274      *B SIDE 0:-ADDRESS INPUT *
00275      * 1:-ERROR INPUT *

```

```

00276      * 2:-RESPONSE INPUT *
00277      * 3:-TRANSFER OUTPUT *
00278      * 4:-MODE OUTPUT *
00279      * 5 INTERLOCK OUTPUT *
00280      * 6 BUFFER CONTROL OUTPUT *
0Q281      * CAZ BUFFER CONTROL OUTPUT *
00282
00283
00284
00285      0033 BE F538      PIAIN  LDX      *PIA      PIA ADDRESS
00286      0036 B4 00      LDA      *00
00287      0038 A7 01      STA      CRA,X      SET FOR WRITE TO DDR
00288      003A A7 03      STA      CRB,X      DITTO
00289      003C C4 FF      LDB      *AWRT2
00290      003E E7 B4      STB      DRA,X      INITIALLY A FOR WRITE
00291      0040 C6 78      LDB      *BREG
00292      0042 E7 02      STB      DRB,X
00293      0044 B4 04      LDA      *DATA
00294      0046 A7 01      STA      CRA,X
00295      0048 A7 03      STA      CRB,X      BOTH NOW DATA RECS
00296      004A B4 40      LDA      *READW
00297      004C 17 0131 0180 LBSR     LSET      SET FOR WRITE
00298      004F B4 18      LDA      *%00011000 TRAN,MODE HIGH
00299      0051 17 0138 018C LBSR     HSET
00300      0054 39      RTS
00301
00302
00303
00304
00305      *GETCM *
00306      * COMMAND LINE INTERPRETER *
00307
00308
00309      0055 30 BD 0557      GETCM  LEAX     STR15,PCR
00310      0059 BD D2A6      JSR      ZOUTST
00311      005C 30 BD 0534      LEAX     STR14,PCR
00312      0060 BD D2A6      JSR      ZOUTST
00313      0063 30 BD 03C5      LEAX     COMST,PCR
00314      0067 BD D2A6      JSR      ZOUTST
00315      006A BD D2B5      JSR      ZLINEI
00316      006D BD D297      JSR      ZGNCHR
00317      0070 B4 7F      ANDA     *07F
00318      0072 B1 0D      CMPA     *CR
00319      0074 27 DF 0055      BEQ      GETCM
00320      0076 B1 52      CMPA     *READ
00321      0078 26 04 007E      BNE     COM1
00322      007A BE 0127      LDX      *AREAD
00323      007D 39      RTS
00324      007E B1 57      COM1    CMPA     *WRITE
00325      0080 26 04 0084      BNE     COM2
00326      0082 BE 0197      LDX      *AWRITE
00327      0085 39      RTS
00328      0086 B1 51      COM2    CMPA     *QUIT
00329      0088 26 06 0090      BNE     COM3
00330      008A BD D783      JSR      CDFM
00331      008D 7E D283      JMP      ZWARMS
00332      0090 B1 4C      COM3    CMPA     *LOAD

```

```

557 022D 30 8D 02B8 LOAD2 LEAX STR11,PCR
558 0231 8D D2A6 JSR ZOUTST
559 0234 8D D783 JSR CDFM
560 0237 39 LOADJ RTS
561 *PRINIT*
562 *INITIALISES THE PROM PROGRAMMER*
563 *BY PULSING INTERLOCK HIGH*
564
565
566 0238 86 20 PRINT LDA #INTER
567 023A 17 FF4F 018C LBSR HSET
568 023D 86 20 LDA #INTER
569 023F 17 FF3E 0180 LBSR LSET
570 0242 39 RTS
571
572
573 *SREAD*
574 *SET UP THE A SIDE OF THE PIA FOR READ*
575
576 0243 108E F538 SREAD LDY #PIA
577 0247 86 00 LDA #00 FOR DDR5
578 0249 A7 21 STA CRA,Y
579 024B 86 00 LDA #ARD SELECT A FOR READ
580 024D A7 A4 STA DRA,Y
581 024F 86 04 LDA #DATA
582 0251 A7 21 STA CRA,Y
583 0253 39 RTS
584
585
586 *SWRITE*
587 *SET UP THE A SIDE FOR WRITE*
588
589
590 0254 108E F538 SWRITE LDY #PIA
591 0258 86 00 LDA #00
592 025A A7 21 STA CRA,Y
593 025C 86 FF LDA #AWRT2 SELECT A FOR WRITE
594 025E A7 A4 STA DRA,Y
595 0260 86 04 LDA #DATA
596 0262 A7 21 STA CRA,Y
597 0264 39 RTS
598
599 *DWRITE*
600 *WRITE ONE BYTE OF DATA TO PROGRAMMER*
601 *CARRY SET ON RETURN INDICATES ERROR*
602 ESTORE EQU -1
603
604 0265 34 56 DWRITE PSHS A,B,X,U
605 0267 1F 43 TFR S,U
606 0269 32 7E LEAS -2,S
607 026B 86 00 LDA #00
608 026D A7 5F STA ESTORE,U
609 026F 8E F538 LDX #PIA
610 0272 86 10 LDA #MODE
611 0274 17 FEE7 015E LBSR CHEKL CHECK FOR CORRECT MODE
612 0277 24 05 027E BCC DWR1 YES OK
613 0279 86 10 LDA #MODE

```

```

00414 027B 17 FF02 0180 LBSR LSET NO 50 SET RIGHT ONE
00415 027E E6 C4 DWR1 LDB ,U UNSTACK DATA, IT WAS IN A WH
00416 0280 E7 84 STB DRA,X AND WRITE IT
00417 0282 86 08 LDA #TRANS
00418 0284 17 FEF9 0180 LBSR LSET AND INITIATE TRANSFER
00419 0287 86 04 DWR2 LDA #RES
00420 0289 17 FED2 015E LBSR CHEKL WAIT FRO RES
00421 028C 25 F9 0287 BCS DWR2
00422 028E 86 02 LDA #ERROR
00423 0290 17 FEDC 016F LBSR CHEKH MAKE SURE NO EROR
00424 0293 25 1A 02AF BCS DWERR2
00425 0295 86 08 DWR4 LDA #TRANS
00426 0297 17 FEF2 018C LBSR HSET
00427 029A 86 04 DWR3 LDA #RES
00428 029C 17 FED0 016F LBSR CHEKH
00429 029F 25 F9 029A BCS DWR3
00430 02A1 A6 5F LDA ESTORE,U
00431 02A3 26 04 02A9 BNE DWR5 ERROR
00432 02A5 1C FE ANDCC #0FE
00433 02A7 20 02 02AB BRA DWR6
00434 02A9 1A 01 DWR5 SEC
00435 02AB 32 62 DWR6 LEAS 2,S
00436 02AD 35 D6 PULS A,B,X,U,PC
00437
00438 02AF 86 FF DWERR2 LDA #0FF
00439 02B1 A7 5F STA ESTORE,U
00440 02B3 20 E0 0295 BRA DWR4
00441
00442
00443 *WRITEA*
00444 *WRITE THE NUMBER IN X AS AFIELD*
00445 *HEX DIGITS MOST SIGNIFICANT*
00446 *FIRST*
00447 *NO ERROR RETURNS FROM HERE*
00448 02B5 34 10 WRITEA PSHS X SAVE FOR RETURN
00449 02B7 B6 06A6 LDA AFIELD
00450 02BA 81 02 CMPA #002
00451 02BC 27 0A 02CB BEQ WRIT1
00452 02BE 17 FF93 0254 LBSR SWRITE SET UP FOR WRITE
00453 02C1 A6 E4 LDA ,S MOST SIG BYTE
00454 02C3 84 0F ANDA #0F MASK FOR RH NIBBLE
00455 02C5 17 FF9D 0265 LBSR DWRITE AND WRITE IT
00456 02CB A6 61 WRIT1 LDA 1,S
00457 02CA 44 LSRA
00458 02CB 44 LSRA
00459 02CC 44 LSRA
00460 02CD 44 LSRA GET LH NIBBLE TO RIGHT
00461 02CE 17 FF94 0265 LBSR DWRITE AND DISPOSE OF IT
00462 02D1 A6 61 LDA 1,S RH NIBBLE, LS BYTE
00463 02D3 17 FF8F 0265 LBSR DWRITE AND DISPOSE OF THAT
00464 02D6 35 90 PULS X,PC HURRAY
00465
00466 *DREAD*
*READ ONE BYTE FROM PROGRAMMER*

```

PROGRAMMER

558 6809 ASSEMBLER

PAGE 014 2:PROG2.TXT 558 6809 ASSEMBLER PROGRAMMER

```

00667          *IN LIST MODE*
00668
00669
00670 02D8 108E F538      DREAD LDY  *PIA
00671 02DC 84 08          LDA  *TRANS
00672 02DE 17 FE9F 0180  LBSR LSET  INITIATE THE READ
00673 02E1 84 04          DREAD1 LDA  *RES
00674 02E3 17 FE78 015E  LBSR CHEK1
00675 02E6 25 F9 02E1   BCS  DREAD1
00676 02E8 E6 A4        LDB  DRA,Y
00677 02EA 84 08          LDA  *TRANS
00678 02EC 17 FE9D 018C  LBSR HSET
00679 02EF 84 04          DREAD2 LDA  *RES
00680 02F1 17 FE78 016F  LBSR CHEKH
00681 02F4 25 F9 02EF   BCS  DREAD2
00682 02F6 39          RTS
00683
00684
00685          *ASIZE*
00686          *ALTER DEFAULT SIZE ATTRIBUTES*
00687          *SETS UP THE BYTE MASK, TOP ADDRESS AND NUMBER OF CH
00688 02F7 30 8D 0229    ASIZE LEAX  STR13,PCR
00689 02FB 8D D2A6       JSR  ZOUTST
00690 02FE 8D D2B5       JSR  ZLINEI
00691 0301 8D D2A0       JSR  ZGETHN
00692 0304 5D          TSTB
00693 0305 26 09 0310  BNE  ASIZE1  WAS CR SO DEFAULTS
00694 0307 84 03        ASIZE2 LDA  *#03
00695 0309 8E 01FF      LDX  *#01FF
00696 030C C6 0F        LDB  *#0F
00697 030E 20 1F 032F  BRA  ASIZE3
00698 0310 8C 0003     ASIZE1 CMPX *#0003
00699 0313 27 F2 0307  BEQ  ASIZE2
0700 0315 8C 0002     CMPX *#0002
0701 0318 26 09 0323  BNE  ASIZE4
0702 031A 84 02        LDA  *#02
0703 031C 8E 00FF      LDX  *#00FF
0704 031F C6 0F        LDB  *#0F
0705 0321 20 0C 032F  BRA  ASIZE3
0706 0323 8C 0001     ASIZE4 CMPX *#0001
0707 0326 26 11 0339  BNE  ASIZE5
0708 0328 84 02        LDA  *#02
0709 032A 8E 001F      LDX  *#001F
0710 032D C6 FF        LDB  *#FF
0711 032F 87 06A6     ASIZE3 STA  AFIELD
0712 0332 BF 06A3     STX  HIGH
0713 0335 F7 06A5     STB  MASK
0714 0338 39          RTS
0715 0339 8C 0004     ASIZE5 CMPX *#0004
0716 033C 26 09 0347  BNE  ASIZE6
0717 033E 84 03        LDA  *#03
0718 0340 8E 07FF      LDX  *#07FF
0719 0343 C6 FF        LDB  *#FF
0720 0345 20 E8 032F  BRA  ASIZE3
0721 0347 8C 0005     ASIZE6 CMPX *#0005
0722 034A 26 8D 0307  BNE  ASIZE2  USE DEFAULTS
0723 034C 84 03        LDA  *#03

```

```

00724 034E 8E 00FF    LDX  *#00FF
00725 0351 C6 FF      LDB  *#FF
00726 0353 20 DA 032F  BRA  ASIZE3
00727
00728          *DELAY*
00729          *DELAYS FOR A LONG TIME*
00730 0355 8E FFFF     DELAY LDX  *#FFFF
00731 0358 30 1F      DELAY1 LEAX -1,X
00732 035A 8C 0000    CMPX *#0000
00733 035D 26 F9 0358  BNE  DELAY1
00734 035F 39          RTS
00735
00736
00737
00738
00739
00740          *AMOD*
00741          *EXAMINE AND PERHAPS MODIFY A PROM ADDRESS*
00742
00743          FFFE     PADD5 EQU  -2
00744          FFFC     TMP1  EQU  -4
00745
00746 0360 1F 43        AMOD  TFR   S,U
00747 0362 32 7A        LEAS  -4,S  GET VARIABLE SPACE
00748 0364 8E 0000     LDX  *#0000
00749 0367 AF 5E        STX  PADD5,U
00750 0369 AF 5C        STX  TMP1,U
00751 036B 84 2A        AMOD2 LDA  *#*
00752 036D 8D D2BE     JSR  ZOUTCH
00753 0370 8D D2B5     JSR  ZLINEI
00754 0373 8D D2A0     JSR  ZGETHN
00755 0376 5D          TSTB
00756 0377 26 07 0380  BNE  AMOD1  DID WE GET A HEX NUMBER
00757 0379 81 0D        CMPA *#CR  YES
00758 037B 26 0E 036B  BNE  AMOD2  IF NOT CARRIAGE RETURN REPEA
00759 037D 32 66        LEAS  6,S  OTHERWISE RETURN
00760 037F 39          RTS
00761
00762 0380 BC 06A3     AMOD1 CMPX  HIGH
00763 0383 25 03 0388  BLO  AMOD4
00764 0385 8E 06A3     LDX  HIGH
00765 0388 AF 5E        AMOD4 STX  PADD5,U  STORE ADDRESS
00766 038A 30 5E        LEAX  PADD5,U
00767 038C 8D D2AF     JSR  ZOUTH  PUT 2 BYTES AS HEX
00768 038F AE 5E        LDX  PADD5,U
00769 0391 8D 7C 040F  BSR  SETUP
00770 0393 17 FEAD 0243  LBSR  SREAD
00771 0396 84 40        LDA  *#READW
00772 0398 17 FDF1 018C  LBSR  HSET
00773 039B 84 10        LDA  *#MODE
00774 039D 17 FDEC 018C  LBSR  HSET
00775 03A0 17 FF35 02D8  LBSR  DREAD  NOW ALL OK FOR A READ
00776 03A3 F4 06A5     ANDB  MASK  SO DO IT
00777 03A6 E7 5C        STB  TMP1,U  PROPER MASK
00778 03A8 84 40        LDA  *#READW
00779 03AA 17 FDD3 0180  LBSR  LSET
00780 03AD 17 FEA4 0254  LBSR  SWRITE  SET UP FOR A WRITE

```

PROGRAMMER

000 0000 REMEMBER

00895	05DB	2A		FCC	'*****'
00896	05EE	0D		FCB	\$0D,\$0A
00897	05F0	00		FCB	\$00
00898	05F1	20	STR16	FCC	/ 77/
00899	05F4	0D		FCB	\$0D
00900	05F5	0A		FCB	\$0A
00901	05F6	00		FCB	00
00902	05F7	0000	DTBEND	FDB	\$0000
00903	05F9	00A6	RFCB	RMB	166
00904	069F	0000	TOP	FDB	\$0000
00905	06A1	0002	BOT	RMB	2
00906	06A3	0002	HIGH	RMB	2
00907	06A5	0001	MASK	RMB	1
00908	06A6	0001	AFIELD	RMB	1
00909	06A7	0002	OPBYTE	RMB	2
00910	06A9	0200	DTABLE	RMB	\$200
00911				END	

TOTAL ERRORS 00000--00000
TOTAL WARNINGS 00008--00663

2) Computer Communications Programs.

```

00781 0380 86 20 LDA #020 SPACE
00782 0382 8D D2BE JSR ZOUTCH PUT IT
00783 0385 1F 31 TFR U,X
00784 0387 30 1C LEAX TMP1,X GET ADDRESS OF BYTE
00785 0389 8D D2AC JSR ZOUTHX PUT AS TWO HEX DIGITS
00786 038C 86 20 LDA #020
00787 038E 8D D2BE JSR ZOUTCH
00788 03C1 8D D2B5 JSR ZLINEI
00789 03C4 8D D2A0 JSR ZGETHN
00790 03C7 5D TSTB ANY HEX DIGITS?
00791 03C8 26 1E 03E8 BNE AMOD5 YES SO GO WRITE
00792 03CA 81 2E CMPA # NO
00793 03CC 27 9D 036B BEQ AMODZ START AGAIN
00794 03CE 81 5E CMPA #
00795 03D0 26 08 03DD BNE AMOD4
00796 03D2 AE 5E LDX PADD5,U
00797 03D4 8C 0000 CMPX #0000
00798 03D7 27 A7 0380 BEQ AMOD1
00799 03D9 30 1F LEAX -1,X DECREMENT LOCATION COUNTER
00800 03DB 20 A3 0380 BRA AMOD1
00801 03DD AE 5E AMOD6 LDX PADD5,U
00802 03DF BC 06A3 CMPX HIGH
00803 03E2 27 9C 0380 BEQ AMOD1
00804 03E4 30 01 LEAX 1,X INCREMENT X
00805 03E6 20 98 0380 BRA AMOD1
00806 03E8 AF 3C AMOD5 STX TMP1,U
00807 03EA AE 5E LDX PADD5,U
00808 03EC 8D Z1 040F BSR SETUP
00809 03EE A6 5D LDA TMP1+1,U GET LSB OF DATA TO BE WRITTE
00810 03F0 17 FE72 0265 LBSR DWRITE WRITE IT
00811 03F3 24 0C 0401 BCC AMOD7
00812 03F5 30 8D 01F8 LEAX STR14,PCR
00813 03F9 8D D2A6 JSR ZOUT5T
00814 03FC AE 5E LDX PADD5,U
00815 03FE 16 FF7F 0380 LBRA AMOD1
00816 0401 AE 5E AMOD7 LDX PADD5,U
00817 0403 BC 06A3 CMPX HIGH
00818 0406 1027 FF76 0380 LBEQ AMOD1
00819 040A 30 01 LEAX 1,X OTHERWISE INCREMENT IT
00820 040C 16 FF71 0380 LBRA AMOD1
00821
00822 *SETUP*
00823 *INITS PROGRAMMER*
00824 *SENDS ADDRESS OF BYTE TO BE READ*
00825 *LEAVES PROGRAMMER IN A WRITE STATE*
00826
00827 040F 17 FE26 0238 SETUP LBSR PRINT
00828 0412 86 01 LDA #ADD
00829 0414 17 FD47 015E SETUP1 LBSR CHEKL
00830 0417 25 FB 0414 BCS SETUP1
00831 0419 86 10 LDA #MODE
00832 041B 17 FD62 0180 LBSR LSET
00833 041E 17 FE94 0285 LBSR WRITEA WRITES OUT THE ADDRESS IN X
00834 0421 17 FE91 0285 LBSR WRITEA TWICE FOR A SINGLE BYTE
00835 0424 86 01 LDA #ADD
00836 0426 17 FD46 016F SETUP2 LBSR CHEKH
00837 0429 25 FB 0426 BCS SETUP2

```

```

00838 042B 39 RT5
00839
00840
00841 *STORAGE#
00842 042C 2D COM5T FCC /-> /
00843 042F 00 FCB 00
00844 0430 50 STR1 FCC /FROM START ADDRESS 7 /
00845 0446 00 FCB 00
00846 0447 50 STR2 FCC /FROM END ADDRESS 7 /
00847 045A 00 FCB 00
00848 045B 44 STR3 FCC /DATA TABLE START ADDRESS 7 /
00849 0476 00 FCB 00
00850 0477 41 STR4 FCC /ADDRESS FIELD ERROR/
00851 048A 0D FCB #0D
00852 048B 0A FCB #0A
00853 048C 00 FCB 00
00854 048D 44 STR5 FCC /DATA ERROR /
00855 0498 0D FCB #0D,#0A
00856 049A 00 FCB 00
00857 0477 STR6 EQU STR4
00858 049B 57 STR7 FCC /WRITE DATA ERROR/
00859 04A8 0D FCB #0D,#0A
00860 04AD 00 FCB 00
00861 04AE 4E STR8 FCC /NON ZERO FIELD ERROR/
00862 04C2 0D FCB #0D,#0A
00863 04C4 00 FCB 00
00864 04C5 50 STR9 FCC /PROGRAMMING ERROR/
00865 04D6 0D FCB #0D,#0A
00866 04D8 00 FCB 00
00867 04D9 42 STR10 FCC /BINARY FILE NAME? /
00868 04EB 00 FCB 00
00869 04EC 45 STR11 FCC /EOF FOUND BEFORE END OF DATA BUFFER/
00870 050F 0D FCB #0D,#0A
00871 0511 00 FCB 00
00872 0512 44 STR12 FCC /DATA TABLE SIZE? /
00873 0523 00 FCB 00
00874 0524 53 STR13 FCC /SELECT NEW SIZE ATTRIBUTES/
00875 053E 0D FCB #0D,#0A
00876 0540 30 FCC /01 = 32 * 8 /
00877 0548 0D FCB #0D,#0A
00878 054D 30 FCC /02 = 256 * 4 /
00879 0559 0D FCB #0D,#0A
00880 055B 30 FCC /03 = 512 * 4 (DEFAULT) /
00881 0571 0D FCB #0D,#0A
00882 0573 30 FCC /04 = 2056 * 8 /
00883 0581 0D FCB #0D,#0A
00884 0583 30 FCC /05 = 4096 * 8 /
00885 0591 0D FCB #0D,#0A
00886 0593 00 FCB 00
00887 0594 53 STR14 FCC /SIZE DEFAULTS TO 512 * 4 /
00888 05AC 0D FCB #0D,#0A
00889 05AE 0000 FDB 00
00890 0580 1A STR15 FCB #1A
00891 05B1 2A FCC '*****'
00892 05C4 0D FCB #0D,#0A
00893 05C6 2A FCC /* FROM PROGRAMMER */
00894 05D9 0D FCB #0D,#0A

```

00200
01000 264C
01002 0003FF01
01006 0003FF21
0100A 00021C2E
0100E 00021DB4
01012 00020008

*
* SIXTH OPERATING SYSTEM FOR 68000
* AUGUST 1981
* REVISION 2.1
* DAVE COWAN
*

ORG 1000
REST DC.W INTE1 RESTART VECTOR
ACIA1 DC.L 03FF01 PORT1 (TERMINAL)
ACIA2 DC.L 03FF21 PORT2 (HOST)
OUT DC.L 021C2E
IN DC.L 021DB4
MACS DC.L 020008

* VARIABLES USED

01016 00002000
0101A 00001300
0101E 0040
01020 1100
01022 0000
01024 0000
01026 263A
01028 0000
0102A 0000
0102C 0000
0102E 2800
01030 0000
01032 00001900
01036 0000
01038 0003FF01
0103C 00000000
01040 0000

MSTCK DC.L 02000
DOSTK DC.L 01300
PREF DC.B 040 PREFIX CHARACTER
STBUF DC.W 01100 BUFFER START
BWORD DC.W 00 START WORD POINTER
EWORD DC.W 00 END WORD POINTER
DLAST DC.W XSWAP LAST DEFINITION POINTER
LAST DC.W 00 LAST WORD FLAG
RDX DC.W 00 CURRENT RADIX
NFLAG DC.W 00 NUMBER FLAG
DP DC.W 02800 NEXT FREE LOCATION
STATE DC.W 00 SYSTEM STATE
OPSTK DC.L 01900 OP STACK
RELO DC.W 00 RELOAD FLAG
PORT DC.L 03FF01
CTIME DC.L 00000 SPACE FOR PTM
DC.W 00000

* ACTUAL PROGRAM START

ORG 2000

002000 0004
002002 4348494E
002006 0000

XCHIN DC.B 04
DC.L 'CHIN'
DC.W 0

* CHARACTER INPUT ROUTINE

002008 2278100E
00200C 20781038
002010 4E91
002012 4E75

SIN MOVE.L IN,A1
MOVE.L PORT,A0
JSR (A1)
RTS

002014 0005
002016 43484F55
00201A 2000

XOUT DC.B 05
DC.L 'CHOU'
DC.W XCHIN

* CHARACTER OUTPUT ROUTINE

00201C 2278100A
002020 20781038
002024 4E91
002026 4E75

SOUT MOVE.L OUT,A1
MOVE.L PORT,A0
JSR (A1)
RTS

002028 0004
00202A 4D414353
00202E 2014

XMAC DC.B 04
DC.L 'MAC5'
DC.W XOUT

* MACSBUG REENTRY POINT
*
MAC MOVE.L MAC5,A1
JMP (A1)

002030 22781012
002034 4ED1

002036 0006
002038 42554646
00203C 2028

XBUF DC.B 06
DC.L 'BUFF'
DC.W XMAC

* SYSTEM-USER IO ROUTINE

00203E 4EB8209A
002042 31F810201024
002048 11FC0000102B
00204E 3038101E
002052 4EB8201C
002056 34781020
00205A 4EB82008
00205E 0C00000D
002062 66000006
002066 14C0
002068 4E75
00206A 0C000008
00206E 66000010
002072 4EB8201C
002076 1222
002078 B4F81020
00207C 6F00FFC0
002080 0C000020
002084 6D00FFD4
002088 4EB8201C
00208C 14C0
00208E 4EF8205A

BUF JSR CRLF
MOVE.W STBUF,EWORD SET UP PARAMS FOR WORD
MOVE 0, LAST CLEAR END OF BUFFER FLAG
MOVE.W PREF, DO PREFIX CHARACTER
JSR SOUT SEND PREFIX CHAR
MOVE.W STBUF, A2 START OF BUFFER POINTER
NEXT JSR SIN GET A CHARACTER
CMPI 000D, DO CR 7
BNE BSP NO
MOVE DO, (A2)+ STORE IT
RTS KILL IT
BSP CMPI 000B, DO BACKSPACE
BNE NPT NO
JSR SOUT ECHOE IT
MOVE -(A2), D1 BACK OFF
CMPA.W STBUF, A2 BACK AT START 7
BLE BUFF RESTART
NPT CMPI 0, DO LOOK AT NON PRINTING
BLT NEXT IF SO IGNORE
JSR SOUT ECHOE THE CHARACTER
MOVE DO, (A2)+ STORE IT
JMP NEXT AND AGAIN PLEASE !!!!

002092 0004
002094 43524C46
002098 2036

XCRLF DC.B 04
DC.L 'CRLF'
DC.W XBUF

* SIMPLE CRLF ROUTINE

00209A 303C000D
00209E 4EB8201C
0020A2 303C000A
0020A6 4EB8201C
0020AA 4E75

CRLF MOVE.W 000D, DO
JSR SOUT
MOVE.W 000A, DO
JSR SOUT
RTS

0020AC 0004
0020AE 574F5244
0020B2 2092

XWORD DC.B 04
DC.L 'WORD'
DC.W XCRLF

* SETS WORD POINTERS FOR FIND

0020B4 31F810241022
0020BA 34781022
0020BE 0C1A0020
0020C2 6700FFFA

WORD MOVE.W EWORD, BWORD SET END - BEGINNING
MOVE.W BWORD, A2 TO SCAN
SPACE CMPI 0, (A2)+ SPACE PERHAPS
BEQ SPACE

2) SIXTH dictionary.

```

1000 CONSTANT EQUATES
EQUATES 2 + CONSTANT ACI1
ACI1 4 + CONSTANT ACI2
ACI2 10 + CONSTANT MSTCK
MSTCK 4 + CONSTANT DOSTK
DOSTK 4 + CONSTANT PREFIX
PREFIX 2 + CONSTANT ST
ST 2 + CONSTANT WB
WB 2 + CONSTANT WE
WE 2 + CONSTANT DL
DL 2 + CONSTANT LAST
LAST 2 + CONSTANT RDX
RDX 2 + CONSTANT NFLAG
NFLAG 2 + CONSTANT DP
DP 2 + CONSTANT STATE
STATE 2 + CONSTANT OPSTK
OPSTK 4 + CONSTANT FRELO
FRELO 2 + CONSTANT PORT
PORT 4 + CONSTANT CTIME
0 CONSTANT 0
1 CONSTANT 1
2 CONSTANT 2
3 CONSTANT 3

```

```

: OCT 8 RDX IW ;
: HEX 10 RDX IW ;
: DEC A RDX IW ;
: DUP POP PUSH PUSH ;
: DROP POP ;
: OVER SWAP DUP POP STK SWAP UNST PUSH ;
: ROT SWAP POP STK SWAP UNST PUSH ;
: HERE DP @W ;
: 1- 1 - ;
: 1+ 1 + ;
: 1 IW ;
: @ @W ;
: *1 DUP @ 1+ SWAP 1 ;
: DPI DP @ 1 DP @ 2 + DP 1 ;
: WNUM WORD NUMBER ;
: L9 7 LEFT 2 LEFT ;
: WNUM2 WNUM + WNUM L9 + DPI ;

```

```

: MOVE IMMEDIATE 2000 WNUM2 ;
: SUB IMMEDIATE 9080 WNUM2 ;
: SUBW IMMEDIATE 9040 WNUM2 ;
: AND IMMEDIATE C080 WNUM2 ;
: PSHS IMMEDIATE 2F00 DPI ;
: PULS IMMEDIATE 201F DPI ;
: MASK POP MOVE 0 1 POP AND 1 0 PUSH ;
: B2 6000 + DPI HERE DUP 0 DPI ROT POP MOVE 0 1 POP SUBW 1 0 PUSH SWAP 1 ;
: BRA IMMEDIATE 0000 B2 ;
: BEQ IMMEDIATE 0700 B2 ;
: BNE IMMEDIATE 0600 B2 ;
: BLE IMMEDIATE 0F00 B2 ;
: BGT IMMEDIATE 0E00 B2 ;
: BGE IMMEDIATE 0C00 B2 ;
: BPL IMMEDIATE 0A00 B2 ;
: BLT IMMEDIATE 0D00 B2 ;
: RTE IMMEDIATE 4E73 DPI ;
: FRAME IMMEDIATE 48E7 DPI FFFE DPI ;

```

```

: SYRES IMMEDIATE 4E70 DPI ;
: ENINT IMMEDIATE 027C DPI F8FF DPI ;
: DISINT IMMEDIATE 007C DPI 0700 DPI ;

```

```

: @INT IMMEDIATE INTEGER ;
: CALL 4EBB DPI ;
: @ IMMEDIATE 4EBB DPI WORD FIND @ + DPI ;
: @@ IMMEDIATE WORD FIND @ + ;
: => IMMEDIATE CALL @@ CALL @INT DPI WORD FIND @ + ;
: <= IMMEDIATE INTEGER => DPI @INT DPI ;
: <DO POP STK POP STK POP STK ;
: *LOOP UNST UNST UNST ;
: DO IMMEDIATE 2D3C DPI 0 DPI HERE 0 DPI => <DO <= HERE ;
: <LOOP UNST PUSH MOVE 0 5 UNST PUSH SUB 0 5 1 + POP STK POP STK MOVE 5 0 ;
: LOOP IMMEDIATE => <LOOP <= @ BGT HERE SWAP 1 => *LOOP <= ;
: ABORT *LOOP PULS ;
: NEXT PULS UNST PSHS UNST PSHS UNST PUSH STK PULS STK PULS STK @ - POP PS ;
: STOP PULS UNST PUSH UNST PUSH UNST PSHS STK POP STK POP STK ;
: QUIT PULS ;
: I UNST PSHS UNST PUSH STK PULS STK ;
: SK IMMEDIATE WNUM HERE + ;
: = POP MOVE 0 1 POP SUB 1 0 SK C BEQ 0 SK @ BRA 1 POP ;
: > POP MOVE 0 1 POP SUB 1 0 SK C BGT 0 SK @ BRA 1 POP ;
: < POP MOVE 0 1 POP SUB 1 0 SK C BLT 0 SK @ BRA 1 POP ;
: , CRLF ;
: BASE RDX @ DUP DEC , RDX 1 ;
: =OSKIP MOVE 0 1 HERE @ + @ BEQ 4EFB DPI 0 DPI ;
: >OSKIP MOVE 0 1 HERE @ + @ BGT 4EFB DPI 0 DPI ;
: IF IMMEDIATE >OSKIP HERE 2 - ;
: THEN IMMEDIATE HERE SWAP 1 ;
: ELSE IMMEDIATE 4EFB DPI 0 DPI @ THEN HERE 2 - ;
: =< OVER OVER < IF DROP DROP ELSE = THEN ;
: >= OVER OVER > IF DROP DROP ELSE = THEN ;
: <> OVER OVER < IF SWAP THEN ;
: BYTE DUP @B SWAP 1 + SWAP ;
: ( IMMEDIATE WB @ DUP 100 1 DO BYTE 29 = IF DROP I + WE 1 ABORT
: THEN LOOP DROP DROP ;
: ARRAY IMMEDIATE 2 * DUP DUP 2D3C DPI 0 DPI DPI
: 2D3C DPI 0 DPI HERE 6 + DPI HERE 4 + +
: @ BRA DP @ + DP 1 ; ( PUTS SIZE, ADDX ON STACK )
CTIME 6 + CONSTANT GT
GT 4 + CONSTANT ST2
ST2 4 + CONSTANT WIDTH
: DELIM WORD WB @ DUP GT 1 GT *1 @B ;
: FILL 0 WIDTH 1 DP @ 10 + ST2 1 DELIM 100 1 DO GT @ @B GT *1
: OVER OVER = IF DROP DROP WIDTH @ GT @ WE 1 0 ST2 @ 1B ABORT
: THEN WIDTH *1 ST2 @ 1B ST2 *1 LOOP ; ( FILLS AFTER THE RTS )
: STRING IMMEDIATE FILL 1 + 2 / @ ARRAY ;
: LOC WORD FIND ; ( LOCATES A WORD IN THE DICTIONARY )
: SPACE 20 TO ; ( TYPE 1 SPACES )
: LIST DO I @B . SPACE LOOP ; ( MEMORY DUMP )
: SAY TYPE ;
: STR1 STRING %THERE ARE % ;
: STR2 STRING % DEFINITIONS % ;
: DEFN DUP @B . SPACE 1 + DUP @B . 1 + SPACE ;
: NAME 3 0 DO DUP I + @B TO LOOP ;
: STR3 STRING %NOT FOUND % ;
: STR4 STRING %DEFINITION KEPT% ;
: BEGIN IMMEDIATE HERE ;
: END IMMEDIATE 4EFB DPI DPI ;
: LOCATE IMMEDIATE LOC ;

```

```

: INTER PULS EQUATES @ POP PSHS ; ( JMP TO INTERPRET LOOP )
: MACSBUG PULS 2013A POP PSHS ; ( JMPS STRAIGHT TO MACS CLI )
: SERROR CRLF STRING %ERROR% SAY CRLF INTER ; ( TRAP ERROR )
: SABORT CRLF STRING %ABORT% SAY
CRLF INTER ; ( ABORT BUTTON HANDLER )
: K VARIABLE ;
: KEEP WORD FIND K I ; ( WRITE PROTECTS DICTIONARY SPACE )
: WHAT CRLF DL @ 1000 1 DO DUP DUP . SPACE DEFN NAME SWAP
  K @ = IF DROP ABORT THEN 4 + @ CRLF DUP 0 = IF STR1 SAY
  RDX @ DEC I . RDX I STR2 SAY
  DROP ABORT THEN LOOP DROP ;
: FORGET WORD FIND DUP 0 = IF
  CRLF DROP STR3 SAY ELSE DUP . K @ = < IF
  CRLF DROP STR4 SAY ELSE DUP DP I 6 + @ DL I
  THEN THEN ; ( FORGETS ALL DEFNS UP TO THE SELECTED ONE )

( INTERRUPT STUFF )
: INSTALL 4 * 60 + LOC @ + SWAP IL ;

: STORE VARIABLE ;
: SETUP SYRES
DISINT 0 STORE I LOCATE SERROR @INT @ +
  100 1 DO DUP STORE @ 4 + DUP STORE I
  IL LOOP DROP LOCATE SABORT
  @INT @ + 7C IL ( LOADS UP VECTOR AREA )

( ACIA SWAPPING STUFF )

: CHECK BEGIN CHIN PUSH 02 = IF ABORT THEN END ;
: ACL 3 OVER IB 15 SWAP IB ;
: A1 AC11 @L PORT IL ;
: A2 AC12 @L PORT IL ;
: STR WORD LENGTH PUSH WB @ ;
: T1 AC11 @L ACL ;
: T2 AC12 @L ACL ;
: TRANS AC11 @L 55 OVER IB FD SWAP 2 + IB ;
: P2 TRANS CHECK T1 T2 ;

( NEW OPEN COMMAND STUFF FOR ANY FILE )

: COM_LINE STR STRING $1:LD & A2 TYPE TYPE 0D TO ;
: WAIT BEGIN CHIN PUSH 0D = IF ABORT THEN END ;
: REP_TEST BEGIN CHIN PUSH DUP 41 = IF POP 1 ABORT ELSE 59 = IF 0 ABORT THEN THEN
: OPEN COM_LINE WAIT REP_TEST A1 DUP 0 = IF STRING & FAILED & SAY THEN ;

: @ A1 STRING %EOF FOUND% SAY RESTART ; ( RUBOUT COMMAND FOR EOF )
: %ENDFILE 0 FRELO I A2 IB TO A1 ;
: COMPILE OPEN 0 = IF %ENDFILE ABORT THEN RELOAD ;
SETUP
RESTART

```

Chapter 5 Listings

1) Portable Controller Program.

(HIGHWAY CONTROLLER TABLES)

(PRIMARY TABLE)

000 CONSTANT PT (PRIMARY TABLE POINTER)
 PT CONSTANT CTUSW (CONTROLLER TERMINAL UNIT STATUS WORD)
 CTUSW 2 + CONSTANT CTUCW (CONTROLLER TERMINAL UNIT CONTROL WORD)
 CTUCW 2 + CONSTANT PTPT (POINTER TO POLLING TABLE)
 PTPT 2 + CONSTANT PTBS (POINTER TO BUFFER STORE)
 PTBS 2 + CONSTANT PTSS (POINTER TO STATUS STORE)
 PTSS 2 + CONSTANT PTST (POINTER TO STATUS STORE)
 PTST 2 + CONSTANT STSP (SELF TEST SCRATCHPAD)
 STSP 4 + CONSTANT REC (RECEIVE ERROR COUNTER)
 REC 2 + CONSTANT RC (REPEAT COUNTER)
 RC 2 + CONSTANT NRC (NULL REPEAT COUNTER)
 NRC 2 + CONSTANT OTA (OUT TIME AVAILABLE)
 OTA 2 + CONSTANT OT (OUT TIME)
 PT 64 + CONSTANT ITA (IN TIME AVAILABLE)
 ITA 2 + CONSTANT IT (IN TIME)

(STATUS TABLE)

C00 CONSTANT STT

(SIZE STORE)

A00 CONSTANT MSS

(BUFFER STORE)

A000 CONSTANT BS

(POLLING TABLES)

900 CONSTANT PTA (POLLING TABLE A)

D00 CONSTANT PTB (POLLING TABLE B)

(CHANNEL CONTROL WORD)

3C000 CONSTANT CCW

(CONTROL WORDS)

2 CONSTANT GO (START TERMINAL UNIT)
 3 CONSTANT CSTOP (STOP TERMINAL UNIT)
 4 CONSTANT OFFINT (SWITCH OFF INTERRUPTS)
 5 CONSTANT ONINT (SWITCH ON AND CLEAR INTERRUPTS)
 7 CONSTANT RESET (RESET AND HALT TERMINAL UNIT)

(FELTEC LCD DRIVERS)

3FF40 CONSTANT PIA (FIRST THE RELEVANT PIA REGISTERS)
 PIA CONSTANT DRAZ
 PIA 2 + CONSTANT DRBZ
 PIA 4 + CONSTANT CRAZ
 PIA 6 + CONSTANT CRBZ

: OBYTE DUP 3FF42 1B 3FF42 0B OVER = IF DROP ELSE
 3FF42 1B 3C 3FF46 1B 7 3FF44 1B THEN 34 CRB2 1B 3C CRB2 1B ;
 : CL*FEL 7F 0 DO 20 OBYTE LOOP ; (CLEAR ONE ENTIRE BUFFER)
 : INIT*FEL 00 CRB2 1B FF DRB2 1B 0C CRB2 1B (ALL OUTPUTS)
 80 OBYTE 82 OBYTE CL*FEL 81 OBYTE (CLEAR BUFF1)
 80 OBYTE A2 OBYTE CL*FEL 81 OBYTE (CLEAR BUFF2)
 90 OBYTE 00 OBYTE ; (RESET CURSOR)
 : PT* VARIABLE ; (BUFFER POINTER FOR FELTEC)
 : SCROLL 84 OBYTE OBYTE 82 OBYTE 1F 0 DO 20 OBYTE LOOP 81 OBYTE ;
 : PT*FEL PT* DUP 0 7F MASK DUP 1F MASK 0 = IF DUP SCROLL THEN SWAP *1 ;
 : T_DIS VARIABLE ; (CURRENT DISPLAY TYPE)
 : FEL*CL 80 OBYTE 82 OBYTE CL*FEL 81 OBYTE 90 OBYTE 0 OBYTE 0 PT* 1 0 T ;
 : OUT*FEL PUSH DUP DUP A = IF DROP (IGNORE LF)
 ELSE DUP D = IF DROP PT* 0 20 + 60 MASK PT*
 ELSE DUP 0B = IF DROP PT* DUP 0 1- SWAP 1
 90 OBYTE PT* 0 OBYTE
 ELSE
 PT*FEL 84 OBYTE OBYTE 82 OBYTE OBYTE 81 OBYTE
 PT* 0 90 OBYTE OBYTE

THEN
 THEN THEN POP ; (LEAVE CHAR IN DO FOR BUFF)
 (REAL TIME CLOCK)

3C020 CONSTANT CLOCK (ADDRESS 0 OF REAL TIME CLOCK)
 : INV -1 SWAP - ; (DAT FROM CLOCK IS COMPLIMENTED)
 : INV F MASK ; (AND ONLY LOWER THREE BITS IS VALID)
 : 4INV INV F MASK ;
 : CCLEAR 2 * CLOCK + 0 INV SWAP 1 ; (CLEARS A CLOCK LOCATION)
 : CREAD 2 * CLOCK + 0 ; (READS FROM A CLOCK LOCATION)
 : STOPCLOCK 0 INV CLOCK E 2 * + 1 ;
 : GOCLOCK 0 INV CLOCK 1 1 INV CLOCK E 2 * + 1 ;
 : CSTORE 2 * CLOCK + SWAP INV SWAP 1 ; (STORES DATA AT CLOCK LOCN)
 : STOD STOPCLOCK 1 0 DO BUFFER WNUM C I - CSTORE LOOP
 S 0 DO BUFFER WNUM 9 I - CSTORE LOOP GOCLOCK ; (SET A NEW TIME)
 : 4INV INV F MASK ;
 : _CREAD 10 1 DO DUP CREAD DUP 4INV F MASK F (IF SWAP DROP ABORT
 THEN DROP LOOP SWAP DROP)
 : GTOD 9 1 DO I _CREAD 4INV LOOP C B DO I _CREAD 4INV LOOP ;
 : TIME GTOD S 1 DO . 3A TO LOOP ;

(HIGHWAY CONTROLLER DRIVERS)

(STATUS TABLE FIELDS)
 : 0NAK 2 * STT + 0 4000 MASK 4000 / ; (STACKS NAK BIT FOR A TERMINAL)
 : 0NR 2 * STT + 0 8000 MASK 8000 / ; (STACKS NR BIT FOR A TERMINAL)
 : 0IMM 2 * STT + 0 FF MASK ; (STACKS INFORMATION MONITOR)
 : 0EM 2 * STT + 0 3F00 MASK 100 / ; (STACKS ERROR MONITOR)

(GET ALL STATUS ON A PARTICULAR TERMINAL)
 : 0GTSTATS DUP 0IMM SWAP DUP 0EM SWAP DUP 0NR SWAP 0NAK ;
 (ORDER OFF STACK -> NAK,NR,EM,IMM)

(CONTROLLER STATUS)

: 0STOP CTUSW 0 1 MASK ; (STACKS START/STOP BIT)
 : 0ACTIVE CTUSW 0 2 MASK 2 / ; (STACKS ACTIVE/PASSIVE BIT)
 : 0OGP CTUSW 0 4 MASK 4 / ; (STACKS OVERRIDE GO PASSIVE BIT)

Chapter 6 Listings

1) Master terminal Unit Program.

```

( NEW MASTER UNIT SOFTWARE )
( DESTINED FOR THE SHIP TRIALS )
( JANUARY 1982 )
( INCLUDES REVISION TO ALLOW USE OF MTD EXTENSION BIT )
( INCLUDES BOTH BLOCK AND SHORT MESSAGE TESTS )
( REVISION 2.1 10/1/82 )
( LONGER REPORTS TO ALLOW DECENT STATUS )
( REPORTS IN SMST )

```

```

( STOREIT AND DOIT INCLUDED IN THIS ONE )

```

```

( TERMINAL UNIT PRIMARY TABLE )

```

```

ADD CONSTANT PR_TAB
PR_TAB CONSTANT IN_INT
IN_INT 1 + CONSTANT IN_NO
IN_NO 2 + CONSTANT IN_POS
IN_POS 1 + CONSTANT IN_TAB
IN_TAB 2 + CONSTANT O_INT
O_INT 1 + CONSTANT O_NO
O_NO 2 + CONSTANT O_POS
O_POS 1 + CONSTANT O_TAB
O_TAB 2 + CONSTANT MES_TAB
MES_TAB 40 + CONSTANT HW_NO
HW_NO 2 + CONSTANT RE_COUNT
RE_COUNT 2 + CONSTANT DAT_STARU
DAT_STARU 2 + CONSTANT RETR_COUNT
RETR_COUNT 2 + CONSTANT BUF_OVER
BUF_OVER 2 + CONSTANT IN_BLK_STAT
IN_BLK_STAT 2 + CONSTANT IN_BLK_SOURCE
IN_BLK_SOURCE 2 + CONSTANT IN_BLK_TOTAL
IN_BLK_TOTAL 1 + CONSTANT IN_BLK_TOT_RECVD
IN_BLK_TOT_RECVD 1 + CONSTANT IN_BLK_ADDRESS
IN_BLK_ADDRESS 2 + CONSTANT O_BLK_STAT
O_BLK_STAT 3 + CONSTANT O_BLK_DESTIN
O_BLK_DESTIN 1 + CONSTANT O_BLK_TOT
O_BLK_TOT 1 + CONSTANT O_BLK_TOT_TXD
O_BLK_TOT_TXD 1 + CONSTANT O_BLK_START

```

```

( END OF PRIMARY TABLE )

```

```

( IN TABLE )
( MASK FOR A SINGLE BUFFER AREA )

```

```

( RELATIVE TO START OF BUFFER )
1 CONSTANT IN_BUF_LEN
IN_BUF_LEN 1 + CONSTANT IN_DEST
IN_DEST 1 + CONSTANT IN_SOURCE
IN_SOURCE 1 + CONSTANT IN_TYPE
IN_TYPE 2 + CONSTANT IN_DAT_BUF

```

```

( OUT TABLE )
( MASK FOR A SINGLE BUFFER AREA )

```

```

( RELATIVE TO START OF BUFFER )
1 CONSTANT O_BUF_LEN
O_BUF_LEN 1 + CONSTANT O_DEST
O_DEST 2 + CONSTANT O_TYPE
O_TYPE 2 + CONSTANT O_DAT_BUF

```

```

TABLE IMMEDIATE ZD3C DPT 0 DPT DPT ZD3C DPT 0 DPT DPT ;
: C ;
: ) ROT * + + ;

```

```

( CHANNEL CONTROL WORD )

```

```

3C000 CONSTANT CCW

```

```

( CONTROL WORDS )

```

```

2 CONSTANT GO ( START TERMINAL UNIT )
3 CONSTANT CSTOP ( STOP TERMINAL UNIT )
4 CONSTANT OFFINT ( SWITCH OFF INTERRUPTS )
5 CONSTANT ONINT ( SWITCH ON AND CLEAR INTERRUPTS )
7 CONSTANT RESET ( RESET AND HALT TERMINAL UNIT )

```

```

( BITS TO CONTROL TERMINAL UNIT )

```

```

40 5900 : IN_TABLE TABLE ;
40 5D00 : OUT_TABLE TABLE ;
: OUT_BUF_NO VARIABLE ; ( 68K'S RECORD OF NEXT FREE BUFFER )
: GET_BUF OUT_BUF_NO DUP @ 1 + F MASK SWAP ! ;
: CLZ DO 0 I 1B LOOP ;

```

```

( MESSAGE SEND ROUTINE )

```

```

: SEND OUT_TABLE ( OUT_BUF_NO @ O_BUF_LEN ) @B
0 = IF ( BUFFER IS FREE SO CARRY ON )
OUT_TABLE ( OUT_BUF_NO @ 5 ) DUP 5 - CLZ
OUT_TABLE ( OUT_BUF_NO @ O_TYPE ) ! ( MESSAGE TYPE )
OUT_TABLE ( OUT_BUF_NO @ O_DEST ) 1B ( DESTINATION )
OVER 0 DO DUP I + @B
OUT_TABLE ( OUT_BUF_NO @ O_DAT_BUF I + ) 1B LOOP DROP
1 + 2 / 3 + 3F MASK OUT_TABLE ( OUT_BUF_NO @ O_BUF_LEN ) 1B
GET_BUF
ELSE POP POP POP POP
THEN

```

```

( BLOCK RECEIVE AND TRANSMIT ROUTINES )

```

```

: TOT&REM ( GET SUB-BLOCK TOTAL AND REMAINDER )
1 + 2 / FFFF MASK ( WORD COUNT )
20 / DUP SWAP ( SUB-BLOCK TOTAL )
3F 10 LEFT MASK
80 / 200 / ( REMAINDER )

```

```

: BLK_SEND O_BLK_STAT @ 8000 MASK 0 = IF
O_BLK_START O_BLK_STAT CLZ ( CLEAR UP TABLE )
O_BLK_DESTIN 1B ( DESTINATION )
2 / O_BLK_START ! ( START ADDRESS )
TOT&REM
O_BLK_STAT !
O_BLK_TOT 1B
80 O_BLK_STAT 1B ( GO GO GO )
ELSE DROP DROP DROP ( GET RID OF PARAMS )
THEN

```

```

: BLK_REC IN_BLK_STAT @ 8000 MASK 0 = IF
DROP DROP DROP ( GET RID OF UNWANTED PARAMS )
ELSE 0 IN_BLK_STAT 2 + 1L ( CLEAR UP )

```

```

( RUN A TEST )
( ASSUMES ALL UNITS ALREADY SETUP CORRECTLY )

RUN NSET SHY          ( SEND THE BK.SRC NUMBER & RESET VARIABLES )
SRUN                 ( TELL THE RECEIVERS TO START )
RESET*REP            ( SET ALL POINTERS TO ZERO )
BEGIN                ( THIS IS WHAT WE CAME FOR )
    8000 0 DO BK.TX LOOP      ( DO A FEW TRANSMISSIONS )
OD TO TEST_BYTE @
    BUF?
    END

```

```

: S2 SETUP ;
: SETUP S2 0 WAITING | RESET*REP AC12 @L 2 + @B ;

```

```

( SHORT MESSAGE SOAK TESTS )
( ASWE SHIP TRIALS )
( REVISION 1.0 JANUARY 1982 )

```

```

ANALYSE CODE
9482  SUB.L D2,D2
2602  MOVE.L D2,D3
2802  MOVE.L D2,D4
265E  MOVE.L (A6)+,A3
245E  MOVE.L (A6)+,A2
221E  MOVE.L (A6)+,D1
3601 A MOVE.W D1,D3
381B  MOVE.W (A3)+,D4
B943  EOR.W D4,D3
670A  BEQ.S B
5242  ADDQ #1,D2
B47C  CMP #69,D2
0009
6E02  BGE.S B
2D03  MOVE.L D3,-(A6)
5241 B ADDQ #1,D1
B5CB  CMP.L A3,A2
6EEB  BGE.S A
2D02  MOVE.L D2,-(A6)
4E75  RTS
0000

```

```

: M_BYTE VARIABLE ;          ( MTB, USED TO GENERATE MESSAGES )
BK_START CONSTANT M_START   ( USE SAME SPACE AS BLOCK TEST )
39  CONSTANT M_LENGTH      ( MAXIMUM DATA MESSAGE LENGTH )
M_START M_LENGTH + CONSTANT M_END
: UCOUNT VARIABLE ;       ( COUNT OF UNITS IN THIS TEST )
: FLAG VARIABLE ;

```

```

: SME* X_COM % UNITS1 % ;
: SME SME* HW_NO @ DISSECT
  DUP 1 = IF DROP OVER 1B
  ELSE 2 = IF ROT OVER 1 + 1B SWAP OVER 1B THEN THEN
  0 0 SEND

```

```

: WAIT_A_WHILE 4000 1 DO LOOP ;

```

```

: UNITS1 U_POINT [ UCOUNT @ ] |
  UCOUNT *1 ;          ( STORE ANOTHER TERMINAL NUMBER )

: M.GEN M_BYTE @ FF MASK DUP @ LEFT + ( FORM GENERATOR )
  M_END M_START BK.GEN ;

: M.SEND DUP M.GEN DROP M_LENGTH M_START
  ROT ROT M_BYTE @ FF MASK
  100 + SEND          ( SET TYPE EXTENSION BIT )
  M_BYTE *1 ;

```

```

: REP*NO VARIABLE ;
B : REP ARRAY ;

```

```

: M.SAVE E - 2 * C + REP SWAP DROP + *1 ; ( INC MESSAGE COUNT )

```

```

: RX_WAIT 0 FLAG | 4000 0 DO RECEIVE 0 = IF STOP
  ELSE I FLAG |
  THEN LOOP ;

```

```

: ERRORTOT VARIABLE ;

```

```

: CL_REP REP DUP 15 + SWAP DO 0 I 1B LOOP DROP ;

```

```

: MSTRIP CL_REP AAAA REP [ 1 ] | ( FLAG ERROR RECORD )
  REP*NO @ REP [ 0 ] |
  A 2 DO REP [ I ] | LOOP
  REP STOREIT ;

```

```

: M.ERRS ERRORTOT @ + ERRORTOT | MSTRIP ;

```

```

: M.ANALYSE FF MASK DUP @ LEFT + SWAP
  POP STK ROT SWAP
  OVER + SWAP ANALYSE
  DUP 0 > IF M.ERRS
  ELSE DROP THEN UNST PUSH ;

```

```

: GTIME1 0 PR_TAB 66 + | 4000 1 DO PR_TAB 66 + @ 8000 = IF STOP THEN LOOP
  2 0 DO PR_TAB 68 + I2 @ OVER I2 | LOOP DROP ;

```

```

: MREPORT          ( REPORT TO ITSELF )
  REP 2 + GTIME1 DROP
  ERRORTOT @ REP [ 4 ] | ( UNDETECTED ERRORS )
  RE_COUNT @ REP [ 5 ] | ( DETECTED ERRORS )
  REP*NO @ REP [ 0 ] | ( REPORT NUMBER )
M_BYTE @ REP [ 6 REP*NO @ + ] | ( TOTAL MESSAGES SENT )
  REP STOREIT          ( DO THINGS THE EASY WAY )

```

```

: SETBITS          ( SET A FEW URGENTLY NEEDED BITS )
HW_NO @ 3F MASK E - REP*NO |
CL_REP 0 ERRORTOT | 0 M_BYTE | ;

```

```
: USAY CRLF STRING $TERMINALS IN TEST:- $ SAY  
SPACE HW_NO @ . ;
```

```
: SMRUN ( SAY HELLO TO EVERYONE )  
DISINT  
RESET*REP  
SETBITS  
UCOUNT @ 1 - ( GET TOTAL NUMBER OF RESPONSES )  
USAY  
0 DO U_POINT [ I ] @ DUP M.SEND  
SPACE . LOOP CRLF
```

```
BEGIN  
LSIZE 1 DO  
RX_WAIT ( WAIT TO RECEIVE ANYTHING )  
FLAG @ 4000 = IF STOP THEN  
DUP 100 MASK 0 > IF  
M.ANALYSE ( ANALYSE RECEIVED MESSAGE )  
M.SEND ( REPLY TO THE SRC TERMINAL )  
M.SAVE ( SAVE COUNT FOR STATUS REPORTS )  
ELSE PROCESS  
THEN  
LOOP  
HREPORT  
BUF?  
FLAG @ 4000 = IF ENINT QUIT THEN  
END ;
```

```
: S2 SETUP ;  
: SETUP S2 IFF 100 DO I S_TYP LOOP  
SETBITS ;
```

```
: SSRUN* X_COM $SMRUN $ ;  
: SRUN 0 ERRORTOT | 0 M_BYTE | 0 UCOUNT | 0 FLAG | ;  
: SRUN1 SRUN SME ;  
: SSCL* X_COM $SRUN1 $ ;  
: SSCL SRUN SSCL* 0 0 SEND WAIT_A_WHILE SME ;
```

```
: SSRUN SMY SSCL WAIT_A_WHILE  
SSRUN* 0 0 SEND  
SMRUN ;
```

```
: SSTOP* X_COM $SSTOP $ ; ( TELL OTHER UNITS TTO STOP SMST )  
: SSTOP SSTOP* 0 0 SEND ;
```

```
: IRESET LOCATE INTER @INT @ + EQUATES | ;  
: _RES RESTART SETUP IRESET INTER ;  
: ZRESET LOCATE _RES @INT @ + EQUATES | ;
```

```
LENDFILE
```

2) Slave Terminal Unit Program.

COUNT2 @ 10) IF QUIT THEN

END

TOP VARIABLE ; (USED TO FLAG A STOP)
SETUP ;
TBITS HW_NO @ 3F MASK E - REP*NO I
CL_REP @ FSTOP I

TUP S2 SETBITS ;

ORT MESSAGE SOAK TESTS)
ME SHIP TRIALS)
VISION 1.0 JANUARY 1982)

.GEN CODE
265E MOVE.L (A6)+,A3
245E MOVE.L (A6)+,A2
2216 MOVE.L (A6),D1
34C1 ONE MOVE.W D1,(A3)+
5241 ADDQ.W #1,D1
B5C8 CMPA.L A3,A2
6CF8 BGE ONE
4E75 RTS
0000

BYTE VARIABLE ; (MTB, USED TO GENERATE MESSAGES)
START CONSTANT M_START (USE SAME SPACE AS BLOCK TEST)
CONSTANT M_LENGTH (MAXIMUM DATA MESSAGE LENGTH)
PART M_LENGTH + CONSTANT M_END
COUNT VARIABLE ; (COUNT OF UNITS IN THIS TEST)
FLAG VARIABLE ;

E* X_COM % UNITS1 % ;
E SMC HW_NO @ DISSECT
DUP 1 = IF DROP OVER 1B
ELSE 2 = IF ROT OVER 1 + 1B SWAP OVER 1B THEN THEN
D 0 SEND

IT_A_WHILE 4000 1 DO LOOP ;

I_POINT ARRAY ; (ARRAY OF TERMINAL NUMBERS OF UNITS IN TEST)

ITS1 U_POINT [UCOUNT @] ;
UCOUNT *1 ; (STORE ANOTHER TERMINAL NUMBER)

EN M_BYTE @ FF MASK DUP @ LEFT + (FORM GENERATOR)
M_END M_START BK.GEN ;

END DUP M.GEN DROP M_LENGTH M_START
ROT ROT M_BYTE @ FF MASK
100 + SEND (SET TYPE EXTENSION BIT)
M_BYTE *1 ;

AVE E - 2 * C + REP SWAP DROP + *1 ; (INC RECEIVE COUNT)

RX_WAIT 0 FLAG 1 4000 0 DO RECEIVE 0 = IF STOP
ELSE I FLAG I
THEN LOOP ;

M.ERRS ERRORTOT @ + ERRORTOT I MSTRIP ;

M.ANALYSE FF MASK DUP @ LEFT + SWAP (USES MTB EXTRACTED FROM)
POP STR ROT SWAP
OVER + SWAP ANALYSE
DUP 0 > IF M.ERRS
ELSE DROP THEN UNST PUSH ;

SREPORT (REPORT TO MASTER TERMINAL)
REP 2 + GTIME1 DROP (TIME WORDS)
ERRORTOT @ REP [4] ; (UNDETECTED ERRORS)
RE_COUNT @ REP [5] ; (DETECTED ERRORS)
REP*NO @ REP [0] ; (REPORT NUMBER)
M_BYTE @ REP [6 REP*NO @ +] ; (TOTAL TXD MESSAGE COUNT)
REP BK.SRC @ 3F MASK 1 SEND ; (SEND TO MASTER)

ZOO CONSTANT LSIZE

SSTOP 1 FSTOP I ; (FLAG A STOP TO SSRUN LOOP)

SMRUN (SAY HELLO TO EVERYONE)
DISINT
SETBITS
UCOUNT @ 1 - (GET TOTAL NUMBER OF RESPONSES)
D 0 DO U_POINT [I] @ M.SEND LOOP (TRANSMIT MESSAGE TO EACH)
BEGIN
LSIZE 1 DO
RX_WAIT (WAIT TO RECEIVE ANYTHING)
FLAG @ 4000 = IF STOP THEN
DUP 100 MASK 0 > IF
M.ANALYSE (ANALYSE RECEIVED MESSAGE)
M.SEND (REPLY TO THE SRC TERMINAL)
M.SAVE
ELSE PROCESS
THEN
FSTOP @ 1 = IF 4000 FLAG 1 STOP THEN (STOP IF FLAGGED)
LOOP
SREPORT
FLAG @ 4000 = IF ENINT QUIT THEN
END ;

S2 SETUP ;
SETUP S2 1FF 100 DO I S_TYP LOOP

SSRUN X_COM %SMRUN % ;
SRUN 0 SEQU 1 0 ERRORTOT I 0 M_BYTE I 0 UCOUNT I 0 FLAG I ;
SRUN1 SRUN SMC ;

1RESET LOCATE INTER @INT @ + EQUATES I ;
_RES RESTART SETUP 1RESET INTER ;
2RESET LOCATE _RES @INT @ + EQUATES I ;

SENDFILE

3) MC6809 Monitor Unit Program.

```

017 * PROGRAM TO STORE THE INFORMATION
018 * PRESENTED AT THE SECOND PORT
019 * BY THE 68000
020 * ASSUMES SECOND PORT IS AT F518
021 * ASSUMES PRIMARY ACIA AT F500
022 * COMMANDS AVAILABLE ARE :-
023 * D DISPLAY DISK STATUS
024 * Q QUIT LOGGING ACTIVITY
025 * A ENGAGE THE AUTO PILOT
026 * N DISENGAGE THE AUTO-PILOT
027 * C CHANGE DRIVES, USE INSTEAD OF GEORGE
028 * R REPORTS LAST MESSAGE FROM EACH TERMINAL

```

```

00229
00230          F500      ACIA1 EQU  #F500
00231          F518      ACIA2 EQU  #F518
00232
00233 0000 B8 0274      START LDX  #TMP5
00234 0003 B8 D2A6      JSR    ZOUT5T
00235 0006 B8 00AA      NINE   JSR    INIT
00236 0009 B8 F518      LDX   #ACIA2
00237 000C B6 03       LDA   #03
00238 000E A7 84       STA   X
00239 0010 B6 15       LDA   #015
00240 0012 A7 84       STA   X
00241 0014 B8 53 0069  BSR    DKINIT  OPEN THE DISK FILE
00242 0016 B8 F500      FIVE   LDX   #ACIA1
00243 0019 A6 84       LDA   ,X
00244 001B B5 01       BITA  #1
00245 001D 27 03 0022  BEQ   SEVEN
00246 001F B8 0146      JSR   SERVE
00247 0022 B8 F518      SEVEN LDX   #ACIA2
00248 0025 A6 84       ONE   LDA   ,X  ANYTHING THERE??
00249 0027 B5 01       BITA  #1
00250 0029 27 EB 0016  BEQ   FIVE  NO 50 TRY AGAIN
00251 002B E6 01       LDB  1,X  CLEAR HANDSHAKE
00252 002D 108E 071D   LDY  #BUFF
00253 0031 C6 40       LDB  #040
00254 0033 E7 01       STB  1,X  TELL 68K WE ARE READY
00255 0035 C6 00       LDB  #0
00256 0037 CE 0000      FOUR  LDU   #0
00257 003A A6 84       THREE LDA   ,X
00258 003C B5 01       BITA  #1
00259 003E 26 22 0062  BNE  TWO  RX'D ANYTHING??
00260 0040 33 41       LEAU 1,U  YES SO GO
00261 0042 1183 FFFF   CMPU  #FFFF COUNT OF LAPSED TIME
00262 0046 26 F2 003A BNE  THREE HAVE I WAITED LONG ENOUGH??
00263 0048 C1 00       CMPB #0  NOT YET I HAVEN'T!
00264 004A 27 EE 003A BEQ  THREE
00265 004C B6 0554    LDA  ERROR  DO WE HAVE A PROBLEM
00266 004F 4D       TSTA
00267 0050 26 05 0057 BNE  TEN
00268 0052 B8 37 008B BSR  OUTPUT YES I HAVE, SO GO DUMP DATA
00269 0054 B8 01FE    JSR  SAVE
00270 0057 B6 0556    TEN  LDA  AUTO
00271 005A 4D       TSTA
00272 005B 27 B9 0016 BEQ  FIVE
00273 005D B8 00E2    JSR  GEORGE
00274 0060 20 B4 0016 BRA  FIVE  AND RETURN TO LIVE ANOTHER D
00275 0062 A6 01 TWO  LDA  1,X  GET THE RELEVANT CHARACTER
00276 0064 A7 A0      STA  Y+  BUFFER IT
00277 0066 5C       INCB
00278 0067 20 CE 0037 BRA  FOUR  AND GO TRY FOR ANOTHER
00279
00280 0069 B8 0557      DKINIT LDX  CFCB
00281 006C B6 01       LDA  #Q504W
00282 006E A7 84       STA  XFC,X
00283 0070 B8 D786      JSR  DFM  WELL, LET THE DFM DO IT FOR
00284 0073 27 0E 0083 BEQ  DKONE  ALL IS WELL SO GO
00285 0075 B8 D2A9      SIX   JSR  ZTYPDE  ALL IS NOT WELL SO TELL THE

```



```

0 0173 8E 023A LDX 0TMP3
1 0176 8D D2A6 JSR ZOUTST
2 0179 39 RTS
3 017A 81 51 51 CMPA 0'Q
4 017C 24 0C 018A BNE 52 QUIT COMMAND ??
5 017E 8E 0253 QUIT LDX 0TMP4
6 0181 8D D2A6 JSR ZOUTST YES SO ACKNOWLEDGE
7 0184 8D D783 JSR CDFM CLOSE ALL FILES
8 0187 7E D283 JMP ZWARMS RETURN TO FACE THE MUSIC!!
9 018A 81 41 52 CMPA 0'A
0 018C 24 0A 0198 BNE 53
1 018E 87 0556 STA AUTO ENGAGE GEORGE, THE AUTOPILOT
2 0191 8E 0318 LDX 0TMP7
3 0194 8D D2A6 JSR ZOUTST
4 0197 39 RTS
5 0198 81 4E 53 CMPA 0'N
6 019A 24 08 01A7 BNE 54
7 019C 4F CLRA
8 019D 87 0556 STA AUTO DISENGAGE GEORGE
9 01A0 8E 0343 LDX 0TMP8
0 01A3 8D D2A6 JSR ZOUTST
1 01A6 39 RTS
2 01A7 81 48 54 CMPA 0'H
3 01A9 24 07 01B2 BNE 55
4 01AB 8E 0366 LDX 0TMP9
5 01AE 8D D2A6 JSR ZOUTST
6 01B1 39 RTS
7 01B2 81 43 55 CMPA 0'C
8 01B4 24 1E 01D4 BNE 56
9 01B6 8E 04D7 LDX 0TMP12
0 01B9 8D D2A6 JSR ZOUTST
1 01BC 8E 0557 LDX CFCB
2 01BF 86 03 LDA 0QSWC
3 01C1 A7 84 STA XFC,X CLOSE CURRENT ONE
4 01C3 8D D786 JSR DFM
5 01C6 10BE 0559 LDY AFCB
6 01CA 10BF 0557 STY CFCB
7 01CE BF 0559 STX AFCB SWAP FCB'S
8 01D1 9D 69 JSR DKINIT OPEN OTHER DRIVE
9 01D3 39 RTS
0 01D4 81 52 56 CMPA 0'R
1 01D6 24 25 01FD BNE 57
2 01D8 10BE 055B LDY 05BUF SAVE BUFF START
3 01DC 5F CLR B
4 01DD A6 A0 56B LDA Y+
5 01DF 5C INCB
6 01E0 8D D2AC JSR ZOUTHX
7 01E3 84 20 LDA 0820
8 01E5 8D D2BE JSR ZOUTCH
9 01E8 C1 18 CMP B 0818
0 01EA 24 08 01F7 BNE 56A
1 01EC 86 0D LDA 08D
2 01EE 8D D2BE JSR ZOUTCH
3 01F1 86 0A LDA 08A
4 01F3 8D D2BE JSR ZOUTCH
5 01F6 5F CLR B
6 01F7 108C 05D3 56A CMPY 05END

```

```

00457 01FB 26 E0 01DD BNE 56B
00458 01FD 39 57 RTS
00459
00460 01FE 31 AB EB SAVE LEAY -018,Y
00461 0201 EC 22 LDD 2,Y
00462 0203 1083 AAAA CMP D 08AAAA ERROR REPORT??
00463 0207 26 01 020A BNE 5A V1
00464 0209 39 RTS YES SO RETURN
00465 020A A6 21 5A V1 LDA 1,Y GET REP'NO
00466 020C C6 18 LDB 0818 RECORD LENGTH
00467 020E 3D MUL OFFSET INTO BUFFER
00468 020F 8E 055B LDX 05BUF BUFFER START
00469 0212 3A ABX POINTER TO RECORD BUFF
00470 0213 C6 18 LDB 0818
00471 0215 A6 A0 5A V2 LDA Y+ GET A CHAR FROM INCOMING REC
00472 0217 A7 80 STA X+ STORE IN 5BUF
00473 0219 5A DECB
00474 021A 2E F9 0215 BGT 5A V2
00475 021C 39 RTS
00476
00477 021D 0000 TMP1 FDB 0 SPACE FOR D COMMAND
00478 021F 20 TMP2 FCC / FREE SECTORS ON DRIVE :- /
00479 0239 00 FCB 0
00480 023A 20 TMP3 FCC / CURRENT LOGGING DRIVE/
00481 0250 0D FCB 00D,00A,00
00482 0253 43 TMP4 FCC /CLOSE ALL FILES AND QUIT LOGGING/
00483 0273 0D FCB 00D,00A,00
00484 0274 2A TMP5 FCC /*****
00485 0293 0D FCB 00D,00A
00486 0295 2A FCC /* DATA LOGGING PROGRAM V1.1 */
00487 02B2 0D FCB 00D,00A
00488 02B4 2A FCC /* DECEMBER 1981 */
00489 02D1 0D FCB 00D,00A
00490 02D3 2A FCC /*****
00491 02F0 0D FCB 00D,00A,0
00492 02F3 45 TMP6 FCC /ENTER FIRST LOGGING DRIVE NUMBER :-
00493 0317 00 FCB 0
00494 0318 45 TMP7 FCC /ENGAGE GEORGE, THE FAITHFUL AUTO-PIL
00495 0340 0D FCB 00D,00A,0
00496 0343 44 TMP8 FCC /DISENGAGE GEORGE, THE POOR BEAST/
00497 0363 0D FCB 00D,00A,0
00498 0366 48 TMP9 FCC /HELP/
00499 036A 0D FCB 00D,00A
00500 036C 41 FCC /A :- ENGAGE THE AUTO-PILOT/
00501 0386 0D FCB 00D,00A
00502 0388 43 FCC /C :- CHANGE DRIVES, USE INSTEAD OF 0
00503 03B1 0D FCB 00D,00A
00504 03B3 44 FCC /D :- DISPLAY SYSTEM STATUS/
00505 03CD 0D FCB 00D,00A
00506 03CF 4E FCC /N :- DISENGAGE THE AUTO-PILOT/
00507 03EC 0D FCB 00D,00A
00508 03EE 51 FCC /Q :- CLOSE FILES AND QUIT LOGGING/
00509 040F 0D FCB 00D,00A
00510 0411 52 FCC /R :- DISPLAYS LAST REPORT FROM EACH
00511 043D 0D FCB 00D,00A,0
00512 0440 2A TMP10 FCC /*****WARNING*****

```

```

13 045E 0D          FCB  00D,00A
14 0460 20          FCC  / CURRENT AND SECONDARY DRIVES /
15 047E 0D          FCB  00D,00A
16 0480 20          FCC  /      BOTH NEARLY FULL      /
17 049E 0D          FCB  00D,00A
18 04A0 2A          FCC  /*****
19 04BE 0D          FCB  00D,00A,0
20 04C1 2A          TMP11 FCC  /*****ATTENTION*****/
21 04D4 0D          FCB  00D,00A,007
22 04D7 2A          TMP12 FCC  /****CHANGE DRIVES****/
23 04EC 0D          FCB  00D,00A,00
24 04EF 2A          FCC  /**SECONDARY FULL***/
25 0502 0D          FCB  00D,00A,007
26 0505 43          FCC  /CHANGE IMMEDIATELY/
27 0517 0D          FCB  00D,00A,007,0
28 051B 45          TMP13 FCC  /ERROR WITH LOGGING FILE/
29 0532 0D          FCB  00D,00A
30 0534 52          FCC  /REPLACE A DISK AND RE-ENTER/
31 054F 0D          FCB  00D,00A,00
32 0552 0002        DONE  RMB  2      A FLAG FOR GEORGE
33 0554 0002        ERROR  RMB  2      FLAG FOR BOTH DISKS FULL
34 0556 00          AUTO  FCB  0
35 0557 0002        CFCB  RMB  2
36 0559 0002        AFCB  RMB  2
37 055B 0070        SBUF  RMB  120
38          05D3        SEND  EQU  *
39 05D3 0003        FCB1  BSZ  3
40 05D6 36          FCC  /68KDAT/
41 05DC 009C        FCB2  BSZ  156
42 0478 0003        FCB2  BSZ  3
43 047B 36          FCC  /68KDAT/
44 0481 009C        FCB2  BSZ  156
45          071D        BUFF  EQU  *
46          END

```

AL ERRORS 00000

AL WARNINGS 00000---00000

BLOCK MESSAGE SOAK TEST)
RECEIVE ROUTINE)
ASME TRIALS)
DECEMBER 1981)

DO CONSTANT BK.START (START OF TEST BLOCK)
) CONSTANT BK.LENGTH
.START BK.LENGTH + CONSTANT BK.END (END OF TEST BLOCK)
TEST_BYTE VARIABLE ; (START OF MESSAGE TEST_BYTE)
ERRORTOT VARIABLE ; (ERROR TOTAL)
BK.SRC VARIABLE ;
STARTING VARIABLE ;
COUNT VARIABLE ; (COUNT OF BK.RX TRIES)
SEQU VARIABLE ; (OUT OF SEQUENCE COUNT)
COUNT2 VARIABLE ;
EACH RX HAS A UNIQUE REP*NO)
AND THE TX USES IT TO REFERENCE ITS ARRAY OF POINTERS)
REP*NO VARIABLE ;

REP ARRAY ;

CL.REP REP DUP 15 + SWAP DO 0 1 1B LOOP DROP ;
MSTRIP CL.REP AAAA REP [1] 1 (FLAG ERROR RECORD)
REP*NO @ REP [0] 1
A 2 DO REP [1] 1 LOOP
REP BK.SRC @ 3F MASK 1 SEND ;

ANALYSE CODE

9482 SUB.L D2,D2
2402 MOVE.L D2,D3
2802 MOVE.L D2,D4
245E MOVE.L (A6)+,A3
245E MOVE.L (A6)+,A2
221E MOVE.L (A6)+,D1
3601 A MOVE.W D1,D3
381B MOVE.W (A3)+,D4
B943 EOR.W D4,D3
470A BEQ.S B
5242 ADDQ #1,D2
B47C CMP #89,D2
0009
4E02 BGE.S B
2D03 MOVE.L D3,-(A6)
5241 B ADDQ #1,D1
B5CB CMP.L A3,A2
4EE8 BGE.S A
2D02 MOVE.L D2,-(A6)
4E75 RTS
0000

SETS UP ERRORTOT OR SEQU DEPENDING ON THE NUMBER OF ERRORS)

BK.ERRS DUP 20 > IF SEQU *1 BK.START @ 1 + TEST_BYTE 1
DROP MSTRIP
ELSE ERRORTOT @ + ERRORTOT 1 MSTRIP
THEN ;

BK.REC BK.LENGTH BK.START BK.SRC @
BLK_REC (SET UP TO RECEIVE THE BLOCK)

BKR.STAT IN_BLK_STAT @B 80 MASK

(CHECK THAT THE RECEIVED BLOCK AGREES WITH THE ONE WE ARE EXPECTING)

BK.ANALYSE TEST_BYTE @
BK.END BK.START
ANALYSE
TEST_BYTE *1

(USE THIS COMMAND TO SET UP A COMMAND LINE)
(WHICH WILL BE SENT ELSEWHERE)
X_COM IMMEDIATE @ STRING OD DP @ 1 - 1B ;

OK? 02 2000 BK.SRC @ 3F MASK 2 SEND ; (ACKNOWLEDGE BLOCK RX)

(RECEIVE A BLOCK IF POSSIBLE)
(EVERY UNSUCCESSFUL ATTEMPT IS COUNTED AND ANOTHER)
(HANDSHAKE IS SENT FOR EVERY 300 TIMES IT FAILS)

BK.RX BKR.STAT 00 > IF
BK.ANALYSE
DUP 0 > .IF BK.ERRS ELSE DROP
THEN
BK.REC OK? COUNT *1
THEN (AVOID A LOCK OUT)

(SET UP A FEW VARIABLES)
(THIS COMMAND IS SENT BY THE TRANSMITTER)
(AND INITIALISES BK.SRC ACCORDINGLY)

SET.TX BK.SRC 1 0 STARTING 1 0 ERRORTOT 1 0 TEST_BYTE 1
0 SEQU 1 0 COUNT2 1 ;

(GET THE FIRST THREE TIME WORDS INTO A THREE CONSECUTIVE LOCATIONS)

GTIME1 0 PR_TAB 66 + 1 4000 1 DO PR_TAB 66 + @ 8000 = IF STOP THEN LOOP
2 0 DO PR_TAB 68 + 12 @ OVER 12 1 LOOP DROP ;

(SEND A REPORT TYPE ONE 'STOREIT' TO TX)
(REPORT THE TIME, ERRORTOT, RE_COUNT AND REP*NO)

REPORT REP 2 + GTIME1 DROP (GET SOME TIME INTO THE SCENE)
ERRORTOT @ REP [4] 1 (THE TOTAL NUMBER OF ERRORS)
RE_COUNT @ REP [5] 1 (RECEIVE ERROR TOT)
REP*NO @ REP [0] 1 (THE TERMINALS REPORT NUMBER)
SEQU @ REP [6] 1 (MESSAGE OUT OF SEQUENCE)
TEST_BYTE @ REP [7] 1 (NUMBER OF MESSAGES, SORT OF)
REP BK.SRC @ 3F MASK 1 SEND ;

(TEST LOOP)

RUN 0 COUNT 1 BK.REC OK? (FIRST HANDSHAKE TRANSMISSION)
BEGIN

8000 0 DO BK.RX LOOP
COUNT @ 0 = IF OK? COUNT2 *1 ELSE 0 COUNT2 1
THEN 0 COUNT 1

REPORT

```

IN_BLK_STAT 1 + 1B      ( REMAINDER )
IN_BLK_TOTAL 1B      ( SUB-BLOCK TOTAL )
0 IN_BLK_STAT 1B      ( GO GO GO )
THEN

```

(MESSAGE RECEIVE ROUTINES)

```

: INU -1 SWAP - ;
: S_TYP      ( SELECT A CERTAIN MESSAGE TYPE )
  DUP F MASK 1 SWAP LEFT SWAP 10 / FFFF MASK 2 *
  MES_TAB + DUP @ INU ROT ROT MASK OVER @ + SWAP ! ;
  ( SETS THE DESIRED BIT IN THE MTT ARRAY )

: CL_TYP      ( DESELECT A CERTAIN MESSAGE TYPE )
  DUP F MASK 1 SWAP LEFT INU SWAP 10 / FFFF MASK 2 *
  MES_TAB + DUP @ ROT ROT MASK SWAP ! ;
  ( CLEARS THE DESIRED BIT IN THE MTT ARRAY )

: IN_BUF_NO VARIABLE ;

: REL_BUF IN_BUF_NO DUP @ 1 + F MASK SWAP ! THEN ;
  ( MOVE TO NEXT INPUT BUFFER, WRAPAROUND AT 'F' )

: RECEIVE      ( CHECKS TO SEE IF A MESSAGE IS AVAILABLE )
  IN_TABLE ( IN_BUF_NO @ IN_BUF_LEN ) @B DUP
  0 ) IF 3 - 2 *      ( SIZE IN BYTES )
  IN_TABLE ( IN_BUF_NO @ IN_DAT_BUF )      ( ADDRESS )
  IN_TABLE ( IN_BUF_NO @ IN_SOURCE ) @B      ( SOURCE )
  IN_TABLE ( IN_BUF_NO @ IN_TYPE ) @      ( TYPE )
  0 IN_TABLE ( IN_BUF_NO @ IN_BUF_LEN ) 1B ( CLEAR IT )
  REL_BUF      ( READY FOR NEXT TIME )
  0      ( EVERYTHING WAS OK )
  ELSE DROP -1      ( NOTHING WENT RIGHT!! )
  THEN

```

```

: TAB_SET RESET CCW 1 800 A00 CL2 6800 5700 CL2
80 IN_INT 1B 10 IN_NO 1B
2080 IN_TAB 1
80 O_INT 1B 10 O_NO 1B
2080 O_TAB 1
0 OUT_BUF_NO 1
0 IN_BUF_NO 1
8000 IN_BLK_STAT 1 ;

```

```

SETUP THE TERMINAL UNIT )
S2 SETUP ;      ( THE SETUP IN THE DICTIONARY MUST BE USED TOO )
SETUP S2 TAB_SET FFFF MES_TAB 1 GO CCW 1 ;

```

THIS ROUTINE ALLOWS THE INSERTION OF HAND ASSEMBLED MACHINE CODE TO SPEED THINGS UP A BIT)

```

CODE IMMEDIATE 100 1 DO FRELO @ 0 = IF BUFFER ELSE LOAD THEN
WORD NUMBER DUP 0 = IF
STOP THEN DPI LOOP ;

```

PTM REGISTERS)

```

FF61 CONSTANT PTM      ( BASE )
TM      CONSTANT WR3
TM      CONSTANT WR1
TM 2 + CONSTANT WR2
TM 4 + CONSTANT T#1
TM 4 + CONSTANT WT#1

```

(USE PTM TO PROVIDE INTERRUPTS FOR 2901 SERVICE ROUTINE)

```

( SET IT TO INTERRUPT APPROXIMATELY ONCE A SECOND )
: SETPTM 0 WR2 1B 1 WR3 1B 1 WR2 1B      ( DIVIDE BY 8 )
  42 WR1 1B      ( CONTINUOUS OPERATION )
  7F T#1 1B FF WT#1 1B      ( AS SLOW AS POSSIBLE )

```

(THIS ROUTINE WILL PERFORM A NORMAL SIXTH)
 (WORD FIND EXECUTE ON THE CONTENTS OF)
 (A TYPE ZERO MESSAGE WHICH HAS BEEN RECEIVED)
 (FROM THE OUTSIDE WORLD BY THE 2901 SUBSYSTEM)

```

: DOIT WE 1      ( START ADDRESS )
  0 LAST !
  30 0 DO WORD FIND EXECUTE      ( NEW INTERPRET LOOP )
  0 LAST @ = IF      ( OK IF = 0 )
  ELSE STOP      ( OTHERWISE GIVE UP )
  THEN LOOP

```

```

: I IMMEDIATE ;      ( I.E THROW IT AWAY )
: J 2 * + SWAP DROP ;
: I2 I 2 * + ;

```

: TX.OK VARIABLE ;

```

: PROCESS
  DUP 2 = IF TX.OK *1 POP POP POP POP
  ELSE DUP 0 = IF      ( TYPE ZERO?? )
  DROP DROP DOIT POP      ( DO AS THE MAN SAYS )
  ELSE POP POP POP POP
  THEN THEN

```

(IRQ5 HANDLES THE PTM INTERRUPT)
 (IT FIRST CHECKS FOR ANY RECEIVED MESSAGES)
 (IF ANY HAVE BEEN RECEIVED, IT TRIES FOR EITHER)
 (A TYPE ZERO, OR A TYPE ONE, OR IGNORES IT)
 (FINALLY IT CLEARS THE PTM INTERRUPT)

```

: IRQ5 FRAME WE @ WB @ LAST @ FRAME      ( SAVE FOR POSTERITY )
  RECEIVE 0 = IF
  PROCESS
  THEN
  UNFRAME LAST 1 WB 1 WE 1
  WR2 @B T#1 @B      ( CLEAR PTM INTERRUPT )
  UNFRAME RTE

```

```

: S2 SETUP ;
: SETUP S2 LOCATE IRQ5 @INT 8 + 74 1L
SETPTM
ENINT

```

NEW SLAVE UNIT SOFTWARE)
DESTINED FOR THE SHIP TRIALS)
JANUARY 1982)
REVISION 3.0 JANUARY 1982)
INCLUDES BLOCK AND SHORT MESSAGE TESTS)
INCLUDES REVISION TO ALLOW USE OF MTB EXTENSION BIT)

STOREIT AND DOIT INCLUDED IN THIS ONE)

TERMINAL UNIT PRIMARY TABLE)

DO CONSTANT PR_TAB
R_TAB CONSTANT IN_INT
N_INT 1 + CONSTANT IN_NO
N_NO 2 + CONSTANT IN_POS
N_POS 1 + CONSTANT IN_TAB
N_TAB 2 + CONSTANT O_INT
_INT 1 + CONSTANT O_NO
_NO 2 + CONSTANT O_POS
_POS 1 + CONSTANT O_TAB
_TAB 2 + CONSTANT MES_TAB
ES_TAB 40 + CONSTANT HW_NO
I_NO 2 + CONSTANT RE_COUNT
E_COUNT 2 + CONSTANT DAT_STARV
IT_STARV 2 + CONSTANT RETR_COUNT
ETR_COUNT 2 + CONSTANT BUF_OVER
RF_OVER 2 + CONSTANT IN_BLK_STAT
I_BLK_STAT 2 + CONSTANT IN_BLK_SOURCE
I_BLK_SOURCE 2 + CONSTANT IN_BLK_TOTAL
I_BLK_TOTAL 1 + CONSTANT IN_BLK_TOT_RECVD
I_BLK_TOT_RECVD 1 + CONSTANT IN_BLK_ADDRESS
I_BLK_ADDRESS 2 + CONSTANT O_BLK_STAT
I_BLK_STAT 3 + CONSTANT O_BLK_DESTIN
I_BLK_DESTIN 1 + CONSTANT O_BLK_TOT
I_BLK_TOT 1 + CONSTANT O_BLK_TOT_TXD
I_BLK_TOT_TXD 1 + CONSTANT O_BLK_START

END OF PRIMARY TABLE)

IN TABLE)
MASK FOR A SINGLE BUFFER AREA)

(RELATIVE TO START OF BUFFER)
CONSTANT IN_BUF_LEN
_BUF_LEN 1 + CONSTANT IN_DEST
_DEST 1 + CONSTANT IN_SOURCE
_SOURCE 1 + CONSTANT IN_TYPE
_TYPE 2 + CONSTANT IN_DAT_BUF

OUT TABLE)
MASK FOR A SINGLE BUFFER AREA)

(RELATIVE TO START OF BUFFER)
CONSTANT O_BUF_LEN
BUF_LEN 1 + CONSTANT O_DEST
DEST 2 + CONSTANT O_TYPE
TYPE 2 + CONSTANT O_DAT_BUF

TABLE IMMEDIATE 2D3C DPl 0 DPl DPl 2D3C DPl 0 DPl DPl ;
(

) ROT * + + ;

(CHANNEL CONTROL WORD)

3C000 CONSTANT CCW

(CONTROL WORDS)

2 CONSTANT GO (START TERMINAL UNIT)
3 CONSTANT CSTOP (STOP TERMINAL UNIT)
4 CONSTANT OFFINT (SWITCH OFF INTERRUPTS)
5 CONSTANT ONINT (SWITCH ON AND CLEAR INTERRUPTS)
7 CONSTANT RESET (RESET AND HALT TERMINAL UNIT)

(BITS TO CONTROL TERMINAL UNIT)

40 5700 : IN_TABLE TABLE ;
40 5800 : OUT_TABLE TABLE ;
: OUT_BUF_NO VARIABLE ; (68K'S RECORD OF NEXT FREE BUFFER)
: GET_BUF OUT_BUF_NO DUP @ 1 + F MASK SWAP I ;
: CLZ DO 0 I 1B LOOP ;

(MESSAGE SEND ROUTINE)

: SEND OUT_TABLE (OUT_BUF_NO @ O_BUF_LEN) @B
O = IF (BUFFER IS FREE SO CARRY ON)
OUT_TABLE (OUT_BUF_NO @ 5) DUP 5 - CLZ
OUT_TABLE (OUT_BUF_NO @ O_TYPE) I (MESSAGE TYPE)
OUT_TABLE (OUT_BUF_NO @ O_DEST) IB (DESTINATION)
OVER 0 DO DUP I + @B
OUT_TABLE (OUT_BUF_NO @ O_DAT_BUF I +) IB LOOP DROP
1 + 2 / 3 + 3F MASK OUT_TABLE (OUT_BUF_NO @ O_BUF_LEN) IB
GET_BUF
ELSE POP POP POP POP
THEN

(BLOCK RECEIVE AND TRANSMIT ROUTINES)

: TOT&REM (GET SUB-BLOCK TOTAL AND REMAINDER)
1 + 2 / FFFF MASK (WORD COUNT)
20 / DUP SWAP (SUB-BLOCK TOTAL)
3F 10 LEFT MASK
80 / 200 / (REMAINDER)

: BLK_SEND O_BLK_STAT @ 8000 MASK 0 = IF
O_BLK_START O_BLK_STAT CLZ (CLEAR UP TABLE)
O_BLK_DESTIN IB (DESTINATION)
2 / O_BLK_START I (START ADDRESS)
TOT&REM
O_BLK_STAT I
O_BLK_TOT IB
80 O_BLK_STAT IB (GO GO GO)
ELSE DROP DROP DROP (GET RID OF PARAMS)
THEN

: BLK_REC IN_BLK_STAT @ 8000 MASK 0 = IF
DROP DROP DROP (GET RID OF UNWANTED PARAMS)
ELSE 0 IN_BLK_STAT 2 + IL (CLEAR UP)
IN_BLK_SOURCE I
2 / IN_BLK_ADDRESS I
TOT&REM

(A TYPE ZERO, OR A TYPE ONE, OR IGNORES IT)
(FINALLY IT CLEARS THE PTM INTERRUPT)

```
IRQS FRAME WE @ WB @ LAST @ FRAME      ( SAVE FOR POSTERITY )
RECEIVE 0 = IF
PROCESS
THEN
UNFRAME LAST | WB | WE |
WR2 @B T@1 @B ( CLEAR PTM INTERRUPT )
UNFRAME RTE
```

```
: S2 SETUP ;
SETUP S2 LOCATE IRQS @INT @ + 74 IL
SETPM
ENINT
```

(PERIODICAL BLOCK TRANSMIT ROUTINE)
(BLOCK MESSAGE SOAK TEST FOR ASWE TRIALS)
(DECEMBER 1981)
(REVISION 2.0 28/12/81)

```
7400 CONSTANT BK.START      ( START OF TEST BLOCK )
800 CONSTANT BK.LENGTH
BK.START BK.LENGTH + CONSTANT BK.END    ( END OF TEST BLOCK )
```

```
: TEST_BYTE VARIABLE ;      ( USED FOR CYCLIC MESSAGE GENERATION )
: RX_COUNT VARIABLE ;      ( TOTAL NUMBER OF TERMINALS )
```

(GENERATE A NEW BLOCK OF DATA)
(FROM THE TEST BYTE)
(SP => START,END,TEST_BYTE)

```
: BK.GEN CODE
245E MOVE.L (A6)+,A3
245E MOVE.L (A6)+,A2
2214 MOVE.L (A6),D1
36C1 ONE MOVE.W D1,(A3)+
5241 ADDQ.W @1,D1
B5CB CMPA.L A3,A2
4CF8 BQE ONE
4E75 RTS
0000
```

```
: BKS.STAT 0,BLK_STAT @B      ( TX BLOCK STATUS BYTE )
80 MASK 0 = IF 0 ELSE -1
THEN
( RETURNS 0 IF FINISHED, -1 IF NOT )
```

(BK.TX CHECKS THAT A HANDSHAKE HAS BEEN RECEIVED)
(IF SO, AND THE LAST BLOCK HAS BEEN TRANSMITTED)
(IT WILL GENERATE A NEW BLOCK, TRANSMIT IT)
(AND UPDATE THE TEST_BYTE)

```
: BK.TX
TX.OK @ RX_COUNT @ >= IF
BKS.STAT 0 = IF ( WAIT FOR THE OK FROM ABOVE )
TEST_BYTE @ BK.END BK.START BK.GEN
```

```
DROP BK.LENGTH BK.START 0,BLK_SEND
TEST_BYTE '1 0 TX.OK |
THEN
THEN
```

(X_COM MAKES A CR TERMINATED STRING)

```
: X_COM IMMEDIATE * STRING 0D DP @ 1 - 1B ;
```

(THESE TWO ROUTINES FORM THE '800A SET.TX' COMMAND SENT)
(TO ALL RECEIVERS)

```
: SCOM X_COM @0000 SET.TX @ ;
: SMY SCOM HW_NO @ DISSECT DROP OVER 3 + 1B
0 0 SEND 0 TEST_BYTE | 0 TX.OK | ;
```

(THESE ARE USED TO START THE TEST OFF)
: SRUN X_COM %RUN % ;
: SRUN SRUN 0 0 SEND ;

(REC.OK IS EXECUTED BY THE TRANSMITTER AS A HANDSHAKE)
: REC.OK TX.OK '1 ;

(RESET ALL REP POINTERS TO ZERO)

```
: RESET*REP 4 0 DO 0 REP*POINT C I J | LOOP ;
```

(DISPENSE WITH REPORTS WHICH ARE CLOGGING UP THE BUFFER)
(PRINTS THEM UP AND RESETS THE POINTER)

```
: WAITING VARIABLE ;      ( COUNT OF DUMP TRIES )
: BUF*SEND A2 DUP 2 * REP*POINT SWAP DROP + DUP @ 1 - 0 DO
OVER 300 * I 14 * +
REP*BASE + DUP
15 + SWAP DO I @B TO LOOP
LOOP
```

```
0 SWAP | DROP 0 WAITING |
ACI1 @L PORT IL
```

```
: ACHECK ACI2 @L @B 1 MASK 0 ) IF ACI2 @L 2 + @B DROP 0
ELSE -1
THEN
```

: OVERRUN STRING %SLIGHT PROBLEM CHAPS, OVERRUN!!!! % SAY
0 WAITING | RESET*REP CRLF

```
: DISPENSE WAITING @ 0 = IF 40 ACI2 @L 2 + 1B
THEN ACHECK 0 = IF BUF*SEND QUIT
ELSE WAITING '1 DROP THEN
WAITING @ 10 ) IF OVERRUN QUIT THEN
```

: BUF? CHECK (SEE IF ANYTHING NEEDS TO BE DONE)
DUP -1 = IF DROP
ELSE DISPENSE
THEN ;

```
: NSET STRING %NUMBER OF RECEIVERS IN TEST?? % SAY
CRLF BUFFER WORD NUMBER RX_COUNT | CRLF ;
```

2 / IN_BLK_ADDRESS I

TOTREM

IN_BLK_STAT 1 + 1B

IN_BLK_TOTAL 1B

0 IN_BLK_STAT 1B

THEN

(REMAINDER)

(SUB-BLOCK TOTAL)

(GO GO GO)

(MESSAGE RECEIVE ROUTINES)

INV -1 SWAP - ;

S_TYP (SELECT A CERTAIN MESSAGE TYPE)

DUP F MASK 1 SWAP LEFT SWAP 10 / FFFF MASK 2 *

MES_TAB + DUP @ INV ROT ROT MASK OVER @ + SWAP 1 ;

(SETS THE DESIRED BIT IN THE MTT ARRAY)

CL_TYP (Deselect a certain message type)

DUP F MASK 1 SWAP LEFT INV SWAP 10 / FFFF MASK 2 *

MES_TAB + DUP @ ROT ROT MASK SWAP 1 ;

(CLEARs THE DESIRED BIT IN THE MTT ARRAY)

IN_BUF_NO VARIABLE ;

REL_BUF IN_BUF_NO DUP @ 1 + F MASK SWAP 1 ;

(MOVE TO NEXT INPUT BUFFER, WRAPAROUND AT 'F')

RECEIVE (CHECKS TO SEE IF A MESSAGE IS AVAILABLE)

IN_TABLE (IN_BUF_NO @ IN_BUF_LEN) @B DUP

0 > IF 3 - 2 * (SIZE IN BYTES)

IN_TABLE (IN_BUF_NO @ IN_DAT_BUF) (ADDRESS)

IN_TABLE (IN_BUF_NO @ IN_SOURCE) @B (SOURCE)

IN_TABLE (IN_BUF_NO @ IN_TYPE) @ (TYPE)

0 IN_TABLE (IN_BUF_NO @ IN_BUF_LEN) 1B (CLEAR IT)

REL_BUF (READY FOR NEXT TIME)

0 (EVERYTHING WAS OK)

ELSE DROP -1 (NOTHING WENT RIGHT!!)

THEN

TAB_SET RESET CCW 1 B00 A00 CL2 6800 5900 CL2

B0 IN_INT 1B 10 IN_NO 1B

ZC00 IN_TAB 1

B0 O_INT 1B 10 O_NO 1B

ZE00 O_TAB 1

0 OUT_BUF_NO 1

0 IN_BUF_NO 1

B000 IN_BLK_STAT 1 ;

SETUP THE TERMINAL UNIT)

S2 SETUP ; (THE SETUP IN THE DICTIONARY MUST BE USED TOO)

SETUP S2 TAB_SET FFFF MES_TAB 1 GO CCW 1 ;

THIS ROUTINE ALLOWS THE INSERTION OF HAND ASSEMBLED)

MACHINE CODE TO SPEED THINGS UP A BIT)

CODE IMMEDIATE 100 1 DO FRELO @ 0 = IF BUFFER ELSE LOAD THEN

WORD NUMBER DUP 0 = IF

STOP THEN DPI LOOP ;

PTM REGISTERS)

FF61 CONSTANT PTM (BASE)

TM CONSTANT WR3

TM CONSTANT WR1

TM 2 + CONSTANT WR2

PTM 4 + CONSTANT T01

PTM 6 + CONSTANT WT01

(USE PTM TO PROVIDE INTERRUPTS FOR Z901 SERVICE ROUTINE)

(SET IT TO INTERRUPT APPROXIMATELY ONCE A SECOND)

: SETPTM 0 WR2 1B 1 WR3 1B 1 WR2 1B (DIVIDE BY 8)

42 WR1 1B

(CONTINUOUS OPERATION)

7F T01 1B FF WT01 1B

(AS SLOW AS POSSIBLE)

(THIS ROUTINE WILL PERFORM A NORMAL SIXTH)

(WORD FIND EXECUTE ON THE CONTENTS OF)

(A TYPE ZERO MESSAGE WHICH HAS BEEN RECEIVED)

(FROM THE OUTSIDE WORLD BY THE Z901 SUBSYSTEM)

: DOIT WE 1 (START ADDRESS)

0 LAST 1

30 0 DO WORD FIND EXECUTE (NEW INTERPRET LOOP)

0 LAST @ = IF (OK IF = 0)

ELSE STOP (OTHERWISE GIVE UP)

THEN LOOP

(BITS TO STORE DATA RECEIVED FROM THE OTHER TERMINALS)

(STOREIT WILL STORE TEN BYTES OF DATA FROM A TYPE ONE)

(MESSAGE IN THE REP BUFFER, AT A LOCATION AS POINTED)

(TO BY REP*POINT, WHICH IS ALSO UPDATED BY THIS ROUTINE)

: [IMMEDIATE ; (I.E THROW IT AWAY)

:] 2 * + SWAP DROP ;

10 : REP*POINT ARRAY ;

: I2 I 2 * + ;

6400 CONSTANT REP*BASE

: STOREIT DUP @ DUP (GET THE REP*NO FROM MESSAGE)

2 * REP*POINT SWAP DROP + DUP @ OVER OVER 1 + SWAP 1

SWAP DROP (UP RELEVANT STORE POINTER)

16 * SWAP 300 * + REP*BASE +

15 0 DO OVER I2 @ OVER I2 1 LOOP (COPY OUT MESSAGE)

DROP DROP DROP

(CHECK THAT NONE OF THE REPORT BUFFERS IS TOO FULL)

(RETURNS EITHER THE REP*NO OF A FULL ONE OR -1)

: CHECK 4 0 DO REP*POINT [I] @ I2 > IF I ABORT THEN LOOP -1 ;

: TX.OK VARIABLE ;

: PROCESS

DUP 2 = IF TX.OK ^1 POP POP POP POP

ELSE DUP 0 = IF (TYPE ZERO??)

DROP DROP DOIT POP (DO AS THE MAN SAYS)

ELSE DUP 1 = IF DROP DROP STOREIT

ELSE

THEN THEN THEN

(IRQ5 HANDLES THE PTM INTERRUPT)

(IT FIRST CHECKS FOR ANY RECEIVED MESSAGES)

(IF ANY HAVE BEEN RECEIVED, IT TRIES FOR EITHER)

```

: C2 CSTOP CCM 1 FEL'CL \STOPPING SAY DEL 20 PT* 1 \OK SAY DEL ;
: C3 RESET CCM 1 0 FAILURE 1 FEL'CL \RESETTING SAY DEL 20 PT* 1
  \OK SAY DEL 1 CTUSW 1 ;
: CA STUCW 0 FFFE MASK DUP 1 + CTUCW 1
  FEL'CL \PASSIVE SAY DEL CRLF \OK SAY DEL CTUCW 1 ;
: CC FEL'CL \SELECT SAY BUFFER WORD NUMBER 1 LEFT
  CTUCW 0 FFF9 MASK + CTUCW 1 CRLF \OK SAY DEL ;

( CHANGE SYSTEM OPERATION COMMANDS )
: BD FEL'CL \NEWSYNCH SAY 0 CTIME 1L 0 CTIME 4 + 1 DEL 20 PT* 1 \OK SAY ;

: BA 0 WHERE 0 7F 0 DO *RES LOOP ;
: BB PTPT 0 1 LEFT DUP PTA = IF PTB ELSE PTA THEN
  OVER 0 OVER 1 7F 1 DO OVER I 2 * + 0 DUP
  0 = IF DROP FEL'CL \NEWONE SAY BUFFER WORD NUMBER
  0000 + OVER I 2 * + 1 DUP 0 SWAP I 2 * + 2 + 1 STOP
  ELSE OVER I 2 * + 1 THEN LOOP DROP DROP
  _CPOL
  DEL CRLF \OK SAY DEL ; ( ADD A SINGLE TERMINAL )

: BC PTPT 0 1 LEFT PTA = IF PTB ELSE PTA THEN
  7F 0 DO FEL'CL \TERMINAL? SAY BUFFER WORD NUMBER DUP
  0 = IF I 0 = IF OVER I 2 * + 1 NEXT
  ELSE OVER I 2 * + 1 STOP
  THEN
  THEN
  0000 + OVER I 2 * + 1 LOOP DROP
  _CPOL DEL
  CRLF \OK SAY ;

: BE FEL'CL \NEWTIME SAY CRLF STOPCLOCK STOD ZTIME DEL DEL ;
( COMMAND LINE INTERPRETER )

: CLI FRAME FEL'CL 0 DISI BUFFER WORD FIND EXECUTE FEL'CL UNFRAME ;

( RUN TIME SYSTEM )

: RUN BEGIN FAILURE 0 0 > IF 4 DISI THEN
  ACHAR 0 0 > IF CLI THEN
  DISPLAY 0 DUP 4 = IF ZFAIL ELSE
  DUP 3 = IF ZTIME ELSE
  DUP 2 = IF ZTERM ELSE
  DUP 1 = IF ZCONT ELSE
  FEL'CL \HEAD SAY 0 DISI DEL
  THEN THEN THEN THEN DROP 3B CRB2 1B FF DRB2 1B 3C CRB2 1B END ;

( THE FIDDLY BITS !!! )

( THE TRAP ERROR AND ABORT BUTTON HANDLER CUTS )
: ALT LOCATE OUT'FEL 0INT 0 + 100A 1L ( ALTERNATIVE O/P ROUTINE )
  LOCATE RZ 0INT 0 + 100E 1L ( ALTERNATIVE I/P ROUTINE )

: TRAP INIT'FEL FEL'CL SET'PAD ALT 0 DUP ALINE 1 DUP ACHAR 1 DUP RP 1
  DUP WP 1 F CSTORE F CREAD A F CSTORE F CREAD DROP DROP
  OFFINT'CCW 1 ONINT'CCW 1 0 FAILURE 1 RESTART DEC ;

: SABORT DISINT CRLF STRING %SABORT% SAY TRAP ENINT INTER ;
: SERROR DISINT CRLF STRING %ERROR% SAY TRAP ENINT INTER ;

: SETUP DISINT 0 STORE 1 LOCATE SERROR 0INT 0 +
  100 1 DO DUP STORE 0 + DUP STORE 1
  1L LOOP DROP ( SET UP FOR TRAP ERROR )

```

```

LOCATE SABORT 0INT 0 + 70 1L ( ABORT BUTTON HANDLER )
LOCATE IRQ4 0INT 0 + 70 1L ( KEYPAD HANDLER )
LOCATE IRQ3 0INT 0 + 60 1L ( CLOCK HANDLER )
LOCATE IRQ2 0INT 0 + 60 1L ( 2901 HANDLER )
SETPER
ALT
PTB 10 0 DO DUP I 2 * + I SWAP 1 LOOP DROP

0 FAILURE 1
0 CONTENTIONS 1
0 ALINE 1
0 ACHAR 1
0 RP 1
0 WP 1
0 WHERE 1
A F CSTORE
F CREAD F CREAD F CREAD
DROP DROP DROP
_CPOL
ENINT ;

: IRESET LOCATE RUN 0INT 0 + EQUATES 1 ;
: ZRESET 264C EQUATES 1 ;
: _RES RESTART SETUP DEC IRESET RUN ; ( RESTART VECTOR HANDLER )
: JRESET LOCATE _RES 0INT 0 + EQUATES 1 ; ( USED ONLY FOR RESTARTING )

: AAA ZRESET 21C2E 100A 1L ( MACSBUG O/P ROUTINE )
  21DB4 100E 1L ( MACSBUG I/P ROUTINE )
  INTER ;

XENDFILE

```

```

: CONTENTIONS VARIABLE ;
: FAILURE VARIABLE ;

: IRQ2 FRAME @CONT 1 = IF CONTENTIONS ^1 ( CONTENTION HAS OCCURRED )
    THEN @FAIL 0 ) IF FF FAILURE ( STORE FAILURE )
    THEN
    UNFRAME RTE ;

: WHERE VARIABLE ;
: WHERE? WHERE @ 3F MASK ;

: BCD DUP 9 > IF A / DUP F 10 LEFT MASK 80 / 200 / ( GET DEC NUMBERS )
    SWAP F MASK ELSE 0 THEN SWAP ;

( GET TOD FROM IN-TIME FIELD, ONLY USED WHEN NOT ACTIVE !! )
: @STOD IT 2 + @ 400 / F MASK BCD ( MONTH )
    IT 2 + @ 20 / 1F MASK BCD ( DAY )
    IT 2 + @ 1F MASK BCD ( HOUR )
    IT @ 400 / 3F MASK BCD ( MINUTES )

STOPCLOCK
9 4 DO I CSTORE LOOP
C 8 DO I CSTORE LOOP
COCLOCK ;

: @RES @ACTIVE 1 = IF @STOP 0 = IF WHERE? 2 * STT + @ C000 MASK
    0 = IF
    ELSE PTPT @ DUP 1 LEFT PTA = IF PTB ELSE PTA THEN
    7F 0 DO DUP I 2 * + DUP @ 3F MASK SWAP OVER SWAP I
    WHERE? = IF DUP I 2 * + WHERE? 8000 + SWAP I
    THEN LOOP

2 /
CSTOP CCW I WSTOP
PTPT I
GO CCW I
0 STT WHERE? 2 * + I
CSTOP CCW I WSTOP
PTPT I
GO CCW I
THEN WHERE ^1 THEN THEN ;

( INTERRUPT HANDLER FOR CLOCK )
( WILL UPDATE OUT-TIME IF OTA IS CLEAR )

WIDTH 4 + CONSTANT TOT
: IRQ3 FRAME 0 T_DIS I F CREAD DROP
    CTUSW @ 3 MASK 2 = IF OTA @ 8000 MASK 0 = IF
    0 TOT I GTOD ( SET UP FOR START )
    A * + 5 LEFT TOT I
    A * + TOT @ + 5 LEFT TOT I
    A * + TOT @ + OT 2 + I ( MONTH, DAY & HOURS )
    0 TOT I
    A * + 6 LEFT TOT I A * + TOT @ + 4 LEFT + OT I
    ( MINUTES SECONDS TENTHS )
    CTIME 2 + @ CTIME 4 + @ CTIME @ ( GET SYNCH TIME )
    1000 * 78D + OT 4 + I ( 1/10THS AND YEAR )
    OT 4 + I
    OT 8 + I ( MULTIPLES OF TENTHS )
    8000 OTA I
    THEN
    20 0 DO @RES LOOP
    ELSE ITA @ DUP 8000 MASK 0 = IF
    ELSE @STOD 7FFF MASK ITA I
    THEN
    THEN
    UNFRAME RTE ;

```

```

( IRQ3 HANDLER AND CIRCULAR BUFFER DRIVING ROUTINES )
( FOR HEX KEYPAD )

```

```

10 : STZ ARRAY ; ( CIRCULAR BUFFER )
: ALINE VARIABLE ;
: WP VARIABLE ;
: RP VARIABLE ;
: ACHAR VARIABLE ;

: IRQ4 FRAME DRAZ @B DUP 9 > IF 37 + ELSE 30 + ( FORM ASCII CHAR )
    THEN WP @ 1 + RP @ = IF DROP UNFRAME RTE ( BUFF FULL )
    THEN DUP 46 = IF DROP @D ALINE ^1 ( USE 'F' AS CR )
    THEN WP @ DUP 1F ( IF WP ^1 ( INC WRITE POINTER )
    ELSE RP @ 0 ) IF 0 WP I ( WRAPAROUND )
    ELSE DROP DROP UNFRAME RTE
    THEN
    THEN STZ SWAP DROP + 1B ( STORE IT )
    ( WE HAVE CHARS SO FLAG IT )

    ACHAR ^1
    UNFRAME RTE ;

( CIRCULAR BUFFER READ ROUTINE )
( WILL READ FROM HEX KEYPAD'S CIRCULAR BUFFER )

: PREAD ACHAR @ 0 = IF FF QUIT ( NO CHARS SO QUIT !! )
    ELSE
    RP @ STZ SWAP DROP + @B ( GET CHAR FROM CIRC BUFFER )
    RP @ 1F = IF 0 RP I ELSE RP ^1 ( FORM THE NEW POINTER )
    THEN
    ACHAR DUP @ 1- SWAP I ( DECREMENT FLAG )
    THEN

( A READ ROUTINE SUITABLE TO BE PATCHED IN TO THE KERNEL )
: PAD_IN BEGIN PREAD DUP FF ( IF QUIT ELSE DROP THEN END )
: RZ PAD_IN POP ; ( LEAVE CHAR I DO FOR BUFF ROUTINE )

( DISPLAY COMMANDS )

: ZNUMBER VARIABLE ;
: DISPLAY VARIABLE ;
: DISI T_DIS I ;
: ZTEST T_DIS @ OVER = IF DROP DROP DROP
    ELSE T_DIS I FEL'CL
    SAY
    THEN ;

: ZFAIL \ITFAILED 4 ZTEST DEL ;
: ZTIME \TIM 3 ZTEST TIME DEL ;
: ZTERM ZNUMBER @ DUP 0 = IF DROP ATDIS
    ELSE 1- TDIS DEL
    THEN ;

: ZCONT CDIS DEL ;

: DISPI DISPLAY I ;
: DB 3 DISPI ;
: DC 1 DISPI ;
: DD 2 DISPI FEL'CL 0 DISI \TERMINAL? SAY BUFFER WORD NUMBER 1 +
    ZNUMBER I ;
: DE 2 DISPI 0 ZNUMBER I ;

( CHANGE CONTROLLER FUNCTION COMMANDS )
: C1 GO CCW I FEL'CL 0 DISI \STARTING SAY DEL 20 PT^ I \OK SAY DEL ;

```

```

: #CONT CTUSW @ B MASK @ / ; ( STACKS CONTENTION BIT )
: #FAIL CTUSW @ FF00 MASK 100 / ; ( STACKS STORE FAIL BITS )
: #CABLE CTUCW @ 4 MASK 2 / ; ( STACKS SELECTED CABLE )

```

```

( GET CONTROLLER STATISTICS )
: #GCSTATS RC @ NRC @ #CABLE #ACTIVE #STOP REC @ ;

```

```

( SOME USEFUL STRINGS )

```

```

: \NAK STRING \NAK STUCK % ;
: \BLANK STRING % ;
: \NR STRING % NR % ;
: \RESP STRING \RESPONDING% ;
: \ERR STRING \ERRORS % ;
: \INFO STRING \INFORMATION MONITOR % ;
: \TERM STRING \TERMINAL NUMBER % ;
: \TIM STRING \SYSTEM TIME % ;
: \HEAD STRING \MICROLINK% ;
: \CONT STRING \HIGHWAY CONTROLLERS% ;
: \NRC STRING \REPEATS % ;
: \NRC STRING \NULL REPEATS% ;
: \CABLE STRING \CABLE % ;
: \ACT STRING \ACTIVE % ;
: \PASS STRING \PASSIVE % ;
: \RUNNING STRING \RUNNING % ;
: \STOPPED STRING \STOPPED % ;
: \REC STRING \RECEIVE ERRORS% ;
: \STARTING STRING \START CONTROLLERS% ;
: \STOPPING STRING \STOP CONTROLLER % ;
: \NEWTIME STRING \SET NEW TIME% ;
: \NEWSYNCH STRING \NEW SYNCH TIME % ;
: \SELECT STRING \CABLE NO. ? % ;
: \PASSIVE STRING \GO PASSIVE% ;
: \OK STRING \OK% ;
: \NEWONE STRING \ADD TERMINAL NO.% ;
: \TERMINAL? STRING \TERMINAL NO. ? % ;
: \RESTERM STRING \RESET TERMINAL ?% ;
: \RESETTING STRING \RESET CONTROLLERS% ;
: \ITFAILED STRING \INTERFACE FAILURE% ;

```

```

: SPACES 4 1 DO SPACE LOOP ;

```

```

( TERMINAL STATISTICS DISPLAY LOOP )

```

```

: TDIS T_DIS DUP @ 2 = IF DROP ELSE FEL*CL
  \TERM SAY
  40 PT* | \ERR SAY
  60 PT* | \INFO SAY
  2 SWAP |
  THEN

```

```

  DUP
  11 PT* | . SPACE ( TERMINAL NUMBER )
  #GTSTATS
  20 PT* | 1 = IF \NAK ELSE \BLANK THEN SAY
  34 PT* | 1 = IF \NR ELSE \RESP THEN SAY
  54 PT* | . SPACES ( ERRORS )
  74 PT* | . SPACES ( IMM )

```

```

: DEL 1000 1 DO LOOP ;

```

```

( DISPLAY STATS FOR ALL OF THE TERMINALS )

```

```

: ATDIS PTPT @ 1 LEFT 40 0 DO DUP I 2 * + @ JF MASK DUP

```

```

0 -> IF TDIS ELSE I 0 = IF TDIS
  ELSE DROP STOP
  THEN

```

```

THEN

```

```

DEL LOOP DROP ;

```

```

( CONTROLLER STATISTICS DISPLAY LOOP )

```

```

: CDIS T_DIS DUP @ 1 = IF DROP ( OK CONT ALREADY DISPLAYED )
  ELSE FEL*CL \CONT SAY
  20 PT* | \REC SAY
  40 PT* | \NRC SAY 57 PT* | \CABLE SAY
  60 PT* | \RC SAY
  1 SWAP | ( NOW CONTROLLER STATS. BEING DISPLAYED )

```

```

THEN

```

```

#GCSTATS
  30 PT* | ( RECEIVE ERRORS )
  37 PT* | 1 = IF \STOPPED ELSE \RUNNING THEN SAY
  17 PT* | 1 = IF \ACT ELSE \PASS THEN SAY
  5E PT* | ( CABLE NUMBER )
  50 PT* | ( NULL REPEATS )
  70 PT* | ( REPEAT COUNT )

```

```

: SETPAD 00 CRAZ IB F0 DRAZ IB 7 CRAZ IB ; ( 4 I/P'S 4 O/P'S )
: SHUTDOWN SYRES 0 F CSTORE DISINT ; ( ROUTINE TO STOP THE INTS )
: CLEARTAB DUP FF + SWAP DO 0 I IB LOOP ; ( CLEAR CONT. TABLE )
: SETPER ( SETUP PERIPHERALS AND CLEAR TABLES )
  RESET CCW | ( NOW FOR THE CONTROLLER )
  PT CLEARTAB
  PTA CLEARTAB
  PTB CLEARTAB
  M55 CLEARTAB
  B5 CLEARTAB
  STT CLEARTAB ( CLEAR A BIT OF ALL THE TABLES )
  PTA 2 / PTPT | ( GIVE IT SOMETHING TO CHEW ON )
  1 CTUSW | ( SET STOPPED TO AVOID CONFUSION )
  0 0 CSTORE
  0 F CSTORE F CREAD F CREAD F CREAD DROP DROP DROP
  A F CSTORE F CREAD F CREAD F CREAD DROP DROP DROP
  ( SET UP THE REAL TIME CLOCK )
  INIT*FEL FEL*CL ( SET UP FELTEC DISPLAY )
  SETPAD ( SET UP HEX KEYPAD )

```

```

: WSTOP BEGIN #STOP 1 = IF QUIT THEN END ;
: _CPOL PTPT @ 1 LEFT DUP PTA = IF PTB ELSE PTA THEN DUP
  ( GET SECONDARY TABLE )

```

```

  2 /
  CSTOP CCW | WSTOP ( FLAG STOP AND WAIT )
  PTPT | ( STORE SECONDARY )
  GO CCW | ( RESTART CONTROLLER )
  STT CLEARTAB
  7F 0 DO OVER OVER I 2 * + @ ( READ FROM NEW TABLE )
  7FFF MASK SWAP I 2 * + | ( PUT IN OLD TABLE )
  LOOP

```

```

  DROP 2 /
  CSTOP CCW | WSTOP ( FLAG STOP & WAIT )
  PTPT | ( PUT BACK MODIFIED NEW TABLE )
  GO CCW | ONINT CCW | ; ( RESTART CONTROLLER )

```

```

( INTERRUPT HANDLER FOR 2901 )

```

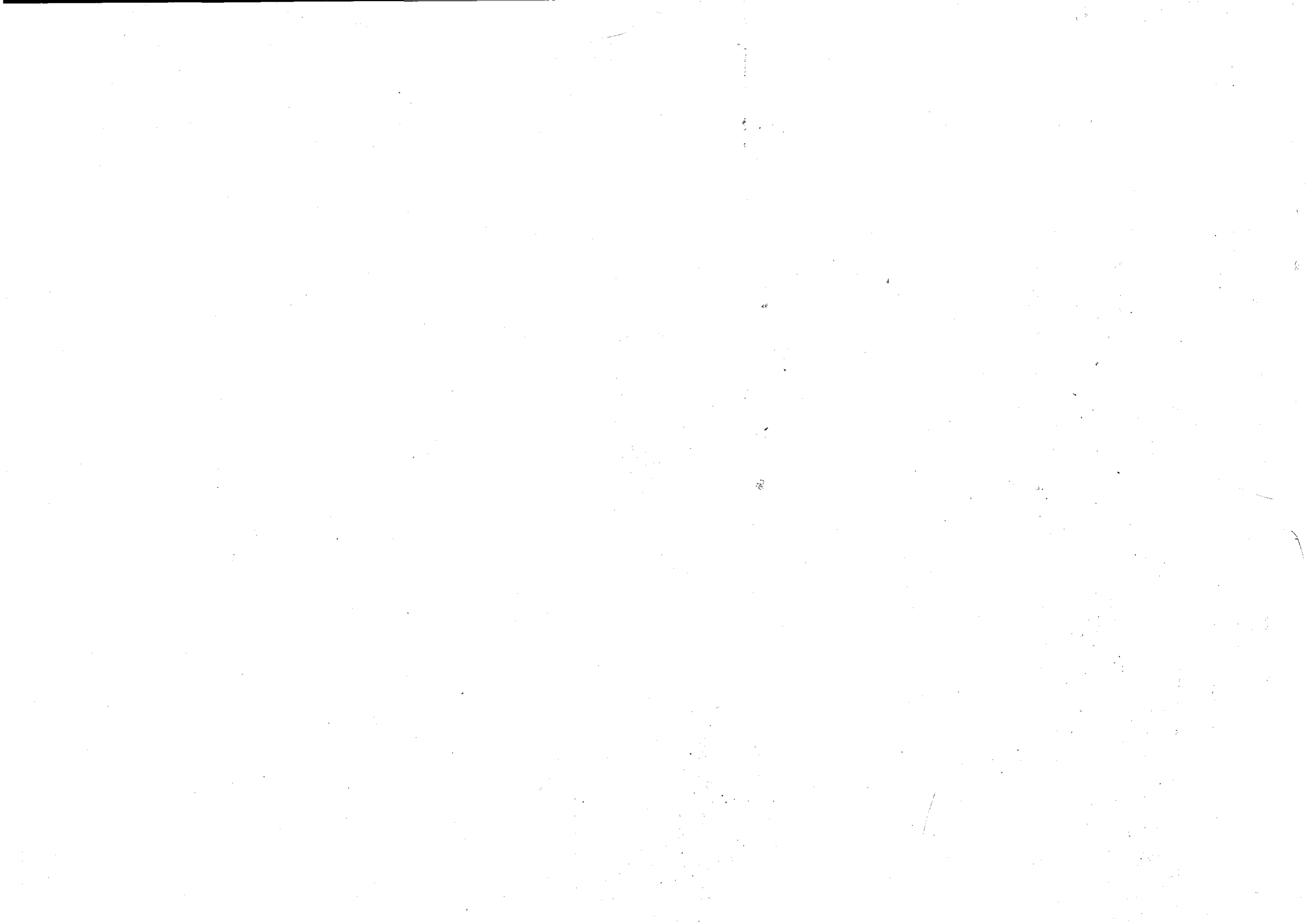

```

0025E2 20202020
0025E6 25D2

0025E8 201E
0025EA 221E
0025EC D280
0025EE 2D01
0025F0 4E75

0025F2 0001
0025F4 2D202020
0025F8 25E0

0025FA 221E
0025FC 201E
0025FE 9081
002600 2D00
002602 4E75

002604 0001
002606 2A202020
00260A 25F2
00260C 201E
00260E 221E
002610 C0C1
002612 2D00
002614 4E75

002616 0001
002618 2F202020
00261C 2604
00261E 221E
002620 201E
002622 80C1
002624 2D00
002626 4E75

002628 0004
00262A 4C454654
00262E 2616

002630 201E
002632 221E
002634 E1A9
002636 2D01
002638 4E75

00263A 0004
00263C 53574150
002640 2628

```

```

XADD DC.B #1
DC.L '+'
DC.W XIL

*
* BASIC ARITHMETIC OPERATIONS
*
ADD MOVE.L (A6)+,D0
MOVE.L (A6)+,D1
ADD.L D0,D1
MOVE.L D1,-(A6)
RTS

*
*
XSUB DC.B #1
DC.L '-'
DC.W XADD

*
* SUBTRACTS 32 BITS
*
SUB MOVE.L (A6)+,D1
MOVE.L (A6)+,D0
SUB.L D1,D0
MOVE.L D0,-(A6)
RTS

*
*
* MULTIPLY 16 BY 16 TO 32
*
XMUL DC.B #1
DC.L '* '
DC.W XSUB

MUL MOVE.L (A6)+,D0
MOVE.L (A6)+,D1
MULU D1,D0
MOVE.L D0,-(A6)
RTS

*
* DIVIDE 32 BY 16 EQUALS 16, REM 16
*
XDIV DC.B #1
DC.L '/'
DC.W XMUL

DIV MOVE.L (A6)+,D1
MOVE.L (A6)+,D0
DIVU D1,D0
MOVE.L D0,-(A6)
RTS

*
*
XLEFT DC.B #4
DC.L 'LEFT'
DC.W XDIV

*
* MOVE LEFT BY N PLACES
*
LEFT MOVE.L (A6)+,D0
MOVE.L (A6)+,D1
LSL.L D0,D1
MOVE.L D1,-(A6)
RTS

*
*
XSWAP DC.B #4
DC.L 'SWAP'
DC.W XLEFT

*
* WILL SWAP THE TOP TWO ON THE OLD STACK

```

```

002642 201E
002644 221E
002646 2D00
002648 2D01
00264A 4E75

```

```

00264C 2E781016
002650 4EBB222E
002654 0C3800001036
00265A 6700000A
00265E 4EBB240E
002662 6000000C
002666 21F810021038
00266C 4EBB203E
002670 4EBB20B4
002674 4EBB2104
002678 4EBB22B0
00267C 0C3800011028
002682 6700FFD0
002686 6000FFEB
Rdas Error code -6

```

[SYS B.6]

```

*
* SWAP
MOVE.L (A6)+,D0
MOVE.L (A6)+,D1
MOVE.L D0,-(A6)
MOVE.L D1,-(A6)
RTS

*
*
* THE INTERPRET LOOP
*
*
INTE1 MOVE.L MSTCK,A7
JSR SREST
INTE2 CMPI #0,RELO
BEQ INTE0
JSR LOAD
BRA INTE3
INTE0 MOVE.L ACIA1,PORT
JSR BUFF
INTE3 JSR WORD
JSR FIND
JSR EXEC
CMPI #1, LAST
BEQ INTE2
BRA INTE3

```

```

0024BE 4E75      RTS
*
*
0024C0 0007      XDI55      DC.B #7
0024C2 44495353  DC.L 'DI55'
0024C6 24B0      DC.W XTO
0024CB 241E      DI55      MOVE.L (A6)+,D2
0024CA 42B3      CLR.L D3
0024CC 42B1      CLR.L D1
0024CE 3202      MOVE.W D2,D1
0024D0 82FB102A  XPRN3     DIVU RDX,D1
0024D4 3B01      MOVE.W D1,D4      DO THIS INSTEAD OF SWAP
0024D6 E0B9      LSR.L #8,D1      WHICH DOESNT WORK
0024D8 E0B9      LSR.L #8,D1
0024DA 42B0      CLR.L D0
0024DC 1001      MOVE.B D1,D0
0024DE 223C00000000  MOVE.L #00,D1
0024E4 3204      MOVE.W D4,D1      DITTO HERE
0024E6 0C000009  CHPI #9,D0
0024EA 6E00000A  BGT XPRN2
0024EE 04000030  ADDI #30,D0
0024F2 60000006  BRA XPRN4
0024F6 04000037  XPRN2     ADDI #37,D0
0024FA 4EBB2164  XPRN4     JSR PUSH
0024FE 5203      ADDQ #1,D3      CHAR COUNT,ALWAYS >=1
002500 0C440000  CMPI.W #00,D4  ANYTHING LEFT??
002504 6600FFCA  BNE XPRN3     YES SO TRY AGAIN
002508 E0BA      LSR.L #8,D2      NOW TRY TO SEE FOR 32 D1
00250A E0BA      LSR.L #8,D2
00250C 6F000028  BLE XPRN6
002510 0C030004  CMPI #4,D3
002514 67000016  BEQ XPRN7
002518 103C0030  XPRN8     MOVE #30,D0
00251C 4EBB2164  JSR PUSH
002520 04030001  ADDI #1,D3
002524 0C030004  CMPI #4,D3
002528 6D00FFEE  BLT XPRN8
00252C 42B1      XPRN7     CLR.L D1
00252E 3202      MOVE.W D2,D1
002530 42B2      CLR.L D2
002532 6000FF9C  BRA XPRN3
002536 1003      XPRN6     MOVE D3,D0
002538 4EBB2164  JSR PUSH
00253C 4E75      RTS
* THE REAL PRINT ROUTINE
*
* X.      DC.B #1
DC.L " "
DC.W XDI55
PRN      JSR DI55
JSR POP
CLR.L D3
MOVE D0,D3
XPRN5    JSR TO
SUBI #1,D3
BNE XPRN5
RTS
*
*
XASMB    DC.B #4
DC.L 'ASMB'
DC.W X.
*
* WILL PUT A NUMBER ON THE STACK AS IS INTO THE DIC

```

```

002568 347B102E
00256C 343C0004
002570 14DE
002572 5302
002574 6600FFFA
002578 31CA102E
00257C 4E75
00257E 4E75

002580 0002
002582 40422020
002586 2560
002588 225E
00258A 42B0
00258C 1011
00258E 2D00
002590 4E75

002592 0002
002594 40572020
002598 25B0
00259A 225E
00259C 42B0
00259E 3011
0025A0 2D00
0025A2 4E75

0025A4 0002
0025A6 404C2020
0025AA 2592
0025AC 225E
0025AE 2D11
0025B0 4E75

0025B2 0002
0025B4 21422020
0025B8 25A4
0025BA 225E
0025BC 201E
0025BE 12B0
0025C0 4E75

0025C2 0002
0025C4 21572020
0025C8 25B2
0025CA 225E
0025CC 201E
0025CE 32B0
0025D0 4E75

0025D2 0002
0025D4 214C2020
0025D8 25C2
0025DA 225E
0025DC 229E
0025DE 4E75

```

```

ASMB     MOVE.W DP,A2
*
* MOVE.W #4,D2
BK3      MOVE (A6)+,(A2)+
SUBQ #1,D2
BNE BK3
MOVE.W A2,DP
RTS
RTS
*
*
XQB      DC.B #2
DC.L 'QB '
DC.W XASMB
QB       MOVE.L (A6)+,A1
CLR.L D0
MOVE.B (A1),D0
MOVE.L D0,-(A6)
RTS
*WORD GET
XQW      DC.B #2
DC.L 'QW '
DC.W XQB
QW       MOVE.L (A6)+,A1
CLR.L D0
MOVE.W (A1),D0
MOVE.L D0,-(A6)
RTS
*LONG WORD
XQL      DC.B #2
DC.L 'QL '
DC.W XQW
MOVE.L (A6)+,A1
MOVE.L (A1),-(A6)
RTS
*
*
XIB      DC.B #2
DC.L 'IB '
DC.W XQL
IB       MOVE.L (A6)+,A1
MOVE.L (A6)+,D0
MOVE.B D0,(A1)
RTS
*
*
* STORE A WORD
XIW      DC.B #2
DC.L 'IW '
DC.W XIB
IW       MOVE.L (A6)+,A1
MOVE.L (A6)+,D0
MOVE.W D0,(A1)
RTS
*
*
* STORE A LONG WORD
XIL      DC.B #2
DC.L 'IL '
DC.W XIW
IL       MOVE.L (A6)+,A1
MOVE.L (A6)+,(A1)
RTS
*
*
*

```

002372 2A4D4143
 002376 53204940
 00237A 554D2056
 00237E 322E312A

002382 0101
 002384 3B202020
 002388 2352

0023BA 043B00011030
 002390 6C000004
 002394 4E8B222E
 002398 347B102E
 00239C 34FC4E75
 0023A0 31CA102E
 0023A4 31FC0040101E
 0023AA 4E75

0023AC 000B
 0023AE 434F4E53
 0023B2 23B2

0023B4 4E8B2272
 0023B8 347B102E
 0023BC 34FC2D3C
 0023C0 4E8B256C
 0023C4 4E8B239B
 0023C8 4E75

0023CA 0007
 0023CC 494E5445
 0023D0 23AC
 0023D2 347B102E
 0023D4 34FC2D3C
 0023DA 4E8B256C
 0023DE 4E75

0023E0 010B
 0023E2 56415249
 0023E6 23CA
 0023E8 347B102E
 0023EC 34FC4E8B
 0023F0 34FC2400
 0023F4 24FC00000000
 0023FA 31CA102E
 0023FE 4E75
 002400 2D17
 002402 5B97
 002404 4E75
 002406 0004
 002408 4C4F4144
 00240C 23E0

```

DC.L '*MAC'
DC.L '*S IM'
DC.L '*UM U'
DC.L '*2.1*'

*
*
XSEMI      DC.B #101
DC.L '*';
DC.W XTITL

*
* ENDS COMPILE MODE
*
SEMI      SUBI #1,STATE
BGE AUTO
JSR SREST      FORCE A RESTART SINCE STATE IS NOW
AUTO      MOVE.W DP,AZ
MOVE.W #4E75,(A2)+
MOVE.W A2,DP
MOVE.W #640,PREF
RTS

*
*
XCONS     DC.B #8
DC.L '*CONS'
DC.W XSEMI

*
* WILL INTERPRET COMPILATION NUMBERS
*
CONS      JSR COLON+6
MOVE.W DP,AZ
MOVE.W #82D3C,(A2)+
JSR ASMB+4
JSR SEMI+0E
RTS

*
*
*INTEGER ROUTINE
XINTE     DC.B #07
DC.L '*INTE'
DC.W XCONS
INTE      MOVE.W DP,AZ
MOVE.W #82D3C,(A2)+      EQU MOVE.L #XXXX,-(A6)
JSR ASMB+4
RTS

*VARIABLE
XVAR      DC.B #10B
DC.L '*VARI'
DC.W XINTE
VAR       MOVE.W DP,AZ
MOVE.W #4E8B,(A2)+      JSR #XXXX
MOVE.W #UAR2,(A2)+
MOVE.L #00,(A2)+      SPACE FOR VAR
MOVE.W A2,DP          GET DP BACK
RTS
VAR2     MOVE.L (A7),-(A6)      GETS ADDRES OF VAR
ADDQ.L #4,(A7)
RTS

XLOAD     DC.B #4
DC.L '*LOAD'
DC.W XVAR

*
* WILL LOAD SOURCE TEXT FROM HOST
* PROGRAM 68KLOAD MUST BE RUNNING
* AND 68KDCIC PRESENT IN THE SYSTEM
*

```

00240E 347B1020
 002412 21FB1006103B
 002418 103C001B
 00241C 4E8B201C
 002420 4E8B200B
 002424 0C00000D
 002428 6600000B
 00242C 14C0
 00242E 60000010
 002432 0C000020
 002436 6D00FF6B
 00243A 14C0
 00243C 6000FFE2
 002440 31FB10201024
 002446 31FC0000102B
 00244C 4E75

00244E 0004
 002450 4F50454E
 002454 2406
 002456 21FB1006103B
 00245C 267C000024B2
 002462 263C0000000D
 002468 101B
 00246A 4E8B201C
 00246E 5303
 002470 6600FFF6
 002474 4E8B200B
 002478 0C00000D
 00247C 6600FFF6
 002480 4E75

002482 52554E2C
 002486 313A4C44
 00248A 2E363B4B
 00248E 0D00

002490 0006
 002492 52454C4F
 002496 244E

002498 11FC00011036
 00249E 4E75

0024A0 0109
 0024A2 494D4D45
 0024A4 2490
 0024A8 347B1026
 0024AC 5212
 0024AE 4E75

0024B0 0002
 0024B2 544F2020
 0024B6 24A0
 0024BB 201E
 0024BA 4E8B201C

```

LOAD      MOVE.W STBUF,A2
MOVE.L ACIA2,PORT
MOVE #1B,D0
JSR SOUT
GETCH     JSR SIN
CMPI #0D,D0
BNE LOAD2
MOVE D0,(A2)+
BRA LOAD3
LOAD2     CMPI #*,D0
BLT GETCH
MOVE D0,(A2)+
BRA GETCH
LOAD3     MOVE.W STBUF,EWWORD      FOR WORD ROUTINES
MOVE.W #0,LAST
RTS

*
*STARTS THE DOS TRANSFER PROGRAM RUNNING
*THIS PROGRAM TERMINATES ITSELF ON
*EOF AND RESPONDS TO ESC PROMPTS
XOPEN     DC.B #4
DC.L '*OPEN'
DC.W XLOAD
OPEN      MOVE.L ACIA2,PORT
MOVE.L #COMM,A3
MOVE.L #0D,D3
OPEN1     MOVE.B (A3)+,D0
JSR SOUT
SUBQ #1,D3
BNE OPEN1
OPEN2     JSR SIN
CMPI #0D,D0
BNE OPEN2
RTS

*
* COMMAND LINE FOR DOS
COMM      DC.L '*RUN,'
DC.L '*:LD'
DC.L '*.68K'
DC.W #0D00

*
*
XRELD     DC.B #6
DC.L '*RELO'
DC.W XOPEN

*
* ALL THIS DOES IS SET THE RELOAD FLAG
*
RELD      MOVE #1,RELD
RTS      IS IT WORTH IT !

*
*IMMEDIATE MODE
XIMM      DC.B #109
DC.L '*IMME'
DC.W XRELD
MOVE.W DLAST,A2
ADDQ.B #1,(A2)
RTS

*
*
XTO       DC.B #2
DC.L '*TO'
DC.W XIMM
TO        MOVE.L (A6)+,D0
JSR SOUT

```

APPENDIX B

An Upgrade of On-Board Memory

Boost μ P-board memory capacity with simple hardware changes

Some minor rewiring and the addition of an inexpensive data selector chip tailors Motorola's MC68000 evaluation board, the MEX68KDM, for a fourfold increase in on-board memory capacity. The board's complement of sixteen MCM4116 RAMs (16-kbit devices) can be replaced with 64-kbit types, such as the 4164. The procedure costs less than one tenth the expense of an EXORciser chassis and additional memory modules.

Key to the modification is in the design of the 64-kbit RAMs. The pinout of these devices is almost identical to that of the 16-kbit devices used in the board. In addition, such 64-kbit devices as the MCM4664 or HM4864 have the same refresh requirements as the MCM4116 used on the evaluation board.

Both sizes of RAM chip require a 128 row-address count with a 2-ms time interval. The board's existing multiplexer/refresh counter (MC3242) and memory controller (MC3480) can be used for the 64-kbit devices since the additional address line to the chip (pin 9 on the 64-k RAMs) is not used during the refresh cycle. Only an SN74LS157 two-to-one data selector is needed to multiplex the extra two address lines onto the 64-k chips.

To accomplish the changeover, the 5-V supply line to pin 1 of the RAMs must be disconnected. All 64-k parts are single-supply types. Etch cuts can be made between the memory chips and the controller so that only one wire must be added to connect together each RAM's pin 1. To allow pin-1 refresh, this rail must be tied high via a 1-k Ω resistor.

The +12-V connection to pin 8 must be disconnected and replaced by a connection to +5 V. A single etch cut and the addition of a single wire accomplishes this change. As shown in Fig. 1, the +5-V connection to pin 9 must be disconnected to allow connection of an additional address line to this pin on the 64-k devices. Four decoupling capacitors must be removed, nine tracks cut, and six wires added.

The address lines to pins 17 and 18 of the MC3480

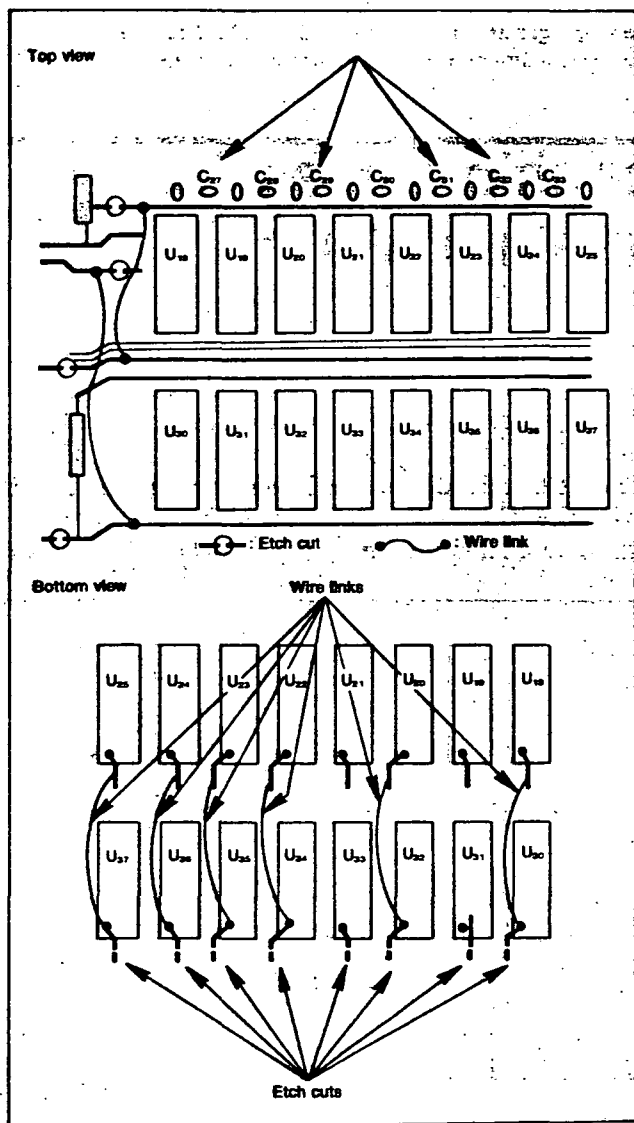

1. Several etch cuts and wire jumpers help reconfigure the MEX68KDM evaluation board for operation with 64-kbyte RAMs. The greater-capacity memory chips boost on-board storage from 32 to 128 kbytes.

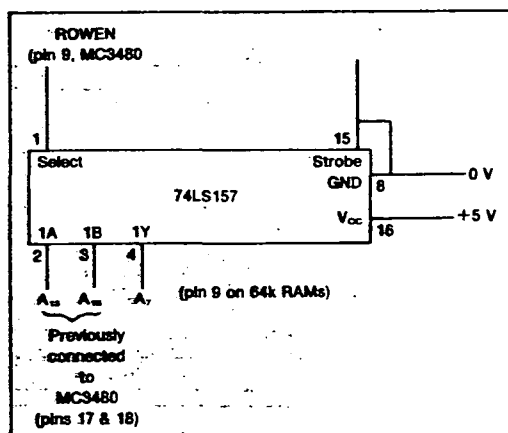

2. An inexpensive data selector chip, the 74LS157, is the only additional hardware required for modification of the evaluation board.

IdeasForDesign

must be disconnected and reconnected to the data selector (Fig. 2). The controller's pins 17 and 18 must be grounded so that RAS₁ and CAS are selected. The remainder of the data selector's pins are connected as shown. The +12 and -5-V connections to the ROM jumper area must be reconnected directly to the supply rails. The board's PROM, an N82S129, must be reprogrammed to the pattern shown in Fig. 3. A 74LS287 may be substituted.

In operation, line A₁₅ or A₁₆ of the board is multiplexed onto pin 9 of the 64-k RAMs, depending on the state of ROWEN (the line used by the MC3242 for multiplexing of the other 14 address lines). During a refresh cycle, the state of the additional address line is not important.

David Cowan, Research Assistant, Department of Applied Physics & Electronics, Durham University, South Rd., Durham DH1 3LE, United Kingdom.

00	0C	0C	0C	0C	0C	0C	0C	0C	0C	0C	0C	0C	0C	0C	0C	0C	0C
10	0C	0C	0C	0C	0C	0C	0C	0C	0C	0C	0C	0C	0C	0C	0C	0C	0C
20	0C	0C	0C	0C	0C	0C	0C	0C	0C	0C	0C	0C	0C	0C	0C	0C	0C
30	0C	0C	0C	0C	0C	0C	0C	0C	0C	0C	0C	0C	0C	0C	0C	0C	0C
40	0C	0C	0C	0C	0C	0C	0C	0C	0C	0C	0C	0C	0C	0C	0C	0C	0C
50	0C	0C	0C	0C	0C	0C	0C	0C	0C	0C	0C	0C	0C	0C	0C	0C	0C
60	0C	0C	0C	0C	0C	0C	0C	0C	0C	0C	0C	0C	0C	0C	0C	0C	0C
70	0C	0C	0C	0C	0C	0C	0C	0C	0C	0C	0C	0C	0C	0C	0C	0C	0C
80	00	08	00	08	00	08	00	08	00	08	00	08	00	08	00	08	00
90	00	00	00	00	00	00	00	00	00	00	00	00	00	00	00	00	00
A0	00	00	00	00	00	00	00	00	00	00	00	00	00	00	00	00	00
B0	00	00	00	00	00	00	00	00	00	00	00	00	00	00	00	00	00
C0	00	00	00	00	00	00	00	00	00	00	00	00	00	00	00	00	00
D0	00	00	00	00	00	00	00	00	00	00	00	00	00	00	00	00	00
E0	00	00	00	00	00	00	00	00	00	00	00	00	00	00	00	00	00
F0	00	00	00	00	00	00	00	00	00	00	00	00	00	00	00	02	02

3. The evaluation board's bipolar PROM, an N82S129, must be reprogrammed as above. An SN74LS287 can be used if a Texas Instruments' programmer is more readily available.

APPENDIX C

DMA Interface Circuit Diagrams

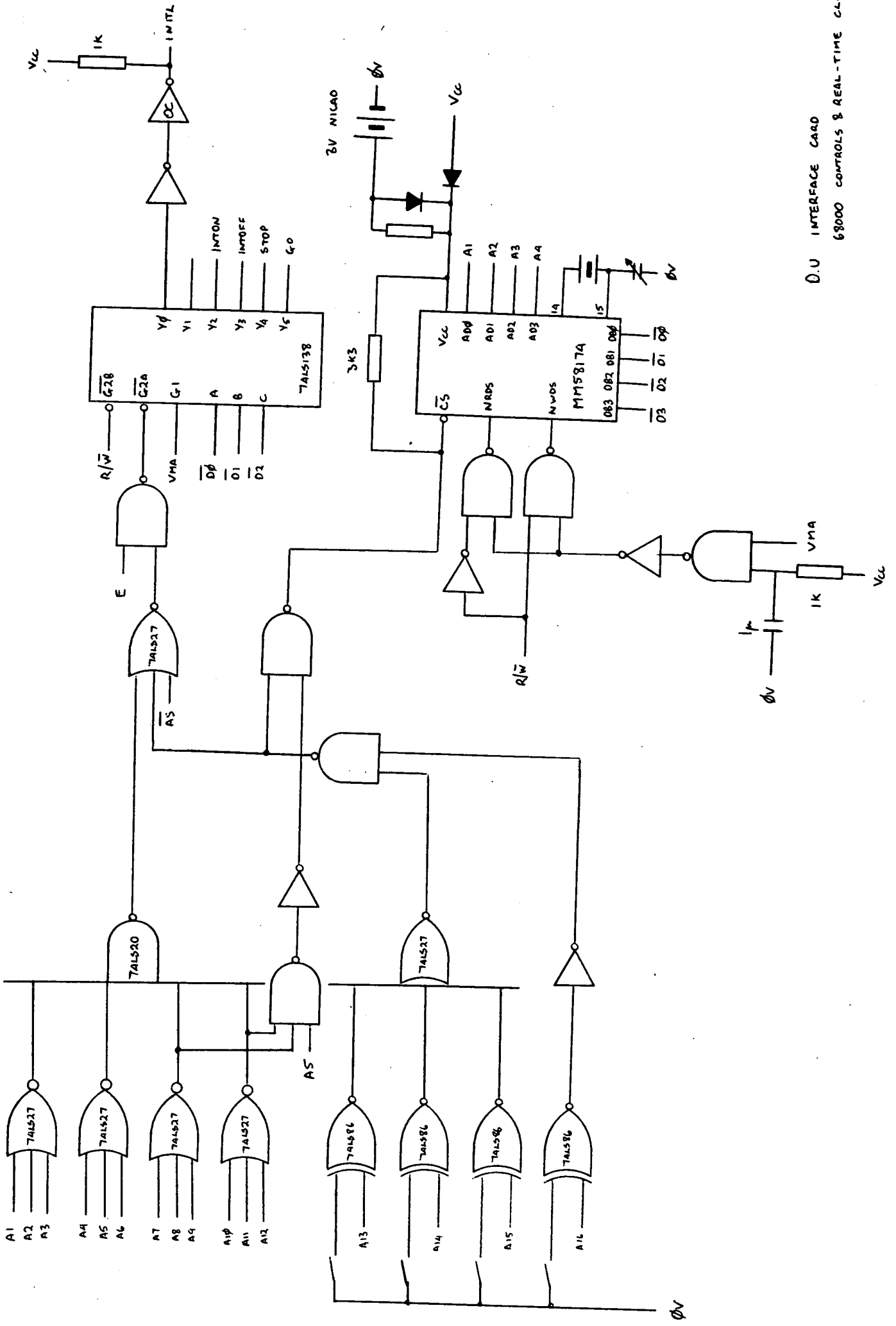

D.U. INTERFACE CARD
68000 CONTROLS & REAL-TIME CLOCK

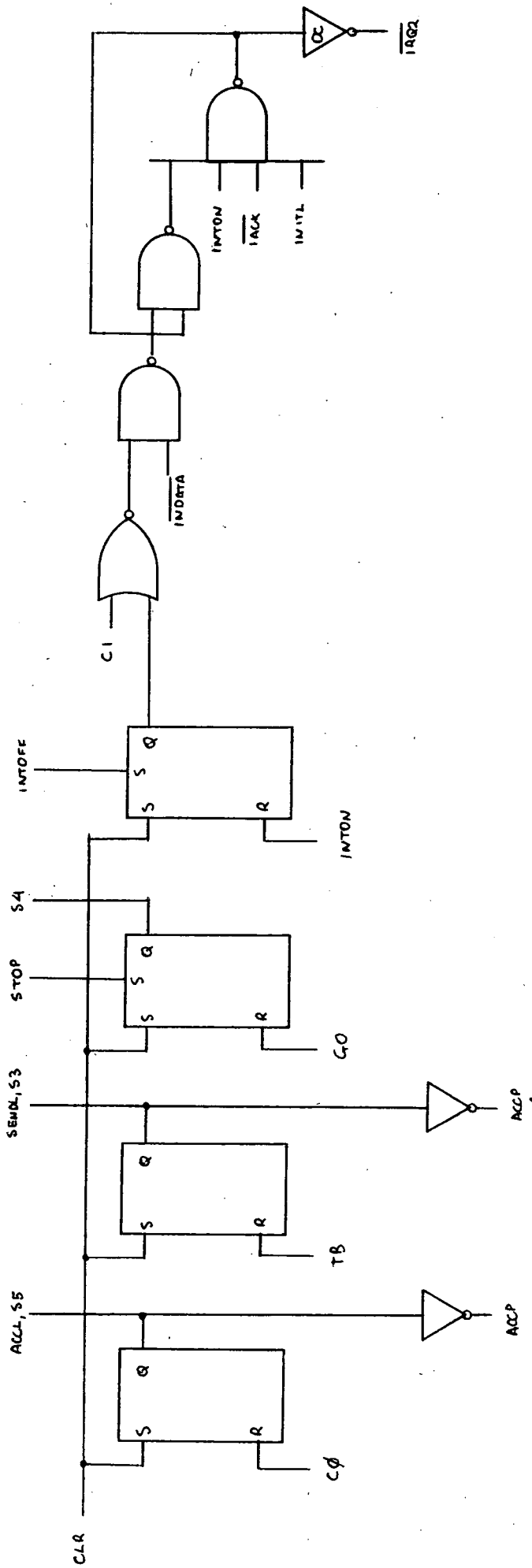

D.U. INTERFACE CARD
2801 CONTROLS

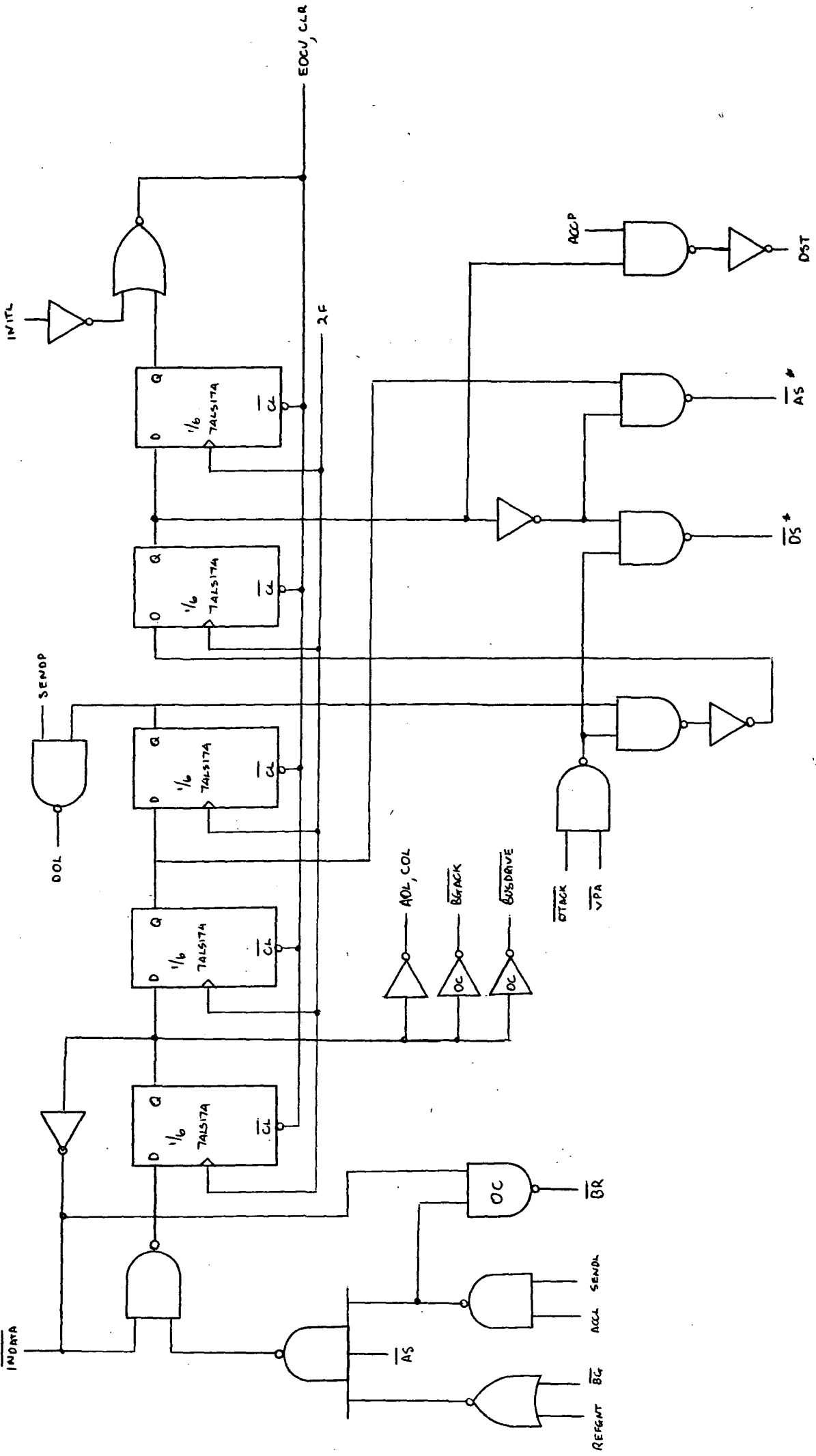

D.U. INTERFACE CARD
MASTER CONTROL SECTION

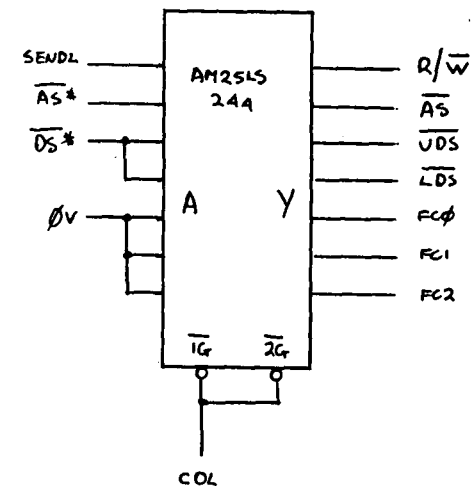
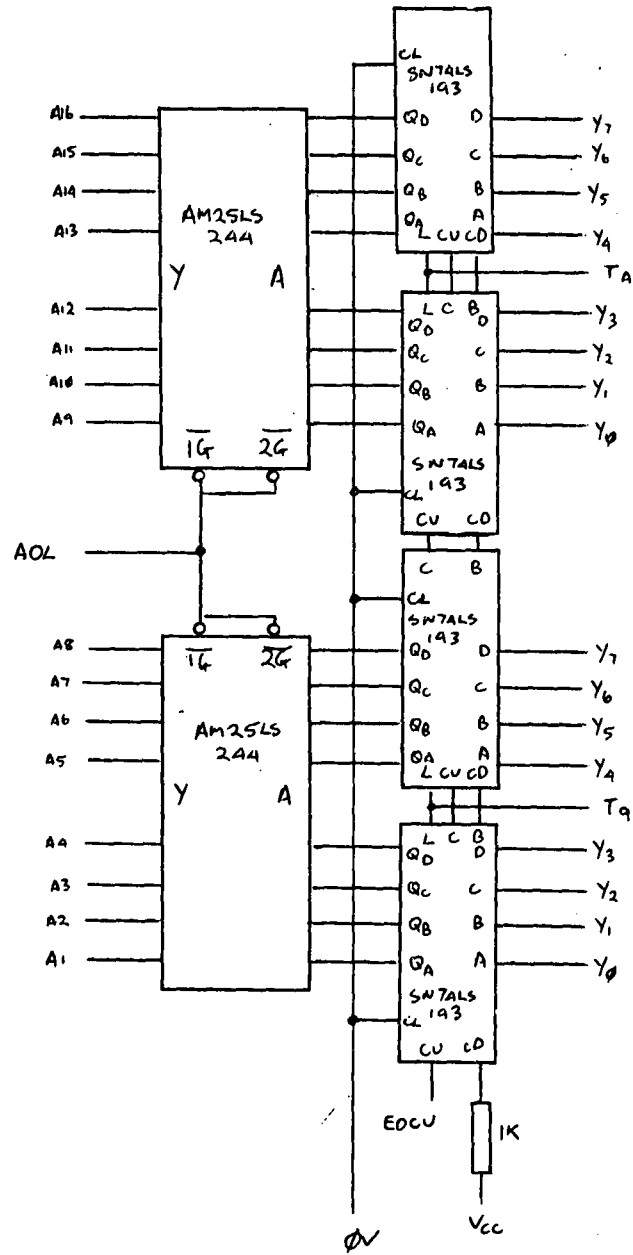
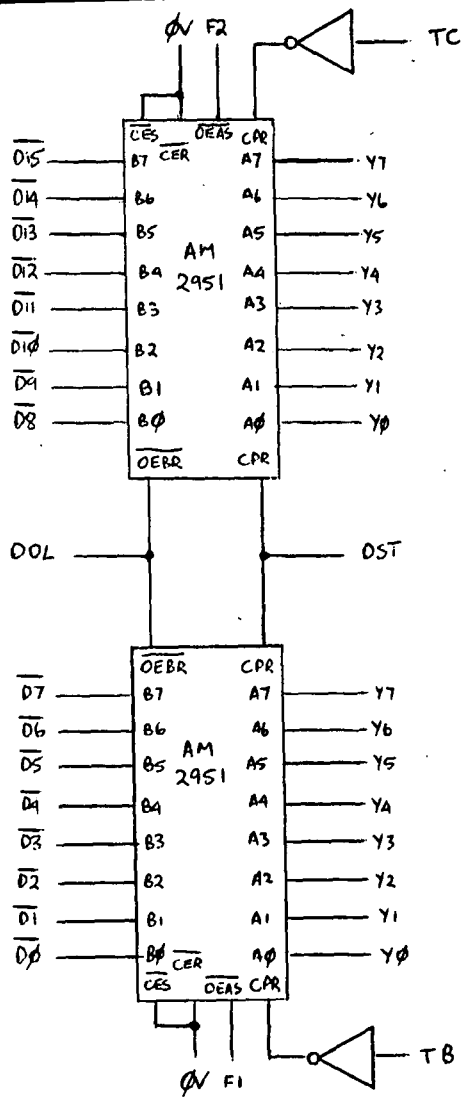

D.U INTERFACE CARD
2901 → 68000 BUFFERS/ADDRESS COUNTERS

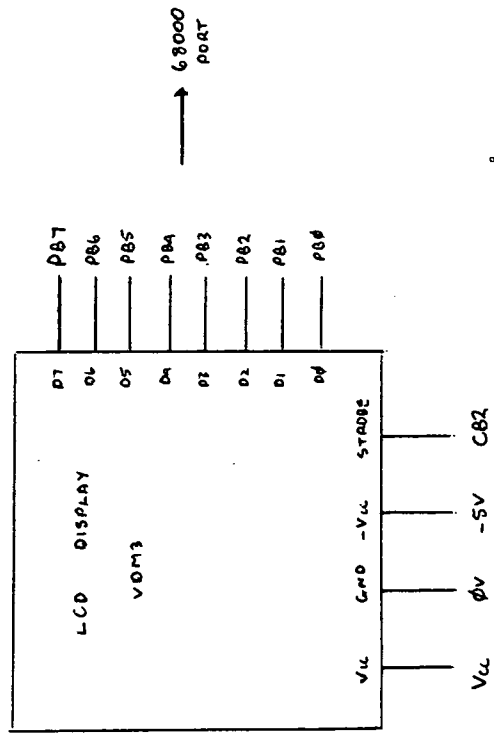
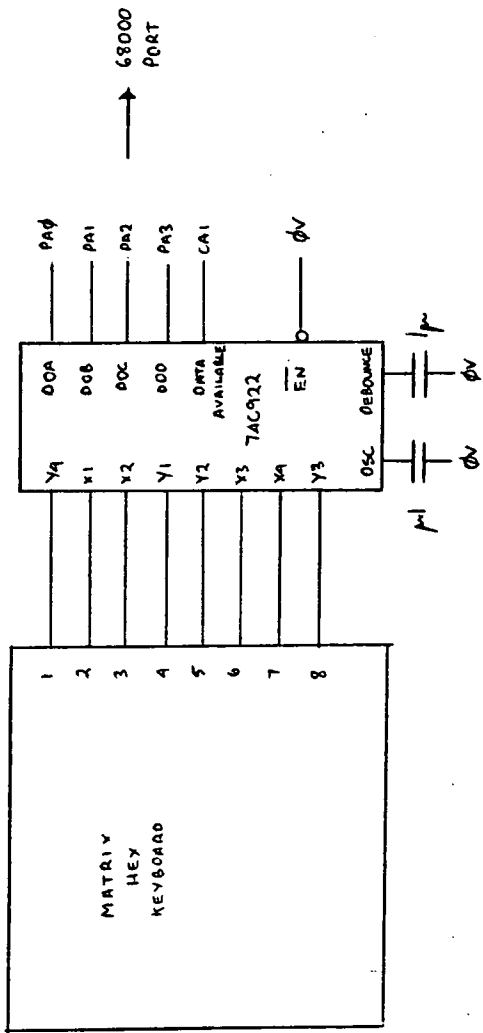

D.U. INTERFACE CARD
KEYPAD & LCD DISPLAY

Appendix D

Portable Highway Controller Commands

Portable Highway Controller Guide

Portable ASH Controller

User Instructions

The instructions which may be used by the operator are normally two character commands, terminated by an 'F'. The commands fall into three groups, as follows:-

Controller Operation

- C1** Start Controller, clear and enable interrupts to the MC68000 host.
- C2** Stop Controller.
- C3** Reset Controller and disable interrupts.
- CA** Direct Controller to 'Go Passive'.
- CC** Change cable, prompts for desired cable number.

General Highway Operation

- BA** Reset a single terminal unit. Prompts for relevant terminal unit.
- BB** Add a single terminal to the polling scheme.
- BC** Set up a complete new polling table.
- BD** Reset the system sync. time to zero.
- BE** Set up a new time of day. Enter a single character per line, as follows:- months*10, months, days*10, days, hours*10, hours, minutes*10, minutes.

Portable Highway Controller Guide

Monitoring Display

DB Display system time.

DC Display controller status.

DD Display statistics for a particular terminal unit.

DE Display the statistics of all terminal units.

Executive Systems

AAA Return executive control to the VDU.

Portable Highway Controller Guide

On power-up, the portable highway controller unit performs a reboot of the operating system for the MC68000. It then resets the ASH controller tables to their normal default conditions, including a polling table which consists of terminal units 0-16 inclusive. The MC68000 will then start the controller, which can then assume control of the ASH system, should it be the only active controller. The polling table may then be reset by the use of the **BB** or **BC** commands. After using the **AAA** command to redirect executive control to the VDU, control may be returned to the keypad/ front-panel display, by typing **_RES.**

Documented Bugs

1) Display Corruption. Due to a fault in the address decoding for the PIAs on the MEX68KDM board, occasional corruption of their control and data register contents can occur. To protect against this, the registers of the PIA which drive the keypad and display are checked and updated more often than necessary. This gives rise to the periodically flashing display unit. It will be possible to remove these additional checks in the next controller, which will not use the MEX68KDM boards.

2) Time of Day. A software fault in the version 1.2 controller software causes the time of day to be updated incorrectly in passive highway controller units. This fault is characterised by a time of day which appears to be stationary.

Appendix E
Graphs of ASH Test Results

ASH SEA TRIAL RESULTS

SMST

START DATE
18/1/81

START TIME
0/17/7

INTEGRATION
PERIOD

60 SECS

TERMINAL

NUMBER

1

VERTICAL SCALE: -
LOG ERROR RATE
HORIZONTAL SCALE: -
TIME (GMT)

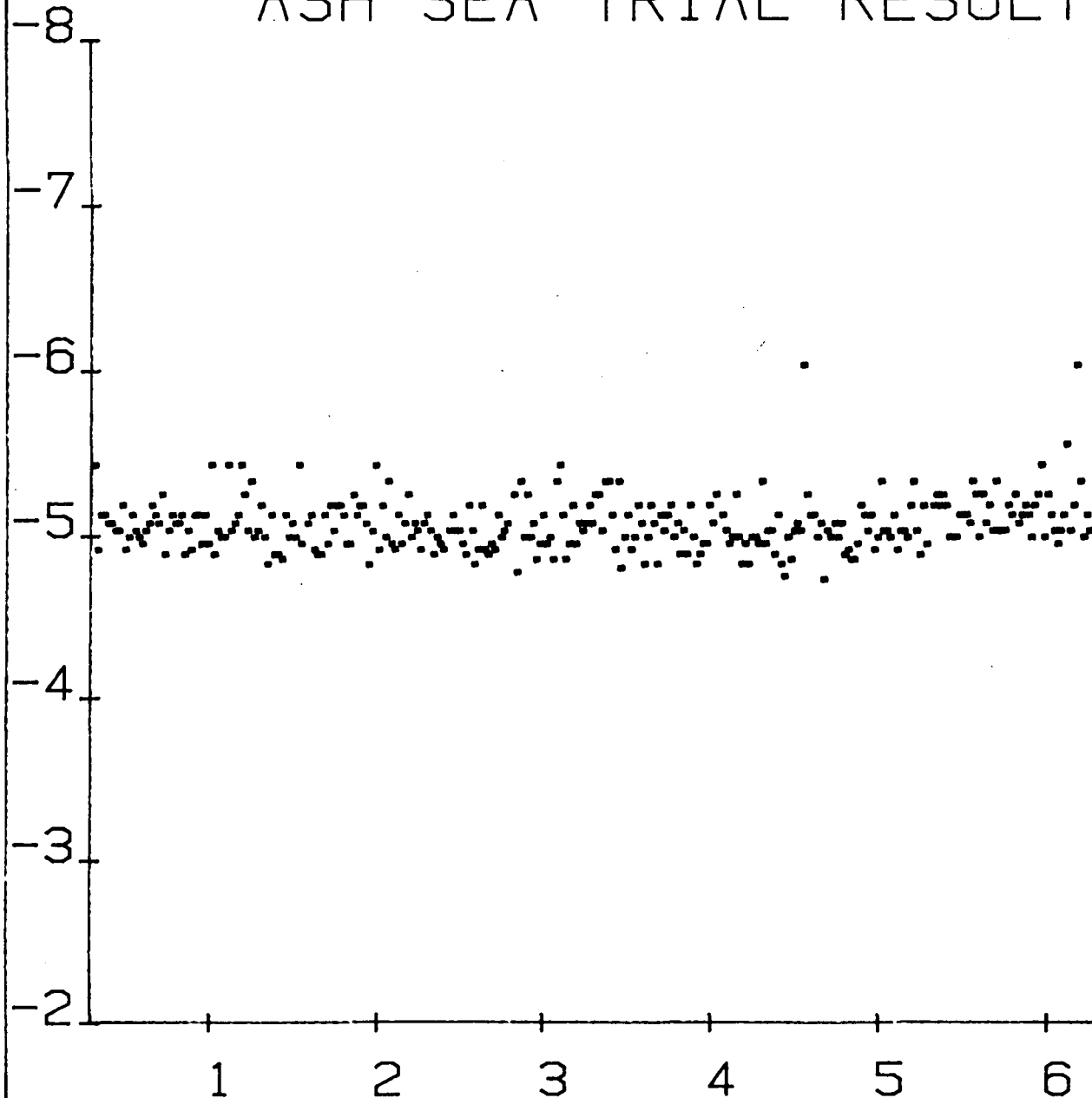

-Graph 1-

ASH SEA TRIAL RESULTS

SMST

START DATE
18/1/81

START TIME
0/17/7

INTEGRATION
PERIOD
300 SECS

TERMINAL
NUMBER
1

VERTICAL SCALE: -
LOG ERROR RATE
HORIZONTAL SCALE: -
TIME (GMT)

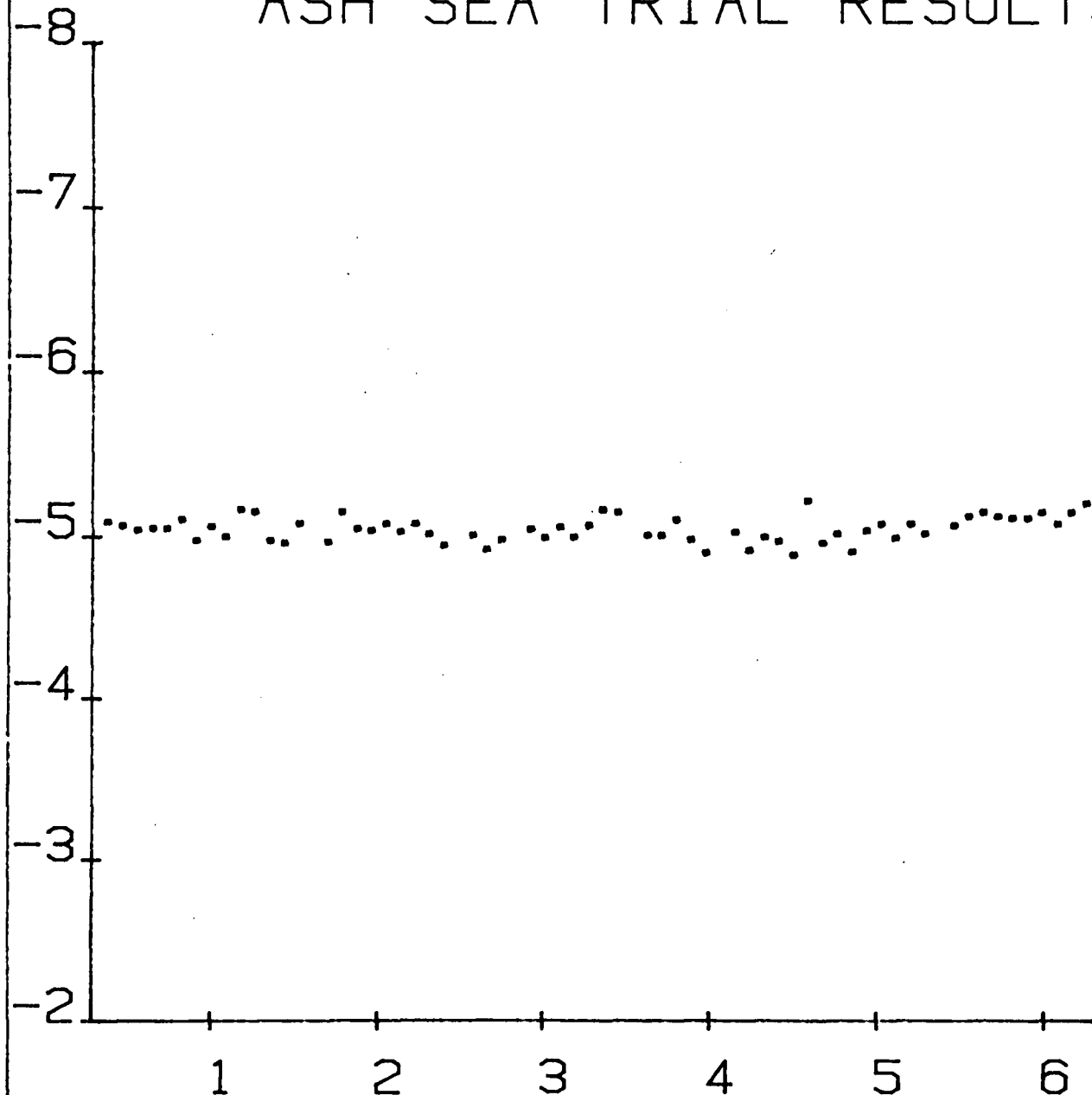

-Graph 2-

ASH SEA TRIAL RESULTS

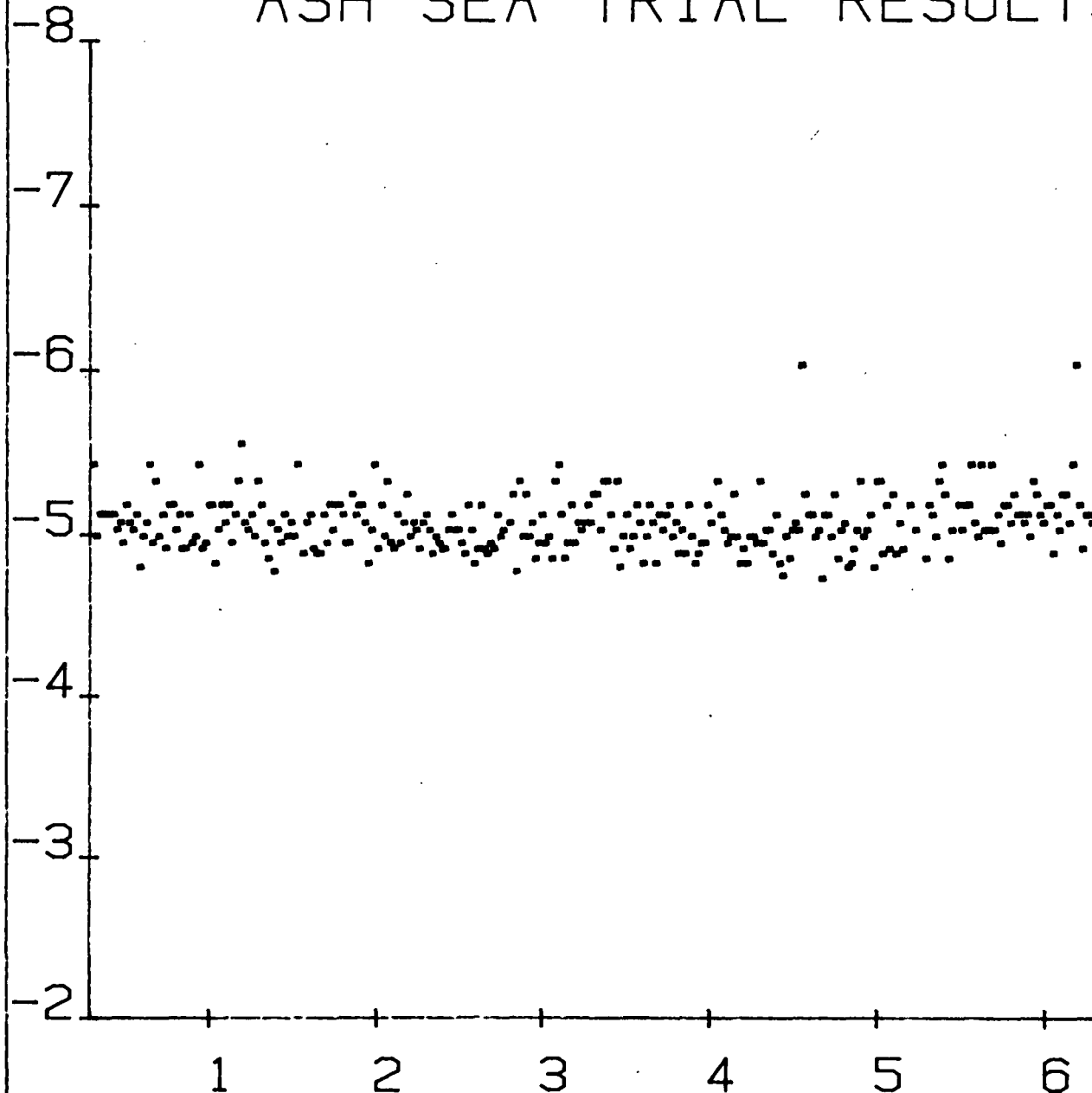

SMST.

START DATE
18/1/81

START TIME
0/17/7

INTEGRATION
PERIOD
60 SECS

TERMINAL
NUMBER
2

VERTICAL SCALE: -
LOG ERROR RATE
HORIZONTAL SCALE: -
TIME (GMT)

ASH SEA TRIAL RESULTS

SMST

START DATE
18/1/81

START TIME
0/17/7

INTEGRATION
PERIOD
60 SECS

TERMINAL
NUMBER
3

VERTICAL SCALE: -
LOG ERROR RATE
HORIZONTAL SCALE: -
TIME (GMT)

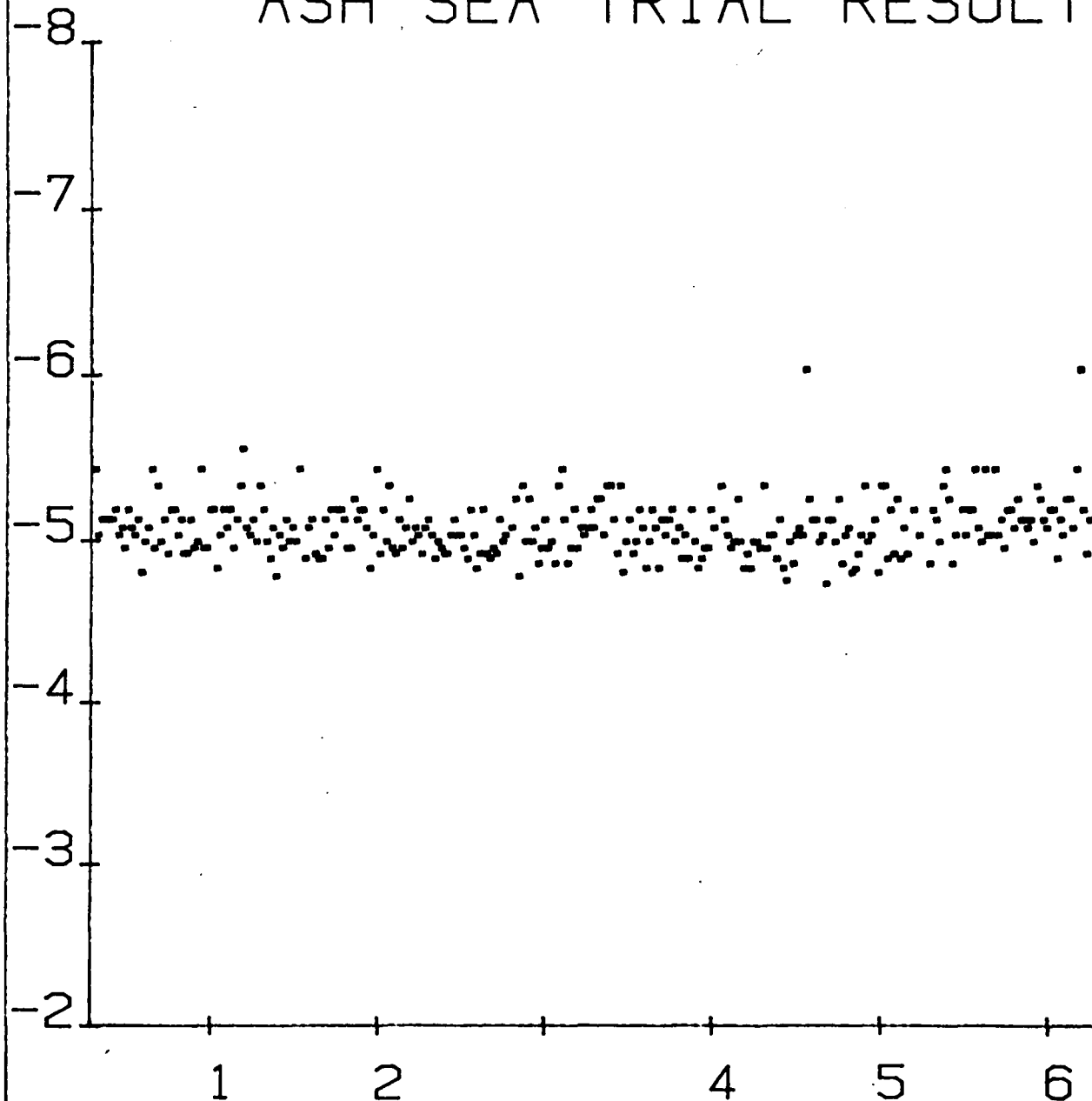

ASH SEA TRIAL RESULTS

SMST

START DATE
18/1/81

START TIME
0/17/7

INTEGRATION
PERIOD
60 SECS

TERMINAL
NUMBER
4

VERTICAL SCALE: -
LOG ERROR RATE
HORIZONTAL SCALE: -
TIME (GMT)

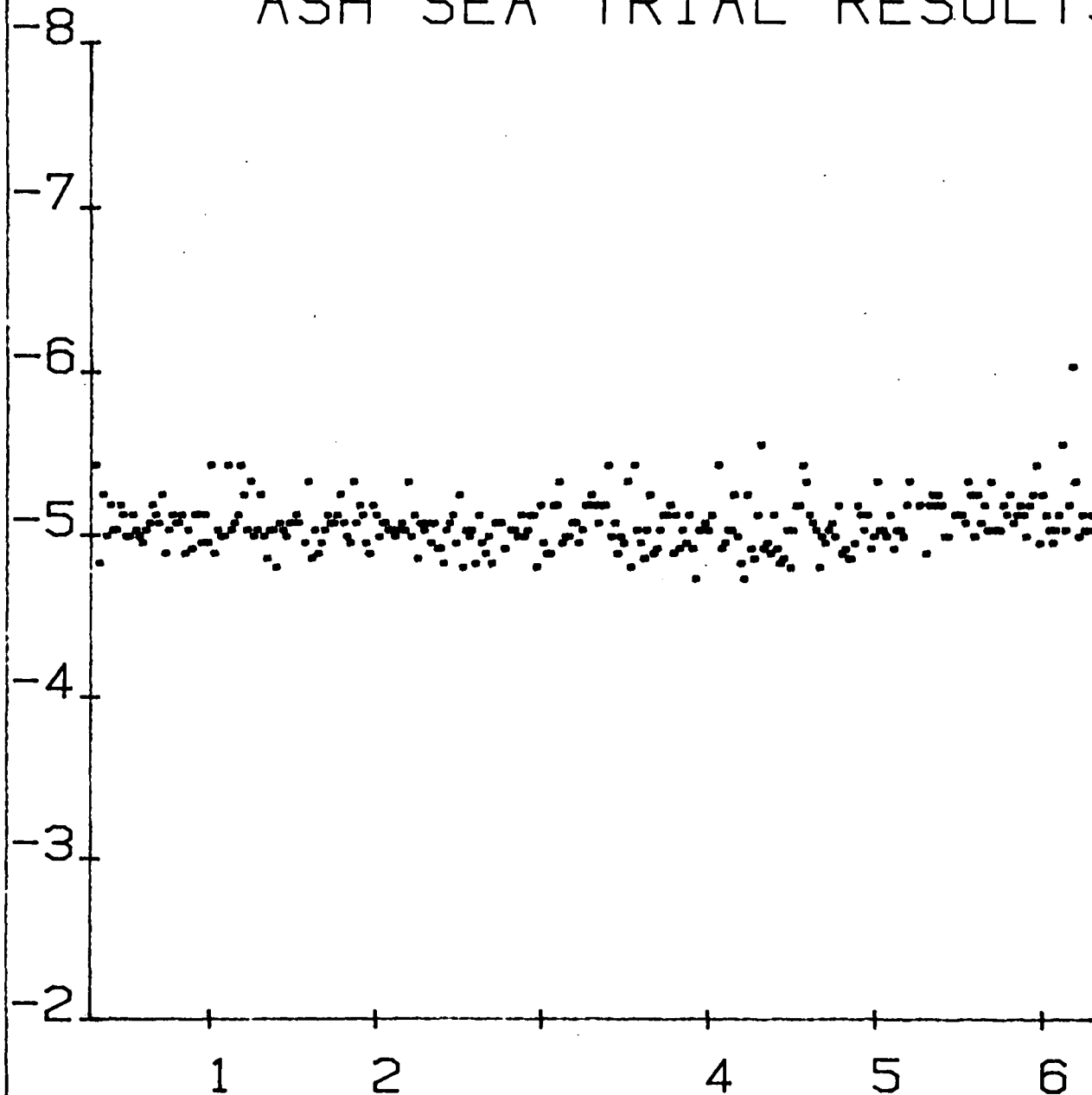

-Graph 5-

ASH SEA TRIAL RESULTS

SMST

START DATE

18/1/81

START TIME

0/17/7

INTEGRATION
PERIOD

1200 SECS

TERMINAL

NUMBER

0

VERTICAL SCALE: -

LOG ERROR RATE

HORIZONTAL SCALE: -

TIME (GMT)

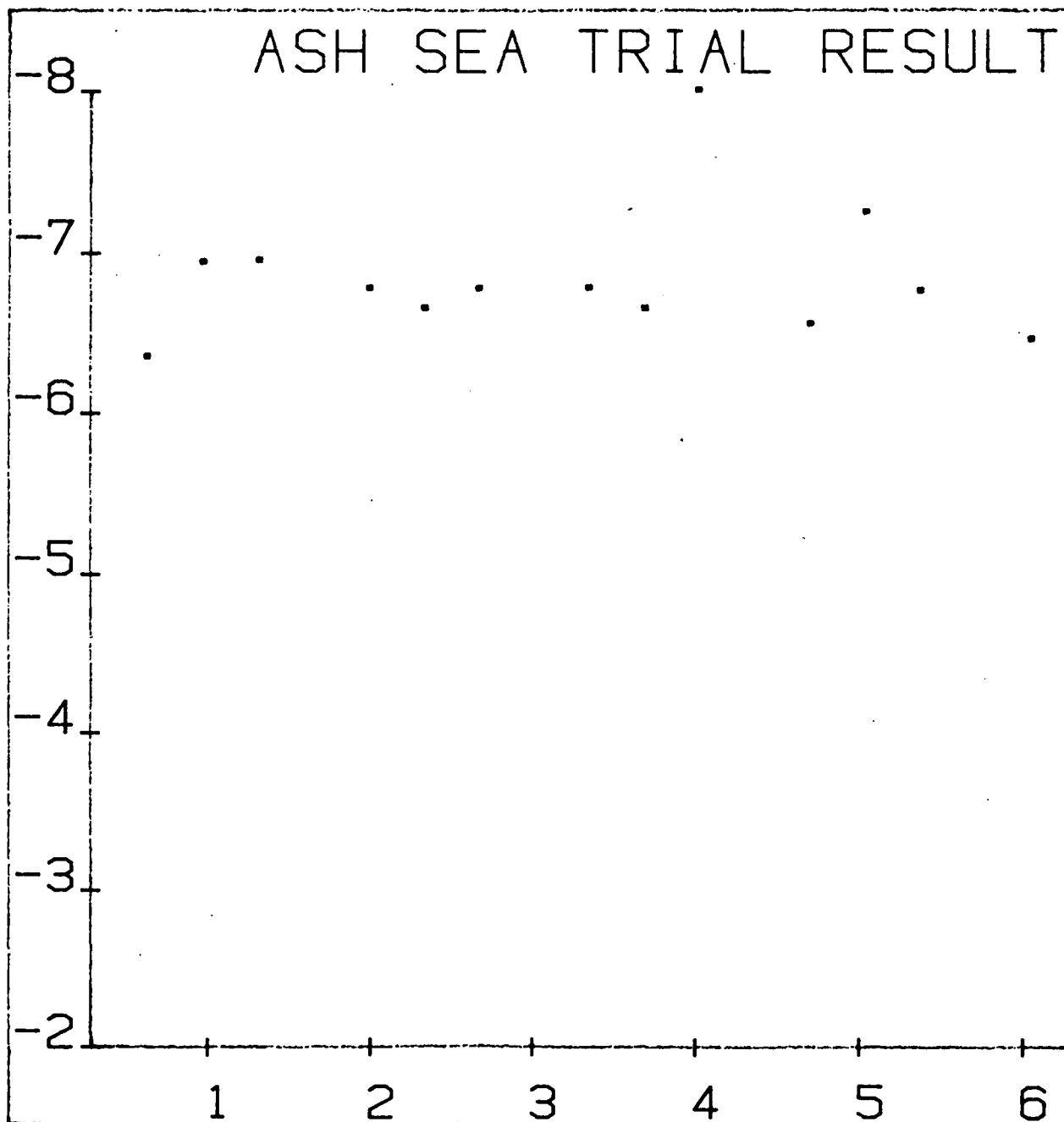

ASH SEA TRIAL RESULTS

SMST

START DATE

19/1/81

START TIME

14/21/36

INTEGRATION PERIOD

300 SECS

TERMINAL

NUMBER

0

VERTICAL SCALE: -

LOG ERROR RATE

HORIZONTAL SCALE: -

TIME (GMT)

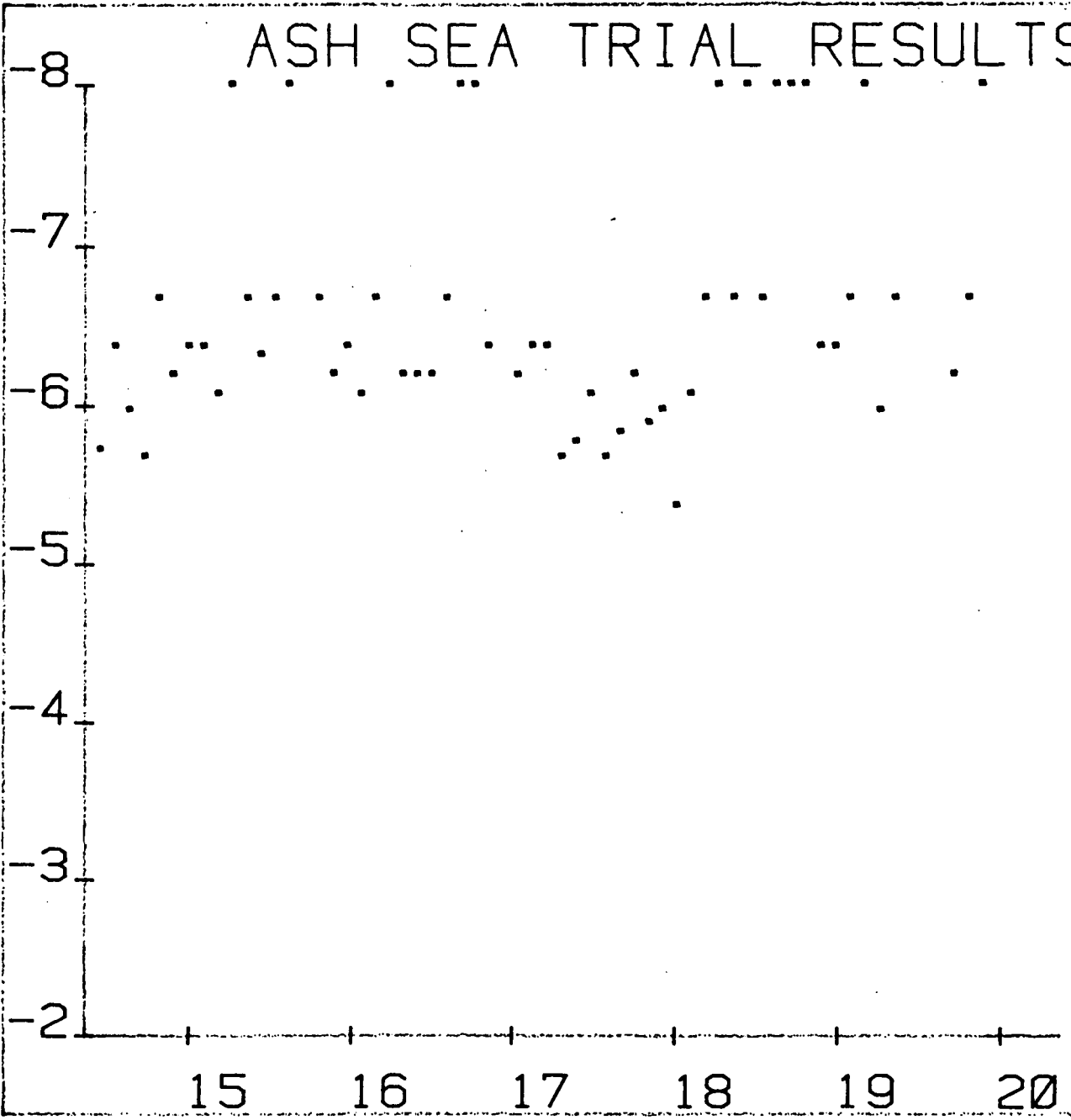

-Graph 7-

ASH SEA TRIAL RESULTS

SMST

START DATE
19/1/81

START TIME
14/22/1

INTEGRATION
PERIOD
60 SECS

TERMINAL
NUMBER
1

VERTICAL SCALE: -
LOG ERROR RATE
HORIZONTAL SCALE: -
TIME (GMT)

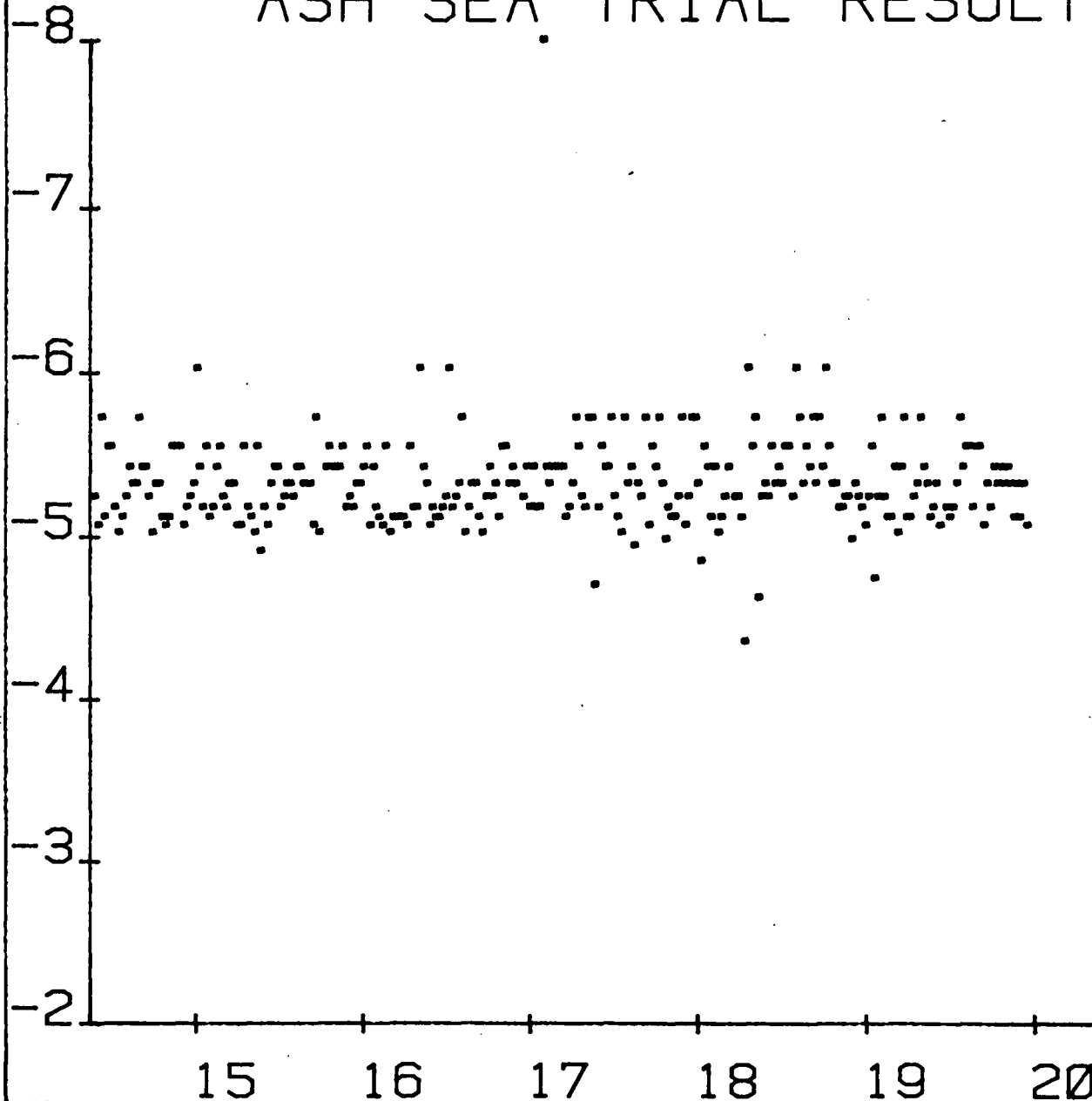

-Graph 8-

ASH SEA TRIAL RESULTS

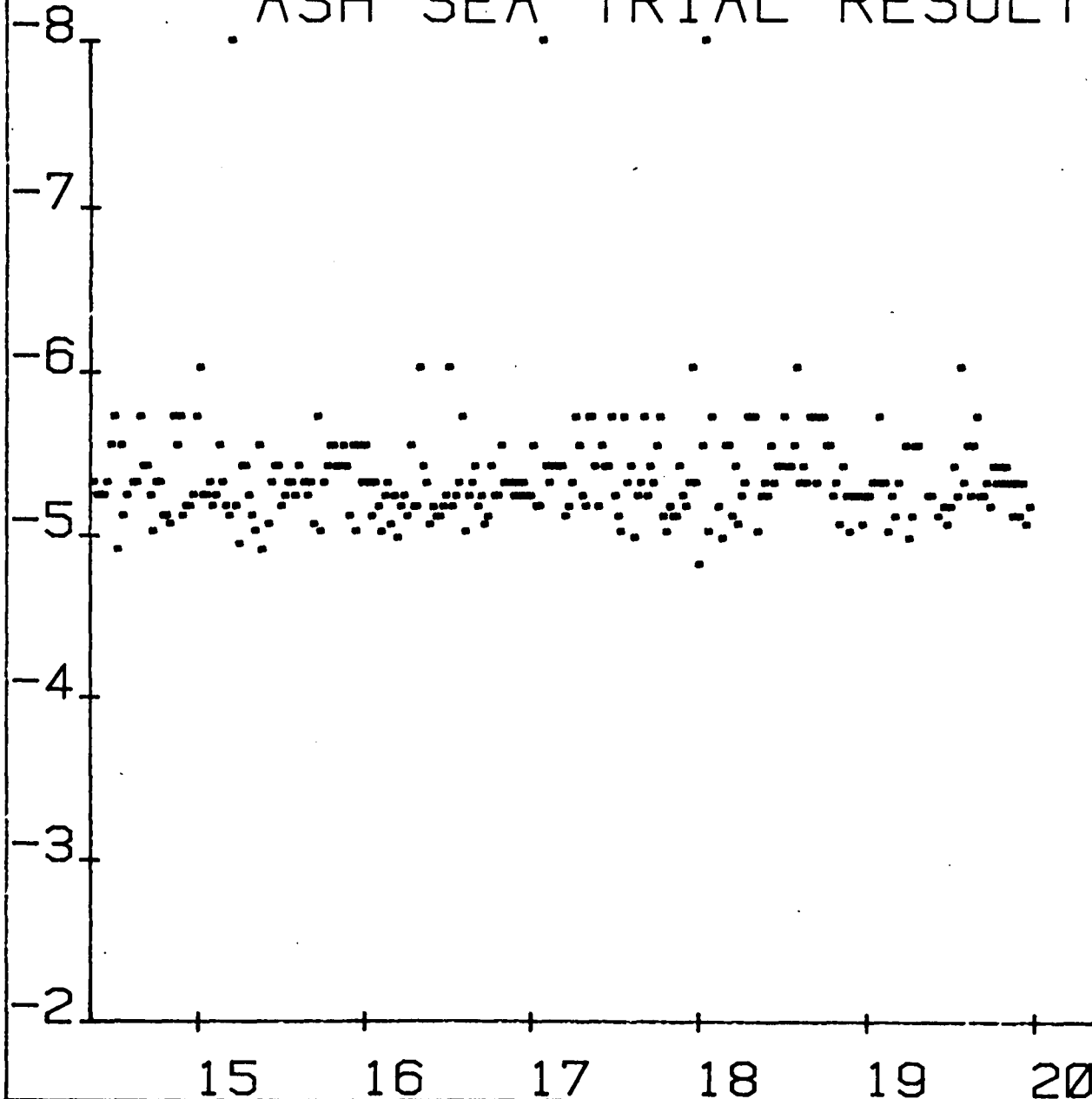

SMST

START DATE

19/1/81

START TIME

14/21/36

INTEGRATION
PERIOD

60 SECS

TERMINAL

NUMBER

2

VERTICAL SCALE: -

LOG ERROR RATE

HORIZONTAL SCALE: -

TIME (GMT)

ASH SEA TRIAL RESULTS

SMST

START DATE

19/1/81

START TIME

14/21/36

INTEGRATION
PERIOD

60 SECS

TERMINAL

NUMBER

3

VERTICAL SCALE: -

LOG ERROR RATE

HORIZONTAL SCALE: -

TIME (GMT)

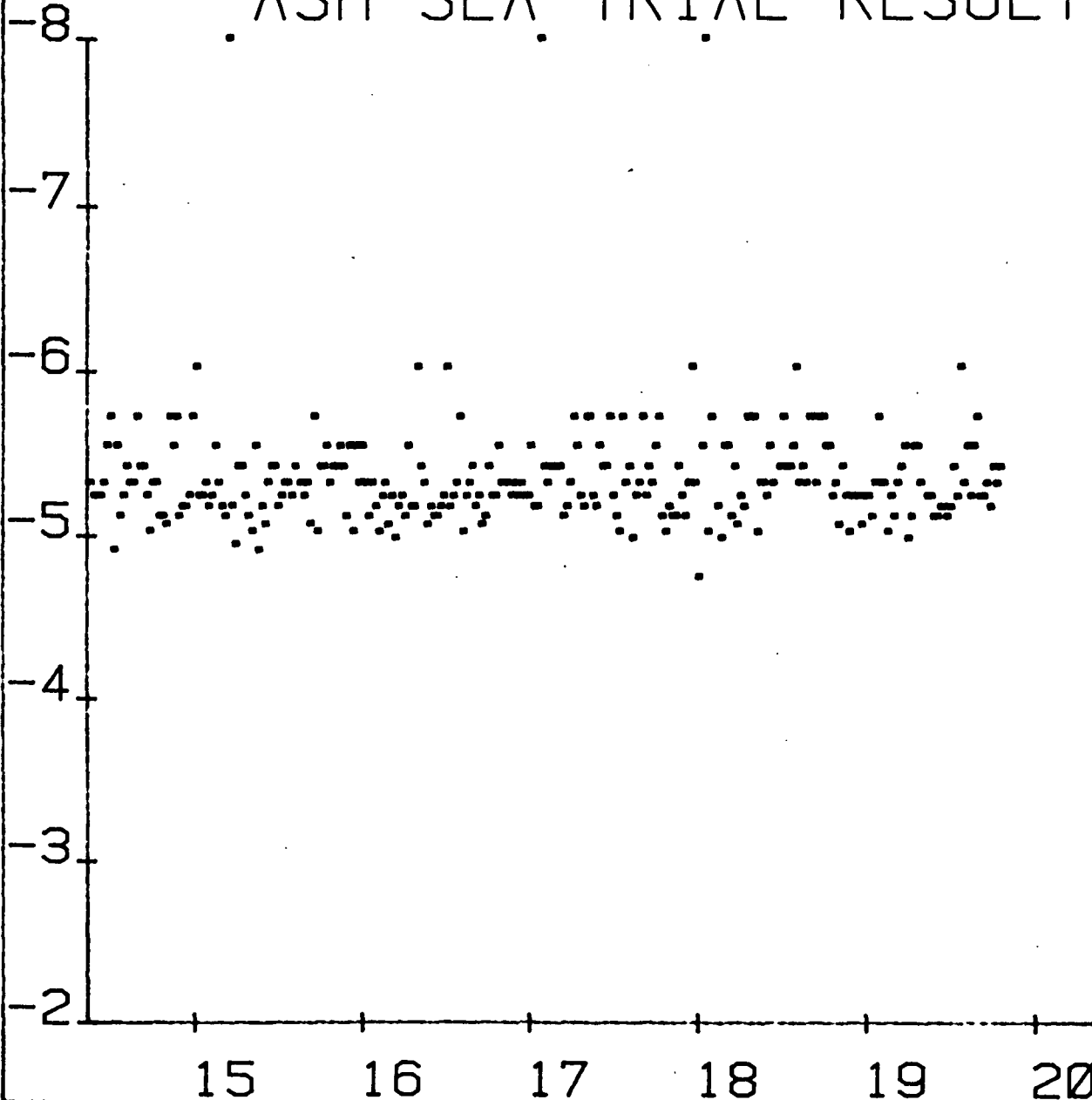

ASH SEA TRIAL RESULTS

SMST

START DATE
19/1/81

START TIME
14/21/36

INTEGRATION
PERIOD
60 SECS
TERMINAL
NUMBER
4

VERTICAL SCALE: -
LOG ERROR RATE
HORIZONTAL SCALE: -
TIME (GMT)

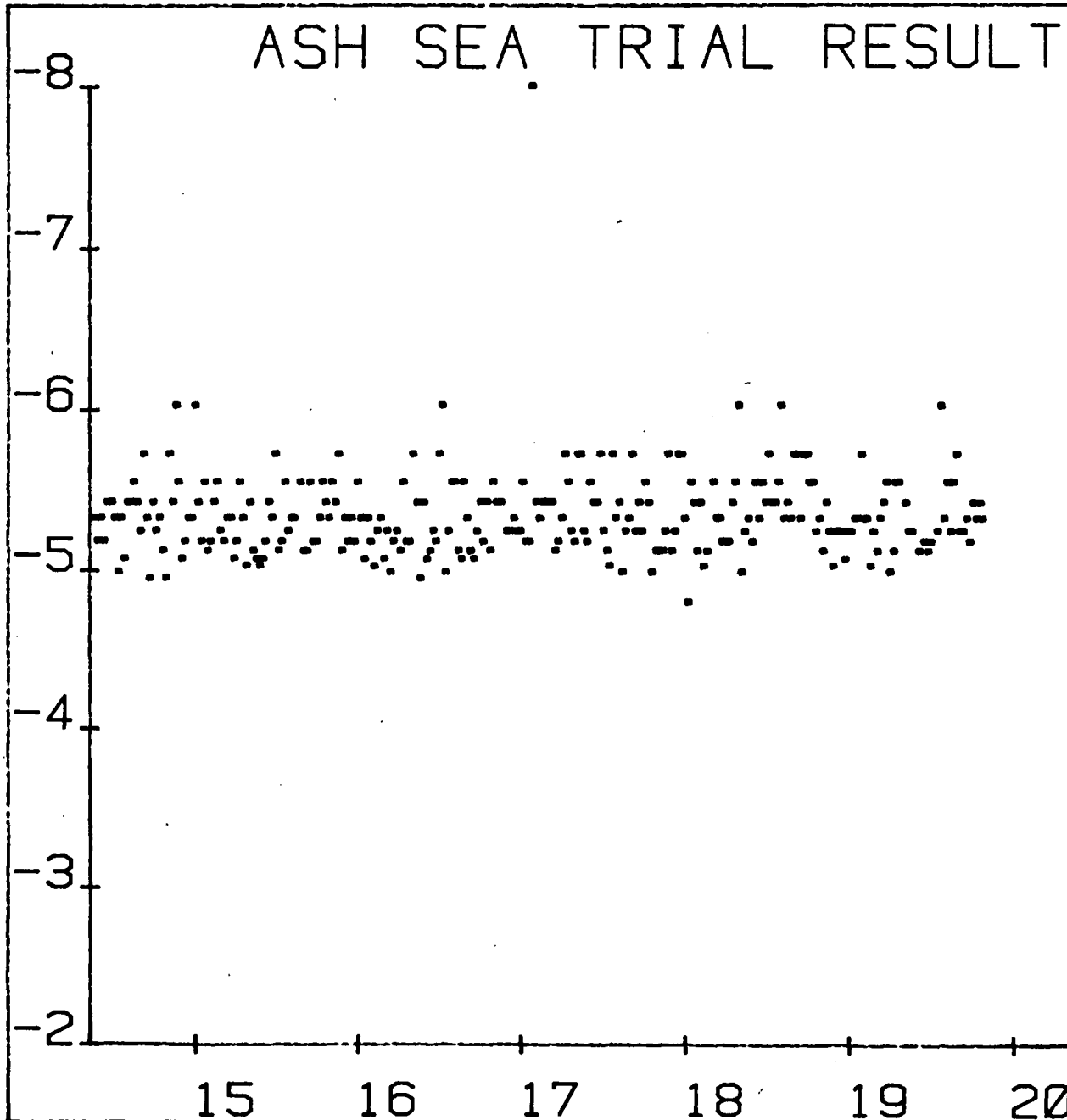

Graph 11-

ASH SEA TRIAL RESULTS

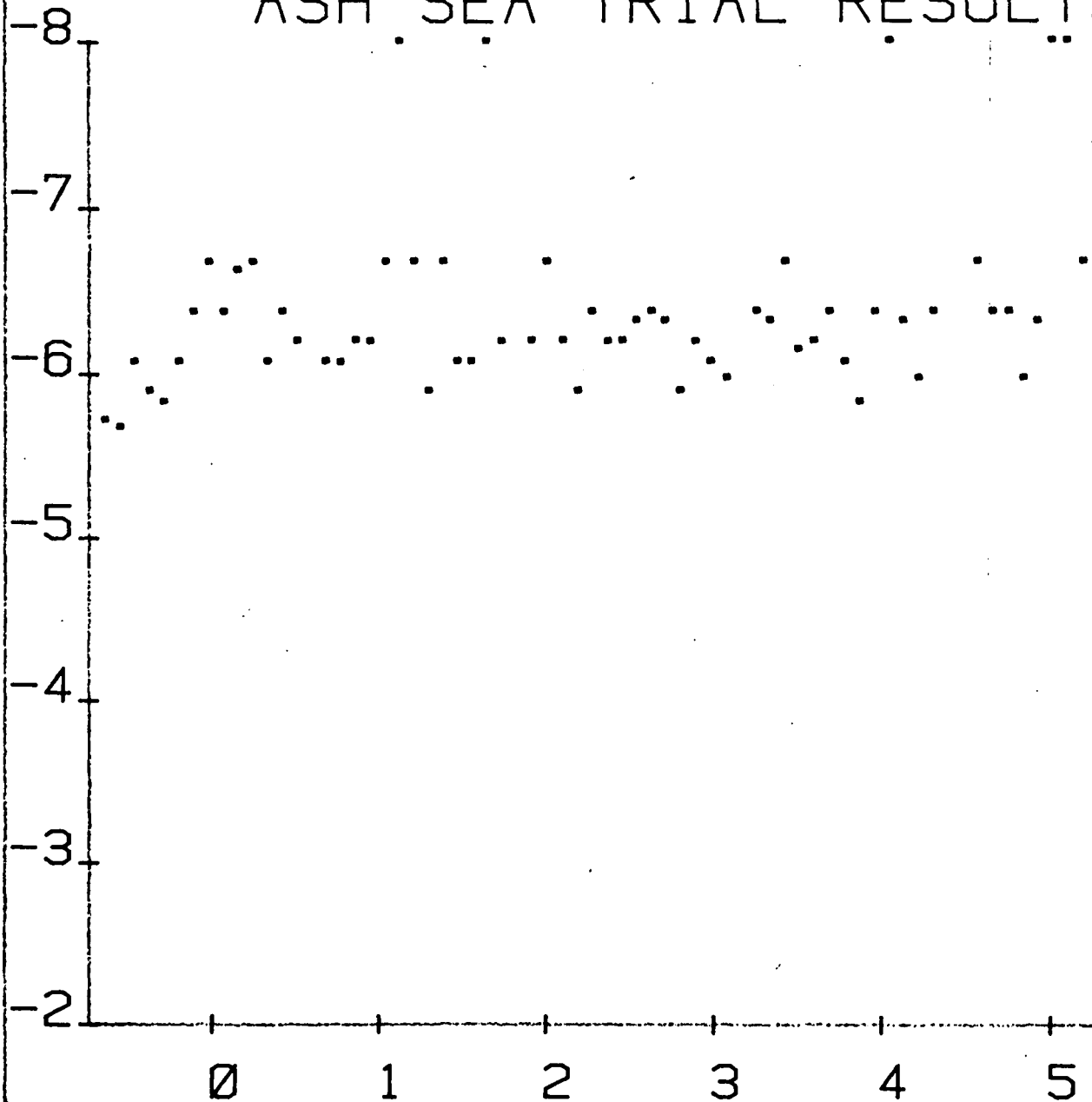

SMST

START DATE
19/1/81

START TIME
23/15/56

INTEGRATION
PERIOD
300 SECS

TERMINAL
NUMBER
0

VERTICAL SCALE: -
LOG ERROR RATE
HORIZONTAL SCALE: -
TIME (GMT)

Graph 12-

ASH SEA TRIAL RESULTS

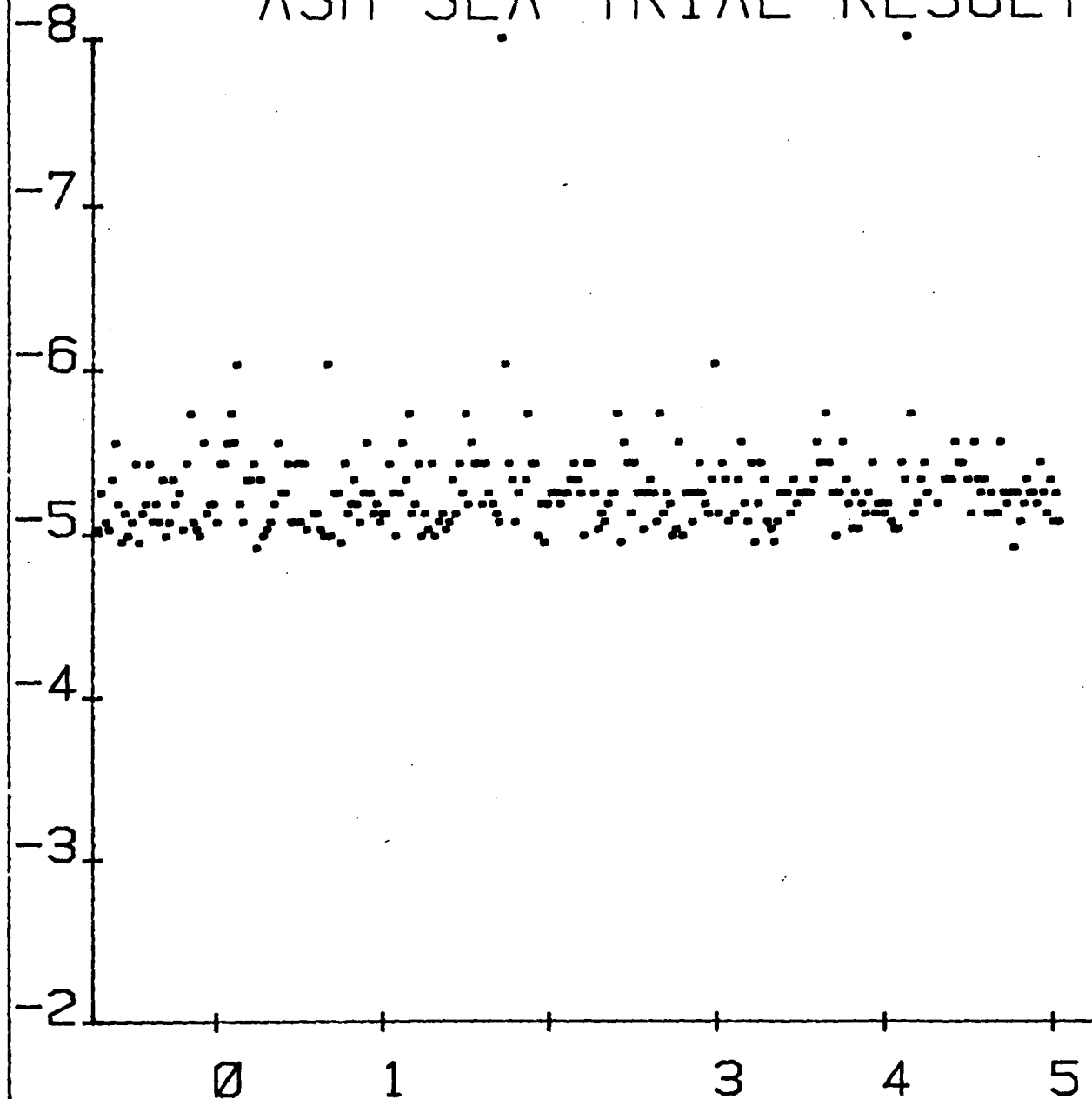

SMST

START DATE
19/1/81

START TIME
23/16/1

INTEGRATION
PERIOD

60 SECS

TERMINAL
NUMBER

1

VERTICAL SCALE -
LOG ERROR RATE
HORIZONTAL SCALE -
TIME (GMT)

ASH SEA TRIAL RESULTS

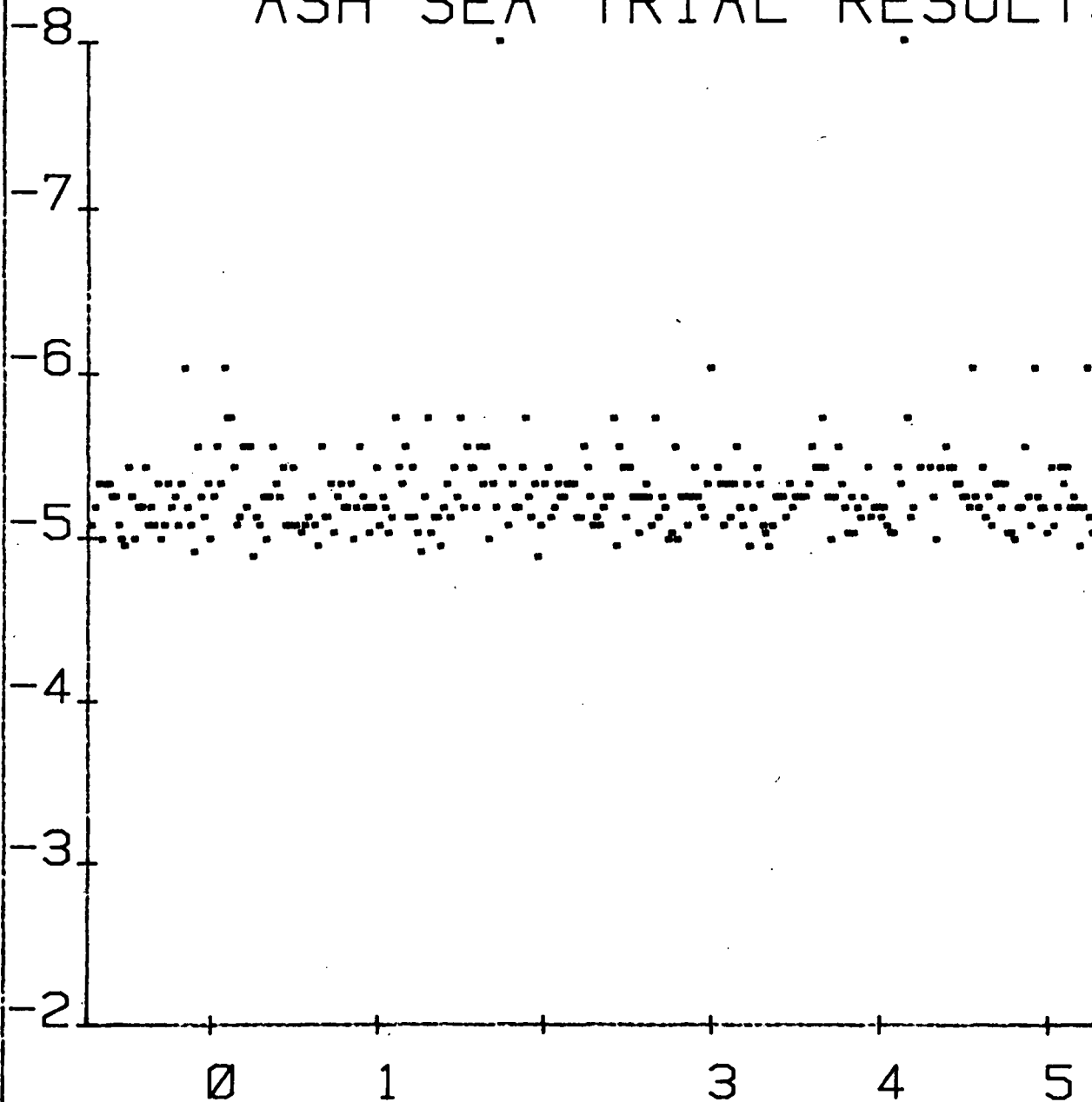

SMST

START DATE
19/1/81

START TIME
23/15/56

INTEGRATION
PERIOD
60 SECS

TERMINAL
NUMBER
2

VERTICAL SCALE: -
LOG ERROR RATE
HORIZONTAL SCALE: -
TIME (GMT)

ASH SEA TRIAL RESULTS

SMST

START DATE
19/1/81

START TIME
23/15/56

INTEGRATION
PERIOD
60 SECS

TERMINAL
NUMBER
3

VERTICAL SCALE: -
LOG ERROR RATE
HORIZONTAL SCALE: -
TIME (GMT)

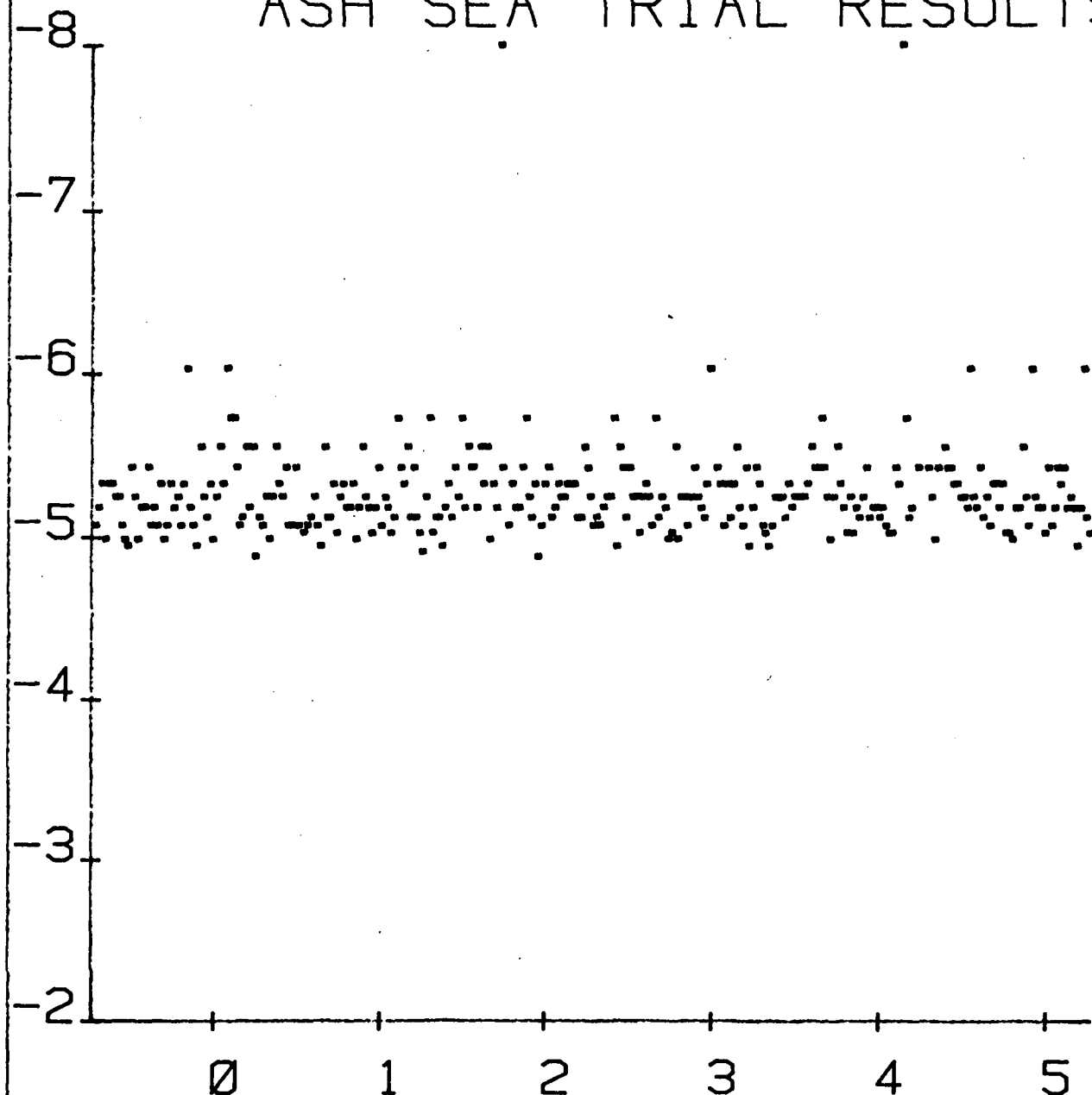

-Graph 15-

ASH SEA TRIAL RESULTS

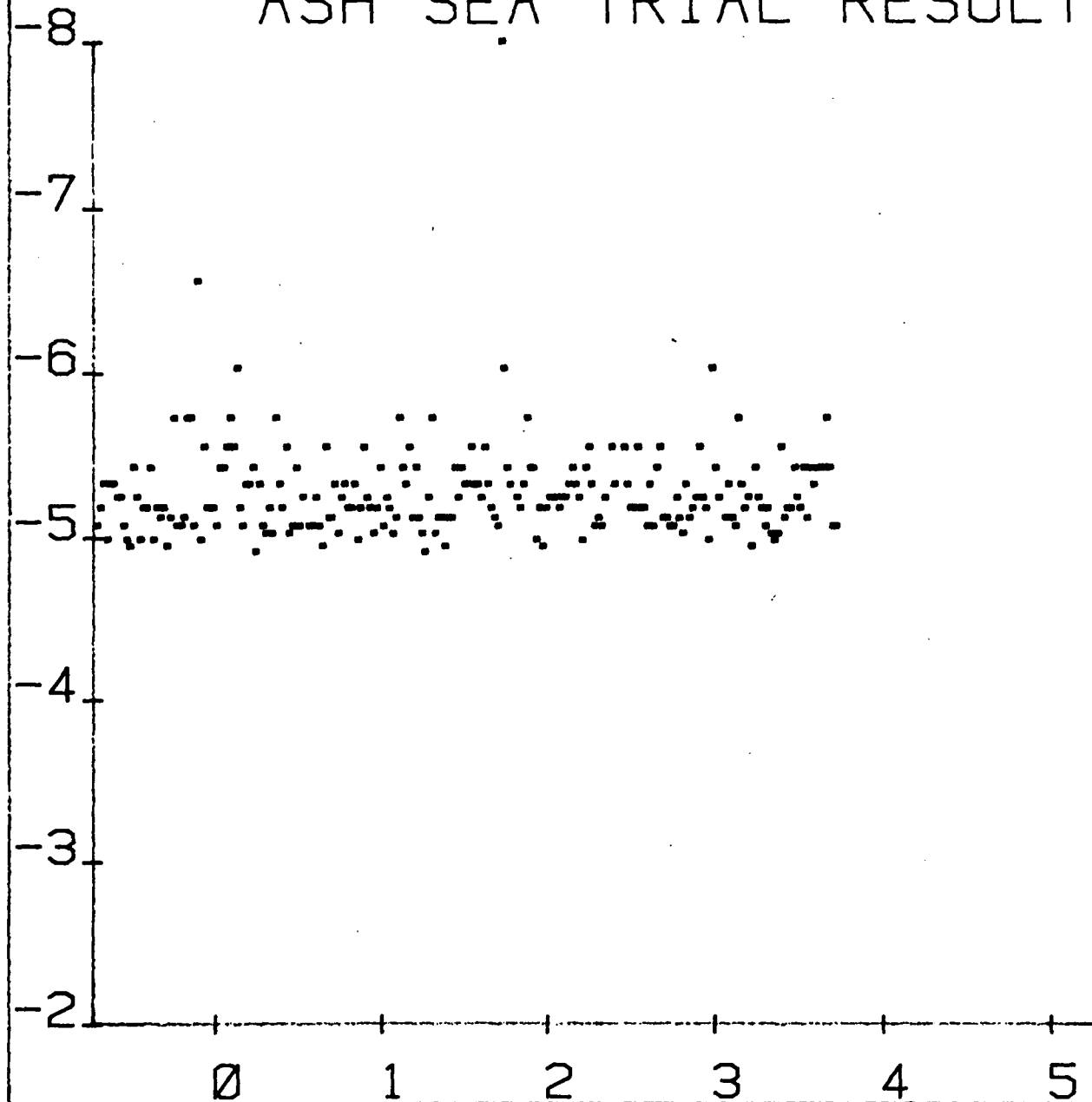

SMST

START DATE

19/1/81

START TIME

23/15/56

INTEGRATION
PERIOD

60 SECS

TERMINAL

NUMBER

4

VERTICAL SCALE: -
LOG ERROR RATE
HORIZONTAL SCALE: -
TIME (GMT)

ASH SEA TRIAL RESULTS

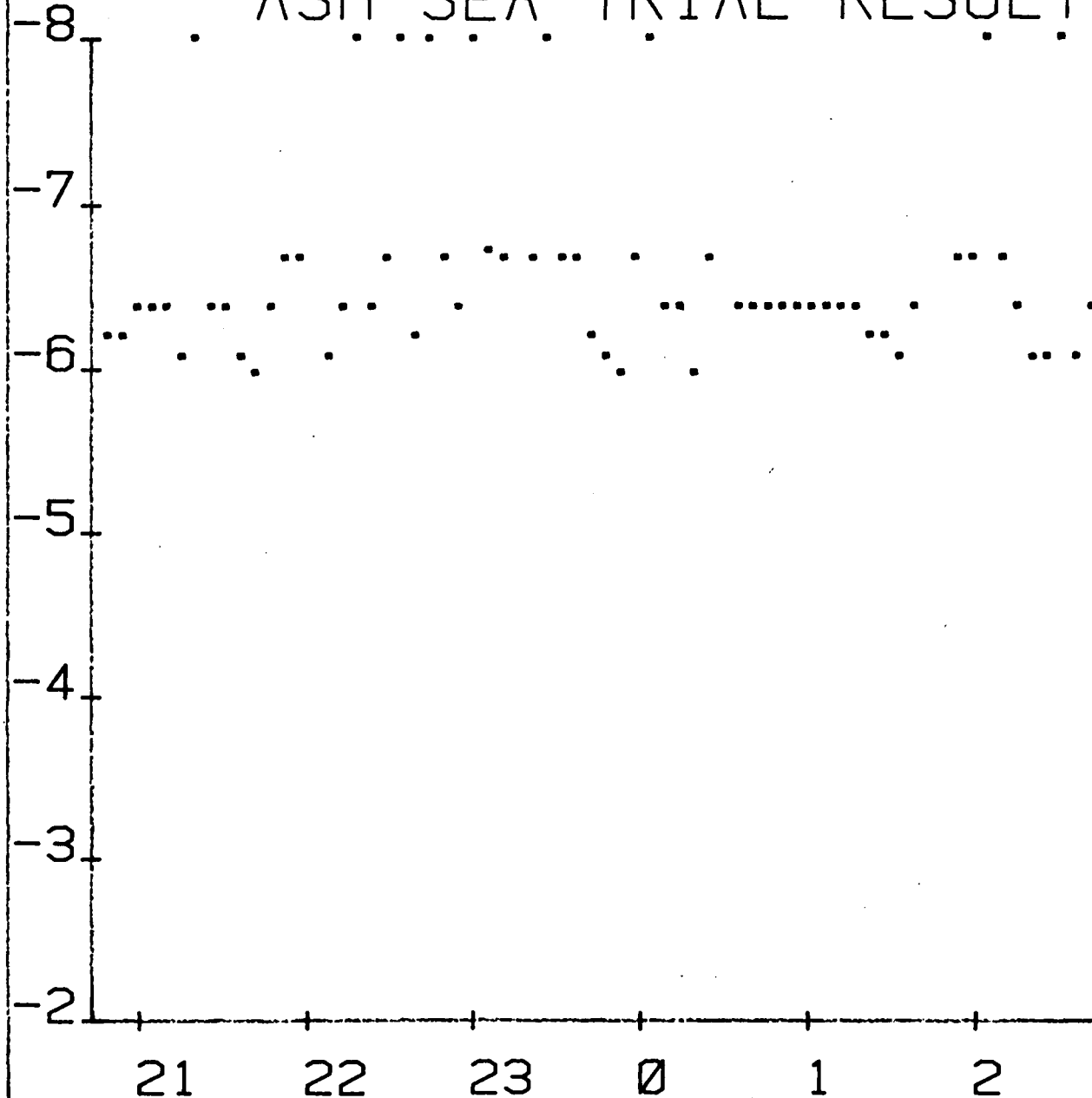

SMST

START DATE

21/1/81

START TIME

20/42/39

INTEGRATION PERIOD

300 SECS

TERMINAL

NUMBER

0

VERTICAL SCALE: -

LOG ERROR RATE

HORIZONTAL SCALE: -

TIME (GMT)

ASH SEA TRIAL RESULTS

SMST

START DATE
21/1/81

START TIME
20/42/44

INTEGRATION
PERIOD

60 SECS

TERMINAL
NUMBER

1

VERTICAL SCALE: -
LOG ERROR RATE
HORIZONTAL SCALE: -
TIME (GMT)

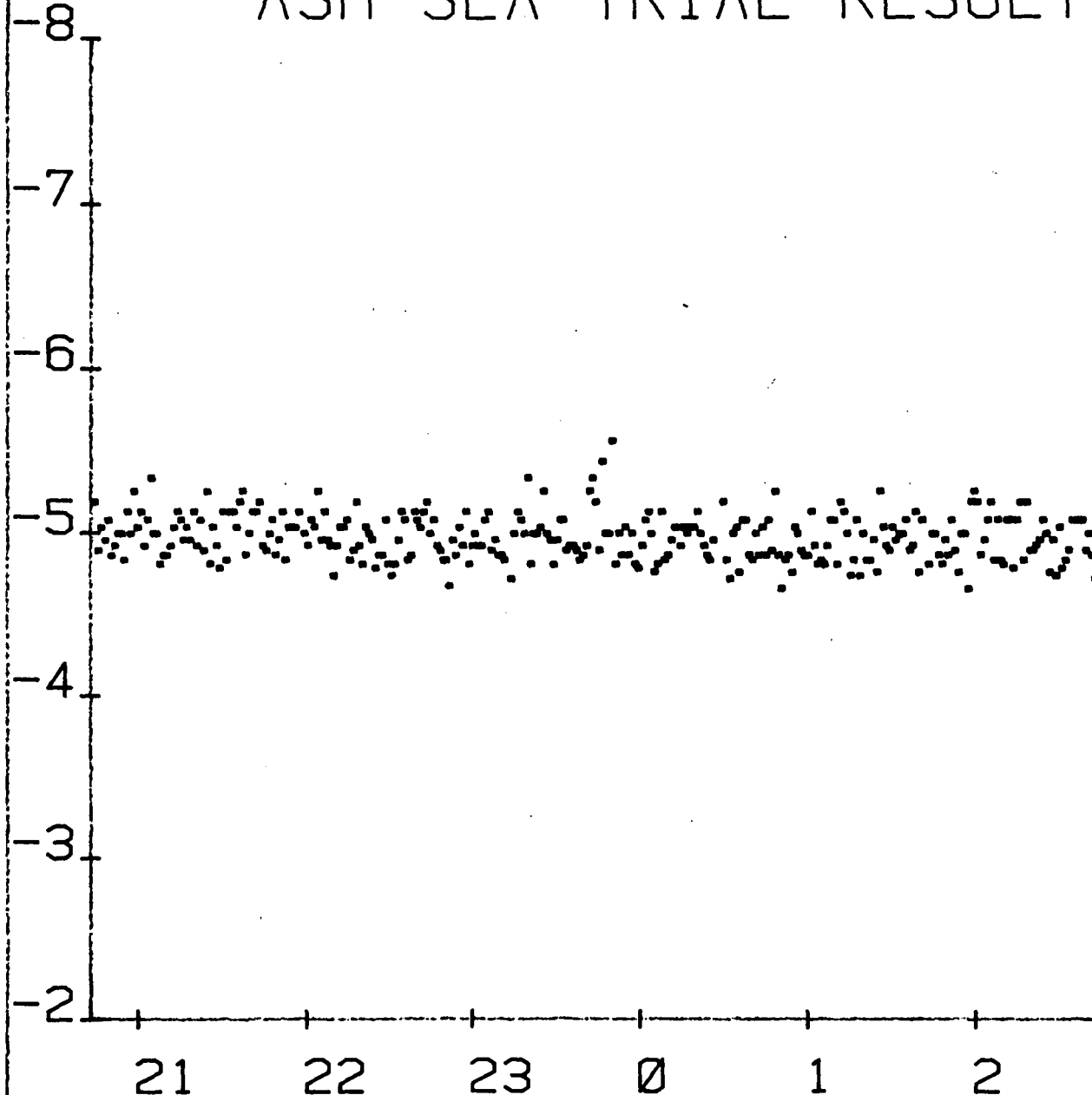

ASH SEA TRIAL RESULTS

SMST

START DATE

21/1/81

START TIME

20/42/39

INTEGRATION
PERIOD

60 SECS

TERMINAL

NUMBER

2

VERTICAL SCALE: -

LOG ERROR RATE

HORIZONTAL SCALE: -

TIME (GMT)

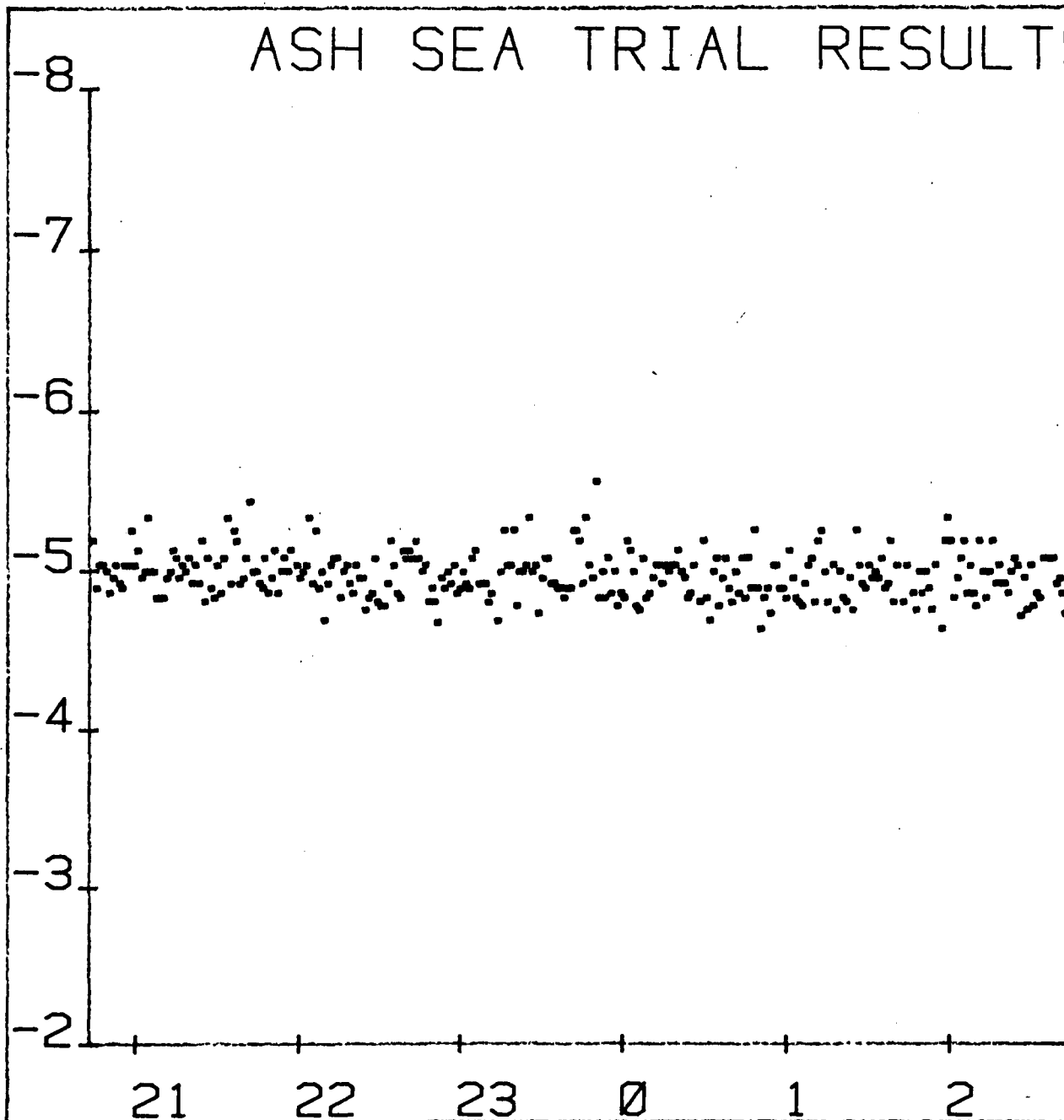

ASH SEA TRIAL RESULTS

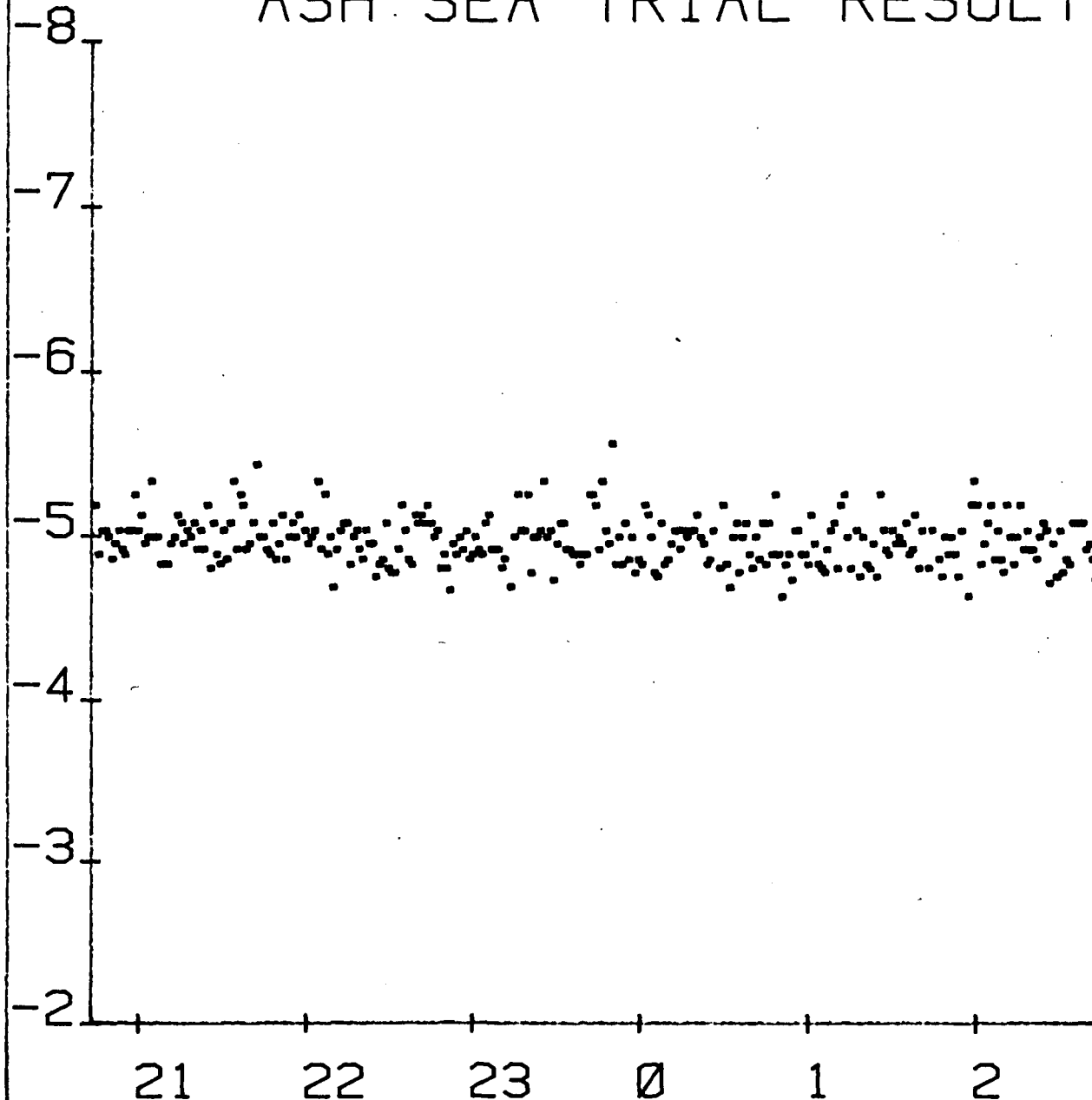

SMST

START DATE

21/1/81

START TIME

20/42/39

INTEGRATION
PERIOD

60 SECS

TERMINAL

NUMBER

3

VERTICAL SCALE: -
LOG ERROR RATE
HORIZONTAL SCALE: -
TIME (GMT)

ASH SEA TRIAL RESULTS

SMST

START DATE
21/1/81

START TIME
20/42/44

INTEGRATION
PERIOD

60 SECS

TERMINAL

NUMBER

4

VERTICAL SCALE: -
LOG ERROR RATE
HORIZONTAL SCALE: -
TIME (GMT)

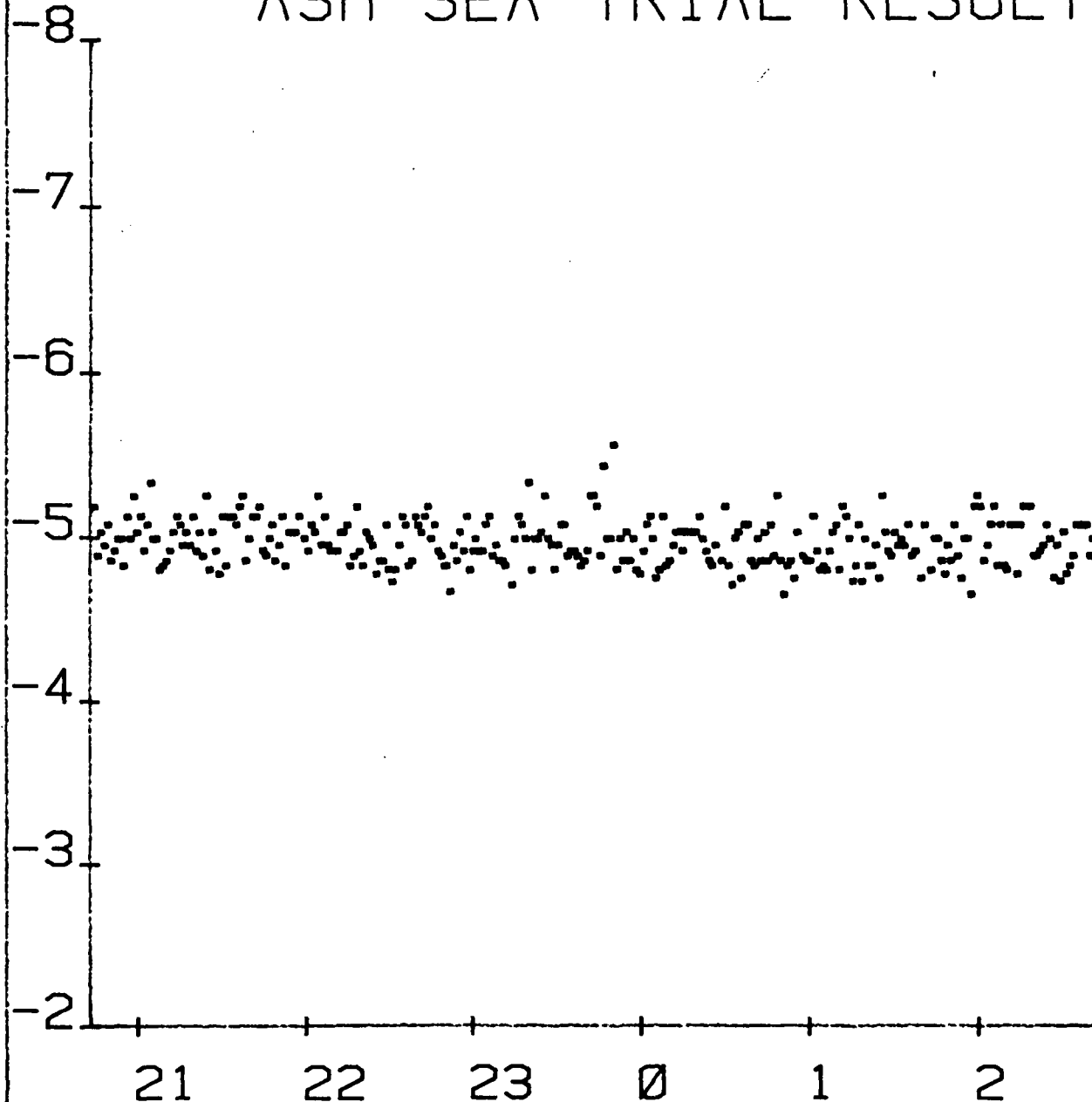

ASH CONTROL RESULTS

SMST

START DATE

1/2/81

START TIME

8/50/56

INTEGRATION

PERIOD

60 SECS

TERMINAL

NUMBER

1

VERTICAL SCALE -

LOG ERROR RATE

HORIZONTAL SCALE -

TIME (GMT)

